

BROADCAST[®] ENGINEERING

October 1985/\$3



1985
salary survey:
How do you rate?

The
state of
stereo TV



Shure's new FP31 Mixer takes a big weight off your shoulders.

Introducing the most innovative field production mixer of its kind. Shure's FP31. You won't find another mixer this small with these features, dependability and ease of operation.

The FP31 measures only 6⁵/₁₆" x 5⁵/₁₆" x 1⁷/₈", and weighs just 2.2 pounds! Incredibly, it offers the same important features as much larger mixers. Plus, a few of its own.

Every channel has a mic/line level and a low-cut filter switch. And to prevent overload distortion, there's a built-in limiter with adjustable threshold.

The FP31 can be powered by two internal 9-volt batteries, or from an external 12-volt source. A green LED flashes to remind you that the mixer is on. Phantom and A-B power are also provided to operate lavalier and shotgun microphones.

A slate tone can be laid

down on the tape for locating specific takes, and there's also a built-in mic for voice slating.

The mixer also has two separate mic/line outputs for 2-camera shoots and a tape output to feed a cassette. For monitoring, there are two stereo headphone jacks—one 1/4-inch and one for miniplugs. The FP31's rugged nylon carrying case allows you easy access to every mixer function and lets you piggyback the mixer on your VCR or other equipment.

For ENG, EFP and film use, Shure's FP31 has everything you need to make your mix a perfect success. Coming from a mixer this small, that's quite an accomplishment.

For more information on Shure's FP31 Mixer, call or write Shure Brothers Inc., 222 Hartrey Ave., Evanston, IL 60204, (312) 866-2553.



SHURE®

THE SOUND OF THE PROFESSIONALS®...WORLDWIDE

Circle (1) on Reply Card

www.americanradiohistory.com

**Put
yourself
in some
good
company.**

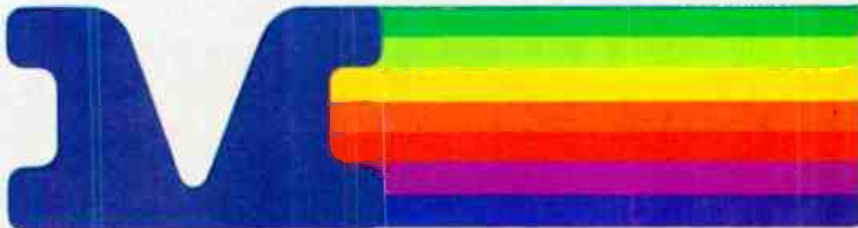
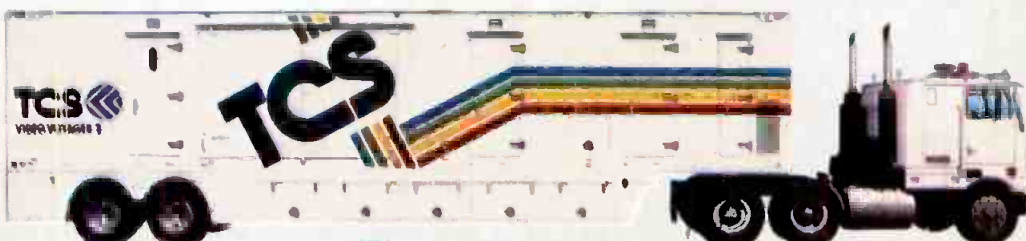
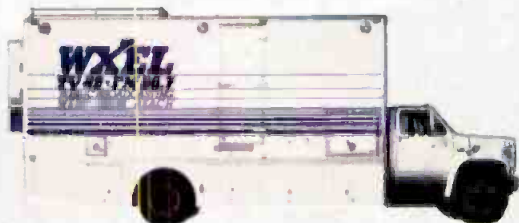

MIDWEST
Communications Corp.

**One Sperti Drive
Edgewood, KY 41017**

**606-331-8990
TELEX 21-4370**

Circle (4) on Reply Card

Edgewood, KY
606-331-8990
Columbus, OH
614-846-5552
Dayton, OH
513-435-3246
Cleveland, OH
216-447-9745
Toledo, OH
419-382-6860
Pittsburgh, PA
412-364-6780
Indianapolis, IN
317-872-2327
Detroit, MI
313-689-9730
Grand Rapids, MI
616-796-5238

Louisville, KY
502-491-2888
Lexington, KY
606-277-4994
Charleston, WV
304-768-1252
Nashville, TN
615-255-2601
Knoxville, TN
615-687-9515
Bristol, TN
615-968-2289
St. Louis, MO
314-569-2240
Kansas City, KS
913-469-6810
Atlanta, GA
404-875-3753

Virginia Beach, VA
804-464-6256
Richmond, VA
804-262-5788
Roanoke, VA
703-960-2584
Charlotte, NC
704-399-6336
Washington, D.C.
301-577-4903
Miami, FL
305-592-5355
Tampa, FL
813-885-9308
Orlando, FL
305-698-1885

Contents

October 1985 • Volume 27 • Number 10



Page 42

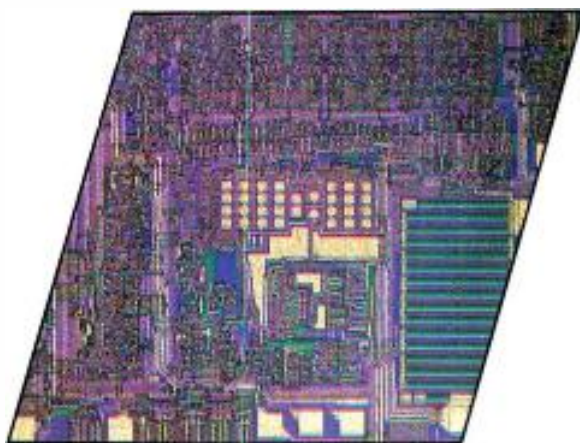

Page 66

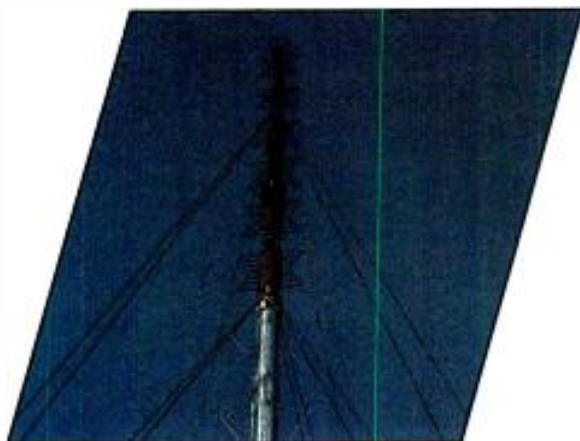

Page 84

ON THE COVER

The subject of salary is illustrated on our cover this month with artwork from a digital graphics system. The currency in the scene was frame-captured into the system, then texture-mapped onto the appropriate surfaces. The other textured surfaces were created in a paint program and mapped into place. There are two light sources in the scene, which create shiny highlights on the smooth-shaded cylinders. The design was created by Susan Crouse-Kemp of Bosch, Salt Lake City, using the Bosch FGS-4000 graphics system.

BROADCAST engineering

BROADCAST INDUSTRY SALARY SURVEY

How does your salary compare with the paychecks of your peers? Our fifth annual salary survey of the broadcast industry reports on pay scales and fringe benefits for three job classifications: engineering, management and operations.

20 1985 Salary Survey

By Brad Dick, radio technical editor

A comprehensive report on the salary trends in broadcasting. A detailed breakdown is given of compensation for radio and TV personnel in various market sizes.

• Give Yourself a Raise

An examination of the effects of SBE certification on the base pay of engineering personnel.

• Money Talks

A sampling of comments from the 1985 salary survey.

BE SPECIAL REPORT: THE STATE OF STEREO TV

38 Introduction

Multichannel TV sound has made a significant impact on the broadcast industry in the short time it has been available. Our examination of the move toward stereo encompasses four important elements:

42 Mixing for Stereo

By Douglas F. Dickey, Solid State Logic

A report on the importance of proper planning of a production console for use at a stereo TV facility.

46 Tuning for Stereo

By Geoffrey N. Mendenhall, Broadcast Electronics

An examination of the requirements for transmission chain performance for acceptable multichannel sound operation.

66 Receiving Stereo TV

By Martin Giles, National Semiconductor

A look at new developments in consumer electronics that are pushing high quality stereo TV receivers into the home.

84 The BE Proof for Stereo TV

By Dennis Ciapura, Starnet Corporation, and Jerry Whitaker, editor

A set of suggested performance targets for a TV station broadcasting in stereo. This expansion of the popular FM proof program applies our tough, real-world measurements to TV audio.

TECHNOLOGY UPDATE

96 Designed for Efficiency

By Carl Bentz, TV technical editor

A detailed report on recent achievements in the design of high-efficiency UHF power amplifier systems.

DEPARTMENTS

4	News	121	Station-to-Station
6	Editorial	122	Field Report: Lexicon 1200B
8	FCC Update	132	Field Report: Fluke 9010A
10	Strictly TV	136	Show Preview: SMPTE Fall
12	re: Radio	143	News Special: Subcarriers
14	Satellite Technology	154	Business
16	Circuits	162	People
18	Troubleshooting	166	New Products

When the Hitachi HR-230's real-time diagnostic system spots a potential problem during operation, it tells you what happened, and exactly where it happened. And it tells you in plain English.

The HR-230's computer controlled self-diagnostics continually monitors 49 different operational, maintenance, and troubleshooting parameters during both playback and recording. And it gives you the whole story up front on a console display and on the monitor.

Plus, you don't have to keep your eyes glued to the machine. Because the HR-230 stores it all in memory—along with the exact location—so you can go back and check later on.

But the HR-230 has a lot more going for it than just a great memory. Our retracting tape guides and tension arms—along with a non-contact



air scanner system dramatically reduce head and tape wear. It's compatible with all major editing systems. And such features as master/slave operation of up to 48 VTRs through its built-in editor, complete autoseup, pre-aligned replacement scanner, and a built-in TBC save you a lot of time and trouble.

And the HR-230 will save you money. Because nobody offers you so complete a machine for so modest a price.

For a demonstration in your studio, contact Hitachi Denshi America Ltd., Broadcast and Professional Division, 175 Crossways Park West, Woodbury, NY 11797. Or phone (516) 921-7200 or (800) 645-7510. In Canada, contact Hitachi Denshi Ltd. (Canada), 65 Melford Drive, Scarborough, Ontario M1B 2G6; (416) 299-5900.



Circle (5) on Reply Card

THE FIRST 1-INCH VTR THAT TELLS YOU WHERE TO GO.



PRC sessions address microprocessor-based equipment

More than 700 public radio broadcasters, representing 202 stations, attended the 1985 Public Radio Conference (PRC) in Denver May 19-22. The annual conference offers specialized training sessions and meetings for staff members of public radio stations. The PRC is well-known for the number and quality of its engineering sessions. This year's conference, however, provided few general sessions on engineering topics.

Troubleshooting

A technical session on the maintenance of microprocessor-based equipment was led by Chuck Kelly, ITC/3M, and Pete Kukura, director of engineering services at NPR. The session provided specific guidelines for installing, interconnecting and maintaining microprocessor-based equipment.

Kukura warned the engineers of the need to provide proper ventilation for digital equipment. He said engineers are often fooled into thinking that small equipment doesn't generate any heat. Kukura said that with modern low-profile equipment, it is easy to overload a rack's cooling capacity. He recommended that blank panels be placed between the units to help keep them cool. Stacking equipment one unit on top of another can only invite trouble, he said.

Kelly discussed noise problems for digital equipment. He said that engineers sometimes forget that ground loops can

exist on digital control lines just as they do in audio circuits. Kelly suggested engineers be as careful when installing control lines for digital equipment as they are when installing audio circuits.

Digital recording

One of the more interesting sessions at the conference was the one on digital recording. Flawn Williams, technical director at NPR, led a discussion on the advantages of using low-cost digital encoding and recording equipment. He demonstrated an example of the quality that can be obtained when using a digital encoder and an inexpensive 1/2-inch video recorder. The major difference, he noted, is the lack of background tape hiss.

Another advantage of using the digital recording process and 1/2-inch videotape is the low cost of the tape. Williams noted that a 2-hour program requires about \$40 worth of 1/4-inch analog tape, but only about \$10 worth of videotape.

Williams said several stations in the NPR system are currently using the digital encoding process to record some of their own programs. Most of these stations rely on the F1 series (Sony) encoder using a 14- or 16-bit digital word. The matching decoder will recognize both word lengths so that interchanging tapes between stations is no problem. Both the St. Louis and Baltimore Symphonies use 1/2-inch videocassettes and the digital recording process in the production of their programs. NPR uses the same recording method for delayed transmission of its news programs, "All Things Considered" and "Morning Edition."

(:? :)))

BROADCAST engineering

Editorial and advertising correspondence should be addressed to: P.O. Box 12901, Overland Park, KS 66212-9981 (a suburb of Kansas City, MO); (913) 888-4564. Telex: 42-4156 Intertec OLPK. Circulation correspondence should be sent to the above address, under P.O. Box 12937.

EDITORIAL

Jerry Whitaker, *Editor*
 Carl Bentz, *TV Technical Editor*
 Brad Dick, *Radio Technical Editor*
 Nils Conrad Persson, *Electronics Editor*
 Tom Cook, *Video Editor*
 Miguel Chivite, *International Editor*
 Fred Ampel, *Audio Editor*
 Rhonda L. Wickham, *Group Managing Editor*
 Paula Janicke, *Associate Editor*
 Dawn Hightower, *Editorial Assistant*
 Joy Culver, *Editorial Assistant*
 Darryll Fortune, *Editorial Assistant*
 Dana Justice, *Editorial Assistant*
 Marjorie Riggan, *Editorial Assistant*
 Pat Blanton, *Directory Editor*

BUSINESS

Cameron Bishop, *Group Vice President*
 Stephanie Fagan, *Promotions Manager*
 Kelly Hawthorne, *Marketing Assistant*
 Dee Unger, *Advertising Supervisor*
 Mary Birnbaum, *Advertising Coordinator*

Advertising sales offices listed in classified section.

ADMINISTRATION

R. J. Hancock, *President*
 John C. Arnst, *Circulation Director*
 Evelyn Rogers, *Circulation Manager*
 Dee Manies, *Reader Correspondent*

TECHNICAL CONSULTANTS

Eric Neil Angevine, *Broadcast Acoustics*
 John H. Battison, *Antennas/Radiation*
 Blair Benson, *TV Technology*
 Dennis Ciapura, *Radio Technology*
 Dane E. Erickson, *Systems Design*
 Howard T. Head, *FCC Rules*
 Wallace Johnson, *FCC/Bdct. Engineering*
 John Kean, *Subcarrier Technology*
 Donald L. Markley, *Transmission Facilities*
 Harry C. Martin, *Legal*
 Robert J. Nissen, *Studio/Communications*
 Hugh R. Paul, *International Engineering*
 Richard Rudman, *Spectrum Management*
 Art Schneider, *A.C.E., Post-production*
 Elmer Smalling III, *Cable/Satellite Systems*
 Vincent Wasilewski, *Communications Law*

ART

Kevin Callahan, *Art Director*
 Todd Meyers, *Graphic Designer*

CORRESPONDING ASSOCIATIONS

American Society of TV Cameramen
 Assn. for Bdct. Engr. Standards
 National Association of Broadcasters
 National Radio Broadcasters Assn.

MEMBER ORGANIZATIONS

Acoustical Society of America
 Society of Broadcast Engineers

Member,
 Association of Business Publishers
 Member,
 Business Publications
 Audit of Circulation

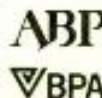

BROADCAST ENGINEERING is edited for corporate management, engineers/technicians and other station management personnel at commercial and educational radio and TV stations, teleproduction studios, recording studios, CATV and CCTV facilities and government agencies. Qualified persons include consulting engineers and dealer/distributors of broadcast equipment.

SUBSCRIPTIONS: BROADCAST ENGINEERING is mailed free to qualified persons within the United States and Canada in occupations described above. Non-qualified persons may subscribe at the following rates: United States and Canada: one year, \$25.00. Qualified and non-qualified persons in all other countries: one-year, \$30.00 (surface mail); \$108.00 (air mail). Back issue rates, \$5, except for the Buyers' Guide/Spec Book, which is \$20. Rates include postage. Adjustments necessitated by subscription termination at single copy rate. Allow 6-8 weeks for new subscriptions or for change of address. Second class postage paid at Shawnee Mission, KS.

BROADCAST ENGINEERING (USPS 338-130) is published monthly (except in the fall, when two issues are published) by Intertec Publishing Corporation, 9221 Quivira Road, P.O. Box 12901, Overland Park, KS 66212-9981. Postmaster, return form 3579 to P.O. Box 12938 at the above address.

Photocopy rights. Permission to photocopy for internal or personal use is granted by Intertec Publishing Corporation for libraries and others registered with Copyright Clearance Center (CCC), provided the base fee of \$2.00 per copy of article is paid directly to CCC, 21 Congress St., Salem, MA 01970. Special requests should be addressed to Cameron Bishop, group vice president, ISSN 0017-1734 \$2.00 + \$0.00.

© 1985. All rights reserved.

INTERTEC
 PUBLISHING CORPORATION

LEADER

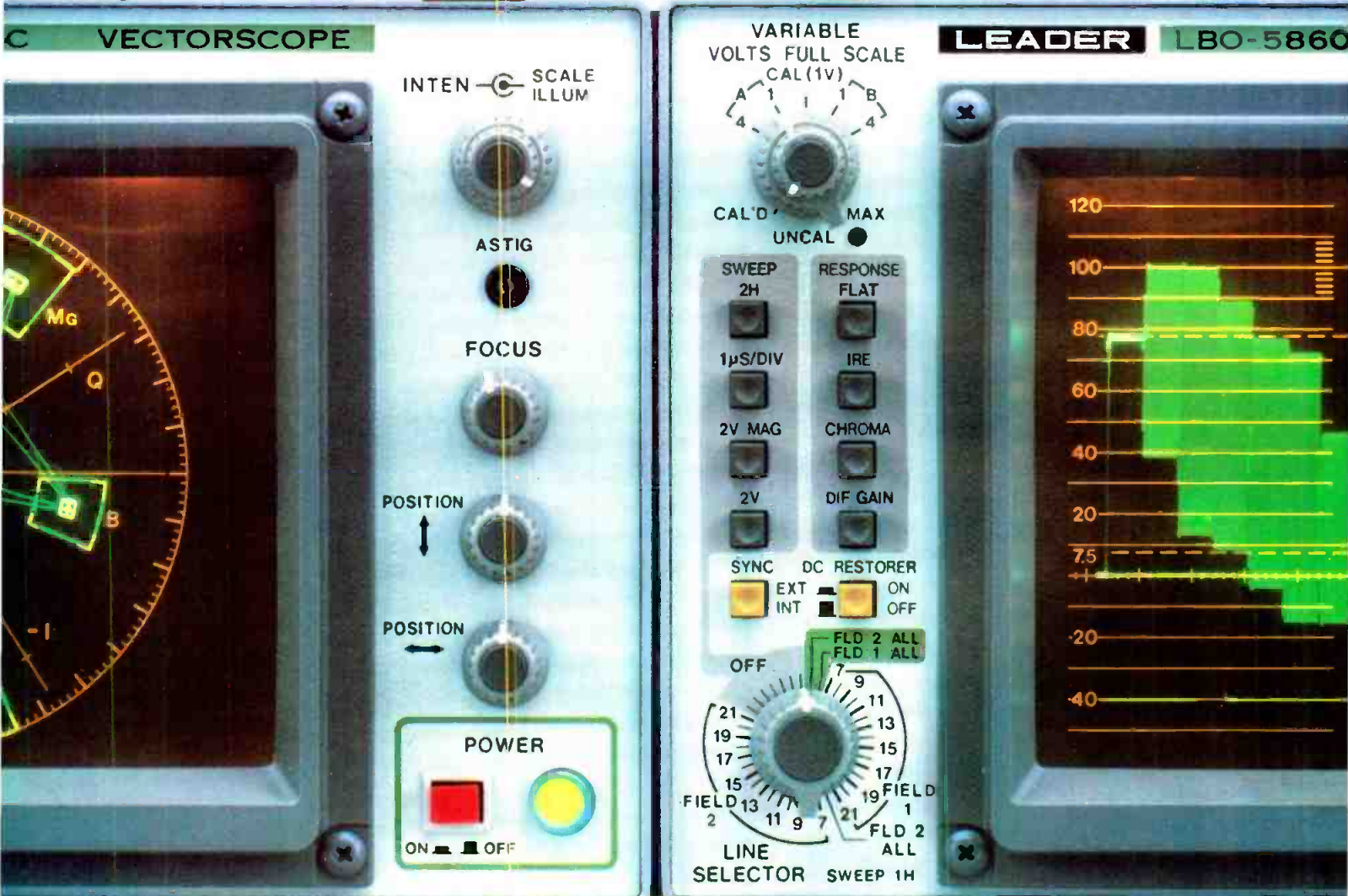

ACTUAL SIZE

Two Leaders with an important following.

Check the racks of the industry's leaders, and you'll find Leader instruments. At ABC, Sony Broadcast, Reeves, Zenith, HBO, RCA, A.F. Associates, Group W, ATC, Midwest Corporation, and NBC, to name a few... where quality is paramount, Leader has been their choice.

You could pay more for others. But you'll get more from Leader.

For instance, our half-rack LBO-5860A Waveform Monitor makes it easy for you to select

lines 14-21 (fields 1 and 2) from the front panel. And there's an L model that shows you lines 7-21 for coding information, too. Our half-rack LVS-5850B Vectorscope is the perfect mate, with selectable, electronically-generated targets* that can be read from across the room. Electronically-generated targets also provide the highest level of measurement accuracy, even if you misalign the CRT center dot. It also has an internal etched graticule, and gives a VITS display with strobe input.

More than just competitively priced.

The convenience of viewing both vector and waveform displays simultaneously gives you uninterrupted monitoring capability.

Top broadcasters rely on Leader quality. It's backed by a two-year warranty (including CRT's) and factory service depots on both coasts.

Ask for a catalog of our waveform monitors, vectorscopes, signal generators and other instruments; an evaluation unit, and the name of your nearest "Select" Leader distributor.

Call toll-free
(800) 645-5104

In New York State
(516) 231-6900

For professionals who know the difference.

LEADER
Instruments Corporation

380 Oser Avenue
Hauppauge, New York 11788
Regional Offices:
Chicago, Dallas, Atlanta,
Los Angeles, Boston
In Canada call Omnitronix Ltd.
(514) 337-9500

Certification pays

Although the first class FCC license is dead and buried, the concept of technical certification of radio and TV engineering personnel remains a top priority with broadcasters across the country. As studio and transmission equipment becomes increasingly sophisticated, the need for trained engineering personnel becomes even more pronounced. If that's the case, you ask, does technical certification result in better pay? You bet! And we have the figures to prove it.

When the commission threw in the licensing towel in 1981, the certification program of the Society of Broadcast Engineers (SBE) became the only game in town. Detractors criticized the society's efforts as a throwback to the old, outdated first class license. Fortunately, these voices of the great "marketplace" were ignored.

Conceived in 1973, the SBE certification program was designed to provide a method whereby technical personnel could be evaluated by their peers. By the mid-1970s, the officers of the society were keenly aware that the first class license had, for the most part, become worthless. They also realized that the commission was at the beginning of a deregulatory process that could only erode the already shaky status of the "first."

The SBE certification program was slow in developing. By 1977, the industry still wasn't ready to accept the need for a standard of measurement. However, with the loss of the first class license a few years later, SBE certification became the only testing method for judging the technical competence of engineering personnel. Broadcasters finally began to realize that without the first, as bad as it was, there was nothing else by which to evaluate broadcast engineers.

The society does not claim that you can't be qualified unless you are certified. Actually, it's quite the contrary. The society says that without sufficient on-the-job experience and training, you can't even pass their test. The SBE has so structured the examination and requalification process that it is practically impossible to obtain, or retain, SBE certification without being *actively* involved in broadcasting. Therein lies the major benefit of SBE certification. It proves to the industry that you not only have a measure of experience, but that you have been able to use that experience and your technical expertise to pass an industry-recognized examination.

If you pass the test, is it worth the effort? The answer is yes.

It pays not only in terms of the pride you feel when you pass the examination, but now, according to statistics from the annual BE salary survey, SBE certification may also pay in the way of a fatter paycheck. The results of the survey (see page 20) show that an SBE-certified radio engineer's median salary is almost 20% higher than a non-certified counterpart. The non-certified radio engineer earns a median salary of \$22,400. The SBE-certified radio engineer, on the other hand, earns a median salary of \$26,800, or \$4,400 more.

The differences in salary for TV engineers are even more dramatic. The non-certified TV engineer earns a median salary of \$30,400. The SBE-certified TV engineer earns \$37,850, or \$7,450 (25%) more! These differences indicate that SBE certification not only pays, but that it pays very well.

Now, some four years after the official demise of the first class license, we finally have a standard by which to measure technical competence. That standard is the SBE certification program. The nature of broadcasting is that we have a way of finding the tools that are needed to get the job done. We needed a uniform, objective standard upon which we could rely to hire personnel. We needed a goal that broadcast engineers could work toward, knowing that they would be rewarded for their efforts. SBE has filled both needs with its certification program. Certification is a welcome addition to our business and we're glad to report that the broadcast industry is in agreement with its objectives.

If you're not an SBE-certified engineer, consider becoming one. Your boss may already be wondering about the need to require certification for some station positions. The benefits just might begin showing up in your paycheck. (:-:)))))

MOBILE TELEVISION UNITS

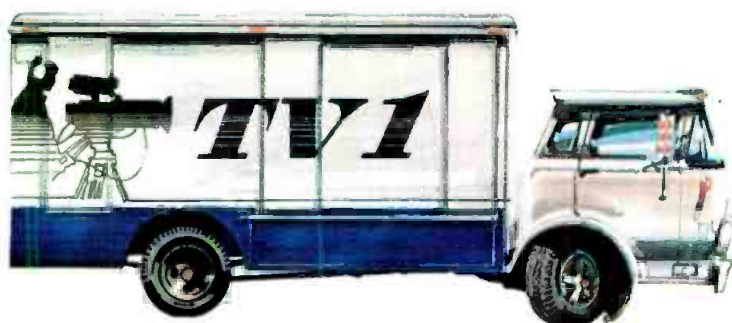
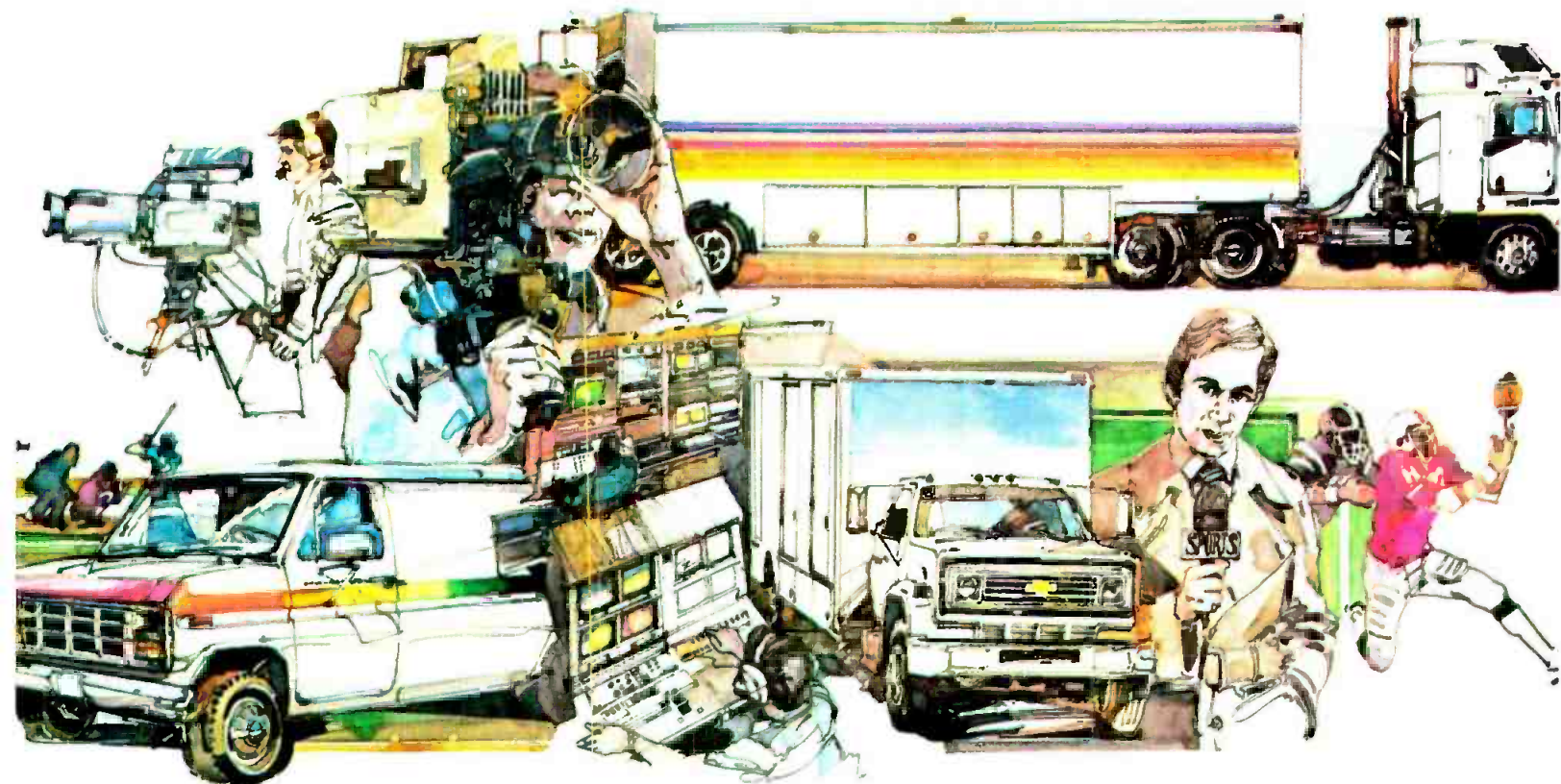

If your future plans include a mini-van, a full scale production truck, or something in between, we can develop your ideas into a complete television vehicle.

Our experienced staff will design and engineer into your vehicle the needs of your organization.

As authorized representatives for leading manufacturers, Lerro provides turnkey installations of state of the art technology anywhere in the continental United States.

To find out more about Lerro and how they can provide your mobile unit, contact Bob McTamney at (215) 223-8200.

THE
LERRO
CORPORATION

3125 N. Broad St., Philadelphia, Pa. 19132
215 - 223-8200

STUDIOS • POST PRODUCTION • MOBILE UNITS • MASTER CONTROL • MICROWAVE • FIBER OPTICS

Fairness Doctrine ...not so fair?

By Harry C. Martin

On August 7 the FCC ended its inquiry into the Fairness Doctrine by concluding that the policy no longer serves the public interest. Still, the commission will continue to enforce the doctrine while affording Congress the opportunity to modify or to restrict it.

The Fairness Doctrine requires broadcasters to give balanced coverage to controversial issues of public importance, and to provide a reasonable opportunity for the presentation of opposing viewpoints.

The commission relied on three considerations in determining that the doctrine is poor public policy. First, the numbers and types of information sources have increased in recent years. The commission found that this information marketplace makes government-imposed obligations unnecessary. Second, based on the record, the commission concluded that the burden of providing time to opposing viewpoints actually leads broadcasters to shy away from presenting controversial issues. Finally, the FCC noted that government restrictions on the journalistic freedom of broadcasters contravene constitutional principles, and open the door to government abuse.

Although the Supreme Court has upheld the constitutionality of the Fairness Doctrine under the First Amendment, the commission indicated that growth in the information marketplace and documentation of the harmful effect of regulation undermine the court's logic.

The commission will not, however, modify or eliminate the long-standing doctrine. Instead, it deferred to Congress the opportunity to act in light of the record and findings in the proceeding. The commissioners believe that section 315 of the Communications Act precludes them from acting on their own to repeal the doctrine.

License hearing for Kansas station

In an order released August 14, the commission found the Fairness Doctrine inapplicable to controversial broadcasts on a Kansas FM station. Nevertheless, in



light of a mutually exclusive application to build another station in the same community, the commission has ordered a comparative license renewal hearing.

The controversial station has been the subject of national attention, as well as petitions to deny its renewal, due to racist and anti-Semitic programming. In assessing the case, commissioner Henry Rivera wrote, "By any contemporary standard, the programs...were bigoted, crude and offensive." The commission concluded, however, that the programs did not amount to a meaningful discussion of public issues. This would be required in order to trigger the Fairness Doctrine.

The order also rejected a petition to deny the station's renewal application on the basis of the controversial programming. Although finding the racist broadcasts highly objectionable, the commission said the First Amendment and the Communications Act both forbid its interference with broadcast speech unless it creates a "clear and present danger" of violent action.

Instead, the commission designated standard issues by which it will decide on a comparative basis whether to renew the existing license or to award it to a challenger. Two additional issues concern the incumbent's failure to maintain a list of community issues and related programs, and its basic character qualifications in light of violations of local law and FCC regulations.

New AM agreement with Mexico

The United States and Mexico have tentatively reached a new AM broadcasting agreement. It will supersede one signed in 1968.

The agreement reflects the technical provisions of the Region 2 Rio de Janeiro AM agreement, with modifications. Under the new plan, U.S. stations will be allowed to operate on Mexican Class I-A channels at night. Mexican stations also will be able to use U.S. clear channel frequencies, on the condition that they protect U.S. clear channel stations. Also, the

commission will be able to extend operation by daytime stations on Mexican clears past the current 6 p.m. limit.

The agreement should be signed and put into effect during the fall of this year.

Determining TV operating power

On June 11 the commission amended its rules for determining and maintaining TV aural transmitter operating power. Station licensees now may select the method of measurement or installation that best ensures that power does not exceed 22% of authorized peak visual effective radiated power.

No lottery preference to women

The commission has concluded that it lacks authority under the 1982 lottery statute to award preferences for either "minority ownership" or "media ownership" based on gender.

It said the lottery statute, adopted in 1982, permits minority ownership preferences only for racial and ethnic groups, and that Congress intended the media ownership preference to be based only on structural criteria such as types of media holdings. The commission added that it has no residual power to create a special preference for women applicants.

Proposal to relax ITFS and EBS rules

The commission is proposing to relax certain technical and operational rules covering the Instructional Television Fixed Service (ITFS) and the Experimental Broadcast Services (EBS). ITFS stations are microwave outlets used primarily to televise educational material and, secondarily, to present commercial programming on a time-leasing basis. EBS licenses are issued to permit research and experimentation with new broadcast technologies.

The proposed amendments would relax the posting and license requirements for both ITFS and EBS stations. Also, the proposals would eliminate all remote-control requirements for ITFS stations and allow unattended operation of ITFS response and relay stations. Interested parties may file replies in mid-October.

[:?~)))))

Martin is a partner with the legal firm of Reddy, Begley & Martin, Washington, DC.

NEW DUBNER CHARACTER GENERATORS

HIGH PERFORMANCE, LOW PRICE

Have you been waiting for broadcast quality graphics at a reasonable price? Wait no longer! Now you can afford the best: Dubner's new 10-K and 20-K. Look at these specs.

10-K A full function real-time character generator. All of the high end features at a low-end price.

STORAGE: Internal memory stores up to 1000 pages and 50 fonts. A 1 megabyte floppy disk is built into the 7 inch electronics unit. Messages store by alphanumeric "names".

FONTS: 24 supplied. Hundreds available from 1 line by 2 pixels to full screen height; bordered, shadowed, 3-D edged, diagonal. Up to 64 colors per character. Letter by letter font type, color, edge, edge color, position, italics, spacing. Anti-aliased fonts. Left or right instant italics. 40 nsec horizontal resolution.

COLORS: 16 million total, any 256 simultaneously. Background in 1 line increments.

TEXT COMPOSITION: 8 font and color presets. Insert/delete/move a character/row left, right, up, down. Tab and justify. Row interchange. Center row/page horizontal/vertical. Flash. Kern. Separate background/foreground!

EFFECTS: 9 speeds of roll, crawl, reveal, scanwipe, tumble, climb, climb together, wipe up/down, animate.

VIDEO: Genlock to sync or video. Internal keyer over video. RGB and composite outputs. Monochrome preview next/status display. Color edit output. Key output.

20-K All operating features of the 10-K in the same size unit, plus:

DISK STORAGE: 10 megabyte disk cartridge stores over 500 fonts and 10,000 pages and graphics and animations.

ANIMATION: Playback of any graphic or animation from a Dubner CBG or Texta disk. They can also be sent directly through telephone modems.

To find out more, contact your local Grass Valley Group representative or call Dubner at our spacious new facility.

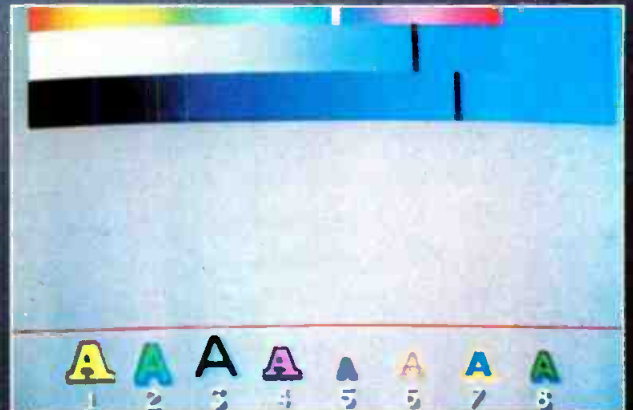

Color palette

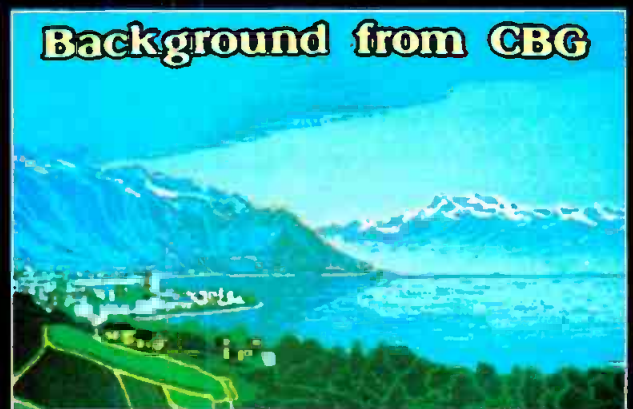

Unretouched monitor photos taken with a 35mm camera.



DUBNER

DUBNER COMPUTER SYSTEMS, INC., 6 Forest Avenue, Paramus, N.J. 07652 (201) 845-8900
A Grass Valley Group Company

www.americanradiohistory.com

Seeing red (and green, and blue)

By Carl Bentz, TV technical editor

White is not white, even on a monochrome TV screen. In reality, we see a combination of blue and yellow light emitted by the tube phosphors. Silver and cadmium ions intermix with zinc sulfide in a complex crystal lattice to form the P4 monochrome phosphor. In the mixture, a copper activator controls the phosphors to achieve what appears as white.

Images on a color CRT are more complex, however, because we see a mixture of three colors: the primaries *red, green and blue*. By using them in various combinations, we can arrive at practically any color of light. Black, however, is the absence of light.

Combining colored light sources to produce other colors is called *additive mixing*. In contrast, creating a picture with paint pigments involves red, blue and yellow primaries and is called *subtractive mixing*. The ink pigments used in the printing of this magazine have been subtractively mixed, creating an illusion similar to the way television achieves some colors.

Blue light from the P22 CRT phosphor is similar to that in a P4 CRT. More intensity results from additional silver ions in the crystal structure of the zinc sulfide. The silver, although an impurity to the crystal, activates the system.

Zinc and cadmium sulfides are commonly used for the green phosphor, again with a copper activator. The amount of the Cu ion is critical. It takes only 0.0000001% of copper in otherwise pure zinc sulfide to impart a green color. To attain the exact wavelength of the desired color requires a tight control of impurity in the sulfide.

Most CRTs include *rare earth* elements to achieve the desired wavelength of red. Yttrium oxysulfide with europium as the activator produces red in most P22 tubes. Another combination, europium yttrium vanadate, may also be used. The choice of the material is determined by the wavelength and the intensity of the light produced.

Of the P22 materials, those creating blue and green are broadband emitters. The yttrium material is a narrowband emitter. In other words, blue and green are not as pure (limited in terms of wavelengths), as red.

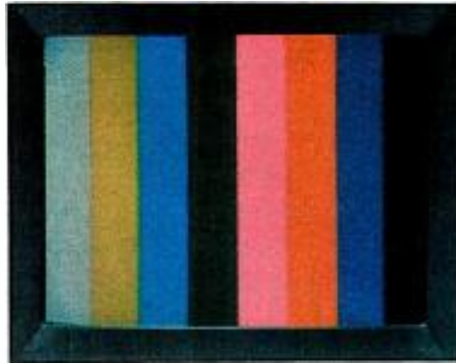

We might expect pictures to be overwhelmingly blue and green, but the bandwidth characteristic is offset by different duration times of phosphorescence. Blue and green glow for a shorter time than red. Also, the eye is less sensitive to blue than to red, and

green is more prevalent in all of nature. Through illusion, then, all seems to work out right.

Why certain impurities take the role of activators with some emitters is determined by electron energies of atoms within emitting materials. The electrons, excited by external energy, emit light as they fall to less excited energy levels. The emitted light color depends upon the path the electron takes to its preferred energy level. If an electron made several stops before its rest orbit, the result could be three different colors of light (*quantum noise*). Such emissions could be undesirable for the color CRT.

The presence of the activator controls the manner in which electrons behave. Europium forces the yttrium electrons to follow a path that produces the desired red. The presence of copper and silver in the green and blue phosphors controls the wavelengths of those emissions.

The energy of the emitted light is determined by its color, that is, its wavelength or electromagnetic frequency. If we view light as particles of energy (*photons*), we may ascribe energy levels to the photons in electron volts. The electron volt, a unit of energy, is equal to 3.8×10^{-20} calories. The range of visible light varies from approximately 1.8eV, a dark red near 6,900 Å, to 3.1eV, a deep violet near 4,000 Å. The Angstrom (Å), the wavelength measurement, is 10^{-8} cm. The result of the radiant energies and wavelengths causes the light-sensing cells in the human eye to detect color.

When the phosphor material for the monochrome CRT is prepared, the two materials are interspersed into a slurry mixture and applied to the back side of the faceplate blank. The better the mixing of the two materials, the more true the white light emitted.

In the P22 CRT, however, the individual color phosphors must be kept separated, in order that they can be controlled. Most tubes use orderly patterns of dots or stripes of phosphors to separate the colors. When only the red gun is on, the screen shows only red.

The composition of phosphors is important to the colors produced, as are placements in the CRT. Next month, we'll consider how a P22 faceplate is prepared.

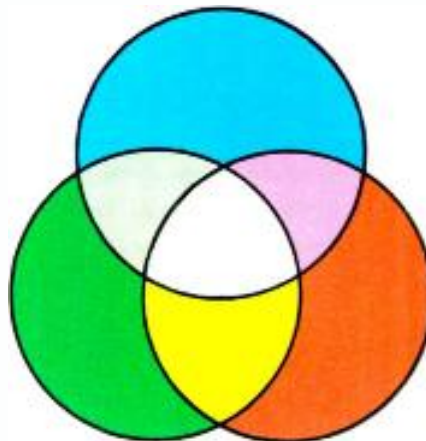

Figure 1. In additive mixing, primaries of red, green and blue allow almost any color of light to be achieved. The proper mixture of all three produces white.

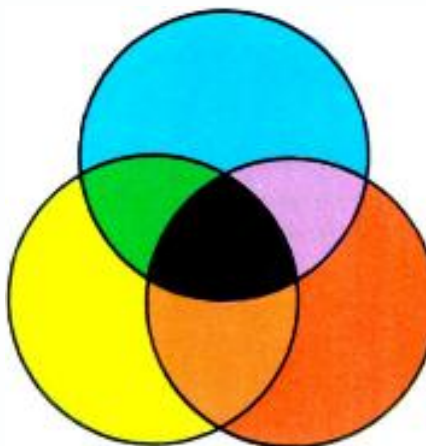

Figure 2. Subtractive mixing of pigment colors with red, yellow and blue primaries can produce almost any other desired color. The proper mixture of all three results in black.

CHOICE

The Lenco 300 Video Terminal System

Manufactured to meet the industry's toughest standards...in a uniquely versatile design to solve your toughest problems.

Any Way You Want It

Take your choice with the Lenco 300 Series — you get all the components you need. And none that you don't.

The unique PFM-300 Main Frame will house up to nine single modules in virtually any system configuration. Choose from the Lenco line of more than thirty video modular components, creating your own system with a degree of flexibility unmatched in the industry. And no extra expense for unnecessary or unwanted features.

Forget obsolescence: plug-in modules make it easy to replace or upgrade components when your needs change.

It's the system of choice. It's the only system that performs exactly the way you want. Because it's the system you design yourself. That's why 1000's of systems are currently in service throughout the world.

Choice Components

Lenco components are designed to the most exacting specifications and crafted for years of reliable performance, every Lenco System is supported by prompt, dependable service. If you should have problems with any Lenco component, we'll supply a loan replacement from our factory. And we'll do it fast — usually within 24 hours.

For complete technical information on the 300 System and the full line of quality Lenco terminal equipment, call toll-free: 1-800-325-8494.



The
Professionals
Choice



300 N. Maryland St.
P.O. Box 348
Jackson, MO 63755
1-314-243-3147
TWX 910/760-1382

Circle (10) on Reply Card
www.americanradiohistory.com

Opportunity shines for SCA users

By John Battison

When opportunity knocks at the station door, the astute operator will always usher it in, especially if it could mean additional revenues. The FCC, with its continuing technical deregulation and increasing latitude in transmitter operation, has presented just such an opportunity for those with FM carriers.

There are probably very few FM radio stations in the United States today that operate with only monaural modulation. In other words, stereo is the norm among FM stations. In addition to the stereo signal, many of these stations also run Muzak or other background music services on their subcarriers. Other subsidiary communications authorization (SCA) uses include data and text transmission.

A few FM stations have also transmitted TV pictures. There's nothing particularly new about this. More than 40 years ago at least one station was transmitting facsimile over FM. FAX transmission is a proven FM accomplishment. Today, television via FM subcarrier can provide expanded opportunities for an FM radio station.

The decision whether to use an SCA channel is frequently influenced by the type of programming the station carries. At a serious classical music station with *golden-eared* listeners, the addition of an SCA signal could meet resistance from the engineering and programming staffs. On the other hand, the staff of a station that programs rock or other kinds of music that don't require a broad dynamic range may be willing to add one or even two SCAs.

Today's subcarrier generators, properly designed and usually integrated into the exciter-transmitter system, should not produce any spurious on-air signals. If the engineering spirit is willing and the test equipment is available, most, if not all of the potential problems with SCA operation—including whistles—can be eliminated. Any whistles or heterodynes will probably be hidden by higher modulation levels anyway.

Although cleaning up an FM system for video transmission should not be difficult, the requirements may seem odd to you. A slow-scan video signal can operate at modulation levels as low as

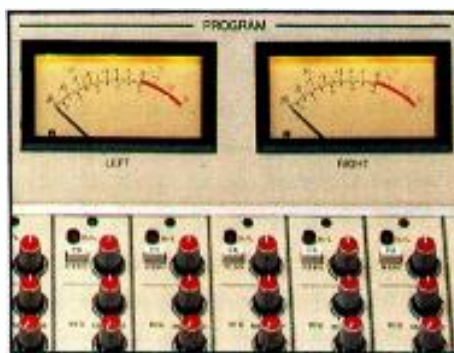

-12dB at 8kHz and -3dB at 10Hz. Because the signals are quite different from typical audio signals, so are the performance requirements.

Slow-scan FM TV

Slow-scan TV pictures can vary in quality from low to high resolution. Obviously, the higher the resolution, the more time is needed to transmit a full frame. For example, a 400-line TV picture requires about 17 seconds for complete transmission. A 280-line picture requires only about half the time (8.5 seconds).

Because slow-scan TV does not have the high definition or quality we've come to expect from on-air video, special care must be taken in the generation of the signal. The originating camera should provide a high-quality image. It is difficult to improve the quality of the picture by reprocessing after the signal has been transmitted.

After the TV camera has turned the im-

vertical columns. The reading rate depends on the bandwidth of the available transmission medium. At this stage, the signals can be easily handled over a twisted pair of wires. Eventually, the equivalent of a 12MHz signal is transmitted over an 8kHz bandwidth subcarrier.

Reproducing the image

The requirements for the slow-scan TV receiver are demanding. The frequency response of the receiver's output stage must extend down as close to dc as possible. The necessity of good low-frequency response is apparent when you consider that most of the picture information is at about 60Hz. The receiver-processing circuits must also provide low distortion performance.

The signals from the receiver are not compatible with standard video monitors. The signals must be processed or expanded before they can be viewed. Because the original signals were, in essence, compressed at transmission, they now must be expanded into their original format.

An expander reverses what took place at the transmitter. The expander converts the audio into a digital signal and

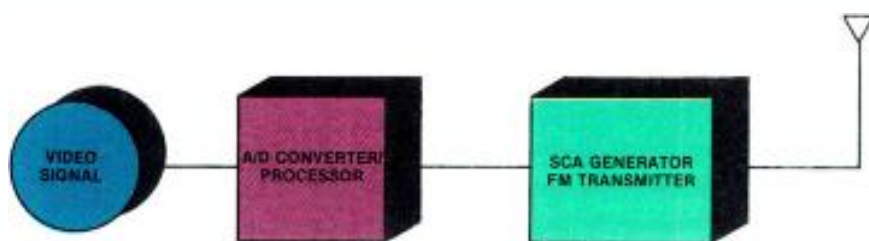

Figure 1. Block diagram of a slow-scan video transmission system using an FM subcarrier.

age into a series of electrical signals, an analog-to-digital converter (A/D) is used to transform the information into a format that the digital-processing circuits can handle. The digitized signal is then fed to a random-access memory (RAM). The RAM stores only one field of the TV signal. Storing only one field realizes a 50% decrease in the volume of data needed for a picture. The processing equipment samples each line of the digitized picture at 512 places, resulting in a further reduction in the amount of data that needs to be transmitted.

With the digitizing and storage process completed, the information is read out in

feeds it to a RAM board. This RAM now contains the necessary information for one field of video. Because two fields are needed to make a frame, the information is read out twice from the RAM. The first reading produces the odd field and the second produces the even field. The combination produces a full frame that can be displayed on a standard video monitor.

For further information on the technical aspects of TV transmission on an FM subcarrier, see "Video Transmission Over FM Subcarriers" (page 164) in this issue.

! : ? -)))

Battison, BE's consultant on antennas/radiation, owns a radio consulting company in Columbus, OH.

THE BEST IS HERE

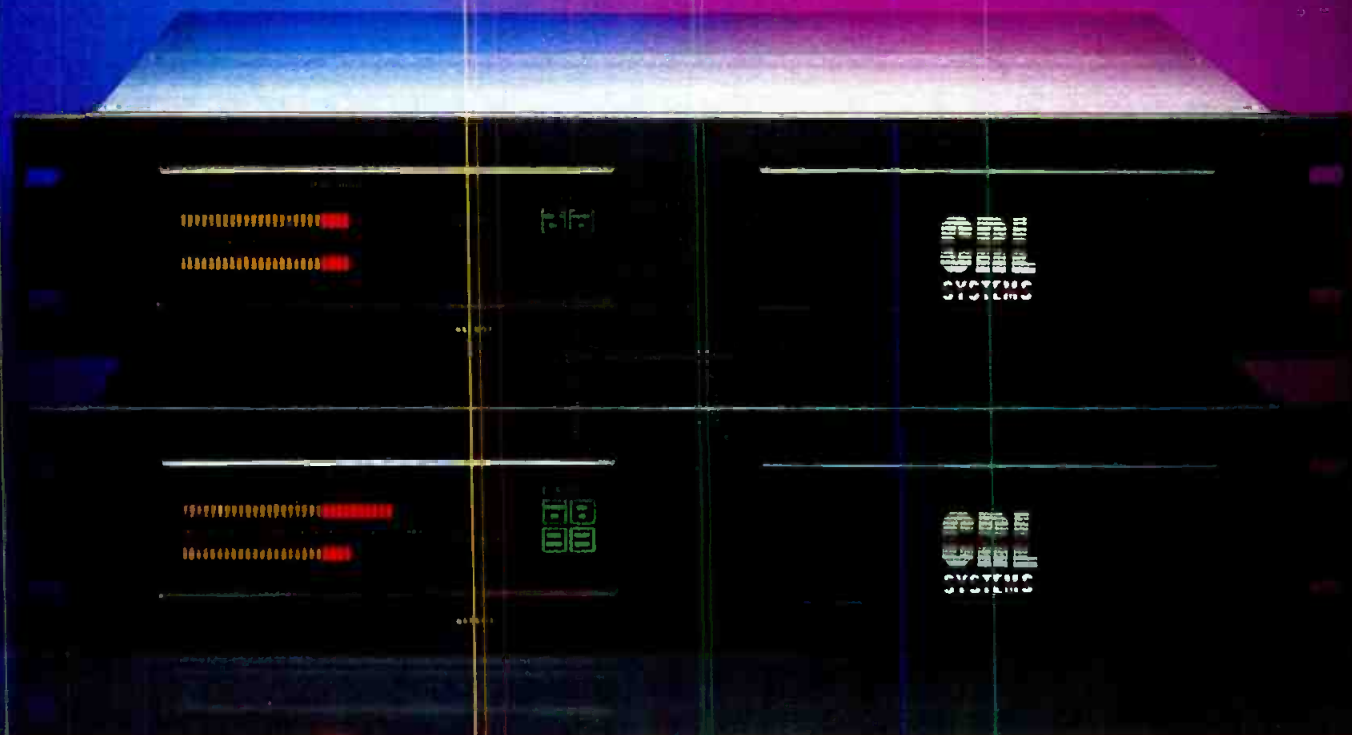

Television Stereo Never Sounded So Good

For almost ten years CRL has been researching and building audio processors. Two years ago we introduced our AM Stereo system. It is now the best selling AM stereo system in the world. A year ago we introduced our SG 800 stereo generator that set new standards for FM stereo quality. Now we extend our expertise to television stereo with the TVS 3000 series. We think you'll agree that television never sounded better. Check these features.

TVS 3001 MULTI-BAND PROCESSOR

*CBS Loudness control
30 db gain reduction range
Patented gain control element
Automatic phase reversal
correction
Input conditioning filter
Switchable gating
Asymmetry removal
Choice of output, discreet
or matrix
Input and output range
- 30 to + 20*

TVS 3002 LIMITER/ GENERATOR

*Meets or exceeds all BTSC
requirements
MTS audio peak limiting system
DBX encoding circuits
No filter overshoot
Automatic switch to mono
during sync loss
Proven digital generator design
Automatic gain drift
compensation
Balanced and unbalanced
composite output
Built-in Bessel tone calibration
Video loop-through
SAP and Pro channel inputs*

Both units are fully remote controllable and offer full metering, including bar graph and tally display. Slide rail mounting is available as an option.



Circuit Research Labs, Inc.

2522 W. Geneva Drive ■ Tempe, Arizona 85282 U.S.A.
800-535-7648 ■ 602-438-0888

Circle (9) on Reply Card

www.americanradiohistory.com

Subcarriers offer stereo, and more

By the BE staff

A recent count showed that more than 100 TV stations are prepared for stereo audio and are, presumably, transmitting binaural signals. So how should stereo programming be distributed? Bicycling tapes is hardly a high-tech method. Satellite networking can provide practical solutions.

Satellite-relayed signals have carried multiple-channel audio for premium CATV programming with stereo and more. Cable systems modulate the stereo audio onto an unused FM channel. For an additional fee, subscribers tie an FM receiver to the CATV outlet to get stereo with the premium video channels.

Most multiple-audio delivery methods via satellite use subcarriers stacked onto the main FM visual carrier. For the most part, the systems are analog in nature, using two subcarriers to carry the binaural information. Some, however, use digital methods to combine two or more signals onto one subcarrier.

Multiplexed analog component (MAC) systems may encode numerous audio signals digitally into the video signal, allowing security against signal piracy. In such a system, eight audio channels could also offer multilingual sound. The service provided will depend somewhat upon the material to be sent.

One analog method is the matrixed sum/difference system similar to broad-



cast FM stereo. Video covers the spectrum up to 4.2MHz (see Figure 1). An L-R subcarrier centers at 5.8MHz above the video, while L+R lies at approximately 6.6MHz. For standard FM broadcasting, the main channel is the L+R sum (to be compatible with monaural receivers), and the subcarrier is the L-R difference signal for demodulation in stereo receivers. By controlling deviation of these subcarriers, others may also be transmitted. Satellite signals for MTV, for example, include an additional 7.4MHz subcarrier for digital stereo transmission.

Another approach uses video with mono sound, accompanied by several discrete left and right audio signal pairs, as shown in Figure 2. The additional pairs could be leased for radio networking, if not needed by television.

In theory, subcarriers may essentially fill the space between 4.5MHz and 8MHz on the video baseband spectrum. As subcarriers are added, the main channel FM video deviation may need to be reduced to remain within the transponder band-

width. As video deviation is reduced, the video signal-to-noise ratio decreases, and will eventually reach a point of objectionable noise, snow or sparkles.

MAC systems may offer flexible audio capabilities with up to eight audio or data channels encrypted into part of the horizontal blanking interval (see Figure 3). Removing the 3.58MHz color subcarrier and transmitting multiplexed video components produces outstanding images, when decoded. Secure signal scrambling, an attribute of some MAC methods, protects against signal piracy.

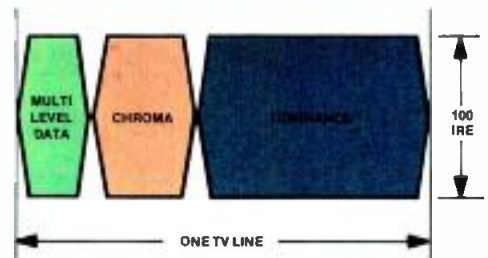

Figure 3. A component system, such as B-MAC, includes up to eight audio channels within the multilevel data packet.

PBS experience

When PBS initiated the satellite interconnect between its affiliates and its technical operations center near Washington, DC, stereo audio was among the plans. A subcarrier at 5.5MHz carried four channels of audio. To use the encoded audio, each member station needed a DATE (digital audio for TV equipment) decoder. For a simulcast, the TV station routed a stereo feed to a cooperating co-market FM station, while carrying a mono mix on the TV signal. Four-channel broadcasts were possible with two willing FM operators.

DATE continues to operate today, along with the standard 6.8MHz monaural audio subcarrier. Because the decoders are quite expensive, only about one-fourth of the member stations acquired the equipment. Now, as the network moves toward complete stereo capability, PBS is planning to institute a much less expensive system.

One plan being considered is that of applying discrete left and right channels to subcarriers through *adaptive delta modulation*. ADM, discussed briefly on page 32 of the February 1985 issue of BE, puts the input signal level in control of digital quantizing step size during sampling. Overall, adaptive sampling reduces the effects of noise and may yield dynamic ranges to 90dB. [:-:-:-)]

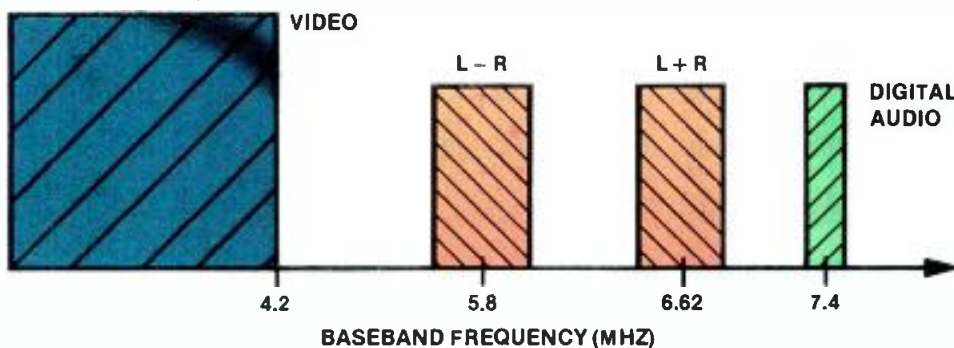

Figure 1. A composite baseband spectrum plan shows matrixed L+R and L-R subcarriers for stereo transmission via satellite.

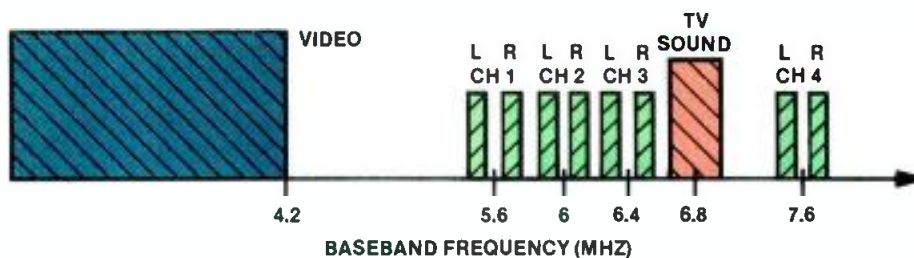

Figure 2. Discrete audio channels may be carried on a satellite signal. The number transmitted depends upon the bandwidth requirements of each signal.

ONE LESS ALLIGATOR

The Broadcast Engineer works with time-line responsibilities few of us will ever experience. He knows that equipment problems can wreck production schedules.

That's why the Otari BII audio machine is so widely used for broadcast, news editing, and production.

Three speed operation, front panel record calibrations, a microprocessor controlled tape counter with LED display, and variable speed control, coupled with "bulletproof" reliability and high level product support all add up to one less alligator snapping at your heels. From Otari: The Technology You Can Trust.

Contact your nearest Otari dealer for a demonstration, or call Otari Corporation, 2 Davis Drive, Belmont, CA 94002 (415) 592-8311 Telex: 910-376-4890



OTARI®

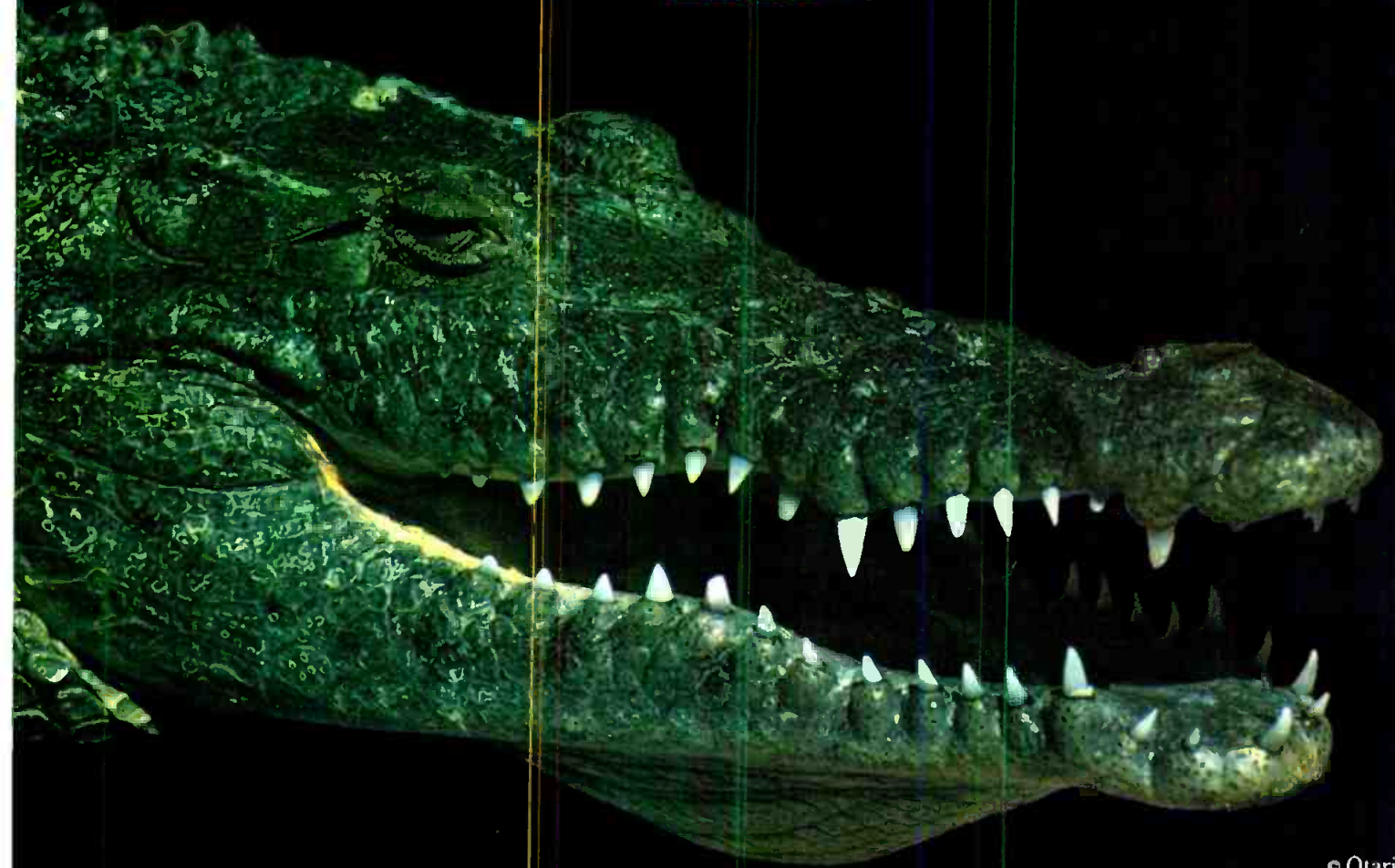

High-voltage power supplies

By Jerry Whitaker, editor

Last month, we discussed the operation of silicon rectifiers commonly used in transmission equipment. We continue our examination with a look at series and parallel rectifier configurations.

Series operation

High-voltage power supplies found in broadcast transmitters often require rectifier voltage ratings well beyond those typically available from the semiconductor industry. To meet the requirements of the application, transmitter manufacturers commonly use silicon diodes in a series configuration to give the required working peak reverse voltage.

For such a configuration to work properly, the voltage across any one diode must not exceed the rated *peak transient reverse voltage* (V_{RM}) at any time. A characteristic of silicon diodes that makes this objective difficult to achieve is the dissimilarity commonly found between the reverse leakage current characteristics of different diodes of the same type number. This problem is normally overcome by connecting shunt resistors across each rectifier in the chain, as shown in Figure 1. The resistors are chosen so that the current through the shunt elements (when the diodes are reverse-biased) will be several times greater than the leakage current of the diodes themselves.

An additional factor that must be considered with a series-connected rectifier stack is the *carrier storage* effect present in each diode after the assembly has

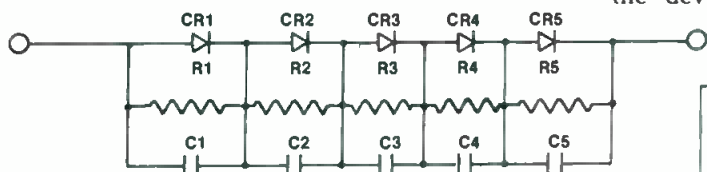
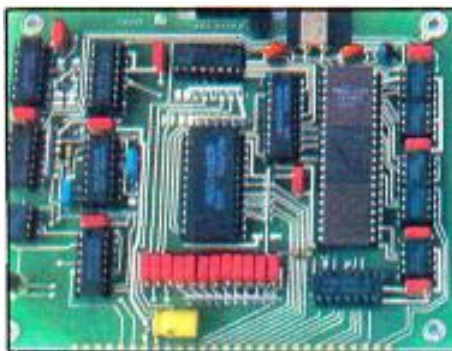

Figure 1. A portion of a high-voltage series-connected rectifier stack.

been conducting a specific forward current. If precautions are not taken, different diode recovery times caused by the carrier storage phenomenon will effectively force the full applied reverse voltage across the first diode in the stack to *block* (recover) when the voltage

Editor's note: Background information from the Howard W. Sams publication, *Reference Data for Radio Engineers*, Sixth Edition. "Troubleshooting" this month examines how to repair high-voltage transmitter power supplies.



Courtesy of ITC/3M

swings to the opposite polarity. This problem can be prevented by connecting small-value capacitors across each diode in the rectifier stack. The capacitors equalize the transient reverse voltages during the carrier storage recovery period of the individual diodes.

In a rectifier stack consisting of a long string of diodes, the effects of stray capacitance must also be considered. The stray capacitance from each diode interconnection, coupled with the diode junction capacitance, forms a capacitive ladder. This, in effect, applies an unfair share of the total reverse voltage across the diodes in the rectifier chain that are connected to the ac input point. This problem can be prevented by keeping the ratio of shunt-to-stray capacitance large, either by increasing the values of the shunt capacitors or by minimizing the stray capacitance of the rectifier assembly through special construction.

Silicon avalanche rectifiers

The silicon avalanche diode is a special type of rectifier that can withstand high reverse power dissipation. For example, an avalanche diode with a normal forward rating of 10A can dissipate a reverse transient of 8kW for 10ms without damage. This characteristic of the device allows elimination of the

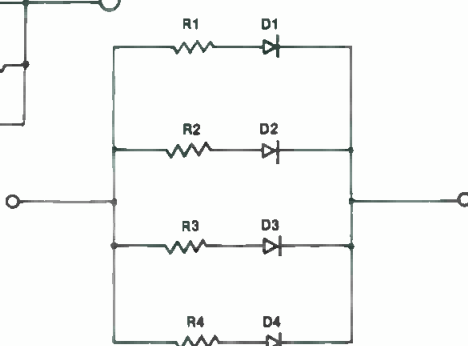

Figure 2. Using buildout resistances to force current-sharing in a parallel rectifier assembly.

surge-absorption capacitor and voltage-dividing resistor networks needed when conventional silicon diodes are used in a series rectifier assembly. Because fewer diodes are needed for a given applied

reverse voltage, significant underrating of the device to allow for reverse voltage transient peaks is not required.

When an extra-high-voltage rectifier stack is used, it is still advisable to install shunt capacitors—but not resistors—in an avalanche diode assembly. The capacitors are designed to compensate for the effects of carrier storage and stray capacitance in a long series assembly.

Parallel operation

Silicon rectifiers are used in a parallel configuration when large amounts of current are required from the power supply. Parallel assemblies are normally found in solid-state high-power transmitter designs, which operate from low-voltage, high-current supplies. The major design problem with a parallel rectifier assembly is *current sharing*, because diodes of the same type number do not necessarily exhibit the same forward characteristics.

Semiconductor manufacturers often divide production runs of rectifiers into tolerance groups, matching forward characteristics of the various devices. When parallel diodes are used, choose devices from the same tolerance group to avoid unequal sharing of the load current. As a margin of safety, allow a substantial derating factor for devices in a parallel assembly to ensure that the maximum operating limits of any one component are not exceeded.

Parallel rectifier assemblies are constructed to provide for equal heat dissipation of all devices. Ideally, the rectifiers are placed on the same heat sink, to facilitate heat transfer among the individual components. The device layout is structured so that the individual diodes are arranged symmetrically, preventing a current imbalance to be caused by unequal external resistances.

The problems inherent in a parallel rectifier assembly can be reduced through the use of a resistance or reactance in series with each component, as shown in Figure 2. The buildout resistances (R1 through R4) force the diodes to share the load current equally. Such assemblies can, however, be difficult to construct and may be more expensive than simply adding additional diodes, or going to higher-rated components in the assembly.

Next month, we will examine ac power control through thyristor servo systems.

[::-)))))



**The Orban OPTIMOD-TV
Audio Processor and
TV Stereo Generator.**

Effective TV audio processing is a challenge: It must provide consistent loudness from source to source, and it must control dynamic range to provide *comfortably listenable sound* on sets with small speakers and small amplifiers while still sounding *open and natural* on today's newer stereo audio and video components. When audio processors are measured against these difficult criteria, the Orban 8182A OPTIMOD-TV Audio Processor emerges as the only serious contender.

The OPTIMOD-TV's perfect mate is the Orban 8182A/SG TV Stereo Generator—an excellent performer in its own right. The servo-stabilized matrix stereo generator in the 8182A/SG is essentially identical to the generator in our industry-standard Orban 8100A OPTIMOD-FM. Its reliability and stability have been proven over five years with literally thousands of units. BTSC "Equivalent Stereo Separation" comfortably exceeds 50 dB, 50-15,000 Hz. The baseband is so clean that no audible crosstalk is introduced into other subcarriers, even under the most critical listening conditions. This is a stereo generator design that has earned its stripes in the real world—a design you can trust to work and keep on working.

Orban's TV Stereo Generator uses genuine dbx®-manufactured compander cards to achieve tightest compliance with the dbx® standard over wide varia-

tions of time and temperature. Full frequency response (-0.5 dB or better) is maintained to 15 kHz, and our filters provide up to 40 dB better aliasing protection than some other generators.

Separation stably exceeds BTSC specifications by 10 dB or more, thanks to rigorous engineering analysis and careful component selection in the complex anti-aliasing 15 kHz sum and difference lowpass filters. And the BTSC specifications *themselves* are conservative. Psychoacoustic studies have shown that further increases in separation will not audibly improve stereo imaging. Indeed, it is downright foolish to improve separation at the expense of other, more audible parameters like frequency response or non-linear crosstalk. Compare before you buy!

The OPTIMOD-TV Audio Processor—for the best sound. The Orban TV Stereo Generator—stable; reliable; an excellent performer. Together, the perfect marriage—and why there are more Orban TV Stereo systems on the air than all other makes *combined*.

Join the family of satisfied Orban users. Contact your favorite Orban Broadcast Products Dealer, or call us direct.

Orban Associates Inc.

645 Bryant Street, San Francisco, CA 94107
(800) 227-4498 or (415) 957-1067 Telex: 17-1480

THE PERFECT MARRIAGE.

orban

Circle (13) on Reply Card
www.americanradiohistory.com

Power supply failures

By Jerry Whitaker, editor

A failure in the high-voltage power supply of a broadcast transmitter is usually a catastrophic event. There is rarely any question that you have a problem. Because of the voltages and currents involved, the failure of a component in the power supply generally leaves telltale clues as to the cause of the problem. The clues may be burnt resistors, charred wiring or leaky capacitors. Sometimes, you won't have to search that far for clues, because you may find pieces of a component scattered on the transmitter floor. The first line of defense for a problem in the high-voltage power supply is the plate overload circuit.

Overload sensor

The plate supply overload sensor in most transmitters is arranged as shown in Figure 1. An adjustable resistor—either a fixed resistor with a movable tap or a potentiometer—is used to set the sensitivity of the plate overload relay. Potentiometer-type adjustments should be checked periodically. Fixed-resistor-type adjustments rarely require additional attention. Most manufacturers have a chart or mathematical formula that may be used to determine the proper setting of the adjustment resistor (R9) by measuring the voltage across the overload relay coil (K1) and observing the operating plate current value.

Clean the overload relay contacts periodically to ensure proper operation.

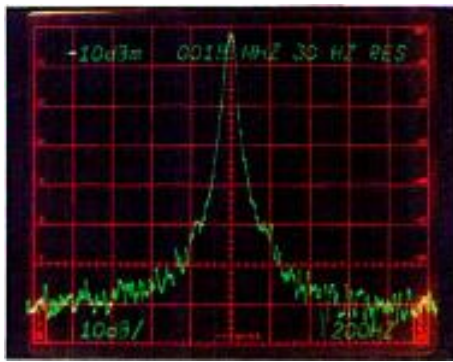

If any mechanical problems are encountered with the relay, replace it.

Transient disturbances

Different types and makes of transmitters have varying degrees of transient overvoltage protection. Given the experience of the computer industry, it is hard to overprotect electronic equipment from ac line disturbances.

Figure 1 shows surge suppression at two points in the power supply circuit. C1 and R4 make up an R/C snubber network that is effective in shunting high-energy, fast-rise time spikes that may appear at the output of the rectifier assembly (CR1-CR6). Similar R/C snubber networks (R10-R12 and C3-C8) are placed across the secondary windings of each section of the 3-phase power transformer. Any signs of resistor overheating or capacitor failure are an indication of excessive transient activity on the ac power line. Transient disturbances should be suppressed before the ac input point of the transmitter.

Assembly CR7 is a surge suppression circuit that should be given careful attention during each maintenance session. CR7 is typically a selenium thyrector assembly that is essentially inactive until the voltage across the device exceeds a predetermined level. At that point, the device will break over into a conducting state, shunting the transient overvoltage.

CR7 is placed in parallel with L1 to prevent damage to other components in the transmitter in the event of a loss of RF excitation to the final stage. A sudden drop in excitation will cause the stored energy of L1 to be discharged into the power supply and PA circuits in the form of a high-potential pulse. The results of this transient can be damaged or destroyed filter, feedthrough or bypass capacitors, damaged wiring or PA tube arcing. CR7 prevents this by dissipating the stored energy in L1 as heat.

Discoloration or other outward signs of damage to CR7 should be investigated. Such an occurrence could indicate a problem in the exciter or IPA stage of the transmitter. Immediately replace CR7 if it appears to have been stressed.

Check spark gap surge suppressor X1 periodically for signs of overheating. X1 is designed to prevent damage to circuit wiring in the event that one of the meter/overload shunt resistors (R1-R3) opens. Because the spark gap device is nearly impossible to test in the field and is relatively inexpensive, it is an advisable precautionary measure to replace the component every few years.

Metering

The plate voltage meter can be checked for accuracy by using a high-voltage probe and a high-accuracy external voltmeter. Be extremely careful when making such a measurement. Follow to the letter the instructions for use of the high-voltage probe. Do not defeat the transmitter interlocks to make this measurement. Instead, fashion a secure connection to the point of measurement and route the meter cables carefully out of the transmitter. Never use common test leads to measure a voltage of more than 600V. Test lead insulation for most meters is not rated for use above 600V.

Next month

In the next "Troubleshooting" column, we will examine failures relating to the primary ac power system. [:-))]]

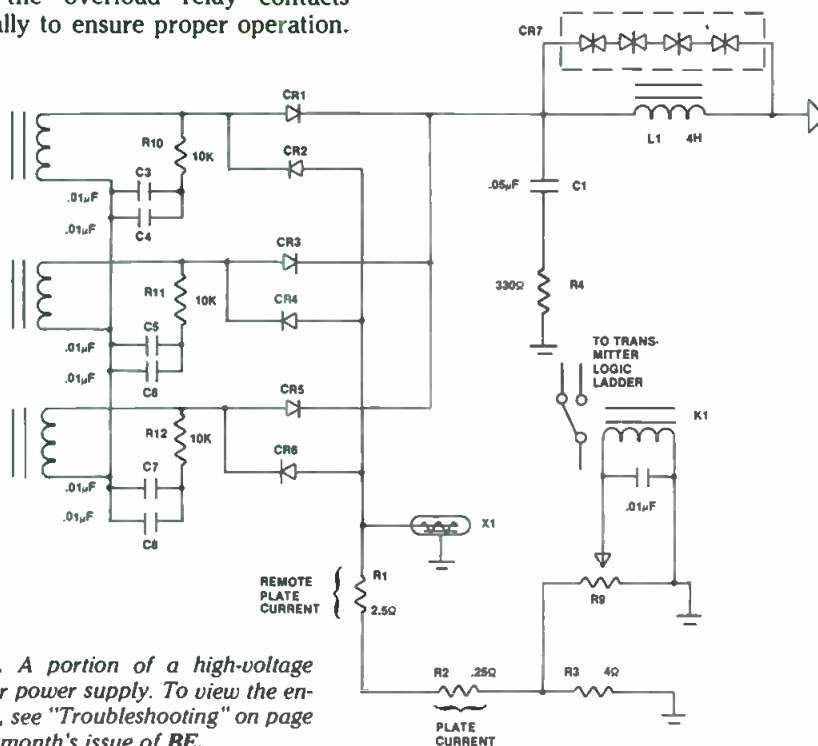

Figure 1. A portion of a high-voltage transmitter power supply. To view the entire circuit, see "Troubleshooting" on page 18 of last month's issue of BE.

Committed to 3/4" U



What better way to show a commitment than to introduce the finest, most innovative 3/4" Editing Recorder ever made? The commitment is JVC's. The recorder is the CR-850U.

CR-850U. With a new level of picture quality!

CR-850U. With a new level of convenience!

CR-850U. With a new level of flexibility!

CR-850U. With a new level of reliability!

SMPT E time code... built-in editing control functions... 47 dB signal-to-noise ratio (the highest available!)... Y-688 dubbing for clean transfer without distortion... rack-mountable... full direct-drive transport... unique diagnostic warning system... front panel test points... connections for serial and parallel remote

controllers... all this and more!

The quality, the convenience, the flexibility, the reliability you've asked for!

Here, now, in the unique JVC CR-850U Editing Recorder!

For more information, call, toll-free:

1-800-JVC-5825

JVC COMPANY OF AMERICA

Professional Video

Communications Division

41 Slater Drive, Elmwood Park, NJ 07407

JVC CANADA, Scarborough, Ontario

JVC®

© 1985 JVC Company of America

1985 Salary Survey

By Brad Dick, radio technical editor

In general, broadcast salaries are up. How does your paycheck compare?

Wanted: Highly qualified engineer. Will be responsible for maintaining state-of-the-art facilities in beautiful surroundings. Salary \$23,000.

Now be honest. Does this description look attractive to you? Do you earn that much money? The salary shown above represents the composite median pay for radio engineers, according to the data received in the 1985 **BE** salary survey. The composite median salary for TV engineers is \$31,500.

There are few of us who don't wonder

just how much money our peers are getting paid. Unfortunately, unless we're all willing to bare the facts, it's difficult to see just how we stack up on the salary scale. Enter the **BE** salary survey.

The results of our sixth annual survey are broken down for radio and television into three basic areas of broadcasting: management, operations and engineering. Those categories are divided further into three market sizes: *top 50*, *top 100* and *below top 100*. Through the survey results, readers can easily compare their own

paychecks with those of colleagues in similar positions within comparable-sized markets.

The 1985 **BE** study was scientifically conducted by the marketing research department of Intertec Publishing, under the direction of Kate Smith. On June 8, 3,031 questionnaires were mailed to recipients of **BE** on an 'nth name' basis. On August 9, 1,205 completed forms had been returned, providing a response rate of 39.8%. The data contained in this report is based on these responses.

Upwardly mobile

As would be expected, the salaries of those in management were shown to be higher than those of either operations or engineering personnel. What was not expected, however, was the amount of change in these salaries since 1984. Last year's survey saw a drop in pay to TV managers. From a 1983 median of

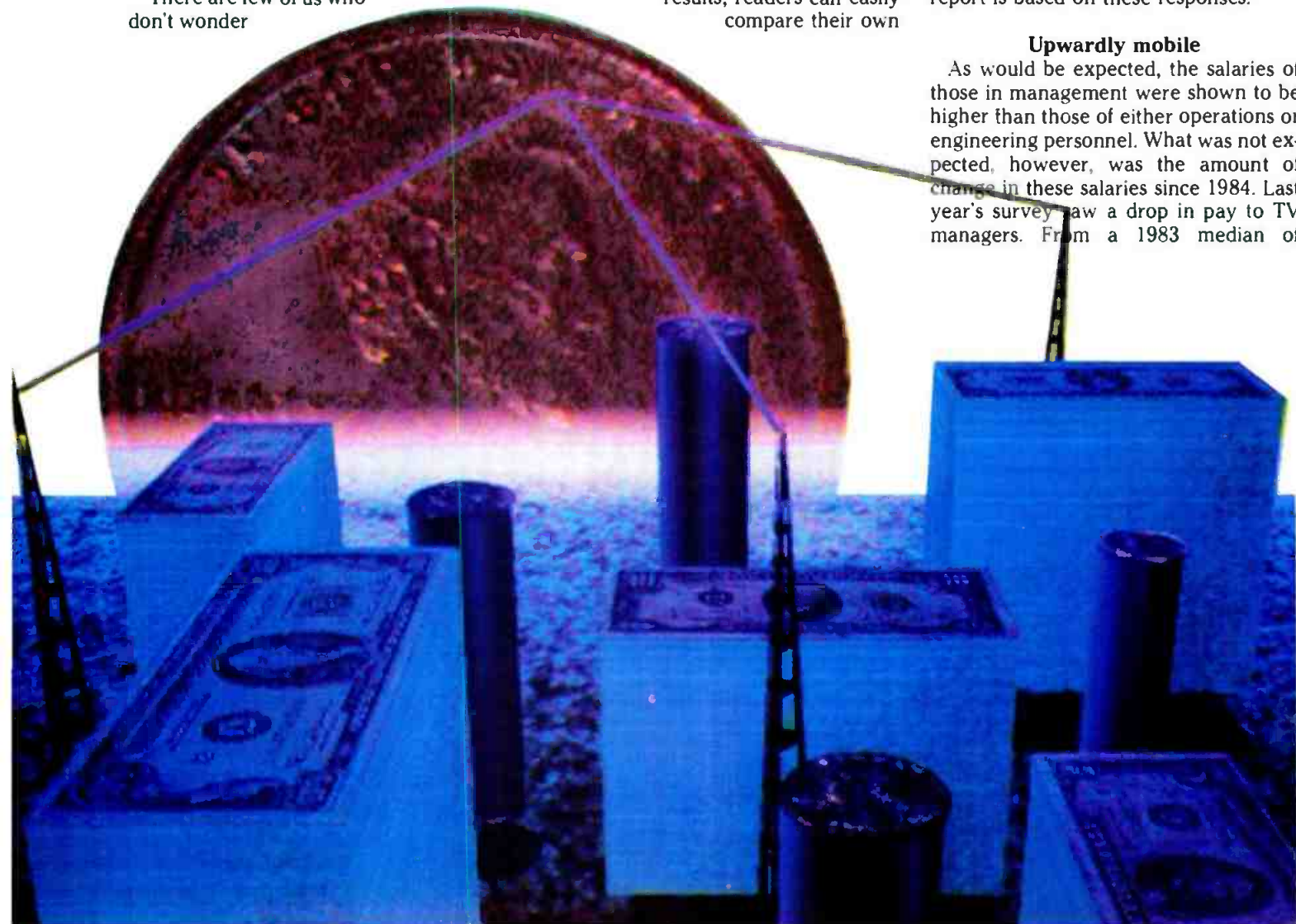

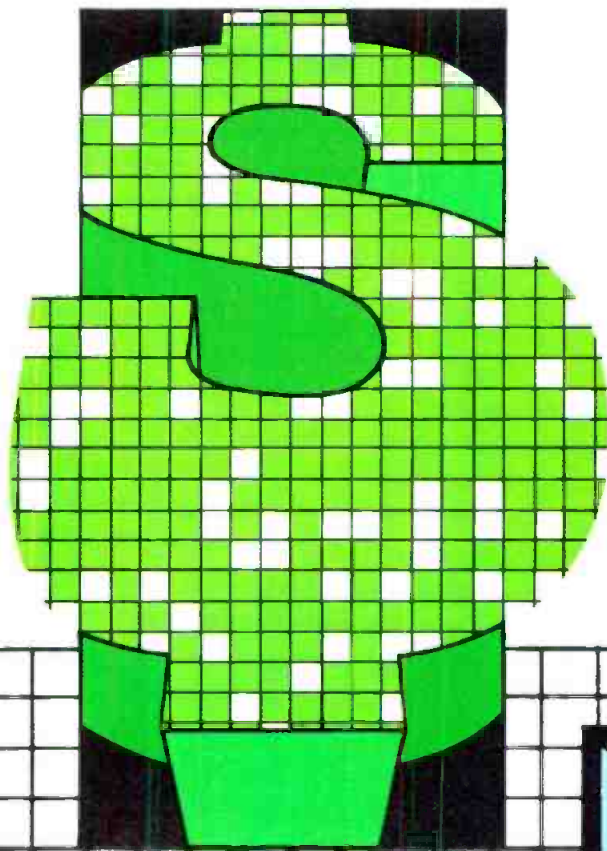

\$60,000, the salary had dropped to \$46,250 last year. This year saw a healthy increase—to \$57,750. A close examination of the survey shows that management received considerably larger salary increases than those with other job descriptions.

An example is the 1985 TV manager's salary, significantly higher than it was in 1984. Comparing this year's results to last year's, we see the TV manager's median salary increased from \$46,250 to \$57,750. The \$11,500 difference represents a whopping 25% increase. Although not as greatly increased, the radio manager's salary went from \$28,300 to \$34,800, for a 23% raise.

The engineers who responded to the survey did not fare quite as well. The TV engineer's median salary increased from \$28,900 to \$31,500 (up 9%). The sad news is that the radio engineer's median salary actually decreased from \$23,700 to \$23,000, for a loss of 3%. An examination of radio engineering salaries by market size shows the decline is caused by a 9% decrease in salaries paid to engineers in the *top 50* markets. Engineers—radio and television—in all other categories posted salary gains.

The median salary of TV operations personnel increased from \$25,300 to \$28,800, providing a substantial 14% increase. For those in radio operations, the median salary increased from \$16,500 in 1984 to \$20,000 in 1985 (up 21%).

These results would seem to indicate that, although engineering salaries were better overall, losses were incurred this year in major market radio. In general, the percentages of increase received by engineers were lower than either management or operations.

If we compare the median salary of the *top 50* markets and the *below top 100* markets by job category, an interesting trend is found. The difference in median salary for TV managers between the two markets is 52%. In other words, as you

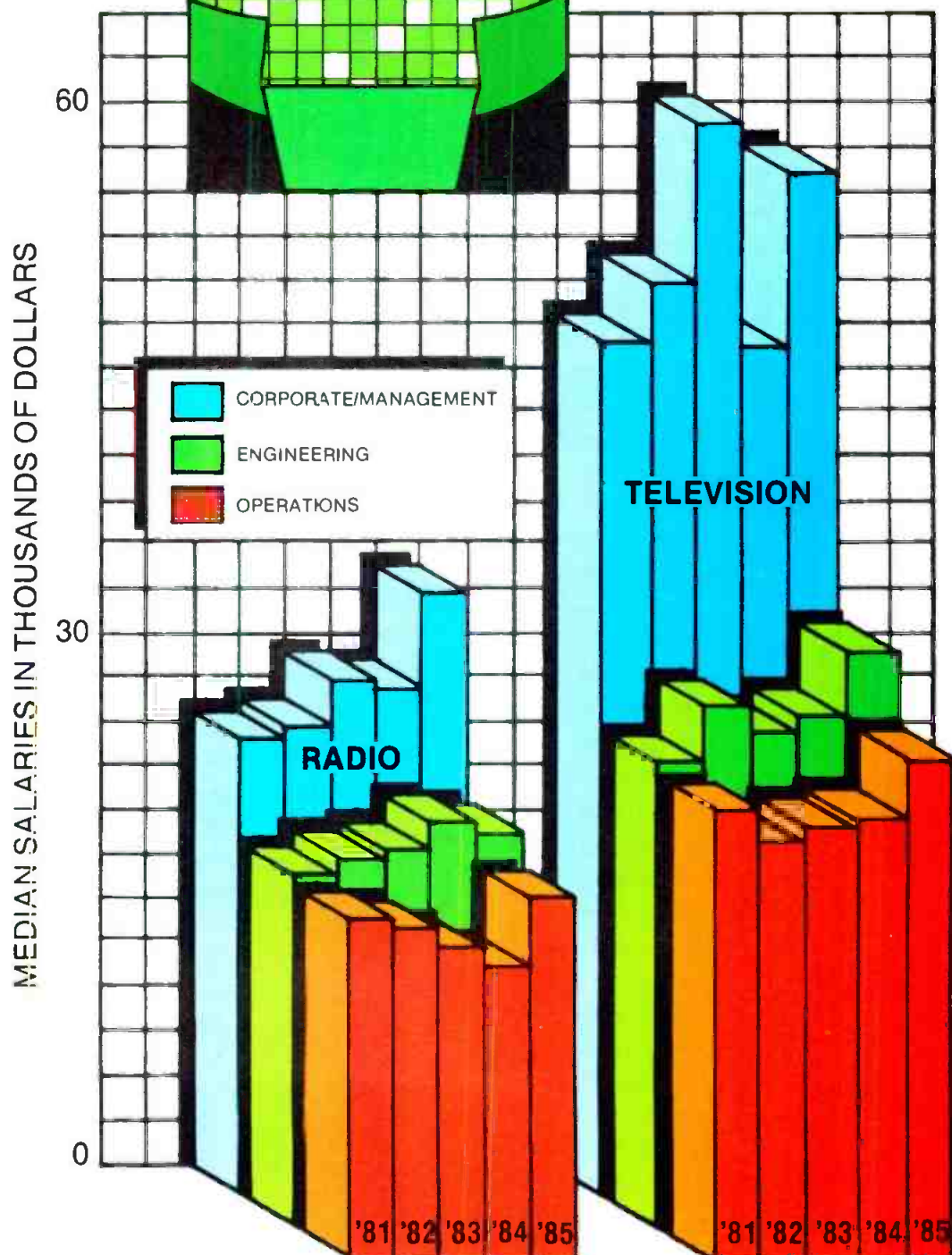
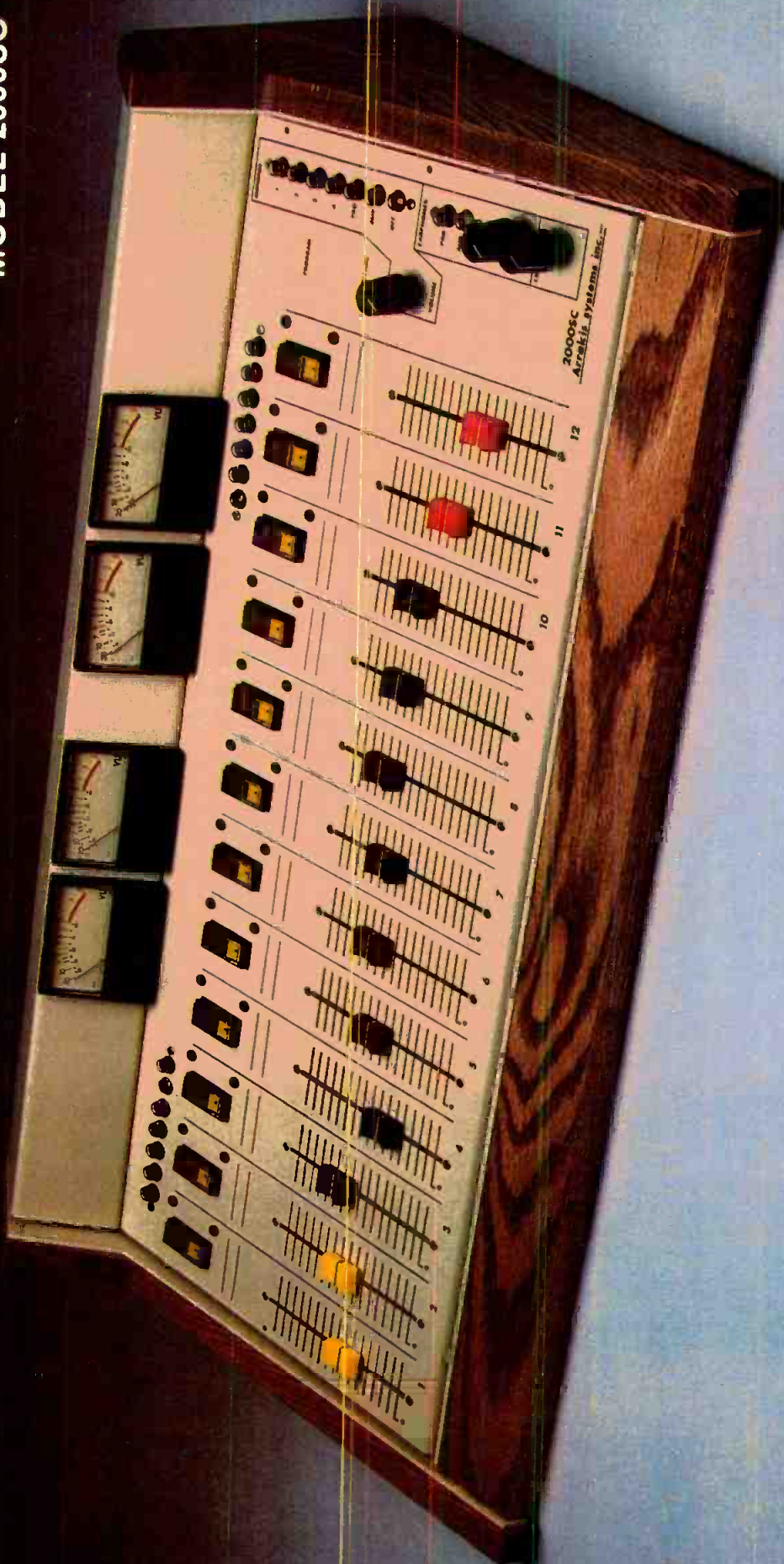

TABLE 1. — MANAGEMENT STAFF PROFILE*

	ALL MARKETS	TELEVISION				RADIO			
	Total %	Total TV %	Top 50 %	Top 100 %	Below Top 100 %	Total Radio %	Top 50 %	Top 100 %	Below Top 100 %
Salary Level									
Less than \$15,000	5.8	2.0	2.3	2.6	7.5	2.3	5.6	9.3
\$15,000 to \$19,999	6.1	1.0	2.6	8.3	4.7	2.8	10.5
\$20,000 to \$24,999	6.7	7.8	7.0	7.9	6.2	2.8	8.6
\$25,000 to \$34,999	22.7	9.8	4.7	9.5	15.8	28.3	23.3	30.5	29.0
\$35,000 to \$49,999	20.7	20.6	14.0	19.0	28.9	20.7	18.6	27.8	19.8
\$50,000 to \$74,999	21.3	28.4	27.9	33.3	26.4	18.3	37.1	19.4	13.0
\$75,000 or more	16.1	30.4	44.1	28.7	15.8	9.9	14.0	11.1	8.6
Not given	.68	1.2
Median =	\$41,000	\$57,750	\$69,750	\$59,000	\$45,950	\$34,800	\$50,750	\$39,500	\$28,600
Received Salary Increase During Past Year									
	58.9	74.5	72.1	81.0	73.7	52.3	67.4	61.1	46.3
Percentage of increase									
Less than 5%	5.3	5.9	7.0	4.8	5.3	5.0	11.6	2.8	3.7
5% to 9%	26.2	38.1	37.2	52.3	31.6	21.2	20.9	25.0	20.4
10% to 14%	14.9	21.6	18.6	19.1	26.3	12.0	20.9	19.4	8.0
15% or more	9.6	6.9	7.0	4.8	7.9	10.8	14.0	8.3	10.5
Not given	2.9	2.0	2.3	2.6	3.3	5.6	3.7
Median =	9.4	9.0	8.8	9.3	9.8	9.6	10.3	10.0	9.3
Fringe Benefits Received (Adds to more than 100% due to multiple answers)									
Medical insurance (paid)	84.8	93.1	95.3	85.7	94.7	81.3	95.3	88.9	75.9
Dental insurance (paid)	34.7	51.0	74.4	42.9	28.9	27.8	41.9	30.6	23.5
Life insurance (paid)	65.0	82.4	88.4	81.0	76.3	57.7	79.1	69.4	49.4
Sick leave	74.1	90.2	88.4	85.7	94.7	67.2	83.7	72.2	61.7
Vacation	86.9	93.1	93.0	90.5	94.7	84.2	95.3	88.9	80.2
Stock purchase plan	10.5	15.7	20.9	14.3	10.5	8.3	16.3	5.6	6.8
Profit sharing plan	18.4	24.5	37.2	19.0	13.2	15.8	16.3	16.7	15.4
Savings plan	11.7	26.5	30.2	23.8	23.7	5.4	14.0	2.8	3.7
Pension plan	29.4	52.0	51.2	61.9	47.4	19.9	32.6	19.4	16.7
Bonus	31.2	39.2	39.5	38.1	39.5	27.8	39.5	19.4	26.5
Trade show/convention/ seminar expense paid	56.3	71.6	74.4	71.4	68.4	49.8	48.8	41.7	51.9
Tuition refund plan	17.5	27.5	25.6	28.6	28.9	13.3	32.6	13.9	8.0
Automobile furnished	50.4	52.0	46.5	61.9	52.6	49.8	46.5	41.7	52.5
Years in Present Job									
1 to 2	20.1	24.5	23.3	28.4	23.7	18.3	23.3	22.2	16.1
3 to 4	18.7	17.7	18.6	19.1	15.8	19.1	16.3	13.9	21.0
5 to 9	25.3	25.4	27.9	19.1	26.2	24.8	25.5	19.4	25.8
10 to 14	12.2	11.8	9.3	14.3	13.2	12.5	14.0	16.7	11.1
15 to 24	15.5	14.7	18.6	19.1	7.9	14.9	16.3	22.2	14.2
25 or more	7.3	5.9	2.3	13.2	8.7	2.3	5.6	9.9
Not given	.9	1.7	2.3	1.9
Median =	7.1	6.6	6.5	5.7	7.0	7.4	6.8	8.6	7.3
Years in Broadcast Industry									
Less than 5	5.3	4.9	2.3	4.8	7.9	5.4	4.7	8.3	4.8
5 to 9	9.0	8.8	11.6	10.5	9.1	4.7	8.3	10.5
10 to 14	9.3	9.8	11.6	9.5	7.9	9.1	14.0	8.3	8.0
15 to 24	31.5	28.4	30.2	23.8	29.0	32.8	41.7	25.0	32.1
25 or more	43.4	48.1	44.3	61.9	44.7	41.5	32.6	47.3	42.7
Not given	1.5	2.1	2.3	2.8	1.9
Median =	23.1	24.3	23.6	27.5	20.0	22.8	21.1	24.4	23.1
Do Part-Time or Free-Lance Work									
	28.3	23.5	20.9	28.6	23.7	30.3	25.6	30.6	31.5
Education									
High school	13.7	10.8	7.0	19.0	10.5	14.9	9.3	8.3	17.9
Two years of college	17.8	10.8	14.0	14.3	5.3	20.7	14.0	25.0	21.6
Four years of college	36.2	40.2	32.6	42.9	47.4	34.4	23.3	33.3	37.7
Post-graduate college	29.2	34.3	37.2	23.8	36.8	27.0	48.8	33.3	19.8
Voc/tech school	9.6	4.9	4.7	4.8	5.3	11.6	7.0	8.3	13.6
Not given	1.5	1.0	4.7	1.7	2.3	1.9
Age, Years									
Under 25	1.2	1.7	5.6	1.2
25 to 34	13.7	6.9	9.3	7.9	16.6	14.0	13.9	17.9
35 to 44	36.1	33.3	27.9	42.9	34.2	37.3	51.1	38.9	33.3
45 to 54	22.7	22.5	16.3	19.0	31.6	22.8	18.6	22.2	24.1
55 or over	24.5	36.3	44.2	38.1	26.3	19.5	16.3	19.4	20.4
Not given	1.8	1.0	2.3	2.1	3.1
Median =	44.5	49.1	52.1	48.8	47.5	43.2	42.0	42.9	43.8

*Management staff: president, owner, partner, vice president, general manager.

MODEL 2000SC



AUDIO CONSOLE PRODUCTS

Arrakis audio console products are designed by broadcast engineers for broadcasters at reasonable prices.

Our products sell themselves. Study our features, specs., and prices. Compare and you will find what thousands have found — The Arrakis Advantage —

FEATURES

- VCA Faders
- P & G Sliders
- .01% Distortion
- Solid Oak Trim
- 10W/CH Monitor
- Remote Start
- Mix - Minus
- Modular Design
- Ultra-Reliable
- Mono Mixdowns
- Stereo Cue
- Full Muting
- Dimensions—
• 30" W x 17" D x 7" H
- Weight—55 Lbs.

MODELS

- 6 Channel Rotary
 - 150SC-6M \$1895
 - 150SC-6S \$1995
- 8 Channel Rotary
 - 500SC-8M \$3550
 - 500SC-8S \$3750
- 12 Channel Linear
 - 2000SC-12M \$4495
 - 2000SC-12S \$4695
- 12 Channel Linear
 - 2100SC-12M \$5495
 - 2100SC-12S \$5695

arrakis
SYSTEMS, INC.



204 N LINK LANE, # 3
FORT COLLINS, CO
80524

(303) 224-2248

Circle (14) on Reply Card

www.americanradiohistory.com

**Sony
Broadcast:**

**The Gold
Standard
At Work.**



It's a broadcast U-matic® with nine years on the job.

A team of one-inch type "C" video recorders that pull a network load around-the-clock.

A Betacam® camcorder that gets that exciting story, or that impossible shot, and gets it on the air. Fast.

It's equipment that works right out of the box. Equipment that works with everything we make or will make.

It's training programs that keep you right on top of things.

It's a service and parts network that blankets the country. And an emergency hot line that's *always* open.

It's a company that came into being to meet your needs. And did.

The commitment continues.

Sony Broadcast.

The gold standard at work. **SONY**
BROADCAST

TABLE 2. — ENGINEERING AND TECHNICAL STAFF PROFILE*

	ALL MARKETS		TELEVISION				RADIO		
	Total %	Total TV %	Top 50 %	Top 100 %	Below Top 100 %	Total Radio %	Top 50 %	Top 100 %	Below Top 100 %
Salary Level									
Less than \$15,000	11.4	6.1	2.9	6.8	12.8	18.4	8.3	25.0	25.5
\$15,000 to \$19,999	14.5	11.0	7.0	10.2	20.5	19.2	7.3	7.1	32.7
\$20,000 to \$24,999	16.2	13.3	10.5	18.6	15.4	20.1	19.8	17.9	20.9
\$25,000 to \$34,999	27.6	30.1	23.3	40.7	37.2	24.4	30.3	46.4	13.6
\$35,000 to \$49,999	21.2	27.5	36.5	18.6	14.1	12.8	25.0	5.5
\$50,000 to \$74,999	7.6	10.4	16.9	5.1	3.8	8.3	3.6
\$75,000 or more	1.1	1.6	2.94	1.0
Not given	.49	1.8
Median =	\$27,800	\$31,500	\$37,550	\$28,500	\$25,300	\$23,000	\$29,800	\$25,000	\$18,600
Received Salary Increase During Past Year									
Percentage of increase	75.5	86.4	89.0	86.4	80.8	61.0	77.0	57.1	48.1
Less than 5%									
Less than 5%	14.7	17.2	11.6	18.6	28.2	11.1	8.3	14.3	13.6
5% to 9%									
5% to 9%	43.9	51.8	57.6	55.9	35.9	32.9	46.9	25.0	23.6
10% to 14%									
10% to 14%	10.9	11.3	13.4	8.5	9.0	9.8	13.5	10.7	7.3
15% or more									
15% or more	5.3	4.2	5.8	1.7	2.6	6.8	7.3	7.1	3.6
Not given	.7	1.9	.6	1.7	5.1	.4	1.0
Median =	7.6	7.4	7.9	7.1	6.4	7.9	8.2	7.9	7.2
Fringe Benefits Received (Adds to more than 100% due to multiple answers)									
Medical insurance (paid)	83.2	87.4	91.9	78.0	84.6	77.8	83.3	75.0	73.6
Dental insurance (paid)	45.5	55.7	65.1	52.5	37.2	32.1	49.0	21.4	20.0
Life insurance (paid)	62.6	68.9	76.7	66.1	53.8	54.3	71.9	57.1	38.2
Sick leave	84.3	95.5	94.8	98.3	94.9	69.7	82.3	67.9	59.1
Vacation	92.3	97.7	97.1	100.0	97.4	85.0	91.7	82.1	80.0
Stock purchase plan	17.3	22.0	34.3	10.2	3.8	11.1	21.9	3.6	3.6
Profit sharing plan	16.4	20.4	21.5	20.3	17.9	11.1	11.5	17.9	9.1
Savings plan	22.5	29.4	41.9	15.3	12.8	13.2	26.0	3.6	4.5
Pension plan	49.9	63.8	69.2	62.7	52.6	31.6	51.0	7.1	20.9
Bonus	12.2	12.6	11.0	15.3	14.1	11.5	14.6	10.7	9.1
Trade show/convention/ seminar expenses paid	30.2	29.8	25.0	39.0	33.3	30.8	43.8	25.0	20.9
Tuition refund plan	32.6	42.1	51.7	37.3	24.4	20.1	31.3	7.1	13.6
Automobile furnished	12.9	11.7	5.8	18.6	19.2	14.5	15.6	25.0	10.9
Years in Present Job									
1 to 2	30.1	32.0	33.8	27.0	32.0	27.8	29.2	25.0	27.2
3 to 4	14.4	12.3	11.6	10.2	15.4	17.1	15.6	17.9	18.2
5 to 9	21.9	19.1	18.0	30.5	12.8	25.6	22.9	39.2	24.6
10 to 14	11.1	11.3	8.1	10.2	19.2	10.7	13.5	14.3	7.3
15 to 24	13.1	14.6	16.9	13.6	10.3	11.1	11.5	13.6
25 or more	7.0	8.4	8.7	8.5	7.7	5.1	4.2	7.3
Not given	2.4	2.3	2.9	2.6	2.6	3.1	3.6	1.8
Median =	6.0	6.2	5.9	7.1	5.5	5.8	5.8	5.7	5.8
Years in Broadcast Industry									
Less than 5	14.9	11.3	11.6	6.8	14.1	7.3	4.2	11.8
5 to 9	14.6	21.4	22.7	17.0	21.8	18.0	18.8	17.9	17.3
10 to 14	16.2	12.0	11.1	11.9	14.1	21.8	22.9	25.0	20.0
15 to 24	26.8	24.0	23.3	37.2	16.7	30.2	36.4	42.8	21.8
25 or more	24.9	28.7	28.4	25.4	30.7	20.1	14.6	10.7	27.3
Not given	2.6	2.6	2.9	1.7	2.6	2.6	3.1	3.6	1.8
Median =	16.1	16.9	16.6	18.7	14.6	15.5	15.7	16.0	15.0
Do Part-Time or Free-Lance Work									
	48.4	35.0	35.5	28.8	38.5	67.1	68.8	64.3	66.4
Education									
High school	29.7	29.4	25.6	33.9	34.6	29.9	18.8	32.1	39.1
Two years of college	29.8	31.7	29.1	32.2	37.2	27.4	30.2	25.0	25.5
Four years of college	26.3	24.6	32.0	16.9	14.1	28.6	33.3	28.6	24.5
Post-graduate college	7.4	6.5	6.4	6.8	6.4	8.5	11.5	10.7	5.5
Voc/tech school	37.9	41.4	39.0	37.3	50.0	33.3	30.2	28.6	37.3
Not given	2.8	2.6	2.9	5.1	3.0	4.2	3.6	1.8
Age, Years									
Under 25	6.3	7.4	7.6	6.8	7.7	4.7	5.2	3.6	4.5
25 to 34	28.8	27.4	28.5	32.2	21.8	30.8	33.3	32.1	28.2
35 to 44	28.2	25.2	24.4	23.7	28.2	32.0	34.4	46.4	26.4
45 to 54	17.5	19.1	15.1	22.0	25.6	15.4	18.8	3.6	15.5
55 or over	16.6	18.1	20.9	15.3	14.1	14.5	5.2	10.7	23.6
Not given	2.6	2.8	3.5	2.6	2.6	3.1	3.6	1.8
Median =	39.8	40.4	40.0	39.6	41.8	39.1	37.9	37.7	41.2

*Engineering and technical staff: technical manager, chief engineer, engineer.

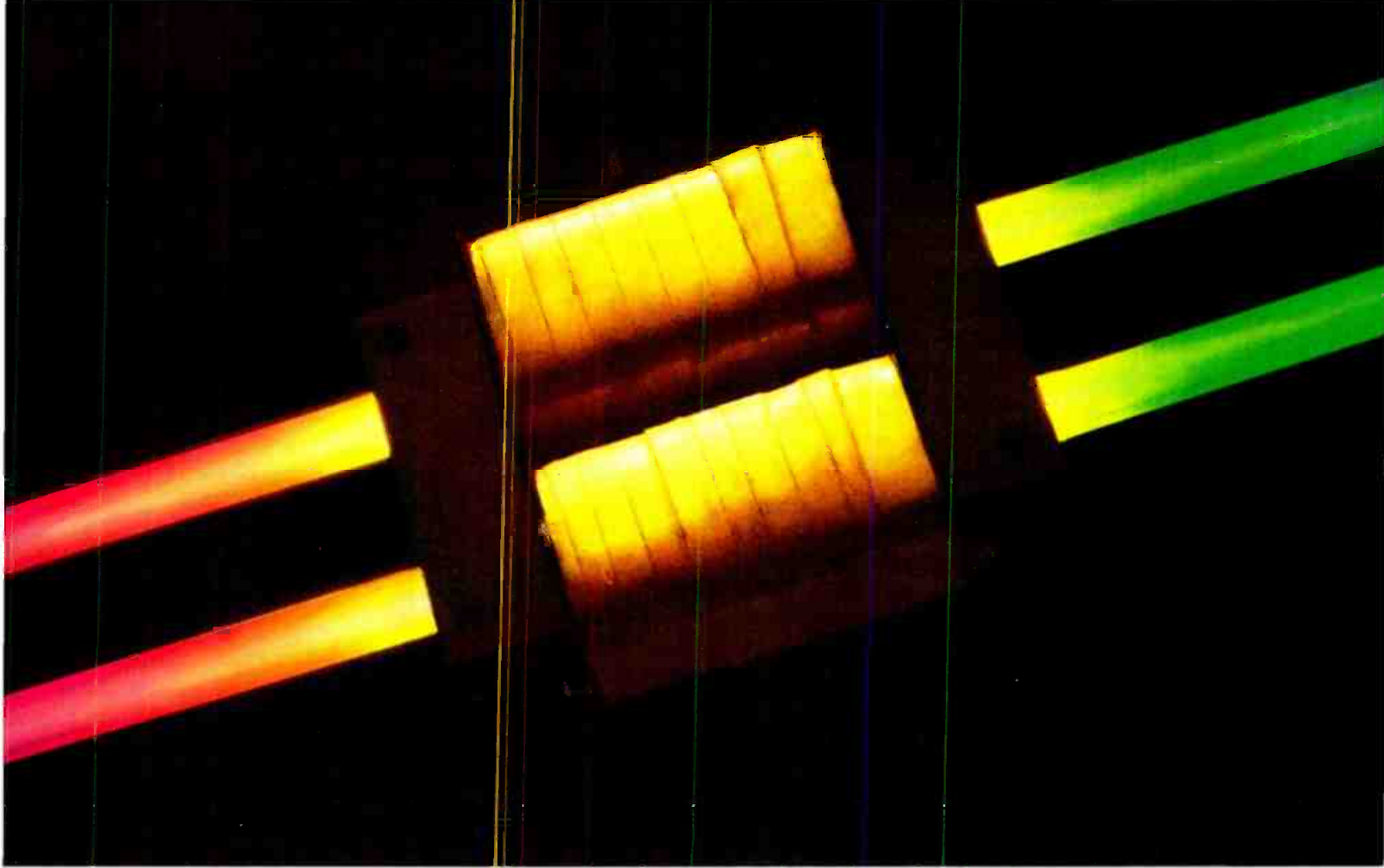

Our painstaking vacuum and coil-winding technology increases efficiency and eliminates acoustical "buzz."

OUR SCIENTISTS HAD TO OPERATE IN A VACUUM TO GIVE YOU A NEW QUALITY OF SOUND.

The quality of any sound system begins at its source. Precision in the power supply is vital to capturing and maintaining the fullness and subtlety of amplified sound. The need for that exactness is why we insist on operating in a vacuum rather than depending on outside sources.

A vacuum tank, to be precise. An environment in which our transformer is created with an air expulsion process. Where air pockets are purged from multi-layers of the transformer's high grade core laminations, and the core made airtight with a special impregnating sealant.

This process gives us impeccable control of transformer function and quality. Which gives you the assurance of the most efficient transfer of power possible, and an end to the acoustical "buzz" that so often fights sound purity.

To a lot of manufacturers the lowly transformer is far down on the list of priorities. For us, every element in the sound system relies on the exacting performance of every other element, and must be painstakingly attended to.

Whether you're driving your studio monitors in a demanding final production mix with our 6000 Series amplifiers, or making critical adjustments to signal quality with our peak or RMS limiter/compressors, you'll find our audio science giving outstanding clarity to your work. To find out which system is designed to meet your needs, contact your authorized JBL/UREI professional products dealer today.

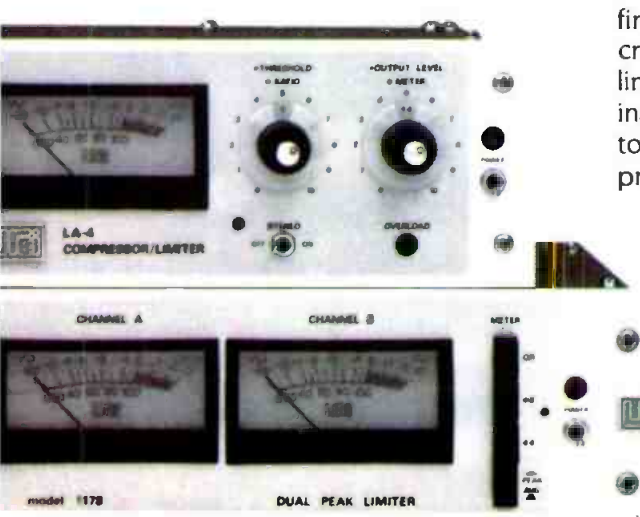

JBL Incorporated,
8500 Balboa Boulevard
P.O. Box 2200,
Northridge, CA 91329
U.S.A.



**UREI
ELECTRONIC
PRODUCTS**

JBL harman international UREI INCORPORATED 1984

Circle (15) on Reply Card

October 1985 *Broadcast Engineering* 27

TABLE 3.— OPERATIONS STAFF PROFILE*

	ALL MARKETS	TELEVISION				RADIO			
	Total %	Total TV %	Top 50 %	Top 100 %	Below Top 100 %	Total Radio %	Top 50 %	Top 100 %	Below Top 100 %
Salary Level									
Less than \$15,000	14.4	8.9	6.0	8.1	16.7	21.4	8.7	17.4	31.0
\$15,000 to \$19,999	19.4	12.3	6.0	16.2	23.7	28.6	17.4	30.6	35.2
\$20,000 to \$24,999	17.2	14.5	10.0	27.0	14.3	20.7	26.1	13.0	19.7
\$25,000 to \$34,999	28.8	38.0	41.0	37.9	31.0	17.1	21.7	30.4	9.9
\$35,000 to \$49,999	11.9	15.1	20.0	8.1	9.5	7.9	15.2	4.3	4.2
\$50,000 to \$74,999	6.9	10.1	15.0	2.7	4.8	2.9	8.7
\$75,000 or more	1.2	1.1	2.0	1.4	2.2	4.3
Not given
Median =	\$24,700	\$28,800	\$31,800	\$24,750	\$23,500	\$20,000	\$24,600	\$20,850	\$17,700
Received Salary Increase During Past Year									
Percentage of increase	77.7	83.8	87.0	83.7	76.2	70.0	73.8	78.2	64.8
Less than 5%									
5% to 9%	11.9	15.6	14.0	24.3	11.9	7.1	8.7	4.4	7.0
10% to 14%	42.0	46.4	50.0	40.5	42.9	36.5	32.6	47.8	35.2
15% or more	14.4	15.1	18.0	13.5	9.5	13.6	13.0	13.0	14.1
Not given	8.8	6.7	5.0	5.4	11.9	11.4	15.2	13.0	8.5
Median =	.6	1.4	4.3
8.2	7.9	8.0	7.2	8.1	8.8	9.0	8.7	8.6	
Fringe Benefits Received (Adds to more than 100% due to multiple answers)									
Medical insurance (paid)	79.9	86.0	92.0	73.0	83.3	72.1	87.0	78.3	60.6
Dental insurance (paid)	41.7	52.5	65.0	45.9	28.6	27.9	43.5	26.1	18.3
Life insurance (paid)	60.2	71.5	80.0	64.9	57.1	45.7	58.7	52.2	35.2
Sick leave	84.0	93.9	96.0	86.5	95.2	71.4	84.8	87.0	57.7
Vacation	93.4	96.6	98.0	94.6	95.2	89.3	91.3	95.7	85.9
Stock purchase plan	14.7	22.3	33.0	8.1	9.5	5.0	8.7	4.3	2.8
Profit sharing plan	12.9	15.1	16.0	13.5	14.3	10.0	13.0	13.0	7.0
Savings plan	15.4	22.9	28.0	18.9	14.3	5.7	8.7	4.3	4.2
Pension plan	42.6	57.5	67.0	45.9	45.2	23.6	34.8	17.4	18.3
Bonus	20.4	16.8	20.0	10.8	14.3	25.0	17.4	21.7	31.0
Trade show/convention/ seminar expenses paid	36.7	42.5	39.0	62.2	33.3	29.3	34.8	39.1	22.5
Tuition refund plan	25.7	33.0	42.0	35.1	9.5	16.4	21.7	17.4	12.7
Automobile furnished	10.7	11.2	7.0	16.2	16.7	10.0	4.3	13.0	12.7
Years in Present Job									
1 to 2	36.4	37.0	39.0	32.4	35.7	35.7	26.1	43.5	39.5
3 to 4	16.9	18.4	18.0	16.3	21.4	15.0	17.4	4.3	16.9
5 to 9	28.2	27.9	27.0	32.4	26.2	28.6	37.0	26.2	23.9
10 to 14	8.5	7.8	8.0	8.1	7.1	9.3	10.9	8.7	8.5
15 to 24	5.3	5.0	4.0	8.1	4.8	5.7	4.3	4.3	7.0
25 or more	.9	1.1	1.0	2.4	.7	1.4
Not given	3.8	2.8	3.0	2.7	2.4	5.0	4.3	13.0	2.8
Median =	4.4	4.3	4.1	5.0	4.2	4.6	5.6	4.0	4.1
Years in Broadcast Industry									
Less than 5	7.5	6.7	8.0	9.5	8.6	13.0	12.7
5 to 9	24.8	26.3	23.0	29.7	31.0	22.8	21.7	26.1	22.5
10 to 14	23.2	21.2	28.0	16.2	9.5	25.7	30.4	17.4	25.4
15 to 24	27.5	29.0	26.0	35.2	31.0	25.7	28.3	17.4	26.7
25 or more	13.5	14.0	12.0	16.2	16.6	12.9	15.2	17.4	9.9
Not given	3.5	2.8	3.0	2.7	2.4	4.3	4.4	8.7	2.8
Median =	13.5	13.7	13.2	15.6	14.4	13.2	14.3	11.9	12.7
Do Part-Time or Free-Lance Work									
	48.0	45.8	44.0	48.6	47.6	50.7	56.5	60.9	43.7
Education									
High school	11.3	8.9	13.0	7.1	14.3	13.0	8.7	16.9
Two years of college	21.6	18.4	13.0	32.4	19.0	25.7	28.3	17.4	26.8
Four years of college	43.3	46.9	54.0	37.9	38.1	38.6	34.8	47.8	38.0
Post-graduate college	17.9	20.1	15.0	21.6	31.0	15.0	19.6	13.0	12.7
Voc/tech school	10.0	7.8	6.0	5.4	14.3	12.9	6.5	21.7	14.1
Not given	3.8	3.4	4.0	2.7	2.4	4.3	4.3	8.7	2.8
Age, Years									
Under 25	6.9	5.0	4.0	2.7	9.5	9.3	6.5	17.4	8.5
25 to 34	46.3	45.8	50.0	37.9	42.8	47.1	43.6	43.5	50.7
35 to 44	27.6	30.2	29.0	35.1	28.6	24.3	32.6	17.4	21.1
45 to 54	11.6	12.3	10.0	18.9	11.9	10.7	6.5	13.0	12.7
55 or over	4.1	3.9	4.0	2.7	4.8	4.3	6.5	4.2
Not given	3.5	2.8	3.0	2.7	2.4	4.3	4.3	8.7	2.8
Median =	33.9	34.5	33.9	37.3	34.2	33.2	34.5	31.5	32.9

*Operations staff: operations manager, station manager, production/program manager.

**The Klystron: Varian VKP-7555 "S" tube
The Transmitter: Harris TVED-220
The Station: WTIC-TV/61 Hartford**



The Bottom Line: America's most powerful television signal.

The group at Channel 61—WTIC, Hartford, CT, found out what's new in super-high efficiency: **Varian and Harris.**

The new **Harris 220kW** transmitter recently installed at WTIC, incorporates all the latest efficiency-improving technologies. At the head of the list is **Varian's** new super-high efficiency, 5-cavity "S" tube.

The new **Varian** klystron provides improved beam efficiency through a unique combination of cavity tuning and loading known as pseudo-harmonic prebunching. Combined with a **Varian** variable visual coupler (VVC), and a

mod anode pulser, peak-of-sync efficiencies approaching 70% can be attained.

For more information on Varian's "S" tube call Varian Microwave Tube Division or contact any Electron Device Group sales organization worldwide.

Varian Microwave Tube Division
611 Hansen Way
Palo Alto, CA 94303
Telephone: 415-424-5675



HARRIS CORPORATION
BROADCAST DIVISION
P. O. BOX 4290
QUINCY, ILLINOIS 62305-4290 U.S.A.
217/222-8200



Circle (18) on Reply Card

www.americanradiohistory.com

TABLE 4. – MEDIAN SALARY SUMMARY FOR 1984 AND 1985, TV

	1984 SURVEY				1985 SURVEY			
	All Markets	Top 50	Top 100	Below Top 100	All Markets	Top 50	Top 100	Below Top 100
Management	\$46,250	\$60,000	\$48,200	\$37,100	\$57,750	\$69,750	\$59,000	\$45,950
Engineering	\$28,900	\$35,750	\$24,250	\$23,250	\$31,500	\$37,550	\$28,500	\$25,300
Operations	\$25,300	\$30,500	\$21,000	\$22,000	\$28,800	\$31,800	\$24,750	\$23,500

TABLE 5. – MEDIAN SALARY SUMMARY FOR 1984 AND 1985, RADIO

	1984 SURVEY				1985 SURVEY			
	All Markets	Top 50	Top 100	Below Top 100	All Markets	Top 50	Top 100	Below Top 100
Management	\$28,300	\$42,500	\$25,000	\$28,200	\$34,800	\$50,750	\$39,500	\$28,600
Engineering	\$23,700	\$32,700	\$19,300	\$17,000	\$23,000	\$29,800	\$25,000	\$18,600
Operations	\$16,500	\$24,000	\$14,150	\$15,000	\$20,000	\$24,600	\$20,850	\$17,700

TABLE 6. – MEDIAN SALARIES ACROSS ALL MARKETS

	TELEVISION				RADIO			
	1982	1983	1984	1985	1982	1983	1984	1985
Management	\$52,000	\$60,000	\$46,250	\$57,750	\$26,900	\$28,600	\$28,300	\$34,800
Engineering	\$29,000	\$27,600	\$28,900	\$31,500	\$20,700	\$20,850	\$23,700	\$23,000
Operations	\$23,800	\$24,750	\$25,300	\$28,800	\$18,650	\$17,350	\$16,500	\$20,000

**TABLE 7. – MEDIAN VALUE PROFILE OF BROADCASTERS
(Radio and TV Combined)**

	MANAGEMENT			ENGINEERING			OPERATIONS		
	1983	1984	1985	1983	1984	1985	1983	1984	1985
Salary Level	\$37,550	\$33,900	\$41,000	\$24,600	\$26,500	\$27,800	\$21,300	\$21,100	\$24,700
Received Salary Increase	57.5%	60.6%	58.9%	73.0%	73.0%	75.5%	73.8%	80.5%	77.7%
Amount of Increase	10.3%	8.7%	9.4%	8.1%	8.0%	7.6%	8.2%	8.5%	8.2%
Years in Present Job	7.1	6.8	7.1	6.4	5.8	6.0	4.3	4.6	4.4
Years in Broadcasting	21.2	21.3	23.1	17.2	15.8	16.1	12.9	11.9	13.5
Does Free-Lance Work	23.4%	30.6%	28.3%	46.2%	46.9%	48.4%	53.6%	47.2%	48.0%
College >2 years	80.5%	76.5%	83.2%	66.3%	66.2%	63.5%	86.0%	86.5%	82.8%
Age, Years	44.9	44.1	44.5	40.6	39.0	39.8	33.3	33.5	33.9

Looking into
ROUTING SWITCHERS...?

Look into
THIS...

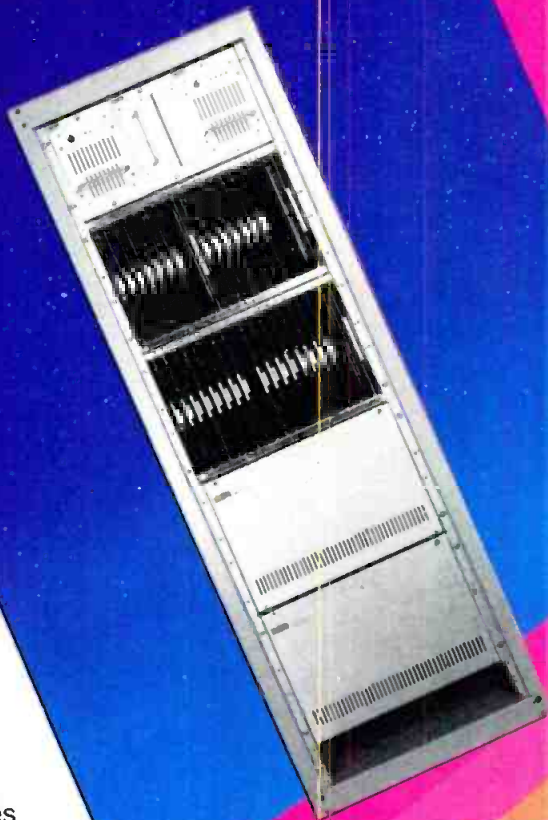

Once you look into the MODULA System, you will realize the advantages of 1986 microprocessor technologies:

- **No video crosspoint card adjustments of any kind**
- **Only 1 adjustment** for the entire video signal path
- **10 year battery backed memory** for absolute system status restoration
- **The fastest (<25 ms) command executions in the industry with BSM's CDS® (Collision Detection System®) switching**

These and many other important features of the MODULA System are described in our current literature. Take a look at the reasons why an increasing number of bid requests are written around MODULA specifications.

Circle (17) on Reply Card

www.americanradiohistory.com

BSM
Broadcast Systems, Inc.
Box 19007 Spokane, WA 99219
(509) 448-0697

Call or write for your FREE COPY

BSM
Broadcast Systems, Inc.

Box 19007
Spokane, WA 99219-9007

(509) 448-0697

move from the smaller market into the top 50 market, the median salary increases 52% for TV managers. Radio managers see an even larger median salary increase of 77%.

That same differential also carries through for the engineering side of broadcasting. A TV engineer's median salary will increase about 48% in the larger market. The radio engineer will see an increase of 60%.

The operations staffs will see smaller raises as they move to larger markets. There is little difference between the radio and TV median salary increases. On the TV side, operations personnel receive increases of 35%; the increase in radio is 39%.

These results confirm that usually there is a financial advantage to working in a larger market. When considering salary only, the radio manager and the radio engineer stand to gain the most by moving to *the big time*.

Across the board

The increases obtained by broadcasters this year were, in general, higher than last year. Management salary increases (by category) were, without exception, higher than any corresponding

increase received by engineering or operations personnel. The lowest median increase for management was 8.8% and the highest was 10.3%. The same comparison for engineering shows a low of 6.4% and a high of 8.2%. Operations staff pay increases ranged from a low of 7.2% to a high of 9.0%.

Tabular results

The details of the 1985 BE salary survey are shown in the preceding tables. Table 1 covers the management and corporate staff; Table 2, the engineering and technical staff; and Table 3, the operations staff. Tables 4 and 5 present a tabular summary of significant salary data for this year and last year. Table 6 summarizes the median salary for all three job categories for television and radio over the past four years.

All tables report *median* salaries, which may be considerably different from *average* salaries. The median salary is the midpoint for the group considered. Half of the group has a value higher than the median and the other half of the group has a lower value than the median. The median value provides a better statistical representation of the overall data and is used throughout this report.

Salary trends

Like other professions, broadcasting is seeing an upturn in the economy. But before you congratulate yourself, consider where you need to be if you want to keep up with inflation.

Based on a 1967 reference value of 100, the consumer price index (CPI) for this past July was 322.8. This means it takes more than three times as much money today to buy the same goods as it did in 1967. Using 1982 as a base, what would your salary need to be to keep up with inflation over just the past three years? If you earned \$29,000 in 1982 as a TV engineer, you would have to be earning \$38,773 today to keep up with the past three years' inflation. According to our survey, that composite salary is \$31,500. You're behind by \$7,273. The same factor, of course, can be applied to other categories.

It is important that we look deeper than the dollar amounts that appear throughout the survey. The real significance of an annual salary survey is that it helps to track the industry's developing trends—and those merit our close examination. As the broadcast industry profits, so too should radio and TV personnel.

A component for every camera. A tube for every transmitter.

Our purpose is clear: to provide the ultimate source for all broadcast related tubes and components. We've geared our entire distribution system to ship virtually every order the same day. Our highly personalized service and technical knowledge is legendary in the industry. Best of all, because of our large volume buying, Calvert has the lowest prices — and cannot be undersold.

PRODUCTS:

Cathode Ray Tubes • Diodes • Klystrons • Monitor Tubes • Plumbicon® Tubes • Receiving Tubes
RF Ceramic Capacitors • RF Transistors • Saticons • Solid State Replacements • Transmitter/Power
Tubes • Tube Sockets • Accessories • TV Linear Devices • Vacuum Capacitors • Vidicons • Vistacons
MANUFACTURERS: Acrian • Amperex • Cetrion • EEV • Eimac • GE • Hitachi • ITT • ITT Jennings
Machlett • National • Philips • RCA • Raytheon • Thomson-CSF • Varian • Westinghouse

Call our Toll Free number now and start saving. **800-526-6362**

CALVERT ELECTRONICS, INC. 

One Branca Road, East Rutherford, NJ 07073 • 201-460-8800 • Telex 423205 CALV • TWX 710-989-0116
Circle (21) on Reply Card

IMPROVE YOUR IMAGE. AUDIBLY.

 **Dolby**
A quiet commitment.



Give yourself a raise

As the survey shows, engineering salaries are up. However, the salaries are not necessarily keeping up with inflation, and they certainly do not approach the kinds of raises that management personnel are getting. There is a bright spot, though.

The BE survey form requested information on whether the respondent held an engineering certificate from the Society of Broadcast Engineers (SBE). Because the data was available, it was analyzed for any correlation between SBE certification and salary. The SBE has maintained for years that its certification program is the only one worth having, and this survey provided the opportunity to challenge or to confirm that view.

The comparison of SBE-certified to non-SBE-certified radio and TV managers produced mixed results. The SBE-certified radio manager's median salary was 4% higher than a non-certified counterpart. However, over

all markets—including both radio and television—the manager with SBE certification earned 12% less than a non-certified counterpart.

Similar results were obtained with the operations staffs. The SBE-certified radio operations staffer earned a median salary almost 14% higher than a non-certified one received. For overall markets—both radio and television—however, the SBE-certified operations staffer's median salary was 15% less than a non-certified counterpart earned.

The real differences, as one might expect, showed up in the engineering categories. In only one case, the below top 100 markets for radio, did the SBE-certified engineer earn less than a non-certified counterpart. That difference was 2%. There were, however, significant differences in the other areas.

In the area of total radio markets, the SBE-certified radio engineer's median salary was \$26,800, or almost

20% greater than the non-certified radio engineer's. In television, the composite SBE-certified TV engineer's salary was \$37,850, or 25% greater than the non-certified engineer's. For all markets, including both radio and television, the SBE-certified broadcast engineer's median salary was almost 18% higher than the non-certified engineer's.

Why the difference? There are probably a number of reasons that SBE certification seems to result in higher engineering salaries. It could be that SBE-certified engineers have been around longer. They may have better skills because they've had to pass a comprehensive engineering test. They also may tend to be engineering managers. For whatever reason, this year's BE salary survey indicated that SBE-certified engineers generally receive higher salaries. Next year's survey will seek to more closely examine the reasons behind this trend.

Editor's note: If you're interested in obtaining SBE certification, contact the SBE national office at 317-842-0836 for further information. Or, write to the certification secretary, Society of Broadcast Engineers, P.O. Box 50844, Indianapolis, IN 46250.

MANAGEMENT									
ALL MARKETS		TELEVISION				RADIO			
	Total %	Total TV %	Top 50 %	Top 100 %	Below Top 100 %	Total Radio %	Top 50 %	Top 100 %	Below Top 100 %
Hold licenses	49.6	30.4	30.2	38.1	26.3	57.7	53.5	55.6	59.3
First phone/general SBE certificate	35.9	28.4	30.2	33.3	23.7	39.0	37.2	36.1	40.1
Restricted third class license/permit	9.9	4.9	7.0	9.5	12.0	11.6	13.9	11.7
Other	2.3	1.0	4.8	2.9	2.8	3.7
	8.2	2.0	4.8	2.6	10.8	14.0	11.1	9.9
ENGINEERING									
ALL MARKETS		TELEVISION				RADIO			
	Total %	Total TV %	Top 50 %	Top 100 %	Below Top 100 %	Total Radio %	Top 50 %	Top 100 %	Below Top 100 %
Hold licenses	87.5	84.5	82.0	93.2	83.3	91.5	89.6	92.9	92.7
First phone/general SBE certificate	80.7	78.6	76.7	86.4	76.9	83.3	83.3	89.3	81.8
Restricted third class license/permit	16.6	12.9	14.0	13.6	10.3	21.4	26.0	21.4	17.3
Other	2.9	2.6	2.9	1.7	2.6	3.4	2.1	3.6	4.5
	9.6	9.4	5.2	11.9	16.7	9.8	8.3	10.7	10.9
OPERATIONS									
ALL MARKETS		TELEVISION				RADIO			
	Total %	Total TV %	Top 50 %	Top 100 %	Below Top 100 %	Total Radio %	Top 50 %	Top 100 %	Below Top 100 %
Hold licenses	45.1	28.5	31.0	21.6	28.6	66.4	58.7	73.9	69.0
First phone/general SBE certificate	22.6	19.0	21.0	13.5	19.0	27.1	19.6	30.4	31.0
Restricted third class license/permit	5.0	1.7	1.0	2.7	2.4	9.3	8.7	8.7	9.9
Other	15.0	7.3	8.0	5.4	7.1	25.0	21.7	34.8	23.9
	3.4	1.7	2.0	2.7	5.7	8.7	4.3	4.2

AFFILIATE, INDEPENDENT OR SUPERSTATION... **ADM** MAKES THE CHANGE TO STEREO EASY

If you are considering making the transition to stereo TV, this is a good time to make the move to ADM. In addition to stereo, you can have the traditional ease of operation, flexibility and quality available only with ADM consoles.

The new S/TV is a full featured stereo console designed for any broadcaster who needs ADM quality at a price that will be gentle on your equipment budget.



NEW S/TV

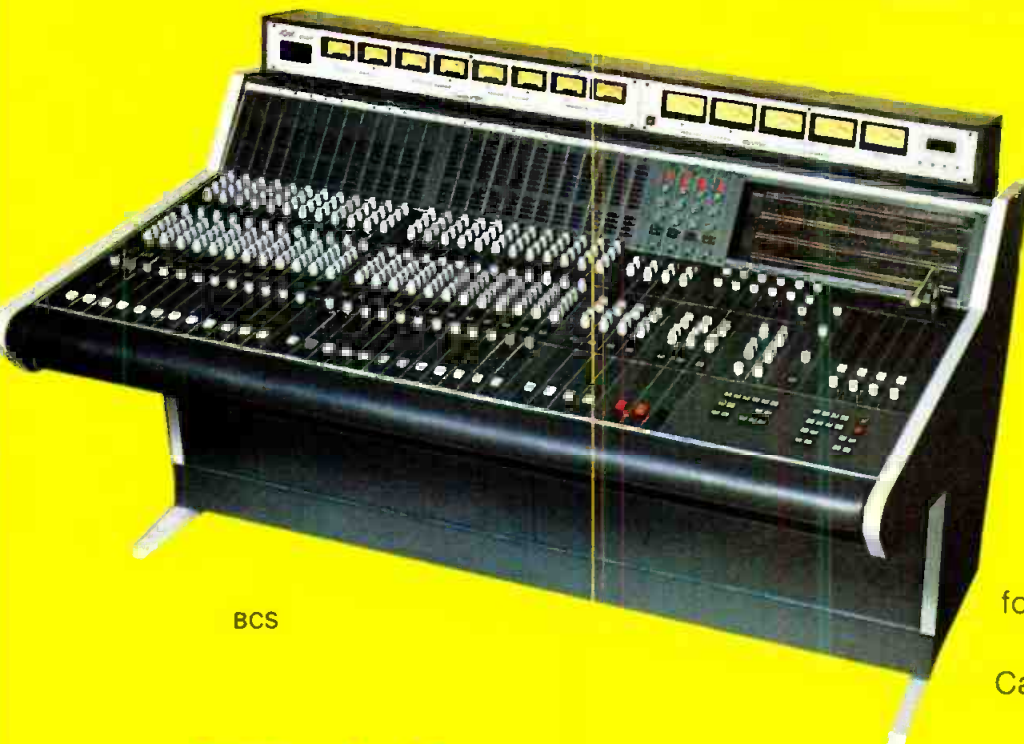

BCS

ADM's top of the line BCS has already proven to be a best seller at major networks, affiliates and independents. Features like input pre-select, dual cue, group mute and our exclusive VCA Slidex[®] attenuator makes life at the console just a little bit easier.

With the ADM five year warranty you can buy it and forget it. It will handle your stereo needs now and in the future. Call us, we like to make life easier for our friends.

ADM[®]
The
Audio
Company

ADM Technology, Inc.
1626 E. Big Beaver Road, Troy, Michigan 48084
Phone: (313) 524-2100 • TLX 23-1114

Circle (120) on Reply Card



Money talks

Perhaps the most interesting aspect of preparing the annual **BE** salary survey is reviewing the written comments on the survey forms. They ran the gamut this year from negative to positive. Radio engineers, on the whole, were generally negative toward current conditions in the industry. The theme echoed by radio engineers centered on low salaries. The responses of TV engineers were about equally divided on this subject.

Radio engineers were particularly outspoken about the need for trained personnel. Many comments reflected frustration with the lack of qualified engineers. "Dependable, skilled radio technicians are hard to find because the good ones can earn higher wages and have better working hours in other technical fields," one said. It may be that radio engineers felt the loss of the first class FCC license more than TV engineers did. The loss of the license was mentioned as a primary concern by a number of respondents. Judging from their comments, it appears that radio engineers are—in general—less satisfied with their positions than are TV engineers.

Compared to last year's, however, this year's respondents were more positive in their reflections on the broadcast industry. Last year's comments were generally quite negative about the conditions within broadcasting. In any case, their thoughts provide a close-up look at how those who work in the trenches feel about their jobs, their industry and their futures. Following are some of the comments we received:

"...I'm only in radio because I like this kind of work, otherwise I'd have to be nuts."

"Since the commission deregulated operator regulations, major markets no longer have a feeder program from small markets. The pool of experienced engineers is drying up fast."

"There is a desperate need for good broadcast engineers."

"I am 48, work all the time, and am not paid for everything I do. But, I wouldn't be in any other business. I started in 1955, when radio was 'dead' and I've watched it grow every year. It's a great business."

"Why is good help so hard to find?"

"The opportunities in the industry are expanding and more competitive

with local stations doing more news gathering and production."

"I think there are unlimited opportunities in the broadcast industry."

"Our station is making tons of money but we, the foundation of the business, are not getting much of it."

"Opportunities in broadcasting are diminishing. This, I believe, is due to

"Why is good help so hard to find?"

low pay and unfavorable working conditions. Also, younger people are not entering broadcasting because of better pay and more opportunities in other industries."

"Broadcasting is a rapidly changing industry and the opportunities are still there. It has been good to me in the past and I don't plan to leave this crazy business anytime soon."

"There is not enough new talent coming into the business."

"Dependable, skilled radio technicians are hard to find because the good ones can earn higher wages and have better working hours in other technical fields."

"The pay is too low to attract young, qualified personnel. They can work in other industries for the same pay or even more, and not be on 24-hour call."

"I find the broadcast industry very challenging as well as rewarding. My plans are to stay in TV."

"Because of the low pay and changing nature of radio engineering, the cream of the crop is being siphoned off into military electronics. The elimination of the first phone license has reduced the stature of the chief engineer and has meant the elimination of many engineering positions, including some chief engineer positions."

"The outlook for radio engineers is

bleak. I'm only in radio because I like this line of work, otherwise I'd have to be nuts."

"I feel the future of broadcasting is brighter than ever."

"It seems to be getting harder to convince managers and owners to spend the extra money to have an engineer, even a part-time engineer, on staff."

"The management sector has gotten greedy with the money they've saved because of FCC rule relaxation. Getting money to make improvements is like pulling teeth."

"The salary level is too low for the technical knowledge required to maintain modern broadcast equipment."

"There will always be a place for bright, creative engineers. Nut and bolt fixers need not apply."

"There are many opportunities for qualified broadcast engineers, but good engineers are becoming harder to find."

"There is a desperate need for good broadcast engineers."

"Broadcast salaries are not competitive with other industries in our area. It's very difficult to find qualified people for RF work in general. We need higher pay and more security."

"There are plenty of opportunities in broadcast engineering at the present time. However, too many owners and managers are willing to accept less than excellent engineering work. They are also not willing to pay salaries that would attract good engineers."

"The people who make a career of this business do so because they enjoy it, not because of the monetary rewards."

"I'm very concerned about the so-called deregulation of the industry. It looks like the well-maintained stations will still do OK. But, the smaller stations will use deregulation as an opportunity to let everything fall apart."

"The sky is the limit."

[:~:~)]))]]

GO WITH THE WINNERS.

DYNAMAX CTR100 SERIES

*"We installed Dynamax CTR100s
at KIIS-FM, #1 in Los Angeles.
We plan to make Dynamax
Cart Machines standard
equipment at all our
stations."*

*Joe Dorton
President
Gannett Radio*

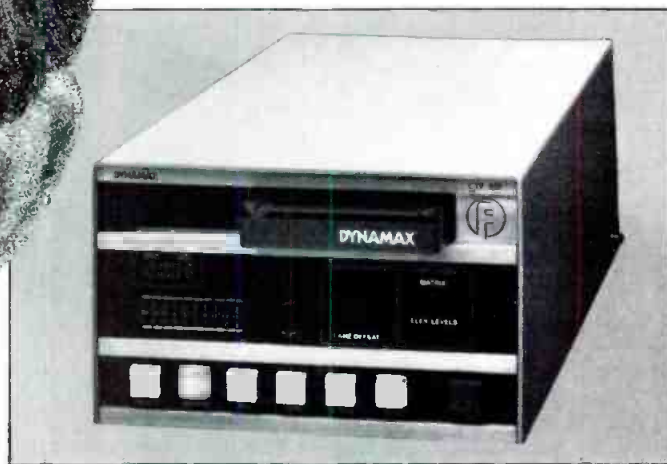

DYNAMAX[®]
BROADCAST PRODUCTS BY FIDELIPAC

Fidelipac Corporation P.O. Box 808
 Moorestown, NJ 08057 U.S.A.
609-235-3900 TELEX: 710-897-0254
 Toll Free 800-HOT TAPE

Circle (52) on Reply Card

The state of stereo TV

Edited by Jerry Whitaker

Stereo television has made great strides since its FCC approval in the spring of 1984, but at hundreds of stations, the *real work* is still ahead.

So you think stereo television is pretty simple. Add a stereo generator, connect a few more crosspoints to the routing switcher, buy yourself a stereo synthesizer and—poof—you're in business. Not so fast! It's not that simple.

Were you around during the conversion from monochrome to color television in the 1960s? If so, you will remember the extensive work that went into making a plant *full color*. You first upgraded the transmission chain, and then the network equipment. Slowly, month by month, other sections of the facility were converted to color operation. Most stations can expect a similar process of gradual conversion for stereo television.

Although we commonly think of stereo as a relatively new technology, the concept has been around for a long time. The first known public exhibition of the *stereophonic effect* was on April 27, 1933. Scientists from the Bell Telephone Laboratories conducted an impressive display of stereo in a landline-based transmission from Philadelphia to Washington, DC. Music played by the Philadelphia Orchestra at the Academy of Music was picked up by microphones placed in front of the orchestra. The signals were amplified and applied to telephone lines that connected to Constitution Hall in Washington. There, amplifiers and high-power 2-way loudspeakers reproduced the program. The exhibition was a great success.

Stereophonic transmissions on FM radio date back to the late 1950s. In 1959, the National Stereophonic Radio Committee was established to examine proposed FM stereo systems and to submit a final recommendation to the FCC. Tests were conducted in the summer of 1960 over KDKA-FM in Pittsburgh, with receivers set up in Uniontown, PA. The system of stereo transmission proposed by General Electric and Zenith Radio was adopted by the commission, and operation under the new mode of broad-

Special report

Our examination of implementing multichannel TV sound includes the following articles:

- *Mixing for Stereo* page 42
- *Tuning for Stereo* page 46
- *Receiving Stereo TV* page 66
- *The BE Proof for TV Stereo* page 84

casting was authorized to begin on June 1, 1961.

TV's turn

On March 28, 1984, the FCC voted unanimously for the use of subcarrier frequencies within the aural baseband of broadcast TV transmitters. The ruling resulted from a 1977 notice of inquiry issued by the commission concerning the possibility of broadcasting TV sound in stereo and adding simultaneous bilingual programming. From the TV industry came three separate proposals for accomplishing this task, along with four separate noise-reduction schemes to help improve the sound quality. After detailed testing, summarized in a nearly 4-inch-thick stack of reports, the Broadcast Television Systems Committee (BTSC) recommended to the commission a multichannel sound system (MCS) that was a combination of an AM multiplex

proposal (made by Zenith Radio) and a noise-reduction companding technique for the stereo and second audio program signals (developed by dbx).

Although other systems may be broadcast, only the BTSC-MCS system may use a pilot subcarrier frequency of 15.734kHz. This is the same frequency as the horizontal line scan frequency used in color television and is the signal used to trigger the stereo decoder. Because of the industrywide support given to the BTSC-MCS proposal, it has become the de facto standard for U.S. TV stereo.

Stereo scorecard

Without a doubt, stereo television is a smashing success. More than 100 stations have converted to multichannel operation, and more are coming on line every day. It is estimated that more than half of the 100-plus converted stations are in the top 30 markets. Competition among stations has resulted in strong pressure on mono facilities within "stereo markets" to make the move as quickly as possible.

In the following series of articles, we examine the process of converting a station from monophonic to stereophonic operation. The conversion effort encompasses production, transmission and reception technologies. It also demands top performance from equipment throughout the broadcast chain. [:-?;-)]

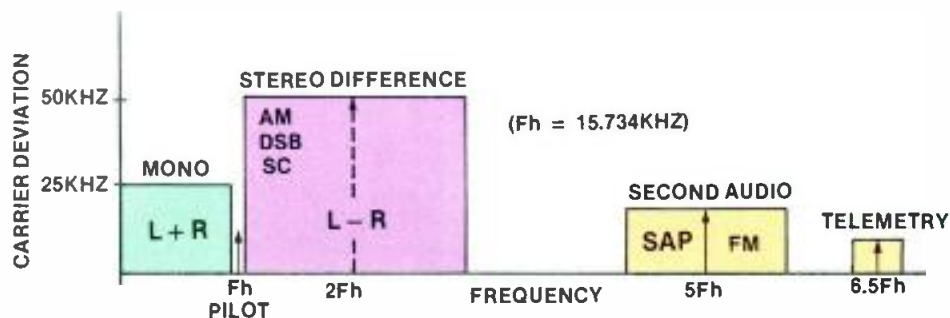

Figure 1. The BTSC multichannel TV sound signal spectrum. Each subcarrier is placed at a multiple of the horizontal line scan frequency. The stereo difference signal amplitude-modulates a suppressed subcarrier at 2Fh, while the second audio program (SAP) channel frequency modulates a subcarrier at 5Fh. Both signals are compressed for noise reduction.

Built especially for the broadcaster, the Ampex ADO™ 2000 special effects system delivers viewers at a price that will amaze you.

No other special effects system is so fast and easy to use for live broadcasting. Instant, single-stroke access to 30 effects, plus all the standard effects that have made the ADO system famous, will give your live programming the look that

glues viewers to their chairs.

And options like rotation, three dimensional perspective and the unique Digi-matte™ key processor give you room to grow. You can even add more channels when you're ready!

Call your Ampex Sales Engineer for a look at the ADO as a stand-alone performer, or teamed with our new AVC switcher for the ultimate in creative power. And

remember, with each Ampex product comes Ampex support and service, worldwide.

Atlanta (404) 491-7112 Chicago (312) 593-6000
Dallas (214) 960-1162 Los Angeles (818) 240-5000
New Jersey (201) 825-9600
(In New York (212) 947-8633)
San Francisco (415) 367-2296
Washington, D.C. (301) 530-8800
Canada (416) 821-8840

AMPEX

Ampex Corporation • One of The Signal Companies

Circle (20) on Reply Card

ADO 2000: Chair Force Recruiter

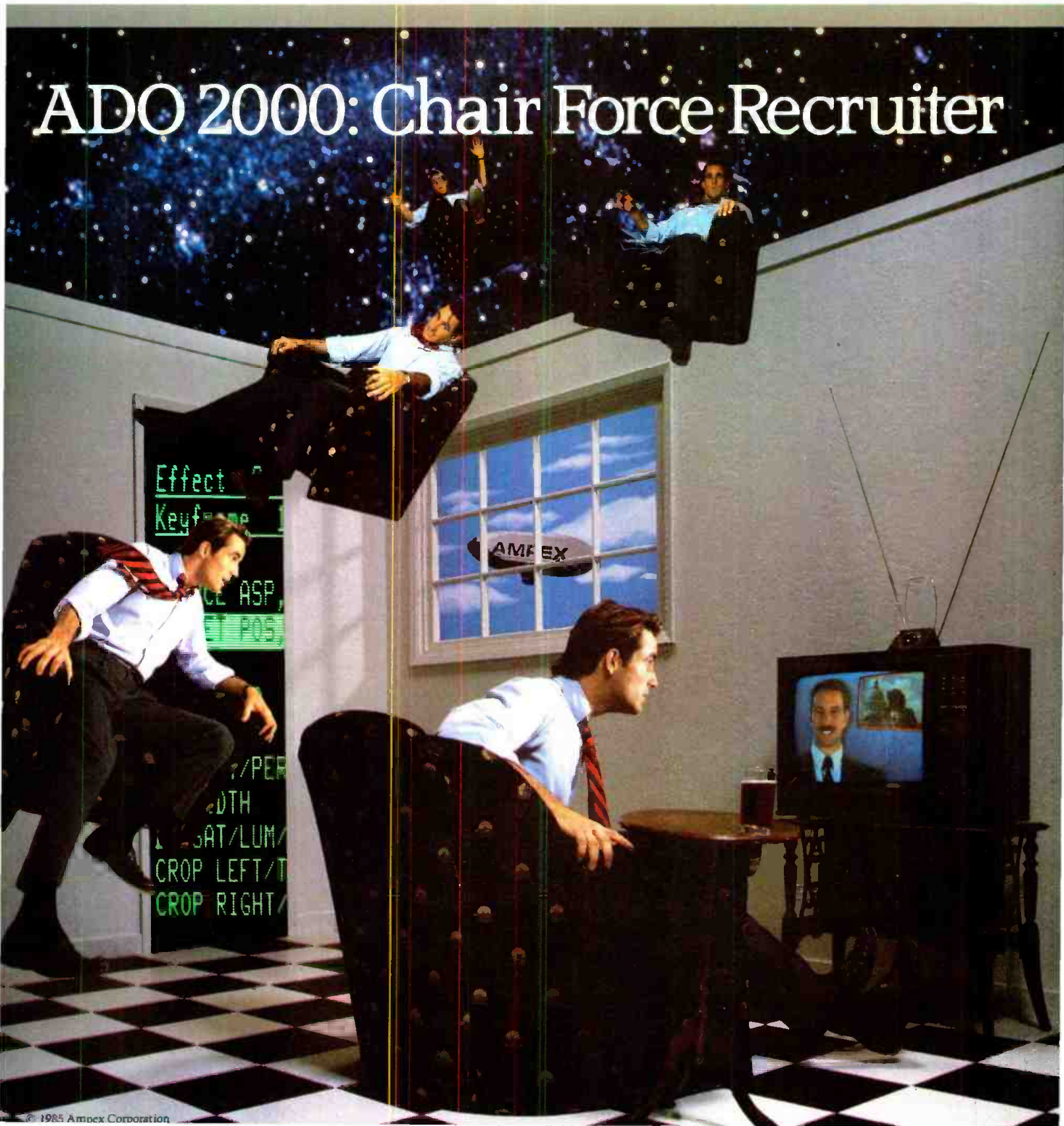

We know that one basic VTR, modified many ways to fit many recording applications, is the most cost-effective way for a manufacturer to *build* a line of VTRs. But we also know that this approach may result in compromised performance and concessions on the part of the user — concessions that at first seem small, but add up quickly in terms of inefficient operation and lost business.

Ampex, video recording, and the

business of video have been synonymous since 1956. And though we've seen the "expedient approach" come and go over the years, the professionals in the video business have repeatedly assured us that their standards leave no room for compromise.

For these professionals, we build a complete line of the very best video tape recorders in the world.

The VPR-3: 500 ips² acceleration/deceleration profile and 20 milli-second single field lockup make it the

fastest and most precise video tape recorder ever designed. With its multitude of sophisticated features, the VPR-3 is ideal for demanding post-production applications.

The VPR-6: Superb video and audio performance, along with the features most users ask for, make the VPR-6 the choice of video professionals for a wide range of applications. Its price, performance and reliability offer a package that makes good business sense for broadcast, production and



post-production users.

The VPR-80: Low cost, but high quality. Ampex brought decades of VTR experience to bear on this most difficult of design tasks. We know that every video facility at some time or other needs a "workhorse" — a VTR that can produce high quality video and audio, and at the same time not strain the budget. The VPR-80 is that machine.

The VPR-5: The video quality and features of a Type C VTR in a pack-

age no larger than a briefcase, allow you to record tapes in the field and edit the same format in the studio. When your productions begin in the field, where rugged and reliable performance is demanded, you need the VPR-5.

Call your nearest Ampex field office for a demo of *the* VTR that fits your needs. We know that one will be a *perfect* fit, either as a stand-alone performer, or teamed with an ACE editor, AVC switcher and an ADO™

in an Ampex Creative Command Center™. And remember, you can count on Ampex product support, worldwide.

Atlanta (404) 491-7112 Chicago (312) 593-6000
Dallas (214) 960-1162 Los Angeles (818) 240-5000
New Jersey (201) 825-9600
(In New York (212) 947-8633)
San Francisco (415) 367-2296
Washington, D.C. (301) 530-8800
Canada (416) 821-8840

AMPEX

Ampex Corporation • One of The Signal Companies

Circle (23) on Reply Card



You've never liked
to make compromises
in your teleproductions.
Now you don't have to.

VPR-80

Mixing for stereo

By Douglas F. Dickey

Producing stereo programs for television requires a systems approach to audio console design.



Photos courtesy of Solid State Logic

The production of stereo and multichannel TV programs will require many changes in the broadcast plant, but if you had to pick the one item of equipment on which the greatest new demands will fall, it would probably be the audio console. However, many chief engineers have been so (necessarily) occupied with transmitter conversion, VTR and switcher upgrades and other storage- and distribution-related issues that their attention is only now turning to the critical area of audio consoles.

What, exactly, are the requirements

for a stereo TV audio console? It depends. Consoles of many types are used throughout the broadcast industry for a variety of specialized functions, ranging from edit and continuity suites to live production studios and master control centers. There is no universal definition of console requirements, but there are a number of features that most consoles must have for efficient and effective stereo and multichannel TV sound production.

System requirements

In researching the requirements for a new generation of MTS-capable audio consoles, several themes recur often enough to be considered fundamental

Although conversion to multichannel TV sound involves all parts of the TV plant, the process begins at the audio console. Through careful planning of a stereo upgrade project, long-term versatility can be assured. Shown is an ABC post-production suite in New York.

design requirements. Interestingly, many of the features in demand are not specifically technical in nature. Rather, they are concerned with fitting stereo into existing operations as smoothly and quickly as possible, and with the greatest flexibility for meeting future needs.

A major concern is that stereo must not significantly impact on the budgets of individual productions. Broadcasters seem prepared to invest the capital necessary for stereo equipment, but they expect that equipment to turn out

Dickey is vice president of design communications at Solid State Logic, Oxford, England. This article was adapted from a paper delivered by Dickey at the 1985 NAB Engineering Conference.

suitable products without increasing production time or daily operating costs.

This is no simple task. The new generation of broadcast audio consoles must handle greater numbers of mono and stereo inputs than their predecessors. They must also provide greater numbers of stereo and mono outputs and accommodate advanced formats such as *triphonics* and stereo plus SAP. The audio they produce must compete with what the consumer has come to expect from Beta and VHS hi-fi and laser discs. Not the least of these demands is that broadcasters want to accomplish all this in about the same amount of time it takes to produce mono.

Moreover, because the operators of these new consoles probably will possess widely varying degrees of skill, basic operations must remain relatively simple and require a minimum of retraining. Simplicity, however, cannot be obtained by sacrificing versatility, because that would slow the advanced operators and limit the level of sophistication that the consoles are capable of reaching.

In order to obtain the requisite versatility and operating speed, new consoles must allow the user to precisely match system features and panel layouts to the exact requirements of highly specialized control rooms. However, the traditional drawbacks of custom consoles (such as long delivery times, high initial costs and difficulty in adapting to future changes) must be eliminated.

Finally, the need to increase the number of functions available, and to maintain or decrease the amount of time required to set up those functions, implies an increased reliance on microprocessors and computers—a precedent that has already been set on the video production side of television. For audio, the challenge is to implement computer assistance inexpensively, while retaining the flexibility of custom specification.

Hardware

These basic criteria point to the need for a system of console architecture based on a series of modular subassemblies that interlock in an unrestricted fashion. This configuration would allow the fundamental requirements to be met throughout a broad range of console sizes and types.

A variety of approaches may be used, including digital and assignable technology, *superanalog* electronics based on thin- and thick-film hybrid designs, digitally controlled electronic switching and interface options for computers. Local controls should be retained for most functions to provide on-air security and to minimize operator retraining.



To maximize efficiency, new stereo TV audio consoles may incorporate computer-controlled switching, centralized routing assignment and specialized output configurations. (Shown is a section of the Solid State Logic SL 5000 M series audio console.)

Centralized master controls can be employed where they provide greater operational speed and/or where they can increase useful functions while decreasing local channel control density. A flexible configuration would allow the capabilities of any given console to be determined by the modules or cassettes fitted into it.

Special features

Controls that may be unfamiliar to a TV engineer, but are nonetheless important, include the *stereo image* and *width* features. These operate along with the more familiar pan pot to match the perspective of stereo sources with the images that they accompany.

With the image pot set to stereo, the left and right (L and R) signals are sent to their mix buses unaltered. Rotating the image pot toward mono gradually collapses the stereo image into a mono signal, simultaneously introducing the pan pot's effect. This allows music and effects originally recorded for wide-screen film formats to be matched to the narrower aspect ratio and smaller screens of television. It also provides audio equivalents of video special effects.

The stereo width feature adds selective out-of-phase L and R signals to the opposite channels, moving the apparent stereo stage outside of the speakers. This is quite effective for exterior ambiances and dramatic crowd effects.

The capability of routing post-channel

fader outputs to additional mix buses via a master assignment system is a good example of how advanced functions and controls may be integrated to gain additional flexibility and increased operational speed. Provisions for two distinct types of mix bus configurations—*audio subgroups* and *independent main outputs*—are a key to this achievement.

Briefly, an audio subgroup is a composite of selected channel outputs that have been mixed together for common processing and routing. An example would be *all audience channels*, which could be collectively assigned to an audio subgroup rather than individually routed to the program mix. The group signal can then be processed through a single compressor and equalizer prior to being routed to program.

An independent main output (IMO), on the other hand, is a separate mix consisting of selected post-fader channels and/or audio subgroup outputs, which may or may not have been routed to the program mix. IMOs are used to create splits, clean feeds, international sound feeds and mix-minuses. For example, although all music, effects and dialogue channels may have been routed to the program mix, each type of channel can be independently routed to a separate output. All music channels can be assigned to IMO A, all effects to IMO B and all dialogue to IMO C. Another important use of IMOs is for the creation of foreign-language feeds for the SAP channel.

In addition to audio subgroups and IMOs, a vital aspect of any stereo TV console is the provision for ample auxiliary sends, which are used to create mixes for echo and effects, as well as foldback for talent and crew. Two aux sends will suffice in many smaller applications. Larger systems, such as those for news operations and feature program production, require additional auxiliary sends on

channels and subgroups.

Some form of audio equalization is another requirement for a stereo TV console. Both mono and stereo channels should include provisions for equalization. Continuously variable gain and frequency selection provides the greatest creative control, and the capability to select the Q or slope of the equalization is also quite useful.

Dynamics control on each channel and group is a highly desirable feature that can greatly improve the overall quality of the final mix, while saving substantial production time. Dynamics control units should include a compressor/limiter and noise gate (at a minimum). Features such as expansion and dynamic-noise filtering are also real timesavers, particularly for the task of cleaning up poorly recorded source material.

For elaborate productions, some method of recording multitrack backups of the proceedings should be provided. Full multitrack capability is a must for effective stereo post-production.

The capability to monitor all of the various feeds on high-quality speakers as well as "typical home stereo" speakers is important, and the capability to switch between stereo and mono monitoring for compatibility checks is absolutely vital.

Computer control

Now, we get to the subject of computers. Mixing-automation and machine-control systems play an increasingly important role in TV post-production. Such systems make it possible to achieve a greater number of functions with fewer operations and, consequently, to bring greater speed and simplicity to production sessions.

The engineer can create a detailed setup for a particular program (with all input sources, output and group assignments, send configurations and so forth), store this setting once, and immediately recreate it at any time. The ideal setup for the evening news can be recalled in an instant. This can be replaced by a completely different console configuration for the midnight movie or the breakfast show. In a fully equipped system, the transition from live to post-production configurations is a snap. Within a given program, setups can be changed instantly between segments. Too, the preferences of different engineers can be accommodated.

This type of computer assistance has been available on some video switchers for some time now. Its appearance in an entire range of custom-configurable stereo TV audio consoles is a strong indication that multichannel sound is ready to take its rightful place as an equal component in broadcast TV production, and demonstrates the sophistication that audio mixing has attained.

Before stereo television can be transmitted, it must be produced. This is not a job for the networks alone. Broadcasters now have the tools to do a superior job within reasonable constraints. It is up to the broadcaster to understand the value and use of stereo audio for television. | : ? (=) | | |

CRYSTAL CLEAR REMOTES FROM ANYWHERE ...ANYTIME



A Comrex® Frequency Extender gives you crystal clear audio from the most remote of remotes. Now, you can have immediate access anytime, anywhere there's a phone. No more due dates that are overdue or line charges that are out of line.

Picking Up Where Phone Lines Leave Off

Raw dial up lines simply can't do justice to audio. That's where Comrex fits in. Sounds never heard on a phone line are brought to life by frequency extension. Something no mere equalizer can do.

Nothing Remotely Resembles a Comrex

From the classic single line model to the advanced two line system, Comrex has the answer. To prove it we'll send you a tape. Or even give you a ten-day trial. Free.

For your next remote (anywhere on earth), use the telephone... but call us first.

1-800-237-1776

COMREX®

60 Union Avenue, Sudbury, MA 01776
TEL: 617-443-8811 TWX: 710-347-1049

Circle (136) on Reply Card

ANNOUNCING THE DAWN

FUJI
VIDEO TAPE

MADE IN JAPAN
Circle (26) on Reply Card

Tuning for stereo

By Geoffrey N. Mendenhall, P.E.

The full benefit of stereo programming cannot be realized if the composite signal won't make it through the transmitter.

Your station could be left in the dust. Although stereo program material is not yet widely available to most TV stations, preparing the transmission system for multichannel sound should be high on the priority list for every facility. Those who do not prepare run the risk of being left behind by competing stations.

The first step in preparing for TV stereo is testing and evaluating the transmitter. One approach to checking the transmission system involves measurement of various audio parameters—including frequency response, stereo separation, crosstalk and distortion—using a BTSC (Broadcast Television Standards Committee) encoder connected to the aural exciter and transmitter and a consumer-type BTSC receiver/decoder for off-air measurements. This approach, however, could lead to an incorrect assessment of

transmission system performance because of possible errors in the encoding/decoding process.

The primary objective of stereo TV is to transmit the BTSC composite waveform to the decoder in the receiver at the correct level (deviation of the aural exciter), without altering the amplitude and phase relationships of the various components within the waveform. The composite signal path from the output of the BTSC encoder to the input of the decoder in the receiver is subject to many interacting and cumulative errors. It is necessary, therefore, to use a test procedure that can identify the magnitude and type of error within each functional block of the system.

There are three primary areas where degradation of the composite signal can occur:

- the composite link to the TV aural FM

modulated before the complete transmission system can give the best possible performance.

The composite link

The composite path from the stereo, SAP and pro generators to the aural FM modulator should be linear in both amplitude vs. frequency and phase vs. frequency. Simply stated, no frequency component within the baseband should be attenuated more than any other frequency component. Furthermore, all frequency components should propagate through the system at the same speed (constant group delay) and arrive at the modulator at the same time. Equations

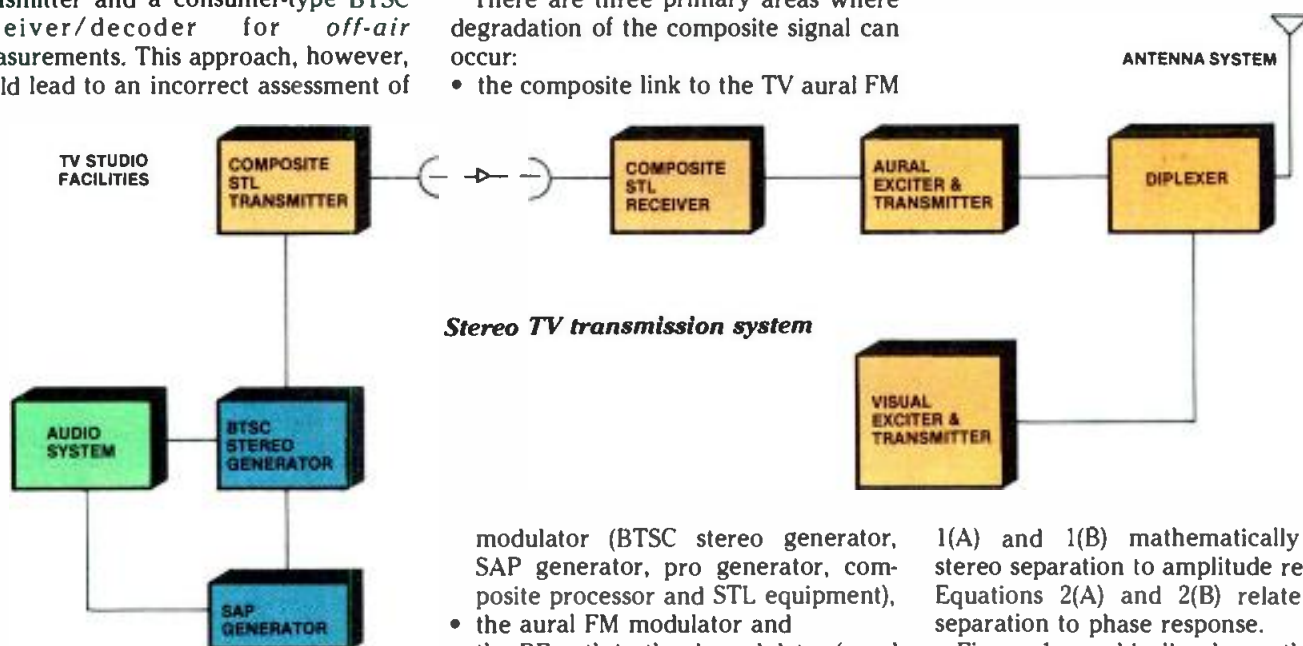

Stereo TV transmission system

modulator (BTSC stereo generator, SAP generator, pro generator, composite processor and STL equipment),

- the aural FM modulator and
- the RF path to the demodulator (aural exciter, IPA, PA, diplexer and antenna system).

Each of these areas has its own special effect on the baseband signal, and each subsystem must be individually opti-

1(A) and 1(B) mathematically relate stereo separation to amplitude response. Equations 2(A) and 2(B) relate stereo separation to phase response.

Figure 1 graphically shows the combined effect of amplitude and phase response on stereo separation between the right and left channels. Correct phasing and equal group delay of the pilot tone is also essential to achieving good

Mendenhall is vice president of engineering at Broadcast Electronics, Quincy, IL. This article was adapted from a technical paper presented by Mendenhall at the 1985 NAB Engineering Conference.

OF A NEW GENERATION.



stereo separation.

The ultimate stereo performance of the complete system will be determined by the algebraic sum of the individual composite amplitude response and composite phase response errors of each device within the composite signal path.

The aural exciter, STL link and any other composite device should specify composite performance parameters so that total system performance can be predicted. In order to maintain a system separation capability of 40dB, the composite amplitude response must be within ± 0.17 dB (50Hz to 47kHz) and the composite phase response must be less than $\pm 1.15^\circ$ from linear phase (50Hz to 47kHz).

Composite processing

In an effort to achieve maximum modulation density (loudness), some FM broadcasters use composite processing to remove low-energy overshoots in the amplitude of the composite waveform caused by complex audio processing. Overshoots will also occur in the peak-to-peak amplitude of the BTSC composite waveform, but are not considered significant to the lower modulation density (wider dynamics) desired in TV broad-

$$A. \text{ SEPARATION } (A, \theta) = \left[\frac{(\cos \theta + A)^2 + (\sin \theta)^2}{(\cos \theta - A)^2 + (\sin \theta)^2} \right]^{1/2} \text{ GENERAL FORM}$$

$$B. \text{ SEPARATION } (A) = \left[\frac{(1 + A)^2}{(1 - A)^2} \right]^{1/2} \text{ IF } \theta = 0 \text{ (PERFECT PHASE)}$$

$$\text{WHERE: } A = \frac{\text{SUB}}{\text{MAIN}} = \frac{L - R}{L + R} = \text{AMPLITUDE RATIO}$$

$$\theta = \text{PHASE ERROR IN DEGREES}$$

Equation 1. Computing stereo separation as a function of amplitude response.

$$A. \text{ SEPARATION } (A, \theta) = \left[\frac{(\cos \theta + A)^2 + (\sin \theta)^2}{(\cos \theta - A)^2 + (\sin \theta)^2} \right]^{1/2} \text{ GENERAL FORM}$$

$$B. \text{ SEPARATION } (\theta) = \left[\frac{(\cos \theta + 1)^2 + (\sin \theta)^2}{(\cos \theta - 1)^2 + (\sin \theta)^2} \right]^{1/2} \text{ IF } A = 1 \text{ (PERFECT AMPLITUDE)}$$

$$\text{WHERE: } \theta = \text{PHASE ERROR IN DEGREES}$$

$$A = \frac{\text{SUB}}{\text{MAIN}} = \frac{L - R}{L + R} = \text{AMPLITUDE RATIO}$$

Equation 2. Computing stereo separation as a function of phase response (group delay).

Why do Jensen Transformers have Clearer Midrange and Top End?

The high frequency rolloff of a *Jensen Transformer* is optimized, by computer analysis, to fit the *Bessel Low Pass Filter* response. This means *minimum overshoot and ringing* and *flat group delay* for best *time alignment* of all spectral components of the musical waveform.

In other words, the harmonics arrive at the same time as the fundamental frequency.

The result is a clear midrange and top end without the harsh, edgy sound which has been one of the most objectionable sonic complaints about transformers.

There's no "midrange smear."

Only *Jensen* has this benefit of hi-tech computer optimization.

Visitors by appointment only. Closed Fridays.

10735 BURBANK BOULEVARD • NORTH HOLLYWOOD, CA 91601 • (213) 876-0059

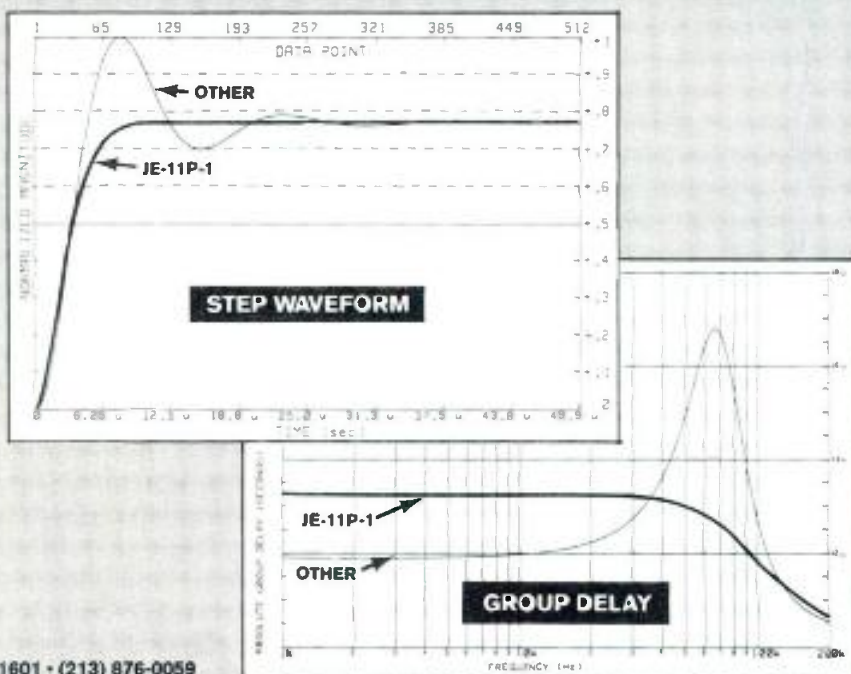

jensen transformers
INCORPORATED

Circle (27) on Reply Card

FUJI
VIDEO TAPE
MADE IN JAPAN

Lot No. 04335-13
SIZE 2.54cm X 910mm
In X-3170r
FUJI H621E
PROFESSIONAL

THE NEW 1" VIDEOTAPE FROM FUJI THAT'S 2dB BETTER.

This business thrives on reproduction. And every reproduction produces potential problems.

That's why you need Fuji's new H621E 1" professional videotape. It's a tape with a video, chroma and audio S/N rating 2dB higher than even *our* best 1" tape. With H621E, you get an extra generation to work with, and a master with unsurpassed picture quality.

It's a tape that can stand up to the new generation of hardware, with an extra-strong binder and improved back-coating that keep the tape running smoothly no matter what you put it through.

And it's a tape from a company with a 25-year reputation for quality in magnetic media.

So make Fuji H621E part of your next production. Because to make it in this business, you've got to produce and reproduce and reproduce.

For more information on our new generation of 1" videotape, call any of the regional representatives listed below toll-free.

 **FUJI.**

Nobody gives you better performance.

FUJI PROFESSIONAL VIDEOTAPE PRODUCTS:

Northeast Region 1-800-526-9030
(in NJ 201-935-6022)

Southeast Region 1-800-241-6005
(in GA 404-441-2222)

Midwest Region 1-800-323-4826
(in IL 312-569-3500)

Southwest Region 1-800-527-0804
(in TX 214-243-2537)

Western Region 1-800-241-7695
(in CA 213-636-0101)

© 1985 Fuji Photo Film U.S.A., Inc., Magnetic Products Div., 350 Fifth Avenue, NY, NY 10118

Circle (29) on Reply Card

BETACART BVC-10

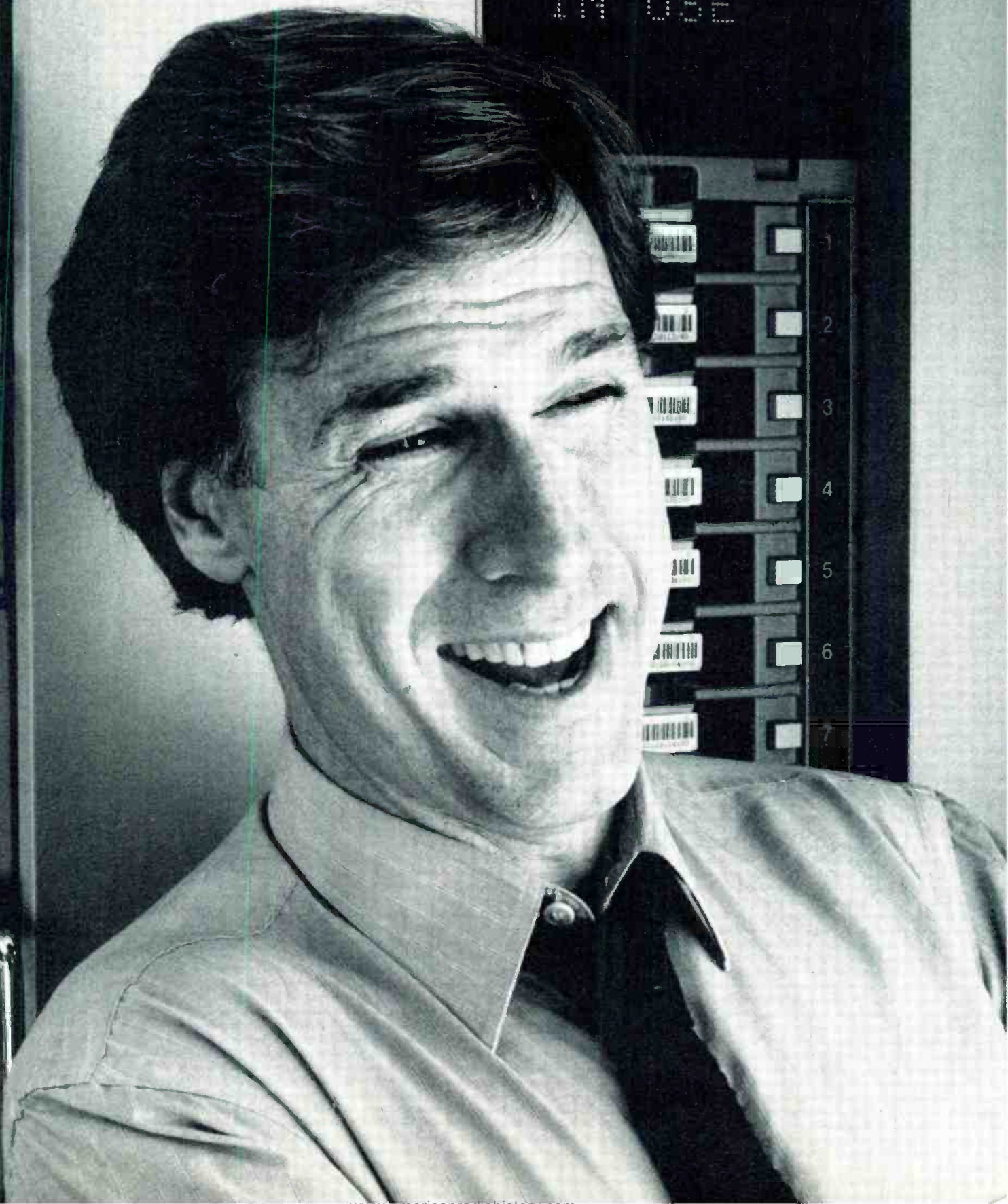

"Makegood? What's a makegood?"

How soon they forget.

All those people from Anchorage to New York who already use Sony Betacart™ Systems.

They forget about downtime. They forget about on-air backup systems. And they forget about ad agencies demanding damngood makegoods.

Why?

Betacart is the smart cart machine.

Microprocessors keep constant track of forty cassettes. They maintain system alignment. They run self-check diagnostic routines.

And Betacart's simple operation not only prevents human error, it prevents human boredom.

Technicians at KDNL, St. Louis use their Betacart to put snap into station breaks. For station IDs they shoot logo artwork, add movement with digital effects and air the cassettes through the Betacart. Now there are no more dull title cards at KDNL.

At WDBJ, Roanoke, commercial delivery has improved dramatically. So has the picture quality of the spots.

Carl Guffey, director of operations, reports: "The sales staff is happy, traffic is happy, the engineers are happy and the general manager is ecstatic."

Want to improve your station's commercial outlook? Put the Gold Standard to work for you.

Call Sony Broadcast at (201) 833-5231.

SONY
BROADCAST



casting. Because overshoots have no effect on compandor tracking or on any other audio performance parameter, other than achieving the last decibel in loudness, composite processing is not recommended for use with the BTSC system. The use of any non-linear devices, such as clippers or limiters, in the composite line will alter not only the peak amplitude of the baseband, but also the frequency spectrum of the baseband. This generates several types of distortion at the receiver.

Figures 2(a) and 2(b) show the waveform and spectrum of unprocessed baseband. Figures 2(c) and 2(d) show the same waveform and spectrum after 1.0dB of composite clipping. The problems caused by composite clipping include the following:

- intermodulation of all baseband frequency components, causing extraneous spectral components,
- harmonic distortion of the baseband signal, causing degradation of cross-talk and separation, and
- modulation of pilot injection level, causing possible loss of lock at the synchronous detector.

Composite clipping results in intermodulation distortion and non-correlated in-

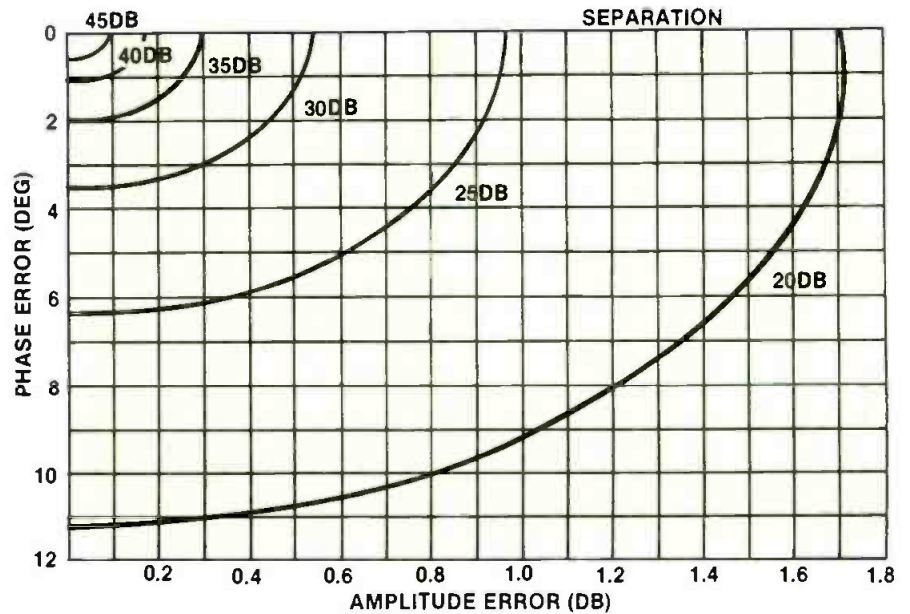

Figure 1. A plot of BTSC stereo separation performance vs. combined amplitude and phase response errors in the composite baseband. Note the tight restrictions on composite system performance required for good (greater than 35dB) separation.

formation in the received audio because of aliasing of extraneous spectral components. If minimum system distortion is the goal, composite clipping should not be used. Audio processing should be performed before the audio is multiplexed into baseband.

Distortion of the composite baseband signal can also result from *transient intermodulation distortion* (TIM) within the amplifier stages. Transient intermodulation distortion of the baseband signal is caused by the same mechanisms that produce TIM in audio signals. Composite

A COMPLETE VIDEO PROCESSOR

ENGINEERS LOVE ITS ABILITY; MANAGERS LOVE ITS PRICE - \$780!

The VC-2000P is perfect for videotape editing, duplicating and for use as a camera control unit. It automatically regenerates all sync, blanking, and color burst signals which will correct most instabilities (such as jitter, bending, and rolling.)

As a camera control unit the video, color, and hue adjustments allow camera matching and correct

levels. In tape editing these controls provide scene to scene matching and fade to black.

Enhancement and noise reduction controls provide dramatic picture improvement and reduce tape duplicate generation loss. Additional features include four video and four audio outputs, and optional plug in RF modulator.

The rack mountable VC-2000P is only \$780.00. Call or write for literature.

ICM VIDEO
701 West Sheridan Avenue • P.O. Box 26330
Oklahoma City, OK 73126
(800) 426-9825 Toll Free

See us at the SMPTE Trade Show
Booth #1649-50



Circle (31) on Reply Card

Compact

without Compromise



Studer 961/962: Small Wonder

It's a wonder how a console so small can do so much ... and sound so good!

The Swiss have a special talent for making great things small. A case in point: the new 961/962 Series mixers from Studer. In video editing suites, EFP vans, remote recording, and radio production, these compact Studers are setting higher standards for quality audio.

Sonic performance is impeccable throughout, with noise and distortion figures well under what you'd need for state-of-the-art digital recording. By refining and miniaturizing circuits developed for our 900 Series production consoles, Studer engineers have squeezed a world-class performance into suitcase size.

The 961/962 Series is fully modular, so you can mix-and-match modules to meet your requirements. The 961/962 features stereo line level input modules with or

without 3-band EQ, plus mono mic/line inputs and master module with compressor/limiter. Other choices include a variety of monitor, talk-back, auxiliary, and communication functions. The 961 frame holds up to 14 modules, the 962 accepts up to 20.

Other new features in the 961/962 Series include improved extruded guide faders, balanced insert points, FET switching, electronic muting, Littlite® socket, and multi-frequency oscillator.

Thanks to its light weight, DC converter option, and sturdy transport cover, you can put a 961/962 mixer on the job anywhere. And, with Studer ruggedness and reliability, you can be sure the job will get done when you get there.

Packed with performance and features, 961/962 consoles will surely

make a big splash in audio production circles. Small wonder. Call your nearest Studer representative for more details.



With snap-on cover, mixer is road-ready in seconds.

STUDER REVOX

Studer Revox America, Inc.
1425 Elm Hill Pike/Nashville, TN
37210/(615) 254-5651

New York (212) 255-4462 • Los Angeles (818) 780-4234
Chicago (312) 526-1660 • Dallas (214) 943-2239
San Francisco (415) 930-9866

Circle (32) on Reply Card

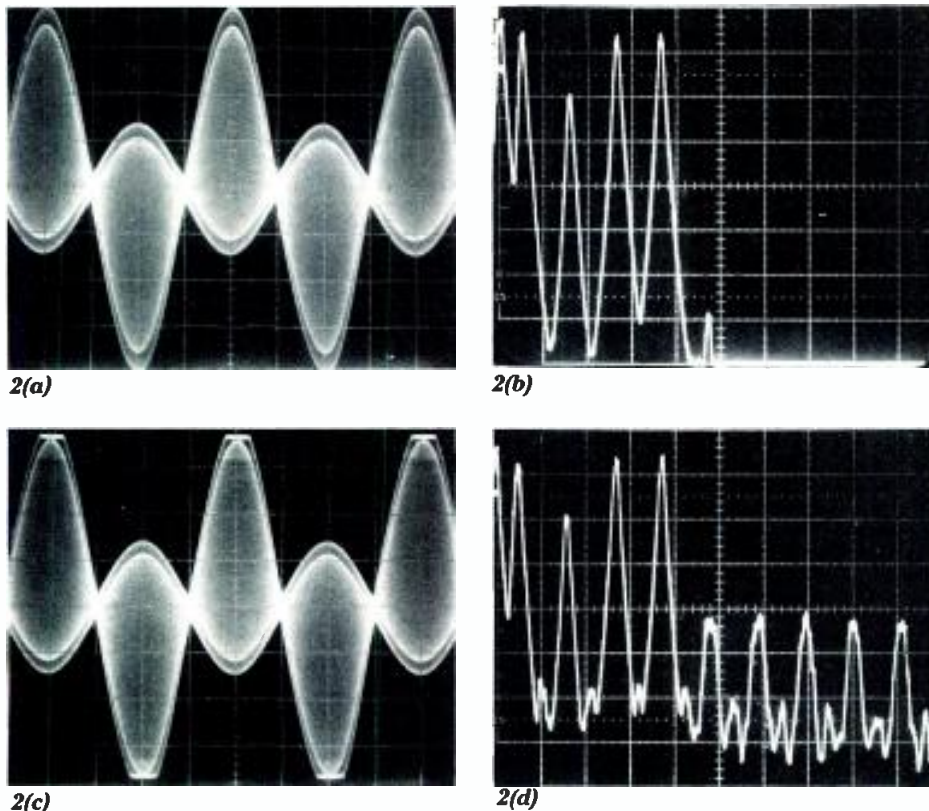

Figure 2. The effects of composite clipping on the BTSC baseband. Oscilloscope photo (a) shows the waveform of the unprocessed baseband signal with one channel modulated at 5kHz and the pilot off. Photo (b) shows the same baseband on a spectrum analyzer. Scope photos (c) and (d) were taken under the same conditions as photos (a) and (b), respectively, but with 1dB of composite clipping. Note the significant distortion that results.

amplifiers must have sufficient feedback bandwidth to accept baseband frequencies to 100kHz and must slew symmetrically to minimize slew-induced distortion. TIM performance is largely a matter of operation amplifier selection and circuit configuration.

Aural modulator linearity

The composite baseband signal is translated to an FM carrier frequency by the modulated oscillator. Frequency modulation is produced by applying the composite baseband signal to a voltage-tunable RF oscillator. The modulated oscillator usually operates at the carrier frequency and is voltage-tuned by varactor diodes in a parallel LC circuit.

To achieve perfect modulation linearity, the RF output frequency must change in direct proportion to the composite modulating voltage applied to the varactor diodes. This requirement implies that the capacitance of the varactor diodes must change by approximately the square of the modulating voltage.

Unfortunately, the voltage vs. capacitance characteristic of practical varactor diodes is not the desired square law relationship. All varactor-tuned oscillators have an inherently non-linear modulating characteristic. This non-

linearity is predictable and repeatable for a given circuit configuration, making it feasible to correct by *complementary predistortion* of the modulating signal. Suitable predistortion can be applied by using a linear approximation to the desired complementary transfer function.

Any distortion of the baseband signal caused by the modulated oscillator will have secondary effects on stereo, SAP and pro channel crosstalk performance. These effects are quite noticeable at the receiver, even with small amounts of baseband distortion. For example, if the harmonic distortion to the baseband is increased from 0.05% to 1%, as much as 26dB additional crosstalk into the SAP channel can be expected.

The RF path

The frequency-modulated RF output spectrum contains many sideband frequency components, theoretically an infinite number. The spectrum consists of pairs of sideband components spaced from the carrier by multiples of the modulating frequency. The total transmitter RF output power remains constant with modulation, but the distribution of that power into the sidebands varies with the modulation index so that power at the carrier frequen-

cy is reduced by the amount of power added to the sidebands.

After examining the resulting spectra, it becomes clear that the occupied bandwidth of an FM signal is far greater than the amount of deviation from the carrier that one might incorrectly assume to be the bandwidth. In fact, the occupied bandwidth is infinite, if all the sidebands are taken into account. A frequency-modulation system requires the transmission of all sidebands for perfect demodulation of information. In practice, a signal of acceptable quality can be transmitted in the limited RF bandwidth assigned to a TV aural channel. The higher-order sidebands will, however, be altered in amplitude and phase. Bandwidth limitation will cause distortion in any FM system. The amount of distortion in a practical FM system will depend on the bandwidth available and the modulation index being transmitted.

Relating the specific quantitative effect of bandwidth limitations imposed by a particular transmitter to the actual distortion of the demodulated composite baseband is a complicated problem. Some of the factors involved are:

- total number of tuned circuits,
- amplitude and phase response of the total combination of tuned circuits in the RF path,
- amount of drive (saturation effects) to each amplifier stage and
- non-linear transfer function within each amplifier stage.

The following design techniques can help improve the RF bandwidth of an aural transmitter:

- Use a broadband exciter and a broadband IPA stage.
- Use a single-tube design or a broadband, completely solid-state design where feasible.
- Optimize both the input circuit and output circuit of a tuned stage for best possible bandwidth.
- Minimize the number of interactive tuned networks.
- Use a delay-equalized multiple-cavity diplexer.
- Use a broadband antenna system with a low standing wave ratio at the aural carrier frequency.

System test procedure

The composite amplitude and phase characteristics must be measured to a high degree of accuracy (tenths of a decibel and tenths of a degree from phase linear). A high-accuracy audio network analyzer could be used to directly measure the composite characteristics, but most stations do not have access to such equipment.

Another simple, yet effective way to evaluate the performance of the system



The mic mixer you would have designed yourself—The Shure M267.

In the space of just two years, the Shure M267 has become one of the most well-known and widely used mixers in the broadcast industry. One look at it will tell you why.

The M267 gives you the improvements you've told us were most important. Every channel has a mic line level switch for maximum flexibility. There's also a built-in limiter to keep the M267 from overloading at critical moments. The unit contains a built-in battery pack that utilizes three standard 9-volt batteries.

Simplex (phantom) power and a peak LED are standard, too.

The M267 oscillator provides a clean 1 kHz tone, and is located on the front of the unit for simple access. The headphone output is also on the front and includes a level control. IC design, along with active gain controls, provides greater headroom and quieter operation.

For location work or even studio post-production, the M267 carries on Shure's reputation for reliability and ruggedness.

For more information on Shure's complete line of mixers, call or write Shure Brothers, Inc., 222 Hartrey Avenue, Evanston, IL 60202, (312) 866-2553.

SHURE®

BREAKING SOUND BARRIERS

Circle (121) on Reply Card

involves the use of a multitone test procedure:

- Feed the main channel (L+R) with a low audio frequency signal.
- Feed the subchannel (L-R) with an ultrasonic frequency signal.
- Adjust the two signals for equal amplitude.
- Observe the resulting waveform on an oscilloscope with sweep synchronized to the low-frequency (L+R) audio

component. A typical waveform is shown in Figure 3.

The amplitude of the L+R and L-R components should be exactly equal at each point throughout the composite system from the input to the demodulator. The propagation time through the system should also be equal for L+R and L-R components.

The composite signal output from the BTSC stereo generator does not have a

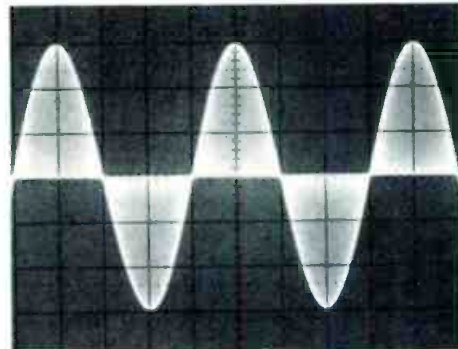

Figure 3. The composite 1:1 ratio test waveform without the pilot.

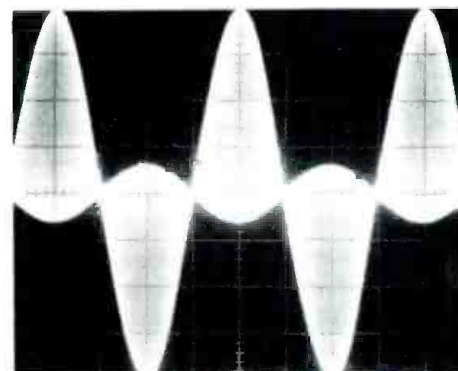

Figure 4. The BTSC composite waveform without the pilot signal. The effects of the companding system make it necessary to measure and adjust transmission system performance using the 1:1 ratio test method.

Why go TV Stereo with Eiden?

No one has more experience in TV stereo

Eiden, the pioneer in Multichannel Television Sound, has *over 17 years* of experience and expertise in the production of MTS equipment. It was Eiden equipment that was used when MTS was first introduced to the world at the International Exposition '70.

Unsurpassed field-proven reliability

Eiden has *over 250 systems* operating successfully worldwide and is used exclusively by NHK, the largest broadcasting network in Japan.

State-of-the-art engineering

Eiden equipment is used as the benchmark for product testing by all major TV manufacturers such as Sony, Sanyo, Panasonic, Sharp, Hitachi, NEC, Mitsubishi, GE, Phillips, etc.

Model 475A-S TV Stereo Signal Generator

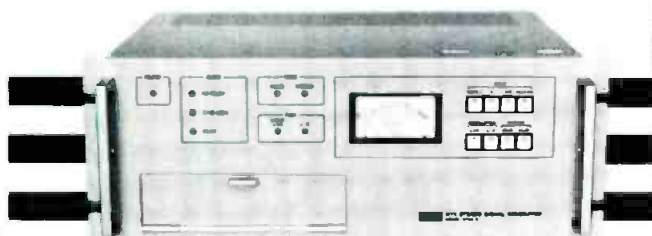

Designed for high reliability, high stability and ease of operation. Meets all requirements of the BTSC's OST #60.

- Input terminals for SAP and PROF-CH.
- Meter for checking Input Levels (Stereo L and R, SAP and PROF-CH signals), Modulation Percentage (L+R and L-R), and Output Levels (COMP and PILOT).
- Peak warning LED flashers for L+R and L-R lines.
- Built-in synchronization crystal oscillator, to assure uninterrupted operation even when video signals are intermittent.
- Front panel signal test inputs for Mono-L and R signals.

Model 466B Multichannel TV Sound Demodulator

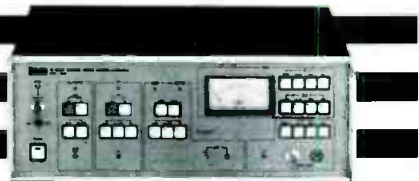

UNIVERSAL
Elecon INC.

Agent for Eiden

903 S. Lake St., No. 102
Burbank, CA 91502
(818) 846-6220

Circle (150) on Reply Card

fixed and equal ratio between L+R and L-R, so it cannot be used for this test. Figure 4 shows how the BTSC composite baseband looks when viewed on an oscilloscope with peak-to-peak amplitude displayed as a function of time. It is difficult to accurately measure the amplitude ratio and phase relationship of L+R to L-R because the ratios vary with the level of companding.

The required composite test signal is available on some TV stereo generators by switching the unit to the 1:1 ratio test mode. Alternatively, the 1:1 signal can be obtained from a standard FM broadcast stereo generator by switching the pilot off and modulating only one channel. The L+R and L-R information is output in equal amounts under these conditions. During such tests, the external trigger input to the oscilloscope is connected to the audio generator, which feeds only one input of the stereo generator. The other audio input is shorted to prevent any residual modulation of that channel.

The composite output from a wide-band RF demodulator is fed to the wide-band vertical input of the oscilloscope. The composite waveform can then be checked at various points within the transmission system to determine the er-



IMAGINE A NEW DVE® SYSTEM YOU'LL HAVE TO SEE TO BELIEVE

It's the DVE® System 10 from NEC. The digital video effects system that puts you on-line in half the time . . . and can do as much as a system about twice as expensive.

And just wait till you see what it can do for you! The System 10 is so advanced—it's easy to use.

But it's powerfully equipped. With an off-line floppy disk storage, which stores up to 100 events. And a 16-bit microprocessor for the most transparent effects processing available. Plus three temporary memories (we call 'em scratch pads) which can recall any page immediately. A three-

dimensional cube maker for 3- or 6-sided cubes. Forced monochrome. Full 3-D rotation and perspective effects. And an onboard combiner to control two systems simultaneously.

You get the most out of the System 10—on-line and off-line.

But don't forget your bottom line. That's the real beauty of this new system; it's only \$79,000.

Just call your local NEC representative for a look at our new video presentation. You really have to see it to believe it. Then you won't have to use your imagination any longer.

NEC

IMAGINE WHAT WE'LL DO FOR YOU

NEC America, Inc., Broadcast Equipment Division • 130 Martin Lane, Elk Grove Village, IL 60007 • 312-640-3792.

DVE® is a registered trademark of the NEC Corporation

Circle (35) on Reply Card

www.americanradiohistory.com

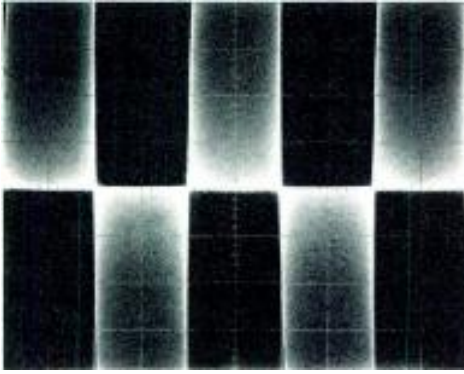

Figure 5. An expanded-scale view of the waveform shown in Figure 3. This procedure is used to check baseline flatness.

ror contribution from each subsystem.

If both the amplitude and phase response are correct, the base line of the waveform will be perfectly flat, even when closely examined by expanding the vertical scale on the oscilloscope (as shown in Figure 5).

Equalization for amplitude and phase errors in the STL or aural exciter will improve overall system performance. The stereo generator may include provisions for such adjustments. The equalizer is set for minimum deviation from a flat baseline while observing the demodulated composite baseband.

If the baseline deviates from flat in a symmetrical, curved or bowed manner, as shown in Figures 6(a) and 6(b), an amplitude error exists in the system. If the baseline deviates from flat in a tilted, straight-line manner, as shown in Figures 7(a) and 7(b), a phase (time-delay) error is present.

Figure 8 illustrates a composite waveform with a mixture of amplitude and phase errors, as indicated by the asymmetric deviation of the baseline from flat. The separation performance of the Figure 8 example can be calculated using the formula shown.

Adjusting the aural transmitter

Performance optimization should be carried out with the transmitter connected to the normal diplexer and antenna system. The transmitter is first tuned for normal output power and proper efficiency, according to the manufacturer's instruction manual. The meter readings should closely agree with those listed on the manufacturer's final test data sheet.

A simple method for centering the transmitter passband on the carrier frequency involves adjustment for minimum *synchronous AM*. Synchronous AM is a measure of the amount of incidental amplitude modulation introduced onto the carrier by the presence of FM modulation. This measurement is useful

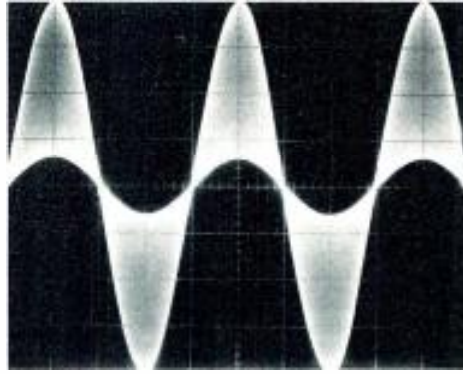

6(a)

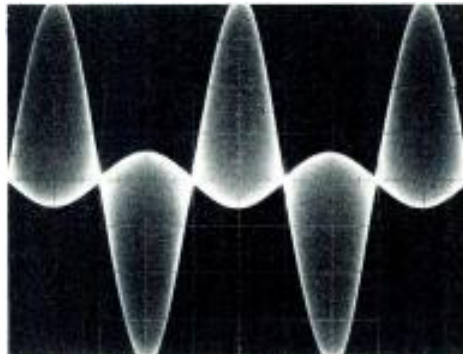

6(b)

Figure 6. Deviation from flat response in a symmetrical, curved or bowed manner—as shown in (a) and (b)—indicates composite system amplitude error.

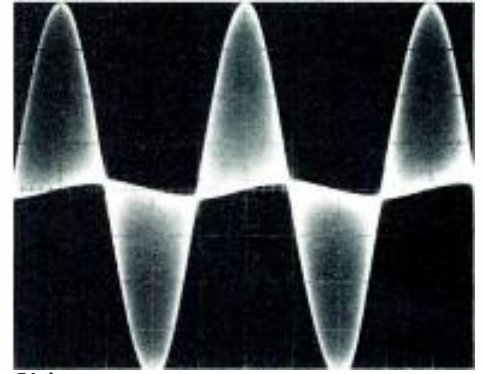

7(a)

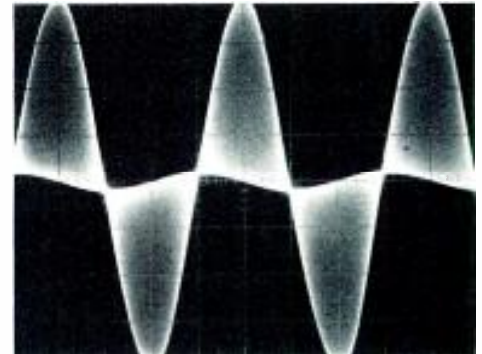

7(b)

Figure 7. Deviation from flat response in a tilted, straight-line manner—shown in (a) and (b)—indicates composite system phase error.

for determining proper tuning of the aural transmitter. Because all transmitters have limited bandwidth, there will be a slight drop-off in power output as the carrier frequency is swept to either side of the center frequency.

This slight change in RF output level follows the waveform of the signal being applied to the FM modulator, causing AM

modulation to be in synchronization with the FM modulation. Minimizing synchronous AM will assure that the transmitter passband is centered on the aural channel.

When making these measurements, care must be taken that the test setup itself does not introduce synchronous AM and give erroneous readings. This would cause the operator to mistune the

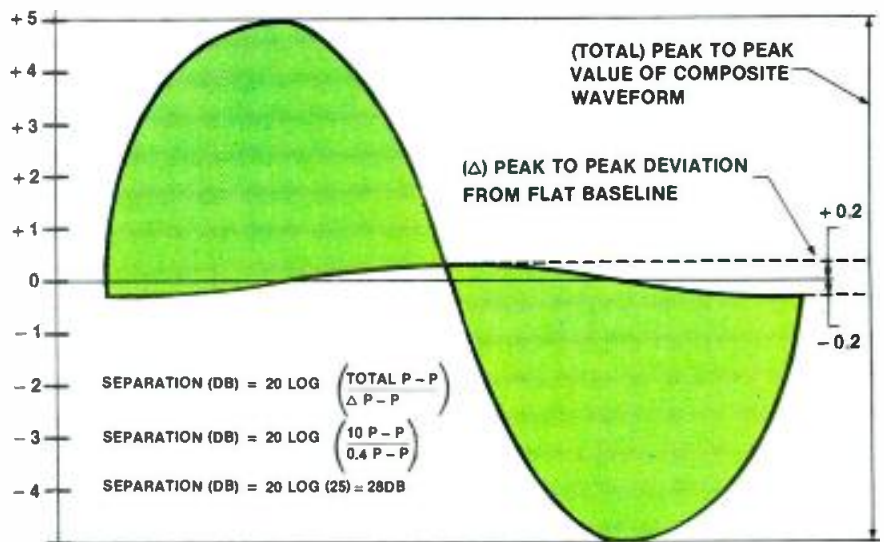

Figure 8. A convenient method of direct measurement of stereo system separation from the composite waveform, with L+R and L-R equal in ratio and the pilot switched off.

Are YOU Suffering From **THE STEREO NIGHTMARE?**

For years, science has known that many people dream in colour. Recently though, large numbers of television audio engineers are experiencing an entirely different phenomenon: The Stereo Nightmare.

The VTR starts arguing with the synchroniser. The multitracks struggle with the VTR. As the music and efx fight the dialogue, the automation is having yet another brilliant disagreement with itself. The clock looms ominously. The producer is emitting homicidal glares. Maintenance tries to reach the scene, but can't break through the writhing mass of incompatibilities. In the middle of this chaos, a nervous voice comes on the intercom and informs you that the entire management structure has just exploded!

The most frightening thing is that The Stereo Nightmare strikes when its victims are wide awake. The syndrome is all too real. And as it spreads, the industry's loss in man-hours and production costs has become staggering.

Fortunately, there is a cure. Developed by dedicated specialists in a private research laboratory near Oxford, England, it's effectiveness has been proved in case after case, by leading broadcasters and post-production houses throughout the world. We call it the SL 6000 E Series Stereo Video System. Our clients call it a dream come true.

If your facility suffers from The Stereo Nightmare, you owe it to yourself and your family to get all the facts. Write for our 40 page colour booklet on the SSL Stereo Video System. Better yet, give our specialists a call. We'll have you working faster and sleeping better — in no time at all.

Solid State Logic

Oxford • New York • Los Angeles • Hong Kong

Stonesfield • Oxford, England OX7 2PQ • (099 389) 8282
200 West 57th Street • New York, New York 10019 • (212) 315-1111
6255 Sunset Boulevard • Los Angeles, California 90028 • (213) 463-4444
22 Austin Avenue, Suite 301 • Tsimshatsui, Kowloon, Hong Kong • (3) 721-2162

Circle (36) on Reply Card

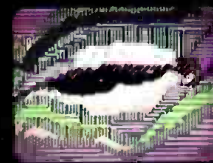

transmitter to compensate for errors in the measuring equipment.

The input impedance of the envelope detector must provide a nearly perfect match for low VSWR on the sampling line. Any significant VSWR on the sampling line will produce synchronous AM at the detector because the position of the voltage peak, caused by the standing wave, moves along the line with FM modulation. Unfortunately, the AM detectors supplied with some modulation monitors do not provide a good enough match to be useful for this measurement. Precision envelope detectors are available that present a good match (30dB return loss) to the sampling line.

The following procedure may be used to adjust the aural transmitter for minimum synchronous AM. Modulate L+R 100% at 400Hz and adjust the transmitter input tuning and output tuning controls for minimum 400Hz AM modulation as indicated by a wideband envelope detector (diode and line probe). It is helpful to display the demodulated output from the AM detector on an oscilloscope during this adjustment.

Note that as the point of minimum synchronous AM is reached, the demodulated output from the AM detector will

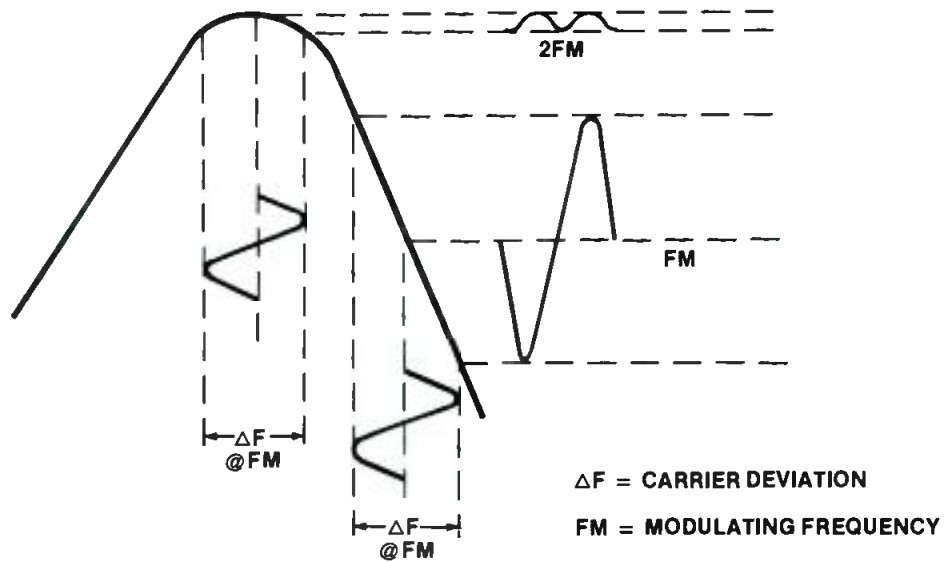
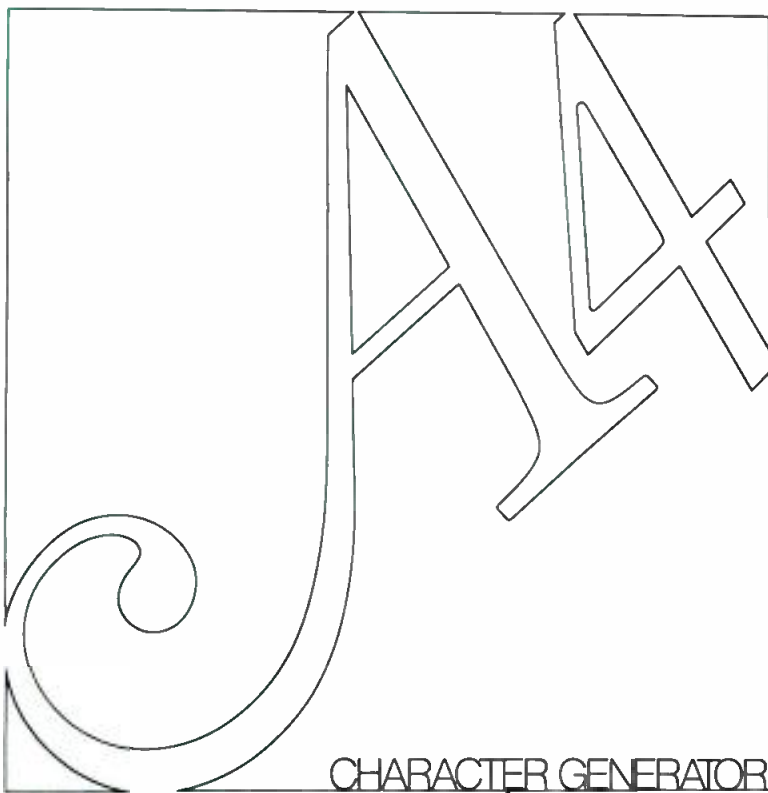

Figure 9. The mechanics of synchronous AM on an FM transmission carrier. Note that when the system is tuned to the center of the operating frequency, the synchronous AM frequency doubles.

double in frequency to 800Hz. This effect occurs because the fall-off in output power is symmetrical about the center frequency, causing the amplitude variations to go through two complete cycles for every one FM sweep cycle. The effect

is illustrated in Figure 9. It should be possible to minimize synchronous AM while maintaining output power and efficiency in a properly designed power amplifier.

A more sensitive test involves tuning



PERFECTION can now be translated to the TV screen with the Aston 4 Character Generator. The Aston 4 will create typography to meet your highest design standards without any hint of display flicker (aliasing) or diagonal stair-stepping. Welcome to the world of perfection. Find out more, call today (913) 782-4007.



LONDON
KANSAS

ASTON ELECTRONICS INC.: 531 N. Murlen Rd. E. • Olathe, KS 66062
Telephone (913) 782-4007

ASTON ELECTRONIC DESIGN LTD: 125 Deepcut Bridge Road
Deepcut, Camberley, Surrey, GU16 6SD, England • Telephone: (0) 252 836221 Telex: 858813

Circle (37) on Reply Card

Panasonic® Recam™. No other camcorder brings as much to the field.



Whether capturing a late-breaking news story or doing field production, only Panasonic Recam puts so much studio confidence in the palm of your hand.

For unmatched confidence in the field, the monochrome viewfinder plays back recorded video images. With the headset jack providing simultaneous audio playback of channels 1, 2 or a mix of both.

And while recording, both audio channels are monitored via bar graphs displayed in the viewfinder to ensure proper signal levels.

Unlike other camcorders, Recam's on-board 4AH snap-on battery delivers up to 1½ hours of recording. Without the need for a cumbersome battery belt.

Recam also gives you the control you need in the field. Two four-position filter wheels (PBO version). Automatic white and black balance with digital memory. Black stretch and soft white gamma. Variable matrix and more. For excellent performance in any shooting situation.

For maximum versatility, Recam can also be used in either a one- or two-piece configuration. Or as a stand-alone camera and VCR. What's more, Recam offers you

a choice of Plumbicon* or Saticon** tubes.

To give you broadcast-ready 1" picture-quality on ½" tape, Recam utilizes the YIQ component analog video recording M-format. Audio quality is broadcast-ready, too. With Dolby † C noise reduction.

The VCR also incorporates a built-in 34-point self-diagnostic routine to ensure quality before you go on location. And a rugged die-cast magnesium frame for both camera and VCR. Two of the many reasons why Recam was chosen to document the historic climb of Mt. Everest.

The Panasonic Recam. If you're not shooting with it, now you know some of what you're missing.

For more information, call your nearest Panasonic regional office: In the Northeast: (201) 348-7336. Southeast: (404) 925-6703. Midwest: (317) 852-5973. West: (619) 941-3387. Southwest: (214) 257-0763. In Canada: (416) 624-5010.

Panasonic
Broadcast Systems

ANOTHER BROADCAST INNOVATION FROM MATSUSHITA ELECTRIC

*Plumbicon is a registered trademark of N. V. Philips.

**Saticon is a registered trademark of Hitachi, Ltd.

†Dolby is a trademark of Dolby Laboratories.

Circle (38) on Reply Card

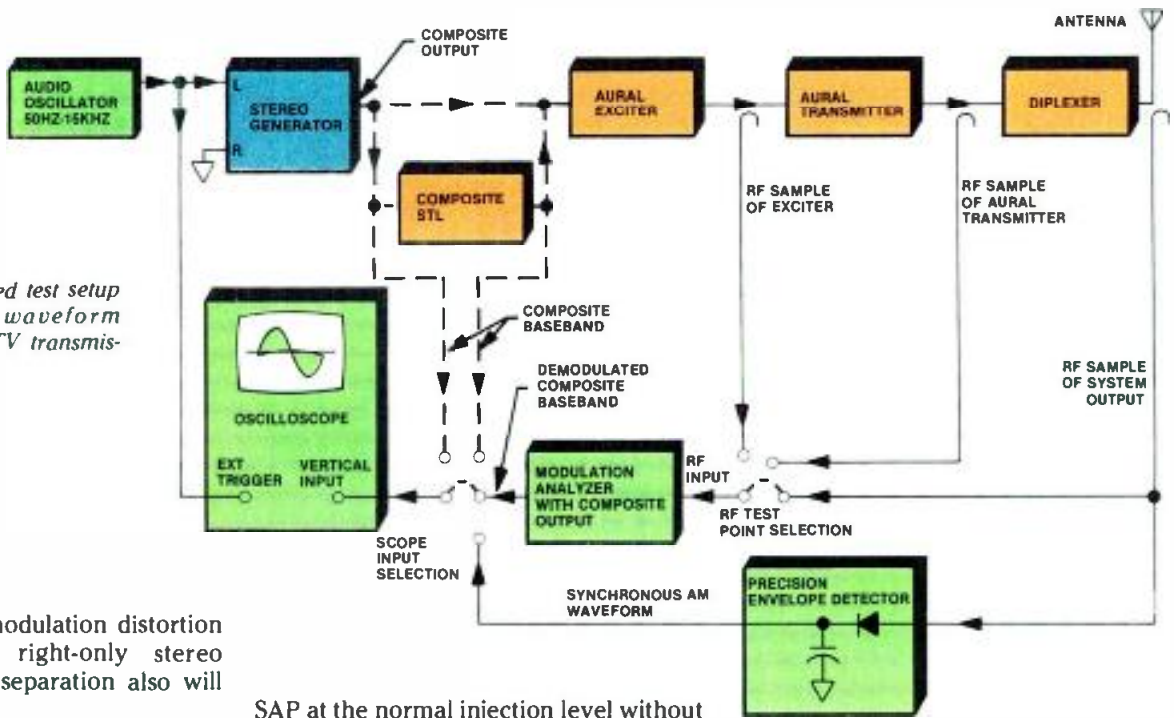

Figure 10. A suggested test setup for composite waveform measurements on a TV transmission system.

for minimum intermodulation distortion with left-only or right-only stereo modulation. Stereo separation also will vary with tuning.

For stations using a SAP channel transmitter tuning is critical to minimizing crosstalk. Modulate only one channel of the stereo generator 100% with a 7,867Hz tone. This will place the upper second harmonic stereo (L-R) sideband on top of the 78.67kHz SAP. Activate the

SAP at the normal injection level without modulation on the SAP. Tune the transmitter for minimum output from the SAP demodulator. This adjustment also can be made by listening to the residual SAP audio while normal stereo programming is being broadcast.

In any of these tests, input tuning is fre-

quently more critical than plate tuning. The impedance match into the input capacitance of the amplifier tube is the primary bandwidth-limiting factor. Even though the amplitude response appears flattened when the input is heavily driven into saturation, the phase response still has a substantial effect on the higher-order FM sidebands.

Test setup

Figure 10 shows a block diagram of the required test equipment for making composite waveform measurements. Note that the composite baseband is checked at various points along the transmission path in order to verify the performance of each subsystem.

Observing the composite waveform while using a low modulating frequency of 50Hz will usually indicate any low-frequency problems caused by coupling capacitors in the system that are of insufficient size. Composite tests using a high modulating frequency of 15kHz will reveal rolloff in the high-frequency response of the system, which attenuates the subchannel (L-R) components more than the main channel (L+R) 15kHz component.

A precision envelope detector is included in the test setup for observing synchronous AM waveforms while tuning the aural transmitter.

Regardless of your station's timetable for implementing multichannel TV sound, the time to start working on the project is now. And the place to start is the transmission plant.

Acknowledgement: The author wishes to thank Rick Carpenter and Bill Resch for their assistance in conducting tests and in preparing this paper. [:-)]

Continental's top performing 25 kW FM Transmitter speaks for a station you know*



Reliability and proven performance make Continental's 816R-3 compact FM transmitter a winner. Crisp clear signal, high fidelity, good stereo separation, very low noise and distortion, excellent frequency stability, simple installation, low power consumption make it a great

KJNE	KOUL	KUER
KNIN	CITE	KRMD
KMPS	WXLK	KKMY
WINZ	WYCO	WEZI
WLVE	WTMI	KCIX
WBHM	KWFM	KTXB
KESI	KVKI	KERG
KTUX		

*Partial list

investment. Combine with duplicate 816R-3 to get 50 kW output. For brochure, call (214) 381-7161 Continental Electronics Division, Varian Associates, Inc. PO Box 270879 Dallas, Texas 75227. © 1985 Continental Electronics/6007



Continental Electronics
A Division of Varian Associates, Inc.



Circle (40) on Reply Card

Put Millions of Dollars in Television Audio Technology to Work— For Only 22 Cents



**Get a FREE Audio Needs
Analysis from Neve for the cost
of a stamp.**

If you're about to make some very important decisions concerning your audio equipment, we'd like to help—at no charge and with no obligation. And with systems beginning at under \$10,000, anyone can take advantage of this offer.

For twenty-five years Neve has maintained its reputation as the leader in audio mixing console technology. We've crossed the hurdles other manufacturers are just reaching and we've reached the heights others will probably never achieve.

That's because, for our total history we've worked hard in the lab and the field to create superior consoles, perfecting the quality of the sound you hear and inventing newer, better and more cost-effective ways to process it.

So stop for a moment. Fill out our questionnaire and return it to our Connecticut headquarters. Or call us. We'd like to hear from you. Remember, there is absolutely no obligation.

Neve

RUPERT NEVE INCORPORATED: Berkshire Industrial Park, Bethel, CT 06801 (203) 744-6230 Telex 969638 Facsimile: (203) 792-7863
 • 7533 Sunset Blvd., Hollywood, CA 90046 (213) 874-8124
 • P.O. Box 40108, Nashville, TN 37204 (615) 385-2727 Telex 786569
 • NEVE ELECTRONICS INTERNATIONAL, LTD. Cambridge House, Melbourn, Royston, Hertfordshire, SG86AU England Phone (0763) 60776

Circle (39) on Reply Card

NEVE QUESTIONNAIRE

For a FREE Neve audio needs analysis, please fill out the following questionnaire and return it in your company envelope to: Rupert Neve, Inc., Berkshire Industrial Park, Bethel, CT 06801.

(NAME) _____

(COMPANY) _____

(TITLE) _____

(ADDRESS) _____

(CITY) _____

(STATE) _____

(ZIP) _____

(AREA CODE) _____

(PHONE NUMBER) _____

Position (please check):

- corporate/management I recommend console purchases.
 technical/engineering I approve console purchases.
 producer/user

Please check the description that applies to your studio:

- television broadcasting jingles/commercials
 video production film
 video post production multitrack recording

Audio Operations Personnel:

- all staff all freelance
 staff & freelance

Number of console inputs required:

mono (mic/line) _____ stereo (line) _____

Number of console outputs required:

stereo _____ mono _____ AUX/FB/cue _____

multitrack (TKS) _____

Console Operation Format:

- mono stereo multitrack
 all of above

Need Automation? Yes No

Current Mixing Console(s) (please list): _____

Please Check:

- Yes, I wish to buy a new mixing console. When? _____
 Yes, I would like a free analysis about my studio's console needs.
 Send info for file only.

My Budget for a New Mixing Console is Approximately:

- \$9,000–25,000 \$75,000–100,000
 \$25,000–50,000 \$100,000–150,000
 \$50,000–75,000 \$150,000 +

We would like your opinion as to the importance of the following on a scale of 1 to 10:

- Ease of operation Reliability
 Sound quality Manufacturer back-up
 Brand name Other _____
 Expandability

Additional comments: _____

Receiving stereo TV

By Martin Giles

New circuit designs are pushing high-fidelity stereo audio into the consumer market.

You've done it. Through blood, sweat and tears, you and your staff have perfected your stereo TV signal. All your efforts, however, will be wasted on the viewer who tunes in on a low-quality TV set...and hears low-quality sound.

The final link in the stereo TV chain is the consumer's receiver. Providing receivers with high-fidelity audio

involves much more than simply adding another amplifier and speaker.

New integrated circuits (ICs) will be developed, not just to decode the stereo portion of the signal, but also to improve the quality of the sound-processing circuits. The need for improvements are obvious when you consider the typical (2W or less) audio power amplifier driving 1½-inch to 3½-inch speakers in present-day receivers. The frequency response of the amplifier often is restricted severely—at the low end to avoid 60Hz hum and cabinet resonances, and at the high end because of noise and the ever-present 15.734kHz horizontal-scan frequency (see Figure 1). Tone controls, where available, are usually for the treble only. They typically operate by simply modifying the de-emphasis corner frequency from the broadcast standard of 2.1kHz by inserting a variable resistor in series with the de-emphasis capacitor.

If, instead of depending on the internal receiver circuits, the user connects the

decoded stereo signals to a high-fidelity amplifier system, the problems of low power and poor frequency response are resolved instantly. Also, because the speakers can be separated by a reasonable distance from the receiver, *stereo enhancement* circuits may not be required. Unfortunately, however, passing the audio signal through a hi-fi setup will reveal *another* serious problem: audible noise. The reason for this situation can be understood if we examine the noise spectrum of a typical TV receiver audio-detector output.

System noise

An FM signal exhibits increasing noise as deviation from the carrier increases. This noise is compensated for, in part, by using signal pre-emphasis at the transmitter and complementary de-emphasis at the receiver to produce a flat noise spectrum with increasing frequency. Even so, the presence of the AM subcar-

Continued on page 75

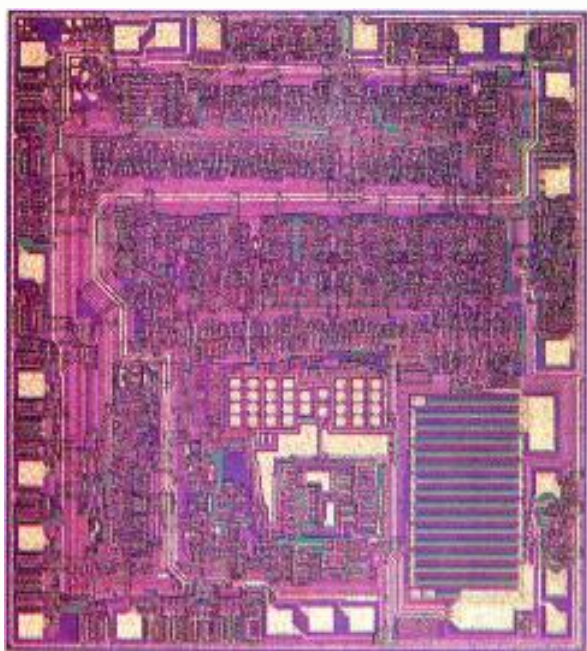

The future of improved TV receiver design is closely tied with semiconductor development. Recent advancements in IC technology have made higher performance TV systems possible at reduced costs.

systems, however, is no easy task. A number of fundamental changes in audio and IF circuit design are required to meet the expectations of consumers for high-quality stereo TV sound. For receiver manufacturers, changing to stereo in-

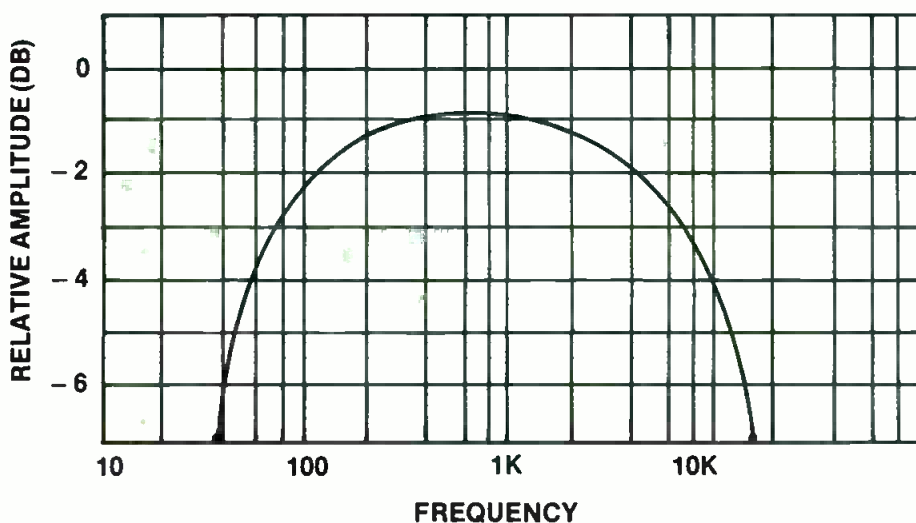



Figure 1. The audio frequency response of a typical monophonic TV receiver.

Giles is applications manager at National Semiconductor, Santa Clara, CA.



You're looking at an electron micrograph of videocassette tape. It dramatically shows the debris that a videocassette's inherent static charge can attract. Hair. Dust. Fibers. Cigarette ashes.

Note the size of these particles in relationship to the read head. Is it any wonder they can cause dropouts and picture quality problems?

Now our patented new Scotch™ Anti-Stat Treatment solves the problem. It's a revolutionary cassette coating that minimizes static attraction, giving our 1/2-inch Broadcast and 3/4-inch MBR videocassettes the industry's lowest electrostatic charge levels.

The result: Fewer transient dropouts. Less color noise. Better signal-to-noise. A reduction of picture problems caused by static-attracted particles.

These new Anti-Stat Videocassettes, recognizable by their distinctive red doors and hubs, are what you've come to expect from 3M. Still another example that no one in the industry is as consistently innovative. Still another demonstration of 3M's commitment to quality. Still another reason we're number one in the world of the pro.

OUR TAPE

ALWAYS AN INNOVATION AHEAD.

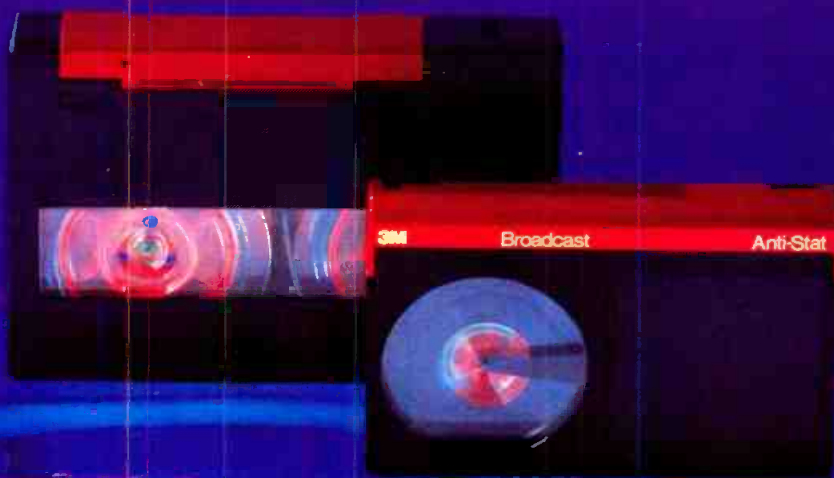

Scotch™
AUDIO & VIDEO TAPES

NUMBER ONE IN THE WORLD OF THE PRO

3M

YOUR WORLD

EVERY MINUTE COUNTS. NO TIME FOR TAPE CRUNCHING, EDGE DAMAGE OR TRANSIENT DROPOUTS.



©1995 3M Co. "Scotch" is a trademark of 3M.

Fifteen minutes to air time, and you have six minutes of videotape to edit into thirty seconds. You don't have any time to worry about whether the machines are aligned perfectly. But you don't have any reason to worry either. Not if you have a tape you can rely on.

We know you need a videocassette that can handle the toughest editing conditions. So we created the Scotch™ 3/4-inch MBR videocassette with a thicker backing to reduce tape "crunching" and edge damage. We also gave it our exclusive Anti-Stat Treatment

for fewer transient dropouts.

Less color noise and better signal to noise, too.

It's available in hanger cases, including Mini U-Matics. With our red doors and hubs for easy Anti-Stat identification. With our engineers just a phone call away. With all the toughness it takes to be number one in the world of the pro.

BASE FILM THICKNESS
(In millimeters)

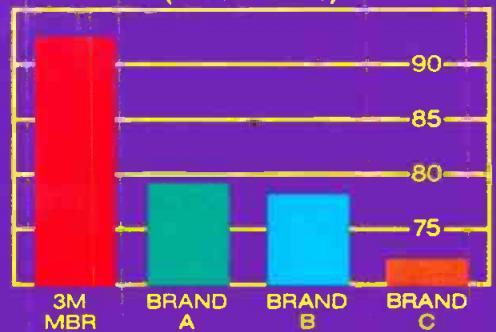

OUR TAPE
NOTHING ELSE MEASURES UP.

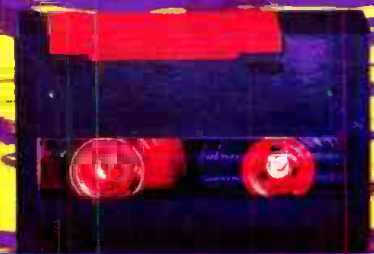

Scotch

AUDIO & VIDEO TAPES

NUMBER ONE IN THE WORLD OF THE PRO





YOUR WORLD

ON LOCATION. DUST AND DIRT.
NO PLACE FOR STATIC CHARGED
VIDEO CASSETTES.

You've waited three hours in the dust and hot sun to get that spectacular finish, only to have your once-in-a-lifetime shots destroyed by transient dropouts caused by particles drawn into your videocassette by a static charge. But that's always been a risk, until now.

We know you need a 1/2-inch videocassette that can go anywhere without picking up static-drawn souvenirs that will destroy your picture. So we developed the exclusive Scotch™ Anti-Stat Treatment, giving our new 1/2" Broadcast Videocassettes the industry's lowest

electrostatic charge levels for unsurpassed dropout performance. With outstanding color reproduction and signal to noise. Hanger cases are available in VHS and Beta, in 10 and 20-minute lengths. All distinguished by our red doors and hubs for easy Anti-Stat identification. All backed by our engineers, just a phone call away. All the more reason we're number one in the world of the pro.

ELECTROSTATIC CHARGE (BETA)

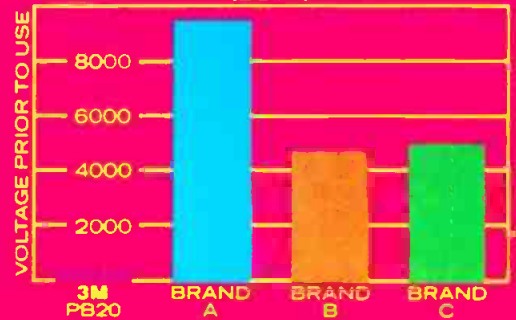

OUR TAPE

ANTI-STAT...ANTI-DROPOUT.

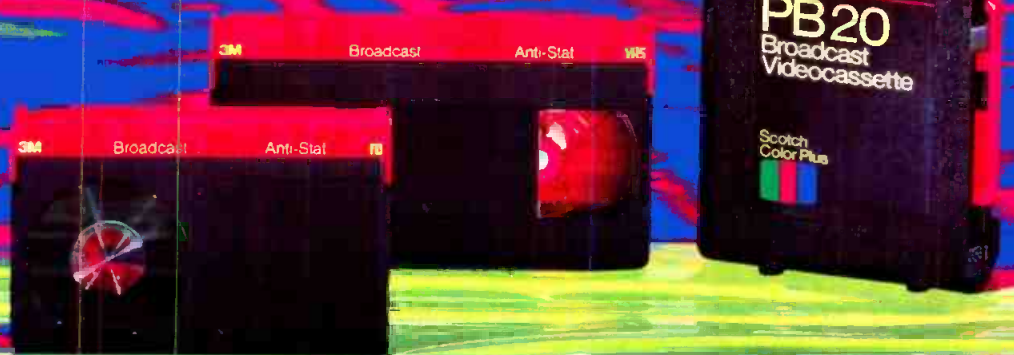

Scotch™
AUDIO & VIDEO TAPES

NUMBER ONE IN THE WORLD OF THE PRO



**3M VIDEO RECORDING TAPES.
WE STAKE OUR PROFESSIONAL
REPUTATION ON THEM.
AND YOU CAN STAKE YOURS.**

*When you use 3M video recording tapes,
you're on the right track.*

*In fact, in 1983, we won an Emmy Award for
pioneering and developing video recording
tape.*

*For over 30 years, we have been setting
industry standards for excellence and quality
assurance. And we back Scotch™ Video tapes
with unmatched service, nationwide. When you
have any questions or problems, technical serv-
ice representatives are just a phone call away.
For all these reasons, Scotch™ Audio and Video
tapes are number one in the world of the pro.*

*For more information about our complete
line of audio and video recording tapes and
diskettes, call for a free brochure.*

1-800-328-1684

Scotch[™]
AUDIO & VIDEO TAPES
NUMBER ONE IN THE WORLD OF THE PRO
3M

Continued from page 66

rier above the normal audio bandwidth of 15kHz in a stereo system means that the noise spectra accompanying the signal on the subcarrier will appear within the audio bandwidth after decoding and signal matrixing. In the case of the BTSC signal, this can be shown to degrade the audio signal-to-noise ratio by as much as 20.6dB. In other words, a monaural S/N of 65dB would degrade to only 44.4dB under certain reception conditions when the user switched to stereo operation.

To combat this problem, the L-R peak signal deviation in the BTSC system was set at 50kHz, compared with 25kHz for L+R peak deviation. This increase in signal level gives an S/N of approximately 50dB. Although it is significantly improved, this S/N level is still not good enough to prevent a noticeable difference between the mono and stereo modes of operation. Therefore, noise companding is used for the L-R signal before transmission. The companding system places the L-R channel noise well below the audible level. If this is the case, however, why do we still hear noise coming from our hi-fi speakers that we didn't hear from the TV receiver speakers?

The answer brings us back again to frequency response. If we take another look at the performance of a typical receiver audio amplifier (Figure 1), we see that frequency response falls off rapidly above 1kHz. Because the human ear is most sensitive to broadband noise in the region from 1kHz to about 8kHz or 10kHz, this frequency rolloff produces a smooth, pleasant sound that is relatively free of noise.

When we design for flat frequency response out to 15kHz, however, any noise in the frequency band will be reproduced. The noise spectrum shown in Figure 2, with the exception of spurs at harmonics of 60Hz and the strong 15.734kHz line-scan component, is relatively uniform over the entire audio bandwidth. A broadband noise measurement will give a peak S/N (referenced to 25kHz peak deviation) of about 60dB—not much better than the average audio-cassette without noise reduction. This is the monaural, or L+R signal, which must remain compatible with the millions of consumer receivers already in use. Although the L-R channel is noise-reduced, companding is not possible for the L+R channel. The overall S/N will, therefore, be comparable with present monaural service.

Dynamic noise reduction

Figure 3 shows one method that may be used to improve the L+R S/N: *non-*

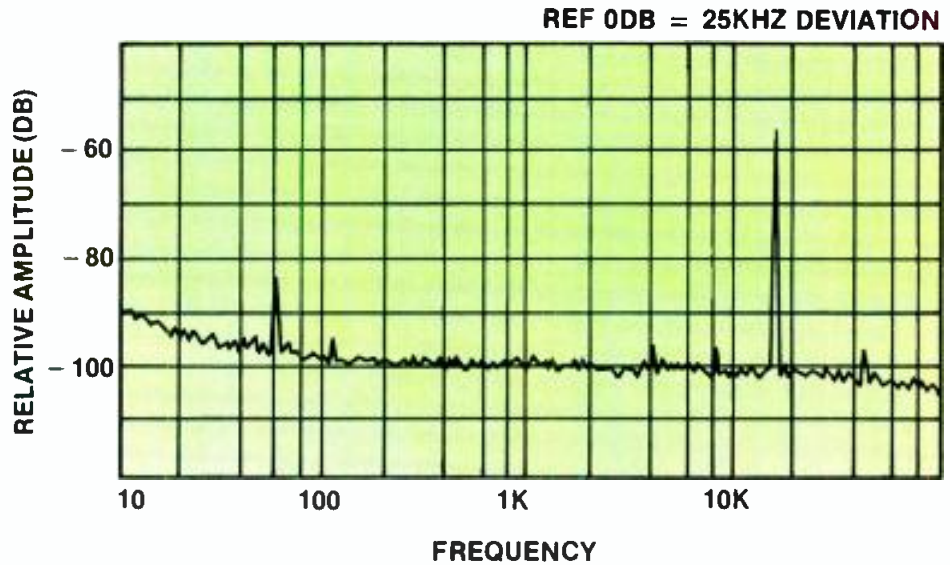

Figure 2. The noise spectrum for a TV audio channel after de-emphasis. Note that noise is relatively uniform over a wide frequency band.

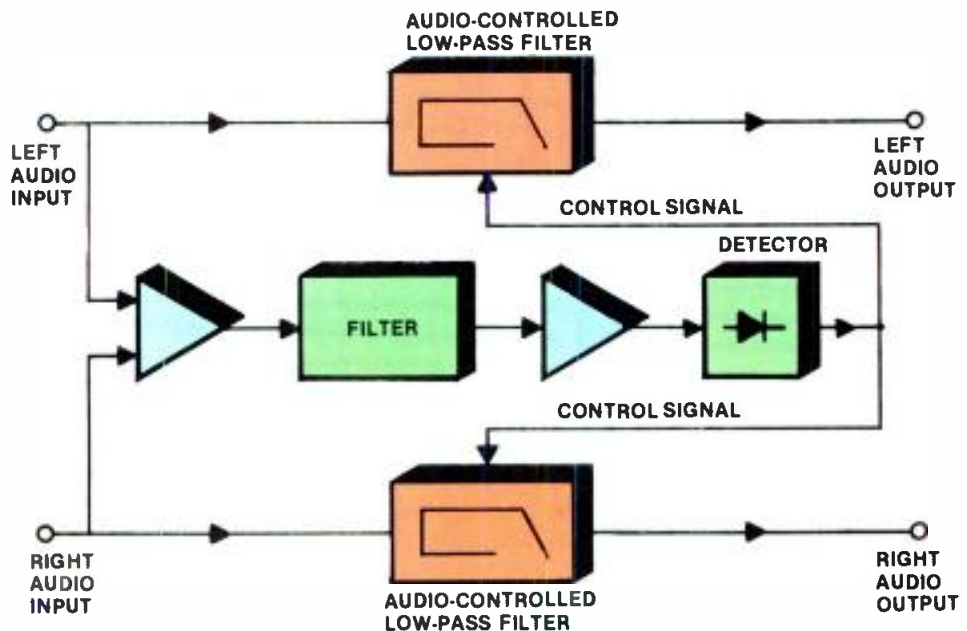

Figure 3. Block diagram of a single-ended dynamic noise reduction system IC, the LM1894 (National). This device is able to provide up to 14dB noise reduction when used with a non-encoded stereo audio source.

complementary dynamic noise reduction. This system is widely used by automotive radio manufacturers for FM and cassette tape noise reduction. By using a dynamically controlled audio bandwidth, responsive to both the amplitude and frequency content of the signal, the system is able to provide up to 14dB improvement in the audio S/N. Because dynamic noise reduction is non-complementary (the audio does not have to be processed in a special way prior to transmission), it is compatible with the present broadcast signal.

Dynamic noise reduction increases the audio bandwidth only when signals are present above the noise floor, so it is important that the threshold level for operation is correctly set. This might appear to be a significant problem because

weak RF signal levels at the antenna could produce high noise levels at the audio detector. Although a threshold adjustment control could be provided, it is generally considered an inconvenience to the user.

Figure 4 shows what will happen to the audio noise level as the amplitude of the RF carrier is reduced. What is not apparent from this chart, however, is what is happening to the picture quality at the same time. As the RF carrier level falls, the picture begins to exhibit noise (*snow*) and weak or streaky color. At some point the picture quality would be so impaired that most viewers would switch to another channel. The RF level at which picture noise is clearly objectionable is about 15dB below 500 μ V, the reference

Continued on page 78

Music



AG-6800 VHS™ Hi-Fi video recorder. Perfect for hi-fi dubbing. Dynamic range is greater than 80dB.

BROADCASTING



AG-6300 High-performance VHS editing deck. Two-frame editing accuracy. Inputs for time base corrector.

HOSPITAL



AG-6300MD Designed for medical applications. VHS recorder conforms to UL-544 standard. Ext. sync in. Time code inputs and outputs.

UNIVERSITY

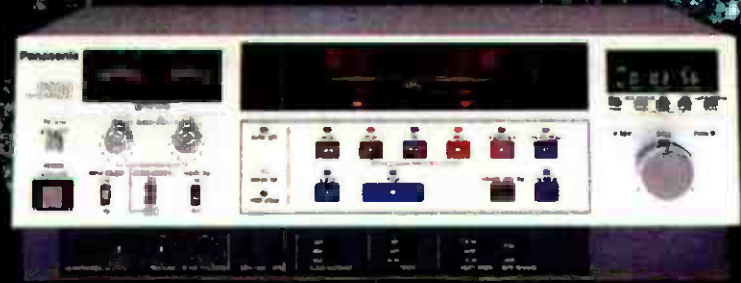

AG-6200 VHS recorder ideal for dubbing. Loop through recording capability. Time code connectors.

HOSPITAL



AG-6200E Multiformal VHS recorder for world-wide use. PAL, CCIR and 4.43 MHz NTSC. 14-step dial search.

WALL ST



AG-6100 VHS playback deck. 14-step dial search. Frame advance, auto-repeat.

PANASONIC[®] HAS A PROFESSIONAL VIDEO DECK FOR EVERY PROFESSION.

From medicine to music. From New York to London. Whether it's industrial training, hi-fi stereo duplicating or international business communications, there's a Panasonic 6000 Series VHS™ deck designed for you.

For long-term stability, all 6000 Series professional decks have a sturdy aluminum diecast chassis. They also have ultraprecise direct-drive video head cylinders to deliver noiseless video images and special-looking special effects.

The 6000 Series also includes all the inputs and outputs professionals demand. Like 8-pin video connectors for direct single

connection to a monitor. BNC connectors for easy interface with other video components. And time code connectors for advanced editing applications.

Still, with all the 6000 Series has going for it, Panasonic knows a professional deck is only as good as the professional support behind it. That's why you'll find regional offices each with a staff of engineers to assist you with matching components for your specific system. And technical service for installation and instruction. So whatever profession you're in, take a look at the video decks designed for your profession. The Panasonic 6000 Series.

For more information, call your nearest Panasonic regional office. Northeast: (201) 348-7620. Midwest: (312) 981-4826. Southeast: (404) 925-6835. Southwest: (214) 257-0763. West: (714) 895-7200. Northwest: (206) 251-5209.

Panasonic
Industrial Company

Continued from page 75
visual carrier level used in Figure 4.

Most TV aural carriers operate at 7dB to 15dB below the visual carrier level. Curves are plotted in Figure 4 aural carriers at -10dB, -20dB and -30dB. Even for an aural carrier at -30dB (with respect to the visual carrier), the audio noise level exhibits little change by the time the picture has become unwatchable. Therefore, a threshold adjustment is unnecessary.

Buzzzzz

Simply processing the audio signal broadband noise is not the solution to the problems of multichannel TV sound. Another irritating form of noise is *buzz*, that harsh, rattling sound that is all too familiar to TV viewers.

The majority of receivers in use today use *intercarrier* sound detection. A common IF amplifier raises the level of both the picture and sound carriers arriving from the tuner and, at the video detector, a difference frequency of 4.5MHz between the carriers is generated. This frequency-modulated 4.5MHz intercarrier is amplified and limited to remove any amplitude modulation. A conventional quadrature detector is used to

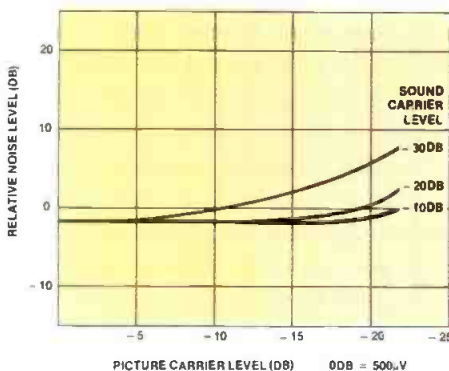

Figure 4. A plot of visual carrier level vs. relative noise in the demodulated audio signal.

recover the audio.

A primary cause of sound buzz is *incidental carrier phase modulation* (ICPM). Because the sound detector depends on the frequency difference between the visual and aural carriers, any change in visual carrier phase as a result of video modulation will transfer to the aural intercarrier and produce buzz.

Buzz has a harsh 60Hz character because the video picture is built up by scanning 60 fields per second, and any video component producing modulation

phase changes will occur at 60Hz and harmonics of 60Hz. Although the broadcaster can—and should—make every effort to reduce the transmitter ICPM, some receiver circuits can also produce ICPM.

Two of the more sensitive circuits are the video IF amplifier selectivity filter and the video/sound intercarrier detector. Because of the vestigial sideband nature of the transmitted TV signal, the receiver IF filter exhibits an asymmetrical response at the picture carrier frequency. This causes an AM-to-PM conversion that is referred to as *Nyquist slope* ICPM. This problem can be solved by using a *quasi-split* sound IF amplifier for the visual and aural carriers that has a filter with symmetrical amplitude response at both frequencies. (See Figure 5.) The intercarrier that results when such a circuit is used will be free of Nyquist slope ICPM. A normal filter and IF amplifier processes the visual carrier for recovering the video portion of the transmission.

Quasi-synchronous or *homodyne* detectors, now popular in many receivers, can also introduce ICPM into the output signal. The limiter stage of the detector, which provides the carrier-switching

The Aphex Compellor.™

Invisible Compression in Stereo or Mono.

The Aphex Compellor is the most acclaimed compressor/leveler/peak limiter ever made. With good reason... you simply can't hear it work. It doesn't add *any* color or other sonic effects. Best of all, the Compellor is easy to use. Set it once and it goes to work automatically... inaudibly controlling your dynamics.

Ask your professional sound dealer for a demonstration of the remarkable Aphex Compellor. Available in monaural and

stereo versions. Or write us for the name of your nearest dealer and more information on the full line of innovative Aphex products.



Aphex Systems Ltd.

13340 Saticoy St., N. Hollywood, California 91605
(818) 765-2212 TWX: 910-321-5762

Compellor is a trademark of Aphex Systems Ltd.

© 1985 Aphex Systems Ltd.

Circle (42) on Reply Card

FROM THE INVENTORS
OF THE PLUMBICON TUBE

Objective Color Monitor Balance

At last, a practical solution to the age-old problem of color balancing your picture monitors—the PM5539 color analyzer.

Working directly off the screen with three color-sensitive photodiodes, the PM5539 gives you quick and easy readings of the three primary colors—separately or simultaneously—referred to a previously-set white standard.

This means that in a matter of minutes every color monitor you need to watch can be set up to have the

same color temperature and intensity.

Once the PM5539 matches all your monitors, you'll see all the difference in the world. The PM5539 is the quantitative way to eliminate the qualitative "calibrated eye-ball."

For nationwide sales and service information call 800-631-7172, except in Hawaii, Alaska and New Jersey. In New Jersey call collect (201) 529-3800, or write Philips Test & Measuring Instruments, Inc., 85 McKee Drive, Mahwah, NJ 07430.



PHILIPS

PHILIPS

waveform for the multiplier circuit, is usually slightly mistuned from the carrier frequency in order to optimize detector efficiency. This has a similar effect on the Nyquist slope.

More modern, true synchronous detectors avoid the limiter-tuning problem by inserting a wide-range, dc-controlled phase shifter between the carrier VCO and the amplitude modulation detector. The shifter gives precise, optimum adjustment of the switching waveform phase. The limiter is center-tuned, yielding a 5dB to 7dB improvement in the audio S/N.

Receiver designs

Some TV receivers are being termed *stereo ready* simply because they provide an output jack with the 4.5MHz intercarrier signal that may be used by an external decoder. For best performance, however, substantial internal changes in the receiver design are needed.

A block diagram of a high-performance receiver is shown in Figure 6. The quasi-split sound IF amplifier is used to avoid Nyquist slope ICPM. The intercarrier sound signal, after limiting to remove any amplitude modulation, is detected and the composite audio signal is applied to the stereo decoder through a filter that attenuates any SAP signal that may simultaneously be present. This filtering is necessary because the SAP carrier is harmonically related to the horizontal line-scan frequency. If allowed through to the PLL of the stereo decoder, the SAP carrier could modulate the decoder VCO, causing crosstalk into

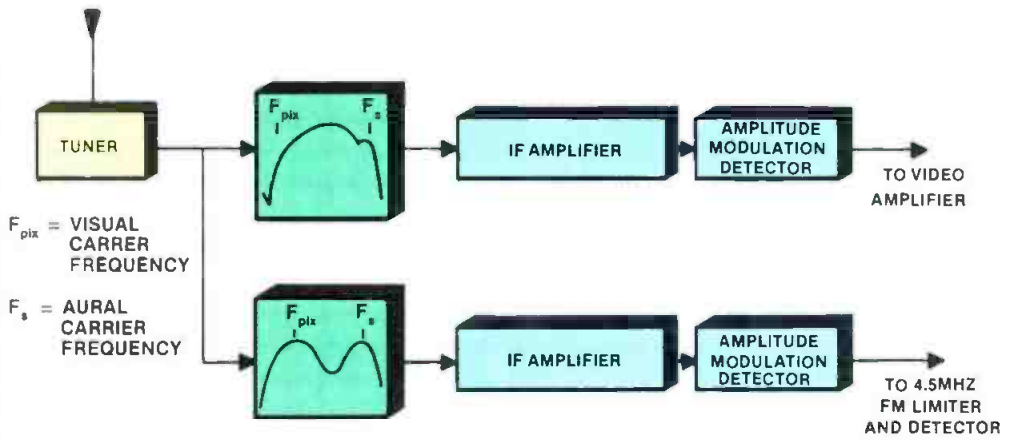

Figure 5. Block diagram of a quasi-split sound IF amplifier. The double-hump filter used for the aural channel ensures symmetrical response at the visual and aural carrier frequencies so that the detected intercarrier is free of Nyquist slope ICPM.

the main audio channel. The stereo decoder itself is similar to the decoders used in FM broadcast receivers, with the exception of the pilot frequency (15.734kHz instead of 19kHz) and the audio outputs, which are L-R and L+R, instead of simply L and R. The latter difference is necessary because the L-R channel is compressed by the BTSC noise-reduction system.

Expansion of the L-R signal at the receiver is no trivial matter. Errors in matching the amplitude and phase response of the two channels will be multiplied by the expansion factor, causing loss of separation. After expansion, the signals are matrixed to give the left and right audio outputs. The expander circuit is switchable from the L-R channel to the SAP channel, which is also compressed upon transmission. Because

the SAP channel is frequency-modulated, a separate FM detector is used after the filter that extracts the SAP channel from the composite baseband.

For both the main audio channel and the SAP signal, additional noise reduction is provided by the dynamic noise-reduction system before efforts are made to modify the overall tonal quality of the audio for individual listener preference.

Another important feature of the system shown is the stereo-enhancement circuit. When the receiver speakers are spaced more closely than would be optimum for stereo listening (inside a 19-inch screen-size receiver cabinet, for example), an improved stereo effect can be obtained by using phase-reversed signal cross-coupling between the audio channels. Approximately 60% cross-coupling is used at frequencies above

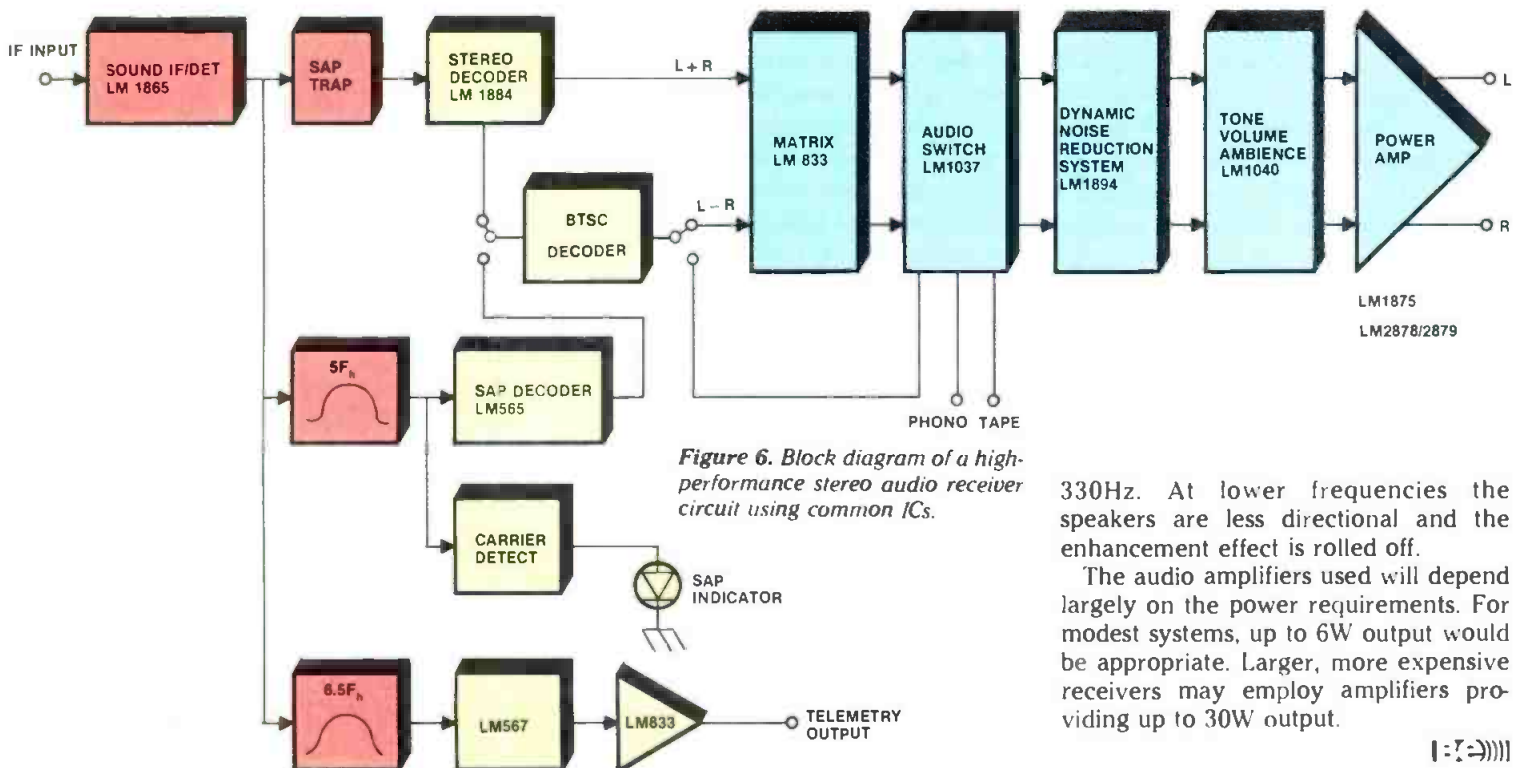

Figure 6. Block diagram of a high-performance stereo audio receiver circuit using common ICs.

330Hz. At lower frequencies the speakers are less directional and the enhancement effect is rolled off.

The audio amplifiers used will depend largely on the power requirements. For modest systems, up to 6W output would be appropriate. Larger, more expensive receivers may employ amplifiers providing up to 30W output.

|| :->))))))

IN SEARCH OF EXCELLENCE.

Long before it was a popular management theory, broadcasters were searching for excellence. Excellence of Sound.

The search is still on, but the goal is now within the reach of every FM broadcaster.

The 695 is an exciter without equal . . . in quality sound . . . in versatility . . . and in value. Any type of distortion you can name (THD, TIM, IMD) is less than .025 percent. This isn't an environmentally controlled lab figure, but rather one that is measurable over the operating temperature range of the equipment. Moreover, noise is so low that it's virtually impossible to measure.

QEI's 695 offers features that the competition has never even dreamed of. A peak counter with LED display, modulation measurements on the front panel, and a measurements grade linear demod built in. It is synthesized, has wideband circuitry, a 3-color LED bar graph for modulation display, a 10-position meter, and many other features that are best described in our new brochure.

For more information on QEI and the 695 Exciter just write or call us. You'll see why our search for excellence has produced the best value on the market today.

QEI Corporation

One Airport Drive P.O. Box D
Williamstown, NJ 08094 (609) 728-2020

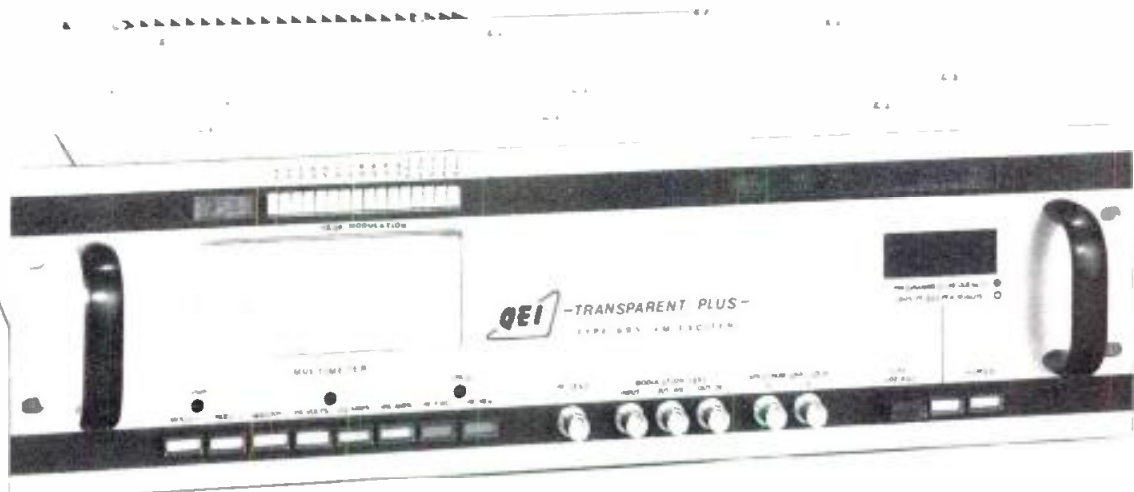

Circle (62) on Reply Card



FROM THE NEWSROOM TO THE BOARDROOM TO THE OPERATING ROOM. PANASONIC® MONITORS.

Video. More and more it's playing a larger role in entertainment, industry, education, even medicine. That's why, no matter what your special application, all you need are the monitors in the Panasonic BT, CT and MT Series.

Our BT Series monitors are ideal for broadcast because they all have the quality and important controls broadcasters require. Like a normal/underscan switch that lets you select either the camera view or the actual monitor picture. Pulse-cross circuits for easy observation of sync detail. And blue only for easy chrominance adjustment. The 13" and 19" BT Series monitors (all screen sizes meas diag) have our special CompuFocus™ picture tube. Add to that a switchable comb filter and the result is increased definition and color sharpness.

Perhaps the most versatile of the BT Series are the 7" monitors. There's one that operates on both AC and DC so it's perfect for field use. Another model includes switchable line inputs, external sync terminals and is

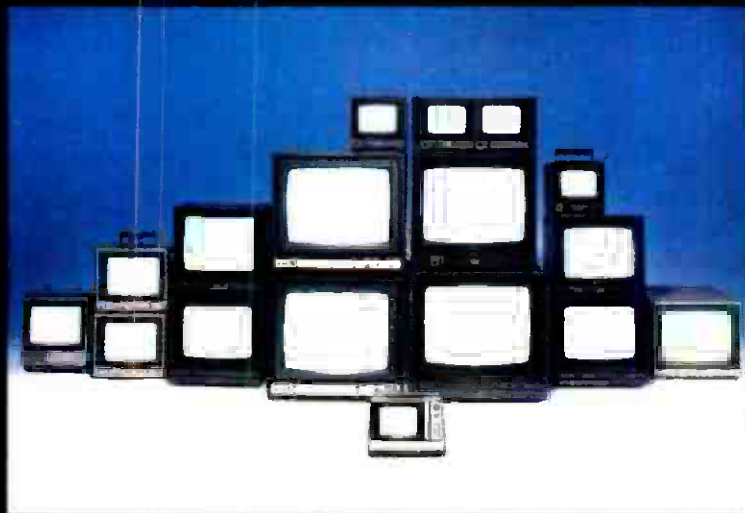

available as a single unit or in a dual rack.

Our CT monitors also come in a wide variety of configurations. You can choose from our 19" models. One comes with a tuner, and one can be used internationally because it lets you switch between NTSC, PAL and SECAM. The CT Series 13" and 14" monitors include

models with a built-in tuner, NTSC composite and RGB inputs for use with computer graphics. And when light weight and portability are important, there's the CT Series 5" monitor receiver.

For medical use, the MT-1340G conforms to the UL-544 standard. Its Data Grade in-line picture tube provides the precise resolution medical applications require. While RGB inputs assure you of critically accurate color reproduction.

By now it should be clear, no matter what your special application, the monitors in the BT, CT and MT Series have the right qualifications. Monitor pictures simulated.

For more information, call your nearest Panasonic regional office. Northeast: (201) 348-7620. Midwest: (312) 981-4826. Southeast: (404) 925-6835. Southwest: (214) 257-0763. West: (714) 895-7200. Northwest: (206) 251-5209.

Panasonic
Industrial Company

Proof of performance for TV stereo

By Dennis Ciapura
and Jerry Whitaker, editor

How good is good? The BE TV proof suggests basic guidelines for stations moving to multichannel sound.

There is a general perception in our industry that TV sound has been treated as a secondary service to the video portion of the broadcast signal. When the need for improvements in TV audio are discussed, the words *ignored*, *forgotten* and *stepchild* often enter into the conversation. Now, however, the rapid growth in multichannel TV sound—and a corresponding concern about audio quality—could sweep away years of neglect.

To assist engineers in this effort, **Broadcast Engineering** has developed a set of suggested performance guidelines for TV stations operating in stereo. The **BE TV proof** is an outgrowth of the popular **FM proof** that was presented in the magazine last year.

In general, our performance objectives are based upon a balance between inherent TV system performance limitations and the desire for audio system transparency. A pragmatic approach is necessary because no transmission medium is likely to serve the needs of the total purist. To be realistic from a business standpoint, we must consider *real-world* performance limitations.

The **BE proof** audio fidelity objectives are based upon actual experimental results reported by audio industry experts. Detailed references are provided in the bibliography so that the reader may review the background data and arrive at his or her own conclusions as to the validity of the assumptions behind the numbers. Like everything else on earth, audio fidelity does reach a point of diminishing return. Improvement beyond a certain point will be noticed by too few viewers to be of any practical consequence.

Ciapura, BE's consultant on radio technology, is president of Starnet, San Diego.



The move to stereo has prompted many TV stations to take a close look at their audio and transmission systems. The BE TV proof suggests a set of performance objectives by which stations can measure their equipment.

General test conditions

The objective of the **BE TV stereo proof** is to simulate as closely as possible the normal operating conditions of the station. Although we suggest sampling the system at the transmitter output, a high-quality off-air demodulator is preferable, if available. An off-air demodulator has the advantage of taking transmitter and antenna bandpass ir-

regularities into account. The demod must, however, be very flat to avoid invalid results. For stations with a wide-band antenna and near unity VSWR, an output line tap makes the most sense.

We assume that diplexer bandwidth and phase shift have been checked and found to be acceptable for stereo operation. Diplexer performance is beyond the scope of the **BE audio proof** program, and conditions vary widely depending on installation details. We assume that this work was part of the initial stereo conversion process.

Frequency Response

Absolute frequency response accuracy over the audible bandpass does make an audible difference. Researchers exploring subtle differences in audio amplifier designs have found that errors as small as 0.2dB can be heard.^{1,2} As a matter of fact, if the levels and frequency responses of good-quality amplifiers are made equal, virtually no one can tell them apart in double-blind testing! Therefore, very flat frequency response (strict adherence to the 75 μ s pre-emphasis curve) is reflected in our performance objectives.

Because most musical content is in the 100Hz to 10,000Hz range, we call for response of ± 0.5 dB within this frequency band. There is no reason on earth that a TV broadcast system can't be absolutely flat over this range and, in view of how critical flat response is to overall fidelity, it pays to optimize here.

Somewhat looser tolerances are specified at the frequency extremes in recognition of practical high-pass and low-pass filter considerations relative to subsonic noise and 15.734kHz pilot filtering requirements. Fortunately, relatively little program material reaches the extremes of the band, so small response

NEW FROM ITC... "OMEGA" CARTRIDGE MACHINES

WHAT THE NEW "OMEGA" SERIES BRINGS TO YOU

OMEGA series cartridge machines embody ITC quality at an affordable price with features to delight everyone... including low-cost stereo performance.

Microprocessor technology brings you many operational flexibilities with easy, economical maintainability. The OMEGA series is covered by the same bold 2-year warranty International Tapetronics Corporation/3M offers on all its new equipment. Additionally, you receive detailed, comprehensive technical manuals, field tested for clarity at the same time the machines were field tested for reliability. All this reinforced by the finest technical service support group in the industry readily accessible to you at no charge via our Toll Free number.

OMEGA stereo reproducers have simple, clean electronics for clear, accurate audio reproduction, and feature:

- Standard 150 Hertz secondary cue tone detection

- Long life stereo heads
- Modular design for easy servicing
- Efficient servo motor providing stable, cool operation
- Flashing ready lamp indicating cartridge has been played

Match your OMEGA stereo reproducers with a high-quality stereo recorder such as the ITC "DELTA" or "99B" recorder and insure optimum playback audio quality from your OMEGA reproducers.

OMEGA mono reproducers and mono recorders have all the features and contain the same rugged, reliable mechanics for trouble-free operation as the OMEGA stereo reproducers. *The OMEGA mono reproducers are even field upgradeable to stereo!* The OMEGA mono recorders have a selectable 1kHz cue tone defeat and include a built-in microphone preamp. With direct microphone input and ITC's "FB-1" telephone interface device, your station can offer automatic dial-in weather information, sports scores, concert dates

and perform a variety of news room and research functions.

CALL US TODAY for more information about the OMEGA series and ask about our trade-in policy and *new lease program* available on ITC's complete line of cartridge machines.

- 99B Cartridge Machines, "The Best"
- DELTA Cartridge Machines, "Today's Most Popular Cartridge Machines"
- OMEGA Cartridge Machines, "Affordable Performance You Can Trust"

When newer technology emerges, it will come from International Tapetronics Corporation/3M, "The Leader In Reliability And Service."

In the U.S., call Toll Free **800-447-0414**, or collect from Alaska, Hawaii and Illinois 309-828-1381. In Canada, call Maruno Electronics, Ltd. 416-255-9108.

International Tapetronics Corporation/3M
2425 South Main Street
P.O. Box 241
Bloomington, Illinois 61702-0241

3M hears you...

Circle (47) on Reply Card

variations have less audible impact. As long as excessive frequency-dependent limiting is not employed, a station meeting the listed objectives would do well against program input in a double-blind test comparing subjective frequency response.

Although there has been much controversy as to whether frequency response above 15kHz is required for perfect fidelity, many researchers have found little, if any, advantage to extension beyond 15kHz, even when the signal source is available for comparison.^{3,4} Snow's research results of 50 years ago are still valid today.⁵ As a matter of fact, experiments have been conducted wherein program material was passed through two cascaded 15kHz toroidal low-pass filters and no audible change could be detected, even with direct-to-disc sources and electrostatic headphones. A strong case, based on objective research, can be made for TV broadcast frequency response not being an audible limitation, if the response within the passband is optimally flat.

The recommended method for

measuring frequency response is as follows:

- Feed the tones into line level inputs at a point in the audio system that represents a *typical* signal path.
- With AGC voltages switched off, but the BTSC companding system fully operational, select a console level near 0VU that produces a convenient modulation level (50%, for example, at 300Hz).
- Vary the input frequency and record the difference in signal generator output required to maintain the same modulation level.
- Compare the recorded results to the standard pre-emphasis curve (75 μ s) to calculate frequency-response error.

An alternative method involves feeding the test signals at an input level that is low enough to keep the total modulation down to about -20dB (excluding pilot) and measuring the response at the de-emphasized audio outputs. This produces quicker results because response is read directly and no calculations are required. Obviously, this procedure is not quite as accurate as the

traditional method because the monitor's de-emphasis networks will have some small error. If exact testing shows that the system is a little off and corrective EQ is required, the de-emphasized output route is a convenient adjustment tool. When everything looks flat, the final check can then be made by the traditional modulation-sensitivity vs. frequency method.

Distortion

Our distortion tests are based upon twin objectives:

1. Keeping the test-tone frequencies low enough so that at least the second harmonic of the highest audio frequency input will fall within the system's 15kHz passband. Therefore, no test time will be spent making harmonic-distortion measurements at frequencies at which the harmonics have been filtered out by the stereo generator, and possibly by the test demodulator/decoder. Virtually everyone who has done an FM stereo proof is familiar with the phenomenon of the distortion at 10kHz and

Performance objectives

General test conditions

- System in BTSC stereo mode.
- Input signals applied to audio console line input(s) used for most program sources.
- System output sampled and demodulated/decoded at transmitter antenna output.
- All processing and EQ left in line and adjusted as usual.
- Operating level defined as 0VU or equivalent at console.

Frequency response Conditions

- AGC voltages switched off (not simply bypassed). Unfortunately, not all processors provide this feature. In such cases, use the *bypass* mode.
- Any convenient modulation level between 50% and 100%.

- Input level as required to maintain reference modulation level.

- Response error expressed as input level deviation required to maintain reference modulation level, compared to the 75 μ s pre-emphasis characteristic curve.

Performance targets

- ± 2 dB 30-15,000Hz
- ± 1 dB 50-15,000Hz
- ± 0.5 dB 100-10,000Hz

Distortion Conditions

- AGC switched on, input levels as required to produce specified console levels. De-emphasis in.

Performance targets

- at standard operating level:
 - THD = 1% 50-7,500Hz
 - IMD = 1% 60Hz and 7kHz, 4:1
- at operating level +10dB:
 - THD = 1.5% 50-7,500Hz

- IMD = 2% 60Hz and 7kHz, 4:1

Noise Conditions

- Measured at each stereo audio channel output with all processing equipment in the line and adjusted for normal operation.
- Noise level is referenced to the output level produced by an input signal at 0VU at the console.

Performance target

- -56dB, 30-15,000Hz, unweighted, de-emphasis in.

Separation Conditions

- Measured at each stereo audio channel output with all processing equipment in the line and adjusted for normal operation.

Performance targets

- 35dB 400-14,000Hz
- 30dB 50-400Hz

DYNAIR SERIES 10

ON LINE

3 0 4 0 0 3 0 0 0 0

RESET

OUTPUT

2

INPUT

3

Presenting the Major Maintenance Tool for Dynair's Series 10 Switch

Right. A feather duster.

We first placed the Series 10 audio/video switching systems in the field four years ago. Today, most are still maintenance-free. Unless, of course, you count dusting the buttons.

Nobody's perfect. But we're close.

In fact, this solidly reliable, solid-state Series 10 switching system is virtually transparent to broadband signals. And the specifications we publish are not "typical" or best case. They are guaranteed, off-the-shelf minimums.

Study them. Then consider your installation. The Series 10 uses a single coax cable for control. That's only one economy.

Compare the cost effectiveness:

- The Series 10 switches both standard and high definition signals.
- A 72-hour battery protects the memory.
- The "in use" status of each channel is constantly displayed.
- Up to four levels of switching are available, including video and multiple video, audio and multiple audio, audio-follow-video and time code.

The Series 10 is also flexible.

Select local or remote control. Panel or desktop operation. Or both. You can start with a single level, then add levels and controls with ease.

All this, and it's almost maintenance free. Ask us for a specification booklet.

Feather duster optional.

DYNAIR

5275 Market Street, San Diego, California 92114 Telephone: (619) 263-7711; TWX: (910) 335-2040

Circle (48) on Reply Card

15kHz being the same whether the test tone is on or off. The test instruments are simply reading noise.

2. Probing system performance at two important levels:

- at operating level, because that's where most of the program energy is most of the time, and
- at 10dB above operating level, to be sure that most program peaks are cleanly reproduced.

When distortion measurements are being made, we have specified that the AGC voltages be switched back on. After all, that's the way stations operate, and that's what the viewer hears. Excessively fast attack-time constants will produce low frequency and IM distortion (in older limiter designs) and excessive high-frequency clipping will increase high-frequency distortion. The new generation TV sets feature improved audio amplifier and speaker systems that will reproduce high-frequency distortion, if present in the transmitted signal.

Although every chief engineer will have an opinion as to what the optimum processor input level should be, high compression figures will make it more difficult to pass the +10dB distortion tests, and will sound worse on the air.

For example, if 0VU on the console is right at the threshold of limiting (under these conditions 6dB to 10dB of compression will be indicated with program material), a 7.5kHz input will be compressed by nearly 12dB because of pre-emphasis. If the level is increased to 10dB above operating level, 22dB of compression will result. Most systems still should provide fairly low distortion at 22dB compression. If 0VU at the console is 10dB above the threshold of limiting, however, the resulting total of 32dB compression at 7.5kHz might let the signal get into the safety clippers.

Although the IMD tests are relatively impervious to system noise, the THD tests are limited by the noise floor. A station with an overall system signal-to-noise reading of 54dB at the audio demodulator/decoder outputs could do no better than a 0.2% residual reading when the distortion tests are made. If a low-frequency spectrum analyzer is available, the distortion components can be picked out of the noise and readings down to 0.1% are possible.

It is a worthwhile goal to try to get the distortion products down to the noise level, and to get the noise level down to -56dB to -60dB at the audio outputs.

Although THD and IMD tests alone do not check for dynamic instability problems, such as transient intermodulation distortion (TIM), the results of careful selection of high-slew rate components in the audio chain and THD/IMD figures down in the noise floor will impress an audience of audiophiles.

Noise

In many cases, system noise is the most frustrating parameter to bring under control. The number of opportunities for poor results are legion and the telco/STL stories are legend.

For many years, program source noise was so much more audible than even a marginal TV station S/N that many engineers have become complacent about this area of performance. With digital source material on the horizon, however, it's a whole new ball game. To make matters worse, new home audio/video systems with sizzling highs accentuate any hiss.

Our performance objectives reflect state-of-the-art transmission system performance (about -60dB) and assume that the noise contribution from the audio chain and STL is minimal. The objective of -56dB reflects a reasonable

This new portable UHF Field Strength Meter gives you accurate readings across the entire band.

Someone once said that "Certainty is Security." That is the main idea behind field strength measurements. They verify the signal level and rf environment at the point of reception. You know for certain what's out there.

It is now easy for UHF stations to achieve this certainty. With the new FIM-72 from Potomac Instruments.

Tune the entire UHF band

From 470 to 960 MHz. The received signal strength is shown in volts and dB, with a 140 dB measurement range. Select peak or averaging detection; wide or narrow IF bandwidth. Seven 20dB logarithmic ranges assures precise readings. Internal demodulators (AM and FM) provide audio monitoring of the selected signal.

It is easy to use

Find the desired signal on the spiral dial. Calibrate the meter using the internal generator, then read the signal strength from the mirrored meter. The field strength is easily determined from the supplied calibration data.

Laboratory applications

The FIM-72 includes a precision rf generator that tracks the tuned frequency. Typical measurements include insertion loss, VSWR, and filter response.

Call Potomac Today

Place your order for this new UHF field intensity meter. Put it to work. And then you will know for certain.



POTOMAC INSTRUMENTS

932 PHILADELPHIA AVE. SILVER SPRING, MD 20910
(301) 589-2662

Circle (49) on Reply Card

Fujinon makes 44X EFP lenses two ways:

The Lightest.

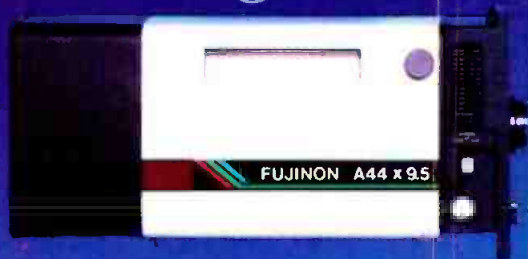

The Fastest.



When you need ultra length in an EFP lens, get ultra performance, too. Only Fujinon gives you this choice:

The New F1.4—lighter, more compact

At 14.5kg, the F1.4 version of the new A44 x 9.5ESM weighs less than half as much as competing lenses. At the full-tele position, it's *faster than any comparable EFP lens*. To be specific, it maintains its F1.4 from 9.5mm to 240mm (F2.5 at 420mm). Moreover, you can see that for yourself. It has a unique LED display panel that reports your focal length and iris.

The new A44 x 9.5ESM (F1.4) is faster and flatter than any other long lens built for 2/3-inch cameras... with one exception.

The New F1.2—the fastest, the flattest.

Here is the kind of performance you would expect only from large format lenses. It can zoom from 9.5mm

to 247mm and maintain its F1.2 maximum aperture. At 420mm, it delivers F2.1 speed. For brightness, edge-to-edge resolution, contrast, MTF and freedom from flare, ghosting and distortion, the new A44 x 9.5ESM (F1.2) leaves the competition—yours and ours—in the dust.

Common characteristics, uncommon quality.

Both 44's come with a built-in 2X range extender that lets you switch from 9.5mm-420mm to 19mm-840mm. MOD for the F1.4 is 2.2m; 2.5m for the F1.2. Auto iris and manual zoom and focus are standard. Options let you have full servo operation, a built-in pattern projector, and the widest choice in pan bar controls of any lens manufacturer—including the most advanced shot boxes on the market.

For more information or a demonstration, contact the Fujinon location nearest you.

FUJINON INC. 672 White Plains Road, Scarsdale, N.Y. 10583 (914) 472-9800 Telex 6818115
SOUTH 2101 Midway, Suite 350, Carrollton, Texas 75006 (214) 385-8902
MIDWEST 3 N. 125 Springvale, West Chicago, Ill. 60185 (312) 231-7885
WEST 148 Savarona Way, Carson, Calif. 90746 (213) 532-2861 Telex 194978



Circle (50) on Reply Card

compromise between audio purity and real-world audio-routing requirements of a major TV plant. The objective of -56dB is also the noise level typically found in current-model 1-inch VTRs.

Although 56dB of dynamic range doesn't look very impressive in this digital age, it's important to bear two facts in mind. First of all, limited dynamic range isn't a limit at all unless the program input exhibits greater dynamic

range.⁶ Most music program material stays within a 20dB range most of the time. Secondly, the *apparent* loudness of program material continues to increase as the threshold of limiting is exceeded and compression begins. The limiter may present a peak modulation barrier, but loudness forges ahead as density increases. Therefore, a station operating program levels a few decibels under the threshold of limiting can present a

somewhat greater apparent dynamic range than is electrically possible.

Stereo Separation

The **BE** TV proof separation tests are made in the traditional FM manner of feeding tones into one channel while measuring the leakage into the other. Our low-end separation objectives are looser than those for middle and high frequencies, in recognition of the non-directional acoustic properties of long audio wavelengths, and the fact that the bass is usually mixed to center for music production. In typical studio practice employing multiple microphones, lower frequencies end up in more than one mic, even when not intentionally mixed to mono, because of the long wavelengths involved.

In the middle and high ranges we look for minimum separation of 35dB to preserve stereo imaging. Program sources rarely provide greater than 30dB of separation, and so we suggest 5dB more than that to ensure the transmission system is not a limiting factor. Separation is measured up to 14kHz (instead of 15kHz) in order to allow for the effects of pilot frequency low-pass filtering in the stereo generator.

Test procedures

The **BE** audio proof of performance program for television has been structured to closely simulate the normal operating conditions at a TV station, and the recommended test procedures reflect this philosophy.

For the test measurements to be of value, the test equipment used must be carefully selected and accurately calibrated. The following instruments will be required to correctly run the **BE** proof:

- a low-distortion audio-signal generator with a metered output and calibrated attenuator,
- a distortion analyzer capable of measuring THD and SMPTE IMD,
- an audio voltmeter capable of accurately measuring signals as low as -65dBm (a function usually provided on distortion analyzers) and
- a properly calibrated TV stereo modulation monitor with a highly accurate BTSC decoder. Because measurements will be made with de-emphasis, the accuracy of the built-in de-emphasis circuits should be verified.

These test instruments are common and any well-equipped engineering shop should have them on hand. A station that does not have such gear in its inventory can usually borrow the missing items from another station in town, perhaps for a nominal fee.

Test equipment also can be rented

SELF-POWERED MONITORS FOR SELF-DRIVEN PROS

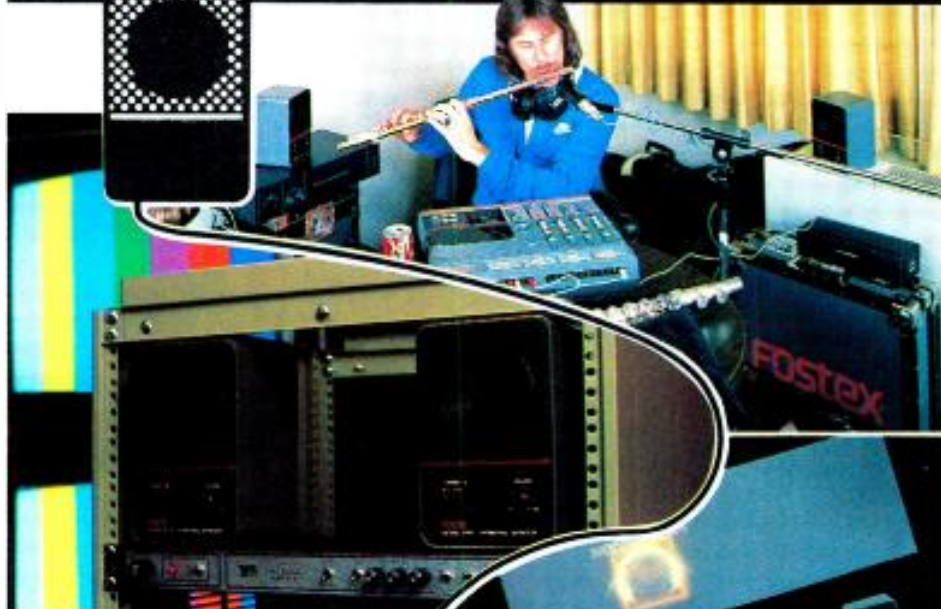

Plug right into Fostex 6301s. These compact, highly portable self-powered monitors will take any line level source — instrument, mixer, tape recorder — and give you 20 watts of powerful sound. Plus, you can use the internal amp separately for driving other speakers or even headphones, when you need that extra cue feed. Listen to the sound preferred by pros everywhere — on the road, at home, producing and presenting. Fostex 6301s. Inside and out, as dependable as a pro. At your Fostex Multitrack Dealer today.



Fostex

15431 Blackburn Avenue
Norwalk, CA 90650
(213) 921-1112

Circle (51) on Reply Card

Closed captioning and teletext are only the beginning

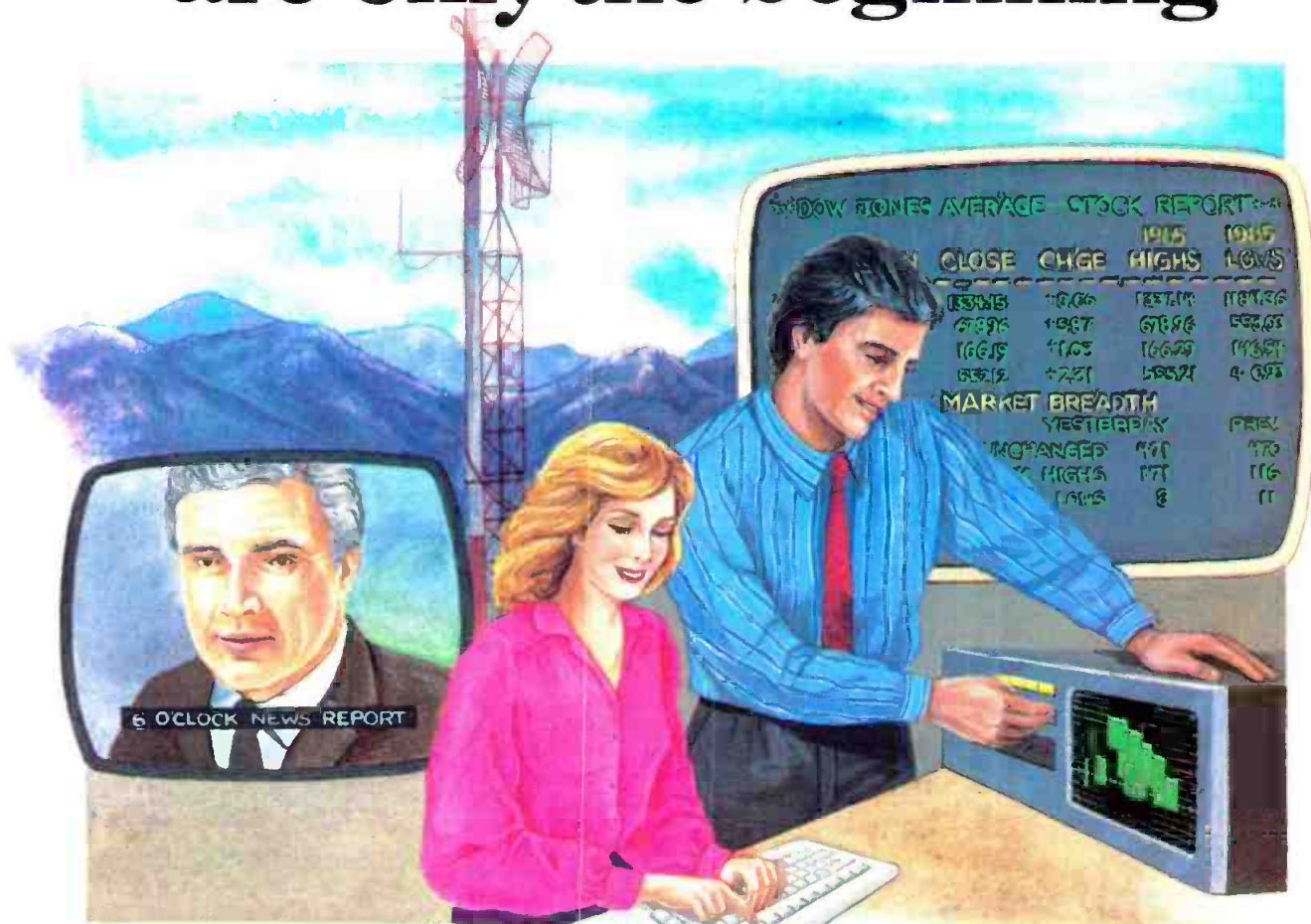

How installing the new Leitch VIP 1101N today gives you an edge on tomorrow.

If vertical blanking intervals only meant blanking, you wouldn't need the new Leitch NTSC vertical interval processor. But this isn't the case as you know. You'll see more and more use made of the VBI in the near future.

You couldn't be better prepared than with the new Leitch VIP 1101N. Because this is a fully programmable stand alone vertical interval inserter/deleter it will not become obsolete. This innovative vertical interval processor doesn't generate any insertion test signals. Instead it handles with remarkable ease and accuracy a number of external insertion signals. The VIP 1101N is easily programmed even from a remote location. It provides complete protection for the VBI and the all important program signal.

Behind this capacity and flexibility is a combination of advanced techniques -- micro-processor control, digital technology and the most recent developments in analog circuit components.

The new Leitch VIP 1101N also offers comprehensive self-diagnostics including set-up and timing modes. Two vertical signal inputs are standard. But the VIP 1101N is expandable to nine inputs -- a feature unique to Leitch. It is also programmable up to 4 fields.

Your program signal couldn't be in better hands. Get the full information on the new Leitch VIP 1101N now. Let us show you how you can keep a sharp eye on the future while protecting your bottom line.

For further information, contact:



LEITCH

Progressive Concepts in Television Technology

Leitch Video International Inc.
10 Dyas Road, Don Mills,
Ontario, Canada M3B 1V5
(416) 445-9640

Leitch Video of America, Inc.
825k Greenbrier Circle
Chesapeake, VA 23320
(804) 424-7920

Leitch Video of America, Inc.
12520 Loma Rica Drive, P.O. Box 1985
Grass Valley, CA 95945
(916) 273-7541

Circle (166) on Reply Card

BROADCAST engineering

PROOF FORM

DATA SUMMARY SHEET
STATION _____ TV

LEFT CHANNEL

RIGHT CHANNEL

NOISE TEST _____ dB	SMPTE IMD _____ %	SEPARATION AT 14kHz _____ dB
---------------------	-------------------	------------------------------

FREQ.	75 μ s CURVE FACTOR*	RESPONSE DEVIATION dB	SEPARATION dB	DISTORTION %		FREQ.	75 μ s CURVE FACTOR*	RESPONSE DEVIATION dB	SEPARATION dB	DISTORTION %	
				NORM	+10dB					NORM	+10dB
30Hz	-0.15dB					800Hz	+0.43dB				
40Hz	-0.15dB					1kHz	+0.72dB				
50Hz	-0.15dB					1.25kHz	+1.14dB				
63Hz	-0.15dB					1.6kHz	+1.80dB				
80Hz	-0.15dB					2kHz	+2.61dB				
100Hz	-0.14dB					2.5kHz	+3.63dB				
125Hz	-0.14dB					3.15kHz	+4.91dB				
160Hz	-0.13dB					4kHz	+6.43dB				
200Hz	-0.11dB					5kHz	+8.01dB				
250Hz	-0.09dB					6.3kHz	+9.77dB				
315Hz	-0.06dB					7.5kHz	+11.15dB				
400Hz						10kHz	+13.50dB				
500Hz	+0.08dB					12.5kHz	+15.37dB				
630Hz	+0.22dB					15kHz	+16.92dB				

*The correction factor that should be applied to the *response deviation* calculation. The 75 μ s *curve offset* value applies to the frequency response characteristics of the standard 75 μ s pre-emphasis curve, referenced to 400Hz. The data is taken from Section 73.333 (Figure 4) of the FCC rules.

GENERAL TEST CONDITIONS

- System in BTSC stereo mode.
- Input signals applied to console line input(s) used for most program sources.
- System output sampled and demodulated/decoded at transmitter output.
- All processing and EQ left in line and adjusted as usual.
- Operating level defined as 0VU or equivalent at console.

Note: Separation refers to the amount of residual signal in the other channel that is caused by modulation of this channel.

ALL TESTS PERFORMED BY: _____

DATE: _____

Go For The Gold!



4-position
stereo
preselector

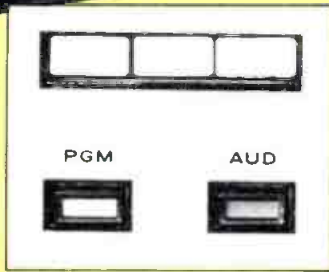

PGM-AUD routing switches



Input punch
block

the MEDALIST_{Au}

The competition is tough, but you'll be tougher with the all new Harris GOLD (Au) MEDALIST Audio Console! It is the only one in its price range with all of these features:

- 36 inputs with logic controlled switching
- Up to 72 sources into 12 input channels
- End-of-message controlled channel-off switching
- Transformerless input/output for best sound quality
- DC control from P&G faders drives VCAs
- Conductive plastic phone, cue and monitor controls
- Stereo tracking within 0.1 dB on all controls
- 0.05% distortion, +0.0/-0.25 dB response, 20 Hz to 20 kHz

- 77 dB S/N on MIC, 95 dB S/N on M-L inputs, 20 Hz to 20 kHz
- Operates in high RF environment (5V/m)
- Superior punch blocks for quick installation
- Comfortable padded arm rest, ch-on/off switches, more ...

More features, better sound, exceptional price... proven by over 300 consoles of the Medalist family in operation. From start to finish, you'll be more competitive with the GOLD MEDALIST on your team! For more information, contact Harris Corporation, Studio Division, P.O. Box 4290, Quincy, Illinois 62305. Phone 217/222-8200.

 HARRIS

For your information, our name is Harris.

from one of several rental/leasing companies. This option often gives the station the opportunity to use the latest high-tech instruments for the proof. The purchase price of such gear may be beyond the budgets of some TV stations, so rental allows even small-market broadcasters to fine-tune their systems on the best test equipment available.

A complete check should be made before attempting to run the proof of the audio-generator and distortion-analyzer frequency response and residual distortion at all frequencies of interest. Response must be flat to within at least 0.1dB from 30Hz to 15kHz. Distortion must be below 0.1% for all frequencies to be measured. The noise floor of the audio voltmeter must be below -65dBm. If adjustments or repairs are indicated in these closed-loop checks, make them before running the proof.

The residual test-equipment distortion values determined during pre-proof compliance tests may not be subtracted from the total system distortion figures obtained when running the actual proof. Subtracting test-instrument residual distortion is not a valid procedure because distortion components do not necessarily add. In fact, the only time they will add is when all of the harmonics are in phase—a near impossibility when you consider that this would have to be true for every modulating frequency used during the proof.

How many frequencies?

In order to accurately evaluate a broadcast transmission system, the performance of the equipment must be checked at a sufficient number of discrete frequencies, or points. The traditional FCC equipment performance measurements (EPMs) required modulating frequencies of 50Hz, 100Hz, 400Hz, 1kHz, 5kHz, 10kHz and 15kHz. Although these points give the engineer a basic idea of how well the system is performing, they fall short of our goal, which is to push the equipment to its maximum performance limits. The frequency spaces in the traditional EPM tests—as much as 5kHz—are far too wide to accurately predict transmission system performance across the audio band.

For this reason, the BE proof testing procedures suggest a substantially greater number of points than the standard EPMs. In all, we recommend checking 28 separate frequencies between 30Hz and 15kHz. These points are based on 1/2-octave international standards organization (ISO) center frequencies, with four minor modifications. The measurement frequencies are shown in the test form on page 92.

The lowest frequency to be measured is 30Hz. The actual ISO frequency is 31Hz. All other frequencies are standard ISO centers, except 7.5kHz (the standard ISO frequency is 8kHz) and 15kHz (the ISO frequency is 16kHz). For stereo separation tests, a frequency-measurement point of 14kHz is also added.

These modifications of the ISO standard 1/2-octave frequencies provide compatibility with the frequencies specified in our performance objectives and compatibility with the old FCC EPM test frequencies. In recognition of the bandpass limits of TV transmission systems, no attempt is made to measure frequencies below 30Hz or above 15kHz.



Over-the-air television is facing stiff competition from cable, VCR and videodisc programming. The best way local stations can counter this threat is to provide a top quality audio and video signal.

Making the measurements

The BE TV proof of performance form (see page 92) lists all measurements suggested for system evaluation. The form should be photocopied to provide a data summary sheet for the left channel and one for the right channel. Measurements should also be conducted in the mono-phonetic mode, if the station is operated in mono on a regular basis.

The tests are arranged on the data sheet in the order that the proof should be conducted. The first step is to check the noise floor, SMPTE intermodulation

distortion and separation at 14kHz. A station that can meet the BE proof suggestions for these parameters should be able to pass the rest of the proof with little difficulty. The reason for conducting the noise, IMD and 14kHz separation tests first is to determine whether the transmission system is operating properly or if it requires adjustments, before substantial time is spent making individual proof measurements.

The next step is to check channel separation, response deviation and harmonic distortion at the 28 test frequencies. Make these measurements with the signal generator connected to one audio input at the control console, and the other input terminated with a 600Ω wire-wound resistor (or other appropriate resistance value).

The test data form includes calculations for response deviation values that should be applied to the frequency-response measurements for a pre-emphasis value of 75μs. A reference value of 400Hz is assumed. Distortion and separation measurements are performed using common techniques.

A look at the future

Achieving the fidelity objectives suggested in the BE TV stereo proof program means more than simply providing outstanding audio. It means that participating stations are in the high-fidelity business and are ready to meet the approaching challenges of the digital audio world. TV broadcasters will find improved source signals widening the gap between TV quality and home system quality, unless television can firmly establish itself as a high-fidelity medium.

The need has never been greater for high performance from every link in the transmission chain.

Bibliography:

1. *The Great Debate: Subjective Evaluation*. Stanley P. Lipshitz and John Vanderkooy (Journal of the Audio Engineering Society) pp. 482-491 (Vol. 29 #7/8-1981 July/August).
2. *The Audibility of Frequency Response Irregularities*. R. Buecklein (Journal of the Audio Engineering Society) pp. 126-131 (Vol. 29 #3-1981 March).
3. *Examination of Audio-Bandwidth Requirements for Optimum Sound Signal Transmission*. Teruo Muraoka, Makoto Iwahara and Yasuhiro Yamada (Journal of the Audio Engineering Society) pp. 2-9 (Vol. 29 #1/2-1981 January/February).
4. *Which Bandwidth is Necessary for Optimal Sound Transmission?* G. H. Plenge, H. Jakubowski and P. Schoene, presented at the 62nd Convention of the Audio Engineering Society, Brussels, 1979 March 13-16.
5. *Audible Frequency Ranges of Music, Speech and Noise*. W. B. Snow (Journal Acoustical Society of America) pp. 155-166 (Vol. 3 - 1931).
6. *Dynamic-Range Requirement for Subjectively Noise-Free Reproduction of Music*. Louis D. Fielder (Journal of the Audio Engineering Society) pp. 504-511 (Vol. 30 #7/8-1982 July/August)

||:~:~:~||

Would you...like to reduce your studio lighting by 40%, 50% or more?

Impossible? No.

The LDK 6 requires only 125 to 150 foot candles operating at optimum f-stop even with teleprompter.

The LDK 6 efficient optics and total computer control can easily cut studio lighting without sacrificing creativity or operating flexibility.

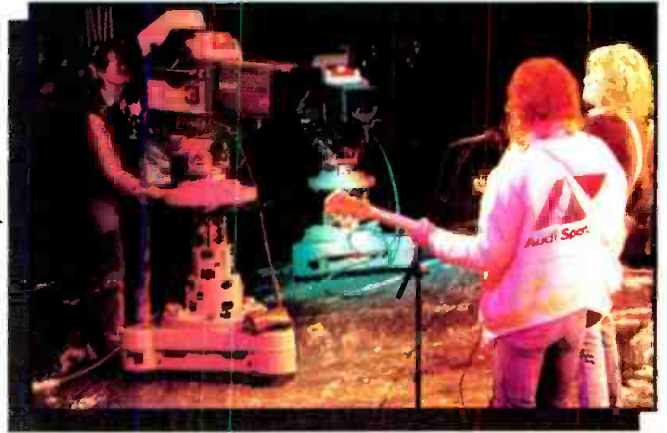

With only 27 foot candles, the LDK 6 can remain at 0 dB and f 1.6, but for the impossible sports shot, 12 dB produces an absolutely quiet picture and gives you the depth of field that you need. Under all lighting conditions a full 3 x 3 linear matrix contributes to outstanding uniformity and color matching.

Total Computer Control extends further this LDK 6 picture quality advantage. Digital correction automatically fine tunes individual zones for exceptional registration, shading and dynamic focus. And, computer controlled anti-comet tail and dynamic beam control circuits ensure excellent highlight handling.



And there are more *Total Computer Control* operating features that clearly separate the new generation LDK 6 from the partial computer control cameras.

- On-line diagnostics warns of a potential problem . . . before it becomes a fault that can result in costly downtime.
- The computer system automatically adjusts for tube ageing. Pictures from a two year old LDK 6 look as good as day one. This is proven daily in the field.
- The LDK 6 triax system greatly reduces cost of cabling and servicing plus ease of moving between studios means fewer cameras.
- A pickup tube can be replaced 15 minutes before air time with no tweaking . . . and a matched tube is not required.

These and many more LDK 6 and LDK 26 features are why the LDK 6 family are the fastest selling cameras in their class, with over 350 sold world wide.

Prove the *Total Computer Control* difference to yourself. A demonstration will prove why the LDK 6 family is years ahead in design, performance and cost-effectiveness.

Call or write for a demonstration or request the descriptive LDK 6 or LDK 26 (2/3") technical brochure.

PHILIPS TELEVISION SYSTEMS, INC.

900 Corporate Drive
Mahwah, New Jersey 07430
(201) 529-1550

Canada: Electro & Optical System Ltd,
31 Progress Court, Scarborough, Ontario,
Canada M1G 3V5
Tel: (416) 439-9333 Telex: 065-25431

LDK 6 – the total computer control camera.



Broadcast Equipment

PHILIPS

Reliability through Quality

Circle (54) on Reply Card

Designed for efficiency

By Carl Bentz, TV technical editor

New devices and operating methods suggest a brighter picture may be on the horizon for the UHF medium.

Could UHF mean Unusually High Finances? Some station operators think so, when the power bill comes due. UHF TV doesn't need to be such a cost-inefficient operation, however. Research has proved that much lower power expenses are possible. We can get a better picture of the problems and solutions if we look at tubes in general.

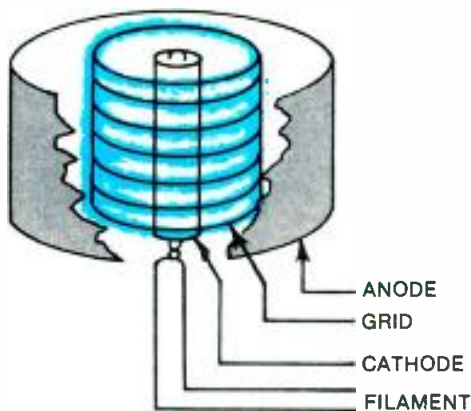

Figure 1. In a cutaway drawing, the grid creates an electrostatic barrier, indicated by blue glow, between the cathode and anode.

Amplifier tubes for audio and low-frequency RF are relatively straightforward. The heated cathode releases *free electrons* into the tube envelope. Meanwhile, a positive potential on the anode creates an electrostatic field to attract the electrons. Electrons reaching the anode form a current that develops an output voltage across the load circuit.

Grid basics

In triodes, a control grid between cathode and anode forms an electrostatic barrier through which the electrons must pass. (See Figure 1.) An input signal, applied to the grid, varies the effectiveness of the barrier and controls movement of

the electrons to the anode. When only a few electrons reach the anode, limited current flows into the load circuit. When many electrons strike the anode, the output current increases.

A negative voltage bias on the grid creates a cloudlike negative *space charge* around the grid element. Electrons, attempting to move through the field to the anode, must fight the negative force.

If the space charge varies (the input signal goes relatively positive and negative from a fixed-grid bias point), the charge density of the cloud decreases and increases, respectively, and either more or fewer electrons reach the anode.

Tetrodes, pentodes

Additional elements may be placed in the tube. Tetrodes include a second grid, the *screen*. A positive voltage applied to this second grid aids in drawing electrons to the anode, but it also forms a shield between the anode and control grid. *Secondary electrons*, dislodged when high-speed electrons from the cathode strike the anode, may fall back upon the anode or be drawn to the screen grid. In either case, they are removed from the path of the stream of electrons coming from the cathode, improving efficiency.

A third grid, the *suppressor*, lies between the screen grid and the anode in

the pentode tube. The suppressor controls secondary electrons. Operating at the same potential as the cathode, the suppressor decelerates electrons headed for the anode. Slower-moving electrons are less apt to produce secondary emission. Those formed are forced back to the anode. Again, efficiency is improved.

Grid trouble

Grid tube amplifiers work well through VHF TV frequencies (50MHz to 220MHz). However, at UHF or microwave frequencies (300MHz to 3GHz), cylindrical-grid tubes become less practical, particularly in high-power applications.

Components associated with grid tubes determine the frequency of operation. Networks of resistors (R), inductors (L) and capacitors (C) form the frequency-sensitive tank circuits of the RF amplifier. (See Figure 2).

Above 300MHz, undesirable characteristics of typical tubes manifest themselves. First, the elements are electrical conductors. Finite in size, they may act as components. A grid, like any piece of wire, has resistance. Current flowing

Continued on page 100

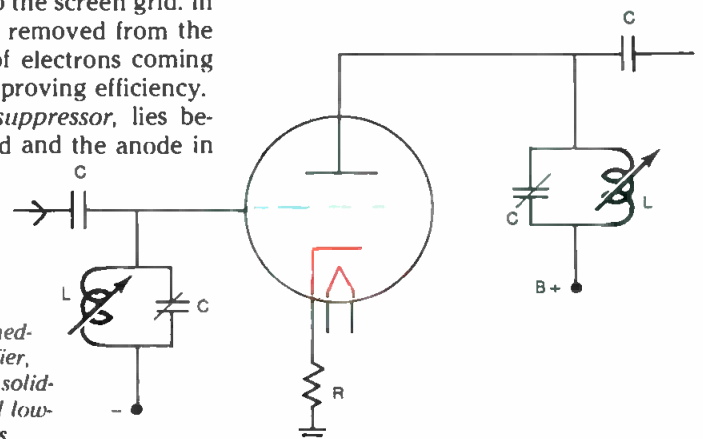

Figure 2. A triode, connected here as a tuned-grid, tuned-plate amplifier, could be replaced by a solid-state device in VHF and low-power UHF applications.



We wouldn't give you an inch until it was perfect.

Maxell perfects the 1" tape.
Introducing Maxell Broadcast Quality 1". Superior videotape technology to satisfy the perfectionist in you.

Perfect for mastering.
Maxell's exclusive epitaxial formulation provides clean, dropout-free video, with RF output consistent to within 0.2dB from head to tail. We've even licked the stiction problem, with uniquely

effective resistance to high humidity and other harsh environmental conditions.

Perfect for editing.
Maxell Broadcast Quality 1" is made tough to resist stretching, scratching and head clogging... yet it's made gentle to minimize head wear. So you can keep it parked in STILL for well over 3 hours, without taking the typical toll on the tape, video output or your sensitive heads.

Perfect for broadcast.
Our superior 1" tape stays that way for up to 2,000 passes. So not only can you achieve perfection in production, but you get more of your money's worth when you take it on the air.

Find out for yourself. Just clip and mail the coupon below. But keep in mind: If we didn't think it was perfect, we wouldn't have called it Maxell.

Give me an inch.

- Give me more information on Maxell Broadcast Quality 1".
- Give me the name of my nearest Maxell Distributor.
- Give me a sales call so I can see for myself.

maxell®
PROFESSIONAL/INDUSTRIAL DIVISION

Maxell Corporation of America
60 Oxford Drive, Moonachie, NJ 07074
(201) 641-8600

Name _____
 Title _____
 Company _____
 Address _____
 City _____ State _____ Zip _____
 Tel. () _____

“Ikegami’s HL-95 Unicam can handle — and more!”

— John Hall, Director of Engineering
WDAF-TV, Kansas City, Missouri



gives you all the action you

The biggest eruption in the professional hand-held television camera market occurred with the introduction of Ikegami's UNICAM, a multipurpose Plumbicon® camera concept with a host of applications.

Utilizing a unique building block approach which incorporates the HL-95B basic camera head, various configurations are possible: Several ENG stand-alone cameras, combined camera-VTR units with a selection of 1/2 inch or 1/4 inch component recorders and remote controlled EFP cameras with multicore

cable or triax cable base stations can be assembled.

The versatility and flexibility of the HL-95 system is provided without sacrificing state-of-the-art performance in the areas of sensitivity, resolution and registration; these are achieved with minimum equipment size, weight and power consumption.

Pound for pound the HL-95 is the hottest little camera you'll ever hold in your hands.

For a demonstration of UNICAM and other Ikegami cameras and monitors, contact us or visit your local Ikegami dealer.

Ikegami

Ikegami Electronics (U.S.A.), Inc., 37 Brook Avenue, Maywood, NJ 07607

• East Coast: (201) 368-9171 • West Coast: (213) 534-0050 • Southeast: (813) 884-2046

• Southwest: (214) 233-2844 • Midwest: (312) 834-9774



Continued from page 96

around the wire, and the proximity of a conductor to other metallic objects creates capacitor effects. Therefore, the elements themselves may cause the tube to behave as if additional components were in the circuit, creating spurious, interference-causing signals. Tubes may even be destroyed if the spurious signals result in excessive currents.

A second problem relates to element spacing. The elements are a finite distance from each other. If they are positioned too closely together, high-voltage potentials may cause arcing to occur. The distance, however, causes capacitance, which is partly responsible for the space charge that controls the electron stream.

It is time-consuming to remove a space charge. The time required to dispel the charge may be longer than the duration of one wavelength at microwave frequencies. We must consider the *transit time* of electrons moving from cathode to anode, and whether sufficient time exists for the field to change and avoid interfering with the electron's travel.

Showing promise

UHF tetrodes for up to 20kW are available. Most 1-tube transmitters on the market use a tetrode device to amplify multiplexed visual and aural



A pyrolytic-graphite grid tetrode, rated at 50kW for UHF TV.

signals.

A device rated at 55kW peak of sync for CCIR UHF channel 50 service has been developed by one company. With 10kVdc on the anode and a 6.9A current, video black power reaches 31.2kW. The cylindrical device, 8 inches high and 5 inches in diameter, weighs in at 13 pounds. Difficulties in development of the required cavities have delayed some

applications of the water-cooled unit to date. However, current predictions suggest units operating up to 1GHz may be a reality by early next year.

A tube without grids

Many U.S. UHF TV stations are licensed for transmitter outputs of 60kW peak of sync power or more. Transmitters for such power levels depend upon power amplifiers designed around klystrons, with at least one device each for the visual and aural signals.

In klystrons, as in grid tubes, a heated cathode develops a stream of electrons. A modulating (mod) anode accelerates and shapes the stream of electrons. The drift tube, broken at intervals with *gaps* (see Figure 3), is surrounded by adjustable tuning cavities. Between the cavities, magnetic assemblies control the path and shape of the beam of electrons. A collector disposes of the spent electron beam at the end of the drift tube.

Variations on a theme

There are two types of klystrons for UHF TV: external and integral cavity devices. (See Figures 4 and 5.) In an external cavity unit, the device consists of the cathode/mod anode, a drift tube (constructed alternately of tubular metal and ceramic sections) and the collector.

In a transmitter, a trolley holds the

SOUND REPUTATION.

AKG has been providing television and radio broadcast engineers with the right microphones to meet their demanding requirements.

Now AKG has developed three new professional microphones all built with AKG reliability and studio quality sound.

These three low-noise condenser microphones meet very specific needs: the C-535 cardioid for hand-held vocals or speech pick-up, the C-567 miniature lavalier for uncanny "live" intelligibility and the C-568 short shotgun for that "extended reach" with switchable roll-off to eliminate rumble and wind noise.

For a sound reputation... choose

AKG.



77 Selleck Street
Stamford, CT 06902
203/348-2121

LA-KART®

*Dual-Channel Has Arrived
At 1/2 The Price!*

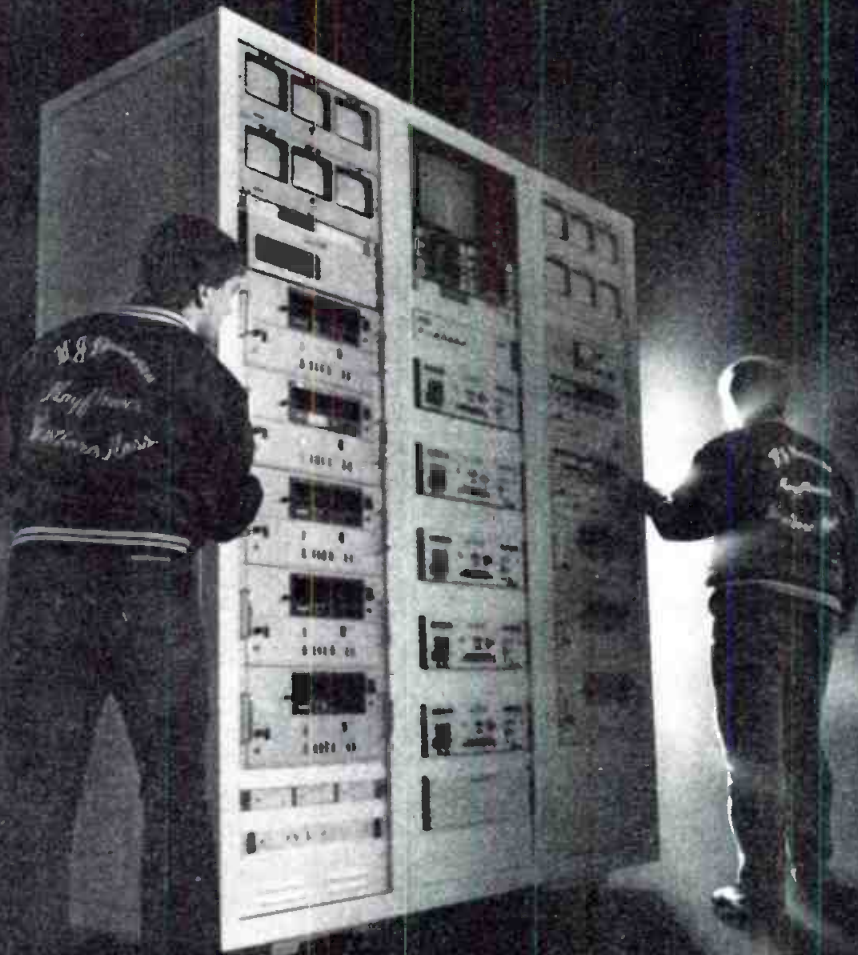

Multi-Channel Systems Starting at \$84,900.00

The new LA-KART Multi-Channel Broadcast Software Package can now address up to 28 VTR's with complete random access. For the past 3 years LAKE'S engineers have responded to the requirements of broadcasters for an automated video cart system with the following features:

1. DUAL CHANNEL
2. MULTIPLE SPOTS ON EACH TAPE
3. COMPONENT PROCESSING FOR IMPROVED SIGNAL
4. CHOICE OF BROADCAST FORMATS: 3/4", 1/2" BETA OR TYPE M, AND 1" TYPE C
5. FAST MANUAL REQUE AND AUTO REVIEW
6. FRAME ACCURATE SWITCHING USING SMPTE CODE
7. STEREO
8. PROGRAM DELAY SYSTEMS
9. ON LINE EDITING PER EVENT OR ELEMENT OF EVENT
10. CATALOG STORAGE OF EVENTS
11. TRAFFIC AND BILLING SYSTEM AVAILABLE INCLUDING COLUMBINE INTERFACE

See us at SMPTE, Booth #1140/1240.

LAKE

The Systems Company

55 Chapel Street, Newton, MA 02160, U.S.A. (617) 244-6881

© Lake Systems 1985

tube assembly in place with the associated cavity and magnet assemblies. The dimensions of the cavities determine an inductance. The gaps form capacitors and, together with the cavities, emulate LC resonant circuits, to

tune the klystron.

Integral cavity klystrons include the same general components, but the inner edges of the cavities are welded directly to the metallic sections of the drift tube. A vacuum in the drift tube extends into the cavities, compared to the external type in which the cavities contain air.

Both types of klystrons require cooling during operation. In the highest-power external cavity types, cooling jackets are

built into each metallic drift tube section and the collector. At lower levels, to 25kW, forced-air cooling fins surround the metal drift tube. Plumbing also passes through the electromagnetic assemblies. Integral cavity klystrons include a water jacket around the entire device.

The liquid coolant is distilled water, and the vapor-phase coolant is steam. Both coolants present hazards near the high voltages (to 24kV) and currents (to 10A). Water-cooled systems may require a flow of as much as 50 gallons per minute. With ethylene glycol (antifreeze) to prevent cold weather damage, a higher flow-rate is suggested.

Vapor-phase cooling replaces some of the problems of liquid pressure with those of superheated water (more than 212°F). A flow-rate of approximately two gallons per minute of water is typical. On the average, one gallon per minute is converted to steam. Heat exchanger units are required for vapor-phase systems or liquid systems to remove heat from the coolant and to dispose of the wasted energy.

The amount of heat removed by the exchanger and the cost of operating the exchanger units must be considered in calculating the overall transmitter plant efficiency. Ingenious use of the heat, however, can cut winter fuel costs within

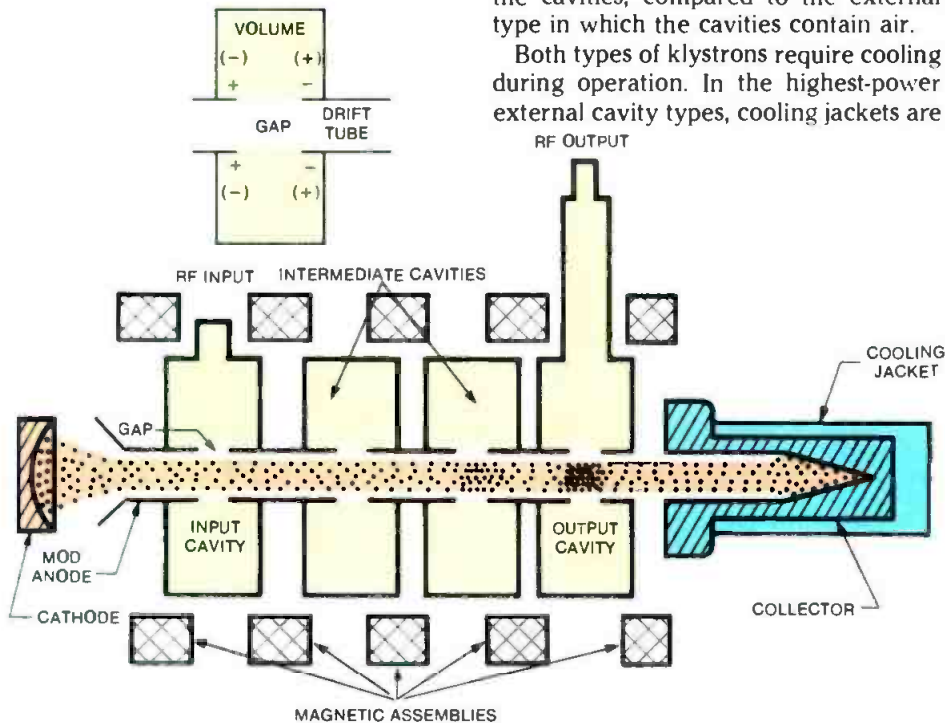

Figure 3. The schematic of a 4-cavity klystron shows the relative placement of its different sections. The inset indicates the change in polarity across the gap as the RF energy cycles.

Talk To Us First... about a Downstream Keyer

It could save you a bundle!

Model 1231

- Up to 6 simultaneous key signals over one background
- Internal matte and masking generators
- Rack or console mount control panels
- Timed key dissolves, or key cuts
- Fade or cut to black
- Edit system control capability
- Optional Analog key bordering

Model 1235

- Mix or cut a single key source
- Fade to black
- Matte generator for colorizing keys
- Optional Analog key bordering

Model 1238

- Versatile single key system
- Self key or external key
- Remote or local key control & adjustment capability
- Many uses for special effects
- Optional matte generator



Call us for a complete brochure

GRAHAM-PATTEN SYSTEMS, INC.

P.O. Box 1960, Grass Valley, CA 95945
916/273-8412

Circle (46) on Reply Card

MASTER CONTROL

Over sixty of our new MC-500 series **MASTER CONTROL** Switchers are in operation at television stations throughout the country, many with full *station automation* also supplied by Utah Scientific. These customers include some of the country's most prestigious broadcasters. Call or write for our 100% Users List to learn firsthand the many advantages offered by this state-of-the-art product.



US UTAH SCIENTIFIC, INC.
DYNATECH Broadcast Group

1685 West 2200 South, Salt Lake City, Utah 84119
Phone: (800) 453-8782 (Toll Free) or (801) 973-6840 • TWX: 910-925-4037
Circle (111) on Reply Card

the transmitter building.

Controlling space

In smaller tubes, the control grid determines the instantaneous number or density of electrons that reach the anode, as a direct effect of the input signal. In a klystron, the input controls the instantaneous current velocity of the electron beam. Electrons from the cathode are shaped into a beam and accelerated along the drift tube.

In the magnetic assemblies, dc current keeps the beam cylindrically shaped and aimed down the middle of the tube. An improperly shaped or misaimed beam could result in a meltdown of the drift tube sections within seconds. At the far end, the collector mass withstands the excess force of the electron beam,

assuming coolant flows at all times.

A low-power signal from the exciter is injected into the first (input) cavity. A small loop physically extends into the cavity to couple the signal energy into the LC tank circuit of the cavity.

The signal excites the cavity, causing an electromagnetic flywheel resonance action, as in typical RF LC-tuned circuits. The intensity of the field in the cavity varies instantaneously with the input signal. RF energy in the cavity appears across the capacitive gap. The electrical polarity across the gap alternates at the frequency of the input signal (the as-

signed UHF carrier frequency).

As the beam passes the first gap (see Figure 3), the instantaneous polarities cause electrons within the area of the gap to decelerate. When the field reverses, the changed polarity causes those electrons in the gap area to be accelerated. The retarding and accelerating forces of the two halves of an RF cycle create an electron bunch that continues along the drift tube toward the second gap.

At the second gap, an electrical field surrounds the bunched electrons and excites the second cavity. A resonant ac-

Figure 4. The mapped features of these external cavity klystrons are similar to those of integral cavity devices (see page 106). The inset shows an external cavity type using an air-cooled drift tube with vapor collector cooling.

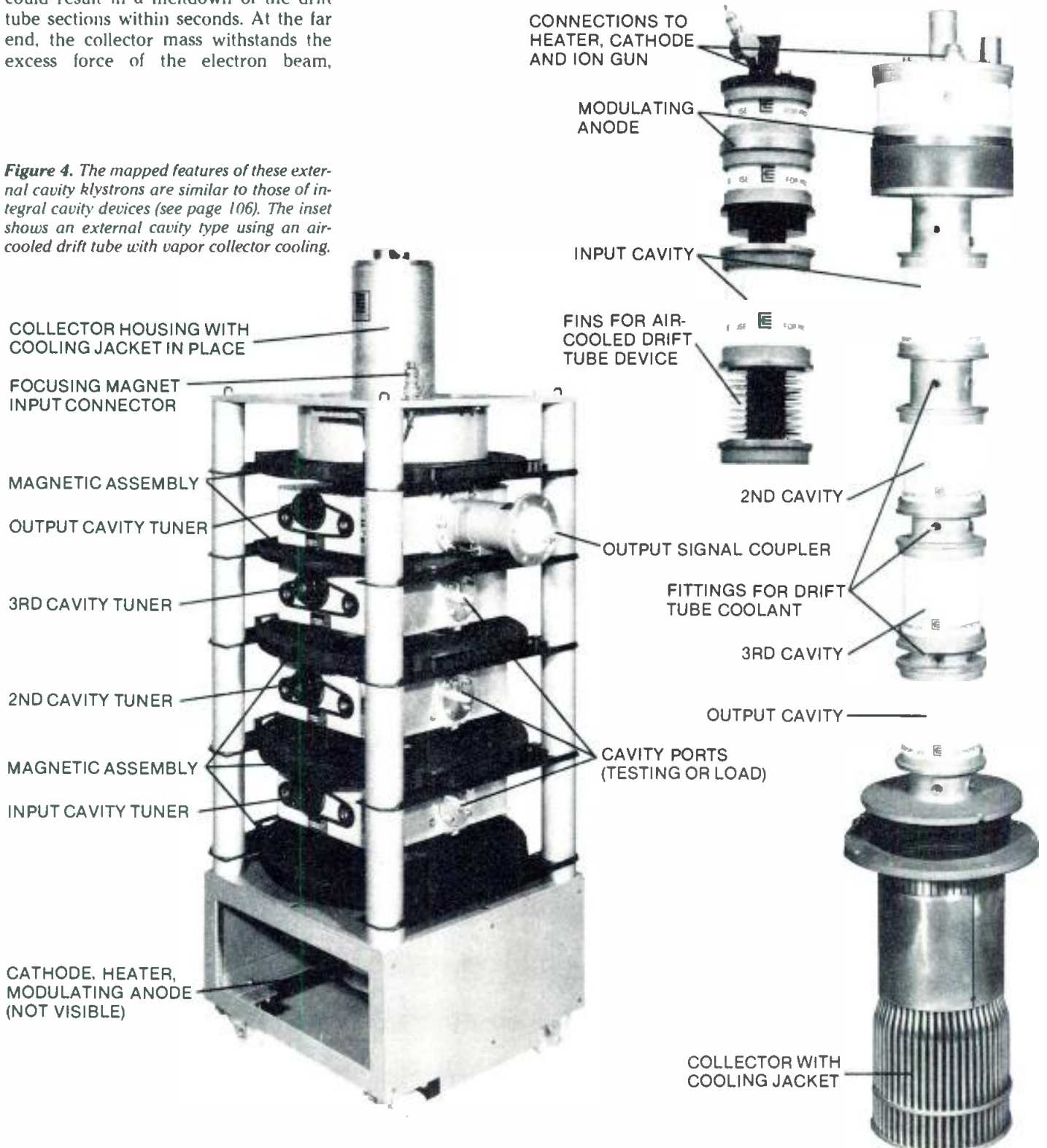

People keep asking our R&D Department “What’s New?”



Here's what's new: the VITAL 3000 Series Production Switcher.

You said you needed lots of keying power. We listened. And our R&D Department created the 3000 Series Production Switcher with 4 video keys... or, a chroma key plus 4 video keys in each M/E. All M/E's have separate key inputs, with discrete filling signals, permitting 16 self-filled keys in our largest 3000 model. You said you wanted simple operation. We listened. And we offer dual handlebars, 2 Auto Transition Units, and our new Simul-Key system to make multiple key entries and exits simplicity itself. Also, key set-ups are automatically placed in memory for instant access in fast-paced switching situations. You said you wanted a switching system that is unmatched in the industry today. We listened. And we put the 3000's keying power under our new PSAS 300 control for a new definition of state-of-the-art.

So if you don't hear from our R&D Department, don't worry. We're probably too busy listening.

Circle (60) on Reply Card

HI TECHNOLOGY
VIDEO PRODUCT INNOVATORS



VITAL INDUSTRIES, INC.

3700 NE 53rd Ave., Gainesville, FL 32601
(904) 378-1581

TWX: 810-825-2370 • TLX: 80-8572-Vital-A-Gain

October 1985 *Broadcast Engineering* 105

Figure 5. The features of an integral cavity klystron, shown below, are in many ways comparable to external cavity devices.

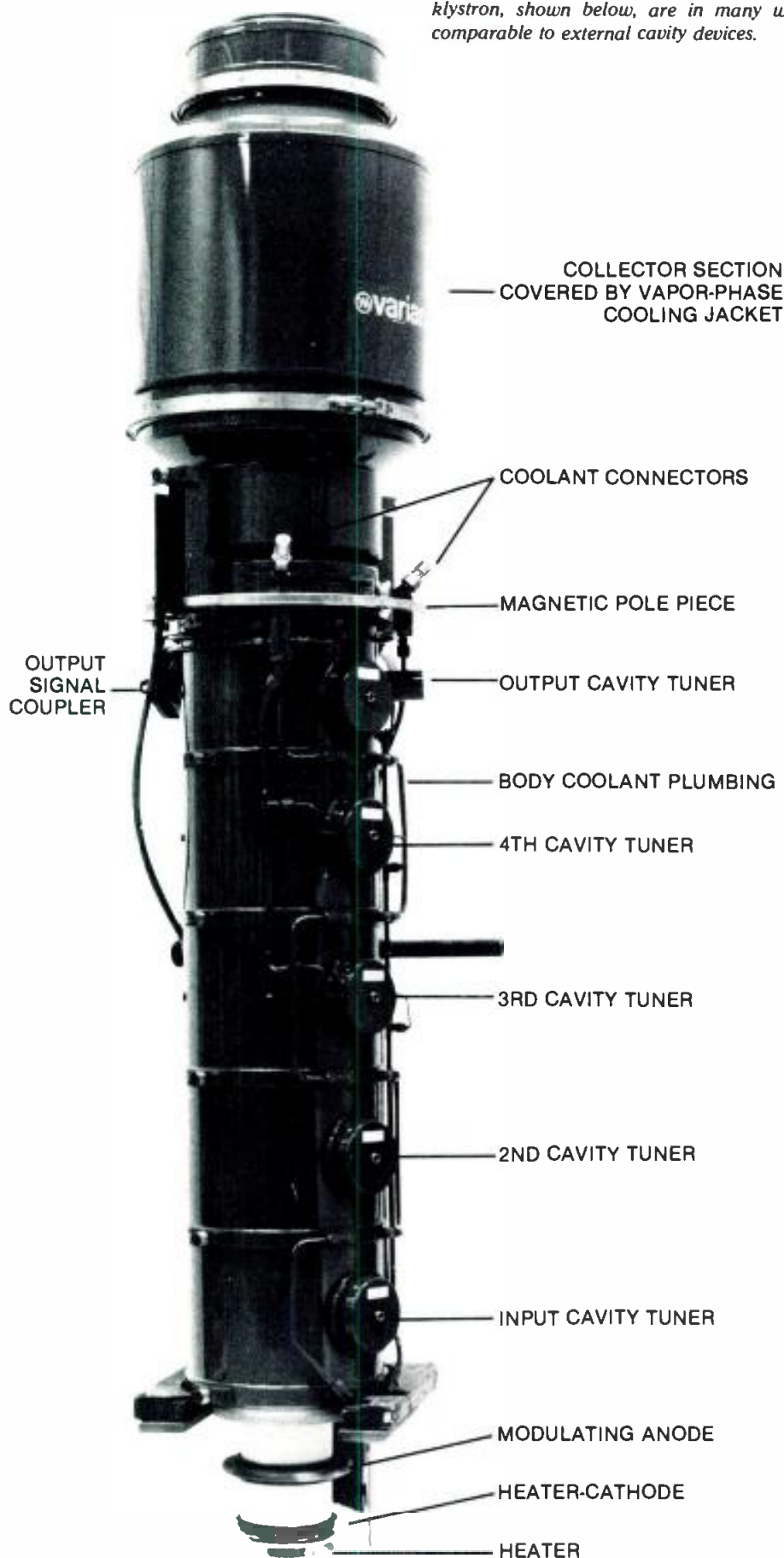

tion begins in the second cavity at a frequency determined by the cavity tuning. The alternating field in the cavity immediately causes additional bunching of those electrons in the gap area. The more tightly grouped the electrons are within a bunch, the greater effect they have on the following cavities, including the final (output) cavity.

In the output stage, the electron stream excites the cavity, but now a coupling loop extracts signal energy. As in the input cavity, the loop is positioned to achieve the maximum transfer of energy between the cavity and the loop.

The beam continues to the collector, where energy not extracted as RF signal is dissipated as heat, and the electrons are returned to the beam power supply.

Input vs. output

Several factors determine the output signal power. First, the gain of the klystron is a function of the number of cavities. Four- or 5-cavity devices are common. Second, the beam power is related to the output. Third, coupling in

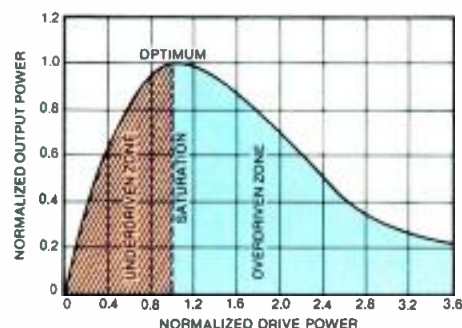

Figure 6. Operating zones of a klystron are shown by a graph of RF output power as a function of RF drive power.

the input and output cavities, as well as the tuning of intermediate cavities, controls klystron gain. Finally, the amount of input power directly affects the output up to a point of beam saturation (see Figure 6). Output power decreases beyond the point of saturation.

If narrowband amplification is desired, the tube operates at the optimum saturation point and maximum RF output power is extracted. For TV visual service, an ideal input power level keeps the operation below the maximum, that is, in the *underdriven zone*. Keeping input power in this zone places the operation on a more linear portion of the klystron transfer characteristic, as shown in Figure 7. The relative peak of sync and peak white amplitudes of the output signal should resemble the input. Operation too close to saturation causes compression of sync or other signal distortion. (See Figure 8.)

Tuning vs. service

The klystron application determines the proper method of tuning the cavities.

Imagine the most creative, complex production you can think of,

To be competitive, you gotta think competitive.

With an ABX production console, you're already one leg up. Creating your own distinctive ID's, spots and programs for today's radio requires a console specifically engineered to handle sophisticated multitrack production — and that's precisely what an ABX can do. But that's not all.

An ABX is also designed to be on-air board too. It's got all the features you need to do double-duty when you need it, instantly, easily.

In fact, there isn't a production board around that has so much, yet is so easy to get to know. And that's a distinct advantage for the owners of PR&E

consoles because all are nearly identical in operation and layout (like our on-air BMX Series).

The standard models of the ABX include mainframes for 18, 26 (pictured) and 34 inputs. The spec's are impressive, the features and options extensive,

and the quality is what you expect when you invest in the best that money can buy.

Stop dreaming about all the things you can do with an ABX, and start producing the kind'a stuff a #1 station creates. Give us a call now for all the details.

It's easy with an ABX.



The Choice for More #1 Stations.

Pacific Recorders
and Engineering Corp.
2070 Las Palmas Drive
Carlsbad, California 92008
(619) 438-3911 Telex: 181777

©1985 Pacific Recorders & Engineering Corp.



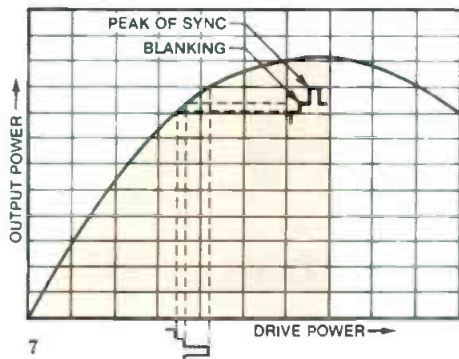

Figures 7, 8. RF output versus input drive indicates correct positioning (7) on the characteristic curve. Incorrect positioning (8) causes sync compression.

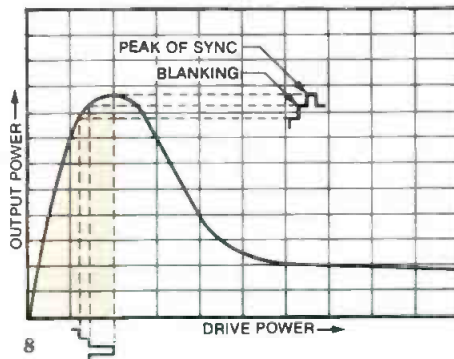

For a narrowband radar signal, all klystron cavities are synchronously tuned, that is, each is adjusted to the same frequency. After tuning, the input power is

increased until the maximum permissible output is obtained.

For TV aural service, the device is first synchronously tuned to the aural carrier frequency. With the tube driven for maximum output, the next to the last (*penultimate*) cavity is tuned higher in frequency until the power drops by 6dB to 10dB. This widens the bandwidth of the tube to handle the deviation of the FM carrier.

Adjustments for TV visual service also start with synchronous tuning at the visual carrier frequency. For 4-cavity klystrons, the penultimate (third) cavity is resonated at the high side of the 6MHz channel, about 5MHz above the visual carrier. The penultimate (fourth) cavity of 5-cavity units moves to about 8MHz above the carrier. Next, the second cavity is tuned below the carrier by 1.5MHz.

If the klystron is a 5-cavity unit, the third is tuned about 4MHz above the visual carrier. Finally, the first (input) cavity is moved to approximately 2MHz above the carrier. The final cavity of all devices is left at the visual carrier.

A spectrum display of the output RF envelope permits minor bandpass corrections to be made for slope with the first and last cavities, and for edge effects or *holes* with the second and penultimate intermediate cavities.

ANVIL®

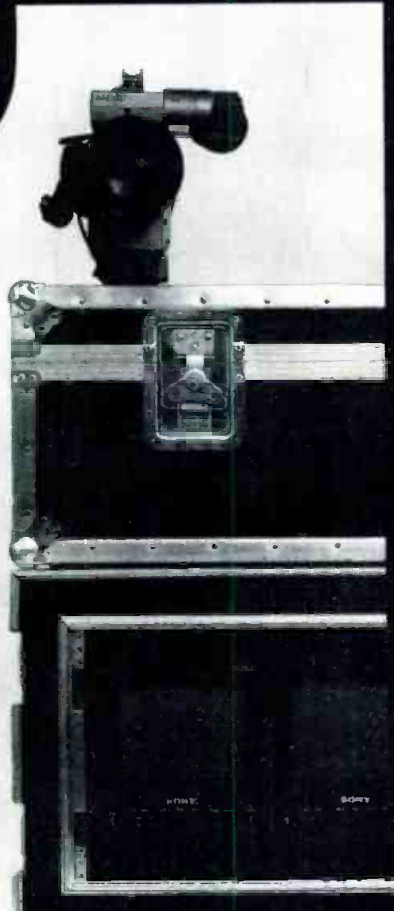
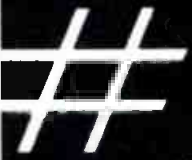

Anvil protects the best.

The best video equipment. The finest musical instruments. The most sensitive computer systems. No matter what it is. If it's worth protecting, Anvil does it best.

That's because Anvil knows cases. From their custom-made, high-impact cases to their shock-absorbent, vibration-resistant, hand-sculptured interiors. Every hinge, handle and corner. Inside and out. No detail's too small when it comes to protecting your investment.

That's why, after more than 30 years, Anvil remains the standard for an industry in which "good enough" isn't. An industry where a small mistake can cost a small fortune.

So, if it's worth anything to you, protect it with Anvil. Don't trust anyone but number one.

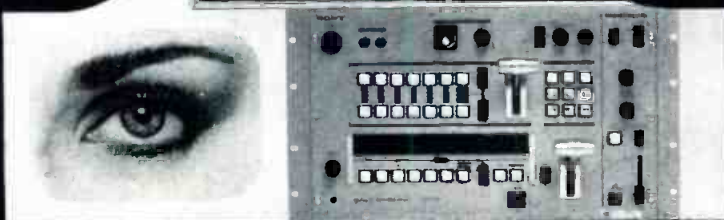

ANVIL CASES, INC., 4128 TEMPLE CITY BLVD., ROSEMEAD, CA 91770 (818) 575-8614

Circle (64) on Reply Card

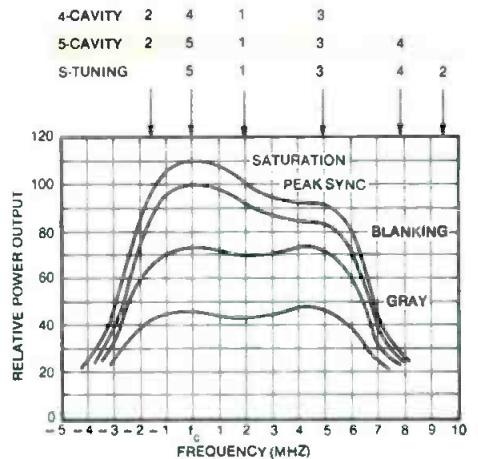

Figure 9. Relative output power plotted against frequency is shown for three specific points within the video signal, as well as at saturation. Color bands above the graph indicate various cavity tuning methods.

In the search for efficiency, new approaches to klystron operation have been suggested. One concerns the licensed maximum output signal power transmitted during peak of sync. Inverted polarity of video, when modulated, avoids excessive noise in the picture. With sync producing 100% modulation, noise spikes cause greater than 100% modulation, but are disguised in black. (Noise with positive polarity would result in piercing whites.) However, effective transmission of pictures does not require that the same level of dc power (relative to the sync pulse) be maintained during the active video line time.

Connoisseur

of communications

Intercom systems.
Headsets. Interfaces.
Complete engineering
support — from
application to
configuration.



Clear-Com • 1111 17th Street, San Francisco, CA 94107 • 415-861-6666 • TWX: 910-372-1087
Export Division: P.O. Box 302, Walnut Creek, CA 94596 • 415-932-8134 • Telex: 175340 CLEAR-COM WNCK

Circle (66) on Reply Card

70 YEARS OF EXPERIENCE IN POWER GRID TUBES...

And still looking ahead! That's your assurance of world-class UHF/VHF-TV tetrodes and coaxial-cavity circuits:

- up to 50 kW UHF output power and 40 kW VHF output power
- up to 18 dB typical gain.

Incorporating decades of innovation and experience with Hypervapotron® anode cooling and Pyrobloc® pyrolytic-graphite grids.

THOMSON-CSF
COMPONENTS CORPORATION
Electron Tube Division
301 Route Seventeen North
RUTHERFORD, NEW JERSEY 07070
Tel. : (201) 438.23.00
TWX : 710989 7286



Belgique BRUXELLES Tel. (32-2) 648 64 85 Tx. 23113 IH8XL B	Brasil SAO PAULO Tel. (55-11) 542 47 22 Tx. (011) 24226 TCSF BR	Canada MONTREAL Tel. (1-514) 288 41 48 Tx. 5560248 TESAFI MTL	Deutschland MUNCHEN Tel. (49-89) 78 79-0 Tx. 522 916 CSF D	Espana MAORIO Tel. (34-1) 405 16 15 Tx. 46033 TCCE E	France BOULOGNE-BILLANCOURT Tel. (33-1) 46 04 81 75 Tx. THOMTUB 200 772 F
Italia ROMA Tel. (39-6) 639 02 48 Tx. 620 683 THOMTE I	Japan TOKYO Tel. (81-3) 264 63 46 Tx. 2324241 THCSF J	Sverige STOCKHOLM Tel. (46-8) 63 50 60 Tx. 12078 THCSF S	United-Kingdom BASINGSTOKE Tel. (44-256) 29 155 Tx. 858865 TESAFI G	U.S.A. RUTHERFORD, NJ Tel. (1-201) 438 2300 TWX. 710989 7286	

Circle (72) on Reply Card

In a standard configuration, the potential on the klystron cathode is approximately -24kV (below ground). The mod anode voltage is much closer to ground, perhaps -1kV to -3kV . For safety purposes, the collector and body of the tube are at ground potential.

By operating the modulating anode at about -7kV during active video, and pulsing it to the -3kV level during sync time, the average dc input beam power to the visual amplifier may be reduced. Switching to the less negative voltage for sync increases acceleration and therefore current, which increases beam power during horizontal sync, about 7% or 8% of the total line time. If the beam current was set to 7A initially and turned back to 5A with pulsing, the power formula would show an immediate change of 48kW (the product of $2\text{Ax}24\text{kV}$).

In essence, a pulser system changes the operating class of the amplifier. The klystron should be as linear as possible during active video, the most inefficient class A mode. During sync, maintaining class A biasing wastes energy. If, for the approximate $4\mu\text{s}$ period, we change the klystron bias point, we can improve the efficiency. Because the sync interval is primarily a pulse, it does not require strict linearity.

A second approach to pulsing requires a new device design, adding a controlling electrode shaped much like a

Safety considerations

The information in this article with regard to tuning is applicable in most cases, but differences in circuits do exist. Readers are advised to check their equipment instruction manuals for preferred klystron adjustments for a particular transmitter. Klystron tuning should be done only by trained individuals. Integral cavity units normally arrive from the factory ready to install and require only minor touch-up tuning.

doughnut. Much lower voltages (hundreds, rather than thousands of volts) can accomplish the beam power reduction in these *annular beam control* devices.

Keeping the phase

At the 1985 NAB convention, Howard Foster (Varian Associates) reported on another method to reduce beam power consumption. Specifically, the *phase* or degree of bunching of electrons in the beam current holds an answer for additional energy savings in a 5-tube integral cavity klystron.

For a random electron in the beam, the energy of that electron, accelerated into the collector, can exceed the energy

delivered to the output field of an equally accelerated, but properly phased electron. That excess energy reduces efficiency.

Recall that the first cavity bunches the electrons, which then excite the second cavity. Additional bunching normally occurs at the second cavity, but the effect is enhanced if the second cavity is retuned to the high end of the passband, perhaps to 7MHz above the carrier. (See Figure 9.) Similarly, the third cavity causes even greater bunching when tuned above the fourth.

The result of this tuning method is reduced klystron gain. Instead of 50dB for a standard 5-cavity device, gain may be as low as 35dB. The circuit Q of the second cavity is lowered even more with a coupling loop and an external load that dissipates as much as 500W. However, under such tuning conditions, fewer unphased electrons appear in the interbunch regions along the drift tube. Tighter bunching at each gap means a greater signal level may be extracted at the output cavity. With more signal energy coupled to the load, less energy waste occurs at the collector.

Components for klystrons that use this tuning method are standard to other klystron types, but the second-cavity parts are specific to this concept. The result is a new klystron design (the S-tube) that reaches an efficiency of 65%

We Interrupt This Program . . .

Now matured and ready to go . . . our dedicated "IFB" System. It insures immediate communication of fast-breaking stories to on-air talent, from any number of locations. This modular

system provides multiple program audio feeds and allows directors to access up to 96 talents wearing belt-pack talent receivers. Expandable, cost-effective, no-fail® IFB. Its time has come.



Clear-Com. Get it right the first time!

1111 17th Street, San Francisco, CA 94107 • 415-861-6666 • TWX: 910-372-1087
Export Division: P.O. Box 302, Walnut Creek, CA 94596 • 415-932-8134 • Telex: 175340 CLEAR-COM WNCK

Circle (24) on Reply Card

Transistors for UHF

Some concepts of tube operation apply to transistors. An input signal controls the flow of current carriers through the transistor. The mechanism by which transistors operate, however, differs. In tubes, electrons carry the current. In transistors, both electrons and holes (the absence of electrons) move through the crystalline semiconductor material to carry the current. Doping material (an impurity), added to silicon, forms the semiconductor and determines the type and availability of current carriers.

Doping creates n or p types of semiconductor material, causing an excess of electrons or a lack of electrons (holes) within the silicon crystal lattice. Two basic types of transistors are available, based on the material used. In bipolar devices (NPN and PNP transistors), current moves across barriers between the n and p materials. In unipolar field effects transistors (FETs), current moves through only one material type.

Of the two types, FETs act much like tubes, operating far into the VHF and UHF spectra. A variety, MOSFETs (metal oxide silicon FETs), take on the

In a MOSFET device, bias pinches the channel (shown by the red area) to vary the resistance of the channel and electron flow (broken arrow) from source to drain.

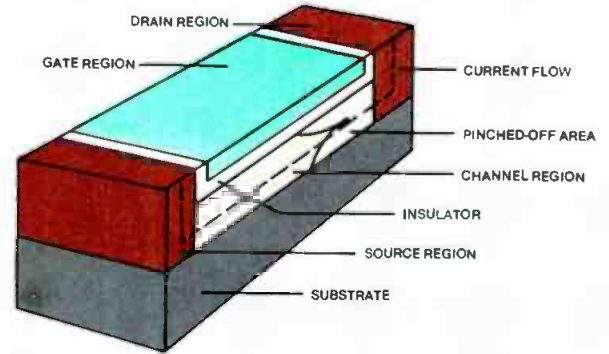

role of UHF power amplifiers.

In a MOSFET, electrons move through a resistive channel between the source and drain terminals. A bias, applied to the gate terminal but isolated from the channel, controls the cross-section volume and, therefore, the resistance of the channel. An RF signal, applied to the gate with the bias, varies the channel resistance and controls the electron flow.

High-power FETs use relatively thick segments of material as the channel and gate elements to aid in heat dissipation. For hundreds or thousands of watts, a number of FET devices operate in parallel. The impedance of several devices in parallel presents a smaller resistance to electron flow than would a single device. A block of MOSFETs can control a much larger current, while the parallel con-

figuration provides an advantage of redundancy.

UHF solid-state power amplifiers usually have a number of multidevice modules connected in parallel. A single-tube power amplifier can leave the station inoperative until a replacement is installed. The FET multiple-component configuration generally keeps the solid-state transmitter operating, although at a reduced level.

Bipolar transistors find little application in high-power UHF systems. The heat produced by electron and hole movement and combinations through the silicon material may produce catastrophic failure of the device. Also, the problems of moving the current carriers through the lattice and across the two p-n junctions of NPN and PNP devices become untenable at UHF frequencies.

Get in Sync with Videotek Value



The new VSG-200 Sync Generator offers you an unmatched combination of standard features:

- 6 isolated Blackburst Outputs
- SMPTE Color Bars
- 1 KHz Audio Tone Output
- RS-170A specifications
- Color Field I.D. Pulse Output
- Front panel adjustments for H Phase and SC Phase
- Adjustable Vertical Blanking Width (lines 16-21)
- Gen Lock Input with SC and Sync Indicators

© Videotek - 1985

A DECADE OF PROGRESS



A DESIGN FOR THE FUTURE

243 Shoemaker Road, Pottstown, PA 19464
(215) 327-2292, TWX 710-653-0125

VIDEOTEK INC.

9625 North 21st Drive, Phoenix, AZ 85021
(602) 997-7523, TWX 910-951-0621

"See the VSG-200 at SMPTE Booth 1507/1508."
Circle (151) on Reply Card

Canon quality. Canon value.

Now available in a full line of camera support products.

MC-200/MC-300 PEDESTALS



Featuring Canon's sophisticated Modular Cassette Counterbalance (MCC) system that makes them far lighter and more mobile, Canon pedestals also feature a very short mounting height, making them ideal for low-angle shooting.

MC-200
Maximum Mounting Weight: 286 lbs.
Elevation: 24-49 inches
MC-300
Maximum Mounting Weight: 242 lbs.
Elevation: 23-60 inches

TR-60/TR-90 TRIPODS



Featuring collapsible tubular leg construction, integral spreaders, flip-tip legs with spikes and rubber padding.

TR-60
Maximum Mounting Weight: 132 lbs.
Elevation: 20-45 inches

TR-90
Maximum Mounting Weight: 198 lbs.
Elevation: 26-48 inches

SC-15 CAM HEAD

Designed for use with all pedestals and tripods, it features a convenient "V" wedge mounting system and center-of-gravity adjustment control. The modular panning rod may be used on both sides.

Maximum Mounting Weight: 330 lbs.
Tilting: $\pm 50^\circ$; Panning: 360°

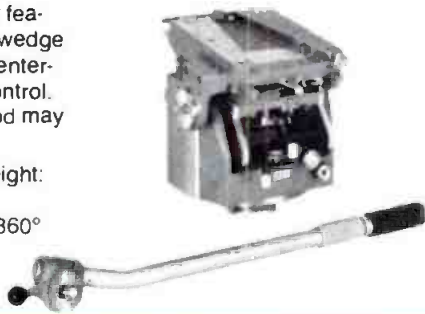

CD-10 DOLLY

Designed for use with both Canon tripods, features a tricycle caster undercarriage that enables both free and single-direction movement.

Maximum Mounting Weight: 198 lbs.

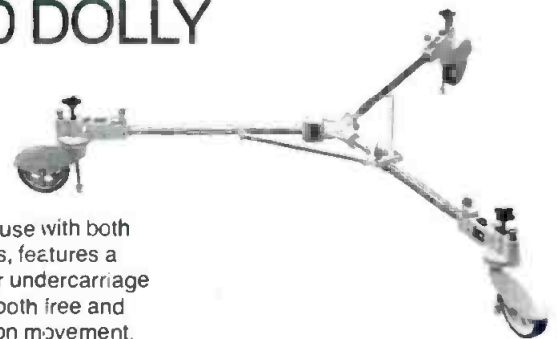

For years, broadcasters have made Canon lenses a top choice for studio, field and news production because they know and trust Canon's proven commitment to quality and value.

Now Canon is proud to introduce a complete, full-featured, high-quality camera support system, built to the same high standards and backed by the Canon service network.

Canon[®]

Optics Division

Canon USA, Inc., Head Office: One Canon Plaza, Lake Success, NY 11042 (516) 488-6700
Dallas Office: 3200 Regent Blvd., Irving, TX 75063 (214) 830-9600. Chicago Office: 140 Industrial Drive, Elmhurst, IL 60126 (312) 833-3070
West Coast Office: 123 Paularino Avenue East, Costa Mesa, CA 92626 (714) 979-6000
Canon Canada, Inc.: 6390 Dixie Road, Mississauga, Ontario L5T1P7, Canada (416) 678-2730

Circle (44) on Reply Card

© 1985 Canon U.S.A., Inc.

Canon Broadcast

Designed to meet all your



PV40x13.5BIE for 30mm and 25mm cameras. The Olympian—proven at the 1984 Olympic Games, its 40X reach is perfect for sports and all outdoor broadcast operations.

Focal length: 13.5-540mm (27-1080mm w/built-in extender)

Max. Relative Aperture*: 1:1.7 through 270mm
*25mm format 1:2.8 at 540mm



P18x15BIE for 30mm and 25mm cameras.

The Widest—a very wide 60° angle of view plus incredible edge-to-edge sharpness, fidelity and sensitivity. Supplied with 1.5X and 2X built-in extenders plus pattern projector.

Focal length: 15-270mm (30-540mm w/2X extender)

Max. Relative Aperture*: 1:2.1 through 218mm
*25mm format 1:2.7 at 270mm



PV14x12.5BIE High Resolution Lens for 30mm and 25mm cameras.

A Unique Design—featuring extensive use of Fluorite lens elements, this lightweight, compact 14X studio lens provides high sensitivity and critical sharpness at all focal lengths.

Focal length: 12.5-175mm (1.5X and 2X extenders built-in)

Max. Relative Aperture*: 1:1.6 at all focal lengths
*25mm format



J15x8.5BIE for 2/3" cameras.

2/3" Economy—full utility for all studio situations, combining a 15X zoom ratio with an M.O.D. of under two feet, a 54° angle of view and high sensitivity throughout the range.

Focal length: 8.5-128mm (17-256mm w/built-in extender)

Max. Relative Aperture: 1:1.6 at all focal lengths



J18x9BIE for 2/3" cameras.

Greater Reach, Lighter Weight—nothing matches the 18X zoom power of this lens—and it weighs less than 4 lbs.! It increases the flexibility of any portable camera.

Focal length: 9-162mm (18-324mm w/2X extender)

Max. Relative Aperture: 1:1.7 through 116mm
1:2.4 at 162mm



J14x8 BIE High Resolution Lens for 2/3" cameras

Super wide (60°) and super sharp from corner-to-corner. This compact lens also provides a 14X zoom ratio and built-in 2X extender.

Focal length: 8-112mm (16-224mm w/built-in extender)

Max. Relative Aperture: 1:1.7 through 91mm
1:2.2 at 112mm



Television Lenses.

needs. Now and in the future.



J45x9.5 BIE for 2/3" cameras.
 Incredible 45X reach with your 2/3" cameras!
 Perfect for sports and all outdoor E.F.P.
 applications.
 Focal length: 9.5-430mm (19-860mm w/built-in
 extender)
 Max. Relative Aperture: 1:1.7 through 201mm
 1:3.0 at 430mm



J25x11.5BIE for 2/3" cameras.
 Greater Reach—a 25X zoom lens designed
 specifically for 2/3" cameras. The power and
 scope of 1" systems, the economy and
 efficiency of your 2/3" cameras.
 Focal length: 11.5-288mm (23-576mm w/2X extender)
 Max. Relative Aperture: 1:1.6 through 220mm
 1:2.1 at 288mm



J20x8.5BIE for 2/3" cameras.
 Two Assignments—use a 13X zoom for ENG,
 use the J20x8.5BIE for studio or outdoor
 broadcast assignments—with the same 2/3"
 camera!
 Focal length: 8.5-170mm (17-340mm w/2X extender)
 Max. Relative Aperture: 1:1.6 through 130mm
 1:2.1 at 170mm



J13x9BIE for 2/3" cameras.
 The Portable Standard—used by cameramen
 around the world under all conditions,
 the J13x9BIE is a proven performer with
 superior sharpness and sensitivity.
 Focal length: 9-118mm (18-236mm w/2X extender)
 Max. Relative Aperture: 1:1.6 through 99mm
 1:1.9 at 118mm



J15x9.5 for 2/3" cameras.
 Quality plus Economy—you can't buy more lens
 for less money. Lightweight and sensitive, it meets
 the needs of both cameramen and accountants
 yet lives up to its Canon name.
 Focal length: 9.5-143mm
 Max. Relative Aperture: 1:1.8 through 112mm
 1:2.3 at 143mm



J8x6 B Ultra Wide-Angle Lens for 2/3" cameras.
 The widest of the ultra-wide zooms at 72.5°
 this incredible 8X lens also has a M.O.D. on
 only 11"—it's great for interviews!
 Focal length: 6-48mm
 Max. Relative Aperture: 1:1.7 through 33mm
 1:1.9 at 48mm

Canon®

Optics Division

Canon USA, Inc., Head Office: One Canon Plaza, Lake Success, NY 11042 (516) 488-6700
 Dallas Office: 3200 Regent Blvd., Irving, TX 75063 (214) 830-9600. Chicago Office: 140 Industrial Drive, Elmhurst, IL 60126 (312) 833-3070
 West Coast Office: 123 Paularino Avenue East, Costa Mesa, CA 92626 (714) 979-6000
 Canon Canada, Inc., 6390 Dixie Road, Mississauga, Ontario L5T1P7, Canada (416) 678-2730

© 1985 Canon U.S.A., Inc.

A class operation

The class of an amplifier defines the current and voltage conditions under which the active device, whether a tube or transistor, operates. A simplified transfer curve, illustrated here, shows three common classes found to be practical in RF circuits.

The biasing point for class A is located along the straightest portion of the curve. At this point, the anode current flows through the amplifier at all times, even without an input signal. The output differs from the input only in terms of amplitude, that is, the circuit is linear. Because current flows at all times, class A is not efficient. The price for a large degree of linearity is, at best, a 50% efficiency. Figures to 25% are more realistic.

Moving the bias point to cutoff (more negative) produces an amplifier that conducts current only with an input signal applied. However, only positive half-cycles of the input appear at the output, causing high distortion. Class B amplifiers normally use two active devices in a push-pull configuration. Careful design allows the pair to produce a linear output with realistic efficiencies reaching 60%. Some circuits use class A-B, biased between A and B to achieve more linearity than B, although less efficiency than B.

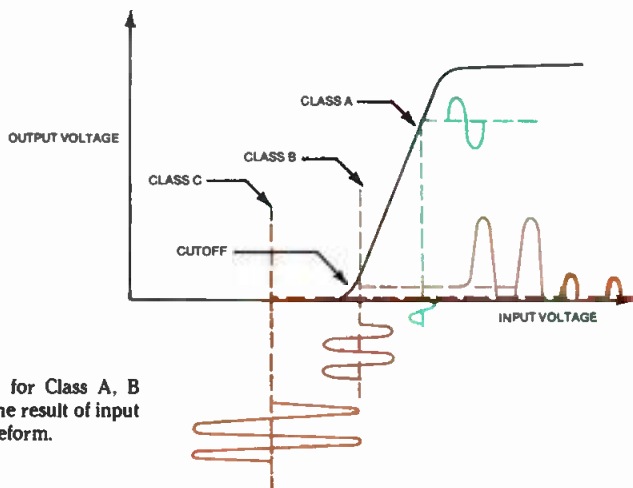

Transfer characteristics for Class A, B and C amplifiers show the result of input bias on the output waveform.

The most efficient common RF amplifier also creates the most distortion. Class C circuits conduct current only on positive peaks of the input signal. The efficiency could easily reach 85%, but the distortion would be considered at 100%. Almost pulselike in nature, class C operation limits designs to generating a carrier. With tuned LC circuits to determine the frequency of operation, the class C amplifier may multiply the input frequency, increase the amplitude at the input frequency or do both simultaneously.

AM and FM radio uses class C amplifier chains to generate the car-

rier. In television, class C amplifiers generate the aural carrier. With separate aural and visual power amplifiers, achieving the final aural output power level may be done in class C as well.

The visual carrier cannot involve class C operation after modulation. Amplitude modulation forms the visual carrier, then bandpass filtering removes most of the lower sideband. The low-power signal must then be boosted from 100W or less to tens of kilowatts for application to the antenna. In order to reach the rated output power without distortion, class A linear amplification is required.

“Everyone here loves it!”

TWA: A SATISFIED CEL ELECTRONICS CUSTOMER

As supervisor of audio-visual aids for Trans World Airlines, it is Vic Segal's job to stay educated and on top of new advances in the video industry. He researches the latest systems on the market, and purchases those that will help his team create the best shows possible for training TWA employees — and keeping them motivated.

Segal bought the CEL Electronics P-147-20 Digital Frame Store with P151-12 Digital Effects Controller, and has been singing the praises of CEL ever since! “It's been a super piece of equipment,” he says. We found out that you can do an awful lot with this system. We use the quad splits and pixelation effects often, and the more we use the equipment, the more we can do with it.”

Our CEL package is a total system, priced at an amazing price . . . **\$9,995.00.**

- Time Base Corrector
- Digital Frame Store Synchronizer
- Proc. Amp.
- Digital Effects (expandable)
- Color Corrector

TALK to users. That's the acid test and we want you to find out from the ones who use our products. ASK us about the quality, the service, support and performance. Discover the many features and worry-free purchase because the CEL P-147-20 is never out-of-date. Always updatable (New 2-line Comb Filter option, includes 4.2 mhz bandwidth; H&V image enhancement: noise reduction . . . quality throughout).

Always the best from Grunder . . . let us prove it today. Call for complete details.





GRUNDER
& ASSOCIATES, INC.
5925 Beverly □ Mission, Kansas 66202
913/831-0188



(Exclusive Distributors for CEL ELECTRONICS LTD., in the United States)

Circle (61) on Reply Card

THE IMPORTANCE OF MICROPHONE ACCURACY IN BROADCAST AUDIO



A distinctive voice remains as important to a successful broadcast announcer as a recognizable visual presence. Microphones are the critical first step in the broadcast audio chain. Acting as a highly accurate sound "lens," they must be sensitive enough to faithfully transmit all of the subtle personal nuances and inflections that distinguish one announcer's voice from another.

Today's sophisticated broadcast productions demand more from microphones. Differences in relative mic performance are more readily apparent, and an inferior microphone stands out like the proverbial sore thumb.

In the most basic sense, any microphone need only capture the sound source exactly and convert it to electrical energy — no more, no less. Obviously, microphones necessarily have different characteristics based on differing transduction technologies and designs. But at Beyer, we believe that the superiority of a microphone is in large part based on how accurately it transduces the source material — with no excuses based on

size or applications.

In broadcast, Beyer's concept of "accuracy" means the difference between a microphone that can focus in on a specific voice and produce a totally realistic, professionally acceptable performance, and a mic that simulates a performance by only capturing the bare outline or "silhouette" of an announcer's voice. We've dedicated the most complex and sophisticated technology in existence to reinforce the truth of this basic premise.

Sensitive and natural-sounding, the MCE5 picks up the "whole truth" of audio broadcast sound because of an unusually wide frequency range (20Hz to 20kHz) and exceptionally fast transient response for any mic, let alone one that is virtually invisible on camera. Because the MCE5 has a uniform omnidirectional pickup pattern, mic placement is not critical and the announcer's head can move without going "off mic." Handling noise is kept to an absolute minimum so the MCE5 picks up the voice, not the rustling sounds of the announcer's expensive silk tie.

The MCE5 is available in various terminations for the widest range of broadcast applications including wireless. Underscoring our longterm commitment to the broadcast industry, the MCE5 is one of a family of reliable Beyer broadcast products designed for ENG, EFP and Film/Radio/Video studio production. It has been widely adopted by discerning broadcast engineers in the U.S. and Europe.

For those engineers who feel that announcers' voices should be as recognizable as their faces, the Beyer MCE5 proves that this level of accuracy exists in a lavalier design.

Beyer Dynamic Inc., 5-05 Burns Avenue, Hicksville, NY 11801.

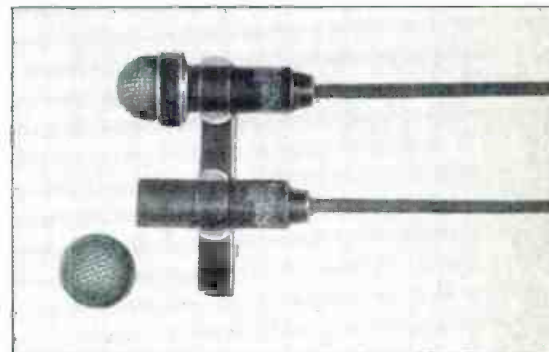

Circle (33) on Reply Card

ACCURACY IN AUDIO

beyerbroadcast 

at peak of sync (a net increase of 10% over previous types). Additional input RF drive overcomes the reduced gain of the tube design.

If the S-tube is used in a standard-tuned configuration, the device operates essentially the same as a standard klystron. At present, only an integral 5-cavity device is suited for this retuning method.

A hybrid approach

The lower power aural carrier may operate at 10% to 20% of the visual peak of sync rating. Stations sometimes use a klystron in the aural system that could operate in the visual amplifier. The device idles along easily at the reduced

level. In emergencies, the unit can be moved to the visual amplifier, providing backup. The price of the device is high, but because of the low-level operation, its lifetime is increased, making this practice more cost-effective.

Tetrodes could operate at the aural frequency, but their gain would be reduced. The favorable attributes of the tetrode and klystron have been combined in a device called the Klystrode (a Varian trademark). The Klystrode uses tetrode grid-controlled, density modulation from an RF cavity-driven grid. A magnetically focused beam carries signal energy to the output cavity, where a pickup loop extracts the desired signal. Remaining

beam energy returns to the power supply through a collector.

The device may be operated as a class B linear amplifier, a more efficient operating mode than class A. The input power varies with modulation depth, which is not the case with klystrons.

At present, such hybrid tubes serve in aural amplifiers rated to 20kW. Work continues on the hybrid concept to achieve the efficiency equivalent to a tetrode for the visual service.

Tomorrow's promise

Is there a next step? The *depressed collector* klystron, introduced in Europe as early as 1961, has found its most practical applications in radar. Beam electrons impacting the collector revert to heat, making cooling systems mandatory. For a device designed for TV service and rated at 50kW, using a 25kV cathode-collector potential difference and a beam current of 6A, 100kW of heat energy remains after the final cavity extracts the RF signal.

The residual beam consists of electrons of varying velocities, most being much less than the equivalent 24kV collector potential. If the collector voltage matched the velocity energy of the fastest electrons still in the beam, reduced collector dissipation would result. A multistage collection process with various potentials would logically be more effective.

Once past the final cavity and magnetic assemblies, electrons in the beam diverge. Slower electrons diverge more quickly to the positive collector field than faster ones, because of inertia. If the slowest electrons carried a 5kV potential, then a section of the collector at 5kV could dissipate them with less heat loss. Perhaps faster electrons would require a 10kV section of the collector to be used. Not every electron would be collected at its most favorable potential, but a significant change would result.

Depressed collector units serve airborne radar equipment, an application in which efficiency is more critical than in broadcasting. Two- and even 3-stage devices are in use, although the operating powers are significantly less than a full-power UHF TV station. The power level has kept depressed collectors in the computer model stage, but such klystrons could appear relatively soon, perhaps within two or three years.

UHF TV promises to be the spectrum of tomorrow because, in the U.S. at least, most of the VHF slots are already taken. Antenna pattern control, combined with the potential for many more UHF channels, suggests that a large number of UHF stations could still be licensed.

Through continued research, substantial relief in the operating-power budgets of UHF stations is possible today. The development of new devices could lift the financial burden from tomorrow's UHF medium.



RVS-210

THE FINEST COMPACT SWITCHER AVAILABLE



See Us At SMPTE Booth 1931

Canada: Ross Video Limited, 500 John St., P.O. Box 220, Iroquois, Ont., K0E 1K0
613-652-4886, Telex 05-811579

U.S.A.: Ross Video Inc., P.O. Box 880, Ogdensburg, N.Y., 13669-0880
Circle (122) on Reply Card

Only Panasonic® delivers a 1/2" recorder with color playback in the field.



Is it a "wrap" or isn't it? Now you can tell right on the spot. Because the Panasonic Recam™ AU-220 is the only 1/2" VCR that gives you the quality of 1" color playback in the field. So you can instantly see what you've shot. Either through the viewfinder or a monitor.

Consider the facts: The Panasonic AU-220 records, utilizing the M-Format, on standard 1/2" VHS cassettes. Yet it delivers the kind of picture quality that's long been the broadcast standard. Luminance is 4.0mHz (typical). Chrominance is 1.0mHz. While the video S/N is every bit as good as 1" with chrominance better than 50dB.

For total flexibility, the AU-220 includes a built-in

switchable SMPTE time code generator. And it's compatible, not only with component analog video equipment, but also with YC and NTSC.

The Panasonic AU-220. 1" color quality from 1/2" tape makes it one of a kind.

For more information, call your nearest Panasonic regional office. Northeast: (201) 348-7336. Southeast: (404) 925-6772. Central: (317) 852-5973. West: (619) 941-3387. Canada: (416) 624-5010.

Panasonic
Broadcast Systems

Circle (81) on Reply Card

ANOTHER BROADCAST INNOVATION FROM MATSUSHITA ELECTRIC

*"Great
sound only
starts
here"*

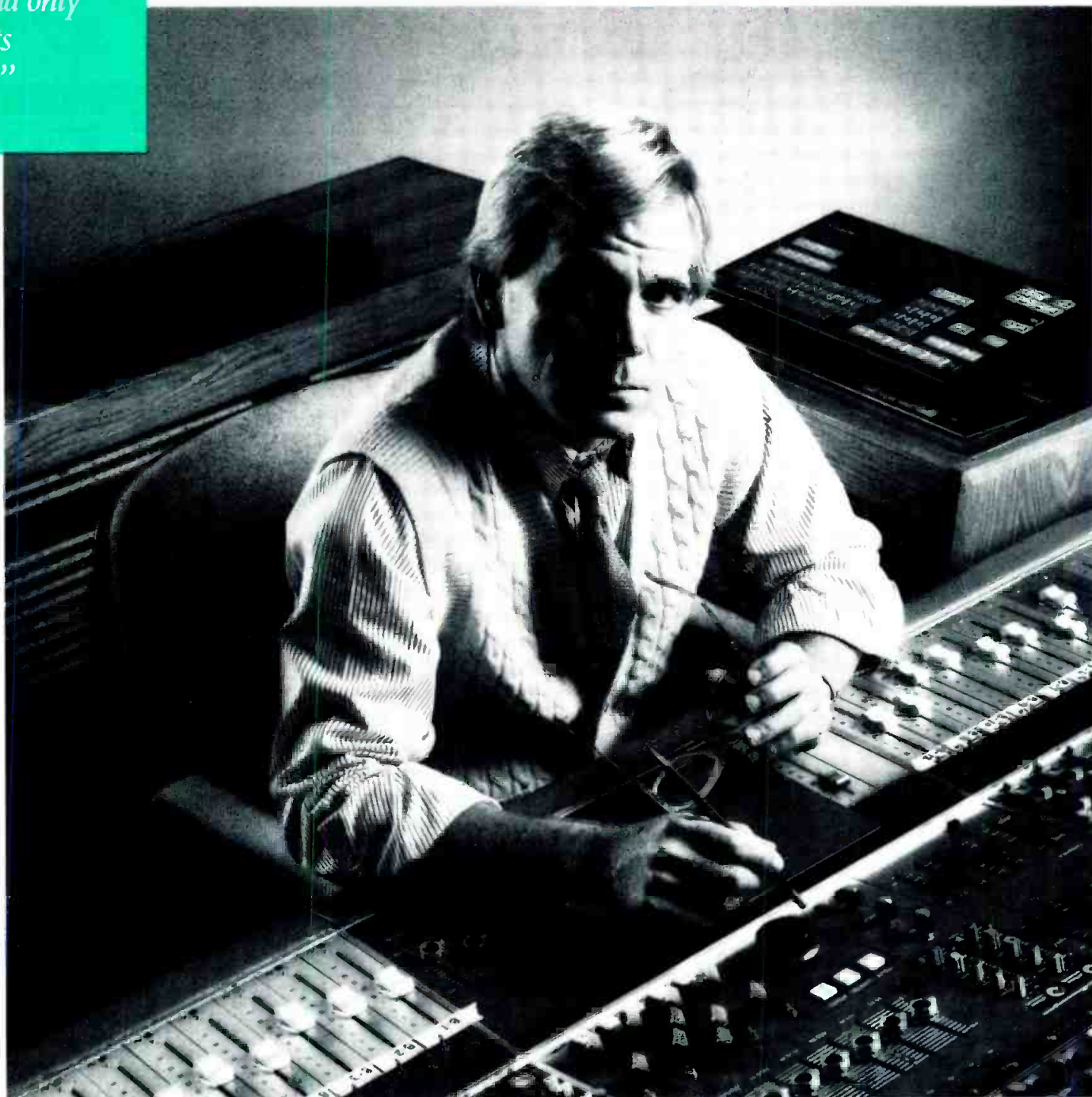

"This audio console is only one important element in the audio chain. I count on each and every device to maintain true signal integrity to keep the great quality sound I started with.

RTS Systems Series 2500

Amplifiers meet my demanding specifications. They offer wide dynamic range, low noise, and minimum phase error. And most importantly—the sound quality doesn't differ from start to finish."

The Series 2500 offers a

variety of devices designed to be absolutely accurate. Included are distribution amplifiers, line drivers, buffer amps, VCA circuits and more.

Call or write for details on how to keep the same great sound you started with.

RTS SYSTEMS

INCORPORATED

THE FIRST NAME IN
INTERCOMMUNICATIONS

Circle (63) on Reply Card

The recorded message is a timely idea

By Chuck Kelly

For years, innovative broadcasters have used automatically answered telephone lines with recorded messages to generate additional revenue. These messages usually provide weather, sports or concert information. Typically, the telephone lines are connected to a cartridge machine through an FCC-registered coupler that starts the machine when the phone rings. The machine then plays the message down the line, releasing the line as soon as the cart cues up again.

The service is sold to an advertiser whose sales message is incorporated into the announcement. The station staff updates the material as often as necessary.

Time announcements, until recently, were provided by telephone companies and were usually underwritten by local advertisers. In some areas of the country, telephone companies have discontinued providing any type of time service.

With a little ingenuity, a cartridge machine and an audio source for the local time, a broadcast station could combine an existing recorded announcement service with a time announcement.

What time is it?

There are several ways to obtain the audio for time announcements. You could use one of the time announcers designed for automation systems. A problem, however, is that they can announce the time only once per minute, limiting the number of calls to a maximum of 60 per hour. Besides that, the system requires two cartridge machines and is expensive.

It would be easy to connect a short-wave receiver to the automatic answering machine, but the audio quality can be poor, depending on conditions. Also, keep in mind that the announced time would not be local time, but universal time, which may confuse callers.

Another option is to use a computer to generate the announcements. With a little programming, a voice synthesizer and a lot of money, you would have an accurate time announcement system. One problem with this system, however, is its sensitivity to power failures. Another is that the hardware can be rather expensive.

There is a method that avoids all of these problems. A *talking clock*, Vox Clock, is available for about \$40 at Radio

Shack. The clock is battery-powered, has reasonably good voice quality and a crystal-referenced time base. The clock is housed in a 2½-inch-square plastic cube and is easy to interface with broadcast equipment.

This clock contains everything you will need for the audio part of your time announcement. In addition to the clock, you will need a telephone interface and a cartridge machine with a secondary cue-tone detector.

Installation

Connecting the clock to the cartridge machine and telephone interface is simple. Figure 1 shows the connections for a mono playback cartridge machine and the Vox Clock. Although this particular combination of equipment has been shown to work properly, adapting this circuit to a variety of machines should not be difficult. If you use other equipment, take adequate precautions against line voltages that may be present.

Recording the announcement

During the recording process, the announcer should record a 150Hz secondary tone at the point at which the time should be announced. When the machine detects the tone, the clock will be triggered. If no tone is recorded, no time will be announced. Of course, because the FB-1 will hang up the phone when the cartridge cues, the cart must be long enough to last through the recorded message and the time announcement.

The talking clock would be a simple and valuable addition to a station that wants to increase listener awareness and generate additional income through time announcements. Given the low cost of the project, almost any station could offer this service to its audience. ☺

Kelly is sales manager for International Tapetronics Corporation/3M, Bloomington, IL.

Figure 1. A typical interconnection diagram for a dial-up time announcement system.

NOTE WHEN USING THE ITC OMEGA CARTRIDGE MACHINE, BE SURE TO INSTALL THE STRAPS AT W203 AND W204. THIS WILL DEFEAT THE FLASHING RUN LAMP AND MUTE FEATURES THAT WOULD COMPLICATE THIS PROJECT. BECAUSE THE SECONDARY CUE DETECT OUTPUT IS AN OPEN COLLECTOR, WIRE THE POSITIVE LEAD FROM THE SWITCH TO PIN 12 OF THE CART DECK.

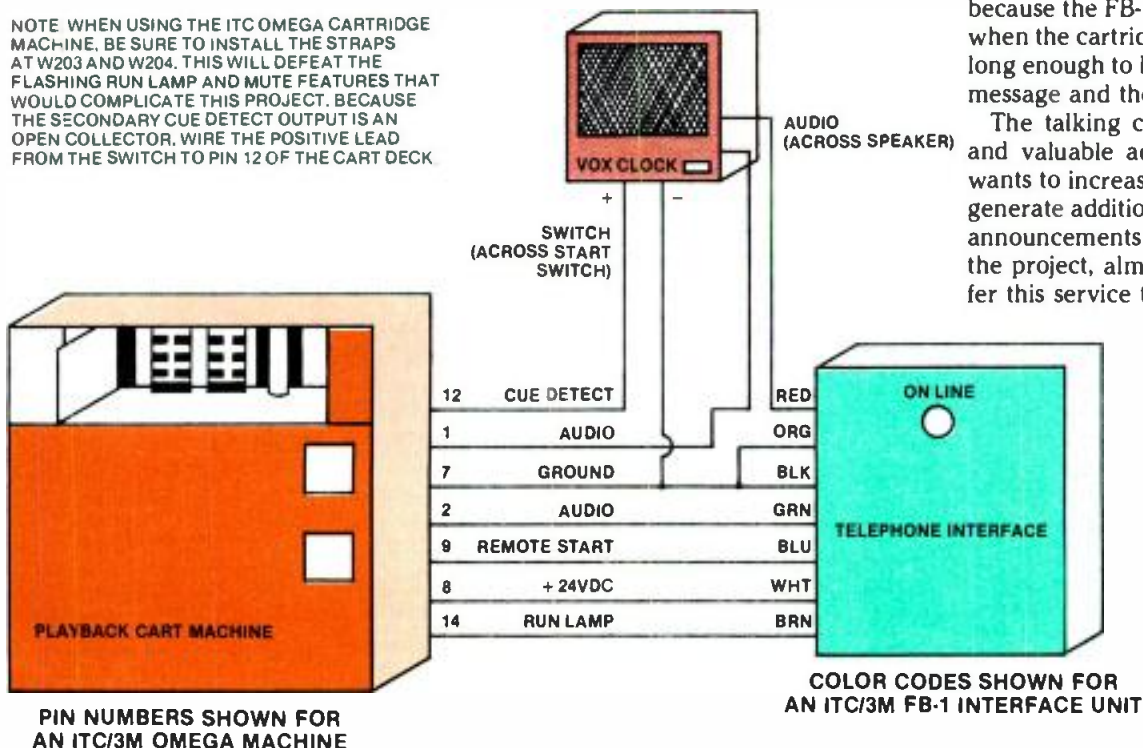

Lexicon 1200B

By David I. Orenstein

We all know that the old saying, "there's never enough time," definitely applies to broadcasting. However, on occasion, there is *too much* time—for instance, when an agency commercial comes in 32 seconds long instead of 30. It used to be that the only ways to remedy the situation were to speed up the tape (highly undesirable) or to cut the copy (unthinkable). Either method inevitably resulted in a distraught account executive, agency representative or client.

Digital technology, however, has solved the long-standing production problem of spots that don't time out correctly. The subject of this report, the Lexicon 1200B time compressor/expander, is an audio processor and machine controller that makes it possible to modify commercial length.

The process

Converting the audio into a digital bit stream opens up a whole range of production possibilities. This digital signal can be modified as necessary to obtain a product of the required length. If the material is to be shortened, the processor simply slices away pieces of the waveform. The amount of material removed depends upon the shape of the original signal and how much time needs to be cut. A reverse process takes place if the material needs to be lengthened.

The 1200B contains in ROM a set of stored algorithms. These algorithms (programs) are based on the shapes of waveforms. Through these programs, the unit analyzes and selects the waveforms or pieces of audio to cut or to lengthen.

Orenstein is an engineer at the ABC Radio Networks, New York.



Several varieties of these algorithms can be selected by the user in order to customize the processing. The operator can also alter the *discard interval*, which affects the rate at which material is added to or removed from the audio signal. When the polarity of the waveform is important, a front panel switch allows the user to invert the signal applied to the processor. There may be situations in which the negative half of the waveform would produce a better result.

The key to the modification process is the capability of the unit to retain the pitch of the original production by changing the clocking rate of the sampling unit. Once the data stream has been modified as necessary, it passes out through a digital-to-analog converter to the user's equipment.

Operating features

The compressor/expander is housed in a 7-inch rack-mount assembly with all user controls located on the front panel. The back panel contains the input and output XLR connectors for audio, remote-control connectors and a tape machine-control connector.

Five vertical faders control the input and output levels and three rolloff filters. Located just above the faders is a multicolor LED display indicating available headroom. The center of the front panel contains a keypad flanked on each side by two vertical rows of func-

tion buttons. Located just above the keypad is a digital LED display. These controls are used to enter, to monitor and to direct the processing functions.

The two controls for pitch and speed are located on the right side of the front panel. The first provides manual control of pitch shift and the second controls speed. The latter also can be used as a constant-pitch variable-speed control. When the manual pitch shift is adjusted, the 1200B displays the change in pitch ratio. If this control is adjusted while the tape machine is playing, it will sound as if the machine is changing speed even though it is not.

Performance

A distorted or choppy sound can result when the 1200B processes some voice qualities. This is especially likely if the voices have a musical quality to them. However, more than 97% of the time, this does not occur. As near as I can tell, this is caused by the machine's inability to process some of the complexities of music. If the distortion is a result of the type of audio being processed, the user can select variations of the two programs used by the machine. This option, coupled with the capability of varying the discard interval, usually solves the problem.

A choppy sound sometimes results from attempting to compress or expand a piece of time-processed material. In this case, portions of the original material are no longer available to the processor. Further removal of material from an area that has already been operated upon is naturally going to increase the distortion. The solution is to locate the original tape for processing.

The unit is a monaural device, which may be a disadvantage to those stations needing to process stereo material. If a stereo format requires time compression/expansion, it can be done by using two 1200Bs or by making a monaural mix onto another tape.

The manufacturer has advised me that a stereo upgrade can be accomplished by adding a second unit plus a stereo matrix. For the newer 1200C, which recently superseded the 1200B, the company has just introduced a stereo upgrade. The system consists of two 1200Cs that have been matched and synchronized with a stereo matrix unit. Among the benefits of the new stereo version, according to the company, are improved machine control for better accuracy and RS-422 communications for VTRs and editors.

Continued on page 128

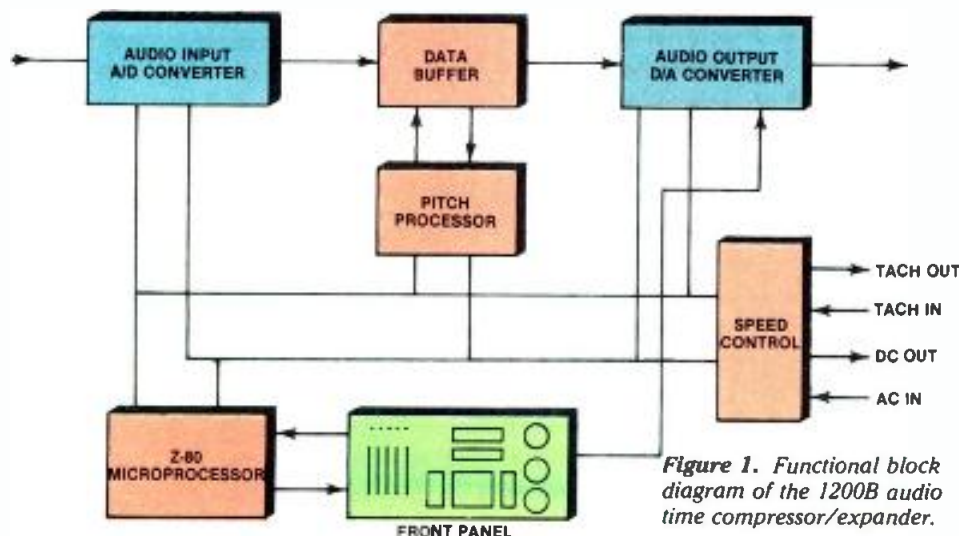
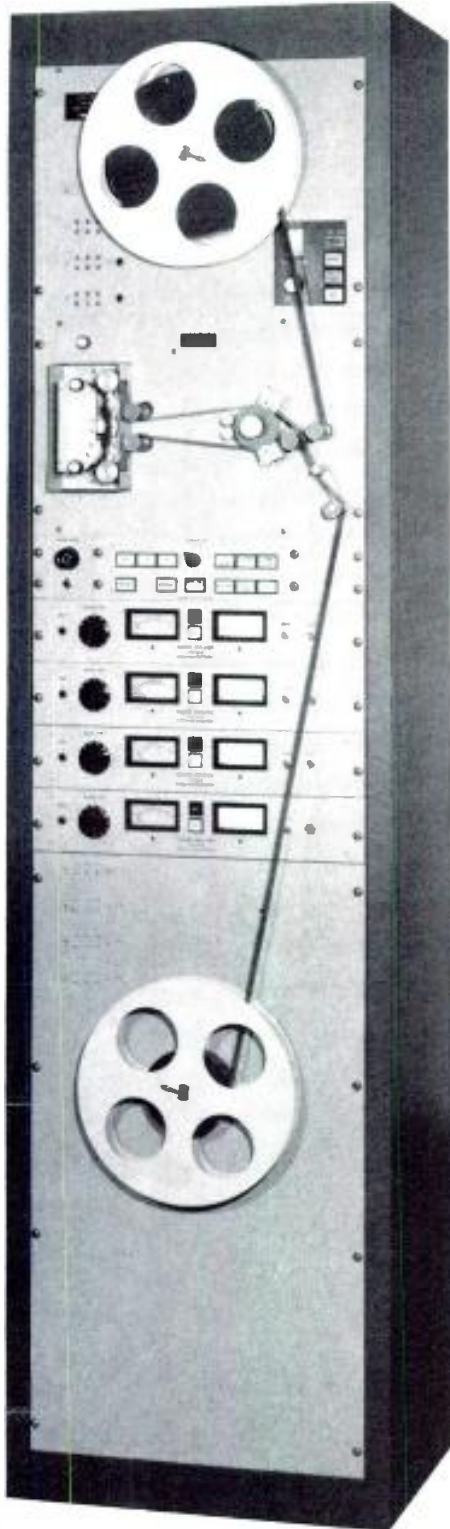

Figure 1. Functional block diagram of the 1200B audio time compressor/expander.



MAGNA-TECH

THE SOUND HEARD AROUND THE WORLD

**Magnetic Film
Recorders and Reproducers
for Television and Film
Sound Post-Production**

HIGH SPEED

Telecine Magnetic Followers
Video Tape-Film Interlock
Electronic Looping
Dubbing Systems
16 and 35mm Electronic Projectors
Total Facility Engineering

WORLDWIDE SALES OFFICES

Paris
Hi-Fidelity Services
4 Rue Semard
75009 Paris France

Sydney
Magna-Techtronics (Aust.)
PO Box 150
Crows Nest NSW 2064
Australia - Telex 24655

Johannesburg
General Optical Co., Ltd.
15 Hulbert Road
Johannesburg 2001,
South Africa

Rome
Alberto Sciarretta
Via Siria 24
Rome 00179
Telephone 7943618

Brussels
A.R.C.
Rue de Boisdé Linthout 45
1200 Brussels Belgium

Hong Kong
Paul Yang and Associates
901 Star House
3 Salisbury Road
Kowloon, Hong Kong

Bombay
Capt. P.K. Vishwanath
234/4 Rama Baug,
Deodhar Road
Bombay 400 019, India

Kehl West Germany
Zenon GMBH
Postfach 1743
Hauptstrasse 128
Kehl am Rhein
Tel: 07851/2991
Telex: 753537

London
Branch & Appleby
42 High Street
Harrow-on-the-Hill
Middlesex HA1 3LL,
England

Kuala Lumpur
Kinematronika Sdn. Bhd.
2852, Jalan Selangor/
Persekutuan,
Federal Hill
Kuala Lumpur, Malaysia

Caracas
Cine Materiales srl
Apartado Postal 61.098
Caracas 106 Venezuela
Madras
S.R.K Menon
A-4 Parsn-Apts-109
G.N. Chetti Road
T.Nagar
Madras 600 107

MAGNA-TECH ELECTRONIC CO., INC.

630 Ninth Avenue, New York, N.Y. 10036

Telephone (212) 586-7240

Telex 126191

Cables "Magtech"

Pretty impressive record.

It's Sony's.

Because as the official videotape of the NBA, Sony has captured every slam, every jump, every dribble, every drive. And after 1022 games, Sony has a record of 1022 wins, no losses.

How have we done it? By formulating a videotape that's the most consistent in the industry line-up.

The K-Series is a tape that's been developed with an eye towards perfect coordination. Available in 3/4" cassette and 1" Type C format, its top players are uniformly dispersed, highly packed and well-oriented magnetic particles.

Complementing their strengths is the binder that distributes them evenly. And a unique surface treatment completes the team.

Then, to ensure that there be no technical fouls, Sony subjects the K-Series to pre-game check-ups lasting over 1000 hours.

By the time the K-Series makes it to the court, it's ready to turn in record-breaking audio and video performances. Play after play after play.

And that, after all, is the point.

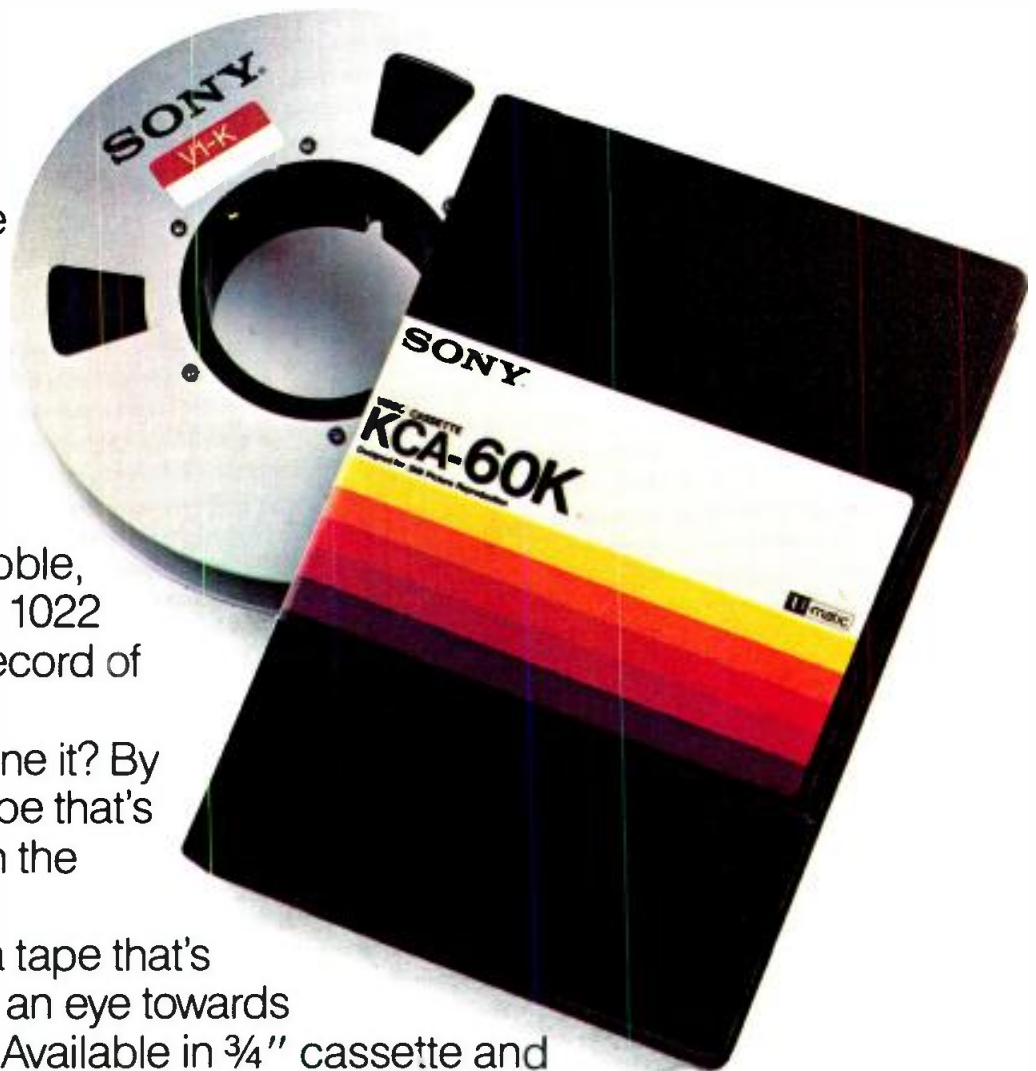

SONY
Professional Tape Division

Create a room

YAMAHA REMOTE CONTROL UNIT RCR-1
FOR DIGITAL REVERBERATOR REV-1

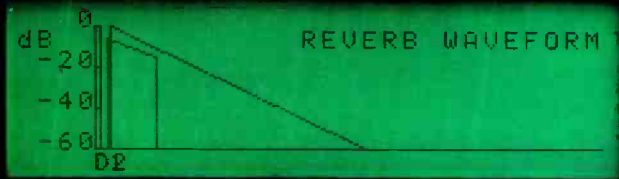

DISPLAY W/F F/C R/T RATIO E/R REV P/S M				E/R MODE 1 2 3 4 5 6 7 8				REV. MODE 1 2 3 4 5 6 7 8				PRESET 1 2 3 4 5 6 7 8			
L R FULL 0 -3 -6 -9 -12 -15 -18 -21 -24 -27 -30 -33 -36 -39 -42 -45 -48 -51 -54 -57 -60 LEVEL METER IN ● OUT				ROOM SIZE 1 2 3 4 5 6 7 8 9 10 11 12 13 14 15 16 17 18 19 20				HIGH 1 2 3 4 5 6 7 8 9 10 11 12 13 14 15 16 17 18 19 20				PANEL P EDIT AUTO			
HPF LPF 400 10K ● 200 8K 100 6K 50 4K				E/R NUMBER 1 2 3 4 5 6 7 8 9 10 11 12 13 14 15 16 17 18 19 20				MID-HI 1 2 3 4 5 6 7 8 9 10 11 12 13 14 15 16 17 18 19 20				MEMORY 67 M STR RCL			
REV. TIME (R/T) 2.6 sec MID-LOW				LIVENESS E/R DELAY 1 (D1) 40 ms				LOW REV. DELAY 2 (D2) 58 ms				FUNCTION R/T D1 D2 M 7 8 9 4 5 6 1 2 3 0 ● CLR UP DWN ENT			
ON DIRECT				AUTO ON EARLY REFLECTION				AUTO ON REVERBERATION				ON MASTER			



with a view.

We'd like to open your eyes to the incredible REV-1 digital reverb. Because it gives you unheard-of control over virtually all reverb parameters. And something that has never been seen in any type of reverb: the capability to "look" at the sound as well as hear it.

The remote unit that controls the nineteen-inch rack-mountable unit has a lighted high-resolution LCD display that graphically depicts the results of the adjustments you make.

So getting just the right reverb sound is no longer a question of trial and error.

The logical grouping of the parameter controls on the remote also makes it easy to create any effect you like. Then store it in any of 60 memories for instant recall.

The remote also contains 9 additional RAMs so you can store programs and carry them with you to use anywhere there's an REV-1.

And there are 30 additional ROMs with factory preset sounds. Many of which can be completely edited (as can the user-programmed sounds) by using the LEDs to tell you the set value or indicate in which direction to move the control so you can easily and precisely match the value of the originally programmed sound.

And the sound itself is far superior to any other digital reverb. The REV-1 uses specially developed Yamaha LSIs to create up to 40 early reflections and up to 99.9 seconds of subsequent reverberation. So the effect can be as natural (or unnatural) as you want it to be.

We could go on about the REV-1. Tell you about its 44.1 kHz sampling rate that provides a full 18 kHz bandwidth to prevent the natural frequency content of the input signal from being degraded.

How it has a dynamic range of more than 90 dB for the delay circuitry and more than 85 dB for the reverb circuitry.

But why not take a closer look at the REV-1 at your authorized Yamaha Professional Audio Products dealer. Or for a complete brochure, write: Yamaha International Corporation, Professional Products Division, P.O. Box 6600, Buena Park, CA 90622. In Canada, Yamaha Canada Music Ltd., 135 Milner Ave., Scarborough, Ont. M1S 3R1.



"EARLY REFLECTION" display mode showing room size and relative level and time of discrete reflections.

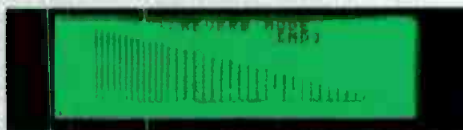

"REVERB DENSITY" display mode showing level and relative time of subsequent reverberation.

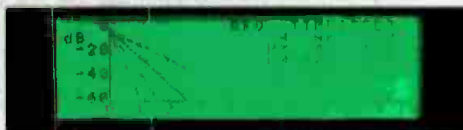

"REVERB TIME" display mode showing difference in reverb time in each of four frequency bands.

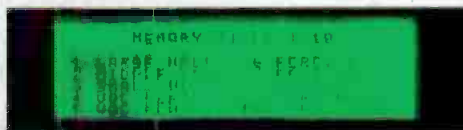

"MEMORY TITLE" display showing the titles of internal ROM memories.

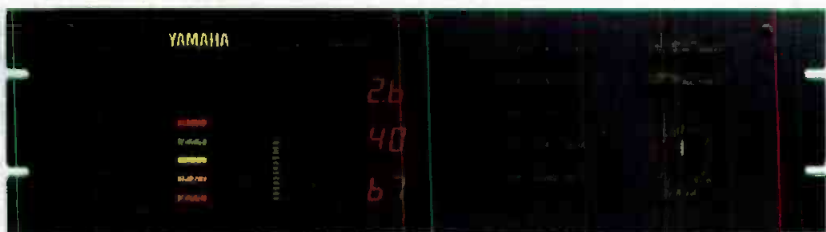

Circle (74) on Reply Card

do you know!

INFORMATION ABOUT SAVING YOUR ELECTRONIC EQUIPMENT

Your Broadcast Operations are in Danger!



The danger is serious and ever-present. In a split second you could be off the air...or operating with a scrambled program-control system...or totally shut down with equipment catastrophically damaged. It's a threat you live with day after day and one that merits your closest attention.

The Threat Abnormal voltage surges that occur on AC power lines, communications lines and data lines are a major cause of misinformation and equipment failure for the broadcaster. Broadcasting equipment is especially vulnerable, with tall antennas reaching up into the skies and with electronic units of unusual sensitivity.

Difficulties manifest themselves in two ways: (1) as physical *damage*...this is obvious damage that occurs directly as the result of an electrical storm, or less obvious failures that seem to occur almost at random; (2) as *misinformation*... where the power surge is coupled into the equipment causing improper events to occur or incorrect data to be presented.

These problems are familiar ones to broadcasters. And now, with the ever-expanding dependence on computer control and the corresponding increase in the susceptibility of these sensitive devices to damage from voltage surges, overvoltages must be controlled and eliminated.

*Allen & Segall/IBM. 1974

MCG

ELECTRONICS INC.

12 Burt Drive, Deer Park, NY 11729 • 516-586-5125

Specialists in Circuit Protectors, Transients, Lightning & Surges.

The Causes Transient power problems originate outside buildings from lightning, ground faults, and public utility switching, and inside buildings from inductive loads, transmitters, air conditioners, fluorescent lights, etc. A study at IBM* identified transients as the cause of 88.5% of all line disturbances. Transients, sudden and extreme "spikes" in voltage, can be as short as a few nanoseconds or as long as several milliseconds. Their effect can range from total failure to the gradual degradation and breakdown of electronic components or systems.

The Solution MCG Electronics provides total protection against these transients for your broadcasting operation. AC power lines and data lines that serve your internal communications network are guarded day and night.

AC Power Line Protection

MCG's Surge-Master™ provides high speed (5ns), heavy-duty protection that limits AC overvoltage spikes to safe levels. Surge-Master protectors are your first line of defense, and are available in configurations designed to meet your needs, from complete building protection to individual equipment protection.

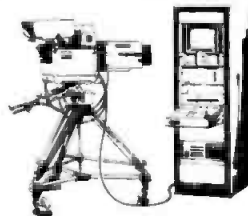

Data Line Protection Interfaced between network equipment and data lines, MCG's Data Line Protectors provide a sophisticated blend of high speed (less than 5ns) and brute force protection against induced transient voltage surges. Available in multiple configurations, they are designed to meet your every need, and will keep your data network out of danger.

MCG Protectors Your most cost effective insurance against downtime and data loss caused by voltage surges and transients.

Call or write for our
FREE CATALOG



Continued from page 122

A problem that I found in the unit, also reported by almost every engineer of my acquaintance who has used the machine, is the front panel. The buttons are too close together and don't have a positive feel. Manipulating the buttons can be difficult for an engineer who has large or unsteady hands, or who is simply in a hurry to finish the processing.

The various functions on the front panel are poorly labeled and not easily understood. The low-end rolloff faders slide in the wrong direction as compared to those on other audio equipment. The unit is well-designed on the inside, but the front panel could be improved.

Although the manual that accompanies the unit provides a full section on interfacing the unit with a variety of equipment, its operating section is not user-friendly. I found it necessary to write an in-house manual to aid those who used the unit. I understand the manufacturer has issued a rewritten owner's service manual for the 1200C.

Model 1200B:

Performance at a glance

- Speed factor range: 75% to 130% of original length
- Pitch correction: $\pm 0.1\%$
- Dynamic range: $> 68\text{dB}$ unweighted
- THD $< 0.5\%$ at 1kHz, at +12dBm, at x1 speed
- Eight storage registers for recalling preset conditions
- Battery backup to retain system memory
- Interfaces with all common types of machine controls
- Stereo-compatible with the addition of another 1200B

Summary

For programming purposes and for consistent timing during air shows, precise timing is required on commercial cartridges. The 1200B can be used to process commercials and PSAs so that their lengths turn out to be exactly what you want. Ordinarily, using a simple variable-speed drive to change the length of a spot will produce a noticeable change in pitch. Naturally, this is not desirable, and it is certainly not acceptable if the talent is a well-known personality who is meant to be recognized. With the use of the compressor/expander, shortening or lengthening a commercial is no longer a problem. Likewise, the unit can correct pitch problems with a previously recorded tape.

Editor's note: The field report is an exclusive BE feature for broadcasters. Each report is prepared by the staff of a broadcast station, production facility or consulting firm.

In essence, these reports are prepared by the industry and for the industry. Manufacturer's support is limited to providing loan equipment and to aiding the author if support is requested in some area.

It is the responsibility of Broadcast Engineering to publish the results of any piece tested, whether positive or negative. No report should be considered an endorsement or disapproval by Broadcast Engineering magazine.

[:T:~))]]

Circle (77) on Reply Card

Wipe out one-inch



Garner 1400
One-inch video
tape eraser

If you've made the decision to invest in state-of-the-art one-inch technology, remember, the quality of your production is only as good as the tape you start with. That's why many studios control tape expense without sacrificing production quality by using a Garner one-inch bulk eraser to quickly degauss high coercivity tape. Only Garner has the magnetic coil design that concentrates the erasing flux to wipe out recorded material by -90dB — cleaner than new!



VTR Erasing

Erasing tape on your VTR increases head wear, ties up expensive equipment, and can take hours to erase, sometimes without delivering complete erasure of audio and control tracks.



Other Bulk Eraser

Bulk erasures not expressly designed for high-coercivity 1-inch can take up to four times longer and can't match Garner's -90dB erasure quality.



Garner 1400

Only Garner offers erasure quality, speed, easy operation and durability—backed by a full two-year warranty.

Call our toll-free number today for a free brochure on the 1400 or any of Garner's other bulk erasers for video, audio or computer recorded material.

Toll-Free 800-228-0275

garner industries

Panasonic just made dead air a



"Please stand by." Three words that make any broadcaster fighting mad. But now you can fight back because the MVP-100 video tape cart machine from Panasonic Broadcast Systems has just eliminated dead air for good. And virtually eliminated your biggest problem. "Make Goods."

Built-in Redundancy

The MVP-100 maintains broadcast continuity with an incredible array of technical achievements. Starting with its automatically threaded tape transport systems. Available in 8, 12, 16, 20, or 24 transport configurations. Each transport can be

individually programmed and controlled. All with the accuracy of SMPTE time code identification through the MVP-100's built-in computer.

Automatic Continuous Programming

News spots, commercials, editorials, station IDs, promos, even program length material can be scheduled in advance and automatically aired. But what really sets the MVP-100 apart is how easily it eliminates dead air. With its built-in recorders and spot players, you can forget about the hassle and expense of "double rolling" a second machine. Because the MVP-100 plays protection copies

ANOTHER BROADCAST INNOVATION

dead issue.



simultaneously. So in the unlikely event that your "on air" transport fails, the MVP-100 can be programmed to switch to the protection copy maintaining broadcast continuity.

What's more, the MVP-100 also eliminates "custom mechanics." Since each removable transport operates independently of each other, individual repairs or maintenance can be done without putting the entire system out of commission.

YIQ Format Delivers 1" Quality from 1/2" Tape

Total, reliable automation of your broadcast day is just one reason to make the MVP-100 an integral

part of your station. The picture quality of its YIQ, M-format is another. Especially when you consider how good it is. One-inch quality from 1/2" VHS tape just about says it all.

The Panasonic MVP-100. Let it make dead air a dead issue for you. Call your nearest Panasonic regional office. Northeast: (201) 348-7336. Southeast: (404) 925-6772. Central: (317) 852-5973. West: (619) 941-3387. Canada: (416) 624-5010.

Panasonic
Broadcast Systems

FROM MATSUSHITA ELECTRIC

Circle (76) on Reply Card

www.americanradiohistory.com

Field report

Fluke 9010A

By Tom Wimberly

When our station experienced a serious malfunction of a new routing switcher, four factory service engineers flew to the rescue. Within minutes of their arrival, they had correctly diagnosed and repaired the problem, which was caused by a faulty RAM memory chip. The factory technician's secret weapon was the Fluke 9010A Micro-System Troubleshooter with custom diagnostic software written expressly for the switcher.

I was so impressed with the results that I decided to buy one of our own. We now use it when testing the digital circuits in our microprocessor-based equipment. It has helped us repair framestore synchronizers, videotape recorders, studio cameras and routing switchers.

A new approach

Much of the TV equipment we buy today makes extensive use of microprocessor technology. Keeping this new breed of computerized equipment properly working poses some unique problems for our engineering staff.

The shotgun approach to repairing microprocessor-based equipment is nothing new to most of us. The engineer begins by swapping boards between the faulty unit and the working one. Once



the problem is isolated to a particular board, new components are substituted for the suspected parts until the problem disappears.

If the boards contain only a few components, this is relatively easy. Newer equipment, however, often has several different boards with dozens of components on each one, making troubleshooting much more difficult. The simplest problems can take inordinate amounts of time to find. And even the most reliable equipment can malfunction just when you need it most. Time, as usual, is the critical factor. You can't spend hours—or wait for days—to correct the problem.

As an aid to the troubleshooting process, some new equipment has built-in diagnostic routines. VPR-80 videotape recorders, for example, can isolate a malfunction to a particular area, such as missing RF, AST or servo faults. The machine then displays a standard error code referenced in the maintenance manual. Although these diagnostics are

helpful, they don't always isolate the faults to a particular part. Also, they don't isolate any faults associated with the microprocessor kernel. The kernel is that portion of the unit under test (UUT) directly connected to or accessed by the microprocessor, such as bus, ROM, RAM or I/O lines. It's in this situation that the 9010A really begins to shine.

Types of tests

Right out of the carton, the unit helps solve, in minutes, those problems that might require hours to work out with regular test equipment. Six built-in tests can be performed at the push of a button. These tests require information on UUT address space, which may be specified by the operator. Or, if custom software is available, these locations are already stored on a cassette tape and then loaded into the troubleshooter's memory.

The *bus test* checks for proper function of the UUT control lines, status lines, data lines and address lines. It identifies defective control lines and any data lines with improper levels. The *ROM test* computes a ROM signature for each block of ROM and compares it with the reference ROM signature stored in memory. Any discrepancies are reported to the operator. The *I/O test* checks the read-write capability of the I/O registers and identifies the I/O address and bit where the error was detected.

The RAM tests can be run in either a long or a short version. The *RAM short* test checks the read-write capability of each RAM and the proper function of the data lines and address decoding. The *RAM long* test is a more exhaustive check of address decoding. It also performs an elaborate pattern sensitivity test for locating soft RAM errors. The *AUTO test* performs, in sequence, bus, RAM short and I/O tests.

Faults uncovered in the microprocessor kernel are usually the most difficult to isolate. Furthermore, they account for approximately 80% of all failures. For this in-depth troubleshooting, the system provides a number of high-level single-key functions to stimulate components such as readouts, relays, interfaces and CRTs.

Faults beyond the bus generally require using the unit's single-point stimulus-and-response probe. By transmitting a predefined pattern, the engineer can command the probe to read the information at a particular point (node). The probe may also be instructed to provide a stimulus at a particular point that, in turn, can be read back through the microprocessor pod. This feature per-

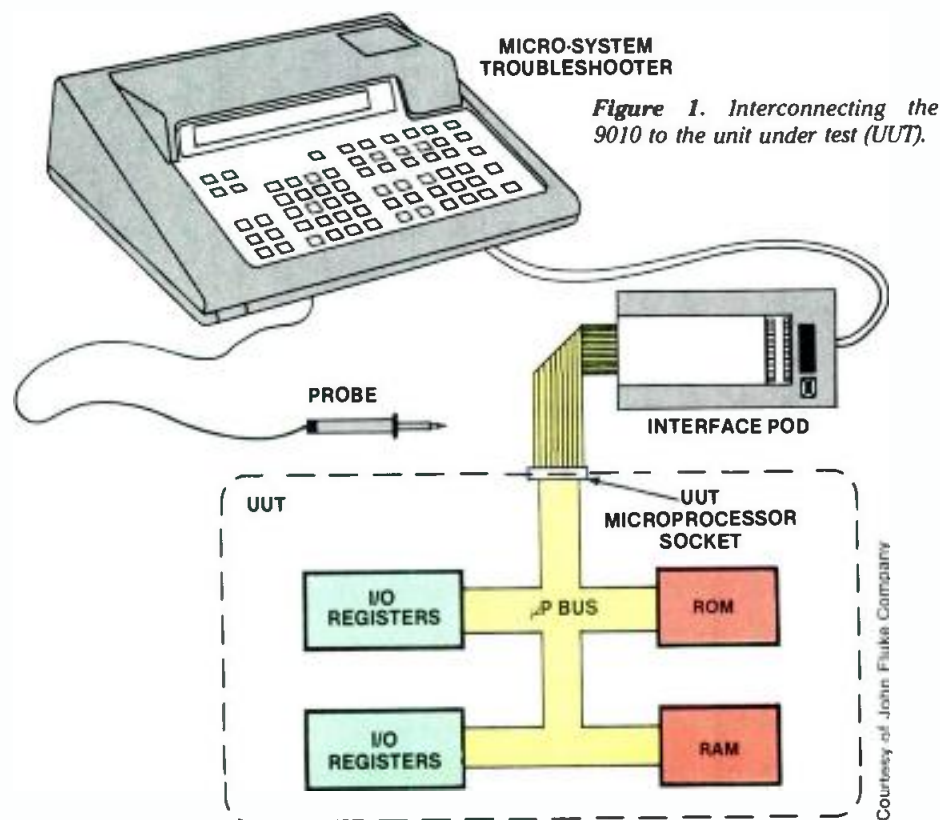



FINISH UP ON TIME WITHOUT SACRIFICING QUALITY.

You want it quick and you want it good. In today's competitive post-production audio/visual scene, the rewards go to those who can produce results that are quick *and* good. That's why TASCAM designed the MS-16 1" 16-track recorder—to bring together top-notch audio quality plus premium features that streamline production and move you ahead of schedule.

Quality reproduction starts with the heads, and TASCAM has three decades of design experience behind the MS-16's new micro-radii heads. They bring "head bumps" under control and ensure flat frequency response. And unlike most tape machines, the MS-16 record/sync and playback heads are identical in performance. Because sync response equals repro response on the MS-16, you can make critical EQ and processing decisions on overdubs or punch-ins without having to go back and listen a second time. You get what you want sooner and with fewer headaches.

The MS-16 cuts down on the time you spend locking up with other audio and video machines as well. A 38-pin standard SMPTE/EBU interface affords speedy, single-cable connection with most popular synchronizers and editing systems. It's the easy, efficient way to get the most out of today's sophisticated synchronization equipment. The MS-16's new Omega Drive transport is tough enough to stand up to long days of constant shuttling... while handling tapes with the kid-glove kindness they deserve.

Record/Function switches for each track allow effortless, one-button punch-ins. Input Enable allows instant talkback during rewinds, fast forwards and cue searches. These features speed you through sessions and let you concentrate on the project at hand... not on your tape machine.

Take a closer look at the MS-16. See your TASCAM dealer for a demo or write us for more information at 7733 Telegraph Road Montebello, CA 90640.

THE TASCAM MS-16 SIXTEEN TRACK



TASCAM THE SCIENCE OF BRINGING ART TO LIFE.

mits the rapid isolation of errors to specific areas of the equipment.

Making connections

Using the unit is straightforward. Simply plug the correct interface pod into the board's microprocessor socket. The interaction between the troubleshooter and the UUT is based on the capability of a microprocessor to read or to write data at a given address. Unlike logic analyzers, signature analyzers and other digital testers, the 9010A does not gather information in the time domain. Through the connection at the microprocessor socket, it actually takes control of the UUT's microprocessor bus and allows the operator to specify read and write operations anywhere in the UUT address space. With the large number of simultaneous operations typically occurring on the bus, control of these operations is mandatory for the tests.

The system can be used with most microprocessors. The microprocessor-dependent features are provided by a particular interface pod designed for a chip or family of chips. By selecting the appropriate pod, the unit can support most 8-bit and 16-bit processors. The mainframe also has upward compatibility for future 32-bit applications.

Custom software

One of the keys to the successful implementation of automated testing of

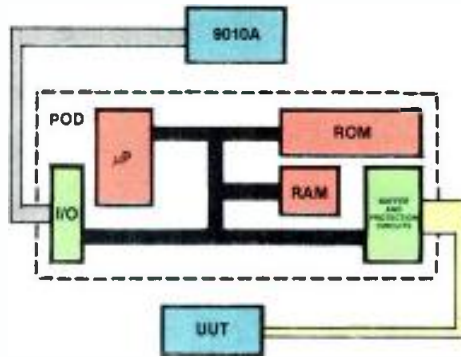

Figure 2. Internal architecture of the microprocessor pod.

9010A Micro-System Troubleshooter:

Performance at a glance

- Provides quick isolation of microprocessor faults
- Compatible with 8-bit and 16-bit processors
- Preprogrammed test routines can automatically check the entire kernel
- Peripheral devices such as CRTs, readouts, relays can be controlled
- Programs available to help user write test routines
- Mag tape stores all kernel tests "learned" in automatic mode
- Full duplex RS-232 interface option available for modems or local connections

microprocessor-based equipment is the development of custom software.



KCST-TV engineer Mike Bell troubleshoots the microcircuit that controls a character and graphics generator.



Digital malfunctions in videotape recorders can be diagnosed using the 9010A's preprogrammed functions.

MINUSCULE.

Until you use it.

**NOW AVAILABLE
IN FLESH TONE.**



SHOWN ACTUAL SIZE

The job of a good lavalier microphone is to be heard and not seen. So we're introducing the new MKE 2 micro-miniature electret lavalier mic—our smallest ever. It comes with a variety of clothing attachments and can even be taped to the wearer's skin. So whether your talent is fully costumed for an epic or scantily clad they'll hardly know it's there.

You'll know it's there, though. Thanks to Sennheiser back-electret technology and an extremely thin, low-mass diaphragm, the MKE 2 gives you uncanny transient response, and frequency response from 40 to 20,000 Hz, all with low sensitivity to mechanical noises. Which means you hear clear voices, not ruffled clothing. See the MKE 2 for yourself, but be prepared to look closely.

SENNHEISER®
Sennheiser Electronic Corporation (N.Y.)
48 West 38th Street • New York, NY 10018 • (212) 944-9440
Manufacturing Plant: D-3002 Wedemark, West Germany

© 1983 Sennheiser Electronic Corporation (N.Y.)

Circle (92) on Reply Card

Without the custom software, the capability of any automated testing device is limited.

The Grass Valley Group was the first manufacturer to offer custom troubleshooting software designed for the 9010A. Chyron also offers optional software packages to be used in troubleshooting its own equipment. Ampex recently began to support stations with custom diagnostic software for some of its equipment.

In our case, the troubleshooter is a tremendous asset to the engineering department. The device offers the staff a new level of repair capability. Because the sophisticated tests the unit performs are identical to those used at the factory, it's much easier for us to work with the factory technicians when their assistance is required. This, coupled with the custom software testing routines, makes the system a most formidable weapon in the fight to keep sophisticated equipment running.

Editor's note: The field report is an exclusive BE feature for broadcasters. Each report is prepared by the staff of a broadcast station, production facility or consulting firm.

In essence, these reports are prepared by the industry and for the industry. Manufacturer's support is limited to providing loan equipment and to aiding the author if support is requested in some area.

It is the responsibility of Broadcast Engineering to publish the results of any piece tested, whether positive or negative. No report should be considered an endorsement or disapproval by Broadcast Engineering magazine.



Ikegami's HL-79E gets me through with flying colors—every time!

Bill Napier, Director of Engineering WBTV, Charlotte, North Carolina

The HL-79E camera is adding another dimension to the phrase "The Great Outdoors" as more users discover that the world's best ENG camera is also the best for EFP.

And with over 5,000 HL-79 cameras sold, the legend continues to soar.

On or off your shoulder, the Ikegami HL-79E is still the unchallenged leader with features that include Dynamic Detail Correction, Chroma Aperture Correction, Highlight Aperture Correction and Auto Contrast Compression. Plus, the HL-79E offers superior contrast range, S/N ratio, registration accuracy, resolution, viewfinder performance and more.

As an EFP camera, the HL-79E can be used in various systems configurations, and controlled remotely by the MA-79 Multicore Adapter through multicore cable (up to 300 meters), or by the TA-79E Triax Adapter through triax cable (up to 2,000 meters). Available viewfinders include 1½, 4½ and 3 inch.

The camera can be set-up using conventional manual techniques or an optional microprocessor assist.

With the HL-79E as an EFP or ENG camera, the sky's the limit.

For a complete demonstration of the HL-79E and other Ikegami cameras and monitors, contact us or visit your local Ikegami dealer.

Ikegami

Ikegami Electronics (U.S.A.), Inc.,
37 Brook Avenue,
Maywood, NJ 07607

- East Coast: (201) 368-9171
- West Coast: (213) 534-0050
- Southeast: (813) 884-2046
- Southwest: (214) 233-2844
- Midwest: (312) 834-9774

Circle (79) on Reply Card

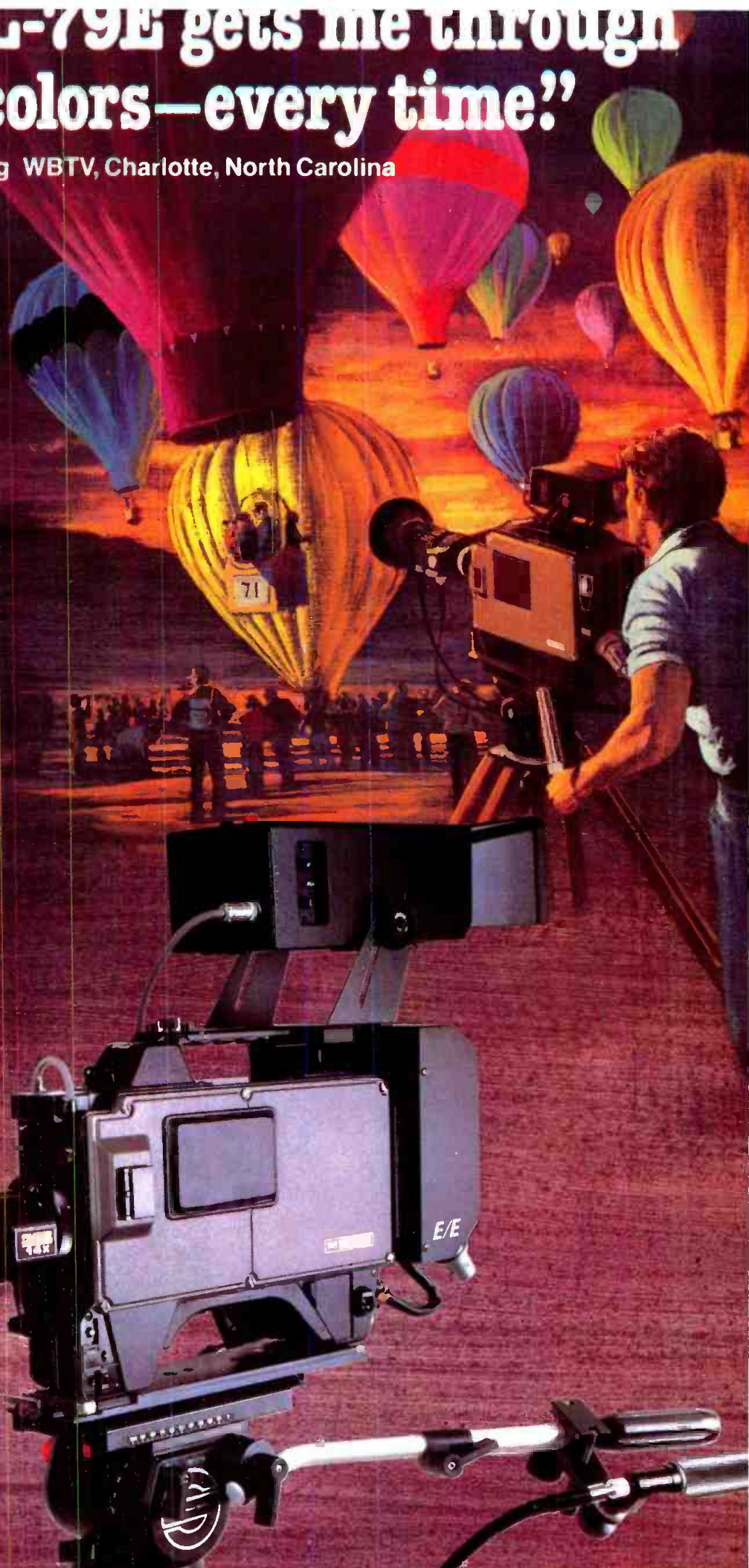

Technology theme set for 127th SMPTE

By Carl Bentz, TV technical editor

The 127th SMPTE technical conference will preview the technology that will shape tomorrow's TV and film industries. The event is scheduled for Oct. 27 to Nov. 1 at the Los Angeles Convention Center. The theme of this year's technical conference and equipment exhibit is *New directions in technology—difficult decisions*.

The digital domain

At the heart of the conference will be technical presentations, covering many aspects of film and TV engineering. Of note on Monday, the day of the conference opening, will be a TV-oriented session discussing applications of personal computers. Topics will range from graphics control to editing to audio measurements. The high-tech theme will continue on Wednesday, addressing digital audio in production, editing and presentation. Electronic imaging and character graphics systems will take the podium on Thursday.

Components and HDTV

The subject of video components, on Wednesday's agenda, will cover individual topics ranging from signal monitoring to signal-quality improvements and component transmission and processing. A view of components at sampling rates less than the standardized 4:2:2 plan will be presented.

Thursday's discussion of high-definition imaging will evaluate perceived needs to be met by an HDTV system, rather than dealing with a multiplicity of approaches to improved definition. In particular, gamma correction and dynamic range will be addressed, and NTSC's role in HDTV will be examined.

For today's systems

Multichannel audio, another topic scheduled for Thursday, will include discussion of operating considerations in a full MTS facility, based partially on work at KTLA-TV, Los Angeles. Problems in achieving proper monaural presentation in stereo systems will be examined.

The Friday symposium will center on TV cameras. Two views on photosensitive material in tubes and solid-state camera sensors are scheduled, as well as a preview of tomorrow's cameras. The

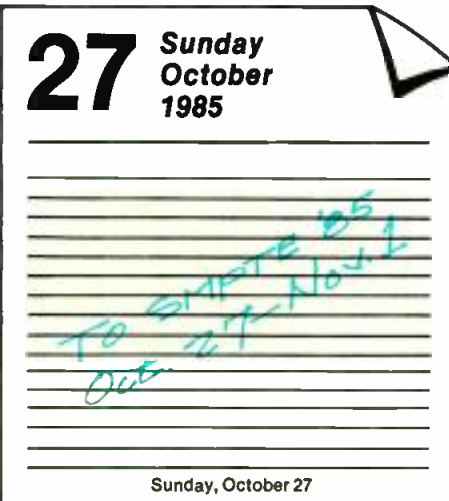

subject of modern camera maintenance should prove valuable.

Discussion of automatic equipment control in TV facilities will touch on editing, program control and transmission. A progress report will be given on the subject of implementation of the SMPTE/EBU control bus.

Recording

The Friday program will include presentations on video recording. The topic of production applications will include the videodisc medium and time-lapse recording. Developments in analog recording and a status report on metal particle tape will be covered, along with a discussion of new image-processing techniques for Type C VTRs.

Awards

Society recognition for outstanding achievement in the industry will

highlight the honors and awards luncheon, on Monday. The society's premier award, the Progress Medal, will be presented to Roland J. Zavada of Eastman Kodak. The honor cites Zavada's contributions to motion picture and TV engineering, including the drafting of ANSI and ISO proposals for Super-8 format standards.

Other individual award recipients will be Leroy E. DeMarsh (Eastman Kodak), Agfa-Gevaert Gold Medal; Allan Curtis (NBC), Eastman Kodak Gold Medal; William C. Shaw (Imax Systems), John Grierson International Gold Medal; Thomas G. Stockham, Alexander Poniatoff Gold Medal; Richard J. Taylor (Quantel), David Sarnoff Gold Medal; Keith Whitmore, Herbert T. Kalmus Gold Medal; and Ioan R. Allen (Dolby Labs), Samuel L. Warner Memorial.

Multiple-recipient awards include the SMPTE Journal award, to be presented to William F. Schreiber (MIT); Denise Q. Humphreys, Paul J. Mutter and Richard C. Sehlin (all of Eastman Kodak). Outstanding Service citations will go to John Barry (Philip A. Lapp Ltd.), Richard L. Cornell (RLC & Associates), John F. Donovan (Atlab Australia), Yvon Jean (Societe Radio-Canada) and Thomas J. McCormick (Audio Visual Supply). The SMPTE Presidential Proclamation will be awarded to Harold Greenberg (Astral Bellevue Pathe), Joe Kelly (Glen Glenn Sound) and William H. Smith (Allied Film & Video).

Associated with the conference, SMPTE study and working groups will meet to discuss standards needs and requirements. In the exhibit stands, about 240 manufacturers and industry service organizations will highlight current products and innovations.

Participation, please

If you are interested in the future of television, the society would like to know your views. This conference will introduce you to those involved in developing standards for equipment and operations. This is an opportunity to make your voice heard.

For more information about this year's technical conference and equipment exhibit, contact SMPTE, 862 Scarsdale Ave., Scarsdale, NY 10583, or phone 914-472-6606.

Technical program

Monday

Conference Opening: Welcoming address by SMPTE President Harold Eady

Tuesday

Laboratory Practices
Film Technology

Wednesday

Digital Sound
Film and TV Production
Film-Tape Interface

Thursday

Graphics, Digital Techniques
Stereo TV Sound
Post Production

Friday

Cameras, Image Sensors
TV Plant and Control Room Design
Video Recording
Personal Computer Applications

EVERYTHING A SYNC AND TEST SIGNAL GENERATOR SHOULD BE. INCLUDING AFFORDABLE.

Now in a single, compact package... the test signals you need plus the advantages of full master and genlock sync capability. With the new TSG-170A you get all this plus Tek quality and performance at a reasonable price.

The TSG-170A is designed for easy operation and flexibility. It includes a 10-bit digital test generator, with a full complement of test signals, and a stable RS-170A sync generator. Genlock timing, sync timing and test signal selection are all easily accessible from the front panel or through the remote connector.

As an option the TSG-170A offers SMPTE color bars with

programmable ID and audio tone output. As a result, bars can be available on a continuous basis for the operational side of your facility.

What's more, the TSG-170A's rugged, 1¾-inch package makes it ideal for remote vans or anywhere space is at a premium.

Get the full story on this flexible test signal and sync generator. Contact a Tektronix Professional Video Dealer, or your local Tektronix Sales Engineer, listed in major-city directories.

BEHIND THE SCENES IN
QUALITY TELEVISION



Tektronix
COMMITTED TO EXCELLENCE

Circle (108) on Reply Card

TV has its Emmy...
Film has its Oscar...
Business Publishing has its Neal...

BE's NEAL Honor Means You're a Winner!

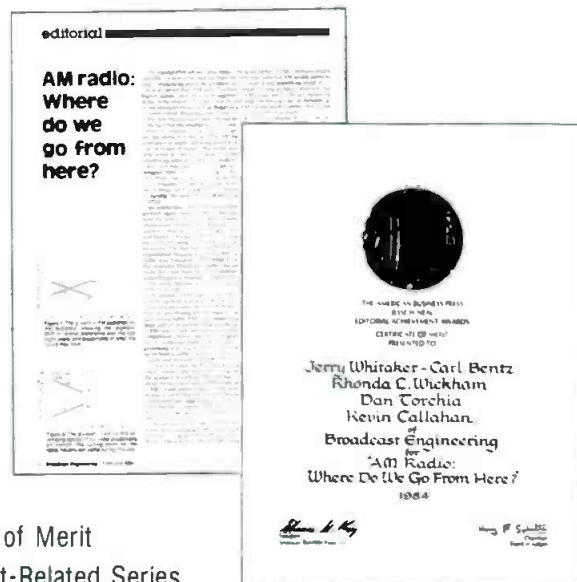

Winner: 1985 Jesse H. Neal Award Certificate of Merit
Category: Best Staff-Written Editorial or Subject-Related Series

The American Business Press' Neal Award is the "Emmy" of the business publishing industry. It's the most prestigious award a trade magazine can receive. So, BE's Neal Award Certificate of Merit proves that you're getting the best editorial package around...when you read Broadcast Engineering.

Indeed, that makes you a winner, too! Because who, if not the reader, is the true beneficiary of a magazine's editorial excellence?

Of course, broadcast industry professionals like you have long considered BE the #1 "must reading" broadcast technology magazine. You've said so in over 14 independently-conducted readership studies over the past several years.

With your ongoing support and feedback, BE will continue to keep its editorial package clear, concise, and right on target with your needs. So as long as you read BE, you'll always be a winner!

BROADCAST
engineering ...the #1 broadcast technology magazine.

With Bosch, Every Piece Fits . . .



BOSCH

Designing A New Facility Or Updating An Existing One?

• Master Control

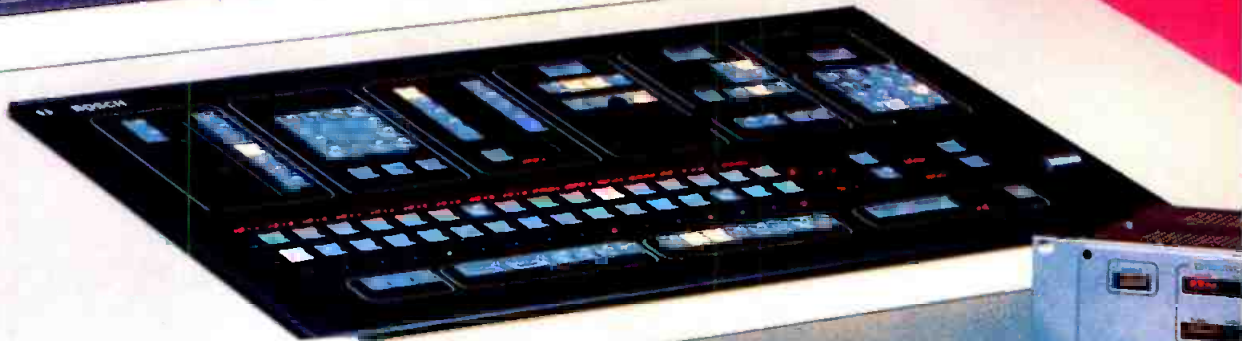

• Machine Control

ARE YOU PUZZLED with the type of switching system to install at your facility? Let Bosch fit all the pieces together for you!

From Master Control to Machine Control, Bosch has all the switching equipment you will need to complete your equipment room requirements. Bosch's complete system of switching equipment includes:

- **Distribution Switcher — TVS/TAS-2000**

The Bosch distribution switcher will provide you with flawless service and unlimited expansion capabilities for video, audio and control signals.

- **Master Control — MCS-2000**

You will have total studio control by combining the versatility of the distribution switcher and the creative capabilities of a production switcher to make the most versatile Master Control Switcher available. You also have full stereo-audio capabilities.

The Bosch Switching



Bosch Switchers Fit!



• Distribution Switcher

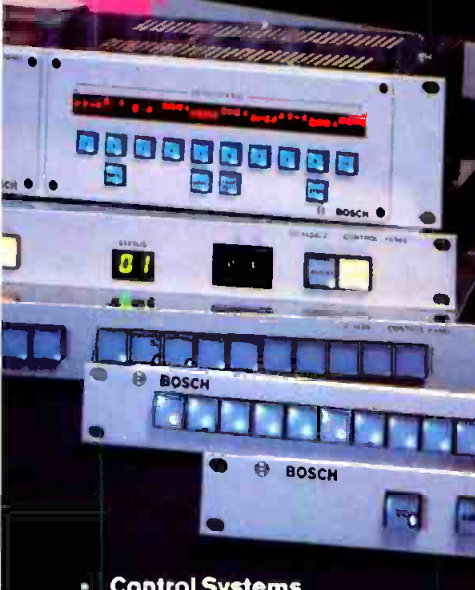

• Control Systems

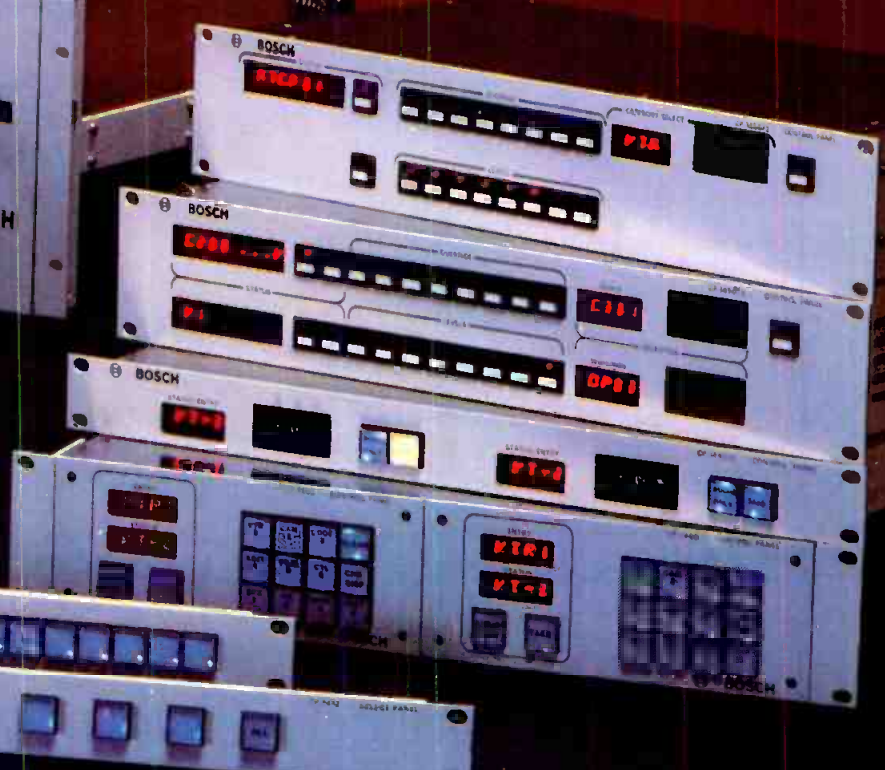

Equipment System



- **Machine Control — TCS-1**

Bosch's Machine Control systems give you remote control of your video production equipment from single or multiple locations, resulting in substantial savings in equipment and manpower. The savings in wiring costs alone often offset the price of the system.

- **Control Systems**

Enhanced serial control systems allow you exceptional flexibility in controlling the switchers.

Bosch offers a five-year warranty on its TVS/TAS-2000 Distribution Switching Equipment.

Don't be puzzled any longer . . . let Bosch supply your facility with the best switching equipment available!

Control Systems Designed For Your Specific Needs . . .

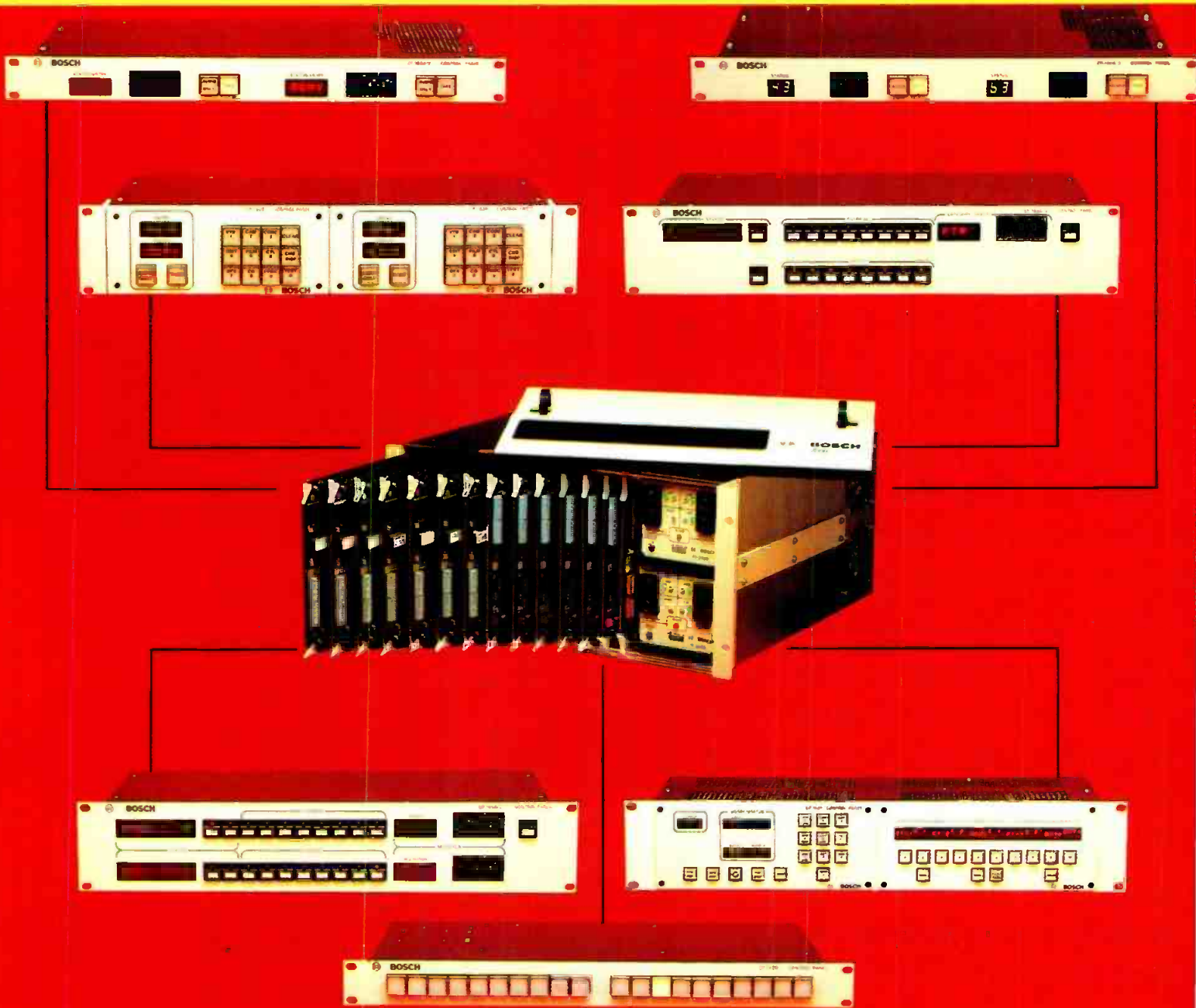

- **Control Panels designed with your control requirements in mind**

Bosch offers a broad line of microprocessor-based control panels to provide you with the most flexible control system for the TVS/TAS-2000 switcher. Readouts give you immediate numeric or alphanumeric status of sources and destinations.

Five-year warranty!

**Let Bosch fit all the pieces
together for you — today!**



BOSCH

Robert Bosch Corporation
Video Equipment Division
P.O. Box 31816 / Salt Lake City, Utah 84131
(801) 972-8000 Telex: TM388352 SLC

Applying subcarrier technology

By John Kean

If you've been hoping to make some money from your FM or TV subcarrier, the prospects are looking up.

Subcarrier development is spreading across the country, but at a rate slower than many expected just two years ago. When the FCC deregulated SCA service, it permitted new commercial and technical operations on FM radio and TV stations. With the recent introduction of new subcarrier commercial data services, the awaited revenues from this potentially lucrative medium may finally be near.

Data via subcarrier

Two of the new data services involve Mutual Broadcasting and ABC, and are intended to compete with other information-delivery systems. Mutual announced its Multicomm satellite-to-subcarrier system in January. The satellite services division of Mutual is now outfitting participating stations in the top 50 markets with satellite receive terminals and subcarrier generators. Subcarrier coverage is hoped to eventually reach 85% to 95% of U.S. businesses through subcarriers on stations in 110 to 115 markets.

Mutual has so far picked up a joint sports/news subscription service from United Press International and American Sports Advisors, and on a trial basis, the Dow Jones News Service.

ABC Video Enterprises has formed a joint venture that will provide high-speed data delivery for business communications. ABC's partners are Epson America (a manufacturer of microcomputer terminals), the Hillman Company (a venture capital group), and the Indesys Management Group (which gives the project its name).

The Indesys system will use the ABC Radio satellite system and FM station

Kean, BE's consultant on subcarrier technology, is a senior engineer with National Public Radio, Washington, DC

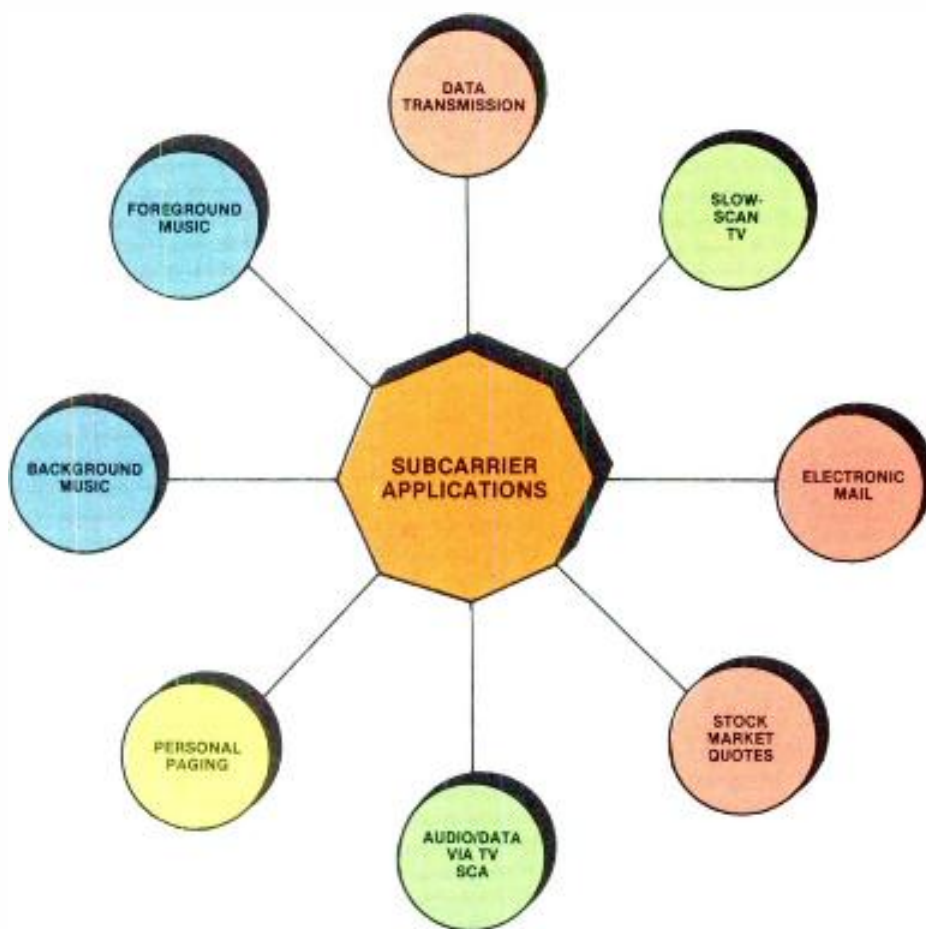

subcarriers. Service is expected to start this month in five cities (with four ABC-owned-and-operated FM stations in New York, Chicago, Los Angeles and Dallas, plus an affiliate in San Francisco). The data will be transmitted via Satcom 1-R to FM transmitters, where the addressable messages will be sent to personal computers equipped with a specially designed receiver board. (See "A Closer Look at Indesys," page 150.)

Other large systems are already under way at this time. Bonneville Interna-

tional has been involved in electronic mail delivery for several years and is currently upgrading the size and speed of its national system.

Several major suppliers of financial and commodity news services are also operating subcarrier systems. Quotes directly from the major stock and commodity exchanges can be gathered, formatted and transmitted within seconds of a trade. PageAmerica, for example, offers *Pocket Quote*, a device the size of a calculator, that relays quotes 15 minutes

behind the market. Dataspeed's *Quotrek* subcarrier receiver displays stock market information on an LCD readout. A desktop version connects to a personal computer and can continuously update portfolios with up to 250 selected stocks or futures.

SCA paging

When the FCC lifted restrictions on the uses of FM SCA, broadcasters saw paging via radio subcarriers as a new source of income. During the past two years, paging has proven to be a technical disappointment for some users.

Subcarrier paging has not yet made a significant impact on the paging industry, either. The growth of this business has been held back, in part, by problems with some of the first pagers. In addition, some manufacturers and paging companies overestimated the penetration of the subcarrier signal for mobile coverage. Because multiplex (SCA) systems enjoy little or no *capture effect*, they are less able than the main channel to reject modulation distortion caused by multipath reception. This effectively reduces their reliability.

The reputation of subcarrier paging may improve as heavyweight broad-

casters enter the market. Earlier this year, CBS Radio agreed to work with a California-based company on a nationwide paging service. The company (American Diversified), is using a numeric-display pager. The unit operates on a 57kHz subcarrier and automatically scans for the strongest FM subchannel when the signal begins to fade. Broadcasters may soon be able to choose from several new types of pagers, including one that provides hard-copy output.

On the whole, paging should continue to be a growth industry. Within five years, 12,479,000 pagers are expected to be in service with total U.S. sales of \$1 billion, according to an industry survey by Frost & Sullivan. A report issued last winter by the New York research company bases its projection on a dramatic rise in consumer use, along with a steady demand from users in the areas of sales, service, construction and health care.

Audio subcarriers

The primary users of subcarriers to date are audio music services. These companies usually produce the programming, market the service, install the receivers, lease transmission time and bill the customers. For these users, FM

subcarriers still provide attractive savings over dedicated telephone lines, despite rising subcarrier lease prices.

Although nearly all the subcarrier music has been *background* programming (for indirect listening), a few subcarriers are being programmed as *foreground* music services. These new services provide music for direct listening in stores and restaurants. This recent application may put new demands on the audio performance of subcarriers. Compression and reciprocal expansion (companding) of the audio signal should provide significant improvements in the perceived audio fidelity of an SCA system. No audio-companding technical standard or stock receivers with expanders have yet emerged, however. It is unclear whether this new foreground service will demand improved audio performance from the broadcaster.

TV subcarriers

In April 1984, the FCC revised its rules permitting expanded subcarrier services on television. The new rules provided a stereophonic sound channel, a second audio program (SAP) channel and other multipurpose subcarrier channels.

According to a recent report from the

STOP COSTLY DOWNTIME

Installed between the power source and equipment to be protected, the LEA line of Surge Eliminators will prevent equipment loss and downtime due to High Current Surges, Overvoltage Transients and EMP.

They're available in powerline current ratings from 10 to 4,000 amperes for computer, Radio/TV Broadcast, industrial and other loads.

LEA Surge Eliminators:

- Handle up to 50,000 joules of energy
- Dissipate 99% of lightning surges
- Handle surge currents up to 200,000 amperes
- Respond in 5 nanoseconds
- Are available in 1 through 3300 KVA ratings
- Automatically reset
- Use a Multistage SERIES hybrid design

The LEADER in pure power technology

Contact Broadcast Systems Group



LEA Dynatech Inc.

12516 Lakeland Road
Santa Fe Springs, CA 90670
(213) 944-0916
TWX: 910-586-1381

Circle (68) on Reply Card

FROM HAIRPIN TURNS TO STRAIGHTAWAYS, THE SPEED OF SOUND HAS NEVER BEEN SO SMOOTH.



For years, sloppy tape transportation and handling have made the audio engineer's day much harder than it had to be.

This tormenting state has come to an end with the introduction of Sony's APR-5000 2-track analog recorder, available in a center-track time code version.

The APR-5000's precise handling and numerous advanced features make the audio engineer's day run much smoother. For example, the APR-5000's 16-bit microprocessor manages audio alignment with a precision that's humanly impossible. And the additional 8-bit microprocessor opens the way for extremely sophisticated serial communications. In tandem, they reach a truly unique level of intelligence.

Not only does the APR-5000 do its job well; it does it consistently. The die-cast deck plate and Sony's long-standing commitment to quality control maintain that the APR-5000 will hardly need time off.

All of which results in a consistent sonic performance that'll stand even the most critical audio professionals on their ears.

For a demonstration of the recorder that transports analog audio to a new fidelity high, contact your nearest Sony office:

Eastern Region (201) 368-5185;
Southern Region (615) 883-8140;
Central Region (312) 773-6000;
Western Region (213) 639-5370;
Headquarters (201) 930-6145.

SONY
Professional Audio



© 1985 Sony Corp. of America. Sony is a registered trademark of Sony Corp.

Circle (85) on Reply Card

Cetec puts your FM signal in its place

If you need a directional CP/FM antenna, you need to know that Cetec Antennas is the really experienced one.



Cetec is the world leader in custom-designed directional CP/FM antennas in the full power range.

- Our custom-made directional antennas are operating coast-to-coast.
- Full-scale antenna measurements on Cetec's all-year, all-weather test ranges.
- Custom-made tower structures. We duplicate your tower for optimum results.
- Ask about Cetec's new low-power educational package.

Give us your requirements and watch us produce.



Cetec Antennas

6939 Power Inn Road, Sacramento, CA 95828 • (916) 383-1177 Telex: 377321

Circle (86) on Reply Card

Electronic Industries Association, more than 100 TV stations are now equipped to broadcast stereo sound. The growth of separate TV subchannel services, however, has been limited in comparison with TV stereo. Certainly, TV broadcasters can be expected to reserve the aural baseband for future stereo broadcasts, but TV licensees appear reluctant to commit the remaining subcarrier spectrum to another service that could block the use of the SAP channel for bilingual TV programs.

A few specialized services have developed with the change in FCC rules. In Trenton, NJ, public TV station WNJT-TV is now carrying a radio reading service on a subchannel. The 15,734Hz stereo pilot is not transmitted, permitting the SAP channel to be used without companding. The non-encoded SAP channel is used to broadcast the reading service programming. By not transmitting the stereo pilot, the station does not have to comply with the commission's MTS rules, which would normally require encoding and corresponding expanders in each of the radio reading service receivers.

WTIC-TV in Hartford, CT, is broadcasting both stereo English and monaural Spanish programming. The station dubs the Spanish audio from tapes, produced for South America, to the third track of the videotape recorder. On playback, the SAP channel switches from an endless-loop cartridge with promotional material to the Spanish-language track of the recorder. At completion of the tape, the SAP channel switches to a promotional cartridge instructing viewers to switch their receivers back to the English-audio channel. The endless-loop cartridge then begins with promotional material about the station's programming and locations where SAP channel-equipped TV receivers can be purchased.

KTLA-TV in Los Angeles also uses its SAP channel for Spanish-language programming. The station uses its professional channel (at 6.5 times the pilot or 102.28kHz) for remote control of ENG microwave transponders at distant sites.

Changes in FCC rules

Effective January 1, 1985, the commission amended its rules to permit all FM stations transmitting stereophonic programming to concurrently use subchannels below 75kHz with up to 20% modulation. The new SCA rules initially had limited this value to 10%. However, the 10% limitation still applies to subcarriers above 75kHz.

The commission also modified its injection limits for SCAs, reportedly to conform with the quadraphonic multiplex rules. Technically, 20% superinjection of a single subcarrier is possible. Under

technical deregulation, the commission is not concerned with the potential side effects (such as birdies or monkey chatter) of any subcarriers. Determination of this risk is the responsibility of the licensee.

On December 18, 1984, the United States and Mexico reached an agreement to permit FM stations within 300 kilometers (199 miles) of the common border to use SCA subcarriers between 20kHz and 99kHz (53kHz to 99kHz for stereo stations). The commission reminds licensees that the amended agreement with Mexico does not yet permit U.S. FM stations within 300 kilometers of the border to increase modulation above 100% when subcarriers are transmitted.

Some FM subchannel services use 57kHz subcarriers, which fall into two specific groups: additive and non-additive to the total modulation. The additive group includes all types with energy directly measurable on the station's main modulation monitor (the 1,200-baud European *radio data* system is an example). The non-additive group covers only narrowband pilot-synchronous subcarriers, which do not register peak modulation. These subcarriers are, in effect, half-amplitude third harmonics of the stereo pilot. The *automotive road information* subchannel (Blaupunkt) is the only known member of this group at present. Lessees should obtain a letter of determination from the FCC if they propose to reduce or to eliminate from modulation considerations the injection contribution of a 57kHz subcarrier.

Some lessees of 57kHz subcarriers are proposing to operate services adjacent to conventional 67kHz frequency-modulated subcarriers, overlapping the subchannels occupied by the two signals. This may result in interference, especially to the 57kHz subchannel, which has less noise immunity and operates at about half the injection of the 67kHz service.

Be prepared

Where does all of this high technology and this catalog of possibilities leave the broadcaster? Certainly, there are a number of applications that can be applied to SCA transmission with predictable results. Background music services have been around long enough that many of the technical problems have been discovered and solutions developed. Some of the new services, however, are not so predictable.

As an engineer, be ready to answer questions on what the capabilities of your transmission plant really are. Be able to discuss with management any limitations you're aware of now, so that when opportunity knocks, you'll be ready.



Promise Born

Promise Delivered

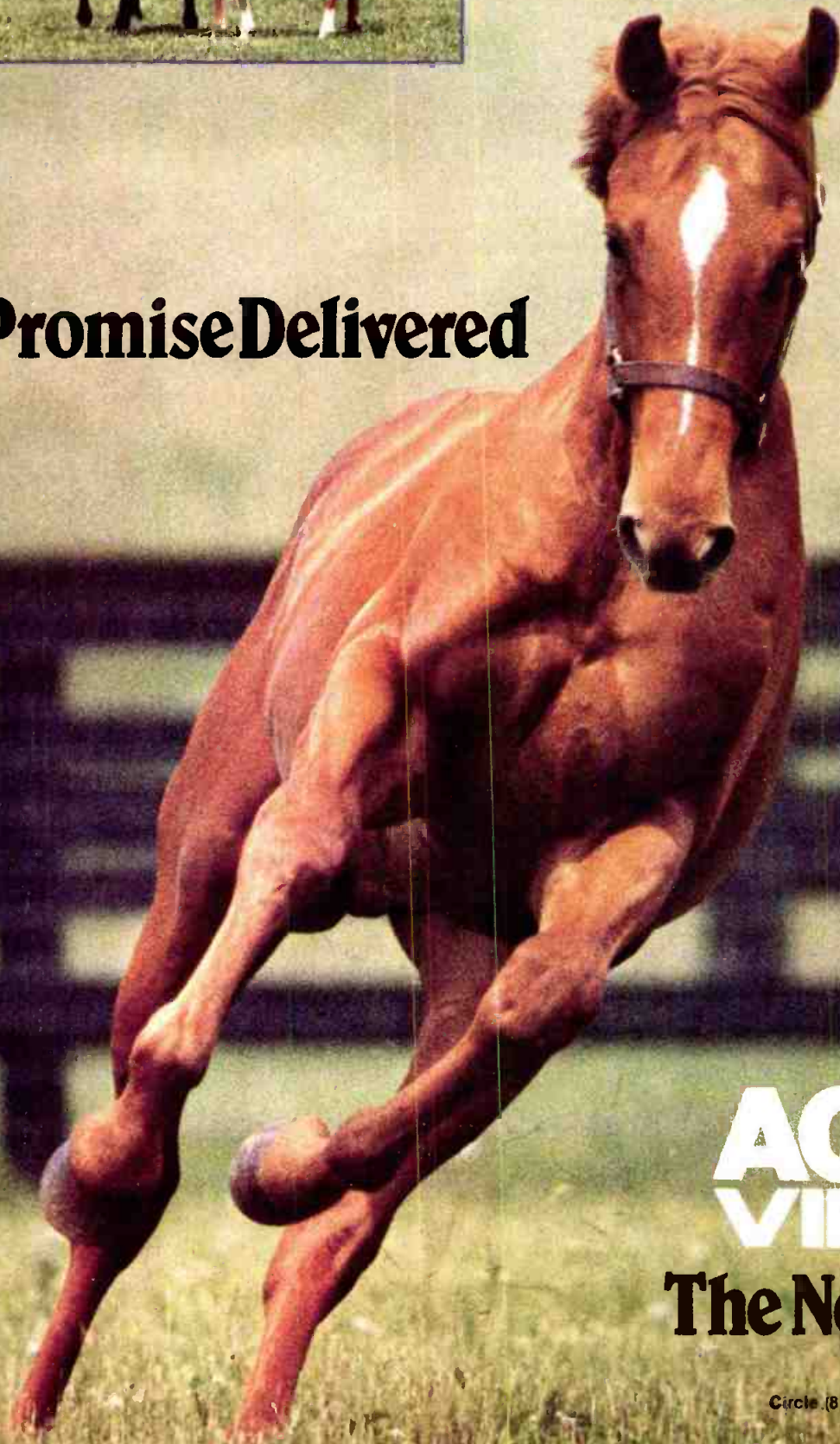

**AGFA
VIDEO**

The New Breed

Circle (87) on Reply Card

Multipath: its effect on SCA

One of the significant problems with expanded uses of subcarriers is the effect of multipath on reception. It is known that multipath accounts for most of the difference between the crosstalk levels experienced in the field and those measured under ideal laboratory conditions. What is not so well known is why multipath affects subcarrier reception to a greater degree than it affects main-channel reception.

Multipath is effectively the mixture of a direct signal from a transmitter to a receiver and one or more indirect signals (see Figure 1). The indirect signals arrive from different paths by reflection or diffraction. Because these indirect signals arrive at the receiver later than the direct-path signals, they cause interference to the desired audio. The time difference in the two (or more) signals causes instantaneous disruptions of the modulation sidebands and distorts the signal in a variety of ways. Figures 2 and 3 depict the vector addition of a direct signal and a noise signal.

In Figure 2, the long vector represents the transmitted or direct signal voltage. If we add to this voltage a shorter noise voltage vector representing the relatively weak multipath component, the vector sum of the two voltages will produce a received signal vector that differs in phase from the transmitted signal by a small angle θ . In Figure 3, the same vector addition is applied to a subcarrier signal. In this case, however, the subcarrier has less than one-tenth the strength of the main-channel signal. Therefore, when the same noise voltage vector is summed with the subcarrier vector, a larger phase error is produced.

A particularly detrimental effect on the subcarrier is the apparent incidental phase modulation (IPM) of signals in the composite baseband. Because IPM occurs at an audio-modulating rate, the subcarrier circuits demodulate the disturbance as coherent noise or crosstalk. This IPM cannot be filtered out by a frequency-modulation subcarrier detector.

Because multipath is a form of co-channel interference, the sensitivity of subcarrier receivers to multipath reception can be measured in co-channel interference tests. Table 1 shows the carrier-to-interference ratios resulting in a 30dB subcarrier signal-to-noise ratio. At this level, the audio is disrupted by breaking noise and is only marginally listenable. Selectivity

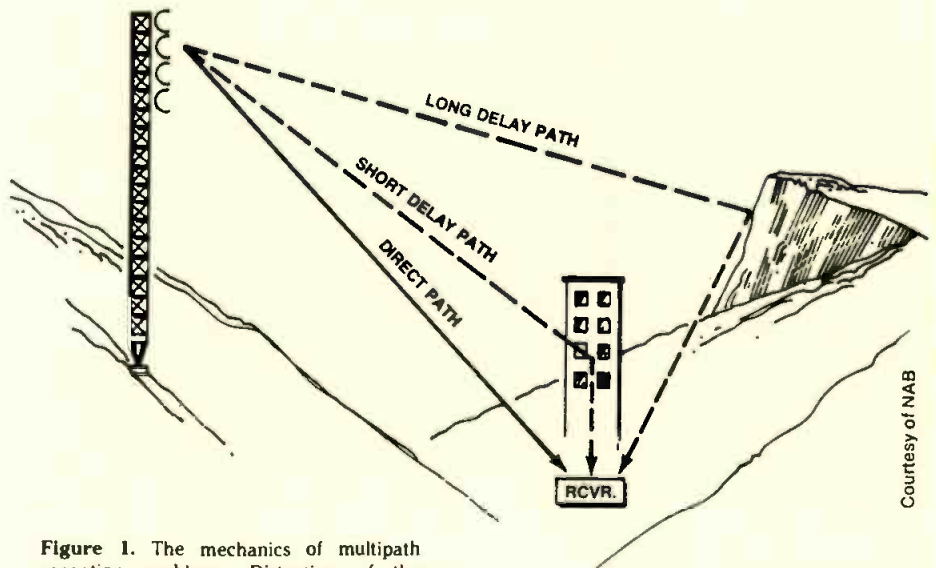

Figure 1. The mechanics of multipath reception problems. Distortion of the demodulated FM signal is related to both the direct/reflected signal ratio and the time delay of the reflected signal.

Figure 2. At right, a representation of an addition of a noise signal to a transmitted signal. Notice the angle θ .

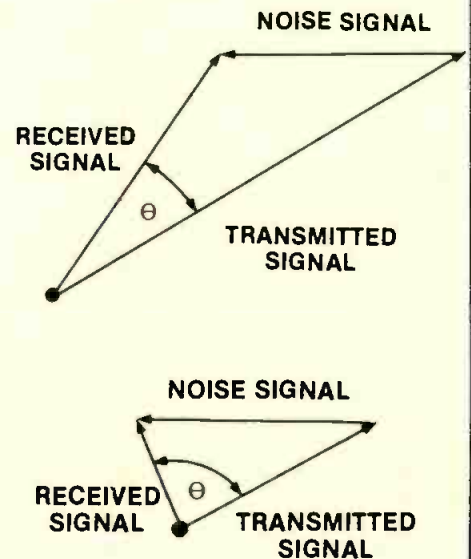

Figure 3. Representation of the same addition of a noise signal to a subcarrier. Notice the greater angle θ .

measurements in the adjacent and alternate channels are also shown.

The measurements show good rejection of alternate channel interference. The undesired signal would be from 47dB to 60dB above the desired signal for the reference interference level. Less selectivity is evident for the adjacent channel condition. The real problems show up when we look at the co-channel measurements.

If the undesired carrier is within 21dB of the desired carrier, the audio in the subchannel is disrupted. Because the subcarrier uses a lower modulation index, multipath that would be undetectable in main-channel audio can cause severe problems for the sub-channel.

DESIRED CARRIER	ALTERNATE	ADJACENT	CO-CHANNEL
45DBF	+ 60.1DB	+ 15.3DB	- 22.0DB
65DBF	+ 52.5DB	+ 16.5DB	- 21.0DB
80DBF	+ 47.3DB	+ 16.3DB	NOT MEASURABLE
TEST RECEIVER: McMARTIN TRE-6			

Table 1. RF carrier-to-interference ratios for alternate, adjacent and co-channels.

Video to go, anywhere.

**CM
TV**

*Wherever you are in the world,
Camera Mart can reach you.*

The Camera Mart, Inc.

456 West 55th Street, New York 10019 • (212) 757-6977

Telex: 275619 / FAX (212) 582-2498

305 Vine St., Liverpool, NY 13088 • (315) 457-3703

Sales • Service • Rental

Circle (90) on Reply Card

A closer look at Indesys

As mentioned in the main article, ABC and a computer manufacturer, Epson, have joined forces to create a nationwide text-delivery system. The joint venture, called Indesys, will use ABC's network of FM stations and Epson's expertise in building computer systems. The stations involved in the initial phase of the program include: WPLJ-FM, New York; KLOS-FM, Los Angeles; WLS-FM, Chicago; WTKS-FM, Dallas; and KOME-FM, San Francisco. The company anticipates that several other markets will be added in early 1986.

The system relies on a new method of modulating an SCA subcarrier. Although officials would not specify the technique used, they did indicate that it was a form of amplitude modulation. It apparently does not rely upon phase-shift keying (PSK). Currently, that technology is considered the most promising method of transmitting high-speed data on an SCA subcarrier.

The text-delivery system transmits information at a speed of 38,400 baud, several times faster than other delivery systems. Because of the amount of space allocated within the packet for customer headers and data encryption,

only about one and one-half pages of text can be transmitted each second.

How it works

The text delivery begins with a customer typing a message into a computer terminal or personal computer, and addressing it to particular locations. Once the message is written and addressed, the customer dials a local telephone number that connects the local system to the central computer. That computer formats the message by adding the private address codes for the specified receive locations, the necessary headers and encryption and then sends the data to a satellite uplink. Satcom 1-R relays the information to the FM stations.

The station's equipment consists of a satellite receiver and SCA generator. The generator also provides the option of customer verification of messages. After a message is transmitted, the customer's computer can call the FM station and verify header and message length. Any detected errors trigger a refeed of the message.

The customer terminal, diagrammed at right, provides the necessary circuits to receive and decode the messages.

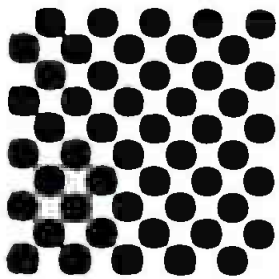
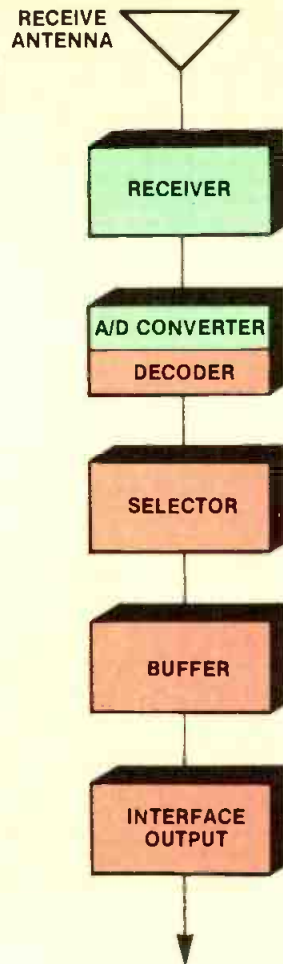

Precision Color Decoding . . . NTSC to RGB



The Faroudja Model CFD-N is a high quality NTSC to RGB comb filter decoder designed for critical applications where high resolution and absence of artifacts are required . . . large screen projection, precise color monitoring, tape-to-film transfer, standards conversion, color keying or computer graphics.

Using a unique active filtering method, the CFD-N suppresses subcarrier dot crawl and cross color without visible loss of resolution.

The exclusive Faroudja chroma enhancement circuitry also eliminates the apparent loss of chroma bandwidth usually associated with NTSC signals.

With a standard NTSC input, the CFD-N decoder provides separate R-G-B plus Y-I-Q outputs, combed chroma & luminance outputs, color differences & sync outputs on the rear panel.

Write or call for additional information.

Faroudja Laboratories Inc.

946 Benicia Ave., Sunnyvale, CA 94086 Telephone: 408/245-1492

YF FAROUDJA

Circle (141) on Reply Card

Faster than a speedy floppy disk,
More powerful than a personal computer,
and able to leap long distance remotes with a single button,
it's...

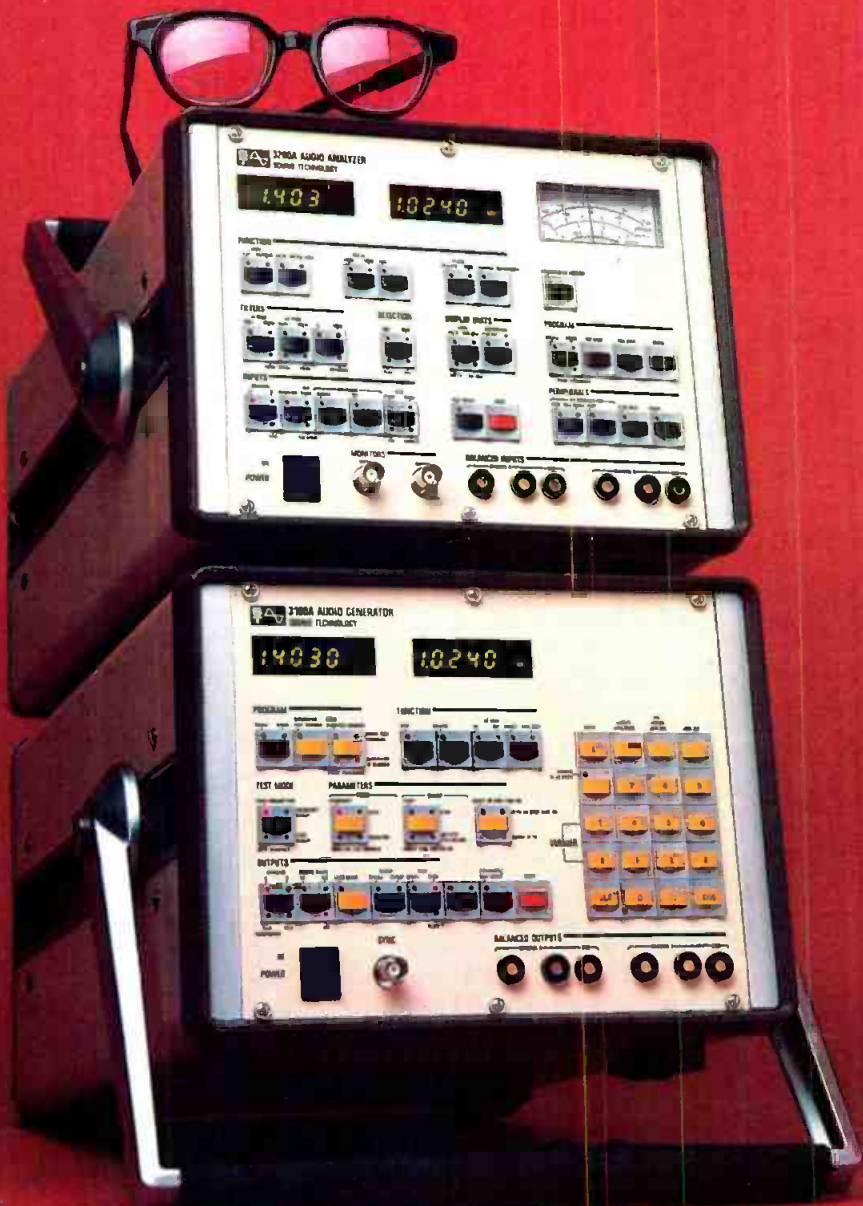

THE NEW SOUND TECH 3000 SuperSeries™ Programmable transmission/ audio test system

Specifically designed for broadcast engineers, our new 3000 Series consists of two fully-programmable, two-channel, compact and portable components: an Audio Generator (3100A) and its companion Audio Analyzer (3200A).

GENERATOR OR ANALYZER, SUPERFAST-SUPERPERFORMANCE.

To accomplish a comprehensive audio proof with other test equipment can take as much as 4 hours. In less than sixty seconds our system will deliver the same precise data.

Just want to check a distortion spec? How about 500 msec? Level? Would you believe 30 msec?

The SuperSeries lets you design your own test routines and store them in programmable, non-volatile memories. Why go through time-consuming, tedious and superfluous external computers or controller programming if you don't have to? In fact, forget flipping floppys entirely!

The Generator outputs sine and square-waves, SMPTE IMD, Tone-Burst and Sine-Step. Output level is +30 to -90 dBm. RF is completely eliminated by fiber-optic signal isolation.

The Analyzer can make more measurements than any other test system presently available: flat & filtered level, S/N, THD vs. Level & Freq., SMPTE IMD, phase error, channel separation - even Quantization noise. Naturally, both units are electronically balanced and floating.

FSK SUPER COMMUNICATIONS

In addition to GPIB and RS-232 interfaces, the SuperSeries can talk to each other easily because of our exclusive FSK communications protocol. This means you can perform any kind of automated test, in any sequence, in any application, without the need for an external computer, controller or separate communications line.

The 3000 SuperSeries are available as separates (pictured) or together in a single mainframe. Options are limited, and there's a 2000 Series for less demanding, but equally important test requirements.

Contact us now for full technical data and prices which will undoubtedly be more good news.

Here on the Daily Planet, and in a world of injustice, your biggest crime would be to ignore the facts from the mild-mannered company.

S SOUND T TECHNOLOGY

1400 Dell Avenue
Campbell, California 95008
(408) 378-6540
Telex: 357445

Put The Best
To Test!

Essential in the trench.



Indispensable on the bench.

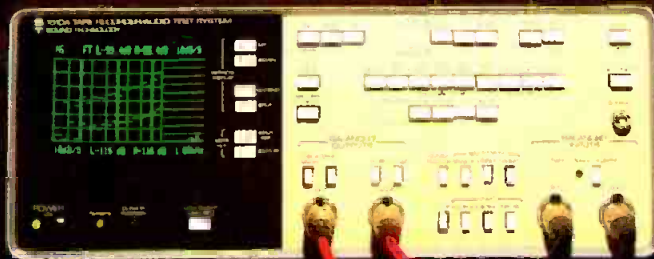
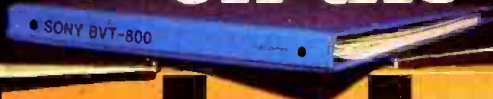

THE SOUND TECH 1500 SERIES TEST SYSTEM

With a microprocessor-controlled Sound Tech 1500 Series test set, you can sort out the fiction from the facts—quickly and easily. Audio manufacturers the world over have come to rely on the 1500 Series. As high-tech goes higher and time seems to get shorter, the benefits of having immediate, precise and critical test data gets even greater. And that's where a Sound Tech 1510A comes in—on your bench, or in the trench.

Whether you're a design engineer or you have the technical responsibility for keeping your facilities up and running, the 1510A is designed to perform all the necessary tests for maintenance, troubleshooting and general check-out of any professional audio device like: tape recorders, film machines, mixing consoles, signal processing equipment, turntables—you name it. With the 1510A's exclusive asynchronous I/O, it's practically a mandatory piece of gear for remote location tests for satellite transmission, conventional transmitters or broadcast studio checks.

When a pro needs to know the truth, he can select from over fourteen different test programs that are stored in the 1510A. Because the instrument is modular, you can easily add options like a one-third octave spectral analysis card for noise & flutter measurements, a GPIB IEEE-488 computer communications interface, an MOL level test, and more. Much more.

With the 1510A's built-in CRT, you have easy to read and interpret alphanumeric and graphical data (on applicable tests). If you add our peripheral printer, you can have a hardcopy of anything displayed on the 1510A's CRT display—accurate, verifiable evidence.

Whether you push pencils or faders, there isn't an all-in-one audio test system around that can do everything the 1510A has been designed to do—as fast and as easy.

Contact us now for full technical and applications information. See for yourself why there are more than 1,000 users who already know something you should.

**S SOUND
T TECHNOLOGY**

1400 Dell Avenue
Campbell, California 95008
(408) 378-6540 Telex: 357445

**Put The Best
To Test!**

Circle (94) on Reply Card
Facilities courtesy of Editel Corp.

RF products division acquired by Gentner

Russell Gentner, president of *Gentner Electronics*, Salt Lake City, and John E. Leonard Jr., president of *Leonine Technology*, San Jose, CA, have jointly announced the acquisition of Leonine Technology by Gentner Electronics. Leonine Technology has been renamed Gentner RF Products Division and will be headed by Leonard.

Gentner RF Products Division will be located in San Jose. The address is P.O. Box 32550, San Jose, CA 95152. The telephone number is 408-729-0600; EasyLink 62894180; Telex 11 910-380-6909 GENTNER UD.

BTC, UPI announce data network plans

Bonneville Telecommunications Company (BTC) and *United Press International* (UPI) have signed a letter of intent for BTC to design and implement an expanded, modernized communications system for distributing UPI's news and data. The system will use Bonneville's satellite and FM subcarrier data distribution technology. General Electric Information Service's Mark*Net Value Added Network will allow dial-up access to the system.

Ampex signs contract with AME

Ampex Corporation's Magnetic Tape Division, Redwood City, CA, announced that it has signed a multi-year 7-digit contract to supply AME, Burbank, CA, with a full line of professional broadcast quality videotape. Ampex will supply AME with Ampex 196 1-inch, 197 ¾-inch, 187 standard U-matic, 101 Beta and 102 VHS videotape.

BMA delivers NEC E-Flex systems

Deliveries of five NEC E-Flex DVE systems in California have been made by *Broadcast Marketing Associates*, San Jose, CA. Recent installations include the Opti-Flex perspective/rotation accessory that permits manipulation of images through all three axes. They include CFI, Hollywood, KMEX TV, Los Angeles, Ambassador College, Pasadena; and McDonnell Douglass Productions, Huntington Beach.

Delta sells equipment to China-based company

Delta Electronics, Alexandria, VA, has sold broadcast equipment to the Import Department of the Shanghai Foreign Trade Corporation. Purchases included the model OIB-3, an operating im-

pedance bridge, and the model RG-4, a receiver/generator.

Delta is also increasing production of its C-Quam AM stereo exciter system. Improvements include better channel separation and frequency response. Changes also have been made to improve long-term reliability and to simplify maintenance.

Investors buy Gotham

Gotham Audio has been sold to a private investment group. The transaction was the result of more than a year's negotiations between the two parties. Gotham will remain at its present address. The name will be retained, but the logo will be redesigned. The product lines from Neumann, EMT, NTP and Klein & Hummel will still be the foundation of Gotham's business.

Soundcraft wins contracts from BBC

Soundcraft Electronics, London, England, has won three separate orders from the BBC for its sound mixing consoles, including a contract to supply the BBC with four systems, which will be used for TV applications during the 1986 Commonwealth Games. The games will be held in Edinburgh, Scotland, July 24 to Aug. 2, 1986.

Four customized 500-series consoles are to be installed at the Broadcast Center in Edinburgh and will be used by both the BBC, as host broadcaster, and ABC Australia. The BBC's Bristol Network Production Center has ordered a customized 500-series to be installed at St. George's Church, Brandon Hill, Bristol, for live broadcasts and recording.

Soundcraft has also supplied eight 16-channel 200-series portable mixing consoles that will be used by BBC Radio outside broadcast units in London.

BSM moves to new facilities

BSM Broadcast Systems, Spokane, WA, has moved its operations to new facilities in the Spokane International Airport Business Park. This move nearly doubles BSM's current administrative and production areas. The mailing address is Box 19007, Spokane, WA 99219-9007. The telephone number is 509-448-0697.

Radio Systems completes turnkey installation

Radio Systems, Edgemont, PA, has completed manufacture and turnkey installation of a travelers information radio station for Stapleton International Airport serving Denver. The station provides routing traffic, flight information and travelers bulletins in case of severe

weather and other emergencies.

The 530 AM station is considered to be the largest, most sophisticated system of this type in the county. The custom-built automated studio includes six digital storage recorders, backup cart capability and county-wide call-in lines to supplement the radio broadcast. The system can be remote-controlled via secure touch-tone phone access in an emergency situation.

Polycom installs Quantel hardware

Polycom Teleproductions, Chicago, has installed Quantel's floating viewpoint for the Mirage. The hardware enables an editor to take 3-D shapes and rotate them in real time with perspective, transparency and expansion, using a tracker ball. Polycom is the first facility in the Midwest to acquire this device, which enhances the features of the standard Mirage. The editor controls the speed of movement and has the capability to provide infinite zoom, with full motion control on all three axes.

BE delivers FM transmitter

Broadcast Electronics, Quincy, IL, has delivered an FM transmitter to KISW-FM's new site on Cougar Mountain, east of Seattle. The 60,000W transmission system, the FM-60, is the second of its kind in service. BE's first FM-60 transmitter has been operational at KGOL-FM, Houston, since July 1984.

RFE/RL awards contract to BE

Broadcast Electronics, Quincy, IL, has received a contract from Radio Free Europe/Radio Liberty (RFE/RL) to supply 110 series 3000 tape cartridge machines and accessories. This is the largest single contract for tape cartridge machines, for broadcast station use, ever received by BE. The equipment for Radio Free Europe will be installed in a new broadcast studio complex at RFE/RL headquarters in Munich, West Germany. Three machines will be used in each of 30 new studios and 16 in master control for each outgoing program line.

BBC places shortwave orders with Marconi

Marconi Communication Systems, Chelmsford, UK, has received two separate orders from the British Broadcasting Corporation for transmitters and antennas to equip a new transmitter station in Hong Kong. When completed in early 1987, the station will improve reception of BBC World Service

They sound like they should be three times the size. And twice the money.

Presenting the Ramsa WS-A70 near field monitors.

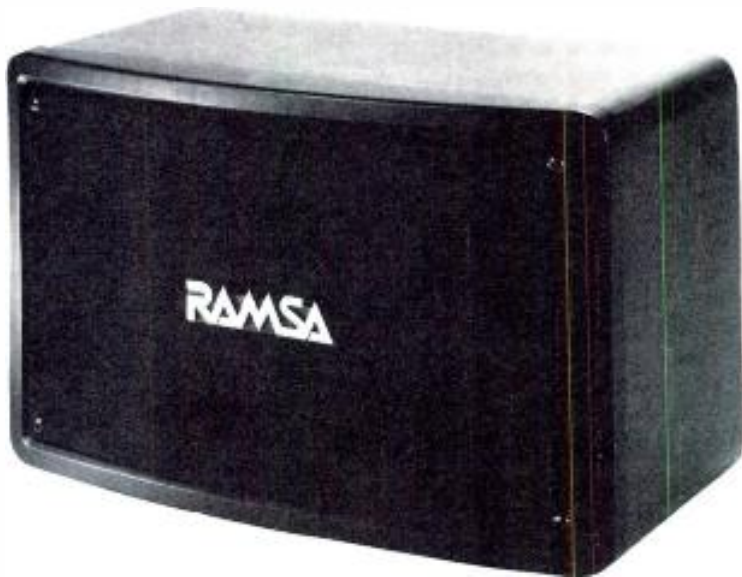

The durable compact design allows the WS-A70 to cover a wide frequency response. While delivering maximum input power of up to 160 watts.

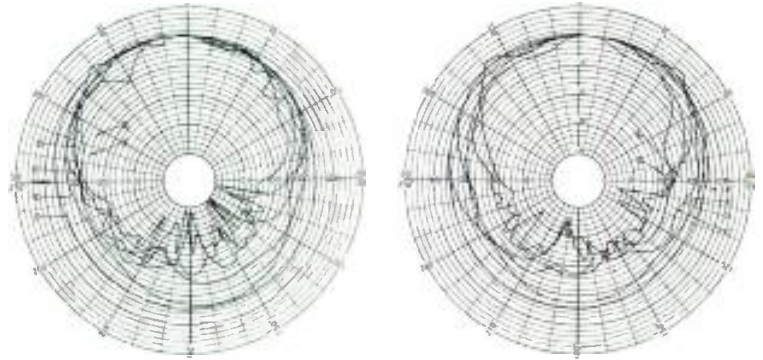

Vertical or horizontal dispersion.

Each Ramsa™ WS-A70 takes up just over a foot of shelf space. But what makes them sound three times their size is the twin bessel horn inside. These high-performance horns offer constant directivity and uniform sound range. And they can be placed either horizontally or vertically.

And to protect video monitors from stray magnetic fields, the Ramsa anti-magnetic design utilizes cancel magnets and shield pots on the woofer.

The built-in auto gain control automatically balances low and high frequencies to deliver clear, sharp dynamic sound.

Anti-magnetic design.



The remarkable Ramsa WS-A70 near field monitors.

Just because your space and budget might be small, doesn't mean your speakers have to sound that way.

RAMSA

Please send me more information about the Ramsa™ WS-A70.

Name _____ PLEASE PRINT

Company _____

Address _____

City _____ State _____ Zip _____

Phone () _____

Return Coupon To: Panasonic Industrial Company, Communications Division, One Panasonic Way, Secaucus, New Jersey 07094.

BE

Panasonic Industrial Company

Circle (118) on Reply Card

programs in the Far East region.

The first order is for two Marconi B6131 250kW transmitters incorporating advanced Pulsam modulation. The transmitters will be equipped for remote control via a digital data link. The second order is for the associated antennas comprising four HF multiband curtain arrays with mode switching.

Dalsat, Centro sign mutual marketing agreement

Dalsat and Centro, manufacturers of SNG systems and ENG and EFP truck units, have signed a reciprocal agreement designed to strengthen each company's marketing goals.

Dalsat is a Texas-based satellite communications engineering company that manufactures Ku-band transportable uplink systems for TV news gathering and commercial telecommunications applications. Its newest SNG-25 mobile Ku-band uplink, transmitting through the GTE Spacenet satellite system, includes a 4.5m collapsible dish antenna, edit bay capabilities and satellite-linked interrupt-feedback communications. Centro, based in San Diego, is an international manufacturer of remote teleproduction vehicles and complete turnkey broadcast system facilities.

CRL acquires MicMix assets

Circuit Research Labs (NASDAQ:CRLI),

Tempe, AZ, announced that it has purchased certain assets of MicMix Audio Products. MicMix was a privately owned Dallas company which manufactured and marketed professional audio sound reinforcement equipment. The purchased assets consisted of inventory, patents, licenses, contract rights and business name.

MA supplies Ku-band equipment

Modulation Associates, Mountain View, CA, announced that the company is supplying, via an on-going agreement, Ku-band satellite uplink and downlink equipment for Hubbard Communications.

The newly designed voice and data network is configured to provide continuous 2-way and multichannel communications between Hubbard's Conus Master Control Center in Minneapolis and the Hubbard Newstar mobile news-gathering vehicles throughout the country. This satellite transmission technology is allowing Conus to transmit a full complement of communications channels independent of the video, including the engineer's private line, IFB line and digital data channels, without interrupting the broadcast programming.

NEC places four TV transmitters

The Broadcast Equipment Division of NEC America, Elk Grove Village, IL, has announced the sale of four PCN-1402SH

2kW solid-state VHF-TV transmitters to the Canadian Broadcasting Corporation. The transmitters will be set up in Sydney (Nova Scotia), Dryden, Gerralton and Katuskasing (all in Ontario). The Canadian Broadcasting Corporation placed the order for the transmitters through NEC's transmitter representative, MSC Electronics, based in Richmond Hill, Ontario.

German studio picks Sony for digital mastering

Sony has delivered a PCM-3324 Dash recorder to West Berlin's Studio 54, to be used for improving mastering facilities. Studio 54 joins Hartmann Digital of Bavaria and the broadcast station West Deutsche Rundfunk as the third German facility to install a PCM-3324.

NOS in Holland also has purchased the Sony recorder.

Pye TVT delivers World Cup equipment

Pye TVT has delivered broadcasting equipment to Televisa S.A. Mexico. This shipment is part of Philips' contract to supply equipment for coverage of the World Cup 1986. The contract includes 100 Philips LDK 6 fully automatic computerized cameras, 60 LDK 14 portable cameras and 11 completely equipped outside broadcast vehicles.

The contract includes a complete video and sound routing switcher system, com-



Winsted®

NEW!
For 1/2" Betacam*

TAPE TRUCK
Model U5024 Ideal for 1/2" ENG or Operations use. Holds up to 120 cased or 180 uncased tapes for easy storage and transport. Optional top shelf for extra work space.

EDITING CONSOLE
Model H8823 The perfect Betacam editing station. Accommodates BVE-800 Controller, BVW-10 and BVW-40 VTRs. A compact, modular console with heavy gauge steel construction. Other models available.

*TM Sony Corp.

For our free full-color FULL-LINE CATALOG and the name of nearest dealer, call toll-free: **(800) 328-2962**

THE WINSTED CORPORATION
9801 James Circle • Minneapolis, MN 55431

TELEX: 910-576-2740
Circle (88) on Reply Card



INSTALL 'EM!
FORGET 'EM!

That's exactly what you can do because our Audio DA system works — day in and day out. It works so well we guarantee it for five years.

- CH-20C Rack Frame with dual power supply and auto changeover holds six transformer or differential DA's.
- Each DA is 1 in — 6 out with individually adjustable outputs and +27dBm clip level.
- 110dB dynamic range for transformer DA.

ADM The Audio Company

ADM Technology, Inc. • 1626 E. Big Beaver Road • Troy, MI 48084
Phone (313) 524-2100 • TLX 23-1114



KEY PERFORMANCE



Performance and Design simplicity enhance Command Decisions.

Horizon International introduces System Four, a computer assisted video editing system that combines creative engineering and user experience to produce a unique video editing system. System Four offers a five year warranty, is user compatible with CMX, ISC and Mach 1, has edit list for 850 events, includes a printer, and has provision for optional paper tape. It controls a combination of video and dual audio tracks from keyboard or track ball. The Horizon's System Four has bi-lingual capability in Spanish or English. This straight line approach to performance editing provides a key decision for a realistic investment.

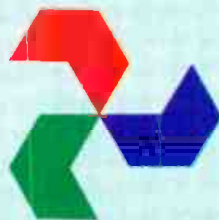

Select
Representative Territories
Available

HORIZON international • 3837 East Wier Avenue, Ste. 1 • Phoenix, Arizona 85040 • Phone 602/437-3800 • Telex 322043

Circle (97) on Reply Card

October 1985 *Broadcast Engineering* 157

ponent digital video effects units, digital graphics slide files, sophisticated caption generators, VTR equipment, cable distribution systems, ancillary equipment and hundreds of monitors, headsets and microphones for the commentary positions. The cameras are being supplied from Philip's camera factory in Breda, Holland. Pye TVT is responsible for the OB vehicles and all that goes with them, together with the main routing system, which will distribute the pictures worldwide by satellite.

Taft TV establishes K.C. teleport

Taft Television and Radio Company announced the establishment of a teleport in Kansas City, located with their TV station, WDAF-TV. The teleport is a modern, fully equipped satellite uplink and downlink facility serving mid-America from Kansas City. The teleport is equipped with two 9.2m uplinks, a transportable downlink and Simulsat fixed dish. Studio facilities, tape record and playback facilities and microwave interconnects are also available. Microwave interconnections are available to and from most major facilities in the area. A connection has been made to I-Net for institutional business transfer of voice, data and video throughout Kansas City. A Ku-band

transmit and receive facility is planned in the immediate future. The teleport will be capable of transmitting voice and data. Satellite time also can be purchased on all satellites through the Kansas City teleport.

The Camera Mart opens two regional offices

The Camera Mart, New York, has announced the addition of two regional offices, one in Evansville, IN, and the other in Huntington Beach, CA. The Midwest regional office, located at 825 Royal Ave., Evansville, is managed by Joe Julian. John Duggin manages the Western regional office located at 16783 Beach Boulevard, Huntington Beach. Each sales office is serviced by the complete sales, rental and technical facilities of the home office in New York.

Rank Cintel telecines to Finland's YLE

Finland's state broadcaster, Oy Yleisradio (YLE), has ordered four ADS 1 solid-state broadcast telecines and another Mk IIIC—its eighth MK III-series machine—from Rank Cintel, England. The equipment is scheduled to be on-line by 1987 in the new transmission complex at YLE's Helsinki Centre, TV 1. The

ADS 1 telecines will be used for on-air transmission from film. The Mk IIIC with Amigo pre-programmer will be installed in a film post-production area designed for film-to-tape transfers.

Other broadcasters who have decided to use ADS 1s alongside Mk III-series telecines include the state broadcast organizations of Holland, Norway, Malaysia, Spain, China, South Africa, the USSR and Ethiopia.

ABC TV affiliate purchases Panasonic equipment

KCEN-TV, ABC affiliate in Waco/Temple, TX, has made an initial commitment to 1/2-inch broadcast equipment by purchasing a wide range of broadcast systems M-format products from Panasonic, Secaucus, NJ. The equipment includes one MVP-100 multifunction video player, six AU-300B studio VCRs, six AK-30 hand-held cameras, three AU-S220 portable M-format VCRs and two AU-S220 adapters. The purchase is part of a 2-phase revamping of the station's facilities. Most of the equipment is intended for studio applications; more machines will be added later for field and ENG operations.

KCEN will integrate the video player and two of the AU-300s into a formatted sequential programming system. Two

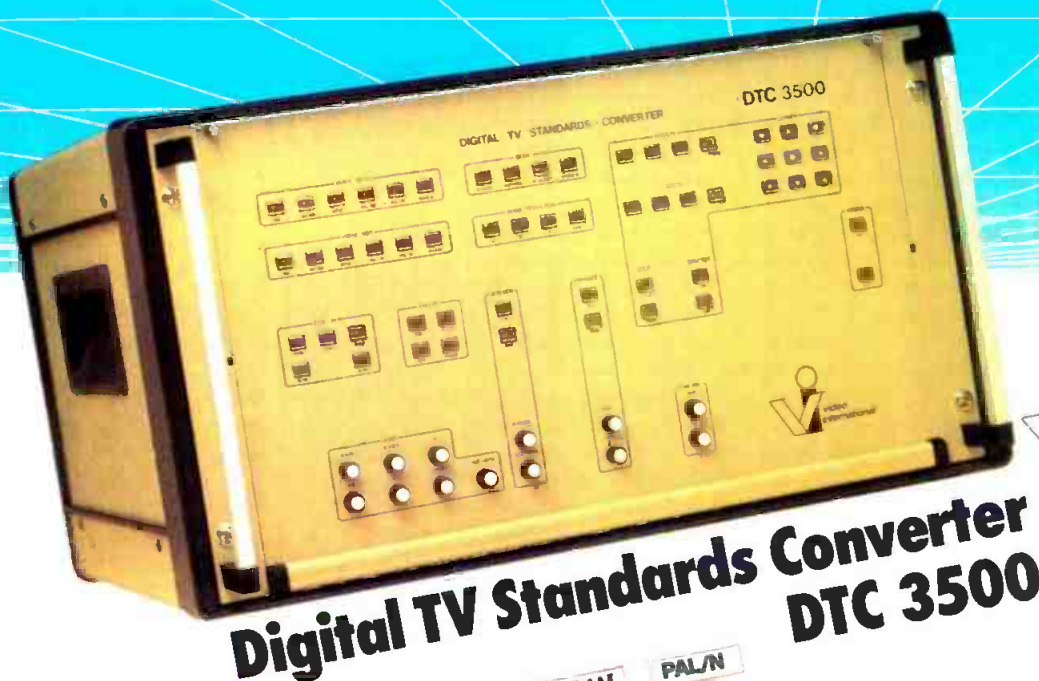

Digital TV Standards Converter DTC 3500

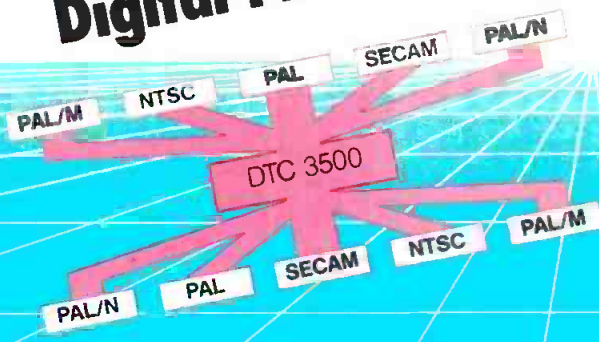

Highest Quality and Reliability

- Digital Standards Converters
- Digital Time Base Correctors
- Digital Decoders

Made in West-Germany

Please contact
 VIDEO INTERNATIONAL DEVELOPMENT CORP.
 1280 Sunrise Highway, Copiague, N.Y. 11726
 Tel. (516) 842 18 15
 Telex 6 45 537
 Telefax (516) 957 5116



Circle (95) on Reply Card

SWISS PERFECTION

NEUTRIK. AUDIO CONNECTORS ON THE CUTTING EDGE.

Audio connectors that can't cut it have no place in today's sophisticated audio market. Which is why sound professionals who demand perfection from their equipment rely on Neutrik products available only from Kulka-Smith and its authorized distributors.

Neutrik is known for a broad, innovative line of superior audio connectors. Like compact, screwless X Series connectors that are simple to assemble and disassemble and will accommodate larger OD cables. High quality XLR straight and right-angle cable connectors. The unique 'D' Series receptacle with a printed circuit mount that requires less panel space than ever. And superior phone jacks and plugs.

In addition, Kulka-Smith offers modules, adapters and a full complement of products that keeps Neutrik's line a cut above the rest. Now, if that sounds like music to your ears, contact us for more information. Kulka-Smith, Inc., 1913 Atlantic Ave., Manasquan, NJ 08736. (201) 223-9400.

**Kulka
Smith**
A NORTH AMERICAN PHILIPS COMPANY



Circle (100) on Reply Card



TELEVISION FACILITY DESIGN AND CONSTRUCTION

Innovative concepts, attention to detail and competitive pricing has identified Centro as an attractive alternative for facilities planning, architectural delineation, systems integration and project implementation.

With a decade of nationwide service and dedication to quality, Centro is a design and engineering firm employing the disciplines necessary to implement successful television facilities and mobile systems.

Call us today and compare our services and prices.



CENTRO CORPORATION
9516 CHESAPEAKE DRIVE
SAN DIEGO, CALIFORNIA 92123

(619) 560-1578

Circle (101) on Reply Card

more AU-300s will record syndicated programs from a satellite feed, and the other two will be employed in editing applications. The portable VCRs and hand-held cameras will be used for studio and ENG purposes.

Microdyne awarded M/A-Com antenna contract

Microdyne, Ocala, FL, has received an order from M/A-Com for 3.7m Ku-band TV receive-only antennas. The antennas will be part of a M/A-Com-supplied system for RCA American Communications that will enable TV broadcasters to receive programming from RCA's Ku-band satellites.

Studer Revox donates recorder

Studer Revox America, Nashville, TN, has donated a PR99 MKII compact professional open-reel recorder to the Museum of Broadcasting in New York. The recorder will be used in the technical department of the museum for transfer to tape of old radio shows now on 16-inch transcription discs. Donation of the recorder was made following a request from Douglas F. Gibbons, director of administration at the museum.

Mitsubishi Pro Audio Group established in UK

Digital Entertainment, a subsidiary of Mitsubishi Electric Sales America, San Fernando, CA, has announced the start of full sales and service operations in the United Kingdom under its recently acquired subsidiary Quad Eight/Westrex Limited. Digital Entertainment Corporation, once its formation is complete, will act as the overall UK subsidiary headquarters. Mitsubishi Pro Audio Group is the primary trading name to be used in the United Kingdom. North American and UK operations will be integrated under one common control.

Faroudja product displayed by Ampex, Bosch and Sony

Three manufacturers of 1-inch helical Type C and Type B VTRs—Ampex, Bosch/Fernseh and Sony—have exhibited improved PAL color multigeneration images by using the PAL-CNR (chroma-noise reducer) accessory from Faroudja Laboratories, Sunnyvale, CA. The PAL-CNR, developed by Yves Faroudja and his associates, provides VTR users improved key video signal parameters. The accessory extends the multigeneration dubbing capability of 1-inch helical VTRs by three to four generations. All three manufacturers agreed to exhibit a PAL-CNR in conjunction with one of their own VTRs on display in Montreux.

Symetrix relocates

Symetrix, Seattle, has announced the

completion of its manufacturing facility. The structure provides 6,700 square feet for manufacturing and office space. A separate structure with 2,000 square feet of floor space will be used for engineering. The new address is 4211 24th Ave. West, Seattle, WA 98199. The telephone number is 206-282-2555.

The Droid Works opens Eastern region sales office

The Droid Works (an affiliate of Lucasfilm and Convergence), San Rafael, CA, has announced the opening of its Eastern region sales and field support office at 645 Madison Ave., New York, NY 10022. The telephone number is 212-753-4077.

New Alta Group to offer video equipment

The Alta Group, San Jose, CA, has been formed to design, manufacture and market a line of digital TV equipment for use in professional 3/4-inch and 1/2-inch videocassette recording production applications.

Alta's initial product offering will be Pyxis, a production system designed for A/B-roll editing.

Fritts responds to "Organized Confusion"

The June issue of *Broadcast Engineering* carried an editorial, "Organized Confusion," that discussed some of the problems, as noted by our staff and reported by various manufacturers, that clouded the 1985 NAB convention. The editorial pointed out the difficulties exhibitors experienced in communicating with the NAB's planning office in St. Louis. In response, the president of NAB, Edward O. Fritts, outlines the NAB's efforts to prevent a similar situation from recurring next year. His comments follow:

"Needless to say, we have had a number of meetings with our key staff, with exhibitors and with our convention manager, Ed Gayou, to iron out the problems we encountered in preparing for the 1985 convention in Las Vegas. As a result, we have taken two major management steps. First of all, Ed Gayou has been authorized to hire an office manager and additional staff as necessary to operate in a first-rate, responsive manner. Secondly, we will rely on the newly formed Exhibitor Advisory Committee to ensure that exhibitor needs and potential problems are thoroughly considered prior to finalizing plans for each convention. We are confident that these steps will resolve the problems you pointed out in your editorial quickly and thoroughly and that as a result, the Dallas 1986 convention will be the best ever for our exhibitors."

1:~:~)))))

Keep your reputation firmly in the groove!

Model AT1010 Tone Arm

Don't trust your modern, lively reputation to old-style tone arms. Get all of the sound from today's records, with the AT1010 tone arm designed to survive the station environment while delivering top-of-the-charts sound.

The AT1010 is a stable, reliable platform for any cartridge. Easy to use, rugged and reliable. And Dynamic Tracing design keeps tracking force constant even with the highest modulation levels.

Learn more about the most important element in your audio chain. See your Audio-Technica sound specialist or write for literature today.



audio-technica.

1221 Commerce Dr., Stow, OH 44224
(216) 686-2600

BE names new technical editor

We at **Broadcast Engineering** believe that it is important to provide our readers with the most up-to-date and accurate technical information available. To do this requires not only a dedicated staff, but also one that is familiar with the problems and needs of the broadcast engineer. Toward this end, we have expanded our editorial staff to include separate editors for both radio and television.

The latest addition to the magazine is **Bradley Dick**, our new radio technical editor. Although Dick comes to **BE** with a background in both radio and television, his emphasis is on the radio side of broadcasting. Many of our readers will be familiar with Dick, who has written for **BE** for more than seven years. Dick also had articles published in other magazines in the United States and



Brad Dick, BE's radio technical editor.

Australia.

Dick has been responsible for much of the radio convention coverage for **BE**. He provided articles on the radio seminars and panels at the NAB conventions, Public Radio Conferences and other broadcast meetings. Dick was responsible for initiating the **BE** "Field Report" and has continued to provide articles on new broadcast equipment and ap-

plications.

For the past 12 years, Dick has served as director of engineering for KANU/KFKU radio at the University of Kansas, Lawrence, KS. In that capacity, he oversaw the reconstruction of both the studio and transmitter facilities and the design of a new broadcast center at KU. The engineering staff of KANU received national recognition for the development of the first single RF channel stereo remote pickup transmitter. The stereo transmitter was later type-approved by the FCC in 1983. Dick's latest project will result in the expansion of the station's signal to an additional seven cities in Kansas and Oklahoma. The expansion is being funded by a \$100,000 grant written by Dick in 1983. The project will provide new transmitters with signal coverage to an additional one-half million potential listeners.

Dick has worked at other radio and TV stations, all located in Kan-

Orban Pro Channel. Now delivering.

Orban ACC-20 Pro Channel Cards. Two cards that plug into your Orban 8182A/SG TV Stereo Generator—generates the Pro Channel signal for communications or data.

Speech processing is carefully tailored for maximum intelligibility and highest modulation to cut through noise. Incorporates compression, frequency contouring, and the patented Orban Clipper/Overshoot Corrector System.

Data conditioning incorporates constant-delay sharp cutoff low-pass filter to assure error-free data transmission at high rates.

For more information, or to place your order for fast delivery, call your favorite Orban Broadcast Dealer, or call us direct.

Orban Associates Inc.

645 Bryant Street, San Francisco, CA 94107
In California: (415) 957-1067. Telex 17-1480
(800) 227-4498

orban

ORBAN PROCESSING KEEPS YOU COMPETITIVE

Circle (103) on Reply Card

The one-line solution for your telephone remotes.



You can save up to 50% on telephone line charges for your remote broadcasts with Gentner Engineering's EFT-1000. The EFT-1000 Extended Frequency Transceiver gives you the great sound of frequency extended lows and Aphex® enhanced highs on **one dial-up telephone line**. In addition, your return cues may be received on the **same line used for transmitting**. Microprocessor-based control logic, internal automatic telephone couplers and automatic encoding capability make the EFT-1000 the clear choice for your next remote broadcast.

The
Clear
Choice

GENTNER

ENGINEERING COMPANY, INC.

540 West 3560 South
Salt Lake City, Utah 84115
(801) 268-1117

Circle (104) on Reply Card

NTI MODEL PM-1,2 DIGITAL PATTERN MEMORY GENERATOR

NETMARK, INFORMATION & TEST PATTERN GENERATOR for NTSC, PAL B.G. H & I, PAL M, PAL N & SECAM..... A Model for Each System is Available

Any picture, netmark, information or test pattern can be memorized in the IC ROM.

Netmarks, information and test signals written into the IC ROM are output in parallel or by switching.

By storing several "PLEASE DO NOT ADJUST YOUR SET" signals in the memory, you can make up simple animation programs that can be read out by switching the combination. With this function, you can retain a program without having to change channels.

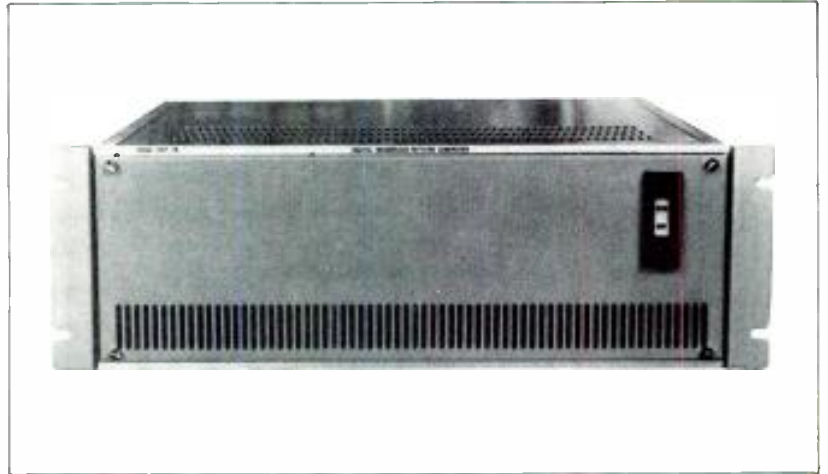

■ Pictures are reproduced in their original colors



NETMARK

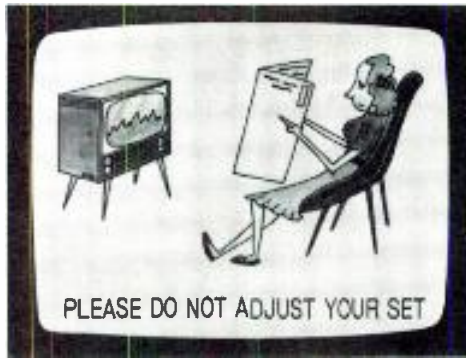

PLEASE DO NOT ADJUST YOUR SET

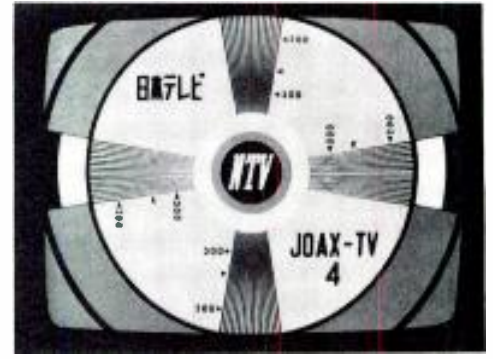

TEST PATTERN

- Pictures sent to us will be processed into memorizable form and delivered to you.
- In NTSC, direct 4-field memory and other systems, Y, B-Y and R-Y are memorized.
- Models, dimensions and memory capacity:

• PM-1 Model 5.2" height for 19" rack mounting
Number of pictures memorized: 4 in the NTSC system, 2 in other systems.

• PM-2 Model 12.2" height for 19" rack mounting
Number of pictures memorized: 10 in the NTSC system, 5 in other systems.

The number of memorizable pictures can be freely chosen within this range, and the contents of the image can be modified.

■ Block Diagram of the PM-1 Model for the NTSC System

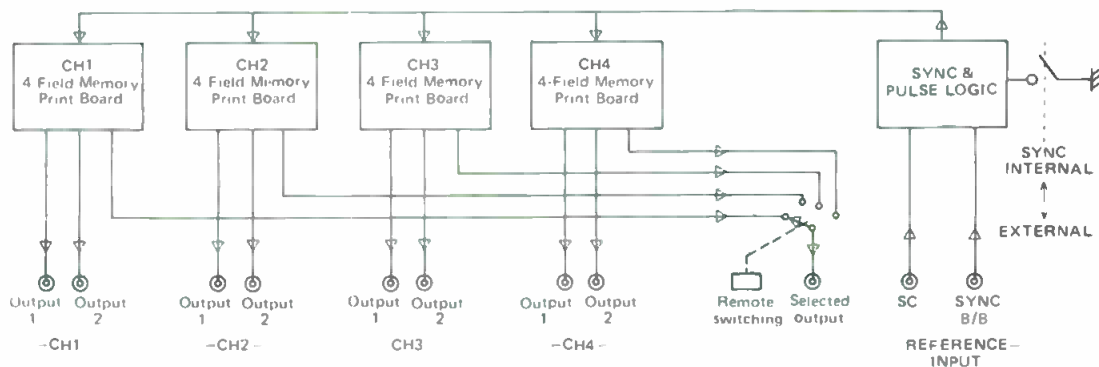

NTI Nippon Television Industry Corporation
26-2, Nishigotanda 1-chome, Shinagawa-ku, Tokyo 141, Japan
Phone: (03) 494-0121 Telex: 2467472

NTI America, Inc.
1680 North Vine Street, Los Angeles, California 90028
Phone: (213) 462-8945 Telex: 215468

AGENTS WANTED: Contact us for details.

Circle (58) on Reply Card

sas. He served as chief engineer at KMUW-FM, Wichita, and also worked at KFH-AM and -FM, KARD-TV and KAKE-TV.

He attended Wichita State University, where he received his bachelor's degree in 1972. Dick graduated from the University of Kansas in 1983 with a master's degree in radio and TV station management.

Currently the national secretary of the Society of Broadcast Engineers, Dick served as chairman of the Kansas chapter for two years. He is also a member of the Audio Engineering Society.

While Dick devotes his time to editorial material that pertains to radio, **Carl Bentz** will continue to concentrate his efforts on providing the latest technical information about television. We are proud of the fact that **BE** editors have worked as engineers at radio and TV stations. Their first-hand broadcast experience allows them to better understand your needs.

Our business is to serve you, the broadcast engineer. If we can be of further help, please give us a call.

Jerry Whitaker
Editor

James L. Schremp has been appointed vice president, manufacturing for Harris Broadcast Group, Quincy, IL. Schremp has had several years of experience at General Electric, with emphasis in plant operations and materials management. He is a specialist in manufacturing resource planning systems.

Bill Harland and **Steven R. Ford** have joined Broadcast Electronics, Quincy, IL. Harland is national sales manager, RF products and will be responsible for marketing and merchandising RF products in the United States and Canada. Ford is advertising manager and will be responsible for space advertising, sales literature, product brochures and catalogs.

Wayne J. Lee, **Michael W. Tallent**, **Ronald D. Long** and **Frank J. Alioto** have founded The Alta Group, San Jose, CA, manufacturer of video production equipment. Lee is president and chief executive officer; Tallent is vice president, advanced product development; Long is vice president, engineering; and Alioto is vice president, marketing and sales.

Tadashi Suzuki has been named president and chief executive officer of NEC America, a subsidiary of NEC, Tokyo. Suzuki succeeds Dr. Ko Muroga, who will rejoin NEC as associate senior vice president and director. Since joining

NEC in 1954, Suzuki has acquired an extensive background in international marketing.

Peter Sidey and **Adrian Bailey** have been appointed to positions at Mitsubishi Pro Audio Group. Sidey will be executive consultant, responsible for UK operations. Bailey will be manager of marketing, manufacturing and technical services at the UK headquarters.

George S. Wicker has been appointed Southeast sales manager for Fortel. Wicker has 14 years of experience in video electronics. He was previously with JVC as Southern district sales manager.

Walter J. Kelley has been appointed vice president of audio-video sales for Lake Systems, Newton, MA. He has been with the company since 1972, and was previously audio-video sales manager.

John Fitzpatrick, **Dan Cole**, **Craig Sloss** and **Jeff Paleczny** have been appointed to positions at Conrac Division, Covina, CA. Fitzpatrick is the regional sales manager for the Southeast and Paleczny has been promoted to regional sales manager for the mid-Atlantic region. Cole is district sales manager for the New England region. Sloss is regional sales manager for the Northwest.

!{:~)))))

Orban SAP Now delivering.

Orban 8182A/SAP OPTIMOD-TV Second Audio Program Generator. A high-performance OPTIMOD Audio Processor and BTSC-standard SAP generator for Multichannel Television Sound.

Orban designed our SAP Generator from the ground up—it's not a rehash of an FM SCA Generator. Accordingly, it includes the built-in audio quality appropriate to the first class broadcast service that SAP was intended to be—multi-band processing equal to the main channel OPTIMOD-TV processing.

For more information, or to place your order for fast delivery, call your favorite Orban Broadcast Dealer, or call us direct.

Orban Associates Inc.

645 Bryant Street, San Francisco, CA 94107
In California: (415) 957-1067. Telex 17-1480
(800) 227-4498

ORBAN PROCESSING KEEPS YOU COMPETITIVE

Circle (106) on Reply Card

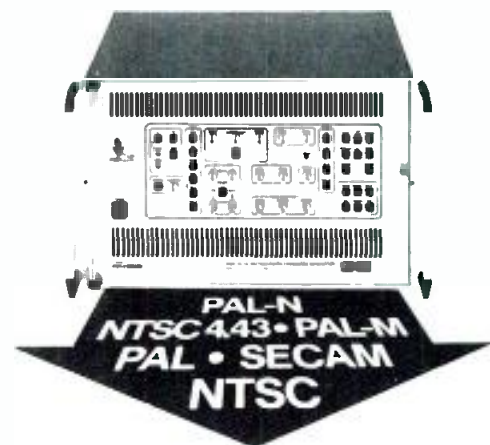

Merlin ME-888 Standards Converter for ALL world video standards

- Automatic conversion between all world television standards — NTSC, PAL, SECAM, PAL-M, PAL-N and NTSC 4.43.
- Digital image processing — color correction, noise reduction, H & V detail enhancement
- Multistandard TBC, color bars, frame synchronization and freeze frame.

MERLIN ENGINEERING WORKS

2440 EMBARCADERO WAY, PALO ALTO, CA 94303

(415) 856-0900 • TWX 910-3731782

TOLL FREE (800) 227-1980

Circle (107) on Reply Card

NOW ALL THE WORLD'S A SOUND STAGE.

No matter what you're recording in the field, from Shakespeare-in-the-Park to "Dancing in the Dark," you'll find a Sony portable mixer that brings the creative control and flawless sonic performance of the studio to wherever you happen to be.

12 FOR THE ROAD.

The big difference between the Sony MX-P61 and other studio-quality 12-channel mixers is that the Sony can be tucked neatly into a small case and carried to any location—thanks to its switching power supply, transformerless design and, of course, the fact that it's made by the company that's best at making big things small.

Its myriad professional features include transformerless, electronically-balanced inputs and outputs, complete equali-

zation for comprehensive signal control and modular construction for reliability and easy maintenance. Along with the phenomenal sonic performance with which the name "Sony" has been synonymous for decades.



Studio quality is no longer confined to the studio.

THE 4-CHANNEL MIXER FOR EVERY CORNER OF THE GLOBE.

The incredibly small and light MX-P42 lessens not only your burden, but the complexities of field recording as well.

That's because each input incorporates a fast-acting compressor/expander with gain make-up control. So input levels can be preset separately, then maintained automatically during recording.

HIGH QUALITY FOR LOW BUDGETS.

The family resemblance between the 8-channel MX-P21 and

Sony's more expensive portable mixers is readily apparent:

The MX-P21 is portable, durable, and has an incredible array of features for its size—including phono EQ, fader-start and cascade interface.

All of which makes the choice between Sony and any other portable mixer a simple one.

Just decide whether you want all your location recordings to be as good as studio recordings.

Or not to be.

For a demonstration or more information, call Sony in the North at (201) 368-5185; in the South (615) 883-8140; Central (312) 773-6000; West (213) 639-5370. Or write Sony Professional Audio Products, Sony Dr., Park Ridge, New Jersey 07656.

SONY
Professional Audio

Circle (163) on Reply Card

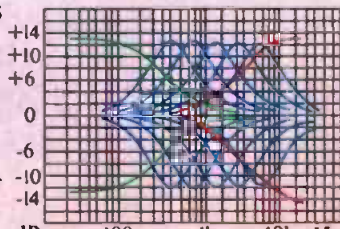

EQ characteristics of the MX-P61.



The Sony MX-P42 weighs in at a scant 8 lbs., 10 oz.



FM exciter

Elcom Bauer introduces the model 6020 FM exciter, designed for use in the 87.5MHz to 108MHz FM band. Distortion figures, both harmonic and intermodulation, are less than 0.1%. Automatic control of the power output is a standard feature. Digital metering is used to monitor parameters and the unit includes a built-in test probe for internal measurements. A color-coded bar-graph display monitors the composite signal and can be expanded to measure stereo pilot and SCA injection levels. The RF amplifier is broadband and requires no tuning.

Circle (200) on Reply Card

Spectrum analyzer

An FFT-based spectrum analyzer is now available from the Instrumentation Department/ACD of *Panasonic*. The VS-3310P OPT.09 features low noise floor, high resolution, pre- and post-triggering of transients and external sampling. The built-in intelligence of the analyzer can be used for go/no-go testing, as well as providing a quick, completely annotated hard copy at the push of a button.

Circle (201) on Reply Card

Editing Systems

CMX introduces the CMX 3400A, a computerized editing system. It features frame-accurate dynamic-motion memory, general-purpose interface with up to 64 channels and parallel or breakaway GISMO controls. The dynamic motion memory uses up to six playback VTRs simultaneously. Sequences may be learned dynamically using the GISMO or keyboard motion controls. The fit-and-fill feature allows expansion or compression of the video material into a predetermined duration. All GPI information is stored in the EDL and is repeatable during the editing process. The system also provides the editor with precue auto assembly, auto clean, eight user-defined keys, multiple EDL files, match-cut calculate and E-MEM in the list.

Circle (366) on Reply Card

TBC series

ADDA has introduced the Vision series of time base correctors. It is an 8-bit component processing, heterodyne-only system, designed for cable, production and professional TV applications. All of its components are on a single board.

Circle (202) on Reply Card

Audio spectrum display

The HSD-20B vacuum fluorescent spectrum display from *Hutco* offers 11 channels, featured as 10 octaves plus one. Each of the ISO center-frequency channels, 31.5kHz to 16kHz, has 20 display segments. The unit features filter slope of 12dB per octave and is switchable from 38dB to 2dB steps or 19dB to 1dB steps.

Circle (317) on Reply Card

Broadcast headsets

Unex Telephone Products has introduced a line of broadcast headsets featuring a modular construction that allows them to interchange connectors and interface with a variety of telephone and intercom systems. The Ventel models III and IV are single and double muff noise-attenuating headsets,

respectively, combining foam-layered ear seals and noise-canceling microphones. The Ventel model V is an over-the-head lightweight headset for use by production room personnel. All headsets include either a 7-foot straight or 12-foot coiled cord, volume control, cord clip and noise-canceling microphone. A push-to-talk switch, quick disconnect and various audio jacks with modular connectors are available.

Circle (329) on Reply Card

Telecommunications DMM

Simpson Electric's model 467-2T digital multimeter is specifically designed for telecommunications servicing. The 3½-digit instrument has direct-reading dB ranges, with switchable 600Ω and 900Ω references for new and old telecommunications systems. There is a built-in 1,004Hz tone generator for line checking and signal tracing, and digital and analog LCD readout with pulse, continuity and low-battery indicators. Voltage and resistance ranges have high voltage transient protection, and all ranges are overload protected, including high energy fusing on current ranges.

Circle (325) on Reply Card

Rack-mount shelf

An equipment shelf for rack-mounting equipment without attached rack-mount panels is available from *CWY Electronics*. The model RR/S7 rack shelf mounts to any EIA-RETMA standard spacing rack and requires only four rack spaces; the support weight rating is 150 pounds.

Circle (326) on Reply Card

Component mixer

Electrocraft has started delivery to Germany, the United States and the United Kingdom for its model VM-8548 8-channel component mixer. Also being considered is the component A-B editor-controlled mixer for use with ½-inch formats and ¼-inch camcorders. Transcoders also allow use of U-matic highband/lowband inputs, giving outputs of RGB, YUV and composite with the use of an encoder.

Circle (328) on Reply Card

Transfer switches

Dow-Key has developed a line of electromechanical intelligent relays for use in RF and microwave transmitter switching applications. The 402 series SPDT and 412 series transfer switches handle high power—350W at 1GHz, and have low insertion loss—0.5dB at 12GHz. They use a MIC detector and solid-state CMOS driver technology internally to detect power and VSWR changes, and switch automatically when preset conditions are met. The smart switches are designed for redundant transmitter applications where automatic switching is required if the power decreases in one channel or the antenna pattern is disturbed.

Circle (313) on Reply Card

Video/voice/data microwave radio

Racon introduces Micropass II, a 23GHz microwave radio for video conferencing and/or voice and data transmission with DS1/T1 or RS170 interfacing. The system is FCC part 94 and 21 accepted for common carrier and general business applications, and operates in the Ku-band, offering simplex video, simplex audio/data subcarrier or simplex video with duplex audio/data subcarrier for transmission of up to eight



ANNOUNCES THE NEW
TTC WILKINSON MODEL X FM EXCITER

**FOR A SOUND THAT SOARS
ABOVE AND BEYOND**



UNSURPASSED PERFORMANCE GIVES YOUR STATION A CLEARER, SHARPER, MORE POWERFUL SIGNAL.

New technology, high performance. TTC Wilkinson introduces the Model X FM Exciter. It achieves breakthrough performance to meet the challenge of digital audio broadcasting and multiple sub-carrier opportunities.

Unparalleled loudness and clarity for a "Stand Out" sound. Flat frequency response and low distortion make the Model X virtually transparent. The result is outstanding signal integrity and clarity. Meticulous AFC design radically reduces modulation-robusting baseline shift. And broadband circuitry eliminates the need for any tweaking and tuning.

Digital audio compatibility. Now that compact discs, digital STLs, and other forms of digital audio are becoming commonplace, new performance capabilities are needed from excitors. Model X provides the ideal frequency response, distortion, and signal-to-noise characteristics to achieve superior digital audio reproduction.

Multiple subcarrier capacity. Since the FCC decision allowing multiple sub-carriers, broadcasters have needed an exciter with enhanced capabilities. Model X is designed to handle up to five sub-carriers with absolutely no loss in quality.

Unprecedented five-year warranty. With quality that truly excels, TTC offers Model X with the industry's only five-year warranty.

For a sound that soars...call or write us today for a free brochure about the new Model X Exciter:

Television Technology Corporation
Wilkinson Radio Division
2360 Industrial Lane
Broomfield, CO 80020 (303) 465-4141
TWX: 910-938-0396 TTC ARDA



Circle (123) on Reply Card

October 1985 *Broadcast Engineering* 167

miles. The Micropass II uses an FM design with a superheterodyne receiver and will operate from a variety of power sources, including solar for remote applications. Systems are supplied with transmitters, receivers, mounting hardware, class II 24V ac power transformers, installation/operation manuals and licensing instructions.

Circle (323) on Reply Card

Slope/delay equalizer

Satellite Transmission Systems, a subsidiary of California Microwave, has introduced a variable group delay/amplitude slope equalizer for use in satellite communications transmit/receive earth stations. The model DEQ702 features continuously and variable group delay adjustments and amplitude slope correction on plug-in modules. Each delay module contains four sections with in/out switching, and each section provides ± 2 ns/MHz bandwidth. Applications for the DEQ702 include FM/FDM message, video, SCPC and high speed digital/TDMA.

Circle (327) on Reply Card

Mobile equipment cart

The mobile equipment cart model G8706 is a roll-up cart for studio or mobile use now available from *Winsted*. Designed with two shelves and four removable 19¼-inch rack rails, the cart features a 2-position bottom shelf which can be fixed at center height for compact electronics. The cart rolls on 3-inch casters (two locking).

The model G8708 cart provides a roll-around electronics support system for equipment used in several locations. Top rack has 19¼-inch of rack space and can be used flat or tilted 10°. Shelf is adjustable and end panels provide 19¼ inches of space to accommodate more rack-mountable equipment.

Circle (203) on Reply Card

High speed wire service printer

United Press International has announced a new generation high speed printer for use with its CustomNews and UPI 1 broadcast computer system. The printer was developed by UPI in conjunction with Micro Peripherals, and is a modification of MPI's Xprinter. It includes an auxiliary processor board that serves as a downline programmable news selector, integrating both computer and printing functions. The wire service printer (WSP) has a print head with a life expectancy of 300 million characters, and a custom-designed roll paper operation including paper roll holder and paper exit guide.

Circle (324) on Reply Card

Remote control system

The DCS-16 remote control system from *Symetrix* is a modular, microprocessor-based system designed to obtain remote indications of status information and to provide direct control of remote equipment. Status changes are detected via 16 optically isolated inputs on the remote module, and commands are executed by 16 user-programmable relays on the same module. Additional alarm relays are provided for serial error, carrier detect and failsafe. Communication between command and remote modules can be through a 2-wire/4-wire telephone loop, an FM subcarrier or a private radio/microwave link.

Circle (321) on Reply Card

Surge suppressors

Perma Power Electronics has introduced two rack-mount surge suppressors to protect sensitive circuitry from damage caused by electrical power line voltage transients. The

Sockets Plus surge suppressors are designed for use with small business computers, microprocessor-based industrial controls, electronic business equipment and medical diagnostic equipment. Both models offer six outlets, single stage suppression of power line transients whether normal or common mode, and Perma Power's shutdown mechanism to prevent inadvertent operation of unprotected equipment in the event a suppression element fails.

Circle (318) on Reply Card

Mixer amps

A new series of 30W, 60W and 100W mixer amplifiers for use in commercial and industrial sound and paging systems has been introduced by *Aiphone*. The PM series offers protective circuitry, 4 Ω , 8 Ω and 16 Ω and 25/75V outputs and independent volume, bass and treble controls for each of the up to eight inputs that can be handled simultaneously.

Circle (319) on Reply Card

Audio duplicator tapes

Ampex Magnetic Tape Division has developed music grade audiocassette duplicator tapes for the high speed duplicator industry. The 615/616 tape features an oxide binder system and has a relative sensitivity of 1.5dB higher than Ampex 603/604. ASA weighted noise is 0.8dB better, and overall uniformity has been improved. It is available in 8,200-foot C60 and 11,500-foot C90 lengths and features color-coded stacking hubs for easy storage and identification.

Circle (320) on Reply Card

UHF cavity amplifiers

Varian EIMAC has introduced six UHF cavity power amplifiers designed for FM, CW, pulse or single-sideband linear service in the 280MHz to 530MHz frequency range.

Using the EIMAC 3CX800A7 high-mu power triode, the cavity amplifiers eliminate equipment design complications and extra power supplies associated with UHF tetrode cavities, and provide comparable stage gain. Power gain in FM or CW service for all cavities is about 11dB with efficiency ratings of more than 55%.

Circle (204) on Reply Card

Sequencer console

Soundcraft Electronics has introduced the SAC 2000, an on-air console with a built-in cartridge machine sequencer. Remote activation of input modules or cart sequences from separate studios or from remote broadcast sites are possible on the SAC 2000 via a special sub-audible tone unit, allowing spot or music presets at the console and their activation from the field. Features on the console include three stereo plus mono outputs, full metering, multiple input selection with logic follow, four channel telephone mix-minus, multiband equalization, delay control and universal machine control logic. The unit is offered in 10-, 16- and 24-output versions.

Circle (322) on Reply Card

Metallized fabric

A nickel-coated metallized fabric that provides screening against electromagnetic interference (EMI) has been introduced by *Mobay Chemical*.

Baymetex T may be used to make protective covers for outdoor broadcast TV cameras where picture quality may be impaired by interference from local radio transmissions and high-powered radar installations.

The screening covers provide weather protection and are tailored to fit the cameras, permitting access to service panels and normal circulation of ventilating air. Low weight, textile character and metal properties make the covers easy to handle and simple to install.

Circle (205) on Reply Card

CLARITY

The purity of images
attained from the
absence of distortion
or imperfections.
Purity from using only
premium magnetic
materials and the most
advanced production
techniques. Purity
resulting in a video
tape of magnificent
clarity. Ampex 196.

AMPEX

Ampex Corporation • One of The Signal Companies

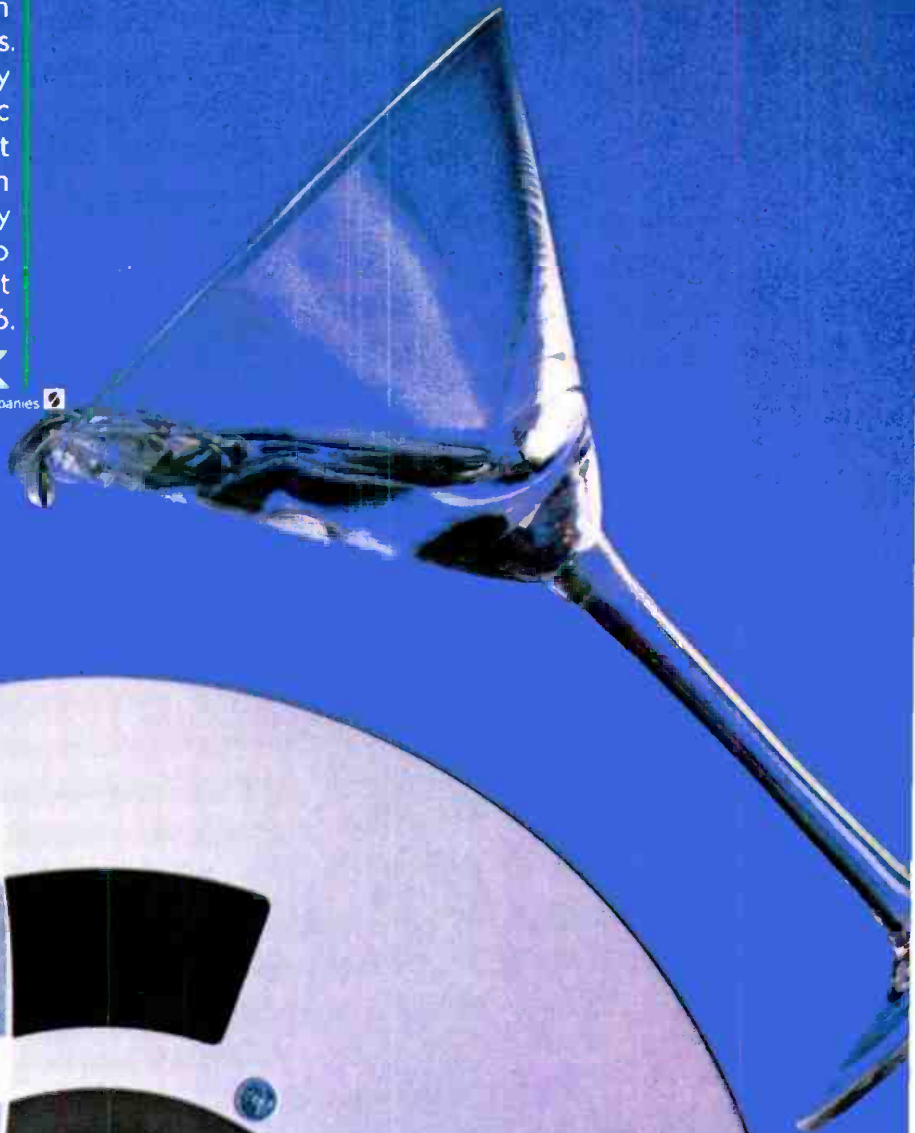

Ampex Corporation, Magnetic Tape Division, 401 Broadway, Redwood City, CA 94063, (415) 367-3809

Circle (140) on Reply Card

TELEVISION TRANSMITTERS CUSTOM TAILORING!



Custom Engineering—for field modernizing and up-powering all makes of VHF and UHF transmitters. Spares for most makes of VHF and UHF transmitters.

We custom design transmission systems when that's the best answer. Our engineering specialists will work with you to custom design a transmission system that will save you dollars.

Townsend Product Lines:

- High power **UHF** to 240 Kw
- High power **VHF** to 50 Kw
- **VHF** and **UHF LPTV** transmitters
- All solid state **MDS** and **ITFS** transmitters

TOWNSEND

The Television Transmission Specialists

Townsend Associates, Inc.

79 Mainline Drive, Westfield, MA 01085 • 413-568-9581

Circle (170) on Reply Card

RPG diffusor module

RPG Diffusor Systems has introduced the QRD-734 to its line of modular acoustical diffusors. The model measures 23 $\frac{5}{8}$ " x 47 $\frac{5}{8}$ " x 8 $\frac{1}{4}$ " and weighs 30 pounds. The diffusors can be wall-mounted in clusters, providing horizontal and vertical diffusion, or ceiling-mounted in standard suspended-grid systems. The diffusor system is a reflection phase-grating room treatment that can enhance the acoustics of any critical listening or performing environment by uniformly diffusing sound without absorption or attenuation. Applications include recording studios, radio/stereo TV production, audio-for-video, film mix, disc mastering, auditoriums and churches.

Circle (370) on Reply Card

Multiline broadcast telephone interface system



Symetrix has announced its entry into the multiline broadcast telephone interface market. The model 108 is a stand-alone electronic telephone system specifically designed for broadcast applications in which multiple incoming phone lines must be routed to an on-air or production audio console. The system facilitates communication between host and callers either on or off the air, and permits control of calls by the on-air personality from a compact, simple-to-use desk module. The system supports a second desk module for use by a call director or off-air assistant. Up to six incoming callers may be placed on-air at once.

The system connects to up to eight incoming telephone lines and routes these signals to three electronic hybrids. Each hybrid is followed by a gated AGC that ensures equal caller levels and freedom from noise in the absence of caller audio. The system is FCC-certified under Part 68 for direct connection to incoming phone lines via standard RJ-11 connectors. Features include capability of a 2500 deskset for outgoing calls, a profanity relay that mutes all caller audio and triggers a user-provided digital profanity delay, a ring relay and an air relay.

Circle (384) on Reply Card

G.E., Sylvania and Wiko long life lamps

Special Prices on many numbers. Phone Toll Free.

Sitler's Supplies, Inc.

Box 10 Washington, Iowa 52353
Ph: 800-426-3938 • In Iowa 800-272-6459

Circle (171) on Reply Card

PRECISION MAGNETIC TEST TAPES

STL



Standard Tape Laboratory, Inc.
26120 Eden Landing Road #5, Hayward, CA 94545
(415) 786-3546

Circle (154) on Reply Card

Have "TWO-SHOT" Will Travel

- Switcher
- Mixer
- Identifier
- Color Monitors



LANG VIDEO SYSTEMS

547 N.E. 26th Court
Pompano Beach, FL 33064 • (305) 946-0622

Circle (155) on Reply Card

PREWIRED AUDIO JACK PANELS



Circle (156) on Reply Card

FREE 32pg Catalog & 50 Audio/Video Applc.



OPAMP LABS INC (213) 934-3566
1033 N Sycamore Av LOS ANGELES CA, 90038

Circle (152) on Reply Card



SESCOM, INC.
1111 Las Vegas Blvd. North
Las Vegas, NV 89101 U.S.A.

"the audio source" FOR ALL OF YOUR AUDIO NEEDS
CALL OR SEND FOR A COPY OF OUR CATALOG
CATALOG REQUESTS & ORDERS: (800)634-3457

OTHER BUSINESS: (702)384-0993 TWX (910)397-8998

Circle (153) on Reply Card

**Reconfirm your involvement in
the broadcast industry!
Renew your subscription
today.**

STANTRON VIDEO CENTER

MODULAR DESK CONSOLES • VTR/VCR RACKS • CABINET CONSOLES • DUBBING RACKS

for
 VIDEO
 • PRODUCTION •
 • POST PRODUCTION •
 • DUBBING •
 • EDITING •



The **STANTRON VIDEO CENTER** series has been designed primarily for production and post-production facilities • The modular "add-on" features allow for maximum flexibility in designing console arrangements for professional, educational, industrial and communication **VIDEO CENTERS** • "Designed-in" structural strength and aesthetic features, required by users, is "standard equipment" for every **STANTRON VIDEO CENTER** unit.

For a **FREE** copy of the **STANTRON VIDEO CENTER CATALOG #200**, please write or call.

MAILING ADDRESS: P.O. Box 9158VC • No. Hollywood, CA 91609 U.S.A.

STANTRON

Unit of Zero Corporation

Toll Free: 1-800-821-0019
 Northern Calif. — Toll Free 1-800-821-0020
 Southern Calif. — Please call 1-213-875-0800
 Factory: 6900-6918 Beck Ave. • No. Hollywood, CA 91605
 TWX: 910-499-2177



Circle (175) on Reply Card

COX THE ENCODER COMPANY



New Options: black stretch, component video inputs.

There's a lot more to encoding than taking a three wire signal and combining it into one. COX, the world's foremost encoder manufacturer has elevated the encoding of color primaries to a fine art. With a time tested, no-compromise design, COX has gained the enviable reputation of building encoders by which others are judged. COX encoders are the choice of manufacturers who lead the industry in telecine systems, computer graphics and matting equipment.

Available in NTSC, PAL, PAL M, SECAM and switchable, multistandard versions. For detailed data and our encoder evaluation check list, call:

EXCLUSIVE NORTH AMERICAN DISTRIBUTOR

broadcast video systems

1050 McNicoll Avenue, Agincourt, Ontario M1W 2L8
Telephone (416) 497-1020 Telex 065-25329

Circle (115) on Reply Card



For AM, FM, SCA
and TV modulation monitors.

WHEN ACCURACY COUNTS...COUNT ON...

Call (215) 687-5550 or write for more
information on Belar AM, FM, Stereo,
SCA and TV monitors.



LANCASTER AVE AT DORSET DEVON, PA 19333

Circle (173) on Reply Card

BUY DIRECT AND SAVE

Write for our complete 40 page catalog
showing RUSLANG'S fine studio furni-
ture and consoles.

RUSLANG

320 Dewey St., Bridgeport, CT 06605

Telephone: (203) 384-1266

Circle (117) on Reply Card

Want more information on
advertised products? Use the
Reader Service Card.

Beta recorder adapter

Ikegami Electronics has introduced the VBA-1, a new Beta recorder adapter for use with the Ikegami HL-79E ENG/EFP camera. The VBA-1 enables the Beta format recorder to be used with an Ikegami camera.

The new unit consists of an adapter that attaches directly to the recorder and a special cable to the VTR connector on the camera. It will satisfy those production needs that require Beta recording and editing.

Circle (505) on Reply Card

DMM with peak hold

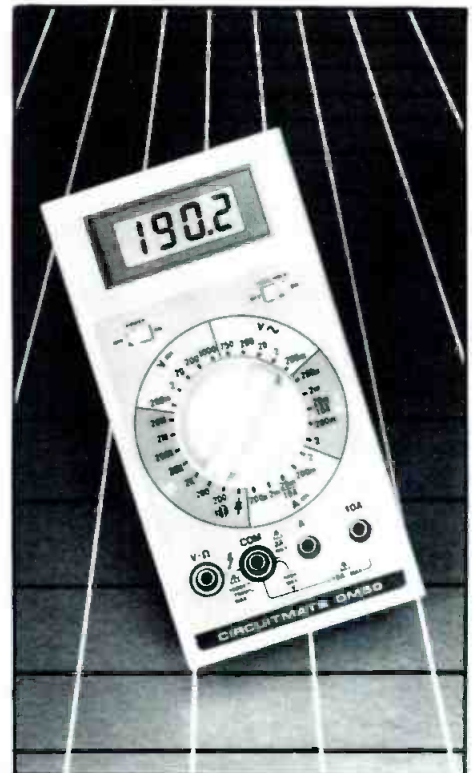

The Instrumentation Products Division of Beckman Industrial has introduced the Circuitmate DM50 digital multimeter with 28 ranges. The meter features peak hold, the capability to detect, store and display voltage or current peaks, even when they are transient (6ms minimum). This is different from a data hold function, which freezes the reading. When used with Beckman Industrial's model CT-233 ac/dc current clamp, the peak hold feature can be used to determine starting currents in ac or dc systems.

A single range/function switch makes measurements fast and efficient. A 3½-digit LCD provides high contrast viewing. Automatic polarity indication plus low battery indication provide feedback to the user. Other features include 0.5% dc volt accuracy, 10MΩ impedance, diode test function, continuity beeper, 10A current range, a tilt bail and safety designed test leads.

Circle (380) on Reply Card

MODEL 9600 HIGH DENSITY ROUTING SWITCHER

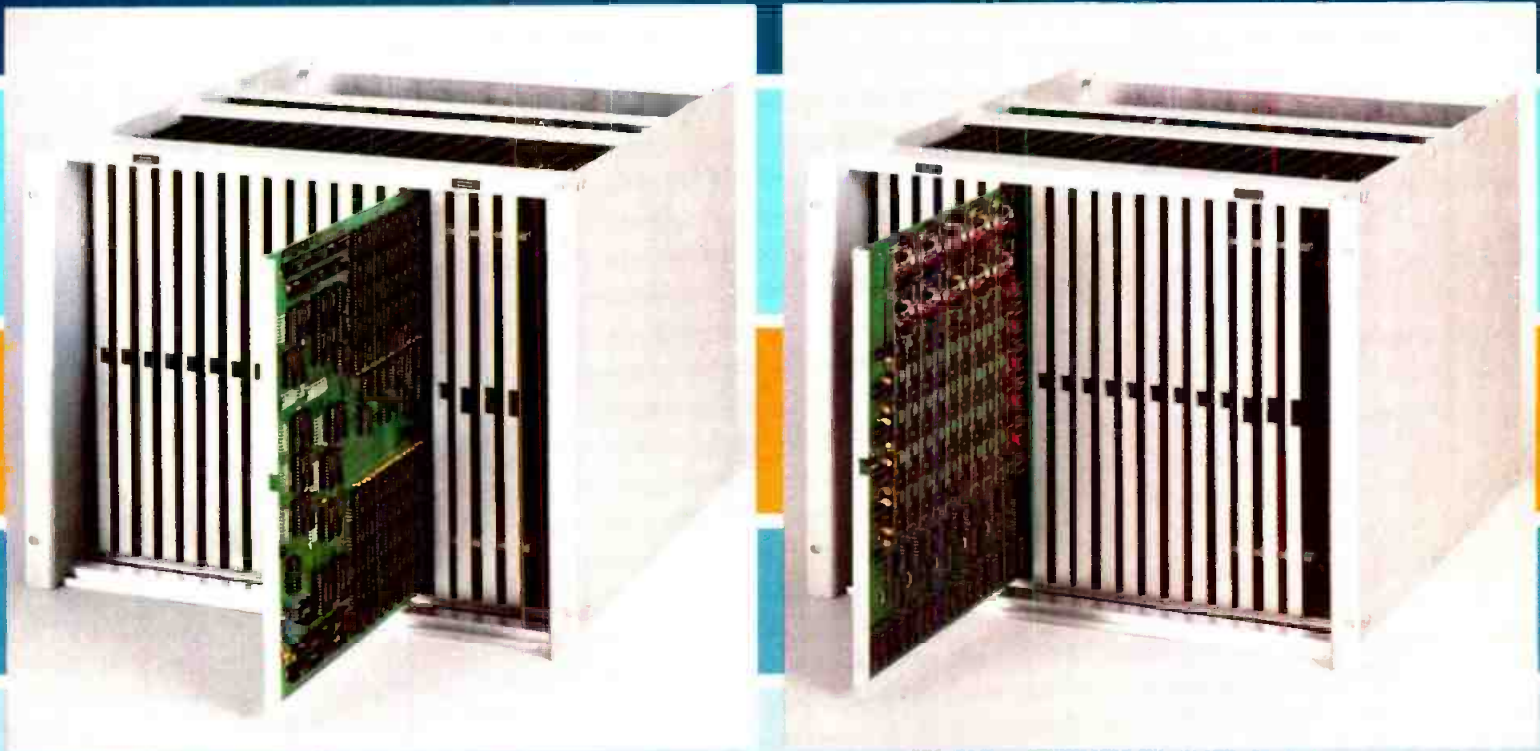

The Image of Excellence

The Model 9600 is the first of a new generation of **High Density Routing Switchers** from **Image Video**. A combination of **state-of-the-art design** and monolithic technology have produced a new level of sophistication in our line of high performance systems.

See us at **SMPTE** Booth # 502 & 503.

FEATURES:

- 40 × 40 video and 2 audio channels in just 16 rack units of space
- 80 × 80 video and 2 audio channels in just 48 rack units of space
- field expandable up to 320 × 320 and modification without disruption of normal operation
- accurate indication of crosspoint status (true tally)
- comprehensive diagnostics package
- infinite number of levels
- full breakaway capability
- compatible with both MAC and High Definition television standards
- no external DA's required for matrices
- compatible with all existing Image Video control panels and operates in conjunction with Image Video 10K control system



IMAGE VIDEO LIMITED

705 Progress Avenue, Scarborough, Ontario, Canada M1H 2X1 Tel. (416) 438-3940 Telex: 065-25392
1051 Clinton Street, Buffalo, N.Y. 14206 Tel. (716) 855-2693, Telex 065-25392

Microphone pole

LTM has introduced a 9-foot telescopic microphone pole. It is assembled in four sections and extends from 32 inches to 9 feet. It is made of anodized aluminum and weighs 15 ounces.

Circle (378) on Reply Card

MR series consoles

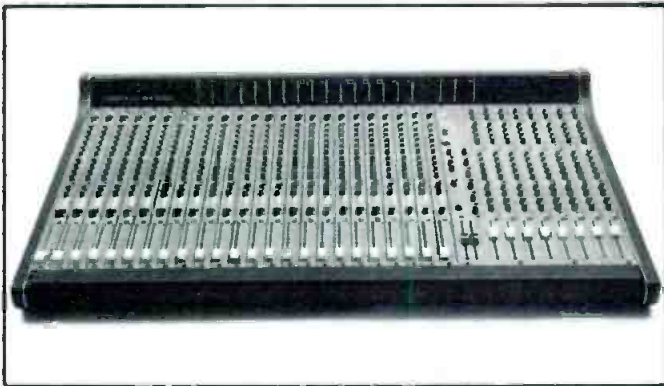

Soundout Laboratories has introduced an addition to the M series range offering full 16-track monitoring. The console facilities include 48V phantom power; -20dB pad; phase reverse; 100Hz high-pass filter; 4-band EQ with two sweepable mid-ranges; EQ defeat; six auxiliaries, two selectable pre/post EQ and four selectable pre/post fade; channel mutes and solos. The majority of input/outputs are +4dBm/-10dBV for compatibility within multitrack machines.

Circle (389) on Reply Card

Filter for microwave TV

Microwave Filter has introduced the model 4850 bandpass filter, which passes an entire ITFS group. It is available for each ITFS group in the allocated 2,500MHz to 2,686MHz band (groups A to H). Low loss is achieved by the use of high Q waveguide cavities. Non-adjacent group isolation is 15dB (minimum). Power is 100W and impedance is 50Ω. Loss at center frequency is 0.5dB (maximum) with a 1dB rollup bandwidth of 42MHz (minimum). VSWR (return loss) is 1.37:1 (maximum) and 16dB (minimum). Connectors are type N female standard and waveguide flange is optional. The filter is 33" x 5" x 3".

Circle (376) on Reply Card

Ceramic-to-metal power triode

Varian EIMAC has developed the EIMAC 3CX1200A7, a compact, high-mu, ceramic-to-metal power triode designed for use in HF radio transmitters, RF amplifiers for plasma generators and other linear amplifiers. The power triode was developed to take advantage of the new FCC regulations permitting amateur radio power output of up to 1,500W PEP.

The power triode's small size permits installation into existing radio cabinets, specifically those using a pair of EIMAC 3-500Z triodes. Although electrically different, the power triode and 3-500Z triodes share similar features, such as identical tube base design and corresponding sockets. The triode is intended to serve as a zero-bias Class AB2 amplifier for cathode-driven circuits. The triode delivers a power gain of up to 20 and is forced-air cooled, rated at an anode dissipation of 1,200W (30cfm at 0.5 inches of water).

Circle (388) on Reply Card

Seeing is believing

Look at what's available now!
The new AN-1000 has been adapted to fit the Tektronix half-rack.

That empty space next to your waveform monitor can be put to use. It can house an AN-1000T, an unbelievably powerful small speaker.

Mosfet output, DC servo offset control and electro-acoustic signal processing are all combined with the acoustically tuned enclosure, producing quality sound that you have to hear to believe.

Anchor Audio, Inc. • 913 W. 223rd St. • Torrance, California 90502 • 213-533-5984 • 1-800-ANCHOR-1

Circle (132) on Reply Card

QUICK-DRAW

Professional Camera Cases

These strong, comfortably portable top-loading cases provide full protection and easy access to fully assembled cameras and camcorders. Pockets, inside and out, carry cable, tripod adapter plate, tapes, batteries, and other gear. Models are available for most broadcast quality cameras and camcorders.

Consult your professional video dealer or K and H Products, Ltd.

K and H Products, Ltd.
Box 246, North Bennington
Vermont 05257 (802) 442-8171

Circle (174) on Reply Card

A TOUGH ACT TO FOLLOW

Genesis 1™ With ACT 1™ \$27,990



Genesis 1 ACT 1, Microtime's high quality, low-cost digital effects system increases creative capabilities to your imagination's limit. Create through self-prompting, icon-driven menus and instructions for sequences involving moves, freeze, flips, tumbles, posterize, shadow, variable aspect ratio, XY mosaic, strobe, and source change.

Genesis 1 ACT 1 offers:

- 3-Axis joystick control
- Keyframe creation of sequences
- Smooth curvilinear movement
- Frame accurate duration of a sequence
- Routing switcher interface for dual input switching when flipping and tumbling
- Three levels of sequence storage:
RAM, internal and portable

Genesis 1 ACT 1... A user-friendly digital effects system for your video productions. An ACT not to be missed at \$27,990.

 **MICROTIME**

A Subsidiary of ANDERSEN GROUP

Visit us at
SMPTE Booth 535

Microtime, Inc.
1280 Blue Hills Avenue
Bloomfield, CT 06002 USA
Tel: (203) 242-4242
TWX: 710-425-1165

Northeast, Ray Bouchard (609) 896-3716
Central, David Everett (312) 934-9191
Southcentral, Steve Krant (214) 644-0232
Southeast, Jerry Rankin (404) 979-4437
Western, Daniel Sofie 1-800-243-1570

Genesis 1 and ACT 1 are trademarks of Microtime, Inc.

Circle (69) on Reply Card
www.americanradiohistory.com

Broadcast headsets



Shure Brothers has introduced two professional broadcast headsets, the SM1 and SM2. Designed for news and sports broadcasting, special events remote announcing, interviewing and intercom systems, the SM1 has a single earphone and the SM2 has a double earphone. Both models feature an all-metal microphone boom that will not snap, and the headband features double-braced all-metal construction. The headband and the ear pads are covered in a durable, leather-soft material.

Both mics are close-talking unidirectional dynamic with a frequency response of 50Hz to 15,000Hz and are specially tailored for voice intelligibility. They discriminate in favor of

close sounds and against distant sounds, and can be used in noisy environments without loss or masking of the voice signal. The microphone boom uses a mounting system that pivots 155° so that the mic can be worn on the left or right side.

Circle (375) on Reply Card

Editing system

The CMX 330XL editing system has been placed on the market by CMX. The system offers a 340XL-type keyboard and screen display, which includes the current event edit and edit decision list on the screen.

The keyboard features the 340XL color-coded keys. The system will operate with three VTRs, plus switcher interface and general purpose interface. It is a 5-port system.

Circle (381) on Reply Card

Industrial logic pulser

The Instrumentation Products Division of Beckman Industrial has added the PR41 logic pulser to its Circuitmate product line. Switchable pulse rate for the PR41 is 0.5Hz or 400Hz. The 100mA pulse output ensures that the device under test will be pulsed, while the short 10 μ s duration of the output pulse makes sure that no damage will be done to the circuit under test. The logic pulser also uses an external sync input. This enables the user to synchronize the pulse output with an external signal. Features include a square wave output, ball-type power clips, coiled power cord and slim easy-to-hold design.

Circle (367) on Reply Card

Transmit 4 ITFS Channels On One Antenna

With the 4630(4) Combiner

- Channel filter outputs are combined with less than 1 db loss to any channel
- Available for any ITFS channel group (4 channel)
- Special models available for extreme temperature environments
- Two and three channel combiners also available



4630(4) - (Group)
Only \$4135
Delivery 30 days or less

The four channel combiner is detailed in free catalog BTV/85 which also includes information on filters for:

● UHF ● MDS ● ITFS

Order your free catalog today

1-800-448-1666

(NY/HI/AK/Canada)

(315) 437-3953

Microwave Filter Company, Inc.

6743 Kinne Street
East Syracuse, NY 13057

Circle (82) on Reply Card

A SIGHT FOR SORE EARS.

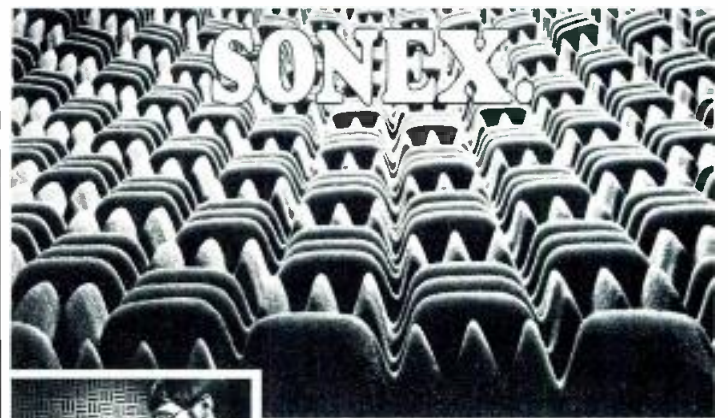

If ears could talk, they'd scream for SONEX.

The only patented acoustic foam with a specially sculptured anechoic design can replace traditional studio materials for a fraction of the cost. SONEX absorbs sound,

controls reverb, eliminates stray reflections, and kills standing waves. What's left is true sound. Your ears know. Listen to them. Simple to apply and economical to buy, SONEX blends with almost any decor and looks clean, sharp, professional. Call or write us for all the facts and prices.

Alpha Audio[®]
2049 West Broad Street

Richmond, Virginia 23220 (804) 358-3852

Acoustic Products for the Audio Industry

Circle (83) on Reply Card

SONEX is manufactured by Illbruck and distributed exclusively to the pro sound industry by Alpha Audio.

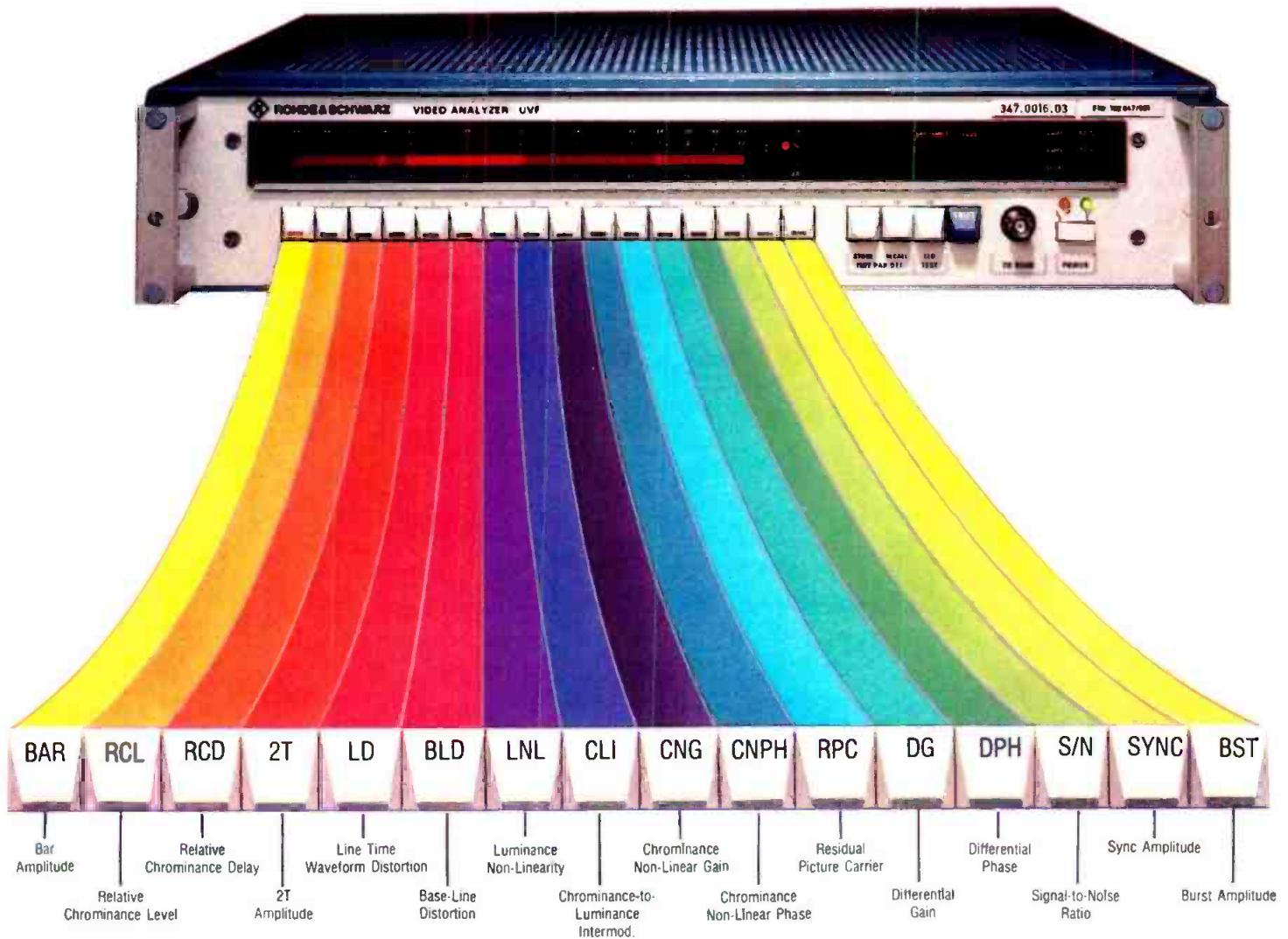

VIDEO ANALYSIS...AT A SPEED AND COST NEVER BEFORE ATTAINABLE.

16 PARAMETERS IN 2.5 SECONDS FOR \$15,500.

The Model UVF is the video analyzer you've been waiting for. It provides fast and precise quality assessment of Insertion Test Signals (ITS) and their adherence to given tolerances. A mere 2.5 seconds after applying the signal, 16 test-line parameters are simultaneously ready for examination, all in accordance with NTC-7 and RS-250B standards.

The lightweight, low cost Model UVF is suitable for all routine measurements on TV links, transmitters and cable networks.

The Video Analyzer features:

- RS-250B compliance
- Reliability even under severe noise conditions
- Latest microprocessor technology
- IEEE-488
- Storage of measured values for signal analysis
- 4 independent sampling programs



Many years of experience and a history of innovation, stand behind the UVF.

Send for complete specifications and our New 1986 Sound and TV Broadcast Catalog.



ROHDE & SCHWARZ
polarad

Rohde & Schwarz-Polarad, Inc., 13 Nevada Drive, Lake Success, NY 11042
Tel: 516-488-7300 TLX 960072

Circle (138) on Reply Card

A SIMPLE IDEA... SIMPLY DONE

VIDEO BARGRAPH AUDIO LEVEL INDICATOR

Sometimes the execution of a simple idea can become extremely complicated. The key is to keep the final result simple. The result in this case is the uniVUer, a fully accurate stereo VU or PPM meter with wide dynamic response, total flexibility, video transparency and stereo phase coherency monitoring (MonSter). Hundreds of uniVUers are in use in major network and independent television facilities worldwide. And getting UniVuer into your facility couldn't be simpler. Just call Real World for the name of your nearest uniVuer dealer.

**THE REAL WORLD
TECHNOLOGIES
GROUP, INC.**

3176 Pullman St., Suite 106,
Costa Mesa, CA 92626 (714) 957-1061

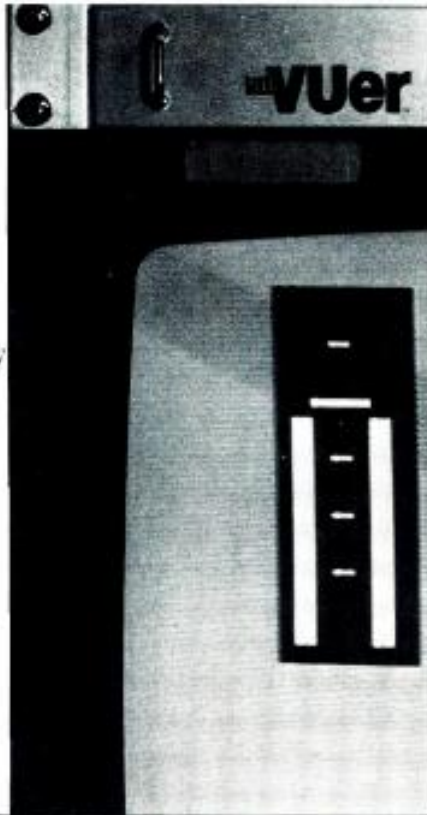

Circle (98) on Reply Card

Stereo audio signal graphic display

B & B Systems has announced the Imagescope, an instrument developed to give a true visual representation of a stereo audio signal. The tool graphically displays the stereo audio signal, showing the actual dispersion pattern of the sound energy as it will appear in a typical listening environment. The Imagescope is a self-contained package that gives the user a visual real time representation of the balance, separation and level of the stereo signal.

Circle (386) on Reply Card

Fresnel light

LTM has announced the availability of the LTM Luxarc 12000 fresnel light. The output level of the light is 25% greater than the 225A carbon arc. It is equipped with a 24-inch diameter fresnel lens and operates on 110V/60 cycles/ac. Major components, including the transformer and striker unit, are built by LTM.

Circle (377) on Reply Card

Video/audio distribution amp

Opamp Labs has introduced the model VA-14 video/audio distribution amplifier (1-in/4-out). In the video mode, it has a frequency response of dc to 8MHz (-1dB), 1V P-P. At 15,750Hz, output capability is 4V P-P. With the audio adapter plugged into the amplifier input, the response is dc to 20kHz (-1dB), +18dBm output and 0.05% THD. Four model VA-14s may be mounted in a 1 3/4" x 19" panel.

Circle (503) on Reply Card

3-phase UPS system

Nova Electric has announced the availability of a 10kVA UPS complete with solid-state transfer switch. Designed for computer applications, the system incorporates the capability to support other loads such as process control, telephone, emergency lighting and communications systems. It is capable of operating single and 3-phase loads simultaneously and can be operated with unbalanced loads. The system incorporates a static transfer switch that transfers the load to/from the utility line within 4ms.

Circle (365) on Reply Card

Standards converters and signal processor

AVS, part of Avesco, has introduced the AVS 6500 TV standards converter and signal processor. The model incorporates gen-lock, SECAM input, RGB output and multigrab facilities. Both units incorporate signal processing, detail enhancement, chroma retiming, noise reduction and freeze-frame.

Circle (382) on Reply Card

"UNEQUIVOCALLY THE BEST TCR-100 CARTRIDGE AVAILABLE"

— Expressed by engineers at over 100 TV stations across the U.S.



THE BEST PRODUCT

Reliability is one of the most important features to look for in a TCR-100 cartridge. You can always trust National Video Service's TCR-100 cartridges. It is manufactured to RCA's TCR-100 specifications, and has Lexan[®] door latches to provide a *lifetime guarantee* against the number one breakage problem of the competition! To provide the best quality, NVS uses only 3M Scotch 400 video tape.

THE BEST PRICE

National Video Service will not knowingly be undersold on any of our services. New one-minute message cartridges are as low as \$24.95.

Emergency? National Video Service offers same day shipping via pre-paid Federal Express.

National Video Service is so confident you too will be sold on our TCR-100 cartridge. That's why we're offering you a **free sample**, one test and you'll be hooked. To receive your free TCR-100 cartridge call (415) 846-1500.



National Video Service
2150 Rheem Drive
Building G
Pleasanton, CA 94566
(415) 846-1500

TCR-100 New Cartridge Sales • Reloading • Trade-In-Exchange

Circle (99) on Reply Card



High Tech

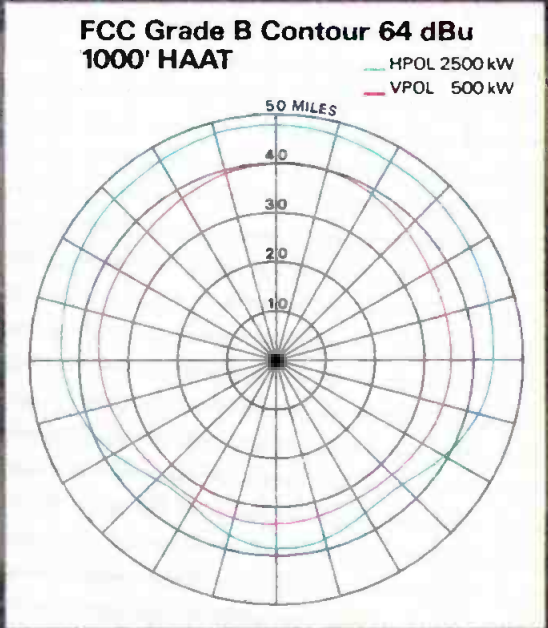

Eleven hundred feet above Memphis, Tennessee this Andrew TRASAR™ transmitting antenna employs the latest concept in UHF-TV broadcasting...elliptical polarization. This feature significantly increases the quality of coverage in markets where the higher start up and operating costs associated with full circular polarization can't be justified. The antenna pictured radiates 20% of its energy in the vertical plane. This component reaches 4/5 the distance of the horizontally polarized mileage contours. In addition to providing improved signal strength and reduced reflections it shares the features of all TRASAR antennas. Exclusive traveling wave slotted array design. Heavy null fill.

Low VSWR. Up to 2.5° beamtilt without gain loss. High power rating and reserve capability. Totally protected in a pressurized fiberglass radome. Broadcasters worldwide look up to Andrew UHF-TV antennas. For the TRASAR antenna best suited to your application write for Bulletin 1083 or call your Andrew Sales Engineer. Andrew Corporation, 10500 West 153rd Street, Orland Park, IL 60462. Telephone (312) 349-3300. Telex: 25-3897.



ANDREW
Our concern is communications.

Fully digital video processor



A video-processing system, integrating newly developed time base correction technologies with advanced video-processing and variable motion capabilities, will be introduced by *Ampex* at the SMPTE exhibition, Oct. 27 to Nov. 1, in Los Angeles. Compatible with the entire family of Ampex Type C VTRs, Zeus 1 is specifically designed to meet the needs of the mid- and high-end broadcaster and post-production facility.

The system combines the following features into a single compact unit: slow motion and program compression; bad color frame edit processing; full-frame store capability; enhanced dropout replacement; improved signal-to-noise; elimination of long time-constant velocity errors; full digital controls and switchable formats.

Circle (383) on Reply Card

Rack-mount mixdown machine

AKAI has introduced its GX912 rack-mount mixdown cassette featuring computer-controlled auto tuning and the Super GX AKAI glass crystal ferrite head. The machine features instant program location system, intro scan, quick memory search, record mutes, headphone out, remote control jack, front and back panel line in/out jacks and spectrum analyzer to determine record levels of mid/low and high frequencies.

The machine features Dolby B and C noise reduction, signal-to-noise ratio 20Hz to 19,000Hz using normal tape, 20Hz to 20,000Hz using CrO₂ and 20Hz to 21,000Hz using metal base. S/N is greater than -60dB. Features include 3-head configuration; Super GX head for recording, Super GX head for playback and an erase head. Wow and flutter is 0.0025% (WRMS), 0.04% (DIN) and distortion 0.6%.

Circle (385) on Reply Card

Digital disc recorder/player

Compusonics has announced that it has begun production of its DSP-1000 digital disc recording/playback system. The first 50 DSP-1000 units will be tailored for use in broadcast applications at radio stations, where the Compusonics system will replace tape cartridge machines. The system is a heavy-duty version of the company's consumer product system, except for the record/play time, which is less than 10 minutes for full-frequency response high-fidelity sound.

Distribution of consumer products through specialty computer dealers will be handled by WMD MicroDistributors, Irvine, CA.

Circle (372) on Reply Card

SAVE TIME

For fast, accurate service, please remove the Peel-Off Label (which is used to address your magazine) and affix it to the Reader Service Card, the Address Change Card, or to any correspondence you send us regarding your subscription.

Power conditioners

Topaz has introduced Line 1 power conditioners, designed to protect microcomputers against electrical noise and high or low voltage. The conditioners feature low output impedance. This enables them to protect microcomputers against power-line disturbances while meeting the peak-current power demands of internal switched-mode power supplies. The conditioners attenuate electrical noise over a broad frequency spectrum of 400Hz to 25MHz.

Providing a maximum 132dB of common-mode noise attenuation and up to 95dB of normal-mode noise attenuation, these conditioners eliminate virtually all noise-related computer problems. Each conditioner is equipped with a rotary switch that allows the user to reduce the input voltage by 5% or to boost it 7.5% to accommodate high or low line voltage. The power conditioners are available in 60Hz and 50/60Hz models, with power ratings from 250VA to 3kVA. Features include compact styling, a power cord and receptacles for easy plug-in installation.

Circle (374) on Reply Card

Software for switcher control

BL-300 is a software package for standard IBM personal computers from *Breneman Labs*. It provides control of Grass Valley model 300 video production switchers that have effects dissolve and serial interface options. The switcher can be controlled at the equipment racks for efficient adjustment and troubleshooting. Several graphic screens provide real time control of the switcher and all options such as digital video effects, audio and master effects memory. An entire mix/effects can be controlled using a single screen. One

joystick is used to select analog controls or push buttons on the screen. The second joystick is used to adjust the selected analog control and to simulate the lever arm.

Diagnostic capabilities are also provided. Because the control panel isn't used, problems could be isolated between the control panel and the main electronics frame. The switcher can be constantly exercised to detect intermittent microprocessor failures.

Circle (371) on Reply Card

Standby power source

The 800VA, 60Hz standby power source (SPS) offered by *Sola*, a unit of General Signal, has been enhanced to provide four NEMA 5-15R output receptacles. It is now UL-approved and features noise attenuation capabilities that meet FCC regulations and VDE 0871 Level B conducted and radiated emissions limits.

The power source is designed to provide off-line battery/inverter backup power for protection against power failures. The SPS features greater economy in less critical applications in which the continuous, clean power of an uninterruptible power system is not required. It is sized to protect smaller electronics, such as POS terminals, electronic lab monitors and test devices, critical process controls, communications equipment and microcomputers.

The compact, lightweight SPS plugs into any standard ac outlet. Its self-contained, maintenance-free, sealed lead-acid battery provides 12 minutes of reserve time running at full load, 20 minutes operating at three-quarter load or 30 minutes at half-load. The model includes a 6-foot power cord with NEMA 5-15P plug.

Circle (369) on Reply Card

ME-318 Stereo Sound

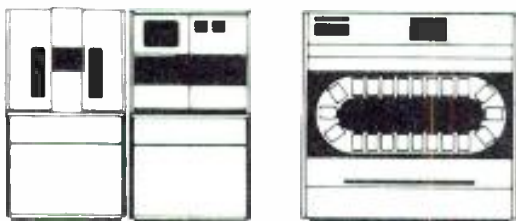

FOR ACR & TCR QUAD CARTS

VISA

Vertical Interval Stereo Audio

Upgrade any ACR or TCR to record and play stereo audio without transport modifications.

Separate encoder and decoder modules are used; multiplexing the two stereo channels into the vertical blanking portion of the video signal in Record and retrieving them during Playback.

MERLIN



MERLIN ENGINEERING WORKS

2440 EMBARCADERO WAY, PALO ALTO, CA 94303

(415) 856-0900 • TWX 910-3731782

TOLL FREE (800) 227-1980

Circle (125) on Reply Card

MC SERIES

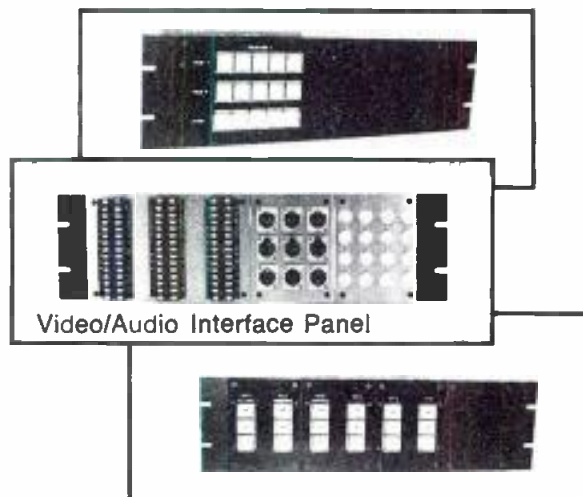

Video/Audio Interface Panel

- Machine control panels
- Audio/video interface panels
- Modular.
- Rackmount frame
- D-sub connectors
- Lighted, high quality pushbutton panels.



BROADCAST SYSTEMS INC.

800/531-5232 800/252-9792 TX

Circle (124) on Reply Card

Real World's RG-341

Three for one, what a value! In the real world we're concerned with space and cash. The RG-341 turns any video monitor into three precision alignment instruments:

- Safe area/safe title
- Pulse cross/blanking verifier
- Micro-mark cursor

Give us a call to find out what a value we have for you.



**THE REAL WORLD
TECHNOLOGIES
GROUP, INC.**

3176 Pullman St., Suite 106, Costa Mesa, CA 92626, (714) 957-1061

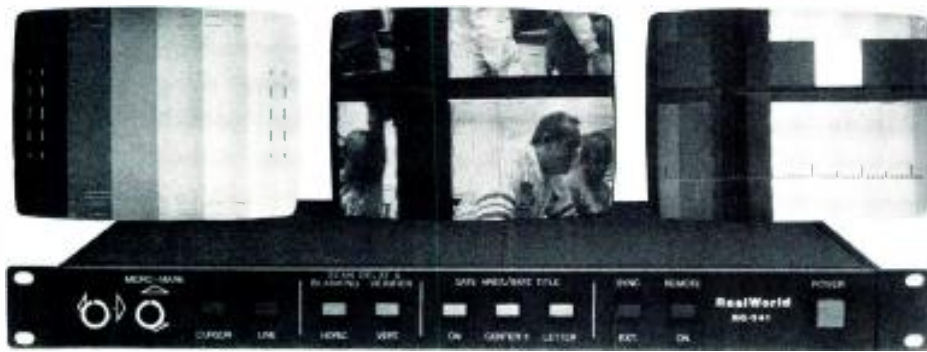

Circle (91) on Reply Card

Videotape eraser

Garner Industries has expanded its line of high-speed bulk tape erasers with the development of the model 1600. With its endless belt and high-efficiency coil design, the model offers a labor-saving means to erase high-energy video and instrumentation tape to -90dB from saturation level.

The 1600's endless belt system accepts cassettes and 1/4-inch to 1-inch reels up to 16 inches in diameter. This method allows for fast 16-second erasure of any format without changing awkward adapters.

Circle (500) on Reply Card

Audio switchers

Logitek Electronic Systems has introduced the Pre-10 and Mon-10, units for switching and monitoring audio sources.

The Pre-10 is a simple 10-in, 2-out passive monaural audio switcher, equipped with rear-panel XLR connectors for use in the field or in the studio. It mounts in a single 1 3/4-inch rack space and includes label strips for each source.

The Mon-10 is a 10-in, 1-out stereo audio switcher, plus a 6-range VU meter and 6W monitor. It all fits in 3 1/2 inches of rack space. After one of the 10 inputs has been selected, the user can choose to meter and monitor the left channel, the right channel, the mono (L+R) sum or the out-of-phase (L-R) difference, making the unit suitable for new stereo TV monitoring applications.

Circle (501) on Reply Card

Shipping cases

Shock-mounted shipping cases from **Environmental Container Systems** are designed to secure delicate electronic equipment from rough handling and environmental hazard.

The cases are constructed of pressure-molded fiber-glass-reinforced plastic and feature 8-point shock-mounted aluminum racks, removable front and rear covers, heavy-duty recessed handles, gasketed closures and pressure relief valves.

Designed for stacking and constructed to standard EIA-RETMA dimensions, these enclosures simplify the combining of any group of instruments and accessories.

Ten sizes are available, varying in height only. Cases are provided with an internal frame measuring 18.3"x18.9" and varying in height from 5.25 inches to 21 inches. External dimensions measure 22.77"x27.16" with overall height varying from 8.94 inches to 24.69 inches.

Circle (502) on Reply Card

CDE CORNELL-DUBILIER

Mica Capacitors

LARGE

STOCK



**VACUUM
CAPACITORS**

JENNINGS

SURCOM ASSOCIATES, INC.

305 Wisconsin Avenue
Oceanside, California 92054
(619) 722-6162

Circle (109) on Reply Card

Laser & Holographic

STAR

Filters by Spectratek



ESS 7838 N. San Fernando Road
Sun Valley, California 91352
(818) 768-8064

Circle (110) on Reply Card

Maintain network-quality color performance with B&K-PRECISION NTSC video test instruments

Model 1270 NTSC Vectorscope \$1995

Model 1265 Waveform Monitor \$1995

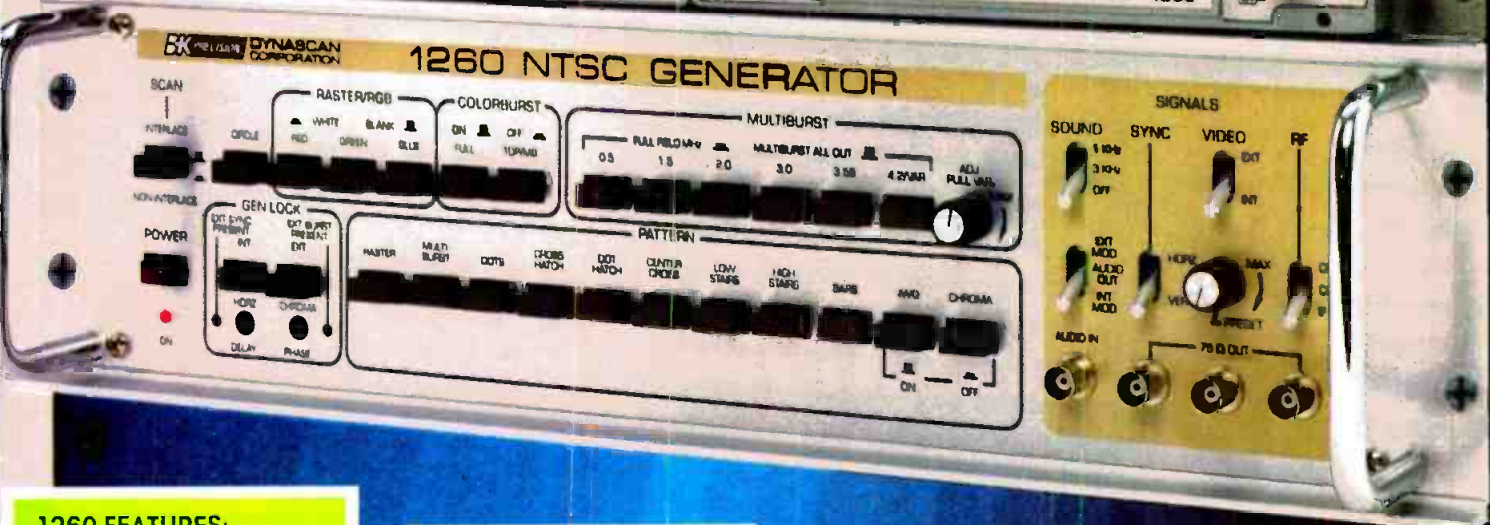

Model 1260 NTSC Generator \$1695

1260 FEATURES:

- RGB OUTPUTS
- GEN LOCK
- INTERLACED OR PROG. SCAN
- BUILT-IN MODULATOR
- MULTI-BURST TO 7.0 MHz
- TCXO STABILITY
- BLACK BURST

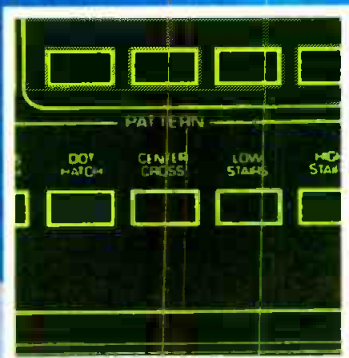

1260 generates 12 patterns, including circle, bar and crosshatch patterns

1265/1270 FEATURES:

- 12 KV ACCELERATION POTENTIAL
- ALL CONTROLS ARE FRONT-PANEL MOUNTED
- STANDARD HALF-RACK MOUNTING
- BUILT FOR CONTINUOUS DUTY OPERATION
- SPLIT FIELD VIEWING OF LINES 13-22 ON 1265

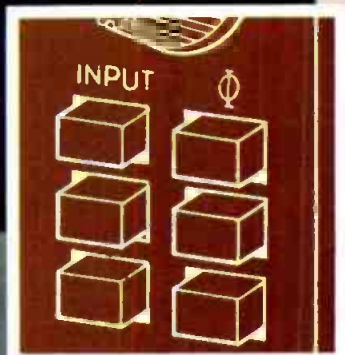

1270 offers simple set-up and selectable inputs

For the complete picture on these new video test instruments, see your local distributor or call B&K-PRECISION at 1 312 889 9087.

B&K PRECISION DYNASCAN CORPORATION

6460 West Cortland Street • Chicago, Illinois 60635 • 312/889-9087

International Sales, 6460 W. Cortland St., Chicago, IL 60635

Canadian Sales, Atlas Electronics, Ontario

South and Central American Sales, Empire Exporters, Plainfield, NY 11803

Circle (160) on Reply Card

www.americanradiohistory.com

Limited Supply



Don't wade
through 1000 different
product brochures...

Use BE' Buyers' Guide **Spec Book** instead!

Now you have two of your favorite issues in one super issue. Broadcast Engineering's **1st Annual Buyers' Guide/Spec Book Combination Directory**. Designed to save you valuable time. Which makes this special issue an essential tool for any broadcast equipment buyer.

Comprehensive Equipment Listings

Buyers' Guide/Spec Book provides reliable specifications on nearly 1,000 different broadcast and broadcast-related products, making it the industry's only single-source equipment comparison reference encyclopedia.

Manufacturer Address Directory

Manufacturers' addresses are listed alphabetically by company name, so you can easily locate and contact the equipment supplier of your choice.

Buyers' Guide/Spec Book Is Unique

It's vastly different from any other industry directory. Because it not only puts you in touch with suppliers, it also lists performance specifications, model numbers and special product features for each piece of listed equipment!

Easy To Read

Buyers' Guide/Spec Book's convenient format, developed from your feedback on past BE Buyers' Guides and Spec Books, allows you to gather information quickly and efficiently. This way, you spend less time searching through product literature, and more time studying valuable

equipment comparison data. All to help you make wise equipment purchasing decisions.

Easy To Use

Each product listed in Buyers' Guide/Spec Book includes a *reader service number*. So you can request additional manufacturer information quickly and easily.

Third Annual SPEC*TACULAR Reader Contest

Your chance to win one of several valuable prizes—worth thousands of dollars! You'll find complete contest rules and an entry blank inside the directory.

For additional copies, send \$20 (each copy) to Broadcast Engineering, P.O. Box 12901, Overland Park, Kansas 66212.

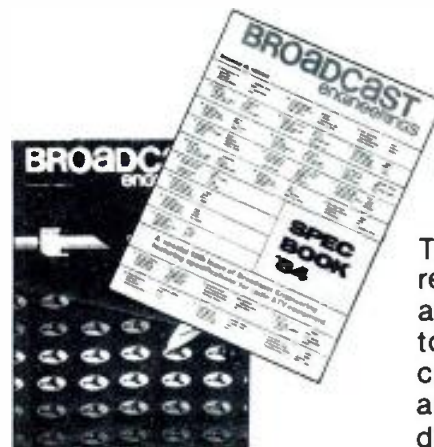

These two great reference tools are now combined, to give you one comprehensive annual purchasing directory!

Audio processor

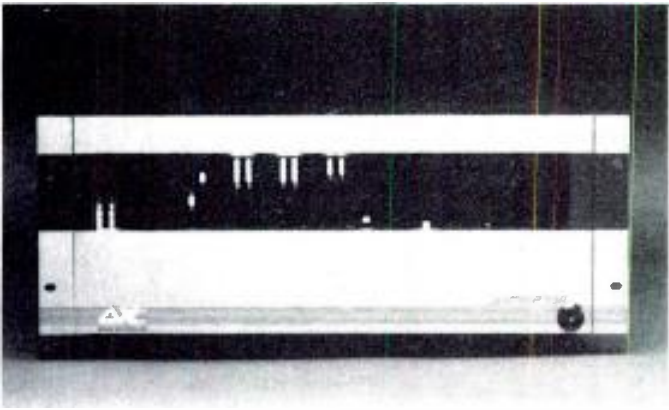

Aphex Systems has introduced a multiband FM audio processor called the Dominator. It uses many of the intelligent circuit principals from the Compellor to produce a loud, clean sound. Its 3-band compressors are program-controlled, so the operating parameters are automatically adjusted.

In the stereo generator, the Dominator uses the Aphex MTH401 IC to simplify and improve the design. Fixed filters have been eliminated, and the processor uses sweeping, program-controlled crossovers instead. These crossovers read the program material and adjust themselves for equal energy in each band, resulting in minimal interaction between compressor sections. The processor features full-function modular construction for easy servicing and a compact 7-inch-high rack package.

Circle (387) on Reply Card

Bandpass filter

Microwave Filter has introduced the model 4711 coaxial bandpass filter, which passes the 3.7GHz to 4.2GHz TVRO band with a maximum 1dB insertion loss and 11dB return loss. Attenuation is at least 20dB at 3.5GHz and 4.4GHz, the closest allocated interference. Suppression is approximately 30dB and 50dB on the public carriers, 2.1GHz and 6.5GHz, respectively.

The filter is designed to fit inside receiving equipment to exclude out-of-band interference. It is a specialized adaptation of standard model 4352 coaxial bandpass filter, which is mounted before the downconverter. The filter is weather sealed, has type N connectors and dc continuity for LNA power.

Circle (379) on Reply Card

Satellite video receiver

Microdyne's 1100 HDR satellite video receiver and low noise converter system offers flexible access to any satellite format available around the world. The receiver is designed for use with the high-performance, low-cost converters now available. With a 750MHz input band, the system provides access to the full range of international satellite broadcasts.

The receiver provides front panel selection of up to 96 channels, 48 of which are factory-set and 48 customer-specified. It can be purchased with optional dual IF filters for half and full transponder operation and dual audio demodulators. Both low noise converters for C-band and Ku-band offer lower noise temperatures. Their output is in the 950MHz to 1,450MHz range.

Circle (390) on Reply Card



The Monroe Model 5002 Remote Control will handle channel selection for two dual audio or voice cue modules for the Scientific Atlanta DAT-32* and the Comtech DART-384*. It will also provide remote transponder selection for the DART-384*.

THE NEW 5002 WILL SAVE YOU TIME AND MONEY AS YOU REDUCE THE NUMBER OF DEDICATED LINES AND CHANNEL CARDS.

- Control by phone
- Access Code
- Memory
- Automatic Disconnect
- Low Priced

Write or phone today for literature.

A NEW DAT REMOTE CONTROL FROM MONROE ELECTRONICS

M **MONROE ELECTRONICS, INC.**
E 100 Housel Avenue, Lyndonville,
NY 14098 Phone: (716) 765-2254
Telex: 756662 Easylink: 62547850

* Registered Trade Names

Circle (80) on Reply Card

THE TRUE MEASURE OF PERFORMANCE

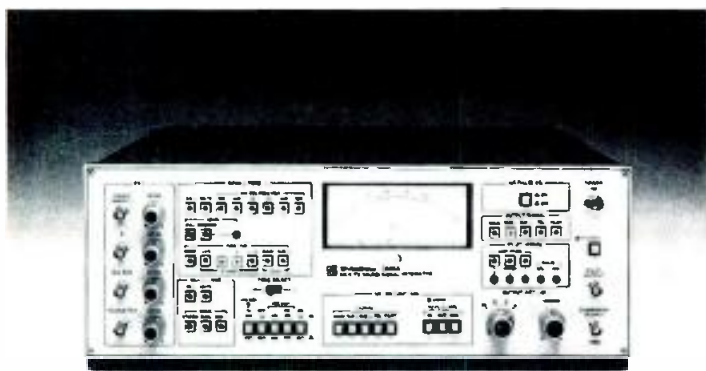

ASACA/SHIBASOKU TA35A MULTI CHANNEL TV SOUND SIGNAL GENERATOR

The TA35A Generates the signals of the Zenith Television Multi Channel Sound System used in the United States

The Main(L + R), 1st Sub Channel (L - R), 2nd Sub Channel (SAP), Telemetry, and Pilot Signals may be used independently or in any combination.

A dbx Noise Reduction Circuit has been built into both the 1st Sub Channel (L - R) and the 2nd Sub Channel (SAP).

A specially designed filter to compensate for delay characteristics due to the dbx circuit has been built into the Main Channel Section (L + R).

Remote Control Operation

Measure Your Performance With The Best
**ASACA/SHIBASOKU TA35A MULTI CHANNEL
TV SOUND SIGNAL GENERATOR**

For complete specifications, write:

ASACA

ASACA/SHIBASOKU CORP. OF AMERICA
12509 Beatrice Street, Los Angeles, California 90066
Sales, Service: (800) 423-6347 • (213) 827-7144

Circle (127) on Reply Card

Film counter/character generator

Gray Engineering Laboratories has introduced the model FC-142 film counter/character generator, a unit that counts film feet/edge numbers and frames during a telecine transfer to identify all film frames in a window dub for edit decision-making. With inputs from a telecine to provide film motion information, and the film feet/edge number, frames and optional ID number entered through front-panel thumbwheels, the generator will burn in the frame count with complete accuracy. The count will track the film during shuttling and variable speed transfers.

Circle (350) on Reply Card

Audio meter panel

An audio meter panel that features four meters in a 3½-inch-rack panel cabinet has been introduced by B & B Systems. The MP-4 can be ordered in any combination of VU or peak program meters. Separate input circuits for each meter include buffered, balanced and active bridging electronics. Installation sites could be transmitter areas, edit, telecine and control rooms as well as quality control and sound studios. The panel is suited for TV broadcasters preparing for stereo sound, for TV production, post-production, radio, film and other stereo audio applications.

Circle (351) on Reply Card

Field production DA

Shure Brothers has announced the FP16, a 1-input, 6-output, compact, self-contained audio distribution amplifier for routing multiple audio feeds without sacrificing signal integrity or clarity. The DA is flexible, portable and durable. A lightweight unit designed for on-location broadcasts, the DA can be permanently rack-mounted. It features wide-range frequency response (30Hz to 20kHz), up to 90dB gain, low noise and isolated outputs. The DA features separate, front-panel gain controls on the input, as well as on each output channel. Three LEDs indicate system status on the front panel.

Circle (393) on Reply Card

Surge and noise suppressor



Kalglo Electronics has announced the model QPC Plus Spike-Spiker. The suppressor has a response time of 1ps and a suppression capacity of 18,200A and 318J. Clamping starts at 131V with a maximum let-through of 232V at 50A. Noise at 10MHz is suppressed by 38dB on common mode and 50dB on differential mode. The unit contains six stages of surge suppression and has four ac outlets with a master on/off switch. This console-type suppressor has a 7-foot cordset and provides five filtering stages on each of two circuits. The two LED indicator lamps, in addition to showing that each mode of suppression is operational, also provide a quick check that the wall outlet is wired correctly.

Circle (373) on Reply Card

Soundmixer for studio/live



Tascam has introduced the 300 series, which features an 8-channel M-308, 12-channel M-312 and 20-channel M-320. A signal-routing system can handle complex foldback, effects mixing, subgrouping and monitoring requirements. It also is compact, rugged and versatile enough to take on the road.

The series was designed to make mixing easy with ample backpanel inputs and outputs combined with a top-panel switch matrix that virtually eliminates the need for patching. Four separate bus systems offer options for individual cue mixes in the studio or separate monitor and housemixes at live shows. Each bus can be separately addressed by the M-300's extensive talkback system.

Each module is built on its own circuit card for better isolation and easy serviceability. The module is then mounted on a steel chassis for optimum strength and security. All internal components are protected by an outer shell.

Circle (368) on Reply Card

Stereo audio analyzer

The SZ 340 stereo sound analyzer from Schmid Telecommunication automatically measures and verifies audio frequency transmission parameters of telephone and stereo circuits. The sweep oscillator creates two independent output signals for application to the stereo lines. Dual independent measuring receivers plot the circuit response on an integral CRT display.

The unit may operate from IEEE-488 bus control or from its internal microprocessor. EEROM and RAM devices allow storage of instructions for 200 measurements. Comparison of measured parameters with programmable upper and lower limits may be displayed or printed by an external device.

Circle (353) on Reply Card

Video animation system

Cubicomp has introduced PictureMaker, a high-performance video animation system that generates professional quality 3-D images on an IBM personal computer. The system allows the creation of solid models of virtually any shape—using more than 65,000 colors—as well as 3-D titles, logos and computer-generated story boards. A motion-scripting capability permits instant previewing before an animated sequence is recorded.

Six linked functional modules providing modeling, rendering, animation, composition, titling and painting features. Modeling is accomplished by creating a character, logo or any 2-D shape on the screen, then sweeping it about an axis to form a 3-D wireframe. These wireframe models can then be rendered into high-quality shaded images complete with smoothly curved surfaces, shines, true perspective and translucency.

Circle (354) on Reply Card

Perfect Timing

PROGRAMMABLE CLOCKS



750 E SERIES
One or Two Events,
Thumbwheel Programming
\$341-430

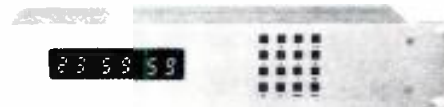

720 SERIES
10 Events,
Micro-Processor Based
\$845-1150



780 SERIES
Up to 96 Events Stored
in Random Access Memory
\$1313-1654



ES 790
1000 Events, Microprocessor-
Based, 32 Output Channels
\$2300



(213) 322-2136

142 Sierra St., El Segundo, CA 90245

Circle (128) on Reply Card

Video/audiotape degausser

Christie Electric has introduced MaxERASE-16B, a universal video/audiotape degausser with a phase change switch that can select the precise horizontal or vertical phase to match the recording. The degausser handles 1/4-inch to 2.6-inch tape, up to 16 inches in diameter. It erases high-coercivity bulk tape up to 1,500 Oersted in a 30-second, fully automatic, 1-pass operation.

The degausser generates higher than previously available levels of magnetic flux. The tape rotates through the magnetic field to prevent spoking, and passes through the magnetic field at a varying speed to provide equal erasure throughout. The degausser is designed for quiet continuous duty usage of most tapes without overheating of the unit or the tape.

Circle (352) on Reply Card

Dynamic vocal microphone

Shure Brothers has introduced the SM48-LC low impedance unidirectional dynamic vocal microphone. The SM48-LC is equipped with its own specially designed Shure cartridge and delivers professional performance in live sound reinforcement (both music and speech), recording studio, remote pickup and broadcast applications.



The microphone uses a cartridge shock mount that reduces handling and stand noise. The cartridge produces a smooth peak-free frequency response, 55Hz to 14,000Hz, with a slight mid-range presence rise for enhanced vocal intelligibility. The mic has a uniform cardioid pickup pattern that reduces off-axis coloration and rejects background noise to permit higher sound system gain before feedback. A built-in spherical windscreen takes the pop out of closeup vocal use and minimizes breath and wind noise pickup.

Circle (358) on Reply Card

Digital multimeter

A.W. Sperry Instruments has announced its 3 1/2-digit, rotary-switch, digital multimeter: DM-3000. Features include pocket-size, overload protection, 10Aac/dc current readings, large 0.5-inch digit, easy-to-read LCD and 200-hour battery life. The DMM incorporates nine functions on 28 ranges, including dcV, acV, dcA, acA, ohm, diode test, battery test. HFE test and continuity buzzer.

Circle (392) on Reply Card

Handheld wireless mic

HM Electronics has introduced the System 87, a handheld wireless microphone system incorporating the Shure SM87 condenser mic element. The mic provides wireless performance that is virtually identical to a hard-wired SM87, including dynamic range, frequency response and maximum

SPL input. Similar in appearance to the System 85, the 87 offers smoother high-end response and greater gain before feedback. The transmitter is the smallest available using an SM87 element.

Circle (395) on Reply Card

Studio monitors

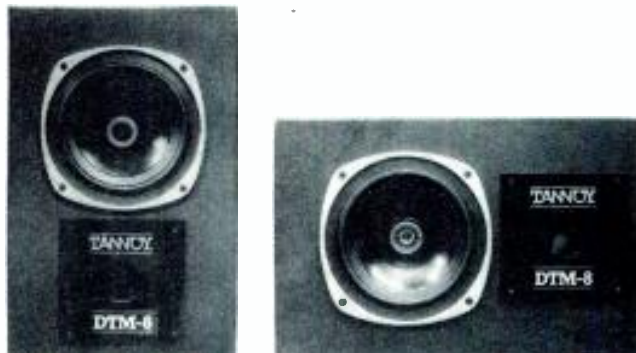

Tannoy has introduced two studio monitors. The DTM-8 is a compact desktop monitor for close-range monitoring that uses the 8-inch dual concentric speaker. It features self-adhesive rubber pads that can be fitted to the side or bottom of the cabinet, creating a firm grip to the console top.

The FSM studio monitor uses the 15-inch dual concentric speaker for high power handling and sensitivity. It features an adjustable LF window to acoustically match free air or soffit mounting.

Circle (396) on Reply Card

Interference tester system

Miralite has developed a portable system to pinpoint terrestrial interference. Clearsite, specifically designed to observe the 3.7GHz to 4.2GHz C band, allows interference contours to literally be seen at any suspect antenna site. Battery operated and handheld, the system powers a low noise amplifier and displays signal intensity, bearing and polarization instantly. All necessary system components are integrated into a self-contained package.

Circle (391) on Reply Card

TV products

Tektronix has announced that it will introduce three TV products at the SMPTE convention. The SPG-170A NTSC sync generator is compact and combines RS-170A sync generation, digital gen-lock and a high-stability color standard, with a set of system timing controls.

The WFM-300 (Lightning), is a component analog video waveform monitor that monitors and measures inequalities in component amplitude and timing.

The BTSC modulation monitor and decoder, a single unit designed for use in stereo applications, can be used in conjunction with the 1450-1 demodulator.

Circle (450) on Reply Card

Software enhancements

Bosch has introduced several software enhancements for the FGS4000 computer animation system. One program, the light source editor, has the capability to render realistic smooth shaded surfaces. The user can position, color and animate up to 16 independent light sources. Lights can be defined as infinite source, local beams or points.

Another enhancement, the terrain modeler, has the capability to generate complex random land surfaces. The

surfaces are effective in creating realistic-looking mountains and other landscapes. Enhancements have also been made to the high quality rendering software package and the smooth shade editor package.

Circle (356) on Reply Card

Audio accessory system

Logitek has added new features to its audio accessory system. Modules for the rack-mountable audio frame include audio DAs with fixed or independently adjustable outputs, a 5-input monitor amp, a dual mic preamp and AGC and VCA modules. Also, indicating front-panel fuseholders and status LEDs have been added to the fully redundant power-supply modules.

The system holds up to 10 audio modules in a 5¼-inch rack height, making it useful for stereo TV audio distribution, where space for the new channel is at a premium. All inputs and outputs are on wire-capturing terminal blocks for quick installation. The system is covered by a 5-year warranty and is available from Logitek dealers worldwide.

Circle (357) on Reply Card

Miniature mic



Shure Brothers has announced the SM98, a professional quality miniature unidirectional condenser microphone designed specifically for instrument and amplifier micing. Its low-noise, low-distortion preamp allows it to withstand close micing of drums, brass instruments, amplifiers and other high SPL sources without distortion. The mic features a wide, flat frequency response with switchable low-end rolloff for accurate reproduction of acoustic instruments. Due to its small size (½-inch in diameter and 1¼ inches long), the mic has a tight cardioid polar pattern at all frequencies.

The SM98 includes a swivel adapter for use with all standard microphone stands, booms and goosenecks. The complete package includes the microphone, windscreen, pre-amp, swivel, adapter and mic-to-preamp cable. All fit into a hinged storage box.

Circle (394) on Reply Card

Data and maps

Data and maps of microwave routes for each state are available from *Microwave Filter*. Installers of TVRO systems may purchase the information to identify sources of interference that may hamper antenna reception. The data includes the transmit-and-receive site for each microwave path in a specified state, frequencies authorized for each path, path length in miles and azimuth of path. Also provided for each transmit site are the FCC call letters, latitude and longitude, county, closest city, transmitter height, user of the link and a short location description.

Circle (359) on Reply Card

IMAGINE TRANSMITTING 30 MILES ON 1 WATT OF POWER

Imagine ultra-small size and 100% solid-state performance in the 7 GHz band. Tx. wgt. 4.6 lbs. With high power output whenever you need it (1 watt standard; optional 5 watt).

Imagine 2 standard audio channels. Plus simplified C-MOS and FET circuitry designed to cut your power consumption. Only 10 watts input for 1 watt output.

Now... imagine what the TVL 800-6F can do for you. Call 1-800-323-6656.

TVL 800-6F ENG MICROWAVE

NEC

IMAGINE WHAT WE'LL DO FOR YOU

NEC AMERICA, INC., Broadcast Equipment Division
130 Martin Lane, Elk Grove Village, IL 60007
In Illinois 312/640-3792



Circle (129) on Reply Card

1-inch videotape

Fuji Photo Film has announced the development of H621E 1-inch videotape. The videotape features better color, a sharper image and increased runnability and durability than the company's H621. Features include improved signal-to-noise ratio; minimal dropouts; better tape transport performance due to a new binder system and backcoating; and reduced instances of print-through. Fuji videotape is available in a complete range of lengths in both the C format and B format. Fuji offers a hard plastic carrying case and a fire-retardant shipper.

Circle (360) on Reply Card

Dual-channel videocart system

Lake Systems has announced the development of its true multichannel all-source to all-destination La-Kart videocart system for the broadcast and cable industries. It incorporates all the features of the La-Kart including multiple spots per tape; components processing; choice of broadcast formats; (3/4-inch U-matic, 1/2-inch Beta or type M and 1-inch type C); random access; catalog storage of events and the capability to interface with a TV station's master control.

Circle (400) on Reply Card

Wide-angle zoom

Schneider Corporation of America has been delivering its new wide-angle studio lens designed for 2/3-inch (type TV66), 1-inch (type TV64) and 1 1/2-inch (type TV65) studio cameras. These high-performance lenses offer a 14.5X zoom range, 56° to 2° horizontal angle of view with built-in 2X range ex-

tender. Maximum aperture is f/1.4 for 2/3-inch cameras, f/1.7 (1-inch) and f/2.2 (1 1/4-inch).



These lenses feature wide viewing angle, short minimum object distance of 17.7 inches, low geometric distortion and high modulation transfer function. They also offer improved color correction throughout all points of zoom range. An optical test pattern diascope is also available.

Circle (361) on Reply Card

Limiting/compressor/ dynamic sibillance processor

Valley People has introduced the model 440, a single-channel device that incorporates a peak limiter, a com-

Ask for our
FREE CATALOG
OF PROFESSIONAL
Sound RECORDING
& DUPLICATING SUPPLIES



Polysette
Blank-Loaded
AUDIO CASSETTES



CASSETTE BOXES
LABELS • ALBUMS



ACCESSORIES
from NORTRONICS
3M • BASF • EDITALL

Switchcraft Connectors
Canare Microphone Cable
Connecronics Cable
Telex Cassette Copiers
Signature Prod. Music Library



TAPES
• CASSETTES
from MAXELL
AMPEX • FUJI • 3M
BASF • AGFA • TDK

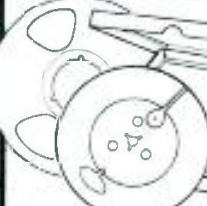

Polyline Empty
REELS & BOXES



NAB BROADCAST
CARTRIDGES

Polyline Corp.
1233 Rand Rd. • Des Plaines, IL 60016
(312) 298-5300

Circle (119) on Reply Card

NOW
Coarc™ "Hub-Loads"
1/2" VHS Videocassettes

- Hub-Loading means winding videotape onto the cassette hubs before the hubs are put into the cassette. It's the best way to do it because hub loading machines wind the tape exactly in the center of the hub without edge damage and with perfect tensioning. All Coarc rebuilt videocassettes are hub loaded — because it is the **only** proper way to reload a 1/4" U-Matic.
- Our new 1/2" videocassettes are hub loaded also because it's the **best** way to load a new 1/2" VHS videocassette. National brands of new, first quality videotape are available under Coarc's brand name with Coarc's guarantee.

Hub Loading — exclusively from Coarc — the people who gave reloading a good name.

CoarcVideo™
CUSTOM LOADED VIDEOCASSETTES

PO BOX 2, ROUTE 217
MELLENVILLE, NEW YORK 12544
518/672-7202

Circle (167) on Reply Card

ALUMA TOWERS
FIXED BASE, MOBILE TRUCK,
TRAILER OR VAN TYPE

**EXCELLENT FOR REMOTE
SIGNAL TRANSMISSION**

- TELESCOPING—TO 100 FEET
- EASY TO ERECT AND USE
- MOBILE OPERATIONS
- INEXPENSIVE
- RELIABLE

**FOR ALL TYPES OF
COMMUNICATIONS**



▲ MOBILE TRUCK TYPE ▼



◀ FIXED BASE TYPE



▶ MOBILE VAN TYPE

ALUMA TOWER COMPANY
BOX 2806BE
VERO BEACH, FL 32960-2806
(305) 567-3423 TELEX 80-3405

Circle (142) on Reply Card

Technical

Technical editorial. Written by technically-oriented editors.

Two reasons why broadcast engineers read Broadcast Engineering. And more often than any other industry publication.

And those are your two most important reasons for advertising in BE.

Call today for a media kit.

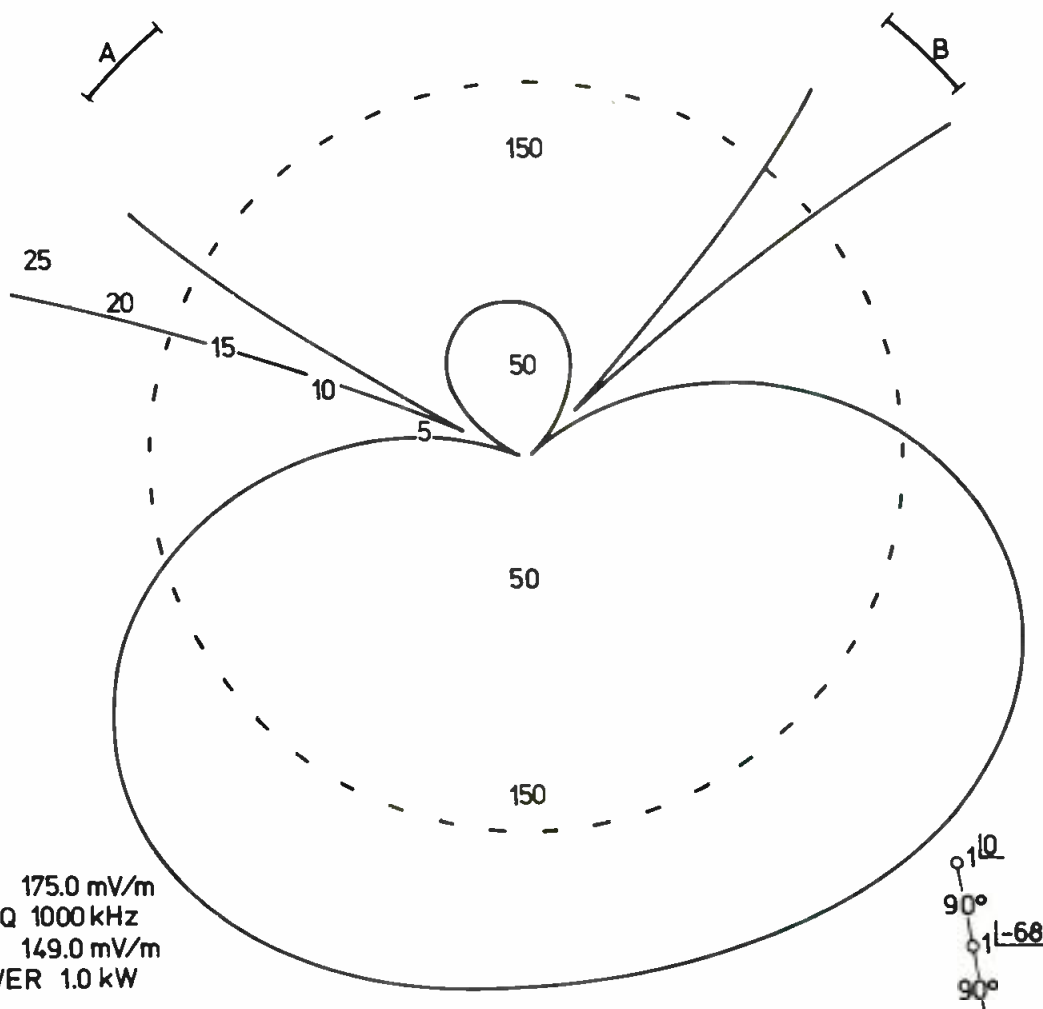

BROADCAST[®] ENGINEERING

Intertec Publishing • P.O. Box 12901, Overland Park, Kansas 66212 • 913/888-4664

pressor/expander package and a dynamic sibilance processor section, each controlling a common VCA (voltage-controlled amplifier). Intercoupling of the control circuit used for each function allows the device to simultaneously limit, compress, expand and eliminate high-frequency components in sibilance.

The compressor control section features continuously adjustable threshold, attack time, ratio and release time. An interactive expander control is integrated with the compressor control circuitry to reduce residual noise that would otherwise be accentuated by the compression process. Special release coupling makes the transition from compression to expansion imperceptible, eliminating problems with separate single-function units. The limiter control section exhibits attack characteristics that are typically 1µs/dB or less, continuously variable threshold, a fixed 60:1 ratio and variable release time. Barrier strip connectors are provided for all inputs and outputs.

Circle (362) on Reply Card

Acoustical wall covering

Alpha Audio Acoustics, a division of Alpha Recording, has introduced Sound-TEX, a thin, acoustical wall covering. This fabric wall treatment is 3/16 of an inch thick, and has a 20% noise-reduction coefficient. The wall covering is a light-duty sound absorbent often used in conjunction with Alpha Audio's Sonex, which has a 95% noise-reduction coefficient. Designed to reduce clatter and high-end reflections in the office, the covering can replace burlap and carpet on walls in most applications. The covering passes the National Fire Protection Agency tests with a Class A fire rating. Sound-TEX is

available in 14 designer colors and two ribbed patterns. The fabric comes in 54-inch-wide bolts like wallpaper and may be applied with standard wallpaper adhesive.

Circle (363) on Reply Card

Studio condenser microphone



Sennheiser Electronic has introduced the MKH 40 P48 studio condenser microphone. Combining a symmetrical capsule with optimal resistive loading results in a highly linear frequency response and an inherently low noise level. The mic responds accurately to both high and low sound pressure levels and is capable of recording the most subtle sonic nuance to the loudest boom without coloration, noise or intermodulation distortion. The mic features a cardioid pattern, 40Hz to 20,000Hz response, weighs 100g and measures 25mm x 150mm.

Circle (364) on Reply Card

GET THE BIG PICTURE



WITH

WIDEFINDER

The Wide-Angle, Anti-Mist Viewfinder for video cameras.

Available for:

Betacam BVW3 + 330

Ikegami HL79D + HL79E



212/213-0620
213/463-8151
Telex 276-540

SMPTE BOOTH 1409

Circle (176) on Reply Card

HEADS & TAILS



Peter Lisand presents a full line of quality-engineered, highly flexible and trouble free camera heads and tripods. We utilize the latest engineering, materials and technology to bring you a simple precision support system for today's high-tech, high-priced cinematography and video cameras. We invite you to call or write us for more information or to arrange for an examination of our new and unique camera support systems.



Peter Lisand
Precision support systems
for your precision instruments

352 River Road, Edgewater, N.J. 07020
Telephone 201 • 943 • 5600

Circle (144) on Reply Card

Limited Supply

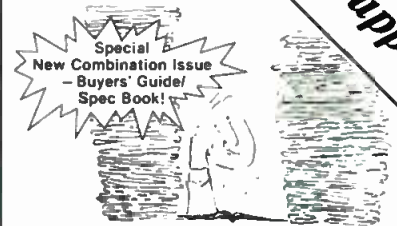

Don't wade through 1000 different product brochures...

Use BE Buyers' Guide

Spec Book instead!

For additional copies, send \$20 (each copy) to Broadcast Engineering, P.O. Box 12901, Overland Park, Kansas 66212.

TERMS:

Payment In Advance
No COD's
FOB Shipping Point
Freight Collect

Prices Subject
to Change
Quantities Limited
All Sales Final



A Subsidiary of Broadcast Systems Inc.

FEATURE PRODUCT
News-Pak Editing System



Includes:
VO-5850
VO-5800
RM-440
2 Color
Monitors
Audio Cart
Audio Mixer
Cabinet
Cables
\$13,445

CAMERAS:

SONY
DXC-M3A 3 Tube Color Camera with Canon 15:1 Lens, Carrying Case, Tripod Adapter, VTR Cable, 1 1/2" Viewfinder, Battery Adaptor, 2 Batteries, AC Adaptor, Battery Charger \$7,245

DXC-1820K One Tube Color Camera with 10:1 Zoom Lens, VTR Cable, 1 1/2" Viewfinder, Shoulder Pad, Carrying Case, Battery, Battery Charger, AC Adaptor \$3,176

MONITORS:

SONY
CVM-1270 Super Fine Pitch 12" Color Monitor/Receiver, Cabinet Model \$ 610

PVM-1220 Super Fine Pitch 12" Color Monitor, Rackmount \$1,606

PVM-1910 19" Color Monitor, NTSC/RGB, Cabinet Model \$ 706

PVM-8000 8" Portable, Color Monitor with Audio, AC/DC \$ 295

PANASONIC

BT-S701N 7" Color Monitor, Cabinet Model \$ 432

BT-S702N 7" Dual Color Monitor, Rackmount \$ 895

BT-S1300N 13" Color Monitor with Audio \$ 477

CT-1010M 10" Color Monitor \$ 319

TR-932 9" Dual B/W Monitor, Rackmount \$ 271

WV-5203B 5" Triple B/W Monitor, Rackmount \$ 557

WV-5410 14" B/W Monitor, Cabinet Model \$ 231

WV-5470 17" B/W Monitor, Cabinet Model \$ 295

CONRAC

5222N19 19" Conrac Color Monitor, Chassis Only (Slides & Cabinets Available), 4 Only \$2,303

SNA14/C 14" Conrac Broadcast B/W Monitor, Cabinet Model, 16 Only \$ 720

SNA17/R 17" Conrac Broadcast B/W Monitor, Rackmount, 3 Only \$ 940

JACK PANELS:

BSI

BJ-240A Prewired Audio Jack Panel, 24 TRS Circuits, Normalled & Selectable \$ 480

BJ-200 Prewired Audio Jack Panel, 26 TRS Circuits, Normalled, One Rack Unit \$ 375

22TP Video Jack Panel System with 22 Self Normalling, Self Terminating Dual Jacks, 3 1/2" Phenolic Panel \$ 695

VTR'S:

SONY

VO-5850 PAC 3/4" Editing System Including VO-5850, VO-5800, RM-440, Cables \$10,384

VO-5800 3/4" Record/Playback \$ 3,290

VO-5600 3/4" Record/Playback \$ 1,838

VP-5000 3/4" Playback \$ 1,433

VO-6800 3/4" Portable Recorder \$ 2,955

RM-440 Edit Controller \$ 1,270

PANASONIC

AG-2100 VHS Industrial Player \$ 583

AG-2200 VHS 2/6 Hr Record/Playback \$ 696

AG-6100 VHS Player with Search \$ 1,115

AG-6200 VHS Record/Playback with Search \$ 1,400

AG-6300 VHS Record/Playback with Search & Ext Sync \$ 1,515

AG-6800 VHS Hi-Fi Record/Playback \$ 1,440

NV-A500 VHS Editor/Controller \$ 1,167

NV-8050 VHS Time Lapse Recorder \$ 2,235

NV-9200A 3/4" Record/Playback, Used, 3 Mo. Warranty, (2 Only) \$ 1,300

CONVERGENCE

SUPER 90 Edit Controller with Time Code Generator/Reader \$ 4,720

FRAME SYNCHRONIZERS, TBC's:

MICROTIME

S-230 Frame Synchronizer/TBC \$11,160

S2E230 Dual Frame Synchronizer/TBC with Digital Effects System \$26,360

T100 TBC \$ 4,976

T120 TBC \$ 5,592

T220 FIT TBC \$ 9,520

HARRIS

HVS-540 TBC \$ 4,712

HVS 540VT TBC with Variable Tracking for BVU-820 \$ 5,200

HVS 550VT TBC with Variable Tracking for BVU-820 \$ 5,960

HVS 632/DNR Package includes Frame Synchronizer, DNR, Compressor/Positioner, Digikey, Remote C/P \$23,325

P.O. Box 15291
Austin, Tx 78761

All items new, in factory cartons except where noted. Used items subject to prior sale.

DISTRIBUTION AMPLIFIERS:

HEBDO

VDA-100 Video DA, 6 Output \$ 198

VDF-100 Video DA Frame, Holds 8 DA's \$ 507

VPS-154 Video DA Power Supply \$ 207

ADA-200 Audio DA, 6 Output \$ 207

ADF-200 Audio DA Frame, Holds 8 DA's \$ 485

APS-155 Audio DA Power Supply \$ 207

PDA-108 Linear Pulse DA (Use VDF-100 Frame), 1 Only \$ 175

VIDEO PROJECTORS:

SONY

FP-60 One Tube Vidimagic Projector with Built In Beta Playback \$ 2,295

FP-62 One Tube Vidimagic Projector \$ 1,650

VPS-60 Portable Screen for FP-60/62, 55" \$ 247

VPH-722Q 3 Tube Projector, 72" Image \$ 4,550

VPH-1010Q1 3 Tube Projector, 100" Image \$ 4,550

VPH-2020Q1 3 Tube Projector, 200" Image \$ 5,055

PROTON

600M 19" Color Monitor, 75 OHM Input, Comb Filter, 5% Overscan, Superb Picture Quality. Cabinet Models Only. Has Audio AMP. \$ 535

602M 25" Color Monitor, Same as 600M, but with 25" Tube. \$ 900

WIRELESS MIKES:

HME

SYSTEM 820 150-174 MHz System with Low Profile Flat Pak Battery Operated Receiver, Compact Body Pak Transmitter. Includes Road Case, ECM-150-1 Lavalier Microphone and AC Power Adaptor for Receiver \$ 1,849

SYSTEM 420 150-174 MHz System with Body Pak Transmitter, Basic Receiver. Includes ECM-150-1 Lavalier Microphone \$ 1,050

TEST EQUIPMENT:

TEKTRONIX

528A Waveform Monitor \$ 1,855

1420 Vectorscope \$ 2,195

1740 Waveform/Vectorscope \$ 3,355

1750 Deluxe Waveform/Vectorscope \$ 5,144

1470 Color Sync Generator with Test Signals & Genlock \$ 3,235

VIDEOTEK

VSM-5 Vectorscope \$ 1,970

TSM-5 Waveform Monitor \$ 1,720

THOUSANDS OF A/V ITEMS CALL FOR PRICES

PHONE TOLL FREE 1-800-762-3304

AUDIO EQUIPMENT:

BROADCAST ELECTRONICS
2100P Tape Cart Machine, Mono, Playback \$ 1,033

2100PS Tape Cart Machine, Stereo, Playback \$ 1,124

2100RP Tape Cart Machine, Mono, Record/Playback \$ 1,551

2100RPS Tape Cart Machine, Stereo, Record/Playback \$ 1,820

3200P Tape Cart Machine, Mono, Playback \$ 1,146

3200PS Tape Cart Machine, Stereo, Playback \$ 1,258

3200RP Tape Cart Machine, Mono, Record/Playback \$ 1,955

3200RPS Tape Cart Machine, Stereo, Record/Playback \$ 2,270

4M50 Four Mixer Audio Console, Mono \$ 945

4S50 Four Mixer Audio Console, Stereo \$ 1,779

5M250 Five Mixer Deluxe Audio Console, Mono, Step Attenuators \$ 2,395

5S250 Same as 5M250, but Dual Channel \$ 3,250

8M250 8 Mixer Deluxe Audio Console, Mono, Step Attenuators \$ 3,295

8S250 Same as 8M250, but Dual Channel \$ 4,195

10S250 Ten Mixer Deluxe Audio Console, Stereo, Step Attenuators \$ 5,270

RUSSCO

STUDIO PRO 2 Speed Deluxe Rim Drive Turntable \$ 405

MARK V Broadcast Deluxe Turntable, Variable Speed \$ 650

RT-700 New Direct Drive Turntable \$ 780

FPSB Stereo Turntable PREAMP. Balanced 600 OHMS \$ 260

RTA-12 Broadcast Tone Arm \$ 180

505-S Stereo Audio Mixer with 20 WATT Stereo AMP \$ 2,150

ELECTROVOICE

635A Microphone, Handheld Dynamic \$ 75

CO90 Microphone, Lavalier \$ 110

100A Sentry Compact Speaker System (Available with Rackmount Accessory) \$ 187

MISCELLANEOUS AUDIO:

APM-2RA Videotek Dual Input Audio Monitor with VU Meter, Speaker and Amplifier, Rackmount

ADA-16 Videotek Audio DA, 1x6, Self-Contained \$ 253

835-0100 Quartzmatic Studio Clock \$ 48

835-0002 "On Air" Light, Horizontal \$ 52

200-3T Bulk Audio Tape Eraser, Handheld \$ 125

1934-3 BSI Custom Audio Cable, 22 AWG Stranded, Foil-Shield, 1000' \$ 75

760-1A or -B TFT EBS Single Channel AM or FM Receiver/Encoder/Decoder \$ 1,129

MODEL 753 TFT AM Modulation Monitor \$ 1,350

MODEL 754 TFT AM RF Preselector with Frequency Readout \$ 1,842

MODEL 844 TFT FM Stereo Modulation Monitor \$ 3,773

MODEL 845 TFT FM SCA Modulation Monitor *Must be purchased with 844 \$ 1,885

MODEL 730A TFT SCA Monitor, 67 KHZ *Must be purchased with 844 \$ 1,885

D75 Audio Amplifier, Dual Channel, 37.5 WATTS per Channel \$ 417

M267 4x1 Compact Audio Mixer \$ 299

FP31 Miniature Portable Microphone Mixer \$ 585

ES45G Luxor Smoke Glass Front Audio Equipment Cabinet, One Only \$ 399

MISCELLANEOUS ITEMS:

21-1060-7 Amphenol Blue Precision 75 OHM Video Cable, 1000 Ft. Roll \$ 295

4-331350-0 AMP BNC Dual Crimp RF Connector For 21-1060-7 or 8281. Minimum Order: 25 \$ 2.25 Each

Used Datatone Vanguard A/B Roll Computerized Editing System with Controller, Data Monitor, Keyboard, Mainframe, Time Code Gen/Read/Ch.Gen, Cable, Manuals, 30 Day Limited Warranty. Good Condition. One Only \$18,350

HR-100 Used Hitachi 1" Portable VTR (No TBC) Including Battery Pack, Battery Charger, AC Adaptor, Carrying Case, Manuals 30 Day Limited Warranty. Good Condition. One Only \$15,800

TT-7000 NEC/3M Used 1" VTR (No TBC) Including Manuals and 30 Day Limited Warranty. Good Condition. One Only \$17,500

In Texas Phone 512-836-6103

Ad index

Page Number	Reader Service Number	Advertiser Hotline	Page Number	Reader Service Number			
ADM Technology, Inc.	156	89	612/893-3000	Leitch Video Ltd.	91	186	804/424-7290
ADM Technology, Inc.	35	120	612/893-3000	Lenco Electronics	11	10	314/243-3147
Agfa-Gevaert Inc.	147	87	201/288-4100	Lerro Electrical Corp.	9		215/223-8200
AKG Acoustics, Inc.	100	59	203/348-2121	MCG Electronics, Inc.	128	77	516/586-5125
Alpha Audio	176	83	804/358-3852	3M	67-74	41	800/792-1072
Aluma Tower Company	190	142	305/567-3423	Magna-Tech Electronics Co., Inc.	123	73	212/586-7240
Ampex Corp. (AVSD)	40-41	20	818/240-5000	Maxell Corp. of America	97	55	201/440-8020
Ampex Corp. (AVSD)	39	23	818/240-5000	Merlin Engineering Works	181	125	
Ampex Corp. (MTD)	169	140	415/367-3809	Merlin Engineering Works	164	107	
Anchor Audio, Inc.	174	132	213/533-5984	Microtime, Inc.	175	69	203/242-4242
Andrew Corp.	179	70	312/349-3300	Microwave Filter Co., Inc.	176	82	315/437-3953
Anvil Cases, Inc.	108	64	818/575-8614	Midwest Communications Corp.	1	4	800/543-1584
Aphex Systems Ltd.	78	42	818/765-2212	Monroe Electronics, Inc.	185	80	716/765-2254
Arrakis Systems, Inc.	23	14	303/224-2248	National Video Service	178	99	415/846-1500
Asaca/Shibasoku Corp. America	186	127	800/423-6347	NEC America Inc.	59	35	800/323-6656
Aston Electronics Inc.	62	37	913/782-4007	NEC America Inc.	189	129	800/323-6656
Audio-Technica U.S., Inc.	161	102	216/686-2600	Neve Inc.	65	39	203/744-6230
B & K Enterprises	183	160	312/889-9087	NTI America Inc.	163	58	218/462-8945
Belar Electronic Labs	172	173	215/687-5550	Opamp Labs Inc.	170	152	213/934-3566
Beyer Dynamic Inc.	117	33	516/935-8000	Orban Associates Inc.	17	13	800/227-4498
Bosch-Fernseh (Robt. Bosch Corp.)	139,141	84	801/972-8000	Orban Associates Inc.	164	106	800/227-4498
Broadcast Systems Inc.	181	124	512/836-6011	Orban Associates Inc.	162	103	800/227-4498
Broadcast Systems Inc.	170	156	800/531-5232	Otari Corp.	15	11	415/592-8311
Broadcast Video Systems Ltd.	172	115	416/497-1020	P.T.S.I.	95	54	201/529-1550
BSM Broadcast Systems Inc.	31	17	509/448-0697	Pacific Recorders and Engineering ...	107	65	619/438-3911
C.O.A.R.C.	190	167	518/672-7202	Panasonic	76-77	30	201/348-7336
Calvert Electronics Inc.	32	21	800/525-6362	Panasonic	82-83	67	201/348-7336
Camera Mart, Inc.	149	90	212/757-6977	Panasonic	155	96	201/348-7336
Canon USA Inc., Broadcast Lens	113	44	516/488-6700	Panasonic	130-131	76	201/348-7336
Canon USA Inc.	114-115	45	516/488-6700	Panasonic	119	81	201/348-7336
Centro Corp.	160	101	619/560-1578	Panasonic	63	38	201/348-7336
Cetec Antennas	146	86	916/383-1177	Peter-Lisand Machine Corp.	192	144	201/943-5600
Circuit Research Labs, Inc.	13	9	800/535-7648	Philips Test and Measuring Instruments	79	43	202/529-3800
Clear-Com Intercom Systems	109	66	415/861-6666	Polyline Corp.	190	119	312/297-0955
Clear-Com Intercom Systems	111	24	415/861-6666	Potomac Instruments	88	49	301/589-2862
Comrex Corp.	44	136	617/443-8811	QEI	81	62	609/728-2020
Continental Electronics Mfg. Co.	64	40	214/381-7161	Real World Technologies, Inc.	178	98	714/957-1061
Crosspoint Latch Corp.	198	135	201/688-1510	Real World Technologies, Inc.	182	91	714/957-1061
Datatron Corp.	118	34		Rohde & Schwarz Sales Co. (USA) Inc.	177	138	516/488-7300
Discount Express	193	145	800/762-3304	Ross Video Ltd.	118	122	613/652-4886
Dolby Labs Inc.	33	16	415/392-0300	RTS Systems, Inc.	120	63	818/843-7022
Dubner Computer Systems	7	8	201/592-6500	Ruslang Corp.	172	117	203/384-1266
Dynair Electronics Inc.	87	48	619/263-7711	Sennheiser Electronic Corp.	134	92	212/944-9440
ESE	187	128	213/322-2138	Sescom, Inc.	170	153	800/634-3457
Faroudja Laboratories Inc.	150	141	408/245-1492	Shure Brothers Inc.	IFC	1	312/886-2553
Fidelipac Corp.	37	52	609/235-3900	Shure Brothers Inc.	57	121	312/886-2553
Fostex Corp. of America	90	51	213/921-1112	Sitler's Inc.	170	171	800/426-3938
Fuji Photo Film USA Inc.	45		212/736-3335	Solid-State Logic	61	36	212/315-1111
Fuji Photo Film USA Inc.	49-50		212/736-3335	Sony Corp. of America (A/V & Pro Aud)	165	163	
Fuji Photo Film USA Inc.	51	29	212/738-3335	Sony Corp. of America (A/V & Pro Aud)	145	85	
Fuji Photo Film USA Inc.	47		212/736-3335	Sony Corp. of America (Broadcast)	24-25		
Fujinon Inc.	89	50	914/472-9800	Sony Corp. of America (Broadcast)	52-53		
Garner Industries	129	131	800/228-0275	Sony Tapes Product Sales Co.	124-125	161	
Gentner Engineering Co., Inc.	162	104	801/268-1177	Sound Technology	153	94	408/378-6540
Graham-Patten Systems Inc.	102	46	916/273-8412	Sound Technology	151	93	408/378-6540
Grunder & Associates	116	61	913/831-0188	Standard Tape Laboratory, Inc.	170	154	415/786-3546
Harris Corp.	93	53	217/222-8200	Stantron/Unit of Zero Corp.	171	175	800/821-0019
Hitachi Denshi America Ltd.	3	5	800/645-7510	Studer Revox America Inc.	55	32	615/254-5651
Hollywood Rental	182	110	818/768-8064	Surcom Associates Inc.	182	109	619/722-6162
Horizon International	157	97	602/437-3800	Tascam division TEAC Corp. of America	133	78	213/726-0303
ICM Video	54	31	405/232-5808	Tektronix Inc.	137	108	800/452-1877
Ikegami Electronics Inc.	IBC	2	201/368-9171	Thomson-CSF/DTE	110	72	201/438-2300
Ikegami Electronics Inc.	98-99	56	201/368-9171	Townsend Associates, Inc.	170	170	413/568-9581
Ikegami Electronics Inc.	135	79	201/368-9171	TTC/Wilkinson	167	123	303/465-4141
Image Video Ltd.	173	25	716/855-2693	Universal Elecon	58	150	818/846-6220
ITC/3M	85	47	800/447-0414	Utah Scientific Inc.	103	111	800/453-8782
JBL Inc.	27	15	818/893-8411	Varian	29	18	415/592-1221
Jensen Transformers Inc.	48	27	213/876-0059	Varian	163	105	415/592-1221
JVC Company of America	19	130	800/582-5825	Video International	158	95	516/842-1815
K & H Productions, Ltd.	174	174	802/442-8171	Videotek, Inc.	112	151	602/997-7523
Kulka-Smith Div. N.A. Philips	159	100	201/223-9400	Vital Industries, Inc.	105	60	904/378-1561
Lake Systems Corp.	101	143	617/244-6881	Ward-Beck Systems Ltd.	BC		416/438-6550
Lang Video Systems Corp.	170	155	415/364-1287	Winsted Corp.	156	88	800/328-2962
LEA Dynatech Inc.	144	68	213/944-0916	Yamaha International Corp.	126-127	74	714/522-9312
Leader Instruments Corp.	5	6-7	800/645-5104	Zellan Optics Ltd.	192	176	213-483-8151

Professional services

VIR JAMES P.C.
CONSULTING ENGINEERS
Applications and Field Engineering
Computerized Frequency Surveys
3137 W. Kentucky Ave.—80219
(303) 937-1900
DENVER, COLORADO
Member AFCCE & NAB

STEIGER, HURRAY & ASSOCIATES INC.
CONSULTING ENGINEER SERVICES
6816 Westview Drive
Cleveland, OH 44141
(216) 526-7187

EVANS ASSOCIATES
CONSULTING TELECOMMUNICATIONS ENGINEERS
AM-FM-TV-CATV-ITFS-LPTV SATELLITE
216 N. Green Bay Road
Thiensville, Wisconsin 53092
Phone: (414) 242-6000 Member AFCCE

R. L. HOOVER
Consulting Telecommunications Engineer
11704 Seven Locks Road
Potomac, Maryland 20854
301-983-0054
Member AFCCE

D. L. MARKLEY & Associates, Inc.
CONSULTING ENGINEERS
206 North Bergan
Peoria, Illinois 61604
(309) 673-7511
Member AFCCE

Radiotechniques

RADIO CONSULTING ENGINEERS
STATION DESIGN AND SERVICE
ELECTRONIC PRODUCT DESIGN
Edward A. Schober, P.E.
402 Tenth Avenue, Haddon Heights, NJ 08035
(609) 546-1841

 **HORIZON INTERNATIONAL**
Broadcast Implementation Engineering
Bcast. & Video Facility Design & Installation
Systems Evaluations & Critiques
Emergency Service & Support
3837 E. Wier Ave., Suite 1, Phx., AZ 85040
602-437-3800

SMITH and POWSTENKO
Broadcasting and Telecommunications Consultants
2033 M Street N.W., Suite 600
Washington, D. C. 20036
(202) 293-7742

BLAIR BENSON
Engineering Consultant
TV Systems Design and Operation
23 Park Lane
Norwalk, CT 06854
203-838-9049

STARLIGHT COMMUNICATIONS, INC.
Satellite Down-Linking
Satellite Systems
Satellite System Maintenance & Repair
BRUCE BLUMENTHAL P.O. Box 523
(312) 459-4122 Northbrook, IL 60085

T & G OPTICS, INC.
71-01 INGRAM STREET
FOREST HILLS, NY 11375
COMPLETE REPAIR SERVICE FOR COLOR TELEVISION
CAMERA BEAMSPLITTER OPTICS, LENSES, COATINGS,
MULTIPLEXER MIRRORS, FILTERS AND PROJECTORS:
WRITE OR CALL GERALD PINCUS (718) 544-8156 twenty
four hour service with pleasure.

R.J. GRANDMAISON, P.E.
ENGINEERING CONSULTANT
BROADCAST AND COMMUNICATIONS
10224 WENDOVER DRIVE
VIENNA, VIRGINIA 22180
(703) 281-1081
Member AFCCE

John Aalto, P.E.
Consulting Engineer
TELEVISION PRODUCTION AND POST PRODUCTION
SYSTEMS DESIGN AND PROJECT MANAGEMENT
4534 Van Noord Avenue
Studio City, CA 91604
(818) 784-2208

SELLMEYER & KRAMER, INC.
CONSULTING ENGINEERS
J.S. Sellmeyer, P.E., S.M. Kramer, P.E.
AM FM TV MDS ITFS LPTV CATV
APPLICATIONS • FIELD ENGINEERING
P.O. Box 841 McKinney, TX 75069
(214) 542-2056

ERIC NEIL ANGEVINE, P.E.
consultant in acoustics
specializing in broadcast studio acoustics
924 West Eskridge Ave. Stillwater, OK 74075
405-624-6043 405-372-1480

TERRY REAVES ENGINEERING
FCC Filings - Turnkey Systems - Coverage Predictions
FM - AM - STL - RPU - 2 Way FM - Satellite
Computerized AM Broadbanding
MAINTENANCE - EMERGENCY OR CONTRACT
(904) 351-0469
5004 N.E. 18th Court, Ocala, FL 32670

Consultation Services
Lightning - Power Conditioning - Grounding
Over 40 years experience, work guaranteed
Roy Carpenter
President
Lightning Eliminators and Consultants
13007 Lakeland Rd. Santa Fe Springs, CA 90670
(213) 946-6886 TWX 910-586-1381

 Professional Services to the
Broadcasting & Production
Industries in
Architecture
Interior Design
Technical Design
Construction Mgt.
(818) 351-5521

FCC ON-LINE DATABASE
dataworld[®]
Allocation Terrain Studies
AM • FM • TV • LPTV • ITFS
P.O. Box 30730
Bethesda MD 20814
(301) 652-8822 1-800-368-5754

Why not run your business card here?
Only \$60 per insertion.
Frequency discounts available.
Call 913/888-4664

Why not run your business card here?
Only \$60 per insertion.
Frequency discounts available.
Call 913/888-4664

Why not run your business card here?
Only \$60 per insertion.
Frequency discounts available.
Call 913/888-4664

Why not run your business card here?
Only \$60 per insertion.
Frequency discounts available.
Call 913/888-4664

Why not run your business card here?
Only \$60 per insertion.
Frequency discounts available.
Call 913/888-4664

Classified

Advertising rates in Classified Section are \$1.25 per word, each insertion, and must be accompanied by payment to insure publication.

Each initial or abbreviation counts a full word. Minimum classified charge, \$30.00.

For ads on which replies are sent to us for forwarding (blind ads), there is an additional charge of \$35.00 per insertion, to cover department number, processing of replies, and mailing costs.

Classified columns are not open to advertising of any products regularly produced by manufacturers unless used and no longer owned by the manufacturer or distributor.

TRAINING

ELECTRONICS DEGREE by correspondence. Earn Associate, then Bachelor's. NHSC accredited. Free catalog. Write Grantham College of Engineering, Dept. EE-5, 10570 Humboldt St., Los Alamitos, CA 90720. 8-82-tfn

CASSETTE RECORDED PREPARATION for FCC General Class license plus one week seminar in Washington, Boston, Philadelphia or Detroit. Bob Johnson Telecommunications, 1201 Ninth, Manhattan Beach, Calif. 90266, Phone 213-379-4461. 6-85-tfn

SERVICES

ONE STOP FOR ALL YOUR PROFESSIONAL AUDIO REQUIREMENTS. Bottom line oriented. F.T.C. Brewer Company, P.O. Box 8057, Pensacola, Florida 32506. 7-71-tf

HELIX-STYROFLEX. Large stock—bargain prices—tested and certified. Write for price and stock lists. Sierra Western Electric, Box 23872, Oakland, Calif. 94623. Telephone (415) 832-3527. 1-73-tf

TRANSMITTER TUBES REPROCESSED—Save 40 to 50%. 3CX2500, 4CX5000, 4CX15000 and many others. Write for details. FREELAND PRODUCTS CO., Rt. 7, Box 628, Covington, LA 70433. (504) 893-1243 or (800) 624-7626. 6-79-tfn

FOR SALE

3 THOMSON MC601 color cameras, Fujin on 14 X 1 lenses, CCU's with Multi core interface, near V.F. zoom & focus controls. Contact Walter Edel, 212-689-1040. 9-85-4t

VIDEO PRODUCTION & POST-PRODUCTION EQUIPMENT, new and used, all types and makes, write or call for latest inventory list. Pioneer Technology Corporation, 1021 N. Lake St., Burbank, CA 91502, (818) 842-7165. 6-85-eom

AUTOMATION FOR SALE: IGM System III w/live assist package, logging, 3 stereo II-42 GO-Carts, 4 Otari R-R, spare power supply, many extras. Excellent condition. Contact Jim Garrett, CE (616) 345-2101. Fetzer Broadcasting Service, 590 W. Maple St., Kalamazoo, MI 49008. 10-85-11

TEKTRONIX TV TEST equipment. 1480R WFM, 650 HR-1 Mon W Vector Display, 6000\$. (818) 352-6619. 10-85-11

QUANTEL DPE 5000 Digital Effects System. Fully loaded single channel machine. Attractive price. Contact Neil Bonanno or Kathy Schick at (303) 320-3680. 10-85-11

VIDEO EQUIPMENT—HR100 portable 1" C complete, including color playback stabilizer, VO4800, VO2860/2260/RM440, VO2610, HL79A, TK76B. Tek 465, 475 and 7603 scopes. 30'x40' studio lighting package. Angenieux 25X and Fuji 22X lenses. Gerstnerslager 38' van, 3 axle, recently rebuilt, new interior. Tripods, dollies and Vinten heads. Call Jack Taylor, WVSCO, 215-367-2800. 10-85-11

HITACHI FP-21 with 14:1 servo zoom lens; remote camera control unit; Bogen 3068-116 fluid head tripod; used very little; contact Chuck Pryor 816-333-1535. 10-85-11

FOR SALE ROUTING SWITCHER

Image Video
60x96 4-level

VIDTRONICS
818-840-7208

SONY DXCM3 CAMERA, 4800 recorder, Miller fluid head, rear zoom control, power supply, battery charger etc. Excellent condition. Must sell to best offer. (515) 472-6678. 10-85-11

BROADCAST EQUIPMENT—Quantel DPE-5000s Digital effects, \$23,500; Harris 630 Frame Store with positioner, \$9,500. Panasonic AU-700 3/4" A-B roll Editing System with Time Code, 12,500; Cameras, other eqp at close out prices, Screen Presentations, Inc., 309 Mass. Ave. N.E., Washington, D.C. 202-546-8900. 10-85-11

DEMONSTRATOR MINI-RAM ENG TRUCK, complete with 32' mast, P&T unit, 4.5KW generator, air-cond. with hot gas by-pass, racks, cabinets, I/O panels, third seat, deluxe interior, ready to work. Never used. Used for shows and sales demos only. \$29,900.00. Call Steve Detch or Paul Roston at Roscor 312-539-7700. 10-85-11

NEC DCME DIGITAL effects 3 years old with all the features, freeze-frame, multi-freeze, time base corrector, tracking key signal, border generator, \$28,500. Contact: Dennis Lusk, F & F Productions, Inc., 813/576-7676. 10-85-11

WANTED TO BUY

WANTED: Pre-1923 radio equipment and tubes. August J. Link, Surcom Associates, 305 Wisconsin Ave., Oceanside, CA 92054, (619) 722-6162. 3-76-tf

1,000 FOOT BROADCAST TOWER WANTED, standing or on ground. Available March, 1986 at the latest. Tower must be 6 to 7 feet on a side, solid steel legs, galvanized. Good overall condition. 813-337-2131. 10-85-11

NEED 1 KW AM AND 1 or 2 KW FM transmitters to replace aux units lost in fire. Ken Blake, KJOY 209-948-5569. 10-85-11

STATE OF THE ART post production equipment, Sony only...cash deal, call 1-800-525-8000. 10-85-11

EMPLOYMENT SERVICES

10,000 RADIO AND TV JOBS a year for men and women are listed in the American Radio job market weekly paper. Up to 300 every week. Engineers, OJs, Newspeople, Program Directors, Production, Sales. All markets, all formats. One week computer list, \$6.00. Special bonus 6 weeks, \$14.95. You save \$21.00. American Radio Job Market, Dept. 3, 1553 North Eastern, Las Vegas, Nevada 89101. 7-84-tfn

WE PLACE TV and Video Engineers COAST TO COAST

[All Levels, But Not Operators]
ALL FEES PAID BY EMPLOYERS

Phone/Resume

KEY SYSTEMS

Westminster Road
Wilkes-Barre, PA 18702

Phone Alan Kornish at
(717) 655-1458

Reconfirm your involvement in
the broadcast industry!
Renew your subscription
today.

HELP WANTED

DIRECTOR OF ENGINEERING, Durham Life Broadcasting, Inc. Raleigh based company in Southeast seeks professional with senior management and state-of-the-art experience. Position requires strong leadership abilities and desire to continue building program. Requires first class radio telephone license and a minimum of 5 years' experience in technical and operations procedures with a minimum of 2 years in an administrative capacity. Must have full knowledge of FCC rules and regulations. Responsible for operation and maintenance of all AM, FM and UHF broadcasting and transmitter facilities. Send resume and salary requirement to Personnel, Durham Life Broadcasting, P.O. Box 1511, Raleigh, NC 27602. EOE M/F. 10-85-11

AUDIO/VIDEO TECHNICIANS: The Mass Communication Division of Emerson College in Boston seeks qualified applications for the following positions:
VIDEO MAINTENANCE TECHNICIAN: Performs daily repair and operations maintenance of studio, control, editing and post production television/video facilities and equipment. Knowledge of U-Matic VTR, camera, switching, distribution, and monitoring equipment required. Sony school experience, SBE Certification, and production company and/or broadcast engineering experience desired.
AUDIO MAINTENANCE TECHNICIAN: Responsibility to include full maintenance and operational integrity of studio and control facilities and equipment for radio stations (WERS-FM, WECB), radio instruction classrooms and editing suites. Knowledge of cart, reel-to-reel, cassette, turntable and console equipment required. Recording studio and/or broadcast engineering experience and SBE Certification desired. These positions require the ability to work well in a student teaching environment. Salary is highly competitive and commensurate with experience; comprehensive benefit packages are offered. Interested applicants should forward letter of application/resume including salary requirements to the Office of Human Resources/Affirmative Action, Emerson College, 100 Beacon St., Boston, MA 02116. Affirmative Action/Equal Opportunity Employer. Minorities and Women are encouraged to apply. 10-85-11

MAINTENANCE ENGINEER for N.Y.C. post-production company. Must have 3-5 years experience in maintaining Sony 1", VGV switcher, Quantel, CMX, Sony 3/4", RCA 2" quads and other related equipment. Experience in systems design helpful. Salary commensurate with experience. Video 44, 219 East 44th St., New York, N.Y. 10017 212/661-2727. 2-85-tfn

ENGINEERS People oriented broadcasting company looking for qualified, dependable, knowledgeable, working maintenance engineers. The kind we want are the old fashioned, hands on, "Stay with it until it's done," engineers. If you are such and love the broadcasting business, we may be just right for each other. We offer long term, career opportunities with good wages and benefits. Send complete resume including work history, salary and references immediately. Equal Opportunity Employer. Broadcast Engineering, Dept. 657, P.O. Box 12901, Shawnee Mission, KS 66212. 9-85-2t

MAINTENANCE ENGINEER—New independent station with all new equipment; AMPEX videotape, GRASS VALLEY switching, IKGAMI camera, RCA film, HARRIS RF. Experience in broadcast equipment maintenance and broadcast system construction necessary. Send resumé to Ted Szyplulski, Director of Engineering, WTIC-TV, One Corporate Center, Hartford, CT 06103. 9-85-6t

COLOR STUDIO LIGHTING SYSTEM COMPLETE, Berkey 36KW Dimmer, Electrical distribution, Grid, Lighting instruments. Excellent condition. New \$25K + sell \$10K 818-845-8306 Bob. 10-85-3t

TV MAINTENANCE ENGINEER. One of America's top independent TV broadcast facilities on the Sun Coast of Florida seeks a qualified maintenance engineer with strong electronics background and 3-5 years hands on broadcast equipment maintenance. Knowledge of 3/4 inch equipment and 1 inch tape machines as well as TCR-100 quad tape machines desirable. Secure future and growth potential for the right person. Send resumé to WTOG-TV, P.O. Box 20144, St. Petersburg, Florida 33742. Attn: Rick Anderson. 10-85-11

SALES CONSULTANTS—Wanted for Southeast Operations of nationally known business. Must have proven track record in sales of Industrial, Broadcast, and Educational video equipment and systems. Excellent opportunity for the person who is an ambitious self-starter. E.O.E. — M-F. Please reply with resumé to Dept. 658, Broadcast Engineering, P.O. Box 12901, Overland Park, KS. 66212. 10-85-11

NEW 1985



7TH EDITION ENGINEERING HANDBOOK

FOR RADIO & TELEVISION

Now Available from NAB.

Latest Edition of the
Industry Standard.

The primary reference for broadcast engineers. Relevant, practical information on building and operating high quality production and transmission facilities.

CALL TODAY
800-368-5644

Advertising sales offices

KANSAS CITY, MISSOURI

Keith A. Willis,
National Sales Mgr.
P.O. Box 12901, Overland Park, KS 66212
Phone: (913) 888-4664

NEW YORK, NEW YORK

Joe Concert
Phone: (212) 682-6630
(212) 682-6631
Josh Gordon
Phone: (212) 687-5076
(212) 687-5077
630 Third Ave., Eighth Floor
New York, NY 10017

CHICAGO, ILLINOIS

Tom Nilsen
Phone: (312) 887-0677
(312) 887-0684
15 Spinning Wheel Rd.
Ste 430
Hinsdale, IL 60521

SANTA MONICA, CALIFORNIA

Herbert A. Schiff
Phone (213) 393-9285
Jason Perlman
Phone (213) 458-9987
Schiff & Associates
1317 Fifth St., Ste 202
Santa Monica, CA 90401

NORWOOD, AUSTRALIA

Hastwell, Willmanson, Rouse Pty. Ltd.
P.O. Box 419
Norwood 5067, Australia
Phone: 332-3322
Telex: AA87113

TOKYO, JAPAN

Haruki Hirayama
EMS, Inc.
Sagami Bldg., 4-2-21, Shinjuku
Shinjuku-ku, Tokyo 160, Japan
(03) 350-5666
Cable: EMSINCPERIOD
Telex: 2322520 EMSINCJ

LONDON, ENGLAND

Nicholas McGeuchin
Suite 460, Southbank House,
Black Prince Rd.
London SE1 7SJ
Telex: 295555LSPG
Telephones: 01-582-7522
01-587-1578



© 1985. All rights reserved.

RCA Astro-Electronics Is Offering Rewarding Challenges That Are Out Of This World!

We're an engineering laboratory and a spacecraft-fabrication and environmental-testing complex that designs, develops, manufactures, and tests space systems. RCA Astro-Electronics has produced all of America's low-altitude, polar-orbiting meteorological satellites for both civilian and military organizations, and has contracts to build more domestic communications satellites than any other company. The challenges, rewards, and stimulating environment are yours if you qualify for any of the following:

Manager, Analog Design

This opportunity requires a dynamic, self-starter who is knowledgeable in all aspects of analog circuit design, feedback control, stability and switching power supplies. Additional needed skills include project scheduling, milestone definition and personnel assignments. You qualify with a BSEE and 10-15 years hardware experience.

Analog Design Engineers

In order to qualify for this specialty, we require experience in the following: Switching DC/DC Converters, PWM, Linear Regulators, Low Frequency Signal Processing, Motor Drive Circuits, Phase-locked loops, AC Stability, BODE Analysis, Magnetics Design. A BSEE is required.

Video Design Engineers

Required qualifications include experience in video-related analog/digital signal processing, capability in conceptual system definition, and leadership skills in directing engineers and technicians in system development. You'll need related experience with various electro-optic sensors including CCD's, vidicons, and IR detectors. Familiarity with bandwidth compression techniques for video transmission will be to your advantage. BSEE required.

Experience all the advantages of leadership. Send your resume and salary requirements, along with your choice of opportunity, in confidence to: Barbara Porcelli, RCA Astro-Electronics, Dept. BE 10-85, P.O. Box 800, Princeton, N.J. 08540.

Equal Opportunity Employer
U.S. Citizenship Required



Astro-Electronics
One Of A Kind.

CHIEF ENGINEER—Major NE FM seeks organized energetic FCC licensed engineer with experience in studio and transmitter facility construction and maintenance. Responsible for budgeting, supervision of technical staff, FCC compliance, equipment acquisition and maintenance. Send resume to: Business Manager, 1265 Boylston St., Boston, MA 02215. An Equal Opportunity Employer, M/F. 10-85-11

ENGINEER FOR TV AND RADIO operation. Five years minimum in maintenance of FM and TV transmitters and studio equipment. Will be chief of FM. Also needed is engineer for location shooting of network production and in-house editing. Experience with Ikegami cameras, Sony 500A VTR, and Ampex VPR-2's, a plus. Send resume to Chief Engineer, Box 416, Corpus Christi, TX 78403-0416. 10-85-21

OPENING IN CHICAGO with major full service audio equipment supplier for experienced individual. Responsibilities include design, specification and sale of control room equipment. Ideal candidate will have production experience and excellent communications skills. Compensation commensurate with ability; Unlimited earnings potential. Reply in confidence with resume and salary history to Broadcast Engineering, Dept. 659, P.O. Box 12901, Overland Park, KS 66212. 10-85-11

TELEVISION/HELP WANTED TECHNICAL: Chief engineer needed for full-service post-production company. Knowledge of CMX, Grass Valley 300 series switcher, CEI cameras and Ampex 1" important. Excellent opportunity for self-motivated person dedicated to quality production with managerial skills. Send resume to Box 660, c/o BROADCAST ENGINEERING, or contact E. Lanny Nass, Director of Engineering, 216-782-1144. 10-85-11

STUDIO MAINTENANCE TECHNICIAN needed by this 14th ADI VHF independent. We need someone with substantial maintenance experience in one or more of the following areas: Sony 1/2" & 1" vtr, GVG production and routing switchers, ENG/EFP, or RCA TK-47/TK-28 cameras. Qualifications include 3-5 years of studio maintenance experience and a General class FCC license. SBE certification, technical school or military electronics training also desirable. EOE. Send resume to: Dept. 661, Broadcast Engineering, P.O.B. 12901, Overland Park, KS 66212. 10-85-11

ASSISTANT CHIEF ENGINEER needed for TV station. KJAC-TV in Port Arthur, TX, is looking for someone with studio and transmitter experience that wants to move up. RCA transmitter VHF, ACT 25, Ampex and RCA quad tape machines, Sony Eng cameras, Sony 1/2" machines. Good salary and company benefits. Send resume to KJAC-TV, P.O. Box 3257, Port Arthur, TX, 77643, Attn: Charlie Ravell. We are an E.O.E. 409/985-5557. 10-85-11

ENG MAINTENANCE ENGINEER: Repair ENG cameras, VCRs, editing facilities and various related equipment. Good technical background plus two years technical television experience desired. FCC license required. Send resume to, Chief Engineer, WAND-TV, 904 Southside Drive, Decatur, IL 62525. EEO. 10-85-11

TECHNICAL WANTED: BROADCAST RADIO ENGINEER for above average broadcast facility in southwest West Virginia—excellent career opportunity. FCC license required. Individual should have a minimum of three years experience in AM and FM stereo broadcast systems. Working knowledge of STLs, downlinks, remote transmitter control, radio automation, and studio facilities. Budget control required. Must be self starter and willing to work with consultants and management. Salary negotiable. An Equal Opportunity Employer. Send resume to Dept. 662, Broadcast Engineering, P.O. Box 12901, Overland Park, Kansas 66212. 10-85-11

KANU, THE UNIVERSITY OF KANSAS, seeks an Assistant Director for Engineering and Operations. Contact Darrell Brogdon, Search Committee Chair, KANU, Lawrence, Kansas 66045-2672. Complete position announcement available. Applications must be received by 5:00 p.m. October 18, 1985. EO/AA Employer. 10-85-11

PERDIEM BROADCAST SERVICES INC., now recruiting additional engineers, technicians, for our nationwide team. P.T. work, top pay; send cover letter to: PERDIEM, BOX 402, 289 PASCACK RD., WASHINGTON TOWNSHIP, N.J. 07675. 10-85-11

SENIOR VIDEO/AUDIO SYSTEMS ENGINEERS

If you have at least 5 years experience in video / audio systems engineering and are a creative person, **WE WANT YOU!** We are offering a challenging opportunity, in sunny San Diego, to join our unique team of system designers. These immediate openings come with a compensation package that includes excellent benefits.

Centro

Setting new standards in the design and integration of teleproduction facilities and remote production vehicles.

WRITE TO:

Chris Genereaux
Centro Corporation
 9516 Chesapeake Drive
 San Diego, CA 92123-1352
 No phone inquiries accepted.

6139

FOR EXCELLENCE IN PERFORMANCE

LED OR INCANDESCENT LAMP PUSH-BUTTONS

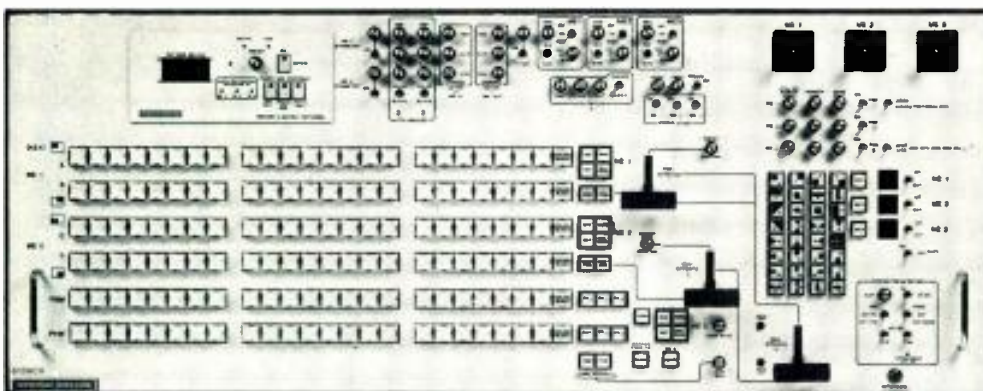

- 3 MIX EFFECTS SYSTEMS
- TEST MODE FOR SYSTEM TIMING
- MASTER FADE TO BLACK
- QUAD SPLIT
- TWO CHROMA KEYERS
- DOWNSTREAM KEYER WITH EDGE
- COMPUTER CONTROL OPTION
- 6800 AUDIO FOLLOW
- ROTARY AND MATRIX WIPE OPTIONS
- BLANKING PROCESSOR

Prices start at \$14,500. for the 8 input version and go up to over \$70,000. with all options.

CROSSPOINT LATCH CORP.

95 PROGRESS STREET • UNION, NJ 07083
 (201) 688-1510 • TELEX 9104901990

CROSSPOINT LATCH IS THE RECOGNIZED LEADER IN EDITOR INTERFACES

The 7239 AUTO DRIVE option (for the "K" series) is the **most sophisticated computerized controller** in the industry. Nothing else comes even close to it — not at any price. It stores 255 entire switcher panel configurations, can perform smooth transitions between Events, **stores** fader arm and positioner **movements** then **reproduces** them exactly, under computer control, can **"EDIT"** single functions in a stored event without disturbing anything else etc.

Circle (135) on Reply Card

'I can describe Ikegami monitors in one word: beautiful!'

Ed Dooley, Chief Engineer WLWT, Cincinnati, Ohio

Beautiful performance is only one reason why Ikegami's 9 series and 10 series broadcast color monitors and 3H series monochrome monitors continue to capture the attention of more and more video monitor buyers.

It's hardly surprising.

Designed to incorporate the latest advancements in picture technology with precision engineering detail, Ikegami monitors are something to behold.

The features are equally impressive: The 9 series broadcast television monitors utilize In-Line Gun self converging cathode ray tubes with American standard matched phosphors and are available in a 20, 14 and 10 inch model.

The 10 series high resolution broadcast television monitors utilize Delta-Gun tubes to achieve maximum brightness and exceptional convergence and are available in 20 and 14 inch versions.

The 3H series broadcast television monitors feature high quality monochrome displays suitable for sophisticated broadcast studio applications and are available in 14 inch, as well as single and dual 9 inch versions.

Ikegami monitors: Poetry in motion.

For a complete demonstration of Ikegami monitors and cameras, contact us or visit your local Ikegami dealer.



Ikegami



Ikegami Electronics (U.S.A.), Inc., 37 Brook Avenue, Maywood, NJ 07607
• East Coast: (201) 368-9171 • West Coast: (213) 534-0050 • Southeast: (813) 884-2046
• Southwest: (214) 233-2844 • Midwest: (312) 834-9774

Circle (2) on Reply Card

Ward-Beck's South Pacific

Across the South Pacific, from Australia to Hawaii, from New Zealand to Fiji, Ward-Beck is as much a part of the broadcasting scene as in North America. Here, in a state-of-the-art stereo studio at 2MMM, Sydney, a Ward-Beck R2000 custom console is set against the magnificent backdrop of Bondi Beach.

Ward-Beck... on top of the world, any way you look at it!



First by Design.

Ward-Beck Systems Ltd.,
841 Progress Avenue, Scarborough,
Ontario, Canada M1H 2X4.
Tel: (416) 438-6550.
Tlx: 065-25399.