

# BROADCAST<sup>®</sup> engineering

AN INTERTEC PUBLICATION

December 1987/\$3

State  
of the  
industry  
special  
report

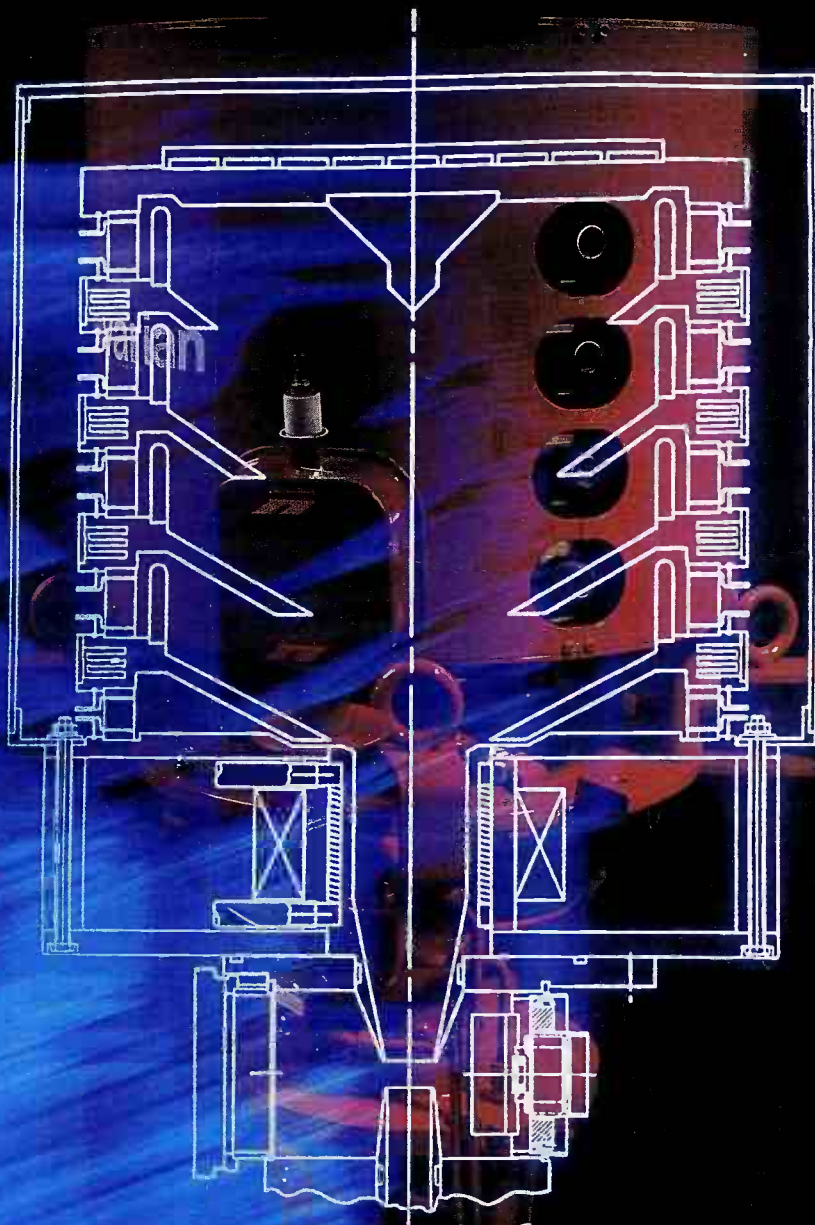

Broadcasting's  
bottom line  
p.62

# CHANGE CONSOLE SETUPS IN SECONDS!

## The New ADM Computer Controlled BCS-PC

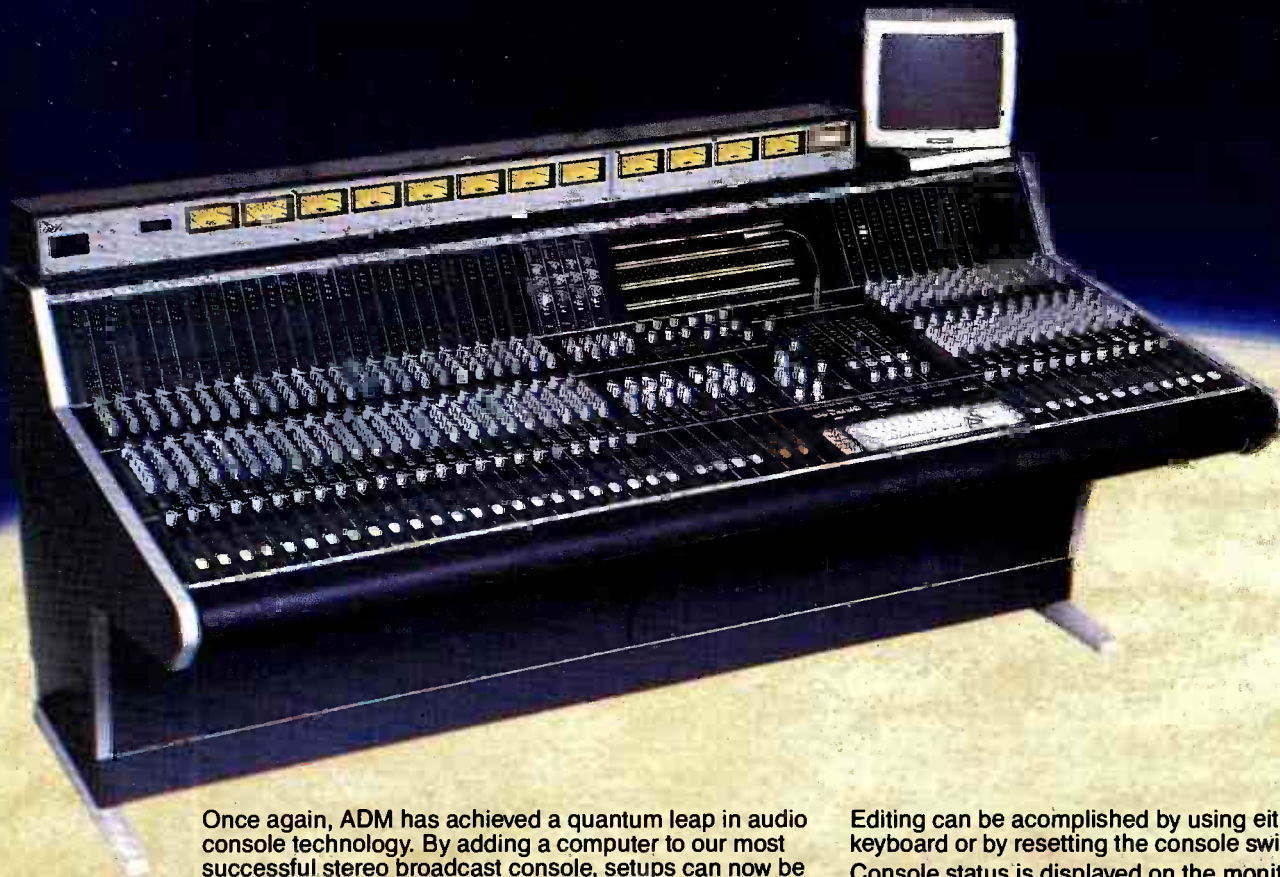

Once again, ADM has achieved a quantum leap in audio console technology. By adding a computer to our most successful stereo broadcast console, setups can now be changed in seconds, not just once, but as often as needed. More important, this is not merely an adaptation of a recording or post production console which lacks essential broadcast features. The BCS-PC is solely designed for broadcast console automation.

With the BCS-PC console it is possible to store and recall many of the most important console operations and make a setup in seconds. You can automate input pre-selection, module on/off status, input group muting and output bus assignment. The BCS-PC can address your house router and save its source and console destination selections along with the console presets.

Easy to use? You bet! Set up the console as you normally would and a couple of key strokes saves that setup for future use.

Editing can be accomplished by using either the integral keyboard or by resetting the console switches manually. Console status is displayed on the monitor as well as by the console LED indicators associated with each push button.

Computer failure? No problem! ADM has engineered the BCS-PC to totally ignore a computer failure. The console continues to operate manually, as it always has.

With the addition of automation to the BCS, ADM has not forgotten its primary goal of providing a fully functional stereo console. The BCS-PC still has such features as: input pre-selection and bussing, VCA control of all main program paths for superior noise free tracking, four band VCA controlled stereo equalizer, five stereo auxiliary busses, 4 independent stereo monitors, operation and muting for up to three studios - plus more. Call your ADM representative or ADM for further information.

**ADM**®  
The  
Audio  
Company

Circle (1) on Reply Card

**ADM Technology, Inc.**

1626 E. Big Beaver Road, Troy, Michigan 48084

Phone: (313) 524-2100 • TLX 23-1114

# Performance and Portability



## The S-1 Flyaway – Another Midwest Innovation

It's the world's first hi-performance, truly portable Ku-band satellite uplink. Each of the 13 A.T.A. approved cases weighs less than 100 pounds, and the complete system conforms to international baggage regulations. Checked as excess baggage, the S-1 arrives when you arrive. Economically.

The system utilizes a Vertex 1.8M offset-fed antenna with a transmit gain of 46.6 dbi. This precision, aluminum surfaced reflector antenna meets the 29-25 log  $\theta$  FCC 2° spacing curves.

Two STS phase combined power amplifiers provide fail-safe redundancy and plenty of reserve power. And an Intelsat-approved exciter

with half and full transponder transmit capabilities allows you to operate on any available satellite system. The S-1 can be set up fast, on-line in less than 30 minutes. And the S-1's modular electronics make system repair or replacement in the field easy.

Video and audio control and monitoring equipment are included in the standard S-1 package. Options include a 2-way communications channel, and an international receive configuration is available. The S-1 is also easily adaptable for data transmission. Contact Midwest for complete information.

The S-1 Flyaway from Midwest. Built to perform. Packaged to go... anywhere.

Circle (3) on Reply Card



**MIDWEST**  
Communications Corp.

One Sperti Drive  
Edgewood, KY 41017  
606-331-8990

# Contents

December 1987 • Volume 29 • Number 12

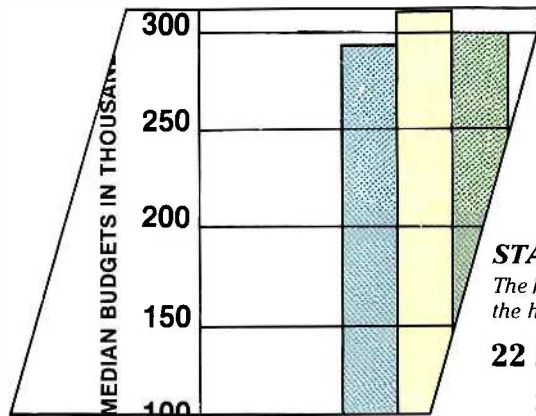

Page 26

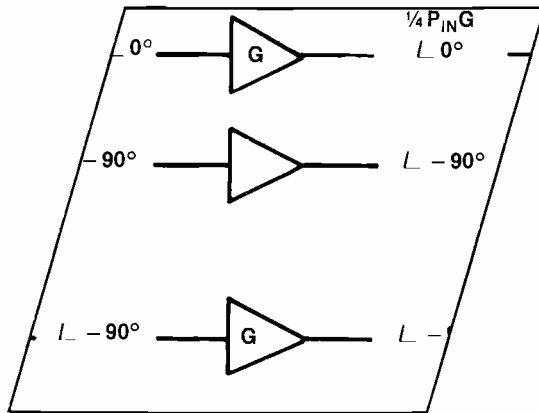

Page 66



Page 138

## BROADCAST ENGINEERING

**STATE OF THE INDUSTRY SPECIAL REPORT:**  
The health of the broadcast industry and the equipment trends on the horizon are the focus of this State of the Industry issue.

### 22 State of the Industry

By Jerry Whitaker, editorial director  
Technology moves at a rapid pace. It can sometimes be a wild ride.

### 26 Who's Spending What

By Brad Dick, radio technical editor  
Results of the annual **Broadcast Engineering** survey of radio and TV stations' buying plans for 1988.

### 40 View From the Top

By Jerry Whitaker, editorial director  
Interviews with the top engineering presidents of ABC, CBS and NBC on where they see technology going in the next few years.

### 54 The State of TV News

By Joseph Barnes, consultant, Martinez, CA  
If you think TV news is having problems, you're right.

### 59 Manufacturing Technology

By Guy Numann, Harris Corporation, Melbourne, FL  
When it comes to manufacturing broadcast equipment, it's not business as usual anymore.

### 62 Broadcasting's Bottom Line

By Jerry Whitaker, editorial director  
Broadcasting is a business, and every business runs on money.

### 66 Digital Amplitude Modulation

By Timothy P. Hulick, Acrodyne Industries, Blue Bell, PA  
For a different approach to digital amplitude modulation, take a look over an RF designer's shoulder at an idea that's still on the drawing board.

### 82 Hot Switches and Combiners

By Dennis Heymans, Micro Communications, Manchester, NH  
Hot switching RF systems may prevent the big chill of being off the air.

### OTHER FEATURES:

### 94 Annual Editorial Index for 1987

### ON THE COVER

Technology and economics are the forces that drive the broadcast industry. Both must be understood to survive in the tough market of today and the uncertainty of tomorrow. We examine both areas this month. Our cover shows an experimental multi-stage depressed collector klystron, designed for high performance in UHF-TV applications. (Photo courtesy of Varian.)

### DEPARTMENTS

4 News	18 Troubleshooting
6 Editorial	20 Management for Engineers
8 FCC Update	134 Show Replay: Radio '87
10 Strictly TV	136 SBE Update
12 re: Radio	138 News Special Report: Bringing Calgary to the World
14 Satellite Technology	147 New Products
16 Circuits	151 Business

## How to re-create instantly -- anytime -- the exact camera adjustments that gave you perfection today.

This problem is both technical and artistic. And the best solution ever developed is the built-in floppy disk system in Hitachi's Setup Control Panel, for SK-97D and SK-970D cameras.



Keep this "perfect look" on file.

For example, suppose you've spent a fussy 55 minutes adjusting your cameras for absolute perfection in tight closeups, for a special on kids and pets.

But as soon as you start shooting, the on-camera narrator becomes very ill and you have to

reschedule. This leaves you not feeling so well yourself. Because you know, in a day or two, you'll have to create that look again.

No problem -- with Hitachi's system. Setup and adjustment data from as many as six cameras and 32 scenes can be filed on a single floppy disk. You can automatically set up your cameras again anytime -- *exactly* the way they were. About two minutes is all it takes.

Other computerized camera systems can't do this. Only Hitachi has the software and the

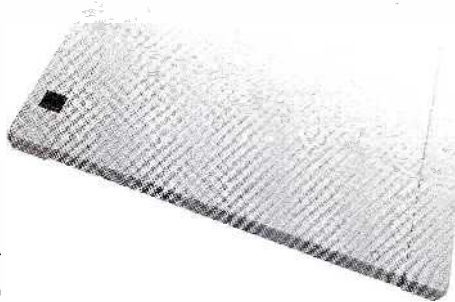

built-in floppy disk drive that does it. On-board micro-computers in Hitachi's SK-970D and SK-97D cameras exchange data with the disk.

Think of the advantages. You can file and re-use camera adjustments that flatter the complexions of specific talent. You can match and keep on file the look of any continuing series.

The bottom line is -- you save time. You add to effective production time by cutting down setup time.

That's why a major network



### Hitachi SK-97D

- Zero method auto setup
- S/N 60dB
- Real time registration compensation
- 2/3" MS LOC DG Plumbicon tubes
- Triax Capability - 10,000 feet

bought 47 of the first SK-970D's and SK-97D's.

Call us for a demonstration. See our Zero Method automatic setup camera system with the built-in disk drive and many more Hitachi features that solve problems and save time. Call now.



Re-create perfection anytime.



### SU-97D

#### Auto Setup Control Panel

- Built-in 3.5 inch floppy disk system
- Data Transfer between files
- Lens extender display
- Numeric keypad for file selection
- Camera number LED display



**Hitachi Denshi America, Ltd.**  
175 Crossways Park West, Woodbury,  
NY 11797 • 516-921-7200 • In Canada,  
Call Hitachi Denshi, Ltd. 416-299-5900

Circle (4) on Reply Card

## KUSW begins international broadcasts

KUSW Worldwide, a 2.5-million-watt shortwave commercial radio station, is scheduled to begin broadcasting from Salt Lake City by the end of 1987.

The station's primary coverage area will include all of North America and also will be heard in Europe and parts of Africa.

KUSW is the second shortwave commercial radio station in the United States. One of the goals of the station is to promote Utah and intermountain west tourist attractions.

The programming will include mostly music, but also will feature news, weather and public affairs, all with an international flavor. The broadcasts will be in English, and will cater to the approximately 2 million Americans who live overseas.

The station has access to a world network of computerized weather data. Special emphasis will be placed on

weather advisories and changes occurring throughout the world.

KUSW will broadcast from 11 a.m. to 11 p.m. Mountain time.

**By Howard T. Head,  
European correspondent**

## Local television catches on in Spain

Much as the early TV translators began in the Western United States, a new form of low-power television is spreading in Northern Spain. About 90 local TV stations, mostly in the Barcelona area, have formed a *Federation for the Legalization of Local Television to Cataluna (Barcelona)* to seek legal status before the Spanish government. Members are quick to distinguish themselves from regular stations and from pirate transmitters reported to be operating in some parts of Spain.

These stations provide locally origi-

nated programs to local audiences, in some cases, to communities of less than 1,000 inhabitants. The first station began operation in Cardedeu, near Barcelona, in 1981. The stations typically operate with about 200W of power, with volunteer participants and with simple studio equipment ranging from home-quality to the professional.

Essentially, all of the programming consists of matters of local interest: local election returns, public debates, first communions, mass for the homebound and local athletic events. Movies aren't carried, although some experimentation is going on with locally produced video material. Subsidies are provided by the local and Catalanian (autonomous community) governments; some institutional advertising is carried, with the revenue being plowed back into operating and construction budgets.

Transmission schedules are highly variable. Some stations have regular daily or weekly schedules. Some of the

*Continued on page 152*

## BROADCAST engineering

### EDITORIAL

Jerry Whitaker, *Editorial Director*  
Brad Dick, *Radio Technical Editor*  
Carl Bentz, *Technical and Special Projects Editor*  
Paula Janicke, *Staff Editor*  
Dawn Hightower, *Associate Editor*  
Tom Cook, *Senior Managing Editor*  
Lisa Martin, *Editorial Assistant*  
Darren Sextro, *Editorial Assistant*  
Pat Blanton, *Directory Editor*

### ART

Kristi Sherman, *Graphic Designer*

### EDITORIAL CONSULTANTS

Fred Ampel, *Audio*  
Nils Conrad Persson, *Electronics*  
Ned Soseman, *Video*  
Michael Heiss, *Consulting Editor*

### BUSINESS

Cameron Bishop, *Group Vice President*  
Duane N. Hefner, *Publisher*  
Stephanie Hanaway, *Promotions Manager*  
Cynthia Sedler, *Promotions Coordinator*  
Dee Unger, *Advertising Supervisor*  
Mary Birnbaum, *Advertising Coordinator*

### ADMINISTRATION

R.J. Hancock, *President*  
Doug Riemer, *Circulation Vice President*  
Jane J. Powell, *Circulation Manager*  
JoAnn DeSmet, *Circulation Fulfillment Manager*  
Barbara Clare, *Reader Correspondent*

*Editorial and advertising correspondence should be addressed to: P.O. Box 12901, Overland Park, KS 66212-9981 (a suburb of Kansas City, MO); (913) 888-4664. Telex: 42-4156 Intertec OLPK. Circulation correspondence should be sent to the above address, under P.O. Box 12937. RAPIDFAX: 913-888-7243.*

### TECHNICAL CONSULTANTS

Eric Neil Angevine, *Broadcast Acoustics*  
John H. Battison, *Antennas/Radiation*  
Blair Benson, *TV Technology*  
Dennis Ciapura, *Radio Technology*  
Dane E. Erickson, *Systems Design*  
Howard T. Head, *European Correspondent*  
Wallace Johnson, *FCC/Bdct. Engineering*  
John Kean, *Subcarrier Technology*  
Donald L. Markley, *Transmission Facilities*  
Harry C. Martin, *Legal*  
Robert J. Nissen, *Studio/Communications*  
Hugh R. Paul, *International Engineering*  
Art Schneider, *A.C.E., Post-production*  
Elmer Smalling III, *Cable/Satellite Systems*  
Vincent Wasilewski, *Communications Law*

### MEMBER ORGANIZATIONS

#### SUSTAINING MEMBERS OF:

- Acoustical Society of America
- Society of Broadcast Engineers
- Society of Motion Picture and TV Engineers

Member,  
Association of Business Publishers 

Member,  
Business Publications  
Audit of Circulation 

BROADCAST ENGINEERING is edited for corporate management, engineers/technicians and other station management personnel at commercial and educational radio and TV stations, teleproduction studios, recording studios, CATV and CCTV facilities and government agencies. Qualified persons include consulting engineers and dealers/distributors of broadcast equipment.

**SUBSCRIPTIONS: BROADCAST ENGINEERING** is mailed free to qualified persons within the United States and Canada in occupations described here. Non-qualified persons may subscribe at the following rates: United States and Canada; one year, \$25.00. Qualified and non-qualified persons in all other countries; one year, \$30.00 (surface mail); \$108.00 (air mail). Back issue rates, \$5, except for the Buyers Guide/Spec. Book, which is \$20. Rates include postage. Adjustments necessitated by subscription termination at single copy rate. Allow 6-8 weeks for new subscriptions or for change of address. Second class postage paid at Shawnee Mission, KS.

**BROADCAST ENGINEERING** Volume 29, No. 12 (USPS 338-130) is published monthly (except in the fall, when two issues are published) by Intertec Publishing Corporation, 9221 Quivira Road, P.O. Box 12901, Overland Park, KS 66212. Second class postage paid at Shawnee Mission, KS, and additional mailing offices. POSTMASTER: Send address changes to BROADCAST ENGINEERING, P.O. Box 12983, Overland Park, KS 66212.

Photocopy rights: Permission to photocopy for internal or personal use is granted by Intertec Publishing Corporation for libraries and others registered with Copyright Clearance Center (CCC), provided the base fee of \$2.00 per copy of article is paid directly to CCC, 21 Congress St., Salem, MA 01970. Special requests should be addressed to Cameron Bishop, group vice president. ISSN 0007 1794 \$2.00 + \$0.00.

© 1987. All rights reserved.

Advertising offices listed on page 155.

**INTERTEC**  
PUBLISHING CORPORATION

# LEADER

**2-YEAR WARRANTY!**  
 All Leader Test Instruments have the highest level of accuracy and reliability. Durable enough to withstand intensive 3-shift production demands, Leader Instruments are the benchmark of quality and performance.

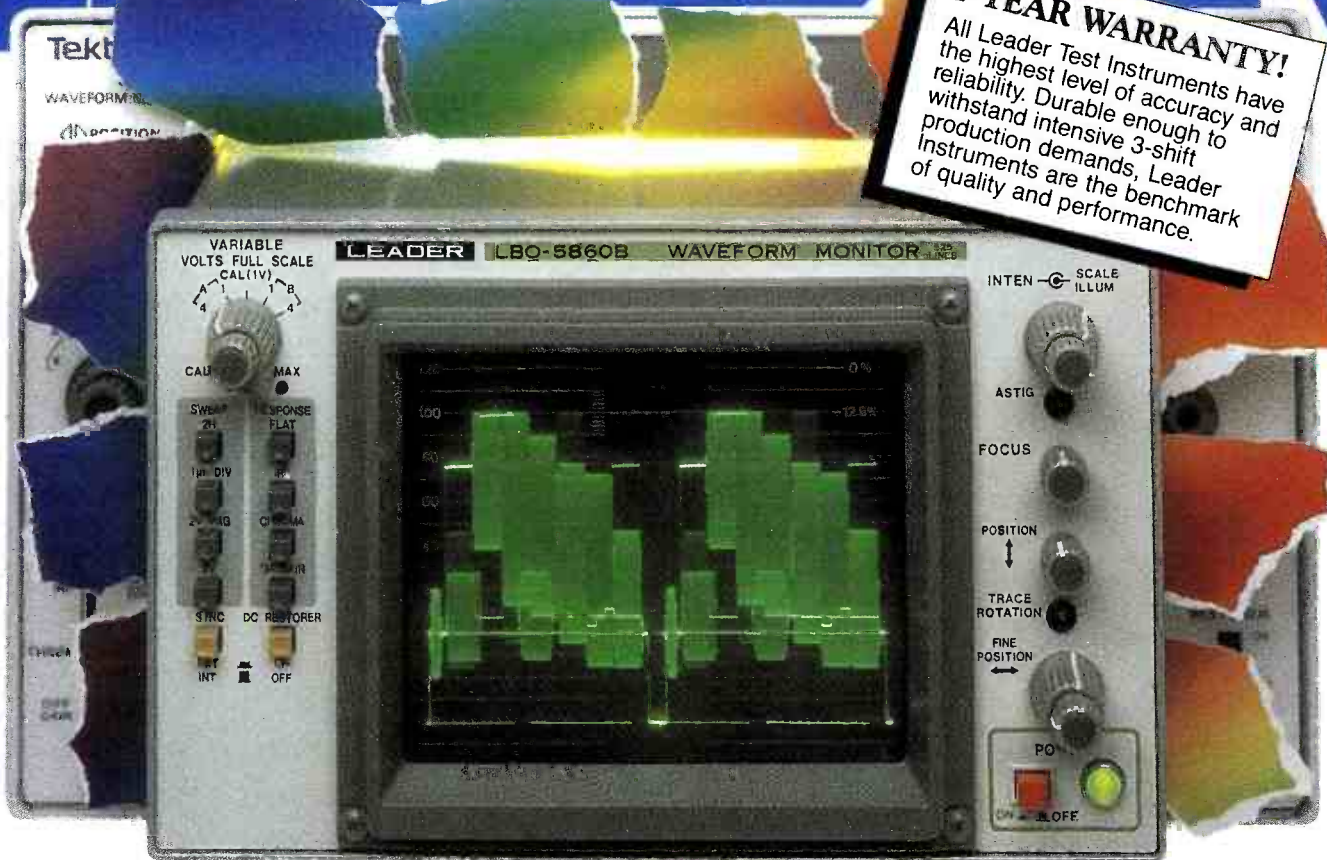

## Goodbye old standard!

Leader's new LBO-5860B Half-Rack Waveform Monitor delivers all its features for \$590\* less!

As good as you were, old standard, your time has passed—The Leader LBO-5860B is better because it's easier to use and delivers all your features for only \$1,740 list. In fact, video pros who swore by you for years will be delighted to have me around.

### The LBO-5860B sets new standards.

Compare the LBO-5860B to any other half-rack unit—be it the Tek<sup>†</sup> 1730 which lists for \$2250\*, or even the old standard, Tek<sup>†</sup> 528A, at \$2,330\*. You'll agree the high-performance LBO-5860B has no equal in ease of use and value:

- RGB at no extra cost; optional YRGB
- Rack-mounts alongside LVS-5850B or any other half-

rack vectorscope • Bright, PDA CRT with internal, etched graticule

- 4 sweep speeds (2-line and 2-field displays, regular and expanded)
- Flat response, IEEE and chroma filters
- Switchable dc restorer clamps blanking at zero IRE
- Switchable internal/ext. sync
- Excellent stability and reliability
- PAL, SECAM and line selector (5860H) models available
- 2-year warranty.

### Raise your vectorscope standards.

**LVS-5850B reduced \$200 to only \$1,995.**



- Easy to use
- Rack-mountable with LBO-5860B or any other half-rack waveform monitor
- Electronically generated CRT targets, and error limits
- Electronic targets eliminate parallax and readout is independent of centering controls.



Buy both for \$3,735. Less than any other high-quality, half-rack pair.

Call toll-free  
**(800) 645-5104**

In NY State  
**(516) 231-6900**

Ask for an evaluation unit, our latest Catalog, more information, or your nearest "Select" Leader Distributor.

For professionals who know the difference.

**LEADER**  
 Instruments Corporation

380 Oser Avenue, Hauppauge, New York 11788  
 Regional Offices:  
 Chicago, Dallas, Los Angeles, Boston, Atlanta  
 In Canada call Omnitronix Ltd. (514) 337-9500

For Product Demonstration Circle (5) on Reply Card

For Product Information Circle (6) on Reply Card

\*All prices are manufacturer's suggested list prices as of 9/3/86. Actual savings may vary since prices are set by the retailer.

†Trademark of Tektronix

## HDTV at the crossroads

The fall SMPTE convention provided a fascinating study in contrasts with regard to high-definition television. Views ranged from opposition to indifference to wholehearted endorsement. More companies showed HDTV products, but products do not begin to tell the whole story.

The future of HDTV will determine, in no small part, the future of over-the-air television. Many ideas have been suggested, from NBC's 6MHz compatible system to some variation of MUSE.

How HDTV will be delivered to consumers will have a profound effect on where TV broadcasters may fit into the equation. The most likely scenario? It depends on whom you talk to. Consider the following insider views:

- Michael Sherlock of NBC will tell you that the compatible 6MHz HDTV system will prevail. It is, he says, the only system that makes sense for broadcasters.
- HDTV pioneer David Niles believes that closed-circuit systems, such as videodiscs, will be the first medium for delivering high-definition pictures. He adds that videodiscs will soon be followed by DBS.
- Joe Flaherty of CBS tells us that HDTV will have its greatest impact first on production. Transmission will follow, he says, but only if the industry faces up to some tough problems regarding spectrum usage.
- ABC's Julie Barnathan, however, argues that people watch *programming*, not technology. Consider his argument: What would win a larger audience—the World Series in NTSC or anything else in HDTV?
- Stephen Weinstein of Bell Communications Research (in a recent article in the "IEEE Spectrum") theorizes that the ultimate delivery system will be switched terrestrial fiber-optic cables.
- Leonard Coleman of Kodak (in a statement to the trade press at SMPTE) says HDTV is interesting but nothing to write home about. He says the true high-definition medium today is 35mm film.

The concept of high definition drives right to the heart of our industry. We love gadgets. We live by technology and, as some AM radio stations have found, we also can die by it.

In his SMPTE keynote address, Daniel Slusser of Universal City Studios wondered what the world would be like if video had been developed *before* film. Consider the excitement, then, that announcement of 35mm film would bring. Picture the press release. It would herald 35mm film as a major breakthrough, providing greatly increased dynamic range and contrast ratios; simple, lightweight camera designs; ready duplication capabilities; and horizontal resolution well in excess of an equivalent 2,000 lines.

Fantasy aside, HDTV is here. It is a reality that must be dealt with. The technology has been likened to a freight train. Broadcasters must hop on board or get out of the way.

HDTV enthusiasts view the technology as the natural progression of video. It represents a threat to some and an opportunity to others. Technology in our business is not always kind. But it is predictable. The future clearly belongs to those with the vision to plan for it and the good sense to know which way the wind is blowing.

High-definition television, insofar as broadcasters are concerned, is at a crossroads from which there may be no return. Which way do you plan to turn?



"We wanted the best sound in town—I think we were successful."  
Martin Brandl, Chief Engineer  
CJMF-FM, Quebec City, Canada  
(Soft Rock)

"The automatic equalization and gently gain riding were just what we were looking for. And thank you for making your updates retrofittable."  
Don Hobson, Engineering Manager  
KJQY, San Diego, CA  
(Light and Easy Music)

"I would highly recommend it to anyone—except my competitors!"  
Ray Fisher, Program Director  
WZLX, Columbus, MS  
(Contemporary Hit Radio)

"Increased our punch and gave us a fuller sound. It's ultimately clean. In a competitive market, regardless of format, the cleaner sound gets (and keeps) the long-term listener. The added controls give us the advantage of tailoring our sound to the listener."  
John Bortowski, Chief Engineer  
WBMX, Chicago, IL  
(Urban Contemporary)

"It's scary! Loud and dense, but not fatiguing. And it's consistent whether we're playing old LPs or a new Huey Lewis CD."  
Duffy Egan, Chief Engineer  
WPRO-FM, Providence, RI  
(Contemporary Hit Radio)

"Clean and loud."  
Barry Mishkind, Chief Engineer  
KFXX, Tucson, AZ  
(Contemporary Hit Radio)

"Clean and natural without being strident. It gives you lots of adjustment capabilities, and will fit almost any format. The manuals are very good as usual."  
David Ficker, Chief Engineer  
KHOO, Waco, TX  
(Adult Contemporary)

"Voices sound clean and open, and the music sounds great."  
John Buckham, Chief Engineer  
KITS, San Francisco, CA  
(Modern Rock)

"Super! The most cost-effective change we've ever made."  
Randy Wells, Chief Engineer  
KREO, Santa Rosa, CA  
(Adult Contemporary)

"It's the biggest bang for the buck—lets us customize our sound for our listeners."  
Matt Conner, Chief Engineer  
WASH, Washington, D.C.  
(Adult Contemporary)

"Lethal."  
Terry Carpenter, Chief Engineer  
KJYY, Houston, TX  
(Vocal Soft Rock)

"Gave us more punch and clarity without any increase in distortion."  
Michael Fast, Chief Engineer  
WPOC, Baltimore, MD  
(Modern Country)

## The OPTIMOD®-FM XT2 Processor: Everything they say is true.

Orban's XT2 Six-Band Limiter is an accessory chassis that works with any 8100-series OPTIMOD-FM. It gives you bass and high frequency equalizers, plus CLIPPING and DENSITY controls that let you customize the sound for your format and target audience. At \$2075\*, it's probably the most cost-effective upgrade you can make to your audio.

For the details, see your Orban dealer, or contact us direct.

**Orban Associates Inc.**  
645 Bryant St, San Francisco, CA 94107 USA  
Phone (415) 957-1067 or (800) 227-4498  
Telex 17-1480 FAX (415) 957-1070

\* (suggested list)

**orban**  
Circle (7) on Reply Card



## The spectrum is still open for HDTV

By Harry C. Martin

In mid-October the FCC voted to defer action on further sharing of the UHF TV band between broadcasters and the land mobile radio services. The action was taken to give the Advisory Committee on Advanced Television Systems sufficient time to file its interim report on the prospects for developing high-definition television (HDTV) systems.

The commission had proposed in 1985 that two to six unassigned UHF channels in eight large urban areas be assigned to the land mobile services. Before the proposal could be adopted, however, the broadcasting industry announced plans to use the affected spectrum for HDTV. The eight metropolitan areas are the most difficult markets in which to find an additional spectrum for HDTV. The major broadcast trade associations and many TV station owners made these points in a petition for special relief filed in February 1987.

In deferring action on the reallocation plan, the commission said that further sharing of the UHF band could not be implemented without affecting options for HDTV development. Because the future of TV technology is at stake, the agency said, it needs more complete information before making a decision or eliminating any options. Meanwhile, the advisory committee's report and the public's comments can be received and studied.

The February petition included a request by the TV industry asking the commission to reserve at least a portion of the 12.2GHz to 12.7GHz band, now reserved for DBS, for possible HDTV use by terrestrial broadcasters. The commission rejected this proposal on the grounds that DBS itself may provide an HDTV service and because reducing the spectrum available to DBS could be highly disruptive to this service before it has even developed. Technical impediments to the use of the 12GHz band for terrestrial HDTV systems also were cited.

### 1,540kHz daytimers may operate at night

Because the Bahamian government indicated that it plans to denounce the

Martin is a partner in the legal firm of Reddy, Begley & Martin, Washington, DC.

NARBA treaty, the commission is authorizing 21 daytimers now operating on 1,540kHz, a Bahamian clear channel, to begin nighttime operations.

As a result of international agreements with Canada and Mexico, rules were adopted last year that permitted daytimers to operate at night on the 14 foreign Class I-A clear channels, including 1,540kHz. Also, eligible stations operating on the Canadian and Mexican clears were authorized to begin nighttime operation. No authorizations were issued on 1,540kHz, however, because it is a Bahamian clear channel still restricted under the old NARBA agreement.

Based on the rules adopted last year that allow use of the foreign clears, a relaxation of restrictions is possible on 1,540kHz, but only outside the 650-mile zone of protection established by NARBA, and only for stations already operating on the frequency during daytime hours. Letting new stations on the frequency would unfairly limit future opportunities for nighttime operation by stations still restricted by NARBA's 650-mile zone. The commission hopes to relax these restrictions and permit greater power for some of the stations when the Bahamas officially denounces NARBA.

### LPTV applications to be granted

By the end of this year the FCC will grant 278 of the 1,200 LPTV and TV translator applications that were submitted in the filing "window" for new proposals. They will be eligible for construction permits unless petitions to deny are filed against them.

The window system, combined with a 5-application "cap," is responsible for the speedy processing. In the past, there was no limit on the number of applications a single person or group could file, and the availability at specific locations of certain channels for LPTV use was announced in advance of filing deadlines. This spawned thousands of speculative applications, causing massive processing delays.

By limiting the number of applications and requiring applicants to ascertain channel availability at particular locations, the new system speeds the authori-

zation of new facilities. As of mid-October, approximately 500 LPTV stations in the United States and 1,150 LPTV construction permits were outstanding.

### No change on call letters

The commission has decided to retain its current systems of assigning call signs on an exclusive basis and of assigning "W" and "K" as the first letter of call signs for stations east and west of the Mississippi River.

In the same action, the call-sign assignment rules were revised to incorporate the previous waiver policy. This policy permitted station owners to retain their call signs in change-of-ownership or call-letter swap transactions with stations in the same market. Assignment of conforming call signs to stations in different services that are not commonly owned will be permitted, but only if the station requesting the assignment obtains written permission from any station already using the desired basic call sign.

The commission abandoned a February proposal to end its long-standing rule permitting exclusive call sign assignments. Under the proposal, any licensee would have been eligible to request any call letters not assigned to another station in its own service, except within the same market. Industry protests convinced the commission to abandon this proposal as well as the companion proposal to eliminate the "K" and "W" system based on geographic location.

1:7-2)))

# Something you'll never have to do...



## ...if you own a Grass Valley switcher.

Whether you are in a live or post production environment, the moment of truth comes when the lever arm is finally moved. Peace of mind is knowing that your

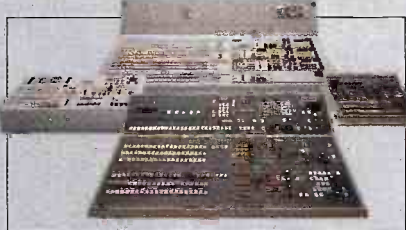

Grass Valley Group switcher won't let you down.

There are four switcher

families with many possible configurations in the Grass Valley line up. From the now legendary Model 300, to the compact, yet extremely powerful Model 100, there are no better switchers anywhere. Every system has the quality, reliability and performance that professionals around the world know that they can expect from Grass Valley Group.

So, uncross your fingers and call us today. Let us

know your requirements, and we will offer a switcher tailored to satisfy your every need.

**Grass Valley Group®**

A TEKTRONIX COMPANY

 THE GRASS VALLEY GROUP INC.

P.O. Box 1114, Grass Valley, CA 95945 USA  
Telephone (916) 478-3000  
TRT: 160432

OFFICES: New York (201) 845-7988; District of Columbia (301) 622-6313; Atlanta (404) 493-1255; Chicago (219) 264-0931; Minneapolis (612) 483-2593; Dallas/Fort Worth (817) 483-7447; Los Angeles (818) 999-2303; San Francisco (415) 968-6680; GVG International Ltd. (UK) +44-962-843939; Grass Valley Group Asia (HK) +852-3-7396632

Model 100 Family Circle (200) on Reply Card  
Model 200 Circle (201) on Reply Card

300 Series Circle (202) on Reply Card  
1680 Series Circle (203) on Reply Card



## Take an objective look at encoders

By Carl Bentz,  
technical and special projects editor

**M**ethods for improving the performance of the NTSC standard were discussed in "Getting More Out of NTSC" in the September 1987 issue. Most of the techniques involved comb-filter designs and were heavily based on technology, but there are inexpensive, practical solutions to the encoder-vs.-NTSC dilemma.

Demonstrations show that comb-filter encoders significantly improve picture quality. Those improvements are particularly spectacular if the image is derived from a complementary comb-filter decoder, but that's where the difficulties begin. How many receivers use comb-filter decoding?

Such decoders often are integral to video monitors but, because of cost, they typically are not found in garden-variety TV receivers. So is the comb-filter encoder really the most practical answer? Remember, the ultimate goal is to achieve the most faithful NTSC reproduction possible, regardless of the final decoder.

The comb filter inherently produces a full horizontal line delay on the composite output. This requires a dedicated sync generator feeding 1-line-advanced sync to compensate for the delay.

If a multiburst signal, containing a black or white reference on every 10th line, is fed to the inputs of a comb-filter encoder, an interesting phenomenon occurs. As observed with a delayed-sweep oscilloscope, lines immediately before and after the white or black luminance line may exhibit up to 30% rolloff using a 50IRE multiburst signal. On the white or black line, more than 150mV of multiburst information appears.

This spurious signal and the selective loss of response produce an impairment particularly noticeable on video originating from graphics generators and paint systems. Other anomalies of comb filters may appear when a 12.5T modulated pulse with a 180° phase shift of the modulation is applied at every 10 lines.

### Check list

If you're the one making the equipment evaluation, you'll have to decide whether to ignore this impairment in favor of some reduction in NTSC cross-

color and cross-luminance. When a requirement for a new encoder arises, you can evaluate various encoders by using the following check list, which treats the RGB inputs as no more than three separate monochrome input ports.

1. Block all ventilation holes and operate the encoder for 12 hours. If color-bar phase or amplitude moves more than 1° or 1%, send it back.

2. How many NTSC outputs are available?

3. Is the design rugged? Are all setup controls available without removal of the unit from the rack and without using board extenders? If not, to what extent are phase-related controls affected by the extension?

4. Can Y, I and Q be switched on and off individually from the front panel?

5. Can RGB inputs be bridged together from the front panel?

6. Will the encoder accept various formats of components besides RGB? Can it be switched between derived luminance and separate luminance?

7. Are there interactions in adjustments of burst gain vs. phase; burst phase vs. I or Q phase; I vs. Q phase; or chroma gain vs. phase?

8. Is the pedestal adjustable?

9. Verify that the burst envelope rise time is about 400ns. Full burst amplitude should not occur prior to 1.5 cycles after the start of burst.

10. How much residual subcarrier remains at blanking and peak white after I and Q balance has been optimized with internal bars? What residual exists with a  $\pm 30^\circ\text{F}$  temperature change? Residual subcarrier should not exceed 3mV in either case.

11. Loop a dot-bar signal through the RGB inputs, and terminate the last port. Monitor the NTSC output on a waveform monitor or scope. Are dot and bar amplitudes equal? Check for symmetrical rise and fall times of the bar and dot signals and for the amount of pre- and post-ringing. Use a delayed-sweep scope to check for spurious video on a white horizontal line.

12. Loop a 50% multiburst with luminance through the RGB inputs.

Check for flat response, particularly on lines before and after a black or white luminance line. Check for spurious video on luminance lines.

13. Loop a modulated 12.5T pulse through the RGB inputs, and observe any luminance/chrominance delay inequality. It should be less than  $\pm 10\text{ns}$ . If modulation on the 12.5T signal switches phase 180° periodically during the field, monitor the response on lines before and after the phase switch.

14. Loop a bounce test signal through the RGB inputs. Output blanking should remain at 0Vdc. If subcarrier appears momentarily after the input bounce, the three inputs are not clamped equally.

15. Loop a luminance 10-step signal through the RGB inputs, and observe overall linearity. Subcarrier at any point of the gray scale indicates unequal linearity in one or two of the channels.

For these tests, you may need to feed composite signals to the encoder inputs for some generators. As a result, some encoders may cause double amplitude sync and distorted colorburst on the NTSC output, but you may disregard these effects for purposes of the evaluation. However, if a 1Vp-p composite signal causes non-linearity, it indicates poor dynamic-range characteristics of the encoder.

An encoder is not a magic black box. Evaluate it objectively, using standard equipment—just as you would examine a video switcher, DA or proc-amp.

**Acknowledgment:** This article is based in part on "Some Plain Talk on NTSC Encoding," a white paper prepared by Bert Verwey, president of Broadcast Video Systems Corporation, Richmond Hill, Ontario, Canada.

!:(~)))))

# FIELD PRODUCTION

*A special job demanding specialized products.*



For your audio needs: a growing line of compact, easy-to-use FP amps and mixers.

Shure FP products are built specifically for ENG, EFP, film, and video work. They're not general audio products that "might" work on remotes. And no one offers as wide a selection with this kind of built-in ruggedness and reliability.

FP32



FP42



**For Stereo Remotes.** The FP32 Stereo Mixer is comparable in size and features to our famous FP31. Its stereo capability, light weight, easy-to-use controls and convenient shoulder harness make it the first choice of field crews. Our FP42 Stereo Mixer simplifies mic cueing, so important in situations like sports remotes. Plus it enables you to easily mix down stereo in your post production booth. It offers all the features of the popular M267 plus stereo capability and a stereo headphone amp.

FP31



FP16



**The Industry Standards.** The FP31 is Shure's original field production mixer. Thousands bet their audio on it worldwide. The FP16, a one-by-six distribution amp with transformer balancing and link jacks, outperforms all competition. It's also ideal as a portable press bridge.

FP11



FP12



**For Long Yardage Situations.** The FP11 Mic-to-Line Amp provides freedom from noise in long line situations, with up to 84 dB of gain in 15 6-dB steps. It converts any mic to line level and includes an invaluable limiter circuit. The FP12 Headphone Bridging Amp is a must for shotgun and boom operators. It keeps them on target without need for a return line. It's ideal for multiple headphone feeds, troubleshooting, and as an intercom.

FP51



**The new FP51 gated compressor/mixer rides gain automatically.** Once you set the compression level, the FP51 adjusts automatically to changing signal levels in critical remote-to-studio feeds to maximize signal output. As a result, your broadcast is quieter, smoother, better balanced and more natural sounding.

For more information on the entire FP line, call or write Shure Brothers Inc. 222 Hartrey Avenue, Evanston, IL 60202-3696. (312) 866-2553.

## SHURE®

THE SOUND OF THE PROFESSIONALS...WORLDWIDE®

Circle (8) on Reply Card

## When the numbers change, the search is on

By John Battison, P.E.

If it has ever happened to you, you know how annoying it is when antenna-monitor readings vary for no apparent reason. You can identify the symptoms, but not the illness. This column will discuss antenna and ground-system problems that could account for erratic readings.

### Take a closer look

If varying ratios or remote base currents are indicated for a specific tower, and the parameters for the other towers in the array are normal, make an immediate inspection of all the elements in the transmission-line system. Starting at the phaser, first check all connections for tightness. If it's practical, check the lines for intermittent shorts or open circuits caused by faulty soldered connections. In one case, the varying base current was traced to worn-out, dirty contacts in the pattern-changing relay at the tower base. When the relay was replaced, the base current returned to normal.

Shortly afterward, the same tower began to exhibit random variations on the phase monitor. This particular trouble eventually was traced to an intermittent connection in the tower sampling loop. From ground-level observations, the loop appeared sound. It was not until a close-up physical check was made that the condition was discovered.

A careless or disinterested operator might have been content to go along repeating the anticipated or normally expected phase readings. Unless the erratic phase-monitor readings occurred while the parameters were being recorded or logged, the variations would have gone unnoticed.

### Solving mysteries

If the antenna-monitor phase and magnitude readings change, but weather conditions have remained constant, first look for external influences. The change could be caused by new buildings or other construction. Perhaps a crane whose boom has changed appreciably in

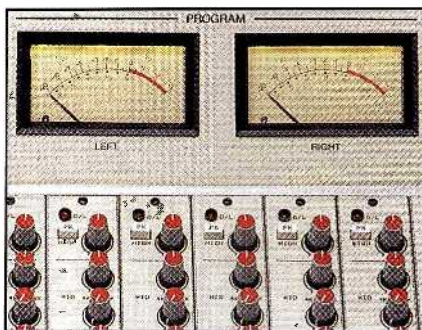

position and length is close to or in the major lobe of a system. If no elements of this type are present, you have a nasty problem.

Check for hot connections, breaks, shorts, open circuits, transmission- or sampling-line problems and all the usual things associated with sudden DA parameter changes. Also look for hot or warm capacitors in the phaser or ATUs.

A capacitor may change value quite suddenly for no apparent reason, only to return to its original value after the system has been retuned. This can be one of the most difficult and frustrating problems to solve. The only certain way is to change one capacitor at a time—say, one a day—until you isolate the faulty one. Obviously, if you change more than one capacitor at a time, you won't know which one is causing the variation.

Incidentally, if you encounter this kind of problem, and your phase-monitor readings indicate that your station is out of tolerance, be sure to inform the FCC by telegram. Request authority to operate at variance from your licensed parameters, pending correction of the condition. If you don't do this, and an inspector comes along, you may be cited for operating in non-compliance with your license.

If the array problem occurs only during wet weather or heavy dew, and you are certain that none of your guy or base insulators are cracked or broken, then the problem is probably due to a deteriorated ground system or a leak in an underground transmission line.

I once came across an "impossible-to-trace" change in parameters. As long as the soil was dry, the array was stable. As soon as it rained, moisture got into the transmission line, and everything changed. I had just about reached the conclusion that the ground system was defective when one of the "old hands" mentioned a transmission-line repair. It seems that one of the transmission lines had burned through and had been spliced with a UHF connector and electrician's tape. The mystery was solved.

### Replacing the ground system

As directional stations reach the age of 30 years or more, it is likely that their

ground systems will require replacement. If your station is approaching this age, and you have begun to experience erratic and random changes—especially changes associated with weather conditions—closely examine your ground system.

Look for broken radials, both near the tower and extending out for a distance of approximately 50 or 60 feet. Close to the tower, you're likely to find some problems from deteriorated and high-current-carrying radials. Copper strap may appear adequate, but give it a good pull to be sure. Check the copper screen too. If the soil in your area is acidic, the screen may have telltale holes to show for it.

Replacing a ground system is expensive, so don't rush into it. First be sure that it will cure the problem.

Battison, BE's consultant on antennas and radiation, owns John H. Battison & Associates, a consulting engineering company in Columbus, OH.

THE NEW CRL IS  
**Digital Friendly**



**The Third Generation "800" Series**

Since the first Compact Discs became available over three years ago, CRL engineers have been working to perfect circuits that would make it possible to get that exciting digital sound through the transmission system to your listener's receivers.

Our totally new **STEREO GAIN CONTROLLER** was designed for digital. It has to be heard to be appreciated. It includes Dynafex® noise reduction for a S+N/N ratio greater than 80 dB!

The new **STEREO MODULATION PROCESSOR** uses our exclusive transfer function limiter for maximum transient quality and impact. Add to that, the new Stereo Soundfield Enhance circuit for maximum separation, and a new filter design for superb baseband protection.

Top it off with our newest version **SG 800A STEREO GENERATOR** with high resolution digital modulator and you have the loudest, most transparent "on air" sound yet! We call it **DIGITAL FRIENDLY**.

For a **DYNAMIC** sound that will thrill your audience and intimidate your competition call now to audition these great new processors on our **SATISFACTION GUARANTEED** sale plan. Cost is just \$4995 for a limited time. . .

800-535-7648

Dynafex® is a registered trademark of Circuit Research Labs, Inc.

**THE  
 PROFESSIONAL'S  
 CHOICE**



**CRL Systems**  
 2522 West Geneva Drive  
 Tempe, Arizona 85282  
 (800) 535-7648 (602) 438-0888  
 TELEX: 350464 CRL TMPE. UD.  
 FAX (602) 438-8227

## Using parabolic antenna systems

By Elmer Smalling III

Most satellite communications today use "dish" or parabolic antenna systems. A brief tutorial including formulas for calculating necessary antenna parameters might benefit system owners and engineers.

The parabolic reflector antenna system is a large reflecting surface several wavelengths in diameter that is illuminated by a single antenna mounted above the surface of the reflector at the focal point. It is at this point that the signal reaching the center of the antenna is 10% greater than the signal reaching the edge of the reflector. (See Figure 1.)

At microwave frequencies, the large reflecting surface is normally between 30 and 120 wavelengths in diameter with its prime focal point between 10 and 20

Smalling, BE's consultant on cable/satellite systems, is president of Jenel Systems and Design, Dallas.

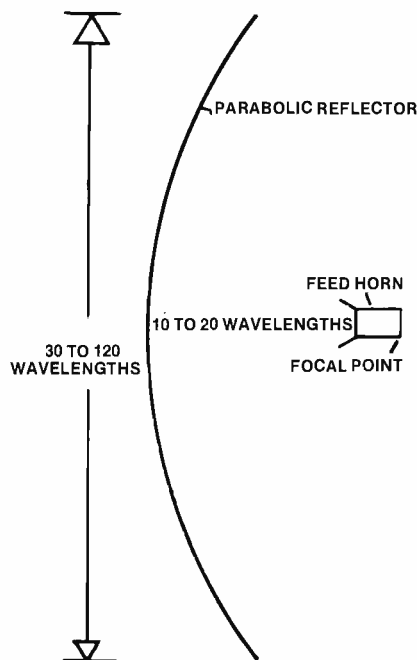

Figure 1. For efficient operation, the parabolic receiving antenna uses dimensions as indicated in this drawing. A reduction in the diameter reduces the amount of signal captured and the resulting gain of the reflector. Movement of the feedhorn too close or too far away removes it from the focal point where the maximum signal would be received.



wavelengths above the reflector surface. (To calculate any wavelength in feet, divide the frequency in megahertz into the constant 984. For example,  $984 \div 3,800 = 0.258$  or a wavelength of 0.258 feet—approximately 3 inches.)

See Figure 2 for the formula for a parabolic antenna. All signal path lengths from the focal point (F) to the reflector, and on to the aperture plane, can be shown by:

$$FP + PA = p + P \cos \theta = p(1 + \cos \theta) = 2f$$

The phase is uniform for all impinging waves. If the feed is not positioned at the exact focal point of the reflector, the system efficiency is reduced by *astigmatism* (axial feed displacement) and *squint* (lateral feed displacement that shifts the beam off-axis). Perfect feedhorn alignment and mounting bracket integrity at

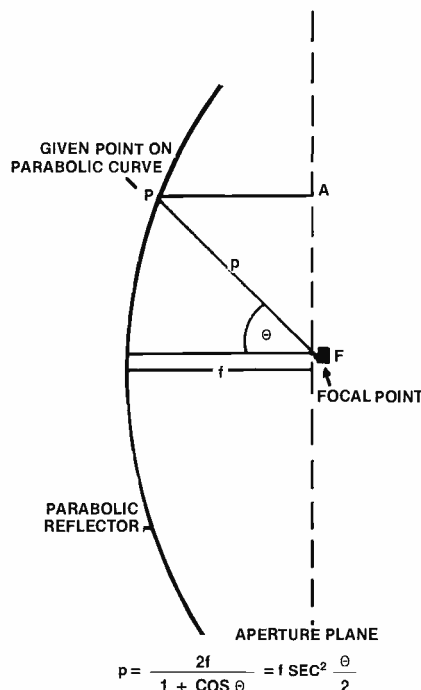

Figure 2. An ideal parabolic reflector surface is derived from relationships from analytical geometry. All rays striking the reflector from a distant source that is essentially in line with the axis of the antenna are concentrated at the focal point.

initial installation are important and worth the extra time it will take to check and recheck.

Parabolic antennas are efficient because of the gain that can be realized compared with other antenna systems such as multiple Yagi or co-linear antenna arrays. Both of these systems require at least twice as much space as a parabolic reflector system with comparable gain. The parabolic system also has an attractive feature used when aiming at satellites that are spaced only  $2^\circ$  to  $3^\circ$  apart, 22,000 miles above the earth—a very narrow beamwidth. Parabolic antenna systems can exhibit half-power ( $-3\text{dB}$ ) beamwidths of less than  $1^\circ$ . This is more than enough to distinguish between two satellites parked a few degrees apart.

In addition to being perfect parabolas, these reflectors must have smooth surfaces with no surface anomalies or "bumps," which can cause impinging rays to become out-of-phase and detract from the total gain of the antenna system. Machined aluminum and metalized plastic make the best antenna components capable of being machined to surface tolerances more than 10 times smoother than spun aluminum or metal petal systems (0.0015-inch surface distortions compared with 0.025 inches).

Three important reflector antenna system calculations are simple to make. They are antenna system gain, beamwidth and focal length. More on this next month.



# SURVIVAL RADIO

It really *is* a jungle out there. And in that jungle, Otari's MTR-10 audio machine gives you the ammunition you need to stay alive—like three speeds, micro-processor control, a built-in cue speaker, and an optional ten-memory autolocator.



The MTR-10's "creative arsenal" helps you keep pace in the tough, competitive world of broadcast.

Whether you're doing spots, editing, or working "live", this rugged machine provides the features you'll need for the recording tasks of tomorrow. As one of our customer's put it, "Everything I even *think* I want to do, I *can* do on this machine."

Now add Otari's legendary reliability and customer support, and your chances of survival become even more certain.

Has a good business decision ever been easier to make? From Otari: The Technology You Can Trust.

Contact your nearest Otari dealer for a demonstration, or call Otari Corporation, 2 Davis Drive, Belmont, CA 94002 (415) 592-8311 Telex: 9103764890

Circle (10) on Reply Card

**OTARI**®

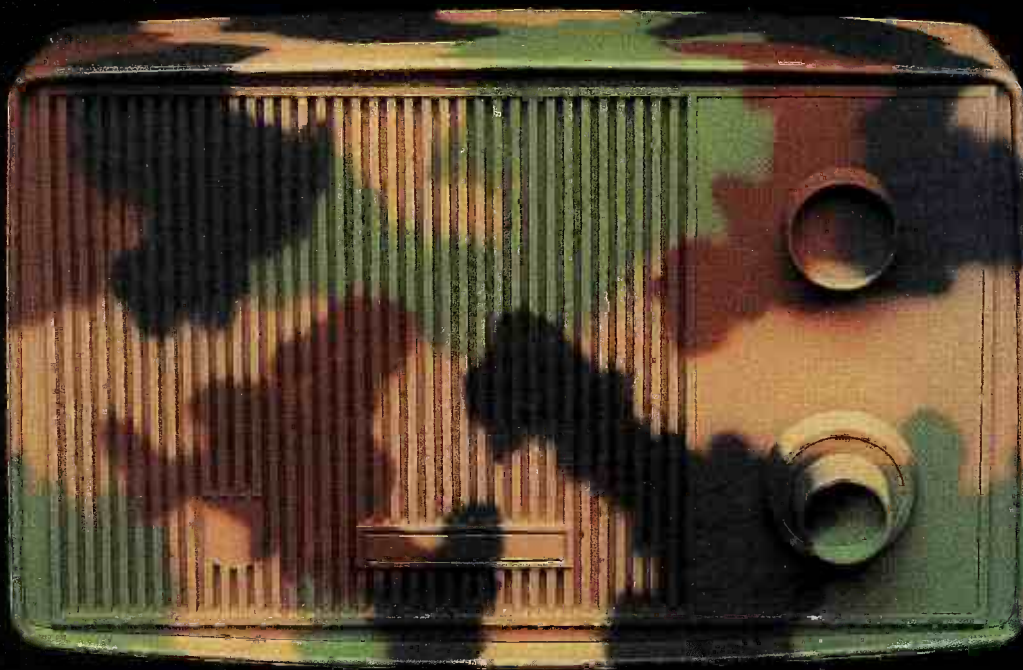

© Otari 1984

## Inside digital technology

By Gerry Kaufhold II

Many different microprocessor devices are available today for broadcast equipment manufacturers, but the fundamental mode of operation can be modeled by the Z-80. The Z-80 microprocessor is typical of devices used in products to control machines in *real time*. We continue our examination of how the Z-80 operates.

### Interrupts

Any computer program is arranged into discrete components, with separate subprograms that handle specific activities. Many times the design criteria

Kaufhold is an independent consultant based in Tempe, AZ.

for an automation system, for example, require that several activities take place at essentially the same time.

Because the Z-80 can execute about 300,000 machine instructions each second, it has no problem managing several functions in a type of "round robin" affair. However, there must be a way to tell the microprocessor which activity to handle and when to handle it.

### Time slicing

The Z-80 family of integrated circuits includes a *counter-timer circuit* (CTC) that can provide an output every few milliseconds. The CTC chip is programmed as part of the reset and in-

itialization sequence that occurs immediately after power is applied to the computer. The CTC signal actually interrupts the Z-80, and it is used to divert the attention of the microprocessor to the next activity to be managed.

The technique of creating programs that are switched every few hundred milliseconds is called *time slicing*. The program that manages the time slicing is a *dispatcher*. The dispatcher program uses volatile read/write random-access memory to store the status of each program it is running. (See Figure 1.)

If your station owns a personal computer, you might note that the program that sends text to the printer runs a time-sliced program. The printer continues printing even while you are running other programs.

The programs written by manufacturers of station-automation systems provide routines called *device handlers* that interface the microprocessor to the VTRs, switchers and routers. These programs include the necessary linkages so they can be interrupted, then restarted when the Z-80 returns to them.

The signals on the system bus will show interrupts occurring randomly in time. Seldom will any device-handler subprogram be executed exactly the same way twice in succession. However, if your logic analyzer has a *clock-qualifier* input, you might be able to capture and display only the bus cycles associated with the interrupt sequences.

The techniques of time-slicing computer operations are just as important as the development of the microprocessor with regard to obtaining maximum utility from the system. Without time slicing and interrupts, computers would not be nearly as useful as they have become. Programs that can be interrupted and later restarted are called *re-entrant programs*.

Because of the complexity and randomness of time-sliced programs running in real time automation systems, the manufacturers of such equipment have invested a great deal in designing and debugging microprocessor programs.

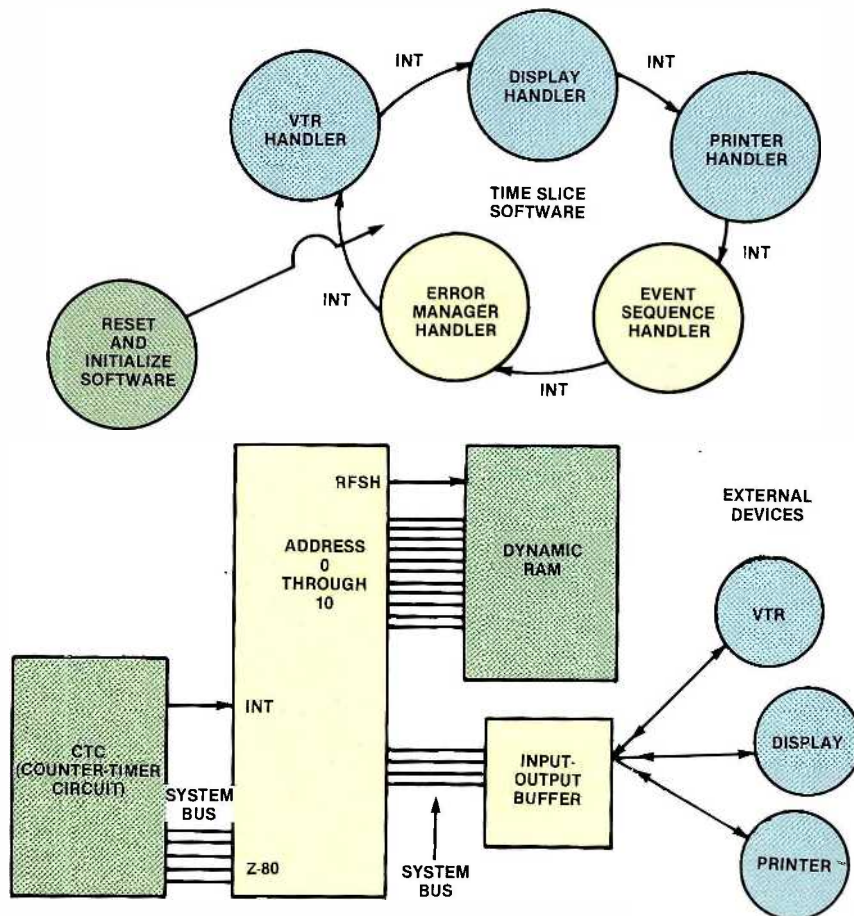
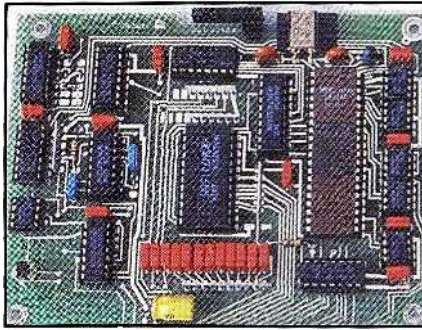

Figure 1. A typical software state diagram and hardware block diagram for a Z-80-based system with automatic dynamic RAM refresh and interrupt for time slicing.

[:(-))]]

# THE SUPERIOR SPREAD.



Orban's new 222A Stereo Spatial Enhancer augments your station's spatial image the way our OPTIMOD™ maximizes your loudness and impact on the dial: Your stereo image will seem magnified, and your listeners will hear more loudness, brightness, dynamics, and depth.

The 222A uses a new proprietary, patent-pending technique that detects and enhances the psychoacoustic directional cues present in all stereo program material. The effect is vivid and compelling—and survives even in San Francisco's brutal multipath environment. On-air tests have also confirmed complete mono compatibility and an audible increase in brightness, punch, and stereo spatial definition that complements your present audio processing.

Creating broadcast-compatible stereo image enhancement is very difficult. Do it wrong, and you can get increased multipath distortion, mono incompatibility, unnatural exaggeration of reverberation, increased sensitivity to vertical tracing distortion in disc playback, and otherwise disappointing results. If an image enhancer uses delay lines, it can drive headphone-wearing DJ's nuts, homogenize the stereo image, and comb-filter the left and right channels.

Orban's new 222A does it right. It avoids the almost endless list of traps and pitfalls, while delivering a sound that stays crisp, dynamic, and well-defined.

Most importantly, this competitive edge is remarkably affordable. At \$895\*, it is within reach of any station—FM or AM—looking to polish its image by enhancing its stereo.

Call or write today for complete information on our powerful new on-air processing tool—the Orban 222A Stereo Spatial Enhancer.

Available Early '88.

\*(Suggested List)



## Orban Associates Inc.

645 Bryant St., San Francisco, CA 94107 (415) 957-1067 Telex: 17-1480 FAX: (415) 957-1070

Circle (11) on Reply Card

## Learn the value of an organized attack

By Gerry Kaufhold II

Perhaps only an engineer on a ship at sea holds more responsibility than the chief engineer of a broadcast plant. Both must always be on call. Both manage a multimillion-dollar plant that is vulnerable to the weather. Both are responsible for saving lives through technology.

The mixture of broadcast hardware that must be kept operating is staggering: directional radar systems, microwave receivers that track helicopters, satellite uplinks and downlinks, high-power transmitters and heavy engine-room equipment, such as 3-phase high-voltage power transformers, diesel-powered generators and industrial-sized air-moving and air-conditioning equipment.

Engineering work areas must be organized, clean and well stocked with replacement parts. Driveways, parking lots, fences and external lighting must be included in the engineering budget, as well as all of the technical equipment that actually produces and transmits the broadcast signal.

More important, however, is the management of human resources. Technicians must be thoroughly trained and have the correct tools at their disposal. They also must be on the scene at the right time to keep the operation running smoothly.

### Enter the manager

When equipment maintenance is discussed, talk usually centers on circuit boards, parts and test procedures. But the management aspect also must be considered. The maintenance supervisor is the key person who can tie together all the elements to produce a functional engineering department. The successful maintenance supervisor often is someone who has worked in fields other than broadcasting, whose breadth of experience provides insights into troubleshooting procedures that might have escaped the veteran radio or TV engineer.

Usually, the term troubleshooting refers to the immediate repair of malfunctioning equipment. A piece of broadcast gear fails, the failure is discovered and is

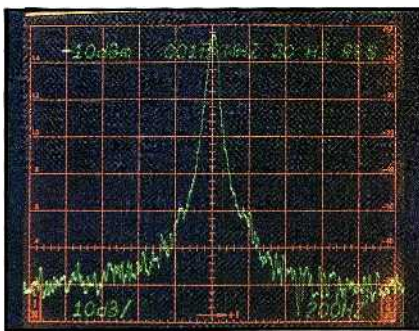

patched around. Then, technicians dig out technical manuals, remove the inspection panels, hook up test equipment and begin the troubleshooting process.

Effective troubleshooting techniques stress the value of an organized attack. Begin with the most general location of a suspected assembly, and follow a tightening spiral of tests until the offending component is identified. Don't overlook the obvious. You probably have your own story, which you'd rather forget, about the time you spent hours trying to fix a piece of equipment that wasn't broken.

In a larger sense, the term troubleshooting also defines a set of values. A systems engineer must be conscious of the shifting forces at work within the broadcast field. Every piece of equipment in use today eventually will break down or become obsolete. This means that no design will be totally complete. You must always allow for changes. A predisposition to think about troubleshooting within the context of change in the physical plant will improve the serviceability of any technical system.

### Put it on paper

Yes, here we go again. Document what you do. If you regularly read **BE**, you've heard this chorus before, but consider again the importance of documentation to the proper operation and maintenance of your plant. A well-marked-up schematic with a few pages of clear, concise notes (preferably typed) can do wonders when that particular piece of equipment fails or modifications to the system are planned. Likewise, an accurate and up-to-date numbering system with cross-references for all wiring in the facility pays for itself every time a change is made in the operation. If you've ever attempted to rely on your memory for documentation of a circuit modification, you know that paper offers a much more dependable method of information storage.

From the standpoint of troubleshooting, good record keeping begins with the organization of all manuals that deal with the installation, operation and maintenance of technical equipment. Extra copies of appropriate handbooks should

be ordered with the new equipment. Extra sales brochures are helpful too.

Create a file for each piece of equipment at the facility. Each new piece of equipment purchased should undergo a series of incoming inspection tests to establish a *baseline* of performance. Include in the equipment files copies of the purchase order and packing slip, just in case questions arise regarding the date of purchase, price, name of vendor or warranty repair work. Also include the date of installation, the installer's name and the results of all equipment tests.

Once the equipment is certified for installation, provide a set of "plain English" instructions for all potential users. This might be simply a photocopy of the operations section of the equipment manual. One successful approach is to create single-page "crib sheets" that are posted at each equipment grouping. These documents should include simplified operator instructions and block diagrams as appropriate. They should be typed and placed in plastic page protectors at convenient locations in the station equipment rooms. The information sheets should detail typical equipment settings and answer the questions most often asked by users.

These crib sheets help prevent false alarms and cut down on the number of equipment trouble reports caused by operator error. The result is a savings of money and time for the maintenance department.

Training sessions can help to bridge the gap between production and engineering personnel. These two groups do not always speak the same language (probably the understatement of the year). Improved communication will result in reduced friction, fewer equipment malfunction "false alarms" and better reporting of problems that do occur.

Detailed documentation pays off for the maintenance department because technicians know where to find important information quickly and can use it to repair or patch around a problem. That means fewer headaches for maintenance personnel and a better on-air presentation for the station.

Kaufhold is an independent consultant based in Tempe, AZ.

**ON THE HEELS OF THE  
CURRENT BUDGET CRUNCH,  
JVC VALUE HELPS POLISH  
YOUR IMAGE WITHOUT  
SELLING YOUR SOLE.**



**JVC<sup>®</sup>**

**ALWAYS A STEP AHEAD...  
TO KEEP YOU A STEP AHEAD.**

Circle (12) on Reply Card

# Management for engineers

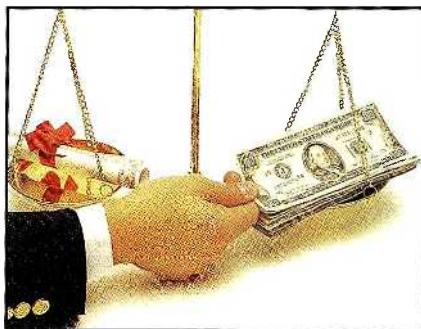

## Time management

By Brad Dick, radio technical editor

Chris was on his way out the front door when the receptionist said the program director wanted him—*now*. It seemed that the main 3/4-inch deck wouldn't hold sync or, as the program director put it, wouldn't "lock up as usual." Chris had spent several hours performing a complete PM on the deck only three days ago. Now it was causing problems during an important production session.

It took only a couple of minutes for Chris to get the stubborn deck working again. Even so, before he could complete the work, the station manager paged him. When Chris returned the call, he was reminded that his budget for FY90 was due yesterday, and the manager wanted to know when it would be ready. Chris was already working far more than 40 hours a week. All he needed was to be reminded that he was late with yet another task.

He left the studio, returned to his office, and began looking in the stack of papers on his desk for the budget report form he was to complete. It took several minutes to find it. Just as he located the form, the phone rang. This time it was the tower crew. They needed access to the transmitter building to begin working on the tower light problem. Now Chris remembered where he had been going

when he got sidetracked to fix the VCR.

### The never-ending battle

Sound familiar? Chris is a good example of crisis management in operation. At no point in the scenario described is he in control of his destiny. He is always responding to someone else's needs.

The underlying cause of crisis management is often a lack of time management. Although you cannot predict every event, especially in broadcasting, you cannot be an effective manager without adequate planning and time management. The primary advantage of proper time management is that it puts you back in control. You call the shots. It also increases your productivity. In short, using good time-management techniques can help break the nerve-racking cycle of crisis management.

### The costs

Let's suppose that you are wasting one hour a day. Think carefully before you deny wasting that much time. One management consultant estimates that 20% to 40% of an employee's time is lost through poor planning and execution. If that's true, then the estimate of one wasted hour may be conservative.

That hour per day translates to five

wasted hours per week and 250 wasted hours per year. If you're paid \$15 an hour, you have just cost your company \$3,750. This represents time for which you were paid, and you produced nothing. Not many engineers would want to list that expense on the budget sheet.

The simplistic solution is to plan your activities. Such a process is far more complex than it seems, but effective time-management techniques can be used by everyone, and they don't cost much.

### Time audit

The first step to effective time management is to identify how you are spending your time. For this, you need to conduct a *time audit*, in which you document all your activities during a certain time frame. The audit should be maintained for at least three days and, preferably, an entire week. Figure 1 shows a typical time-audit log with several sample entries. It can be modified as necessary for your needs. The important thing is to be thorough and accurate. If you find yourself taking 22 minutes for a cup of coffee, list it. Don't log it as "thinking time" or some other activity. Only you will see the log, so be brutally honest.

Try to pick a week in which your activities are typical, but don't put off conducting the audit because you are involved in a major project. In general, even during construction projects, engineers tend to conduct themselves according to their standard schedules.

People usually are quite surprised by the results of their time audits. They often find that they spend much less time on important activities that could make them successful than they do on tasks that are "fun" or could be delegated to someone else. Perform the time audit this month. Next month, tabulate the results, and use them to develop priorities. If you can regain control of your time, you can be in control of your job.

TIME AUDIT				
Start	End	Total	Activity (who, what, why)	Category
9:00	9:04	:04	Pick up mail, coffee.	
9:04	9:15	:11	Read mail, interrupted by Joe - question on remote	
9:15	9:35	:20	Call from Tim to repair tape #1 in studio B	
9:35	9:51	:16	Begin working on FY '90 budget	
9:51	9:54	:03	Phone call, Acme transformer	
9:54	10:13	:19	Worked on FY '90 budget	

Figure 1. Create a time-audit form for yourself, and complete it as honestly and thoroughly as you can. The results may surprise you.

Editor's note: If you would like to have your time-audit results compared with those of other engineers, send a copy (anonymously, of course) to: Technical Editor, Broadcast Engineering.

!:-:)))

# NEW FROM ARRAKIS SYSTEMS

## 5000 SERIES

The First No-Compromise  
Modular Radio Console...



...At A Down-To-Earth Price: 16 Channels, Under \$10,000.

#### THE FEATURES YOU WANT —

- 16 Modular Stereo Channels.
- Program, Audition and Mono Mixdown Balanced Outputs.
- Telephone Mix-Minus Buss.
- Full Monitoring Facilities.
- Remote Equipment Start/Stop.
- Remote Module Control.
- Standard Digital Clock and Timer.
- Optional EQ and Effects Modules.

#### THE DEPENDABILITY YOU NEED —

- DC Controlled — No Audio On Pots.
- Rugged Modular Construction.
- Penny & Giles Slide Faders.
- ITT Schadow Switches.
- NE5532 IC Module Design.
- External Regulated Power Supply.
- Superb Audio Performance Specs.
- Most Important, Arrakis Systems Designed-in Ultra Reliability!

For features, performance, price and reliability,

**NOBODY BUILDS CONSOLES LIKE ARRAKIS.**

Call (303) 224-2248

Circle (13) on Reply Card

ARRAKIS SYSTEMS INC. 2609 RIVERBEND COURT FORT COLLINS, CO 80525



By Jerry Whitaker, editorial director

# State of the industry special report

**Technology moves at a rapid pace.  
It can sometimes be a wild ride.**



**D**ecember is a good time to reflect on what the last year has seen and what next year will bring. We would like to tell you that the future course of radio and TV broadcasting is clear and free of hidden icebergs. We would like to say that, but we can't.

The business of broadcasting during 1987, viewed now in retrospect, forms a complex web of paradoxes. First on most readers' minds is that many broadcast stations are being run by investment bankers and other "undesirables." However, this has not always been bad. Frankly, our business could probably use a

good dose of Wall Street insight and bottom-line orientation. For a long time, many broadcast operations have been run more like hobbies than businesses.

Before you write me to report your personal horror story regarding station trafficking, let me emphasize that much of what has gone down during the past year or so has not been good for the industry or the individuals who make their livings by it. But this is the reality we currently face, and we will have to deal with the situation, like it or not.

Philosophy aside, the broadcast business overall appears to be on the

upswing, or at least everybody is hoping so. This issue contains an in-depth look at the health of the industry in a series of reports. We will examine where we are and what the future holds in the following articles:

- **"Who's Spending What"** ..... page 26  
The results of our annual survey of radio and TV station buying plans for next year. See what your peers are planning to do in 1988.
- **"View From the Top"** ..... 40  
Interviews with the top engineering chiefs of ABC, CBS and NBC. As



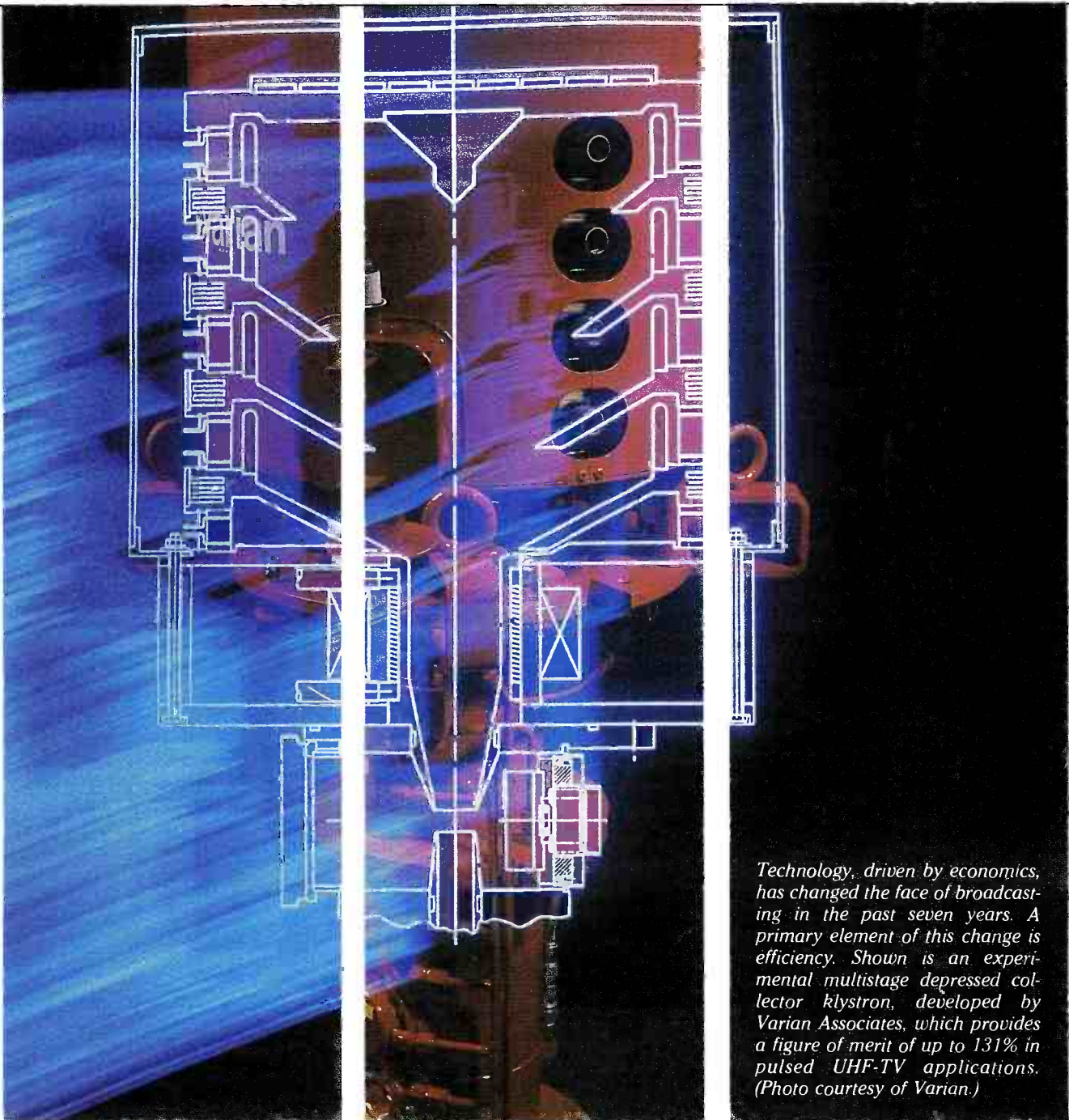

*Technology, driven by economics, has changed the face of broadcasting in the past seven years. A primary element of this change is efficiency. Shown is an experimental multistage depressed collector klystron, developed by Varian Associates, which provides a figure of merit of up to 131% in pulsed UHF-TV applications. (Photo courtesy of Varian.)*

the networks go, so goes the nation.

- **“The State of TV News”** ..... 54  
News departments have been the recipients of much of the technological developments of the last 10 years. But economic realities are beginning to cramp the style of many news operations.
- **“Manufacturing Technology”** ..... 59  
To a great extent, what the broadcast industry can buy depends on the ingenuity of manufacturers. But, today, product innovation in itself is not enough. Productivity and quality

control also are key elements.

- **“Broadcasting’s Bottom Line”** ..... 62  
The lifeblood of our industry is advertising. If the sales department doesn’t sell it, then engineering can’t spend it.
- **“Digital Amplitude Modulation”** ..... 66  
The science of generating higher-power AM radio signals is well-advanced. Most new work will involve the use of improved modulation methods that can be applied to TV broadcasting.

- **“Hot Switches and Combiners”** ..... 82

Equipment reliability is the bedrock of broadcasting. New approaches to RF switching offer alternatives to conventional backup arrangements.

Successful broadcasters today and tomorrow will be those with the vision to see the future and the insight to know their market. Good luck.

*Jerry Whitaker*

Jerry Whitaker,  
editorial director

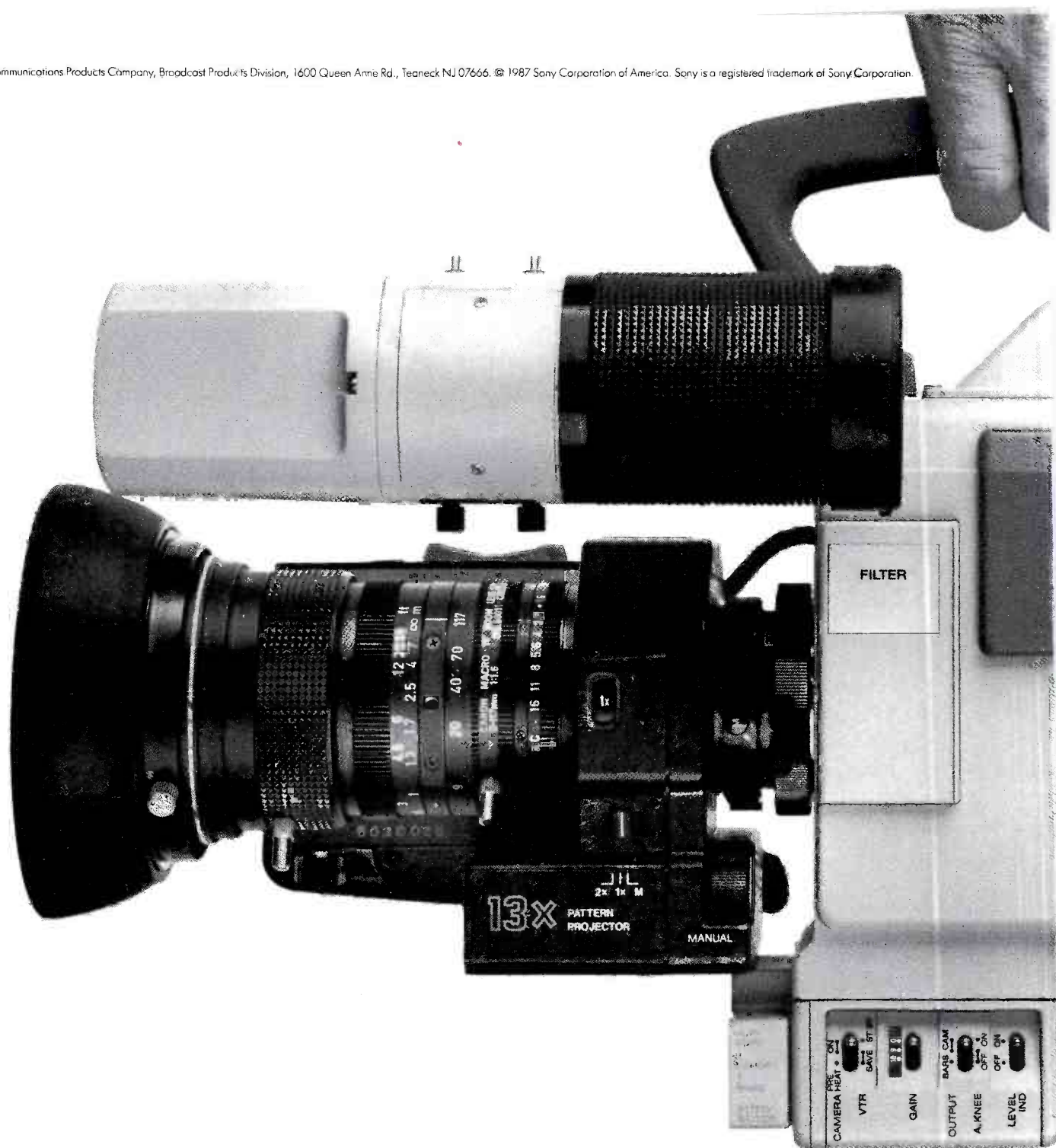

# The hardest soft

You're looking at an EFP camera with a split personality: the new, top-of-the-line Sony BVP-350.

It's the first portable with true "Hard" camera performance. Because it has F1.2 optics, a 60dB S/N ratio, and digital zonal registration. Yet it's so light, so balanced, so thoughtfully designed, that it's a superb "Soft" camera too.

The viewfinder rotates 360 degrees and adjusts up, down and sideways—so you don't have to. And its unique "peekaboo" handle means that no matter how you shoulder it, there's no blind side.



# camera ever.



But what makes it even more remarkable is that it's a perfectly matched companion to the Sony BVP-360. Using the same breakthrough FET and Mixed-Field tube technology. Even the same circuit boards. And that shows up as the best picture performance in history.

For a good, hard look at the world's most advanced "Soft" camera, contact your Sony Broadcast representative. Or call Sony at 1-800-635-SONY.

**SONY**<sup>®</sup>

Broadcast Products

Circle (14) on Reply Card

By Brad Dick, radio technical editor

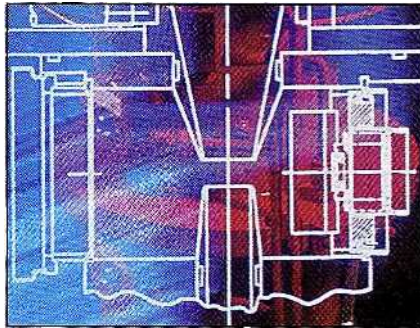

# Who's spending what

Hang on to your seats.  
It may be a rough ride.

You've stood in line for what seems like forever to ride the roller coaster. You can't wait to ride it. But when the lap-bar drops over your legs, you change your mind. You panic. How did you ever let yourself get into this situation?

Broadcast engineers and technical managers may be experiencing a similar wave of anxiety as they look to 1988. This business should be fun and interesting. However, the pleasure—or pain—derived from it is almost completely dependent on the financial condition of the station. Few people want to work at a station that cannot adequately support the staff or the facilities. Although the next 12 months look smooth for radio expenditures, TV engineers appear to be heading for a roller-coaster ride.

This year's survey shows a weakened commitment on the part of TV stations to spend money for new equipment in 1988. This trend also is reflected in the many negative comments from survey respondents. They complain about the lack of innovation and planning within their stations. A common grievance is that television and radio are no longer run by broadcasters. According to the survey, the new bean-counter and bottom-line philosophy is hurting the industry and the public.

## Trends and conditions

The BE annual state of the industry survey is the second part of a 2-stage overview of trends and conditions in broadcasting. The

first part is the annual salary survey, which looks at the salaries and benefits received by management, engineering and operations personnel at radio and TV stations. The salary survey also tracks concerns expressed by the respondents. The results are published annually in October, making it one of the most sought-after issues of the year.

The second stage of the analysis is the annual state of the industry survey, which closely examines the projected purchasing plans for TV and radio stations. It also looks at industry concerns from the perspective of staff members working within these stations.

The survey was scientifically conducted by the marketing research department of Inter-tec Publishing, under the direction of Kate Smith. On Sept. 23, 1,895 questionnaires were mailed to BE recipients on an "nth name" basis. By Oct. 28, 667 questionnaires had been received, representing a 35.2% response rate. The data in this report is based on those responses.

## TV plans

Although the majority of TV respondents indicated plans to modernize or replace equipment, the number was lower than last year. In 1988, 81.5% of the TV stations plan to improve their facilities. This percentage of stations planning upgrades is the lowest it has been in three years.

In the top 50 markets, the number of TV stations planning equipment upgrades dropped from 90.4% to 80.6%, a reduction

of 11%. The number of stations planning equipment upgrades in the top 100 markets increased by 2% and decreased by 8% in the below top 100 markets. A look across all TV markets reflects a 7% reduction in the number of stations planning for new equipment. Projected spending by equipment category for TV stations is shown in Figure 1.

Some equipment categories show sizable cutbacks from last year's levels. For instance, planned spending for TV master-control equipment is down by approximately 21% across all markets. Planned spending for ENG systems shows similar reductions, ranging from 11% to 22%.

Offsetting these changes, however, is that a larger number of TV stations plan to purchase antenna systems. Even though antenna equipment is eighth in terms of preference ranking, the number of stations planning such purchases increased by 25% to 51%.

The No. 1 category of planned TV purchases is production equipment. This category has remained the top priority over the past three years. In 1986 and 1987, the No. 2 spending category was master-control equipment. This year, however, that equipment category fell to No. 3, and editing suites became the No. 2 category. In 1986 and 1987, the No. 3 category was editing suites. Relative spending by category is shown in Figure 2.

In the top 50 markets, 30.1% of the TV stations plan on redesigning their facilities. This is slightly higher than the 26.9% figure from

# Perfect Control

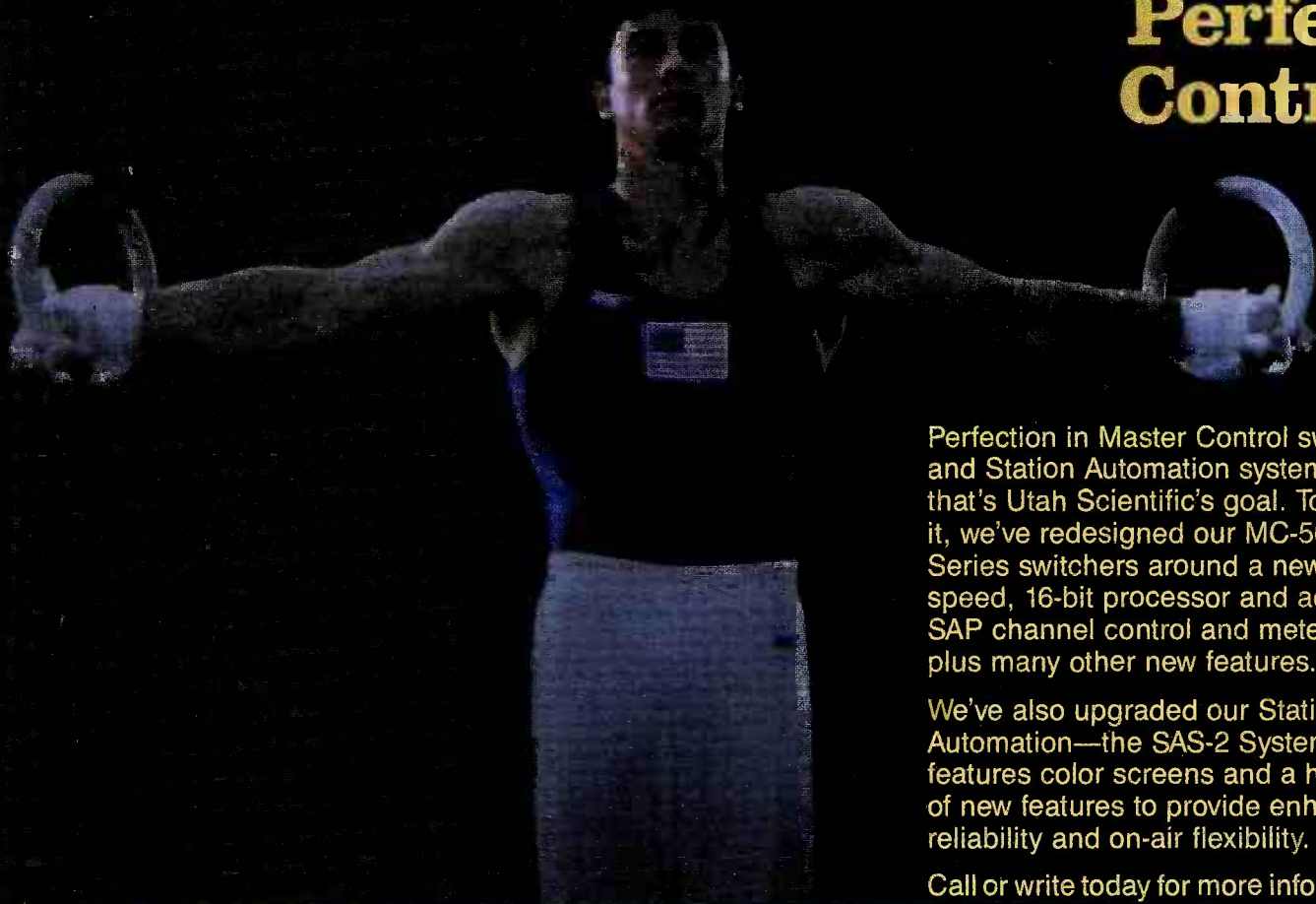

Perfection in Master Control switching and Station Automation systems—that's Utah Scientific's goal. To reach it, we've redesigned our MC-500 Series switchers around a new high-speed, 16-bit processor and added SAP channel control and metering, plus many other new features.

We've also upgraded our Station Automation—the SAS-2 System features color screens and a host of new features to provide enhanced reliability and on-air flexibility.

Call or write today for more information.



**US UTAH SCIENTIFIC, INC.**  
DYNATECH Broadcast Group

1685 West 2200 South, Salt Lake City, Utah 84119

(801) 973-6840 • Toll Free 1-800-453-8782 • TLX: 269-916 • FAX: 801-973-0255

Circle (15) on Reply Card

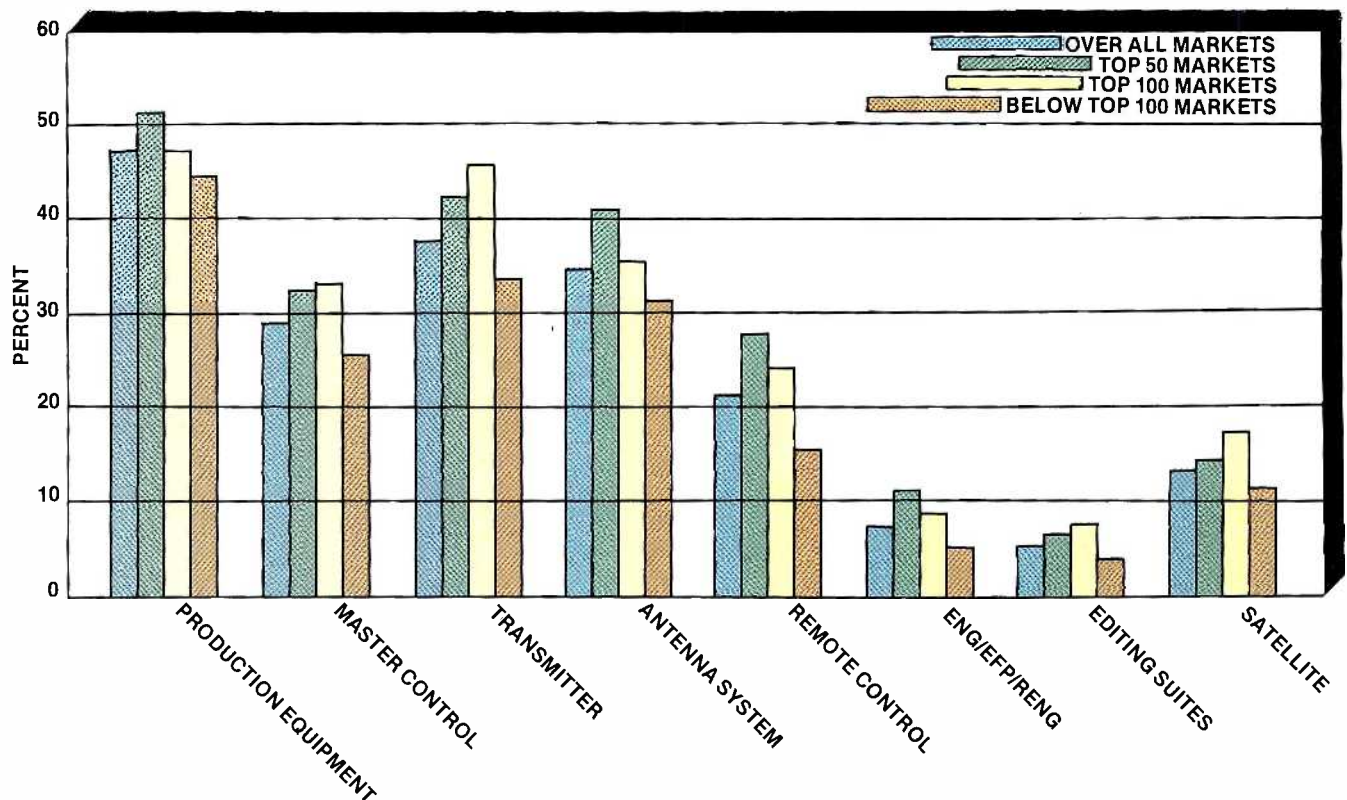

Figure 4. Relative spending plans of radio stations for 1988, broken down by equipment category and market size.

Conversely, over the past three years, the number of consultants used by TV stations has continued to climb. This increased use of consultants in television is accompanied by a decrease in staff size. It will be interesting to track this phenomenon over the next few years. Although staff-size changes can be tied to automation in television and other technology issues, the role of the consultant should not be overlooked.

### Conventions

One of the more exciting facets of the broadcast engineer's job is travel to conventions and seminars. Shows provide invaluable exposure and enlightenment and can rejuvenate a career.

Total convention attendance appears to be up. Although at least one exhibitor has estimated that only one-third of those who attend the NAB convention are broadcasters, the survey shows an across-the-board increase in the number of convention-goers, with the NAB being the primary convention for both radio and TV engineers.

Figure 8 summarizes how respondents plan to spend their convention dollars. The pie charts show the relative percentages of those planning to attend the listed shows. The survey indicates that although convention attendance should be up in 1988, NAB may capture a smaller portion of the convention market than last year. This is especially the case for the category of radio engineers, for which planned NAB convention attendance

is down 12%. Planned attendance at both the Radio '88 and AES conventions is up by approximately 3%.

The SBE national convention continues to show strong growth. Of those planning to attend conventions, more than 32% say they will go to the Denver show next September. Based on survey results, the SBE convention appears to be affecting NAB attendance. The SBE show is now the second most-attended show for radio engineers, while SMPTE continues to be the second most-attended show for TV engineers. For a show that is only two years old, the increase in planned attendance to the SBE national convention is quite dramatic.

### Insider views

One of the most enlightening aspects of the survey process is the commentary that accompanies the responses. This year's survey asked respondents to comment on what they thought was the most important issue facing the broadcast industry. That question hit some hot buttons. Three common concerns were expressed repeatedly in the 1,000-plus responses.

The issue most often lamented might be described as a lack of concern for the quality of the product. This seemed to be a source of worry for both the radio and TV survey respondents.

Today's technical managers and operators see the recent selling of broadcast properties as a step backward for both the public and

the industry. As these respondents see it, the singular concern for making a profit has reduced product quality, forced qualified engineers to leave the field and limited the use of high-technology (quality) equipment.

New owners were severely chastised for a bottom-line approach to decision-making. Respondents related stories of stations being sold time and time again, with each transaction increasing the debt burden and reducing station resources.

One respondent asked, "Can the industry maintain its tradition of public service, technical innovation and production creativity while adjusting to the new economic climate in which short-term profit overrides all other considerations?" Another said, "... the industry is being torn apart by the attitudes of new owners (who) take over stations solely for financial reasons and have little interest in broadcasting."

The concern of radio and TV broadcasters about station trafficking transcends all markets. Comments such as, "Non-broadcast ownership is hurting our industry," were typical. Even the operators seem to recognize the importance of having long-term, broadcast-related owners. A common theme was the unwillingness of management to make decisions in the best long-term interests of the station.

A surprising number of respondents also chided new owners for a lack of management skills. They indicated a desire to work for

*Continued on page 36*



# EIMAC cavities cover 54 to 970 MHz at power levels to 30 kW —our design or yours

Varian EIMAC has complete cavity design and production capability. We make sure that tube and cavity are compatible. If it isn't an off-the-shelf-item, we have the designers and engineers for any specific job.

EIMAC has expertise in all disciplines including pulse, CW, FM, and TV. We match tube, power,

bandwidth and operating mode to achieve optimum performance.

More information on EIMAC cavities and tubes is available in our Cavity Capability brochure from Varian EIMAC. Or for prompt consideration of your special design requirements, contact Product Manager, Var-

ian EIMAC, or the nearest Varian Electron Device Group sales office. Call or write today.

Electron Device Group  
Varian EIMAC  
301 Industrial Way  
San Carlos, California 94070  
415-592-1221

Varian A.G.  
Steinhauserstrasse  
CH-6300 Zug, Switzerland  
Tel: (042) 23 25 75  
Telex: 78 841

EIMAC Cavity	Matching EIMAC Tube	Tuning Range (MHz)	Power Output
CV-2200	4CX20,000A	86-108	30 kW
CV-2220	3CX1500A7	86-108	1.5 kW
CV-2225	4CX3500A	86-108	5 kW
CV-2240	3CX10,000U7	54-88	10 kW†
CV-2250	3CX10,000U7	170-227	10 kW†
CV-2400	8874	420-450	300/1250 W*
CV-2800	3CX400U7	850-970	225 W
CV-2810	3CX400U7	910-970	190 W

\* pulsed power

† peak sync, or 2.5 kW combined in translator service



varian

Circle (19) on Reply Card

# **MII. ONE SIZE FITS ALL.**





At JVC, we know what it's like to be in your shoes. Every day you have to tap dance between a barrage of equipment and format changes.

Fortunately, MII can make your job a whole lot easier. It's the first truly universal format that answers the needs of people in the field, in the studio and in production — while delivering broadcast quality results. And MII delivers these results in half the space and with less than half the weight of 1" C systems.

As you might expect, our new MII component video recording systems more than live up to the JVC reputation for value. In fact, to pack any more value or features into our economical MII units would probably take a shoehorn.

For example, you'll find features to choose from like four audio tracks, a time base corrector, an integral longitudinal and vertical time code, time/date generator with presettable user bits, automatic backspace editing and Dolby-C noise reduction...to name just a few.

## **FINALLY! THE UNIVERSAL FORMAT THAT TAKES YOU FROM ACTION, TO EDITING, TO OVER-THE-AIR WITHOUT MISSING A STEP.**



Plus, by combining the CTCM (Chrome Time-Compressed Multiplex) recording system with high-density metal particle tape, JVC's MII format can deliver up to 90 minutes of broadcast quality recording/playback time in VHS-sized 1/2" cassettes. All without worrying about format switches or losing quality during editing — even several generations down the line.

Most importantly, *only* JVC gives you a choice. This means you can select a less sophisticated MII system, say for ENG/EFP, and a more advanced MII system for studio work. Also, since each unit is completely compatible with each other, you can virtually build your own system, feature for feature. And upgrade at any time.



JVC's MII. The affordable, universal format you've been waiting for.

For literature or demonstration, call toll free: 1-800-JVC-5825.

JVC Professional Products Company,  
41 Slater Drive, Elmwood Park, NJ 07407.

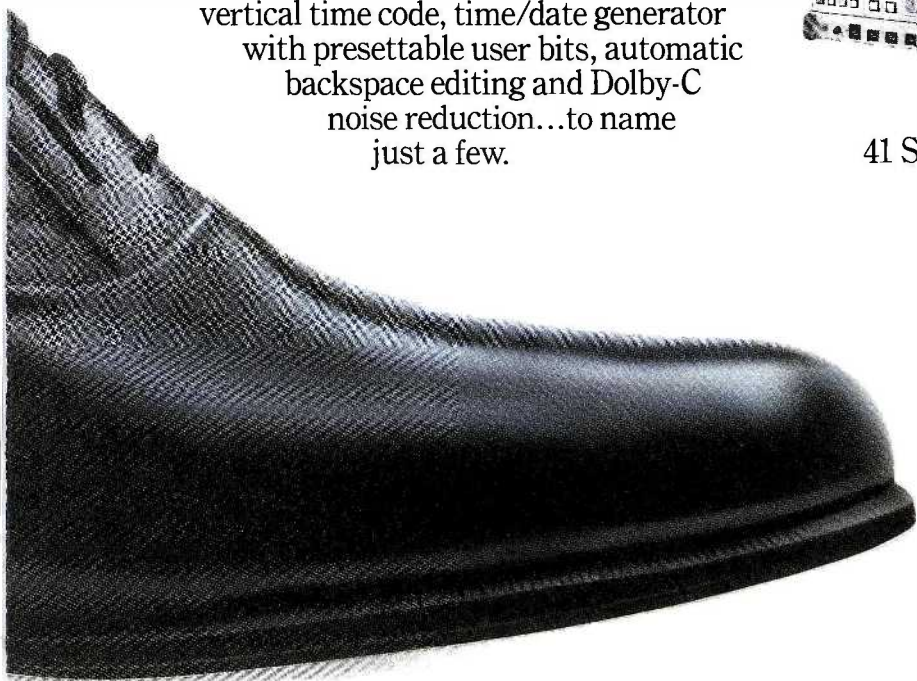

# **JVC®**

**ALWAYS A STEP AHEAD...  
TO KEEP YOU A STEP AHEAD.**

Circle (20) on Reply Card

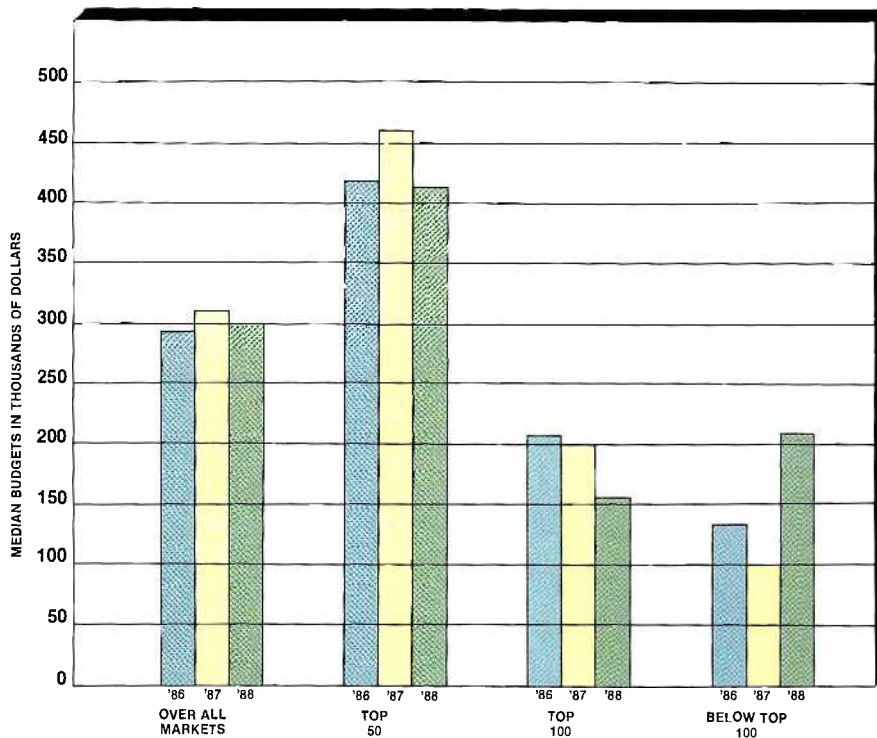

Figure 5. TV station equipment budgets for 1986, 1987 and 1988.

Continued from page 32  
managers who understand broadcasting and its technological implications, as well as how to manage people and resources. The comments reflected a genuine interest in working for managers who can make, for lack of a better term, "intelligent" decisions.

#### On the subject of AM

The second most-mentioned area of concern was the sad state of affairs in the AM industry. Of course, the FCC took it on the chin for not adopting an AM stereo system. Although some respondents suggested a particular standard, the majority indicated that they didn't care what system was selected as long as one was chosen.

For every couple of statements calling for AM transmission standards, there was at least one calling for better receivers. For years, engineers have recognized the AM receiver as the limiting factor in reception. They now are calling for improvement in receivers as a critical element in the salvation of AM radio.

#### Getting the right people

Following trafficking and AM problems, the third most-mentioned issue was obtaining and retaining qualified technical staffs. Many respondents asked where trained people could be found. These comments closely

# New "CHARGER" from PACO

**Simplifies recharging of Ni-Cad Batteries with Built-in Discharger, that eliminates memory.**

**INTRODUCING the PACO KD 120 A "DEMEMORIZER" EASY, FAST and EFFICIENT!**

4 Batteries at a time  
PACO DP-11, (Sony NP-1)  
OR  
PACO DP-1240, (Sony BP-90)

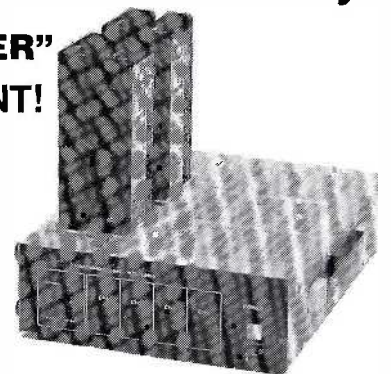
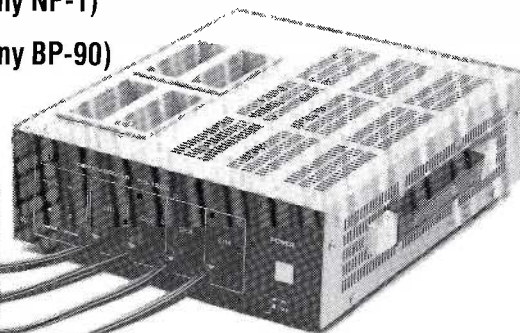
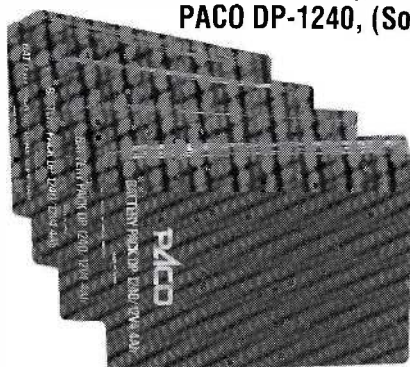

Tel: 213-617-9323  
FAX: 213-687-3524  
TLX: 756923

**PACO ELECTRONICS U.S.A., INC.**

World Trade Center  
350 So. FIGUEROA St. (Suite 364) LOS ANGELES, CA 90071

Operation without switching to AC 100V~240V 50/60Hz

Circle (21) on Reply Card



## There can be no compromise!

Tour the premier recording studios of the world — from London to New York to L.A. — and you'll find they have one thing in common: "no compromise" recorders from Studer of Switzerland.

Sure, their Studer multitrack mastering decks are a big investment, but you can make an equally sound choice for your production needs for a whole lot less. You can own a two-track production recorder with the same Studer heritage — a machine that has many of the same production features, the same uncompromising audio performance and the same level of manufacturing perfection that has made Studer Revox recorders the world standard — THE REVOX PR99 MKII is the machine!

Like its "big brothers" in the top studios, the PR99 MKII is a professional machine built for long-term perfor-

mance. From the solid diecast aluminum transport chassis and head block to the servo capstan motor and the modular electronics, everything is milled, drilled and mounted with Swiss precision. The parts fit together right — and stay there.

The PR99's professional features are perfect for efficient, accurate tape production:

- RealTime counter that reads both plus and minus hours, minutes and seconds;
- True Auto Locator allows precise, automatic search-and-cue to any preselected address point;
- Zero Locate to return the tape to the zero counter location — EXACTLY!
- Auto Repeat to continuously replay a tape segment of any length.

Plus: • Built-in, front-panel variable speed; • Self-Sync; • Input and output mode switching; • Edit mode switch; • Tape dump; • Calibrated and Uncali-



PR99 MKII Real Time Counter and Autolocator.

brated "+4" balanced and floating inputs and outputs; • 10½" reel capacity.

As for sound quality, the Studer heritage again allows no compromise. We think you'll find the Revox PR99 MKII to be sonically superior to anything in its price range. Audition the Revox PR99 MKII at your Studer Revox Professional Products Dealer, or contact: Studer Revox America, Inc., 1425 Elm Hill Pike, Nashville, TN 37210; (615)254-5651.

**STUDER REVOX**

Circle (22) on Reply Card

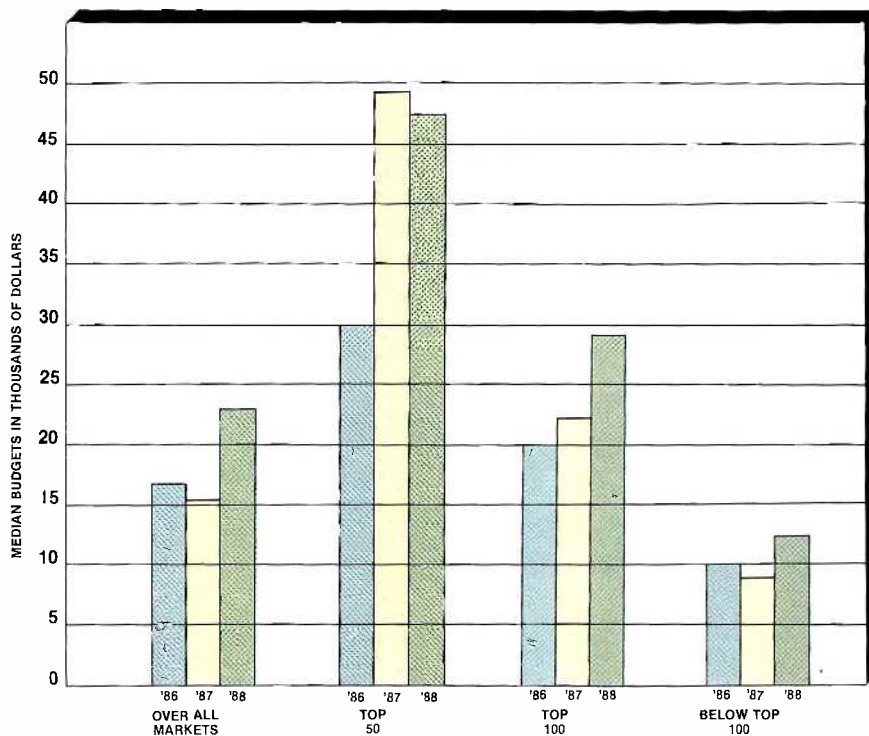

Figure 6. Radio station equipment budgets for 1986, 1987 and 1988.

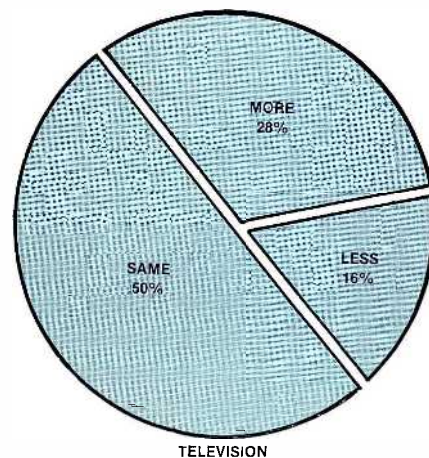
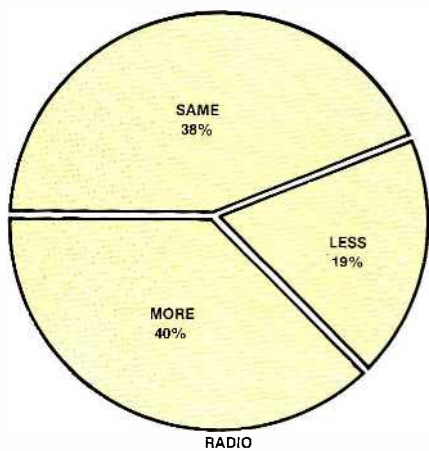

Figure 7. How stations see their budgets for 1988, compared with 1987.

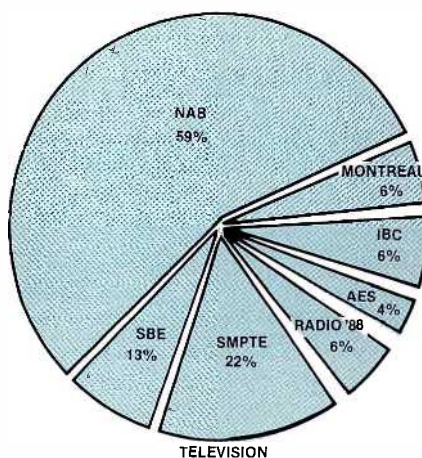
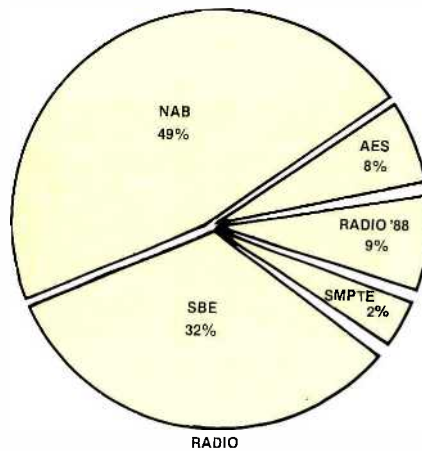

Figure 8. Convention attendance plans for radio and TV engineers.

paralleled those expressed in the salary survey.

A move seems to be underfoot to replace full-time employees with part-time employees. Comments from all segments indicated that this trend was creating problems for the workers as well as undermining product quality.

The comments might be summarized by the question, "Why should anyone enter broadcasting when they can work better hours for more money in other areas?" One of the most chilling comments was, "... broadcasters are no longer employers of choice; they are employers of near last resort."

The problem of obtaining qualified personnel is not a new one. Other industries used to help by training technical people, who then moved into broadcasting. Nowadays, the opposite is true. After employees obtain a minimum level of experience at a station, they often move into better-paying, less stressful jobs.

The need for proper training is an important issue and was stated in many ways by the respondents.

### The future

Despite the negative elements revealed by the survey, broadcasting still is considered a fun business. If you ask why someone is in the business, the response is likely to be, "For the fun of it." However, management would do well to look beyond that attitude. As apparent from the salary survey, today's broadcast employees have many more options in terms of employment. The old glamour of broadcast engineering is gone for many of them. Engineers are now more willing than ever to seek employment elsewhere.

Production studios, cable systems and industrial video sites not only need technical personnel, but also offer similar benefits with fewer of the hassles associated with 24-hour-per-day commercial broadcasting. If the technological growth seen over the past 25 years in the broadcast industry is to continue, technical employees need to know they can play an important part in that development. After all, it's not the equipment that makes broadcasting successful—it's the people. Any manager who forgets that fact may live to regret it.

The future of broadcast, on the whole, still looks positive and exciting. Many survey TV respondents look forward to the future with HDTV and the challenges it offers. Radio engineers speak of new bands and mention techniques that keep them excited about their jobs. How about you? Would you trade your job for one outside of broadcasting? Maybe we'll ask that question next year.

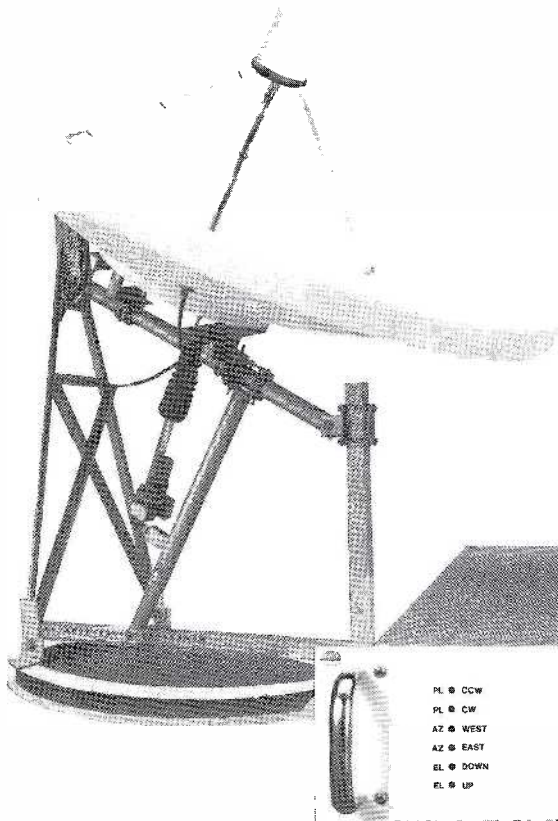

# MAPS

# 4

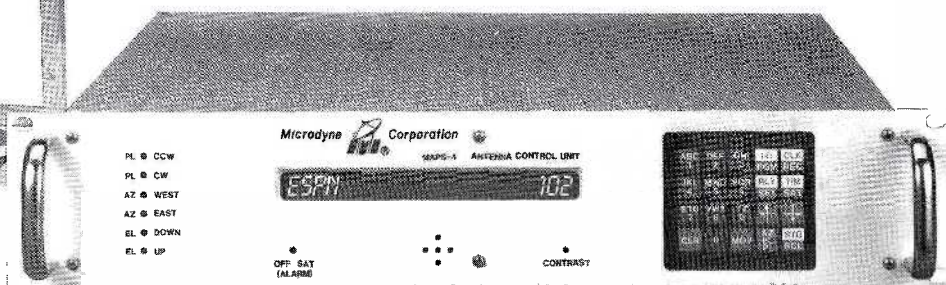

## The Only Antenna Positioner That Does The Whole Job.

The trouble with most satellite antenna positioners is that they only do half the job.

But our new MAPS 4 not only provides you with over 260 satellites and polarity presets for virtually unlimited programming access, it finishes the job that other systems only start.

### Exclusive automatic peaking

The MAPS 4 not only drives the antenna to the correct position, our exclusive auto-peaking fine-tunes the alignment, so you are assured of optimum reception every time you reposition. Accuracy like this is only possible with the Microdyne MAPS 4. Once you've seen it work, you'll wonder how you ever got along without it.

There are other great features too, such as our non-volatile memory that protects you from power outages and interrupts, our remote control capability, and the alarm that lets you know about a problem with an audible tone as well as a warning light.

### Rock-solid performance and stability

Of course the MAPS 4 system includes the Microdyne/AFC reflectors known worldwide for their superior design and performance characteristics. Their rugged construction ensures the stability you need when the weather turns rough—times when lesser equipment shows its weakness.

The mounts are also fast. The MAPS 4 system scans the entire satellite arc in less than two minutes, putting any satellite

within your reach. The system is compatible with either C- or Ku-band satellites, and is available with either a polar or elevation-over-azimuth mount.

### Competitive price

The Microdyne MAPS 4 is the most advanced satellite antenna positioning system available, yet it is very affordable. Especially when you consider that you're getting the time-tested Microdyne name for quality and reliability. So, don't settle for a positioning system that does only half the job. Call us today at (904) 687-4633 and get one that does the whole job.



**Microdyne Corporation**

491 Oak Road • P.O. Box 7213  
Ocala, FL 32672 • TWX: 810-858-0307

Circle (23) on Reply Card

December 1987 **Broadcast Engineering** 39

By Jerry Whitaker, editorial director

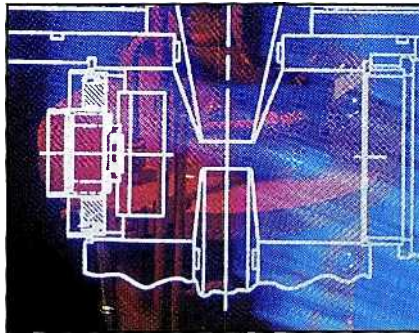

# View from the top

The “big three” networks set the pace  
for the rest of the broadcast industry.

The pinnacle of broadcast technology resides at ABC, CBS and NBC. The *big three* exercise enormous influence on the business of radio and TV broadcasting. They push technological advancements and pull the industry along on their coattails.

You certainly can find examples of bold technological moves on the part of group owners, cable outlets and local stations. However, year in and year out, the big three call the shots.

To get an overview of how those at the top see broadcast technology, I talked with the engineering chiefs of ABC, CBS and NBC. The interviews provide an interesting contrast of three men who wield far-reaching influence over the direction of professional audio and video technology.

The same basic questions were put to each of them. Their responses reflect some common ground as well as differing viewpoints.

**Julius Barnathan**  
**President, ABC Broadcast**  
**Operations and Engineering**

**Q: Do you think Beta SP and/or M-II are viable alternatives to 1-inch tape?**

**A:** No. They are viable alternatives in cer-



tain functions of 1-inch. They can be used for network record and network delay, things like that. They're fine for first generation, second generation, etc. But if you're going to

start doing what you do now in post-production, where you have 5, 6, 7, 8, 9, 10 generations, forget it. It's not in the same ball game. It is no way near it.

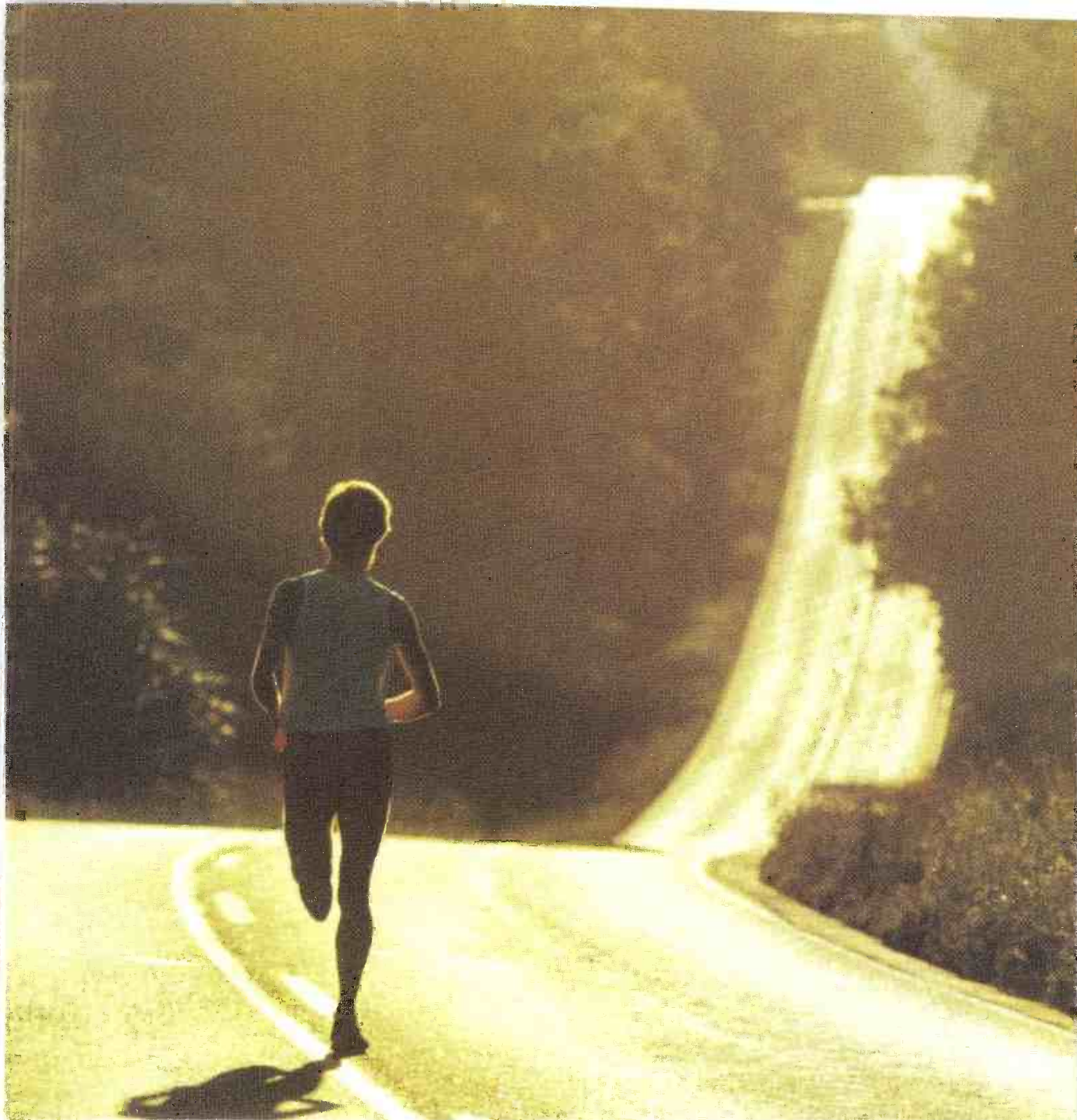

## Commitment.

To Ampex, it means millions of dollars committed to new Betacam manufacturing facilities around the world.

It means millions committed to research and development for unique, new Betacam products.

And it means millions committed to customer support for all Betacam and Betacam SP\* products, *regardless of the manufacturer.*

Ampex. Committed to Betacam.

**AMPEX**  
**We're committed to Betacam.**

Circle (24) on Reply Card

©Ampex 1987 \*Betacam and Betacam SP are registered trademarks of Sony Corporation.

# Good Reasons To Call RTS When You Need A High-Performance Amplifier System.

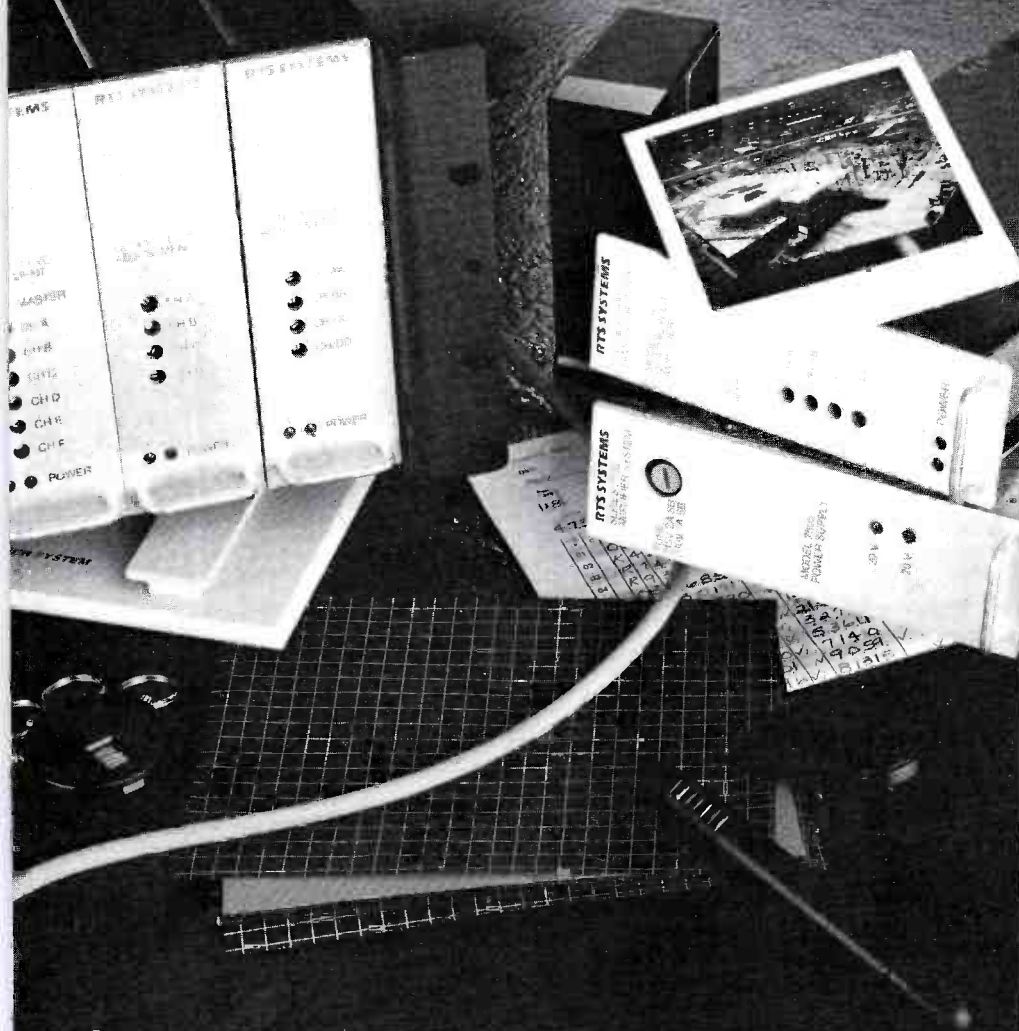

Our Series 2500 Amplifier System affords a broad range of amplifiers with top-rated specifications that sound great! For example, distribution amplifiers, line drivers, buffer amps, VCA circuits, and microphone preamps. Special products include a mix-minus matrix, summing switcher, multiple relays, and more.

We think you'll agree with our sound reasoning. Please call or write for detailed literature.

PROFESSIONAL INTERCOMMUNICATIONS • PROFESSIONAL AUDIO PRODUCTS

**RTS SYSTEMS**

INCORPORATED

1100 West Chestnut Street • Burbank, California 91506 • Telephone 818 840 7119 • Telex 194855 • Telefax 818 842 4921

Circle (28) on Reply Card

**Q: What are your thoughts about the D-2 composite digital format?**

A: We're very impressed with it. We have a brand new plant. In fact, it is not even finished yet. We've spent millions and millions of dollars. We're not about to go change it to a component system. It's going to be a composite system. Now, inside, there will be digital islands. The digital domain of composite digital offers a lot of the benefits of component digital. So, for tape machines, and a lot of different uses we have here, we believe it will be (particularly with multiple generations) a D-2 world.

There may be places, particularly in graphics, where we will use the purist

---

**“Stereo TV is kind of a chicken-and-egg question. We're going to be drawn into it whether we like it or not.”**

---

approach of full component digital. But that will be something different, where many generations and special effects manipulations are required. I think that's rare. Most of it will be composite digital.

**Q: Will D-2 be the replacement for 1-inch type C?**

A: I think that's very reasonable. Of course, a good reason is because D-2 uses a cassette, a very important factor for efficiency, as compared to the reel-to-reel.

**Q: What about tape cartridge machines?**

A: Well, we're buying Betacarts. We're also looking at the D-2 cartridge system very carefully. There's no such thing as the perfect system, but we're hoping that D-2 will come along and solve some of our problems in that area.

**Q: Where do you see component analog video in the network picture?**

A: Only in clean-rooms and setups where you want to do special projects, such as documentaries. Let's talk about documentaries. Say you want to do 20-20. You want to go out and shoot in 1/2-inch. You may want to continue to edit in component analog video. But, once we finish and go out into the world of today, it has to be composite.

**Q: Can you foresee building an entire plant around CAV technology?**

A: I don't know. I understand NBC is planning to do it. Why don't you ask them?

What about an entire plant in CAV? A lot of money, and for what? I don't see that much



# The News



# The News Tape

BC-20  
**AMPEX**  
BETACAM™ FOR USE  
**198**

PROFESSIONAL BROADCAST BETA VIDEOCASSETTE

Capturing the news is tough, and you need a video tape that gets the whole story. From location to air, the choice is Ampex 197, 198 and 199 Videocassettes. Built to provide the consistent performance you need to deliver the news.

With a rugged cassette mechanism made from the toughest ABS materials, so it stands up to the toughest handling.

**AMPEX**  
**199**

PROFESSIONAL BROADCAST VIDEOCASSETTE VHS

And a cassette shell molded from anti-static plastics to reduce static charge, so dust and debris stay in the field. Plus a unique labeling system that helps you find material fast. Because you don't have time for delays.

When you choose Ampex 197, 198 and 199 Videocassettes, you don't just get video tape. You get the news tape.

**AMPEX**  
**197**

U-matic

**AMPEX**

Ampex Corporation, Magnetic Tape Division, 401 Broadway, Redwood City, CA 94063, 415/367-3809.

Circle (91) on Reply Card

improvement. I mean, what are we doing here? What are we trying to prove? This is not the Second Coming, you remember.

I guarantee, if we had the Second Coming shot in 8mm and we got it, we'd run it.

**Q: In your opinion, how far have CCD cameras come?**

A: They are almost there, and they should be there very shortly. That's why we didn't go forward with any CCDs at this time. We felt that they were at least a year away. But, we think they're coming. For high-quality field operations, I think the CCD is a little way off.

**Q: Do you see a day when fiber-optic landlines will replace satellite distribution for networks?**

A: Yes. All incoming material, contributory stuff, should be on satellites and outgoing distribution should be by fiber optics or some other hard connection. Now, when? I think by the year 2000 we'll see this shift.

I see us using two more birds. We have a satellite now that's good until 1992. The next one will take us up to '99. At that time I think



---

**“...an entire plant in CAV? A lot of money, and for what? What are we trying to prove?”  
This is not the second coming....”**

---

that fiber optics will be attractive for distribution. Not for incoming feeds, because it's not practical.

The high cost that we had on terrestrial lines was not the network's contract service. It was always the *occasional circuits*. The phone company has had to keep facilities sitting in Lubbock, TX, for example, that might be used just three times a year.

**Q: What about plans for stereo TV?**

A: Stereo TV is kind of a chicken-and-egg question. We're going to be drawn into it whether we like it or not. We now have 8 hours of our 22 hours of programming done in stereo and broadcast that way. And I see that trend continuing.

A big problem was our old plant. It had just a single-channel audio switcher. The new router has capabilities for four audio channels.

Our West Coast operation handles stereo very well now. And we'll handle it well here, too. We're working on stereo and getting it done. We do it with great pain. It is similar to captioning. Today captioning is second nature. It's all over the place. We don't even think about it anymore.

**Joseph Flaherty  
Vice President and  
General Manager  
CBS Engineering  
and Development**

**Q: Do you see M-II or Betacam SP as a viable replacement for 1-inch type-C videotape?**

A: Well, we are now in the process of evaluating that. We haven't come to a conclusion. It certainly looks as if it is a viable proposition for commercials. A lot of this depends on the number of generations you are going to have. If it is a final release product, then it appears that is satisfactory. If it is part of the production process, you just can't make as many generations with the smaller formats as you can with 1-inch.

The digital machines are right on the heels of it. So, from a production viewpoint, the changeover will probably go from 1-inch to digital. But for broadcasting or distribution output, 1/2-inch appears to be a viable proposition. We are evaluating the concept at the present time.

**Q: Can you envision an entire TV plant being wired for component analog video? Is there that much performance improvement to be gained?**

A: Well, we did that in our new hard news center. The basic tape machines themselves are becoming inexpensive enough that we can do more dedication than we could in previous times. Not only are the machines less expensive initially, but they are also less

expensive to operate and they are more reliable. So, the concept of a central tape room through which every feed passes is going away.

I doubt that we would rewire our entire plant with any single system again. News at CBS has a completely stand-alone, isolated facility that is designed specifically to meet the needs of our news broadcasts. Program production has a separate area. Post-production consists of a series of stand-alone islands that are wired, right now, in composite and analog component. Here is where

---

**“The concept of a central tape room through which every feed passes is going away.”**

---

digital technology is pressing the hardest, because special effects machines are already digital component systems.

It appears, therefore, that the old-style plant with central switching facilities is disappearing in favor of a series of isolated islands dedicated to the job at hand. We are approaching it that way.

**Q: How good is CCD technology? How long until we see it in studio cameras?**

A: Well, I think the next generation of CCD devices will be studio quality. I think we've bought our last vacuum tube pickup device cameras. There are still problems with the CCDs in yield and resolution. There is a sharp

# TFT SUPERSONICS 8 OREGON SNAILS 0



## BTSC MODULATION MONITOR ALL-STAR GAME

At the top of the ninth, the game looks like a shut out victory for the team from Santa Clara, California.

If you're thinking about betting on The Boys From Beaverton, you may want to ask yourself why so many fans have already bought over 300 Model 850 BTSC Stereo Aural Modulation Monitors from TFT.

Contact the TFT team for all the details on the BTSC Stereo Monitoring game. We'll also send you the Rule Book—BTSC STEREO: TV Aural Proof-of-Performance Guide. Play Ball!

KEY PLAYS	THE TEAMS	
	TFT 850	TEK 751
1. Performs a complete Proof-of-Performance test (20 parameters from RF to composite).	YES	NO
2. Requires precision video demodulator.	NO	YES
3. Provision for built-in Distortion Analyzer.	YES	NO
4. Remote metering capability.	YES	NO
5. Easy-to-read, conventional meters.	YES	NO
6. Aural Modulation Monitor experience.	17 years	?
7. Price.	\$10,350.	\$26,900.*
8. Delivery.	2 weeks	10 weeks

\* Price based on available information 6/87. Includes 751 Monitor and required 1450-1 Demodulator. TEK, 751 and 1450-1 are trademarks of Tektronix, Inc.

### TFT INC

3090 Oakmead Village Drive  
P.O. Box 58088  
Santa Clara, California 95052-8088  
☎ (408) 727-7272  
TWX: 910-338-0584  
FAX: (408) 727-5942

Where New Things  
Are Happening!!!

Circle (26) on Reply Card

cutoff, after all, at whatever the element number is. There is a way to go, but we certainly see advantages to CCD systems.

There are so many controls and circuits that are removed altogether from the camera: all the scanning, registration, linearity, height and size circuitry, plus all the mass of controls that are adjusted by computer today. In CCD systems, those circuits just go away. The best way to increase the reliability of a system is to remove entire subsystems.

The life and ruggedness of CCD devices is a fantastic improvement, and it makes the

camera more of a foolproof, reliable device.

**Q: What do you see as the future for single camera/recorder units?**

A: Actually, there are no major problems. It is a compact unit. It is a big improvement because one of the weak links in the previous system was the cable and its associated connectors. People would trip over them, or the cable would fail because of damage or abuse. The all-in-one package affords a big improvement in reliability.

The cassettes are also smaller with the 1/2-

inch format. There is no end to the need for camera sensitivity. Turning on the lights is a difficult proposition in some news situations. We are still looking toward improved CCD units and higher sensitivity.

---

**"I think we've bought our last vacuum tube pickup device cameras."**

---

For soft news production, that is for documentary news programs, you want longer playing times. We would like to get up to an hour of playing time, and that will come as improvements in packing densities are realized.

**Q: What are your plans regarding stereo TV?**

A: As you know, stereo came late in the NTSC game, having been implemented a couple of years ago. Stereophonic broadcasts on relatively small screens do not provide very great speaker separation. The stereo effect is, likewise reduced. But it is moving ahead, and it does provide a new dimension. And it is being used.

There are, I think, some clouds on the horizon, however. We are just now implementing a stereophonic transmission system at a time when digital compact discs, and perhaps digital audiotape, are sweeping the consumer market. So, the consumer is becoming accustomed to digital sound. I don't think we can ignore that forever from the broadcasting side, including FM radio broadcasting.

---

**"It's not a problem of recording digital stereo audio, but the cost of decoding the signal."**

---

So, we have launched a new service that we see a need to supplement, if not replace, in the near future. Remember, many of the competitive systems are, or easily can be, digital if they wish, such as VCRs. It's not a problem of recording digital stereo audio, but the cost of decoding the signal. It is only a question of when a decoder is economically practical. Terrestrial broadcasting has to consider this fact.

Coming on the heels of digital stereo is high-definition television, where the large screen becomes practical. By that, I mean 3-foot to 5-foot-wide screens. At that point, wide stereophonic sound becomes achievable.

# ISLATRON®

## ...before the damage is done

An Islatron® power line conditioner safeguards both your income and your broadcast equipment investment. Its high-speed Active Tracking® Filter intercepts and attenuates unexpected high voltage spikes and transients that affect broadcast performance, cause failures and accelerate equipment deterioration. Your sensitive electronics are protected because Islatron® continually tracks, attenuates and clamps incoming spikes and transients, absorbing the destructive energy and filling short duration undershoots. The results? Prevention of catastrophic equipment failure and loss of air time. Emergency maintenance problems are minimized. Islatron® is designed specifically for AM/FM-TV Broadcasters to meet all your requirements, from low power studios to high power FM and UHF transmitters.

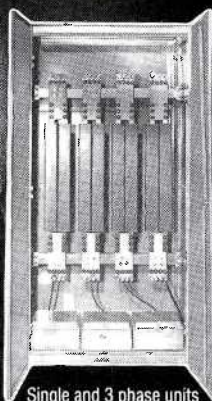

Single and 3 phase units through 1200A. Mean time between failure (MTBF) in excess of 100,000 hours, 5 year warranty.

...before the damage is done, call us or circle the reader service number. Control Concepts Corp., 328 Water Street, P.O. Box 1380, Binghamton, NY 13902-1380. Phone 1-607-724-2484.

See Islatron® in action NAB Booth 4159

**CONTROL  
CONCEPTS  
CORPORATION**

Circle (39) on Reply Card

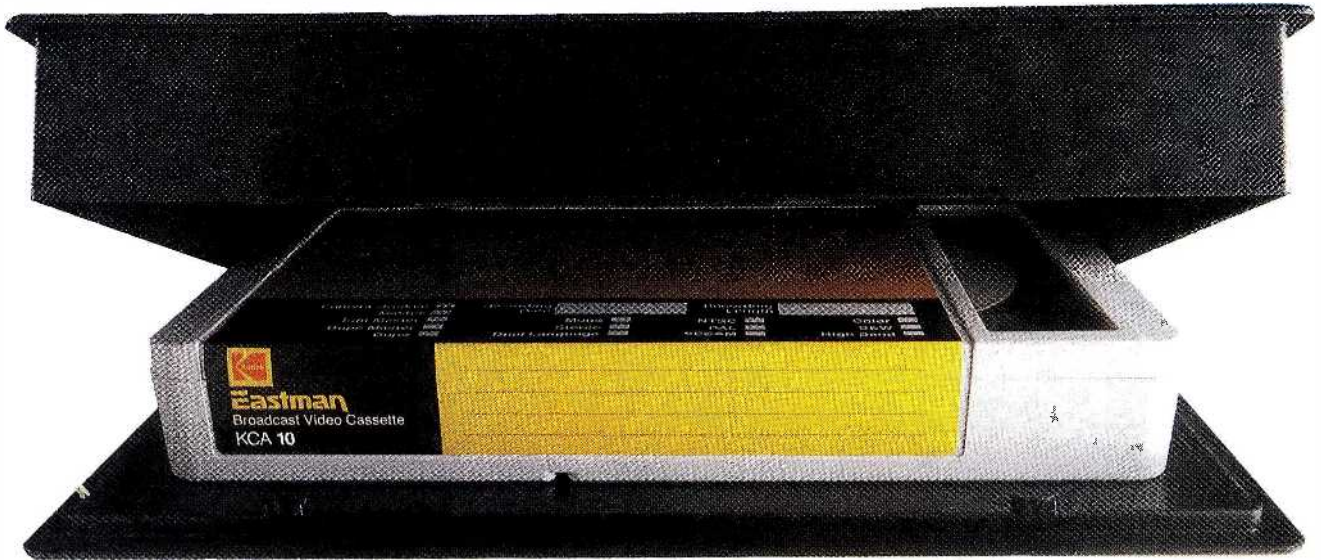

# No Surprises In This Package.

## New EASTMAN EB-950 Broadcast Video Cassettes.

You expect outstanding quality in EASTMAN Professional Video Tape Products. So it's no surprise that our new 3/4-inch video cassettes are made to the same uncompromising standards.

They are also designed to match the potential of sophisticated U-matic hardware. The dropout rate is typically only 3 per minute—even under heavy use. Color is sharp and clean; audio crisp and clear.

Physical characteristics are equally impressive. The surface is smooth and flexible, yet very tough. The result is reduced modulation noise and increased editing durability.

These and other advantages make our new video cassettes outstanding for ENG and EFP applications. Standard and mini U-matic cassettes are both available.

And, as with all EASTMAN Professional Video Tape Products, they're backed by in-depth engineering support as well as a firm commitment to a dependable supply.

For more information, call  
1 800 44KODAK  
(1 800 445-6325),  
Ext 850.

© Eastman Kodak Company, 1987



Circle (27) on Reply Card

**Eastman**  
Professional Video Tape Products



# For Excellence In Antennas

- A complete line of TV and FM Broadcast Antennas
- Modern 7,000 ft. test range facilities
- Innovative Engineering Careful construction
- Two Year Warranty on Product and Workmanship



With over 1500 delivered, we've helped more stations penetrate their market.

FCC Directionals  
 Pattern Studies  
 Multi-Station Arrays  
 Full Scale Measurement

**JAMPRO ANTENNAS, Inc.**  
 6939 Power Inn Road  
 Sacramento, CA 95828  
 (916) 383-1177    TELEX 377321

Circle (120) on Reply Card

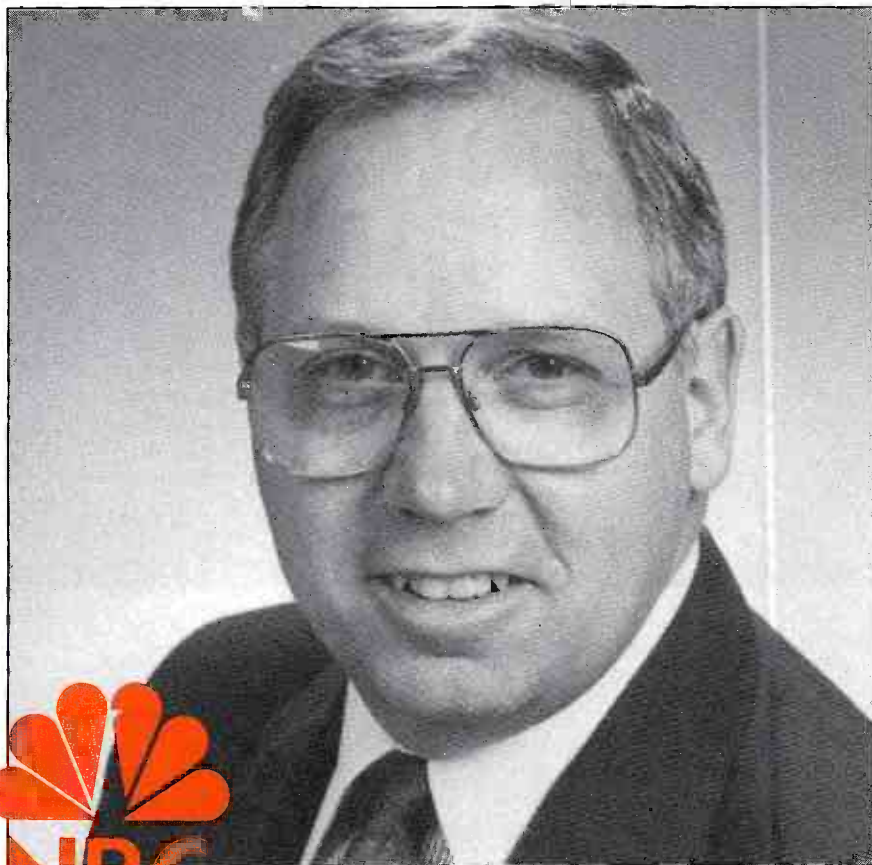

**Michael Sherlock**  
 Executive Vice President,  
 Operations and Technical  
 Services NBC-TV

with M-II.

**Q: What are your plans regarding automated spot playback for the network?**

A: We have some really sophisticated plans in this regard. We are working with Matsushita to develop a whole 1/2-inch library and spot playback system, and with other manufacturers, as a matter of fact. We call it the ARPS program, Automated Record and Playback System.

**"I would say that most of our product now is going out on the air in M-II."**

**Q: In what areas of operation do you feel M-II or Betacam-SP hardware is a viable replacement for 1-inch type C?**

A: We're using M-II in every area of operation, even post-production editing. However, in the very high-level post-production editing environment, we can see that component digital will be that much better.

Right now, all of our nighttime product is being delivered to us from the packagers in the M-II format. Right now, every piece of material that is broadcast in the Mountain and Pacific time zones is going out—if not live—on M-II.

I would say that most of our product now is going out on the air in M-II. We have converted most of our tape equipment to M-II.

**Q: Proponents of the D-2 digital composite format say it will be the ultimate replacement of type C. Do you agree?**

A: We see it certainly as an advance and my engineers tell me that it puts out an excellent product. Just right now, however, D-2 doesn't fit into our strategic plans because we're extremely satisfied—and think we've got, for the time being, the quality we need—

We clearly envision having, within the next year and a half, a robotic library that gets rid of all our TCR-100 machines and replaces them with brand new automated spot playback machines in the M-II format.

**Q: What are your thoughts on component analog video, and where does that fit into your plans in terms of inside-plant distribution?**

A: With all of our M-II gear, we're already  
*Continued on page 52*

**Announcing the Pro Series  
S-VHS video production  
system—by any standard  
of measurement in  
a class by itself.**

**Panasonic**





# The Panasonic Pro Series 400-line high-resolution video production system.

In this S-VHS System, dot interference has been completely eliminated. The luminance and chrominance signals are output separately. This gives S-VHS video signals extremely clear color gradations and truly brilliant colors. All this—without sacrificing upward compatibility with standard VHS.





# Improved Cost/Performance.

## Equipment:

Upgrade your system even as you cut your costs: lower equipment/operating costs. Higher 400-line resolution.

VCR FORMAT COMPARISON*			
Edit VCR	VHS	3/4	Pro Series
List Price \$	4,400	8,000	5,900
Max Rec Time (Min)	120	60	120
ENG Rec Time (Min)	120	20	120
Tape Cost \$	9	40 Studio 30 ENG	20
Resolution In Color Mode	240 +	260 +	400 +
S/N (In color mode)	45dB +	46dB +	47dB +

## System Simplification:

Typical 3/4" 2-hour playback system—costly, complicated components.

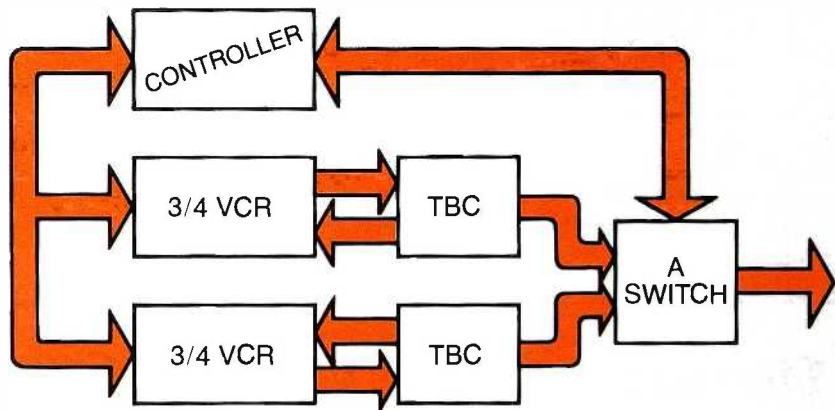

Panasonic Pro-Series S-VHS 2-hour playback system—requires no controller, only 1 TBC, only 1 VCR.

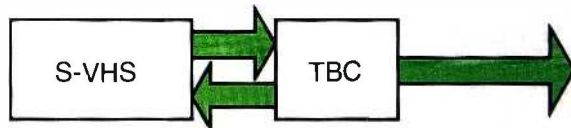

## Lower Tape Running Costs:

It takes six 3/4" 20-minute cassettes to equal the ENG recording time of one S-VHS cassette.

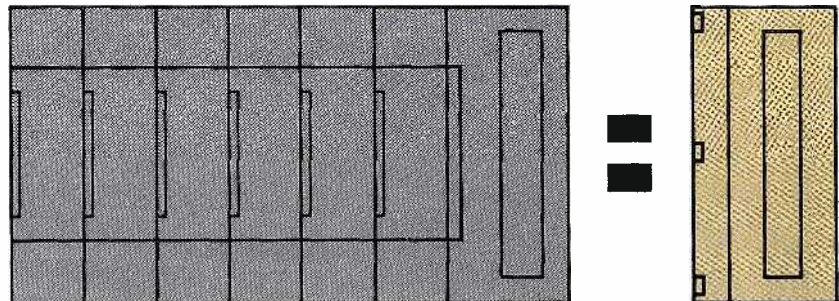

# Panasonic

Professional/Industrial Video

\*Based on Panasonic Edit Machines

Call Panasonic Industrial Company at 1-800-553-7222 for more information and the name of your nearest Panasonic Professional/Industrial Video Dealer.

Circle (30) on Reply Card

Continued from page 48

in component analog in individual pieces of equipment. We believe that by learning to deal with components now, we'll be that much better off when component digital comes, which will be the ultimate. All we're waiting for now is for the price of component digital to come down to match component analog. That may take some time.

**Q: Can you see an entire plant wired for component analog video?**

A: I can envision an entire plant wired for component digital. I think a step in getting there is wiring pieces of it in component analog. I don't think any of us are thinking that component analog is the end, so I wouldn't rewire the whole plant just for that. I would need the strategic goal of getting to component digital.

**Q: What is your assessment of CCD technology? How good is it?**

A: We love it. We absolutely love it. It is easier to maintain. It ends up giving a better product, a more stable product, and our engineers look forward to studio cameras becoming CCD.

**Q: How have single-camera recorder units, such as M-II, impacted produc-**

**tivity, efficiency and staffing at NBC?**

A: There's a real simple answer. It has allowed us to cut down by one person on a crew. We used to need a person carrying the camera and another person carrying the recorder. Now it's just totally unnecessary.

Because the tape cassette is so much smaller, the camera itself is lighter. It has allowed us to be much more mobile and quick and, therefore, productive.

The new M-II tape machines, when we get them in the building, are easier to handle. They take less space. We used M-II extensively during the recent strike, and it was simple to teach the non-technical people how to work that equipment. And it performed just beautifully.

**Q: Can you envision a day when networks would move to terrestrial fiber-optic cables for distribution of programming to affiliates?**

A: I can envision that. I think it is 20-25 years off, but I can envision that.

**Q: How much of NBC-TV programming is now done in stereo?**

A: Virtually all of the prime-time programming, the late-night programming (Carson, Letterman) and even some of the music bumper shots on news programs are done in

stereo. And we're looking forward sometime in the future to getting some of our daytime programming produced in stereo.

We are way out in front of our competition with regard to stereo, and have been for a couple of years now. We are to a point today where (according to our projections) 92% of the United States is covered by stations that are stereo-capable. That's really progress.

**Q: Is the public reaction to stereo about what you expected?**

A: Yes, I think it is running almost true to what our expectations were. Actually, the conversion of stations to stereo is running a bit ahead of schedule, as far as we're concerned. You know, it costs a station some money each time they convert to stereo, and there's a certain amount of faith that the station owner and station general manager has to have in order to convert, because there is always the "chicken-and-egg" question. We're providing the incubator.

**Editor's note:** What do the "big three" think about high-definition television and where it fits into terrestrial broadcasting? That topic will be examined in **View From the Top, Part 2**, to be carried in the February issue.

||:~:~)))))

## This new portable UHF Field Strength Meter gives you accurate readings across the entire band.

Someone once said that "Certainty is Security." That is the main idea behind field strength measurements. They verify the signal level and rf environment at the point of reception. You know for certain what's out there.

It is now easy for UHF stations to achieve this certainty. With the new FIM-72 from Potomac Instruments.

### Tune the entire UHF band

From 470 to 960 MHz. The received signal strength is shown in volts and dB, with a 140 dB measurement range. Select peak or averaging detection; wide or narrow IF bandwidth. Seven 20dB logarithmic ranges assures precise readings. Internal demodulators (AM and FM) provide audio monitoring of the selected signal.

### It is easy to use

Find the desired signal on the spiral dial. Calibrate the meter using the internal generator, then read the signal strength from the mirrored meter. The field strength is easily determined from the supplied calibration data.

### Laboratory applications

The FIM-72 includes a precision rf generator that tracks the tuned frequency. Typical measurements include insertion loss, VSWR, and filter response.

### Call Potomac Today

Place your order for this new UHF field intensity meter. Put it to work. And then you will know for certain.



**POTOMAC INSTRUMENTS**  
932 PHILADELPHIA AVE. SILVER SPRING, MD 20910  
(301) 589-2662

Circle (31) on Reply Card

# Solid as a Sony.

## Sony videotape has a rock-solid reputation as the toughest you can buy.

One word sums up everything we tried to achieve with VI-K videotape: durability.

From its cross-linked binder system to its adhesive base film, it was perfected for the real world of constant jogging, still frame editing, shuttling... and deadlines.

And its ultrafine Vivax™ magnetic particle formulation was made to deliver astonishing picture quality, higher stability and optimum S/N ratio with the lowest headwear rate of any major one-inch videotape.



What we did for VI-K benefitted BCT Betacam® too, resulting in trouble-free still frame editing, totally reliable repeated playback and worry-free long-term storage.

And new Sony BRS and XBR U-matic® cassettes have all of the above plus the new Sony Carbonmirror™ back coating, as well as Sony's anti-static shell, which we introduced in BCT Betacam. They deliver a new level of durability, runability and especially fewer dropouts.

So, after all, Sony professional videotape is just like any other Sony: standard-setting video and audio with a "solid as a rock" reputation. That's why it's the only videotape you can treat like a Sony.

**SONY**  
THE ONE AND ONLY.

Circle (32) on Reply Card

© 1987 Sony Corporation of America. Sony, Vivax, Betacam, U-matic, Carbonmirror and The One and Only are trademarks of Sony.

By Joseph Barnes

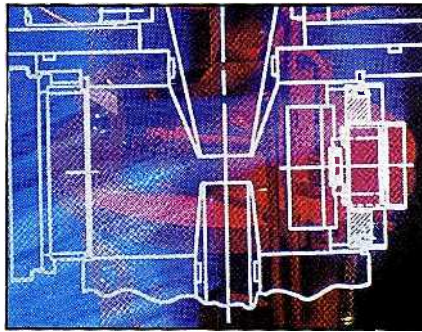

# The state of TV news

If you think TV news is having problems,  
you're right.

**F**or many years, TV news was the darling of the media. Successful ratings for many stations, increasing revenues, big annual equipment purchases, news expansion and the advent of local anchor "stars" all contributed to the perception that any news is good news. But now, all that's changing.

TV news of the late 1980s is suffering major budget cutbacks, declining shares in many markets, escalating anchor salaries (which many broadcasters believe are far too high), increasing representation of news personnel by agents, and a growing number of broadcast journalists whose training is adequate at best.

And, as if these problems aren't enough, TV news is probably too infatuated with itself to look at the future. Today, one good idea shows up all across the country instantaneously, and there are too few good ideas.

## Communication

For an industry based on communications, there is frightfully little of it at many stations. If you are a chief engineer who sees the news director only when there's a problem or at budget meetings, you're probably not alone. Regular conferences between news and engineering

are a rarity.

However, there are exceptions. One station on the West Coast holds regular short posts after each newscast. In attendance are representatives of news management, engineering management, production, art, promotion and news production. When these sessions are held in a positive vein, and not in a blame mode, they open avenues of daily dialogue and

---

***"Lay out the (station's) goals, then budget to achieve those goals."***

*Allen Neuharth,  
Chairman, Gannett,  
Rochester, NY.*

---

foster increased teamwork. Problems are fixed quickly, and the station takes advantage of new opportunities.

At another station, the news director meets with the chief engineer and promotion manager in separate meetings once a week to discuss short-term and long-range opportunities and strategies.

Meetings that are too long or too frequent can drag everyone down, but too little communication can mean the death of good ideas. If communication is lack-

ing at your station, fix the system now. Effective communication is the lifeblood of broadcasting. It will help you survive into the 1990s.

## Technology

The next decade will continue to witness major technological advances. The key to success won't be what you have, but how you use it. Purchases now and in the future should be based on real need, not made simply because the competition down the street has it.

When everyone jumped into live helicopter coverage years ago, some stations found that buying a copter was far more than they needed. Now, as broadcasters graduate beyond microwave to satellite news gathering, it is important that departments within a station work more closely than ever before to evaluate technological purchases based on new programming and coverage needs. In the business climate of today and tomorrow, it's the prudent business approach.

Broadcasters setting their sights on major equipment purchases such as SNV (satellite news vehicle) trucks must ask themselves: *Do we want live coverage from around the country? The region? Do we have tough terrain that leaves many dark microwave areas? In terms of finances and personnel, can we make the commitment to staff and maintain a truck?*

---

Barnes is a TV news consultant based in Martinez, CA.

# THE FIRST INTELLIGENT BROADCAST COLOR MONITOR



BARCO INDUSTRIES' new CVS professional broadcast monitor is microprocessor-based to make it intelligent in operation and easy to use.

It has both a digital and an analog bus for maximum flexibility. Plus four "open" slots that let you plug in today's options and those yet to come. As new features do come along, you'll be able to add them through software - no hardware changes!

All CVS functions are controlled from the front of the monitor or from a remote keyboard. An optional master remote permits control of a series of monitors.

WE PUT THE FUTURE IN THE PICTURE.

**BARCO  
INDUSTRIES**

You can also store, and automatically call up, either calibrated presets or your own preferred presets.

Like our best master control monitors, the CVS has Automatic Kinescope Biasing (AKB) to maintain color and black level stability.

The CVS also generates more internal test patterns than any other monitor. They include white field, cross hatch and color bars.

The CVS is available in both 14 inch and 20 inch versions, and provides outstanding picture quality in any TV standard.

For complete specifications, contact your local BARCO INDUSTRIES Dealer or BARCO INDUSTRIES, 170 Knowles Drive, Suite 212, Los Gatos, CA 95030. Phone : (408) 370-3721.

BARCO INDUSTRIES is a member of the ACEC-group.  
Circle (33) on Reply Card

These questions may sound basic but, in many cases, stations wait too long, overevaluate a purchase, procrastinate until the competitive impact is reduced, or do not fully analyze their equipment needs and application goals and benefits.

But that's not all. How many times do news directors go to RTNDA to evaluate major equipment empty handed, without the chief engineer or general manager? It's a tough sell for the vendors and for the news directors when they get home.

My advice: *communication*. The chief engineer and general manager should actively participate in such major evalua-

Later, when it came time to make a purchase, the president recommended new funds to pay for the equipment rather than robbing the cash from another news project. He had seen the truck in action and knew the station needed it for news coverage.

***“Effective communication is the lifeblood of broadcasting.”***

***“What delineates you from competitors isn't a piece of video...but your treatment of it.”***

*Natalea Brown, WJZ-TV news director, 1987 RTNDA Convention, Orlando, FL.*

**Coverage and technology**

It is indisputable that satellite technology has opened up a new world of opportunities for TV news, especially for local news operations.

Now, regional and national coverage can become local instantly. It's an explosion of technology, but how it is used now and in the future will determine the fate of TV news. If satellite news gathering is used primarily for local spot news coverage, the opportunities will be limited. Many markets don't have enough daily spot news that requires SNV equipment.

However, if SNV and C-band are used

effectively by stations or groups, the industry may see plenty of new information programming opportunities. Who is to say that stations in various parts of the country can't create regional network newscasts, live for their time zones, with fewer Washington and New York stories and more regional news coverage?

Consider new types of live programming. Why must talk shows be in the studio? Why can't they regularly go on the road? What would this do to magazine shows? Would there be a resurgence?

The explosion of SNV technology also has opened up new relationships. Gone are the simple days of affiliates trading video with one another. Now, with successful satellite-based news organizations, trading and technological relationships are crossing affiliate lines. It may be confusing now, but in the end, a more open system of trading spurred by Ku-band technology will permit better cov-

tions. At one major East Coast group, a station came out ahead just because the president of the company went to RTNDA to see an SNV demonstration.

***“Know your station's mission before you start talking about cost-cutting.”***

*Al Buch, KSNW-TV VP and general manager, 1987 RTNDA Convention, Orlando, FL.*

erage for local stations, providing more video and new alternatives.

**News programming**

As costs for syndicated shows skyrocket, this observer expects that locally produced news and information shows will again become a viable alternative. One major station recently turned down the opportunity to buy “The Cosby Show” and “Wheel of Fortune,” and will, instead, expand local news and information programming. Why? Because the station's profit margin from news expansion, even if not rated No. 1, is dramatically greater.

As program costs swell and the viewer's thirst for information grows, the coming decade should see expanding news programming. The audience shares may decline, but prudent business practices should pave the way for better profit margins.

Another change will be the expansion of news and information programming beyond traditional formats. News doesn't exist only at noon, 5, 6, 10 and 11.

The possibilities for TV news are boundless, but it will take ingenuity and a willingness to try something new.

!:-:~)))))

***15KV of Portable Broadcast Maintenance.***

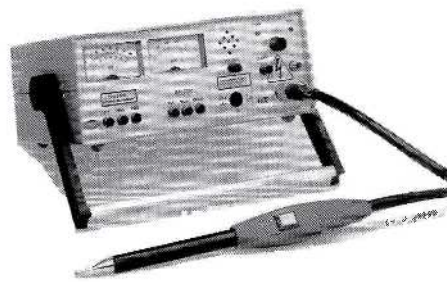

**The JP15 Non-Destructive DC Insulation Tester.**

Station maintenance engineers have found the JP Hi-pot testers to be useful tools for checking the on-ax cable running up antenna towers. Poor insulation within the cable, or malfunctioning tower insulators are easily identified with the 15KV output range of the JP15.

The JP15 operates on AC or DC power. DC current is supplied by either standard dry cell batteries or rechargeable Ni-CD batteries stored in the bolt-on battery pack.

The unit is compact and weighs only 9 1/2 lbs. It features minimal

discharge energy for protection, and continuously variable output voltage. Test voltage is applied by a probe with a High Tension switch for one-handed operation.

In addition to antenna maintenance, the JP15 is ideal for other applications such as checking transient suppressors. Call us today for more information.

**RE • INSTRUMENTS** 

Electronics for Test and Communications

RE INSTRUMENTS CORPORATION  
31029 Center Ridge Road, Westlake, Ohio 44145  
Telephone (216) 871-7617, Telex (216) 871-4303

Circle (34) on Reply Card

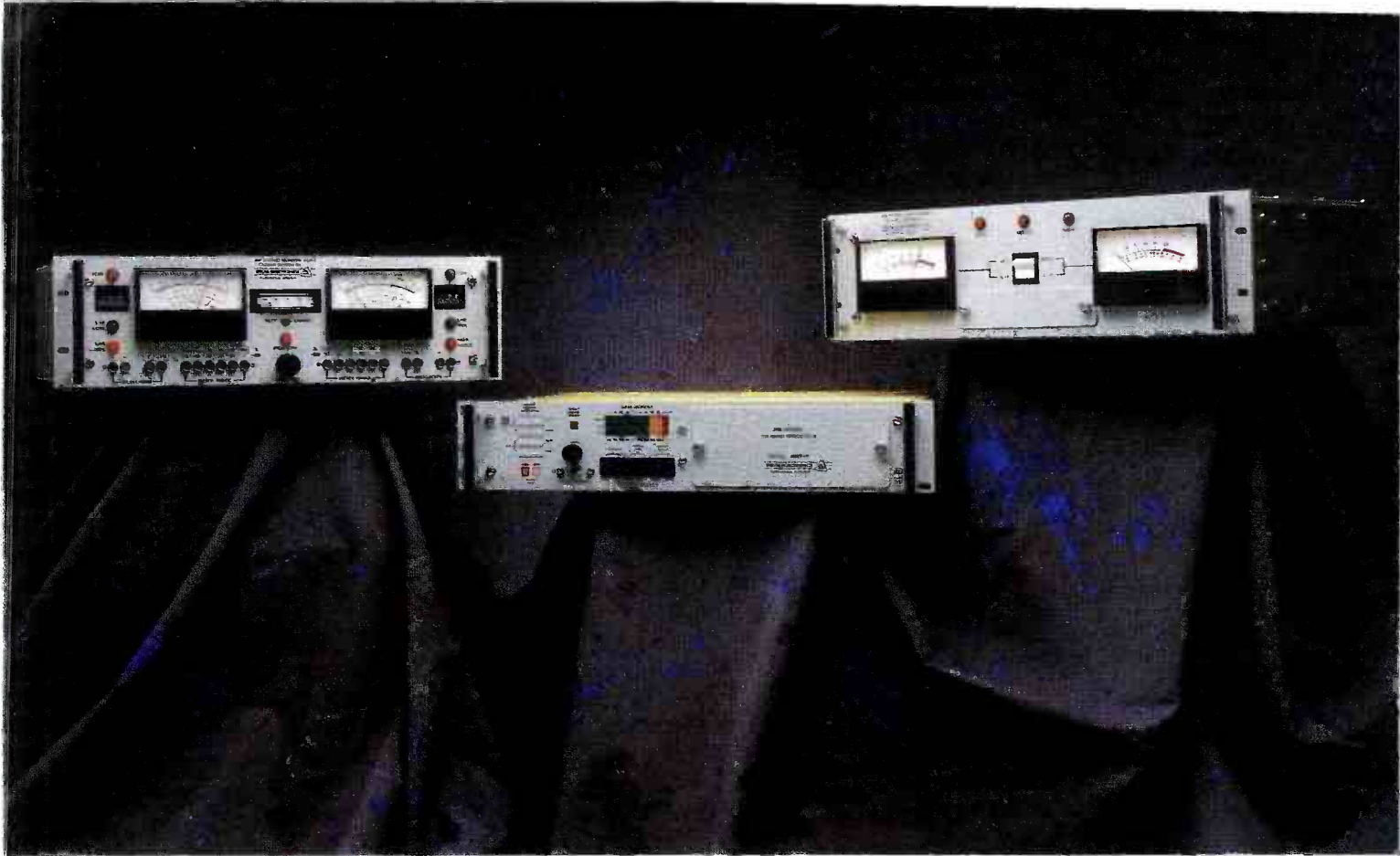

# THE ABOVE STANDARD INDUSTRY STANDARD.

In Canada, Australia and Brazil, C-QUAM® has been named the AM stereo industry standard. When you stop and think about it, it's quite obvious why the Delta C-QUAM® AM Stereo System is the above standard industry standard. Just one look at the engineering that goes into our system and you'll see it's built to last a lifetime.

The ASE-1 Exciter, ASM-1 Modulation Monitor and the all new AMP-1 Tri-Band Processor all work together in perfect harmony to bring you unmatched stereo performance.

Day-in and day-out Delta delivers pure, clean sound and optimal separation from your existing transmitter. And the system's active balanced input/output circuits we've included give excellent frequency response as well as outstanding low distortion. Plus, the Tri-Band Processor complements the performance of the Exciter with impressive modulation peak control.

But how can a system that sounds so good be so tough? It's the Delta difference.

You'll notice little details that make the Delta system fit for the long haul. Things like a ruggedly constructed

chassis. Zero insertion force card edge connectors for longer life. Stable crystal oscillators in both the Exciter and Monitor, as well as extensive quality assurance testing and a dynamic burn-in.

You'll also notice that we used common sense when we designed the Delta system. It's easy to install thanks to the extra RF and logic level outputs we've included. For further flexibility there's a day/night or main/auxiliary audio equalization board available at no extra charge. Factory authorized system installation is also included. And every system is backed by over 25 years of dedication to AM broadcasting and customer satisfaction.

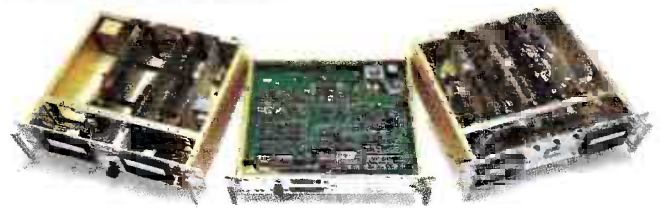

To find out more about the Delta C-QUAM® AM Stereo System and attractive package pricing, give us a call at (703) 354-3350. Or write Delta Electronics, 5730 General Washington Drive, Alexandria, VA 22312.

Years from now when you look back on your decision to install a Delta C-QUAM® AM Stereo System, you'll recognize it for what it really is—an above standard decision.

Over 25 Years  
of Quality.

**DELTA ELECTRONICS**



C-QUAM is a registered trademark of Motorola, Inc. Manufactured under license from Motorola, Inc. ©1987 Delta Electronics.

Circle (35) on Reply Card

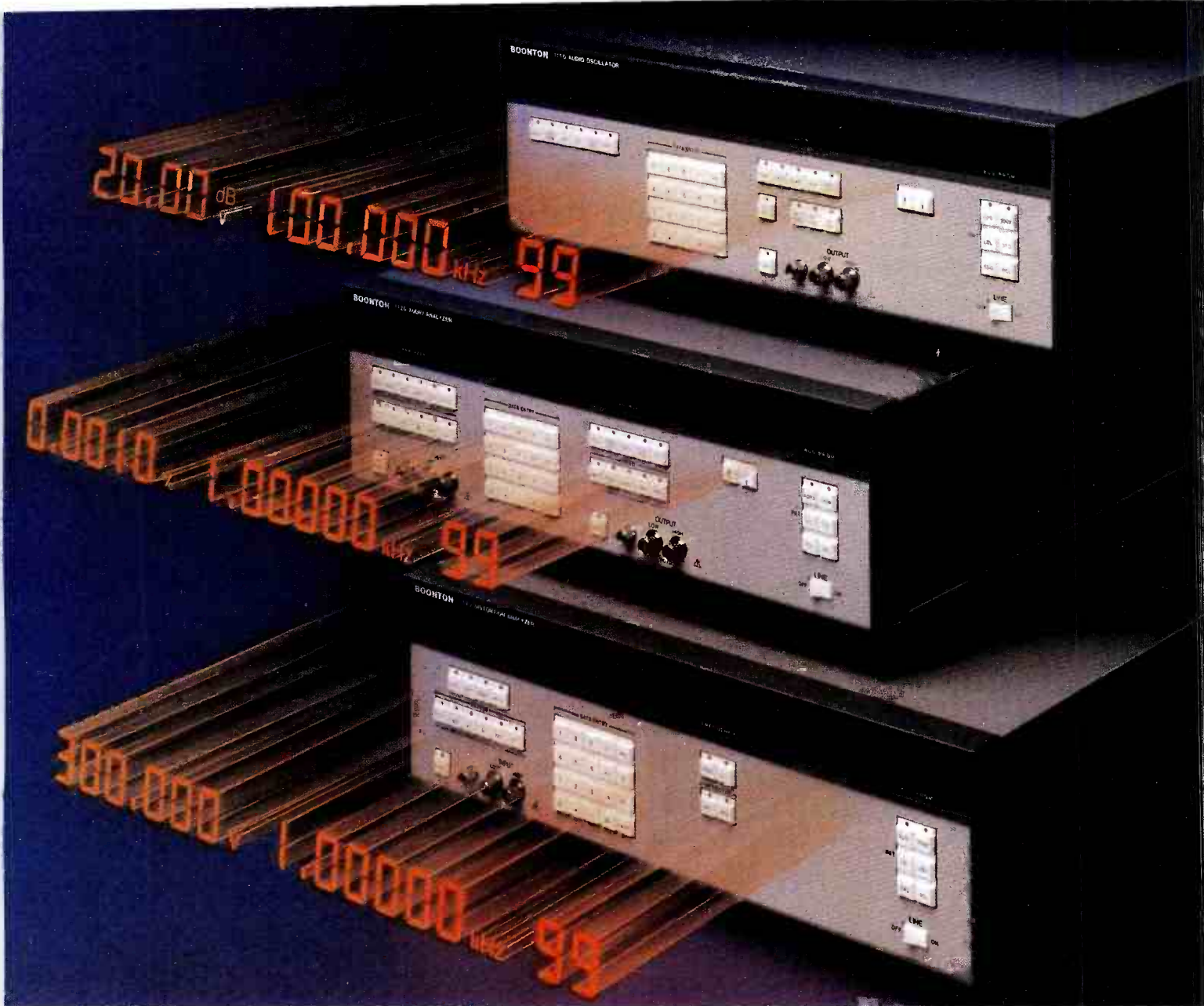

# THEY'RE HERE!

## Boonton's Family of High Performance Audio Instruments

For your most demanding requirements, Boonton has just the instrument to generate or characterize audio signals with unbeatable accuracy. Whether you're working on the bench or with an ATE system, they provide fast, low cost solutions to all your audio testing needs.

### 1110 Audio Oscillator

- High power output to +30.5 dBm
- 10 Hz – 150 kHz with ultra-low distortion (typically 0.001%)
- Resolution to 0.001 Hz
- Variable output impedance (50, 150, and 600  $\Omega$ )
- Swept frequency or level

### 1120 Audio Analyzer

- All-in-one source and analyzer, 10 Hz–140 kHz
- Frequency counter
- AC/DC voltage

- Distortion in %THD or SINAD
- Signal-to-noise

### 1130 Distortion Analyzer

- Distortion, 10 Hz–140 kHz, with 3 mV sensitivity
- SINAD, frequency, and AC/DC level
- Programmable notch filter
- Standard and optional filters
- Ultra-low residual distortion and noise

All Boonton audio instruments feature non-volatile storage for up to 99 complete panel set ups. IEEE 488 interfaces are standard. Call your local representative today for a convincing demonstration.

## Boonton Electronics Corp.

791 Route 10, Randolph, NJ 07869

Telephone (201) 584-1077

Circle (36) on Reply Card

Signal Generators ■ Modulation Analyzers ■ RF Power Meters ■ RF Millivoltmeters ■ Capacitance Meters and Bridges ■ Audio Test Instruments

**BOONTON**



By Guy W. Numann

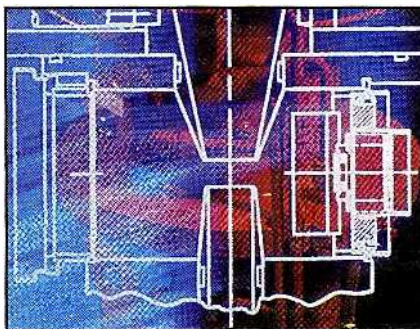

# Manufacturing technology

When it comes to manufacturing broadcast equipment, it's not business as usual anymore.

The broadcast industry is now recovering from a period of financial turmoil caused by mergers, acquisitions, tax law changes and increased competition from alternative entertainment sources. These pressures have accelerated some fundamental changes in the way broadcast equipment manufacturers view their markets, and how they make their products. The result will be the availability of more reliable, cost-effective products for radio and TV customers.

## The one-stop shop

The days of the one-stop shop for broadcast equipment needs from a single manufacturer are dead and gone. In its heyday, RCA was probably the only company to almost achieve the distinction of being able to supply an entire station, from the microphones and cameras to the transmitting antenna.

Today, the sheer economics of product development makes it virtually impossible for any one company to stay technologically competitive in all areas. Whether for radio or TV equipment, there are logical break points that divide functions and applications. The users' needs are best served by *niche marketing*. It still is

possible to obtain almost all the equipment you need for a project from one supplier, but it will have been built by any number of different companies.

## Gearing up for competition

Market forces have caused broadcast equipment manufacturers (and others, as well) to re-evaluate their approaches to design, manufacturing and service. A

---

***"The team concept has resulted in radical changes in the way products are assembled."***

---

number of simple concepts have been implemented to increase product performance and reliability, to reduce manufacturing costs, and to speed the process of bringing a new product to market.

One of the most popular concepts is *just in time* (JIT) designed to cut inventory costs and to improve reliability. JIT involves a scheduling effort between suppliers and the manufacturer by which components and subassemblies are delivered to the manufacturer when they are needed for production, not before. In this way, production of finished products

pulls supplies through the system. This is a critically important difference from conventional manufacturing, which basically works the other way around.

In traditional manufacturing, parts and subassemblies were shipped to the manufacturer at random times and stockpiled until needed. This procedure resulted in extra cost for the manufacturer, who passed it on to customers.

JIT also allows problems to be spotted at an earlier point in the production process. If a component is defective, it will be identified immediately and the supplier can be notified of the problem before large quantities of the component are produced.

Another concept that is catching on in broadcast equipment manufacturing is team management. It can be described as *flat organizational manufacturing*. Under this approach, no more than two levels of management exist from the head of manufacturing to the most junior assembly-line worker.

The team concept has brought radical changes in the way products are assembled. Classic manufacturing techniques incorporated an assembly-line arrangement in which each person performed a specific task. It was generally accepted that plant efficiency could best be accomplished by making the individual subsys-

Numann is senior vice president, Harris Corporation (Melbourne, FL) and sector executive, Harris Communications Sector.

tems (printed circuit boards, cable, sheet metal and other items) most efficiently. But, the result was often less than optimum; parts of products were spread out all over the plant, quality was difficult to control, and the production process was lengthy. Furthermore, inventory costs were substantially higher, and employee motivation was probably lower.

The team concept, on the other hand, takes a group of people and weds them to a specific project. The team, under a single group leader, builds an entire product, from stuffing printed circuit boards to performing final tests. Under the most efficient form of management, each team leader reports directly to the vice president of manufacturing, resulting in only three management levels in an entire plant.

When employees work as teams, they can identify design problems and ways to improve product quality. This approach has been shown to work in real-world factories, resulting in fewer product defects, reduced labor costs, lower material costs and better inventory control. In short, the company wins, and the customer wins.

Industry also has taken the team concept to the front end of product design by including manufacturing personnel on

the design team, as well as one or more customers. A product-design cycle no longer consists of a serial hand-off from one department to another, but involves a continuous team effort that incorporates all areas of product design, manufacturing and marketing from product conception to shipment.

These concepts have been shown to work in the manufacture of broadcast products. Further improvements will come that benefit both the customer and

***"In a well-run manufacturing plant today, everybody is a customer service representative."***

the equipment supplier. The industry has just begun to see what new approaches to management style can achieve.

#### **Moving products to market**

The theme for successful businesses today is *better products to market quicker*. The definition of better is higher quality and greater customer features and benefits. Getting those types of products to market fast is critically important as tech-

nology speeds ahead. One way to shorten the development cycle for new products is to perform the required steps in *parallel*, rather than in the more familiar serial approach. This author has seen cases in which it took three to five years to get a product to market. In today's business climate, the goal should be 18 months, maximum.

In the broadcast equipment business, service is all there is. To buy a product and do without service is unacceptable. Look for manufacturer reorganization in which sales and service personnel work more closely with order-entry people to keep customers happy. In a well-run manufacturing plant, everybody is a customer service representative.

Coupled with this is another concept that says everyone in the company is a salesperson. This drives home the point to employees that delivering a quality product to the customer for a reasonable price is not the responsibility of any one department, but of all employees at the company. Engineering and manufacturing should work together with marketing to get orders. It is good for the customer and good for the company.

In today's business climate, employees at a manufacturing company should do only two things: fill customers' needs or

# AT LAST! STEREO FIELD MIXING COMES OF AGE!

**Professional Net  
Only \$1295**



Until you try the new AT4462, you'll never fully realize what other mixers put you through, just to get a stereo signal on tape, on film, or on the air. Because simply adding pan pots or another output to a mono mixer is not enough for today's stereo.

#### **Field Tested and Refined**

We went to network and independent broadcast engineers, and leading film and A/V audio people to learn your problems and needs first-hand. And we returned again and again to test our solutions. These tough critics agree that the new AT4462 sets up far faster, provides better signal control, and results in better audio...even in the hands of inexperienced personnel.

**NEW AT4462  
STEREO FIELD MIXER  
WITH EXCLUSIVE  
MODU-COMM™**

#### **Introducing Modu-Comm™**

The AT4462 is designed for the real world. For instance, let's assume you're doing a simple sports remote. You set up microphones for the sportscaster and the color announcer, plus a stereo mike for the ambient crowd noise. Normally you would also have to run a

**For name of  
nearest A-T Sound Specialist  
CALL 1-800-992-ATUS (2887)**

lower costs.

As the broadcast industry changes with the onset of the "global market," expect to see a number of moves on the manufacturing side. First, there are likely to be increased numbers of acquisitions and corporate consolidations, including the formation of so-called strategic alliances. This movement began several years ago, and will continue to accelerate as the stakes climb, and as it becomes more expensive to compete on the global market.

American manufacturers will see increased competition from Japan and Europe. The United States is viewed by many foreign manufacturers as a lucrative market that invites additional players. However, as Japanese and European companies mount marketing efforts, additional U.S.-based companies will eye overseas locations, principally Europe, as promising markets for their products. Far Eastern countries, particularly the People's Republic of China, also present excellent opportunities for U.S. vendors.

Expect to see a slowing of start-up manufacturing companies, here and abroad. Product manufacturing is a game that few can afford to play.

Customization of hardware and software is desired by many stations and group operators. However, the econo-

mies of scale make it difficult to customize most products for a price that is acceptable to the user. Manufacturers that are willing to make a product a different way for certain customers, and are able to because of their business and product design approach, will be market-share winners.

Development in the 1990s and beyond will be based on expandable systems that allow users to grow with the product. Look for families of products, rather than

**"The theme for successful businesses today is better products to market quicker."**

stand-alone offerings. The economies of scale favor family-product design. This concept also helps prevent the problem of design obsolescence due to rapidly moving technology. Systems of today and tomorrow will be built around workhorse hardware and supercharged software. Software is easier to change than hardware, and users know that.

Few companies building for the broadcast equipment market can afford to be experts in every area of design and fabri-

cation. For this reason, you have seen—and will continue to see—more cases in which subsystems of a larger product are handled on an OEM (original equipment manufacturer) basis. There is no point in trying to develop a better small computer system than an IBM XT, so, why do it? It is cheaper in the short- and long-term (and better for the customer) to simply buy the guts of the system from IBM, then customize to fit a particular application.

As another example, switching power supplies are commonly used in low-power computerized equipment. Many companies serving the computer industry are spending hundreds of thousands, or even millions, of dollars each year finding new ways to improve power-supply designs. The economics of the broadcast industry won't support this level of investment in a subsystem of a large project. It makes good engineering and economic sense to OEM the box out to another supplier.

The broadcast industry, in which you make your living, is changing. And although change of any type may be uneasy, or even painful, it has to come. Whether you're a consumer or a producer, you'll be better for it.

||:~))|||

wired or wireless feed to the sportscaster for his cue phone.

But with the AT4462 and Modu-Comm, cue is fed through the announcer's mike cable already in place. Add a small accessory decoder to the end and plug both the cue phone and the microphone into the same cable. Cue can be program, an outside line, or "talk over" from the mixer. No extra wires, no crosstalk, and no change in audio quality! Nothing could be simpler or more efficient.

### Now, No-Fuss Stereo

Actual stereo mixing is equally straightforward. The sportscaster and the color announcer in our example appear on separate pannable inputs so they can be centered as desired in the sound field. The stereo crowd pickup goes to a stereo input, with clutch-ganged controls for one-hand level control. And there's a second stereo input for another mike or line level source

(a second field mike perhaps, or for pre-show interviews on tape).

### True Stereo Limiting Plus LEV-ALERT™

Adjustable limiters can operate in tandem, or individually as you prefer. And our Lev-Alert system can give you peak level audible tone warnings in your headphones when you can't watch the VU meters. Trust Lev-Alert to keep your standards high...even when it isn't easy!

### Take A Close Look

When you examine the new AT4462

you'll see a host of other features to help you do your job: Cue on every channel...Separate headphone amplifier...Phantom power for all types of mikes...Three-frequency tone oscillators...Slate mike...Supplied carrying strap and protective case...Powered either by internal 9-volt batteries or any external 12-18 VDC supply, any polarity

### A New Era in Stereo Begins

We've made the new AT4462 a working tool that helps you and your staff take full advantage of the production values stereo has to offer. And a hands-on test will quickly prove it. To learn how the AT4462 can help you create better audio every day, call or write us now.



**audio-technica**

1221 Commerce Drive, Stow, OH 44224 • (216) 686-2600

True 600Ω Stereo/Mono Outputs  
Mic/Line Level Out  
Mic/Line Switch on All Inputs  
20 dB Pad on All Inputs

MODU-COMM™ Line Level Adjust  
Limiter Level Adjust

External 12-18VDC Either Polarity

Cue on Each Input  
Two Mono Inputs with Pan Controls  
Slate Mic with Frequency-Selectable Tone

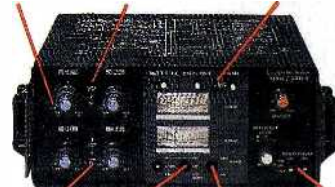
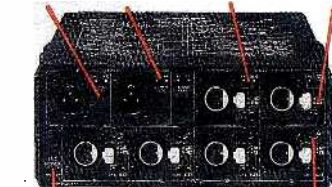

Phantom 12V Power for All Inputs

All Inputs and Outputs Transformer-Coupled

Flat/Lo Cut Filter on All Inputs

9V Internal Batteries (3)

Strap Bracket Protects Face

Headphone Outputs (2)

MODU-COMM™ External Mic/Line Inputs

Bus In/Out

Two Stereo Inputs with Dual-Clutch Controls

LEV-ALERT™ for Audible or Visual Peak Level or Limiting Warning

Stereo Limiter Switchable to Dual Mono

MODU-COMM™ Full Duplex Communication over Existing Mic Lines

Circle (150) on Reply Card

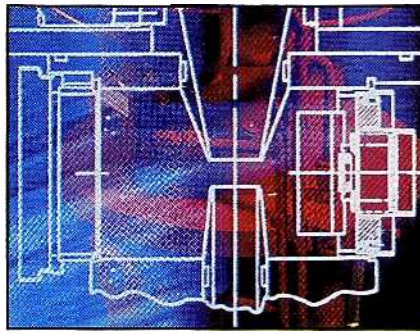

# Broadcasting's bottom line

**Broadcasting is a business, and every business runs on money.**

It is no secret that radio and TV broadcasting have gone through some tough times lately. Increased competition from alternative entertainment mediums, such as cable television and pay channels, VCRs and Walkman-type compact discs, have eaten into the traditional strongholds of over-the-air broadcasting. Let's face it, advertising pays the bill for salaries, equipment purchases, utilities and

all the other things that make a station operate. Projections of next year's advertising performance are, therefore, of more than just passing interest.

### Advertising projections

The Chicago-based investment research and financial consulting firm of Duff & Phelps predicts a strengthening of the sluggish national advertising environment in 1988. The report, which applies to both the broadcast and print media, is certainly no harbinger of spring for the industry, but it does offer at least a glimmer of hope that better times are coming.

James C. Goss, author of D&P's "Media Trends" report, sees the generally positive outlook to be, in part, a result of media cost reductions and tax reform benefits. He also cites recovery from the effects of mergers of major national advertisers.

Despite the improved outlook, Goss says the TV networks probably will remain flat, with gains being posted in other sectors. He is encouraged, however, by the positive momentum of the recently completed network upfront selling season. Advertisers showed they were willing to pay higher prices this year than last, reversing a situation that developed in 1986, when both CBS and

ABC absorbed declines in upfront ad sales.

The broadcast media's biggest competition for advertising dollars is newspapers, as shown in Table 1. Although television continues to gain ground against newspapers, print holds a significant lead over TV's market share of the ad dollar.

This disparity exists even though broadcasting is much more diverse in

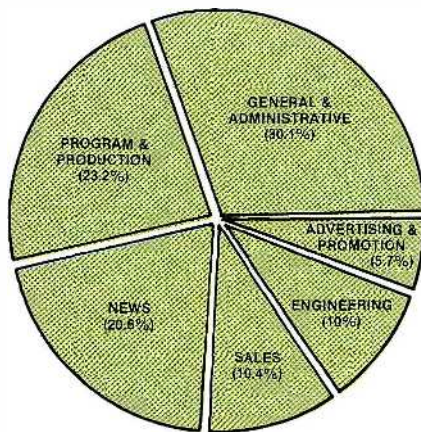

**Figure 1.** A breakdown of typical TV station departmental expenses for a network affiliate. This chart is based on 1985 expenses, which averaged \$5.449 million for the stations surveyed. (Source: NAB.)

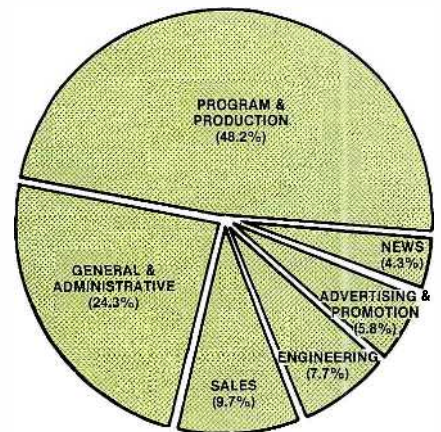
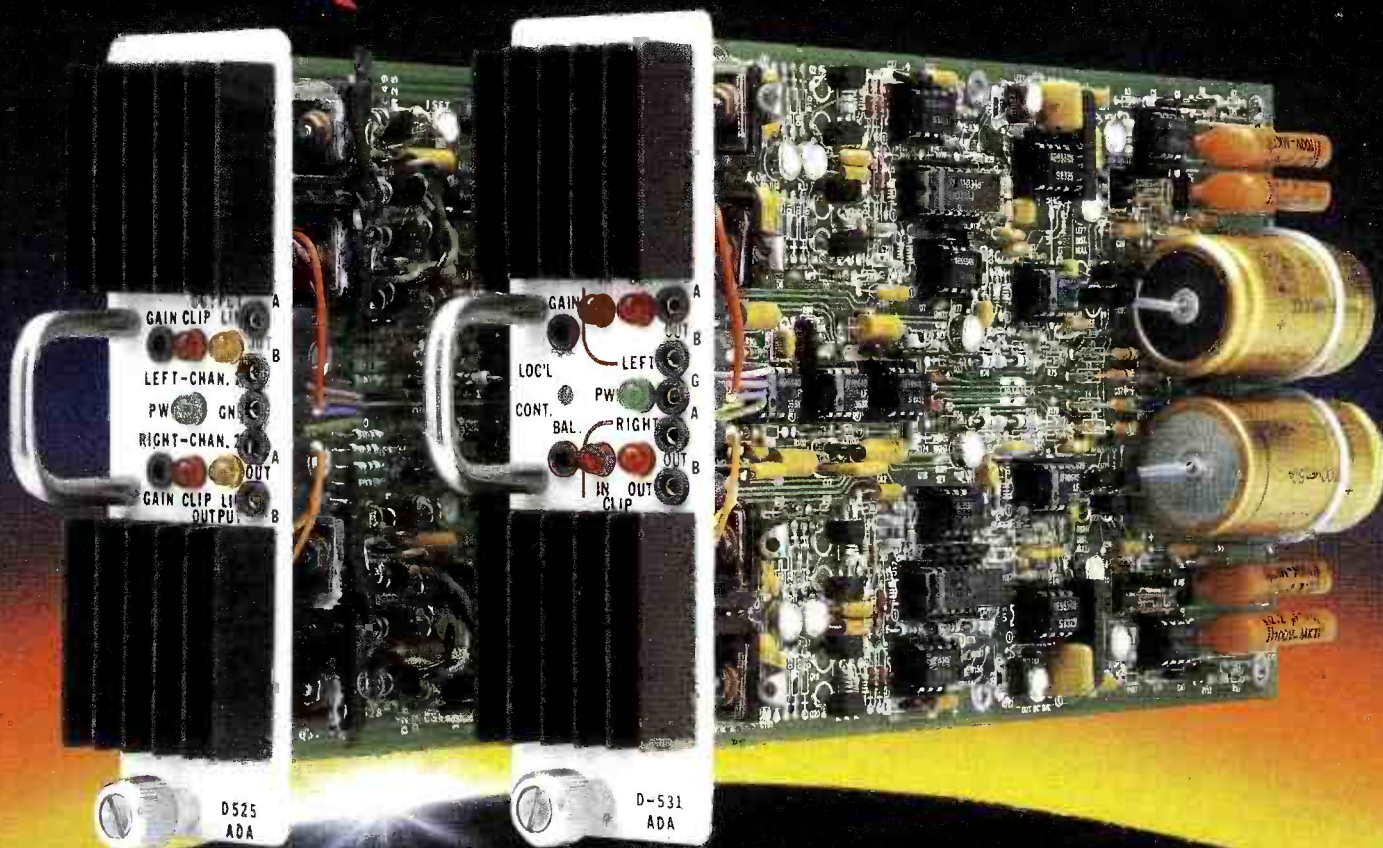

**Figure 2.** Typical TV station departmental expenses for an independent outlet. This chart is based on 1985 expenses, which averaged \$6.309 million for the stations surveyed. (Source: NAB.)

Our World  
Of Audio DAs  
Is Growing...

**DATATEK**

# Now TWO Stereo Audio DAs Available From Datatek!



## D-525 DUAL CHANNEL/STEREO AUDIO DA

- Two isolated channels for use in stereo or dual distribution amplifier applications
- Used for one stereo input and 6 balanced stereo outputs, one monaural input with 12 outputs, or 2 monaural inputs with 6 balanced outputs each
- 0.05% max. distortion at +27 dBm

## D-531 STEREO AUDIO DA WITH REMOTE GAIN

- Local and/or remote control of gain and balance, with accurate tracking over the gain range
- Six balanced stereo outputs with 0.05% max. distortion at +27 dBm
- Two balanced mono sum (L+R) outputs at up to +28dBV available simultaneously with stereo outputs

*For a descriptive  
brochure and  
further information  
call or write:*

**D**  
**DATATEK**  
CORP.

1121 Bristol Road, Mountainside, N.J. 07092 • 1-800-882-9100 • 201-654-8100 • TELEX 833-541

Circle (46) on Reply Card

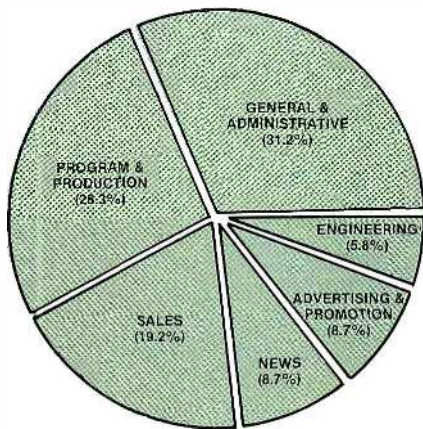

**Figure 3.** Typical full-time AM station departmental expenses breakdown. This chart is based on 1985 expenses, which averaged \$622,000 for the stations surveyed. (Source: NAB.)

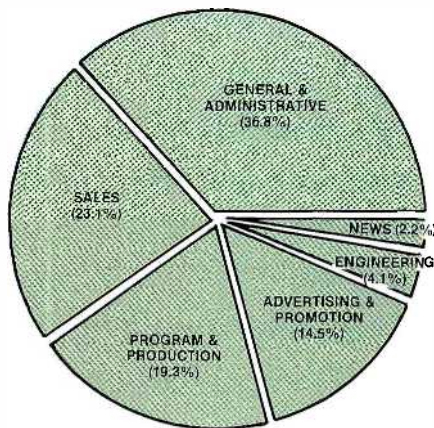

**Figure 4.** A breakdown of typical FM station departmental expenses. This chart is based on 1985 expenses, which averaged \$1.061 million for the stations surveyed. (Source: NAB.)

number and dispersion of outlets than the newspaper industry. More than 10,000 radio stations and 1,200 TV stations in the United States compete with 1,670 daily newspapers.

The Television Advertising Bureau estimates that revenue will grow about 12% in 1988, thanks in part to election-year advertising and the upcoming Olympics. The organization estimates total TV advertising during 1988 to reach \$26.5 billion.

The bureau predicts that the boost provided by the political campaigns and Olympics will provide only a one-shot improvement in ad performance. TVB expects 1989 advertising revenue gains to slip back into the single-digit values.

TVB figures show that 1987 income posted a disappointing increase of just 4% for the networks and 6% for both national spot and local advertising. Adjusted for inflation, these gains amount to lit-

	TOTAL (%) SHARE OF MEDIA ADVERTISING		
	NEWSPAPERS	TELEVISION	RADIO
1975	29.9	18.6	7.0
1980	28.5	20.7	6.7
1985	26.8	21.7	6.8

**Table 1.** Market share of advertising dollars for newspaper, television and radio over the past 15 years. (Source: NAB.)

tle actual growth compared with 1986.

1987 was not a banner year for radio advertising either. The Radio Advertising Bureau reports that at the end of the third quarter (through September), 1987 billing was up just over 4% relative to year-ago levels.

The RAB expects the radio industry to see a 6% increase in ad sales for 1988. This modest estimate assumes no radical rule changes by the FCC that would, for example, preclude the advertising of alcoholic beverages. The RAB cites the national elections as a major reason for the expected gains next year, not because of political revenues that would be generated, but because a change in office generally brings re-evaluation on the part of business. The Olympics are not expected to directly affect radio advertising revenues.

Stock market uncertainty and company mergers and acquisitions have affected the radio industry, but primarily on the national level, according to RAB. The organization says local radio has generally not been seriously affected. RAB says fully three-fourths of all radio advertising is done on a local basis.

#### TV news stats

For local TV stations, the best vehicle

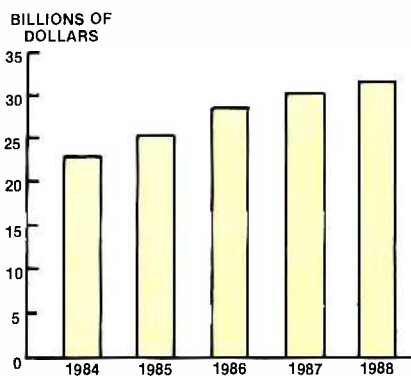

**Figure 5.** Total factory sales of consumer electronic products. Sales figures through 1986 were drawn from actual market activity reports. Projected sales for 1987 are based on market activity reports published as of June 1987 (seasonally adjusted) and on data submitted by individual manufacturers. Estimated sales for 1988 are based on a consensus of various industry sources. (Source: EIA.)

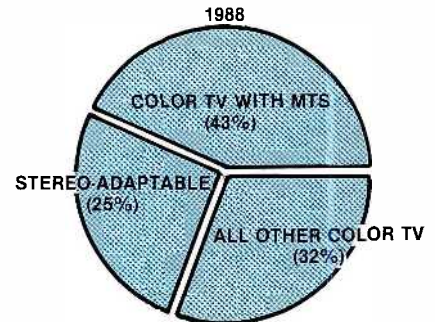

**Figure 6.** Breakdown of predicted total factory sales of color TV sets for 1988. (Source: EIA.)

for advertising is usually local news programming. For this reason, and a variety of others, twice as many network affiliates increased their early evening local TV news programming during the past year as decreased it, according to a report from the Television Information Office (TIO).

The findings also show that 249 stations now broadcast one hour or more of local news between 4 p.m. and 7 p.m., up 13 from levels of one year ago. Statistics show that television is regarded as the primary source of news by about 66% of the American public.

The TIO findings are based on A. C. Nielsen data from 214 reportable Nielsen markets, covering 638 affiliate stations.

#### Statistical profile

By and large, most people just love statistics. It is a way to gauge market success and efficiency of operation. And with increased pressure on radio and TV stations to improve operational efficiency, the numbers are more than just a little important. In a recent survey of its member stations, the NAB compiled statistics on operating expenses for each major function within radio and TV stations.

Expenses for TV stations vary greatly, depending upon whether they are network affiliates or independents. As illustrated in Figures 1 and 2, the primary difference shows up in the costs for programming and production. Radio station expenses are shown in Figures 3 and 4, broken down into AM and FM categories.

On the consumer side, the amount of money spent by the public for electronic

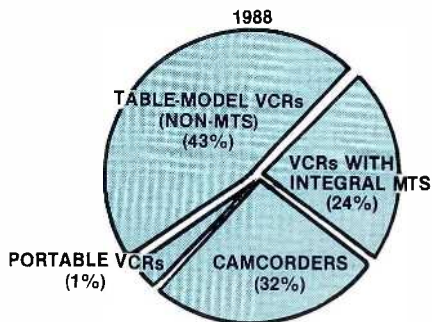

**Figure 7.** Projected 1988 sales of videocassette recorders, divided by type of configuration. (Source: EIA.)

products continues to grow. The marketing services department of the Electronic Industries Association (EIA) estimates that more than \$30 billion will be spent by consumers next year for electronic products of various types. (See Figure 5).

Projections for TV set sales show an impressive penetration of stereo (MTS) units being produced in 1988. According to EIA figures, 43% of all color televisions made next year will include MTS decoders (see Figure 6). That number is up 6% from 1987 estimates.

VCR sales for next year are expected to be strong, with the percentage of camcorder sales up 3% from 1987, and the number of VCRs with integral MTS decoders up 2% from '87 levels. (See Figure 7.)

**Good news, bad news**

U.S. consumers have demonstrated an insatiable appetite for new electronic gadgets. Radio and TV broadcasters have, in the past, been the benefactors of this growth market. Now, however, consumers are branching out from traditional over-the-air entertainment mediums, putting broadcasters in a whole new ball game.

A broadcast license used to be almost a permit to print money. You could take a big bucket out to the antenna and wait for money to drop from the sky. An exaggeration, to be sure. However, technology has provided new tools and new forms of competition. How broadcasters survive in the long run remains to be seen.

Complicating matters is the marketing of radio and TV stations. Indications are mixed as to whether Wall Street investors have soured on broadcast properties. It is certainly apparent, however, that the frenzied buying and selling of stations has slowed significantly. This is a positive sign for the industry as a whole, because most would agree that broadcasting is best run by broadcasters.

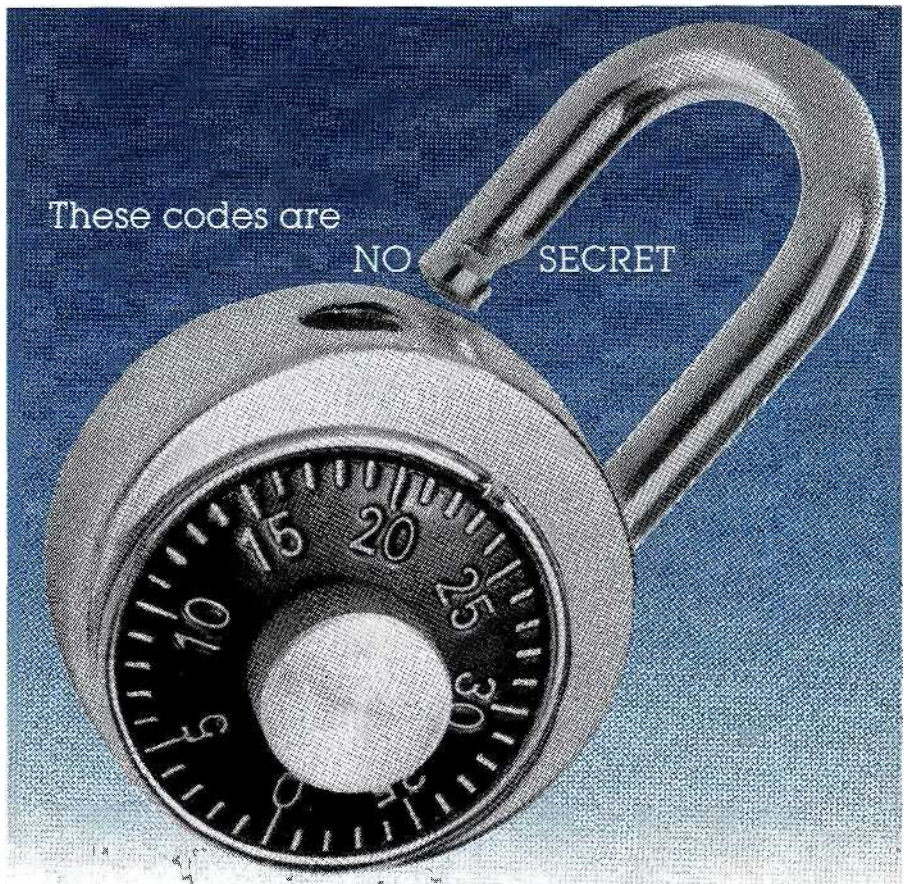

The word is out!

The CDI-735 CD time code reader with 8-channel coincidence detector gives today's professional advanced code reading plus peripheral equipment control.

The CDI-735L is ideal for rapid, off-line "news bay" type editing. It features a frame-accurate front end for computer-related applications by utilizing optional parallel or serial RS-232/422 data ports, and a highly legible LED readout for time and user data display.

Designed for affordable video production, the CDI-735V allows error-free, frame accurate decoding of time and user data. It features a multi-function integral video character inserter that supplies a monitor display of combined code information superimposed over program video. Ideal for generating "burned in" workprints. All CDI-735 Series products are microprocessor-based and include an error bypass feature across a full range of codes.

Each unit carries a 3 year warranty.

For more details on the CDI-735 Series contact Cipher Digital today. Call (800) 331-9066.

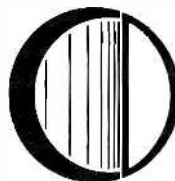
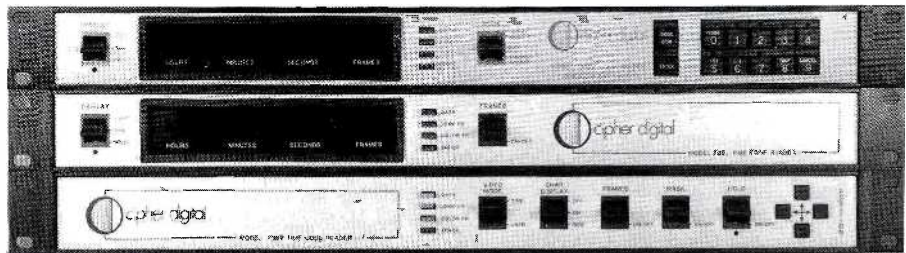

**cipher digital, inc.**

P.O. BOX 170/FREDERICK, MD 21701  
(301) 695-0200 TELEX: 272065

*Timely today, consistent with tomorrow.*

Circle (140) on Reply Card

By Timothy P. Hulick, Ph.D.

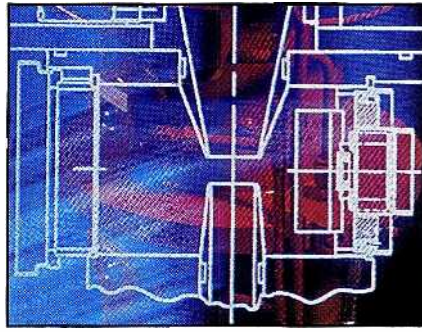

# Digital amplitude modulation

For a different approach to digital amplitude modulation, take a look over an RF designer's shoulder at an idea that's still on the drawing board.

Amplitude modulation is the oldest method of impressing information onto an *electromagnetic carrier*. Its beginnings date back to the early days of spark-gap transmissions. With spark came 100% amplitude modulation and the adoption of the Morse Code (later the International Morse Code), and still later, voice amplitude modulation, which has been shortened simply to AM.

AM usually refers to full-carrier amplitude modulation with a single set of in-phase sidebands containing the information to be transmitted and received. Any modulation system that causes the instantaneous composite amplitude of the waveform to vary in accordance with the information transmitted is (or should be) termed AM. This includes single-sideband suppressed-carrier emissions and vestigial-sideband television as well.

AM can be generated in many ways, but it always can be expressed by the familiar trigonometric identity:

(Equation 1)

$$(1 + \cos \omega_m t) \cos \omega_c t = \cos \omega_c t + \frac{1}{2} \cos(\omega_c - \omega_m) t + \frac{1}{2} \cos(\omega_c + \omega_m) t$$

where  $\omega_m$  = modulation frequency,  
 $\omega_c$  = carrier frequency and  
 $t$  = time.

Hulick is vice president of engineering, Acrodyne Industries, Blue Bell, PA.

This relationship commonly applies when the modulating waveform is a simple sine wave. More complex modulating waveforms may be expressed as a Fourier series of sine or cosine terms, but carrier and sideband terms retain the same form, and the modulation coefficient  $m$  modifies the amplitude of the  $\cos \omega_m t$  term.

Any approach to develop the carrier and associated sidebands of equation 1 is fair game as a method to generate AM. The purpose of this article is to present a new method of generating pseudo-continuous amplitude modulation at any carrier frequency and at any modulation (depth) index between zero and one by using any class of amplifier (A, AB, B, C, D, H, S) as an RF source. First, however, it is necessary to review the operation of a common, yet often unfamiliar, RF component.

## The combiner/splitter

The *quadrature hybrid power combiner/splitter* is well-known in some circles, but completely unknown in others. It is favored for microwave systems because of its small size at those frequencies and because it provides a practical way to sum the RF output power of many signal sources, producing a much larger signal than that available from any single source. The device seldom is found in RF designs below about 50MHz, because the size and cost become prohibitive. Its theory remains valid at all RF frequencies, however. Throughout this discussion, the device may be referred to as a *hybrid*, a *combiner*, a *splitter* or a combination of these terms.

A quadrature hybrid combiner is a 4-port component that consists of two or more parallel conductors placed inside, but isolated from, a common outer conductor, such that the two lines share the same *E* and *H* fields. For this basic definition, disregard any restrictions on such factors as characteristic impedance of the coaxial arrangement or the location of terminations. Simply stated, two conductors that share a common field mutually induce current in one another according to laws of physics. The TV section of the "NAB Engineering Handbook" contains a vector analysis of the

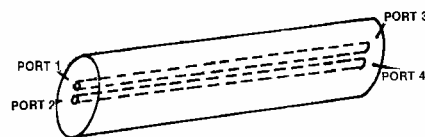

Figure 1. A quadrature hybrid is a 4-port device with two coupled lines inside a common outer conductor. The outer conductor is normally grounded.



# AMEK

# AMEK BCII-Compact Audio Engineering for Broadcast Production

Preferred for Film and Video Post · Audio Post for Radio · Stereo  
Television · Foley · ADR · Transfer · ENG · On-Location Recording ·  
Corporate Video Production.

AMEK's BCII System responds to the needs of the contemporary Broadcast Production environment for a higher standard of performance and flexibility in compact audio production consoles.

Our in-depth understanding of operational and creative requirements has led to the inclusion of many new and valid design ideas. Our innovative approach has created an audio-mixing system which is truly compatible with almost any operating environment; whilst its competitive pricing makes the BCII extremely budget-efficient.

A range of interchangeable modules in both Mono and Stereo formats utilising plug-in subassemblies, combined with comprehensive control facilities, allow many tasks to be accomplished in a number of ways. Customization of signal flow paths using internal links, optional Dynamics modules and several chassis variations, further serve to increase the capabilities of the system.

The robust, all-metal chassis design fully screens the electronics from stray electromagnetic fields; ultra-low-noise circuitry, balanced outputs, and the use of balanced bussing provide exceptional performance characteristics. The AMEK equalizer has a very wide operating range, suited to any application from delicate track sweetening to severe, corrective equalization.

The monitoring system allows comprehensive handling of gallery/control room requirements. Various metering arrangements are available.

Furthermore, the BCII has ports for AFV (Audio Follows Video) which can be configured for either Remote Muting in the standard version or for remote DC control of fader levels in the VCA version.

In essence, an outstanding product specified worldwide by a diverse range of clients, from owner-operators to major, multi-installation broadcasters such as the BBC and NBC.



AMEK BCII  
IN 8/4/2 VERSION



AMEK BCII  
IN 24/4/2  
STUDIO CHASSIS  
VERSION

Head Office, Factory and Sales: AMEK Systems and Controls Ltd, Islington Mill,  
James Street, Salford M3 5HW, England. Tel: 061-834 6747.  
Telex: 668127 AMEK G E-MAIL: AMEK-UK. Fax: 061-834 0593.

In the USA: AMEK Controls Inc. 10815 Burbank Blvd, North Hollywood, CA 91601.  
Tel: 818/508 9788. Telex: 662526 AMEK USA E-MAIL: AMEK US. Fax: 818/508 8619.



# AMEK



Circle (64) on Reply Card

**STANTRON**

# CENTER

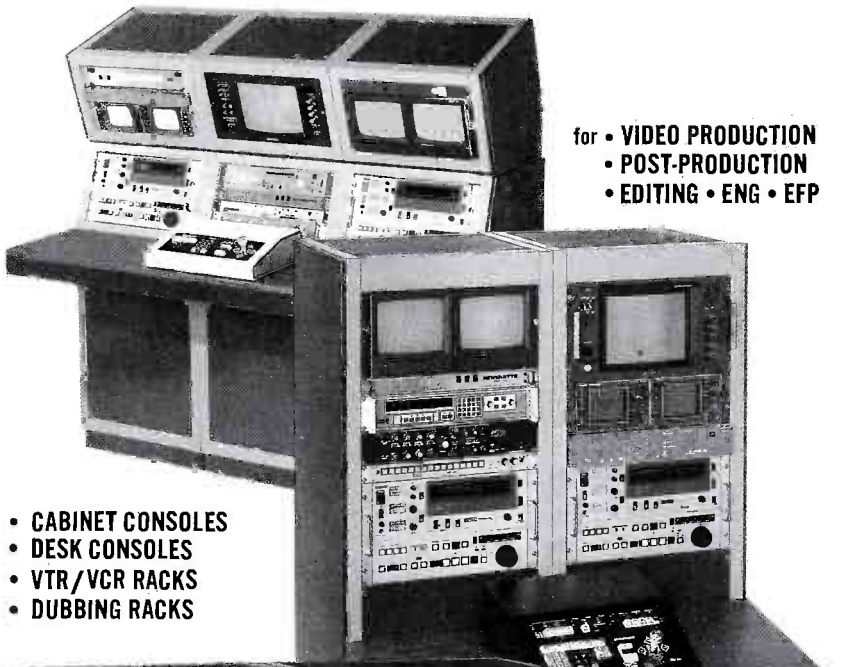

for • VIDEO PRODUCTION  
• POST-PRODUCTION  
• EDITING • ENG • EFP

- CABINET CONSOLES
- DESK CONSOLES
- VTR/VCR RACKS
- DUBBING RACKS



**STANTRON VIDEO CENTER**  
Designed for **YOUR VIDEO EQUIPMENT** has modular "add-on" features that allow maximum flexibility and versatility in designing console arrangements for professional, industrial, communication and educational **VIDEO CENTERS.**

Write or call for **FREE VIDEO CENTER CATALOG # 200**

mailing address: P.O. Box 750VC  
No. Hollywood, CA 91605 U.S.A.  
or call Toll Free: 1-800-451-0019  
No. Calif. Toll Free: 1-800-451-0020  
So. Calif. please call 1-213-775-0800  
TWX 910-495-2177

# STANTRON

Unit of Zero Corporation

factory:  
6900-6918 Beck Ave.  
No. Hollywood, CA 91605

Circle (42) for CALL ME, I'M INTERESTED  
Circle (43) for SEND LITERATURE ONLY

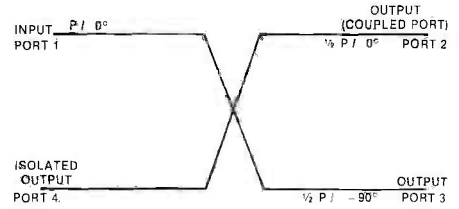

**Figure 2.** A schematic representation of the quadrature hybrid power splitter. If power is fed into port 1, it is split equally between ports 2 and 3 with the phase relationships shown. Ideally, no power leaves port 4.

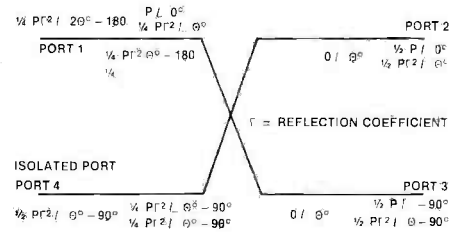

**Figure 3.** For the same type of mismatch at ports 2 and 3, all reflected power is transferred to port 4. Reflected powers to port 1 cancel each other because of phase relationships shown.

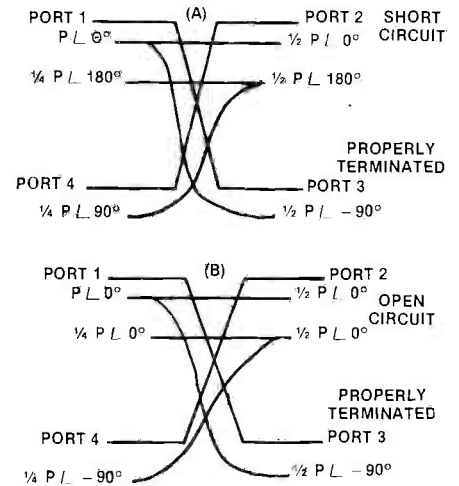

**Figure 4.** Output ports 2 and 3 are isolated from one another's mismatch. (a) shows signal paths when port 2 is terminated in a short, and (b) shows the paths when port 2 is terminated as open.

device.

The hybrid device exhibits several interesting and significant properties. Figure 1 shows coupled lines at the center of a common outer (grounded) conductor. Four ports, where appropriately sized connectors may be attached, are identified. The hybrid is shown schematically in Figure 2.

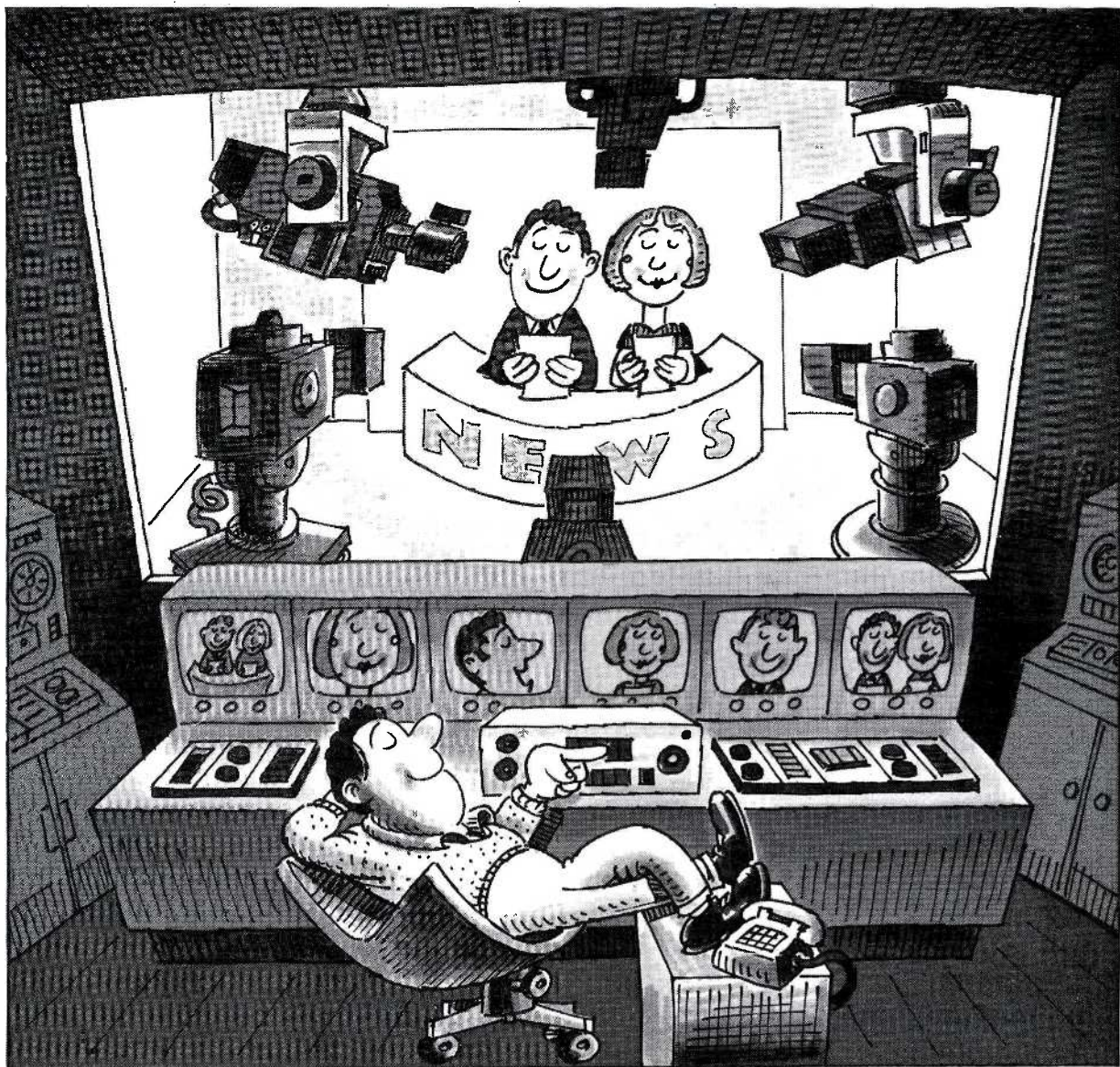

# MULTIPLE CAMERAS. ONE OPERATOR.

Impossible? Not if your cameras are mounted on EPO Servo-Controlled pan and tilt heads. These extraordinary, labor-saving devices, which first found favor in legislatures where remote-controlled, unobtrusive coverage was a key factor, are now the basis for complete remote-controlled news studios.

#### Just look at these outstanding features:

- Up to 500 preprogrammed positions per camera, including control of iris and black levels
- Programmable fade modes that provide smooth transition from preprogrammed shots

- Ability to zoom and focus
- Unobtrusive
- Can be operated via telephone lines or microwave in a remote studio away from the main studio location
- Wide range of pan and tilt heads, for full studio cameras with teleprompters to ENG type cameras
- Wide range of control options, from panels with multiple-shot memories to simple joy stick remote controls.

It's flexible, affordable—and it's sold and serviced exclusively in the U.S.A. by A.F. Associates.

## THE RADAMEC EPO REMOTE CAMERA CONTROL SYSTEMS

Your news show's bottom line will never look so good.



### A.F. ASSOCIATES INC.

ADVANCED SYSTEMS AND PRODUCTS FOR THE VIDEO INDUSTRY  
100 STONEHURST COURT NORTHVALE NJ 07647 (201) 767-1000  
10650 SCRIPPS RANCH BLVD SUITE 200 SAN DIEGO CA (619) 530-2970

Circle (121) on Reply Card

**SOME THINGS  
NEVER CHANGE...  
JUST GET BETTER**

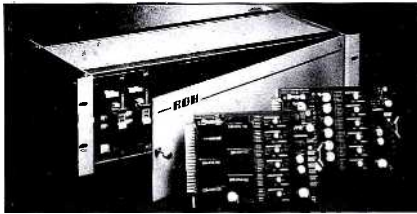

**AUDIO DAs**

- ° ONE INPUT, SIX TRANSFORMER OR DIFFERENTIAL BALANCED OUTPUTS
- ° MASTER GAIN CONTROL PLUS INDIVIDUAL CONTROLS ON EACH OUTPUT
- ° MAXIMUM HEADROOM
- ° FIELD-PROVEN RELIABILITY
- ° COMPATIBLE WITH EXISTING SYSTEMS
- ° SUPPORTED BY A LARGE SELECTION OF CONTROL/BUFFER/INTERFACE MODULES AND POWERED RACK ENCLOSURES

THE BROADCASTERS CHOICE  
INTERCOM, DISTRIBUTION, MONITORING SYSTEMS



913 West 223rd. Street Torrance, CA 90502  
(800)262-4671 inCA:(213)533-5984  
Telex:9102 400 141 Fax:(213)533-6050

Circle (89) on Reply Card

**Now get the same  
service and equipment  
on this coast...**



**as you do on this coast.**



East Coast or West Coast. Now the same complete selection of sophisticated video equipment you've come to expect from Camera Mart/New York is yours to rent or buy from CMTV/Burbank.

The same great service, too. So now, you can have the best of both coasts.

*We've been big in video since  
it was small.*

**The Camera Mart, Inc.**  
SALES • SERVICE • RENTAL

456 West 55th St, NY 10019  
(212) 757-6977 Telex: 275619/FAX (212) 582-2498  
1900 W. Burbank Blvd., Burbank, CA 91506 (818) 843-6644

Circle (90) on Reply Card

If the device, configured as a splitter, is of the correct dimensions for a given frequency, then the power of an input signal applied to port 1 is divided equally between ports 2 and 3. The signal at port 2 exhibits the same phase as that at port 1, excluding small propagation delays. At port 3, the phase is  $-90^\circ$  with respect to ports 1 and 2.

Whether the power is split equally between ports 2 and 3 depends upon the electrical length of the lines and the degree of coupling, which, in turn, are re-

lated to the shape and proximity of the lines. The characteristic impedance ( $Z_c$ ) depends upon the cross-sectional geometry of the entire structure. If the lines and outer conductor are of circular cross section, the ratio of the inside diameter of the outer conductor to the outside diameter of one of the lines should be 4 for  $Z_c = 50\Omega$  at each of the four ports. If the lines are circular, and the outer conductor is square in cross section, then the ratio of the inside length of one of the sides of the outer conductor to the outside diameter of one of the lines should be 3.5 for  $Z_c = 50\Omega$ .

The degree of coupling depends upon the spacing between the lines, while the length of enclosed line determines the frequency range over which the degree of coupling remains reasonably constant. The device maintains a degree of coupling to within a few tenths of a decibel more than an octave of bandwidth ( $f$  to  $2f$ ) and a nearly constant  $90^\circ$  phase shift to the quadrature port. Outside the octave bandwidth, coupling decreases in both directions, and the phase angle departs

*Continued on page 74*

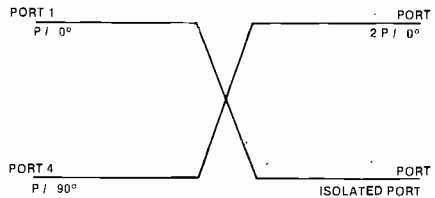

**Figure 5.** A schematic representation of the quadrature hybrid as a power combiner. The device is the same as the splitter, but is connected as shown.

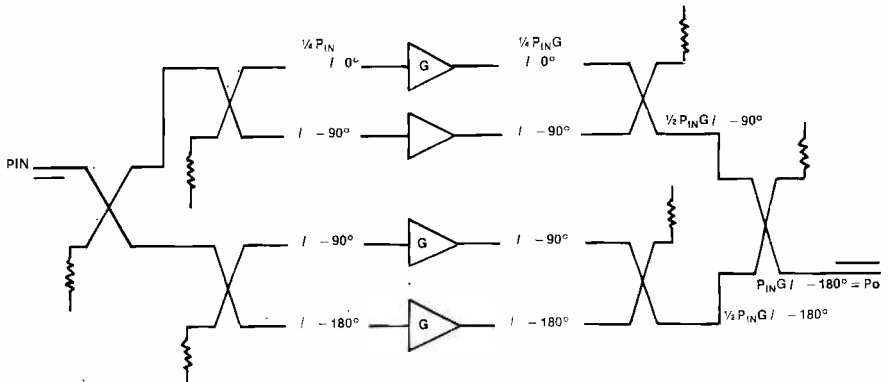

**Figure 6.** A configuration of three splitters and three combiners is connected to preserve phase. In the output signal, the four gain blocks (g) will appear as a single amplifier.

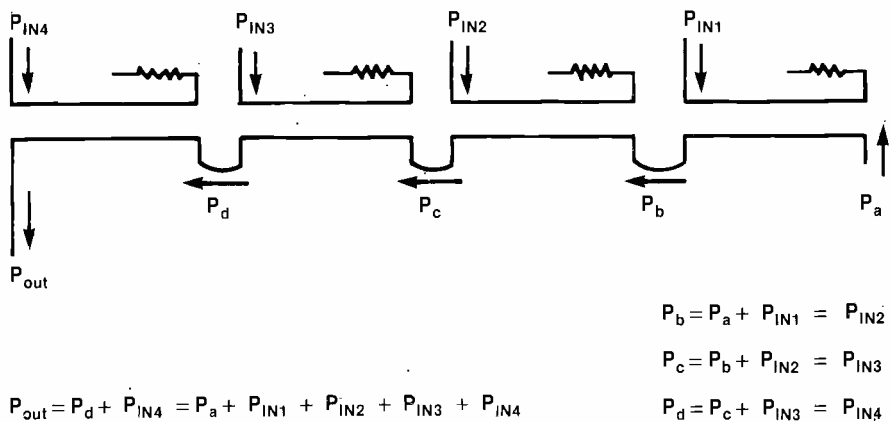

$$P_b = P_a + P_{IN1} = P_{IN2}$$

$$P_c = P_b + P_{IN2} = P_{IN3}$$

$$P_d = P_c + P_{IN3} = P_{IN4}$$

$$P_{out} = P_d + P_{IN4} = P_a + P_{IN1} + P_{IN2} + P_{IN3} + P_{IN4}$$

**Figure 7.** Four power-combining hybrids are connected with the output of each, feeding one input port of the unit to its immediate left. Input power at each input port doubles from the previous one, moving from the right, so that they are summed at  $P_{OUT}$ .

**360 Million Miles  
Travelled.**

---

**52,000 Hours  
of Continuous Transmission.**

---

**40+ Programmers  
Served to Date.**

---

**7,000+ C-Band  
Headend Antennas.**

---

**35,000,000+ Subscribers.**





# Six Years

*Satcom III-R was launched six years ago, and since then it has racked up some numbers worth celebrating.*

The hours and the miles haven't affected III-R's signal strength. In fact, the bird is performing as well as ever. This year's test data prove it — transponders meet or exceed the original performance specifications.

And Satcom III-R's protection system — a system offering in-orbit

replacement for *all* protected transponders on III-R — has always been and still is the best in the business, a standard for the industry.

With that kind of strength and security, it's not surprising that Satcom III-R commands the confidence of many prominent programmers.\*

A number of major programmers — including Arts & Entertainment Network, CBN, ESPN, Lifetime

and Trinity Broadcasting Network — have already expressed their opinions by signing contracts for the entire life of the satellite, through 1992.

In addition to serving today's leading programmers on Satcom III-R and its companion bird, Satcom IV, we're taking steps to help launch the programmers of tomorrow. Our "grow-with" rates, for example, help

\*Today, programmers on Satcom III-R include: Arts & Entertainment Network, Black Entertainment Network, Cable Value Network, ESPN, Financial News Network/Telshop, HBO/Cinemas, Home Shopping Network, The Learning Channel, Lifetime, QVC Network, Reuters Monitor Service, Shop Television Network, TEMPO Television, The Travel Channel, Trinity Broadcasting Network, USA Network.



# s Young.

newcomers get into the business on Satcom I-R and II-R without going into the red.

All the programmers on III-R, successes and start ups alike, have 7,000 things in common: that's how many operators' antennas are pointed at our bird. And it represents a potential reach of 35 million subscribers.

Satcom III-R's success runs in

the ever-growing Americom family of satellites. By any measure — services, hours, antennas or dollars invested — the GE Americom fleet is the leader in C-Band. Bill Berman, Director of CATV Services, (609) 987-4073, can fill you in on the facts.

*You're invited to our party at the show.* Come join the GE Americom family when we celebrate Satcom III-R's birthday in our booth, 246, at

the Western Cable Show. You'll eat cake, make noise, and remember how it feels to be six years young again.



*GE American Communications*

Circle (141) on Reply Card

December 1987 **Broadcast Engineering** 73

# The digital modulator-transmitter: a general derivation

Recall that the general formula for amplitude modulation is:

(Equation 1)  

$$(1 + \cos\omega_m t)\cos\omega_c t = \cos\omega_c t + \frac{1}{2}\cos(\omega_c - \omega_m)t + \frac{1}{2}\cos(\omega_c + \omega_m)t$$

where  $\omega_m$  = modulation frequency,  
 $\omega_c$  = carrier frequency and  
 $t$  = time.

Furthermore, in a hybrid combiner, the output power produced by inputs  $P_{IN1}$  and  $P_{IN2}$  is:

(Equation 2)  

$$P_O = ((P_{IN1}/2)^{1/2} + (P_{IN2}/2)^{1/2})^2$$

The power directed toward the isolation/reject port is:

(Equation 3)  

$$P_{ISO} = ((P_{IN1}/2)^{1/2} - (P_{IN2}/2)^{1/2})^2$$

For the general case, let  $n$  be the number of bits in the binary word, such that  $n$  equals the number of power input ports to an  $n$ -port combiner. The first port will be referred to as the *zeroth* port, with all ports numbered from zero to  $n-1$ .

$p$  is the least significant power level to the *carry* input from imaginary lower-level combiners. Let  $P_{CI}$  be the total power into the combiner from those amplifiers that are gated on. Then,

(Equation 4)  

$$P_{CI} = p + p_1 + p_2 \dots p_k + \dots p_{n-1} + p_n \text{ or}$$

(Equation 5)  

$$P_{CI} = p + m_1 2^0 p + m_2 2^1 p + \dots m_k 2^{k-1} p + \dots m_{n-1} 2^{n-2} p + m_n 2^{n-1} p,$$

where  $m_k = 1$  for the  $k$ th amplifier on,  
 $m_k = 0$  for the  $k$ th amplifier off,  
 $p$  = the smallest unit of input power and  
 $p_k = m_k 2^{k-1} p$ .

Written more conveniently as a series, it follows that

(Equation 6)  

$$P_{CI} = p(1 + \sum_{k=1}^n m_k 2^{k-1}).$$

Let  $V_{IN}$  be the total binary weighted logic voltage gating the amplifiers, and let  $V_i$  be the actual logic level for a *logic 1* state. Then,

(Equation 7)  

$$V_{IN} = V_1 + V_2 + \dots V_k + V_{n-1} + V_n \text{ or}$$

(Equation 8)  

$$V_{IN} = m_1 2^0 V_1 + m_2 2^1 V_1 + \dots m_k 2^{k-1} V_1 + \dots m_{n-1} 2^{n-2} V_1 + m_n 2^{n-1} V_1$$

where  $m_k = 1$  for the  $k$ th bit = logic 1 (kth amplifier on),  
 $m_k = 0$  for the  $k$ th bit = logic 0 (kth amplifier off) and  
 $V_k = m_k 2^{k-1} V_1$ .

This is conveniently noted in series form as,

(Equation 9)  

$$V_{IN} = V_1 (1 + \sum_{k=1}^n m_k 2^{k-1}).$$

Remember that the actual logic level gating each of the  $n$  amplifiers is  $V_i$ . All  $V_1$  through  $V_n$  are binary weighted voltages assigned by position in a binary word and corresponding power level of the associated amplifier.

Let  $P_{OUT}$  = total power out of the combiner/modulator according to which  $m_k = 0$  and  $m_k = 1$ . The combiner interstage power levels may be found according to the following series of equations derived from equation 2, or:

(Equation 10)  

$$p'_2 = ((p'_1/2)^{1/2} + (p_1/2)^{1/2})^2,$$

$$p'_3 = ((p'_2/2)^{1/2} + (p_2/2)^{1/2})^2,$$

$$p'_k = ((p'_{k-1}/2)^{1/2} + (p_{k-1}/2)^{1/2})^2,$$

Continued from page 70  
 greatly from 90°.

## Terminations

If ports 2 and 3 are terminated in the proper characteristic impedance, no power is coupled to port 4. On the other hand, if the same magnitude and phase mismatch exist at both output ports 2 and 3, then they effectively become input ports for the reflected waves produced. As shown in Figure 3, the mismatch conditions previously described cause all reflected power to appear in port 4. Port 1, however, does not see the mismatch conditions, so a perfect termination is maintained at the expense of power lost to port 4.

If the mismatches at ports 2 and 3 are not alike, some power is reflected back to port 1, because amplitude and phase cancellation cannot occur at port 1. This presents a problem if loads connected to port 2 or 3 of a hybrid power splitter change in some way. The problem in the splitter configuration is less serious than it might appear, however, because power levels to the splitter generally are much lower than those to a combiner.

Port 4 is called the *isolated* (or *reject*) port, where a dummy load is connected to absorb reflected power. It is sized according to the expected worst-case reflected power. If the loads connected to ports 2 and 3 were always perfect, a dummy load at 4 would not be needed, and the port could be left unterminated.

That the two output ports ideally do not see each other is a significant property of the hybrid. A mismatch may occur at one output port, yet the other sees no reflected power. This is true (see Figure 4) whether a port is short- or open-circuited. It is possible because, for a signal returning into port 2 (or 3), the opposite output port 3 (or 2) becomes the new isolated port for the reflected wave. With all other ports properly terminated, no power goes to the new isolated port. It appears that the output ports are isolated from each other, but the real degree of isolation is within the range of 20dB to 30dB.

## Signal combining

Figure 5 illustrates the hybrid as a power combiner, corresponding to the splitting configuration of Figure 2. Because the hybrid is a reciprocal device, the analysis is the reverse of the splitter. Two equal-amplitude signals with a split in phase of 90° are applied to ports 1 and 4. They combine into port 2, while port 3 becomes the isolated port. It retains all the properties of the splitter, likewise affording input ports isolated with respect to one another.

If a hybrid is constructed to be a 3dB splitter or combiner, power is equally



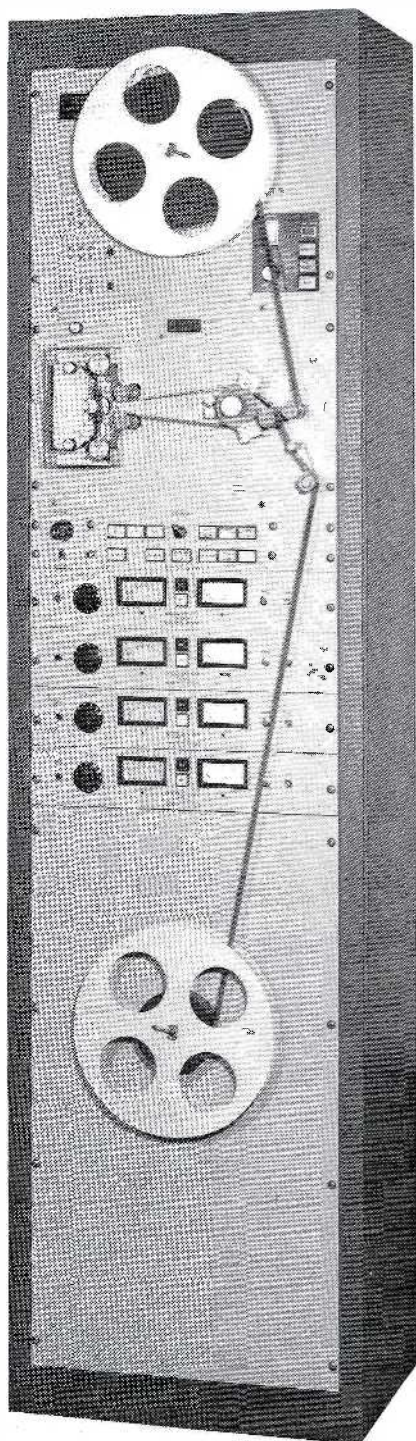

# MAGNA-TECH

## THE SOUND HEARD AROUND THE WORLD

Magnetic Film  
Recorders and Reproducers  
for Television and Film  
Sound Post-Production

### HIGH SPEED

Telecine Magnetic Followers  
Video Tape-Film Interlock  
Electronic Looping  
Dubbing Systems  
16 and 35mm Electronic Projectors  
Total Facility Engineering

#### WORLDWIDE SALES OFFICES

**Paris**

Hi-Fidelity Services  
4 Rue Semard  
75009 Paris, France

**Sydney**

Magna-Techonics (Aust.)  
PO Box 150  
Crows Nest NSW 2064  
Australia — Telex 24655

**Johannesburg**

General Optical Co., Ltd.  
15 Hulbert Road  
Johannesburg 2001,  
South Africa

**Rome**

Alberto Sciarett  
Via Siria 24  
Rome 00179  
Telephone 7943618

**Brussels**

A.R.C.  
Rue de Boisde Linthout 45  
1200 Brussels Belgium

**Hong Kong**

Paul Yang and Associates  
901 Star House  
3 Salisbury Road  
Kowloon, Hong Kong

**Bombay**

Capt. P.K. Vishwanath  
234/4 Rama Baug,  
Deodhar Road  
Bombay 400 019, India

**Kehl West Germany**

Zenon GMBH  
Postfach 1743  
Hauptstrasse 128  
Kehl am Rhein  
Tel: 07851/2991  
Telex: 753537

**London**

Branch & Appleby  
42 High Street  
Harrow-on-the-Hill  
Middlesex HA1 3LL,  
England

**Kuala Lumpur**

Kinematronika Sdn. Bhd.  
2852, Jalan Selangor/  
Persekutuan,  
Federal Hill  
Kuala Lumpur, Malaysia

**Caracas**

Cine Materiales srl  
Apartado Postal 61.098  
Caracas 106 Venezuela

## MAGNA-TECH ELECTRONIC CO., INC.

630 Ninth Avenue, New York, N.Y. 10036

Telephone (212) 586-7240

Telex 126191

Cables "Magtech"

Circle (49) on Reply Card

$$p'_n = ((p'_{n-1}/2)^{1/2} + (p_{n-1}/2)^{1/2})^2,$$

$$P_{OUT} = ((p'_n/2)^{1/2} + (p_n/2)^{1/2})^2 \text{ and}$$

$$P_{OUT-MAX} = P_{OUT} \text{ for all } m_k = 1.$$

Furthermore, for the condition that  $p'_n = p_n$ , all  $m_k = 1$ , because the sum of all amplifier output powers necessarily adds to  $p_n = p'_n$ . It follows that:

(Equation 11)

$$P_{OUT-MAX} = ((p'_n/2)^{1/2} + (p_n/2)^{1/2})^2 = (2(p_n/2)^{1/2})^2 = 2p_n.$$

Because  $p_n = 2^{n-1}p$ , for  $m_n = 1$ ,

(Equation 12)

$$P_{OUT-MAX} = 2p_n = 2(2^{n-1}p) = 2^n p.$$

Shown another way for the same case, that is, all  $m_k = 1$ , no power is lost in the reject loads and

(Equation 13)

$$P_{OUT-MAX} = P_{CI}, \text{ for all } m_k = 1.$$

From equation 6,

(Equation 14)

$$P_{OUT-MAX} = p(1 + \sum_{k=1}^n 2^{k-1}).$$

From the identity

(Equation 15)

$$2^n = (1 + \sum_{k=1}^n 2^{k-1}),$$

it again follows that

(Equation 16)

$$P_{OUT-MAX} = 2^n p.$$

It was stated previously, and shown by example, that the square of the input power to the combiner is numerically equal to the power output and that this square law is actually what provides the perfection of modulation linearity when voltages gate powers on and off. This leads to the following relationship:

(Equation 18)

$$P_{OUT} = P_{CI}^2 / P_{OUT-MAX}.$$

By combining equations 6 and 16, it follows that

(Equation 19)

$$P_{OUT} = ((p^2(1 + \sum_{k=1}^n m_k 2^{k-1})^2) / 2^n p) \text{ or}$$

$$P_{OUT} = ((p(1 + \sum_{k=1}^n m_k 2^{k-1})^2) / 2^n).$$

At this point in the general development, expressions are known for  $P_{CI}$ ,  $V_{IN}$ ,  $P_{OUT}$  and  $P_{OUT-MAX}$  in like terms. It is possible to determine combiner/modulator system gain,  $G$ , from logic voltage levels to output power,  $P_{OUT}$ .

By definition,

(Equation 20)

$$G = V_{OUT} / V_{IN} = (P_{OUT} R_L)^{1/2} / V_{IN},$$

where  $R_L$  is the load resistance connected to  $P_{OUT}$ . Substituting equation 19 into 20 yields

(Equation 21)

$$G = (((p(1 + \sum_{k=1}^n m_k 2^{k-1})^2) / 2^n)^{1/2}) ((R_L)^{1/2} / V_{IN}) \text{ or}$$

$$G = ((p R_L) / 2^n)^{1/2} (1 + \sum_{k=1}^n m_k 2^{k-1}) (1 / V_{IN}).$$

Substitution of equation 9 into 21 leaves

(Equation 22)

$$G = 1 / \sqrt{p R_L / 2^n}.$$

Furthermore, from equation 16,

$$P_{OUT-MAX} = 2^n p,$$

and substituting into equation 22 gives

split in amplitude to two ports or combined completely from two equal-amplitude ports. If power levels at the two combiner input ports are unequal, some power will be lost in the isolation-port load. Because vector voltages are combining to produce power, the output  $P_O$  is related to the input power levels  $P_{IN1}$  and  $P_{IN2}$ , according to:

(Equation 2)

$$P_O = ((P_{IN1}/2)^{1/2} + (P_{IN2}/2)^{1/2})^2.$$

The power sent to the isolation port becomes:

(Equation 3)

$$P_{ISO} = ((P_{IN1}/2)^{1/2} - (P_{IN2}/2)^{1/2})^2.$$

If  $P_{IN1} = P_{IN2}$ , then equation 2 reduces to the sum of the input powers, while equation 3 goes to zero. If either  $P_{IN1}$  or  $P_{IN2}$  is zero, half the power of the remaining active input goes to the output port, while the other half appears at the isolation-port dummy load. The input ports remain isolated from one another.

Multiple quadrature hybrid sections may be connected in various ways to achieve a desired purpose. Figure 6 illustrates an interconnection to split drive power among four output ports to drive four separate amplifiers. The outputs of the amplifiers are applied to a combiner configuration, summing the signals back to a single output port.

### Cascades of digital gates

Combining properties of the basic quadrature hybrid and relationships (equations 2 and 3) produces the configuration shown in Figure 7. The symbol for this application of the hybrid is changed to more closely reflect the actual construction of the device and is helpful in preventing crossed lines interconnecting the cascaded combiners. In all hybrids shown, the dummy or reject load is connected to the isolated port with respect to the two output ports. Power input doubles in moving from right to left, so that  $P_{IN2} = 2P_{IN1}$ , and  $P_{IN3} = 2P_{IN2}$ , and so on.

System power levels are selected so that they sum to one, but the most important relationship is that the input power levels are weighted relative to the placement of digits of a binary number made of ones and zeros. Moving from the right in a binary word, each succeeding character has twice the numerical weight of the number to the immediate right. In Figure 7, all inputs are on. That is, if input port activity is controlled by a one or a zero digit of a binary word, they all would be the same—one or zero. (For the sake of simplicity, logic one conventionally means on, and logic zero corresponds to input power off.)  $P_a$  always ex-

# GOOD BREEDING SHOWS.

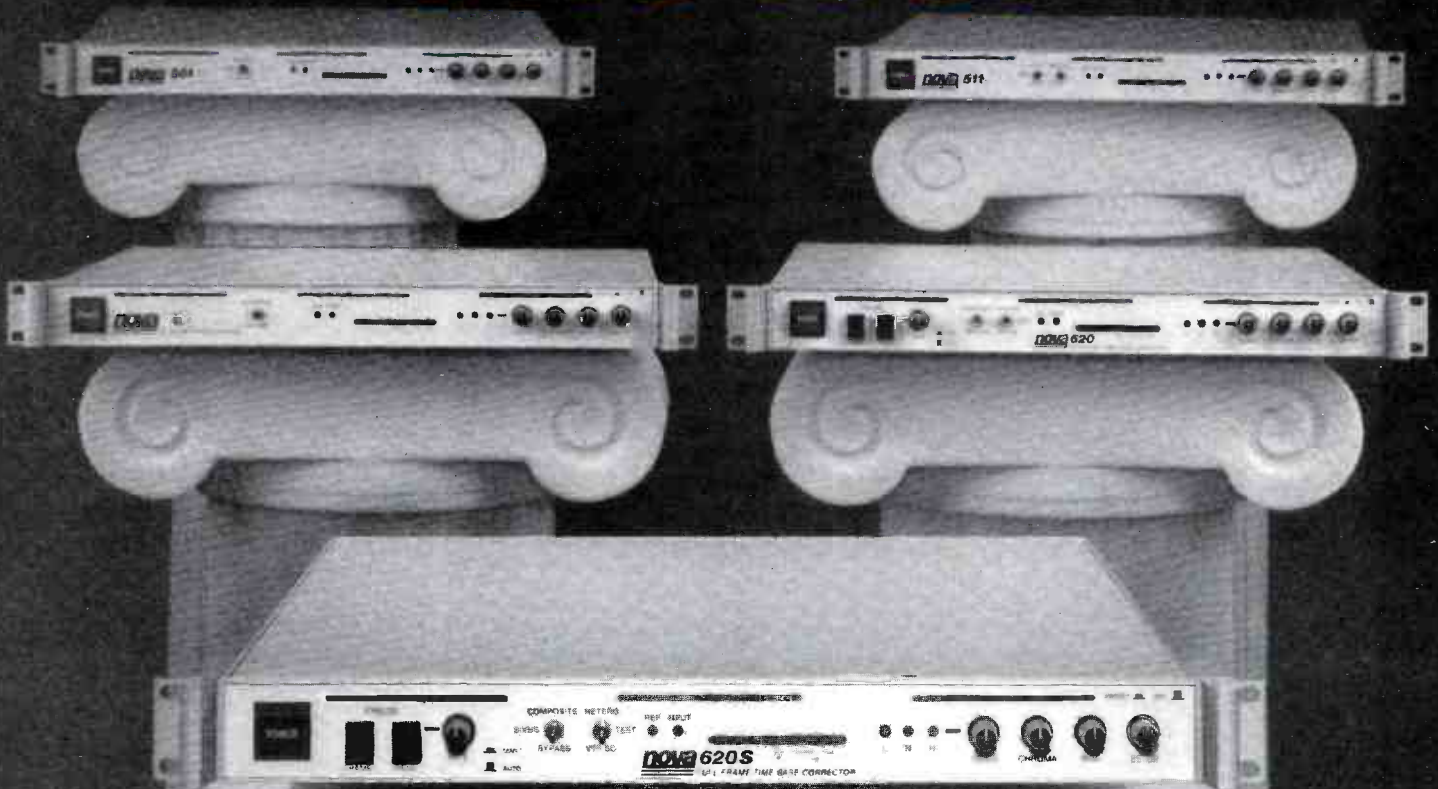

## ***NOVA* 620S S-VHS TBC.**

NOVA's 620S TBC with S-VHS processing is the latest in a long line of high-quality time base correctors. It inherits all the fine features of the NOVA 620... and it's the first TBC to interface with S-VHS VCRs. That means you maintain the quality of video, every generation. And if you own a NOVA 620, you can also exercise your "S" option, which upgrades your unit to a 620S.

From the first one-rack, low-cost TBC in 1983 to the 620S, each addition to the NOVA family clearly demonstrates our commitment to excellence. And if a problem ever develops, we stand behind our TBC family by offering quick, 24-hour turn-around service. It's a heritage we're proud of... and a heritage you can rely on.

Call us, or ask your professional video dealer about our fine family of TBCs, including the NOVA 501, 511, 620 and low-cost 700.

***NOVA... the clear leader in TBC technology.***

***NOVA***

**SYSTEMS, INC.**

50 Albany Turnpike Canton, CT 06019 (203) 693-0238  
Circle (48) on Reply Card

**Equation 23**

$$G = p / \sum_{k=1}^n m_k^2 / (100 - \eta_{in})^2$$

Equation 23 shows  $G$  is a constant and is not a function of input or output power. It is perfectly linear without accounting for quantization error that takes place if  $m$  is less than infinity.

To find the efficiency of the combiner, it is known by previous numerical example that it is only theoretically perfect for the case when all amplitudes are on, that is, all  $m_k = 1$ . Efficiency  $\eta$  is defined to be:

$$\eta = P_{out} / P_{in}$$

From equations 19 and 21:

**Equation 24**

$$\eta = (p(1 - \sum_{k=1}^n m_k^2)^2) / (2p(1 - \sum_{k=1}^n m_k^2) - \sum_{k=1}^n m_k^2 \cdot 2^k - 1)$$

$$= (p(1 - \sum_{k=1}^n m_k^2)^2) / (2p - 2)$$

$\eta$  is a function of  $m_k$  and is less than unity except when all  $m_k = 1$ , because power must go into the reject leads to maintain linearity.

For all  $m_k = 1$ :

$$\eta = (2^2 - 1) / (2 \cdot 2 - 2)$$

and from equation 15:

$$\eta = 2^2 / 2^2 = 1$$

For all  $m_k = 0$ :

$$\eta = 0 / 2^2$$

Although  $\eta$  is infinitesimally small for large  $n$ , the power that is actually being wasted is most of the power contained in  $p$ , the least significant power level. As an example, for a 4-bit combiner, in the word  $1101$  according to DQ34 with  $A$  as the least significant figure, Combiner/modulator efficiency is determined by using equation 24 and  $p$  substituted according to the 4-bit word.

When all inputs are off,  $p$  is still injected into the carry port of the combiner and becomes a source of quantization error of the modulator.  $p$  is representative of the modulator's inability to generate a power smaller than  $p$ , if that power is what is called for by the analog waveform being digitized. Likewise, the analog-to-digital converter driving the modulator cannot resolve a waveform amplitude that is less than that represented by the least significant bit.

To reduce quantization error,  $p$  is made large enough so that  $p$  may be made small enough to be imperceptible. For audio,  $n$  should be 12 or greater. The minimum value for  $n$  for video is unknown to the author, but is probably at least 12.

ists and is not considered to be controlled by a binary digit, but represents the total power coming from all previous stages, if they exist.

The result is an amplitude modulator that can be controlled by the binary representation of the instantaneous value of the amplitude of an arbitrary waveform. Obviously, a mixture of ones and zeros results from any sample taken. For a modulator of this type, it is necessary for the power output of the combiner to produce the proper RF power level representing the modulation level sampled. Otherwise, modulation will be non-linear, and distortion will occur.

Figures 8 to 12 show numerical examples of the resultant summed power with one or more inputs turned off by a logical zero, assuming the same configuration as shown in Figure 7. For simplicity, assume the summed power to be one unit of power (1W). Four input ports allow a 4-bit word of 16 possible states.

The lowest power input becomes one divided by 16, or 0.0625W. Equations 2 and 3 allow intermediate power levels to be found. Figure 8 indicates that a logical word of  $1101$  produces an output level of 0.765 power units, while the input sum  $P_{IN}$  is 0.875. In Figure 9, a control word of  $1011$  produces the output 0.5625 from an input total of 0.75. Figure 10 shows an output power of 0.25, with an input sum of 0.5.

It is worth noting (and essential to the linearity of the modulator) that the output power is numerically equal to the square of the input power ( $0.875^2 = 0.765$ ,  $0.75^2 = 0.5625$ ,  $0.5^2 = 0.25$ ). If carried through for all 16 cases of the 4-bit word, the relationship holds. At first, it appears the square law relationship would render the combiner useless as a linear amplitude modulator. However, the digital voltage representations of an arbitrary waveform are just that—voltages controlling powers that automatically square the voltages into powers so that the squaring is canceled. In effect, the digital voltage word is squared into a power word that is perfectly linearly proportional to the power at the summed port  $P_{OUT}$ .

The linearity of the modulator is independent of the type of power source, as long as available power to each port remains precisely double that of the next lower power-input port. The proper amount of waste power automatically finds its way to a reject load, and not to  $P_{OUT}$ , to maintain linearity.

It also may seem, at first glance, that the modulator is terribly inefficient, because power must be dumped into reject loads for the system to work. The combiner/modulator is theoretically 100% efficient with all inputs on. Efficiency de-

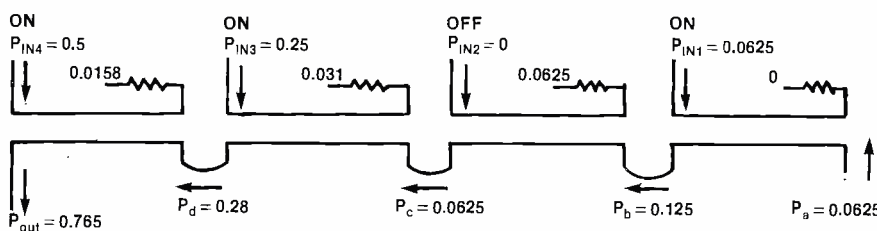

**Figure 8.** Combining hybrids with  $P_{IN2}$  in the off condition. Power levels shown represent a relationship to a total power of one unit if all inputs were on.

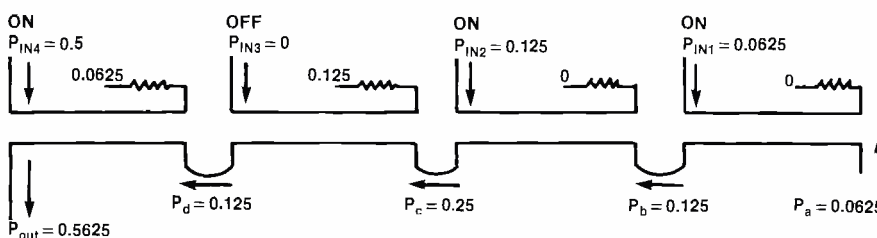

**Figure 9.** The system illustrated with  $P_{IN3}$  in the off condition.

## The Abekas A42 Digital Still Store

The Abekas A42 is used daily at television stations and production facilities all across the United States and Canada. With over 450 machines delivered, the A42 has proven to meet the performance and reliability demands of a wide variety of customers. Networks such as ABC, CBC, CNN, HLN, and NBC. Major independents like KCOP, WWOR, and WTBS. Post production houses like Action Video, One Pass, and Unitel. Mobile trucks

such as Clearwater, Greene Crowe, and Northwest Mobile. Rental houses like All Mobile Video, Bexel, Video Rentals.

In short, the A42 has become the clear choice of all those who want to juggle thousands of pictures with cost-effective ease.

The A42 Digital Still Store offers a wide variety of operating advantages, including: on-line hard disk storage of up to 1050 frames/2100 fields... advanced digital signal processing... outstanding multi-generation capa-

bility for graphics composition... digital tape cartridge for cost-effective off-line storage... optional library system for sophisticated management of both on-line and off-line pictures... single or dual channel configurations.

To find out why the A42 has become the most popular still store, contact: Abekas Video Systems Inc., 101 Galveston Drive, Redwood City, CA 94063. (415) 369-5111.

**Abekas**

Video Systems, Inc.

Now Anything is Possible.

Circle (50) on Reply Card



The most popular still store

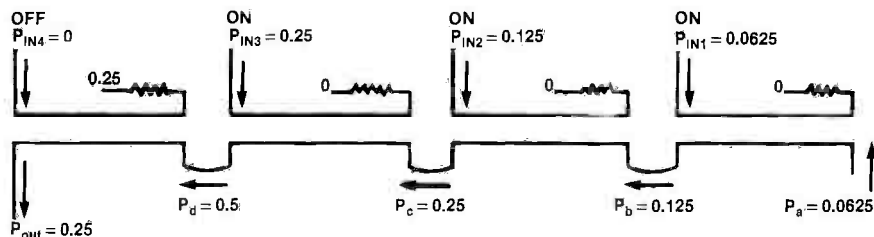

Figure 10. The system illustrated with  $P_{IN4}$  in the off condition.

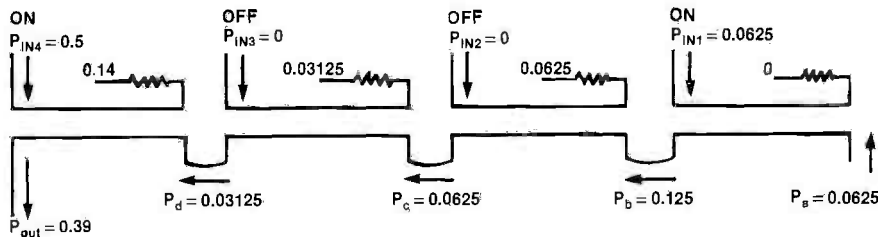

Figure 11. The system illustrated with  $P_{IN2}$  and  $P_{IN3}$  in the off condition.

creases as some inputs change to the off condition, but so does total consumption. A discussion of an example set of com-

biners working as a perfectly linear amplitude modulator is not proof that the modulator retains all its properties in the

most general case. If you are interested in following this through a rigorous mathematical development of all important parameters, see "The Digital Modulator-Transmitter: A General Derivation," page 74.

#### A technological concept

Digital technology is making significant inroads into the broadcast industry. As that technology moves more toward signal processing and transmission, the approach to digital modulation discussed in this article allows for analog simulation of a digitized signal in an amplitude-modulated broadcast system. Reception is possible with ordinary radio or TV receivers.

Digital AM transmitters for medium-wave applications exist, but the technology that makes them possible uses a different approach than that presented here. Power combiners in those transmitters do not offer port-to-port isolation. That is, no reject loads are associated with the power combiner, which acts as a transformer with a single secondary and many primaries. Also, an isolated combiner is not necessary at medium wave, where switch-mode RF amplifiers form the modulator/RF source. Such a

Stereo echo, to be exact. There's also stereo chorus and flanging. Pitch change. Four kinds of reverb. Plus reverb and gate.

Thirteen different kinds of effects in all. In our new SPX90II, an encore performance of the most successful digital processor in audio history.

And now we've expanded the delay times. And expanded the possibilities.

There are 30 preset variations, each with up to nine separate controls. So you can get precisely the sounds you want.

But that's just the beginning. Because there's also room for 60 more custom variations, your own "signature" sounds that you can create and store in memory.

The SPX90II lets you label each custom effect with its own title. And you can instantly

# There's an e



source impedance is either near zero when gated on, or approaching infinity when gated off. Switch-mode amplifiers are not yet possible much above the medium-wave frequencies, suggesting that another method is required.

The modulator described here, because of the port-to-port isolation, maintains an impedance of  $R_L$  at all ports whether or not adjacent amplifiers are on. As a result, it is useful at all RF frequencies with any class of amplifier. Its speed is limited only by the ability to gate an amplifier in consonance with the analog-to-digital converter sampling rate. No doubt, logic glitches may result as amplifiers are turned on and off, but a careful design should overcome this problem.

The modulator described would not work for vestigial-sideband transmission in its current configuration. The technique for partial lower-sideband cancellation is not developed at this time, nor is it known to exist, but it deserves future consideration. Even if it does not exist, a high-level vestigial filter could be constructed to pass the appropriate spectral components of the double-sideband signal for NTSC TV transmission.

Because of the absolute linearity of the

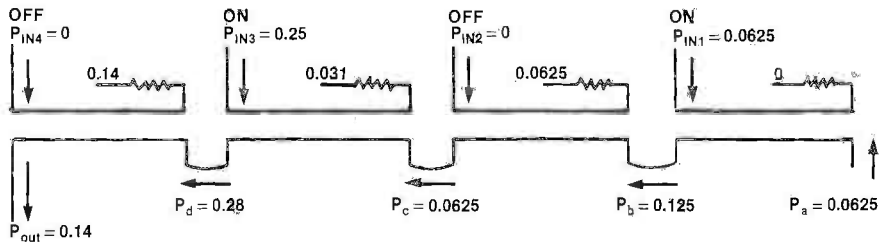

Figure 12. The system illustrated with  $P_{IN2}$  and  $P_{IN4}$  in the off condition.

modulator, it is expected that usual non-linearities of TV RF amplifiers would be non-existent. Non-linearities, such as differential phase and gain, group delay and low- and high-frequency response seem to disappear. Analog-to-digital circuitry with anti-aliasing and replicating spectra filters to counteract the sampling process is deliberately omitted from this discussion because those circuits and processes are well-known. They would apply equally to the output bandpass filter to suppress the radiation of spurious signals.

The application of this modulator would be a reverse trend to high-level

modulation in TV transmission. It is more than a modulator, however. It is a transmitter in which the modulator and RF power amplifier sections are inherently one. Through logic and numerical analysis, the advantages of digital technology appear to be applicable to the transmitting system as well. Perhaps in the future, an operating model based on these concepts will prove the theory.

Editor's note: Application has been made for a patent for the digital modulation method described here.

[:T(=))]]

call up an effect with either our MFC1 MIDI foot controller, remote controller or just a standard footswitch (all optional).

But even if you don't need custom tailored sounds, the factory preset effects give you maximum signal processing in minimum rack space.

So whether you're an acoustical consultant, a sound contractor or audio engineer, see

and hear the new SPX90II.

It'll have some terrific effects on you. Yamaha Music Corporation, Professional Audio Division, P.O. Box 6600, Buena Park, CA 90622. In Canada, Yamaha Canada Music Ltd., 135 Milner Avenue, Scarborough, Ontario M1S 3R1.



# cho in here.



Circle (51) on Reply Card

By Dennis Heymans

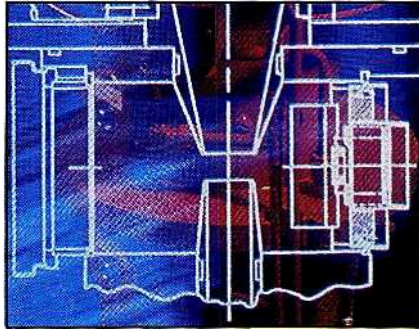

# Hot switches and combiners

Hot switching RF systems may prevent the big chill of being off the air.

Switching RF is nothing new to broadcast engineers. The process usually involves coaxial switches coupled with the necessary logic to ensure that the switch takes place with no RF on the contacts. The station generally goes off the air for a few seconds while the switch is completed. Through the use of hybrid combiners, however, it is possible to redirect RF signals without taking the transmitter off the air. This process is called *hot switching*.

The advantages of hot switching go beyond the ability to reroute RF signals. The audio and video equipment used by today's audiences often is equipped with remote controls. And, as any station manager will tell you, viewers and listeners use them. If a station goes off the air, perhaps even for a brief time, some of that audience will tune away. If RF sources or loads can be switched while the systems are operating, through hot switching, the audience will have one less reason to hit the remote-control button.

## Switch types

The two basic types of RF switches are *coaxial* and *hybrid* or *combiner*. The

Heymans is marketing manager for Micro Communications, Manchester, NH.

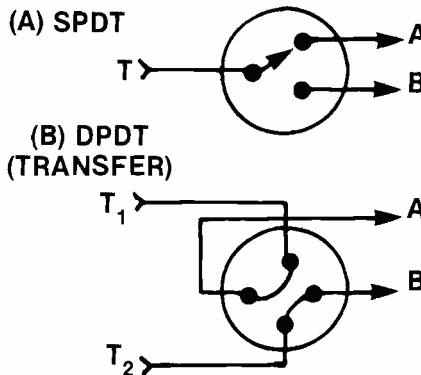

Figure 1. The most common type of switch used in RF applications is the coax switch. Typical configurations are shown here.

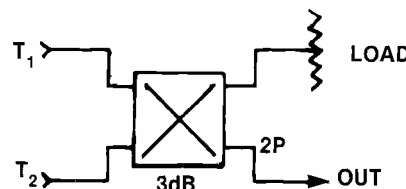

Figure 2. The 3dB hybrid combiner sums the power from two equal-power transmitters into a single output.

coaxial switch requires that RF be removed before the contact make or break occurs. The existence of RF may destroy the switch contacts or damage the transmitter or antenna system.

To prevent the switch from taking place while RF is being applied to the contacts, a complex series of safety interlocks are required. The interlocks ensure that the transmitter shuts down before the switch. Typically, a minimum of 60ms delay is necessary before a break can be made in the RF path. This delay helps prevent any fault-detection circuits from misinterpreting the change in RF path as a VSWR or overload condition.

Additional logic circuits usually are needed to supervise the entire switching process. All of these factors can add as much as 3s to the total downtime of the transmitter and increase the complexity of the switching system.

Figure 1 shows some typical coaxial RF switching configurations. The SPDT switch simply transfers the RF source from one load to another. The common DPDT switch could be used to connect a main or auxiliary transmitter to a main or auxiliary antenna system.

## Hybrids

In broadcast applications, the terms hybrid and combiner often are used interchangeably. In the strictest sense, the



# TAPE MACHINE TESTING AND LOTS MORE!

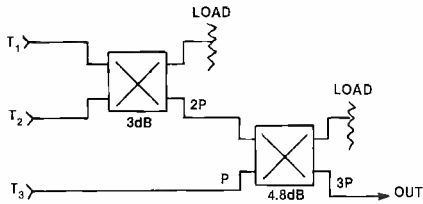

**Figure 3.** A 3-transmitter combiner requires the addition of a 4.8dB hybrid combiner for the second stage.

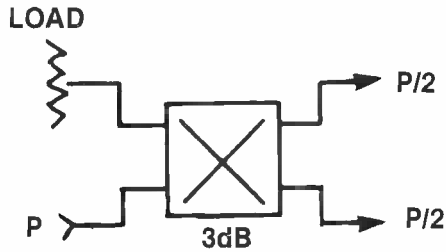

**Figure 4.** For comparison, the power divider takes a single input and divides it equally between two outputs.

hybrid is a circuit that performs the function of combining RF signals.

It may be worthwhile to review the basic theory about hybrids. A hybrid is a 4-port device, sometimes described as a scattering matrix. Vectors will be used to show how the hybrid operates. Why is the hybrid called a 4-port device? Read on, and refer to Table 1.

In 3dB hybrids, two signals are fed to the hybrid inputs. A signal arriving at port 1 with  $0^\circ$  phase will arrive in phase at port 3 and at port 4 with a  $90^\circ$  lag ( $-90^\circ$ ) referenced to port 1. If the signal at port 2 already contains a  $90^\circ$  lag ( $-90^\circ$  referenced to port 1), both input signals combine in phase at port 4. The signal from port 2 also experiences another  $90^\circ$  change in the hybrid as it reaches port 3. Therefore, the signals from ports 1 and 2 cancel each other at port 3.

If the signal arriving at port 2 leads by  $90^\circ$ , (mode 1), the combined power from ports 1 and 2 appears at port 4. If the two input signals are matched precisely in phase, then output ports 3 and 4 contain one-half of the power from each of the inputs.

If one of the inputs fails, as in the case of a transmitter failure, only one hybrid input receives power. The hybrid outputs then have only one-half the operating power. For this reason, the system reject

Tape machine testing is just part of Audio Precision System One's repertoire. For tape, System One does:

- response on stereo machines—or multi-tracks to 192 tracks
- distortion across the entire spectrum
- wow and flutter, rotational and scrape
- MOL
- SOL
- separation (worst-case crosstalk on multi-tracks)
- azimuth adjustments
- phase vs frequency
- gap scatter on multi-tracks
- spectral analysis of noise

**ANALOG TAPE:** System One tests VTRs, ATRs, reel-to-reel, cart, cassette formats—two or three head—using tapes you make or standard reference tapes, even with voice between tones.

**DIGITAL TAPE:** System One's  $-100$  dB (0.001%) distortion levels make it the selection of the leading manufacturers of digital recording systems. Try measuring the  $-85$  to  $-90$  dB distortion 16-bit PCM systems with a test set with  $-75$  dB residuals!

**AND LOTS MORE:** Audio Precision's System One tests all audio equipment in your inventory—compact disc players, consoles, power amps, distribution amplifiers, switchers, transmitters. Even acoustical tests on loudspeakers and microphones.

Features such as:

- three forms of imd including transient
  - complete, automatic custom test procedures created without knowledge of programming languages
  - fast on-screen graphic or tabular results
  - low-cost graphic hard copy via dot matrix printers
- make System One the most powerful choice in audio testing.

Call or write Audio Precision today for complete technical data and prices on System One.

**Audio precision**

P.O. Box 2209, Beaverton, OR 97075  
503/627-0832 1-800/231-7350

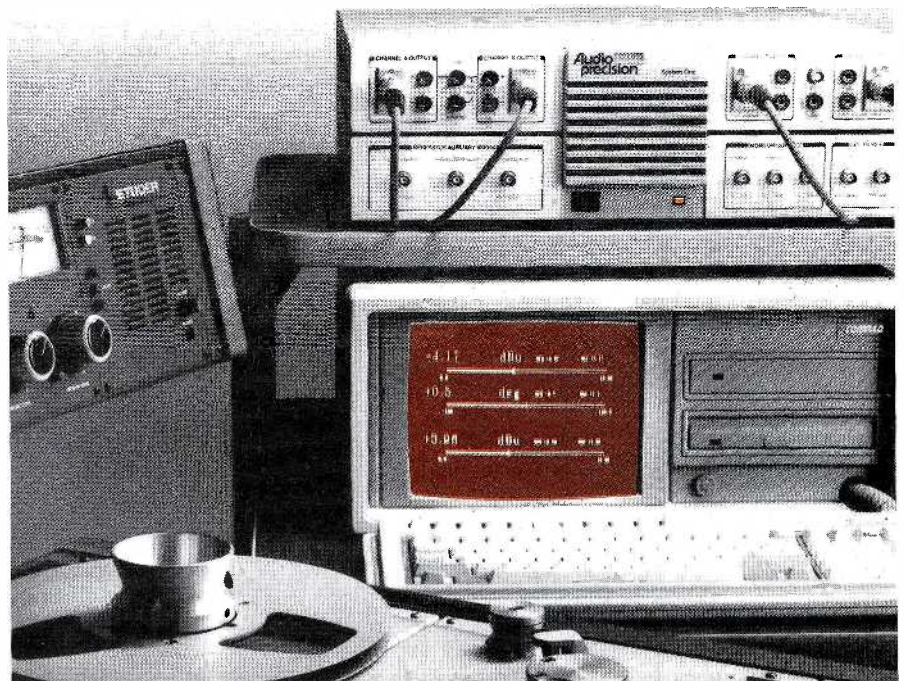

Circle (52) on Reply Card  
December 1987 *Broadcast Engineering* 83

MODE	INPUT		SCHEMATIC	OUTPUT	
	1	2		3	4
1	$P_1 \angle 0^\circ$	$P_2 \angle -90^\circ$		0	$P_1 + P_2$
2	$P_1 \angle 0^\circ$	$P_2 \angle 90^\circ$		$P_1 + P_2$	0
3	$P_1 \angle 0^\circ$	$P_2 \angle 0^\circ$		$P_{1/2} + P_{2/2}$	$P_{1/2} + P_{2/2}$
4	$P_1 \angle 0^\circ$	$P_2 = 0$		$P_{1/2}$	$P_{1/2}$
5	$P_1 = 0$	$P_2 \angle 0^\circ$		$P_{2/2}$	$P_{2/2}$

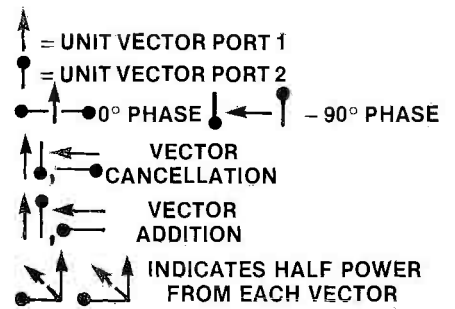

Table 1. Single 90° hybrid system operating modes.

load must be capable of handling one-half of the rated transmitter power.

### Combiners

Combiners are used to mix the output signal from two or more transmitters into a single output. A common configuration uses parallel (equally powered) transmitters. This design offers redundancy in that if one transmitter fails, the other can pick up the load. A dual, equal-power transmitter hybrid-combiner system is shown in Figure 2.

If equal-power transmitters are used, a 3dB hybrid is required. If the transmitters are unequally powered, as is the case for the 3-transmitter system shown in Figure 3, a 4.8dB hybrid is used as the second combiner.

A combiner might be considered the

Put the Tascam CD-501 next to any other broadcast compact disc player, and you'll find there's no comparison.

Nothing can compare to the purity, clarity, and accuracy of its sound, thanks to breakthroughs like Tascam's proprietary ZD Digital Circuit and double oversampling.

And in the split-second, high-speed, high-pressure world of the broadcast professional, it's the only machine you can depend on, 100% of the time.

Which figures, since the CD-501 is not an adapted consumer deck, but a highly-engineered system that's built for broadcast. Nothing else offers its combination of professional features, including 19" rack-mountability, balanced outputs, and a hard-wired remote that lets you completely control and program either of two decks in any mode.

Call or write for more information on the CD-501. Find out about a new, higher level of digital quality. And digital toughness.

# TASCAM



Circle (53) on Reply Card

# Digital defined.

© 1987 TEAC Corporation of America, 7733 Telegraph Road, Montebello, CA 90640. (213) 726-0303.

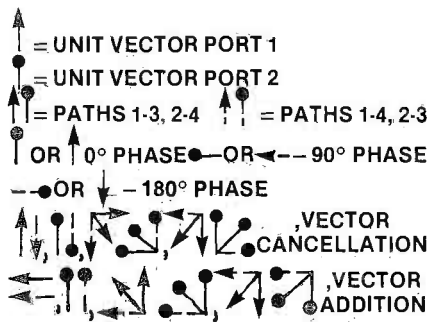

**Table 2.** Dual 90° hybrids and single-phase shifter combiner operating modes.

reciprocal of a power divider. The power divider shown in Figure 4 equally separates the input power (P) into two half power (P/2) outputs. This analogy is appropriate because, for any lossless 4-terminal device, the law of reciprocity applies. Consider the combiner shown in Figure 5. The power applied to the two input terminals is summed and appears on a single output. The output (assuming equal inputs) is then twice the power of either input.

**Switching**

An RF hybrid does more than combine transmitters. Its unique phase-related properties also allow it to be used as a switch. The input signals to the hybrid in Figure 6 (a) are equally powered (P), but they differ in phase by 90°. Because of

MODE	INPUT		$\phi$	SCHEMATIC	OUTPUT VECTOR	OUTPUT		
	1	2				3	4	
1	$P_1 \angle 0^\circ$	$P_2 \angle 0^\circ$	0°		$P_2$	$P_1$	$P_1$	$P_2$
2	$P_1 \angle 0^\circ$	$P_2 = 0$	0°		0	$P_1$	$P_1$	0
3	$P_1 = 0$	$P_2 \angle 0^\circ$	0°		$P_2$	0	$P_2$	0
4	$P_1 \angle 0^\circ$	$P_2 = 0$	180°		$P_1$	0	$P_1$	0
5	$P_1 = 0$	$P_2 \angle 0^\circ$	180°		0	$P_2$	0	$P_2$
6	$P_1 \angle 0^\circ$	$P_2 \angle 0^\circ$	90°		0	$P_1 + P_2$	$P_1 + P_2$	0
7	$P_1 \angle 0^\circ$	$P_2 \angle 0^\circ$	-90°		$P_1 + P_2$	0	$P_1 + P_2$	0

# It's 3:55 a.m. Do you know what your transmitter is doing?

Now your transmitter can alert you to problems by phone—anywhere, anytime with the VRC-1000 Remote Control. A preprogrammed, synthesized voice quotes parameters; you make adjustments right on your Touch-Tone® phone. Or, you can dial from any-

where for fast trouble-shooting capability.

- VDT and printer options
- Full automatic commands
- Fully secure
- Automatic alarm reporting and correction

**GENTNER** Patent Pending  
RF PRODUCTS DIVISION

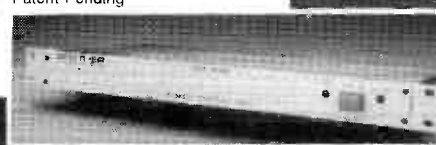

Circle (53) on Reply Card

P.O. Box 32550 • San Jose, California, 95152 • (408) 926-3400 Telex II 510-600-1445 GENTNER RF PRD

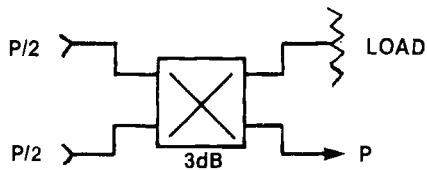

**Figure 5.** The typical combiner relies on equal-input power levels to develop twice the power output. Transmitters often operate at half-power in this configuration, providing even more redundancy.

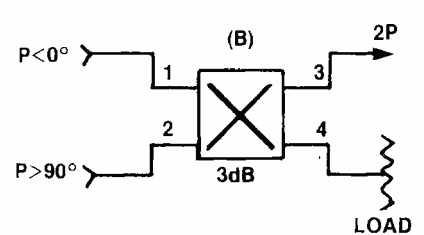
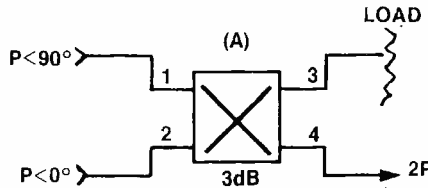

**Figure 6.** The combiner can act as a switch if the relative phase between the inputs is controlled. In (a), the power is routed to output port 4. Because the phase is changed by 180°, the power is transferred to output port 3.

this phase difference, the combined signals are routed to the output terminal at port 4. If the relative phase between the two input signals is changed by 180°, the summed output appears on port 3, as shown in Figure 6 (b). The 3dB hybrid combiner has just become a switch.

This configuration allows the switching of either of two transmitters to either of two antennas. In other words, an SPDT switch has just been created. Remember, however, that the switch took place when the phase difference between the two inputs was 90°. To perform the switch in a useful way, you must add a

SINGLE INPUT	∅ DEGREES	VSWR	INPUT		OUTPUT	
			1 (dB)	2 (dB)	3 (dB)	4 (dB)
T1	180°	1.06	—	39	0.1	39
T1	0°	1.05	—	39	39	0.1
T2	180°	1.05	39	—	39	0.1
T2	0°	1.06	39	—	0.1	39
DUAL INPUT						
T1 + T2	270°	1.06	—	—	0.1	36
T1 + T2	90°	1.06	—	—	36	0.1

**Table 3.** Performance of a dielectric vane phase shifter.

# Raise your standards.



To understand the superiority of the Tascam ATR-60/2N, begin with the heads: no other 2-track production recorder has heads that can provide sync response fully equal to repro response—an advantage that allows you to save time by making critical audio decisions without rewinding.

Next, look at its direct-drive reel motors, its PLL servo capstan, and its 3-motor servo controlled tape handling system—all factors that lead to the ultimate in fast, accurate, and stress-free tape handling.

Finally, consider that the ATR-60/2N gives you all this and more, hour after hour, year after year.

Then call or write today about the Tascam ATR-60/2N. And take your broadcasting to a higher level.

# TASCAM

# LEITCH OFFERS MORE CHOICES

8 outputs from \$175



- Reliable video DAs for every application.
- 600/150 Ohm & Lo-Z audio DAs to match the performance of our video line.
- Two styles of one and two rack unit mounting frames.
- Six or eight outputs per card.
- Up to 12 cards per two rack unit frame.
- Full power supply back-up.
- Lowest cost per output with two-year warranty.

**Audio/Video Distribution Amplifiers  
to match all your needs...**

**LEITCH**

Leitch Video International Inc., 10 Dyas Rd., Don Mills, Ont., Canada M3B 1V5 - Tel: (800) 387-0233 Fax: (416) 445-0595 Telex: 06 986 241  
Leitch Video of America, Inc., 825K Greenbrier Circle, Chesapeake VA 23320 - Tel: (804) 424-7920 or (800) 231-9673 Fax: (804) 424-0639

Circle (56) on Reply Card

[www.americanradiohistory.com](http://www.americanradiohistory.com)

high-power phase shifter to one input leg of the hybrid. The phase shifter permits the full power to be combined and switched to either output. Figure 7 schematically depicts this function.

The usefulness of this technique becomes apparent when you consider its application in the field. Such a configuration could:

- Switch a pair of transmitters (parallel system) to a main or auxiliary antenna or
- Switch a main or standby transmitter to one antenna.

However, one important switching function cannot be accomplished with this configuration of a single hybrid and phase shifter: switching a main or standby transmitter to a main or auxiliary antenna (DPDT). To accomplish this additional function, a second hybrid and phase shifter can be added, as shown in Figure 8. This configuration allows the following switching functions:

- Transmitter 1 routed to output B
- Transmitter 2 routed to output A
- Transmitter 1 routed to output A
- Transmitter 2 routed to output B

A reflectionless high-power phase shifter is critical to the development of this type of switch. The phase shifter's

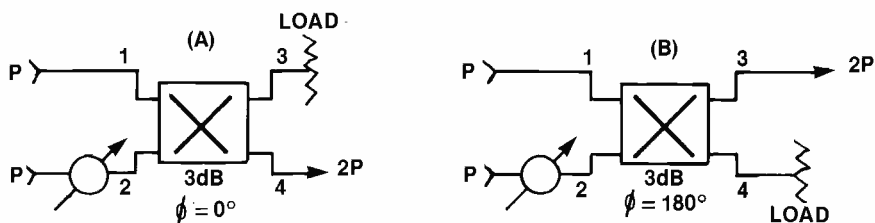

Figure 7. The key to using a hybrid as an RF switch is the addition of a phase shifter. (Assume all inputs are in phase.) In (a), the phase shifter is set to  $0^\circ$ , routing power to output port 4. When the phase shifter is changed to  $180^\circ$ , the RF appears at port 3.

SINGLE INPUT	$\Delta$ DEGREES	VSWR	INPUT		OUTPUT	
			1 (dB)	2 (dB)	3 (dB)	4 (dB)
T1	$180^\circ$	1.06	—	36	0.1	52
T1	$0^\circ$	1.04	—	36	50	0.1
T2	$180^\circ$	1.06	36	—	52	0.1
T2	$0^\circ$	1.07	36	—	0.1	50
DUAL INPUT						
T1 + T2	$270^\circ$	1.06	—	—	0.1	36
T1 + T2	$90^\circ$	1.06	—	—	36	0.1

Table 4. Performance of a variable-phase hybrid phase shifter.

# On time. On budget. On air.



The Tascam 42B makes other 2-track recorders seem downright slow.

That's due in part to an ingeniously accurate tape handling system, and in part to Tascam's unique head technology. (Its heads provide sync response fully equal to repro, so you don't waste time rewinding to make audio decisions.)

And because the 42B probably offers more features per dollar than any equivalent machine, it makes everything else seem downright expensive, too. (+4 dBm balanced inputs and outputs, plus easy-access calibration are just a few of its standard features.)

For more information, call or write about the Tascam 42B today. It's a new and vastly improved way to keep meeting your deadlines.

And your budgets. **TASCAM**



## *...or high water.*

Don't get stuck with a fair weather truck. Neither rain, nor snow, nor 40 mph winds with gusts to 60 mph, will keep Centro's Satellite Networker™ from getting your signal through. This sleek, low profile, high performance SNV can turn any story into more than a remote possibility, and link you instantly to the rest of the world.

Centro is building everything from single thread uplink only utility trucks, to fully redundant SNV's with microwave capability, full compliment of production gear, and complete communications packages. And, Centro can build exactly the truck you need. Just the way you want it. On time, and within budget.

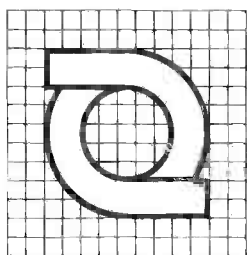
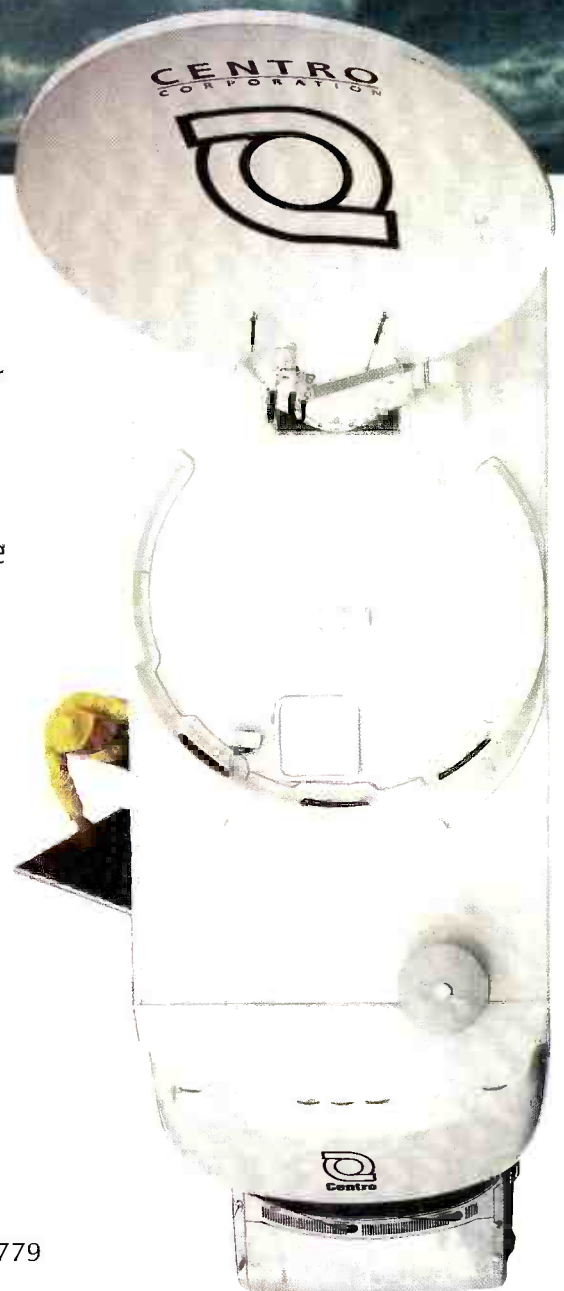

**CENTRO**  
CORPORATION

369 Billy Mitchell Road, Salt Lake City, Utah 84116 (801) 537-7779

© 1987 - Centro Corporation

Circle (58) on Reply Card

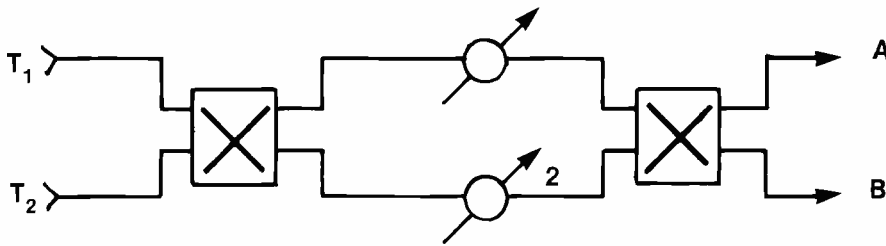

Figure 8. Additional switching and combining functions can be developed by adding a second hybrid and another phase shifter.

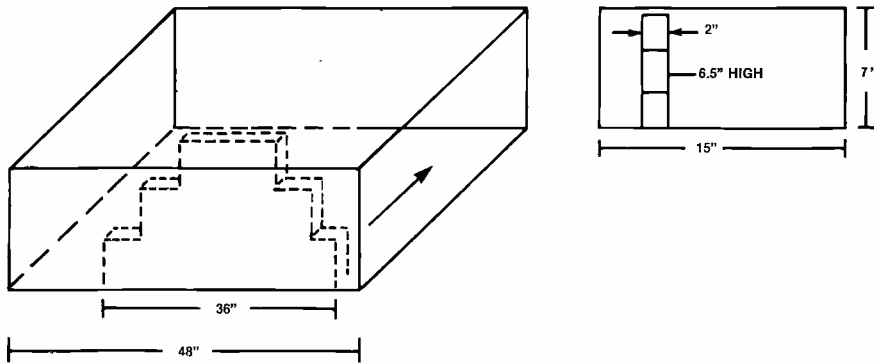

Figure 9. The dielectric vane is a long dielectric sheet mounted within a section of rectangular waveguide.

purpose is to develop a phase difference between the two signals applied to the second hybrid. In this particular configuration, the phase shifter allows the line between the hybrids to be electrically lengthened or shortened. The capability to adjust the relative phase between the two input signals to the second hybrid provides the control needed to switch the input signal between output ports A and B.

If a continuous analog phase shifter is used, the transfer switch shown in Figure 8 also can act as a hot switchless combiner, so that transmitters 1 and 2 can be combined and fed to either output A or B. The switching or combining functions are accomplished by changing the physical position of the phase shifter.

It doesn't matter whether the phase shifter is in one or both legs of the system. It is the phase difference ( $\theta_1 - \theta_2$ ) between the two input legs of the second hybrid that is important. With 2-phase shifters, dual drives are required, but the phase shifter needs only two positions. One-phase shifter designs require only a single drive, but the phase shifter must have four positions.

To better understand the dual-hybrid switching and combining process, ex-

# 10 years from now, it'll still be the standard.

The undisputed standard for broadcast cassette decks has always been the Tascam 122B. But that standard has just been surpassed.

Presenting the 3-head Tascam 122MKII. Its leadership is founded upon features such as Tascam's Cobalt Amorphous tape head technology. Plus a choice of built-in Dolby systems: not just B and C, but also HX-Pro, for virtually perfect high-end frequency response.

More than any comparable deck, it maintains constant tape speed and tension, thanks to a tape handling system that includes Tascam's Hysteresis Tension Servo Control.

And when it comes to handling, the 122MKII is the complete professional tool, with cue and review functions (manual cue), balanced XLR +4dBm inputs and outputs, and rack-mountability.

Call or write for more information about the 122MKII. Get it now, and use it for decades.

© 1987 TEAC Corporation of America, 7733 Telegraph Road, Montebello, CA 90640. (213) 726-0303. Dolby HX-Pro, Dolby B, and Dolby C are trademarks of Dolby Laboratories Licensing Corp.

# TASCAM



Circle (59) on Reply Card



amine Table 2. It lists the various combinations of inputs, relative phase and output configurations that are possible with the single-phase shifter design.

Using vector analysis, note that when two input signals arrive in phase (mode 1) at ports 1 and 2, with the phase shifter set to  $0^\circ$ , the circuit acts as a crossover network. The power from input port 1 is routed to output port 4. Power from input port 2 is routed to output port 3. If the phase shifter is set to  $180^\circ$ , the routing changes; port 1 is routed to port 3, and port 2 is routed to port 4.

Mode 2 represents the failure of one of the dual-input transmitters. The output signal from the first hybrid arrives at the input to the second hybrid with a  $90^\circ$  phase difference. Because the second hybrid introduces a  $90^\circ$  phase shift, the vectors add at port 4 and cancel at port 3. This effectively switches the working transmitter connected to port 1 to output port 4, the antenna.

By introducing a  $180^\circ$  phase shift between the hybrids, as shown in modes 4 and 5, it is possible to reverse the circuit. This allows the outputs to be on the same side of the circuit as the inputs. This configuration might be useful if transmitter 1 failed, and all the power from transmitter

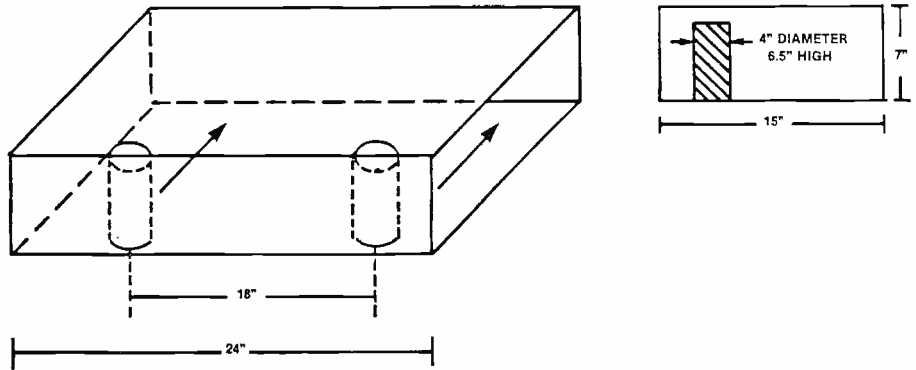

**Figure 10.** Dielectric posts are similar to dielectric vanes. The posts move within the waveguide, providing the necessary phase shift.

2 had to be directed to a diplexer connected to output 4.

Normal operating configurations are shown in modes 6 and 7. When both transmitters are operating properly, you can route their combined power to either output port. The switching is accomplished simply by introducing a  $\pm 90^\circ$  phase shift between the hybrids.

Table 2 shows that a single-phase shifter makes it possible to operate in all of the listed operational modes, as long

as the shifter provides four different phase positions. A similar analysis shows that a 2-phase shifter design, with two different phase positions for each shifter, is capable of providing the same operational modes.

#### Phase shifters

The key to making these hybrids switch properly is the phase shifter. The dual  $90^\circ$  hybrid combiner previously discussed requires a phase shifter capable of



## The choice of the professionals...

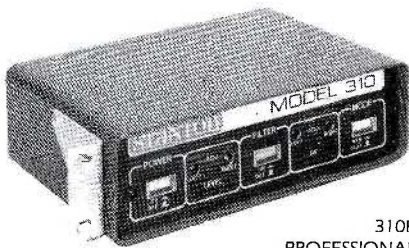

**310B**  
PROFESSIONAL  
PHONO PREAMP/EQUALIZER  
... Interfaces magnetic phono cartridges for optimum calibration of audio systems. Available with balanced or unbalanced output.



**PBR ANNOUNCER'S EARPHONE** ...  
Ideal for on camera studio work and remote coverage.

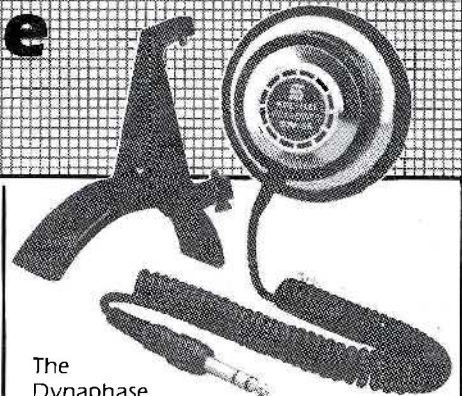

The  
**Dynaphase**  
**30M/SR** is a shoulder rest single cup headphone that provides the ultimate in convenience, comfort and superb sound quality. Made to rest on either your left or right shoulder, or shoulder rest can be detached and used as a single cup hand-held monitor.



**680EL** ... Delivers sound excellence and stands up to backcueing, vibrations and mishandling.

Stanton is the company with a total commitment to quality and reliability—producing products for the Recording Industry, the Broadcast Industry and the Professionals in Audio.



200 Terminal Dr., Plainview, NY 11803



**500AL** ... For heavy duty on wide tracking force range.

Circle (61) on Reply Card

December 1987

introducing a fixed phase shift of  $-90^\circ$ ,  $0^\circ$ ,  $+90^\circ$  and  $+180^\circ$ . This can be accomplished easily at low power levels through the use of a sliding (trombone-type) line stretcher.

Because of the high currents and voltages present in UHF applications, however, the sliding line stretcher is not an appropriate design choice. In these cases, the phase shifter must be capable of handling as much as 120kW. Three other designs often are used in such applications: variable-dielectric vanes, di-

electric posts and variable-phase hybrids.

The variable-dielectric vane consists of a long dielectric sheet mounted in a section of rectangular waveguide. (See Figure 9.) The dielectric sheet is long enough to introduce a  $270^\circ$  phase shift when located in the center of the waveguide. As the dielectric sheet is moved toward the wall, into the lower field, the phase decreases. A single-sided phase shifter can easily provide the four required positions. A 2-stage  $1/4$ -wave transformer is used on each end of the sheet

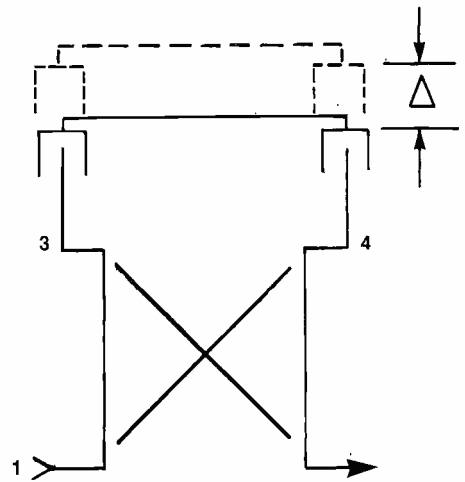

Figure 11. Variable-phase hybrid designs rely on a  $90^\circ$  hybrid and non-contacting-type short circuits.

## TAKE IT ON THE ROAD. SEE WHAT IT WILL DO.



Rack-Pack™ cases are tough. Hit the road with them and you'll know just what we mean. Bumps and jolts typical of location shooting can take its toll, even when you're being careful.

That's why we put those unique little ribs in the pliant high density polyethylene shell, to absorb shock. The Rack-Pack does just that, it repeatedly handles virtually all impact. Minimal vibration reaching the interior is instantly overcome by the elastometric shock mounts supporting your equipment.

Delicate equipment stays totally unharmed. And, versatile Rack-Packs ensure both front and rear equipment can be

prewired in advance. You can be up and running in minutes, not hours. Also, interlocking Rack-Packs can be stacked to form modular workstations.

So, the next time you and your equipment decide to hit the road, you'll be better off leaving those fragile old plywood and fiberglass cases at home. Move out with Thermodyne cases, and you move out with total confidence.

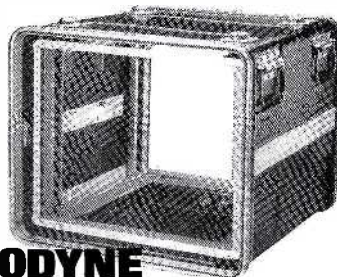

**THERMODYNE  
INTERNATIONAL LTD**

Long Beach, CA 90810 (213) 603-1976

Circle (62) on Reply Card

December 1987

to maintain a proper match for any position in the desired operating band. Table 3 shows the performance of a typical switchless combiner using the dielectric vane.

Dielectric posts (see Figure 10) operate on the same principle as dielectric vanes. A single-sided phase shifter must operate in four different positions to provide the required phase shift. In a 2-sided phase shifter, only two operating positions are required on each side. The dielectric posts are positioned  $1/4$ -wavelength apart to cancel any mismatch and to maintain minimum VSWR.

The variable-phase hybrid, shown in Figure 11, relies on a  $90^\circ$  hybrid, similar to that used in a combiner. With a unit vector incident on port 1, the power is split by the  $90^\circ$  hybrid. The signal at ports 3 and 4 is reflected by the short circuit. These reflected signals are out of phase at port 1 and in phase at port 2.

The hybrid's relative phase can be changed by moving the short circuit. Mathematically, the phase difference can be described by the following equation:

$$\Phi = \frac{2\pi}{\lambda g} \times 2\Delta \text{ where } \Delta = \text{the length of the shorting element.}$$

The variable-phase hybrid design is quite linear with respect to position. Non-contacting choke-type short circuits, with high front-to-back ratios, commonly are used in the devices. The performance of a typical high-power variable-phase switchless combiner is shown in Table 4.

The possibility of performing hot switches is exciting to any engineer who has heard those four dreaded words: "We're off the air!" Look for further developments and applications as this technology improves. [:-)]

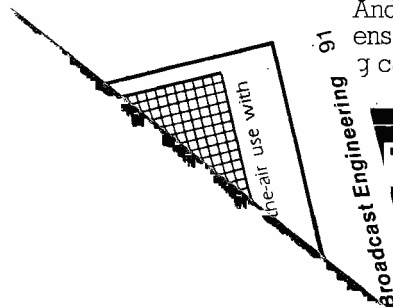

1987

# Annual editorial index

Compiled by Carl Bentz,  
technical and special projects editor

The "Annual Editorial Index" is designed to put a year's worth of **BE** at your fingertips. Here's how to use it.

At the beginning of the index, you'll find a cross-reference listing of articles and columns, arranged alphabetically by general subject area. If you know you saw an article about a particular subject, but can't remember the issue, this listing will guide you in the right direction, and maybe lead you to a related article.

Following the subject listing is a month-by-month compilation of all feature articles, regular columns and field reports that appeared in the magazine during the past year. Each article review includes a brief list of key words, words and phrases that are defined and used in the story, along with a reader interest classification. Related article material is indicated, when applicable, with each article summary.

## SUBJECT LISTING (Monthly listing begins on page 102)

### ANTENNAS/TOWERS/TRANSMISSION

### SYSTEMS

*re:Radio/Learning the Basics* . . . 1-12 through 12-12

Radio Field Production . . . 1-26

*Troubleshooting/Prevent Problems by Planning Ahead* . . . 5-18

Evolution of Broadcast Transmission Lines . . . 5-64

Curve-Fitting Program for Building and Operating a Tower Facility . . . 5-93

AM Improvement . . . 8-92

Flat Antennas . . . 10-14

*Satellite Technology/Hot Switches and Combiners* . . . 12-82

*Strictly TV/To Be Aurally Sound* . . . 1-10, 2-10

Radio Field Production . . . 1-26

Audio Equipment . . . 2-124

Planning for Audio Post-Production . . . 3-130

Audio Equalization for Cartridge Recording . . . 3-272

*Applied Technology/DBS Digital Sound-Coding Format* . . . 3-302

Station-to-Station/Pan Pots Add Versatility . . . 3-316

Inside Monitor Loudspeakers . . . 6-162

Interconnecting Audio Equipment . . . 7-24

Interacting Monitor Amplifiers . . . 7-36

Multidimensional Audio for Stereo TV . . . 7-46

*Applied Technology/Installing Acoustic Materials* . . . 7-76

Applied Technology/Modifying Time-System Considerations . . . 8-104

Wireless Microphone Frequency Compatibility . . . 9-96

Transformers in Audio Design . . . 9-104

The Evolution of Audio Recording . . . 10-54

*Applied Technology/Dolby Spectral Recording* . . . 10-138

Expanding on the Image . . . 11-122

Testing Stereo Audio for Mono Compatibility . . . 11-106

### AUTOMATION/COMPUTER-RELATED

*Circuits/Inside Digital Technology* . . . 1-16 through 12-16

*Satellite Technology/Ka Frequency Gets a Head Start* . . . 1-14

*Troubleshooting/The Answers May Be at the Interface* . . . 1-18

Networking the Newsroom . . . 1-94

*Troubleshooting/A Failure to Communicate* . . . 3-18

Editorial/People Make It Work . . . 4-6

Planning for TV Automation . . . 4-26

Serial Data Control Systems . . . 4-44

Computer Power Protection . . . 4-88

*Applied Technology/Control via Dynabus* . . . 4-106

Station-to-Station/Transmitters Wired for Remote Control . . . 8-113

Video Signal . . . 10-166

Station-to-Station/Retrieving Data From a Remote Control . . . 10-166

Radio Field Production . . . 1-26

An RENG Case History . . . 1-52

Planning a Remote Production Vehicle . . . 1-68

Taking to the Skies . . . 1-76

Monitoring Satellite System . . . 1-76

# THOMSON-CSF

## THE FURTHER WE GO, THE FURTHER YOU GO.

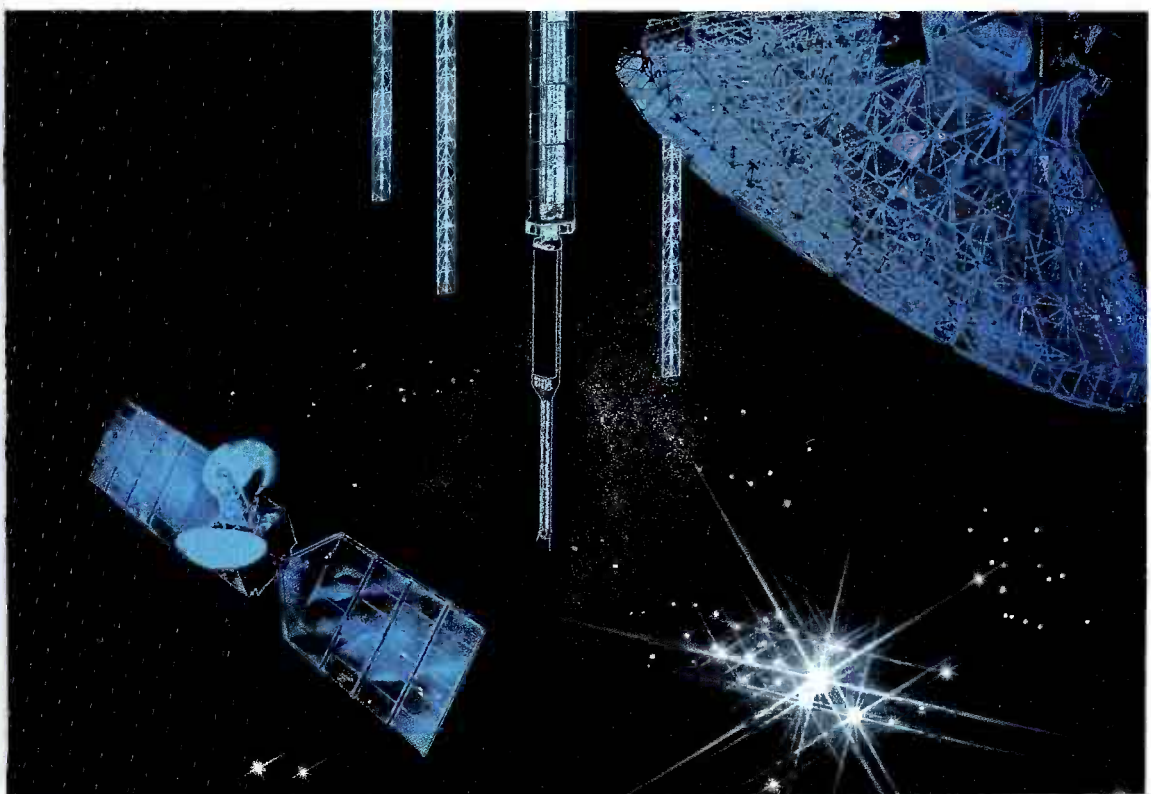

At Thomson-CSF we've been pioneers in developing the use of high-power tetrodes in transmitters for more than 70 years.

Over the years we've stayed ahead with such developments as Pyroloc® grids and the Hypervapotron® cooling system.

We offer: A complete line of tubes for radio broadcasting applications from FM to the most powerful SW

and LW transmitters - the quality of our 500-600 kW tubes has been amply demonstrated in 15 years of service in over forty transmitters worldwide.

A complete line of power grid tubes and their associated cavities for UHF/VHF TV transmitters. Thanks to their efficiency, reliability and tight tolerances, systems makers can offer their customers substantially more cost-effective products.

Matched cavities for best results.

UHF and VHF tetrodes up to 50 kW. PM tetrodes up to 100 kW.



Earth station tubes up to 18 GHz (1.5 kW) or to 3.35 kW (6 GHz)

High efficiency space TWTs (including 50 W and 100 W Ku-band for next generation DBS Satellites)

A complete line of klystrons and TWTs for ground stations and space TWTs for direct broadcasting satellites (DBS) designed to last for at least a decade.

And we also produce high-resolution image pick-up tubes and devices (CCDs), and high-luminosity CRTs for top range professional applications.

In radio and television, telecommunications, military and civil aviation, as well as in a wide range of scientific and medical applications, Thomson-CSF know-how gets your systems moving. Fast.

The world's most powerful tubes for radio and TV broadcasting.



**THOMSON-CSF**  
ELECTRON TUBES

THOMSON ELECTRON TUBES  
AND DEVICES CORPORATION  
550 Mount Pleasant Avenue  
P.O. Box 6500  
DOVER, NEW JERSEY 07801

Tel.: (201) 328-1400, TWX: 710987 7901.

**Belgium** - BRUXELLES  
Tel.: (32-2) 646 64 65  
Tel.: (32-1) 542 47 22  
Tel.: (31-1) 24 226 1CSF BR  
Tel.: (31-1) 24 226 1HCSF J

**Brazil** - SAO PAULO  
Tel.: (55-11) 542 47 22  
Tel.: (55-11) 542 47 22  
Tel.: (55-11) 542 47 22

**Canada** - MONTREAL - QUEBEC  
Tel.: (514) 288 41 48  
Tel.: (514) 288 41 48  
Tel.: (514) 288 41 48

**Germany** - MÜNCHEN  
Tel.: (49-89) 78 79 40  
Tel.: (49-89) 78 79 40  
Tel.: (49-89) 78 79 40

**Spain** - MADRID  
Tel.: (34-1) 405 16 15  
Tel.: (34-1) 405 16 15  
Tel.: (34-1) 405 16 15

**France** - BOULOGNE-BILLANCOURT  
Tel.: (33-1) 46 84 81 75  
Tel.: (33-1) 46 84 81 75  
Tel.: (33-1) 46 84 81 75

For additional information on our complete line of audio products, contact:

**MODULAR AUDIO PRODUCTS**  
50 Orville Drive  
Airport International Plaza  
Bohemia, NY 11716

**(516) 567-9620**

Your best source for low cost, high quality audio systems.

# INSTANT AUDIO SYSTEMS IMPAC SERIES

FOR IMPAC SERIES  
PLUG IN CARDS

FRAME ACCOMODATES  
WIDE RANGE OF  
MODULES:

- MIC Preamps
- Line Amplifiers
- Phone and Tape Preamps
- VCA Modules
- Monitor Amplifiers
- Power Supplies
- Switcher Cards
- Distribution Amps
- Peak and VU Indicators

NOW AVAILABLE WITH  
ULTRA LOW NOISE

1 NANOVOLT  $\sqrt{\text{Hz}}$  MODEL 5006

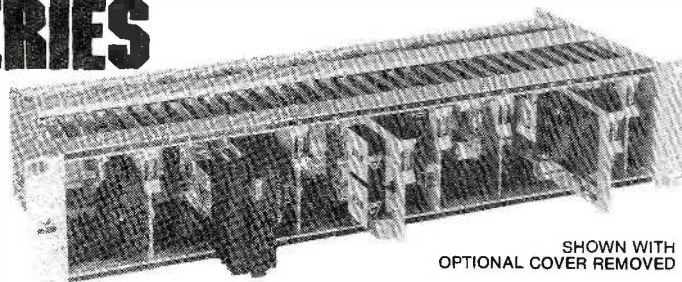

SHOWN WITH  
OPTIONAL COVER REMOVED



Model 5006  
OPERATIONAL  
AMPLIFIER

Name \_\_\_\_\_  
Title \_\_\_\_\_  
Company \_\_\_\_\_  
Address \_\_\_\_\_  
City \_\_\_\_\_  
State \_\_\_\_\_ Zip \_\_\_\_\_  
Telephone \_\_\_\_\_

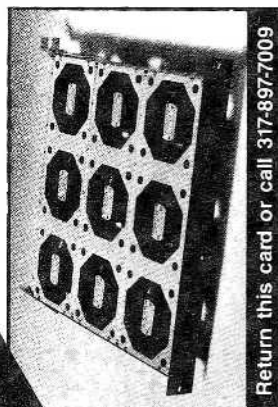

Return this card or call 317-897-7009

Cooling  
Module  
from  
General  
Devices

LOW PRICE  
LOW PROFILE

- Designed for 19" rack mounting
- All mounting hardware included, with adjustable rear brackets
- Low profile—only 1U panel space (1.75 inches)
- Fan specifications: 108 CFM (single fan), 115 V AC, 50/60 Hz
- Designed to meet UL, CSA and VDE requirements

To Order: Indicate desired number of each fan configuration

Three fans: \$138.19

Row A modules \_\_\_\_\_ Row B modules \_\_\_\_\_

Row C modules \_\_\_\_\_

Six fans: \$194.74

Row A&B modules \_\_\_\_\_ Row A&C modules \_\_\_\_\_

Row B&C modules \_\_\_\_\_

Nine fans: \$251.29

\_\_\_\_\_ modules

Row A	Row B	Row C
○ ○ ○	○ ○ ○	○ ○ ○

Name \_\_\_\_\_ Title \_\_\_\_\_  
Company \_\_\_\_\_  
Street Address \_\_\_\_\_  
City \_\_\_\_\_ State \_\_\_\_\_ Zip \_\_\_\_\_  
Phone \_\_\_\_\_  
My company manufactures \_\_\_\_\_  
 Yes! Send me \_\_\_\_\_ modules totaling \$ \_\_\_\_\_ shipped UPS COD.  
 Please send more information.  
P.O. No. \_\_\_\_\_  
Signature \_\_\_\_\_



Use Dynatech's  
Video Patches  
in these Applications:

- Television & Radio
- Broadcast Communications
- Data Communications
- Telemetry and Instrumentation
- Low Frequency
- Control

**Dynatech**  
Data Systems  
800-368-2210

## Here's Why Dynatech's Video Patches Are Better...

- Normal-thru connection
- Cross-patching
- Non-interrupt monitoring
- Automatic termination
- 30 day delivery (standard requirements)

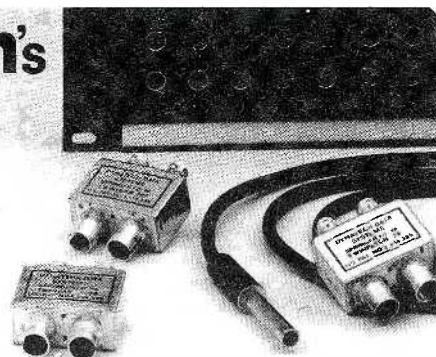

Name \_\_\_\_\_ Street \_\_\_\_\_  
Phone ( ) \_\_\_\_\_ City \_\_\_\_\_  
Title \_\_\_\_\_ State \_\_\_\_\_ Zip \_\_\_\_\_  
Company \_\_\_\_\_ 800-368-2210 703-569-9000



NO POSTAGE  
NECESSARY  
IF MAILED  
IN THE  
UNITED STATES

**BUSINESS REPLY MAIL**  
FIRST CLASS PERMIT NO. 62 BOHEMIA, NY 11716

POSTAGE WILL BE PAID BY ADDRESSEE

**M** MODULAR AUDIO PRODUCTS  
50 Orville Drive  
Airport International Plaza  
Bohemia, NY 11716

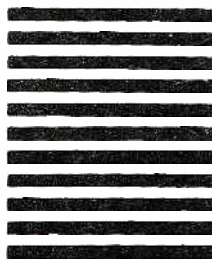

For additional  
information on our  
complete line of audio  
products, contact:

**M** MODULAR AUDIO PRODUCTS  
50 Orville Drive  
Airport International Plaza  
Bohemia, NY 11716

**(516) 567-9620**

Your best source for  
low cost, high quality  
audio systems.



NO POSTAGE  
NECESSARY  
IF MAILED  
IN THE  
UNITED STATES

**BUSINESS REPLY MAIL**  
FIRST CLASS PERMIT NO. 1129 INDIANAPOLIS, IN

POSTAGE WILL BE PAID BY ADDRESSEE

**General Devices Co., Inc.**  
P.O. Box 39100  
Indianapolis, IN 46209-3994

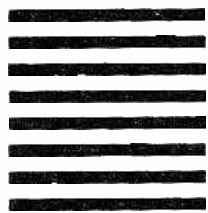

**GENERAL  
DEVICES**  
Electronic Hardware  
Manufacturers



NO POSTAGE  
NECESSARY  
IF MAILED  
IN THE  
UNITED STATES

**BUSINESS REPLY MAIL**  
FIRST CLASS PERMIT NO. 4200 SPRINGFIELD, VA

POSTAGE WILL BE PAID BY ADDRESSEE

**Dynatech**  
Data Systems

7644 Dynatech Court  
Springfield, VA 22153-2891

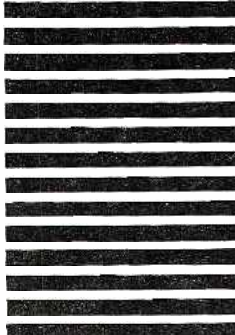

For more information  
feel free to contact your local  
Dynatech Video Patch Sales  
Office.

**NEW ENGLAND &  
MIDATLANTIC**  
Conn., ME, VT, MA, NH, NJ,  
PA, NY, RI  
**201-256-0455**

**MIDWEST**  
MI, IL, IN, IOWA  
**313-349-7910**

**NORTHERN CALIFORNIA**  
**415-592-0357**

**CANADA**  
**416-444-8497**

**800-368-2210**

## CONNECTORS

BNC, TNC, F, N and  
PATCHING

Also - TWINAX, TRIAX

FREE T-15  
CATALOG

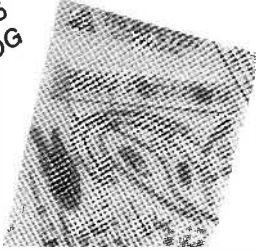

**T** **TROMPETER**  
ELECTRONICS

Circle (107) on Reply Card  
P.O. Box 5069, Thousand Oaks, CA 91359  
(818) 707-2020/TWX 910-494-1210

## COAX TWINAX TRIAX SYSTEMS

**TROMPETER'S** all new 76 page, **T-15** catalog is crammed full of **Connectors, Patching, Cable & Cable Assemblies**. Connector lines have been expanded to include new **lug** configurations, **Filtered** connectors, cable entry **Bend Relief**, terminations, adapters, and much more, for your EMI/RFI applications. Fill in information below for your copy.

### Please Check Area of Interest:

- Local Area Networks, Computer Installation
- Military Data Bus per MIL-STD-1553 or 1397
- Telecommunications
- Broadcast & Video (TV, LPTV, Cable, etc.)
- Other \_\_\_\_\_

Company \_\_\_\_\_

Name \_\_\_\_\_ M/S or Dept. \_\_\_\_\_

Address \_\_\_\_\_

City/State/Zip \_\_\_\_\_

Bus. Phone ( \_\_\_\_\_ ) \_\_\_\_\_

PHONE (818) 707-2020 TWX: 910-494-1210 FAX (818) 706-1040

**FREE**  
CATALOG

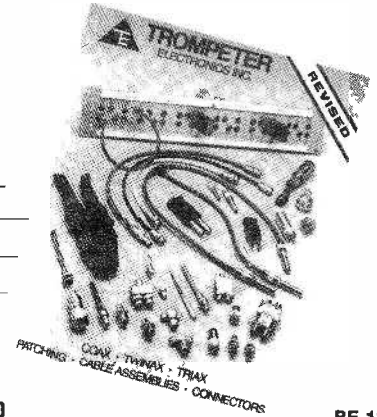

BE 12/87



# Moving?

## Take us with you.

Just peel off the subscription mailing label and attach it to the address change card located at the front of this issue. Please allow 6-8 weeks to process your address change.

# BROADCAST<sup>®</sup>

## engineering

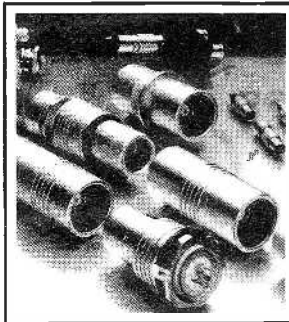
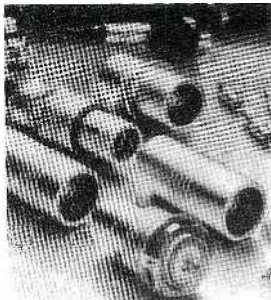

**L** **LEMOUSA INC**  
ELECTRONIC CONNECTORS

P.O. Box 11488, 335 Tesconi Circle,  
Santa Rosa, CA 95406 (707) 578-8811  
Telex 340-933 (LEMO USA SARO),  
Telefax 707/578-0869

**THE QUALITY CHOICE**

**L** **LEMOUSA INC**  
ELECTRONIC CONNECTORS

Telephone (707) 578-8811, Telex 340-933 (LEMO USA SARO)

## Audio-Video Connectors

- Video Triax ■ Multicontact ■ Stereo
- Short Type ■ Coaxial ■ Miniature

Name \_\_\_\_\_

Title \_\_\_\_\_

Company \_\_\_\_\_

Address \_\_\_\_\_

City/State/Zip \_\_\_\_\_

Telephone \_\_\_\_\_

My Application is:

Video Triax

Stereo

Miniature

Multicontact

Other \_\_\_\_\_

My need is:  Immediate  3-6 Months  Literature Only



NO POSTAGE  
NECESSARY  
IF MAILED  
IN THE  
UNITED STATES

**BUSINESS REPLY MAIL**  
FIRST CLASS PERMIT NO. 21 CHATSWORTH, CA

POSTAGE WILL BE PAID BY ADDRESSEE



**TROMPETER**

ELECTRONICS

31186 LA BAYA DR.

P.O. BOX 5069

WESTLAKE VILLAGE, CA 91359-9972

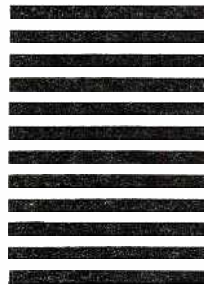

**CONNECTORS**

BNC, TNC, F, N and  
PATCHING

Also: TWINAX, TRIAX

FREE T-15  
CATALOG



**TROMPETER**

ELECTRONICS

Circle (107) on Reply Card

P.O. Box 5069, Thousand Oaks, CA 9135

(818) 707-2020/TWX 910-494-1210



# Moving?

## Take us with you.

Just peel off the subscription mailing label and attach it to the address change card located at the front of this issue. Please allow 6-8 weeks to process your address change.

# BROADCAST<sup>®</sup> engineering



NO POSTAGE  
NECESSARY  
IF MAILED  
IN THE  
UNITED STATES

**BUSINESS REPLY CARD**  
FIRST CLASS PERMIT NO. 0365 SANTA ROSA, CA

POSTAGE WILL BE PAID BY ADDRESSEE

**LEMO USA INC.**

P.O. BOX 11488

SANTA ROSA, CA 95406

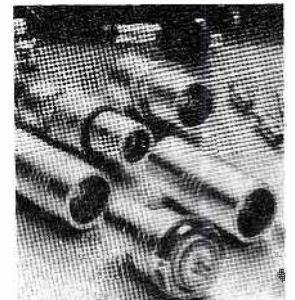
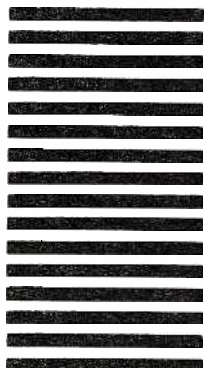

**LEMO USA INC**  
ELECTRONIC CONNECTORS

P.O. Box 11488, 335 Tesconi Circle,  
Santa Rosa, CA 95406 (707) 578-8811  
Telex 340-933 (LEMO USA SARO),  
Telefax 707/578-0869

**THE QUALITY CHOICE**



# TOO MANY OF TODAY'S MICS ARE YESTERDAY'S NEWS.

*When you're in the fast-paced business of news, why use outdated microphones? Time marches on, and old habits become bad habits if you don't keep up with the times.*

*The M 58, on the other hand, proudly benefits from new technical developments like a unique design employing a tiny, low mass diaphragm. Highly sensitive and accurate, its contoured upper frequency response produces unprece-*

*dentented intelligibility, even off axis.*

*A sophisticated modern internal shock-mount system reduces handling noise and vibration down to new levels. The 58 is scientifically "weight balanced" for greater comfort during lengthy interviews. Its slim, elegant profile and special "on-camera" finish look exceptional—in an understated way—on camera. The mic's thoroughly rugged and reliable construction*

*stands out in a world of "disposable" mics.*

*If your news microphone is old news, audition an M 58 at your authorized Beyer dealer and experience the sound of modern news mic technology. Or contact:*

**beyerdynamic U.S.,**  
5-05 Burns Avenue,  
Hicksville, New York 11801,  
(516) 935-8000,  
FAX (516) 935-8018.



**ACCURACY IN AUDIO**

**beyerdynamic** 

Canada: ELNOVA Ltd. 4190 Rue Sere, St. Laurent, Quebec H4T 1A6  
Tel. (514) 3 41 69 33 Telex 5824086

Great Britain: beyerdynamic, Ltd., Unit 14, Cliffe Industrial Estate  
Lewes, Sussex BN86JL Tel. 273 479 411

Australia: Hi-Phon Distributors Pty. Ltd., 356 A-358 Eastern Valley Way  
Chatswood N.S.W. 2067 Tel: (02) 417 7088

Germany: Eugen Beyer Elektrotechnische Fabrik GmbH & Co., Theresienstrasse 8,  
Postfach 13 20, D-7100 Heilbronn Tel: (07131) 617-0 Telex 728771

Circle (64) on Reply Card

Performance .....	8-76
News Special Report: Bringing Calgary to the World .....	12-138

**FACILITY PLANNING/DESIGN/RENOVATION**

Planning a Remote Production Vehicle ..	1-68
Planning for Audio Post-Production .....	3-130
A Design Approach to Lighting .....	3-262
Planning for TV Automation .....	4-26
Serial Data Control Systems .....	4-44
<i>Applied Technology/Installing Acoustic Materials .....</i>	<i>7-76</i>
Wiring an Audio-Video Facility .....	9-73
Controlling ac Line Disturbances .....	11-26
Who's Spending What .....	12-26
News Special Report: Bringing Calgary to the World .....	12-138

**FIELD REPORTS**

Polaroid/Toshiba FreezeFrame video image recorder .....	2-116
Ampex AVA-3 video recorder .....	3-308
Media Touch 2005 automation controller .....	4-98
Orban 275A stereo synthesizer .....	5-136
Rank Cintel ADS 1 telecine .....	7-86
Pacific Recorders Micromax reproducer .....	9-116
Sony BVP-360 studio camera .....	10-156
JVC CR-850U videocassette recorder .....	11-136

**GENERAL INTEREST/MISCELLANEOUS**

<i>Editorial .....</i>	<i>1-6 through 12-6</i>
<i>FCC Update .....</i>	<i>1-8 through 12-8</i>
<i>Circuits .....</i>	<i>1-16 through 12-16</i>

<i>SBE Update .....</i>	<i>1-138, 2-130, 3-22, 4-116, 5-146, 7-96, 8-116, 9-122 10-162, 11-142, 12-136</i>
<i>Show Preview/SMPTE-TV Conference .....</i>	<i>1-112</i>
<i>Show Replay/128th SMPTE Conference/Exhibit .....</i>	<i>1-116</i>
<i>Show Replay/SBE National Convention .....</i>	<i>1-128</i>
<i>The Future of HDTV .....</i>	<i>2-60</i>
<i>Strictly TV/Comparing Similar Video Products .....</i>	<i>3-10</i>
<i>Reliability and Maintainability Special Report .....</i>	<i>3-35</i>
<i>Repairing Surface-Mount PC Boards .....</i>	<i>3-116</i>
<i>LCD Display Technology .....</i>	<i>3-284</i>
<i>Strictly TV/In Answer to That .....</i>	<i>4-10</i>
<i>Planning for Engineering Automation .....</i>	<i>4-76</i>
<i>Show Preview/15th ITS (Montreux) .....</i>	<i>5-134</i>
<i>Assembling the Technology Puzzle .....</i>	<i>6-23</i>
<i>Keeping Up With Technology .....</i>	<i>6-36</i>
<i>Pick Hits of NAB '87 .....</i>	<i>6-60</i>
<i>Show of Shows/NAB Exhibits .....</i>	<i>6-76</i>
<i>Troubleshooting/The Unexpected Citation Source .....</i>	<i>7-18</i>
<i>New Approaches to AM Improvement .....</i>	<i>8-92</i>
<i>Show Replay/Montreux .....</i>	<i>9-124</i>
<i>Show Preview/129th SMPTE .....</i>	<i>9-127</i>
<i>News Special Report: On the Receiving End .....</i>	<i>9-114, 10-160</i>
<i>Wiring an Audio-Video Facility .....</i>	<i>9-73</i>
<i>Show Preview/SBE National Convention/BE Conference .....</i>	<i>10-150</i>
<i>1987 Salary Survey .....</i>	<i>10-22</i>
<i>Strictly TV/Round Three (S-VHS) .....</i>	<i>11-10</i>
<i>Satellite Technology/Satellite User's Conference .....</i>	<i>11-14</i>
<i>Controlling ac Line Disturbances .....</i>	<i>11-26</i>
<i>Who's Spending What .....</i>	<i>12-26</i>
<i>View From the Top .....</i>	<i>12-40</i>
<i>The State of TV News .....</i>	<i>12-54</i>
<i>Manufacturing Technology .....</i>	<i>12-59</i>
<i>Broadcasting's Bottom Line .....</i>	<i>12-62</i>
<i>Digital Amplitude Modulation .....</i>	<i>12-66</i>
<i>Show Replay/Radio '87 .....</i>	<i>12-134</i>
<i>News Special Report: Bringing Calgary to the World .....</i>	<i>12-138</i>

# INEXPENSIVE BY DESIGN

Here is audio engineering at its affordable best. The McCurdy Series 'S' Console can be tailored for any size budget and broadcast requirement to provide precise audio mixing, monitoring and control. The very latest in analog and digital electronics is coupled with full electronic audio switching to assure the highest quality.

As complete or as basic your budget allows, the Series 'S' offers McCurdy's unsurpassed audio quality and ultra-reliability. Available in a wide choice of modules in three sizes to accommodate up to 26 input mixing modules.

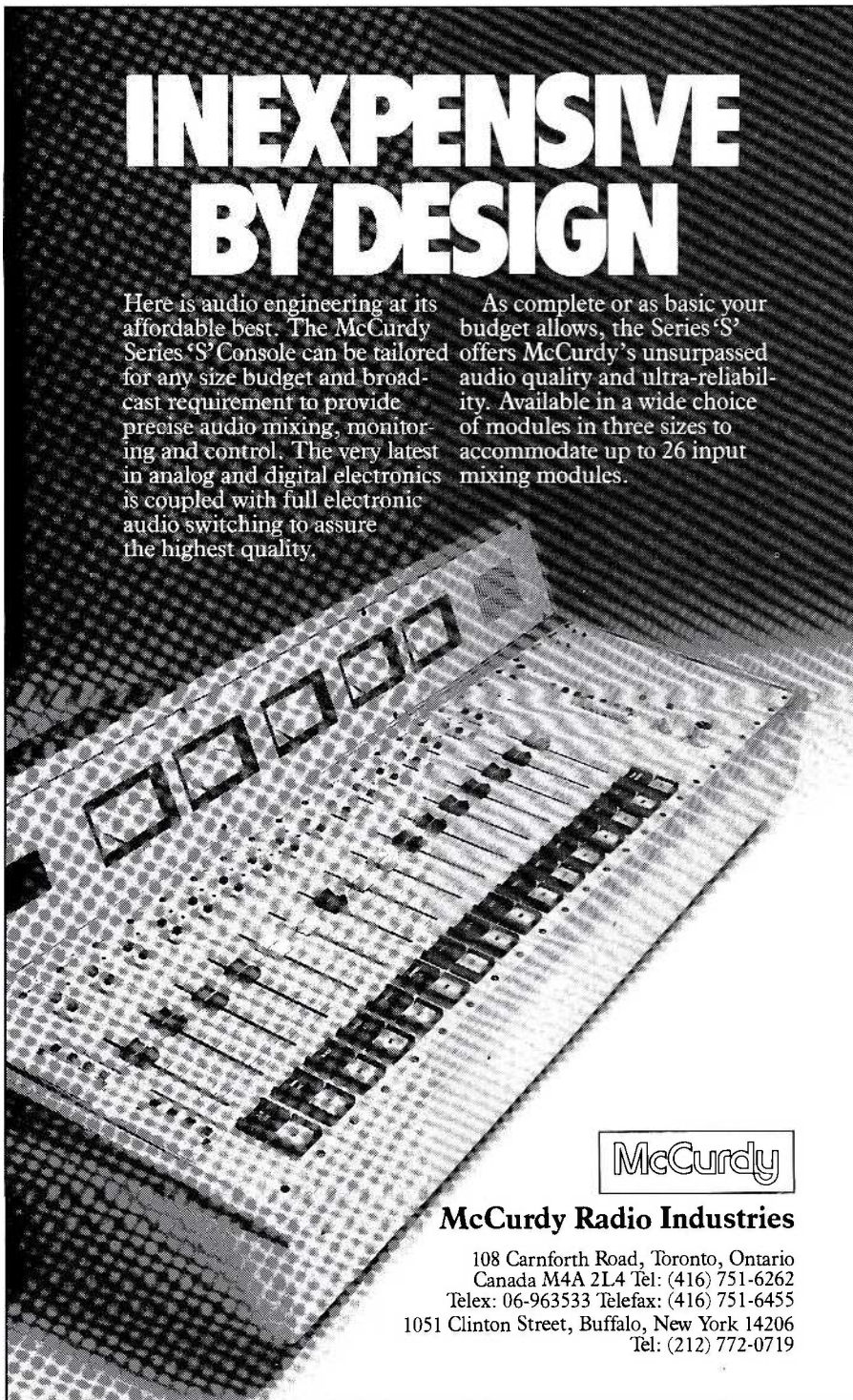

**McCurdy Radio Industries**

108 Carnforth Road, Toronto, Ontario  
 Canada M4A 2L4 Tel: (416) 751-6262  
 Telex: 06-963533 Telefax: (416) 751-6455  
 1051 Clinton Street, Buffalo, New York 14206  
 Tel: (212) 772-0719

Circle (65) on Reply Card

**MANAGEMENT**

<i>FCC Update .....</i>	<i>1-8 through 12-8</i>
<i>Management for Engineers .....</i>	<i>1-20 through 12-20</i>
<i>SBE Update/Frequency Coordination Effort Grows .....</i>	<i>1-138</i>
<i>The Future of HDTV .....</i>	<i>2-60</i>
<i>Planning for TV Automation .....</i>	<i>4-26</i>
<i>Editorial/Catch 22 .....</i>	<i>9-6</i>
<i>1987 Salary Survey .....</i>	<i>10-22</i>
<i>Editorial/Protecting the Bottom Line .....</i>	<i>11-6</i>
<i>Who's Spending What .....</i>	<i>12-26</i>
<i>View From the Top .....</i>	<i>12-40</i>
<i>Manufacturing Technology .....</i>	<i>12-59</i>
<i>Broadcasting's Bottom Line .....</i>	<i>12-62</i>

**MEASUREMENT/MONITORING/TESTING**

<i>Troubleshooting/Test Instruments Can Be Rented .....</i>	<i>2-18</i>
<i>Troubleshooting/Plan for Changes in DMM Design .....</i>	<i>4-18</i>
<i>Seeing Between the Lines .....</i>	<i>5-116</i>
<i>Troubleshooting/Switching-Voltage Regulators .....</i>	<i>8-18 through 11-18</i>
<i>Video in Transition .....</i>	<i>8-50, 9-40, 10-108</i>
<i>Monitoring Satellite System Performance .....</i>	<i>8-76</i>
<i>Satellite Technology/Basic Operations of a Spectrum Analyzer .....</i>	<i>9-14</i>
<i>Using Digital Oscilloscopes .....</i>	<i>11-94</i>

Continued on page 101

Continued from page 96

Testing Stereo Audio for Mono Compatibility ..... 11-106  
*Applied Technology*/Binaural Sound:  
 Expanding on the Image ..... 11-122  
*Troubleshooting*/Learn the Value of an Organized Attack ..... 12-18

**RECORDING/EDITING/PLAYBACK**

Audio Equalization for Cartridge Recording ..... 3-272  
*Strictly TV* ..... 6-10, 7-10, 8-10  
*Troubleshooting*/Maintaining a Reel-to-Reel VTR ..... 6-18  
*Editorial*/Recipe for Change (S-VHS) ..... 8-6  
 The Mysteries of Video Editing Revealed ..... 8-67  
*Applied Technology*/Modifying Time—System Considerations ..... 8-104  
 Tape as a Recording Medium ..... 10-48  
 The Evolution of Audio Recording ..... 10-54  
 The Evolution of Video Recording ..... 10-67  
 Preserving Magnetic Tape ..... 10-84  
 Erasing Magnetic Tape ..... 10-90  
 The Art of Film-to-Tape Transfer ..... 10-98  
*Applied Technology*/Dolby Spectral Recording ..... 10-138

**RF/RADIO FREQUENCY**

*re:Radio*/Learning the Basics . 1-12, 2-12, 3-12  
 Audio Transmission on 23GHz ..... 1-82  
*Strictly TV*/The Klystrode Stirs Interest at NAB ..... 5-10  
*Satellite Technology*/Traveling Wave Tube Basics ..... 5-14  
 Fine-Tuning FM Final Stages ..... 5-46  
*Satellite Technology*/Low-Noise Amplifiers ..... 6-14  
 Return of the Synchronous Amplifier . 6-176  
 New Approaches to AM Improvement . . 8-92  
 Digital Amplitude Modulation ..... 12-66  
 Hot Switches and Combiners ..... 12-82

**SATELLITE USE**

*Satellite Technology* ..... 1-14 through 12-14  
 Radio Field Production ..... 1-26  
 Coping With Solar Outages ..... 3-276  
*Applied Technology*/DBS Digital Sound-Coding Format ..... 3-302  
 Monitoring Satellite System Performance ..... 8-76  
 The State of TV News ..... 12-54

**STEREO TV**

Multidimensional Audio for Stereo TV ..... 7-46  
 Testing Stereo Audio for Mono Compatibility ..... 11-106  
*Applied Technology*/Binaural Sound:  
 Expanding on the Image ..... 11-122

**SWITCHING SYSTEMS**

Planning for TV Automation ..... 4-26  
 Serial Data Control Systems ..... 4-44  
*Applied Technology*/  
 Control via Dynabus ..... 4-106  
 The Ins & Outs of Video Switching ..... 9-52  
 Hot Switches and Combiners ..... 12-82

**TRANSMITTERS**

*Strictly TV*/The Klystrode Stirs Interest at NAB ..... 5-10  
*re:Radio*/Reviewing FCC Field-Strength Rules ..... 5-12, 6-12  
 Inside FM Power Amplifiers ..... 5-26  
 Return of the Synchronous Amplifier ..... 6-176

*Troubleshooting*/The Unexpected Citation Source ..... 7-18  
*Station-to-Station*/Transmitters Wired for Remote Control ..... 8-113  
 Digital Amplitude Modulation ..... 12-66  
 Hot Switches and Combiners ..... 12-82

**VIDEO**

Digital Graphics From the Inside Out . . . 2-22  
 The All-Digital Studio ..... 2-42  
 The Future of HDTV ..... 2-60  
*Applied Technology*/Technology Behind DVE System 10 ..... 2-108  
 LCD Display Technology ..... 3-284  
 Seeing Between the Lines ..... 5-116  
*Applied Technology*/NEC SP-3A CCD Camera Technology ..... 6-186  
 Maintaining TV Cameras ..... 7-60

*Editorial*/Recipe for Change (S-VHS) ..... 8-6  
 TV Camera Technology Update ..... 8-26  
 Video in Transition ..... 8-50, 9-40, 10-108  
 The Mysteries of Video Editing Revealed ..... 8-67  
*Applied Technology*/Modifying Time—System Considerations ..... 8-104  
*Strictly TV*/Adding Local Color ..... 9-10  
 Getting More From NTSC ..... 9-26  
 The Ins & Outs of Video Switching ..... 9-52  
 The Evolution of Video Recording ..... 10-67  
 The Art of Film-to-Tape Transfer ..... 10-98  
*Station-to-Station*/Retrieving Data From a Video Signal ..... 10-166  
*Strictly TV*/Take an Objective Look at Encoders ..... 12-10

**When There's No Room For Compromise...**

*We have the Solution...*



**AN AUTOMATED AUDIO MIXER WITH A TRACK RECORD FOR RELIABILITY AND COMPATIBILITY.**

The Model 608 Edit Suite Audio Mixer incorporates the features of our larger mixers into a smaller package, at a significant cost savings, without sacrificing quality or ease of operation.

Audio sources are controlled with the 608 in much the same way as video sources are controlled using a production switcher. This concept allows you to edit audio quickly, along with video or separately, using the same editing system.

Our proven editor interface, supported by most major edit system manufacturers\*, allows hands-free control of audio mixing right from the editor. Yet, at any time the mixer may be operated manually or with a combination of manual and editor control.

The Model 608 has eight inputs, each with its own fader, with separate inputs for the record VTR and tone. Outputs are stereo for both the program channels and built-in preview switcher.

Call us for a complete brochure.

\* mixers are currently in use worldwide with the following editing systems: Ampex Ace, CMX, Calaway, Convergence, Grass Valley Group, PALTEX, and other systems capable of operating a video switcher.

**GPS** **GRAHAM-PATTEN SYSTEMS, INC.**  
 P.O. Box 1960, Grass Valley, CA 95945  
 Inside CA: (800) 422-6662 • Outside CA: (800) 547-2489  
 TWX 910-333-6065 • FAX: 916-273-7458

PHOTO COURTESY OF SAN FRANCISCO PRODUCTION GROUP

Circle (94) on Reply Card



**Videotek's new DM-140S looks as great as it sounds.**

When broadcast engineers look to Videotek, they like what they see. Take our MTS Stereo/SAP tuner-demodulator. The first of its kind designed specifically for broadcast, CATV and closed-circuit applications. It boasts 140-channel tuning, balanced and unbalanced audio outputs, an internal 3-inch speaker, remote stereo speakers, a membrane control panel and more. What's best, these features cost much less than you'd expect.

Take a close look at the new DM-140S and all Videotek's value-engineered products at your dealer today.

243 Shoemaker Road, Pottstown, Pennsylvania 19464  
(215) 327-2292 TWX 710-653-0125 FAX (215) 327-9295



Circle (67) on Reply Card

**PLUG INTO AUDIO-LINE PRODUCTS**

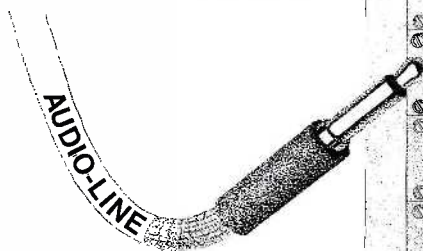

**Long-Frame & MINI:**

- Telephone Jacks
- Jack Panels
- Patch Cords
- Pre-Wired Patch Panels

Call or write for information on these and other Audio-Line products.



AUDIO ACCESSORIES, INC., MILL STREET, MARLOW, NH 03456 (603) 446-3335

Circle (68) on Reply Card

**Theme: Broadcasting From the Field**

**Editorial (page 6)**

- Still Hope for AM  
(The survival of AM radio depends upon a national technical standard. After four years of confusion, AM stereo receivers are disappearing. Without them, what next?)

**FCC Update (page 8)**

- FCC Eases Transmitter Modification Rules
- FCC Conducts Further Review of EEOC
- FCC Refuses to Extend Deadline for FM Upgrades

**Strictly TV (page 10)**

- To Be Aurally Sound, Part 1  
(Considerations to improve TV sound.)

**re: Radio (page 12)**

- Learning the Basics, Part 6  
(Maximum expected operating value, AM radiation patterns.)

**Satellite Technology (page 14)**

- Ka Frequency Gets a Head Start in New Year  
(Ka-band: 10-40GHz, the millimeter band; ACT: advanced communications technology; ISDN: integrated services data network.)

**Circuits (page 16)**

- Inside Digital Technology, Part 4  
(Memory organization of digital storage; addressing, device types.)

**Troubleshooting (page 18)**

- The Answers May Be at the Interface  
(DCEs, DTEs, RS-232C, RS-422.)

**Management for Engineers (page 20)**

- If it's Goodbye, Make it Good, Part 2  
(When employees are terminated, special precautions may be required.)

• **Radio Field Production (page 26)**

By Brad Dick, radio technical editor  
Remote production for radio contains hidden traps that make the engineer's life difficult. Awareness of these traps and the escape routes can mean a successful remote.  
*Interest:* audio, radio engineering, production, technical management.

*Key words:* remote, IFB, telephone lines, codecs, frequency extenders, RPU, frequency coordination, ICRs, path engineering, ARS (automatic relay stations), wireless microphones, satellite link back-haul.

• **An RENG Case History (page 52)**

By Mike Armatta, KTRH-AM/KLOL-FM, Houston  
The versatility of the RPU remote van is a matter of design.

*Interest:* radio engineering, production, technical management.

*Key words:* RPU, IFB, remote production van.

• **Planning a Remote Production Vehicle (page 68)**

By Ned Soseman, TV technical editor  
Many aspects of the remote production vehicle (RPV) are unique to the specific TV station. The design must serve all present and foreseeable requirements.

# The new standard of dependability: VHF TV transmitters from NEC.

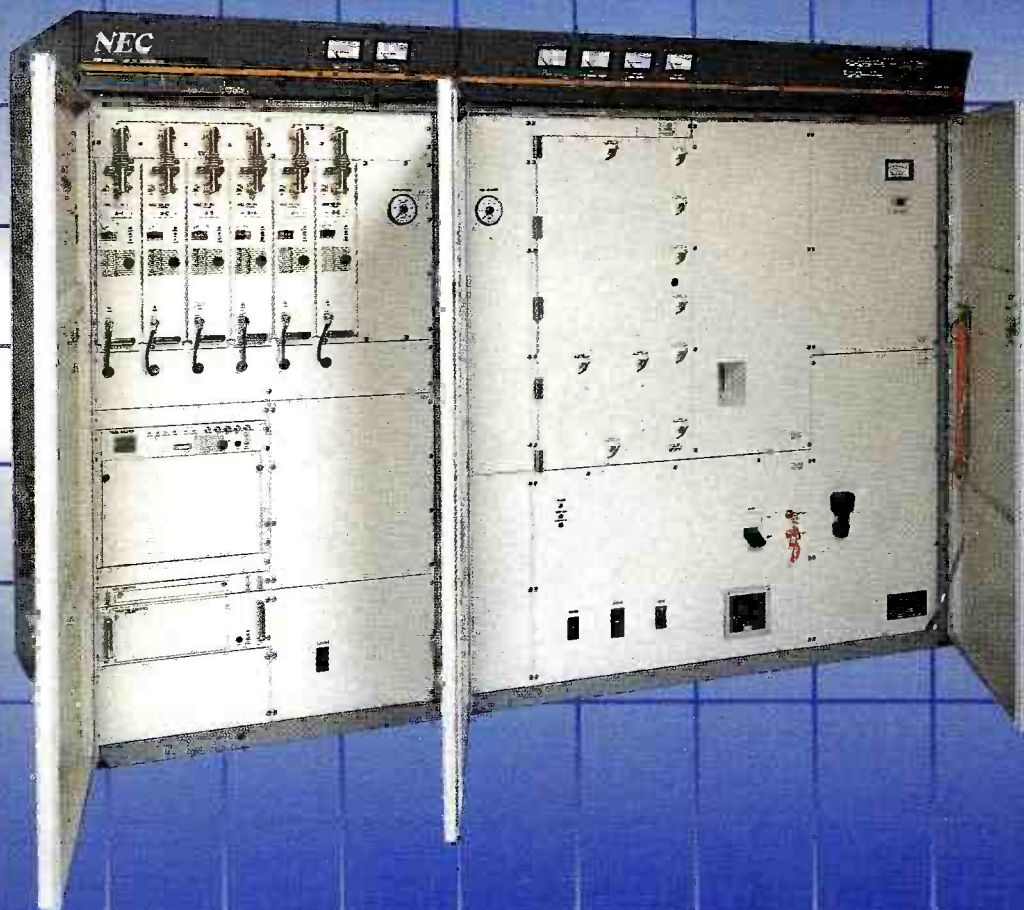

## 35kW high-band and 30kW low-band models meet your needs for the next decade.

High power transmitters are a major investment. You have to work with them, maintain them, and profit from them over the years. Our PCN-1400 Series transmitters reward your investment. Because they give you over a decade's worth of daily dependability, easy maintainability and superior performance.

### SINGLE-UNIT, HIGH-PERFORMANCE EXCITER.

Our hybrid IC technology slashes component count by 30%—thereby boosting reliability, making it

possible to build all modules into a single unit. Design refinements include sophisticated circuits to correct linearity, and stereo capability without modification.



### HIGH-POWER TRANSISTOR PA.

The solid state PA uses high-power, high-gain transistors newly developed by NEC.

The aural section is 100% solid state. There's only one tetrode in the final video amp.

The PCN-1400 Series gives you a wide choice of models from 500W to 35kW, high or low channels. And all models up to 10kW are 100% solid state.

30 YEARS EXPERIENCE,  
1,600 INSTALLATIONS.

NEC has installed over 1,600 transmitters in 30 years. We back our customers with 24-hour service. So take the risk out of your next investment. Call NEC and find out about the new standard of dependability in TV transmitters.

**NEC America, Inc.**  
Broadcast Equipment Division,  
1255 Michael Drive, Wood Dale, Illinois 60191  
Tel: 312-860-7600.

**C&C**  
Computers and Communications.

Circle (69) on Reply Card

# NEC

*Interest:* video engineering, production, technical management.

*Key words:* RPV (remote production vehicle), budgeting, vehicle chassis, custom-built, remote power source.

- **Taking to the Skies** (page 76)  
By Steven D. Hardy, WHIO-TV, Dayton, OH

The helicopter as a part of the news department ENG equipment is an expensive consideration. Other applications beyond ENG and broadcasting may make the chopper attractive to the station.

*Interest:* engineering, technical management.

- **Audio Transmission on 23GHz** (page 82)  
By Mark Timpany, WQFM-FM, Milwaukee

Congested STL and ICR frequencies can be alleviated by expanding relay use to the 23GHz band.

*Related:* Gunn diodes.

*Interest:* engineering, technical management, production.

*Key words:* licensing, PCM encoding, path considerations, rainfall, reliability.

- **Networking the Newsroom** (page 94)

By Carl Bentz, special projects editor

A variety of network types exist. Their applicability to newsroom use depends upon the capabilities required.

*Interest:* general, technical management, news production, engineering.

*Key words:* Baudot, ASCII, LAN, point-to-point, collision detection, packet switching,

codecs, CRC, Ethernet, ESBUS, CCITT, ISO theoretical network, token ring, CSMA/CD.

*Show Preview* (page 112)

- San Francisco to Host SMPTE TV Conference  
(The 21st annual SMPTE TV conference.)

*Show Replay* (page 116)

- Today's Technology, Tomorrow's Reality  
(The 128th SMPTE technical conference and equipment exhibit.)

*Show Replay* (page 128)

- SBE Convention is "Show Me" Success  
(The first SBE national convention, St. Louis.)

*SBE Update* (page 138)

- Frequency Coordination Effort Grows Nationwide  
(A list of SBE national frequency coordinators provided.)

## FEBRUARY 1987

**Theme: Digital Technology for Audio and Video**

*Editorial* (page 6)

- Are Standards Obsolete?  
(There is a definite place for technical standards in the broadcast industry.)

*FCC Update* (page 8)

- Cable Systems to Use TV Auxiliary Frequencies
- Freeze Imposed on Daytime AM Applications
- Metric AM Groundwave Curves Date Deferred
- FCC Comments in EPA RF Radiation Proceeding

*Strictly TV* (page 10)

- To Be Aurally Sound, Part 2  
(Considerations to improve TV sound quality.)

*re:Radio* (page 12)

- Learning the Basics, Part 7  
(Standard pattern conversions.)

*Satellite Technology* (page 14)

- Double Illumination  
(Using one satellite transponder for more than one signal is possible, but certain observations are necessary.)

*Circuits* (page 16)

- Inside Digital Technology, Part 5  
(Memory organization, nibbles, access cycles.)

*Troubleshooting* (page 18)

- Test Instruments Can Be Rented  
(If the purchase price is too much for the station's budget, high-ticket instruments can be rented and leased.)

*Management for Engineers* (page 20)

- Managing the Maverick  
(Dealing with the independent-minded employee and customizing management techniques.)

- **Digital Graphics From the Inside Out**  
(page 22)

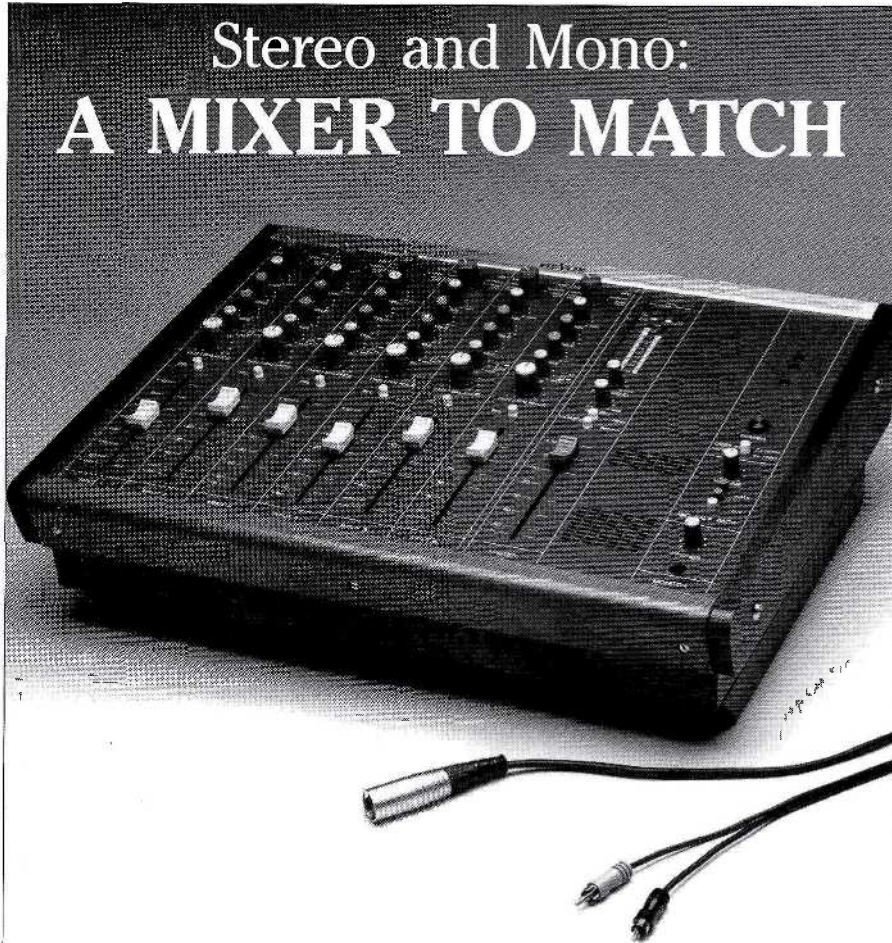

# Stereo and Mono: A MIXER TO MATCH

**Every input on the Studer Revox C279 mixer is a stereo input... and a mono input.**

Line level stereo, balanced mono and balanced microphone, each with a separate input position. Mix them or match them with all six channels of the C279.

Built to strict Studer Revox standards, the C279 makes no compromises in durability or sonic performance. No "small mixer" short cuts here.

If you're looking for a compact mixer built like the big boards, the compact C279 mixer is tough to match.

Details available from your Studer Revox Professional Products Dealer, or contact Studer Revox America, Inc., 1425 Elm Hill Pike, Nashville, TN 37210. (615) 254-5651.

**STUDER REVOX**

Circle (70) on Reply Card

# EEV KLYSTRONS SO MUCH MORE TO OFFER

*The most comprehensive range of  
External Cavity UHF TV Klystrons*

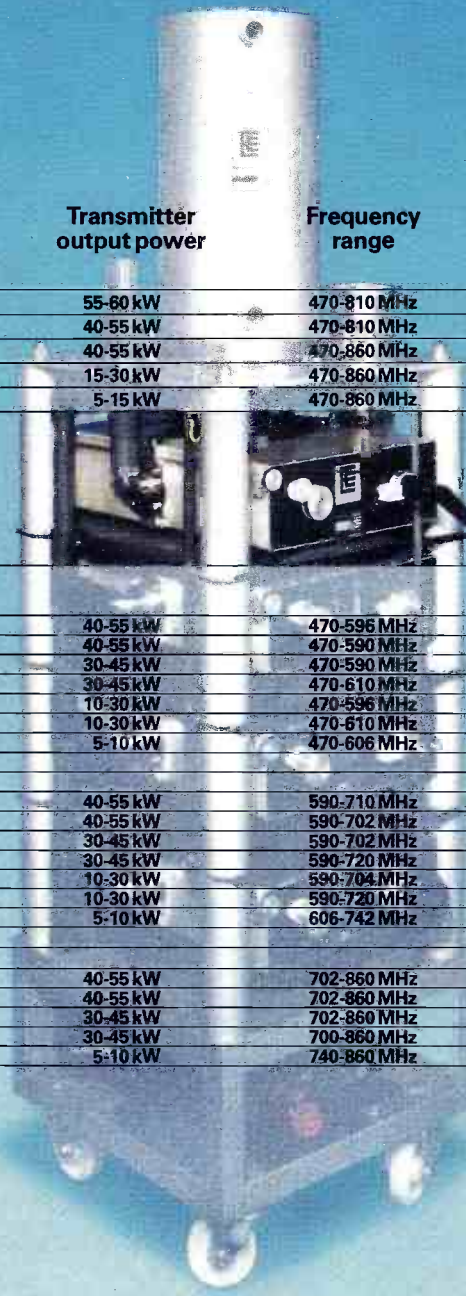

	Transmitter output power	Frequency range	Typical Sync efficiency
<b>WIDEBAND SERIES</b>			
K3672BCD	55-80 kW	470-810 MHz	44% to 48%
K3572BCD	40-55 kW	470-810 MHz	43% to 46%
K3272WBCD	40-55 kW	470-860 MHz	42% to 45%
K3271BCD	15-30 kW	470-860 MHz	42% to 47%
K3270BCD	5-15 kW	470-860 MHz	42% to 47%

## **STANDARD SERIES**

<b>Low Band</b>			
K3276HBCD	40-55 kW	470-596 MHz	38% to 43%
K3382BCD	40-55 kW	470-590 MHz	38% to 42%
K3217HBCD	30-45 kW	470-590 MHz	40% to 42%
K3282BCD	30-45 kW	470-610 MHz	30% to 40%
K3230BCD	10-30 kW	470-596 MHz	40% to 42%
K376L	10-30 kW	470-610 MHz	34% to 40%
K370/W series	5-10 kW	470-606 MHz	29% to 35%
<b>Mid Band</b>			
K3277HBCD	40-55 kW	590-710 MHz	38% to 43%
K3383BCD	40-55 kW	590-702 MHz	38% to 42%
K3218HBCD	30-45 kW	590-702 MHz	40% to 42%
K3283BCD	30-45 kW	590-720 MHz	30% to 40%
K3231BCD	10-30 kW	590-704 MHz	40% to 42%
K377L	10-30 kW	590-720 MHz	38% to 45%
K371/W series	5-10 kW	606-742 MHz	32% to 35%
<b>High Band</b>			
K3278HBCD	40-55 kW	702-860 MHz	38% to 43%
K3384BCD	40-55 kW	702-860 MHz	38% to 42%
K3219HBCD	30-45 kW	702-860 MHz	40% to 42%
K3284BCD	30-45 kW	700-860 MHz	30% to 40%
K372/W series	5-10 kW	740-860 MHz	32% to 35%

AVAILABLE TODAY **EEV** Klystrons

USA: EEV Inc., 4 Westchester Plaza, Elmsford, NY 10523, USA Telephone: 914 592 6060 Telex: 6818096 Fax: 914 592 8342  
 UK: EEV, Waterhouse Lane, Chelmsford, Essex CM1 2QU, England Telephone: (0245) 261777 Telex: 99103 Fax: (0245) 50424  
 CANADA: EEV Canada Ltd, 67 Westmore Drive, Rexdale, Ontario M9V 3Y6 Telephone: 416 745 9494 Telex: 06 989363 Fax: 416 745 0618

Circle (71) on Reply Card

By Carl Bentz, special projects editor

How a graphics system behaves internally involves a complex structure of computer hardware and software. Access to the computer and its capabilities is coordinated through control panels, minimizing the operator's need for computer knowledge.

*Interest:* general, video engineering, production.

*Key words:* algorithms, Bresenham, vectors, matrix algebra, pipelining, virtual space, fills, fractals, Mandelbrot sets, Phong, Gouraud, ray tracing, graphics engine, B-spline, Bezier, 3-D, bit-map, bit-slicing.

• **The All-Digital Studio** (page 42)

By Ned Soseman, TV technical editor

Le Studio Numerique, Rennes, France, is an operational all-digital studio. An experimental project, the facility was a cooperative venture to allow technical research, development, implementation and training on digital TV systems.

*Related:* What is 4:2:2?

*Interest:* general, video engineering, production.

*Key words:* 4:2:2, 4:4:4, A/D, D/A, serial-parallel, perfect electronic editing.

• **The Future of HDTV** (page 60)

By Ned Soseman, TV technical editor

An overview of HDTV discusses the problems of standardization and some of the present applications.

*Related:* Hi-Vision comes to America.

*Interest:* general, video engineering, production.

*Key words:* MUSE, goals, 1125/60, progressive scanning, Hi-Vision, NAB/MST.

• **Inside Digital Delay Systems** (page 86)

By Richard Cabot, Audio Precision, Beaverton, OR

Although it is finding more and more applications, digital signal processing is still in its infancy. Caution should be exercised with digital audio effects.

*Interest:* general, audio engineering, production, technical management.

*Key words:* sampling, quantization, bits of resolution, anti-aliasing, A/D, D/A, aperture time, reconstruction filter, dither, reverb.

*Applied Technology* (page 108)

• **Technology Behind DVE System 10**

By K. Kashigi, K. Hirayama, T. Yamashita and S. Kawabe, NEC, Tokyo (Methods used inside the NEC System 10 digital effects unit to achieve various image manipulations.)

*Field Report* (page 116)

- Polaroid FreezeFrame video image recorder

*Station-to-Station* (page 124)

• **Power Supply is Heart of Audio Equipment**

By Jon Gaines, Ashly Audio, Rochester, NY

(A well-regulated power supply for audio equipment.)

*SBE Update* (page 130)

- Ennes Foundation Fills Officer Positions
- Fellowships Conferred
- Docket 86-367
- Non-Ionizing Radiation

**MARCH 1987**

*Pre-NAB Show Issue*

*Editorial* (page 6)

- **Broadcast Quality...Use it or Lose it!** (Increased consumer awareness of technology means the technical quality of a broadcast presentation is as important as the content. Is broadcast quality lagging behind state of the art?)

*FCC Update* (page 8)

- Commission Stays Must-Carry Rules
- Proposed Changes in Multiple Ownership
- Deletion of Reservation of 20 Class A FM Channels
- Plan of Action for AM

*Strictly TV* (page 10)

- Comparing Similar Video Products (Trade shows, a shoot-out, designing your own test.)

*re:Radio* (page 12)

- Augmentation in Practical Operation (Practical applications and the augmented AM directional pattern.)

*Satellite Technology* (page 14)

- Spring Check List (Assessing the earth-station facility for winter damage.)

*Circuits* (page 16)

- Inside Digital Technology, Part 6 (Clock and write cycles, digital bus)
- Continued on page 110*

# Take Me Out To The Ball Game

Or just take me out. The STLX extender/console puts you on the air when you're on the road.

With the STLX, when you leave the studio you don't leave studio quality behind. The built-in **Comrex Dual-Line** frequency extender with multiband noise reduction will deliver full program audio on two dial telephone lines—anywhere in the world.

And everything you need is all together in one professional package. This is a studio-quality console that's rugged enough for the road, with a four-input mixer (Penny & Giles® faders are standard), complete telephone interface, full monitor system with talkback, AGC, PA feed and more. An optional battery pack is available as well as a custom shipping case that will stand up to the airlines.

For more information on how Comrex can help your road games, call or write Comrex Corporation, 65 Nonset Path, Acton, MA 01720 (617) 263-1800. TWX 710-347-1049. FAX (617) 635-0401. 1-800-237-1776.

**COMREX®**

Circle (72) on Reply Card



# Well Sent... Well Received.

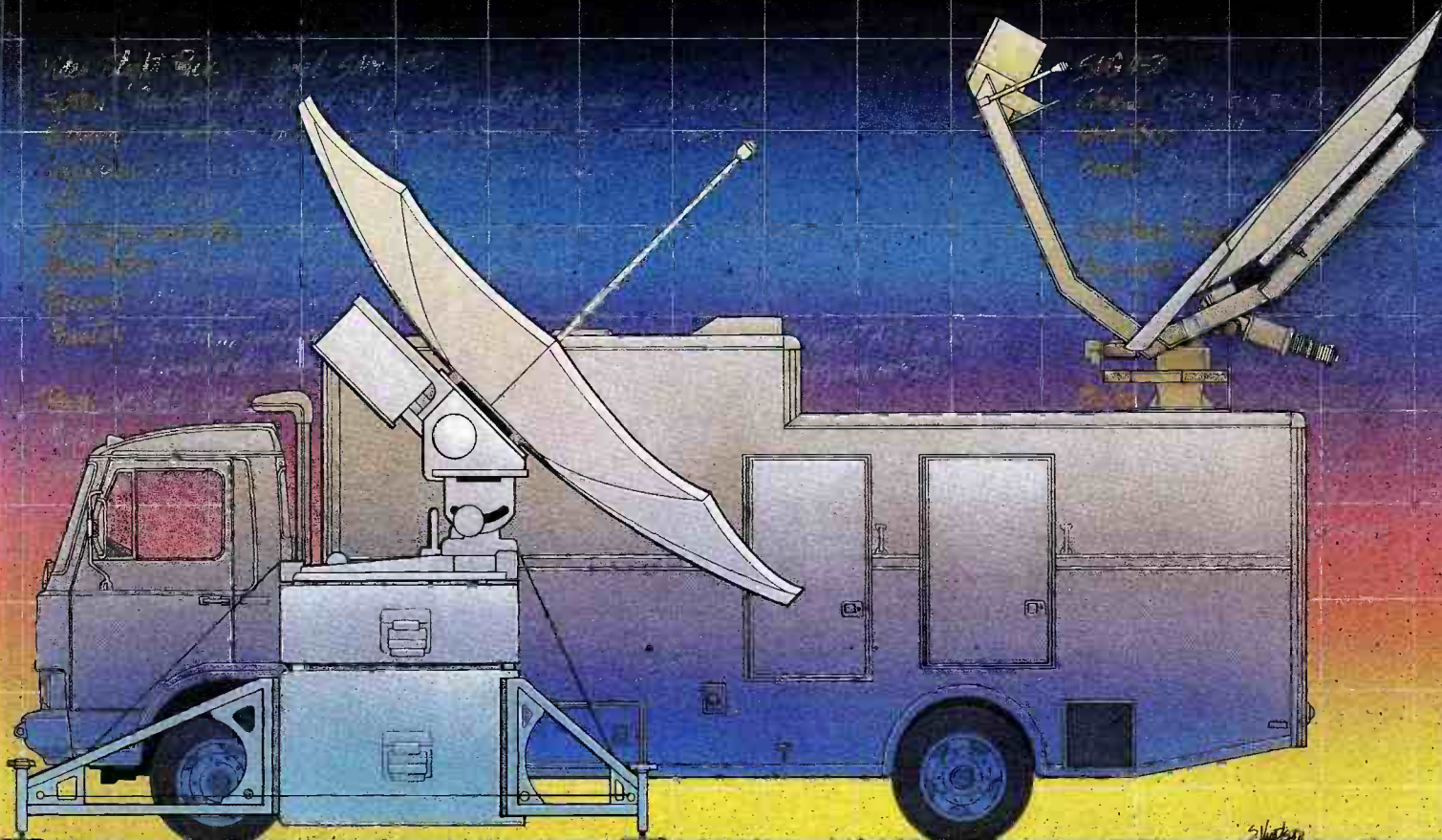

**When it comes to satellite communications systems, HUBCOM is the leader going away...and coming back.**

HUBCOM is your source for everything you need in satellite communications equipment. Our SNG® trucks were the first ones ever built in the U.S. — and we have more at work than everyone else combined.



We offer a complete line of SNG® vehicles. Choose the model. Choose the chassis. The choice is HUBCOM.

HUBCOM's Video Flight Pack is a marvel of "go anywhere technology" that is packed in portable cases, and can be shipped on any airline. Our Audio Flight Pack is even smaller.

And knowing that it is just as important

to receive, HUBCOM has a complete line of earth station downlinks for every application.

So whatever your satellite communications needs, call HUBCOM — you'll be well received.

## HUBCOM

**HUBBARD COMMUNICATIONS, INC.**

*The last word in technology from  
the first name in the industry*

A subsidiary of Hubbard Broadcasting Inc.

12495 34th St. N., Ste. D, St. Petersburg, FL 33716 (813) 577-7759

Circle (73) on Reply Card

# The only name you need to know



No matter what kind of business you're in, when it comes to answering all your video needs, there's only one name you need to know: Panasonic®. And one number you need to call: 1-800-553-7222. Once you do, you'll see that Panasonic offers you one of the largest selections of video components and accessories. But it's what's behind our product line that really sets us apart.

Take our dealer network. There are over 300 authorized Panasonic Professional/Industrial dealers throughout the country. Each with the expertise and technical know-how to help you select and design the video system that's just right for you.

Just as important and equally impressive is our nationwide service network. Each of our service centers is staffed by technicians who've gone through

# for all your industrial video needs.



*intensive training programs on the repair and maintenance of every professional/industrial video product we sell.*

*So whether you're into video production, post-production, training, or sales demonstration, when it comes to video, it's easy to see just how much Panasonic Professional/Industrial Video can do for your business.*

## **Panasonic** Professional/Industrial Video

*Call Panasonic Industrial Company at 1-800-553-7222 for more information and your nearest Panasonic Professional/Industrial Video dealer.*

Circle (74) on Reply Card



## SONEX kills background noise beautifully.

Crutchfield Corporation — Telemarketing  
Depr., Charlottesville, VA

SONEX is a special acoustic foam that absorbs noise four times better than acoustic tile or carpeting. It makes you sound like a pro — inexpensively — because your voice comes across clear, clean, and intelligible. Use SONEX for video, remote conferencing, voice-overs, radio communications, audio production, or anywhere else you need to sound crystal clear. Kill background noise beautifully — and save the true sound — with SONEX. Send for all the facts. SONEX is manufactured by Illbruck and distributed exclusively to the pro sound market by Alpha Audio.

**Alpha Audio**  
2049 West Broad Street  
Richmond, Virginia 23220 USA (804) 358-3852  
Telex: 469037 (ALPHAUD CI) FAX: (804) 358-9496  
*Acoustic Products for the Audio Industry*

Circle (75) on Reply Card

## NEW! Wireless Clear-Com



### 6 Beltpacks— No Wires!

FCC Approval applied for

- ▲ Clear-Com quality audio
- ▼ Extends range of wired system with up to six wireless transceivers
- ▲ Full-duplex, high band operation
- ▼ Developed for the professional user
- ▲ Exceptional RF performance — virtually transparent from the wired system

CONTACT YOUR  
CLEAR-COM DEALER,  
OR CALL/WRITE:

**Clear-Com**  
Intercom Systems

1111 17th Street  
San Francisco, CA 94107  
415-861-6666

Circle (85) on Reply Card

Continued from page 106

transmission lines, reading from memory.)

*Troubleshooting* (page 18)

- A Failure to Communicate (Breakout boxes provide an effective way to check communications bus activity.)

*Management for Engineers* (page 20)

- Study Theories Before You Implement One (Management by objectives and quality circles theories of management.)

*SBE Update* (page 22)

- MS-DOS Permits Remote Access to Databases
- Computer Standard (and Fido Net)
- UNICOM
- Certification
- CompuServe Forum

• **Reliability and Maintainability Special Report** (page 35)

By Jerry Whitaker, editorial director  
For equipment to be useful in broadcasting, it must be reliable. The "best" system is of little value if it does not work. On the other hand, if it fails, the equipment design should allow repair and return to service within the shortest possible time. A look at the various components of electronics systems, reasons for their failure, troubleshooting techniques and methods to avoid failure due to preventable causes.

*Interest:* management, engineering management, engineering.

*Key words:* statistical reliability, environmental stress screening, avalanche breakdown, thermal runaway, alpha multiplication, punch through, transients, transmitter tuning, VSWR overload, transistors, thyristors, SCRs, contactors.

• **Repairing Surface-Mount PC Boards** (page 116)

By Christopher Fenton, Western Reserve Tool and Machine Company  
Modern circuit design places new responsibilities on repair technicians. Surface-mount technology simplifies circuit construction and reduces manufacturing costs. It also requires proper tools and correct procedures to make repairs without additional damage to the circuit board.

*Interest:* engineering management, engineering technicians.

*Key words:* conductive heating, convective heating, surface-mount component, dual-inline, leadless ceramic chip carrier, pre-tinning, small outline integrated circuit, thermal coefficient of expansion, through-hole board, hot air repair terminal.

• **Planning for Audio Post-Production** (page 130)

By Richard Maddox, recording engineer, Lynnwood, WA  
The growing need for stereo audio post-production provides new opportunities for recording studios to find additional revenue sources.

*Related:* SMPTE EBU time code.

*Interest:* management, engineering management.

*Key words:* studio design, engineering talents, synchronization, equipment, time code

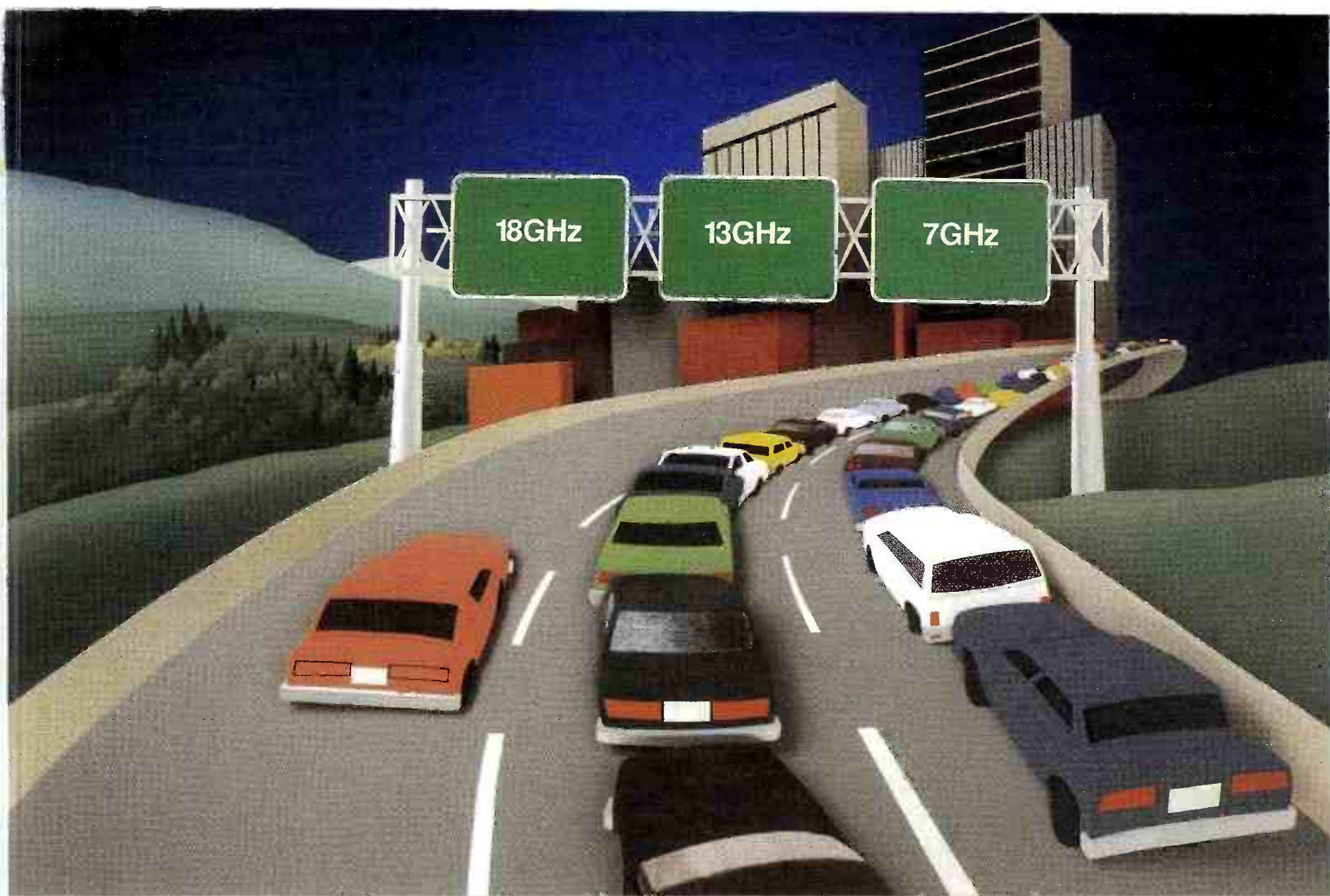

# Beat the traffic.

M/A-COM opens up a new lane for broadcasters with our new 18GHz microwave system.

If you've been looking for an open frequency at 7 or 13GHz, you're not alone. In many areas, they simply aren't available: there's too much traffic and not enough spectrum.

M/A-COM's new 18GHz microwave system gives you another option: a wide-open band which the FCC has assigned to broadcast. It gives you 50% better link availability (or 40% longer range) than 23 GHz, and none of the congestion of the lower frequencies.

The MA-18CC is a fully-featured microwave system, designed to meet or exceed all RS-250B short-haul performance

specifications. It is field tunable, and a single gunn oscillator covers a wide selection of frequencies so spare parts can be kept to a minimum.

For over 20 years M/A-COM MAC has specialized in providing microwave radio equipment to broadcasters. Every unit with our name on it is built in our own factory, so we not only control the quality, but we know how to service it.

For more information on how you can streamline your microwave needs, contact M/A-COM MAC, Inc., 5 Omni Way, Chelmsford, MA 01824, (617) 272-3100.



Circle (77) on Reply Card

(VITC, LTC).

• **A Design Approach to Lighting**

(page 262)

By Eric Neil Angevine, P.E., Oklahoma State University School of Architecture, Stillwater, OK

Effective and proper lighting results from a carefully thought-out design approach and a plan to place the required illumination at the right location.

*Interest:* facilities designers, management.

*Key words:* illumination, visibility.

• **Audio Equalization for Cartridge Recording** (page 272)

By Douglas W. Fearn, WKSZ-FM, Media, PA

The efforts to perfect the station's sound can be aided through customized equalization when material is recorded onto cartridges.

*Interest:* engineering, audio technicians.

*Key words:* turntable deficiencies, cartridge-machine deficiencies.

• **Coping With Solar Outages** (page 276)

By John Loeffler, Mannamedia, Denver

Annual solar outages on earth-station receiving systems are predictable to within minutes. Performing a few calculations can help to avoid an on-air outage or the need for program re-feeds.

*Interest:* engineering.

*Key words:* solar transit, C- and Ku-band transmission, equinox, Coordinated Universal Time, Greenwich Mean Time, longitude, latitude, azimuth, elevation, peak outage.

• **LCD Display Technology** (page 284)

By Conrad Persson, electronics editorial consultant

Displays based on LCD and other flat-panel technologies, rather than traditional CRTs, are finding more applications. Through the effects of electrical potentials on optical properties of specific organic compounds, the transmission of light can be controlled effectively.

*Interest:* general, engineering, technicians.

*Key words:* LCD, LED, matrix displays, cholesteric, nematic, smectic, ferroelectric smectic, TFT thin-film transistor.

*Applied Technology* (page 302)

- **DBS Digital Sound-Coding Format**  
By Carl Bentz, special projects editor (Adaptive delta modulation as used in the Dolby SoundLink digital sampling and sound coding method provides advantages over PCM and straight delta modulation techniques.)

*Field Report* (page 308)

- Ampex AVA-3

*Station-to-Station* (page 316)

- **Pan Pots Add Versatility**  
By Bill Harris, KRZN-AM and KMJI-FM, Englewood, CO  
(Adding panning capability aids in stereo production.)

## APRIL 1987

**Theme: Automation in Broadcasting**

*Editorial* (page 6)

- **People Make It Work**  
(No matter how elegant the automation

system, the human element is still a necessity to make it all run right.)

*FCC Update* (page 8)

- FCC Examines Call Letter Restrictions
- New Rules for Booster Stations
- LPTV, TV Translator Rules Amended
- Filing Fees Imposed

*Strictly TV* (page 10)

- **In Answer to That...**  
(An experimental project for instantaneous viewer response to VBI encoded, on-screen or audio questions.)

*re:Radio* (page 12)

- **Reviewing FCC Field-Strength Rules, Part 1**  
(Although a more relaxed attitude has been adopted for proof-of-performance checks and audio performance, spurious and harmonic emission tests are still important and required.)

*Satellite Technology* (page 14)

- **Advantages of SCPC Satellite Services**  
(The differences between subcarrier and single-channel-per-carrier systems.)

*Circuits* (page 16)

- **Inside Digital Technology, Part 7**  
(Signal timing and divide-by flip-flops can be observed by dual-trace oscilloscopes and logic analyzers.)

*Troubleshooting* (page 18)

- **Plan for Changes in DMM Design**  
(Future digital multimeter products will include microprocessors and surface-mount components.)

*Management for Engineers* (page 20)

- **You'll Find a Balance by Combining Theories**  
(An individual management style can be developed from studying various theories.)

• **Planning for TV Automation** (page 26)

By Don Edvalson, BTS, Salt Lake City

Successful automation requires appropriate interfacing to just about everything in the station. The purpose of the system is to assist the operator. To the extent that it does not, the effort to automate has failed. Operator assistance is dependent upon the interfacing and the ease with which the operator can respond to system activities.

*Interest:* engineering, technical, operation and station management.

*Key words:* prompts, terminal design, switcher interfacing, machine-control interfacing, traffic interfacing, automated cart-machine interfacing.

• **Serial Data Control Systems** (page 44)

By Waldemar S. Wisniewski, HEDCO, Grass Valley, CA

The expansion of automation duties suggests that the wire-per-crosspoint approach be replaced with a more versatile method. Serial data transmission reduces the number of conductors needed to control a large number of individual units.

*Related:* remote control with the EBus.

*Interest:* engineering, technical, operation and station management.

*Key words:* bytes, significant bits, ASCII, data words, serial, parallel, GPIB, RS-232C, RS-

422A, RS-423A, RS-485, duplex, star connection, loop, party line, polling, token passing, collision detection, Manchester, bi-phase encoding, NRZ/NRZI, baud rate, parity, cyclic redundancy check, error detection.

• **Planning for Engineering Automation** (page 76)

By Joseph P. Geerling, KWMU-FM, St. Louis

An electronic assistant may be the key to efficient engineering department operation. Computers provide many application programs to aid engineering.

*Interest:* engineering, management.

*Key words:* applications programs, word processing, spreadsheet, communications, equipment remote control.

• **Computer Power Protection** (page 88)

By Mark Hill, ITC/3M, Bloomington, IL

With the trend toward computer-related products in the broadcast environment, the need for clean power is crucial. A variety of power irregularities that could cause computer damage or malfunction can be avoided.

*Interest:* engineering, management, operations.

*Key words:* RFI, EMP, spikes, transients, sags, brownout, blackout, noise sources, UPS systems.

*Field Report* (page 98)

- Media Touch 2005 control system

*Applied Technology* (page 106)

- **Control via Dynabus**  
By Carl Bentz, special projects editor  
(An automation control bus designed by Utah Scientific is explained.)

*SBE Update* (page 116)

- Look Ahead to 1987 National Convention
- 1986 Convention Review
- New SBENET System Operator
- Election Ballot
- New Treasurer
- Update on Coordinators

## MAY 1987

**Theme: Transmission Systems**

*Editorial* (page 6)

- **Building Upon Success**  
(The cooperative effort enjoyed by BE and SBE during the planning of the SBE national convention will continue to thrive.)

*FCC Update* (page 8)

- Audits Discourage False Financial Certification
- New Ownership Reporting Requirements
- FM Reclassification Procedures

*Strictly TV* (page 10)

- **The Klystrode Stirs Interest at NAB**  
(Varian Klystrode application in Comark transmitter.)

*re:Radio* (page 12)

- **Reviewing FCC Field-Strength Rules, Part 2**  
(The FCC rules may seem to say that only AM radio must make annual tests, but FM and TV operations must be able to prove compliance.)

# Picky, Picky, Picky.



When it comes to choosing a video systems company, you can't afford *not* to be picky.

That's why we ask that you take a closer look at Roscor Corporation. Whether your needs are for a turnkey post production system, mobile production vehicle, satellite news vehicle, RF system or if you're simply looking for a systems design consultant, chances are Roscor can help.



#### FIXED VIDEO SYSTEMS

Roscor Corporation has amassed extensive experience in the design, construction and installation of editing suites, production studios, video conference rooms, computerized archival systems, CCTV, medical video applications and much more. Intelligent engineering, functional ergonomics, premium construction and skillful installation are all trademarks of a Roscor video system.

#### MOBILE VIDEO SYSTEMS

From ENG vans to 45 foot long "Super Trucks" and everything in between, Roscor continues to make a

name for itself with mobile video systems that are not only long-lasting and functional, but beautiful. Custom body work by experienced fabrication personnel and renowned Roscor engineering and craftsmanship go into every vehicle in Roscor's Elite Fleet™. The newest member of the Fleet is Roscor's "Star Fleet 21" Satellite News Vehicle. Packed with innovative design features and backed by years of R & D, the "Star Fleet" vehicles represent the industry standard for SNV's.

#### RF SYSTEMS

Roscor is experienced in diverse RF applications, including system design, installation and consultation on fixed satellite uplink/downlink systems, STL, Intercity and ITFS microwave systems.



#### CONSULTATION

Being one of the leading video systems companies in the country, Roscor is uniquely qualified to consult you on any video system or related need:

system design, architectural consultation, interior design, environmental considerations, audio applications, and more.

When it's time to be picky, it's time to pick Roscor.



## ROSCOR

**ROSCOR CORPORATION**  
1061 Feehanville Drive  
Mount Prospect, IL 60056  
Phone (312) 539-7700

**ROSCOR WISCONSIN**  
4701 West Schroeder Drive  
Suite 110  
Milwaukee, WI 53223  
Phone (414) 357-8000

**ROSCOR MICHIGAN**  
27260 Haggerty Road  
Suite A12  
Farmington Hills, MI 48018  
Phone (313) 489-0090

Roscor Corporation  
Communications Systems Engineering

Circle (78) on Reply Card

*Satellite Technology* (page 14)

- **Traveling Wave Tube Basics**  
(An explanation of the operation of TWT, the power-amplifier device of most uplink systems.)

*Circuits* (page 16)

- **Inside Digital Technology, Part 8**  
(Counters are constructed of flip-flops and gates.)

*Troubleshooting* (page 18)

- **Prevent Problems by Planning Ahead**  
(Sharing of towers and transmission lines is possible through crossband coupling and in-band combining networks.)

*Management for Engineers* (page 20)

- **Bring About Change, Not a Tug of War**  
(The management approach to new technology can mean smooth implementation or organizational problems.)

• **Inside FM Power Amplifiers** (page 26)

By Jerry Whitaker, editorial director, and Clarence Daugherty, Harris, Quincy, IL

Cavity amplifiers are predominant in power-amplifier designs for FM transmitters. Quarter-, 1/2- and folded 1/2-wave systems are used. Theory of operation and adjustment are discussed.

*Interest:* radio RF engineering.

*Key words:* cavity amplifiers, 1/4-wave,

1/2-wave, folded 1/2-wave, output capacitance, line lengths, coupling.

- **Fine-Tuning FM Final Stages** (page 46)  
By Geoffrey N. Mendenhall, P.E., Broadcast Electronics, Quincy, IL

Correct and efficient operation of FM transmitters requires more than simple peak-and-dip tuning procedures. Theory of FM modulation, bandwidth vs. distortion, sidebands and types of unwanted AM modulation all play a part in proper tuning.

*Interest:* radio, RF engineers.

*Key words:* tuning, loading, modulation index, Bessel functions, synchronous/asynchronous AM modulation, matching, APC headroom, SCA crosstalk.

- **Evolution of Broadcast Transmission Lines** (page 64)

By Geza Dienes, Andrew Corporation, Orland Park, IL

Transferring RF energy is an art and a science involving RF plumbing. The development of different types of transmission products is described.

*Interest:* general.

*Key words:* telegrapher's equation, 2-wire lines, coaxial line, waveguide.

- **Curve-Fitting Program for Transmission Lines** (page 78)

By Dane E. Ericksen, P.E., Hammett & Edison Consulting Engineers, Alameda, CA

A program for the HP programmable calculator aids in selecting the best transmission line for the application. Based on the Hoerl function, the program uses the operating frequency, specific attenuation and a least squares curve-fitting technique.

*Interest:* engineering.

*Key words:* Hoerl function, curve-fitting.

- **Building and Operating a Tower Facility** (page 93)

By Ray Upsahl, Skilling Ward Rogers Barkshire, Seattle

Tower design, installation and maintenance all play a part in the longevity of the antenna support structure. Understanding the forces active on the structure will help you to keep it standing.

*Interest:* engineering, management.

*Key words:* inspections, stiffness, period of vibration, loading, wind speed.

- **Seeing Between the Lines** (page 116)

By Carl Bentz, special projects editor

The final check on video-image quality places a great deal of confidence in video monitors in the facility. Being able to trust what the monitor shows depends on its reliability, design and other factors.

*Interest:* video operators, engineering.

*Key words:* delta-gun, PIL, dot-matrix, beam control.

*Show Preview* (page 134)

- **Symposium to Attract International Attendees**  
(15th International TV Symposium and Technical Exhibit, Montreux, Switzerland.)

*Field Report* (page 136)

- **Orban 275A Stereo Synthesizer**

*SBE Update* (page 146)

- **What SBE is Doing for You**
- **Certification, Membership Services**

## Now! A Single Channel BBE with Mic Level, Line Level and Phantom Power!



The clarity, definition, presence, texture and voice intelligibility for which BBE has become world renowned is now in a single channel format. For *all* microphone uses—from vocalists to instrumental soloists and lecturers to distributed sound systems, the BBE 401 will become indispensable.

High or low impedance mics and musical instruments can plug directly into the front or rear panel jacks. The BBE 401 has its own preamp with gain controls, can be used as a direct box and will accept -10dBu line levels. 24 volts of phantom power are available from the low impedance mic output.

The BBE processors achieve time alignment of harmonic and fundamental frequencies that were present in the live performance but became reshuffled in the often convoluted paths of recording, playback and broadcast of audio.

### The BBE 802

For use in broadcast, recording and large concert systems and industrial audio. Balanced and unbalanced lines +24 dBu headroom, hard wire bypass. The ultimate BBE for professional use.

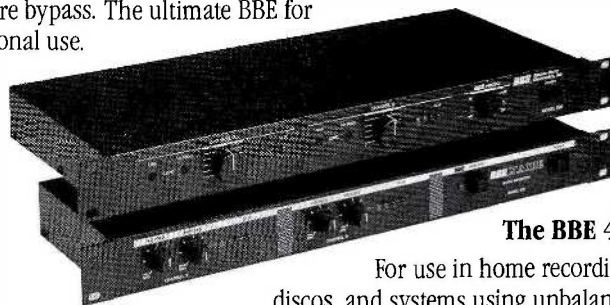

**The BBE 402**

For use in home recording, clubs, discos, and systems using unbalanced lines.

+14 dBu headroom -10 dBu levels. Home audio and cassette copies are greatly improved.

# BBE

5500 Bolsa Ave., Suite 245, Huntington Beach, California 92649

714-897-6766 • 800-233-8346 (USA) • 800-558-3963 (CA)

(In Canada contact Daymen Audio, 3241 Kennedy Rd. #22 Scarborough, Ontario M1V2J9 or call 416-298-9644)

Circle (79) on Reply Card



# ENCORE

## encore

*The all digital  
digital effects system*

Quantel's Encore is a very, very effective effects system, the crème de la crème. Every year it gets better and better, with more and more unique features. Like the brilliant accuracy of Corner Pinning which no-one but no-one else can do. And Starlight, the two-source lighting effect, to highlight the highlights and shade the shadows. And Flash, Sparkle, Caterpillar and Montage, just a few of Encore's brilliant track and trail effects. All in addition to the most magnificent swoops, tumbles, turns and other picture effects. All in real real-time.

What's more, Encore's operating system is going up and up in reputation; the Floating Viewpoint Control and Spacetraks give pinpoint positioning you can never, never get from a joystick.

For real broadcast-quality quality, Encore stands alone as a standalone effects system, equally at home in broadcasting or post-production. And, as an evolutionary part of Quantel's Digital Production Future, it will go on and on, for ever and ever. Well, almost.

So we'll say it again: Encore, the very, very effective all-digital digital effects system. See it for yourself yourself.

*ENCORE -  
for very, very effective effects*

**QUANTEL**

Quantel Inc,  
655 Washington Boulevard,  
Stamford, Connecticut, CT 06901  
Tel: (203) 348 4104 Fax: (203) 356 9021

*Now with corner pinning*

Circle (80) on Reply Card

- CompuServe Forum
- Certification Guides
- New Officer and Board Member

**JUNE 1987**

**Theme: NAB Convention Replay**

**Editorial (page 6)**

- Under New Management (Ed Gayou retires from NAB show management. His replacement is Richard Dobson Jr.)

**FCC Update (page 8)**

- FCC Rules on Indecency and Obscenity
- Main Studio Rule Relaxed
- Must-Carry Becomes Effective

- Commission Moves on HDTV
- UHF Impact Policy and Carroll Doctrine to be Eliminated

**Strictly TV (page 10)**

- Format War Ends, Marketing War Begins, Part 1 (The Betacam-vs. -M-II format fight, and where the big three networks stand on the battlefield.)

**re:Radio (page 12)**

- Radio Wave Propagation, Part 1 (WARC, Region II, radiating systems, grounding systems.)

**Satellite Technology (page 14)**

- Low-Noise Amplifiers

(LNA, LNB, LNC defined and compared.)

**Circuits (page 16)**

- Inside Digital Technology, Part 9 (Master clock signals and glitches.)

**Troubleshooting (page 18)**

- Maintaining a Reel-to-Reel VTR (Tape handling, cleanliness and routine maintenance.)

**Management for Engineers (page 20)**

- Workers Are Ultimate Enforcers of Change (Management may be in charge, but without the willing acceptance of workers, changes simply don't get made.)

**Assembling the Technology Puzzle (page 23)**

By Jerry Whitaker, editorial director  
An overview of the NAB '87 convention notes highlights of the luncheons, exhibition and technical program, as well as apparent industry trends and NAB surveys.  
*Interest: general.*

**Keeping Up With Technology (page 36)**

By Brad Dick, radio technical editor  
Among the many topics covered in the NAB Engineering Conference, quality was often mentioned, particularly with attention to the desires of critical viewers and listeners.  
*Interest: general.*

**Pick Hits of NAB '87 (page 60)**

By Ned Soseman, TV technical editor  
Radio products were:  
—Broadcast Electronics Phase Trak 90  
—Continental Electronics (Varian) type 314F solid-state AM transmitter  
—CRL Systems SPF-300 pre-emphasis filter  
—Denon America DN-950F CD cart player  
—Harris Corporation DX-10 10kW AM transmitter  
—International Tapetronics/3M Audio Switcher  
—Kahn Communications Flattener antenna broadbanding network  
—Leader Instruments LCD-100 digital multimeter/storage oscilloscope  
—Bandive/Connectronics SECK 1282 8-track audio mixer  
—Shure Brothers BC series phono cartridges

TV products were:  
—AKG Acoustics C 522 stereo ENG microphone  
—Ampex AVC Vista switcher  
—Grass Valley Group GVG-200 20-input switcher  
—Gentner Engineering Digital Hybrid  
—Imageering Laser Disk Systems ICMS PaintStore optical disk system  
—NEC America SR-10 solid-state digital video recorder  
—Panasonic Broadcast Systems M.A.R.C. II automated M-II cassette system  
—Pinnacle Systems Video Workstation  
—Townsend Broadcast Systems TB-10TM 10kW TV transmitter  
—Videotek Times Six gen-lock, adjustable blackburst generator

**Show of Shows (page 76)**  
By Carl Bentz, special projects editor  
A compendium of short descriptions of new products introduced at NAB '87.

# WEIRCLIFFE BULK ERASERS, A QUANTUM EXCLUSIVE.



Weircliffe bulk tape erasers for all audio and video formats including new MII and BETA SP.

**BTE 1905**

No need to tie up valuable production machines just to erase your audio or video tape. Now you can get erasure better than -70dB with Weircliffe's new line of bulk tape erasers. Whether you're looking for conveyor or non-conveyor units, or have a variety of formats to accommodate including MII and BETA SP, we have a degausser designed to meet your needs.

Weircliffe products are exclusively distributed in the U.S., Canada, Central and South America by Quantum. For the name of your local Quantum dealer, contact Quantum Audio Labs, Inc., 2752 Walnut Avenue, Tustin, CA 92680 or call (714) 838-8833. TWX 910-333-8535 FAX (714) 838-9619

**QUANTUM**  
A PALTEX INTERNATIONAL COMPANY

Circle (81) on Reply Card



**To air  
is human**

PREVIEW



**To err  
is human**

PROGRAM

## To Preview is Divine.

*Get It Right the First Time and  
On Time with Quanta's New  
Preview Channel for the  
QCG-500 Character Generator.*

Preview and the QCG-500 let you handle live situations quickly and confidently. Now you can create a new page or edit an existing one and switch it to air *instantly* with a single keystroke.

Or create multi-layer images for live or post production by mixing two pages together and getting one composite video and RGB output. The end result is true dual-plane operation that allows deep shadows and double-layer graphics. And you won't have to tie up your switcher since Preview does the mix for you.

Add preview and mix capabilities to the already outstanding features of the QCG-500 (29ns resolution, FONT-FLEX™, keystroke sequencing, camera capture and paint options) and get a powerful system for your facility.

Find out today how Preview and the QCG-500 will improve your on air performance for under \$14,000. Contact your nearest Authorized Quanta Dealer or call us at (801) 974-0992, 2440 South Progress Drive, Salt Lake City, UT 84119, USA.



**Make No  
Mistake  
With  
QUANTA**

A/B mix mode



*We liberate the imagination.*

**QUANTA®**

DYNATECH Broadcast Group

Northeast  
(203) 797-1179

Intermountain  
(801) 485-1913

Midwest  
(313) 423-5168

West  
(818) 355-8224

Southeast  
(615) 266-6937

International  
31-2977-23473

Corporate  
(801) 974-0992

Circle (82) on Reply Card

• **Inside Monitor Loudspeakers** (page 162)

By Brad Dick, radio technical editor

The sound transmitted by any broadcast station depends heavily upon the equipment used to generate and process it. To assess the quality before the transmission, a final quality-control check—the monitor system—should not be left to brand loyalty or minimum cost.

*Interest:* engineering, management, audio technicians.

*Key words:* direct-radiator speaker, diaphragm, spider, restoring force, damping, back EMF, infinite baffle, crossovers, near-field monitoring.

• **Return of the Synchronous Amplifier** (page 176)

By Chip Behal, WLLH-AM, Lowell, MA

Synchronous AM transmission was used in the '30s to lock stations together on the same frequency. European experience with equal-powered transmitters has been successful. Now, the idea is being used in the United States with different power levels to extend the coverage area of a station.

*Interest:* engineering, management, RF technicians.

*Key words:* multiplexing, interference zones, interference predictions, frequency control, distortion effects, null fill.

*Applied Technology* (page 186)

- NEC SP-3A CCD Camera Technology  
By S. Ikeda, H. Nakjima, E. Oda, K. Umise, M. Shimizu and R. Deinhart, NEC Broadcast and Video Equipment Division, Wood Dale, IL, and Tokyo (Improvements in non-tube-type sen-

sors for solid-state cameras.)

## JULY 1987

### Theme: Audio Technology Update

*Editorial* (page 6)

- Follow the Crowd  
(The SBE National Convention and BE conference will be an opportunity to see, hear and touch the latest in broadcast technology.)

*FCC Update* (page 8)

- Night Operation for Daytime AM Stations
- New EEO Forms and Standards Adopted
- Inquiry Into FM Assignments
- FCC Lifts Freeze on LPTV Filings

*Strictly TV* (page 10)

- Format War Ends, Marketing War Begins, Part 2  
(ABC and CBS commit to Betacam, and NBC stays with M-II.)

*re:Radio* (page 12)

- Ground Systems for AM Stations  
(Ground screens, installing radials and identifying broken ones.)

*Satellite Technology* (page 14)

- Innovations in Microwave Circuitry  
(Microstrip and microlithic circuitry.)

*Circuits* (page 16)

- Inside Digital Technology, Part 10  
(Decoders, microcontrollers; clock, re-

set, instruction decoders, accumulators, address line drivers.)

*Troubleshooting* (page 18)

- The Unexpected Citation Source  
(Spurious aural carriers from the transmitter can bring FCC citations.)

*Management for Engineers* (page 20)

- Managing Upward, Part 1  
(Effective management calls for understanding your superiors as well as those who report to you.)

• **Interconnecting Audio Equipment** (page 24)

By Cal Perkins, Fender Musical Instruments, Brea, CA

The difference between theory and practice becomes evident when it comes to connecting the many components of audio systems. Interfacing of mic, cable and pre-amplifiers; component interconnection; output connections; grounding, shielding and safety; and providing power are covered theoretically and practically.

*Interest:* audio technicians, engineers.

*Key words:* XLR grounded shell, common-mode rejection (CMR), transformer coupling, slew rate, technical power, technical ground.

• **Interfacing Monitor Amplifiers** (page 36)

By Richard Cabot, Audio Precision, Beaverton, OR

The specifications for a monitor amplifier might be glowing on the brochure, but its performance after installation may not meet expectations. The reason is that some of those

# Two Ways to Energize Your Video

*Pyxis*

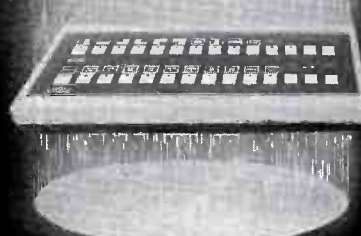

**Pyxis**, ALTA's dual TBC/Switcher for A/B Roll. With VTRs or cameras, create over 30 video effects. Even audio mixing. On location or in post, produce broadcast quality video for only \$6,250.

**Cygnus**, an infinite-window TBC/Synchronizer with Digital Picture Freeze and variable posterization, mosaics, colorization and strobing. Plus 4x1 Video/Audio switching and image enhancing. All for \$4,990.

ALTA products offer 8-bit resolution and are backed by a full two year warranty.

*Cygnus*



**ALTA  
GROUP, INC**

535 Race Street  
San Jose, Calif. 95126  
408-297-ALTA

Circle (83) on Reply Card

# Hear the great wireless sound.

Consider the size advantages...

Cetec Vega's R-33 PRO PLUS wireless microphone receiver mounts inconspicuously on a camera. Or on a tiny corner of your sound cart. Or in your pocket. Or on your belt, providing you with program-quality headset audio.

With the R-33 you have a wide choice of transmitters...any Cetec Vega DYNEX® II bodypack or handheld. A full complement of useful accessories is included.

The R-33 provides 8 hours of operation on a single 9-volt battery. Audio is studio-quality (e.g., over 100 dB S/N).

All this, in a rugged package less than 12 ounces, and only 3/4 x 3-1/4 x 5-5/8 inches (HWD). Available in two colors... PRO Brown/Cream or Camera Black.



## Cetec Vega

...the professional's wireless  
9900 Baldwin Place  
El Monte, CA 91731-2204  
(818) 442-0782

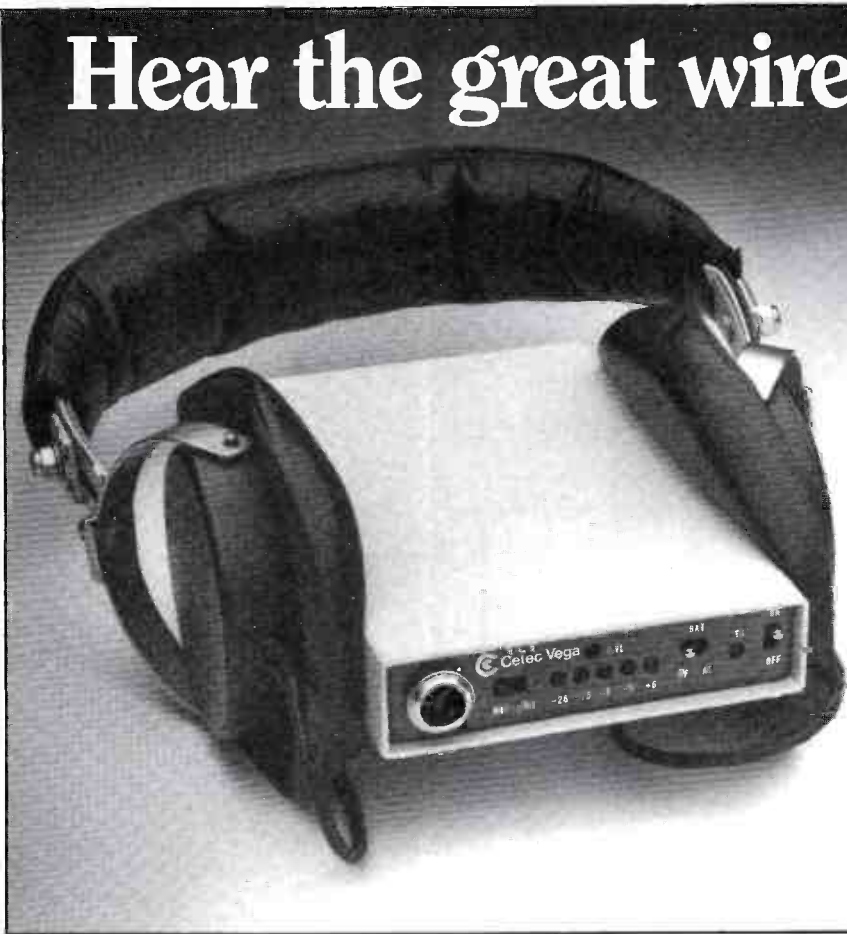

Circle (84) on Reply Card

# SAVE TIME

*For fast, accurate service, please remove the peel off label used to address your magazine, and attach it to the Reader Service Card, the Address Change Card or to any correspondence you send us regarding your subscription.*

**AS-101 AUDIO SWITCHER**

- Illuminated and legible control buttons
- Instant or overlap switching
- Front panel accessible level controls
- Optional RS-232 Interface
- Optional relay follow switch outputs
- Plug-in screw-clamp terminals

**CONEX** ELECTRO SYSTEMS

P.O. Box 1342 Bellingham, WA 98227 (206) 734-4323

Circle (86) on Reply Card

**Interested in ordering article reprints out of this or another issue? \* Reprints can be excellent learning tools for your technical staff and great marketing tools for your sales staff. Call or write Cynthia Sedler at Intertec Publishing Corp., P.O. Box 12901, Overland Park, KS 66212; (913) 888-4664.**

**\*Minimum order 1,000 copies**

specs take on less importance when the unit is connected with other components. The effects of input loading, output loading and power-supply effects on monitor operation are discussed.

*Interest:* audio technicians, engineers.

*Key words:* common-mode voltage/range, frequency response, rolloff, damping factor, load resistance, power regulation.

• **Multidimensional Audio for Stereo TV** (page 46)

By William Mead, Dolby Laboratories, San Francisco

Additional sound channels can enhance the experience of viewing motion pictures. Through special encoding systems, some of which can be applied to TV, additional sound-channel information may be provided for stereo and surround applications. Dimensional audio requires close attention to the size of the image and the volume of the acoustic space being developed.

*Interest:* audio technicians, engineering, production.

*Key words:* spatial encoders/decoders, surround channel, matrix encoding/decoding, compatibility, dimensional enhancement.

• **Maintaining TV Cameras** (page 60)

By Ned Soseman, TV technical editor

The product of the TV station—pictures—can be no better than the images originated by its cameras. Most of the maintenance procedures necessary to keep a camera operating at its peak are common sense; the others are included in the operations manual. In the long run, the cameras and the station's on-air picture reflect the attitude of staff and management.

*Interest:* engineering, video technicians, management.

*Key words:* mean time between failure (MTBF), operator maintenance, optics cleaning, test bench procedures, 9-step vs. 11-step chip chart.

*Applied Technology* (page 76)

• **Installing Acoustic Materials**

By Peter D'Antonio and John H. Konert, RPG Diffusor Systems, Largo, MD (The construction and acoustical treatment of the room used as an audio-production facility is determined by the use of absorptive, reflective and diffusive material. This tutorial explains how these materials may be applied for different requirements.)

*Field Report* (page 86)

- Rank Cintel ADS 1 Telecine

*SBE Update* (page 96)

- SBE Pushes for Frequency Coordination
- Board Appointment (Ed Roos to replace Warren Pritchard)
- Ennes Foundation (five scholarships granted)
- SBE Fights for Hams
- Call for Papers

**AUGUST 1987**

*Theme: Video Technology Update*

*Editorial* (page 6)

- Recipe for Change (Comments about S-VHS consumer format VCRs.)

**When  
it's time to  
move up  
from  
U-matic,  
move up  
to  
U-matic.**

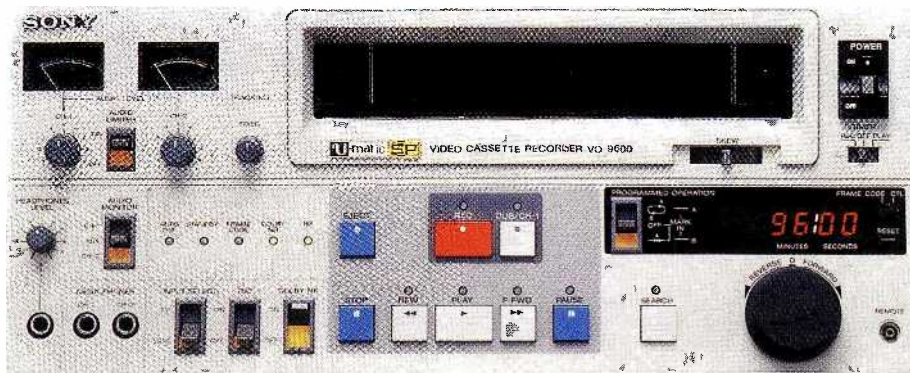
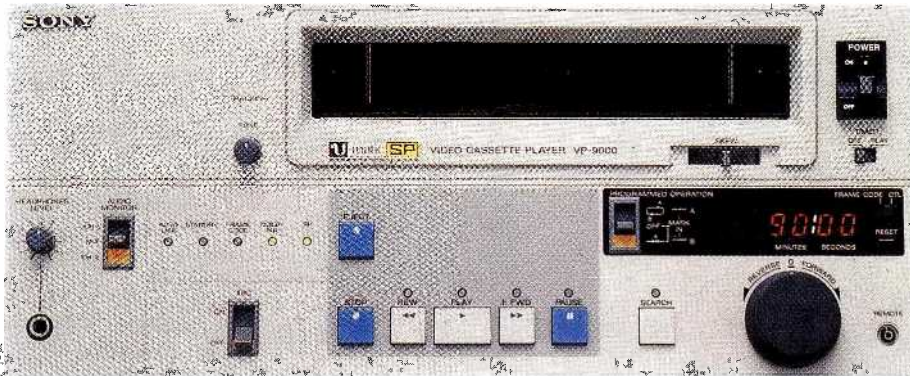
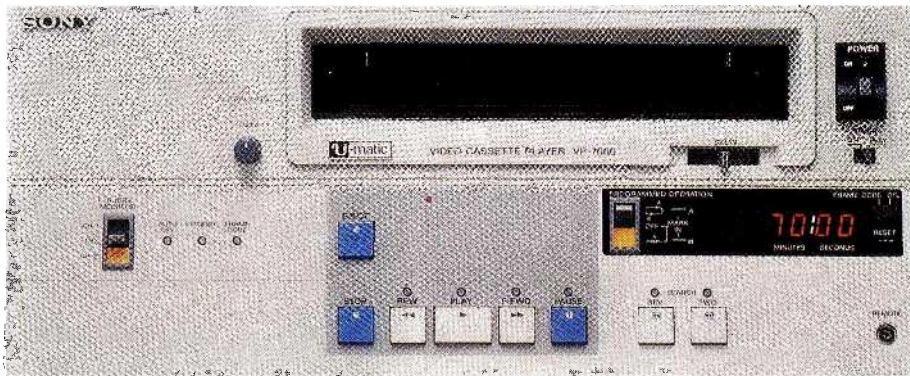

Some video experts would have you believe that the only way to upgrade your video equipment is to throw it out and start over.

At Sony, we see it differently. And you will too when you see the new TYPE VII and TYPE IX series of U-matic players and recorders.

Not only are they compatible with your existing U-matic equipment, they offer performance that until now you could only get at twice the price.

For starters, you get SP technology on the TYPE IX models, which means superior picture quality on both originals and copies. You also get a new form of absolute address called Frame Code. As well as a computer interface which lets you preset players and recorders to start and stop at certain times.

More impressive, however, is the price. We've designed these U-matics to fit into your budget as easily as they fit into your facility.

To learn more about TYPE VII and IX, or to attend a Sony video workshop, please write to Sony, P.O. Box 6185, Department U-2, Union, NJ 07083.

With U-matic, moving up to a new standard in video could be as simple as opening a box and plugging it in.

**SONY**<sup>®</sup>  
Professional Video

© 1987 Sony Communications Products Co., a division of Sony Corp. of America, 1600 Queen Anne, Teaneck, NJ 07666.

Circle (88) on Reply Card

# BROADCAST THE NEWS WITHOUT THE NOISE.

## The new SM84 Lavalier Mic.



A super-cardioid pickup pattern enables the new SM84 Condenser Microphone to reject unwanted background noise without compromising audio quality. So even if there's activity near your reporter or newscaster, the only thing the viewers hear is the news. The SM84 also provides greater gain before feedback than other lavalier condenser mics.

The microphone's tailored frequency response provides professional sound that's unusual in chest-mount applications. The 730 Hz filter compensates for chest resonance, while the high-frequency boost provides flatter, more natural response. The 12dB/octave low-end rolloff (below 100Hz) reduces room noise

and other low-frequency signals. In addition, excellent shielding yields low RF interference and hum pickup.

### Easy to use.

The mic runs on phantom power or a standard 9-volt battery. The unique side-exit cable minimizes "cable hiding" problems. And universal mounting clips are included to handle virtually all attachment requirements.

Plus, it's built with Shure's legendary emphasis on ruggedness, reliability and performance.

*Shure Brothers Inc.,  
222 Hartrey Ave.,  
Evanston, IL 60202-3696  
(312) 866-2553.*

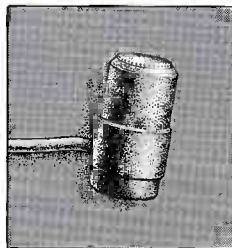

When background noise isn't a factor, consider the SM83 Omnidirectional Lavalier Microphone.

Note: mics shown actual size.

# SHURE®

THE SOUND OF THE PROFESSIONALS®... WORLDWIDE

### FCC Update (page 8)

- Daytimer Preference Is Affirmed
- FCC Revisits Presunrise Question
- License Modification Rules Amended

### Strictly TV (page 10)

- Format War Ends, Marketing War Begins, Part 3  
(The war is over, but it seems that everybody has won.)

### re:Radio (page 12)

- Building a Multitower Grounding System  
(Construction, preventive maintenance on radial systems; ATU enclosure housekeeping.)

### Satellite Technology (page 14)

- MMICs Are the Trend  
(Monolithic microwave integrated circuits are described.)

### Circuits (page 16)

- Inside Digital Technology, Part 11  
(Serial data transmission, synchronization and parallel-to-serial data conversion.)

### Troubleshooting (page 18)

- Servicing Switching-Voltage Regulators, Part 1  
(Components and operation of switching-type regulators.)

### Management for Engineers (page 20)

- Managing Upward, Part 2  
(In the workplace, personality conflicts may cause more serious problems than the quality of the work performed.)

### • TV Camera Technology Update (page 26)

By Larry Thorpe, Sony Broadcast Products, Teaneck, NJ

The continuing development of type and solid-state image sensors for TV cameras has made an impact on the camera and its specifications. This tutorial considers factors such as resolution, registration, shading, lag and noise characteristics of pickup devices.

*Related:* specsmanship—what do camera specifications portray?

*Interest:* video operators, engineers, production, general.

*Key words:* CCD transfer mechanisms, lag, shading, registration, resolution, noise, magnetic/electrostatic focus and deflection.

### • Video in Transition (page 50)

By Victor L. Kong, Magni Systems, Beaverton, OR

Encoding of analog video components into a video baseband composite signal places limitations on bandwidth and dynamic range. By maintaining signals in the component environment throughout all production processes, the effects of bandwidth limiting and sub-carrier degradation are kept to a minimum. Observations provided by the sine-squared pulse test may be introduced to component systems with a dual timing pulse.

*Interest:* video operators, engineering.

*Key words:* baseband video, component analog video (CAV), luminance-chrominance delay, RGB, YIQ, Y/CTDM, amplitude inequalities.

Continued on page 126

Circle (45) on Reply Card



# Richardson Electronics, Ltd. We're Plumbicon® People

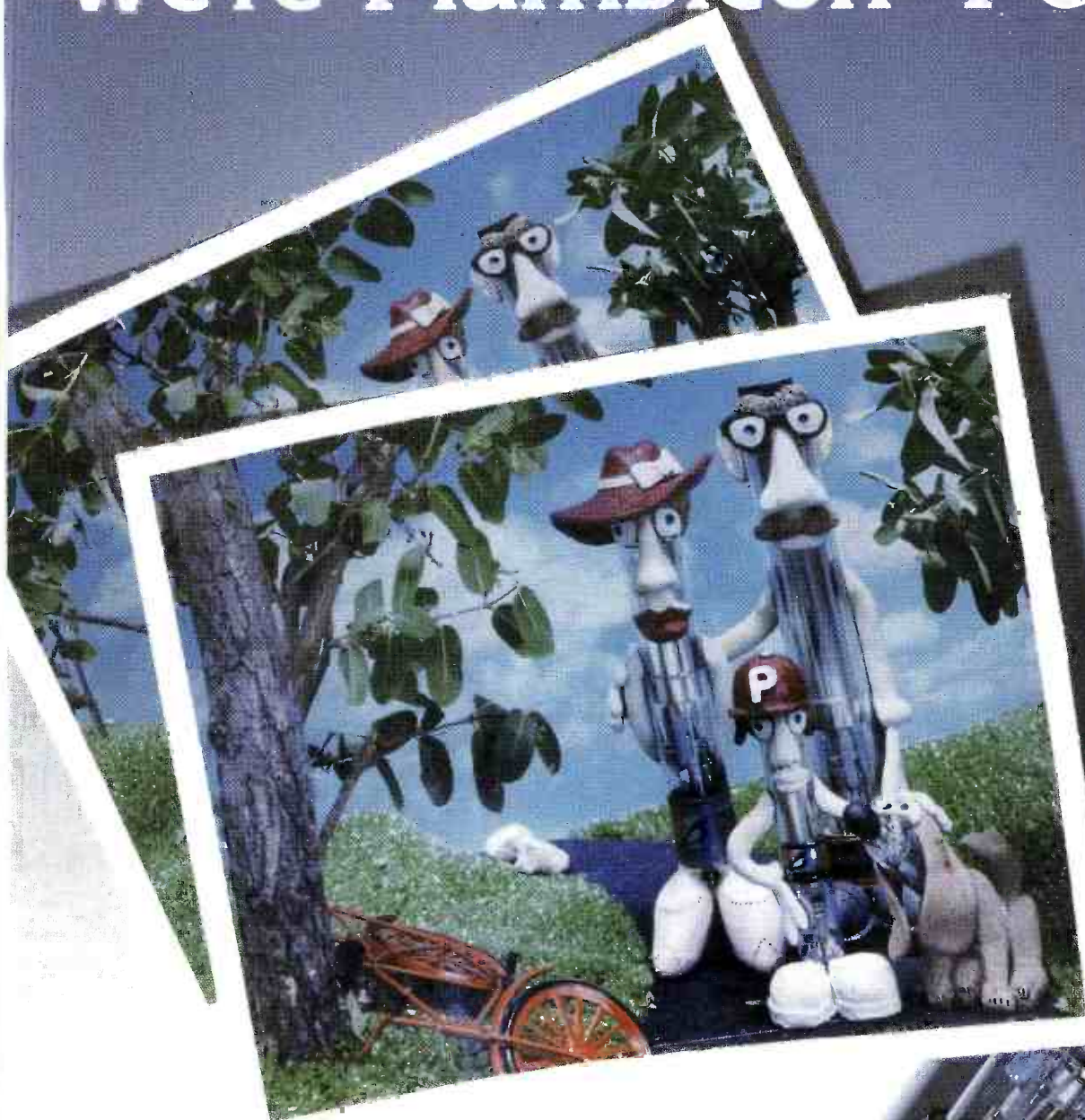

When you think of the Plumbicon tube, think of us — Richardson Electronics. Be part of the happy family where same day shipments, great prices and technical factory backups are a part of everyday service. We stock replacements for all cameras, wherever they are made; and all warranty replacements are handled quickly and efficiently.

**Master stocking distributor for the Plumbicon tube,  
Richardson Electronics — We're Plumbicon People.**

■ Richardson Electronics, Ltd. □ 40W267 Keslinger Rd. □ LaFox, IL □ 60147 □ (800) 323-1770 □ (312) 232-6400 □ Fax: (312) 232-1071 □ Telex: 283461 ■ Broadcast Division □ Brooklyn, NY □ (800) 221-0860 □ (718) 646-6300 ■ Eastern: (800) 645-2322, (800) 221-0860 ■ Southeastern: (800) 348-5580 ■ Northeastern: (617) 871-5162 ■ Central: (800) 323-1770 ■ Western: (800) 348-5580 ■

Circle (25) on Reply Card

# GE IS THE LIGHT THAT TAKES THE HEAT OFF THE PERFORMERS.



**GE Lighting lights up the night while generating 35% less heat than ordinary stage and studio lights.**

The pace is frantic. Five minutes to airtime. Late breaking news has just been handed in. As the countdown begins... the lights go on.



For the performers, ordinary stage and studio lights can be torturous, because they generate so much heat. That's why GE invented the GE Watt-Miser Quartzline® lamp. This Quartzline lamp, with a revolutionary infrared reflecting coating, delivers 90% of the



light of ordinary stage and studio lights while using up to 35% less wattage. It generates less heat, which means more comfortable working conditions for the people onstage and the people backstage. It also reduces the load on the air conditioning system and fits existing fixtures.

With features like these, it's not surprising that more and more people are using them. Because when what's onstage is hot, GE Lighting keeps it cool.

**GE is Light.**



**GE Lighting**

Circle (93) on Reply Card

• **The Mysteries of Video Editing Revealed** (page 67)

By Frank Davenport, technical development laboratory, NBC, New York

In the process of editing, signal timing and color subcarrier phase must be correct to prevent anomalies in the edited product. One method to control color phase problems is through strict adherence to SC/H phasing or RS-170A sync. For non-technical editing operators, a time-code sync monitor has been developed in England.

*Interest:* video engineering, technicians, editors, post-production.

*Key words:* time code, SC/H phase.

• **Monitoring Satellite System Performance** (page 76)

By Guy Lewis, Tektronix, Beaverton, OR

The growth of satellite transmission as a method of TV signal transportation calls for special efforts to monitor satellite activity. Spectrum analyzers or specialized instruments called spectrum monitors are useful for this purpose. Spectrum monitors provide the necessary functions, but do not include the full capability of most analyzers.

*Interest:* RF transmission engineers, technicians, management.

*Key words:* spectrum analyzer and monitor, percentage of FM modulation, L-, Ku- and C-band, antenna-pointing guide (BASIC program).

• **New Approaches to AM Improvement** (page 92)

By Brad Dick, radio technical editor

The National Radio Systems Committee (NRSC) has proposed pre-emphasis standards for AM radio and examined the 10kHz channel of AM stations in comparison with the AM service occupied bandwidth. Bandwidth limiting to 10kHz is a key to better fidelity without interference. Other considerations involve new antenna designs, such as the anti-skywave antenna and Prestholdt VH antenna.

*Interest:* radio engineers, radio management.

*Key words:* NRSC, pre-emphasis, bandwidth compression, splatter, percentage of AM modulation, synchronous transmission and detection, skywave radiation.

*Applied Technology* (page 104)

- **Modifying Time—System Considerations**

By Lawrence Rich, Lexicon, Waltham, MA

(The system considerations of time modification equipment are discussed in this look at time compression, expansion and pitch control.)

*Station-to-Station* (page 113)

- **Transmitters Wired for Remote Control**  
By Mike Armatta, KTRH-AM and KLOL-FM, Houston  
(Apple II+ computer, Moseley MRC-1600C used for remote control of KTRH-AM, Houston.)

*SBE Update* (page 116)

- **Making Inroads in Frequency Coordination**
- **Example Success** (Los Angeles "home channel plan")
- **New** (Nashville) Tennessee Chapter
- **Frequency Coordinator's List**

**Theme: Audio-Video Control**

*Editorial* (page 6)

- **Catch 22**  
(FCC Part 74 and Heller's "Catch 22" compared.)

*FCC Update* (page 8)

- **Status of Advanced TV Systems Is Reviewed**
- **Review of AM Assignment Criteria**
- **FM and TV Booster Use Expanded**

*Strictly TV* (page 10)

- **Adding Local Color**  
(Transparency material provides attractive backlit backgrounds for TV production.)

*re:Radio* (page 12)

- **Prewinter Antenna Maintenance**  
(Maintain records of antenna components on system measurements and meter accuracy to help in troubleshooting.)

*Satellite Technology* (page 14)

- **Basic Operations of a Spectrum Analyzer**  
(Learning effective use of an analyzer with the satellite communications equipment.)

*Circuits* (page 16)

- **Inside Digital Technology, Part 12**  
(Types of computers and their applications, state machines in automation systems.)

*Troubleshooting* (page 18)

- **Maintaining Switching-Voltage Regulators, Part 2**  
(Buck and boost regulators, forward converters.)

*Management for Engineers* (page 20)

- **Managing Upward, Part 3**  
(Know yourself, your performance and the system before asking for the raise.)

• **Getting More From NTSC** (page 26)

By Carl Bentz, technical and special projects editor

The introduction of component analog video components has pointed out some problems with NTSC (as well as PAL and SECAM TV standards). Through special processing of signals with multiple delay lines prior to encoding, much of the degradation caused by the encoding process (sampling by the subcarrier) can be significantly reduced. This look at methods to improve NTSC and other format signals examines ideas that can be applied without loss of compatibility.

*Interest:* engineering, video system designers, technicians.

*Key words:* NTSC, PAL, SECAM, HDTV, interleaving, comb filters, scan sampling, cross-luminance, cross-chrominance, video bandwidth limiting, aliasing, compatibility, K-factor, Nyquist criteria.

• **Video in Transition, Part 2** (page 40)

By Paul McGoldrick, Magni Systems, Beaverton, OR

Testing component video equipment requires signals that can be transcoded from one format to another. In the process, infor-

mation about what is happening between channels must be ascertained. The dual time pulse waveform is one method. Composite, Y/C and 3-component signal formats all have their own special requirements.

*Interest:* engineering, video technicians, management.

*Key words:* luminance and differential jitter, moire and chrominance noise.

• **The Ins and Outs of Video Switching** (page 52)

By Carl Bentz, technical and special projects editor

Chroma-key and a variety of special and production effects are based upon the concepts of vertical interval switching and ultra-linear analog circuitry. This examination of switching considers the vertical interval switch, crosspoints, non-synchronous signal switching, simple effects and types of keying in different types of video switching systems.

*Interest:* engineering, video technicians, general.

*Key words:* vertical blanking interval (VBI), switching contact forms, video sync signal, linear/luminance/chroma-key.

• **Wiring an Audio-Video Facility** (page 73)

By Ned Soseman, TV technical editor

System efficiency, and maintenance efficiency in particular, are enhanced by a logical approach to facility wiring. An easily operated facility doesn't just happen; it is the result of planning all aspects of the project before the purchase of cabling, connectors and other equipment. Grounding, rewiring, rack installation, cable preparation, proper documentation all are part of the process.

*Interest:* engineering, technicians, management.

*Key words:* documentation, grounding, project management.

• **Wireless Microphone Frequency Compatibility** (page 96)

By Ken Fasen, HM Electronics, San Diego, CA

When a production application requires the use of more than one wireless microphone, certain restrictions are immediately in effect. Six factors come into play: separation between operating frequencies, transmitter spurious products, 2-signal intermodulation, 3-signal intermodulation, receiver local oscillator radiation and receiver image frequency sensitivity.

*Interest:* engineering, audio technicians, production.

*Key words:* intermodulation, spurious transmission products, image frequencies.

• **Transformers in Audio Design** (page 104)

By Bruce E. Hofer, Audio Precision, Beaverton, OR

The interest in portability has replaced transformers with solid-state coupling in many products. High-quality audio can be obtained with transformers if you remember that there are far more important audible problems than failing to achieve 0.001% residual distortion or dc-to-light frequency response.

*Related:* transformer distortion.

*Interest:* engineering, audio technicians.

*Key words:* core saturation, transformer turns ratios, Faraday shielding, bifilar, trifilar, quadfilar, direct boxes.



## **EIDOPHOR,<sup>®</sup> because big pictures mean big impact.**

Professionally organized conventions require a professional audio visual medium. EIDOPHOR TV projectors deliver pictures up to 12 X 16 meters or 40 by 50 ft. and vividly portray even the fine detail

for every participant. The pictures are so bright, there's no problem with note-taking.

EIDOPHOR —  
A very visible difference in quality.



Althardstrasse 70, CH-8105 Regensdorf/Zürich, Switzerland, Phone (01) 8421111, Telex 825 853, Telefax (01) 842 21 00

Circle (92) on Reply Card

December 1987 *Broadcast Engineering* 127

• **News Special Report: On the Receiving End, Part 1** (page 114)

By Michael Heiss, Bell & Howell/Columbia Paramount, Los Angeles

A look at S-VHS, ED Beta, DC-V and R-DAT consumer products brings some of the competition for broadcast into perspective.

*Field Report* (page 116)

- Pacific Recorders Micromax reproducer

*SBE Update* (page 122)

- NFCC Meets FCC
- Coordination Goes International
- The 1987 Convention
- 1988 Convention Site Selected
- New SBE Chapters

*Show Replay* (page 124)

- Postcard From Montreux  
(Trends and observations from the 15th International Television Symposium, Montreux, Switzerland.)

*Show Preview* (page 126)

- SMPTE Goes Hollywood  
(Technical session overview of 129th SMPTE technical conference and equipment exposition.)

## OCTOBER 1987

**Theme: Salary Survey/Magnetic Media Special Report**

*Editorial* (page 6)

- The Bottom Line  
(One engineer speaks out about less-than-favorable working conditions.)

*FCC Update* (page 8)

- Enforcement of Fairness Doctrine Ends
- Curbing Misuses of Petition Procedures
- Re-study of Nighttime Use of Foreign Clear Channels

*Strictly TV* (page 100)

- 601 and Half a Dozen Others  
(A look at what was happening five years ago in the industry, from topics of interest in the October 1982 "EBU Review-Technical.")

*re:Radio* (page 12)

- Maintaining Your Transmission System  
(Deregulation doesn't mean you should ignore your system. Read monitors, monitor points and maintain proper paperwork.)

*Satellite Technology* (page 14)

- Flat Antennas  
(Phased array antennas for satellite K-band reception.)

*Circuits* (page 16)

- Inside Digital Technology, Part 13  
(Z-80 microprocessor, power supply, clock circuit, control signals, addressing and data buses.)

*Troubleshooting* (page 18)

- Maintaining Switching-Voltage Regulators, Part 3  
(The ac-line input stage, regulating output stage, low-voltage supply stage.)

*Management for Engineers* (page 20)

- Managing Upward, Part 4

(More on seeking a raise, preparing for the meeting with your manager and countering objections.)

• **1987 Salary Survey** (page 22)

By Brad Dick, radio technical editor

The percentage salary increases, measured over all markets, were lower than in past surveys. TV management salaries increased, but radio management showed almost no change. In the engineering category, radio reflected a small increase, while TV saw a slight decrease. Radio operations experienced a slight decrease, and TV operations salaries were up.

*Related:* does SBE certification pay?

*Interest:* general.

• **Tape as a Recording Medium** (page 48)

By Robert N. Herman, 3M Magnetic Media Division, Minneapolis

The formulas of recording media are designed to meet special requirements. While research continues in the search for improvements to existing products, new formulations often are developed to meet the needs of a new recording format. As such, the formulation involves cooperation with the equipment manufacturer.

*Interest:* general, recording engineers.

*Key words:* S-VHS, metal particle, evaporated metal, characteristics.

• **The Evolution of Audio Recording** (page 54)

By Doug Beard, Studer Revox America, Nashville, TN

The basic principles of audio recording have not changed significantly over the years. Recorded sound quality, however, has improved dramatically as a result of electronics and recording system components. Control of the systems also has undergone major changes.

*Interest:* general, audio engineers.

*Key words:* heads, phase correction, ferrites, operating levels, digital.

• **The Evolution of Video Recording** (page 67)

By Carl Bentz, technical and special projects editor

The technical requirements for recording video information on a magnetic medium haven't changed much, even though recording equipment has gone through various stages. From the pre-quad acruate developmental format to today's 1/2" and digital video format, faithful recording of video means high effective writing speeds, minuscule head gaps and highly controlled transport mechanisms.

*Interest:* general, video engineers.

*Key words:* acruate, quad, variable tracking, helical scan, velocity compensation, servo, packing density.

• **Preserving Magnetic Tape** (page 84)

By Walter E. Davies, Gamma Omega Associates, (The Last Factory), Livermore, CA

A discussion of several tape parameters, base films, binder degradation and possible tape defects leads to helpful suggestions for prolonging the life of recording media and its magnetically stored contents. Chemical formulations have been found that halt or significantly reduce degradation processes. Guidelines for magnetic tape storage also are listed.

*Interest:* general, recording engineers.

*Key words:* base film, humidity, headwear, storage, binders, defects, hydrolysis.

• **Erasing Magnetic Tape** (page 90)

By Robert A. Schultz, Data Security, Lincoln, NE

As recording systems move toward the use of higher-energy tapes to increase data-packing densities, more attention must be given to complete erasure of previously recorded material. A look at degausser systems includes suggestions to achieve proper erasure.

*Interest:* general, recording engineers.

*Key words:* high energy, oersteds, magnetic saturation, retentivity, coercivity, form factors, erasure.

• **The Art of Film-to-Tape Transfer** (page 98)

By Colin J. Brown, Rank Cintel, Valley Cottage, NY

The process and quality of transferring video material from film to videotape have become major considerations in post-production. The transfer requires more than simply moving the video information. The type of transfer system and available signal processing are critical in production and broadcast environments.

*Interest:* post-production, video engineers.

*Key words:* color timing, CCD telecine, gamma, luminance, 4:2:2 systems, flying-spot scanners.

• **Video in Transition, Part 3** (page 108)

By Paul McGoldrick, Magni Systems, Beaverton, OR

The trend toward component analog video calls for a new set of measurement tools to keep the equipment in top working order. *Interest:* engineering management, video technicians.

*Key words:* component analog video (CAV), amplitude/frequency response, multiburst, bar tilt, modulated time-squared pulse, chroma/luma/gain/delay, group delay, linearity, intermodulation, crosstalk, comb filters, noise coring.

• **23GHz Microwave Propagation** (page 124)

By John E. Matz, Motorola, Schaumburg, IL

To avoid frequency congestion, some stations are moving to 23GHz. The higher frequency for microwave systems offers advantages, but reliable operation requires careful path calculations and special consideration of fade margin.

*Interest:* engineering management, RF engineers.

*Key words:* fade margin, multipath fading, rain fading.

*Applied Technology* (page 138)

• **Dolby Spectral Recording**

By Brad Dick, radio technical editor  
(The processes of Dolby spectral recording for improved-quality analog audio are explored.)

*Show Preview* (page 150)

- Building on Last Year's Success  
(A schedule of events for the SBE National Convention and Broadcast Engineering Conference.)

*Field Report* (page 156)

- Sony BVP-360 camera

# PHASE TRAK 90™

The Stereo Solution for Every Cartridge

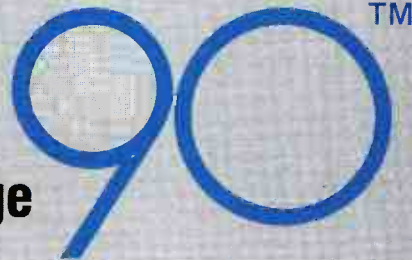

Continuous  
Electronic  
Phase  
Correction



The PHASE TRAK 90's LED "phase eye" display shows phase correction activity as it happens.

Just imagine: A cartridge machine that could automatically correct phase errors in the playback audio of any cartridge—regardless of what equipment was used to record it originally. No encoding. No matrixing. Just instant, accurate phase correction every time a cartridge is played.

Sound impossible? Then meet the new PHASE TRAK 90 from Broadcast Electronics!

At the heart of the PHASE TRAK 90 is a revolutionary non-encoding phase correction circuit. (Patent pending.) Whenever a cartridge is played it continuously checks and corrects the phase relationship of the right and left channel playback audio.

But phase correction is only one of the unique features of this new machine. The PHASE TRAK 90 also offers built-in, non-encoding noise reduction, an FSK decoder, digital cue detection, automatic "hot tape" sensing, an optional timer and more. Its superb signal to noise and frequency response characteristics ensure audiophile performance with every cartridge.

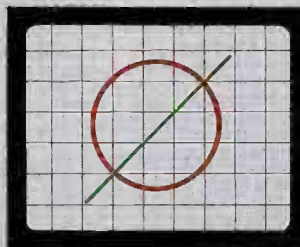

Red circle: Typical Lissajous pattern, right and left channel audio 90 degrees out of phase.

Green diagonal: Typical Lissajous pattern after PHASE TRAK 90 phase correction. Right and left channel audio in perfect phase.

Contact your Broadcast Electronics distributor today or call:

217-224-9600

PHASE TRAK 90™ is a trademark of Broadcast Electronics

Circle (66) on Reply Card



**BROADCAST  
ELECTRONICS INC.**

4100 N. 24th ST., P.O. BOX 3606, QUINCY, IL 62305-3606, (217) 224-9600, TELEX: 250142

• **News Special Report: On the Receiving End, Part 2** (page 160)

By Michael H. Heiss, Bell & Howell/Columbia Paramount, Los Angeles

Inside S-VHS: What's in it for the professional? An examination of the recently introduced consumer recording format and its promise of improved resolution.

*SBE Update* (page 162)

- National Elections in Progress
- Meet the Candidates

*Station-to-Station* (page 166)

- **Retrieving Data From a Video Signal**  
By Stephen Hobrecht, National Semiconductor, Santa Clara, CA  
(When data is retrieved from a video signal, in particular the vertical blanking interval, the TV receiver can become a data demodulator for various information services.)

## NOVEMBER 1987

**Theme: 4th Annual Station Maintenance Special**

*Editorial* (page 6)

- **Protecting the Bottom Line**  
(Training for engineers is a means of protecting station profitability.)

*FCC Update* (page 8)

- FM Technical Rules Are Amended
- Proposed Rules for Non-Licensed RF Devices
- Cable Rule Proposals and Changes

*Strictly TV* (page 10)

- Round 3  
(Yes, BE editors have seen S-VHS and say that it could have future use in broadcast production.)

*re:Radio* (page 12)

- **Know Your DA**  
(Tracking down the correct directional array parameters and correcting logging.)

*Satellite Technology* (page 14)

- **Satellite User's Conference**  
(Trade show in Dallas stresses digital products to small audience.)

*Circuits* (page 16)

- **Inside Digital Technology, Part 14**  
(Address and data signals, the Z-80 family of microprocessor devices, memory refresh, refresh timing cycles.)

*Troubleshooting* (page 18)

- **Maintaining Switching Power Supplies, Part 4**  
(The control stage, planning for maintenance, inspection before installation and finding the problems.)

*Management for Engineers* (page 20)

- **Managing Upward, Part 5**  
(Planning career goals, lateral moves, socializing, promotions.)

• **Controlling ac Line Disturbances** (page 26)

By Jerry Whitaker, editorial director

Transient overvoltages represent the greatest single threat to equipment reliability. Combinations of voltage surge, sag, transient

disturbances and momentary power interruptions are far more prevalent than you might expect. A 3-part overview discusses the problems and prevention methods:

- **The Scope of the Problem** (page 30)
- **Facility-Protection Methods** (page 42)
- **Circuit-Level Applications** (page 72)

*Interest:* engineering, management, technicians.

*Key words:* surge, sag, transient interruptions, SCRs, staged suppression.

• **The Commission is Watching** (page 87)

By Brad Dick, radio technical editor

The trend set by the Fowler FCC was one of deregulation. The remaining regulations cannot be ignored, however, and may be even more strictly enforced. A discussion of FCC inspection and citation policies.

*Interest:* engineering management, operators.

• **Using Digital Oscilloscopes** (page 94)

By Ed Caryl, Tektronix, Beaverton, OR

The challenge of maintaining a broadcast facility requires equipment capable of monitoring video, pulse, audio and RF signals. One answer to this dilemma is an oscilloscope of digital design that can fit into such an environment. Suggested applications for the digital scope.

*Interest:* engineers, operators, repair technicians.

*Key words:* bandwidth, sampling, repetitive acquisition, averaging, smoothing, automation.

• **Testing Stereo Audio for Mono Compatibility** (page 106)

By Mike Coleman, Tektronix, Beaverton, OR

Among the requirements for stereo TV audio signals is compatibility with monophonic reception equipment. Mono listeners should hear the sum of right and left if the stereo system is operating properly. Some suggestions for checks to ensure mono compatibility.

*Interest:* engineers, audio technicians, operators.

*Key words:* audio vectorscope, Lissajous patterns, phase errors.

*Applied Technology* (page 122)

- **Binaural Sound: Expanding on the Image**  
By Claus Wittrock, Philips Professional Television, Copenhagen, Denmark  
(Stereo sound can be added to television by several means and still be reasonably within the constraints of current TV standards. Analog and digital methods are compared. Test equipment can be based on a single base instrument with various modules.)

*Field Report* (page 136)

- JVC CR-850U videocassette recorder

*SBE Update* (page 142)

- Coordination Software Now Available
- A Well-Coordinated Papal Visit
- Check in on CompuServe

## DECEMBER 1987

**Theme: Technology Forecast for 1988**

*Editorial* (page 6)

- **HDTV at the Crossroads**  
(High-definition television is a threat to

some and an opportunity to others, but it is a reality to be reckoned with. Some insider views about delivery of HDTV to the consumer.)

*FCC Update* (page 8)

- The Spectrum is Still Open for HDTV
- 1,540kHz Daytimers May Operate at Night
- LPTV Applications to be Granted
- No Change on Call Letters

*Strictly TV* (page 10)

- **Take an Objective Look at Encoders**  
(Comb-filter encoders have been shown to significantly improve NTSC picture quality, but they must be evaluated objectively. A check list is included for a methodical examination of the equipment.)

*re:Radio* (page 12)

- **When the Numbers Change, the Search is On**  
(Unexplainable and seemingly random variations in antenna-monitor readings might be the result of unusual conditions at the antenna or ground system.)

*Satellite Technology* (page 14)

- **Using Parabolic Antenna Systems**  
(Dishes, or parabolic antenna systems, bring several advantages to system owners and engineers. Formulas for calculating necessary parameters are included.)

*Circuits* (page 16)

- **Inside Digital Technology, Part 15**  
A further look into the operation of the Z-80 microprocessor.

*Troubleshooting* (page 18)

- **Learn the Value of an Organized Attack**  
(Effective troubleshooting techniques require a methodical approach and a tightening spiral of tests that lead to the identification of a faulty component. Documentation is invaluable to successful troubleshooting and maintenance.)

*Management for Engineers* (page 20)

- **Time Management, Part 1**  
(If you find yourself constantly responding to someone else's needs and, in general, not being in control of your own activities, you're in the throes of crisis management. It's time to take stock of the way you're spending your time.)

• **Who's Spending What?** (page 26)

By Brad Dick, radio technical editor

An examination of projected purchasing plans of radio and TV stations for 1988. Trends and conditions in broadcasting are tracked.

• **View From the Top** (page 40)

By Jerry Whitaker, editorial director

Interviews with the top engineering chiefs of ABC, CBS and NBC. As the major networks go, so goes the nation.

• **The State of TV News** (page 54)

By Joseph Barnes, TV news consultant, Martinez, CA

News programming, like other aspects of broadcasting, is seeing many changes, many





# Telex, a broadcast headset in perfect balance.

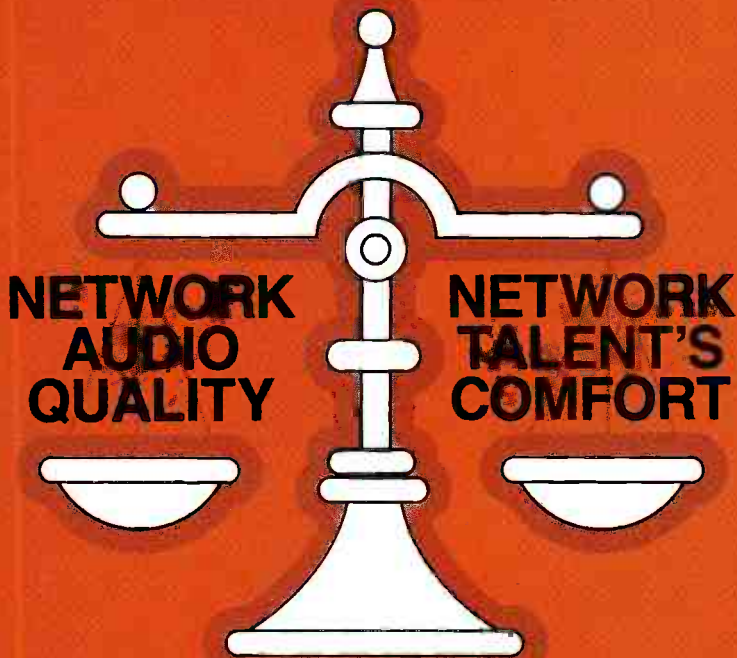

## Telex satisfies the comfort needs of network sports announcers while meeting high network audio standards.

For years Telex has worked diligently with network audio engineers and network talent—searching for the ideal combination of sound and comfort. The PH-24 and PH-25 lightweight Sportscaster headsets offer the perfect balance of both needs. Two of the three major networks have already adopted it as their standard for all sports events where excessive crowd noise is not prevalent.

Ideal for golf, tennis, baseball and football in most stadiums, these professional headsets deliver the ultimate in sound and comfort. The same microphone quality is available in the PH-91 and PH-92 full ear-encapsulating, noise attenuating headsets designed for noisy stadiums, basketball arenas or auto races.



PH-24 (Monaural) and PH-25 (Binaural) Lightweight Professional Headsets



Charlie Jones, network sports announcer says that since using the PH series headset from Telex his old problem of "halftime headaches" has disappeared.



PH-91 (300 ohm) and PH-92 (6000 ohm) binaural Professional Headsets

# TELEX®

TELEX COMMUNICATIONS, INC.

9600 Aldrich Ave. So., Minneapolis, MN 55420 U.S.A.

Circle (96) on Reply Card

of them budgetary. A discussion of methods of information acquisition, equipment and presentation.,

*Interest:* general, management, programming.

- **Manufacturing Technology** (page 59)

By Guy W. Numann, Harris Corporation, Melbourne, FL

In order to cope with economic pressures and meet the demand for product, manufacturers must change their methods of operation. Today's marketing trends include the concepts of "just in time" product delivery, group management and a parallel approach to product development.

*Interest:* general, management.

*Key words:* niche marketing, just in time (JIT), team management.

- **Broadcasting's Bottom Line** (page 62)

By Jerry Whitaker, editorial director

In addition to general economic difficulties, broadcasters are facing more competition than ever before from other entertainment media. According to advertising projections, however, the situation appears to be headed for improvement.

*Interest:* general, management.

- **Digital Amplitude Modulation** (page 66)

By Timothy P. Hulick, Acrodyne Industries, Blue Bell, PA

Although it's still in the developmental stages, an approach to amplitude modulation using directional couplers driven by digitally controlled amplifiers suggests a method to achieve high-level AM modulation with reasonable efficiency. An examination of directional coupler operation and a mathematical proof of the digital AM process are included.

*Interest:* engineering, RF engineers, system designers.

*Key words:* directional coupler, hybrid, RF splitter, linearity.

- **Hot Switches and Combiners** (page 82)

By Dennis Heymans, Micro Communications, Manchester, NH

RF switching systems can play an important part in keeping stations on the air. Without moving parts to fail, hot switching allows fast changing of signal feeds to the antenna.

*Interest:* engineering, system designers.

*Key words:* directional couplers, phase shifters, combiners, hybrids.

- **Show Replay** (page 134)

- Optional Seminars Attract Attendees (Attendance was up at Radio '87 in Los Angeles.)

- **SBE Update** (page 136)

- Rudman Leaves Legacy of Success
- Growth (membership, Ennes Foundation, national convention)
- Cooperation
- New Fellows
- Election Results and Board of Directors

- **News Special Report: Bringing Calgary to the World** (page 138)

By Jean-Louis Major, Ampex Canada, Mississauga, Ontario, Canada; and Keith Lissak, HartFerd Communications, Hollywood, CA

CTV, the host broadcaster of the 1988 Winter Olympics, and ABC-TV prepare to meet the technical challenges of broadcasting the events.

!{:(-))]]]]

# The SL 5000 M Series

## The World's Most Advanced Stereo Broadcast Consoles

**T**he SL 5000 M Series is designed to meet the demands of today's broadcasters – offering a new level of operational and creative flexibility in a practical format.

Built from a wide range of audio and control cassettes housed in a variety of mainframe sizes, the SL 5000 M Series offers all the advantages of customised functions and layouts, even for the smallest consoles. Larger organisations will also benefit from common operating procedures, parts stock and maintenance routines.

The SL 5000 M Series is designed for a wide diversity of applications – live radio, continuity, outside broadcasts, film and video post. It will satisfy your requirements for many years to come.

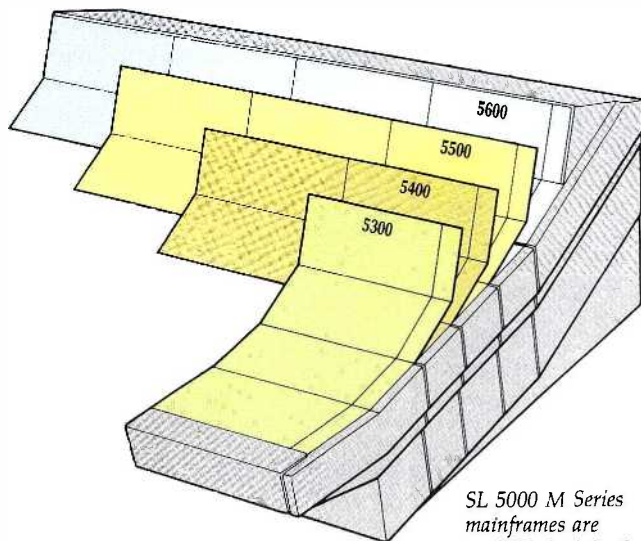

*SL 5000 M Series mainframes are available in 4 depths and from 8 to 72 channels wide, allowing consoles of almost any size and capacity.*

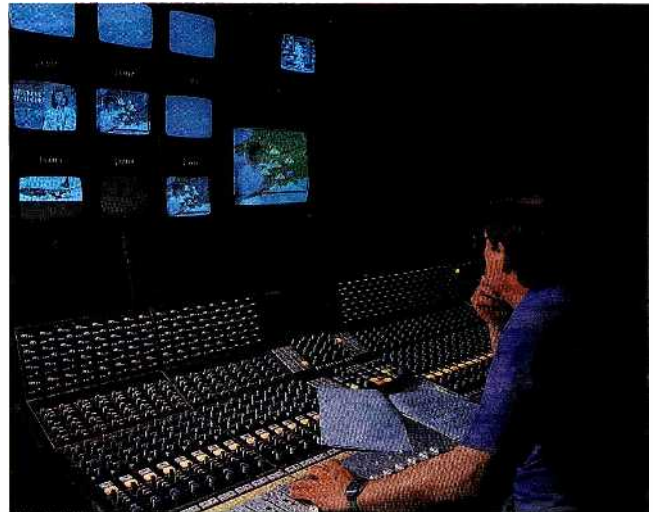

HTV – Bristol  $\Delta$

Film Australia – New South Wales  $\nabla$



Whether you are looking for an eight input on-air console, or a 72 input multitrack desk, call us now and join the growing number of broadcasters equipped for the 1990s.

## Solid State Logic

Oxford • Paris • Milan • New York • Los Angeles

Begbroke, Oxford, England OX5 1RU • (08675) 4353  
1 rue Michael Faraday, 78180 Montigny le Bretonneaux, France • (1) 34 60 46 66  
Via Cesare Cantu' 1, 20092 Cinisello Balsamo, Milan • (2) 612 62 81  
320 West 46th Street, New York, NY 10036 • (212) 315-1111  
6255 Sunset Boulevard • Los Angeles, California 90028 • (213) 463-4444

## Optional seminars attract attendees

By Brad Dick, radio technical editor

When the NAB moved Radio '87 to the highly populated Los Angeles area, it reaped the benefit of increased attendance. Fine weather, coupled with the attraction of nearby Disneyland, resulted in an additional 200 attendees, compared to Radio '86.

The engineering side of the convention also was improved. Three optional seminars scheduled in conjunction with the convention addressed the topics of directional antennas, RF radiation and the NRSC standard.

Attendees took advantage of the added opportunity to hear from industry experts, as well as touring the convention floor and sitting in on other technical sessions.

The directional antenna seminar had the highest attendance, with approximately 50 engineers taking part. The RF and NRSC seminars each were attended by about 40 engineers.

### Directional antenna seminar

Scheduling the directional antenna seminar in conjunction with a convention was a first for the NAB. A keen interest in the antenna seminar was most likely the reason many of the engineers attended the convention.

Topics included vector analysis, use of the Smith chart, broadbanding systems and reradiation problems. Each of these areas was approached in such a way that even the newcomer could grasp the important elements. Panelists also answered questions in greater detail for engineers with several years of experience.

If you would like additional training on AM directional antenna systems, consider attending Radio '88. The directional antenna seminar is tentatively scheduled in conjunction with the radio convention again next year.

### NAB petitions the FCC

AM improvement was the key issue at the convention, and proponents of the NRSC standard were everywhere. According to the NAB, more than 390 stations have adopted the NRSC recommended standards. Unfortunately, that number is much lower than the association had hoped.



After the convention, it was learned that the NAB planned to petition the FCC, asking that the NRSC standards be incorporated into the rules. The petition asks that all transmission specifications contained within the original voluntary NRSC standards be made mandatory for all AM stations. Stations would be allowed a grace period to complete the equipment installation.

Stations interested in implementing NRSC standards must take three basic steps: First, turn off any transmitter clipper circuits, and rely on the audio-processing equipment. Second, broadband the antenna system as much as possible. Finally, reduce IM and IPM as much as possible. Although these seem to be straightforward suggestions, some stations forget that just installing the NRSC filtering is not sufficient to obtain maximum transmission-system performance.

### Cart technology

One of the more interesting convention sessions discussed new tape-cart-ridge technology. Presenters from several cart machine companies discussed their equipment design philosophies and the state of audio quality for carts.

The session quickly broke down into two viewpoints: those who believe that current technology is adequate for the foreseeable future and those who want digital technology applied to carts—now.

One member of the audience challenged the manufacturers to be aggressive and to bring to the market new ideas and new-technology cart machines. He claimed that foreign competition could beat them to the marketplace with new designs that would be supported by the broadcasters.

Most of the manufacturers disagreed, saying that there are not enough reasons to develop a digital cart machine. The companies indicated they are not interested in developing products for the sake

of technology. One panelist said, "Technology no longer drives this business; product performance drives the business."

The argument that playing CDs requires a digital cart machine did not sit well with most of the panel members. A survey conducted by one company indicated that most stations actually are playing CDs from carts, not direct-to-air. The reason is convenience.

One panelist said that a digital cart deck won't be necessary until the (AM and FM) medium becomes clean enough for the audience to hear the difference. Another panelist said digital cart machines will become popular only when they make money for the stations.

A representative from one company currently producing a digital cart deck said that, although analog cart decks may be around for 10 to 15 years, the future lies in digital products for those stations wanting higher quality.

### Next year

Next year's convention will be in Washington, DC. If you want to attend the specialty seminars, consider the added benefits of attending the convention. You will have the chance to learn from some of the industry's most qualified experts and, for a couple hundred dollars more, you can attend a less hectic convention in an interesting location.

# AMBER

## Your TOTAL SOLUTION for Automated Audio Testing



Amber offers the only GPIB based total automated test system package for audio, broadcast and communications testing. The package includes the Amber model 5500, a GPIB Programmable Audio Measurement System with state-of-the-art performance, comprehensive measurement capability, fast operation and modular expansion. Amber AudioCheck™ software runs on any IBM XT/AT compatible computer and can program complete sequences of tests including sweeps, testing against limits, control of other GPIB instruments, storage and retrieval of tests and data and output of hard copy on printers and plotters.

A fully professional system, the Amber 5500 has stereo balanced inputs and outputs and "16-bit digital" performance (distortion to below 0.001% / - 100dB, noise below - 120dBm/1μV). The 5500 is comprehensive — it can measure THD + N, two kinds of IMD, quantizing distortion, wide band and narrow band level with four selectable bandwidths, crosstalk, frequency and phase. Other options add even more capability. An easy to use smart front panel and non-volatile memory for instrument setups facilitate bench-top operation. A wide selection of noise weighting filters and detectors allows measurement to virtu-

ally any standard including ANSI, DIN, CCIR, IEEE and others.

The Amber system is fast. Fast to set up and fast to run. Complex test sequences can be programmed in just minutes using the easy to use AudioCheck™ software program. Intuitive pop-up menus with simple keyboard or mouse selection, resident sample files and context sensitive help screens take the expense and risk out of custom programming. Whether its a sophisticated family of curves for R & D purposes, a complex product test procedure or a simple Go/No-Go acceptance test, technicians not familiar with programming can be in business just hours after installation.

AudioCheck™ offers unparalleled flexibility in screen and hard copy output. Text, user prompts, bar graphs,



*Amber also makes one of the most popular portable high performance audio measurement systems — the 3501. Half the weight and size of comparable instruments, the 3501 has one of the best reliability records in the industry and was the recent winner of a US Navy requirement for over 400 instruments.*

**DEMO DISK AVAILABLE** An AudioCheck™ demonstration disk and manual with all features except GPIB commands are available for your evaluation. System requirements: MS-DOS computer with 640k RAM and CGA monitor card. Send \$10 for your copy.

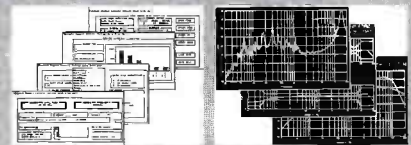

XY graphs and messages can be inter-mixed. Hard copy reports on dot matrix printers or multi-color pen plotters can incorporate all of these attributes. Linear and log sweeps with easy selection of range and parameters, even sophisticated asynchronous, reciprocal and adaptive sweeps with complex settling algorithms are just a few keystrokes.

The Amber system uses universal standards such as IEEE-488 and MS-DOS. You can easily integrate other GPIB instruments into the system like RF generators, programmable power supplies, switch matrices, digital multimeters and function generators (although you'll find the modular and expandable 5500 remarkably complete by itself). Your test data is saved on disk in industry standard formats for easy export to your data base, spread sheet, statistical analysis and scientific analysis programs.

Let us show you how easy and powerful the Amber Total Solution is. Call or write for our brochure.

Amber Electric Design Inc.  
4810 Jean Talon West  
Montreal Canada H4P 2N5  
Telephone (514) 735 4105  
Telex 05-827598  
US Toll free 800-361 3697

**amber**

## Rudman leaves legacy of success

By Bob Van Buhler

As Richard Rudman steps down from his 2-year term as SBE president, it is appropriate to look back at the changes that occurred during his tenure. Rudman began serving at the national level as the first chairman of the SBE national frequency coordinating committee. He was appointed later to a position on the society's board of directors, which had been vacated by the resignation of an elected director. After completing his term as a board member, Rudman was elected SBE vice president. He was elected president in 1985 and served the full 2-year term.

This month Rudman will take a new and quite different post—immediate past president (a position sometimes referred to as old past president, or OPP). He succeeds Roger Johnson in this position. As the immediate past president, Rudman will be the senior adviser to the new president and his officers. He will attend board meetings for as long as the current president, Jack McKain, is in office.

### Growth

One of several important accomplishments during Rudman's presidency was membership growth. During these landmark years, general membership exceeded the 5,000 active member mark.

In addition to membership growth, the certification program also prospered. In today's radio and TV marketplace, posted job openings for engineers and technicians frequently say "SBE certification preferred," or "general-class license or SBE certification required." This growth and industry recognition is possible because the program's integrity is strictly maintained.

The establishment of the Ennes Foundation during Rudman's presidency reflects SBE's strong commitment to the members in the area of educational support. The foundation provides the proper corporate and financial organization that is necessary to support future program expansion.

The Rudman years also saw the development of the SBE National Convention and **Broadcast Engineering** Confer-



ence. These tremendously successful conventions are a source of pride for all SBE members. This year's convention was even better-attended than the first in 1986, providing the society with the necessary momentum to sustain its growth in the coming years.

### Cooperation

Even though Rudman was president during this time of progress, he is quick to point out that it is the result of a team effort. "The officers, the board and the office staff all got behind the programs. It is clear that we were all on the same page. Things got done because when people were asked to do them, they followed through and did the work," Rudman said. "I would like to be remembered for having a role in bringing the SBE's past and the present together."

He was instrumental in urging the society's first president, John Battison, to serve as the conference coordinator for the national conventions. Rudman also enlisted Charles Hallinan, an early SBE president and first chairman of Chapter 1, to serve on the national level as chairman of the bylaws committee. The result of Hallinan's efforts appeared on the national ballot in this year's election. "Cooperation between the old and the new elements in the society is particularly gratifying," Rudman said.

### Election Results

#### President:

Jack McKain

#### Vice President:

Bob Van Buhler

#### Secretary:

Richard Farquhar

#### Treasurer:

Bill Harris

#### Board of Directors:

Phil Aaland

Terrence M. Baun

Dane Ericksen

David G. Harry

Tom Weems

Larry L. White

In a parting message to the membership and the industry, Rudman advises everyone to "keep it fun, and keep it a people business. This business was started as a hobby for engineers. The engineers made things happen because it was interesting, a good people business and a team effort.

"There seems to be a tendency to automate, and remove people from the process. If the basic need for people disappears, the motivation for many of us to remain in the business will disappear also," Rudman said.

### New Fellows

At the national convention, SBE announced the induction of three new Fellows: James McKinney, Frederick Remley and Brad Dick.

McKinney is the outgoing chief of the FCC's mass media bureau and is a certified broadcast engineer. He entered government service in 1963 and has served in a variety of engineering and management positions at the FCC. In July, he was appointed Deputy Assistant to the President and Director of the White House Military Office. His duties include management of radio, landwire, microwave, satellite and wideband secure communications; Air Force One and the Presidential helicopter fleet; the White House motor vehicle fleet; food services; and medical support to the President. McKinney is a member of the Broadcast Pioneers and a Fellow of the Radio Club of America.

Remley has been active in SMPTE standards setting and SBE work for several years. He chaired the standards committees on D-1 and type C video recorders and authored a chapter in both the "Data Handbook for Electronic Engineers" and the "TV Engineering Handbook."

Dick was awarded senior-level certification from SBE and has served as Kansas chapter chairman, certification chairman and national secretary. He has held several posts at radio and TV stations, including the positions of chief engineer and director of engineering and operations. Dick now serves as the radio technical editor for **Broadcast Engineering** magazine.

Van Buhler is chief engineer for WBAL-AM and WIYY-FM, Baltimore.

# WATTS UP?



**When-and-if you're ready to UP your transmitting power, will your FM transmitter be ready too? If it's one of the QEI "New Reliables" FMQ series, the answer is YES!**

Our new 3.5KW, 5KW and 10KW transmitters were designed to give you a clear upgrade path to higher power. In just a few hours, your 3.5KW or 5KW QEI FM transmitter can be upgraded to a factory-equivalent 5KW or 10KW unit, right in the field. QEI's unique modular solid state drivers and interchangeable P.A. assembly make these power upgrades easy...and very economical.

If you're shopping for a 10KW unit in the first place, the QEI FMQ-10000 has lots to recommend it. No other FM transmitter packs this much power, reliability and performance into a single 24" wide rack cabinet. And the FMQ-10000 is designed to operate on single-phase power, so there's no need to pay for installing new three-phase electric service.

What's more, for upgrades to power levels beyond 10KW, each of these FMQ series

transmitters can serve as the driver section for QEI's 20, 30 or 60KW transmitters, again resulting in major cost savings.

Every QEI "New Reliables" FM transmitter is built to deliver ultra-dependability and performance. So—whether your station is thinking of upping its power down the road, or if the power you start with is the power you stay with—you'll be glad you chose QEI. Call us toll-free at (800) 334-9154 for the full story.



**The New Reliables**

One Airport Drive, P.O. Box D  
Williamstown, NJ, 08094 (609) 728-2020

Circle (123) on Reply Card

## Bringing Calgary to the world

By Jean-Louis Major and Keith Lissak

It won't be long until the torch is lit at the 1988 Winter Olympic Games in Calgary, Alberta, Canada. The TV broadcasters who will be covering this event have been planning for this technical challenge almost since the close of the 1984 Winter Games in Sarajevo, Yugoslavia.

Canadian Television (CTV), the host broadcaster of the Calgary Games, and ABC-TV have been especially busy. CTV will provide complete Olympic coverage for international broadcast companies, and ABC will televise the Games in this country with 98½ hours of mostly live coverage. With the opening ceremonies just weeks away, both networks are deep into the details of preparing their facilities and personnel for the challenges ahead.

### Feeding the world

CTV has perhaps the longest road to travel. One of two Canadian TV networks, CTV is owned by a group of affiliate stations that originate most of the network's programming. Although some programming is produced by the network itself, its headquarters in Toronto are primarily administrative offices and on-air playback facilities. As the host broadcaster of the Winter Games, however, CTV is responsible for building and maintaining the International Broadcast Center (IBC), where the world feed from every Olympic venue will be processed, synchronized and distributed to rights-holding international broadcasters. It is a huge task that demands much more than providing playback facilities.

Providing the world, or multilane, feed is always the top priority of the host broadcaster. This NTSC feed must be made available to any country that requests it. It is a raw signal consisting of video, ambient sound picked up at the venues and basic graphics (an athlete's national flag and the name of the country in English). If a broadcast company wishes to send commentators to the venue, commentary facilities must be provided. Up to 500 commentator positions

Major is president and general manager of Ampex Canada, Mississauga, Ontario, Canada. Lissak is with HartFerd Communications, Hollywood, CA.



servicing both television and radio eventually will be fed back to the IBC.

Another necessity for CTV is videotape facilities. The Olympic charter states that the host broadcaster must record all events for archival purposes. CTV will accommodate that provision and will prepare 30-minute and 1-hour summaries of each day's events for rights-holding broadcast companies. These summaries, which also are produced without commentary, generally are broadcast in countries with only a perfunctory interest in winter sporting events. However, all rights-holding broadcast organizations, news agencies and cable networks have access to them. A provision in the Olympic charter specifies that these tapes must be used expressly for news purposes.

### Construction and configuration

One of CTV's early problems concerned the facility chosen to house the International Broadcast Center, The Big Four Building in Calgary's Stampede Park. Selected by the Olympic Committee Olympic '88 for its size and locale, The Big Four Building is the world's largest curling rink. With approximately 120,000 square feet of usable space, this 2-story arena certainly is large enough to serve as the IBC site, but it was badly in need of renovation. The network inherited the responsibility of performing those renovations.

Before the host and world broadcasters could move in, major changes had to be

made, such as installing carpeting and air-conditioning, increasing power and lighting levels and providing a proprietary power supply. Construction and remodeling of the arena's top floor commenced in January 1987. Reconfiguration of the lower floor began at the close of the curling season in April 1987.

Perhaps the greatest obstacle was acquiring the necessary broadcast and videotape equipment to stock the IBC. Network management originally intended to bring in equipment from the affiliate stations, but it soon became apparent that there simply were not enough components to go around. With that realization, CTV hired a manufacturing and systems design contractor (the turnkey systems division of Ampex Canada) to oversee construction and maintenance of its central TV facilities.

CTV presented the contract engineers with rough sketches of plans for the IBC, and the engineers completed the conceptual design. Along with these finished blueprints, CTV received an equipment list specifying the components necessary to turn The Big Four Building into a functional international broadcast facility.

International TV broadcasters will have access to up to 15 simultaneous feeds provided by the network. Originating from locations throughout Calgary and the surrounding area, these feeds will enter the IBC master-control area via microwave, fiber optics, satellite and underground cable. The master-control room, where all video and audio

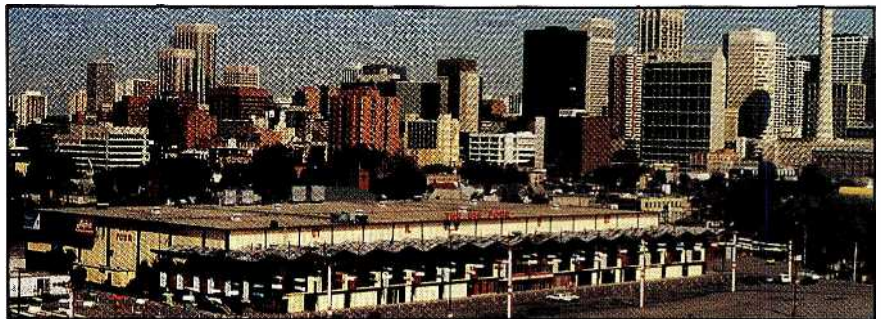

The Big Four Building in Calgary's Stampede Park is the site of the 1988 Winter Olympics International Broadcast Center.



The World's First  
4:2:2 Telecine

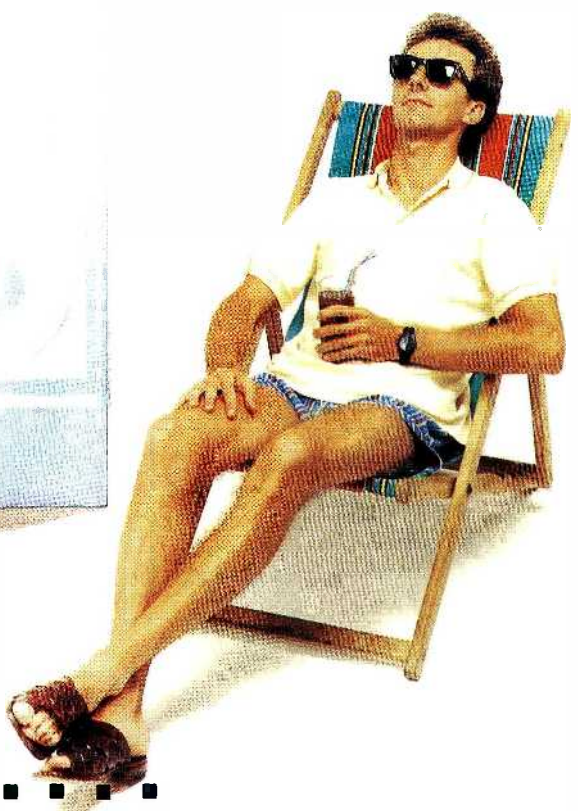

# The no hassle . . . . . broadcast telecine

## ADS 1 Advanced Digital Scanner

With ADS 1, Rank Cintel has applied its unique film-scanning experience to the specific needs of the broadcaster.

Developed in close co-operation with the British Broadcasting Corporation (BBC), this CCD multiplexed broadcast-telecine is designed for easy 'on-air' operation and transfer of film to tape prior to transmission.

The incorporation of solid-state imaging technology is an example of Cintel's continuing development philosophy.

Latest component technology, cost-conscious design and modern manufacturing techniques have been

exploited, without compromising performance and reliability. The result is a telecine system which is technically advanced while at the same time being economical to operate. That is not all, ADS 1 also features a unique electronic dirt and scratch concealment system. Add all this together . . . . . and you have the ideal broadcast-telecine package.

**Take the hassle out of film broadcasting — call us at 268-8911-2-3 (914)**



**Rank Cintel Inc. Head Office U.S.A.**  
P.O. Box 710,  
704 Executive Blvd.,  
Valley Cottage,  
New York,  
10989-9998, U.S.A.  
Tel: 268-8911-2-3 (914)  
Fax: 268-5939 (914)



# Rank Cintel Inc.

Circle (124) on Reply Card

**West Coast Sales and Service**  
13340 Saticoy Street,  
North Hollywood,  
California 91605, U.S.A.  
Tel: 765 7265 (818)  
Telex: 182694 RPI LSA  
Fax: 765 3315 (818)



ABC's master control room is being built on wheels. It will consist of four 40-foot containers that will be driven into The Round-Up Centre and set up, eliminating major assembly on-site.

is processed and distributed, will occupy approximately 5,000 square feet on the upper floor of the IBC.

To handle the workload, 15 identical input racks will distribute the signals to the various broadcast organizations. Arranged side by side in a semicircle, the

input racks also will serve as a showcase for visitors to the IBC.

Each rack is a complete video-processing station. Built and assembled in Toronto by the contract engineers and shipped to Calgary, each has the capability to accept, monitor, synchronize and

distribute a signal to the central switching system, which feeds the broadcast organizations. Rack components include a feed-selector switch (each rack can accept either a main venue feed, a standby feed or a feed from another rack), audio amplifier, color monitor and distribution amplifier.

Once the incoming signals are processed, they will be fed into a 50x56 routing switcher with video, audio and time code and directed into one of 18 videotape recorders. The output of the VTRs will be sent to international broadcasters via the central routing system.

Videotape and production facilities at the IBC include two editing suites, a unilateral production studio available on a rental basis and a quality-control studio. CTV will use the two editing suites to piece together the daily videotape summaries. When the suites are not in use, they will be available to other broadcasters. The quality-control room will serve as the network's production nerve center, but it also can serve as an additional edit room. Containing a bank of color monitors and a switcher, the room will receive feeds from the venues and display them to CTV directors. The directors can communicate

## Our new 20 x 10 router is no big thing.

Announcing our new 20-TEN™ and our TEN-20™, the newest additions to the GVG compact video and audio router family. Both are full function systems that need just one rack unit per matrix, and fit your budget, too.

When it comes to saving space — and money — you always have room for a little innovation.

**Grass Valley Group**

STRENGTH YOU CAN RELY ON

20-TEN

GRASS VALLEY GROUP

THE GRASS VALLEY GROUP, INC. — P.O. Box 1114 — Grass Valley, CA 95945 USA  
Telephone (916) 478-3000 — TRT: 160432 —  
OFFICES: New York (201) 845-7988; District of Columbia (301) 622-6313; Atlanta (404) 493-1254  
Chicago (219) 264-0931; Minneapolis (612) 483-2594; Dallas/Fort Worth (817) 483-7447;  
Los Angeles (818) 999-2303; San Francisco (415) 968-6680. A TEKTRONIX COMPANY

Circle (125) on Reply Card

**FREE 32pg Catalog & 50 Audio/Video Applic.**

PWR SUPP. EQ., PHONO, MIC, TRANS, ACN, TAPE, VIDEO, LINE, OSC

Stereo/Mono Pwr Ampl. 9-in/2-out, 12-in/4-out, 18-in/4-out

Video & Audio Dist. Amps. TV Audio & Recd Prod Consoles

**OPAMP LABS INC (213) 934-3566**  
1033 N Sycamore Av LOS ANGELES CA, 90038

Circle (97) on Reply Card

### PRECISION MAGNETIC TEST TAPES

**STL**



Standard Tape Laboratory, Inc.  
26120 Eden Landing Road #5, Hayward, CA 94545  
(415) 786-3546

Circle (98) on Reply Card

Grow  
Professionally!  
Join &  
Participate in

**SMPTE**

For Information —  
Call: 914-761-1100

their instructions for camera angles and positions to the on-site operators.

The TV facility contractors also designed the transmission control center, where all outgoing signals will be monitored. Essentially a picture-quality checkpoint, this room contains a bank of monitors that will show the images each international broadcast organization is sending back to its respective country. Host and world broadcast producers will use this room to monitor picture quality and resolution.

Equipment has been streaming into the facility since August. Three-quarters of a million feet of cable were laid in August and September and, theoretically, as the equipment arrives, it can simply be plugged into the system. All the equipment must be operational by Jan. 1, 1988. Testing will take place for the following two weeks, and an intensive training period for equipment operators will lead right up to the Games, which begin on Feb. 13.

When the Games end 16 days later, CTV will have transmitted approximately 550 hours of Olympic coverage. Two months later, The Big Four Building will once again be the world's largest curling rink.

#### **Working against the clock**

ABC-TV faces a different set of challenges. With 98½ hours of live coverage scheduled, the network must broadcast from a facility configured for high-speed, flexible editing. However, unlike CTV, ABC is not concerned with the logistics of building such a facility. It is the tearing down of the facility that is the problem.

The building leased by ABC to house its broadcast operations is The Round-Up Centre, which is actually a convention center. And five days after the Olympic flame is extinguished, The Round-Up Centre will be home to a truck and auto show. That gives the technicians approximately 120 hours to dismantle a broadcast facility larger than most TV stations.

The Round-Up Centre is a massive structure adjacent to The Big Four Building. ABC is leasing a 50,000-square-foot chunk of the building—as well as 10,000 square feet of temporary accommodations outside the facility—and will establish the equivalent of a network substation. The production center will contain a 150x150 routing switcher, master-control room, main control room, mini control room, preset control room, play-to-air room, eight 1-inch editing bays, ¾-inch videotape rooms with edit consoles, sound effects and lay-over rooms, ENG editing areas, a graphics room, a 35x55-foot full-production studio, a 200x240 4-wire communica-



*ABC's Winter Olympic staging facility in New York where equipment is received, tested and configured.*

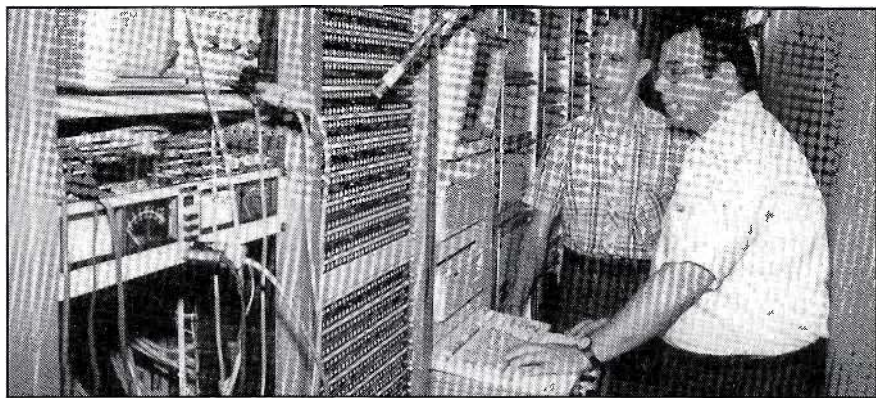

*The master routing, communications systems, audio and video patching and distribution matrices are being built into trailers.*

tions matrix and offices.

For past Olympic coverage, ABC has moved equipment into its temporary broadcast facilities by assembling the various systems in racks at the network's New York home base. For a room such as master control—which contains the master routing switcher, communications systems, audio and video patching and distribution matrices and all other in- and outgoing feed lines—the equipment usually was built into 20 or more racks. The racks would be assembled and tested, then disassembled for shipping to the Olympic broadcasting site, where they were reassembled and eventually disassembled again.

The need for quick disassembly precludes the use of this system in Calgary. Instead, ABC has put its Olympic operations on wheels. The network has built its major facilities, including master control, into mobile units and will simply drive the vehicles into The Round-Up Centre. Master control actually will be built into four 40-foot containers so that only one assembly of those facilities will be required. The trucks will pull into the facility and, within a day or two, master control will be on the air.

This mobility is not only a time-saver, but also is economical. Because the equipment can remain in the trailers, it can be easily reused for other broadcasting events, such as the 1988 political conventions, once the Games are over.

ABC cannot, however, assemble its entire Olympic broadcast center in tractor-trailers. The special air-conditioning requirements of high-speed edit facilities, for instance, financially prohibit the use of prefabricated trailers. Instead, the edit consoles will be housed in temporary rooms constructed from 2'x4' studs and plasterboard.

Stocking the bays with high-speed versatile editing equipment was another concern, and for that task, the network contracted (with Ampex Canada) to integrate and assemble the post-production facilities: seven identical editing suites, a mini control room and a play-to-air room.

The standard ABC edit bay is an updated version of the 1-inch edit rooms designed by the network for the 1984 Olympic Winter Games. For the Calgary Games, seven systems will include three VTRs, an editor-controller, a switcher, audio mixer and digital effects system.



The first of nine fully equipped edit suites built by the turnkey systems division of Ampex Canada.

To accommodate the need for mobility, the contract engineers designed edit consoles that can be easily assembled and disassembled. Similar to the way Swedish furniture is constructed, individual panels are notched with male and female adapters, and a half-turn of a

screwdriver locks the panels into place. This setup is not only highly efficient, but the consoles are strong and easy to ship.

#### Rooms with a view

ABC will use two other edit rooms in Calgary: a mini control room and a play-

to-air room. These suites are similar to the seven edit bays, but will perform important additional functions. The mini control room will switch and provide the feeds for the main control center, where the network's production staff actually will put each show on the air. Like the edit bays, it contains three VTRs, but also will provide additional camera and VTR feeds and expanded communications capabilities.

The play-to-air suite is an 8-inch machine room that can be subdivided into two parts. A 3-machine section can be broken away to function as a stand-alone edit bay or, when combined with the 5-machine section, as an expanded-function edit room. During network feed time, all eight VTRs will be used expressly for playback.

Because of the live schedule, versatility in the editing rooms is a necessity, not a luxury. Weather is almost always a factor at winter sporting events, and if an event is postponed in Calgary because of the elements, ABC has to be ready to fill the allotted time slot. The network can do this in a variety of ways: by going to live coverage of a different event, showing a taped summary of an event recorded earlier in the day, or by pulling

*Continued on page 146*





- Free-floating column
- Adjustable counterbalance
- Position readout
- 120 lb. capacity

AEROPEL



**State-of-the-art**... portable studio pedestal designed and manufactured by the people who created the first true fluid head over 35 years ago.

O'Connor Engineering Labs  
100 Kalmus Drive • Costa Mesa, CA 92626 • (714) 979-3993



Circle (63) on Reply Card

**NEW!** AEC-1 \$995!

**10 x 1 Routing Switcher**



■ Broadcast Quality ■ 30 MHz Video BW

1-800-782-2321

Adrienne Electronics Corporation  
11994 MARJON DRIVE, NEVADA CITY, CA 95959

Circle (142) on Reply Card



**Don't Lose Your Head!**  
Check Head Wear On All Video Formats  
With Our Head Protrusion Gauge

Other Gauges For VCR Repair...

✓ Dial Torque Gauge ✓ Tape Tension Gauge  
✓ Spindle Height Gauge

TENTEL

(800) 538-6894  
(408) 379-1881  
1506 Dell Ave. Campbell, CA 95008

Circle (143) on Reply Card

ISOLATION  
WITHOUT DEGRADATION  
The Best Audio Transformer

- Wide bandwidth
- No overshoot or ringing
- Flat group delay
- Low hysteresis distortion

jensen transformers

INCORPORATED

10735 Burbank Blvd. • North Hollywood, CA 91601  
(213) 876-0059  
Visitors by appointment only. Closed Fridays

Circle (144) on Reply Card

Now In Operation Around The World...  
**9600 SERIES — WE DELIVER!!**

# WE WOULD LIKE YOU TO ASK US SOME TOUGH QUESTIONS

If the only foolish question is the one you didn't ask, then don't be foolish when buying your mid-sized video production switcher.

Ask for the 9600 Series System Integration Guide from **INTERGROUP.**

We have excellent answers for your toughest questions!

It will change your standard for comparison!



*\*A.S.A.P.\* \*\$40K?  
 VERIFY THE PRICE!!  
 GET BACK TO ME -  
 TODAY*

*QUESTIONS (GET DELIVERY FOR INTERGROUP INFO.)*

- 1. WHAT IS M<sup>4</sup>-KEY? IS IT REALLY 100% USER TRANSPARENT?*
- 2. "285 KEY MEMORY REGISTER MIS-PRINT?? (THAT'S A LOT MEMORY.)*
- 3. "PAMS" IS SO LOGICAL! (WHY DOESN'T HAVE IT*

FOR INFORMATION CONTACT:

## INTERGROUP

2040 N.W. 67TH PLACE  
 GAINESVILLE, FLORIDA 32606 U.S.A.

1-800-874-7590  
 (904) 335-0901  
 TWX 810-825-2307

Circle (126) on Reply Card

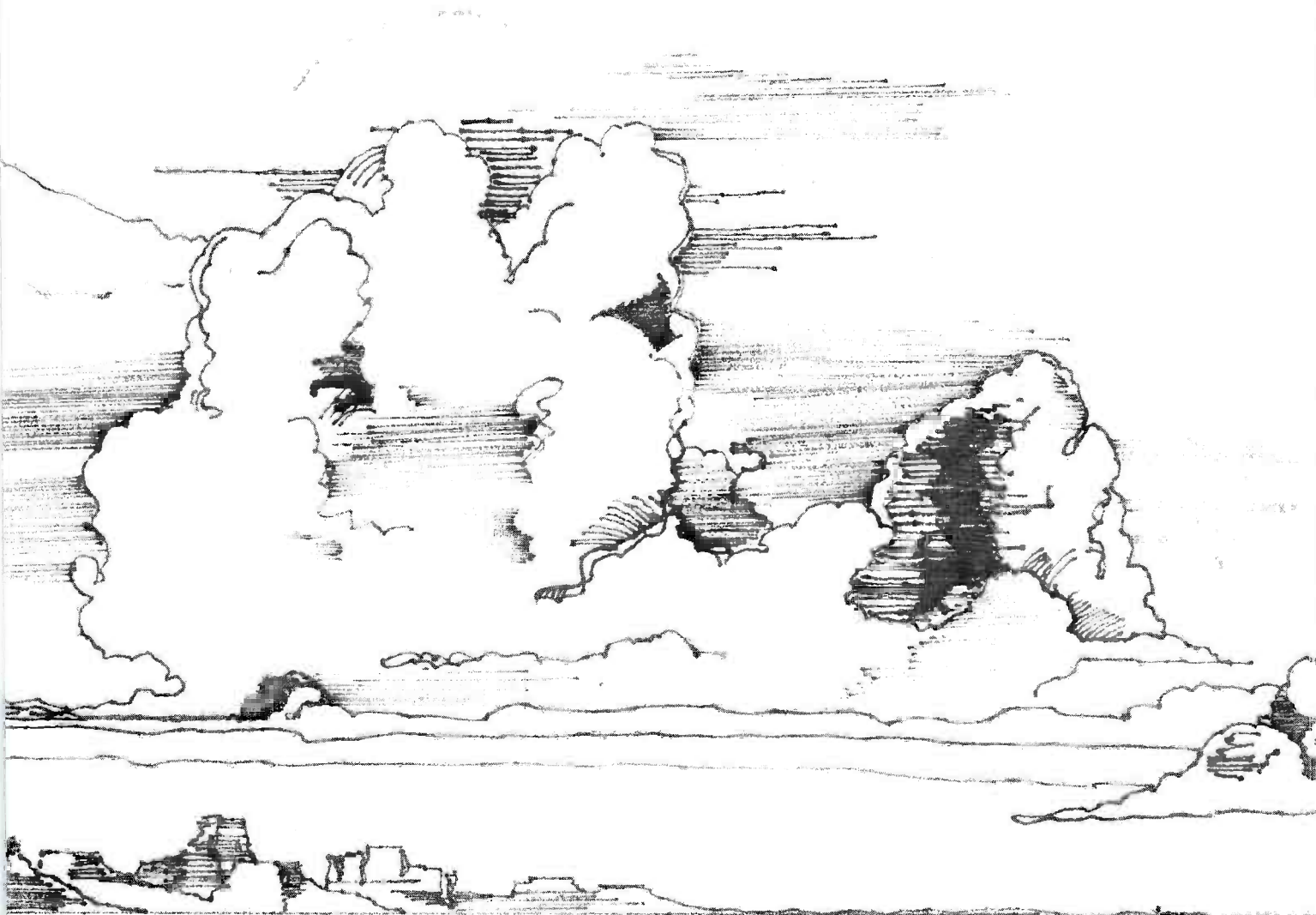

**You may be 1,000 miles from civilization.  
800 miles from mass transportation.  
And 3 days from the nearest watering hole.**



**But you're never more than  
24 hours away  
from an MII Service Engineer.**

When you call the MII service hot-line, several things happen that may surprise you. For one thing, someone answers 24 hours a day, 7 days a week, 365 days a year. If it's a board that needs replacing it will be sent out and will be in your hands within a day. If it requires a service call, a Panasonic MII Service Engineer will be on your premises within 24 hours to repair your equipment on the spot.

And with 6 service locations across the country, replacement parts are never far away.

It's a remarkable service program to

support a remarkable system, the Panasonic MII. The first half-inch broadcast system to offer single-system capability. So you get overall reductions on everything from man and equipment hours to lower training costs. Tape consumption alone may be reduced by as much as 70%.

If you're looking for a system that offers high broadcast quality, overall cost reductions and the finest support programs in the industry, look into MII

from Panasonic.

The broadcast system that makes business sense.



For more information, call  
1-201-348-7671.

**MII Panasonic**  
**Broadcast Systems Company**

Circle (130) on Reply Card



One of the 40-foot containers equipped with communications systems, audio and video patching and distribution matrices.

Continued from page 142

material from their inventory of recorded features and athlete profiles.

Speed is a necessity in Calgary because there will be a great deal of simultaneous action. In past Winter Olympics, no more than three events happened at the same time. The Calgary Games, however, will

see up to eight simultaneous live events. If ABC is covering an event such as figure skating, and suddenly the emerging story is ice hockey, the network must make that switch quickly. That kind of flexibility demands that the post-production rooms double as both live on-air record and playback facilities.

ABC will use the 15 world feeds provided by CTV, but the American network will supplement that coverage with nine unilateral feeds. These feeds will highlight the events most familiar to American TV audiences, including ice hockey, figure skating, ski jumping, Alpine skiing and speed skating. ABC also will position ENG camera units in and around the city to capture images of city life and scenic pictures of surrounding regions.

As the Olympic Winter Games draw closer, activity at both the International Broadcast Center and the ABC production facility gradually will escalate. The flow of equipment and personnel into Calgary will gain momentum, turning the town into a world-class broadcast center. By the time the Olympic torch is lit, approximately 1,000 ABC personnel (including regular employees and local hires) will staff the network's Olympic broadcast center. Close to 3,000 international broadcasters will be based inside the IBC.

No matter where the broadcasters are based, however, all will have one thing in common: They will have traveled a long road to get to the Games. This winter, all roads—no matter how bumpy—lead to Calgary.

[=7=)]))]]

**Winsted®**

**FREE CATALOG**



**Video Furniture Systems**

Big, full color catalog includes complete descriptions, pricing and ordering information on:

- Editing Consoles ● Video Consoles
- Equipment Cabinets ● Micro Computer Stations
- Tape & Film Storage Systems

*Winsted Systems ... the Perfect Match for all professional Video Equipment*

**THE WINSTED CORPORATION**  
10901 Hampshire Ave. So. • Minneapolis, MN 55438  
TELEX: 510-601-0887

Call for your nearest dealer  
**Phone Toll Free (800) 447-2257**  
**FAX: 612-944-1546**

Circle (145) on Reply Card

**PORTA-BRACE QUICK DRAW**

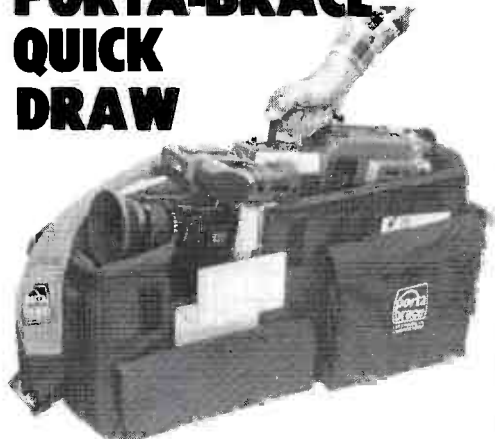

► This professional case is a convenient way to carry and protect your camera on the ground, in your car and in the air. With its hard shell construction and aluminum viewfinder guard, this padded nylon case means lightweight security for your camera. Call or write for information.

**porta brace**

**K&H Products, Ltd.**  
Box 246  
North Bennington  
Vermont 05257  
802-442-8171

Circle (131) on Reply Card



# New products

## Digital audio master tape

Agfa-Gevaert has introduced the PEM 291D, a digital audio master tape formula. It has been designed for the current generation of DASH and PD format digital recorders. It is compatible with existing multitrack PCM machinery. The tape is available in 1/4-inch, 1/2-inch and 1-inch widths, each in 5,000-foot, 7,500-foot and 10,000-foot lengths.

Circle (350) on Reply Card

## Second-generation digital audio recorder



Digital Audio Research has introduced SOUNDSTATION II, a second-generation digital audio recorder and production center. It combines multichannel digital audio recording with direct-access sound editing, as well as digital signal processing. The system consists of the control console—used to perform all system operations—and the processor and storage unit, which contains the system hardware, software and the disk drives used to store digital audio data. The recorder features the Touch Screen display, which is used to select the sound segments to be edited or relocated, and displays the lists of sound segments stored within the system. The recorder has 4-channel recording and editing with expandability up to eight channels. Analog and digital balanced inputs and outputs are provided for each channel with XLR connectors. The AES/EBU digital interface is standard.

Circle (351) on Reply Card

## 80-minute digital audiocassette

Ampex Magnetic Tape Division has expanded its line of 467 U-matic digital audiocassettes with an 80-minute tape. It joins the 30-, 60- and 75-minute lengths and is qualified for PCM performance.

Circle (352) on Reply Card

## Broadcast compact disc player

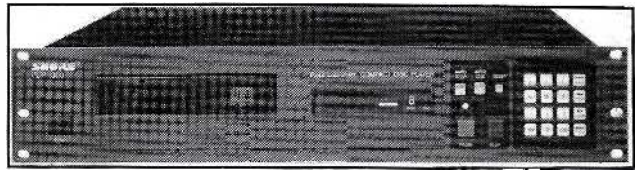

Shure has introduced the PDP1000 professional compact disc player. The player offers front-panel, on-unit controls or wiring for control at the studio mixing board or another location. It features auto cue and auto stop, complete skip and scan capability, random-access programming and 15-stack memory, allowing the programming of up to 15 tracks in any order for automatic or semi-automatic playback. The system also includes digital and analog filtering, dual high-speed D/A converters, full 16-bit processing with oversampling and a 3-beam laser. The player incorporates active-balanced line-level XLR inputs, and the unit can be mounted in a 19-inch rack.

Circle (353) on Reply Card

## MFX post-production package

Fairlight Instruments has introduced the MFX (music and effects) package. It comprises a hardware/software upgrade for the CMI series III digital audio work station. The CMI series incorporates a custom control console for audio post-production sweetening, plus the Cue-List software program. The MFX console consists of the QWERTY keyboard and numeric keypad, sound triggering keys, function keys, LCD displays of user-designated function keys, LED displays of tape-machine locations and cue points, and a Jogger Wheel for cue point locations with the series disk recorder. The Cue-List software serves as a master controller for all of the series functions.

Circle (354) on Reply Card

## Computer graphics systems

AVS has introduced the following products:

- The Artstyle is a computer graphics system that features a CPU capable of running most industry-standard software. The system features a drawing board with inlaid digitizing pad, pen, keyboard, menu monitor, gen-lockable SPG and encoder, graphics processing board with extended memory, 20Mbyte hard disk and 1.2Mbyte floppy. The system is IBM compatible and has a high-resolution output to PCR or QCR. It also features optical disk interface, vector fonts, color and

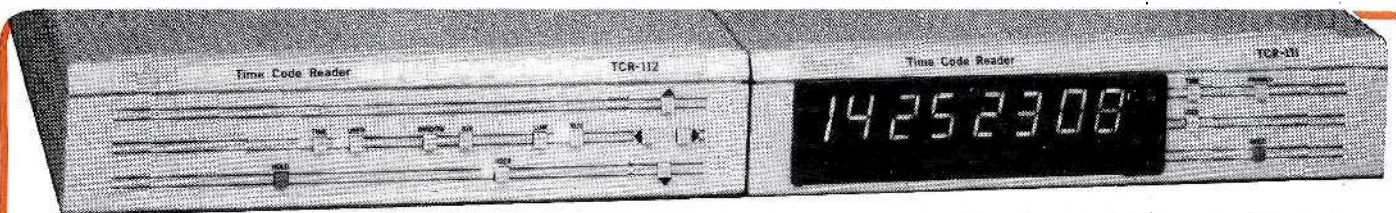

**Two new  
Time Code Readers  
from skotel**

AVAILABLE  
...NOW.

All new... from front panels to advanced reader and error checking electronic circuits. Enhanced full reader features and performance... read from 1/40 up to 80X play speed... small, smart packaging designed for desk or rack mount (1/2 rack width).

For all those who told us... "All I want is an LTC reader with a video display for window dubs."

**It's the TCR-112 at \$1350.** (F.O.B. Destination)

- Simultaneous display of Time and User bits.
- 4 character heights... highly legible font.
- Positionable over full raster.

For those who say... "I only need an LED display."

**It's the TCR-111 at \$1100.** (F.O.B. Destination)

- Large green LEDs for visual comfort.
- Reshaped code output (also TCR-112).
- Dual standard SMPTE/EBU (also TCR-112).

Call or write for name of your nearest dealer and our latest Product Guide.

Skotel... for 10 years a pioneer of VITC, color field ID, User bit and video display applications.

**Skotel Corporation**, 1445 Boul. Provencher  
Brossard, Que., Canada J4W 1Z3  
(514) 465-8990 In U.S. 1-800-361-4999

Circle (127) on Reply Card

black-and-white bit-selectable Framegrab, output to printer, dual-screen operation, cut and paste, perspective, rotation, distortion, mirror, scaling and user-definable brushes. All functions are menu driven.

- The Artstyle II has all the same features of the Artstyle and also features an advanced software package.
- The Artmaster system features full-facility on-screen menus; IBM AT compatibility; rotoscoping; a 720x576 resolution; real color Framegrab, RGB, PAL or CCIR 601; stencil; user-definable brushes; airbrush; two work screens and two utility screens; texture filling; vector fonts and output to printer.

Circle (355) on Reply Card

### Dual program equalizer

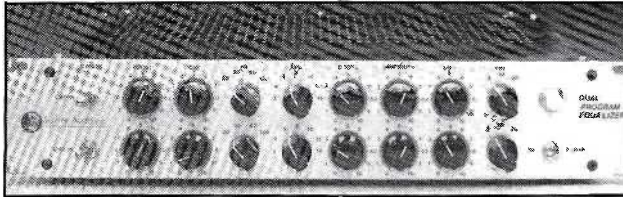

Summit Audio has introduced the EQP-200 dual program equalizer. It features two independent channels, switch-selectable frequencies, continuously variable boost and cut, silent in/out switch, unbalanced output using 990 operational amplifiers, output impedance of 600Ω or more, maximum output of +25dBm, and electronically balanced input with an in-

put impedance of 40kΩ. Power is 35W, 115V-230V, 50Hz or 60Hz. Gain loss is overcome by a vacuum tube amplifier. The unit is housed in a steel chassis, and all components are shock-tested and shielded.

Circle (356) on Reply Card

### U-matic cassettes and audio splicing tape

3M has introduced the following products:

- The AUD 30-minute and AUD 75-minute digital audio-cassettes offer a complete anti-static system and low CRC error rates. Both shell halves and internal components are treated with a topical compound that permanently dissipates static electricity. Other features include an anti-stat leader and trailer, a highly conductive backside treatment and high-impact plastic door.
- The No. 8175 digital audio splicing tape features a synthetic adhesive to ensure roll-to-roll tack consistency. It also uses a black backing that eliminates translucencies.

Circle (357) on Reply Card

### Computer monitoring system and multichannel receiver

Sennheiser Electronics has introduced the following:

- A computer-based monitoring system that is capable of simultaneously monitoring and visually displaying the signal strength, audio output and frequency error of wireless microphones on as many as 27 channels. The receiver consists of an interface unit, a microcomputer processing unit and master monitor.
- The model RS-2012 is a portable 6-pack wireless multichannel receiver. The case carries up to six SK 2012 VHF body

### Total Audio Control, Yet Very Affordable!

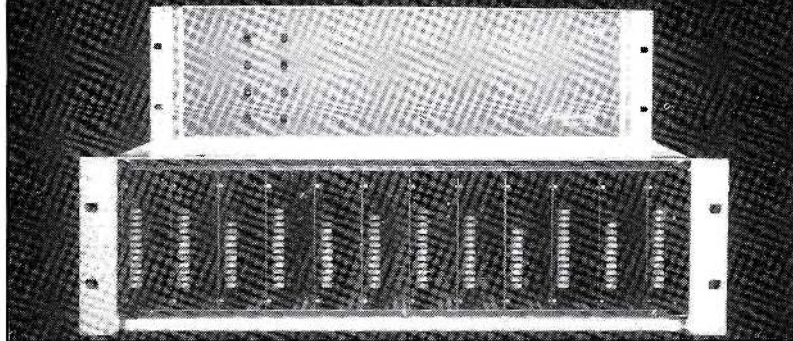

When the engineers at Superstation WGN-TV were ready for an audio rebuild, a product search led them to the Benchmark System 1000 DAs. With all the potential pitfalls in the audio chain, control was a key issue. The MTX-02 stereo control daughter board gave them complete control of output format on the stereo DAs. Remote selection between Left only, Right only, Mono mix, Discrete Stereo (normal and reversed channels), or Matrix stereo for M/S-mic ENG playback-decoding are all on the stereo DA! Remote right channel polarity inversion is the icing on the cake. WGN uses this combination with every VTR. "I have complete control," says Rick Craig, Project Engineering Supervisor. "No matter what production brings in, we can handle it." WGN even makes their SAP selections via daughter boards.

Discover the power of the daughter board. The MTX-02 is just one of four audio controllers. Find out how the finest DA system can also be the most cost effective.

*Benchmark*  
...the measure of excellence™

Call **NOW** 800-BNCHMRK, in NY 315-452-0400

BENCHMARK MEDIA SYSTEMS INC.  
3817 Brewerton Rd. North Syracuse, NY 13212

Circle (128) on Reply Card

CDE CORNELL  
DUBILIER

### Mica Capacitors

LARGE

STOCK



VACUUM  
CAPACITORS

JENNINGS

SURCOM ASSOCIATES, INC.

305 Wisconsin Avenue  
Oceanside, California 92054  
(619) 722-6162

Circle (129) on Reply Card

pack transmitters and houses up to six EK 2012 VHF body pack receivers, with each receiver using both powering voltage and RF from a common dc power supply and antenna diplexer. Each of the audio outputs terminates with an XLR male connector and features an adjustable output-level potentiometer.

Circle (358) on Reply Card

### Audio studio system

*Solid State Logic* has introduced the G series master studio system. It is a fully integrated working environment. The system has increased power and features total recall, the Synchronizer Controller, master transport selector and events controller.



Circle (359) on Reply Card

### Software refinements and audio recorder

*Sony Professional Audio* has announced the following:

- Software enhancements for the MXP-3036 recording/mixing console include vacuum fluorescent light meters and a wild fader option. The meter offers four different ballistic types: VU, BBC, DIN and Nordic. It displays dc levels to represent the status of VCA faders, a peak hold display that ranges from off to infinity and an overload indicator. The Version 2.0 software has greater storage capacity and improves user-interface. Features include a rehearsal mode, improved file utilities and recall function and edit cue function. With the wild fader module, the user can increase the number of effects in a mix without the aid of the automation system.
- The DAL-1000 digital audio limiter, the DMU-30 digital remote meter and the PCM-3324 software enhancements. The limiter offers full 16-bit linear quantization. It also is capable of six programmable preset memories for parameter setup, operates at three sampling frequencies and uses a wired remote control. The meter features a 32-segment LED-type metering section. The software makes it possible to change crossfades within the range of 1.5ms to 370ms.
- The APR-5002W recorder has a headblock design to improve frequency response. Each head stack can have its own preset alignments. Three alignments per speed can be stored in non-volatile memory, allowing for nine stored alignments.
- Enhanced software for the APR-5000 recorder series includes add-on platforms, and software PROMS refine synchronization capabilities. A synchronization servo system provides a self-optimizing capability that heightens the recorder's performance in establishing sync and in chase operations. Time-code output features allow a time code to be simultaneously output to any other longitudinally corrected device without the need for subsequent offset adjustment.

# Winsted®

## space-saving tape or film MOVABLE STORAGE SYSTEMS

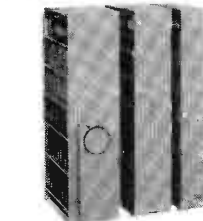

• HIGH CAPACITY SYSTEM

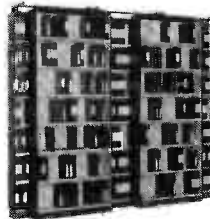

• SUPER DENSITY SYSTEM



• PULL-OUT SYSTEM

Organized, efficient storage for all types of film and videotape. Sliding cabinets move effortlessly on low-profile tracks for easy access and maximum storage capacity in limited space.

Available in a variety of designs and sizes, with 5" to 36" depths, to suit your special storage needs. All steel construction.

For Free Full-color FULL LINE CATALOG  
Write or call toll-free

## 800-447-2257

THE WINSTED CORPORATION

10901 Hampshire Ave. So. • Minneapolis, MN 55438

TELEX: 510-601-0887

FAX: 612-944-1546

Circle (132) on Reply Card

# MASTERKEY™



*Much more than  
a Linear Keyer!*

- Switchable between **LINEAR** and **FAST** key modes
- Smooth **SEAMLESS INLAY** of DVE's and Paint Boxes
- Preserves the clean edge of anti-aliased equipment
- Separates down to **5 IRE** anywhere in grey scale
- Variable **SOFT** key • **INVERT** key
- **CUT to KEY, MIX to KEY or A/B MIX**
- All user controls on remote panel
- Optional **AUTO MIX** via G.P.I.

THE ONLY WAY TO KEY

## broadcast video systems Ltd.

40 West Wilmot Street, Richmond Hill, Ontario L4B 1H8  
Telephone: (416) 764-1584 Telex: 06-964652

Circle (133) on Reply Card

**STOP**

## GROUND-LOOP HUM!

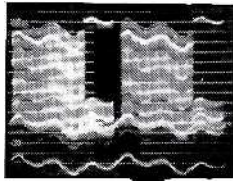

VIDEO HUM  
STOP COIL...HSC 1

Will ELIMINATE HUM and other INTERFERENCE in Video Lines caused by differences in Ground Potential.

- For Color and Black and White.
- FLAT-DC to 6.5MHz.
- No Low-Freq. or Hi-Freq. Roll-off.
- No Differential Phase Distortion.
- No Differential Gain Distortion.
- No Envelope Delay.
- Passive Device-Failure Free-Low Price.
- Small Compact Package 4"x4"x2 1/4".

ELIMINATES HUM  
AND INTERFERENCE:

IN STUDIO AND FIELD

- Between Buildings
- On Long Runs in Buildings
- Between Studio and Transmitter
- On Incoming and Outgoing Circuits
- Between Remote Truck and Microwave
- For Intertruck Hookup
- For VTR Units
- For Monitoring Lines

**\$190**

FREE 10 DAY TRIAL

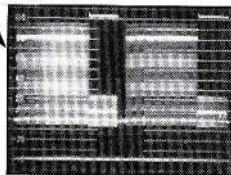

**AUDIO VIDEO ENGINEERING COMPANY**  
65 NANCY BLVD., MERRICK, N.Y. 11566  
(516) 546-4239

Circle (134) on Reply Card

Punch-in/out operations are enhanced through the refined bias/erase timing.

Circle (360) on Reply Card

### Multitrack recorder and audio event meter

*New England Digital* has introduced a stand-alone series of direct-to-disk digital multitrack audio recorders incorporating 100kHz, 16-bit digital audio recording fidelity and advanced editing software. The software provides automated editing features including individual track offsets, automatic punch-ins and multiple loops on every track. The software also provides a visual display of all track information on the terminal. With a mouse controller, the user can identify splice points with 10ms precision, instructing the computer to digitally crossfade from section to section. The original tracks are never altered, permitting the construction of dozens of different edits from the same material.

Circle (361) on Reply Card

### Multitrack recorders and cassette deck

*Studer Revox* has introduced the following products:

- The A820-8 1-inch 8-channel multitrack series can accommodate up to 14-inch reels. The A820 capstan system uses its own processor and software.
- The A807 VUK is a 3-speed microprocessor-controlled audio recorder. It features a separate meter overbridge configuration and roll-around tiltable floor console. It also features a die-cast chassis and headblock assembly. The audio electronics and transport functions are digitally controlled and the machine has parallel and serial control ports. Other additions include Dolby HX Pro, phase-compensated audio electronics and built-in phantom powering for microphones.
- The A721 professional cassette recorder features four motors, dual capstan, die-cast transport and headblock. The headblock and main transport castings join with a tri-point conical bearing system. Dolby B and C noise reduction are standard, as well as the Dolby HX headroom extension system.

Circle (362) on Reply Card

### Automated console and modular mixer

*Soundtracs plc* has introduced the following products:

- ERIC (ergonomic, resettable integrated console) is a 24-bus digitally routed mixing console. A 6800 based computer, integrated into the console, provides control over digital routing, muting, input selection, insert point activation and a 32-external-event controller.
- The FME modular mixer offers full modularity of inputs, outputs and groups, in 22- and 30-module mainframe sizes. The module types include mono input, mono input with remote start switch, stereo input including RIAA and line in with remote start, monitor input with eight monitor sends, group output with upper and lower monitor sections, monitor output and stereo master module. Metering is provided via 12 LED bar graphs. The mixer is freestanding. A 19-inch rack-mounted power-supply unit and dust cover are standard.

Circle (363) on Reply Card

### Stereo module

*Total Audio Concepts* has announced the S1200 stereo module for fitting to the Scorpion range of mixing consoles. It features two electronically balanced line inputs with an impedance of 10kΩ. Gain for both inputs is controlled from the same rotary pot, covering -10dB to +30dB. The module also features 3-band stereo equalization and two stereo auxiliary sends.

Circle (364) on Reply Card

||:~(=)))||

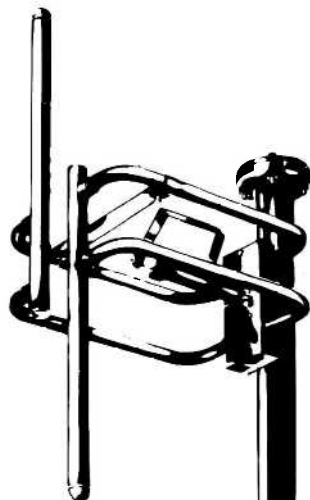

FM Antennas  
FCC Directionals • Multistations  
Rigid Transmission Line  
Pattern Studies  
Combiners

# Shively Labs

a division of Howell Laboratories, Inc.

36 Harrison Rd.  
Bridgton, ME 04009  
(207) 647-3327

TWX-710-223-8910 SHIVELY BRGT  
call or write for more information

Circle (135) on Reply Card

## KBS adopts Panasonic M-II video system

*Matsushita Electric*, Secaucus, NJ, will be delivering its M-II format broadcast-use 1/2-inch video systems to the Korean Broadcasting System (KBS), the national network of Korea, for broadcasting the 1988 Seoul Olympic Games.

The company will deliver 40 M-II-format studio VTRs (AU-650). They will be installed at the network's international broadcast center and used for the production and transmission of programs from Seoul during the Olympic Games.

Matsushita will have a technical support center in Seoul to support M-II system users before and during the Games. The company also plans to rent its M-II video systems to other broadcasting companies who come to Seoul to cover the Games.

The company is a worldwide Olympic sponsor of the 1988 Olympic Games—both the summer games in Seoul and the winter games in Calgary—and is providing a range of Panasonic products to the Olympic organizing committee.

## Andrew opens customer support center

*Andrew*, Orland Park, IL, has opened a customer support center to provide customers with rapid order entry and order follow-up information by means of a toll-free telephone number: 1-800-255-1479. The center also will provide a point of contact for rapid literature requests and price and delivery information on all standard products.

Business hours are 7:30 a.m. to 5:30 p.m., Central Time, Monday through Friday. After business hours, messages will be recorded and calls returned when the center reopens.

## Barco signs contract with Thomson Video Equipment

*Barco-Industries*, Los Gatos, CA, and Thomson Video Equipment, Christopher, France, ratified a contract stipulating cooperation in the development and marketing of a digital parallel and serial interface for Barco microprocessor-controlled CVS monitors. The monitors will be used to visualize pictures from Thomson Video's digital production switcher and mixer, but also can interface with other digital equipment (4:2:2 CCIR 601).

## ColorGraphics and New England Technology Group merge

*ColorGraphics Systems*, Madison, WI, and New England Technology Group (NETG), have announced a merger agreement whereby NETG will become part of ColorGraphics, but will maintain its corporate identity in the videodisc market. The merger will help the two companies broaden their markets with products that will offer both video and film output for the production of high-quality presentation graphics.

## COMSAT celebrates TV service at New York Teleport

*COMSAT International Communications*, Washington, DC, has announced the inauguration of international TV services via a 13-meter earth station at the teleport on Staten Island, New York.

COMSAT provides full-time international TV reception services from the United Kingdom to the United States for ABC News Intercontinental and CBS. A regional fiber-optic network links CICI's earth station with these broadcasters' studios in New York City and CICI's Technical Operations Center in lower Manhattan. This month, the European Broadcasting Union begins full-time transmission service to Europe.

[ :-(-) ]]

# Perfect Timing

## MASTER CLOCK SYSTEMS

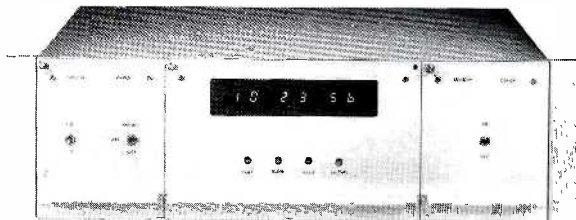

## MASTER CLOCK SYSTEMS

If seeing the same time on all your clocks is important, select **ES 192E-Line** frequency timebase, for only \$376.

If a guaranteed accuracy of three seconds per month is what you want, choose **ES 160**—\$1250.

How about one second per month? **ES 160/1**—\$1450.

Or National Bureau of Standards accuracy! **ES 199** is synchronized to Radio Station WWV to provide a Master with unquestioned accuracy. \$1687 with receiver and antenna.

**ESE Master Clock Systems are simple to install. All Masters have a Serial Time Code output, able to drive twenty slave displays without buffering. Slaves range in size from .4" LED to 2" LED displays, priced from \$183 to \$520.**

**IF YOU ALREADY HAVE A SYSTEM AND WANT TO EXPAND IT**, get the **ES 167B** Serial Time Code Generator (\$169), then add any number of our low cost slaves.

Many, many options and accessories are available. Ask us about them. Our brochure tells the whole story, but not for long. We keep adding new products.



Write, Wire or Call: (213) 322-2136  
142 SIERRA STREET • EL SEGUNDO, CALIFORNIA 90245

Circle (136) on Reply Card

# Live Assist and more!

CABS delivers an integrated Computer Aided Broadcasting System from Library Maintenance to Analysis of Aired Events.

- Music and commercial library management
- Sophisticated programming and scheduling criteria
- Live assist with full control of audio peripherals



- Announcer information, live tags and schedule enquiry
- Analysis of formats, aired events and their relationship to station ratings.

## DKW SYSTEMS INC.

#730, 9919-105 Street  
Edmonton, Alberta Canada T5K 1B1  
(403) 426-1551

SMALL WONDER - WE WORK 24 HOURS EVERY DAY WITHOUT A BREAK!

Circle (137) on Reply Card

## DIAL ACCESS CONTROL

Use any touch phone and ordinary dial-up lines to operate up to eight separate remote site functions and also check the states of up to eight external inputs. Audible telemetry acknowledges commands and indicates the on/off condition of each external input.



- Rack and wall mount versions
- Four selectable modes
  1. Latched
  2. Momentary
  3. 1 of 4 exclusive OR latched
  4. 1 of 8 exclusive OR latched
- User programmable access code
- Master reset function
- Eight form C relay outputs
- Eight ext. sense inputs
- Auto answer on 1-8 ring
- LED status indicators
- + 12 VDC powered

**\$449**

Inquire about Simplex, Half Duplex and Full Duplex phone patches and other DTMF controller products.



**CONNECT SYSTEMS INC.**

23731 Madison St., Torrance, CA 90505 (213) 373-6803

Circle (138) on Reply Card

## News

Continued from page 4

smaller ones, however, don't always follow schedules. The operators of the transmitter serving the small town of Alella have a novel way of announcing that they are on the air—a rocket is sent up from the town square.

## Crackdown on unauthorized transmitters

Spain has begun a crackdown on unauthorized FM broadcast transmitters. Although no reliable statistics are available, a new, highly computerized \$3 million monitoring station, which opened recently near Madrid, detected 541 of these transmitters even before its official opening. A number of unauthorized low-power TV transmitters also are known to be in operation. Spain has 246 medium-wave and 606 licensed FM broadcast transmitters.

Offenders range from ordinary pirate transmitters to so-called *radios libres*, which are free radios, unencumbered by any restrictions and, in many cases, stations operated by the municipalities themselves.

Two factors add urgency to the crackdown. First, the Geneva plan for FM frequency allocations entered into force this past July, and transmissions in all countries must be brought into compliance. This will not be an easy task. Second, a bill establishing a Law for the Organization of Telecommunications (LOT) is pending before the Spanish Cortes, and is expected to be voted into law this month.

In the meantime, proceedings have been brought against 70 of the offenders, and more are planned, thanks to the stepped-up monitoring program. Disciplinary action can range from taking the illegal transmitters off the air to fining.

[:(=)]

## STATION to STATION

with the  
**Wireless & Intercom SPECIALISTS**

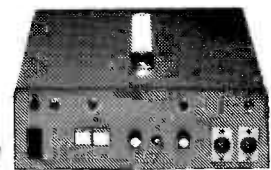

**Clear-Com**  
Intercom Systems

BEYER  
CLEAR-COM  
HME  
RTS  
SAMSON  
SENNHEISER  
SONY  
TELEX  
VEGA



Toll Free 50 States  
**800-356-5844**

**TELEX**

**FULL COMPASS SYSTEMS**

Wisconsin: 800-362-5445  
Consultation: 608-271-1100  
Fax: 608-273-6336

6729 Seybold Road • Madison • WI 53719-1393

Circle (87) on Reply Card



**O**tari's compact EC-201 SMPTE/EBU time-code reader is a natural for field or studio operation, and it costs only \$495. It offers 1/20 to 60X playspeed reading, 40 hour continuous use on battery power, and re-shaping circuitry on the loop output.

This advanced reader features a full hexadecimal user bits display (with a hold-button for edit logging), a -10 to +10 dBV input range, balanced XLR inputs/outputs, and includes an AC adapter, belt clip and batteries. It measures 1.5" x 4.2" x 5" and weighs 18 oz.

Contact Otari at (415) 592-8311 for your nearest dealer. From Otari: Technology You Can Trust. Otari Corporation, 2 Davis Drive, Belmont, CA 94002.

**OTARI**

**TIME OUT!**

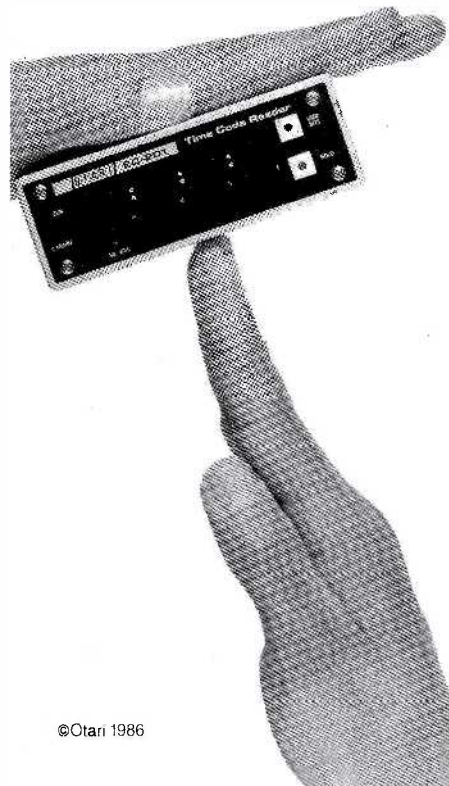

©Otari 1986

Circle (139) on Reply Card

# Professional services

## Buying Service For Broadcasters

Our Buying Power Will Save Your Company Significant Dollars  
22 Years Broadcast Equipment Purchasing Expertise  
(212) 541-6611

### BUYGROUP LIMITED

1775 Broadway, NY, NY 10017

## Engineering Consultant

- Video Systems Design
- Computer Graphics
- Automation
- Editing
- Production

Gene De Santis  
181 Long Hill Rd.  
Little Falls, NJ 07424  
201-266-8141

## Run your business card here.

Only \$65 per insertion.  
Frequency discounts available.  
Call (913) 888-4664.

## BROADCASTING CONSULTANTS AND ENGINEERS

- FCC Applications and Field Engineering
- Frequency Searches and Coordination
- Tower Erection and Maintenance
- Facility Design and Construction

### Contact:

KENNETH W. HOEHN  
23400 Michigan Avenue  
Dearborn, MI 48124

**Teletech, Inc.**  
COMMUNICATIONS CONSULTANTS & ENGINEERS  
(313) 562-6873

# Classified

Advertising rates in Classified Section are \$1.50 per word, each insertion, and must be accompanied by payment to insure publication.

Each initial or abbreviation counts a full word. Minimum classified charge, \$35.00.

For ads on which replies are sent to us for forwarding (blind ads), there is an additional charge of \$40.00 per insertion, to cover department number, processing of replies, and mailing costs.

Classified columns are not open to advertising of any products regularly produced by manufacturers unless used and no longer owned by the manufacturer or distributor.

**SONY BVH500A** one inch recorder, HT500A chroma stabilizer, AC power supply, four BP90 batteries and Anvil shockproof shipping case. All equipment in mint condition. Will entertain realistic offer. 212-982-1277. 12-87-1t

**RCA TTU 110C UHF TRANSMITTER**—tuned to Channel 23 in excellent condition. Available April 1988. Out of service due to channel change. Complete with efficiency options. 5 years old. Call Chief Engineer at (304) 757-8823. 12-87-2t

**RCA TFU 28DAS**—Peanut pattern antenna tuned to Channel 23. Excellent condition. Out of service due to channel change. Will produce 5000KW with 110KW Transmitter. Call Chief Engineer at (304) 757-8823. 12-87-2t

## TRAINING

**ELECTRONICS DEGREE** by correspondence. Earn Associate, then Bachelor's. NHSC accredited. Free catalog. Write Grantham College of Engineering, Dept. EE-5, 10570 Humbolt St., Los Alamitos, CA 90720. 8-82-tfn

**FCC GENERAL RADIOTELEPHONE operators** license through cassette recorded lessons at home plus one week seminar in Boston, Washington, Detroit or Philadelphia. Our twentieth year teaching FCC license courses. Bob Johnson Radio License Preparation, 1201 Ninth, Manhattan Beach, Calif. 90266, Telephone (213) 379-4461. 8-81-tfn

## SERVICES

**ONE STOP FOR ALL YOUR PROFESSIONAL AUDIO REQUIREMENTS.** Bottom line oriented. F.T.C. Brewer Company, P.O. Box 8057, Pensacola, Florida 32506. 7-71-tf

**TRANSMITTER TUBE REBUILDING SINCE 1941:** 3CX2500, 4CX5000, 4CX15000 and many others. Write for details. FREELAND PRODUCTS INC., Rt. 7, Box 628, Covington, LA 70433. (504) 893-1243 or (800) 624-7626. 6-79-tfn

## FOR SALE

**COPPER!**#8 & #10 ground radials; 2, 3, 4, 6, 8" strap; flyscreen; ground screen. 317-962-8596. Ask for copper sales. 11-87-6t

**MA/COM 23GHZ**—two complete single channel MA/COM 23VFM Video Microwave Systems—tuned to 21825MHZ and 21925MHZ. Call Today 312/869-8001. 12-87-1t

**FARINON MICROWAVE**—two complete single channel point to point 10 watt Video Microwave systems covering 2450-2500MHZ, both with fully synthesized ENG Receivers and 8 foot Anixter Grid antennas. Call Today 312/869-8001. 12-87-1t

**THREE (3) RCA TK45 Camera Chains** with Schneider TV 10 (12-1) lenses, 1000 ft. cable. Excellent condition. Can be seen in operation at WTAE-TV Studios until December 31, 1987. CONTACT: MARTY FAUBELL, WTAE-TV, 400 Ardmore Boulevard, Pittsburgh, PA 15521. PHONE 412-244-4517. 12-87-1t

**MUST LIQUIDATE!** Complete A/B roll system, (2) Sony VO-5850s, BVU 820 w/dyn trac, Crosspoint 6139 SEG, Convergence ECS-103 w/time code, Microtime TBCs Tek test instruments. Much more! Also portable production system Sony 5850 & 5800 RM-440, Microtime T-100 TBC, Crosspoint 6112 SEG, Tek test instruments, 3 Hitachi FP-22 cams w/CCU and more. All in attractive Anvil cases. Audio Equipment: Adam Smith synchronizer, Tascam, 16 track recorder, 8 track, MICs and much more. Call now! STS Electronics, (305) 979-1939. 12-87-1t

Want more information on advertised products?  
Use the Reader Service Card.

## WANTED TO BUY

**HIGHEST PRICES** for 112 Phase Monitors, vacuum capacitors and clean, one kw or greater powered AM and FM Transmitters. All duty and transportation paid. Surplus Equipment Sales, 2 Throncliffe Park Dr., Unit 28, Toronto, Canada M4H 1H2, 416-421-5631. 3-86-tfn

**WANTED:** WW-II German and Japanese radio equipment. Unused US Navy and Signal Corps radio equipment before 1943. Pre-1923 radio equipment and tubes. August J. Link, Surcom Associates Inc., 305 Wisconsin Ave., Oceanside, CA 92054, (619) 722-6162. 7-86-tf



## WE PLACE ENGINEERS

ALL CATEGORIES FOR TV, PRODUCTION,  
VIDEO, CATV (EXCLUDING OPERATORS)

America's Leading Source for a Decade  
ITV STATIONS, PRODUCTION FACILITIES, CORP. TV, MFG., CATV  
For information phone or write Mark Kornish



### KEY SYSTEMS

479 Northampton Street  
Kingston, PA 18704

Employer  
Paid Fees

(717) 283-1041

## HELP WANTED

**CHIEF ENGINEER** needed for Miami Christian UHF Station. Strong on transmitters. Contact Ben Miller, Vice President, Engineering, Trinity Broadcasting Network, 714-665-2145. E.O.E. 11-87-4t

**VIDEO SYSTEM INSTALLATION SUPERVISOR.** Major New York-Metro Area full service video system engineering company is seeking a candidate for supervising system installations. Knowledge of and experience in: standard wiring practices, mechanical assembly, employee supervision, and client-vendor relations is necessary. Experience in video and audio equipment type and application a plus. Grow with a small but expanding company, we're working at the leading edge of television technology. Salary commensurate with experience. Forward resume to Broadcast Engineering, P.O. Box 12901, Dept. 688, Overland Park, KS 66212. 12-87-1t

**ITFS TECHNICIAN II:** Applicant must have strong background in broadcast equipment repair down to component level. Possess a valid General Radiotelephone operator license. Major responsibilities include maintenance and repair of all types of industrial broadcast equipment. Experience in repair of Apple Computer System desirable. \$25,284-30,732 yearly. Anaheim City School District, 890 South Olive, Anaheim, California 92805, (714) 535-6001 Ext. 250. 12-87-1t

**ASSOCIATE DIRECTOR, A/V SYSTEMS, PBS.** PBS seeks an engineer to plan/design new installations and updates of our complex technical plant. Candidate will be responsible for assessing the equipment and facilities in our plant against the requirements of the PTV system and other users of our facilities. If you have 3-5 years experience in television plant design, (prior experience as a chief or assistant chief engineer in design construction of state-of-the-art television plant facilities a plus) and the ability to conceive and design television electronic systems, respond with letter of interest, resume and salary requirements to: PBS, ATTN: Carla A. Gibson, 1320 Braddock Place, Alexandria, VA 22314. 12-87-1t

**NEEDED:** entry level broadcast maintenance engineer. Must have knowledge of basic electronics. Opportunity to learn studio and transmitter maintenance. Send resume to: J.R. Middleton, Drawer D, Hardin, MT 59034. 12-87-1t

**MAINTENANCE ENGINEER:** for NBC affiliate. Need technician with experience in RCA VHF transmitters, Ampex Quads, VPR-2's, and Sony ENG equipment. Send resume, references and salary history to: KJAC, P.O. Box 3257, Port Arthur, TX 77643. Attention: Chief Engineer. EOE. 12-87-2t

**ENGINEER NEEDED** leading Mid-Atlantic Production/Post Production Facility. Need qualified engineer with experience on: Ampex 2BS, VPR6 ADO, CMX 340x, Chyron, Grass Valley, Ikegami, Betacam, Paint Box, Dubner, E-Flex. Salary negotiable, based on experience. Resume to: Spicer Productions, 1708 Whitehead Road, Baltimore, Maryland 21207. 12-87-1t

**KRIV-TV. FOX TELEVISION** is seeking a qualified maintenance engineer. Requirements include a minimum of 5 years television maintenance experience. Applicant will be responsible for the set-up and maintenance of all technical equipment associated with station. Primary area of responsibility are 1 inch video-tape maintenance and as an alternate to our primary transmitter engineer. Must have held FCC license or be SBE certified. Must have background in both digital and analog electronics. qualified applicants send resume to KRIV-TV, P.O. Box 22810, Houston, Texas 77227 ATTN: Engineering Dept. No phone calls. E.O.E. 12-87-1t

**CHIEF ENGINEER:** Texas Group is seeking experienced individual to oversee its technical operations. Must have take charge approach with excellent organizational skills and ability to communicate effectively. Good compensation and benefits. Send resume, references, and salary history to Broadcast Engineering, Dept. 689, P.O. Box 12901, Overland Park, KS 66212. EOE. 12-87-1t

**WORLD WRESTLING FEDERATION** needs for its soon to be completed major post production/syndication facility in Stamford, CT.

**MAINT. ENG. —** Must be fully familiar with Grass Valley 300-Switcher, Sony 1" VTR, studio cameras. Must have design capability and be able to grow with the facility.

**SR. V.T. EDITOR —** At least 5 years experience in creative editing of weekly syndicated programming.

Send resume & salary requirements to:

Director of Personnel  
Titan Sports, Inc.  
P.O. Box 3857  
Stamford, CT 06905



## Put Your Future In Your Hands

BTS (A joint Company of Bosch and Philips) announces the beginning of a visual Arts Training Institute. The Institute will offer courses using the BTS animation and paint system. In addition, you will utilize other Bosch equipment including cameras, Film-to-Tape Transfer equipment, editors and production switchers. Classes are limited and fill up very fast. Now is your chance to open the door to your career in computer graphics!

For more information, call today (801) 972-8000, or write us at P.O. Box 31816, Salt Lake City, Utah 84131.

# BTS

## SR. MAINTENANCE ENGINEER

One of the nation's largest video facilities seeks experienced individual to repair and maintain all broadcast and audio equipment, order and maintain inventory of equipment parts, assist in planning and design of system expansion. Min. 3-5 years broadcast or related experience. Actual working experience on 1" VTR's. Send resume with salary requirements to:

**HUMAN RESOURCES (SME)**  
P.O. Box 2520  
Newbury Park, CA. 91320-8520

Equal Oppty. Employer

## Advertising sales offices

### CHICAGO, ILLINOIS

Tom Nilsen  
Telephone: (312) 435-2361  
Telefax: (312) 922-1408  
55 East Jackson  
Ste. 1100  
Chicago, IL 60604

### NEW YORK, NEW YORK

Diane Gottlieb-Klusner  
Telephone: (212) 702-3404  
Telefax: (212) 702-7802  
Josh Gordon  
Telephone: (212) 702-3405  
Telefax: (212) 702-7802  
866 Third Ave.  
New York, NY 10022

### SANTA MONICA, CALIFORNIA

Herbert A. Schiff  
Telephone: (213) 393-9285  
Telefax: 213/393-2381  
Jason Perlman  
Telephone: (213) 458-9987  
Telefax: 213/393-2381  
Chris Woodbury-Leonard  
Telephone: (213) 451-8695  
Telefax: 213/393-2381  
Schiff & Associates  
501 Santa Monica Blvd., Ste. 504  
Santa Monica, CA 90401

### NORWOOD, AUSTRALIA

Hastwell, Williamson, Rouse Pty. Ltd.  
P.O. Box 419  
Norwood 5067, Australia  
Telephone: 332-3322  
Telex: AA87113

### LONDON, ENGLAND

Nicholas McGeachin  
Intertec Publishing Corp.  
Roseleigh House  
New Street  
Deddington  
Oxford OX5 4SP  
England  
Telephone: (0869) 38794  
Telefax: (0869) 38040  
Telex: 837469 BES G

### TOKYO, JAPAN

Haruki Hirayama  
EMS, Inc.  
Sagami Bldg., 4-2-21, Shinjuku  
Shinjuku-ku, Tokyo 160, Japan  
Telephone: (03) 350-5666  
Cable: EMSINCPERIOD  
Telex: 2322520 EMSINCJ

Want To Talk  
Broadcasting?  
GO **BPFORUM**  
ON COMPUSERVE

John Hoffman  
Net Administrator  
76703, 1036

# Ad index

	Page Number	Reader Service Number	Advertiser Hotline		Page Number	Reader Service Number	Advertiser Hotline
A.F. Associates, Inc.	69	121	213/466-5066	K&H Products Ltd.	146	131	802/442-8171
Abekas Video Systems	79	50	415/571-1711	Leader Instruments Corp.	5	5,6	800/645-5104
ADM Technology, Inc.	IFC	1	313/524-2100	Leitch Video of America, Inc.	87	56	804/424-7290
Adrienne Electronics Corp.	142	142	800/782-2321	Lemo USA Inc.	99-100		707/578-8811
Alpha Audio	110	75	804/358-3852	Lexicon Inc.	30	17	617/891-6790
Alpha Wire Corp.	29	16	800/52 ALPHA	M/A-COM Mac. Inc.	111	77	617/272-3100
Alta Group Inc.	118	83	408/297-2582	Magna-Tech Electronics Co., Inc.	75	49	212/586-7240
Amek Systems and Controls Ltd.	67	41		McCurdy Radio Industries	96	65	416/751-6262
Amber Electro Design Inc.	135	146	514/735-4105	Microdyne Corp.	39	23	904/687-4633
Ampex Corp. (AVSD)	41	24	415/367-2911	Midwest Communications Corp.	1	3	800/543-1584
Ampex Corp. (MTD)	43	91	415/367-2911	Modular Audio Products	97-98		516/567-9620
Arrakis Systems, Inc.	21	13	303/224-2248	NEC Corp.	103	69	800/323-6656
Audio Accessories	102	68	603/446-3335	Nova Systems, Inc.	77	48	203/693-0238
Audio Precision	83	52	800/231-7350	O'Connor Engineering	142	63	714/979-3993
Audio-Technica U.S., Inc.	60-61	150	215/443-0330	Opamp Labs Inc.	140	97	213/934-3566
Audio-Video Engineering Co.	150	134	516/546-4239	Orban Associates Inc.	17	11	800/227-4498
Barco Industries Inc.	55	33	408/370-3721	Orban Associates Inc.	7	7	800/227-4498
Barcus-Berry Electronics	114	79	800/233-8346	Otari Corp.	154	139	415/592-8311
Benchmark Media Systems	148	128	315/452-0400	Otari Corp.	15	10	415/592-8311
Beyer Dynamic Inc.	95	64	516/935-8000	Paco Electronics	36	21	213/747-6540
Boonton Electronics Corp.	58	36	201/584-1077	Paltex Inc.	116	81	714/838-8833
Broadcast Electronics Inc.	129	66	217/224-9600	Panasonic Broadcast Systems Co.	144-145	130	201/348-7336
Broadcast Video Systems Ltd.	149	133	416/764-1584	Panasonic Industrial Div.	49	29	201/348-7620
BTS Broadcast Television Systems (US)			801/972-8000	Panasonic Industrial Div.	108-109	74	201/348-7620
Camera Mart, Inc.	70	90	212/757-6977	Panasonic Industrial Div.	50-51	30	201/348-7620
Centro Corp.	89	58	619/560-1578	Pesa Electronica S.A.	131	95	800/872-7372
Cetec Vega	119	84	818/442-0782	Potomac Instruments	52	31	301/589-2662
Cipher Digital, Inc.	65	140	301/695-0200	QEI	137	123	800/334-9154
Circuit Research Labs, Inc.	13	9	800/535-7648	Quanta Corp.	117	82	801/974-0992
Clear-Com Intercom Systems	110	85	415/861-6666	Quantel Ltd.	115	80	415/856-6226
Comrex Corp.	106	72	617/443-8811	R.E. Instruments	56	34	216/871-7617
Conex Electro Systems	120	86	206/734-4323	Rank Cintel	139	124	312/297-7720
Connect Systems Inc.	152	138	213/373-6803	Roscor Corp.	113	78	312/539-7700
Control Concepts	46	39	607/724-2484	Richardson Electronics Ltd.	123	25	800/323-1770
Datatek, Inc.	63	46	201/654-8100	ROH	70	89	800/262-4671
Delta Electronics	57	35	703/354-3350	Roscor Corp.	113	78	312/539-7700
Di-Tech Inc. IBC	2	2	516/667-6300	RTS Systems, Inc.	42	28	818/843-7022
DKW Systems Inc.	152	137	403/426-1551	Shively Labs	150	135	207/747-3327
Dynatech Data Systems	97-98		800/368-2210	Shure Brothers Inc.	11	8	312/866-2553
EEV, Inc.	105	71	914/592-6050	Shure Brothers Inc.	122	45	312/866-2553
Eastman Kodak Co.	47	27	212/930-7500	Skotel Corp.	147	127	514/465-8990
ESE	151	136	914/592-6050	Solid State Logic Ltd.	133	122	212/315-1111
Full Compass Systems	152	87	800/356-5844	Sony Corp. of America (AV Pro Video)	121	88	800/662-SONY
GE Americom Video & Audio Services	72-73	141	609/987-4073	Sony Corp. of America (Broadcast)	24-25	14	800/662-SONY
GE Americom Video & Audio Services	71		609/987-4073	Sony Mag. Tape Div.	53	32	800/662-SONY
GE Commercial Indust'l. Light	124-125	93		Standard Tape Laboratory, Inc.	140	98	415/786-3546
General Devices Co., Inc.	97-98		317/897-7009	Stanton Magnetics	91	61	212/445-0063
Gentner	85	54	801/268-1117	Stantrom/Unit of Zero Corp.	68-42	43	800/821-0019
Graham-Patten Systems Inc.	101	94	800/547-2489	Studer Revox America Inc.	37	22	615/254-5651
Grass Valley Group, Inc.	9	200-203	916/273-8421	Studer Revox America Inc.	104	70	615/254-5651
Grass Valley Group, Inc.	140	125	916/273-8421	Surcom Associates Inc.	148	129	619/722-6162
Gretag AG, Regensdorf	127	92		TASCAM Div. TEAC Corp. of America	86	55	213/726-0303
Hitachi Denshi America Ltd.	3	4	800/645-7510	TASCAM Div. TEAC Corp. of America	84	53	213/726-0303
Hubbard Communications, Inc.	107	73	813/577-7759	TASCAM Div. TEAC Corp. of America	90	59	213/726-0303
Intergroup Video Systems, Inc.	143	126	800/874-7590	TASCAM Div. TEAC Corp. of America	88	57	213/726-0303
JamPro Antennas Inc.	48	120	916/383-1177	Telex Communications, Inc.	132	96	612/887-5550
Jensen Transformers Inc.	142	144	213/876-0059	Tentel	142	143	800/538-6894
JVC Company of America	19	12	800/582-5825	TFT, Inc.	45	26	408/727-7272
JVC Company of America	34-35	20	800/582-5825	Thermodyne International Ltd.	92	62	213/603-1976
				Thomson-CSF/DTE	93	38	
				Total Spectrum Manufacturing, Inc.	31	18	914/358-8820
				Trompeter Electronics, Inc.	99-100	107	818/707-2020
				Utah Scientific Inc.	27	15	800/453-8782
				Varian	33	19	415/592-1221
				Videotek, Inc.	102	67	602/997-7523
				Ward-Beck Systems Ltd.	BC		416/438-6550
				Winsted Corp.	146	145	800/328-2962
				Winsted Corp.	149	132	800/328-2962
				Yamaha International Corp.	80-81	51	

# YOU NAME IT.

di-tech inc.  
Model 9001

CRT System Controller V2.0  
Mode: X-Y Matrix Status

Dev	Vid	Aud1	Aud2	AUX	Dev	Vid	Aud1	Aud2	AUX
NETW	NETW			SMPT	TBC3	BVU2	BVU2	BVU2	BVU2
VTR2	FLM1	FLM1			PREV	TBC2	TBC2	TBC2	TBC2
VTR3	FLM2	FLM2			PROG				
VTR4	FLM3	FLM3	FLM3	FLM3		VTR3	VTR3	VTR3	VTR3
VTR5	VTR1	VTR1	VTR1	VTR1	GM	LIVE	LIVE	LIVE	LIVE
VTR2	VTR2	VTR2	VTR2	VTR2	CONF	NETU	NETU	NETU	NETU
VTR7	BLCK	BLCK		SMPT	SHOP	TEST	TEST	TEST	TEST
BVU1	VTR4	VTR4	VTR4	VTR4	NEW1	LIVE	LIVE	LIVE	LIVE
BVU2	VTR5	VTR5	VTR5	VTR5	NEW2	LIVE	VD 1	SMPT	
	VTR6	VTR6	VTR6	VTR6	NEWS	SAT2	SAT2	SAT2	SAT2
BVU4	VTR3	VTR3	VTR3	VTR3	KEY1	CAM3			
BVU5	SAT2	SAT2	SAT2	SAT2	KEY2	NEWS	NEWS	NEWS	NEWS
	BVU2	BVU2	BVU2	BVU2	D032	STD1	STD1	STD1	STD1
ENG1	BVU3	BVU3	BVU3	BVU3	D033				
ENG2					D034				
ENG3	BVU5	BVU5	BVU5	BVU5	D035				
ADD1	CAM4				D036				
ADD2	BVU6	BVU6	BVU6	BVU6	D037				
TBC1	BVU1	BVU1	BVU1	BVU1	D038				
TBC2	BVU4	BVU4	BVU4	BVU4	D039				

di-tech inc.  
Model 9001

CRT System Controller V2.0  
Mode: Edit Grp/SET Names

Set 1	Set 2	Set 3	Set 4	Set 5
Grp Name	Grp Name	Grp Name	Grp Name	Grp Name
00= ENG	00=	00=	00=	00=
01= VTR	01= LIVE	01= VTR	01=	01=
02= BVU	02= NEW2	02= BVU	02=	02=
03= FLM	03=	03= CAM	03=	03=
04= NETU	04= NETU	04= KEY	04=	04=
05= TBC	05= TBC	05= TBC	05=	05=
06=	06=	06= ADD	06=	06=
07=	07=	07=	07=	07=
08=	08= SAT	08=	08=	08=
09=	09=	09=	09=	09=
10=	10= SFX0	10=	10=	10=
11=	11= SMPT	11= SMPT	11=	11=
12= BLCK	12= BLCK	12= BLCK	12=	12=
13= BARS	13= BARS	13= BARS	13=	13=
14=	14= TEST	14= TEST	14=	14=
15=	15=	15=	15=	15=

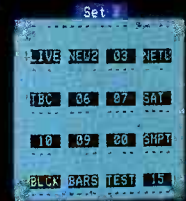

## With the Model 9001 you can create up to 80 alpha numeric labels for simplified studio operation.

When it comes to using a routing switcher matrix, most engineers agree that names make more sense than numbers. But 16 labels just may not be enough to describe the various departments and types of equipment found inside today's broadcast facility. That's why the Di-Tech Model 9001 Serial Controller permits as many as 80 *user-defined* names to be in use simultaneously!

Complementing this flexible naming system is a powerful set of configuration "tools" to make the best possible use of each and every control panel. All

major operating modes can be accessed by a single keystroke. Crisp, color screen displays provide key status information in an easy-to-understand manner. Among the many other features of the Model 9001 are switcher diagnostic routines, 4 level control, salvo operation, and one of the most important... the 5 year warranty... backed by the Di-Tech name.

For more information and a demonstration, call or write us today.



## MODEL 9001 COLOR CRT SYSTEM CONTROLLER



**di-tech inc.**

48 Jeffryn Boulevard, Deer Park, New York 11729  
Telephone (516) 667-6300, Telex No. 971806

Circle (2) on Reply Card



## Nobody does it better!

Ward-Beck's all-new D8212 Audio Distribution System is totally transparent! Absolutely nothing else on the market today can compare for precision, performance, packaging or price!

Check these features:

- Twelve high-performance modular DAs each with 8 outputs.
- Dual switch-mode power supplies.
  - 3 1/2" rack mounting frame.
- Unique hinged/quick-release front panel.
  - Gold-plated terminals throughout.
  - Integral typewriter designation strip.
- Unmatched overall performance specifications.
- Renowned Ward-Beck Reliability and Quality.
  - Priced right.



First by Design.

### The Ward-Beck D8212 System – An Investment in Quality!



Ward-Beck Systems Ltd., 841 Progress Avenue, Scarborough, Ontario, Canada M1H 2X4. Tel: (416)438-6550 Tlx: 065-25399.