

BROADCAST engineering

AN INTERTEC PUBLICATION

August 1990/\$4.50

Video
technology
update

DAI in the professional
environment
p. 50



When you need extra hands mixing audio, Shure's AMS can help.

Until recently, you needed outstanding hand-ear-eye coordination to mix audio in multiple-microphone broadcast situations.

Now there's a system that gives you broadcast-quality audio when you can't cover all the faders at once. It's the Shure Automatic Microphone System (AMS), featuring patented direction-sensitive gating.

The Shure AMS continuously compares audio signal levels from two matched unidirectional condenser microphone cartridges located back-to-back in each AMS microphone. The rear-facing cartridge monitors ambient sound, while the front-facing cartridge handles sound from the desired source. When the front cartridge output exceeds the rear cartridge output by 9 dB, the AMS mic channel gates on automatically in .004 seconds.

Because of this unique gating concept, an AMS microphone channel will *only* gate on

when addressed from within a 120-degree "window of acceptance" centered at the front of the microphone. AMS mics *not* addressed from within this angle remain off. So the number of open microphones is kept to a minimum automatically, with no need for manual control.

Since the Shure AMS automatically keeps track of the number of open microphones and adjusts the overall gain to compensate, your broadcast level stays constant as mics open and close, without troublesome gain-riding.

Direction-sensitive gating makes the



Shure AMS the best system to use in multiple-mic situations, from panel talk shows to game shows to hearings on Capitol Hill. More and more broadcast engineers are discovering the advantages of having broadcast-quality multiple-microphone



audio without the headaches of manual mixing or the time-consuming setup of so-called automatic mixers.

With AMS you not only get all the advantages of a truly automatic microphone system, you also get the broadcast-quality audio and reliability of Shure microphones.

For a comprehensive AMS literature packet, call us at 1-800-257-4873. For AMS technical support, call Michael Pettersen at 1-708-866-2512.

SHURE®

The Sound of the Professionals®...Worldwide.

Circle (1) on Reply Card

www.americanradiohistory.com

The Vertex 2.6 DMK Ku Band Uplink Antenna – The Heart of the S-23 RF System

And one of the reasons there are over 30 Midwest S-23's in service today. In the U.S., Italy and Japan.

Over the past year, the Vertex 2.6m DMK outsold all comparable antennas in its class. The reason?

No prime focus antenna can perform as efficiently as the Vertex 2.6m DMK, due to its offset Gregorian feed system. The sub-reflector offers more complete illumination of the main reflector, and the offset configuration insures that the antenna meets the FCC 2° spacing curves, while providing a nominal transmit gain of 50.1 dB. Including 4 port diplexer. Cross polar isolation performance exceeds 35 dB.

Unlike most other mobile antennas, the Vertex 2.6 DMK is built to withstand many years of rugged service. A 25" diameter azimuth ring bearing insures stable mounting of the antenna while large DC drive motors provide all the power necessary to point the antenna even during high wind conditions.

If you're considering a mobile satellite system, compare the actual performance measurements of the Vertex 2.6 DMK to any other antenna in its class. Ask the space segment providers which antenna outperforms all others.

Then you'll know the reasons there are so many Midwest S-23's on the road today. **Contact us for complete specifications and information.**

See us at RTNDA #1126

Partial List Of Midwest S-23's Currently In Service:

Cycle Satellite (2 units) Forest City, IA	KTTV-TV Fox Broadcasting Los Angeles, CA	Telemundo Miami, FL	WHAS-TV Louisville, KY	Sugarman Productions New York, NY
J/C SAT Tokyo, Japan	KTVY-TV Oklahoma City, OK	Telespazio (2 units) Rome, Italy	STS Hauppauge, NY	WBRC-TV Great American Television & Radio Birmingham, AL
EDD Tokyo, Japan	KWCH-TV Wichita, KS	Trinity Broadcasting Santa Anna, CA	WKRC-TV Great American Television & Radio Cincinnati, OH	WBIR-TV Multimedia Broadcasting Knoxville, TN
EGW-TV King Broadcasting Portland, OR	Northstar Microwave Redmond, WA	University of Florida Gainesville, FL	WSPA-TV Spartan Radiocasting Company Spartanburg, SC	
KOMO-TV Fisher Broadcasting Seattle, WA	RAI (2 units) Rome, Italy	WBNS-TV Dispatch Printing Columbus, OH	WTKR-TV Knight-Ridder Broadcasting Norfolk, VA	
WTVJ-TV NBC Miami, FL	Rainbow Network Communications (2 units) Floral Park, NY	WEWS-TV Scripps-Howard Broadcasting Cleveland, OH		



One Sperti Drive
Edgewood, KY 41017
(606) 331-8990

Circle (3) on Reply Card

Contents

August 1990 • Volume 32 • Number 8

BROADCAST ENGINEERING



Page 26

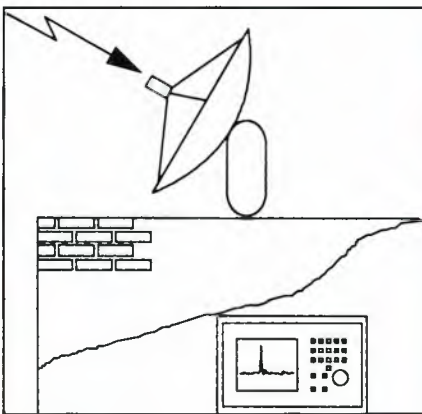

Page 38

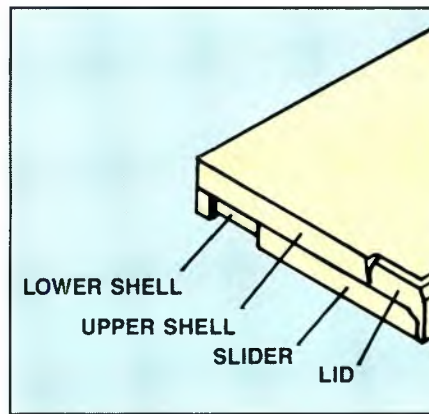

Page 50

VIDEO TECHNOLOGY UPDATE:

The power of computers, coupled with innovative approaches to analog and digital signal processing, provides the broadcaster with exciting new video opportunities. Perhaps the biggest challenge is to integrate the technologies into a cohesive and user-friendly system. This month we look at how stations can take advantage of different new systems to improve their competitiveness.

FEATURES:

26 Integrating Systems: WFTV's Story

By Bebe F. McClain, technical marketing consultant, and Paul Warnock, chief engineer
Production systems can do their best work by pulling together.

38 Automating Audio Measurements

By Adolfo Rodriguez, Tektronix
Test audio in 30 seconds — automatically.

DEPARTMENTS

- 4 News
- 6 Editorial
- 8 FCC Update
- 10 Strictly TV
- 12 re: Radio
- 14 Uncommon Engineers
- 16 Circuits
- 18 Troubleshooting
- 20 Management for Engineers
- 74 Show Preview: IBC
- 76 SBE Update
- 78 Field Report: Tascam CD-701 CD player
- 86 Station-to-Station
- 104 New Products

OTHER FEATURES:

50 DAT in the Professional Environment

By John Monforte, University of Miami
DAT is an inexpensive route into digital recording, but some questions still remain as it matures into a fully professional broadcast format.

68 Audio: The Sound Product

By Ronald F. Balonis, WILK-AM
The ultimate output of any audio chain is sound, a phenomenon with both "hard" and "soft" aspects.

ON THE COVER

Today's high-tech video systems provide quality images never before possible. As consumers learn to expect these new graphics on the screen, broadcasters look for the equipment that can help them outshine the competition. (Cover credit: Thompson CSF.)

One of Our CCD Cameras Should Be One of Yours

Presenting the Hitachi SK-F Series...
A Line-up of Five High Performance
Broadcast CCD Cameras.



Use the **SK-F700/710**
for studio & field production
work. A choice of RGB
Triax, Composite Triax or
Multicore gives you total
system flexibility.



The **SK-F3** is our top-of-
the-line EFP portable with
400,000 pixel FIT CCD's.



The **SK-F2** is our broad-
cast ENG camera featuring
IT CCD's with 700 lines of
resolution.



The **SK-F1** is our ENG/
EFP model that makes FIT
technology affordable.

Hitachi Denshi America, Ltd

150 Crossways Park Drive, Woodbury, New York 11797 Tel: (516) 921-7200

Pizzi joins BE editorial team

Intertec Publishing is pleased to welcome Skip Pizzi to the editorial team of *Broadcast Engineering* magazine.

Pizzi joins *BE* as technical editor after 13 years at National Public Radio, where he served in various technical, management and training positions. He is well-known within the public radio community for his training of radio and TV personnel at the highly regarded NPR Music Recording Workshops, and other training courses he developed for the technical staffs of NPR and its member stations.

While at NPR, he engineered and directed many programs, which received national and international broadcast awards. His recording work is still heard daily on NPR news program themes and musical bridges.

Pizzi is a familiar speaker at local and national meetings of the SBE, AES and NAB. He recently chaired the AES 8th International Conference, "The Sound of Au-



dio." Until his move to *BE*'s offices in Overland Park, KS, he also was chair of the District of Columbia section of the AES. He has been a guest lecturer at universities and a consultant to various govern-

ment and private organizations.

Pizzi co-authored a book on radio production, *Telling the Story*, wrote a chapter in the *NAB Engineering Handbook* and was a regular contributor to several other broadcast industry publications. Until January 1990, he was audio editor for *BME* magazine.

Before joining NPR, Pizzi received a bachelor's degree in fine arts from Georgetown University.

SBE requests FCC ruling for licensing regulations

The Society of Broadcast Engineers (SBE) has filed a request for a declaratory ruling with the Federal Communications Commission (FCC) to establish a policy of limited federal pre-emption of state and local regulation of technical operators of broadcast stations. In the filing, SBE asks the FCC to prevent state and local authorities from licensing technical operators of

Continued on page 120

BROADCAST engineering

Editorial and advertising correspondence should be addressed to: P.O. Box 12901, Overland Park, KS 66212-9981 (a suburb of Kansas City, MO); (913) 888-4664. Telex: 42-4156 Intertec OLPK. Circulation correspondence should be sent to the above address, under P.O. Box 12937. RAPIDFAX: (913) 541-6697.

EDITORIAL

Brad Dick, *Editor*
 Carl Bentz, *Technical and Special Projects Editor*
 Rick Lehtinen, *Technical Editor*
 Skip Pizzi, *Technical Editor*
 Tom Cook, *Senior Managing Editor*
 Dawn Hightower, *Senior Associate Editor*
 Tim McNary, *Associate Editor*
 Suzanne Oliver, *Editorial Assistant*
 Pat Blanton, *Directory Editor*

ART

Stephanie Chiles, *Graphic Designer*

EDITORIAL CONSULTANTS

Fred Ampel, *Audio*
 Nils Conrad Persson, *Electronics*
 Ned Soseman, *Video*
 Michael Heiss, *Consulting Editor*

BUSINESS

Cameron Bishop, *Group Vice President*
 Duane Hefner, *Group Publisher*
 Jerry Whitaker, *Associate Publisher*
 Evelyn Hornaday, *Promotions Manager*
 Darren Sextro, *Promotions Coordinator*
 Dee Unger, *Advertising Business Manager*
 Mary Birnbaum, *Advertising Production Supervisor*
 Sally Nickoley, *Advertising Coordinator*

ADMINISTRATION

R.J. Hancock, *President*
 Chuck Rash, *Corporate Circulation Director*
 Sandra Stewart, *Circulation Director*
 Doug Wilding, *Circulation Manager*
 Customer Service: 913-541-6633
 Kevin Callahan, *Creative Director*

TECHNICAL CONSULTANTS

Eric Neil Angevine, *Broadcast Acoustics*
 John H. Battison, *Antennas/Radiation*
 Blair Benson, *TV Technology*
 Dennis Ciapura, *Radio Technology*
 Dane E. Ericksen, *Systems Design*
 Howard T. Head, *European Correspondent*
 Wallace Johnson, *FCC/Bdct. Engineering*
 John Kean, *Subcarrier Technology*
 Donald L. Markley, *Transmission Facilities*
 Harry C. Martin, *Legal*
 Robert J. Nissen, *Studio/Communications*
 Hugh R. Paul, *International Engineering*
 Art Schneider, *A.C.E., Post-production*
 Elmer Smalling III, *Cable/Satellite Systems*
 Vincent Wasilewski, *Communications Law*

MEMBER ORGANIZATIONS

SUSTAINING MEMBERS OF:

- Acoustical Society of America
- Society of Broadcast Engineers
- Society of Motion Picture and TV Engineers

Member,
 Association of Business Publishers

ABP

Member,
 Business Publications
 Audit of Circulation

BPA

BROADCAST ENGINEERING is edited for corporate management, engineers/technicians and other station management personnel at commercial and educational radio and TV stations, teleproduction studios, recording studios, CATV and CCTV facilities and government agencies. Qualified persons include consulting engineers and dealer/distributors of broadcast equipment.

BROADCAST ENGINEERING (ISSN 0007-1794) is published monthly (except in the fall, when two issues are published) and mailed free to qualified persons within the United States and Canada in occupations described here by Intertec Publishing Corporation, 9221 Quivira Road, Overland Park, KS 66215. Second-class postage paid at Shawnee Mission, KS, and additional mailing offices. POSTMASTER: Send address changes to **Broadcast Engineering**, P.O. Box 12960, Overland Park, KS 66212.

SUBSCRIPTIONS: **Broadcast Engineering** is mailed free to qualified persons in occupations described above. Others may subscribe at the following rates: United States, one year, \$50; all other countries (surface mail), one year, \$60. Rates include postage. Foreign air mail and Canadian First Class options are available at the annual subscription rate of \$115. Single copy price \$4.50, except for the annual Buyers' Guide/Spec Book back issues \$20. Adjustments necessitated by subscription termination at single copy rate. Allow six to eight weeks delivery for change of address or new subscription.

Photocopy rights: Permission to photocopy for internal or personal use is granted by Intertec Publishing Corporation for libraries and others registered with Copyright Clearance Center (CCC), provided the base fee of \$2.00 per copy of article is paid directly to CCC, 21 Congress St., Salem, MA 01970. Special request should be addressed to Cameron Bishop, group vice president. ISSN 0007-1794 \$2.00 + \$0.00.

©1990 by Intertec Publishing.
 All rights reserved.

Advertising offices listed on page 115.

INTERTEC
 PUBLISHING CORPORATION

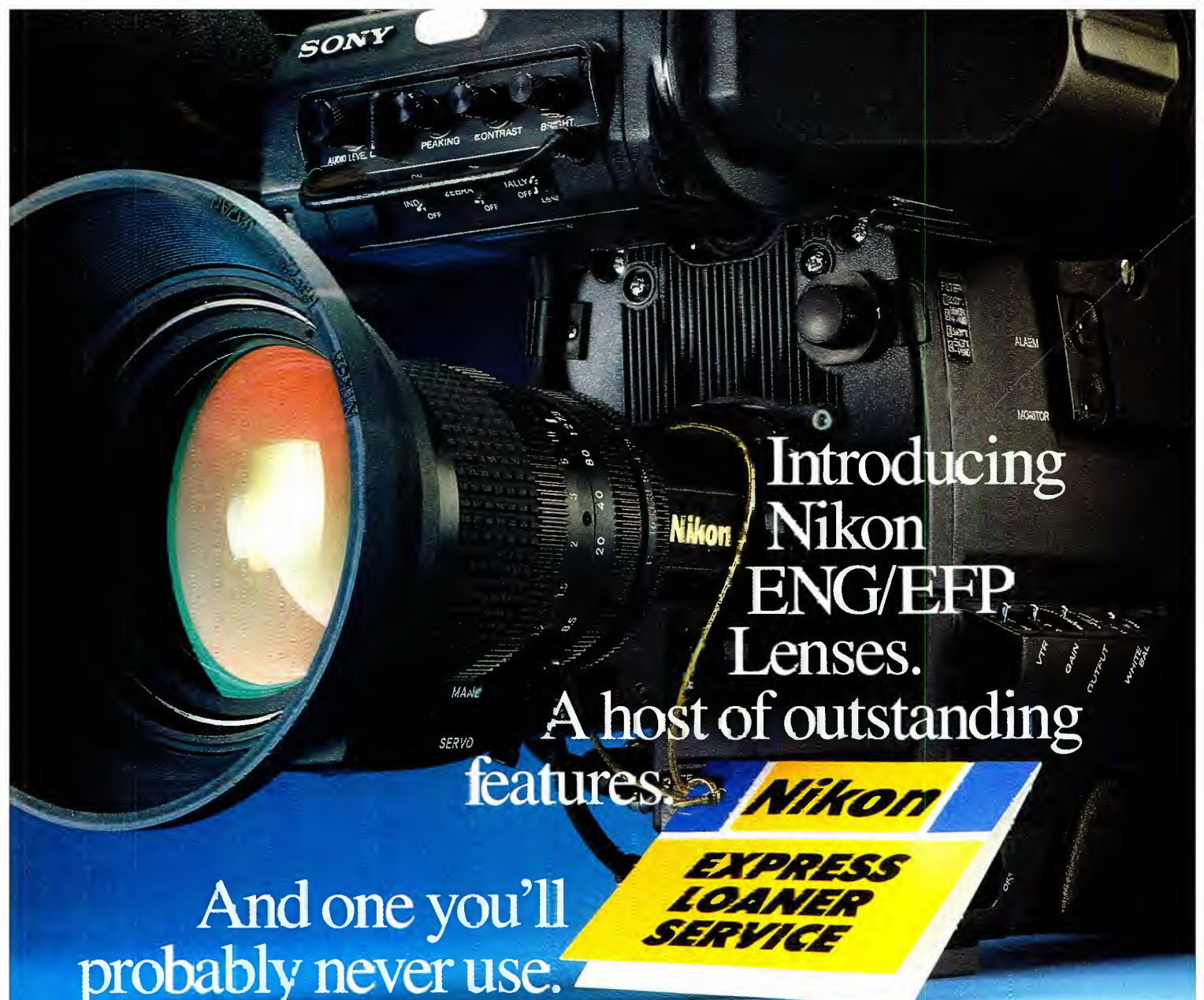

Introducing Nikon ENG/EFP Lenses.

A host of outstanding features.

And one you'll probably never use.

Selecting an ENG/EFP lens for your $\frac{2}{3}$ " CCD camera is a creative decision. It should be lightweight, responsive and zoom smooth as silk at any speed. Its design should utilize Extra-low Dispersion Glass to minimize chromatic aberration. It should include an anti-reflection coating for improved spectrum transmission ratio. And it should have an advanced design that improves corner resolution and produces a high, flat MTF curve. In short, it should be a Nikon.

But selecting an ENG/EFP lens is also a business decision. And on that score we provide something almost as compelling as Nikon quality — our unique Express Loaner Service. Simply register the Warranty, then in the unlikely event your lens needs service we'll get you a loaner lens overnight. All your investment in equipment and crews is more secure than ever before.

A service like this is remarkable in itself. But not quite as remarkable as our lenses.

As with all Nikon products, our new ENG/EFP lenses have all our renowned quality, tradition and technology built right in. Our growing line is also fully accessorized, including adapters that allow the use of your entire arsenal of Nikkor 35mm SLR camera lenses for special effects.

To find out more, call or write for our complete brochure: Nikon Electronic Imaging, Dept. D1, 101 Cleveland Avenue, Bayshore, NY 11706, (516) 222-0200 Ext. 324. Or call 1-800-NIKON-US (645-6687) for the dealer nearest you.

Nikon
ELECTRONIC IMAGING

© 1990 Nikon Inc.

Circle (4) on Reply Card

www.americanradiohistory.com

Leading the challenge

I was thinking about a recent press release describing a new type of technology that would soon be available to broadcasters. My first reaction was, "Wow, wouldn't that be a neat addition to a TV station?"

After a minute's pause, I realized that I was taking the viewpoint of the station engineer, not the owner. As an engineer, I readily appreciate new technology. Changes are exciting and most engineers love taking advantage of the nifty ideas now being developed.

Unfortunately, this technology could cost the typical TV station approximately \$500,000. Would I have the courage to try to get the station owner to adopt it? Some engineers I know wouldn't think twice about promoting new ideas to their owners and managers. Others shrink from anything new that costs money or involves major changes. You see, it's more comfortable to wait and let others lead the way.

At the risk of misclassifying engineers, I feel they could be divided into at least two groups. I'm sure there are more, but these two are common. The first group of engineers share an excitement about new technology. They look for it, try to buy it and, in general, see advantages in using the latest high-tech idea as soon as possible.

The second group of engineers is the opposite. They see the implementation of new ideas as a bother. What works now is good enough for them. They feel more comfortable doing things as they've always done them. If the idea or technology was good enough then, it's good enough now.

The first group of engineers are always pushing their limits. They ask for more, demand more and look forward to change. The second group is satisfied with the status quo. After all, if it ain't broke, don't mess with it.

Unfortunately, the second group may be a result of the draconian principles implemented by short-sighted

managers and visor-equipped bean counters. After you've been beaten on the head and told no for the umpteenth time, you have a tendency to duck and run for cover every time trouble looms on the horizon.

This is unfortunate because the stations operated by these chiefs will never be as successful as they could be. The stations will struggle to hold their position in the marketplace, but often find themselves continuing to fall behind the competition.

It won't be long before the rest of the staff is infected with the same attitude problem. If the engineering team doesn't push the frontier of technology and strive for the best, why should the production, news, sales or even accounting departments be any different?

Stations run by the first group of engineers will look and sound better, and the audience and staffs will recognize the difference. Engineers at these stations will be the technological driving force behind their station's success.

The technical staffs will be flexible and willing to take a chance on new ideas. They'll agree to be guinea pigs for almost any new device. Given the chance, they'll work nights and weekends installing the latest product on the chance it will make their station a little bit better. And when there isn't enough money to upgrade, they'll take pride in getting another year's use from that tape machine or 100 hours from that tube.

I never want to fall into the "comfortable" group of engineers. It must be boring never to feel the excitement of seeing a new idea work properly for the first time. Without the challenge of building or installing something you gave birth to, why stay in broadcasting? If you want sameness, join land mobile or repair copy machines.

I choose to remain in broadcasting where the excitement continues. The challenges of tomorrow's technology, such as HDTV, direct satellite transmission and digital radio, are things I don't want to miss. And I bet that most *Broadcast Engineering* readers feel the same way.

So, bring on those new ideas and challenges. We broadcast engineers are proud of our contribution to the success of our stations. We can't wait to get our hands on tomorrow's technology and lead our stations to being number one.



Brad Dick, editor



We aimed for undetectable transmission limiting . . .

And we reached our goal.

We designed this product to meet a challenge offered by one of the world's largest broadcasting organizations. In a series of independent listening tests, their panels agreed that the sound of the 4000A was virtually indistinguishable from the original source when below threshold, when, in maximum (15dB) gain reduction, when processing voice, or when processing dynamic symphonic music.

Sophisticated peak control.

The 4000A provides absolute peak level control with no overloads. And with no audible artifacts, or unnatural gain changes, a common problem with delay-line type designs.

Our proprietary-design high-frequency limiter prevents overload due to the pre-emphasis found in most transmission systems, without causing any high-frequency dulling! It's selectable for 25 μ s, 50 μ s, 75 μ s, 150 μ s, NICAM's J.17 pre-emphasis, or OFF.

You set your limits.

Setup is very easy. The only operating controls are INPUT LEVEL and OUTPUT LEVEL.

Remote-controllable switching supplies a calibrated TONE at 100% modulation; just adjust the 4000A's OUTPUT LEVEL to match the overload point of your transmission system. Then switch to OPERATE, and adjust the INPUT LEVEL for the desired drive level (or unity gain). And you're ready to go on-the-air.

Unbeatable product reliability and technical support.

The new 4000A Transmission limiter is from Orban, the company that manufactures the world-famous OPTIMOD Audio Processors for AM/MW, FM/VHF, TV, and HF used by tens of thousands of broadcasters all over the world.

Orban products are known for their high standard of construction and reliability. We're proud of our products and stand behind them with technical support from broadcast engineers who understand your needs. Contact your Orban agent or dealer for more information or a demonstration.

orban

LISTEN TO THE DIFFERENCE.

a division of AKG Acoustics, Inc.
1525 Alvarado Street, San Leandro, California 94577 USA
Telephone (1) 415/351-3500 Fax (1) 415/351-0500

Circle (5) on Reply Card

www.americanradiohistory.com



Forfeiture authority to increase

By Harry C. Martin

The commission has amended its rules to modify the forfeiture amounts that it may impose in accordance with a recent amendment to the Communications Act.

If the entity subject to a forfeiture penalty is a broadcast station, cable TV operator or an applicant for any broadcast or cable TV operator license, permit, certificate or other type of authorization issued by the commission, it may assess up to \$25,000 per violation, or day of a continuing violation, provided the total does not exceed \$250,000 for any single act or failure to act. If the entity subject to forfeiture is a common carrier or an applicant for a common-carrier authorization, the commission may assess up to \$100,000 for each violation, or day of a continuing violation, provided the total does not exceed \$1,000,000 for any single act or failure to act.

With respect to other entities subject to a forfeiture penalty, the commission may assess up to \$10,000 for each violation, or day of a continuing violation, provided the total for a continuing violation does not exceed \$75,000 for any single act or failure to act.

Lottery rules amended

The commission has amended its rules governing the broadcast of lottery information to implement the Charity Games Advertising Clarification Act of 1988.

Federal lottery law, which is enforced by the commission when electronic media are involved, has been interpreted as prohibiting the broadcast of advertisements or other information regarding lotteries. However, several exceptions to this prohibition exist, including one that exempts broadcasts concerning state-conducted lotteries when the broadcast station is licensed in the state conducting the lottery or in an adjacent state that also conducts a lottery. The commission, in response to the new law, has expanded the exceptions to the general prohibition against lottery advertising.

Under the FCC's new standards, broadcasters are permitted to advertise lotteries authorized or not otherwise prohibit-

ed by the state in which they are conducted if they are conducted by the following:

1. A not-for-profit organization as defined in Section 501 of the Federal Tax Code.
2. A governmental organization.
3. A commercial entity, provided the lottery is clearly occasional and ancillary to the primary business of the commercial organization.

The broadcast of information regarding state-conducted lotteries remains subject to a narrower restriction and is permitted only in the state conducting the lottery or in any states that have such lotteries. In contrast, broadcasts concerning lotteries conducted by other governmental organizations are permitted in any state regardless of whether lotteries are authorized in that state. The lottery should be lawful in the state in which it is conducted.

Despite the new federal exemptions, broadcasters still may be subject to state and/or federal penalties for airing certain promotions. When considering a particular promotion, broadcasters should remember the following points:

- Many states have lottery laws that are more stringent than the new federal law. Because state law has not been preempted by the Charity Games Act, broadcasters and cable operators should consult their local counsel or state trade association if questions arise regarding the legality of a promotion under state law.
- The change has not affected the ban on advertising of casino gambling. Regardless of whether your state has authorized casino gambling, state law is pre-empted by federal law in this instance.
- Under federal law, ads for lotteries sponsored by commercial organizations may be aired only if the event is promotional and "clearly occasional and ancillary" to the organization's primary business.

IF protection rules for FM affirmed

The commission has upheld its decision of last year to provide a uniform 36mV/m level of protection for FM radio receivers from intermediate frequency (IF) interference.

Two FM stations are IF-related when their assigned frequencies are 10.6MHz or

10.8MHz (53 or 54 channels) apart in frequency. IF interference to FM broadcast receivers may occur when the receivers are located in an area served by two strong signals from IF-related stations. When these related signals are picked up by a receiver, they have the potential to mix together and produce a third interfering signal within that receiver.

The uniform 36mV/m protection level replaced an earlier scheme using distance separations to reflect different levels of protection for certain classes of stations.

Changes in environmental rules

The commission now requires that where construction of a communications facility is permitted without prior FCC authorization, the applicant must determine, prior to construction, whether the facility may have a significant environmental effect.

If the facility may have such an effect, the applicant must file an environmental assessment and await a commission ruling on the need for an environmental impact statement before construction. If preauthorized construction already has commenced, it must cease if it is discovered that construction may have a significant environmental effect.

The new requirements are necessary to ensure the agency can address environmental issues early in the licensing process to fulfill its obligations under federal environmental laws and safeguard against preauthorized construction resulting in irreversible damage to the environment.

The commission expects its revised rules will affect few facilities. Applicants seeking to construct facilities for which prior FCC construction approval is not required generally can assess whether there may be a significant effect on the environment during preconstruction planning.

Broadcast auxiliary stations will continue to be categorically excluded from environmental requirements as far as RF radiation is concerned, but the commission refused to extend this exclusion to minor modifications that may be made to broadcast stations without prior FCC authority. (See FCC rule 73.1690.)

Martin is a partner with the legal firm of Reddy, Begley & Martin, Washington, DC.

More.



- *The familiar feel of the industry standard Model 100, with more power, more control and more features than ever.*
- *The extra quality of linear keying.*
- *10 E-MEM® Effects Memory registers at your fingertips for fast learn and recall of switcher effects.*
- *New KeyLink™ combines the Model 110 and DPM-100 Digital Picture Manipulator for more creative effects.*

**The new Model 110
Production Switcher.
GVG raises the
standard for
professional video
and small studio
production.**

Again.

Introducing the compact and affordable Model 110.

For the new, more powerful standard in professional video and small studio production, nobody supports you like GVG.®

Grass Valley Group®

A TEKTRONIX COMPANY

At the heart of Television

NORTH AMERICA Grass Valley, CA (916) 478-3000

SOUTH AMERICA Miami, FL (305) 477-5488

EUROPE Basingstoke, Hampshire (0256) 817817

ASIA Hong Kong 7874118

Circle (6) on Reply Card

www.americanradiohistory.com

Interchannel timing in component systems

By Steve Talley

Component signal processing involves much more than the 3-wire component signal. Figure 1 shows a block diagram of a component videotape recorder, such as a Betacam or MII machine. A component, 3-wire input leads to a time-compression circuit, where the B-Y and R-Y signals are time compressed, pre-emphasized and delayed by one line from the corresponding Y line. This 2-wire signal is what gets recorded. (Betacam calls this CTDM, and MII calls it CTCM. These are different and not interchangeable, but the principles are the same.)

The playback system takes the 2-wire signal, de-emphasizes it and removes the time compression and its delays to make the 3-wire signal again.

The input side also has an NTSC decoder, which converts the NTSC signal into a 3-wire signal. The output side has an NTSC encoder, which converts the 3-wire signal back to a 1-wire, NTSC composite signal.

Talley is applications engineer for Magni Systems, Beaverton, OR.

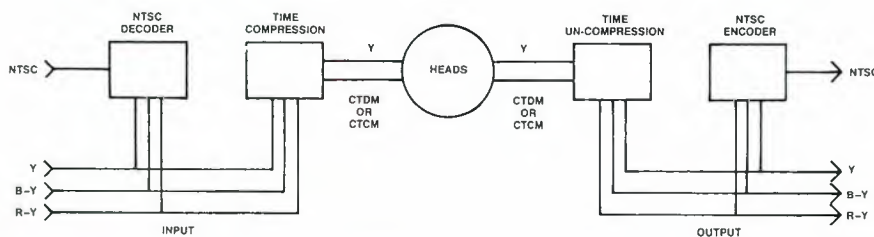

Figure 1. Generic CAV VTR block diagram.



Dual timing pulses

After you have adjusted the timing of the system for 3-wire in/3-wire out, how is the timing to be adjusted through the decoder and encoder?

A special signal, called dual timing pulses, can help. It consists of two 12.5 T pulses on the Y channel, with one 12.5 T pulse on the B-Y channel coincident with the earlier Y-channel pulse, and one 12.5 T pulse on the R-Y channel, coincident with the later Y channel pulse. The amplitudes of the signals are arranged so that when they are encoded to NTSC, they produce 12.5 modulated chrominance pulses, just like what has been used over the years to measure chrominance-luminance delay. (See Figure 2.)

If the bottom of the modulated pulses are flat, all is well. If they bulge up or down, like in the rightmost pulse of Figure 2, there is a gain inequality between the two channels. The first of the two pulses compares the Y and B-Y channels, and the second pulse compares Y to R-Y, so there is a slight gain problem in the Y/R-Y channel. If a time delay exists be-



Figure 2. Dual timing pulses indicate a slight gain equality in the Y/R-Y channel, and a timing delay in the Y/B-Y channel.

tween two channels, you will see a display like the one in the leftmost pulse in Figure 2. This shows that the B-Y channel is delayed from the Y channel, but the Y to R-Y timing is all right.

A point to remember is that this display shows time delay that may be in the NTSC encoder or the component circuits, so it is imperative to first eliminate component problems. For the final check, insert an NTSC version of dual timing pulses into the NTSC input decoder to see how it comes through the entire system.

Table 1 lists the advantages and disadvantages to various systems of measuring time delay and gain inequality. It also is possible to measure the time delay and the gain inequality by using a nomograph. This is rarely done, however, because it is more important to reduce or eliminate the delay than to measure it.

SYSTEM	ADVANTAGES	DISADVANTAGES
Lightning display	Uses widely available signal (color bars)	Requires special display device Does not check NTSC path
Timing Bowtie	Uses common display devices Can be made in many frequencies for finer time measurements	Requires component signal generator Does not check NTSC path
Dual timing pulses	Checks NTSC encoder and decoder timing	Requires special signal

Table 1. This chart summarizes the characteristics of some of the ways to check interchannel timing.





MIX TRAK 90™

Tom Achterhoff, President
 Greater Muskegon Broadcasters, Inc.

YOU'RE LOOKING AT IT!

It's not easy to sort through the crowd of radio consoles in search of the *perfect* model. The search for this *perfect* console isn't really so hard. You're looking at it! That's why many of America's top broadcasters have selected the Mix Trak 90 above all other consoles.

There are lots of benefits to owning a Mix Trak 90 such as:

- Three Mix-Minus busses for phone or monitor feeds.
- Built-in provisions for separate speech and music processing.
- Straight forward modular design; simple to operate and maintain.
- Rugged, reliable construction.
- State of the Art audio performance.
- RF Interference protection.
- No tricks or shortcuts which hamper installation.
- Balanced inputs and outputs throughout, even all patch points.

To learn why the Mix Trak 90 is your best choice for a radio console contact your Broadcast Electronics' Representative or call Bob Arnold at **217-224-9600**

Circle (7) on Reply Card



4100 N. 24th ST., P.O. BOX 3606, QUINCY, IL 62305-3606 U.S.A., PHONE (217) 224-9600, TELEX 250142, FAX (217) 224-9607

www.americanradiohistory.com

Save our AM system

By John Battison, P.E.

Blaming the FCC for the state of the AM band in the United States has become almost a custom in recent years. The commission has been challenged for the proliferation of stations with a minimum of separation and for permitting too many co-channel stations.

The FCC is required by the Communications Act of 1934 to issue construction permits for any proposal that complies with the commission's rules. Many detractors claim that the rules are too easy, do not consider the changed radio station environment and do not allow for the effect of integrated interference. This is evident at night, when the effects of skywave become apparent. The NRSC channel limits take into account daytime adjacent-channel effect to a greater extent than before, fortunately.

How we got here

The 10% rule was in effect until about 1962. It permitted the construction of a station, provided that it did not produce or receive interference greater than 10% of its, or the other station's, 0.5mV/m/service contour. This allowed some unique station combinations to develop. One that I recall occurred in Kent and Canton, OH. The applicants specified directional systems operating at 1,520kHz with 1kW.

The two cities are no more than 40 miles apart. WKNT-AM located its transmitter south of Kent and WINW-AM's was located north of Canton. Four in-line towers were used for each station. By means of a tight pattern, the mutual interference was kept to 10% or better for each station. In the area between the stations where there was a 0.5mV/m contour area, the interference varied considerably in magnitude and extent. Most listeners in the interference area were able to receive some service from their favorite station.

At WINW-AM, a small river ran between towers 2 and 3, which was normally crossed by a plank. When the rainy season came, rubber boots, and then waders, were required equipment to read base currents. The water came up eventually, high

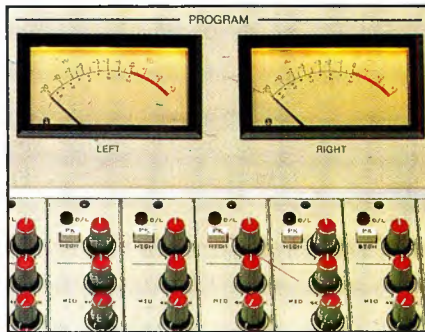

enough to cut off the two towers. When the water finally receded, the monitor points for the station had remained within tolerance.

These stations were constructed in the days of *maximum expected operating voltage* (MEOV) limits on directional proposals. Because the commission had no hard and fast rules to cover MEOV, the custom was to specify 5% of the theoretical value on the critical radials. It also became the norm to specify an MEOV around the whole pattern to provide leeway for final pattern adjustment.

Following the 10% rule, an AM freeze began in 1962 and lasted for approximately two years. When the freeze was lifted, there was an unbreakable go-no-go rule. Any interference served to disqualify. Then came the 1mV/m protected contour and number of services criteria.

Standard patterns

The commission instituted the *standard pattern* approximately 10 years ago. This made the consulting engineer's work easier when determining the pattern of a station to be considered in a pending application. Prior to the standard pattern, you needed to obtain all the applicable material from the commission's files, if possible. The pattern was calculated, and MEOV was allowed to determine if a proposed pattern would fit. The actual percentage of MEOV used was not always easily discovered.

The standard pattern of today is the theoretical pattern modified by a given and known constant so that anyone can calculate the pattern of the stations involved with certainty and know that it can be reliable. Does it always work? Not exactly.

Augmentation

A directional pattern sometimes will *not* fit because of local conditions, and a bulge develops. A troublesome dip does not occur often in the measured pattern. If the bulge proves impossible to correct, and interference requirements are met, the commission will allow an *augmentation*, an accepted discrepancy between the proposed and the measured patterns. It extends more than 10° or more generally and is a departure from the standard pattern.

An engineer who needs to know the actual operating pattern can obtain a data sheet showing the full description of any DA in the United States. This sheet contains the standard pattern values and data. If an augmentation has been used, it also is shown so it is possible to know exactly how the DA in question is operating and to determine its effect on an application.

Decreasing number of AM stations

There is an attempt to decrease the number of AM stations in the United States. The AM industry is our oldest broadcast system. It offers the greatest interest and challenge in application and operating work and provides some phenomenal coverage effects.

I cannot see the end of AM as forecast by some pessimists. It is the only medium that makes wide-area communication possible with a minimum of equipment.

European markets

In England, AM is alive and well. The guiding powers have a new and different concept, however. Ever since the beginning of radio in England, the BBC has provided one or more national medium-wave (MW) services that more or less covered England. Because of new thinking by England's radio control board, the BBC will lose its current four MW frequencies and use FM almost exclusively for all programming by 1992.

England is the last of the English-speaking countries to permit commercial radio. There is no purely local radio; it is more like a regional setup, with stations in large cities only.

The newspapers have referred to a "big bang" to be complete by 1992, when up to 400 new AM commercial stations will exist. These stations will use relinquished BBC nationwide frequencies, and there will have to be frequency duplication and some impressive DAs.

The implementation of up to 400 AM stations in two years is a rate of growth comparable with our post-war period when everyone jumped into broadcasting, which has led to our full medium-wave spectrum.

Battison, BE's consultant on antennas and radiation, owns John H. Battison and Associates, a consulting engineering company in Loudonville, near Columbus, OH.

Let's compare automated audio test equipment performance:

KEY PERFORMANCE SPECS	AUDIO PRECISION SYSTEM ONE	H-P 8903B	S-T 3000B	TEK AA5001/SG5010
Flatness 20-20k Hz, gen/analyzer	0.03/0.03 dB	0.06/0.2 dB ¹	0.1/0.1 dB	0.05/0.1 dB
Amplitude accuracy, gen/analyzer	0.1/0.1 dB	0.2/0.2 dB	0.2 dB/no spec	0.2/0.3 dB
Generator amplitude range	+ 30 to -90 dBm	+ 17 to -68 dBm	+ 30.6 to -90 dBm	+ 28 to -72 dBm
System THD + N 20-20kHz, 90 k BW	0.0015%	0.01%	0.0018% ²	0.0032%
Min. amplitude for THD + N function	25 microvolts	50 millivolts	30 millivolts	60 millivolts
Residual noise (30 kHz BW)	3.0 μV	15 μV	4.0 μV	3.0 μV
Analyzer stereo separation (> 20 kHz)	140 dB	function not avail.	100 dB	function not avail.
Common mode rejection ratio	70 dB, 50-20kHz	60 dB, 20-1kHz	100 dB @ 60 Hz	50 dB, @ 50/60 Hz
Speed, THD function (autorange)	10 sec 16-pt sweep	1.5 sec to 1st rdng	2.5 sec to 1st rdng	2.5 sec to 1st rdng
Speed, amplitude function (autorange)	10 sec 30-pt sweep (2 chan simultaneous)	1.5 sec to 1st rdng (1 channel)	1.3 sec to 1st rdng (per channel)	2.0 sec to 1st rdng (1 channel)
PRICE (U.S. DOMESTIC)				
Computer-interfaceable instrument	\$7350	\$6250	\$10280	\$9795-\$10205
Software package	included	none available	\$595-\$2580	none available
Typical controller	\$600-\$3000 ³	\$6080 ⁴	\$1000-\$3400 ⁵	\$1000-\$3400 ⁵

¹ Analyzer flatness not specified separately; analyzer accuracy 0.2 dB 20 Hz-20 kHz

² Total system THD + N not specified; generator THD plus analyzer distortion specs added together equal 0.0018%

³ Personal computer; Interface card included in instrument price.

⁴ H.F. Model 332MMA IEEE-488 compatible

⁵ Personal computer plus IEEE-488 interface card

Comparative data compiled from H-P 1990 catalog, S-T data sheet 3000A 1987, price list 1989, Tektronix 1990 catalog.

For a much more complete comparison of these and other audio test systems, call or write Audio Precision.

System One



Audio precision

P.O. Box 2209, Beaverton, OR 97075
503/627-0832 1-800/231-7350
FAX: 503/641-8906, TELEX: 283957 AUDIO UR

Circle (8) on Reply Card

Robert Gross



By Elmer Smalling III

Robert Gross' career no doubt was launched by his ham radio interests as W2GKO. He was born in 1920 in Hasbrouck Heights, NJ, where he spent part of his youth watching the George Washington Bridge go up and haunting the stores of "Radio Row" in Manhattan for electronic parts. His family moved to California in 1939, where he attended evening classes to advance his radio education. During World War II, he enlisted in the Navy submarine service, spending 2½ years in Freemantle and Perth, Australia.

Upon discharge from the Navy, he married and joined the Pacific Telephone Company. After 10 years of climbing telephone poles and crawling under houses, he was assigned to the television department in 1948. He arrived just in time to install the first microwave equipment used between Hollywood and Mount Wilson. The gear still is in use today as backup equipment.

End of the kinescope

In 1951, Gross began a 27-year career with the Columbia Broadcasting System (CBS). KTSL was the CBS-owned station in Hollywood, which later was changed to KNXT. One of his first projects with CBS was to move the KNXT transmitter from atop Mount Lee to Mount Wilson. Gross then was transferred to the CBS Television City facility to help construct the black-and-white facility with the country's only video-recording kinescope. Soon, two new control rooms were designed for live color broadcasting. A broadcasting event then shook the industry; Ampex demonstrated the first rotating-head videotape recorder on a stage at Television City. This major breakthrough marked the end of kinescope recording.

In 1957, Gross was transferred to KNXT as assistant chief engineer and given another challenge. The station had to vacate 1313 Vine Street. The choice was to either rent space and equipment from the network at Television City or move to a new KNXT facility. The decision was made to keep the CBS Stations Group facilities separate from the network and use part of the radio facility at 6121 Sunset Blvd. for

Smalling, BE's consultant on cable/satellite systems, is president of Jenel Systems and Design, Dallas.

Profile

- Installed the first microwave equipment used between Hollywood and Mount Wilson for the Pacific Telephone Company
- Helped to construct a black-and-white facility with a video-recording kinescope for KNXT, Hollywood
- Built a self-contained color news vehicle for WCAU-TV, Philadelphia
- Relocated KTVU in Oakland/San Francisco to Jack London Square
- Designed a TV station in South Carolina
- In 1984, he built an independent station on Mount Baldy in southern California

KNXT-TV.

KNXT employed many innovations, but Gross says, "The most outstanding one was the use of a digital computer that used discrete components and a drum memory as a station-break switcher." This same switcher now resides in the Smithsonian Institute in Washington.

A variety of projects

Following a year in New York, Gross returned to Hollywood and completed the KNXT installation without a second of downtime, a day before the lease expired. His next big assignment occurred in 1963, when he was named director of engineering at WCAU-TV in Philadelphia. He was charged with making WCAU a full-color operation and to increase its coverage. But, Gross notes, "Philadelphians traditionally went to the New Jersey shore every summer. Unfortunately, WCAU-TV did not cover the shore area very well and lost many summer viewers."

A terrain study highlighted the need for a taller transmitting tower. Gross had 170 feet added to the existing antenna tower in the suburb of Roxborough and had the batwing antenna replaced with a traveling wave antenna.

He also had the transmission line detuned by changing the length of the sections to eliminate a long-existent ringing problem. The original 20-foot sections of line were a multiple of the station's channel 10 wavelength. Another of Gross' projects at WCAU was the completely self-contained color news vehicle. This fore-

runner of modern ENG vehicles was built in a windowed van to avoid the commercial vehicle restrictions on some of the better roads in the Philadelphia area. This was no mean feat, considering the signal generator occupied an entire equipment rack.

An atypical retirement

In 1977, after 15 years at WCAU, Gross took early retirement. "The reason I liked engineering was the challenges it offered. Retirement was not for me. Therefore, I decided to start on my own as a consultant."

Consulting has kept Gross busy over the years and has involved him in many interesting projects. He helped move KTVU in Oakland/San Francisco across Jack London Square. This project was completed without one second of lost air time. Following the KTVU move, Gross designed an independent station in Santa Rosa, CA.

Next, a request came to design a TV station in South Carolina, and he jumped at the opportunity. He installed a 1,600-foot guyed tower with a panel antenna on top to get the best coverage. Because of the mountainous terrain, Gross decided on a 50/50 circularly polarized antenna. This would handle the highest power permitted so that he could reduce the gain and provide the best vertical null fill possible. The transmitter has four 55kW visual and one 55kW aural klystrons, which made it the highest-power transmitter in use at that time.

Reaching new heights

In 1984, Gross built an independent station on Mount Baldy, which rises 8,600 feet in southern California. This facility incorporated the first all-Klystrode 120kW transmitter. Presently, Gross is busy at work on another mountaintop project on Little Mount San Gorgio in California.

Gross thinks it is important for young people to choose a vocation "that they can get involved in and one that will stretch one's abilities." Gross chose his line of work because of the challenges, and he has not been disappointed. "Although things are much different today than they were years ago, challenges still are out there for the asking," he says.

! : ? ~ :)))

Radio's Top Ten!

Many of our customers understand that this is more than a hollow boast. They know that when a manufacturer offers them a broad choice of products, it means money in their pockets.

How? Simple. You can select *exactly* the right equipment for your specific application.

And when you're not forced to make compromises in features or performance, your station not only sounds better to your listeners, it is also much more efficient in its day-to-day operation.

Otari has machines for news editing, on-air, and production with features to fit any application or budget.

To make a point, let's say you are in the market for a multitrack.

You can choose from our top of the line MTR-10 that gives you all the features you'll ever need, or our BQII, MKIII/4, MKIII/8, or the MX-70 with 8 or 16 tracks.

Need a 2-track?

How about our famous "workhorse" MX5050 BII, or the MKIII/2, or the MX-55NM with gapless, seamless, punch-in, punch-out and HX-Pro*.

And don't forget the MX-50, perhaps the most affordable professional 2-track on the market.

We also offer three models of our CTM-10 cart machine. And if yours is an automated radio station,



our ARS-1000 reproducer is the most popular machine in the world.

You could say we have a *broad cast* for broadcast. But as we've pointed out, it can mean a lot more to you than just a phrase.

Call your nearest Otari dealer today, or call Otari at (415) 341-5900 for more information.

OTARI



*HX-Pro is a trademark of Dolby Laboratories Licensing Corporation

Filter functions with Smith charts

By Gerry Kaufhold II

The past several columns have dealt with the graphical techniques of Smith chart solution. This month, we will overview the kind of filters that can be constructed with the aid of Smith charts.

Smith charts generally are used with an accompanying overlay. Series components are treated as reactances and are plotted directly onto the Smith chart. Shunt components are treated as susceptances and are plotted on the Smith chart overlay.

Filter functions

The four basic filters are high-pass, low-pass, bandpass and notch.

The high-pass filter comes first. (See Figure 1.) Its components are selected to provide a cutoff frequency that is at the bottom of the bandpass range.

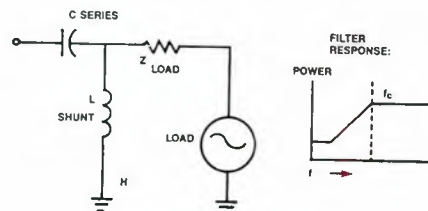

Figure 1. To design a high-pass filter, plot the shunt inductor as susceptance on the overlay, and the series capacitance as reactance on the Smith chart itself.

The capacitive element is connected in series, so the capacitance is calculated using reactance, which is plotted directly on the Smith chart. The inductance is shunt, so it is plotted onto the Smith chart overlay, and its values must be converted from

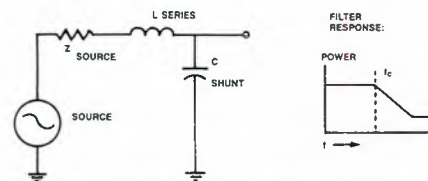

Figure 2. To design a low-pass filter, plot the shunt capacitance as susceptance on the overlay, and the series inductance as reactance on the Smith chart itself.

Kaufhold is a market development engineer for SGS-Thomson Microelectronics, Phoenix.

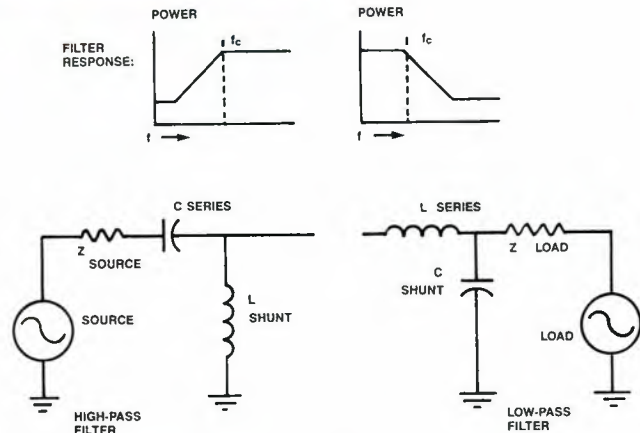
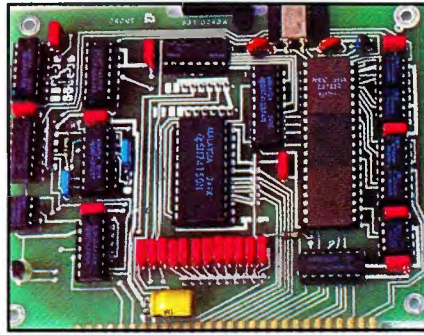

Figure 3. A bandpass filter consists of a high-pass and low-pass filter in series.

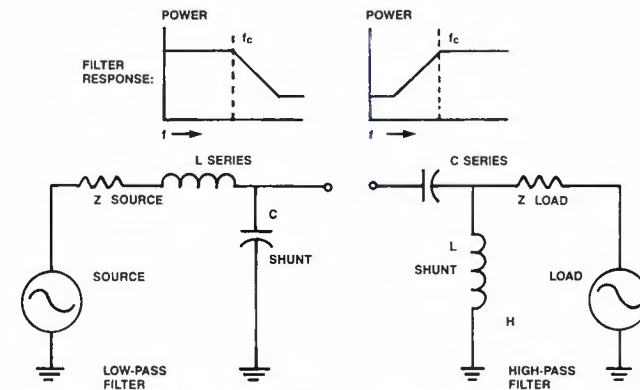

Figure 4. A notch filter consists of a low-pass and a high-pass filter in series.

susceptance to reactance before obtaining the final in-circuit values.

The low-pass filter is designed to provide a cutoff frequency at the top end of the band to be passed. (See Figure 2.) For the low-pass filter, the inductance is in series and is treated as a reactance, so it is plotted on the Smith chart. The capacitance is shunt and is plotted on the overlay. It must be converted from susceptance to reactance before solving for the final component values.

The bandpass filter consists of a high-pass and low-pass filter in series. (See Figure 3.) The two inductive components are connected directly together. A tapped inductor could be used to reduce the component count and simplify the design. In

addition, by varying the relationship between capacitance and inductance, you can vary the bandwidth of the circuit.



The notch filter is similar to the bandpass filter except that the two capacitors cannot be combined into a single component. (See Figure 4.)

By varying the ratio of the capacitance to the inductance, the depth of the notch (decibel of attenuation) can be varied, as well as the center frequency of the notch.

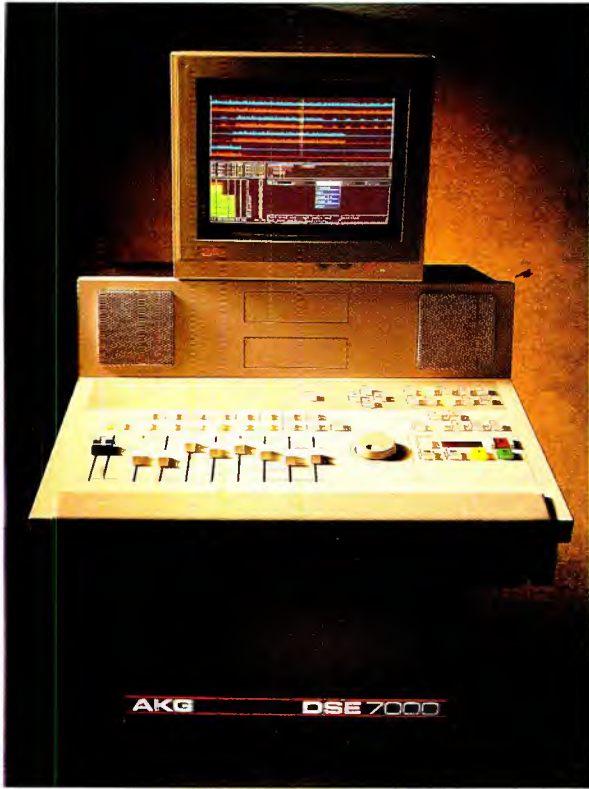
HE SAID,  "You can write almost anything you want about this machine and put my name under it." SO WE DID.



THE DIGITAL SOUND EDITOR. STATIONS FROM BOSTON TO SAN DIEGO ARE MAKING IT THE HOTTEST BOX IN RADIO.

Dan McCoy was the first production director in radio to use the DSE 7000, and he saw it revolutionize the way production is done at WZOU-FM,  one of the top stations in Boston. A spot that used to take an hour to produce now takes 20 minutes. Without tape. Without razors. Without a single dB of generation loss. Even agency dubs now go right to the DSE for levels, sound enhancement 

and tags; then onto carts. Creativity has exploded, too. With the DSE's instant UNDO feature, the fear of trying new things is gone. You simply try another take, assemble a different edit, or test a new effect. If you don't like the results, UNDO it instantly. No wonder WZOU has designed their production facility around the DSE.  And no wonder Dan McCoy calls this machine "the most impressive thing that's ever happened to radio." His words, not ours.

 **AKG**®
AKG ACOUSTICS 1525 ALVARADO STREET, SAN LEANDRO, CALIFORNIA 94577, USA. (415) 351-3500. FAX: (415) 351-0500



DSE 7000 • THE NEW SPEED OF SOUND™



Reviewing video basics

By Mark Everett

The concept of SC/H phase was introduced in last month's column. Now let's consider why it's important to a properly operating video system. We will begin by reviewing the math, which describes the signal relationships.

The math

Subcarrier divided by 227.5 gives the horizontal sweep rate. This means that there are 227.5 cycles of subcarrier per line of video. An obvious result is that reference burst on each line is exactly half cycle out of phase with the line before or after that line. Another important point is that the horizontal rate can be divided by 262.5 to get the vertical sweep rate. A different way to view that is to say that there are 262.5 lines of video per field. Multiplying 227.5 times 262.5 equals 59,718.75 cycles of burst in a field of video. Multiplying this result by 2, 3 or finally 4 provides an even number of cycles of burst in four fields, 238,875.

So what, you say? It takes four fields to complete the color cycle and two fields of color TV video to form a complete picture. That's why we can say that it takes four fields to make a color picture.

Almost any color sync generator can sync together two video sources. The problem is to get two of them to behave exactly the same in a gen-lock environment. The problem is that in older, non-SC/H-phased sync generators the subcarrier and horizontal lock and phase adjustments are totally independent. In the older generators, gen-lock will allow one generator to lock a second generator exactly two color fields out of phase.

The reason is that the vertical and horizontal pulses in color fields 1 and 3 (or 2 and 4) are identical. The only difference is the phase of the subcarrier. Because these generators have separate locking circuits, they don't care about the phase relationship between subcarrier and horizontal sync. The burst phase difference between field 1 and 3 (or 2 and 4) is half a cycle. When you adjust burst phase, you are actually moving the picture (relative to its own horizontal sync) left or right by

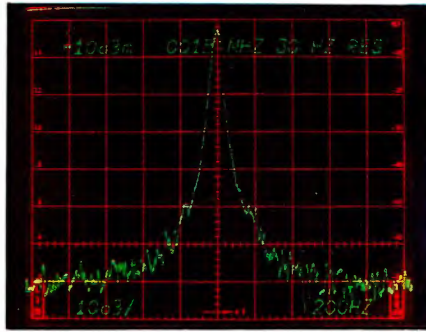

something less than $1/227.5$ of the picture width. That may not be much, but it's obvious when doing match-frame edits.

SC/H solution

The best solution is to use SC/H-type sync generators. An SC/H-phased sync generator performs all the internal timing to assure that all stand-alone pulses are timed from the same source. Any timing drift will affect all pulses equally. These generators then have to be able to gen-lock so that they will not destroy the integrity of the pulse relationship.

The subcarrier phase adjustment on a SC/H-phased sync generator moves the horizontal with the subcarrier. The horizontal phase adjustment has to move the subcarrier in 360° increments. It's similar to having course and fine adjustment controls.

To ensure every sync generator is properly synced together, you must have a common reference point. The start point is found on line 10 of color field 1. The subcarrier phase is observed at the leading edge of the horizontal sync, where it should be at a zero crossing and going positive. Nothing is magic about line 10, field 1 or subcarrier going positive; it's just an agreed-upon reference.

Now you know what it takes to be able to switch between sources without shifts in image or color. The only thing still required is a device to perform the math in the real world.

Frame synchronizers

Frame synchronizers represent an advancement in the idea of syncing everything together properly in a video environment. They record, store and play back frames of video. The purpose of the frame synchronizer is to lock a video source to a local system when it's not possible to use gen-lock. This might be the case with a remote, network or satellite feed. The process is a form of delayed broadcast; it's just that the delay is only a fraction of a second.

A frame synchronizer has the ability to digitally record a certain number of fields of video (usually 1, 2 or 4). A 2-field synchronizer is suited for situations where the primary function is to receive a remote

signal of active video and synchronize that signal to the studio. Such units are used for teleconference, satellite and microwave applications, which mix remote and local video for live broadcast or for recording on $1/2$ - or $3/4$ -inch VTRs. A 4-field device is the only type of synchronizer that can absolutely maintain SC/H phase relationships in all situations.

Time base correctors

Before we finish discussing synchronizers, it's important to eliminate any misunderstanding about another type of time-shifting device, the time base corrector (TBC).

A time base corrector corrects for errors produced by the mechanical portions of videotape recorders. When recording or playing back, even the best analog videotape recorder produces some variations in the time base signals. The produced error is the same thing as wow and flutter in audiotape machines.

A common sign of time base problems might be when you are trying to mix or wipe from a VTR playback to a camera or other VTR playback. If the VTR in use has any time base error, picture tear and roll occurs because the switcher and monitor cannot lock to two different sync rates or color rates at once. They must be exactly the same. The primary difference between a TBC and a synchronizer is that a TBC is designed to first fix any incoming errors in wow and flutter of the video signal.

Another sync pulse

Let's consider another type of sync pulse. The *color field identification* signal (CFID) is the latest addition to the sync signal family. This pulse is a marker that locates the first field of the 4-field color sequence. It then appears only once every four fields, or 15 times per second. It is used in video systems requiring full bandwidth, such as 1-inch VTRs, and can be helpful in making SC/H phase measurements.

Everett is manager of corporate communications with Videotek, Pottstown, PA.

DSK

DSK

The Switch Is On

To JVC's Line of Special Effects Generators



KM-3000U
Component



KM-1600U
S-VHS (Y/C)



KM-2500U
Composite



KM-1200U
Composite

At JVC, we've created just the right switcher for you. Our special effects generators are designed to meet all of your application and budget needs while providing reliable and outstanding performance. To find out why the switch is on to JVC, call 1-800-JVC-5825.

JVC[®]

PROFESSIONAL

Circle (11) on Reply Card

Finances and today's engineer

By Brad Dick, editor

Getting your budget approved means convincing others of its necessity. Don't hesitate to document your requests.

Developing a budget is only the first step in getting the financial resources you need. The most well-developed budget is worthless if management doesn't allocate what you've requested. Selling a non-technical person on the value of your ideas often is difficult and frustrating.

Don't speak a foreign language

The most common mistake made by engineers when developing and presenting their budget or resource requests is speaking the wrong language. How would you feel if your doctor explained why you needed an operation in technical terms only he understood? Yet many engineers try to sell their ideas to the station manager with such technical terms as lower distortion, maximum performance, 20-bit vs. 16-bit advantage, zero setup capability and 10dB better S/N. It's no wonder those budgets don't get approved.

Begin by speaking *their* language. Don't expect your manager to understand all the technical mumbo-jumbo unique to your field. Instead, use easy-to-understand terms. If you try to snow your boss with technical jargon, you've lost the battle for dollars from the start.

Do your homework

Look upon getting your budget approved as a sales job. A good salesperson investigates the client before making a pitch. When the pitch is made, the salesperson already knows as many of the needs, wants and peculiarities of the client's business as possible.

You're trying to convince the manager to purchase your product or service. The purchase price is the allocation of station resources to your department. There are five basic steps to selling your product.

1. Identify the station's needs.
2. Evaluate your station's economic environment.
3. Identify your competitors for station funds.
4. Establish realistic budget expectations.
5. Start now on the next budget cycle.

Let's look closer at how to complete these steps.

- *Identify the station's needs.* Notice I didn't say "equipment needs," which is a com-



pletely different matter. You should know, or at least learn, what the station needs. It might be new programming, staff or equipment. This goes back to the primary issue of knowing the station's mission and goals. If you don't know them, you're wasting your time and the station's money.

Several good sources for finding what those needs are include your boss, your boss's boss, your subordinates or another station in the company. Even governmental agencies may determine your station's needs. For instance, if the FAA declares new lighting requirements for your tower, a set of needs are placed on you by a governmental agency. Similar needs often are mandated by local groups. Environmental and safety issues can determine where your resources should be placed. Look outside your station when assessing station needs.

Watch the competition closely. Do they have some technical advantage you've missed? If you can identify such a factor, it's much easier to sell your client (boss) on purchasing the item.

- *Evaluate your station's economic situation.* You'll have a better chance of getting what you want and need if the station is profitable. That also applies to the entire industry. Do external financial factors handicap or help your station? For instance, what effect will higher taxes have?

If your station is profitable, it may be the best time to convince the manager to spend the needed money to retain that competitive advantage. It's easy to become complacent, especially when you're in the lead. Remind your manager of the importance to stay ahead by reinvesting in the station's infrastructure, the equipment that keeps it on the air.

It's easy to say, "My station's losing money, it will never allocate any money to engineering." That's certainly going to be the case if you adopt that attitude. Although it is difficult, you can sell the idea that spending money can help make money. Maybe you can see a way to use technology to open a new profit center. Could you add SCA capability to the FM transmitter and sell the time? If so, could some of that money be used for replacement tubes or other engineering needs? Be creative. Look for opportunities, not opposition.

- *Identify your competitors for station funds.* Every department head in the station is vying for the same money you are. Know who your competition is. Try to find out what they plan on requesting. Do they have a sales plan to support their request? Is their problem real or imagined? Be ready to out-document them at budget time.

Document your performance all year long. Use the same achievement standards of your boss, who probably is measured on profit. Can you develop any profit from the engineering department? Probably, but you may have to be creative.

In some cases, it pays to gain a friend at budget time. If two or more departments request funding for the same equipment or project, there is at least twice the chance of it being granted. If the news department wants to expand, try to coordinate technical capability between both departments. If you both ask for six 2-way radios or a \$25,000 remote truck, there is a much better chance of success. Besides, both department heads will appear to be working together, which looks good to any station manager.

- *Establish realistic budget expectations.* You can ask for the sky, but don't expect it. On the other hand, if you received 22% of the total budget last year and have developed no new projects or improved your productivity, why should you receive any more? If you're doing what you've always done, it's unlikely you can justify more financial support.

Show how you can improve productivity or produce new programming. Set the goals high enough to be challenging, but not so high as to be unobtainable. Get your staff excited about new opportunities, and show the boss you can deliver.

- *Start now on the next budget cycle.* The last step should have begun a year ago. Don't wait until the budget cycle begins to document your efforts.

Think about next year's budget all year long. Look for opportunities to presell your manager on a project or piece of equipment. When inadequate resources become a problem, write a memo outlining the problem and the solution. Look for ways to improve your staff's performance.

||:~:~)))))

MODEL 2000 SCT



AUDIO CONSOLE PRODUCTS

Arrakis audio console products are designed by broadcast engineers for broadcasters at reasonable prices. Our products sell themselves. Study our features, specs., and prices. Compare and you will find what thousands have found — The Arrakis Advantage —

TURBO FEATURES

- * VCA Faders
- * P & G Sliders
- * .01% Distortion
- * Solid Oak Trim
- * 10 W/CH Monitor
- * Remote Start
- * Mix-Minus
- * Modular Design
- * Ultra-Reliable
- * Mono Mixdowns
- * Stereo Cue
- * Full Muting
- * Dimensions —
- * 30" W x 17" D x 7" H
- * Weight — 55 Lbs.

MODELS

- 6 Channel Rotary (18 Inputs)
 - 150 SCT-6M \$2395
 - 150 SCT-6S \$2495
- 8 Channel Rotary (22 Inputs)
 - 500 SCT-8M \$3495
 - 500 SCT-8S \$3595
- 8 Channel Linear (22 Inputs)
 - 1500 SCT-8M \$4395
 - 1500 SCT-8S \$4495
- 12 Channel Linear (24 Inputs)
 - 2000 SCT-12M \$4895
 - 2000 SCT-12S \$4995
- 12 Channel Linear (34 Inputs)
 - 2100 SCT-12M \$5895
 - 2100 SCT-12S \$5995

arrakis
SYSTEMS, INC.



2619 Midpoint Drive
Fort Collins, Colorado
80525

(303) 224-2248
Circle (12) on Reply Card

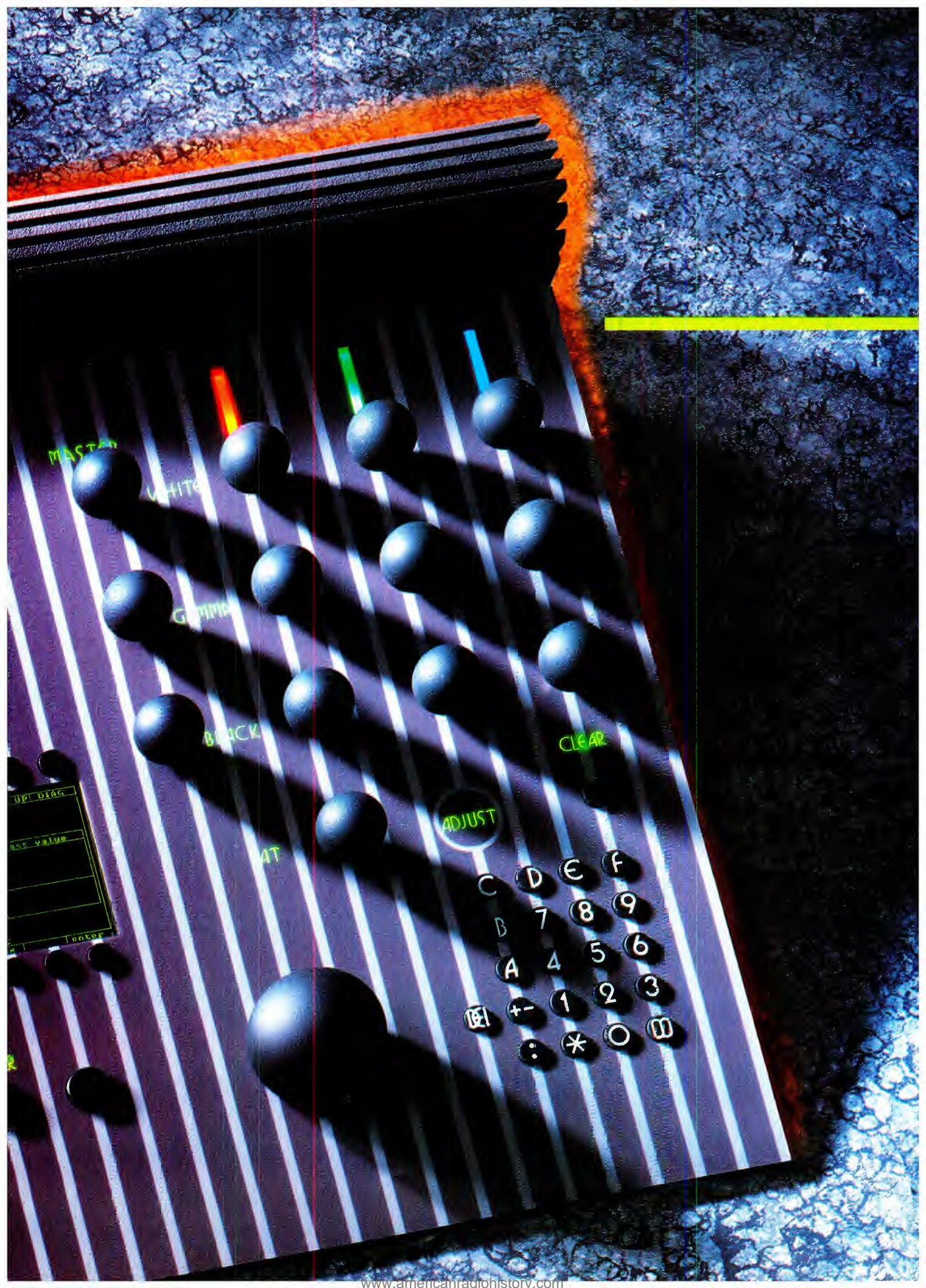

MASTER

WHITE

GREEN

BLACK

CLEAR

ADJUST

AT

C

D

E

F

B

7

8

9

A

4

5

6

⊞

+ -

1

2

3

:

*

O

⊞

UP! DIAG

BASE VALUE

ENTER

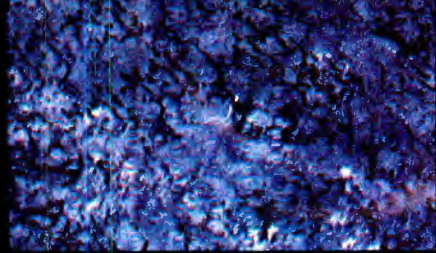

Networking lets equipment
do more than one thing.

Video: technology on a roll

At one time, each piece of equipment did one thing, and did it independently. The signals passed from box to box within a station, and each box did something to it. In today's broadcast facilities, the boxes each do more. Also, many boxes have become capable of modifying what they do based on communications from the other boxes. This means that in addition to the signal interconnection, today's busier boxes need a control interconnection as well. One good buzzword for this networking of equipment is *integration*.

Modern facilities, such as WFTV, in Orlando, FL, which is featured in "Integrating Systems for Flexibility," rely on integration to achieve efficiency and flexibility.

If computerized, integrated broadcast systems are creating the signals, there is no reason such systems cannot test them as well. One method making noise these days is the CCITT and ANSI automatic audio test sequences. Given 30 seconds and the appropriate hardware, these standards give engineers the tools they need to do an amazingly complete diagnosis of a complex audio path, such

as from an ENG unit to the control room. This testing will clearly revolutionize the quality-control aspects of our industry.

This month we will feature the following topics:

- "Integrating Systems for Flexibility: WFTV's Story" page 26
- "Automating Audio Measurements" 38

No doubt, over time, knowledge of the interconnections used between pieces of equipment will be as common as the knowledge of video and audio interconnection today. For now, it is a technology on a roll— an opportunity just waiting for engineering pioneers to seize it.



Rick Lehtinen,
issue editor

Most broadcasters have become attached to their analog video tape recorders. Which makes perfect sense. After all, they've never had any other choice. Not to mention the fact that analog VTRs do seem to get the job done.

But while those machines may still be



First, you have to continually adjust and

tweak an analog VTR just to maintain an

While your video tape recorder works fine now, you can only go as far as

working quite well, their technology isn't. Fact is, analog VTRs are full of limitations. And

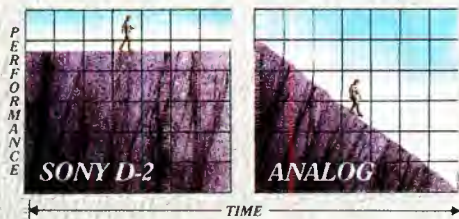

Over time, analog's performance tends to go downhill. D-2's doesn't.

those limitations can really hold you back.

To begin with, an analog VTR's performance will always deteriorate over time. A fact that results in two troublesome limitations:

acceptable level of performance.

Second, depending on how old your VTRs are and how well they've been maintained, some will undoubtedly perform better than others. Which means some will also perform worse.

With Sony D-2 Composite Digital™ VTRs, none of this is true. Because a D-2

With analog you're restricted by the condition of your video tape.





VTR performs consistently over time and minimizes the need for adjustments.

quality of your video consistently high.

Furthermore, the sound quality of an analog VTR could never be as advanced as D-2's.

Because an analog machine could never give you D-2's CD-quality digital audio. With accurate and consistent stereo phasing. No wow and flutter. An expanded frequency response.

Sony Corporation's Products Company, 1000 Queen Anne Road, Torrance, NJ 07466. © 1990 Sony Corporation of America. Sony and D-2 Compressive Digital are trademarks of Sony.

Order may be quite advanced, its technology will let you.

Another limitation of analog video is something called tape dependency. Which means that the quality of your video can only be as



Compared to D-2, the sound quality of analog seems rather archaic.

good as the condition of your video tape.

But in D-2, this limitation doesn't exist.

D-2's powerful error correction and Sony's unique error concealment systems keep the

And a wide dynamic range of more than 90db.

These are just some of the ways D-2 has expanded the limits of video technology. To learn more, call 800-635-SONY.

Because even if your analog video tape recorder has been engineered with the highest technology, some technologies are simply higher than others.

SONY

B R O A D C A S T P R O D U C T S



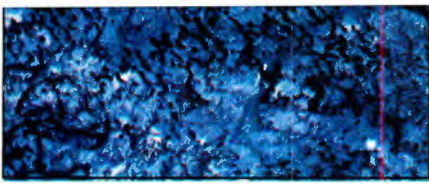

Production systems can do their best work by pulling together.

Integrating systems: WFTV's story

By Bebe F. McClain and Paul Warnock

This past January, WFTV, channel 9, in Orlando, FL, went on the air from a new facility. It was the result of many painstaking hours of planning, debating over equipment selection and working through and modifying equipment interfaces to achieve the outlined goals.

The station's plan was to create a facility that would serve well into the 21st century. To achieve this, the engineers worked to make the routing, intercom and still-store/graphics systems/library systems as flexible as possible.

To begin at the beginning

Almost two years ago, Paul Warnock, WFTV chief engineer, received word that Cox Broadcasting had approved plans to build a new facility. Cox selected the architect and builder; Warnock designed the facility.

Some of the early research included a joint effort between the engineering and operations departments to determine the operational needs of the facility. Cardboard models of control-room consoles were built to see what layouts were most workable. Rolls of paper with monitors drawn on them were tacked to ladders, which were placed in front of desks supporting cardboard mockups of consoles to

determine heights and grouping arrangements. All details of each functional area were addressed.

Warnock had decided upon certain equipment from the start, which included production switchers, a still-store/library system, audio consoles and color monitors. More investigation was needed for the routing, intercom and graphic systems. Special attention was given to these areas, because they had been troublesome in the past.

Systems for the next century

The router, which was the first system tackled, had to be integrated with the master-control switcher, the switchers in the two main production control rooms and the on-line edit suite switcher. The goal was to have every switcher in the house see every source in the house in time and in phase. Warnock wanted switcher register control of the routable inputs to the switchers for speed of setup, especially in a news environment.

In the old facility, signals from the routing switcher were retimed into the control-room switchers with frame synchronizers and a delegation system that adjusted system timing for each source. Sources had to be physically changed at the router if production rooms were to access anything other than the standard setup. At the new facility, a few frame syncs are used only

McClain is a technical marketing consultant based in Asheville, NC. Warnock is chief engineer, WFTV, Orlando, FL.

THE MOST IMPORTANT AUDIO CONTROL EQUIPMENT WORKS FROM HERE TO HERE

Keeping sound clean and accurate can make or break your audio projects. SONEX from illbruck ensures that you're getting the sound you want. Our complete line of acoustical materials gives you total control—in the studio, the control room, or wherever sound quality is critical. There's a reason SONEX continues to lead—nothing works better. Put the leader to work for you; call today for all our performance specs and application guides—800-662-0032.

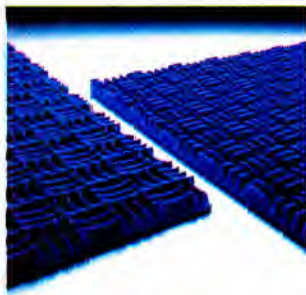

SONEX

The only acoustical foam with the illbruck anechoic-wedge—over 400% more surface area than flat materials. Controls reverb, reflections, and resonances—beautifully. The proven performer.

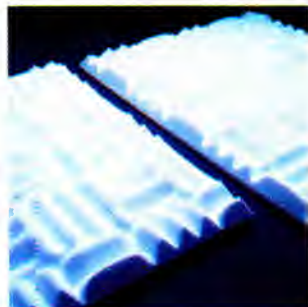

SONEX 1

The same unbeatable performance of SONEX but in materials that meet all Class 1 regulations. For demanding applications where heat or fire are factors. Safe for you but deadly for sound.

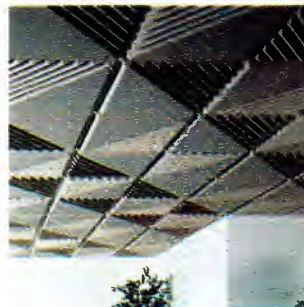

SONEX CEILINGS

Suspended ceiling treatments that deliver new levels of acoustical performance. Unique, contemporary designs. Available in a variety of styles and colors.

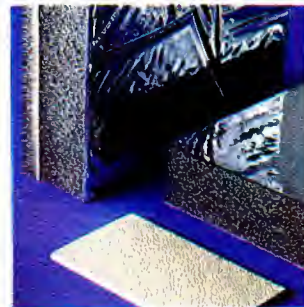

BARRIERS & COMPOSITES

When the problem requires more than absorption, illbruck barriers deliver. Single layer vinyls to multi-level laminates. Lead performance without lead price or problems.



illbruck

Sonex Acoustical Division
5155 River Road N.E.
Minneapolis, MN 55421
1-800-662-0032
In MN: 612-521-3555

for "out-of-house" non-synchronous sources, such as ENG or satellite feeds, and to handle the delays involved in using Newsmatte backgrounds. Once past the synchronizers, these sources, like the other 128 video sources and the 64 audio sources, can be called up in time, anywhere.

Sources can be fed to master control directly through the production switcher or through the router and production switcher. Cable lengths were precisely cut for the different routes, and delays were incorporated where needed to keep the signals in time and in phase. (See Figures 1 and 2.) Because Teflon cable was used, the engineers had to consider that the propagation velocity was different when timing was computed.

Bugs

To achieve the goal of "any source, anywhere," involved much debugging of the master-control-to-router interface. In theory, the system should have worked perfectly, but integrating it into the switcher brought the usual headaches associated with interfaces. Machine controls would mysteriously lockup. Pushing the roll but-

ton for a tape machine in master control would intermittently yield nothing. Cards were changed, then software was rewrit-

ten in an attempt to solve the problems. The most serious problem did not emerge until operation actually began. As

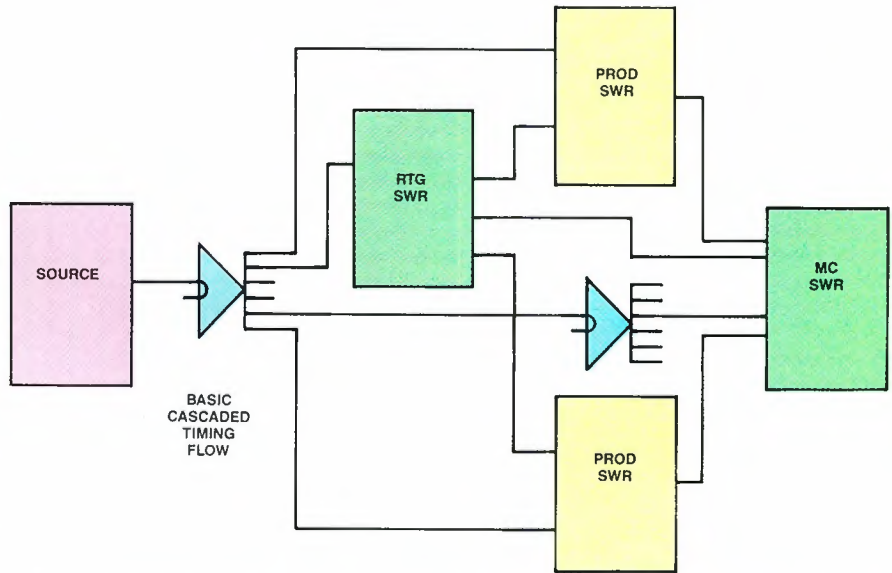

Figure 1. Basic timing philosophy of WFTV allows any source to appear anywhere and be in time.

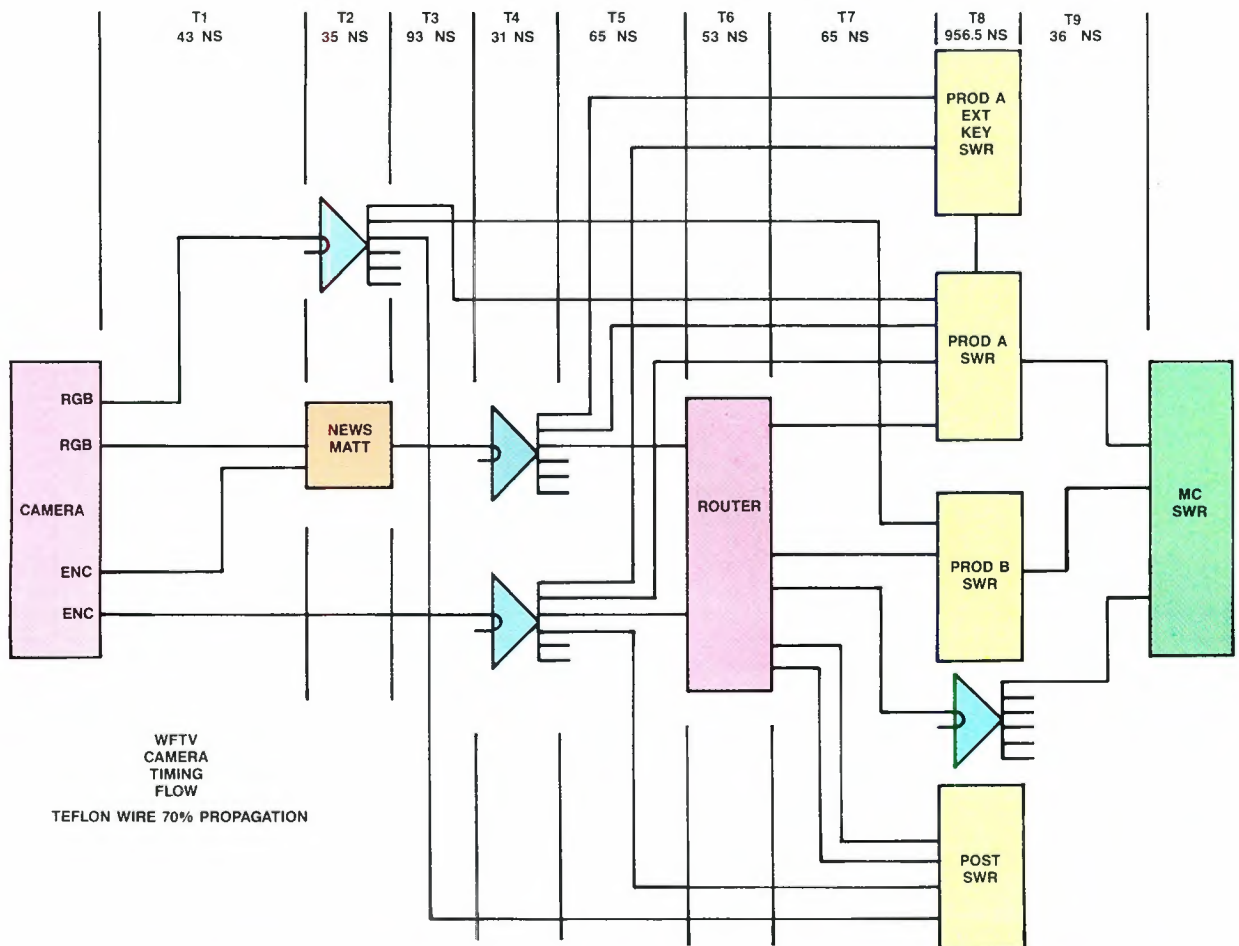

Figure 2. The timing flow diagram of the studio camera system shows that cameras can appear at any switcher in time.

**24 inputs
at a
remarkable
price.**

*This 24 input switcher
has all the features
that people have
come to expect ...*

*but it's the price
that has them
talking.*



model RVS
424

Featuring:
the unequalled
keying capability
of the Ross
Downstream
Multi-Keyer



ROSS VIDEO LIMITED

"The Production Switcher People"

For the name of the
Ross dealer near you,
call
(613)652-4888

Ross Video Limited, PO Box 220, 500 John St., Iroquois, Ont. Canada K0E 1K0 Phone 613-652-4886, Fax 613-652-4425
Ross Video Inc., PO Box 880, Ogdensburg, New York, USA 13669-0880

Circle (14) on Reply Card
www.americanradiohistory.com

explained previously, the router panel at master control could call up any source in the building. It also had machine control to start and stop tape machines. The master-control operator could use the router to assign any source to any of eight inputs on the master-control switcher, and then use the master-control switcher to activate the sources. A priority system was installed that put master control as the top user. If a tape machine was being used by master control, everyone else was locked out.

The problem arose when the master-control operator pushed the switcher button to roll a tape because there was no button on the switcher to stop the tape. The operator couldn't use the stop button on the router panel because the VTR had been delegated to the switcher, and, therefore, the router panel was locked out. The only way the master-control operator could stop the tape was to yell into the tape room to an operator standing by who could stop the tape manually. Fortunately, master control opens into the tape room.

Engineering personnel were uneasy about abandoning the priority structure. They were haunted by the possibility that someone in a production area might grab a VTR that was needed during a live broadcast. A plan was devised to program the master-control router panel in parallel with the switcher. The master-control operator could then use the master-control switcher to start the tape and reach up to stop it using the machine controls on the router when needed.

Losing control

Although automation provides flexibility, it has a few tradeoffs. The former mechanical systems could be repaired with mechanical means. Computer-based systems make the user more dependent on the manufacturer for maintenance that is beyond the scope of station personnel. Software problems can be elusive and the user loses control.

However, computer-based equipment does have the advantage of incorporating software that allows hierarchy structure for machine control.

The whole exercise reinforced the decision to use the same vendor for the switcher and the router. The station did not want to have two vendors blaming each other for problems, but wanted one company responsible for solving the many integration problems that such a large system portends. This was particularly important because the vendor had never attempted to integrate such a large system.

Switcher-to-router interface

Control rooms A and B are next door to each other and are exactly alike. Matching consoles hold the identical equipment



The new facility, WFTV, Orlando, FL, went on the air Jan. 1, 1990.

laid out in the same manner. If disaster struck, this would allow the news production team to instantly move from control room A to control room B while on the air. All sources in the plant are available to control rooms A and B.

Above each switcher is a router control with eight buses. The adjacent keypad can be used to place any of the 128 sources in the buses. The eight sources read out on LEDs above the eight router buttons on the switcher as well as on the router monitors. The cameras are wired directly into the switcher and also through the router. Alongside is another router control panel with eight buses dedicated to the digital effects system. The effects system talks to the switcher through a serial in-

terface adapter.

Control-room interchangeability also is facilitated by memory registers on the switchers. The setup diskette could be grabbed on the way out the door and used in the adjacent control room to quickly configure the switcher exactly like the one abandoned. Digital effects moves, also on diskettes, could be transferred on diskette. Because of the careful integration of the routing switcher and control-room switchers, even if it took a few minutes to get all of the sophisticated hardware ready to roll in the new control room, news would stay on the air.

Intercommunications

The second system to be dealt with was the intercom system. Whether at a station or a large remote broadcast, it is a perpetual battle for internal communications. Who will be able to talk to whom, and what are the priorities?

Even the largest intercom matrix does not allow everyone to talk to everyone. Therefore, a definitive list had to be derived, and it had to be changeable. In order to determine what communication could take place on a limited number of intercom keys, the producers, directors and switcher operators were given a wish list of those with whom they wanted to converse.

Once the sources were determined, a master list was developed, and assignments were made to the individual panels throughout the tech center. The two computers that drive the intercom system provide the flexibility to customize the sys-



WFTV master control has a router panel with keypad where the operator can call up any of the 128 sources in the house and assign any eight to the small switcher. LED readouts in black windows in the center of the switcher indicate sources assigned.



THE BUCK STOPS HERE.

What makes us unique is that we take full responsibility for every broadcast transmission system we supply. Even if you specify other equipment and suppliers for parts of your LDL installation.

And it's a responsibility we can afford to take. Because LDL stands for LeBlanc & Royle towers, Alan Dick antennas and LARCAN transmitters. Leaders in their fields.

At the same time, we're members of the LeBlanc Communications Group. So LDL also stands for the vast broadcasting resources and experience of our other affiliated LeBlanc Companies.

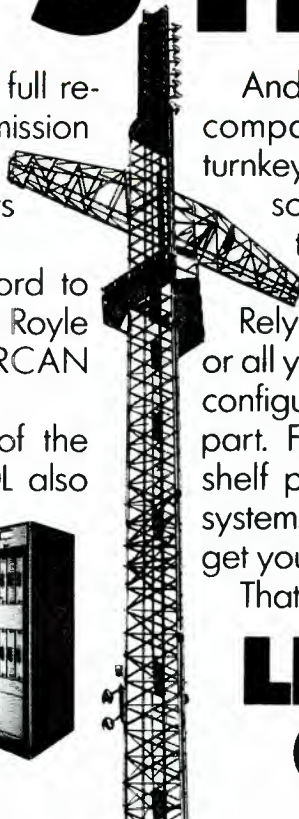
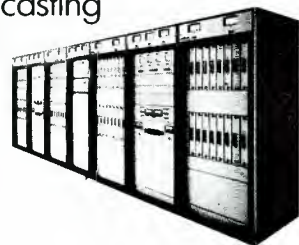

And that makes us one of very few companies who can handle complete turnkey systems with our own internal resources. So you get every benefit of total systems integration. On schedule, within budget.

Rely on us. As your one source for any or all your needs. From the most complex configuration to the smallest replacement part. From custom-designed or off-the-shelf products to upgrades for existing systems. We've got whatever it takes to get you on the air. And keep you there.

That's LDL. Responsive and responsible.

LDL COMMUNICATIONS, Inc.
A MEMBER OF THE LeBLANC COMMUNICATIONS GROUP



LeBLANC

14440 Cherry Lane Court, Laurel, MD 20707
Tel: (301) 498-2200, Fax: 3014987952.

Circle (15) on Reply Card

THE LEADER IS AT IT AGAIN!

WE'VE ALREADY BUILT AND INSTALLED AN OPERATIONAL HDTV SYSTEM!

Just ask KBLR-TV39 in Las Vegas, Nevada. JAMPRO provided their antenna which permits the transmission of an HDTV signal.

State-of-the art technology and JAMPRO continue to grow together . . . we were on the leading edge when we developed the first circular polarized television antenna . . . and that tradition continues today.

OUR SYSTEM PROVIDES

- Pattern stability
- Non-scanning characteristics
- A band width wide enough to provide the superior broadcasting of a high definition signal.

FOR DETAILS

(916) 383-1177 • Telex: 377321
FAX (916) 383-1182



6939 Power Inn Road
Sacramento, CA 95828

Circle (16) on Reply Card

tem to in-house needs. Changes involve only a few keystrokes. Also, a diskette can be made of a particular setup of all terminals as they were assigned for a specific requirement and then recalled when needed.

No manual labeling is required when assignments are changed. If someone requests a change in the standard assignment and entries are made using the keyboard in the rack room, the LED labels above the keys at each station change when the entry is made.

The intercom system handles all IFB plus the 2-way radios. The IFB portion of the intercom system has 24 outputs, eight of which are assigned to the news studio A, eight to studio B and eight to the phone interface for the field. The IFB sources are from the audio boards (mix-minus) plus off-air. Of the 17 inputs on the IFB assignment panels, eight are from audio A, eight are from audio B and one is the off-air feed. In control rooms A and B are the program assign panels for IFB so the remote coordinator can assign any IFB audio source to any output. This is done by entries into the keypad.

Priorities for interrupt were set as follows:

1. Producer
2. Director
3. Technical director
4. Remote coordinator

The system can handle up to 40 party lines where up to 80 people can join in, plus point-to-point communications.

On all of the 33 regular intercom panels in the station there is a blue key, called a "wild card," which has a flashing LED above it. Anyone trying to call you who



Identical switchers in control room A and B have a router mounted above that can call up any of the 128 sources in house and assign them to eight positions on the switcher. (See eight LED readouts at upper left of photo.)

is not assigned to your panel will appear on that key and be connected. There had previously been a problem of not being able to communicate with people at entry doors, now any intercom station can talk to someone at any door. Security has been greatly improved.

Graphics

The third large system that took con-
Continued on page 36



A graphics operator can access the central storage library and can use the keyboard to access the still-store.

SEE WHAT A LITTLE FIBER CAN DO FOR YOUR SYSTEM.



No doubt about it. Adding fiber to your system can put you in great shape. Especially if you need to fit more signals in cable trays or conduits. Run cable up to 5km. Eliminate EMI interference and ground loops. And ensure signal security.

And *especially* at \$900 per link. Because now there's the DYN AIR Series 400 and Series 1200 video distribution system. With the industry's best differential phase/gain and signal-to-noise.

Consider our Series 400, stand-alone fiber links that fit anywhere, go anywhere: Building-to-building, on-location, in the studio. With our fully compatible Series 1200, running both fiber and coax is a snap. Run fiber in/coax out. Or coax in/fiber out. Or fiber to fiber. And coax to coax. All in one modular package.

You can upgrade to serial D2 and wideband, too. Without changing frames or power supplies. Of course, all this is just to whet your appetite. For the full DYN AIR fiber story, call or fax us today.



DYN AIR

Call 800-854-2831. Or fax 619-264-4181.

Circle (17) on Reply Card
www.americanradiohistory.com

With most cassette make countless system, and manually And they call th

When you think of auto-
mated cassette systems,
manual labor isn't usually the first thing that comes to mind.
But fact is, some systems can create more work than they



eliminate. Especially systems that
use what we call a "Variable
Cut" method of automation.

*Variable Cut systems are kind
enough to warn you about
potential problems. But you'll
have to correct them yourself.*

A Variable Cut system
allows you to put more than one

spot on each cassette. A method of automation which at first
may seem quite efficient. But when compared to Sony's
advanced multi-cassette systems, a Variable Cut system is
actually rather labor-intensive.

To begin with, a Variable Cut system requires you to
make dubs manually. With Sony's multi-cassette systems, all
you have to do is push a button.

And it will automatically make

*With a Variable Cut
system, you may have to make
a lot of dubs by hand.*

two dubs for you right in the machine. Secondly, a Variable



systems, you have to dubs, devise a filing correct system errors. at automation?

Usually by making more dubs than you bargained for.

But system requires you to figure out how to file your spots on your cassettes. Which means you'll have to start working even before your multi-cassette system does. How will you classify your spots? By advertiser? By product type? By running time? In the end, the burden is on you.

With a Sony system, however, tape conflicts aren't a problem. So you won't have to spend all your time and energy correcting them.

Variable Cut systems require you to devise a filing system before they'll operate efficiently.

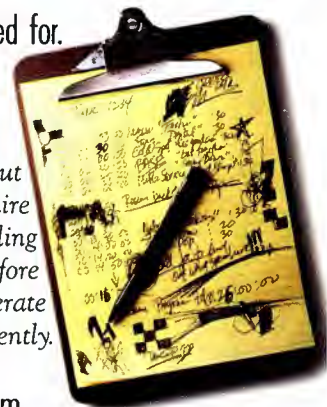

But with a Sony system, filing is done by the machine. All you have to do is load the source tapes,



With a Variable Cut system, tape wear can become a visible problem.



There are many other ways Sony's multi-cassette systems are easier to use than a Variable

and the system files them. Automatically.

Lastly, Variable Cut systems tend to have difficulty dealing with tape conflicts. More often than not, their solution is just to flash a warning. Which simply indicates that you'll have to correct the problem manually.

Cut system. But we don't want to belabor the point. So call 1-800-635-SONY for more information. Because if your multi-cassette system is really working, then you shouldn't be, too.

SONY®

BROADCAST PRODUCTS

Continued from page 32

siderable planning concerned graphics. The station did not want to create graphics in the NTSC domain, but did need to convert to that standard right before going on the air. The next best choice was to have all signals in RGB. The preferred choice was to have the still-store, paint systems and central library all operating in the CCIR 601 (D1) format.

A paint system that operated in 601 and RGB had recently come on the market. Warnock wanted to buy the system as a second paint box for the new station. The station had a large investment in its present paint system that used RGB (not 601) and it couldn't justify scrapping it and buying two new ones. Because the plans required that the old and new graphics hardware operate on the same system, this would limit the station to RGB. It appeared that it would go RGB for the entire system until it was discovered there was only one RGB input for the new paint system and thus to the library system. This presented a problem because the station had to connect two RGB sources, a graphics camera and a paint system.

At first, Warnock thought he could simply use a switcher to alternate camera and paint box inputs. He soon discovered there was no single RGB switcher and that he would need three switchers — one each for R, G and B. It was becoming a nightmare.

Just when all seemed lost, the manufacturer announced that it could supply

several boards and software to convert the old paint system to 601. This was the missing piece that would allow the system to be assembled consisting of the old paint system, three still-stores and a new central library system all talking to each other in 601 with final conversion to NTSC. (See Figure 3.)

Another concern was how many terminals there would be for accessing the library. The two graphics systems needed access for storing graphics produced. Other terminals were needed in the news control room A, production control room B, the on-line edit suite and master control, each of which had a dedicated still-store that accessed the central library. Although there are two keyboards for each of the three still-stores, only one keyboard at a time can be used per still-store. Delegation is by keyboard commands from each terminal.

Lessons learned

The station engineers discovered that even the best laid plans often cannot foresee practical operational problems. They also became convinced of the wisdom of one of their overall decisions at the outset of the project, which was to select vendor companies who were tops in their fields, had the manpower and expertise to follow through and would not risk failure in satisfying a customer.

A new station is not a collection of equipment, but rather a tapestry woven by systems. When asked what lessons

Warnock learned that could be passed on to others, he responded with this list.

- Give yourself more time than you originally estimated to install the technical center.
- Be prepared for all the people and political problems that arise from such a large undertaking.
- Have a larger miscellaneous budget than first estimated. Not until you move do you realize all the little systems you've put in, and all those non-integrated systems and non-line items you've forgotten.
- Limit your hands-on involvement. Your job is to keep the present station running smoothly, and you must delegate as much work as possible concerning the new facility. Oversee the project.
- Even though you want your own people to install all the new equipment so that they will be familiar with the system and its operation, you must contract out a lot of this work if your present station is to run smoothly.
- Select vendors who will stand behind their promises. They must be dependable companies who will make it work no matter what it takes and no matter how long it takes.
- Be prepared for a mild state of depression when it's all over. After working on a project for two years and being preoccupied with all the problems associated with giving birth to a new station, there is a reaction akin to the "blues" once it's completed. Perhaps, it's just a suppressed query: "What do I do to top this?"

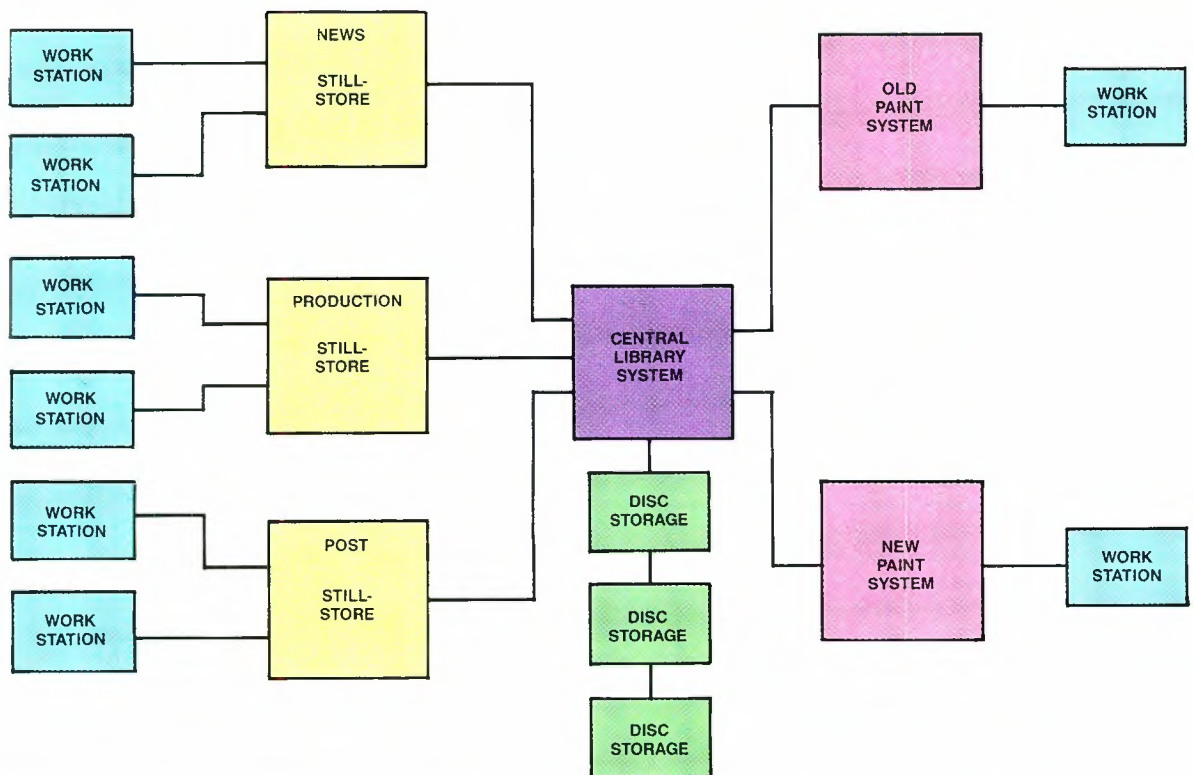

Figure 3. WFTV uses a central image storage system to share images between two paint systems and still-stores in three control rooms.

Panasonic® Pro Series Monitors.



**Designed for production quality...
With an eye on your budget.**



Panasonic presents two very versatile, high-grade color monitors--the BT-D1920Y and the BT-M1310Y. Built for performance, these BT-Series monitors offer you the quality and reliability you've come to expect from Panasonic. Not to mention a wide array of features at an affordable price.

Our BT-Series provides you with the controls and connections necessary for studio applications--while serving a host of industrial, educational and professional video needs.

For maximum performance and versatility, both monitors offer complete, direct compatibility with the new S-VHS format--in addition to conventional signals. And video reproduction on the BT-Series is superb. As a matter of fact, the BT-M1310Y boasts a horizontal resolution of more than 560 lines, while the BT-D1920Y offers you greater than 550 lines.

What's more, each monitor provides you with a full set of front panel controls. Like Line A/B split, S-Video input

connectors, Blue signal-only switch, pulse-cross circuit, preset picture off/on, comb/trap filter selectable and normal/underscan switch, just to name a few.

So when you are looking for professional quality, but still need to keep an eye on your budget, look into the Panasonic BT-Series high-grade monitors.

For more information and your local dealer, call your nearest regional office.
Eastern Zone: (201) 348-7620 Central Zone: (708) 981-4826
Southern Zone:
Dallas Region: (817) 685-1117 Atlanta Region: (404) 925-6841
Western Zone:
Seattle Region: (206) 285-8883 Los Angeles Region: (714) 373-7275

Circle (18) on Reply Card

Panasonic
Professional/Industrial Video

How far can desktop video go?

By Rick Lehtinen, technical editor

Imagine you are a reporter sitting before a terminal on an advanced newsroom system. You have to report on a press conference you attended about airport expansion. Your script is prepared from your notes and a portable cassette recorder. Now you need to put the story together.

You have some videotape of the press conference, including a handout tape with a computer-graphic simulation of the new terminal. The first thing you did when you got back to your desk was to play the tapes into the newsroom computer where they were digitized, and they wait as compressed files. You call them up, and they appear in a window over your text. With the arrow keys or the mouse you shuttle past a few bad takes. You click your mouse on a couple of standups you like. Time-code numbers are transferred into your story file, and you type in slugs for easy recall. Tiny icons representing the start and end point for the takes you selected pop up in a window near the bottom of the screen.

Next comes the interview. The subject was coherent for two 15-second segments. You click on them and type in slugs. You move the tape window out of the way so that you can read the subject's name from the script. You use this to order the computer-graphic super.

Some background information would be beneficial, so in another window you scan the archive for stills of the airport. Fortunately, there are some and you call them up, but quickly discard most of them. Three look promising, however, so you call them back full screen and pick the best two. By clicking the mouse, their file numbers are transferred into your document.

You recall that there is opposition to the airport expansion plan. A section of town that is trying to declare itself a historic area would have to cope with a taxi way being moved a thousand yards closer. First, you check the library for a map of the city. You scan a compressed version of archived footage from a story done last year. Two segments have snow on the ground and wouldn't be appropriate. One is clear, and with the mouse, the reel number prints out on a terminal near the producer's desk. Someone tosses a key to an intern who grabs the slip and heads downstairs.

Finally, you call up a selection of city maps and make a few marks, by way of suggestion, for the art department to create a graphic.

You mail a copy of your script to an awaiting producer who reviews it and corrects a citation in which a company

name was not spelled according to the station stylebook.

The newsroom of the future will most likely resemble the computerized news-



The newsroom terminal of the future most likely will have the ability to present textual and visual information, and use a graphical interface to communicate with the user.

room of today, except that the computer's flow of information will be more user-friendly. More information will pass through the computer, and more information will be presented to the user in the computer domain. Low-resolution versions of archived stills and videotapes will be available to reporters on their terminals, which will aid in selecting graphics. Items that are error prone, such as the typing and retyping of interviewees' names, will be minimized. This will be accomplished by keeping the information in data form once it is entered.

This implies an adoption of some technologies that are making big waves outside of the broadcast industry. "Multimedia solutions," that is, using the computer to control a number of external presentation devices, such as VTRs and MIDI sequencers, are already available for several computer platforms. Compression techniques, such as digital video interactive (DVI) and compact disc interactive (CDI), allow images and moving video to exist in the system and appear on the screen without the tremendous bandwidth overhead of conventional digitized video.

What is available now compared to what was described previously is not such a big step. Most of the pieces are available now. Others are in the back rooms of newsroom system manufacturers.

Later, after cutting some voice-overs, you enter the edit bay with your field

tapes and the archive tape. The editor builds a rough EDL by moving some segments that are marked on the screen by head and tail icons. After looking at the package in sequence, you decide which standup you like best.

The tapes are loaded into the editing machine, and the editor pulls the icons around to finish the package. All the elements of the story fall quickly into place. "This is just like cutting film," the editor says.

Much research has been done recently into using the computer as an edit controller. Several manufacturers already promote their ability to drive tape machines. The big news, of course, is that the video signal itself may shortly enter the computer. Several manufacturers have announced new bus configurations that can work at video bandwidth.

Before the newscast, the anchor reviews her prompter copy on a terminal at her desk, and again later at a table at the side of the news set. She takes a small stylus and writes a couple of notes on the side, underlines a few words and makes some diacritical marks, which she alone understands, to guide her in the pacing and pronunciation of the material while she's on camera.

Back in the newsroom, the meteorologist takes a last look at the latest set of images available on the service to which the station subscribes. Because the volume of images and raw weather data available from the government has mushroomed, these services produce new graphics constantly. With a few key clicks, he leaves a macro that will automatically update the files he will show on the air in a few minutes.

Today, computer prompter files are often in ASCII format. Many times these have embedded command codes that initiate action on the part of automatic broadcast systems.

Sometimes prompter files are downloaded by the newsroom computer into the teleprompter system as each story moves up the rundown. If the producer reorders the stories, there is no cause for panic or page flipping. The computer merely discards the unneeded files and sends the current one. Some systems feature special express modes that allow the system to keep up with last minute changes.

Some systems are available with color screens. Another new technique proposes that the prompter files be treated as images files, not text files. This would

Continued on page 98

EVV	TVNZ	WITF	WTVH	KPIX	WVIZ	WVTV
ARK	CCTV	KJTV	KGBT	KSEE	WGAL	KVVU
ELO	VOK	WISN	KRGV	KRMA	KOAT	KPHO
CBS	TTV	WCVB	KTXS	WOFL	WUTR	WHMM
DVM	RAI	WAKA	WSLS	WATL	WCET	WAVY
TOL	KBC	KSTS	WHME	WHO	WSYX	WXEX
EHT	BTQ-7	WJCL	WJZY	WGN	WCAU	WOWK
BRZ						KBDI
MOX						KWHY
AIT						WTVT
NEM						WGNX
SLA						WAVE
ETK	STW-9	WIPB	WETK	WTVW	WNEP	WECT
LVI	BCV-8	WTVJ	KHJ	WPSD	WVIA	WMHT
ETK	KBS	KGUN	KARK	KPLC	WIS	KWTV
FCF	CSSR	KCOY	WYAH	WJZ	WSMV	KABY
FQC	BBC	WHCT	WTTV	KMOV	KCOS	WSAV
FMT	WABI	WMAZ	KFME	WFIE	KPRC	WBTV
BFT	WCCB	WBAL	KLTV	WHAS	KTRK	WFMY
CITV	WETM	WBFF	WSFA	KLFY	WWCP	WCPO
KVR	WXXI	KSPR	KPNX	WDSU	WYFF	WCIV
KVU	KEZI	WPTZ	KICU	WMAR	KBTX	KUTV
JOH	WTAE	WHYY	KSBW	WLOS	KFDM	KUSA
BUT	KSFY	KLRN	KCNC	WXII	KSAT	KXLY
IVM	WCFE	KTMD	WRC	WRGB	KVUE	KXAS
HSV-7	WTTW	KODE	WXEL	WBNS	KSL	KWCH

These stations had to pay us to get on this list.

What we mean, of course, is that they all have purchased Ampex switchers, and we don't exactly give those things away. But what's more important is what the TDs and directors at stations like these are saying about our switchers . . .

"We can configure the switcher any way we choose, fast! Between live news and some spot breaks we have only 30 seconds to change TDs, directors, everything! With Century we can do it, with time for a sip of coffee to spare."

"Key clip level, gain level, etc., are all stored *per source* in the Century's key memory—we *never* have to adjust a key on-air."

"We store all of our switcher setups on the same disk where we store our program options. Then we can pop the disk

in and have our entire switcher ready, bingo, for the whole program . . . with all the panel memory setups . . . in 3 or 4 seconds!"

So if you're considering a switcher for your broadcast facility, get the full story before making a decision. Call **1-800-25AMPEX** for a poster and an information kit.



AMPEX

If you're looking to
image in field pro
we suggest you lose a



improve your production, few pounds.

When we set out to produce the best image acquisition tool for field production, we knew the competition would be heavy. Which is exactly why the Sony BVW-400 comes out on top.

No other imaging device puts such extraordinary performance into such a compact, lightweight camcorder.

The BVW-400 Betacam SP® camcorder is engineered with Sony's most advanced CCD sensor technology—the Hole Accumulated Diode (HAD) 768 FIT chip. So you can shoot video with 700 lines of resolution. With virtually no vertical smear.

At the same time, the BVW-400 weighs only 15 lbs. It's just 15 inches long. And its low profile offers an unobstructed peripheral view.

There's also an optional adapter for simultaneous Betacam SP® recording on an external VTR.

All this performance in such an easy-to-handle package will give you a degree of creative flexibility that you've never had before.

Of course, when you consider Sony is the originator of one-piece technology, a camcorder this good should come as no surprise.

For more information about the BVW-400, call 1-800-635-SONY.

After all, while a camcorder should be designed to weigh as little as possible, its performance should never be taken lightly.

SONY®

BROADCAST PRODUCTS

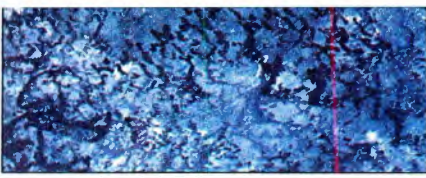

Test audio in 30 seconds — automatically.

Automating audio measurements

By Adolfo Rodriguez

TV viewers do more than just view. They listen, too. And today, viewers are particularly sensitive to audio quality, which has been heightened recently by digitally mastered CDs. Stereo TV programming has become increasingly popular for combining the visual experience with an impressive audio experience. Even for monaural, “sounds good” has become as important as “looks good” for buyers purchasing a new TV set, and choosing what programs to watch.

This increased emphasis on audio quality places a new set of measurement demands on TV broadcast engineers. Audio-channel performance must be kept at peak quality from remote source or ENG van to final signal delivery. This requires thorough evaluation of audio-channel parameters (frequency response, THD+N, signal-to-noise (S/N) ratio, gain and phase difference between channels); performance monitoring (stereo balance and monaural compatibility); and troubleshooting various audio problems.

Without some help, the additional burden of high-performance audio testing becomes heavy. Fortunately, there is help in the so-called “30-second test” originally established by CCITT. When digitally implemented, this test can be fully automated for testing to the ANSI standard T1.502-1988, EIA/TIA-250-C or CCITT 0.33 via stored measurement programs. The result

is complete evaluation and display of audio parameters all in about 30 seconds from start to finish. (See Figure 1.)

The 30-second test

The information shown in Figure 1 is difficult to obtain with traditional manually operated instruments and measurement methods. Setting up the tests takes considerable time and skill. The traditional approach often requires measurement coordination between two people, one to set up test signals and one to make measurements. Sometimes this coordination must take place between a remote site or van and the studio facility — all of which complicates the issue.

The CCITT 30-second test eliminates the need to provide complete, timely and efficient audio-path evaluation. The basic scheme is to automatically generate the necessary test information, test frequencies and signal levels at one end of the audio path. As shown in Figure 2, an automated measurement set performs the necessary evaluation at the other end of the path.

The automated test sequence concept is further illustrated in Table 1. The test tone sequence begins with a 1-second FSK signal that provides initial test information. The FSK signal is unique to the tone sequence to be generated (ANSI or CCITT). The FSK signal contains a 4-digit ASCII ID code that can be programmed to indicate the physical or geographical source of the

Rodriguez is marketing manager for TV Measurement Systems, Tektronix, Beaverton, OR.

Dolby SR improves the medium for your message.

TAPE RECORDERS

Dolby SR provides the performance attributed to digital systems while maintaining such analog virtues as economy, editing ease, and tape interchange.

CARTS

Along with their familiar ruggedness and all-around utility, carts with Dolby SR capture the full dynamics of all your source material, digital or analog.

1-INCH VTR'S

With Dolby SR, video can sound as good as it looks. Signal purity is maintained through the multiple tape generations necessary in today's post-production techniques.



DISCRETE STL'S AND RPU'S

Dolby SR improves headroom and lowers noise, while suppressing the effects of interference and fade.

TV STL AUDIO SUB-CARRIERS

With Dolby SR, there's no need to re-allocate subcarrier frequencies or replace existing equipment in order to deliver high quality audio to the transmitter.

SATELLITE AUDIO

Dolby SR improves analog channels without audible side effects yielding performance rivaling digital systems.

Listeners today expect better sound wherever they go — at home, at the movies, in the car. To keep up with their expectations, you need Dolby SR. Two channels, with the compact, easy-to-operate Dolby Model 363 (shown). Or up to 24 channels, with Dolby Laboratories' multitrack products.

Dolby SR dramatically reduces noise, increases headroom, and lowers distortion from initial production to final transmission. That means you can deliver your message today with the clarity you've been expecting from the technology of tomorrow.

sequence (ENG 1, ENG 2, etc.), and to specify the measurement program or procedure to be used by the automated measurement set.

The initial FSK start signal is followed by a programmed sequence of tones for audio-path evaluation. In the case of the CCITT 0.33 sequence shown in Table 1, the generated sequence completes in 32 seconds. The ANSI sequence takes less than 10 seconds.

Ideally, the test tone sequence is generated by a single, self-contained, fully automatic audio-signal generator. The generator should be installed in-line as close to the program source as possible to eliminate cable changing whenever a test needs to be done. Starting a complete audio-channel evaluation is a matter of pressing a button on the front panel of the signal generator. If the signal generator has a voice-message storage facility, a stored message can be issued to warn personnel that a test tone sequence is about to be inserted. At the completion of the tone sequence, the signal generator automatically returns to its bypass mode, leaving the audio lines free for audio program transmission.

An automated measurement set at the other end of the audio path may continu-

ously monitor the audio lines in a background mode. Upon receiving the FSK start signal, it can set itself up for the speci-

fied audio test, follow the tone sequence and perform the corresponding programmed measurement functions. When

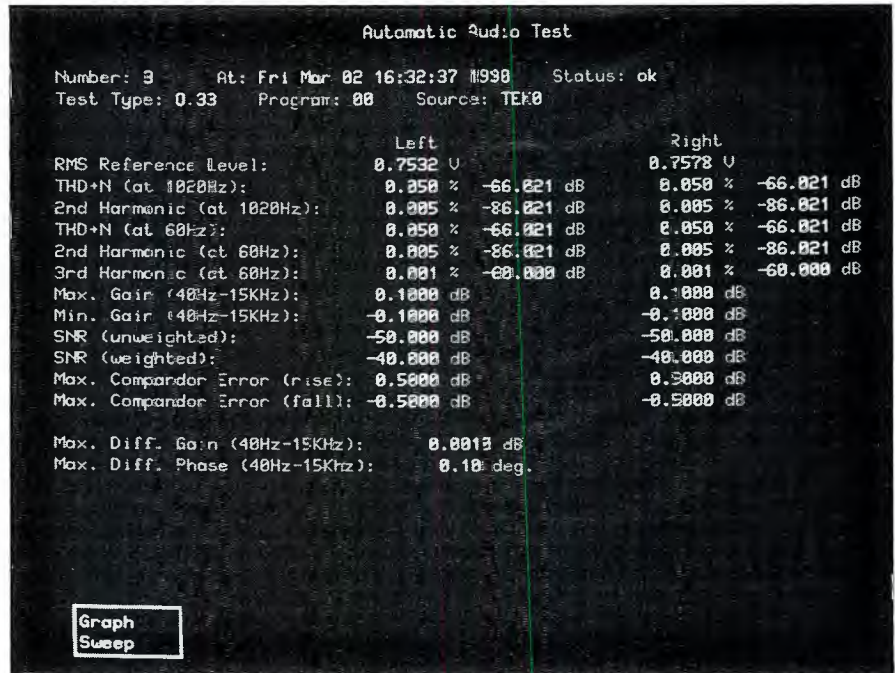
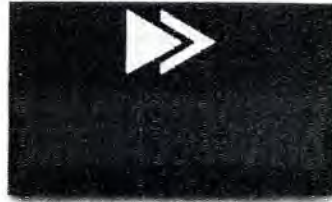

Figure 1. Display of automated audio test results for stereophonic pairs measured according to CCITT Recommendation 0.33.

THE BROADCAST DECK FOR PUSHY PEOPLE.



No tape deck gets pushed around more than a professional broadcast deck.

Round-the-clock fast forwarding and rewinding can burn out motors fast, while relentless play takes its toll on the tape heads. That's why the standard for broadcast decks is the 122MKII from Tascam.

Its FG-servo direct-drive capstan motor was designed to prevent tape damage and deliver perfect performance under heavy workloads. The unique Hysteresis Tension Servo Control actually lets you adjust take-up, back tension, torque and azimuth with open-reel precision. All without ever taking the

machine off the rack.

At the same time Tascam's proprietary three-head design delivers crisp, clean sound that's enhanced even more by a choice of Dolby® B, C and HX-Pro.

With 4-track, 2-channel stereo, Cue and Review, and easy serviceability, the rack-mountable 122MKII lives up to its reputation as the professional broadcast deck.

Call or write for more information about the 122MKII. Or ask other broadcast professionals. They're the people who really push our buttons.



TASCAM®

© 1989 TEAC America, Inc., 7733 Telegraph Road, Montebello, CA 90640 213/726-0303 ®Dolby B, C and HX-Pro are trademarks of Dolby Laboratories Licensing Corp.

Circle (20) on Reply Card

If you thought they were just for HDTV,



think again:

Sure, our TSG 1000 Series Television Generators support the major proposed HDTV standards. But they're good for a lot more than high definition.

The fully programmable TSG 1001 and companion SDP 1000 Signal Development Program, for example, support signal generation in NTSC, Betacam®, MII and HDTV formats. With the PC-based SDP 1000, signals can be defined in arbitrary line and field rates.

FORMAT	TSG 1001	TSG 1050	TSG 1125	TSG 1250
525/59.94/2:1	•	•		
525/59.94/1:1	•	•		
787/59.94/1:1	•			
1050/59.94/2:1	•	•		
1050/59.94/1:1	•	•		
1125/60/2:1	•		•	
625/50/2:1	•			•
625/50/1:1	•			•
1250/50/2:1	•			•
1250/50/1:1	•			•
GBR	•	•	•	•
Y. Pb. PR	•	•	•	•
Analog	•	•	•	•
Parallel Digital	•	•	•	•

The TSG 1050, TSG 1125 and TSG 1250 generate signals in HDTV as well as lower line rate interlaced formats.* With an optional RAM or PROM board and the SDP 1000, signals can be generated in a wide range of line and field rates. Plus, a programmable zone plate generator is included in the TSG 1001 and is available as an option with the rest of the family.

All in all, once you get the full story from your nearest Tek representative, we think you *will* think again about looking anywhere else!

*TSG 1125 excepted.

the sequence completes, the test results can be displayed or printed in a manner similar to Figure 1.

Depending on the breadth of integrated capabilities, it is possible to perform other audio- and video-signal evaluation functions with the same automated measurement set. When strategically installed, a combined audio and video measurement set becomes a highly efficient and compact test station. Efficiency and flexibility are further heightened if automated tests can occur in the "background" without interrupting other measurements being done manually in the "foreground." Automated tests occurring in the background can automatically log results to internal memory or to a printer for later perusal. If the measurement set allows alarm limits to be programmed, an alarm can be issued for out-of-bound parameters requiring immediate attention. Availability and use of alarm limits further lighten the test engineer's burden.

Stereo audio monitoring

Although the 30-second test evaluates and verifies audio-path integrity, it does not say anything about the quality or balance of the audio signals. This requires some form of stereo signal monitoring.

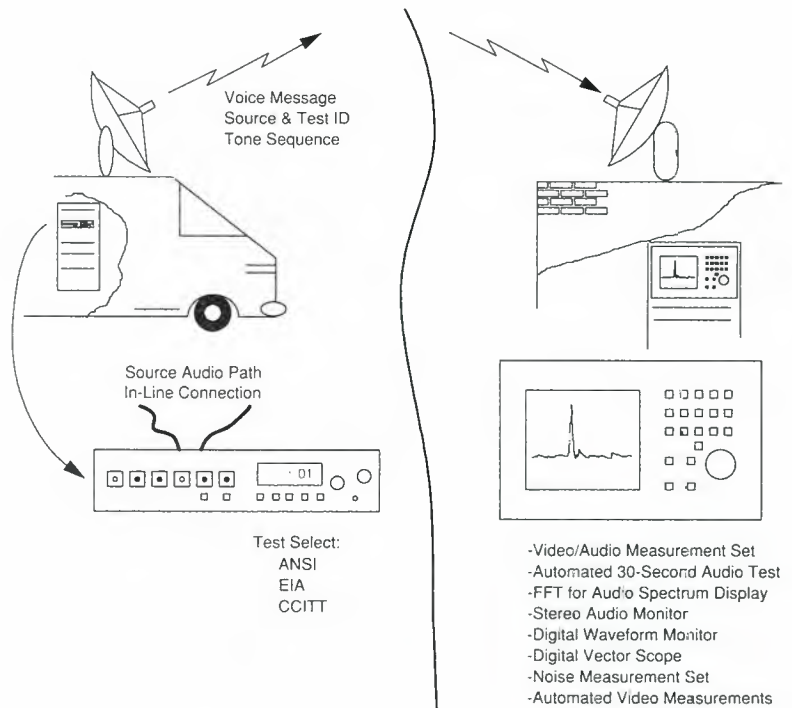

Figure 2. A typical installation for audio-path evaluation using automated instruments for the 30-second test. In practice, 30-second test generators would be installed in-line at each audio programming source, and tests would be conducted automatically for all paths.

The engineers who know RF best already know us very well.



If you're looking for superior rigid coaxial transmission line and RF components, your transmitter or tower might be a good place to start. Take a look around—you'll probably find the bright blue Myat logo. TV and radio RF engineers at Harris, Acrodyne, QEI, Micro Communications, and Broadcast Electronics all routinely specify our products. And so do the antenna experts at Jampro and the engineers for the Navy's top airborne radar system.

All of these manufacturers demand long life and superior efficiency. They expect the highest quality materials, the toughest construction techniques, plus the most effective expansion compensation designs. And, like you, they have budgets and schedules to meet. All of them demand Myat, because they know Myat delivers.

Next time you need rigid transmission line or RF components, call your favorite RF equipment distributor or phone us direct at (201) 767-5380. For quality, durability, value and service, **Myat is the name to know.**

MYAT, INC. • 380 CHESTNUT ST. • P.O. BOX 425 • NORWOOD, NJ 07648
TELEPHONE: (201) 767-5380 • FAX: (201) 767-4147

Circle (22) on Reply Card

1952
1953
1954
1955
1956
1957
1958
1959
1960
1961
1962
1963
1964
1965
1966
1967
1968
1969
1970
1971
1972
1973
1974
1975
1976
1977
1978
1979
1980
1981
1982
1983
1984
1985
1986
1987
1988
1989

35 YEARS AGO WE PIONEERED
THE FIRST TRANSMISSION LINES...

FLEXWELL

TODAY WE'RE STILL LEADING THE WAY!



Cablewave Systems 6-1/8", 8", 9" and 12" high power *Flexwell* coaxial cables represent the largest semi-flexible transmission lines of their kind in the world. Produced in continuous lengths, large capacity corrugated copper and aluminum *Flexwell* cables are designed to meet the high power requirements of medium wave and shortwave international broadcast installations.

The family of *Flexwell* transmission lines are produced and marketed worldwide by member companies of the Radio Frequency Systems Group. *Flexwell* corrugated transmission lines range in size from 1/4 inch jumper cable to 12 inch high

power broadcast cable with up to 9 megawatt RF power handling and *Flexwell* elliptical waveguide from WR42 through WR430....Cablewave Systems covers the whole spectrum.

For more information on the *Flexwell* family of RF transmission lines, contact Cablewave Systems division of Radio Frequency Systems Inc. North America, 60 Dodge Avenue, North Haven, CT 06473. (203) 239-3311.



Cablewave Systems

Circle (23) on Reply Card

Audio signals can be viewed and evaluated to some extent on an oscilloscope. However, a display, such as the one shown in Figure 3, provides a more comprehensive and understandable view of stereo signal levels and relationships.

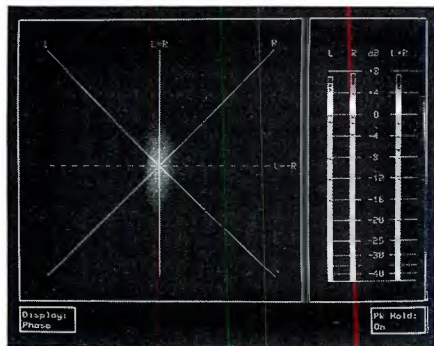

Figure 3. A Lissajous-style pattern display provides "at a glance" monitoring of stereo audio channel balance, phasing and energy distribution. In this case, the vertically oriented pattern indicates stereo well suited for monaural reception.

The two bar graph displays to the right in Figure 3 depict left and right channel levels, and a third bar graph can show the two channels' sum or difference. Bar graph displays are a quick and convenient means to check and set audio levels. The bar graph response can be in VU or PPM and the bars also can be scaled for level measurements in familiar units.

The Lissajous-style pattern display to the left in Figure 3 provides a graphic indication of stereo separation and phase correlation. For example, the pattern display in Figure 3 shows balanced stereo well suited for monaural reception, while Figure 4 shows out-of-phase stereo unsuited for monaural reception. This ability to determine monaural compatibility is particularly important.

Other patterns quickly reveal other stereo channel conditions. For example, a 45° left or right tilt of the pattern display indicates stereo with strong left or right content. An open, nearly circular, pattern indicates little correlation between channels. A squaring-off of pattern edges indicates signal clipping.

Spectra up close and fast

Automatic 30-second test results will quickly verify audio path quality. (See Figure 1.) Following this with stereo pattern monitoring verifies signal levels, balance and phasing. (See Figure 3.) However, there can still be audio signal problems that may not show up in these tests. Even if these test methods do indicate a problem, some other means of testing or measurement may be necessary to define and diagnose the problem.

A clipping problem indicated in the pattern display may need to be investigated further with standard oscilloscope displays and troubleshooting methods. This is made easier if the stereo pattern monitor can be switched to the amplitude-vs-time format of an oscilloscope display. The same tool can be used to view the pattern display or each channel's signal as troubleshooting needs dictate.

In other cases the problem may not be readily distinguishable or easily isolated with an oscilloscope or audio-monitor display format. For example, the 30-second test may reveal an unacceptably low S/N result, which indicates a noise problem. But what kind of noise is it, and where is it coming from?

Noise problems are often best viewed, identified and diagnosed in the frequency domain where signals are displayed as a frequency spectrum. This means hooking up an audio spectrum analyzer, or if

the audio-measurement set has a fast Fourier transform (FFT) function, the FFT can be used in lieu of a spectrum analyzer for viewing frequency spectra.

A spectral display shows you all of the signal components, audio as well as noise, existing on a channel. (See Figure 5.) You see the noise floor and can quickly tell if it is too high relative to the audio signal components or a test tone.

An overall high noise floor could be caused from a loose cable connection. Jiggling cables or connectors can verify this with corresponding variations in noise floor level in the spectral display.

On the other hand, the general noise floor may be satisfactorily low with the exception of a few spikes. If these spikes are stationary, they are probably interference-coupled in from a nearby source, such as a transformer or motor hum, or signal artifacts, such as sync buzz or intermodulation products. If the noise spikes jump

Time Interval	Channel A Sending Unit		Channel B Sending Unit		Program Number: 01
Seconds	Frequency (Hz)	Level (dBm0)	Frequency (Hz)	Level (dBm0)	Measuring Function
1	1650/1850	-12	—	—	Start/source/program identification
1	1020	0	1020	0	Received level
1	1020	-12	1020	-12	Frequency response interchannel gain and phase
1	40	-12	40	-12	
1	80	-12	80	-12	
1	200	-12	200	-12	
1	500	-12	500	-12	
1	820	-12	820	-12	
1	2000	-12	2000	-12	
1	3000	-12	3000	-12	
1	5000	-12	5000	-12	
1	6300	-12	6300	-12	
1	9500	-12	9500	-12	
1	11,500	-12	11,500	-12	
1	13,500	-12	13,500	-12	
1	15,000	-12	15,000	-12	
1	1020	+9	1020	+9	Total harmonic distortion
1	60	+9	60	+9	
1	2040	-12	—	—	Crosstalk and circuit transposition
1	—	—	2040	-12	
1	800	+6	800	+6	Compandor test
1	800	-6	800	-6	
1	800	+6	800	+6	Signal-to-noise ratio
8	—	—	—	—	

Table 1. Measurement sequence for stereophonic pairs, CCITT recommendation 0.33.

around or appear spuriously, they could be the result of switching noise or transient interference, such as motor-brush arcing or the air-conditioning unit turning on or off.

If an audio spectrum analyzer is being used, it is possible to miss spurious or low-level noise components. This has to do with the analyzer's spectral scanning rates and dynamic range.

A properly implemented FFT can compute spectra so fast as to be considered real time in the audio-frequency ranges. Real time means that the displayed results are being updated fast enough that no transient or spurious information is missed. This is essential for identifying and tracing spurious noise or interference.

A test for real-time capability in either a spectrum analyzer or FFT is to use them to view the spectra of a musical score containing several cymbal crashes. If the instrument is real time, you'll see every cymbal crash in the spectrum. If the instrument is not real time, chances are that most, and possibly all, of the cymbal crashes will be missed.

Also, the FFT's dynamic range is essentially determined by the digitizing resolution used for signal capture. This can be 16 bits in the audio-frequency range (16 bits gives $2^{16} = 65,536$ digital levels or quanta of signal amplitude resolution and provides 96dB of dynamic range). This degree of resolution shows low-level noise, such as sync hum, that can barely be heard and may not even appear on a typical spectrum analyzer. The resolution and dynamic range available from 16-bit digitizing and 24-bit computation also allows the FFT to be used for other spectral measurements, such as checking intermodulation distortion levels.

DSP advantages

The FFT is a digital implementation of the classical Fourier transform, with some special algorithmic twists for speed. The key point is that the FFT is possible only through digital signal processing (DSP). Without DSP, the traditional stand-alone spectrum analyzer would be the only tool available for viewing signal spectra.

DSP goes beyond the FFT in importance to audio measurements. For example, the 30-second test sequence in Table 1 is readily implemented with DSP. Moreover, virtually any tone sequence can be programmed, allowing the same DSP implementation to generate sequences for several different testing standards. DSP implementations also have a history of providing high test and measurement repeatability with greater cost-effectiveness.

The ability to implement and automate all of the necessary audio-measurement functions in a single measurement set is important. This integration of multiple functions can go well beyond those

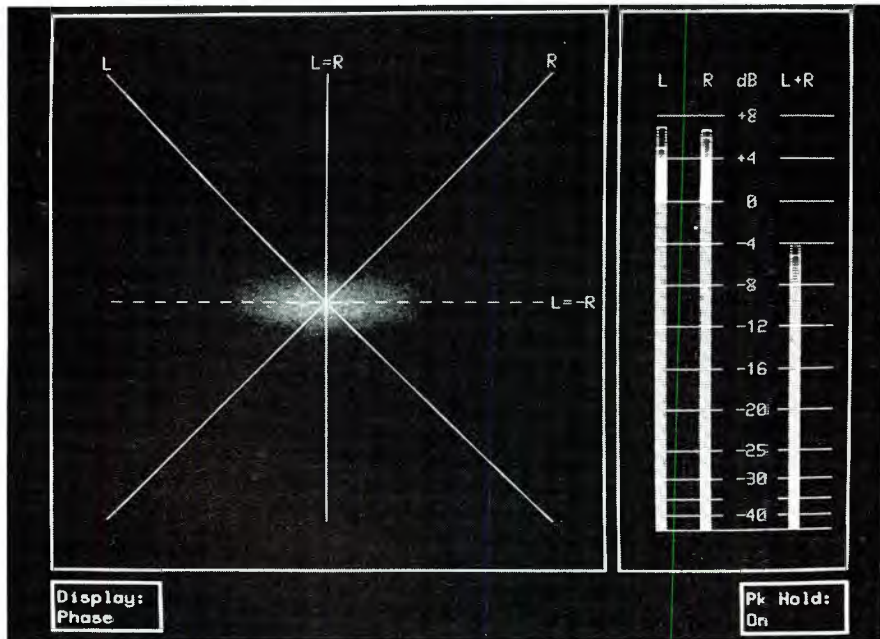

Figure 4. Pattern display showing out-of-phase stereo channels. This would be unsuitable for monaural reception.

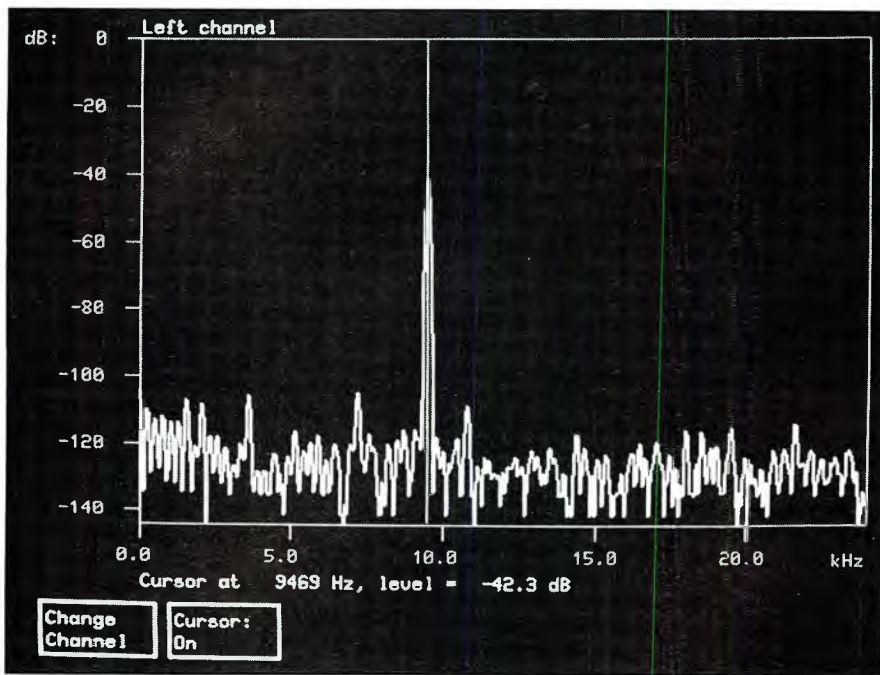

Figure 5. An FFT display is similar to a spectrum analyzer in that it shows frequency spectrum. However, the dynamic range and display update capabilities of an FFT may exceed those of a typical audio spectrum analyzer.

needed for just the 30-second test. The FFT capability can also be included in the same DSP-based measurement set. The same is true for the stereo audio-monitoring capabilities shown in Figure 3. Those can be implemented in software or firmware for integration in the same measurement set used for the 30-second test.

The same DSP approach to measurement implementation, integration and automation can be carried to video measurements as well.

||:~(=))))||

DAT in the professional environment

By John Monforte

DAT is an inexpensive route into digital recording, but some questions still remain as it matures into a fully professional broadcast format.

In 1983, manufacturers convened the first DAT standards conference. Their mission was to draw on the lessons learned in the standardization of videotape recording formats, as well as other digital audio formats, to develop recorders and tape for inexpensive digital audio recording. To date, 85 member corporations are involved in the development of recorders or tape for the DAT format.

DAT is unique among recording formats in that it was designed for consumer and professional use. Therefore, the pro audio market can take advantage of the cost benefits provided by the consumer market. Now that the industry has begun tooling up for the manufacture of tape, head assemblies and the special VLSI circuits needed for reading and writing to DAT, professional recorders with advanced production features can be adapted from these general-purpose machines cheaper than machines designed only for professional use.

DAT as a consumer medium has fallen short of its goal. Originally hailed as the next wave of the new home appliances, DAT was expected to turn up in households worldwide with eventual penetration equivalent to the VCR and CD player. But DAT's entry into the U.S. market was thwarted by protracted wrangling over copyright and piracy issues. Now that

Monforte is director of Recording Services at the University of Miami.

these are essentially settled (see the related article, "SCMS," page 66) DAT's consumer promise may begin to be fulfilled.

Early DAT sales in Japan and Europe, where no such political obstacles existed, have been disappointing. This could be a result of a market perception that DAT is only an interim technology, and will be made obsolete by recordable optical discs. This perception has faded somewhat as more has been learned about the complexity and cost of erasable optical. However, sales are by no means brisk in any consumer market at this time. Meanwhile, where interest has grown, a few manufacturers have developed specialized DAT recorders for professional use. The computer industry also has begun to adapt DAT as a data backup format. Even with the languishing consumer DAT market, the format continues to develop and gain a foothold.

Data formats

Six data formats currently are allowed by the DAT standard. (See Figure 1.) Others may be added later, as dictated by market demand. Three have 32kHz sample rates to afford compatibility with direct satellite broadcasts (not available in the United States), as well as higher recording densities. Two of those use 12-bit resolution, one in a 1/2-speed, 2-channel format, and the other in a normal speed, 4-channel configuration. All other formats

are 16-bit. There is a 44.1kHz mode for CD-format signals using wider tracks, such as higher linear tape speed, for use with high-speed-duplicated tapes made by a contact printing method. It results in a one-third reduction in record-time capacity. Originally designed as a play-only format for consumer decks, this also may be useful in making real-time recordings on cheaper, non-metal particle tapes. The sixth mode uses 48kHz sampling, the same as is used in other professional digital recorders. Although originally disallowed within the format, now many recorders allow 44.1kHz recording in this mode as well.

All six allow for the use of emphasis, a treble boost on record with a complementary cut on playback. (Because music tends to have less energy in the high-frequency bands, the boost can be done without much worry of overload. The complementary cut process reduces high-frequency noise, giving a wider perceived dynamic range.) The emphasis used in DAT has the same characteristics as the CD and other professional format recorders.

Program material is recorded along with subcode data that indicates mode, emphasis status and other information, such as program number, timing and table of contents. Although similar in function to the subcode in CDs, more than four times the data space has been allotted in DAT.

Winsted®

VIDEO CONSOLES

WINSTED CONSOLES are designed for complete compatibility with your electronics, your facility, your requirements, and your decor.

A WIDE RANGE of editing and production models accommodate virtually every major brand of electronics. Modular components let you create consoles to match your rack mounted VTRs and controllers.

CORNER CONSOLES with wrap-around design let you utilize space efficiently. And attractive wood trimmed consoles let you match your studio decor. You can expand your system as needed with versatile add-on components.

ONLY WINSTED offers such a complete line of consoles, compatible with your requirements.

All Winsted Consoles Feature:

- Sturdy, heavy-duty steel construction
- Adjustability to fit your needs
- Easy access for maintenance and installation
- Ergonomic design for operator comfort
- Slope console models available
- Multiple bay models
- Free planning and design service



Write or call for **FREE** full line
catalog **1-800-447-2257**

(in MN call collect:
612-944-8556)
FAX: 612-944-1546



THE WINSTED CORPORATION

10901 Hampshire Avenue So.
Minneapolis, MN 55438

Preferred by Professionals Worldwide

Circle (27) on Reply Card



PHILIPS

Scope Buster Prices!

call

800-882-NTSC

Waveform monitors

800-882-NTSC

Vectorscopes

800-882-NTSC

Complete line

800-882-NTSC

Lowest prices...

800-882-NTSC

Anywhere

800-882-NTSC

Cash discount

800-882-NTSC

Immediate shipment

800-882-NTSC

Free 2nd day air

800-882-NTSC

Quality

800-882-NTSC

Who ya gonna call?

800-882-NTSC



TEST &
MEASUREMENT
INC.

7500 Six Forks Road
Raleigh, NC 27615

Circle (28) on Reply Card

NUMBER OF CHANNELS	2	2	2	4	2
SAMPLING FREQUENCY (kHz)	44.1/48	44.1		32	
QUANTIZATION (bit)	16	16	16	12	
TAPE WIDTH (mm)	3.81(+0 -0.02)				
TYPE OF TAPE	MP	OXIDE	METAL PARTICLE		
TAPE THICKNESS (μm)	13±1				
TAPE SPEED (mm/s)	8.15	12.225	8.15	8.15	4.075
TRACK PITCH (μm)	13.59	20.41	13.59		
TRACK ANGLE (TAPE RUNS) (DEG)	6° 22' 59.5"				
RECORDING TIME (MIN)	120	80	120	120	240
HEAD GAP AZIMUTH ANGLE (DEG)	±20				
RECOMMENDED CYLINDER SPECIFICATIONS	30mm dia/90° wrap/2,000 rpm				1,000 rpm
WRITING SPEED (m/s)	3.133	3.129	3.133	3.133	1.567
MODULATION SCHEME	8-10				
RECORDING DENSITY	61k BPI				
ERROR DETECTION AND CORRECTION CODE	DOUBLY ENCODED RSC (C ₁ =32, 28, 5) (C ₂ =32, 26, 7)				
REDUNDANCY (%)	37.5	42.6	58.3	37.5	37.5
TRANSMISSION RATE MB/s	2.46				1.23
SUBCODING CAPACITY kB/s	273.1				136.5
TRACKING SYSTEM	ATF				
DIMENSION OF THE CASSETTE (mm)	73×54×10.5 (W×D×H)				

Figure 1. Basic specifications of the DAT system.

Enough information is available for CD mastering, and the subcode information can be recorded separately (added to already-recorded audio). This means that CD mastering can be performed on equipment that costs a fraction of what is in use today.

Neither hardware nor software developments have done more than scratch the surface of the possibilities offered by the full DAT format. Few prerecorded DAT tapes are available, and no 4-channel hardware or software has been announced. Moreover, the recording of some subcode information is highly non-standardized between manufacturers.

Heads and tracks

Rotary head transports are crucial to making the format cost-effective. Spinning a head across the tape creates a high tape-to-head speed, while allowing the tape to move at a crawl. Also, the data can be packed tightly along the length of the tape without resorting to the expensive thin-film recording-head technologies needed to make tiny magnetic gaps.

The format was designed to allow the tape to wrap over a small angle of the drum. This permits lower tension and less critical adjustments. Tape wear also is drastically reduced. This provides the ability to search at high speeds with the tape wrapped to the drum, allowing data (including the subcode) to be read without waiting for the tape to unwrap and wrap, like it does on a VCR.

Because of this, a fixed-head control track is not necessary. The two data tracks (called A and B, but not related to left and right) are recorded by a pair of heads that

have a different azimuth. Figure 2 shows how the tracks are printed on the tape. Because each head only senses tracks recorded with the same azimuth, the offset angles allow for material to be recorded densely while minimizing crosstalk. Tracks can be placed in an overlapping fashion without guard bands.

The design of the track layout allows for punch-ins, but there is no provision for crossfade on any current machines. Without crossfades, in-music edits have a tendency to pop, which means the punching can only be performed quietly in quiet or muted portions of the tape. Consumers have no need for in-music edits, but professional DAT electronic-editing machines will have to accommodate crossfading in their design. A few manufacturers have shown prototypes of decks that will incorporate this feature, which will be available this fall.

Depending on the head drum configuration, there may not be a continuous datastream coming off the drum. This, of course, is smoothed out in error-correction buffers that clock a continuous bitstream. Figure 3 shows three examples of drum designs allowed in the format. All three use the same rotation speed and can use the same servo-control ICs.

The 15mm drum will probably be useful in portable machines that can afford to sacrifice some professional features in order to save space. The other two types offer advantages in professional applications. A second pair of heads have been added to a few (currently high-end) decks, using 30mm drums, which will read the tape during the "off" times of the recording pair. This read-after-write capability is

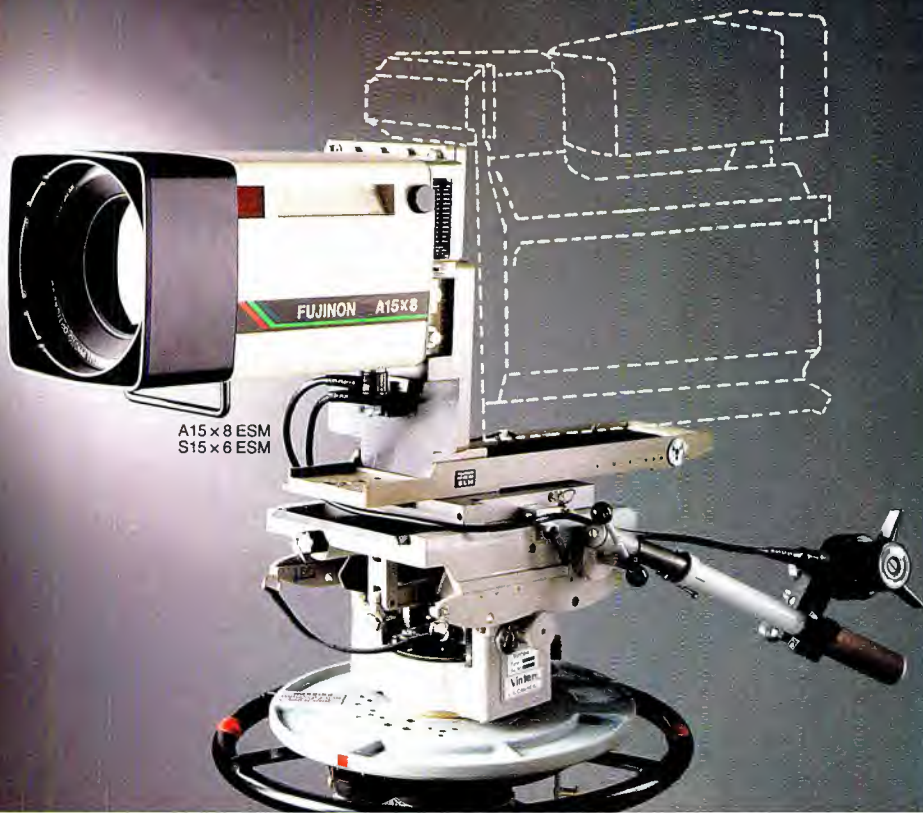

A15 x 8 ESM
S15 x 6 ESM



A18 x 8 ESM
S18 x 6 ESM



A20 x 7 ESM
S20 x 5.4 ESM



A55 x 9.5 ESM
S55 x 7.3 ESM



A4 x 9.5 ESM
S4 x 7.3 ESM



A34 x 10 ESM
S34 x 8 ESM

FUJINON'S FOCUS ON THE FUTURE.

THE BEST LENSES FOR TODAY'S CCD STUDIO CAMERAS.

The reason FUJINON delivers all the performance advantages of the new 1990 CCD studio cameras is our *focus on the future*.

Long before anyone seriously considered CCD cameras for studio use (more than 3 years ago), FUJINON was developing and perfecting lenses in anticipation of today's cameras. To meet their far higher transmission requirements, the drastically lower distortion, and advanced electro-mechanical demands, FUJINON made the commitment and the investment. The same resources

and experience responsible for making FUJINON the leader in HDTV optics make FUJINON first in CCD lenses today.

Every studio and field lens shown above — for 2/3" and 1/2" cameras — is available now. And every one delivers maximum performance, total compatibility. That's a FUJINON exclusive. So is our focus on the future.

If new CCD studio cameras are in your future, focus on FUJINON. For more information or a demonstration, call your nearest FUJINON representative.

FOCUSED ON THE FUTURE.

FUJINON INC. 10 High Point Drive, Wayne, New Jersey 07470 (201) 633-5600
Southern 2101 Midway, Suite 250, Carrollton, Texas 75006 (214) 385-8902
Midwestern 3 N. 125 Springvale, West Chicago, Ill. 60185 (708) 231-7888
Western 129 E. Savarona Way, Carson, California 90746 (213) 532-2851



FUJINON

10 High Point Drive, Wayne, N.J. 07470

Circle (29) on Reply Card

www.americanradiohistory.com

essential for off-tape monitoring (called "confidence checking" in the computer industry), and makes electronic editing relatively straightforward.

Time code

There has been one primary obstacle to DAT's complete acceptance by professionals. The standard does not allow for operation with SMPTE/EBU time code. The principal problem is the frame rate. The 2,000 rpm drum bundles data in A/B frame packets that occur at 33.3 frames per second. This is different from the four frame rates currently provided in the SMPTE standard, and is different from any proposed future standard for film or video.

The DAT format has its own time code for locating segments on the tape, but the frame-rate problem prevents editing out a whole number of video or film frames and carrying along a whole number of audio frames. Audio must be chopped into fractional frames to conform to SMPTE code.

Sony attempted the first time-code technique in its portable recorders. DAT has space near the tape edges for two auxiliary tracks that can be used to record analog signals with a fixed head. SMPTE data can be recorded here just as it is done

in analog recorders.

The main difficulty with the original method lies in the slow longitudinal tape speed of the format (8mm/second or approximately 1/3ips), which leaves each frame to be recorded on only 2mm to 4mm of tape. A slight misadjustment of

the distance between the fixed head and the rotating drum is all that is needed to throw off the frame location. Also, because of transport instabilities and the servo requirements of the rotating heads, the actual tape speed also varies widely, causing

Continued on page 58

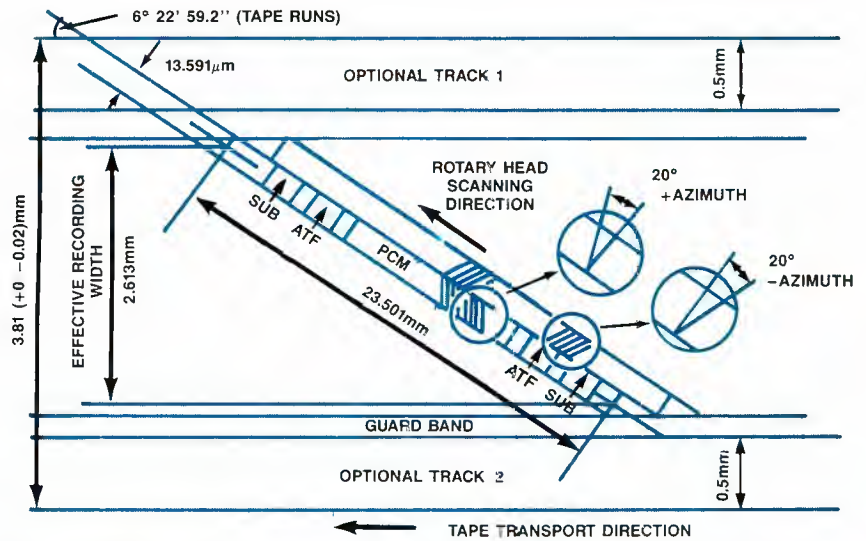

Figure 2. DAT track format.

NEW

How's your Audio?

The PC3000 can tell you!

The new PC3000 Audio Analyser from Consultronics is the easiest way to test mono or stereo program channels, tape recorders, and other professional audio equipment. DSP circuitry, EL graphic display and easy to use menus make the PC3000 ideal for all your Audio testing needs today and tomorrow.

Call today for more information...

Consultronics
533 Valley Way,
Milpitas, CA 95035 USA
Phone: 408-263-2600
FAX: 403-263-E717

Consultronics
160 Drumlin Circle
Concord, ONT L4K 3E5 Canada
Phone: 416-738-3747
FAX: 416-738-3712

Consultronics/Boyd
Third Avenue, Millbrook
Southampton, SO1 0LE England
Phone: 0703 705252
FAX: 0703 705151

Circle (50) on Reply Card

NEED BROAD-BAND COAXIAL RELAYS? FROM 2 TO 24 THROW, MATRIX HAS THE ANSWER



Our versatile 7000 series of coaxial relays have band-widths from DC up to 800 MHz. They're available from 2 to 24 throw. And by using our 9000 series cross-straps, switching matrices of any size can be configured.

Why have Matrix broad-band relays become the industry standard? Because we construct them of precision machined anodized aluminum alloy, all signal shield paths are silver plated, and basic switch elements are hermetically sealed in nitrogen filled gas envelopes with rhodium plated contacts to insure non-stick operation.

The end result is extremely low crosstalk, EMI and VSWR. Another plus, all switchpoints are individually field replaceable.

The units are plug compatible with Matrix 6100A and 1600 Series Logic Modules for compatibility with RS-232, RS-422 and IEEE-488 Interface busses as well as 16 bit parallel.

Non-blocking Matrix configuration may be easily assembled

using our self-terminating relays and 5100A series power dividers. Built-in Video/RF amplifiers allow zero insertion loss designs.

So if you're looking for broad-band relays, it pays to deal with Matrix. After all, we've been designing state-of-the-art reed relay and semiconductor switching systems for over 18 years.

Our customers include government agencies, defense contractors, the TV industry, ATE and telecommunications companies—and more.

Phone: 818-992-6776
TWX: 910-494-4975
FAX: 818-992-8521

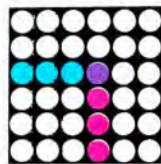

MATRIX
SYSTEMS CORPORATION

5177 NORTH DOUGLAS FIR ROAD
CALABASAS, CALIFORNIA 91302

Circle (31) on Reply Card

www.americanradiohistory.com

**Ampex D2.
A better business machine . . .
from the ground up!**





Yes, it's true that our new VPR-200 and VPR-250

D2 video recorders are designed and built specifically for broadcast operations. It's also true that they offer the broadcaster superior signal quality. But a much more important consideration is that these machines make *business sense*. Here's how.

You probably amortize your recorders over 5 or 7 years, but the "200" and "250" are built to be around a lot longer than that—you're not going to find any "bent metal" here! Precision-milled castings and pre-aligned guide assemblies not only give you dependable long life, but also low maintenance costs.



Time-code information, error messages, even audio level bargraphs can be displayed over a separate video output. On-board speakers reduce equipment costs, save rack space, and make installation easier.

Replaceable heads and easy access components reduce downtime.

We've given your operators some help, too.

For example, these are the only D2 machines designed specifically for broadcast

that make it easy to change program length. With *program compression*, your operators merely enter the program length required and the machine does the rest. You get no bounce, no blur video, and recovery



Streamlined control functions reduce operator errors and cut training costs. All machine selections are clearly displayed and easily changed without cumbersome menus.

of all four audio channels! And because all machine selections are clearly displayed and easily changed without cumbersome menus, operator training time and operator errors are significantly reduced.

Then there's virtually instant lock-up and 60 × shuttle speed to save you time and money,

The VPR-200 mounts all 3 cassette sizes for flexibility from spots to movies. The VPR-250 handles small and medium size cassettes if that's all you need.



plus air lubricated tape guides, and . . . but you get the idea.

You may not have thought of video recorders as "business machines" before, but we think your first VPR-200 or 250 will change your mind. Call **1-800-25AMPEX** for more information.

AMPEX

Continued from page 54

ing severe flutter problems for the code. These obstacles make this technique virtually unusable.

Fostex introduced another method. The frame data for the SMPTE code is recorded in the subcode area. The subcode also is the home of other essential information. Users need the ability to record time code at any time, and provisions must be made to overwrite only the time-code portion of the subcode. This is accomplished in a 4-head system. The first pair reads the old subcode data and the second rerecords it along with the new time code.

Shortly after the introduction of the Fostex method, AES and IEC set about to devise an industry time-code standard for professional DAT that can harmoniously coexist with the subcode needs of the consumer. At the time of this writing, the details had been worked out on a system developed through research efforts at Matsushita, Sony, Fostex and the NHK. The essence of the standard revolves around a method of recording in the subcode an amount of phase delay that shows where the SMPTE frame edge is in relation to the DAT frame edge. The IEC, currently the guardian of DAT standards, is expected to ratify this so-called "R-code" as a worldwide standard before the end

of this year.

Problems

Although the future of DAT in the broadcast facility looks promising, there are certain pitfalls. Principally, the format was designed to be compact and convenient. The high data densities that result from this approach leave a larger quantity of data at risk for a given-size dust particle or tape crease. We cannot expect the tape to be as rugged as the current professional formats are in dealing with abuse or improper storage. There is still concern about whether the medium is suited for archiving. (See the related article, "The Care and Handling of DAT Cassettes," page 60.)

Because there is no generation loss in digital recording, backups can be made easily. But beware that an age-related problem will not show itself incrementally, as it would in analog recording. It will exhibit itself in a "binary" fashion, as in "here today, gone tomorrow." Error-correction and concealment systems in the playback hardware will mask aging problems until one day the losses become too great to cover up and a dropout is heard. At that point, it is too late to fix the problem by rerecording. Some routinely scheduled backup procedure should be considered.

Another problem is compatibility among different players. Tapes that are playable only on the machine that recorded them are not uncommon. Although misadjusted machines can operate quite well by themselves, rotary-head recording requires several precise adjustments to conform to standard. These recorders are essentially the same as video recorders and require the same care in setup.

Tape tension, for example, must be adjusted with much higher precision than fixed-head machines. New test tapes and some specialized training for audio technicians who have not had experience with rotary-head recorders will go a long way toward solving this problem. Still, extremely high-density recording always leaves less room for error.

Perhaps most vexing of all is the inaccuracy of real-time tape counters on some current (non-time-code) decks. These machines' timers operate on mechanical counting of tape platter turns, and because linear tape speed is so slow, a slight mechanical slip translates to a significant time-display error. Of course, actual playing time is not affected. (The format's record/playback timing accuracy is one of its chief advantages to broadcasters, especially for those using it for network time-delay

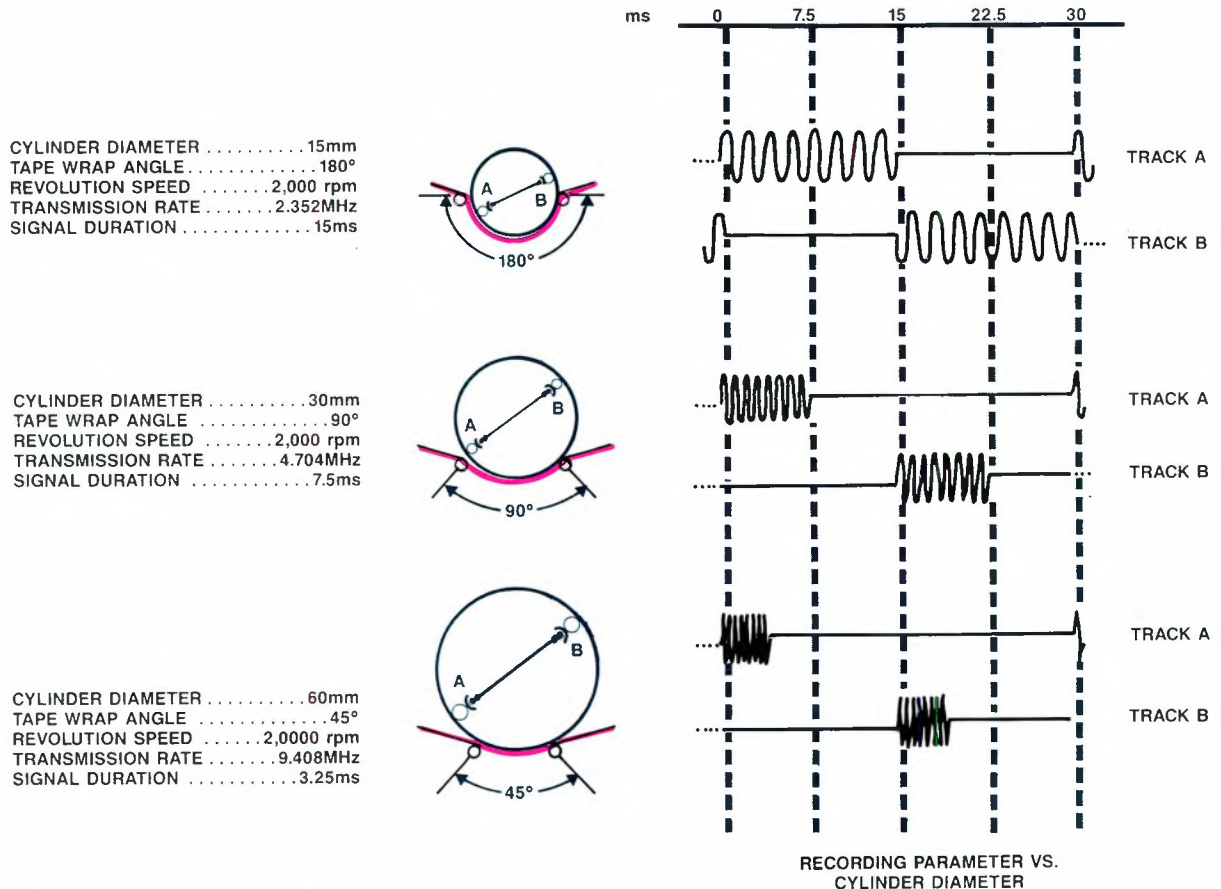

Figure 3. DAT head drum configurations.



THE HEART OF A GREAT TV TRANSMITTER!

Thomson Tubes Electroniques!

Make sure the UHF transmitter you invest in comes with the unique competitive advantage of a TH563 tetrode from Thomson. With 25 kW in common and 35 kW in vision-carrier amplification, the TH563 is based on the same principles as the TH582, which routinely achieves more than 20,000 hours of operational lifetime.

Efficient, compact, linear - TV transmitters using the new TH563 tetrode from Thomson outperform their competitors with unsurpassed reliability.



Circle (32) on Reply Card

For additional information, mention code **T T**

France : BOULOGNE-BILLANCOURT
Tel.: (33-1) 49 09 28 28
Fax: (33-1) 46 04 52 09

Italie : ROMA
Tel.: (39-6) 639 02 48
Fax: (39-6) 639 02 07

Brasil : SAO-PAULO
Tel.: (55-11) 542 47 22
Fax: (55-11) 61 50 18

Japan : TOKYO
Tel.: (81-3) 264 63 46
Fax: (81-3) 264 66 96

Deutschland : MÜNCHEN
Tel.: (49-89) 78 79-0
Fax: (49-89) 78 79-145

Singapore :
Tel.: (65) 284 34 55
Fax: (65) 280 11 57

España : MADRID
Tel.: (34-1) 519 45 20
Fax: (34-1) 519 44 77

Sverige : TYRESÖ
Tel.: (46-8) 742 02 10
Fax: (46-8) 742 80 20

Hong-Kong : WANCHAI
Tel.: (852) 865 32 33
Fax: (852) 865 31 25

United Kingdom : BASINGSTOKE
Tel.: (44-256) 84 33 23
Fax: (44-256) 84 29 71

Inde : NEW DEHLI
Tel.: (91-11) 644 7883
Fax: (91-11) 644 7883

U.S.A. : TOTOWA, NJ
Tel.: (1-201) 812-9000
Fax: (1-201) 812-9050

Sennheiser.



Still setting the standards.

Sennheiser's dedication to state-of-the-art technology, coupled with quality engineering, earned our microphones an Academy Award*. Sennheiser continues to set the standard in the industry, this time with the MKH 60 and MKH 70, our newest shotgun microphones. They display all the ruggedness that you need in audio production and the reliability that Sennheiser has become famous for.

Sennheiser. The first and last authority on shotguns!

Ask your Sennheiser Representative for a demonstration.

 **SENNHEISER®**

SENNHEISER ELECTRONIC CORPORATION
6 Vista Drive, P.O. Box 987, Old Lyme, CT 06371
(203) 434-9190 FAX# 203-434-1759
Manufacturing Plant: D-3002, Wedemark,
Federal Republic of Germany

*©A.M.P.A.S.®

Circle (35) on Reply Card

applications.) The new generation of time-code decks should eliminate this problem.

Compared to what

DAT may always be considered the poor man's digital format. But that may be a small negative when compared to the cost savings it offers as a functional, professional format. In fact, DAT could become an ideal RENG format. The anticipated new generation of DAT recorders, editors and synchronizers may be a more appropriate audio-production system for broadcasters than the digital workstation, especially for those facilities that have not employed multitrack recorders in the past.

The workstation's requirement of real-time upload of audio from the source format, such as DAT recordings from the field, to the computer's memory or disk, is an additional step that consumes facility and staff time. For the facility that is not already performing such a transfer step as a normal part of multitrack production, this can be an undesirable step backward. On the other hand, having the ability to place DAT field tapes directly into a DAT editing system and come out with a finished DAT master, would be a valuable advantage to the broadcaster used to multimachine-style production. It would provide advantages of speed and quality. The proposed DAT editors shown so far also incorporate a limited amount (20 to 30 seconds) of RAM, to allow rehearsal of edits, increasing flexibility and speed. Adding a little digital signal processing (DSP) to such a rig provides what one manufacturer has already called "the unworkstation."

A lot of this professional DAT R&D (and pricing) still depends on consumer demand, however. DAT's measure of success during the rest of this year and next will have great impact on its viability for the broadcast industry.

Care and handling of DAT cassettes

By Joe Martinez

The surface of DAT is composed of metal particles dispersed at an electromagnetic density of 1,500Oe. (Conventional audiotape has a surface density of only 200Oe to 400Oe.) The high density makes it resistant to data loss

Martinez is president of DIC Digital Supply, Hackensack, NJ.

25kW UHF TV Transmitters with all the advantages of VHF and more. That's advanced UHF tetrode technology!



- Highest overall plant efficiency
- No diplexer
- Inherent tetrode linearity
- Simplistic VHF-type correction
- Full 10% aural power
- Tube change in minutes
- Proven over time
- Sensibly priced

New advances in tetrode technology and transmitter design now offer the UHF broadcaster the huge benefits enjoyed by VHF stations for years. . . and then some! Only from Acrodyne.

Call us for all the details.

Tetrode-equipped transmitters for 20 years

ACRODYNE

Acrodyne Industries, Inc.
516 Township Line Road
Blue Bell, PA 19422

1-800-523-2596

In Pennsylvania, (215) 542-7000

FAX: 215-540-5837



◀ Gino Ricciardelli,
chief engineer;
WICZ-TV,
Channel 40,
Binghamton, NY

©1990 Acrodyne Industries, Inc. All rights reserved

Circle (34) on Reply Card

caused by environmental factors. DAT cassettes should not be stored near objects with strong magnetic fields because this may cause the loss of recorded material. DAT can't be completely bulk-erased. Degaussers used to erase analog tape cannot totally eliminate the signal encoded on the high-density surface. Once a signal is encoded on the tape it can only be removed by rerecording.

DAT tapes should be protected from extreme sunlight, heat, cold, moisture and dust, as well as strong magnetic charges. Like other tape formats and vinyl records, don't store them in a sunny window, on a radiator or near air-conditioning vents. Temperature will affect any polyester-based film. In cold, it tends to stiffen; in extreme heat, it can become pliant.

An interesting feature of most DAT hardware is a moisture-prevention cutoff. If any moisture enters the unit via the tape, it will stop running and begin to heat up. Once the heat has dried the moisture, the unit will begin to function again.

To guard against stretching, manufacturers have paid special attention to the DAT base film — the structural backbone of the tape. (See Figure 1.) In addition

to building in extra strength, manufacturers generally tensilize, or prestretch, the base film. Normal wear and tear should not cause the tape to stretch. Today's cassettes should endure thousands

of passes, with no stretching or signal degradation.

Another important feature is tape consistency. Unlike conventional audiocassettes, which package a thinner and less

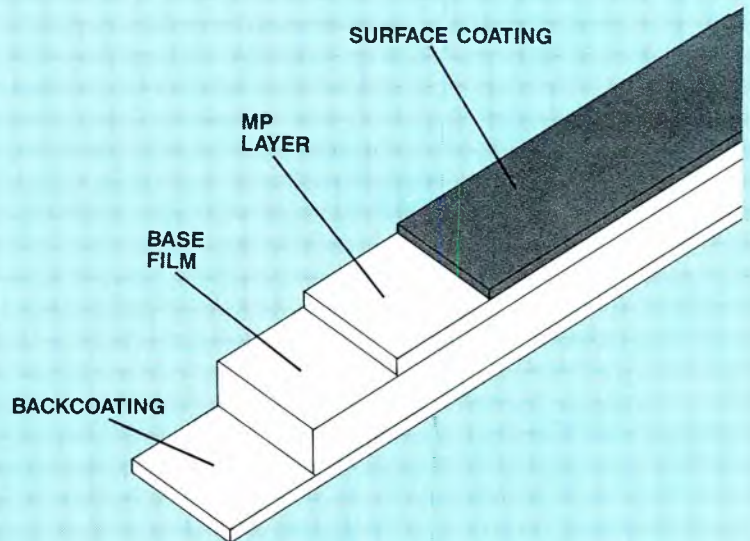

Figure 1. A cutaway view of DAT magnetic media. (MP = metal particle.)

COMPLETE YOUR DEFINITION OF "CLASS A," CALL CONTINENTAL ELECTRONICS



500/1000W



3.8 kW

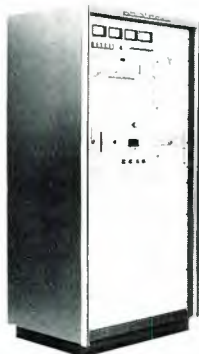

2.5 kW



5 kW

Continental Electronics is here to assist you with your new definition of "Class A." You can increase power, increase revenue base, and expand your listening audience by upgrading your transmitting facility.

Continental has engineered four transmitters to meet your needs. The 500/1000 Watt transmitter is single phase and is only 42 inches tall. This transmitter and the 3.8 kW are totally solid-state and designed for high efficiency and reliability.

The 2.5 kW and the 5 kW transmitters are single tube transmitters. All Continental FM transmitters include an internal harmonic filter and the Ultimate 802A Exciter.

For service after the sale, call the Continental 24-hour tech line. At Continental, service is an attitude, not a department.

So, call your Continental Sales Manager to get the complete definition of "Class A."

varian 

continental electronics division

P.O. Box 270879 Dallas, Texas 75227

Telephone: 214-381-7161 Fax: 214-381-4949 Telex: 73398



Nobody does it better



Vega Pro Plus Wireless, the Performance Standard

Vega Pro Plus systems featuring the new R-42A receiver, have become the accepted standard for the most demanding applications from broadcast and film production to concerts and major live events.

Offering true-diversity operation, unparalleled RF selectivity, and resistance to overload, no other wireless system performs as well in severe RF environments. Usually, 25 or more systems may be used in one location. Pro Plus systems also feature third generation Dynex® III audio processing for the highest obtainable signal-to-noise ratio, lowest distortion, unequalled transient response and the widest dynamic range. When it comes to dependability, Vega is second to none. Major live events almost always use Vega systems because of their rock-solid reliability and exceptional performance. In other words, if you've got only one shot at it, you better have a complement of Vega Pro Plus systems.

The handheld transmitters are available with the new Electro-Voice concert vocal capsule, the N/D857, the popular N/D757A, and a variety of Shure microphone elements. The bodypack transmitter offers flexible microphone biasing and interface, making it compatible with just about any lavalier microphone.

Nobody does wireless better than Vega. The Vega Pro Plus series, clearly the world's best wireless system.

For additional information, literature and technical assistance, please call James Stoffo at 1-800-877-1771.

 **Vega**
a MARK IV company

durable tape in 120-minute formats, the tape in longer-playing DAT cassettes is of the same thickness and durability as that within shorter-playing cassettes.

As with videocassettes, don't insert DAT tapes upside down. Keep the drawer of all DAT players and recorders closed when not in use, and never deliberately open the cassette slider to expose the tape. (See Figure 2.)

The reason for these precautions is dust, the main enemy of consistent, high-quality performance. Dust won't harm the tape, but it can be carried into the DAT hardware and lodge on the heads, clogging them and impairing output and possibly input.

With conventional tape, friction between the 2,000 rpm rotary head and the tape could be enough to cause considerable shedding, which also could clog the head gaps. DAT has a built-in safeguard to resist this problem, being the only kind of audio-recording tape that is fully encapsulated. Its high-density metal particle surface is protected by a low-abrasion coating that reduces head wear and prevents shedding.

It is important for all tape that touches the recording heads of DAT hardware to

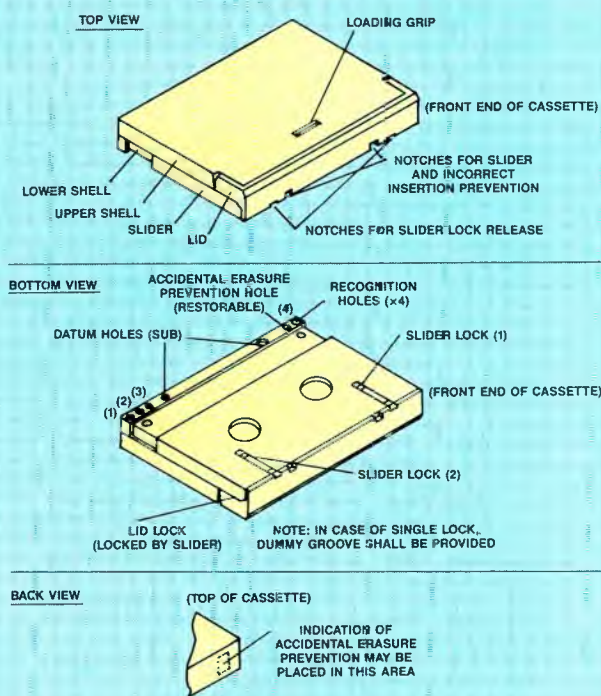

Figure 2. Outside view of DAT cassette shell.

Pinnacle's Digital Studio.



See Pinnacle at
I.B.C.—Booth F36

Paint, Effects, Transitions, Still Store, 3-D Modeling, Animation
and 3-D Digital Optics. All in a single Video WorkStation.™

Pinnacle Systems, Inc. • Phone (408) 970-9787 • Telex 362364 • Fax (408) 970-9798

Circle (37) on Reply Card

www.americanradiohistory.com

FLIPS AND TUMBLES

ALTA's new Pictoris EDE delivers first-class digital effects like flips, tumbles and curvilinear moves—all at a price that'll make you smile.

There's more—the EDE features 5.5 Mhz bandwidth in both composite and Y/C modes, a built-in keyer, auto transition keys and a bag full of effects including strobing, posterization and mosaic.

Create your own custom moves and



transitions, then store them in removable memory as small as a credit card.

Video quality? Shrink it down—way down. You'll like what you see. Images are crisp, clear—terrific. Try that with the other guys!

The EDE can be purchased as a stand-alone product, or as an upgrade—simply replace the keyboard on any existing Pictoris.

Like our other products, the Pictoris EDE is built to deliver reliability that our customers say is like money in the bank.

The Pictoris EDE from ALTA. Smart. Cost-effective. Easy. Check it out.

Call or fax us today for more information or to request our demo tape. Let us show you how to get flips and tumbles that won't leave you tossing and turning.

**1-800-677-ALTA or
Fax 408-297-1206.**

ALTA
GROUP, INC.

Dynatech Broadcast Group

535 Race Street
San Jose, California 95126

AT A PRICE THAT WON'T MAKE YOUR HEAD SPIN.

NEW

Ask about another new ALTA product—the new Pegasus video production switcher.

Circle (38) on Reply Card

www.americanradiohistory.com

have as low a friction coefficient as possible. This includes cleaning cassettes. Only wet-type cleaning cassettes are recommended; these require a friction-reducing liquid to be applied before they are run through the player. Dry-type cleaning cassettes can shear off particles from recording heads and lead to clogging.

DAT cassettes available today exhibit a variation in the roughness of their surface coatings. Rougher coatings do a bet-

ter job in keeping heads continually clean, thereby reducing dropout, but these tapes will wear heads faster. Smoother tapes will prolong head life, but will not prevent head clogging during operation as well as their rougher counterparts. In any case, DAT heads wear much more than tapes, and will require eventual replacement.

Static is another enemy of DAT. Like the video playback process, R-DAT requires a length of tape be drawn from

the cassette and wound through a fairly complex series of pins and guards before making contact with the recording head. Static buildup can make the tape stick to the inside of the covering lid, causing a jam. The use of DAT cassettes with antistatic treated plastic can help. All DAT hardware also should be properly grounded. When packaging DAT for shipment, remember that certain packing materials can generate static. Avoid packing DAT in expandable polystyrene "peanuts" that haven't been static-treated. Never wrap DAT in polyethylene film that hasn't been static-treated.

The DAT cassettes are quite sturdy. The best way to mail them is wrapped in padded mailing bags. And, like analog tape, DAT is not affected by airport X-rays. If used with care, the DAT format can be an effective tool for the professional.

Our New Satellite Video Receiver Has No Options

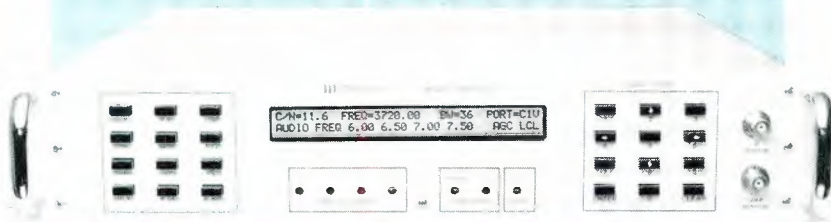

Everything you need for broadcast-quality reception is built into the standard unit.

Signal quality you will brag about. Both Video and Audio meet the requirements of RS-250B, C and NTC-7. Plus four, separately tunable, audio channels.

Works twice as hard for you by receiving both NTSC and PAL broadcasts. From L, S, C, and Ku band transponders. With any standard scrambler format.

Select operating parameters with pushbutton ease. Menu driven format guides you through the selection process. You see your options then select the ones you want.

Entire front panel is remoteable. You have complete control of all receiver functions. From any standard PC or digital logic controller. From any location.

For additional details just give us a call at (904) 687-4633. Let us show you how top quality, satellite video reception is now easier than ever before.

Microdyne
Excellence In Communications Technology

491 Oak Road • Ocala, Florida 32672
Phone (904) 687-4633 • Fax (904) 687-4780

SCMS—the Serial Copy Management System

By Skip Pizzi, technical editor

Unlike earlier attempts at copy prohibition for DAT, the Serial Copy Management System (SCMS) has a design that is truly worthy of today's technology. It is a comprehensive and elegant system, with no deleterious effect on audio quality (it exists only in the channel status area of subcode data), and strikes a masterful compromise between the rights of copyright holders and consumers. Its forward-thinking design also will accommodate future developments in the industry with ease.

Because of its sophistication, a full explanation requires more space than we have. But here is a summary of SCMS points salient to broadcasters.

1. It will *only* be implemented on consumer DAT hardware. Truly professional products will *not* be affected.
2. It will only affect digital copying. Analog dubbing will not be controlled. Some examination of a future system covering analog copying is under way, and is supported in principle in the pending DAT legislation before Congress.
3. It is a flexible system, allowing the originator of a digital recording to determine whether unlimited copies can be made.
4. It prohibits digital "serial" copying, meaning the dubbing of a dub. For ex-

Continued on page 113

Circle (39) on Reply Card

ProdigyTM

Experience the
genius of Videotek.

You're burning the midnight oil...Final edit's due at 8 a.m. Be glad you have Prodigy—the switcher with more brainpower in a smaller package.

Forget about old two mix/effect systems.

A reliable video switching and special effects system follows the industry standard—multi-level effects with look-ahead preview—then raises it with features no one else has, even on their most expensive systems. Prodigy offers stereo audio-follow-video, editor interface, effects memory and a programmable downstream keyer. Independent inner/outer border

software control is standard. An RGB chroma keyer is also available.

Have it your way.

Modify Prodigy to suit your style and create memorable performances. Program up to 99 events into Prodigy's 68000 microcomputer and preview the results instantly. Ten programmable sequences link 80 on-line memory registers and ten learned operator transitions track your actions over time. With Videotek's exclusive Times Six Plus black burst generator, system timing is virtually automatic.

Prodigy is multi-talented.

Equally at home in the post-production facility, newsroom or

studio—Prodigy rack-mounts in minutes and its software talks to a wide range of popular editing controllers.

Get your hands on a Prodigy and let the performance begin! For details or your nearest Prodigy dealer, call Videotek today.



VIDEOTEK INC.
American made technology.
And value.

243 Shoemaker Road, Pottstown,
Pennsylvania 19464 • (215) 327-2292
TWX 710-653-0125 • FAX (215) 327-9295
A Zero Defects Company

Audio: the sound product

By Ronald F. Balonis

The ultimate output of any audio chain is sound, a phenomenon with both “hard” and “soft” aspects.

Sound has two different natures. The first is empirical, a physical quantity of vibrations in a medium that can be measured easily; the second is a psychophysical subjective perception in the listener. Of course, the second can be described as being simply a result of the first, but there is more to it than that. Sound's mysterious complexity and enormous power to evoke emotion just by combinations of seemingly innocuous vibrations, is a fundamental basis of the broadcast industry.

In broadcasting, progress always is ushered in with a technological push or a market pull, or some combination thereof. Each era brings a new level of scientific precision, and lessens the “art” a little. The industry is continually presented with the potential to make broadcast audio, the sound product, better. Competitive media also gets the same opportunities concurrently, so it behooves the broadcast engineer to constantly optimize audio hardware and operations.

Broadcast audio, the sound product

In a unique way, broadcasting is a manufacturing business. Its product is a flowing mix of sounds that entertain, inform and have the power to change how people think, act and believe.

As a manufactured consumer product, sound is no different from any other, and like them, the uses to which it's put or the reason it's purchased, can be different

from what the manufacturer intended. A station's sound is seldom defined only on its technical or physical qualities; rather, the sound is heard and defined with other cultural, social or psychological criteria. The listener gives the sound meaning.

How the product of broadcasting is perceived impacts directly upon its purchase (ratings), and indirectly on how best to design, operate and maintain the audio systems used in its production. The perception of sound quality becomes important to the broadcast engineer, and the concepts of psychoacoustics are a necessary tool.

Sound as audio

The theory of sound is a branch of applied physics, and its characteristics can be measured scientifically. Sound, in its generation and transmission, is caused by the mechanical vibration of physical materials. As a function of a material's physical properties (elasticity), these vibrations exhibit a wavelike periodicity until the energy in them dissipates. Sound can be described by three basic physical characteristics: frequency (or vibration, periodicity, oscillation); intensity (or amplitude, magnitude, volume); and phase (the positional part of a sound's waveform along the time axis, with respect to frequency). A sound's waveform can be further analyzed as being composed of a fundamental frequency and one or more harmonics (arithmetic multiples of the fundamental). A wide range of tonal or timbral qualities exist among various sounds,

which are determined by their harmonic content. The fundamental frequency defines a sound's pitch.

By definition, sound as we hear it is the vibration of air molecules. It is an acoustic event, set off by some physical disturbance of air molecules at rest, stimulating them to carry the vibration thus begun in a chain reaction — a kind of sonic domino game. Audio, on the other hand, is an electrical representation of the actual sound, with oscillations occurring in the charges of molecules in a conductor, rather than in the motion of molecules in the air. The reproduced sound that listeners hear and perceive has typically gone through at least three transformations of energy state: mechanical to electrical (via microphone), to electromagnetic radiation (via transmitter/antenna) back to electrical (via antenna/tuner) and finally back to mechanical (via loudspeaker).

All of this creates an “audio-is-sound-is-audio” dilemma in the maintenance, design and adjustment of audio systems and equipment. It is often difficult to find firm common ground between empirical measurements and subjective impressions in the audio chain.

Audio as sound

In broadcasting, our primary domain of operation is audio; we form our product as an electrical voltage or current. In terms of assessing audio quality, we must rely on rational specifications that measure audio-signal transparency in the three dimensions of sound: amplitude, frequen-

Balonis is chief engineer of WILK-AM in Wilkes-Barre, PA.



FM sound so clear, it's like Carnegie Hall when no one coughs or blows their nose.

The day our engineers went a little crazy.

Three years ago, the engineers at TFT had a crazy idea. They decided it was high-time someone improved the quality of FM sound—dramatically. So they got to work. What they discovered didn't surprise them. The weakest link in total FM audio performance was *still* the STL Receiver's demodulating circuitry. Since the FCC's allowable RF bandwidth precludes the use of 950 MHz digital STL, the challenge now became how to eliminate that demod—forever.

Introducing The Reciter.[™] And 10x better FM sound.

In most cases improved sound is subjective. Not with the Reciter.

Numbers don't lie. This remarkable new technology combines all the functions of an STL Receiver and an FM Exciter in one box,

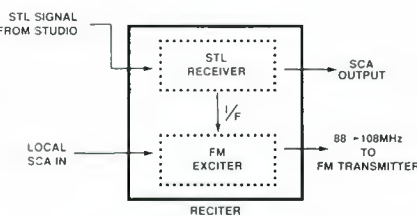

New TFT Model 8900 Reciter eliminates baseband demodulation/re-modulation completely. The result is a 10x improvement in FM sound quality.

using an Intermediate Frequency (IF) as the interface. *By using the IF to transfer FM modulation from the STL Receiver to the Exciter, it's*

not necessary to demodulate the STL signal to the baseband. The result is a 10x improvement in FM sound quality.

Hear something truly exciting. Proven results.

There's nothing wrong with being skeptical about whizbang ideas. But after 20 years in broadcast technology, we're not about to introduce something we invented overnight or isn't proven. So if you'd like to hear something truly exciting, call us for complete information on the new Reciter. Contact TFT, Inc. 3090 Oakmead Village Drive, Santa Clara, CA 95051. **TFT INC** 1-800-347-3383.

Sound Quality for 20 Years

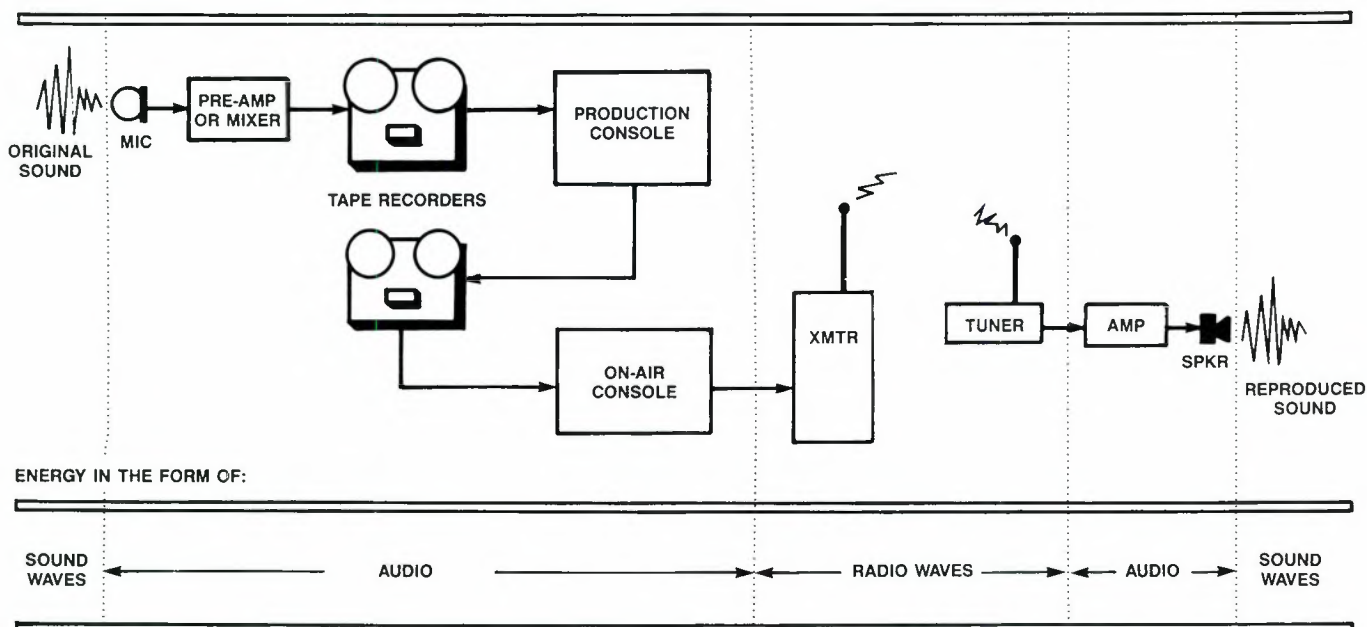

Figure 1. Objective and subjective degradation can occur at any place along the audio chain. Places where the energy changes its form are most susceptible.

more functional than operational. In broadcasting, the audio systems are designed for linearity, minimum distortion and the widest frequency response.

Our hearing system is designed or has evolved to have non-linear relationships between frequency and pitch, between sound level and loudness and between frequency and sound level. This gives it some unique features. The amount of distortion tolerated or perceived varies inversely with frequency. The wider the frequency response, the more sensitive the ear is to distortion. It also creates its own intermodulation products, and, depending on the spectral composition of a complex sound, it enables us to hear frequencies that are missing. It can, in effect, extend the frequency response.

Most people can hear frequencies from approximately 20Hz to in excess of 15,000Hz, and can perceive sound levels over a range of 120dB, from the threshold of hearing (a barely perceptible rustling of leaves, for example), to the threshold of pain (a jet taking off nearby) — a sound pressure ratio of more than a trillion to one. We can perceive differences in sound levels as low as 0.25dB, and differences in pitch as small as a few hertz, depending on the sound's level and the frequencies that make it up.

The sensitivity of the ear is amazing. The displacement of the eardrum (or tympanic membrane, the part of the middle ear that functions like a microphone's diaphragm) for a sound at the threshold of hearing has been measured to be about $\frac{1}{100}$ of the diameter of a hydrogen atom. But in terms of transfer characteristics or

fidelity, the ear would seem to be a poor instrument, indeed. However, its purpose is not for a one-to-one transparent transformation of an enormously cluttered and noisy world of sound, but for our evolutionary survival in it.

The hearing sense' primary purpose is the sorting and differentiation of sounds. Normally, we are not aware of its technical limitations. Although most everyone can hear relatively slight distortions and spectral imbalances in sounds, it often is impossible to do the same for even gross distortions and spectral imbalances within our own ears. To us, the distortions and the selective filtering, if present consistently as part of our life experience, are part of our aural reality. The so-called defects are cognitively integrated into the hearing system, and they add spatial and quantitative information rather than qualitative degradation to the sounds.

The ear is more than a sensitive microphone. It is our means of transforming mechanical sound energy into bioelectric impulses for direct neural transmission to, and processing in, the brain's auditory system. Sound is not just heard, it is perceived.

Sound is a physical phenomenon in our world; audio is an electrical phenomenon in our equipment; and sound triggers psychoacoustic phenomena in our consciousness.

Psychoacoustics

The sounds we hear are mental events. It is, of course, in the mind that, after sensing a sound's basic characteristics — frequency, amplitude and duration — we at-

tach meaning to it. Pitch correlates (roughly) to frequency, loudness (roughly) to amplitude and timbre (roughly) to the complexity of the sound. But the mind makes the great leap from this sort of perception to the discernment of sounds as speech, music or noise; as pleasant or dull; as important or unimportant; as interesting or boring.

This "in-the-mind" aspect of sound is what the research and the experience of psychoacoustics is about — the mental and auditory aspects of sound as a container, full of meaning.

The combination of sound variables in pitch, frequency and duration, as heard through two ears placed at slightly different positions, yields an almost infinite number of cognitive possibilities. This cognition allows us to attempt to identify a sound's source and its location, two important elements in the survival aspect of hearing.

There are almost countless varieties of sounds to hear and know. For these, like most of our cognitive skills, we acquire knowledge about them through a combination of imprinting, learning and conditioning. Every stage of life, from birth onward, adds to the perceptual storehouse of aural patterns, symbols, meaning and connotation, for the sounds around us. We learn these symbols and their meaning in various family, social and cultural contexts. They enable us to all hear the same sounds, to all interpret the same meaning, and to communicate with sound. Yet, because everyone's life experiences differ, we will not all have identical interpretive

Continued on page 84

This switcher handles standard bandwidth like it's going out of style.



TVS/TAS-3000 Distribution Switcher

The new TVS/TAS-3000 video/audio distribution switcher from BTS handles standard bandwidth switching in stride. But the fact is, standard bandwidth may not be the standard much longer. And that's why the TVS/TAS-3000 is not your standard switcher.

With the advent of wide bandwidth video, you'll need a switcher that can handle the new higher bandwidth signals. The 3000 will. It provides a video bandwidth of more than 50 MHz, measured with a full-amplitude sine wave or video signal. Which makes it upwardly compatible with HDTV or computer graphics—no matter what the standard.

The TVS/TAS-3000 also delivers the cleanest signal and expands to accommodate any matrix size to meet your specific needs.

And if high bandwidth capacity isn't a require-

ment, BTS still has you covered with our best-selling switcher, the TVS/TAS-2000. The 2000 represents the same advanced technology and quality as the 3000 in a standard bandwidth switcher. BTS also offers a full-range of control panels and distribution amplifiers for a complete system designed, tested and guaranteed by one supplier.

All BTS switchers undergo 100% computerized factory testing and are protected with a 5-year warranty. In the unlikely event you do have a problem, simply return the board for a free replacement.

Dependable, performing switchers from BTS. Anything else is substandard. Call for information and technical specifications today: **1-800-562-1136, ext. 21.**

BTS
The name behind
what's ahead.

BTS is Broadcast Television Systems, a joint company of Bosch and Philips, P.O. Box 30816, Salt Lake City, UT 84130-0816.

Circle (45) on Reply Card

www.americanradiohistory.com

IBC is larger than ever

By Skip Pizzi, technical editor

With a record-breaking 270 exhibitors, the biennial International Broadcasting Convention (IBC) will present the latest in broadcast hardware to the European community. IBC '90 will be held Friday through Tuesday, Sept. 21-25, in its traditional location of Brighton, England.

In addition to display areas at the Metrople Conference and Exhibition Centre, the Brighton Centre, the Grand Hotel and exterior exhibits, additional space will be provided in four adjacent temporary buildings constructed especially for the conference along the Brighton waterfront. The exhibit area will occupy more than 15,000 additional square feet than the last IBC convention.

The exhibits will open at noon on Friday, Sept. 21 and at 9:30 a.m. Saturday, Sept. 22 through Tuesday, Sept. 25. Exhibits will close at 6 p.m. each day.

Technical sessions will be held Saturday through Monday and will include presentations on the subjects of HDTV, EDTV, DBS, RF transmission, digital audio broadcasting, digital audio and video signal processing, CCD camera technology, DAT,

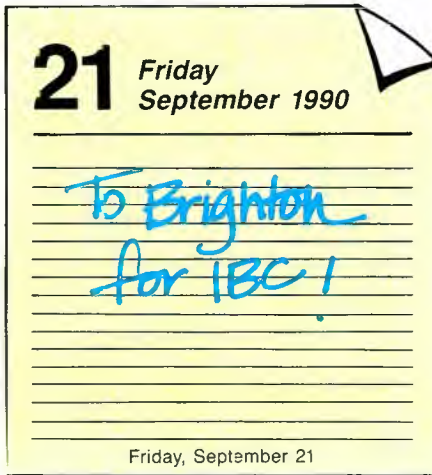

RDS and more. Keynote addresses will deal with advanced TV issues from the European, American, Japanese and Soviet perspectives.

Convention organizers have selected a wide range of the most original papers that were submitted to be presented. No more than two sessions will be presented concurrently. Present and future directions will be covered.

No technical papers will be presented on Tuesday, in order to allow attendees of those sessions, sufficient time to view the enlarged exhibition.

A champagne buffet will be held Saturday evening, from 7:30-9 p.m. at the Brighton Corn Exchange. The IBC Award will be presented at this event. Admission to the buffet is included for full-time registrants. A limited number of guest tickets will be available for purchase.

An excellent spouse's program, which will consist of tours, luncheons, demonstrations and teas also has been prepared, with functions scheduled from Sept. 21-25. There is no charge for spouses of full registrants.

Brighton, located on England's southern coast, is a 30-minute train ride from London's Gatwick airport, and a 55-minute train ride from Victoria Station. By road, the London-to-Brighton trip takes approximately two hours. Car ferry service is convenient from the continent, as well.

Preregistration deadline is Sept. 7. For further information, contact: IBC Secretariat, c/o The Institution of Electrical Engineers, Savoy Place, London WC2R 0BL, United Kingdom; telephone: 071-240-1871, ext. 222; telex: 261176 IEE LDN G; fax: 071-240-7735.

Travel information is available from: Expotel Executive Travel, Banda House, Cambridge Grove, London W6 0LE, United Kingdom; telephone: 081-741-4468; telex: 896778; fax: 081-741-7225.

The IBC management committee has announced that beginning with the next convention in 1992, the IBC will move to Amsterdam, Holland, marking the first time the show will be held outside of the United Kingdom. According to IBC organizers, the change has been made because the convention has exceeded the Brighton venue's capacity to comfortably contain it. Future shows will be held in the RAI Exhibition and Congress Centre, a large, purpose-built exhibition facility, located close to Amsterdam's downtown and to Schiphol, the international airport. Parking, highway access and hotels also are convenient.

The 1992 move is coincidental with the European Economic Community's establishment of its "single common market." The Amsterdam location will make the show more accessible to the whole of that increasingly united and growing European broadcast community. In '92, the convention will switch to an early July date, but will return to its traditional mid-September placement in 1994.



An exterior view of the Brighton Convention Center.

||:~:)))))

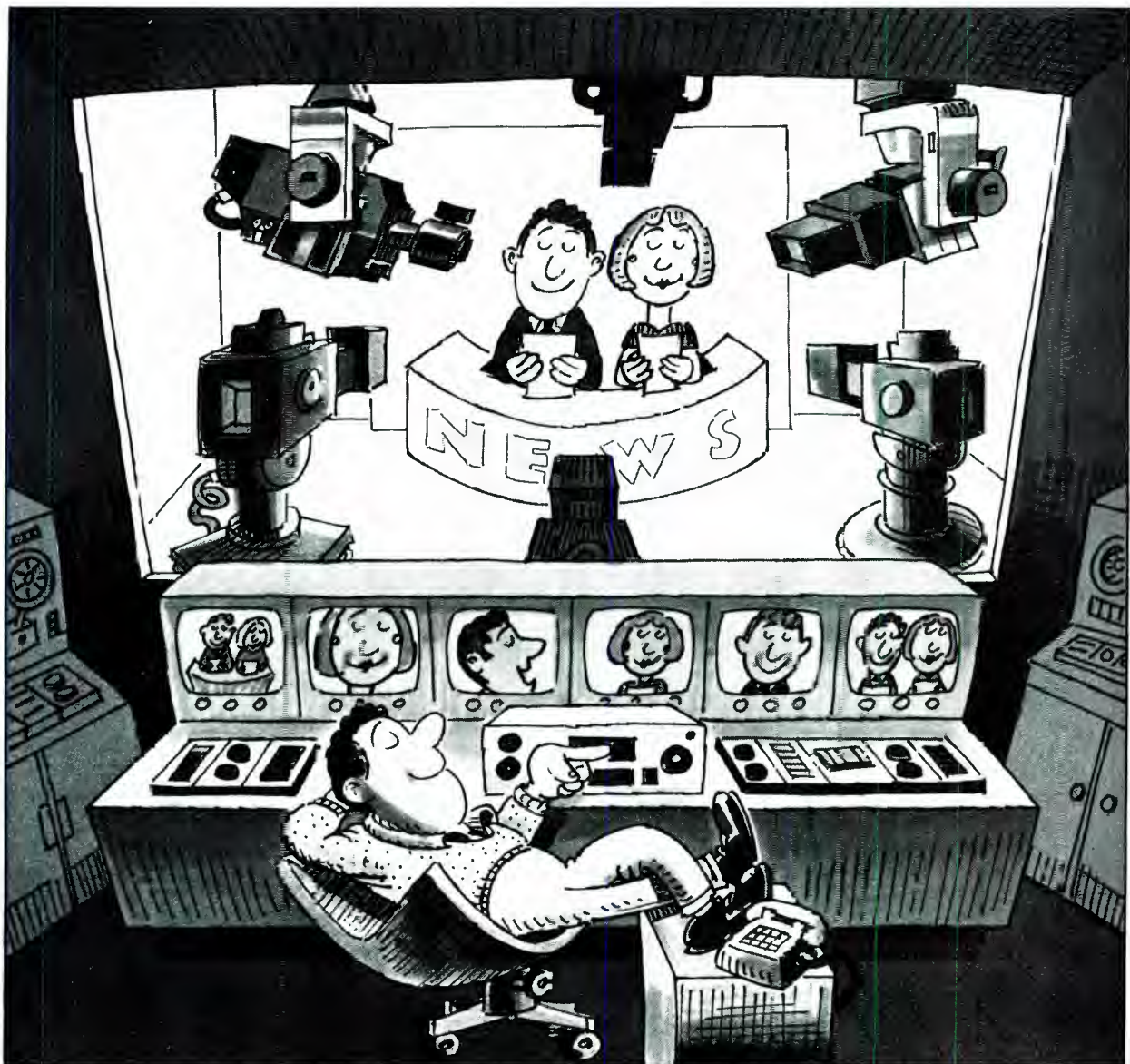

MULTIPLE CAMERAS. ONE OPERATOR.

Impossible? Not if your news studio is equipped with the RADAMEC EPO ROBOTIC CAMERA CONTROL SYSTEM.—the system that is changing the way television stations, networks and cable systems are presenting their news.

- Up to 500 preprogrammed positions per camera, including control of pan, tilt, height, zoom, focus and iris and black levels
- Programmable fade modes that provide smooth transition from pre-programmed shots
- Ability to operate via telephone lines or microwave
- Pan and tilts heads for a wide range of cameras—from full studio to ENG types

It's flexible, affordable—and it is sold and serviced in the U.S. by A.F. Associates.

NEW! THE AFA ROBOPED

Designed expressly for the Radamec EPO Camera Control System.

This laser-positioned, free-roaming robotic pedestal glides smoothly and silently at up to 1.5 ft.-per-second anywhere in a studio without relying on a pre-determined path—without floor tapes, without target tiles. It's got a built-in intelligent collision-avoidance system that works faultlessly, and an incredibly simple manual override for special production needs.

THE RADAMEC EPO CAMERA CONTROL SYSTEMS



A.F. ASSOCIATES, INC.

ADVANCED SYSTEMS AND PRODUCTS FOR THE VIDEO INDUSTRY
100 Stonehurst Court, Northvale, NJ 07647 (201) 767-1200
Western Region (619) 227-0291; Southern Region (404) 242-1661
A Video Services Corporation Company.

Circle (46) on Reply Card

Society hires executive director

By Bob Van Buhler

Stephen L. Ingram has been hired as SBE's first professional executive director. He is a certified association executive (CAE) by the American Society of Association Executives (ASAE). He will direct the society's efforts at the Indianapolis headquarters.

His responsibilities include developing new member benefits, coordinating convention activities, facilitating the development of a well-researched and effective strategic plan and identifying new marketing opportunities.

Ingram, with eight years of experience as a professional association manager, holds the highest level of professional certification from the ASAE. He serves on the board of directors of the Indiana Society of Association Executives and is a member of the membership development committee of the ASAE.

Ingram's hiring caps a long-term effort by previous presidents and boards to fill an important need within the society. At the 1989 SBE convention, the committee of past SBE presidents emphasized the importance of hiring an executive director.

The expertise Ingram brings should provide the society with the continuity and stability needed to carry out the board's long-range goals.

Prior to his hiring, SBE commissioned Ingram to perform an association evaluation of the society. His report was presented to the board of directors at their meeting at the NAB convention in Atlanta. The report and its presentation gave the board an opportunity to examine Ingram's methods and performance and to assess his personality prior to his hiring.

The board approved the hiring of an executive director at the NAB meeting, which meets one of the major goals of president Brad Dick. He said, "Steve brings extensive management ability to SBE and will be instrumental in helping the society plan strategically for our future. It's important for SBE to continue the record growth we've enjoyed and take advantage of the many existing opportunities. We're looking forward to being able to provide our members with many new benefits and programs as a result of Steve's expertise."

Van Buhler is manager of engineering at KNIX-AM/KCWW-FM, Phoenix.

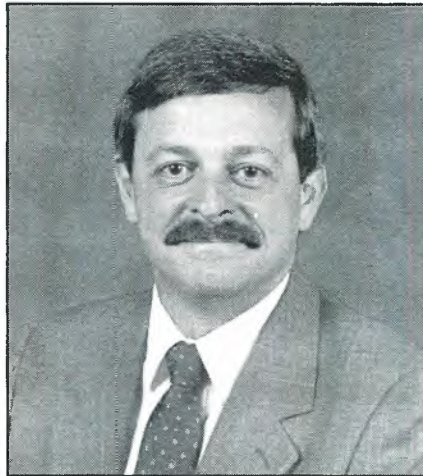

Newly hired SBE executive director, Stephen L. Ingram (CAE), announced his goal to help the officers and board of directors to implement a successful long-range strategic plan for the society. It will be based on the well-received membership survey, 1989 past president's committee report, focus on group work and a board/officer survey.

Election slate of candidates

The official slate of candidates has been presented to the national office. The nominating committee, former SBE vice president Bob Van Buhler and former president and Ennes Foundation executive director Jim Wulliman, presented the national office with the candidates for the four officer positions open for election in September. No director positions expire this year.

President Dick was nominated for a second term. He is a certified SBE professional broadcast engineer and served the four terms as its secretary, prior to his election last year as president. Dick currently is editor of *Broadcast Engineering* magazine.

Vice president Richard Farquhar is a nominee for a second term. He achieved that office after serving on the board of directors and the SBE certification committee. Farquhar is in charge of industry and public relations for the SBE. He is vice president, operations and engineering of SOS Productions, a video production company in Columbus, OH.

Secretary Paul Lentz has been renominated. He is a retired chief engineer of

WTOL-TV, Toledo, OH. He has been active in the communications aspect of the frequency-coordination efforts and was responsible for the membership directory.

Robert Goza of St. Louis has been nominated as SBE treasurer. He currently is a director of SBE, has served on every year's convention committee and is now convention chairman. SBE's current treasurer, Bill Harris of Denver, will not run for a third term, citing professional and personal obligations.

Because of Goza's expertise on the SBE financial procedures and its accounting software, the nominating committee believes he is best suited to succeed Harris as treasurer. Goza is engineering supervisor at KMOV-TV, St. Louis.

To comply with the bylaws, write-in candidates must have complied with the Aug. 6 deadline. Ballots are to be mailed to each member by Sept. 3 and returned to the national office no later than Oct. 1, which is the official election date.

The lack of director nominations is the result of a bylaw revision approved by the membership in 1988, which changed the term of office of directors from two to three years. The 3-year term changes the previous practice of requiring 50% of the directors to stand for election each year and creates years in which no director terms expire. It also creates years in which a majority of director terms expire.

SBE and DANTES

The Defense Activity for Non-Traditional Education Support (DANTES) and SBE have discussed the possibilities of adopting SBE's certification program in the U.S. military services. Andrew Byes, manager of program development for DANTES, and Ennes Foundation executive director Jim Wulliman have discussed the use of DANTES test centers throughout the world to administer certification exams to qualified military personnel with proper credentials in radio and TV engineering.

"Every chance I get to use the Auditronics 400 is a real treat,"

Clay Freinwald
Chief Engineer
KBSG-FM 97.3
Seattle, Washington
Viacom Broadcasting



says Vic Orlando, Production Director at Seattle's K-Best. "I use the 400 mainly for station promos, and I find its ease of operation simply incredible. Though most of my energy goes into our own work, there's a lot of commercial production done here as well. In fact, many of our advertisers and agencies prefer to use our facility to produce their commercials. For a work load like ours, the 400 is the ideal production console."

"We wanted all modular consoles for our new studios here in the Metropolitan Park, East Tower," says K-Best chief engineer Clay Freinwald. "The serious contenders were Pacific Recorders, which there's a lot of in our region due to its being a west coast brand, and Auditronics, which our corporate director of engineering, Frank Kramer, said Viacom had good success with at WLAK in Chicago, and WMZQ in DC."

"So we went to NAB and talked to everybody, including Duncan Fuller at Auditronics. And dollar for dollar it seemed to us that Auditronics was equal to or better than anything else out there. So we bought two 219s for on-air and a 424 for production. It's nice equipment. I got just what I wanted: the "Best for K-Best".

"The operators love the consoles. They're insanely simple to run. And there have been no failures to take us off the air. Factory support has been good. The bottom line question is would I buy Auditronics consoles again? Yes, I'd buy them again."

Call Auditronics today toll-free at 800-638-0977 for information on the consoles Vic Orlando specified for K-Best - (KBSG).

Auditronics, inc.
3750 Old Getwell Road, Memphis, TN 38118
501 362-1350

Vic Orlando, Production Director, KESG-FM 97.3, Seattle Washington, Viacom Broadcasting

Circle (47) on Reply Card



Tascam CD-701 CD player

By John Collinson

Compact discs have taken the audio world by storm, and few radio broadcasters can ignore them completely. As CDs steadily drive vinyl records out of production, an avalanche of CD players has invaded the marketplace. The choice of players is as diverse as tone arms and cartridges only a few years ago.

Consumer or professional?

Many stations are having to choose between a consumer model CD player, which they could trade with a local dealer, or the more expensive professional models, which require high cash outlays. If the CD player is used occasionally, inexpensive consumer units might be acceptable, but any engineer who has tried to keep a consumer player running in a high-demand operation knows it's an uphill fight. Even for occasional use, the players require an interface to convert the nominal -10dBV high-impedance-unbalanced outputs to regular broadcast standards. When the consumer unit fails, you have virtually no chance of getting a service manual. It's rare when a service shop can repair the unit if there is serious damage, but if it can be repaired, the cost may be more than the player is worth.

Professional machines are designed for use in professional applications. They are more rugged and have balanced, line-level outputs. Service information and support also is available. For stations planning to use CDs, the professional models are the only way to go.

Tough choice

Choices also have to be made with professional machines. In most cases, the programming department should be involved in selecting the features needed for the operation, while engineering looks at the technical merits. When WDAF-AM needed a player for on-air use, all options were considered. The program director preferred a conventional-type player rather than the cartridge-shell approach used at sister station KYYS-FM.

Reliability was the primary consideration, but the cost had to be reasonable.



Performance at a glance

- Frequency response: 20Hz to 20kHz, $\pm 1\text{dB}$
- Distortion: 0.008% at 1kHz
- Signal-to-noise ratio: 96dB (A-weighted)
- Output: up to $+8\text{dBm}$ at 600 Ω
- Digital output: through RCA jack
- Cuing time: within 2s
- Discs: either 8cm or 12cm CD, no adapter needed
- Dimensions: $8\frac{1}{16} \times 5\frac{1}{8} \times 19\frac{5}{16}$
- Weight: $20\frac{15}{16}$ pounds
- Power consumption: 23W

Deliberation led to the Tascam CD-701. Even though it was a new model, our past experience with Tascam equipment encouraged the decision.

First impressions

When the player arrived, it took two men just to lift it out of the box. Everything about it gave the impression of rugged construction. If any machine could stand up to disc jockeys, we felt this one could.

The case is steel, which provides excellent shielding against incoming and outgoing electromagnetic interference. A massive heat sink on the back panel barely gets warm. The player is large, which could be a negative factor in tight locations. Controls are well marked and the display is bright and easy to read.

Initial operation was flawless. With a touch of the *open/close* button, the loading tray slides out smoothly. Operation is unlike the spring-loaded catapult arrangement in some players. To keep dirty fingers off of the CD, the tray has a clever thumb hole so the disc can be grasped between thumb and forefinger and laid in the tray without touching the playing surface. Another touch of the button retracts the tray into playing position. If a disc jockey decides to ram the CD in manually, no harm is done, the tray continues to retract into position.

Attempts to measure performance showed more limitations with the test equipment than with the player. Frequency response is specified at $\pm 1\text{dB}$ from 20Hz to 20kHz. Measured response was

better than specified within 0.5dB from 15Hz to 20kHz. Equipment and RF constraints prevented accurate measurement of noise and distortion, but indications show that published specifications were probably met.

On the air

Installation was basic. The output jacks are standard XLR connectors. The machine is 19 inches deep and filled the rack space completely with the connectors installed. If a station uses two players, the units sit side by side in a standard rack shelf. With the heat sink on the back there would be no heat problem. The only other connection needed was a switching pair to the D connector on the back panel for remote start. All that's required is a simple closure to ground.

Sound quality is superb, which is to be expected from today's generation of professional machines with 4X oversampling and top-quality audio sections. There is a notable difference in sound quality from older units with lesser sampling rates, especially in the purity of high-frequency passages. Cuing is quick and positive.

The most impressive features were the safeguards against interruptions in the sound. The open/close button won't work in play mode. A thump on the top of the player that would have shut down any other machine in the house, didn't faze the unit. When laid on its back in mid-song, it kept on playing. These stunts may not indicate resistance to skipping, but they were taken as a good sign.

After eight months of use, the player has only skipped once, and a quick lens cleaning ended that. Although CDs are not as perfect as record companies would have us believe, it's still the player that gets blamed for any problems. In our case, the programming and engineering departments were satisfied with the unit's performance.

Options galore

The player can be operated from the front panel or from two remote controllers. Basic operation, such as straight on-air playback may be done without a con-

Continued on page 81

Collinson is chief engineer, KYYS-FM, WDAF-AM, Kansas City, MO.



The Performance Name In Camera Tubes Means Energy Savings In UHF Klystrons Too.

The broad Philips line of Plumbicon® tubes includes broadcast, ENG and EFP types, low-power and high-definition types. With lots of options. And they're available overnight.

Philips broadcast experience in camera tubes also covers UHF transmission. With UHF klystrons, Philips is a global leader in terms of market share and innovation. Immediate U.S. availability, strong technical field

support, and energy-saving MSDC design are yours from Philips.

Philips. Components for TV imaging and transmission. With guaranteed supply continuity. And worldwide availability.

Philips Components
Discrete Products Division **1-800-447-3762**
 2001 W. Blue Heron Blvd. Fax: 407-881-3300
 P.O. Box 10330
 Riviera Beach, FL 33404

More Products. More Solutions.

Philips Components



PHILIPS

Improve the Means to the End

Introducing Our New Extended Benefits Package:

Model MCE325 Programmable User Station



Think of it...

a versatile intercom user station with a wide range of operational and packaging formats.

Physical benefits include a five way modular packaging technique for permanent or portable applications. While headset operation comes standard, adding our MCS325 Speaker and a plug-in microphone supports an open-listening setting.

Operator benefits sport user-friendly software and hardware based programming; the MCE325 can be operationally and functionally configured to suit individual requirements.

As for the small print: the MCE325 works in conference-line or dedicated-line environments, with 2-channel split talk/listen or 4-channel combo talk/listen, in 2-wire or 4-wire line mode, or a combination of both. Also featured are two channels of IFB, two program inputs, and call signaling. Modular packaging includes: rack mount or portable headset station, rack mount or portable speaker station, or console mount headset station.

Please call or write for details.

The First Name In Intercommunications

Professional Intercommunications
Professional Audio Products

1988 - 1989
Engineering
Emmy Award



Circle (49) on Reply Card

RTS SYSTEMS

A Telex Communications Company

1100 West Chestnut Street
Burbank, California 91506
Phone 818-566-6700
Fax 818-843-7953

Continued from page 78

troller. In this case, the machine automatically cues to the beginning of a cut, not to first audio. Manual cuing may be done with the *skip* button. Remote start requires a continuous contact closure to the D connector on the back. Also on the D connector is a closure at the end of the cut to trigger a warning or the next event.

Back-panel dip switches on the player head the option list. The digital output may be switched on and off. Mono operations will delight to find a stereo/mono switch that eliminates an outboard mixing scheme. If you use one of the controllers, the front-panel controls (except open/close) may be locked out. Control of the auto-cue sensing level also is provided.

At WDAF, we use the RC-7 remote control, which provides remote operation of all panel functions plus variable pitch to $\pm 6\%$, auto-cue to first audio, a number of repeat modes, looping and direct keypad-entry cuing to any point in any cut. Serious production operations may want to use the RC-701, which can control all the above functions for four machines. The device also provides readout displays, a jog wheel for cuing and pitch control and a plethora of programming and sequencing possibilities. A station with an effects li-

brary on CD may find this an attractive way to build complex productions in one pass without editing or generation loss.

Also valuable for production use is the BU-1 RAM buffer, which plugs into the inside of the player. This allows instant start of audio without the fraction of a second (up to 300ms) delay normally encountered. Because operators are accustomed to similar start delays for cart machines, this seems unnecessary for on-air use. A summary of the player's highlights is shown in Table 1.

A peek inside

Removing four screws frees the top cover. Be careful to avoid damaging the ribbon cables that run along each side of the frame. Everything you'd normally need access to is accessed from the top. Remove two more screws and the audio board hinges up to allow access to the output level pots, tray drive-speed control and a jumper to select split-cue or single-cue operation.

In split cue, the XLR outputs are muted while cuing audio is fed only through the

PRODUCT HIGHLIGHTS

1. Rugged construction with drive unit shock-mounted.
2. Four times oversampling for extremely high audio quality.
3. Two remote controllers allow a variety of programming and control functions.
4. Bright, clear display indicates operating modes as well as two possible time readouts.
5. Active-balanced line-level XLR outputs plus EIA-J/SP-DIF standard digital output.

Table 1. The Tascam CD-701 provides many useful features to the operator and engineer.

Rackmount Slide Kits
 SONY
 JVC
 PIONEER
 PANASONIC
 800-635-9297
 714-632-1763
Ergo Industries, Inc.



Circle (51) on Reply Card

PRECISION MAGNETIC TEST TAPES
STL
 Standard Tape Laboratory, Inc.
 26120 Eden Landing Road #5, Hayward, CA 94545
 (415) 786-3546



Circle (52) on Reply Card

VIDEO IDENTIFIER
 Low cost insertion of ID or any message up to 20 characters.
 • Stores 32 ID's in EPROM • White or black characters • One rack unit
 • Fully positionable • With Box background or without • Power off relay bypass
 • Variable size • NTSC or PAL • Remote controllable
 Great for source identification, "spoiling", serializing work tapes, preventing piracy, etc. Keeps your CG available for more important tasks. \$849
 For more information call or write
QUEUE SYSTEMS
 7985 Santa Monica Bl. Ste. 109-295, W. Hollywood, CA 90046 (213) 656-0258

Circle (53) on Reply Card



- Genuine Ampex replacement parts
- 35,000 different parts in stock
- Parts for out-of-production recorders
- For overnight delivery, call 1-800-227-8402

AMPEX
Ampex Customer Support

AND FOR AN EXCITING OFFER, TURN THE PAGE!

headphone/monitor jack. In single cue, the XLR and headphone outputs are active at all times. The boards are cleanly laid out and screened with part identification. It is inconvenient to have the level pots buried inside, but once set, they should rarely need adjusting.

The drive mechanism also is visible from the top. It is obvious at a glance why the machine is resistant to mechanical shock. The flywheel/drive disc is massive compared to those on other machines,

and the whole drive is suspended on an elastic mounting. Solid construction is evident inside the player as well as outside. Thumping the drive unit directly while playing didn't cause skipping.

With the board tilted up, the lens is readily accessible for cleaning. When stopped, it slides to its rearmost position, out from under the flywheel. Although it is inconvenient to tear into the machine to this extent just to clean the lens, the outer case and the circuit board help protect it from

accumulating dirt and smoke film.

Nobody's perfect

Our only disappointment concerns the operation manuals provided with the machine. The CD-701 and RC-7 are covered in one manual, and the RC-701 is covered in a separate manual. What is designated as an "operation/maintenance" manual doesn't mention the need to clean the lens, much less how to do it. There are several pages of warnings about improper use, and use and abuse of CDs. Only the last



Front view showing novel tray design.



page addresses anything inside the cabinet; the output level and tray speed adjustments and cue jumper are mentioned. Installation of the RAM buffer is covered briefly. That is the extent of maintenance information provided.

To its credit, the manual does an excellent job of explaining all operating controls and programmable functions. This section is useful for operators. The installation and setup sections give just enough information to get the machine up and running. These manuals will probably discourage any consumer types from toying with anything inside the machine. A number of comical translations are scattered throughout the material, but for a professional machine the manuals seem out of character.

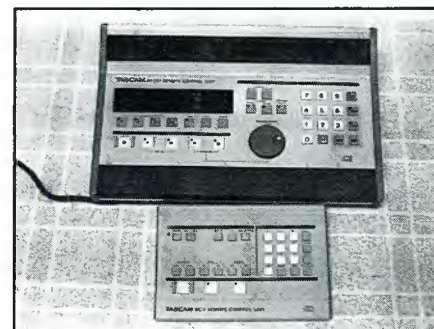
However, the service manual is excellent. I would recommend to anyone pur-



Two types of remote controllers are available. If all you want to do is air CDs you may not even need one. Production applications may benefit from the RC 701.





INTRODUCING :

NAUTEL AMPFET ND25/50, 25 KW & 50 KW

SECOND GENERATION ALL SOLID STATE AM TRANSMITTERS

- Solid state design utilizing digital circuit techniques results in superior audio performance and high efficiency
- Specifically designed for NRSC Standards compatibility and AM Stereo operation in support of improved AM radio
- Parallel modular configuration provides true active reserve without need for operator intervention
- On air serviceability features allow module removal without interruption in broadcasting
- Built-in duplicate exciter sections offer complete backup of critical low level control circuitry



ALL SOLID STATE AMPFET ND SERIES AM MEDIUM WAVE TRANSMITTERS

POWER RANGE UP TO 100 KW

Phone:(902)823-2233 Canada-Fax:(902)823-3183-Tlx:019-22552



NAUTEL
(Nautical Electronic Laboratories Limited)
RR#1, Tantallon, Halifax County
Nova Scotia, Canada B0J 3J0

Nautel Maine Inc.
201 Target Industrial Circle
Bangor, Maine
04401 U.S.A.



Circle (57) on Reply Card

chasing this player to consider buying the service manual along with the machine. All adjustments are covered in detail. Block diagrams and schematics are well drawn and easy to follow. Internal logic diagrams are given for each integrated circuit. Board layouts are spread out to make them easy to read. Parts lists cover every nut, bolt and lock washer. The player and remote-control systems are covered in one book. The manual is written in English and Japanese. The only thing lacking is a circuit description. A simplified block diagram of the player is shown in Figure 1.

Because the CD-701 was a new product when it was purchased, we were the beta-testers for Great American Broadcasting. Given our experience, several other players have been bought, and all reports have been highly positive. If we had to make a choice again, we would buy the player without hesitation. [:-T-:)]

Editor's note: The field report is an exclusive *BE* feature for broadcasters. Each report is prepared by the staff of a broadcast station, production facility or consulting firm.

In essence, these reports are prepared by the industry and for the industry. Manufacturer's support is limited to providing loan equipment and to aiding the author if support is requested in some area.

It is the responsibility of *Broadcast Engineering* to publish the results of any piece tested, positive or negative. No report should be considered an endorsement or disapproval by *Broadcast Engineering* magazine.

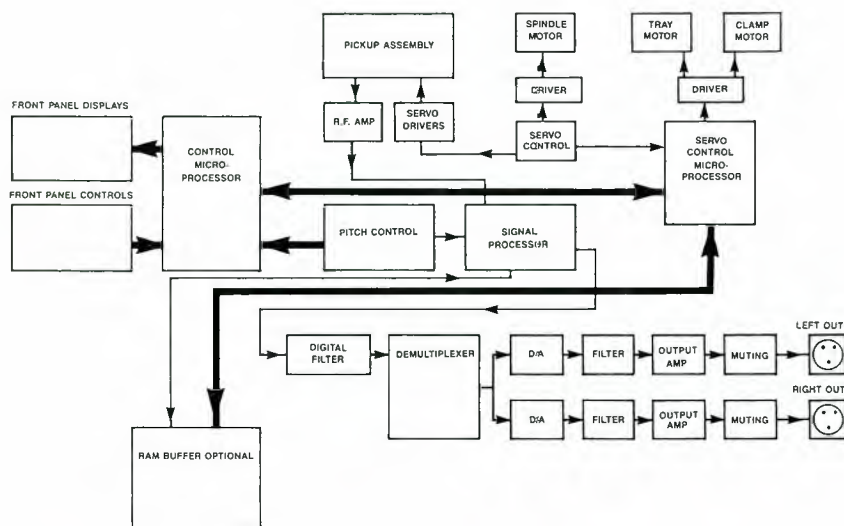

Figure 1. This simplified block diagram belies the complexity of the sophisticated CD player.

Free Catalog & Audio/Video Applications
 Mic, EQ, Line, Tape, Phone, Osc, Trans., Video, ACN, Pwr. Supp.
 Press Boxes 1-in/16-out Video/Audio 2-in/24-out Audio
 Routing Switchers (St-A/V) (24, 16, 12, 8, 4, 2 stations)
 Video & Audio Dist. Amps. 1GB-Sync. Dist. Amps.
OPAMP LABS INC (213) 934-3566
 1033 N Sycamore Av LOS ANGELES CA, 90038

Circle (71) on Reply Card

TIMECODE TRANSLATOR
 CONVERT TIMECODE INTO RS232/RS422 DATA FOR PROCESSING BY YOUR COMPUTER!
 A timecode translator made by QUEUE SYSTEMS will convert longitudinal timecode into serial data in either RS232 or RS422 format at selectable data rates from 150 to 19.2 Kbaud which can be read and acted upon by your personal computer! Completely frame accurate! Our software can be customized to respond with timecode data in response to a query from your computer or continuously! Many extras! Call or write for details! \$849
 QUEUE SYSTEMS 7985 Santa Monica Bl. Ste. 109-295, W. Hollywood CA 90046 (213) 656-0258

Circle (72) on Reply Card

SOCIETY OF
MOTION
PICTURE &
TELEVISION
ENGINEERS
 JOIN
 PARTICIPATE
 913-761-1100

**NOW,
 ONE HEAD IS BETTER
 THAN TWO, THREE...**

- New Universal AST™ head fits Ampex VPR-80, VPR-6, VPR-3, and VPR-2
- Cuts your inventory costs and reduces maintenance errors
- Genuine Ampex heads—One year or 1000 hour warranty
- Call 1-800-227-8402 for fast delivery

AMPEX
Ampex Customer Support

NEWTON Cable Racks

AND ASSOCIATED HARDWARE

MANY SIZES ARE
STOCKED FOR
FAST DELIVERY

- Bar type cable rack.
- Channel type cable rack.
- Trough type cable rack.
- Tubular side bar type cable rack.
- Cable rack made to your special size and color.



Write or call for our free catalog — it is an engineering manual with helpful illustrations on installation procedures.

NEWTON
INSTRUMENT COMPANY, INC.

11 EAST "A" ST • BOX 727 • BUTNER, N.C. 27509
PHONE (919) 575-6426 or FAX (919) 575-4708

MANUFACTURERS OF AUXILIARY FRAMING, CABLE RACKS, MISC. HARDWARE,
EQUIPMENT RACKS, MAIN FRAMES AND TERMINAL BLOCKS.

Circle (59) on Reply Card

Continued from page 72
maps. The sounds you hear can depend upon who you are.

Psychoacoustics also tells us that the ear, like the other sense organs, takes orders from the brain. For the sake of psychic survival, or just for convenience, it can choose to hear what it needs to, or wants to. The so-called "cocktail-party effect" allows us to concentrate on one person's voice amid a cacophony of others. Memory also plays a part. Over years of hearing, we accumulate a large amount of psychic sound capital, and a current sound's sensations can resonate with memories of earlier similar ones. Susceptible listeners can be seduced into hearing it as it was before, or should be.

Psychoacoustics and demographics

Sound has demographics. The young hear better, but naively so because of time-limited hearing experience. A 16-year old can typically hear sounds from less than 20Hz to more than 20,000Hz. High-frequency hearing loss (presbucis) begins to set in during the late twenties and early thirties. For men, the ability to hear a 4,000Hz tone declines at the rate of 1dB per year beyond this point, reaching a loss of 35dB or more by the age of 70; for women, the decline is somewhat less steep, with a rate of 0.5dB per year, reaching a loss of 28dB or more by the age of 70.

The young are more open to finding new sounds and are more likely to be receptive to them, having fewer sound memories for comparison. Older listeners, with their larger storehouses of sound memories, tend to prefer familiar and mild sounds, perhaps with less response, stridency or distortion. For these listeners, even with part of the music muffled or not heard at all, the mind's melody memory fills it in, evoking the same responses and meaning of another time.

Psychoacoustic research tells us why we hear sound as we do. It's a mixed-up, hybrid science, borrowing from biology, physics, engineering, acoustics and psychology. The understanding it brings of the sound product of broadcasting is, like the product itself, still evolving. A recent Audio Engineering Society (AES) Conference on "The Sound of Audio" examined many of these issues in great detail, and its proceedings are available from AES headquarters in New York City.

Although psychoacoustics may seem like an obscure or nearly occult science to some, it has intrigued a number of practitioners for many years, and the fruits of their labors are now being realized. The things that psychoacoustic research tells us about sound, and about ourselves, are as real as they can be.

[-?(-=)]

Second Generation AF75



Wide Bandwidth TBC/Frame Synchronizer
**Excellent Wideband Component
Processing Technique**

\$2,800.00

Compatible with
S-VHS, VHS
U-MATIC & U-MATIC SP,
Y/C INPUT & OUTPUT



HOTRONIC, INC.
1875 S. Winchester Blvd.
Campbell, CA 95008
408/378-3883

- Time base correction for Heterodyne VTRs
- Synchronize noisy satellite feeds, microwave, ENG, remote broadcast van and other non-synchronous sources
- Full bandwidth operation in all modes with no 3.58 sub-carrier needed
- Adaptive comb filter
- Full bandwidth freeze field/freeze frame (field 1 or field 2 selectable)
- Y/C and Composite Input and simultaneous Output (Composite - Y/C Transcoder)

Circle (60) on Reply Card

On the surface, most dual video jacks look exactly alike.



Ours is a little different.

A video chain is only as strong as its weakest link. Why route signal produced by today's technology through yesterday's connector?

No other dual video jack can match Canare's incredible bandwidth, up to 600 MHz. You get several times the bandwidth needed for consistently high performance by today's sophisticated technology, and probably tomorrow's. The durability is instantly apparent when you peek inside the sealed shell and see the PCB mounted microswitches. Bottom line, you get at least 30,000 I/O cycles for years of trouble-free operation.

Our dual video jack is anywhere from \$2 to \$20 less than the ones you're using now, so you can easily afford to upgrade your video patchbays. Contact us today for complete specifications.

CANARE™

511 5th Street, Unit G, San Fernando, CA 91340, (818) 365-2446

Circle (58) on Reply Card

www.americanradiohistory.com

Station-to-station

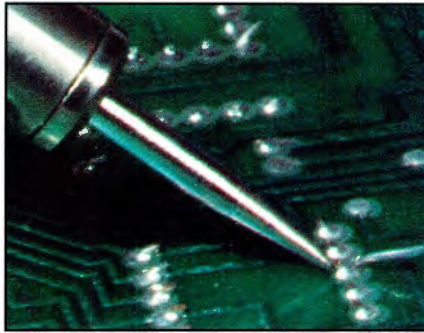

Building a remote switcher

By Russell Brown

If your station is similar to most in urban centers, you don't have your C-band satellite dish located next to your studio. The dish probably is located several miles away where it's shielded by hills, if you're lucky, and remotely controlled.

Transmitter remote controls have been around for years and are fairly standard, but satellite downlink remotes are newer, and definitely not standard. A computer screen and keyboard are commonly used to control the dish, receiver(s) and video switchers at the downlink site. How these remote devices are controlled, and how much is automated, vary greatly. Some remote downlinks require that all system components come from the same manufacturer, which can limit your options.

Brown is an engineer at KTSF-TV, San Francisco.

Needed solution

These were the problems facing KTSF-TV, San Francisco, when the studios were moved from the transmitter site to a new building about two miles away. Before the move, controlling the satellite dish and associated equipment was easy. The dish was located on the other side of a hill with a control cable and coax strung on the power company poles to our transmitter/studio building. The receivers and the dish controller were mounted in our studio racks where they could be reached easily.

What KTSF-TV needed was a transmitter remote control, a satellite downlink remote control, an STL and a TSL. The transmitter remote control used a Moseley MRC-1600 and the STL/TSL used a Harris 23GHz microwawe. The satellite dish

controller could be remotely controlled through a serial data port while the two satellite receivers required contact closures to select any of the 24 channels. Three 16-input wideband video switchers for the two TSLs and local monitoring also were needed. Two of the switchers had to be remote controlled.

Building our own

Because it was more economical and flexible, we built our own video switcher and satellite downlink remote control. The satellite downlink remote-control system consists of a computer located at the studio and linked by modem to the transmitter site. At the transmitter, the remote parallel interface (RPI) is equipped with a modem and performs all interfacing to the satellite dish controller, two satellite

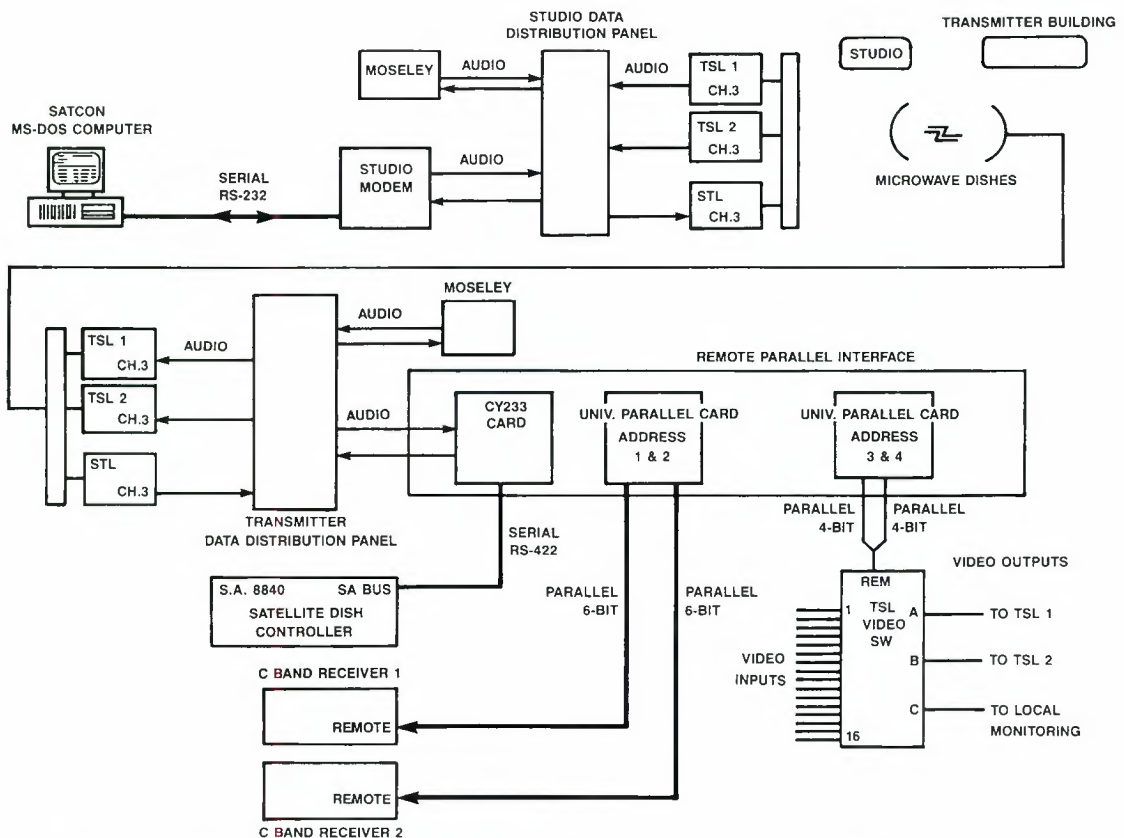

Figure 1. Overall system diagram. It relies on an PC-based computer, two TSLs, one STL to control two C-band receivers at the transmitter site.



The standards converter with the smoothest moving image of any system.

OKI's Digital Television Standards Converter Model LT2000 achieves *True Motion Continuity*. Next Generation Technology has produced the "Motion Vector System" (MVS™), making possible the first portable standards converter to eliminate motion discontinuity, or jerkiness, that occurs with high-speed camera panning and fast-action video program material. Other standards converters, using the 2-and 4-field interpolation systems, fail to reduce motion discontinuity, and as a result have been objectionable to the professional market.

MVS™ divides each field of video into pixel sections for motion vector detection and measurement, using the Interactive Gradient Method (IGM). IGM, the most advanced method ever

developed for precise and finite motion detection, allows the LT2000 to produce the smoothest moving image of any system available. MVS™ accomplishes this without the resolution loss common on other high-end standards converters. The displayed video picture is not only free from conversion artifacts, but also without interpolation resolution loss. The end result... a clean, sharp picture with *True Motion Continuity!*

With the LT2000, your only problem is telling the output from the input!

*IGM is a development of Kokusai Denshin Denwa Co., Ltd



TV STANDARDS CONVERTER
LT2000TSC

Head Office: Overseas Marketing & Sales 10-3, Shibaura 4-chome, Minato-ku, Tokyo 108, Japan
Tel: (03) 454-2111 Fax (03) 452-5214 Telex: J22627

Local Oki Distributor
MAL-Danmon Ltd.
Dancon House,
North Circular Road
London NW 10 7SS, U.K.
Tel: (081) 965-9575
Fax: (081) 961-9329
Telex: 923056

SAECO INTERNATIONAL
1122 East Chevy Chase
Drive, Glendale,
CA 91205, U.S.A.
Tel: (213) 245-7708
Fax: (818) 241-2691

ALEX L. CLARK LTD.
30 Dorchester Avenue
Toronto, Ontario M8Z 4W6,
Canada
Tel: (416) 255-8594
Fax: (416) 255-9260

Techtel Pty. Ltd.
Unit 1, 2 Campbell Street,
Artarmon, NSW 2064
Australia
Tel: (02) 906-1488
Fax: (02) 906-1480

OKI

Oki Electric Industry Co., Ltd.
Tokyo, Japan

Circle (61) on Reply Card

www.americanradiohistory.com

Time Code Is Not Black or White.

It's Gray.

Gray Engineering Laboratories

Gray can solve even your most difficult time code engineering problems quickly and easily. Not only do we have the right product for every application, but engineers know they can rely on the quality and precision of our instruments.

Turn to the source for Time Code Receivers, Generators and Transmitters, Vertical Interval Decoders and Encoders, Code Phase Correctors and Indicators, Video Reticule Generators, Film Counter/User Bit Multiplexers, and other products.



All Gray Engineering equipment is covered by a Five-Year Warranty, including parts and labor.

GRAY ENGINEERING LABORATORIES

504-P W. Chapman Avenue
Orange, CA 92668 714-997-4151

© 1988 Gray Engineering Laboratories

Circle (62) on Reply Card

New Concept
The state of the
art technology!

SANIX

**Bulk
Erasers**

**Continuous duty!
Quick erase!
Full automatic!
Very low power
consumption!**

**The erasing level
reach there own
tape noise!**



6000 \$13,950
up to D2 Large and
up to 14" Reel size
METAL-OXIDE,
MASTER ERASER



2300 \$6,450
for Pancake OXIDE
Tape, Full Auto



4800 \$9,950
for D2-M, etc.
METAL-OXIDE,
Full Auto 4.5 sec.



3800 \$9,450
for BETACAM-SP,
etc.
METAL-OXIDE,
Full Auto 4.5 sec.



3300 \$8,450
for U-matic, VHS, Beta
MII, etc.
OXIDE-METAL,
Full Auto 3.0 sec.



2000 \$5,950
for Reel and Cassette
OXIDE Tape,
Full Auto



200 \$3,450
for Reel and Cassette
OXIDE Tape,
Manual operation

SANIX CORPORATION

SANIX Plaza 101
1-29-1, Kaminoge, Setagaya-ku, Tokyo 158, Japan
Telefax: 81-3-702-9654

Circle (63) on Reply Card

receivers and the TSL switchers. While the wideband video switcher and the RPI were being built, a computer programmer was hired to write the software to control the system and to provide an easy-to-use and sensible interface.

Before the programmer could start, all information on how the dish controller communicated as well as how the RPI unit would communicate had to be collected. Information on the dish controller was obtained from the manufacturer, while the information on the RPI had to wait until it was designed. Specifications for the control program and the different screens needed were defined through a careful analysis of operator simplicity and hardware needs. Whenever software is custom-written, the more effort you put into the analysis, the greater the chance of getting a system that does exactly what you want.

The program

The program was written in BASIC and then compiled to machine language for speed. We chose BASIC because we could change the program without hiring a programmer. After a couple of false starts, an MS-DOS-compatible computer was chosen because of its hardware and software.

The operator interface provides a main screen and all information about the system can be monitored. The main screen displays the position of the dish, the satellite name, selected receiver channels and the video source that is selected on the two TSLs.

From this screen an *event* can be executed, which tells the system to move the dish to a satellite, select a transponder and place it on a selected TSL. For flexibility, selection of the receiver and the TSL is made at the time of execution. An operator can set everything up in advance and execute the event with the touch of a button.

Other screens may be selected with the function key for programming events, updating satellite position information or controlling the TSL video switchers. Manual control also is possible.

Remote parallel interface

The RPI was built using a card cage, ribbon cable and insulation displacement connectors, which makes construction easier. A common address and databus are used, which means that a card is addressed and then data transferred to or from the card. This is important because each card can control two different 8-bit ports and each can be addressed separately. The RPI can handle up to 16 8-bit parallel ports for 128 control lines and 128 status lines. Two dual parallel interface boards control the satellite receivers and the TSL video switchers. A single 5V power supply runs the entire unit.

A CY-233 chip inside the RPI acts like

A DIGITAL EFFECTS SYSTEM THAT CAN'T BE OUTGROWN

The CEL range of digital effects units forms an organic system with full compatibility and single, dual, or multichannel capability. The breadth



of our range means we can fulfil all requirements; the depth of our research means you can rely on our technology. And the efficiency of our design makes outstanding quality – and some unique features – available at a remarkably low price. The high level of modularity of our products gives you the room to evolve your own system as your needs expand.

Meanwhile, at CEL the evolution continues – by design.

The Art of Image Control



CEL Electronics Inc., 4550 W. 109th Street, Suite 140
Overland Park, KS 66211 Tel: (800) 325-CEL1 Fax: (913) 345-2771

Circle (64) on Reply Card

www.americanradiohistory.com

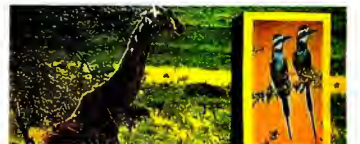
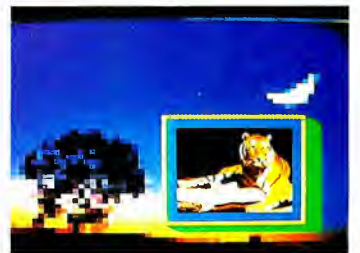

a smart UART. The CY-233 accepts serial data and transfers this information into parallel address and data lines. It also can accept parallel data and translate it to serial data. A command list sets this chip apart from most UARTs. With the commands, it's possible to read and write by remote as well as test the system.

The modem, display LEDs and the CY-233 IC are located on the same board. The card provides a 9-pin D connector and an 8-position DIP switch for testing. The switch lets an operator monitor the data or take control of the RPI.

Communications

The STL is equipped with three audio channels, two for program and one for the datalink. The two TSLs have only one audio subcarrier at 7.5MHz, which is used only for data. Return audio is provided by the aural subcarriers on the composite video outputs from the satellite and microwave receivers. These aural subcarriers are demodulated at the studio with tunable modulators, which are part of the TSL receivers. Sound from remote pickups and ENG units are also fed into the TSL switcher as composite signals. A baseband noise detector, squelch circuits and filters protect the data channel from receiver noise and the subcarriers provided by the receivers.

The third audio channel on the STL and

TSL serves as the link between the RPI at the transmitter and the MS-DOS computer at the studio. Because this link also must serve the transmitter remote control, we had to find a way to share this channel; the solution was frequency multiplexing.

The transmitter remote-control system uses frequencies from 1,200Hz to 1,800Hz. Therefore, SATCON's link had to use frequencies above this. The solution was found in a single-chip modem from MX-COM. The modem chip contains a modulator, a demodulator and a switched-capacitor filter to keep out unwanted signals. Its output is capable of driving the microwave equipment directly.

The IC data book shows a 1MHz crystal connected to the modem chip, which controls the frequency of the modem and the filter. Unfortunately, the standard frequencies for this modem would overlap the transmitter remote-control's modem. By replacing the 1MHz crystal with a 3.57MHz crystal, the modem's frequencies were shifted to 5kHz-6kHz. This circuit has worked well with no problems for more than a year.

A separate modem was built into the studio interface for the MS-DOS computer and the TSL-STL. This modem uses a wall-mount power supply and has LEDs that indicate power, transmit data and receive data.

Two audio splitter/combiner panels were

built to share the data channel with the transmitter's remote-control panel and SATCON. In addition to sharing the audio, they provide test points. The one at the studio is equipped with a switch for selecting either of the two TSLs for return data. Although the switchover could be automatic, we made it a manual operation.

Serial data flow

Here is an example of how the SATCON system works. When the system is not being controlled by an operator, the program will request the position of the satellite dish from the dish controller about once a second. The program sends a properly formatted command through the MS-DOS computer's serial port, which is connected to the studio modem. The studio modem converts the digital data into an audio signal and sends it to the studio data-distribution panel. This device accepts the studio modem's signal as well as the output of the Moseley unit. The two signals are combined and sent to the STL's channel 3 input (7.5MHz).

When the signal reaches the transmitter site, the channel 3 output from the STL is fed to the transmitter data-distribution panel. This panel splits the signal and feeds it to the transmitter remote control and the RPI. The modem inside the RPI converts the audio into digital data and routes it to the CY-233 chip and the RS-

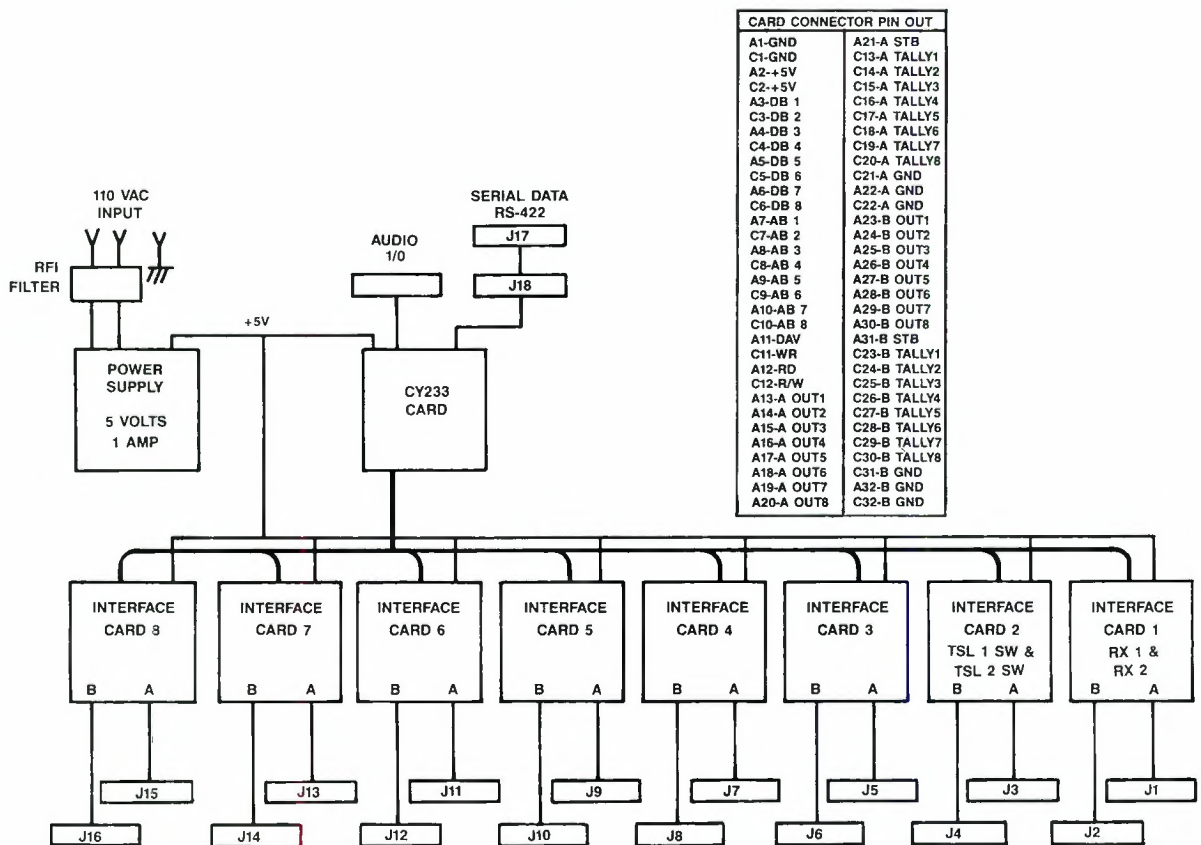

Figure 2. The remote parallel interface provides the control signals to the receivers and TSL switches. Each card controls up to two devices, and up to eight cards can be supported.



Sony's new definition of still video recording: 500 lines of resolution.

Words can hardly describe the image clarity when viewing 500 lines of resolution. Which is precisely what Sony has added to the new MVR-5600 still video recorder/player.

It lets you record, play back and store video signals from just about any video source, in never before seen sharpness. Whether it's still video pictures, frames from video cameras, video-tape recorders, copy stand and video scanner images or computer graphics. With the MVR-5600, you have immediate

random access to any image on the 2" floppy disc in as little as 30 milliseconds. Which in turn makes it easy to integrate high quality images into broadcasting, video pro-



duction, computer imaging, business presentations and demonstrations. You can even use it as a low cost video still-store device or for image-archiving applications.

For a demonstration of this revolution in resolution, call Sony at 1-800-833-6302. We'll put you in touch with a Sony Still Image dealer who'll show you our full line of products. And what 500 lines of resolution means for you.

SONY

Sony Still Image Systems Division, Sony Drive, Park Ridge, New Jersey 07656 © Copyright 1989 Sony Corporation of America. All rights reserved. Monitor picture simulated.

Circle (65) on Reply Card

www.americanradiohistory.com

422 port on the back of the unit. The CY-233 ignores this data because it does not contain a correct command or address for the CY-233. When the data reaches the dish controller, it responds with the position of the dish.

The data from the dish controller is sent to the RPI's RS-422 port and is routed to the modem chip because the CY-233 is not transmitting. The modem converts the signal to an audio signal and sends it to the transmitter data-distribution panel where

it is combined with the output of the transmitter's remote control. This signal is split and fed to the channel 3 input on both TSLs. When the signal reaches the studio site, the channel 3 outputs of the TSLs are fed to the studio data-distribution panel.

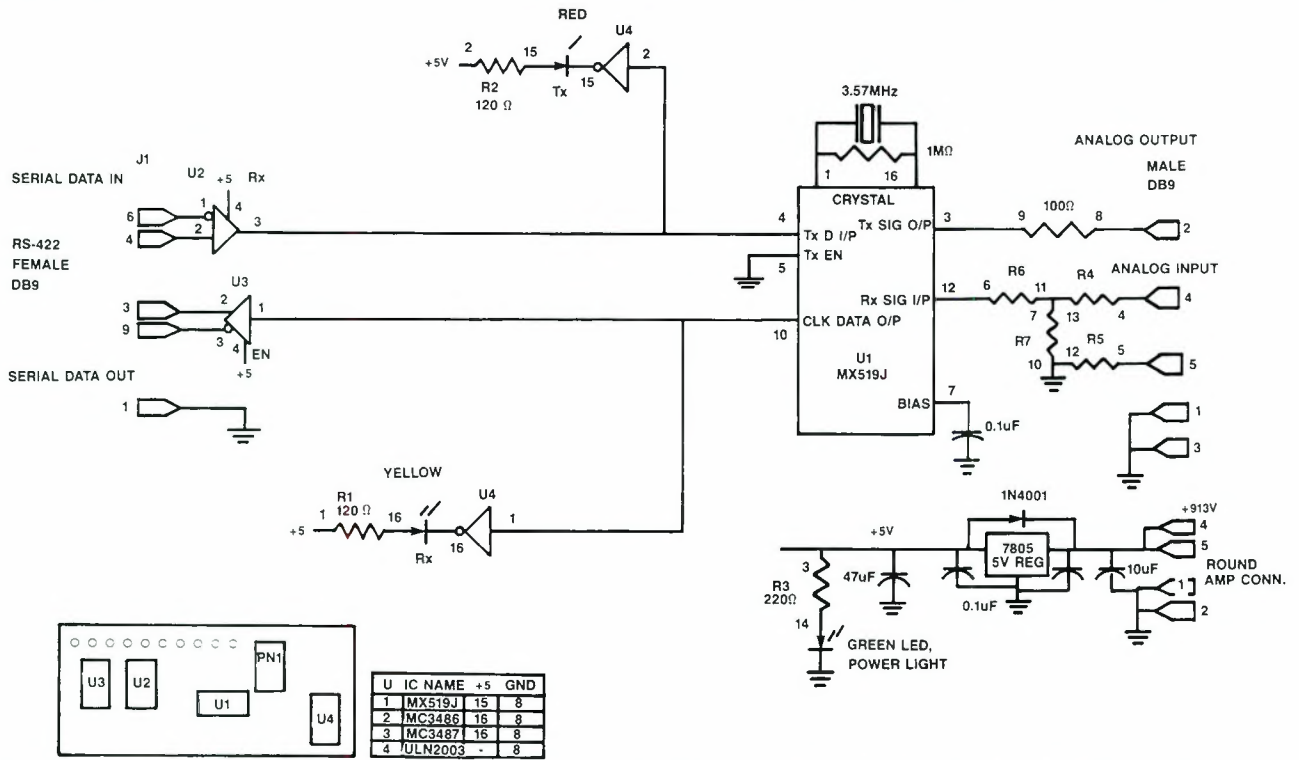

Figure 3. The MX519J modem chip provided a solution to the need to transmit analog data on non-standard modem frequencies. Substituting a 3.57MHz crystal for the standard 1MHz crystal, shifted the audio approximately 6kHz. This permitted two modem signals on the same link.

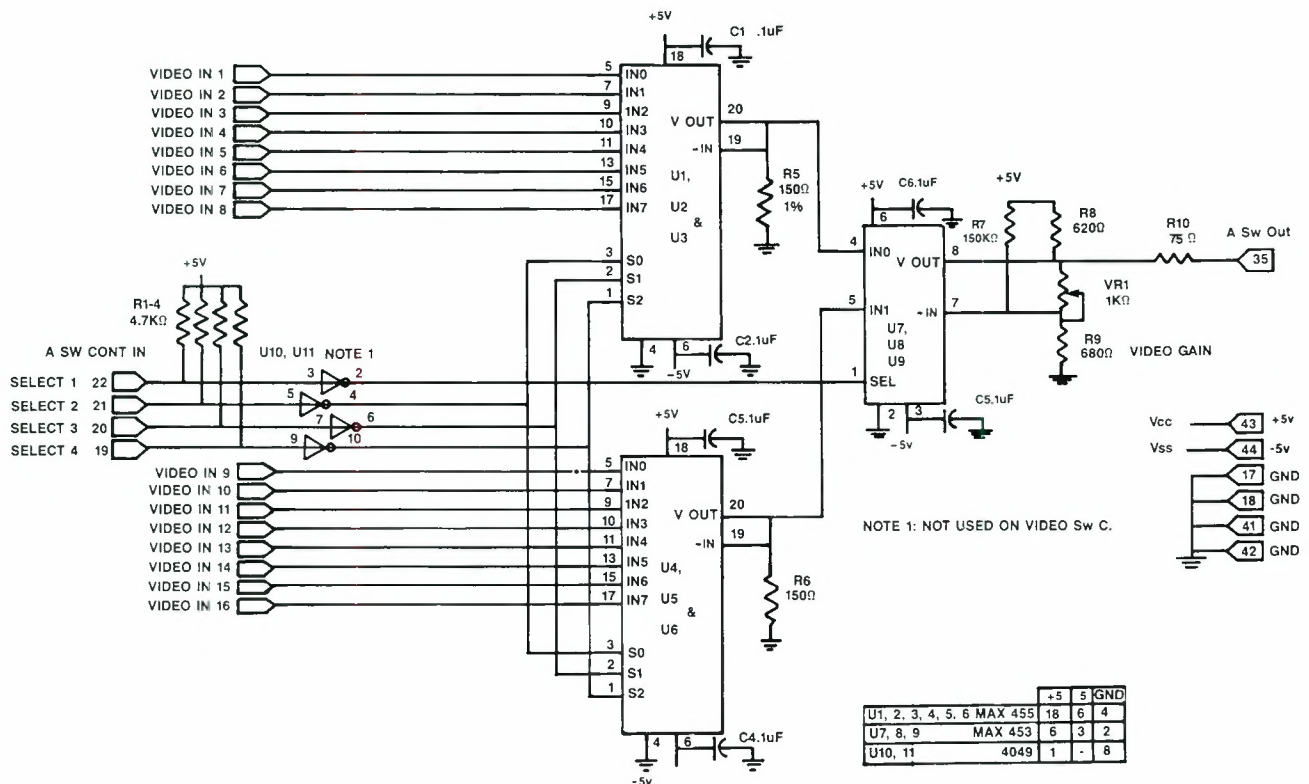
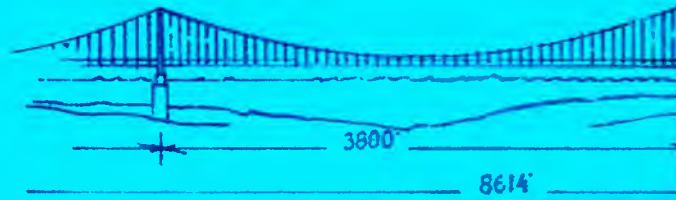

Figure 4. Switcher provides 16x1 operation with only three ICs.

BRIDGING THE GAP.



BARCO intelligence—spanning the distance between independent products to create an intelligent system.

The BARCO BVR5 Routing Switcher extends the concept introduced by the Emmy Award-winning BARCO CVS monitor, the first broadcast monitor crafted with micro-processor control of every function. Designed to accept any composite or component source, the routing switcher reaches new horizons in flexibility, and can be easily expanded to meet future needs. Used in conjunction with the CVS monitor, the switcher provides an unambiguous on-screen source or "destination" ID, while the monitor functions as a menu-driven remote control panel for the routing switcher.



BARCO, Inc.
1000 Cobb Place Blvd.
Kennesaw, Georgia 30144
(404)590-7900
Fax: (404)590-8042

Northeast: (201)729-0700
Southeast: (404)590-7900
Midwest: (708)213-3114
Western: (916)631-8113

Circle (66) on Reply Card



BARCO

INTELLIGENCE RUNS IN THE FAMILY

A switch allows selection of either TSL1 or TSL2. The output of the switch is split and sent to the studio transmitter remote control and to the studio modem. The studio modem converts the studio signal into digital data and sends it to the computer's serial port.

TSL switcher

A remote-controlled 16x3 video switcher lets us select different video sources to feed the TSLs. Two of the outputs are remote controlled while the third is manually controlled from the front panel of the switcher, which provides local monitoring. The first inputs to the switcher are used to monitor terminal equipment and transmission points. The other inputs include the two satellite receivers and the local horse-racing feed via microwave. Because this is a video-only switcher, all audio must be on subcarriers and ride along with the

video. Wideband video IC switchers were used for the construction of the video switcher.

The SATCON has been in operation since July 1988, with few problems. The system is easy to operate, and the staff learned how to operate it quickly.

As the station adds more equipment to the transmitter, the SATCON system can expand to control them with only the addition of an interface card and some programming.

Video switcher on a chip

Until recently, most video switchers were built with discrete parts, transistors, resistors, diodes and capacitors. Exact voltages were required to bias the transistors. Control voltages had to be converted from digital levels to the voltages needed by the circuit, which sometimes required a positive to negative voltage swing. Relay switchers were useful in certain situations, but if more than one switcher or vertical interval switching was needed, an electronic video switcher was required.

Printed circuit boards also were required for proper trace layout and ground plane. All of these factors contributed to the complexity and cost of building a custom video switcher. Except for the most determined and well-financed engineering departments, you either bought your video switcher off the shelf or did without.

Then came the electronic switches, such as the 4016 and the 4066 (quad bilateral switches), which meant there were four separate switches that let current flow in both directions. These switches seemed to be the answer, but there were problems. These electronic switches provided little isolation at higher frequencies (above 1MHz). At 3.58MHz, color bars would bleed through black. Another problem was that the control voltage had to match the chip's supply voltage, so you still had to deal with bipolar control voltages. As the switches improved, only two switches were put on a chip, improving the switch-to-switch isolation. The control voltages were changed to normal logic levels.

The best results are obtained by using a T configuration of switches. Three switches are used, two in series and the third one in the middle with one side connected to ground. When the two series switches are closed, the middle switch is open resulting in a closed crosspoint. When the two series switches are open, the middle one is closed, grounding any remaining signal, which produces an open crosspoint.

This configuration can provide approximately 90dB of isolation at 10MHz. Although the T configuration works well, at least four chips are needed for every 2x1 crosspoint (three dual-switch ICs and an inverter) to drive the ground switch.

Modem IC switches

All that has changed. Today you can buy a video switcher on one IC. There are at least five different manufacturers of video switchers on a chip. Most of these companies offer a wideband mul-

THE NEW **MASTERKEY** SERIES FROM



Flawless **LINEAR KEYS** of anti-aliased DVE's and CG's. Halos, comet tails, air brushed edges and sparkles are no longer a keying problem.

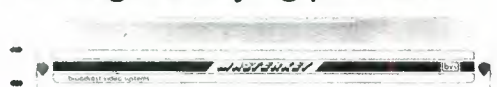

FOUR MODELS WITH FEATURES AND CONTROL SYSTEMS FOR EVERY APPLICATION.

- Downstream or stand alone
 - Frame accurate mix to key, fade to black
 - Serial remote control • GPI interface
 - Key source input switcher • Processed black
 - Key set memory • Preview output
 - Internal key area masking

broadcast video systems Ltd.

40 West Wilmot St., Richmond Hill, Ontario L4B 1H8
Telephone: (416) 764-1584 Fax: (416) 764-7438

Circle (67) on Reply Card



For AM, FM, SCA and TV modulation monitors.

WHEN ACCURACY COUNTS...COUNT ON...

Call (215) 687-5550 or write for more information on Belar AM, FM, Stereo, SCA and TV monitors.



Circle (68) on Reply Card

THE REVOLUTIONARY COLORADO. COLOR CORRECTION RAISED TO THE POWER OF 4:2:2.

Colorado. The world's only 4:2:2 component digital color corrector is ready to give you total control of your image.

THE QUALITY YOU'VE BEEN WAITING FOR.

With analog systems, color correction used to be limited to adjustments at the point of origination. Colorado changes that by giving you the power to execute perfect color matching in post production. Because Colorado is digital, you can make all the modifications you want without any loss of picture quality.

THERE'S NO PENALTY FOR CREATIVITY!

Colorado takes you beyond color correction, giving you the power to accentuate, modify and sculpt the exact image you want at any point during post production. Image quality will never be sacrificed. With Colorado, color becomes a new and powerful dimension of your creativity. Colorado. It's the new state of perfect creative control.

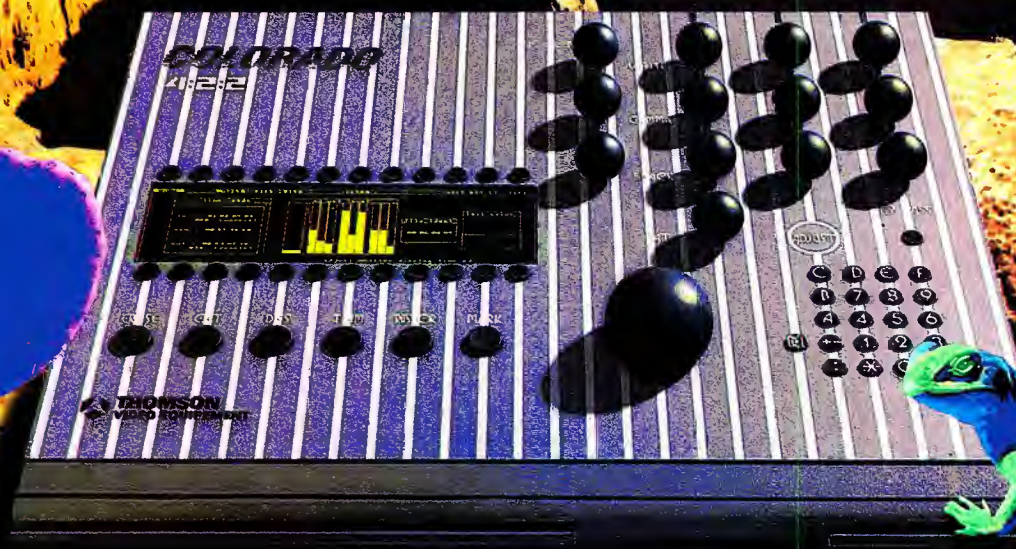

THOMSON VIDEO EQUIPEMENT
THE FUTURE OF DIGITAL DESIGN.

Circle (69) on Reply Card

THOMSON VIDEO EQUIPEMENT - 17, rue du Petit Albi - BP 8244 - 95801 CERGY-SAINT-CHRISTOPHE CEDEX FRANCE - Phone : (33-1) 34.20.70.00 - Telex : 616 780 F - Fax : (33-1) 34.20.70.47

THOMSON BROADCAST INC. 49 South Ave. www.americanradiohistory.com



DPS-175A

Smile and Say "Freeze."

And let our TBC/FRAMESTORE freeze your frames or fields with 525-line buffered memory. It handles incoming monochrome, heterodyne or direct color (with 3.58 feedback) tape sources. And its dynamic tracking capabilities give you high performance. At low cost.

Because our equipment freezes frames, not your bank account. Get it now at the warm price of \$4,995.



DIGITAL
PROCESSING SYSTEMS INC.



MIDWEST
Communications Corp

One Sperti Drive
Edgewood, KY 41017
(606) 331-8990

DIGITAL
PROCESSING SYSTEMS INC.
DPS-175A TBC/FRAMESTORE

Circle (73) on Reply Card

plexer IC. A couple of companies offer ICs that are built specifically for switching video signals. These IC switchers have bandwidths ranging from 30MHz all the way to 500MHz. The ICs provide one to eight switches per chip, some even come with a built-in output driver that will handle a 75Ω load.

Typical specifications of some chips include:

- 1×1 or 4×1 crosspoint switching.
- 30MHz to 10CMHz bandwidth.
- 117dB isolation at 3.58MHz.
- Differential gain of 0.03%.
- Differential phase of 0.012°.
- 5Vdc logic switching.

Another video-specific IC manufacturer offers three different sizes of video switchers: 2×1, 4×1 and an 8×1. The ICs have a bandwidth of 50MHz and run on ±5V supplies. Input impedance is 10¹¹Ω. The output is capable of driving one 75Ω load with the use of external resistors.

Control of the video switcher chip is accomplished through the BCD-coded inputs at standard logic levels (0V-5V). Differential gain is rated 0.3% and differential phase at 2°. The 8×1 comes

in a 16-pin DIP, the 4×1 in a 14-pin DIP and the 2×1 in an 8-pin DIP. By using eight 2×1s all feeding into another 8×1, you could build a 64×1 video switcher with the video signal passing through only two active devices. It doesn't get much simpler.

When KTSF-TV needed to switch composite video with audio subcarriers, we used two 8×1 ICs feeding into a 2×1 IC to get a 16×1 TSL switcher. The way the BCD code works, the lower three bits control the 8×1s together while the high bit controls the 2×1. All we had to do was send a 4-bit code to control each of the two 16×1 TSL switchers. The system works well, in fact, the first switcher was handwired point-to-point and still provides good isolation.



AUDIO SERVICES CORPORATION



Rycote

*Neither
WIND nor RAIN
nor dark of night
will keep us from
our appointed
SOUNDS!*

Headquarters

10639 Riverside Drive
North Hollywood, CA 91602
(318) 980-9891 (800) 228-4429
FAX (818) 980-9911

Topham Audio, Inc.

4403 Vineland Road Ste. B-3
Orlando, FL 32811
(407) 649-6444 (800) 486-6444
FAX (407) 648-1352

SALES SERVICE RENTAL ENGINEERING

Circle (70) on Reply Card



“For Dependability and Quality, You Can’t Beat the Odetics Cart Machine...”

“Since we switched over to the Odetics TCS2000 Cart Machine, on-air discrepancies have dropped from about six per day to virtually none. And the quality has improved dramatically .

Our old machines were labor intensive. Too much time was spent daily pulling carts from storage and programming. We needed a machine that would do away with human effort...and human error.

I shopped and compared for over two years before I settled on the TCS2000. The other machines I researched didn’t have the Odetics level of automation, and they were not nearly as dependable.

I’ve been especially impressed with the Odetics machines ability to download from our traffic computer and generate a play list. Not only does that feature save time and effort, it eliminates

the error factor. And, of course, if we don’t have on-air failures, we don’t worry about makegoods.

The on-air appearance of the station is 100% better now. That’s a big morale booster for everyone here. And the machine has certainly made my job easier. I don’t miss those phone calls about our old machines problems at all hours of the night.

I didn’t know a lot about Odetics before I bought their equipment, so I asked for a factory tour and demonstration. After I saw the large-scale robotics work the company was doing for the space industry as well as the broadcast business, I knew Odetics had the automation expertise I needed. In fact, I would strongly recommend that any chief engineer looking at cart machines take that factory tour. Also, I knew

Odetics had already installed about 80 machines at other stations, so I called some of those chief engineers. I didn’t talk to anyone who wasn’t happy with the Odetics machine.

Most of the engineers I talked to emphasized the exceptional after-sale service and support Odetics provided. We found that out for ourselves when our new machine was installed. The training and support our operations people got was efficient, thorough and highly professional.

If you’d like to know about what the Odetics cart machine has done for KPHO, why not get some firsthand information? Feel free to give me a call at (602)264-1000.”

**Bill Strube, Director of Engineering
KPHO, Phoenix**

Odetics Broadcast

1515 South Manchester Avenue, Anaheim, California 92802-2907 Phone (800) 243-2001 or (714)774-2200

Circle (74) on Reply Card

www.americanradiohistory.com

Continued from page 38
allow talent to mark and highlight them as if they were paper.

As for the weather systems, so-called value-added distribution of raw weather data will increase dramatically the options available to station meteorological personnel. NEXRAD, the atmospheric profiler network, and GOES NEXT, will provide more raw weather data than has ever before been produced. Companies that specialize in weather information products will compete to make sense of this data and present it to stations in broadcast-ready form.

During the newscast, a late-breaking story did not clear editing in time for its slot on the rundown. The producer reaches up and presses an icon on a touchscreen. The icon expands, showing all the events that were to occur at that point in the script. Scanning the display, the producer calls out, "move up the airport story!" The director switches some icons around on a terminal screen. Your story is now next.

You watch in the control room as the newsroom computer calls your tape, rolls it, executes all the supers and presets the switcher for each transition.

The stills you wanted are called up automatically and mixed in at the switcher. The whole thing goes flawlessly. "Wow," you whisper, "these computers sure make things easy!"

Acknowledgments: We wish to thank Jim Cundiff, vice president of sales, Basys, Yonkers, New York; and Robert Turner, Siscorn, Boulder, CO, for assistance in preparing this article.

The emerging role of ethernet in broadcast

By Mike Hashimoto

The future of broadcast systems will evolve around how broadcasters will get data from one place to another. This will become an increasingly dominant issue as the size of data and its effective throughput become key to TV station operations. Although data communication is not new to the industry, the need for higher-level entities to interface in a peer-to-peer relationship has been missing.

What is ethernet?

Ethernet is a protocol for a local area network (LAN). It uses a bus topology, and is usually implemented in broadcasting using coaxial cables and BNC connectors. Figure 1 shows a typical ethernet network layout. Ethernet permits a number of tributaries to run off of a main backbone. With repeaters, the network can be extended beyond the practical needs of most broadcast applications. The bus approach eliminates countless point-to-point connections, and removes the central connecting point as a single-source of communication failure.

Ethernet runs at 10Mbits per second at a raw data level. However, effective application throughput is considerably less, as higher communication protocol layers add increasing functionality to provide higher-level network services.

Network access

Ethernet is an example of a carrier-sense, multiple access with collision detection (CSMA/CD) access method network. In layman's terms, this means a "free-for-all" when it comes time for anyone to access the network.

Although this first-come-first-served philosophy may not seem inviting at first glance, it is efficient thanks to a random back-off algorithm that is employed in

Hashimoto is senior software engineer/project leader for Odetics, Anaheim, CA.

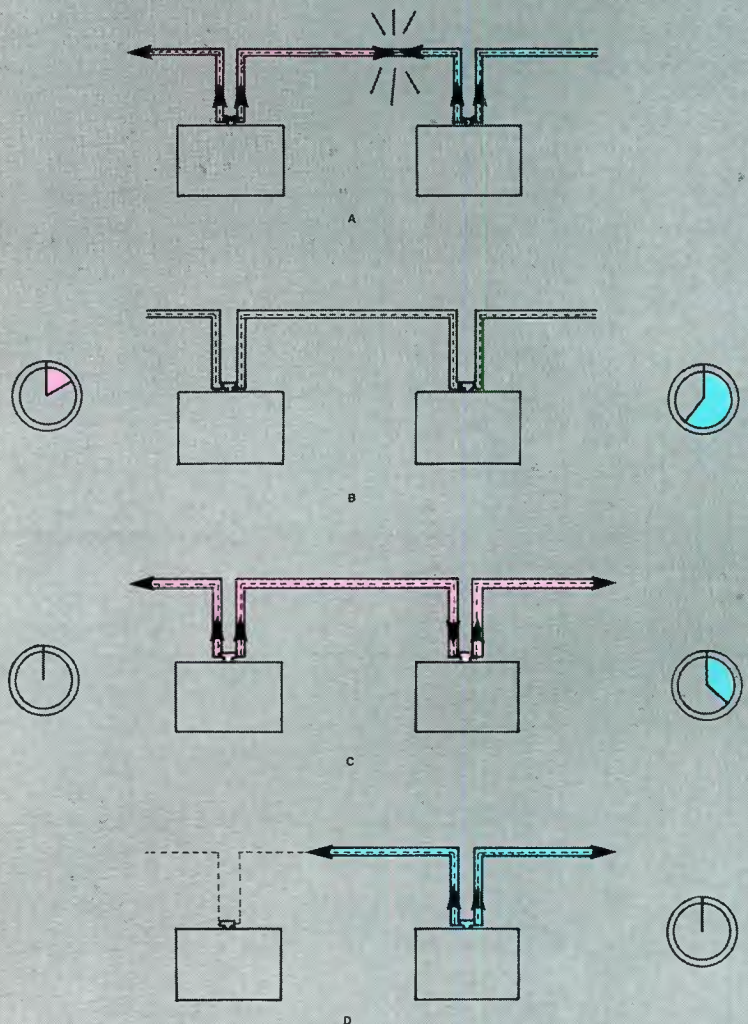

Figure 1. When users compete for the bus in a carrier-sense, multiple access with collision detection (CSMA/CD) system, it results in data collisions (a). To avoid data contamination, both users abandon the message, and back off for a random interval (b). Message packets are then retransmitted (c,d). If secondary collisions occur, the process is repeated.

INTRODUCING YOUR NEW MASTER CONTROL SUPERVISOR



Wrong operator decisions can cause downtime. And what could be worse than dead air. Meet the *Moseley PC-based MRC 2 Remote Control System*. It automatically assumes command in crisis situations and supervises your day-to-day operations.

MRC 2

Intelligent- Customer pre-programmed responses automatically take charge in crisis situations, eliminating operator error and guesswork.

Accurate- The MRC 2 achieves greater facility management through fast and accurate real-time control of all desired parameters.

Diverse- The MRC 2 is a true building block system. Remote terminals, control terminals and display options can be configured to your facility's specific requirements.

Accessible- 24-hour *dial-up* access is available over the public telephone network via the PC and modem.

Diagnostic- The historical data generated from the system is automatically stored for reporting and trend analysis purposes.

*Thanks to KCCO for use of their master page



Relax- Let the Moseley MRC 2 take charge!

Moseley

Moseley
Associates
Incorporated

111 Castilian Drive
Santa Barbara, CA
93117 3093

a
Flow General
Company

Phone 805 968 9621
Telex 658448
FAX: 805 685 9638

Circle (75) on Reply Card

www.americanradiohistory.com

the event of a collision. The latter occurs when two or more nodes attempt to access the network at the same time. Chances of a collision increase with the length of the network cable, such as propagation delay, heavier traffic (the overall frequency of use) and message packet size. However, statistics show that recovering from collisions is efficiently handled until nearly a 90% traffic saturation occurs, at which point, performance can degrade exponentially.

Advantages

The advantages of ethernet are:

- *Speed.* Ethernet is fast and reliable.
- *Proven.* A plethora of ethernet vendors, equipment and embedded computer applications use ethernet.
- *Migration to the future.* Fiber-optic-distributed data interface (FDDI) will become the heir apparent to ethernet and promises even higher throughput (100Mbps) using the same bus topology.
- *Broadcast vendor support.* A host of major broadcast vendors have or will have ethernet-compatible networking schemes in place for their products.
- *Standards.* Currently, TCP/IP (a trans-

port control protocol), developed by the Department of Advanced Research Projects Agency (DARPA), is typically melded with ethernet as the communication foundation upon which are built higher network services, such as transparent file access across the network.

- *Peer-to-peer communication.* Simplifies network roles and removes the central communication master as a point of network failure.
- *Network applications.* Although effectively built on layers above ethernet, many vendors are using remote network applications, such as the network file system (NFS) by Sun, for example, which permits files stored on remote disks to appear to a network node as if they were local files. This network transparency promotes resource sharing and thereby utilization.

Disadvantages

The disadvantages of ethernet are:

- *Non-deterministic.* During collisions, random back-off retries could possibly be met with further collisions. The randomness of the retry could limit how fast a message can get through. At

high traffic levels ethernet cannot be relied upon to be frame accurate or real time.

- *Heavy traffic.* A saturated network (90% or more of the available bandwidth) will render the network ineffective. This is akin to "thrashing" in computer virtual memory schemes, where so much time is spent trying to overcome the problem (collisions), that you contribute to the traffic load problem with continued retries.
- *Propagation delay.* The longer the network cable becomes, the longer it takes to get a message through the entire ethernet cable. This propagation delay increases exposure of a given message to collision, thereby degrading performance.

Broadcast environment

So what do we do? If the intent was to run a network at 90% to 100% capacity continuously, ethernet would not be a good solution. Network studies should be carried out to determine the actual amount of traffic that the network is intended to support.

In broadcast applications, the amount of actual data is not extremely sizable, nor frequent. In broadcast, the use of auxiliary control subnetworks, such as RS-422 buses, augments the overall network scheme, and reduces or eliminates time-critical data, such as control signals from having to appear on the ethernet.

Computer applications are more prone to the kinds of communications overload alluded to here, yet ethernet survives. Traffic balancing and identification of peak periods and effective remedial strategies seem the best course of action when traffic load problems arise.

In the past, computer graphics have played a major role in consuming network bandwidth. Graphic presentation, however, is likely to be part of the presentation scheme of future broadcast user interfaces. With the advent of new X-window technology and X-terminals that internally support the X-window protocol, the amount of network traffic is reduced. Therefore, smarter devices can get by with less presentation data.

Files, lists and editing comprise the bulk of the types of data transmitted over broadcast networks.

Although ethernet is not a pure panacea for all network scenarios, it does present an effective, proven and available network alternative when network traffic conditions are analyzed and strategies are set in place to provide a moderate data load. For this reason, its use is likely to increase.

THIS YEAR'S THEME FOR THE S.M.P.T.E. CONFERENCE IN NEW YORK

"FILM AND TELEVISION: ONE WORLD?"

5 Days of Technical Sessions
4 Days of Equipment Exhibits



**THE 132ND S.M.P.T.E.
TECHNICAL CONFERENCE
AND EQUIPMENT EXHIBIT**

OCTOBER 13, THRU 17, 1990

**AT THE
JACOB K. JAVITS CENTER
IN
NEW YORK**

**THE CONFERENCE AND EXHIBIT THAT
DEFINES MOTION PICTURE AND TELEVISION TECHNOLOGY**

**Be Part of this Industry Standard by attending the
1990 S.M.P.T.E. TECHNICAL CONFERENCE AND EQUIPMENT EXHIBIT**

[-:~:~)]))

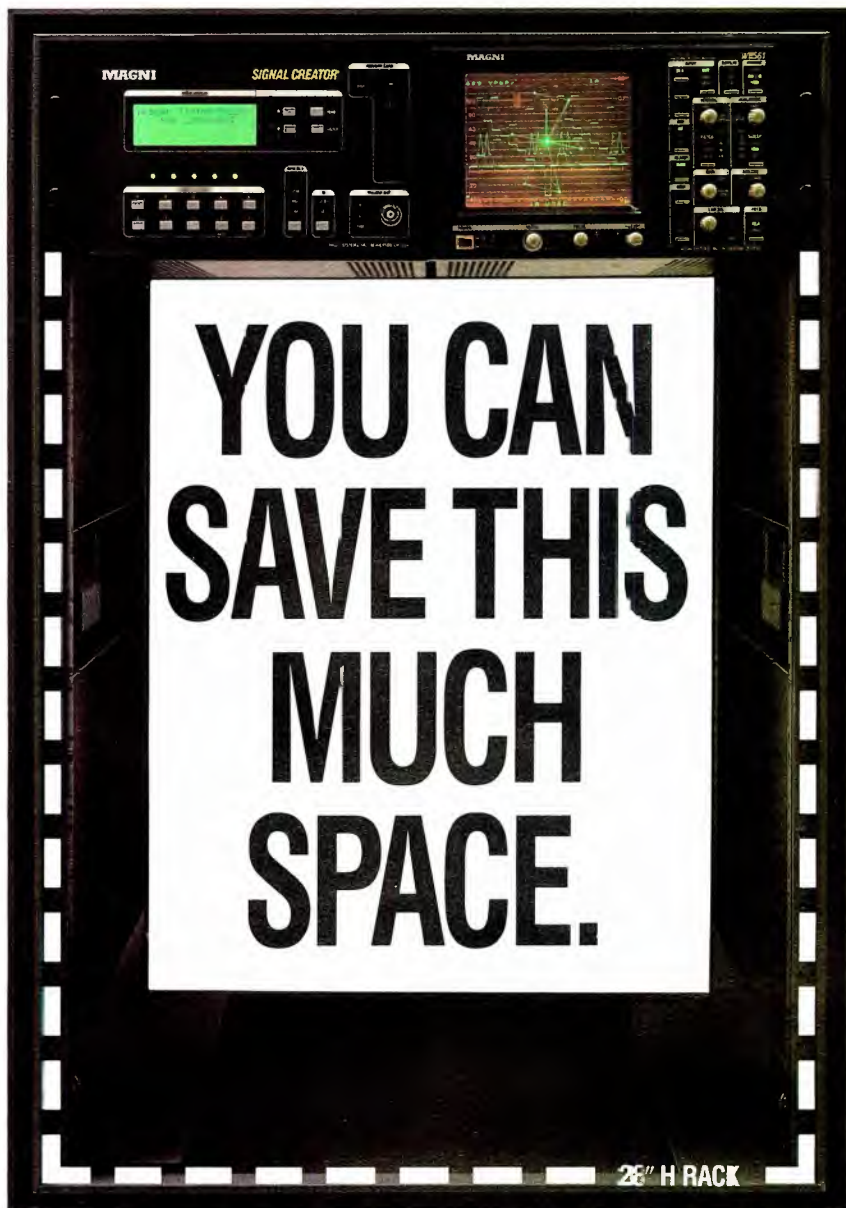

To get all the features of Magni's Signal Creator™ and WV561, you'd have to fill more than 20" of rack space with somebody else's equipment.

No generator of its size gives you more test signals in more formats than Signal Creator can. It's configurable to your needs, for NTSC, PAL, component, D1 and D2 signals (in 525 and 625 lines!), or all of the above. And because your signal sets are stored on a pocket-sized memory card, you're not limited to just a few signals in each format: use the full range at a touch of a button.

For multi-format video monitoring, the WV561 can look at a full six inputs — of component, NTSC, and PAL signals in any combination. Waveform/vector overlays, measurement cursors,

diff phase and gain, SC/H phase and color framing indicators are all at your fingertips.

Together, these two instruments are all it takes to handle your operation's most complicated test and measurement needs ... in just over five inches of rack space.

Now what will you do with the space left over?

MAGNI®

MAGNI SYSTEMS, INC.
9500 SW Gemini Drive
Beaverton, OR 97005 USA
(503) 626-8400
(800) 237-5964
FAX (503) 626-6225
TLX 650-2769743MCI

Magni is a registered trademark of Magni Systems, Inc. Magni Systems and Signal Creator are trademarks of Magni Systems, Inc.

Circle (76) on Reply Card

www.americanradiohistory.com

Talk To The People Who Use It



Smooth productions depend on your intercom not letting you down. From master control to on-site remotes, Clear-Com has a reliable intercom system to meet your exact needs. With belt packs that work in the rain and interfaces that connect to just about anything, Clear-Com has a proven commitment to reliability and innovative design. But don't just take our word for it, call us for a comprehensive list of satisfied customers and talk directly to the people who use it.



USA/Canada:

945 Camelia St., Berkeley, CA 94710, TEL 415-527-6666 FAX 415-527-6699

International:

FAX 415-932-2171

News

Continued from page 4

broadcast and other FCC-regulated communication facilities.

In order to protect the job interests of SBE members and other broadcast engineers, the society strongly opposes state regulations. SBE president Brad Dick noted that the imposition of local and state statutes posed a threat to the member's employment.

Also, the possibility of regulation by individual states' regulatory boards could further hurt station employees by limiting their employability outside any state in which they might be registered. Engineers could be required to pass exams by the state that do not include material applicable to the broadcast field. Engineers also could be subject to fines and other alleged unauthorized practices of engineering.

NBC to hold affiliate meeting at SBE Convention

The NBC network will hold its affiliate engineering meeting at the 1990 SBE Convention, Oct. 4-7 in St. Louis.

The convention will provide more than 3½ days of training in TV and radio broadcast technology. Coupled with the largest exhibit ever assembled by the SBE, engineers will be able to see and test the latest in broadcast equipment and technology. The Ennes workshops will be held Oct. 3.

New era for European broadcast standards

The European Broadcasting Union (EBU) and the European Telecommunications Standards Institute (ETSI) are joining forces in broadcast standards. This will bring together all of the major broadcast organizations in Europe. A new Joint Technical Committee (JTC) is being created to agree on standards for the transmission of broadcast signals, over-the-air broadcasting and cable networks. EBU and ETSI will keep their existing structure. A working relationship also will exist with CENELEC, covering the interests of the European consumer electronics industry.

New SMPTE section created in Germany

A SMPTE section has been established in Germany. The meeting will be held Sept. 27 in Munich, two days after the IBC Convention in Brighton, England.

||:~:~)))))

Circle (77) on Reply Card



ALL OF THE EXISTING
JAZZ EFFECTS WORK WITH
THE NEW UPGRADES
FOR ONE OF A KIND
FUNCTIONALITY.

It's our most
creative edit ever.
Jazz Systems in-
troduces a variety
of site upgrades
that eliminate the

need for a switcher. So now you can
perform professional editing with digital
video effects at a fraction of the cost.
What's more, these upgrades include
Internal Luminance Key and Chromakey

functions. Or you can play around
with our new Dissolve Func-
tionality and Transparent
Drop Shadows.

JAZZ'S NEW
DISSOLVE
FUNCTIONALITY
SETS AN INDUSTRY
STANDARD.

can be combined with the

But best of
all, these new
functions

existing Jazz effects to create entirely new
combinations!

And like our Jazz Digital Effects
System, the new upgrades are designed
to save you time. The commands are
clean and simple. And you can access
the phase controls right from the con-
trol panel. So you'll never have to fiddle
around with a screwdriver again.

Of course, these new upgrades are
just some of the exciting options we'll
be bringing you in the future. All of
which will be offering new innovations
in creativity and
affordability.

So if you're
serious about
professional video production, don't
switch on a switcher. Switch on Jazz.



We've just made editing easier by editing out the switcher.



For more information, contact Marilyn Weber at Jazz Systems, 809 Wellington St. N., Kitchener, Ontario, Canada N2G 4J6,
1-519-749-3134. Jazz is a trademark of Electrohome Limited.

Circle (78) on Reply Card

www.americanradiohistory.com

Music via satellite

By 3M Sound Products

• **DBS receiver:** Ku-band satellite receiver; component of 3M DBS Network produces line-level signals at 600Ω output impedance; 2-channel unit may be programmed to receive 3M "Starchannels" for light instrumental, adult contemporary vocal, current hits or a blend of jazz, new age and classical selections; typically requires 30-inch satellite antenna in con-

tinental United States and portions of Canada and Mexico.

Circle (351) on Reply Card

Videoprompter

By Q-TV

• **FDP-9:** lightweight, flat-display portable prompter; 10-pound unit incorporates high-efficiency optics with a brightness control to produce easily read scripts at

distances to 20 feet; accepts RGB or composite video drives.

Circle (400) on Reply Card

Bulk media eraser

By Sanix

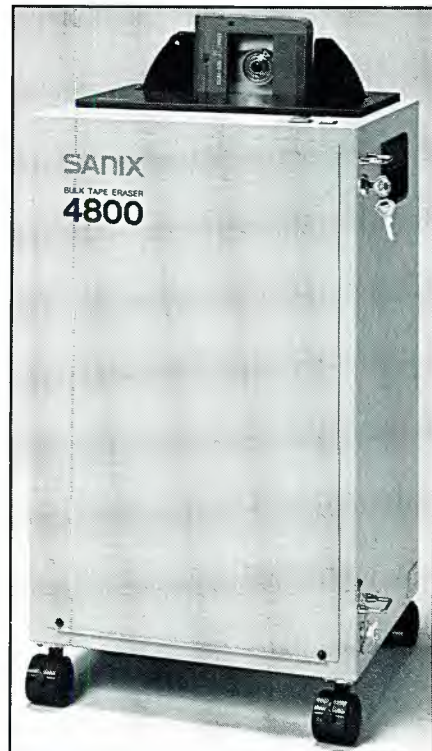

• **4800 series:** fully automatic bulk tape eraser; moving cassette elevator rotates cassette through 90° within the demagnetizing field; each cycle requires 4.5s; -90dB erasure for oxide, -80dB for metal particle; accommodates D-2 medium and small, Betacam SP large and small, U-matic/SP, MII, Beta ED metal, VHS, Beta, computer and audio media; 4811 adapter available for small cassettes, floppy disks.
Circle (407) on Reply Card

Performer microphones

By Peavey Electronics

• **PVM 535N:** vocal mic with flat low-frequency response and slight rise in upper vocal range; cardioid and supercardioid patterns maintain minimum feedback; low handling noise from internal shock-mount system; neodymium magnetics.

• **BPX wireless:** beltpack wireless transmitter; separate power and standby switches; LED indicator shows standby and transmitting status of unit; 9V operation; six highband operating frequencies; miniature lavalier mic; long-range operation.

Circle (395) on Reply Card

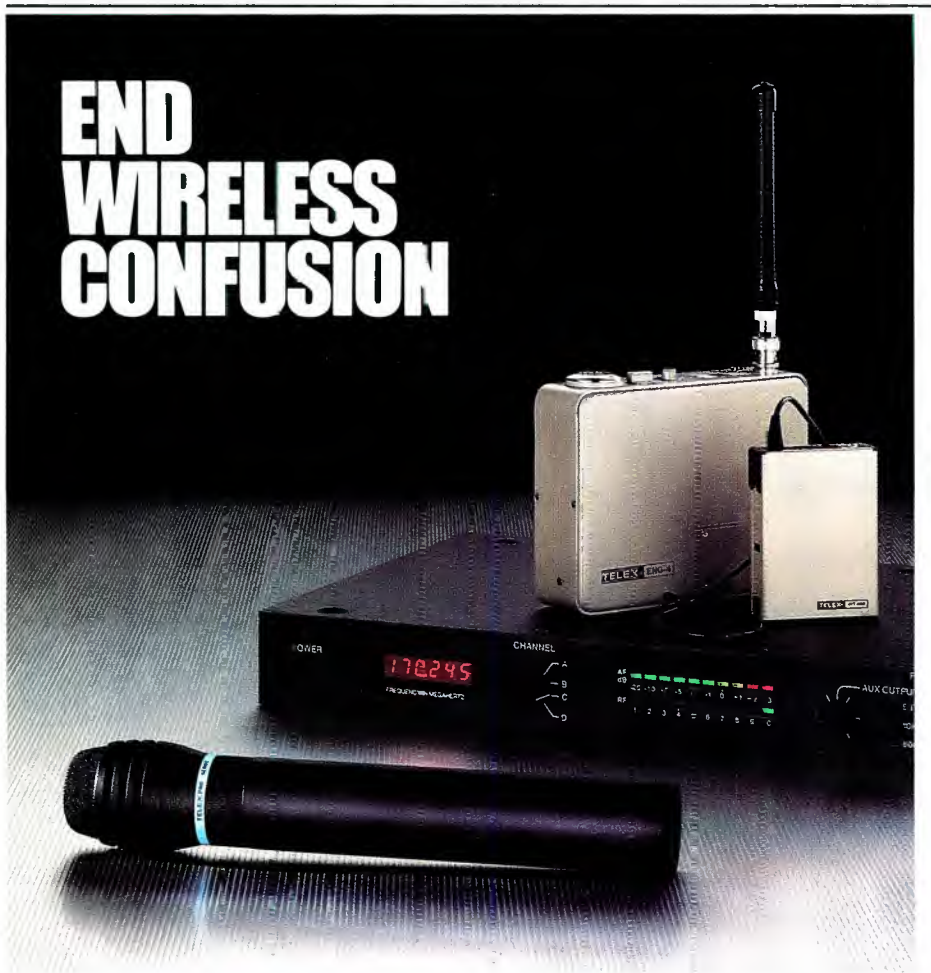

Rely on Telex. They know this business inside and out.

With all the newcomers to the wireless microphone business, it's hard to know where to turn for advice. You want a proven product, a trusted brandname, a USA manufacturer and expertise that's readily available. Telex offers all of that plus the widest selection in the industry. So, when it's time for you to get serious about wireless, turn to the people who are serious about the wireless business. For complete details, write to Telex Communications, Inc., 9600 Aldrich Ave. So., Minneapolis, MN 55420.

© 1990 Telex Communications, Inc.

TELEX®

Circle (79) on Reply Card

Mini UPS systems

By Atlas Energy Systems

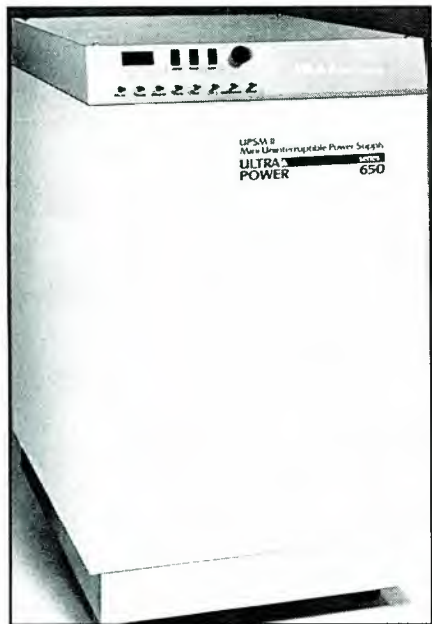

- **Series 650:** rated from 5kVA to 30kVA in seven models; computer grade output from 3-phase rotary UPS at 50Hz, 60Hz and 400Hz; small sizes requires limited floor space; 17 μ s response to power load changes; interface to computer mainframes; less than 1% ripple voltage.

Circle (360) on Reply Card

Audio, U-matic media

By Ampex Recording Media

- **Type 617, 618 tape:** for C-60, C-90 audiocassettes in duplication applications; Type I high-performance, extended frequency response media; formulation includes oxide and binder with consistent, uniform dispersion of magnetic particles.

- **U-matic upgrades:** increased transverse tape stiffness for reduced tape creasing and edge damage; affects Ampex types 187, 197, 297 media.

Circle (357) on Reply Card

Audio analysis

By Audio Control Industrial

- **SA-3050A:** audio spectrum analyzer; based on 1/3-octave real-time analysis; 30 4th order bandwidth filters; integral pink noise source; 9x30 LED display produces visual presentation of spectral response; six internal memories have battery back-up; 92dB display range from balanced mic input, balanced phone jack or unbalanced BNC connector; calibrated microphone instrument included.

Circle (361) on Reply Card

Portable prompting

By Blue Feather Company

- **Prompt Box/Laptop:** IBM PC laptop computer prompter; reads IBM format floppy disks; requires no external monitor but drives a camera-mounted display if desired; weight with camera display is 30 pounds; operates for four weeks from AA batteries; also available for compatible laptop systems.

Circle (364) on Reply Card

Enhanced audio editing

By Editing Machines

- **F.A.S.T.:** flatbed audio style tracks multitrack feature for EMC2 editing system; operates similar to 6-plate flatbed film editing table; allows editor to create multiple finished tracks, but only two can be monitored at one time; direct support for 4-channel D-2; permits a full set of tracks to be mixed to single track if desired.

Circle (372) on Reply Card

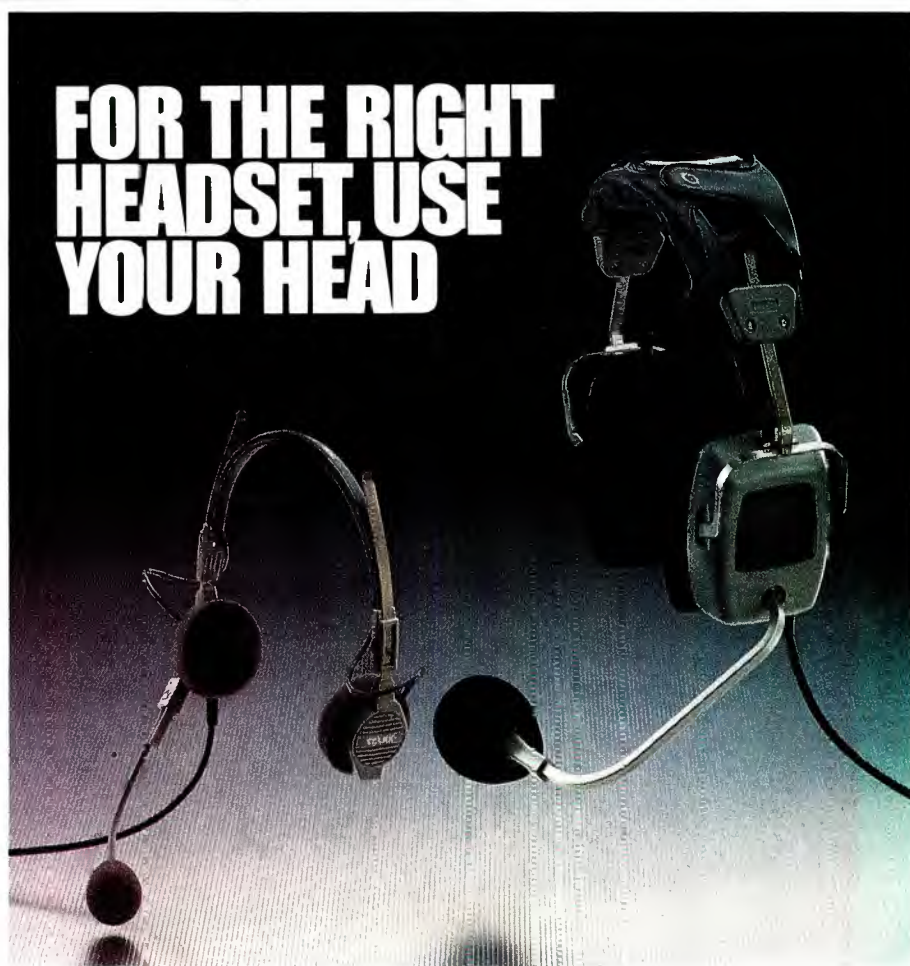

Telex headsets. Feel the comfort, hear the quality.

Discover what professional sportscasters in baseball, basketball, football, and golf already know. Telex has the best variety of top quality headsets on the market. You'll enjoy rich, natural sound whether you need full cushion isolation, lightweight comfort, or something in-between. There is a studio quality mic to fit your needs, too, from omnidirectional electrets to noise cancelling dynamics. For the complete story, write to Telex Communications, Inc., 9600 Aldrich Ave. So., Minneapolis, MN 55420.

©1990 Telex Communications, Inc.

TELEX[®]

Circle (80) on Reply Card

Wide Band



Video Distribution +/- 0.75 dB @ 60 MHz!

Model 220

- 1 input, 6 output
- high performance spec.
- +/- 3 dB gain

Model 222

- Switchable Clamper
- Eq. to 1000' 8281 cable
- Slew rate > 250 V/μsec.

Moderately Priced. Ideal for
HDTV, RGB and all general uses



di-tech

48 Jefryn Boulevard, Deer Park, NY 11729
Tel: (516) 667-6300 • Fax: (516) 595-1012

Circle (81) on Reply Card

TIMECODE

The 690 "ET" Everything Timecode

690 "ET" Everything Timecode



- Vertical Interval & Longitudinal Timecode •
- Reader/Generator • Character Inserter/Raster •
- Display • Calendar • Computer Data Input
to User Bits — (RS-422), ect., ect. •

SHINTRON

45 Winthrop Street, Concord, MA 01742
Tel: (800) 358-NTSC Fax: (508) 371-7554

Circle (82) on Reply Card

Dial-up information service

By Accu-Weather

• **FeatureFone:** telephone system provides service and entertainment information to subscribers; a variety of additional types of information is updated, along with local weather forecasts, TravelWeather, beach and boating forecasts or resort and ski reports; includes feature for automatic tabulation in public polling operation.

Circle (352) on Reply Card

Audio reference media

By AGFA



• **AGFA SR-XS:** Type II chrome cassette media formulated for recording studio reference applications; in C-60, C-90 lengths; cassette shell assists in maintaining correct phase relationship; ratings include MOL 6dB at 315Hz, SOL -7dB at 10kHz, bias noise of 61.5dB and S/N of 67.5dB.

Circle (353) on Reply Card

Video filtering

By BAL Limited

• **Ultra Sharp BSC series:** extremely sharp cut filters for low-pass filtering of signals to separate video and audio; available as open PCB-mounted components or boxed filter units; tight group delay limits; transition ratio of 1.07 with peak-to-peak amplitude ripple of 0.1dB; BSC0510 transparent to 5.10MHz with more than 42dB attenuation at 5.44MHz.

Circle (362) on Reply Card



POPULAR PRODUCTIONS

Betacam is rapidly becoming one of the most popular production formats in both field and studio applications. And Ampex 198 Betacam and 298 Betacam SP video-cassettes are popular professional choices for a full range of needs. When

you need high reliability in an ENG/EFP tape, the choice is Ampex 198. Or, when you need the ultimate in performance, the choice is Ampex 298, with its high-coercivity metal-particle formulation. Both offer you high-impact ABS plastic cassettes for rugged dependability and the unique Ampex labeling system for easy access and

storage. And all backed by the industry's most acclaimed service and support organization. No wonder they're so popular. They're from Ampex.

AMPEX
THE PROFESSIONAL CHOICE

Ampex Recording Media Corporation
401 Broadway, Redwood City,
CA 94063, (415) 367-3809

Circle (83) on Reply Card

ANVIL M.I.C.S.™ — MODULAR INTERLOCKING CASE SYSTEM

- M.I.C.S.'s unique case lics can be converted into table top and work stations (for computer, military, broadcast, exhibits, etc.)
- Custom measuring and designing available
- Building quality cases since 1952



CALL FOR
OUR NEW
CATALOG!

Call Today For More Information:

ANVIL CASES
SUBSIDIARY OF ZERO CORPORATION

15650 Salt Lake Ave., City of Industry, CA 91745 • P.O. Box 1292, La Puente, CA 91747

(800) FLY-ANVIL (800) 359-2634

Circle (84) on Reply Card

LOOK TO SIERRA FOR WIDEBAND VIDEO DAs.

- 10 Outputs — Use fewer amplifiers per system for improved performance.
- Wide Bandwidth — Ideal for HDTV and high resolution graphics systems.
- Front Edge Gain Control — A 15-turn control for precision level adjustment.
- Two Mounting Frames — 1 RU for 3 amplifiers and 3 RU for 10 amplifiers.
- Redundant supplies available.

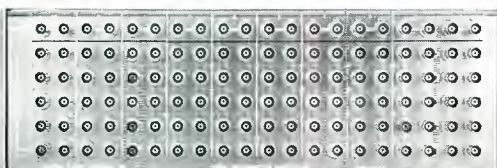

SVS

SIERRA
VIDEO
SYSTEMS

P.O. Box 2462
Grass Valley, CA 95945
Tel: 916-273-9331
Fax: 916-273-9390

Circle (85) on Reply Card

Speech processing

By Allied Broadcast Equipment



- **Pro Announcer:** Air Corp unit offers low-noise balanced inputs from mic to program level signals; 3-section boost/cut EQ; symmetry correction enhances talk power; compression system includes integral noise reduction; on-board noise gate; headphone jack simplifies setup.

Circle (354) on Reply Card

Acoustical products

By Alpha Audio/Automation

- **Azonic:** series of acoustical foam products to control low-frequency absorption; pyramid patterns available in various colors; sound coefficient levels surpass many others based on ASTM procedures; uniform pattern material is easily installed; attractive consistent appearance.

Circle (355) on Reply Card

Audio monitoring, wireless mic

By Altec Lansing

- **MAESTRO series:** audio speaker systems for various applications; 55-4A 2-way, 60W; M200 2-way, 40W; M300 2-way, 75W; M400 2-way, 150W; M500 with 900 driver and horn, 250W; M600, 150W; all power ratings based on pink noise with crest factor of 6dB; bandwidth limited response to 20kHz, except M600 at 15kHz.
- **9446A:** power amplifiers; dual channel with 400W per channel to 8Ω load; "Output-Z Protection" feature avoids damage from shorted output terminals or impedance loads.
- **ALPHA series:** wireless systems for short-range and long-distance; diversity and non-diversity receivers with hand-held, lavalier or bodypack transmitters.

Circle (356) on Reply Card

Distribution switching

By Di-Tech

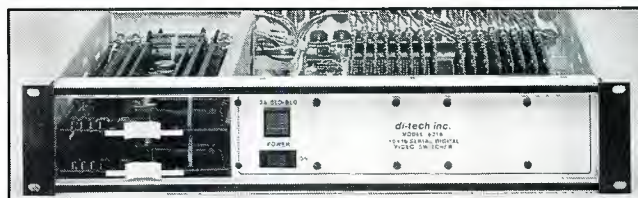

- **Model 5217:** video routing switcher with 100MHz bandwidth; crosstalk rating at 100MHz is -40dB; slew rate specified at 235V/μs 16×16 matrix housed in rack unit of 3.5-inch height; input, output expansion in increments of one; expands beyond the 16×16 form with additional frames and combiners.
- **Model 5216:** serial digital video router; passes D-1 and D-2 signals; high slew rate and wide bandwidth avoids conditioning and reclocking of datastream.

Circle (371) on Reply Card

No still store stores stills like Picturebox...

...because Picturebox is more, much more, than a still store. It is, quite simply, the most complete graphics origination, storage and presentation system ever developed. It's compact, powerful and affordable.

And Picturebox is modular, so your installation matches your needs, whether for a single stills station or a multi-user, central library based network.

Whatever the configuration, picture handling versatility and speed are unequalled, and the sophistication of Picturebox's unique cut/paste and floating graphics will transform your look on air.

So if you thought still stores only store stills, you should check out Picturebox.

Call us now, there's still time.

Picturebox

QUANTEL

Quantel Inc., 655 Washington Boulevard, Stamford, Connecticut CT 06901 Tel: (203) 348 4104

Circle (86) on Reply Card

www.americanradiohistory.com

WE'VE MADE DEAD AIR A DEAD ISSUE.

There are worse things in radio than dead air. But not many.

And if your CD players aren't built to resist tracking errors, you could find yourself listening to some very embarrassing silence.

Not with the new CD-701 from Tascam. Its unique disc clamping system is a technological triumph that virtually eliminates disc vibration. So you never hear the awful hush that means a tracking error has occurred.

What you do hear is the finest sounding CD unit you can buy, with the same proprietary "ZD Circuitry" praised by two of Japan's top audio magazines* for eliminating low-level digital distortion.

Then there's the optional RC-701 Remote Control with Auto Cue so you can cue to the music instead of the track (for even less dead air). Or you can add the Ram Buffer for true, instantaneous startup.

And with four times oversampling and 16-bit D/A converters in an extra-rugged chassis, the CD-701 is superbly designed for the broadcast environment.

Can a CD player really deliver this kind of performance, track after track, disc after disc? Only if it's a Tascam.

Contact us or visit your Tascam dealer for more information about the CD-701. And take the sounds of silence off your playlist.

TASCAM



© 1989 TEAC America, Inc., 7733 Telegraph Road, Montebello, CA 90640, 213/726-0303
*Radio Technology Component Grand Prix '88, CD Division, Stereo Sound Component of the Year (1988) & Best Buy (1988)

Circle (87) on Reply Card

PC-based weather radar

By Ellason Avionics



• **E-250B:** color weather radar includes intensity and location of precipitation in an area to 240 miles from your location; four colors indicate light, moderate, heavy and turbulent moisture conditions; tilt control allows height of rain or snow area to be determined; AT-style computer permits picture storage and recall.

Circle (373) on Reply Card

||:~::~)))))

Next month...

AUDIO-VIDEO CONTROL SYSTEMS:

• Planning a Facility Control System

A number of factors must be considered when designing a new facility. The architecture used to implement the control of audio/video/data is a key element in building an efficient and reliable system. This article takes an overall look at how stations can integrate the control process.

• Audio-Video Routing Switcher Design

A routing switcher is a major investment for any facility. The system must be designed so that it can expand as the facility changes and grows. This article looks at modern switcher design from the inside out.

• Applying Fiber-Optic Technology

Most engineers and technical managers agree that fiber-optic technology will become an important element of TV station operation during this decade. This article will examine the current technology for TV fiber-optic applications and how engineers can apply it to their stations.

• SBE Show Preview

A complete rundown of the most important fall broadcast engineering show Oct. 4-7 in St. Louis.

This is the most complicated control you'll find on the new PeopleLink™ telephone system.

PeopleLink translates your every desire into reality. Our new multi-line modular telephone system is no more complicated to operate than a simple tone pad and most functions can be initiated with the touch of a single button. PeopleLink is a powerful multi-purpose system that is absolutely user friendly. It is expandable, allowing you to spec exactly what you need to meet today's requirements

PeopleLink provides the ability to custom program "personalized" applications. A few simple keystrokes and each operator can easily pre-set their preferred applications and quickly access their program from any control surface in the system.

PeopleLink is human engineering with the emphasis on human.



with the GUEST feature, protects VIP callers from accidental disconnection.

Running contests on-air couldn't be easier. Simply select the number of callers, announce the contest, and punch the CONTEST button. PeopleLink answers the calls, delivers a pre-recorded message and instantly puts the "winner" at your fingertips.

Recording calls is as easy as punching one button. Depress the REC button and PeopleLink sends audio to the recorder and rolls tape. Because PeopleLink includes Gentner's DH-2 Digital Hybrid, you always get the finest audio quality possible.

How To Get In Touch With A Very Simple Solution.

We've only touched on the versatility of PeopleLink. To fully grasp its potential, its flexibility and expandability, its ease of installation and operation, just pick up your phone and give us a call. It's that simple.



The new PeopleLink integrated telephone system, designed for broadcasters by broadcasters, brings to its uniquely designed control panel every capability and every function you ever wanted.

with an open-ended design that easily grows with you. The system handles up to 40 lines and works with any KSU.

The First Fully Personalized Phone System

Multiple control surfaces may be connected to the system and used in simultaneous independent operation.

A Variety Of Applications Handled With A Single System.

PeopleLink makes caller access clean and simple. Touch a single button to take the next call. PeopleLink ends the previous call and puts the new voice on-air. PeopleLink allows multiple callers to be on-air at the same time and,

GENTNER

*Gentner Electronics Corporation
1825 Research Way
Salt Lake City, UT 84119
(801) 975-7200
Fax: (801) 977-0087*

VIR JAMES P.C.
CONSULTING ENGINEERS
Applications and Field Engineering
Computerized Frequency Surveys
3137 W. Kentucky Ave. — 80219
(303) 937-1900
DENVER, COLORADO
Member AFCCE & NAB

TOWER NETWORK SERVICES

STROBE LIGHT REPAIR
DISCOUNT RATES
FLASH TECH / EG+G
Timer
(305) 989-8703
NATIONWIDE SERVICE

EVANS ASSOCIATES
CONSULTING TELECOMMUNICATIONS ENGINEERS
AM-FM-CATV-ITFS-CELLULAR
216 N. Green Bay Road
Thiensville, Wisconsin 53092
Phone (414) 242-6000 Member AFCCE

• TERRAIN SHADOWING
• POPULATION DENSITY
• CONTOUR COVERAGE
• SPECIALS
(301) 652-8822 (800) 368-5754

D. L. MARKLEY
& Associates, Inc.
CONSULTING ENGINEERS
2401 West Moss Ave.
Peoria, Illinois 61604
(309) 673-7511
Member AFCCE

K. BLAIR BENSON
Consultant
Television Technology
23 Park Lane
Norwalk, CT 06854
203-838-9049

TEKNIMAX
TELECOMMUNICATIONS
DENNIS R. CIAPURA
PRESIDENT
11385 FORESTVIEW LN.
SAN DIEGO, CA 92131 (619) 695-2429

SMITH and POWSTENKO
Broadcasting and Telecommunications
Consultants
2033 M Street N.W., Suite 600
Washington, D. C. 20036
(202) 293-7742

Robert J. Nissen
THE NISSEN GROUP, INC.
Communications Technology Consultants
32 Ridge Drive · Port Washington, New York 11050
(516) 944-5477

CHUCK JONES
ANTENNA SYSTEMS SPECIALIST
618-564-2481
SOUTHERN ILLINOIS ANTENNAS
ROUTE 3 BOX 114
METROPOLIS, IL 62960

ERIC NEIL ANGEVINE, P.E.
consultant in acoustics
specializing in broadcast studio acoustics
910 Lakeridge Drive Stillwater, OK 74075
405-744-6444 405-372-3949

CALL US For New and Rebuilt
Radio Broadcast Equipment

(804) 974-6466
1305-F Seminole Trail · Charlottesville, Va. 22901

UNUSED CALL LETTERS
MAILING LABELS
AM · FM · TV
dataworld
301-652-8822 800-368-5754

PATCHPRINTS VIDEO TIE LINES
In 1 2 3 4 Aux
Custom Patch Bay Labeling
By
PATCH BAY DESIGNATION COMPANY
Div. of Glendale Rubber Stamp & Printing Co., Inc.
P.O. Box 6278, Glendale, CA 91205 Telephone (818) 241-5585
4742 San Fernando Road Glendale, CA 91204 FAX (818) 507-5050

Consulting Communications Engineers
• FCC Data Bases
• FCC Applications and Field Engineering
• Frequency Searches and Coordination
• AM-FM-CATV-ITFS-LPTV

OWL ENGINEERING, INC.
Consulting Communications Engineers
1306 W. County Road F, St. Paul, MN 55112
(612) 631-1338 "Member AFCCE"

East Coast Video Systems
ON LINE IN TIME
A full service company providing...
• Consultation
• Engineering & Design
• Installations
• Training
Serving...
• Cable Systems
• Corporate Facilities
• Broadcast Facilities
• Teleproduction Facilities
52 Ralph Street, Belleville, NJ 07109 (201) 751-5655

NETCOM (201)837-8424
NETWORK COMMUNICATIONS CONSULTANTS
931 TEANECK RD TEANECK, N.J. 07666
STATE-OF-THE-ART ENGINEERING FOR AUDIO & VIDEO
• FACILITY PLANNING
• SYSTEM DESIGN
• CAD SERVICES
JAMES TRONOLONE
ENGINEER

BROADCAST DATABASE
dataworld
MAPS
Coverage/Terrain Shadowing
Allocation Studies · Directories
P.O. Box 30730 301-652-8822
Bethesda, MD 20814 800-368-5754

JOHN H. BATTISON PE.
CONSULTING BROADCAST ENGINEER,
FCC APPLICATIONS AM, FM, TV, LPTV
Antenna Design, Proofs, Fieldwork
2684 State Route 60 RD#1
Londonville, OH 44842
419-994-3849

MAILING LISTS
AM FM TV
Labels or Diskette
StationBase
(800) 359-2818

Why not run
your Business
Card here?
It's a great way
to promote
your service
and increase
business, all for
as low as \$110
per insertion.
For information
just call
Renée
Hambleton
at
(913) 888-4664

Continued from page 66

ample, a digital DAT copy could be made from a CD, but no digital copies can be made from that DAT copy. However, unlimited first-generation digital copies can continue to be made from the same CD. Unlimited analog copies and generations can be made from the digital DAT copy. 5. It contains provisions for encoding future digital broadcast signals, allowing broadcasters to exercise some control over the audience's ability to record or copy recordings of transmissions.

6. Any analog source recorded by an SCMS-equipped DAT deck (even personal or studio production material) will be treated as if it were copyrighted, because the recorder can't tell without any digital identification coding and copyright flagging, and its default status is to copy-protect. This means that only *one* digital generation of copying is permitted from any DAT recording made through the analog (mic or line) inputs.

Perhaps the most important issue is the last point mentioned. If a broadcaster were putting spots onto a DAT cassette from an analog-output production mixer, using a consumer DAT recorder, then wanted several digital copies of this tape for various studios, they would all have to be made from the original master tape. If one of those copies were sent to another sister station, that station could not make a digital safety copy of it. (However, they could make an analog copy.)

You can see the reasoning behind the copyright holders' and record industry's fears, in that potentially every product sold could be the root of a theoretically endless chain of perfect copies — their worst nightmare, and quite different from bootlegging in an analog world. SCMS protects them from this possibility by nipping the digital chain in the bud, but still allows the consumer to step up to digital copying for "personal" use, and continue analog dubbing, leaving a situation no worse than status quo from the record companies' perspective.

Although the broadcaster should be aware of how this system works — especially for future digital broadcast SCMS encoding — the prohibitions of the SCMS system can be completely avoided by purchasing exclusively professional DAT hardware for production use. An SCMS-equipped deck might be handy for the recording of any DAT cassettes to be distributed to listeners or other broadcasters, however, where control over subsequent digital copying is desirable.

Full specifications of the SCMS system are contained in an amendment to the standards document IEC 958, "Part 6: Serial Copy Management System for Consumer Audio Use DAT Recorders."

I=I=)))

Classified advertising now available as Classified Display or By-the-word.

Classified Display: \$100 per column inch, per insertion, with frequency discounts available. 1 inch minimum, 10 inches maximum per ad. Blind ads \$40 additional. Reader Service number \$50 additional. Spot color available for \$150 (color determined by publisher).

By-The-Word: \$1.75 per word, per insertion. Initials and abbreviations count as full words. Blind ads \$40 additional. Minimum charge \$40 per insertion.

Contact Renée Hambleton, at (913) 888-4664, for information on frequency and pre-payment discounts. To place your classified ad send your order and materials to Broadcast Engineering, Classified Ad Mgr., P.O. Box 12901, Overland Park, KS 66212.

HELP WANTED

STUDIO MAINTENANCE ENGINEER

WTEN/WCDC-TV the ABC affiliate in Albany NY is searching for an experienced studio maintenance engineer to join our excellent technical staff. Three years studio maintenance background is preferred troubleshooting to a component level; Sony 1" and 1/2" VTR's, Sony camcorders and Grass Valley switchers. Competitive salary and benefits (health insurance, paid vacations, holidays and 401k).

**Send Resumes to WTEN-TV,
341 Northern Blvd., Albany, NY 12204,
Attn: Skeeter Lansing, Chief Engineer. EOE.**

KTVA-TV IS SEEKING A TECHNICAL DIRECTOR/MASTER CONTROL OPERATOR. Individual must be an experienced technical director and also be able to perform some master control and light production duties. Send resumes to Chief Engineer, KTVA, 1007 W. 32nd Ave., Anchorage, AK 99503. EOE. No phone calls please. 08-90-21

HELP WANTED

TECHNICAL SUPPORT ENGINEERS

SONY, the recognized leader in Broadcast and Professional technologies, is currently seeking qualified Technical Support Engineers throughout the U.S. In addition, SONY will be expanding its **Cypress, California** customer service operations to meet the growing Southern California market. As a result of this expansion, SONY has several positions available for Technical Support Engineers to join their Cypress Customer Service team.

We seek those rare individuals who can combine technical expertise with above average communication skills and a dedication to the customer. The ideal candidates will have experience in the repair, maintenance and servicing of Broadcast and Professional Video Products with knowledge of digital recording, digital video effects, CCD cameras, or opto-electronics a plus. An appropriate technical education (BSEE/AA) or equivalent experience desirable.

SONY offers you the challenge of working for an industry leader and the opportunity to develop your technical skills on state-of-the-art equipment. In addition, we have an excellent salary and benefits package. For immediate consideration, please send your resume, indicating geographic preferences, to SONY CORPORATION OF AMERICA, Professional Staffing, Dept. BE1, 677 River Oaks Parkway, San Jose, CA 95134. We are proud to be an EEO/AA employer M/F/H/V. Also, we maintain a drug free workplace and perform pre-employment substance abuse testing.

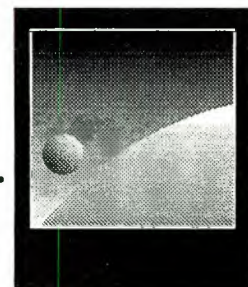

SONY
Technology Never Looked So Good.

HELP WANTED

CONSULTING ENGINEERING FIRM

based in San Francisco and specializing in AM-FM-TV broadcasting, CATV, and microwave systems needs competent, personable, self-assured associate. BS in engineering essential, higher degrees desirable. Systems design, FCC applications, forensic engineering, some field work and travel. P.E. registration essential but may be obtained later. Salary commensurate with qualifications and experience. Enjoy the benefits of a small specialized professional firm with an established nationwide practice. All replies confidential. Send resume to Hammett & Edison, Inc., Box 280068, San Francisco, California, 94128.

TV BROADCAST TECHNICIAN, responsible for maintenance, repair, installation and adjustment of typical TV broadcast equipment. FCC 1st class, general or SBE certification, 2 years experience as a broadcast technician. Salary DOE. Reply: Frankie Crowley, KTOO, 224 4th St., Juneau, AK 99801. EOE. 08-90-11

TELEVISION MAINTENANCE ENGINEER. For Camrac Studios in Reno, Nevada. Experience required for 3-tube & chip cameras, switchers, 1", BETA-SP, 3/4 & 1/2 inch duplicators, graphics, ADO, stereo audio, multi-track, terminal equipment and general maintenance. Computer experience an asset. Join our team for clean air, blue skies, skiing at Lake Tahoe with good benefits and career opportunity. Salary commensurate with experience. Send resume & cover letter to Jim Mitchell, 1775 Kuenzli Lane, Reno, NV 89502. 08-90-11



TELEVISION ENGINEERS

Turner Broadcasting System, the leading News, Sports and Entertainment system in satellite communications, has career opportunities for engineers with broadcast maintenance experience. These positions demand an extensive background in television engineering and at least two years of training in electronics technology. Turner Broadcasting System offers an excellent benefit and compensation program. Send resumes to:

Mr. Jim Brown, Engineering
Turner Broadcasting System, Inc.
One CNN Center
P. O. Box 105366
Atlanta, Georgia 30348-5366
404-827-1638

TBS is an equal opportunity employer.

MAINTENANCE ENGINEER: Florence/Myrtle Beach, South Carolina. Progressive Company, excellent benefits. Three years minimum TV studio maintenance experience required. Extensive background in Odetics, Beta, Sony ENG systems and general digital systems servicing a necessity. Send resume to: WPDE-TV, Personnel Department, P.O. Box F-15, Florence, SC 29501. EOE. M/F. 08-90-11

MASTER CONTROL OPERATOR/MAINTENANCE ENGINEER for UHF ABC affiliates. Must have technical schooling and minimum of 3 years maintenance experience. Send resume to Chief Engineer, WAND-TV, 904 Southside Drive, Decatur, Illinois 62521. An E.O.E. 08-90-11

**Use BE
classified ads**

HELP WANTED

CHIEF ENGINEER — wanted for state-of-the-art Post Production facility. Must have minimum 10 years experience as Manager of Engineering and be extensively familiar with all phases of video tape post production, digital technology, and earth station operations. Send resume and salary requirements to: **Century III at Universal Studios**
2000 Universal Studios Plaza
Orlando, FL 32819-7606
(407) 354-1000

TV MAINTENANCE ENGINEER
needed for a national Christian studio post production satellite uplink facility. Three years component level maintenance experience. Ampex, AVC, ADO, VPR-3, Beta, Scientific Atlanta Uplink. Positions available in San Diego and Dallas. Competitive salary and benefits (Paid vacations, holidays, incentive programs, medical & dental insurance) with an exciting organization. Send resume to: Personnel Dept., Word of Faith, P.O. Box 819099, Dallas, TX 75381-9099

FOR SALE

Portable Sound Panels



- Isolate specific areas
- Many sizes and options
- Panels start at \$19.95/ea. Complete w/foam

Island Cases

Write for free catalog
1121-I Lincoln Ave., Holbrook, N.Y. 11741
800-343-1433 • In N.Y. 516-563-0633

HIGHEST PRICES for 112 Phase Monitors, vacuum capacitors and clean, one kw or greater powered AM and FM Transmitters. All duty and transportation paid. Surplus Equipment Sales, 2 Thorncliffe Park Dr., Unit 28, Toronto, Canada M4H 1H2, 416-421-5631. 6-89-1fn

Dcode TC-1 TIME CODE READER



- Reads Time Code from 1/50 - 50x speed
- Reshapes Time Code for copying
- 60 hz sync from 24 or 30 frame code

\$395

DENECKE, INC.

5417-B Cahuenga Bl., No. Hollywood, CA 91601
(818) 766-3525 • FAX (818) 766-0269

FOR SALE

FACTORY DIRECT

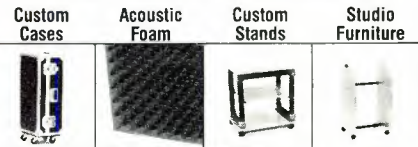

Request Catalogue 800-343-1433, 516-563-0633
Island Cases, 1121-20 Lincoln Ave., Holbrook NY 11741

FOR SALE: Recent on line ACR-25 with 3000 carts. Make best offer. Contact Don Clausen. (402) 978-8911. 08-90-11

IKEGAMI HL-79E with Ikegami component Beta adapter and an Ampex CVR-35 Betacam SP player/recorder. Excellent condition, low hours (will sell camera separate) \$45,000 for both. (716) 546-8435. 08-90-11

COPPER! All sizes of wire and strap for AM, FM and TV. Construction, counter poise, grounding. (800) 622-0022. 08-90-8t

NEW 24' PRODUCTION TRUCK, production switcher, 16 channel Tascam audio board, Sony monitors, 2 6.5Kw generators, Sigma distribution system 500, RTS comms, and much more. 305-893-6627. 08-90-11

RCA TP-66 Film proj's fully refurbished \$2500 takes the pair. **RCA TP-7B** Slide proj fully refurbished \$350. **SIMBER BROADCAST SERVICES, INC.**, (609) 435-1091. 08-90-11



VIDEO/AUDIO/RF
Buy • Sell

Consign • Service
Over 3000 items
in inventory

Burbank, CA 818.845-7000
New York, N.Y. 212.268-8800

Circle (95) on Reply Card

**For
Classified
Advertising
Call
Renée Hambleton
at (913) 888-4664**

THIS IS THE 90'S.... DO YOU NEED DIGITAL ? anything audio

offers a full range of professional Digital Audio products for every application and budget. Let our staff of sales engineers and technicians design a system to meet your facilities needs, from R-DAT to multi-track digital, new or used we have what you need to get the job done easily & cost-effectively. We carry a complete line of new & used audio and video equipment with prices and services unmatched nationwide. Call today and start saving time and money now!
Take a look at some of our quality product lines...

ALPHA AUDIO DR-2 Hard Disk Recorder & Boss-2 Editing System • AUDIOMATION Moving Fader Automation • DIGITAL DESIGNS • AUDIO-KINETICS-MASTER MIX II Automation • AKG • VALLEY • T.C. ELECTRONICS • BSS • SOUNDTRACS PLC • KLARKTEKNIK • NEOTEK • EVENTIDE • HAFLER

USED SPECIALS - NEVE V-60 w/48 i/o auto. \$250K • API 3232-Call • SSL 4056E/G-\$256K • MCI JH-24-\$235K • 4 AKG C-60 Tube w/6caps-\$2.5K • Studer A820-24 1 yr. \$65K • Otari MTR-90-II \$31K • Mits X-850 \$87K • Neumann U47 Tube-CALL • 2-MCI-428 20 in—\$6.5K • AMS Audiofile Loaded \$55K • Many Tascam MS-16 \$5K-7K • AKG TUBE-New \$1,950 • Tascam 600 32x16x32 w/ob (lk new) \$12.5K • WE WANT YOUR USED AND TUBE EQUIPMENT-CASH PAID!!! List your 4-sale equip w/us FREE!!

anything audio

professional audio and video systems
Equipment Sales System Design Installation

THE DIGITAL AUDIO SOURCE
NEW • USED • RARE • BUY • SELL • TRADE
PHONE 617-426-2875 FAX 617-426-2763
63 MELCHER STREET BOSTON, MA 02210

Advertising sales offices

NEW YORK, NEW YORK

Diane Gottlieb-Klusner
Telephone: (212) 332-0633
Telefax: (212) 332-0663
Mike Trerotoli
Telephone: (212) 332-0632
Telefax: (212) 332-0663
888 7th Avenue, 38th Floor
New York, NY 10106

CHICAGO, ILLINOIS

Vytas Urbonas
Telephone: (312) 435-2361
Telefax: (312) 922-1408
55 East Jackson
Suite 1100
Chicago, IL 60604

SANTA MONICA, CALIFORNIA

Herbert A. Schiff
Telephone: (213) 393-9285
Telefax: (213) 393-2381
Jason Perlman
Telephone: (213) 458-9887
Telefax: (213) 393-2381
Schiff & Associates
501 Santa Monica Blvd, Ste. 504.
Santa Monica, CA 90401

OXFORD, ENGLAND

Nicholas McGeachin
Intertec Publishing Corp.
Roseleigh House
New Street
Deddington
Oxford OX5 4SP
England
Telephone: (0869) 38794
Telefax: (0869) 38040
Telex: 837469 BES G

TOKYO, JAPAN

Masuyoshi Yoshikawa
Orient Echo, Inc.
1101 Grand Maison
Shimomiyabi-Cho 2-18
Shinjuku-ku, Tokyo 162, Japan
Telephone: (03) 235-5961
Telex: J-33376 MYORIENT

FREWVILLE, SOUTH AUSTRALIA

John Williamson
Hastuelli, Williamson, Rep. Pty. Ltd.
109 Conyngham Street
Frewville 5063
South Australia
Phone: 799-522
FAX: 08 79 9522
Telex: AA87113 HANDM

CLASSIFIED ADVERTISING

OVERLAND PARK, KANSAS
Renée Hambleton
P.O. Box 12901
Overland Park, KS 66212
913-888-4664

FOR SALE

DEMO & USED EQUIPMENT BROKER

Hundreds of items listed up to 70% off!
MOBILE TRUCKS—25 foot, 1988 fully outfitted, sports truck w/new Ike cameras, 1" & Chyron — \$1,400,000; 18 foot, 1979, 38,000 miles, monitors, some equip. — \$40,000; 24 foot, 1981 Ford chassis w/14.5 ft. box, 19,000 miles, monitors, da, s, test, routing, 12 channel audio — \$120,000; 16 foot, 1978 Chevy Stepvan, 3 Ike H1-83, monitors — SOFFERS; **BETACAM/1" EDIT SUITE**—w/Scribe, NEC 10 DVE, more — \$195,000; **BETACAM/1" EDIT SYSTEM**—Ampex VPR-3/BVW-40/15/10, Calloway MK-II, NEC DVE-10 3D DVE, GVG-100N Tascam M-320, Dubner 20K graphics, monitors, etc. — \$145,000; **BETACAM 1" EDIT SYSTEM**—BVW-60SP/BVW-15DT, 2) BVH-1000 1", BVE-3000 editor, C/L 6139 switcher, 2) VO-5800 w/1F-500, 1" refurbished 18 mo. ago — \$63,000; **U-MATIC A/B ROLL**—2) VO-5800, VO-5850, ECS-103 editor — \$13,500; **1" VTR'S**—Ampex VPR-3/TBC-7 — \$38,000; Sony BVH-2000 — \$33,000; **BETACAM & M-2**—BVW-40 — \$13,500; JVC KR-M800 (demo) — \$6,150; **CAMERAS**—Ikegami HK-357/40x lens, tripods — \$55,000; Ikegami HL-79EAL TRIAX w/18x lens & tripods — \$30,000; **C.G.'S**—Chyron 4100XB — \$38,000; Laird 1500DD — \$5,500; **DVE'S**—Abekas A-52 — \$16,500; ADO-3000 — \$38,000; **EQUIPMENT FROM THE GOODWILL GAMES**: GVG routers, 200-2N & 100N switchers, VPE-141 editor, Abekas A-53D w/warp, A-42, A-62, Quantel paintbox, lots more. **LET US SHOP FOR YOU!!!**
PROVID SUPPLY CORP. ANDY TURNER 708-215-9010

CAPACITORS OVERNIGHT

- Power Supply—computer grade: up to 450VDC
- Transmitting - MICA — Sangamo, Cornell-Dubilier
- Oil Filled — Non-PCP Oval, Rectangular

Relays • Filters • Transistors
Any Parts starting with 1N or 2N

1-800-323-0460 FAX 1-802-425-3664
Kellner Electronics, Inc., Charlotte, VT 05445

FOR SALE: Tubes 3CX1500A7, 4CX250B, 4CX5000A, 4CX3000A, and more. We carry lg. inventory, all major brands (EIMAC, AMPEREX, RCA) Call Stew 1-800-842-1489. 01-90-121

USED—16 mm & 35 mm telecine equipment. Lowest prices. Video Image—213-822-8872. 08-90-11

Use BE classified ads

COMPUTER SOFTWARE

IBM PC AP/UI WIRE CAPTURE SOFTWARE. Key features: Captures ANPA low/high speed wires. Sorts wire to DOS 3.2 or 3.3 directories. NETWORK Compatible Novel, 3COM, etc. Special directory viewing software, keyword SEARCHING, file archiving, translates data to ASCII format, compatible with wordprocessors, Eliminates need for printers, helps to automate the newsroom. Contact: Porter Communications, 579 D.W. Highway, Merrimack, N.H. 03054. Tele: 603-424-4161. 05-90-121

SERIAL DATA CAPTURE TO DISK IN BACKGROUND ON IBM PC. Collect data from multiple asynchronous ports to individual files while running foreground programs. Eliminates printers. \$35. Source code, \$380. Satisfaction guaranteed. Charles Whittlatch, 901 W. Mohawk Lane, Phoenix, AZ 85027. 08-90-21

COMPUTER INDEX... Stand alone, menu driven, categorized index to Broadcast Engineering 1989. Search for title, author, date, Keyword, etc. Printout of search. \$10.00 each. O'Rourke Information Service, 7795 Kay Street, Franklin, Ohio 45005. IBM PC, XT, AT and compatibles. 5 1/4" disk, 256K. 08-90-11

EQUIPMENT WANTED

WANTED: USED VIDEO EQUIPMENT. Systems or components. **PRO VIDEO & FILM EQUIPMENT GROUP:** the largest USED equipment dealer in the U.S.A. (214) 869-0011. 04-90-11n

EQUIPMENT WANTED—AM 10K, prefer Harris, Continental 1982 or later, also stereo generator, monitors. Rocky Payne (404) 424-9850. 08-90-11

STOLEN FROM KELO SIOUX FALLS, S.D. JUNE 9: Tektronix O'scope 465B serial BO36365. Tektronix spectrum analyzer 2710 serial BO20697, Potmac Field Strength meter FIM-71 serial 368, Hewlett Packard Frequency Counter 5315B serial 589068. Any info contact KELO-TV (605) 336-1100 or Minnehaha County Sheriff (605) 335-4300. 08-90-11

USED SNAP-ON® (PROPAC 13/14) BACKPLATES OR BATTERIES—\$50 each — CALL (914) 347-5776. SNAP-ON, PROPAC are registered trademarks of Anton/Bauer, Inc. 08-90-11

SERVICES

WE PLACE TV MANAGEMENT, SALES & ENGINEERING PERSONNEL

America's Leading Source For A Decade
For Information Phone or Write
Mark Kornish



**key systems
international, inc.**

479 Northampton Street
Kingston, PA 18704

Phone (717) 283-1041
Fax (717) 287-5889

Employer
Paid Fees

TAPE TRANSFER SERVICE

We transfer all obsolete video tape formats, one inch AMPEX, IVC, TYPE B, and SONY EV series. Also, all half inch black and white open reel formats, including PRE-EIAJ standard. No job too small.

**TAPE TRANSFER SERVICE
PHILA., PA 19116
215-464-3158**

TRANSMITTER TUBE REBUILDING SINCE 1941: 3CX2500, 4CX5000, 4CX15000 and many others. Write for details. FREELAND PRODUCTS INC., 75412 Hwy. 25, Covington, LA 70433. (504) 893-1243 or (800) 624-7626. 6-79-11n

UHF KLYSTRON TUBE REBUILDING. SAVE 50-76% on External/Integral cavity Klystrons. New tube warranty. Major market stations use our services. CALIFORNIA TUBE LABORATORY. For full details (901) 324-4490 or (805) 995-1072. 04-90-61

TRAINING

FCC GENERAL CLASS LICENSE. Cassette recorded lessons with seminars in Washington, Newark, Philadelphia. Bob Johnson Telecommunications, Phone (213) 379-4461. 05-90-11n

New, Lower BE Classified Display Rates for 1990!

Want more
information on
advertised
products? Use the
Reader Service
Card.

Ad index

	Page Number	Reader Service Number	Advertiser Hotline		Page Number	Reader Service Number	Advertiser Hotline
A.F. Associates, Inc.	75	46	201/767-1201	Matrix Systems	55	31	818/992-6776
Acrodyne Industries	61	34	800/523-0596	Media Technology, Inc.	70	43	314/576-4222
AKG Acoustics, Inc.	17	10	415/351-3500	Microdyne Corp.	66	39	904/687-4633
Alta Group, Inc.	65	38	408/297-2582	Midwest Communications Corp. ...	1	3	800/543-1584
Ampex Corp. (AVSD)	39,56-57,81,83		800/25AMPEX	Midwest Corp., DPS	96	73	606/331-8990
Ampex Recording Media	107	83	415/367-2911	Moseley Associates, Inc.	99	75	805/968-9621
Anvil Cases, Inc.	108	84	818/575-8614	Myat	46	22	201/767-5380
Arrakis Systems, Inc.	21	12	303/224-2248	Nautel	82	57	902/823-2233
Audio Precision	13	8	800/231-7350	Newton Instruments	84	59	919/575-6426
Audio Services Corp.	96	70	818/980-9891	Nikon Corporation	5	4	516/222-0200
Auditronics, Inc.	77	47	901/362-1350	Odetics, Inc.	97	74	800/243-2001
Barco Industries, Inc.	93	66	408/370-3721	OKI Electric Industry Co., Ltd. ...	87	61	213/245-7708
Belar Electronics Laboratory, Inc. .	94	68	215/687-5550	Opamp Labs, Inc.	83	71	213/934-3566
Benchmark Media Systems	70	42	800/BNC-HMRK	Orban, Div. of AKG Acoustics, Inc.	7	5	800/227-4498
Broadcast Electronics, Inc.	11	7	217/224-9600	Otari Corp.	15	9	415/341-5900
Broadcast Store, Inc.	114	95	818/845-7000	Panasonic Pro Industrial Video ...	37	18	800/553-7222
Broadcast Video Systems, Ltd. ...	94	67	416/764-1584	Philips Components	79	48	800/447-3762
BTS Broadcast Television Systems	73	45	800/962-4BTS	Philips Export B.V.	52	28	800/882-NTSC
Cablewave Systems	47	23	203/239-3311	Pinnacle Systems, Inc.	64	37	408/970-9787
Canare Cable, Inc.	85	58	818/840-0993	Quantel, Ltd.	109	86	203/348-4104
CEL Electronics, Inc.	89	64	913/831-0188	Queue Systems	81,83	53,72	213/656-0258
Clear-Com Intercom Systems ...	102	77	415/527-6666	Ramsa/Panasonic	48A-48B	26	714/895-7277
Consultronics	54	30	416/738-3741	Ross Video, Ltd.	29	14	613/652-4888
Di-Tech, Inc.	106	81	516/667-6300	RTS Systems, Inc.	80	49	818/843-7022
Dolby Labs, Inc.	43	19	415/558-0200	Sanix Corporation	88	63
Dynair Electronics, Inc.	33	17	619/263-7711	Sennheiser Electronic Corp.	60	33	203/434-9190
Electro-Voice, Inc.	63	36	616/695-6831	Shintron Electronics	106	82	800/358-6872
Electrohome	103	78	579/744-7111	Shure Brothers, Inc.	IFC	1	708/866-2553
Ergo Industries, Inc.	81	51	714/632-7045	Sierra Video Systems	108	85	916/273-9331
Fujinon, Inc.	53	29	201/633-5600	SMPTE	100		914/761-1100
Gentner Electronics Corp.	111	88,89	801/975-7200	Sony Communications Prod./ Broadcast Div. ...	24-25,34-35,40-41		800/635-SONY
Grass Valley Group, Inc.	9	6	916/478-3000	Sony Corporation/Pro Mavica ...	91	65	800/222-0878
Gray Engineering Laboratories ...	88	62	714/997-4151	Standard Tape Laboratory, Inc. ...	81	52	415/786-3546
Hitachi Denshi America Ltd.	3		800/645-7510	Switchcraft, Inc.	69	41	312/792-2700
Hotronic, Inc.	84	60	408/378-3883	Tascam, Div. TEAC Corp. of America	44,110	20,87	213/726-0303
illbruck	27	13	804/358-3852	Tektronix, Inc.	45	21	800/452-1877
Jampro Antennas, Inc.	32	16	916/383-1177	Telex Communications, Inc. ...	104-105	79,80	612/887-5550
JVC Professional Products Co. ...	19	11	800/582-5825	TFT, Inc.	71	44	800/347-3383
LDL Communications	31	15	301/498-2200	Thomson Tubes Electroniques ...	59	32	201/812-9000
Leitch Video of America, Inc.	IBC	2	804/424-7290	Thomson Video Equipment	95	69	203/348-1995
Magni Systems, Inc.	101	76	503/626-8400	Varian, CED (Continental Electronics)	62	35	214/381-7161
				Videotek, Inc.	67	40	602/997-7523
				Ward-Beck Systems, Ltd.	BC		416/438-6550
				Winsted Corp.	51	27	800/447-2257

GET KEYED-UP ABOUT YOUR STILLS



Key in on the STILL FILE by Leitch, and move into a new creative dimension of still presentation. The STILL FILE will update the look of your productions with a comprehensive array of visual effects. Compression and positioning. Bordering. Digital transitions. Internal and external keying. All easily preset into a sequence you can recall with the stroke of a key. Call 1-800-387-0233 today for a hands-on demonstration of the STILL FILE's creative abilities.

Get keyed-up and add a new excitement to your stills.



Don't just reach for the nearest brand name ... reach for the best. STILL FILE by Leitch.



D-2

LEITCH

Leitch Video of America, Inc., 825K Greenbrier Circle, Chesapeake, VA 23320 — Tel: (800) 387-0233 Fax: (804) 424-0639
Leitch Video International Inc., 10 Dyas Rd., Don Mills, Ont., Canada M3B 1V5 — Tel: (800) 387-0233 Fax: (416) 445-0595

Circle (2) on Reply Card

www.americanradiohistory.com



Ward-Beck's Beltpack ... the mobile link for your professional intercom system!

Now total communications has become a reality with the new high-performance WBS Interphone Beltpack.

This superbly designed two-channel, single pair wired, compact unit interfaces with Ward-Beck's advanced four-wire, programmable MicroCOM system. It assures studio quality voice communications to your outermost mobile location.

Beltpack moves quality communications yet another step ahead of the rest of the pack and at a very attractive price!



Ward-Beck Systems Ltd., 341 Progress Avenue, Scarborough, Ontario, Canada M1H 2X4.
Tel: (416) 438-5550. Fax: (416) 438-3865.