

BROADCAST[®] ENGINEERING

An INTERTEC[®] Publication

September 1994/\$5.00

Production Equipment

- Broadcastable studios
- Recording equipment
- Editing
- Mixing systems

#BXNCFHL***** 3-DIGIT 331
#00304584# 23 BEQ 0005
PRES DIR
RAYMOND MEYERS
BENCHMARK COMMUN CORP
4700 SW 75TH AVE
MIAMI FL 33155-4473

Also Featured

- Wireless microphones
- Audio data compression



**Constant
Change.**



Constant.

ADC's New LightSwitch™ — The "Future-proof" Digital Router.

As digital formats come and go, so does a lot of expensive equipment. But while changing formats often requires upgrading cameras, decks and other source equipment, it doesn't have to affect your switching system.

Introducing the new LightSwitch digital router from ADC. A switching system that literally doesn't care what format you use. By avoiding internal reclocking, the LightSwitch router is able to switch any true digital signal, regardless of format—even ones that don't exist yet! It can interface with either coax or fiber and features on-site matrix mapping, group takes, chop mode and RS232/RS485 control panel interfaces.

So, regardless of what digital format the future holds—from D1 to HDTV—turn on the LightSwitch router from ADC. For more information about LightSwitch or our digital video and audio fiber optic links and DAs, call us at **1-800-726-4266** or circle the reader service card below.



Circle (1) on Reply Card



Get Ready.

Digital video is here. Now! Are you ready to take advantage of the technical benefits digital has to offer? More important, are you prepared to take advantage of the financial benefits?

Digital technology is not just a good engineering choice, it's a good business decision. You know digital video gives you the highest

signal quality, but did you know it provides you with new avenues to be more competitive, to make more money?

But pathways abound. Parallel or Serial; Component or composite; Imbedded or Discrete; Compressed or Non-compressed. Take the wrong path, and it can cost

you money. But who can you trust to put you on the right path? Harris Allied's experience allows us to be the leader in this developing technology. And with over 70 years of broadcast experience, we know what it takes to get the job done.

Harris has a proven track record in digital

systems design and installation. All over the world. In all formats. So, if you have any questions on how digital technology can help, technically or financially, call us. And get ready.

**7920 Kentucky Drive
Florence, KY 41042 USA
606-282-4800
Fax: 606-283-2818**



Contents

September 1994 • Volume 36 • Number 9

BROADCAST[®] engineering



Page 26



Page 40

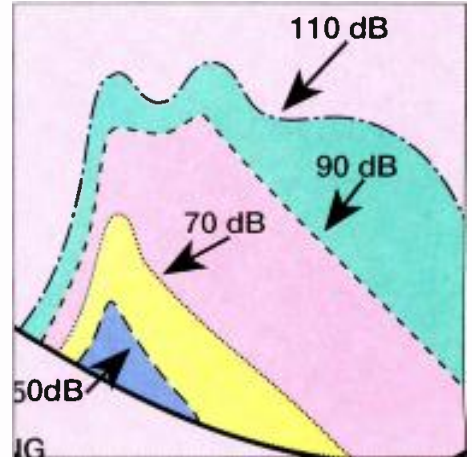

Page 78

PRODUCTION EQUIPMENT:

With the wide range of new production technology available for the asking, the question is not whether to adopt the new technology, but which of the many options to choose. This month's issue offers guidance in seven applications.

DEPARTMENTS:

- 8 **FCC Update**
Broadcasters Seek to Protect ENG
- 10 **Strictly TV**
A Look at 8-VSB (Part 2)
- 12 **Management**
Equipment Acquisition (Part 3)
- 14 **Production**
Production Test Equipment (Part 2)
- 16 **Troubleshooting**
Industrial Computers (Part 3)
- 18 **Technology News**
Hard Drives
- 100 **SBE Update**
FCC Liaison
- 102 **Applied Technology**
RCI Video Disk Recorder
- 108 **Field Report**
Panasonic AT-H1905D Digital Monitor
- 114 **Field Report**
Matrox Studio
- 118 **Field Report**
Data Translation: Media 100
- 124 **New Products**

COLUMNS:

- 4 **News**
- 6 **Editorial**
- 122 **Industry Briefs**
- 133 **Classifieds**
- 136 **Advertisers' Index**

THIS MONTH...

- 26 Cable Production**
By Eleni Zuras Tsigas
Through quality in-studio and remote production, cable can bring programming closer to home.
- 40 Non-linear editing systems**
By David Leathers
With technology's help, these systems have grown up.
- 48 Linear Editing Systems**
By Curtis Chan
Recent reports of their death have been greatly exaggerated.
- 52 Upgrading TV Studio Lighting**
By Brad Dick
New lighting technology can improve your station's look and bottom line.
- 62 Production Facility Software**
By Chris Leonard
Computerizing the facility management process can improve profitability.
- 70 On-Line Captioning Systems**
By Carlos Suarez
Getting it done in real time takes specialized skills and equipment.
- 78 Audio Data Compression 101**
By Steven E. Forshay
Successful application of data compression requires a working knowledge of basic coder operation.
- 92 Wireless Microphone Technology**
By Glen Ballou
Wireless microphones continue to grow in popularity among broadcasters.

ON THE COVER:

This month's unique cover was produced by Rhonda Graphics, Phoenix, AZ, as part of an entirely animated commercial for a truck dealership. The commercial was composed using 3-D truck models from Viewpoint Datalabs, which were then animated using Wavefront Advanced Visualizer and Dynamation software from Wavefront.

Digital Video Testing Just Got Easier . . .

The S310 Digital Video Analyser is the only patented, all-in-one analyzer designed to take the frustration out of digital video testing. The S310 performs real time, on-line tests of key signal parameters for both composite and component, serial or parallel digital video, without complex and time consuming interpretation.

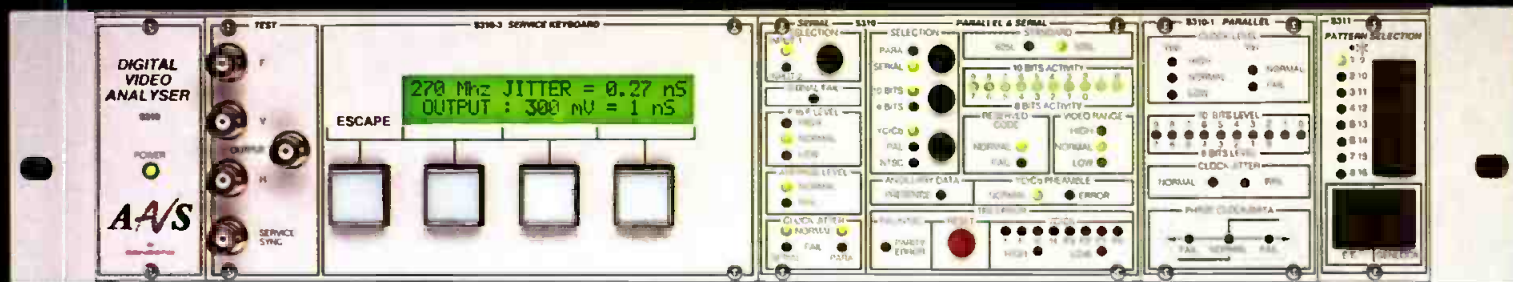

With The S310 Digital Video Analyser

PATENTED

With over 18 different, easy-to-use tests and measurements, the S310 provides you with critical performance data such as:

- Serial jitter
- Parallel clock jitter
- Common mode voltage
- Clock to data skew
- Correct luminance & chrominance levels
- Individual luminance & chrominance sample analysis
- Signal levels
- DC offset
- TRS analysis
- Presence of reserve codes in active video
- Analog signal output
- And many more

In addition, the S310 is equipped with:

- ◆ User-selectable alarm thresholds that provide out-of-limit parameter warnings.
- ◆ Remote control software with an RS232C/RS422 port for remote control monitoring and data logging.
- ◆ A comprehensive CCIR 601 component pattern generator with 34 test patterns, and exclusive error introduction.

Take the frustration out of your digital video testing by calling **1-800-769-AAVS** to schedule a demonstration, reserve an evaluation unit, or to order a FREE video tape.

See Us At

WORLD MEDIA EXPO
Booth #759 October 13-15

Circle (5) on Reply Card

A-S By Sencore

The Name To Know In Digital Video Testing

Advanced Audio Visual Systems by Sencore
3200 Sencore Drive, Sioux Falls, SD 57107
TEL: 1-800-769-2287 FAX: (605)335-6379

By Dawn Hightower,
senior associate editor

EON and IVDS to develop IVDS spectrum use

EON Corporation and the Interactive Video and Data Services (IVDS) have signed a letter of intent that will lead to a final agreement to mutually develop the Washington, DC IVDS radio spectrum.

The two companies have agreed to develop interactive communications services that use wireless IVDS technology. Services will be developed that will let consumers enhance their TV viewing experience.

EON has formed alliances with national and local leaders in the broadcast industry that will allow Washington-area viewers to interact with local news and network sports and prime time high-profile programming. EON has agreements with Capital Cities/ABC; Allbritton Communications, parent company for WJLA-TV, the ABC affiliate for the Washington market; and ALLNEWSO, the supplier of Washington's regional 24-hour cable news channel. The agreement will allow viewers of various programs to respond to interactive opportunities.

DIRECTV launches second DBS

DIRECTV, a unit of GM Hughes Electronics, has launched DBS-2, the second direct broadcast satellite in the nation. The company will be able to deliver up to 150 channels of entertainment and informational programming to homes across the United States equipped with the RCA brand Digital Satellite System, which features an 18-inch satellite dish.

Minorities represented well in broadcast workforce

The broadcast industry has been successful in providing equal employment opportunities for women and minorities, according to the National Association of Broadcasters (NAB).

Women hold 90% of the broadcast management-level jobs and other decision-making positions created since 1975. Minorities hold nearly 40% of these top leadership positions.

According to data supplied by the Federal Communications Commission (FCC), the broadcast industry employs women at 87% of the available labor force over-

all; 75% of the available labor force in decision-making positions and managers' jobs. Minorities are employed at 80% of available labor force overall, and 55% of labor force in top leadership positions. FCC guidelines require a 50% labor force level and the broadcast industry exceeds that level in almost every case.

Because of these employment levels NAB said there is no need for expanding the broadcast EEO requirements, such as additional reporting efforts and record-keeping.

NAB has also argued for greater relief in record-keeping for small-market broadcasters. In small communities, broadcasters have a difficult time recruiting and retaining qualified engineers because of low wages, minimal benefits and communities with few amenities. Also, small-market broadcasters have limited financial and personnel resources, which make extensive recruitment efforts difficult.

According to NAB, the FCC needs to encourage joint recruitment efforts, such as broadcast job fairs and employment clearinghouses. These type of efforts should be given more weight by regulators, particularly when reviewing a licensee's EEO efforts.

NAB seeks reconsideration on satellite fees

The National Association of Broadcasters (NAB) has submitted a petition of reconsideration of the FCC's Report and Order regarding the decision to impose on satellite TV stations the same fees that would be charged to full-power stations offering a regular program service.

In comments filed in response to the Notice of Proposed Rulemaking, NAB argued that satellite TV stations should be assessed for fiscal year 1994 the same level of fees as translator stations. The FCC failed to respond to many of NAB's arguments in the Report and Order, so NAB feels the FCC should reconsider its decision to require satellite stations to pay the same level of fees as full-service stations.

According to NAB, imposing a full regulatory fee on satellite TV stations would be inconsistent with Congress' objectives in enacting Section 9 of the Communications Act. Congress adopted a schedule of fees that placed a greater financial burden on TV stations in large markets with greater revenue bases. Imposing a full fee on satellite stations would result in stations in sparsely populated TV

Continued on page 20

EDITORIAL

Brad Dick, *Editor*
Skip Pizzi, *Technical Editor*
Steve Epstein, *Technical Editor*
Dawn Hightower, *Senior Associate Editor*
Deanna Rood, *Associate Editor*
Tom Cook, *Senior Managing Editor*
Carl Bentz, *Directory Editor*

ART

Ruth Knotts, *Associate Art Director*

BUSINESS

Raymond E. Maloney, *President*
Cameron Bishop, *Group Vice President*
Dennis Triola, *Publisher*
Tom Brick, *Marketing Director*
Stephanie Hanaway, *Group Director, Special Projects*
Kathryn Buckley, *Promotions Manager*
Sandra Tomczak, *Promotions Coordinator*
Dee Unger, *Director Advertising Services*
Nancy Hupp, *Advertising Production Manager*
Susan Jones, *Advertising Coordinator*
Chris Coughlin, *List Rental Sales Representative*
Doug Coonrod, *Corporate Art Director*
Barbara Kummer, *Circulation Director*
Eunice Longanecker, *Circulation Manager*
Customer Service: 913-967-1711 or 800-441-0294

TECHNICAL CONSULTANTS

Jerry Whitaker, *Contributing Editor*
Eric Neil Angevine, *Broadcast Acoustics*
John H. Battison, *Antennas/Radiation*
Dennis Ciapura, *Radio Technology*
Dane E. Erickson, P.E., *Systems Design*
John Kean, *Subcarrier Technology*
Donald L. Markley, *Transmission Facilities*
Harry C. Martin, *Legal*
Curtis Chan, *Audio/Video Technology*

MEMBER ORGANIZATIONS

Sustaining Members of:
• Acoustical Society of America
• Society of Broadcast Engineers
• Society of Motion Picture and TV Engineers

Member,
American Business Press

ABP

Member,
BPA International

BPA
INTERNATIONAL

BROADCAST ENGINEERING is edited for corporate management, engineers/technicians and other station management personnel at commercial and educational radio and TV stations, teleproduction studios, recording studios, CATV and CCTV facilities and government agencies. Qualified persons include consulting engineers and dealer/distributors of broadcast equipment.

BROADCAST ENGINEERING (ISSN 0007-1994) is published monthly (plus three special issues) and mailed free to qualified persons within the United States and Canada in occupations described above. Second-class postage paid at Shawnee Mission, KS, and additional mailing offices. POSTMASTER: Send address changes to Broadcast Engineering, P.O. Box 12902, Overland Park, KS 66282-2902.

SUBSCRIPTIONS: Non-qualified persons may subscribe at the following rates: United States and Canada; one year, \$50.00. Qualified and non-qualified persons in all other countries; one year, \$60.00 (surface mail); \$115.00 (air mail). Subscription Information: P.O. Box 12937, Overland Park, KS 66282-2937.

Authorization to photocopy items for internal or personal use, or the internal or personal use of specific clients, is granted by Intertec Publishing, provided that the base fee of U.S. \$2.00 per copy, plus U.S. \$0.00 per page is paid directly to Copyright Clearance Center, 222 Rosewood Drive, Danvers, MA 01923. The fee code for users of this Transactional Reporting Service is ISSN 0361-0942/1994 \$2.00+.00. For those organizations that have been granted a photocopy license by CCC, a separate system of payment has been arranged. Prior to photocopying items for educational classroom use, please contact CCC at 508-750-8400.

CORRESPONDENCE

Editorial and Advertising: 9800 Metcalf, Overland Park, KS 66212-2215. Telephone: 913-341-1300; Editorial fax: 913-967-1905. Advt. fax: 913-967-1904.

© 1994 by Intertec Publishing

All rights reserved.

INTERTEC
PUBLISHING

FOCUS ON QUALITY WITHOUT LOSING

SIGHTS



S19 x 8 BI

- Focal length of 8-152mm
- Built-in 2x extender— for maximum range of 304mm
- Lightweight— just 1.65kg
- 0.9m minimum object distance

\$13,576



S15 x 8.5 BI

- Longest zoom in its class — 127.5mm
- Built-in 2x extender — for 255mm zoom performance
- Shortest length in its class — only 177mm
- Lightest in its class — just 1.25 kg. with lens hood

\$7,995



S9 x 5.5 BI

- Longest zoom in its class — 49.5mm
- 0.3m minimum object distance
- Internal focus system
- 77.3 degree wide angle

\$14,725

It's easy with Nikkor ENG lenses from Nikon. Nikkor TV lenses use the same glass and coating technologies that have made Nikon optics the professionals' standard for quality, worldwide. And when you compare costs with other 2/3 inch ENG lenses, you'll be convinced of the value Nikon delivers.

Plus, Nikon service is second to none. We have service facilities across the country, and you are guaranteed a free loaner lens within 48 hours through our Express Loaner Service program.

Quality, performance, affordability, service — when you add it all up you'll see why more and more video professionals are choosing Nikkor TV lenses.

To learn more about the value of owning Nikkor TV lenses, call 1-800-52-NIKON or (908)935-0175 for our brochure. Or write to Nikon Electronic Imaging, 1300 Walt Whitman Road, Melville, NY 11747.

Qualifications be damned

FCC chairman Reed Hundt recently announced changes at the commission which, on the surface, should cause broadcasters to quake in their boots.

Although few of us would classify the commission as the most efficient and loved governmental body, there are qualified individuals in key positions, and work has progressed steadily over the years. And that's not always been easy given the financial belt tightening and lightning speed changes in technology. Even so, most of us who deal with the commission have come to trust those in leadership positions as doing a commendable job, often under difficult circumstances.

Now comes not-so-new FCC chairman Hundt, who, in essence, is throwing out the baby with the bath water. In one fell swoop, Hundt recently replaced three key individuals who have served our industry admirably for years. The replacements include two female unknowns, one an attorney and one a senate aid.

At the same time, he established the Office of Workplace Diversity to ensure that the FCC's hirings promote equal opportunity. Give me a break! The changes, called by Mr. Hundt as *trying to stay ahead of the curve*, look more like political favoritism and biased hiring practices than good management.

The controversy is only now beginning to surface as broadcasters and industry leaders realize that three key individuals they've come to trust and respect, Dick Smith, Ralph Haller and Tom Stanley, have been demoted to subordinate status to the "new hires." These men are no longer in positions to continue the agency's progress. Such wholesale staff demotions, without visible cause, smells all the way from the Potomac River to the left coast.

No one (at least no one in their right mind) would oppose changes in the commission that will result in better service. And reasonable people would not question the appointment of qualified men and women to positions of responsibility.

The SBE has for several years been trying (without much luck) to get the FCC to admit that good technical regulation requires technical expertise. I don't want to make too much of this, but replacing engineers with attorneys here is like substituting the person rowing the boat with someone who not only doesn't know *how* to row the boat, but whose primary skill is telling everyone why they *can't* row the boat.

Hiring quotas have never been the answer at the local station level and they are not the answer in Washington either. Broadcasters can only hope that the chairman's action doesn't portend what he expects them to do at the local level.

Given the chairman's spoken emphasis on equal employment opportunities, I suggest his new Office of Workplace Diversity's first action be to investigate Mr. Hundt's own hiring practices. If there are any further openings at the FCC, looks to me like qualified male engineers need not apply.



Brad Dick

Brad Dick, editor



See spot.



See spot run.



See spot run without
aggravating the entire audience because it's
too damn loud.

Who needs the aggravation? With the new OPTIMOD-TV DIGITAL you never have to worry about poorly mixed programs, complaints from irate viewers, or advertisers devising

diabolical new ways to "punch" their sound. The 8282 handles it all quietly, digitally, and automatically. The OPTIMOD-TV is fully programmable to optimize audio processing of

your programs. And with built-in presets, general programming, news, sports, film, fine arts and other broadcasts will always sound great at home. Never too loud, too soft, or too spotty.

orban[®]

H A Harman International Company

1525 Alvarado St., San Leandro, CA 94577 USA Phone 1•510•351•3500 Fax 1•510•351•0500.

© 1994 AKG Acoustics, Inc. Orban and OPTIMOD are registered trademarks of AKG Acoustics, Inc. All other trademarks are property of their respective companies.

Circle (18) on Reply Card

www.americanradiohistory.com

FCC Update



Broadcasters seek to protect ENG

By Harry C. Martin and Andrew S. Kersting

The NAB, MSTV, and the major broadcast networks filed joint comments in response to a Notice of Inquiry opposing a plan to advance the effective date, from 2005 to 1996, of the WARC-92 allocation of the 1,970-2,010MHz band for Mobile Satellite Service (MSS) operations.

The WARC-92 Final Report and Addendum allocated the 1,970-2,010MHz band globally for primary use in MSS earth-to-space operations. However, in the United States, the 1,990-2,110MHz band is currently allocated primarily for auxiliary broadcast operations (including ENG). The commenters noted that increased reliance on ENG has resulted in intense congestion, especially in major metropolitan areas. The commenters stated that further crowding of this band will lead to serious service disruption and hinder further service improvements in the future, particularly with respect to ENG operations.

The commenters also noted that ATV/NTSC dual mode broadcasting will create an additional need for broadcast auxiliary spectrum, which will significantly increase with the advent of ATV. According to the commenters, the existing spectrum allocation for auxiliary broadcast operations is barely capable of absorbing existing NTSC demands in larger markets. It also is insufficient to meet the anticipated ATV needs for TV broadcasters.

Consequently, the commenters strongly urged that global implementation of the WARC-92 1,970-2,010MHz band allocation not be accelerated from 2005 to 1996. The commenters noted that the 2,390-2,420MHz band might provide an appropriate alternative for MSS, and suggested that the availability of this band be resolved before the United States commits to an expedited implementation schedule for the WARC-92 1,970-2,010MHz band allocation. In addition, to ease congestion, the commenters proposed allocating the 4,660-4,685MHz band (one of three being made available to private industry) for broadcast auxiliary use.

Martin and Kersting are attorneys with Reddy, Begley, Martin & McCormick, Washington, DC.

Court rejects FCC's forfeiture standards

The U.S. Court of Appeals for the D.C. Circuit has invalidated the FCC's standards for assessing forfeitures against its licensees.

In 1991, the FCC abandoned its traditional case-by-case approach of imposing monetary fines on licensees for violations of the Communications Act, and, without notice and comment, issued an order adopting specific standards for assessing fines. The forfeiture standards contemplated a base amount for each type of violation, and were calculated as a percentage of the statutory maxima for the different services. The fines schedule also provided for adjustments to the base amount depending on various aggravating or mitigating factors.

The U.S. Telephone Association (USTA) sought reconsideration of the forfeiture standards, but was unsuccessful. After its petition for reconsideration was denied, the USTA filed an appeal with the D.C. Circuit claiming that the FCC had violated the Administrative Procedure Act (APA) by issuing its fine standards without notice and an opportunity to comment. The USTA also contested the base fine amounts, asserting that the FCC's percentage-of-maxima approach arbitrarily discriminated against common carriers by subjecting them to greater fines than other licensees for the same conduct.

The court held that the FCC's forfeiture standards, because of the consistency of their application, were not a "policy statement," and, therefore, should have been subjected to notice and comment in compliance with the APA. Although not deciding the issue, the court stated that the FCC cannot determine that common carriers, as a class, will be subjected to heavier fines than other licensees without explaining their reasons or subjecting that explanation to judicial review. Accordingly, the court noted that the commission must elicit comment on its proposed position and be prepared to justify its resulting rule.

The court's decision could well signal the demise of the FCC's new EEO forfei-

ture standards, which were adopted in the same manner as the fine schedule. Consequently, the NAB has asked the commission to rescind its EEO policy statement and cancel the enforcement actions that have been undertaken pursuant to that policy.

AM station classifications

In 1992, the system of classifying AM stations was changed to make U.S. classifications consistent with the international system. The new regulatory fees vary depending upon station classification. Thus, AM stations need to be aware of their present classification in order to determine the amount of their fee.

Old Classification:	New Classification:
I-A, I-B, I-N	A
II, II-A, II-B, II-C, III	B
IV	C
II-D, II-S, III-D, III-S	D

Table 1. Old AM classifications and their corresponding present classifications.

Internationally, AM stations are classified as A, B and C. In order to conform as closely as possible to international classifications, certain subclasses of U.S. stations were combined into Class B and Class D stations. Class D stations are a special class of U.S. stations that don't have fully protected unlimited time operation. Because there is no international classification for such stations, Class D stations are notified as Class B facilities. (See Table 1 for chart classifications.) ■

Dateline

On Oct. 1, 1994, commercial radio and TV stations in the following states and territories must file their annual ownership reports or ownership certifications: Alaska, Florida, Guam, Hawaii, Iowa, Missouri, Oregon, Puerto Rico, Samoa, Virgin Islands and Washington. On or before Oct. 10, 1994, all radio and TV stations must place in their public files their listings of issues and responsive programming for the quarter ending Sept. 30, 1994.

Buy a digital camera or else.....

Or else you may be stuck with a camera left behind by digital technology.

As we all know, communications, video, information...everything is going digital. Isn't it time cameras did? Today's digital camera not only outperforms the best analog can offer but sets new benchmarks in video quality, features, stability and reliability. The days of the analog camera are numbered because digital offers too many advantages to be ignored.

With DIGITAL advantages such as a new video transparency, flesh tone detail to soften facial blemishes, precision detail correction, precision transfer of setups between cameras, a plug-in memory card to recreate exact setups of all cameras weeks or months later and serial digital outputs for D-1 or D-2/D-3 VTR's, now is the time to consider what all cameras will be...digital.

Introducing the *Digital SK-2600*

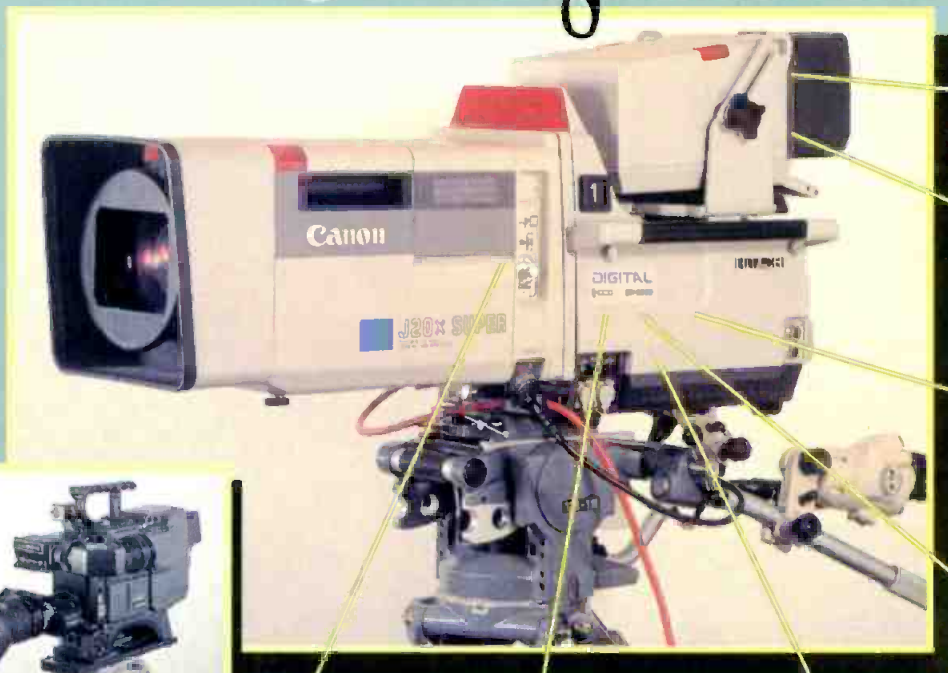

Unique PIP (Picture in Picture) Allows a second video source to be windowed with camera video in any of four quadrants or reversed with camera video

Separate H&V detail generator for viewfinder makes focus "pop" for camera operator

The Hitachi developed single LSI device provides full 13 bit digital processing for RGB video including detail and masking. Only Hitachi offers 13 bit video processing.

The 600,000 pixel CCD yields 900 TV line resolution and dramatically reduces aliasing. An optional, 520,000 pixel CCD is available allowing switching between 4:3 and 16:9 aspect ratios at the push of a button.

High performance Ultra-Band triax system (12MHz Green) or Field triax system for long cable lengths or Digital optical fiber system

Plug-in 6 position ND and CC filter wheels allow easy insertion of special effects filters



SK-2600P Portable Companion

- "No Diascope" internal automatic camera setup
- "Thru-the-Lens" automatic setup with standard grey scale chart

Network Users:
CBS TV City, Los Angeles
CBC Toronto, Canada

Call today for more information or a demonstration.

HITACHI

Hitachi Denshi America, Ltd.

New York	(516) 921-7200	Atlanta	(404) 242-3636
Los Angeles	(310) 328-6116	Dallas	(817) 488-4528
Chicago	(708) 250-8050	Canada	(416) 299-5900

Strictly TV

A look at 8-VSB

Reception

By Curtis Chan

Last month the discussion of VSB centered on the transmission side. This month we will look at the 8-VSB receivers. But first a quick look at the 8-VSB modulator.

The VSB signal is derived by generating two modulated signals in quadrature. The lower sidebands cancel one another when added together at the output while the upper sideband is retained. The same processing step also filters the modulating signal by adding predefined roll-offs near the channel edges and shapes the symbols. A SAW filter is then used to control the excess energy around the channel edges and in the adjacent channels. From here, the signal is upconverted and transmitted, then recovered with a receiver that might resemble the one shown in Figure 1.

In the receiver, the tuner is a high side injection double-conversion type with three local oscillators and a first IF frequency of 920MHz. The first LO and broadband tracking filtering are controlled by a microprocessor and determine which channel the receiver is tuned to. The second LO is controlled by a frequency and phase lock loop (FPLL) and is used in



with a 0dB or lower S/N ratio, even in the presence of heavy interference.

Sync recovery

The data segment sync signals are recovered with a narrow bandwidth filter. The segment sync detector creates a 10.762MHz reference data clock as well as an AGC control signal. The next step is the recovery of the data field synchronization. This is accomplished by comparing each received segment with an internal reference copy of the field sync segment.

The NTSC rejection filter is a comb filter used to create nulls at the frequencies corresponding to the NTSC visual and aural carriers and the color subcarrier. The filter provides seven nulls within the NTSC 6MHz bandwidth channel with each null being roughly 57Hz wide. The frequency nulls fall slightly off of the visual and aural carriers but fall exactly on the color subcarrier. Because more energy is centered on the visual and aural carriers, a carrier offset +45.8kHz in the ATV transmission spectrum can shift the signal so the nulls coincide more accurately with the carriers. Interference to the upper

EQ and data recovery

Equalization takes place after the NTSC rejection filter. The adaptive equalizer uses as a reference the pseudo-random sequences in the field sync intervals and compensates for echoes and frequency tilts in the channel response. The equal-

Prototype receivers can recover the carrier with a 0dB or lower S/N ratio, even in the presence of heavy interference.

izer will compensate for a variety of distortions that may plague the receiver, such as transmitter, antenna, path and receiver component distortions. The phase tracker removes additional phase noise that has not been removed by the IF PLL operating on the pilot.

From here, the signal goes through the

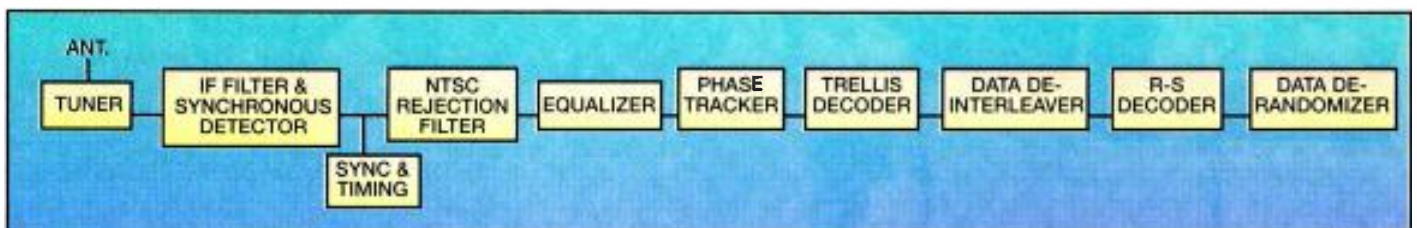

Figure 1. Block diagram of the possible layout of an 8-VSB receiver. Because of reduced interference problems, a 16-VSB cable receiver can be even simpler.

the second mixer whose output is the 44MHz second IF frequency. A third fixed LO is used as the reference for synchronous detection of the received signal. The frequency loop uses in-phase (I) and quadrature-phase (Q) pilot signals. Prototype receivers can recover the carrier

adjacent channel caused by this offset are minimal.

The receiver compares the received signal with and without the rejection filter and chooses the best signal path for optimal signal integrity because the filter degrades the noise performance of the system by approximately 3dB. A side artifact that is generated from the filter is intersymbol interference, which is caused by the signal delay through the filter.

trellis decoder, which operates in one of two modes: one for when the NTSC rejection filter is used and the other for when it is not. The signal is then de-interleaved. After de-interleaving, it is decoded using the Reed-Solomon decoder and de-randomized. At this point, the original bit-stream, or close approximation of it, has been reconstructed in the receiver.

Chan is president of Chan and Associates, a marketing consulting service for audio, broadcast and post-production, Fullerton, CA.

AirPlay.™

Tapeless commercial playback will make you an Avid fan.

Today, more broadcasters choose Avid AirPlay over any other disk-based playback system to replace their aging cart systems.

They're becoming Avid fans with good reason. AirPlay provides instant access to commercials, promos, and news stories. It's flexible and easy to use, so you can juggle playback schedules right up to the last minute. Even while playing to air.

AirPlay is scalable, allowing you to grow from single- to multi-channel playback. It handles up to 56 hours of online storage and offers multiple redundancy options, including RAID-3. AirPlay's unique architecture also eliminates single points of failure for exceptional reliability. "Make goods" are a thing of the past.

Fully compatible with Avid's online editing systems, AirPlay is the only disk-based playback system that can be

networked with your promo production and news-gathering operations. For maximum efficiency, it can also be integrated with your traffic and billing systems, automation systems, and newsroom computer systems.

With over 4,000 systems installed, Avid is the world leader in disk-based technology for recording, editing, and playback. Call us today. We'll help you become an Avid fan of AirPlay! 1-800-949-AVID (#2)

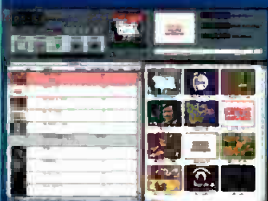

AirPlay's user interface is designed for quick and easy operation.



Avid is a registered trademark and AirPlay is a trademark of Avid Technology, Inc.

Avid Technology, Inc., One Park West, Tewksbury, MA 01876

Circle (20) on Reply Card

Management



Equipment acquisition

Acquiring the equipment

By Rick Morris

Part 1 of this series reviewed how equipment acquisition is primarily based on equipment replacement, equipment upgrade and technological changes. Part 2 discussed equipment acquisition as an opportunity to look for productivity increases. Now is the time to evaluate the equipment you wish to purchase.

Equipment evaluation

Equipment information and comparison is principally done through contact with manufacturers. This occurs at trade shows, such as NAB and the fall World Media Expo (the combined show of SBE, SMPTE, RTNDA and the Radio Show.) To many convention attendees the equipment exhibition is the best place to gather information and meet with manufacturer's representatives. Even more valuable is the opportunity to hear manufacturers and users discuss the latest technical developments in the technical sessions. Also, proceedings of the major conferences contain papers on issues that may be important to you. Paper reprints can be obtained from the manufacturer or author that presented it. Industry trade magazines, such as *Broadcast Engineering*, also do an excellent job of covering major issues in broadcasting.

Once you have enough information to narrow your choices, consider additional evaluation. Visit existing installations, ask the manufacturer for a demonstration or borrow the product for testing and evaluation in your own shop. On-site evaluation is important if you're making a major technology change. Include the operations and production staffs in the evaluation. It's a significant mistake to buy something based solely on technical performance if the equipment is operationally wrong for your facility.

Calculate operational costs for various pieces of equipment. For example, if media cost is higher for one piece of equipment compared to another, it may cost many times more to operate than any initial savings on equipment. Prod-

ucts that use consumable media should consider the media's cost. Also, investigate the requirement for maintenance spares and the cost that this may add to your purchase.

The purchase decision

The purchase decision will be driven by all of the factors discussed in this series.

- Will this piece of equipment allow you to achieve your goals/projections?
- Will this equipment lead to operational or maintenance savings?
- Will the equipment improve productivity?
- How does this equipment perform technically?
- What are the equipment's reliability and maintenance considerations?
- What are the ongoing operational costs of this equipment?
- Are there any special requirements for its use or installation?

Does the return on investment economically justify the purchase?

- What support and warranty does the manufacturer offer?
- Calculate the return on investment (ROI). Does the ROI economically justify the purchase?

After evaluating the questions appropriate for your situation, you'll be better able to make the correct decision.

Pre-design

Prior to the equipment purchase, your engineering staff should "pre-engineer" the installation. They should design the major elements of the installation. The staff should confirm equipment layout and requirements for ancillary equipment, such as distribution amplifiers and jackfields. They should also review man-

ufacturer's literature and technical manuals for installation requirements. With this preparation, you'll be assured of purchasing all the major components required to complete the installation. Also, review heat loads to determine if the HVAC is sufficient. Check floor loading specifications if the equipment is heavy. Money should also be reserved for "project contingency," to purchase items that slip through the best-laid plans.

Implementation

Once your equipment arrives, you'll begin installation. But, the time between the order and the arrival of your equipment should be used for final and detailed engineering. This will include rack layouts, cable schedules, single-line functional diagrams and connector wiring. You'll need equipment manuals for this and most manufacturers are glad to ship their manuals with an order. Order connectors and cable. Pre-wire as much as possible. If you're using a systems contractor to install equipment, use the time to review and approve their plans.

Project reconciliation

Keep records of the projections that you made and look at the goals you set. Did the equipment bring the desired results to your station's operation? Perhaps the goals were an increase in productivity through combining jobs, and decreasing machine downtime. How many man hours are you now saving? How many lost commercials are you saving because of more reliability? How much maintenance time are you saving? Has the return on investment met your projections?

Successfully meeting your goals and sharing these successes with your boss can lead to enhanced credibility and respect. And this can pave the way for future capital for equipment purchases.

Next month begins a new series on employee training.

Morris is an assistant professor of radio/TV/film at Northwestern University. He is a former chief engineer and a former manager of engineering and maintenance for a major TV network.

MAKE A CLEAN SWEEP WITH PORTABLE ONE



Replace the clutter on your audio test bench with the Portable One Plus from Audio Precision. With one instrument you can make 12 different audio measurements. All in a test set designed from the start with 2 channel level, crosstalk and phase measurement capability.

Use the unique AC Mains check function for monitoring power line problems and the built-in wow & flutter meter for measuring analog tape & disc.



The Portable One Plus is built to Audio Precision performance and durability standards... so you know you'll get the same superior performance in the field as on the bench.

Clean sweeps are a breeze with the graphic sweeping capabilities of the Portable One Plus. Plot amplitude or level (stereo), phase or distortion versus frequency.

The graph may be rescaled after a sweep, and the graphic cursor with numeric readout gives you data readings for each measured point.

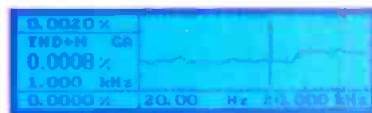

Connect a dot matrix printer for hard copy printouts of both graphs and tabular data, as well as instrument panels and bargraphs.



The Portable One Plus... the single instrument solution for both your bench and portable audio testing.



Audio precision

P.O. Box 2209, Beaverton, OR 97075-3070
 (503) 627-0832 FAX: (503) 641-8906
 US Toll Free: 1-800-231-7350
 Circle (6) on Reply Card

INTERNATIONAL DISTRIBUTORS: **Australia:** IRT Electronics Pty. Ltd., Tel: 2 439 3744 **Austria:** ELSINCO GmbH, Tel: (1) 815 04 00 **Belgium:** Trans European Music NV, Tel: 2 466 5010 **Brazil:** INTERWAVE LTDA., Tel: (21) 325-9221 **Bulgaria:** ELSINCO, h.e. Sirelishtie, Tel: (2) 59 61 31 **Canada:** GERRAUDIO Distribution, Tel: (416) 696-2779 **China, Hong Kong:** A C E (Intl) Co. Ltd., Tel: 424-0287 **Croatia:** AVC Audio Video Consulting, Tel: (41) 624 622 **Czech Republic:** ELSINCO Praha spol. s r.o., Tel: (2) 49 66 89 **Denmark:** nph Elektronik aps, Tel: 86 57 15 11 **Finland:** Genelec OY, Tel: 77 13311 **France:** ETS Mesureur, Tel: (1) 45 83 66 41 **Germany:** RTW GmbH, Tel: 221 70913-0 **Greece:** KEM Electronics Ltd., Tel: 01-6478514/5 **Hungary:** ELSINCO KFT, Tel: (1) 269 18 50 **India:** HINDITRON Services PVT, Tel: 22 836-4560 **Israel:** Dan-El Technologies, Ltd., Tel: 3-6478770 **Italy:** Link Engineering s.r.l., Tel: 0521/648723 **Japan:** TOYO Corporation, Tel: 3 (5688) 6800 **Korea:** B&P International Co., Ltd., Tel: 2 546-1457; B&P (Kumi Office), Tel: 0546 53-7347/8 **Malaysia:** Test Measurement & Engineering Sdn. Bhd., Tel: 3 734 1017 **Netherlands:** Heynen b.v., Tel: 08851-96300 **New Zealand:** Audio & Video Wholesalers, Tel: 7 847-3414 **Norway:** Lydconsult, Tel: (47) 66-988333 **Poland:** ELSINCO Polska sp. z o.o., Tel: (22) 39 69 79 **Portugal:** Acultron Electroacustica LDA, Tel: 1 9414087/9420862 **Singapore:** TME Systems Pte Ltd., Tel: 747-7234 **Slovakia:** ELSINCO Bratislava spol. s r.o., Tel: (7) 784 165 **South Africa:** SOUND FUSION Broadcast, Tel: 11 477-1315 **Spain:** Telco Electronics, S. A., Tel: 1 531-7101 **Sweden:** Tai & Ton Elektronik AB, Tel: 31 80 36 20 **Switzerland:** Dr. W.A. Gunther AG, Tel: 1 910 41 41 **Taiwan:** R.O.C.: Cha Wei Electronic Trading Co., Tel: 2-5612211 **Thailand:** Massworld Company Ltd., Tel: 662-294-4930 **United Kingdom:** Trubly Trandar Instruments, Ltd., Tel: (0480) 412451

Production



Production test equipment

Digital solutions

By Jeff Noah

Video production with digital equipment should be identical to production in an analog environment, as long as the equipment is properly installed and operating correctly. For monitoring levels and making other operational adjustments, traditional analog displays from units with digital inputs work well. Installing and troubleshooting digital production gear, however, requires a different tool set and approach.

Digital tools

Attempting to determine the cause of an equipment or transmission path problem in a temporary digital production system by viewing a traditional video waveform is not effective. In fact, many digital system problems result in no video waveform at all. It's the digital signal itself that must be analyzed.

Examining high-bandwidth digital signals requires specialized tools to scrutinize jitter, eye height, clock frequency and other parameters. Unfortunately, the typical oscilloscope found in a video facility doesn't have the bandwidth needed for this application. Also, serial digital receivers use a SMPTE-specified time base and triggering methodology. To get an accurate and meaningful look at the digital signal, the analysis tool must meet the SMPTE criteria.

Digital systems can operate close to the point of failure with no visually apparent problems.

It takes two specialized devices to proof a fresh installation or minimize the time spent tracking a problem that's holding up a production: a digital analyzer and generator. The analyzer, unlike its analog counterpart, the waveform/vector monitor, doesn't necessarily need to display

Noah is a technical writer for the Tektronix Television Division in Beaverton, OR.

the signal. It does, however, need to lock to the signal and analyze and display the data it contains and the parameters already mentioned.

Digital generators must provide signals to stress a new installation, thereby making sure the installed equipment will operate reliably under normal circumstances. Digital systems can operate close to the point of failure with no visually apparent problems. Stress testing ensures the digital system, both the equipment and transmission path, is not operating too close to the edge of its limits. For tracking down the various types of problems peculiar to digital video systems, a generator must also provide a complement of specific digital signals. An additional set of signals should be available to confirm correct operation of equipment used to transfer the digital signal back to an analog composite format.

Problem sources

Problems in digital video systems can be separated into three categories. First, is transmission path problems, where the correct signal is being sent, but for some reason it is distorted and cannot be recovered by the receiver. The second category is format problems, where the digital data being sent isn't formatted correctly or isn't what the receiver expects. The third is equipment malfunctions. Some of the possible faults from each category are more likely to occur than others during a production in an established facility where no new equipment is being installed.

Transmission problems can stem from a bad cable or connector, improperly terminated lines, too long a cable run, or an open, shorted or wrong impedance segment of cable patched into the transmission line. With the exception of too long a cable run, any of these problems could occur at inopportune times in a mature digital facility. Most likely is a disruption to the line at a patch panel.

Connecting just one end of a patch cord into a digital transmission line could have the effect of grounding the signal when working with the high data rates used in digital video. A digital receiver that pro-

vides any eye pattern or an eye height indication will tell you how badly a signal is attenuated or distorted. As in analog systems, you'll need to inject a test signal of known parameters to provide a standard for comparison.

The same digital receiver/analyzer can help identify difficulties arising from format problems. Although not common in existing facilities, format problems can be troublesome any time equipment is installed. Possible format problems include equipment set for the wrong line/field rate or for the wrong component or composite format. A digital analyzer can also warn of illegal data values and check for the correct use of reserved data values.

Equipment malfunctions can produce format problems or the same symptoms as transmission problems. Conventional troubleshooting techniques are helpful, but work only with the correct digital tools.

A serial generator supplying stressful but legal signals can help identify marginal performance in system components. Modern hand-held generators include Serial Digital Interface (SDI) checkfields to test equalizer and clock recovery circuitry, a variable launch amplitude to test a receiver's equalizer, and a 50-meter simulated cable element for testing transmission path headroom.

Do digital

The superior quality of digital video formats and the reliability of serial transmission systems continues to draw attention whenever equipment is being replaced or new installations are being equipped. Although operational monitoring remains basically the same as in analog, the equipment needed to install and proof a digital production setup has changed. Equipped with the right tools and an understanding of the potential difficulties, you can ensure that digital productions deliver all the benefits promised by digital technology. ■

➔ For more information on digital test equipment, circle (301) on Reply Card. See also "Test & Maintenance Products," pp. 72-74 of the BE Buyers Guide.

Finally, technology has caught up to your imagination.

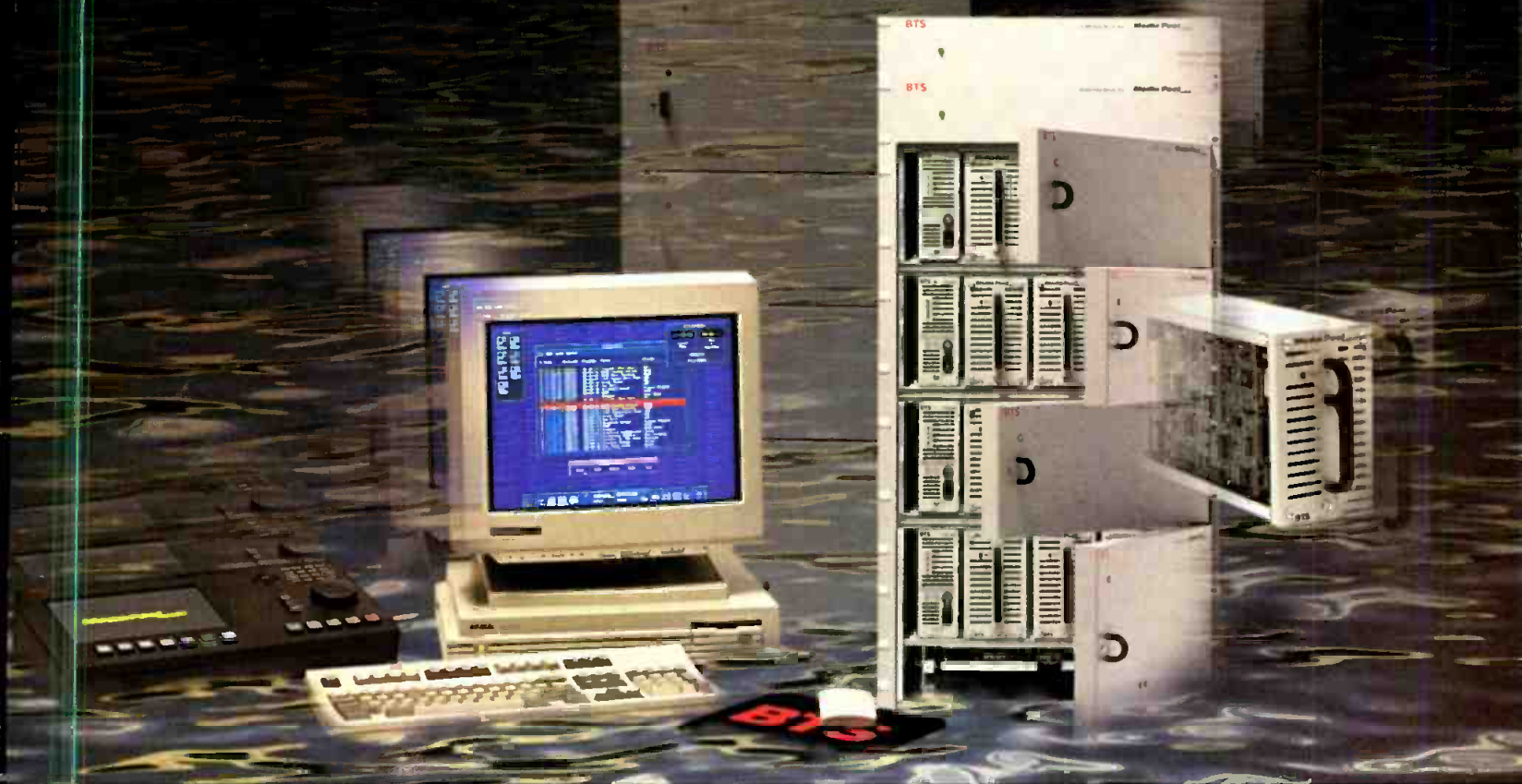

Media Pool for Broadcast

Imagine putting the finishing touches on a news story moments before the director calls for it - or even editing the ending while the beginning is being aired.

Imagine editing a commercial spot minutes before traffic has it scheduled - it's as if you could edit inside your cart machine.

Imagine having all video and audio media available simultaneously - wherever and whenever it's needed.

Imagine a system where quality is never compromised - component digital video and better than CD audio quality.

Imagine recording full bandwidth, or using our variable compression option - choose the level of space-saving DCT compression - 2:1, 3:1, 20:1, you name it - every time you record.

Media Pool gives you the storage, the common access, the bandwidth, the resource management tools, the interfaces, and the video know-how to turn your imagination into reality.

BTS

Call toll-free (800) 962-4BTS
Outside the U.S. and Canada,
call (805) 584-4700

A PHILIPS COMPANY

Troubleshooting

Industrial computers

Maximizing PC system performance

By Mike Vaughn

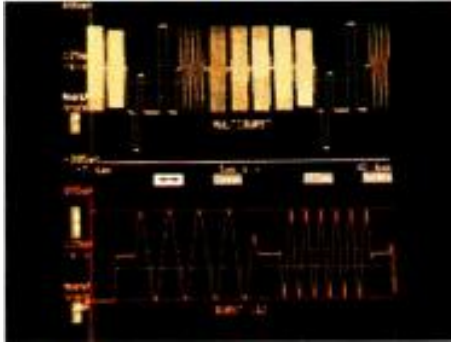

This month's installment considers maximizing system performance, primarily concerning developments in processors and popular local bus architectures. This should help inform your decisions on the platforms and architectures that are most appropriate and cost-effective for your applications

The first major development, Intel's 66MHz, 64-bit *Pentium*, offers 70% more processing power than maximized 486 systems, but its lack of pin compatibility with current 486 chips makes upgrading existing office-style motherboard systems almost impossible. (Passive backplane-based industrial PC systems are different, as explained later.) As a band-aid, Intel's new 32-bit P24T offers users significantly more power, plus pin compatibility with the 486s. It's only a half-step, however, and users who want Pentium power have to bite the bullet and upgrade to the real thing. Pentium plug-in CPU cards are available for industrial users. A few ruggedized PC vendors are already selling units that are compatible across a range of bus architectures and operating systems, including DOS, Windows, Unix, OS/2 and Windows NT.

Apple/IBM/Motorola's *PowerPC*, the second major new development, is moving aggressively into the low-end personal systems market, and will soon branch into other market sectors. Touting superior size/performance advantages over Pentium, *PowerPC* boasts that it will bring workstation-like performance to low-cost PC systems. *PowerPC*'s integer performance is equivalent to Pentium's, but the 40% better floating-point performance of *PowerPC* will help for graphics, video, spreadsheets and other applications. The *PowerPC* also runs cooler (8.5W vs. 16W) and costs less.

The third major contender is the first microcomputer chip to be classed as a supercomputer. Systems based on Digital Equipment Corporation's (DEC's) *Alpha* CPU will provide a speedy platform for imaging, multimedia, simulation and

voice-recognition applications in broadcasting, telecommunications and other industries. This 150MHz, 64-bit super-scalar chip can simultaneously execute multiple independent instructions at the rate of 300 million per second (MIPS). The Alpha offers a quantum leap forward in performance and an open architecture that can run everything from PCs to embedded controls and data centers, across a broad spectrum of buses and operating systems. The first PC system to use this engine, the DEC AXP, is already shipping. Running Windows NT, AXP offers twice the performance of Pentium for about the same price. In number-intensive applications Alpha is estimated to run up to 10 times faster than 486-based PC systems.

Local bus architectures

The Video Electronics Standards Association (VESA) local bus continues to be a stop-gap measure with limited board development and inconsistency between manufacturers. The typical VESA board may work in one slot but not another in

A good, universal rack-mount PC system is more easily upgraded than an office PC.

the same chassis; or it may work in one manufacturer's VESA slot but not in another's. Overall reliability and compatibility remain highly questionable.

On the other hand, the 32-bit Peripherals Component Interconnect (PCI) local bus allows a variety of plug-in cards to be used successfully and consistently with an assortment of external devices, via Ethernet, token ring, FDDI, ATM and other interconnection schemes. Developed by Intel along with DEC, IBM and Apple, PCI is more noise-immune than VESA — a significant advantage in broadcasting and telecommunications. Because the PCI bus interfaces a platform's processor and memory as a combined unit to everything else (backplanes, peripherals and SCSI controllers), there is no limit to what

you can hook up. Additionally, a PCI bridge, now under development and testing at DEC, will further expand the PCI bus to allow even more capacity.

As for PS/2, it lacks the PC bus's flexibility and depth of product because of the strict controls placed on it by IBM and its licensees. It should therefore be avoided. Other specialized buses, such as VME or PCXI are too expensive because the sales volume — which drives prices down — just isn't there, and users who don't need all the specialized bells and whistles are just throwing money away.

The most market-driven bus in the industry, the Industry Standard Architecture (ISA) bus, also has a spin-off — Extended ISA (EISA) that offers some advantages. Where throughput is important, EISA's 32MB/s transfer rate may be more appropriate than ISA's 8-11MHz bus rate. PCI can also be considered a descendant of ISA, and its 132MB/s transfer rate may be even more useful. The major beneficiaries of faster-throughput buses are video and disk storage functions. EISA is finding a lot of use in network file-server applications, and PCI promises to be even better.

So how does all this affect you?

A good, universal rack-mount PC system is easier to upgrade than an office PC because the latter usually has little unused space and is hard to get apart. The industrial rack-mount chassis could store an EISA, ISA or PCI backplane, a motherboard or a RISC-based system. A rack-mount ISA-bus PC that was purchased six years ago can be easily upgraded today because a Pentium plug-in CPU card uses the same AT connectors. Consider the savings gained by using the same rack equipment and passive backplane when upgrading. For this reason, the question of service life applies more to the office-style system. With the industrial PC, you simply install a different backplane bus, plug in the power supply, and the upgrade is complete.

Next month's column will consider methods of maximizing PC-system reliability.

Vaughn is product marketing manager at Industrial Computer Source, San Diego. Respond via the BE FAXback line at 913-967-1905.

The Only Thing It Can't Do Is Open A Bottle Of Wine.



Telex V-Series headsets do it all. Their unique modular design make them the most versatile headsets you can buy, with interchangeable mic and cable assemblies that let you use one headset for most any application.

Comfort and sound quality are second to none, with revolutionary floating earcups that automatically adjust to any head size. And, like our other Telex headsets used by pilots and NFL coaches, the durability is built in. Of course, parts and accessories are easy to get and always available.

See and hear for yourself. For the Telex pro audio dealer nearest you, call 1-800-392-3497 (416-431-4975 in Canada).

The V-Series. Maybe we should have called it the swiss army headset.



The V-Series headsets, models V-220 and V-210

Made with pride in the USA.

©1994 Telex Communications Inc.

TELEX

Circle (8) on Reply Card

www.americanradiohistory.com

Technology News



Hard drives

By Curtis Chan

For non-linear editing and computer-based systems, hard disk technology is a technological miracle and a lesson in humbled arrogance. One of the keys helping to bring about this dramatic shift toward alternative storage mediums is head technology.

Gains in capacity, latency and transfer rate are the hallmarks of every new generation of hard disk drives. However, head technology is also making a strong contribution. Three main recording head technologies are in use today: ferrite, thin film and magneto-resistive (MR). Let's talk about each briefly and take a glimpse at the future.

One way to improve drive performance is to fly the head as close to the magnetic medium as possible.

Ferrite systems

Ferrite technology is the oldest and uses monolithic and composite ferrite heads comprised of a wire-wrapped ferrite core. The latest generation uses a technique known as metal-in-gap (MIG) and double metal-in-gap (DMIG). MIG uses metal sputtered in the recording gap on the trailing edge of the head. MIG's higher-density recordings come from the highly permeable and not easily saturable metal that creates a sharp gradient of the magnetic field at the trailing edge of the gap, resulting in a well-defined record pulse.

About a year and a half ago, DMIG was developed by adding additional magnetic material to the head. It was found to improve head signal response without altering the flying head height. This head technology is popular with the 100-200MB drives, but may well have seen its last

days as newer thin-film and MR head technologies push capacities upward using the same form factor.

Thin-film

With roughly 500MB from two platters on a 3.5-inch form factor, thin-film technology is becoming the mainstay for the current generation of hard disk technology. Employing production processes similar to those for semiconductors, thin-film technology permits stringent control geometry and wider design freedom. Through sputtering, thin film heads offer an extremely small controlled gap area that results in 2,500tpi (tracks/in.) and better. Also, because of their low inductance and impedance characteristics, higher write frequencies can be used, again resulting in higher capacities.

These attributes may well push this technology beyond the capabilities of ferrite and (D)MIG in the near future. New manufacturing processes may decrease head size from a mini-size head to micro or nano-size. When this is economically realized, Gigabyte level drives using actuators operating over several high-speed platters will become as commonplace as today's 100-200MB versions.

Magneto-resistive heads

In the continuing quest to achieve higher drive capacities, companies are using a new head technology on 2.5- and 3.5-inch form factor units. The magneto-resistive (MR) head operates by using a strip of nano-sized magnetic material in the read gap whose resistance is sensitive to magnetic flux. As the head's resistance is modulated in proportion to the magnetic flux from the spinning disk, the readback signal is created. The change in resistance affects the bias current running through the strip. In addition, MR heads have two independently optimizable gaps, one read and one write. This dual gap allows for wide write/narrow read capability. This feature can be optimized for better off-track capability at higher tpi specifications.

However, MR heads present some new engineering challenges. In order to produce higher performance gains than thin-

film technology, MR uses a different specification for the magnetic properties of thin film media as well as requiring changes to pre-amp/servo and firmware. This is because the dual head construction requires a new way of thinking to address the issue of servo patterns.

Future technologies

The newest frontier in head technology focuses on a development called *contact recording architecture*. One of the ways to improve drive performance is to fly the head as close to the magnetic medium as possible. Typically, drives use either an air bearing or the not-so-popular liquid bearing to sustain the gap between the head and platter. Typical glide heights between the head and platter are in the order of two micro inches. This sounds quite large until you consider that a human hair with a diameter of roughly 3,000 micro inches can potentially cause catastrophic damage to the head with a disk spinning at 5,400-7,200rpm.

The new contact recording technology under development promises to do away with air or liquid bearings completely. It uses an ultralow mass contacting assembly and will be initially available for small form factor drives like PCMCIA types. The heads will be produced monolithically on a wafer. The transducer assembly will be thin film, but with an alumina dielectric. Also, the heads will use vertical recording techniques rather than horizontal to extract the highest capacity possible from the media. The head's mass and the force of contact from the head to the newly developed media has also been taken into account and no damage is the intended goal along with average 3ms seek times. When fully developed, units will be able to fully record from the inner diameter, thus eliminating the current standard non-recordable parking area.

As hard drive technology continues to improve, look for higher-capacity drives in smaller form factors, both of which will expand potential uses for the broadcast and post-production environments.

Chan is president of Chan and Associates, a marketing consulting service for audio, broadcast and post-production, Fullerton, CA.



We design your **studio ceiling**, the complete **lighting equipment**, **suspension systems** (motor-driven or manual operation) as well as **positioning** and control systems – all with Sachtler products!

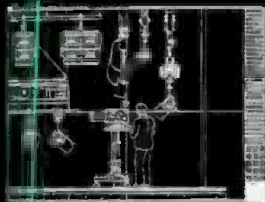

Why don't you write us or give us a call? We are happy

to provide you with detailed **information**.

Eastern Europe: Sachtler Vertriebsgesellschaft

m.b.H., Germany, Segelflieger Damm 67, 12487 Berlin,

Telephone (0 30) 6 36 43 11, Fax (0 30) 6 36 34 66

Headquarters: Sachtler AG, Germany, Gutenberg-

straße 5, 85716 Unterschleißheim bei München,

Telephone (089)32158200, Fax (089)32158227.

Telex 5 215340 sac d

U.S.A.: sachtler® corporation of

America, New York office: 55, North

Main Street, Freeport, N.Y. 11520, Phone

(516) 8 67-49 00, Fax (516) 6 23-68 44

アミック ザハトラー株式会社

Japan: Amic Sachtler Corp.

東京都世田谷区三軒茶屋

1-2-21 〒154

電話 (03)3413-1212

Fax (03)3413-0888

Lighting and Studio Technology

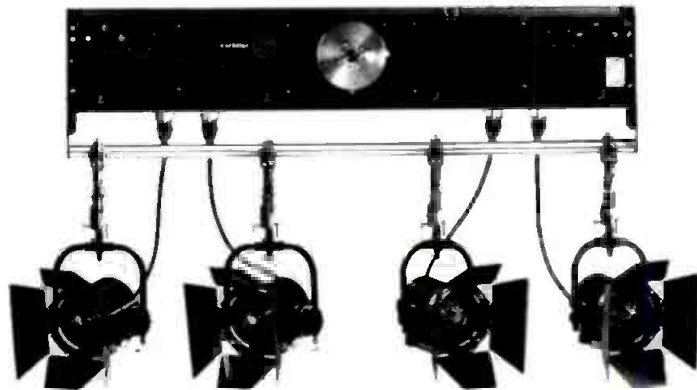

sachtler

Support & Lighting

You can't miss us: IBC, Amsterdam, Sept. 16-20, 1994, Hall 8, Stand # 8341
Photokina, Cologne, Sept. 22-27, 1994, Hall 14.2, Stand C8 (Eucam booth)

Circle (9) on Reply Card

Continued from page 4

areas, paying regulatory fees greater than the fees paid by the licensees of stations in the largest TV markets.

Furthermore, NAB argued that satellite stations function as translators, fulfilling their programming and public service obligations almost entirely through the programming of their parent station. Therefore, they impose virtually no independent regulatory burden on the FCC.

NAB reaction to NII recommendation on performance rights

In a statement from Jeff Bauman, general counsel and executive vice president of the National Association of Broadcasters, they appreciate the personal support of Commerce Secretary Brown. He favored an exemption for broadcasters from new performance rights legislation being considered by Congress. However, NAB is disappointed that the NII working group still wants to impose a performance

right on broadcasters.

According to Baumann, the administration's position undermines American business interests. It places a higher priority on advancing the interests of a largely foreign-owned recording industry over 11,000 American owned-and-operated radio stations.

Further development of the information superhighway is an important task, but the administration's report fails to explain why imposing a performance right fee on broadcasters needs to be one of the rules. Broadcasters don't provide the type of pay-to-use, commercial-free and easy-to-copy digital music services that allegedly threaten record sales. A performance fee shouldn't be imposed on broadcasters if others threaten record sales in tomorrow's digital world.

Broadcasters already pay more than \$300 million each year in music licensing fees, so NAB feels there is no need for record companies or performers to charge broadcasters for publicizing their

recordings. Also, imposing such fees will do nothing to help implement NII.

EIA praises FCC action on cable compatibility rules

The Electronic Industries Association's Consumer Electronics Group (EIA/CEG) has praised the new cable compatibility rules issued by the Federal Communications Commission (FCC).

The decision essentially requires cable systems to provide a uniform signal so that consumers who buy cable-ready sets will be able to use features on their TV sets. In addition, millions of consumers will not need cable converter boxes and will be able to buy cable products from local retail stores.

J24WHF Series Serial/Digital Patch Jacks

PREMIUM Normal-through video patch jacks that meet present and future broadcast standards!

Trompeter's J24WHF series 75Ω patch jacks provide an extended band width up to 360Mbits (720 MHz) with a typical return loss of ≥ 40dB through 720MHz. They meet and exceed present and proposed analog and digital standards.

24WHF and J24WTHF-75 (self-terminating)



The J24WHF Series also offers:

- Greater reliability.
- 2.5 lbs. minimal withdrawal force to eliminate accidental removal.
- Long life, low contact resistance, consistent contact force.
- Superior dielectric and electrical contact properties.
- 100% compatibility with existing patch plugs, looping plugs and support equipment.

Trompeter's premium quality patching products and connectors are your best investment for ultra-high quality, reliable broadcast component performance.

Quality doesn't cost...
It pays.



31186 La Baya Drive • Westlake Village CA 91362
(818) 707-2020 • Fax (818) 706-1040

Contact your local representative or call us toll free - (800) 982-2629 for sales, service or technical support.

Now Available to Developers and OEMs

Digital Video Building Blocks

Choose the pieces you need to build **your** application.

- Broadcast-quality Digital Video
- CD-quality Digital Audio
- Realtime, 60 Field Motion-JPEG
- Industry-standard DV MCI Software Toolkit
- GUI Accelerator with Live Video
- 32-bit Videographics
- DVE, Switching, Mixing, Keying
- Nonlinear Random Access
- Machine Control
- TI MVP Array Processor



Digital Video Building Blocks deliver the superior performance required in demanding applications like: nonlinear editing, multimedia authoring, automated broadcast spot insertion, video-on-demand servers, instant access nonlinear VTRs, scientific visualization and simulation, medical image enhancement, professional multimedia kiosks, and video teleconferencing.

We know the Digital Video Building Blocks work. We've used them to create two blockbuster products of our own — Matrox Studio, the only desktop video editing system with nonlinear productivity and linear production power combined and Matrox Animation Xpress (MAX), a professional realtime digital animation recorder.

Tap into our expertise. Some of your competitors are probably using these tools. You owe it to yourself to check out our PROVEN state-of-the-art hardware and the best software development tools in the business.

To speed your product to market, Matrox Digital Building Blocks are backed by the outstanding technical support team that has made Matrox a leading supplier of graphics, video and imaging solutions to OEMs the world over.

For more information call 1-800-361-4903 or (514) 685-2630

Matrox is a registered trademark and Matrox Studio, Matrox Digital Video Building Blocks and Matrox Animation Xpress are trademarks of Matrox Electronic Systems Ltd.
Matrox Electronic Systems Ltd.
1055 St-Regis Blvd., Dorval (Quebec) Canada, H9P 2T4
Fax: (514) 685-2853

matrox
≡ VIDEO PRODUCTS GROUP ≡

Circle (21) on Reply Card

The production

With extra capability, your station can outshine the competition in local production.

“There is gold in them thar hills” might be the cry for local broadcasters. Many TV stations and cable systems have rediscovered an important key to survival: local production.

For cable systems, that usually means all new facilities. While they may have the RF system in place, the equipment needed to produce and record newscasts and local programs often does not exist. It's like building a small TV station. Eleni Zuras Tsigas guides you through the conceptual and design process when building local origination capability into your cable system. The article will answer many of your questions on getting started—and prevent costly mistakes.

For TV studios, replacing cameras often means replacing the lighting



environment

system. New CCD technology allows for lower operating light levels, which benefits both facility and talent. Choosing the appropriate technology for your new lighting system requires careful thought. Helpful guidance lies in "Upgrading TV Studio Lighting."

The battle for your editing dollar continues to heat up as manufacturers of both approaches bring new solutions to market. Before you make any decision, learn about the options and pitfalls in the two articles "Non-Linear Editing Systems" by *Broadcast Engineering* magazine's Digital Media Lab director, David Leathers, and "Linear Editing Systems" by consultant Curtis Chan.

Finally, anyone who has used wireless microphones knows they can be both a blessing and a disaster. Often the difference lies in how the microphones are used. Author Glen Ballou provides detailed answers on the proper use of wireless mics.

Many solutions to your cable or TV studios' production needs lie just ahead. Read on.

Brad Dick

Brad Dick, editor

- "Cable Production"page 26
- "Non-Linear Editing Systems" 40
- "Linear Editing Systems" 48
- "Upgrading TV Studio Lighting" 52
- "Production Facility Software" 62
- "On-Line Captioning Systems" 70
- "Audio Data Compression 101" 78
- "Wireless Microphone Technology" 92

**THE FACT THAT OUR COMPETITORS
ARE SUDDENLY PUSHING S-VHS
IS A SURPRISE TO EVERYONE,
BUT US.**



BR-S822U

GY-X2

BR-S822U



JVC
PROFESSIONAL

At JVC, we figured it would only be a matter of time. And now that other video manufacturers have jumped on the bandwagon by making an even bigger commitment to S-VHS, they've confirmed that S-VHS is truly "the format of choice."

But as all videographers know, a duplication is never as good as the original. That's why so many of them have turned to JVC's S-VHS. As the originator of S-VHS, JVC has invested all of its energies into just this one format. Year after year, this intense product commitment has enabled us to offer exactly what was needed: a broad spectrum of innovative acquisition and editing products, incredible flexibility for easy upgrading, superior

workmanship for excellent picture quality and utmost reliability, and tremendous forethought to affordability. It's for these reasons that we've managed to consistently increase our loyal customer base, which is the reason that our biggest competitor has even gone S-VHS. Our customers know who built the "wagon," and those

who are merely going along for a ride. But from all of us at JVC, we'd still like to thank our competitors for their support.

For additional information on JVC PROFESSIONAL PRODUCTS, or for the name of your nearest JVC dealer, please call 1-800-JVC-5825.

A CHRONOLOGICAL HISTORY OF JVC'S DEDICATION TO S-VHS.

- | | |
|---|---|
| 1987 – Developed and introduced the revolutionary S-VHS format. | 1993 – The first full-size S-VHS 3-CCD camcorder, the GY-X2. |
| 1988 – The 10 Series, our first professional S-VHS editing and acquisition. | – The BR-S422, the lightest docking portable recorder. |
| 1989 – The 11 Series, a professional S-VHS system with refined and upgraded editing and acquisition capabilities. | – The world's first and only variable tracking S-VHS player, the BR-S525. |
| 1991 – The first S-VHS-C 3-CCD camcorder, the GY-X1. | – Advanced DNR with motion compensation. |
| 1992 – The 22 Series, JVC's most sophisticated professional S-VHS editing. | 1994 – "The Edit-Desk System," the most affordable S-VHS system with time code. |
| | 1995 – The world will just have to wait. |

JVC S-VHS. The Original, The Best.

Circle (22) on Reply Card
www.americanradiohistory.com



Cable production

Through quality in-studio and remote production, cable can bring programming closer to home.

By Eleni Zuras Tsigas

The Bottom Line

Now, with the onset of hundreds of channels of programming cable will soon offer, viewers will be glued more than ever to their couches and remote controls. Losing touch with the local community is a concern for subscribers. Local origination (LO) can bring the community closer to home. And, in the process, become a profit center by providing more than just "homegrown" programming to its viewers. One cable company shares advice on how it started in the LO business, and what it took to plan such a facility.



Cable programming has already begun to undergo the drastic expansion that has been promised (or threatened) for years. As cable systems prepare to offer subscribers 500 channel choices — an overwhelming selection — the average viewer finds more excuses to stick closer to his couch and remote control, and moves farther and farther from his surrounding community. The information superhighway enables us to stay closer to home, perhaps never leaving in order to accomplish the most rudimentary tasks. Therefore, the need for community programming becomes greater than

ever, lest we lose complete touch with our neighbors and the world around us.

Cable companies are in the unique and enviable position of providing that local "homegrown" programming that brings our "real world" to the only spot we're guaranteed to access it...on our TV sets. The cable company provides a wonderful and much-needed service to its subscribers and, in turn, gains a more positive public image. It's called *Local Origination* (LO). This article will outline the planning and technical considerations that a cable company needs to get into the LO business.

Justification for LO business

Business is the operative word. This is not just about cable programming or pro-

Tsigas is public relations manager for Montgomery Community Television, Montgomery County, MD.



The control room at Montgomery Video Productions helps support a full-service production facility for the Montgomery Community Television cable system. The production capability of many cable systems now approaches that of smaller-market TV broadcasters.

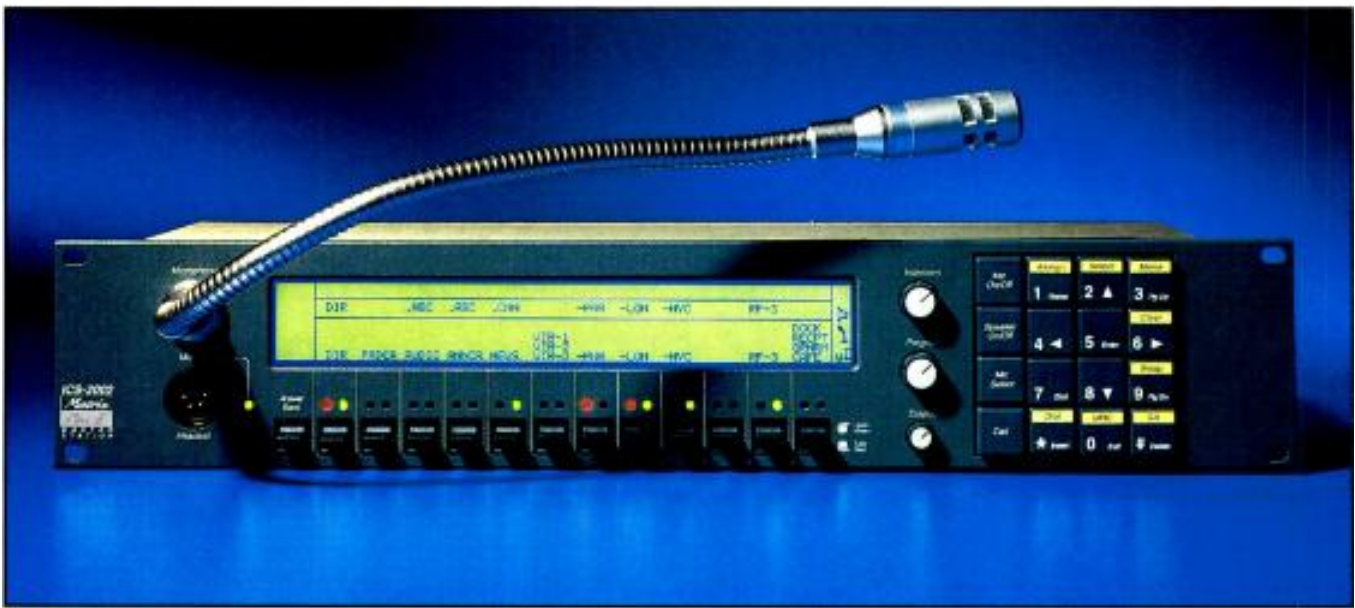

The ICS-2002 Visual Display Control Station.

Your Station Needs This Station.

TV stations around the world choose the ICS-2002 when they want the most **powerful** intercom station available: its backlit supertwist display screen identifies key functions and puts system-wide programming capabilities at your fingertips.

Flexibility is just one of the reasons that the Matrix Plus II intercom system is the new **industry standard** for high-performance intercoms.

With a wide variety of stations, interfaces and



Prefer Push-Buttons? Choose the new ICS-2102 Master Station

accessories, the Matrix Plus II makes all of your communications

easy and trouble-free.

The system is **fully integrated**, with built-in IFB and a comprehensive modular interface system that neatly ties together cameras, two-way radios, telephones, and party-line intercoms. And it comes with the highest level of service and support in the industry.



The Matrix Plus II connects instantly to all intercoms.

From two to one-hundred stations, there is a Matrix Plus II system that will fit your needs and your budget. Want all the details? Call us at 510-527-6666.

Matrix Plus™ II
FROM CLEAR-COM INTERCOM SYSTEMS

© 1994 Clear-Com Intercom Systems.
Matrix Plus II is a trademark of Clear-Com.

Domestic Sales: Clear-Com Intercom Systems
945 Camelia Street, Berkeley, CA 94710.
Tel: (510) 527-6666, Fax: (510) 527-6699

Export Division: Clear-Com International
PO Box 302, Walnut Creek, CA 94597
Tel: (510) 932-8134, Fax (510) 932-2171

Circle (23) on Reply Card

www.americanradiohistory.com

duction. From the onset of planning, management must have the mindset that the LO operation is a profit center, which is distinct from the core business of distributing signals from other program providers. Local origination is not just about more cable programming.

Montgomery Community Television (MCT), one of the most extensive community TV companies in the country, has many missions including local origination, public access and client production services. Although it is not the local cable franchise holder, MCT does engage in many of the typical services that the LO operation of a cable company would pursue. Thus, it is called upon to serve as a learning model — for what is right about our LO operation and what could be better. Scattered throughout this article are the lessons we have learned, so take heed.

Planning

In order to alleviate future major problems, several factors need to be addressed in the early planning of a LO facility. Elements,

such as the market to be served, programming goals, personnel resources, hours of operation, available capital and future annual budgets need to be considered.

Research the demographics of the cable subscribers that will be served by the LO channel. Socio-economic status, education level, age and sex, and political affiliations all contribute to the commu-

nity-mindedness of the viewers and their programming interests.

For instance, Montgomery County, Maryland, where MCT operates, lies in the shadow of Washington, DC — one of the most influential cities in the world. Broadcast news and public affairs TV coverage focuses almost exclusively on downtown DC, national or international news. This greatly shortchanges the distinct and unique programming needs of our fairly wealthy, educated suburban population. Local politics are a key concern to what is a relatively high percentage of civic activists and politically in-tune residents. High school sports are exceedingly important to our large population of young and growing families. Other cable companies serving a suburban population would do well to examine the unmet needs of a community often living as a neglected stepchild of a larger metropolitan area.

Cable companies operating in more rural areas have different, but equally important, programming challenges. They must pro-



Locally originated programming by cable systems is increasingly important to the bottom line. A simple set like this one can allow a system to provide locally grown programming, which translates into additional ad dollars. (Photo courtesy of Larry Ruggieri.)

PRODUCTION CONTROL ROOM NEEDS

- One switcher with at least two M/E buses
- One digital effects machine
- Two electronic still-stores
- Four VTRs (See notes on format)
- Console area, monitors
- 16-channel audio mixer board w/stereo outputs
- Standard wired lavalieres
- Audio sources: DAT, card and CD
- IFB (interrupted fold/feedback) system
- Intercom system (dedicated and isolated)
- Control room should be big enough to accommodate four people in the front row and four people in the back row
- Window is not needed between control room and studio

ENG FIELD PACKAGE NEEDS

- Two to three 3-chip CCD camera package (\$15,000 to \$20,000/camera price range)
- Two to three tripods — light and rugged (carbon fiber products available that can be both)
- One shotgun mic
- One fresnel light to mount on front of camera
- Parabolic reflector to take advantage of natural light
- Three lavalier mics
- Three hand-held mics

Optional: portable waveform monitor, portable color monitor to provide a gauge for quality of product.

TELEPRODUCTION VAN NEEDS

- One-ton van-style vehicle with carpeted walls and floors, finished overhead with appropriate lighting in operating areas
- Removable light-blocking material for windows exposed to the operating area
- Capable of running on 120V single phase power 120V one-phase or off its own internal generator; all power is regulated
- Auxiliary air conditioning
- Seating for three operating positions inside the operations area
- Two camera systems including base stations, 150-foot camera cables and studio configuration kits; two additional camera control units (CCUs), 150-foot camera cables and monitoring facilities will be installed so two cameras may be added to convert the mobile unit into a 4-camera truck; two VTRs configured as record units from the switcher; two additional I/O facilities so two additional VTRs can be added
- Time-code generation and distribution equipment capable of providing time code to all (up to four) VTRs for ISO records with common time code
- Patching or alternative method of distribution of isolated camera feeds to each VTR for ISO recording purposes
- Video production switcher
- 8-channel audio mixer
- Intercom facilities will be RTS to support a 2-camera production with extra belt-packs and headsets to increase to a 3- or 4-camera production
- Video and audio distribution and monitoring equipment

STUDIO NEEDS

- Three or four 3-chip cameras (dedicated studio cameras — not shared by ENG)
- Camera pedestals that allow for smooth movements
- Teleprompter
- Lighting systems to light entire studio
- Three cycloramas
- Lighting board
- Sound proofing (acoustical tiles)

POST-PRODUCTION A/B ROLL EDIT SUITES

- A/B roll editor
- 8-16 input video console
- 1-2 MEs
- Four VTRs
- Digital video effects
- Still-store
- DAT and CD audio sources (stereo)
- PC graphics system
- Character generator
- Should be a component, not composite suite (RGB stays separate, does not mix down until last outsource)

SONY

GET OUT OF THE SAME OLD LOOP.

Tired of going around and around with your old cart machine? Then it's time to head straight for Sony's digital MiniDisc Cart. A direct result of Sony's leadership in MiniDisc technology, the MiniDisc Cart is a simple plug-in replacement for your NAB cart. And it gives you advantages analog simply can't deliver. Like superior sound quality, random access, low-cost/re-recordable discs with up to 74 minutes of record time each, and more. Learn how you can get out of the tape loop. Call 1-800-635-SONY ext. MD.

INNOVATION AT WORK.



MD PLAYER MDS-B2P



MD RECORDER MDS-B1

Sony Broadcast and Professional Products Division, 10000 Wilshire Blvd., Suite 1000, Beverly Hills, CA 90210 © 1994 Sony Electronics Inc. Reproduction in whole or in part without written permission is prohibited. All trademarks, trade names and the MiniDisc logo are trademarks of Sony.



Go Tapeless!

High Capacity Uncompressed Component Digital Video Disk Recorders.

That's right. The tapeless suite is here. For virtually any project.

The *Quick-Frame™* is redefining creative opportunities for satisfied clients all over the world—3 to 90 minutes in less than 37 inches of rack space.

Starting at under \$39,000, *Quick-Frame* offers seamless real-time non-linear playback for telecine, broadcast, edit suite and animation/effects. Just plug it in—no need for expensive equipment re-investments—and no need for tape!

SCSI and Ethernet, of course.

Quick-Frame

...it's DL...it's here...and it works!

Call for Information
(702) 831-7837
Fax: (702) 831-5710



Circle (15) on Reply Card



A studio that supports interview formats allows a system to become highly visible in local issues, elections, debates and the popular sports forecasting shows. (Photo courtesy of Larry Ruggieri.)

vide what may be the only outreach to the more remote reaches of their viewership, creating Marshall McLuhan's "global village" on a smaller scale. A community's fragmentation caused by too many cable choices can only be patched together via a locally oriented channel.

Because a LO channel must be run like a business, the bottom line will be an important issue. How will revenue be generated? Will commercial spots be produced for businesses seeking local insertions? Is the cable company's master control/playback prepared to handle local insertions?

This evaluation of the potential viewership and the resulting programming choices and goals must be made before any facility planning or construction begins. Which needs will you choose to serve?

Only with those answers in hand do you hire a TV (not cable) engineering consultant who knows everything about making TV pictures. Then the negotiations, designs, bids and facility planning begin. Prepare to re-prioritize your initial vision.

Meeting the needs

The most likely programming choices may include a daily (five to seven days/week) newscast, one or more public affairs/news analysis programs, debates and campaign coverage during election years, live town meetings or talk shows with studio audiences and callers (see *BE*, January 1994, p. 38), on-location coverage of high school and/or college sports, and coverage of community events, such as parades, fairs and rallies.

In addition to LO programming, revenue requirements may call for outside rentals and the production of commercial spots. If your goals necessitate the creation of a multifunction facility, it's important to have a strong production

management team to orchestrate scheduling, maintenance and coordination of equipment and facilities. Beware the challenges: Many in the business consider in-house productions and outside clients a paradox. Staff burnout is common because of multiple missions, long days and answering to too many bosses.

A pervading lesson throughout all this planning is to prepare for expansion. It will happen because concessions will probably have to be made in the initial design phase. A good engineering consultant will listen and understand your visions and your hidden dreams. Where do you really see the LO operation going? Without announcing it, the engineering consultant should plan for the inevitable expansion.

If you can't afford to do it right, wait until you can do it correctly. For example, news needs two crews with good equipment, instead of three crews with mediocre equipment; one A/B roll edit suite rather than three cuts-only suites.

Plan for expansion with extra real estate. Leave unfilled areas, open rack space,



Lessons learned

An 8-channel audio mixing board is too small for news. A 16-channel mixer should be enough. On the rare occasion when it's not, a small portable mixer can be added to pre-mix a few mics or other audio sources before feeding into a 16-channel audio mixer.



Space age CCD-cameras don't fit on iron age pedestals

The new Sachtler Vario Pedestals offer unique features for studio and OB operation:

1 Continuous column stroke, for shooting from sitting to standing person's height – Vario Ped 2 - 75.

2 Rock steady and 50 kg/110 lb lightweight, to carry equipment up to 90 kg/200 lb – Vario Ped 1 - 90.

3 Carriage and column can be disassembled in seconds – compact modules for ease of transportation.

4 Quickfix, allows instant change of fluid heads for flexibility – included.

5 Track width, narrow and wide, symmetric and asymmetric – set

in no time and you well can



expect precise, easy steering and crabbing, smooth and jerkfree column movement thanks to the patented Sachtler pneumatic system. Test for yourself the optimum camera support for all compact Studio/OB cameras, now!



55 North Main Street
Freeport, N.Y. 11520
Phone (516) 867-4900
Telex 140 107 sac frpt
Fax (516) 623-6844

California office:
3316 West Victory Blvd.
Burbank, CA 91505
Phone (818) 845-4446



sachtler
corporation of america

See us at World Media Expo,
Booth #4042.

Circle (16) on Reply Card

a routing switcher with more crosspoints than you ever think you'll need, extra patch panels, and a large enough production switcher to accept more inputs. If the initial design calls for eight inputs, install a 16-input switcher (you may want to add a PC graphics station, another ESS or satellite downlinks).

Studio and control room

Don't kid yourself. If you plan on producing a newscast, dedicate a studio, a control room, an A/B roll edit suite, two cuts-only edit suites and two to three

Decision tree

1. What types of programs will be produced? Prioritize the types of programming required. Will it be a commercial venture and, if so, will LO personnel/facilities produce spots?
2. Hire a TV engineer, not a cable engineer. A cable engineer knows RF, a TV engineer knows about making pictures.
3. Let an engineer design the hardware/facility.
4. From the design comes an estimated cost assessment.
5. Budget/hardware costs will in turn drive No. 1, which may mean re-prioritizing programming needs.

Negotiation ensues between production, general manager and in-house engineering with the outside engineering consultant serving as part of the management team. And the process begins again.

ENG field packages to that effort.

Disaster will strike if you justify sharing these facilities with other in-house or, worse, client productions. Technically, news will be the most costly aspect of your I.O operation, but it will also be the most beneficial to the community.

When it's not on the air, news is constantly in preproduction requiring graphics preparation, videotape logging and editing, and studio space for taping segments. A large studio (50' x 50') could accommodate two to three permanent sets including the news set and one or

two interview-style sets in the other corners. These could even interface with the news set or serve as sets for public affairs talk shows.

If studio rentals or more complex types of programs are envisioned, then the demand on the studio and control room is greater and must be accommodated separately. Plan this studio with the most challenging show in mind. For example, studio audience shows, entertainment, gardening, dance and theater.

If planning two studios, allot 30' x 40' for the news studio and 40' x 60' effective area for the other studio. For client work, at the very least, a small insert studio should be allowed.

Ceiling height presents several options. A lower grid is often fine for a newscast. In fact, the director may call for a camera to shoot down through the lights for an overhead wide shot. However, to preserve the mystique of television and to avoid seeing hanging lights in a wide shot means allowing for an 18-foot ceiling (measured to the grid). A 24-foot ceiling is optimal and will be the most efficient for climate control. The higher the ceiling, the higher off the floor the heat load builds up. A low grid will have to run a much higher volume of air conditioning to turn the air over and out so it doesn't build up at the people level where heat causes makeup to run and talent to get annoyed. At 24 feet you can get a large enough intake and outlet, and a slow enough fan speed, to let the heat build up high into the grid and then slowly suck it out. This is also much better for acoustics because larger fans and air moving about at microphone levels will degrade audio quality.

Most LO operations can't afford perfect acoustical construction. However, one helpful alternative is to wrap the studio in a black velour cyclorama that provides some level of absorption. Also, line the studio with acoustic tiles. Every studio needs three cycloramas (cyc): a black cyclorama made of velour; a scrim (also called sharktooth or leno bounce) cyc that can have light bounced against it; and a chroma-key cyc.

A hard cyc, which is a wall built with a ground row to give the illusion of infinity, is restrictive for a large variety of shows and is unnecessary for a I.O operation. Plus, the hard surface of this cyc intensifies sound problems.

All doors going into a studio have to be professional sound lock doors. An 8' x 8' door is the smallest you should install and would allow for all standard 4' x 8' flats to be brought in. A 12' x 8' door is better for getting larger, odd-shaped objects into the studio.

The scene shop, generally placed next to the studio, also needs a large sound-lock door connecting the two. And the



Lessons learned

If you foresee wanting a car in the studio, build the loading dock and the scene shop doors large enough to fit most vehicles. Does having vehicle access meet programming goals?

The MCT guarantee: No matter how large you build your scene shop/storage area, you will never have enough room. A TV station's "stuff" expands or contracts to fit the space available.

loading dock, generally attached to the scene shop, needs an equally large door.

Building sets

The conventional approach to set building requires a set to be designed and built for each specific show. This exacerbates the storage problem. Production managers would do well to encourage the use of multifunctional Uni-Set systems and other neutral flats and risers. Risers, unfortunately, are the most difficult set pieces to store because they can only be stacked. Vertical storage should be designed for flats, as well as establishing a standardized model for flat construction.

For the studio size, a 50' x 100' storage room is recommended. Down the road, off-premise storage space may be acquired or a simple shelter could be built nearby. (Cameras and pedestals are outlined in "Studio Needs," p. 28.)

Paper teleprompters are popular because news directors move stories around within a newscast, often as it is happening. If you want an electronic prompter,



Lessons learned

MCT purchased the same model camera for field and studio production. This proved beneficial because any camera could be used elsewhere to shore up a problem. Today, many industrial quality chip cameras would fill multiple needs.

DIGITAL BETACAM NOW.

SONY



We knew when we moved to digital component it had to be compatible with our current systems. Digital Betacam® VTRs hook up to what we have without A/D or D/A converters on every piece of equipment. You can buy Digital Betacam next week and not have to worry about the analog equipment you already have. You don't have to start over. As far as quality, Betacam SP® format is good, but when you put the two side by side, you can see a visible difference. I also like the four channels of digital audio, particularly for multilingual applications. We get great service from Sony, and their being an international company ensures excellent service around the world, which is very important to us. For us, Digital Betacam equipment is a perfect fit—a good marriage. I think that the Digital Betacam format is the most innovative thing that Sony's ever done.

— E.B. (Gene) Wright, VP/Engineering, Turner Broadcasting System



With Digital Betacam equipment we're able to service clients who, in the past, were using analog component equipment, like Betacam SP. We give them improved picture quality without additional costs. In addition, the playback quality of an analog tape is actually better, when played on a Digital Betacam VTR. What's important to us is that Digital Betacam has closed the gap in digital formats between D-2 and D-1. We have a central machine room that has almost 100 VTRs. The Digital Betacam machines just plug in and fit the system. We've never run into a situation that anybody was complaining or that anyone could even point to artifacts that were a result of compression. It's performed flawlessly.

It's the best introduction of a new format that I've ever experienced.

— Moshe Barkat, President, Modern Videofilm



We air all our movies on the Encore™ and Encore 8/Starz!™ channels on Digital Betacam VTRs. When Starz! was conceived, we wanted to be on the leading edge of digital technology, so it was natural for us to go with Digital Betacam VTRs. It holds a two hour movie on one tape and is compatible with our analog library. The technical quality of the picture is sharper, clearer and the colors are more vibrant. Put the same movie side by side, analog vs. digital, you see a difference. In our post-production area, Digital Betacam VTRs allow us to do pre-read. For an editor/producer team, it really simplifies their life. Sony makes the best tape machines on the market. I believe that in 5 or 10 years, we'll be in a non-linear world. Since I'm digital (on tape) with Digital Betacam equipment now, when file server technology is enhanced, I'll be in a great position to make that transition. I think this is the first step into the non-linear world.

—Warren P. Kaplan, VP/Program Operations, Encore Media Corporation

DIGITAL BETACAM. THE NEWS IS OUT.

The move to digital component is here. With Digital Betacam equipment you get the image quality of 4:2:2 without the expense. You get a flexible format that will address your applications. And you get it all at your own pace. Digital Betacam's unique compatibility lets you transition your facility a little at a time—and leaves plenty of room for future developments.

MARKET PROVEN. MARKET INSPIRED.

The Digital Betacam format makes sense. With customer input

and evaluations, Digital Betacam equipment was developed to address your needs today as well as tomorrow. You've had a glimpse of the future, and its promises, and videotape is clearly the medium of choice and will continue to be for years to come. And even in a world with non-linear workstations, the Digital Betacam format positions you to feed digitally onto a file server. The move to digital is yesterday's news. The Digital Betacam format offers the best digital component

solution—from acquisition to on-air playback—with the 4:2:2 quality you're looking for in a format that applies to the real world today and tomorrow.

Call 1-800-635-SONY ext. 422 for more information or better yet, call your Sony Account Manager or Representative for a practical demonstration as Gene Wright, Moshe Barkat and Warren Kaplan did.

INNOVATION AT WORK.



Sony Business and P-rofessional Products Group
3 Paragon Drive, Montvale, NJ 07645-1735.
© 1994 Sony Electronics Inc.

SONY

Reproduction in whole or in part without written permission is prohibited. All rights reserved.
Sony, Betacam and Betacam SP are trademarks of Sony.

research the software to make sure it is especially created for newscasts.

Studio lighting

Choose a studio lighting system that meets your needs for quality, reliability and price. If only news and public affairs will be produced, the studio lighting board only needs to store two or three fixed lighting plots in memory. A theatrical lighting board capable of scene changes, lighting effects and electronic patching would be beneficial for more complex productions.

Purchase enough lighting instruments to be able to light the largest, busiest set imaginable.

Choose a studio lighting system that meets your needs for quality, reliability and price.

To cater to clients, the design needs to address the aesthetics of the LO facility. A sterile, functional environment is fine for internal use only. Consider more aesthetics and amenities for client work. Amenities are relative to competition, what they expect, geography and culture.

ENG field packages

News ENG crews need vehicles. One vehicle per crew can be leased or purchased depending on available capital. The advantages to leasing are the flexibility that comes from a short-term commitment. Space requirements may change. No matter how many rules you set for the vehicle's care, it will suffer heavy abuse. The maintenance is more tolerable when the vehicle can be exchanged after a year or two.

A minimum of two complete ENG packages and crews is recommended for news coverage. Under the worst scenario, one package may serve as a backup. The actual number of crews and packages should be driven by the market and the geographical area that news would be expected to cover. Consider the wide range of available small formats for your ENG crews. Depending upon quality, budget and proposed use, various formats may be better suited for the task. Higher-priced professional units will perform better in high use/abuse operations. (See "ENG Field Package Needs," p. 28.)

If client productions or commercial spots are part of the mix, then an additional ENG package may be required.

Multichannel automation: What to consider

By Douglas A. Hurrell

Automation requirements for the broadcaster and cablecaster continue to merge, and now multichannel automation needs are commonly found in the cable and call letter environments.

In its simplest form, cable automation may require nothing more than a system to control commercial insertion over a single channel. Just about any automation system can do this. However, the days of such simple applications are passing quickly. Automation decisions are considerably more complex than in the past.

Today's cable operations often involve multiple channels of program material intermixed with commercials. Sometimes the program material is identical, with different interstitial material being sent to specific regions. At other times the program material varies with each independent channel, as does the interstitial material. Occasionally, both of these situations exist, and must be combined with time-shifting live inserts, as is the case with All-NewsCo., Channel 8 in Washington, DC.

To keep abreast of the changes occurring in the cable world, today's automation systems must be modular, have the ability to import multiple channel logs, determine where the material is located, and automatically cue it and play it back at a future time. Reconciliation for billing purposes is crucial. Comprehensive media tracking and management within the facility are also essential.

In a multichannel operation a system is needed that will allow commercial breaks to be compiled in advance using independent machines, cart machines or digital video servers. A solid automation system will even compile "pull" lists across channels.

In some areas, certain legal requirements prohibit duplicate programming over multiple channels, so alternate programming has to be switched out by timed switching of the router. This means the automation system must have a "source-to-destination" channel, which allows any input on any router destination to be selected at any time of day, and keep track of router feeds throughout the day.

Many larger cable operations have sophisticated satellite needs requiring automation of feed recording, dish positioning, timing receivers, switching program materials to record devices, and rolling the material once it has been recorded. The system should provide all these features for you.

Hurrell is president of Alamar Electronics USA, Inc., Campbell, CA.

Managing the data

As your channels grow and the numbers of programs and commercials within your facility grow, the automation system must provide a fast library management program. This will not only accommodate present materials, but also those that will arrive in large quantities in the future. This is not just a catalog or listing capability. It also means that a tape can be put on any machine in the system and the automation system will find the necessary material and play it back on the correct channel at the proper time. UNIX-based systems offer this multitasking, multi-user capability, as well as gateways to other network systems such as Novell.

Keep your experienced gear

Regardless of the size and complexity of your operation, the automation system should not require you to discard existing equipment. A good automation system will accommodate not only serial machines, but also older parallel equipment and equipment requiring GPIs.

Look for a system with a wide variety of equipment interfaces that fits easily into the existing facility and the standard operations mode. You should never be required to change the way in which you operate in order to accommodate an automation system. Rather, the automation system should be flexible so it can be customized to fit nicely into your method of doing things.

Consider the future

Continued channel growth will demand usage of more and more automation equipment and software by cable operators in order to stay successful and profitable.

Be sure the automation system you choose is designed and backed by a company with adequate resources to continue to develop new features and grow your system as the industry grows. The system must be expandable and upgradable, and able to incorporate new products such as digital video servers. Be sure the manufacturer has adequate engineering resources to respond to technical issues that may arise or perhaps have not even been considered at this time.

Finally, cable is a 24-hour-per-day industry. Make sure your automation company offers 24-hour-per-day service, 365 days per year.





AnthroCarts!

AnthroCarts will knock your socks off! Imagine how great it'll be when you find the perfect furniture for your equipment — just the right size, tough-as-nails construction and dozens of accessories.

And you'll find our service so real and responsive, you'll get a kick out of ordering direct!

Call for a free catalog!



Lifetime Warranty.

Lots of choices.

Space saving.



800-325-3841

6:00 AM to 5:00 PM PST, M-F
3221 NW Yeon St.
Portland, OR 97210
Fax: (800)325-0045

GSA contract no. GS-OOF-5040A. Available for OEM applications. Prices from \$149.00
Anthro, AnthroCart and Technology Furniture are registered trademarks of Anthro.



Lessons learned

Build a separate announce booth — well-padded and acoustically as perfect as possible.

Post-production suites

The news operation must have two cuts-only edit suites, an A/B roll edit suite with three VTRs and a small switcher. To allow news constant access to a larger on-line edit suite would be an inefficient allocation of resources.

If outside client work is to be a revenue stream, the post-production suite must meet the market's minimum equipment requirements. Research will be most helpful.

For MCT, the initial negotiation process uncovered a need to build in a revenue-generating component. Therefore, an edit facility was planned that went beyond in-house needs to support client expecta-



Lessons learned

The engineering department or a knowledgeable consultant needs to stay in the decision-making process throughout all phases of the LO channel's development.

Operating costs can be lessened by bringing all equipment maintenance in-house. This takes time by outside trainers to meet this goal, and it will probably be a gradual process. MCT performs about 50-60% of its own maintenance. The goal is 100%.

tions. We increased the quality of the equipment (larger switcher, DVE, etc.) to become an upper-middle market facility with a solid production platform. (See "Post-Production A/B Roll Edit Suites," p. 28.)

Teleproduction van

Local sports — high school and college — as well as community events like the State Fair and the Apple Blossom Festival are best produced with a mobile van. A basic teleproduction van can be assembled for approximately \$250,000. (See



THE ADVENTURES OF
PROF. WARHOL FROM
ULTIMATTE[®]
a SALESMAN CALLS ON
a POST-PRODUCTION HOUSE...

Howdy, Neighbor! Have I got a COMPOSITING SYSTEM FOR YOU!

SORRY BUDDY. We use **ULTIMATTE** HARDWARE AND **ULTIMATTE CINEFUSION** SOFTWARE. IT'S THE BEST!

Well, yes, it **IS** the best. BUT IT'S SO HARD TO USE! **OUR** SYSTEM IS MUCH SIMPLER!

OH, YEAH? SIMPLER THAN WHAT?

Well, when compared to the **ULTIMATTE-4**...

THE **ULTIMATTE-4**?! HA! YOU'RE A COUPLE OF GENERATIONS BEHIND! LET ME TELL YOU A STORY...

ONE DAY AT **ULTIMATTE LABS**...

MASTER! THE **ULTIMATTE-4**! IT'S PERFECT!

IF ONLY IT WERE SIMPLER TO USE...

BUT PROFESSOR, YOU'VE DONE ALL YOU CAN!

THERE **IS** ONE WAY!

NO PROFESSOR! I MUST!

THROW THE SWITCH, IGOR!

YES, MASTER!

THE TRANSFERENCE WORKED! THE **ULTIMATTES 45 AND 6**, THE ALL-DIGITAL **ULTIMATTE-7** AND **ULTIMATTE CINEFUSION** SOFTWARE ALL GOT A PART OF THE PROFESSOR'S WONDERFUL BRAIN!

THANKS TO **ULTIMATTE INTELLIGENCE**, IT TAKES ONLY A PUSH OF A BUTTON OR A FEW CLICKS OF A MOUSE TO SET UP A PERFECT MATTE IN ALMOST ALL SITUATIONS!

WOW! DID THE PROFESSOR SUFFER ANY SIDE EFFECTS?

I DON'T WANT TO TALK ABOUT IT.

NKR

Cartoons by Keith Robinson/Making It Productions 310-378-4345

Get smart! (Without harmful side effects!)
CALL TODAY FOR A DEMO OF HOW EASY **ULTIMATTE** REALLY IS!
Phone: 818-993-8007 Fax: 818-993-3762

ULTIMATTE[®] 20554 Plummer Street
Chatsworth, CA 91311

Your Video System.



Your Video System With Super Glue.



Introducing Super Glue digital converters designed by Alpha Image. Now there's a solution for every digital need. From

SUPER GLUE

simple monitoring

D to As, to high

quality encoders, Super Glue is the bond that keeps your signal path robust and maintenance free. Call 1-800-453-8782, ext.

201 for a nearby Dynatech Video dealer.

utah scientific



• Alpha Image • Cable Products • Colorgraphics • da Vinci
• DigiStore • EMC • NewStar • Quanta • Utah Scientific

© 1994 Dynatech Video Group, Inc.

Circle (26) on Reply Card



With standard broadcast production equipment like that shown here, Montgomery Video Productions provides clients with full-feature production capabilities. Cable systems offering this type of service stand to gain ad revenue because they can offer custom spots just like the "big guys."

"Teleproduction Van Needs," p. 28.)

For live remotes, sending the signal back from the truck via microwave is too expensive and often impossible. However, a cable company is in the enviable position of dropping 2-way cable lines in key locations throughout the viewing area. City hall, the local mall, schools and prominent community centers can serve as sites for remote feeds.

A cable company is in the enviable position of dropping 2-way cable lines in key locations.

No matter what the growth pattern of your LO operation, consistency of formats is important. Don't mix the formats of the recording, editing and playback functions. This is a common downfall when decisions are made on monetary factors only. To buy cheap, one-of-a-kind items guarantees that failures will occur without the resources to repair them. The engineering department can't keep

up with it all. Often, repair manuals for consumer products are unavailable. More important than the type of format you choose, is the consistency of that format throughout the facility. Fewer intermittent failures occur when formats don't have to be compatible. (See *BE*, January 1994, p. 56.)

Spare nothing

Although it may appear necessary to meet initial budgetary requirements, don't skimp on name brand equipment. In most cases, if you buy off-brand names because they are cheaper, you will pay for it later in reliability, service and maintenance. Often, there is only a small difference in the price between the name brands and off-brand products and that difference will disappear in no time at all.

Build in a tape format that you can afford throughout several expansions. Don't start with an expensive system then downgrade. Photographers, engineers, producers and viewers will complain if your productions looked great in Beta-cam, but suffer degradation in S-VHS.

There is no right formula for every LO facility. Programming goals, revenue requirements and budgetary guidelines all contribute differently to define different priorities. ■

C-COR/COMLUX

Single Channel Digital Video System

**Replacing
yesterday with
tomorrow...today!**

C-COR/COMLUX

single channel

3300 series video

transmitters and

receivers.



C-COR/COMLUX, the first provider of a single channel digital video fiber optic system, offers you the product you'll need to upgrade, replace or add new video service.

- ▲ Replaces yesterday's FM technology
- ▲ Cost Effective
- ▲ Uncompressed Digital Video
- ▲ Up To 8 Channels Digital Audio
- ▲ Broadcast Quality Specifications
- ▲ Multi or Single Mode
- ▲ Distances up to 100 km

**Access C-COR/COMLUX...
Today's Digital Video Solution.**

C-COR ® **COMLUX, INC.** ✱

47323 Warm Springs Blvd.
Fremont, CA 94539-7462
USA
510-440-0330

60 Decibel Road
State College, PA 16801
USA
800-233-2267

P.O. Box 10.265
13C1 AG Almere
The Netherlands
31-(0)-3240-64199

Circle (35) on Reply Card

Tektronix brings non-linear thinking

Introducing **Profile**[®]
Disk-Based Video and Audio
File System.



Specify **Profile**[®]
from your
video system
integrator.

© 1994 Tektronix, Inc. Profile[®] and Intelligent Compression[™] are trademarks of Tektronix
Betacam[®] is a registered trademark of Sony Corp.

to an otherwise linear world

This is no mere evolutionary advance. The new *Profile*® Disk-Based Video File System is a quantum leap forward in form, function and value.

For starters, *Profile* provides CD quality audio and first generation Betacam® SP quality video. While Intelligent Compression™ lets you specify the exact video quality you need for every application.

Tektronix Image Quality *Profile* makes the many advantages of disk recording both affordable and practical.

Intelligent Compression™ With four independent record/play channels, a single

Simultaneous Record/Play Across All Channels *Profile* streamlines commercial

insertion, newsroom editing and program delay operations that tie up multiple tape machines. And it does so more simply and economically. With virtually no downtime.

Integral Video Router

Open Architecture An integral 32x32 digital router makes it easy to integrate *Profile*

Multiformat into any video environment.

High Reliability And, its open architecture lets you expand and upgrade with plug-in cards.

Don't be limited by linear thinking. For complete information call your local Tektronix sales office.

Tektronix

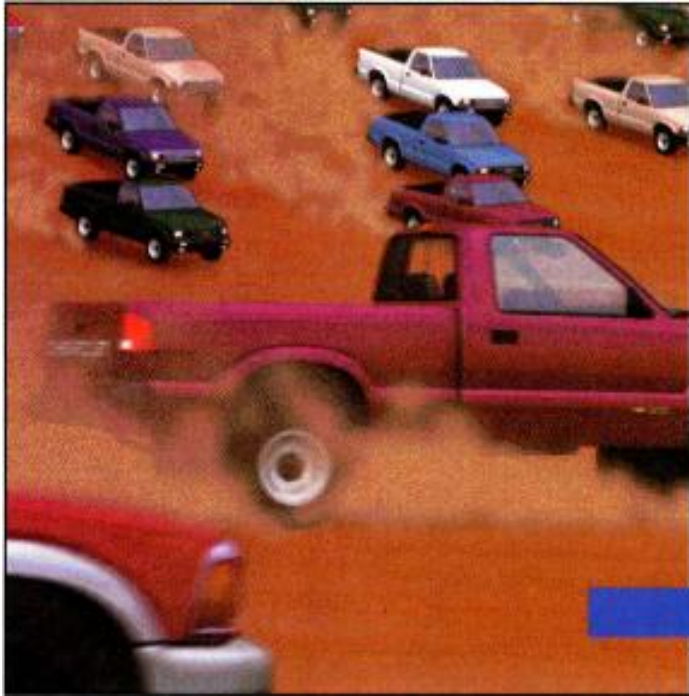

Non-linear editing systems

With technology's help, these systems have grown up.

By David Leathers

The Bottom Line

We are quickly moving from a time of sometimes disappointing compromises to a relative abundance of capable systems. Over the next year, many new systems will appear and those that are already out there will continue to evolve rapidly. In a relatively short time, the questions facing buyers have shifted from "Which one works?" to "Which one works best?" to "Which one works best for me?"



Now that the smoke has cleared from NAB '94, a new level of quality in digital non-linear editing is upon us. As the first half of the decade fades into Cyberspace (a place that hardly existed before), the years of 1990 through 1994 will be remembered as the pioneering years in desktop video and multimedia technology. For those blazing the trail, there have been many failures, false starts and other learning experiences. There is definitely some roadkill on the InfoBahn (sorry), but the power of computer technology has captured the imaginations of so many developers that the momentum continues to build in the development of new products and the merging of computer and video technology. Enormous obstacles have already been overcome and the convergence of rapid parallel developments in processors, software, compression, storage, video and audio processing and networks are creating many new systems possibilities.

Depending on who you are and what you're trying to do, the answer to which one works best can vary considerably. Producers wanting a system for off-lining shows will have different considerations than those of a facility owner who provides on-line services. Free-lance editors wanting to increase income by renting a system to editing clients will have different requirements than a multimedia developer wanting to create finished video elements for CD-ROMs. Different types of applications require different system solutions. Many systems either shipping now or within the next few months will

provide the buyer with a wide range of alternatives in price, features and functions.

Desktop vs. non-linear

One area of confusion surrounding many of the newer systems is the question of exactly what they are. Many people assume if it's a desktop system then it's non-linear, or if it's non-linear then it's a desktop system. In some cases these assumptions may be true, but not always. Desktop systems are generally defined as software and/or hardware solutions that run on a standard computer platform, usually an IBM PC, Macintosh, Amiga or Silicon Graphics workstations. Non-linear systems, on the other hand, are editing systems that use random access devices (i.e., hard drives, DDRs) in-

Enormous obstacles have already been overcome and the convergence of rapid parallel developments are creating many new systems possibilities.

stead of linear storage methods (video-tape) to assemble the final production. Improvements in hard drive technology have allowed these new non-linear systems to flourish.

Editing controllers, or what are today referred to as linear editors, were only part of a traditional editing system. The controllers were used to tie all of the edit suite's equipment together. Non-linear

Leathers is the president of Eye Square and director of Broadcast Engineering and Video Systems Digital Media Lab, Hollywood, CA. Respond via the BE FAXback line at 913-967-1905.

If you've been quietly suppressing a monumental **urge** to smash the living **HECK** out of every single noisy, clumsy **CARTRIDGE** that's been jamming up your carts for the last *umpteens* years, **NOW** would be an *extremely opportune* time to **VENT** all that pent-up **Rage!**



Take out that old NAB cart and plug in Otari's new MiniDisc!

It's as easy as that! And you get fast random access editing, auto-programming for commercial sequences, digital I/O, and high quality digital sound for transparent copies. For flexibility, Otari's MiniDisc recorder/player delivers a next-play function and auto cue, plus optional RS-422.

In short, Otari's MiniDisc is the perfect cart replacement.

And at the same time, you get Otari's legendary "workhorse" reliability for on-air dependability. Call your local Otari dealer for information about how the powerful, yet easy-to-use Otari MiniDisc cost-effectively meets your on-air and production requirements.



Otari Corporation
U.S.A.
Phone (415) 341 5900
Fax (415) 341 7200
N.Y. Sales (212) 297-6109
L.A. Sales (818) 972-3687

Otari Inc.
Japan
Phone (81) 4 2481 8626
Fax (81) 4 2480 8633
Telex J26604 OTRDENKU

Otari Deutschland GmbH
Germany
Phone (49) 2159 50861 62/63
Fax (49) 2159 1778
Telex 8531638 OTEL O

Otari Singapore Pte., Ltd.
Singapore
Phone (65) 284 7211
Fax (65) 284 4727
Telex RS36935 OTARI

Circle (37) on Reply Card



editors, or in most cases, non-linear systems tend to be the entire edit suite.

Today's desktop systems, whether linear or non-linear, tend to be stand-alone edit suites requiring only the addition of tape machines for image capture and final output. Desktop systems may be comprised of a video switcher, audio mixer, edit controller and, in the case of the non-linear systems, the storage medium as well. Few if any non-linear systems are capable of controlling multiple tape machines. However, several mid- to high-end systems are coming to market that are linear/non-linear hybrids capable of operating in either mode or both modes simultaneously.

Along with the question of linear or non-linear is the question of on-line or off-line. Off-line systems produce as their primary product an edit decision list (EDL). On-line systems, on the other hand, are capable of assembling the production in its complete and final form. Many times the EDL created in off-line is used in on-line to automatically create the final product, depending on the sophistication of the off-line EDL and whether it interfaces completely with the on-line system.

The ins and outs of disk storage

When considering non-linear systems, the storage medium is of primary importance. Hard disk drives are currently the medium of choice. Magneto-optical and tape drives (data) can be used for auxiliary storage, however, they lack the data throughput needed to playback on-line quality video in real time. Various compression systems are used to reduce throughput requirements. Among them are JPEG, motion JPEG, MPEG-1 and MPEG-2, wavelets, and proprietary methods from several manufacturers. All but MPEG allow for editing.

Various hardware implementations are used to store and play back video from hard drives. One of the most common is RAID (Redundant Array of Inexpensive Drives). Individual bits of the data are striped (written) across the drives. During playback they are read back simultaneously and reassembled into a datastream. Drives allow for video playback in several ways — some need to be formatted specifically for video, others simply need an area partitioned specifically

for video playback. Today, many drives offer real-time playback and record, but few systems offer true random access on a field-by-field basis. Most, however, are capable of playing back standard productions and promotions at either field doubled 30fps or true 60fps.

In most instances, once material is captured and written to the drive, it remains where it was written. The non-linear edit-

drives recalibrate themselves as they change temperature. During recalibration, the drive is unusable for data. Older drives recalibrate as needed automatically, sometimes interrupting data flow. In strictly data operations, thermal recalibration is not much of a problem, however, in video applications it can cause several fields to be dropped. Newer drives have smart controllers that do not allow the drive to thermally recalibrate when in use.

Finally, there is audio. Although most systems use some form of video compression, only a handful of systems compress audio. Most support two output channels, however, many have up to eight channels available internally. Some systems store audio on a separate hard drive, others integrate the audio into the video datastream. In the past, problems have arisen with audio/video synchronization. For the most part those problems have been resolved in the current generation of systems.

The digital suite

Turning from the technology to current offerings, at the high end of video non-linear editing products is at least one fully functional D-1 editing system. Because it is top-of-the-line, it provides an extensive array of effects. An off-line companion allows an edit decision list complete with effects and transitions

to be created off-line. Although touted as an off-line system, the unit's output is such that some finish work can be done on it.

Coming from traditional manufacturers of on-line devices, there is an emerging generation of edit controllers designed to replace the current alphanumeric edit controllers in today's on-line facilities. Ultimately, these controllers will perform non-linear and linear editing and control everything in the edit bay using a non-linear interface.

One system combines an editor with an interface to a digital disk recorder (DDR). It can provide random access to almost 30 minutes of D-1 or an hour of D-2 quality video on-line. Editors can control up to 48 devices simultaneously as well as external TBCs, switchers, audio levels, router assignments and effects devices without leaving the keyboard. There are extremely powerful routines for assisting the editor in loading and storing material and dealing with the technical parame-



A mid-range non-linear editing system that uses wavelet compression. Because the system is compact, it can be located almost anywhere. (Photo courtesy of Immix.)

ing process does not move the material around, but rather develops a list of fields or clips that is used to determine how the images are played back. When additional clips are added in the middle of the sequence, those numbers are simply added into the playback list, rather than shuffling information on the drive.

This is an efficient way of handling the data, however, it is not without problems. Because of the high data rates involved, the drive may not be able to get from one clip to the next in time. This can cause missing and/or repeated fields, making the video unusable. To get around the problem, drives rearrange the data in order to assure that the sequence of clips will playback properly. Compiling clips in this manner can be time consuming. Newer drives are much faster and have reduced this problem in most cases.

Another problem with hard drives is thermal recalibration. Because of tight tolerances, drives are sensitive to temperature. To compensate for this, many

WFLD WGN KDFW KMOV KKTV WHD
 ATU KCBS ABC KDKA KFME FOX KMG
 BO KRON KSTP KTLA KVBC CBS WATL WHI
 WWT WSOC WTTW WXIX KPIX KOMO NB
 VEC WMAQ KOTV KABC KCNC WBRC WB
 AF WFAA KCPQ KYW WCVB KXAS WVI
 TVD KUSA WPHL KPNX WRTV WTKR WTS

Just why is Picturebox® so popular?

Quite simply, Picturebox® offers outstanding value. After twenty years of on-air experience, Quantel has a reputation for providing the best solutions to broadcasters' needs - systems that perform above and beyond their price tag. That's why Picturebox is



the backbone of so many on-air operations across the US and around the world.

Unbeatable at the basics

No still store stores stills like Picturebox. Its innovative filecard system flies through intelligent search routines. Its on-air panel is the most comprehensive



in the industry. Its hardware is custom built for blistering speed and total reliability.

Picturebox delivers; the right pictures, in the right order, at the right time, every time.

The power to grow

On its own, Picturebox has the power to make your station look good on air.

Networked, Picturebox offers total flexibility - from seamless integration with Paintbox to a 128 machine network that spans continents.

Sophisticated architecture guarantees unbeatable performance, yet connection is simple, reliable and open to everything from 3D computer graphics to newsroom systems.

Picturebox will handle both your current needs and future plans precisely. And no matter how you grow there's no redundancy, no replacements and the quality stays the same, the quality stays Quantel.

More than just a still store

Picturebox beats the squeeze on station resources, space and budgets. It can create soft-edged and multilayered floating graphics, eye-catching dynamic transitions, headline text and lower thirds on its

own, with no need for DVEs, paint systems, cap gens and extra operators.

Modular Picturebox technology frees broadcasters to meet presentation needs without waste or compromise.



A long term investment

Quantel has always built for the future. That's no hype, ask the many broadcasters who bought our still stores in the '80s.

Solution Specific technology guarantees the highest levels of quality and reliability and the lowest running and maintenance costs. It also provides the framework for Quantel's renowned

in-service development programs; Picturebox isn't just the best there is today, it will stay the best for years to come.

So if you care about getting the best value and results for your station, if you care about future performance as well as current needs, Picturebox isn't your cheapest option, it's your only option.



PICTUREBOX®

More, much more than a still store.



For a full Picturebox Information pack call Graig Sherter at (203) 656 3100

Circle (38) on Reply Card

**INSTALL 'EM!
FORGET 'EM!**



That's exactly what you can do because our Audio DA systems work - day in and day out. they work so well we guarantee them for five years.

- CH-20C Rack frame with dual power supply and auto change over holds six transformer DA's.
- CH-27 Rack frame with redundant power holds 10 stereo DA's, each DA can be strapped as a 2 X 6 or a 1 X 12, a 13th summed output available for IFB feeds.

ADM The Audio Company

ADM SYSTEMS, Inc. P.O. Box 250334 West Bloomfield, MI. 48325
Phone 810 524-2100 FAX 810 932-1991

Circle (84) on Reply Card

**Tired of fighting ac power system problems?
Get the answers you need.**

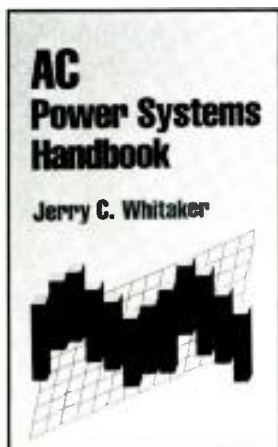

- 330 pages
- 200+ illustrations
- Topics include:
 - AC transients
 - Lightning effects
 - Grounding
 - Power distribution
 - AC system design
 - Standby power
 - Power conditioning
 - Safety

Written by Jerry C. Whitaker, an authority on ac power system design and transient suppression.

From CRC Press and the *Intertec Information Age Catalog*, **AC Power Systems** is an authoritative handbook that explains what you need to know to protect electronic systems from power outages, transients, and related disturbances.

To order call 1-800-543-7771
Catalog #CT-714 \$39.95



A mid-range system being used to edit episodes for daily and weekly programs direct-from-disk. (Photo courtesy of Avid.)

ters of on-line editing. This is done from a graphic interface with a time line and icon-based scene manager.

Another system runs on the SGI line of computers and provides much of the same functionality, but is designed to allow users of paint, graphics, animation and compositing software to perform on-line editing. Several systems using the SGI Indy were introduced at NAB. One provides on-line control of up to 30 devices, as well as switchers, mixers, TBCs and other external devices simultaneously from the keyboard and/or mouse. It uses a graphical time line interface that can also show the editing information numerically.

Desktop linear systems with non-linear capabilities

A number of desktop systems currently function primarily as linear tape-based systems, but with non-linear graphical time line interfaces. The design trend is toward a compact edit suite-in-a-box design. These systems are less expensive than traditional multidevice tape-based systems and are rapidly developing non-linear capabilities.

One system consists of a set of five boards for a 486 EISA PC and includes cables, software and manuals. There is a routing switcher, DVE, TBCs and keyers on two video processor boards, a graphics board, VTR controller board and an audio card. The boards are joined inside the computer by several sets of jumpers and auxiliary buses.

The main software package is the editing environment. Also included, (bundled and integrated) with the system are a paint and retouching software package as well as a titling software package. Formerly sold as a board and software set, the company now sells several versions of the system, which include the computer. The system is completely integrated by the factory.

Another system provides two channels of 60fps video playback from disk with scalable compression and eight channels of digital audio. It also comes with a 19-inch rack-mount control box with three RS-422 and RS-232 control interfaces, a time-code generator, three time-code readers, eight balanced audio inputs, LAN-C and gen-lock. A YUV component interface is available as well as various optional configurations.

Disk-based non-linear on-line

It was little more than a year ago when Macintosh-based non-linear systems started to appear that could seriously be called

FREE 44pg Catalog & 80 Audio/Video Applic.

PWR SUPP. EQ. THE PRODUCTS
PHONO, MIC, TRANS. ACN, TAPE, VIDEO, LINE, OSC / PRESS BOXES

SYHS DA VIDEO DA

1-in/16-out Video/Audio
1-in/16-out Video/Audio
2-in/24-out Audio Only
1-in/32-out Video/Audio

Video & Audio Dist. Amps.
RGB-Sync Dist. Amps.
Routing Switchers

OPAMP LABS INC (213) 934-3566
1033 N Sycamore Av LOS ANGELES CA, 90038

Circle (86) on Reply Card

SADiE 2.1

There's a lot more behind a SADiE™ than you might think. Our job doesn't finish when you purchase your SADiE™ system.

For a start you can telephone for advice, support or just a chat from early morning 'til late evening, seven days a week and because we combine our sales and service into one customer support operation, you'll most likely be speaking to the same person that sold you your SADiE™. And if your system stops working (don't let anyone tell you "break-downs never happen!") customer support will get you up and running again as rapidly as possible. As our support team often work

with clients on actual projects, we really understand SADiE™ and the pressures of audio production. Every SADiE™ user has the latest software - we know you are the best advertisement for SADiE™ so free software updates are a sound investment for all of us.

Finally, we don't try to make money out of maintaining your SADiE™ - an extended 3 year hardware maintenance contract will cost you less than \$1,500 and you don't have to purchase it until the end

of the 12 month free maintenance period. The price of a SADiE™? - same as ever - a complete system for \$9,995 (plus the odd local tax, duty and delivery, where applicable)

NEW IN VERSION 2.1

fader, pan and mute automation

auto-conforming

machine control

CMX support

even faster editing

background networking

playlist overview

CD-R support

all this in addition to SADiE's phenomenal editing and proven audio processing capabilities.

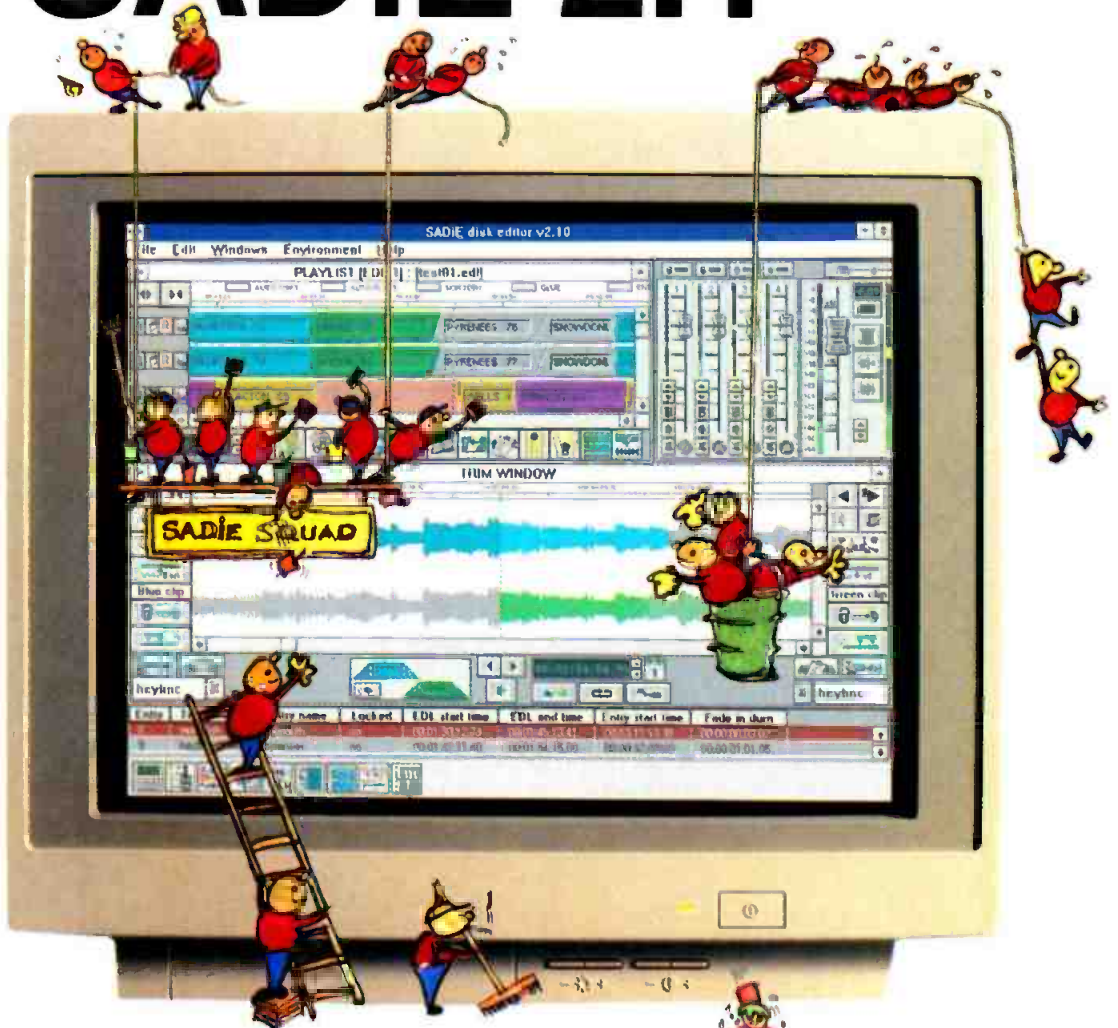

It's the little things that matter



FOR FURTHER INFORMATION CONTACT:

Studio Audio Digital Equipment Inc
1808 West End Avenue,
Suite 1119, Nashville, Tennessee 37203 USA
TEL: +1 615 327 1140
FAX: +1 615 327 1699



Circle (27) on Reply Card
SADiE™ DISTRIBUTORS WORLDWIDE

Argentina Kappa T 081 31 0818 F 081 31 1493 • Asia Pacific VW Marketing T +44 372 728481 F +44 372 724009 • Australia TVC T 09 249 6688 F 09 249 6858 • Canada JSGS Ltd. T 416 751 7907 F 416 751 7975 • Denmark SC Sound T 43 99 88 77 F 43 99 80 77 • Finland Oy HedCom AB T 90 682 866 F 90 682 8489 • France Coach Audio T 87 77 00 00 F 87 77 01 21 • Germany Stefan Mayer Audio Engineering T 0 6851 6519 F 0 6851 6519 • Israel Sontronics Electronic Equipment T 03 5705223 F 03 6199297 • Korea Avix Trading Co. Ltd. T 02 565 3565 F 02 565 3561 • New Zealand Videx T 09 444 6085 F 09 444 3837 • Philippines Tracks T 2 631 3277 F 2 631 3267 • Poland Unico T +44 223 63025 F +44 223 301488 • South Africa Tru-ff Electronics SA (Pty) Ltd T 011 462 4256 F 011 462 3303 • Spain Lexion T 93 203 48 04 F 93 280 40 29 • Sweden Tranzicom T 08 730 3710 F 08 730 5125 • Switzerland Media Solutions T 064 41 57 22 F 064 41 00 35 • Taiwan Acesonic T 2 716 8896 F 2 719 2065 • Thailand KDM Trading T 2 318 2724 F 2 318 6186 • USA SADiE Inc T 615 327 1140 F 615 327 1699 •

*Windows is a registered trademark of Microsoft Inc. Studio Audio & Video Ltd reserve the right to change specifications without prior notice.

www.americanradiohistory.com

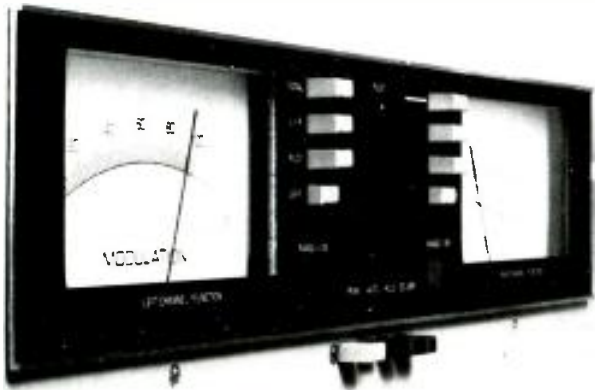

BELAR
STEREO MONITOR

You can measure...

with the best monitor and the most accurate test set.

The FMM-2/FMS-2 series monitors provide an even greater degree of precision measurement than ever before... **You can measure S/N below 90 dB, You can measure crosstalk below 85 dB, You can measure separations of better than 70 dB, You can measure frequency response to better than 0.25 dB, You can measure distortions to lower than 0.01%, and much more...** Our uncluttered panels and autoranging voltmeters make these measurements a dream.

BELAR CALL 610-687-5550 Fax 610-687-2686
ELECTRONICS LABORATORY, INC.
LANCASTER AVENUE AT DORSET, DEVON, PENNSYLVANIA 19333
Call or write for more information on Belar AM, FM, Stereo, SCA and TV monitors.

See us at World Media Expo, Booth #2815
Circle (82) on Reply Card



Connector panel used with a desktop non-linear system. Panel can be used on a tabletop or rack-mounted for easy connection. (Photo courtesy of Data Translation.)

on-line systems. Since then, these systems proved beyond any doubt that disk-based on-line editing could and would be happening sooner rather than later.

The real excitement around the industry is all about the emerging on-line capabilities of desktop, disk-based editing systems. Using advanced JPEG boards, some systems have achieved levels of quality that users are quickly deeming broadcast quality. In addition to the higher resolution, the new boards provide multiple streams of video and hardware assisted real-time color correction, dissolves, wipes, supers and fades. In a quest to move into more mainstream on-line applications, real-time titling and DVE functions will be offered in subsequent releases.

User-defined open platform non-linear editing systems

As the technology progresses and users and manufacturers gain experience, non-linear editing is taking place in environments that are being configured by users. The availability of high-quality video processing cards, high-capacity disk drives and powerful software programs will continue this trend. These flexible user-definable systems can be built by users, manufacturers or professional system integrators.

The design of these systems generally includes hardware and software from multiple manufacturers. Because many users are doing more than just editing, the flexible systems can be built with an editing, graphics, animation, audio and/or multimedia focus.

As technology advances, non-linear systems will continue to improve. Hard drive capacities and throughput increase almost daily while costs plummet. At a recent trade show, one manufacturer demonstrated just how far drive technology has come. A single drive was used to playback 60 field/second high-quality images. Admittedly, the drive was close to its limits and the compile time was considerable, but even a few months ago, this type of demo was not possible. As stated earlier, the question is no longer "Does it work?" But rather "Which works best for me?" With the wide range of capable systems available, its easy to find several to choose from.

bvs

D100 NTSC DECODER



**A HIGH END DECODER
WITHOUT THE HIGH END
PRICE TAG**

\$4950⁰⁰

- 5 MHz bandwidth
- 36 db subcarrier rejection
- 8 bit digital, adaptive comb filter
- NTSC and YC inputs
- RGBS, Y/R-Y/B-Y, YC outputs
- Pinnable sync on RGB outputs
- Digital control with recall
- Programmable filter weighting
- Optional remote control panel

broadcast video systems Ltd.

40 West Wilmot St., Richmond Hill, Ontario L4B 1H8
Telephone: (905) 764-1584 Fax: (905) 764-7438

Circle (83) on Reply Card

➔ For more information on non-linear editing systems, circle (305) on Reply Card. See also "Desktop Video" on pp. 60-61 and "Editing Controllers" on p. 62 of the BE Buyers Guide.

The one audio tester you can use in mixed company.

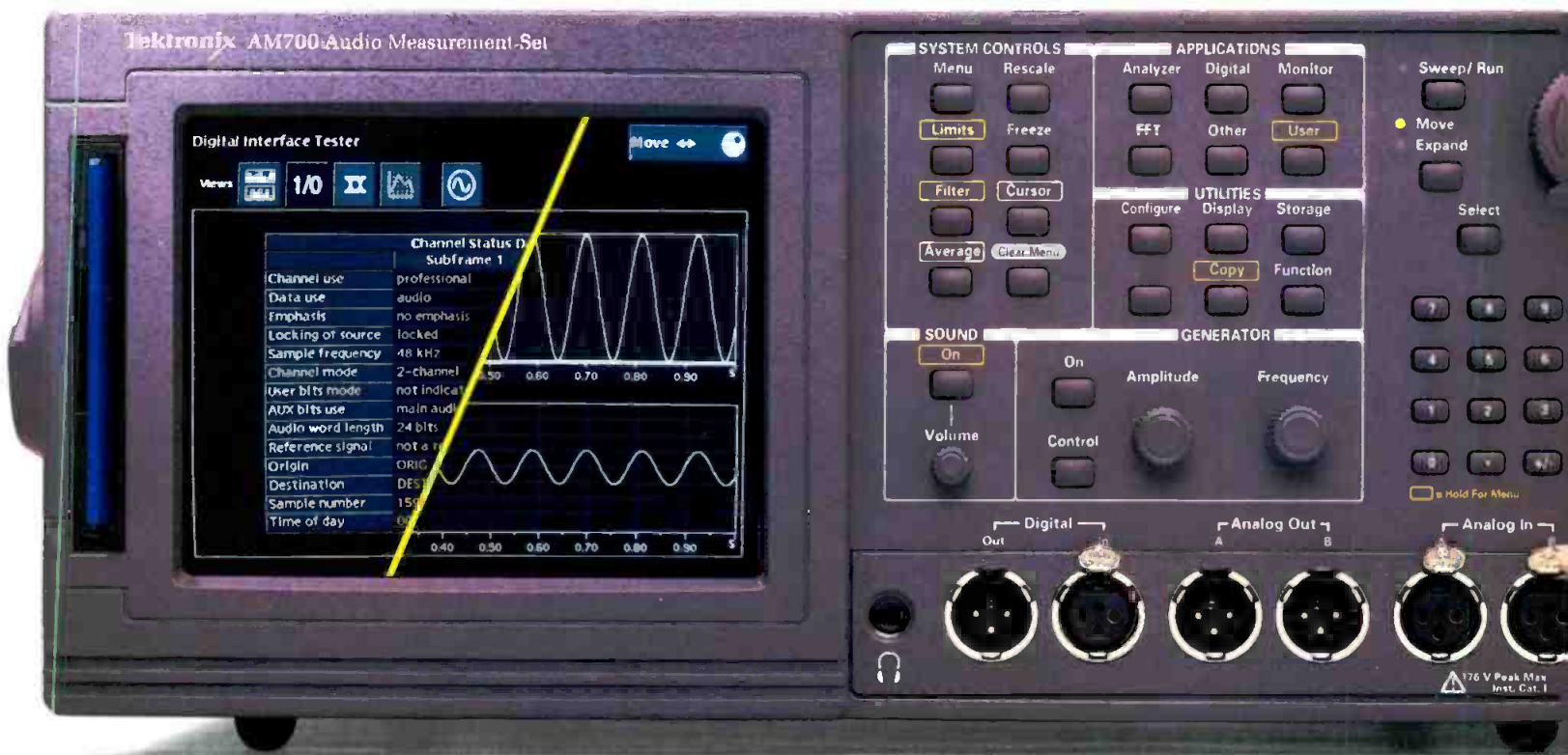

THE TEKTRONIX AM700. THE HIGH PERFORMANCE MIXED SIGNAL AUDIO TESTER THAT'S VERSATILE AND EASY TO USE. ■ Meet a real crowd pleaser.

■ The AM700. It's designed for virtually any audio test application—analogue or digital. Making it the perfect choice for testing car radios, recording equipment, radio and television audio broadcast systems, and more. ■ For starters, it's fast and easy to use. There are no complex commands to learn. Just a simple interface that guides you to any function you need. And a high performance processor that gets the job done pronto. ■ Plus, the AM700 lets



Input and output ports allow you to generate test signals for both analog and digital domains.

you work any way you want. Automatically, semi-automatically, or manually. It's ideal for design engineers working at the bench level, test engineers on the production line, and everywhere in between. ■ And it's

completely portable, too. Everything's included in one compact instrument.

■ No wonder it knows exactly what to do in mixed company. ■ Make an appointment for a demonstration by calling your local Tektronix sales office or call **1-800-TEK-WIDE ext.TV**

Tektronix

Circle (28) on Reply Card

www.americanradiohistory.com

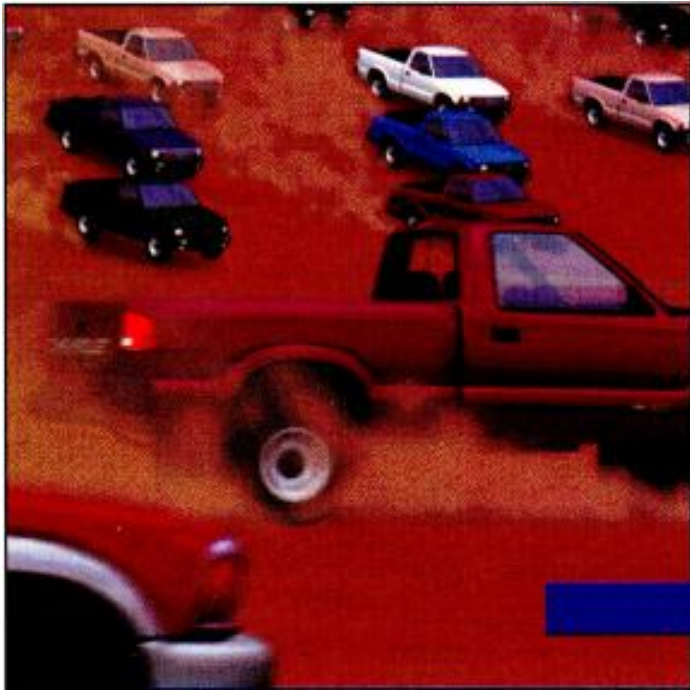

Linear editing systems

Recent reports of their death have been greatly exaggerated.

By Curtis Chan

The Bottom Line

As the industry continues to evolve, we are bombarded by those touting new technologies. Much of this new technology is of the better, cheaper, faster variety. Some, however, break with tradition and provide new solutions to old problems. In some instances the new solutions are clearly better, in others, they are simply different. Linear editing systems have a proven track record, and in the hands of a skilled operator, are highly efficient and remain a viable production tool.



Since the early days of commercial television, a variety of methods, including razor blades, have been devised to edit videotape. Despite this, the process remains less than perfect and the perfect editing system remains somewhat elusive. In the meantime, this article will address some of the issues confronting current linear editing systems in today's ever-changing world.

As a side reference just to make sure we're talking about the same thing, an on-line editing system has as its primary product a video program. An off-line editing system's primary product is an edit decision list (EDL) that is later used to assemble or on-line a video program in a separate procedure. The bridge between the two is the EDL. It contains the in and out points of the clips, information on the transitions between video segments, and other pertinent information.

Basic systems

Starting at the low-end, many companies offer value-priced systems targeting the VHS/S-VHS, Hi-8mm, U-Matic and low-end Betacam (SP) camps. These editors provide traditional A-roll, A/B roll and interformat A/B roll offerings. Traditional 3-VTR control via RS-422 9-pin is common at this level, as are systems using V-LAN control. Dedicated and computer-based units are available. In dedicated units, there is usually a layout similar to the edit and transport control panels associated with VTRs. Most controllers will have two search dials, one each for the recorder and player, which enable convenient VTR control. Transport con-

trol, source selection, and edit mode selection keys are logically laid out for ease of operation. For computer-based units, a monitor and keyboard take the place of the dedicated hard keys and status display. In both cases, tactile hard keys provide functionality. Many editors also allow for dynamic motion control of VTRs equipped with dynamic tracking. This allows simplified editing of slow motion and reverse picture material. Moving onward, basic systems at this level accept time code (LTC/VITC), control track and relative time code as editing references. Many systems allow each VTR to be set separately. Also, many systems can be gen-locked for synchronized operation.

Moving away from the cuts-only-type system, more sophisticated systems offer optional interfaces for effects switchers and audio mixers. With these options in place, a wide range of picture transitions can be accomplished. In fact, most low-end editors can control basic switcher functions including crosspoint assignment and transitions referenced to the edit number. Audio can also be controlled via a parallel or serial interface. Last, GPIs enable basic control of peripherals, such as audiotape recorders, title generators and other equipment.

Mid-priced bargains

Moving upward to the high-end corporate and low-end post off-line/on-line systems, there is a general split in direction. The split is between the traditional stand-alone editor and the new multifunction systems comprised of integrated editor, effects switcher and audio mixer.

In the dedicated and PC-based systems, common functions are broken down into

Chan is president of Chan and Associates, a marketing consulting service for audio, broadcast and post-production, Fullerton, CA.

**WHEN IT CAME TIME TO OFFER
A BONUS WITH OUR
A82 AND A83 SWITCHERS, WE KNEW
YOU'D WANT SOMETHING OUTRAGEOUSLY
VALUABLE AND TOTALLY WARPED.
SO WE'RE GIVING IT TO YOU.**

You want something incredibly valuable? Buy our A82 or A83

Digital Switcher with a 100 second Cache Recorder. Its multi-element
timelines give you visual, independent control of effects on each
section of the switcher plus the A57 or any other peripheral devices
under switcher control.

Then, get this.

We'll throw in an A57 Digital Effects System—FREE.*

That's tens of thousands of dollars worth of every effect imaginable.

Not to mention some unimaginable.

But call soon. Even our switchers can't make the A57 price tag

dissolve forever. Offer expires 9/30/94.

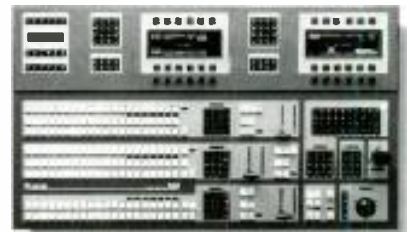

Abekas
A Carlton Company

a radical
departure

*Buy an A82 or A83 standard (2ME) Control Panel 100 second Cache Recorder with LINC and receive the A57 Standard System and Control Panel free. No other discounts apply.
For Details: 415 369-5111 • Atlanta 404 451 0637 • Chicago 708 699 9400 • Dallas 214 385 4544 • Los Angeles 818 955 6446 • New York 515-939 9000 • San Francisco 415 599 3078

Circle (29) on Reply Card
www.americanradiohistory.com



One of three CMX Omni 1000s installed at Digital Magic, Santa Clara, CA.

five categories: 1) VTR/equipment interfaces, 2) switcher interface, 3) audio mixer interface, 4) control interface and 5) edit list management.

The VTR/equipment interface allows versatile machine control in various editing configurations using either RS-422 or V-LAN. In some systems, up to 12 VTRs can be connected, with any six controlled simultaneously. Dynamic motion control is available at this price range as is full

recorder assignment. Because VTRs of this level usually have 4-channel audio, many editors in this price range can independently control all four channels with full audio split capability. In fact, most can assign the four audio channels with separate timing parameters by setting preset values or by marking splits for individual channels. Color framing options are usually available as well. Time-code source selection of each VTR can be handled as can discontinuous time code. If VTRs have pre-read capability, this class of editors can provide two machine transitions with live pictures on an edit by edit basis. GPIs are also provided for CGs and ATRs and

GPIs can be activated multiple times during edits.

For sophisticated effects in post, interactive communication between the edit controller and the switcher is essential. At the basic end, editors of this class can control crosspoint assignment, wipe pattern recall, keyers including downstream keying functions, and M/E attributes. Also, expect to find sophisticated snapshot and recall capabilities as well as monitor switcher control.

On the audio side, most editors support serial and parallel modes of control. For instance, ESAM I and II can be supported via the 9-pin serial control port along with a variety of other mixers using a 15-pin parallel interface. New to the editing scene are professional DAT machines and many editors have interfaces that allow for their control. In addition, with memory options fitted to some DAT machines, memory jog and variable program play functions can be accessed.

Expect also to find improved human interfaces at this level. In the dedicated and PC-based systems, improved screen displays complemented with well laid out key assignments and the use of a multifunction joystick or control knob adds to productivity. Programmable function keys and assignable (on-the-fly) macros are a plus as are pop-up interactive help menus. For easier operation, pop-up menus combined with a comprehensive graphic display can show the current edit status at a glance. Other features may include two edit windows for running different edit scenarios, pop-up time-code calculators and auto program run-time calculators as well as menu-driven switcher control and event time line displays.

Edit list management is essential. Good editors provide facilities to store, review and modify edit data for efficient editing. Along these lines, the ability to import

and export major EDL formats (CMX, Convergence and others) is a must. So too is the ability to have single key recompute and backtime operations, multiple EDL bin windows, and the ability to modify, clean and sort EDLs efficiently. Finally, most editors have event memories where event files can be stored along with notes and remarks for each edit. These files can be stored on internal hard drives and floppy disks for recall and/or use later.

On the other end of the mid-priced spectrum are fully integrated editor systems. These systems trade off the ability to mix and match video switchers and audio mixers for dedicated all-in-one solutions. To shorten the learning curve, keys and buttons are logically grouped by function and usually color-coded for quick identification. To simplify operation and minimize button/key clutter, most units also have a push-to-change (multifunction) style jog/shuttle dial. In addition, many have the ability to display multiple modes of operation simultaneously. Because these systems have an integrated switcher, built-in frame synchronizers and an internal blackburst generator make installation a snap. Most units support composite and Y/C, adding to their versatility. Along with combining multiple effects from the internal switcher, many of these units have a chroma-keyer and a luminance keyer. Add to this the ability to do color correction and you have nearly unlimited versatility for scene creation. To this we add audio mixing. Aside from audio split capability, some units sport aux and mic inputs for flexible audio mixing of background music, effects or vocals.

Money-is-no-object systems

Continuing upward into the nose-bleed category, we find ourselves in the company of editing systems that help set the standards. These editors follow the golden rule of excess in features and performance. Expect to find a well-balanced system concept approach in this category. Although these systems still have to interface to third-party equipment, optimized interfaces and evolutionary software provide near-seamless integration to many vendors' products. In addition, expect to find well-thought-out modular expandability and solid functionality including: learn functions, keyframe effects, advanced preview functions and color correction.

First, fast processing speed is essential to create the illusion of hardware transparency. Editors in this class either use dedicated hardware or fast PC-based systems. In the case of dedicated systems, individual CPUs are used for program number crunching/housekeeping and I/O processing. System expandability and flexibility is a must. Expect to find optional

Trade In Your Editor!

Limited time offer!!

Your old PALTEX or other on- or off-line edit controller may be worth a substantial cash credit toward the purchase of a new professional SES Editing System.

Call today to find out how easy it is to get up and running with one of the world's finest and most popular editing systems!

Strassner Editing Systems

10419 McCormick Street, North
Hollywood, CA 91601
(818) 508-6966 Fax: (818) 508-8588

Circle (30) on Reply Card

interfaces to many of the major recorders, switchers, DMEs, audio mixers, monitors, color correctors and still-stores. Also, mix and match VTRs and ATRs for perfect editing synchronization and unsurpassed control of digital and analog recording devices. Some units can control up to 14 VTRs in any given edit. Player/recorder reassignment is easily accessed from the keyboard and a temporary REC function is also available in most units, both important tools for the efficient creation of multilayered scenes.

Another interesting note is that many high-end systems give users the choice of ASCII (QWERTY) keyboard(s) or well-thought-out dedicated one(s). As mentioned, this class of editors also has sophisticated monitor switcher and color-correction interfaces. For monitoring audio and video, such control provides an advanced preview function that simplifies multigeneration editing. The color-correction interface results in the ability to store and recall color-correction parameters in an instant. Expect also to find a floppy disk system capable of not only storing and retrieving EDLs but the operator's personal setup as well. Many systems also sport an internal hard disk drive to save/load EDLs as well as set up data. On the user interface side, color

displays are the norm and different colors can be chosen to differentiate between functions and status displays. To aid in editing, many systems also have character superimposition (composite and component) so that time-code data, editing status and other pertinent information can be displayed on the master monitor and the submonitors for each VTR. Last, full edit list management is standard, including trace and clean functions. EDL memory capacity is upward of 10,000 edits/lines, with upward of 16 different EDLs supported in the internal memory. Of course, these limits can be expanded by the addition of an internal or external hard disk drive. Finally, high-end systems usually have extensive on-line help menus and diagnostics to aid in system operation and maintenance.

Conclusion

Production and broadcast facilities have different requirements and it is those requirements that will determine the direction of the current technology. The future will see linear and non-linear solu-



A Strassner SES-2050 in the linear post-production suite at the Post Place, Calgary, Alberta.

tions employed to meet the various applications of the production and broadcast industries. ■

Editor's note: The author would like to thank Norm Strassner, president of Strassner Editing Systems; Russell Srole, president of Editing Technologies Corporation and Verner Dixon of Chan & Associates for their help with this article.

➔ For more information on linear editing systems, circle (300) on Reply Card. See also "Desktop Video" on pp. 60-61 and "Editing Controllers" on p. 62 of the *BE Buyers Guide*.

DISPLAY INTELLIGENCE

Tally Display Corp. offers the technology to keep track of all your sources. Automatically. With interactive alpha-numeric displays that continually change messages, color and intensity in response to different status. It's a clear display of intelligence.

Whether programmed to interface directly with your router, automation system or from a stand-alone PC, TDC displays continuously up-date themselves for accurate and efficient operation. In addition to source ID, the displays provide source status, machine assignment status, tally and multiple message capabilities.

TDC displays feature 1" high characters and are available in 18, 13 and dual 9-character widths. Economical static displays are also available for less demanding applications. And for when space is an issue, TDC offers displays that are only 0.7 inches deep.

Display intelligence in your control room. With interactive displays from TDC. For more information call 914-365-6393, or fax 914-359-7078.



Circle (31) on Reply Card



Upgrading TV studio lighting

New lighting technology can improve your station's look and bottom line.

By Brad Dick, editor

The Bottom Line

Many of the lighting systems now in TV studios were installed some 20 years ago when the technological demands were quite different. For instance, today's cameras need far less light than did those of yesteryear. This, combined with the need to improve a station's on-air-look and the opportunity for lower power bills, has encouraged many TV stations to replace or upgrade their lighting systems. In many cases, the savings in operating costs alone can quickly cover the cost of a new lighting system.



Lighting systems are an area of TV production seldom given any thought once they are installed. Stations may have the same system they installed when they switched to color. Parts of the system may be even older, dating back to the days of black-and-white TV production. Fortunately, the early systems were fairly reliable and many work fine for some stations today. However, as technology changes, so do the needs and demands placed on a TV production studio's lighting system.

Why mess with it?

The first question often asked is why even consider changing a studio's lighting system if it's working? The answer is complex and simple. The complex answer is based in the new technology available for lighting systems. Nowadays, there are many ways to light a set, from the traditional incandescent system to an RGB approach. Any station looking to improve its on-air look may want to consider changes in the lighting system.

The simple, and most common, reason why a lighting system needs to be upgraded relates to another area of technology — cameras. If your facility changes cameras, you may need to update your studio lighting. In fact, this is the most common reason TV studios upgrade their lighting system. Let's see why that's important.

The old-style (circa 1970) studio cameras used to require approximately 150fc of light. This light level was usually specified at what is called setup level, usually f4, which was the setup level specified by camera manufacturers. This is a high level of illumination, as anyone who's had to sit in front of them for any period of time will tell you. The lights were extremely bright — and hot.

Although today's cameras offer many improved features and performance, it's their ability to operate properly at reduced lighting levels that allows for many changes in the studio lighting. Cameras today are typically capable of operating at 50fc with the lens set at f4. Some shows, for example the "John Larroquette Show," use even less light, with light levels of 30fc at f3. Such a dramatic decrease in

Continued on page 56



KVBC-TV, Las Vegas, installed the first focused VIDESENCE SRGB system in 1993. The system provides 125fc for each talent zone. The entire studio lighting system requires less than 4kW of power.

ENERGY SAVING EEV IOTs

...the tubes with the proven track record!

EEV has been a prime mover in energy efficiency improvements throughout its involvement in the US UHF television industry. One of the most recent technologically advanced products added to the EEV range is the high power UHF TV IOT. In addition to its energy saving features, the EEV IOT has shown that it is ideally suited to combined amplification transmitters for conventional NTSC service, together with the requirements of digital HDTV transmission.

EEV IOTs follow the Company's established philosophy of providing customers with products that are user friendly, while satisfying their technical requirements. This, together with applications engineering support and a reputation for service second to none, has established EEV as the market leader.

Why not contact EEV today to find out how you can save up to 50% on your electric power bills.



IOTs are presently available for 40kW and 60kW visual service and combined amplification powers of up to 42/4.2kW.

EEV Power Tubes

USA: EEV Inc, 4 Westchester Plaza, Elmsford, NY 10523
Telephone: (914) 592 6050 or 'Toll Free' 1-800-DIAL-EEV
Fax: (914) 682 8922

UK: EEV Ltd, Waterhouse Lane, Chelmsford, Essex CM1 2QU, England
Telephone: (0245) 493493 Fax: (0245) 492492

CANADA: EEV Canada Ltd., 67 Westmore Drive, Rexdale, Ontario M9V 3Y6
Telephone: (416) 745 9494 Fax: (416) 745 0618

FRANCE: EEV France, Division Tubes Electroniques et Optronique de GEC France s.a.
2 Rue Henri Bergson, 92665 Asnières, Cedex
Telephone: (331) 4080 5400 Fax: Paris (331) 4733 1131
Subsidiary of the General Electric Company plc of England **sbc**

Circle (39) on Reply Card



0-3 DIGIT

For more information call: 1-800-528-8601 (Upon request enter product code 04) One Panasonic Way, Secaucus, NJ 07094.

www.americanradiohistory.com

The Wide, Wide World of D-3.

Consider the world-class caliber of customers who rely on D-3. Virtually all of NBC's prime time programming airs on D-3. 90% of the BBC's air-time is transmitted over D-3 VTRs. Televisa, the world's largest telecaster, uses D-3 for 80% of its production and 100% of on-air playback. USA Networks utilizes digital M.A.R.C. systems for automated playback of all on-air programming and commercials. ESPN deploys D-3 VTRs for time zone delay of its international programming. At the local level, stations like KIRO-TV in Seattle, Washington, facilitate on-air playback with a digital M.A.R.C. machine.

Selecting a D-3 digital video recorder for your facility simplifies design and implementation into existing systems and maximizes all the quality of composite video. (Installing component video recorders in a composite environment can actually *reduce* the quality of pictures.) With D-3, broadcasters large and small enjoy the format's superior specifications, such as full bit rate recording (with no artifacts from decoding and compression), four hours of record time from one cassette, and upgradability to D-5 component digital, widescreen television and HDTV.

For today and tomorrow, whether your business interests are near or worldwide, D-3 is the first choice in composite digital video. From Panasonic. First in Digital Video.

Panasonic
Broadcast & Television Systems Company

the amount of light has a tremendous impact on the requirements of the lighting system.

After installing new cameras, it's time to adjust the lighting. At first that may seem relatively easy. But in fact, it is not. Whether to keep your old system or replace it is not an easy decision to make. Let's look at the two general approaches. First we'll consider reusing many of the old components in a facility's lighting system. This is usually the least expensive approach.

Modifying an old lighting system

Although there are ways to reuse some of the components in your old lighting system, changes need to be considered carefully. It's not as simple as it might first seem. The first task is to reduce the amount of light on the set. In general, there are two ways to accomplish that. The first approach would be to reduce the amount of light from each fixture. This helps reduce the number of physi-

cal changes needed. The second is to use the dimmer system to adjust the lighting level.

The old fixtures can be reused by replacing the lightbulbs (that's globes in the lighting business) with smaller wattage devices. Replacing the typical 2,000W globe with a 1,000W device lowers the light level by 50%. However, the process is not as simple as changing out the bulb. Let's look at the physics of replacing a globe in a typical spotlight.

A spotlight is designed to do exactly what the name implies, project light into a small area (spot). The fixture radiates a beam of concentrated light along a single path. Figure 1 illustrates how a spotlight works. Light first radiates from the globe's filament, bounces forward from the reflector and enters the fresnel lens. Although the light rays enter the lens from a variety of angles, the lens is designed to focus the light into a single beam.

It may seem a simple matter to replace

the existing globe with a smaller device, but the results may not be what you desired. In Figure 1, note the line marked LCL, (light-center-length). Pay particular attention to the spatial relationship between the placement of the filament, center of the reflector and the center of the lens. This straight line between these three points is called the LCL.

It is possible to reuse an old fixture with a smaller globe. However, the proper LCL must be maintained. This can be accomplished with a simple adapter, called a riser.

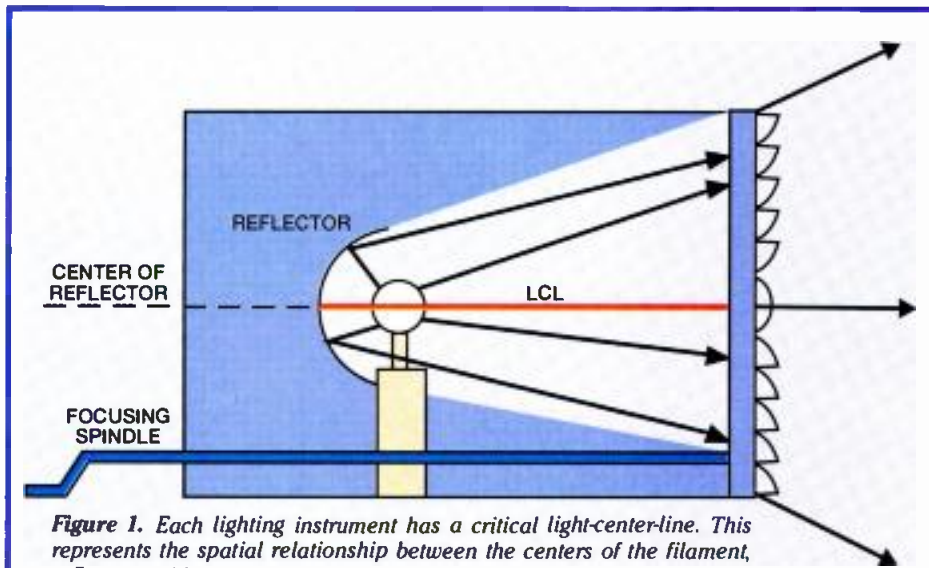
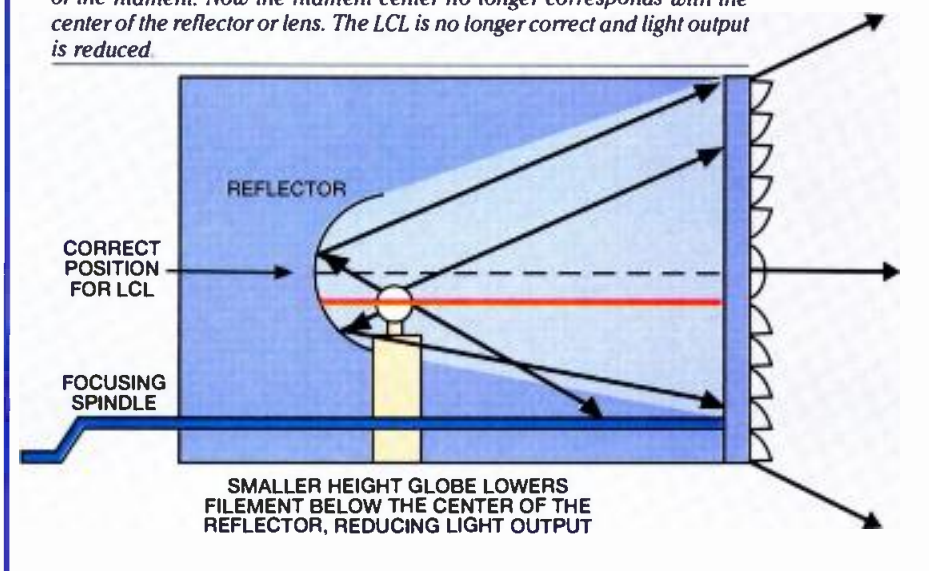

Figure 1. Each lighting instrument has a critical light-center-line. This represents the spatial relationship between the centers of the filament, reflector and lens.

Figure 2. Replacing a globe with a physically smaller one can create problems as shown here. The smaller height globe has lowered the center of the filament. Now the filament center no longer corresponds with the center of the reflector or lens. The LCL is no longer correct and light output is reduced.



Replacing the globe with a smaller device changes this important parameter. Figure 2 shows the original fixture with the new, smaller globe. Note that the new globe is shorter than the original globe. Now the distance relationships between the filament, the reflector and the center of the lens has been changed. The spotlight no longer operates as efficiently as it was designed.

It is possible to reuse an old fixture with a smaller globe. However, the proper LCL must be maintained. This can be accomplished with a simple adapter, called a riser. This adapter will ensure that the original LCL for that instrument remains the same with a smaller globe. Using the riser places the new globe in the proper position so the fixture operates properly. This technique will allow you to reuse old fixtures at lower light levels without sacrificing their performance characteristics.

Dimmer systems

The second solution to the need for lower light levels might be to merely dim the lights. This is seen as the simplest solution, but there is more involved than reducing the amount of current in each globe.

Although the light level will be lowered, so too will color temperature, which is an important parameter. Dimming a light to approximately 70% of its standard output of 3,200° K will reduce its color temperature about 600°. Trying to use a camera properly aligned to operate at 3,200° with an actual set level of about 2,600° is guaranteed to make everyone "red faced," including you. If you dim the lights, you have to color correct.

The error in color temperature can be corrected with a color-correction medi-

DID YOU SAY ODETICS DISK SYSTEMS?

The CacheMachine™ From Odetics. The Automated On-Air System for Today and Tomorrow.

You've heard lots of promises about play-to-air disk systems. But only Odetics, a world leader in on-air presentation, gives you the first real-world disk solution for today's television station. With a new system called the CacheMachine.

The CacheMachine overcomes the barriers to successful on-air play from disk — without forcing you to go backward in station automation. It allows you to play programs as well as commercials automatically and cost effectively. It provides support for multiple channels from a single system. You don't have to abandon your present technology or change your format. And you don't need a crystal ball to tell you which data compression format will become standard.

How is this possible? Because the Odetics CacheMachine uses a technique called *disk caching* to maintain your valuable commercials on archive tape in an uncompressed format for a fraction of the cost of archiving them on disk. Then the spots are automatically loaded into a disk recorder, which later plays them to air on one or two channels — with all the speed and flexibility that disk provides.

Experts agree the CacheMachine is today's only real-world disk automation solution. But there's not enough space here to tell you all its great benefits. One thing's for sure. You can't afford to make a decision or an assumption about on-air automation until you talk to Odetics.



Director of Sales
Bill Keegan
(714) 774-2200

Northeast
Ray Baldock
(201) 305-0549

Southeast
Emerson Ray
(813) 960-0853

Odetics
Broadcast

© Odetics 1994 BD7654

West
Chuck Martin
(818) 999-9796

North Central
Bill Boyd
(612) 894-2121

South Central
David Scally
(404) 917-9506

Circle (42) on Reply Card

www.americanradiohistory.com

um. However, this can be a tricky process. If you decide to use the dimmer approach be prepared for a lesson in lighting design. (Editor's note: Correcting for color temperature error with filters and correction medium is beyond the scope of this article. Contact your lighting designer for more assistance or circle the Reader Service Number at the end of this article for additional information.)

RGB lighting

So far all we've talked about is incandescent lighting. Though that's the standard for Hollywood, TV production is finding that a new type of lighting offers many features.

Sometimes called sustained red-green-blue (SRGB) lighting, the patented process and its products are manufactured by VIDESSENCE. The illumination is produced by operating trichromatic fluorescent lamps with high-frequency electronic ballasts.

Although the light is being emitted from fluorescent lamps, it does not fit any definition of fluorescence — the primary difference being that SRGB lighting is far

more intense than fluorescent light.

The light is of constant intensity and presents 100% relative spectral energy (visible light) from the mouth of a fixture. The color temperature of SRGB lighting is



Modern CCD cameras and new lighting technology allow designers to creatively light video sets without cooking the talent under sun-level illumination. (Shown here is the news set at KPFX-TV, Phoenix, AZ.)

absolutely constant and set by the chemistry of the lamps. Spectral color temperatures of 3,000K, 3,200K, 4,100K and 5,000°K are available.

Although the technology offers several important advantages, three deserve particular consideration for TV applications.

First, these fixtures produce only red, green and blue light in consistent form, representing the perfect stimulation for modern CCD cameras. Second, compared to incandescent lighting the SRGB lamps are efficient, producing 90+ lumens per watt. A typical SRGB lighting system requires only 10% of the power and produces only 5% of the heat of comparative incandescent systems. Third, a complete line of accessories is available including optical films, control screens and a variety of mounts and hardware to solve most lighting problems.

Although it is possible to mix SRGB and incandescent lighting, keep in mind the different technical aspects of the two systems. The lighting director must be well-versed in both technologies in order to obtain the creative options desired.

Reports on SRGB lighting suggest lower operating and maintenance costs. One TV station claimed to have saved \$100,000 over five years in utility bills. In addition, stations can often receive a sizable rebate from the utility company because of the reduced power demand.

80% Digital

0% Fat

100% Fiber



FIBOX



Keeps Your Audio Signals Regular Over The Long Haul.

Even Over Short Hauls It's a Remarkable, High Quality Microphone, Pre-Amp, and 20 BIT A/D - D/A Converter —All In One Affordable Package.

- 2.5 Miles transmission distance
- Eliminates RFI & EMI interference
- Eliminates Ground Loops & 60 cycle hum
- 108 dB dynamic range (A Weighted)
- 48V Phantom power
- 70 dB continuously variable gain control

- Field powered by 12Vdc
- Frequency Response .1hz - 21.5 Khz
- \$1499 Stereo pair transmit - receive

Call your local rep or dealer for more information. Or for a demo call.

LIGHTWAVE SYSTEMS, INC.

900 Jackson Street, Suite 700, Dallas, Texas 75202 ♦ Phone (214) 741-5142 ♦ 1-800 525-3443 ♦ Fax (214) 741-5145

pro-bel

At the *Heart* of your System



Digital Test Equipment



Control Panels



Signal Processing & Distribution

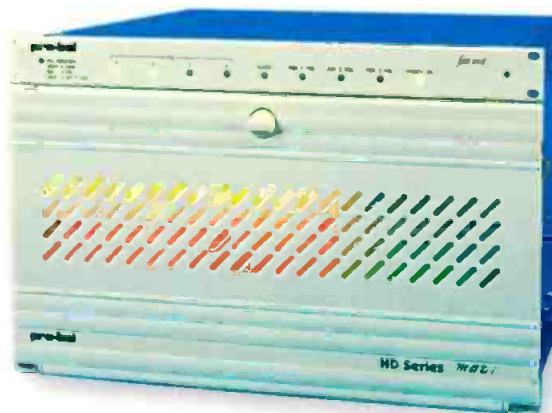

HD Series Routers



Trilogy Commander Intercom



Procion Control Systems

The **pro-bel** Group of companies – Pro-Bel, Procion Innovative Control Systems and Trilogy Broadcast combine their resources to bring you complete systems capability.

- ♥ ANALOG A/V ROUTERS
- ♥ DIGITAL A/V ROUTERS
- ♥ INTERCOM SYSTEMS
- ♥ TOUCH SCREEN APPLICATIONS
- ♥ MODULAR TERMINAL EQUIPMENT
- ♥ PROTOCOL CONVERTERS
- ♥ SYNC PULSE GENERATORS
- ♥ USER FRIENDLY CONTROLLERS

AND MUCH MORE

pro-bel

4480 North Shallowford Rd.
Dunwoody, GA 30338-6410

Telephone: (404) 396-1971
Fax: (404) 396-0595

Atlanta • San Francisco • Boston • Orlando and growing!

Circle (73) on Reply Card

www.americanradiohistory.com

Finally, because of the SRGB system's different color temperature, the talent must use specialized makeup (available from the manufacturer). This is one of those fine points that must be included when discussing lighting changes with management and talent.

Building a new set

Often times, the arrival of new cameras, and the resulting need for lighting changes, encourages a station to build a new news set. This approach affords the station or production facility the maximum flexibility in overall set design. It also eliminates the problems that are associated with applying fixes to old hardware.

If you're in this fortunate position here are several guidelines to keep in mind. First, try to stay within one manufacturer's line of products. While manufacturers will claim their products are directly interchangeable, that's not always the case. The lighting product companies that have been around for a while all have good products and offer a wide variety of accessories and features. So once you've selected a vendor, stay with it. The exception would be when intermixing RGB and incandescent instruments. You would still want to select a single vendor for both types of technology and remain true to their products.

Second, decide if you need a lighting consultant. The answer to this question may depend on the talent available from your own staff. Smaller stations or teleproduction houses probably won't have anyone knowledgeable enough to assist with the overall design process. Large stations, or those in the unique position of having someone who's been around a while, may be able to get by with their own expertise.

You don't need to have all of the work done by someone else. A consultant can tackle any part or all of the project. Some stations initially bring in the expert to meet with the staff to help set operating specifications. Once the consultant understands the operational demands and the types of shows needed to be produced, he can create a general specification, which is then used to develop the parts list for bidding purposes.

Typical systems

Many features are available on modern lighting systems. Let's look at some of those most useful for local production applications.

The dimmer system can be as simple or as complex as you desire. Modern systems can even be interfaced with automation systems. For instance, it's possible to have the system reconfigure auto-

for the set. Don't skimp on the AC. Plan on providing 400-800A per phase of 3-phase power for the lighting system.

Even if you're short on floor space, there are ways you can still have a lot of flexibility, but it comes at a price. A motorized grid can be installed, which makes lighting reconfiguration a snap. Another trick would be to place the news set on a wagon and move it out of the way for most of the day. This would free the entire studio for production work.

Such capability could be accomplished with as little as a 60-foot x 60-foot space with a 25-foot high ceiling. Add to this 92 dimmers, a portable rack-mounted console and you have a highly flexible system.

Sophisticated, fully automated systems are now possible. Several manufacturers offer lighting systems that completely reconfigure the set without human intervention. Lighting levels, positioning and location are all changeable with such systems. Although such a complex system would be highly unusual for TV stations, parts of such automation may offer creative options worth investigating.

As TV studios improve the electronics, the demands of the lighting system change also. In most cases, the new technology can actually save a station money over time. The lower lighting levels save power and can reduce maintenance costs.

Perhaps the most important reason to re-examine your lighting system is your station's future. Broadcasters need to re-emphasize their strength of programming, not just delivery. In many cases, this will require the production of that programming, whether it be news or variety shows. Modern lighting technology will allow you to meet the needs of this expanded production capability easily and cost-effectively.



Incandescent lighting systems are familiar to most production staffs, which is sometimes an important element in the decision process. An example of a highly effective incandescent design is illustrated by the news set at KTHV-TV, Little Rock, AR. (Photo courtesy of Devlin Design Group, copyright 1994.)



The contemporary look of the WJAR-TV news set illustrates how SRGB lighting system can be effectively used in a TV studio. The Devlin Design Group received an Emmy for the design of this news set in May 1994. (Photo courtesy of Devlin Design Group, copyright 1994.)

matically the lighting first for the noon show and then again for the 5 p.m. newscast. Although you may not need automated dimming, do plan for sufficient capability in the beginning.

Design the initial system for 48 dimmers. Using any more will require additional power and probably be overkill for most TV studios. Don't select dimmers greater than 2.4kW. You don't need them. Also, given that you don't need sun-level lighting, stay with 2,000W or smaller fixtures. This combination provides a margin of safety and will afford plenty of light

Acknowledgment: Appreciation is expressed to Alan Walker, Alan Walker Associates, and Paul Costa. VIDESENCE for their help with this article.

➔ For more information on TV studio lighting, circle (302) on Reply Card.

There's A New Way To Store And Retrieve Digital Video In Real Time.

Introducing The Spectra 6000 Disk Array.



An Authorized Silicon Graphics
Independent Hardware Developer

Visual computing just got a whole lot easier. By taking an open system approach to storing and retrieving digital video, Ciprico's Spectra 6000 disk array delivers real-time performance together with unmatched flexibility.

Seamless integration with Silicon Graphics workstations give you the flexibility to switch between digital video applications, i.e. from paint to composite to animation to on- or off-line editing. This impressive versatility eliminates the need for "dedicated use" digital disk recorders (DDRs) and can save you plenty.

Spectra 6000's performance characteristics redefine the concept of productivity. Standard SCSI-2 drives support real-time data transfer rates. Plus, now you can work with storage capacities of *several minutes* of on-line digital video (as

opposed to the old DDR capacity limitations of under a minute!). Each array can provide up to 16GB of storage and can be combined with other arrays for additional capacity. Spectra 6000's fault tolerant design and optional redundant power supply assure continuous on-line performance and no loss of data.

For more information about the Spectra 6000 disk array—the *new way to store and retrieve digital video*, call us at **1-800-727-4669**.

In the USA
2800 Campus Drive
Plymouth, MN 55441
1 800 SCSI-NOW (727-4669)
In MN: (612) 551-4000
Fax: (612) 551-4002

In Europe:
7 Clerewater Place, Lower Way
Newbury, Berkshire RG13 4RF
England
(44) 635-873666
Fax: (44) 635-871996



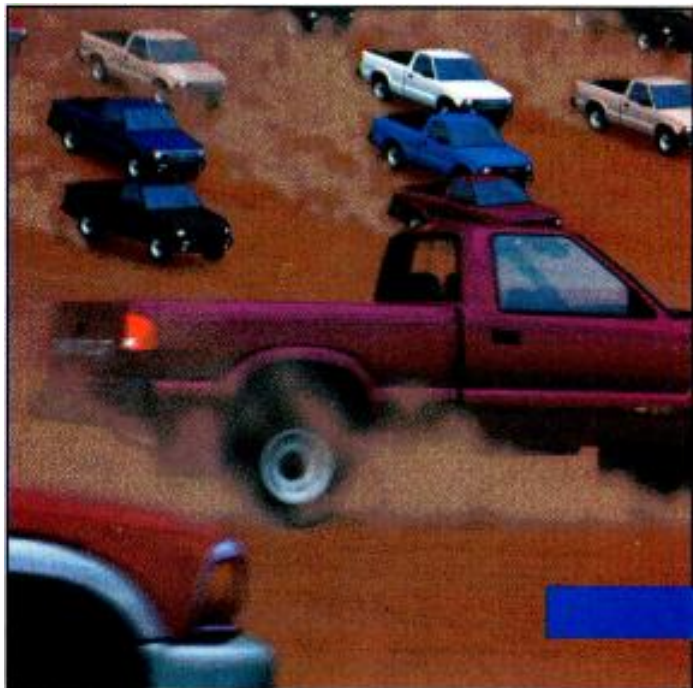

Production facility software

Computerizing the facility management process can improve profitability.

By Chris Leonard

The Bottom Line

There isn't a TV station, cable system or post-production facility that has enough money or time to purchase or accomplish all that it wants. Therefore, choices must constantly be made to get the most output from the least input, as applied to staffing, dollars and time. Automating the business operations of a facility can make such optimization consistently possible, even in the face of changing market conditions.



A new study by Brynjolfsson and Hitt of MIT's Sloan School of Business reports an 81% gross return on investment (ROI) for computer capital investments by major manufacturing and service companies. Compare that kind of return to what your production switcher, satellite uplink or telecine operator offers. Even if you believe that this statistic doesn't apply to the broadcast industry, cutting the percentage in half still commands inspection.

Although this doesn't imply that a business should take all its capital and invest it in computers, it does point out potentially excellent new investment directions. Given the amount of capital and operating costs that are involved in running facilities, it makes obvious business sense to maximize your current and previous investments' value and focus on future ROI. Well-planned computerization of facility operations can help do that.

Start by asking yourself a few basic questions:

- What is my most profitable department or function?
- How can I make my staff more effective?
- How much am I losing in equipment downtime or lost billings?
- What future revenue stream is the most promising?

A good facility management system should help provide clear answers to these questions and more. ROI should

provide you with the tools to maximize all your resources and investments.

Other qualitative factors that should be considered include the following:

- What are my growth plans, and do my current operations support this growth?
- Can I easily produce and retrieve crucial business tracking data?
- Are my clients (internal and/or external) happy with my operations?

A new MIT study reports an 81% gross return on investment for computer capital investments.

Although intelligently automated facility operations alone probably won't pull in clients, lack of good customer service due to slow or sloppy operations certainly can chase clients away.

The expression that "nothing worth having is free" is especially true for computerization. Implementing or changing systems is painful, but the quantitative and qualitative returns may be worth the effort.

Where to begin

The smarter you are in designing your computerized operations system, the more benefits you'll reap from it. The essential starting point is a thorough *needs assessment*. This is the time to get people involved, including man-

Leonard is a technical writer based in Englewood, CO. Respond via the BEFAXback line at 913-967-1905.

This Isn't A Job For Your Regular Babysitter.

Let the VRC-2000 watch your remote transmitter site.

This is Mary Beth, your babysitter. Sure, she's great at tossin' a frozen pizza in the oven, finding *Knot's Landing* reruns, and tucking the kids in. But would you trust her with your "baby" at the transmitter site? With millions of dollars of equipment and thousands of dollars of FCC fines and downtime at stake, watching over your remote transmitter isn't your average babysitting gig.

The answer is the VRC-2000 Remote Control from Gentner. It not only monitors your transmitter, it can make changes for you automatically. If something goes wrong, it calls you or your technical staff to report the problem. Usually the problem can then be fixed by the VRC-2000, as you talk to it through your phone or your PC. Plus, you can access the VRC-2000



from virtually anywhere. It's like having a person on duty at your remote transmitter site 24 hours a day, only it's more reliable and won't get cheese on the equipment.

Utilize the VRC-2000 to monitor and adjust everything you need at your transmitter, then relax — the babysitter's on duty.

Call 1-800-945-7730 for more VRC-2000 information. And while on the line, ask about Gentner Conference Call Services.

 **Gentner**

The World Leader in Broadcast Telephone Interface Products

ment, staff and clients. The more initial input and staff involvement you generate, the better the later phases of the project will go.

Take a look at all your resources, forms and styles of doing everyday business. Be thorough and inclusive. From these initial investigations, establish a written list of objectives, an initial timetable and a detailed system criteria. Although these criteria are likely to change as the process moves forward, it is important to focus on the goals and be open to some possible operational changes that may be generated. This document will provide an invaluable point of reference for all involved.

Next, designate a dedicated project leader. Computerizing operations is a major endeavor, and there must be one person who will oversee this process from the planning stage through implementation and final refinements. This person should be familiar with computers and fully understand the workings of your business.

Concentrate on maximizing ROI throughout the process. A first step in this respect involves determining the right type of system for your business.

Three approaches

to computerization

There are three general methods of automating facility operations. The first combines manual systems with some off-the-

*The expression that
"nothing worth having
is free" is especially
true for
computerization.*

shelf management software packages, running on stand-alone or networked PCs. Until recently, this was probably the most common approach, and it attained varying degrees of success. The ideal environment for this method is a small business, where the information flow is limited, direct and informal.

One key advantage to such an off-the-shelf system is its initial low cost. Basic software programs such as Filemaker Pro and Quick Books can help get a small operation on its computerized feet. Soft-

ware development tools like Lotus Notes and Visual Basic have become much more sophisticated in recent years and can help a small operation gain some degree of customization. Accounting packages like ACCPAC can help set up basic accounting procedures. This approach is normally user-friendly and it allows easy initial set up and training.

There are, however, many limitations to this approach. Growth potential is quite limited, as are support and service. These vendors are generalists. Because they must support an almost endless number of industries, they are rarely familiar or sympathetic to any specific industry, much less your specific business needs. There is no industry-specific customization possible, so you might have to use arbitrary practices that may not be totally efficient or comfortable. The reporting capabilities also may leave much to be desired. There is also no integration, so departments may have difficulty working together or sharing data. This often creates inefficient duplication of effort and murky communication flow, resulting in slower and less accurate customer service and internal tracking.

Company	Platforms supported	Scheduling	Tape Library w/barcode	Sales Management	Accounting, Administration	Payroll	Time-card	Purchase Orders	Engineering	Reply Card #
Computer Assisted Technologies	DOS Windows	Y	N	N	N	N	N	Y	Y	307
Interface Software	DOS MAC Unix	Y	Y	Y	Y	Y	Y	Y	Y	308
J. Brownell & Associates	DOS MAC	Y	N	Y	Y	N	Y	Y	Y	309
NDG Phoenix	DOS MAC	Y	Y	Y	Y	N	Y	Y	Y	310
Orth-Tec	MAC	Y	Y	Y	N	N	Y	Y	N	311
Paul Mitchell Systems	DOS	Y	Y	Y	Y	N	Y	Y	Y	312
VizuAll	DOS MAC Windows	Y	Y	Y	Y	Y	Y	Y	Y	313
Xymox Systems	DOS MAC Unix Windows	Y	Y	Y	Y	Y	Y	Y	Y	314

Table 1. A listing of production facility management software systems comparing some of their basic parameters.

Ikegami's Digital. The Perfect 10.



Ikegami's HL-57 is another video first: TV technology's Perfect 10. The HL-57, 10 Bit Digital Processing Portable Camera, provides exceptional picture quality with stability and repeatability, obtainable only through digital video processing.

Among the many advanced performance and operating features are: a horizontal resolution of more than 750TVL, a S/N of better than 62dB, a new Super V for improved vertical resolution, matrix correction for optimized colorimetry, a new menu-driven control system for operator

convenience and an extended-range continuously-variable electronic shutter.

A detail enhancement system includes such advanced functions as: Skin Detail, Diagonal Detail, Soft Detail and Slim Detail. Together they produce a very high resolution, yet smooth picture.

The Perfect 10 can accommodate on-board Beta SP[®], Beta[®] or MII[®] VCR's, or can be fitted for triax remote control. Most Unicam[®] accessories are compatible.

To learn more about Ikegami's Perfect 10, the HL-57, contact a Regional Sales Office.

T H E P R O F E S S I O N A L ' S C H O I C E

Ikegami Electronics (U.S.A.), Inc. 37 Brook Avenue, Maywood, NJ 07607 East Coast: (201) 368-9171
West Coast: (310) 534-0050 Southeast: (305) 735-2203 Southwest: (214) 869-2363 Midwest: (708) 834-9774

Beta SP[®] is a registered trademark of Sony. MII[®] is a registered trademark of Panasonic. Unicam[®] is a registered trademark of Ikegami.

Circle (45) on Reply Card

www.americanradiohistory.com

Ikegami

TRANSCODER

RGB to Components

Components to RGB



Perfect
transcoding
with the
highest accuracy
and
transparency.



FAROUDJA

675 Palomar Avenue
Sunnyvale, California 94086
Telephone 408/735-1492
FAX 408/735-8571

Circle (46) on Reply Card



Production facility software can turn your desktop computer into an efficient, integrated management system.

service and internal tracking.

The second approach to computerization (which is often born from the first approach) is developing your own proprietary system. Whereas an off-the-shelf environment allows limited control, a proprietary method gives you total control over every facet of the system from initial development to support. This can be a 2-edged sword, of course. You have the opportunity to develop programs that are customized to your business needs

*The more initial input
and staff involvement
you generate, the
better the later phases
of the project will go.*

and style, but no one outside your company will totally comprehend your system.

The greatest strength of a proprietary system is its total customization. If your business is unique and no off-the-shelf or industry vendor offers the solutions that you need, this may be your only alternative. System features, configuration and growth can be added or changed when and how you deem necessary, and your support can, at least in theory, be immediate and always on hand.

But there are many caveats to this approach. It is imperative that you have a full-time, in-house, experienced programmer or programming staff who knows your business. You should also have backup personnel in the event that your primary programmer(s) leaves the company. Your system also must be fully documented. Although this could cost tens of thousands of dollars in staff time to create, it keeps you from being held hostage to the minds of your programmers. It also helps your users learn the system's operations more effectively. Additionally, with only one or two programmers for the system, you may occasionally incur some lengthy delays when adding or debugging new features.

Consider also that you are on your own with problem-solving and upgrades. You may be reinventing the wheel because needed features may exist in another software package. This can be incredibly expensive because you must pay for every feature or enhancement out of your own pocket rather than sharing the expense with many other system users. Because there is no user support group, you also have no opportunity to benefit from ideas and solutions brought up by other users.

Recouping development costs with a proprietary system can be a difficult and lengthy process. The costs involved should be carefully weighed against the expected return. There is a growing agreement in the industry that this method

SONY

EVERY DAY, SONY'S
DIGITAL BETACAM FORMAT
PERFORMS FOR THE TOUGHEST
JUDGES IN THE WORLD.

ONE NIGHT, THIS SUMMER,
THEY RETURNED THE FAVOR.



This year, the worldwide membership of the International Teleproduction Society gave Sony a special achievement award in engineering. It recognizes Digital Betacam® VTRs as one of the most important technological advances in the industry. Of course, the next morning, it was back to work.

Sony Business and Professional Products Group, 3 Paragon Drive, Manville, NJ 07048-1735. ©1994 Sony Electronics Inc. Reproduction in whole or in part without written permission is prohibited. All rights reserved. Sony and Betacam are trademarks of Sony. International Monitor Awards is a trademark of the International Teleproduction Society.

should only be considered if there is really no workable alternative.

The third method uses software from one of several industry-specific vendors. In the past several years, a number of such companies have been established. They offer a variety of solutions tailored specifically to broadcast, cable, production and post-production facility management. In general, these vendors have a degree of expertise in these applications. They also have created software with features that specifically address

There must be one person who will oversee this process from the planning stage through implementation.

the requirements and styles inherent to this business.

Some packages address only specific areas of need, while others offer a fully integrated management system. Full integration is becoming increasingly important for addressing the interrelationship between departments and/or resources and for accessing full system support with only one phone call. Many products are offered in modules so you can purchase only those features that apply to your operation. Pricing varies and is usually based on a basic package price that is adjusted by the number of users at your site, as well as features desired.

As these vendors have become more sophisticated, this approach offers a

number of benefits. The first is that the software is application-specific, so features will be less arbitrary and better suited to your business practices. Features may include integrated scheduling, advance bidding, work-order management, tape library management, employee time tracking, general ledger, accounts receivable/payable and flexible reporting capabilities.

Software development, upgrade and documentation costs are spread throughout a customer base, so an individual facility's costs in these areas are reduced. The support and service that customers receive will normally be more knowledgeable and sensitive than a general business software vendor. Many vendors offer software customization and on-site training. Look for a user group that can become a think tank environment for generating new ideas and additional software enhancements. Because these products have been tested and proven in other facilities, customers assume much less risk in terms of development, support and software bugs.

Using an industry vendor does have its own set of concerns, however. The close, ongoing relationship that a customer develops with such a company will require a level of comfort with the vendor's staff and support. It is also important to determine their financial health and commitment to the industry. A long-term view is essential in determining whether a specific vendor can support current and future needs of its customers. Other factors to consider are the cost, speed, responsiveness and depth of their service and support. Get these in writing.

A final note on this approach: Although such industry-specific systems offer a high degree of customization, beware of performing these adjustments yourself. This is one of the easiest ways to wreak havoc in a system. Changes and custom

features need to be applied within the framework of the complete system and need to be documented accordingly or

Production facility software can turn your desktop computer into an efficient, integrated management system.

you can potentially alter current features and their integration. If you doctor a vendor's software, you may also risk losing access to future upgrades because they may no longer be compatible with your changed programming.

Conclusions

No matter what approach you find best for your facility, there are a variety of costs that should be weighed against your specific operational needs and your potential long-term ROI. They include the following:

- Development costs
- Documentation costs
- Staff involvement costs
- Opportunity costs for the time it takes to complete a system installation
- Costs for changes or upgrades in design after completion
- Ongoing programming costs

If you've completed a comprehensive needs analysis, appointed a dedicated project leader, and conducted a full investigation into the right type of system for your business, you will be well on your way toward maximizing your return on these computerization expenditures.

You are in business to make a reasonable profit. To accomplish this, you must obviously offer quality goods and/or services at competitive rates, know and monitor your business, and above all, keep your customers happy. In support of these objectives, automating the business operations of your facility can be a worthwhile investment. ■

Coming in October

Managing technology

Broadcast Engineering magazine will offer a foothold for station managers and engineers striving to stay on top of changing technology with these jam-packed features

- Contract Engineering: A Manager's Guide
- Broadcasting, Cable & Telco: Convergence or Confusion?
- New Recording Media: Optical vs. Magnetic
- The Annual Salary Survey
- Camera Lenses

In addition to our regular column lineup

➔ For more information on facility management software, circle Reply Card numbers listed in Table 1, p. 64. See also "Computers & Peripherals" and "Engineering Software," p. 71 of the BE Buyers Guide.

Dana McDaniel can tell you anything you want to know about broadcast automation. But make it quick, ok?

As they say at ChicagoLand TV News, you've got five seconds. Four. Three. Two. Welcome to news when it happens, not when you expect it, or have the staff to handle it. It's broadcast on double espresso. Where any second a producer can override your play list and scream "Let's go live!"

So how *does* an Operations Supervisor keep her sanity at 24 hour news station? Meditation? Primal screaming? Sanka? Try total station automation, by Louth. From the moment it hit the airwaves on January 1, 1993, the entire station has been running on Louth: ADC-100 automation, Autoscreen media management, and the Traffic Interface Manager to tie it all together. All of which gives Dana and her staff absolute flexibility and control under any conditions. From merely frantic to those last second edits to 10,000-event playlists.

If you're considering broadcast automation, talk to the people who use Louth—like Dana. And don't be afraid to get right to the point. After all, air time is money. And she doesn't have a moment to waste.

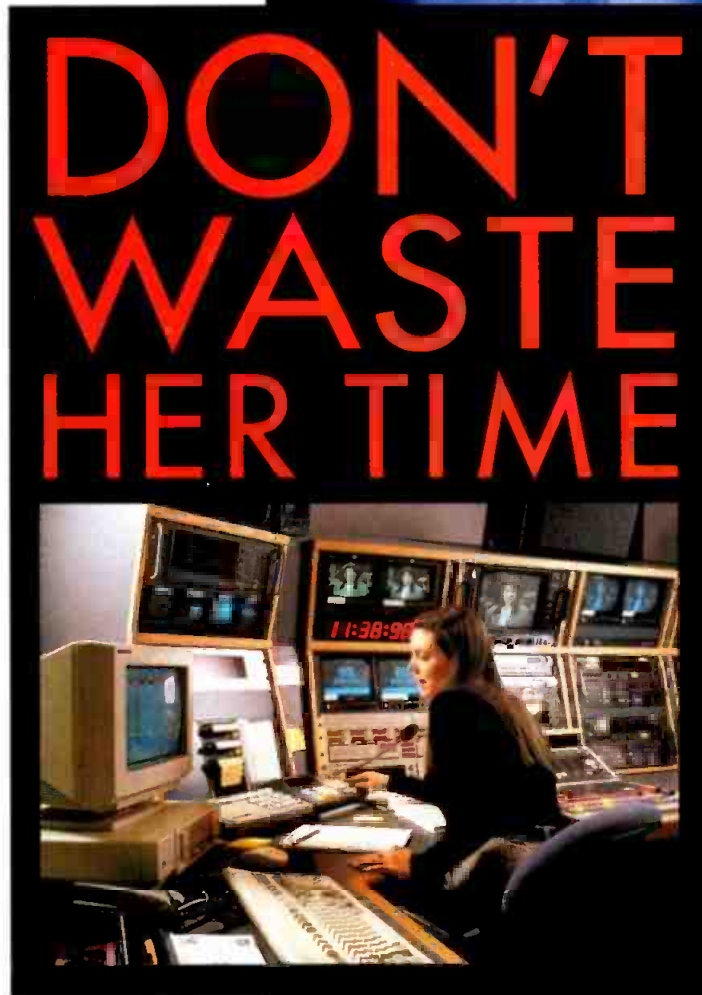

L O U T H
A U T O M A T I O N

545 Middlefield Road, Menlo Park, California 94025
(415) 329-9498 Fax: (415) 329-9530

Circle (57) on Reply Card

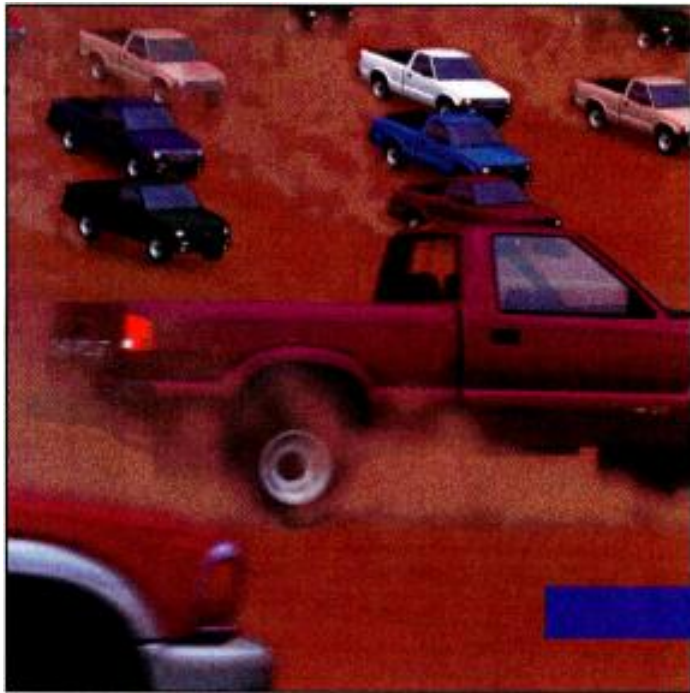

On-line captioning systems

Getting it done in real time takes specialized skills and equipment.

By Carlos Suarez

The Bottom Line

Real-time captioning systems are quickly propagating with increased capabilities. Teleprompter-based systems are the most widely implemented, but many can only provide a less-than-complete solution. Stenographic-based systems are rapidly emerging as the new standard and provide complete coverage for the strict demands of live environments.



1990 was a landmark year for increasing the civil rights of a highly unrepresented and often forgotten group, the 43 million disabled. The largest subset of this group is the deaf and hard of hearing, representing approximately 24 million people. As a result of laws passed in 1990, the market among broadcasters and video producers for closed-captioning products and services has increased significantly.

As of July 1, 1993, every TV set with a screen 13 inches or larger manufactured for sale in the United States must, by law, have a closed-caption decoder built in. Closed captioning products come in several varieties, including on-line teleprompter-based solutions, off-line SMPTE time-code-based systems, and on-line stenographic-based systems for live broadcasts. This article will examine on-line systems, focusing primarily on stenographic solutions. On-line systems are most often used in live environments, such as news, sports, weather and talk shows.

On-line captioning systems

Two classes of solutions are available today for real-time captioning environments: teleprompter news room systems and stenographic-based systems. Teleprompter-based systems are the simplest to implement and represent the larger installed base. Unfortunately, the teleprompter-based systems provide a less-than-complete solution. If not implemented correctly, they can produce captions that are more of a distraction than an aid.

Suarez is principal of the Naples Cupertino Group, a marketing and technology consulting service for interactive television and media technology, Santa Clara, CA.

Stenographic solutions are rapidly growing in popularity and produce a more complete set of captions. However, stenographic-based systems can be somewhat more costly to implement.

Teleprompter-based captioning systems emerged directly from news room environments. First sold as an extension to news room teleprompter or automation systems, the teleprompter feed is used as the source for captions. In basic implementations, the prescribed stories are fed directly to the teleprompter and the captioning encoder.

As of July 1, 1993, every TV set with a screen 13 inches or larger manufactured for sale in the United States must, by law, have a closed-caption decoder built in.

The encoder embeds closed-captioning codes into line 21 of the vertical blanking interval (VBI). This embedded information is later interpreted by the decoder. Decoded information is then displayed on the viewer's TV screen and appears much like subtitles with a black background. The FCC standard provides for up to four rows to appear at once anywhere on the TV screen. However, two rows are the norm for pre-recorded captions, three rows are most commonly used for live programming.

The next level up in teleprompter-based

SEARCH NO MORE.



The Pioneer Rewritable VideoDisc Recorder puts an end to the endless search. With 0.3 seconds average access time and two playback heads, you can be cued and ready to move to the next segment long before the current one ends.

That's why just about anyone doing anything with video -- from the major broadcast and cable networks to sports arenas -- is doing it with Pioneer VideoDisc Recorders.

The search is over for scores of O&O's, affiliates, independents, PBS facilities, nationwide networks, production houses, and corporations. Discover why KRON, KESQ, KMEX, Prevue Networks, TNN: The Nashville Network, WSFP, WFMZ, KCOP, KCNC, KDFW, Videofonics, NIKE, and many others chose the Pioneer VDR-V1000.

If you're searching for a quick return on investment, the

Pioneer Rewritable VideoDisc Recorder is your ideal machine. Call today to find out why:

Northeast-Joe Wellman at (201) 236-4180; Midwest-Jim Burger at (201) 327-6400; South-John Leahy at (214) 580-0200; West-Craig Abrams at (310) 952-3021.

PIONEER
The Art of Entertainment

Pioneer is a registered trademark of Pioneer Electronic Corporation.

Circle (58) on Reply Card

See us at World Media Expo,
Booth #728.

products are dually stored and edited solutions, where the stories can be edited to different forms for different types of viewers. An example of this would be editing a story for a news anchor vs. the viewer at home. This type of system generally allows for feeding the captioning information on separate channels and at different rates. Caption feed rates can be programmed for either manual or automatic control. A dually stored and edited teleprompter system yields a more readable result compared to basic implementations. However, this type of system still does not provide a complete solution. A more significant limitation is that only news segments prescribed prior to broadcast (and taped segments that have been transcribed) can be captioned.

Teleprompter systems leave many of the most important live segments of the broadcast without any type of captioning. This is the main limitation of all currently available teleprompter-based news room implementations. The result is that approximately half the broadcast is uncaptioned with communication to the deaf or hard of hearing viewer being constantly interrupted. To the hearing viewer, this level of communication would almost certainly be considered unacceptable and could result in numerous protests and declining ratings.

On-line stenographic-based captioning systems

Stenographic solutions represent the high end of the real-time captioning world, providing the most complete end result for the viewer. The heart of a stenographic system is computer-aided-translation from steno machines that were first developed for courtroom applications.

A complete on-line stenographic-based captioning system consists of a live TV feed, a picture monitor, personal computer, software, steno machine and an



Coverage of the 1994 Winter Olympics included relocatable real-time captions. (Photo courtesy of The Caption Center/WGBH.)

encoder/decoder as shown in Figure 1. On-line stenographic-based captioning systems are centered on the computer software. A steno machine, similar to those used in courtrooms, is used to input the data, which is a phonetic representation of the spoken word. The "steno" is then translated by the computer into its English equivalent by comparing the steno shorthand to a phonetic lookup table of words and phrases. Intelligent systems have special capabilities such as a phoneticizer that translates steno with no dictionary entries into a phonetic equivalent.

All the companies that presently manufacture such systems emerged from the world of computer-aided-transcription (CAT) systems for courtroom environments. These CAT companies were best suited to develop this market because

their steno-to-English translation engines were already developed. Steno input is required because it is the only method available today for accurately keeping up with the spoken word. On-line captioning requires the steno-captioner to write at the speed of 200-250 words per minute, much faster than even the fastest of typists.

Top-of-the-line systems also have a number of other features including the ability to make new dictionary entries quickly and changes on the fly. Making changes quickly is critical in live applications such as news room environments where these systems were first applied. Good on-line systems also have the ability to switch between prescribed information (or files) and steno feeds. In news room environments, the ability to prescribe information is particularly important where all information, with the exception of live segments, is usually written and produced beforehand. This frees the steno-captioner from having to stroke the information for the entire newscast.

In news environments, the captioner is often times assisted by a coordinator who performs activities such as feed changes, new dictionary entries, global-word-change entries, story queuing, formatting changes, queuing of dictionaries and other maintenance activities. Steno-captioners go through the same training program as court reporters, requiring from three to five years of formal study and practice followed by a rigorous certification exam. The drop-out rate is high. Normally only one out of 10 people make it through the program. Most court reporting schools, however, do not prepare them for the demands and high accuracy levels required for real-time cap-

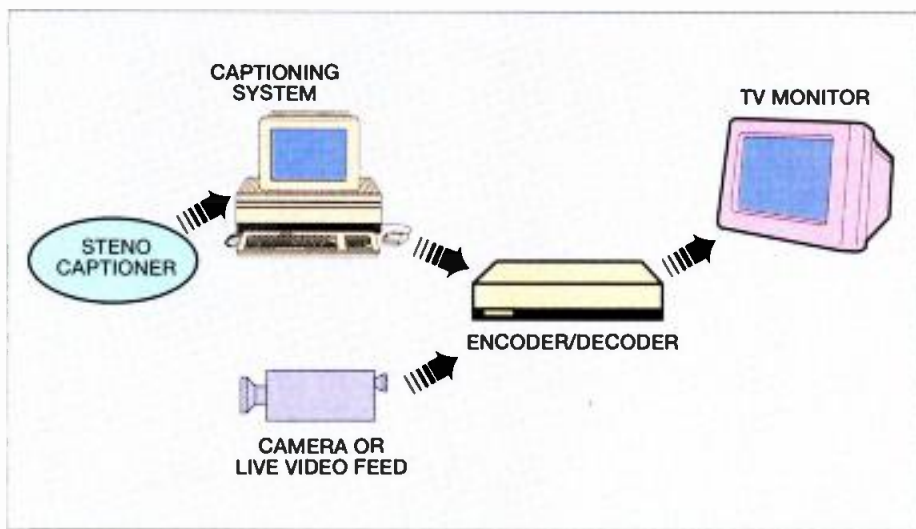
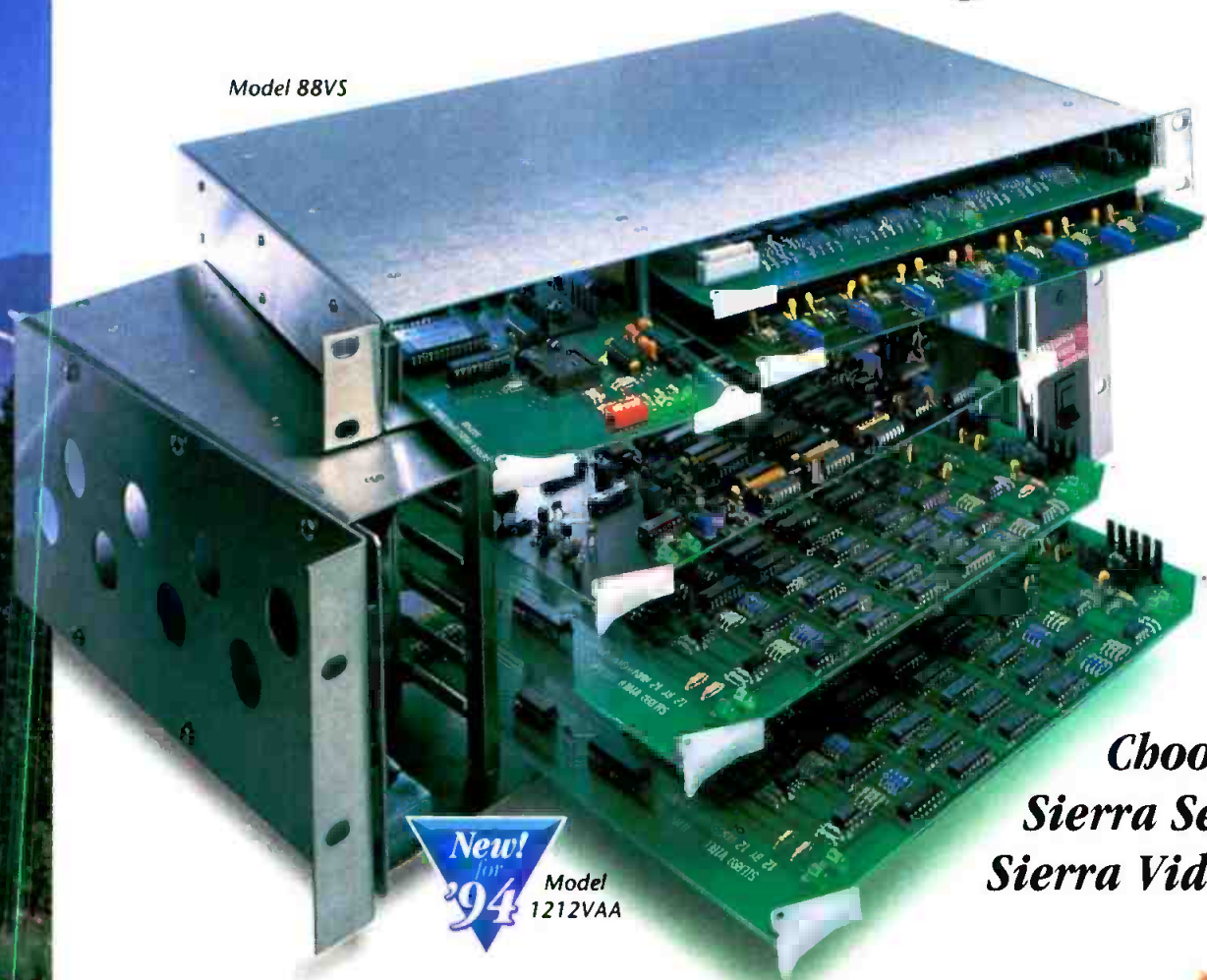

Figure 1. Basic equipment and signal flow used for on-line real-time captioning.

Choosing a Compact Routing Switcher?

Model 88VS



New!
for '94
Model 1212VAA

**Choose the
Sierra Series from
Sierra Video Systems!**

If you're planning an investment in a small router, be sure to plan for a Sierra Series routing switcher. Why? Because quality on the outside begins with quality on the inside, and you need both. These professional-grade routing switchers are available in a wide range of compact sizes. Regardless of your application, we have one that's right for it.

Our newest models in the Sierra Series include our Model 88VS in just 1 RU and a new line of 12x12 routing switchers—the Model 1212 family. They offer high-end performance and reliability in a very affordable package—an unbeatable value by anybody's standards. But that's not all. You also get the security of our Seven-Year Warranty—the best in the industry backed by the best in the industry.

No one builds routing switchers better than Sierra Video Systems. Don't settle for second best. Settle for Sierra. *Here's why:*

- ▶ Easy to maintain with plug-in construction
- ▶ Smaller models too, from 5x1 on up
- ▶ Composite and component video models available
- ▶ Wideband RGB versions available
- ▶ A broad selection of control panels
- ▶ No design compromises
- ▶ Broadcast-quality video
- ▶ CD-like audio specs
- ▶ Serial interface capability
- ▶ Expandable design—buy what you need now, add on later



For more information
on choosing a *Sierra Series* routing
switcher, see your local SVS dealer or
call Sierra Video Systems at
(916) 478-1000.

**SIERRA
VIDEO
SYSTEMS**
...you can see the difference!

P.O. Box 2462
Grass Valley, CA 95945 USA
Tel (916) 478-1000
Fax (916) 478-1105

Circle (59) on Reply Card

Winsted®



VIDEO WORK STATION

Desktop Convenience For
Today's Multimedia Electronics.

Integrated workstation provides a full 72" wide work surface. Both keyboard shelf and plotter shelf pull out 3", tilt 0°-5°, and adjust 3" up or down. Spacious 19¼" Rack Cabinet rolls on swivel casters.

• Ergonomic design for user comfort. • Ample work area and storage space. • Attractive 2-tone finish in Dove Grey and Black Granite.

For FREE CATALOG, write or call TOLL-FREE **1-800-447-2257**

THE WINSTED CORPORATION

10901 Hampshire Ave. So. • Minneapolis, MN 55438 • FAX 612-944-1546

Preferred by Professionals Worldwide

Circle (60) on Reply Card



Some of the equipment used for real-time captioning at The Captioning Center/WGBH.

tioning environments. Usually three to six months of additional training and practice are required to reach accuracy levels required for live broadcasts.

On-line captioning requires the stenocaptioner to write at the speed of 200-250 words per minute.

Other necessary features for on-line software include:

1. Supporting stock captions for regularly used information.
2. Programmable format keys to change the caption display formats quickly.
3. A history window to view captions already sent, allowing global changes to be made when a word is not stroked correctly.
4. Support for multiple customized dictionaries.
5. The ability to support global word changes.
6. The ability to quickly search the text of prescribed stories and make changes on the fly.
7. Support for all existing encoders and decoders.
8. The ability to save information in portable ASCII formats.
9. Support of the numerous types of steno machines.
10. Support for all the various caption types, special characters, special effects and formats.
11. The ability to block or pass existing captions.
12. The ability to queue a number of stories in succession and feed them or change their order as needed.

On-line captioning software is sophisticated and few vendors offer products that support the demands of live environments.

On the hardware end, it is somewhat simpler. Most modern day steno machines used by trained personnel, stenocaptioners and court reporters, are adequate if equipped with the ability to support serial data outputs. Once the steno is translated, it is fed to a hardware encoder that inserts the appropriate codes in line 21 of the VBI. A decoder is then used to

GEPCO INTERNATIONAL

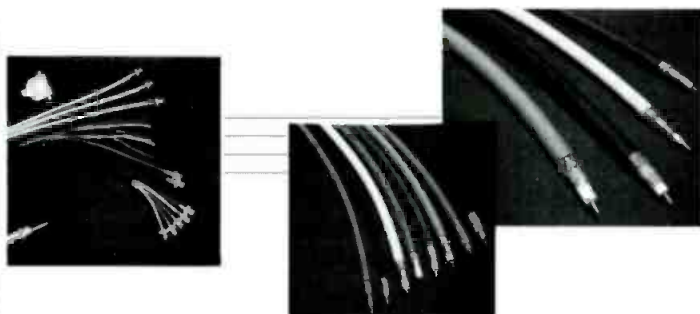
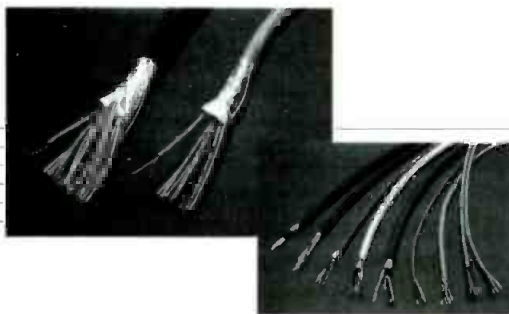

Audio, Video & Broadcast Cable Products



2225 W. HUBBARD ST., CHICAGO IL 60612-1613
(312)733-9555 FAX (312)733-6416 (800)966-0069

See us at World Media Expo, Booths 737-739
Circle (61) on Reply Card

Quick. Find the first shot fired at the Russian White House.



Quick. Find the first shot fired at the Russian White House.

Project/Title: Moscow 10/4/93 Client: _____
 Reel #: _____ Page: 1 Date: Tue Jan 11 1994 13:31:32

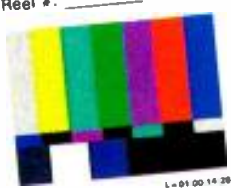

This is a historic moment in video. Logged automatically. On plain paper. With time code. Using a standard HP office printer. This is the HP VidJet Pro. And this is just the beginning.

It's the VidJet Pro video print manager from HP. And it'll change everything that's kept video printing specialized, clumsy and expensive.

It moves video printing to your HP LaserJet or color DeskJet printer. Allowing you to grab, format and print images in any size or color. On plain paper or transparencies.



From thumbnails to posters, storyboards to logsheets, the HP VidJet Pro even logs and archives tapes automatically—with time code and scene changes—up to 50 images per page. And prices start at just \$3,490*.

For a free brochure and samples of the HP VidJet Pro's output, call 1-800-452-4844 ext. 8318. And discover why everything else is old news.

*U.S. List Price

© 1994 Hewlett-Packard Co. TMVID 655BE



There is a better way.



Circle (62) on Reply Card

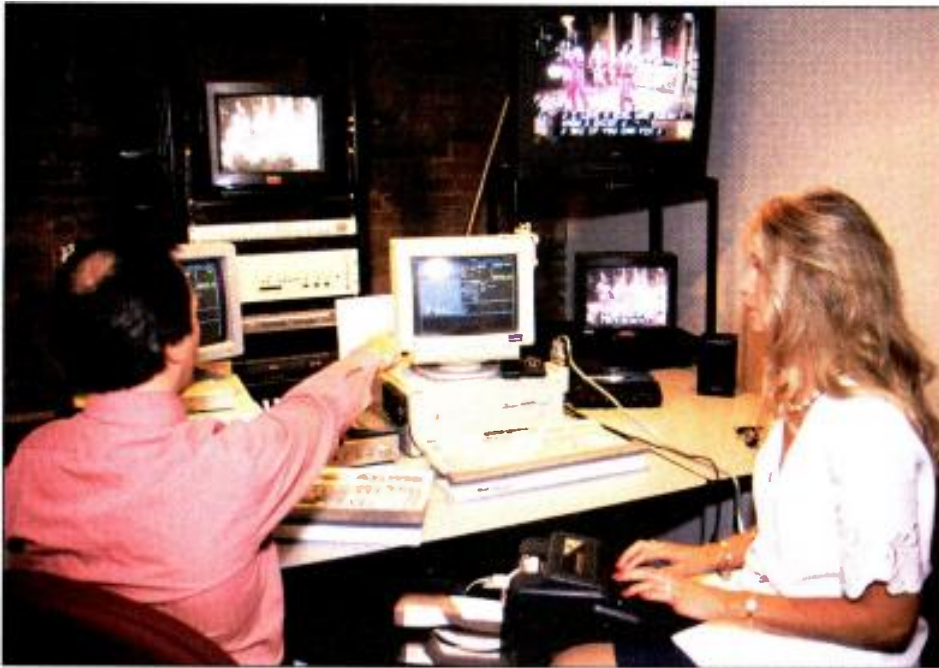

Real-time captioning with a stenographer and coordinator at VITAC, Pittsburgh. (Photo by Edgar Payne.)

interpret the code on line 21 and display the captions. Older decoder devices have several limitations. They only allow characters to be displayed on the top or bottom of the screen, and rollup-style cap-

tions which are used for live programming can only be displayed at the bottom of the screen. Many times they may cover graphics placed at the bottom of the screen.

Decoders built since July 1993 must meet new FCC specifications that allow pre-recorded or live captions to be displayed anywhere on the screen, under the captioner's control. For more information, EIA has published a comprehensive set of recommended practices (EIA-608) for caption service providers.

Conclusion

Exciting times lie ahead in the world of captioning. Each month millions of homes are coming on-line with TV sets with this technology built in. Captioning will open new channels of communications to millions. It will benefit not only the 24 million deaf and hard of hearing, but will also assist the 27 million functionally illiterate and 30 million elementary school students learning to read, along with the rest of us who often find ourselves in loud and noisy environments where it becomes difficult to hear. ■

➔ For more information on captioning systems, circle (317) on Reply Card. See also "Captioning" on p. 60 of the BE Buyers Guide.

Sound Connection



Sound Perfection

Our all metal XLR connectors feature a wide range of color coded collars for quick and easy system identification.

Unsurpassed Noise Rejection

DGS
PRO-AUDIO

DELTRON

Gotham

800-292-2834

P.O. Box 170426, Arlington, TX 76003

Circle (63) on Reply Card

NOVEMBER PREVIEW

Measuring Serial Digital Signals – Testing serial digital signals requires sophisticated test equipment and an understanding of the test results. Learn how to test serial digital video signals for integrity.

Automated Test Equipment – As the source and processing equipment become more complex, the need to carefully monitor their performance also increases. Learn how to automatically perform tests on digital and analog equipment.

Testing Fiber Systems – From fiber splicing to data error rates, using and testing fiber requires a whole new set of skills. This tutorial will provide a base of instruction for video engineers first encountering fiber in their facilities.

Testing Digital Audio/Video Systems – Engineers can know if their equipment is performing properly with the right test equipment. This is a review of test equipment.

Maintaining Power Tubes – Proper maintenance of transmitter tubes for TV and radio transmitters can mean the difference of cents per operating hour – or dollars per operating hour. Take advantage of the check list of tips on obtaining maximum tube life.

Moving to Server-Based Production – A look at the cost efficiencies of digital on-air playback systems.

Standards Converters – A buyer's guide update complete with a tutorial on the latest technology inside standards converters.

The Agile Omni Global VU option gives you one touch access to all satellite formats.

More channels, more signals, more frequencies — life in the down link is becoming more complex every day.

What you need is something to simplify your life.

What you need is the Global VU Model CAM830 Control Access Monitor from Standard Communications.

Direct or remote control.

Used in conjunction with the Agile Omni receiver, the Global VU gives you simplified access to all satellite formats from easy front-panel controls or from a PC comfortably situated on your desk, miles away.

Directly or using the straightforward Windows[®]-based software, the CAM830 lets you add or modify formats, then scan them by RF frequency and/or audio subcarrier. It gives you complete control over all three audio

subcarrier demodulators, as well as international video features such as PAL, SECAM and NTSC. It gives you control of video and audio output levels with individual channel memory.

And we're just getting started.

Spectrum analysis.

Want to really see what's going on? The Global VU gives you a screen-filling display of the RF spectrum for each satellite on your remote PC. It also gives you a real-time look at the C/N ratio without any time-consuming precalibration.

And there's more. As a field retrofit or optional add-on, the CAM830 gives your Agile Omni more easy-to-use control than you may have ever thought possible. To get the full story fast, including complete specifications, fax Standard today at 800/722-2329

(California and International numbers, 310/532-0397) and we'll fax it right back to you.

Be a know-it-all. Get your hands on a Global VU.

The Right Technology for Right Now.

 **Standard
Communications**

**SATELLITE & BROADBAND
PRODUCTS DIVISION**

P.O. Box 92151 • Los Angeles, CA 90009-2151
310/532-5300 ext. 280 • Toll Free 800/745-2445
Fax: 800/722-2329 (Toll Free) • 310/532-0397 (CA & Int'l Only)

Canadian Address: 41 Industrial Pkwy S., Units 5 & 6
Aurora, Ontario Canada L4G-3Y5
905/841-7557 Main • Fax: 905/841-3693
Sales: 800/638-4741

Knows all. Tells all.

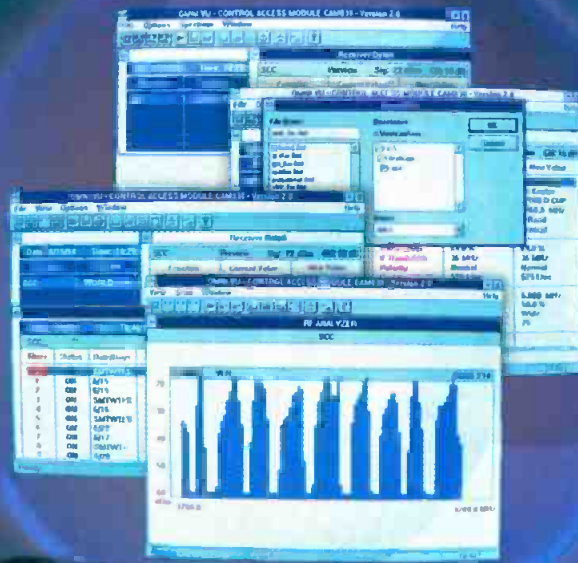

Circle (48) on Reply Card
www.americanradiohistory.com

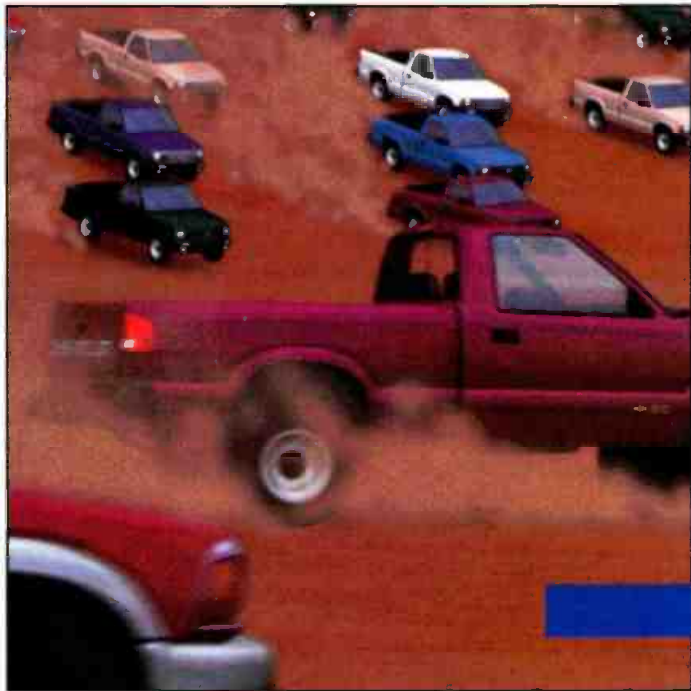

Audio data compression 101

Successful application of data compression requires a working knowledge of basic coder operation.

By Steven E. Forshay

The Bottom Line

Key among today's technologies for audio production, storage and delivery are systems for coding high-quality digital audio at low bit-rates — often referred to as data compression, or more specifically, data reduction. Use of low bit-rate audio coding can offset the limitations that exist in current storage and transmission capacity. It may also enable expansion of program services.



Low bit-rate coding for high-quality digital audio is a daunting process. Systems are expected to perform well with a nearly unlimited variety of sounds, delivering little or no loss in fidelity. Therefore, earlier coding strategies that used statistical analyses of the bitstream or mathematical models of specific program sources (such as human speech patterns) are impractical.

Coder developers have turned to studies of human hearing's properties and limitations, seeking ways to exploit them for the coding of wideband audio signals. Knowledge of *psychoacoustics* (the science of human auditory perception) is essential to the successful development of such an audio coder.

Foremost among the psychoacoustic principles involved in this perceptually based, low bit-rate coding is *auditory masking*. This phenomenon allows a loud signal to "mask" or hide lower-level signals. Everyone has experienced difficulty in understanding conversation with loud music playing nearby, or listening to a low-level music passage in a noisy airplane or car. These are examples of masking in action.

Masking and critical bands

To understand masking (and the related concept of *critical bands*), a useful starting point is the *threshold of perception*. It is the absolute sound pressure level below which the ear cannot perceive sound signals. It is a frequency-dependent function: Hearing sensitivity in people of normal hearing is quite good

throughout the middle frequency range, but falls off rapidly at the frequency extremes.

This perception threshold is dynamically amended in the presence of aural stimulus by *frequency-domain masking*. This phenomenon causes an increase in the ear's threshold of perception around the frequency of a loud signal. This leaves the ear "deaf" to lower-level signals at or near the same frequency as long as the loud signal is present. Early psychoacoustic studies determined the effective bandwidth of this desensitization in tests using low-level, single-frequency sine-wave tones. These areas of influence are called *critical bands*, and their characteristics are a generally accepted, fundamental tenet of psychoacoustics.

The width of these critical bands varies across the frequency spectrum. Lower-frequency tones create a masking effect over a wider area than higher-frequency tones, hence LF critical bands are broader. Frequency-domain masking is also level-dependent, however. Masking effects are minimal (i.e., narrowly contained around the masker tone) within the first 30dB above the threshold of hearing, but as the amplitude of the masker is increased, the masking effect occurs over a broader frequency range. This means that a single, loud tone can mask a spectral zone that extends beyond its "home" critical band to encompass several adjacent bands. (See Figure 1.) This broadening of the masking effect with increasing sound level is also spectrally asymmetrical. It occurs to a greater extent at frequencies above the masker than below it, giving rise to the term *upward masking*.

Forshay is vice president of engineering at Dolby Laboratories, San Francisco. Respond via the BE FAXback line at 913-967-1905.

Continued on page 84

Be Quiet!



The original Shure FP32 set the standard in field production for portable stereo mixers. Now, with the new FP32A, you can count on getting even less. Noise, that is...30dB less! In fact, the FP32A is so quiet and improved that it's perfect for use with DAT and other digital recording media.

Professional Mixing You Can Take Anywhere.

The Shure FP32A is a 3-input, 2-output portable mixer specifically designed for:

- remote audio recording
- electronic field production
- electronic news gathering
- location film production

The FP32A weighs just 3.5 lbs and is only 2-1/4" H x 6-3/8" D x 7-1/4" W in size.

With 8 hours use from two 9V alkaline batteries — or powered by any 12 to 30 VDC source — the FP32A goes wherever you do. And since it's from Shure, you can count on its durability and ruggedness.



So Many Features In So Little Space.

You get all the features of the original FP32 plus:

- 48V phantom power
- pop-up pan pots
- input level LED indicators
- mix bus jack and cable
- headphone mode switch
- mixer/monitor switch
- adjustable peak output LEDs
- stereo link for inputs 2 and 3
- more than 30 other new features and improvements

So go to your nearest dealer and pick up an FP32A. Once you use it, you'll see why we're making so much noise about something so quiet.

For the Shure FP dealer nearest you, call 1-800-25-SHURE.

SHURE®

The Sound of The Professionals® Worldwide.

Circle (49) on Reply Card
www.americanradiohistory.com

Until recently, R&D efforts in low bit-rate coding were exclusively targeted at single- and 2-channel applications. Within the last few years, however, low bit-rate coding research has led to development of techniques for simultaneous (or composite) coding of discrete front and rear channels in a multichannel soundfield.

The concept of multichannel sound is not new. Multichannel movies have existed since the 1940s. The 4-2-4 variable matrix surround-sound technology used on motion picture soundtracks since the mid 1970s has more recently expanded into broadcasting. The most prevalent form allows three front channels (left, center and right [L, C, R]) and a bandwidth-limited mono surround channel (S) to be delivered as a matrixed 2-channel signal that is compatible with mono and stereo transmission/reproduction. The L, C, R and S information is recovered using a variable matrix decoder that preserves a high degree of the isolation found in the original discrete channels.

The use of matrix surround sound is expected to dramatically expand in the coming years. Composite multichannel coding techniques that exploit the ear's limitations in directional perception will bring a greater level of realism to future broadcast sound reproduction, with a relatively modest increase in bit-rate compared to high-quality 2-channel coders.

Perceptual localization limits

Low bit-rate multichannel coders employing composite coding techniques exploit not only spectral and temporal masking principles but also limitations in the sound localization capabilities of the ear. As background, it is important to note that the phase difference between the signals arriving at the two ears allows them to determine the direction of origin of low-frequency sound. However, above about 2kHz, direction is largely determined on the basis of signal amplitude.

The primary perceptual limitations exploited in multichannel coding are the ear's inability to independently detect the direction of signal components that are closely spaced in frequency. Also, at high frequencies the ear tends to function as a "carrier detector," which follows the envelope of the signal. Thus, if 1) the high-frequency signal components in each channel of a multichannel signal are divided into narrow frequency bands and combined (summed) band-by-band into a single, composite channel, and 2) the composite channel signal is delivered to each reproduction channel along with information conveying the loudness level for the individual frequency bands, the directional characteristics of the original multichannel soundfield can be preserved.

A significant reduction in bit rate can be achieved by coding and transmitting only the composite signal in any high-frequency bands that exploit the ear's limitations in directional perception. Frequently used multichannel bit-rate reduction strategies include use of a psychoacoustic model to take advantage of intrachannel frequency and temporal masking, allocation of bits from a common global bit pool, and use of composite coding done either on a band-by-band basis, in groups of bands, or in all bands above a certain frequency. Generally, conventional frequency/time-domain masking principles are applied first. If they do not provide the desired sound quality at the available bit-rate, composite coding strategies are employed.

The 5.1 channel system

The combination of three front channels, two independent surround channels (Ls and Rs) and a low-frequency effects channel was first used by the motion picture industry with the 70mm release of *Apocalypse Now* in 1979. The low-frequency channel generally covers only a single octave (the lowest) of the 10-octave audible spectrum. It is therefore referred to as a 0.1-channel.

In 1989, SMPTE recognized this 3/2/.1 (front/rear/subwoofer) format as the most practical way of providing the desired soundfield imaging with proper localization of dialogue and off-screen sound effects. The so-called 5.1 channel format was standardized for the next-generation digital film systems. Since then, the ITU-R (formerly CCIR) has conducted further investigations of channel configurations. It has also settled on a 3/2 format as the recommended channel configuration for broadcast production facilities mixing multichannel sound.

In mid 1992, the first low bit-rate multichannel coder (Dolby AC-3) was launched for commercial application on motion picture soundtracks. In the film application of this technology, 5.1 channels of coded audio are carried at a bit rate of 320kb/s in an optical soundtrack on a compatible 35mm release print.

Awareness of the commercial viability of the first multichannel technology led to efforts within the ISO/IEC-sponsored Moving Pictures Experts Group (MPEG) to develop multichannel extensions of the 2-channel MPEG-1 audio coding technology. From November 1993 through March 1994, these multichannel implementations were tested at bit-rates of 256, 320 and 384kb/s along with two non-backward compatible (to MPEG-1) coders tested at 320kb/s only. Test results indicated that none of the coders tested performed with total transparency for all program selections at any bit-rate. The non-backward compatible coders,

however, which were not constrained by MPEG-1 backward compatibility matrixing, outperformed the MPEG coders.

Mono/stereo/surround compatibility

Multichannel coder developers have addressed compatibility with mono and stereo reproduction systems in different ways. The MPEG strategy involves use of an encoder compatibility matrix, which allows a 2-channel decoder to decode a compatible 2-channel signal that is a subset of the multichannel stream. The use of compatibility matrixing, which involves subtraction of the coded signal in one channel from that of another, can result in cancellation of signal components and unmasking of coding artifacts. The results of the listening tests for the MPEG-based multichannel coders also confirmed that there is a bit-rate penalty associated with maintaining backward compatibility.

The alternative AC-3 approach involves transmission of the discrete multichannel coded bitstream and use of downmixing in the decoder to mix the appropriate L, C, R, Ls and Rs signals for the available number of reproduction channels. Although more memory is required in downmixing decoders, the downmixing approach allows simultaneous optimization of the service for listeners with mono, 2-channel stereo, matrix surround sound, and full multichannel digital reproduction systems.

ATV applications

The U.S. broadcast industry, as represented by the Advanced Television Systems Committee (ATSC), the FCC's Advisory Committee on Advanced Television Service (ACATS) and the Grand Alliance industry consortium, has taken an active leadership position in standardizing an AC-3 multichannel sound coding technology for advanced TV applications. HDTV system field testing is planned for late 1994. The ACATS standard recommendation to the FCC is expected in 1995.

The U.S. cable industry will also deploy digital TV hardware in 1994/95 incorporating this multichannel coding technology. Cable set-top hardware will incorporate low-cost decoders that will initially receive 2-channel bitstreams. The hardware will also downmix future 5.1 channel multichannel bitstreams into a matrix surround sound-compatible, 2-channel output.

Bitstream outputs from receivers with 2-channel decoders will provide interoperability with future outboard audio/visual receivers that contain full 5.1-channel decoders for digital surround sound reproduction. Interoperability between digital TV systems and other future media, such as digital videodisc applications, is also being addressed by industry leaders involved in technology development and standardization activities. □

In videotape, quality is everything.

Processes that introduce dropouts — whether they are in manufacturing, shipping, storage, or usage — need to be identified and the sources of dropouts removed. ⓧ That's why we at Ampex Recording Media Corporation have never taken our eyes off one goal: *No Dropouts.*



Every day, 365 days a year, we're identifying — and removing — the causes of dropouts *wherever* they are. This includes a world-class Quality Improvement Program within our manufacturing facility — but it also includes helping our customers improve *their* storage, handling, and usage of tape, to minimize dropouts.

AMPEX | Recording Media

Circle (50) on Reply Card

PLEASE CALL OUR TOLL-FREE NUMBER

800/240-7042

AND REQUEST A COMPLIMENTARY COPY OF OUR BOOKLET:

**ACHIEVING EXCELLENCE IN VIDEO PRODUCTION —
VIDEOTAPE QUALITY IS *EVERYONE'S* BUSINESS.**

THIS BOOKLET PROVIDES THE AMPEX APPROACH TO REACHING THE GOAL OF "NO DROPOUTS."
www.americanradiohistory.com

Why not get everything professional Digital Audio Workstations have to offer?

Create your best part out of 10 recordings and use it in five different places... record 100 takes in the same place, on the same track... synchronize sound FX to a picture in less than a second... erase a word and bring it back a week later... and do all this on a machine that gives you instant access with incredible editing speeds, the sound quality you want, and the reliability you can count on, project after project.



Optional DM-80-S Multitrack Manager control for the Macintosh*— easy to learn, fast to use.

the Word.

Problem is, many DAWs just can't give you all of these things.

Here's why:

Problem: Some systems use a single computer for graphic user interface *and* for audio information processing. This slows the whole system down, and makes you wait.

The Answer: A workstation that separates the hardware "engine" from the user interface computer. This way, audio information processing is not slowed down by the user interface, and the interface computer operates without the load of additional tasks. And you save time and money.

Problem: A system crash in the middle of a complicated project could cost you as much in time lost as some of the less professional DAWs are worth. You should expect reliability you can count on from your DAW, and get it.

The Answer: First, call around. Check the reputation of DAWs. We have DM-80s working every day all over the world in high volume production environments. Our customers will tell you they're reliable.

Problem: Some systems don't give you a user interface that's familiar and easy-to-use.

The Answer: Buy a DAW that lets you choose either a dedicated hardware remote that gives you familiar tape recorder controls, or computer software control that is simple to understand and easy to operate.

Problem: Some DAWs are the weakest link in the audio chain. The DAW you buy should deliver sonics as good or better than any piece of audio equipment you own.

The Answer: Choose a DAW from a company that knows professional audio, not just a company that knows computers. But most of all, ask audio professionals who own one.



We believe you'll find all these answers and more in the Roland DM-80 Digital Audio Workstation. Call us at (213) 685-5141, ext. 337, or FAX (213) 722-0911 for a brochure. Or better yet, schedule a demo. You're going to like what you hear.

"The thing is just impossible to screw up! The DM-80's non-destructive editing is the only way to go—revisions are extremely easy, and very quick."

— DAVID ESCH
DIRECTOR OF COMMERCIAL PRODUCTION
WPNT CHICAGO



"Edits fast, sounds great, and doesn't break. The DM-80's multilayering capabilities and simultaneous recording on all tracks gives us the flexibility to do whatever we want."

— JOEL VALENTINE
PRESIDENT
21ST CENTURY SOUND DESIGN, HOLLYWOOD
("NORTHERN EXPOSURE")

the Word on the street.

"The first DM-80 paid for itself in two months, so we bought a second one... I like the editing ease—no waiting. It's my 'word processor' for audio."

— MICHAEL STANTON
COMPOSER/ARRANGER
AUDIO PRODUCTIONS, INC., NASHVILLE



"The DM-80 is our secret weapon! It's a very enabling technology."

— MAZ & KILGORE
GRAMMY NOMINATED PRODUCERS
NEW YORK

"What goes in... comes out! And the sound is wonderful. Easy editing, plus easy sync to video lets me concentrate on the creative aspects of the production."

— RICHARD FREITAS
EMMY AWARD NOMINATED AUDIO PRODUCER
THE DOVE TAIL GROUP, CONNECTICUT



"Operational speed and ease of editing make the DM-80 the greatest thing since sliced bread! We use it for all our production."

— VINCENT FUMO
SENIOR EDITOR
INDEPENDENCE BLUE CROSS, PHILADELPHIA

"The DM-80's power and speed allow me to complete a half-hour television documentary every week. As an investment, the DM-80 has proven to be a very smart choice."

— JIM HEFFERNAN
EMMY AWARD WINNING SOUND DESIGNER/PRODUCER
VIDEOSMITH, INC., PHILADELPHIA
("1ST FLIGHTS WITH NEIL ARMSTRONG")



Circle (51) on Reply Card

www.americanradiohistory.com

Continued from page 78

Such data is pivotal to low bit-rate coder design because signal components that are masked can be coded at lower precision, or even completely ignored. The exact degree of masking is a complex function of the amplitude and distribution of the frequency components of the audio signal, and much remains to be learned in quantifying these complex masking effects. In summary, current research indicates that human hearing's frequency selectivity (at its best) approximates that of a 25-band spectrum analyzer. For frequencies below 500Hz, this analyzer's filter bandwidths are approximately 100Hz. Above 500Hz, constant fractional bandwidths of approximately one-fifth of center frequency ($Q=5$) are required. Coders that do not meet these critical-band-based filter criteria will require higher bit rates than coders based on such design to achieve a given sound quality.

Temporal masking

To achieve the best performance at the lowest possible data rates, time-domain or *temporal masking* characteristics must be considered. This important effect results from the close proximity of two or

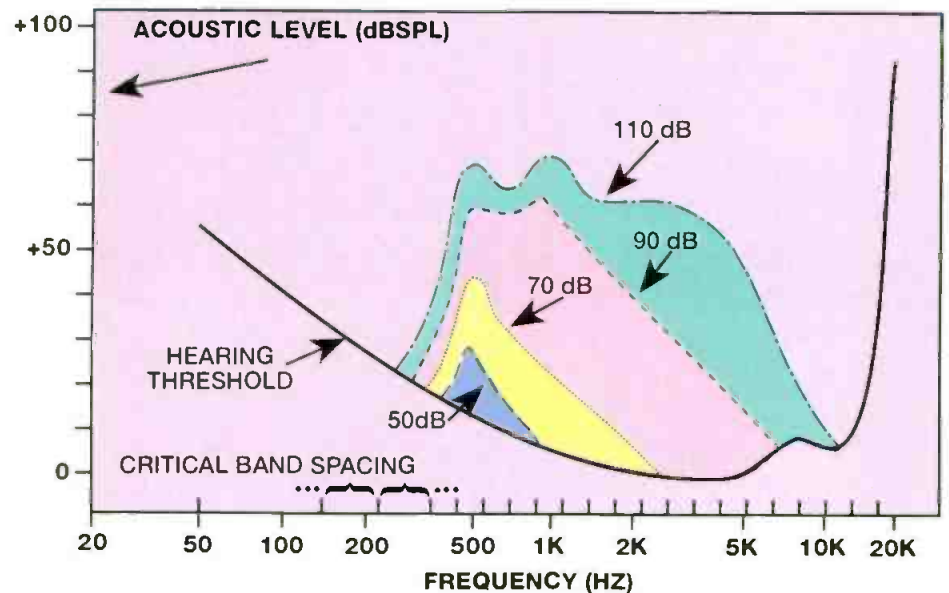

Figure 1. Masked threshold curves for a 500Hz masking tones at several amplitude levels. As masker-tone level increases, masking effect extends over multiple critical bands. (Note critical-band bandwidths on horizontal axis.) Masker tones below 500Hz exhibit even more pronounced spreading, while higher frequency tones produce less.

more sounds in time. Here again, an increase in the threshold of audibility is caused by the transient presence of a sound. But in this case, the masked sound occurs either just after, at the same time as, or just before the louder masking

sound. These three different cases of temporal masking are called *forward masking*, *simultaneous masking* and *backward masking*, respectively.

The most curious effect is that of backward masking, which implies that a given

If You Think We Only Supply Bulk A/V Cables ...



Think Again.

Clark Wire & Cable provides custom high quality cables, cut to length and terminated to your specifications.

- Patch Cords
- ADAT Harnesses
- DA-88 Harnesses
- DT-12 Audio Snakes/Harnesses
- RGB Cables
- Remote Camera Cables
- Digital A/V Assemblies
- Complete Facilities
- And More!



1-800-CABLE-IT!
151 S. Pfingsten Road #B
Deerfield, IL 60015

Circle (52) on Reply Card

If You Think We Only Supply Cable Harnesses ...



Think Again.

You should see the quality and pricing on Clark Wire & Cable bulk cable and connectors.



Clark Wire & Cable has industry standard audio and video cables available in as many as ten jacket colors. Our customized A/V cables are designed with your needs (and pocketbook!) in mind.

1-800-CABLE-IT!
151 S. Pfingsten Road #B
Deerfield, IL 60015

Circle (53) on Reply Card

Sonic fidelity.
Rugged reliability.
And you can't trip
over the cord.



News gathering and field production may seem light years away from rock and roll. But not to Ramsa. On the world's largest tours or in the unpredictable arena of breaking news, Ramsa technology delivers reliability and quality sound. Introducing Ramsa Wireless Microphone Systems.

- 800 MHz UHF operation.
- Phase Lock Loop (PLL) for stable carrier frequencies.
- Digitally switching diversity system dramatically reduces dead spots, drop outs and noise.
- Compander system enables a dynamic range of over 100 db.
- 49 user selectable channels.

©1994 Panasonic, 6550 Katella Ave., Cypress, CA 90630.

For detailed information and specifications, call 1-800-777-1146, Code 01.

RAMSA

Panasonic

Broadcast & Television Systems Company

Circle (64) on Reply Card
www.americanradiohistory.com

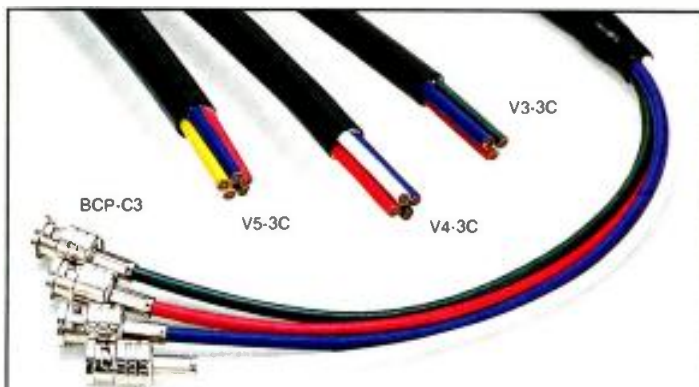

CLEANER & SHARPER VIDEO RESOLUTION

- Optimize the signal to your video monitor with Canare high performance cables and connectors.
- Ideal for computer graphics, video projectors, component (RGB) broadcast and digital VTR's.
- Component coax cable: super flexible, 75 Ohm (<2.2 nanosecond differential delay time). Matched with 75 Ohm BNC connectors (<1.1 VSWR to 2 GHz).
- Available in bulk or pre-assembled fan-to-fan tails.

CANARE
CABLES & CONNECTORS

511 5th St., Unit G, San Fernando, CA 91340
Phone: (818) 365-2446 FAX: (818) 365-0479

REQUEST
FULL-LINE
CATALOG

Circle (65) on Reply Card

Sensational Sound Over Switched 56/ISDN



The CDQ1000, Crystal Clear Digital Audio™ at an affordable price.



Transmit 10 kHz Over a Single Digital Circuit!

CCS, the pioneer of digital audio codecs, proudly presents the CDQ1000, the only codec that lets you transmit up to 10 kHz of audio over a single switched 56 or ISDN line.

Preserve Your Past Investments in Codecs!

The versatile CDQ1000 is fully compatible with G.722, 7.5 kHz codecs such as the CCS Micro56 and Micro66i. It also interoperates with the CCS CDQ2000 ISO MUSICAM® codec. You can now achieve universal compatibility with a single codec!

- Three modes of operation: 7.5, 8.2, or 10 kHz
- CCITT G.722 or enhanced MUSICAM compression
- Two-way mono transmission
- 56 kbps or 64 kbps data rate
- Both V.35 and X.21 digital interfaces



CCS Audio Products
33 West Main Street
Holmdel, NJ 07733, USA
(908)946-3800 FAX: (908)946-7167



CCS Europe GmbH
Ludwigstrabe 45
D-85399 Hallbergmoos
Phone 49811-5516-0 FAX 49811-5516-055

Circle (66) on Reply Card

See us at World Media Expo, Booth 2234

sound can mask events that *preceded* it. This results from the ear's process of integrating sound events that occur over a short period of time, and packaging them in "bursts" of data to the auditory cortex. (This is opposed to the more intuitive concept of a continuous and instantaneous response to sound events.)

This process of quantization – the coding of frequency-domain signal components to reduced precision – is the mechanism by which a reduction in bit-rate (or coding gain) is achieved.

Figure 2 shows the relative time duration of backward and forward masking effects. Backward masking is effective only when the onset of the masking transient occurs within 10ms of the onset of the masked sound. The effect is strongest when the onset time differential is less than 5ms. The steep slope of the curve in the backward masking region implies the time resolution of the ear is of the order of 2ms to 4ms. In the forward masking region, significant masking can occur for 50ms to 100ms after the masking transient ceases, while the effect completely disappears within 200ms. This is consistent with the accepted principle that 200ms is the time interval over which the ear integrates sound intensity. The temporal resolution of the ear provides a key metric for low bit-rate coder design.

Coder architecture

Implementing these psychoacoustic principles into the operation of a low bit-rate coder involves a number of steps. These include: 1) generation of a frequency-domain representation of the audio signal; 2) quantization of the frequency components of the signal at reduced precision based on masking principles; 3) bit allocation to meet varying demands of the quantizers in the individual frequency bands; and 4) reconstruction of the low bit-rate coded approximation of the original time-domain waveform following transmission or storage of the quantized frequency-domain data. (See Figure 3.)

To provide suitable frequency selectivity, an analysis filter bank generates the frequency-domain representation of the audio signal. The most prevalent techniques used include variants of the discrete Fourier transform (used in so-called *transform coders*) and polyphase digital filters (used in *subband coders*). Combinations of the two are also employed. Transform-based coders can exhibit a moderate performance/cost advantage because filter banks with the necessary frequency selectivity can be implemented with lower computational complexity.

Next, masking thresholds for the frequency components in each band of the filter bank are established. More powerful and flexible coders calculate masking thresholds based on a sophisticated psychoacoustic model, while others work on the basis of general masking principles or simplified, preprogrammed masking curves. Masking principles are applied to determine which frequency components are masked by other larger signals nearby in frequency or time. They also determine to what degree of accuracy the relevant (audible) frequency com-

Meet the hottest...



...UHF wireless

**Red hot performance
and solid reliability...**

The UCR190 narrow-band UHF receiver utilizes the proven UNICHANNEL[®] design with helical resonator front-end filtering and narrow band crystal IF filtering. An all new dual-band compandor provides low distortion and a high signal to noise ratio. Aimed at broadcast ENG applications, the UCR190 receiver provides unmatched interference and IM rejection.

The 195 Series wide-band UHF system utilizes ± 75 KHz deviation for outstanding dynamic range and signal to noise ratio. An exclusive dual-band compandor and pulse counting detector provide audio quality well suited to the most demanding digital recording techniques. The balanced audio output is adjustable from mic level up to +8dBm studio levels.

More transmitter output power, plus higher receiver sensitivity than any other brand we've tested, all adds up to more operating range than you will probably ever need.

Belt-pack and plug-on transmitters are available in both narrow-band and wide-band UHF versions. Audio outputs are balanced XLR types with separate monitor outputs. All housings and panels are made of machined aluminum for a precise fit and lasting ruggedness. Shock mounted crystals and surface mount components withstand the toughest field use.

Inside Lectrosonics UHF products you will find advanced RF engineering, superb mechanical design and the very latest in surface mount technology. This is the present state of the art in wireless systems.

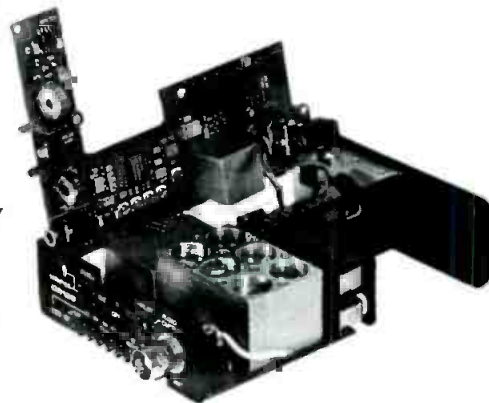

Call for more information

800-821-1121

and a free copy of the 50 page "Wireless Guide"

Distributed in Canada by MILLER CANADA

We invite you to compare these systems with any other wireless system, at any price.



LECTROSONICS

581 Laser Rd., Rio Rancho, NM 87124 USA
Ph: (505) 892-4501 FAX: (505) 892-6243

Circle (67) on Reply Card

www.americanradiohistory.com

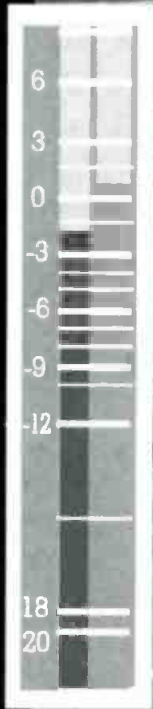

chromatec

Monitor audio levels, phase and picture simultaneously, with Chromatec's TVD series of audio level monitors.

bel
DIGITAL AUDIO

The BDE series of audio digital delays, lay-off recorders and synchronizers offers the ultimate in audio performance using digital techniques.

Imported Exclusively by...

ADM SYSTEMS

P.O. Box 250334
West Bloomfield • MI 48325
Phone: (810) 524-2100
FAX: (810) 932-1991

Circle (68) on Reply Card

ponents must be quantized to keep coding noise below the masking threshold for that combination of signal elements. This process of quantization — the coding of frequency-domain signal components to reduced precision — is the mechanism by which a reduction in bit-rate (or *coding gain*) is achieved.

Once the appropriate signal-to-quantization-noise ratios are established for all the frequency bands, bits

are allocated to the bands (within the limits of the available bit pool) to achieve the best possible sonic quality. In a typical coder, quantized frequency components in each band are scaled or normalized to make optimum use of the dynamic range of the respective digital signal processing system. Gain factors that represent the gain adjustment required for normalization are typically assigned to each of the frequency bands and are stored or transmitted for subsequent decoding along with the quantized frequency components. In the decoder, the gain

Audio signals include nearly steady-state elements as well as transient signals that change rapidly with time.

factors are used to restore the frequency components in each band to their original quantized levels.

The frequency components are then passed through a synthesis filter bank (which is typically identical in frequency response to the encoder's analysis filter bank) to constrain the wideband noise introduced in the quantizing process back into critical bandwidths. This ensures that such noise products will be masked by signal energy in each band.

Spectral vs. temporal resolution

Audio signals include nearly steady-state elements as well as transient signals that change rapidly with time. Com-

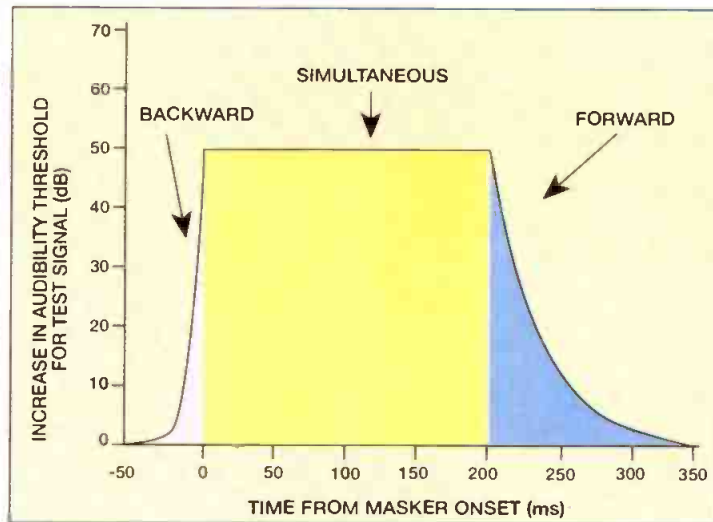

Figure 2. Effectiveness of backward, simultaneous and forward masking as a function of time difference between onset of masked and masking tonebursts (after Zwicker and Fastl, 1990). Mapped value indicates the increase in the threshold of audibility for a short tone burst created by the presence of a longer-duration transient masker.

ponents that change slowly over time are best coded using a filter bank with a high degree of frequency selectivity. This ensures that coding errors are confined to the spectral region of the signal, taking full advantage of frequency-domain masking.

On the other hand, transient signals are best coded using a filter bank with time resolution comparable to that of the ear. This avoids coding errors (quantization noise) that may spread in time beyond the audibility limits set by temporal masking. One consequence of quantizing the frequency-domain signal components in sets that correspond to blocks of time-domain samples, is that quantizing noise is introduced for the entire duration of a block of samples. Thus, if a transient occurs within a given block of samples, the coder must have sufficiently good time resolution to prevent the quantizing noise from spreading beyond the backward masking window.

Such high-frequency selectivity and short time resolution are typically mutually exclusive. Therefore, filter-bank design can involve a compromise between time and frequency resolution with sufficient bit rate allocated to meet temporal and spectral masking constraints, and/or an *adaptive* filter bank that can optimize either time or frequency resolution as the characteristics of the coded signal vary. Both techniques are employed in low bit-rate audio coders. More powerful coders adapt to the signals' steady-state or transient characteristics by trading frequency for time resolution, and vice versa, on a moment-by-moment basis.

Tandem connection of low bit-rate coders

The International Telecommunications Union's Radiocommunications Bureau,

known as ITU-R (formerly CCIR), has defined several terms that are useful in characterizing coder applications for broadcast applications. *Contribution* applies to initial acquisition and production of programs, where many generations (e.g., six or more) of low bit-rate coding are likely. *Distribution* refers to the dissemination of programs to various broadcast outlets, wherein two or more generations may be encountered. These include network feeds to affiliates, time-zone tape delay and STL/ICR hops. *Emission* applies to the final broadcast link to consumers, where a single coding generation is anticipated.

The main difference between coders designed for these three applications is the coding margin between the true masking threshold and the actual level of coding noise under a given signal condition.

The coder with the least coding margin in a multigenerational chain will typically have the greatest influence on overall sound quality.

Listening experiments with a wide variety of critical program material support the conclusion that coding artifacts, even those from dissimilar coders, tend to be additive. Because noise artifacts essentially add in an rms sum, the first several encode/decode operations of any class of coder will contribute the most degradation to the signal. The coder with the least coding margin in a multigenerational (or tandem-coded) chain will typically have the greatest influence on overall sound quality.

Coders that are classified as emission types may operate with little to no coding margin. Those designed for distribution and contribution applications will have sufficient margin for transparent or near-transparent operation after a prescribed number of generations. The latter also should apply psychoacoustic models in a conservative way to preserve signal information that may be close to the masking thresholds for a downstream emission coder.

The subjective performance of a perceptual coder is always a strong function of bit rate — increase in bit rate will generally result in an increase in coding margin. This is not to suggest that an emission coder can be used in a contribution application simply by increasing its bit rate, however. Emission coders

MPEG LAB™ PRO

REAL-TIME MPEG VIDEO COMPRESSION

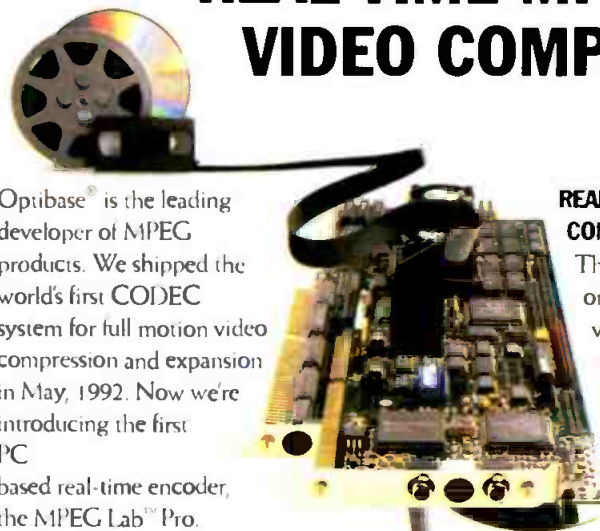

Optibase® is the leading developer of MPEG products. We shipped the world's first CODEC system for full motion video compression and expansion in May, 1992. Now we're introducing the first PC

based real-time encoder, the MPEG Lab™ Pro.

THE COMPLETE SOLUTION.

The MPEG Lab™ Pro is the first complete, fully automatic solution for ISO-standard MPEG-1 compression and decompression of video and audio with professional quality. Operating in real-time on a PC/AT, it pre-filters, compresses and interleaves audio and video signals for video-on-demand application development, and generates both MPEG-1 and CD-i system files. To complete the process, the MPEG Lab™ Pro then decompresses the files for playback.

MULTIPLE INPUT SOURCE CAPABILITY.

MPEG Lab™ Pro accepts industry standard NTSC and PAL video in Composite and S-Video formats. Our unique users interface provides complete device control for laser disks and over 40 models of frame accurate VCR's and VTR's. It's ideal for broadcast applications (i.e. video on demand, barker channels, ad insertion, etc.), training systems, point-of-information kiosks and CD-i entertainment applications.

PRE-FILTERING FOR HIGH QUALITY OUTPUT.

Intelligent pre-filtering with optional 3:2 pull down is performed in real time, converting the input CCIR-601 video into an MPEG-complaint SIF format. The digitized file is then ready for compression ratios of over 200:1. MPEG Lab™ Pro allows the user to control the bit rate, input source, video and compression parameters.

REAL-TIME AUDIO AND VIDEO COMPRESSION.

The MPEG Lab™ Pro delivers one-to-one symmetrical conversion of audio and video in real-time. From analog to digital immediately. That saves valuable time!

MPEG Lab™ Pro digitizes the analog video and audio, pre-filters

the video to MPEG SIF resolution, compresses the audio and video and then completes the process by interleaving the two compressed files into a single MPEG complaint system file. Instantly!

THE MPEG LAB™ PRO COMES COMPLETE!

It's a complete solution! Two boards, (the MPEG-4000 for compression and the PC Motion™ Pro for playback and audio encoding) are the key components of the package. Windows compatible software featuring device control, parameter adjustment and batch mode processing, means the package is easy to use. All this, plus unmatched technical support, make MPEG Lab™ Pro from Optibase the only complete solution for high quality video, images and sound.

The future is digital. Call now, and step into the future with MPEG Lab™ Pro and Optibase.

For more MPEG Lab™ Pro info:

Phone 800-451-5101 or 214-239-5242
U.S. ONLY

FAX 214-239-1273

Bulletin Board 214-239-0249

Optibase, Inc.

Dallas, Texas

Circle (70) on Reply Card

OPTIBASE®

DIGITAL VIDEO, IMAGES & SOUND

COMPAQ
Qualified
Solution

Windows is a registered trademark of Microsoft Corporation. MPEG Lab™ Pro and PC Motion™ are trademarks of Optibase, Inc. The Compaq Qualified Solution logo is a trademark of the Compaq Computer Corporation.

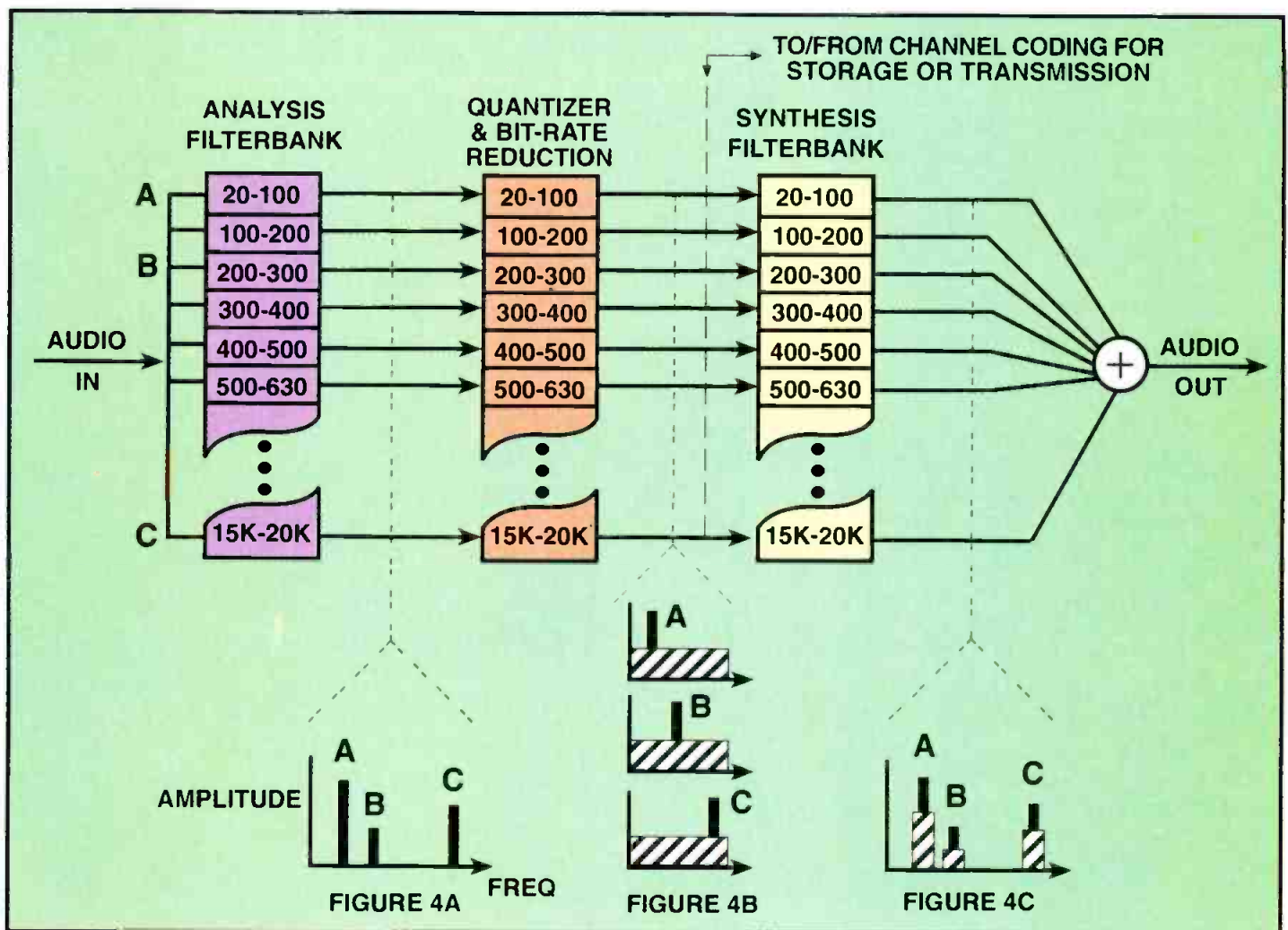

Figures 3 & 4. Conceptual model of multiband, low bit-rate coding system. In Figure 4A, critical-band-based filter bank converts low- (A), middle- (B) and high-frequency (C) components of digitized time-domain audio waveform into frequency-domain representations, where masking parameters are determined by assessing loudest frequency components in each band. In Figure 4B, signals requiring coding are normalized and quantized with enough accuracy to keep quantization noise below masking threshold in each critical band. This reduces bit-rate, but introduces wideband noise (crosshatched areas) that spreads beyond critical-band limits. In Figure 4C, filter bank in the decoder limits wideband noise to each critical band, thus keeping it below masking thresholds. (Low bit-rate storage or transmission takes place between Figures 4B and 4C.)

aggressively exploit masking principles and may not be suitable for use in distribution or contribution applications without major modifications.

In an ideal world, all coder designers would classify their coders as previously outlined and specify the recommended bit rates for the respective applications. In the real world, however, broadcast engineers should work closely with an experienced coder vendor to understand the impact of coder performance on the broadcast facility, and on downstream users who may record broadcast signals on media employing additional low bit-rate coding. Future consumer recording devices (e.g., digital VCRs) will record low-bit-rate-coded data as received, thereby avoiding the generation loss of re-coding received signals. In the meantime, it is not surprising that coder artifacts can become audible when emission coders are misused in tandem connections for contribution or distribution applications. For broadcast engineers, an improved understanding of the design trade-

offs in low bit-rate coders should allay recent industry concerns with tandem connection issues.

Conclusions

Providing cost-effective storage and transmission of high-quality digital audio has been a primary goal for coder developers, and the design of low bit-rate coders necessarily involves a trade off between the amount of bit-rate reduction and subjective audio quality. Nearly transparent performance for 20Hz to 20kHz bandwidth audio signals is possible today at data rates of 96 to 128kb/s/channel. Similar degrees of transparency are possible with the best stereo coders at 170 to 192kb/s/2ch, and for the best 5.1-channel multichannel coders at data rates of 384 to 448kb/s. (See related article, "Multichannel Audio Coding," p. 80.) These figures may improve as future coder research and improvements in psychoacoustic models yield improvements in transparency and equivalent sound quality at moderately lower data rates.

Because of this expectation, many coders designed today allow compatible encoder improvements to be introduced without negative impact on the installed base of decoders, thereby providing the flexibility needed for future performance improvements. Digital signal processing (DSP) and custom large-scale integrated (LSI) circuit devices will continue to provide the required computational horsepower and economy for coder implementation in the professional and consumer audio environments.

➔ For more information on low bit-rate audio coders, circle (304) on Reply Card. See also "Coders and Decoders, Digital Audio," p. 52 of the BE Buyers Guide.

“Network” your wireless mics...

...for complete audio- system control

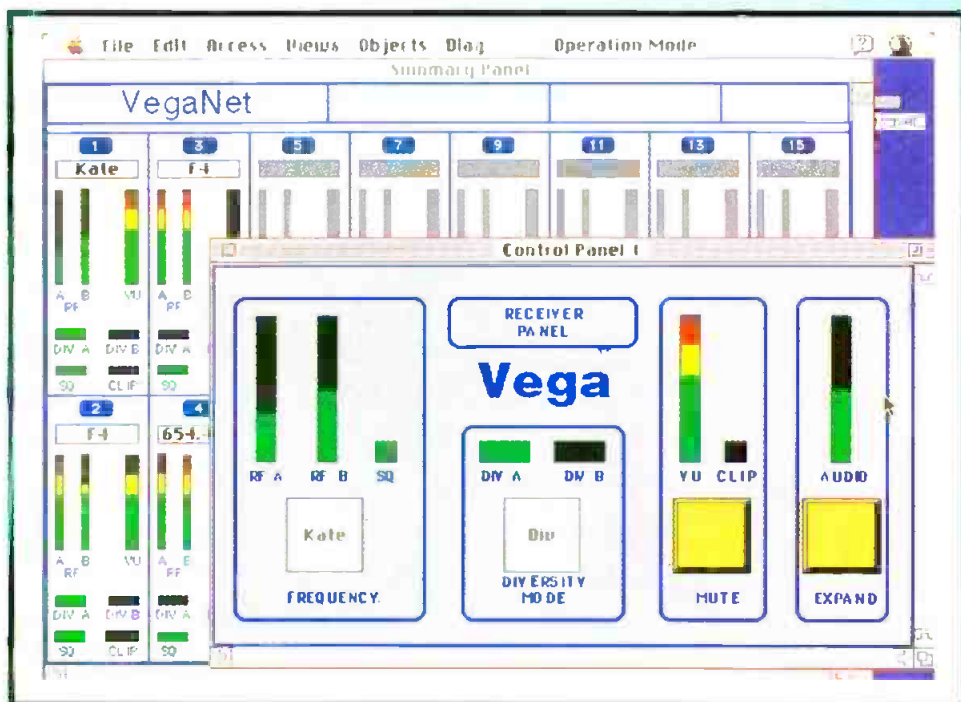

VegaNet™

Gain complete control of your wireless-microphone system. Remotely control and monitor all of your compatible Vega wireless-microphone equipment via VegaNet™. Using either Macintosh or IBM-compatible per-

sonal computers, VegaNet™ hardware and software provides a previously unavailable degree of control over medium to larger wireless installations.

With Vega's modular interface unit, you can expand from as few as two wireless systems to literally dozens easily and simply. Vega's NE-8 enclosure holds up to eight NE-2 interface modules, each of which provides control and monitoring interfaces for two receivers. If your needs grow beyond 16 systems, additional NE-8 enclosures can be added easily.

The control computer can be located hundreds of feet away from the receivers. Multiple display and control locations are easily accommodated. Even off-site control and monitoring can be implemented simply via standard data modems.

VegaNet™ software is available for Macintosh computers running System 7 or PCs operating under Windows 3.1 or higher. In addition to VegaNet™ hardware and software, a complete system requires Lone Wolf's VNST™ operating-system software, a network interface bridge (both available sepa-

rately), and a Mac or PC with the appropriate system software.

With this system you can generate customized display and control screens without programming, using almost any paint program. The “drag and drop” feature of Lone Wolf's VNST™ operating system then allows active control and monitor elements to be “pasted” to the display. These custom panels are not limited to wireless equipment; they can integrate any of the other network equipment such as power amplifiers, EQs, delays, etc.

The system supports multiple active display panels, one windowed over the other or tiled on the screen. At your touch, hidden active screens can be brought forward for instant use. VegaNet™ is fully Lone Wolf MediaLink™ compatible and conforms to the AES draft standard for audio networking.

Get the whole story on this exciting new technology, whose applications are limited only by your imagination. Call 800-877-1771 today for details.

VEGA

a MARK IV company

9900 East Baldwin Place
El Monte, California 91731-2294
Telephone: (818) 442-0782
Toll-Free Telephone: 800-877-1771
Fax: (818) 444-1342
FaxBack: (818) 444-2017
Toll-Free FaxBack: 800-274-2017

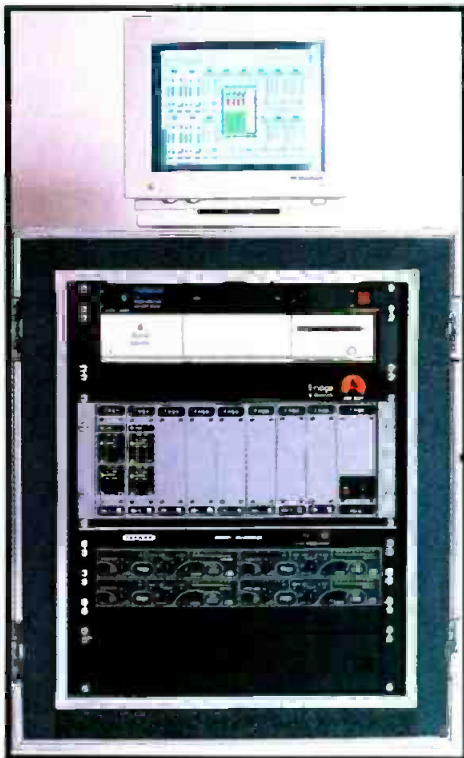

Circle (71) on Reply Card

www.americanradiohistory.com

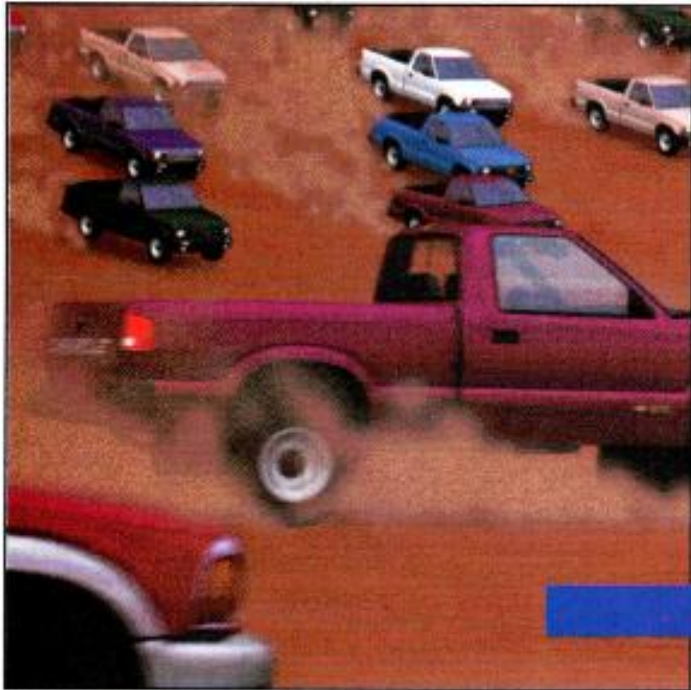

Wireless microphone technology

Wireless microphones continue to grow in popularity among broadcasters.

By Glen Ballou

The Bottom Line

Wireless microphone systems can make many previously impossible projects seem almost routine. Yet the conveniences that wireless microphones bring to broadcast talent and producers are countered by the additional challenges such systems pose to technical personnel. Understanding how wireless microphones operate can help broadcast engineers solve the many problems that can arise when using such systems.



When choosing a wireless microphone for professional use, a number of criteria need to be considered. First, it should work well in a variety of tough environments. It must be usable near strong RF fields, lighting dimmers and other sources of electromagnetic interference. This factor relates directly to the type of modulation: Standard FM and narrowband FM both are used in today's professional systems. It also relates to the operating frequency (HF, VHF or UHF) and to the receiver sensitivity and selectivity.

A wireless microphone system also should be reliable and must operate at least five hours (preferably eight hours or more) on one set of disposable batteries, or on each recharge if NiCad batteries are used.

Spectrum usage

Wireless microphones are licensed on several frequencies. The four most common bands are as follows:

- VHF lowband: 25MHz-50MHz and 72MHz-76MHz
- FM broadcast: 88MHz-108MHz
- VHF highband: 150MHz-216MHz
- UHF: 450MHz-530MHz and 902MHz-952MHz

With the exception of a few AM systems in the VHF lowband, FM is used by wireless systems to improve noise performance.

The VHF lowband is often used for low-cost, non-professional systems. It is in the noisiest radio spectrum, and because

the wavelength is approximately 20 feet (6m), quarter-wave antennas are five feet (1.5m) long. The VHF lowband is also susceptible to ionospheric skip, making these systems prone to interference from distant transmitters.

Professional wireless microphone systems use the VHF highband and the UHF bands. Although the VHF highband is favorable for most applications, the UHF band is increasing in popularity. Table 1 lists the advantages and disadvantages of these bands.

Although the VHF highband is favorable for most applications, the UHF band is increasing in popularity.

The VHF highband has low noise and interference, and it allows good range at low power — up to 1,000 feet (300m) line-of-sight at 50mW RF power output (the maximum power allowed by the FCC for VHF highband systems). The frequencies between 174MHz and 216MHz are normally used, corresponding to TV channels 7 to 13. A good VHF highband receiver will have adequate selectivity to reject nearby TV or FM broadcast signals. The VHF highband is free of other occasional users, such as citizens band or business radio. Any VHF broadcast stations in the area that might cause interference are well-known, and can be easily avoided.

Using multiple wireless microphones

Ballou is the editor of Handbook for Sound Engineers: The New Audio Cyclopaedia. Respond via the BEFAXback line at 913-967-1905.

First LARCAN bought a TTC transmitter...

We were so impressed, we bought the company.

LARCAN was called on to supply a reliable UHF IOT transmitter to one of our loyal solid state customers.

We had to make the right choice... our own reputation was riding on it. So we shopped the worldwide market, asked a lot of tough questions. And after all the research, we chose TTC's HDR over all its competition..

Our reasons were simple and compelling:

- ✓ **HDR** proved to be 9-12% more efficient than any of its competitors – our customer sure liked the power cost savings.
- ✓ **HDR** has a real-world track record – it was the world's first air-cooled IOT transmitter.
- ✓ **HDR** features TTC's high-performance XLS-5 Exciter; plus air or water cooling – our engineers heartily approved.
- ✓ **HDR** transmitters are High Definition Ready – they can be on air today and be used for HDTV tomorrow.

In fact, the more we found out about TTC and its design philosophy, the more we liked what we saw.

We knew TTC's product line – including their industry-standard low power UHF transmitters and outstanding FM transmitters–would be a perfect fit with LARCAN's advanced solid state VHF and UHF technology. So the two companies joined forces.

Now you can get the strength of one of the largest, most successful transmitter companies joined with the world's most efficient UHF high power transmitter.

How can you beat that?

Circle (54) on Reply Card

228 Ambassador Drive
Mississauga, Ontario CANADA L5T 2J2
Tel: 905-564-9222. Fax: 905-564-9244

LARCAN

www.americanradiohistory.com

650 S. Taylor Avenue
Louisville, CO 80027
Tel: 303-665-8000, Fax: 303-673-9900

on adjacent frequencies requires receivers with high selectivity and excellent capture ratio. (See "Using Wireless Microphones," October 1993.) For reliable multichannel operation, narrow-deviation FM systems are generally required, using as little as 12kHz modulation per channel. Wide-deviation systems (75kHz modulation or more) can suffer from adjacent-channel interference in multichannel applications. Narrowband FM systems, however, are inherently disadvantaged in terms of overall audio quality. Wider FM bandwidths provide better overall frequency response, lower distortion and inherently better S/N. Wireless system designers must therefore trade spectrum efficiency and interfer-

phone Interference Problems," p. 98.) The most important single factor in controlling interference is proper fre-

Using multiple systems on adjacent frequencies requires receivers with high selectivity and excellent capture ratio.

quency selection. Because wireless microphone usage is almost always sec-

Therefore, omni antennas are typically used at both ends of the wireless RF channel, resulting in much of the transmitted radio signal coming to the receiver via bounce-paths, creating the potential for another form of interference familiar to broadcasters — multipath. As talent moves, multipath can cause RF fading and dropouts to occur in the received signal.

Multipath effects are combated with diversity receive antenna systems, in which multiple, spaced antennas are used. (See "Diversity Reception for Wireless Microphones," January 1993.)

Receive antenna systems

Three types of diversity wireless micro-

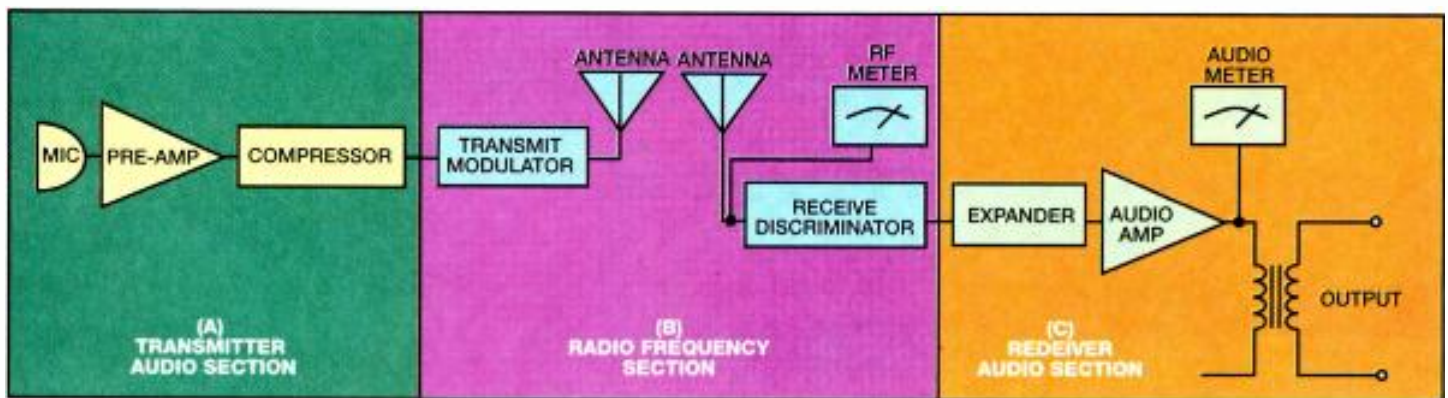

Figure 1. Basic block diagram of a wireless microphone system.

ence-free operation with audio quality, while observing FCC Part 74 regulations throughout. These regulations limit deviation to $\pm 15\text{kHz}$ for wireless microphones operating in the VHF range and $\pm 75\text{kHz}$ for UHF.

To accommodate these divergent needs, most current wireless microphones use a companding system. (See Figure 1.) Such companding can provide a dynamic range of 90dB to 105dB instead of the 50dB or 60dB found in a non-companded system using the same deviation. Companding can also reduce the perceived effect of transient noise events that occur in the transmission channel.

Interference control

Just as in broadcast transmission, interference in wireless microphone systems is caused by a familiar list of possibilities: co-channel interference, intermodulation of multiple frequencies (especially 2A-B), spurious radiation from other radio services (such as land mobile, public service or CB radio), insufficient EMI suppression on nearby electrical equipment (such as vehicle ignition noise) and spurious radiation from electronic equipment (such as light-control equipment, digital displays, synthesizers, digital delays and computers). (See related article, "Solving Wireless Micro-

phone systems are common: phase-switching diversity, dual-receiver/post-detection combining and antenna-combination diversity.

ondary to most other uses of its assigned bands, the wireless system is the one that must make the accommodation. Therefore, proper initial frequency choices will save time and trouble later. In most cases of interference from electric and electronic devices, severe problems occur only if the wireless receiver is mounted immediately adjacent to the offending device. A few feet of separation will often resolve any problems. Digital

Multipath effects are combated with diversity receive antenna systems, in which multiple, spaced antennas are used.

devices may also create interference on the shared AC power lines in audio equipment installations. In this case, separate power sources for the wireless equipment might be necessary.

Regarding antenna gain, FCC rules do not permit the use of high-gain transmitter antennas, and high-gain, directional receive antennas aren't usually used because the talent is typically moving.

Phase-switching diversity sums the outputs of two appropriately spaced antennas, adaptively switching the polarity of one antenna's output when the relative phase of the received signal between the two antennas approaches 180° .

Dual-receiver/post-detection combining (often referred to as *true diversity*) uses two spaced antennas each feeding a separate receiver operating on the same frequency. The demodulated audio signal from each receiver is fed to a high-speed audio switch that selects the output from whichever receiver is picking up the stronger RF signal at the moment. This approach also provides redundancy at the receive end.

Variations on this theme use adaptive circuitry to monitor the RF outputs of the two antennas, switching the stronger signal (or optimally combining the two antennas' outputs) into a *single* receiver's RF input.

An antenna-combination diversity system uses three antennas, the outputs of which are actively summed and fed to a single, standard receiver. Because the output is the vector sum of the signals, the receiver always has the benefit of the

WHEN HUGO BLEW OUR ANTENNAS AWAY



OUR PIROD TOWERS JUST STOOD THERE AND WATCHED.



David Sharp
Vice President, Operations
The Virgin Islands
Telephone Company

"When Hugo hit, our solid rod PiRod towers just stood there and took it. The storm ripped away many structures in this area . . . I think our PiRod towers were among the very few towers left virtually undamaged. I remember . . . I purchased new antennas, called the people at PiRod for new brackets and we were back in business!"

Solid Rod, Solid Service, Solid Value



Solid rod, free-standing or guyed towers custom designed to your specifications.

For a free guide to tower selection and fast, courteous response to your requests for quotation, contact:



PIROD INC.

P.O. Box 128
Plymouth, Indiana 46563-0128
Telephone (219) 936-4221

signals present at each antenna location (unlike a passively combined system, which would act as a single array).

When transmit antennas are worn close to the body, the effective range can be greatly reduced.

True diversity receivers are becoming the standard of today's high-end systems. Their latest incarnations typically include microprocessor-based control of diversity switching or combining.

Placement of transmit antennas

Body-pack wireless transmitters often use a flexible wire for an antenna. It should be kept separate and run in the opposite direction from the microphone cable. (Bundling the antenna and microphone cable together electrically shorts out the antenna, reducing the range to as little as 10% of normal.) Although circumstances might dictate other methods, the preferred practice is to orient the antenna vertically and to place it as high on the body as possible.

When transmit antennas are worn close

to the body, the effective range might be reduced to one-half to one-fifth of that achieved by a free-standing, isolated transmitter. The loss depends on body size and mass, body position relative to the transmit and receive antenna locations and other factors. The antenna pattern is also altered. The effective orientation of the antenna usually tilts forward through the vertical plane of the body.

The proximity of the antenna to the skin reduces signal, especially when the performer is perspiring. The body — especially its perspiration — is somewhat conductive and tends to short out the antenna. Spacing the antenna even a few millimeters away from the body improves range significantly.

Hand-held wireless microphone transmitters use either internal or external antennas. In the VHF range, hand-held systems are generally too small to include efficient antennas. (At 180MHz, a full-size antenna is about 33 inches [84cm] long.)

For UHF hand-held transmitters, the size of the transmitter body is considerably closer to optimum. For units with internal antennas, however, part of this advantage is offset by the RF absorption of the hand. Therefore, UHF designs with external antennas, although sometimes lacking in aesthetic appeal, can have high RF efficiency compared to other types of transmitters.

Placement of receiver antennas

The wavelengths of VHF and UHF wireless microphone systems typically allow quarter-wave receive antennas to be connected directly to the rear panel of receivers. For most diversity systems, mounting multiple antennas across the rear panel of a rack-mount receiver provides adequate antenna spacing to eliminate most multipath effects. Phasing types of diversity receivers are the exception — they require greater spacing than is typically provided on receiver chassis.

For portable, ENG-type diversity receivers, two antennas can be mounted on a single, pocket-sized UHF receiver. Portable VHF receivers require a larger chassis (available in backpack or shoulder bag

As more wireless microphones are sold, the VHF band is becoming increasingly saturated.

styles), or they can use one "inboard" and one "outboard" antenna. (For example, one antenna may be mounted on a receiver attached to a video camera while the other is attached to a shoulder mount worn by the camera operator, and

connected to the receiver via a short length of coax cable.)

For some fixed-receiver applications, a near-antenna/far-antenna system is preferable. The near antenna, (nearer to the transmitter) produces most of the signal most of the time. The far antenna(s) could be offset in elevation and position, thereby reducing the possibility of multipath nulling over a wide area.

When using a remote antenna, however, significant RF signal losses can occur. One solution puts the wireless microphone receiver at the antenna's remote location, with a balanced line-level audio cable running back to the mix position instead of an RF cable. If long runs of antenna cable must be used, be sure

	ADVANTAGES	DISADVANTAGES
VHF	<ul style="list-style-type: none"> • Less expensive • More product choices • Many price/performance levels • Easier to use • More forgiving of application errors or poor conditions • Less complex • Potentially more reliable • Easier to maintain • Easier and less expensive antenna distribution networks 	<ul style="list-style-type: none"> • Many more existing systems in use (over 300,000), with over 25,000 sold in U.S. each year using same 5 or 6 frequencies • Fewer available channels • Higher potential for interference • Large multichannel systems may be impossible due to limited spectrum availability
UHF	<ul style="list-style-type: none"> • Fewer systems in use • More channels available • Less likelihood of interference • Higher power allowed in U.S., providing greater range • Smaller antennas allow easier concealment, more practical portable diversity receivers and high-gain antennas • Majority of recent development focused on UHF, so most systems are of modern design and include latest features 	<ul style="list-style-type: none"> • Relatively more expensive • More complex operation in some cases • Antenna distribution networks often needed, which can be complex and expensive • For full power operation, battery life or size can be problematic

Table 1. UHF- and VHF-band wireless microphone systems compared.

Continues on page 110

ONE GENERATION AHEAD



J15ax8B IRS

IFplus

Internal Focus

The future of broadcasting is here. The J15ax8B is Canon's first lens to feature new **IFplus** technology. The challenges of wide screen technology require lenses with higher resolution, higher MTF, and reduced chromatic aberration. Canon's **IFplus** technology meets these challenges.

Highest Optical Quality

IFplus features Hi-UD Glass which provides extraordinarily low dispersion, and effectively corrects chromatic aberrations. These high-quality optics also make optical specifications previously thought unattainable a reality

Highest MTF

16x9 wide screen applications will require a scanning line density of 20% higher than today's standards. Canon's **IFplus** technology offers the higher MTF required.

Highest Specifications

- Widest standard lens, with a wide angle of 8mm (57.6°)
- Longest Focal Range: 8~120mm
- Shortest MOD in a standard ENG Lens: 0.65m

Each generation must face the challenges of the future. Face the future of broadcasting by using **IFplus**, one generation ahead in lens technology. For additional information about **IFplus** or any lens question, call us at 1-800-321-4388 (In Canada call 905-795-2012).

Canon
The Number One Lens

Circle (44) on Reply Card

www.americanradiohistory.com

Our Commitment Continues

Introducing the Graham-Patten Systems *D/ESAM*® 820 Digital Edit Suite Audio Mixer... designed to meet your edit suite audio needs of today *and tomorrow*.

- **NEW** 20 bit digital input cards with optional Sample Rate Converters provide unmatched audio fidelity and allow easy integration of non-professional devices such as CD players and DAT machines in your edit suite.
- **NEW** Advanced Digital Signal Processing technology maintains the exceptional audio performance your clients demand without the artifacts often associated with digital audio processing.
- Graham-Patten Systems' innovative Virtual Input Matrix and output routing provide flexibility in handling audio signals without the need for external routing systems and patch panels.



1990/91 Emmy Award
Outstanding Achievement
Engineering Development
© ©

- **NEW** enhanced D/MEM register capabilities include 20 Suite Configuration Registers for instant recall of complex edit suite, machine, and mixer configurations. Hundreds of mixer snapshots for quick and easy system setup and editing operations are now standard on every *D/ESAM*® 820 system.
- Like all Graham-Patten mixers, the new *D/ESAM*® 820 operates with any edit controller using ESAM II Protocol. ESAM II allows serial control of mixer operations and complete transfer of mixer setups and internal registers to your edit list for precise recall by your edit system.
- Best of all, every existing *D/ESAM*® 800 mixer can be upgraded to the capabilities of the new *D/ESAM*® 820 system.

To learn more about *D/ESAM*® mixers, call Graham-Patten Systems at (800) 422-6662 in the United States or +1 (916) 273-8412.

See the entire array of Graham-Patten products at IBC Stand 10, 125 Delta Hall.

© 1994 Graham-Patten Systems, Inc. *D/ESAM* is a registered trademark of Graham-Patten Systems, Inc.

Solving wireless microphone interference problems

Although interference in wireless microphone systems is relatively rare, it can be disconcerting when it does occur. Multipath and intermodulation are the most common sources of wireless interference, but an increasing number of problems come from ambient RF noise.

One common ambient interference source is electrical noise, usually generated by electrical discharges and arcing. This can be caused by insulation failure, arcing of relay and switch contacts, worn rotating contacts on electrical machinery, spark plugs on automobiles or high-voltage breakdowns. In larger cities, especially in industrial areas, there is usually a high ambient RF noise level from the accumulated effects of electrical noise from many minor sources.

For wireless microphone systems without audio processing, this ambient RF can cause noticeable audio noise. With audio processing, the effect is usually negligible. More serious

are periodic high-intensity noise bursts, usually caused by defective electrical equipment. Even the best wireless equipment will be affected in cases involving large amounts of electrical energy.

For interference caused by electrical equipment, the quality of the wireless microphone receiver is a major factor in how susceptible the system will be. Well-designed receivers (i.e., those with narrowband RF front ends, a high degree of IF selectivity and good limiting characteristics) are more immune. Operating frequency is also a factor. This type of noise is most severe at low frequencies and falls off rapidly with increasing frequency. Therefore, wireless systems operating at 49MHz or 72MHz are much more likely to be affected by electrical noise than are systems operating above 150MHz.

Neon lighting equipment is regaining popularity and is sometimes used at performance venues and on sets, causing many users to be concerned about its interference potential. Although

neon tubes do increase ambient RF noise, severe interference is rare. When problems do occur, they are almost always caused by arcing or corona in high-voltage distribution wiring. Corona is sometimes difficult to detect visually, even in near-total darkness, but it can be heard clearly in quiet surroundings. You will probably have to eliminate arcing or corona to obtain good results with wireless systems.

Problems with neon systems are occasionally caused by the use of electronic dimmers, because the tubes become electrically noisy when operated near the point at which they extinguish. Cabling between the dimmer controller and the transformer, and between the transformer and the neon tubes, are occasional sources of problems, especially if the electrical grounding system is deficient.

Radiation from digital systems

Digital equipment of all types can cause interference for wireless micro-



D/ESAM® 820

Digital Edit Suite Audio Mixer



GRAHAM-PATTEN
SYSTEMS, INC.

P.O. Box 1960, Grass Valley, CA 95945
Tel: (916) 273-8412 Fax: (916) 273-7458

Circle (74) on Reply Card

phone systems. This includes digital effects generators, digital delay devices, microprocessor-based instrumentation and control computers (including personal computers — especially some laptop/notebook models). Wireless receivers mounted directly on ENG TV cameras may also be affected by the digital circuitry in the camera.

Wireless receivers mounted on ENG TV cameras may be affected by digital circuitry in the camera.

Interference from digital equipment is of two types: clock harmonics and general wideband noise. The first type occurs when a wireless system operates on a harmonic of a clock frequen-

cy in the digital device. Because extremely fast logic and a large amount of circuitry are both common in digital systems, harmonic emissions may extend into the microwave frequency range. Even if the digital system fully conforms with current emission regulations, a sensitive wireless receiver tuned to a frequency near one of the harmonics could have problems, especially if it is physically close to the digital device.

The second type of interference caused by digital equipment is broadband noise, generally resulting from switching of the digital logic in the device. PCs and other computing devices are especially likely to generate this form of spurious emission.

Power-line filters, such as the ones used in the better-quality power-protection devices sold for use with personal computers, sometimes help solve interference problems that can occur on power circuits shared by wireless receivers and digital equipment.

Another interference problem that end users sometimes consider an equipment defect is opening of the receiver squelch when the transmitter is turned off. With sensitive wireless receivers, small spurious signals can cause the receiver squelch to open up, usually resulting in an extremely noisy output. This is not really a design problem or device failure. An on-channel signal is being received — it just isn't the one that's desired. Of course, the receiver squelch can be adjusted to require a much larger signal to be present before the squelch opens, but this sacrifices some of the wireless system's operating range.

It is critically important for operators to understand and be able to identify the various forms of interference they might encounter when using wireless microphones. Without this awareness, it will not be possible to provide the quick solutions to interference problems that are required in the heat of production. □

Applied Technology

RCI video disk recorder

By Ron Earwood

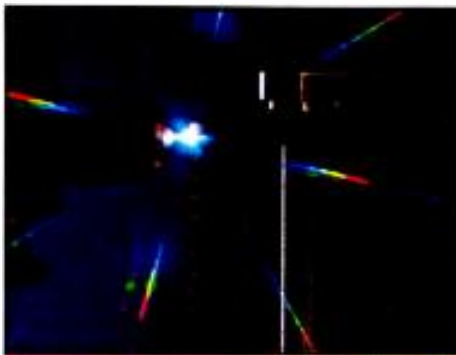

Off-line non-linear editing is somewhat immune to the resolution of the imagery. If an off-line editing system has to deal with high-definition video, there is always the option of using more compression or increasing the amount of sub-sampling. High-resolution video is reduced to the level that standard monitors, storage equipment and editing methods can easily handle. It's in the transition from off-line to on-line editing of high-definition video that significant differences from the familiar D-1 environment emerge.

New advances in standard resolution VTR, DDR, DVE and editing equipment are making it easier to take off-line-created EDLs into the on-line suite for non-linear processing. Random access disk drives, real-time effects generators, and VTRs with time line capabilities speed the conversion of EDLs to production video. Editors working with high-definition video, however, are faced with the fact that most of the non-linear equipment is in the resolution of D-1 or D-2. High-definition editing is done in a linear fashion with only a few tools available that operate in real time.

A new high-definition video disk recorder developed by Recognition Concepts, Incorporated (RCI) offers the same

non-linear features in video storage at high definition as is found at lower resolutions. The disk recorder is based on the same array technology used in the company's line of D-2 and D-1 models. No compression is used and data precision is maintained at eight bits or 10 bits. The high-definition disk is actually an array of arrays where four standard D-1 disks are slaved together and combined into a common video card using the SMPTE 260M format. The high-definition disk emulates a VTR and works transparently in standard editing environments.

The high-definition disk emulates a VTR and works transparently in standard editing environments.

It's a linear world

Although resolution and time space are arbitrary in an off-line situation, the move to on-line means returning to real data in real time. All of RCI's disk products are designed to keep the non-linear functions internal to the disk and make it appear as a linear device externally. This approach guarantees the disk will work with all existing linear editing equipment because

it operates in a manner indistinguishable from that of a standard VTR.

Figure 1 is a graphical example of the disk's unique ability to access data in non-linear space while appearing to play back along a linear time line. The absolute addressing graph indicates the actual location of the six segments of source material used in the example. The source segments are stored without compression in the linear 10-minute space of the disk. The time code at the top of the graph represents the disk's normal linear mode of playback.

When the disk is switched to non-linear playback, the relative addressing graph indicates the non-linear video sequence. Note that the time code is still linear even though the video is random accessed. The disk appears as a VTR playing from zero to seven minutes. The non-linear playback is controlled by a segment play list (SPL) with up to 800 entries. The SPL is created by putting the disk in linear mode and using standard shuttle/jog functions to locate the desired transitions and marking the IN points and OUT points. Another method of creating the SPL is to download an EDL using the disk's RS-422 control port, FDDI or Ethernet.

Special effects in software

Digital video effects generation at standard resolution is commonly handled by special-purpose real-time hardware.

Earwood is director of marketing for Recognition Concepts Incorporated, Carson City, NV.

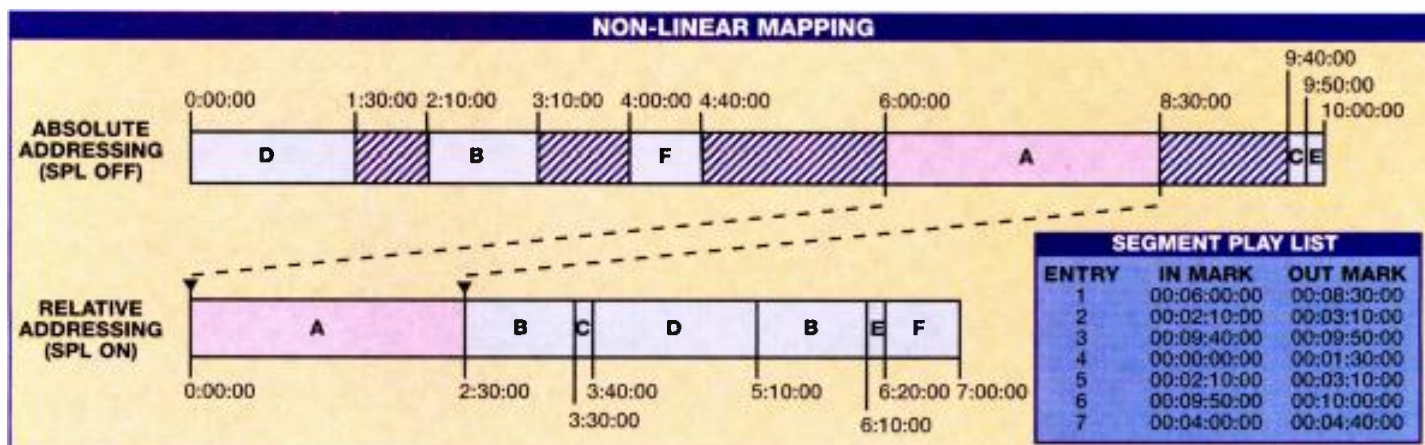

Figure 1. An example of how a segment play list (SPL) is used to reorder the playback of clips. Internally original time-code numbers are used to order the playback, while a different set of time-code values are output to make the playback appear as if it were coming off a standard VTR.

Unforgettable.



More Memory Is Only One Reason Our 18-Input Switcher Is So Unforgettable.

With a 100-event memory — much more than any other switcher its size — our new PDG-418 has all the features of our popular Prodigy.TM Plus lots more that you told us you wanted. Like a downstream keyer that can either be linked to the multi-level effects transition system or operated separately. An optional border generator for the downstream keyer. A key loop that allows key bus cut and fill to be looped through an external effects processor. Even a clean feed/third program video output that bypasses the downstream keyer and blanking processor. All of which makes our PDG-418 the best value around in a compact, affordable switcher. Call us today to find out more about the new PDG-418. Another American-made innovation from Videotek.

 **VIDEOTEK**TM
First, we listen.

243 Shoemaker Road, Pottstown, PA 19464 1 (800) 800-5719 (215) 327-2292 Fax: (215) 327-9295

Circle (88) on Reply Card

www.americanradiohistory.com

Prodigy is a trademark of Prodigy Services Company.

The extreme clocking frequencies of high-definition video make it nearly impossible to create a complex effect in real time using on-line hardware. The non-linear mode of the high-definition disk can be used to solve this sticky problem. The special effects are created one field or one frame at a time with a workstation and transferred to the disk via SCSI, FDDI or Ethernet. The location of the special effects scene on the disk is arbitrary because it is entered into the SPL as a segment and fetched in real time during a non-linear playback.

Some effects are as simple as a playback direction change or speed change of a segment. The segment can be recreated on the disk with the fields or frames reordered to produce the desired effect. A COPY command has been designed into the disk to facilitate

the reordering of frames. This command works in the same way as the COPY function in word processing. The copy func-



The video disk recorder from Recognition Concepts, Incorporated.

tion in a word processor moves words, sentences or paragraphs while the video copy command moves fields, frames or scenes. Because data moves internally to the disk and at video rates, a complex

reordering of a segment is accomplished quickly and easily. Once the desired playbackmotion effect is achieved, the newly created scene is entered in the segment play list as a segment and is fetched in real time during a non-linear playback.

An entry-saving feature of the SPL allows any segment to be repeated a number of times as specified in the list. For example, a single dark or neutral image can be stored and used as a one-second transition effect by entering a repeat count of 30 in the SPL for that entry.

Automatic cine add/remove

One other important function to be realized when bringing high-definition video on-line is the conversion from 24fps to video rates and the subsequent removal of the conversion process. The

Tapeless Technology in Radio Applications - the Users Point of View

SYPHA has published the results of an extensive survey into the use of tapeless technology for cart replacement, station automation and production. Over 500 radio stations in the United States and United Kingdom took part and the issues examined include:

- Awareness and opinion of systems and technology
- Reasons for system selection and purchase
- Expectations of system performance
- Operational and technical support
- Applications and features required
- Investment decisions and future plans
- Sources of information and advice

Broadcast Engineering magazine, AMS Neve, Basys, Broadcast Electronics, Computer Concepts, Harris Allied, Korg, RCS, Sony and Studer Digitec provided the sponsorship necessary to conduct the survey. However, the method and results were independently managed by SYPHA.

Broadcast Engineering readers are entitled to a reduced price of \$325 (reg. \$380). To order your copy of *Tapeless Technology in Radio Applications - the Users Point of View*, enclose this ad with your order and mail to:

**SYPHA, 216A Gipsy Road, London, SE27 9RB, UK
or telephone +44 181 761 1042, fax +44 181 244 8758**

SYPHA specializes in providing consultancy and research services on the use of random access technologies for audio and picture recording, editing and replay. Other publications available from SYPHA include:

- **The Nonlinear Buyers Guide** - a buyers guide to random access video systems covering nonlinear and mixed mode editors, digitizing cards and software, video disks, video servers and RAM stores;
- **The Tapeless Directory** - a buyers guide to digital audio workstations covering production, post production, cart replacement and station automation systems.

With guaranteed **HDTV** compatibility, proven

TETRODE TV systems technology  in 5kW

to 60kW transmitters, affordable **Solid**

State UHF TV transmitters ranging



from 10W  to 10kW, patented Advanced Digital

Amplitude Modulation technology called



it's quite clear why we are more than just another

TV transmitter company.



The digital TV transmitter company.

ACRODYNE

Acrodyne Industries, Inc. 800-523-2596 or
516 Township Line Road (215) 542-7000
Blue Bell, PA 19422 USA FAX: (215) 540-5837

Circle (89) on Reply Card

disk handles the upconversion with a special 3:2 playback mode. The conversion is non-destructive and leaves the data stored on the disk in the convenient 24-frame format.

Automatic cine remove is accomplished by first recording the upconverted video onto the disk. The disk then uses an image-processing algorithm to automatically detect the phasing of the cine. Once the phase is detected, a variant of the COPY command is used to remove the redundant fields and return the video to 24-frame film format.

Non-linear preview of film

High-definition video can be used as a relatively inexpensive method of previewing film resolution data. The high-definition disk with its non-linear playback capability is especially effective in this role.

Film images with a resolution of 4,000 x 2,000 are subsampled or rendered at lower resolution such that they fit within the 1,920 x 1,080 square pixel framing size of the high-definition disk. The subsampled frames are transferred to the disk over FDDI or SCSI. The disk is placed

The location of the special effects scene on the disk is arbitrary because it is entered into the SPL as a segment and fetched in real time during a non-linear playback.

in the cine add (3:2) playback mode and used to preview the film material. Non-destructive changes in scene composition and special effects are examined by creating an SPL and enabling the non-linear playback mode. With careful calibration of viewing monitors, a certain amount of confidence can be gained from a video presentation before making the expensive commitment to full-resolution rendering and film production.

All of the features and functions of the high-definition disk are also standard in RCI's line of D-1 and D-2 video disk recorders. D-2 models are upgradable and software switchable to D-1. D-1 models are upgradable and software switchable to high-definition. RCI video disk recorders have been interfaced to many popular on-line editing systems. A 10-minute high-definition disk has been recently installed at Sony Pictures High Definition Center, Culver City, CA, and connected to a Sony BVE 9100 editor. A 6-minute non-interlaced high-definition disk has been installed at Graphics Communications Laboratories, Tokyo, Japan. ■

The Most Accurate SMPTE Time Code Generators On The World

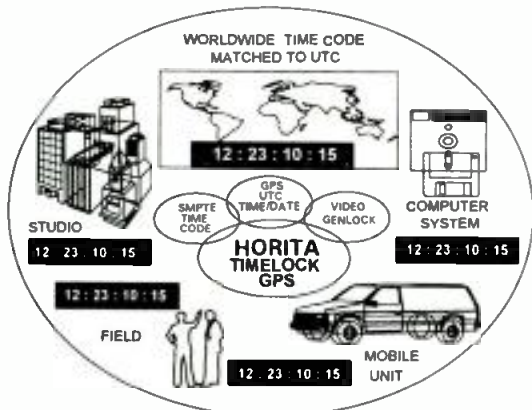

TL2100

PORTABLE TIMELOCK GPS SYSTEM

The TL2100 is a *portable* video black burst generator, SMPTE time code generator with user bit ID, and six channel GPS receiver integrated into a single unit. Video and time code from the TL2100 are locked to UTC time and date from the atomic clocks of the Global Positioning System of satellites so that without any cables, time code in one location exactly matches that in another, whether up in the air, separated across a TV or movie set, backlot, sports field, mountain trail, lake, city, state, continent, or the entire globe. This is the TL2100 TIMELOCK GPS(tm) system. *Take it anywhere!* \$1785

GPS-MTG

STUDIO MASTER SMPTE TIME CODE GENERATOR

Introduced in 1993, the GPS-MTG(tm) is a GPS based worldwide SMPTE master time code generator which generates SMPTE time code matched to UTC (local) or GMT time and date, day-after-day, month-after-month, year-after-year, unattended, anywhere in the world. A precision global real time clock/calendar source for your studio time and date displays, computers, video inserters, automation systems, remote vans, etc. Complete system with auto daylight savings time, fail-safe alarm signal, software to set and maintain your PC's clock/calendar. \$1985

HORITA™

P.O. Box 3993, Mission Viejo, CA 92690 (714) 489-0240

Circle (90) on Reply Card

➔ For more information on the RCI video disk recorder, circle (306) on Reply Card.

9.5" x 2.5" x 1"

Remote Control By Telephone



Control 10 latching relays and check 10 logic-level inputs from any touch-tone phone. User determined access code. Just \$339.00

CONEX ELECTRO SYSTEMS 
P.O. Box 1342 Bellingham, WA 98227

1-800-645-1061

Circle (91) on Reply Card

BROADCAST engineering®

is seeking highly qualified technical writers for broadcast, post-production, telephone/cable production applications and solutions.

For more information contact:

Editor
Broadcast Engineering
9800 Metcalf Ave.
Overland Park, KS 66212-2215
Phone: 913-967-1737 • Fax: 913-967-1905

30th
Inter BEE
Anniversary

Inter BEE '94

30th International Broadcast Equipment Exhibition



November 9-11, 1994

Nippon Convention Center (Makuhari Messe), Japan.

Don't miss this opportunity to attend Asia's largest international exhibition of broadcast equipment and new ideas. The 30th International Broadcast Equipment Exhibition highlights products, services and developments in broadcasting, audio-visual technology, post-production and multi-media. You can meet other professionals from around the world to exchange information, make valuable connections and catch up on the latest innovations.

At the same time, forums, seminars and symposiums will be conducted by experts in their field, and in which you can participate freely.

Come face-to-face with the future in new equipment, new applications and exciting new possibilities at InterBEE '94.

Japan Electronics Show Association

Tokyo Chamber of Commerce and Industry Building

3-2-2, Marunouchi, Chiyoda-ku, Tokyo 100, Japan.

FAX: 81 (3) 3284-0165.

www.americanradiohistory.com

Circle (92) on Reply Card

Field Report

Panasonic AT-H1905D digital monitor

By Clyde W. Spear

In August of 1993 All Post began to evaluate its technical requirements and make recommendations on equipment needed to begin upgrades into the new digital era. As monitor requirements were determined, it became apparent that All Post, like many other facilities in the post-production business, needed the ability to monitor many sources in the analog and digital domains. Although All Post feels that clients should see their product in the composite NTSC or PAL standard it will be broadcast in, there is still a need to monitor the numerous analog and digital standards.

At All Post the equipment list is extensive. Among the many types and standards are 22 VTRs (NTSC and PAL) with parallel and serial CCIR 601 and Digital Betacam, 15 Rank Cintel Flying Spot Scanners with parallel CCIR 601 outputs, 28 VTRs with parallel and/or serial D-2, more than 100 NTSC and PAL VTRs with analog composite outputs and 25 VTRs with

Spear is vice president engineering/corporate for All Post, Burbank, CA.



Performance at a glance:

- 900+ lines of horizontal resolution
- Serial and parallel digital inputs
- Analog component inputs
- Three analog composite inputs
- 4:3 and 16:9 switchable
- Switchable color temperature
- Programmable front-panel switches
- Wired and wireless remote control
- Optional auto setup
- Better than 40dB chroma suppression with a digital comb filter

component analog outputs (RGB, Y R-Y B-Y, YPrPb). The question was could a monitor be found that meets all the standard requirements for monitors (SMPTE C phosphor, high-voltage stability, good frequency response and good luminance/chrominance delays) and still satisfy a primary goal of avoiding excessive encoding, transcoding and decoding of digital signals.

At the fall SMPTE Conference in Los

Angeles, Panasonic presented a paper that described the digital monitor (AT-H1905D). The new monitor had parallel and serial digital inputs plus three analog inputs. In addition, it had analog RGB, Y R-Y B-Y as a standard feature that did not use any of the three analog inputs. A monitor was acquired for in-house inspection and testing, and it was indeed a completely digital processing monitor except for the analog inputs with their ADC and output (RGB DAC to the CRT) stages. (See Figure 1.)

The monitor could also be equipped with NTSC/PAL decoders, a must for dual standard facilities. It also had the capability to switch to 16:9, which was necessary for our domestic and European clients. Inside, there is also a clearly marked and easy to reach switch that selects 6,500, 3,200, or 9,300°K. The 3,200°K setting is used for material that will be used on film stage monitors. This is a bonus feature for our facility. The monitor also has a user setting position that can be adjusted to suit individual requirements. This may become useful if the rear screen projector systems need new standards, such as 5,400/5,500°K.

Because the monitor has parallel and serial digital (in addition to the analog) connectors on the back, they can be connected to jack fields. This makes it possible to patch any signal to the monitor. This in effect allows the monitor to be used as a piece of test equipment – a fast digital go/no-go signal analyzer.

In testing the monitor's dual standard capabilities, it was found the monitor did not provide identical black levels and chroma phasing when switched between PAL and NTSC. Also, white levels were not identical between 4:3 and 16:9 aspect ratios. Panasonic identified the problems and provided a hardware and software correction within two weeks. In fairness, most manufacturers do not check out their monitors in the dual standard mode, they simply check out the standard (NTSC or PAL) for the country they are supplying. This fortunately is beginning to change as more manufacturers recognize the need for dual standards.

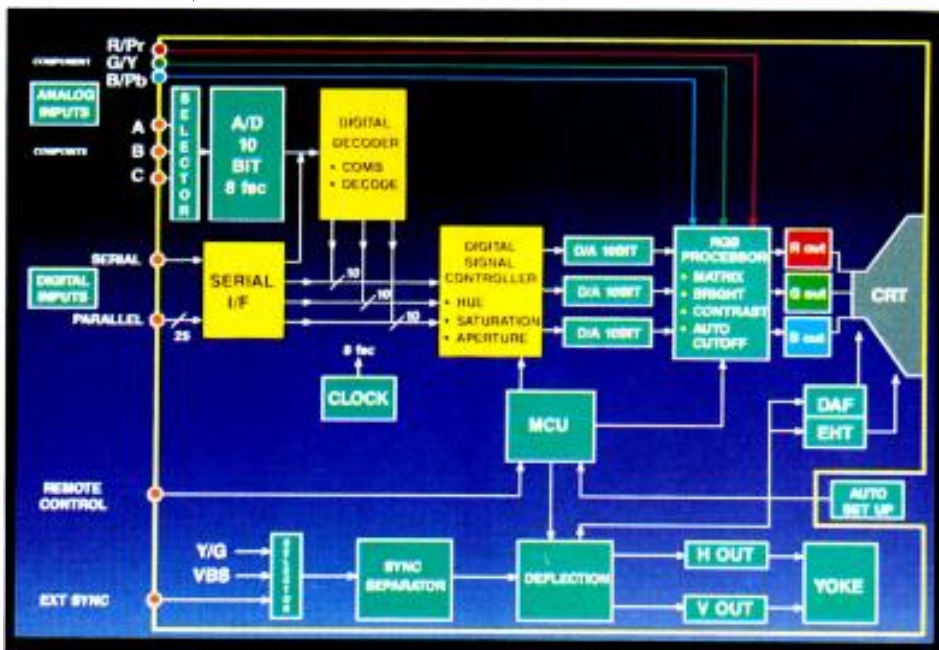
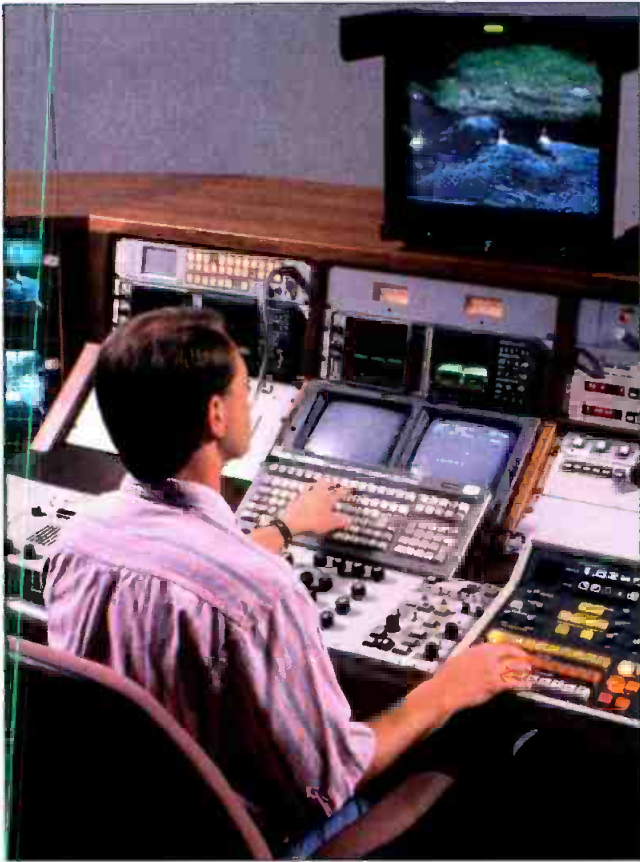

Figure 1. Block diagram of the Panasonic digital monitor.



The monitor in use in one of the edit rooms at All Post.

Since purchasing the monitors, we keep finding nice little surprises, like the ability to program the front panel A/B/C buttons to select the digital signals as well as the analog signals. For example, A is an analog signal, B is D-2, C is parallel D-1. This allows each monitor station to be customized. Remote control can be wired or wireless. The monitor also has an extremely good 5-line filter that removes all dot crawl, allowing editors to check the quality of analog keys.

As of July 1994, 15 of these monitors have been installed in various locations within the facility, and the overall response has been satisfactory. For me, the best part of this monitor is the ability to view digital signals before encoding/transcoding. This has shown that the NTSC/PAL encoding schemes cover a lot of deficiencies. In addition, I believe the ability to monitor analog and digital signals will allow tighter control of the facility in the future.

Editor's note: Field Reports are an exclusive BE feature for broadcasters. Each report is prepared by the staff of a broadcast station, production facility or consulting company.

These reports are performed by the industry and for the industry. Manufacturer's support is limited to providing loan equipment and aiding the author if requested.

It is the responsibility of *Broadcast Engineering* magazine to publish the results of any device tested, positive or negative. No report should be considered an endorsement or disapproval by *Broadcast Engineering* magazine.

➔ For more information on the Panasonic AT-H1905D digital monitor, circle (316) on Reply Card.

HIGH DEFINITION VIDEO DISK

RCI's series of high definition video recorders combine up to 160 disks in parallel to meet the speed demands of realtime HD video. Compression is not used and pixel precision can be selected up to 16 bits in both interlaced and non-interlaced formats. A unique look ahead cache provides the disk array with realtime random access that supports true on-line, non-linear editing. Get the video disk with the speed to handle today's high resolution sensors and monitors.

FEATURES

- Sustained rates up to 384 MBytes/sec.
- Large capacity without compression
- Standard and non-standard video
- Up to 16 bits per pixel
- Monochrome, YPbPr, RGB, RGBA
- Standard VTR control emulation
- FDDI, Ethernet, SCSI-2
- SMPTE 259, SMPTE 260, Raw Data I/O
- Two year warranty



- 1024 x 1024
- 1280 x 720
- 1600 x 1280
- 1920 x 1035
- 1920 x 1080
- 1920 x 1152
- 4000 x 2000



Try our fast fax service

Recognition Concepts, Inc.

Video Storage Solutions

5200 Convair Drive
Carson City, NV 89706

Ph: (800) 2 GET RCI
Ph: (702) 882-7817
Fax: (702) 882-5381

Circle (75) on Reply Card

See us at World Media Expo. Booth # 4550

they are of the low-loss type. RG-58U, for instance, has a loss of 14dB per 100 feet at 700MHz, whereas RG-11 foam has only 3.9dB loss per 100 feet at the same frequency. Furthermore, using a whip antenna attached to a cable is an inefficient approach, often resulting in an operating range of less than 25% of that with the whip attached directly to the receiver.

Always make a "walkaround" test part of your setup: Operate the transmitter at all positions where it will be used.

Ground-plane antennas are preferable for such remote applications.

Whip and dipole antennas require at least an 18-inch (0.5m) spacing from metal surfaces. Ground-plane-type antennas need proper spacing above the ground

plane, but may be close to metal below the ground-plane elements.

As you'd expect, the height of the receive antenna(s) is critical. For maximum range, the antenna should be well above the height of the transmit antenna(s). Antenna orientation also is important. For non-diversity systems, the antenna orientation should be the same as the transmit antenna, which in most cases is vertical. For diversity operation, the recommended orientation calls for the two receive antennas to be placed at right angles to each other, preferably with each one at about 45° from vertical.

Other receive-antenna placement tips include avoidance of niches or doorways, keeping a minimum distance of three feet (1m) away from metal objects (including reinforced concrete walls), and positioning at least one antenna as close as possible to the location of the transmitter(s).

Always make a "walkaround" test part of your setup: Operate the transmitter at all positions where it will be used. Mark all points where field strength is weak. Try to improve reception from these points by changing the receive-antenna position(s). Repeat this procedure until

you achieve optimum results.

Current trends

As more wireless microphones are sold, the VHF band is becoming increasingly saturated. In rural areas this is not a serious factor, but in large urban centers (especially around multifunction areas and theater districts), the VHF wireless microphone spectrum may be too crowded to use. The UHF band does not yet have this problem, however. There is generally spectrum to spare there even in the worst cases. Frequency-synthesized, user-tunable systems allow flexible channel adjustment in the field if interference is encountered. Some multichannel systems using phase-locked-loop (PLL) technology can be adjusted to any one of 4,800 frequencies, allowing up to 50 channels to operate simultaneously.

When multiple microphones are used, antennas for all the receivers can quickly become unwieldy, especially with diversity systems. Many manufacturers now produce antenna/power-distribution systems so that four or more receivers can be connected to a single pair of "master" diversity antennas.

Computer-controlled systems are also available, allowing the control and monitoring of multiple wireless microphones on a Macintosh or IBM-compatible PC.

To counteract the problem of breaking squelch with the wrong signal or noise, a few wireless microphone manufacturers have added a tone-squelch (sideband) identification function similar to 2-way radio. To break squelch, an RF signal above threshold and a specific sideband signal produced by the desired microphone transmitter must be present.

Other recent developments include plug-on transmitters that can convert any hand-held or shotgun microphone into a wireless system, and circuits that improve battery life to 20 or more hours on a single set/charge.

Wireless microphones have come a long way in their quarter century of existence, and developers continue to make giant steps toward refinement of their products. Meanwhile, broadcast users are reaping the benefits of these developments as they find ever more applications for this useful technology.

HOW DO YOU EXPLAIN THE ADVANTAGES OF FIBER OPTIONS?
 You don't. You experience them.

Experience Fiber Options' full line of transmission systems offering multimedia capabilities for voice, video, and data.

Highest quality products • With a five-year warranty
 Priced competitive • And customer support

Optical Fiber. The powerful advantage whose time is now.

Call or write for more information today.

Fiber Options, Inc.
 80 Orville Drive
 Bohemia, NY 11716-2533
 Call 516.567.8320 or 1.800.342.3748
 Fax 516.567.8322

FiberOptions
 ...light years ahead

➔ For more information on wireless microphones, circle (303) on Reply Card. See also "Microphones, Wireless," p. 55 of the BE Buyers Guide.

Circle (76) on Reply Card



Look who's going to improve your image.

You've heard a lot about Switchcraft, a leading manufacturer of quality audio components for more than 40 years. Now, see what we can do. Because Switchcraft can supply you with video components, too.

Look to us for standard video broadcast equipment, all made with the reliability and high quality you expect from Switchcraft. When it comes to our

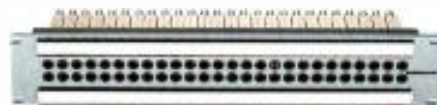

video insulated patch panels, you'll find our eye for detail is second to none.

Each one can accommodate up to 26 jacks for a variety of requirements. Dual jacks provide a normal-through signal path without the use of looping plugs or patch cords. And, each panel comes with large designation strips for your own labeling.

Our video patch cords are available in popular lengths and colors – all built for efficient video signal transmission. Our patch cords come with rugged metal handles and optional rubber "boots" for a better grip. The "boots" offer enhanced flex relief and are available in your choice of colors – red, black, green or blue. Switchcraft is dedicated to making your studio time as productive as it can be.

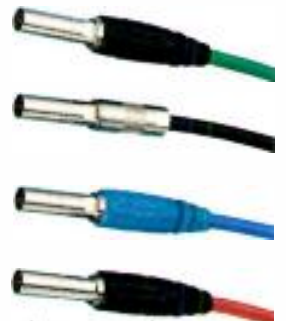

So whether you're thinking video or audio components, think Switchcraft. We've always done wonders with sound. Now we can improve your image, too.

For more detailed information, phone or FAX our Marketing Communications Department and ask for New Product Bulletins 426 and 427.

Switchcraft

A Raytheon Company

Switchcraft, Inc.
5555 N. Elston Avenue
Chicago, IL 60630
(312) 792-2700
(312) 792-2129 (FAX)

Circle (77) on Reply Card

www.americanradiohistory.com

An Intel 486 CPU gives you impressive speed today. If you need more tomorrow, add the latest chip for better throughput, providing more responsive control.

Future compression and networking technology will slip into standard PC expansion slots. You'll always have optimal storage capacity and video quality, as well as improved interfaces and quicker links to traffic and automation systems.

DigiStore will let you add removable media options as they become available. That means quick, easy video file transport.

Recent advances in hard drive technology allow you to add a four-fold storage upgrade with just the addition of a new drive pair.

The DigiStore Spot Playback System Is Loaded With Impressive Features. But That Doesn't Mean You Can't Load More.

Will today's "state-of-the-art" spot playback system still be that way tomorrow? It will if it's DigiStore.™

Unlike other systems, DigiStore's industry-standard

PC architecture lets you take advantage of technology as it becomes available, without major system modifications or costly overhauls. When there's a new hard drive with more memory, you drop it in. When there's more powerful software, you load it. As PC technology advances so will your DigiStore. That's flexibility no other solution can match.



as it becomes available, without major system modifications or costly overhauls. When there's a new hard drive with more memory, you drop it in. When there's more powerful software, you load it. As PC technology advances so will your DigiStore. That's flexibility no other solution can match.

Maintenance? Make-Goods? Forget It.

DigiStore's digital technology will save you thousands in maintenance and support alone. No broken tapes. No dirty heads. No more decks to recalibrate. Just superior digital performance, reliability and clarity.



If industry accolades mean anything, your DigiStore's future performance will be rivaled only by its past.

And forget the problems of rewinds, prerolls and TRELs. DigiStore automatically retrieves and plays each spot as scheduled. Instantly. Make-goods from miscues and mechanical failures become a thing of the past.



DigiStore combines instant access and digital clarity for superior spot playback.

DigiStore Gives You Connections.

DigiStore plugs easily into your existing system thanks to a wide array of connectivity options. In fact, it links to your traffic department, scheduling and external automation systems (including Dynatech's own TAS) right out of the box. No system offers more interfaces.

Is DigiStore For You? It's Your Call: 800-453-8782, ext. 101.

Because it's a product of Utah Scientific, you can be sure DigiStore is designed and built by people who've been turning out quality broadcast solutions for fifteen years. And of course you'll get our celebrated 24-hour, 7-day service.



DigiStore gives you more than twice the capability in half the space.

Call 800-453-8782, ext. 101 to find out more about all of DigiStore's impressive features, or to arrange a free demonstration.

When you consider cost, reliability and flexibility, DigiStore is today's #1 choice for spot playback systems. And tomorrow's.

utah scientific



Alpha Image, Cable Products, Colorgraphics, da Vinci, DigiStore, EMC, NewStar, Quanta, Utah Scientific

© 1994 Dynatech Video Group, Inc.
The Intel logo is a registered trademark of Intel Corp.

Circle (72) on Reply Card

www.americanradiohistory.com

Field Report

Matrox Studio

By David Leathers

The Matrox Studio (reviewed here) and the New Matrox Studio represent one of the most complete and integrated solutions available today. Definitely a desktop system in terms of its design, user interface and developing non-linear capabilities, the New Matrox Studio interfaces with current videotape machines, from S-VHS to Betacam SP, to provide full-featured, high-quality A/B/C roll linear on-line editing.

System description

The unit consists of a set of five boards for a 486 EISA PC and includes cables, software and manuals. There is a routing switcher, DVE, TBCs and keyers on two video processor boards. An Illuminator Pro graphics board, a VTR controller board and a Virtuoso audio card round out the set. The boards are joined inside the computer by several sets of jumpers and auxiliary buses.

The main software package is the Personal Producer, which is an editing environment. Also included (bundled and integrated) is the Inscribe CG titling software package. Wave for Windows is included on systems with the digital audio option. Formerly sold as a board and software set, the company now sells several versions that include the computer, completely integrated by the factory.

Our system consisted of a 486 EISA PC running at 33MHz with 8MB of RAM. This turned out to be enough, because most of the work is done on the boards and the auxiliary buses handle the throughput. The non-linear option started shipping in July 1994, but was not tested for this review. However, the pack-



Performance at a glance

- Desktop linear editing
- Non-linear capabilities
- 4:2:2 processing
- Five layers of video/graphics mix effects
- Up to three channels of 2-D or 3-D DVE, four channels with Super F/X
- Digital audio processing and mixing
- CMX-style color-coded keyboard
- Optional jog/shuttle knob

age did include the optional analog component input. Depending on how the inputs were used, it was possible to have up to three analog component (Betacam) inputs, four S-Video inputs or eight composite analog inputs. The system also allowed one analog component, two S-

and simplifies the cabling process.

After turning on all the external devices, the computer was started. In Windows, icons for various programs, including Personal Producer, Inscribe/CG and Wave for Windows were present. We launched Personal Producer. Normally, it starts by asking if an existing or new storyboard, clip collection or both is desired. However, the first time the program is opened it automatically opens the system configuration dialog box.

Using Personal Producer

Personal Producer is a Windows program, and uses many of the conventions familiar to Windows users. The editing interface uses linear and non-linear conventions. The non-linear time line concept is there, but so are the CMX-style keyboard commands. A color-coded

CMX-style keyboard and tape jog/shuttle knob are now available. Software allows for reading and writing industry standard EDLs, and the EDLs can be displayed in standard formats. Even though virtually all Personal Producer operations could be accomplished with a mouse, editing evolves into a combination of using the mouse to drag-and-drop icons in the time line interface and using standard keyboard commands for familiar machine control operations.

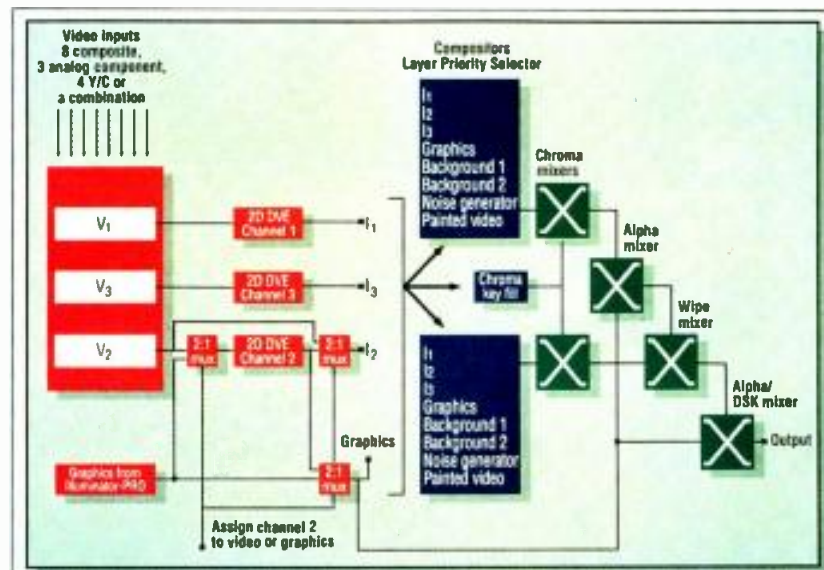

Conceptual block diagram of the linear version of the Matrox Studio.

Video and two composite analog outputs. An auxiliary input connector allowed for video from the recorder and an external sync input provided for gen-lock.

The system includes high-quality cables that break-out into an array of audio, video and control connections. The cables are thinner than standard cables, but are well-built and sturdy. A rack-mountable breakout box is now standard,

There are two ways to approach editing with Personal Producer. One is to use the clip editors to create clip collections and then use the clips as sources for building the storyboard. This finished storyboard (or section) is auto-assembled to tape. This method provides access to all the capabilities of the program, including transitions and effects.

The cuts editor is designed for punch-and-crunch editing needs. It allows cuts

Leathers is the president of Eye Square and director of Broadcast Engineering and Video Systems Digital Media Lab, Hollywood, CA.



AT THIS YEAR'S WORLD CHAMPIONSHIPS ONE PERFORMANCE IS HEADS ABOVE THE REST.

At soccer's World Championship Tournament, held at sites across America for the first time in 1994, one of the most powerful performances is being turned in by one of the smallest performers — Schmid's SIAT-MAX Audio Test Generator.

Using the portable, hand-held SIAT-MAX unit at live broadcast sites, along with a Schmid measurement receiver at its control center, the European Broadcast Union can quickly, repeatedly check site-to-center audio links. In doing so, EBU can assure the quality of its transmissions under the most challenging, time-critical conditions.

Innovative audio testing applications like the EBU's are what SIAT-MAX — and Schmid's entire family of short interval audio testing products — are all about. Portability, speed, accuracy, ease-of-operation and low cost all add up to the best, fastest, most versatile audio test solutions on the market today.

Whether you need to conduct audio proofs from remote sites or conduct fully automated tests across your entire network... whether you need to troubleshoot in the field or test audio paths in-house... Schmid has the products to give you peak audio performance. For more information or to arrange a free demo, call 800-438-3953 toll-free today.



 **Schmid**
Telecommunication
Intelligent by design

Sales Offices
Corporate Headquarters
Schmid Telecom AG
Binzstrasse 35
CH-8045 Zurich
Switzerland
Tel: 41-01-456-1111
Fax: 41-01-461-4888

U.S. Sales and Service
Schmid Telecommunication
America, Inc.
522 South Broadway
Gloucester City, NJ 08030
Tel: 800-438-3953
Tel: 609-742-1878
Fax: 609-742-0485

Schmid Telecom France
23, rue Colbert
F-78885 St-Quentin
Cedex
Tel: 33-1-3064-8006
Fax: 33-1-3058-2021

Circle (78) on Reply Card

**INTRODUCING A PROFESSIONAL VIDEO
GATEWAY TO YOUR COMPUTER
WORK STATION**



SCSI: TO 4:2:2 COMPUTER INTERFACE

- 4 SCSI-2 ports
- Full support of CCIR 601
 - 4:2:2
 - 4:2:2:4
 - 4:4:4:4 Y, Cb, Cr
 - 4:4:4:4 GBR
- Archiving of high resolution images or data files on 4:2:2 medium
- Computer platform independent



MIRANDA 8055, Trans Canada, St-Laurent, Québec, Canada
Tel: (514) 333-1772 Fax: (514) 333-9828

Circle (80) on Reply Card

Manage your AUDIO

Fast Trac II Voice-Over Workstation
Solves audio management headaches!



NEW! *Fast Trac II* is a 6-input stereo "micro-console" that's perfect for TV and Radio audio!

- ✓ Voice-Over recording with auto-ducking
- ✓ Audio control for digital editing systems
- ✓ Machine start with pre-roll compensation
- ✓ Stereo level and balance control
- ✓ Stereo line-source switching
- ✓ Comprehensive monitoring

Fast Trac II – it's "A Studio-In-A-Box."



HENRY ENGINEERING

503 Key Vista Drive
Sierra Madre, CA 91024 USA
TEL (818) 355-3656
FAX (818) 355-0077
FAX-on-Demand Doc #116 (818) 355-4210

Circle (81) on Reply Card

See us at World Media Expo, Booth 1828

to be performed directly from a selected source to the recorder. As the cuts are made, a clip collection and storyboard are automatically built in the background and saved. In this manner, a piece edited "cuts only" in the cuts editor can be brought into the storyboard.

The video clip editor

Using the storyboard method starts with collecting and managing clips. The first step is to use the dialog box to open an existing clip collection or start a new collection. New Clip is then chosen from the edit pull-down menu. The source is then selected. It can be any of the connected tape machines or internally stored graphics or audio files. If it's a tape source, a prompt requests a source reel number. If internal graphics or audio is chosen, a file name is required. However, because this is Windows menus simplify the task.

After a tape source is indicated, the Video Clip Editor window opens. This window provides a video window of the source machine, controls for the tape deck, a marks table, as well as controls for the incoming audio and video. Marks are set by using the mouse or traditional keyboard commands. Once the clip is satisfactory, it is added to the clip collection. Video and audio adjustments stay with the clip when it is later moved to the storyboard.

Once the clips have been collected, they are ready to be dropped into the storyboard. The storyboard is laid out horizontally with separate tracks for graphics, three video sources, three audio sources, audio mix effects and video mix effects. The clips are dragged from the clip collections into the desired position in the time line. In the video M/E line, a graphic indicates the presence of and relative foreground/background relationships of the video clips. The GUI of the M/E makes it easy to visualize what's happening. Available in the M/Es are an array of sophisticated effects tools. The internal processing of the system is all 4:2:2 and the effects and transitions are extensive.

The test project

As a test project, a music video was edited on the system. The project selected had some shots that were out-of-focus and shots that needed color correction. There were many quick cuts, and due to the failure of the smart slate at the shoot, all of the vocal cuts had to be re-synched visually. No off-line had been done and a visual concept was still needed to tie it all together. The system was used to combine the off-line and on-line editing.

The first step in doing an on-line session is to make sure the recorder tape is prepared properly. Personal Producer has a dialog box for blacking and coding masters. It also has provisions for laying in color bars and audio tones at the beginning of the tape. After preparing the master, the audio track was laid down.

Next, the audio sync problems were tackled. The director had used a method of stopping the camera every few seconds to create flash frames that he wanted as an effect. This meant that each two or three seconds of the video had to be lined up to the audio. There were three complete master shots of the song shot at different focal lengths all shot with this flash frame technique. Without a time-code reference, approximately 150 edits were required just to get the material in sync.

The cuts editor was used first, but using the storyboard turned out to be a much better method. AB roll and C roll was made of all the source video footage. Then, starting at the beginning of one complete take of the song, the clip editor was used to make separate clips of each video snippet between the flash frames. A separate clip collection was made for each of the three master shots. All the clips from the first collection were laid into the video 1 line on the time line. As each shot was dropped in, it was tested for sync. If needed it was dragged

along the time line until it was right. Each attempt had to be previewed, but after a short time, clips fell in sync quickly.

Similarly, the second collection was dropped into the video 2 line and the third collection was dropped into the video 3 line. Clicking the mouse in the video M/E line revealed the video M/E editor dialog box. Within this box are the controls for selection of sources and their priorities, the keyers, masks and backgrounds. This section alone warrants extensive investigation. For now, however, the primary interest was in finding a way to key and blend the layers of source footage placed in the video time lines. The chrominance and luminance keyers are of surprisingly good quality, because the effects are all digital. For this project, which was shot at night, the luminance keyer was used to composite the various layers of video. The flash frames made nice highlights and the one track of video that was out-of-focus could be buried in the key.

The technique was used in various permutations throughout the video. The results were amazing. Because of the way the clips were staggered in the time lines, the final cut contained hundreds of quick cuts and transitions. Unfortunately, this production didn't require the use of the built-in DVEs.

The future

The New Matrox Studio continues to build on the Matrox Studio concept. A high-resolution editing display (1,024x768) is included, and a built-in cuts-only non-linear option is now available, with full non-linear capability in development. Artifact-free scaling comparable with today's stand-alone devices will be available for 2-D and 3-D effects. Complete proc amp controls and single key dissolves with automatic cross-fading are included in the current software version. After reviewing the product, new options were announced including the Super F/X option, which integrates 2-D DVE capability on the graphics layer and offers the potential to control external devices such as character generators and paint systems. Future software versions will include dynamic motion control (DMC) and control track editing.

The New Matrox Studio challenges the traditional manufacturers in their own backyard. It is available in six versions: three NTSC and three PAL, four of which will be upgradeable to the non-linear version.

Editor's note: The Digital Media Lab is an ongoing project of *Broadcast Engineering* and *Video Systems* magazines. Operated by David Leathers, president of Eye Square, the lab evaluates computer-based audio and video production systems for use in broadcast, recording, production and post-production applications. *Broadcast Engineering's* responsibility is to publish the results of such evaluations, positive or negative. No report should be considered an endorsement or disapproval by *Broadcast Engineering* magazine. Companies manufacturing such desktop-type equipment may request an evaluation of their product by contacting the editor of *Broadcast Engineering* magazine.

➔ For more information on the New Matrox Studio, circle (315) on Reply Card.

Nothing could
compete with the
wildly popular
EV 635A—until now.



Introducing
the 635N/D—the
same “nail-hammering”
durability—infused
with the power of N/DYM®

THE ELECTRO-VOICE 635N/D AND 635N/D-B (CAMERA BLACK) MICS MAY LOOK AND SOUND LIKE THE LEGENDARY 635A, BUT THERE ARE SOME VERY POWERFUL DIFFERENCES. WE'VE ADDED A NEW, ULTRAHIGH-OUTPUT NEODYMIUM IRON BORON MAGNET ASSEMBLY (N/DYM®). THEN CRADLED IT IN AN EVEN MORE PROTECTIVE STRUCTURE—FOR QUALITY AUDIO UNDER EVEN THE MOST DEMANDING NEWS/FIELD CONDITIONS.

WHEN THERE'S ONE CHANCE TO GET IT RIGHT
CALL 800/234-6831.



Electro-Voice, Inc. a MARK IV company 600 Cecil St. Buchanan, MI 49107 616/695-6831 In Canada: 613/382-2141

Circle (93) on Reply Card

Field Report

Data Translation: Media 100

By David Leathers

With first prototypes appearing at trade shows in 1990, the Media 100 from Data Translation has benefited from a substantial development effort. Development focused on obtaining the best picture quality possible in a cost-effective Motion JPEG-based non-linear editing system. The Media 100 is a non-linear editing system based on a set of two NuBus boards and software for Macintosh computers. It requires a Macintosh Quadra 950 or 800 with a minimum of 32MB of RAM and a minimum 1GB hard drive. Additional external hard drive space is necessary for most editing uses.

Picture quality and image compression

In the past, JPEG compressed video images have been less than acceptable for on-line quality video work. Media 100's highest-quality images (currently 60kb per frame) eliminate almost all the noise and blocking artifacts associated with JPEG. At its highest compression rate, currently 20kb per frame, significant JPEG artifacts are present. The lower-quality images are acceptable for off-line situations where maximum storage capacity is needed and quality images are not as important. At 60kB per frame, about nine minutes of video can be stored per gigabyte. Unlike some systems, video clips stored at different resolutions can be mixed and matched in the editing environment and generic hard drives will work with the Media 100. Data Translation recommends that audio be stored on a separate hard drive. The audio isn't compressed and uses the 44.1MHz sampling rate.

A Macintosh Quadra 800, 950 or 840AV with 32MB of RAM is needed to run Media 100. For optimum performance, fast and large SCSI hard drives along with a separate video card are needed. We started with an 840AV with 40MB of RAM, a RasterOps video display card and a 16-inch Apple monitor. Two Media 100 cards were then installed. The Media 100 software,

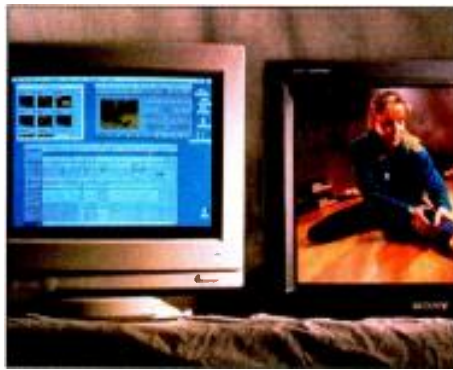

Performance at a glance:

- Non-linear performance
- On-line video quality
- Extended disk recording time
- Multitrack digital audio
- Real-time fades, fast dissolves
- Adobe plug-in effects architecture

version 1.02a, was loaded from three floppy disks. The supplied Anubis disk-formatting utility program was loaded from another disk. Finally, the Media 100 EDL option and the FX option were loaded from a pair of floppies.

Two Seagate Barracuda 2.4GB drives were added in separate external cases with power supplies configured by Rorke Data Systems. For videotape input and output, a Sony UVW 1800 Betacam SP editing player/recorder was used.

The Media 100 has composite BNC and S-Video inputs and outputs. It also has balanced XLRs for audio I/O. The S-Video connections were used for video I/O to the tape machine, with the composite

*Unlike some systems,
video clips stored at
different resolutions
can be mixed and
matched.*

video output used for a monitor feed.

The Anubis program, included with the Media 100 software, was used to format and initialize the two Barracuda drives. The Media 100 program was then launched. At startup, the video monitor showed the program's full field color bars. However, at present, there are no SMPTE split bars or audio tones available on board for output calibration.

Editing interface

Since its first showing in 1990, the Me-

dia 100 has reappeared at many industry trade shows in various evolutionary stages. It is apparent that feedback from the industry was sought and heeded in the final interface design. The result is an interface that gets an "A" for visual simplicity. It is logical and intelligent. It allows an editor to limit what he has to look at to screens relevant to the task at hand. Processor power is not wasted attempting to create large high-resolution (and irrelevant) images on the computer screen.

The interface consists of three windows. There is the "bin" window, the "program" window and the "edit suite" window. The appearance is clean and uncluttered. The three windows are continuously interactive, so that changes made in a window are reflected in the other windows.

As video clips are digitized, they are stored in the bin windows. The clips can be viewed in an edit list format called text, with additional space for names and comments, or as icons in a catalog. In the icon mode, there is quite a bit of flexibility. The icons can be scaled to three different sizes and either in or out frames can be viewed. Names, durations, source reel information and comments are all easily accessible. Icon shape also reveals whether the clip has been trimmed. Clips can be color coded to identify related clips. Clips can also be automatically sorted by name, color, selection order, duration or in time, or dragged around the bin manually and multiple bins can be created and used.

The program window is the familiar time line window where clips are edited. Media 100's program window interface is exceptionally uncluttered and functional. The basic view shows one video and two audio tracks with an expand/contract toggle. Expanding the video track reveals three separate tracks called "a" "b" and "fx." This expanded window is used for creating transition effects.

When the audio tracks are expanded, they reveal audio level and pan controls. After making the necessary adjustments, the tracks can be contracted to leave a less cluttered interface. This is straightforward, however, the system is limited to two tracks of audio. Like the bin win-

Leathers is the president of Eye Square and director of Broadcast Engineering and Video Systems Digital Media Lab, Hollywood, CA.



Media 100 full screen video with overlays.

dows, multiple program windows can be used at any time.

The edit suite window is the main control window, and the display changes relative to the task. The three main modes

are digitizing, clip editing and program. The edit suite window uses a small quick-time monitor for reference and like the other windows, unneeded controls and displays remain hidden until needed.

Digitizing footage

The edit suite window has four main screen configurations: digitize, edit clip, program and transition. They are changed via a pull-down window. When digitize is selected, the interface presents start and stop buttons, a field for entering source reel numbers, a field for selecting the primary incoming image type and a field for selecting image quality. There is an indicator for remaining disk storage time. An arrow in the lower right corner reveals three additional submenus: one for selecting the destination drive for the incoming material, one for setting incoming audio levels and one for comments that will stay with the clip. The display also contains a 160 x 120 pixel non-interlaced video window. A time-code read-out, with the EDL option installed, will display original source time code.

The start and stop buttons begin the digitizing process and control the tape source. The system works with numerous decks from several manufacturers. It would not control the UVW-1800 decks, but could read the time code through the 9-pin serial cable connected to the MAC modem port. The UVW machines require a different driver than other Betacam units, which will be added in a future software update.

Universal Audio/Video Sync Generation

Digital Audio Transmission

Synchronous AES/EBU Digital Audio Routing

RS-422 Control Data Routing

Digital Audio Conversion, Processing & Sync

Digital Audio Sample Rate Conversion

AES/EBU & Time Code Routing

NVISION

DEFINING THE CREATIVE EDGE OF DIGITAL TECHNOLOGY

Call for our Digital Audio Design Handbook and Product Catalog
 NVISION, INC. • P.O. Box 1658
 Nevada City, CA 95959
 916/265-1000
 800/719-1900

Circle (94) on Reply Card

The downside

The video window in the Mac display does not function during the digitizing process. The output video monitor shows the input video being passed through EE, so there is no way to monitor the digitized video. Basically you can only look at the source. The incoming audio gain can be adjusted, but there are no controls to adjust any parameters of the incoming video. In fact, there are no hue, saturation, video level or pedestal controls at any point in the system between input and output. This allows no way to correct for deficiencies in the incoming video or to match sources with differing characteristics. This means video must be corrected before coming into the system.

Also, there are no logging or indexing functions in the present software. Many systems allow incoming material to be logged or indexed on-the-fly. For instance, in a different system, as the video is being digitized, each time the enter button is pressed, a new clip is automatically indexed into the source bin. Each indexed clip has its own video image and time-code references. With the Media 100, the digitizing process must be stopped and restarted to generate each separate clip. This makes the digitizing process less efficient and more time consuming. These items were discussed in the company and are being addressed in the next software version.

Editing

When digitizing is complete, the edit suite window is switched to program mode. The upper panels in the digitize window are replaced by a miniature version of the time line and mark in and mark out buttons. To edit, the clips are dragged from the bin window (or the edit clip

window) onto the time line in the program window. Double clicking on the clip in the program window time line will change the edit suite window display to edit clip mode. The clip length and audio levels can be adjusted and then applied

create a transition, two video clips are dragged into the a and b tracks so that they have some overlap. Then you click on the fx track in the overlap to reveal the transition window in the edit suite window. The type of transition is selected

from a pull-down menu and the length is set by dragging pointers in the time line or by entering values numerically.

Once the parameters of the transition are entered, it must be rendered to a hard disk, which can take from a few seconds to a few minutes, depending on the length and complexity of the effect and the clips involved. It is important to set the picture quality for the transitions to match the picture quality of the clips and to make sure one of the fast SCSI drives is selected for the rendered transition's storage. Dozens of transition effects are available that have been adapted from Adobe Premiere.

The resulting video transitions are clean and there is a variety of possibilities. Version 1.1 of the software will allow keying of PICT files imported from other Mac programs over video. More complex effects, keys and compos-

ites can also be created in other Mac programs and imported as video into Media 100.

Using Media 100 for on-line

The picture quality of Media 100 is acceptable for most applications for which 1-inch tape would qualify. However, most on-line editing sessions involve performing functions that are not available in the system's editing software. For instance, the ability to adjust the video signal parameters is something that on-line edi-

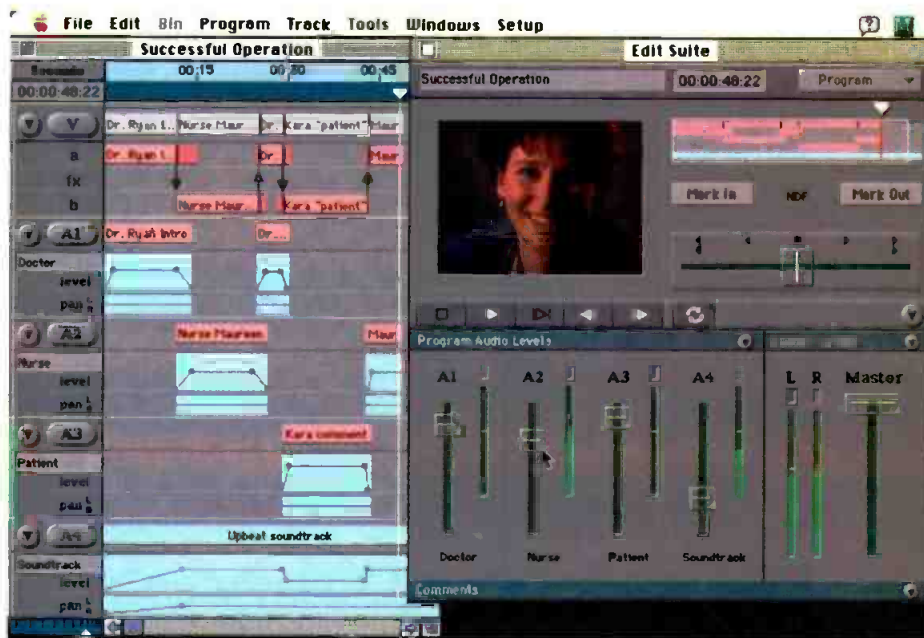

Screen shot of the time line display and the edit suite window.

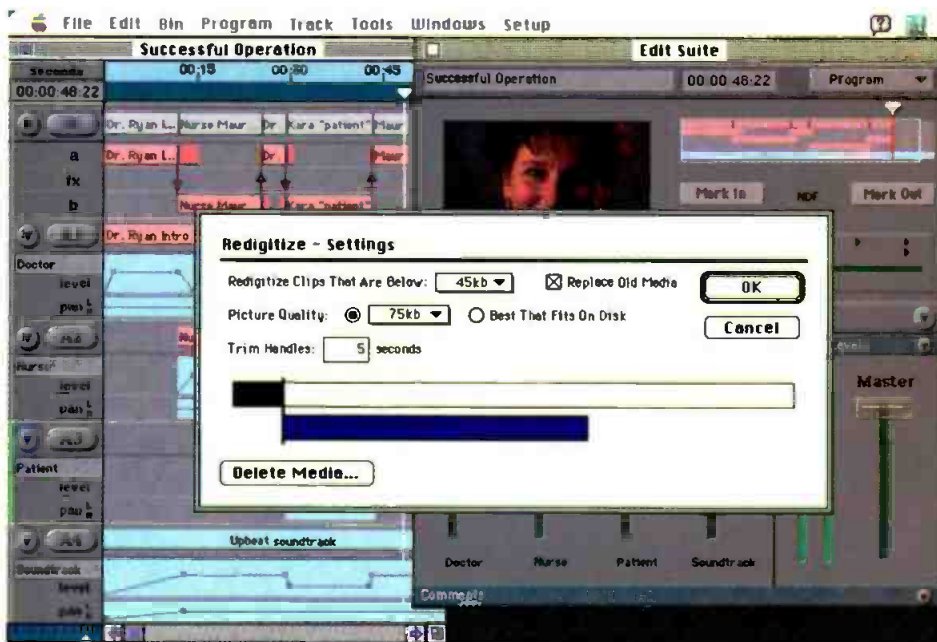

Adjustable parameters available when redigitizing clips.

to the time line.

To trim the outgoing and incoming sides of a transition, the cursor is positioned at the trim point, the mouse is held down and the transition point is moved along the time line. Only the outgoing video is visible in the monitor during this operation. If either side of the transition is to be trimmed independently, it is done by editing the clip and then making adjustments to the time line.

The video track in the time line can be expanded to reveal three video tracks. To

tors generally need to have access to. For editing sessions where the incoming video is clean and well-matched and the maximum requirements are cuts, dissolves and transitional wipes, the Media 100 works well.

More demanding editing sessions will require better signal control and more real-time effects possibilities. Although the Media 100 has many good transition effects, frequent requirements in more advanced sessions include compositing, layering, positioning, cropping and various types of keys. Although many of these things are, in fact, possible by importing work done in other programs, it is a more complicated and time-consuming way of doing things. This adds to the time problem non-linear editing systems, which require the extra step of digitizing video to hard drives, have in on-line and broadcast environments. The relatively high costs of talent and facilities and the frequent presence of impending deadlines does not tolerate delays well. In a production company or corporate environment with less time pressure, the Media 100 may provide a viable way to finish a project without spending on-line money at a facility.

In our case, we considered the Media 100 for two projects. For a 10-minute non-broadcast video shot in Betacam SP, a project could be completed with excellent results and in less time than if we had gone tape-to-tape. The other project was a fairly complicated music video involving numerous keys and signal processing functions. If we had a lot of time, we could have used the Media 100 and several other Mac programs (Cosa After Effects, Video Fusion, Morph, Flo, Photoshop, Premiere, etc.) to create a great program. But ultimately, we went tape-to-tape because of the lack of time and the need for complex multilayered key effects.

Data Translation has a solid hardware foundation in Media 100 and is dedicated to developing the software package to accommodate a wider range of on-line editing needs. On the Mac platform, this is one of the best analog video JPEG boards available. The audio characteristics of the system are also good. Media 100's compatibility with PICT and Quick-time files gives it a great deal of potential.

Editors note: The Digital Media Lab is an ongoing project of Broadcast Engineering and Video Systems magazines. Operated by David Leathers, president of Eye Square, the lab evaluates computer-based audio and video production systems for use in broadcast, recording, production and post-production applications. Broadcast Engineering's responsibility is to publish the results of such evaluations, positive or negative. No report should be considered an endorsement or disapproval by Broadcast Engineering magazine. Companies manufacturing such desktop-type equipment may request an evaluation of their product by contacting the editor of Broadcast Engineering magazine. ■

➔ For more information on the Media 100, circle (318) on Reply Card.

HILOMAST

TELESCOPIC PNEUMATIC MASTS

Applications

- Remote ENG
- Communications
- Field Strength Measurements
- Pop-up Jamming
- Remote Surveillance
- Noise Level Measurements
- Temporary Floodlighting
- Environmental Sensors
- Military Communications

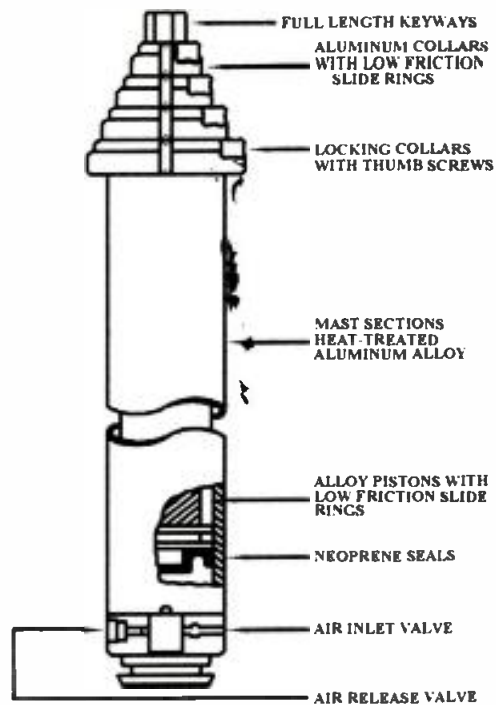

for Further Information Contact Jim Osborne

ALLEN OSBORNE ASSOCIATES, INC.
756 LAKEFIELD RD. Bldg. J
WESTLAKE VILLAGE, CALIFORNIA 91361
Tel:(805)495-8420 Fax:(805)373-6067



Circle (95) on Reply Card



**The TR2
Rackmount
Console**
-
**all the
features
without
the size**

- A full-size console in a 7RU 19" rack
- 12 Mixers with up to 36 inputs
- Expandable to 24 mixers and 84 inputs
- 5 Styles of input mixers to choose from
- 2 Program, cue and 2 mix/minus/IFB busses
- 4 Metered outputs with distribution amps
- 2 Monitor drivers plus cue amp & speaker
- Machine control & tally outputs, On/Off inputs
- Heavy duty modular construction
- Detachable meter bridge

Logitek

Call 800-231-5870 or 713-782-4592
for your nearest Logitek dealer

Circle (96) on Reply Card

Industry Briefs

BUSINESS SCENE

Ampex, Redwood City, CA, received its fourth Monitor Award for Special Achievement in Engineering at the 1994 International Teleproduction Society's Annual Forum in Washington, DC. The award was for the DCT 700d tape drive.

Editel, Los Angeles, has chosen Ampex DCT products for its new edit suite.

Marshall Space Center, Huntsville, AL, has chosen to record video data on Ampex 398 Betacam SP videotape.

Abekas, Redwood City, CA, has installed an A83 component digital switcher and an A57 special effects system at McHale Videofilm, Honolulu, HI.

Thomson Broadcast, Englewood, NJ, has sold a 9200 digital component switcher to Arc Pictures, New York. Advanced Digital Services, North Hollywood, CA, has purchased four 9200s.

Tentel, El Dorado Hills, CA, has announced training programs for the BT Betacam series. The training programs will be offered at the facility in the Sierra Mountain foothills, between Sacramento and Lake Tahoe, CA. Call 800-336-VCRS (8277) for more information.

Editel, Hollywood, CA, has switched all of its character generators over to Quantal Delta recorders.

Graham-Patten Systems, Grass Valley, CA, has supplied two D/ESAM digital edit suite audio mixers to The Frame Store, Soho, England.

Hewlett-Packard, Palo Alto, CA, has sold its HP broadcast video server to KOLD-TV, Channel 13, the CBS affiliate in Tucson, AZ.

Continental Electronics Corporation, Dallas, has acquired a majority interest of Lensa S.A., Santiago, Chile.

Andrew, Orland Park, IL, has opened a Heliac distribution and cable assembly facility in Hong Kong. Andrew has also opened an Earth Station Antenna System European Support Office in Buc, France.

Softimage, Montreal, Canada, has sold the Creative Toonz cel animation software, Creative Environment 3D animation software, and Eddie & Eddie Paint Systems to Universal Pictures/Ambliation.

JL Cooper, Los Angeles, has expanded its Los Angeles-based headquarters to house training facilities, demonstration rooms, a video editing suite and a larger warehouse.

Avid Technology, Tewksbury, MA, has sold AirPlay commercial and news playback systems to Western Tele-Comm, Littleton, CO; KAYU, Spokane, WA; KMVU, Medford, OR; KCY, Yakima, WA; KLBK, Lubbock, TX; WXVT, Greenville, MS; WDBB, Tuscaloosa, AL; WIFR, Rockford, IL; CBS Newsnet, New York. Disk-based NewsCutter systems have been purchased by KOB-TV, Albuquerque, NM; WBZ, Boston; and CBS Newsnet, New York.

Utah Scientific, Salt Lake City, has sold a distribution system to Christian Broadcasting Network, Virginia Beach, VA.

Quantel, Darien, CT, has delivered the V-series Paintbox to Boeing, Seattle; NBC, New York; New England Sports Network, Boston; Sonalysist, Waterford, CT; and Southern California Gas Co., Rosemead, CA. KPIX-TV, San Francisco has integrated Hal and Harriet with its existing Picturebox and Picturenet.

ADM Systems, West Bloomfield, MI, has been appointed exclusive U.S. representative for Bel Digital Audio Ltd. and Chromatec Video Products Ltd.

Rorke Data, Eden Prairie, MN, has acquired AdGraphics Europe B.V., based in the Netherlands.

Recognition Concepts, Inc., Carson City, NV, has delivered the first non-interlaced HDTV disk to Graphics Communication Laboratories, Japan. RCI has installed a second HD disk recorder with 10 minutes of uncompressed storage at Sony Pictures High Definition Center, Culver City, CA.

National Public Radio has relocated to 635 Massachusetts Ave., NW, Washington, DC 20001; phone 202-414-2000.

Alamar USA, Campbell, CA, and **Avid Technology**, Tewksbury, MA, have announced a joint effort to provide control of Avid's AirPlay disk-based multichannel playback system from Alamar's automation systems for broadcast and cable systems operators.

Advent Communications, England, has sold a Lynx 2000-MA uplink vehicle to Reuters.

Nikon, Melville, NY, has received the 1994 World-Class Award from *Macworld* magazine for the LS-10 Coolscan 35mm film scanner.

Grass Valley Group, Grass Valley, CA, has sold two Model 4000 component digital production switchers to Post Perfect, New York.

Canon, Lake Success, NY, has sold five J55x Super lenses, four J18x hand-held lenses and two J50x lenses to Mountain Mobile, Denver. Bexel Corporation's New York office has purchased another J33ax11 lens.

National Mobile Television, Itasca, IL, has purchased three Canon J55x Super lenses.

Solid State Logic, New York, has delivered an SL 8040 GB on-air production console to Unitel/New York.

SSL has also delivered a Scenaria digital audio/video post-production system to Creative Technologies, Akron, OH.

ImMIX, Grass Valley, CA, has sold five VideoCube digital video post-production workstations to the NBC facility, Burbank, CA.

Parallax, London, has sold six licenses of ADVANCE to Warner Bros. Imaging Technology.

The National Film Board of Canada has purchased two DIPSS licenses from Parallax.

Parallax's Matador software was used by Industrial Light and Magic to create digital effects in "The Flintstones" film.

Jampro Antennas, Sacramento, CA, has opened an East Coast sales office in Ft. Lauderdale, FL. The phone number for sales and customer support is 305-771-7180.

Sony, Park Ridge, NJ, has sold a range of Sony products to The Ten Network to upgrade facilities in Brisbane, Sydney and Melbourne, Australia.

Wegener Communications, Duluth, GA, has received an order from Legiao Da Boa Vontade, Brazil, for a digital audio network.

Stantron Cabinets, Pacoima, CA, has met seismic requirements under the Uniform Building Code Regulations allowing its products to be used in applications that are subject to earth movement.

Industry Briefs

Advent Communications, England, has delivered the first of three new, light-weight, self-contained SNG/OB vans to INTRAX International Satellite Services, the Netherlands.

JVC, Elmwood Park, NY, has sold 60 KY-F55U cameras for use at the World Cup games.

Harrison, Nashville, TN, has sold a Series Twelve automated audio console to The Lyons Group, Allen, TX.

Intelligent Resources, Arlington Heights, IL, has received a patent for a video display system that provides synchronization of multiple video datastreams.

The Educational Services Division of Broadcast Communications, New Glarus, WI, has been recognized by the Society of Broadcast Engineers for recertification credit for the Tower Technology I course. Five Continuation Education Credits can be obtained by attending the 5-day course.

Antec, Rolling Meadows, IL, and **Sumitomo Electric Lightwave**, have jointly announced the signing of a letter of intent to form a joint venture company to manufacture optical fiber cable in Research Triangle Park, NC.

Antec has acquired the assets of Engineering Technologies Group, Littleton, CO.

Ultimate, Chatsworth, CA, has sold two Ultimate 45 systems to Plus 8 Video, Los Angeles.

Alpha Image, member of the Dynatech Video Group, Salt Lake City, has sold the Alphie SX production switcher to Hollywood Digital, Hollywood, CA.

Kub Systems, Foster City, CA, has signed Illinois-based Serial Scene as the independent sales representative for the Dance product line. Serial Scene will represent Kub in Illinois, Wisconsin and Minnesota.

Kub Systems has also signed Oklahoma-based Digital Dynamic Systems as the independent sales representative for the Dance product line in Oklahoma, Arkansas and northern Louisiana.

HHB Communications, London, has delivered Portadat PDR1000 location DAT recorders to BBC's Outside Broadcasts Radio unit.

Accom, Menlo Park, CA, has delivered its audio option for the RTD real-time disk recorders to USA Networks.

Accom has received a 1994 Monitor Award for Special Achievement in Engineering Excellence from the International Teleproduction Society for its Axial 2020 visual on-line editing system.

PEOPLE

Terrance L. Barnum has been appointed director and general manager of Pro-Bel, Dunwoody, GA.

Michael C. Creamer has been appointed national sales manager at Lightwave Systems, Dallas.

Chuck Thompson has been appointed vice president and general manager of J.L. Cooper, Los Angeles.

E. Kirk Ellis has joined Lawrence Behr Associates, Greenville, NC, as director of project integration.

Philip Altenburg has joined Walters-Storyk Design Group, New York, as a design associate.

Mary Ann Fialkowski has been promoted to senior vice president of marketing and business development at Rank Video Services America, Deerfield, IL.

Steven Helland has been appointed vice president of operations for the Grass Valley Group, Grass Valley, CA.

Russ Johnson has been named vice president of sales (Americas) for the Grass Valley Group, Grass Valley, CA.

John Parker has been named operations manager for the Grass Valley Group's Hong Kong facility.

Larry Poor has been named director of technology marketing for Dolby Laboratories Licensing Corporation, San Francisco, CA.

Tony Gilkey has been promoted to director of operation for The Post Group, Los Angeles.

Jim Dorriety has been named general manager of Venture Productions, Miami.

SANIX®

new concept
"Capacitive-Discharge"
 800Hz PULSE GENERATION
BULK ERASERS
FAST
COMPACT
EFFICIENT
RELIABLY ERASE
METAL TAPES

All Models operate on 117V at 3 Amp.
 24 hour continuous duty, no heat build-up.



3800

For BETACAM-SP
 Digital BETACAM, M.I.I.,
 VHS, Beta etc
 1/2" w METAL-OXIDE



4800

For D2(D1),
 BETACAM-SP,
 Digital BETACAM,
 U-matic, etc.
 3/4" w · 1/2" w
 METAL-OXIDE



5500

For D2(D1), D3, DCT
 Large and M·S
 3/4" w · 1/2" w
 all cassette.
 METAL-OXIDE
 TABLE TOP MODEL

5500

For D2(D1), D3, DCT
 Large and M·S
 3/4" w · 1/2" w
 all cassette.
 METAL-OXIDE
 TABLE TOP MODEL



6000

For D2(D1), D3, DCT
 Large and M·S
 all cassette.
 Up to 1" w · 14" reel
 all Reel Type
 METAL-OXIDE
 MASTER ERASER



6000

For D2(D1), D3, DCT
 Large and M·S
 all cassette.
 Up to 1" w · 14" reel
 all Reel Type
 METAL-OXIDE
 MASTER ERASER

U.S.A. DISTRIBUTOR
RTI-RESEARCH TECHNOLOGY INT'L.
 4700 CHASE AVENUE
 LINCOLNWOOD, IL 60646 U.S.A.
PHONE: 708-677-3000
FAX : 708-677-1311

SANIX CORPORATION
 TOKYO, JAPAN FAX: 81-3-3702-9654

Circle (97) on Reply Card

New Products

Video server

By Vela Research



- **Perspective 2000:** stores digitized video in compressed digital format (MPEG-1, MPEG-1+, and MPEG-2); features RAID disk array technology providing ability to hot swap a failed disk without stopping playback; can be controlled from a local or remote Site Manager system; can output to multiple NTSC playback channels.

Circle (351) on Reply Card

Portable standards converter

By AVS Broadcast

- **EOS:** field performance converter; features 4-field, 4-line conversion aperture, NTSC comb filter decoder, and component Y, C, C_b, and S-VHS Y/C inputs and outputs; bidirectional conversion between PAL, NTSC, NTSC 4.43, SECAM, PAL-N and PAL-M; also features extensive signal enhancement facilities.

Circle (353) on Reply Card

Portable amp/mixer

By Pertek Engineering

- **MonitorMate:** personal monitoring system has ability to sample a signal and give monitoring control to the user; provides field announcers with a mix of mic and line sources; sources can be monitored by stereo headphone output; features balanced mic and speaker/line inputs, independent mix of mic/line, and balanced mic send level control with selectable direct out; also features 15W speaker, separate stereo headphone, and stereo line level outputs of mix.

Circle (359) on Reply Card



Lens

By Canon

- **J14ax17B KRS V:** broadcast quality optical image stabilizing lens that uses Vari-Angle Prism technology; features zoom ratio of 14x with a focal length of 17-238mm in the size and weight of a standard ENG broadcast lens; slim configuration.

Circle (354) on Reply Card

Inclined orbit tracking system

By Astroguide International

- **Trax III:** revised to provide program track options for the user based on outside data of satellite location; provides options for tracking in addition to step tracking for AGC and following the map of previous signal strength tracking; can interface with other computer terminals to download satellite location data; includes automatic calculation of tracking parameters based on antenna size and satellite location.

Circle (399) on Reply Card

High resolution monitor

By Asaca/Shibasoku



- **CM14A:** designed for monitoring NTSC or PAL color video signals; rack mountable in VTR console or standard rack; features composite and component signals with Y/C; operable with optional D-2 and D-3 digital signals; in-line dot CRT of 0.31mm dot pitch; horizontal resolution is 650 lines; built-in high-performance comb filter with on/off switch.

Circle (352) on Reply Card

Feedback control

By Sabine

- **FBX 901 and FBX-1802:** automatically sense feedback, determine its frequency, and place one of nine narrow digital notch filters to cancel only the ringing frequency; uses 1/10-octave digital filters; user can lock the products' fixed filters to prevent them from going deeper than original setting; user can also limit number of activated filters.

Circle (360) on Reply Card

Desktop disk recorder

By Abekas Video Systems



- **Diskus:** a real-time 10-bit graphics disk recorder; offers 30 to 60 seconds of 10-bit CCIR-601 recording capacity; also features synchronous SCSI-1, fast and wide SCSI-2, VTR control, Targa file format support, and time code in and out; optional broadcast quality composite, S-video, 4:4:4 digital, and 4:2:2:4 I/O.

Circle (358) on Reply Card

Framestore synchronizers

By Tekniche

- **Genesis 8070:** full broadcast specification component (RGB/YC_bCr) framestore and synchronizer; internal 4:4:4 architecture for full bandwidth RGB picture with option of a key channel; switchable between 625 and 525 lines; features full frame and field freeze facilities with local and remote controls; accepts RGB or YC_bCr signals and outputs in same format.

- **Genesis 8080:** serial digital framestore; 270 Mbits/second (component) transmission system sends and receives a 10-bit 4:2:2 digital broadcast signal over 300 meters of high grade coaxial cable; features full frame and freeze, local and remote controls, and auto-sensing 625/525; works in parallel (CCIR-656) and serial digital formats; fully 10-bit compatible.

Circle (380) on Reply Card

Software

By Audio Kinetics

- **ES.Lock software:** enables comprehensive external control of the Tascam DA 88 digital audiocassette system; allows rapid locating and accurate synchronization, with fully adjustable time-code offsets; remote record track selection can be effected across all eight audio tracks, subject to the installed controller software levels of each unit; full control achieved via the 9-pin RS-422 control port fitted to the optional Tascam SY 88 interface card.

Circle (357) on Reply Card

New Products

Commercial insertion system

By Applied Digital Technology

- **VSS.Spot Management System:** tapeless commercial insertion system; offers up to 12 or more hours of storage; interframe and intraframe compression are varied.

Circle (368) on Reply Card

Custom digital cable

By Apogee Electronics

- **Wyde Eye:** cable designed specifically for carrying digital signals; available in pre-terminated lengths of 0.5, 1, 3, 5, and 10 meters for AES/EBU, SPDIF and word clock applications; also available in bulk for custom applications.

Circle (408) on Reply Card

Wireless mic system

By Panasonic/Ramsa



- **Ramsa wireless microphone systems:** operates in the UHF TV band; features 49 pre-programmed channels in the receiver and transmitter; Phased Lock Loop Synthesizer Systems monitor and adjust carrier frequency; transmit compressed signals; systems includes WX-RP110 and WX-RP158 hand-held wireless mics; WX-RP300 lavalier belt-pack-type transmitter, WX-RP810 true diversity single receiver; WX-RP820 UHF band true diversity receiver; WX-RP921 UHF band booster antenna and SX-RP900 distributor.

Circle (362) on Reply Card

Editing system

By PALTEX International

- **EDDi and Clio:** linear desktop video products; both feature slow motion control, drag-and-drop edit point and Marks transfer, and interfacing to all professional RS-422 VTR formats; Clio also has

C-Roll capability, slave play, support for four audio channels, user-selectable ESAM audio mixer control, and an additional serial control port that addresses the VTR emulation aspects of Pinnacle's Alladin and Prizm DVEs.

Circle (364) on Reply Card

Monitor

By SSAC

- **WVM series:** continuously monitors phase-to-phase voltages; features microcomputer-based circuitry with 10 fault non-volatile memory; a 6-LED status readout displays faults from memory, active faults, time delays and status of 10 amp SPDT output relay contacts; includes true random start delay; available for line voltages of 208/240, 380/415, 440/480, and 550/600 volts, 50/60Hz AC.

Circle (365) on Reply Card



Real-time graphics compositing

By Abekas Video Systems

- **Hexus production disk system:** modular system offering from two to six 1-minute, 10-bit disk recorder/players; can reconfigure disks from the control panel to offer a single 6-minute record/play channel, six independent 1-minute channels or any combination; two channels may be locked together.

Circle (366) on Reply Card

Edit suite mixer

By JLCoooper Electronics

- **AV8r:** 8-channel rack-mounted edit suite mixer; allows precise audio edits such as dissolves, cuts, and crossfades; edits can be performed manually or by remote control; industry standard protocols GVG-100, GPI, and ESAM (I and II) are fully supported; levels can be controlled in real time from a GVG-100 or ESAM II compatible edit controller.

Circle (412) on Reply Card

Two-channel networking system

By ADC Telecommunications/BEC Technologies

- **Sigmanet series:** line of fiber optic audio and data multiplexing equipment; provides a basic 2-channel net-

working system to receive, convert, and transmit audio and data signals; series includes AD2 and AD2F (2-channel analog input modules) and DA2 and DA2F (2-channel analog output modules); each module has a capacity of up to 64 audio channels; communication between modules uses high speed digital RS-422 datastreams; each input module functions as an in-add-through device; each output unit provides in-drop-through functions.

Circle (378) on Reply Card

Video modules

By Opticomm

- **MMV-100 video modules:** transmit computer-generated camera video signal that complies with RS-170 standard; MMV-100XMT and MMV-100/RCV operate at 820nm with 50-100um core diameter multimode optical fiber; wide operating temperature and voltage supply range; MMV-100 A/B/C/D video system uses a linear modulation method to transmit video signals up to 6,600 feet.

Circle (369) on Reply Card

Teleprompter software

By Questar

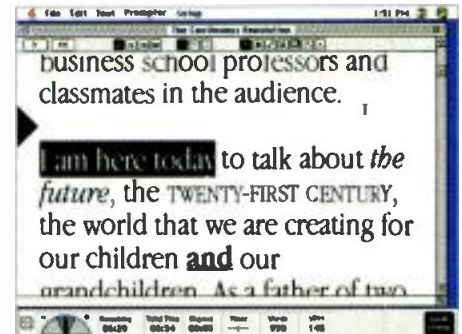

- **QuickPrompt 1.0:** member of Questar's family of teleprompter software products for Macintosh; can prompt scripts in any size or font; features auto-configuring and auto-syncing, word processing, and importing capabilities; also features automatic scrolling and non-verbal cues; nameable "QuickMarks" provide rapid access to script.

Circle (363) on Reply Card

Video server

By P.E. Photon

- **Oscon Box:** video server for SGI workstations; provides interface between graphics workstation and video devices without compressing image signals; can be fitted with up to three input channels and two output channels.

Circle (393) on Reply Card

New Products

Video print card

By Hewlett Packard



- **HP E2534A:** a component 4:2:2 serial digital video card; accepts digital bit-stream at 270Mbits/s to provide CCIR-601 video prints directly on plain paper from 525- and 625-line digital video sources; also features an auto-selected NTSC/PAL composite monitor output for reviewing captured video frames on TV monitors.

Circle (370) on Reply Card

Sound reduction panels

By NetWell Noise Control

- **Acoustic Wall Art Panels:** 1-inch hard-board panels made from fiber glass hard-board, wrapped in fabric, with layered acoustic foam wrapped in decorative suede; available in more than 60 colors and 700 designs.

Circle (386) on Reply Card

Median filter noise reducer

By Nova Systems

- **NovaMNR:** eliminates impulse noise and transmission sparkles from satellite, microwave and fiber feeds; can also be used as universal drop-out compensator for all videotape and CODEC sources; features full bandwidth digital processing with noise threshold and motion sensitivity controls; available as a stand-alone unit for stable composite video sources, an option card for the NovaSync3 frame synchronizer and an option card for the NovaMate XT TBC suitable for component, Y/C and composite video sources.

Circle (371) on Reply Card

Catalog

Contact East

- **Spring 1994 Contact East catalog:** test instruments and tools to service electronics; includes products for testing, repairing, and assembling electronic equipment.



Circle (372) on Reply Card

Interface

By Abekas

- **Plug-in for Adobe Premiere 4.0 for Macintosh:** CCIR-601 compatible method of importing uncompressed digital video into Adobe Premiere; provides direct link via the SCSI bus between Abekas A65/A66 digital disk recorders and Adobe Premiere 4.0; allows user to import video clips from A65 or A66 into Adobe Premier, manipulate clips, and export back to the DDR.

Circle (373) on Reply Card

Software

By ScheduALL

- **Windows version of ScheduALL:** Tele-production scheduling and management software system; written entirely in C++ for optimum performance; maintains the functionality of the current DOS version; operates on a single PC or fully networked; optional modules include facility scheduling, billing/accounts receivables, project management with enhanced project tracking, personnel management, library, and reporting.

Circle (374) on Reply Card

Monitor

By Tannoy//T.G.I. North America



- **PBM 5 Mark II:** full bandwidth small monitor; weighs nine pounds and stands less than a foot in height; features hard wired crossover, hand selected polypropylene capacitors, air core inductors and injection molded polyolefin low frequency cones; speaker elements are suspended with a single roll of nitril rubber; also features soft dome HF element, rear porting, gold-plated 5-way binding post and a removable grill; frequency response is rated at 63Hz - 20kHz \pm 3dB, nominal impedance is 6 Ω , peak power rating is 85W.

Circle (376) on Reply Card

Prompting software

By QTV

- **CueMac:** prompting software for Macintosh; completely customizable full-screen display; can create, organize, and

scroll scripts; can translate fully formatted fields from many word processing programs; displays prompting text in any font or style; features smooth scrolling, go to marks, integrated word processing, search and replace, and auto save.

Circle (377) on Reply Card

Video matrix switch

By Network Technologies Inc.

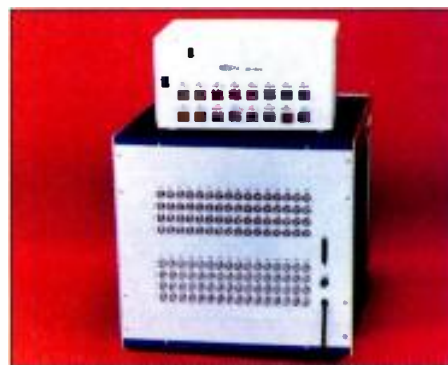

- **SM-16x16-RGBS-150M:** video matrix switch with 150MHz bandwidth; capable of connecting 16 RGBS inputs to 16 RGBS outputs; can control 1280x1024 computer video without loss of resolution; can be controlled up to 50 feet away using the IRT-20x16 infrared transmitter.

Circle (356) on Reply Card

Video op amps

By Elantec

- **EI2166:** current feedback op amp for use in video, RGB and test equipment amplifiers; features 3dB bandwidth of 110MHz at a gain of +2 and a TTL compatible disable function; designed to drive a double-terminated 75 Ω coax cable to video levels; enable/disable time is less than 75ns.

Circle (385) on Reply Card

Video products catalog

By Stantron Cabinets

- **1994 Video Products Catalog:** contains complete product descriptions, specifications and color photos of suggested system layouts; includes consoles, cabinets and racks for video production, broadcasting, and sound reinforcement applications.

Circle (379) on Reply Card

New Products

Virtual recorder line

By ASC Audio Video Corporation

• **Virtual recorder line expansion:** six new products for tapeless random access player for spot insertion for TV stations and instantaneous digital picture for digital audio workstations at post facilities; includes play list, on-line non-linear editor, slow motion controller, LiveDelay, LiveCache, and FiberNet; products available separately, or as upgrades and option to exiting VR systems.

Circle (381) on Reply Card

Video junction box

By Data Translation

• **Video Junction Box:** an interface between the Media 100 hardware system and external video equipment; offers a single panel to connect and disconnect cables running between Media 100 and video and audio equipment.

Circle (383) on Reply Card

Belt pack

By Telex Communications

• **BP-1000 and BP-2000:** additions to the Audiocom Intercom line; units feature one touch talk button, call indicator with programmable audible alert option, sidetone level control, and a recessed



headset volume control with 30 detented positions to protect against inadvertent bumping; both models are compatible with balanced and unbalanced intercom systems as well as 20kHz and DC call signal formats via an internal selector switch; also feature all metal alloy housing with a mar-resistant powder coated matte black finish.

Circle (382) on Reply Card

Combiner for MDS and MMDS bands

By Microwave Filter Company

• **Model 9119:** high-power dual combiner splits MDS and MMDS bands prior to transmission from two separate broadcast antennas; passbands are 2150-2162 and 2,500-2,686MHz; insertion loss is 0.5dB maximum and VSWR is 1.25:1; power is 2,000W combined and pressurization is 7PSI maximum; connectors are 7/8" EIA flanges.

Circle (392) on Reply Card

Relay I/O card

By Sealevel Systems

• **Latch-16:** a 16-latching relay output adapter for the IBM PC/XT/AT and compatibles; power (+5, +12) and ground provided on connector; features DB-37 male connector for relay outputs and selectable port address; optional cable and terminal block; relays remain in existing state even when PC is powered down.

Circle (390) on Reply Card

Enhancer/decoder

By Nova Systems

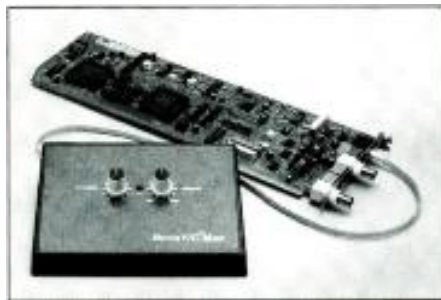

• **Y/C Max:** has ability to sharpen picture details and correct color bleed problems while decoding from composite video to Y/C or encoding from Y/C to composite video; can plug into a computer (Amiga or PC) or one of the NovaChassis for tabletop or rack-mount configurations; remote control is included for computer installation and a front panel control is provided for NovaChassis installation.

Circle (384) on Reply Card

Videotape editing controller

By Strassner Video

• **EdiQit:** editing system that operates using a standard mouse-driven interface or an industry standard color-coded keyboard; system uses the V-LAN Universal VTR Control Network; features multiple Edit Decision List bins, professional VVV, VBV, and BVB editing previews, advanced variable speed editing control, import/export from and to all major EDO formats, manual and automatic assembly, general purpose interface, and original script or paper cut referencing.

Circle (387) on Reply Card

Low-angle prism

By Century Precision Optics

• **Compact low-angle prism:** designed primarily for use with 16mm, super 16 and video cameras and interfaces with various 35mm cine cameras; provides a point of view two inches above the floor; easily inverts for high angle shots.

Circle (416) on Reply Card

Camera mount

By Miller Fluid Heads

• **Pro-Jib:** camera mount for ENG, location, and studio use; offers pan, tilt and tracking movements in a single mount; folds down to 52-inch length; features precision bubble level on pan head and a camera plate that combines with an adjustable secondary arm for leveling.

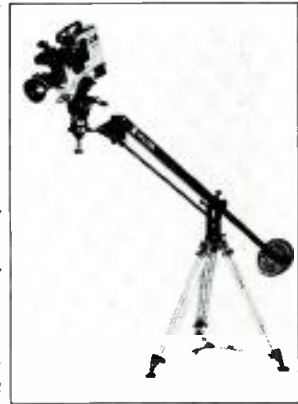

Circle (389) on Reply Card

Enhanced spectrum analyzer series

By Anritsu Wiltron

• **Expanded MS2610/MS2620 spectrum analyzer series:** five spectrum analyzers available in the B Type featuring a 3-mode multi-marker function, normalizer function, and level offset function; offer a dynamic range of 75dB, resolution bandwidth of 30Hz, and a 1Hz frequency count.

Circle (388) on Reply Card

Enclosures catalog

By Emcor Products/Crenlo Inc.

• **Instant Emcor catalog:** free 24-page, color catalog; Instant Emcor program includes modular electronic cabinetry, computer support furniture, cooling devices and component accessory items; choice of vertical, slope front, low silhouette and turret style frames; 12 new color choices; all frames, desks and accessory items available in smooth or textured paint finish.



Circle (381) on Reply Card

Acoustical panels

By illbruck

• **Fabrix:** non-woven, fire-resistant fabric backed by a porous melamine foam designed to absorb and dissipate extraneous noise; all materials are fiber-free and meet Class 1 building codes.

Circle (396) on Reply Card

New Products

Editing controller

By Technical Aesthetics Operations



- **StudioNet series:** editing controllers with A-Z Roll capability; offered in three packages ranging from simple cuts only, to an A/B roll, to an ABC roll system; operator can control VCRs, laser disks, hard drives and audio recorders in addition to audio and video switches and mixers.

Circle (395) on Reply Card

Video shielded monitors

By KRK Monitoring Systems

- **Model 6000BS and 7000BS:** compact, high-powered, full range monitors featuring drivers shielded with metal alloy "can" (known as mu/metal) which isolates magnetic flux and protects video and computer monitors.

Circle (394) on Reply Card

Tape archival and tracking system

By Nesbit Systems Inc.

- **Video Tape Library System for Windows:** merges power of DOS-based system with the graphical interface of Microsoft Windows; allows for storage and retrieval of graphic skills and other video inputs as part of the VTL database; query of the database provides summary list of tapes with all defined record attributes including video or still-store graphics associated with the tape as well as its current location.

Circle (407) on Reply Card

Analog comb decoder

By Link Electronics

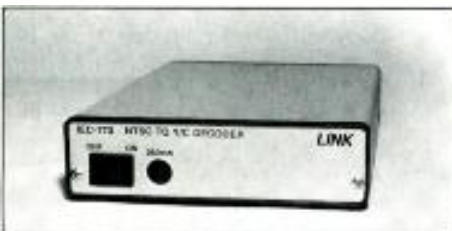

- **IEC-773:** high-performance analog comb decoder for separating NTSC composite video signal into its luminance (Y) and chrominance (C) components; allows almost any composite

video signal to be integrated into a Super-VHS system; calibrated to provide accurate unity gain transmission of the input signal; compact stand-alone package.

Circle (402) on Reply Card

Passive monitor

By KRK Monitoring Systems

- **Model 15P-3:** a passive, 3-way main monitor system for high-power control room applications; single 15-inch monitor features proprietary passive cross-over points; internal crosspoints are set at 400Hz and 40kHz enabling system to be powered by a single amplifier.

Circle (391) on Reply Card

Digital audio workstation

By Timeline Vista



- **Studioframe DAW-80:** utilizes technology based on the industry standard Intel/Windows platform; offers eight tracks of recording and editing capability; features icon-driven editing; audio operations can be interfaced into multimedia production and post-production.

Circle (355) on Reply Card

Testing and monitoring tool

By Current Technology

- **DTS-2 diagnostic test set:** replaces the DTS 1000 analog model; connects to any Current Technology industrial grade or commercial grade product; monitors on-line distribution system voltage and actively tests the level of surge suppression system performance; offers testing or monitoring in line-to-neutral, line-to-line, line-to-ground, and neutral-to-ground modes.

Circle (398) on Reply Card

Digital optimizer

By Audio Intervisual Design

- **dB3000 digital optimizer:** multi-function digital audio processor for sample rate/data format conversion, monitoring, measurement, debugging and correction for professional and consumer digital audio.

Circle (400) on Reply Card

Logo capture/storage/key

By Prime Image

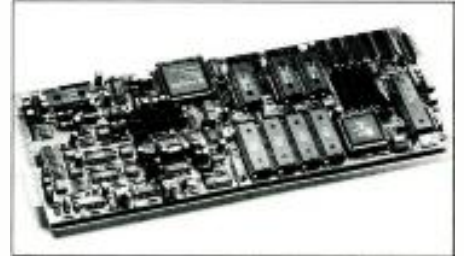

- **Logo Insertion Still Card:** captures and stores images in less than 10 seconds; built-in linear keyer/mixer allows preview before airing and automatically displays still image if video is lost; standard feature include non-volatile storage of two high-quality images (two fields/one frame with option for four fields/two frame storage); offers proc-amp control, composite program and preview from the mixer/keyer, Y/C still-only output, H position and high-impedance gen-lock.

Circle (397) on Reply Card

Lens brochures

By Fujinon

- **Studio lens brochure:** 6-page brochure; features full specifications and photos of six lens, technical descriptions and line drawings, and two pages of accessories.

Circle (415) on Reply Card



- **Field lens brochure:** 4-page brochure; features full specifications and photos of six lens.

Circle (403) on Reply Card

Software

By Intelligent Resources/MediaWare Development Group

- **Video Navigator:** transforms Intelligent Resources' Video Explorer into an on-line video post-production system; combines functions of many dedicated video production tools into a single workstation; allows precise A/B roll edits with real-time transition effects and frame-accurate control of one record and up to a maximum of eight source decks that adhere to the RS-422 serial protocol.

Circle (404) on Reply Card

Continued on page 132



"THE PROFESSIONAL'S SOURCE"



For Orders & Info Call

800-947-9928
212-444-5028

For Fax (24 Hours)

800-947-9003
212-444-5001

119 WEST 17TH STREET • NEW YORK, N.Y. 10011

Come see us at VIDEO EXPO/IMAGE WORLD at the Javits Convention Center in New York on September 11, 12, and 13 at Booth #412 — 423

SAMSON

MR-1 Wireless System

- The MR-1 micro receiver is a professional VHF wireless receiver measuring less than 4" long and 2" wide
- PCB tenced in 14 channels from 174 MHz to 213 MHz.
- Truly switchable balanced mic level (600 ohms) to unbalanced (-10 dBm) output
- 60% noise reduction to simultaneously increase dynamic range and eliminate noise
- Receiver switches level & headphone level output controls
- Can be powered by a 9V battery for 10 hours
- SM 2 hand-held transmitter can be used with mic elements like Shure SM 58 dynamic mic or Audio Technica Pro 4
- S* 2 (L) body pack transmitter can be used with leading lavalier mics like Sony ECM-144 or Audio Technica B31

Lavalier (clip mic) Systems

- S* 2 (L) ECM-144 Transmitter with Sony mic & MR-1 Receiver 367.50
- S* 2 (L) ECM-44 Transmitter with Sony mic & MR-1 Receiver 419.95
- S* 2 (L) AT B31 Transmitter with Audio Technica unidirectional mic & MR-1 Receiver 419.95

Hand-Held Systems

- S* 2-PR4 Audio Technica Dynamic mic element & MR-1 Receiver 367.50
- S* 2-58 Shure SM58 Dynamic mic element & MR-1 Receiver 434.95
- S* 2-85 Shure SM-85 condenser mic element & MR-1 Receiver 592.50

SUPER 10 SERIES TRANSMITTERS

For the serious professional who wants true step-up quality features. Lavalier (clip mic) systems each includes:

MR-1 Micro Receiver TX-3 Body-Pack Transmitter Lavalier Mic with Multi Pin Plug

- Sony ECM-144 507.95 Sony ECM-44 544.50
- Sony ECM-58 653.50 Sony ECM-77 724.95
- Shure MKE-2 747.95

SENNHEISER

RECORDING MICROPHONES

MKH 60 P48U3

Supercardioid/Lobe (Short Shotgun)

Short interference tube RF condenser, lightweight metal alloy, transformerless, low noise. Symmetrical capsule design, smooth off-axis frequency response, switchable low cut filter (-5 dB at 100 Hz), high frequency boost (+5 dB at 10 kHz) and 10 dB attenuation. Handles extremely high SPL (135 dB), ideal for broadcasting, film, video, sports, recording, interviewing in crowded or noisy environments. Excellent for studio voiceovers.

MKH 70 P48U3

Supercardioid/Lobe (Shotgun)

Extremely lightweight RF condenser, rugged, long shotgun, low distortion push-pull element, transformerless, low noise, switchable presence (+5 dB at 10 kHz), low cut filter (-5 dB at 50 Hz), and 10 dB preattenuation. Handles 133 dB/SPL with excellent sensitivity and high output level. Ideal for video/film studios, theater, sporting events, and nature recordings.

MKH 416 P48U3

Supercardioid/Lobe (Shotgun)

Transformerless, RF condenser designed as a combination of pressure gradient and interference tube microphones. Very good feedback rejection, low proximity effect, 128 dB/SPL. Rugged and resistant to changing climate conditions. Ideal for boom, fishpole, and camera mountings. A long-distance microphone for video, film, and studio recording. Excellent for interviewing for reporters, podium or lecture microphone.

MKH 816 P48U3

Ultra-directional Lobe (Shotgun)

Narrow-beam pattern, transformerless RF condenser microphone. Handles 124 dB/SPL and has high output voltage. Perfect for crowded news conference, movie sets, TV stages, sporting events and nature recording.

MKH 816 TU3

Same as MKH 816 P48U3, but designed to use 12 volt audio wire (A-B) powering

MKH 20 P48U3

Omnidirectional

Low distortion push-pull element, transformerless RF condenser, flat frequency response, diffuse/near-field response switch (6 dB boost at 10 kHz), switchable 10 dB pad to prevent overmodulation, handles 142 dB SPL. High output level ideal for concert, Mid-Side (M-S), acoustic strings, brass and wind instrument recording.

MKH 40 P48U3

Cardioid

Highly versatile, low distortion push-pull element, transformerless RF condenser, high output level, transparent response, switchable proximity equalization (-4 dB at 50 Hz) and preattenuation of 10 dB to prevent overmodulation. In vocal applications excellent results have been achieved with the use of a pop screen. Recommended for most situations, including digital recording, overdubbing vocals, percussive sound, acoustic guitars, piano, brass and string instruments, Mid-Side (M-S) stereo, and conventional X-Y stereo.

Panasonic

Broadcast & Television Systems



WJ-MX50 Digital A/V Mixer

- Four input switcher and any two sources can be routed to the program buses
- 2-channel digital frame synchronization permits special effects in each of the A/B buses
- Combination of 7 basic patterns and other effects creates 287 wide patterns
- External edit control input for RS-232 or RS-422 serial controls. Also has GPI input
- Wide boundary effects: soft/border (bold, 8 back colors available)
- Digital effects including strobe, still, mosaic, negative/positive, paint, monochrome, strobe, trail, and AV synchro
- Fade-In and fade-out video, audio, titles individually or synchronously faded
- Real-Time Compression - the entire source image is compressed inside a wipe pattern
- Scene Grabber - makes it possible to move a pattern, upholding the initially immed-in picture integrity
- Non Additive Mix (NAM) selects between A and B sources, passing only the signal with the highest luminance value
- Down Stream keyer with selectable sources from character generator or external camera
- Incorporates 8 separate memories that enable virtually instant recall of frequently used effects
- 8 preset effects include Mosaic Mix, Position Stream, Corkscrew, Bounce, Flip, Shutter, Vibrate, and Satellite
- Audio mixing capability of 5 sources with 5 audio level adjustments



AG-DS840/AG-DS850

S-VHS Slow-Motion Editing System

Editing machines truly designed for professionals

The AG-DS840 player and AG-DS850 Editing VCR are state-of-the-art S-VHS editing machines that provide the quality required for professional video production and even broadcast systems. Equipped with Panasonic's advanced digital technology they offer features such as Digital VHS Circuitry, Digital 3-0 Time Base Correctors, Digital Slow Motion, and Digital Noise Reduction. They also have built-in Time Code Generator/Readers for frame accurate editing, and component video output for connection to Mil and Betacam machines.

AG-DS840 & AG-DS850 Features:

- They provide clear, noise-free, high quality slow playback. Playback speed, including Digital Shift is selectable in 10 steps (-14, +18, +16, +1/25, D, -1/25, +1/16, +18, +14, +1/2)
- Built-in enhanced performance, 3-dimensional digital TBC with a correction range of one field. With the VCRs continuously retaining one field in memory, the data is used for 3-D type processing thereby providing excellent dropout compensation
- Digital Signal Processing for improved picture quality, and for maintaining uniform picture quality during editing. A Chroma Aperture Compensation (CAC) circuit eliminates color blurring and expands chroma bandwidth
- Other digital signal processing (DSP) circuits include:
 - Digital Noise Reduction (DNR): Processes Y and C signals separately to boost S/N Ratio by minimizing noise during playback
 - Digital Comb Filter: Uses an advanced 3-dimensional system for complete Y/C separation. The result is reduced color and luminance blurring
 - Switching Noise Mask Circuit: Effectively eliminates noise caused by head switching during slow motion playback
 - Employs amorphous video heads that have a higher magnetic coercivity than conventional ferrite heads. Expanded color signal frequency response from the amorphous heads enhances picture quality by minimizing color blurring
 - They have built-in LTC/VITC (Longitudinal/Vertical Interval) time code reader/generators for absolute frame accurate editing
 - Equipped with component outputs allowing easy connection to other component video equipment. This allows high quality transfer of S-VHS source material to Betacam or Mil
 - Equipped with RS-422 (9-Pin) serial interface. The standard control system for professional broadcast machines
 - IQ (Intelligent Quest) mechanism delivers precise, high-speed operation, plus the reliability needed. The dual-loading system achieves high-speed response while protecting tapes and heads from damage. The tape transport mechanism uses five direct drive motors, including two reel drive motors. Automatic head cleaning is also provided
 - Capstan Control System with large capstan spindle allows high-speed search at 32x normal speed
 - Four channel audio including two hi-fi stereo channels with a dynamic range of 90dB as well as two linear channels with Dolby NR. Each audio channel has its own input (AG-DS850 only) and output with individual channel-level setting capability. All audio channels use XLR connectors
 - Provides 16:9 wide aspect compatibility, so they are fully equipped for the next generation of televisions
 - 3 rack units high, they are unbelievably compact for easy space saving installation. 19" rack-mountable with optional AG-M730.



MII "W Series" AU-W32H/W33H/W35H

For years, Panasonic's MII VCRs have consistently brought professionals the superior broadcast quality of component recording. Now the "W-Series" brings the power of quality component recording to an ever wider range of users. The "W-Series" delivers the familiar MII quality that professionals around the world have come to depend on, at a substantially reduced cost. And with the "W-Series", there are no compromises to the format, or to the bandwidth required for true component recording. They are equipped with 3-D type TBC for exceptional playback stability and excellent dropout compensation. All models have built-in SMPTE time code readers and generators (AU-W35H) and they each feature color framing — so essential for animation and editing.

- Uses true component recording technology, with separate tracks for the luminance (Y) and chrominance (C) signals. Delivers vivid colors and super sharp details — thanks to the full 4.5 MHz luminance bandwidth. Because the signals never mix during recording, the quality remains exceptionally high, even during repeated editing and dubbing
- You don't have to worry which kind of tape to select, because there is only one tape. MII uses metal tape to achieve high picture and sound quality. You can record and playback 90 minutes on a VHS size cassette
- Each is equipped with a digital 3-dimensional type TBC boasting a correction range of one full field (262.5 H lines). The memory continuously retains an entire video field of information in memory, and is used for 3-D processing, providing excellent dropout compensation and horizontal and vertical jitter
- All models have four high-quality audio channels. There are two Hi-Fi channels, with a dynamic range of 85 dB and two linear channels with Dolby NR
- "W-Series" models offer high precision time code editing, with a 0 frame accuracy. Both players include a SMPTE time code reader, while the AU-W35H has a time code reader/generator. The AU-W35H records VITC and LTC separately, and MII VCRs automatically switch between them during playback, according to tape speed, for consistent, reliable time code identification. User bits are recorded in either LTC or VITC (or both), with the capability of making either one (or both) an internally generated time of day clock
- AT (Auto Tracking) is a standard feature on the AU-W33H player. When used with an edit controller or the AG-A300 Slow Motion Controller, the AU-W33H provides noiseless still, slow-motion and quick-motion playback with a range of -1x to 2x normal speed. It also allows fine control over playback speed — highly effective for situations where "fit and fill" capability is required
- They allow TBC adjustment on the VCRs itself. Conveniently located adjustment knobs for all TBC controls, including video level, chroma level, chroma phase, setup level sync and subcarrier phase. A 15-pin terminal allows external TBC remote control



LEADER

Model 5850C

Vectorscope

An ideal companion for the 5860C waveform monitor, the 5850C adds simultaneous side-by-side waveform and vector monitoring. Featured is an electronically generated vector scale that precludes the need for fussy centering adjustments and eases phase adjustments from relatively long viewing distances. Provision is made for selecting the phase reference from either (A or B) inputs or a separate external timing reference.

Model 5860C

Waveform Monitor

A two-input waveform monitor, the 5860C features 1H, 1V, 2H, 2V, 1 μs/div and 2V MAG time bases as well as vertical amplifier response choices of flat, IRE (low pass), chroma and DIF-STEP. The latter facilitates easy checks of luminance linearity using the staircase signal. A PIX MON output jack feeds observed (A or B) signals to a picture monitor, and the unit accepts an external sync reference. Built-in calibrator and on-off control of the DC restorer is also provided.

5864A



Model 5864A

Waveform Monitor

A fully portable waveform monitor for field use, the Model 5864A is a two-channel unit that provides 2H and 2V sweeps with MAG, FLAT and IRE response, and normal and X4 gain.

Model 5854

Vectorscope

2-channel portable vectorscope is ideal for field use and features A and B phase reference, fixed and variable gain. Both units shown with optional battery holder and RP-1 type battery.

MAGNI



MM-400

- The MM-400 is a combination waveform and vector monitor especially conceived for the cost-conscious producer. A low-cost alternative to CRT-based waveform monitoring the MM-400 produces a video picture of the input signal's waveform and displays it on any video monitor. It provides a simple, affordable and accurate way to set camera levels before a shoot, or to check time base correctors and color fidelity in edit. Problems like hue shift, smearing, muddy contrast and loss of detail are easily identified for correction.

FEATURES:

- Converts waveform or vector display information into a standard video signal which can be displayed on a video monitor or routed around a video facility no need for additional expensive monitors. Switch between pictures and waveforms at the push of a button
- Incorporates an advanced SCM phase and color frame indicator that is a must for editing and post production. At a glance it tells you if a signal's subcarrier-to-horizontal phase is properly adjusted and if the signal's color frame matches the house black burst connected to the MM-400 external reference input
- Works anywhere and with any analog video format—NTSC, PAL, Component or S-Video. It has automatic detection between NTSC and PAL formats
- Three loop-through inputs can accept three composite signals of one component, or RGB signal
- No complex displays or special test signals are required for component video monitoring
- Interchannel timing and amplitude display make component analog monitoring easy. Has color bar limit markings for Betacam, Mil and SMPTE formats
- Waveform and vectorscope controls, including channel, sweep speed, position control, phase rotation are on easy-to-use dedicated pushbuttons
- Besides instant toggling between picture and waveform a mix mode combines waveform and picture displays for simultaneous viewing
- The MM-400 can be readily used by even novice operators. It has easy-to-understand set-up menus for display color, interchannel timing, SC/H phase alarm
- Usable in any video facility of any size for displaying signals. Its low cost makes it affordable by the smallest studio, while its features and performance make it ideal for monitoring in high-end facilities as well.

WE ARE AUTHORIZED PANASONIC INDUSTRIAL VIDEO DEALERS. ALL PANASONIC VIDEO INCLUDE ONE YEAR USA WARRANTY ON PARTS AND LABOR.

Circle (99) on Reply Card
www.americanradiohistory.com

FOR ORDERS CALL:
800-947-9928
212-444-5028

OR FAX (24 HOURS):
800-947-9003
212-444-5001

**OVERNIGHT AND
RUSH SERVICE
AVAILABLE**

PROFESSIONAL VIDEO TAPE



H471S S-VHS Double Coated			
ST-30	7.69	ST-60	8.49
ST-120			9.09
M221 Hi 8 Double Coated			
Metal Particles		Metal Evaporated	
P630HMP	4.99	E630HME	8.79
P660HMP	7.19	E660HME	11.89
P6120HMP	9.69	E6120HME	15.79

AMPEX

187 KCA 3/4" U-matic Broadcast (In Box)			
KCA05	6.79	KCA10	7.29
KCA20	7.99	KCA30	8.69
KCA60			12.19
197 BCA 3/4" U-matic Master Broadcast (In Box)			
BSC10 (min)	8.59	BCA10	8.59
BSC20 (min)	9.59	BCA30	10.29
BCA60			14.39
297 SPA 3/4" U-matic SP Master Broadcast (In Box)			
SPS10 (min)	10.19	SPA10	10.19
SPA20	10.89	SPS20 (min)	10.89
SPA30	12.49	SPA60	16.29

398 Betacam SP Master Broadcast (In Box)			
BC-5A (small)	16.79	BC-10A (small)	18.49
BC-20A (small)	20.49	BC-30A (small)	22.39
BC-5LA	15.99	BC-10LA	18.49
BC-20LA	20.49	BC-30LA	22.39
BC-60LA	31.79	BC-90LA	49.59

maxell.

BQ Certified 8mm High-Grade			
P6-60 HG BQ	5.09	P6-120 HG BQ	6.69
BQ Certified Hi-8 Metal Cassettes			
P6-60 HM BQ	5.89	P6-120 HM BQ	7.89
P1 PLUS Expatial VHS			
T-30 Plus	1.69	T-60 Plus	1.99
T-90 Plus	2.09	T-120 Plus	2.19
HGX-PLUS Expatial VHS (Box)			
HGX-T-60 Plus	2.69	HGX-T-120 Plus	2.99
BQ Broadcast Quality Expatial VHS (Box)			
T-30 BQ	4.39	T-60 BQ	4.99
T-120 BQ			5.89
BQ Certified Professional S-VHS (In Box)			
ST-31 BQ	6.09	ST-62 BQ	6.69
ST-126 BQ	7.39	ST-182 BQ	13.59

SONY

Hi-8 Professional Metal Video Cassettes			
P6-30 HMPX	5.79	P6-30 HMEX	7.99
P6-60 HMPX	8.19	P6-60 HMEX	11.49
P6-120HMPX	11.09	P6-120HMEX	15.49
PR Series Professional Grade VHS			
T-30PR	2.39	T-60PR	2.59
T-120PR			2.79
PM Series Premier Grade Professional VHS			
T-30PM	3.49	T-60PM	3.99
T-120PM			4.79
BA Series Premier Hi-Grade Broadcast VHS (In Box)			
T-30BA	3.59	T-60BA	4.09
T-120BA			4.89
MQ Master Quality S-VHS (In Box)			
MQST-60	7.99	MQST-120	8.39
BRS 3/4" U-matic Broadcast Standard (In Box)			
KCS-10 BRS (mini)	8.29	KCS-20 BRS (mini)	8.99
KCA-10 BRS	8.19	KCA-20 BRS	8.69
KCA-30 BRS	9.69	KCA-60 BRS	13.49
XBR 3/4" U-matic Broadcast Master (In Box)			
KCS-10 XBR (mini)	8.79	KCS-20 XBR (mini)	10.19
KCA-10 XBR	9.29	KCA-20 XBR	10.69
KCA-30 XBR	11.99	KCA-60 XBR	15.69
KSP 31/4" U-matic SP Broadcast (In Box)			
KSP-S10 (mini)	9.59	KSP-S20 (mini)	11.09
KSP-10	10.09	KSP-20	11.59
KSP-30	12.99	KSP-60	16.99
BCT Metal Betacam SP Broadcast Master (In Box)			
BCT-5M (small)	16.39	BCT-10M (small)	17.39
BCT-20M (small)	21.29	BCT-30M (small)	23.29
BCT-60ML	33.19	BCT-90ML	51.99

BTS

Broadcast Television Systems



Betacam SP-2000 PRO Series PBC 2600 Player

- More than 90 minutes of playback time using L-size Metal or Oxide cassettes
- High-speed picture search provides recognizable color pictures at up to 10 times normal speed in forward and reverse (24 times normal speed in monochrome)
- Two longitudinal audio channels with Dolby C-type NR
- Equipped with RS-422 9-pin serial interface
- Built-in Time Base Corrector with advanced high quality digital dropout compensator
- Optional BVR-50 provides remote control of the TBC
- Built-in LTC/VITC/User Bits reader, and character generator
- Y/R - Y/B-Y component signal outputs via BNC or 12-pin Betacam DUB connectors. Also has S-Video output
- Optional BKW-2020 provides U-matic DUB output capability.

PBC 2650 Player with Dynamic Tracking (DT)

- Same as PBC-2600 plus-
- Dynamic Tracking (DT) provides broadcast quality noiseless playback within -1 to +3 times normal speed

PBC 2800 Player/Recorder

- Same as PBC-2600 plus-
- Built-in comprehensive editing facilities
- Dynamic Motion Control with memory provides slow motion editing capability (when used with a player VTR equipped with DT function)
- 90 minutes of recording/playback using L-size Metal or Oxide (for playback only) cassettes
- Built-in LTC/VITC/User Bits generator and reader

WV-F700 3-CCD Digital Processing Camera

- Three 2/3" high sensitivity 380,000 pixel CCDs with on-chip optics, plus precision f1.4 high resolution prism deliver 750 lines of horizontal resolution, and S/N ratio of 62dB
- Achieves a sensitivity of 18.0 d at 2000 lux and minimum object illumination is 7 lux at f1.6 with +24dB gain (4 lux at f1.4)
- *Emmy Award-winning Digital Signal Processing DSP technology*
Dark Detail Circuit enhances contours under varying lighting conditions. Uses luminance sensitive algorithms to determine the optimum degree of enhancement in dark areas of the picture without altering the brightness of other areas in the picture. Enhances contours of objects as fine as strands of human hair, even under challenging lighting conditions
- Chroma Detail compensates for poor resolution in high chroma areas of the picture. Provides a wide dynamic range image with clear reproduction in the chroma area.
- 2-Dimensional Low Pass Filter reduces cross-color caused by high level brightness signals mixing into the sub-carrier. Reproduces fine stripes and lattice patterns with a minimum of color blur
- Highlight compression circuit expands the dynamic range of highlighted areas and prevents halation. Produces detailed images when viewed against a bright background
- Switchable R-Y, B-Y, or Y/C system allows direct docking to S-VHS, M-11, or Betacam SP docking VCRs



- To further enhance operational speed and flexibility, a total of four easy to use Scene File modes are available:
 - Scene File One is the Standard Mode which sets the WV-F700 to adjust to studio lighting
 - Scene File Two is the Illuminance Mode, which provides for different shades of black to be reproduced clearly in dark locations without requiring lighting alterations
 - Scene File Three is the Fluorescent Mode. Under fluorescent lighting certain color hues tend to be reproduced slightly in the blue

- spectrum. With Scene File Three, these hues are adjusted while using the white balance to provide natural tones
- Scene File Four is the User Mode for flexible data setting. Twenty different digital adjustments can be set including gamma, knee-point, chroma detail, detail, matrix and shading. Individual settings are available for 11 of the 20 items at gains of 0dB, +9dB, +18dB and +24dB. These digital adjustments also allow the WV-F700 to be matched to other color cameras in a studio environment for quick set-ups



JVC KY-27UB 3-CCD Color Video Camera

- New 1/2" CCDs with 380,000 pixels (360,000 effective) with advanced electronics delivers resolution of 750 horizontal lines and reduced smear
- Sensitivity of 18.0 d at 2000 lux. Min illumination 7.5 lux with f1.4 lens. +18dB
- LOLLUX mode allows shooting scenes that were previously impossible due to insufficient lighting. CCDs are maximized for low light sensitivity equivalent to an electronic gain of 24dB plus a JVC pixel readout system which provides an additional 6dB. Together they provide +30dB without the noise and picture degradation normally associated with this much gain.
- Equipped with Variable Scan function. This allows flicker-free shooting of any computer screens. Variable scan enables a precise shutter speed from 1/60 to 1/30 of a second in 256 increments to be set, matching a computer scan rate.
- Star filter creates dramatic 4-point star effects. Users can also select from a wide range of optional filters.
- Advanced Memory System (AMS) stores customizable settings for various shooting conditions
- Uses just 12.4 watts of power with camera adapter and viewfinder, so battery time can be allocated to VTR operation
- Easily adjustable pedestal and detail enhancement through the Camera Setup Menu
- Docks directly to JVC BR-S422U, BR-S411UB and BR-S420CU professional S-VHS recorders. Model KY-27 UPCH docks directly to Hi8 and Betacam.

sachtler VIDEO 14/100 FLUID HEAD

- Sachtler Touch and Go System
- Integrated sliding battery plate
- Strengthened dynamic counterbalance in 2 steps
- Frictionless leak proof fluid damping with three levels of drag
- Vibrationless vertical and horizontal brakes
- Built in bubble for horizontal leveling
- Compatible with wide range of tripods series 100

HOT POD TRIPOD SERIES

Especially developed for use in ENG, the Hot Pod tripod is the tallest in the world. The central locking system is located on all three legs at the same time, while the pneumatic center column easily makes it possible to have the lens at a height of over 7 feet. The elevation force of the center column is factory set and doesn't require any setup. When moving to another location it can be carried by its handle located at the center of gravity.

ENG TWO-STAGE TRIPOD SERIES

Sachtler two-stage tripods have an enlarged height range (lower bottom and higher top position) so they are more universal. Legs can be locked in seconds with Sachtler's quick clamping. There are also heavy duty versions for extra stability. The heavy duty aluminum has a 20mm diameter tube vs 16mm and the heavy duty carbon fiber has a 24mm diameter tube vs 22mm. Also all heavy duty two-stage tripods have a teiding tripod handle

SACHTLER SYSTEM 14 PACKAGES

SYSTEM 14 PRO I — Economic standard with two-stage aluminum tripod video. includes: 14/100 Fluid Head + ENG 20 Two-Stage Aluminum Tripod + SP100 spreader + ENG 2 Padded Bag	SYSTEM 14 PRO II — Light standard system with two-stage carbon fiber tripod video. includes: 14/100 Fluid Head + ENG 2 CF Two-Stage Carbon Fiber Tripod + SP100 spreader + ENG 2 padded bag	SYSTEM 14 PRO III — Quickest tripod system, extremely high extension possible by the pneumatic center column. includes: 14/100 Fluid Head + Hot Pod Tripod + Padded Bag 100 II
3450.00	3995.00	3695.00



Nova NovaBlox VIDEO PROCESSING SYSTEM

The NovaBlox Video Processing System is comprised of individual function modules called NovaCards. The range of NovaCard modules includes time base correctors, frame synchronizers, sync generators, encoders, decoders, transcoders, distribution amplifiers and routing switchers. NovaCards have the flexibility of plugging into either a computer or one of four NovaChassis that hold from one to 15 modules. NovaCards fit into an IBM or compatible expansion slot including Amiga. Most of the NovaCards utilize RS-232 serial data for operational control and include DDS, Windows, and Amiga Software. For desktop and portable applications, the C-2B chassis hold two cards. There is also the C-4 single rackmount chassis that accommodates up to four NovaCards and the three rack C-15 NovaFrame, which features 15 slots. To provide operational control when using one of the NovaChassis there are two NovaTrio Serial Control Units to choose from. They provide LCD status display with four button operation of the NovaTrio/2 which has enhanced operation with dedicated function controls and LCD status display.



NOVAMATE TBC/Frame Synchronizer

One of the NovaCard modules of the NovaBlox system, the Novamate is a unique TBC/Frame Synchronizer that satisfies a wide range of VCR signal correction and video interface requirements from desktop video to satellite systems. Novamate plugs directly into a computer or one of several chassis configurations. Control is performed either by software or NovaTrio control units. The flexibility of its modular design and microprocessor control plus its superior quality make Novamate the ideal alternative to stand-alone and computer based TBCs

WE CARRY ALL OTHER NOVACARDS:
ENCODERS, DECODERS, TRANSCODERS,
DISTRIBUTION AMPLIFIERS AND ROUTING SWITCHERS

HORITA

BSG-50 Blackburst/Sync/Tone Generator

The BSG-50 provides an economical means for generating the most common RS-170A video timing signals used to operate various video switchers, effects generators, TBCs, VCRs, cameras and video edit controllers.

- 6 BNC video/pulse outputs
- Now available 6 blackburst, 4 sync, 2 subcarrier
- Each sync output individually settable for composite sync, composite blanking, H-arise, or V-drive
- Separate buffer for each output—maximum signal isolation
- 1KHZ, 0dB sinewave audio tone output, locked to video
- Outputs can easily be configured to meet specific user and equipment needs



CSG-50 Color Bar/Sync/Tone Generator

- Generates full-SMPTE color bars, blackburst and composite sync signals
- Built-in timer can automatically switch video output from color bars to color blank after 30 or 60 seconds. Easy and convenient for producing tape leaders and stripping tapes with color bars and black
- Front panel selection of full-field or SMPTE color bar patterns or colorback (blackburst) video output
- Includes crystal-controlled, 1KHZ, 0dB audio tone output
- Outputs video, sync, ref frame, 1 KHZ, 0dB
- Audio tone switches to silence and color bars change to black when using 30/60 second timer
- Fully RS-170A SC/H phased and always correct.
- No adjustment required

WE STOCK THE FULL LINE OF HORITA PRODUCTS INCLUDING:

WG-50 — Window Dub Inserter	TG-50 — Generator/Inserter
TRG-50 — Generator/Inserter/Search Speed Reader	TRG-50PC — Has all of the above plus RS-232 control.
VG-50 — VITC Generator, LTC-VITC Translator	VLT-50 — VITC-To-LTC Translator
VLT-50PC — VITC-To-LTC Translator / RS-232 Control	RLT-50 — Hi8 (EVO-9800/9850) ITC to LTC Translator
TSG-50 — NTSC Test Signal Generator	SCT-50 — Serial Control Titrator "Industrial" CG
SAG-50 — Time-Date Stamp, Time Code Captioning	Safe Area, Convergence Pattern and Oscilloscope Line Trigger and Generator

FOR PHOTO & VIDEO"



TO INQUIRE ABOUT YOUR ORDER:

800 221-5743 • 212 807-7479

OR FAX 24 HOURS: 212 366-3738

119 WEST 17TH STREET, NEW YORK, N.Y. 10011

Store & Mail Order Hours:

Sun 10-4:45 • Mon & Tues 9-6 • Wed & Thurs 9-7:30 • Fri 9-2 • Sat Closed

RUSH OR OVERNIGHT SERVICE AVAILABLE (extra charge)



TASCAM DA-88 Multi-Track Recorder



The first thing you notice about the eight channel DA-88 is the size of the cassette - it's a small Hi-8mm video cassette. You'll also notice the recording time - up to 120 minutes. These are just two of the advantages of the DA-88's innovative use of Bimn technology.

- Intrinsic to the 8mm video format is the Automatic Track Finding (ATF) control system. This approach records the tracking control information, along with the program material, using the helical scan (video) head. Competing S-VHS based systems record the tracking data with a linear recording head, independent of the program data. The S-VHS tape must be run at a higher speed (thereby delivering shorter recording time) to deliver control track reliability, and requires some form of automatic or manual tracking adjustment. Synchronization and tracking must be adjusted, either automatically or manually (just like on your home VCR) as the machine ages, or if the tape is played back on another machine.
- On the other hand, the ATF system ensures that there will be no tracking errors or loss of synchronization. The DA-88 doesn't even have (or need) a tracking adjustment. All eight tracks of audio are perfectly synchronized. What's more, this system guarantees perfect tracking and synchronization between all audio tracks on all cascaded decks - whether you have one deck or sixteen (up to 128 tracks!).
- Incoming audio is digitized by the on-board 16-bit D/A at either 44.1 or 48KHz (user selectable). The frequency response is flat from 20Hz to 20KHz while the dynamic range exceeds 92dB. As you would expect from a CD-quality recorder, the wow and flutter is unmeasurable.
- One of the best features of the DA-88 is the ability to execute seamless Punch-ins and Punch-outs. This feature offers programmable digital crossfades, as well as the ability to insert new material accurately into tight spots. You can even delay individual tracks, whether you want to generate special effects or compensate for poor timing. All of this can be performed easily on a deck that is simple and intuitive to use.

OPTIONS

- IIC-808 - Single Unit Remote Control
- IIC-848 - System Remote Control
- MU-8824 - 24-Channel Meter Unit
- SY-88 - Complete SMPTE/EBU Chase Synchronizing and MIDI Machine Control interface

Fostex RD-8 Multi-Track Recorder



This digital multitrack recorder is designed specifically for the audio professional. Fostex has long been a leader in synchronization, and the RD-8 redefines that commitment. With its built-in SMPTE/EBU reader/generator, the RD-8 can stripe, read and jam sync time code - even convert to MIDI time code. In a sync environment the RD-8 can be either Master or Slave.

- In a MIDI environment it will integrate seamlessly into the most complex project studio, allowing you complete transport control from within your MMC (MIDI Machine Control) compatible sequencer.
- Full transport control is available via the unit's industry-standard RS-422 port, providing full control right from your video bar. The RD-8 records at either 44.1 or 48KHz and will perform Pull-Up and Pull-Down functions for film/video transfers. The Track Slip feature helps maintain perfect sound-to-picture sync and the 8-Channel Optical Digital Interface keeps you in the digital domain.
- All of this contributes to the superb sound quality of the RD-8. The audio itself is processed by 16-bit digital-to-analog (D/A) converters at either 44.1 or 48KHz (user selectable) sampling rates, with 64X oversampling. Playback is accomplished with 18 bit analog-to-digital (A/D) and 64X oversampling, thus delivering CD-quality audio.
- The S-VHS transport in the RD-8 was selected because of its proven reliability, rugged construction and superb tape handling capabilities. Eight tracks on S-VHS tape allow much wider track widths than is possible on other digital tape recording formats.
- With its LCD and 10-digit display panel, the RD-8 is remarkably easy to control. You can readily access 100 locate points, or cross-fade time is fully controllable in machine to machine editing. Table of Contents data can be recorded on tape. When the next session begins, whether on your RD-8 or another, you just load the set up information from your tape and begin working. Since the RD-8 is fully ADAT compliant, your machine can play tapes made on other compatible machines, and can be controlled by other manufacturers ADAT controllers. Your tapes will also be playable on any other ADAT deck.
- In addition to familiar transport controls, there are a number of logical, user-friendly features. This is the only unit in its class with an on-board, backlit variable contrast LCD display. It provides all of the information you'll need to keep track of effects, punch points, generator functions and other pertinent data. Three function keys, combined with HOME, NEXT and UP/DOWN buttons, enable you to navigate the edit menus effortlessly. If you need to have access to the front panel controls, the optional model 8312 remote control gives you remote command of the most common functions.

SONY EVW-300

Hi-8 3-CCD CAMCORDER



Features:

- Equipped with three high density 1/2" IT Hyper HAD image sensors. Has an excellent sensitivity of F8.0 at 2,000 lux, high S/N of 60 dB, and delivers over 700 lines of horizontal resolution.
- Provides high quality PCM digital stereo and single channel AFM Hi-Fi recording. Has XLR balanced audio connectors.
- Quick start 1.5" viewfinder with 550 lines of resolution plus Zebra pattern video level indicator and color bar generator.
- Built-in 8mm Time Code generator (non-drop frame or drop frame mode may be selected). Also incorporates a variety of time code features such as Time Code PRESET, REC RUN/FREE RUN and User Bits.
- A variety of automatic adjustment functions for different lighting conditions are incorporated into the EVW-300:
 - ATW (Auto Trace White Balance) - when ATW is turned on optimum white balance is always ensured during recording, even for changes in color temperature. Conventional white balance adjustment is still provided with the Auto White Balance.
 - AGC (Automatic Gain Control) - in addition to manual Gain Up AGC provides linear gain up in the range of 0 dB to 18 dB.
 - Intelligent Auto Iris - for situations where the lighting between subject and background is different (subject is underexposed) the Intelligent Auto Iris automatically examines the scene and adjusts the lens iris for proper exposure.
- Selectable Gain-up from 1 dB to 18 dB in 1 dB steps for Mid & High positions.
- Clear Scan function - provides a variety of selection of shutter speeds ranging from 60-200 Hz allowing recording of almost any computer display without flicker.
- Compact, lightweight (12 lbs with NP-1B) ergonomic design provides well balanced and extremely comfortable operation.



JVC GY-X2 3-CCD S-VHS CAMCORDER

3-CCD S-VHS CAMCORDER

- Three 1/2" CCD image sensor delivers 650 lines of horizontal resolution
- New micro-lens technology provides exceptional sensitivity of F7.0 at 2000 lux and new LD/LUX mode lets you shoot with almost no light! Shoot superb footage with excellent color balanced at a mere 3 lux illumination
- Variable Scan View allows flicker-free shooting of a computer monitor
- Quick Record Mode - when turned on the camera is set to the auto iris even if lens is set at manual. Also activated is (ALC) Automatic Level Control and EEI Extended Electronic Iris which provides both variable gain and variable shutter. Now you can shoot continuously from dark room to bright outdoors without having to adjust gain, iris or ND filter.
- Full Time Auto White circuit lets you move from incandescent to fluorescent to outdoor lighting without changing white balance or the filter wheel.
- Genlock input allow synchronization with other cameras.
- Dual output system allows camera output to be connected directly to an external recorder.



TOSHIBA TSC-200 3-CCD Hi-8 Camcorder

- 3 1/2" CCD chips mounted with spatial offset technology deliver resolution of 700 horizontal lines.
- Low noise design provides extreme sensitivity of F8.0 at 2000 lux. Min. illumination 7.5 lux with excellent color reproduction.
- New LNA (low noise amplifier) delivers a S/N (signal-to-noise) ratio of 62dB - the highest achieved for this type of camera.
- 26-pin connector outputs Y/C or component video signal allowing hook up to a portable S-VHS, Hi8 or Betacam recorder and simultaneously record with S-VHS.
- Quick-start 1.5" viewfinder needs no warm up time so you never miss a shot. Zebra pattern in the viewfinder alerts operator to excessive video levels.

- Genlock capability allows synchronization with other cameras. Full calibration functions built-in as well as color bar generator.
- Variable high speed shutter from 1/60 to 1/2000 second to every frame.
- Built-in 8mm time code generator records an absolute address to every frame.
- High-performance back electret condenser mic records to all three audio tracks. Low cut filter eliminates wind noise.
- Very low power consumption. Draws only 16 watts per hour allowing 100 minutes of recording time with 1 NP-1B battery.
- Body made of magnesium alloy previously only on broadcast cameras. Still only 13 lbs. In standard configuration.

Panasonic AG-DP800 SUPERCAM S-VHS 3-CCD Digital Signal Processing Camcorder



- Three high-density 380,000 pixel CCDs with half-pitch pixel offset to achieve over 700 lines of horizontal resolution of f8 at 2000 lux exceeding 60dB and remarkable sensitivity of f8 at 2000 lux result in simply extraordinary image quality. Additionally the Frame Interline Transfer (FIT) CCDs minimize vertical smear, so you maintain impressive picture quality even in very bright illumination.
- Advanced digital signal processing circuitry provides four valuable benefits:
 - 1) Consistently reliable up-to-spec performance.
 - 2) Fine adjustment of a wide range of parameters.
 - 3) Memory storage and instant recall of specific settings.
 - 4) More flexible and higher quality image processing, as well as easier maintenance.
- Some of the DSP circuits and their functions:
 - CHROMA DETAIL - This function compensates for poor resolution in the high chroma areas of the picture.
 - DARK DETAIL - Determines optimum degree of contour enhancement in dark areas to deliver crisp, natural-looking images.
 - HIGHLIGHT COMPRESSION - Expands the dynamic range of the highlighted areas and prevents halation. The highlight compression circuit allows a wide dynamic range producing detailed images even against bright backlight or daylight.
 - FLARE CORRECTION CIRCUIT - Compensates for unsteady black caused by light or by a subject's movements.
 - Six Scene File modes. There are two user modes for custom digital parameter settings including Horizontal Detail, Vertical Detail, Chroma and Dark Detail, and Color Correction. The four preset modes are normal, fluorescent, special and sparkling.
 - In addition to regular AGC (Automatic Gain Control), Supercam has a Super High Gain mode. At F1.4 this enables shooting under illumination as low as 2 lux while retaining detail and color balance.
 - SyncScan Scan function allows flicker-free shooting of computer monitors. Electronic shutter increments can be set variably from 1/51 seconds to 1/253 of a second.
 - Built-in Internal time code generator lets you record with SMPTE LTC/VTC (Longitudinal/Vertical Internal) time code.
 - 26-pin connector for direct signal output from camera sensor for easy backups using 2nd VCR equipped with 26-pin connector.
 - Two hi-fi stereo audio channels with a dynamic range of 80 dB, as well as two linear audio channels with Dolby NR. Normal/Hi-Fi recording is selectable. Uses XLR connectors to further ensure high-quality sound.
 - Phantom power can be supplied to an optional microphone. Power can be switched off to prevent battery drain when not in use.

WE BUY SELL AND TRADE USED VIDEO EQUIPMENT



Quick-Draw Professional FOR CAMCORDERS OR STAND ALONE CAMERAS



- Designed for working from the back of a van or the trunk of your car. The top loading case has a wide open fold back top that stays neatly out of the way. It's lighter and more compact than shipping cases, thus saving valuable storage space. With other equipment crowded around it the sturdy built-in frame provides added protection.
- Heavy duty shoulder strap & comfortable leather hand grip.
- Carry it in crowds - crush proof aluminum guard protects viewfinder.
- Fits into back seat and fastens securely with seat belt.
- Holds camera with on-board battery attached.
- Lid closes with Velcro for quick-opening or secure with full-length zippers.
- Two trim exterior pockets and clip board pocket.
- Dual purpose rear pouch is an expandable battery chamber or all-purpose pocket.



Logic Series DIGITAL Gold Mount Batteries



The Logic Series DIGITAL batteries are acknowledged to be the most advanced in the rechargeable battery industry. In addition to the comprehensive sensors integral to all Logic Series batteries, each DIGITAL battery has a built-in micro-processor that communicates directly with Anton/Bauer InterActive chargers, creating significant new benchmarks for reliability, performance, and life. They also complete the communications network between battery, charger and camera. With the network in place, DIGITAL batteries deliver the feature most requested by cameramen: a reliable and accurate indication of remaining battery power.

DIGITAL PRO PACS

The Digital Pro Pac is the ultimate professional video battery and is recommended for all applications. The premium heavy duty Pro Pac cell is designed to deliver long life and high performance even under high current loads and adverse conditions. The size and weight of the Digital Pro Pac creates perfect shoulder balance with all camcorders.

- DIGITAL PRO PAC 14 LOGIC SERIES NICAD BATTERY
14.4v 60 Watt Hours 5 1/8 lbs
Run time: 2 hours @ 27 watts 3 hrs @ 18 watts
- DIGITAL PRO PAC 13 LOGIC SERIES NICAD BATTERY
13.2v 55 Watt Hours 4 3/4 lbs
Run time: 2 hours @ 25 watts, 3 hours @ 17 watts

DIGITAL COMPAC MAGNUM

Extremely small and light weight (almost half the size and weight of a Digital Pro Pac), the powerful Digital Compac Magnum still has more effective energy than two NP style slide-in batteries. The high voltage design and Logic Series technology eliminate all the problems that cripple conventional 12 volt slide-in type batteries. The Digital Compac Magnum is the professional choice for applications drawing less than 24 watts. Not recommended when using an UltraLight.

- DIGITAL COMPAC MAGNUM 14 LOGIC SERIES NICAD BATTERY
14.4 v 43 Watt Hours 2 3/4 lbs
Run time: 2 hours @ 20 watts, 3 hours @ 13 watts
- DIGITAL COMPAC MAGNUM 13 LOGIC SERIES NICAD BATTERY
13.2v 40 Watt Hours 2 1/2 lbs
Run time: 2 hours @ 18 watts, 3 hours @ 12 watts.

ALL VIDEO COMES WITH A SEVEN-DAY SATISFACTION MONEY-BACK GUARANTEE

Circle (99) on Reply Card

www.americanradiohistory.com

New Products

Continued from page 128

Video level meter

By Dorrough



- **Model 40-N:** meter features 40 segment LED bargraph; 30 LEDs represent zero to 120 IRE and indicate mathematical computation of waveform translated into peak and average luminance; 10 LEDs indicate sync level; also features sync and setup violation LEDs; alarm closure functions also available; Model 40-P/S is scaled in volts and features blanking.

Circle (375) on Reply Card

Virtual sets

By Ultimatte

- **Virtual Studio:** comprised of an Ultimatte memory head and appropriate camera, PC utilities package, Ultimatte-7, a Silicon Graphics ONYX computer and proprietary software developed by Innovative Medientechnikund Planungs; virtual sets can be created off-line with any number of paint programs and imported as an image file.

Circle (405) on Reply Card

Rack slide kit

By The Winsted Corporation



- **Model F8806 rack slide kit:** accommodates Sony's new UVW series of Betacam VTRs; adjustable finger brackets allow rack mounting in slope or vertical racks; VTRs pull out easily on heavy-duty ball-bearing slides; lifetime guarantee.

Circle (411) on Reply Card

Blackburst generator with tone

By Link Electronics

- **IEC-722:** gen-lock blackburst generator; provides six precision blackburst outputs for system distribution; a high-quality 1KHz tone for audio system testing is provided; rear panel terminal block al-

lows for easy connection; balanced, low-impedance output conforms to AES standards.

Circle (406) on Reply Card

Fresnel light

By Lowel-Light Manufacturing

- **Fren-L 650:** accepts 650W, 500W and 300W lamps; features 7:1 focusing range, sharp shadow quality, and ball-bearing rack-and-pinion lamp carriage; single-yoke design also features state-of-the-art, double-wall convection cooling system and oversized swing-down handle.



Circle (367) on Reply Card

Conformal coatings

By Hub Material Company

- **Konform:** protects rigid and flexible PC boards, thick film circuits, and electrical and electronic components and assemblies against moisture, thermal shock, current leakage, and mechanical abuse; available in four formulations: elastoplastic silicone coating; acrylic coating; urethane coating; UV-curable acrylic/urethane coating; all formulations meet MIL-I-46058C and are manufactured with a UV indicator for positive QC inspection.

Circle (409) on Reply Card

Screwdrivers

By Hub Material Company

- **Portable AC-powered torque screwdrivers:** electric screwdrivers designed for vertical insertion of fasteners; plug directly into 110V power outlet; features and AC/DC converter built into the tool's power cord for silent operation; drivers are designed to (\pm 2.5% torque accuracy; torque is externally adjustable; advanced electronics stop motor rotation at preset torque preventing over- and under-tightening.

Circle (410) on Reply Card

Color frame switcher

By Vicon Industries

- **V4108DE:** user-programmable Memscan color frame switcher; allows video from up to eight inputs to be recorded on a single tape recorder with virtually no loss of information; built-in synchronization; can accept any mixture of black-

and-white or color inputs without adjustment; on-screen programming menus provided; on-screen information includes time and date, input channel number, and a title of up to 16 characters; character set includes 95 letters, numerals and symbols; additional displays announce alarm inputs and video loss detection.

Circle (413) on Reply Card

Hand-held lens

By Fujinon

- **S14X7.5BRM:** a 1/2-inch hand-held zoom



lens with a focal length of 7.5 to 105mm and a maximum aperture of F1.4 to 75 mm and F1.8 at 105mm; 1.1m MOD (0.04 in macro mode); incorporates electron beam coating for control of ghosting and flare.

Circle (414) on Reply Card

- **A20X8EVM:** a 2/3-inch hand-held zoom lens; utilizes Aspheric Technology and



inner focus; includes V-Grip servo and adjustable zoom speed; focal length is 8 to 160mm and a maximum aperture of F1.7 to 115mm and F2.4 to 160mm; 0.85m MOD (0.4 in macro mode); maximum photometric aperture is T 1.8.

Circle (417) on Reply Card

Professional Services

JOHN H. BATTISON PE.
CONSULTING BROADCAST ENGINEER,
 FCC APPLICATIONS AM, FM, TV, LPTV
 Antenna Design, Proofs, Fieldwork
 2684 State Route 60 RD #1
 Londonville, OH 44842
 419-994-3849

NETCOM
 STATE-OF-THE-ART ENGINEERING FOR AUDIO & VIDEO
 TURN-KEY SYSTEMS
 DESIGN & DOCUMENTATION
 EQUIPMENT SALES
 CAD SERVICES
 1465 PALISADE AVE., TEANECK, NJ 07666 / (201) 837-8424

East Coast Video Systems
 ON-LINE... IN-TIME
 A full service Company providing...
 • Consultation
 • Engineering & Design
 • Installations
 • Training
 Serving...
 • Cable Systems
 • Corporate Facilities
 • Broadcast Facilities
 • Teleproduction Facilities
 52 Ralph Street, Belleville, NJ 07109 (201) 751-5655

CHAN & ASSOCIATES
 BUSINESS DEVELOPMENT • STRATEGIC MARKETING • PUBLIC RELATIONS
CURTIS J. CHAN 2212 HERITAGE WAY
 PRESIDENT FULLERTON, CA 92633
 PHONE: (714) 447-4993
 FAX: (714) 578-0284
 PAGER: (714) 506-1357

BE CLASSIFIEDS
 ☎ 913-967-1732
 Ask for Renée.

BIGGER HALF MEDIA SYSTEMS INC.
 CORPORATE AND COMMERCIAL
 VIDEO AND MULTI-MEDIA ENVIRONMENTS
 DESIGN - INSTALLATION - CONSULTATION
 TEL. (919) 489-5580 **JOEL APPELBAUM**
 PRESIDENT

Classified

FOR SALE

"PRIORITY, PROFESSIONAL & QUALITY SERVICE"
 CALL US TODAY!
BROADCAST VIDEO ENGINEERING, INC.
 New & Used Broadcast/Production Video & Audio Equipment.
 Sales, Service, Rental.
 System Design & Maintenance.
 2525 Wilson Blvd., Arlington, VA 22201
 (703) 841-2406/(703) 841-2409 (Fax)

Factory Direct Cases
 Our prices can't be beat.
 Custom or Stock Sizes

 Call for Catalogue or Quote
Roadie Products, Inc.
 800-645-1707
 In NY 516-563-1181
 Fax: 516-563-1390



HAVE CABLES
 ASSEMBLED • BULK • CUSTOM



HAVE PROFLEX™
BELDEN
CANARE
WEST PENN WIRE
MOGAMI

FREE CATALOG of Audio/Video Tape, Cable, Equipment, Accessories, Supplies
518/828-2000
 309 POWER AVE, HUDSON, NEW YORK 12534

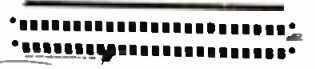
DEALER INQUIRIES WELCOMED

dp Machine Control Patching System
 RS-422 NORMALLED PATCHING

919/435-6179

Circle (101) on Reply Card

This Just In!
 DUBNER 20-K Character Generator with 10MB Bernoulli Drive and Presentation Graphics Software. \$10,000
 GVG 100-N Switcher w/ Serial Interface. \$5,500
 RANK MK-III Digiscan IV Telecine System with Time Logic Control Editor, DaVinci Color Corrector, and more! Call for a faxable description. CALL!
 SONY BVU-950 U-matic-SP VTR. CALL!
 SONY BVW-70 Betacam-SP VTR. CALL!

MICOR VIDEO EQUIPMENT
 CHICAGO 312 334 4300

THE 6X GPI MATRIX
 • 3 GPI's 24 Devices
 • Opto-Isolated
 • Lighted Switches
 • Solid State Relays
 • One Rack Unit High
 • Easy to Gang
OEI ELECTRONIC SYSTEMS INC. • 908-735-0543
 P.O. Box 265 Pittstown, NJ 08867

Circle (102) on Reply Card

TBC REMOTE CONTROL
 • Control up to four VTR's.
 • Four memories per VTR.
 • Digital readouts to record settings for future sessions.

 CALL FOR MORE INFORMATION.
Comprehensive VIDEO SUPPLY CORPORATION
 148 VETERANS DRIVE, NORTHVALE, NJ 07647
 (800) 526-0242 FAX (201) 767-7377

SONY • AMPEX • BTS • DUBNER GRASSVALLEY • PANASONIC
 If You're Looking For the Best in Used Equipment and You Want the BEST: • DEAL • VALUE • SERVICE
CALL MIDWEST: (708) 251-0001 • CANADA (604) 850-7969

midwest AUDIO/VIDEO EXCHANGE, INC.
 1131 Central Ave. Wilmette, Illinois 60091
 International Brokers and Appraisers Serving the Audio / Video Industry

Circle (100) on Reply Card

BROADCAST engineering 9800 Metcalf, Overland Park, KS 66212
 (913) 967-1732 Fax (913) 967-1735
 Call Renée Hambleton for all your advertising needs

Classified

FOR SALE

FOR SALE: PANASONIC - RAMSA - SANYO - SHARP - TASCAM - TECHNICS - BOGEN - MAXELL: Professional/Industrial/Security Video & Audio Equipment. Wholesale Prices! Factory New Warranty! Sales - 800-233-2430, Support - 607-687-0545.

VIDEO EDITING SUITE FOR SALE: Complete SONY VO-9850 PACK. Includes: RM-450 controller (time code modules), VO-9850 and VO-9800 units, two PVM-1340 monitors and all cabling. ONLY 200 hours of use. New, \$16K; sell \$10.5K/offer. Call (212) 307-4763.

Don't Miss It!

The 1994 Annual Buyer's Guide in Broadcast Engineering & Video Systems Magazines!

Do you have a service or product that is needed by BOTH the Video and Broadcast Industries? Take advantage of year-long exposure by advertising in the Classified Section and reap the benefits of hot, qualified sales leads!

Why? Because Directory Issues are:

- ◆ Kept over one year
- ◆ Referred to nearly 3 times per month
- ◆ Passed along to 4 extra people
- ◆ Referred to by 4-out-of-5 people who

check the listings and 1-out-of-2 who contact advertisers*!

Call me by October 3rd or fax your ad to me. We make it simple!

Renée Hambleton, Classified Ad Manager
913-967-1732 Phone ◆ 913-967-1735 Fax

Broadcast Engineering's Classified Rates

(per column inch)			
1x	3x	6x	12x
\$119	\$112	\$107	\$102

or \$1.75/word with a \$40 minimum

*Cahner's Advertising Research Report

RS422 VTR REMOTE CONTROL
with **TIMECODE DISPLAY & JOGWHEEL**

SONY, AMPEX, JVC, BTS
PANASONIC, HITACHI

Low Cost — Lots of features

DNF INDUSTRIES

(213) 650-5256 • LA, CA 90069

• **STUDIO EXCHANGE •**
BURBANK

(818) 840-1351 • FAX (818) 840-1354

NEW & USED
VIDEO EQUIPMENT

BUY, SELL, CONSIGN; 25 YRS EXP

TAPE ERASERS

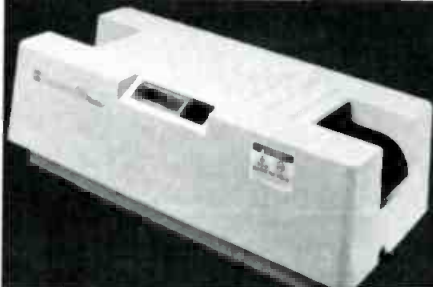

garner

WHEN COST IS
IMPORTANT AND
QUALITY IS CRITICAL

1-800-228-0275

Erases all formats in
quantities of 1 to 1,000,000



4200 North 48th Street • Lincoln, NE 68504

Circle (104) on Reply Card

Replace incandescent
indicator lamps with
high reliability LED
equivalents.



Eliminate the need to
relamp your control panels,
switches and indicators

Bright LED's
Standard Lamp Bases

- 100,000 hour (11 year) shockproof life.
- 5, 6, 12, 14, 24, 28, 48, 60 and 120 volts.
- Wedge, bayonet, midget flanged, grooved, telephone slide, and other bases.
- Red, green, yellow: Specials -- warm white, blue.



RIGHT BULB.
RIGHT PRICE.
RIGHT DELIVERY.

**LAMP
TECHNOLOGY,
INC.**

1645 Sycamore Ave.

Bonemia NY 11716

516-567-1800

Fax: 516-567-1806

1-800-KEEP LIT

Circle (103) on Reply Card



Advertise in *BE* Classifieds and
see how your money
speaks for you.

Call Renée Hambleton TODAY!
at (913) 967-1732 or
fax (913) 967-1735

BCS

NEW & USED Recorders Switchers Cameras Tripods Audio

- Sony BVP-7 3-CCD Camera-10,500
- Panasonic AG-7750 S-VHS Editor-4,250
- Ikegami HC-340 3-CCD Camera-7,500
- Sony VO-9850 3/4" SP Editor-6,500
- Sony PVW-2800 Betacam Editor-14,000
- Sony BVH-2000-22,000
- Grass Valley 200-2ME-52,000

BUY CONSIGN SELL SERVICE TRADE CATALOGUE

BCS-LA:818-551-5858 BCS-NY:212-268-8800



Sensational
ALL NEW
SUMMER

"Intelligent" Automatic Default Video Switch

2 Inputs; 1 Output. Audio follows Video.

Active video sensor detects the absence of video. Rejects unacceptable video playback from clogged heads or damaged tape.

\$145.00 (plus \$5.00 S&H)

COMMERCIAL VIDEO Maintenance Corp.

(603) 742-4891 Fax (603) 743-0890

BIG RESULTS FOR A SMALL INVESTMENT *BE* REACHES 89,000 READERS

Classified

HELP WANTED

DIRECTOR/VIDEOGRAPHER for Public Broadcasting Station: Experienced person to shoot and edit a nationally-syndicated hunting program. Applicant should be creative and physically fit. Hunting experience a plus. Salary range is \$20,000-\$25,000. Send resume to WNPE-TV, 1056 Arsenal Street, Watertown, NY 13601.

CHIEF ENGINEER: WNAC-TV, Fox affiliate for Providence, RI, is offering an exceptional opportunity for a professional to manage the engineering department and maintain UHF transmitter. Qualified candidates will have minimum 5 years managerial experience including complete knowledge of station operations and equipment, knowledge of FCC rules & regs, effective written and oral communication skills, experience in budgeting, and knowledge of computer hardware and software. Submit resume to Station Manager, WNAC Fox-64, 33 Pine Street, Rehoboth, MA 02769. No calls. EOE/M-F

WOMX-FM IN ORLANDO, FLORIDA has an immediate opening for a full time engineering assistant. Applicant should have a minimum of two years experience in radio broadcast engineering, and at least a two year Associate degree in electronics or equivalent. Knowledge of and experience with personal computers and remote broadcasts is required. Must have good communication skills and an ability to work well with people. SBE certification is a plus. EOE. Please send resume to Chief Engineer, WOMX, P.O. Box 8105, Winter Park, FL 32790.

MAINTENANCE ENGINEER. KUHT Television, an auxiliary enterprise of the University of Houston System, is seeking an experienced Studio Maintenance Engineer. Successful applicants will be able to install, calibrate, operate and repair analog and digital audio, video, and radio frequency equipment. A BSEE or BSEET is required (Equivalent professional experience and education may substitute.) as well as a General Class FCC Radio Telephone Certificate and knowledge of current FCC rules and regulations applicable to a network television broadcasting environment. Also required: SBE certification or equivalent professional recognition of technical accomplishment and three years demonstrated maintenance success to the component level, in a professional broadcast or production environment. This is a full time position with a good benefits package which is currently open. Interested candidates should send a letter of application, including resume and three professional references, to: Ms. Flor Garcia, KUHT-TV, 4513 Cullen Boulevard, Houston, Texas 77004, postmarked by September 30, 1994. Minorities and women are encouraged to apply. The University of Houston is an Equal Opportunity Employer.

ENGINEERING SUPPORT & SERVICE MANAGER: Leading intercom manufacturing company seeks skilled engineer experienced with analog and digital broadcast audio technology. BSEE or equivalent required, four years minimum experience. Must possess excellent technical, interpersonal, and management skills. Talented leader will manage service team, and will deal directly with broadcast engineers worldwide. Will be required to diagnose, evaluate and solve technical problems with a wide variety of state-of-the-art intercom products. Some travel. Excellent benefit package and competitive salary. Send resume, references, and salary history to Human Resources Director, Clear-Com Intercom Systems, 925 Camelia Street, Berkeley, CA 94710. No phone calls, please.

CATV PROJECT MANAGER: Southern California area, seeking aggressive person with extensive knowledge of head end, TVRO, microwave, S/A scrambling and distribution builds. Strong communication skills are required to be able to effectively support contractors and customers. Design & Troubleshooting skills a must. Ability to handle projects from survey through completion. Travel required. Excellent benefits package. Please mail or fax cover letter, resume and salary history to: Director of systems Engineering, Interactive Cable Systems, Inc., 13743 Ventura Blvd., #290, Sherman Oaks, CA 91423. FAX: 818/386-0519.

WE PLACE

(Technical Engineers-Editors-Colorists)

•All Levels, Locations & Disciplines•

Employer Paid Fees
Guaranteed Confidential
15 Years Service

Contact Mike Kelly
Fax 717-654-5765 • Phone 717-655-7143



KEYSTONE INT'L. INC.
16 Laffin Road
Pittston, PA 18640

CABLE TELEVISION: CABLE TECHNICIAN, So. Calif., Houston & Dallas, Tex., Nashville, Tenn., & North-Eastern areas (NY, NJ, Penn., etc.). At least 3 years experience. Travel required. Knowledge of Head-end S/A scrambling, TVRO distribution and microwave a must. Have own car and tools. Excellent benefits package. Please mail or fax cover letter, resume and salary history to: Director of Systems Engineering, Interactive Cable Systems, Inc., 13743 Ventura Blvd., #290, Sherman Oaks, CA 91423, FAX: 818/386-0519.

TRANSMITTER SUPERVISOR: Seattle public television station desires hands-on engineer to supervise all RF systems (transmitter, microwave and ITFS) and facilitate maximum performance, inspection and repair of transmission-related technical equipment. Familiarity with emergency systems, design, installation and necessary documentation a must. Candidate should have five years VHF transmitter management experience (college degree may be substituted for 2 years experience). To apply, send two copies EACH of cover letter and resume to Margaret Feige, Personnel Coordinator, KCTS/9, 401 Mercer Street, Seattle, WA 98109. Resumes will be accepted until the position is filled; however, KCTS plans to begin screening for this position between August 31-October 7, 1994. KCTS/9 is an EEO and encourages women and minorities to apply.

KRQE-TV, CBS affiliate in Albuquerque, New Mexico, offers outstanding opportunity for accomplished professional to manage the engineering and maintenance of main facility and allied facilities located throughout New Mexico. Minimum ten years experience in broadcast engineering, maintenance and electronics. Knowledge and experience operating RF electronics, high voltage broadcast transmitters, translators, microwave, and studio equipment. Supervisory experience. Knowledge FCC rules and regulations. Experiences organizing and coordinating variety of work activities. Effective written and oral communication skills. Knowledge computer hardware and software. Travel required. Qualified individuals send resumes to: Human Resources Department, KRQE, 13 Broadcast Plaza SW, Albuquerque, NM 87104. (505) 243-2285. FAX (505) 842-8483.

BROADCAST ENGINEER: The MNN Radio Networks seeks a broadcast engineer to service and maintain studio broadcast equipment; provide technical customer support to affiliated stations; service and maintain satellite equipment. Ideal candidate will have a minimum 5 years studio broadcast maintenance experience including: DOS and Windows 3 software/hardware; Novell; IA2 key system and electronic telephone; SCPC/Digital satellite experience (uplinks and downlinks); customer service skills. Some travel required. On-call weekends. Send resume and cover letter describing your technical strategic planning experience, and experience in a customer service environment to: Human Resources (701R), The MNN Radio Networks, 445 Minnesota Street, Suite 500, Saint Paul, MN 55101. An AA/EEO Employer.

CHIEF ENGINEER: Savannah Valley Broadcasting, Augusta, GA. is seeking a hands-on Chief Engineer. Responsible for maintenance, repair and installation of all technical facilities of 2 Class C FM's and a Class C AM. Send resumes and references to Savannah Valley Broadcasting, PO Box 2066, Augusta, GA. 30903. EOE.

CHIEF ENGINEER for northeastern Ohio UHF TV station. Must be experienced in UHF transmitters (TTU-110 desirable) and studio facilities such as Sony beta VTRs and studio cameras. Candidate should have an FCC diploma style license and 5 years minimum Chief Engineer experience. A BSEE degree is a plus. Computer literacy, knowledge of building and facilities maintenance including strong engineering and management background are desired. EOE. Send resumes: John Grdic, General Manager, 101 W. Boardman St., Youngstown, OH 44503. Fax 216-744-3402.

TELEVISION ASSISTANT CHIEF ENGINEER: Must have minimum five years experience in television broadcast maintenance; be able to troubleshoot digital and analog equipment to component level; FCC General Class license or SBE Certification required; UHF transmitter experience a plus; be able to climb ladders and pull cables. Primarily a maintenance position. Starting salary high 20's to mid 30s DOE. Immediately send resume to: Engineering Search Committee, WNIT Television, P.O. Box 3434, Elkhart, IN 46515. WNIT is an Equal Opportunity Employer. Women and Minorities are encouraged to apply.

MAINTENANCE ENGINEER - with experience in all phases of broadcast operations and be able to perform general maint. on various studio, production, videotape equip. and microwave systems. Minimum 2 years experience in TV Broadcasting, SBE or FCC First Class certification preferred. Must be able to work on call when needed. Send resume to Gene Brewer, WAGM-TV, Box 1149, Presque Isle, ME 04769.

PROMOTION MANAGER. Single station market, ABC Affiliate with FOX football, beautiful Shenandoah Valley of Virginia awaits the experienced promotion person. Must be able to write, edit and produce on air promos. Media planning and implementation credentials important. Send resume to Bob Ganzer, General Manager, WHSV-TV, P.O. Box TV 3, Harrisonburg, VA 22801. EOE.

MAINTENANCE ENGINEER: Top 50 market affiliate seeking a broadcast maintenance engineer. Four years of broadcast experience preferred. Experience with Ampex & GVG switchers. Chyron CG's, and studio cameras a must. PC and computer related experience a big plus. RF experience helpful. Send resume to the attention of Mike Nichols, WSMV-TV, 5700 Knob Rd., Nashville, TN 37209. EOE.

EQUIPMENT WANTED

WANTED: USED VIDEO EQUIPMENT. Systems or components. PRO VIDEO & FILM EQUIPMENT GROUP: the largest USED equipment dealer in the U.S.A. (214) 869-0011.

SPECIAL OFFER

FREEWARE EDITOR Powerful Mach One.5 online system controls 6 VTRs, switcher, mixer, and TBC. Software and docs on CompuServe (800-524-3388) in the Broadcast Professionals Forum. Directed Path Ent., 7980 Price-Hilliards Rd., Plain City, OH 43064 (CompuServe 75216.263).

TRAINING

FCC GENERAL CLASS LICENSE. Cassette recorded lessons for home study. Our 30th year preparing radio technicians for the license. Bob Johnson Telecommunications. Phone (310) 379-4461.

For Classified Advertising or Professional Services information Call Renée Hambleton at (913) 967-1732 FAX (913) 967-1735

SERVICES

BIG DOG COMMUNICATIONS

System Design and Integration

Installation • Troubleshooting

DIGITAL • VIDEO • RF • AUDIO

(209) 962-6254

P.O. Box 39, Groveland, CA 95321



Freeland Products, Inc.

Serving the world with quality
rebuild tubes since 1940.

75412 Highway 25 • Covington, LA 70433
800-624-7626 • 504-893-1243
Fax 504-892-7323

Ad Index

	Page Number	Reader Service Number	Advertiser Hotline		Page Number	Reader Service Number	Advertiser Hotline
AAVS/Div. of Sencore	3	5	800-769-AAVS	Logitek	121	96	713-782-4592
Abekas Video Systems	49	29	415-369-5111	Louth Automation	69	57	415-329-9498
Acrodyne Industries, Inc.	105	89	800-523-2596	Matrox Electronic Systems	21	21	800-361-4903
ADC Telecommunications	IFC	1	800-726-4266	Midwest Audio/Video Exchange	133	100	708-251-0001
ADM Systems, Inc.	44,88	84,68	313-932-1993	Miranda Technologies, Inc.	116	80	514-333-1772
Ampex Recording Media	81	50	800-240-7042	Nikon Electronic Imaging	5	17	800-52-NIKON
Anthro Co.	34		800-325-3841	NVision, Inc.	119	94	916-265-1000
ASACA/Shibasoku Corp.	IBC	2	310-827-7144	Odetics, Inc.	57	42	800-243-2001
Audio Precision	13	6	800-231-7350	OEI Electronic Systems, Inc.	133	102	908-735-0543
Avid Technology	11	20	800-949-AVID	Opamp Labs, Inc.	44	86	213-934-3566
Belar Electronics Laboratory	46	82	610-687-5550	Optibase, Inc.	89	70	214-239-5242
B&H Photo - Video	129,130-131	99	800-947-9928	Orban, Div. of AKG Acoustics	7	18	510-351-3500
Broadcast Video Systems Ltd.	46	83	905-764-1584	Allen Osborne Assoc.	121	95	805-495-8420
BTS Broadcast TV Systems	15	7	800-962-4BTS	Otari Corp.	41	37	415-341-5900
Canare Cable, Inc.	86	65	818-365-2446	Panasonic Broadcast & TV	54-55		800-524-0864
Canon USA Broadcast Lens	97	44	201-816-2900	Ramsa/Panasonic	85	64	800-777-1146
C-Cor Electronics	37	35	800-233-2267	Pioneer New Media Tech.	71	58	800-421-6450
CCS Audio Products	86	66	908-946-3800	Pirod, Inc.	95	55	219-936-4221
Ciprico	61	32	800-727-4669	Pro-Bel, Inc.	59	73	404-396-1971
Clark Wire & Cable	84	52,53	800-CABLE-IT	Quantel	43	38	203-656-3100
Clear-Com Intercom Systems	27	23	510-527-6666	Recognition Concepts, Inc.	109	75	702-882-7817
Conex Electro Systems	106	91	206-734-4323	Roland Corp. US	82-83	51	213-685-5141
DGS Pro Audio	76	63	800-292-2834	Sachtler AG	19	9	32-158-200
Dynatech Video Group	36,112-113		800-453-8782	Sachtler Corp. of America	31	16	516-867-4900
EEV, Inc.	53	39	800-DIAL-EEV	Sanix Corp.	123	97	708-677-3000
Electro-Voice	117	93	616-695-6831	Schmid Telecommunication	115	78	609-742-1878
Faroudja Laboratories	66	46	408-735-1492	Shure Brothers, Inc.	79	49	800-25-SHURE
Fiber Options	110	76	800-342-3748	Sierra Design Labs	30	15	702-831-7837
Garner Industries	134	104	800-228-0275	Sierra Video Systems	73	59	916-478-1000
Gentner Communications	63	33	800-945-7730	Sony Business			
Gepco	74	61	312-733-9555	& Professional	29,32A-D,67		800-635-SONY
Graham-Patten Systems, Inc.	98-99	74	800-422-6662	Standard Communications	77	48	310-532-0397
Harris Allied	1	4	606-282-4800	Strassner Editing Systems	50	30	818-508-6966
Henry Engineering	116	81	818-355-3656	Studio Audio & Video Limited	45	27	615-327-1140
Hewlett Packard Vid	75	62	800-452-4844	Switchcraft, Inc./Div. Raytheon	111	77	312-792-2700
Hitachi Denshi America	9	19	516-921-7200	Sypha	104	79	81-244-8758
Horita	106	90	714-489-0240	Tally Display Corp.	51	31	914-365-6393
Hughes Communications, Inc.	101	87	213-607-4377	Tektronix, Inc.	38-39,47	36,28	800-TEK-WIDE
Ikegami Electronics, Inc.	65	45	201-368-9171	Telex Communications, Inc.	17	8	800-392-3497
Intertec Info Age Books	44		800-543-7771	Trompeter Electronics	20	10,11	818-707-2020
Japan Electronics Show Assoc.	107	92		Larcant-TTC	93	54	303-665-8000
Jem-Fab Corp.	133	101	919-435-6179	Ultimate	35	25	818-993-8007
JVC Professional Products	24-25	22	800-JVC-5825	Utah Scientific/Dynatech			
Lamp Technology	134	103	516-567-1800	Video Group	36,112-113	26,72	800-453-8782
Lectrosonics	87	67	800-821-1121	Vega, A Mark IV Company	91	71	818-442-0782
Hedco/Leitch	BC	3	800-231-9673	Videotek, Inc.	103	88	800-800-5719
Lightwave Systems, Inc.	58	43	214-741-5142	The Winsted Corporation	74	60	800-447-2257

Advertising sales offices

NEW YORK, NEW YORK

Gordon & Associate
Josh Gordon
 210 President Street
 Brooklyn, NY 11231
 Telephone: (718) 802-0488
 FAX: (718) 522-4751

Joanne Melton
 888 7th Avenue, 38th Floor
 New York, NY 10106
 Telephone: (212) 332-0628
 FAX: (212) 332-0663

OXFORD, ENGLAND

Richard Woolley
 Intertec Publishing Corp.
 Unit 3, Farm Business Centre,
 Clifton Road, Deddington,
 Oxford OX15 4TP England
 Telephone: +44 (0) 1869 338794
 FAX: +44 (0) 1869 338040
 Telex: 837-469 BES G

AGOURA HILLS, CALIFORNIA

Duane Hefner
 5236 Colodny Ave., Suite 108
 Agoura Hills, CA 91301
 Telephone: (818) 707-6476
 FAX: (818) 707-2313

SANTA MONICA, CALIFORNIA

MC² Magazine Communications Marketing Corp.
Jason Perlman
 Telephone: (310) 458-9987
 FAX: (310) 393-2381

Deborah Kern
 Phone: 310-458-8080
 FAX: 310-393-2381
 501 Santa Monica Blvd., Suite 401
 Santa Monica, CA 90401

CHICAGO, ILLINOIS

Vitas Urbanas
 55 East Jackson, Suite 1100
 Chicago, IL 60604
 Telephone: (312) 435-2361
 FAX: (312) 922-1408

TOKYO, JAPAN

Orient Echo, Inc.
Masuyoshi Yoshikawa
 1101 Grand Maison
 Shimomiyabi-Cho 2-18
 Shinjuku-ku, Tokyo 162, Japan
 Telephone: (3) 3235-5961
 FAX: (3) 3235-5852
 Telex: J-33376 MYORIENT

CLASSIFIED ADVERTISING OVERLAND PARK, KANSAS

Renée Hambleton
 P.O. Box 12901
 Overland Park, KS 66282
 (913) 967-1732 FAX: (913) 967-1735



No One Measures Up To ShibaSoku® Accuracy

Designing and producing superior test instruments that are the industry's measure for accuracy

Performance engineering is clearly seen in ShibaSoku's CM205N Auto Setup Color Monitor. It reproduces images with the highest Color and Luminance Fidelity, but never adds or masks even minor video defects.

True NTSC Monitor

Utilizing Test and Measurement expertise, **ShibaSoku manufactures monitors to true NTSC specifications.** The NTSC Decoder uses I Q Chroma Demodulation, tuned to Human-Eye color perception, for richer, more accurate Chroma saturation with less cross-color noise. The 205 has excellent Luminance Frequency response and uses a 0.28mm Dot Pitch. 20" Precision In-Line Dot CRT, able to display over 900 TV lines with Adjustment Free Convergence, accurate to $\pm 0.2\text{mm}$.

Auto Setup—Plus

ShibaSoku's Auto Setup system provides acute accuracy and longer-term color temperature stability with impeccable chromaticity reproduction, to ± 0.002 points on the CIE x/y scale — accurate as the best color analyzer. Unlike other systems, the Optical Sensor and CPU circuitry reduce measurement errors from compensation adjustments and eliminate optical filters in the probe. Auto Setup operation is executed with an internal CAL signal generator. Five Color temperature memories store Contrast and Brightness data, the R,G,B, Gain and Bias levels. Manual Front panel controls have Preset/UNCAL switches for two

separate settings without using Auto Setup. High Voltage Beam current detection circuitry ensures better Luminance stability plus higher luminance performance (to 88fL).

Standard Features/Options

- + 3 Composite Video inputs
- + Component and RGB inputs
- + Y C input
- + D1 Component Digital Option
- + D2, D3 Composite Digital Option
- + Auto Setup on any Input Signal
- + PAL Decoder Option
- + Dynamic Double Focus system
- + Wideband CCD Comb filter
- + 3 Line Comb filter
- + High Voltage Protection
- + HV Stand-by function (Saves CRT life)
- + Power supply monitoring & protection
- + Sync. Burst circuit monitoring
- + Automatic Degauss operation
- + Chroma Gain compensation circuit
- + Variable Aperture compensation
- + Color Mono Split Screen function
- + Independent Preset/UNCAL switches
- + Residual Subcarrier indication
- + H V Pulse Cross modes

Full Line of Companion Models

The Multi-standard CM206N (900 TV line CRT) is capable of a combination of 3 decoders: NTSC, PAL, SECAM, D1, D2 and D3. Auto Setup is optional in addition to the decoders. Other Auto Setup models include: the 20"

CM201N, 14" CM141N, and Multi-standard CM202 and CM142, all 700 TV line CRTs.

Lasts Too Long

ShibaSoku's monitor design philosophy, anchored in Test and Measurement precision, is dedicated to giving video pros the means to inspect a video signal for ANY flaws or errors. There are many picture monitors, but only one line of Reference Quality monitors offers years of reliable, stable service. You get longer-term stability, sharper focus and resolution, and higher luminance control, which truly let you see what you've been missing in your video signal. Optimum ShibaSoku performance is demanded by top professionals. In fact, some users report having our monitors On-line for over a Decade. It seems the only way to get a new one into service is by engineering the Advancements you need.

Find out more about the monitor that lets you see what you need to see — circle the reader service card number below.

ASACA®

Asaca/Shibasoku Corporation of America
12509 Beatrice St., Los Angeles, CA 90066
(310) 827-7144 FAX (310) 306-1382

Circle (2) on Reply Card

SWITCH



TO

HEDCO

If you need simple 4x1 switching or multilevel 32x32 routing, HEDCO has a range that fits. Whether it's mono, stereo, composite, component, new digital formats or RS-422, HEDCO has an answer. Manufactured to the highest standards, HEDCO gives you affordable choice, quality and performance.



When you need a switcher.....switch to HEDCO

HEDCO

Leitch Incorporated / HEDCO, 920 Corporate Lane, Chesapeake, VA 23320, U.S.A. - Tel: (800) 231-9673 or (804) 548-2300 Fax: (804) 548-4088
Leitch Video International, Inc., 220 Duncan Mill Road. # 301, Don Mills, ON, Canada M3B 3J5 - Tel: (800) 387-0233 or (416) 445-9640 Fax: (416) 445-0595
Leitch Europe Limited, 24 Campbell Court, Bramley, Basingstoke, Hants., U.K. RG26 5EG - Tel: +44 (0) 256 880088 Fax: +44 (0) 256 880428
Circle (3) on Reply Card

www.americanradiohistory.com

THE CART MACHINE GOES DIGITAL! INTRODUCING THE DENON MD CART.

As the company that first employed digital technology to record music, it's not surprising that Denon has become the broadcast standard for on-air CD playback with its CD Cart Players.

Now, Denon is about to repeat its groundbreaking tradition with the introduction of Denon MD Cart Recorders and Players.

Based upon digitally recorded, removable MD technology, Denon has created the DN-990R MD Cart Recorder and DN-980F MD Cart Player... and in the process has effectively replaced the 25 year-old NAB Cart.

Erase and re-record for commercial/spot production and playback using widely available blank MDs. Record and re-record with CD-like sound quality, durability and reliability.

Audition Denon MD Cart machines today. And remember, whenever digital broadcast equipment is made better, it will be made by Denon.

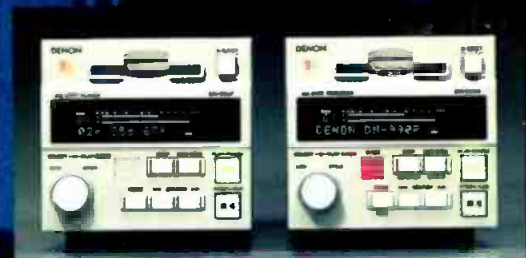

DENON
The First Name in Digital Audio

Every City Has One.



A Number One Station.

The A-6000 On-Air Console is for you.

 **Wheatstone Corporation**

7305 Performance Drive, Syracuse, NY. 13212
(tel 315-452-5000 / fax 315-452-0160)

Circle (2) on Reply Card

AD INDEX

SALES OFFICES

	Page Number	Reader Service Number	Advertiser Hotline
AEV	28	19	39-51-950349
Aphex Systems Ltd.	3	3	818-767-2929
Arrakis Systems	IFC	1	303-224-2248
Audio Precision	17	7	800-231-7350
Computer Concepts Corp.	13	4	913-541-0900
Continental Electronics	19	8	214-381-7161
Denon	BC	201-575-7810
Fostex Corp. of America	11	13	800-7-FOSTEX
Harris Allied	23	15	217-222-8200
Intraplex, Inc.	29	17	508-692-9000
LPB, Inc.	27	18	215-644-1123
Mackie Designs, Inc.	21	14	800-898-3211
Nautel Electronics	16	6	902-823-2233
Orban, Div. of AKG			
Acoustics	15	5	510-351-3500
Radio Design Labs	25	20	805-684-5415
Shure Brothers, Inc.	7	11	800-25-SHURE
TFT	29	16	800-347-3383
Thomcast	9	12	34-90-3100
T M Century Inc.	5	10	800-937-2100
USA Foam	31	21	800-95-WEDGE
Wheatstone Corporation	IBC	2	315-452-5000

NEW YORK, NEW YORK

Gordon & Associate
 Josh Gordon
 210 President Street
 Brooklyn, NY 11231
 Telephone: (718) 802-0488
 FAX: (718) 522-4751

Joanne Melton
 888 7th Avenue, 38th Floor
 New York, NY 10106
 Telephone: (212) 332-0628
 FAX: (212) 332-0663

CHICAGO, ILLINOIS

Vytas Urbonas
 55 East Jackson, Suite 1100
 Chicago, IL 60604
 Telephone: (312) 435-2361
 FAX: (312) 922-1408

AGOURA HILLS, CALIFORNIA

Duane Hefner
 5236 Colodny Ave., Suite 108
 Agoura Hills, CA 91301
 Telephone: (818) 707-6476
 FAX: (818) 707-2313

SANTA MONICA, CALIFORNIA

MC² Magazine Communications
Marketing Corp.
 Jason Perlman
 Telephone: (310) 458-9987
 FAX: (310) 393-2381

Deborah Kern
 Telephone: 310-458-8080
 FAX: 310-393-2381
 501 Santa Monica Blvd., Suite 401
 Santa Monica, CA 90401

OXFORD, ENGLAND

Richard Woolley
 Intertec Publishing Corp.
 Unit 3, Farm Business Centre
 Clifton Road, Deddington,
 Oxford OX154TP England
 Telephone: +44 (0) 1869-338794
 FAX: +44 (0) 1869-338040
 Telex: 837469 BES G

TOKYO, JAPAN

Mashy Yoshikawa
 Orient Echo, Inc.
 1101 Grand Maison
 Shimomiyabi-Cho 2-18
 Shinjuku-ku, Tokyo 162, Japan
 Telephone: (3) 3235-5961
 FAX: (3) 3235-5852
 Telex: J-33376 MYORIENT

CLASSIFIED ADVERTISING OVERLAND PARK, KANSAS

Renee Humbleton
 P.O. Box 12901
 Overland Park, KS 66282
 (913) 967-1732 FAX: (913) 967-1735

Re: Radio continued from page 20

primary voltage varies widely from the nominal 120V or 240V. (I have seen recent cases in the United States where the incoming 120V supply is 122V at 6 a.m. and 112V by noon.)

When installing a new tube, it should be properly tuned and run at rated voltage for approximately 100 hours to allow any remaining gas to be absorbed by the getter and thus ensure the best possible vacuum. Filament voltage then should be reduced slowly until performance falls off. Go back up by 0.1V to 0.2V above the fall-off point. If you stop at the fall-off point, any primary fluctuations downward will do more harm to the tube's life than primary increases.

When emission begins to fail (indicated by decreased power output), power can often be restored by raising the filament voltage slightly, even above rated if necessary. But when the latter occurs, it is a sign that the tube is headed for the big restorer in the sky.

Reports from the field

I have received reports of increasing difficulty in finding smaller AM tubes, such as 250As or 500s that will

give anything like full life. One engineer says that the new Chinese 4-250s last about three weeks and then lose emission. He commented that it is increasingly hard to find "good" original manufacturer tubes. Unfortunately, I know of no tube rebuilders who find it worthwhile to rebuild these small tubes.

Shelf life is another controversial topic. Some engineers hold that a tube will last indefinitely on a shelf. Others say a year at the most. Actually, a lot seems to depend on the tube type and even the manufacturer. There is one tube used in TV translators that seems to go soft after about a year on the shelf. On the other hand, many of the smaller power tubes seem to have an almost indefinite shelf life. Some engineers put spare tubes in the transmitter for an hour or so every year with only filament on, followed by low power for an hour before replacing on the shelf. They swear that this works, and it does sound reasonable. My only concern is that any tube life extension may be nullified by the potential damage done to pins and other contacts in the process.



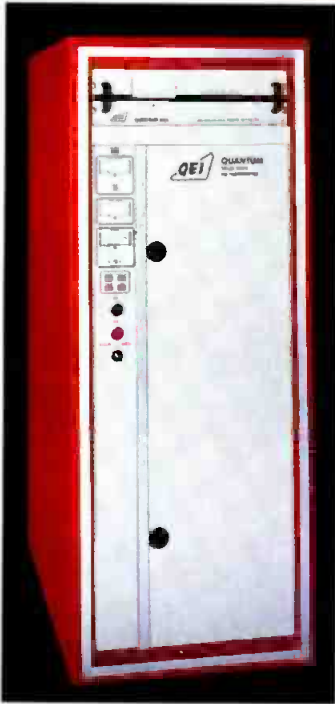

Solid-state FM transmitters
QEI

• **Quantum series:** transmitters with modular FET power amplifiers; power levels from 1.2 to 6.0kW; available in 600W power increments; feature high-power advanced technology 300W exciter.

Circle (169) on Reply Card

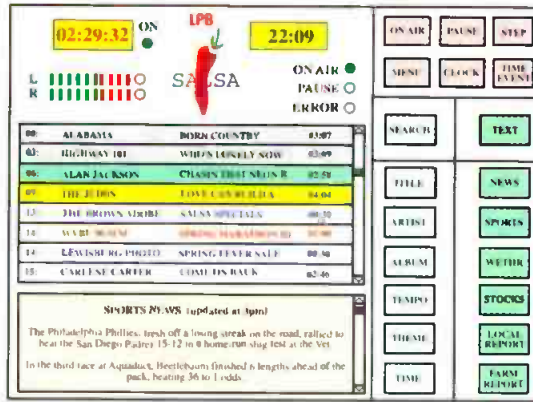

Digital audio system
LPB and Systemation

• **SALSAs:** provides satellite automation, live studio assist plus production with optional remote control and full automation; standard package features 1Gbyte hard drive for audio and text storage; available options include networked production SALSAs offering direct remote recording to on-air unit without interruption of on-air functions and controls; optional telephone interface.

Circle (170) on Reply Card

Companion program for SAW
Innovative Quality Software

• **SAW Utilities Rack #1:** add-on program that runs inside SAW version 3.0; features EDL file management and file conversion between WAV/SND, mono/stereo, and 8/16-bit resolution; also features 7-band fully parametric equalizer, echo effects generator and auto-panner; compressor/limiter has noise gate, audio compressor, peak limiter, and digital normalizer.

Circle (168) on Reply Card

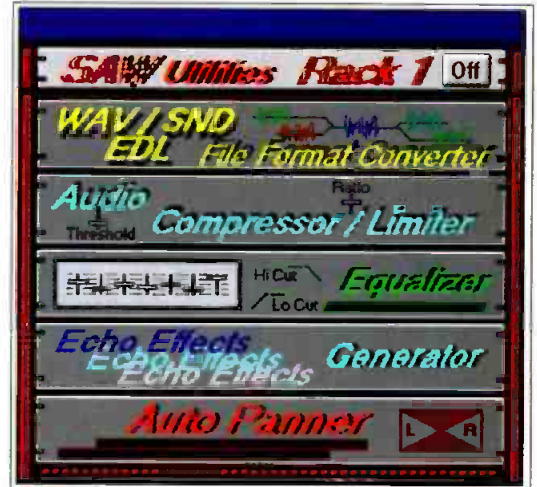

BE CLASSIFIED
Radio

Here's what you get when you advertise in BE Radio...

- a BPA audited circulation so you know exactly who's reading your ad. i.e. corporate, operations & technical management.
- exposure to subscribers who can buy your product/service.
- an educational publication which offers realistic solutions to help you understand the technology & equipment problems you face.

Call Renée Hambleton at 913/967-1732 or fax your ad to 913/967-1735 for the November issue. Ad closing is October 7.

EQUIPMENT WANTED

WE NEED YOUR HELP!
Non Commercial - Non Profit
Christian Music Radio Station
Needs Radio Equipment.

- Transmitter
- Carts & Machines
- Reel to Reels
- Control Boards
- Etc...



South Central Oklahoma
Christian Broadcasting, Inc.
99.7 FM - 25,000 watts

CONTACT: RANDALL CHRISTY
(405) 265-4392
P.O. Box 1343, Ada, OK 74820

FOR SALE

BAD SOUND SUCKS.
LET US SMOOTH OUT YOUR ROOM WITH THE WORLD'S BEST ACOUSTIC FOAM.

Studiofoam™
Sound Absorbent Wedges
The industry's most absorbent foam! Uniform cut for clean & easy installation. Up to 60% more effective than other name-brand foams that can cost 5 times as much! Passes California firecode; is 48% more flame retardant than Sonex. Available in 1", 2", 4" & 12" (bass trap) sizes in sheets that measure 2'x4'. Long-lasting, doesn't crumble like other brands can. Superior shape retention! Wide range of colors. What Value!!
1"-\$7.99 • 2"-\$10.99 • 4"-\$20.99

Sonomatt™
Convuluted Acoustic Foam
Cut in the industry-standard "eggcrate" shape, 4'x8' or 2'x4' sheets, 2 inches thick, charcoal gray. 85% as effective as Studiofoam Wedges, but still beats other brands that cost up to 5X as much! Made of the same stock, it's just as flame retardant & long-lasting. 4'x8' sold in pairs only @ \$34.99 per sheet. 2'x4' minimum 1 box @ \$9.99 per sheet. Unbelievable absorption for dollar spent. The world's best value!

Agents: Dennis DeYoung (Soyl) - Kodak - The EPA - Warner Bros. Balwain Piano - Opryland USA - Mike Wanzel (John McLaughlin)
We Also Have Bass Traps, Barriers & Adhesives
Min. 1 Box • MC Visa Discover AmEx • No CODs
Call For Free Catalog & Samples!
USA Foam • Box 20384 • Indianapolis IN 46220
1-800-95-WEDGE

Circle (21) on Reply Card

SERVICES

Antennas
Transmission Line
Filters

DIELECTRIC

a Unit of General Signal Corporation

JAY S. MARTIN
Manager, FM Systems

P.O. Box 949
Tower Hill Road
Raymond, Maine 04071
207-655-4555
800-341-9678
FAX: 207-655-7120

HELP WANTED

Customer Service Rep.: Major broadcast equipment manufacturer is looking for an individual with good technical knowledge, good written & verbal language skills. You will administrate the in-house customer repairs and interface with customers by telephone. Full employment benefits. Send resumé to: 1044 El Camino Real #5, Suite 367, Sunnyvale, CA 94087



Channel expander

Mackie Designs

• **24-E 24-channel expander console:** optional expansion board available for Mackie 32-8 and 24-8 mixing consoles; provides 24 full-featured input channels plus an additional 24 tape returns; connects via a proprietary multipin cable; can be daisy-chained to configure 8-bus system with 72, 80, 96 or more full input channels with double that number of inputs during mixdown.

Circle (166) on Reply Card



Diaphragm condenser mic

AKG Acoustics

• **C3000:** offers large diaphragm, studio-quality sound; features switchable polar patterns, cardioid and hypercardioid; also includes internal windscreen, switchable -10dB pre-attenuation pad and bass rolloff switch.

Circle (162) on Reply Card



Digital mixer

Yamaha

• **ProMix 01:** programmable digital mixer; features automation capability, instant reset of all parameters and moving faders; new DSP chip combines processing power of previous chips and adds digital dynamics processing capability in one consolidated DSP LSI.

Circle (163) on Reply Card

Audio switcher

Link Electronics

• **Model ASW-826 16x1 RS-232:** 16-input RS-232 stereo audio switcher; audio input impedance is 20kΩ and differential balanced loop-through permits multiple units to be stacked for a number of destination outputs; signal-to-noise is greater than 100dB and crosstalk is greater than 95dB.

Circle (167) on Reply Card

Stereo audio consoles

LPB

• **7000 series:** 12-channel (model 7012) and 18-channel (model 7018) stereo, linear-fader consoles; features include two inputs per channel, three stereo buses, microphone processing ports, level trim pots on input plug-in cards, built-in timer, fully programmable muting for each input, four independent mutable monitor outputs, independent cue bus with individual mixer cue defeat, talk-back built-in and user selectable; digital logic controls; separate rack-mount power supply, and mixdown plug-in for utility bus output that may be used to create mix-minus.

Circle (164) on Reply Card



CD autochanger

Pioneer

• **CAC-V180M:** 18-disc CD autochanger with built-in RS-232C computer interface connector; automatically locates, loads, and plays up to 18 CDs; compact dimensions (9"x6-5/8"x17-3/8"); weighs 14.5 pounds.

Circle (165) on Reply Card

YOU CAN RELY ON LPB®

Everyone knows the LPB Signature Series is the industry standard for rugged reliability. The LPB tradition of durable, reliable, easy-to-use consoles continues in our new linear fader consoles.

Industry Standard LPB Signature III Series



With over 3,000 units in operation worldwide, the LPB Signature III console represents a standard others are still unable to match. The Signature Series has proved its ability to perform on 6 continents, in settings ranging from metropolitan to jungle. With an incredible record of ruggedness and easy maintenance, it's no wonder over half of the Signature console owners have more than one. Features include 3 inputs per channel, two output buses and plug-in electronics. LPB Signature III consoles are available in 6, 8, 10, and 12 channel stereo and 6, 8, and 10, channel mono models.

The LPB 7000 Series takes the standards of the Signature III a step further, adding more features than any other console in its price range. With front panel switches rated for 5,000,000 operations, gold contacts, plug-in modular electronics and more, the LPB 7000 Series has the durability radio and TV stations worldwide expect from LPB. Features include two inputs per channel, three stereo output buses with one mono-mixdown standard and two more optional, user configurable muting and remote starts, and much more. Available in 12 and 18 channel stereo models.

All New LPB 7000 Series



It doesn't matter which LPB board you choose, you'll get a console you can count on 24 hours a day. One you'll keep for a long time. Ask any LPB console user – they're all around you.

LPB®

28 Bacton Hill Road • Frazer, PA 19355 • (215) 644-1123 • Fax (215) 644-8651

Circle (18) on Reply Card
www.americanradiohistory.com

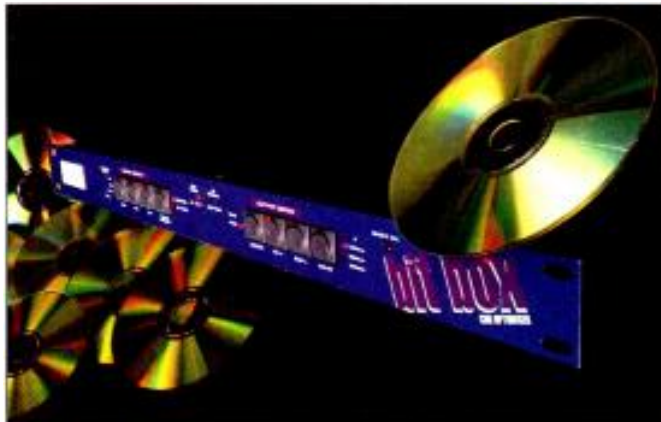

CD-R optimizer

HHB Communications

- **Bit Box:** translates Start ID markers from a DAT source to corresponding CD-R track increment flags and automatically converts the sampling rate to 44.1kHz; features built-in delay to compensate for late index points and automatic conditioning of the digital signal for input to the CD recorder; compatible with Marantz CDR-1, CDR-600 and CDR-610 and other Philips-based CD-R hardware; digital inputs and outputs in AES/EBU, IEC958/SPDIF electrical and optical formats.

Circle (151) on Reply Card

Digital recorder

Otari

- **RADAR:** disk-based multi-track recorder; available in 8, 16 and 24 track configurations; standard functions include cut, copy, paste, slip, loop, move, modify, auto punch, auto play, locate, varispeed, and undo; unit comes with time-code synchronizer that will chase lock to 24, 25, 29.97, 29.97DF, 30 and 30DF rates (offsettable); supports 32, 44.1, 44.056, 47.952 and 48kHz sampling frequencies; all hardware is contained in one 4-space rack unit; optional remote control.

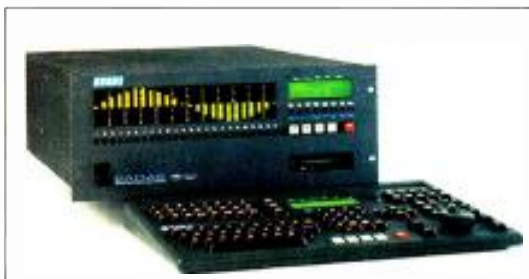

Circle (150) on Reply Card



Portable mixer

Shure Brothers

- **M367:** 6-input, portable microphone mixer designed for professional applications in electronic news gathering, electronic field production, and general audio mixing; handles up to six microphones or line-level signals; can be used with any balanced, low-impedance dynamic or condenser microphone; features input clipping LEDs, detachable power cord, power-on LED, and headphone monitor circuit.

Circle (152) on Reply Card

Cart replacement system

Scott Studios

- **CompuCart:** features touchscreen with six cart players' start buttons; can play clusters manually or sequenced automatically; cart labels show legible out-cues; digital clocks count down remaining time and flash an end light before each spot finishes; finished spot labels turn red, unplayed events stay green and a yellow back-to-music marker appears at the end of a spot cluster.

Circle (155) on Reply Card

ISDN audio codecs

SystemBase

- **C100xr, C110xr, C120xr, and C200xr:** range of 1U 19-inch rack-mount audio codecs featuring full digital audio metering system (ranging from +12B to -48dB) and self-calibrating analog inputs; based on the apt X-100 coding system.

Circle (154) on Reply Card



DAT deck

Tascam

- **DA-60:** DAT deck with off-tape monitoring, instant-start RAM buffer, error monitor LED, auto cue and auto punch-in/out with rehearse capability; optional features include SMPTE chase/lock synchronization with offset and pull-down, A-Time-to-SMPTE conversion, RS-422 port and MIDI machine control.

Circle (153) on Reply Card

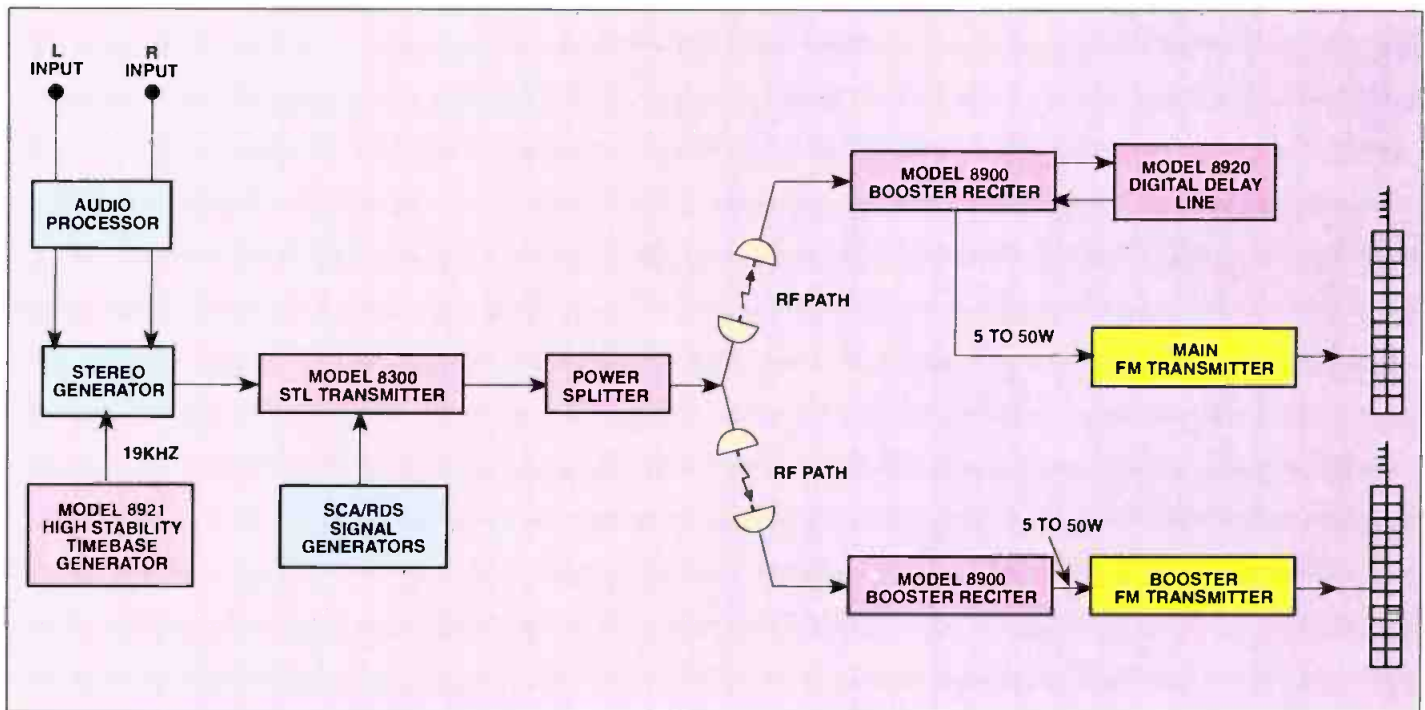

Figure 2. Typical application of the Reciter in a synchronous FM booster system. (Depending on the location of booster relative to interference zone, delay unit may sometimes be placed at booster site.)

mitter can be synthesized and made frequency-agile across the entire aural STL band. Because the frequency deviation of the STL transmitter is only $\pm 37.5\text{kHz}$ instead of the normal $\pm 50\text{kHz}$, the occupied bandwidth is reduced by 25%, conserving available spectrum.

In the event of a failure of the STL or the broadcast transmitter, the FM exciter at the studio, operating at full power (50W in many cases), can be connected to an antenna for use as an emergency backup from the studio site.

At the FM transmitter site, the Reciter receives the STL signal, processes the RF input through a narrowband cavity filter and downconverts the RF signal to the first IF frequency, where it is passed through a surface acoustic wave (SAW) filter. The SAW filter provides additional selectivity with linear phase response. Next, the signal is downconverted to a 10.7MHz IF before being delivered to a 2.5MHz loop-through to the exciter portion of the unit. The 2.5MHz input is then upconverted to the appropriate frequency in the FM band at $\pm 75\text{kHz}$ peak modulation. The output frequency of the Reciter is either phase-locked to an internal oven-controlled crystal oscillator or to the 19kHz pilot carrier in a synchronous booster application. PLL frequency correction and stabilization techniques built into the unit maintain the operating frequency of the FM transmitter well within FCC requirements (stability and accuracy within $\pm 2\text{ppm}$).

By using an IF-interface system, the weakest link in the FM broadcast chain — the STL receiver demodulating circuit — is eliminated.

The signal is maintained in the FM-carrier domain from the output of the FM exciter (at the studio) to the broadcast antenna.

Figure 2 shows how the TFT 8900 Reciter can be used to construct an FM booster system. A digital delay line is inserted into the 2.5MHz loop at the main (or booster) transmitter location to compensate for propagation delays resulting from path-length differences.

Despite the benefits of an IF interface system, this approach is not appropriate for all applications. The received signal strength at the broadcast transmitter site is the principal limiting factor. Approximately 100-V received level must be maintained at all times for proper operation. (A digital STL offers at least a 14dB advantage.) Furthermore, a digital STL may provide better overall performance if strong adjacent channel or low-level co-channel interference problems exist at the broadcast transmitter site. Nevertheless, the IF inter-

face system is proving its value through many recent installations at FM stations around the country.

FM broadcasters today have two cutting-edge STL technologies from which to choose when constructing or upgrading to a digital studio: an IF interface system or a narrowband digital system, both using conventional aural STL channels. Each approach has its benefits and drawbacks. By analyzing the requirements of a given application, the appropriate choice for any station can be determined.

➔ For more information on the TFT Reciter circle (37) on Reply Card.

BE
Radio

STICK-ONS™

When Quality, Performance and Value Count
in Broadcast Utility Products,
Take a Closer Look at the Innovators, Look to RDL™



RDL Radio Design Labs

SPECIALISTS IN PRACTICAL PRECISION ENGINEERING

(805) 684-5415 or (800) 281-2683

Circle (20) on Reply Card

September 1994

BE Radio

25

repeated for several generations. This problem is compounded in today's digital radio studio because more applications for such processing are becoming available. There is also no single bit-rate reduction standard established, so returning the signal to linear PCM or even analog audio may be required for interconnection between devices in the production or air chain.

Unlike the familiar composite analog STL, digital STL systems for FM broadcast operate like discrete analog STLs. They accept audio inputs at the studio site and deliver audio outputs at the transmitter site (in either analog or AES/EBU digital form). For this reason, the stereo generator must be located at the transmitter site, not at the studio. In addition, the audio processor may also have to be located at the transmitter site. Advanced processors and stereo generators with remote-control capabilities still permit adjustments to be made on this equipment from the studio, albeit with less convenience.

An alternate approach

New hardware is available now that offers FM broadcasters the benefits of the digital studio without any of the drawbacks of data-rate reduction or audio processor/stereo generator relo-

cation. The TFT *Reciter* (a trademark of TFT) represents an improvement over the analog STL method. The Reciter takes the place of an STL receiver and its subsequent FM exciter. It eliminates the demodulation process in the STL receiver and remodulation in the FM exciter. These functions at the station transmitter site are replaced by an IF interface, frequency-synthesized converter. The IF interface eliminates audio

RF delivery for aural STLs is on the increase, yet the spectrum allocated for this service is not.

deterioration in the demodulation and remodulation that occurs in a conventional STL receiver and FM exciter. The only source of modulation in the entire process is the modulator in the STL transmitter. Further improvement in overall system performance can be made by relocating the station's high-performance FM exciter, analog or digital, back to the studio. (See Figure 1.)

By locating the FM exciter (with its superior performance) to the studio and by using the exciter as the only source of modulation in the entire FM broad-

cast chain, the shortcomings of the STL (digital or analog) no longer become the limiting factors in providing excellent on-air audio quality. Related benefits include:

- Ease of interfacing with digital audio equipment at the studio.
- The stereo generator/audio processor is located at the studio site.
- Availability of backup FM transmitter at the studio for emergency situations.
- Ease of expansion into a synchronous FM booster system.

In the IF-interface system, the STL transmitter (located at the studio site) accepts the output of an FM exciter at frequencies between 88MHz and 108MHz (output port attenuated to approximately +10dBm). The STL transmitter divides the frequency and deviation by two, then upconverts it into the aural STL band. The resulting output is fed to the STL antenna for delivery to the transmitter site. The quality of modulation offered by the FM exciter is preserved through this process. By using the frequency-division method and up-conversion, rather than multiplication, no degradation of S/N, THD and stereo separation is introduced.

The output frequency of the STL trans-

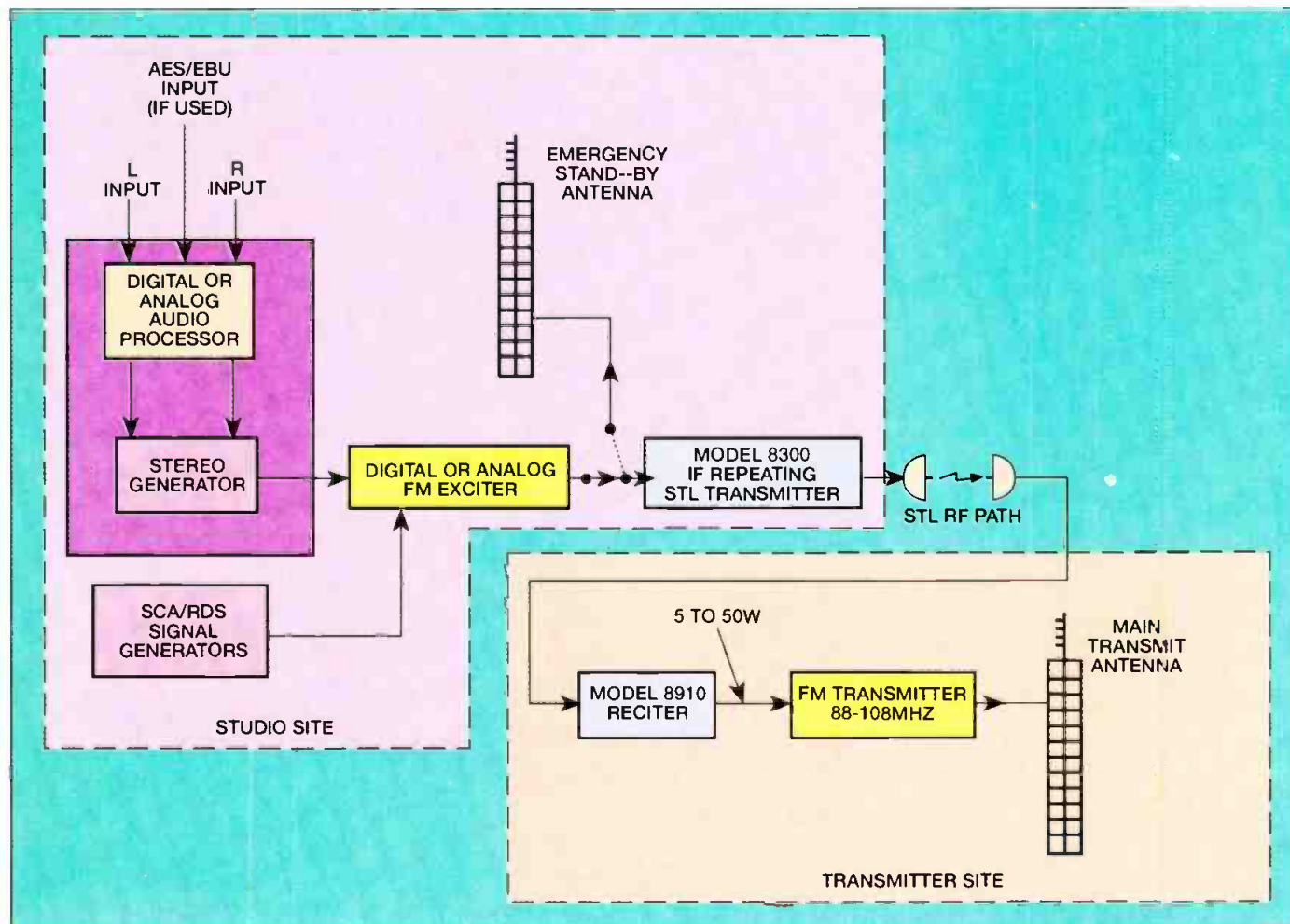

Figure 1. Basic block diagram of an STL using the IF interface system to relocate the FM broadcast exciter to the studio location.

HARRIS PLATINUM SERIES®



200,000 Hours' Fault-Free Performance. And Counting.

That's the level of reliability more than 70 users of Harris Platinum Series® 2-20 kW FM transmitters are experiencing from our FET solid state modules.

Broadcasters from Cyprus to Australia. New York to Madrid. China to Malta. Argentina to Slovenia. Toronto to Taiwan. North Dakota to Arkansas.

Beyond continuous transmitter availability, Platinum users are enjoying such benefits as:

- On-air service capability, up to 90% less routine maintenance and no requirements for tuning or adjustment;
- Superb signal quality under any combination of operating extremes;
- Immense flexibility in system design with such options as the world's first truly digital FM exciter with CD performance, N+1 capability, and switchless combining for high power transmitters.

To learn how a Platinum Series FM transmitter can work for you, please contact us:

U.S. and Canada:

Telephone: 217-222-8200

FAX: 217-224-1439

International:

Telephone: 217-222-8290

FAX: 217-224-2764



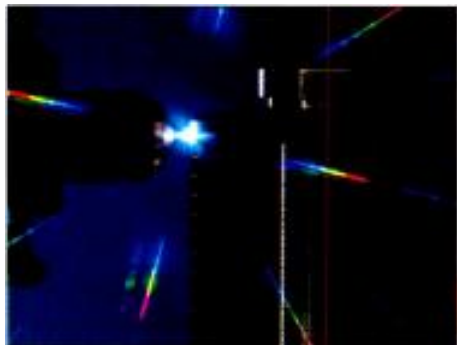

High-quality STL with or without data compression

By Joe Wu

Broadcasters have a choice for improved STL performance.

RF delivery for STLs is on the increase, yet the spectrum allocated for this service is not. In fact, the Federal Communications Commission (FCC) has been encouraging users in the 944MHz - 952MHz band to increase the number of channels available by decreasing their occupied bandwidth and offsetting from 500kHz channel centers.

With the desire for improved STL receiver performance, analog radio requirements have necessarily placed increasing demands on designers for improved selectivity and adjacent-channel rejection, simultaneous with the desire for improved audio performance. With more FM stations in metropolitan markets further compacting the already congested 950MHz band, performance of these STLs has improved significantly. Design trade-offs must be managed to support these requirements, including improved receiver sensitivity and selectivity, to make more efficient use of the available baseband bandwidth.

Digital STLs

Digital STL systems offer a number of benefits to the user. They are not without potential drawbacks, however. The principal strengths of digital coding for transmission vs. analog methods include the following:

- Greater immunity to noise and interference in the transmission path (improvement of 20dB S/N is common).

- Elimination of transmission-path-dependent artifacts, such as harmonic distortion, intermodulation distortion, frequency response errors and crosstalk.
- Efficient use of baseband and RF spectrum.
- Efficient and predictable regeneration of the digital signal.
- Easy and effective encryption for path equalization and error-correction coding purposes.
- Uniformity in transmitting audio and data signals.

In order to accommodate the audio requirements of FM broadcasting, the bandwidth of higher-order encoding schemes (such as 16-bit linear PCM) requires DS1-class data rates for adequate transmission (approximately 1.5Mb/s). This is too large for the spectrum allocated under Part 74 of the FCC rules for aural STL service below 1GHz. New spectrum in the 23GHz region was made available for this purpose. It has not been widely implemented, however, because of problems with path attenuation and rain fade in that band. The only practical approach for digital STLs involves the use of data-rate reduction ("data compression") of the digitized audio signal before transmission over a standard 950MHz STL channel.

Reducing digital audio data rates

When data-rate reduction using so-called *perceptual coding* algorithms is applied to a digitized audio waveform, only the information necessary to

closely reconstruct the audible signal is sent and redundant information is discarded.

The more efficient coding of such systems offers a vast range of options to radio broadcasters. It also raises some important questions, however. Cascading of data-reduction systems is under study by engineers around the world. The real effects of successive encoding and decoding, if any, are not yet fully understood. Until standards of test and measurement can be agreed upon, end users must make their own evaluations. This situation, of course, is nothing new to radio broadcasters. The industry has seen a countless number of audio processing systems in the market that offer widely varying degrees of transparency.

A second factor to be considered is the delay that the program audio may experience through the digital coding system. The ability to monitor an off-air signal is important in radio, and even small delays can be distracting. The time delay at which speech difficulties begin to occur is not well defined in scientific literature, although 10ms appears to be a reasonable limit. Time delays for a representative sample of today's audio coding systems range from 4ms to 25ms. Therefore, depending upon the coding algorithm chosen, compromises may be necessary.

Digital system considerations

As good as today's perceptual coding schemes may be, they are not without their drawbacks. As mentioned previously, data-rate reduction may degrade the original audio signal if the process is

Wu is president of TFT, Santa Clara, CA. Respond via the BE Radio FAXback line at 913-967-1905.

EVERYBODY TELLS US THAT BROADCAST ENGINEERS ARE VERY CONSERVATIVE. OKAY. READ THIS AD NOW AND THEN BUY A CR-1604 IN FIVE YEARS.

We understand why broadcast engineers have a wait-and-see attitude about new products. Your station (and job) depend on rock-solid reliability and performance you can count on.

We'd like to introduce you to Mackie Designs. Over the last six years, we've gained a serious reputation for building high-value, trouble-free mic/line mixers with legendary headroom, ultra-low noise and unique features.

Mixers so good that they're regularly used to create major label compact discs, feature movie soundtracks, and more commercial production work than you can shake an RE 20 at. For example, our CR-1604 16-ch. mic/line mixers are used nightly on the Tonight Show, Conan O'Brian and David Letterman Shows¹.

As for use at broadcast facilities, well, we're not total newcomers. Over 70 U.S. radio stations already have Mackie mic/line mixers in place.

Does that mean you folks aren't quite as conservative as everybody says? If so, call your favorite broadcast supply house, or dial us toll-free for complete information on Mackie's line of mixers.

If you are conservative, keep an eye on us, anyway. We want your business even if we have to wait five years.

3-band equalization done right: $\pm 15\text{dB}$ at 80Hz, $\pm 12\text{dB}$ at 2.5kHz (perfect for voices), $\pm 15\text{dB}$ at 12kHz. Far more useful than traditional 100Hz, 1KHz, 10KHz EQ.

Sealed rotary controls - resist contamination from dust, liquids and smoke.

Individual channel signal metering via solo function.

7 AUX Sends from 4 knobs. AUX1 doubles as a headphone monitor cue via the MON. Sends 3 & 4 become AUXs 5 & 6 via the SHIFT button.

Two extra buses. Mute buttons route the channels' signals to an extra stereo bus called ALT 3/4. Route it to the headphones, for monitoring advance audio cues. Preview a signal that hasn't been brought up in the mix yet... then add it by unmuting the channel.

UnityPlus gain structure gives high headroom and low noise at the same time. Set the fader to center-detent Unity Gain, press channel solo to monitor the channel via the CR-1604's LED meters, adjust the input trim ONCE, and you're ready. Because there's 20dB MORE gain available on the fader, you won't need to constantly re-adjust the trim.

Maximum RF protection. Both mixers use metal jacks and washers plus a shunting capacitor to de-rail RF before it gets to any circuit traces.

Rugged design and construction. All of our compact mixers have mil-spec, double-sided, thru-hole-plated fiberglass circuit boards (horizontally-mounted on brass stand-offs for impact-resistance), double-parallel-wired faders for 2-times redundancy, and electronic protection against power surges, impedance mis-matches and static discharges.

The Mackie Designs 16x2 CR-1604 Mic/Line Mixer. Suggested retail price, \$1095². Available at America's top broadcast supply houses.

Six recording studio-grade microphone preamps with +48VDC phantom power. Discrete circuitry with four conjugate-pair, large-emitter geometry transistors delivers -129.6dBm E.I.N., 300K bandwidth, 0.005% THD...and incredible headroom.

Solid steel main chassis.

8 mono or 4 stereo AUX Returns with individual level and balance controls. All have 15dB additional gain above Unity to boost weak effects.

Powerful headphone amp (with volume control) drives any phones to head-banging levels even an AOR production person will appreciate.

Unique, multi-way convertible physical configuration. CR-1604's input/output pod rotates to back (creating a space-saving 7-rack-space mixer shown in Fig. 1), or to front (10 rack spaces, shown in Fig. 2) with our optional RotoPod bracket. Use the CR-1604 on a tabletop with jacks on the same plane as the controls via the RotoPod bracket (Fig. 3 below), or jacks to top (Fig. 4 below). Our **XLR10 Mic Preamp Expander** can also be added in any of these configurations.

Better-than-digital specs and headroom.

Both the 16-ch. CR-1604 and 12-ch. MS1202 have a dynamic range of 108dB and an internal S/N ratio of -116dB . You're getting a mixer that can handle the output of digital workstations, CDs and DAT tapes without overload.

A chip off the old block: Perfect for remotes, our MS1202 12x2 Mic/Line Mixer has 4 of the same superb mic preamps that distinguish our larger CR-1604, plus phantom power, 2 AUX sends/ch., 2 stereo AUX returns, channel patching, 2-band EQ, 3-way 12-LED peak metering, headphone monitor amp with level control, built-in power supply. Suggested retail is just \$399¹!

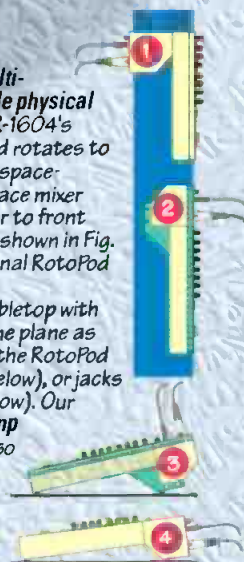

¹ Mention in this ad denotes documented useage only. Mention is not intended to infer endorsement by any of the television shows listed.

² Price is slightly higher in Canada.

Circle (14) on Reply Card

MACKIE.

20205 144th Ave NE • Woodinville • WA • 98072 • 800/898-3211 • FAX 206/487-4337
Outside the US, call 206/487-4333 • Represented in Canada by S.F. Marketing • 800/363-8855

More tube tips



By John Battison, P.E.

Some hints for extending a tube's glowing season.

In last month's "Re: Radio" (*BE*, August 1994), the lack of tube experience among many of today's engineers was noted, along with some discussion of theory and operation for tubes in radio transmitters. This month's column contains more tube tips, starting with how to handle new tubes.

Many engineers merely check the packing slip and the tube's physical condition when a new shipment arrives, then put the new tubes away into safe storage. This is not the best thing to do. Always check for physical damage, and place the tube in service for a few weeks at rated voltages, if possible. Note the date on a tag attached to the tube, and record all operating voltages and currents. If the tube operates properly, remove it from service and store in its box in a safe place. Be sure to label it clearly on the outside.

If you have an older transmitter that uses mercury rectifiers (don't laugh, there are still lots of these around), be sure to store these tubes upright. Doing this will usually allow you to turn on high voltage without risk much sooner after placing them in the power supply. Normally you should place these tubes into service with only filament on for half an hour, in order to vaporize any mercury on the filament. By storing them upright and handling them carefully during installation, however, you can often reduce down time during tube replacement to only a few minutes.

Battison, *BE*'s consultant on antennas and radiation, owns John H. Battison and Associates, a consulting engineering company in Loudonville, near Columbus, OH. Respond via the *BE* Radio FAXback line at 913-967-1905.

Besides heat, another dastardly foe of tubes is dirt. Dirty filters restrict airflow and allow tubes to overheat. Severe overheating in nickel tubes is shown by discoloration. Because nickel resists color changes from normal heating, any significant discolorations are strong evidence of overheating.

Just because there is a blower on the chassis, don't assume it is working. In one recent case, an older transmitter with two squirrel cage blowers (one for modulator and one for PA stage) was requiring frequent replacement of one final tube (in a parallel stage). Examining the transmitter quickly revealed that the blower cooling the two PA tubes wasn't running — and probably had been out for months. As soon as the blower was replaced, the tube failure problems ended.

Believe it or not, tube pins also can affect operation. Loss of power output of smaller power tubes that have several sturdy pins can often be traced to dirty pin and socket contacts.

Tube safety

It is always easy to become careless, but especially when working on smaller transmitters with plug-in power tubes. All transmitters have interlocks that prevent the application of power unless all doors are closed. They should also have shorting pins that ground the high voltage when the doors are opened, and bleeder resistances to provide a drain to ground. These bleeders sometimes take appreciable time to discharge a high voltage and high capacitance. Unfortunately, these safety devices

don't always work. As a result, B+ can still be left in charged capacitors, waiting to catch someone. This kind of accident is particularly possible in some transmitters where a certain modulation transformer circuit is used.

Many engineers have to cope with high power tubes that use finger stock contacts. These devices can be troublesome. Fingers can break off and fall into cavities, or they can lose their springiness and fail to make good contact — with subsequent burning and arcing. Always check for full contact all around, and replace weak or damaged fingerstock.

Operating voltage

It is unfortunate that most smaller and older transmitters do not have voltmeters to measure filament voltages on the large tubes. In order to get the most for your tube dollar, it is essential to monitor filament voltage closely. This means measuring *at the tube pins on the socket*. Several tenths of a volt too high can shorten tube life considerably. Conversely, too low a voltage can do the same. When connecting a voltmeter to the pin socket, be sure they are properly secured.

In the case of smaller transmitters, provision is not made for varying the filament voltage. It should be possible to install a Variac, however, and thereby adjust the voltage accurately. For a really accurate and higher cost installation, a Sola regulating transformer can be used. This is often desirable where

Continued on page 32

Worlds of Excitement...

Continental's 802B THE ULTIMATE EXCITER

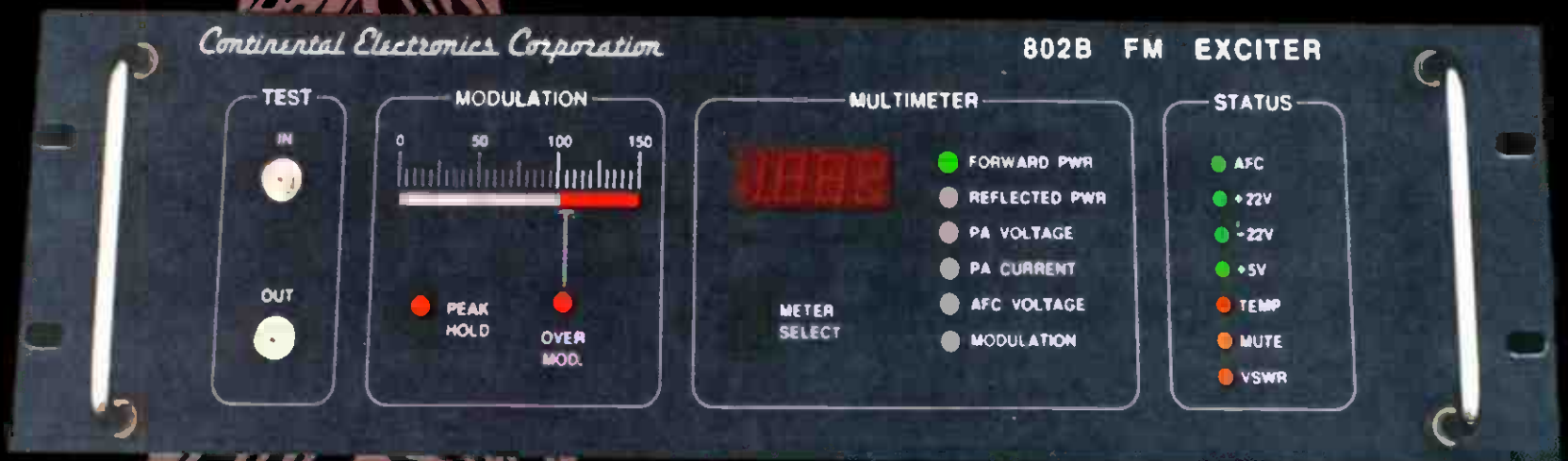

Continental Electronics Corporation

P.O. BOX 270879 DALLAS, TEXAS 75227-0879
214-381-7161 TELEX: 73-398 FAX: 214-381-4949

Circle (8) on Reply Card

rooms have varying requirements for background noise levels, depending on their intended use. Monitoring environments must be isolated from noise that could interfere with critical listening. Control rooms operating with open mics that go to air may need to be even quieter.

Get some help from a bona fide acoustical consultant to quiet down the HVAC problems. Move the noisy computer CPUs, outboard gear and power supplies to a machine room. To control noise from adjacent spaces that feed into your control room, adjust the acoustical seals on the doors or add them if they don't exist. Better yet, install a sound-rated door that provides predictable sound isolation performance. Most of the time the weak sound transmission link between two spaces is not the wall but the door, penetrations and flanking paths.

Monitor speaker placement

Locate and mount the audio monitors to optimize their performance at the listening area. Ideally, audio monitors should be mounted at ear level or slightly above. Convention and classical literature suggests 12° to 15° above ear level. Beyond 18°, imaging and frequency response begins to suffer, partly because of the way the pinnae/brain interface convolves sound sources from overhead and partly because there is an increased possibility of interaction between the direct and reflected sound at the listening area.

Whenever possible, mount audio monitors on massive pedestals or support stands that mechanically tie the monitor to the floor. You achieve a more efficient mechanical transfer by setting a monitor *on* something (*compression*) rather than hanging it *from* something (*tension*). Hanging monitors from walls or flimsy ceiling structure often leads to sound isolation problems and monitoring inaccuracy. If special precautions are not taken, structure-borne low-frequency energy from improperly mounted monitor speakers can promote unwanted sound transfer from one room to another. In addition, low-frequency energy that excites the walls or ceiling can be re-introduced into the room later in time to combine with the direct sound, causing "swimming" low-frequency sound and uneven spectral distribution.

Rubber mounts are often touted as providing speaker-to-structure vibra-

tion isolation. Unfortunately, the weight of most monitor speakers won't deflect the rubber enough to effectively isolate

Acoustical finishes cannot overcome the limitations of a room that is too small or improperly shaped.

anything below several hundred hertz. Such mounts may provide a degree of emotional support for those who believe in them, but they usually offer little practical acoustical benefit. *Point-mount-*



In National Public Radio's air control room for "All Things Considered" and "Morning Edition," careful shaping allows a large expanse of glass and improved air talent/production staff communication while maintaining an accurate monitoring environment. Monitor speakers (left, center, right) are mounted on point-loaded concrete pedestals.

ing the monitor speaker has proven to provide the best combination of sonic performance, vibration isolation, efficient bass propagation into the listening area and cost. Point-mounted pedestal and stand techniques can be easily adapted to free-standing or soffit-type monitor mounting configurations.

Cookbook solutions, while tempting, won't produce results that meet your expectations.

Watch your back (and sides)

Reflections from racks, tape machines, technical equipment, open doors, furniture, and other reflecting elements can cause severe acoustical anomalies in the listening area. Racks, equipment and furniture should be no higher than (and preferably well below) the median plane of the ears. Careful attention should also be paid to angled equipment racks and the possibility of reflected energy finding its way back into the listening area.

While you're at it, watch your front,

too. The acoustically reflective areas between you and the monitor speakers can also be a source of frequency and imaging anomalies. There is a proliferation of support equipment at the front of most radio control rooms: computer display(s), status and security indicators, transmitter control and monitoring equipment, video monitors, main and alternate monitor speakers, copy stands, signal-processing gear, interview guest stations, cabinetry and other acoustically reflective and problematic stuff. Often, careful placement or reconfiguration of the equipment layout can greatly improve, if not eliminate, a whole host of acoustical problems.

The monitoring gestalt

By now you should understand that it is not possible to completely separate the issues that affect audio monitoring from the larger issues of the room's functional layout, the design of appropriate sound and vibration isolation, or the integration of the mechanical, electrical and technical wiring systems.

Whether your space needs an acoustical face-lift or you're building from the ground up, get help from someone who understands how your kind of facility functions and has experience with your unique prob-

lems. Acoustics is an applied science. Cookbook solutions, while tempting, won't produce results that meet your expectations for quality or performance. Someone with experience can help you find creative, cost-effective and practical solutions to your problems.

When thinking about high-quality audio monitoring, remember these primary issues: maintain bilateral symmetry about the centerline of your listening area; provide an appropriate room size and shape; keep HVAC and equipment noise to a minimum; properly mount the audio monitors; and avoid reflected energy that could convolute the signal in the listening area. Aside from about three dozen other things, that's all it takes to make your monitoring environment as accurate as it can be.

BE
Radio

MAKE A CLEAN SWEEP WITH PORTABLE ONE

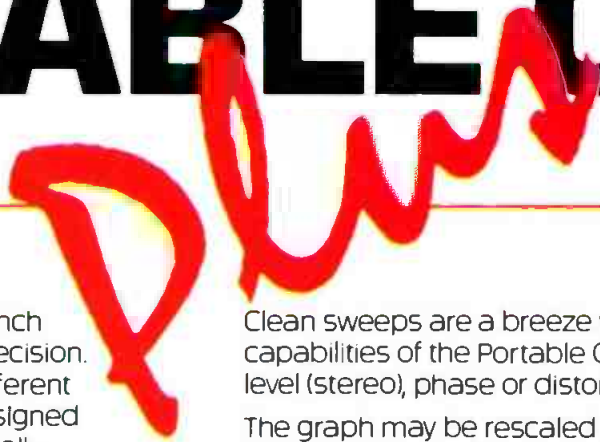

Replace the clutter on your audio test bench with the Portable One *Plus* from Audio Precision. With one instrument you can make 12 different audio measurements. All in a test set designed from the start with 2 channel level, crosstalk and phase measurement capability.

Use the unique AC Mains check function for monitoring power line problems and the built-in wow & flutter meter for measuring analog tape & disc.

Clean sweeps are a breeze with the graphic sweeping capabilities of the Portable One *Plus*. Plot amplitude or level (stereo), phase or distortion versus frequency.

The graph may be rescaled after a sweep, and the graphic cursor with numeric readout gives you data readings for each measured point.

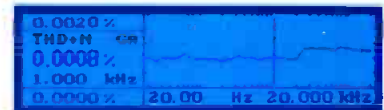

Connect a dot matrix printer for hard copy printouts of both graphs and tabular data, as well as instrument panels and bargraphs.



The Portable One *Plus* is built to Audio Precision performance and durability standards... so you know you'll get the same superior performance in the field as on the bench.



The Portable One *Plus*... the single instrument solution for both your bench and portable audio testing.



Circle (7) on Reply Card

**Audio
precision**

P.O. Box 2209, Beaverton, OR 97075-3070
(503) 627-0832 FAX: (503) 641-8906
US Toll Free 1-800-731-7350

INTERNATIONAL DISTRIBUTORS: Australia: IRT Electronics Pty. Ltd., Tel: 2 439 3744 Austria: ELSINCO GmbH, Tel: (1) 815 04 00 Belgium: Trans European Music NV, Tel: 2 466 5010 Brazil: INTERWAVE LTDA., Tel: (21) 325-9221 Bulgaria: ELSINCO, h.e. Stralshite, Tel: (2) 58 61 31 Canada: GERRAUDIO Distributors, Tel: (416) 696-2779 China: Hong Kong: A C E (Intl) Co. Ltd., Tel: 424-0387 Croatia: AVC Audio Video Consulting, Tel: (41) 624 622 Czech Republic: ELSINCO Praha spol. s r.o., Tel: (2) 49 66 89 Denmark: ngn Elektronik aps, Tel: 86 57 15 11 Finland: Genelec OY, Tel: 77 13311 France: ETS Mesureur, Tel: (1) 45 83 66 41 Germany: RTW GmbH, Tel: 221 70913-0 Greece: KEM Electronics Ltd., Tel: 01-6478514/5 Hungary: ELSINCO KFT, Tel: (1) 269 18 50 India: HINDITRON Services PVT, Tel: 22 836-4560 Israel: Dan-El Technologies, Ltd., Tel: 3-6478770 Italy: Link Engineering s.r.l., Tel: 0521/648723 Japan: TOYO Corporation, Tel: 3 (5688) 6800 Korea: B&P International Co., Ltd., Tel: 2 546-1457; B&P (Kumi Office), Tel: 0546 53-7347/8 Malaysia: Test Measurement & Engineering Sdn. Bhd., Tel: 3 734 1017 Netherlands: Heynen b.v., Tel: 08851-96300 New Zealand: Audio & Video Wholesalers, Tel: 7 847-3414 Norway: Lydconsult, Tel: (47) 66-988333 Poland: ELSINCO Polska sp. z o.o., Tel: (22) 39 69 79 Portugal: Acuitron Electroacustica LDA, Tel: 1 9414087/9420862 Singapore: TME Systems Pte Ltd., Tel: 747-7234 Slovakia: ELSINCO Bratislava spol. s r.o., Tel: (7) 784 165 South Africa: SOUND FUSION Broadcast, Tel: 11 477-1315 Spain: Telco Electronics, S. A., Tel: 1 531-7101 Sweden: Tai & Ton Elektronik AB, Tel: 31 80 36 20 Switzerland: Dr. W.A. Gunther AG, Tel: 1 910 41 41 Taiwan: R.O.C.: Cha Wei Electric Trading Co., Tel: 2-5612211 Thailand: Massworld Company Ltd., Tel: 662-294-4930 United Kingdom: Thurly Thandar Instruments, Ltd., Tel: (0480) 412451

www.americanradiohistory.com

The quest for ceiling height

Strive to maintain the maximum feasible room volume. Adequate ceiling height is a nearly universal problem. The height required is primarily determined by the number of people in the room who need to make critical audio monitoring judgments and the low-frequency bandwidth of the program being monitored. There is no amount of acoustical magic that will overcome inadequate control room volume.

Most commercial building construction has a *clear height* (the distance from the floor to the underside of the structure above) between 10'-6" and 12'-

0." After accommodating the HVAC, plumbing, electrical wiring, fire-suppression systems and telephone between the finish ceiling and the structure, you're left with a room that's eight to nine feet high. For a standard office space, this works quite well.

If you attempt to cram a broadcast control room in the same space, however, things get much more difficult. First, the HVAC ductwork gets larger to allow low velocity airflow (duct sizes can easily double), even larger to accommodate internal duct liner (for sound absorption), and then it must be held clear from the construction of the

room to control vibration. In a typical office building it also will be necessary to install a sound isolation ceiling to provide an acoustical barrier between the room and the structure above.

Next, there must be provision for the

There is no amount of acoustical magic that will overcome inadequate control room volume.

signal cabling, whether by means of access flooring or an infrastructure of cable raceways, ladders and conduit. The old adage, "A good facility is never done" is predicated on flexible wire management for the technical systems. If you can't quickly and easily reconfigure your technical interconnect to accommodate new equipment, your facility may be crippled. Finally, absorptive acoustical finishes must be provided, either applied directly to the gypsum-board ceiling or suspended in the form of a secondary ceiling.

If your building shell has a clear height of 10' x 6" and you take out 24 inches for low-noise ductwork, six inches for wire management, another six inches for a sound isolation ceiling, and 12 inches for a lay-in acoustical tile ceiling, you are left with less than seven feet from the floor to the room's finish ceiling. This doesn't meet minimum building code requirements in any local jurisdiction, and you haven't even begun to shape or slope the flat ceiling or to consider what room volume is desirable.

"But wait a minute," you say. "Once upon a time, back in the good old days, we built this control room that was so small..." Well, yes, but what price did you pay for an inappropriately low ceiling height? The main problems likely included inaccurate low-frequency monitoring in the speech range and below (in most of today's music and effects production audio, bass is everything), inaccurate mono monitoring and stereo imaging, proportional reduction of the area of good listening (and listening quality in general), logarithmic increase in costs and difficulty of construction, and a workspace that looked and felt confined.

So what is adequate ceiling height? Try for a minimum of 14 feet clear for broadcast control rooms — even more height is preferred. Remember that acoustical finishes cannot overcome the limitations of a room that is too small or improperly shaped.

Noise annoys

Keeping noise to a minimum is another critical issue. Broadcast control



The inventor of high powered solid-state AM has perfected solid-state FM

You know us as worldwide suppliers of cost-effective, power-efficient solid-state AM transmitters.

Now we are proud to offer Nautel reliability, efficiency, and serviceability in three new solid-state FM transmitters.

AMPFET FM4 4kW
AMPFET FM7 7kW
AMPFET FM10 10kW

Get the full story on our complete line.
Call, write or FAX today.

Phone: (902) 823-2233 Canada • Fax: (902) 823-3183 • Telex: 019-22552

Nautel
(Nautel Electronic Laboratories Limited)
R.R. #1, Tantallon, Halifax County,
Nova Scotia, Canada B0J 3J0

Nautel Maine Inc.
201 Target Industrial Circle
Bangor, Maine 04401 U.S.A.



Circle (6) on Reply Card See us at World Media Expo, Booth #2432

COMPETITIVE EDGE.



Today's AMs face too much competition for too few advertising dollars. That's why Orban's OPTIMOD-AM has become the weapon of choice for competitive broadcasters in every market.

OPTIMOD-AM produces maximum loudness, consistency and clarity on all types of AM radios, using every last watt of your authorized power to extend your listenable area and increase your billing opportunities.

A powerful six-band limiter and patented distortion-canceling multi-band peak controller deliver deep, tight lows and clean, transparent highs. You get the closest thing to FM sound, with maximum intelligibility in the essential voice frequencies.



Comprehensive controls and metering allow you to easily fine-tune your sound, keeping it distinct and aggressive in a changing marketplace.

Fully NRSC and EBU/CCIR compliant and with mono units easily field-upgradable to stereo, OPTIMOD-AM meets today's standards and protects your investment as you grow.

And Orban's superior customer service is there if you need it to provide world-class support for you and your in-house or contract engineering staff.

Give your programming a chance by making sure it gets heard. Call your Orban dealer today for an on-the-air evaluation, and put OPTIMOD-AM to work protecting your bottom line.

© 1993 AKG Acoustics, Inc.
Orban and Optimod are registered trademarks of AKG Acoustics, Inc.
AKG is a registered trademark of Akustische u. Kino-Geräte Ges.m.b.H., Austria.

orban[®]
A Division of AKG Acoustics, Inc.
1525 Alvarado Street, San Leandro, CA 94577 USA
Tel: (1) 510/351-3500 Fax: (1) 510/351-0500

Circle (5) on Reply Card

www.americanradiohistory.com



Control-room monitoring

By Russ Berger

Hearing how the product sounds is an essential part of on-air operations.

It seems like a simple enough question: "What's most important about monitoring audio in a radio control room?" Depending on who is asking and what kind of program they're monitoring, however, many answers are possible. Subtle differences as to whether it's for an on-air or production room, for live or prerecorded shows, for music or speech, greatly influence the way audio is monitored and dictate what approach the engineer should take to execute the job.

Audio monitoring is usually only one of many simultaneous tasks that a broadcast audio engineer or operator must perform. It fits in somewhere between tracking cue sheets, scripts and logs; fielding visual and verbal cues from the talent and production staff; inserting telephone call-ins, sound effects, commercials, breaks, IDs and walk-ons; dealing with complex routing systems, consoles, signal processors and status annunciators; and performing on-the-fly diagnosis and work-arounds for faulty equipment. That leaves plenty of time to continually monitor the audio program for level, quality, perspective, bandwidth, timing and placement. (Did someone say "surround"?)

Design criteria

Accurate monitoring must compete with the equally worthy goals of main-

taining good eye contact with talent and production staff, keeping equipment and displays conveniently placed, and having adequate work surfaces for materials. Often these things seem mutually exclusive. To assume that the requirements of pristine audio can be placed above all else is naive. However, certain principles of high-quality audio monitoring should be kept in mind and used as a touchstone in making appropriate compromises.

Whenever you place a sound source inside a room, you have just "committed acoustics."

Whenever you place a sound source, such as a monitor speaker, inside a room, you have just "committed acoustics." The orientation of the listener, monitor speaker, equipment and the room's boundary shapes form a complex acoustical relationship. Regardless of the program or application, the following are important objectives in creating an accurate monitoring environment:

- Obtain the best monitor chain you can afford. Don't skimp on monitor speakers, amplifier or cable — they are your reference. Carefully audition and select equipment. Listen to audio samples that you are familiar with, both music and speech. Speech is processed

on a different side of the brain from music. Its use as a program source can lead to some interesting revelations during auditioning.

- Maintain bilateral symmetry to promote accurate imaging and minimize frequency anomalies. Basically, do unto the left side of the listening area that which you have done unto the right. This includes room shape, acoustical finishes, console millwork, equipment racks and HVAC diffusers and grilles. Lack of symmetry in the monitoring environment can cause image shifts in the stereo program that may be frequency dependent, and the mono program can prove to be uneven as you move throughout the listening area. If acoustics are considered in handling the inevitable irregularities, such as reflective door and window surfaces, their impact can be minimized.

- Size the room and shape the walls and ceiling to promote diffusion, to support sound propagation from the monitor speakers, and to avoid common resonances and flutter echo. There is more and less to this than appears in most audio texts on the subject. The principles are widely published in even the most basic texts on acoustics, but their importance and practical application are generally less than clear and often not intuitive.

Berger is president of Russ Berger Design Group, Dallas. Respond via the *BE Radio FAXback* line at 913-967-1905.

OUR DIGITAL AUDIO WORKSTATION IS NOW PERFORMING WITH THE FOLLOWING GROUPS



ADAT is a registered trademark of Alesis Corp.



Vermont Public Radio

Sam Sanders, a happy Foundation 2000 user since January, estimates that he has cut his production time in half.

Our unique Edit Controller looks and feels just like the recorders you work with every day—no keyboards, front-end computers or mice to slow you down. The built-in touch screen shows you a wave form picture of your sound for instant visual reference. There's even an ASRC option so that you can convert one sample rate to another.



Audio Mixers, New York

Fred Venitsky (pictured) and Jimmy Regan have the distinction of owning and operating the most used Foundation 2000 on the planet.

Foundation 2000 is fast and easy to use. Audio scrubbing is so clean, you'll swear you're rocking reels. Edits are seamless. Fades are smooth and glitch-free. Plus, you can specify the "Light Pipe" for direct interface with the popular ADAT™ and RD-8™ digital recorders.

FOUNDATION 2000LS

Designed specifically for broadcast production, this random access recorder/editor features the speed, the ease of use, and uncompromising audio quality of Foundation 2000—for less than \$15,000! It's the same dedicated user interface with touch screen display, real time operation, event based editing, wave form display, and expandability to a full Foundation 2000 at any time—the only workstation of its kind to offer this important feature. Test drive the high performance Foundation 2000LS in your studio. Call 1-800-7-FOSTEX or 212-529-2069 today to schedule a demo.



Fostex

Circle (13) on Reply Card

www.americanradiohistory.com

consoles allow the operator to place the channel into cue using a dedicated button (a *pre-fade listen* button in recording console parlance). Typically, the cue function is automatically disengaged when the channel-on button is activated. This eliminates confusion resulting from audio appearing at both the cue speaker(s) and main monitor speakers during a critical crossfade. Another handy cue feature is the ability to remotely engage the cue function on the appropriate input with a switch adjacent to a CD player, tape deck or turntable feeding that input.

It is also helpful to be able to *meter* the cue signal. Although this may not be required for all broadcast operations, stations that quickly mix numerous sources (especially live remotes, where level may vary widely) will find cue metering invaluable.

Level control

The most commonly used part of any audio mixing console is certainly the fader. Although rotary pots are still available, linear faders are far more popular today for reasons of space, ease of operation, precision, uniformity, longevity and serviceability. Color coding of fader knobs can improve source identification for operators.

Most consoles provide 10dB or 15dB of "in-hand" fader gain above nominal operating level. A mark is typically provided along a graduated scale to indicate to the engineer the *design center* of the fader and its associated amplifier circuits (the point at which gain structure of the channel is optimized). When the fader is at this position, the input level trim pots should be adjusted to produce a reading of 0VU with a standard reference level (typically +4dBu or +8dBu) from the source feeding that input. This assures adequate headroom and optimal signal-to-noise performance. Look for consoles that can provide in the neighborhood of 30dB of headroom above this nominal value to minimize the effects of high peak levels and sloppy operation.

Although most broadcast console designs have traditionally placed audio directly on the fader, the *voltage-controlled amplifier* (VCA) has become more common in the radio console marketplace. Only recently have VCAs been able to provide performance specifications considered sufficient for professional broadcast applications. Although VCAs may deliver slightly less head-

room, they can provide superb stereo phase and gain tracking across their entire range. Keeping audio off the fader also improves reliability and avoids "crackling" crossfades. VCAs can add a handy migration path to the console, as well, because they may be easily integrated into future computer-controlled applications.

Routing

Many stereo consoles allow the operator to configure the input mode of the module by selecting from the following options: left channel input to both mix-bus channels, right channel input to both mix-bus channels, sum of left and right input channels to both



The Wheatstone A-500 is an on-air console with automatic sequencing for salvo playback, split processing buses and flexible telephone interfacing.

mix-bus channels (often with automatic -6dB gain adjustment so that fader design center doesn't change when this mode is selected), or the nominal stereo operating mode where the left and right channels remain discrete throughout. This feature helps the operator isolate audio source faults, and may allow other flexibility. It can also be used to reduce azimuth error (or other relative phase problems) and splice dropouts on playback of 2-track mono analog tape formats, by feeding one rather than both input channels to the mix bus.

Typically, a stereo audio broadcast console offers at least two stereo pairs of output buses (usually called *Program* and *Audition*). In some cases, a third bus (often called *Utility*) may be included. These extra buses are especially handy in news and talk-radio applications, where multiple mix-minus backfeeds are commonly required.

Some consoles are available with automatic telephone mix-minus circuitry that configures itself with the push of a

button. Another variation is a discrete mix-minus output available from each input module — a sort of "inverse direct output" feature. Although creation of a mix-minus may seem straightforward to broadcast engineers and experienced operators, it can be confusing to many. User-friendly mix-minus systems are an essential feature for today's flexible radio studios.

Verify that any console you're considering can feed audio from the input modules to all output buses simultaneously. Not all units can do so. Also be alert to console designs that cause a -6dB level drop on each bus when more than one bus is selected. Also look for comprehensive bus metering.

Nearly all broadcast consoles today offer selection of at least two input sources at every input position. In most cases, this is adequate. A well-conceived configuration will provide sufficient modules so that normal operations of the air console involves a minimum of input source switching.

Most consoles have provisions for selecting from multiple inputs on at least one of the input channels. Modular consoles can make available numerous remote line-selector options, which can increase the console input capacity for sources that are infrequently used and do not require any interface with the console logic. Because only the audio (and not the logic) is

switched to the module input by these selectors, avoid placing sources on the multi-input selector that require a remote start or a tally, for example.

A few on-air consoles offer insertion of inboard or outboard audio processing on individual inputs. The most common application for this feature is the addition of compression, EQ and/or de-essing on an announcer's microphone input.

Physical design

Not all consoles that appear modular really are. Consider the impact of down time due to maintenance and the cost trade-off of such designs. A properly designed modular console should allow the maintenance engineer to remove a defective module, repair it, and replace it without removing the console from service. At least one spare module of each type used (or at least each input and output module type) should be included in the budget plan of a new console. If this is out of the question, exam-



When millions of eyes and ears depend on you, you'd better depend on Thomcast.

We are a company that stands for total commitment to radio and television transmission, from service, maintenance and spare parts to transmitters, systems and full turnkey operations.

Thomcast unites the most experienced and knowledgeable radio and television frequency engineers and project managers worldwide, providing the highest quality equipment solutions at the leading edge of technology.

Broadcasters all around the world need a sound and reliable partner with great innovation capabilities. Thomcast meets that need.

Circle (12) on Reply Card

THOMCAST / 135, rue du Fossé Blanc, BP 156, 92231 Gennevilliers - FRANCE / Tel : 33 (0) 46 13 20 00 - Fax : 33 (0) 46 13 31 74
THOMCAST AG / Bahnhofstrasse CH-5300 Turgo - SWITZERLAND / Tel : 41 (56) 79 44 44 - Fax : 41 (56) 28 11 25
THOMCAST GmbH / Ohmweg 11-15 D-68197 Mannheim - GERMANY / Tel : 49 (0621) 8101 270 - Fax : 49 (0621) 8101 290
COMARK / PO Box 506 - Rte 309 & Advance Lane - Colmar PA 18915 - USA / Tel : 1 (215) 822 0777 - Fax : 1 (215) 822 9129

 **THOMCAST**

1, rue de Hautil, 78702 Conflans Sainte Honorine Cedex - France
Tel : 33 (1) 34 90 31 00 - Fax : 33 (1) 34 90 30 00 - Telex : 696 833 F

Selecting an on-air console

By Christopher M. Durso

The Bottom Line: Even in the face of the digital revolution and its movement toward virtual, screen-based radio station operations, the mixing console remains the preferred heart of on-air program origination. But consoles are changing with the times. Today's systems offer an ever-widening array of features, and a variety of price ranges to match. Assessing these parameters will help you decide on the console that's right for your station.

\$

Examine a wiring diagram from almost any radio station and you'll find at each control room's core a traditional audio mixing console — the "board." These consoles, and the rooms in which they reside, are designed for either *on-air* or *production* use. Typically, consoles used for on-air applications have fewer features than those suited for production, but the elements of an on-air board are often more critical to a station's operation. Specific requirements for an on-air board also can vary widely between stations.

Durso is chief engineer at KPBS-FM, San Diego. Respond via the *BE Radio* FAXback line at 913-967-1905.



Pacific Recorders and Engineering AMX-34 in the new KABC/KLOS facility, Los Angeles.

An on-air console should be straightforward in design and layout to minimize operator mistakes. In its basic form, the typical on-air console consists of input selector switches, module on/off switches, cue-bus features, level controls, output bus assignment, metering, monitoring and communications. Occasionally, clocks and timers may be included. Microphone input modules often add a pan pot that may be switched in and out of the circuit. Some limited audio processing may also appear on higher-end units. Recessed input gain trim-pots are another common feature. These elements and perhaps a few others

appear in myriad variation throughout today's on-air console marketplace. Finding the right combination at the right price is your challenge when selecting a console. The following pages cover some of the more important issues to assess during that process.

Logic and control

Besides controlling audio flow through a fader, an input on/off switch can also remotely control devices assigned to that input channel, such as speaker muting or

remote tape starts. Most consoles today provide isolated logic signals for the external equipment control. This is much more desirable than simply looping control signals from the external devices through spare contacts on the module switch. Bringing wires from the outside world into the controlled environment of the audio console could quickly degrade the performance of the console by introducing stray, unwanted signals onto the mix bus — an especially important consideration in high-RF environments.

Although the use of external logic interfaces is usually required, this is a small trade-off to keep the audio path as clean as possible. Some console designs even allow for the use of the lamp in the push button to indicate the status of the equipment attached to that module (such as "cart ready").

Today's fully featured consoles provide all module signals for remote connection including on/off, cough, talkback and all tally signals. This is useful when it is desirable for news anchors or other talent to operate their microphone and start carts from a nearby position without intervention from the console operator. It can also put nervous guests at ease when they can see if their microphone is on and have the ability to press a button to clear their throat off-air.

The cue function

Although few vinyl discs are "cued up" for airplay by operators anymore, the console cue function still has an important role. In addition to traditional subfader cue switching, many of today's

Be Quiet!



The original Shure FP32 set the standard in field production for portable stereo mixers. Now, with the new FP32A, you can count on getting even less. Noise, that is...30dB less! In fact, the FP32A is so quiet and improved that it's perfect for use with DAT and other digital recording media.

Professional Mixing You Can Take Anywhere.

The Shure FP32A is a 3-input, 2-output portable mixer specifically designed for:

- remote audio recording
- electronic field production
- electronic news gathering
- location film production

The FP32A weighs just 3.5 lbs and is only 2-1/4" H x 6-3/8" D x 7-1/4" W in size.

With 8 hours use from two 9V alkaline batteries — or powered by any 12 to 30 VDC source — the FP32A goes wherever you do. And since it's from Shure, you can count on its durability and ruggedness.

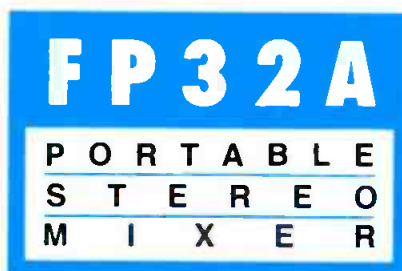

So Many Features In So Little Space.

You get all the features of the original FP32 plus:

- 48V phantom power
- pop-up pan pots
- input level LED indicators
- mix bus jack and cable
- headphone mode switch
- mixer/monitor switch
- adjustable peak output LEDs
- stereo link for inputs 2 and 3
- more than 30 other new features and improvements

So go to your nearest dealer and pick up an FP32A. Once you use it, you'll see why we're making so much noise about something so quiet.

For the Shure FP dealer nearest you, call 1-800-25-SHURE.

SHURE®

The Sound of The Professionals* Worldwide.

Circle (11) on Reply Card

www.americanradiohistory.com



TM Century's Ultimate Digital Studio (UDS) system is another popular audio management platform, shown here with outboard CD jukebox drives (at right).

some stored audio elements (such as commercials, PSAs and news/weather/sportscasts).

A different kind of multi-user application has been taken on by other developers who have implemented a modular approach to their operating software, while retaining a monolithic storage infrastructure. This allows a single audio management system to support

multiple PCs in multiple rooms, but with each PC able to run different applications. For example, the computer in the on-air studio can run an automation/sequencing package, while the computer in the production studio runs a digital audio workstation (DAW) system. Meanwhile, the newsroom PC runs simple cut-and-paste audio editing plus wire-capture and word processing, and

the office PC runs a traffic program. The computers are networked and files produced on one can be instantly accessed by another.

An interesting and cooperative variation on such multitasking capability has been recently demonstrated by two separate developers. One offers a well-established automation/audio management system and the other makes a popular DAW. Both systems are Windows-based and share common audio file formats. Each system's hardware takes up a single peripheral slot on a PC, and both can run simultaneously on a sufficiently fast platform. Switching from the production application to the automated playback function on a properly outfitted computer is a simple Windows Alt-key function. Both systems support networking as well. This allows great flexibility in a radio station or radio network studio environment.

The final frontier for these systems includes embedded auxiliary data management.

The road goes ever onward

The final frontier for these systems includes embedded auxiliary data management. If significant datacasting really is in the radio broadcaster's future, then simple and flexible management and monitoring of multiple auxiliary datastreams will be required within a station's computerized environment. A

specialized networking architecture and file transfer protocol may also be necessary for radio operations — the so-called Radio LAN or R-LAN. (See "The Changing Face of Radio Automation," *Broadcast Engineering*, April 1994.)

It is becoming clear that the radio station of the future will exist in some sort of virtual, networked computer environment. Today's audio management systems provide a convenient entrance ramp to the highway from here to there.

➡ For more information on audio management systems, circle (36) on Reply Card. See also "Playback Automation," p. 72 of the BE Buyers Guide.



The ITC DigiCenter is a modular audio management system with a wide variety of configuration options.



TM CENTURY[®] Inc.

ULTIMATE DIGITAL STUDIO II

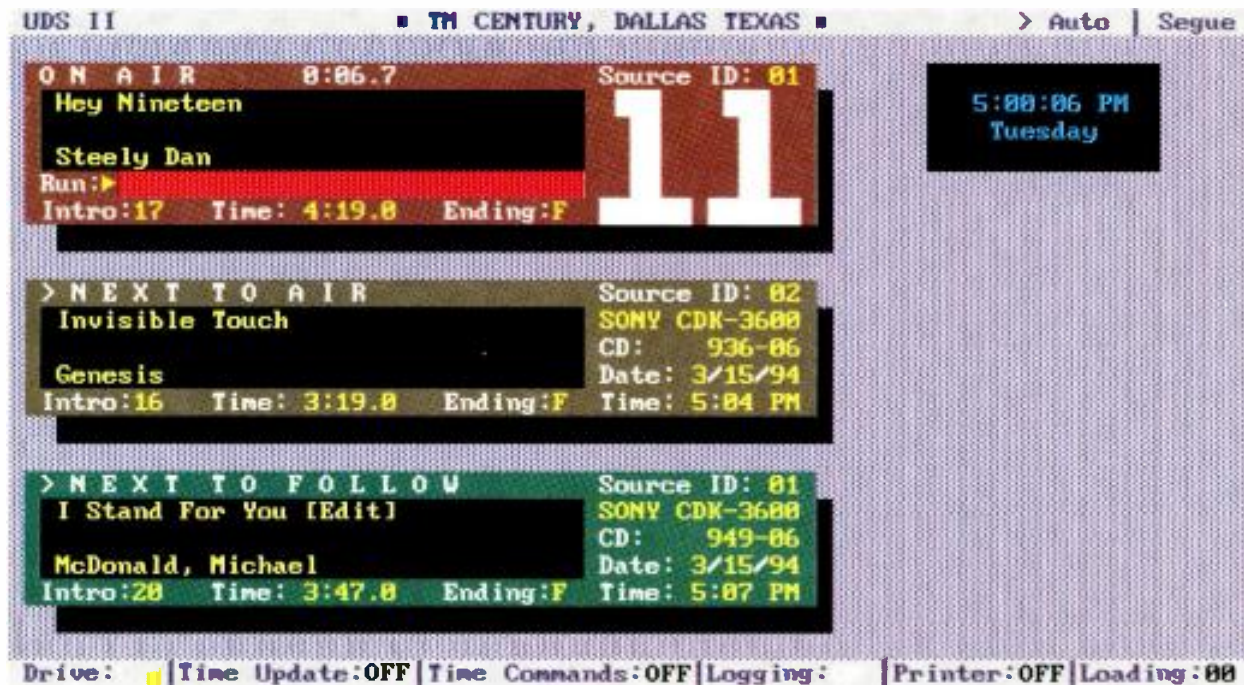

- Our new A-4000 framed based audio controller provides complete control of ALL audio levels, including crossfades between sources, even microphones and remote lines. Expandable to 100 stereo channels, the A-4000 replaces the need for a traditional console. (The Virtual Audio Console is here!)
- Interfacing for second generation CD players, including the Sony CDK-3600 36D disc, dual head player and the NSM-31D1 100 disc player.
- Options for interfacing with almost all digital audio hard drive storage devices including a serial interface with the Computer Concepts Digital Commercial System.
- Remote control for complete control of all your programming with a standard laptop computer, eliminating the need for anyone to be at the station during remotes.
- Real-time control for multiple program clock updates and network joins.
- On-screen displays for Weather, News, Commercial and Liner text, End of event Countdown Clock, Calendar, Calculator, and internal utilities.
- Support for local area networks, allowing for importing Program logs, Liners, Weather and News updates, Copy and Tag information, plus exporting of executed event files.
- Utilities for importing of CD music databases. Merging capabilities with almost all music scheduling programs and traffic and billing programs.
- Still, you get the original concept of a simple, easy to look at, clutter free screen with our intro countdown clock and triple deck style display that have made the UDS one of the most copied screen styles in the business.

For More Information call (800) TM CENTURY
See us at NAB Booth 2600

Circle (10) on Reply Card

ments include traffic system interfacing, automation, switching/mixing and networking options.

From an operational perspective, probably the most important part of the audio management system is its user interface.

Traffic system support may exist as either a one-way log-downloading process or a 2-way system that includes as-run log reporting. Automation is typically offered in live-assist and walkaway modes. Some systems include machine control features that allow the automation to manage internally stored audio files and external storage devices (such as CD-jukeboxes or DAT decks). Besides playback automation, a few systems also offer automated control of recording, allowing fully automatic time-shifting of satellite-fed programs, for example.

A growing number of systems incorporate networking via some form of LAN. This permits several computers to coexist on the same system, but just how this is handled varies widely among systems. Prospective purchasers should research this point deeply to find out what a system really offers — and what network architecture/speed it requires — when it says “networking available.”

A related variable in the networking context concerns storage architecture. Does the system use a central file server/RAID array or a distributed storage approach — or can both be accommodated?

User interface

From an operational perspective, probably the most important part of the audio management system is its user interface. Most systems use a PC screen for display, but user control can come from a variety of devices. These range from standard computer input hardware (keyboard, mouse or trackball to touchscreens) to purpose-built, dedicated hardware controllers. Some systems can be interfaced to existing radio studio equipment, as well (such as the remote starts on a broadcast console).

A key issue involves how much of the operation is contained within the audio management system and how much remains external to it (i.e., still using conventional broadcast equipment). For

example, in a combo operation, spots and music may all be handled by the audio management system, feeding a single input of traditional on-air consoles, while live mic announces, voice-overs, interviews and telephone call-ins will feed the board directly, operating independently from the audio management system. The transition between the computerized and non-computerized functions must be smooth and simple for the operator.

Other items worth exploring include



Computer Concepts' DCS system was introduced in 1990. It is now in place at more than 600 stations around the world.

how the audio management system displays elapsed or remaining time to the operator, and how easily it switches between manual, live-assist and fully automated operations.

Data-rate reduction

Storage of audio files using data-rate reduction (or “data compression”) is now possible on many audio management systems. Several manufacturers offer a choice of two or more on-board perceptual coding algorithms for this purpose. Some allow multiple coding schemes to be used within a single system, with files stored in a mix-and-match configuration. File-header data allows automatic detection of the coding algorithm used on the file (if any) for proper decoding during playback. Sampling rates and other coding parameters may also be varied on a file-by-file basis. This allows spots to be stored with lower

sampling rate and/or higher rate-reduction ratio than music cuts, for example. Some systems also include the capacity to edit files in the rate-reduced domain.

Digital audio rate reduction serves two main purposes in the audio management environment. The first and more obvious advantage is the significant reduction in disk storage requirements. A 1GB drive that holds approximately 1½ hours of uncompressed audio could store about 10 hours of perceptually coded audio. Second, such rate reduction also reduces bandwidth requirements. It therefore speeds up the access time for retrieval of audio files from disk and reduces a platform's RAM requirements. It also extends the effective bandwidth of a LAN, by increasing the number of audio operations or file transfers that can take place on the network simultaneously.

Current development

The eventual goal of an audio management system is complete or near complete inclusion of all radio station operations within a single computer network. Although no system has yet achieved this level of functionality, most developers are hard at work trying to get there. Knowing where things are headed will help you in choosing among today's systems. Some offer more fertile upgrade paths than others.

Two major issues confronting manufacturers at present are capacity for multi-user or multicasting implementations and simultaneous management of audio, text and auxiliary data within a single system. Several recent developments show promise in meeting these challenges. For example, while most

Once the choice is made for a computer-based system, however, a more complex decision process is launched.

DOS-based systems are limited to three or four simultaneous stereo audio operations (i.e., recording or playback of a file), one new UNIX-based system offers up to 16 simultaneous audio operations on a single file server. This kind of capability would serve well in a consolidated facility where two or more radio stations multicast from the same audio management system. Added efficiency results in this case if the stations share

The Aphex Audiophile Air Chain



Higher Quality and Extended Coverage!

Smart broadcasters know that quality sound is essential to attract and keep loyal listeners ... and advertisers.

That's why premier stations around the U.S.A., and around the world, rely on the Aphex Audiophile Air Chain.

Now there's one more reason to turn to Aphex — better coverage of your listening area.

Stations that have installed the powerful combination of the Aphex *Compellor*® Model 320, *Aural Exciter*® Type III, *Dominator*™ II Model 720 and the *new Digicoder*™ digitally controlled stereo generator — as well as their listeners — are raving about better signal quality and a reduction in multipath.

"A surprise bonus has been the apparent increase of coverage in fringe areas — we are getting very positive responses from listeners in Sacramento, 100 miles away."
- Tim Pozar, CE, KKSF-FM, San Francisco.

"Immediate improvements in fringe signal quality were noted. These improvements included a reduction in multipath and picket-fencing."
- Gary Greth, CE, KLON, Long Beach, CA.

"We have gotten a few responses from listeners in the fringes of our coverage area saying our signal is much stronger. They are reporting the actual carrier level has increased and they can hear us where they could not get a clear signal before." - Herb Squire, CE, WQXR, NYC.

The Aphex Audiophile Air Chain allows maximum loudness and modulation while maintaining the natural dynamic feel of the program. Quick and easy to set up, it maintains the same high quality regardless of the type of programming or who is controlling the board.

Other processors need to be tuned for almost every song, and achieve loudness only by crunching to the point of listener fatigue. But Aphex helps you reach more listeners — and keep them longer.

If you want to be a winner in the "no win modulation wars", contact your Aphex dealer to arrange a demonstration of the Aphex Audiophile Air Chain. You can't buy better quality at any price.

Circle (3) on Reply Card

APHEX *Improving the way the world sounds*SM
SYSTEMS 11068 Randall Street, Sun Valley, CA 91352 ■ (818) 767-2929

Compellor, Dominator, Aural Exciter and Digicoder are trademarks of Aphex Systems Ltd.

©Aphex Systems

www.americanradiohistory.com



Audio management

By Skip Pizzi, technical editor

The Bottom Line: *The reinvention of the radio station is already under way. The craft of making radio is moving from its traditional set of dedicated analog devices to a virtual, computer-based environment. This brave new world can be intimidating, yet it's full of opportunity for increased cost-effectiveness and greater productivity. The process will not occur overnight, however, and each step along the way must be taken carefully.*

\$

A

udio management — what does it mean? Like any nascent terminology, it can be defined in different ways depending on who you're talking to. At *BE Radio*, the term is used to describe an integrated audio storage system designed for delivery of radio station programming to air. It may or may not include automation, external device control, internal mixing ability and interfaces with traffic, satellite and

telephone systems. It may also exist in a single, stand-alone platform or it may incorporate multiple workstations on a local area network (LAN).

These various incarnations will be explored in a hierarchical context. This is a helpful way to understand audio management systems, because it is often how they are implemented at radio stations — via gradual transition using a building-block migration path.

elegant solution. Some observers see the computer-based system as the inevitable choice, anyway — the only question is when. This reasoning implies that a digital cart machine approach, however well-reasoned today, will be only an interim step to an eventual integrated, computer-based audio management system.

Few stations are interested in purchasing new analog cart machines to replace their older ones any more.

Cart replacement

The catalyst for many stations' embarkation on this path is a requirement to replace cart machines with something better. Few stations are interested in purchasing new analog cart machines to replace their older ones. This puts the first issue squarely in the face of a station's decision-maker: Should the analog cart machines be replaced with digital cart machines, or should some sort of centralized hard disk storage system be considered? To most long-time broadcasters, the latter approach seems riskier and less user-friendly, but upon inspection (and with some hands-on exposure), it may seem less daunting and a more

Once the choice is made for a computer-based system, however, a more complex decision process is launched. Although the digital cart machine approach requires only a few choices, the computer-based methodology presents many more options. The digital cart machine path might be considered a single-ended spur while the computer approach opens up a broadly branching interchange of possibilities, with greater likelihood of accommodating undefined future requirements. Of course, this makes researching and implementing a computer-based audio management system commensurately more challenging.

Computer-based system components

Beyond basic hard disk audio file storage, audio management systems integrate a variety of other components that enhance their attractiveness to radio broadcasters. Commonly found ele-



The Arrakis Digilink is a cost-effective and well-established audio management system, shown here at a radio station in Japan.



Plan B for DAB?

While the pot simmers at the EIA/NRSC tests of DAB formats, consider this: Has a de facto decision for an in-band system already been made? Even though the tests include formats that use new spectrum (Eureka 147 at L-band and VOA's S-band satellite system), none of this spectrum is available to existing U.S. broadcasters. The only new spectrum allocated to U.S. DAB (2,310MHz-2,360MHz) will be devoted exclusively to direct broadcast satellite radio (DBS-R) services, if current FCC directions hold their course. "Terrestrial" or "local" broadcasters, as radio stations must now begin to think of themselves, therefore may have in-band DAB or nothing as their digital delivery options. This is a tenuous position, because none of the in-band systems has ever been demonstrated to perform at the level that Eureka 147 can. Meanwhile, Canada and some European countries continue their terrestrial Eureka 147 implementations.

Of course, in-band DAB formats will always be at a comparative disadvantage given the narrower channel bandwidths, far greater interference and backward compatibility requirements that they must contend with. It's to the in-band developers' credit that their systems work as well as they do. Nevertheless, Eureka 147's presence in the EIA/NRSC tests may put U.S. broadcasters in the position of comparison shoppers who, after a tough day at the mall, finally decide on a particularly attractive item on display only to find that it's not available at their location. It's a comparison of apples and oranges in which the apples are contraband.

The bigger question may be (as one Canadian GM recently asked me), "What's 'Plan B' for U.S. radio?" Indeed, what if the EIA/NRSC tests show that no in-band system is considered viable? Then what recourse will American broadcasters have? Will any of the S-band still be available by the time such a decision is made, or will it all be parcelled out to satellite

interests? (Note that the Canadians will share their L-band allocation between DBS-R and terrestrial DAB services.) Could S-band even be made to work for terrestrial DAB? Could the U.S. L-band prohibition be revisited?

If in-band doesn't work, and all new DAB spectrum is devoted to DBS-R, U.S. terrestrial DAB may be effectively regulated out of existence, or at least back to its earliest drawing boards. The worst-case scenario then has DBS-R coming on line in the late 1990s, with U.S. terrestrial radio having no digital counterattack ready to muster. It's not a pretty picture, and from what I'm hearing, it may not be that far-fetched.

Trust in unproven technology based on its theoretical or business-related projections is no more than wishful thinking. It can lead to techno-debacles like the Denver International Airport baggage system, to pick a recent example. U.S. radio broadcasters and regulators should therefore keep their options (and their minds) open until reliable, comparative data on all proposed DAB formats is in hand.

As always, your comments are invited.

Skip Pizzi, technical editor

BE Radio FAXback: 913-967-1905
Internet: 4757418@mcimail.com

READER FEEDBACK

NRSC-2 compliance

To the editor:

In the May 1994 issue of *BE Radio*, Chip Morgan's article "Complying With the New NRSC-2 Regulations" (p. 18) states, "...communications receivers, communications monitors and field-strength meters are not usable for these measurements." I would like to offer a different opinion, specifically referring to the use of a Potomac Instruments model FIM-41 field-intensity meter for performing NRSC-2 measurements.

FCC 73.44 allows the use of "specialized receivers or monitors with appropriate characteristics..." The FIM-41 falls into this category. I suggest the FIM-41 be used as follows:

1. Choose a measurement location using the FCC 73.44 criteria. Measure the carrier field intensity.
2. Employ a 12VDC to 120VAC power inverter, such as the Tripp-Lite model PV-300FC. The inverter will power a frequency counter and RF signal generator, such as a Lodestar model SG-4162AD. Feed the RF generator via a BNC Tee connector to a frequency counter and to an unshielded loop antenna.
3. Adjust the RF generator to carrier frequency plus 11kHz as verified by the frequency counter. Place the unshielded loop in close proximity to the FIM 41 located in a fixed monitoring

position. Tune the FIM-41 to the RF generator frequency. Turn off the RF generator and measure peaks of splatter during a musical selection on the FIM-41. Record the highest peak field intensity. Repeat this procedure for carrier frequency minus 11kHz and then +/-15kHz, +/-20kHz, +/-25kHz and +/-30kHz. An oscilloscope can be connected to the recorder front-panel jack for more precise measurements. Calibrate the FIM for each new frequency and do not move the FIM-41.

I believe that the above procedure is sufficient to demonstrate compliance with FCC 73.44. Should the engineer desire to know precisely how many dB down specific side-band products are, a spectrum analyzer with max hold function and appropriate resolution bandwidth would be required. My experience using the FIM-41 in the manner described has proven sufficient to demonstrate compliance with NRSC-2 specifications. Furthermore, I have not found a station that wasn't easily able to meet specs when employing an NRSC-1-compliant audio processor.

Sincerely,
 Thomas Gary Osenkowsky,
 Radio Engineering consultant
 Brookfield, CT





Join the Digital Revolution

Digilink by Arrakis is a digital audio workstation that does it all while increasing your profits.

You can replace your live on air cart machines while adding CD or satellite automation for nights or weekends. You can use just one workstation or network as many as 15 and send your spots & schedules in perfect digital between your studios. Add a Trak*Star eight track digital audio editor for under \$5,500 and you can quickly and easily produce spots that would have taken forever

or been impossible with tape.

Digilink is also easy to schedule. You can use the standard Digilink traffic & CD scheduling system or import music

and traffic schedules from all of the most popular 3rd party programs.

Features like simultaneous Play, Record, & Network transfer; hard disk to hard

disk & CD crossfade; cart rotation; Autofill; Smart-squeeze; Macros; and incredible ease of use make Digilink perfect for live & automation studios.

Call or write today for more information on why Digilink is #1—with more than 600 workstations sold worldwide from Moscow, to Japan, to Barbados, to your own back yard.

- *Replace Cart machines Live On Air plus add CD, Satellite, or Tape Automation*
- *On Air Base Price starts under < \$8,000*
- *8 Track Editor base price starts < \$5,500*
- *Use just '1' Workstation or Network > 15*

Digilink

by Arrakis

The Digilink screen shown above is in Japanese text and is reprinted with permission of Otaritek, the distributor for Digilink in Japan.

COVER STORY



Audio management

No part of today's radio broadcast facility is undergoing as much change as is the on-air audio delivery equipment. An unending stream of new products for program assembly seems to be coming to market, and none of them look like anything radio used to be made on. Technical editor Skip Pizzi blazes a trail to the new frontiers of audio management.

2

Selecting an on-air console

Amidst all the changes in broadcast studios, one constant remains — the on-air mixing console. When a station reconfigures its on-air operation with digital storage and transmission systems, a new analog on-air board is often part of the package. Chief engineer Chris Durso describes how new console designs fit into today's updated on-air control rooms.

8

Radio in Transition: Control room monitoring

The last link in the studio chain is the audio monitoring system. It is often an afterthought in control room design, yet it plays a critical role in quality control of the product. Award-winning studio designer Russ Berger presents a real-world primer on the special audio monitoring needs of the radio control room.

14

EDITORIAL/FEEDBACK	1
RE: RADIO	20
APPLIED TECHNOLOGY	22
NEW PRODUCTS	26
AD INDEX	32

A Supplement to:

BROADCAST[®]
engineering