

A MACTIER PUBLICATION JULY 1965

# BME

THE MAGAZINE OF BROADCAST MANAGEMENT/ENGINEERING

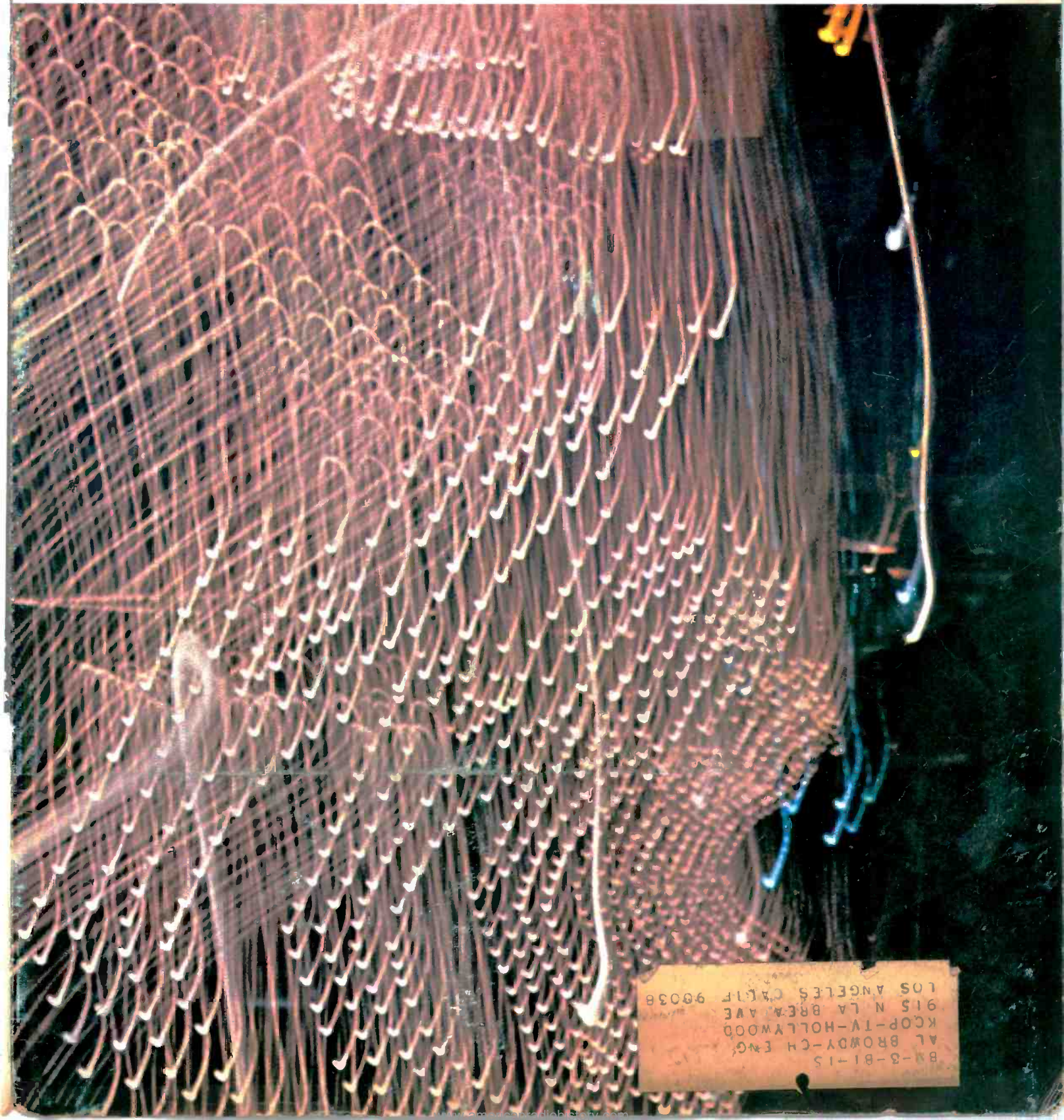

BM-8-B1-15  
AL BROWDY-CH ENG  
KOP-TV-HOLLYWOOD  
915 N LA BREA AVE  
LOS ANGELES CALIF 90038

# JERROLD

## INTRODUCES THE GOLDEN AGE OF CATV

Be our guest throughout the National Community Television Association Convention, July 18-21, at the Denver Hilton.

See what's happening—and is yet to happen—in this, CATV's biggest year. Enjoy Jerrold hospitality as you view the latest in CATV technology.

We'll be looking for you at our booth *and* our suite (1217-20). Come in, relax, and go forth refreshed. You'll learn first-hand why Jerrold calls this the Golden Age of CATV.

**Jerrold Night** • Plan to spend Monday evening, July 19, with Jerrold . . . a big entertainment bonanza.

### **JERROLD FIRST IN CATV**

The nation's largest, most experienced manufacturer-supplier of CATV equipment and services



New, from Electro-Voice! Sentry Series Professional Monitor Loudspeakers . . . guaranteed flat  $\pm 3$  db from 40 to 20,000 cps!

No longer must you improvise with theatre or home-type hi-fi speakers designed for some other purpose. Gone is the guesswork when equalizing . . . you know you'll get *exactly* what you hear through an E-V Sentry Monitor. That's because each Sentry is simple, reliable and as flat in response as modern science can make it!

Gone are "balance" switches or knobs that vary response . . . each Sentry is adjusted flat at the E-V laboratories before you ever see or hear it! And because of this simplicity, the E-V Sentry Series speakers are modest in size and price.

## NEW VOICE OF AUTHORITY!

The natural-finish hardwood cabinets are available in a sloping-front style for wall or ceiling mounting . . . or in an upright floor model for fixed or portable applications. They are all identical in sound. Built-in transformer matches studio output impedance of 8, 16 and 600 ohms.

If you want to end equalization guesswork . . . if you want to know that the sound you hear is an exact duplication of the original . . . the E-V Sentry Series Professional Monitors were designed for you. Write for complete specifications, or see your E-V Professional Products Distributor, today!

*Sentry II Floor Model, 32"H, 20"W, 13"D. List Price \$290.00. Sentry I Wall or Ceiling Model, 17"H, 37"W, 21 $\frac{3}{4}$ "D. List Price \$275.00. (Normal trade discounts apply.)*

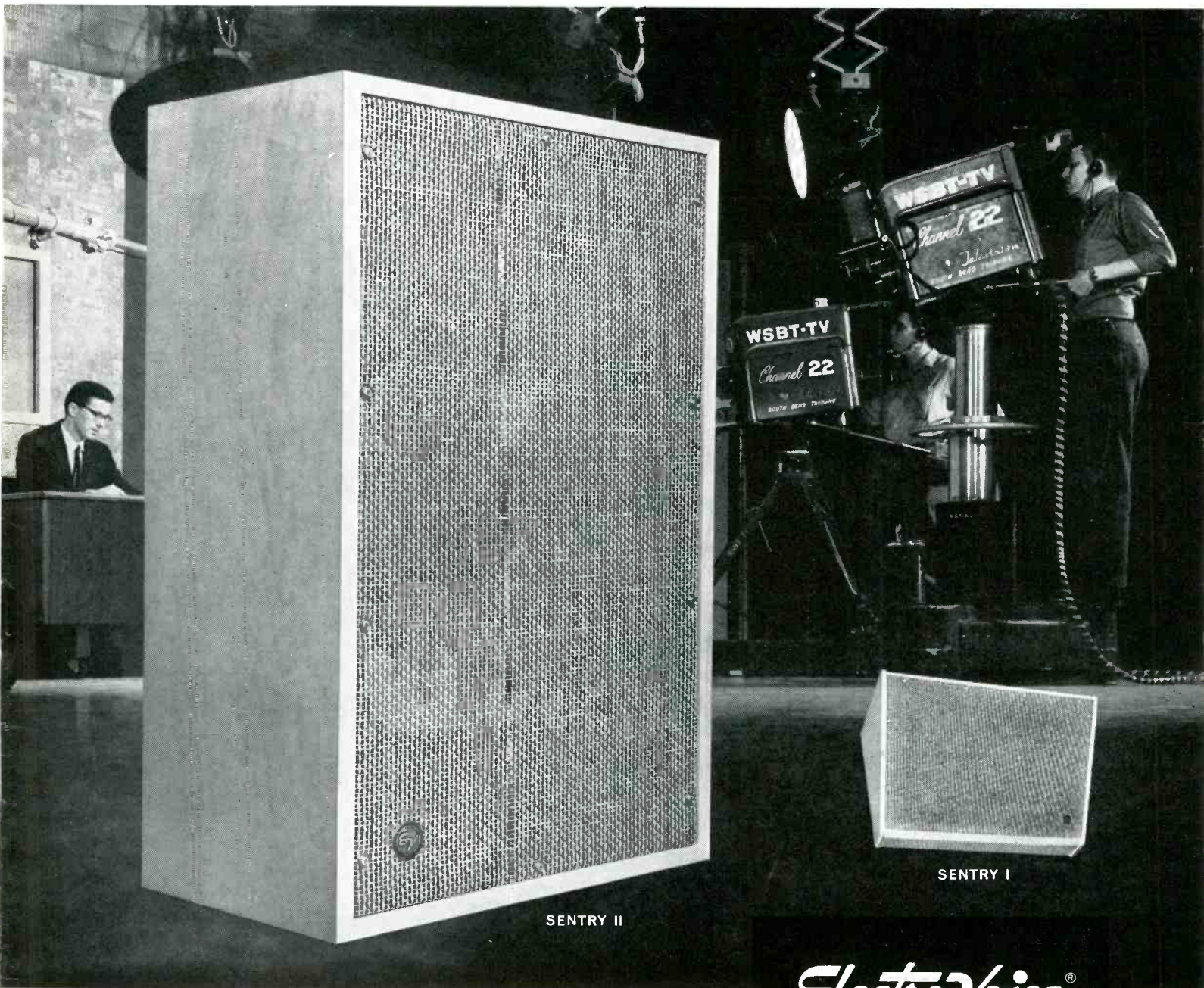

SENTRY II

SENTRY I

**Electro-Voice®**

ELECTRO-VOICE, INC., Dept. 751EM, 614 Cecil Street, Buchanan, Michigan 49107  
Circle 4 on Reader Service Card

# BM/E

THE MAGAZINE OF  
BROADCAST  
MANAGEMENT/  
ENGINEERING

Publisher:  
**MAL PARKS, JR.**

Editor:  
**VERNE M. RAY**

Corporate Editorial Director:  
**JAMES A. LIPPKE**

Art Director:  
**GUS SAUTER**

Associate Editor:  
**CHARLES BUFFINGTON**

Production Manager:  
**HELEN HORAN**

Editorial Production:  
**INEZ ATHEY**

Circulation Director:  
**H. C. GAINER**

Circulation Fulfillment:  
**J. EDWARDS**

Reader Service:  
**R. R. BELL**

Promotion Manager:  
**E. L. GRAY**

Assistant Promotion Manager:  
**R. BATTLE**

Classified Advertising Manager:  
**EILEEN HESSION**

The eye of the camera misses nothing. For our cover this month, the camera's eye saw and recorded a sweeping interlace of moving lights. To be sure your eyes miss nothing at the NCTA Convention in Denver this month, see our sweeping coverage in this issue—a complete preview of exhibits and events—in the 8-page Convention Guide bound in the center section. Interested in a different camera's eye view? See the Color TV Camera feature beginning on page 38.

- 6 **Broadcast Industry News**  
Timely reports on events, people, and companies.
- 12 **Broadcasters Speak**  
Comments from BM/E readers.
- 15 **Interpreting the FCC Rules & Regulations**  
Pointers on setting up the public inspection file. Also, radio station operator license requirements.
- 20 **Preparing Engineering Data for Form 301**  
Part 3—Guidelines on filing for new or improved TV facilities.
- 24 **Guidelines for Obtaining a CATV Franchise**  
Even the big-time operators lose out to a competitive applicant with local backing.
- 27 **NCTA Convention Guide**  
A handy pull-out pocket guide to the events and exhibits, Denver Hilton Hotel, July 16-23.
- 38 **Selecting a Color Camera**  
What the experts have to say regarding pickup tubes, plus a roundup on available equipment.
- 41 **Remote Control of TV Transmitters**  
A complete report, describing the systems used and the results achieved during station tests coordinated by NAB.
- 48 **Broadcast Equipment**  
Reports on newly introduced products and components.
- 53 **Advertisers Index**
- 54 **Literature of Interest**  
Valuable data you can obtain by using the Reader's Service Card on page 55.
- 55 **Reader's Service Card**  
Use this FREE postage-paid card to receive more information about advertising and editorial in this issue.

---

Mactier Publishing Corp., Bryce Gray, Jr., President  
820 Second Ave., New York, N. Y. 10017, 212 MO 1-0450  
BM/E Editorial Offices: 18 Frederick Rd., Thurmont, Md. 301 271-7151

Publishers also of:  
EEE—the magazine of Circuit Design Engineering  
Electronic Procurement  
Volt/Age—the magazine of Electrical Apparatus Maintenance

---

BM/E, the magazine of Broadcast Management/Engineering, is published monthly by Mactier Publishing Corp. All notices pertaining to undeliverable mail or subscriptions should be addressed to 820 Second Ave., New York, N. Y. 10017.

BM/E is circulated without charge to those responsible for station operation and for specifying and authorizing the purchase of equipment used in broadcast facilities. These facilities include AM, FM, and TV broadcast stations; CATV systems; ETV stations, networks and studios; audio and video recording studios; consultants, etc. Others please write for subscription prices.

Copyright © 1965 by Mactier Publishing Corp., New York City. Controlled Circulation postage paid at Philadelphia, Pa.

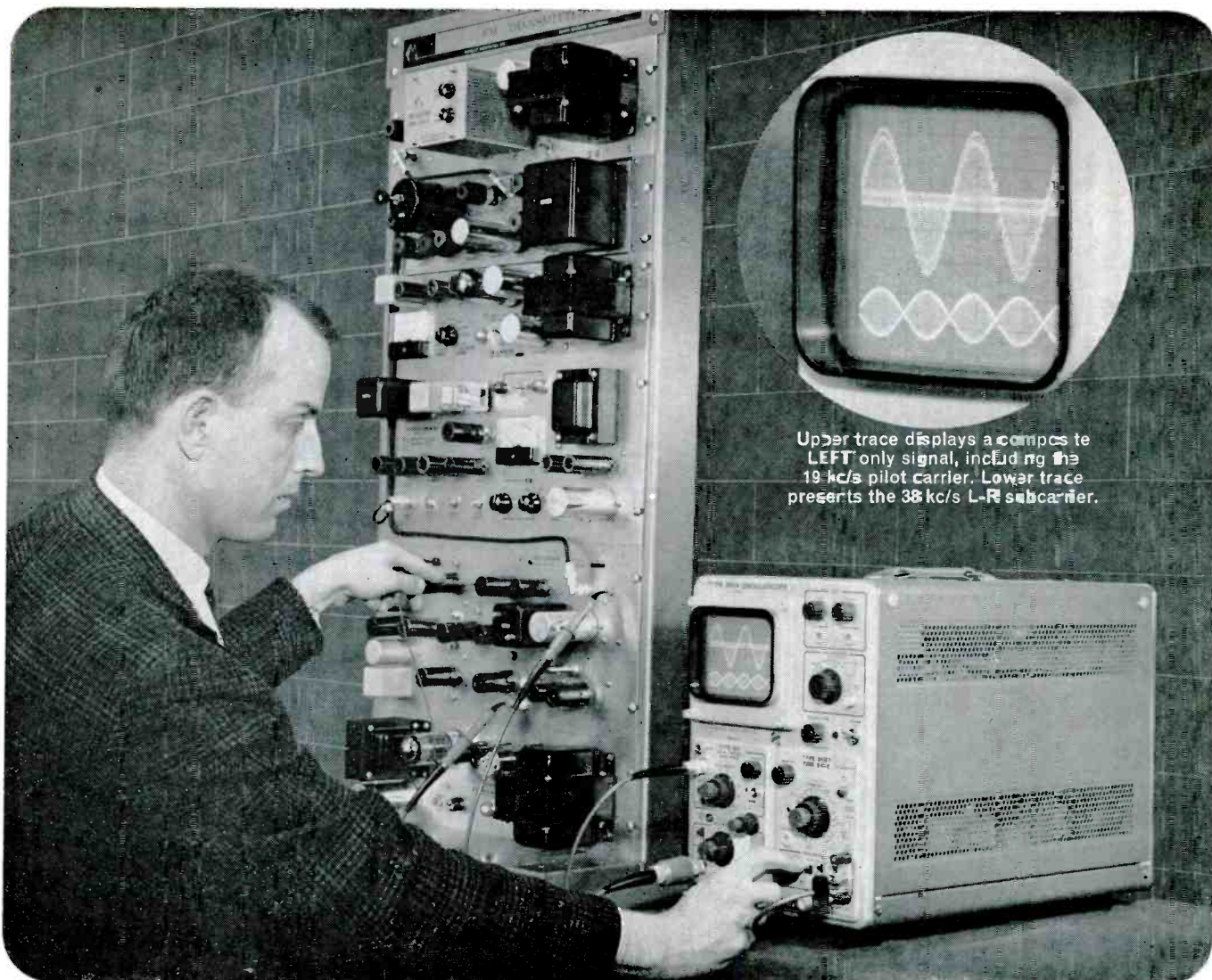

Upper trace displays a composite LEFT only signal, including the 19 kc/s pilot carrier. Lower trace presents the 38 kc/s L-R subcarrier.

peak stereo performance  
**for FM STATIONS**  
*with the aid of a Tektronix Oscilloscope*



At Moseley Associates, Inc., an engineer uses a Tektronix Type 561A Oscilloscope to check performance characteristics of their FM Stereo Generator and Ten Watt FM Transmitter.

Making adjustments and observing the waveform displays, the engineer tests generator/transmitter operation quickly and conveniently, monitors equipment performance simply and reliably, and thus effectively evaluates operational features of the stereo instrumentation. High in performance, moderate in cost, the Type 561A ideally suits test applications of the FM Stereo Broadcaster.

Whatever your broadcast equipment test needs, the Type 561A can very likely meet them.

You can use any of 17 amplifier and time-base plug-in units for many different types of application.

You can display single or multi-trace presentations.

You can observe no-parallax displays and sharp trace photography over the full 8-cm by 10-cm viewing area. For the crt has an internal graticule with controllable edge lighting.

Type 561A Oscilloscope \$500

Plug-Ins illustrated

Type 3A1 Dual-Trace Unit \$450

Type 2B67 Time-Base Unit \$210

15 other plug-ins available.

For rack mounting, in 7 inches of

standard rack height, order Type

RM561A \$550

U. S. Sales Prices f.o.b. Beaverton, Oregon

oscilloscope prices without plug-in units

For your test needs, there is a Tektronix Oscilloscope to fit every quality-assurance program—and comprehensive field services to back up every instrument. For information call your Tektronix Field Engineer or representative now.

**Tektronix, Inc.**

P. O. BOX 500 • BEAVERTON, OREGON 97005  
 Phone: (Area Code 503) 644-0751  
 Telex: 03E-691 • TWX: 613 291 6305  
 Cable: TEKTRONIX

OVERSEAS DISTRIBUTORS IN OVER 30 COUNTRIES  
 TEKTRONIX FIELD OFFICES in principal cities  
 in United States. Consult Telephone Directory.

Tektronix Australia Pty. Ltd., Melbourne, Sydney.  
 Tektronix Canada Ltd., Montreal, Toronto.  
 Tektronix International A.G., Zurich, Switzerland.  
 Tektronix Ltd., Guernsey, C. I.  
 Tektronix U. K. Ltd., Harpenden, Herts.

Circle 5 on Reader Service Card

# BROADCAST INDUSTRY NEWS

## Mono TV Sales Dip, Radio Up

Distributor sales of monochrome TV sets for the first quarter of 1965 dipped slightly as compared with last year, but sales of radio sets climbed substantially, according to EIA's Marketing Services Dept. First-quarter sales of b & w sets totaled 1,904,302, down 9.8% from last year. Radio sales (excluding auto) totaled 2,641,069, up 33.5% over last year. Color TV sets produced during the first quarter totaled 502,857, more than 75% greater than the number produced in the first quarter of last year.

A truly great year is predicted for FM; first-quarter production of FM radios was 693,560, 77% more than last year. RCA is featuring FM in more than half the 28 models in its 1966 radio line, including a new series of FM/AM transistor portables. Bryce S. Durant, Pres., RCA Sales Corp., predicts that 2.5 million FM and FM/AM radios will be sold during 1965, an increase of 25% over last year. FM set sales now account for nearly 20% of the domestic radio market, according to Mr. Durant, and virtually all phono consoles now feature FM/AM combinations.

## "Turn-Key" for UHF's

For smaller communities needing local TV service, lacking backers with broadcast experience, two firms have teamed up to put interested investors into UHF on a pay-as-you-go plan. Electronics Leasing Corp., controlled by RKO General, and Kamen Associates, broadcast consulting firm based in New York, have joined forces to provide complete turn-key services — from application, construction, to operation and programming. The idea is to set

up local TV broadcast service on a sound financial basis, using the combined knowledge and experience at the command of the two firms. Basic station "blueprint" calls for 100w transmitter and 100-gain antenna for ERP of 10 kw. 5-year lease agreement, with no down payment. \$2,000 to \$5,000 monthly payments puts an operator in business.

## CAS Has New Address

CAS Mfg. Co., pioneer in the manufacture of solid state amplifiers for CATV systems, has expanded their facilities and integrated their operations into a central region near Dallas, at 3301 Royalty Row, Irving, Tex.

## Brand-Rex Consolidates

Brand-Rex, wire, cable and dielectrics div. of American Enka Corp., has combined its former activities at Concord and Acton, Mass., and Windham, Conn., in a centralized operation at Willimantic, Conn. Manufacturing area of the new plant is 340,000 square feet under one roof.

## RCA Cuts Color TV Prices

RCA Sales Corp. announced it would lower optional retail prices on all its home entertainment products, including a new low starting price for color TV sets of \$349.95 (a cut of \$30), effective with passage of the excise tax cut bill. Suggested retail price cuts for color TV sets range up to \$100 for top-of-the-line models. To enable retailers to offer lower prices immediately, RCA plans to give distributors and dealers excise tax refunds on existing inventories, instead of waiting for Federal rebates to be processed.

## Another Broadcaster in CATV

WSBT-AM-TV, owned by South Bend (Ind.) Tribune, is negotiating for the purchase of yet unnamed CATV systems. The station's general manager, Arthur O'Neil, was appointed to a newly created position as assistant to the president for electronic media. His primary responsibility is developing and directing the firm's CATV activities.

*(Continued on page 10)*

New York City — ABC is using the isolated camera technique to replay key actions in network game-of-the-week baseball series. Key to the operation is an Ampex VR-660 portable television recorder which tapes all the game action and permits both slow and stop motion playback to show critical actions or disputed decisions. The program director has the option of taping from a live camera or a stand-by camera, giving him a broader selection of shots to catch close-up actions as they develop. Any play may be televised immediately or during the half-inning break, as desired.



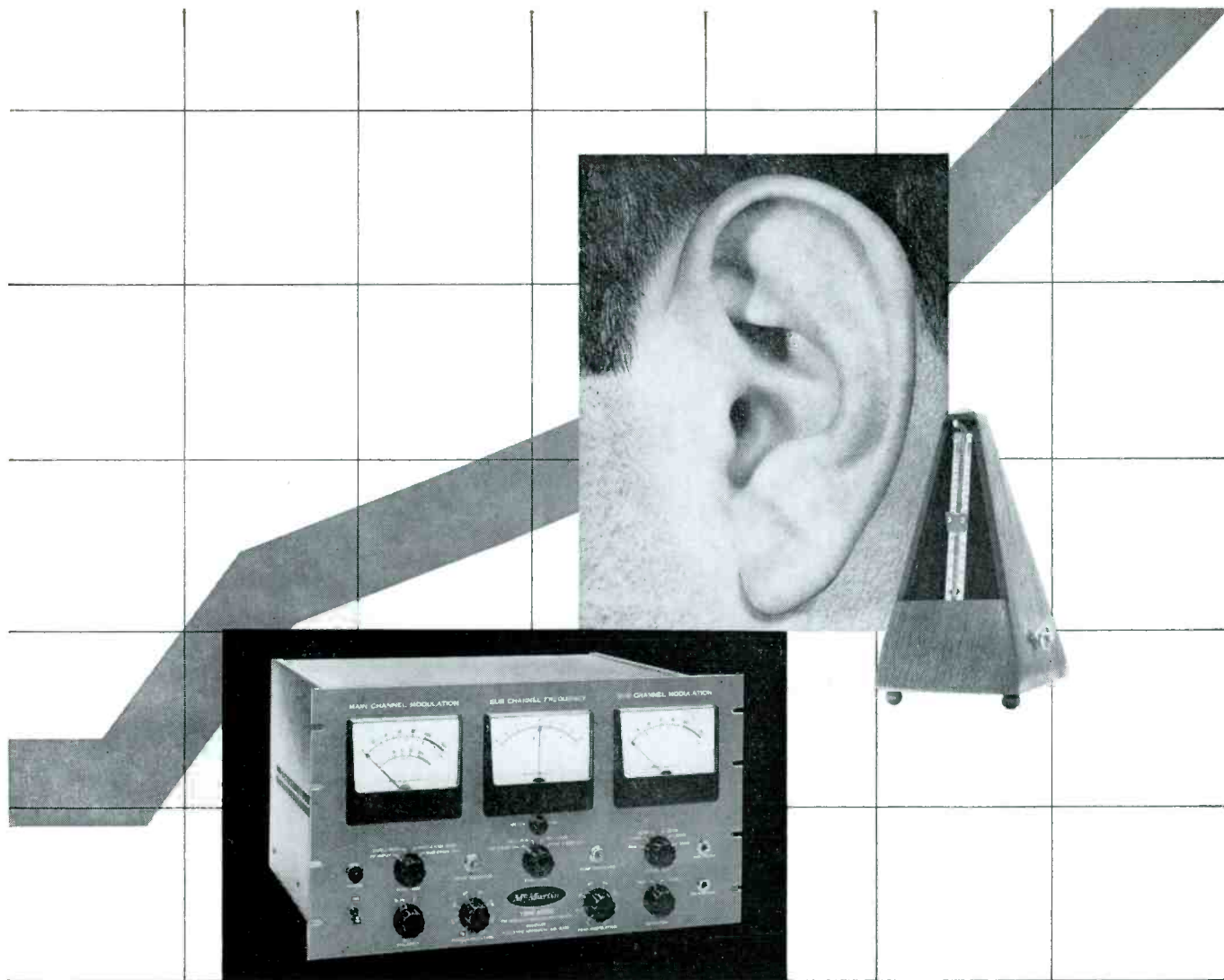

## We're Graded on the Curve

A sales curve is generally an indication of Customer Acceptance. That's why we're particularly impressed by the rapid and dramatic growth in our sales during the last year. ■ Each Customer who contributed to that has judged us upon the value that he received versus the money that he spent. We like to believe that he got his money's worth through product excellence. ■ Product excellence is no accident. It results from training the workmen, inspiring the supervisors, and having pride in putting your name on a quality product. ■ There is something new, exciting and different going on at McMartin. It's reflected in the products that we produce for the broadcast, background music and commercial sound industries. If you're now a Customer, look for continued satisfaction; if you're not yet a Customer, why not let us send you our catalog — no obligation, of course; just write to:

**McMARTIN INDUSTRIES, INC.**  
605 North 13th Street  
Omaha, Nebraska 68102



Circle 6 on Reader Service Card

# CINEMA PRECISION AUDIO EQUIPMENT



## AUDIO ATTENUATORS

Cinema's new compact rotary slide-wire attenuator is now available for your mixing consoles as single or ganged units. A must where smooth control is desired. Other standard types are also available for applications demanding precision noiseless attenuation, reliability and long term stability.

## GRAPHIC EQUALIZER

The Cinema Graphic Equalizer offers a compact system of extreme flexibility. Each of the six controls permit the operator to equalize or attenuate that portion of the spectrum 8 db. This is an active unit having zero insertion loss and up to 35 db additional gain.

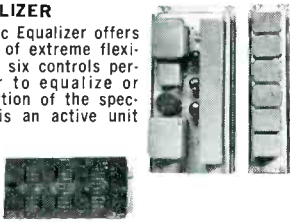

## DIP FILTER

Features a notch depth of 50 db minimum and which is continuously variable from 30 to 9,000 cps. Extremely useful for removing single frequency noise and for harmonic distortion measurements.

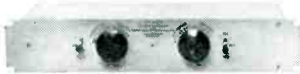
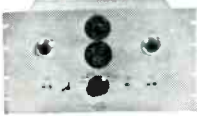

## PROGRAM EQUALIZER

Provides for accurate frequency response corrections in audio equipment. Easy operation of the two control knobs allow over 395 curve combinations. Detented action of the controls permits reference dial settings for future duplication of desired characteristics.

## DEGAUSSERS

Cinema bulk degaussers are a favorite with sound men throughout the world. Provides erasure of program material and residual noise from magnetic tapes on reels up to 17 inches in diameter, and 2 inches wide. Also, "Pencil" type degaussers are available for erasing small areas thus avoiding splicing.



Hi-Q's Cinema precision audio equipment is backed by an enviable reputation generated by over 25 years of outstanding service in critical sound recording, broadcast and laboratory applications. Many other custom audio products are available. Put the benefit of our experience to work for you. Write for Hi-Q's Cinema precision audio equipment literature today.

**Hi-Q** AEROVOX  
DIVISION CORPORATION  
CINEMA PLANT

1100 CHESTNUT STREET, BURBANK, CALIFORNIA 91503  
PHONE: 213-849-5511 • TWX: 213-846-3578

Circle 10 on Reader Service Card

## NAMES in the NEWS

M. C. Hegdal is new V-P of 3M's Magnetic Products Div., St. Paul, Minn. He has 20 years' experience in magnetic tape R&D. In addition, Andrew H. Persoon has been appointed to the post of technical director for the division, replacing R. A. von Behren who is now technical director of the firm's Revere-Mincom Div., Camarillo, Cal.

Dwain A. Keller will continue as manager of the enlarged marketing div. of Dynair Electronics. Robert A. Jacobs will assist Mr. Keller as supervisor of sales engineering, and George Geppelt has been appointed sales coordinator and applications engineer. All appointments were made from within the Dynair organization by E. G. Gramman, Pres.

Bennewitz Assoc. are new sales Reps for American Electronic Labs., Lansdale, Pa., in N. M. and El Paso, Tex.

Lawrence Weiland has been named manager of TV products for Ampex. Previously, he was manager of video product planning. Prior to his Ampex association in 1960, he was manager of advanced planning with NBC in New York.

Leon Papernow has resigned as executive V-P, H & B American Corp. Is forming Community Cablecasting Corp., group CATV system owner.

Donald R. Atwell has been named president of American Cable Television, Inc., Phoenix, Ariz., a recently formed organization which coordinates CATV companies across the country. Atwell was with H&B Com-



Donald R. Atwell



E. J. Pleszko

munications, Jerrold, and Williamsport TV Cable.

E. J. Pleszko has been appointed manager, New Products Dept., Preformed Line Products Co., Cleveland. He will serve as consultant to industry on new product applications. Pleszko joined the company in 1958 as project engineer and has worked most recently as assistant manager of the department.

Donald L. Guthrie and Robert H. Symons, TelePrompTer Corp. CATV systems managers, have been advanced to newly-created positions in the New York headquarters. Guthrie will serve as CATV Marketing Director, while Symons is Director of Budgets.

Wilbur Riner has been appointed Microwave Marketing Manager for Fairchild Semiconductor Div., Fairchild Camera and Instrument Corp. Previously, Riner was sales manager of the semiconductor div. of Microwave Associates.

J. W. Brewer has been added to the field engineering staff of Viking, Hoboken, N. J. Brewer was formerly a communications sales engineer for a leading electronics firm in southern Miss.

## BROADCASTERS SPEAK

Please accept my congratulations on your magazine. I find your concise roundup of Broadcast Industry News the most valuable in the trade magazine field. I especially appreciate your regular FCC Rules & Regulations features.

Bill Collins  
Program Dir., WRFD-AM  
Columbus, Ohio

My experience has been limited to that of General Manager. Therefore, any information on how to maintain control would be most welcome.

J. M. Schaller  
Gen. Mgr., WRJC  
Mauston, Wisc.

How about a question & answer column for management?

R. A. Egli  
Gen. Mgr. WVIC  
East Lansing, Mich.

*If readers will ask the questions, we'll get the answers.*

I have heard from seemingly informed sources that stereo-FM is on its way "out" on the west coast and is just now on its way "in" in the east. Perhaps some of your readers could [verify this rumor].

A. R. Steele  
Manager, WSMC  
Collegedale, Tenn.

*We think your "informed sources" are all wet.*

We appreciate the news item on page 8 of your May issue for our client, Continental Electronics, but would like to point out a minor flaw: The photo used shows the Type 317C 50-kw AM transmitter—the copy refers to the PROLOG System, which is a different item altogether.

Peter Kaufmann  
Evans, Young, Wyatt Advertising  
Dallas, Texas

*Guess we'll have to cut down on the "Red-Eye" during proof-reading time. We assure you we know the difference. Anyway, you'll have to agree it's a unique way to cover two items at once!*



# Would you have accepted these two lengths of CATV cable?

ROME UNIFOAM

O.A. - 190

ROME CABLE DIVISION OF ALCOA

SIZE .412" 75 ohm  
 TYPE UNE Plain  
 DATE 4/13/65

R. F. Cable Inspection Report

F.O. No. 70319  
 C.O. No. \_\_\_\_\_  
 CUSTOMER \_\_\_\_\_

TRACE NUMBER	LENGTH	CONTINUITY	VISUAL	SELECTED 3.5KV MIN. DIMENSIONS	CORONA LEVEL	INSULATION RESISTANCE	CAPACITANCE		ATTENUATION				V <sub>p</sub>	Z <sub>0</sub>	RETURN LOSS		
							meas. pf	pf/ft	MCS	100 MCS	220 MCS	MCS					
A070A11	1 1217	ok	44" 54"	ok	—	ok	20300	16.7	12.0	.988	18.2	1.5			80.6	75.5	29
B070A2	2 1218	"	"	"	"	"			12.3	1.01	18.6	1.53					32
B070A12	1 1219	"	"	"	"	"			12.0	.986	18.2	1.49			REJ @ 68 MC		24
B070A18	1 1214	"	"	"	"	"			11.9	.980	18.1	1.49					29
A070A18	1 1218	"	"	"	"	"			12.0	.986	18.3	1.50					29
A070A13	1 1217	"	"	"	"	"	20300	16.7	12.0	.988	18.3	1.50					27
B070A13	1 1220	"	"	"	"	"			12.0	.985	18.3	1.50			REJ @ 127 MC		22
A070A12	2 1215	"	"	"	"	"			11.9	.980	18.2	1.50					34
A070A9	2 1217	"	"	"	"	"			12.3	1.01	18.3	1.50					32
B070A14	1 1218	"	"	"	"	"			12.1	.995	18.4	1.51					26
B070A19	1 1214	"	"	"	"	"	20200	16.6	12.0	.988	18.3	1.51			50.4	76.2	27
B070A15	1 1215	"	"	"	"	"			12.0	.988	18.4	1.51					28
A070A15	1 1220	"	"	"	"	"			12.1	.993	18.3	1.50					28
B070A16	1 1218	"	"	"	"	"			12.0	.986	18.3	1.50					30
B070A17	1 1200	"	"	"	"	"	20000	16.7	11.9	.992	18.1	1.51					29
A070A5	1 1210	"	"	"	"	"	20000	16.6	11.9	.985	18.1	1.50			81.0	75.6	30
A070A17	1 1228	"	"	"	"	"			12.2	.995	18.4	1.50					28
A070A14	1 1220	"	"	"	"	"			12.1	.993	18.3	1.50					27
A070A20	1 1220	"	"	"	"	"			12.1	.993	18.2	1.49					30
B070A11	1 1213	"	"	"	"	"			12.0	.990	18.3	1.51					26

Remarks:

*File Frank R. Ralston Maycock @A.*

Inspector *[Signature]*

They're only a little off spec. You might not ever have noticed it. But we did. So these two lengths of Rome Unifoam® cable were never shipped. You see, when it comes to producing uniformly high quality CATV cable, we're good. But we're not perfect. Not yet anyway. That's why we examine every reel we make. And why we still have to reject a few lengths.

For example: This test sheet lists routine factory tests and inspection on 20

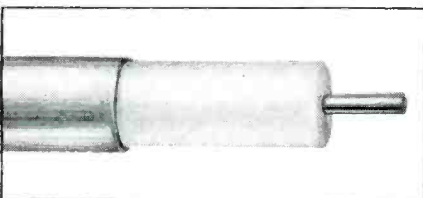

This is the Rome Unifoam CATV cable used in the majority of installations: unjacketed, unvarying, unbeatable.

reels of .412" 75 ohm Rome Unifoam CATV cable. Length B070A12 was rejected by the inspector because it failed to meet our quality standard on the 20-220 mc return loss test. The note on the test sheet explains that the 'scope traced showed a spike at 68 mc that was only 24 db down. Our acceptance standard requires that all cable be at least 25 db down at any frequency, 20-220 mc.

**Cable for tomorrow's system:** The inspector also rejected length B070A13 because the 'scope display showed a return loss spike at 127 mc that was only 22 db down, and our quality standard is 25 db minimum, 20-220 mc. What does this prove? It proves that Rome Unifoam quality is uniform across the entire 20-220 mc spectrum, not just TV channels 2-13. If it isn't, it won't get past our inspectors. This cable

is ready to handle tomorrow's added program services anywhere in the spectrum. Where else can you buy cable like this?

**Rome Unifoam can save you money.** Can you save a few repeaters in your system by buying cable with lower attenuation? Can you save time and worry if you know your cable lengths are essentially identical mechanically, dimensionally, and electrically? If so, get acquainted with Rome Unifoam CATV cable. Ask for our fact-filled folder on the subject. Just call your nearest Rome/Alcoa representative or write Rome Cable, Division of Alcoa, Dept. 4475, Rome, N.Y. 13440.

\*Rome Unifoam — Trademark of Rome Cable Division of Alcoa.

**Rome Cable**  
 DIVISION OF ALCOA

SEE US IN DENVER, CATV CONVENTION, JULY 18-23 AT BOOTHS 68, 69, 70

Circle 11 on Reader Service Card

# GUARANTEED

# 5

# YEARS

## Raytheon's NEW KTR II Microwave Equipment Carries Industry's First 5 Year Warranty Against Failure and Drift

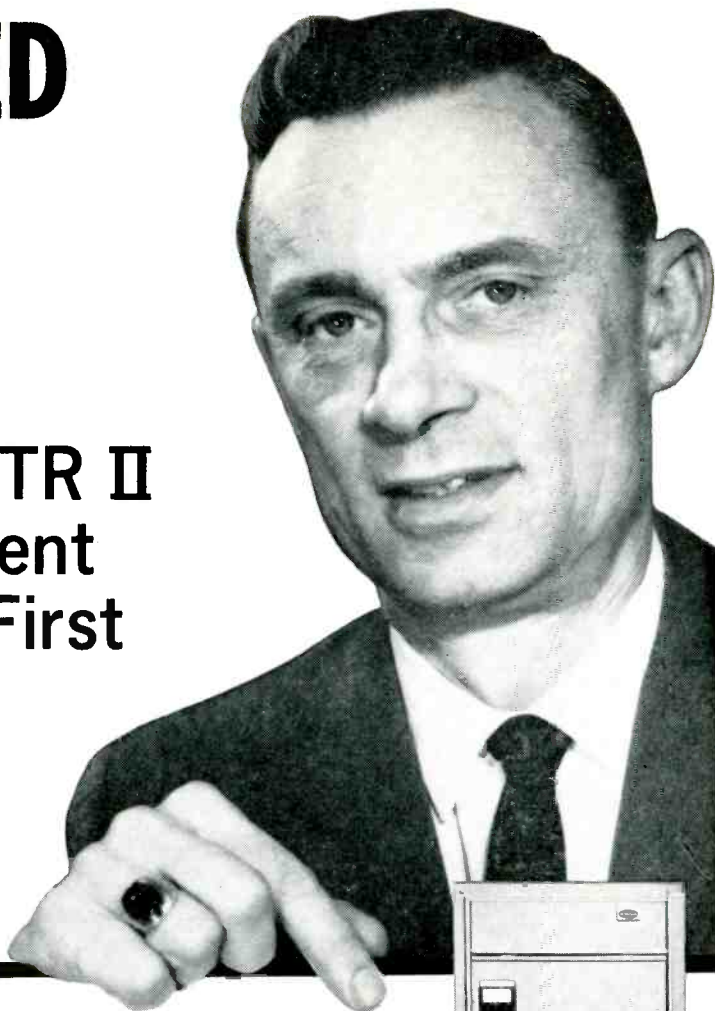

Only Raytheon demonstrates confidence in superior microwave equipment design with a full 5 year warranty against failure and drift in excess of specifications. This precedent-breaking warranty is the result of years of successful development and life testing *plus* Raytheon's novel utilization of infrared testing techniques to accurately predict component life.

In addition to the benefits of solid-state design, KTR II offers customer options, such as transmitter AFC and tunnel diode amplifiers, packaged separately to keep initial equipment and expansion costs at a minimum. Transmitter or receiver units can be removed without disrupting service on other channels and complete front-access packaging is provided for simplified "in-service" maintenance.

Not only is KTR II competitively priced but its novel design features help reduce maintenance and repair costs. For complete information, write: *Equipment Sales Manager, Raytheon Company, CADPO, 1415 Providence Turnpike, Norwood, Massachusetts.*

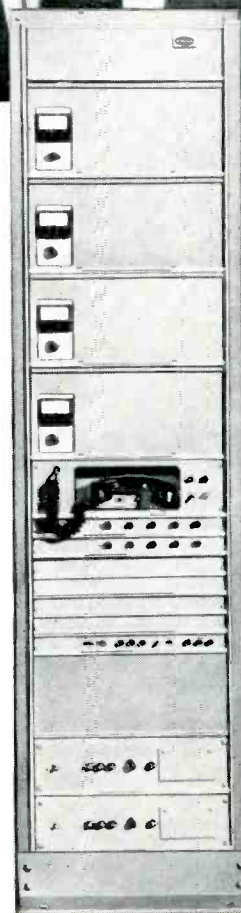

### SPECIFICATIONS:

output:	1 watt minimum
freq. range:	5.9 — 8.4 gc
capacity:	960 FDM channels; color TV; or 12 megabit data
freq. stability:	±0.002% with AFC, ±0.02% without AFC
noise figure:	10 db (5.5 with tunnel diode)
temp. range:	-30°C to +60°C
power options:	24 vdc, 48 vdc, 115/230 vdc

Circle 12 on Reader Service Card

# INTERPRETING THE **FCC** RULES & REGULATIONS

## Setting Up the Public Records File

ON March 31st, the Commission adopted Section 1.526 and amended Sections 0.417, 1.580, and 1.594 of the Rules. The changes became effective May 14, 1965.

The new rules require every broadcast applicant, permittee, and licensee to maintain a file for public inspection. In addition, public notice must be given, under Sections 1.580 and 1.594, advising of the availability and location of this file.

The specific procedures followed in providing for local inspection are left to the discretion of each station; however, they must make it reasonably possible for any member of the general public to inspect the files for any purpose whatsoever. Broadcasters who fail to comply in any respect with the rules are subject to a citation by the field inspector, or to payment of a forfeiture not to exceed \$1,000 for each day of willful or repeated failure to observe any rule or regulation of the Commission. (The maximum penalty is limited to \$10,000.)

### What the Rules Say

Since the effective date of the new rules is May 14, 1965, any request for information filed prior to that date may be denied.

(1) *Times for Inspection.* Normal workday business hours have been established as the period for inspection. Requests for inspection outside the usual office hours for the station need not be honored.

(2) *Location of Local File.* Section 1.526 states that the local public file shall be maintained at the main studio of the station or at any other accessible place (such as a public registry for documents or an attorney's office) in the community for which the station is or proposes to be licensed.

(3) *Applications.* The local file must consist of copies of applications and other documents relating to the following: (a) construction permit for a new broadcast station; (b) renewal of station license; (c) changes in programming; (d) construction permit for major changes in facilities of an existing station; (e) requests for additional time to complete construction granted by previous permits; (f) any assignments or transfers of control; and (g) all amendments to any of the aforementioned.

(4) *Ownership Reports.* The local file must contain all ownership reports filed with the Commission by the licensee or by a corporation which controls the licensee. This requirement also extends to all supplemental ownership reports. If the licensee or permittee is a multiple station owner, each station's files must contain a separate copy of the report.

(5) *Letters to the Commission.* Copies of any correspondence addressed to the Commission and any replies therefrom, pertaining to any of the applications mentioned above, or supplemental "letter ownership reports," must be included in the local file.

(6) *Contracts.* Copies of all contracts referred to in paragraph 6 of the Ownership Reports must be included. Network and similar agreements are excluded because the Commission considers them to be confidential. However, loan agreements, stock option or sale agreements, consultant agreements, bulk time contracts, and other contracts required to be filed with the Commission under Section 1.613, must be included.

(7) *Program and Operating Logs.* Copies of all logs filed with the licensee's renewal application must be kept in the local file.

(8) *Decisions.* All initial, interim, or final decisions of the Commission affecting the permittee or licensee must be kept in the local file.

(9) *Requests for Political Time.* Sections 73.120(d), 73.290(d), and 73.657(d) presently require the licensee to "keep and permit public inspection thereof" copies of all requests, letters, exhibits, or other related information pertaining to political broadcasts.

(10) *Incorporation by Reference.* All references in applications or other material submitted to the Commission, stating that information is already on file with the Commission, must be carefully employed. Such references will require all such material (except network contracts) to be included in the local file.

### You Need Not Include

*Applications:* (1) for minor changes in facilities which do not involve changes in programming and for which public notice is not required; (2) for licenses to cover construction permits; (3) for extension of time to complete construction of other than new stations; (4) for remote pickup, studio-transmitter links, or other such auxiliary facilities; (5) for direct measurements of power or other similar changes.

*Hearings Before the Commission.* All pleadings, briefs, interrogatories, depositions, transcripts, and other material associated with hearings on applications (except decisions and FCC orders) are not required in the local file.

*Correspondence.* All letters and records of other communications with attorneys, consulting engineers, suppliers, networks, press service, and similar business transactions are not required.

*Contracts.* Network, music licensing, national or regional representation, transcription, film or press service, and the usual staff employment contracts are not required.

**INDISPENSABLE**

**GIANT: 8x14 size**

Reference for CATV Systems Owners, TV Station Management, Microwave Common Carriers—and anyone interested in TV-CATV.

# CATV SOURCEBOOK

including Exclusive Data Tables on TV and Microwave

by **Dr. MARTIN H. SEIDEN**

**CATV SOURCEBOOK**

150 pps.

**N**OW—**SPECIAL PREPUB PRICE** only **\$7.95**

—from the files and research of Dr. Martin B. Seiden, author of the FCC Report "An Economic Analysis of CATV Systems and the TV Broadcasting Industry," comes this mammoth, thorough, compilation of exclusive facts, figures, forms, agreements and other revealing data. "CATV SOURCEBOOK, including exclusive Data Tables on TV and Microwave," contains much information available nowhere else—any one of its numerous Tables and Charts could be worth the small cost.

### An Authoritative Compilation

Now you can have, at your fingertips, this carefully-planned reference source chock-full of significant facts, figures, and operating guidelines. This detailed compilation of helpful data is the answer to the need for an organized gathering of CATV data—and information on TV, microwave, and related areas. This practical info will help you solve many problems and will save you hours of time

and effort in hunting up needed data. And, much of the information in "CATV SOURCEBOOK" is exclusive data available nowhere else. Assembled for the first time in book form, "CATV SOURCEBOOK" is the result of months of intensive study and research by Dr. Martin H. Seiden, the noted economist selected by FCC to report on CATV.

### Invaluable Information

The partial listing of Contents at left can provide only a small idea of the invaluable data contained in "CATV SOURCEBOOK." Here is a wealth of exclusive data, such as CATV Systems ranked by number of subscribers; Number of CATV Systems and Subscribers by State; TV Station Assignments Available in Top 10 Markets; Percentage Distribution of TV Stations within CATV Penetration Categories; Group Ownership of TV & CATV; Common Carrier Microwave Companies receiving CATV's, and their Tariffs; etc. Here, too, you'll find a suggested standard accounting format, listing all normal expense items incurred in operating a CATV System—plus data on pole space tariffs, local CATV franchise clauses, etc. In all, a wealth of essential data everyone interested in CATV-TV and microwave will find of lasting value.

### Limited Time Offer

"CATV SOURCEBOOK" regularly sells for \$9.95. Through July 31, however, the Special Prepublication price of only \$7.95 prevails. Order at our risk for 10 days FREE examination. *Send no money!* Simply fill in and mail NO-RISK coupon below for this up-to-date Sourcebook!

**PARTIAL LIST OF CONTENTS**

- No. of CATV Systems and Subscribers By State
- CATV Systems With Over 4,000 Subscribers, Ranked by Size
- TV Translators By State
- Station Assignments Available in Top 10 Markets
- TV Satellites & Parent Stations
- Number of Stations by Size of Market & Station Affiliation
- Number of Unprofitable TV Stations by Size of Market
- TV Viewing by No. of Stations Serving Market
- Percentage Distribution of TV Stations Within CATV Penetration Categories by Station Characteristics
- Effective Non-duplication Agreements
- Group Ownership of CATV Systems
- Co-ownership of TV and CATV
- Examples of Microwave Tariff Filed With FCC
- Common Carrier Microwave Companies Receiving CATV's, Signals Delivered, and Tariffs
- Microwave Service to CATV
- TV Stations Renting Microwave Signals From Common Carriers Serving CATV Systems
- Schools Receiving Microwave
- Bell Telephone Pole Rental Policies
- Tariff For CATV Pole Space
- Local CATV Franchise Clauses
- State Regulation of CATV
- CATV Basic Accounting Items

**EXAMINE FOR 10 DAYS AT OUR EXPENSE!**

Order on approval for 10 days FREE examination. If at the end of 10 days you don't want the book, return it and we'll cancel invoice.

### NO RISK COUPON—MAIL TODAY

TAB Books, Drawer D, Thurmont, Md. 21788  
Please send me \_\_\_\_\_ copies of "CATV SOURCEBOOK" at the special Prepublication price of only \$7.95 (regular price \$9.95) I enclose \$ \_\_\_\_\_

Please invoice on 10-day FREE trial  
Name \_\_\_\_\_  
Company \_\_\_\_\_  
Address \_\_\_\_\_  
City \_\_\_\_\_ State \_\_\_\_\_ Zip \_\_\_\_\_  
BS 765

**Annual Financial Reports.** Unless incorporated by reference in a document which must be included in the local file, such reports *need not be made public.*

**Commission Inquiries.** Questions emanating from the Commission concerning inspections, contests, complaints, and related matters, *are not required.*

### So Here's Free Advice

In view of the fact that broadcasters will become the subject of more intense scrutiny than ever before, we recommend the following:

(1) All applications which will become a part of the local files should be prepared with great care. All material which is unnecessary or not essential to the grant of the application should be excluded.

(2) Remember that application entries which state "On File" or words to that effect means that the material incorporated by reference must then be placed in the local file.

(3) Members of the staff should be on hand to direct the public to the files. All individuals requesting access to the files can be asked to identify themselves in some manner, such as filling out a requisition slip, giving name, address, and telephone number. This procedure should minimize the possibility of theft from the file. Whenever possible, a staff member, such as a secretary, should remain in the same area with the visitor. However, it is not necessary to render any assistance beyond making the file available.

(4) Wherever the files are located (main office, studio, or attorney's office), they should be kept under lock and key, and you should not permit any person to remove papers from the file. In fact, do not allow the removal of the file from the supervised area by other than your own authorized personnel. For example, requests to remove the complete file or portions thereof for photocopying or duplicating should be politely but firmly denied.

(5) You must maintain the material accumulated in the file for a minimum of two years.

(6) Multiple station owners are required to maintain a *separate file for each station*. Each station's file need contain only data that relates to the particular station. Keep in mind, however, that if a multiple owner follows the usual practice of filing one ownership report for all the stations (including all supplemental reports), then copies of that report must be kept in all the station's files.

(7) Treat all requests by citizens to inspect the files courteously; however, you may absolutely refuse to make available confidential material or material that antedates May 14, 1965.

It is incumbent upon all licensees to be sure that their files contain all the information required by the new rules. If you have any questions regarding the information required, or problems with various citizen requests for inspection, be sure to contact your legal counsel.

## Operator Requirements

The Commission's public notices in recent months indicate an upsurge in violations of the

Circle 13 on Reader Service Card

Rules pertaining to operator requirements for AM and FM stations. Evidently, many broadcasters operating lower power stations either have not awakened to the Commission's one-year-old operator rules, or they have decided to ignore them.

On July 10, 1963, the Commission adopted a Report and Order (RM-294, Docket No. 14,746) pertaining to Amendments to Sections 3.93, 3.265, 3.565, and 13.21. The changes modified the operator rules for nondirectional AM stations of 10 kw or less, and FM stations of 25 kw or less. A comparison of the prior rules with the new amendments seems to be in order.

Under the provisions of the previous rules, many lower-powered stations employed persons holding *restricted* radiotelephone operator permits for routine transmitter operation. Such permits were the lowest type of operator authority issued by the Commission. Holders of such permits had only to sign a declaration stating that they were familiar with the regulations governing the authority granted, and that they understood their responsibility to keep currently familiar with the provisions of the Rules. They were not required to demonstrate, through examination or otherwise, that they did in fact possess the required knowledge.

The Report and Order changed the Rules:

(1) It raised the minimum operator authority for routine transmitter operation at lesser-powered stations, from the restricted permit to a third-class permit "endorsed" for broadcast station employment. Third-class license holders are required to pass written examinations which qualify them to engage in various types of operator activity. The new rules require them to pass an *additional examination* in order to obtain an endorsement which qualifies them for employment at broadcast stations. Thus, the new requirement is greater in two respects, requiring not only a third-class operator for routine transmitter operation, but one who has, in addition, passed the broadcast-endorsement examination.

(2) It requires that station licensees train their lesser-grade operators to insure that they are properly instructed in the duties of routine transmitter operation and capable of performing such duties when not under the immediate supervision of a first-class license holder.

(3) The *prior rules* permitted lesser-powered stations to utilize the services of other than first-class operators for routine transmitter operation, provided that they also had in regular full-time employment a first-class operator with certain responsibilities. The Report and Order changed this by permitting the first-class operator in such cases to be employed either on a full-time basis *or on a contract part-time basis*.

The new operator rules require that stations, in the power classes mentioned, for *routine* transmitter operations, use persons holding at least third-class permits endorsed for broadcast operation. Basically, these rules *help* licensees in that they reduce, in some instances, the class of operator which stations must have on duty, but they raise the standards for those seeking lower-class operator permits. Stations still operating under the old rules are advised to modify their practices accordingly. ●

## Is your market coverage suffering from voltage fluctuations at the transmitter?



### Protect your signal strength and equipment by specifying the Solatron line voltage regulator

- Assures signal coverage and quality right out to fringe areas; protects tubes and components from early failure.
- No moving parts, maintenance free; considerably smaller and lighter than other regulators of equal capacity.
- Fast response: 90% correction in less than 0.08 second, complete correction in 0.16 second.
- No harmful waveform distortion.
- Output voltage adjustable; can be set at optimum voltage and held constant within  $\pm 1\%$ .
- Available in ratings from 1 to 100 KVA and all standard input voltages.



Division of Basic Products Corporation  
**SOLA ELECTRIC CO.**,  
 1717 Busse Rd., Elk Grove, Ill., HEmpstead 9-2800  
**IN CANADA: SOLA BASIC PRODUCTS, LTD.**,  
 377 Evans Avenue, Toronto 18, Ontario

Industry's voltage regulation headquarters

Here's how I'd like to use the Solatron regulator; send me the facts covering this application.

.....  
 NAME .....

TITLE .....

COMPANY .....

ADDRESS .....

CITY..... STATE..... ZIP.....

Circle 14 on Reader Service Card

**This is  
Sealmetic<sup>®</sup> Coaxial-  
the cable  
Anaconda designed  
especially for  
CATV**

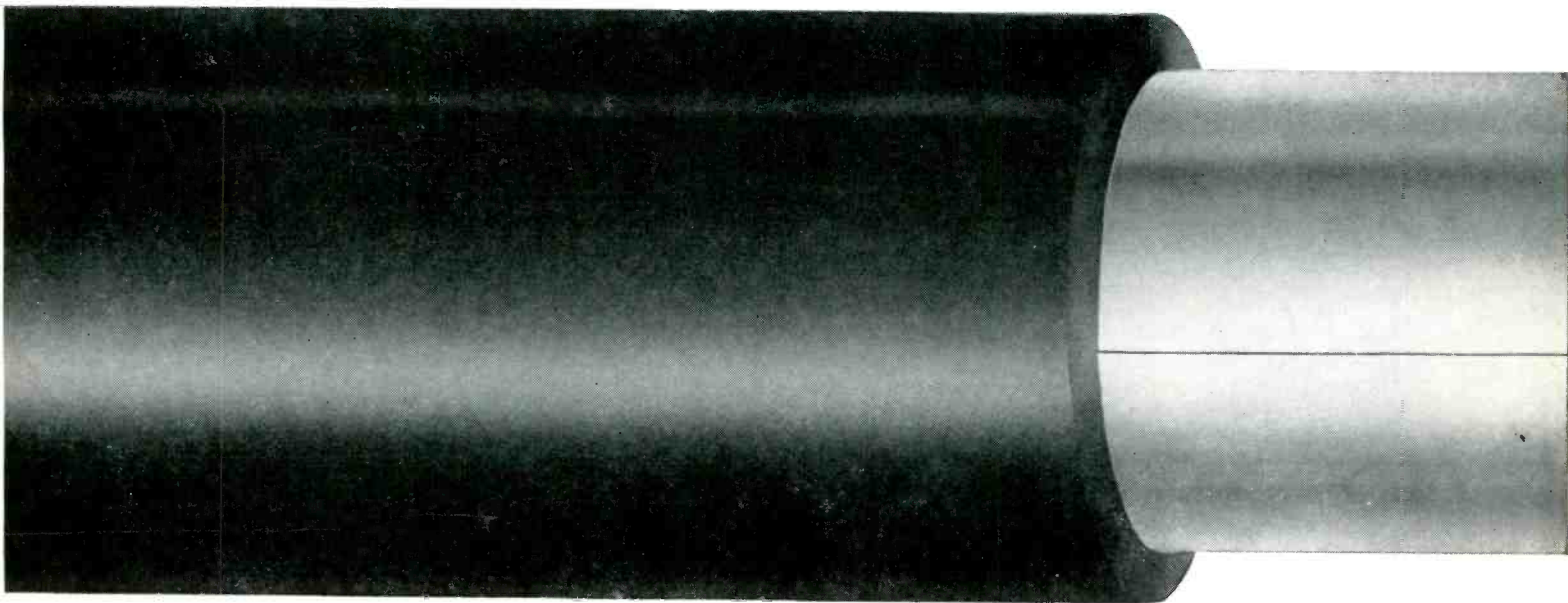

**Sealmetic's positive moisture barrier makes the big difference.** The Sealmetic sheath is hermetically sealed at the shield overlap, and is bonded between the entire outer conductor and the polyethylene jacket to form a unitized sheath. Moisture or humidity can't get between the shield and the jacket nor enter the core. The core stays dry and maintains the electrical characteristics of the cable.

Sealmetic Coaxial is the flexible, moistureproof CATV cable—the cable that solves attenuation problems.

**More flexible, easier to install than any other CATV cable.**

The bond at the shield overlap has been balanced against the bond between the entire outer conductor and jacket, resulting in a completely homogeneous composite sheath. This unique design allows easy bending without kinking, cracking or rupturing of the sheath. Sealmetic is less susceptible to installation damage; installation goes faster and costs less, and the cable will last once it's installed.

When you're considering CATV, you should know about Sealmetic Coaxial. For more information, contact your Anaconda man, or write to Anaconda Wire and Cable Company, 605 Third Avenue, New York, N. Y. 10016. 65221

ASK THE  MAN FROM  
**ANACONDA**<sup>®</sup>  
ABOUT NEW SEALMETIC COAXIAL CABLE

®Registered Trademark Design Patents Applied For

OUTER CONDUCTOR BONDED TO POLYETHYLENE JACKET

HERMETICALLY SEALED OVERLAP

CO-POLYMER BONDING MATERIAL  
COMPLETELY OVER SHIELD



Circle 15 on Reader Service Card

# Preparing Engineering Data for Form 301

Part 3—If you're planning a new TV station, or major changes in your present TV facility, here are some guidelines for filing data with the FCC.

by Harry A. Etkin

THE DATA required by FCC Form 301 for standard and FM broadcast facilities has been dealt with in the two preceding issues. This third and final part concerns information required by Section V-C and the costs involved in preparing engineering data for TV facilities.

## Channel Selection

Channels assigned to TV broadcasting are listed in Par. 73.603, subpart E, Vol. III of the Rules. The channel you request must be listed in the Table of Assignments, Par. 73.606. If the city has no assigned channel and does not qualify under the 15-mile regulations, or if authorizations have already been made on the channels listed in the Table, you will have to petition the FCC to change the Table. (Par. 73.607). The petition must comply with the separations in Par. 73.610.

## Transmitter

Manufacturer's specifications list the rated power for both the aural and visual transmitters. If the rated power is listed in watts or kilowatts, the power in dbk may be determined by the formula:

$$\text{Power in dbk} = 10 \log_{10} \times \frac{\text{Power in kw}}{1.0}$$

Power output of transmitters is usually determined by feeding the output into a dummy load with a standard black picture input, and measured by a voltmeter coupled to the transmission line. Visual and aural reflectometers are directly calibrated to read power from the dummy. During normal operation, transmitter power is maintained by adjusting for a constant reflectometer reading. Method of control for each manu-

Mr. Etkin is a staff engineer with WQAL-TV, Philadelphia, Pa.

facturer and the accepted method is on file with the FCC.

Aural power can be directly or indirectly measured as required by the Rules, Par. 73.689 (2) Operating Power. Using the direct method, the operating power is

## Facts About TV Antennas

Stacking one element on top of another and feeding the elements in proper phase increases the far field voltage.

The field at the horizon increases with additional bays, and additional nulls and lobes appear between the first null and the horizon.

Nulls over populated areas can be avoided by phasing or power splitting or a combination of both. Determine the vertical angle to be covered.

## Costs for TV Engineering Data

The average cost for engineering, design work, tests and measurements, calculations, computations, compiling of data, and filing Form 301 for a TV facility would be between \$750 and \$1250. Usually, there is an additional charge of \$100 for personnel expenses and the cost of obtaining and entering the data for:

- a. Geographical coordinates
- b. Topographical maps
- c. Profile maps
- d. Sectional aeronautical maps
- e. Aerial photography
- f. Predicted field strength patterns and contours
- g. Instrument approach or landing charts
- h. Other incidental materials

Charges for design and measurements for a directional array or other changes in an existing facility, would cost about \$500.

the product of the plate voltage ( $E_p$ ) and the plate current ( $I_p$ ) of the final stage and an efficiency factor:

$$\text{Operating power} = E_p \times I_p \times F$$

The manufacturer's data will tell you the established efficiency factor.

## Antenna Site and Structure

Applicants proposing to locate an antenna within 200 feet of another TV antenna operating on a channel within 20% of the frequency of the proposed channel, or if the channel applied for is 5 or 6 and is within 200 feet of an FM antenna, must describe the effect expected of such operation. (Par. 73.685).

If the tower of a standard broadcast station will be used as a supporting structure for the TV antenna, an application for changes in the radiating system of the AM station must be filed. If a substantial change in height or radiation or radiation characteristics of the AM station antenna is necessary, a formal application (Form 301) must be filed, otherwise an informal application will be acceptable. When the tower of any other class of station will be used, an application may also be necessary.

If the TV antenna will be installed in the vicinity of an AM directional array, and it appears that the operation of the directional system may be affected, an engineering study must be filed with the TV application detailing the effect of the TV antenna on the AM pattern. Readjustment and field intensity measurements of the AM directional array may be required after the TV antenna is built.

The height of the antenna radiation center is the physical center of the radiating elements if uni-



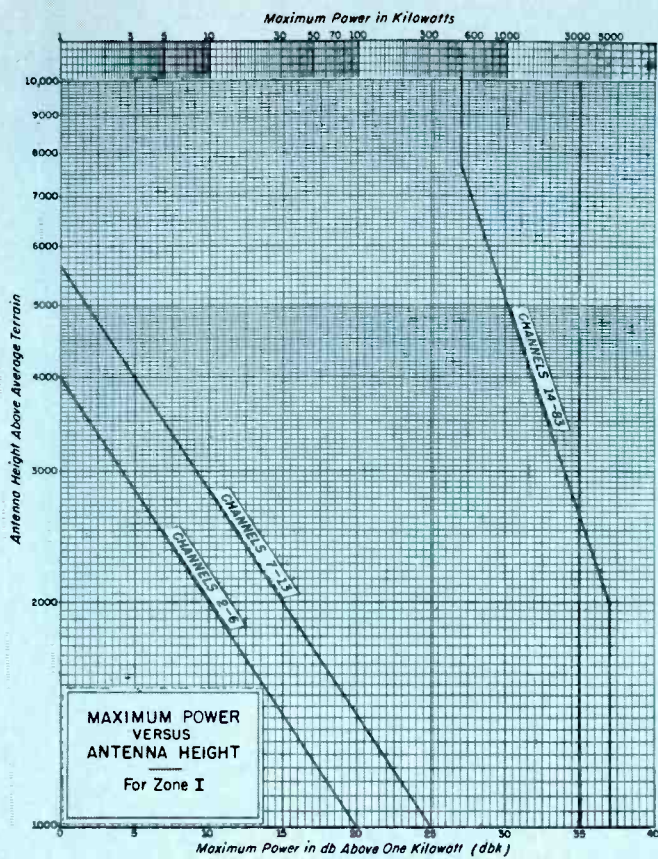

Fig. 1. Relationship between antenna height and power for Zone 1.

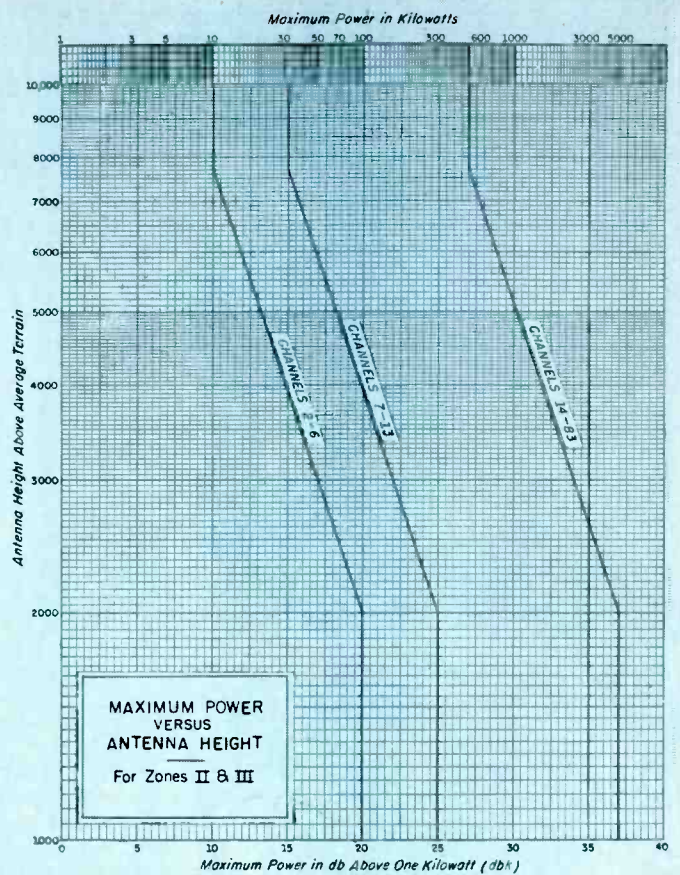
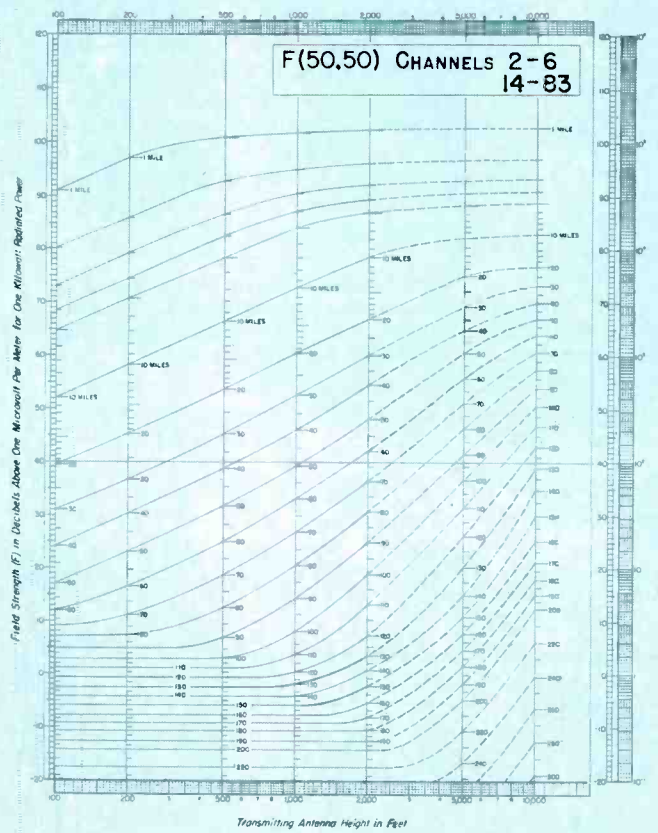
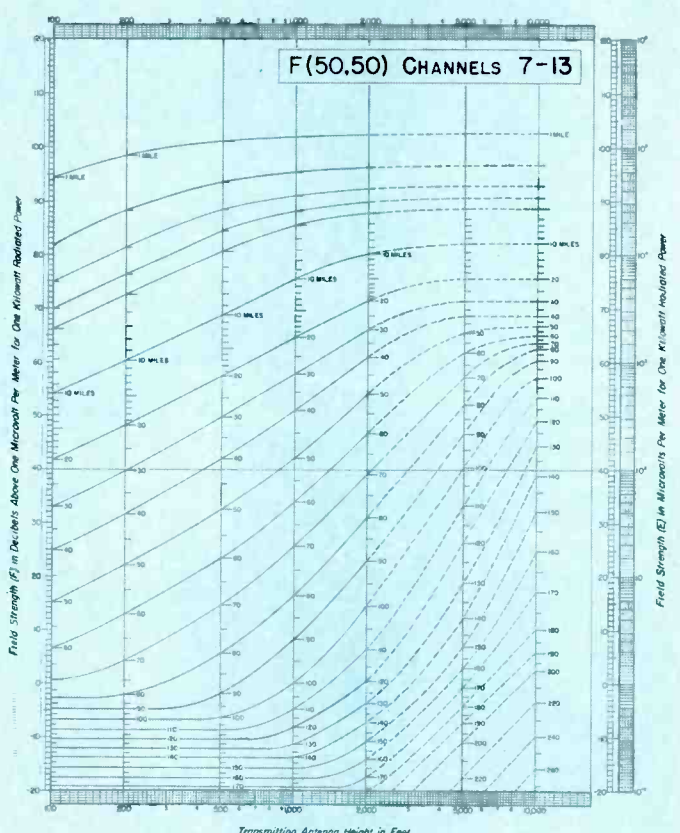

Fig. 2. Relationship between antenna height and power for Zones 2 and 3.



TELEVISION CHANNELS 2-6, 14-83  
ESTIMATED FIELD STRENGTH EXCEEDED AT 50 PERCENT OF THE POTENTIAL RECEIVER LOCATIONS FOR AT LEAST 50 PERCENT OF THE TIME AT A RECEIVING ANTENNA HEIGHT OF 30 FEET

Fig. 3. Chart for predicting field strength for Channels 2-6, 14-83.



TELEVISION CHANNELS 7-13  
ESTIMATED FIELD STRENGTH EXCEEDED AT 50 PERCENT OF THE POTENTIAL RECEIVER LOCATIONS FOR AT LEAST 50 PERCENT OF THE TIME AT A RECEIVING ANTENNA HEIGHT OF 30 FEET

Fig. 4. Chart for predicting field strength for channels 7-13.

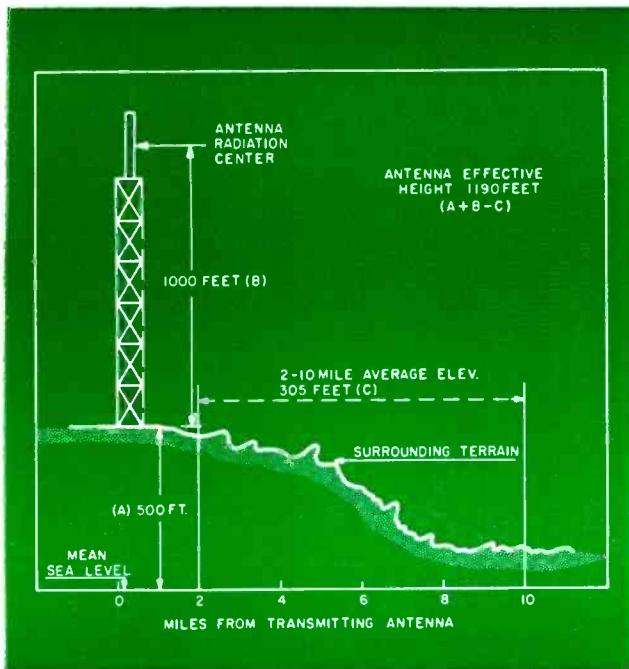

Fig. 5. Sketch showing computation of effective height for a typical radial.

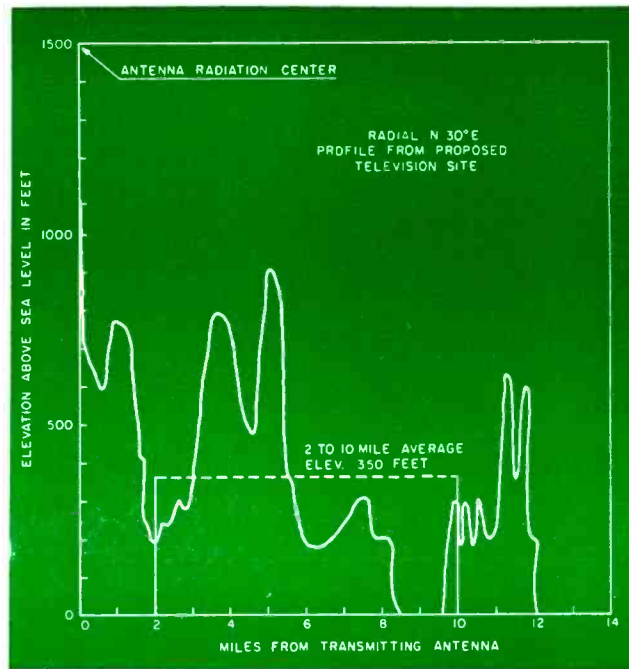

Fig. 6. Sketch of a typical radial profile graph.

form power distribution is used. If a split-feed system with non-uniform power distribution is to be used, the height of the radiation center will not be the same as the physical center.<sup>1</sup> The formula for computing the power gain in db is:

$$\text{Gain in db} = 10 \log_{10} \times \text{power gain}$$

Normally, the visual and aural signals are diplexed through the same antenna.

A directional antenna may be used only to improve service, not to reduce minimum mileage separation requirements. The following regulations apply:

1. The ratio of maximum to minimum radiation in the horizontal plane must not exceed 10 db. (Max. 3.162/1).

2. Minimum ERP in any horizontal direction may not be less than the applicable minimum.

3. Maximum ERP in any horizontal or vertical direction must not exceed the applicable maximum listed in Table I and Figs. 1 and 2. When the antenna height above the average terrain is above the listed heights, the maximum designated ERP is reduced as shown in Figs. 1 and 2.

4. Radiation above the horizontal must be as low as state of the art allows and cannot exceed the value in the same vertical plane.

Applications for directional systems must be accompanied by:

1. Complete description of the proposed system.

2. Orientation of array with respect to true north, time phasing of fields from elements (degrees leading or lagging), space phasing of elements (in feet and degrees), and ratio of fields from elements.

3. Horizontal and vertical radiation patterns, showing free-space field intensity in millivolts per meter at one mile and the ERP in dbk for each direction. Methods used to compute or measure radiation patterns must be fully described, including formulas and equipment used, sample calculations and tabulations of data. Enough vertical plane patterns should be included to clearly show the radiation characteristics of the antenna above and below the horizontal plane. Horizontal plane patterns should be plotted on polar coordinate paper with reference to true north and vertical patterns on rectangular coordinate paper with reference to the horizontal plane.

### Transmission Line

Transmission line make, type no., size in inches, coax or waveguide, is determined by frequency, desired efficiency to produce the required ERP, and cost considerations. The length in feet is the horizontal run from the diplexer to the base of the tower plus the length up the tower to the point where the antenna gain is rated. The manufacturer's specifications should be used to determine the power loss in db for the length of line. The formulas for these calculations are:

ERP in dbk equals transmitter power in dbk, less multiplexer loss in db, less transmission line loss in db, multiplied by antenna gain in db.

$$\text{Power in dbk} = 10 \log_{10} \frac{\text{Power in kw}}{1.0}$$

$$\text{Power in kw} = \text{Antilog}_{10} \frac{\text{Power in dbk}}{10}$$

Table I—Maximum ERP and Antenna Height

Channel	ERP	Ant. Height Zone I	Ant. Height Zones II and III
2-6	20 dbk ( 100 kw)	1000 feet	2000 feet
7-13	25 dbk ( 316 kw)	1000 feet	2000 feet
14-83	30 dbk (1000 kw)	2000 feet	2000 feet

The rms value should be used if a directional array is employed; however, the maximum value must be entered for item 7(b) of Form 301.

The visual output is measured at the output of the vestigial side-band filter, if one is used. Visual and aural losses in the diplexer or multiplexer are given in the manufacturer's specifications.

### Expected Coverage Information

Profile graphs of the terrain from 2 to 10 miles must be furnished for 8 or more radials from the transmitter location. At least 8 uniformly spaced radials, one or more passing through the principal city, should be plotted on a topographic map.<sup>2</sup> The profile graph for each radial should be plotted by contour intervals of from 40 to 100 feet, and where possible, at least 50 points of elevation should be used for each radial. The graphs should show accurately the actual topography, and plotted with the distance in miles as the abscissa and the elevation in feet above mean sea level as the ordinate. The elevation of the antenna radiation center and the source of topographic information should be shown on each graph.

Topographic information may also be obtained along roads which are along radials from the transmitter by using a sensitive altimeter in an automobile. The average elevation of each radial may be determined from the profile graphs with a planimeter or by averaging the median values of mile or half mile segments. The height of the antenna radiation center above average elevation of the radial is the height of the radiation center above sea level (item 7a on the form) minus the average radial elevation previously calculated. The ERP in each radial direction is equal for a non-directional antenna (item 9a). For a directional antenna, the value should be taken from the

horizontal pattern for each azimuth bearing of the individual radials.

The predicted distance to the Grade A and B contours are determined from Figs. 3 and 4. The F(50,50) field intensity charts (Figs. 9 and 10 of the Rules, Par. 73.699) should be used to predict the field intensity contour distances. The charts are based on an effective power of 1 kw. The sliding scale associated with the charts should be used as an ordinate scale for higher powers.<sup>3</sup> For example, if on channel 7 you have an ERP of 17 dbk and an antenna radiation center 2,000 feet above average terrain for radial A, the equivalent contour for Grade A service will be 71 dbu-17 db on the 1-kw curve on the 2,000 feet elevation line of Fig. 4 (Fig.

### Significant Factors in Filing

If an application is submitted for changes in an existing station, all paragraphs relating to the proposed changes should be completed. The remaining paragraphs should be marked "On File—No Change."

Furnish engineering exhibits to support the application, but data submitted in previous Form 301 filings should not be repeated.

10 of the Rules, Par. 73.699). 54 dbu is at a distance of 54 miles.

The terrain in one or more directions from the antenna site may differ to some extent from the average elevation of the 2 to 10 mile sector. The prediction method may indicate contour distance values different from what may be expected in practice; a mountainous area may indicate the practical limit of service while the prediction method indicates otherwise. The prediction method should be followed in these cases, but a supplemental tabulation indicating contour distances deter-

mined by other methods should be made, describing the procedure and including sample calculations. Maps of predicted coverage should include the predicted coverage by the supplemental and regular methods, the same information required when measurements are necessary. Where there are special terrain problems, a supplemental tabulation of expected coverage must be included together with a description of the method used to predict coverage. The FCC may require additional information about terrain and coverage. The transmitter location, the radials used in items 14a and 15, and the Grade A and B contours should be plotted.

The minimum field strength required over the principal community is shown in Table III. The field strength in your case may be calculated by determining the depression angle below the horizon from the antenna height and distances to certain parts of the community. The dbu value may be determined from Figs. 9 and 10 of Par. 73.610, using the ERP value for the correct depression angle for the proposed antenna vertical pattern. Par. 73.610 and 73.611 explain separation requirements.

Figs. 5 and 6 are examples of typical graphs which must be filed for each of the eight radials with the transmitter at the center. Each radial is 45° apart and each is averaged for its effective antenna height figure; the contours are computed for the individual radial height. ●

### FOOTNOTES

1. Ground level elevations can be determined from USGS topographical quadrangle maps. For specific area maps, contact the U.S. Geological Survey, Dept. of Int., Washington, D.C. 20240. West of the Mississippi: USGS, Denver 15, Colo. Sectional aeronautical charts are available from the U. S. Coast and Geodetic Survey, Dept. of Commerce, Washington, D. C. 20235.

2. Topographic maps for most areas are available at a nominal cost from U.S. Geological Survey, Dept. of Int., Washington, D. C. 20240. If maps are not published for your area, use the information in Par. 73.684: Prediction of Coverage, subparagraph g.

3. See Par. 73.684: Prediction of Coverage for the proper application.

Table II—Required Field Intensities

Channel	Grade A	Grade B
2-6	68 dbu	47 dbu
7-13	71 dbu	56 dbu
14-83	74 dbu	64 dbu

Table III—Permissible Field Strength Over Principal Community

Channel	dbu
2-6	74
7-13	77
14-83	80

# Guidelines

by Robert B. Cooper, Jr.

**D**URING 1961 an acquaintance of mine began an intensive campaign for securing CATV franchises in six southwestern towns. The first step in what he expected to be a long, drawn-out campaign was to inform the respective city councils of his interest in providing cable service to their communities. He did this by sending them a form letter, along with a copy of a CATV ordinance which had been passed recently in his area.

In short order five of the six responded with letters notifying him that he was scheduled to appear before the council on such and such a date. The sixth did not respond for nearly a month, and just when my friend was about to write them off, he received a letter

Mr. Cooper is Vice-President of Valley-Vision, Inc., a Modesto, Cal., CATV firm which has secured several franchises.

from the City Administrator. Enclosed with the letter was a *new* copy of the sample CATV ordinance he had submitted—only the sample ordinance was now that town's cable ordinance. My friend had been awarded a cable franchise by mail!

Well, those days are certainly gone forever. Mail-order franchises, and uncontested or unchallenged franchise applications, simply don't happen anymore. The 1965 CATV franchise race is without a doubt the most competitive, hard-fought, nerve-wracking experience cable men have faced since this industry began. Competition is something new to most cable franchise seekers, something they haven't yet learned to cope with. We did.

## Local Appeal is the Key

The history of cable systems supports the strong appeal of local

system ownership. This key factor has not yet been emphasized much by large group owners desiring to expand their holdings. Moreover, group-owned systems are far outnumbered by locally owned and operated systems. Most of today's multiple systems began as local projects, and were later sold to chain owners.

It has been our experience that a local group has a considerable head start on any outside group. A local group, with local personal contacts, can lay the all-important groundwork which must precede any competitive hearings. For sake of example, and to provide a guide to those contemplating franchise negotiations, let's review how a recently let franchise progressed from start to finish.

## The Town

The town has a population of 12,000. Off-the-air TV reception

Atwater, Cal. City Council hearing June 14, 1965 discussing CATV franchise yet to be awarded. The three applicants are General Electric Cablevision, Storer Broadcasting Co., and Valley-Vision, Inc.



# for Obtaining a CATV Franchise

The first of a 2-part feature, dealing with the mechanics of securing a cable TV franchise.

consists of signals from three VHF stations with grade B coverage, two grade B UHF stations, and seven other VHF channels grade C or poorer. Color reception was passable from the grade B VHF stations, but only with 50-foot antennas that averaged \$150 to install.

## The Groundwork

A new corporation, called Valley-Vision of Town X, Inc. was outlined, and a local attorney was engaged. (The best attorney in town is a good investment; if you don't engage him, your competition probably will.) The attorney and our group made up a list of the prominent business people in town, being careful to avoid any of the city councilmen or other political figures. The attorney and a representative from our firm then called on several of these locally prominent figures to explain

what cable TV was, and to outline what our company had to offer. No mention was made of securing local investment at this point.

Within a week two of the most interested businessmen were revisited, and a complete cable program (including the channels we planned to offer) was laid before them. We told each of them we were also discussing the program with the other, to avoid any misunderstandings. Our attorney had already ascertained that they had no local animosities.

At this juncture our representative made mention that our cable program was based on local appeal, with some local investors. We emphasized that we wanted the business to have a local flavor, without the appearance of an outside group seeking to subdue the town with outside money. Each of the two indicated considerable interest in being investors. We thanked them for their interest

and set up a meeting for the following week to bring them together with our own financial people and acquaint them further with our locally oriented program.

At this meeting an agreement was drawn up, and the two businessmen pledged to invest in stock which gave them, collectively, 25% ownership in the system. (This has been the maximum our corporation has allowed local investors, except in towns requiring over \$400,000 investment and/or with over 40,000 population.)

## A Few Cornerstones

Keep in mind that no public announcement of the cable system plans had been made. Contact up to this point was confined strictly to the potential local investors. However, at about this time two large national concerns *did* file formal applications with the city, and asked to be placed on the agenda of the city council. The stage was set for CATV.

With the local participation set down in agreement form, we went to work at the local level. One of the investors made a trip with our man to his "friend," the local newspaper editor. We left the newspaper man with a complete outline for our system and gave him honest, factual answers to all of his questions. They were mostly concerned with Pay TV. Once he was assured that cable TV was not "pay-to-see TV," and that our firm would operate in the "local public interest" with local backing, the editor was on our side 100%.

Next stop was city hall, and the Mayor and City Manager. With our local investor leading the way, we were soon on a first name basis with both of these key people, and the city attorney joined us. We explained our local approach to cable TV, and pointed out that if outside groups could offer this service, so could local people, thus keeping the business at home.

(Continued on page 36)

## What is a Franchise?

There are two types of franchises—exclusive and nonexclusive. An exclusive franchise permits the system to be operated in a controlled environment, under regulation and without competition, provided it is operated under the terms of the franchise. Fewer than 5% of the franchises let today are exclusive, and nearly all of these are in small towns.

A nonexclusive franchise is in reality not a franchise at all, but a business license, in most states. It is a specialized form of business license, with dictated terms, and with special dispensations awarded to the firm receiving the license, such as permission to utilize rights of way, etc., established by the city for public utilities. The terms of such an award are almost always spelled out in a specially prepared city ordinance which considers the problem and conditions unique to cable television. Usually the ordinance does two things: (1) It authorizes the city council to grant a CATV franchise (which is in reality a controlled form of business license unless it is exclusive); and, (2) It sets up the technical terms of the contract between the grantee and the city.

Obviously the cable firm should have a hand in the drafting of the cable ordinance, since the system will have to be operated under the terms of the "contract" for the period of the franchise (or license).

# YOU CAN GO 100 MILES WHEN YOU

Prove it to yourself. Visit Ameco at the NCTA Convention and see for yourself . . . a 100% solid-state cable system on demonstration. Just as the man from Missouri said, "You have to show me", Ameco will show you just how dependable solid-state can be. No matter where your system is located, you'll never put equipment through such punishment or ask for performance under such conditions.

**BOOTHS 49-53, 75, 76 — DENVER HILTON**

## AMECO SOLID-STATE HEADEND

A complete, solid-state headend is available now from Ameco. The dependability of solid-state for signal distribution has been demonstrated. Now this same dependability is available in headend receiving equipment from Ameco.

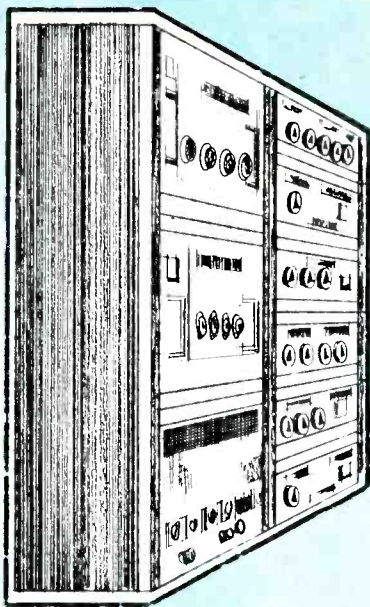

## AMECO SOLID-STATE AMPLIFIERS FOR CATV

The Ameco "70" series solid-state, etched circuit amplifiers will be demonstrated under conditions most systems would never encounter. Recognized for its low noise figure, high output, wide temperature operating range, and cascability, the "70" is a popular CATV amplifier.

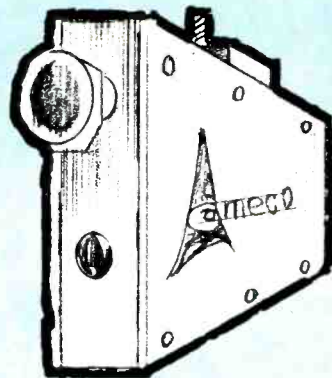

# 100% SOLID-STATE GO AMECO!

Ameco's Research and Development Department pioneered and perfected the solid-state, cable-powered, all-band concept. Introduced to the cable industry three years ago, Ameco's solid-state concept is now the standard. From head-end to active tap, Ameco offers a complete 100% solid-state cable system. Equipment designed for the maximum in dependability, the maximum in economy of operation and the maximum in performance.

**PHOENIX, DENVER, COLORADO JULY 18-23!**

## AMECO SOLID-STATE AMPLIFIERS FOR CATV

The Ameco "65" series amplifiers are new to the Ameco product line. The "65" has the same operation characteristics as the "70" series, but is housed in a pole mount configuration. This provides an opportunity to the system operator to convert to a solid-state, cable powered, all band system at a conservative cost figure.

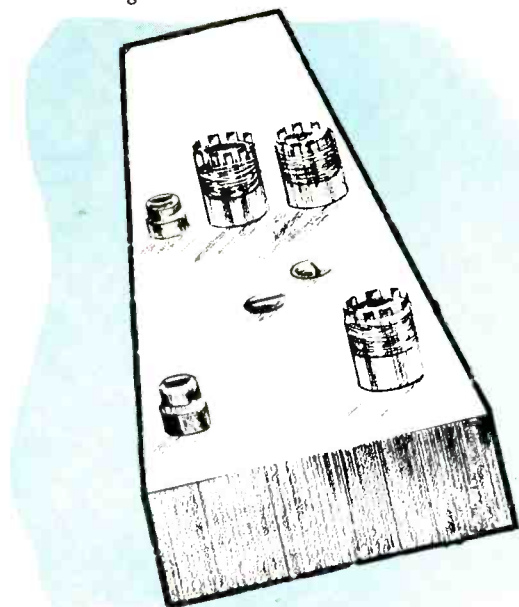

## AMECO WEATHER-MATIC

A revolutionary new concept in information channel programming . . . the Ameco Weather-Matic. This is an electronic system for sequential display of time, temperature, wind velocity and direction, as well as news. And in COLOR, too!

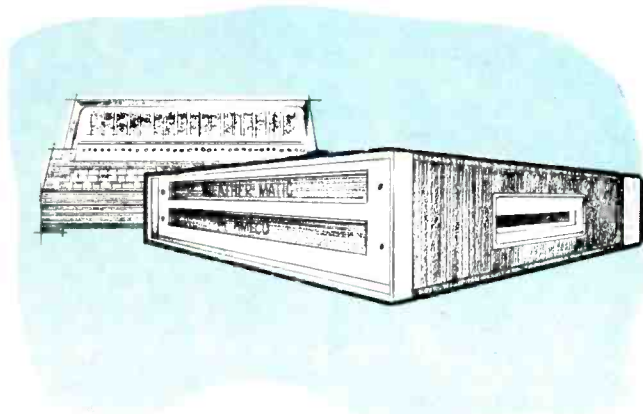

**ameco**

P. O. BOX 11326 / PHOENIX, ARIZONA 85017 / (602) 252-6041

## CATV Franchise

(Continued from page 25)

In the following week, before we made a formal application to the city ourselves, we spoke at a local Junior Chamber of Commerce meeting and the local Kiwanis Club. In each case one of our local investors introduced us to the group as "a locally supported company which wishes to bring cable television to our town."

During this period, and for several weeks thereafter, our two local investors prepared a simple 8½ x 11" sheet which explained what cable TV was and how our local firm planned to serve the city. This sheet was distributed to all local TV service shops, and the service people were given the opportunity to question us on such key points as, "Would our firm service or sell TV receivers, or FM radios?" (The answer to this, of course, was an emphatic NO, and we stated that we would like to see that provision written into the cable TV ordinance.)

### More Local Support

When the formal application was tendered to the city, the local newspaper headlined the item with "LOCAL CABLE TV FIRM APPLIES FOR CITY FRANCHISE."

Another public relations visit was made to the Superintendent of the City Schools. He was told about the free drop we planned for each school. The school system was too far from the regional ETV station to make use of its programs, but through the cable system the ETV signal would be of local quality. We left the school administrator with the latest ETV station material, including the current program schedule, so he could determine how the programming might be worked into the school's curriculum.

The week prior to our actual appearance before the city council, our local investors visited each of the councilmen. By this time our local investors were quite well versed on cable TV, and could answer nearly all the questions which came up. For the initial cable-to-councilman visit, we felt it best to let the local investors make the call alone. The Valley-Vision cable program was explained in considerable detail to each councilman, and they were

left with this question: "All things being equal, in service to the residents and remuneration to the city, wouldn't you rather see a local group receive the franchise than some outside group?" The question carries deeply into the heart of a man who believes his duty is to build and promote his own town.

### The Finale

At the city council meeting, our complete proposal (except our offer of percentage to the city) was brought out as a matter of public record. The councilmen asked several questions (which they had undoubtedly been requested to ask by their constituents), and the local news reporter took it all down. One of our com-

your other business interests may be, your best competitive edge will come as a result of inducing local people to participate with you in the cable program.

If one of your local investors has the talent, let him make the formal application to the city council. Or, have one of your own talented orators and the local attorney appear to sell the proposal. Don't assume you are going to impress the local citizens by sending your most distinguished and *big-town* (out-of-town) firm member to appear before the council. We have found you are better off appealing on the local level with local people. Small towns tend to be closely knit. The people resent a purely outside group coming in and *telling* them. Never tell—*suggest*.

Table I—Financial Arrangements for New Systems

	\$0-\$4	\$4-\$6	\$6-\$15	\$15-\$25
Monthly Rate	0	14	1	1
Installation Fee	6*	0	6	2
Percent of Gross Receipts to City	0-2%	3-4%	5-6%	6% up
	4	9	6	1
Franchise Period	0-4 yrs	5-9	10-15	15-up
	0	1	3	10

Extremes of the franchises studied by the author ran from one which called for no installation fee and a monthly charge of \$4.95 with 10% of the gross to the city, to a \$35 installation fee and \$5.95 per month with 2% of gross to city.

\*Six franchises specified no installation fee.

petitors followed us with his presentation, and opened up by announcing "My name is Mr. X and I am from Los Angeles." A short silence followed—then one of the local business people (not connected with Valley-Vision) remarked, loudly enough for all to hear, "That takes care of you, brother!" The entire council chamber broke into peels of laughter and our competitor was never quite the same.

### Here's Good Advice

If you are new in the cable field, no matter how important

Do your engineering homework, and offer the best system you can. If the town has a potential of 2,000 drops or more and your head-end costs will not exceed \$1,000 per channel, offer a full 12 channels (or 11 channels plus a weather channel).

What do you pay the city? No one talks in terms of less than 2% of the gross receipts anymore—one recent award specified 10%! A breakdown of the financial arrangements for nearly 100 franchise awards made across the country this spring is given in Table I. You don't want to over-offer, but you also don't want to



be left out in the cold by offering something lower than your competitors.

Always specify in your proposal that you will commence operation within XXX days of receipt of your pole line agreement with the local utility company, *not* within XXX days of receipt of the franchise. Some pole line agreements may take 45 days to secure, others may take a year or more. You don't want to be placed in the position of having to go back to the city and ask for additional time to commence operations "because the telephone company is taking so long with the pole line agreement." Make it plain to the city that your group will exercise every possible effort to expedite an agreement for the poles, but that neither your group nor any other competitor is in a position to guarantee when such an agreement might be reached.

We have also found it helpful to hint that your firm will do everything it can to use local people in system operation, installation, and maintenance. The old "hire and bank locally" adage will make your appeal just that much more local in nature. If you plan to finance your system, you will frequently find that the local banker will finance the system with 15-20% down. With local investors, this makes an attractive package to the bank. And with local investors, the rate of interest will usually be as low as you could obtain elsewhere. Never underestimate the influence the local banker carries in a small to medium sized town.

### Bigger Cities, Too?

Does this local appeal work as well in a larger town? We have found the formula is working well in a city of over 250,000 population, where we are currently active in a long, drawn-out franchise program. People are people all over, and in many of the larger towns (which are isolated from other large areas of population by virtue of distance), local pride is just as strong or stronger than in the smaller towns.

Are there other formulas? If you are a broadcaster, you may find an alliance with other local broadcasters beneficial. If you form an alliance with the local newspaper, you have a good head start on competitors. But no matter what formula you use, be sure to include the key factor—local appeal.

## ANOTHER MAJOR

# BREAK-THROUGH

## BY DYNAIR



### RX-4A

## SOLID-STATE TV TUNER

### FEATURING:

- Solid-state circuitry
- Unsurpassed color or monochrome performance
- All-channel (VHF and UHF) operation
- Video, audio, 4.5-mc aural or multiplexed outputs
- Optional crystal-controlled oscillator
- Meter on front panel for monitoring video, audio, B+ and B- levels
- Completely self-contained, including regulated power supply

**GET THE FACTS** on our new TV tuner at the NCTA show, booth 73. See it and our interference-free 12-channel head-end system in operation, along with other professional TV equipment by DYNAIR.

See it demonstrated with off-the-air, microwave and test signals — color and monochrome. Judge for yourself.

Remember — July 18-23  
Denver Hilton Hotel  
Booth 73

**DYNAIR**

ELECTRONICS, INC.  
SAN DIEGO, CALIFORNIA

6360 FEDERAL BOULEVARD • SAN DIEGO, CALIFORNIA • TELEPHONE (714) 586-9231

Circle 17 on Reader Service Card

# Selecting a COLOR CAMERA

**Literally hundreds of TV broadcasters are making a concerted effort to set up color originating facilities. This report on the NAB Color Camera Panel discussion will aid those trying to decide between 3-tube and 4-tube equipments.**

**I**N PLANNING TO CONVERT to color one of the important decisions today concerns the purchase of color camera equipment. Until recently, the question was, "Should we invest in color yet?" If you decided to install color film or live camera equipment, it was simply a matter of ordering. Now, however, there are several new developments in color camera equipment. Some manufacturers, notably General Electric and RCA, have introduced 4-tube models (using a separate channel for monochrome pickup). North American Philips introduced their 3-tube model, using newly designed Plumbicon pickup tubes. So the big question today is, "Should we buy 3-tube or 4-tube models?"

During the recent NAB Convention in Washington, color cameras were closely scrutinized by hundreds of engineers and managers. An Engineering Conference panel session explored the subject of color cameras in depth. The following is an interpretation of the thoughts and comments introduced during this panel session.

The four panelists represented three companies who currently make color cameras, plus one firm which does not. Moderator was

Mr. Frank Marx of ABC. Panelists were R. T. Cavanaugh, Gen. Mgr. of Studio Equipment, North American Philips Co.; A. W. Malang, Chief Engineer, Whittaker Corp.; R. E. Putman, Manager, Audio/Video Development Engineering, General Electric Co.; Dr. H. N. Kozanowski, Manager, TV Advance Development, Radio Corp. of America.

## The 3-Tube Plumbicon

Mr. Cavanaugh, in presenting his particular philosophy, naturally concentrated on discussing the advantages of the 3-tube Plumbicon design. He pointed out that the Plumbicon tube, although only recently in production, was the product of 10 years of research and development to optimize resolution, sensitivity, lag, and spectral characteristics. Future improvements are expected in several of these characteristics.

Operating advantages of the Plumbicon described by Mr. Cavanaugh include:

1. Low dark current, on the order of a few nanoamperes.
2. Gamma of 0.9.
3. Sensitivity of 400 ua per lumen.
4. Resolution: 40% depth of modulation at 400 lines (5 mc).
5. Lag is extremely short.

The most significant factor, as far as color cameras go, is the fixed gamma, which holds independently of light level. Because of the low dark current, no shading compensation is used anywhere in the camera system.

For typical operation of an RGB color camera, Mr. Cavanaugh related, "We think in terms of operating at 150 foot candles and scene illumination F/4.0. When we talk F/4, because the image format is roughly one-half the diagonal of an I.O., the depth of field is related to F/8 on an I.O.

"The wide channel in the camera is set for a 40 db signal/noise ratio out of the encoder. The cameras are set for 80% depth of modulation at 400 lines center resolution—again, wide channel.

"Because of the size (which is very, let's say, fortuitous and very good for a 3-tube color camera), plus weight and color fidelity advantages, the Philips Plumbicon RGB color camera will be continued in production in Holland and in the U. S. As Philips' research and development on the

Plumbicon 4-channel YRGB camera progresses, future availability will be determined."

Based on the present state of the art, obviously, a 4-tube Plumbicon camera must be larger and heavier than the 3-tube model. Moreover, it will require linear matrix correction for luminance-chrominance matching. However, the linear characteristics of the Plumbicon simplify such corrective circuitry.

## Whittaker Corp. Undecided

Mr. Malang, whose company does not at present offer a color camera, discussed the two different color camera applications — studio and film. Speaking of film cameras, he said, "Recent experience has convinced us, and I believe most members of the industry, that a separate luminance channel is a very desirable feature for a film chain," particularly because most stations have a hybrid operation — partial color, partial monochrome.

"I think we are fairly well convinced that the best pickup tube for a film chain is the vidicon, although I must confess that the conviction is not absolute yet. There are a family of new pickup devices becoming available, principal among them our old friend from years back, the dissector. It could conceivably turn out in the very near future that the dissector may take over a part of the film work, the obvious problem being that you need transports of a more continuous light application nature. However, continuous motion transports are commercially available and, of course, the slide doesn't have this problem." Generally, Mr. Malang concluded that the 4-V chain, in the present state of the art, is the principal workhorse and best choice for film use.

On the other hand, Mr. Malang felt the considerations for studio cameras were not quite so clear cut, stating, "We have convinced ourselves that the 4-tube camera is the desirable approach, principally because it eases the problem of going from monochrome to color and back again, which is something we have to face up to for awhile. The problem is . . . which 4-tube combination?" He further pointed out that there hasn't been enough work done in lighting techniques to be able to easily choose among the many tubes available for the chrominance channel, stat-

ing, "One can talk in terms of vidicons, small image orthicons, and Plumbicons. For the luminance channel, I think our opinion is beginning to settle on an image orthicon. But for the chrominance channel, we just cannot make up our mind.

"So, in essence, we do not have a camera, nor are we in a position to rigidly say, if we had to build a camera tomorrow, what we would build. We intend to spend a great deal more time surveying the situation to determine what is the most desirable combination of characteristics. Or, if you will, to approach this honestly, what is the least burdensome set of compromises necessary to do an effective job in a live studio. We hope to induce people to do something more effective in the lighting area. It is difficult to envision live color production continuing and growing in a situation where dimming and mood lighting is as difficult as it is today. Maintaining color balance from a tungsten incandescent-type fixture will make a person gray very fast.

In this respect Mr. Malang felt that the 4-tube camera offered a slight advantage in that as the color temperature of the incident illumination changes, the presence

of the three chromo channels would permit "a kind of color masking" to be evolved for live operation. "But it would certainly be a great deal more desirable," Mr. Malang concluded, "to be able to eliminate the problem in the first place and establish as completely as possible total stable camera operation."

### And Speaking for 4-Tube

Mr. Putman was strongly inclined to feel that cameras of the future would have a separate luminance channel. He commented that the choice of tubes for the chrominance channel was "the biggest bag of worms" there is today, citing the Japanese two-tube camera which derives color information from a striped filter as an example. Implied, however, was the alternate use of vidicons, Plumbicons, Selenicons, and I.O.'s.

Mr. Putman's argument for a separate luminance channel is based on his philosophy that there is a color error. He pointed out that "people have proposed to use separate luminance and then put a correction signal back into the luminance to make it absolutely correct. I think the main problem with the correction is how you derive the correction signal. There

is no doubt that a 4-tube camera or anything greater than three is a more complex camera. It has more in it. I think, though, with present-day technology and the design of cameras, this is no problem."

In discussing signal-to-noise, Mr. Putman stated that noise in the chrominance channel is not a problem. Overcoming noise in the luminance channel, he feels, is one of the important factors in a camera of the future. He added that operational ease was one of the real pluses—ease in camera setup, coupled with stability of the circuitry to remain in adjustment.

"The advantage of the separate luminance system," said Mr. Putman, "is that absolute registration is not going to affect either signal-to-noise or resolution," and that a little better black-and-white picture would result. Summing up, he admitted that a 3-tube camera "puts out a beautiful picture, and is less sensitive to knob twisters."

### Another 4-Tube Advocate

Dr. Kozanowski, in general, agreed with Mr. Putman, stating that the 4-tube approach, with a separate luminance channel, provides high resolution and good sig-

*(Text continued on page 46)*

See Overleaf for Camera Photos

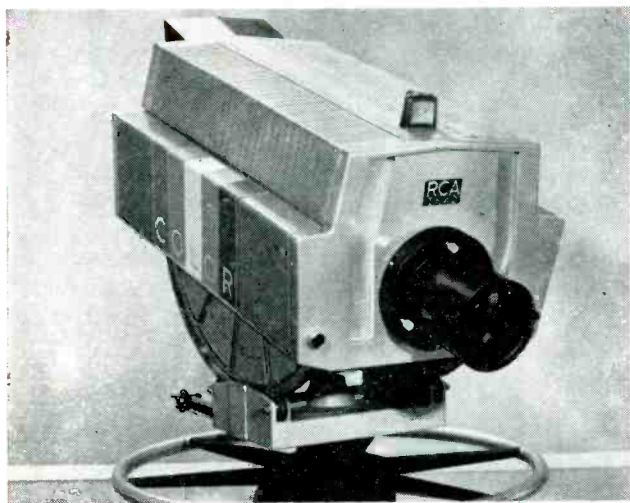

**RCA TK-42 Color Camera** uses 4½" I.O. for separate luminance channel, electrostatically-focused vidicons for the 3 chroma channels (will use Selenicons when available). Incorporates built-in dual zoom lens, 8" viewfinder, and setup control panel, weighs 280 lbs. Control console contains color balance and remote control panels, 17" color monitor. Power supply, colorplexing and signal processing circuits are rack-mounted. Price complete is \$72,500.

**Norelco PC-60 Color Camera** uses 3 Plumbicons, weighs 165 lbs. Removable Angenieux 10:1 servo-controlled zoom lens is optional, as is shot-box for pre-set zoom-focus positions. Console control unit incorporates iris, master gain, and master black-level controls. Price of camera head, with zoom lens, Plumbicons, and cables is \$35,850. Control console, excluding picture and waveform monitors, is \$18,920. Remote control panel and fully transistorized encoder also available.



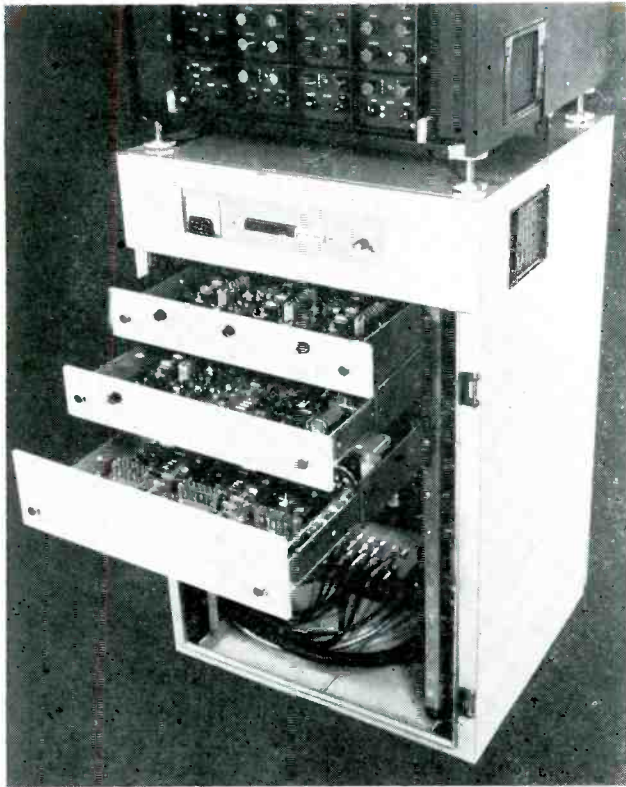

**G. E. PC-16-A Color Film Camera** is heart of PE-24 4-V film chain system. Includes video processing circuitry, registration controls, and monitor selector panel. Purchased separately, price is \$30,195.

EMI Type 204 Color Camera uses 3 field-mesh vidicons, weighs 160 lbs. Features include exclusive optical system, 7" b & w hooded viewfinder. Camera control unit contains all setup controls on front of pull-out chassis. Although no longer in production, International Broadcast Industries, Chicago Heights (successors to GENCOM as exclusive sales agents) advises a limited number of units available on "prior sale" basis for \$22,000 (about half regular price). EMI will have a solid-state 4-channel camera ready for delivery next year.

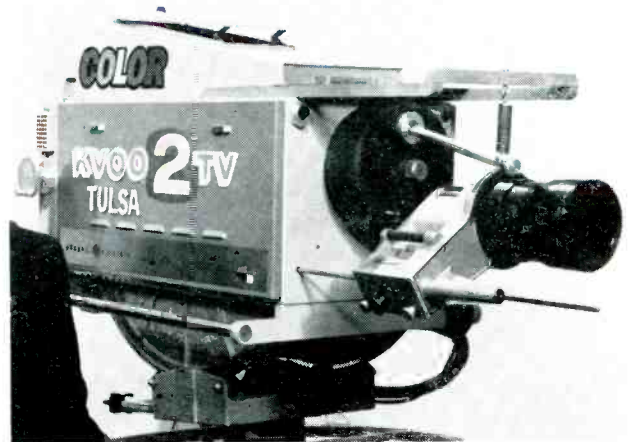
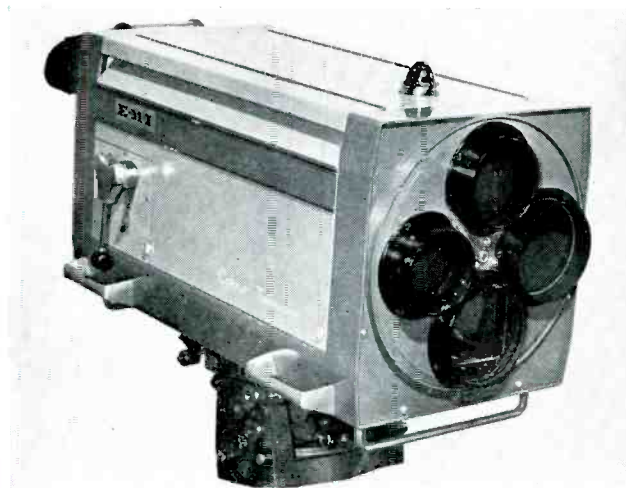

**G. E. PE-25-A Color Camera** uses 3 I.O.'s, weighs 215 lbs. Incorporates push-button selection of encoded picture at 8" viewfinder. Control console includes channel amplifiers, calibration and picture monitors. Power supplies, encoder, aperture corrector, and automatic balance control are contained in floor-mounted cabinet rack. Price of camera (sans lenses) is \$34,380. Control console, complete, is \$6,660. Calibration monitor is \$3,260. Rack equipment is about \$7,950. Complete camera chain, including the above, is \$58,000.

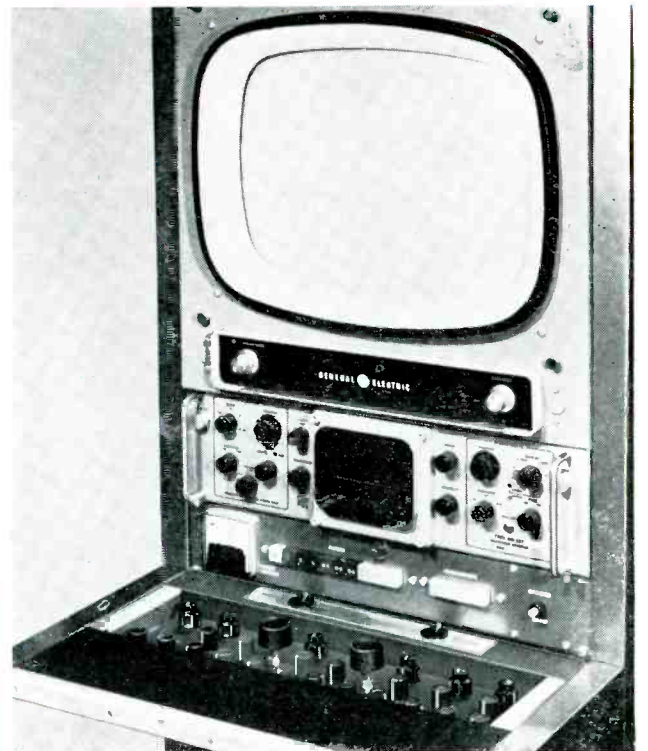

**G. E. PE-24 4-V Color Film System** includes PC-16-A camera and rack or console mounted remote-control panel. Complete PE-24A console system, with 19" monitor console cabinet, 14" monitor, Tektronix waveform monitor, encoder, automatic balance control, etc., is \$39,500. PE-24B rack-mounted version, without picture and waveform monitors, sells for \$37,800.

# Remote Control of TV Transmitters

The NAB Petition, Rulemaking No. 735, shows that control, metering, and logging of VHF telecasts is dependable and practical. FCC approval may soon be forthcoming.

ON February 24, 1965, the National Association of Broadcasters petitioned the FCC to extend to VHF stations the privilege of operating TV transmitters by remote control (Rulemaking No. 735). UHF stations have had this permission since May 6, 1963. The main issue is whether such remote control would, in any way, result in a degradation of the Commission's standards.

The NAB contends that the experimental field tests conducted at four VHF stations prove conclusively that remote control and metering can be accomplished in compliance with FCC rules and standards.

The four stations involved in these tests (WABI-TV, Ch. 5, Bangor, Me.; WGEM-TV, Ch. 10, Quincy, Ill.; KFMB-TV, Ch. 8, San Diego, Cal.; and KKTV, Ch. 11, Colorado Springs, Colo.) had the advance approval of the Commission.

There were two basic methods of remote control used: circuits using telephone lines, and subcarrier multiplex for relaying both control and metering information, or a combination of multiplex for control and a separate transmitter for metering data. The telephone line method, naturally, depends on common-carrier reliability, while the reliability of radio operation is wholly under the control of the licensee. In addition to the pursuit of the two system philosophies in this experiment, remote control equipment especially designed for each particular station was used along with readily available "off-the-shelf" systems which required only slight modification.

This four-station test represents approximately 12,100 hours of operation; transmitters were controlled from remote control points without a single malfunction during this time. Of course, all stations maintained engineering personnel at their transmitters during all hours of operation.

## Tests at KKTV

Tests at KKTV began February 8, 1962 and ran through December, 1962, using RCA multiplex equipment. Automatically logged data was taken from September 1, through December 26, 1962.

Transmitter modifications were not necessary, since the RCA transmitter was originally designed for remote control. All basic control and metering functions, as well as motor control systems, wiring, rectification units, etc., are an integral part of the transmitter.

Control information was carried to the transmitter from the studio control center by a subcarrier on the existing STL. Metering data was relayed back to the studio on an aural transmitter subcarrier. Existing equipment was used for control and data transmission both ways, without the use of telephone lines or any added expense for studio-transmitter connections, although lines could be used if they were required.

This system has a capacity of 20 control functions and/or meter indications, selectable in any sequence, and 8 independent and simultaneous alarm circuits. The binary and analog units of this system are slightly modified versions of equipment which has proven extremely reliable in other remote control applications.

The tests at KKTV proved that remote control of a VHF-TV transmitter can be accomplished, at a reasonable cost and without sacrificing FCC standards of engineering. Once the system had been installed and calibrated, it worked faultlessly, and remote readings tracked reasonably with readings taken manually at the transmitter. A few problems were encountered with the automatic logger due to altitude and low humidity, but these inconsistencies could be simply solved. In any case, meter readings can be read manually from the remote unit if they fail to be recorded on the automatic logger.

## Tests at KFMB-TV

KFMB-TV conducted its experimental remote operation, using equipment manufactured by Moseley Associates, from June 25 to December 27, 1962.

The equipment used was a slightly modified Moseley Model RRC-10 system. Generally, it employs an STL to relay program, control tones, and subcarriers to the remote location. This equipment has been operating well in FM stations for several years.

In the KFMB-TV installation, the control tones were superimposed on the aural subcarrier and transmitted via the existing STL. KFMB's transmitter was not designed for remote operation, and some changes were therefore necessary. A Conrac receiver was used at the studio to recover the metering subcarrier from the transmitter, and fed into the studio unit of the Moseley equipment.

Nine control and metering functions were used in these tests, with fail-safe operation similar to that used in FM broadcasting. Although it wasn't used, automatic logging is possible with these Moseley units by simply adding a mechanical "code wheel."

Control and remote metering at KFMB-TV was considered a success, and proved that an existing multiplex remote control unit can be adapted for VHF use without extensive modification. The control of the transmitter didn't result in any degradation of performance, and the comparison between remote

and manual meter readings was quite acceptable. Any deviations were due to calibration or time discrepancies in readings.

### Tests at WGEM-TV

The WGEM-TV tests established that existing wire-line remote control equipment can be used with a transmitter not designed for remote control, and that reliable methods could be developed to observe the characteristics of the video signal and modulation percentage of the aural signal. Experimental authorization from the FCC wasn't necessary, since wire lines were used, but the Commission was informally notified on June 18, 1963. Tests were carried out from June through October of 1963.

The remote control system used in these tests was a Gates Model RDC-200A, an advanced design DC system using two pairs of telephone lines between studio and transmitter. Eight control and 23 meter-

### STL Remote Control Installation at KKTU.

Three FSK channels perform all control and metering functions. One 20.4-kc subcarrier is diphxed on the aural STL carrier, transmitting control information in a bandwidth of 250 cps. Two subcarriers, injected into the TV transmitter aural exciter, are recovered at the studio from the audio output of the rebroadcast receiver and fed into the FSK receivers. Subcarrier frequencies are 20.4 kc ( $\pm 125$  cps) and 21.5 kc ( $\pm 125$  cps), providing alarm circuit and transmitter telemetering data, respectively, in a bandwidth of 1.6-kc each. Total deviation is less than 10% of the 25 kc allowed for what is considered 100% modulation of the aural carrier. Fail-safe operation is assured by constant scanning of the transmitter "On-Off" function. Should this function fail, the transmitter in-

stantly shuts down. Automatic logging information is obtained by scanning all necessary transmitter parameters with a sequential switch. The timer is located at the transmitter and timed by a synchronous motor. The output of the scanner is fed to one of the control function positions, providing the automatic logger at the studio with the data it needs. Each parameter is scanned once every 30 minutes. Any of the 20 parameters may be read manually by actuating the appropriate button on the control console. The output of a Conrac receiver was fed into a master monitor where characteristics of the visual signal could be seen on the picture monitor and oscilloscope. Reference white level was displayed by feeding the output of an external chopper into the Conrac receiver, in addition to sync pulse amplitude, modulation depth and set-up.

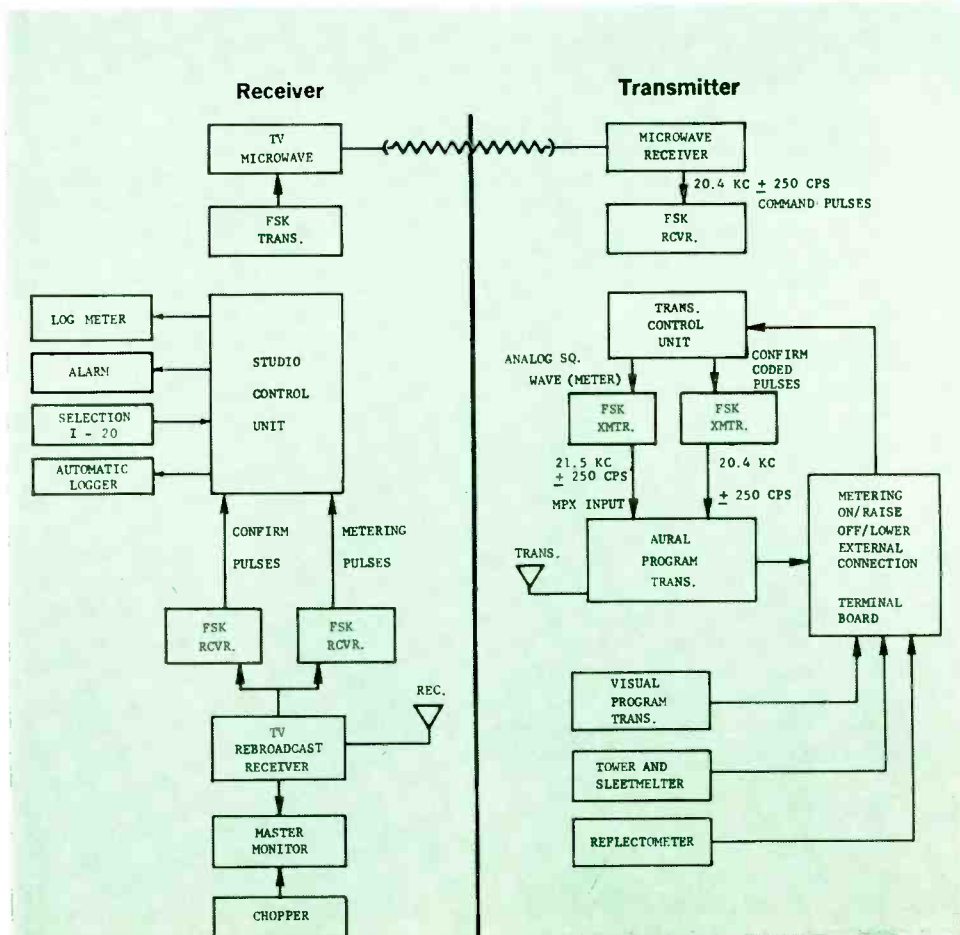
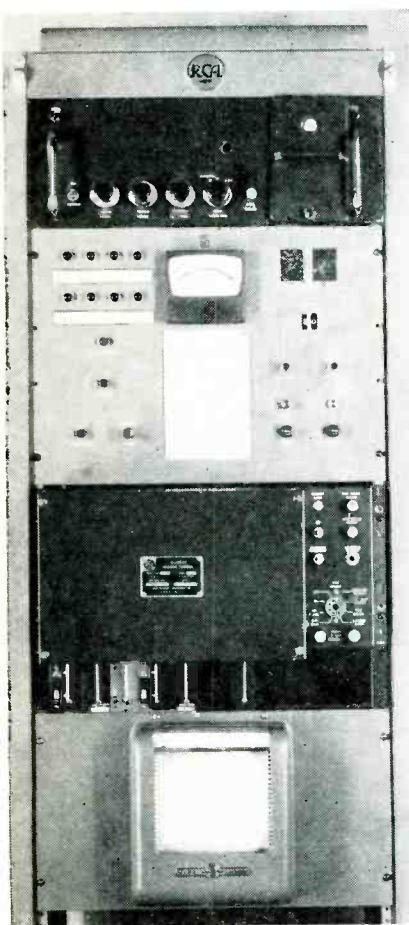

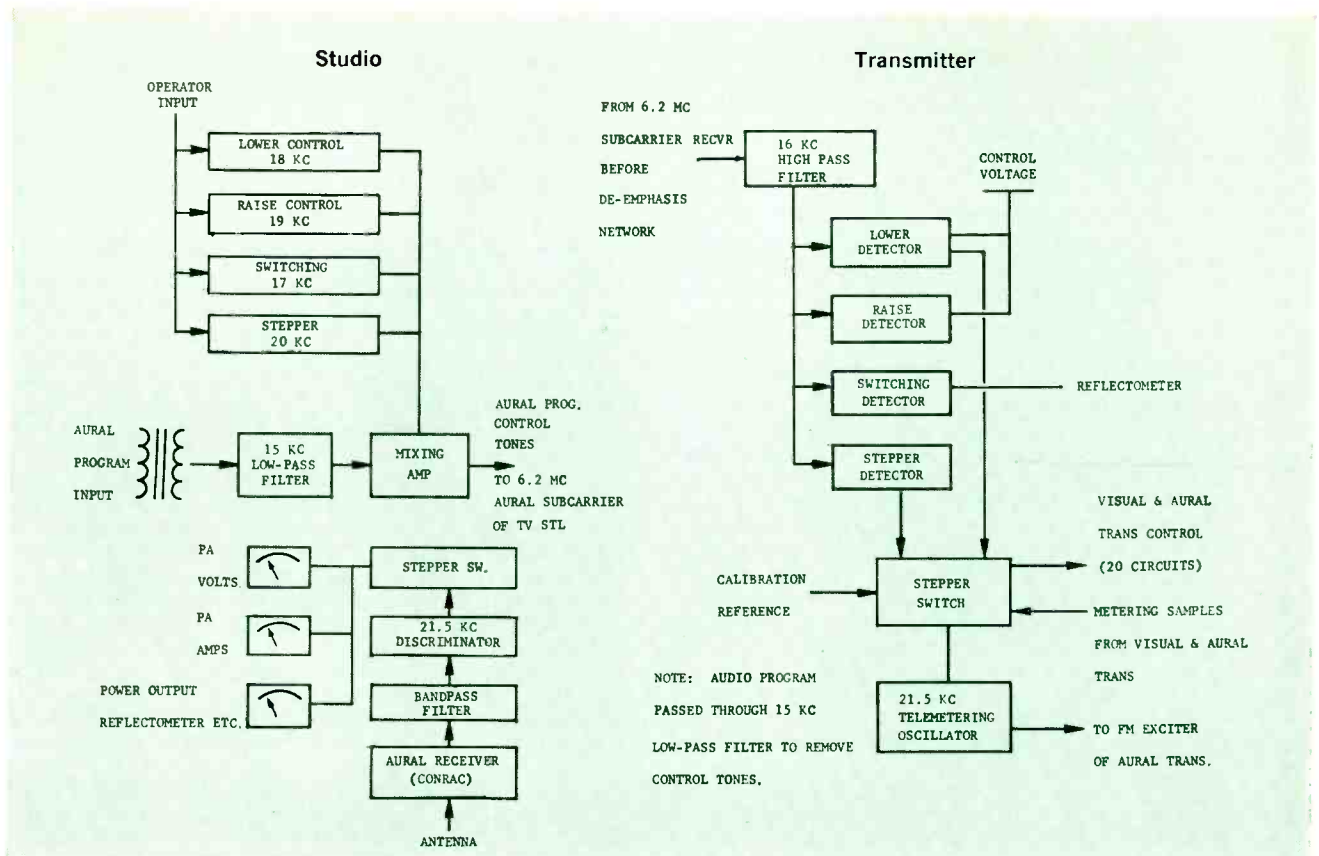

### Remote Control Installation at KFMB-TV

Control tones are injected into the aural subcarrier on the STL and recovered at the transmitter ahead of the de-emphasis network in the 6.2-mc receiver. The outgoing control signals are well below main channel modulation and therefore do not materially affect bandwidth. The four tones generated by the studio unit provide for lower, raise, switching, and stepper/reset and operate in the 20-23 kc range. The stepper/reset tone operates a 10-position, 3-level stepper switch at the transmitter. A pulse duration technique synchronizes the position of the stepper switch with the selector control at the studio. By operating either the raise or lower oscillators, commands appear at the output of the transmitter control unit terminals. A 15-kc low-pass filter in the studio unit prevents spurious-signal interference which could affect control. A 21.5-kc subcarrier was multiplexed on the TV aural carrier. Metering range is obtained by shifting the subcarrier frequency between 21.5 and 21.9 kc. At the studio, a Conrac receiver was used to recover the metering subcarrier. A frequency discriminator in the studio unit produces a DC voltage representing the value being measured. The control tones are taken from the STL re-

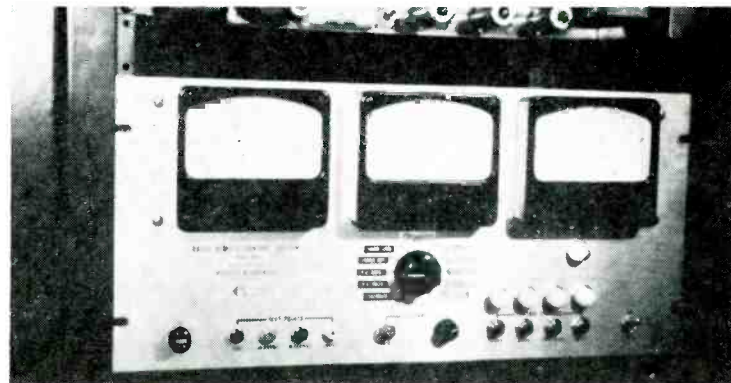

ceiver at the transmitter and fed into the remote unit. Power output of both transmitters is controlled by two reversible motorized rheostats. The system is calibrated by a 1.4v mercury cell fed into the "Home" position. The AGC or squelch relay in the STL receiver controls transmitter plate power, providing fail-safe operation.

ing functions were used with the system, although it is capable of more.

The studio control point was equipped with a monitor for the visual and aural signals; a Conrac receiver and tuner, with a few modifications, fed a standard waveform/picture monitor and a modulation percentage meter. Since the Conrac receiver is an intercarrier design, it was adapted to operate both visual and aural failure alarms.

During the 5 months these units were in operation, control metering and monitoring systems operated very well; the remote meter readings corresponded reasonably well with those taken at the transmitter by the attendant engineer. WGEM-TV's system of monitoring the signals actually being transmitted

proved very successful, making this phase of the test a "showcase" operation.

### Tests at WABI-TV

Rust Corp. furnished control and logging equipment for the WABI-TV tests. The control equipment used two telephone lines between studio and transmitter, making formal experimental authorization unnecessary. The Commission was notified by letter and the tests were carried out between July 1 and October 30, 1964.

WABI-TV's transmitter was not equipped for remote control, and required the addition of sampling circuits. A Rust Basic D system was used, performing 12 control and metering functions. Due to transmitter design, it was not feasible to utilize full ad-

vantage of the Rust control capability.

The automatic logger used with this system shared the meter line, leaving the control line undisturbed for reliable fail-safe transmitter operation. The Rust AL-9 logging system will work with a DC remote control equipment without modification.

Control functions in this experiment were limited due to transmitter design, and in some cases, extensive changes would have been necessary to extend functions to all circuits. However, this test proves that an existing DC wire-line unit can be used with

### Simplified DC System Used at WABI-TV.

The Rust Basic D system uses two pairs of telephone lines to interconnect the studio and transmitter units—one pair for control voltages and pulses, the other pair for metering. The system can remotely control and meter 24 functions, and control can be applied wherever relays or reversible motors can be used. Fast-acting and slow-release relays are the major feature of the system. The raise-lower operation is possible due to the magnitude of the control voltages sent to relays of different sensitivities. Each sampled parameter is converted to a low DC voltage in the conventional manner. The remote metering circuits are connected to the metering read-out unit through a sensitive relay system. In this test case, the electrical-mechanical designs of the station's transmitter imposed some limitations on the remote functions which could be performed. The Rust AL-9 logging system was used in this test. It is designed to operate in conjunction with any DC remote system. The logger records the transmitter readings on pressure-sensitive paper from the sequentially sampled parameters. Should any reading deviate from adjustable limits, an alarm is actuated. These limit alarms can be used in any or all chart recorder positions.

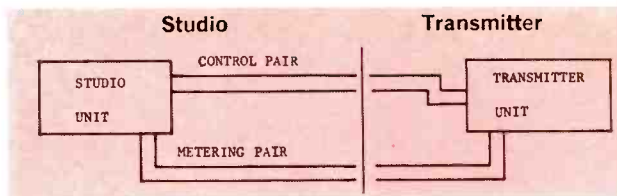
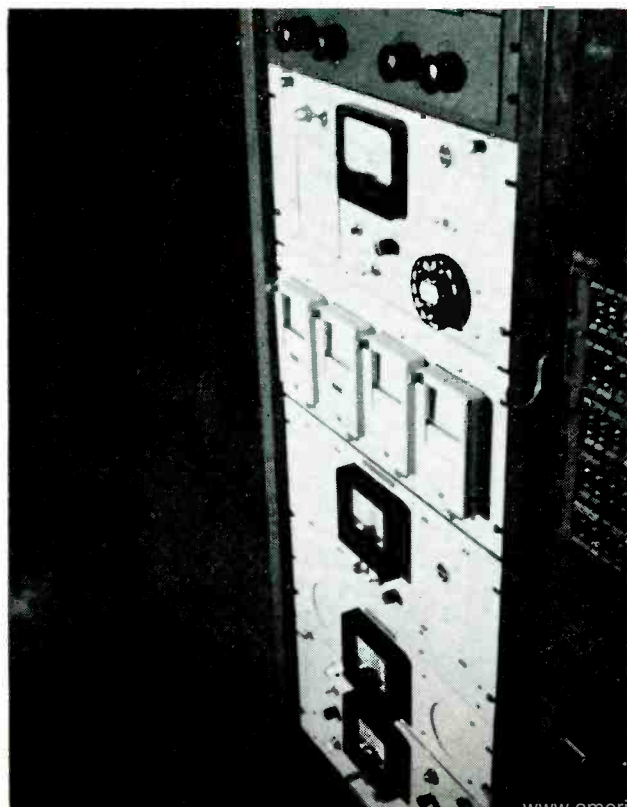
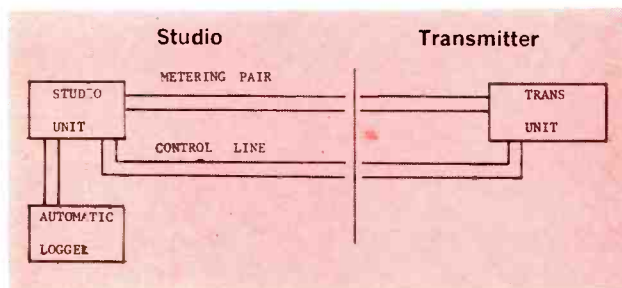

### Simplified DC System Used at WGEM-TV.

Both studio and transmitter units are independently operated with self-contained power supplies. Voltages of certain magnitudes and polarities applied to the control line select the control circuits. Pulse-reset functions use the metering line. Activating either the pulse or reset circuits operates transfer relays at the transmitter and studio, substituting pulse-reset circuits for metering. Four main switching channels are used in the transmitter unit; increase-on, decrease-off, fail-safe, and transfer. Each channel is composed of two relays: a sensitive type, operated from the control line; and a slave which performs the actual switching function. The studio unit has two power supplies: a 6v DC source which operates the stepper solenoid; and a 75v regulated source which supplies the pulse-reset relays in both the studio and transmitter units and furnishes various operating voltages for selecting control circuits. For metering transmitter parameters, a voltage sampling network, or rectified RF or AC, provides acceptable DC to the remote control circuitry. A crystal-controlled Conrac HUC-10 tuner, chosen for bandpass and phase response characteristics, was used to monitor the aural transmission at the studio, in conjunction with a Conrac AV12E TV receiver for video monitoring. The audio from the Conrac receiver was fed into a modulation meter; video was fed into a Tektronix scope and picture monitor. A white reference keying pulse was fed from a pulse gate generator into the Conrac receiver through a specially installed coax jack. The intercarrier feature of the Conrac receiver was used to actuate both a visual and aural carrier alarm. DC voltage from the grid of the receiver limiter stage was used, since the absence of either carrier would remove the bias and operate the alarm.

transmitters not designed for remote control. The remote metering and logging aspects of these tests were quite successful.

### What the Tests Proved

While the installation of remote control equipment in a VHF station may not necessarily mean a reduction of personnel, it will certainly allow a station to make better use of engineering man hours. Automatic logging will free personnel previously obligated to observe and record meter readings at half-hour intervals to perform other important duties. Unless a station can economize with fewer people, or make better use of the existing engineering staff, remote control would be quite illogical. Of course, during these tests, all stations had to have an engineer on transmitter watch as usual, but the installation of remote control and logging would undoubtedly present management with many possible economies.

As for which system a station might choose, these tests have proved that the DC wire-line and radio remote control systems work quite satisfactorily. If the transmitter site is within a reasonably short distance of the studio, and the transmitter is easily reached, the telephone line system would require less capital investment. If the transmitter-studio distance and transmitter accessibility are extreme, the radio system would be a more logical choice. If an STL is already in use, this would, of course, enter into the decision. ●





**SOLID-STATE  
REPEATER AMPLIFIER—28 VOLT**

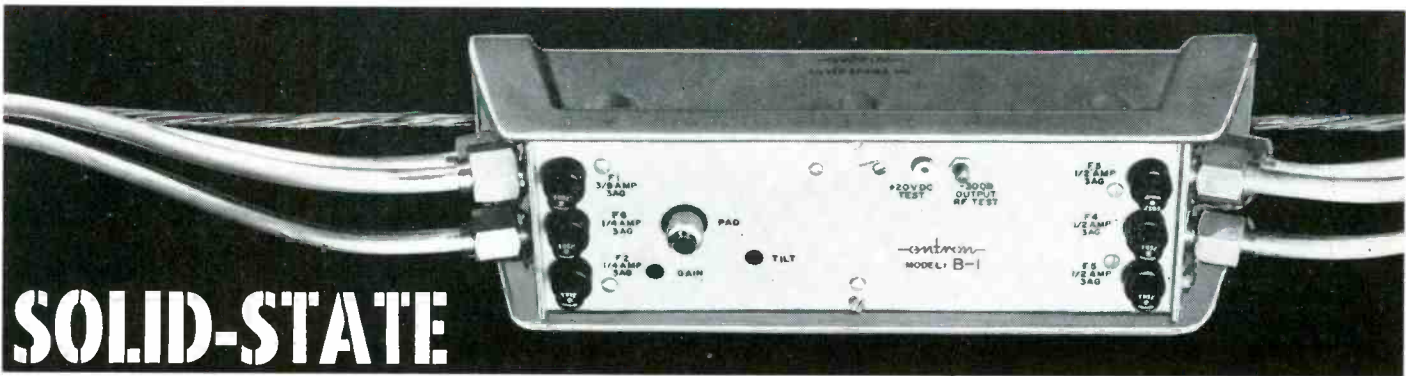

**SOLID-STATE  
BRIDGING AMPLIFIER—28 VOLT**

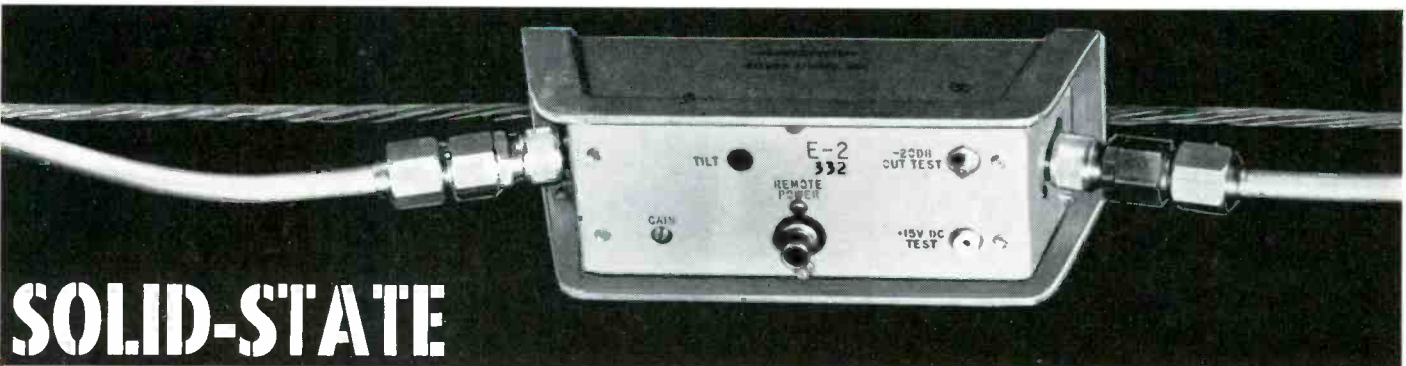

**SOLID-STATE  
EXTENDER AMPLIFIER—28 VOLT**

**A TRIO OF CATV COMPATIBLES:** The **B** Series Bridging Amplifiers—the **R** Series Repeater Amplifiers—and the **E** Series Extender Amplifiers. All manufactured by the firm which set the industry standard for competence and reliability. All three remotely powered by **28 VAC**.\* All three **STRAND-MOUNTED**, with shallow, no-fuss drip-loops. And all ready to go to work in **ANY SYSTEM**—vacuum tube or **SOLID-STATE**—regardless of equipment manufacturer.

*\*(also available for 60 vac.)*

See them all at Booths 54 thru 57 at the Denver Hilton.



2141 INDUSTRIAL PARKWAY  
SILVER SPRING, MD. 20904

AREA CODE 301  
622-2000

Circle 18 on Reader Service Card

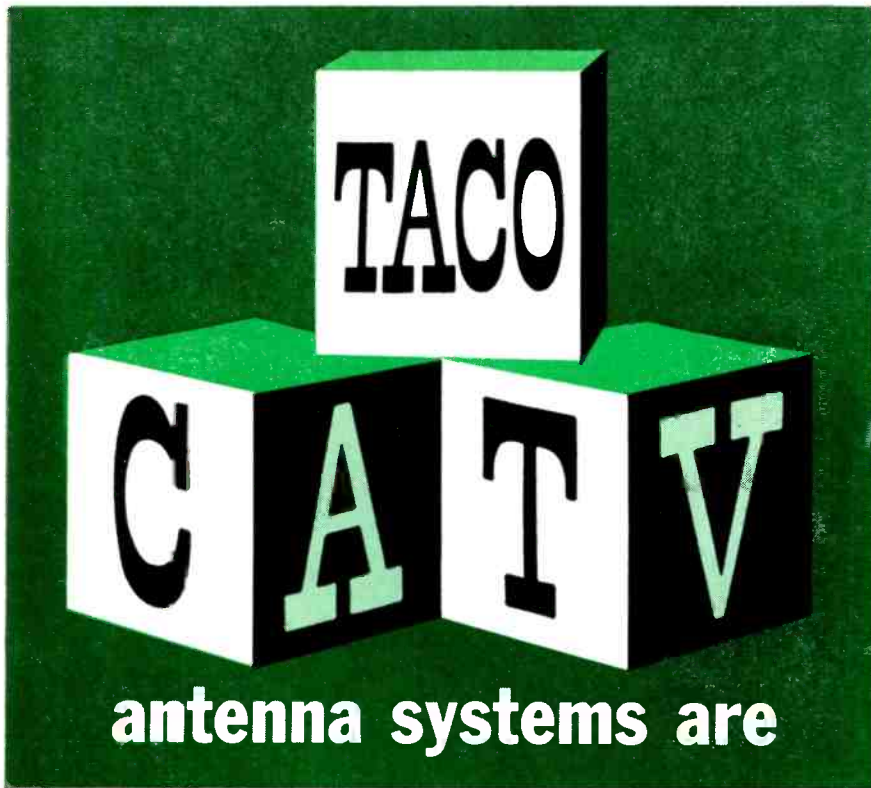

# BUILDING BLOCK SIMPLE

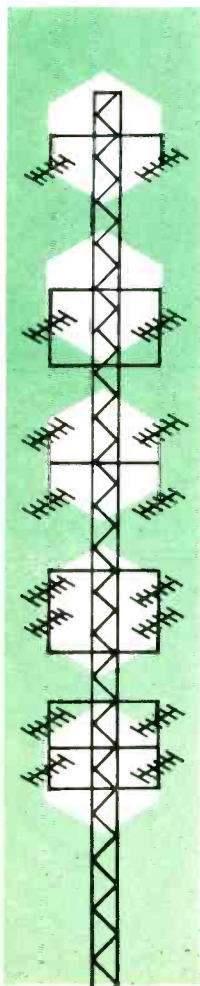

TACO design know-how knifes through annoying installation problems by providing completely pre-planned CATV Antenna Systems. This pre-planned and pre-stressed construction results in stronger, clearer CATV signals. The new, exclusive, easy-to-use TACO mounting components reduce installation time and permit complete on-the-ground assembly and simple on-tower antenna orientation.

Every TACO CATV antenna array will withstand windloads of 58 PSF with no ice; and 30 PSF with 1/2" radial ice.

Save Time . . . Save Dollars . . . order your next CATV installation from the people who specialize in Antenna Systems . . . TACO.

Complete details on TACO CATV Antenna Systems sent on request.



A subsidiary of THE JERROLD CORPORATION

**TECHNICAL APPLIANCE CORPORATION**  
 Defense & Industrial Products Division  
 SHERBURNE, N. Y.

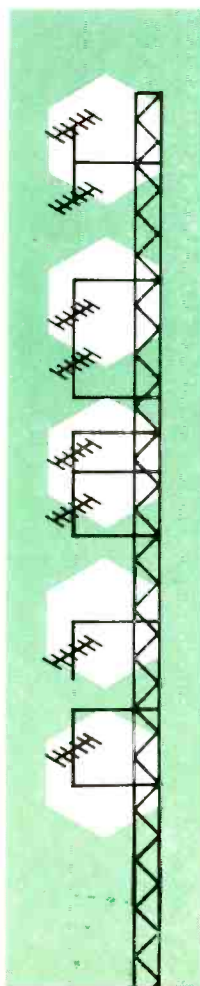

## Color Camera

(Continued from page 40)

nal-to-noise characteristics. He emphasized that being able to obtain a luminance signal which was independent of color tube registry was a "very, very important thing. [Black and white] is your bread and butter for a long time while you're getting warmed up on color." Dr. Kozanowski also favors an image orthicon in the luminance channel because "it has a built-in knee for taking care of highlights and glints." As for the chrominance channel, he did not feel image orthicons of present design were the best choice, primarily because of their complexity.

Speaking of advantages of the 4-tube camera, he pointed out that

According to a Sarkes Tarzian spokesman, the Bloomington, Ind. firm will have a complete color camera line, including a 4-tube studio camera using Plumbicons, by the first of the year. A 4-channel color film chain will be offered late this fall. Reportedly, all equipment will be solid-state.

it "has a built-in cushion for doing things wrong and not really bleeding from the effect." In other words, the 4-tube design allows for a much greater margin of error than the 3-tube. Further, Dr. Kozanowski pointed out that the 4-tube approach permitted a "poetic license" approach on outdoor scenes, enabling compression of white highlights and increasing the chrominance level to achieve more favorable and pleasing color without detrimental affects on the monochrome signal.

On "redirect," Mr. Cavanaugh countered this viewpoint, stressing that we should strive for the best fidelity we can achieve. He stated that both color and monochrome fidelity was much easier to achieve if the transfer characteristics of the color pickup tubes were matched. In this vein, however, he added that the color registration requirement for a 4-tube camera is not significantly different than for a 3-tube camera.

Dr. Kozanowski then concluded it would be nice to design the ideal tube, but meanwhile the .9 gamma characteristic of the Plumbicon and Selenicon required correction to eliminate color harshness. He implied that gamma correction was already being used to correct color characteristics, and it was therefore no crime to use poetic license.

## The Choice is Yours

With the different philosophies offered by these experts, the ultimate choice for a standard color camera design will be some time in coming. In the face of this year's high interest in color, however, many stations are faced with making a choice soon. There doesn't seem to be much question that the 4-channel approach is the answer to today's film-slide needs. As for live telecasting, both the 3-tube and 4-tube cameras available today are vast improvements over previous designs.

Ultimately, of course, black-and-white television, and the need for a monochrome channel, will be passe. But that time is in the future, perhaps many years. By Fall 1966, competitive stations will find color originating facilities a most important factor in market ratings. Indeed, in at least the top 50 markets, color will be a major deciding factor this year. ●

RCA TK-27 Color Film Camera is 4-channel system, with 8480 1½" vidicon in luminance channel. Draws less than 200w, takes only 3 sq. ft. of floor space. Complete system, including remote control panels, picture and waveform monitors (color monitor optional), is priced at \$51,900.

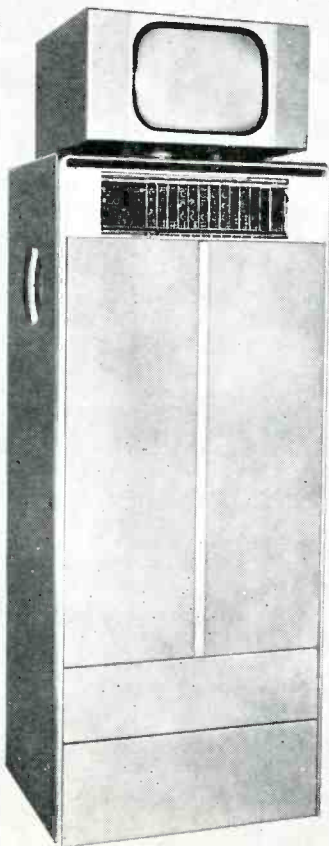

# A NEW HEART FOR YOUR STUDIO

## Studio 96

QUALITY DESIGNED FOR BROADCASTERS AND SOUND STUDIOS



Two speed tape transport with automatic sequence braking, choice of hyperbolic head configurations, hysteresis capstan drive and heavy duty reel drive motors, remote control jacks and 10½" reel capacity. Superbly smooth tape handling — interlocked "fool-proof" switching — fit for every studio.

Rack mount ready from \$585.45

MATCHING SOLID STATE ELECTRONICS

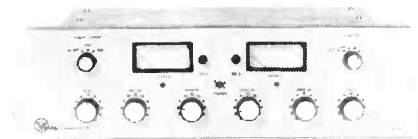

Record and playback amplifiers of modular design with interchangeable plug-in options, mixing controls, A-B monitoring, illuminated VU meters, exceed NAB standards.

Rack mount ready

Monaural RP110-R2 \$299.00  
Stereo RP120-R2 \$399.00



MADE BY SKILLED AMERICAN CRAFTSMEN AT

**Viking** OF MINNEAPOLIS®

9600 Aldrich Ave. S. Minneapolis, Minnesota, 55420

# BROADCAST EQUIPMENT

# HELP!

Gentlemen:

I need help in

- finding a job.  
 filling one.

Please send

- job order form.  
 application form.  
 Resume enclosed.

Name \_\_\_\_\_

Street \_\_\_\_\_

City \_\_\_\_\_

State \_\_\_\_\_

Need help in finding help?

... or a new and better job?

TSC offers a unique personnel placement service, designed to match qualified applicants with sales promotion, technical, management opportunities in the burgeoning CATV industry.

Employers and job seekers alike benefit from TSC's industry "know-how" and vast experience in personnel evaluation. They like TSC's prompt, confidential service.

Call for help today. 215-TU 4-6635. Or clip and mail the coupon above to TSC.

Personnel Placement Division

**TSC** TeleSystems Corporation

113 South Easton Road, Glenside, Pa. • 215-TU 4-6635

KNOW HOW... THAT'S TELESYSTEMS!

Circle 21 on Reader Service Card

## Quick-Change Tape Heads

A line of tape heads and adapter mounts has been developed by Nortronics Co. Inc., Minneapolis, Minn. They are designed to equal

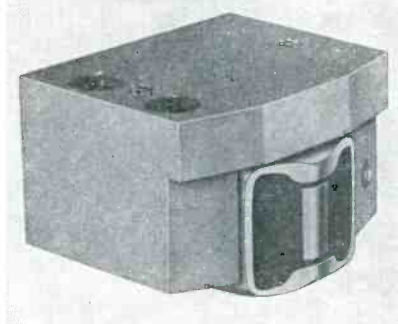

Ampex original equipment performance and are adaptable to the shield cup of Ampex head nests with a one-time installation of the QK-76 kit on 300, 350, 351, 400, 3000, and 3200 series. Track style changes are simplified by loosening a set screw to remove and replace a head.

Circle 41 on Reader Service Card

## Microwave Cable Clampers

Clamper amplifiers designed for microwave radio or cable systems handling NTSC color or monochrome TV signals are being manufactured by Raytheon CADPO, Lexington, Mass. Low frequency amplitude and phase distortion are reduced, and signal-to-noise ratio is improved. All models suppress 60-cycle interference by 30 db. The units are built of solid-state, plug-in printed cir-

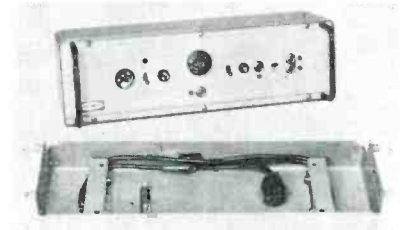

cuit modules and can be operated as clamper amplifiers or as flat 20 db gain wideband video amplifiers. One portable and two rack-mounted models are available.

Circle 42 on Reader Service Card

## New Mark XX Lens for Vidicon Cameras

Zoomar, Inc., Glen Cove, N.Y. and Hollywood, Cal., has announced the development of the Mark XX lens, the newest of the remote control vidicon Zoomar



Mark Lenses, incorporating a high precision F/6 Angenieux lens with a 20:1 zoom ratio in focal lengths from 15 to 300mm and field angles from 55° to 3°. The lens support mounting rail furnished with the Mark XX permits it to be adapted to different make vidicon cameras.

Circle 43 on Reader Service Card

## Mic With Variable Reverb

Reverberation effects surpassing the results of echo chambers and electronic delays, cathedral sounds in small churches, and a theatrical dimension in live broadcasts are features cited for the DX-11 dynamic cardioid microphone marketed by North American Philips Co., New York. Variable reverberation is accomplished by external control of a built-in transistorized amplifier; range is continuous from maximum delay cutoff point where the mic performs as a normal unit. An on-off switch is part of the variable control; matches high or low impedance input.

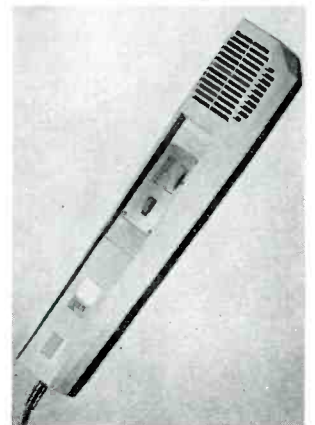

Circle 44 on Reader Service Card

# The CATV Cable that GUARANTEES FULL-SPECTRUM CAPABILITY

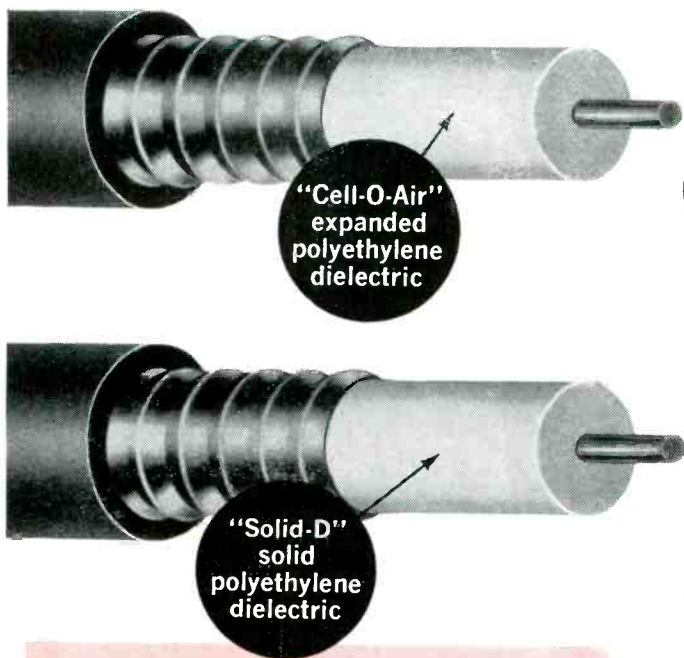

## SUPERIOR Coaxial Cable with "Coppergard"

Superior Coaxial Cable with Coppergard guarantees no attenuation discontinuity over the continuous range — through 219 MCS *and beyond!* This means you can *use* all the frequencies available to you. Unlike ordinary cables, which offer only the television band, Superior Coax was specifically designed for CATV to provide for full utilization of the frequency range in aerial and buried plant.

When you buy cable, insist on the brand that gives full-spectrum capability at no extra cost. Install Superior Coaxial Cable with "Coppergard," the cable your system will never outgrow.

### CHOOSE SUPERIOR CELL-O-AIR® COAX FOR AERIAL PLANT

Guaranteed Maximum Attenuation db/100' at 68° F

	Ch. 2	Ch. 6	108 mc.	Ch. 7	Ch. 13
4920	0.75	0.93	1.08	1.41	1.57
4930	0.58	0.68	0.80	1.07	1.20

### CHOOSE SUPERIOR® SOLID-D COAX FOR BURIED PLANT

Guaranteed Maximum Attenuation db/100' at 68° F

	Ch. 2	Ch. 6	108 mc.	Ch. 7	Ch. 13
6020	0.74	0.91	1.05	1.38	1.55
6030	0.56	0.67	0.79	1.05	1.13

*Every Reel Sweep-Tested  
Over Its Full Length*

See Us at  
the NCTA Show (Booth 47-48)

For detailed information and prices, write



## SUPERIOR CABLE

SUPERIOR CABLE CORPORATION • HICKORY, NORTH CAROLINA

Circle 22 on Reader Service Card

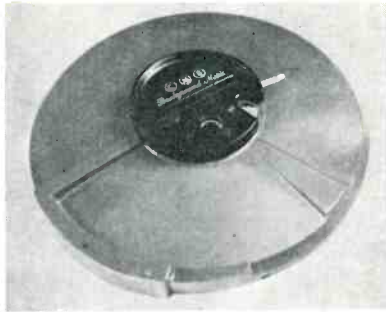
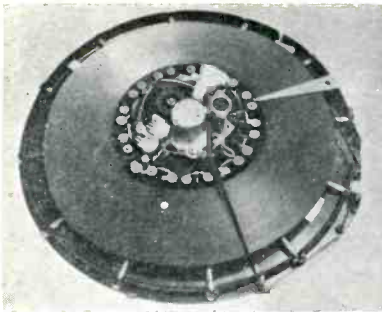

### Turtable Tape Transport

The "Tape Top," an automatic turntable tape transport, has been developed by Casco Music Systems, Inc., Hyde Park, Mass. The unit features a continuous tape cartridge which mounts directly on any turntable or phonograph. Operating power is taken from the turntable and the capstan is engaged by inserting a single plug. Output from the one to eight track head is fed into any preamp or amplifier and the cartridge is normally available with 3200' of 1/4" tape; as much as 88 hours of program material may be recorded. Priced from \$99.50.

Circle 45 on Reader Service Card

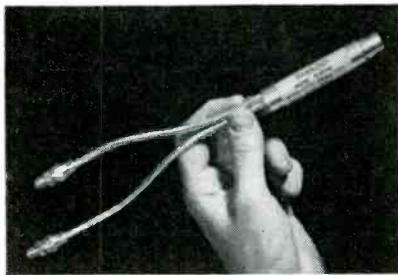

### Coaxial RF Load Resistor

Bird Electronic Corp., Cleveland, claims to have accomplished a thousand to one breakthrough in size reduction for a coaxial RF load resistor. Its Model 8710 1 kw load weighs only 5 oz. The units are designed for reflection-free

termination of 50-ohm coaxial systems, and for performance over the frequency range of DC to 4000 mc. Price is \$200 each.

Circle 46 on Reader Service Card

### New 25" Monitor

A Model CEA25 25" monitor is available from Conrac Div. Gianini Controls Corp., Glendora, Cal. The unit provides quality pictures in high ambient light areas, and is voltage regulated



for stable operation under varying line voltage conditions. It reportedly has a picture area comparable to 27" monitors; physical size for the large display area is proportionately smaller than other monitors, made possible by

## HOW TO GET MORE RELIABILITY FOR LESS MONEY

—SPECIFY CAS

ALL-TRANSISTORIZED EQUIPMENT  
FROM HEAD-END TO TV SET

Because of the growing demand for CAS all-transistorized, all-band CATV equipment — most reliable in the industry — we have moved into a new and larger plant, specifically designed to manufacture the finest CATV equipment at economy prices.

SEE US IN NCTA BOOTHS 59-60

- All transistorized All-band AMPLIFIERS
- Full line of FITTINGS and ACCESSORIES
- Turn-key ENGINEERING and CONSTRUCTION



P. O. BOX 47066 • DALLAS, TEXAS 75207

WRITE FOR FREE CAS ALL-TRANSISTORIZED EQUIPMENT BROCHURE

Circle 23 on Reader Service Card

using a shorter 110° CRT. The CEA25 weighs 104 lbs, more than 85 lbs lighter than conventional 27" monitors. Center resolution is 800 lines; corner resolution is 600 lines. Price is \$430.

Circle 47 on Reader Service Card

### New TV Waveform Monitor

Type RM529 video waveform monitor, from Tektronix, Inc., Beaverton, Ore., was designed for vertical interval testing, sine-squared testing, signal level monitoring, bandwidth measurements, linearity checks, modulation percentage measurements, and RBG or YRGB displays. The unit fits a standard 19" rack and requires only 5¼" vertical space. Bandwidth is flat to 8 mc. Price is \$1100.

Circle 48 on Reader Service Card

### Miniature Cardioid Mic

The Neumann U-64 miniature cardioid condenser microphone is being distributed in the U.S. by Gotham Audio, N.Y. A Mylar

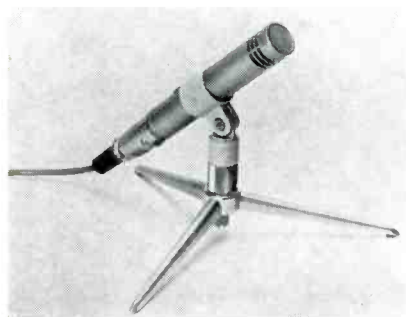

base vacuum gold-steamed element with acoustical delay network is incorporated, providing linear frequency response from sound pick-up angles of ±135°. The amplifier uses a type 7586 nuvistor and features a built-in switchable 10 db overload protection and a foam rubber anti-pop screen. There are four power supplies for 1 to 6 microphones. A single U-64 system is \$360.

Circle 49 on Reader Service Card

### Solid-State Video Mixer

A completely solid state VMA-1 video mixing amplifier from Northern Electric, Belleville, Ont., Can., is designed to mix two composite or noncomposite synchronous 75-ohm, monochrome video sources in complementary and noncomplementary modes of operation. Color signals may be mixed in a complementary mode in the Model VMA-2.

Circle 50 on Reader Service Card

### Ruggedized M/Wave Passive Reflector

A passive reflector with face flatness assured to within ±1/16" and rigidity for 12,000 mc systems has been developed by Advance Industries, Sioux City, Ia. The new design will withstand heavy ice loads (65 lbs. per sq. ft. of ½" ice), is stiff-arm stabilized and incorporates vertical and azimuth adjusting features. The face is fabricated from extruded aluminum panels with no loosely riveted face skin, a common source of problems. Comes in 4 x 6', 6 x 8', 8 x 12', 10 x 15', and 12 x 17' models

Circle 51 on Reader Service Card



# PERFECTION

... ANOTHER KEY TO **SPARTA SUCCESS**

**ANNOUNCING...**  
**THE NEWLY ADVANCED**  
**SPARTA-MATIC 300B**  
**TAPE CARTRIDGE SYSTEM**

300B-P  
PLAYBACK UNIT  
**\$495.00**

300B-R  
RECORD AMPLIFIER  
**\$230.00**

**JUST LOOK AT THESE NEW 300B FEATURES!**

- Meets or exceeds latest NAB Standards.
- New improved cartridge deck for fast cartridge insertion and removal.
- Second and third tone cues available.
- Perfected drive mechanism for years of added service.
- New Nortronics tape heads for superior sound reproduction and micro-adjusting head mount are included as standard equipment.
- Latest plug-in solid state modules.

**For further details, contact your SPARTAMAN TODAY!**

**SPARTA**

**ELECTRONIC CORPORATION**

6450 FREEPORT BLVD. • SACRAMENTO, CALIF. 95822

Circle 24 on Reader Service Card

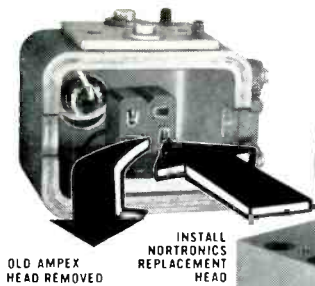

# NEW!

## NORTRONICS REPLACEMENT HEADS FOR AMPEX RECORDERS!

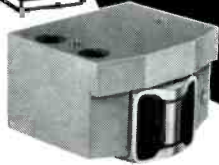

### QK-76 ADAPTER PERMITS FAST REPLACEMENT . . . RAPID CHANGEOVER IN TRACK STYLES!

Now - cut costs in replacing heads on Ampex 300, 350, 400, 3000 and 3200 series professional tape recorders . . . eliminate "down time"! New Nortronics heads and QK-76 adapter equal Ampex original equipment performance . . . easily mount within the shield cups of Ampex head nests.

- VERSATILE - You pick the head and track style! QK-76 adapts Ampex recorders to accept Nortronics full track, 2-track, 3 or 4 channel or 4-track styles . . . Record, Playback or Erase heads!
- FAST - No waiting . . . no units "out of service"! Head replacements made by simply loosening set screw and disconnecting plug! You make initial changeover . . . you schedule service or maintenance!
- HIGHEST QUALITY - Utilizes original equipment Ampex shield cups plus professional quality Nortronics replacements!

Nortronics offers the *largest* available variety of track and channel styles . . . *widest* selection of impedances and gap lengths . . . *greatest* versatility in mounting! Write today for detailed information.



8173-G 10th Ave. No.  
Minneapolis, Minnesota 55427

Circle 25 on Reader Service Card

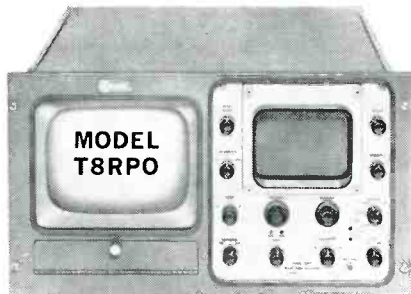

## PROFESSIONAL TRANSISTORIZED MONITORS BY MIRATEL

Here's reliable solid state performance in monitors made to the broadcaster's high standard of quality. 800 line center screen resolution. Minimum maintenance. 8, 14 and 17 inch sizes. 13 custom, rack, cabinet and console models. Write to Miratel Electronics, Inc., 3600 Richardson Street, New Brighton, St. Paul, Minn. 55112.

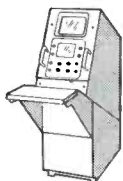

MODEL T8RPOC



MODEL T8MP



MODEL T8RTP



Standard line of video monitors available in all types and sizes . . . custom designs available.

Circle 26 on Reader Service Card



## PROLOG®

An easily operated system that automatically performs PROGRAMMING, LOGGING and AUTHENTICATING by utilizing the station log which is prepared on any standard typewriter.

write for details today

**LTV**  
Continental Electronics  
BOX 17040 / DALLAS, TEXAS 75217

Circle 27 on Reader Service Card

## Bulbless Illuminated Button

The Glo-Button X series, by Switchcraft, Inc., Chicago, Ill., looks and works like an illuminated button but requires no

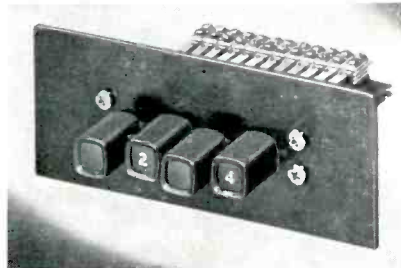

bulb or electrical power. When the button is pushed the legend on the face lights due to reflected ambient light. Presently, the button is being made with 1 through 18 numerals, letters A through R and ON and OFF. The Glo-Button will fit any switch with plunger action and a maximum 1/16" fallback.

Circle 52 on Reader Service Card

## Solid-State TV Monitors

Miratel Electronics, St. Paul, Minn., has designed a series of general purpose TV monitors

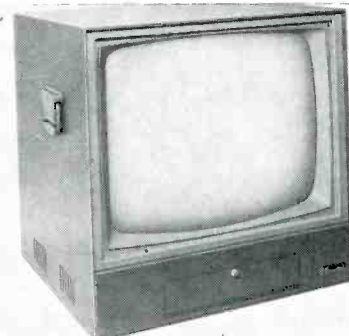

with transistorized and printed circuit construction, featuring glass epoxy module boards and plug-in transistors. Video bandwidth is 10 mc and the units come in 8 through 23" tube sizes in standard mounting designs.

Circle 53 on Reader Service Card

## Microwave TV

### Transmitter/Receiver

A highly portable solid-state transmitter and receiver, designed to operate in the 1990-2110 mc range, is being marketed by Telequip Corp., Glen Cove, N. Y. Intended for mobile operation from helicopters or on the ground, the transmitter uses vidicon or I.O. cameras and has a microphone input, providing simultaneous video and audio transmission. Output is 1w, weight is 14 lbs. and size is 5" x 10" x 7". The receiver is 23 lbs., 8 3/4" x 12" x 8".

Circle 54 on Reader Service Card



# BM/E

## ADVERTISERS' INDEX

Aerovox Corp., Hi-Q Div. ....	12
Ameco, Inc. ....	26, 35
Anaconda Wire & Cable Co. ....	18-19
Bauer Electronics Corp. ....	54
CAS Mfg. Co. ....	50
Continental Electronics ....	52
Dynair Electronics, Inc. ....	37
Electro-Voice, Inc. ....	3
Entron, Inc. ....	45
General Electric Co., Visual Communications Products ....	8-9
Jerrold Electronics Corp. ....	Cover 2
McMartin Industries, Inc. ....	7
Miratel Electronics, Inc. ....	52
Moseley Assoc., Inc. ....	10
Nortronics Co., Inc. ....	52
Raytheon Company, CADPO Div. ....	14
Riker Industries, Inc. ....	Cover 3
Rome Cable Div. of Alcoa ....	13
Sarkes Tarzian, Inc. ....	Cover 4
Sola Electric Co. ....	17
Sparta Electronic Corp. ....	51
Spencer-Kennedy Labs., Inc. ....	54
Superior Cable Corp. ....	49
Technical Appliance Corp. (TACO) ....	46
Tektronix, Inc. ....	5
TeleSystems Corp. ....	48
Television Factbook ....	54
Viking Cable Co. ....	11
Viking of Minneapolis ....	47

## ADVERTISING SALES OFFICES

**Bryce Gray, Jr., President**  
**Mal Parks, Jr., Publisher**

### NEW YORK AREA

820 Second Ave., New York, N. Y. 10017  
Ralph Richardson 212-MO 1-0450  
Charles E. Moodhe

### NEW JERSEY/PHILADELPHIA

820 Second Ave., New York, N. Y. 10017  
Charles C. Lenz 212-MO 1-0450

### NEW ENGLAND

228 Main St., Stoneham, Mass.  
Harold Short 617-438-3743

### MIDDLE ATLANTIC

18 Frederick Rd., Thurmont, Md. 21788  
Mal Parks, Jr. 301-271-7151

### MIDWEST

612 No. Michigan Ave., Chicago, Ill.  
William L. Klusack 312-MI 2-3774  
22310 Blossom Dr., Rocky River 16, Ohio  
Allen "Bud" Prymmer 216-228-1550

### SOUTH CENTRAL

Media Sales Co.  
2600 Douglas Avenue, Irving, Texas  
Joe Sissom 214-BL 5-6573  
Parker Harris

### WEST COAST

1245 E. Walnut Street, Pasadena, Calif.  
Lawrence C. Papp  
Pasadena: 213-795-1528  
Los Angeles: 213-684-0590  
Jules E. Thompson Co.  
681 Market Street, San Francisco, Calif.  
Jules Thompson 415-DO 2-8547  
William Healey

# Helpful Books that Belong in Every Station—Now on 10-Day FREE Trial!



## AUDIO CONTROL HANDBOOK

For radio-TV broadcasting. An extremely practical aid for studio control operation—all phases of audio control are fully explained and illustrated. A real step-by-step "how-to-do-it" manual. Numerous Review questions at the end of each of the 16 Chapters provide a helpful

refresher. 160 pps.; BIG 8 $\frac{1}{2}$ "x10" size; 131 illus.  
Order TAB-67 .....only \$6.95



## Planning the Local UHF-TV Station

This brand-new guide describes all requirements for planning, building and operating a UHF station. Contains practical data on eqpt., layout and economic factors involved. Includes many do-it-yourself hints and cost-cutting tips. 12 fact-filled Chapters.

Order TAB-43 .....only \$10.00



- 9 BIG Sections
- 1728 pages
- 1306 Tables & illus.

## NAB ENGINEERING HANDBOOK

A. Prose Walker, Editor-in-Chief

Let this GIANT reference help you solve broadcast engineering problems quickly & accurately!

Revised 5th Edition now covers entire range of radio-TV engineering. Contains thousands of recommended procedures, fundamentals, standards, rules, and "how-to" working instructions on all phases of radio and TV. Keeps you abreast of such developments as TV translators, remote control, transistor applications, automatic logging techniques, etc. Written with your everyday working needs in mind, this standard reference contains 9 comprehensive Sections: Rules, Regulations & Standards; Antennas; Towers and Wave Propagation; Transmitters; Program Transmission Facilities; Remote-Pickup Facilities; Measurements, Techniques and Special Applications; Charts & Graphs.

Order TAB-35 .....only \$28.50

## FAMOUS 'TECHNIQUES' BOOKS

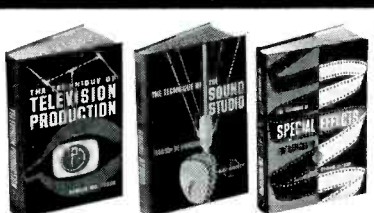

Known the world over, these "Techniques" books provide practical know-how of value to all radio-TV professionals. All are exceptionally well illustrated. Sold on a Money-Back Guarantee!

Technique of TV Production: 1180 illus.; 416 pps. Order TAB-59 .....only \$10.00  
Technique of the Sound Studio: 110 illus.; 288 pps. Order TAB-58 .....only \$10.50  
Technique of Documentary Film Production: 75 illus.; 256 pps. Order TAB-64 .....only \$10.00  
Technique of Film Animation: 250 illus.; 352 pps. Order TAB-68 .....only \$10.00  
Techniques of Film Editing: 189 illus.; 288 pps. Order TAB-69 .....only \$9.95  
Techniques of Film Music: 75 illus.; 304 pps. Order TAB-70 .....only \$10.00  
Techniques of Film & TV Make-Up: 200 illus.; 256 pps. Order TAB-71 .....only \$10.00



Antenna Engr. Handbook Current state of the antenna art is fully covered in this data-packed handbook. Provides a wealth of essential principles, methods and data to help solve all kinds of antenna problems. Virtually every type of modern antenna is dealt with. Helps in checking out impedance, gain, radiation patterns and other antenna properties. 1013 pages; 993 illus.; 35 Chapters.

Order TAB-40 .....only \$23.50

## RADIO-TV MANAGEMENT BOOKS

### Television Station Management

This long-needed book discusses the practical day-to-day problems of managing and operating a TV station. No theory—for each of the 17 Chapters has been written by a broadcast executive with wide experience. Covers the independent, network affiliate, and ETV station. 5 BIG SECTIONS include: The Business of Broadcasting; Managing the TV Station; Programming, Production, Publicity; Sales Management for the TV Station; Technical Services and Management. A MUST book for any telecaster! 256 pps.

Order TAB-57 .....only \$6.95

### Radio Station Management

A clear, cogent presentation of complex station problems. Discusses organizational setup, programming, engineering, personnel, accounting, sales and promotion. Offers a wealth of stimulating ideas in the management of a station. An indispensable source book. 338 pps.

Order TAB-61 .....only \$5.75

### EXAMINE FOR 10 DAYS AT OUR EXPENSE!

Order on approval for 10 days FREE examination. If at the end of 10 days you don't want the book, return it and we'll cancel invoice.

## NO RISK COUPON—MAIL TODAY

TAB Books, Drawer D, Thurmont, Md. 21788  
Please send me book(s) listed below.  
I enclose \$ 8765  
 Please invoice on 10-day FREE trial.

Name .....  
Station or Co. ....  
Address .....  
City ..... State .....

## Radio-Electronic TRANSMISSION FUNDAMENTALS

This basic guidebook fully covers high-power electrical energy of radio-frequency, including transmission lines (and coax cable) radio antennas and transmitters. 17 Chapters on Radio Antennas; 14 on Transmitters. A virtual library of transmission facts & techniques. 68 Chapters in all!

Order TAB-39 .....only \$10.75



## RADIO OPERATING Q & A

This latest Edition of a standard work that has helped men pass their exams for 40 years provides all the data needed to pass Elements 1 through 9 of the FCC exams. For ease of understanding, all material is grouped by topics, such as Laws, Power Supplies, and Theory. 608 pages; 153 illus.; 2000 answers.

Order TAB-37 .....only \$8.25



## RADIO TRANSMITTERS

All the essential working data on radio transmitters is covered in this authoritative 452-p. book. Emphasizes the practical aspects to help you efficiently operate and maintain all types of radio transmitters. 14 Ch., 408 illus.

Order TAB-36 .....only \$13.00

1965 Edition • NO. 35

# Television Factbook

THE AUTHORITY REFERENCE FOR THE ADVERTISING, TELEVISION AND ELECTRONICS INDUSTRIES  
PUBLISHED BY TELEVISION DIGEST, INC., WASHINGTON, D. C. 20006

a  
service  
of

**TELEVISION DIGEST, INC.**  
Publishers of Television Factbook and Television Digest Newsletter  
2025 Eye Street, Northwest, Washington, D. C. 20006

## THE MOST AUTHORITATIVE REFERENCE FOR THE TELEVISION AND ELECTRONICS INDUSTRIES

The 1965 edition of Television Factbook is here. Expanded and completely up-dated it contains even more information and reference material than ever before.

A full page on each TV station, with coverage map, ARB circulation data, Grade A and B coverage contours, personnel, engineering data, etc.

Detailed data on all CATV systems; ownership, personnel, number of subscribers, rates, stations, and all franchises and applications pending in the U. S.

Full data on all Educational TV stations.

Weekly circulation and coverage data on all Canadian stations in multiple-station markets.

Directories of network executives, basic time rates and affiliates.

Directories of TV program sources, leading advertising agencies and public relations organizations.

Plus much more invaluable information for media directors, time buyers and executives.

The price is only \$19.50 (\$17.00 each for five or more) and we pay the shipping costs if payment accompanies your order.

A Service of Television Digest, Inc.

Write:

### TELEVISION FACTBOOK

2025 Eye St., N.W. Washington, D. C. 20006

Circle 29 on Reader Service Card

## LITERATURE of INTEREST

For additional data, circle No. shown on Reader Service Card.



Electrical components catalog covering tube sockets, plugs and connectors for commercial and industrial applications offered by Amphinol. 68 pages. 104

Lighting Equipment, including flasher and obstruction lights, in illustrated product brochures from Rohn. 68

UHF TV Translator Systems are discussed in 8-p. booklet from Adler Educational Systems, replete with Q&A and translator basics, photos, specs, and charts. 69

Antenna Towers for AM-FM-TV and microwave, plus advanced tower antenna structures and accessories including tower elevators, lights, etc., are described in 16-p. booklet from Dresser Ideco. 63

Video Switching Systems, one a solid state vertical interval unit and the other a master control, are available from Ward Electronic Industries, and are described in two 8-p. booklets. 96

Program-gated amplifier, Gates Level Devil, described in leaflet. 126

TV transmitters, UHF and VHF, with one-design drivers and add-a-unit amplifiers to meet any power requirements, illustrated in brochure from Standard Electronics. 123

Retraflex elastic wire and cable applications described in bulletin from Birnbach Radio. Data on cable types, jacket materials, and conductor sizes. 151

CATV Business Booster, monthly bulletin published by Ameco, contains new ideas for system promotion. 112

TV antennas for CATV, MATV, translators, etc., listed in a short-form catalog from TACO. Also describes new line of UHF cylindrical parabolas. 134

Magnetic mat recorder/reproducer which uses circular magnetic mats instead of tape reels or cartridges illustrated in brochure from Ampex. 140

Transmitter Cubicle combinations for 1, 5, 10, and 35 kw with VHF visual-aural power ratios from 2:1 to 10:1 described in G.E. brochure. 147

Sequential intermix Prolog system, illustrated in fact sheet from LTV Continental. 157

Tape cartridge handler, rack-mount reel-to-reel transport, and compact recorders, illustrated in folders from Viking of Minneapolis. 156

CATV Article Reprints tell how to plan a CATV antenna system, describe systems set-ups including 10 steps to a successful system. From Jerrold. 81

18-Page Availabilities Brochure includes details on CATV transmission systems, typical installations, plus data on Entron's services and capabilities. 65

Flyers from McMartin illustrate, describe, and spec FM stereo monitor, SCA multiplex monitor, RF amplifier, FM/SCA signal generators, transistorized pre-amps and new facsimile through CCA multiplex. 86

CATV products, advanced technology, research engineering, manufacturing, quality control, sales and service: The Viking Story. 158

Solid State Computer Programmer for TV automation in 6-p. bulletin from Sarkes Tarzian Broadcast Eqpt. Div. Full description of operation, applications, specs of APT-1000 unit. 159

Tape recorder head and amplifier data published in Customer Engineering Bulletins from Nortronics. 160

Video distribution equipment described in a package of info sheets from Dynair. 161

Standby TV microwave equipment; automation transmitter switching and duplicating receiver protection for STLs in fact sheet from Raytheon. 162

**SPENCER - KENNEDY  
LABORATORIES, INC.**

Complete CATV Service  
EQUIPMENT... ENGINEERING... FINANCING

1320 Soldiers Field Road  
Boston, Mass. 02135 Tel. 617/254-5400

**WANTED—ENGINEER, CHIEF**

New, 2500 mc ETV for large private school system. PE/EE preferred, 1st-class ticket. Experience as chief engr., transmitter/studio construction, operation, maintenance. Opportunity for person willing to grow with system.

Write Box #7-1  
c/o BM/E, 820 2nd Ave., New York 10017



### NEW....PEAK LIMITING AMPLIFIER!

The Bauer "Peak Master" is the smallest, completely self-contained limiter available that can be used in critical broadcast, recording and motion picture audio applications • 3½" of Rack Space • Vernier Input—Output Controls • Switchable VU Meter • Fast Attack Time • Adjustable Release Time • \$440.00 • Send for Complete Details Today!

**Bauer** ELECTRONICS CORPORATION  
1663 Industrial Road, San Carlos, California  
Area Code 415 591-9466

Circle 30 on Reader Service Card

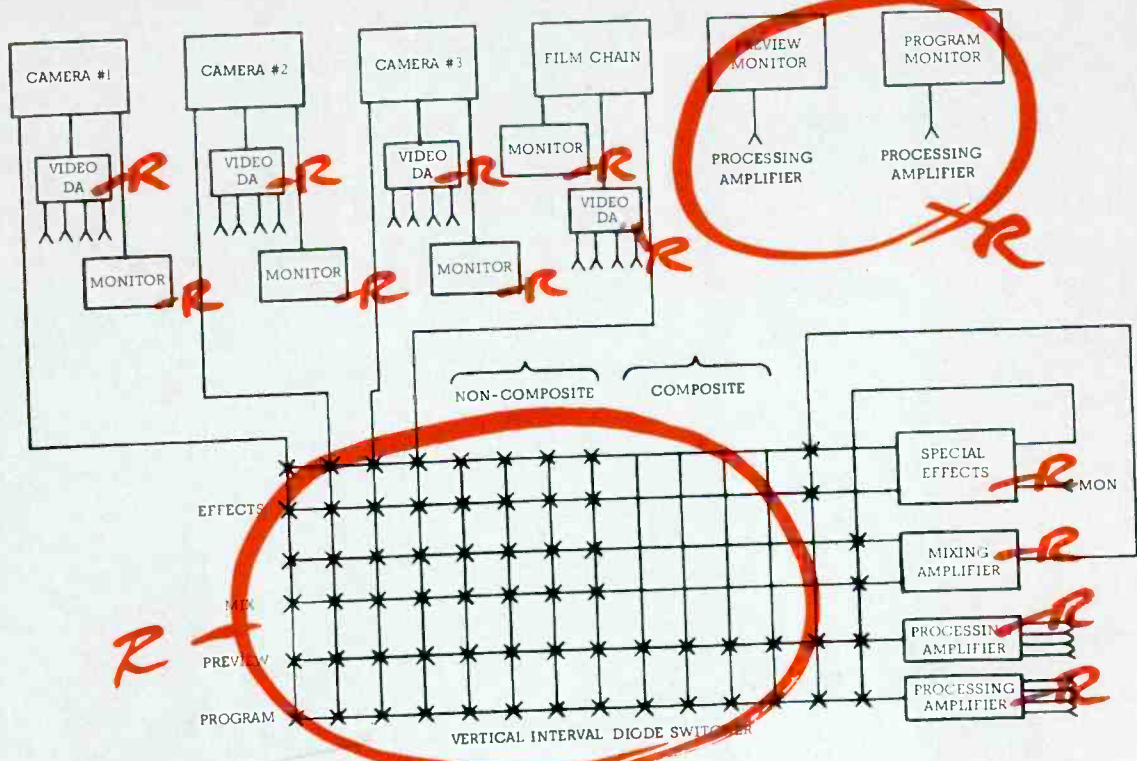

SIDNEY MCCOLLUM  
V. P. MARKETING

Dear Evan:  
We are returning the  
block diagram you sent  
us. All the equipment  
marked "R" will be man-  
ufactured and supplied  
by us - estimate and  
spec sheets are  
enclosed. Delivery  
is no problem.  
Cordially, Sid

RIKER INDUSTRIES, INC.

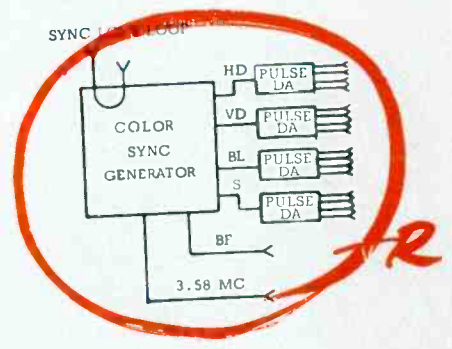

... YES, when it comes to VIDEO  
**RIKER** makes complete systems

SEND FOR OUR QUOTATIONS ON  
YOUR VIDEO REQUIREMENTS,  
FROM INDIVIDUAL INSTRUMENTS  
TO COMPLETE SYSTEMS.

**RIKER INDUSTRIES, INC.**

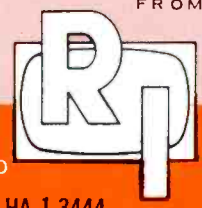

...thinking always of tomorrow

NORDEN LANE, HUNTINGTON STATION, NEW YORK: PHONE 516 HA 1-3444

• MIAMI • LOS ANGELES • DETROIT

Circle 2 on Reader Service Card

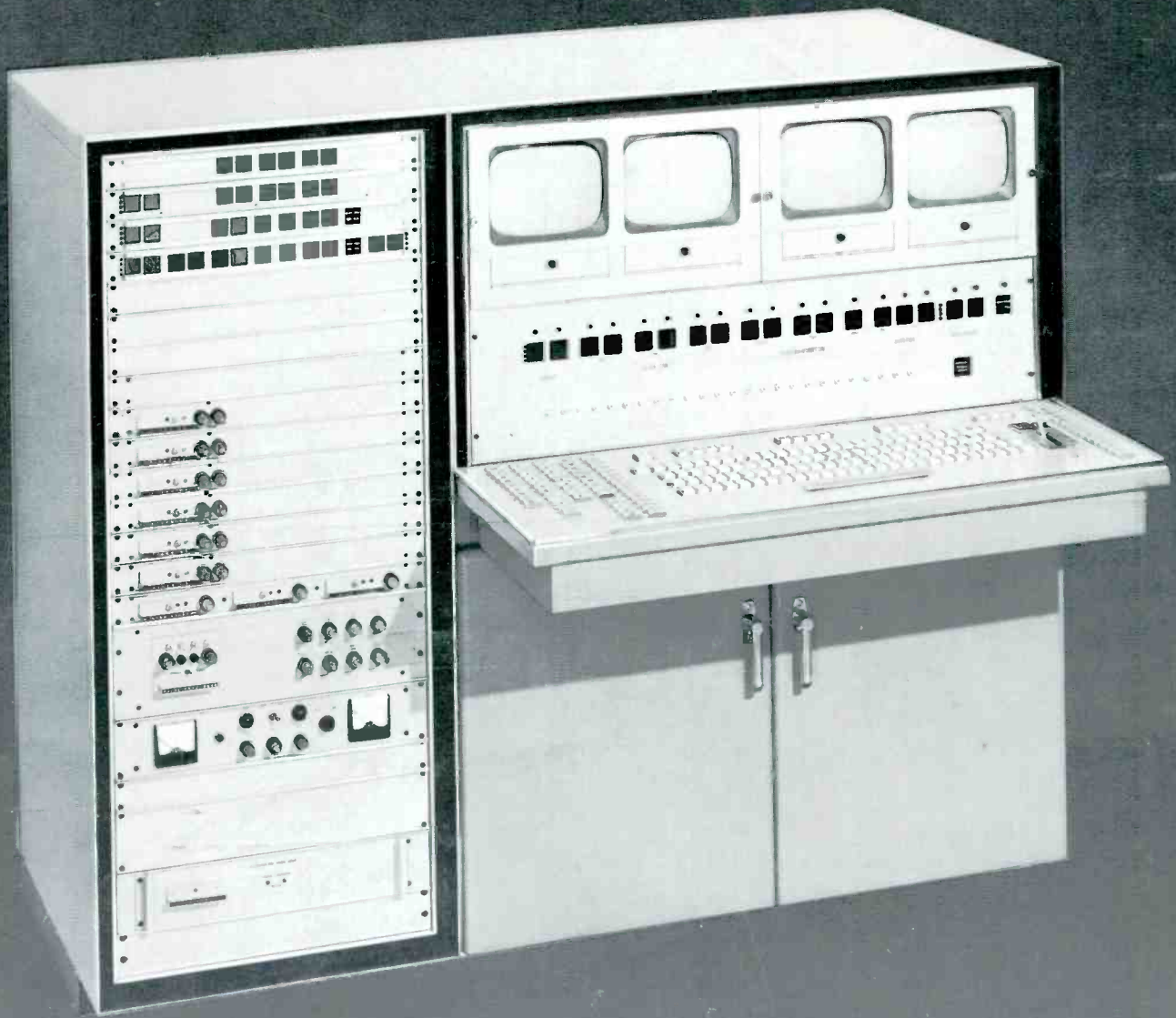

# APT-1000

AUTOMATIC PROGRAMMER FOR TELEVISION

**SOLID STATE  
COMPUTER  
PROGRAMMER**

Can't panic . . . prime time or any time. Puts an end to make goods. Tarzian's computer programmer—designed solely for flawless television programming—eliminates operator error in all program

periods. Productions run smoother . . . faster . . . automatically. APT is a true computer. It's all solid state. It interfaces readily with existing equipment. A call or letter brings brochure with all the details.

**S A R K E S**  
BROADCAST EQUIPMENT DIVISION



**T A R Z I A N**  
BLOOMINGTON, INDIANA

Circle 3 on Reader Service Card