

# BME

BROADCAST MANAGEMENT/ENGINEERING

**Coordinate Your Modernization Ideas**

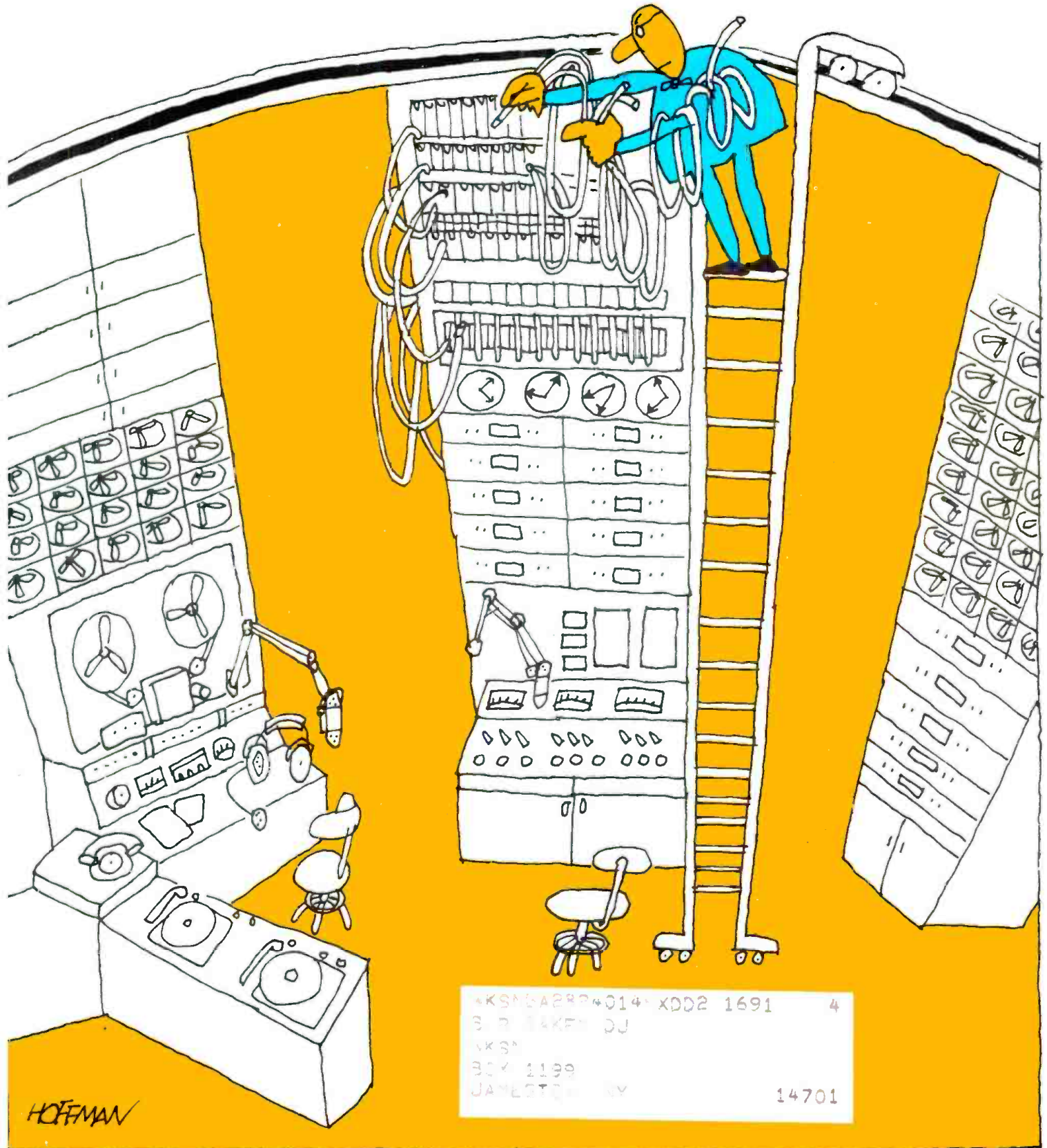

\*KSNB-APR-014- XDD2 1691 4  
S. D. BAKER DJ  
KSNB  
304 1199  
JAMESTOWN, NY 14701

HOFFMAN

**ONE COMPANY**

in the  
television industry  
offers a complete  
line of solid-state  
instrumentation for  
video analysis,  
simulation, processing  
and control.

**RIKER VIDEO**

100 PARKWAY DRIVE SOUTH, HAUPPAUGE, L. I., NEW YORK 11787

A Subsidiary of THE RIKER MAXSON CORPORATION

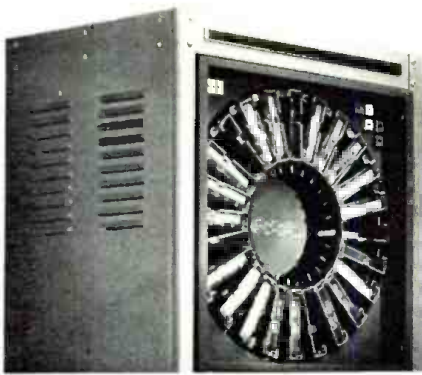

## THE TAPE-ATHON 5000 SYSTEM

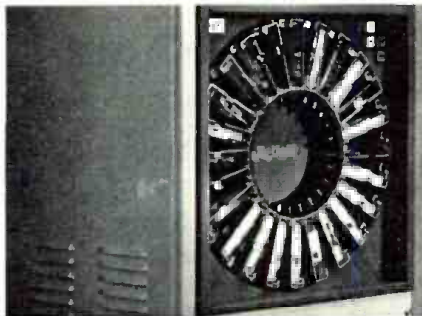

## IS DESIGNED AND PRICED TO GET ANY STATION INTO SOPHISTICATED AUDIO AUTOMATION

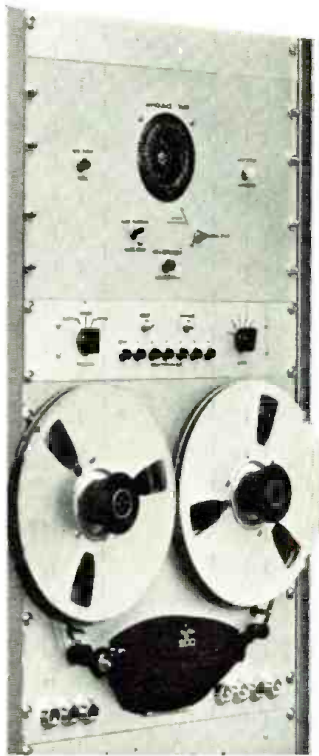
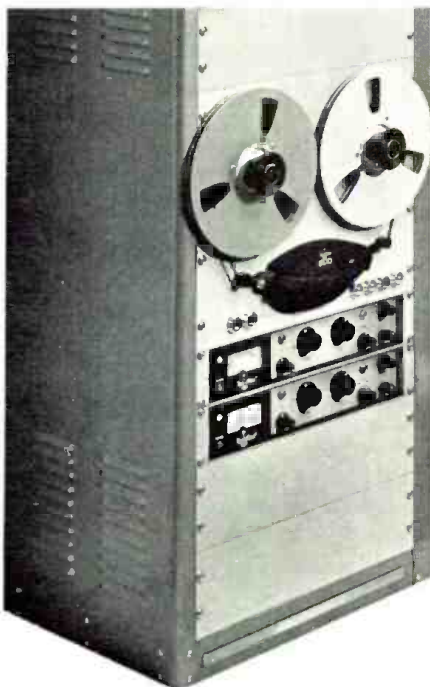

By incorporating a "building block" engineering concept and using high quality mass produced equipment, Tape-Athon can deliver a sophisticated audio automation system for 1/3 less than comparable units. Starting with standard "Carousel" cartridge decks (from one to eight per system) we add *our own* tape transports (up to 9 if you like) and our logger/recorder (optional). The Tape-Athon master timing control and solid-state intersperser permit a wide range of music sequencing.

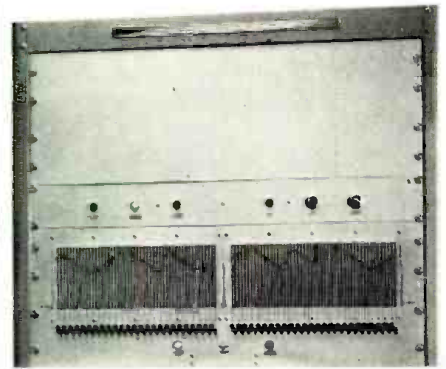
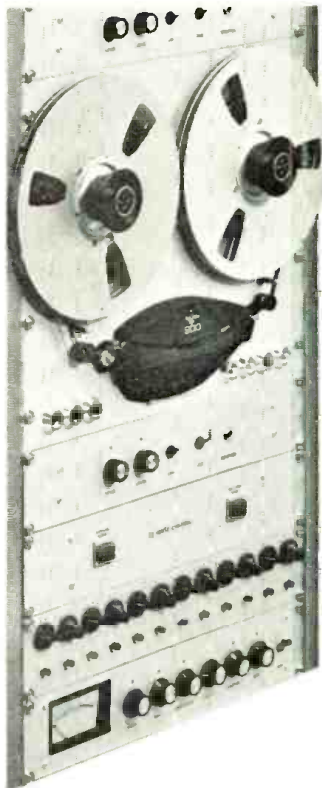

The ultimate in programming of course is provided by one or more of these switchboards which allow an infinite variety of music/announcement ratios and timing.

Before you invest in any system, contact your Tape-Athon rep or write for our 5000 System brochure giving complete details.

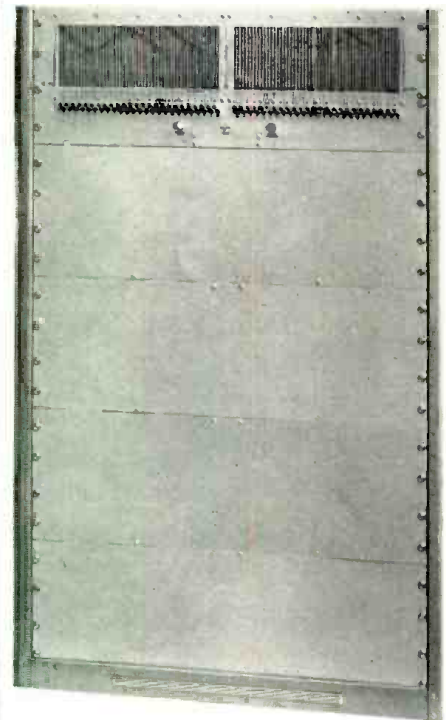

# Tape-Athon Corp.

502 S. Isis, Inglewood, Calif. 90301  
Tel: (213) 776-6933

Visit Tape-Athon at Booth 50B, MOA Convention, September 5, 5, 7  
Circle 102 on Reader Service Card



# BROADCAST MANAGEMENT/ ENGINEERING

Editor:  
JAMES A. LIPPKE

Managing Editor:  
WALTER G. SALM

Assistant Editor:  
HILARY E. ABRAMSON

Art Director:  
KAREN WEINSTEIN

Editorial Director:  
GEORGE ROSTKY

Production Manager:  
ARLINE G. JACOBS

Circulation and Reader Service Manager:  
RITA MARKEL

Sales Promotion Manager:  
RHODA GLENNER

Research Manager:  
IRENE CHERVIN

Marketing Services Manager:  
JACK LOW

President:  
RALPH E. RICHARDSON

This month's cover: It's a rare station that has everything in well ordered layout. Too often, equipment and "modernization" gear is just tacked on wherever it'll fit. The perplexity of such an added-on station reaches a climax with the librarian's ladder in artist Sandy Hoffman's cover. Before your station gets to that state, turn to pages 38-44 for some modernization ideas.

- 6 **Broadcast Industry News**
- 15 **Interpreting FCC Rules & Regulations**  
The Supreme Court Speaks on Fairness
- 23 **Convention Log**  
1969 NCTA Convention
- 32 **New for Cable—Fm Stereo that Works**  
Plagued by technical problems in the past, cable stereo is now ready for customers.
- 34 **Radio Formatting in New York—Part 2**  
Fierce competition in the glutted New York market sends stations scampering for new ideas.

---

## SPECIAL SECTION: STATION MODERNIZATION

---

- 38 **KOWN: Radio in the Marketplace**  
A radio station in a shopping center's not a new idea, but this one invites ogling with picture windows.
  - 40 **Radio Broadcasting from a "Goldfish Bowl"**  
On the mezzanine of Pittsburgh's first vertical garage, WJAS lets pedestrians look in on all-talk station.
  - 42 **Studio Runs TV Gamut Without Frills**  
Design flexibility and high-caliber professionalism keeps this teleproduction house on the move.
- 
- 47 **Broadcast Equipment**
  - 52 **New Literature**
  - 54 **Names in the News**
  - 58 **Crosstalk**
  - 64 **Focus on CATV**
  - 65 **FCC Actions**
  - 70 **Editorial**  
Business Sense vs Business Ethics
- 

**Mactier Publishing Corp.**  
820 Second Ave., New York, N.Y. 10017, 212 661-0450

Also publishers of:

**BROADCAST EQUIPMENT BUYERS GUIDE**

**EEE**

**ELECTRO-PROCUREMENT**



*BM/E*, Broadcast Management/Engineering, is published monthly by Mactier Publishing Corp. All notices pertaining to undeliverable mail or subscriptions should be addressed to 820 Second Ave., New York, N.Y. 10017.

*BM/E* is circulated without charge to those responsible for station operation and for specifying and authorizing the purchase of equipment used in broadcast facilities. These facilities include a-m, fm, and TV broadcast stations; CATV systems; ETV stations, networks and studios; audio and video recording studios; consultants, etc. Subscription prices to others are: U.S., its possessions and Canada—\$10.00 one year, \$18.00 two years; elsewhere—\$15.00 one year, \$25.00 two years.

Copyright © 1969 by Mactier Publishing Corp., New York City. Controlled Circulation postage paid at Duluth, Minn.

# It's here.

## The only demodulator designed specifically for use in CATV head-end systems.

A new approach to  
perfect off-the-air color  
... for only \$1275



Now you can have high-fidelity off-the-air color from your head-end. Utilizing completely new filtering and signal-restoration concepts, the DYNA-TUNE provides superior adjacent-channel color performance in either microwave-fed or demod-mod systems. These important developments allow the DYNA-TUNE to actually improve the color signal in many critical areas over that produced by the broadcast RF transmission system.

You can also forget the problems inherent in outdated tube-type tuners . . . the DYNA-TUNE uses a field-effect front end and the latest in integrated circuits to provide performance and reliability previously unattainable in this type of equipment.

Mail the coupon today for complete information on this important product.



**DYNAIR Electronics, Inc.**  
6360 Federal Boulevard  
San Diego, California 92114  
Telephone: (714) 582-9211

Please send me complete information on the RX-4B CATV Head-End Demodulator.

NAME \_\_\_\_\_ TITLE \_\_\_\_\_  
COMPANY \_\_\_\_\_  
ADDRESS \_\_\_\_\_  
CITY \_\_\_\_\_ STATE \_\_\_\_\_ ZIP \_\_\_\_\_

Circle 103 on Reader Service Card

# BROADCAST INDUSTRY NEWS

## Cigarette debate— round number???

About the only sure thing to date in the cigarette controversy is that both the broadcasting and tobacco industries have respectively opted for self-regulation vs government control. The National Association of Broadcasters' TV and Radio Code Boards have concurred on a plan to phase out cigarette ads by September 1, 1973, and the NAB Board of Directors has accepted it. The tobacco industry has just about dwarfed the significance of this move by offering to halt all radio and television cigarette advertising three years earlier than proposed by the NAB—by September 1970.

Appearing before the Senate consumer subcommittee on July 22, the Tobacco Institute representative, Joseph F. Cullman 3rd, said that cigarette makers want to continue advertising in printed media without a health warning.

The question now is, what of the Senate's action on the House bill (see July 1969, *BM/E*, p. 11) and the more restrictive proposals of the Federal Trade Commission and the Federal Communications Commission?

### TV Board Plan

Under the Television Board's part of the phase-out plan, the three networks and 399 subscribing stations (64.4 percent of the nation's 623 commercial TV stations) would compute the number of minutes that each devoted to cigarette advertising from July 1, 1968, to July 1, 1969.

Ninety percent of that time would be available for sale to cigarette advertisers from next January 1 to September 1, 1970. This figure would then be reduced to 75 percent on September 1, to 50 percent on September 1, 1971 and to 25 percent on September 1, 1972. By September 1, 1973, cigarette advertising by subscribing members would be nonexistent. And the stations and networks would be losing about \$200 million a year in cigarette billings.

In addition to accepting unanimously the phase-out plan presented by Alfred R. Schneider of ABC, the Television Code Review Board also moved that:

- Cigarette commercials in or adjacent to any program directed primarily to youth be prohibited.
- TV Board Chairman Robert W. Ferguson appoint a subcommittee "to work with the Code Authority to review the Cigarette Advertising Guidelines and, where necessary, establish additional guidelines to further reduce the unique appeal of certain aspects of television cigarette advertising to youth."

Ferguson immediately set up a Special Subcommittee on Youth-Appeals Guidelines to which he appointed himself, Robert D. Kasmire, vice president of NBC and William H. Tankersley, vice president of CBS-TV.

### Radio Board Plan

According to the Radio Board's part of the plan, subscribers—the four national radio networks and 2412 radio stations—would also progressively reduce cigarette advertising until elimination on September 1, 1973, and lose about 10 percent of television's loss in cigarette billing a year.

In adopting the proposal, the Radio Board said, "The relationship between cigarette smoking and health is a problem for our entire society that should be resolved across the board and not just by one segment of one industry—broadcast advertising.

"Nevertheless, because both the Congress and the FCC have recognized the powerful influence broadcasting has on the American public, the Radio Code Board urges all stations to assume a positive role in the promotion of public health campaigns so that the people may be made fully aware of the effects involved in the use of cigarettes."

Radio Code Board Chairman John Alexander also appointed a subcommittee to review Code guidelines on cigarette advertising, and, where necessary, to establish

new ones. Other than Alexander, members include Grace M. Johnson, director of broadcast standards and practices, ABC, New York, and Martin E. Pinsker, director of program practices, CBS Radio, New York.

### FTC, FCC Threat

Far from background threats to the NAB's self-regulation are the FCC and the FTC. The FTC supported for the first time the FCC's proposed ban on radio-TV cigarette ads in its July 11 third annual report to Congress on current practices of cigarette promotion, required by the 1964 Cigarette Labeling Act.

Arriving 10 days late, the report urged Congressional passage of "death" warning on cigarette packages and in all advertising and spoke about "futility of relying on voluntary regulation" of cigarette advertising to achieve any significant changes in meaning.

FTC Chairman Paul Rand Dixon said that more important than banning ads on broadcast media was having full "death" warning spread over every possible medium.

The NAB has contended that only the FTC or Congress—not the FCC—has authority to ban cigarette advertising.

## FCC upstages Appeals Court in legal arena

FCC response to the U.S. Court of Appeals' allegedly unprecedented way of handling WLBT(TV) case was itself almost without precedent. For in early July, the Commission charged the Court with error, urging it to grant a rehearing or clarification of opinion.

Supreme Court Chief Justice Warren E. Burger's last written opinion as a District of Columbia court member took the resolution of the WLBT case entirely out of FCC hands.

This marked the second time in three years that Judge Burger wrote an opinion overruling the Commission in the same proceed-

# Both Great

Great color, great sound,  
great broadcast, great CATV, great.



Gentlemen:

Send me literature on the B-Line total-solid-state microwave relay.

My application is:

- Broadcast
- Industrial
- Common Carrier
- CATV
- Educational
- Government
- Public Safety

- Portable
- Fixed
- Airborne
- Turnkey
- 525 Line
- 625 Line
- Message
- Data

- 0.7 — 1.0 GHz
- 1.7 — 2.5 GHz
- 3.7 — 4.2 GHz
- 4.4 — 4.9 GHz
- 5.9 — 7.2 GHz
- 7.1 — 8.4 GHz
- 10.5 — 13.3 GHz



**MICROWAVE ASSOCIATES**  
Communication Equipment Division  
Burlington, Mass. 01803

Comments \_\_\_\_\_

Name \_\_\_\_\_ Title \_\_\_\_\_

Company \_\_\_\_\_ Telephone \_\_\_\_\_

Address \_\_\_\_\_ City \_\_\_\_\_

State or Province \_\_\_\_\_ Country \_\_\_\_\_ Zip \_\_\_\_\_

ing—started when the United Church of Christ, Jackson, Mississippi, charged racism in WLBT's programming. But here, the tone was condemning and the action was unusual for the Court.

Although it didn't disqualify WLBT from operating on channel 3 until hearings are completed, or from filing an application, the Court did revoke the license of the Lamar Life Insurance Company, condemned the FCC and directed it to invite new applicants for the facility.

### "Dangerous" Climate

Viewing the decision as the complement to the Supreme Court's recent support of the fairness doctrine and personal-attack rules (see July 1969, *BM/E*, p. 8), Washington, D.C. communications attorneys have been talking about the "new and dangerous," regulatory climate in the capital. Considering that the Court condemned the Commission for placing the burden of proof on the intervenors rather than the station, one attorney has likened the threat to the licensee posed by renewal application protests to that of competing applications.

Supreme Court Justice Byron R. White, Judge Burger discouraged broadcasters from thinking that the frequencies they occupy are "theirs," and that the Communications Act's statement they're not "common carriers," protects them from being required to give time to anyone requesting it:

"The infinite potential of broadcasting to influence the American life renders somewhat irrelevant the semantics of whether broadcasting is or is not to be described as a public utility . . . By whatever name or classification, broadcasters . . . must meet the highest standards which are embraced in the public interest concept."

### Case History

The case came again before the Court as the church's and civic co-complainants' appeal from an FCC action last year renewing WLBT's license (with dissent from Commissioners Cox and Johnson). The church has been challenging WLBT's license renewals since 1964.

Questions about the station's programming could be traced back to 1959, when the Commission found the licensee "wanting" in

performance of its fairness doctrine obligations. In 1965 the FCC granted WLBT a short-term renewal because of the complainants' allegations: that the station promoted segregationist points of view to the point of cutting off network programs concerning the civil-rights issue, that it ignored programming needs of Negroes who comprised 50 percent of the area's population and that it referred to Negroes in a derogatory way. WLBT denied charges.

Judge Burger wrote of his "profound concern" over the way the case was handled—in particular by Examiner Jay Kyle, who conducted the renewal hearing, granted a three-year license renewal and concluded that the complainants had "woefully failed" to sustain "their serious allegations." He said that the Court considered in its conclusion, the Commission's "impatience with the public intervenors, hostility toward their effort to satisfy a surprisingly strict standard of proof . . ." and "plain errors in rulings and findings . . ." The Judge also said that "the administrative conduct reflected in this record is beyond repair."

### FCC Charge

The FCC submitted as "a wholly illogical inversion of the licensing scheme of the Communications Act," the Court's decision that

## New NCTA slate

**Newly elected officers of the NCTA include:** Chairman—M. William Adler, Weston, W. Virginia, who heads his own communications consulting firm; Vice Chairman—Ralph L. Weir, Jr., Junction City, Kansas, who created Junction City Television, Inc., in 1958 and is president of six other CATV microwave and broadcasting operations; Secretary—Monroe M. Rifkin, who is president of American Television & Communications Corporation, Denver, Colorado; Treasurer—W. Randolph Tucker, chairman and chief executive officer of Cypress Communications Corporation, New York City. With the exception of Richard Gamble—one of the Board of Directors' members who has already served one year—the new officers will serve for three years.

WLBT could submit an application, but couldn't be renewed. The Commission went on to say: "This Court has . . . invariably recognized that it cannot determine the ultimate disposition of licensing controversies or 'direct the Commission how to exercise its discretionary powers.' Were it to do so, it would be engaging in the exercise of administrative rather than judicial judgements, the very thing Congress intended to preclude in the 1930 amendment to the Radio Act."

## 3rd giant merger try fails vs government

When the proposed Metromedia-Transamerica Corporation merger (see March 1969, *BM/E*, p. 6) was cancelled by mutual consent on June 10, it became the third major communications-industry effort to self-destruct recently, at least in part from fear of government disapproval.

Failure to obtain quick approval from government agencies also led ABC and International Telephone & Telegraph (on January 1, 1968) and Westinghouse Electric Corporation and MCA (on April 24, 1969) to abandon respective plans to merge. (MCA, by the way, proposed in mid-July to merge with the Firestone Tire & Rubber Company. Unlike Westinghouse, Firestone hasn't any apparent interests in communications or entertainment.)

A Metromedia spokesman said: "Metromedia took this action upon receipt of opinion of outside counsel that the current and growing opposition of federal government agencies to large mergers in the radio and television industry makes the successful consummation of the proposed merger with Transamerica Corp. very remote."

A decline of about \$100 million in the market value of Metromedia from the time merger terms were set to the time it was called off, was said to have also figured in the decision.

## Study reveals ETV color shortage

In a study released by the National Association of Educational Broadcasters, it was disclosed that of 185 educational television stations surveyed, only 15 are equipped for complete color programming.

The first study of its kind con-





# kiss cueing jitters goodbye

DENON

AUTO

STAND BY

PLAY

STOP

## Only the Denon Music Detecting System cues selections automatically

Any turntable plays records.

All you have to do is place the stylus at the right spot. At the right time. With the right touch.

Sure. But that's where the jitters start.

Now—with the touch of a button—the amazing new Denon player (33 $\frac{1}{3}$  and 45 rpm) cues your music selections *automatically*.

You can forget manual cueing. And on-the-air confusion.

It's easy enough for a child to operate.

Place stylus at start of desired record band selection. Press PLAY switch and listen until you hear music. Then press AUTO switch. Record reverses *automatically* to exact spot where music begins. Selection is ready to play at control console signal. No hands needed.

No longer do you need fear miscues, blurred startups, damaged records or ragged nerves.

You can easily install complete Denon Automatic Cueing Players and operating panels in your own cabinets. All components are of highest professional quality.

Write for further technical information to Nippon Columbia Corporation of America, 6 East 43rd Street, New York, N. Y. 10017. Or call (212) 661-5530.

Our engineering staff will be happy to consult with you.

As one pro to another.

## **DENON**®...different by design since 1910

*Nippon Columbia Corporation of America—a subsidiary of Nippon Columbia Co., Ltd., Tokyo.*

*Other DENON quality professional equipment: Turntables, Auto Slide Projectors, M. M. Cartridges, Spot Programmers, Public Address System, Single-pickup-tube Color Cameras, sophisticated Tape Recorders and Audio-editing Systems—all with differences professionals appreciate.*

Circle 105 on Reader Service Card

[www.americanradiohistory.com](http://www.americanradiohistory.com)

# Go ahead and expand

## ...your McMartin Monitors won't become obsolete

McMartin Monitors are programmed for expansion—designed so that you don't obsolete your present equipment when FM monitoring needs grow. To give you this assurance, McMartin now offers the only monitor line that's complete for every FM situation. Monaural ...monaural with SCA...stereo...stereo with SCA...they're all easily handled with a McMartin "McMonitor package". Our new "McMonitor Guide" lets you match your needs precisely with one of eight different packages. Send for your copy today—and stop worrying about monitor obsolescence.



### **New Stereo Modulation Monitor TBM-2200**

New transistorized model with two meters which simultaneously indicate left and right channel modulation. Also indicates pilot injection, crosstalk, separation, frequency response and FM s/n ratio. Compact, modular design uses plug-in cards. Can be used in combination with TBM-3500A for monitoring FM stereo or with TBM-4000A for FM stereo/SCA.



### **New FM Frequency Monitor TBM-3000A**

A new transistorized digital frequency monitor. Measures carrier frequency and 19 kHz stereo pilot frequency of FM broadcast stations. Digital readout provides maximum ease of operation. Optional outputs for driving automatic logging equipment or remote meters. Contact closures (activated by greater than 2 kHz frequency error) may be used for an alarm indicator or transmitter control. By far the most versatile frequency monitor available at its price.



### **New FM Modulation Monitor TBM-3500A**

New transistorized model with plug-in modular design. Basic modulation monitor for FM monophonic stations. Monitors total modulation, main channel modulation, AM/FM noise and frequency response. Can be used in combination with other McMartin monitors for FM stereo, FM/SCA and FM stereo/SCA. FCC Type Approval Number 3-161.

Write Dept. B-8 for free "McMartin McMonitor" Guide.

**McMartin industries, inc.**  
3104 Farnam Street, Omaha, Nebraska 68131



Circle 106 on Reader Service Card

ducted by the NAEB, the report—"A Summary of ETV Station Information," was undertaken to determine deficiencies in ETV station facilities. It found that 22 stations are equipped for live color, 48 for color film, 45 for color slides, 35 for color tape and 80 for network color. Of the 185 stations, 90 (or 51 percent) have no color facilities.

Results also showed that of the 185 stations surveyed, 47 percent of ETV antennas are significantly lower (100 ft) than commercial antennas in the same area; 82 percent of all ETV stations are operating below maximum authorized visual power for their frequencies.

The report is available from the Office of Research and Development, NAEB, 1346 Connecticut Ave., N.W., Washington, D.C. 20036.

## Fm gets push for all-channel radio

With the formation in early July of the All-Industry Committee for Radio All-Channel Legislation, the fm industry got an organized force behind its work for a law that all radio receivers be able to receive both fm and a-m.

At its first meeting in New York on July 10, the Committee stated its objectives as obtaining Congressional hearings by the end of the year on pending legislation, and passage in early 1970.

Fund raising for the group was assigned to Jerry Lee, WDVR (FM) Philadelphia, Pa.

## FCC reverses itself on WPIX-TV renewal

In late June, the FCC canceled its May 22 license renewal of WPIX-TV, channel 11, New York, pending investigation of charges that the *New York Daily News* owned-and-operated station distorted news shows with doctored film.

By doing this, the Commission revived an unsettled controversy, reopened the door to competitive struggle for the license and raised new questions in the case of the station, which has been valued as high as \$50 million.

The original controversy concerned a charge by would-be applicant Forum Communications Inc. that the FCC granted the renewal with unusual haste, allegedly to protect WPIX from a competing application—Forum's. For it was 10 days before the old station license expired and hours before

the Forum application, based on criticism of WPIX's programming, was filed, that the Commission staff routinely—without the Commissioners' knowledge—granted the license renewal. The charge was never answered.

Also unexplained was why news distortion charges—alleging mis-labeled news clips and out-dated film used to illustrate current events—revealed in *Variety* last January, hadn't been investigated by the Broadcast Bureau before the staff renewed the license.

### Who's to Blame?

Another question has been, who is to blame for the delay in acting on the complaints—the Broadcast Bureau or Commissioner Nicholas Johnson?

For it has been learned that a letter written by a former member of the WPIX news staff, Nancy McCarthy, to freelance television producer friend Arthur Alpert, was sent by Alpert to Commissioner Johnson last January. Commissioner Johnson, who disclosed the letter hours after the renewal was granted, has given the parties' urgent requests for keeping the letter confidential as reason for the five-month delay in releasing the contents. Miss McCarthy has said that she never made such a request; Alpert has said he recalls asking that her name be protected, but that nothing was said about not divulging the letter's contents.

Commissioner Johnson has blamed the staff for not following up on charges in *Variety* and has disagreed with the Commission's refusal to grant Forum's request for a safe period in which to file an application.

Since disclosure of the letter, the Commission has received an "oral" complaint, alleging that film shown on July 6 and 7 news programs was taken earlier than was represented on the air. This film and copy has been held for the FCC's study.

## Hyde to retain post temporarily

Rosel H. Hyde has agreed to President Nixon's request that he remain FCC chairman until a replacement has been designated and confirmed.

In his June letter to Chairman Hyde, the President noted that important issues pending before the

Commission require a chairman "capable of providing effective leadership." Noting that more than half of Hyde's 44 years in government have been with the FCC, the President wrote, "It is only factual to say that the success of the FCC has been due in major measure to the leadership which you have given to the Commission."

## CBS to reveal color EVR, BEVR in late '69

The color version of CBS electronic video recording, EVR, and its broadcast counterpart, BEVR, should be demonstrated before the end of the year, according to Dr. Peter Goldmark, president of CBS Laboratories.

As demonstrated last December, the monochrome EVR records material on film that is cartridge and played through an attachment to regular television sets.

For color programming, the color signals will be encoded electronically on the monochrome film alongside images imprinted photographically. The cartridge will play 25 minutes; the film will be 8.75 mm wide.

Unlike the EVRs, which are being and will be produced for the home as well as for industry, BEVR will offer a color technique solely for the broadcast industry. The film that goes into the camera will be monochrome; the film that emerges will be color. Because color isn't built in, there is no color to be distorted. Each tape will hold 50 minutes worth of viewing. TV commercials are expected to be among the first applications for the BEVR.

## Newsman gets grove for 'The Trees'

How many broadcasters have received a grove of trees as an award? If trees may seem a paltry substitute for, let's say an Emmy, they were no less distinctive to KSTP-TV news-caster-reporter Bob Ryan on June 22.

On that Sunday, Ryan received a two-part award from the annual Minnesota State Convention of Jewish War Veterans for his half-hour color film about Israel—"The Tree."

Ryan received the first part of his award at the banquet—a small plaque. The second part of the honor—a grove of 20 young trees—are rooted in his name in a new forest in Israel.

# IVC-300 THE 3-PLUMBICON\* COLOR CAMERA PRICED AT \$29,500.

Now there's a 3-Plumbicon color camera you can afford. It's IVC's "Maverick." For the first time, studio, remote and commercial colorcasting is now easier and less expensive. The IVC-300 gives true Plumbicon flexibility, registration and stability. It is versatile enough to be used as a front-line studio camera, a utility, auxiliary or back-up unit. The IVC-300 is compact (weighs 67 lbs. without lens), mobile, transportable — an easy one-man operation. Low light level performance is outstanding. Fast action pick-up produces superior results. All the sophistications are built-in — Varotal XX, 10:1 zoom lens, with local or remote servo-driven iris, negative registration, adjustable gamma correction, 9-inch viewfinder, built-in filter wheel, R/G/B sequencer (optional) and cable corrector.

The IVC-300 is priced for every broadcaster's application — at \$29,500. It's flexible, affordable and available. Made in the U.S. by IVC, the company that built and sold more color television cameras in the last year than any other manufacturer. Phone (408) 738-3900 or write International Video Corporation, 675 Almanor Avenue, Sunnyvale, California 94086 for literature and a demonstration.



\*TM N.V. PHILIPS

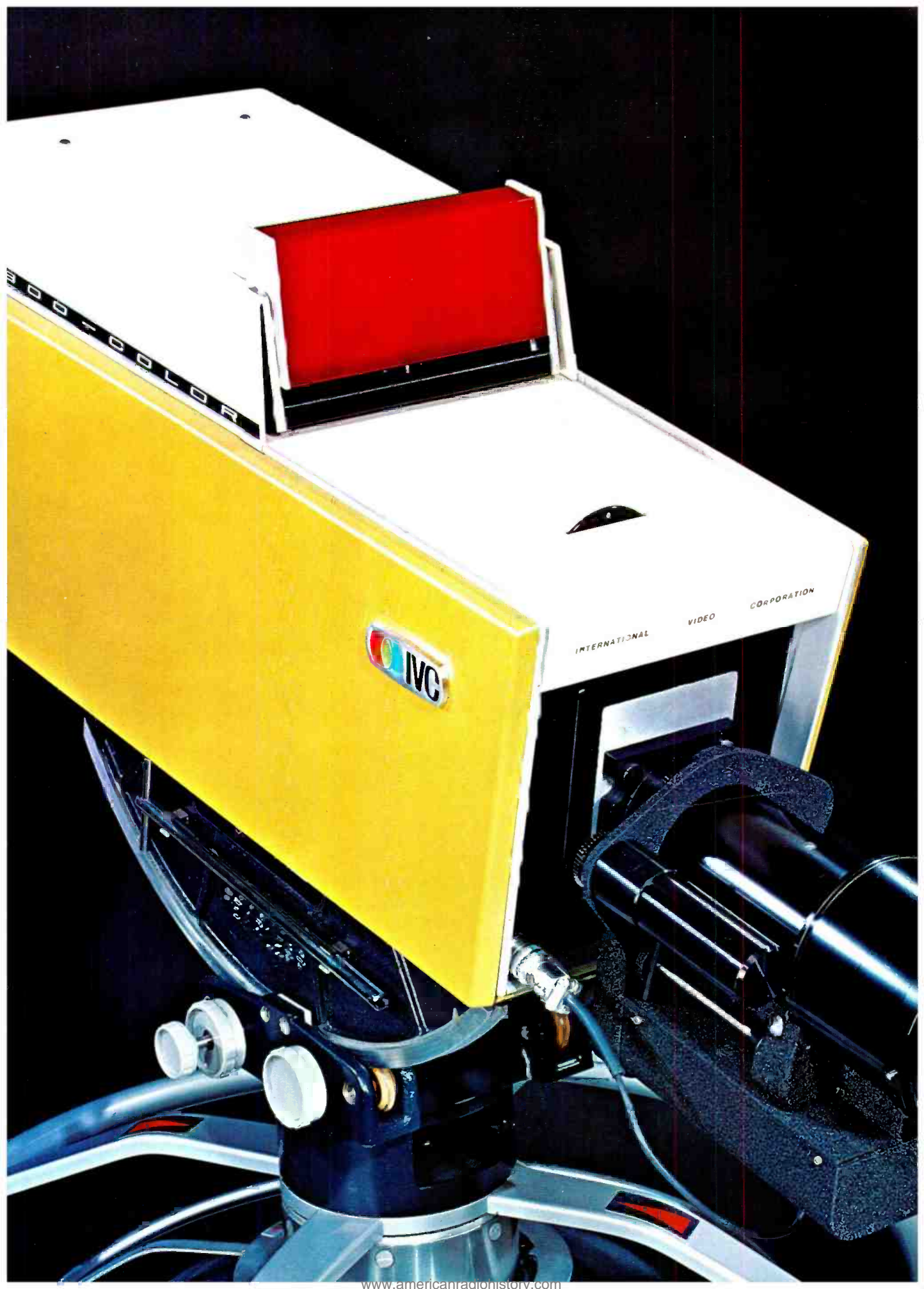

# all solid state TELEVISION MICROWAVE RELAY LINKS for high quality color and monochrome TV systems

Use as rack mounted STL  
or Remote TV Pick-up  
or for Intercity Relay

- Meets EIA, CCIR,  
and FCC standards
- Available in all  
FCC authorized bands
- High fidelity color

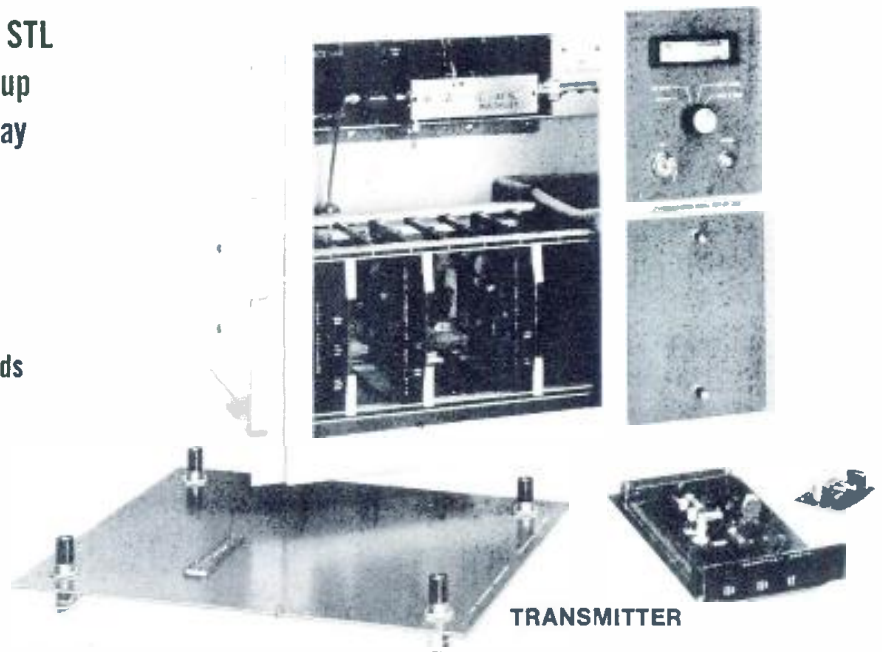

TRANSMITTER

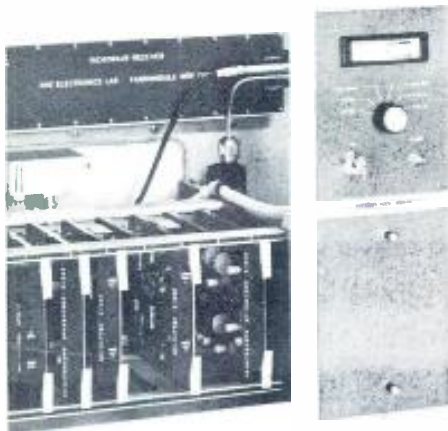

RECEIVER

- Ferrite isolator
- All Solid State RF Module
- Key lock switch
- Removable power supply module
- Plug in pre/de-emphasis
- Plug in printed cards
- Optional audio subcarriers

RHG, a leading supplier of military TV relay links, now offers Series MRS to the broadcast industry. Transmitters and receivers, with advanced field proven designs provide solid state reliability, no warmup, and low power drain.

To improve your color transmission quality and to insure trouble free operation specify RHG equipment fully described in Bulletin 69C. Call for "no obligation" demonstration.

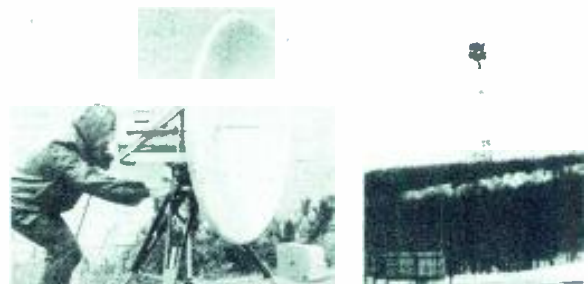

RHG ELECTRONICS LABORATORY, INC.

94 MILBAR BOULEVARD  
FARMINGDALE, LONG ISLAND  
NEW YORK 11735 (516) 694-3100

RHG at WESCON—Booths 5403-4—South Hall  
Circle 108 on Reader Service Card

# INTERPRETING THE FCC RULES & REGULATIONS

## The Supreme Court Speaks on Fairness

The widely-heralded Red Lion—RTNDA case was decided by the U.S. Supreme Court on June 9, 1969. In this case, a consolidation of two conflicting lower court decisions granted certiorari, the Court finally settled the constitutionality of the Fairness Doctrine and Personal Attack Rules.

### The Fairness Doctrine

The Fairness Doctrine requires that broadcast licensees: (1) encourage, implement and foster the carriage of programming designed to expose public issues and (2) afford a reasonable opportunity for airing all sides of important, controversial issues carried over the broadcaster's station.

The Cullman Broadcasting Co. case, 25 RR 895 (1963), required the broadcaster to provide *balanced* exposure of controversial issues—at his own expense, if necessary. Another series of cases—including Metropolitan Broadcasting Corp., 19 RR 602 (1959)—required broadcasters to carry all sides of such issues, at their own expense, if necessary, and to initiate special programming when necessary in order to provide balanced coverage of controversial issues. In 1959, the United States Congress amended the “equal time for political candidates” requirements of Section 315 of the Communications Act. Almost parenthetically in that amendment Congress alluded to “. . . the obligation imposed upon them (broadcasters) under this Act . . . to afford reasonable opportunity for the discussion of conflicting views on issues of public importance.” The Commission viewed this language as a statutory approval of the Fairness Doctrine. And now, so do the courts.

Since its first formal articulation in the Commission's 1949 *Report on Editorializing*, 13 FCC 1246, the Fairness Doctrine has thus acquired substantial support from the Commission's policy statements and case precedent, and received indirect approval from the United States Congress. But until Red Lion—RTNDA, there was, nevertheless, extensive controversy as to the legal validity of the Fairness Doctrine.

The Fairness Doctrine was held constitutional in a June, 1967, decision by the U.S. Circuit Court of Appeals for the District of Columbia. But then, in September, 1968, one aspect of the Fairness Doctrine—the Personal Attack Rules—was held unconstitutional by the U.S. Court of Appeals for the Seventh Circuit (Chicago). It was this conflict

that brought the Supreme Court to consider the question.

### The Personal Attack Rules

Unfortunately, there is an unavoidable overlap between the Fairness Doctrine and Section 315 of the Communications Act. Section 315 pertains *only* to political candidates. The Fairness Doctrine, however, concerns the licensee's *broad* obligation to air all sides of a controversy of public importance. Obviously, a hotly contested campaign for public office (normally covered by Section 315) might also constitute a “matter of public importance,” apparently falling under the Fairness Doctrine and obligating the broadcaster to offer “free” time, if necessary, for “fair” coverage of all sides of the controversial matter.

Into this overlap the personal attack rules began to emerge in the early 1960's. Personal attacks tend to arise from discussions of extremely controversial issues and/or discussions by one political candidate (or his spokesman) about another political candidate. The Fairness Doctrine, because of its breadth, would be applicable to both situations. A logical extension of the Fairness Doctrine would (the Commission decided) require broadcasters to provide the person or group attacked with an opportunity to respond—not on an equal time basis (pursuant to Section 315 of the Act), but on a reasonably comparable time basis (pursuant to the Fairness Doctrine).

After the considerable delay typical of its gradual, back-door approach to major new regulation, the Commission proposed in 1966 to adopt Personal Attack Rules. On July 5, 1967, the Commission revised its Rules by adding Section 73.300 (AM), 73.598 (FM), and 73.679 (TV) to provide, in substance that:

(1) If during program presentations of controversial issues, an attack is made upon the honesty, character, or integrity of an *identified* person or group, the licensee shall (within a week after the attack) provide the parties attacked with the specifics of the attack (a script or tape of the attack or, if neither be available, an accurate summary of the attack) and offer a reasonable opportunity to respond on-the-air. This principle would be applicable to a statement by a representative of a political candidate whenever an attack is lodged against the opposing candidate. (Naturally, if a political candidate is the one launching the attack, Section 315 of the Act comes into play. The broadcaster is required to provide the opposing candidate with “equal time.”)

(2) The provisions of the Personal Attack Rules have not been made applicable to attacks by foreigners or to comments made on bonified newscasts.

(3) In the case of editorials, in which the licensee endorses or opposes legal candidates, notice and an

This section, providing broad interpretation of FCC rules and policies, does not substitute for competent legal counsel. Legal advice on any given problem is predicated on the particular facts of each case. Therefore, when specific problems arise, you would be well advised to consult your own legal counsel.

offer of time must be given within 24 hours.

In the 1967 *Red Lion* case, the complainants launched an unsuccessful challenge against the entire Fairness Doctrine. In the 1968 *RTNDA* case, the Chicago appellate court, while not ruling that the *entire* Fairness Doctrine was unconstitutional, did hold that the Personal Attack Rules would inhibit broadcast dissemination of views on political candidates and controversial issues, that the Commission's Personal Attack Rules were too vague, that the First Amendment of the Constitution applies equally to the press and the broadcast media, and that the Personal Attack Rules contravene the First Amendment and as such are unconstitutional. The Chicago Court concluded that the Commission's Order adopting the Personal Attack Rules must be "set aside."

#### The Fairness Doctrine and Personal Attack Rules—the Court's Dicta

The Supreme Court stepped in to resolve the issues, pointing out in *Red Lion—RTNDA* dicta that:

(1) The United States Congress has authorized the Fairness Doctrine and the Commission's Rules on personal attacks and political editorial.

(2) Such Rules and policies do not abridge the freedoms of speech and press protected by the First Amendment but, instead foster those objectives; accordingly, they are legally valid and constitutional.

(3) Wherever a personal attack has been lodged against the person involved in a pub-

lic issue, the Fairness Doctrine and the Commission's Rules require that the individual attacked be offered an opportunity to respond.

(4) The Fairness Doctrine compels broadcasters to provide adequate coverage of issues and to be fair in its treatment and exposition of opposing views. Such opposing views must be offered, even if it must be done at the broadcaster's own initiative and expense.

(5) If one candidate is endorsed in a political editorial, the other candidates must be offered time to reply either personally or by spokesman. (In effect, the Supreme Court has made it most imprudent for any broadcaster to carry an editorial endorsing a political candidate, because the opposing candidate will then be able to claim the opportunity to appear personally.)

(6) The Commission has broad power ("not niggardly, but expansive") to make sure that broadcasters operate in the public interest. Arguments that the Personal Attack Doctrine and/or the Fairness Doctrine in general contravene the basic freedoms of speech and press were vastly outweighed, the Court decided, by the broad mandate Congress has given the FCC.

(7) The Court explained at length the statutory background of the Fairness Doctrine, so as to assert the legal basis of the Commission's powers in this area.

(8) The public-interest language of the Communications Act, the Court noted, authorizes the Commission to *require* licensees to use their stations for discussion of public issues. The Commission is free to implement this requirement by

*Continued on page 18*

## ONE OF THE BEST REASONS FOR BUYING A TAPECASTER CARTRIDGE MACHINE

# today, is tomorrow.



There are many good reasons for purchasing a TAPECASTER cartridge machine: its superb performance is insured by the use of only the highest quality components, each subjected to

rigorous quality control testing by trained TAPECASTER technicians. Its advanced solid state design offers a new industry standard for excellence and dependability.

Standard in all TAPECASTER units is the new SUPER-TORQUE hysteresis synchronous motor. It is twice the weight of motors found in competitive units, contains extended life bearings and is rated for continuous duty with an estimated three times longer life.

The SUPER-TORQUE motor, exclusively in TAPECASTER units represents a significant breakthrough in professional tape cartridge machine



design and promises far better performance with years of trouble-free operation.

Before you buy a tape cartridge machine today, consider tomorrow and you will find yourself buying TAPECASTER.



**TAPECASTER® TCM, INC.**  
BOX 662 — 12326 WILKINS AVENUE  
ROCKVILLE, MARYLAND 20851

Please send additional information:

Name & Co. ....  
Street .....  
City ..... State ..... Zip .....



**TAPECASTER® TCM, INC.**  
Box 662 — 12326 Wilkins Avenue, Rockville, Maryland 20851  
Phone: 942-6666 Area code 301

Circle 109 on Reader Service Card



# DON'T TAKE OUR WORD FOR IT...

## Read what experts say about Seeburg Background Music:

**"Seeburg background music has corrected 95% of our problems . . .**

Prior to switching to Seeburg we had all kinds of problems. Poor programming flexibility, mechanical failures, tape breakage, limited music selections. Now, our entire operation is more efficient and profitable."

**EDWARD WOLFF, President**  
Station KDVR, Sioux City, Iowa

**"Seeburg provides the most flexible programming in the business . . .**

With the use of three program timers, we can tailor the music to the exact needs of our area. And Seeburg's three libraries give us 3,300 selections to work with."

**WALTER C. PRIDHAM, Special Products Division**  
Satterfield Electronics, Inc., Madison, Wisconsin

**"Seeburg requires much less maintenance than any other equipment . . .**

There are no dust problems and, of course, there are no heads. We only touch the machine about once every three months to add new Seeburg records."

**ROBERT RATCLIFF, Executive V.P., Manager**  
Station WKPT, Kingsport, Tennessee

**"When it comes to service problems, we don't have any . . .**

We have found the Seeburg Studio to be as trouble free as the on-premise equipment, which has an undisputed reputation for dependability.

**WILLIAM LEE MARTIN, Owner**  
Martin Sound Service Co., Oklahoma City, Oklahoma

**"A music story that really sells . . .**

Now, with Seeburg, we can really tell the story on the music itself, the years of research, the distinct libraries and the Seeburg name. It's easier to sell new products and switch customers over to our service."

**DAVID GOTTSBALL, Manager**  
Station KWLW-FM, San Angelo, Texas

Now you have the word of experts. They've tried other music systems. Then they discovered that only Seeburg gives them the most flexible, trouble free background music system . . .with none of the difficulties of tape. And Seeburg's tailored programming gives them a system that sells and sells . . . and sells.

Your success story can be next. Contact Mr. Hards at Seeburg. He'll be glad to show you how to increase your profits in the background music market. And he'll tell you about the fully protected Seeburg franchise.

The Most Popular Background Music  
System On Record

 **SEEBURG**

Seeburg Music Library, 1500 North Dayton St.,  
Chicago, Illinois 60622

Circle 110 on Reader Service Card

SAVE \$2.00 ON THIS SPECIAL PREPUB OFFER!

A Brand-New Authoritative Reference and Guide to Audio System Design. A MUST for Engineers and Technicians.

# AUDIO SYSTEMS HANDBOOK

**NEW!**

- ◆ BRAND-NEW
- ◆ 192 PAGES
- ◆ HARDBOUND
- ◆ OVER 125 ILLUS.
- ◆ ONLY \$5.95



BY NORMAN H. CROWHURST

### Indispensable for:

- Chief Engineers
- Studio Technicians
- Recording Engrs.
- Stereo Experts
- All Audio System Technical Personnel

This brand-new volume encompasses audio systems of all types—studio, public address, commercial sound, hi-fi reproduction, intercom, etc. Coverage is complete—from microphones to loudspeakers, from mixers and filters to amplifiers. Here is essential technical data on such important facets as loudness compensation, low-level distribution, noise suppression, pre-emphasis, equalization, constant-voltage lines, remote controls, radio feeds, phono and tape pickup, compression and limiting, and much, much more.

### CHAPTER TITLES:

- Amplifiers
- Equalizers, Mixers and Filters
- Distribution Systems
- Program Sources
- Special Devices
- The Overall System
- Commercial Sound
- Studio Systems
- Loudspeaker Systems

"Audio-Systems Handbook" is an authoritative guide to the requirements of professional audio systems. Its purpose is to aid professional audio engineers and technicians in evaluating and selecting (or designing) system components to achieve flawless performance. Moreover, the data can be used to improve performance of present systems and provide the basis for meaningful tests and measurements to check component and system performance. Yes, this new book will prove to be an invaluable guide and workbook for all technical broadcast personnel! "Audio Systems Handbook" is published to sell at \$7.95. For a limited time, however, the Special Prepublication price of only \$5.95 will prevail. Order at our risk for FREE 10-day examination. Send no money! Simply fill in and mail NO-RISK coupon below to receive your own copy of this helpful volume.

### PUBLISHER'S GUARANTEE

Put the information in this book to work for you for 10 days. If it doesn't prove to be worth several times its cost, return it and we'll cancel invoice.

### NO RISK COUPON—MAIL TODAY

TAB BOOKS, Blue Ridge Summit, Pa. 17214  
 Please send me \_\_\_\_\_ copies of "Audio Systems Handbook" at the Special Prepub price of only \$5.95 per copy.  
 I enclose \$\_\_\_\_\_  
 Please invoice on 10-day FREE trial.  
 Name \_\_\_\_\_  
 Company \_\_\_\_\_  
 Address \_\_\_\_\_  
 City \_\_\_\_\_  
 State \_\_\_\_\_ Zip \_\_\_\_\_  
 Save postage by remitting with order. BA8-69

Circle 111 on Reader Service Card

## FCC Rules

Continued from page 16

reasonable rules and regulations, as long as it does not abridge freedom of speech and press and is not performing censorship as proscribed by Section 326 of the Act. (Unfortunately, the language is not helpful in outlining what boundaries, if any, limit the Commission in dictating the amount and content of public issue and/or other programming that must be carried by licensees. In fact, the dicta of the case may well be read some day as the foundation of program censorship and control by the Federal Government. Many current regulatory powers of the Commission were once viewed as equally ludicrous.)

(9) Perhaps the decision implies that the First Amendment standards (and protections) are different for broadcasters than they are for the public. The Court noted that where there are substantially more individuals who might seek broadcasting facilities than there are frequencies to allocate, it would be inane to accord the broadcasters with full First Amendment rights. (This observation seems inconsistent with a number of cases decided by lower federal appellate courts and appears to give the Commission the broadest sanction it could have hoped for.)

(10) It is the right of viewers and listeners which is paramount, not the right of broadcasters.

(11) The Commission could require broadcasters to share their frequencies with others. The First Amendment confers on broadcasters no right to prevent others from broadcasting on their frequencies and no right to an unconditional monopoly of the scarce resource.

(12) There is at least a possibility that the Personal Attack and Political Editorial Rules will lead to elimination of coverage of controversial issues. However, the Commission has the power to insist that licensees give adequate and fair attention to public issues. It does not violate the First Amendment to treat licensees as trustees for the entire community, obligated to give suitable time and attention to matters of great public concern.

(13) Despite the Court's extremely broad language, it did not ratify every past and future decision by the Commission with regard to programming. It did, however, create the impression that there are no effective prohibitions against greatly increased regulation of broadcasting by the Commission.

### Conclusion

Ostensibly, this case stands for little more than the premise that the Fairness Doctrine and related Personal Attack Rules are legally valid and constitutional. Unfortunately, the overtones of the case appear to transcend the relatively narrow boundaries of the Fairness Doctrine. In effect the Red Lion—RTNDA case gives the Commission a "green light" to adopt virtually any regulation that appears feasibly related to the ephemeral concept of public interest. Clearly, it is a case you should pay close attention to and review with your legal counsel.

BM/E

SHURE

SM53

UNIDIRECTIONAL  
DYNAMIC  
MICROPHONE



one or all of these provable advantages can make this your most effective and reliable microphone!

**1. WIDER FRONT WORKING ANGLE**

The SM53 allows *greater freedom of performer movement*—*tonal quality is unaffected by movement throughout the broad effective pickup area. Eliminates "holes" and "hot spots" when using multiple microphones. These valuable attributes stem from a broad, true cardioid frontal pattern at all frequencies, in all planes*—freeing the user from the restrictions of overly tight angular sensitivity.

**2. MORE EFFECTIVE REJECTION OF UNWANTED SOUNDS**

The SM53 prevents sound coloration due to off-axis reflections or reverberation—and, in addition, unwanted sounds (even air conditioner rumble) are effectively controlled. These properties are achieved through the polar pattern which is singularly uniform with frequency (even at the extreme low end) and is symmetrical about its axis.

**3. MECHANICAL NOISE ISOLATION**

Built-in effective shock mount significantly reduces the objectionable stand, cable, and handling noises associated with many unidirectional microphones. The SM53 can be used in many applications where conventional units have proved marginal or unusable.

**4. EXTRAORDINARY RUGGEDNESS**

You can even drop the SM53 directly on its nose without damaging the microphone element—and it will maintain its excellent performance characteristics.

**5. SUPERIOR HUM REJECTION**

Built-in hum-rejection system reduces magnetic hum susceptibility by as much as 20 db compared to other units! Makes it far more usable in distant pickup applications and in areas with extremely high magnetic fields.

**6. LESS SUSCEPTIBILITY TO "POP"**

Integral "pop" filter minimizes explosive breath noise without external screening. Works well where other microphones are marginal or unusable.

**7. MINIMIZED PROXIMITY EFFECT**

Uniform tonal quality is maintained (without objectionable low-end build-up) regardless of whether the microphone is worked close up or from a distance.

**8. FIELD SERVICEABILITY**

Element (cartridge), connector, front screen, roll-off switch can all be replaced in minutes.

SHURE BROTHERS INC., 222 Hartrey Avenue, Evanston, Illinois 60204

© 1969 SHURE BROTHERS, INC.

Circle 112 on Reader Service Card

# The switch- hitters

**THE PHILIPS PC-70** ... the prime time king of color cameras ... serves on more live and taped studio color shows, by far, than any other camera.

And it's a fantastic switch-hitter. If the PC-70 is a winner in studio work, in the field it's no contest. For major outdoor news and sports events, the PC-70 consistently takes the most valuable player award.

Why? Its unsurpassed color picture, faithful and sharp. There are over 700 Philips 3-Plumbicon<sup>®</sup> cameras in use worldwide. A videoman's dream. The cameraman's camera. Management's assurance of the best, most reliable, and most economical performance.

When a better camera is built, Philips will build it.\*  
In the meantime, the PC-70 is the ticket.

\*The Philips PC-100, announced at NAB '69, will be available early in 1970.

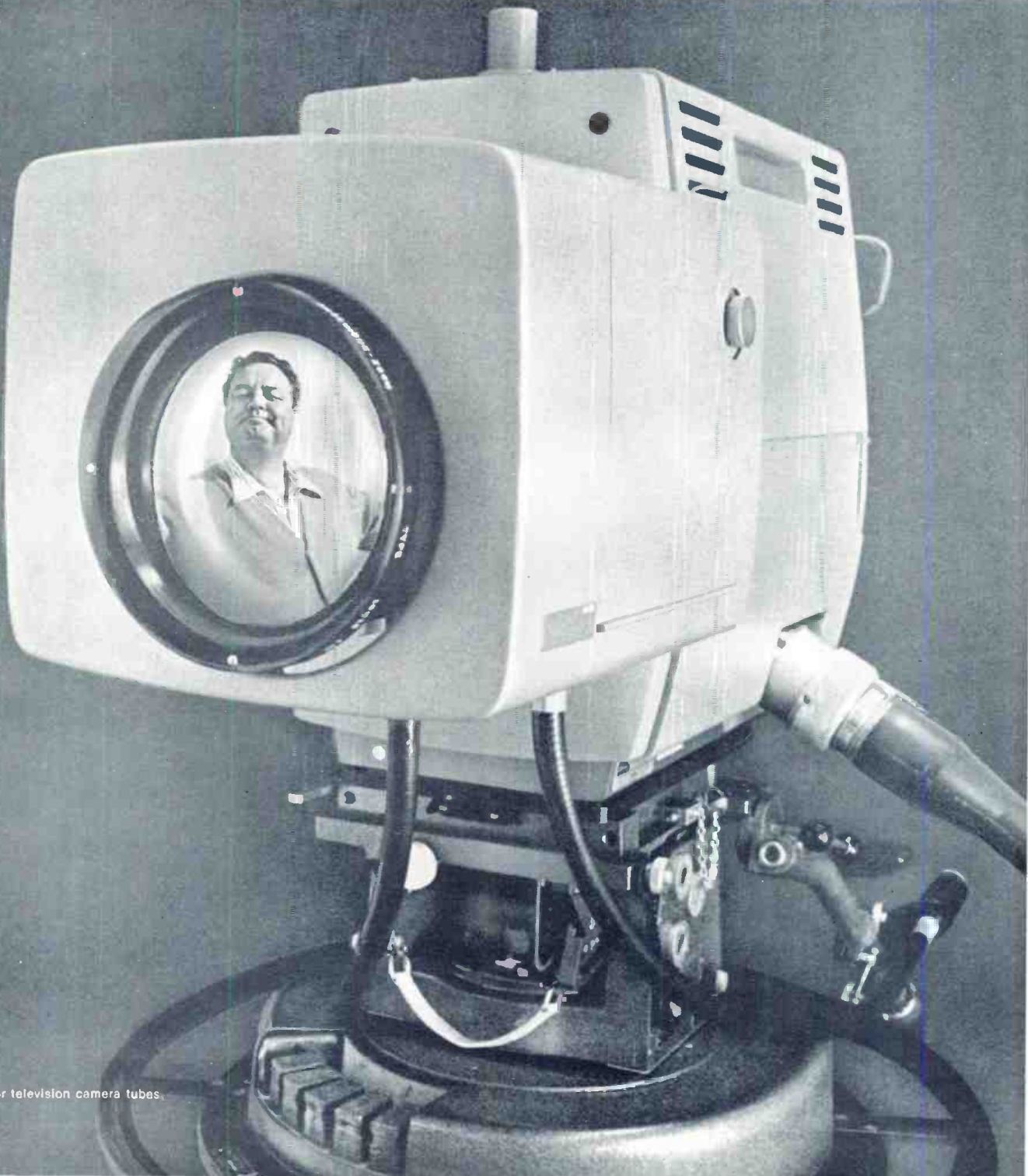

© Tracemark for television camera tubes.

**THE PHILIPS PCP-90** digitally controlled "Minicam" takes the field alongside the PC-70 as the most mobile and versatile of portables. Operating wireless or on small, cost-reducing triax, the 3-Plumbicon Minicam brings total flexibility to broadcast-quality telecasting.

The PCP-90 is designed basically as a field camera. Controls may be beamed from as far away as 30 miles. Signal processing is done in the backpack. The Minicam produces a real-time color-composite signal for direct broadcast. Or it can go into the field with a portable recorder to tape interviews or other action—totally unencumbered.

And here again, you have a star switch-hitter. Three new one-inch Philips Plumbicon tubes perform to broadcast standards, bringing the Minicam right into the studio.

Training camps for Minicam prototypes included crowded conventions, major sports, the inauguration and other events. Now it's ready to sign with you.

**PHILIPS**

**PHILIPS BROADCAST  
EQUIPMENT CORP.**

One Philips Parkway, Montvale, N.J. 07645 • 201, 391-1000

A NORTH AMERICAN PHILIPS COMPANY



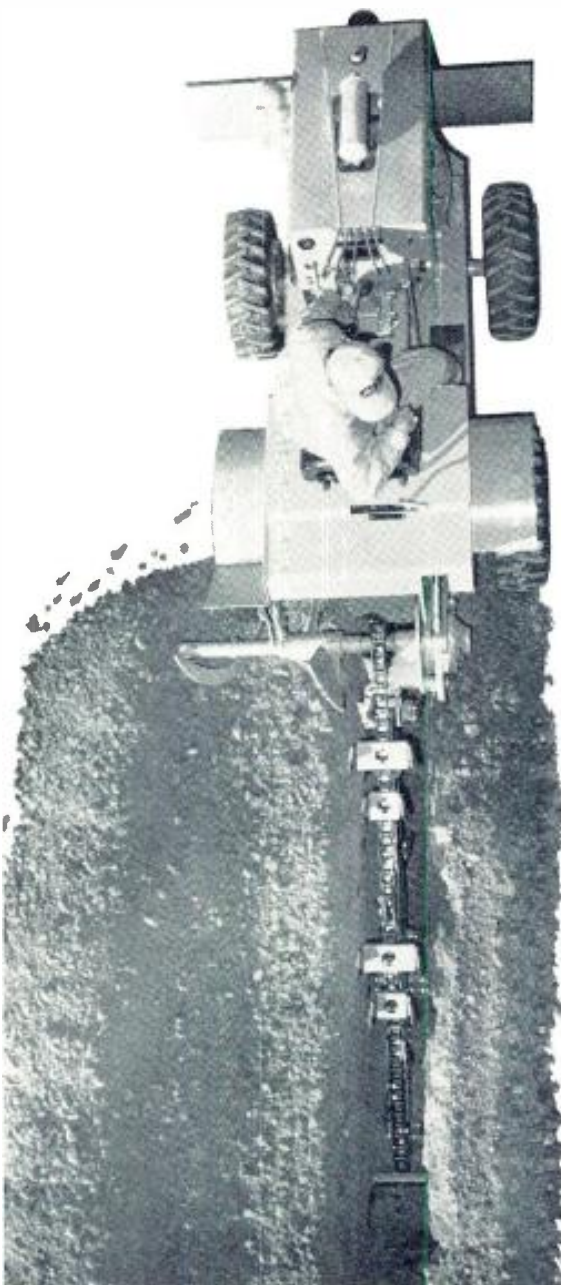

# Independent digging-chain control...

Only Ditch Witch gives you a variable hydraulic control system that permits the operator to vary travel speed independently of the mechanically-powered, multiple-speed digging chain. Only Ditch Witch lets you adjust travel speeds to changing soil or terrain condition hydraulically — then shift mechanically-powered chain speeds up or down to take advantage of all available engine power.

We call it independent digging-chain control. Another reason why we want to *demonstrate*. Any time! Any place. Against any competition!



Contact your Ditch Witch man today.



### C & M Series

Compact, highly maneuverable, fully self-propelled design available with 7, 9, or 12½ h.p. engine. Capacity up to 10 fpm. C Series trenches to 2' deep, 6" wide. . . . M Series up to 5' deep and 12" wide.



### H12

The first two-wheel, steerable-drive, riding-type trencher. Choice of 12½ or 18 h.p. engine for trenching up to 5' deep and 12" wide. Has capacity up to 12 fpm. Features power steering, hydraulically controlled boom, and variable crowd control.



### J20

An 18 h.p. trencher featuring 4-wheel drive, floating front axle, power steering and 3-mechanical digging chain speeds, plus reverse, and independent hydraulic travel speed control. Has capacity to 16 fpm, digging range to 5' deep and 12" wide.



### V30

A 30 h.p. machine with full hydraulic control of all systems, 4-wheel drive, floating front axle. Independent hydraulic travel-speed control and 4 mechanical digging chain speeds, plus reverse. Capacity to 20 fpm, to 6' deep, 12" wide.



### R60

A 60 h.p. trencher with full hydraulic control of all systems, steering-wheel control, 4-wheel drive, floating front axle, independent travel speed control, 4 digging chain speeds plus reverse. Capacity to 36 fpm, to 7' depths, 24" widths.



### Backhoe & Plow

For 30 and 60 h.p. machines. Backhoe: 9' reach, 10,600 lb. pry-out pressure, 180° swing, digs to 7' depths. V30 Plow lays material up to 1¼" in diameter to 24" depth; R60 lays up to 1½" diameter to 30" depth.

DIVISION OF CHARLES MACHINE WORKS, INC. **DITCH WITCH** 1847 ASH STREET, PERRY, OKLAHOMA 73377  
Circle 114 on Reader Service Card

FOR SESSION DETAILS,  
SEE PAGE 64.

# CONVENTION LOG

## NCTA '69—My How We've Grown

IF THERE WAS a single all-pervading theme on the exhibit floor at this year's NCTA Convention, it was one of vastly increased equipment sophistication. A lot of manufacturers are putting their money on the line and betting heavily on cable TV's future—this in spite of the seeming setbacks of the past eight months.

The latest "setback," the NAB's summary rejection of the carefully hammered out NAB/NCTA accord, was viewed in many quarters as a triumph. "Good," seemed to be the consensus. "that's their last chance. Now we'll really ram it to them." Cable industry spokesmen indicated in no uncertain terms that they believed the NAB to be on the defensive with this latest rejection. Others observed that the relatively huge size of the San Francisco convention reminded them of the NAB of 20 years ago. NCTA is definitely on the rise, it was felt, and will soon overtake the NAB in size and importance.

### Color Cameras

Publicly demonstrated for the first time, Commercial Electronics' low-level color camera focused on a colorful parrot with 10 footcandles of illumination. The camera uses high-sensitivity Westinghouse SEC vidicons—a fact that makes neutral density filters necessary in daylight. Price is about \$35,000, and the camera will be available later this year.

Prominently displayed was the RCA single-vidicon color camera, type PK-730. The camera had its first public showing at last November's NAEB. An improved model was operated at this year's NAB. Now, the PK-730 has traveled the circuit and RCA promises production by this fall. Price will be under \$10,000, and the camera will see service in CCTV and CATV local origination.

Brand-new in the RCA booth was its PAM-1 four-channel audio mixer, designed for small studio, CATV and industrial use. Com-



(1) Low-light-level camera by Commercial Electronics uses SEC vidicons. (2) Sylvania mono camera offers automatic operation. (3) RCA audio console aids origination. BM/E Photos

compact size means it can fit into many wall, rack or top-of-console locations. It has eight separate input channels, along with cueing, monitoring and switchable input selection.

Showing its bottom-of-the-line IVC-100 camera, International Video Corp. stressed low-cost color origination and unveiled (first time at NCTA) its economy IVC-600 series recorders. These new machines have a single-motor drive and use an oxide-out wind instead of the oxide-in that's standard on the company's other recorders.

Tapes are fully compatible with all other IVC machines.

### Big Bag of Tricks

TeleMation opened a sackful of new goodies designed to give the cable operator more operating flexibility and better picture quality. Topping the list was the TMP-2500 automatic non-duplication programmer. The basic switcher uses digital in-line integrated circuits arranged on 19 printed-circuit boards. Integral to the unit is a miniature magnetic disc memory system that contains 10,000 bits of



1

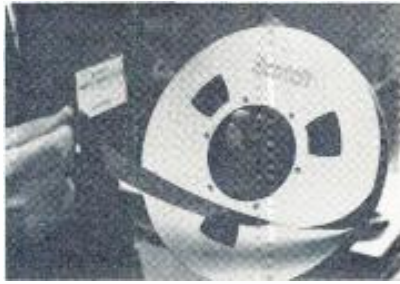

5



8



2



6



7



3



4

(1) Origination multiplexer started for Philips. (2) Tape-A-Thon's portable audio origination. (3) IVC-600 economy VTR by International Video. (4) TeleMation's new non-duplication unit. (5) 3M's "400" TV tape. (6) New amplifiers by Jerrold. (7) News service from Television Presentations. (8) Quick-Set's new heads.

BM E Photos.

of information. These vertical interval signals can be used in a number of ways: as a carrier for information such as wire service teletype, for remote control information for VTRs and possibly hundreds of other new services. Cable operators using microwave for importation can install the VITS system at the microwave headend to check out system performance.

#### Don't Touch

Among the several unusual camera accessories exhibited by GBC was an attention-grabbing motion sensor. A CCTV camera, focused on a \$100 bill that reposed in a goldfish bowl, was rigged to sound an alarm if anyone made a grab for the money (lots of people did). The motion sensor—two suction-cup-tipped photocells on the face of a small monitor screen—triggered the system whenever the C-note was in jeopardy. Less spectacular, but an important GBC entry, was a new TV control console.

Brand-new from Dynair was its head end demodulator. Called the RX-48 Dyna-Tune, the demod uses FETs and integrated circuits. Unit is said to use completely new filtering and signal restoration techniques and is designed for use in either microwave-fed or demod-cable systems.

#### Microwaves to the Rescue

A new entry in cable television, Electronics Development Corp. showed its line of up-and-down converters for importation of fm stereo programs via microwave. Equipment is designed to carry fm channels "on the coattails" of regular TV channels, providing a plus feature for cable systems. For more details, see article on pages 32-33.

On display in the Microwave Associates' booth was the BX series microwave relay gear. Compact units feature power output of

information—all that's required for full non-duplication control.

A portable origination studio concept was unveiled in two convenient-size cases. Called the "Porta Studio," one case contains the needed switching and video control gear, while the other has two video monitors and a Shure audio control. The system is designed to give the CATV operator studio quality and flexibility at remote locations.

Another item in the TeleMation grab-bag is a new, proprietary electronic character generation system. Using line-scan instead of the more conventional dot-scan, characters are 14 raster lines high with 14-line space between lines.

Another new item from TeleMation is its vertical interval encoder/decoder. The system permits selection of any or all of eight available vertical interval lines, each one of which can carry 48 bits





1  
 (1) Entron showed line of amplifiers. (2) Systems concept for 21 channels by Vikoa. (3) Guts of Spencer-Kennedy's set-top converter. (4) A.E.L. starred superband amplifier. (5) Showing its muscle, Kaiser piled the floor high with Phoenixians. (6) Blonder-Tongue emphasized low-cost and easily serviced headends. (7) CAS expanded into MATV systems.

BM/E Photos

2 watts in the 2-GHz range, 0.5 watt in the 6- to 7-GHz range, 0.25 watt in CARS band (12.7 to 12.95 GHz) and 0.1 watt in the 10.7-13.25-GHz range.

Equipment displayed by Collins was not new for this year's NCTA, but the MW-808D relay has been seeing service in the CARS band. The equipment line is all solid-state except for the transmitter klystron.

Key to new headend installations is the antenna, and RF Systems unveiled its LP-213 log periodic for all-band coverage. Using this antenna, it's possible to cover the entire VHF band with a single unit, cutting down substantially on equipment cost and maintenance. It can be used singly or in arrays, is said to have low VSWR and it mates with standard F-61 connector.

### Cable Gets Better

Cable for drops, cable for trunks and a feast of cabling accessory items were almost everywhere. American Pamcor, in addition to its regular line of heat-shrink products, showed a new A-MP coax connector designed for aluminum cable. The new design is said to eliminate leakage, conductor pull-out, multiple-size center conductors and connector mismatching. Connector accepts both polyethylene and the new polystyrene cables.

Spearheading Times Wire & Cable's broad line of cables was the 2000 Series low-loss "Dynafoam." The cable is available both plain and jacketed for aerial stringing, with a sealant for direct burial, and armored with double jacketing and sealant. Times also showed off its 1000 Series "Alumifoam" semi-flexible seamless aluminum cable.

Introduced by Phelps Dodge, the "Spirafil II" air-dielectric coax is said to solve moisture problems in CATV lines because of its internal pressurization.

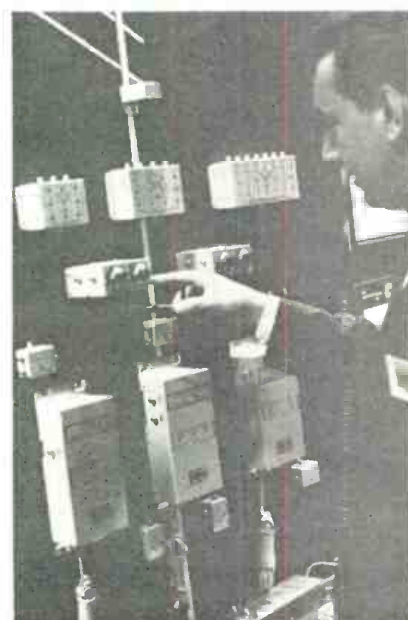
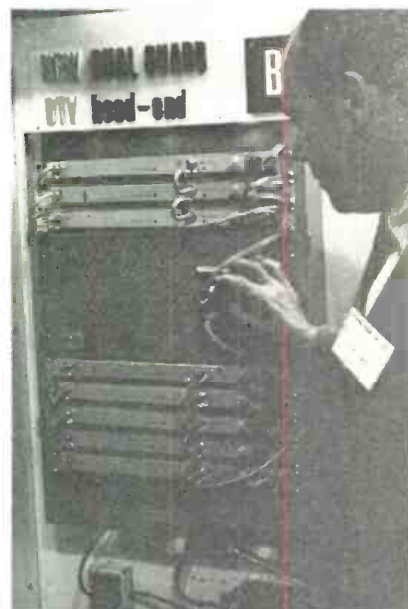
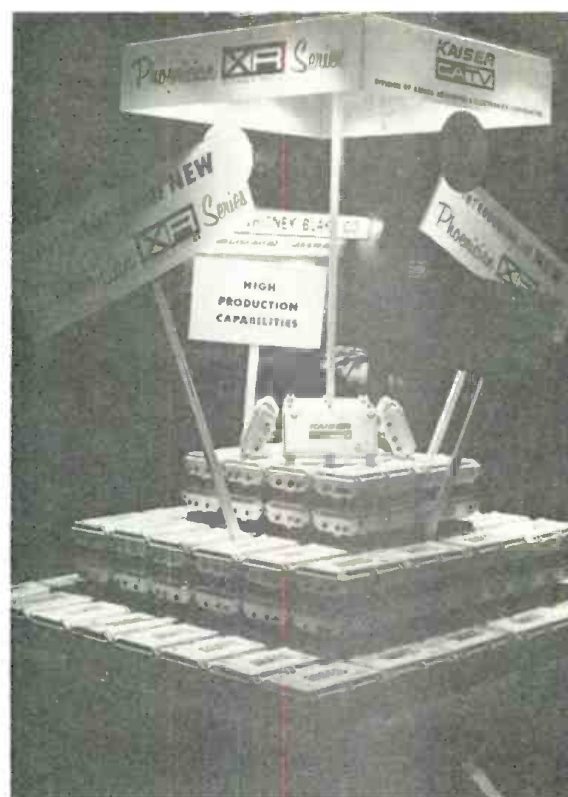
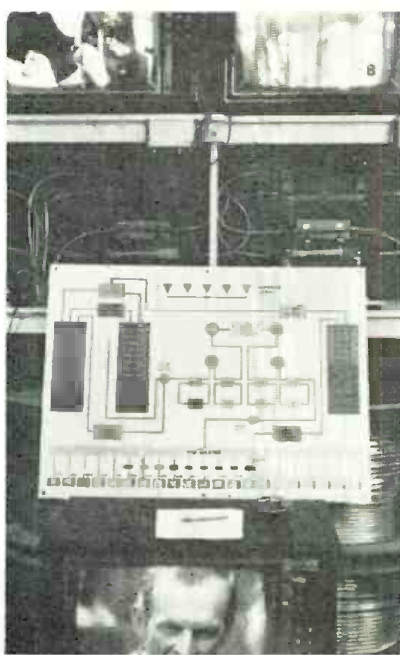

A four-way bonded cable shown by Anaconda (type SLM-ABD) has internal bonds between each element. The Polyfoam is bonded to the center conductor, the aluminum shield is bonded to the polyfoam, zetabon layer is bonded to the aluminum and the outer polyethylene jacket is bonded to the zetabon.

Heat-shrinkable splice seals from Sigma ("Sigmaform") were called a "tough, tight splice seal for aerial or underground use. Whitney Blake featured its seamless drawn aluminum cable with solid copper or copper-clad aluminum center conductor. Comm/Scope Corp. showed its new "Lamgard" cable for house drops distinguished by its laminated shield. A line of cable hardware—cable strain reliefs, crossover clamps, suspension clamps and ground clamps, was exhibited by Diamond Expansion

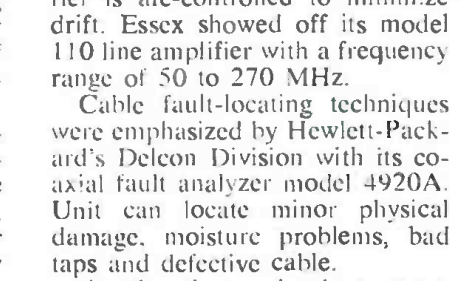
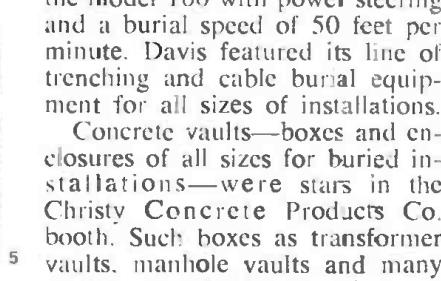
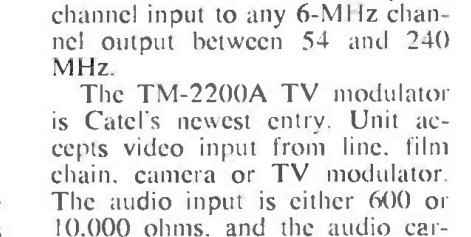
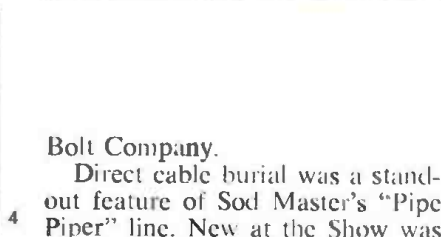
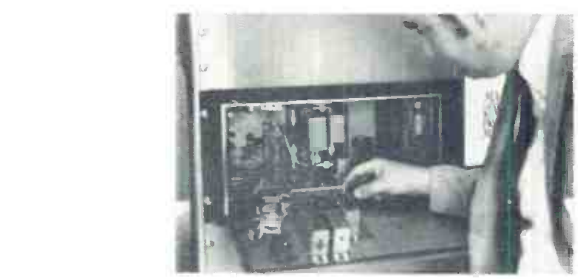
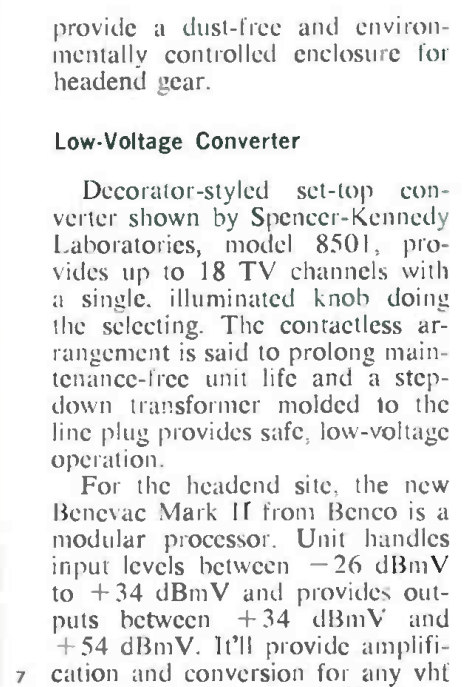
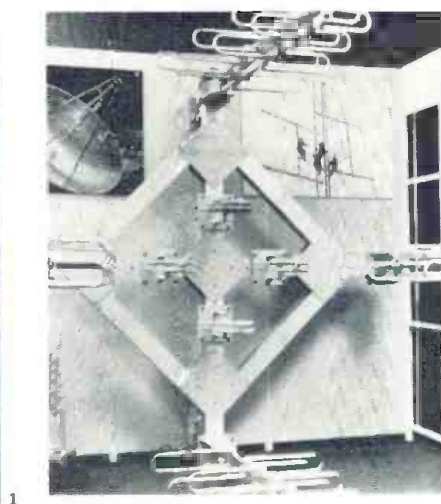

{1} Hewlett-Packard showed cable fault locator scope. {2} Ameco emphasized test gear in lab lineup. {3} Microwave Associates had new import link. {4} Benco's Benevac Mark II. {5} C-Cor stressed high-gain amplifier line. {6} Headend arrays from Systems Antenna Co. {7} Test equipment at Anaconda booth included sweep system. {8} Dynair's "Dyna-Tune" headend demodulator.

BM/E Photos

provide a dust-free and environmentally controlled enclosure for headend gear.

**Low-Voltage Converter**

Decorator-styled set-top converter shown by Spencer-Kennedy Laboratories, model 8501, provides up to 18 TV channels with a single, illuminated knob doing the selecting. The contactless arrangement is said to prolong maintenance-free unit life and a step-down transformer molded to the line plug provides safe, low-voltage operation.

For the headend site, the new Benevac Mark II from Benco is a modular processor. Unit handles input levels between -26 dBmV to +34 dBmV and provides outputs between +34 dBmV and +54 dBmV. It'll provide amplification and conversion for any vhf channel input to any 6-MHz channel output between 54 and 240 MHz.

The TM-2200A TV modulator is Catel's newest entry. Unit accepts video input from line, film chain, camera or TV modulator. The audio input is either 600 or 10,000 ohms, and the audio carrier is afc-controlled to minimize drift. Essex showed off its model 110 line amplifier with a frequency range of 50 to 270 MHz.

Cable fault-locating techniques were emphasized by Hewlett-Packard's Deleon Division with its coaxial fault analyzer model 4920A. Unit can locate minor physical damage, moisture problems, bad taps and defective cable.

Another time-saving instrument, the "sweeper," was introduced by CAS. The unit provides visible readout of total vhf band by sweeping entire bandwidth. It replaces conventional field-strength meters and allows accurate amplifier tilt and gain adjustments, as well as being a help in balancing line and distortion amplifiers.

**Bolt Company.**

Direct cable burial was a stand-out feature of Sod Master's "Pipe Piper" line. New at the Show was the model 100 with power steering and a burial speed of 50 feet per minute. Davis featured its line of trenching and cable burial equipment for all sizes of installations.

Concrete vaults—boxes and enclosures of all sizes for buried installations—were stars in the Christy Concrete Products Co. booth. Such boxes as transformer vaults, manhole vaults and many smaller sizes for housing line amplifiers and tapoffs were on display.

Another type enclosure—a prefabricated metal building was shown by Ft. Worth Tower Co. Capable of being installed at a headend site in five minutes (as long as it takes to hoist the building off the truck) these prefabs can



Brand-new in the headend and distribution field, Sylvania introduced a complete line of converters, line amps and taps. Floor space was already committed to the company's origination display, so the headend and line gear were shown in the Sylvania suite. On the floor, a new low-light-level monochrome camera was unveiled, using a field-mesh pickup tube. Camera resolution was stated as 800 lines and the unit can operate completely automatically.

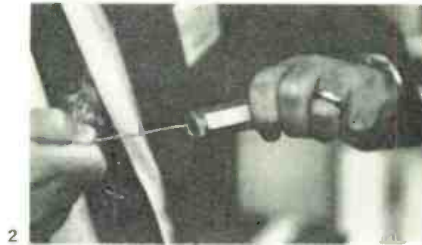

### Improved Sub Systems From Small Companies

So intense has been the activity in passive components that not one but two companies came up with the "first" CATV stripline directional tap—Craftsman and Aqua Instruments Corp.

Aqua has the lead in actually getting the product to the market place but Craftsman claims its is flatter;  $\pm 1$  dB from 54-300 MHz. Stripline techniques, borrowed from the microwave industry, reduce through loss and provide high isolation.

Stripline was used by Scientific Atlanta to come up with an 8-input combining network. Result is an easy way to convert the outputs of signal processors, modulators, fm amplifiers and pilot carrier to the trunk cable. Chief new item at S-A booth was a new demodulator that eliminates quadrature distortion by use of a phase-locked synchronous video detector system.

One new company hoped to pay its way at NCTA by offering fully-encapsulated splitters, taps and other passive devices. View-All Television Products says the potted units don't vary with weather conditions.

Craftsman is moving into new CATV areas and unveiled at the convention a new 25-channel converter. (More was unveiled at the

company's suite where movie starlets performed topless).

Another expanding company was Lindsay whose product line includes redesigned passive components, new wall directional taps (20 dB directivity), push-pull line extenders and a variety of antennas.

Benco was showing its muscle by exhibiting a 25-channel head-end processor system. Jerry Conn and Associates looked like a Pruzan by tying Canadian principals Delta (test equipment, passive components) and Trim-Line Connectors into adjacent exhibit space. Included in the same area was Eltech, of Smithtown, N.Y. a supplier of log periodic antennas. Pruzan, incidentally, manned its booth with a synthetic cable man made up of parts from the 25 companies it represents.

Back again as a second-year ex-



(1) Electronics Development Corp. showed off fm stereo converters. (2) No center pullout was feature of Gilbert connector. (3) Collins displayed microwave gear. (4) New connectors held lovingly by American Pamcor gal. (5) Microwave system displayed by Raytheon. (6) New cable and bender from Times Wire & Cable. (7) Texas Instruments (Massachusetts) showed copper-clad coax cable.

BM E Photos

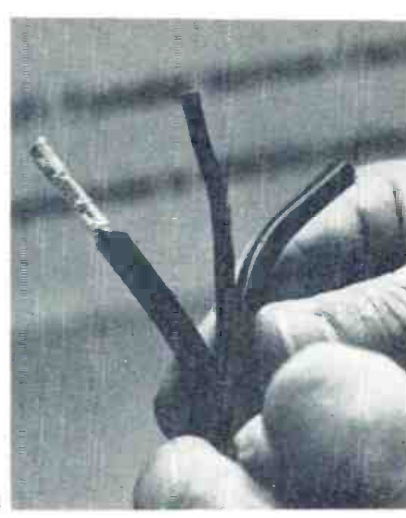
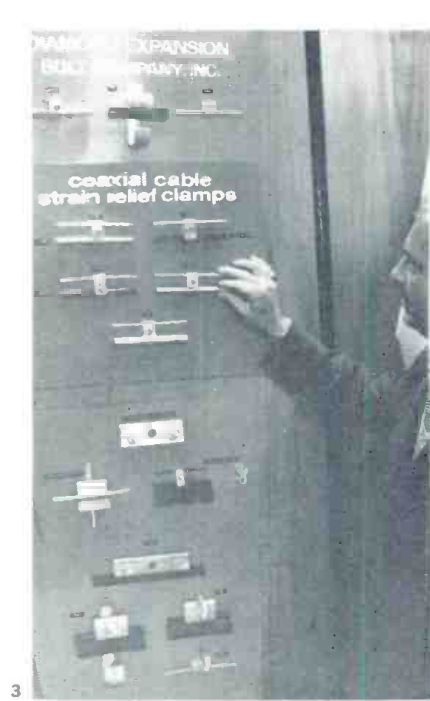

(1) Compath clad cable by Systems Wire & Cable. (2) Sigma's heat-shrink splice jackets. (3) Clamps and hardware started for Diamond Expansion Bolt Co. (4) Handful of cables by Whitney Blake. (5) Lindsay showed new passive components. (6) Plastic laminated shield was new feature of Superior Continental's cable. (7) One of new striplines, Aqua Instrument's "Versa-tap." (8) "Spirafil" cable by Phelps Dodge.

BM/E Photos

Telemet. The company displayed its demodulator and modulator gear for monitoring and measuring incoming and processed television signals.

In the adjacent booth was a hot new company spawned by the cable industry, J-Tec of Fresno, Calif. J-Tec unveiled an \$829.95 spectrum analyzer for the operator who didn't have the dough for a conventional analyzer, but didn't have time for tedious use of a field strength meter. Measurements of adjacent-channel signals, band pass, roll-off, intermodulation and equalization of fm levels were demonstrated.

A new sound-by-cable service to get the cable operator into the background music business was also unveiled by J-Tec. Available was a complete package called MusiCable, J-Tec offers a tape deck and 12 distinctly different music programs, a 50.5 to 53 MHz fm modulator to inject the signal at the headend and crystal-controlled receivers. One transmitter and one receiver are capable of handling 4 channels at a time. MusiCable is intended to compete with Muzak and fm subcarrier systems.

hibitor was a new trunk line amplifier manufacturer, HTV Systems. Unusual feature is ability, through use of filters, to carry channels on the sub-band below 50 MHz.

More than a sub-system supplier is Essex International. By buying up Amphenol Cable and the manufacturing division of Telesis, the company offers cable, trunk line amplifiers, passive devices and program switchers.

A new source of cable is Systems Wire and Cable Inc., of Phoenix, Arizona. First samples off the new production line were shown at San Francisco.

New antenna supplier was Systems Engineering Inc., of Sylacauga, Ala. SEI proudly showed a low-weight high gain log-log Z antenna.

The CATV system operator's growing concern with quality drew a new broadcast-class exhibitor,

### Systems Manufacturers Play It Cool

There was a different aura that surrounded the major CATV systems producers this year. The tone was definitely less sex and more specs—engineering specs that is. No one was trying to steal attention by playing channel capability games, although most did feature an expanded bandwidth amplifier.

Hard times in view of the CATV freeze cooled some exhibitors; AEL, Entron and Spencer Kennedy took smaller exhibit space than in previous years and Jerrold dropped its annual banquet. In contrast, however, several smaller systems producers came up extra

# NEW Model 1300 Directional Tap

CATV'S FIRST FLAT STRIPLINE-DIRECTIONAL TAP: 1db 54-300 MHz



1



2

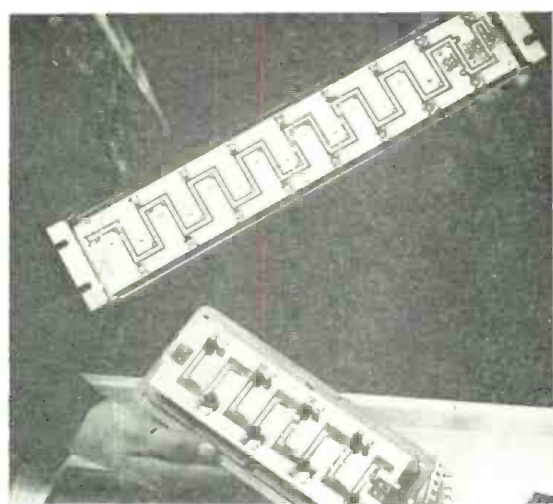

3

strong: C-Cor, CAS and Cascade.

C-Cor is apparently making good headway with its high output amplifier design which permits increased spacing between amplifiers. C-Cor offers 3 series to fulfill any system need. The 100 series covers channels 2 through 13; the 200 series with extended bandwidth permits 20 channels (each one single-octave) between 120 to 240 MHz, or optionally 2 to 13 regular channels plus four more in the mid band. The 300 series is all push-pull for low second-order distortion, and allows 8 mid-band channels to be used plus 4 super-high-band channels (between 216 and 240 MHz).

CAS Manufacturing, now part of the Avnet conglomerate, came on strong displaying a full lineup of equipment from headends, down to a variety of taps, splitters, connectors and fittings. CAS's rounded line included a new sweep meter to check out any system easily and includes tilt-setting gain adjustments and line balancing. CAS stressed MATV accessories also.

Cascade continues to flow in from Canada like a strong north wind. It unveiled its Unicom amplifier with the claim it would satisfy any requirement in the foreseeable future. It includes a two-way facility that permits one to look at what's happening at individual amplifiers from a remote control point. Same feature lets one get a video signal from some point on the trunk back to the head end.

In general, systems suppliers broadened their lines to include improved tapoffs, drops, MATV accessories and test equipment. Taps offered boasted less attenuator loss and better directivity.

Anaconda's emphasis of simple products exemplified the general trend toward rounded product lines and better specs. Included in this category was a new apartment house amplifier and the 7000 series

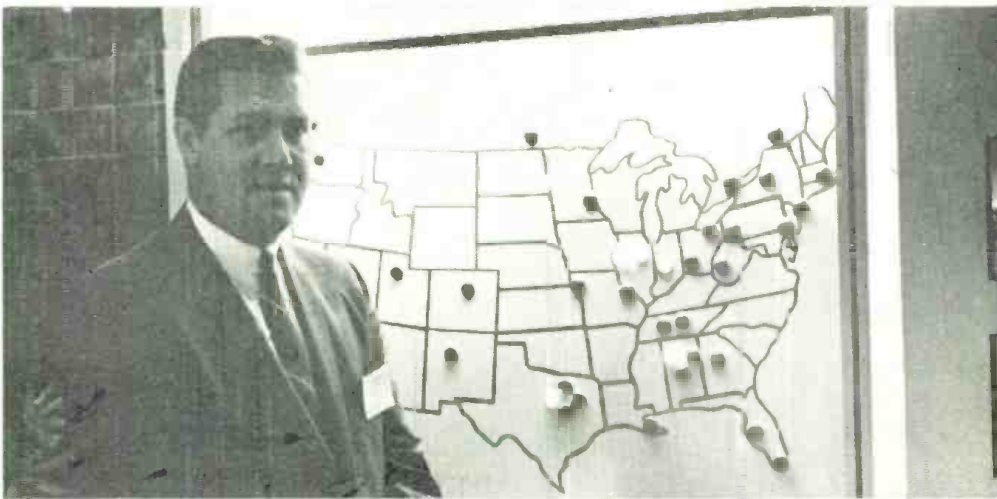

4



5



6

of directional taps. The indoor tap used stripline techniques and featured 16 outputs at from 12 to 18 dB. Insertion loss was less than 6 dB and return loss 20 dB minimum. Isolation between channels was high. Similar combining networks for headends were shown along with the model 6900 CATV modulator and the 8800 amplifier. More dramatic was the display of the new sweep and spectrum analyzer that combined 7 instruments into one. The SSA analyzes headends, sweeps the system and characterizes all components. It measures level, gain, loss and return loss, distortion, percent modulation and spectral purity.

AEL stressed primarily its superband amplifier claiming 50 to 270 MHz bandpass. Twenty-channel capability is possible without push-pull circuitry.

Ameco came on strong as a to-

(Continued on page 62)



7

(1) Stripline directional tap by Craftsman. (2) Sod Master direct-burial machine has power steering. (3) Anaconda's new strip-line. (4) Roha talked about its systems capability. (5) Line amplifier by Essex. (6) Motion sensor by GBC focuses on dollar bill; \$100 bill was out to lunch. (7) Matching network shown by Delta.

BM/E Photos

# We just widened the generation gap.

It's the significant lag between "our own things" and the also rans.

The first time we did it (a couple of years ago) we came up with the first all-digital sync generator with a near perfect time base stability (4 nsec typical) and pulse jitter spec. Nobody else can touch it.

Now we've added a color encoder with all plug-in boards and built-in color bars. It has balanced modulators using linear IC's. Provisions for contours out of green. The works.

And still another first. A television programmer with magnetic disc memory. Whether used for CATV non-duplication or station automation, it gives maximum capacity and flexibility at minimum cost. Like 200 events on 26 output channels with one second resolution. Repeats to 7 days. (So you could say 1400 event capability.) Greatest reliability. Simplest operation.

Then we have a broadcast electronic character generator. Format is 14 lines of 40 characters each. Raster (not dot) generation assures

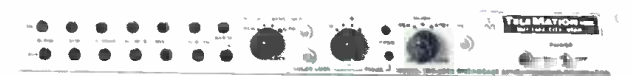

TSG 2000 series  
All digital sync generator



TCE 1600 video color encoder

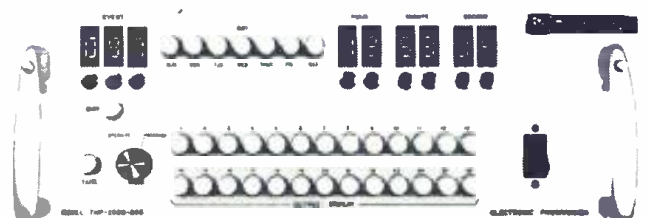

TMP 2500 programmer

# (again)

maximum readability even on poorest home receivers.

And EIA video test generators. Multiburst. Stairstep.  $\text{Sin}^2$ —Window. Modulated 20T pulse. Color bar. All EIA/NTSC/VIT compatible. Can be used singly or with new electronic sequential switcher to provide single continuously switched output. Has it all.

Now for the sleeper. A Vertical Interval Data Transmission system. Transmits data from news wires or character generator over existing video channels. Provides VIT keying pulse and adds test signals. Works with any video, local or remote. Encodes. Decodes. Erases. 8 line selection. So many applications it boggles the mind.

These are just some of our new ideas. If you take time to check the parameters of the products we've mentioned, you'll find no one else is half as close in concept. Let alone delivery.

So when you want some real help with your ideas, talk to TeleMation.



**T M**  
*The Total System Supplier*  
2275 South West Temple  
Salt Lake City, Utah 84115  
(801) 486-7564



TCG 1440 Character generator

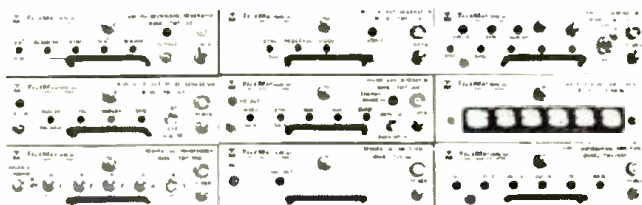

TMT 100 series video test generators

Circle 115 on Reader Service Card

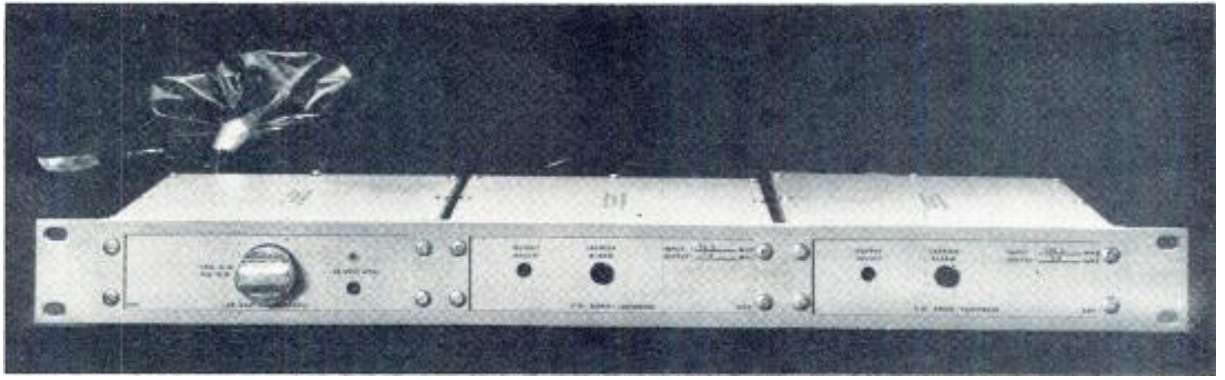

Down-converter is heart of fm stereo transmission system. One converter is needed for each station carried.

# New for Cable—Fm Stereo that Works

**Plagued by technical problems in the past, the promise of cable fm stereo has now been fulfilled. A new family of sophisticated down- and up-converters at long last puts good music in the pipe. "But what about sync buzz?" asks the operator. Funny thing you should ask . . .**

THE TYPICAL HOMEOWNER will go out and pay \$600 for a color TV receiver and will shell out \$1600 or more for a good stereo system. This contention—made by Rex Orton of Electronics Development Corp.—is the basic philosophy behind the company's new service for cable TV subscribers—fm stereo via cable.

In the first operating installation, EDC's up- and down-converters carry a four-station import that brings in fm by microwave from San Francisco and Sacramento to Oroville—involving distances of up to 150 miles for the Bay City stations. Orton feels that fm, and especially fm stereo, have been pretty much neglected by the burgeoning cable TV industry. Yet this mode of transmission has enough adherents to make a "piggy-back" transmission not only technically feasible, but economically viable. The fm signals ride the coattails of the TV channels in the cable system, so no additional installation or bandwidth are needed.

At the subscriber's end, an fm coupler is added, and that's all there is to it. Tuning is ordinary conventional fm tuning, although the station will probably be at a different frequency to avoid multipath problems. The subscriber already on the cable is asked for a nominal fee—90¢ to \$1.50 per month—for the fm stereo if he wants it. Mono stations aren't carried on the cable, since it's felt that monos are sufficiently numerous to satisfy

most tastes with regular off-the-air pickup. Another factor: mono reception isn't anywhere near as critical as is good stereo reception.

## SCA Problem Solved

The presence of SCA subchannels can present a problem in an fm stereo cable system. EDC's system itself provides full 200-kHz bandwidth, so there's no problem there. It's just that some SCA/stereo stations have poor metering and as a result the stereo signal suffers from SCA interference. The EDC system cleans up the signal by filtering out the SCA in such cases. Where the signal isn't contaminated by SCA, the subchannel can be piped through unchanged, thus extending the potential reach of authorized SCA services.

The basic system ends at the cable headend. Once the fm stereo is put on the cable, the transmission technique is up to the CATV operator. Common carriers might want to sell fm stereo service to CATV operators already receiving imported video from their links. In this case, the carrier would buy the down-converter and install it at his pickup site along with the microwave equipment. He could also supply the up-converter for the headend location. Or the common carrier could work out a split deal with the operator who would buy his own up-converter.

Generally, the fm converter equipment deal is made with the common carrier. In the Oroville installation, by coincidence, the local cable operator and the common carrier were one and the same, so there was no split deal possible.

## Recognizing the Need

"The CATV operator served by microwave recognizes the need for fm stereo," states Board



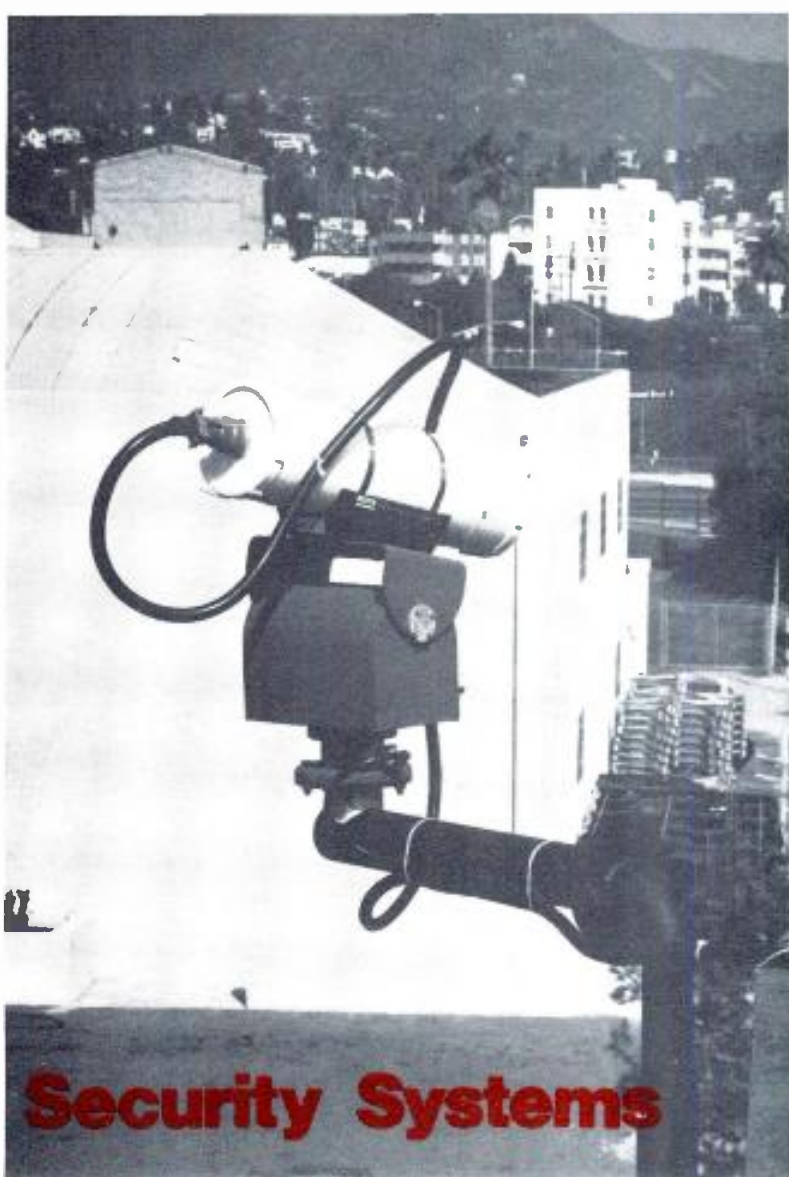

Part 3 of a 3-part Series

## An introduction to **Security Systems**

---

By R. H. Coddington

---

It is the function of the control unit to respond to a signal from any one of several sensors by energizing some signaling or alerting device. Somewhere, someone must be informed in some manner that an intrusion (or fire, or hold-up) is in progress. This is the job of one or more signaling or alerting devices, which were briefly mentioned before.

The choice of signaling devices will be made on the basis of available facilities, location of the premises, local police regulations, and the philosophical priority of apprehension versus minimizing of losses.

### **Local Bells, Sirens, Howlers**

The most popular local, audible alarm is a loud bell, mounted high on an outside wall (and wired so

that no wiring is externally accessible). Standard alarm bells usually have a ten-inch gong that covers the striking mechanism. It is available in voltages from 6 to 120, with DC or AC mechanisms, and it may be mounted inside a louvered, weatherproof box. This enclosure may be interlocked, so that any attempt to open it triggers the alarm long before the bell is accessible for silencing.

The standard alarm bell produces a distinctive sound, and it is very efficient: a 6V DC type may draw under 200 milliamperes. This simplifies the wiring requirements and assures operation from a modest standby battery. However, there is no reason why any other large, loud bell could not be used, provided that wiring, power supply, and weatherproofing conditions permit.

A popular alternate audible alarm is the motor-driven siren.

Resembling those long used in emergency vehicles, it is available in a variety of voltage ratings and it can be similarly enclosed in a weatherproof, tamper-resistant box.

In general, motor-driven sirens make heavy demands on standby power sources, and their electronic counterparts are finding increasing use. A solid-state siren module—available at the corner electronics dealer—drives a horn-type loudspeaker to produce a penetrating, siren-like sound. Another variation is the "curdler", an electronic security item generating a sound that is indescribable but designed to discourage the most intrepid intruder. These electronic devices have minimal power requirements, and their reliability is not so critical as is that of sensors and control units, for the simple reason that the signaling devices operate only infrequently.



The camera at left is one of a network used in a closed circuit system at KBSC. The camera is focused on the two remote vans in the parking lot. In the picture above, you see the monitor display, just as the security guard below sees it in his remote office.

(Photo courtesy of Cohu.)



**Central Station Alarm Devices**

If the central station system is provided by the local security system dealer, he of course will provide his own terminal equipment. If it feeds a police station offering central station service, either they will supply the terminal equipment, or the system's owner will be required to supply commercially made equipment of a specific type.

It is when a telephone answering service is employed as a "central station" that the customer may provide terminal equipment of his own design, perhaps similar to that diagrammed in Figure 1. This circuit operates from a supervised telephone line, requiring that the control unit at the protected premises supplies a reversible line voltage.

When all is well, relay K1 in the sensing unit is energized, and the meter reads "normal". K2 is not

energized at this time. However, if the line is cut, or shorted even momentarily, K1 drops and K2 is closed by the charging current through C1. K2 then latches itself and sounds the horn or buzzer; in the meantime, the center-zero meter has swung to indicate "trouble", and the red pilot lights. The horn or buzzer may be released by the attendant, but the red light remains on to indicate a continued abnormal condition.

A similar sequence occurs when an actual alarm signal is received, but for one exception: the reversed current in the line deflects the meter to the "alarm" indication. The diodes substitute R1 for the coil of K1 when the current is reversed, so the ensuing relay action is identical to that following a severed line condition.

With the aid of the meter, the attendant can distinguish between a line fault and an actual alarm

signal. The horn alerts him in either case, however, since the "trouble" indication may in fact be caused by an intruder's precautionary cutting of the leased line at the premises.

**Dialers**

In its usual form, the dialer utilizes an endless tape cartridge, upon which are recorded tone bursts for dial pulses, followed by appropriate voice announcements. The electronics accompanying the tape mechanism include circuits for sensing the tones on the tape and relays to convert them into line seizure, rotary dialing, and line release signals. And of course there are audio stages to build the voice to line level, and circuits to start and stop the tape.

Some units now use digital electronics to perform the dialing functions. Others provide two discrete channels and starting circuits, so that one may be used for burglary

and the other for fire, for instance. Few of the commercial dialers provide recording functions without requiring additional equipment.

These dialers can be connected directly to a regular telephone dial exchange line. (Since most Touch-Tone exchanges also accept rotary dials, dialers also may be connected to them.) Legally, though, the usual interface device is required, along with its accompanying monthly cost. The dialer manufacturer stipulates the particular telco coupler to use—which

the local telco may never have heard of. It is available through telephone supply sources, though, and a little persistence on the customer's part will eventually convince the telco that the recorder coupler they've wanted to substitute is **not** what's needed!

The more reliable commercial dialers are relatively expensive, retailing in the \$400.00 range. However, the broadcast operation having a retired but workable cartridge deck has a good start toward making their own. This and an en-

gineer's ingenuity (plus a sound knowledge of telephone exchange and coupler requirements) may produce a thoroughly satisfactory dialer with a minimum of additional cost.

### **Using Remote Control Equipment**

There is one further alarm approach that may be readily applicable to some broadcast operations: utilization of the transmitter remote-control facilities for alerting studio personnel to any intrusion at the transmitter site. In a 24-hour operation, in particular, this provides continuous surveillance by station employees without using devices that signal the police automatically. This reduces the possibility of involving the officers in false or inadvertent alarms.

It is only necessary that the transmitter remote-control system be able to distinguish, through appropriate querying by the studio operator, between intrusion and any equipment malfunctions that also operate the system's alarm. The operator then can make the decision to call the police and/or key station personnel, as policy may dictate.

For stations so equipped, the problems of direct lines, telephone couplers, and legal prohibition of dialers can be eliminated. Of course the remote-control system, unless carried via STL, is subject to defeat by the cutting of phone lines.

Some stations presently have intrusion sensors connected to their remote-control alarms, but probably few incorporate anything more comprehensive than a set of contacts on the transmitter building's door. For a quite modest expenditure of time and money, they could extend their alarm coverage to include any of the devices outlined here that may be applicable to their needs.

### **Other Considerations In Planning**

Retail firms, vulnerable to heavy

**This unit**, triggered by system sensors discussed in this series on security systems, will send a telephone message to the local police department. For further information, use circle number 50, on our Reader Service Card.



### **Alarm System**

**Mountain West Alarm** has announced a new automatic telephone dialer that features a self-contained message programmer.

The R2 Dialtronic permits fast, silent communication of pre-recorded alarm voice messages over existing phone lines to police, fire department, or any designated party. This quality instrument responds to inputs from either fire or burglar alarm detectors or both. Two channels permit the sending of separate messages for two types of emergencies. Up to 6 separate parties may be contacted on each channel.

In the most basic application of the R2 dialer, burglar alarm sensors such as open circuit magnetic contacts may be directly connected to one channel while fire detectors may be connected to the other. The phone output circuit permits direct connection to the phone lines or can be used with a telephone company coupler where required. The

system then is ready to go; no control box is needed.

A self-contained programmer permits recording of both phone numbers and voice messages at the owner's convenience. A dialer codes the phone numbers and a microphone is provided for recording voice messages.

Other operational features include precedence of fire channel over burglar and an adjustable (0-30 seconds) time delay input circuit to delay dialer activation until constant alarm is indicated. Also permits testing. Self-contained loudspeaker also allows testing and demonstration.

Battery pack provides power independently from the vulnerable 115 vac power. Meter shows battery condition.

The modern R-2 dialer is packaged in a locked, tamper resistant cabinet. Heavy gauge steel box measures 12" wide × 10½" deep × 4½" high, weighs 18 lbs.

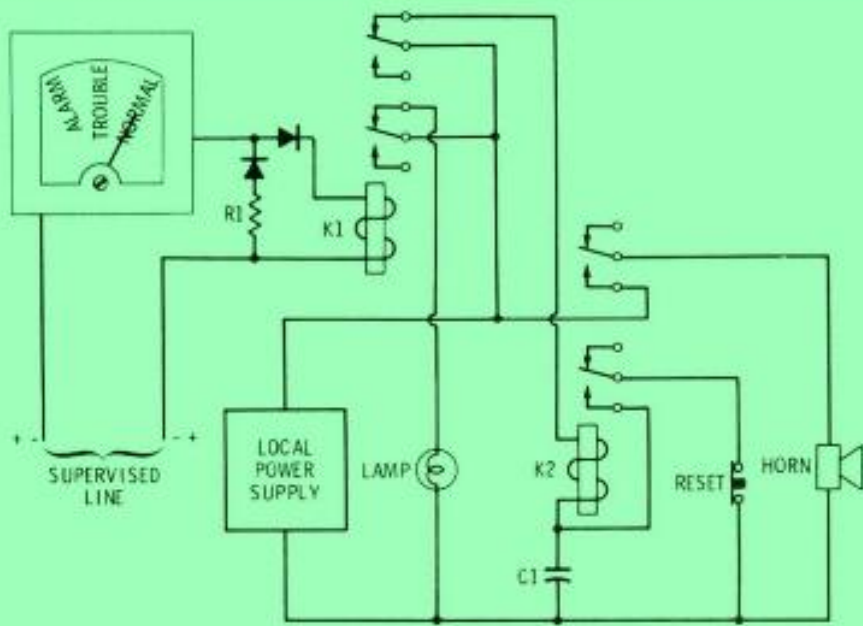

Schematic for a central station signal device.

inventory losses through burglary, may in some cases receive more favorable insurance rates when they install security systems. Generally, the accommodating insurer requires an "approved" system. The "approval" carries the sanction of the Underwriters' Laboratories, but this does not mean merely using UL approved equipment. It means having the system installed and certified by a professional security system firm that has earned certification rights by satisfying the UL on a number of previous installations. The chances of obtaining insurance premium relief on the basis of a "home-made" system are minute.

When contemplating a security system of any kind, it is tempting to try outwitting the wiliest of intruders. Somewhere in the planning stages, though, it will be necessary to settle on some degree of protection short of the absolutely impenetrable, for what one man can design, some other can defeat. No system is 100 percent invulnerable.

The planner must decide upon the probable technical sophistication of the most likely intruder, and design his system to be just good enough to frustrate his entry. An attempt to thwart the underworld's most ingenious burglar will lead to

system sophistication and expense that are not justified by the remote chance that such criminal elite will waste their talents on broadcast operations.

Apart from its cost, unnecessary sophistication is to be avoided because—to reiterate—it invites an embarrassing situation, since the police, who must respond to a call, take a dim view of the "boy who cries 'Wolf!'" Of course, their reaction may seem a bit exaggerated when they know that, statistically, 97 percent of the automatically-triggered burglary alarms they respond to are false or inadvertent.

It's only good business sense to reduce the chances of false alarms as far as possible, although the very simplest "system" may seem like it carries simplicity to an ineffective extreme. Nevertheless, many businessmen consider the printed notice on their doors to the effect that

**THESE PREMISES ARE PROTECTED by XYZ SECURITY SERVICE** is their best way to discourage potential burglars. In fact, some printers have made a small sideline of supplying professional-appearing (and sometimes counterfeit) display cards and decals to stores with no security systems at all—and for handsome prices, too. □



# what's the poop on the super SCOOP

Our new Scoop's so good we call it Super Scoop, and that's no poop! • Super Scoop is far more powerful than other scoops. We use a rugged socket to take advantage of a new 2000 watt mogul screw base lamp with a phenomenal lamp life of 750 hours at 3200°K. The mogul screw base gives excellent heat dissipation, eliminates lamp base cracking and mis-alignment. Super Scoop is an extremely efficient floodlight, achieving 80% field efficiency in flood focus. Its Alzak® aluminum reflector provides an exceptionally uniform field. • Focusing is a Super Scoop extra. An approximate 3 to 1 focus ratio controlled by a pole loop provides that extra zap when you need it. • So... for no poop and lots of Scoop, get the Super Scoop by Colortran.

## Berkey Colortran

A division of Berkey Photo Inc.  
1015 Chestnut St.,  
Burbank, Ca. 91502

For More Details Circle (48) on Reply Card

# Performance Royalties.... Or Who Pays The Freight

By Oliver Berliner\*

Officially, the United States of America is the only country in the world that has not one but two music performance societies. Its neighbor, Canada, had none ... because our ASCAP and BMI operate there, too. What are their functions and their *raison d'être*?

## Ownership Rights

There are two kinds of rights in

\*President of Telaudio  
Centre, Burbank, Calif.

music copyright ownership (by the way, an author rarely owns his copyrights ... his publisher does): small rights and grand rights. Essentially the latter refers to the performance of a musical work (a song) in the legitimate theatre as a part of a dramatic show. All other rights are "small" ... including concerts in theatres and arenas, nightclubs, jukeboxes, radio and television broadcasting, sidewalk organ-grinders (oh, yes, in Italy, organ-grinders on the street must

pay music performance royalties because they're playing music for profit), amphitheatres, skating rinks, stadiums, etc.

Obviously, since few composers (legally referred to as authors) are lucky enough to have their songs (legally called works) included in a stage play, the bulk of their income is derived from the small performance rights.

It is only fair that if a niteclub, for example, offering dance music is using that music to attract pa-



Morley Kahn (right) accepts the 1972 "Maker of the Microphone Award" from Oliver Berliner, grandson of Emile Berliner, inventor of the microphone and disc record. Kahn accepted in behalf of Dr. Ray Dolby for his development of a noise reduction system for magnetic tape recordings.



## Need a low cost, high quality, station "in house" monitoring system?

A television station "in house" monitoring system designed around the EiE CTM1 Color Television Modulator and the CTD1 Color Television Demodulator can be an effective, low cost and relatively simple method of meeting your station's monitoring requirements.

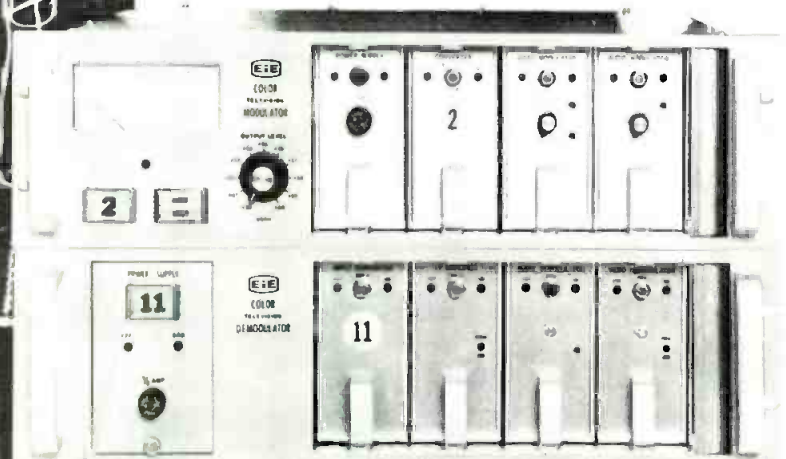

An EiE RF Distribution System eliminates the disadvantages associated with video/audio distribution systems such as prohibitive cost, system complexity and restricted monitoring capability. With the CTM1 Color Television Modulator which can be equipped to meet the FCC group delay predistortion requirements, station staff personnel can receive faithful reproduction of their product on consumer quality color TV receivers. Once the system is installed, anyone in the station who needs private monitoring can be accommodated for little more than the cost of the receiving/display equipment.

Write or phone today for more information on how your station can install an RF Distribution System for "in house" monitoring.

For More Details Circle (49) on Reply Card



**Electronic  
Industrial  
Engineering**  
A Division of RCA

7355 FULTON AVENUE · NORTH HOLLYWOOD  
CALIFORNIA 91605 · PHONE (213) 764-2411

trons and thus derive income, the man who wrote that music is entitled to compensation, without which he couldn't continue to function in the "business" of song-writing. In order that he may confine his efforts to artistic endeavors, the author assigns certain of his rights to a music publisher, the businessman who spends his money to print, publish, protect and promote the musical work. But even a rich and powerful publisher would be unable to "police" all of the thousands of users of his music throughout the country (and the world). Thus, enter the music performance society . . . ASofCAP.

### ASCAP Collects Royalties

The American Society of Composers, Authors and Publishers does not own copyrights nor does it participate in the collection of mechanical royalties (sales of records) or the sale of sheet music. ASofCAP (ASCAP) is a music performance society having authors and publishers as members, that is given certain nonexclusive authority by its members to collect performance royalties (but only the small rights) for these members.

The total amount received from the users of music-for-profit is called the "melon", and after deducting its operating expenses, the melon is divided-up among the members based upon a complicated formula that considers not only what songs got performed but the "availability" of certain songs that did not get performed.

### The Sample Base

But even mighty ASCAP (gross income about \$50 million annually) cannot police all of the users of music (economically, that is) so it relies on a sampling based upon a plan created by Joel Dean.

Who does ASCAP sample? You guessed it—you! ASCAP (and BMI) believes that the broadcaster, particularly the radio station, "has his finger on the pulse" of the musical desires of the nation. And inasmuch as broadcasters are easier to check, the sample is derived here . . . in addition to the fact that the broadcaster is in-

cluded among those who perform (yes, playing a record is a "performance") music and thus must pay for its use.

(A frequent broadcaster's argument is that they promote the sale of records by playing them and that this is sufficient compensation to the copyright proprietor. But relatively few broadcasters actually create "hits" or even lesser extents of public demand for records; besides the fact that in return for playing the records on the air the broadcaster usually gets his "programming" free or at modest cost from the record companies).

ASCAP takes its sample by secretly monitoring selected radio



"TALK ABOUT AN ULCER INDUSTRY.....!"

stations throughout the country. Supposedly, one never knows when which stations are being monitored. Although ASCAP denies this, such a system contains a flaw in that it may completely miss a regional hit.

Latin American music is popular essentially in such cities as New York, Miami, Baltimore-Washington, Los Angeles, San Francisco, Chicago, Tucson and El Paso. But if ASCAP's logging team is monitoring Omaha, Pittsburgh, Cleveland, Madison and Peoria while the "latin" stations are "laying on" a particular tune, that poor song is doomed, performance-wise.

(I have recommended, as a broadcaster/publisher, to both ASCAP and BMI, that "ethnic" stations—by the way, the now powerful country and western music used to be regarded by the

societies as "ethnic"—be sampled separately and continually, rather than being considered as part of the whole and thus sampled only occasionally. Neither society has accepted this proposal.)

### FM Miscue

Another "flaw" in both ASCAP's and BMI's thinking is with respect to music performances on FM stations. Because FM contributes comparatively little revenue to the performance societies, due to FM's lower gross income, as compared to payments by AM stations, performances logged on FM stations carry less "weight" than if the songs were played on AM stations. This is nonsense when you consider that in certain towns, San Francisco and Philadelphia, for example, FM stations probably dominate the market.

At one time, the most listened to Orange County (pop. 1¼ million) California station was a tiny Class A FMer paying only modest royalties to the societies. But even if its payments had been large, its weight would still have been small . . . because it was, FM. The point is that payment to authors should be based on listenership rather than on financial status.

Remember ("I Dream Of") "Jeannie with the Light Brown Hair"? A few decades ago all of ASCAP's radio station licenses terminated, and because the broadcasters balked at paying higher license fees they were unable to play the ASCAP repertoire . . . or risk copyright law violation penalties of \$250 for each unlicensed use. (Interestingly, United States copyright laws are weak compared with those of other enlightened countries, yet this type of violation has always been clearly punishable.)

One of the few public domain musical works was "Jeannie . . ." and boy, did it get a workout! Simultaneously, the networks and other major broadcasters were taking steps to see to it that this situation would never reoccur (one should, however, never say "never"). The result was the formation of a competing performance society—Broadcast Music, Inc. (BMI), owned by broadcasters. This is why the United States has

two performance societies.

### Broadcast Music, Inc.

With broadcaster backing, BMI's rise to riches was meteoric. In fact BMI is today rather unhappy that although (it claims that) more BMI music is broadcast than ASCAP's, the "big A" receives more broadcast revenue. At the time of its "humble beginning in Rockefeller Center" BMI showed special interest in limited-market (specialty and ethnic, including C & W) music.

With the transfer of the important Edward B. Marks Music Co. catalog from ASCAP to BMI, other major publishers followed. Because Marks was heavily into Latin American music (the rumba was "king" at the time) BMI owes its initial success largely to Latin music, but today regards it and all "ethnic" music as an "also ran." Today, rock, and its offshoots, is predominant.

Although the goals of the two societies are similar, their attitudes and methods are not. ASCAP the-

oretically pays out all its income to the members, based upon the distribution formula and after deduction of operating expenses. On the other hand, BMI agrees to pay so many pennies per logged performance, and does not agree to pay out all the money it receives, nor does it agree to submit financial statements. ASCAP offers the author the privilege of deferring to later ("leaner"?) years a portion of his current income, while BMI has no such plan and pays current monies on current performances (although the accountings take about nine months to compile for payment, after the song has been logged).

BMI will ask (but not require) a station to submit a list of the songs it plays during a certain 3-week period, and claims that each radio station in America is contacted once in about a 3-year period, although in practice the period seems to be much longer than this.

ASCAP will pay performance royalties on songs that are used in commercials, whereas BMI, being broadcaster oriented, does not.

BMI pays pennies per performance; ASCAP pays points per performance. BMI has three radio station categories: AM Group 1, AM Group 2, and (poor little) FM. Performances on FM pay the author far less than the same number of plays on "AM local 1."

### TV Scramble

In television we encounter a number of complications, the first of which is known as "licensing at the source." If a TV show is videotaped only for convenience, and thus is still a live "one shot," there would be no source licensing. But if a show were filmed, for example, for various runs and reruns, or if it were a movie or movie-for-television, it would be subject to source licensing.

Here the publisher makes a direct deal with the producer wherein he sells the producer the right to use his song in synchronization with the picture information. These are called **synchronization rights**, and essentially cover the exhibition

(Continued on page 109)

# HOW TO DELIVER AN FM SIGNAL WITH

# SOCK!

It's easy to do. Not too expensive either. Good stereo demands low VSWR. Our circular polarized "Penetrator" antenna guarantees a VSWR of 1.1 to 1 before it's even mounted. And after installation it may be field trimmed to reproduce a VSWR value of 1.08 to 1. This provides a superior stereo signal.

The "Penetrator" will also increase your audience by penetrating difficult areas and by reaching more car receivers and small portables. It's the only circularized FM antenna with variable horizontal-to-vertical gain ratios. It delivers a signal with sock!

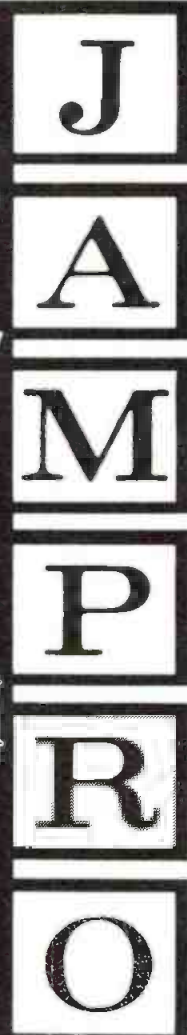

**JAMPRO ANTENNA COMPANY**  
A DIVISION OF COMPUTER EQUIPMENT CORPORATION  
PHONE (916) 383-1177  
6939 Power Inn Road • Sacramento, CA 95828

For More Details Circle (51) on Reply Card



# Calculating... A Breath of Freedom

By Fred Fowler\*

**Editor's Note:** Occasionally there comes along a simple, inexpensive device that is so helpful that an engineer can spill over with superlatives. There are other pocket calculators available. What we are really saying here is that such devices can be a very real (and needed) engineering aid. This is a review of how one such device operates and how it can be used in broadcasting.

Someone already used it, or we might have said, "What hath God wrought?" The HP-35 Pocket Calculator has descended upon us with much the same impact as the original telephone. Hewlett Packard took a quote from 300 years ago as part of their introductory brochure and it certainly bears repeating here:

\*KOMO-TV, Seattle, Wash.

"It is unworthy of excellent men to lose hours like slaves in the labor of Calculation."

Gottfried Wilhelm Leibniz  
(1646—1716)

We shall take the liberty of voting ourselves "excellent men" and agree with Gottfried Willy that this HP-35 sure does away with a lot of floundering around. Anything that makes a science easier, automatically guarantees it will be a more useful science.

Calling it an Electronic Slide Rule is not original with us, but a direct comparison is inevitable. We have found the HP-35 easier to learn to use, and easier to use. Accuracy, of course, is much greater than that of a Slide Rule.

The unit weighs 9 ounces, fits easily in a hip pocket and seems eager to solve problems in all facets of Engineering or Mathematics. A battery charger is furnished. The average is five hours of use before recharging is needed.

Four registers store information

temporarily for use as the calculation proceeds, usually this is with automatic recall. The 5th or "S" register serves as a more permanent memory, returnable when needed by depressing the RCL (Recall) key. A very handy feature as it reduces scratch pad notation in a multiple part problem.

The term "Reverse Polish Notation" is enough to melt down even a most hardy soul, but after it is understood, it can be easily accepted. The HP-35 demands this notation, so we'll outline it briefly.

Jan Lukasiewicz wrote a book on formal logic in 1951. His methods of mathematical notation without parentheses show the operator as a prefix, or as a postfix. In honor of Lukasiewicz, this prefix method is called Polish and, of course, postfix or the operator after the expression is Reverse Polish Notation.

$$(A \times B) - (C + D) = ?$$

This is standard notation.

$$AB \times CD + - = ?$$

**Fig. 1** KOMO-TV engineer Lloyd Jones checks an audio pad with the calculator while the author tries to keep pace with a slide rule.





## NEW ANTENNA FOR CARS BAND

Andrew has developed a new series of economical and versatile antenna systems for use in CARS band local distribution systems. An optional rear mounted enclosure allows mounting of radio equipment directly on the back side of the reflector, the complete RF assembly, including feed can be readily removed for maintenance without disturbing antenna path align-

ment. These LDS antennas offer the best value available for reliable local distribution of CATV by microwave.

For further information write for Bulletin 1051A or contact your Andrew Sales Engineer.



**ANDREW**

ANDREW CORPORATION 10500 W. 153rd St., Orland Park, IL, U.S.A. 60462

ANDREW ANTENNA SYSTEMS Lochgelly, Fife, Great Britain KY5 9HG

ANDREW ANTENNA COMPANY LTD. 606 beech St., Whitby, Ontario, Canada

ANDREW ANTENNAS 171 Henty St., Reservoir, Victoria, Australia 3073

For More Details Circle (52) on Reply Card

[www.americanradiohistory.com](http://www.americanradiohistory.com)

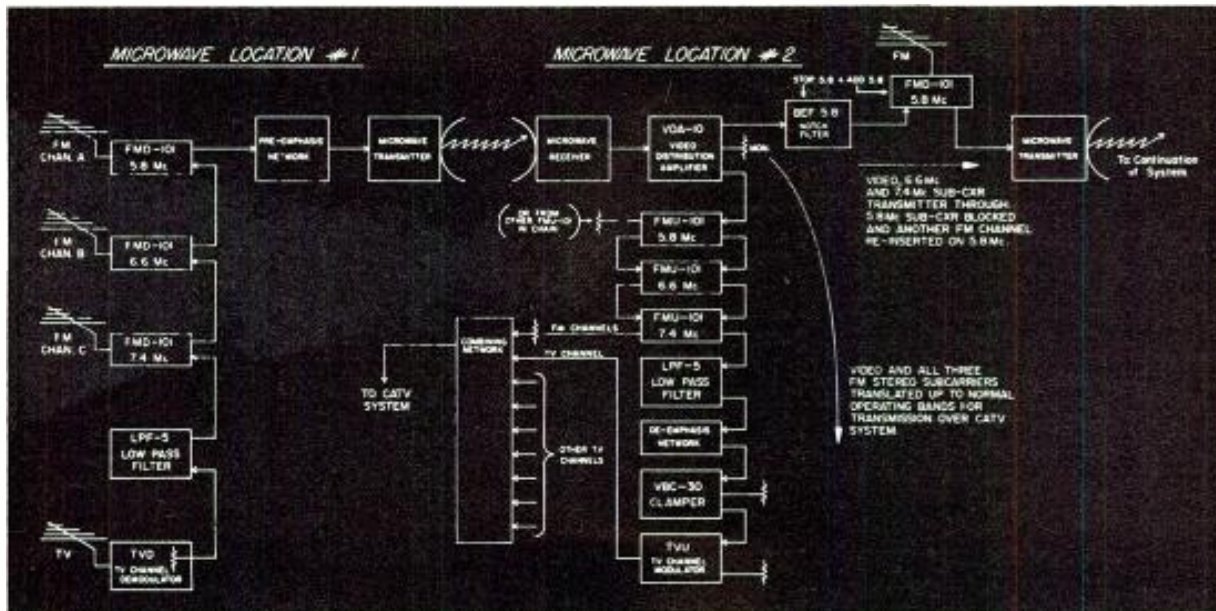

Block diagram shows basic system setup for three fm stereo channels.

Chairman A. C. (Colonel) Lowell. "He's had so many technical difficulties in the past that now he's skeptical of the ability to perform satisfactorily," continues Lowell. "The CATV operator wants proof that the system works, and this is one of the reasons why the Oroville installation is so significant. It clearly demonstrates that the technical problems are no longer there."

A single converter is needed for each stereo station in the pipe, but any number of fm channels can be carried on a CATV system. You just need a down- and up-converter for each station. In effect, the total number of stations carried is limited only by the number of converters installed in the system.

The equipment has been designed primarily to work with microwave links. Where CATV systems are being served by microwave, it's possible to transmit the stereo signals to several cable headends simultaneously. The microwave headend uses down-converters, and any number of headends served by the same microwave system can up-convert the fm for local distribution.

### Success Means Dollars

The Oroville installation has been operating for a little over a year. Orton estimates that at least 15,000 subscribers are currently being served by the fm stereo cable hookup. Every subscriber who has video coming into the house has fm channels available. This part of the installation is the cable operator's responsibility.

Primary customer for this equipment will not be the cable operator, but the common carrier which provides the microwave links for cable systems.

The future for fm on the cable is potentially vast, according to Colonel Lowell. Says Lowell,

"In general, the CATV operator who's served by microwave recognizes the need for fm stereo. He's had so many technical difficulties in the past, that now he's skeptical. We took this on as a challenge, and solved the fm-stereo problem." Lowell also points out that many CATV franchises include a provision for addition of fm stereo as soon as it is available.

One seemingly insurmountable problem in the past, according to Orton, has been the TV sync buzz which rode in on the fm channel. "Manufacturers just couldn't get rid of that buzz. We have successfully eliminated that gremlin. As a result of these past problems, there's now some reluctance on the part of system operators to go again to fm stereo, since they've already been burned once and in some cases, even burned twice. This is a psychological problem that we've got to overcome." Orton also feels that the present program of extensive field testing is vital in proving the system's viability for the cable operator, as well as demonstrating its financial desirability.

In some cases, Orton has found that many cable subscribers actually prefer the fm stereo over video. Interest of this kind has run high. Stereo on the cable certainly looks like the wave of the future, and may well be classed as one of those "extra" services that will be available in the total wired city concept, as cable continues to grow. **BM/E**

### Want Cable Fm?

For more information on EDC's cable stereo technique, write directly to: Rex Orton, Electronics Development Corp., 1533 Monrovia Ave., Newport Beach, Calif. 92660.



# CARTRIDGE EQUIPMENT



	PLAYBACK	R/P
MONO	\$495	\$695
STEREO	\$725	\$995

- DIRECT DRIVE
- BUILT IN 150 Hz TONE
- COMPACT—ONLY 5¾" WIDE
- UNEXCELLED SPECIFICATIONS

## Q R K

EAST

716 JERSEY AVENUE  
GLOUCESTER CITY, N. J. 08030  
PHONE: (609) 456-1716

WEST

1568 NORTH SIERRA VISTA  
FRESNO, CALIF. 93703  
PHONE: (209) 251-3008

A subsidiary of

CCA ELECTRONICS CORP.



# "FUTURA" CONSOLES



	MONO	STEREO
6 CHANNEL	\$1095	\$1695
10 CHANNEL	\$1995	\$2495
6 CHANNEL PIREWED SYSTEM	\$2095	\$3145

## Q R K

EAST

716 JERSEY AVENUE  
GLOUCESTER CITY, N. J. 08030  
PHONE: (609) 456-1716

WEST

1568 NORTH SIERRA VISTA  
FRESNO, CALIF. 93703  
PHONE: (209) 251-3008

A subsidiary of

CCA ELECTRONICS CORP.

This one is Reverse Polish Notation.

Both expressions mean the same. To wit; (A times B) minus (C plus D). This is for information only. The pocket calculator teaches you in minutes how to tell it your problem and it is not necessarily required that the expression be altered to Reverse Polish Notation before calculation. We find it simple to remember to push the operator button after punching out the last number, and that does it!

More specifically, the Reverse Polish expression illustrated is almost a description of how to program the problem into the calculator. Only the addition of a push of the Enter button need be added.

Actual feed of this problem is as follows: A, ENTER, B, ×, C, ENTER, D, +, -, with each instruction requiring a push of the appropriate button. Now, by the numbers. Let's say; A = 3, B = 5, C = 2 and D = 6, and we'll do it again. 3 ENTER, 5, ×, 2, ENTER, 6, +, - = 7. How about that? If the answer happens to come out negative, you'll be the first to know as a minus sign will appear when and where it belongs. This description applies to the lower section of the calculator where it is similar to, but in some ways superior to, the average desk calculator. The upper portion is what separates the men from the boy calculators.

The numbers on the LED display are considered to be "X". As you inspect the keyboard something appears called 1/X. This item is useful in the design of a band pass filter where capacitive reactance is always a struggle of the good guys versus the powers of ten.

$$X_c = \frac{1}{2} \pi F C$$

(2, ENTER, pi, ×, Frequency in Hertz, Capacity in Farads, ×.) Once we've dispensed with all these things in the denominator, we come to full appreciation of 1/X. Push that button and we have capacitive reactance in Ohms with the decimal point where it belongs. 1/X becomes a highly accurate replacement for the "CI" or reciprocal

scale on everybody's slide rule.

Many audio attenuator pads are required in our plant. Audio levels are important, we check them on a continuous basis. Amplifier gains are in the same category.

Charts don't help much, as they are usually depicted on a one to one impedance ratio. We must have gains or losses to fit myriad impedances. Watch the mini-calculator slay this dragon.

$$10 \log \frac{P_{OUT}}{P_{IN}} = 10 \log \frac{20 \text{ Watts}}{.5 \text{ Watts}} = \text{dB}$$

$$20, \text{ENTER}, .5 \div, \log, 10, \times = 16.02059991 \text{ dB}$$

A minor league dragon to be sure! However, it illustrates the fact that problems in power or voltage gain as expressed in decibels can be knocked off before the slide rule can be removed from its case. Incidentally, writing the order of button pushing as above takes considerably longer than actually making the entry of the problem.

Recent redistribution of AC power from a three phase source brought us power factor problems. Power factor is the Cosine of the phase angle. Resistance/Impedance = P.F. The calculator will solve this as a division problem. If it desired to know the phase angle, put in the P.F. number and push Arc, then Cos. The answer is in degrees and decimal fraction of a degree. This answer offended one engineer, he wanted degrees and minutes. Moments later this appeared, as the same machine will multiply the decimal fraction by 60 to produce the more recognizable notation of an angle.

Notice when using the upper section of operators on a number appearing in X, we do not push the enter key. This is because the operation is performed automatically on the visible numbers. Actuating the ENTER key would do no harm, it just isn't needed in this case.

We bemoaned the absence of an anti-log key. Pushing a few buttons soon showed anti-logs are available and this discovery made logs seem more sensible than ever before. The common log of 789 is determined by pushing buttons 7, 8, and 9, then log.



Fig. 2 A close-up of the HP-35 pocket calculator shows the possible functions which will give a readout on the LED's.

It is 2.897077003  
 The common log of 456 is 2.658964843  
 The sum is 5.556041846

Jog your memory a bit, this sum represents the logarithm of the product of  $789 \times 456$ .

Remember what common logarithms are. "The power to which ten must be raised in order to equal the number"?

In this case;  $10^{5.556041846} = 359,783.9999$ . This is the calculator's answer. Check it with the same calculator by simple multiplication of  $789 \times 456$ ; that comes out to 359,784. Not exactly the same but, oh! so close.

"Anti-log", or, "what number does this logarithm represent?" may be found with this simple process. Feed in the exponent, push ENTER, feed in 10 and push the  $X^Y$  key. The ENTER function has nudged the exponent up to the Y register so when 10 appears on the display, it becomes "X". You have asked the calculator, "What is 10 to the power existing in the Y register?" The answer, in fact, the whole problem is completed before the book of tables can be located in the Engineering Library.

This is a learning exercise only, but file it for the time you have a logarithm and need to know, from what number it was derived.

For those of us who use mathematics sporadically in our work  $\ln$  or  $E^X$  can be downright scary. This one turned out to be even more simple. The Natural Log is permanently programmed in; just push the keys to install the log in the X display, then  $E^X$  re-creates the number. Again, Freely translated,  $E^X$  is the anti-log of the Natural Log system. Have you forgotten what number E represents? We decided E to the 1st power is E, and asked the calculator, "What is E?" in this manner. To the ninth decimal place,  $E = 2.718281828$ .

Reduced to basics, the natural log of any number in the X register, (visible display) may be procured by query of the  $\ln$  key. A push of  $E^X$  converts it back to the original number.

Pi would require 4 key strokes on any machine; this one has a single button. This feature alone looks like a dream in an electronics problem.

Electronics calculation are irrevocably tied to trigonometry, so are architectural problems which crop up occasionally. The HP-35 just about relegates the Trig tables to the back room dead file. The keys: Arc, Sin, Cos and Tan all refer to the designated function as applied to the number appearing in the visible display. Whack one of them and your answer comes up in less than one second.

The role of math often fades as the Broadcast Engineer drifts in other directions dictated by the requirements of "Show Business". We foresee a rejuvenation. The man who avoided "Ohms Law" is now dusting off a trig problem on the Pocket Calculator.

Hewlett Packard is silent on questions about future price cuts. We feel free to predict the price will drop. Mass marketing tends to cause that to happen. Other companies are in close pursuit and a competitive device should appear soon.

AMI and Mostek produce the chips, and they will be available to anyone. There are 5 chips of MOS/LSI, each chip is the equivalent of 6,000 transistors. Translation: MOS/LSI means, Metal Oxide Semiconductor/Large Scale

# REK-O-KUT

## S-320 TONE ARM

### THE STANDARD OF COMPARISON

PRICE  
\$54.95



REK-O-KUT COMPANY, INC.  
 1568 NORTH SIERRA VISTA, FRESNO,  
 CALIF. 93703 • Phone: (209) 251-4213

A Subsidiary of CCA

CCA ELECTRONICS CORP.  
 716 JERSEY AVE., GLOUCESTER CITY,  
 N. J. 08030 • Phone: (609) 456-1716



## 1st in Turntables and Accessories



- 12" & 16" TURNTABLES
- TONEARMS
- EQUALIZED PREAMPS
- CARTRIDGES
- FURNITURE



EAST  
 716 JERSEY AVENUE  
 GLOUCESTER CITY, N. J. 08030  
 PHONE: (609) 456-1716

WEST  
 1568 NORTH SIERRA VISTA  
 FRESNO, CALIF. 93703  
 PHONE: (209) 251-3008

A subsidiary of  
**CCA ELECTRONICS CORP.**

For More Details Circle (54) on Reply Card

Integration. The term "Large Scale Integration" seems inverted because the chips are so small. Large scale, however, in this case just indicates the most stuff in a small space.

If it's hard to visualize 30,000 transistors in this small package, join the party. We at KOMO-TV ignore that and just ask, "What will it do for us?" Then we make it dance to our tune.

We'll not dwell on the technicalities of HP-35's innards, as Hewlett-Packard covers the subject very thoroughly.

We've not touched all the bases yet, let's briefly do so.

R is "roll down". You may inspect the contents of each temporary storage register without disturbing these contents.

CH S is "change sign" and used for entry of any negative number.

X Y reverses the information in the X and Y registers, pretty handy if you've inserted a division problem upside down.

E EX signifies "Enter Expo-

nent". It applies to scientific notation including the powers of ten. Remember that E EX allows the next number to be entered as a power of ten.

Square root appears as  $\sqrt{X}$ . After some use of this, we stumbled on the rather obvious fact that a number may be squared by keying in the number, key ENTER, then push the multiplication operator. We'll leave this to the reader to determine why this occurs.

CLR, the Clear Key, erases all registers. If an improper request is made, i.e. a problem having no solution, you see a blinking zero. Ask for the Arc Sin of 2, that'll frustrate the little guy.

Hewlett-Packard designed a unique keyboard and switch system. Due to the over-center snap, you know when you have pushed a key to make contact. This cuts down chance of accidentally depressing more than one. In case of error, CL X (Clear X) gives you another chance without affecting

information already stored in the other registers.

Longevity of the individual HP-35 remains to be seen; but an exploded view made us feel replacement of parts could probably be accomplished in a reasonable manner. No doubt this privilege would be accorded to the factory.

The imagination wanders as complex problems turn easy. "What is the role of an Electronic Slide Rule in Education?" Considering \$20,000 plus for a professional education, \$395.00 seems a small outlay for such an efficient tool. This is akin to giving back countless hours of life to a student of Engineering, that he may spend widening his knowledge, rather than meticulously working out long problems.

It's fun to talk about, fun to use, and fits our philosophy of life. "The good Engineer is the one who finds the answer to the problem he's faced with, quickly." It matters not where, nor how, the answer is come by. □



**\*New digital V.O.M. works well in near field environment. Only \$299.**

Here's the best low cost digital voltmeter ever made for broadcast and communication use. It's got all the resistance range, voltage resolution, high ac accuracy you'll ever need plus 30 second warm-up to full accuracy. Fluke's new Model 8000A measures in 26 ranges ac/dc volts, amps and resistance from 100  $\mu$ V to 1200 V, 0.1  $\mu$ A to 2 A, and 100 milli $\Omega$  to 20 meg $\Omega$ . Basic dc accuracy, 0.1%. Full year guarantee. Option choice includes rechargeable battery pack, printer output, deluxe test leads, HV probe, RF probe, 600-amp ac current probe, carrying case, dust cover and rack mount. Unique self-zero eliminates offset uncertainty. Electronics are securely mounted in high-impact case. Service centers throughout U.S., Canada, Europe and Far East for 48-hour turnaround repair.



P.O. Box 7428,  
Seattle, Washington 98133.

Get all the details from your nearest Fluke sales office. Dial toll-free 800-426-0361 for address of office nearest you.

For More Details Circle (55) on Reply Card

**ERASE  
RECORD  
REPRODUCE**

**MONO - STEREO**

Professional Direct Replacement Heads with complete written and pictorial instructions

Our factory will clean, rebuild, adjust and test your head ASSEMBLY...install new MM1 heads...replace minor hardware and modify your gate to accept our "NON-POPPING" springs

**36 HOUR SERVICE - LOANERS AVAILABLE**  
(612) 884-7393

**MINNEAPOLIS MAGNETICS, INC.**  
8125 PLEASANT AVE. SO., MINNEAPOLIS, MINN. 55420

For More Details Circle (56) on Reply Card  
**BROADCAST ENGINEERING**



Bill Wertz, VP of WQLR, checks the chronometer, as Dennis Weidler is poised to put the station on the air. Pat Dyszkiewicz and Eric Toll watch.

## Stanton. Brings on the new.

A new Station, and a new sound hits the air in Kalamazoo, Michigan. WQLR STEREO starts serving the market in June, 1972 with all new equipment and new programming. Every cartridge on every tonearm at WQLR is a Stanton. Vice President, Bill Wertz states, "We chose Stanton because we were starting fresh and we needed to impress the community with the quality of our sound from the very first on-the-air minute. Naturally, the well-documented reliability of Stanton's 500 series cartridges helped influence our choice."



Artie Altro makes the WOR-FM sound, while Eric Small, Sebastian Stone and Promotion Director, Kim Olian look over a new album.

### Radio stations all over the nation specify Stanton.

For on-the-air use, Stanton 500 series cartridges have the ability to withstand rugged handling without any lessening of audio quality. They meet all standards for reliability and sound quality, both in on-air playback usage, and in the production of transfers. These characteristics, which assure high quality sound with minimum maintenance, make them ideally suited not only for professional use, but for home stereo systems as well.



Scott Muni, WNEW-FM, cues in on a new release.



Engineer Brian Morgan of WDRG AM/FM, gets ready for on-air playback.

You can enjoy the professional audio quality of Stanton Products whether your purpose involves broadcasting or home entertainment.

Write today for further information to Stanton Magnetics Inc., Terminal Drive, Plainview, New York 11803.



All Stanton cartridges are designed for use with all two and four-channel matrix derived compatible systems.

For More Details Circle (57) on Reply Card

# SBC-415 TAKES THE WORRY OUT OF MEETING AURAL PROOF-OF- PERFORMANCE

That's right. Our SBC-415 FM Subcarrier is the sound diplexer system that guarantees peace of mind when you sign-off your aural proof-of-performance statement.

SBC-415 adds a big margin of safety to your TV-STL operation because it's first in extra low distortion, (0.5%, maximum); first in video interference rejection.

SBC-415 combines ultra-linear modulation and highly selective demodulation with a precise 60 dB isolation delay equalized filter system.

We designed it that way to meet your most critical broadcast requirements. SBC-415 is a unique departure from ordinary subcarrier design that delivers unequalled performance at a price that's right.

But, see for yourself. Write for the facts, today. Better still, call us.

**SCOTT  
BUTNER**  
Coastcom

534 Twentieth Street • Oakland, CA  
94612 • Telephone: (415) 465-5900

## ENGINEER'S EXCHANGE

### Skeleton Proof No Spoof

By Mel Hart, Station WIL

Yearly "skeleton proofs" required for directional stations operating by remote control are required by the FCC and can be an aggravating chore. Perhaps the

worst problem is getting organized so that the job can be completed in a minimum of time without travelling unnecessary miles because you forgot a map or got lost (again).



The cassette recorder is mounted on the transmission hump where it can be easily reached. Also visible is the 2 Meter FM gear at right.

A method that I have used for two years has proven itself extremely useful. Attempting to make the measurements alone entails driving the car, reading Topo maps, or worse yet the sub-miniaturized version that every consulting engineer includes in his engineering proof. The reproduction and binding of these booklets is probably a conspiracy with the auto body and fender industry. Try sailing down a country road and looking up "figure 4J"!

I have installed a small wood

tray on the transmission hump in my car to hold a cassette tape recorder. A tape is pre-recorded with complete directions for each radial. All that is necessary then is to flip the tape player on and off as you drive from one point to another. The directions follow the format:

"to reach point 7 . . . drive North on Highway 3 two miles to Judith Lane . . . Shell station on corner . . . turn right and go East four tenths of a mile. Measuring point 7 is 250 feet South of the curb di-

*(Continued on page 78)*



# LOOK NO FURTHER!

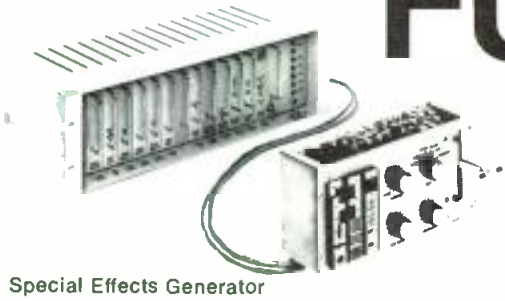

Special Effects Generator



Waveform Monitor

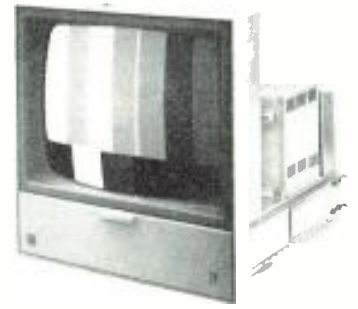

Large Screen Color Monitor

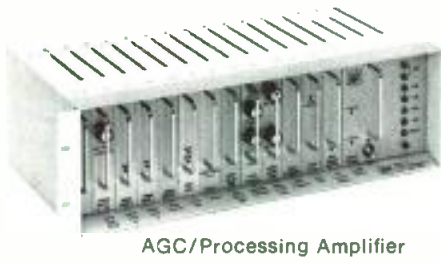

AGC/Processing Amplifier



Data Color Monitor

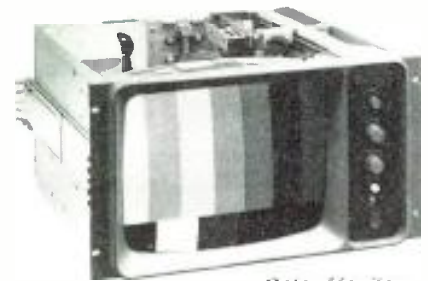

Color Monitor

Large Screen Monochrome Monitor

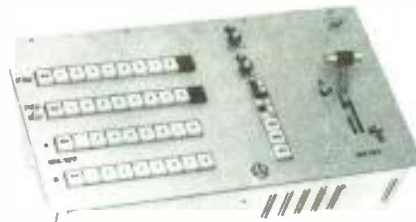

Video Switcher

Twin Monochrome Monitor



## Look to Miratel for your Broadcast and CATV studio equipment needs.

Who developed the first solid-state broadcast video monitors?

What company has more solid-state experience than any other video/display manufacturer?

Which broadcast equipment manufacturer has developed a long-term reputation for reliability and performance?

That's three for us. Miratel is now the fastest growing manufacturer of TV accessory equipment. Miratel has been turning out the best in solid-state televisual equipment for broadcast and EDP use since 1960. Installations? You'll find Miratel equipment everywhere, from space center installations to large broadcast

studios; from mobile production centers to CATV stations. In addition, Miratel is one of the largest suppliers of video displays to the computer industry.

Miratel color monitors have licked stability and service problems through a combination of long-term broadcast experience, and aerospace quality design of critical circuitry. You can't buy more dependable monitors. The same design care goes into our processing/AGC amplifiers, special effect generators, video switchers, and other signal control and conditioning equipment. We stand on our reputation for design sophistication and customer support. Look to Miratel for your broadcast and CATV studio equipment needs.

May we tell you more? Please call or write today.

### MIRATEL DIVISION

BALL BROTHERS RESEARCH CORPORATION • 1633 TERRACE DRIVE • ST. PAUL, MINNESOTA 55113 • (612) 633-1742

For More Details Circle (59) on Reply Card

# Spotmaster

The incomparable

# Ten/70



## World's finest cartridge tape equipment

Here is the bold new standard in cartridge tape performance, versatility and ruggedness—the equipment that has *everything!* Five models of the magnificent Ten/70 are offered to meet every recording and playback application. All have identical dimensions. Any combination of two will fit in our sleek 19-inch roll-out rack panel, just 7 inches high.

Control features and options include manual high-speed advance, exclusive Auto-Cue with automatic fast-forward, automatic self-cancelling record pre-set, front panel test of cue and bias levels, built in mike and line level mixer, color-coded design for easiest possible operation.

Inside is a massive U.S.-made hysteresis synchronous "Direct Drive" motor, solid state logic switching, modular construction and premium components throughout, separate heads for A-B monitoring, full bias cue recording, transformer input and output, flip-top access to heads and capstan.

**THE CLASSIC 500 C SERIES.** Long the industry standard, SPOTMASTER'S 500 C series is still offered. Performance and specifications are second only to the Ten/70.



For complete details about SPOTMASTER cartridge units (stereo, delayed programming and multiple cartridge models, too), write or call today. *Remember, Broadcast Electronics is the No. 1 designer/producer of broadcast quality cartridge tape equipment . . . worldwide!*

## BROADCAST ELECTRONICS, INC.

— A Filmways Company —

8810 Brookville Road, Silver Spring, Maryland 20910 • (301) 588-4983

## Engineer's Exchange

(Continued from page 76)

rectly South of power pole no. 377/4."

To reach point 8 . . . drive East on Judith Lane to Falling Springs Road . . . turn left and go North one half mile to first stop sign . . . turn left . . . etc.



The engineer's compass is used to fix the direction to the transmitter. A convenient landmark, such as a chimney or large tree is sighted through the upright guide.



This method even beats having a "navigator" to read the maps. A description of each point is given to allow you to return to the exact same spot next year. A windshield compass in the car and a hand held "engineers" compass with sighting bars is used to establish the direction to the station if re-radiation is a problem.

At the end of each radial directions to reach the end of the following radial or to return to the city via the best route are given.

During the rest of the year I use the cassette recorder to play 30 and 35 word per minute code tapes to keep my CW speed up! I have also used it to pre-record sections of technical texts for maintaining and improving technical knowledge.

# \$50<sup>00</sup>

## SPOTMASTER DISCOUNT CERTIFICATE

# \$50<sup>00</sup>

Limited time offer—Get any Spotmaster tape cartridge machine or system for \$50.00 off the regular price!

### SAVE THIS VALUABLE CERTIFICATE AND SEND WITH ORDER

Offer applies to Spotmaster Ten/70, 500 and 400 series and all multi-cart players including new 3D3 and 305 Mini-Series, Five-Spot and Ten-Spot. Limit: One Discount Certificate per order.

Can be redeemed through local authorized distributor; or call or write for catalog and price list: BROADCAST ELECTRONICS, INC., 8810 Brookville Road, Silver Spring, Maryland 20910 • (301) 588-4983

Offer expires April 30, 1973

# Canon offers the perfect zoom lens for the camera of your choice



More and more people are discovering how significantly superior Canon Zoom Lenses are for TV broadcasting purposes. Their outstanding color characteristics, even in dim light, is one of the many reasons why Canon was chosen for telecasting the Munich Olympics.

Canon's wide range of excellent zoom lenses encompass three types of operation control— all-servorized, via flexible cables and by effortless push-pull rod control. And it can be attached to

fit and operate with any make of TV camera. Shown on this page are only a few examples of the quality lenses Canon has available to more than meet your particular demands. Specify Canon to stay ahead.

The following are Canon TV Zoom Lenses for the Plumbicon® color cameras currently available on the market:

Size of image tube	Lens	Image format covered
1 1/4" Plumbicon® color camera	P10 x 20B4	17.1 x 12.8mm (21.4mmφ)
	P17 x 30B1	
	P17 x 30B2	
1" Plumbicon® color camera	PV10 x 16B1	12.8 x 9.6mm (16mmφ)
	PV10 x 15B2	
	PV17 x 24B1 PV 6 x 18B1	

® Reg. TM N.V. Philips of Netherlands.

#### The Canon TV Lenses Naming System



Applications	Image Format	Pick-up Tubes
P	21.4mmφ	1 1/4" Plumbicon
PV	16mmφ	1" Plumbicon

Apart from the above, Canon has available TV zoom lenses for 3" or 4-1/2" image orthicon cameras and can also build special lenses to fit your requirements.

# Canon

● CANON U.S.A., INC.: 10 Nevada Drive, Lake Success, Long Island, New York 11040, U.S.A. (Phone) 516-488-6700 ● CANON U.S.A., INC.: 457 Fullerton Ave., Elmhurst, Illinois 60126, U.S.A. (Phone) 312-833-3070 ● CANON OPTICS & BUSINESS MACHINES CO., INC.: 3113 Wilshire Blvd., Los Angeles, California 90005, U.S.A. ● CANON AMSTERDAM N.V.: Gebouw 70, Schiphol Oost, Holland ● CANON LATIN AMERICA, INC.: Apartado 7022, Panama 5, Panama ● CANON INC.: 9-9, Ginza 5-chome, Chuo-ku, Tokyo 104, Japan

# DELTA-BENCO CASCADE

**ANNOUNCES:**

**THE TS-010D**

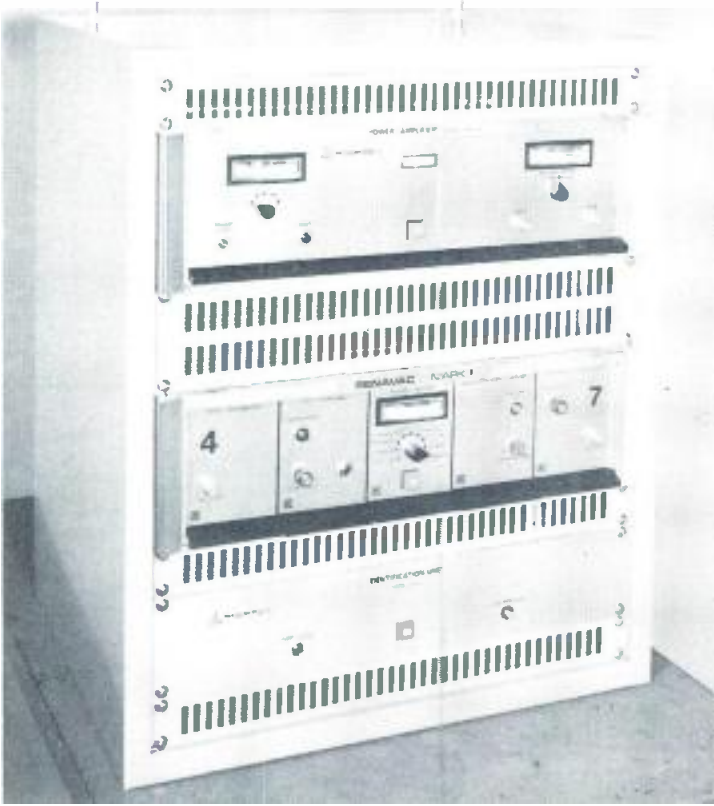

MODEL TS-010D with IU-TS

**SOLID STATE  
10 WATT TV  
REBROADCAST  
TRANSMITTER**

**FCC APPROVED**

The Model TS-010D comprises two self-contained units, the Benavac Mark II dual heterodyne channel processor and the VPS-10 amplifier. Any off-air channel 2 to 83 can be converted and re-transmitted on any VHF channel 2 to 13.

When required, an identification unit, Model IU-TS, is available to provide automatic station identification by superimposing a 4 KHz, AM modulated code signal on the aural carrier of the transmitter channel.

**D-B-C**  **Delta-Benco-Cascade Ltd.**

124 BELFIELD ROAD, REXDALE, ONTARIO, CANADA M9W 1G1  
telephone (416) 241-2651 telex 06-965552.

For More Details Circle (61) on Reply Card

# COMPUTER-ASSISTED REMOTE CONTROL

FULLY DIGITAL  
CONTROL — TELEMETRY  
STATUS—AUTOMATIC LOGGING

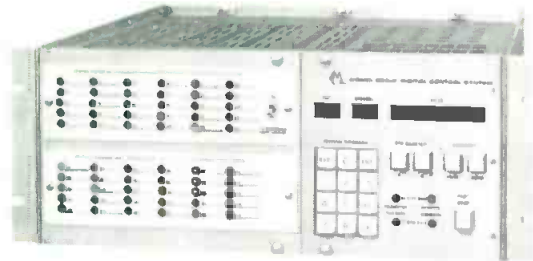

MODEL DCS-2



Computer option: up to 30 parameters displayed simultaneously, tolerances on all channels . . . even totally automated transmitter operation.

---

## AURAL STUDIO - TRANSMITTER & REMOTE PICK-UP LINKS



### SYSTEMS FOR

- 148—174 MHz    ■ 215—240 MHz
- 300—470 MHz   ■ 890—960 MHz
- Others on special order

New models RPL-3 and RPL-4 compact remote pick-up systems for 160 MHz and 450 MHz . . .

For the international AM broadcaster, the new model PCL-101 STL for 148-240 MHz . . .

And all the time-proven Moseley STL's.

---

## ANALOG REMOTE CONTROL

Stepperless 15-channel model TRC-15A. Pushbutton model PBR-30A. Both systems available for wire and wireless service.

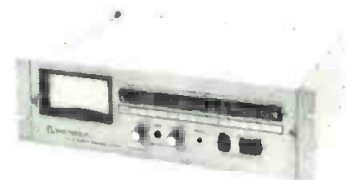

See us in Booth 313, Sheraton Park, during the NAB, or write for details.



MOSELEY ASSOCIATES, INC.  
SANTA BARBARA RESEARCH PARK

111 CASTILIAN DRIVE  
GOLETA, CALIFORNIA 93017  
TELEPHONE (805) 968-9621  
TELEX 658448

# Radio Formatting in

From contemporary music through psychedelic, chicken and old rock to MOR formats—so went some of New York City's 47 radio station program categories as they cavalcaded through Part 1. As for the balance, variety is as endless as formatting is competitive.

By Thomas R. Haskett

SEARCHING FOR A CATCHY format to attract mature, money-making people, a radio-station owner coined the term "good music" over 10 years ago. His staff immediately dubbed the format "syrup." In the New York City metro area, six stations do the syrup bit: WPAT AM-FM (Paterson, N.J.), WRFM (FM), WTFM (FM) (Lake Success, N.Y.) and WVNJ AM-FM (Newark, N.J.). Syrup music consists chiefly of album cuts by artists like Frank Purcell, the Living Voices, Andre Kostalanetz, Ray Bolger, Morton Gould, Buddy DeFranco and

---

Thomas Haskett is a New York-based electronics writer and consultant.

BM/E Photos

Age: newsman Charles Scott King holds forth on WINS.



# SSI | PROFESSIONAL Broadcast Products

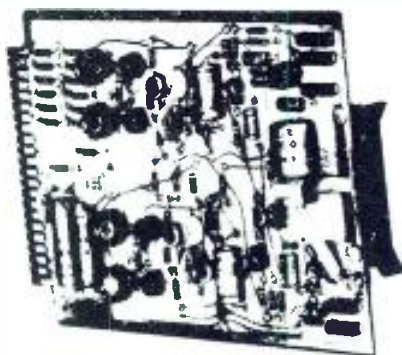

## IC OP AMP AUDIO DISTRIBUTION AMPLIFIER

Model SA-200

- ◆ Six Source Terminated Outputs
- ◆ All Silicon Devices – Socket Mounts
- ◆ High Output Line Isolation
- ◆ Proven Reliability
- ◆ 12 SA-200's Mount In The Standard Frame



## AUDIO DISTRIBUTION PACKAGE

Consisting of 12 Distribution Amplifiers, and Regulated Power Supply, in a 5¼ inch high Frame – 12 Inputs – 72 Outputs – \$2,495.00

### SA-300 For Smaller Systems Requirements

The SA-300 Package, which consists of 2 SA-200 D.A.S. in a 1¼ inch high frame. Complete with power supply is available for the modest price of **\$540.00**

The SA-200 is one of a complete line of Audio Modules in the 200 Series.

SSI's other Broadcast Products include:

- ◆ Custom Audio Consoles
- ◆ Studio Intercom Systems
- ◆ Studio Monitor Amplifier/Speaker Systems
- ◆ Video and Pulse Distribution Amplifiers

Call or write for further information

## SCIENTIFIC SYSTEMS, INC.

293 Oak Ridge Road, Clark, New Jersey 07066  
(201) 381-1088

For More Details Circle (138) on Reply Card

## Broadcast Rule Revisions

By John Mullaney

As promised, the Commission has announced a further revision of the Rules governing radio and television broadcasting. This represents the second major revision resulting from the continuing efforts of the Commission's Task Force concerned with modernization of the Rules. The initial changes were reported in the December, 1972 issue of **Broadcast Engineering**.

The current Rule changes eliminate many of the requirements which have proved burdensome to the licensee, as well as to the Commission. These changes are principally directed toward reducing unnecessary paper work. In addition, many of the existing Rules are clarified or revised to conform to the Commission's current policies.

The table summarizes the announced revisions in the Commission's Rules, giving a brief description of the present requirements as well as the changes which becomes effective April 4, 1973. These revisions, although individually relatively minor, represent a significant overall improvement in the present requirements and can be implemented without adversely affecting operating performance. The new requirements allow more flexibility to the licensee in determining the exact methods of compliance with the technical criteria established elsewhere in the Rules and in no way compromise the technical requirements.

Although further changes in the Rules by Commission Order may be forthcoming as the situation arises, the time is approaching for more substantive changes which would require Notices of Inquiry and Notices of Proposed Rule Making. The Task Force is currently studying portions of the Rules dealing with, among other things, such diverse areas as ascertainment requirements, frequency monitors, contracts, automatic transmitters and directional antennas, and formal notices will be issued from time to time on these and other matters as the study progresses.

The Commission, to date, has received approximately 600 letters containing suggestions for improving the Rules, as well as approximately 175 letters of commendation. All interested parties are encouraged to continue to contribute further ideas, since many of the changes already implemented resulted from such input. Only a single copy of an informal letter is necessary to get your ideas considered.

The address is: Broadcast Bureau, Re-Regulation Task Force, Federal Communications Commission, Washington, D. C. 20554.

I repeat—Keep those letters coming!

*(Continued on page 84)*

**Win An Oscilloscope Vector Display  
At Booth 700, Shoreham Hotel  
Beston Electronics**

# OURS

When our RF circuit brought condenser microphones out of the recording studio and into the world, even we had no idea of the many applications you'd put them to. But what our technology made possible, your ingenuity extended in many different directions. What was once a fragile luxury, you made a necessity in location filming, audience participation shows, press conferences,



rock concerts, opera, cinema verite . . . the list grows daily in recording, broadcasting, filmmaking, education and technology. We have not rested on achievements either. Creating and improving condenser microphones with new features, new capabilities. And happily, you adopted them to an extent that has made us the industry standard. Perhaps though, you are unaware just how large the "first family" of professional condenser microphones and accessories has become. For the latest information, please write or call us.

 **SENNHEISER**  
ELECTRONIC CORPORATION  
10 West 37th Street, New York 10018 (212) 239-0190

Manufacturing Plant: Bissendorf, Hannover, West Germany



## Summary of Rule Changes\*

Description	Requirement Before April 4, 1973	Requirement After April 4, 1973
1. Testing and Logging Requirements-Auxiliary Transmitter (AM, FM, TV)	Tested at least once a week and at specified hours. Data must be entered at least once a week in maintenance log.	Tested when determined necessary by licensee, and at any time, to assure proper operation. Data must be entered in maintenance log only when such voluntary tests are made.
2. Operating Power-Auxiliary Transmitter (AM, FM)	Operating power may be less than authorized power but in no event greater than such power.	If licensed for lower power than regular transmitter, then operation at no more than 105% of regular transmitter's licensed power is permissible as long as required performance specifications are met.
3. Operating Authority-Auxiliary Transmitter (FM, TV)	Limited to 5 days of operation without Commission authority; longer periods of usage require a request to Commission.	The five-day restriction on usage without further authority is deleted.
4. Maintenance of Minimum Operating Power and Minimum Hours of Operation (AM, FM, TV)	If minimum operating power or minimum hours of operation cannot be maintained within prescribed limits due to causes beyond control of licensee, reduced power for up to ten days is permissible provided Commission and Engineer in charge of radio district are notified immediately.	Immediate notification not required if such problems develop. Written request to Commission is only required to obtain further authority beyond ten days. This request must be written no later than 10th day for such additional time as necessary.
5. Visibility of the Transmitter, Monitors and Meters or Remote Control Instruments (AM, FM)	Operator must have ready access and clear visibility from normal operating position.	The words "clearly visible" are deleted and Rules are clarified to require that meters be observable at any location within 360° arc of operator.
6. Requirements for Notification of Engineer in Charge of Radio District (AM, FM, TV)	Required notification for: defective modulation monitor, defective indicating instruments, defective frequency monitor, problems with maintaining minimum operating power or minimum operating schedule, departure from regular schedule of share-time operation, commencement of stereophonic broadcasting, transmission of point-to-point messages during emergency operation.	Notifications to Engineer in charge of radio district are not required in these cases. Limit of time (60 days) for operation without certain equipment still applies and the Commission must still be notified in particular cases in accordance with existing Rules.
7. Temperature Variation of crystals used in transmitters (AM)	Specifications are included on temperature variations permitted and requirements to monitor temperature.	Specifications concerning temperature variations are deleted. Frequency stability must be maintained, however.
8. Circuit Diagram of Transmitter and Associated Equipment (FM, TV)	Circuit diagram of equipment must be retained at transmitter location.	This requirement is deleted.
9. Equipment Performance Measurements--Filing Procedure (AM, FM)	Data on equipment performance plus description of instruments and procedure, signed by engineer making measurements, shall be kept on file and available at transmitter for period of two years.	Such data and information may be kept on file at either transmitter or remote control point. Also, Report must be dated as well as signed.
10. Spare Tower Lamps (AM, FM, TV)	A licensee must maintain a supply of spare lamps.	This requirement is deleted. Licensee can use his judgment on how to comply with provisions of Rules which require replacement as soon as practical.
11. Logging Requirement for each Interruption of Carrier (AM, FM, TV)	Entry required in operating log for each interruption of carrier where restoration is not automatic.	This requirement is deleted except where interruptions are of significant duration as covered elsewhere in the Rules.
12. Contracts with Part-Time First-Class Radiotelephone Operators (AM, FM)	Signed copies of such contracts must be filed with Commission and Engineer in charge of radio district and must be available at transmitter or control point.	Signed copies need not be filed with Engineer in charge of radio district.
13. Logging Requirements For Transmission Line Meter Readings (FM, TV)	Required to enter RF transmission line reading in operating log at specified intervals.	Clarified to make exception when power is determined by indirect method which is entered in accordance with another provision of Rules.
14. Attended Operation of One-Hop Aural STL's, Aural Intercity Relays and TV STL's (Aural STL and Intercity Relay, TV Auxiliary Broadcast)	Such operations must be attended, although intermediate stations in multihop circuits may be unattended.	Such operations may be unattended to be consistent with the present Rules concerning intermediate stations in multihop circuits in aural services and in TV intercity relay stations, TV translator relay stations and multihop TV STL circuits.

\*Refer to the Rules for complete explanation

Still using  
lead oxide vidicons  
in your  
color camera?



# GET THE LEAD OUT!



This greatly magnified photo shows General Electric's revolutionary Silicon and Silicon Dioxide target. It makes lead oxide vidicons obsolete.

Improve your camera performance  
with General Electric's Z-7900  
30 mm Epicon™ Silicon Target Vidicon

- Improved red response
- Higher sensitivity
- Sharper pictures
- Burn resistant

Now you can replace the lead oxide tubes used in your PE-350, PC-70, and TK-44 color cameras with something better: General Electric's new 30 mm Z-7900 Epicon. It is so sensitive that it can be used for remote pick-ups where low light levels are often a problem. Get the lead out! Put General Electric's Z-7900 Epicon in. For details, contact the Imaging Devices Operation; Bldg. 6, Room 123; Electronics Park; Syracuse, New York, 13201. Phone: (315) 456-3210. Or use the reader-service card.

GENERAL  ELECTRIC

365-06

For More Details Circle (66) on Reply Card

# IT'S PRODUCT RELIABILITY

THAT MAKES  
RICHMOND HILL  
LABORATORIES  
EQUIPMENT SUPERIOR



Engineers expect product reliability.  
That's why it's built into every RHL product.

At the NAB Convention, our feature demonstration will be the newest addition to our family of VPM Series Video Switchers. Model VPM-41.

The VPM-41 is a new, low-cost, 10-input, 4 bus Video Production Switcher with colour broadcast specifications. The unit utilizes an integrated control panel and electronics assembly to maintain its compact size, portability, and ease of maintenance.

Be sure. Buy product reliability. Specify RHL.

## RICHMOND HILL LABORATORIES INC.

142 Central Avenue  
Clark, New Jersey 07066

**EASTERN U.S.**  
142 Central Ave.  
Clark, N.J. 07066  
(201) 381-5955  
Telex: 138245

**MIDWEST U.S.**  
370 Nottingham Lane  
Hoffman Estates, Ill. 60172  
(312) 882-4622

**CANADA**  
1240 Ellesmere Rd.  
Scarborough, Ont.  
M1P 2X4  
(416) 291-7921  
Telex: 02-29803

**ENGLAND**  
Pinewood Studios  
Pinewood Rd.  
Iver, Bucks.  
SLO ONH  
Telex: 847505

## Special Product Section

(Continued from page 52)

management people in broadcasting who have had technical training and still others who have also held a First or Second Class License. However, the onslaught of the new technology in the form of components and circuits demands a daily foot race even for the engineers to keep pace.

**Table 2**

Which of the following equipment do you think your station may purchase during 1973?

Video Monitor .....	23.7%
Antenna System .....	7.9%
Automatic Equipment Control .....	9.3%
Video Tape Recorder .....	30.9%
Automatic Tape Cart Control .....	10.9%
Automatic Transmitter Logging .....	10.0%
Color Camera .....	22.5%
Film Cine Camera .....	9.3%
Character Generator .....	13.2%
Video Studio Console .....	7.4%
Image Enhancer .....	12.1%
Film Chain Equipment .....	16.2%
Special Effects Generator .....	11.6%
Lenses .....	5.8%
TV Lighting Controls and Systems .....	10.0%
Microphone .....	20.0%
STL Equipment .....	9.5%
Remote Control System .....	12.3%
Switcher .....	17.6%
Video Tape Editor .....	9.5%
Transmitter .....	11.6%
Audio Console .....	15.1%

Obviously, the Chief Engineer keeps coming up as the single most influential person in deciding what kind of equipment is purchased. So as you'd expect, station personnel with technical training will become even more involved in the specification and decision making process for equipment purchases. At least this is what our latest survey tells us. (35 percent say influence will grow, 58 percent say it will remain the same, and 7 percent say it will decrease.)

With these figures and trends in hand, convention exhibits are bound to become even more crowded than they have been in the past. Convention sessions for both management and engineering will need to reflect the trends in needs. And the manufacturers will find an ever growing need to fill the early cracks of what could—without concentrated attention—become a deadly information gap.

(Continued on page 88)

**An Oscilloscope Vector Display  
Will Be Given Away At Booth 700  
By Beston Electronics  
Shoreham Hotel**

# If You Want To Hear Something Great, Read This.

Stop by our booth at the NAB Convention in Washington, March 25-28, and listen to our pitch.

You'll hear it loud and clear on our new Scully 280B magnetic recorder/reproducer. (The 280B has, to our knowledge, the best signal-to-noise ratio in its price range.)

The 280B also has a new feature that lets you switch directly from "record" to "play" without stopping at "stop." And it has one, two and four channel capability.

We'll also demonstrate our new Metrotech 400 Series Logger and 4400 Time Code Generator. A new track format on the 400 lets you log twice as much programming on a standard reel of tape.

Which, simple mathematics tells you, can cut your tape costs by half.

So drop by Booth 614 in the Ambassador Room of the Shoreham Hotel.

While you're in Washington, we can go through channels together.

▶ **Scully/Metrotech**

*Division of Dictaphone Corporation*

# STOP GROUND-LOOP HUM!

VIDEO  
HUM STOP COIL  
HSC-1

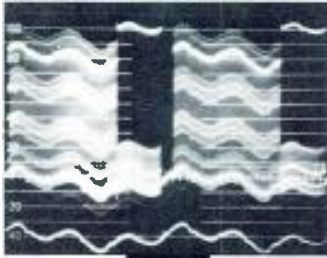

NEW!



NEW!

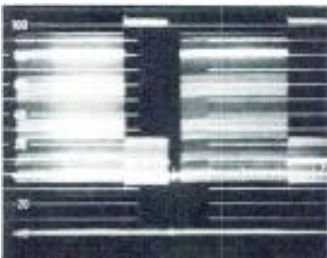

- Will ELIMINATE HLM and other INTERFERENCE in Video Lines caused by differences in Ground Potential!!

- For Color and Black & White
- FLAT — DC to 6.5 MHz.
- No Low-Freq. or Hi-Freq. Roll-off.
- No Differential Phase Distortion.
- No Differential Gain Distortion.
- No Envelope Delay
- Reversible.
- Passive Device — Failure Free.
- Small Compact Package 4" x 4" x 2 1/4".
- Low Price.

**\$110.—F.O.B. NY**

**ELIMINATES HUM & INTERFERENCE:**

- IN FIELD: Betw. Remote Truck & Telco.  
Betw. Remote Truck & Microwave  
For Intertruck Hookup  
For VTR Units  
For Monitoring Lines
- IN STUDIO: Between Buildings  
On long runs in Buildings  
Between Studios & Transmitter  
On incoming TELCO circuits  
On Outgoing TELCO circuits

**AUDIO-VIDEO ENGINEERING COMPANY**  
65 Nancy Blvd., Merrick, N.Y. 11566  
Tel. (516) 546-4239

- Please send Add'tl. Inform. on HSC-1
- Please send me . . . . HSC-1 coll(s).
- Enclosed is remittance of . . . . .
- Please Invoice on 10 day Free Trial

Name . . . . .  
Station or Co. . . . . Title . . . . .  
Address . . . . .  
City . . . . . State . . . . . Zip . . . . .

For More Details Circle (69) on Reply Card

## Special Product Section

(Continued from page 86)

### Color TV Cameras

Reflecting the recent major expansion of its television broadcast equipment line, the Gates Division of Harris-Intertype Corporation will demonstrate live and film color TV cameras at the 1973 NAB Convention.

In its exhibit, Gates will show the 40-pound TE-201 live color camera, the "top-of-the-line" PE-400 live color camera, and the four-vidicon PE-245 color film camera, all in operation.

The TE-201 is an economical live color camera that offers complete broadcast quality, unusual long-term stability, and superior low-light-level lag performance in a compact, lightweight package. For portability in remote pickups and easier maintenance, the plug-in viewfinder unlocks and detaches in a few seconds. Operating controls are located at the camera control unit.

The PE-400 live color camera offers excellent color fidelity, easy setup and color matching, an auto-

matic circuit which preserves detail in high contrast ratio areas in remote and studio work, and excellent pickup tube life.

The PE-245 color film camera incorporates state-of-the-art optics and solid-state circuitry for excellent video performance, reliability, and reduced maintenance.

### Directional RF Wattmeter

Bird's new model 4372 THRU-LINE® Directional High Power Wattmeter covers 25 to 500 MHz from 1 Watt full scale to 500 Watts full scale without changing plug-in elements. This universal flexibility is accomplished by eight easily switched ranges: Four forward power levels (10-500 Watts) and four reflected power values (1-50 Watts).

The lower reflected power ranges are also available for forward readings by reversing RF connections.

In operation, a precision machined 50-Ohm reference line-section is inserted between the signal



For More Details Circle (156) on Reply Card

BROADCAST ENGINEERING

**We'll have  
news  
for you  
at  
NAB\***

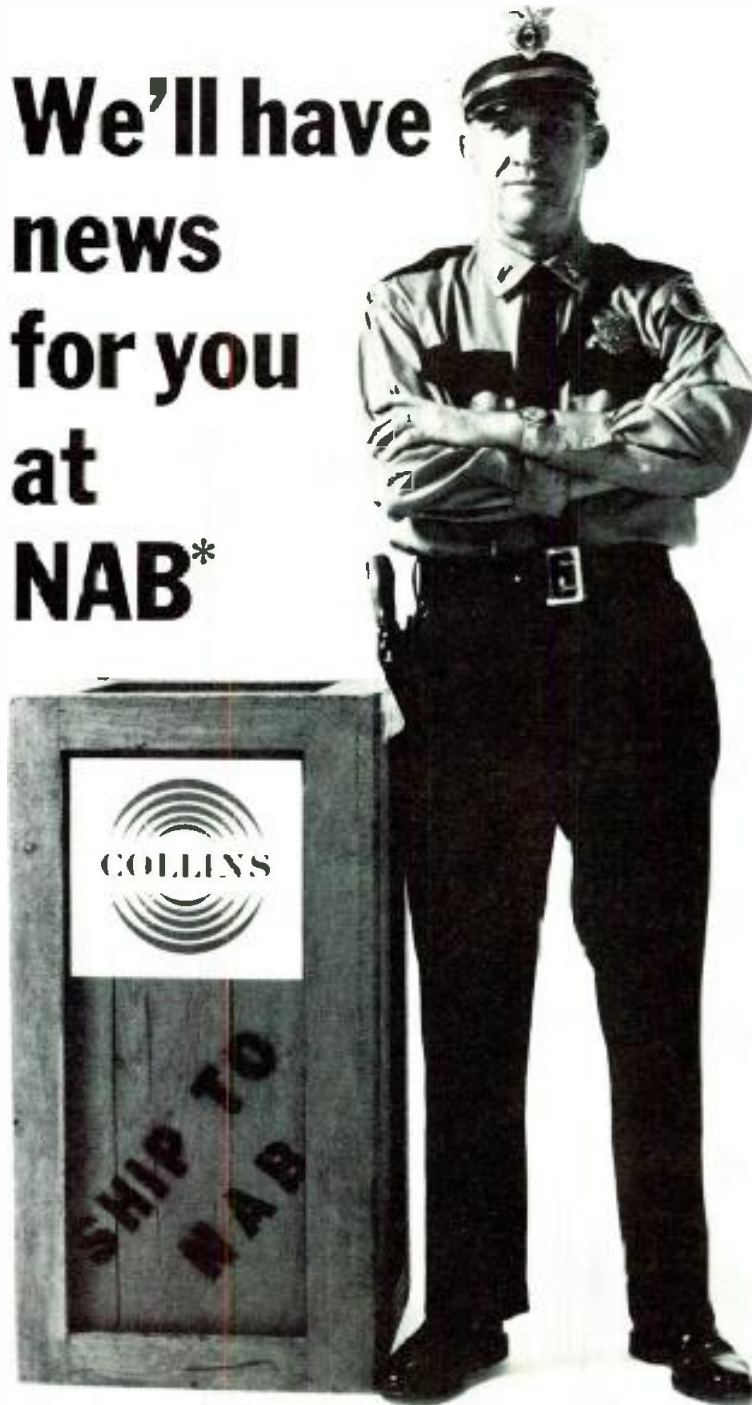

\*See us at Booth 208

(Continued from page 88)

source and the antenna, load or other component under power test. Directional power sensors incorporated in this line-section produce DC signals proportional to both incident and reflected RF main-line power, for readout on scales calibrated in Watts as well as dB.

All variable measurement parameters—frequency range, forward/reflected power and full scale values—are switched right on the front panel. The read-out unit and the line-section may be separated by as much as 3 feet for operational convenience.

For More Details Circle (157) on Reply Card

### Rack/Cabinet Systems

AMCO is an old line manufacturer of cabinets, consoles, and racks that have been used in everything from NASA to broadcast fa-

Being introduced at the March, NAB Show, Booth #558, Shoreham Hotel is a complete, all new system of racks, consoles and small instrument cabinets designed and styled for the broadcast and TV industry. The entire system is covered in a well detailed, 4 color Catalog 400, entitled Econo-Rack Systems.

Within this system are offered virtually unlimited combinations of control, instrument and monitoring console arrangements presented in a unique, simplified ordering system.

An all new system (perimeter styling) is offered to satisfy individual requirements of appearance, cooling and light protection.

To satisfy small enclosure instrumentation, a new Poly-Dimensional small instrument cabinet series is offered in not only normally accepted standard sizes, but due to the versatility of design meets any size and angular configuration, or combinations of vertical or horizontal panel mounting may be achieved in the Poly-Dimensional cabinet series. Size variations, from 6" to 12' in height, width or depth, as well as no restriction on horizontal, angular configurations are a featured advantage of the Poly-Dimensional cabinet. The simplicity of ordering complete console arrangements, either

sloped or vertical, equipped with varying selections of turrets, is simplified to the extent a simple, 4 digit number will provide all that is needed to order a complete console.

For More Details Circle (158) on Reply Card

### TV Cam Head

Listec Television Equip. Corp. will introduce the Vinten Mark V Cam Head. It is a lightweight design, developed specially for modern, compact broadcast cameras.

Its main advantages are a 60 degree tilting angle and extremely light weight in relation to its load carrying capacity. The Mark V weighs an easy-to-carry 24 lbs. yet accommodates an all up weight of 175 lbs.—Perfect for remotes. As with the widely used Vinten Mark III Cam Head, the Mark V employs the well-proven Vinten cam and roller bearing system. In both pan and tilt modes operation is smooth throughout the whole range of movement. Friction controls, which are quite separate from braking, are adjustable to a fine degree.

MICRO-TRAK MICRO-TRAK MICRO-TRAK MICRO-TRAK

**THE PACKAGE**

740 303

6401

**TRY IT**

**MICRO-TRAK**  
FORMERLY GRAY RESEARCH

HOLYOKE, MASSACHUSETTS 01040

MICRO-TRAK MICRO-TRAK MICRO-TRAK MICRO-TRAK

For More Details Circle (72) on Reply Card

**BROADCAST ENGINEERING**



# YOU FIND COMARK DEMOD-FILTERS IN THE NICEST PLACES

The CI-2910 Demod with its FLAT response for ANY TV channel and proprietary Nyquist Filter at VIDEO reduces the effects of quadrature distortion to a new all-time low for demods. Users have already found it extremely versatile and indispensable as a fast, accurate check on the performance of the more expensive, unpredictable and hard-to-calibrate precision demods now in use.

The CI-2910 always SPEAKS THE TRUTH!

- ALL SOLID STATE
- BROADBAND AND FLAT
- NO WORRISOME TUNING OR ADJUSTMENTS
- NO POWER SUPPLY

P&A: \$268.00 List from stock



**comark**

INDUSTRIES INC.  
P.O. Box 196  
Main Line Industrial Park  
Westfield, Mass. 01085  
(413) 568-1870

For More Details Circle (71) on Reply Card

# WILKINSON HAS EVERYTHING

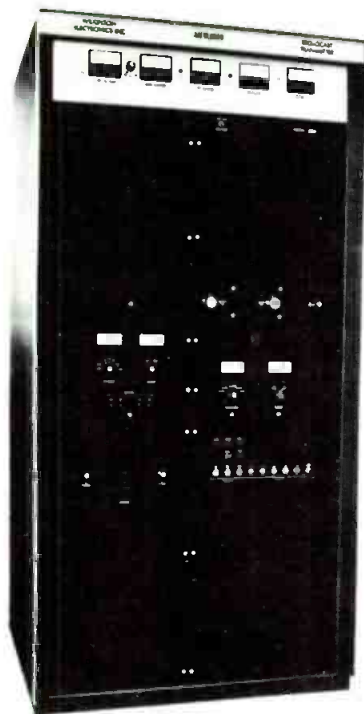

AM TRANSMITTERS - 250 W  
1 KW - 5 KW - 10 KW - 50 KW



LIMITERS - Mono and Stereo



AGC AMPLIFIERS - Mono and Stereo



REMOTE AMPLIFIERS

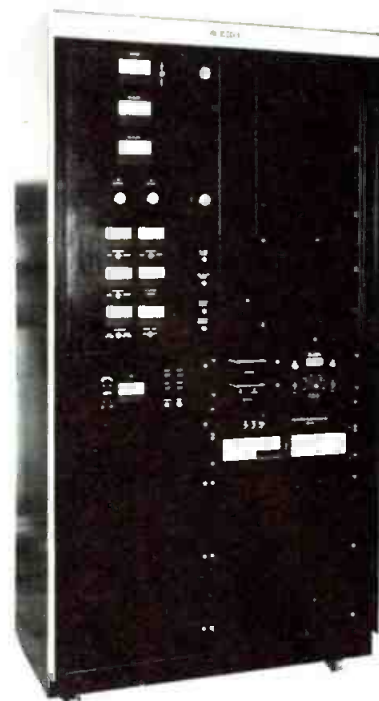

FM TRANSMITTERS 10W - 50W  
250W - 1 KW - 2.5 KW - 5 KW  
7.5 KW - 10 KW - 20 KW - 40 KW



MONAURAL CONSOLES



STEREO CONSOLES



FM EXCITERS



STEREO GENERATORS

AND ALSO FROM WILKINSON . . . . AM RF Amplifiers, line surge protectors, AM Monitors, field intensity meters, line amplifiers, monitor amplifiers, distribution amplifiers, FM receivers, antenna tuning units, phasers, dummy loads and silicon rectifiers.

**WILKINSON**  
**ELECTRONICS, INC.**

1937 W. MacDADE BLVD., WOODLYN, PA. 19094

TELEPHONE (215) 874-5236/874-5237



# New York—Part 2

the Glenn Miller orchestra—it's mostly instrumental music.

Syrup is most closely related to MOR and classical music, with some elements of Spanish-language music creeping in. The prime consideration seems to be sweet, unobtrusiveness and aging romanticism, from the Fred Astaire-Ginger Rogers 1930's Hollywood musical era and Broadway show tunes. Most listeners are over 45 and live in upper-middle suburbs. The six syrup-music stations share one outstanding characteristic: The announcers don't comment or ad-lib much, usually only intro'ing and outro'ing album cuts in ten-minute blocks. (WPAT doesn't even identify its music.) All the stations sound automated, although some may be live now and then. Most plug their commercials into airlines, expensive restaurants and resorts.

WPAT and WPAT-FM—"The Preferred Music Stations"—operate 24 hours, and fm is stereo. Its formula is to work each half-hour around a single motif. A show built around a two-note motif may range from "Michelle" to selections from Brubeck, Edgar Varese and Peter Nero. Sometimes such experimentation yields musical combinations that create anything but "background music." A-m and fm sometimes simulcast, but usually carry separate but similar music.

WRFM (FM) operates 24 hours in stereo, with featurettes like "Voice of Unity."

WTFM (FM)—"Stereo New York"—is another 24-hour operation, whose gimmick is continental culture, using French-accented DJ Charles Duval and lots of sticky strings. As mentioned earlier, WTFM deviates from its format from 2 to 6 a.m. for Rhett Evers' jazz show.

Despite WVNJ AM-FM's slogan—"The Grown-Up Sound of Today"—they play yesterday's music. The stations do not simulcast, doing separate-but-equal a-m/fm splitting. Both are on the air from about 6 to 1 a.m., the fm being stereo.

## Classical Music

Seven stations in the metro area use serious-music formats; each is different.

When the FCC nonduplication rule went into effect, NBC began a taped classical-music service for the fm stations it owns in six cities. Thus, WNBC-FM (stereo) is (and sounds) automated. Announcing is stiff, although music is fairly well balanced. WNBC-FM is on the air from 6 a.m. to midnight, but duplicates its a-m sister eight of those hours. Although theoretically a commercial operation, NBC's fm outlet carries mostly public-service announcements and a-m promos.

WNCN (FM)—"Your Radio Concert Hall"—is the only New York City station that carries classical just about 24 hours a day, with only brief respites for things like "Doctor's News Report." Music is well balanced, all stereo, and announcers are live and conversational. The most popular WNCN personality is all-night-man Bill Watson, a wry commentator whose music is largely Baroque and late Renaissance. The station carries syndicated broadcasts of the Cleveland and Chicago symphony orchestras. The light commercial load is aimed at upper-middles.

The City of New York is one of the few municipalities in the United States to own noncommercial broadcast stations. WNYC AM-FM theoretically serve the citizens of the nation's largest city; it is doubtful, however, that the majority of New Yorkers mostly listen to classical music, as is programmed by WNYC. "Your City Stations" do cover other subjects—interviews, consumer questions and reports, penetrating reviews of the foreign press, mayoral and city-agency reports, and traffic and weather information. But most of the time, WNYC and WNYC-FM broadcast classical music; a-m and fm are usually split-programmed. Sometimes a talk program is aired on a-m while fm carries classical music. Now and then, both stations carry separate serious-music concerts, offering a choice between Brahms and Villa-Lobos. Both have serious music and information. WNYC announcers are live, but restrained. WNYC-FM operates 24 hours and is stereo; WNYC operates for a limited time, signing off nights.

WQXR AM and FM—"The Radio Stations of the New York Times"—carry a heavy schedule of symphonic, operatic and chamber music as well as a respectable slice of other programs like "This Week in New York." The stations are usually split-programmed, with a-m light classical and fm more serious. Some favorites, like "Symphony Hall" (8:07-9 p.m.) are simulcast. The stations carry broadcasts of the Boston and Pittsburgh symphonies and the Philadelphia Orchestra; there is also some jazz now and then. A longtime favorite of classical fans along the eastern seaboard, WQXR has many commercials. The programs and commercials are aimed at the monied citizens of Manhattan and the plush suburbs. Announcers are live but usually formal. WQXR broadcasts 18 hours daily, while WQXR-FM (stereo) is on for 20.

WRVR (FM) is a noncommercial station owned by the upper-class, liberal Riverside Church. It's a 24-hour operation which plays classical music as well as jazz, interviews, plays and poetry readings; Bill Minkin's all-night show is largely psy-

# ?

## YES, IT'S TRUE.

Fairchild Sound invades the low-cost standard console field.

Everything you've wanted in inexpensive consoles, including extras available only from the custom technology of... Fairchild/Robins.

The Debut: March 25-28  
Booth 309 • NAB '73

**FAIRCHILD** **ROBINS**

FAIRCHILD SOUND EQUIPMENT CORP.  
A ROBINS INDUSTRIES CORPORATION  
75 AUSTIN BLVD., COMMACK, N.Y. 11725  
CABLE: ROBINSOVERSEAS COMMACKNY  
15161 543-5200

For More Details Circle (74) on Reply Card

## Special Product Section

(Continued from page 90)

Listec will also have on display the new Vinten Tripod/Dolly combination. Outside Broadcast Pneumatic Pedestal and Fulmar extended range pneumatic Pedestal. Also featured will be the revolutionary two-man Low Angle Dolly with counterbalanced jib and floor to cam head mounting face range of 4" to 26".

For More Details Circle (159) on Reply Card

### Circularly Polarized FM Antenna

Jampro Antenna Company, a division of Computer Equipment Corporation, has developed an FM transmitting antenna with outstanding performance capabilities. Designated as Jampro Model JSDP, this new product will be on display at the NAB. A three bay version of this antenna has been delivered to WASH-FM, Washington, D.C., a Metromedia station, and should be installed and in operation by convention time. The measured performance of this an-

tenna is as follows:

Horizontal Plane Circularity. Hpol. 2.16 dB Vpol 2.85 dB: Axial Ratio, 1.89 dB; Maximum VSWR 89 to 108 MHz. 1.10/1; Maximum input power, 70kW.



Power input rating on the three bay, three panel. WASH-FM antenna is 70 kW. By using 1 5/8" interbay feed cables, power input ratings of 240 kW are possible with this antenna.

For More Details Circle (160) on Reply Card

### Cassette Alignment Tape

The Recorder Care Division of Nortronics Company, Inc., manufacturer of magnetic heads and professional recording accessories—has introduced their new AT-200 Professional Cassette Alignment Tape.

One of Nortronics' QM-Series™ family of products, the new Cassette Alignment Tape is designed to verify and maintain cassette recording equipment. Each tape is recorded from an original signal source to maintain laboratory standard accuracy of frequencies and levels. To ensure professional quality, a graph of characteristics is made for each serialized tape, and this original graph is included with each tape.

The AT-200 alignment tape is divided into five sections to enable

# R<sub>x</sub> We Cure Your Head-aches



Head for higher profits by letting Taber supply your tape head needs with the kind of precision work you can't find elsewhere.

Three new heads installed in your full track Ampex assembly for only \$97.50, Scully \$186.00. Or, wear permitting, Ampex or Scully 3-head assembly reconditioned for only \$45.00.



VTR priced at only \$310.00 for 4 new heads installed, or \$100.00 for 4 reconditioned heads. (Add \$25.00 if monitor post needs lapping.)

Whether VTR or Audio—no other head manufacturer offers this quality at these prices!

Send for free brochure today

**TABER**  
MANUFACTURING & ENGINEERING CO.

2081 Edison Ave. • San Leandro, Ca 94577  
Phone: (415) 635-3831



For More Details Circle (75) on Reply Card

SEE US  
AT NAB  
BOOTH 317

# DYNAIR's price catalog describes these new products and over 150 others.

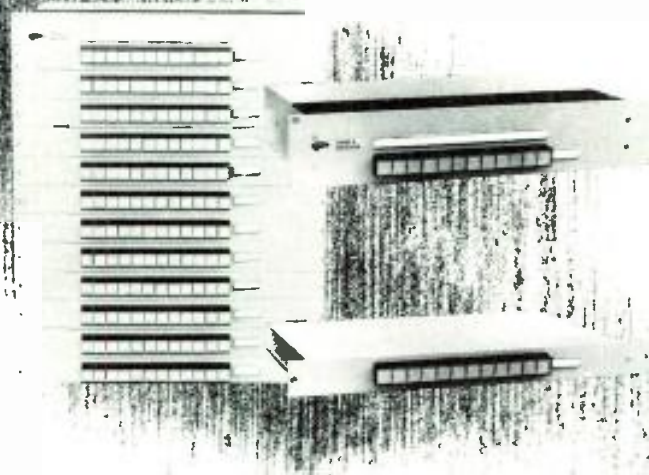

## NEW "PATCH CABLE ELIMINATOR"

DYNAIR's new Series-X Video-Audio Switchers eliminate the custom fabrication usually required for routing switchers. These units are totally modular, allowing off-the-shelf assembly of almost any input-output configuration, either video-only, or audio-follow-video. And, expansion is easy too . . . you simply add input or output expansion modules as required.

The basic unit is video only, with options including audio, sync-mixing and tally provisions. Illuminating pushbuttons are standard, with provisions for easily labeling the individual inputs and outputs. The new Series-X provides exceptional performance at prices which are, in many cases, much less than our earlier version of the Series-X.

## NEW SPECIAL EFFECTS GENERATORS

DYNAIR's new SE-70A and SE-70A-R Special Effects Generators allow basic effects to be easily and inexpensively added to any television system. These broadcast quality units operate equally well on color or monochrome signals, with either broadcast or industrial sync. A quality locking-type gear-driven effects mechanism is used, allowing effects to be easily implemented.

The units provide horizontal and vertical wipes, inserts from any corner with diagonal expansion, and internal and external keying and matting. The SE-70A is self-contained for console mounting and the SE-70A-R is an electrically identical remote-controlled unit, the control panel of which may be easily mounted in custom panels.

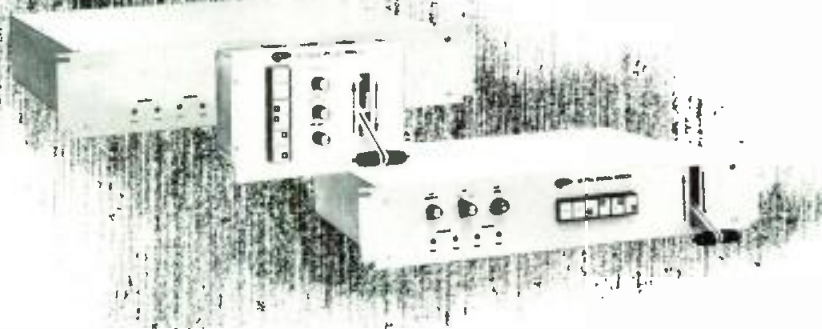

## NEW DYNAIR "PRICE CATALOG"

DYNAIR's new price catalog has been designed to provide you with a quick look at the large variety of equipment we manufacture and our current price on each item. We think that you will appreciate the convenience of this new catalog/price list combination . . . it's a very handy reference guide to DYNAIR's world of television.

Request your copy today . . . we think you'll like what you see.



## DYNAIR ELECTRONICS, INC.

6360 FEDERAL BOULEVARD  
SAN DIEGO, CALIF. 92114 U.S.A.  
TELEPHONE: 714-582-9211

DYNAIR

UP TO

# 65% SAVINGS

Plus performance that is creating excitement in Engineers around the country! "Fantastic sound"... "Very Clean"... "Superb!... Send two more..."

Proof? Our standard 10 day evaluation period lets you see and hear the performance and the full service. 2 year warranty demonstrates the reliability.

Place your order today. Then prepare yourself for a very satisfying experience!



TURNTABLE PREAMPLIFIERS

MP-8 (Mono) \$60  
SP-6 (Stereo) \$90

Outstanding sensitivity and near perfect reproduction. RIAA/NAB equalized -0.5 mv sensitivity @ 1 KHz for +4 dbm out - Balanced 600 ohm out - minus 65 db S/N ratio - +20 dbm out max - =1 db freq. response - Internal power supply - Table top/bracket mount. Shipping weight, 3 1/2 lbs.



MIC/LINE AMPS

MLA-1 (Mono) \$68  
MLA-2 (Dual) \$96

Dual function utility amp. Inputs for mic and/or line - 600 ohm balanced outputs - mic input, -65 db for -4 dbm out - +20 dbm out max. - =0.5 db response, 10 Hz-20 KHz - 0.1% or less dist. - Internal power supply - Tabletop/bracket mount. MLA-2, Stereo/Dual Mono. MLA-1, Mono. Shipping weight, 4 lbs.



DISTRIBUTION AMP  
6 BALANCED OUT

DA-6 \$95

One third the cost of comparable units. Six 600 ohm balanced outputs - Balanced bridging input - 26 db gain - +20 dbm out max. - Input level control - 0.1% or less dist. - =0.5 db response, 10 Hz-20 KHz - Internal power supply - Tabletop/bracket mount - Shipping weight, 4 lbs.



TAPE CARTRIDGE  
LOADER (AUTOMATIC)

ACL-25 \$159

Precision winding without guesswork. Dial in the minute and/or seconds desired, throw switch to run. That's it! The exact amount of tape is fed onto the cartridge hub to the second, and shuts off automatically. No waiting around, no guesswork and 1 sec. accuracy. Also has exclusive torsion control for proper tape pack and winding of various cart hub sizes. TTL digital control circuitry. Shipping weight, 30 lbs.



RAMKO RESEARCH

2552 "E" Albatross/P.O. Box 5031  
Sacramento, Calif. 95860 (916) 489-6695

verification and testing of azimuth, reference level, frequency response, and flutter. Each section is preceded by a voice announcement describing the test that follows.

Nortronics' alignment tape is packed in high-quality cassettes and recorded on professional quality .150" magnetic tape.

For More Details Circle (161) on Reply Card

## Control Circuit Relay Module

Multronics, Inc., who has for over a decade designed "failsafe" Control Circuits as a part of its Phasing and Branching Systems for Directional Antennas, is now making available packaged Control Circuit Relay Modules, which the Station Engineer can install to control RF Contactors in existing systems.

Designated the FSR Switching System it allows modification of existing Phasing Systems to meet recent FCC regulations for Directional Stations desiring to employ third class operators. Among its features are: 1. Time delay (adjustable 0.1 to 1.0 seconds) to prevent arcing of RF Contacts. 2. Indicator lamps to show position of all RF Contactors, as an option. 3. Fully interlocked circuitry to turn off plate power if contactors fail to switch, as required by the FCC. 4. Fully compatible with remote control systems. 5. Available either as chassis to be installed within existing phasor cabinets, or in self contained control panels for standard 19" relay racks. Price on application. Write Multronics for detail.

For More Details Circle (162) on Reply Card

## Frequency Deviation Counter

An exceptionally fast, accurate and easy to operate frequency deviation counter that's particularly useful for low frequencies has been introduced by the Electronics Division of Bulova/American Time Products.

Designated Model B-9957, the instrument measures frequency deviation in  $\pm$  PPM with 1 PPM (.0001 percent) resolution in a 1 second computation time. It also measures frequency in Hz and time interval of 1 to 999,999 periods in  $\mu$  Sec., for frequencies as low as 1 Hz.

For frequency deviation, place the function switch in the "Freq. Dev." mode, and set the thumb-wheel switch to the nominal frequency of the input, readout automatically displays deviation of the input frequency from the nominal in  $\pm$  PPM, and displays sign as well as deviation.

For More Details Circle (163) on Reply Card



"CHECK THE BATTERIES."

## "8" CHANNEL AUDIO CONTROL

# console

SEE US AT  
NAB /73  
Booth 213

### B-800 series

the B-801 monaural

\$2350

the B-802 stereo

\$3200

B-803 dual channel

\$2650

for complete information  
please contact:  
the Director of Sales  
Dept. B-80



McMartin

MCMARTIN INDUSTRIES INC., 605 NORTH THIRTEENTH STREET  
OMAHA, NEBRASKA, 68102 TELEPHONE (402) 342-2753

For More Details Circle (77) on Reply Card

For More Details Circle (78) on Reply Card

BROADCAST ENGINEERING

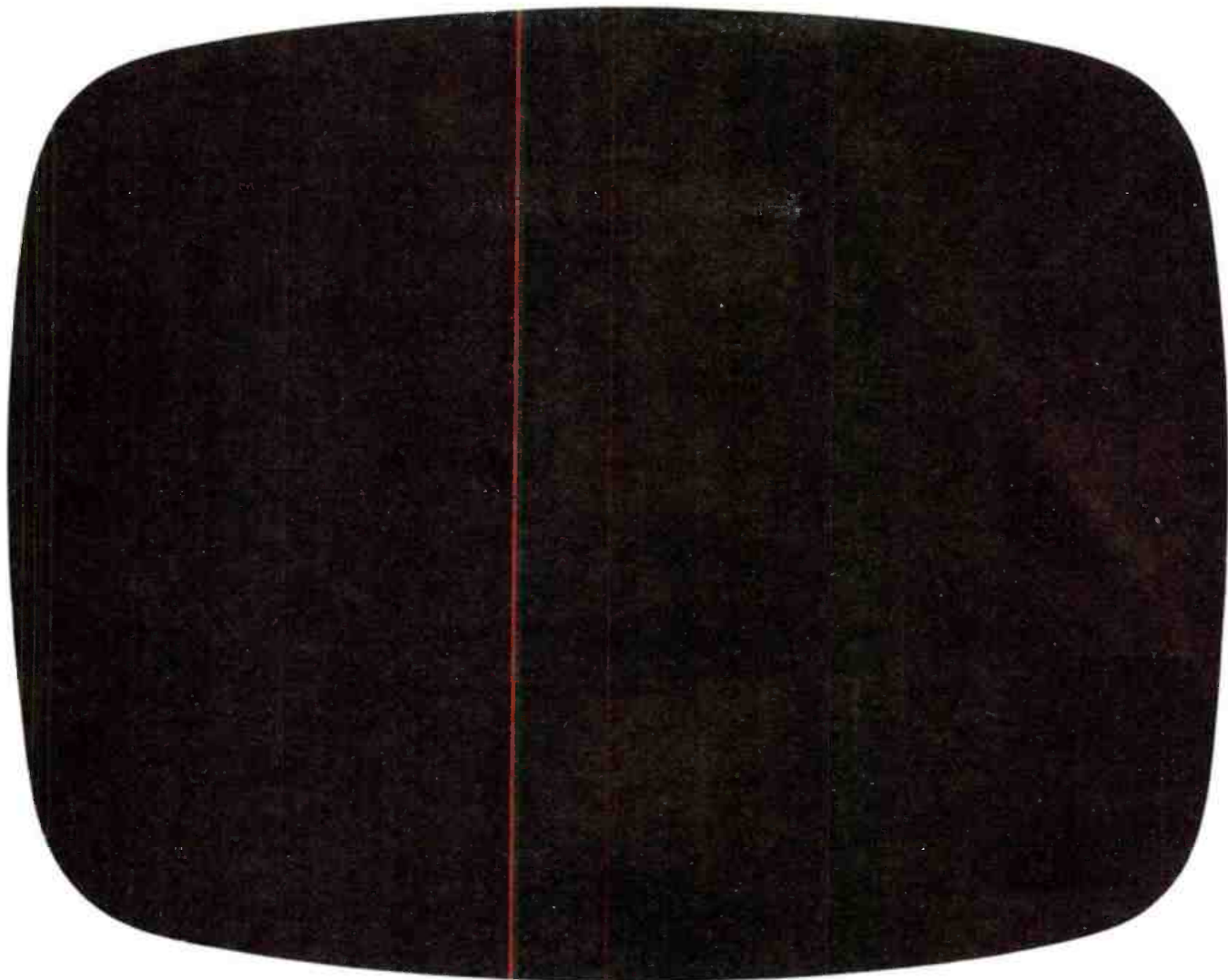

# This is a picture of your picture.

(during a power failure)

Yours may be the finest broadcast facility around. But you aren't transmitting much of a signal when the power is off.

Admittedly, chances of a prolonged power failure aren't great. Yet they do happen.

That's where Onan standby power comes in.

It provides "insurance" against a crippling power outage.

It doesn't have to replace utility power totally. But it can keep you on the air.

It can keep heating and ventilating equipment working. Elevators running. Lighting in critical areas burning.

So when you're ready to talk seriously about standby power for your TV or radio station, remember this:

Onan is the world's number one builder of standby power plants.

Only Onan gives you total system responsibility for the engine, generator and load transfer controls. We build 'em, test 'em, install 'em and

certify that they will perform as rated. Only Onan warranties the complete system for 5 years.

Call your local Onan Distributor (in the Yellow Pages under Generators) or send coupon.

#### FREE STANDBY POWER BOOKLET

Onan  
1400 73rd Avenue N.E.  
Minneapolis, Minnesota 55432

Please send a copy of "Standby Power . . . who needs it?" to:

Name \_\_\_\_\_

Firm \_\_\_\_\_

Address \_\_\_\_\_

City \_\_\_\_\_ State \_\_\_\_\_ Zip \_\_\_\_\_



**ELECTRIC GENERATOR SETS •  
LOAD TRANSFER CONTROLS • INDUSTRIAL ENGINES**

For More Details Circle (14) on Reply Card

### Audio-Video Tape Eraser

"Taberaser" is the name given to the new tape eraser introduced by Taber Manufacturing & Engineering Co. to the television and recording industries.

The new "Taberaser" is precision made to erase audio, video, instrumentation tape, and magnetic films from 150 mil to 2" widths. The new eraser is designed so that tapes on reels or in cartridges can be degaussed without the necessity of unpackaging.

According to Taber, an added feature of this tape eraser is that the field is automatically diminished slowly at the end of each 30-second cycle, thereby eliminating the well-known "Thump." Between 30Hz and 15kHz the depth of erasure is 76dB below saturation.



The unit will not overheat and is kept below 71°C by the "Taberaser's" Automatic Heat Limiting circuit, which activates an internal blower until the unit returns to the correct operating temperature.

The 45-lb. eraser measures 6¼" high by 14½" wide and 16" deep. Power requirements are 95-135 VAC, 58-62 Hz, 1 phase, 3 wire and uses less than 8 amps under any condition.

For More Details Circle (164) on Reply Card

clamp circuitry assures exceptional reduction of hum, tilt, and noise.

The CLD-1300 can also be used simultaneously as a standby sync generator by adding an accessory board.

For More Details Circle (165) on Reply Card

### Automatic Dimmer Control System

Skirpan will introduce their programmable-automatic lighting system.



This system will allow a great number of lighting information entries from a CRT into the computer section for later recall. This new system deserves up close inspection, because it marks a real step forward in lighting control.

For More Details Circle (166) on Reply Card

### Video Processing Amplifier

CBS Laboratories introduces the CLD-1300, a new Video Processing Amplifier.

A truly universal amplifier for "restructuring" composite color or monochrome signals. Independent control of video, chroma, reference burst, sync, and blanking enable optimum restoration of video signals to original, or improved quality.

For helical or quad tape use, signal rehabilitation and restructuring can be effected for extraordinary improvements. The CLD-1300 will even fill in the "drop-out" inherent in some helical scan VTR's, thus assuring a continuous sync train.

Front panel control permits an operator to precisely optimize "lock gain" for maximum stability in virtually any playback condition.

Differential input and effective



WITH  
**TELAN** thermoelectric generators

GENERATOR OR BATTERY SYSTEM? There's really no need to choose between the two. TELAN thermoelectric generators can work *with* your battery system—charging for those peak loads. Power from 10 to several hundred watts. 12-24-48 VDC standard. Operates on natural gas or propane.

**TELEDYNE ISOTOPES**

110 W. Timonium Rd., Timonium, Md. 21093 Phone. 301-252-8220 Telex 87-780

For More Details Circle (81) on Reply Card

# only from Cētec



## THE LANGEVIN BROADCAST CONTROL CENTER

VIDEO/AM OR STEREO/FM CONFIGURATIONS

### FEATURES:

- 10 Stereo inputs, each controlled by a straightline attenuator which controls left and right input signals. 10 Stereo inputs offer 20 individual inputs.
- Input switching for selection of stereo group "A" or "B" at each of eight stereo input channels. Two input channels capable of switching to any of four stereo remote inputs.
- Bus select which allows stereo input switching to "Audition" or "Program."
- Channel select which allows each input to be programmed to main stereo bus as stereo or mono input to either left, right or center position.
- "Monitor," "Audition" and "Program" master individual controls for each function and for the left and right channel.
- Two 10-watt power monitor amplifiers which feed studio loudspeakers directly.
- Quadraphonic or two-bus video options available.

SEE THIS UNIQUE CONSOLE AT BOOTH 500, THE SHOREHAM HOTEL, AT THE NAB SHOW.

# Cētec

13035 Saticoy, North Hollywood, California 91605  
Phone: (213) 875-1900 - TWX 910-499-2669  
INC. A subsidiary of Computer Equipment Corp.

EUROPEAN OFFICE: Cētec U.K.  
Shaftesbury Street, High Wycombe  
Bucks, England · Phone: High Wycombe 37326  
Telex: 778200

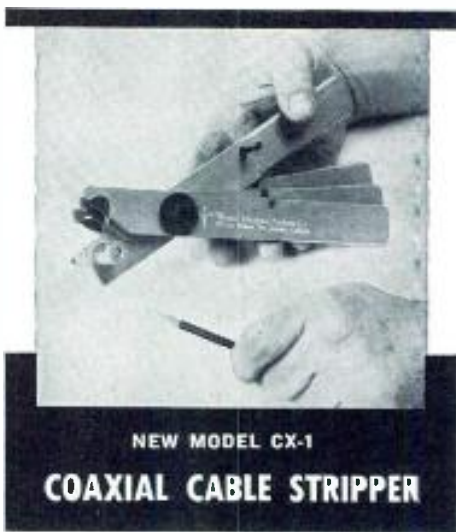

NEW MODEL CX-1

## COAXIAL CABLE STRIPPER

Developed and used by NASA ■ Prepares cable for connectors in 10 seconds ■ Adjusts for stripping requirements of all standard co-ax connectors ■ Close-tolerance adjustment prevents nicked conductors ■ With removable inserts, accepts cable from .075" to .435" OD.

**PRICE \$44.50 F.O.B. San Clemente**  
Specify cable O.D. when ordering

**Western Electronic Products Co.**  
107 Los Molinos, San Clemente, Calif. 92672

For More Details Circle (141) on Reply Card

## Eight Channel Console

The LPB S-15 8-channel Console provides full mono capability for up to 19 input lines. Features include step attenuators, leaf-type telephone switches, 12-Watt monitor amplifier and muting relays. All active components are on plug-in modules while external wiring connections are made via barrier-strip screw terminals.

Because both the program and audition channel outputs provide identical performance specifications, the console can be used as a



monaural dual-output console. This feature allows the program channel to be used for on-air programming while the audition channel is simultaneously used for production and recording.

For More Details Circle (167) on Reply Card

## Digital Antenna Monitor

Delta Electronics has introduced a true Digital Antenna Monitor (DAM-1) with a direct reading, digital display of the relative phase and current ratio (or relative amplitude) for up to 6 towers in any configuration.

Operating in the frequency range from 500 KHz to 2 MHz, the rack

mounted unit provides relative phase measurement accuracy of one degree and current ratio accuracy to  $\pm 2$  percent. Antenna selection and day/night pattern selection is accomplished with front panel pushbuttons.

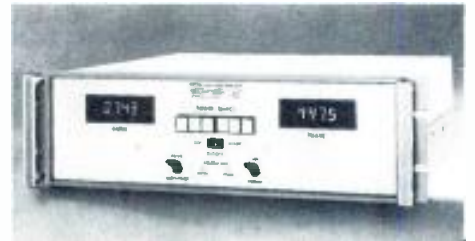

Installation is greatly simplified by factory programming the all digital circuitry to the station frequency; thereby eliminating initial calibration procedures. Standard TTL interfacing is provided for both remote control and display application.

Available options include frequency range from 10 KHz to 5 MHz; monitoring capabilities for up to 12 antennas; and remote control and display panels.

For More Details Circle (168) on Reply Card

## Stereo Headphones

Stanton Magnetics will display their Dynaphase stereophonic headphones at the NAB convention.

The Dynaphase Forty utilizes an advanced speaker system designed for the head instead of the shelves. Its unique wide-range dynamic reproduction system is acoustically mounted to channel the highs and lows into each ear.

The Dynaphase Forty has fully

# A broadcast **LOGGER** that runs and runs and runs and runs and runs and runs and runs and runs and runs and runs.



This Tape-Athon 900 Logger not only runs for 409 hours with a single reel of tape, but it also runs for years with very little care and feeding. We recently heard from a 900 owner requesting a service manual. He had a problem with his unit—after 7 years of studio use. That's the kind of service you need in a broadcast logger—long playing time and long longevity. See your Tape-Athon representative, or call us collect for complete specs.

## Tape-Athon Corp.

502 S. Isis Ave., Inglewood, Calif. 90301  
(213) 776-6933

(very slowly)

For More Details Circle (83) on Reply Card



# PRODUCTION LIMITATIONS ?

CHECK the many advantages of ADC's

*Custom  
Configured*

## 570 Series Production Systems

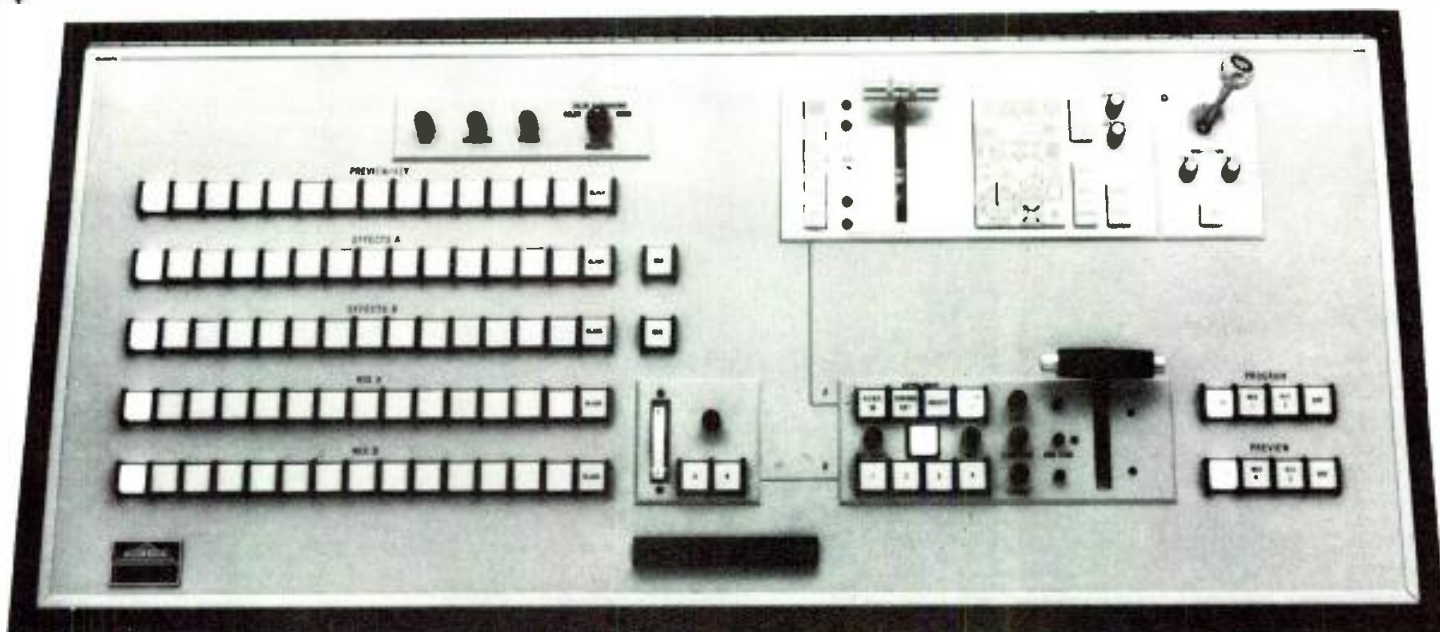

MODEL 570.3 is a deluxe production switching system employing the latest video assembly techniques. A full special effects system together with two mix-key units provides all the advantages of double re-entry systems plus such features as key-on-key, super-over-effect, triple inserts, down-stream keyer, the ability to dissolve chroma key backgrounds, fade to non-synchronous sources, and titling over network. This five buss switcher has the flexibility of much larger switchers costing half again the price.

- ✓ VERTICAL INTERVAL SWITCHER
- ✓ DUAL MIX SYSTEM
- ✓ INTERLOCKED TALLY
- ✓ NON SYNC CROSS FADES
- ✓ SPECIAL EFFECTS
- ✓ CHROMA KEY
- ✓ UP TO 3 KEY SYSTEMS
- ✓ PROGRAM AND PREVIEW OUTPUT SWITCHING

SEE US AT NAB - BOOTH 610 - SHOREHAM AMBASSADOR ROOM

— CALL OR WRITE TODAY —



## AMERICAN DATA CORPORATION

*Video and Communications*

4306 GOVERNORS DR., S.W.

P. O. BOX 5191

HUNTSVILLE, ALABAMA 35805

TELE. (205) 837-5180

# REQUIRE ACCURACY? ....THEN BUY BELAR

## MONITORS



The least you can afford is the best possible monitoring of your program material. The Belar TV Monitoring System (VHF or UHF) guarantees your getting what you need . . . accurately.

The Belar TVM-1 Modulation Monitor is the most accurate monitor available. Our advanced design starts where others leave off. TVM-1 Monitors both positive and negative modulation simultaneously and registers the higher of the two. Yes, it even tells you whether the modulation is positive or negative and calibration accuracy can be checked from the front panel modulation calibrator at any time.

The TVM-2 and TVM-3 Digital Frequency Monitors will measure TV visual carrier

and aural carrier independently or aural intercarrier. These monitors provide continuous monitoring with inhibited off-frequency alarm drivers, switch settable to either  $\pm 500$  or 1000 Hertz. It requires three successive errors to produce an alarm. This means *no* false alarms for you.

For remote control operations add the RFA-3 for off-air monitoring.

If your TV monitoring requirements include ease of operation, functional checks and ACCURACY, call or write today for more information. We know you'll make the right decision and BUY BELAR.

(Continued from page 92)

adjustable headband and softly cushioned earpieces. Stanton claims its distortion figure is less than one percent at 115 dB SPL. And the phones come in 8 and 600 Ohm versions. Total weight is 21 ounces.

For More Details Circle (169) on Reply Card

### Remote Control System

Using no rotating stepper switches, the new Moseley Associates Model TRC-15A 15-channel system offers a dramatic step forward in remote control equipment. Basic reliability is increased by removal of the customary mechanical stepper switch. Individual relays in the TRC-15A have replaced the stepper switch. All socketed relays are identical, and are retained by a spring clip simplifying replacement. Total consideration has been given the serviceability of the TRC-15A. Full access to all functional circuitry is provided by slide-out drawer mounting. All transistors and integrated circuits are socketed.

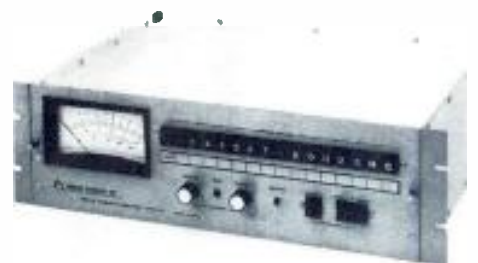

Complete shielding in both studio and transmitter units makes the TRC-15A extremely immune to RF energy. A second shielded compartment is provided in the transmitter unit to further isolate the circuitry from high RF fields. Further, all wiring to this section is passed through feed-thru RF filters.

Two versions of the TRC-15A are available: the TRC-15AW for operation over a single telephone line, and the TRC-15AR for total wireless operation. Field conversion to either configuration is straightforward. Options include a telemetry subcarrier (SCA) generator and telemetry subcarrier (SCA) demodulator.

For More Details Circle (170) on Reply Card



## BELAR ELECTRONICS LABORATORY, INC.

LANCASTER AVENUE AT DORSET, DEVON, PA. 19333  
BOX 826 • (215) 687-5550

Where Accuracy Counts . . . Count On Belar

For More Details Circle (43) on Reply Card

# VIDEO TAPE Problems

Why wait until a video tape problem arises before buying a **RECORTEC**? Start saving by joining the hundreds of satisfied users of our equipment.

## VIDEO TAPE CONDITIONER



- Extends tape and head life by removing loose oxide and debris from tape surfaces.
- Improves quality of video recording due to reduced dropouts.
- Minimizes tape damage by improving the tape pack.
- Options such as erase, splice count, audio playback, etc., are also available.

PRICE \$4450

## VIDEO TAPE EVALUATOR



- Display total number of edge damages.
- Display total number of surface defects.
- Display total tape time.
- Tape fully cleaned, uniformly packed and degaussed.
- Increases VTR utilization.

PRICE \$12,500

UPGRADEABLE

# RECORTEC, INC.

777 Palomar Street • Sunnyvale, California 94086 • (408) 735-8321

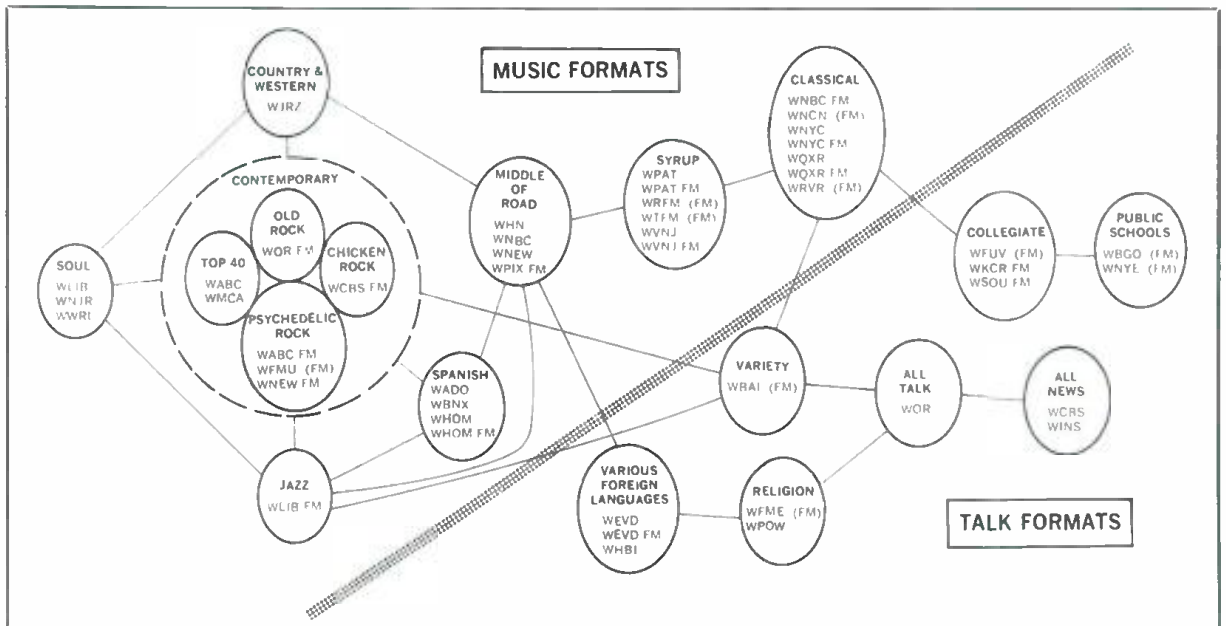

New York's 47 radio stations fall into distinct format groups, with some interrelationships.

chedelic rock. WRVR announcers are live and personable.

As the chart indicates, classical is linked to the mainstream of music through the syrup stations. Other stations do program serious music from time to time; crossing the format line are artists like Andre Kostalanetz and Morton Gould.

### Spanish-Language Music

The sizable population of Spanish-speaking people in and near New York City is served by four stations—WADO, WBNX, WHOM and WHOM-FM. Their broadcasts are almost entirely in Spanish and the music reflects the culture of the audience—Puerto Rican, Cuban, Mexican and some from other Central- and South-American countries. Although Latin-American music properly belongs in its own category, there are links with jazz, psychedelic rock, MOR swinger-music and syrup. In addition to the English-language version that made number one in the top 40 in '68, Herb Alpert did a Spanish-language take of "This Guy's in Love With You." Other English-language top tunes are also taken twice for the Spanish market.

The Spanish stations are just as commercially hip as their English-language brothers; all use live, talky DJ's. WADO—"Radio Wado"—uses reverb, jingles, and runs 24 hours. WBNX—"Radio X"—uses jingles and is on the air all night, although it shares some of its daytime channel with another station. WHOM-FM usually duplicates its sister a-m station; both operate about 19 hours daily. Commercials on Spanish stations are often done live by announcers, but pre-taped spots using ethnic talent are common. Singing commercials are often split-channel taped, using the same music but separate Spanish and English voice tracks. This makes for good product identification on both English and Spanish stations. One

important point: The Spanish DJ's ad-lib in English now and then, and lots of Puerto Rican teenyboppers are learning English by listening to Top-40 jocks. All three stations break format now and then for community-service announcements and other featurettes.

### Various Foreign Languages

Three stations broadcast a talk-and-music format aimed at the many, tiny ethnic groups in the New York metro area which speak languages other than English or Spanish. These groups include Albanian, Arabic, Armenian, Bulgarian, Filipino, German, Greek, Hungarian, Irish, Italian, Japanese, Jewish, Lithuanian, Norwegian, Polish, Portuguese, Rumanian, Russian, Scandinavian, Slovakian, Turkish, and Ukrainian people. Some programs are live, others are taped. Commercials are ethnic. WEVD and WEVD-FM often simulcast, but WEVD shares time on its channel with two other stations. Therefore, WEVD-FM is on the air by itself now and then, and carries some jazz and classical music in stereo. Both stations sign off at 3 a.m. WHBI operates around the clock. WPOW also does some foreign-language broadcasts, but that's not its principal format.

### Religion

Nearly every U.S. station carries a few religious programs—usually on Sunday morning. WFUV broadcasts some Roman Catholic programming; it's owned by a Catholic university. But such stations generally follow other formats, and religious programming is the exception.

WFME (FM) (Newark) and WPOW are the only New York metro-area stations that follow a fairly standard format in various cities around the country, consisting of Bible readings, sermons, lectures, interviews and discussions. Music consists of hymns and other church music, although

NOW WHEN YOU  
THINK SMALL...THINK

## Xcelite Mini driver sets



Smaller than a matchstick, Xcelite's "Mini-Screwdrivers" put product precision in your hands for fine work. Technicians, servicemen, assemblers, model makers, hobbyists welcome these color-coded little screwdriving gems.

Instruments, apparatus, machinery, optics, cameras, watches, clocks...useful wherever screws as tiny as 0000 are involved.

Two handy kits in see-thru plastic cases: M50—five drivers for slotted screws, tips from .040" to .100". M60—same plus 00 Phillips driver and piggyback torque-amplifier handle.

REQUEST GENERAL CATALOG 171

*nationwide availability  
through local  
distributors*



# XCELITE

XCELITE, INC.

118 Bank Street, Orchard Park, N.Y. 14127  
In Canada contact Charles W. Pointon, Ltd.

## beat the heat with this handy little heat sink



This is No. 80, Xcelite's little gem for absorbing and dissipating heat when soldering fine wires or working close to delicate electronic components. Solder won't adhere to copper jaws because they're nickel plated. They're spring loaded to "stay put" and have a smooth surface to avoid marring or scratching.

Insulating cushion grips protect fingers. Made in U.S.A. to highest standards.

Request Free Tool Catalog

*nationwide availability through local distributors*

# XCELITE

XCELITE, INC.

118 Bank Street, Orchard Park, N.Y. 14127  
In Canada contact Charles W. Pointon, Ltd.

For More Details Circle (27) on Reply Card

### Product Section (Continued from page 100)

#### Automatic Image Enhancer

A new Automatic Image Enhancer has been introduced to the Video Industry by Dynasciences Video Products.



The Model 875 is automatic for optimum enhancement of color or monochrome pictures. It features comb filter, single-knob detail gain control, and automatically balanced vertical and horizontal signal.

The Automatic Image Enhancer automatically maintains picture sharpness without double enhancement if a previously enhanced program passes through the unit. A

threshold control permits adjustment of the amount of pre-enhancement required to inhibit local enhancement.

The automatic function can be disabled for use as a standard image enhancer.

Dynasciences Corp., Video Products, manufactures a com-

plete line of Video Products: Editor-Programmer, Sync Generator, Test Equipment, Video Processing Amplifier System, Vertical Aperture Equalizer, Program Switcher, Image Enhancers, Black Burst, Sine<sup>2</sup> Generator, Multi-Burst, Distribution Amplifiers, Convergence Generator—and is constantly developing new products.

For More Details Circle (171) on Reply Card

#### Mini Soft-Lite

Berkey Colortran, Inc., a division of Berkey Photo, Inc., will introduce the new Mini Soft-Lite. Weighing 8¼ lbs., the unit is designed for two 500, 750, or 1000-Watt long life lamps. Each lamp is individually switched for maximum versatility and intensity control. Area coverage is the same with one or two lamps on.

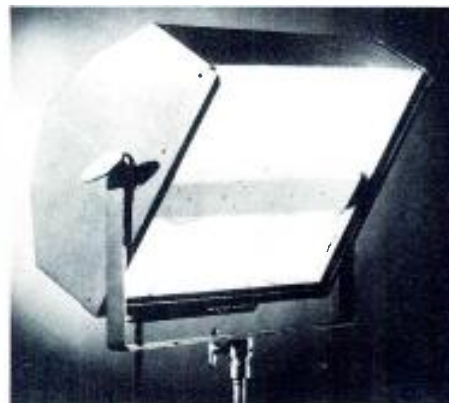

The new combo mounting stud permits the luminaire to be mounted on stands with 5/8" studs or 1 1/8" females. The Mini Soft-Lite is supplied with 25 feet of cable.

For More Details Circle (172) on Reply Card

#### 50 kW AM Transmitter

The development of the Model AM-50KD AM Broadcast Transmitter is announced by American Electronic Laboratories, Inc. (AEL).

Designed for high reliability, low maintenance commercial broadcast service in the 530 kHz to 1640 kHz band, AEL's Model AM-50KD Broadcast Transmitter can provide up to 55kW output and is intended for operation under Part 73 of the FCC rules.

The transmitter is housed in a three-section modern cabinet featuring AEL's center control panel concept which places all metering, control and indicator functions at a level for easy observation while making tuning and operating adjustments. Positive pressure cabinet ventilation reduces the accumulation of dust and dirt.

All low level RF and audio circuits, as well as control logic and rectifiers of this four-tube transmitter, utilize solid state devices.

(Continued on page 104)

BROADCAST ENGINEERING

**YOU ARE WASTING  
TIME AND MONEY  
IF YOU TAKE MORE THAN**

**5 SECONDS  
FOR THIS  
SHOT SEQUENCE  
USING ONLY ONE CAMERA**

SEE US  
AT OUR  
NAB BOOTH 109  
SHERATON PARK



675mm (NO CLOSE-UP LENS)

EARRINGS



18mm (VERY WIDE ANGLE)  
(FROM ONLY 6 FEET AWAY)

SMALL STUDIO

**CONFIDENTIALLY  
ONLY THE  
angēnieux 15 to 1  
CAN DO THIS FOR YOU!**

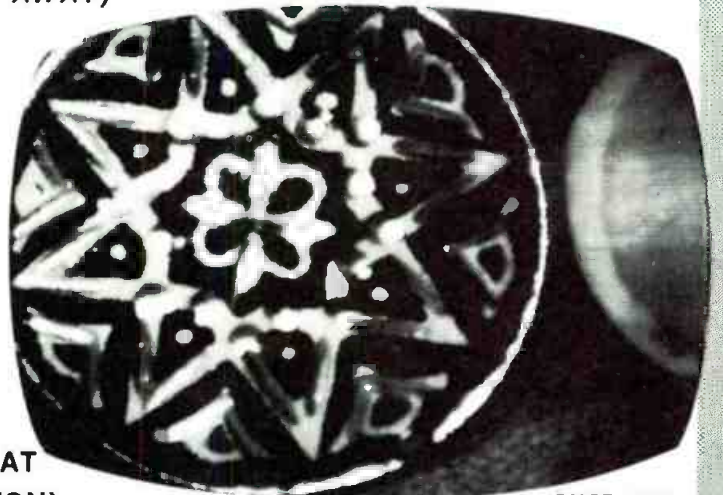

675mm (375 to 1 RANGE AT  
THE PUSH OF A BUTTON)

CUFF LINK

**angēnieux** corporation of america  
440 merrick road, oceanside, n.y. 11572 • (516) 678-3520

# Sony's award presenting microphone.\*

\*Used at Academy Award and Emmy Award T.V. presentations 1972.



Featuring a high-performance condenser capsule of electret design, the ECM-53 is specifically designed for broadcast, recording studio, public address and similar applications.

The cardioid capsule assembly contains a permanently charged condenser capsule and FET/IC amplifier. A Cannon connector houses the battery supply.

- Frequency Response: (Frontal  $\pm 3$  dB): 40 Hz to 16 kHz
- Output Impedance (at 1 kHz  $\pm 20\%$ ): 50, 250, 600 ohms Balanced
- Maximum SPL (1 kHz): 134 dB

Also Consider:

Tie-tack/lapel condenser mic ECM-50.

Telescopic (from 7 $\frac{3}{4}$ " to 17 $\frac{1}{2}$ ") condenser mic ECM-51.

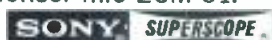

©1972 Superscope, Inc., 8211 Vineland Ave., Sun Valley, Calif. 91352. Send for free literature.

For More Details Circle (146) on Reply Card

The RF section consists of dual selectable solid state oscillator circuits utilizing nontemperature sensitive crystals. Modern solid state logic circuits are used to establish the required operating frequency. A solid state power amplifier provides grid drive to a 4-400C IPA stage. The PA is a 4CX35000C tetrode operated in a high effi-

ciency circuit which, with its large cooling system reserve, provides for long, reliable life.

Other features include high level plate modulation, oil filled modulation transformer and reactor, vacuum tuning capacitors, and fast restart after momentary power failures.

For More Details Circle (173) on Reply Card

## Audio Tape Recorder

For the first time **Revox Corporation** are exhibiting their **Revox A77 Dolby B** at this year's NAB Show.



The addition of two Dolby encoders and two Dolby decoders to the already popular **Revox A77 Mk.III** has produced a tape recorder that is becoming a standard feature in radio stations broadcasting, or planning to broadcast, Dolby encoded programs. The inclusion of four Dolby processors enables the user to monitor the deprocessed signal at all times and this feature makes the machine ideal for the station recording its own Dolby encoded material.

**BEYER DYNAMIC**, who have been serving the broadcaster for more years than any other microphone manufacturer, will be at the show with many of their special ribbon microphones, so popular with the industry. The latest innovation from Beyer is the new **M201**, a super cardioid moving coil mike, especially developed for the T.V. and Film Industry. It is one of the smallest supercardioid dy-

amic microphones available, offering the uncompromising performance characteristics one expects from a manufacturer such as Beyer Dynamic.

The **Beyer M201** incorporates a sintered bronze cap to prevent popping, and this combined with a unique transducer mounting feature keeps handling noise at a minimum making the **M201** ideal for reporting vocalist or instrument soloist situations where isolation from background noise is essential.

For More Details Circle (174) on Reply Card

## New 5 kW Small-Pak

**Kliegl Bros.** announce the availability of their new 5 kW **Small-Pak**.

A **Fresnel Luminaire** developed for a compact studio requirement. Featuring light weight and reduced size; a 15" front to back dimension; a new Quartz type Mogul Bipost Lamp Holder; a sturdy integral on-off switch; a solid brass focus mechanism with front and rear handles; a three-conductor rubber-covered cable; tilt knobs on both sides; available with clear or black-riser lenses; light output and ventilation comparable to that of the standard 5 kW.

For More Details Circle (175) on Reply Card

## Standard Consoles

A whole new line of standard broadcast audio consoles will be introduced at the NAB Show by **Fairchild/Sound Equipment Corp.** The new line will be marketed under the trade name of **FAIRCHILD/ROBINS**.

**George Alexandrovich**, Fairchild Vice President, explained that prior to this time, all of the companies' consoles were moderately expensive custom-built systems.

He said that this new standard  
(Continued on page 106)



BROADCAST ENGINEERING

# The solid state, modular 100 watt UHF translator:

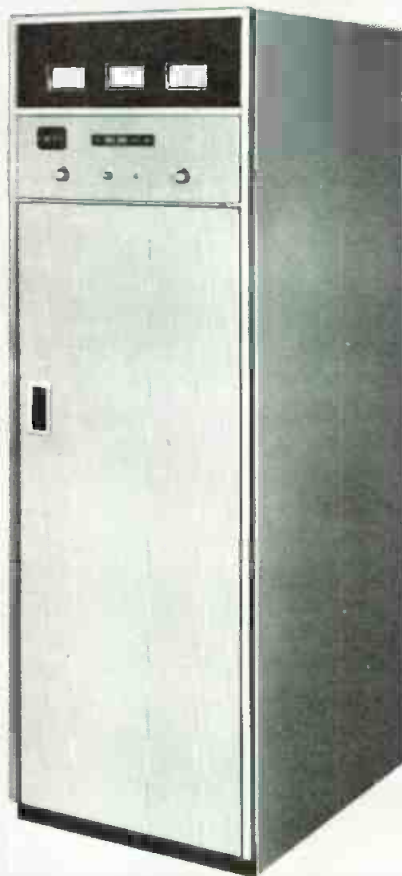

from the translator specialists,  
of course!

If you want reliability and advanced design features in your translator system, you simply have to specify Emcee.

The modular, solid state 100-watt translator above is just one example. This FCC type-accepted unit adds optimum performance and ease of maintenance to the traditional Emcee reliability. It's available in models for VHF or UHF input and provides the ultimate color performance on any UHF channel or CCIR Bands IV and V.

And the same advanced, modular solid state design is now incorporated in the Emcee 1 watt and 10 watt UHF and VHF translators. Again, for that Emcee combination of reliability and performance.

See the whole Emcee line at NAB '73. In Emcee booth 316 at the Sheraton Park Hotel.



**EMCEE BROADCAST PRODUCTS**, a division of  
ELECTRONICS, MISSILES & COMMUNICATIONS, INC.  
White Haven, Pa. 18661 (717) 443-9575



Here's the big one.  
The first 1 kw UHF color translator.  
Developed by EMCEE, of course.



**Product Section**  
(Continued from page 104)

line, which will be unveiled at the Show, will feature many engineering advances formerly available only in high-priced units. And, that the new line will give Fairchild's customers a broad price range to fill their requirements.

For More Details Circle (176) on Reply Card

**2.5 kW FM  
Transmitter**

American Electronic Laboratories has introduced their new 2.5 kW FM transmitter. As you can see in the picture, the front panel design is based on human engineering.

Almost entirely solid state, the FM 2.5KD transmitter features automatic recycling, allowing three overloads within one minute before shutting down the transmitter.

The driver section uses a 4X150A power tetrode which feeds a CX1500A7 final amplifier.

AEL uses positive forced air cabinet and tube cooling to insure long tube life and to decrease dust



accumulation. Remote control readings and other functions are conveniently provided as parallel circuitry to the main transmitter metering and control.

Automatic power output and VSWR metering and control are optional.

For More Details Circle (177) on Reply Card

**Automatic Logger**

McBee Laboratories has introduced their Automatic Digital Logger that records and prints out all necessary meter readings, saving valuable engineering time and insuring total accuracy.

The VII/21 Automatic Digital Logging System is a completely self-contained system, including a printer which can display and print-date identification, time, channel number and meter readings in volts, amps, watts, etc. The system is capable of sampling, measuring, displaying and recording analog inputs from single or multiple sources. In addition, the unit is equipped with a real-time, solid state, 24-hour digital clock, so that exact time can be both visually displayed and printed out.

The VII/21 Automatic Digital

---

**Product Section  
Begins On  
Page 50**

---



**RUSSCO'S BRAND NEW AUDIO-MIXER  
the STUDIO/MASTER 505  
BREAKS THE PRICE BARRIER!**



**JUST LOOK AT THE FEATURES!**

- 5 Mixing Channels, 4 channels each with built-in Preamps! Each adjustable for mic, phono or hi-level! Channel 5 has 5 hi-level push-button balanced inputs!
- Built-in 25 Watt Monitor Amp!
- Built-in Cue speaker! Cue on any Channel!
- Push-button Key Switching with LED indicators!
- Built-in Headset Amplifier!
- Allen-Bradley Mod Pots! FET Monitor Muting!
- Rack mounts in 5 1/4" or Attractive cabinet!
- Mod Colors! Maroon & Black face, Blue-grey combo!
- PRICES START AT UNDER \$500!!!



**ELECTRONICS MANUFACTURING INCORPORATED**  
1070 BROOKHAVEN, CLOVIS, CALIF. 93612 (209) 299-2167

Logging System is a compact unit; only 7" high. Virtually maintenance free, the system utilizes plug-in printed circuit cards for quick and easy replacement. The system can be made even more versatile with optional elements and equipment.

For More Details Circle (178) on Reply Card

### Reel-To-Reel Recorder/Reproducers

International Tapetronics Corp. is displaying for the first time at the 1973 NAB its new line of broadcast oriented reel-to-reel equipment. The reel-to-reel units are designed along the same rugged lines as the heavy-duty ITC tape cartridge machines for strictly professional broadcast applications. A 10½ inch reel-to-reel recorder/reproducer is shown in the photograph.

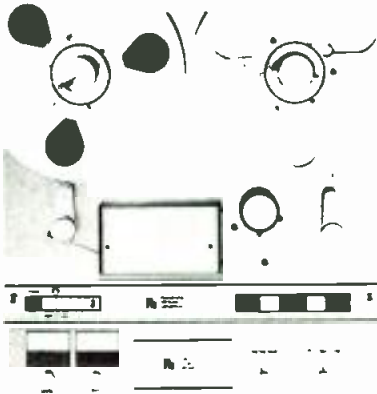

The ITC three-motor design includes direct capstan drive, both 10½ and 14 inch reel models, single or dual speed, motion sensing, edit mode, play/record synchronization, and IC logic.

The complete line of ITC single and multiple-deck cartridge units will also be on display in the exhibit hall in the Shoreham Hotel.

For More Details Circle (180) on Reply Card

Acrodyne will be displaying its high quality TV modulators which will have a number of applications, including its incorporation into a VHF linear amplifier such as those available from Acrodyne, to form a low power TV transmitter.

They will also be displaying the standard advertised line of TV translators, low power TV transmitters, linear amplifiers and peripheral equipment.

For More Details Circle (181) on Reply Card

### Audio Mixer

Rusco Electronics introduces their new professional broadcast audio-mixer, the Studio/Master 505.

The compact Studio/Master 505 features integrated circuitry throughout. It can be rack mounted in a 5¼ inch space or is available in an attractive cabinet. A break from tradition in appearance, the 505 has a deep maroon anodized aluminum faceplate and a blue-grey cabinet.

Other features include: 5 mixing

channels, 4 channels with built-in preamps, each channel adjustable for mic, phono or hi-level. Channel 5 has five hi-level balanced inputs with push-button key switching. Also featured are: built-in 25 Watt Monitor amp, built-in cue speaker, built-in headphone amp for headset, FET monitor muting and long-life LED indicators. The Studio/Master cues on any channel and uses Allen-Bradley MOD POTS.

For More Details Circle (179) on Reply Card

### Frequency Standard

Tracor has introduced a new rubidium frequency standard for use by the broadcast industry. The Model 600A is a compact and rugged atomic frequency standard designed for color subcarrier generation. This unit is priced substantially lower than earlier models without compromising any of the performance characteristics of

importance in color subcarrier generation.

The Model 600A has a built-in time scale selector which allows the unit to be set to the current atomic time scale or to be set to agree with previously utilized time scales which still prevail in existing equipment.

For More Details Circle (182) on Reply Card

## Quality speaks for itself

high speed  
in-cassette  
and  
open reel  
duplicators



Two position (Stereo) slave module  
Model S-140

"Quick Copy" (Stereo)  
Cassette to Cassette duplicator  
Model C-140



Tri-Master "Editor"  
(Stereo) Duplicator  
Model C-1343-12

Pentagon understands the relationship between product quality and professional results. That's why today, Pentagon is recognized as the leader in the development of truly reliable high speed in-cassette and open reel duplicators. With over 54 different models to pick from, we feel certain you'll find a model best suited to meet your every need.



At last . . . A cassette specifically designed to meet the exacting needs of professionals, regardless of application. Whether it be voice, music, pulse tone, or a combination of program requirements, Pentagon cassettes have proven repeatedly to be one of the few reliable ones. And surprisingly — it's modestly priced!

An eight page brochure is available upon request covering Pentagon's complete line of duplicators and cassettes. Write or call

**Pentagon**  
Industries, Inc.

4751 NORTH OLCOTT AVENUE  
CHICAGO, ILLINOIS 60658  
(312) 867-9200

Creators of quality in cassette duplicators

**SHIVELY LABORATORIES  
ANNOUNCES A NEW GENERATION  
OF CIRCULARLY POLARIZED  
FM ANTENNAS**



TYPE 6814 • 25 KW PER BAY



TYPE 6813 • 3 KW PER BAY



TYPE 6811 • 1 KW PER BAY

**RADOMES OR DEICERS  
AVAILABLE FOR ALL MODELS**

WRITE FOR INFORMATION ON  
ANTENNAS  
TRANSMISSION LINE  
FILTERS  
RF LOADS  
COAXIAL SWITCHES  
POWER COMBINERS



**SHIVELY LABORATORIES,  
INC.  
RAYMOND, MAINE 04071  
PHONE 207 655-3841**

NAB Booth 546

For More Details Circle (82) on Reply Card

**Closed Circuit  
Color Monitors**

Universal Media Corporation, introduces a complete line of color monitors specifically engineered for broadcast, closed-circuit, cable and teleproduction applications. The Unimedia SMT Series Monitors include 9-inch, 12-inch, 15-inch and 17-inch models. Each features the Sony Corporation Trinitron picture tube. The single-gun Trinitron system eliminates convergence problems and moire and produces brighter, sharper pictures with excellent colorimetry and stability.

All monitors rackmount in standard 19-inch racks, with the 9-inch model available as a dual installation or in a frame for use with a half-rack waveform monitor.

Primary controls are all front mounted and talley lamps are provided. A built-in audio speaker/amplifier may be included. Three professional features may be ordered as options—a front panel switch control of underscan, A-B selection of two inputs, and switchable horizontal and vertical pulse-cross display.

For More Details Circle (183) on Reply Card

**Automatic  
Switching System**

Vital Industries, Inc. will demonstrate their Computer-Automated Switching System and VIX-100-4 Production Switcher with novel features that delight production personnel.

Many new versions of vertical interval switching systems including: Large Routing Systems, Audio and Video DA's, and Video Processing Equipment.

For More Details Circle (184) on Reply Card

**Broadcast  
Cartridge Recorder**

IVC will introduce its new BCR-200 Broadcast Cartridge Recorder at the 1973 NAB with a program of live demonstrations in the IVC booth (#220).

The BCR-200 is a fully automatic, multi-deck playback system costing 40 per cent less than quadruplex cartridge or cassette systems. It is available in six-deck and twelve-deck models, each in-

cluding a sophisticated programmer with highly simplified controls and shared playback electronics. Programming can be random or sequential. Reprogramming and preview controls are included.

Each system includes at least one self-contained record/playback deck that is used to record any video source and to add cue tones to tapes—even while the rest of the system is playing back on the air.

Each cartridge contains up to an hour of one-inch tape on a standard reel. An entire hour program can be played back, with commercial breaks automatically inserted. The system meets full broadcast quality requirements.

For More Details Circle (185) on Reply Card

**Distribution  
Amplifier**

The new Taft audio distribution amplifiers will be shown. These are not "black boxes" or prototypes. The model 5200 distribution amp uses IC's, has 18 isolated 600 Ohm outputs, equalization and rolloff for signal conditioning before distribution, and displays 20 to 20 kHz  $\pm 0.5$ dB, 0.5 percent total distortion (with "EQ" and "Rolloff" in flat position).

Other features include balanced inputs and outputs, continuous monitoring of output level, and a two-year parts and labor warranty.

For More Details Circle (186) on Reply Card

**Audio Control Console**

McMartin Industries, Inc., announces the availability of a dual-channel version, the Model B-503, supplementing the previously available B-501 Monaural and B-502 five-mixer audio control consoles.

The B-503 features dual program channel capability at a nominal +8 dBm, 600 Ohm balanced output. The B-503 provides extreme input flexibility with plug-in modules to accommodate microphone or high-level input requirements for each of the five input mixing channels. Two inputs per channel are available through interlocked push-button preswitching.

(Continued on page 110)

(Continued from page 69)

of the picture in movie theaters. But when that movie gets on television, the broadcaster is faced with the fact that the songs in the film (or tape) are being "performed" on the air. BMI has three local performance categories for such uses: (1) TV Theme & Cue, Background usage—the lowest-paying category; (2) TV Movies; and (3) TV Picture Performance, the highest-paying category.

The way a song is used in a motion picture determines the money it earns. In addition to the local-station rates, there are network rates for synchronized music as well as the other types of performances, including parades and ball games.

The three television networks have filed suit against ASCAP and BMI claiming that they pay too much for the music. The "nets" are willing to pay substantial fees, but only for the music they actually perform. The societies take the position that even though the networks, and all television stations, for that matter, can pinpoint their usage of every musical work, and even though they use comparatively little music throughout the broadcast day, the entire society repertoires are available to the nets to pick and choose from, and that the networks are obligated to pay for the privilege of being "choosy." The societies similarly contend that if all broadcasters paid only for the songs they actually used it would stifle the output of music from the authors' pens, with the result that the broadcasters would have far less music, and music of poorer "quality," to choose from.

### Enter Cable TV

CATV operators believe they should be exempt from performance royalties in instances where they are merely providing improved TV reception. They make a strong case for the fact that they provide a better and less expensive reception service than the viewer could accomplish for himself individually, even if he had the time, skill, wherewithall and the inclination.

But what happens when the cableman retransmits grade-B contour or non-local stations? And

couldn't the networks similarly claim that they are not broadcasters, per se, but merely provide an interconnect service to the broadcasters . . . besides offering the public better-produced shows than the individual stations could create alone?

Then there's the matter of air checks. In the United States you can make a recording of a radio or television broadcast with impunity, provided the recording is for private use and non-profit. But the German performance society, GEMA, has convinced the Bonn government otherwise. So, when you buy a tape recorder in Germany there is an extra fee included at the time of purchase which is collected by the dealer and ultimately remitted to GEMA, under the theory that even a private individual will at one time or another use his recorder commercially. Perhaps, too, when one is able to record a broadcast or other performance of a song and then reproduce that song via tape play-back at another time, perhaps time and time again and for many listeners, that is essentially the same as if the

song were broadcast over radio or television, if admittedly on a reduced scale.

Authors are truly entitled to compensation for all of the avenues in which their musical works are used . . . probably even in the non-commercial areas such as education (after all, the author and publisher of a textbook receive remuneration).

Educators think nothing of photocopying sheet music (including "hits" and "standards") for supposedly non-commercial use for the benefit of their students. But I bet that those same teachers would rebel if they had published a textbook, then other teachers photocopied portions of it and avoided buying the book.

What constitutes fair compensation, fair sampling and the proper basis of determining what a user should pay, are academic. Hopefully, this article has given you a reasonable idea of "the nature of the beast." By the way, ASCAP and BMI are considering entering the field of licensing of non-musical works (comedian's monologs, for example); so watch out! □

## You won't believe what we did to the TAPEX cartridge.

We threw out pressure pads for starters. Big deal? You bet it is. Because pads cause unnecessary wear on the tape and heads. With Tapex, you get longer life on both.

So now you ask, "how do you keep the tape on the head?" Easy. Tension is set on each Tapex Cartridge at the factory. And a unique stereo phase stabilizer keeps the tension just right during use.

This is just one way we've made Tapex a little better. Find out the rest. Write for details today.



Tapex Corporation/P.O. Box 796/West Des Moines, Ia. 50265  
YES! Please send me a detailed Tapex Cartridge flyer and price list.

Name \_\_\_\_\_

Address \_\_\_\_\_

City \_\_\_\_\_ State \_\_\_\_\_ Zip \_\_\_\_\_



**TAPEX**  
CORPORATION

BE-3

For More Details Circle (84) on Reply Card

**15 day free trial shows you why ITC tape cartridge equipment is an industry leader.**



**SP SERIES REPRODUCER**

A two week test in your own broadcast facilities is the only fair way for you to evaluate the performance of ITC's premium line cartridge equipment. Advertising statements are no longer simply claims, but become actual facts proven first hand. Find out for yourself how ITC has built in all the features demanded by broadcasters since tape cartridge equipment was invented. If ITC equipment fails to measure up, you're under no obligation. You'll find that ITC dependability is something on which you can rely completely.

**RP SERIES RECORDER/REPRODUCER**



**Call us collect to arrange a 15 day free trial 309-828-1381**

**INTERNATIONAL TAPETRONICS CORPORATION**

2425 South Main Street, Bloomington, Illinois 61701

For More Details Circle (64) on Reply Card

Each program channel delivers frequency response characteristics of  $\pm 0.5$  dB, 30-15,000 Hz with THD of 0.5 per cent or less at a +18 dBm output level.

Individual VU meters for each output channel are included.

The completely self-contained unit includes 4-Watt RMS monitor amplifier output and complete cue facilities.

Now, all of the FIVE mixer models are available with step-type attenuators.

The B-503 is particularly suited for TV production and subcontrol applications.

For More Details Circle (187) on Reply Card

**Telefilm Recorder**

Teledyne will show its CTR-2 color telefilm recorder.

Designed for simple, reliable operation, the CTR-2 will produce sharp color-balanced 16mm film from tape masters.

This unique camera uses compressed air to pull down and stabilize film in less time than the TV vertical blanking period. This results in a full frame recording without mid-field splice or shutter bar. The well known DBM-64B camera forms the heart of the new CTR-2.

Control panels are designed for maximum ease of use. All components are accessible from the front on slide out racks which allow drawers to be rotated for additional access. Two doors open up on the TV display for additional access.

Test points on printed circuit

cards used in conjunction with built-in waveform monitor allow operation, adjustment and troubleshooting without the need for a separate oscilloscope.

The system is supplied with a special test waveform generator used in conjunction with a built-in photometer. Each color is switched on independently and the background (black) level is set. A special test signal is then applied to the display and a similar sequence for each color allows the adjustment of the highlight (white) level.

For More Details Circle (188) on Reply Card

**Multiple Monitors**

SC Electronics, manufacturer of Setchell Carlson TV monitors and monitor/receivers recently introduced its new Triple-6 & Single-6 monochrome monitors.

Models 6M917T (Triple-6) and 6M917 (Single-6) are American-made professional quality monochrome monitors with single or three-in-a row, side-by-side 6-inch picture tubes with a horizontal resolution of 600 lines, 100 per cent solid-state circuitry, and the most advanced Single Module Circuit Board currently available.

This unique Single Module is a one-piece, easily removable chassis which permits rapid, on-the-spot maintenance—for reduced maintenance costs and the elimination of valuable downtime.

Other features include attractive, highly compact design ideal

(Continued on page 118)

**Matthey Video Delay Lines**

Type M200/47001

Delay range:

5-155 ns. in 5 ns. steps

Equals:

3½ to 100 feet of coax cable

Insertion Loss/Frequency:

0.5 dB max. at 5.5 MHz

Over-all Attenuation:

0.5 dB — not greater than 6%

Impedance:

75Ω

Price

\$25.00

17.00

16.25

Quantity

1-10 units

11-49 units

50-Plus units

You can forget about whittling coax cable to correct phase and timing errors. Matthey video delays have better performance, are easier to install, don't change with temperature or humidity, and are less expensive than cable. They don't take up space: in one hand you can hold video delays equivalent to thousands of feet of coax cable.

Matthey fixed and variable video delays can be cascaded for a maximum delay of 4,000 ns. (2500 ft. of cable). Matthey video delays are available in PC modules, in metal boxes with BNC connectors, infinitely variable with switches and vernier, and rack-mounted. Try one without obligation.

Details from

Bill Pegler

phone (516) 628-8068

**Television Equipment Associates**

BOX 1381 BAYVILLE, N. Y. 11709

For More Details Circle (65) on Reply Card

**Hi-Fi Stereo Handbook**

The 400-page **Hi-Fi Stereo Handbook**, written by William F. Boyce, explains the difference between monophonic, stereophonic, and three-dimensional sound systems; the meaning of high fidelity; the different sources of program material; the various kinds of distortion; etc.

The three major stages in hi-fi reproduction are thoroughly covered: the program-source equipment, preamplifier and amplifier sections, and the speaker system. For the audiophile, there is advice and instruction on selection, installation, and operation of equipment for all modes of four-channel sound: discrete, derived, matrixed, synthesized, live, stored, and broadcast. Beginners and veterans alike will appreciate the discussion on stereo and the material on designing, selecting, and installing simple, medium, and complex systems to suit any taste and pocket-book.

This fourth edition includes new material on stereo needles, headphones, adapter circuits, tape-cartridge players, and speaker equalizers; Dolby noise reduction and multiplex operation; Stereo-4, SQ, QS, and other encoders and decoders; 4-4-4, 4-2-4, and 2-2-4 systems of processing four-channel sound; 4-D speaker arrangements; and operation to produce optimum effects with the latest equipment.

Whether you're a beginner on the verge of buying your first piece of equipment, or an experienced audiophile who wants to gain more knowledge about hi-fi, stereo, and surround-sound (four-channel sound), you'll find this book invaluable:

This book is available through Howard W. Sams & Co., Inc., Indianapolis, Ind.

For More Details Circle (203) on Reply Card

**Camera Chains**

**Television Broadcasting Camera Chains** has been written by Harold E. Ennes. The 464-page book contains 11 chapters covering: studio lighting; the system concept; camera mounting, interconnection facilities, and power supplies; video preamplifiers; video processing; pulse processing and timing systems; camera control and setup circuitry; the subcarrier and encoding system, color picture monitoring systems; and preventive maintenance.

The purpose of this book is to provide the fundamental and advanced training that is necessary if full benefit is to be obtained from the information in modern instruction books. To do this most effectively,

*(Continued on page 112)*

**LOW COST  
DIGITAL  
CLOCKS,  
TIMERS AND  
COUNTERS**

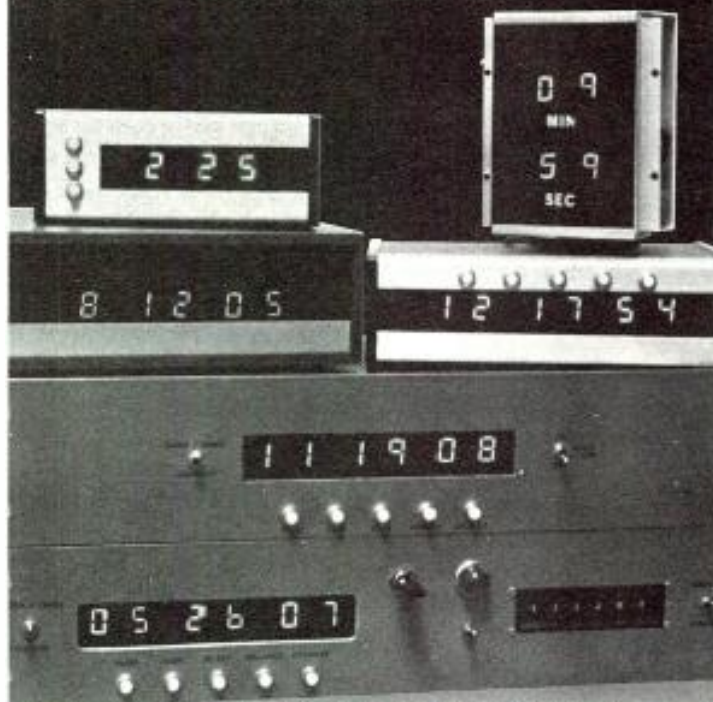

All ESE digitals are designed and constructed using the latest solid state electronic components and circuitry. This equipment is perhaps the most economical line of digital clocks, timers and counters available. Circuit efficiency and lasting quality are designed into every ESE digital product. Constructed with the built-in ruggedness necessary for studio use. No moving parts.

Special custom items, like the video tape/counter editor, a monitoring system with unique display configuration, 12 and 24 hour clocks or timers, 10 minute timers, 3 digit, 4 digit, 6 digit, record seconds in tenths, hundredths or thousandths . . . All available from ESE. Options include: Thumbwheel switch or patchboard programming, BCD outputs, relay closure outputs, and solid state buffered outputs. Many products available in kit form.

**MOST EFFICIENT DIGITAL CLOCKS/TIMERS AVAILABLE ANYWHERE:**

- ES-112/124, 12 hour or 24 hour clock: 6 digit — Records hours, minutes seconds . . . . . \$ 90.00
- ES-300, 100 minute up/down counter. Displays up to 99:59 — Easy pushbutton: Reset — Count up — Count down — Advance seconds — Advance minutes — Stop . . . . . 135.00
- ES-400, 10 minute timer: Displays up to 9:59 — Pushbutton: Start — Stop — Reset . . . . . 75.00
- ES-500, 12 hour clock/timer: 6 digit — Records hours, minutes, seconds. Start — Stop — Reset — Slow and Fast Advance buttons. Displays up to 12:59:59 . . . . . 120.00
- ES-510, 60 minute timer: Displays up to 59:59 — Pushbutton: Start — Stop — Reset, Only 3¾" deep for flush mounting into walls or std. alum. case . . . . . 100.00



WRITE, WIRE OR CALL TODAY:

506 MAIN ST. • EL SEGUNDO, CA. 90245 / (213) 772-6176

For More Details Circle (91) on Reply Card

some classical and semiclassical stuff is broadcast. Typical programs on these two stations include: "Billy Graham," "New Testament Light," "Lutheran Hour," "Sacred Melodies," "Back to God Hour," "Calvary Baptist," "Back to the Bible," and "Lifetime." WFME—"Family Radio"—is on the air 24 hours; WPOW—"Power of the Word"—shares time with two other stations, and is on the air about 52 hours a week. Roughly a third of WPOW's air time is devoted to foreign-language broadcasts. Announcers at these stations are unobtrusive; the format is just broad enough to appeal to the conservative wing of most Protestant denominations.

### Variety

Special in the big town, WBAI (FM) follows what can only be described as a variety format. The station is noncommercial and listener-sponsored, running from 7 to 4 or 5 a.m., using live announcers but with many pretaped programs. Music includes classical, jazz, folk, Top-40, psychedelic rock, C&W, soul and John Cage. WBAI played Jerry Jeff Walker, the Fugs, Tiny Tim, before any other stations. Free from sponsor pressure, WBAI is able to present neutrally things like a discussion by homosexuals, a BBC radio drama, "Whatever Became of the Green Hornet?" "The History of Bastardy," a review of the Soviet Press and an interview with some New York Black Panthers. Most-popular DJ's are Larry Josephson, an anti-morning man in a radio world of bushy-tailed professional wake-up jocks, East Village hippie Bob Fass and a kid from the Bronx named Steve Post.

### All Talk

Probably the oldest broadcast format is conversation, WOR's specialty. The station is a 24-hour operation which emphasizes interviews and monologues. There is little music, but lots of talk, including personalities like Peter Lind Hayes and Mary Healy, Arlene Francis and Margaret Truman. The station carries a heavy commercial load, selling everything to everybody. Jean Shepherd does a nightly 45-minute monologue and Berry Ferber works the all-night shift doing interviews. The popular morning man is John Gambling.

As already noted, WNBC was a conversation station until injecting MOR music in its format. It retains Brad Crandall's telephone call-in show, and all-night man Long John Nebel (hired earlier from WOR), who interviews UFOlogists and politicians. Also around is Dr. Joyce Brothers, who offers psychological advice to phone-in listeners.

### All News

Closely related to all talk is the format used by WCBS and WINS. WCBS—"Newsradio 88"—deviates slightly from the ideal, carrying the elderly housewife's idol Arthur Godfrey from 1:30 to 2 p.m. and the mon-fm insomniac's idea of cultural



News Director Dick DeFreitas, handles multitude of jobs at WHN including news and public affairs.  
BM/E Photo

music—"Music 'Till Dawn"—from 12:30 to 5:30 a.m. WINS does nothing but news 24 hours a day. WCBS and WINS news operations are unfortunately beyond the scope of this article.

### Collegiate

Three metro-area stations serve their respective college campuses as well as the general community: WFUV (FM) at Fordham University in the Bronx, WKCR-FM at Columbia University in Manhattan and WSOU (FM) at Seton Hall University in South Orange, N.J. All are noncommercial and operate afternoons and evenings with live announcers. WKCR-FM is stereo. The collegiate stations' staffs are mostly students and music is a mixture of rock, folk, classical and jazz. Other program elements include instruction, comment, discussion, sports, and news; some programs are amateurish, while others are outstanding. Announcers on music programs are often conversational and there are a lot of talk shows.

### Public Schools

Newark's WBGO (FM) and New York City's WNYE (FM) are quite similar. Each is noncommercial, operated by the respective city's Board of Education, operating during school hours only, and carrying in-school broadcasts which are tutorial rather than merely entertaining. Most shows are pretaped and aimed at specific class groups, which are furnished with printed material to accompany the lesson. WNYE carries some programs in Spanish for Puerto Rican students.

To serve the needs of eight million New Yorkers and several million suburbanites, New York City metro-area radio stations have developed specialized formats with the finest distinctions in the country. Perhaps some of these formats will be useful to you in determining your "brand" of programming.

BM/E

## A NEW FAMILY OF ONE-GUN RACK-MOUNT COLOR MONITORS FROM

**unimedia**



**UNIMEDIA SMT-12 COLOR MONITOR**  
\$795

Not just one model, but a whole family of studio quality color monitors specifically engineered for broadcast, closed-circuit, cable and teleproduction applications. The inherent simplicity of the single-gun Sony Corporation Trinitron® picture tube eliminates convergence problems and moire for brighter, sharper pictures.



**UNIMEDIA SMT-17 COLOR MONITOR**  
\$995

All models are available with switch control underscan, A-B input selection and pulse-cross display (optional). Each SMT chassis is constructed of heavy gauge aluminum and all primary controls are front mounted. Optional built-in audio speaker/amplifier is available on all models. SMT-9 is also available in dual and single half-rack versions.

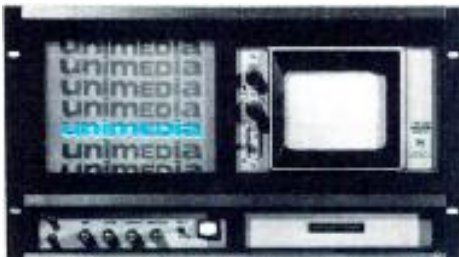

**UNIMEDIA SMT-9/528 COLOR MONITOR**  
\$745

**unimedia**  
**unimedia**  
**unimedia**  
**unimedia**

28971 HOPKINS, HAYWARD, CA 94545  
PHONE: (415) 782-2600

UNIVERSAL MEDIA CORPORATION

### Book Review

(Continued from page 111)

where possible, complete, detailed schematics have been avoided, and, instead, use has been made of block diagrams with simplified diagrams of individual blocks under discussion. The overall system concept is stressed so that the reader can more readily grasp the meaning of a specific circuit adjustment in terms of its effect on system performance.

This book is available through Howard W. Sams & Co., Inc., Indianapolis, Ind.

For More Details Circle (204) on Reply Card

## Transistor Audio Amplifiers

Today, the design of audio amplifiers requires a thorough understanding of transistor characteristics and the various circuit possibilities. Also, since a design is usually a compromise between several factors such as cost and performance, it is important to understand the basis of the performance requirements. **Transistor Audio Amplifiers**, written by P. Tharma, considers these aspects of design in detail, and is based on the work done by the audio application group of the Mullard Central Application Laboratory.

The first two chapters deal with transistor characteristics: following chapters cover circuit design and measurements, and a final section of the book considers various applications and describes circuits to illustrate the design principles. Particular attention is given to the extensive use of direct-coupled audio amplifier circuits. Noise and "acoustic roughness" due to non-linearity are considered in detail. The book contains 399 pages and includes 245 diagrams.

This book is available through Van Nostrand Reinhold Co., New York.

For More Details Circle (205) on Reply Card

### Short Circuits

The Commission has waived the "beep-tone" requirement for recording telephone interviews for later air broadcast, provided callers fully understand that their conversations are being recorded for this purpose . . . the Commission has declined to permit "scrambled" TV broadcasts of medical instructional material, holding this to be a wasteful use of spectrum space . . . the Commission will permit, and has encouraged, both aural and visual coverage of FCC proceedings, including hearings in individual cases . . . All-We-Need department: The Illinois State Citizens Band Association has asked that the limit on the height of Class D CB antennas be raised from 20 feet to 100 feet (next, higher power?).



# PEOPLE IN THE NEWS

Eastman Kodak Co. directors elected a vice-president and three assistant vice-presidents. The new vice-president is **Robert C. Burton**, assistant general manager, Eastman Chemicals Division. The assistant vice-presidents are: **Paul A. Barbee**, **Wendel W. Cook**, and **Anthony Frothingham** . . . **Cohu, Inc.** announced the following organizational changes for the Electronics Division: **James W. Barnes** has been appointed vice president and general manager of the Division, **Robert J. Schlicht** has been appointed vice president of marketing, and **Jeffrey Stewart** has been appointed vice president of manufacturing . . .

Nine people were elected to the Board of Directors of the Institute of Electrical and Electronics Engineers, Inc. (IEEE). Those elected by the Annual Assembly were: Vice President Publication Activities, **Dr. Robert F. Cotellessa**; Vice President Regional Activities, **Seymour Cambias, Jr.**; Vice President Technical Activities, **Joseph K. Dillard**; Region 10 Director, **Faqir C. Kohli**; Secretary, **William H. Thompson**; Treasurer, **Arthur P. Stern**; Chairman Educational Activities Board, **Dr. Robert M. Saunders**; Vice Chairman Technical Activities Board, **Bruce B. Barrow**; Executive Director, **Donald G. Fink**.

Television Microtime, Inc. has made two key appointments: **James Fazio** joined TMI as Project Engineer responsible for design and packaging of an increasing family of accessories to the Delta 44 Time Base Corrector. **Joseph L. Stickley** has been named Senior Applications Engineer . . . **TeleMation, Inc.** announced the appointment of **John J. Kope, Jr.** as Vice President, Marketing . . . **Richard W. Bock** has been appointed midwest regional Sales Manager by the Miratel Division, Ball Brothers Research Corp. . . . The appointment of **Henry E. Rhea** as Broadcast Sales Representative has been announced by Electronic Laboratories, Inc. (AEL) . . .

**Edward S. Ely** has been appointed chief engineer for **KSAN-FM** a Metromedia stereo station . . . **Shirley B. Gillette** has been elected to the Instructional and Professional Services board (NAEB) . . . **Dennis G. Christensen** has been named national sales manager, broadcast products, at International Video Corporation, and **Frederick J. Haines** has been named manager, product services . . . **John J. Bubbers** has been appointed to the position of Director of Engineering, Acoustic Research, Inc. . . . **William A. Begalke, Jr.** has been appointed manager of TeleMation's New Mexico office in Albuquerque . . .

(Continued on page 114)

## UNMATCHED CAPABILITY

CHANNEL TWO TELEVISION COMPANY  
**KPRC TV**  
 July 13, 1972

Mr. Morris T. Covington  
 Director of Research  
 Taft Communications Systems, Inc.  
 4808 San Felipe Road  
 Houston, Texas 77027

Dear Morris |

This long overdue letter will let you know how very pleased we are with the continuing good service from our Taft Audio Distribution Amplifiers.

As you know, I had six of these amplifiers on the test bench for six weeks and abused them in every way possible. I did not experience a single failure; in addition, they held their specifications in every way.

I had evaluated several "well-known" distribution amplifiers before I tested the Taft DA, and I knew then that this was the DA for us. It is right in every way: size, individual power supply, number of outputs and performance. After several months of hard and continuous service, I am still well pleased with all fifty two of them.

I will recommend your Model 5002 Audio Distribution Amplifier, and also your Model 4002 Monitor/Power Amplifier without a moment's hesitation.

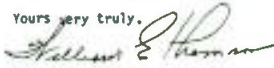
Yours very truly,  
  
 William E. Thomson  
 Audio Engineer



Note these unique features of the Taft Model 5002 Audio Distribution Amplifier:

- (1) 18 isolated 600 ohm outputs (80 db)
- (2) 20 - 20 KHZ  $\pm$  0.5 db, 0.5% total distortion (with "EQ" and "Rolloff" in flat position)
- (3) Equalization and Rolloff feature provided for signal conditioning before distribution
- (4) Input and outputs are balanced
- (5) 20 db gain (can be increased to 40 db)
- (6) Noise better than 80 db below 0 dbm signal
- (7) All integrated circuits for very efficient operation - units may be stacked without air spaces
- (8) Output level is continuously monitored
- (9) Two year parts and labor warranty

New Price: \$295.00 (includes input transformer - specify 150, 600 or 15K input impedance)

If you are interested in evaluating the 5002, call us collect or check the information card.



**COMMUNICATION SYSTEMS, INC.**  
 4808 San Felipe Road | Houston, Texas 77027 | (713) 622-1010

## MAINTAIN YOUR ANTENNA SYSTEM AT PEAK EFFICIENCY



**Model OIB-1**  
Operating Impedance Bridge measures in circuit impedance of networks transmission lines and antennas. Accuracy  $\pm 2\% \pm 1$  Ohm. Power rating, 5 kW modulated; 10 kW CW — VSWR 3:1.



**Model RG-1**  
Receiver/Generator combines a high output power signal generator with a shielded receiver for use with Model OIB-1 or any other impedance bridge.



**Model CPB-1** Common Point Bridge measures resistance to  $\pm 2\% \pm 1$  Ohm and reactance to  $\pm 5\% \pm 1$  Ohm at full power.

With Delta's monitoring equipment, you can either "spot check" or continuously and accurately monitor actual "on-the-air" operating impedance of transmission lines, networks and antenna systems to maintain a "clean signal" peak operating efficiency.

If you're operating with a directional antenna, there's real value in being able to keep the radiating system in close adjustment at all times...continuously verify common point impedance to insure full power output...plus locating and correcting any antenna problems — fast!

Complete details and application data are available without obligation — just write or call Bill Cottles, DELTA ELECTRONICS, INC., Department A, 5534 Port Royal Road, Springfield, Va. 22151 703/321-9845.

**DELTA ELECTRONICS**

NAB Show • Booth 532

Exporter: DELTA ELECTRONICS, INC.  
International Division, 154 E Boston Post Rd.  
Mamaroneck, N. Y. 10543, Telex 1 37327, Art Rocke



Bernard V. Vonderschmitt became the head of the RCA Solid State Division January 1973 . . . Roger Faust has been appointed International Sales Manager for Consumer Products, Altec Division, Altec Corp.

### Cable

John D. Sanfratello has been appointed vice-president for the New York based cable TV production company, Videomation, Inc. . . . Paul Fox, formerly of the Common Carrier Bureau at the Federal Communications Commission, has joined the staff of the Cable Television Information Center . . . Magnavox Co., CATV Division has announced the appointment of Charles E. Hively as Executive Vice President . . . Tom Athans has been named Western Area Manager by Cerro Wire & Cable, CATV Division . . .

John J. Sie has been named to the position of Division Manager, Terminal Products and Services Division, Jerrold Electronics Corp. . . . John L. Buchanan has been named Executive Vice President of Ameco, Inc. . . . Paul Albert has been appointed to the position of Director of Technical Facilities for Ithaca College . . . Edward E. Worrell, Jr. has been named General Manager of Sammons Communications, Inc.

Essex International, Inc., Communications & CATV Division, announces the appointment of Erwin F. Jones to its national sales organization . . . Kenneth C. Klein has been appointed Engineering Foreman for the CATV Equipment & Installation Operation of GTE Sylvania Inc. . . . Jack L. Ross has been promoted to Pacific Northwest Manager of Anixter-Pruzan . . . TeleVision Communications Corp. (TVC) has named Jack L. Williams as director of programming for TVC cable television systems throughout the country.

## FCC Amends Remote Control Rules

The remote control Rules for directional AM stations have been amended and relaxed for readings at the transmitter, if provisions are made by the licensee for the reading and logging of phases at the remote control point. These changes are effective as of April 20, 1973.

The new Rules (out of Docket 18455) require readings at the transmitter every second day for each directional pattern, if phase readings are taken on a type approved monitor and are read at the remote control point.

It appears that if the readings are timed right (immediately before and after switching), both patterns may be checked in one day and no visit will be required the following day.

Other pertinent points include:

- Stations with a single pattern may omit readings at the transmitter on alternate days.
- No more than 54 hours may elapse between

successive readings at the transmitter for each pattern.

- No readings are required at the transmitter if the directional operation is for less than one hour.

- Licensees who do not have remote phase monitoring facilities will continue to make transmitter readings under the current rules.

The specific amendments are contained in Sections 73.113 (Operating log) and 73.114 (Maintenance log). In order to resolve certain inconsistencies generated by the recent amendment of Section 73.93 (Operator rules, Docket 18930) base current and other readings for stations not remotely controlled will be required only five days a week, instead of once a day as the licenses of many directional stations now require. The parameters which had to be checked at hourly intervals may now be read on the three hour schedule established for other parameters. The new rules also require that readings made on a five-day-a-week schedule be entered in the maintenance log, which must be maintained by a first class operator.

The new rules require the calibration of indicating instruments at the remote control point at weekly intervals. The procedure must be entered in the maintenance log. The Commission said that while this practice is generally followed by licensees, up to now there has been "no unambiguous requirement for calibration" in the rules. They said that the new maintenance log rule includes a general schedule for readings of the base currents in the elements of directional antennas.

Until the recent amendment of the operator rules, there was no specified requirement for these readings, which were included in the station authorization, the Commission pointed out. By including the base current observation requirement in Section 73.114, the Commission said, there will be no need to include it in each station authorization. They said that by reducing the daily observation to five times a week for each pattern, the only additional burden placed on licensees is that involved in meeting the specific requirement that deviations of the ratios of the observed currents from licensed values be computed and recorded.

In the case of stations operating by remote control, licensees may find it more convenient to enter these readings in the maintenance log rather than in the operating log, the Commission said. Since both logs will now be required to give a complete picture of the technical operation of the station, it will modify Section II of FCC Form 303 (renewal application) to require the submission of the maintenance log in addition to the operating log for the composite week.

#### Station Count

The Federal Communications Commission has announced the following totals for broadcast stations on the air as of December 31, 1972:

AM Radio—4,382  
FM Radio—2,411  
Educational FM—554  
UHF Television (Commercial)—189  
VHF Television (Commercial)—511  
UHF Television (Educational)—131  
VHF Television (Educational)—91

## TWO NEW TEST INSTRUMENTS FOR DIRECTIONAL ANTENNAS



**FSM-1  
FIELD STRENGTH METER**  
Frequency: Any frequency in the AM band  
Field Strength Range: 100 $\mu$  V/m to 1V/m  
Power: Internal battery  
Calibration certificate supplied  
Size: 5-1/2" x 8" x 5" (closed); Weight: 4-3/4 lbs. with batteries

### DAM-1 DIGITAL ANTENNA MONITOR

Frequency: Any frequency in the AM band; Phase Range:  $\pm 180^\circ$ ;  
Phase Accuracy:  $\pm 1.0^\circ$ ; Phase Resolution:  $\pm 0.1^\circ$ ; Ratio Range: 0.100 to 2.000;  
Ratio Accuracy:  $\pm 2.0\%$ ; Ratio Resolution:  $\pm 0.001$ ; Input Impedance: 50 or 75 ohms



Delta's new Field Strength Meter and Digital Antenna Monitor will help keep your directional antenna system within FCC specifications.

The DAM-1 Antenna Monitor meets the new FCC requirements for remote control. It is a true digital instrument using the latest integrated circuit and TTL techniques. Reads phase and true current ratio for up to six towers with different reference towers and different powers for DA-2. Monitors for larger arrays available on special order.

Delta also offers remote panels and interface units for controlling and reading the DAM-1 Phase Meter over multiconductor, two wire, UHF, or microwave circuits with no reduction in accuracy.

The FSM-1 Field Strength Meter is smaller and much simpler to operate than other field strength meters because it is fixed tuned to your frequency by plug-in modules. If you have to check more than one station, order the FSM-1 with additional frequency modules. For monitor point checks and extensive proof of performance work the FSM-1 will minimize errors and speed up field measurements.

DELTA ELECTRONICS, Department A  
5534 Port Royal Rd., Springfield, Va. 22151  
703/321-9845

**DELTA ELECTRONICS**



NAB Show • Booth 532

Exporter: DELTA ELECTRONICS, INC.  
International Division, 154 E Boston Post Rd.  
Mamaroneck, N. Y. 10543. Telex 1 37327, Art Rocke

# Program Log Rule Would Be "Unrealistic"

The National Association of Broadcasters has urged the Federal Communications Commission to abandon as "totally unrealistic" its proposal to require broadcasters to make program logs part of their public file.

It said in comments that the "hastily-proposed rulemaking" constitutes a "major change in policy" that would impose excessive, needless and costly new burdens on broadcast licensees "without any measurable benefit to the public."

It said FCC's stated objective—encouraging dialogue between broadcasters and the public—would not be achieved since program logs contain no additional information that would be of help to community groups. Actually, it said, the proposal would "substantially reduce" prospects for such dialogue by establishing such a rigid framework for inspection of station files that "neither the licensee nor the general public is likely to achieve any understanding of each other's problems."

The Association chided FCC for describing the proposal as merely adding "one item" already kept by every broadcast station to the public file."

Stating that "the blinders must come off," NAB noted that the Commission itself conceded that program logs "are bulky and may require special handling in storage to enable their easy retrieval." It said the

"very minimum accumulation" of logs over the license period, plus 90 days, would run to five thousand pages for a radio station and 10 to 20 thousand in television.

In automated stations, at an added cost of man and machine hours, personnel would have to supervise the retrieval of information to guard against inadvertent damage to the equipment . . . or "a clever prankster (who) could erase program tapes with the flick of a switch."

If FCC thinks NAB is "being too sensitive concerning the mischievous propensities of the public," NAB said in a footnote, "persons posing as FCC engineers are . . . carrying out station inspections in the midwest." It added that "whatever their purpose . . . it ain't good."

"Many licensees," NAB said, "have expressed concern that logs would be subject to mishandling, theft, alteration, and destruction at the hands of the public . . . Unfortunately, this fear is quite realistic; libraries and other public places are constantly subjected to vandalism and deliberate destruction. Even carelessness, in the form of spilled coffee or errant cigarette ashes, poses a direct threat."

## ALL OF YOUR SYSTEM EQUIPMENT REQUIREMENTS CAN BE MET BY LENCO ELECTRONICS



### UNIVERSAL POWER SUPPLY



UNIVERSAL MOUNTING  
FRAME ACCEPTS UP  
TO 8 D.A.'S

### VIDEO DISTRIBUTION

Our video D.A. is adaptable. The basic amplifier has plug-in accessories to provide:

- Differential input
- Equalization
- High gain
- Breezeway clamp
- Sync adder

You can change accessories with your changing requirements.

### SUBCARRIER DISTRIBUTION

Regenerated Subcarrier  
Continuous phase control of all four outputs  
Independent phase control of two outputs  
Loop-thru input  
Output amplitude adjustable 0-3 V.P.P.  
This unit is actually two cascaded D.A.'s

### PULSE DISTRIBUTION

Our pulse D.A. is adaptable  
**Basic Amplifier:**  
Loop thru input  
Regenerates pulses at their half amplitude width  
Input level 0.5 to 8.0 V.P.P.  
Output amplitude 4.0 V.P.P.  $\pm$  5%

#### Plug In Delay Accessory

One control delays both leading and trailing edges  
Delay 250  $\eta$  sec. to 60 $\mu$  sec.

Write for our complete catalog



## LENCO ELECTRONICS

A DIVISION OF LENCO, INC.

319 WEST MAIN ST.  
JACKSON, MO. 63755

PHONE 314/243-2394 OR 243-3141

## Seventh Annual Acoustics Conference

At the Seventh Annual Midwest Acoustics Conference to be held April 7 at Northwest University, the loudspeaker experts will square off for what is expected to be a technical battle royal.

Presenting varied subjective evaluation techniques are C. G. McProud of Audio Magazine and Julian Hirsch of Hirsch-Houck Laboratories. And presenting opposite but differing views on objective measurements are such advocates as Dan Queen, proponent of reverberant field measurements and Ed Long for free field methods. Paul Klipsch will use his great depth of experience to introduce the subject and place it in historical perspective.

Advance registration fee is \$3.00. Write to: Midwest Acoustics Conference, c/o D. Burkhard, Industrial Research Products, Inc., 321 Bond Street, Elk Grove Village, Ill. 60007, or phone 312-439-3600.

## SMPTE: April Meeting

Hartwell T. Sweeney, Eastman Kodak Co., has been named Program Chairman for SMPTE's 113th Semiannual Technical Conference, it was announced by SMPTE Editorial Vice-President Richard E. Put-

man, Philips Broadcast Equipment Corp.

The Conference is set for April 8 to 13 at the Hyatt Regency O'Hare Hotel in Chicago.

Topics for the Conference have been tentatively established, with the following Topic Chairmen in charge:

William Bowles, Calvin Communications, **Non-Video Display Systems**; Harry Paney, Arthur Anderson & Co., **Industrial TV and Motion Picture Operations**; Dick Kramer, Iowa State University, **Motion Pictures and Television in Education**; William Hunter, WHAS-TV, **Television/CATV**; Si Becker, Allied Film Lab, **Laboratory Practices**, and Henry Kakehashi, International Film Bureau, **Short Film Subjects**.

SMPTE is continuing its policy of holding a two-day special subject symposium the last two days of the Conference (Thursday and Friday). The subject this time will be "Video Cartridge, Cassette and Disc Player Systems—Packaged Programming." Symposium Chairman, according to Editorial Vice-President Putman, is George W. Tressel, Battelle Memorial Institute.

---

**Get Results  
With Classified Ads  
In  
Broadcast Engineering**

---

# NAGRA SYNCHRONOUS RECORDERS

ADAPTABLE TO ANY CAMERA THAT HAS  
ANY TYPE OF SYNCHRONIZING INDEX  
SEE NAGRA — BOOTH 702 — NAB EXHIBIT



**NAGRA 4.2**

STANDARD OF THE WORLD FOR  
STUDIO AND LOCATION SHOOTING



**NAGRA SNN**

One Pound And One Ounce, Crystal  
Sync And Automatic Level Control  
A NEW BREAKTHROUGH IN  
LIGHTWEIGHT RECORDERS

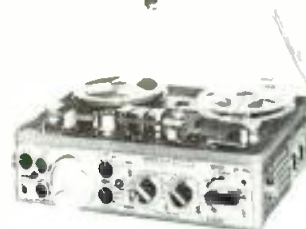

**NAGRA SL SYNC STEREO**

Shoot stereo sound, just release monaural and  
have the stereo track for premium priced re-runs.

DESCRIPTIVE BROCHURES SENT ON REQUEST

United States Distribution — Service — Sales



**NAGRA MAGNETIC RECORDERS, INC.**

19 WEST 44th STREET, ROOM 715 • NEW YORK, NEW YORK 10036 • (212) 661-8066

Southern California Sales and Service RYDER MAGNETIC SALES CORP. 1147 North Vine St. Hollywood, California 90038

(213) 469-6391

# 3 in... 2 out



## Lose a Color?

YES, ON PURPOSE WITH  
THE NEW LOW-COST UAP

## CHROMA KEYS

Broadcast-quality special-  
effects at a price  
everyone can afford.



## Ultra Audio Products

Box 921 • Beverly Hills  
California 90213 • (213) 849-1433

Request Bulletin No. **BE 373**

For More Details Circle (67) on Reply Card

(Continued from page 110)

for desktop, rackmount or console-mount applications (Depth is only 10"; requires only 7" of vertical rack space); easily replaceable regulator and deflection transistors, readily accessible components for ease of maintenance and testing; inter-compartment shielding to prevent crosstalk between adjacent units.

Applications: Broadcast preview, security/surveillance, educational, industrial and medical monitoring, and VTR display.

For More Details Circle (189) on Reply Card

### Custom Audio Console

Sparta's new CENTURION II custom audio console has features not previously available in a broadcast model, including four-channel capability.

Each mixer position is a self-contained plug in module, internally selectable for high or low level inputs. Up to 12 mixers can be supplied, with three switched inputs to each for a maximum of 36 stereo inputs. Illuminated pushbuttons and electronic audio switching provide convenient operation completely free of mechanical or electrical noise. Each mixer feeds either the Program, Audition, or Utility busses, any one of which in turn can feed the Mono Output.

The Program and Audition channels are separately metered so that two adjacent mixers can be used to originate quadrasonic broadcasts, or make four-channel recordings.

Extensive use of motherboards and ground plane PC techniques has virtually eliminated cable harnesses in the CENTURION II. Either vertical or rotary attenuators are available, along with other options.

For More Details Circle (190) on Reply Card

### Decoder

Telemet has introduced a new decoder, Model 4706, designed to put a station's existing RGB Chroma Keyer in-line and providing zero horizontal delay NTSC Chroma Keying.

The unit eliminates Chroma Crawl and can use different encoded video sources. This includes standard and triaxial cable color TV cameras, video tapes, remotes

or any other composite NTSC signal, without restriction to a particular one.

In addition, the Decoder can be interfaced in any part of the system without any complicated cabling. All that is required is that the user has an existing RGB Chroma Keyer.

Telemet can also supply a complete Decoder/Chroma Keyer system if the station requires one.

For More Details Circle (191) on Reply Card

### Mini Playback Audio Tape Cart

Broadcast Electronics, Inc. will introduce the Model Three-70 Mini Playback Audio Tape Cartridge Unit at the NAB Convention. Pre-production field evaluation reports by selected key broadcasters has reinforced our belief that the Three-70 will soon become one of the most popular audio tape cartridge units available to the broadcaster.

This new unit features a direct-drive system in a completely modular package. Its size; 5.625" wide × 5.75" high × 12.5" deep enables the broadcaster to locate the unit within his control operating area, or to rack mount as many as three units in one 7 inch high rack space.

Other features include circuit board interchangeability with the Ten-70 series, glass epoxy boards, plug-in playback deck, remote control and telephone answering facilities.

### Time-Lapse Video Recorders

The only time-lapse video tape recorders using the standard EIAJ-1 format and which are solenoid operated are being marketed by GBC Closed Circuit TV Corp.

The units, which are remote controllable, are available in 12 hour (model TVR-321-12), 24 hour (model TVR-321-24) and 48 hour (model TVR-321-48) modes to provide a continuous visual record of events.

The GBC Time-Lapse Video Tape Recorders are designed for professional time-lapse recording where low cost is a major consideration and maximum performance a must. They are the only recorders

BROADCAST ENGINEERING

capable for surveillance use of over 300 lines of horizontal resolution with playback at time-elapse speed, normal speed or still frame. Conversion from 12 to 24 hour modes, or 24 to 48 hour modes can be accomplished in the field by a VTR technician.

The machines, which use a 7" reel of 1/2" video tape, offer such outstanding features as stop motion, solenoid operated controls, auto-cycling and automatic gain control. Tapes made on these units can be played back on any standard EIAJ recorder.

Although GBC Time-Lapse Video Tape Recorders are designed primarily for video time-lapse recording, special models are available which also provide excellent audio in the 12 and 24 hour modes of broadcast logging.

For More Details Circle (192) on Reply Card

### Computerized Audio Control

New this year in the equipment exhibit of IGM, are two models of computerized audio control systems which the company happily reports have accounted for more than \$1,500,000 in orders from some 30 stations in the past few months.

In full operation will be an IGM Model 740 with integral mini-computer plus two IGM 48-unit "Instacarts," two stereo reel-to-reel transports, IGM automatic time-and-temperature announcer and complete high speed English log printout. Programming will be IGM's taped "Country Living" show. A second computerized model, an IGM 760, will be shown to the extent of a control unit equipped with dual magnetic tape memory and twin CRT's with keyboards to demonstrate how program events are stored, scheduled, called up or changed at will.

Other equipment not previously shown at NAB will be IGM's new "BAT 1000"—a computerized

system to provide broadcast management with integrated control of traffic, billing, payroll and accounting work. Two further equipment exhibits will consist of a simplified, two-rack IGM Model 400 control system, demonstrating "Sounds for All Seasons" taped programming, and an IGM Model 502-4 system with Instacart and direct access MOS memory, featuring the Don McMaster show.

For More Details Circle (193) on Reply Card

### Video Production Switcher

The Cohu Model 9501 is a complete production video switcher in a single compact unit which occupies less than one cubic foot of space.

This switcher offers features found only in larger, more expensive units. Mix, effects, inserts, wipe key, external keying and self-keying are standard modes of operation. Additive or non-additive mixing is panel selected.

There are eight synchronous and two non-synchronous/synchronous inputs with all synchronous inputs being composite or non-composite. Other standard features of the Model 9501 include momentary pushbutton controls, vertical interval switching, matte generator for any shade of gray or one preselected color with variable luminance, preview of all mix/effects, and panel indicated video flow paths.

For More Details Circle (194) on Reply Card

### Solid State Remote Control

Rust Corporation will demonstrate a new Sophisticated-Uncomplicated all solid state remote control system that can operate via microwave or land line or both. The RC-2600B is the first step in the Rust building block system to total "transmitter installation"

(Continued on page 120)

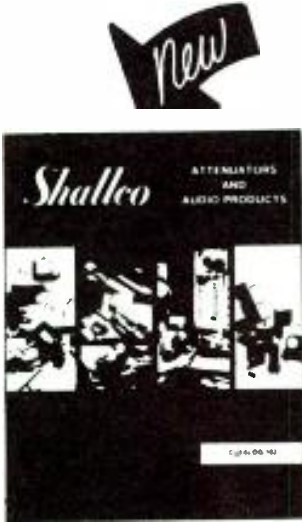

**ATTENUATORS AND AUDIO PRODUCTS**

The above catalog provides 16 pages of information, including applications, charts, tables, and a selection guide. Send for your copy today.

**Shalleo**

P. O. BOX 1089 HIGHWAY 301 SOUTH  
SMITHFIELD, N. C. 27577

For More Details Circle (139) on Reply Card

**For your magnetic tape head requirements ask for Vikron's FREE catalog.**



Vikron magnetic tape heads are designed to meet specific customer requirements. Our engineering department is happy to assist development engineers in determining the model and type of head best suited for their application. Send for your FREE catalog today.



**VIKRON**

3300 Raleigh Ave. South  
Minneapolis, Minnesota 55416  
(612) 927-7533

For More Details Circle (80) on Reply Card

**VIF** INTERNATIONAL

CUSTOM AUTOMATION SYSTEMS. WE WILL SUPPLY ALL OR PART. INTEGRATE YOUR EXISTING TAPE TRANSPORTS, OR WE WILL SUPPLY MAKES AND MODELS OF YOUR CHOICE.

PO BOX 1555, MOUNTAIN VIEW, CALIF. 94040 • TELEPHONE (408) 739-9740.

**IF YOU NEED  
ATTENUATORS  
YOU NEED THIS  
CATALOG!**



**AUDIO AND RF ATTENUATORS  
TO MEET ANY REQUIREMENT**

Here in one compact and informative 24 page booklet is all the data you need to select a Precision Audio and RF Attenuator for your application.

Reference Charts, Circuit Diagrams, Types and Uses, Current and Voltage Ratio Tables, Ratings, Etc., make this a handy and invaluable reference.

SEND FOR YOUR FREE COPY TODAY.

**TECH LABS, INC.**

Drawer "B"  
Palisades Park, N. J. 07650  
Tel.: (201) 944-2221  
TWX: (201) 947-0825

For More Details Circle (92) on Reply Card



with Fidelipac's new Cart-E-rase hand held and table top Demagnetizers. Built to the same standards that have made

Fidelipac the number one name in Automatic Tape Cartridges, the Cart-E-rasers can be used for erasing cartridges, reel-to-reel tape, magnetic film sound striping, tools, etc.



**FIDELIPAC®**

3 Olney Avenue  
Cherry Hill, N.J. 08034  
(609) 424-1234

See us at NAB Booth 511  
Shoreham Hotel

For More Details Circle (93) on Reply Card

automation.

The second step is the all new ALD-B digital printout logging system. A totally new integrated circuit system, smaller in size and components but bigger in capability than ever before.

The third step is a new Status/Alarm system with add-on capability. This basic 15 position system can have any of its positions field strapped to be either alarm notification or simply a status indication.

In addition Rust will also introduce for all non-directional AM stations and all FM stations a low cost, four position, strip chart recorder logging system that can operate through almost any remote control system of any make.

For More Details Circle (195) on Reply Card

**Tape Evaluator**

Recortec will have at its booth their Video Tape Evaluator—a stand alone video tape deck capable of testing tape longitudinally to report on its total length, number of surface defects, edge damages, and splices. An optional printer provides the locations of all problem areas detected. Tapes are also cleaned, degaussed, and precision wound after testing. Total test time is less than 8 minutes for a one hour reel.

Also, their Video Tape Conditioner—a stripped down version of the Evaluator providing cleaning and winding operations only. A timer provides indication of total tape length and an optional full width eraser may be added to degauss tape while winding.

Another useful option is to stop winding at the detection of a cue signal recorded on tape followed by automatic cutting of tape to achieve tailoring of duplicated tapes into spot reels or cartridge spools.

For More Details Circle (196) on Reply Card

Rupert Neve Incorporated announces its Portable Sound Mixing Console—PSM12/2. The Neve PSM is a fully professional portable sound mixing console of extremely compact dimensions (26.625" wide × 18.25" deep × 9.875" high), designed for high quality mono or stereo broad-

casting and recording.

Twelve (12) full mixing input channels with equalization and two principal output buses are provided, each controlled by precision horizontal faders. Each input channel amplifier module has: a single turn switch covering the range of -80 dB to +10 dB in 5 dB steps; a high pass filter with 12 dB/octave slope; a high frequency boost/cut control having a range of +15 dB; a presence control with a choice of 6 switched frequencies and a variable amplitude control covering the range of +15 dB to -15 dB.

There are also two direct input channels, auxiliary output, studio foldback, communication, cueing, speaker and headphone monitoring, and signalling facilities. Modular amplifiers are used throughout. All active circuitry is on plug-in modules employing the highest grade professional components. All inputs and main outputs are balance and ground free.

For More Details Circle (197) on Reply Card

**Film Processor**

Technology Inc., HF Photo Systems Div. will introduce their "Little Max." Little Max is a very small self contained film processor for Super 8, 16 and/or 35mm Ektachrome films in the ME-4 or CR-100 Process.

Little Max offers low initial investment and the lowest possible cost of operation. It is designed primarily for the small to medium size television station where fast access to relatively low film volumes is important.

For More Details Circle (198) on Reply Card

**Video Production Center**

The Miratel Division of Ball Brothers Research Corp. has introduced an updated version of their Video Production Center (VPC). Miratel VPC units, with switching and special effects capabilities, are designed to provide quality programming control for broadcast television, CATV and instructional television.

The new VPC model features an interlocked and fail-safe switching technique which prevents loss of program control by operator error.

For More Details Circle (199) on Reply Card



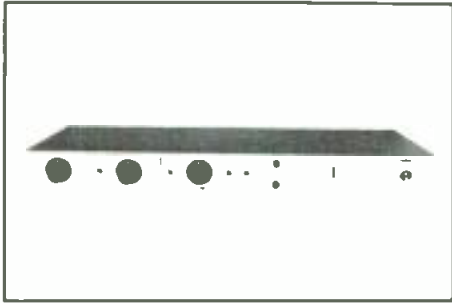

### DUAL LIMITER

The Inovonics Model 200 incorporates both a fast acting Peak Limiter and a separate Average-Responding Limiter in a single package. The two limiting modes permit optimization of program level with minimal "pumping" or "ducking". Fully calibrated, detented controls facilitate setting the unit to any desired limiting characteristic.

Inovonics Booth 543

For More Details Circle (154) on Reply Card

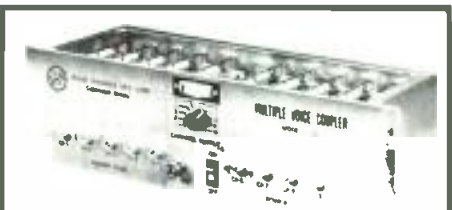

### MULTI-CHANNEL LINE DRIVER

Set up your own DDD Sports Net Up to 10-60 DB Isolated Line Outputs for driving loops, couplers or lines direct. 19" rack mount. Flexible - Order number of channels needed - Add up to 10 later.

Model 183 ..... \$333.95

Model 283 (w/built-in Voice Coupler) \$384.95

(Above are 10 Channel Prices)

**PULSE DYNAMICS MFG. CORP.**

Colchester, Illinois 62326  
Phone (309) 776-4544

For More Details Circle (96) on Reply Card

### Frequency And Modulation Monitors

Belar Electronics Laboratory will exhibit complete frequency and modulation monitoring systems for AM, TV, FM, Stereo and SCA. Highlight of the demonstration will be live off-air monitoring, featuring the monitors and their companion RF amplifiers.

TV stations will be particularly interested in the Belar TV monitoring system, for both VHF and UHF channels, since the RF amplifier is a separate unit to eliminate the problems encountered when a monitor with a built-in RF amplifier is used at the transmitter site.

Of particular interest to the AM broadcaster, in view of the FCC requirement for accurate measure-

ment of 125 percent positive peaks, will be the use of test signals to demonstrate the accuracy of the Belar AMM-1 frequency and modulation monitor in measuring these peaks. The AMM-1 also features a separate 100 percent negative peak indicator.

For More Details Circle (202) on Reply Card

### Moving?

Send Your Change

Of Address To:

Broadcast Engineering

1014 Wyandotte

Kansas City, Mo. 64105



### ELIMINATE THE LIGHTNING HAZARD with LEA Dissipation Array

• Guaranteed No Stroke • Tailored To Any Situation • Less Than Conventional Rods. LIGHTNING ELIMINATION ASSOCIATES, 9102 Firestone Boulevard, Downey, California 90241. Call: (213) 923-1268.

For More Details Circle (152) on Reply Card

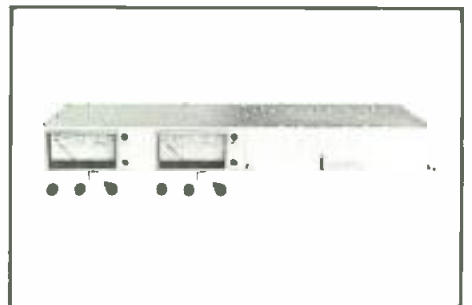

### TAPE ELECTRONICS

The Inovonics Model 355 (2-channel) and Model 360 (single-channel) are high-performance, very reliable tape electronics for upgrading older recorders or for original installations. Both units interface directly with popular professional transports, and accommodate a wide variety of original and replacement heads.

Inovonics Booth 543

For More Details Circle (153) on Reply Card



**3 in 1 Meter:**  
Power & VSWR

New THRULINE® Dual RF Wattmeters display forward AND reflected power simultaneously and monitor VSWR at the intersection of the two meter pointers. Models for 1-5/8, 3-1/8 and 6-1/8 lines, 2 - 1000MHz to 250kW start at \$350.

Peak Reading Wattmeters also available.



**BIRD #539**

For More Details Circle (97) on Reply Card

March, 1973



New TERMALINE® RF Load Resistor Series 8891-500 dissipates 9000 watts continuously with only 3 gal/min cooling water yet costs no more than the aircooled 5000 watt Load: \$750.

Units available with 1 5/8 or 3 1/8 flanged or unflanged connectors, 50 or 51.5 ohms. VSWR below 1.1 from DC to 1000 MHz.

**BIRD ELECTRONIC CORPORATION** Cable BIRDELEC  
30333 AURORA RD • CLEVELAND (SOLON) OHIO 44139 • Phone 216 248 1200

For More Details Circle (98) on Reply Card



MODULOAD® Self-Cooled Load Systems No external water supply is needed for the 10, 20 and 40kW Self-Cooling MODULOAD RF Load Resistors. The integral heat exchanger permits continuous rated dissipation in 5° to 45° C ambients (-20° to +20° C with antifreeze). Ratings are increased to 25 and 50kW in 5° to 30° ambients.

MODEL	POWER	FREQ.	CONNECTOR	PRICE
8032	10kW	0-1.4GHZ	3-1/8 EIA FI	\$2350
8641/2	20kW	0-1.3GHZ	3-1/8 EIA FI	3300
8651/2	40kW	0-1.3GHZ	3-1/8 EIA FI	5200

**BIRD Booth #539**

For More Details Circle (99) on Reply Card

# KOWN: Radio in

**Locating radio studios in a shopping center isn't a new idea; KOWN just makes it seem that way. The tempos of the station and the community really gel; the combination has made KOWN a smash.**

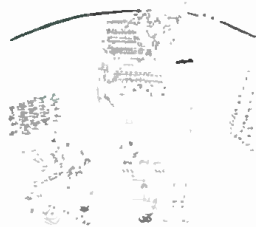

WHEN RETIRED COLLEGE TEACHER Kay Owen put KOWN on the air in 1958, it was the sole broadcast facility in Escondido, California. Serving a population of 12,502, the 250-watt, fulltime radio station was operating at 1450 kHz from cramped quarters in a remote field. Today, KOWN is

serving more than 34,000 people in "California's Fastest Growing Municipality" from the \$10-million, quarter-mile-long Escondido Village Mall. Only the transmitter remains in the field.

The big move came in 1964. Partners Alan Skuba and Dean Kiner, new KOWN owners, thought that locating studios in the new shopping center was "a promotional natural." Heavy pedestrian traffic was assured, since the Mall would probably host much of Escondido's \$95 million in retail sales.

This turned out to be more than a hunch. Since 1964, KOWN's gross billing has increased 625 percent. By 1966, fully-automated KOWN-FM was on the air with 3kW stereo signal. KOWN then provided twice as much entertainment to market-area listeners, because the fm didn't duplicate its a-m sister. In 1968, when KOWN became a family affair (Skuba and his father bought out Kiner), it was evident that the five-year investment in KOWN had been more than worthwhile; a new home and new equipment had helped shape up KOWN for the part it plays in '69—a modern, dynamic station involved in a young, modern community.

Part of KOWN's success is due to its position as San Diego county's only fast-paced, 24-hour, C & W music station; and part is due to a heavy local news coverage—KOWN keeps two mobile cruisers roving. The news staff regularly covers city council meetings, club affairs and fire and police reports. Even the AP newswire promotes the station; passers-by can read the latest copy through the window of the newsroom.

The surest way to radio success is to get your audience involved. So goes KOWN's recipe, which attracts successfully both listeners and advertisers. The station runs 18 contests and promotions each year, mixing fun and sales. Examples include giving a free birthday cake to a KOWN "Birthday Club" listener every day and spotlighting the "Businessman of the Day." Regular listeners who join the KOWN "Country Club," get cards and spe-

The public comes to KOWN—watching deejay through glass on shoppers' mall.



# ADVERTISERS' INDEX

Amco Engineering Co.	50
American Data Corp.	99
American Electronic Labs.	38
Amperex	43
Ampex Corp.	18-19, 54-55
Andrew Corp.	71
Angenieux Corp. of America	103
Audio Video Engineering	88
Belar Electronics	100
Berkey Colotran, Inc.	65
Beston Electronics, Inc.	41
Bird Electronics	121
Robert Bosch Corp.	60-61
Broadcast Electronics	14, 36, 78
Broadcast Tower Service	32
CBS Labs	51
CCA Electronics	72, 73
Canon	79
Capitol Audio Tapes	31
Central Dynamics	21
Cetec	97
Collins Radio	89
Colorado Video, Inc.	44
Comark Industries Inc.	90
Continental Electronic Mfg.	47
Continental Electronic Wholesale Corp.	17
Delta Benco	80
Delta Electronics	114, 115
Dictaphone Corp.	87
Ditch Witch	CE-3
Dynair	93
Dynasciences Corp.	7
ES Enterprises	111
Electrohome Ltd.	11
Electronic Industrial Engineering, Inc.	67
Electro-Voice, Inc.	IFC
Emcee	105
Fairchild Sound Equip. Corp.	92
Fidelipac Div. Telepro Industries	120
Fluke	74
Gates Div., Harris-Intertype Corp.	45
General Electric	85
Grass Valley Group, Inc.	3
Ingersoll Products Div. Borg Warner	52
Inovonics	128
International Tapetronics Corp.	110
International Video Corp.	26-27
Jampro Antenna Co.	69
Jensen Tools and Alloys	122
Lenco Electronics	116
Lightning Elimination	121
McBee Labs	8
McMartin Industries, Inc.	94, 122
Mediatech, Inc.	16
Micro Trac	90
Mincom Div. 3M Co.	CE-5
Minneapolis Magnetics Inc.	74
Miratel Div. Ball Bros. Research	77
Moseley Associates	81

Nagra Magnetics	117
Rupert Neve, Inc.	24
Nortronics	12
Onan	95
Pentagon Industries	107
Polyline Corp.	122
Pulse Dynamics	121
Qualitape	25
Quick-Set	CE-7
RCA Electronics Components	29
Ramko Research	94
Recortec	101
Revox Corp.	15
Richmond Hill Labs.	86
Roh, Inc.	48
Rohde & Schwartz	IBC
Russco	106
SC Electronics	33
Sarkes Tarzian	1
Scientific Systems	82
Scott-Buttner/Coastcom	76
Sennheiser Electronic Corp.	83
Shallco	119
Shively Labs	108
Shure Brothers, Inc.	BC
Sony	CE-8-CE-9
Sparta Electronic Corp.	13
Spotmaster	14, 38, 78
Stanton Magnetics	75
Superscope	104
Switchcraft	28
Systems Marketing Corp.	35, 37, 39
Taber Mfg. & Engineering Co.	92
Taft Communication Systems Inc.	113
Tape-Athon Corp.	98
Tapex Corp.	109
Tech Laboratories	120
Technology Inc. HF Photo Systems Div.	34
Teledyne Isotopes	96
Television Computer Corp.	10
Television Equipment Assoc.	110
Telex Communications Div.	9
Tracor	30
Ultra Audio Products	118
Universal Media Corp.	112
Utility Tower Co.	CE-6
Varian-EIMAC	59
VIF International	119
Vikron	119
Vital Industries	5
Western Electric Products	98
Wilkinson Electronics	42, 91
Xcelite, Inc.	102

# PROFESSIONAL SERVICES

**VIR JAMES**  
**CONSULTING RADIO ENGINEERS**  
 Applications and Field Engineering  
 345 Colorado Blvd.  
 Phone: (Area Code 303) 333-5562  
**DENVER, COLORADO 80206**  
 Member AFCCE

**SMITH and POWSTENKO**  
 Broadcasting and Telecommunications  
 Consultants  
 2000 N Street, N.W.  
 Washington, D.C. 20036  
 (202) 293-7742

**CAMBRIDGE CRYSTALS**  
**PRECISION FREQUENCY**  
**MEASURING SERVICE**  
**SPECIALISTS FOR AM-FM-TV**  
 445 Concord Ave. Phone 876-2810  
 Cambridge, Mass. 02138

**RALPH E. EVANS ASSOCIATES**  
 Consulting Radio Engineers  
 AM - FM - TV - CATV - ITFS  
 3500 North Sherman Blvd.  
**MILWAUKEE, WISCONSIN 53216**  
 Phone: 414-442-4210

**COURTRIGHT**  
**ENGINEERING, INC.**  
 MORRIS COURTRIGHT, Jr., P.E.  
 Automation - Applications Field Engineering  
 ELECTRICAL AND BROADCASTING  
 Route No. 1, Box 854A, Flagstaff, Ariz. 86001  
 Phone (602) 774-8206

**Plastic Reels**  
**FOR MAG TAPE**  
*Shipped from Inventory*  
**POLYLINE** (312) 489-1757  
**CORP.** 2449 N. Western, Chgo. 60647  
 For More Details Circle (206) on Reply Card

**SESCO, Inc.**  
 47 NICHOLS AVENUE  
 P. O. BOX 518  
 (206) 378-2137  
 FRIDAY HARBOR,  
 WASHINGTON, 98250

**MINI "5" CHANNEL ACCU-FIVE \$495**  
 the compact rack mount console ideal for CATV/CCTV audio for complete information please contact the Director of Sales Dept. B-5R

**console**

**SEE US AT NAB '73 Booth 213**



**McMartin** MCMARTIN INDUSTRIES INC., 605 NORTH THIRTEENTH STREET OMAHA, NEBRASKA. 68102 TELEPHONE (402) 342-2753.  
 For More Details Circle (95) on Reply Card

**FREE CATALOG TOOLS**  
**HARD-TO-FIND PRECISION TOOLS**  
 Lists more than 1700 items—pliers, tweezers, wire strippers, vacuum systems, relay tools, optical equipment, tool kits and cases. Also includes four pages of useful "Tool Tips" to aid in tool selection.

**JENSEN TOOLS**  
 3117 N. 64th Street, Phoenix, Ariz. 85018

For More Details Circle (207) on Reply Card  
**BROADCAST ENGINEERING**

# USE OUR CASH FOR YOUR NEW EQUIPMENT

You choose the equipment; we will lease it to you—3-4 or 5 years with option to buy.

## Broadcast Equipment Leasing Co.

DIVISION OF ANCHOR LEASING CORP.

Grant Building  
Pittsburgh, Pa. 15219  
Area Code 412-281-3768

For More Details Circle (105) on Reply Card

## TRAINING

**PASS FCC EXAMS** with Ameco books. Each book contains FCC questions plus simplified answers plus FCC-type exams and answers. 3rd class 75c, 2nd class \$2.25, 1st class \$1.50. Free catalog. Ameco Publishing, 314G Hillside Ave., Williston Park, N. Y. 11596 8-72-tf

**FIRST PHONE** through tape recorded lessons at home plus one week personal instruction in Washington, DC, Atlanta, Boston, Detroit, New Orleans, Minneapolis, Seattle, Denver, Portland, Los Angeles. Proven results. Our 17th year teaching FCC license courses. Bob Johnson Radio License Preparation, 1060D Duncan, Manhattan Beach, Calif 80266. Phone 213-379-4461 1-69-tf

**PASS FCC** first and second class exams with new 21 lesson, 450-page course. Starts with basic electricity Over 600 FCC-type, multiple-choice questions and sample exams included. No previous technical knowledge required. Commercial Radio Operator Theory Course, #15-01. Only \$5.95 Ameco Publishing, 314G Hillside Ave., Williston Park, N Y 11596. 8-72-tf

**EARN ELECTRONICS DEGREE**, mainly by correspondence F.C.C license preparation included at your option Accredited by Accrediting Commission of NHSC G.I Bill approved. Free brochure Write: Dean, Grantham School of Engineering, 1505 N Western, Hollywood, California 90027 8-72-tf

## WANTED

**WANTED:** All surplus broadcast equipment especially clean A.M. & F.M transmitters, contractors, capacitors. Surplus Equipment Sales, 2 Thorncliffe Pk. Dr. Unit 28 Toronto 17, Ont. Canada 1-73-tf

**WANTED TV** studio lighting & equipment. Gifts to non-profit schools are tax deductible. Contact Robt. Jungels, Rhode Island School of Design, 2 College St., Prov. R. I. 02903. 2-73-2t

## EQUIPMENT FOR SALE

**MOTORS FOR SPOTMASTERS**  
NEW Paps hysteresis synchronous motor HSZ 20 50-4-470D as used in series 400 and 500 machines Price \$39.00 each prepaid, while they last 90 day warranty Terms check with order only. no COD's Not recommended for Tape-caster series 600 or 700  
TAPECASTER TCM, INC., Box 662,  
Rockville, Maryland 20851 1-72-TF

**COLLINS TWINTAPE** with record unit for sale. Excellent condition. New \$1800, now \$1000. WUVT-FM, Squires Center, Blacksburg, Va. 24061. 3-73-1t

## EQUIPMENT FOR SALE CONT.

New Moseley ADP-220 transmitter automatic logging system, \$5900. Contact T. A. Bone, WPRI TV, Providence, R.I. Phone 401-521-4000. 3-73-3t

**COLLINS PREAMP** model 356A-1 brand new unused, plug in type, for Collins 212E-1 console. \$50.00. Write Dept. 279, Broadcast Engineering, 1014 Wyandotte St., Kansas City, Mo. 64105. 3-73-1t

**SURPLUS AUDIO PATCH PANELS.** All Standard Configurations. Gulf Telephone & Electronics, Inc., P.O. Box 42130, Houston, Texas 77042. 7-72-tf

**TEN WATT TRANSMITTER**, used, to start high school station. Send details to James Selway, Sparrows Point High School, Edgemere, Md., 21219. 3-73-1t

**"NEW & USED TOWERS, Buy, Sell or Trade, Erect. Ground wire 85c lb. Bill Angle, 919-752-3040, Box 55, Greenville, N.C. 27834."** 2-71-tf

Two RCA TR-4 low band, air bearing videotape recorders, SN4267 equipped with ATC, LLO, \$10,000. SN4244 equipped with ATC, CATC, LLO, auto guide servo, electronic editor, \$18,000. Three Philips studio plumbicon cameras, LDH-200, six camera cables, remote control units, \$8,000 each. One Philips film chain, plumbicon, LDH-150, \$2,500. All equipment in excellent condition. Contact: R. J. Files Diocesan TV Center Uniondale, N.Y. 11553. 3-73-2t

**ONE STOP** for all your professional audio requirements. Bottom line oriented. F. T. C. Brewer Company, P.O. Box 8057, Pensacola, Florida 32505. 7-71-tf

**AMPEX PARTS**, head stacks and head assemblies, complete inventory - write for price quotation. ACCURATE SOUND CORPORATION, P.O. Box 2159, Garland, Texas 75041. (214) 278-0553. 12-72-4t

**QUALITY AUDIO CONSOLES** are our specialty. Modern styling with slide potentiometers and "soft" audio switching. We manufacture 8 standard consoles at very competitive prices. However we'll manufacture a custom system to your specifications if you prefer. Also plug-in audio modules including distribution amplifiers, preamplifiers, monitor amplifiers, etc. Write or phone for pricing and specifications. SYSTEMS ENGINEERING COMPANY, P.O. Box 49224, Atlanta, Ga. 30329. 404-482-2446. 2-73-12x

**CARTRIDGE TAPE EQUIPMENT** —Rebuilt. New paint, heads, flywheel, pressure roller, belts, etc. Spotlessly clean and thoroughly tested. 30 day money-back guarantee, 90 day warranty Also contact us for possible discounts on new equipment and accessories. AUTODYNE, Box 1004, Rockville, Maryland 20850, (301)762-7626). 7-72-tf

**HELIX-STYROFLEX.** Large stock—bargain prices—tested and certified. Write for price and stock lists. Sierra Western Electric, Box 23872, Oakland, Calif. 94623 Telephone (415) 832-3527. 1-73-tf

**SCOTCH 2400' STUDIO TAPE** on 7" reel, degaussed and boxed, 12 For \$11 POSTPAID. Free price list. WIDE RESPONSE, 2926 BENTLEY AVE., LOS ANGELES, CALIF. 90064. 2-73-2t

Available: RCA TK-42-43 Color Cameras & TR-22 Video Tape. R. W. Flanders, A.C. 317 635-9788 WRTV, Indianapolis. 3-73-1t

**FAIRCHILD 663 LIMITERS** -five available at \$100.00 each Fairchild Model 675 Dynamic De-esser - one available at \$100.00 ACCURATE SOUND CORPORATION, P. O. Box 2159, Garland, Texas 75041 (214) 278-0553. 12-72-4t

**RCA BTF-5A kw FM transmitter.** Available February. Reasonable. Also plate transformer for BTF-3B. Contact Chief Engineer, WDBQ, Dubuque, Iowa. 319-583-6471. 3-73-2t

**LIVECAST CONSOLE**, used, set up for rock, 10 input stereo, all professional components, Electrodyne preamps, Daven pots, with panpots, que, E.Q., etc. \$2,500.00 Call (415) 989-1130 or write, Lumiere Productions, Inc., 759 Harrison St., S.F. 94107. 3-73-1t

**RCA 16" Tone Arm M1-11895** For RCA Type 70 or BQ-2 Turntable. New \$15. WIDE RESPONSE, 2926 BENTLEY AVE., LOS ANGELES, CALIF. 90064. 2-73-3t

**BUILD YOUR OWN TV AND RADIO PRODUCTION EQUIPMENT.** Easy, inexpensive, (mostly IC). Plans or kits: Special Effects Generator. Automatic Logger. Vertical Interval Video Switcher. Solid State Lighting Board. Preset Audio-Video Board, Preset Lighting Board. Crystal Controlled Wireless Mikes with matching receivers. Subsonic Tone Control for audio tapes. 8MM SOF Cameras and Projectors. Distribution Amplifiers (Sync. Video, Audio). Audio Control Boards (Studio & Remote) Proc-Amp with compensation and regeneration for adapting Helical Scan VTR's to broadcast standards. PLUS specialized correspondence courses in Telephone Engineering (\$39.50), and Integrated Circuit Engineering (\$49.50). Plans from \$5.95 to \$15. SUPER CATALOG plus years updating of new devices Air Mailed \$1.00 Don Britton Enterprises, PO Drawer G, Waikiki, Ha. 96815. 1-73-4t

**"TWO RCA TK-42 color camera chains** complete with auxiliary electronics and controls. \$15,000.00 each E Newton Wray, General Manager, KTBS-TV, Shreveport, La 71104. Telephone 318-868-3644." 1-73-3t

**FIDELIPAC CARTRIDGES**, NAB approved Factory New. All carts have minimum of 6 minutes worth of tape. Sold in cartons of 50 units only \$1.00 each. Send check with order. Satisfaction guaranteed. Gately Electronics, 57 W. Hillcrest Avenue, Havertown, Pa. 19083. 2-73-3t

## RECORDING STUDIO CONSOLE

Ideal for sophisticated TV audio. 18 microphone or high-level inputs with EQ & echo on each. EQ on each of the 4 output channels. Built-in multi-freq. oscillator. Group submastering; channel masters; grand master. 4 reverb devices. 4 dual-60 watt amps. Intercom while recording; talkback (mic's. included). Audition any input while recording. "Silence" button prevents performer ruining audio by disturbance during echo "overhang" at end of "take". Producer's desk; all audio in accompanying rack. Very compact! Slightly used, guaranteed. Sacrifice for half of new value.

SounDesign  
Box 291, Beverly Hills, Calif. 90213

## TV EQUIPMENT INVENTORY CLEARANCE

STUDIO QUALITY COLOR CAMERAS  
NEW  
\$12,000 (LESS P60 TUBES) 6 AVAIL.

CONTACT:  
RON ADAMSON

SARKES TARZIAN, INC.  
812-332-7251

WE ARE EXPANDING

# CLASSIFIED

Advertising rates in Classified Section are 15c per word, each insertion, and must be accompanied by cash to insure publication.

Each initial or abbreviation counts a full word. Upper case words, 30c each.

Minimum classified charge, \$2.00.

For ads on which replies are sent to us for forwarding, there is an additional charge of \$2.00 to cover department number, etc., which is printed in advertising copy, and processing of replies.

Classified columns are not open to advertising of any products regularly produced by manufacturers unless used and no longer owned by the manufacturer or a distributor.

## SERVICES

**CRYSTAL & MONITOR SERVICE.** Frequency change, repair or replacement of oven type broadcast crystals. Also frequency change and recalibration or repair of AM frequency monitors, and H-P FM monitors. Fast service at reasonable prices. 30 years experience! Call or write: Edson Electronic Co. Box 96, Temple, Tx. 76501. Pho 817 773-3901. 9-70 tf

**CARTRIDGE RELOADING.** Send us your worn cartridges for reconditioning. Carts cleaned, new pressure pads installed, and minor parts replaced. Tops replaced at manufacturers cost. 48 hour service. Competitive prices. New cartridges also available. Call or write: Mar in Cartridge Co., 195 Prentiss Ave., Drew, Miss. 38737 (601) 745-8380. 11-72-6t

**TOWER FABRICATION,** erection and painting. Antenna and Electrical work our specialty. Security Tank & Tower Corp., P. O. Box 913, Henderson, Kentucky 42420 (502) 827-2509. 1-73-6t

## HELP WANTED

Established station in all U market needs maintenance supervisor with experience in VTR's and color cameras. Salary commensurate with experience. Equal Opportunity Employer. Send resume to Dept. 278, Broadcast Engineering, 1014 Wyandotte St., Kansas City, Mo. 64105. 3-73-1t

**JOB HEADQUARTERS** for all Radio and Television Engineers. Immediate openings exist in 9 western states and elsewhere for qualified engineer and technical personnel. All categories from trainees to experienced transmitter maintenance, chief, assistant chief, live color video maintenance and technical operations. Send us your complete resume now. The AMPS Agency, 11661 San Vicente Blvd., Suite 300, Los Angeles, Calif 90049 Telephone 213-820-2678. By Broadcasters--For Broadcasters 11-68-1f

## BROADCAST FIELD ENGINEERS

If you have experience in the maintenance of television tape, UHF, VHF and TV transmitters, or color studio equipment, we can offer you a career opportunity as a Field Engineer. Positions are in the Mid-Atlantic, Midwest and West Coast areas.

RCA offers outstanding benefits including liberal vacation, paid holidays, life insurance, retirement plan. Plus free medical insurance for you and your family.

Write: C. H. Smith, RCA Service Company, Bldg. 204-2, Cherry Hill, Camden, N.J. 08101. We are an equal opportunity employer M/F.

# RCA

## HELP WANTED CONT.

# COLOR CAMERA DESIGN COHU NEEDS YOU IN SAN DIEGO

FOR DESIGN OF ONE AND THREE TUBE COLOR TELEVISION CAMERAS.

EE or Physics Degree required. MS preferred. Three-ten years direct experience a must.

Cohu's modern facility is 15 minutes from bay and ocean, 50 minutes from mountains. Excellent Health/Life Insurance. Profit Sharing Retirement Program. Five institutions provide excellent graduate study opportunities.

Call (collect) or write, (resume) J. L. Kimball, V. P. Engineering, to arrange a personal interview. COHU INC., Box 623, San Diego, CA 92112. Phone 714-277-6700. An Equal Opportunity Employer.

## BROADCAST FIELD ENGINEERS

### WE ARE EXPANDING

If you are experienced in maintenance of color studio equipment we have an excellent growth opportunity for you in a new career with challenge and real advancement possibilities.

WRITE: SARKES TARZIAN, INC.  
BROADCAST EQUIPMENT DIV.  
E. HILLSIDE DRIVE  
BLOOMINGTON, IN 47401

## FERNSEH

### SALES & SERVICE REPRESENTATIVES NEEDED

Rapidly expanding company selling and servicing (nation-wide) world's finest television equipment is seeking high caliber, thoroughly experienced Sales and Service Engineers to staff 5-regional offices in the U.S.

Send letter and resume, stating salary requirements to R. F. Goodspeed, Manager.

Fernseh Division  
Robert Bosch Corporation  
2800 South 25th Avenue  
Broadview, Illinois 60153

An Equal Opportunity Employer

## HELP WANTED CONT.

## TELEVISION DEVELOPMENT ENGINEERS

### WE ARE EXPANDING

If you are now doing development work in TV equipment we have an excellent growth opportunity for you. We need engineers skilled in analog & digital circuit design to join in the development of equipment which is at the forefront of the state of the art. You can see some of it at NAB; in the meantime--

CONTACT AL BUSCH  
812-332-7251  
SARKES TARZIAN, INC.

## SALES POSITION

High Level technical sales of quality line of video switching and terminal equipment to TV stations. Great opportunity for ambitious man willing to travel the East Coast, based New York area.

Contact or write Marketing Mgr.



VITAL INDUSTRIES, INC.  
3614 S.W. Archer Road  
Gainesville, Florida 32601

**MAINTENANCE ENGINEER:** With experience in maintaining Ampex VTR's and Norelco color cameras. Employment based in Seattle with some travel. Send resume to Northwest Mobile Television, 320 Aurora Avenue North, Seattle, Washington 98109. 3-73-1t

# MEET FCC SPECS ON RADIATION, SPURIOUS, HARMONICS AND INTERMODS

with

## VHF FIELD-STRENGTH METER

25 to 300 MHz

### Fields of Application

Measurements of propagation and coverage  
Radio monitoring  
and radio interference measurements  
Measurement of wanted-  
and interfering-signal field strengths  
Measurement of vision carriers, FM carriers,  
AF carriers, system noise, radiation, hum level,  
intermodulation, cross modulation, co-channel  
interference  
Selective microvoltmeter

Higher accuracy  $\pm 2$  dB as a selective  
microvoltmeter,  $\pm 4$  dB in conjunction with  
its easily attached antenna operating as  $\lambda/2$   
dipole over range 60-300 MHz and shortened  
dipole below 60 MHz.  
Optional pulse weighting unit (only in  
50  $\Omega$  unit)  
Higher sensitivity and improved selectivity  
Lower RF leakage and higher (40 dB) linear  
overdrive capability

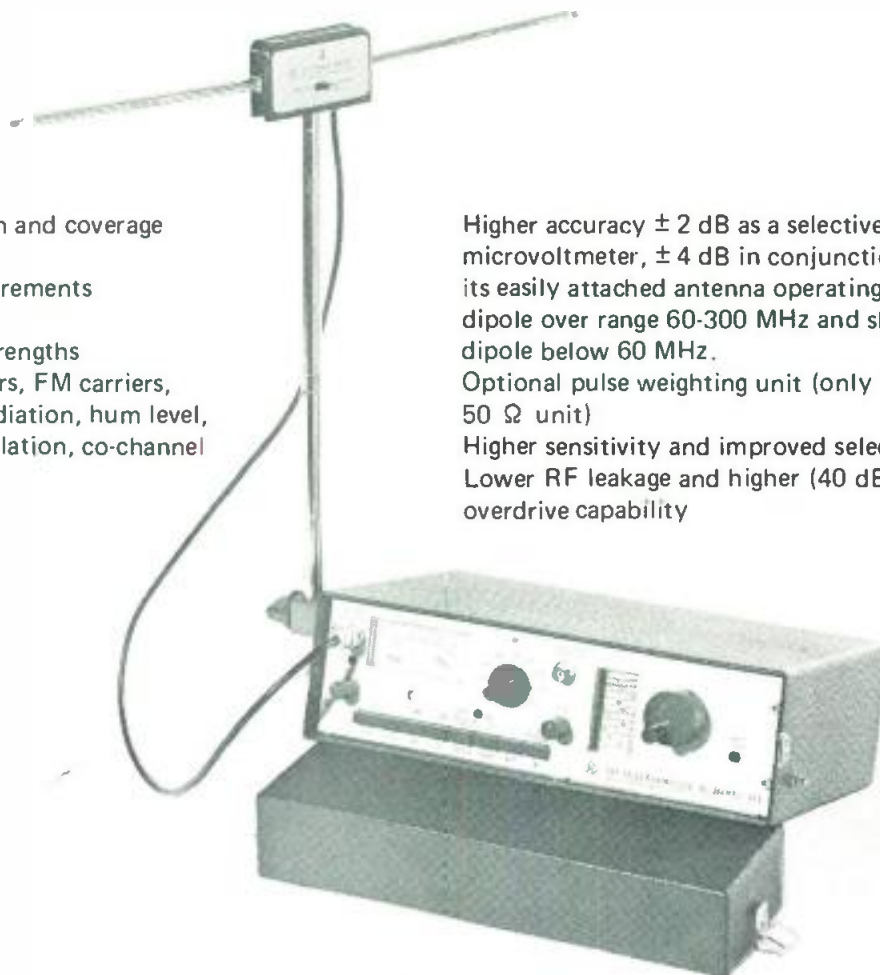

- Continuous tuning without band switching
- Direct voltage calibration in dB ( $\mu$ V)
- Measurement range 100 dB (log. 130 dB)
- Internal calibration at any frequency with pulse generator
- Available in 50 and 75  $\Omega$

- Linear (20 dB) and logarithmic (60 dB) indication
- Peak- and average-value measurements
- Rotatable and tiltable dipole
- AC supply and 8 hour Ni-Cad battery operation

"See us at NAB booth 312"

Get The Extra Capability,  
Greater Reliability, and  
Longer Useful Life Of . . .



### ROHDE & SCHWARZ

111 LEXINGTON AVENUE, PASSAIC, N. J. 07055 • (201) 773-8010

For More Details Circle (2) on Reply Card

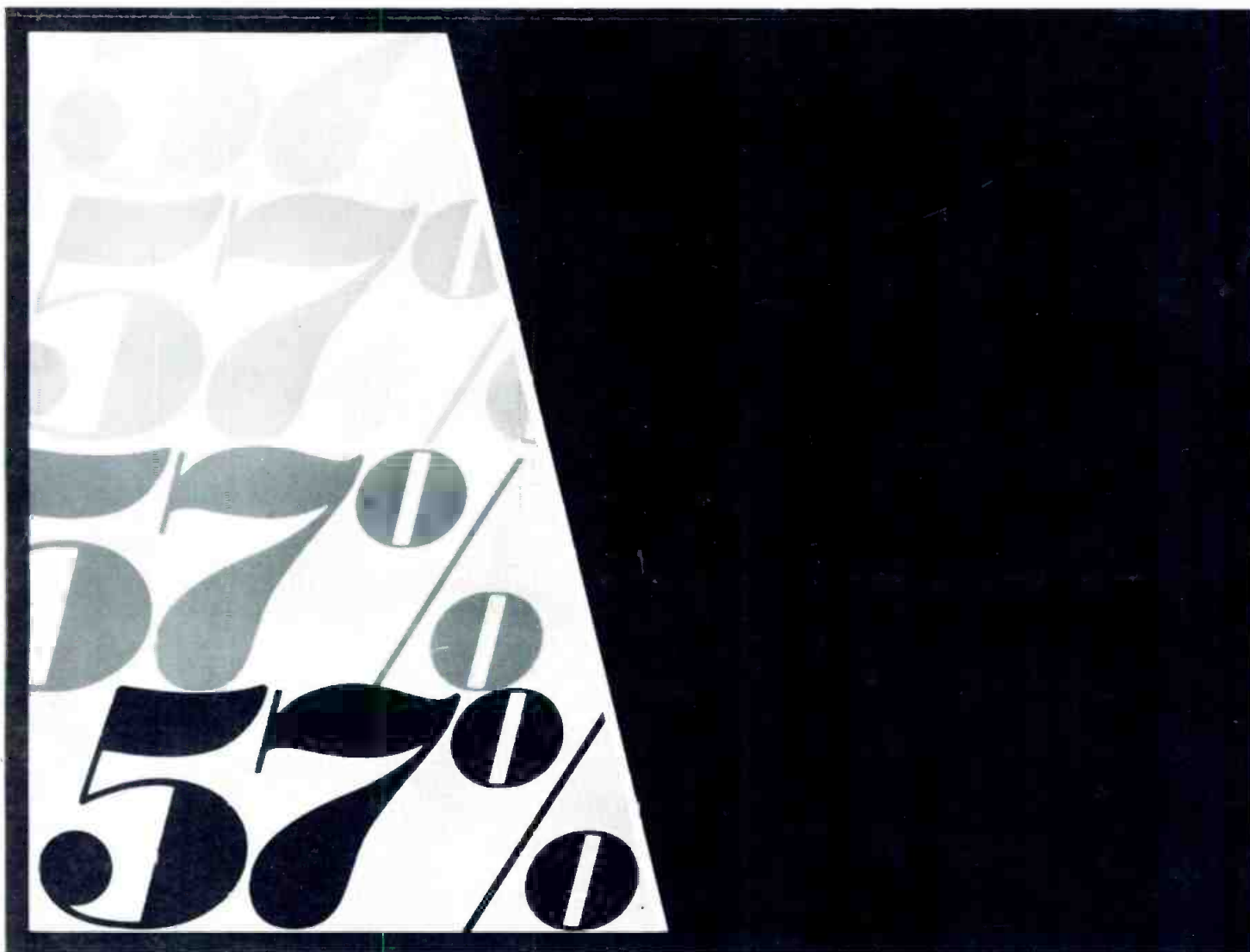

it's on record...

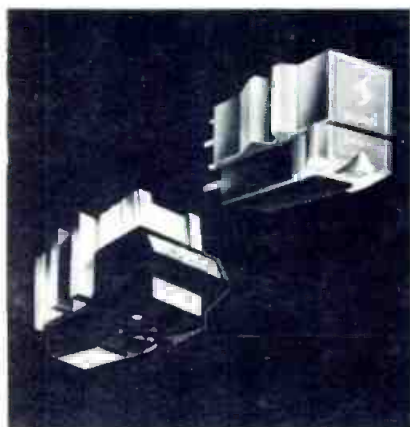

Now it's official! An association equipment survey quoted in *BM/E* magazine produced some very revealing information on FM broadcast industry preferences — particularly in the category of phono cartridge usage, where a whopping 57% of the respondents expressed their preference for Shure cartridges . . . *more than all other brands combined*. It didn't particularly surprise us because we know our M44 series with its uncommon combination of clear sound, low cost, exceptional ruggedness and excellent back-cuing characteristics, has been the broadcast standard for years. And our peerless V-15 Type II Improved? There simply isn't a better cartridge for "high fidelity" FM operations. Write for the free Shure "Guide to the Conversion of Monophonic Broadcast Facilities for Stereo Records," as well as the complete Shure Phono Cartridge Catalog.

Shure Brothers Inc.  
222 Hartrey Ave., Evanston, Ill. 60204

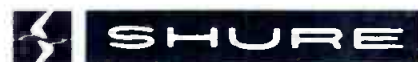

For More Details Circle (3) on Reply Card