

AUGUST 1975

# BME

BROADCAST MANAGEMENT ENGINEERING



### Place-A-Commercial Game Rules

- 16 Minutes Per Hour
- 8 Time Slots
- 120 Seconds Per Time Slot
- 3 Units Per Cluster
- Red=60 Second Spots
- Black=30 Second Spots
- No Product Adjacencies

If you have trouble  
placing these commercials,  
you need a computer.



## System 90 puts Harris ahead in program automation

- System 90 is a complete program automation control package, with many standard features that are usually considered optional in other systems.
- All programming is handled from a single control console, which can be conveniently located up to 150 feet away from the system. The console also provides continuous display of important operating data.
- Flexible design lets you expand as your needs expand . . . with additional consoles, memory expansion, source expansion, automatic memory load and a choice of clear text or numeric logging.

And there's lots more. For complete information about the dependable, easy to operate, competitively priced System 90, write Harris Corporation, Broadcast Products Division, 123 Hampshire Street, Quincy, Illinois 62301.

**HARRIS**



COMMUNICATIONS AND  
INFORMATION HANDLING

# THE ADC 553

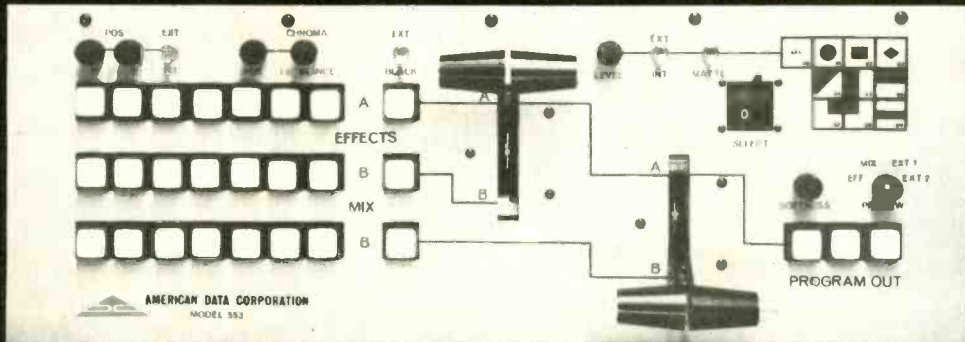

## A TOTALLY NEW PACKAGE DESIGNED ESPECIALLY FOR:

- ★ THE LARGE MARKET
- ★ THE SMALL MARKET
- ★ THE MEDIUM MARKET
- ★ CABLE, CCTV, MOBILE
- ★ ONLY \$3,950

The ADC Model 553 Vertical Interval Color Production Switcher is designed to provide small studio and remote van operators with a broadcast quality switching system that incorporates the latest state-of-the-art advances. SOFT WIPE and LINEAR KEY are standard features, but a new development from ADC allows the combining of two 553 systems for a system of unmatched capability and economy.

The special effects generator provides nine wipes, including a circle, square, diamond, diagonal, H&V splits and corner inserts. In key mode, the special effects generator provides a choice of self or matte key on internal or external sources, and an external chroma keyer may be used on the external input. True SOFT WIPES are provided, with control for degree of softness. The keying system is LINEAR in nature so that edge crawl and key breakup are minimized.

The Model 553 is self-contained and designed to mount in a standard 19 inch console or rack housing. Input selector buttons are momentary contact, illuminated with re-legendable lens caps. A blackburst and color background generator is included in the switcher to provide fades or wipes to any color or black, and in conjunction with the matte keyer, will provide colored insert keying.



**AMERICAN DATA CORPORATION**

AN **AIRPAX** COMPANY

315 WYNN DRIVE, N.W. P. O. BOX 5228 HUNTSVILLE, ALABAMA 35805 TEL. 205-837-5180

1729 WILMOUNT DRIVE  
ATLANTA, GA. 30329  
404-633-2100

5504 WATERWAY  
ROCKVILLE, MD. 20853  
301-460-1454

3250 WILSHIRE BL. STE900  
LOS ANGELES, CA. 90010  
213-387-7756

2908 MULBERRY  
PASADENA, TX. 77502  
713-941-7272

**AIRPAX ELECTRONICS**

Cambridge Division  
Cambridge, Md.

Circuit Breakers & Switches  
Controls Division  
Ft. Lauderdale, Fla.

Tachometry & Control Instrumentation

Circle 101 on Reader Service Card



If you've played Compu/Net's game you know how its done. With a system of priorities, a computer can place commercials optimally. Make aces highest priority, kings next, etc. With the 12 o'clock slot as position 1 the answer is:

- |                |               |
|----------------|---------------|
| 1. AH, KS, 10C | 5. AC, KD, 8C |
| 2. QH, JC, 9S  | 6. QC, JD, 7C |
| 3. AD, KC, 10S | 7. AS, KH, 8S |
| 4. QD, JS, 9C  | 8. QS, JH, 7S |

**BROADBAND INFORMATION SERVICES, INC.**  
274 Madison Ave.  
New York, N.Y. 10016  
212-685-5320

Editor  
**James A. Lippke**

Associate Editor  
**Robin Lanier**

Contributing Editor  
**Robert Wollins**

Editorial Assistant  
**Karen Goudket**

Art Director  
**Gus Sauter**

Manager  
Publication Services  
**Djuna Zellmer**

Circulation Manager  
**Barbara B. Connolly**

FCC Counsel  
**Pittman Lovett Ford  
and Hennessey**

Publisher  
**Charles C. Lenz Jr.**

---

## AUGUST 1975/VOLUME 11/NUMBER 8

---

**6 Broadcast Industry News**  
*FCC makes more room for new AM services*

**22 Interpreting the FCC Rules & Regulations**  
*Sponsorship Identification Rules*

---

### Special Emphasis on Automation—Part II

---

**28 Radio Automation Hardware**  
*Using today's equipment to make broadcasting easier, less error-prone and more creative.*

**32 Automating Talk Shows**  
*At WERE in Cleveland automation didn't mean loss of spontaneity.*

**38 "Total Automation"**  
*How WTCN, Minneapolis automated all phases of their operation from receiving an order to billing.*

**39 TV Switching Automation at CBS: A Second Generation**  
*New automated A-V switching systems at the CBS O&O's in Chicago and Hollywood will be interfaced with the broadcast management information system*

**52 Update: DCC's Automation Switching Interface**  
*One company's attempt to develop a system that can be an industry standard*

---

**42 Montreux Symposium 1975**  
*Broadcasters from 50 countries meet to view the latest in equipment*

**53 The Great Idea Contest**  
*Readers share their ideas*

**58 Broadcast Equipment**  
*New and significant products*

**63 New Literature**  
*Useful reading materials*

---

**Enter the Best Station Award contest—  
see page 6 for complete information**

---

**BPA** BM/E, BROADCAST MANAGEMENT/ENGINEERING, is published monthly by Broadband Information Services, Inc. All notices pertaining to undeliverable mail or subscriptions should be addressed to 274 Madison Ave., New York, N.Y. 10016. BM/E is circulated without charge to those responsible for station operation and for specifying and authorizing the purchase of equipment used in broadcast facilities. These facilities include AM, FM, and TV broadcast stations; CATV systems; ETV stations; networks and studios; audio and video recording studios; consultants, etc. Subscription prices to others: \$15.00 one year, \$25.00 two years. Foreign: \$20.00 one year, \$35.00 two years. Foreign Air Mail: additional \$24.00. Copyright © 1975 by Broadband Information Services, Inc., New York City. Controlled circulation postage paid at East Stroudsburg, PA.

# 3250 SERIES

## EQUIPMENT FOR SINGLE-LINE PULSE DISTRIBUTION SYSTEMS



MASTER



SLAVE



CHANGEOVER

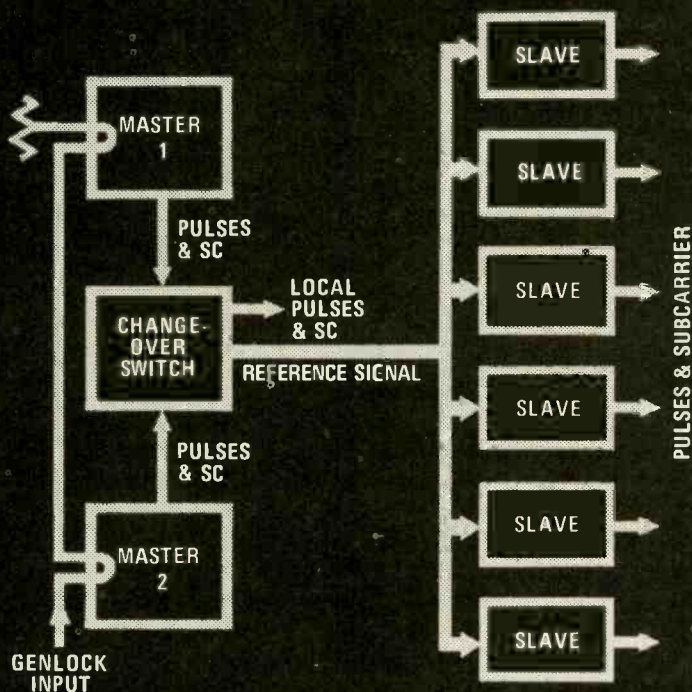

Excellent stability, *plus* color frame accuracy, can be achieved with GVG 3250 Series single-line pulse distribution system components.

The master sync generators include genlock facilities and provision for an external rubidium input—complete with slewing controls. The outputs of two master generators can be applied to a changeover switch to provide automatic transfer to the standby generator in the event of failure of an input signal.

Slave generators lock to a unique reference signal provided by a master unit, and outputs can be either *advanced* or *retarded* with respect to this reference. In the absence of this signal, a slave unit continues to provide normal outputs, referenced to an internal crystal standard.

The equipment utilizes digital techniques throughout, including a custom-designed LSI integrated circuit. Systems are available for both NTSC and PAL applications.

THE GRASS VALLEY GROUP, INC.   
A TEKTRONIX COMPANY

Station Plaza East  
GREAT NECK, NY 11021  
(516) 467-1311

4419 Van Nuys Blvd, Ste 307  
SHERMAN OAKS, CA 91403  
(213) 990-6172

1644 Tullie Cir, NE  
ATLANTA, GA 30329  
(404) 634-0521

P.O. Box 482  
MABANK, TX 75147  
(214) 887-1181

810 W Bristol Street  
ELKHART, IN 46514  
(219) 264-0931

# BROADCAST INDUSTRY NEWS

## FCC Makes More Room For New AM Services

Reaching the conclusion from recent hearings on the subject that the rules on licensing of new AM services were too tight, the Federal Communications Commission has issued modifications that make it easier in many situations to get a new AM station on the air or to enlarge the service of an old one.

The new rules, going into effect August 22, 1975, change the basis of acceptability from the older requirement that 25% of the area to be served lacks any interference-free AM or FM signal, to a new standard: new service will be acceptable if the area presently has less than two services during the time period of the proposed addition. The new rule applies to proposals for

daytime-only operations, for unlimited time stations, for nighttime operation for existing day-only stations, and for increases in power that enlarge service areas. Furthermore, the FCC said an application would be considered for an unlimited time station that would be within the two-services limit at night, even if that would result in more than two services during the day.

The service-rule relaxation does not mean, the FCC emphasized, any change in the existing overlap and nighttime interference regulations.

Another restriction removed was one requiring applicants for suburban AM stations that would put a 5 mv/m daytime signal into an adjoining community of 50,000 or more, with at least twice the population of the suburb, to rebut the presumption they were proposing to

serve the larger community. This burden will no longer be imposed when an application is uncontested, the FCC said.

A further change is the addition of a 2.5 kW power rating to the AM series, which previously had 250 watts, 500 watts, 1 kW, 10 kW and 50 kW.

## Television Hit Dollar Peak in 1974

The television broadcast industry took in more money and kept more in 1974 than in any previous year, according to a survey reported in June by the National Association of Broadcasters. The "typical" station, meaning the middle one in the series of 365 that answered the NAB questionnaire, had time sales of \$2,337,500 and net revenue of \$2,114,400, up 8% and 7% respectively from 1973, and above \$2 million for the first time in history.

Pre-tax profit of the typical station was also at an all-time peak of \$358,600, although the profit rate was down slightly, from 17.4% in 1973 to 17% in 1974.

Revenue of the typical station came from \$1,082,000 in local advertising (up 7.6%); \$937,300 in national and regional spot (up 11.9%); and \$317,900 from network sales (up 0.9%).

Especially significant was the fact that UHF stations, reported separately by the NAB, also rode up the profit scale. The typical UHF, says the NAB, was in the black with revenue of \$1,473,400 and profits of \$69,700. That put the profit rate at 4.7%, up from the 2% of 1973. The UHF survey was based on data from 82 stations, or about 44% of all UHF stations on the air.

## Entries Invited for BM/E's 1975 Best Station Award

BM/E will repeat in 1975 the "Best Station Award Contest" which had a highly successful run in 1974, its first year.

The objective of the contest is to show broadcast studio or overall plant designs or modernizations that increase operating efficiency, to assist dollar-smart operation. A complete broadcast plant, or any important sector, could be the subject of an

continued on page 8

## Prize-Winning Broadcast Building in Austria

The roughly circular building shown at right is the home of the Austrian Broadcasting Corporation's ORF radio and television center in Salzburg. The main idea of the design is the arranging of the wedge-shaped studios, offices and technical rooms around the central two-story hall. Aluminum is used throughout the building, for structure, piping, etc. The building won the R.S. Reynolds Memorial Award for the architect, Gustav Peichl of Vienna. The \$25,000 prize, donated by the R.S. Reynolds Metal Co. in memory of its founder, is administered by the American Institute of Architects, which chose the jury and gave the award to Mr. Peichl at the annual AIA Convention in Atlanta on May 18th.

The large wedge with stepped roof to the right of center holds the main TV studios. Other wedges, moving counter-clockwise, are the disc and tape production studios, the radio studios, the master control area. Two-story office complex is at the left.

Aluminum piping and structure are left exposed wherever possible, as can be seen in photo of central hall.

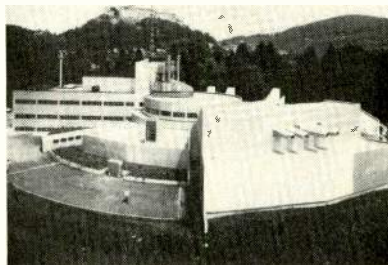

# Total station automation one year later: **SMOOTHER ON-AIR LOOK**

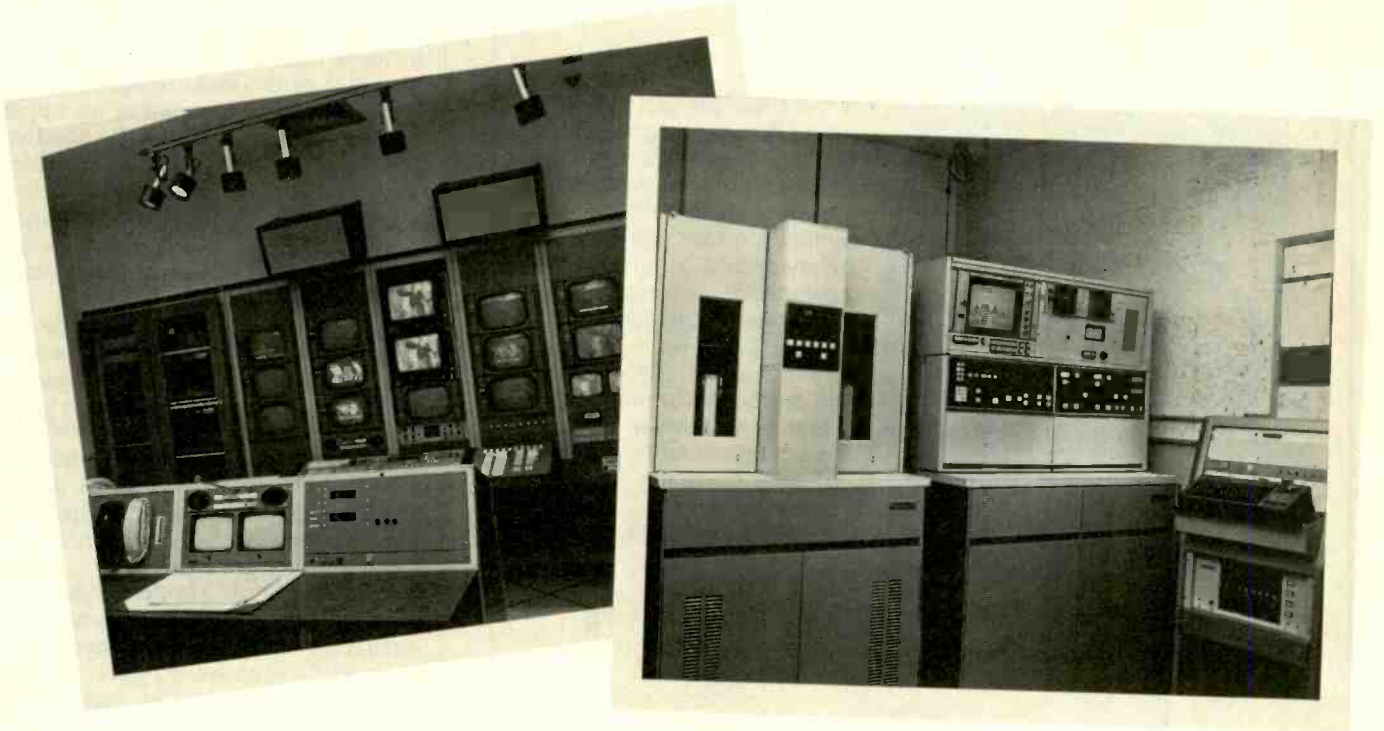

## **Ampex ACR-25s with ADA contribute to system success at Metromedia stations.**

When Metromedia committed itself to complete station automation, it took the courage of an industry leader.

Who could be sure automation would actually work?

Of its 6 stations, WTCN-TV, Minneapolis, was the first to receive the full automation face-lift. All others are following suit; latest to update is WNEW-TV, New York.

In July of last year, WTCN-TV went on stream with an Ampex ACR-25 Automated Cassette VTR, and early this year, an Ampex ADA, Automation Data Accessory. Also in the system loop is a BCS traffic management system, a CDL APC 610-200 switching system, and a DEC PDP-11 minicomputer.

Keyed to ACR-25's exclusive "total station automation" compatibility, the entire system can now program a spot from order confirmation to air-time with split-second timing and accuracy.

Technically, the purpose of the automation was two-fold: (1) achieve a more finished-looking on-air product, and (2) achieve higher manpower efficiency.

WTCN-TV's master control function is now performed by just three people: one at the master control console, one in the film projection room, and the third in the tape room.

Other benefits have surfaced. No more daily spot reel. Reel-to-

reel machines are freed for revenue-producing assignments. The tape operator just loads cassettes at random in ACR-25's empty bins, so he is free for other duties. More ways to increase and vary outside production have been found, and more tape room time is available.

The management of WTCN-TV is convinced that they are definitely transmitting a better looking product. And morale has been boosted considerably. But it goes deeper than that. The sales people believe that the enhanced production capabilities and improved look have given them a considerable edge. Time buyers and sponsors are impressed, both locally and nationally.

These experiences and others proved to Metromedia that their commitment to automation was a wise decision, especially in today's economy.

Like Metromedia's WTCN-TV and WNEW-TV, you can discover that today's economy is not your enemy if it helps you discover the Ampex ACR-25 and ADA. Station managers in markets of all sizes are looking to automation today, not in the future, in order to save overhead dollars right now.

For details, contact your local Ampex Broadcast Video Sales Engineer, or write for information.

**AMPEX**

Ampex Corporation  
Audio-Video Systems Division  
401 Broadway  
Redwood City, California 94063

Circle 102 on Reader Service Card

# The MASTER CART from FIDELIPAC®

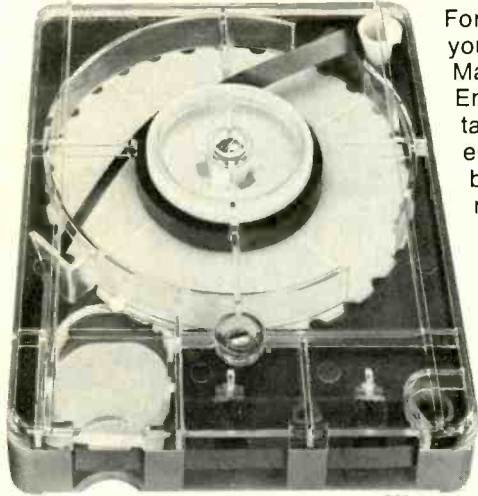

For the cleanest cart sound your station can broadcast, Master Cart is the answer. Engineered to use natural tape flow patterns that eliminate erratic tape behavior and assure repeatability both from cartridge to cartridge and usage to usage. Provides that added edge in stereo performance that conventional cartridges *can't* deliver. Fewer parts for simpler maintenance . . . and greater reliability.

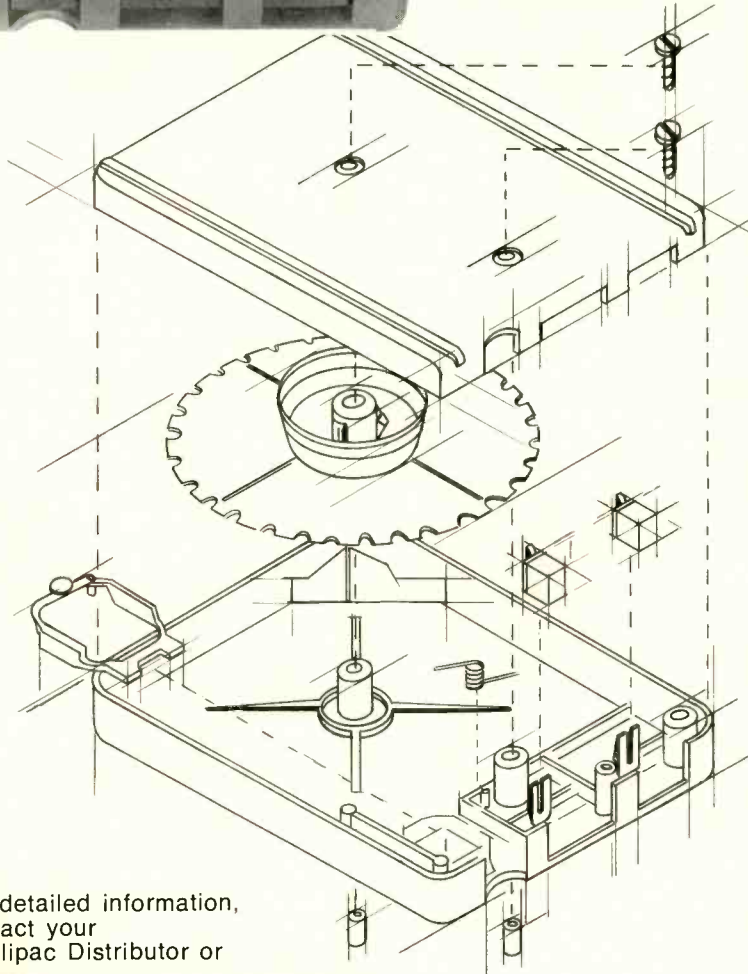

For detailed information, contact your Fidelipac Distributor or



**FIDELIPAC®**

109 Gaither Drive • Mt. Laurel, NJ 08057  
(609) 235-3511

® Trademark

Set us at Booth  
#71, Atlanta

Circle 103 on Reader Service Card

## NEWS

entry. For example, among the winners in the 1974 contest was a combined console and studio design of FM station WNHU, at the University of New Haven.

The contestant should describe the design or modernization fully enough to make clear the logic, in cost effectiveness, of the main design choices. However, BM/E is setting an upper limit of 1500 words to make possible the publishing of as many entries as possible. Schematics, floor plans, photos should be included as judged desirable; because of space limits BM/E may be forced to select from among them.

All entries deemed acceptable by BM/E's editors will be published in the December, 1975 issue. Readers will be asked to vote for the top entry in each of three classes: AM, FM and TV. The winners will be announced in the March, 1976 issue. Each of the three winners will get a plaque designed to enhance any studio, visitors' lobby or manager's office.

Smaller stations should not fear that their designs or improvements will necessarily lose out to the more elaborate and expensive projects. Experience indicates that readers vote for the plan on its appropriateness to the station's requirements.

Entries must reach BM/E no later than October 20, 1975. Address: Best Station Award, BM/E, 274 Madison Avenue, New York, N.Y. 10016.

**PRESS TIME BULLETIN: FCC calls off '77 Cable Re-build Rules.**

### Develop Quality of Children's TV

Bob Keeshan, Captain Kangaroo of TV, urged broadcasters to begin serious efforts to develop the quality of children's programming at the recent National Conference on Children's Television.

Keeshan emphasized that television has an "enormous influence" on children. He said that 10% of their lives are spent watching TV by the time they enter the first grade.

The TV personality also urged his audience to stop thinking about the competition and program in the interests of young people.

### Conference Scheduled

The National Communications Forum (NCF) and National Electronics Conference (NEC) have been scheduled for October 6-7-8 at Chicago's Hyatt Regency O'Hare.

The conference program will include  
continued on page 10



# Future Shock... Now!

**The tempo is increasing  
and the response time  
is decreasing.**

You're handling a schedule with 600 to 900 events per day that requires thousands of manual operations . . . loading *and reloading* machines, verifying *and reverifying* material, sorting *and rearranging*, deleting *and inserting new events*, checking *and rechecking*, making machine assignments *and reassignments*, multiple prerolls, and complicated audio/video switching sequences . . . *all by different people* . . . and this schedule must be accurately confirmed on an FCC log.

**Today's near impossible task . . .  
is rapidly approaching the impossible.**

## Help is Available... Now!

CDL's System 100 TV Automation System, *under your control*, will store and retrieve the schedule with entry error checking, make automatic time corrections, perform complicated audio/video switching sequences, assign machines, verify material, and print the "As-Aired" FCC log . . . **all automatically.**

*In addition, optional modular accessories are available to automatically control the Ampex ACR-25, and to communicate directly with a Business/Traffic Computer System.*

**Sooner or later  
you'll need this type  
of system to manage  
and control your station.  
It's just a matter of time!**

Send for our brochure and data bulletins.



**CENTRAL DYNAMICS LTD**

Canada: 147 Hymus Blvd., Montreal, Que., H9R-1G1 514-697-0811  
U.S.A. 230 Livingston Street, Northvale, N.J. 07647 201-767-1300

Circle 104 on Reader Service Card

# DO YOU WANT THIS?

- Lowered overhead?
- Quick sales info?
- Faster financial data?
- Billing out quickly?
- More avails detail?
- Better controls?
- Less "indispensable" staff members?
- More management data?

Our "BAT" Computerized billing, accounting, traffic and payroll Systems could give you all these features as they have for scores of stations in large and small markets, group and independent. Your call will get you complete details and, at no obligation, a professional survey of your situation, with a comprehensive cost analysis.

Call toll free **800-426-8872**  
or clip the coupon and mail to:

**PPI Paperwork Systems Inc.**

P. O. Box 38 2000 "A" St., Bellingham, WA 98225 (206) 733-8510

- I want all those things! Send details and arrange for an analysis.
- Send details — no survey now!

Name \_\_\_\_\_  
 Title \_\_\_\_\_  
 Stations \_\_\_\_\_  
 Address \_\_\_\_\_  
 City \_\_\_\_\_  
 State \_\_\_\_\_  
 Phone \_\_\_\_\_

Circle 106 on Reader Service Card

## NEWS

18 Technical Paper sessions, reflecting the current state of communications technology and 12 New Technology Seminars providing more detailed treatment of selected topics. In addition to the papers, there will be panel discussions and lectures.

For further information, contact the NEC office, Suite 103, 1301 W. 22nd St., Oak Brook, IL 60521; (312) 325-5700.

### Phoenix To Get New Pay-TV Service

American Cable Television and Microband Corp. of America have jointly announced a new pay-tv service for the Phoenix, AZ metropolitan area called The Private Channel Club. The service will be distributed to cable systems, apartment houses, condominiums, hotels and motels through a microwave service called Multipoint Distribution Service, which is authorized by the FCC to operate WPF47 which will deliver a full color, closed-circuit television picture to hundreds of points within a 25 mile radius of its Phoenix transmitter.

First run motion pictures, uncut and without commercials, will be shown each evening and on weekends along with special live events from time to time.

### New Satellites Will Cut TV Transmission Costs

When Western Union's Westar satellites begin video transmission this summer, they will offer broadcasters savings ranging up to 66% over land-based transmission. Rates for various arrangements of satellite video channel service were filed with the FCC. The rates were scheduled to go into effect July 14.

Service for the Westar system, which includes two satellites, was begun last July. Rates for voice/data circuits and wideband service, up to whole transponders, already are providing businessmen savings of up to 50% over land services. Rate savings will depend on the type of service and the service route selected.

Initially, service will be provided in the Westar access cities of New York, Los Angeles, Chicago and Dallas.

### Color Phase Matching Wins Patent for CMX

The CMX color phase matching system, used in that firm's videotape editing equipment, is the subject of a U.S. Patent, No. 3,890,638, issued June 17, 1975, according to Donald E.

continued on page 12

**Finally...  
 an EBS  
 encoder/decoder  
 in a compact  
 package at an  
 affordable price!**

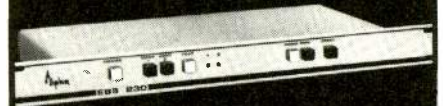

**THE ALPHA  
 EBS-230  
 ONLY \$295**

We've broken the price and size barrier with our new two-tone EBS-230. It's priced at one-third less than some competitive models and combines both encoder and decoder in a package that's half the size of anything on the market. Check these outstanding features:

- Low profile--1 1/2" high x 19" wide, rack-mountable
- Versatile--program channel loop-through standard
- Output--three modes: balanced, unbalanced, floating
- Higher output level-- +12 dBm
- Adjustment controls for both tones, front panel accessible
- Built-in step attenuator--0, 20 or 40 dB
- Self-test feature
- Meets all proposed FCC specifications\*

You're assured of quality and reliability when you buy the EBS-230. We've been in the "tone" business for more than a decade, and our advanced thick-film hybrid circuitry offers the ultimate in stability.

Don't wait. The new FCC regulations on two-tone attention systems go into effect on January 15, 1976. Be ready for them with the lowest-cost, smallest-profile and most versatile unit available--the Alpha EBS-230.

Alpha also offers a separate encoder with remote capability and a decoder--the EBS-210 and EBS-220--at comparably low prices.

Write or call us today for complete technical specifications.

\*Like all other EBS equipment manufacturers, Alpha is awaiting FCC type acceptance finalization.



**Alpha Electronic Services, Inc.**  
 8431 Monroe Ave., Stanton, CA 90680  
 (714) 821-4400

Circle 105 on Reader Service Card



## Introducing a Color Corrector for Electronic News Gathering.

Electronic News Gathering makes tough demands upon the broadcaster. Color imbalance and colorimetry problems are frequently encountered. Matching remote camera shots to indoor studio programs or assembling tapes from different locations or cameras is "chancy" at best. Often that fast-breaking story doesn't allow for camera rebalancing!

Thomson-CSF Laboratories now provides a solution to such difficult encoded signal color problems. With the Model 5500A Color Corrector, you'll be able to rebalance and match video signals *after* encoding. It can be used either after the play-back tape machine or following the microwave receiver during live coverage. In most cases, a noticeably improved color picture will result. For ease of operation, a Remote Control unit is included as standard equipment.

As an added feature, an optional automatic Sensor unit is also available to control the Color Corrector for telecine use.

Whether for Electronic News Gathering, tape production or telecine use, the Thomson-CSF Laboratories Color Corrector System should be working for you. Interested? Give us a call.



**THOMSON-CSF LABORATORIES, INC.**

37 Brownhouse Road, Stamford, Connecticut 06902

(203) 327-7700 / TWX (710) 474-3346

Circle 107 on Reader Service Card

# FCC Rule 73.69 + \$1660 =

## AM-19(204)

ANTENNA MONITORS

The FCC now says that you must have an approved Antenna Monitor. Since this is an added expense, consider carefully what is required of the monitor versus what it will cost.

At \$1660\*, the Model AM-19 (204) is the lowest priced, FCC type approved Antenna Monitor available.

Now after several years of use at many stations, it has proven its reliability. And, it is compatible with virtually every type of wire or wireless remote control system.

Contact us now on this and other FCC type approved Antenna Monitors.

\*Based upon 2 tower, DA-2.

# POTOMAC INSTRUMENTS

932 PHILADELPHIA AVE.  
SILVER SPRING, MARYLAND 20910 (301) 589-3125

Circle 108 on Reader Service Card

# RADIOWAVES

"AM radio with FM sound."

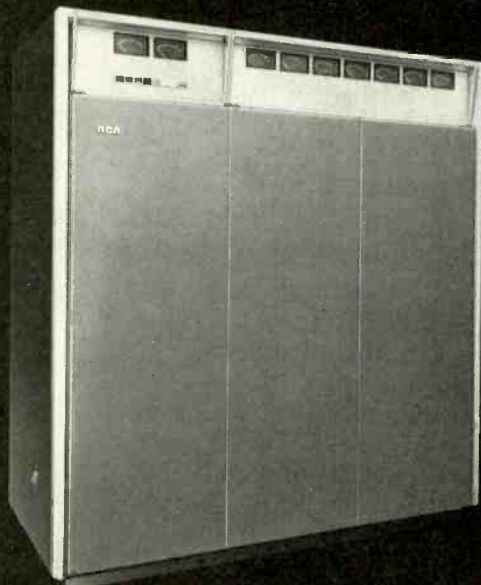

That's the way many broadcasters refer to RCA AM Transmitters.

And with good reason. They've heard the clear, crisp sound that comes from RCA's wide frequency response, low distortion, and 125% positive peak modulation.

RCA AM (medium-wave) Transmitters are available from 250 watts to 200 kW. 5 kW and above use the exclusive RCA Ampl phase modulation system.

See your RCA representative or send for our new Amplphase booklet. RCA Broadcast Systems, Camden, N.J. 08102.

# RCA

AM & FM Transmitters and Monitors • Antennas • Microphones • Consoles  
Tape and Transcription Equipment • Automation Systems • Amplifiers and Speakers

Circle 109 on Reader Service Card

## NEWS

Prather, general manager of CMX.

The method, says Prather, "derives color frame identification from the recorded time code, then matches it to a system reference. The system automatically controls the capstan servo to insure that splices will occur at those points where color bursts will be in phase."

This eliminates "color whip" and luminance shift from color phase shifts, which have often caused repeated attempts at finding the edit point on some earlier systems. Prather added that CMX will offer licensing of the system to other manufacturers.

### Exhibit Space Going Fast For Radio Conference

Exhibit space at the National Assoc. of FM Broadcasters' 1975 National Radio Broadcasters Conference & Exposition to be held September 17th through 20th in Atlanta was 75% sold out by mid-June.

A NAFMB spokesman reports that virtually every exhibitor that participated in last year's show has signed up for this year's show and most have taken more space than last year.

Nearly every important manufacturer and supplier of radio equipment and hardware will exhibit.

### FCC ACTIONS Further DeRegulation Announced by FCC

The Commission issued in June, with an effective date of June 18, some additional relaxations of the broadcast rules, in continuation of the reregulation program of the last two years. Among the June 18th actions were the following:

- Changed the requirement that frequency measurements be noted weekly; the new rule is for frequency measurements at intervals of not more than 40 days.
- Eliminated the requirement that stations immediately terminate remote control operations if a malfunction develops; the new rule allows a station up to one hour to make corrections, before operation must be terminated.
- Removed the requirement that stations must have type-approved antenna phase monitors by June 1, 1974, if the station has made timely efforts to obtain the monitor, and could not get delivery from a supplier.
- For stations operating by remote control, which presently use monitors made after January 1, 1965, and which could not get delivery of new ones, the date is moved up to June 1, 1976.

continued on page 14

# NAB Show-stopper:

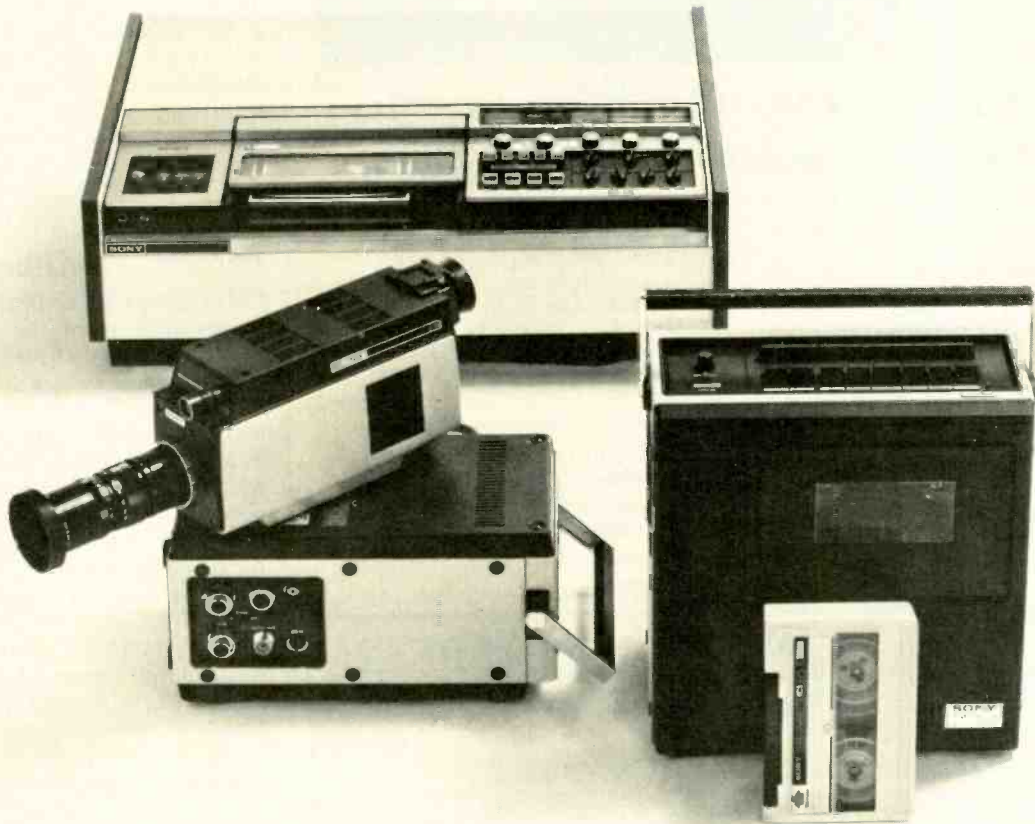

The ENG (Electronic News Gathering) sessions stood them in the aisles. And Sony stood them on their ears with the complete ENG System.

Things like this were said at the Show: "If you don't invest in ENG now, your news department may be obsolete in just a few short years."

So write now for information about the only ENG System that goes all the way through editing using videocassettes.

On your letterhead to Sony Corporation of America, P.O. Box 1594, Trenton, New Jersey 08607. Attn: Broadcast Services BM/E-085-221

Circle 110 on Reader Service Card for more information  
Circle 111 on Reader Service Card for a demonstration

# The Sony ENG System.

**IGM's  
RAM—**  
runs like a  
Tiger and  
thinks like  
a Fox—

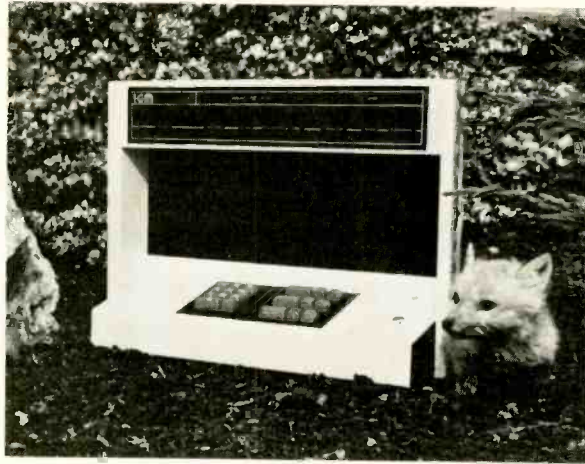

## RAM these new capabilities into your existing automation system:

- 2048 or 4096 switching events
- up to 19 audio sources, each with 79 sub-sources
- random access direct addressing to all sources
- "look-ahead" advance search
- flagged event editing
- multiple audio overlap
- event link, cancel-back, and time update
- exclusive IGM Audabus chassis
- simple installation—simple operation
- operates as a "main brain" too
- WORKS WITH ANY AUTOMATION SYSTEM
- would you believe all this, and much more, at a realistic price you'll love

Call or write today for full information. You may just prevent your present system from becoming an endangered species.

**IGM**  
a division of NTI

IGM's Random Access Memory—automatically  
... the best there is!

4041 Home Road • Bellingham, WA 98225  
(206) 733-4567

SEE US AT THE NAFMB—BOOTH 73-74  
Circle 112 on Reader Service Card

## Canon 10X UNIVERSAL ZOOM

1¼-Inch Plumbicon Color Camera Zoom



© N.V. PHILIPS

**20mm to 200mm; f/2.2**

- 10X Zoom Range
- High Efficiency Coatings
- Excellent Technical Quality
- Small Size
- Lightweight
- Fast Change Range Extenders
- Operational Back Focus
- "Macro Focus" Operation
- Includes Range Extenders & Shipping Case

**Canon**  
BROADCAST OPTICS

CANON U.S.A., INC., 10 NEVADA DRIVE, LAKE SUCCESS, N.Y. 11040

(516) 488-6700

Circle 113 on Reader Service Card

## NEWS

- With respect to the new rule allowing use of lower-grade operators for routine transmitter operation, if under supervision of a first-class operator, the Commission removed ambiguity in the rules that seemed to leave certain classes of stations out of this—the new rule applies across the board.
- Removed was a rule requiring logging of the amount of time spent in transmitter inspection.
- Also eliminated the requirement that all "original" data in rough form be retained—the FCC says it is no longer necessary to keep "match-book covers, paper tissue boxes, shirt cuffs and assorted scraps of paper."

### Inquiry On CATV Access and Channel Rules

Cable groups have won their fight to get reconsideration of the rules adopted March 31, 1972, which require older cable systems to meet, by March 31, 1977, certain standards. As originally adopted, the rule required, among other things, a minimum 20-channel capacity; four "public" channels; equivalent non-commercial bandwidth for each broadcast channel; technical capacity for two-way operation; program origination facilities for the public channels.

The Commission has opened an inquiry to consider alternatives to the rule, inviting comments from all interested parties. Among the possible alternatives listed by the Commission were: simply advance the date; require compliance when a system had a "natural rebuild" underway; eliminate the requirements of the rule, and let stations meet demands. Comments were originally due by July 18, but it seems likely as this is written that the date will be extended.

### AES Meeting Reflects An Active Industry

The largest number of exhibitors ever assembled for an Audio Engineering Society convention gave evidence of a flourishing audio industry at the Society's meeting May 13-16th at the Los Angeles Hilton Hotel. The 101 firms on the exhibit floor represented an increase of more than 20% above the previous peak exhibit roster.

Attendees at the convention were at a high level too, with more than 4,000 persons paying for registration. The attendees came for active participation; a number of the technical sessions put the SRO sign out, and the only complaint was that the time for questions and answers was too short. Among the most popular sessions were those on ar-

continued on page 16

Broadcast equipment designed today for the day after tomorrow.

# AN RCA F-LINE VHF TRANSMITTER IS LIKELY TO DO EVEN MORE FOR YOU YEARS FROM NOW THAN ON THE DAY YOU BUY IT.

**No wonder it's the best-selling transmitter in the country.**

It's your investment in the future. Because the next transmitter you buy should last you a long time. And it will, if it's RCA.

F-Line transmitters are designed for savings both now and in the future. They use far fewer tubes and blowers, fewer tuned linear amplifiers, and have more "solid-

state" content than any other transmitter for the same power level.

A new unit of comparable power will probably take less than half the floor space of your original transmitter. Further F-Line savings can come with remote control now and the prospect of "unattended operation" in the future.

No wonder the F-Line is the country's best seller — with more than 100 transmitters delivered to date.

So plan ahead, if you are not already a most satisfied customer, chances are you will be. Your investment in the future can begin right now. See your RCA representative.

## **RCA**

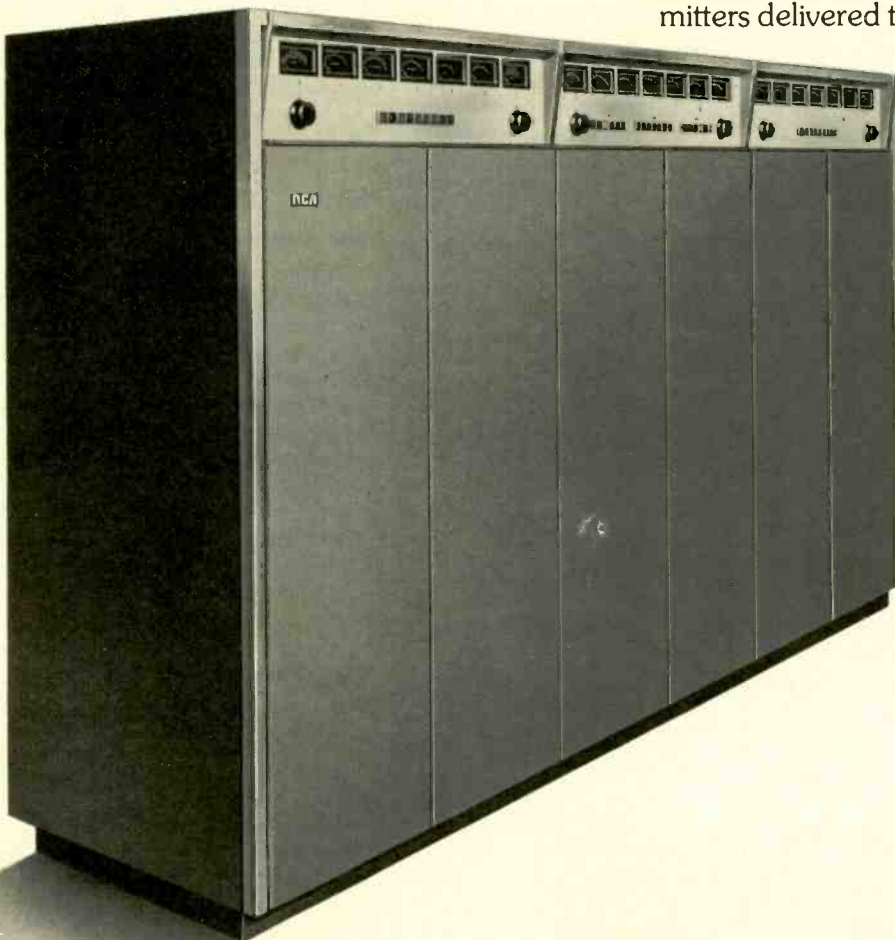

## MCMARTIN / BA-1K 1000/500/250 watt AM

BA 1K—the perfect transmitter for your new AM station or updating your existing operation

FCC TYPE ACCEPTED

unique interior accessibility front and rear

all solid state except for four 4-500A power tubes

125% positive peak capability

pushbutton Hi-Lo power operation

full remote control/metering capability

power driven vacuum variable tuning/loading controls

built-in dummy load

from the "FULL-CHOICE" line

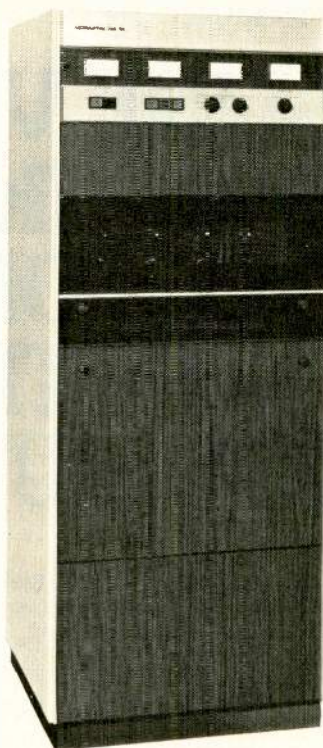

# transmitters

### McMartin

McMartin Industries, Inc. 4500 South 76th Street, Omaha, Nebraska 68127 (402) 331-2000

Circle 114 on Reader Service Card

## Listen to the Sound of Dependability

STL test tapes maintain a reputation as the most dependable and accurate tapes you can buy because of the consistently high standards produced on the finest precision equipment.

In addition, they are available in more sizes than that offered by any other manufacturer in the world.

Listen to the sound of dependability . . . and accuracy. Order STL test tapes and find out where your system really is.

All audio widths from 150 mil. to 2-inch. Prompt delivery insures freshness.

For the distributor in your area—Call or write:

**TABER** Manufacturing & Engineering Company

2081 Edison Ave. • San Leandro, Ca. 94577 • (415) 635-3831

Tennessee distributors: Audiotronics, Inc., Studio Supply Company

Circle 115 on Reader Service Card

## NEWS

chitectural accoustics and on sound reinforcement techniques.

Among the exhibits were the usual consoles sporting modular construction with, in some cases, dubious human engineering; although there seemed to be fewer than last year. No new microphones or monitor loudspeakers incorporating revolutionary principles were evident. Amber Design Ltd. from Montreal showed an audio spectrum display. Europa Film displayed its advanced disc-plating machine. Electro Sound demonstrated a high-speed semi-automatic 8-track cartwinder, also an automatic tape splicer. Sheffield Products showed the Marshall Time Modulator, a catch-all/do-all device that does phase, frequency and time base shifting, among a multitude of other audio gimmickery.

Also, at last perhaps thanks partly to opinions expressed in these pages, an array of sound reinforcement gear was in evidence. The AES has finally awakened to the fact that commercial sound is a part of the audio world. Notable was an omni-directional spherical speaker for use with certain musical instruments from Sculptured Sound, boasting 360° horizontal and 240° vertical dispersion, 500 watts RMS capacity over 30-2kHz bass frequency. High-power amplifiers and mixing consoles designed for field audio were abundant. Hopefully this aspect of the AES exhibits will be on the increase. Well done.

### UHF "Taboos" To Be Examined by FCC

Advances in receiver design are the main factors in leading the Commission to re-examine the "taboos" on UHF assignments designed to eliminate interference. The new inquiry asks such questions as: "Considering the performance of contemporary television receivers, can taboos be reduced or eliminated without degradation of service?" "What receiver improvements would help?" "What other techniques would be useful against taboos?" Comments are due August 29, and reply comments September 17.

### TelePrompTer Still Barred In Johnstown

The Commission has refused to remove from Teleprompter the onus of illegality in obtaining the franchise for a cable system in Johnstown, Pa., that arose from the bribery of Johnstown officials in 1966 by Irving Kahn, former president of TelePrompTer. The FCC has recently refused to certify a

continued on page 18



# We wrote the book on FM Antennas!

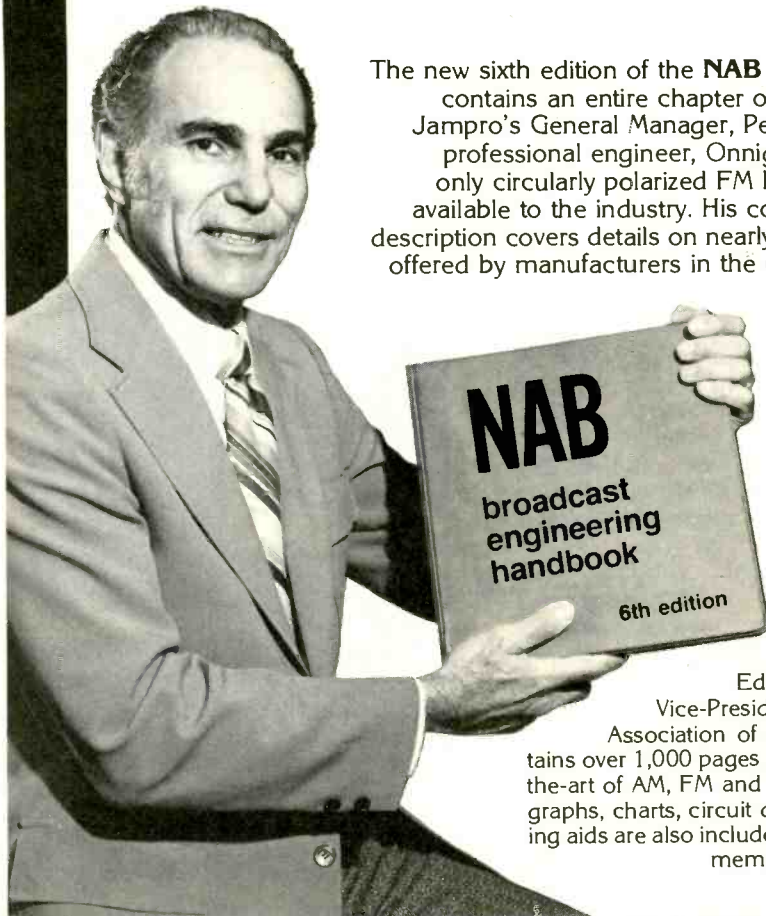

**PETER ONNIGIAN**  
General Manager, Jampro Antenna Co.

**It's a fact.**  
The new sixth edition of the **NAB Engineering Handbook** contains an entire chapter on FM antennas, written by Jampro's General Manager, Peter Onnigian. A registered professional engineer, Onnigian holds a patent on the only circularly polarized FM broadcasting antenna now available to the industry. His complete in-depth technical description covers details on nearly all FM antennas currently offered by manufacturers in the United States and Europe.

## YOURS FREE!

You can have a free copy of the **NAB Engineering Handbook** if you buy and take delivery on a Jampro FM antenna between August 1 and December 31, 1975. If you're not in the market for an FM antenna, we suggest you buy a copy of this excellent broadcast handbook, anyway.

Edited by George W. Bartlett, Vice-President of Engineering, National Association of Broadcasters, the book contains over 1,000 pages of information on the state-of-the-art of AM, FM and TV. Many illustrations, photographs, charts, circuit diagrams, and other engineering aids are also included. The price is \$45.00 to non-members and \$30.00 to members.

Contact: NATIONAL ASSOCIATION OF BROADCASTERS  
1771 N. Street Northwest, Washington, D.C. 20036

**This same expertise in FM broadcasting antennas also allows JAMPRO to offer the most complete line of antennas. SO WHY NOT BUY YOURS FROM JAMPRO — THE PEOPLE WHO WROTE THE BOOK.**

### JJCP — THE PENETRATOR

As its name indicates, this most popular model of the Jampro line has the penetrating power of the best circularly polarized FM antenna on the market. Each bay is conservatively rated for 10 KW of input power, with excellent VSWR bandwidth of  $\pm 200$  KHz under 1.1 after mounting on the tower! It also has an excellent axial ratio, for better signal penetration into all sorts of FM receivers. Available for deicers or radomes.

### JLCP — THE PERFORMER

For Class A stations, and low power educational stations, this ring stub antenna is an excellent elliptically polarized performer! Each Bay is rated at 3 KW, is lightweight, and may be mounted on smaller towers. Like all Jampro FM antennas, it comes complete with galvanized mounting hardware for normal uniform cross section tower mounting. Electrical deicers are available for moderate or heavy ice conditions.

### JHCP — THE BRUTE

Each single bay of our JHCP line can handle full 40 KW, so we've named it the Brute! . . . excellent as a standby antenna, or for that 5 bay antenna with a 40 KW transmitter for 100 KW ERP, in the most difficult terrain. Not affected by snow, ice, heavy fog or rain. No corona or flash overs. The Brute is available with deicers for heavy icing conditions. A single bay with its own ten foot support pipe has an azimuth circularity of  $\pm 0.5$  DB!

### JSD — MULTI-STATION ANTENNAS

Designed to be mounted on the three sides of a triangular tower, or the four sides of a square tower, the JSD series operates throughout the 20 MHz FM band, with a VSWR of under 1.1 across the entire band! This antenna is supplied with two input connectors, and accepts as many as six stations operating on different frequencies, each with a 40 KW transmitter. Diplexers and radomes are available.

J

A

M

P

R

O

ANTENNA  
COMPANY

A SUBSIDIARY OF  
CETEC CORPORATION  
(916) 383-1177  
6939 POWER INN ROAD  
SACRAMENTO, CALIF.  
95828

Replace  
Mercury  
Vapor  
Tubes  
Directly  
with

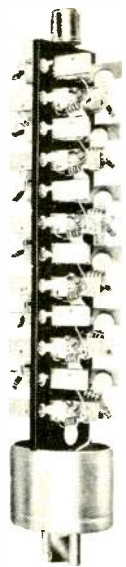

**WILKINSON**  
**Silicon Rectifier**  
**Stacks!**  
**Because...**

- Only non-encapsulated WILKINSON Silicon Rectifiers can be repaired in seconds with low-cost replacement diodes!
- Exclusive "GO, NO GO" indicator automatically warns when the reverse leakage of any diode is in excess of 50 microamps.
- Only WILKINSON Silicon Rectifiers are available in a complete tube replacement range of from 866 to 857B.
- WILKINSON Silicon Rectifiers function in ambient temperatures of from - 85 F to +158 F.
- No more filament heat and consequent filament burnout... lower power cost and reduced hum, too.
- No warm up time is necessary... instantaneous operation!
- Just plug in WILKINSON Silicon Rectifiers... no re-wiring is necessary.
- Only WILKINSON Silicon Rectifiers are fully guaranteed and have a safety margin well in excess of tube rating.

For complete details write today to:

**WILKINSON**  
**ELECTRONICS, INC.**

1937 MacDADE BLVD. • WOODLYN, PA. 19094  
• TELEPHONE (215) 874-5236 874-5237

Circle 117 on Reader Service Card

## NEWS

Teleprompter system for the city, although Johnstown has agreed to franchise Teleprompter under a totally new arrangement.

The FCC contends that even the new franchise was "illegally" obtained, and that certification would therefore not be in the public interest.

## Briefs

INTV, the Assoc. of Independent Television Stations, Inc., has moved to larger offices at 19 W. 44th St., N.Y., NY 10036, telephone (212) 575-0577 . . . . **Cramer Electronics, Inc.**, international distributor of electronic components and video equipment to industry, has announced that the firm's Video Division products are now available through all 40 Cramer divisions worldwide . . . . **WFAA Radio**, Dallas, TX, a strong M-O-R/personalities/news/sports station has become a CBS Radio Network affiliate . . . . **Blonder-Tongue Laboratories** is celebrating its 25th year.

Reynold Johnson, a video sales veteran, has opened **A-VID Electronics Co.** to specialize in video equipment sales (Sony), service, rentals and the complete design and installation of closed-circuit and broadcast television systems. A-VID is located at 1655 E. 28th St., Long Beach, CA 90806; telephone (213) 426-5526 . . . . The operations of **Jerrold Int'l**, a subsidiary of General Instrument Corp., with European headquarters at 70 Chaussée de Charleroi, 1060 Brussels, Belgium, will be expanded with new facilities in the Brussels area for warehousing, a fully-equipped engineering/test laboratory and customer demonstrations . . . . Jack Valenti, President of the Motion Picture Assoc. of America, will be the guest speaker at the Get-Together Luncheon of the 117th Conference of **SMPTE**, set for the Century Plaza Hotel in Los Angeles Sept. 28 to Oct. 3.

The Broadcast Products Division of **Harris Corp.** has announced the recent sale of two Harris MW-50, 50 kW medium wave transmitters—one to WCAW, Charleston, WV and one to the Security Agency of Iran . . . . The Gov't of Iran has recently adopted the **SECAM** color television process for its national color service . . . . Polish Radio and Television, a state-owned network reaching viewers/listeners in Poland, has installed three of **RCA's** most advanced AM radio transmitting systems.

The new warship U.S.S. Nimitz is equipped with a **C-COR Electronics** continued on page 20

30 Man-Years  
In the Making

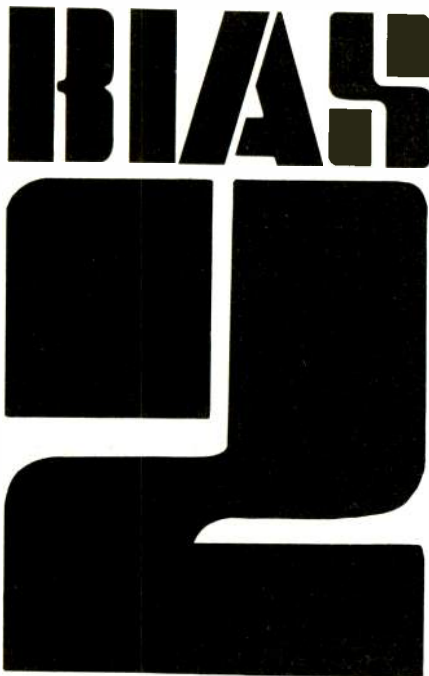

More than 30 people have worked for over a year updating and modifying all existing programs and developing new computer programs to use the expanded facilities, and increased efficiencies made possible by the Burroughs 6700 computer, now the heart of the BIAS system.

Join the satisfied customers coast to coast and in England and Canada, working with BIAS-2 . . . the world's largest on-line broadcast computer system, providing management information on all areas of radio and TV station operation.

Call 901-332-3544 collect; ask for Pat Choate, Director of Marketing.

**BROADCAST INDUSTRY AUTOMATION SYSTEM**  
a division of Data Communications Corp.  
3000 Directors Row, Memphis, Tennessee 38131

Circle 118 on Reader Service Card

AUGUST, 1975—BM/E

# TRENCH OR PLOW WITH ONE MODULAR UNIT... THE DITCH WITCH COMBO!



When you leave for the job site, there may be an uncertainty as to whether the job calls for plowing or trenching. It makes no difference if you own a Ditch Witch Combo. Switch from one operation to the other and back again without changing or adding attachments, turning your machine around or leaving the operator's seat. The Combo is a combination vibratory plow and offset trenching module all in one neat package that mounts on the rear of Ditch Witch Mod-

ularmatic vehicles. It plows in material to 36" deep and trenches to 42" deep. The modular Combo concept originated with Ditch Witch and is available only from Ditch Witch. It's available for Ditch Witch Modularmatic vehicles in power ranges from 30-HP to 65-HP. Tell your Ditch Witch man you want a free job-site demonstration of the Combo. He can show you just another reason why today, more than ever, Ditch Witch Makes \$ense!



"Ask the man you see wearing this emblem how Ditch Witch Makes Sense for you!"

*Ditch Witch . . . equipment from 7- to 195-HP.*

**CHARLES MACHINE WORKS, INC.**  
P. O. Box 66  
Perry, Oklahoma 73077®



**(217)  
222-8200**

**This  
number  
puts the  
Harris  
service  
team  
at your beck  
and call**

The Harris Service Department is ready to help if broadcast equipment problems should arise.

Emergency service. Field service. Technical assistance. Installation. Check-out. Parts. Repairs.

What we want to do is make your life easier. And we mean it when we say Harris takes "Pride in Service."

Remember our number—  
24 hours a day—  
(217) 222-8200. Harris Corporation, Broadcast Products Division, 123 Hampshire Street, Quincy, Illinois 62301.

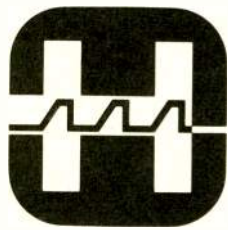

**HARRIS**

**COMMUNICATIONS AND  
INFORMATION HANDLING**

Circle 120 on Reader Service Card

## NEWS

CATV system which will be used for entertainment purposes . . . . The first turnkey Commander III signal-processing system, manufactured by **Jerrold Electronics**, has been installed at Video Enterprises Inc., Holyoke, MA . . . . **Ampex Corp.** has established an 11-region U.S. sales representative network to market its video disc recorders for video image storage in scientific applications such as medical and industrial x-ray analysis, educational instruction, meteorology and communications.

## People

**Gene Edwards** has been promoted to the position of Vice President-Marketing of Harris Broadcast Products Division . . . . **William C. Bollinger** has been named Director of Marketing for Capitol Magnetic Products, recording taped division of Capitol Records, Inc. . . . . **D. Brainerd Holmes** has been elected President of Raytheon Co. . . . . General Cable Apparatus Division recently appointed **Roger J. Waindle** to the position of International Manager.

Warner Cable Corp. has named **Kenneth L. Tryggestad** as system manager for its CATV complex in Kern County, CA. . . . The newly elected officers of the Catholic Television Network are: **Msgr. Pierre Du Maine**, San Francisco, president; **David Moore**, Los Angeles, vice-president; **Sr. M. Irene Fugazy**, New York, treasurer; and **Charles E. Hinds**, Chicago, secretary . . . . **Dr. Michael Retsky** of Zenith Radio Corp.'s Display Device Research and Development Laboratory has been awarded "first prize for scientific importance" in a micrographic competition recently sponsored by the Royal Microscopical Society of Oxford, England. Retsky's winning entry was an electron microscope picture showing single atoms of silver on a thin carbon film.

The following promotions and appointments have been announced at International Video Corp.: **Bert H. Dann** has been named Vice President, Engineering; **Robert G. Marmioli** has been named National Distributor Sales Manager; and **Hugh H. Gillogly** has been appointed Direct Regional Manager for broadcast sales in the Central Region . . . . **Larry Deovlet** has been appointed national sales manager for Uher of America, Inc. . . . . **Norman H. Hansen** has been appointed product manager in the professional audio products group for Telex Communications, Inc.

**The No. 1 number for  
tape cartridge  
equipment**

**309-828-1381**



### 3D SERIES REPRODUCER

A collect call to the above number will bring you all the facts you need to know about tape cartridge equipment. One call will establish a working relationship between you and our broadcast oriented people...a relationship that delivers dependable performance at a truly competitive price. The relationship will last as long as you use ITC equipment...in the selection of equipment, proper servicing, and adaptation of machines to your broadcast requirements. If you're thinking tape cartridge equipment, find out why hundreds of stations depend on ITC.

### WRA SERIES RECORDING AMPLIFIER



**Call collect for  
details on ITC's  
equipment and  
leasing plan**

**IT** INTERNATIONAL  
TAPETRONICS  
CORPORATION

2425 South Main Street,  
Bloomington, Illinois 61701

Circle 121 on Reader Service Card

# Our customers get results from the 1440 Automatic Video Corrector.

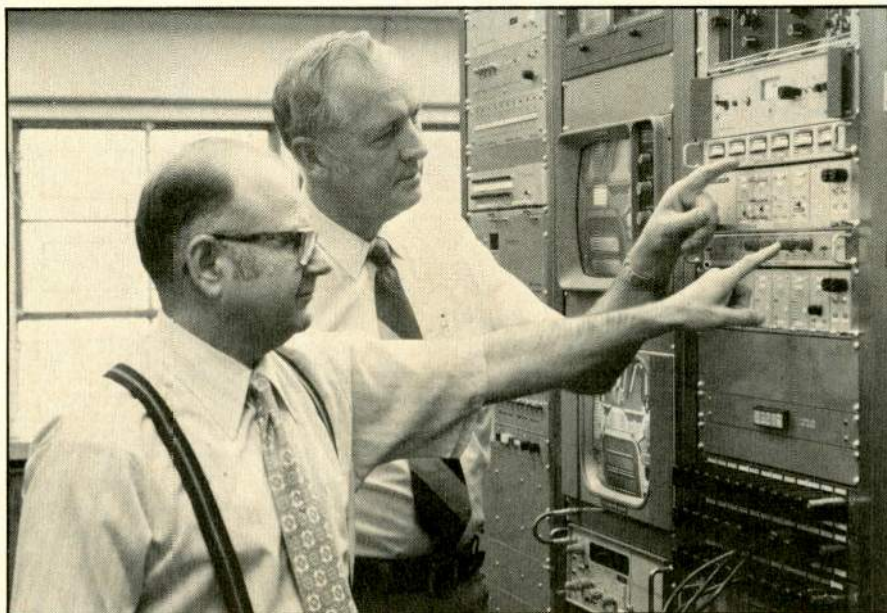

The 1440 Automatic Video Corrector takes the work and worry out of video signal quality control . . . with fully automatic correction of overall video gain, black level, color saturation, burst phase and gain, and sync level. *You can take our customers' word for it.*

## "A must for every video installation."

"The most remarkable device for video control to appear on the market in the last decade is, without challenge, the TEKTRONIX 1440 Automatic Video Corrector.

"Together with all of its bonus features, this instrument is a must for every transmitter installation."

*William Vandermay,  
Chief Engineer  
KATU Channel 2,  
Portland OR*

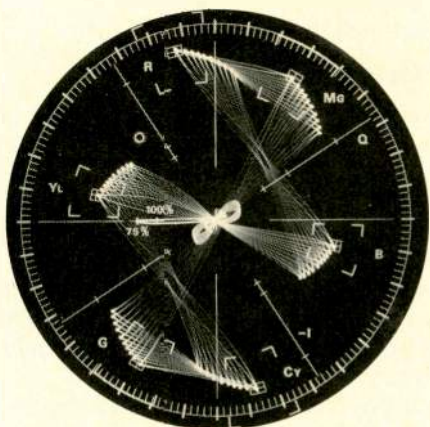

## "A most convenient way to automate modulation levels and signal parameters."

"We have found that a most convenient way to automate modulation levels and signal parameters is to use a TEKTRONIX 1440 Automatic Video Corrector in a closed loop mode around a transmitter such as an RCA TT-30FL or TT-50H."

*T. M. Gulyas, Staff Engineer  
RCA Broadcast News, Oct. 74*

## "The 1440 has revolutionized our transmitter operation."

"To be able to adjust power with no apparent sync or video level changes is something I am not used to yet.

"Our Hartford transmitting operation has become precise and nearly automatic. The power output stability exceeds FCC standards by a factor of ten to one. The VIR operated signal corrector is the major reason."

*John Kean, Vice President  
Connecticut Educational  
Television Corporation*

"Our transmitter is about nineteen years old. The TEKTRONIX 1440 automatic color corrector has stabilized our output signal to a degree never before attainable."

"The one most noticeable improvement is the maintenance of proper sync-video ratio during line voltage variations and changes in transmitter excitation.

"Our transmitter has some differential phase, but having the 1440 match burst to VIR phase results in a very acceptable picture. In fact, a comparison of transmitter output and microwave receiver output does not indicate any difference in the two pictures.

"When the show on VTR is a network playback, the VIR will control the six parameters available. The most impressive thing here is that the VTR operator can vary the color phase control on the VTR with no noticeable change of color phase being observed on the air picture.

*John Hitt, Chief Engineer  
KSLA-TV, Shreveport LA*

## "I just wanted to let you know how pleased we are with the 1440 Automatic Video Corrector."

"This unit will be the key to allowing us to have automatic power control of our UHF transmitter. As we automatically control the 110 KW output with a computer control system, the 1440 will maintain the correct percentage of modulation."

*Robert F. Schlieman,  
Engineering Manager  
KMHT-TV, Schenectady NY*

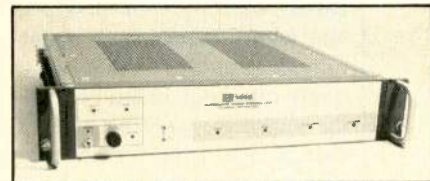

Call your Tektronix Television Field Engineer for a special packet of information about automatic video correction. He can demonstrate how the 1440 and other correction products will work for you at incoming network feed, remote feeds, master switcher output, transmitter input, and other key points. Tektronix, Inc., Box 500-A, Beaverton, Oregon 97077.



**TEKTRONIX®**

committed to  
technical excellence

Circle 122 on Reader Service Card  
for a demonstration  
Circle 123 on Reader Service Card  
for literature

# INTERPRETING THE **FCC** RULES & REGULATIONS

## Sponsorship Identification Rules

By Frederick W. Ford and Lee G. Lovett  
Pittman, Lovett, Ford and Hennessey, Washington, D.C.

A little more than a decade ago, a prominent politician decided to run for Governor of a southern state. A local television station soon thereafter carried a program critical of this gubernatorial hopeful's past record. The program was sponsored by "The Committee for Good Government." The television station announced that the program was sponsored by this Committee, although it knew that the Committee was actually a front for the opposition candidate's campaign organization.

As sometimes happens, the true story came to the public notice. Eventually, the Commission found the television station liable for forfeiture for violating its Rules requiring sponsorship identification of the person "in whose behalf such agent (here meaning the Committee) is acting." Although the Commission was effectively overruled in the Federal Courts (due, primarily, to the imprecise wording of the Commission's Rules), this case is significant for two reasons. First, the court decision prompted the Commission to institute a rulemaking proceeding<sup>1</sup> to precisely define the type of identification required for political and controversial issue broadcasts. Second, the case illustrates the dangerous ground tread by stations when broadcasting political and controversial issue programs—especially in our Country's current post-"Watergate" atmosphere.

### Proposed Rulemaking

The Commission's *Notice of Proposed Rulemaking*<sup>2</sup> proffered two amendments to the existing sponsorship identification rules. The first dealt directly with the "true sponsor" identification problem and was precipitated by the gubernatorial campaign case discussed above. Very simply, the proposed rule was designed to "close the loophole" in the existing rule which permitted the broadcast of political and controversial issue programs

<sup>1</sup>*Notice of Proposed Rulemaking in Docket No. 19513*, 34 FCC 2d 1104 (1972).

<sup>2</sup>*Id.*

<sup>3</sup>*Id.* at 1105.

<sup>4</sup>*Report and Order in Docket No. 19513*, \_\_\_\_\_ FCC 2d \_\_\_\_\_, 33RR 2d 2d 975 (1975).

without requiring identification of the person or organization really "behind" them.

The Commission explained that the purpose of the rule change was

... to clear up any misunderstanding about whether the statute and rules require a licensee who knows or has reason to know the facts, to adequately identify the person or persons paying for or furnishing the material broadcast. We believe it clear that the requirement for full and fair descriptions of the person or persons paying for or furnishing the consideration for the matter broadcast is reasonable and dictated by the public interest; and that where a political broadcast is presented promoting one candidate directly or through criticism of his opponent, by a committee which is really a campaign instrumentality for a candidate or a political organization, the public should be made plainly aware of the latter fact. The public's basic right to know by whom it is being informed, particularly as to a political matter or controversial public issue, is too basic to need lengthy discussion here.<sup>3</sup>

The second amendment dealt with relaxation of list retention requirements for noncommercial broadcast matter. The thrust of this proposal was to eliminate some burdensome paperwork and record keeping for stations that was of negligible benefit to the public in trying to identify the true sponsors of a program.

### Amendments Adopted

The Commission adopted its proposed amendment to close the "true sponsor" identification loophole. Henceforth, a broadcast must announce (1) the name of the person (or organization) that is paying for the air time or (2) the name of the person (or organization) "on whose behalf" the program is being sponsored.<sup>4</sup>

*Example 1:* John Doe is running for State Senate. He personally purchases air time on a local television station to acquaint voters with his platform. The broadcast must announce that it was paid for by John Doe.

*Example 2:* Joe Jones is also running for State Senate. The "Committee for Popular Laws" purchases air time on a local television station during which a spokesman

continued on page 24

# Why is Datatron the leading supplier of Electronic News Gathering Systems?

## Here are five good reasons

1. Viducie is the simplest system to operate
2. It offers complete expandability
3. It can be interfaced to any servo controlled VTR — Quad, helical or audio
4. It can operate manually or automatically under computer control
5. It features our exclusive jam-sync eliminating pre-recording of SMPTE edit code on tape

## Here's what WLAC-TV says about Viducie

We asked Ralph Hucaby, Vice President & Director of Engineering at WLAC-TV why Datatron's editing system was chosen.

"Because it's more accurate and easier to use," replied Hucaby. "Single frame accuracy is very important — particularly in audio where we often need to edit between words. Also we found we could easily train non-technical



Ralph Hucaby, Vice President & Director of Engineering at WLAC-TV, Nashville, Tennessee operating his Electronic News Gathering System which includes a Datatron Model 5050.

people to use the editor. Several of our news personnel became very proficient on the Viducie with only a short period of training."

### System can be expanded at will

The beauty of the Datatron editing system is its simple expandability. It defies obsolescence. You can expand from two to three machines at will. Or move up in logical steps to a completely automatic on-line, off-line system where edit times are stored in a computer and a punched tape prepared. Using this tape, a precisely edited show can be automatically transferred from low cost helicals to quads in minutes. Our system can handle up to 9 VTR's. And special effect switcher too.

**A complete system including VTR's for \$32,000**  
Here's an offer you shouldn't refuse.

Datatron's \$25,000 Model 5050 Viducie Editing System and a pair of \$6000 Sony Model 2850 Cassette Recorders, all interfaced and ready to save you time and money for only \$32,000!

Why are we making this offer? To give you an incentive to move into Electronic News Gathering now. We think it's one of the most powerful tools a TV station can have. And forward thinking stations like WLAC-TV in Nashville agree.

With portable minicams, mobile vans equipped for microwave transmission and Datatron's 5050 Editing System, Electronic News Gathering is revolutionizing the nightly newscast and providing instant coverage of important events as they occur.

So phone Datatron today. Or send for our complete list of features. There are many more than we've described here.

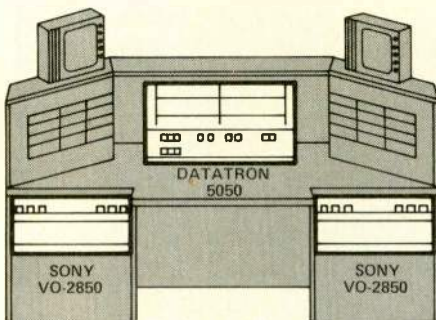

Datatron offers this complete Electronic News Gathering System including a \$25,000 Viducie editor and two \$6000 Sony Model 2850 Cassette Recorders for only \$32,000.

# datatron, inc. EDITING SYSTEMS DIVISION

1562 Reynolds Ave., Santa Ana, California 92705 (714) 540-9330 • TWX 910-595-1589  
Mailing Address: P.O. Box 11427, Santa Ana, California 92711

Circle 124 on Reader Service Card

## FCC RULES & REGS

criticizes John Doe's campaign platform. The "Committee for Popular Laws" is a straw entity for the "Joe Jones Election Committee." The broadcast must announce that it is being aired on behalf of Joe Jones.

*Example 3:* Assume the same facts as above except that the "Joe Jones Election Committee" directly sponsors the broadcast. An announcement that the "Joe Jones Election Committee" is the sponsor is sufficient because it clearly informs the public on whose behalf the program is being aired.

The second proposed amendment was also adopted. The list retention requirements was relaxed for sponsors of programs that do *not* (1) advertise commercial products, (2) contain political matter or (3) address controversial issues of public importance. The rule change was directed at easing the paperwork required of ostensibly public interest programming matter presented by organizations such as the Red Cross. Such organizations need no longer maintain listings of upper echelon officers and directors at a local broadcast station's offices. However, an announcement must still be made during the program identifying the sponsoring organization.

### The Rule As Revised

The above-discussed rule amendments must be understood in the context of the sponsorship identification rules as a whole. The Commission consolidated the previously separate AM, FM and TV rules<sup>5</sup>. Cable televi-

sion is covered by a separate but similar rule<sup>6</sup>.

In general, all broadcasts for which a station charges for the air time must contain an announcement identifying the sponsor or the person on whose behalf the broadcast is in reality being aired. Such an announcement need not be made if the station airs the program for free so long as the sponsor is not providing use of the film or tape to secure "free advertising" for itself or someone else. The broadcast station has the duty to use "reasonable diligence" in obtaining the program sponsor's name (or the name of the person on whose behalf the program is aired) to make the required identification announcement. The Commission specifically recognized problems inherent in determining a straw organization's true source of funds. Did the funds emanate from the opposing candidate's campaign organization or from one of his/her supporters? The Commission answered this question by saying:

In those instances a licensee must exercise reasonable diligence to ascertain the facts. We do not require more of him. But we do not condone less.

A program of five minutes or more that addresses a political matter or a controversial issue of public importance must be preceded and followed by a sponsor identification announcement. A program of less than five minutes duration need only make one such announcement at the program's beginning or conclusion. A commercial product advertisement that at least once clearly

<sup>5</sup>New Section 73.1212.

<sup>6</sup>Section 76.221

continued on page 26

# Broadcast quality video switching NOW under \$30 per crosspoint.

Input-output configurations are virtually unlimited with this modular, building-block, solid-state, video switch. And . . . this flexibility comes at reduced cost.

Starting with a single 14-inch by 19-inch rack frame assembly, the user can build to a 20-input by 20-output configuration by selecting plug-in switching and amplifier modules. Using the appropriate modules, configurations such as 10-in by 5-out, 20-in by 10-out or other configurations can be assembled. Greater capacities can also be accommodated . . . just add.

Control? . . . DYNAIR has it all, from pushbuttons to computers. The 1400 Series plug-in switch modules accept control from 15 to 25 VDC or 5-volt negative logic steady state levels. With optional plug-in circuitry, encoded logic level signals can provide the control. A complete line of control hardware is available from us.

Performance is state-of-the-art. Using field effect transistor circuitry, the 1400 Series frequency response is flat within  $\pm 0.1$  dB to 8 MHz ( $\pm 0.5$  dB to 12 MHz). Differential phase is less than 0.1 degree, and it is DC coupled. Top color performance for NTSC and PAL systems.

Best of all, users will really appreciate the economy. By specifying the initial and future capacity for the system, the buyer purchases only the hardware needed now without being penalized later. High reliability solid-state video switching costs can be cut below \$30 per crosspoint . . . less than competitive switching systems. Compatible with our Series 8100 Solid-State Audio Switching Equipment, the new 1400 Series offers, spec for spec, the lowest cost quality switching equipment available today!

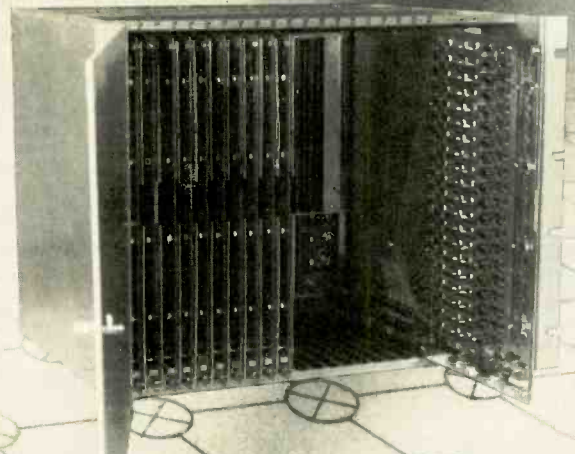

**DYNAIR ELECTRONICS, INC.**  
6386 FEDERAL BLVD, SAN DIEGO, CALIF. 92114  
TELEPHONE: 714-582-9211 TWX: 910-335-2040

**DYNAIR**

Circle 125 on Reader Service Card



# Despite the unprecedented demand, you don't have to queue up for our CP-16R's.

The reason? Our spacious, modern facilities and automated production techniques make it possible for us to meet the ever growing demand here and abroad. Easily.

After all, we are the largest manufacturer of professional motion picture camera equipment in the United States. And, of course, we use the most advanced and sophisticated technologies in design, engineering and manufacturing to deliver to you the most outstanding 16mm reflex and non-reflex sound camera systems.

At competitive prices. With no compromise on quality. And with a full range of options and accessories to suit all your requirements: newsfilm, documentary, television commercial or studio-type film production.

With more than 2000 reflex and non-reflex cameras actually delivered in a mere three years, our CP-16's have already proven themselves in the field beyond any question.

Furthermore, our CP-16's are backed by a world-wide network of dealer service centers, staffed by factory-trained technicians, and well stocked with critical replacement parts.

Our CP-16R is the quietest, most reliable 16mm reflex camera system ever. And it is available here and now.

So, why settle for "pie-in-the-sky" promises from various camera manufacturers whose highly touted prototypes never quite seem to make it to the production line?

Don't wait. See your local CP-16 dealer now.

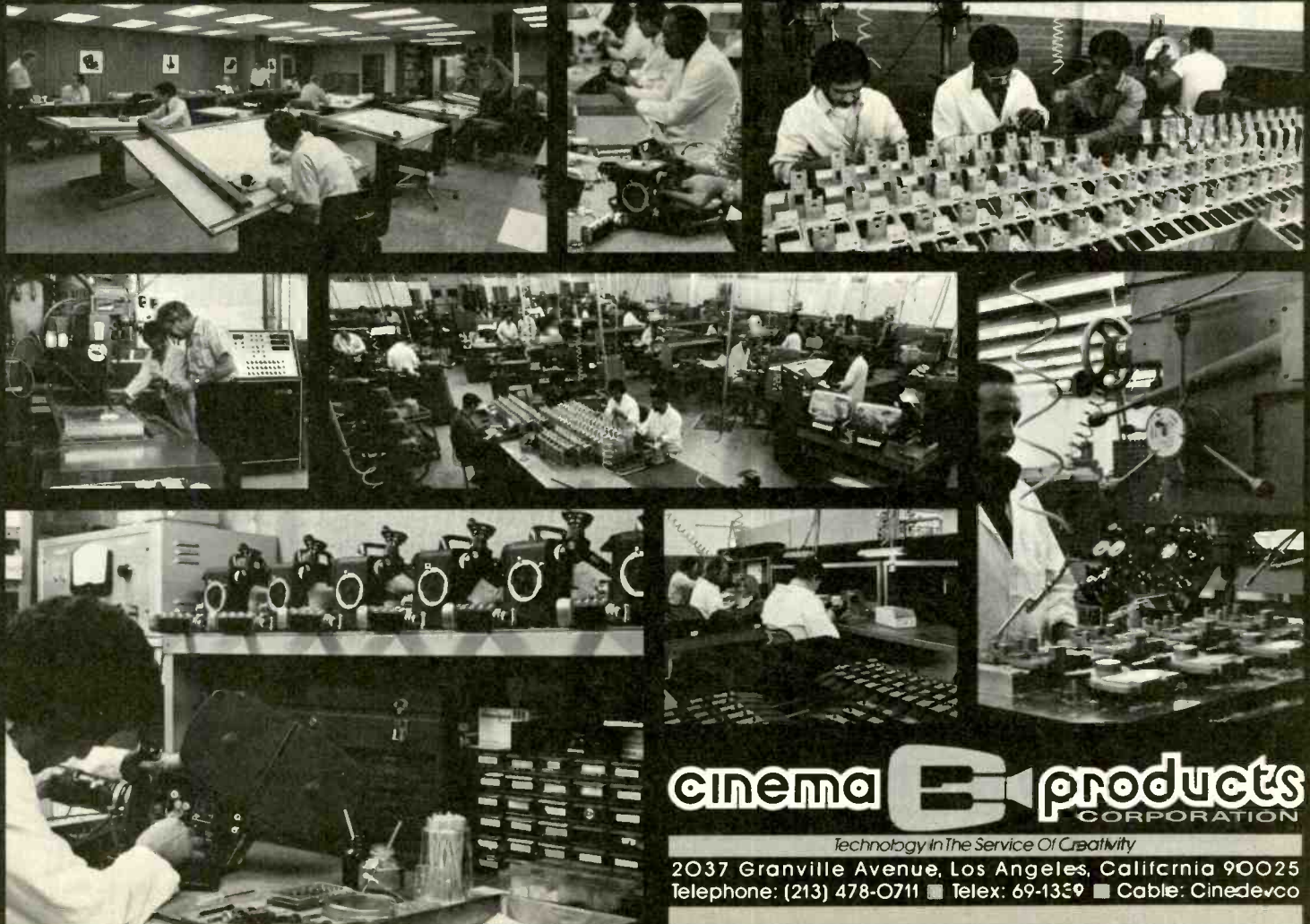

**cinema E products**  
CORPORATION

*Technology In The Service Of Creativity*

2037 Granville Avenue, Los Angeles, California 90025  
Telephone: (213) 478-0711 ■ Telex: 69-1359 ■ Cable: Cinedevco

## FCC RULES & REGS

states (1) the product's name, (2) the sponsor's trade name or (3) the sponsor's corporate name is deemed to have complied with the identification rule. Even if the advertisement exceeds five minutes in length, it is still deemed in compliance and two identification announcements are not required.

Licensees broadcasting political material or matter dealing with a controversial issue of public importance that was paid for or furnished by a "corporation, committee, association or other unincorporated group, or other entity" must compile a list of the "chief executive officers or members of the executive committee or of the board of directors of such organizations." The list must be placed in the licensee's public inspection file for two years. While organizations such as the Red Cross and United Giver's Fund are exempted from this "listing of officials" requirement, they are still subject to the sponsor identification announcement requirement.

### Exceptions To The Rule

The identification announcement rules do not apply in three situations.

First, "want ads" or classified ads sponsored by an individual are exempted. Businesses, be they individual proprietorships, partnerships, or corporations, are not deemed to be within this exception. However, when the exception does apply, the station must do the following.

- (1) List the name, address and phone number of the individual advertiser;

- (2) attach a copy of the list to the station's program log for the day the advertisement was aired; and
- (3) permit access to the list to any person having "legitimate interest" in the material contained therein.

Second, the sponsor identification announcement need not be given regarding any "feature motion picture film produced initially and primarily for theatre exhibition."

Third, any program filmed or recorded on or before June 20, 1963 is exempted from the identification requirement rules.

### Conclusion

The November elections, bringing with them the fall campaign season, will be upon us shortly. Commission Rules relating to the broadcast of political matter and controversial issues of public importance should be reviewed by licensee personnel immediately.

The single most important point to be gleaned from the newly amended sponsorship identification rules is that the license must exercise "reasonable diligence" to discover on whose behalf campaign candidate or controversial issue material is being broadcast. "Reasonable diligence" means making a bona fide effort to discover "straw" organizations. Licensees should always keep in mind the principle underlying the sponsor identification rules:

"... the public has a basic right to know by whom it is being informed, particularly as to a political matter or controversial public issue."

## End the Identity Crisis in your videotape library! Model 367 Post Production Switcher for the 'Videotape Generation' \$3,780.00 List

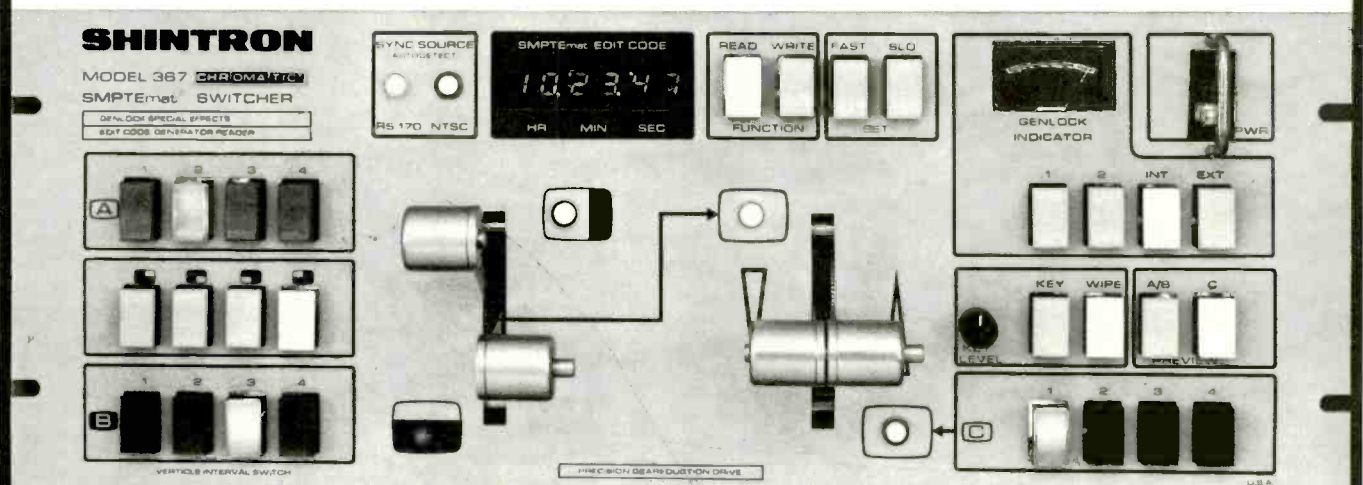

- total color switcher + SMPTE edit code generator/reader
- + color count-down genlock (to Helical VTR)

**SHINTRON**  
Cambridge, MA 02142 (617) 491-8700

**...The Precision People**

# When you've got something as good as the Akai VTS-150, you change it.

## Introducing the Akai VTS-150B.

We call our VTS-150B the Hustler. And it has 5 things our VTS-150 doesn't (servo vertical lock, video AGC and sync stabilizer, battery condition warning blinker, exposure indicator and RF output for dropout compensator).

But some things you don't change.

The Hustler is just as small as our VTS-150 (the 16 pound recorder

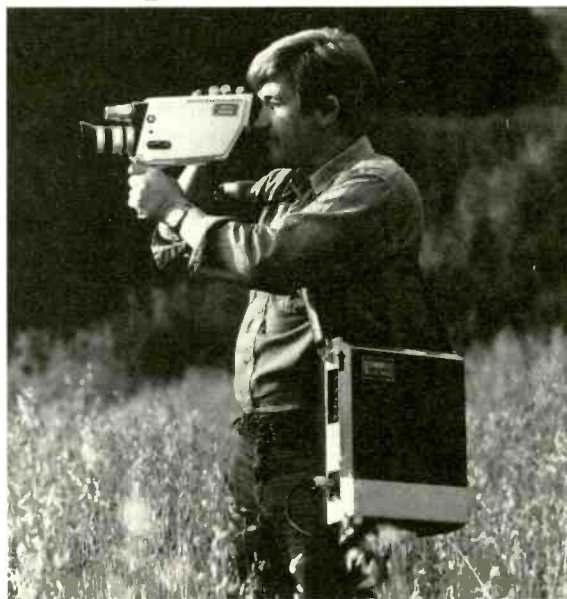

fits into one neat little package you sling over your shoulder).

It's just as light (the camera weighs a mere 6 pounds).

And just as easy to use (pull the trigger, edit the tape automatically, dub in new sound).

The Hustler from Akai. It's been a change for the better.

**AKAI**<sup>TM</sup>

2139 E. Del Amo Blvd., Compton, Ca. 90220

Circle 128 on Reader Service Card

# Radio Automation: The Good Right Arm of the On-Air Man

A survey of new radio automation hardware in use shows that management can choose to give a station a "local," "live" personality, with the automation making the job easier, less error-prone, more creative, than manual operation.

Syndicated programming is available for radio stations that will do everything but announce visitors at the station's front door. Automation hardware can run a station for days without the touch of a human hand. Put the two together and a radio station can be a highly efficient machine for transmitting programming assembled elsewhere, with almost no in-house effort. Along with the programming often come centrally-hired on-air personalities to flavor the material, set the backgrounds, even do some station promotion.

Many stations are running that way, and in smaller markets it often makes sense. The syndicated DJ's may well be more valid and interesting than any talent the station could find locally, or could afford to hire from out of town.

But a good number of stations, especially among those in medium and larger markets, have the resources and the management desire to create an individual voice, one that listeners will learn to know and seek out. For such stations the latest automation hardware can do a tremendous job. The whole programming effort can be more creative, less subject to error, much freer of operational burdens, than "manual" operation.

This theme appears—not by BM/E's planning—in every one of the stories on radio automation in the July issue and in this issue. In July we told about the Schafer/NTI computerized systems going into all seven of the CBS-owned FM stations. The very large memory available in these systems is used to give the live DJ one-button control of music sequences, commercials, PSA's, ID's, etc., with up to several days of events storable. The memory is also a very big aid to each program director in assembling programs that are fine-tuned to his market (each of the seven stations has its own, locally-oriented format). The title and 20 other parameters of each cart are stored in the memory, so that lists of "compatible" music can be had in short order.

Also in July Gerald Klabunde of WBEN, Buffalo, described their carefully designed system, largely custom built by Ward-Beck and the station staff, that gives a nearly free hand to the DJ. He talks for the approximate time assigned, expanding or contracting the

time as the creative need dictates. Then he pushes the button for the next music sequence or cluster of commercials. The system alerts him when to go on "live" again; he knows at every moment what is being aired, and what the following items in the sequence are. Setting up the sequences is easy and leaves personnel the time to "enjoy being broadcasters," says Klabunde.

In this issue Robert Groome tells a somewhat similar story about WERE in Cleveland. There the automation system, custom designed by the engineering staff using mostly Gates equipment, allows the talk-show host to control the automated sequences. Again, the system tells him when to come on live again, and exactly what is being done at every moment.

The same theme appears in other stories of automation equipment in use. The following in-use stories concern items introduced at the recent NAB show in Las Vegas.

**Audio Services System 1**—In use at WGPR-FM in Detroit, this new system is run by a microprocessor. It stores up to five events. The combo man starts the sequence with one button. It can interface to any multi-cart system, or to open-end machines. The on-air man can hold the sequence, repeat any item, reject one. A digital readout tells the operator what's on and what's coming. WGPR makes a special use of the system on remotes. There are many remotes in the program schedule, and the remote material has to be synchronized and sequenced with recorded material. Errors were greatly reduced, operation made smoother and surer, with a portable push-button control that operates the automation from "outside." Signals from the portable box reach the station over telephone lines using FSK digital modulation. The remote man has the same control functions as a man in the studio.

**Harris System 90**—Run by a micro-computer, this system has a standard input capability of 16 sources, and memory of 1200 events (expandable to 32 sources and 3700 events). The software allows program entries to be made on a time basis or sequence basis; the computer puts them in the right order, regardless of entry order. True time and "compare time" are both shown on the control console, along with the item on-air and coming

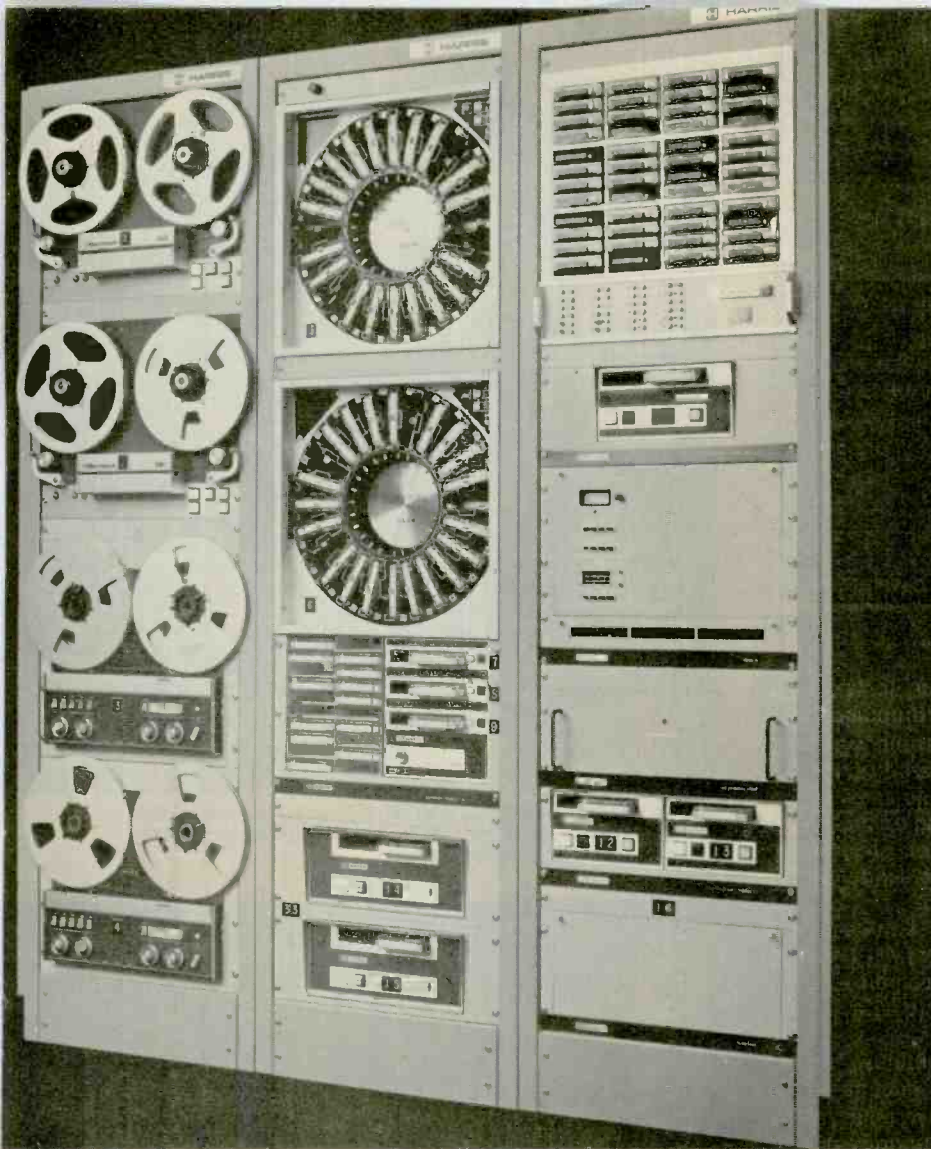

Harris System 90 (left) has minicomputer, memory, audio switching and power supply in third rack, below multicart machine. Example shown has one audiofile, two Carousels, four reel-to-reel machines; other configurations are readily made (system handles up to 16 inputs).

Control console for Harris System 90 (below) can be remote from main racks; two or more consoles can be used. System is fully operated from keyboard; displays include real time, "compare" (or running) time, current event, next event, edit operation, system status.

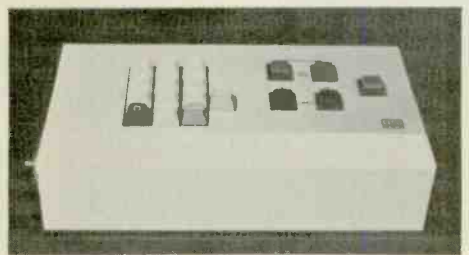
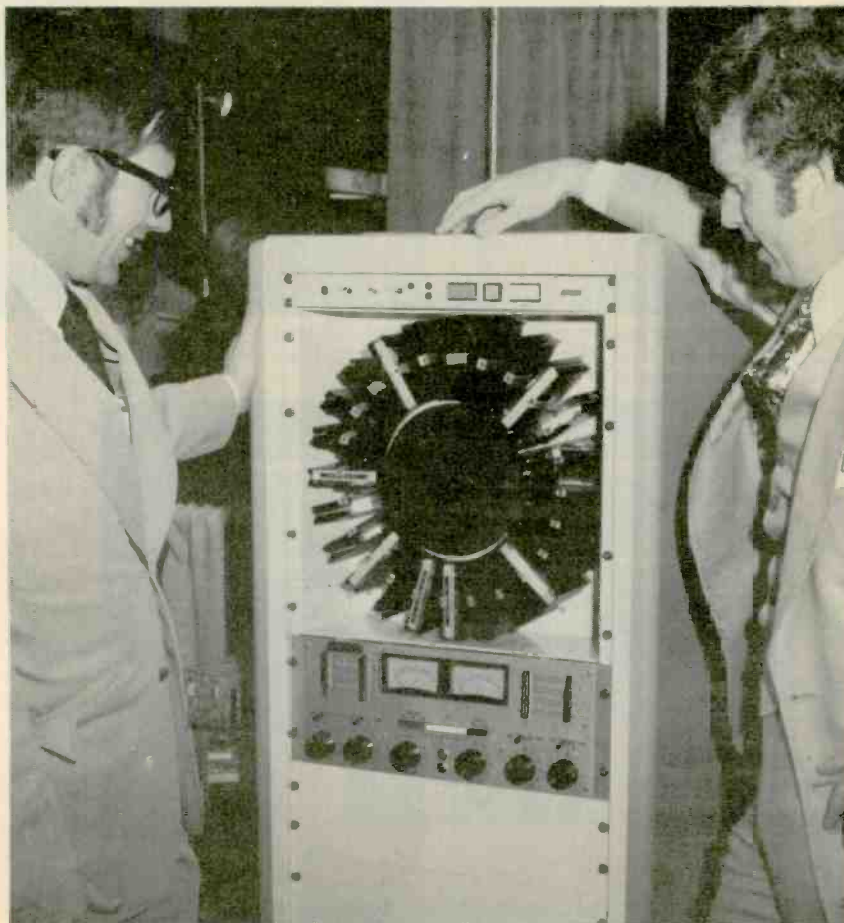

Control box for Audio Services' System 1 automation system (above) can be used remote from studio, connected to studio by FSK digital signals over telephone lines. Remote man has same control of system has in studio.

"Rotocart" (left) is new rotary cart machine introduced at NAB 1975 by Ampro. Drum holds 24 carts has random access of 7 seconds maximum.

## RADIO AUTOMATION

up. Random access to the memory makes last minute changes available.

The system includes all the operation features found desirable in "full" radio automation systems—automatic network join, automatic voice tracking to sequence recorded voice with music; time announce built in; many others that make this one of the most convenient, most fully "automated" systems available. Is also has full provision for operation by a "live" DJ, who can call up any individual item or any sequence using the console. This allows the on-air man, again, to create the show. The extremely extensive array of automation features make program assembly and operation simple. Such powerful aid to program creativity was a major consideration for Lake Enterprises, in Fresno, California, who are installing the system in their newly-acquired FM station there.

**Schafer Stand-Alone Control for Audiofile**—This new unit is designed specifically to give the DJ intimate control of the Audiofile multicart machine, outside of, or alongside, an automation system. At KVOO, in Tulsa, Oklahoma (see BM/E, December, 1974), the management wanted the DJ to make his comments "live," to answer the phone, again to create the show. A new



*Schafer 903 system (above) with MOS memory is shown with two Audiofiles (third rack), six reel-to-reel machines, complete control electronics (first rack).*

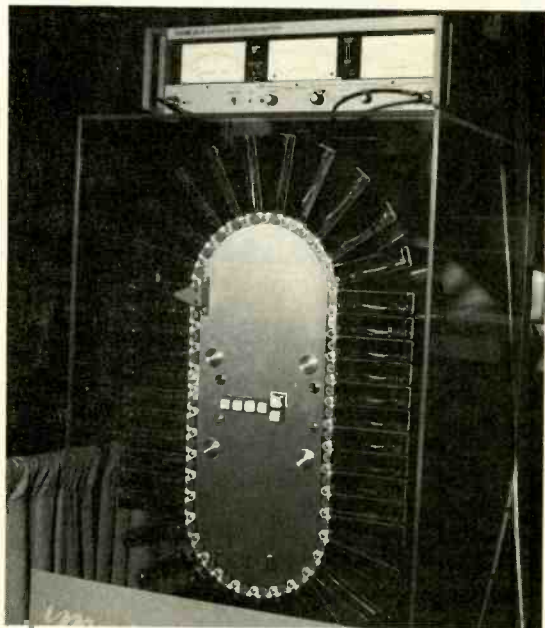

*IGM's new moving-cart machine (above) is called the "Go-Cart," holds 42 carts, with option for expansion to 100.*



*New fixed-cart system, the Carostat (above), was introduced by SMC at Las Vegas. It has 12 or 24 carts, each with own playback system. The cart cued in moves 1/16th inch to drive system.*

*A random-access memory system (right), the RAM from IGM, holds 2048 events, (expandable to 4096), and can switch up to 19 sources, with each controlling up to 79 sub-sources. Unit can be a master controller or sub-controller in automation system.*

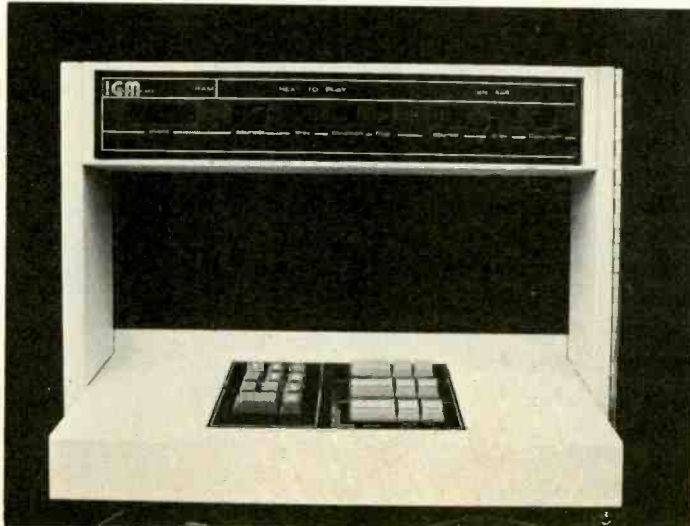

pushbutton unit allows him to call up any cart from 96 on two Schafer Audiofiles. Within certain broad restrictions set by the format, the DJ can play any music he wants, as often as he wants. The "automation" makes it easy, eliminates all panic and scrambling to load playing equipment.

**Full automation—the main sources**

Serving program creativity in their several ways are, of course, full automation systems that have been available for a number of years. Those most familiar to the industry have come from Schafer, IGM, Harris (Gates) and SMC; and more recently from Control Design and RCA. Simple but effective systems are marketed by Autogram, CCA, and Sparta. Also available is the "Semi-automation" of Broadcast Electronics' cart sequencer, which can play a series of carts with a one-button start.

Also, backing up the movement to "creative radio automation" is the proliferation of new multi-cart machines that appeared in Las Vegas, as noted in the May Show-In-Print issue. Reviewing briefly, we have new multi-cart systems, plus older ones, as follows:

New in 1975

**Ampro Rotocart**—24-cart rotary, "Carousel" type, maximum access time 7 seconds.

**IGM "Go-Cart"**—42-cart assembly, expandable to 100 carts; micro-processor chooses fastest access to next cart; second playback position can be added for back-to-back spotting.

**RCA "Kartwheel"**—24-cart rotary, drum removable for loading/storage, random access 7 sec. max.

**SMC "Carostat"**—A fixed-position system, with 12 or 24 carts in "bookshelf" configuration, each with its own playback system, each pulled up about 1/16 inch to drive shaft, giving instant access.

Among the older multicart systems in very active use are the following:

**SMC "Carousel"**—the one that started the rotary cart movement; used in many of the "full automation" systems.

**IGM "Instacart"**—Fixed-cart system, with 12, 24, or 48 carts in flat trays.

**Schafer Audiofile**—Vertically-stacked, fixed-position carts 16, 32, or 48, with playback mechanism moving vertically in back of each stack.

**Other new hardware**

Another unit introduced at NAB with important potential for high-creativity automation is the IGM RAM, a random access memory system which can act as the automation master or sub controller—even storage and switching—with almost any combination of tape transports, cart machines and other audio sources. The standard system has 2,048 directly addressable, directly programmable events, expandable to 4,096. There are up to 19 audio sources, with sub-source capability of up to 79 within each source. The unit is programmed through its own integral front panel keyboard. A number of operation features allow for flexibility and ease in setting up, repeating, changing, program items.

Control Design added to its systems two reel-to-reel audio machines designed especially for automation use, with cue tone generators built in. **BM/E**

# LIVE ELECTRONIC JOURNALISM



INSTANT REMOTE TV BROADCASTS WITH THE NEW NURAD MICROWAVE ANTENNA SYSTEMS.

ONE OR MORE NURAD QUAD POLARIZED ANTENNA SYSTEMS ARE OPERATING IN THE FOLLOWING METROPOLITAN AREAS:

- NEW YORK • LOS ANGELES • CHICAGO • PHILADELPHIA
- SAN FRANCISCO • WASHINGTON • CLEVELAND • PITTSBURGH
- ST. LOUIS • MINNEAPOLIS / ST. PAUL • HOUSTON • ATLANTA
- NASHVILLE • COLUMBUS • CHARLOTTE • NEW ORLEANS
- DAYTON • WICHITA • KANSAS CITY • ALBUQUERQUE

For further details on this unique equipment contact:

NURAD 20 QPI QUAD  
POLARIZED 2 GHZ  
MICROWAVE ANTENNA  
SYSTEM BEING INSTALLED

**NURAD**  
**INCORPORATED**

2165 DRUID PARK DRIVE / BALTIMORE, MARYLAND 21211 U. S. A.  
PHONE (301) 462-1700

Circle 129 on Reader Service Card

# Automation Lets the Talk Host Run the Whole Show

by Robert R. Groome

WERE, in Cleveland, had to get more "Competitive" with the one-man, combo operations at other stations in the area. Properly planned automation put their talk host in control, while maintaining his on-air, live spontaneity.

First, let's examine the problems confronting WERE that made us even consider automating our all-live talk operation.

- The Cleveland radio market has moved over the past few years from the traditional engineer-announcer, two-man operation to "combo," meaning that one man now does it all, much as it has always been in medium and small markets
- The very nature of talk radio makes it more expensive than music stations. WERE's adult audience dominance has been proven for over two years. Our listeners are held by talk hosts, not music. There are so few announcers who hold good ratings day in and day out that they are expensive. Add to this the entire engineering crew necessary for good operation and the profit margin is squeezed by the more competitive combo music stations. We had to become more competitive. And we did!

To summarize briefly, our successful system does this: the talk host runs totally live, and can shape the program, respond spontaneously, without a rigid time pattern within which he must operate. When the (approximate) time comes for commercials, PSA's, ID's, etc., he pushes one button, and the automation takes over until that sequence is completed. The system alerts him to go on the air again—and at the end of another segment of his program, he starts the automation again to run through the *next* sequence of recorded material.

Many technical obstacles had to be overcome on the way to this goal. In combo music stations the announcer has time, while his records play, to set up commercials, PSA's, etc. There is no such set-up time with live talk.

Editing undesirable telephone calls or guest comments is usually done by a delay recording technique, recording on an endless tape cartridge and playing back continuously. This allows time for the engineer to delete objectionable material.

WERE has been using a full one minute delay for several reasons: the longer delay time gives longer tape life, typically three days at 20 hours of delay broadcasting a day, before the tape begins to show wear. Fewer passes of the splice allow less chance for splice

breakage; and fewer changes of the delay tape mean fewer program interruptions. And the 60-second delay allows easy entry/exit from delay without any interruptions.

Many sales orders require accurate time records to be kept. Whatever changes are to be made, accurate, easy-to-read records must be kept automatically. Remember the operator doesn't have the time to keep these records and do a great show.

Some method must be provided to allow automatic recording of the CBS network delayed broadcasts, promos, news feeds, etc. And a back-up must be used to record them if the main one fails.

WERE's transmitting facilities are remote controlled. So provision was deemed necessary to alert the announcer that the transmitter site had been entered. The burglar alarm provides total perimeter control. There are no shunt keys used. If someone enters who is cleared (such as the FM or TV station personnel to whom we rent space), they know the alerting procedure which prevents us from calling the police.

As most announcers are not skilled in technical operations, all systems must take care of themselves. Automatic generator switch-over at studio, STL, and transmitter and switch-over in case of failure of the main is necessary. Signaling of those events is necessary also.

Some means was desired to 'cue' the announcer when (1) live copy is coming up soon (2) when to read the live copy (intros, donuts, and tags). In addition, we had to have automatic control of all levels without bringing up background noise.

But most important, as already indicated, *any system change was not to restrict the air talent*. Nothing except scheduled news is geared to time. The programming must stay spontaneous and flexible.

## How we went about it

Here is how these objectives were met. Obviously, station management was committed to the proposal, or you wouldn't be reading this article. The scheme would reduce operating expenses by over \$56,000 per year.

Several systems capable of holding in memory our daily commercial and PSA loads were investigated. By format checks, we found we need about 900 events of memory per day which would call up random accessible cart players (Carousels). We needed to use special codes

---

Mr. Groome is Chief Engineer, WERE.



on commercials placed in the memory to alert the announcer that live copy was involved. Automatic program logging was mandatory and at least 19 audio inputs were needed.

Many suppliers could provide all this. It became a simple matter of costs and delivery; so, we bought the Gates package. This made up a part of our automatic console. The heart of our system consists of the remote-controlled Gates SSC and SSC-X in combination with a ROH package of mike pre-amps and a combiner card used in conjunction with automatic gated gain-controlled amplifiers.

The nineteen inputs are as follows:

- 01—5 mikes (selectable 1 to 5) plus our telephone system.
- 02—08—RA-10 controlled Carousels.
- 09—Ampex AG350.
- 10 & 11—Gates CB1200 turntables.
- 12—Ampex 351. 13—Remote line (used many times daily). 14—Revox. 15—Two-way receiver (copter reports and news). 16, 17 & 18—Gates CCIII—3 deck cart player.
- 19—CBS network.

Because we use live-talk telephone programming 20 hours a day, our phone equipment is critical. We own our ITT telephones and equipment, which are interconnected as provided by Bell tariffs to the eight outside lines, plus two switchboard extensions of our main nine-trunk PBX.

The phones are set up to cross-conference any number of calls at once. Each conference tie-in drops the level by about 3dB and we seldom conference more than three callers. The person on the incoming phone call hears our studio announcer and guests by way of a ROH summing card at the output of the mike pre-amps through an AGC amplifier. This is true, regardless of whether the studio is on or off the air.

A selector switch prevents the calling party from getting on the air until *we are ready* (so we can alert him he's on the air *before* he gets put on, if we called him).

We are the only station in Cleveland providing traffic reports via helicopter. We use a duplex system whereby our copter reporter hears pre-delay audio at a low level and when it's time for a report, the announcer in the studio touches a button to increase the copter receiving level. Both carry on telephone-type conversations, and



One of the control boxes for automation system at WERE is in foreground, with engineer Peter Chin aiding telephone-talk host Merle Pollis, in studio, rear (a rare two-man operation). Pollis also has control box on studio desk (turned around for visibility in photo).

Talk host Gary Dee reads a live commercial; his box for automation control is hidden by other equipment in picture. Guests on "live" talk shows use mikes in foreground, from seats in front of console.

# TALK SHOW

both can be heard on WERE; or just the copter reporter.

By way of patches, we are able to have an announcer do his normal show in another city (we've been to San Francisco, Toronto, Pittsburgh and New York City, etc.) via simple telephone circuits. This means the distant host can talk to Cleveland callers as if he were actually in the studio. We can take live talk telephone radio anywhere!

Another difficult project was editing. As already noted, our scheme uses a 60-second audio delay tape cartridge. And we have another delay 55 seconds long with constant tone applied. If the tone is eliminated, 55 seconds later there will be a loss of program.

So, the announcer who wants to delete some part of programming has 5 seconds to react. He then holds the edit button for the desired time. He continues his show, knowing that later the material will be deleted. If for some other reason, he decides at some time beyond the 5 second reaction window that material must be cut, it can still be done. He plays some 60 second commercial, PSA or whatever and listens to program after delay in his headphones. By pushing the PANIC button, the objectionable material is deleted. We wipe a minimum of 5 seconds of programming automatically, plus the time the

operator held the EDIT button, to be sure we get the words dumped.

As mentioned earlier, a function code is used to alert the announcer that he has live copy to read soon. We decided to use a 25Hz tone on the program track to allow our production manager to cue the cartridge so the talk host will know when to read. In preparing the tape cartridge, the production manager, John Preuter, puts under the recorded material (on the program track) a 25Hz tone which illuminates a light when copy (donut, intro or tag) is to be read.

The Gates RA-10 sub-programmer is not keyed to time. We can run commercials anytime. If serious events (presidential resignation, weather crises, etc.) occur, during the special program, we can simply reprogram the RA-10, if necessary.

To catch the network db's an automatic clock comparator was chosen. When the proper preset time comes along, a Revox Recorder is started. The machine will stop when (1) the tape runs out, (2) it is manually stopped, or (3) when the Revox sees clear leader tape spliced in the tape supply. In addition, a cartridge recorder is set up for news room operation via a clock to pick-up direct-to-cart special news feeds and is our back-up.

The automatic log covers anything run in the seven

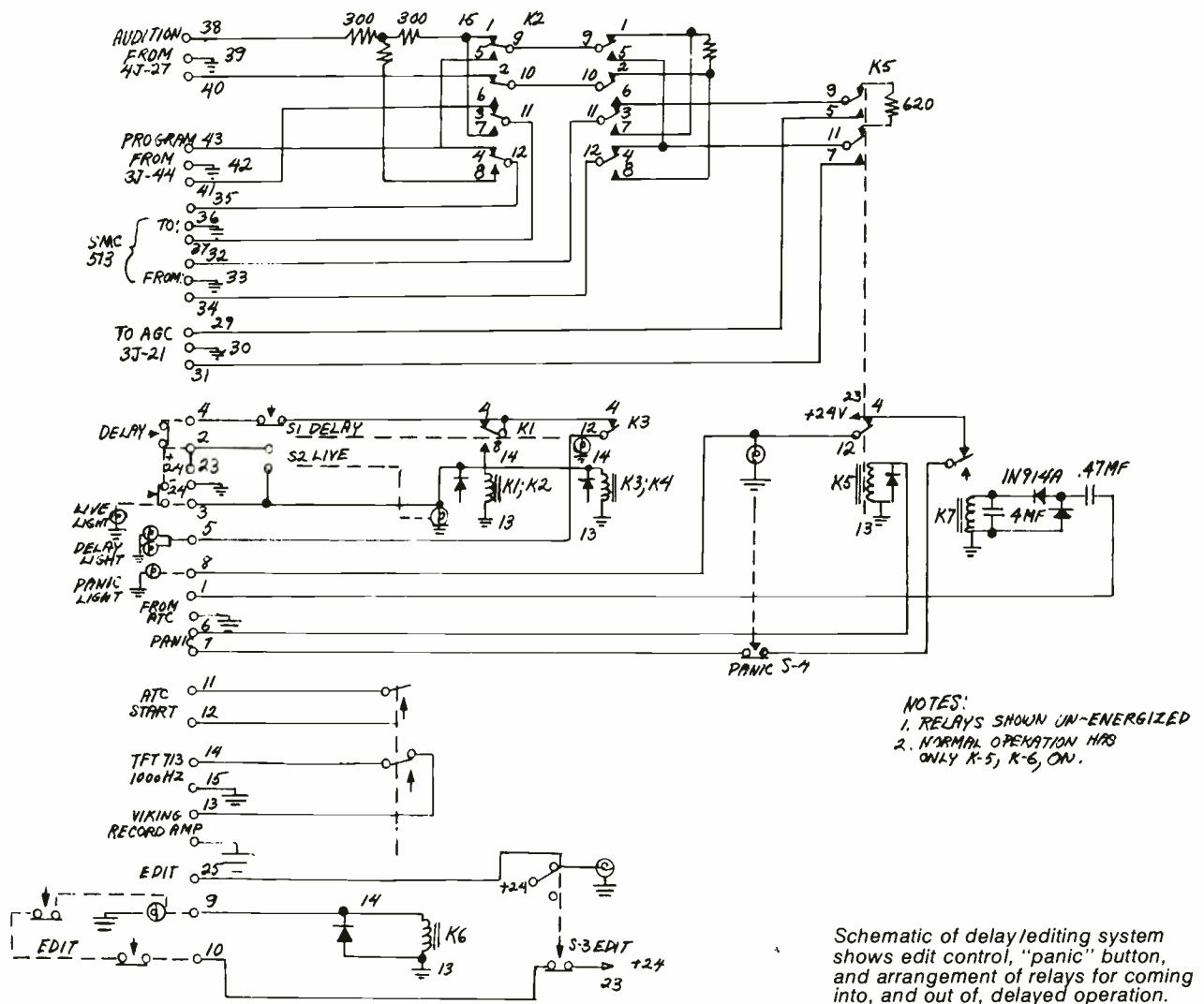



Two racks to right in photo show part of main equipment used for automation at WERE. Harris (Gates) control, memory, and electronic switching equipment are in third rack; three of the seven rotary cart machines are visible in the fourth rack.



Author Groome studies a print-out from the ASR-33 machine to check out operation of all units in system.



John Preuter, production manager, puts the 25 Hz cue tone on a commercial which will alert announcer for "live" talk.

carousels, three deck playback, or the network logger deck. Provisions are made in the FCC rules to allow a separate log sheet for live commercials. This is attached to the automatically kept log at the end of each shift.

The burglar alarm uses a telco provided LPL circuit. When our transmitter perimeter is broken, the device rings up the LPL and feeds audio from the transmitter site (a microphone pick-up). The announcer will hear the phone ring when the control room mikes are off and can pick up this phone without moving from his chair. There is also another phone to allow off-air call-ins by authorized people who enter the transmitter site. The burglar alarm is reset from the studio via remote control.

We have also provided closed-circuit TV to the only after-hours access to our studios. The door is solenoid-operated by the announcer when authorized people are to be allowed to enter.

Many backups are used. The studio has a diesel generator, which can operate all AC except the large building air conditioner. A small air conditioner is used to cool the studios during a power failure. The switch over is automatic . . . both ways. Our clock system works off a crystal oscillator with Gates Master Clock and will not lose time during a power failuer and keeps good time when we operate off our generator which is not always 60Hz. The E. S. E. 100K slaves can run on the AC line should the Master Clock fail.

The STL site has back-up power. The entire system works off two trickle-charged batteries when commercial power is off. By simplexed phone lines, we can observe at the studio when AC service is on/off, plus the condition of the battery (volts).

The transmitter site is a bit more elaborate. In case of power failure, the generator switches over automatically and the transmitter goes back on, also automatically. If the main transmitter fails, the auxilliary is warmed up and switched on-the-air automatically. The only ways to get off the air are: 1) to damage the antenna system; 2)

destroy both transmitters; or 3) to turn the system off by remote control.

#### A few operational details

Some operation notes might give more insight into our system. The SSC and SSCX audio system is operated by remote control. The labels are in clear English (CART-1, TAPE, etc.) rather than numbers to reduce operator error. The five mike circuits have gated AGC on each channel to provide constant levels. The mikes used by the announcer and news man have expansion turned off to reduce background noises. These are combined with AGC-controlled telephone (receiver) audio to form one input to the system. The mike preamps (ROH) are also fed to a combiner so set up that the output of a 213 combiner is controlled by a Gates AGC to feed the modified PCI-55B Speakerphone so the caller can clearly hear what's happening in the studio.

We also have our pre-delay programming arranged, so the waiting caller on "hold" can keep up with what is currently being discussed. The announcer can call out by using the normal phone set or a special switch (automatically turns off speaker phone) if the party called is not to be heard on the air. We use a VIP number which is given to city government officials, civic boosters, and other Very Important People. This gives these people a direct line to call and jump in on the current discussion.

The daily system sounds difficult to operate, but it isn't. To go live from delay, the operator stops doing anything for one minute and then pushes the LIVE button. He is now live. To go from live to delay, the operator loads two sixty second items in the three deck and starts them at the same time. After sixty seconds, he pushes the delay button and is now operating in delay.

An override circuit is used to allow the announcer to be on the air with any other source. In this way, we can have patter between the announcer and copter reporter with both conversations heard on the air. A similar tech-

# TALK SHOW

Modifications to E.S.E. 100 KHz clock allow the clock to be synchronized with AC line or with the master clock in the Gates automation system.

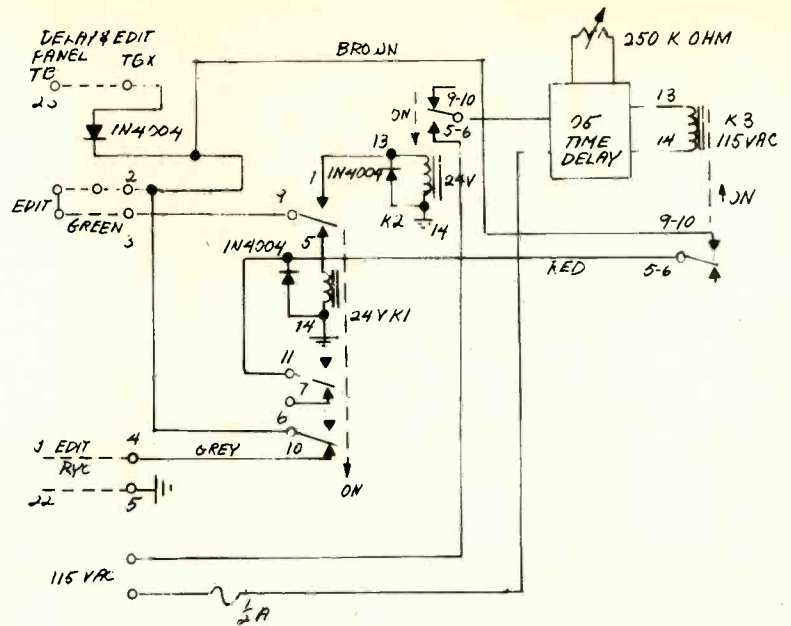

Block diagram shows main features of remote control system, together with metering for the STL transmitter.

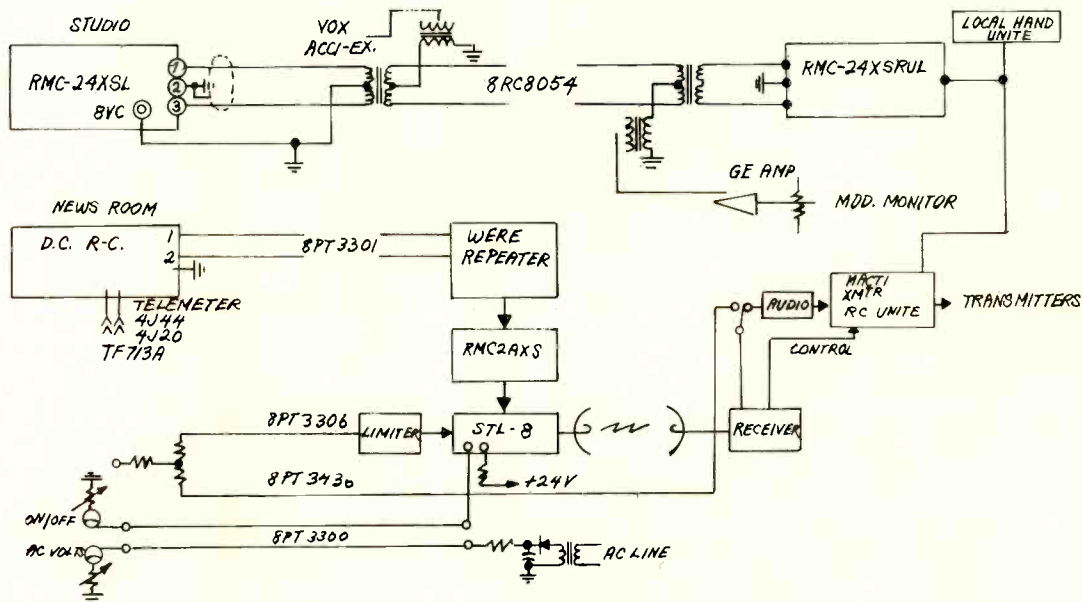

nique is used to handle our morning sports which is done by phone lines. An equalized line connects the sportscasters with the studio. The announcer calls him by phone and puts the call on hold, so the sportscaster can hear pre-delay audio. Both can talk on the air at the same time.

We use two logger (audio) systems. One is a Metrotech triple reverse four track machine, that we change every other day. The other is a Sony TC-105A. The higher quality tapes from the Sony machine are used to make "Best of Tapes" for later rebroadcast. Both also come in handy when we have to answer alleged personal attacks.

Our studio is unfortunately box shaped. Acoustical treatment uses high density concrete blocks on all four walls with plaster studs—acoustical fiberglass and (audio) transparent perforated wall material on both sides of the walls. The floor is poured concrete covered by heavy industrial carpet and pad. There is a double ceiling, the two layers separated by about 6" of air space. The topmost has acoustical tile glued to plaster over wire mesh and fiberglass. Lighting is fluorescent with all bal-

lasts located external to the room in a wall-mounted box for easier service and a quieter control room. To keep our announcer's quality consistent, we use headphones with attached mikes (Astrolight). This not only sounds good, it allows the announcer more freedom in moving about, without ever being off mike.

In conclusion, after installing well in excess of a mile of wire, numerous relays, and lots of equipment, we believe we have successfully automated a live-talk radio format. We have substantially reduced our operating expenses and now can be quite competitive with the music stations for profitability.

In retrospect, it would behoove any station considering this type of operation to give more than two weeks of training to the end users . . . the announcers. The more time they play with it, the more creative each becomes. Our system has been on the air since July 1, 1974 and we've had no serious problems. This must reflect the more than three months of planning and three months of installation and check-out we put in before we went on the air.

Yes, live-telephone talk can be automated! **BM/E**

# portability is the key to eyewitnessing events



PV4800 EIAJ-1  
tape deck for use  
with camera.

Video is the now medium. As the action unfolds, you can't afford to be bound by heavy or bulky video equipment. Enter the 7.8 pound JVC color camera. The only mini-cam with a wooden hand grip designed to help you follow the action in comfort.

Combine all this lightweight portability with a revolutionary, 2 tube vidicon system and you get a camera that is not only rugged but easy to maintain.

The black & white, 1.5" square viewfinder/monitor automatically shows you when all proper aperture settings have been made. You're ready to shoot. Zooming in or out for any focal length from 15 to 60mm to get the picture you want. The built-in electret condenser microphone won't miss any of the sound to make your picture complete.

Light, portable and comfortable to operate, the JVC GC 4800. Get all the facts about the camera and its companion 1/2" EIAJ-1 tape deck, the PV 4800 today.

*JVC Best by Design*

# JVC

**JVC INDUSTRIES, INC.**

Circle 130 on Reader Service Card

JVC Industries, Inc. • 50-35 56th Road,  
Maspeth N.Y. 11378 • (212) 392-7100  
BM/E-85

Please send me information on:

- Camera
- VTR
- Complete system
- Please arrange a demonstration

Name \_\_\_\_\_

Title \_\_\_\_\_

Organization \_\_\_\_\_

Address \_\_\_\_\_

City \_\_\_\_\_

State \_\_\_\_\_ Zip \_\_\_\_\_

Telephone \_\_\_\_\_

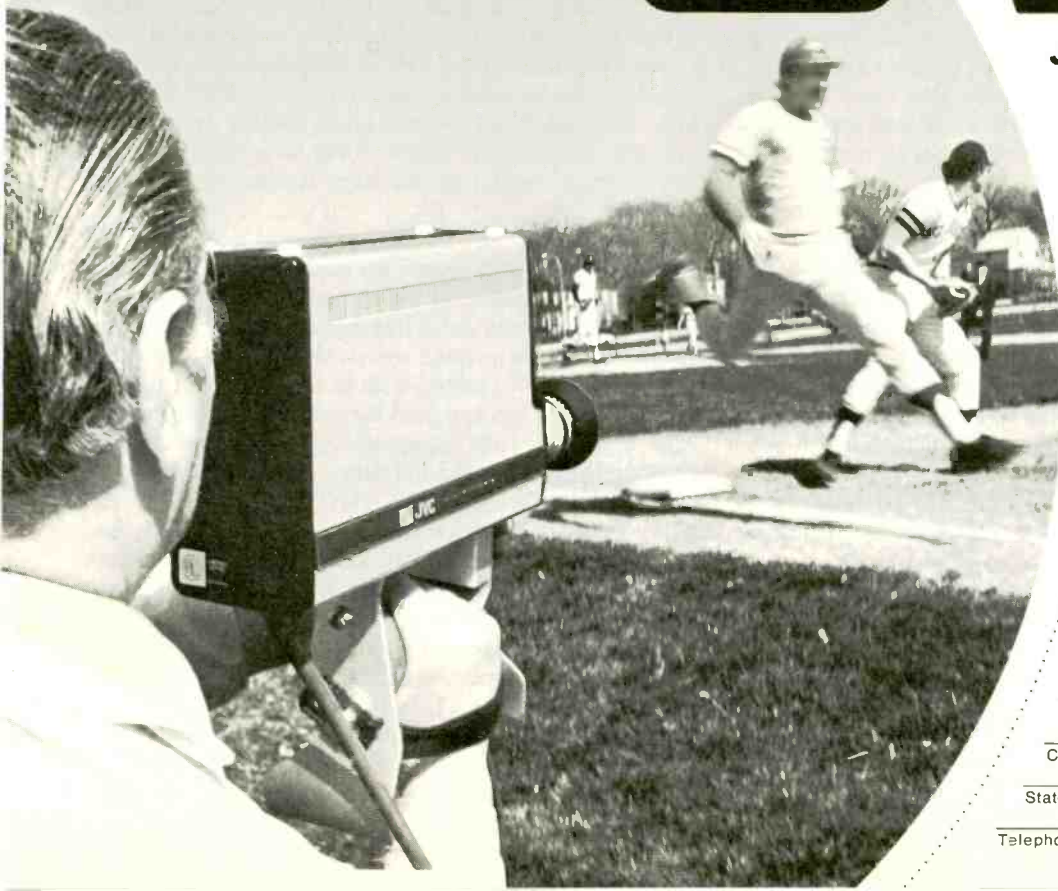

# Progress Report on "Total" Automation

It's beginning to happen:

1. At WTCN, from one input an order goes through sales, scheduling, switching and back to billing with only minor human intervention.
2. At CBS stations in Hollywood and Chicago new automated A-V switching systems will be interfaced with the company's broadcast management information system.
3. Data Communications Corp. is moving toward a system that can be an industry standard—for reps, agencies, and stations alike.

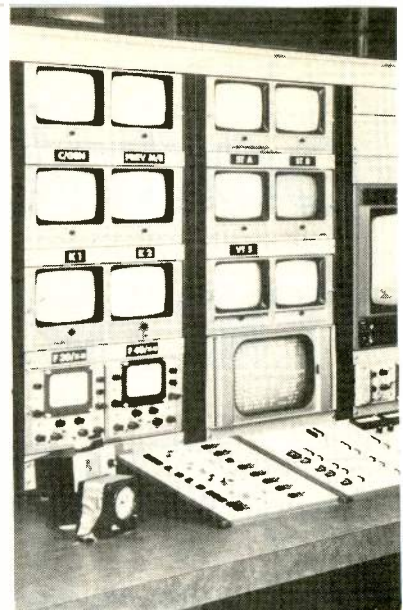

## "Total automation. Period."

This material was prepared by Kaman Science.

On May 30, Kaman and Central Dynamics, Ltd. effected a hard-wired interface between the BCS 1100 business automation system and the CDL APC 610/200 switcher at WTCN, Minneapolis (BM/E July, 1975). Now for the first time in broadcast history, orders are going from initial sale through final log and billing—all by computer. Here's a brief look at how it works.

The BCS mini feeds complete schedules to the CDL mini (both are DEC PDP-11s) with instructions for each event to be aired. It specifies event title, scheduled air time, agency instructions, event source and type, duration, in-house facility code, and the audio/video source and effects. This schedule file is also retained by the BCS mini for on-line editing and modification by the traffic department until shortly before air-time. Last minute changes can still be entered on the CDL system until minutes before actual air-time, and these changes are flagged on the log file to show traffic and accounting exactly what aired—a feature that all but eliminates billing discrepancies.

As an added bonus, the final log can also be archived on microfiche by BCS, at the option of the station.

Metromedia management is excited about the benefits of the BCS-CDL interface. Hal Christiansen, Metromedia Vice President, calls the system as it operates at WTCN, "The only total automation system within the reach of virtually every station." He notes some of the tangible advantages WTCN is already realizing. "Reliable preemption reporting, greater dependability in billing due to more precise log maintenance, and significant management aids at both the local and group levels." Summing up Metromedia's reaction to the historical interface, Christiansen concludes, "This is more than auto switching and auto traffic—this is what every broadcaster dreams of when he hears 'total automation.' From one input, an order goes through sales, scheduling, switching and back to billing without significant human intervention. Who could ask for more?"

At WPIX-TV, New York, BCS and CDL have com-

pleted two of the three phases in totally automating that station. That is, logs now can be produced with exact event timings and machine assignments. All that remains is to link the hardware—a step that will occur as soon as the vendors and WPIX agree on the physical medium of exchange. At this writing, the principal candidate is cassette tape.

The fact that both WTCN and WPIX use CDL switching system is significant, but not essential to their successful interfacing with the BCS 1100. The BCS technical staff has designed their interface to be compatible with virtually every switching system on the market . . . and some that haven't yet been released.

Vital Industries, Inc., Gainesville, Florida and Computer Image Corporation, Denver, are both actively working on a BCS interface. The Grass Valley Group, one of the front runners in computerized switching, has already demonstrated its ability to link its APC 2000 to the BCS 1100. The Grass Valley Group's NAB exhibit in Las Vegas held quite a surprise for unsuspecting delegates, who watched the APC 2000 switching a schedule sent from the BCS booth across the aisle. BCS fed two-hour schedule blocks to the Grass Valley switcher on demand, assisting the Grass Valley switcher throughout the show in displaying its large repertoire of special effects.

According to Al Larrabee, Kaman's Director of Systems for the BCS group, the ready acceptance of their interface is evidence of its versatility and generalized format. "Our communications protocol and data transfer format have been adopted almost verbatim by all switching vendors we've talked with to date. As we expected last year when we designed the interface, our format is now stabilizing and standardizing traffic-to-switching communications for the industry," he says.

A closer look at the BCS 1100 system will help explain how it talks to switchers—early. First of all, the 1100 is based on the distributive processing concept (BM/E, July 1975). This means the station has its own minicomputer in-house to handle the on-line responsibilities and a large-scale computer at a remote site to handle the large processing jobs that don't require up-to-the-minute response. This approach saves phone line costs and puts the appropriate level of computing power

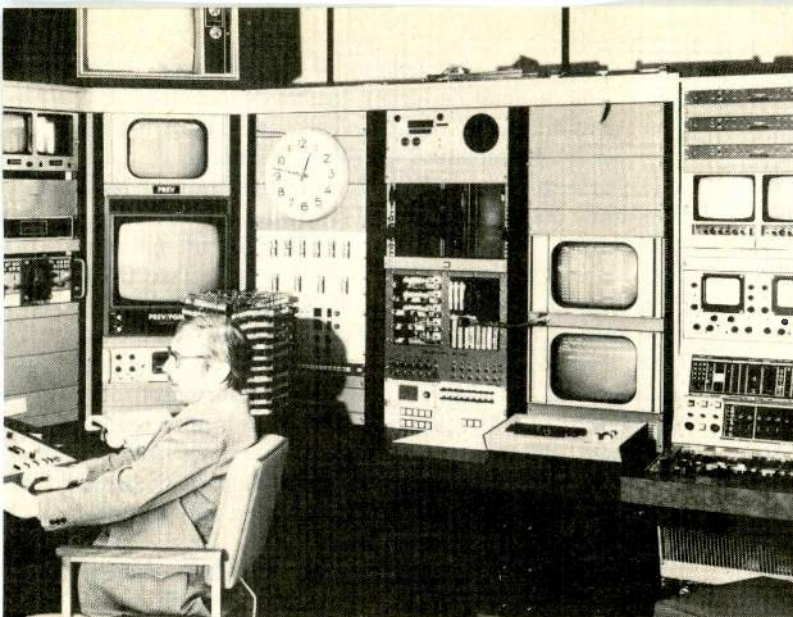

Master control room of WTCN showing Central Dynamics switcher, CRT display and as-aired program log.



The BCS 1100 system computer which interfaces with the Central Dynamics computer (not shown).



The BCS 1100 input terminal.

to work where and when it's needed.

In the case of the 1100, however, the concept allows some unique advantages that go beyond the norm. For example, using a Digital Equipment Corporation PDP 11/05 as its in-house minicomputer, the BCS 1100 system has the extra processing capacity to support both hard-wired and telephone communications with other computers while handling virtually unlimited CRT and printer terminals at the business end.

This means an 1100 user can place CRTs and printers in remote sales installations, rep offices, corporate headquarters or anywhere else he chooses. He even has the option to provide briefcase terminals to his salesmen. What's more, for group stations, a minicomputer network is readily available between stations for interaction between group and station management, and both radio and TV can run on the same system. The 1100 also boasts a new conversational data base management system that gives traffic and accounting increased flexibility and control in file maintenance and inquiry, plus a selective printout feature which allows a station to receive only those reports which fit its particular method of operation.

Users report favorable results with the new system. KOOL-TV, Phoenix, the first BCS customer back in the days of batch processing, was also the first station to upgrade from a BCS 800 to the new 1100. Operations Manager, Eve Hatounian, talks about the advantages of her new system. "As pioneers in broadcast automation, we have welcomed each new breakthrough BCS has made. Now we believe we have it all—five terminals, super-fast log editing, selective printout—we're even adding radio on the same system. And, even though we think the system works great, BCS is always improving it. That's the beauty of BCS—they never stop enhancing the system." KOOL radio will be put on the 1100 system next month to run simultaneously with TV. This will add two more CRTs, bringing the total to seven.

Other recent 1100 installations include WXIX-TV, Cincinnati and WNEW-TV, New York. WTTG-TV, Washington, D.C. is soon to go on the system.

Jack Finlayson, BCS Manager for Kaman, attributes the quick acceptance of the new system to its greater flexibility. He says, "It's the only system on the market

that can interface with switching, support remote terminals, print all reports and billing right in the station at ultra high speed and communicate readily with other computers. And, it does all that while still offering the most comprehensive rotation package we know of."

The rotation scheduling and other traffic features of the 1100 are based on the system's forerunner, the BCS 800. Kaman still actively markets and supports the 800 system for stations who don't require the added features of the 1100.

## TV Switching Automation At CBS: A Second Generation

The material in this section was prepared by Adrian B. Ettlinger, technical consultant, Hastings-On-Hudson, N.Y.

A milestone in the history of television switching automation is being reached during the current year as CBS is embarking on a second generation of installation at its network and owned-and-operated stations. Pioneer automation station KNXT, Hollywood, is getting a new computer and a new A-V switching equipment. WBBM-TV, Chicago, will follow suit.

The earliest history of television switching automation began in the 1950's, with punched paper tape programmed systems. The very first was designed and installed by NBC in 1956 at WBUF, a UHF station it then owned in Buffalo, N.Y. Subsequently, RCA marketed systems based on the NBC work, and a number of installations were made, including major ones at WKRC-TV, Cincinnati and NBC-owned WRC-TV in Washington. Other vendors and some stations independently created a small variety of switch-programmed and pinboard-program devices which were used at scattered stations around the country. These systems established the basic viability of switching automation and most were operated successfully for several years, but later generally discontinued or replaced because of their relative lack of flexibility as compared to that offered by newer technology becoming available.

## TOTAL AUTOMATION

When CBS in 1959 began planning a new broadcasting plant for KNXT at Columbia Square, in Hollywood, it was decided to automate the program continuity switching function, and the result was television's first computer-operated switching system. This system went on the air on December 31, 1960. It subsequently became CBS practice to install switching automation at its network and station facilities in all newly-constructed installations. In sequence, the network Broadcast Center in New York, which also serves WCBS-TV (1964), WCAU-TV in Philadelphia (1968), and KMOX-TV in St. Louis (1968), all of which were complete new television plants, were equipped with switching automation in various forms. The fifth CBS owned-and-operated station, WBBM-TV in Chicago, whose present plant had been originally designed and built in the middle 1950's, remained a manual operation.

The pioneer computer installation at KNXT in Hollywood used a computer manufactured by TRW Computers Division of Thompson-Ramo-Wooldridge, which in the late 1950's and early 1960's was the leading supplier of industrial process control computer installations. The computer is a so-called "second-generation" vintage machine, i.e., using solid-state dis-

crete components, (but not, as of then, integrated circuits), and a rotating drum memory-processor. The system has a capacity of 220 events, and data is loaded manually by the technical operating personnel.

The system which CBS placed in operation in New York three and one-half years following the KNXT installation, on July 20, 1964, may be considered as a direct lineal descendant of the KNXT system. Two TRW computers, of the same generation as the KNXT unit but of more advanced design, (TRW model 330) were used to operate two independent program continuity switching facilities, and, in addition, an audio-video-control routing switcher of 100 inputs by 100 outputs is operated for automated assignment of facilities to using studios. Switching data for the New York system is prepared off-line on punched paper tape and entered into the computers from a traffic service area.

Automation installations made at CBS stations WCAU-TV in Philadelphia and KMOX-TV in St. Louis a few years later represented the technology available at their time, also. A system manufactured by Hancock Telecontrols, based on core memory technology but employing hard-wired logic rather than a computer, was installed to control WCAU-TV's program continuity switching in 1967-8. This system has a capacity of 30 events and data is loaded manually by technical per-

continued on page 51

### BIAS, Which Grew Up In TV, Starts in Radio With WHN, NY

The BIAS computerized automated data system for broadcasters, developed by Data Communications Corp. of Memphis and in use by more than 125 television stations, recently added the first major-market radio station to its roster by going on-line at WHN-AM, Storer station in New York City.

As described in last month's BM/E, BIAS II, the current version of the system, is based on a high-speed Burroughs 6700 computer at headquarters in Memphis, connected by 24-hour, dedicated telephone lines to BIAS subscribers around the country. Each subscriber has input and output equipment, plus an in-station mini-computer (a Nova II), which does many routine, day-to-day jobs on the spot, and speeds the flow of data to and from the central computer.

### COMPU/NET Spreads from Radio to Television

Moving toward service to both radio and television in the counter direction from BIAS (see accompanying story), is COMPU/NET, Inc. With more than 40 radio stations on-line for automated data handling, COMPU/NET recently signed up Nationwide Communications, Inc. for service to all eight radio and three television stations of this multi-station operator.

The COMPU/NET system is based on two large computers at their processing center in Los Angeles. Clark Pollock, vice-president and general manager of NCI, says that NCI will be the first broadcast group to interconnect multiple radio and television stations to a single on-line data-handling computer system. "Management information systems and research information for more creative selling will be the major benefits of the system to NCI stations," he added.

Dick Jansen, who was sales manager at NCI's WGAR in Cleveland when business automation first

At WHN, input is through two keyboard-CRT units, and output to the CRT's and two high-speed line printers. The high speed of the system has delighted the management of WHN and brought the advantages of computerized traffic, sales, and accounting in full measure. Pat Munson, Traffic Manager, says: "We can do so many things so fast—provide more clearing time for clients, verify avails far more quickly, give the sales manager much more time for decisions . . . We can also manipulate the inventory to achieve maximum benefit long before we even air the spots. This flexibility, with our high volume, is extremely important to our competitive stance in the New York market."

DCC's BIAS II, compared with the earlier BIAS, operates about four times as fast, with greater throughput as input devices operate independently of the print-out. DCC, according to Norfleet Turner, president, plans a major expansion effort in the AM radio field.

began and now heads up all radio operations for the system, says instant access to availabilities is extremely valuable. Jansen likes the way the computer can juggle a large number of orders and optimize scheduling.

He says the television system has the ability to automatically select and schedule, reschedule and handle makegood scheduling for both horizontal and vertical rotation plans. It also assists in selecting, scheduling and makegood scheduling for orbit plans. COMPU/NET has recently added another feature to its system which gives radio stations an on-line research capability for analyzing competitors' schedule proposals and evaluating its own rate card based on each new market survey.

Nationwide's television properties include WXEX-TV, Richmond, VA.; WATE-TV, Knoxville, TN.; and WBAY-TV, Green Bay, WI. Its radio stations are WGAR (AM) and WNCN-FM, Cleveland, OH; WNCI, Columbus, OH; WLEE, Richmond, VA.; and WPOC, Baltimore, MD.



# Instrumentation Precision in Broadcast Terminal Products

## TeleMation's *Precision* Line Terminal Equipment

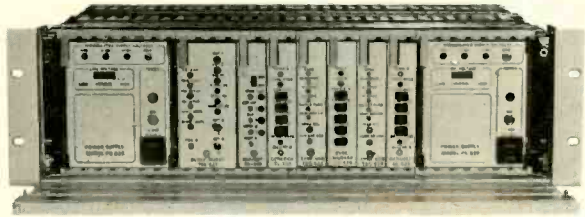

Within TeleMation's "525 Series" audio and video terminal product line, certain units are designated *precision* as distinguished from their *broadcast* counterparts. The *precision* designation is much more than a simple "marketing label". *Precision* is a demarcation assigned through TeleMation R&D that puts a particular product into a separate, unique attention category, from design concept through manufacture and quality-assurance verification. All this to assure the buyer that the product not only meets or surpasses all known competitive products in its performance parameters, but also that it is designed to operate for months and even years without need for periodic adjustment or any other routine maintenance. This philosophy and practice, then, take the *precision* units in the 525 Series terminal equipment into a quality/stability/reliability realm that is usually associated with instrumentation electronics.

TeleMation has used a number of design techniques in accomplishing the high performance and stability achieved by these products. For example, one-percent-tolerance resistors having a temperature coefficient of 20PPM/°C are generally used as gain-determining elements and wherever drift would affect stability. They provide both freedom from temperature drift and freedom from the effects of aging that are common to the less expensive resistors normally used in video products. Junction matching — each PN junction being matched with an NP junction to cancel the characteristic 2.2mv/°C drift of silicon junctions — is also employed to improve stability and prevent offset drift in DC-coupled outputs.

Feedback is extensively used in *precision* grade units as a means of insulating performance characteristics from the effects of component variables. Audio amplifiers are typically high-gain op-amps inside 100-dB feedback loops, while video amplifiers are typically transistor pairs inside 40-dB feedback loops. In these applications, a 2:1 change in the gain characteristic of any active component will have negligible effects on overall circuit performance.

The advantages of push-pull, cascode, and complementary symmetry circuits are exploited to provide low distortion, wide bandwidth, and high signal handling capability. Current-sourcing techniques are also employed as a means of minimizing distortion that otherwise can result from operating semiconductor junctions over wide current ranges.

TeleMation engineers also have successfully coped with capacitor leakage (another source of long-term drift) in the *precision* series designs. Capacitors are either operated with minimum DC voltage drop or the effects of increased leakage with age are otherwise eliminated, as in the TVA-524 and TVA-525 video distribution amplifiers where the capacitance of a small capacitor having extremely low leakage current is "amplified" by a high-gain op amp; the result—longer time constant, less tilt, and greatly improved long-term stability.

Our TVA-525 video distribution amplifier, whose performance characteristics are listed below, is a representative application of the quality and stability factors inherent in the *precision* series product.

### TVA-525 PERFORMANCE SPECIFICATIONS

	TYPICAL	PUBLISHED
Differential Phase @ 3.58 or 4.43MHz	0.12°	0.2°
Differential Gain @ 3.58 or 4.43MHz	0.11%	0.2%
Frequency Response to 5.5MHz	0.05 dB	0.1 dB
Frequency Response to 10MHz	0.20dB	0.25dB
Hum and Noise	72dB	66dB
Distortion, 50Hz Squarewave DC Mode	.1%	<.15%
Distortion and Tilt, 50Hz Squarewave AC Mode	.20%	<.25%
Output return loss @ 5.5 MHz	38dB	35dB
Input return loss @ 5.5 MHz	43dB	40dB
Bounce and Overshoot DC Mode	1%	—
Bounce, AC Mode (Monotonic)	8 sec.	5 sec.
Overshoot, AC Mode	None	None
K Factor	.25%	0.5%
Input Offset Compensation Range	>3VDC	>2VDC
Common Mode Rejection, 60Hz	>70dB	>60dB
Common Mode Rejection, 5MHz	>43dB	>40dB

A functional schematic of this amplifier along with a product description is available on request. We suggest you compare this circuit to that of any competitive product. We feel you will agree that the stability and long-term quality performance intrinsic to our *precision* design will justify whatever small additional initial cost might be involved through including such quality electronic devices in your broadcast system.



**TeleMation**

P.O. BOX 15068, SALT LAKE CITY, UTAH 84115  
(801) 487-5399, TELEX: 388-352

Circle 131 on Reader Service Card

# International Interest in TV High; Broadcasters From 50 Countries Attend Montreux Symposium

Solid-State CCD cameras, ENG, direct-to-home satellite broadcasting, dual audio, more conversion of equipment to digital, were topics of widespread interest. Digitally coded news on TV sets begins in U.K., CATV filled 20 per cent of program.

There were visitors from every continent and about 50 countries at Montreux May 23 to 29—altogether over 4,000 eagerly seeking out the latest information on what's happening in TV and cable TV technology. In the exhibit area, the wares of 130 companies hailing from 15 countries were poured over—especially so by large delegations from the People's Republic of China, Kenya, Zambia, Rhodesia and various Persian Gulf states. These statistics made the 9th International Television Symposium, held under the auspices of Swiss Posts, Telephones and Telegraphs, the leading TV symposium in the world. The success of the event shows clearly, said Mr. F. Lochner, Dir. of Swiss PTT, "There is a need for personal contact and discussion, in an age whose mass of information may be one of the causes of increasing human isolation."

The Montreux Symposium is different from NAB Conventions in several aspects. The International TV Symposium is all technical but whereas the NAB technical papers cover what is or has been, participants at Montreux talk about the future; what will be—hence the emphasis on future cameras, satellites, and digital techniques. In the U.S. the technical directors of the three commercial networks are not likely to reveal precisely what new equipment they are developing or funding for obviously competitive reasons. There is no such prescription holding back technical directors of nationalized PT&Ts. Further, since the latter are in charge of the only game in town, they function independently of commercial pressure and can set the timetable on what will happen when. Indeed they can set the rules. Thus a PT&T can declare that direct satellite to home broadcasts are to become operational at sometime in the future on purely technical grounds. Such an event could not happen in the U.S. because there is no way, politically, that the rules would be changed to eliminate the need for over 700 privately owned stations. Similarly, individual countries can edict that stereo be broadcast nationally and it will happen. By the same token they can hold back on the number of program channels that can be broadcast—or carried by cable TV. Thus on the one hand one sees exciting techniques emerging by government fiat. On the other hand, some changes come more slowly and Montreux sessions on automation, for example, would

be old hat to American visitors.

## More flexible cameras of keen interest

From the lecturns, engineering heads of various countries tended to play down the need for instant electronic news gathering. News viewing hours are later in the evening in Europe (during prime time in the USA) so that there is ample time to develop film. Further, there's little competition to scoop. But in terms of interest shown in ENG cameras on exhibit and in attendance at ENG sessions (chaired by Joe Flaherty, CBS), Montreux attendees are extremely interested in ENG—if not for news, for on-location production. As was pointed out on the first day, it is getting less costly to take portable equipment out on location, than to create artificial scenery. Thus portable cameras and particularly mini ENG types got lots of attention.

Ampex unveiled at Montreux a new ENG entry, the BCC-2. This is a mini unit with the head weighing 15 lbs. and the backpack under 18. Ampex went for full quality using three 1-inch Plumbicons, including an extended red Plumbicon. Thus high sensitivity is offered. Ampex says a usable picture is obtained in 2 to 3 seconds from standby mode or 1 minute from cold start.

Ampex stressed a complete ENG at Montreux: the BCC-2 in conjunction with the VR3000B quad recorder and the TBC-800 time base corrector. The system price was about \$125,000.

RCA stressed ENG most heavily and, as at NAB, showed nearly all of the components of a complete system: The TK-76 camera, the TR-1000 U-matic recorder, the TBC-1000 time base corrector, the TVM-1000 portable microwave system and two-way FM radio for communication. For use with OB vans; RCA, showed its portable TK-45P cameras.

Bosch-Fernseh showed off prominently its KCN "hand-held" camera (displayed at NAB) but sensing that production was perhaps bigger than news in Europe called it a electronic production/journalism unit. Bosch also had new hand-portable VTR but more on that later.

Philips had a model of the LDK-11 shown prominently at NAB on hand but it was off in a corner and not demonstrated. In the portable category Philips stressed the LDK-15. Similarly, Thomson-CSF stressed the TTV

1515, and Marconi the Mark III portable. Sony's DXC-1600 was also shown.

One of the newest hand-held cameras on display was a portable high-quality one-tube design from Siemens. Called Interplex, this promising camera uses new silicon diode vidicon tubes developed by Siemens. The tube features high sensitivity and linear characteristics. A special stripe filter and a special decoding circuit produced a camera with high color fidelity.

In the studio class, prominent new cameras were the Ampex BCC-1 (unveiled at Montreux), the Bosch-Fernseh KCK (unveiled at NAB), the Philips moderately priced LDK-25 (unveiled at NAB.) Other major camera exhibitors were Thomson-CSF, Marconi, and Link Electronics. Link showed the type 110 which was introduced at the London International Broadcast Convention last September. As a current generation camera, it offered good stability and features fast line-up. The Link 110, like most other cameras, intended for international sales, was shown operating in both PAL, SECAM, through the use of a transcoder. A low cost color camera designed for mobile vans was shown by Schlumberger. A number of exhibitors had CCTV tube cameras.

### Solid state cameras discussed

Charged coupled devices (CCD's) captured a lot of attention at Montreux. RCA demonstrated its experimental color camera (the same one shown at NAB, Las Vegas). The three CCDs in the RCA camera are  $512 \times 320$  element devices. (163,000 picture elements). At Montreux, Bell Labs described a CCD camera with 250,000 picture elements. The imaging area was designed to be equivalent to one-inch tubes. The chip measures  $16 \times 20$ mm. It has 496 vertical interlaced lines and 475 horizontal picture elements.

J.H. Scott of RCA, M.F. Tompsett, Bell Labs, and P. Rainger of the BBC, explored the future of CCD devices

in various papers and on the panel concerned with future developments. All agreed that broadcast quality units for color were about five years away. Resolution of 525 lines is no problem, registration is perfect, and CCD devices have no lag. They can also handle bright reflectors without smears. There are problems in spectral response, yields, and dark current.

Sensitivity is good but right now there is absorption of blues because light has to pass through the electrode structure and blue is attenuated considerably. A solution to the problem would be to make the substrate thin so that the optical image can be formed on the rear face of the substrate.

Tompsett of Bell Labs said major problems are blemishes or defects in the structure, which should be perfect over the whole chip area, and dark current. He saw dark current being controlled to less than  $5 \text{ nA cm}^{-2}$ , but to equal Plumbicons, device coolers in the  $50^\circ\text{C}$  range might be necessary. This would be a small price Tompsett said. The Bell Lab's camera consumes only 4 watts of power. An electron beam exposure system was used to make the photolithographic mask.

Consensus of opinion was that CCDs are likely to appear on the market first as memory devices and then in surveillance cameras but they will eventually replace tubes in broadcast cameras.

### VTRs—more and more formats

Following Montreux of two years ago something of a show down was expected in VTRs. The EBU issued guidelines for compatible recorders which it thought had to be helicals: low operating cost, low initial cost, video and audio equal to quad and two full quality audio tracks.

IVC in consort with Rank Cintel in the UK and Thomson-CSF in France said its segmented helical scan format on 2 inch tape was the ideal answer. But at the

Distant signal CATV antenna outside the Maison des Congrès set up by Catec AG.

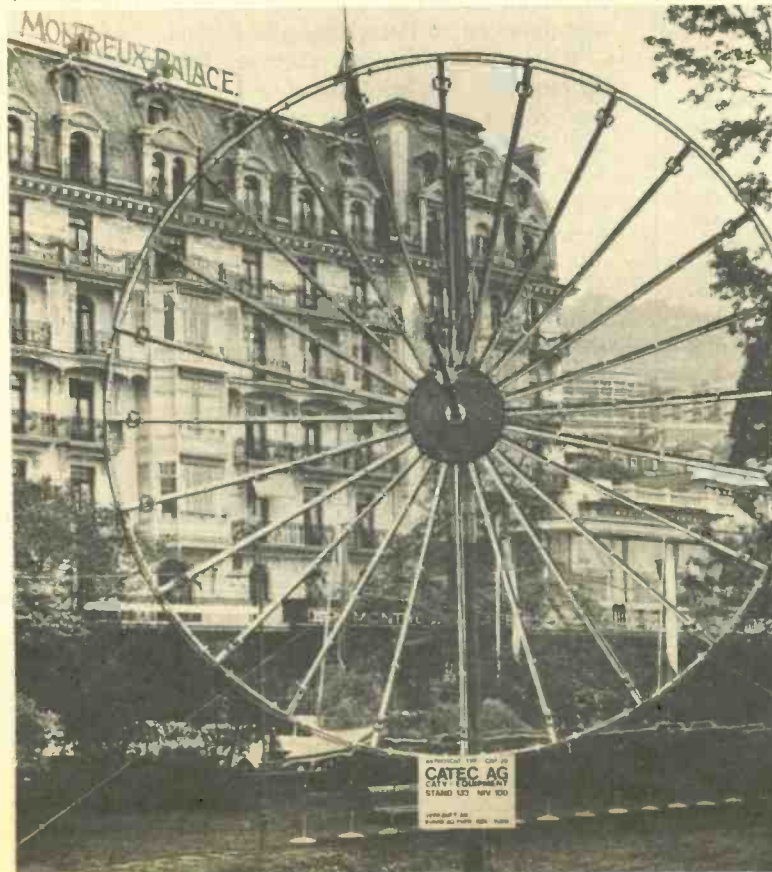

Chip on shoulder of model is RCA's charge-coupled device for the solid-state camera of the future. To left is ENG camera the TK-76.

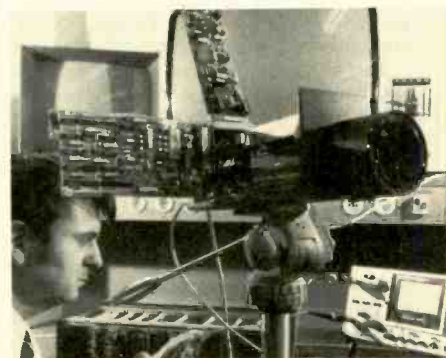

Inside view of the new broadcast quality single-tube color camera, the Interplex, demonstrated by Siemens.

## MONTREUX SYMPOSIUM

same time Philips and Bosch were collaborating on a 1 inch helical format which they said was the lowest cost approach to meeting EBU requirements. RCA dampened some of the enthusiasm toward helicals by talking about Quad II which could offer the best of both worlds and Ampex cautioned broadcasters about the pitfalls in moving away from standard quad. The race was on.

By Montreux 1975, however, there was no winner—indeed the issue was more confused. The IVC consortium's IVC 9000 machine did not sell as expected apparently because the price was too high but it was still in there pitching. Philips and Bosch had split with each company offering differing approaches. New on the scene was Echo Science introducing Pilot-1 and claiming for it "What the '9000' should have been for EBU . . . Pilot 1 is!" Ampex had unsettled things further last year by introducing the AVR-2—it only partially met EBU requirements, but was attractive in size, price and



*New Bosch BCN 20 hand-held VTR which can be used for field production recording.*

### Satellite Broadcasting Foreseen; Planning Underway

While there is no urgent need to go to satellites for extra programming channels, most Europeans feel satellite broadcasting will be adopted in the future. Satellite broadcasting is viewed as more economical than terrestrial distribution methods. And it's likely that developing countries will want to use satellites soon. Anticipating the need, the International Telecommunications Union will convene a Planning Conference on satellites in 1977. The E.B.U. now has studies underway to report at that conference. Several companies—Mullard, Valvo, Philips—have been studying converters and antennas for direct reception.

The assumption is that each country will have its own satellite service (carrying four channels) and the coverage pattern will be pretty much restricted to individual countries. The 12 GHz band rather than 2.5 GHz will be used because there are no power flux density limitations with the former. (The 2.5 GHz band may be used for some educational purposes.) For direct reception, the power of the transponder should be in the 400 Watt vicinity and the cost of the receiver adapter to convert the 12 GHz (FM) is expected to be in the \$120-300 range. (The signal-to-noise ratio for the picture would be at least 33 dB and for audio, 50 dB.)

Among the studies underway are how to calculate optimum antenna beams, orbit positions, and frequency assignments.

convenience. Ampex demonstrated it could go further by adding super high band and pilot tone. The result was good multiple generation copies at 7½ ips. RCA demonstrated a working Quad II approach (for both the TR-70 and TR 600): super high band and pilot at 7.8 ips and two channel audio. (Ampex also offered two channels of audio but did not claim them to meet EBU demands.)

There was no compatibility among these varied offerings except that modified quad approaches could play standard quad. Although RCA and Ampex approaches were not identical it was assumed both would agree to an SMPTE set standard.

Philips offered the one-head, one-inch BCR model demonstrated in 1973. It discussed three models: BCR 40 the heart of the system; BCR 50 with time base corrector and BCR 60, a unit with a monitoring bridge. Bosch showed three units also: the BCN 20, the 40 and the 50. Bosch, too, took a modular approach but each module was its own separate transportable package similar to the AVR-2 approach. The smallest unit, the BCN 20 was a 44 lb. hand-carried unit that could be taken with Bosch-Fernseh's KCN handheld camera. Its one-inch format included 3 audio tracks plus one for control. Bosch elected to go with 2-heads and a segmented scan approach.

Bosch's tape deck design was patterned after the US Echo Science machine and it was clear that there was some agreement and license between these two companies. But Echo Science (now a part of Arvin Industries) who didn't go to the NAB convention this year did travel to Montreux to introduce yet a different format in its six models of Pilot 1. The scanner was similar to that which it has sold successfully to the military (400 units and which Bosch adapted) but to the recorder was added a pilot tone. Echo Science said that very super high band circuitry with pilot gave signal performance superior to quad and enhanced interchangeability.

All three companies, Philips, Bosch and Echo Science, indicated they would be at NAB next year to probe the U.S. market. There was some speculation at Montreux that Bosch and Echo Science might reach an agreement on an interchangeable format.

What will be the likely outcome? The Philips machine operates from the handicap of being susceptible to tracking problems due to tape stretch, etc. Bosch was not using pilot and it may have banding problems. Echo Science has no track record with broadcasters. IVC does not have portable models and its teleproduction model is expensive. Thus all helical contenders have handicaps. The modified quad approaches (Ampex and RCA) have to make some compromises for audio. In the face of this confusion—no new compatible standard meeting all EBU requirements may ever emerge. In the meantime its becoming clearer that European broadcasters are willing to settle for less than the whole cake and modified quad without ideal audio meets many requirements.

### Test Equipment Plentiful

Generally speaking U.S. monitors weren't of high enough quality for European demands and European units are too high priced for the U.S. market. This pattern was broken this year with the Belgian made Barco unit being imported by the U.S. (Kallman Associates). At Montreux, a reverse flow was noted. Conrac was there with a completely new color TV monitor designed especially for PAL and SECAM, "intended for precision

*continued on page 46*

# RCA BEGINS THE COUNTDOWN.

**This winter, the first of a new generation of domestic communications satellites will be launched by RCA — the people who pioneered them.**

The RCA Satcom System was the first to provide coast-to-coast satellite communications—and at substantial savings.

We've been providing this service for 20 months—and this is just the beginning.

Our new advance-design satellite will handle twice the traffic of any satellite now in orbit, operating with a growing network of earth stations in major cities. It will make the RCA Satcom System even more cost-effective. And it will be followed by other RCA-designed, new generation satellites.

**The RCA Satcom System. Here's what it can do for you now.**

Today's most advanced means of voice, data and video communications offers these benefits:

Major rate reductions in voice-grade, coast-to-coast leased-channel communications;

High-speed data transmission for low-cost computer interface;

More private-line switching systems for company-wide telephone systems;

Fast communications and processing of data from offshore oil rigs to land-based headquarters;

Expanded use of video transmission for business.



For complete information on any aspect of the nation's most experienced domestic satellite communications service, contact Walter Pioli or John Mehrhoff, Satcom Marketing, RCA Global Communications, Inc., 60 Broad Street, New York, N.Y. 10004. Phone: (212) 363-3986.

**The RCA Satcom System. America's new link with America.**

**RCA** Global Communications

# VISCOUNT 1150B PRODUCTION SWITCHER

**PROFESSIONAL...  
and... AVAILABLE**

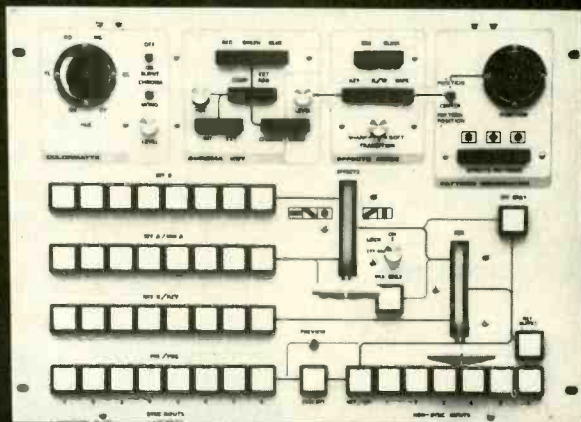

## KEY FEATURES:

- \* 14 inputs - 8 sync, 6 non
- \* 4 busses
- \* 27 std. wipe patterns
- \* int., ext., chroma key
- \* composite, ext. RGB
- \* soft key, wipe of key
- \* mix-blink on wipe-key
- \* spot light effect
- \* black burst, clr. mat. gen
- \* 'on-air' inputs indication
- \* full preview
- \* colour timed, any path
- \* vert. int. switching
- \* processing amplifier
- \* remote control panel

\* \$9250 - '1150B'  
(shown above)  
also available:  
\$ 7500 - '1150A'

**VISCOUNT INDUSTRIES LTD.**



105 EAST 69th AVENUE  
VANCOUVER, BRITISH COLUMBIA  
CANADA V5X 2W9  
PHONE (604) 327-9446 TELEX (04) 508-605

## MONTREUX SYMPOSIUM

broadcast applications." As a new generation solid state device the Conrac 6000 was extremely compact and at the same featured the "utmost in stability" and precise color inetry through the use of a newly designed fully active convergence system. The 6000 uses a special picture tube with 625 line shadow mask and matched EBU phosphors.

New lines of test equipment were introduced by several companies. Philips showed five new instruments: a TV demodulation PM5560 (which features both envelope and synchronous detection); a text generator PM5542 (which inserts text automatically such as station identification or messages "we regret the breakdown in sound"), a stable TV modulator (crystal controlled); a color analyzer (to measure primary colors) and an ITS generator (made to a German standard).

Systems Video Ltd. showed the new PAL and NTSC generator in compact 3½-in high-rack packages. SVL also showed a new ITS waveform analyzer with high brightness and digital indication of line number.

Among American manufacturers present showing test equipment were Tektronix and Telemet.

### New telecine shown

One of the big crowd pullers at Montreux was a silent telecine unit, the Rank Cintel Mark 3 which uses a superior flying spot conversion technique at a new low cost. A sprocketless capstan drive results in silent operation and minimum wear. Designed to handle both 16mm and 35mm film, the Mark 3 has a 10 times forward and reverse shuttle speed. Unit can be used with either 625 or 525 line systems.

Another new telecine system at Montreux was the OMY 40 designed by Bosch-Fernseh. Its feature was the variety of combination of 2 outputs and 4 inputs available: one camera, two cameras/16mm, 35mm, Super 8, slides. The two camera set-up allows color preview monitoring.

Eastman Kodak described its new video news film 7420 and the VNF-1 process for lower cost and process simplification. The new American company, Hollogon Optical Systems Corp., was there showing its Rotary Projection System for shutterless, flickerless projection.

*New Rank Cintel flying spot telecine.*



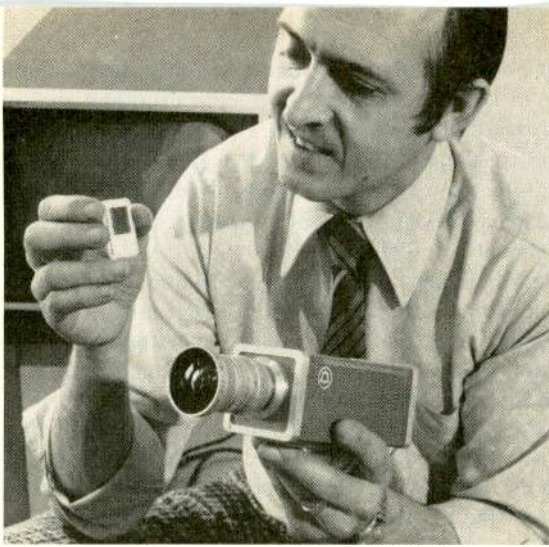

Experimental solid-state TV camera shown by Bell Labs. Chip is charged-coupled image sensing device.



TV set modified with decoder to pick up data transmitted during horizontal blanking. Numbers are different "pages" viewer can select.

### Digital Comes On Strong

The British Post Office has used PCM since 1972 to distribute stereo signals to various FM transmitters in England and the service is being extended to Scotland. At the International TV Symposium, speakers were speculating that radio and TV systems would be all-digital right down to the transmitter. Some eleven papers were read describing work being done in one or another area. In discussing the impact of digital technology on program production in the studio, Frank Davidoff, CBS Television Network, said there are three steps to digital: 1. introduction of digital black boxes that do things better than analog black boxes; 2. using digital black boxes that out perform analog boxes for a given function; 3. adopting a completely digital plant.

Examples of the first are TBC's and synchronizers. So far there are no examples of the second. The third is of keen interest to Europeans one reason being the simplification of handling different color standards such as PAL, SECAM and NTSC. Davidoff said the cameras output signal would likely be a luminance and color difference signal (YIQ or YUV) format. At the transmitter modulator the program would be converted to analog.

A sampling rate of four times the subcarrier frequency is considered desirable for many functions but this uses a lot of bandwidth and digital video recording becomes expensive. How to get around this problem has not been

continued on page 48

# On the Air®

with a full range of high reliability

**TV TRANSLATORS**

**TV TRANSMITTERS**

**TV AMPLIFIERS**

**@j acrodyne**  
industries, inc.

21 Commerce Drive • Montgomeryville, Pa. 18936  
(215) 368-2600 TWX 510-661-7265

Circle 134 on Reader Service Card

## Try it. You'll buy it.



We know that our Senstrol Model SFE-1 automatic splice finder and bulk eraser can save you, the busy broadcaster, both production time and money. And, we're

more than willing to let you prove it to yourself, at our expense. Here's how:

Send us a purchase order for \$360.00. We'll ship your SFE-1 right from stock. Then, use it for 30 days. If you decide to keep it, pay our invoice. If you don't, send it back. Your order will be cancelled, no explanations needed.

We don't get many returns.

**Offer good through September 30, 1975**

**UMC**

SENSTROL DIVISION  
UMC ELECTRONICS CO.  
460 Sackett Point Rd. North Haven, CT 06473

Circle 135 on Reader Service Card

solved. Another disadvantage is difficulty in monitoring the picture.

However, the advantages are numerous in terms of the elimination of adjustments, increased stability and reliability, elimination of non-linear distortion, etc. Other factors, said Davidoff, are initial and operating costs. It is expected that the initial cost would be high although in the long run digital equipment will be less expensive than analog. Operating costs should be reduced except for VTRs. Maintenance should be less, all in all. Davidoff said CBS feels certain the future of the television industry lies in digital technology.

A specific example of how digital TV is affecting the industry is in the area of standards conversion. And pre-eminent in this role is DICE which stands for Digital Intercontinental Conversion Equipment designed by engineers of the Independent Broadcasting Authority (UK).

The latest version of DICE will convert 525-line NTSC color pictures as used in the USA and Japan into 625-line PAL or SECAM pictures used in most other parts of the world, and vice versa. DICE is described as the world's fastest computer.

The standards conversion is essential not only for "live" relays via satellite but also where program material or videotape is exchanged between countries working to different picture standards.

A number of different types of standard converters have been developed over the years, but Independent Broadcasting Authority engineers were the first to develop the unit based on digital techniques to eliminate the need for careful alignment and adjustment and to provide conversion without perceptible picture impairment.

DICE solves the technically complex process of conversion between systems using 30 pictures a second—as in North America and Japan—and those using 25 pictures a second as in Europe—entirely electronically and without picture distortion and is capable of satisfying a global demand for high quality pictures by satellite. It also lets program companies making television recordings for world-wide sale to offer high quality pictures no matter which standard was used during production.

The original DICE, designed for conversion from 525-line to 625-line pictures only, was first used for the US Presidential Election relays to Europe in November 1972. In March 1973, although originally intended only

as a one-way prototype, it was installed in the London studios of Independent Television News and has been in regular operating use since then. (This work earned IBA the Geoffrey Parr Award of the Royal Television Society, and the Pye Color Television Award for "The most significant technical contribution during the year to the development of color television.") An agreement signed on February 3rd, 1975, gave Marconi Communication Systems Limited, a GEC-Marconi Electronics Company, exclusive world-wide manufacturing and marketing rights of DICE. DICE equipment was on display in the Marconi exhibit area.

Another important piece of digital equipment at Montreux was the NEC FS-20 Frame Synchronizer on display in the TeleMation booth. (The FS-20 is an improved version of the FS-10 introduced at the NAB Convention in Houston in 1974.) The word "digital" popped up in many exhibits. Marconi talked about the European debut of a digital vision mixer (production board) the B3730. The special effects generator used digital techniques. Siemens showed a modular A-V distribution system which was digitally controlled.

A "first" at Montreux was the aural program distribution transmission system using digital techniques shown by Moseley Associates. Digital techniques overcome the limitations of the classical analog distribution methods (baseband, FM subcarrier, or frequency division multiplex) such as signal-to-noise ratio, low-end audio response (under 50 Hz), and for stereo and four-channel quadraphonic, the phase relationship between channels. Digital pulse code modulation (PCM) techniques overcome these and a number of other transmission difficulties. Moseley pointed out that in digital transmissions, "the degradation of the received signal by the transmission system does not alter the information content until the degradation becomes so severe that the receiving equipment reads a pulse as no pulse or vice versa . . . (further) the signal can be regenerated before the degradation becomes severe." The system Moseley demonstrated at Montreux provides two audio channels, such as might be used for stereo. It was a full PCM transmission system, providing two 7500 Hz channels, whose SNR is in excess of 70 dB, distortion of less than 0.5% for optimum input levels, and low-end response to 10 Hz.

One of the new services possible through digital techniques is the insertion of news, weather, travel in-



*Still the industry's* **MOST POPULAR**

## **VIDEO TAPE CONDITIONER**

- Cleans and winds tapes
- Prolong tape life and reduce dropouts
- Hundreds installed worldwide
- Leasing program available

**RECORTEC, INC.** 777 PALOMAR AVE. SUNNYVALE, CA. 94086 TEL: (408) 735-8821 TWX: 910 339 9367

Circle 136 on Reader Service Card





The large outside broadcasting van so popular in Europe gets trimmed down. This 17-foot RCA outfitted unit carries two portable color cameras and two transportable VTRs.



Smart industrial design was apparent at Montreux, but this Thomson-CSF microwave system was outstanding.

formation, etc. into the field blanking interval of the television signal. Such systems, known heretofore as Ceefax and Oracle, have been experimented with by both the BBC and the Independent Broadcast Authority in the UK. The experiment is "going public" now under the name of "Teletext."

Decca Radio & TV Ltd. is producing a color TV set with a decoder in it to display digital coded information which will be transmitted by the BBC and IBA. Information will include news, weather, sports, stock market prices, etc. Nobody knows just how many decoder equipped sets will be sold (price addition will run about \$100 initially) or whether the audience will use the new service. But the service is off and running. P. Rainer of the BBC described the bit rate as 6.9375Mbits/s. He said each line has 40-characters per row, with 24 lines per page. The system accommodates 60 pages total which would require a maximum access time of 15 seconds.

#### Other Digital Equipment

Editing was a much hotter topic than ever before at Montreux. Two years ago Central Dynamics and Albrecht Elektronik (Germany) were the only exhibitors showing editors. This year Bosch Fernseh showed a computer controlled system capable of both off-line or on-line operation using a mixture of quad and helical machines. Datatron was present showing its 5050 system coupled to AVR-2.

Similarly, special effects got more attention at Montreux this year. Prowest showed some interesting dynamic wipes. Various wipe patterns were based on multiple rectangles which were progressively wiped from input A to B over preset time scales.

Thorn Lighting, one of the worlds principal suppliers of electronic control systems for stage and TV studio lighting showed a new portable system known as the Thorn QT 120 for outside broadcast use. It's a compact floor standing desk in two parts.

A growing competitor to Thorn in lighting control is Dynamic Technology Ltd. The DataLite 300 is a digital computer controlled system and the South African Broadcast Authority has one of the most elaborate systems installed to date. Through digital storage the control panel does not grow in size. DataLite includes a mimic panel to display at all times what is going on. A feature of the system is a CRT mimic display operated

continued on page 50

Still the industry's MOST DESIRED

## VIDEO TAPE EVALUATOR



- Tape evaluation at 16 times speed
- World wide customer base
- Standard in the industry
- Leasing program available

**RECORTEC, INC.** 777 PALOMAR AVE. SUNNYVALE, CA. 94086 TEL: (408) 735-8821 TWX: 910 339 9367

Circle 137 on Reader Service Card

## MONTREUX SYMPOSIUM

This means a signal coax can distribute status information with an optional color CRT: red shows what is "on," green the preset lights.

### Cable TV Big at Montreux

In terms of sessions, exclusive of the roundtable conferences on the opening weekend, cable TV was the single most important topic at the International Television Symposium dominating one third of the program for two days. One of the key subjects was system considerations for multi-channel capacity. (In Europe, using the CCIR B standard on VHF, only six programs can be received due to frequency allocations and standard IF.)

Interestingly, in contrast to developments in the USA, is the European effort to use uhf distribution systems. This means that the uhf tuner on the TV set can be used and there is no need for a set-top converter. This approach is reasonable in Europe since uhf tuners are on a parity with vhf tuners and reception of 20 channels or more without interference is possible. For large systems, there is the problem of uhf attenuation. This is overcome by carrying the channel in the vhf band (including mid-band) on trunks and using block converters for uhf distribution on feeder lines.

There is hope that new generation TV receivers will appear on the market to receive midband and top band channels with adjacent channel operation possible. Ideally for adjacent channel operation, the bandwidth should

be 8 MHz—identical to the CCIR G standard.

This position was advocated by W.M. Mathijssen, an engineer with Philips of Eindhoven. Such pleas for an ideal receiver would go unheeded in the U.S. as impractical. In Europe, the public can be convinced to buy more expensive sets (they are viewed as a long-term investment and not what is the cheapest buy) and a few PTTs might be able to nudge manufacturers.

One of the highlights of the CATV program was the rundown of CATV in the countries of West Germany, Italy, Austria and France. In general, one could conclude that while there is keen interest in all of these countries and some building of limited channel systems in non-metropolitan areas, cable systems for the denser areas lie sometime in the future. The various PT&Ts which regulate cable's development are experimenting (in a limited way) with what might eventually become the national system. Italy, for example, is considering a switched wideband network as part of overall integrated telecommunication system.

Italy's proposed system would carry TV signals in the high frequency band, each of 24 to 48 channels transmitted separately on a pair of telephone wires. The network configuration is described as tree-star—integrated with the local telephone network and electronically switched.

France is considering a 15 channel system. In Germany the interest is in a system of plants with each plant operating in an area defined by a circle about 15 km in diameter. The objective is a 43 dB signal to noise ratio at the home receiver.

BM/E

## ask about our new am | fm | tv monitors



Call or Write ARNO MEYER

**BELAR ELECTRONICS LABORATORY, INC.**

Lancaster Ave. at Dorset, Devon, Pa. 19333

(215) 687-5550

Circle 138 on Reader Service Card

## the new TWO-TONE EBS generator

the TG2/EBS—available when you need it, meets the new FCC requirements effective January 15, 1976

Precise, crystal-derived 853 and 960 Hz tones, manual, or automatic 22 sec. output duration with remote "start" provision

delivery late 1975



TG2/EBS

**McMartin** McMartin Industries Inc., 4500 South Seventy-sixth Street  
Omaha, Nebraska 68127 Phone (402) 331-2000

Circle 139 on Reader Service Card

## SHOCKED



**BY THE HIGH COST  
OF MASTER CLOCK  
SYSTEMS?**

See *Synchron* the one that combines high accuracy and more features with a lower price tag.

Booth 97-98, NAFMB Atlanta.



3140 EAST JEFFERSON AVE.  
DETROIT, MICHIGAN 48207  
(313) 567-0555  
TWX: 810-221-1267

Circle 140 on Reader Service Card

## TOTAL AUTOMATION

continued from page 40

sonnel. The system which went into service in July, 1968 at KMOX-TV is interesting in that it anticipated a number of the characteristics of present-day switching automation technology. It employed an early model minicomputer (the original Digital Equipment Corp. PDP-8), and used an early version of a CRT display for status read-out.

A major innovation pioneered by this system was the "associative memory" concept, by which the computer identifies the technical source of program material by correlating a material identification number input to it from the source. The technique was implemented by use of a credit-card size plastic punched card prepared in the traffic department for each item of program material, which is fed into and read by an individual card reader at each film projector and VTR machine. The KMOX-TV system has its data prepared off-line on punched cards. The computer itself has a limited memory capacity of 20-30 events, depending upon content, and memory is updated by automatic period loading from a punched card reader.

### Early systems now being updated

This first generation of CBS automation installations, all of which have remained in operation continuously to the present time, is now destined for replacement or major updating. In New York, the operational interface will remain as initially installed, but the computers

themselves are being replaced by more modern machines. CBS is now testing the first of two Bunker-Ramo 1018 computers (Bunker-Ramo acquired the successor organization to the old TRW Computers Division) which will replace the twelve-year-old 330's. For its owned and operated stations, CBS has placed the first two orders for completely new automated audio-video switching systems which will replace the pioneer KNXT system in Hollywood and equip WBBM-TV in Chicago. These systems will be supplied by the Grass Valley Group, Inc., and will consist of the master control version of Grass Valley's new 1600 video switcher, operated by a Digital Equipment Corp. PDP 8-E computer. These systems will have a capacity of 2000 switching events, and will receive data over data communications circuits directly from CBS's "BMIS" (Broadcast Management Information System) in-house computerized traffic accounting system. Each automation system will also be interfaced to two Ampex ACR-25 cartridge VTR's, and will use the ACR-25 Automatic Data Accessory to identify and play cartridge announcements by correlation of material identification numbers.

The original KNXT system, which will be replaced, is believed to occupy a unique place in the history of computer process control applications. So far as is known, it represents the longest period of service yet achieved for any computer in a process control application, and will have given fifteen years of service by the time it will be shut down early in 1976. Thus, despite the fact that computer automation applications cannot exactly be said to have proliferated in the television industry over the

continued on page 52

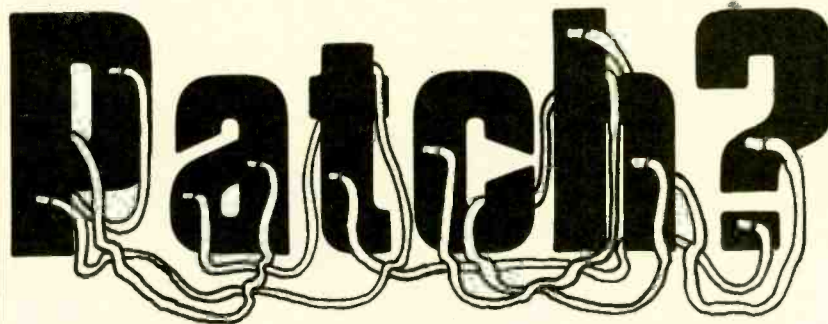

## Switch to Dynasciences Routing Switchers!

Dynasciences Routing Switchers now give you the opportunity to replace that messy patch panel. Signal routing is easier because of illuminated push-button selection.

Expansion? It's simple. Just add modules as you need them.

Reliability? The 8300/8500 Series gives you top performance. Crosstalk between channels: 50 dB down at 12 MHz; Frequency Response:  $\pm 0.25$  dB to 12 MHz; Differential Gain: Less than 0.3% at 3.58 MHz/channel.

These are only a few of the reasons to contact Dynasciences Video Products.



8300/8500 SERIES  
LOCALLY-CONTROLLED ROUTING SWITCHERS

**DYNASCIENCES**  
A SUBSIDIARY OF **Whittaker**

**video products**

TOWNSHIP LINE ROAD • BLUE BELL, PA. 19422  
Telephone: (215) 643-0250 • Telex: 84-6358

Circle 141 on Reader Service Card

## TOTAL AUTOMATION

past fifteen years, television broadcasting has nevertheless given computer process control one of its most enduring installations.

### Update: DCC's Automatic Switching Interface

Material in this report submitted by Patrick Choate, Data Communications Corp.



Howard A. Shepard (far left) and John R. McConkey (near left) of CDL discuss standards with Don Rogers (standing) and Jim Cook (right) of DCC. First station to have CDL/BIAS interface will be WNAC-TV, Boston.

Data Communications Corporation (DCC) parent company of the BIAS (Broadcast Industry Automation System) system has, for the last two years, been actively promoting an industry standard interface, between all makes of automatic switching equipment and all business computer systems. Details of how this standard interface would accomplish the joining of the engineering and front office logging operation were printed in the August, 1974 edition of BM/E magazine.

As is almost always the case in any burdgeoning field, and particularly in an area so volatile as electronics the proposed standard interface has not been met with swift acceptance. However, presently DCC's research and development department is working with two manufacturers of switching equipment, Central Dynamics, Ltd., of Canada, and Vital Industries, Inc., Gainesville, Florida, making the necessary hardware and software changes needed to accomplish the connection between the switcher and the BIAS system.

Commenting on the progress made in this area, Jim Zielger, DCC's vice-president of research and development says, "We're satisfied with the progress made in recent months, and we feel this new BIAS system feature (automatic switching) will be ready for marketing by late fall."

Although DCC has been talking with most major manufacturers of switching equipment over the past three years, most of the actual development bolt-and-nut work has been done during the last six months with Vital Industries, Inc. According to Jim Ziegler, "Vital Industries is so enthusiastic about this project that we've made great progress in a short amount of time."

Standardization has always been one goal of automation, and in the broadcasting industry it has been an uphill battle. Broadcasters have been, through the years,

forced to resort to having their equipment and operational tools custom-made to fit their unique requirements. With 110 BIAS customer TV stations, the front office sales, traffic and accounting operation is standardized—only the master control switching equipment varies from station to station. The obvious answer to the problem is a standardized interface.

Another major manufacturer of switching equipment, Central Dynamics, Ltd. (CDL), is currently working with DCC ironing out design specifications in an attempt to further facilitate the standard interface.

Howard A. Shepard, CDL's product manager, states, "Both CDL and DCC are committed to establishing a working interface within a 9 month time frame." The 9 month time table relates to CDL's response to a request by WNAC-TV (RKO, Boston, Mass.) for an automated switching system which will tie-in with the BIAS system (WNAC-TV is a BIAS customer station). Shepard and his associate, John R. McConkey, supervisor, automation software, are impressed with DCC's standard interface specs; quoting Shepard again, "DCC's approach to a standard interface shows a good insight into the technical problems experience in the engineering/operations area of a TV station."

### Automating Both Tape and Film in the Station Breaks

Automation has a long history at WBRE-TV, in Wilkes-Barre, Pa. An RCA TSA-1 allowing 15 events to be set up on the relays for automatic sequencing, was installed in the late 1950's. A Sarkes-Tarzian system, allowing the set-up of 40 events in advance, went on line in 1967, and is still in use.

Added in 1972 was the RCA TCR-100 for automatic play of video carts. And in April of this year the management installed an RCA TCP-1624 automatic film cart player.



The TCP-1624 being loaded at WBRE-TV.

With all these units on line, the Sarkes-Tarzian system controls the TCR-100, the TCP-1624, and, if wanted, the film island, the open reel machines, etc. But most of the load of commercials, PSA's, etc., is divided between the TCR-100 and the TCP-1624. George Andresky, chief engineer, says that having film cart play available saves time and money for many advertisers who make commercials originally on film—no transfer to tape is needed. He finds the film machine handling about 80 plays a day, and the TCR-100 tape machine handling about 100 carts a day.

The lesson is: any station operation pattern (including use of a lot of film material) can get the particular advantages of automation.

# GREAT IDEA CONTEST

Share your good ideas  
with other broadcasters.

## 21. TP-66 Cueing System Modification.

Richard Kihn, Engineer,  
KFDM-TV, Beaumont, Texas

**Problem:** To automate notification of director of news story endings without the use of visual cues.

**Solution:** Until the circuit modification was made, a man stood beside the TP-66 film projector and informed the director of approaching end-of-film. A cue at the head of each story stopped the projector, as the cueing system was designed to do.

With the modification system in use, a cue is placed seven seconds before the end of the news story, and another cue is placed on the film at the head of the next story.

When the seven-second-to-end cue is sensed, TB701-8 (to which the cue sensor was moved from TB701-7) is momentarily placed at ground potential, causing relay K1 to pull in. The sequence: Relay K1 contacts 11 and 7 to hold it in; contacts 9 and 5 turn the buzzer on; contacts 10 and 6 complete the ground circuit for the coil of K2.

The coil voltage for K2 starts to build up and reaches sufficient potential to pull K2 in. With values shown,

this delay is about 1/3 second. This is sufficient time to allow the 1/4-inch wide cue tape to clear the cue sensor.

Relay K2 contacts 11 and 7, then connects TB701-7 to TB701-8, effectively putting the projector into the "normal" operating mode. Contacts 1 and 9 then cut the buzzer off.

When the start-of-next-story cue is sensed, the projector stops. The -12 volts obtained from K111 (cue defeat relay) is removed; K1 drops out, and the circuit resets itself.

The local state indicator lights (I1, I2 and I4) are mounted in the bypass switch, and are intended to indicate the state of the relays and to expedite trouble shooting if it becomes necessary, as well as to serve as on/off indicators during operation.

The remote state indicator lights (I3 and I6) serve as on/off indicators only for benefit of the director. Resistors R1, R4 and R6 are used to extend the life of the 327 lamps.

Separate buzzers could be used for each projector, but it was desirable to use the same buzzer for the complete system in our installation. Although designed for use on our projectors, this system should be adaptable to others.

continued on page 54

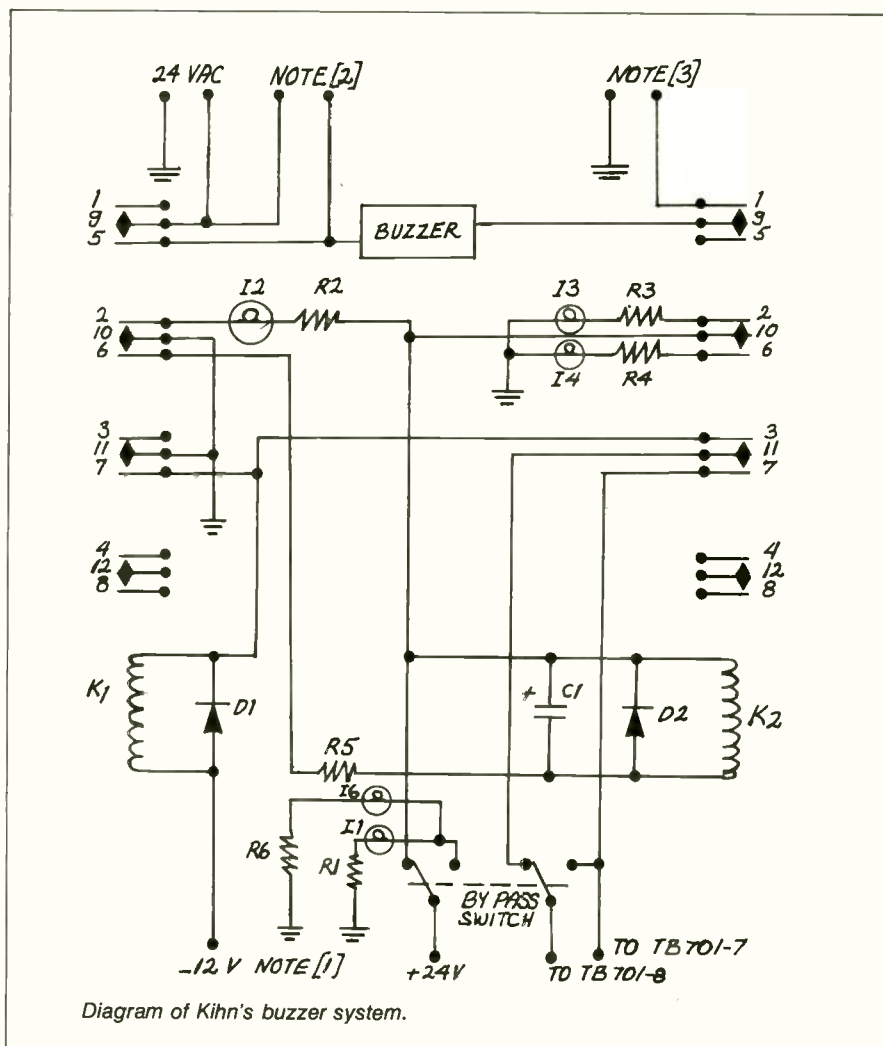

Diagram of Kihn's buzzer system.



# PROTECT your broadcast equipment against lightning surges with WILKINSON AC LINE SURGE PROTECTORS

Excessive voltage surges caused by lightning, transformer arcing and induced transients are everyday occurrences that cause heavy damage to valuable broadcast equipment.

Now through the use of WILKINSON voltage sensitive Line Surge Protectors you can protect your equipment from line surges that may exceed even twenty times the normal line voltage.

A WILKINSON pulse compensated Line Surge Varistor, is placed across a line of its rated voltage. Should a surge or increase of voltage occur, the resistance of the varistor decreases at log scale as the voltage increases, thus acting as a momentary load or short circuit to the surge. WILKINSON Line Surge Protectors draw little or no current and are capacitor compensated for microsecond surges, thus damping all line disturbances as well as excessive voltage increase.

A small investment in WILKINSON Line Surge Protectors is your assurance that your valuable broadcast equipment will not be damaged due to line surges.

Model SIA-1 110 V. Single phase \$195.00

Model SIA-2 220 V. Single phase \$395.00

Model SIA-3 220 V. Three phase \$495.00

Model SIA-4 440 V. Three phase \$595.00

For complete details write to:

## WILKINSON ELECTRONICS, INC.

701 CHESNUT ST. • TRAINER (CHESTER) PA. 19013

• TELEPHONE (215) 497-5100

Circle 142 on Reader Service Card

## GREAT IDEAS

### 22. Novel Control Circuit Needs No Common Bus.

Jeremy R. Burnham, Engineer,  
KKDJ-FM, Hollywood, Calif.

**Problem:** To use a single-pole momentary-contact pushbutton switch to remote-start cartridge machines and reset a common digital electronic clock in a situation where no ground or common bus can be used.

**Solution:** Series diodes are placed on both sides of the pushbutton switches in both the clock and cart

machine circuits, with proper polarity to isolate the two circuits from each other. The clock floats with respect to ground because of its internal power transformer. It makes no difference if either side of the cart machine circuitry sees a ground.

For simplicity, the clock re-set and the cart machine remote start circuits have been re-drawn with their equivalents. The circuit is easily understood when we realize that, with the switch open, no current flows in either circuit. When a button is pressed, current flows in both the clock and cart machine circuits independently. Since the two circuits are effectively coupled at only one point, there is no interaction between the two whatsoever. Any number of machines using any combination of direct current control

## GREAT IDEA CONTEST 1975: RULES

**1. Eligibility:** All station personnel are eligible. Consultants to the industry may enter if the entry indicates the specific station or stations using the idea or concept. Manufacturers of equipment or their representatives are not eligible.

**2. How to Enter:** Use the Official Entry Form on this page or simply send *BM/E* a description of your work. State the objective or problem and your solution. Include diagrams, drawings, or glossy photos, as appropriate. Artwork must be legible but need not be directly reproducible but not exceeding three in number. Camera reproducible material is preferred. Length can vary, but should not exceed 500 words. *BM/E* reserves the right to edit material. Entry should include: Name, title, station affiliation, and the class of station—TV, FM, AM. Indicate if idea is completely original with you.

**3. Material Accepted for Publication:** *BM/E* editors will make all decisions regarding acceptability for publication. If duplicative or similar ideas are received, *BM/E* editors will judge which entry or entries to accept. A \$10 honorarium will be paid for each item published.

**4. Voting:** Every reader of *BM/E* is entitled to rank the ideas published. This can be done on the Reader Service Card in the magazine or by letters or cards sent to the *BM/E* office. To vote, readers should select the three ideas they like best and rank them 1, 2, or 3.

**5. Winners:** Relative ranking of each month's entries will be published periodically. Top-rated entries for various categories will be republished in late 1975 for a second and final round of scoring. Final winners will be picked in February 1976 and notified by mail. Winners will be published in the March 1976 issue of *BM/E*.

**6. Prizes and Awards:** Three top prizes will be awarded: a color TV set for the entry receiving the most votes in the respective categories of AM, FM and TV. Ten AM-FM radios will be awarded as secondary prizes for the highest voted entries in the following additional categories (except the three top winners): audio (three prizes one each in categories AM, FM, TV); (three prizes one each in the categories of AM, FM, TV); Control (three prizes one each in the categories of AM, FM, TV); Video (one prize in TV).

See April or May for Entry Form

Mail to: Editors, *BM/E*  
274 Madison Avenue  
New York, New York 10016

Entry Form

Name \_\_\_\_\_ Title \_\_\_\_\_

Station Call Letters \_\_\_\_\_

City \_\_\_\_\_

State \_\_\_\_\_ Zip \_\_\_\_\_

Telephone No. \_\_\_\_\_

Licensee \_\_\_\_\_

Class of Station at which idea is used (check one) TV \_\_\_\_\_ FM \_\_\_\_\_

AM \_\_\_\_\_

Category: Audio \_\_\_\_\_ RF \_\_\_\_\_ Video \_\_\_\_\_ Control \_\_\_\_\_

Objective or Problem: (in few words; use separate sheet for details) \_\_\_\_\_

Solution: (Use separate sheet—500 words max)

I assert that, to the best of my knowledge, the idea submitted is original with this station; and I hereby give *BM/E* permission to publish the material.

Signed \_\_\_\_\_ Date \_\_\_\_\_

voltages can be connected in this manner, and any number of buttons may be pressed simultaneously. KKDJ employs a Heathkit GC-1005 digital

clock inexpensively modified to re-set to zero, coupled to six ITC cart machines, and controlled with touch switches.

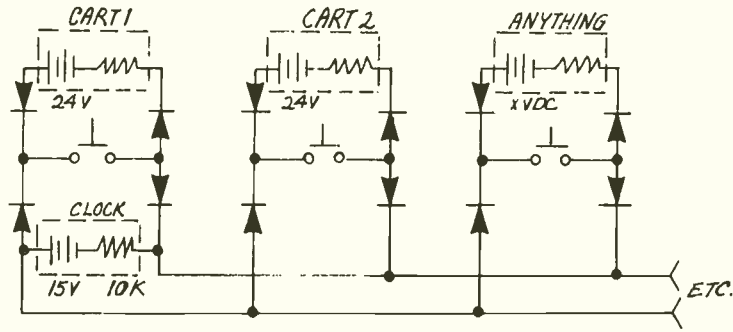

Burnham's Control Circuit

### 23. Optical Multiplexer Features Remote Control.

Roderick E. Davis, Engineer,  
KUSV-TV, Lawrence, KS.

**Problem:** To remote control a Zie-Mark model 3200 optical multiplexer used in conjunction with a television film and slide telecine. The manufacturer offers a remote control unit, model 3100-4, but it does not have momentary switches as do our slide and film projectors. Our control circuit was built for about \$20 including two Potter-Brumfield relays, and three Switchcraft lighted momentary switches.

**Solution:** The circuit was designed to function with momentary switches. I mounted two relays on the local Zie-Mark model 3100 tray. First, identify the supply wires and plug J1 that conducts the control voltage to K1, K2, and K3. It made good sense to use the existing power supply. When both left and right relays are relaxed, the multiplexer will be in the center port or slide. When the left relay is energized the left film will show, and when the right relay is energized the right film will show. My right/left relationship is reversed as normally considered. Reason is, I had to have the same relationship to the telecine as the remote TV producer's console.

with or without  
**FREQUENCY MEASUREMENT**

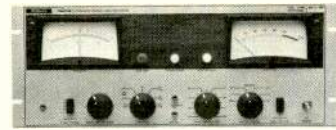

TBM 3700 for  
FREQUENCY/MODULATION  
MONITORING

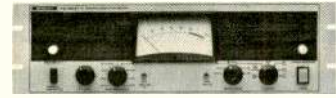

TBM 3500B for  
MODULATION MONITORING  
ONLY

either can accommodate

TBM 2200A for STEREO

TBM 2000B for SCA

either capable of  
OFF-AIR remote operation with

TBM 2500C with TBM 3700

LL 35B with TBM 3500B  
(plug-in card)

the "FULL CHOICE" line

**McMartin.**

McMartin Industries Inc. • 4500 South 76th Street  
Omaha, Nebraska 68127 • Phone (402) 331-2000

Circle 143 on Reader Service Card

**FM monitors**

**WORRIED**



**ABOUT MEETING THE  
F.C.C.'s NEW EBS TEST  
REQUIREMENTS?**

See us in **Booth 97-98, NAFMB  
Atlanta.** We've got the solution  
plus a few surprises.



3140 EAST JEFFERSON AVE.  
DETROIT, MICHIGAN 48207  
(313) 567-0555  
TWX: 810-221-1267

Circle 144 on Reader Service Card

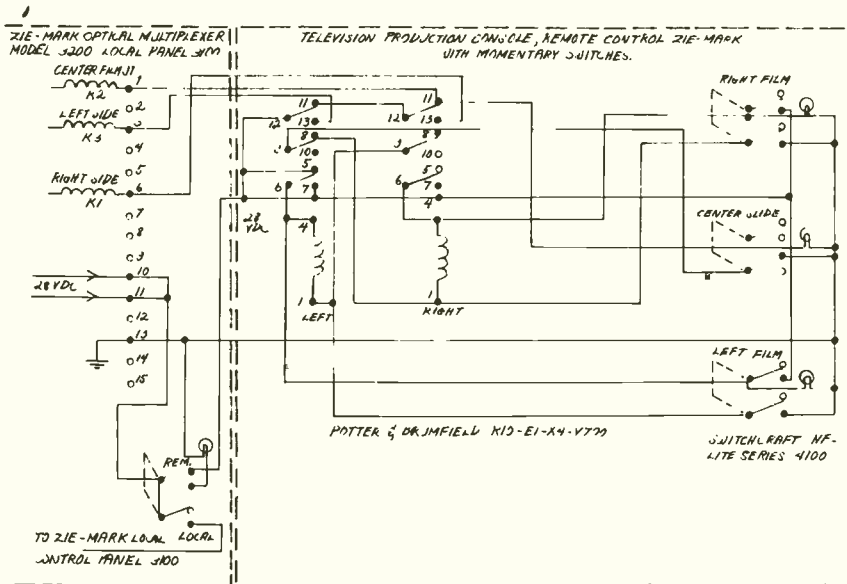

Optical Multiplexer remote control designed by Davis

Great Ideas continued on page 56

# RADIOWAVES

An FM Transmitter is no better than its exciter.

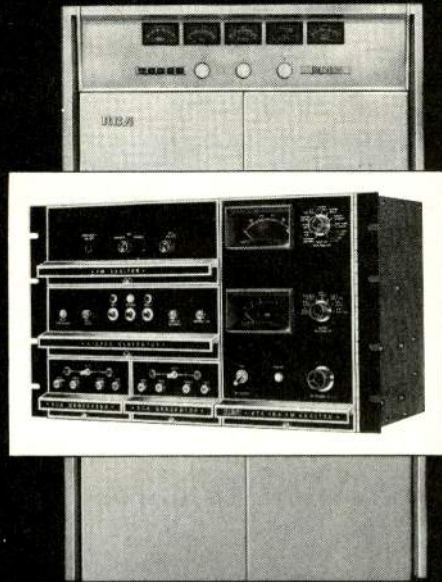

## RCA

AM & FM Transmitters and Monitors • Antennas • Microphones • Consoles  
Tape and Transcription Equipment • Automation Systems • Amplifiers and Speakers

Circle 145 on Reader Service Card

And it's easy to get excited over our exciter. A lot of broadcasters do!

Why? For one thing, it's all solid state for super reliability and performance.

For another, it uses Direct FM to give you wide frequency response, low distortion and low noise.

All RCA FM Transmitters use the BTE-15A Exciter and are available with transmitter power outputs of from 10 watts to 40 kW.

See your RCA representative. And see what all the excitement is about. RCA Broadcast Systems, Camden, N.J. 08102.

## GREAT IDEAS

### 25. Keeping Slides in Order on a TP-7.

*J. Richard Severe, Engineer,  
Maryland Center for Public Broad-  
casting, Owings Mills, Md.*

**Problem:** To keep slides from getting out of order when double-punching a TP-7 slide projector. When using an RCA TP-7 slide projector, the machine alternates from drum to drum each time the slide-change button is pressed. When changing slides in a remote location, such as a studio control room, you must be careful not to double-punch the slide projector. Chances are, only one drum will rotate, throwing your slides out of order. Since the projector has a capability of 36 slides, you have to punch the slide advance button through all your slides, one at a time if you make a mistake.

**Solution:** This modification of the TP-7 will keep your slides from getting out of order. Also, by holding down the pushbutton, your slides will re-cue themselves in the shortest time possible, and at the same time keep the drums in order. This is accomplished since the change command is enabled only after rotation of the drums is completed. Two diodes sample voltage from ready lights I104 and I105. These lights only light up when the drum rotation has completed its cycle.

## Football Sportscasters

ISN'T IT TIME YOU GAVE YOURSELF A HELPING HAND ???

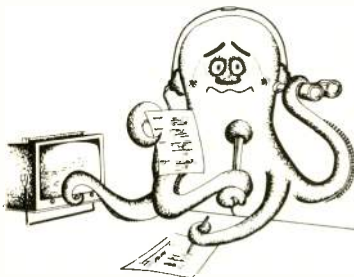

Hands-free communication is within your reach. Television Equipment's well-proven Sportscaster headset, with integral dynamic boom mike, gives you complete freedom of movement — just right for those tense moments when you need to consult your references.

The headset has a . . .



Price: \$ 86.00

Delivery from stock

Dynamic Boom Microphone; 400 OHMs, frequency range 50-15,000 Hz, sensitivity 2mV (loaded) for close speech. A noise cancelling 400 OHM dynamic microphone with frequency range of 50 to 50,000 is available at additional cost of \$29.00.

Double Headphones: independently wired, 200 OHMs each, frequency range 50-15,000 Hz.

Ventilated foam cushions eliminate perspiration and let you hear ambient sound (optional ear-enveloping cushions).

Weight: 6½ oz. Practically unbreakable components. Optional cough switch.

**For your helping hand phone today. . .**

*Television Equipment Associates, Inc.*

Box 1391 • BAYVILLE, N.Y. 11709

BILL PEGLER 516 • 628 - 8068

Circle 146 on Reader Service Card

## Great Idea Feedback

*BM/E readers respond to Great Ideas*

Dear Sirs:

In the Great Idea Contest section of BM/E magazine (June 1975) a circuit was given for a "Waveform Generator Synthesizes Steady Tones" (Great Idea #12). I thought the circuit was very clever and inventive and intend to use it for a few projects I have in mind. I would suggest using a 74159 instead of a 74154 as shown in the circuit diagram. Use of the 74159 instead of the 74154 will prevent the setting of one pot from affecting the adjustment of the other pots. Use of the 74159 will also make the diodes unnecessary.

The 15 volts at the top of R1 should be changed to 5 volts or you stand a good chance of zapping the 74159. With these two changes the circuit should work quite well and I'm looking forward to building it.

**James F. Reid**





## Crowd controller.



Talk about trouble-free remotes! The Shure SE30 Gated Compressor/Mixer gives you mixing, "hands-free" gain riding, and 600-ohm line output capability—all in one portable, professional package. Its unique Gated Memory circuit licks the "pumping problem" by holding the compression level constant during program pauses, and releasing it when the signal returns—eliminating crowd noise build-up between words and sentences. In news, sports, and special events remotes, the SE30 compresses *in the field*, so signal-to-noise ratio is optimized for superior telephone line transmission and higher program quality—without manual gain riding! Functionally engineered, with self-contained standby battery power supply, built-in tone oscillator, VU/dB compression meter, and full compatibility with associated professional equipment. For complete information, write:

Shure Brothers Inc.  
222 Hartrey Ave., Evanston, Ill. 60204  
In Canada: A. C. Simmonds & Sons, Limited



Circle 147 on Reader Service Card

# BROADCAST EQUIPMENT

For more information  
circle bold face numbers  
on reader service card.

**Videotape editing system** designed specifically for electronic news operations provides frame accurate edits, jogging (frame advance), 100-edit memory. System 40 uses Sony U-Matic format, reads time code in



fast modes, is available for two or three VTR's. Options include a full monitor console. System allows re-edit and auto-assemble from a decision list. \$20,500 to \$44,375 depending on options. CMX SYSTEMS **300**

**New VTR system** uses one-inch tape, segmented helical scan, very-super-high band color, and pilot tone, in aim for top quality. "Pilot 1" system will be available in several forms, including a studio console, a back-pack portable, a desk-top console. Writing speed is 1470 ips, with 7-segment interlace on 60 Hz field rate. Heads are

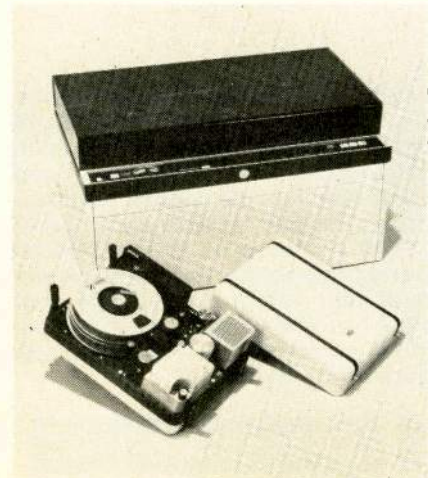

hot pressed ferrite for 1000-hour life. Pilot tone, at 5.3 MHz, is added to baseband before modulation and used for time base correction, and for color phase correction. Claimed specifications include frequency response  $\pm 0.5$  dB, 30 Hz to 4.2 MHz; differential phase, less than 3 degrees; differential gain less than 3%; s/n ratio, greater than 47 dB; moire, greater than 46 dB; time base stability, (correction built in)  $\pm 3$  ns. Also: continuous drop-out compensation, insert and assembly editing, output sync processing, genlock sync generator, full automatic color edit framing, continuous velocity correction, two audio channels. ARVIN/ECHO **301**

**Search-to-zero accessory** allows setting of a zero or cue point anywhere on an audio tape, with automatic push-button return to that point as wanted. Accessory for the MM-1100 multi-channel recorder controls speed automatically to prevent overshooting. Digital readout indicates whether tape is ahead or behind the zero point. Machine can also be set to go immediately into play after reaching the zero point. Kit can be installed in the field by a qualified technician. \$895.00 AMPEX **302**

**Digital logging system** will record up to 20 parameters plus time of day in

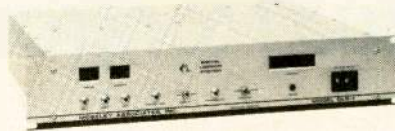

columnar form at preset time intervals. Model DLS-1 also records out-of-tolerance conditions. It has selective channel muting and external digital input. It can be used independently or in connection with the Model DRS-1A remote control system. MOSELEY ASSOCIATES **303**

**Portable high sensitivity frequency counter** has 9-digit LED display, frequency range 5 Hz to 520 MHz. Model 1920A has direct and pre-scaled inputs color coded to match function switches. A "rapid-access" gate cuts measurement time by "free-running" to open promptly when a signal is sensed. Optional pre-scalers

extend range to 1000 MHz and 1250 MHz. RF bursts of 2 ms or longer duration can be measured. JOHN FLUKE MFG. CO. **305**

**Multi-channel mixer** provides six inputs, four outputs. Model 2 has high

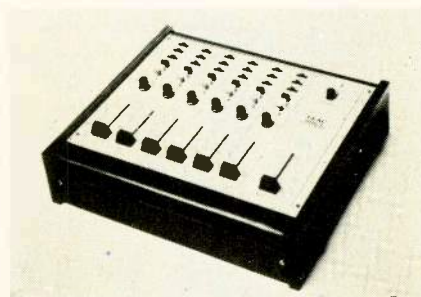

and low cut filters, panning on each input, and cue out, buss in, accessory send/receive patch points. \$299.50 TEAC **304**

**True RMS digital voltmeter** reads directly in decibels as well as in volts. Model 3630A operates from 0.1 Hz to 1 MHz, with  $4\frac{1}{2}$  digit readout, giving 0.01 dB resolution on decibel ranges and 1 microvolt resolution on the 10 mV range. Autoranging is standard. The 19,999-count meter uses analogy computation to determine the true RMS value; signals with crest factor up to 50:1 can be handled; accuracy is maintained with distortion of 5% or greater. \$2450. BALLANTINE LABORATORIES **306**

**Adapter makes "C" mounted lenses compatible** with the TGX-16mm cine sound system. Model GCM-101 takes all existing "C" lenses. \$175.00. GENERAL CAMERA CORP. **307**

**Wireless sound system** consists of a lavalier microphone, transmitter and receiver. The "All-Purpose" wireless system converts any sound system or audio input to wireless operation. ED-COR **308**

**Spectrum analyzer** gives CRT readout of absolute frequency with counter accuracy. Model 7L5 covers a range to 5 MHz. Built-in microprocessing provides "intelligence" to decode control settings and process readings for CRT readout of parameters. Calibrated reference level is read out in 1 dB steps over the range  $-1125$  dBm to  $+21$  dBm. A dBv and linear volts mode are also provided. Average or peak can be displayed, with the averaging ad-

justable from bottom to top of signal. Digital storage makes displays easy to read and photograph. \$4200. TEK-TRONIX 309

**Electronic sound modules** produce dependable sound effects. Gunfire, explosion, airplanes, police siren, crowd cheer, many more, are created without tape, disc or other memory systems. UNIVERSAL RESEARCH LABORATORIES 310

**Wireless microphone** for single-system movie cameras attaches to side of camera. Swintek "Hitchhiker" uses highband VHF crystal-controlled transmitter and crystal front-end receiver for operation as close as 50 kc to other systems without interference. Transmitter mounts on such cameras as CP-16A, General, and Frezzolini, also on Nagra recorder or MA-11 amplifier, adding only 3/4" in width and 15 1/2 ounces in weight. ALLAN GORDON ENTERPRISES 311

**Message generator** for TV alphanumeric displays has 16 pages of memory, each 8 lines of 32 characters a piece. Model CG-1000 has a 10 x 14



dot character, character blink, full editing capability, standard typewriter keyboard, time and temperature inputs, 2-speed crawl, page printout for news, two colors. \$2995. VIDEO DATA SYSTEMS, INC. 312

**Tape cleaning device** includes four-edged sapphire blade, precisely ground to remove debris without damage to tape. The "NOVA BLOCK" is attachable to almost any video or audio

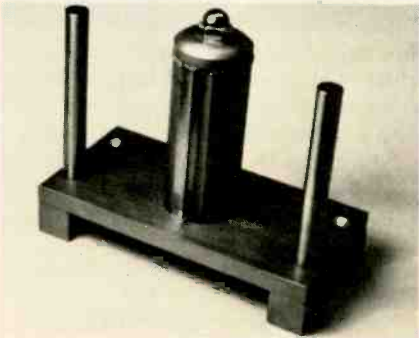

tape recorder, in most cases by user's technician. The block provides an alternate tape path, eliminating wear on head stack, guides, etc. during cleaning passes. \$340, 2 inch; \$240, 1 inch; \$140, 3/4 inch; \$100, smaller sizes. N.O.V.A. CORP. 313

**New tape** for 3/4-inch video cassettes claims improved color performance and higher resolution than earlier tapes. Beridox iron-oxide tape uses a new coating, berthollide iron oxide which has high-density magnetic particle dispersion. The maker says it is superior in chroma level, video sensitivity and s/n ratio to chromium dioxide. FUJI PHOTO FILM USE 314

**Studio switcher/special effects generator**, the 200 series, is a six-input, three-buss effects/dissolve switcher and mini teleproduction

center. All buss switching is performed during the vertical interval. Functions included are horizontal and vertical wipes, corner wipes, mix (lap-dissolved type) and external key. A key level control is provided to set the gain on the key input buffer amplifier. A pushbutton fade-to-black switch is provided on both effects channels. The unit is available with or without 2:1 sync, in black and white or color. List price starts at \$995. VIDEO CONCEPTS 315

continued on page 60

KRVR (FM) in Davenport, Iowa has been on the air since December, 1974. This profitable stereo station follows a strict philosophy of quality and reliability.

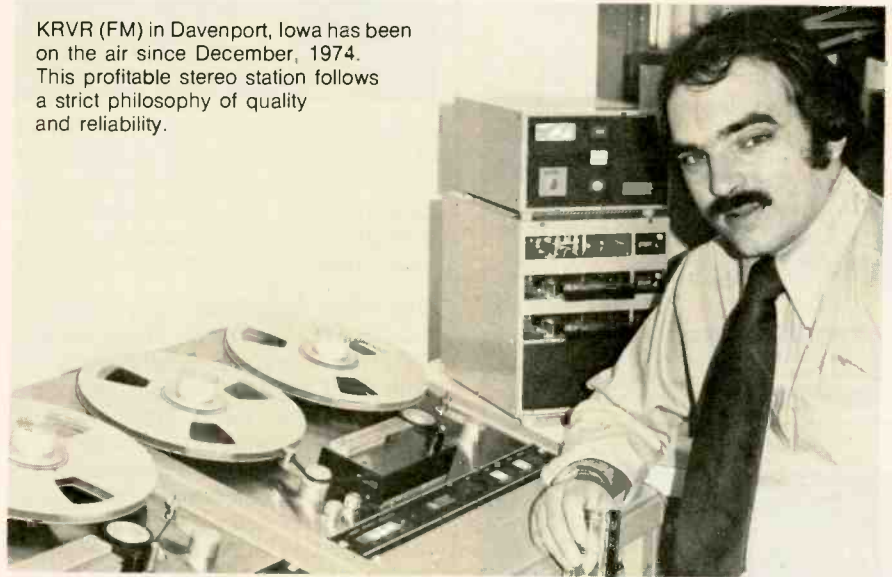

### **Peter Burk, Chief Engineer for WQUA and KRVR (FM), chose to use six ITC Open Reel Units in KRVR's Automation System. Why?**

"The decision to use reel-to-reel was dictated by the Stereo Radio Productions (Schulke) format. It was then a matter of narrowing down the available machines to the one that would perform the best in both production and automation uses. We found that ITC's 850 would satisfy all our requirements. Everything went together into a machine that has virtually all the features we could ask for. The Micro-Marker is a classic example. Editing has been made easier and more accurate. It is just one of the things that makes the 850 a superior production machine.

"Virtually every feature in the edit mode is used at one time or another. The interesting thing is that the features don't interfere with each other. Start Memory and Motion Sensing are assets, especially in

automation. We can avoid tape spillage and tape breakage, and reduce the amount of time spent cueing-up.

"The phase stability from one end of the tape to the other is excellent. That's a prime consideration for stereo operations. The front-panel limited-range level controls have been invaluable. We can be sure our stereo balance is always correct and that the level between tapes is very consistent.

"As Michael Moore, KRVR's engineer, said, 'The serviceability, the simplicity, the cleanliness of how everything is placed on the 850, has to be one of its best features. You don't have to look through the forest to find the trees.' I'd certainly agree with him."

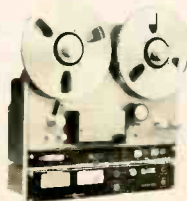

Find out more. Call us collect (309/828-1381) and ask us your questions about the 850 Series.

**it** INTERNATIONAL TAPETRONICS CORPORATION  
2425 South Main Street • Bloomington, Illinois 61701  
Marketed exclusively in Canada by McCurdy Radio Industries Ltd., Toronto

Circle 148 on Reader Service Card

## SPACE SAVERS FOR YOUR CROWDED STUDIO

- Same built-in performance and reliability as our famous single units.
- 3, 5 or 15 deck units, cabinet or rack mount.
- Mono and stereo with record, switcher, electronic cross fading, sequencer, and remote control options.
- May be incorporated into programmed automation systems.

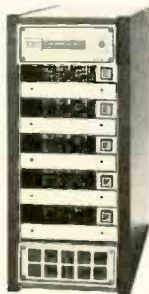

*Spotmaster*<sup>®</sup>  
ALSO  
SINGLE DECK  
CARTRIDGE  
MACHINES AND AUDIO  
CONSOLES



BROADCAST ELECTRONICS  
8810 Brookville Road  
Silver Spring, Maryland 20910  
Phone: 301-588-4983

Circle 149 on Reader Service Card

## Going ENG?

(ELECTRONIC NEWS GATHERING)

FOR SONY VO-3800 VIDEO CASSETTE RECORDER

FOR REMOTE BROADCASTS  
MODEL MA 3C  
MIXER-AMPLIFIER



\$595.00

- 3 MIKES OR 2 MIKES AND HI - LVL INPUT (XLR PLUGS)
- AGC W/DEFEAT SWITCH
- HEADPHONE AMPLIFIER
- 2" X 4" X 5"

NOW IN USE BY MAJOR NETWORK NEWS CREWS!!

**Transist-O-Sound**

851 N. Eustis Drive  
INDIANAPOLIS, INDIANA 46229  
AREA CODE 317 897-1549

Circle 150 on Reader Service Card

## PRODUCTS

Thermo-formed glare suppressant filters eliminate reflections and improve the contrast and visibility of color or monochrome video images. They are formed to the exact shape and size of cathode ray tubes and cost less than non-glare glass faceplates. The filters

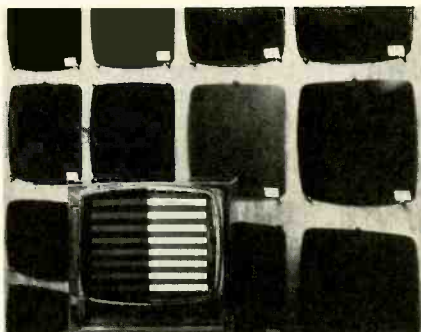

are available in colors for all phosphors to enhance contrast and sharpness of the image. The formed filter can be adhered to the face of the tube which provides maximum sharpness of the video image. PANELGRAPHIC CORP 316

Electronic interface, named Auditec II, is designed to link the MM-1100 and AG-440 series recorder/reproducers with the RA-4000 automatic programmer. It permits the multiple tracks of voice, music and sound effects to be recorded and mixed in synchronization with the video. Electronic splices may be set up, previewed and executed or maintained in memory so that entire audio-video edit sequences may be accomplished in a single continuous operation. Price is \$6,500. AMPEX 317

Reel tape deck accessory for use with the MM-1100 and AG-440 recorders inserts edits in multichannel recording. Called Pick Up Recording Capability, the accessory permits the editing or dubbing of new material over previously recorded material without creating errors at either end of the new insert. Prices range from \$170 to \$675. AMPEX 318

Stereo generator, model SCG-9, offers a front panel peak-reading dB meter and stereo/mono mode selector.

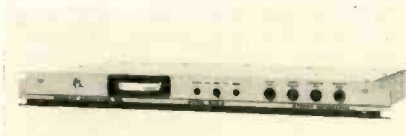

Circuitry is all solid-state. It may be used with most direct FM exciters. MOSELEY ASSOCIATES 319

Video delay package accommodates any delay from 10 to 2,120 ns. The series 5.25 consists of a 5 1/4-inch Vero card frame which accepts eight cards

# WONDERING



## HOW TO LOWER THE COSTS OF BOTH STUDIO AND REMOTE BROADCASTS

While at the same time improving your station's cartridge handling ability? See System 1 do just that plus a host of other slick tricks. Booth 97-98, NAFMB Atlanta.



3140 EAST JEFFERSON AVE.  
DETROIT, MICHIGAN 48207  
(313) 567-0555  
TWX: 810-221-1267

Circle 151 on Reader Service Card

# Bulbs, Sockets to go.

Now exclusive national distributor of sensational new OSRAM HMI bulbs — all wattages in stock! Most complete STTV-A/V bulb and socket source in the country. Instant in-stock delivery on GE, Sylvania, Leecraft. If light is your living, we've got it all — for you!

Send for 108-pg. stage/tv Lighting Handbook (\$ .50 mail and handling, please).

Nationwide service for over 25 years.  
Same-day shipment anywhere in US.  
Rush delivery in Manhattan.

(212) JUDSON 6-1620  
**BARBIZON ELECTRIC**

426 W. 55, NYC 10019

Circle 152 on Reader Service Card

Puzzle:

# How do you get a lot of SWITCHER for a little MONEY?

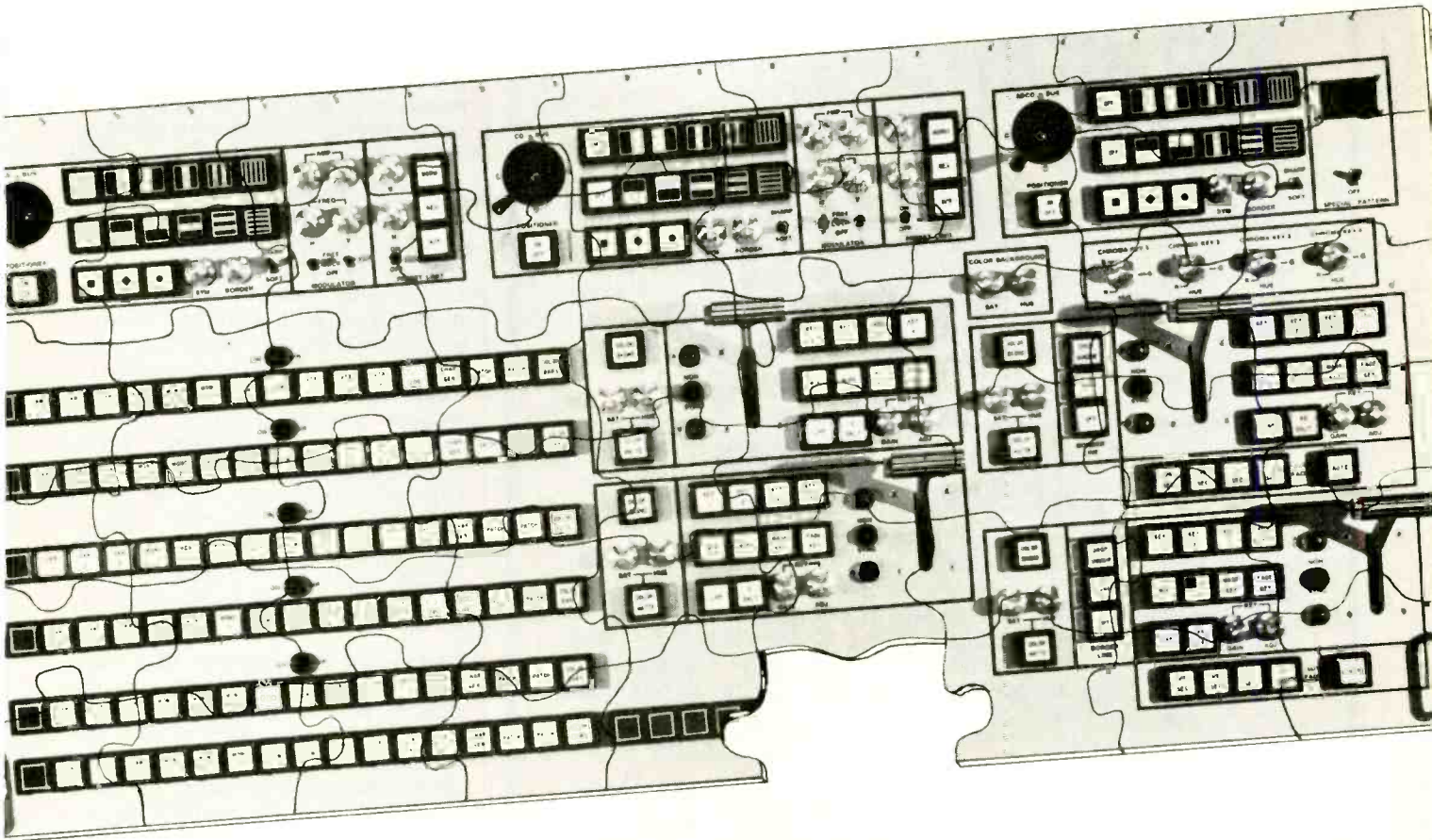

**Answer: The Computer Image "Pre-wired" Modular Video Controller System.**

Now there is a way to plan for the ultimate in switching potential with the least initial outlay.

If you can afford the industry's finest broadcast quality switcher with all the latest state of the art techniques and capabilities... fine! Computer Image will deliver a Model 7243 with 7 buses, 24 inputs, four mix/effects amplifiers, preview and program buses with computer compatible control, and save you money!

If however, your budget is tight, then you may choose a Computer Image Model for as low as \$10,000 — have it pre-wired for options you know you'll need and have a broadcast quality switcher today that will not soon be obsolete.

Computer Image Video Controllers are designed with circuit-element building blocks... to give you every advantage of add-on capabilities, and reliability of functions. Your basic purchase can be pre-wired for the options found in the most complete switching system.

If your future requirements can be estimated at the time of ordering a basic unit, all the add-on options can be pre-wired for only 10% of each option. And, any options ordered within six months of initial delivery will be credited that 10% pre-wire charge! The installation of any option, because it's pre-wired and completely modular, is almost as simple as plugging in the morning coffee pot!

**COMPARE THE VIDEO CONTROLLER WITH ANY OTHER SWITCHER... AT ANY PRICE!** Ask about price, performance, versatility, reliability, guarantee and delivery... and ask about some very happy Video Controller users!

**Represented nationally by:**

**Broadcast Communications Devices, Inc.**  
5526 East LaPalma Avenue  
Anaheim, California 92807  
(714) 528-9505

**Broadcast Communications Devices, Inc.**  
1850 Warburton Avenue, Suite 203  
Santa Clara, California 95050  
(408) 984-6614

**Didier/Denver**  
P.O. Box 1599  
Evergreen, Colorado 80439  
(303) 674-6000

**H. M. Dyer Electronics**  
31185 Ten Mile Road  
Farmington Hills, Michigan 48024  
(313) 478-2157

**Landy Associates**  
12 Buxton Road  
Cherry Hill, New Jersey 08003  
(609) 424-4660

**Landy Associates, Inc.**  
20 Winslow Street  
Plymouth, Massachusetts 02360  
(617) 326-6050

**Radford Associates**  
3203 Lanier Drive  
Atlanta, Georgia 30319  
(404) 237-6097

**The Gene Sudduth Company**  
2809 Raintree Drive  
Carrollton, Texas 75006  
(214) 242-2690



For further information call or write:  
Vice President, Marketing, Video Controller Division



**COMPUTER IMAGE CORPORATION**

2475 West 2nd Avenue, Denver, Colorado 80223  
(303) 934-5801

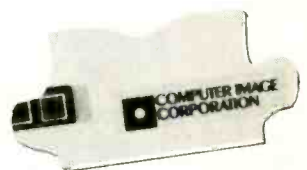

Computer Image, 1972 Emmy winner for outstanding achievement in engineering development for its unique electronic animation systems for television.

Circle 162 on Reader Service Card

## ALL SOLID-STATE AURAL STUDIO-TRANSMITTER LINKS

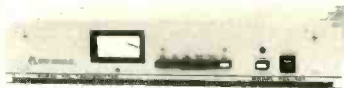

■ MONAURAL AND  
COMPOSITE VERSIONS

OPERATION IN  
ALL STL BANDS —  
890-960 MHz

- 450-470 MHz • 300-330 MHz
- 200-240 MHz • 148-174 MHz

All solid-state aural STL's to fulfill almost every requirement. Moseley Associates has pioneered many STL concepts — solid-state systems, true direct FM modulation, and composite operation (FM stereo on a single link)...just to name a few. Front-panel metering of all important parameters is included on all Moseley STL transmitters and receivers. Subcarrier capability enables wireless remote control, secondary program service, or intercom service.

Circle 153 on Reader Service Card

## TRANSMITTER REMOTE CONTROL SYSTEMS

### Analogue



Fifteen telemetry and thirty command functions are provided by the TRC-15A. The **Model TRC-15AR**, when used in conjunction with a Moseley STL, or other radio link, will provide total wireless operation. The **Model TRC-15AW** is for use on leased telephone, or other wired circuits.

### Digital



Fully digital remote control of a remotely located transmitter point is provided by the **DCS-2 Digital Control System**. Multiple transmitter site operation—a standard option. **Command, telemetry, and status** provided in groups of thirty channels. **Automatic parameter logging** available. Computer-assisted operation of the DCS-2 is another standard option, and can provide **totally automated plant operation**. The **Model DRS-1 Digital Remote System** provides many of the features of the basic DCS-2 at an affordable price. Up to 30 telemetry functions and 24 status channels to a single transmitter site.

Circle 154 on Reader Service Card

## REMOTE PICKUP LINKS

**Models RPL-3 and RPL-4 Remote Pickup Links** provide unsurpassed audio performance for remote broadcasts. Two full-time microphone and high-level line audio inputs are standard. The RPL-3 and RPL-4 Transmitters are only 4 inches high and weigh a mere 16 pounds—complete with audio mixing and AC/DC power supplies.



For 148 to 470 MHz operation

Circle 155 on Reader Service Card

## OTHER MOSELEY PRODUCTS . . .

- FM Subcarrier Generators and Detectors ■ Stereo Generators
- STL Accessories ■ Remote Control Accessories

VISIT US IN BOOTHS #4 AND #5 AT THE NAFMB CONVENTION



111 CASTILIAN DRIVE, GOLETA, CALIFORNIA 93017  
Telephone (805) 968-9621 / Telex 658448 / Cable: MOSELEY

Circle 156 on Reader Service Card

## PRODUCTS

and is supplied with BNC connectors. The cards are delivered with the final 150 ns. of delay unconnected for completion by the installer. Cards for mounting pulse and blanking delays are also available. TELEVISION EQUIPMENT ASSOCIATES **320**

**Composite noise barrier materials** are suitable for direct application to equipment and enclosures. Designated type KC Single and KC Double Composition, the materials are composites of limp, flexible, loaded PVC with one or two permanently laminated polyester urethane absorption foam layers. These materials are available with or without pressure-sensitive adhesive backing on one foam surface. Maximum continuous operating temperature rating is 200°F. Single composite materials are available with two types of barriers and three foam thicknesses. Standard rolls are 54-in. wide and 50 or 60 feet long. CONSOLIDATED KINETICS **321**

**Low leakage connectors** have been specifically designed for the following Belden bonded foil shielded coax cables: 9280, 9281, 9310, 9293-9296, 9283-9289. The two-piece connectors use a captive pin, instead of the cable conductor, and are available in 50-ohm, 75-ohm BNC, TNC and F styles. TROMPETER ELECTRONICS **322**

**Flexible cable lens drive system** for the Sony DXC-5000 color camera gives individual control of zoom and focus. The handles can be attached to a dual handle tripod head. The price, \$600, includes cables, zoom handle and clamp, focus handle and clamp. EAST COAST CAMERA CENTER **323**

**Sound-on-film projectors**, in Super-8 and 16 mm format, the ST-1200TC and F-16TC respectively, project directly into a color vidicon TV camera. Both projectors accommodate magnetic and optical sound and feature remote control forward projection. Reel capacity of the Super-8 model is 1200 feet, that of the 16 mm projector is 2000 feet. The 150 watt projection lamp in the Super-8 model offers high-low brightness control; the 16 mm model projection lamp is rated at 250 watts. ELMO **324**

**Cartridge record/playback** offers continuous program delay, network program delay, normal recording, and normal playback. A separate third head/amplifier is used in the delayed playback mode. RP Delay takes A-, B- or C-size carts, and can be cued by automation or network trip tones. Price of the mono version with 1 kHz cue is \$1,500. ITC **325**

# NEW LIT

For copies of these literature offerings, circle number for appropriate items on Reader Service Card.

Technical data sheet on **IF Amplifiers** for Telecommunications Applications describes amplifiers where very low group delay, very low VSWR and extremely flat amplitude characteristics are required. Microwave Power Devices. **250**

A revised short form catalog describing **closed-circuit television products** is now available. It includes information on the 7300 series ISOCON and Intensified ISOCON low light television cameras, 4410/4415 series compact self-contained cameras, and the Model EES-1 Edge Enhancement System. Cohu. **251**

**New frequency modulation broadcast receiver standard**, IEEE Std 185-1975/IHF 200-T, 1975, Standard Methods of Testing Frequency Modulation Receivers, has been published by cooperation of the Electronics Industries Association, Institute of Electrical and Electronics Engineers, and Institute of High Fidelity. It provides the first up-to-date standard method for testing and comparing FM receivers that has received endorsement from all segments of the industry. The single copy price is \$6.00 and can be obtained from the Institute of Electrical and Electronics Engineers, 345 East 47th St., N.Y., NY 10017.

Short form catalog listing 35 unique **video instruments**, including slow scan equipment, video digitizers, quantizers, disc memories, and video x-y devices is now available. Colorado Video Inc. **252**

**Television, Motion Picture Lighting and Production Equipment** price list and brochure describing new lensless Follow Spot design is now available. Berkey Colortran. **253**

**WTFDA TV Station Guide**, a comprehensive reference of North and Central American television station data, features maps (by channel) showing the location, call letters, network, and offset frequency for almost every TV station in those areas. The price is \$5.00 postpaid and is available from WTFDA, PO Box 163, Deerfield, IL 60015.

Eight-page brochure and price list on **digital equipment** describes complete line. ESE. **254**

# Digitrol

## Automatic Videocassette Control System

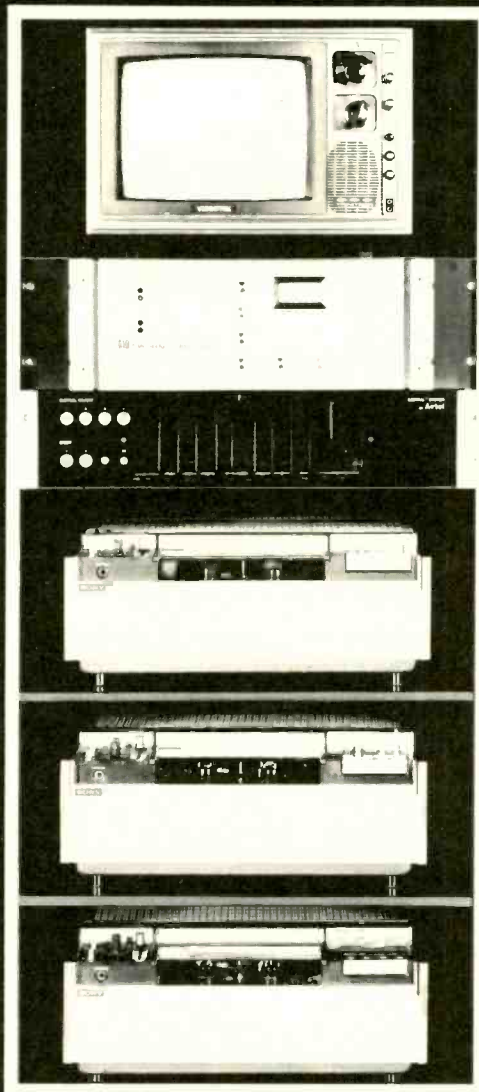

Fully automatic

Digital TBC provides full RS-170 sync and NTSC signal specifications

Multiple back-up safety features

Designed-in versatility and expandability

Vertical interval switching (optional)

Commercial insertion capability (optional)

Proven digital design

Low cost

Both play and record models available

# Avtel

Avtel  
1280 Blue Hills Avenue  
Bloomfield, Connecticut 06002  
(203) 242-4242 TWX 710-425-2390

# BM/E CLASSIFIED MARKETPLACE

## CLASSIFIED ADVERTISING RATES

DISPLAY CLASSIFIED ADVERTISING: \$32.50 per inch 1x; \$30.00 per inch 6x; \$27.50 per inch 12x. ALL OTHER CLASSIFIED ADVERTISING 35¢ per word; minimum \$3.50. BLIND BOX NUMBER: \$1.00 extra charge. Replies sent to address below will be forwarded to you. PAYABLE IN ADVANCE; send check with order. CLOSING DATE: 5th of 2nd month preceding issue date.

**BM/E, Monterey and Pinola Avenues, Blue Ridge Summit, Pa. 17214 Phone 717/794/2191**

## EMPLOYMENT OPPORTUNITIES

### FIELD SERVICE ENGINEER

Extensive Travel. All Benefits. Experience in Color video and switching systems preferred. Contact: **Mr. Buzan, Vital Industries, Inc., 3700 N.E. 53rd Avenue, Gainesville, FLA. 32601 Phone: (904) 378-1581.**

### WANTED VICE PRESIDENT/ENGINEERING

I have 135 miles of 30-channel bi-directional plant expanding to 375 miles. We are an all converter establishment now carrying 26 channels. We have 10 channels of FM microwave, 3 headends and \$250,000 in mobile color production facilities.

If you have your engineering degree and at least five years systems experience and are a hands-on working engineer with the ability to lead and administrate then we have an excellent position for you in Hawaii.

Send full resume and references with current salary to John Calvetti, President; Oceanic Cablevision, Inc. P.O. Box 27087; Honolulu, Hawaii. 96827.

### NATIONAL SALES MANAGER

Successful San Francisco Bay Area Company engaging in the manufacturing of RF Equipment for Broadcast Industries, seeks an aggressive Sales Engineer to head the Sales Department. Three (3) year minimum sales experience in Radio Market required. College degree desirable. Send resume to: Box 875-1. c/o BM/E, Blue Ridge Summit, PA. 17214.

### SALES MANAGER

We are looking for an aggressive Sales Manager to sell our complete line of console components for recording, broadcast and sound reinforcement. Individual must be an experienced pro with a proven performance record. National distribution.

**Modular Audio Products  
1385 Lakeland Ave.  
Bohemia, N.Y. 11716  
(516) 567-9620**

**WANTED**—Engineer with heavy maintenance experience for two AM Massachusetts stations. Good money, top benefits and stable company. Contact Mr. Vaughn or Mr. Roberts, W-A-R-E Radio, Ware, Mass. 01082.

Chief Engineer—Troubleshooter and man who likes exciting audio sounds wanted to caress carousel, activate automation, and make our small Midwestern daytimer sound better than anyone else. Good salary and good challenge with extra money for extra skills. Reply to Box 775-1, c/o BM/E, Blue Ridge Summit, PA. 17214.

## EQUIPMENT FOR SALE

**SPOTMASTER PARTS**—24 hour service—repairs and rebuilding of your equipment. Franchised SPOTMASTER repair service. COMMUNICATION MEDIAS/BROADCAST COMPONENT DISTRIBUTORS, P.O. Box 54, Allentown, PA. 18105. (215) 437-0607.

E.N.G. IVC 870C color VTR & Spectravision Backup, edit and insert capability, excellent condition, \$6,500. Sun Life Assurance Co. of Canada. (617) 237-6030. Ext. 381.

## EQUIPMENT FOR SALE (Cont'd)

Broadcast mixer for remote out of studio programming. Can be used as inexpensive second console for college and small radio stations. D.J.'s can now originate programming at home. Simultaneous mixing of two stereo phonographs, a tape machine and a microphone. Precise for all inputs with built in monitor headphone amplifier. Send for literature, \$325. Professional discount, use letterhead. G.L.I. Box 2076, DEPT BM E, Brooklyn, N.Y. 11201 Phone: (212) 875-4892.

Solid-state audio modules-console kits, power amplifier kits, power supplies, Octal plug-ins, mic, eq, line, disc, tape play, tape record, amplifiers, Audio & tape bias oscillators. Over 50 audio products. Send for free catalog and applications. Opamp Labs, Inc. 4033 N. Sycamore Ave. Los Angeles, Calif. 90035 (213) 931-3565.

**WHATEVER YOUR EQUIPMENT NEEDS**—new or used—check us first. We specialize in broadcast equipment. Send \$1.00 for our complete listings. Broadcast Equipment and Supply Co., Box 3111, Bristol, TN 37620.

One stop for all your professional audio requirements. Bottom line oriented. F.T.C. Brewer, Box 8057, Pensacola, Florida 32505.

AMPEX, SCULLY, TASCAM, all major professional audio lines. Top dollar trade-ins. 15 minutes George Washington Bridge. PROFESSIONAL AUDIO VIDEO CORPORATION, 342 Main Street, Paterson, N.J. 07505. (201) 523-3333.

MICA AND VACUUM transmitting capacitors. Large stock; immediate delivery. Price lists on request. SURCOM ASSOCIATES, 1147 Venice Boulevard, Los Angeles, Calif. 90015. (213) 382-8985.

### UP TO 45% OFF

on Stage, Studio and Projector lamps. Complete stocks. Rapid service. **SITLER'S SUPPLIES, INC., 215 N. Iowa Ave., P.O. Box 10-M, Washington, Iowa 52353. Phone (319) 653-2123.**

745' Stainless G-5 tower, in service \$17,000—cash or trade. 880' 6" transmission line \$12,000. Write WXON-TV, Box 2020, Southfield, Mich. 48075 or call (313) 355-2901.

**BROADCAST AND RECORDING EQUIPMENT:** Scully, V.I.F. International, Metrotech, Langevin, Electrodyne, Q.R.K., Micro-Trak, MRL, Nortronics, McMartin, U.R.E.I., E.V., A.K.G., Stevenson, Gately, D.B.X., Advent, Altec, Fairchild, Audio Designs, 3M, Magnecord, Telex, Inovonics, Nagra, Uher, Tape-Athon, Package Deals, Installations. Service. Request Flyer. Weigand Audio, Middleburg, PA. 17842. (717) 837-1444.

**CHARACTER GENERATORS:** Demo/Trade-in equipment available—Models include D-2400, D-1500, D-1032, DT-1, and MG-1. All Warranted—Reasonably priced. First come basis. Contact: Anthony Matfia, Datavision Video Products, 3M Company, 15932 Shady Grove Road, Gaithersburg, Md. 20760. Phone: (301) 948-0460.

Over One Million Dollars in used recording-sound-tlm equipment. Send \$1, refundable for list to the **EQUIPMENT LOCATOR**, P.O. Box 99569, San Francisco, CAL. 94109.

**ONE COMPLETE** ready to go IGM "500" Automation System with spare parts and instruction manuals. For more information contact Dave McGowan, Chief Engineer, KWPC, Muscatine, Iowa 52761. Phone: (319) 263-2442.

**SYLVANIA LAMPS 50% OFF!** Quartz, Projection, Studio, Enlarging, Movie Lamps, in stock for immediate delivery. Write or call for price list. Sawyer Camera Company, 6820 Santa Monica Blvd. Hollywood, CAL. 90038. (213) 466-6113.

**SPOTMASTER, FIDELIPAC, RUSSCO, ROH, ELECTRO-VOICE, OTARI, RAMKO, SCOTCH, STANSON, NORTONICS, SHURE, SENNEHEISER, TELEX, MAGNECORD AND VIKING** are all items distributed and serviced by **COMMUNICATION MEDIAS/BROADCAST COMPONENT DISTRIBUTORS**, P.O. Box 54, Allentown, PA. 18105. (215) 437-0607. "Sudden Service" our specialty.

## EQUIPMENT FOR SALE (Cont'd)

### AUTOMATION STEREO SYSTEM FOR SALE

**SCHAFFER 800 C/W ALL OPTIONAL EQUIPMENT** and six years old:

- 10 stereo sources, 1 stereo output +4DBM, 6 rows of sequence switches (5 optional) make it possible to run 6 different formats with format selector
- Network joiner provides 15 function and the capability to terminated the program in one second
- Program control is by means of a 25Hz tone, photo cell and window tape or by real time using internal pin clock
- An Audio clock provides live time announcements at one minute intervals on reel to reel machines
- Four TRU-8 record units (3 optional) will allow to prepare program material for the Automation System on Auxiliary Equipment
- Silence sensor and many other features

### BEST OFFER

**FOR INFORMATION CONTACT:  
Mr. Kurt Mayer  
Ryerson Polytechnical Institute  
50 Gould Street  
Toronto, Ontario  
M5B 1E8 595-5287**

500 feet of FXA-158-50H Phelps Dodge 1 1/2 inch coax not used. Make offer. Gary Harrison—(417) 326-7777.

**VIDEO TAPE RECORDER**—Three AMPEX VR7800—16 with editing. New Heads. Excellent condition. Sold lump sum/individual. Send offer to Quality Telesharing Corporation, Box 43, Mayaguez, Puerto Rico 00708. Attention: Mr. Laracuente.

**Lebow Labs Inc.  
56 Chestnut Hill Ave.  
Boston, Mass. 02135**

New England's foremost pro audio/video distributor. Representing over 100 major manufacturers. Sales, consulting, design, and service by expert staff. Broadcasting, industrial, educational, and recording installations. Contact: Frank Petrella (617) 337-6303 or (617) 782-0600

2 — newly refurbished, RCA Low-Band headwheel panels. Make offer. George Woody. (218) 727-6864.

## EQUIPMENT WANTED

**WE NEED USED** 250, 500, 1KW, 5KW AM Transmitters, 250, 1000 Watt FM transmitters. No junk. Guarantee Radio Supply Corp., 1314 Iturbide St., Laredo, TX. 78040

Used cart machines and turntables suitable for rebuilding. S.J. Broadcast and Program Service, Box 816, North Cape May, N.J. 08204. FCC First Class Phone.

**WANTED**—Top \$ paid for U-47's (tube type), M-19's, KM-56's, U-67's and Telefunken 251's. SIGMA AUDIO SYSTEMS, P.O. Box 2469, Hollywood, CA. 90028. (213) 462-8515.

CBS Volumax and Audimax or just Volumax. Good condition. State price. Jack Smith, KVVU/TV, 1800 Boulder Highway, Henderson, Nev. 89015. (702) 565-9755.



"FREE" CATALOG ... Everything for the Deejay! Custom I.D.'s, Promos, Airchecks, Wildtracks, Books, FCC Tests, Comedy, and more! Write: Command, Box 26348-A, San Francisco 94126.

Deejays! New Comedy! 11,000 classified one-line gags, \$10. Catalog FREE! Edmund Orrin, 2786-M West Roberts, Fresno, CA. 93705.

"Ramblings" is a short radio commentary fulfilling a need in a world that cries out for hope, humor, inspiration and motivation. 30 programs a month, \$30. Pierce, Box 91, Spanish Fork, Utah 84660.

**INSTRUCTIONS**

First phone through tape recorded lessons at home plus one week personal instruction in Washington, D.C., Atlanta, Boston, Detroit, New Orleans, Minneapolis, Seattle, Denver, Portland, Los Angeles. Proven results. Our 17th year teaching FCC license courses. Bob Johnson Broadcast License Training, 1060D Duncan, Manhattan Beach, Calif. 90266. 213-379-4461.

Professional Engineer's License Guide. \$6.95 from P. E. Guide, Box 1897, Rockville, Md. 20850.

**FRANCHISES AVAILABLE**

The VILLAGE of NAPLES, in ONTARIO County, New York invites applications for a cable television franchise. Applications shall be prepared and submitted in accordance with a "Request for Proposals" available from the undersigned. Applications will be accepted until 4:00 P.M. August 12, 1975, and all applications received will be available for public inspection thereafter during normal business hours at the Village Hall between 9:00 A.M. and 4:00 P.M.

MARY LOU REX, Village Clerk, Village Hall, Main Street, Naples, New York 14512, 315-374-2435

**VILLAGE OF FREDONIA AND TOWN OF POMFRET, NOTICE TO BIDDERS**

Request for Proposals—The Village of Fredonia and Town of Pomfret, New York hereby invite the submission of sealed bids on a Cable Television Franchise for the above named Village and Town. Bids will be received until 4:30 P.M., Eastern Standard Time on the 15th day of September, 1975, at the Village Clerk's Office, Village Hall, at which time and place all bids will be publicly opened and read. Applications shall be prepared and submitted in accordance with specifications and notice to bidders available from the Village Clerk. Any bid submitted will be binding for 180 days subsequent to the date of bid opening.

**PROFESSIONAL CARDS**

**COHEN & DIPPEL, P.C.**  
CONSULTING ENGINEERS  
527 Munsey Bldg.  
(202) 783-0111  
Washington, D. C. 20004  
Member AFCCE

**RALPH E. EVANS ASSOCIATES**  
Consulting Telecommunications Engineers  
AM-FM-TV-CATV-ITFS  
3500 North Sherman Boulevard  
MILWAUKEE, WISCONSIN 53216  
Phone: (414) 442-4210  
Member AFCCE

**Midwest Engineering Associates**  
Consulting Engineers  
F.W. Hannel, P.E.  
BSEE; MSEE  
7304 N. Oxford, Peoria, Illinois 61614  
(309) 691-3426

**B-800 the eight mixer series**

a professional series of high performance consoles with plug-in modular design, select your model, monaural, stereo or simulcast



**B-500 the five mixer series**

a practical console, stereo or monaural, designed with flexible plug-in modules, perfect for production or small stations.



**ACCU-FIVE**

a versatile 5 mixer 3 1/2" rack mount console



from the "FULL CHOICE" line

AM/FM MONITORS • RECEIVERS • AM/FM TRANSMITTERS

**McMartin.**

McMartin Industries, Inc. 4500 South 76th Street, Omaha, Nebraska 68127 (402) 331-2000

Circle 158 on Reader Service Card

audio control **CONSOLES**

# Announcing VTC-1000



end.  Lowest prices. Guaranteed quality. And immediate, personal attention to every video tape product or service you need.\* And we'll pay the freight anywhere in the continental U.S. with each order of 6 or more reels! (In California, add 6% for sales tax.)  
**Call collect: (213) 985-1666**

## All-new Mastering Video Tape \$160.00 per hour\*

From the Video Tape Company—the firm that promptly supplies any of your video tape needs!  Prices lower than all competition—including Program Duplicating Stock @ \$125.00 per hr./ Spot Duplicating Stock @ \$1.00 per min. \*—(22 min. max. length)  100% guaranteed.  VTC-1000 promises: low dropouts  hi signal-to-noise  excellent color performance  extended headwear  exceptional durability  each reel tested end-to-

THE VIDEO TAPE CO.

4212 Lankershim Blvd.  
N. Hollywood, Ca.  
91602  
Keith Austin, Pres.

Mail this coupon today for free price-and-information brochure.

Name \_\_\_\_\_

Title \_\_\_\_\_

Company and/or Channel \_\_\_\_\_

City \_\_\_\_\_

State \_\_\_\_\_ Zip \_\_\_\_\_

BM/E-75A

Circle 159 on Reader Service Card

## ADVERTISER'S INDEX

Acrodyne Industries, Inc. ....	47	Jampro Antenna Co. ....	17	UMC Electronics Co. ....	47
AKAI America Ltd. ....	27	JVC Electronics, Inc. ....	37	Video Tape Company ....	65
Alpha Electronic Services Inc. ....	10	McMartin Industries, Inc. ....	16, 50, 55, 65	Viscount Industries, Inc. ....	46
American Data Corp. ....	3	Microtime Inc., Artel Div. ....	63	Wilkinson Electronics, Inc. ....	18, 54
Ampex ....	7	Moseley Associates, Inc. ....	62		
Audio Services, Inc. ....	50, 55, 60	Nurad, Inc. ....	31		
Barbizon Electric Co. ....	60	Paperwork Systems ....	10		
Belar Electronics Lab., Inc. ....	50	Potomac Instruments, Inc. ....	12		
BIAS ....	18	RCA Broadcast Systems ...	12, 15, 56		
Broadcast Electronics, Inc. ....	60	RCA Global ....	45		
Canon, USA, Inc. ....	14	Recortec, Inc. ....	48, 49		
Central Dynamics Ltd. ....	9	Shintron Co., Inc. ....	26		
Cinema Products Corp. ....	25	Shure Bros., Inc. ....	57		
Computer Image ....	61	Sony Corp. of America ....	13		
Datatron, Inc. ....	23	Systems Marketing Corp. ....	Cover III		
Ditch Witch Trenchers ....	19	Taber Mfg. & Engrg. Co. ....	16		
Dynair Electronics, Inc. ....	24	Tektronix, Inc. ....	21		
Dynasciences Video Products ....	51	TeleMatlon ....	41		
Fidellipac ....	8	Television Equip. Associates ....	56		
Fluke Mfg. Co., Inc., ....	66	Television Research Intl. ....	Cover IV		
Grass Valley Group, The ....	5	Thomson, CSF Labs., Inc. ....	11		
Harris Corp., Broadcast Equipment Div. ....	Cover II, 20	Transist-O-Sound ....	60		
IGM ....	14				
International Tapetronics Corp. ....	20, 59				

## SALES OFFICES

### Broadband Information Services, Inc.

274 Madison Ave.  
New York, New York 10016

### EASTERN & MIDWESTERN STATES

274 Madison Avenue  
New York, New York 10016  
212-685-5320  
Kenneth F. Luker, Jr.

### WESTERN STATES

1212 Hearst Building  
San Francisco, California 94130  
215-495-0990  
William J. Healey

P.O. Box 49206

Los Angeles, California 90049  
213-476-6451  
Art Mandell

### JAPAN

Nippon Keisoku Inc.  
P.O. Box 410  
Central Tokyo, Japan  
Tokyo (03) 667-7681  
Yoshi Yamamoto

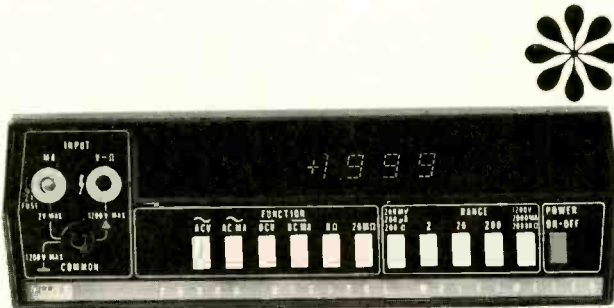

**\* Think of it as the best tester  
in your bag. Only \$299**

Now you can get a high performance Model 8000A Digital V.O.M. from Fluke, America's foremost maker of quality digital multimeters, especially designed for TV, radio, stereo and audio service. No other digital V.O.M. gives you the resistance range to check breakers and switches, the high resolution voltage to look at emitter base and other transistor voltages, excellent ac accuracy and full accuracy with a 30 second warm-up.

Measures in 26 ranges 100  $\mu$ V to 1200 V, 0.1  $\mu$ A to 2A, and 100 milliohm to 20 megohm with a basic dc accuracy of 0.1%. Full year guarantee. Low cost options include rechargeable battery pack, printer output, deluxe test leads, HV, RF & 600-amp ac current probes, carrying case, and rack mount. Unique self zero eliminates offset uncertainty. Electronics securely mounted in high-impact case. Service centers throughout U.S., Canada, Europe and Far East for 48-hour turnaround repair.



P.O. Box 7428,  
Seattle, Washington 98133.

Get all the details from your nearest Fluke sales office. Dial toll-free 800-426-0361 for address of office nearest you.

Circle 160 on Reader Service Card

Coming in  
September.

The  
Source.

1. instant source locator 2. alphabetical guide to all manufacturers 3. . . . the equipment they produce 4. verified information 5. field sales offices 6. cross reference to manufacturers' ads 7. local rep sales help 8. phone numbers

# Profitable programming begins with Automated Systems from SMC

You can make the most of your staff's time and talents when you automate with SMC. From the makers of the famous Carousel®, choose the system that works best for you and frees your air staff for other duties—like selling or production.

The SMC DP-1 system has 2,048 separate events and 20 audio sources, all completely computerized for any format.

The SMC 3060 Sequential system is especially designed to let you plug-in additional equipment as your program or commercial needs increase. The 60-event sequential programmer permits scheduling from as many as 10 or more different audio sources.

Automatic logging is available on both the DP-1 and the 3060.

There are SMC systems for *every* music format plus top-quality cartridge equipment—all designed to help you do a more profitable job. Why not let SMC help you plan or finance the system that can do the most for you. SMC also has information on every major music format. Phone us today—or return the coupon below—all replies are strictly confidential. It could be the most profitable event in your station's life!



**Systems Marketing Corporation** 1019 West Washington St.  
Bloomington, Illinois 61701 (309) 829-6373

*Broadcast Automation—our only business*

Circle 61 on Reader Service Card

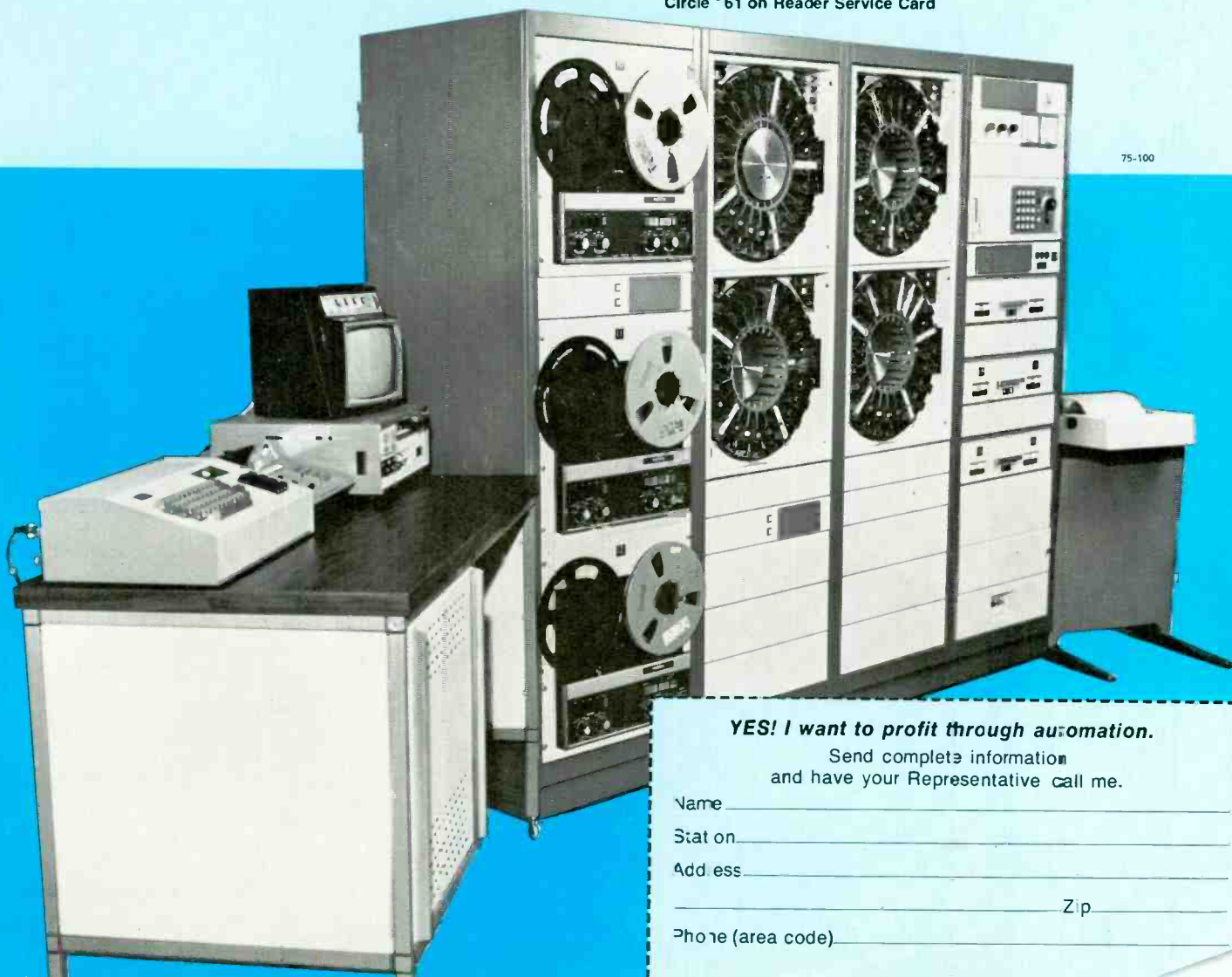

75-100

**YES! I want to profit through automation.**

Send complete information  
and have your Representative call me.

Name

Station

Address

Zip

Phone (area code)

TRI has solved the problem. We've engineered a simple, direct, interface with our EA-5 Editing System which opens up all sorts of creative possibilities.

Here's what you can now do with a Sony 2850:

- Preview edits
- Edit accurately to video or audio cues
- Edit with frame accuracy
- Search at up to 5 times play speed in either direction
- Interface the 2850 with other makes or models
- Adjust the edit point after preview

- Make your edit decisions with true still-frame assistance
- Control end insert point from the console
- Monitor audio and video at the console

Still another friendly message from TRI involves price. It doesn't take an arm and a leg to add the EA-5 to your existing VTRs. The cost? Less than \$6,000. Installation time? Less than an hour. Training period? It might take as long as a half hour.

A quick word to the needy, we're delivering right now.

Somehow the word got out.

For a "hands-on" demo, or more information, contact us or the best video distributor in your area.

Chances are he's our distributor.

**Television Research International, Inc.**  
1003 Elwell Court  
Palo Alto, California 94303  
415/961-7475

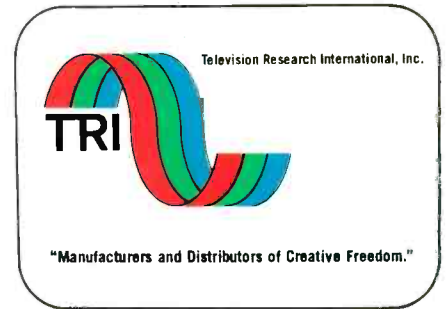

## Here's a brief, friendly message for frustrated editors trying to make frame accurate edits on the Sony 2850 \*U-Matic VTR.

# Relax!

