

MARCH 1978

BME

BROADCAST MANAGEMENT/ENGINEERING

LAS VEGAS '78
NAB STAKES BROADCASTERS
TO EXCITING NEW EQUIPMENT
FOR RADIO AND TV



SS 7800

AUDIO PRODUCTION CONSOLE



McCURDY RADIO INDUSTRIES
TORONTO • CHICAGO • NEW YORK

(416)
751-6262

(312)
640-7077

(201)
327-0750



Circle 100 on Reader Service Card

CMX is showing the same old stuff at NAB

CMX is the industry standard for editing. The most flexible, versatile, accurate, dependable, innovative and cost effective system in the world. Not one CMX system introduced over the last seven years has ever been taken out of service.

and then some.

Since this is a competitive world, you'll have to drop by to see what we've come up with this year — you can be sure you won't see flashy options or complicated consoles. CMX innovations must improve the human operability of the system or they don't become CMX. See us at booth 801.

cmx systems
ORROX

3303 Scott Boulevard, Santa Clara, CA 95050 Phone: (408) 988-2000 Telex: 910-338-0554

Circle 101 on Reader Service Card

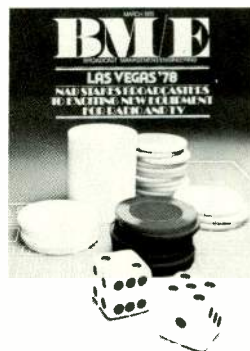

Broadcasters attending this year's NAB Convention in Las Vegas won't have to gamble on seeing the latest in technology. Once again, NAB has gathered together the greatest collection of broadcast industry suppliers ever housed under one roof.

**BROADBAND
INFORMATION SERVICES, INC.**
295 Madison Ave.
New York, N.Y. 10017
212-685-5320

Editor

James A. Lippke

Managing Editor

David Hawthorne

Senior Editor

Robin Lanier

Creative Director

Gus Sauter

Manager

Publication Services

Djuna Zellmer

Production Manager

Karen A. Tubridy

Assistant Editor

Daryl Winer

Comptroller

Joseph W. Kutner

Reader Service

Aetna Dowst

FCC Counsel

**Pittman Lovett Ford
and Hennessey**

Publisher

Charles C. Lenz Jr.

MARCH 1978/VOLUME 14/NUMBER 3

6 Broadcast Industry News

NAB urges early authorization of AM stereo; Common carrier and field operations; NAB calls for tighter technical licenses

35 Radio Programming & Production For Profit

Making the big city a community; Putting on drama in a small town

38 BM/E's Program Marketplace

Profile of Century 21 Productions and Programming

42 Television Programming & Production For Profit

Complex Hanna-Barbera production shows benefit of editing off-line before editing on-line

45 How To Get Closer To FM Sound On The Standard AM Receiver

Sophisticated audio processing promises improvement in AM sound

51 How An FM Station In A Small Community Built A Valuable Emergency Alert Net

WWST-FM uses EBS two-tone alert for local emergency broadcasting

55 The Automated Console: One Hundred Hands For The Recording Engineer

The recording engineer and broadcaster can exercise great creativity in the mix-down with the aid of automation

65 AM Stereo: The FCC Needs Your Help

Summary of two reports on AM stereo delivered to the FCC

67 Making Money With No Help From Compression

How a rebuilt FM station pushed the technology to new heights and succeeded with all-classical programming

77 NBC Television Network Simulcast Uses New Diplex System For Audio; FM Station Participants Surprised By High Quality

Bell Diplex System is the key to a new standard of excellence in simulcasting

80 Automated Camera Setup Comes To WLS-TV

Computerized control of camera setup reduces camera crew requirements and shortens routine setup time

84 Stored News Footage Speeded To NBC News By Computer-Assisted Microfilm Retrieval

Computer system provides rapid access to news film morgue

91 It's A New Era For Radio And TV On The Campus

A new perspective on radio and TV as instructional media

103 NAB CONVENTION ISSUE

Banner year for new equipment - ENG equipment in abundance for TV; Radio broadcasters to see new audio processing in AM stereo gear

120 Complete listing of exhibitors and their products

163 SMPTE Winter Conference Updates Industry On 1-Inch VTRs and Digital Technology

Formidable progress being made in television technology with digital techniques and 1-inch tape

179 British Stage Day Of Digital Broadcasting Demos

Digital VTR and other digital devices demonstrated in London

183 Speak Out: Jack Matranga Takes On "Super Stations"

187 Great Idea Contest

Win a calculator - enter the Great Idea Contest

193 FCC Rules And Regulations

Substantial differences between programming promises and performance can begin license renewal nightmare

197 Broadcast Equipment

BM/E's survey of new products

208 Business Briefs



BPA BM/E BROADCAST MANAGEMENT ENGINEERING is published monthly by Broadband Information Services, Inc. All notices pertaining to undeliverable mail or subscriptions should be addressed to 295 Madison Ave., New York, N.Y. 10017. BM/E is circulated without charge to those responsible for station operation and for specifying and authorizing the purchase of equipment used in broadcast facilities. These facilities include AM, FM, and TV broadcast stations, CATV systems, ETV stations, networks and studios; audio and video recording studios, consultants, etc. Subscription prices to others: \$18.00 one year, \$28.00 two years. Foreign: \$24.00 one year, \$38.00 two years. Foreign Air Mail, additional \$30.00. Copyright 1978 by Broadband Information Services, Inc., New York City. Controlled circulation postage paid at East Stroudsburg, PA.

GRASS VALLEY GROUP 

M-200 MODULAR SYSTEM...

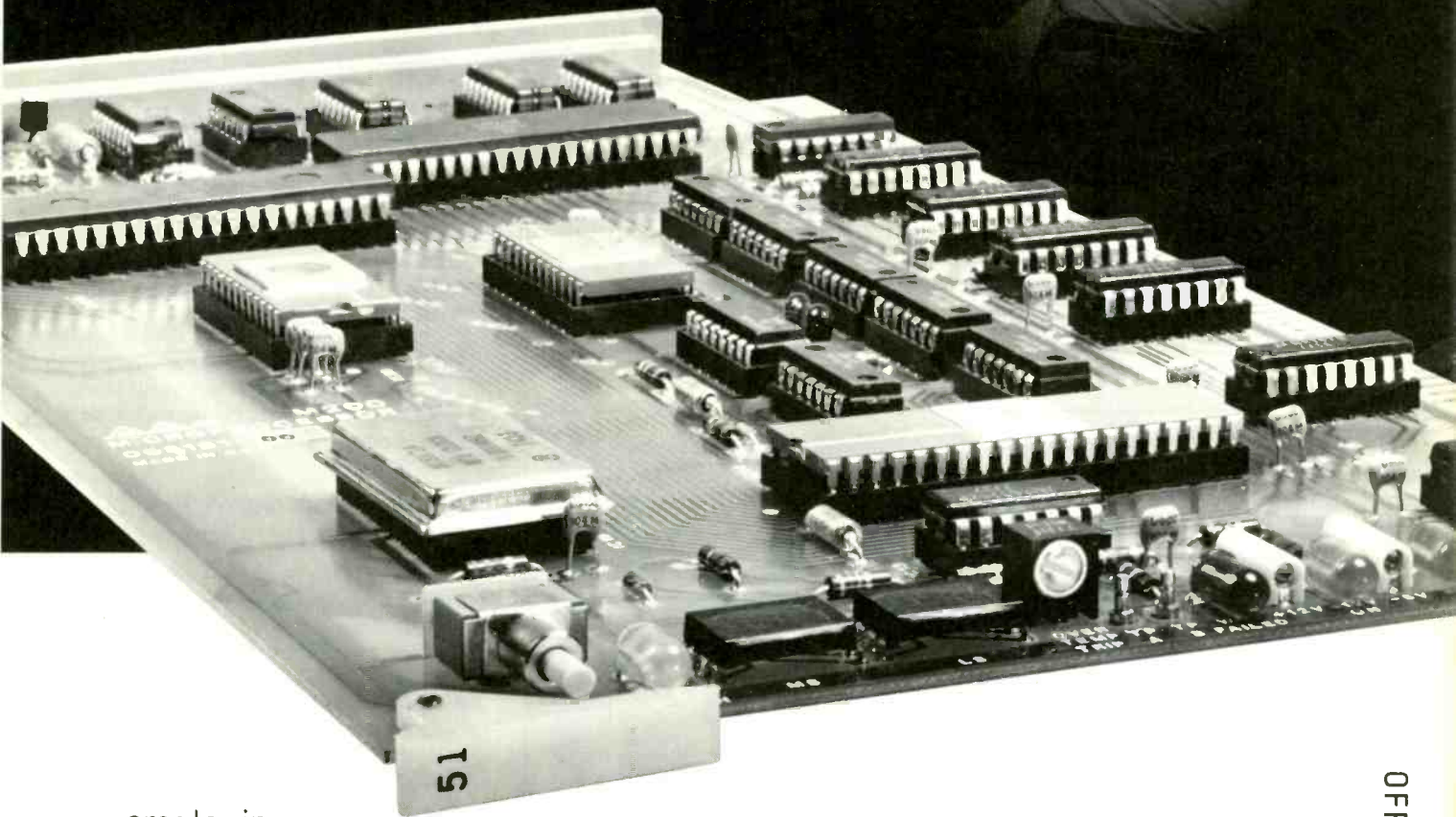

employing
a compact
microprocessor computer,
lets you start with the automation you need. . .
today.

And add as much automation as you will need. . .
tomorrow.

M200; a practical, building block approach to
TV automation.

OFFICES:

P.O. Box 482
MABANK, TX 75147
(214) 887-1181

810 W Bristol Street
ELKHART, IN 46514
(219) 264-0931

1644 Tullie Cir, NE
ATLANTA, GA 30329
(404) 321-4318

Station Plaza East
GREAT NECK, NY 11021
(516) 487-1311

4419 Van Nuys Blvd, Ste 307
SHERMAN OAKS, CA 91403
(213) 990-6172

NAB '78 BOOTH 813

THE GRASS VALLEY GROUP, INC.

A Tektronix Company

BROADCAST INDUSTRY NEWS

NAB Urges Early Authorization Of AM Stereo

The National Association of Broadcasters says that while it does not at this time endorse a specific AM stereo system, the authorization of AM stereo broadcasting should be a "top-priority" item on the Federal Communications Commission agenda. The report on tests of three AM stereo systems by the National AM Stereophonic Radio Committee (NAMSRC) was submitted to the FCC. NAMSRC tests indicate that these systems are capable of transmitting and receiving stereo sound with fidelity comparable to FM stereo, are basically compatible with existing radio receivers and stations, and do not occupy substantially more spectrum space than standard AM. Two other systems are now being tested and will be included in the AM stereo proceeding.

NAMSRC sponsors are the NAB, the Electronic Industries Association, the Broadcast, Cable and Consumer Electronics Society of the Institute of Electrical and Electronics Engineers, and the National Radio Broadcasters Association.

NAB Urges FCC To Tighten Technical Licenses

The National Association of Broadcasters has asked the FCC to use its proposed dual radio license structure as a basis for enhancing the proficiency of those responsible for a station's technical operation. NAB believes that those responsible for installation, maintenance, servicing and adjusting of transmitter equipment should have to satisfactorily complete an FCC examination regarding the individual's technical proficiency. Those responsible for the routing operation of a station

should be licensed by declaration but also be required to complete a certificate of instruction issued by a licensed individual at the station. The certificate would permit operation only at that station.

NAB also said that the FCC's examination procedure should be stiffened; many licenses are obtained by persons having little, if any, technical expertise, the organization maintains.

A further refinement, proposed by the NAB, is that of two basic classes of technician licenses: Broadcast Technician and Radio Technician. The former would be offered three endorsements — radar, directional antenna and television, and the second would be offered a radar endorsement. This system would mean that applicants desiring broadcast only privileges would no longer be forced to take examinations concerning non-broadcast operation. The NAB also said it is "unequivocally opposed" to any plan which might not grandfather the rights of present First Class license holders.

Common Carrier & Field Operations Bureaus

FCC's fiscal 1979 budget request includes 24 new positions for Field Operations Bureau and 20 for Common Carrier. Other increases would be five new positions to the Chief Engineer's Office for WARC preparations, and 10 new positions to the Office of Plans and Policies, which would receive \$1 million for research, an increase of about \$400,000 over current year. No additional employees are requested for either Broadcast or Cable Bureaus.

RTNDA Survey Confirms: ENG Is Leading To More News Coverage

According to an abstract of a recent RTNDA (Radio and Television News Directors Association) survey appearing in that organization's newsletter, *RTNDA Communicator*, TV stations with electronic news gathering are covering more stories than those with only newsfilm in markets of comparable size.

The survey also found that hard news, particularly on government, re-

continued on page 8



BM/E editor, James A. Lippke and Robert N. Hurst, of RCA accept Certificates of Merit from Charles Mill, president of American Business Press, Inc., and Floyd G. Arpan, professor of journalism, Indiana University, chairman of the 1978 Neal Board of Judges (left to right are, Mill, Lippke, Hurst, and Arpan).

BM/E Takes Two Awards For Distinguished Journalism

BM/E received two Certificates of Merit in the Jesse H. Neal Editorial Achievement Awards competition conducted annually by the association of the American Business Press.

One Certificate of Merit was awarded for "Best staff-written series of articles appearing in a single issue." The Award was presented to James A. Lippke, editor; David Hawthorne, managing editor; David Hawthorne, managing editor; Robin Lanier, senior editor; and Gus Sauter, art director, for their work on the January 1977 *BM/E* special issue: "ENG Alias EFP Tackles New Jobs."

The second Certificate of Merit was awarded for the "Best contributed article

or series thereof," and was presented to Lippke, Hawthorne, and Robert N. Hurst of RCA. Hurst received the award as author of the *BM/E* series, "An Introduction to Digital Television."

The awards were presented at the Twenty-Fourth Annual Awards Ceremony held at the Americana Hotel in New York, February 16, 1978. Winners were selected from among 412 entries in three classifications and five categories. The awards "recognize outstanding accomplishments by business press staff members..." and are judged on the basis of "extent of service to the field served, journalistic enterprise, and editorial craftsmanship."

The Thomson-CSF Laboratories Microcam® is the lightest broadcast-quality portable color television camera in the business. And if your business is covering news, sports or special events, you want to make sure it all gets covered. While other cameramen are pausing for a breather, you're still going strong.

Total system weight is:

- Camera head (with 6:1 lens) and viewfinder 8½ lbs.
- Shoulder pad 6.3 oz.
- Electronics pack 3 lb. 8 oz.
- Interconnect cable 1 lb. 2 oz.

Microcam will go anywhere. Capture anything. Live or on tape. And Microcam's ability to operate at extreme low-light levels makes it especially valuable for ENG.

Microcam's low power consumption of 24 watts provides a full hour of operation from a 2½ lb.

built-in battery pack. And for extended operation, a 4 lb silver-cell battery belt operates Microcam 5 hours on a single charge.

With a two line vertical image enhancer and comb filter as standard equipment, Microcam will effectively upgrade your present system. And Microcam is priced lower than most portable cameras.

The Thomson-CSF Laboratories Microcam. Less weight. Less power consumption. And less on your budget.



THOMSON-CSF LABORATORIES, INC.

37 Brownhouse Road, Stamford, Connecticut 06902
(203) 327-7700 / TWX (710) 474-3346

Lighten Up.



News

mains the staple for both ENG and film. The adoption of ENG has not led to an upswing in police-call news and soft features, as some critics have feared. Said the report, "Our results indicate that the types of stories covered by TV news depends more upon what happens in a community than upon changes in camera-reporting technology."

Stations with ENG were shooting more stories than those with only newsfilm, according to the report, regardless

of market size, though generally larger market stations tended to shoot more stories than smaller market stations regardless of technology. The number of stories shot per week ranged from a low of 39 per week for newsfilm stations in the bottom 100 markets to a high of 85 stories per week for ENG stations in the top fifty markets.

The study was a follow-up on an earlier ENG survey done by RTNDA in 1976. The new report, conducted by Vernon Stone and John DiCioccio, of the University of Georgia, also showed that ENG has reached near saturation

levels. More than 500 of the nation's roughly 650 non-satellite commercial TV stations now use at least some ENG equipment. Only 11 percent of the stations surveyed still report that they are in markets with no ENG, and these tend to be the bottom 100 -ADI rankings.

FCC Will Not Limit Cable Carriage of Radio

Ending a rule-making proceeding begun in February, 1972, the FCC has decided that it will impose no restrictions on the carriage of AM and FM radio stations by cable television systems. The action denied petition by the National Association of FM Broadcasters (now the National Radio Broadcasters Association) that cable systems be barred from offering cablecast radio programs; and a petition from the National Association of Broadcasters that such cablecasting be prohibited unless the cable operator carries all local FM stations.

The FCC noted that during the lengthy proceeding no evidence was brought forward showing that cablecasting of radio stations, whether local or "imported" from distant cities, has any measurable effect on local radio audiences or revenues, or that it degrades the available local radio service in any way. "Cablecast radio programming," said the FCC, "offers a unique opportunity for citizen access to a mass communications medium...by increasing the diversity of programming available to the listener...It unquestionably furthers the aims of the Communications Act...and does not impose any realistic threat to the structure of over-the-air aural broadcasting."

Study Finds Engineers Prefer Tape Medium For National Spots

For a variety of reasons, station chief engineers would prefer to receive national spot commercials on the videotape medium by a five to one margin over film, according to a study sponsored by 3M.

The study, conducted by Stephen K. Plasman & Associates, surveyed 201 television engineers, 101 of whom worked in stations in the top 100 markets, and 100 of whom worked in smaller markets. Among the reasons cited for this preference (which showed tape preferred by 50 percent, film by 10 percent and "no preference," by 40 percent) were better quality, better transfer characteristics, and ease of handling.

Nearly all stations transfer all or some of their material to tape regardless of what medium it comes in on.

continued on page 10

Are you as tough as this Ampro console?

Can you work 24 hours a day, 7 days a week, 365 days a year...year after year without a vacation?

Consider the physical abuse that this console is forced to take. Could you perform up to your capabilities if you had 17 pairs of hands working you over with no concern for your general welfare? Ampro Audio Consoles can do it.

They're built to sound better and last longer.

It's a rough world and Ampro Consoles are tough enough to take it. Ampro tough!

Quality, reliability and ruggedness. That's why hardworking Ampro is the choice of the broadcasting professionals.



AMPRO BROADCASTING INC.

850 PENNSYLVANIA BLVD., FEASTERVILLE, PA 19047 • (215) 322-5100
Professional Equipment for Broadcasting Professionals

VISIT US AT BOOTH NO. 100, NAB SHOW

Circle 103 on Reader Service Card

SQUEEZOOM™

is...
One Channel

FRAME SYNCHRONIZER

Locks all remote signals to house sync. Network, ENG, Remote pick-ups, and satellite signals will mix with local signals with no disturbance.

Sampling video at 4 times subcarrier for superior technical standard and picture quality.

TIME BASE CORRECTOR

Will "NTSC" COLOR and sync of low cost VTR's.

FRAME FREEZER

Will act like having another camera in the studio for still shots. Will freeze any full frame picture. Will retain last frame of interrupted incoming signal automatically until picture is restored.

VIDEO COMPRESSOR

No matter how a slide or scene comes in, you can compress and/or change its aspect ratio as you wish, down to one picture element, and position it anywhere on the screen.



ELECTRONIC ZOOM

See or read information not possible without zoom.

In sports, determine if ball is good, simply freeze and enlarge. Call foul plays more accurately. Zoom capability on a remote or recorded scene. Zoom while chroma key tracking.

VERY SPECIAL EFFECTS

With 2 channels or more, open new unlimited vistas of movie-type effects.

GENERATE your own effects with Vital's pre-programmed micro-processor.

Record 4 pictures on one recorder and play back any one full screen with no perceptible degradation.

Observe or monitor 4 TV channels on one receiver; listen to any one audio.

Conceived, designed, and manufactured in Florida by Vital Industries, Inc.-makers of the VIX-114 Series Switching Systems.

Or up to 4 Channels in One



You will not be locked out with one video channel "Squeezoom." Add other channels as you wish. Too many exciting features and applications to describe. Call us toll free 1-800-874-4608.



HI TECHNOLOGY PRODUCT INNOVATORS

VITAL INDUSTRIES, INC.

MAIN OFFICE: 3700 N.E. 53rd Ave., Gainesville, Fla. 32601 U.S.A. • Tel.: Area 904-378-1581.

MORRELL BEAVERS Midwest
2644 North Seventh St.
Terre Haute, Indiana 47804
Phone 812/466-3212

ROBERT McALL Northeast
34 Autumn Lane
Hicksville, N. Y. 11801
Phone 516/735-0055

GORDON PETERS Southwest
P. O. Box 912
Arlington, Texas 76010
Phone 817/261-6855

ERIC KING Southeast
Fox Hill Road
Lynchburg, Va. 24503
Phone 804/384-7001

BARRY HOLLAND West Coast
7960 West Beverly Blvd.
Los Angeles, California 90048
Phone 213/653-9438

News

Moreover, 56 percent of all stations use either a cart or cassette machine to air commercials, while in the larger markets, such machines are used at 75 percent of the stations.

NAB President Outlines Pending Issues Before FCC

Among the items of unfinished broadcast business before the FCC are the following: Refund of fees, UHF TV,

overall radio allocations policy, automatic transmission systems, easing restrictions on rebroadcasts, tax certificate proposal, standing to file petitions to deny, ex parte restrictions, cable carriage of radio signals and syndicated exclusivity. In a letter to FCC Chairman, Ferris, Wasilewski outlined the current status of these issues and the NAB's position on them, saying that these are "long-pending matters that would seem ripe for action."

Wasilewski also mentioned proposals relating to "elimination of unnecessary paperwork, notification of broad-

casters by collect telegram of FCC action on their license renewal applications and a monthly mailing to broadcast licensees advising of new Commission rules and policies."

Silverman To Head NBC

Programming dynamo, Fred Silverman was named to become president of NBC last month where he will reportedly receive a \$1 million per year salary for the duration of his three-year contract. The word at ABC where Silverman is currently programming chief, is that he will not be working actively in that capacity and will not be allowed to join NBC until his current contract expires June 1st.

RCA president, Edgar Griffiths is reportedly ready to give Silverman "all the money he needs to put NBC in the number-one position." Though doubts have been voiced about Silverman's ability to head a network rather than just its programming arm, immediate reaction on Wall Street showed confidence in the decision. RCA's stock jumped a \$1.25 while ABC's stock was actively traded closing on Friday, Jan. 20th, down \$1.75.

Silverman will replace NBC's current president, Herbert Schlosser. Schlosser has been offered an executive vice-presidency at RCA.

FCC Approves WJLA-TV — KOCO-TV Trade But Swap Still in Doubt

In a five-two vote, FCC commissioners have approved the trade of WJLA-TV Washington, DC for KOCO-TV Oklahoma City.

Five commissioners expressed doubt about the transaction (two of those, Fogarty and Brown, dissenting) between Joe Albritton, owner of WJLA-TV, and Combined Communications, owner of KOCO-TV; and several parties opposing the swap are considering appealing the decision.

Two con position concerns: Were minorities given an opportunity to acquire the Washington, DC station, as promised by Albritton when he acquired the station and the *Washington Star* newspaper in 1975? And would Albritton's stock share (550,000 preferred non-voting shares worth \$55 million) give him too much influence and control over the station? On the pro side: Albritton is insulated from control of KOCO-TV. The move is important to the saving of the *Washington Star* newspaper.

State Courts Should Not Get Involved In Regulation Of TV Advertising

Issues relating to children's television advertising should not be considered by

continued on page 12

8-Bits VIDEO A/D 16-MHz

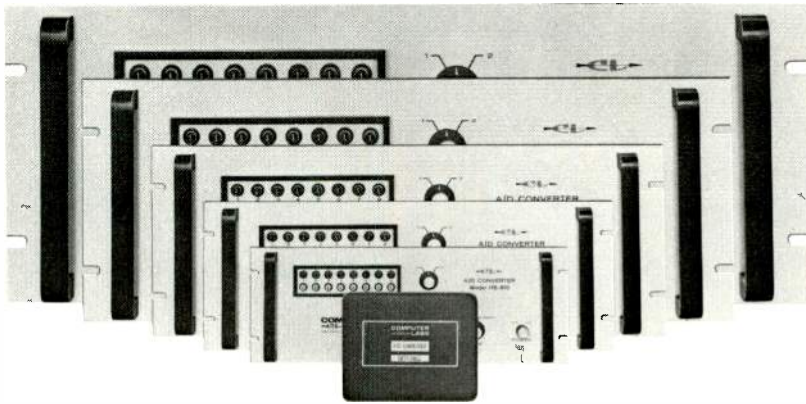

Now a small module!

The MATV-0816 is the first completely self-contained modular A/D with internal T & H and timing circuitry. And it's designed for PC-board mounting. This 8-bit, 16-MHz converter is designed for color TV digitizing at rates thru four times NTSC for digital video applications. It's also ideal for radar signal processing, laser pulse analysis, and medical electronics applications.

The encode command input, data-ready output, and digital bit outputs are all TTL compatible. Write or call us today for the complete story.

COMPUTER LABS

COMPUTER LABS, INCORPORATED
505 EDWARDIA DR. • GREENSBORO, N. C. 27409
919/292-6427 • TWX 510-922-7954

Today's performance requires the best in an audio test source. That's the new Sound Tech 1410A.



No question about it, the new Sound Tech 1410A is the finest audio test source available. It provides both sine wave (10 Hz - 110 kHz) and SMPTE intermodulation test outputs.

We classify it as an ultra-high-performance audio signal generator. Here's why:

Besides providing an ultra-pure test signal (typical distortion is less than .001% over most of audio range), the test signal is adjustable by precision output attenuators. And you have an exceptionally large output level range: from +26 dBm to -89.9 dBm in 0.1 dB steps. That +26 dBm can be a powerful help in line testing (no pun intended).

The output system on the 1410A is Sound Tech's special circuit. For minimum distortion, it has no output transformer, yet it's **both fully isolated and balanced**. That means you can connect to any load: **balanced or unbalanced, floating or grounded**.

INTERMODULATION TESTING

For intermodulation measurements, the 1410A provides the standard 60 Hz signal combined with a 7 kHz signal. You can vary the LF/HF ratio over a 100:1 range. The IM signal is provided from the same flexible output system discussed earlier.

With the high performance possible in today's audio systems, the 1410A

(or its relative, the 1710 system) is what's needed for adequate testing.

CALL FOR DATA

Call Mike Hogue/Larry Maguire and get our literature on the industry's most advanced audio test source.

They can also arrange a demo for you almost instantly.



REMOTE TESTING

In broadcast work involving remote transmitters, you can test by using the 1410A with the Sound Tech 1710A Distortion Measurement System. With its 1/2 watt of audio power, the 1410A can be used, say, at the studio to test studio-transmitter links, amplifiers, etc., while the 1710A is measuring at the transmitter.



SEE AT NAB

You can see the new 1410A at our Sound Technology exhibit at NAB.

I'll be at booth number 1308 to demonstrate the 1410A.

See you there.

Rosemary.

ST

SOUND TECHNOLOGY

1400 DELL AVENUE
CAMPBELL, CALIFORNIA 95008
(408) 378-6540

In Don Mills, Ont., Canada: The Pringle Group

Circle 106 on Reader Service Card

There are few things in life as durable as a Scully

Take our new, rugged 250 Recorder/Reproducer for instance.

The die-cast Scully 250 will take on all assignments. For portable needs, just plug in the mic preamps for news, sports, or whatever. Solve your studio needs and use only 19¼" of rack space. Configurations include full or half track mono, two or quarter track stereo. The 250 is loaded with lots of other Scully professional features, including full front access for easy alignment.

For Reproducer needs only we've designed the compact Scully 255... same Scully dependability, engineering, and durability... perfect for your automated system.

Prices? Much less than you'd expect.

The 250/255... another classic performance by Scully.

For complete details, write or call Scully Recording Instruments, Division of Dictaphone Corp., 475 Ellis Street, Mountain View, California 94043, (415) 968-8389 TLX 34-5524.

News

state courts, said the National Association of Broadcasters, in a friend of the court filing with the California Superior Court. The filing is in response to a class action brought against Mattel, Inc. NAB argues that the matter of the propriety of TV advertising of children's products to children is one that is the proper concern of the FCC, not to individual states. If states got involved, the same advertisement could be subjected to 50 or more separate juries with 50 or more separate opinions as to what is appropriate.

It would be unreasonable to expect broadcasters to be able to anticipate correctly all the possible results. "The end result would be regulation which is confused and compliance would be difficult if not impossible," the NAB filing stated.

INTV Convention Draws Record Attendance — Boasts Record Year

Over 450 registrants and 106 members (both records) attended the fifth annual convention of the Association of Independent Television Stations in San Diego, last week, and the atmosphere was redolent with the sweet smell of success; the aura attracted a record number of program salesmen and syndicators all primed to offer the independent TV operators the finest available off-network programming for their schedules.

Confidence was the keynote of this INTV convention. Independent TV station operators, for the first time since the INTV launched its organization in 1972 for about 48 participants, exuded a sense of well-being and prosperity indicating that they felt they had finally achieved a responsible and viable role in the television marketplace.

Their confidence was further bolstered by reports from INTV President, Herman Land, and Leavitt J. Pope, Chairman of the Board of the association. Noting that "the Fourth Market is a reality, in terms of independent TV station competition in many markets," Mr. Land added that "the independent TV stations are blessed with the finest sales forces in the industry." In addition the association staff was going all out to implement the effectiveness of the individual sales efforts with greatly increased research and a national campaign of presentations to advertisers and agencies promoting the values of independent TV stations as effective advertising vehicles.

Mr. Leavitt, President of WPIX-TV, Inc., New York, also sounded an upbeat note for the convention delegates,

continued on page 14

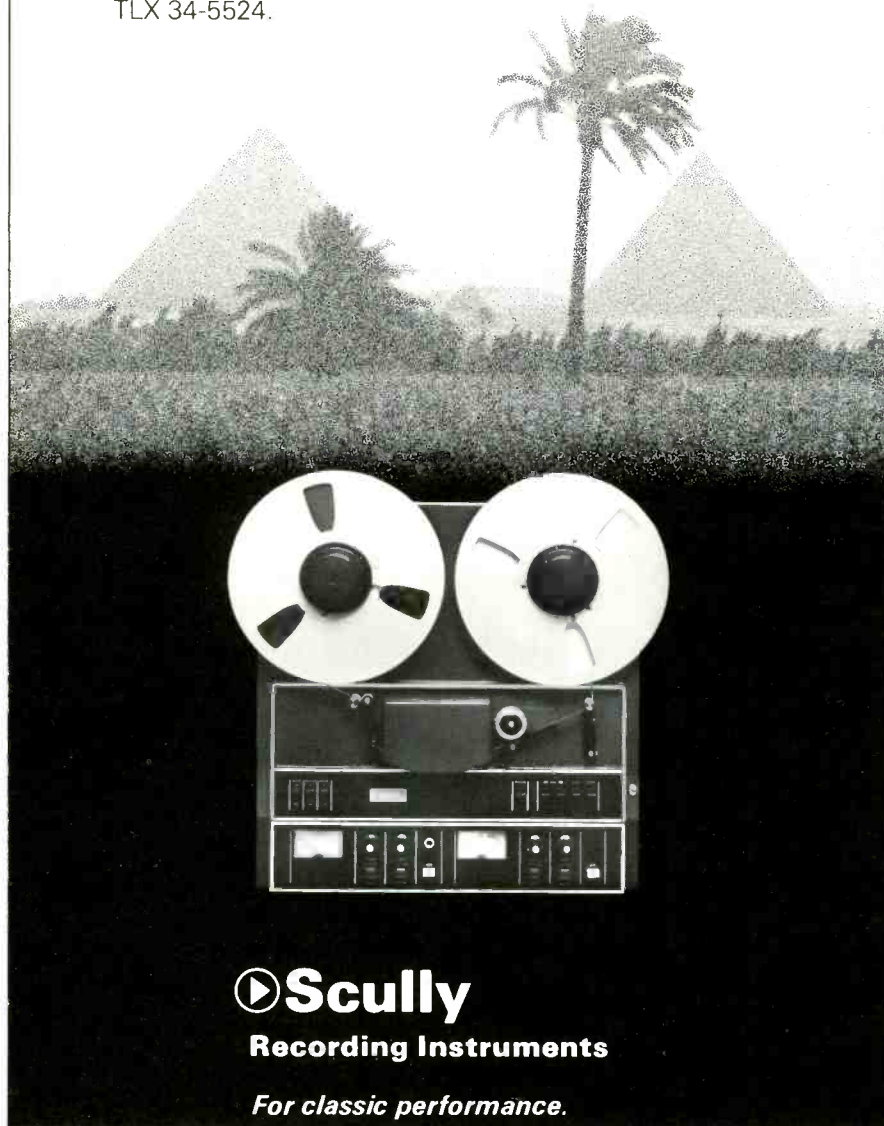

▶ Scully
Recording Instruments

For classic performance.

Circle 107 on Reader Service Card

See you at the Scully Booth 305.



EASTMAN 7250 FILM

A NEW HIGH-SPEED FILM FOR "AVAILABLE DARKNESS"

If you've ever had to pass up a story for lack of light, we'd like you to know about new Eastman Ektachrome video news film high speed 7250 (tungsten).

It is a companion film to our Ektachrome video news film 7240 and uses the same Process VNF-1 procedures. It is, however, far faster (EI 400), and it can be pushed two stops and still provide you with an image of excellent broadcast quality.

It is an ideal solution for news assignments when additional lighting would be inappropriate or prohibitively expensive.

For available light, available twilight, or "available darkness," Kodak has a film to help you get the news. For literature or a call from one of our Sales and Engineering Representatives please write: Eastman Kodak Company, Dept. 640, Rochester, N.Y. 14650.

Film is good news.

Circle 108 on Reader Service Card



**QEI's
Model 7775 ATS
automatic
transmission system:**



*excluding freight charges or special order items

**for under \$3,000*,
works like
a million,
saves you
thousands . . .
and we'll explain
it for
NOTHING!**

Whether your FM transmitter is on site or 20 miles away, we've a little book showing why our Model 7775 ATS is essential to your station's operation. Now, eliminate hand transmitter logging and the need for a full time third class endorsed operator. The 7775 is completely self-contained, easy to put on line, easy to read even by non-technical personnel, fail safe and, most important, ready NOW for delivery and installation!

Contact your QEI representative or the factory today.



Quality-Excellence-Integrity

CORPORATION

Route 73 Kresson, NJ 08053 (609) 767-8052

See us at NAB Booth 329

Circle 109 on Reader Service Card

News

pointing out that profits for all independent TV stations in 1976 had been "Upwards of \$121 million," and that 1977 had been an even greater year for the independent TV stations.

Perhaps the most positive indication of the independent TV station operators' new sense of their future potential was their unanimous decision to mount an advertising campaign budgeted at \$350,000 to promote the value of the independent TV stations as "the alternative medium" and to enhance the image of the independent TV stations as viable "fourth market" entities.

Ted Barash & Company, New York, was commissioned to mount an advertising campaign which will be launched within the next two months. The campaign, which will be underwritten by INTV members based on an "ability-to-pay" ratio, will be carried out in the print media, in newspapers, and business and trade press for the first year. If the campaign is successful and continued after the first year, according to Mr. Land, some funds might then be shifted to television.

With an advertising campaign amounting to more than two-thirds of its annual budget, (estimated to be \$500,000 annually), it is obvious that the independent TV station operators are serious in their determination to prove that they are equitable competitors for the advertising dollars in their markets.

The feeling of restrained eagerness to "go get 'em" by the independents was further emphasized in the reaction to most of the speakers at the convention and was typified by the enthusiastic and exuberant reception of FCC Commissioner Abbott Washburn's speech dealing with the growing importance of the independent TV stations and their value as alternate programming sources. Mr. Washburn's speech was interrupted several times by applause from the floor. The atmosphere was particularly enthusiastic when the Commissioner referred to a possible announcement by the Office Telecommunications Policy that they "foresee the possibility by the year 1990 of broadcast service without over-the-air signals. The wired nation." Said Commissioner Washburn, "No way," a comment which brought the delegates to their feet, cheering.

An INTV First — News On Independent TV Stations — A Hit Panel

For the first time since the Independent TV Station Association launched its
continued on page 17

**The AUTOMATIC
Audio Test System**

That Measures. . .

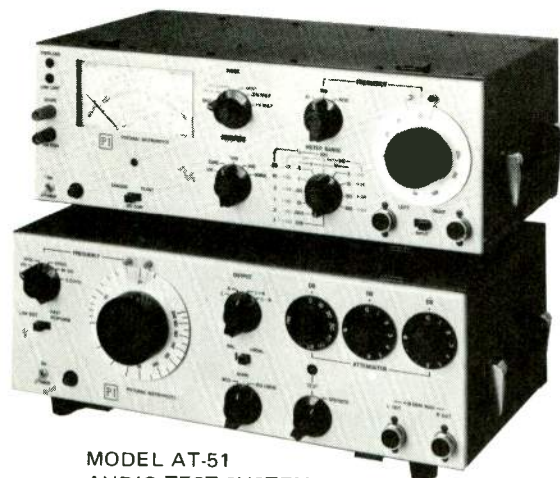

MODEL AT-51
AUDIO TEST SYSTEM

- Harmonic Distortion
- Intermodulation Distortion
- Volts
- dB
- Signal + Noise / Noise Ratio
- Wow and Flutter
- Stereo Phasing
- Differential Gain in Stereo Channels

Contact Us Now For Complete Details And Descriptive Literature.

POTOMAC INSTRUMENTS

932 PHILADELPHIA AVE.
SILVER SPRING, MD. 20910
(301) 589-2662

Circle 110 on Reader Service Card

See 9 new Ikegami Broadcast TV Products at Booth 1013 1978 NAB.

1. New Ikegami HL-79 ENG camera. Smallest, self-contained, full-performance broadcast-quality ENG camera ever. Lower battery drain. Delivers all the features and benefits that make Ikegami the front-page name in ENG. A total breakthrough in ENG camera technology.

And that's not all you'll see.

2. New Ikegami HL-52 portable EFP camera runs on super-flexible cables up to 650 feet between head and control unit. Also a removable RCU for small vans.

3. New Ikegami TM20-8R 19-in. rack-mountable broadcast color monitor.

4. New Ikegami TM20-8RH 19-in. rack-mountable high-resolution broadcast color monitor. With comb filter.

5. New Ikegami TM14-8R 14-in. rack-mountable broadcast color monitor.

6. New Ikegami MA-78 ENG camera control system for remote operation of HL-77A and HL-79 by wireless link or up to 4000-ft triax cable.

7. New Ikegami microprocessor 45-second auto-setup computer for HK-312 studio camera. Handles up to six cameras sequentially.

8. New auto-color balance feature in the TKC-950B broadcast color film chain camera.

9. New HK-357 studio and field camera with highest performance plus triax plus computer setup.

If you can't make it to the show, get all the details from your Ikegami distributor or Ikegami Electronics (USA) Inc., 29-19 39th Ave., Long Island City, N.Y. 11101

Circle 111 on Reader Service Card

Electro

introduces the first completely portable
SMPTE/EBU Time Code Generator.
(Including keyboard entry of user bit data)

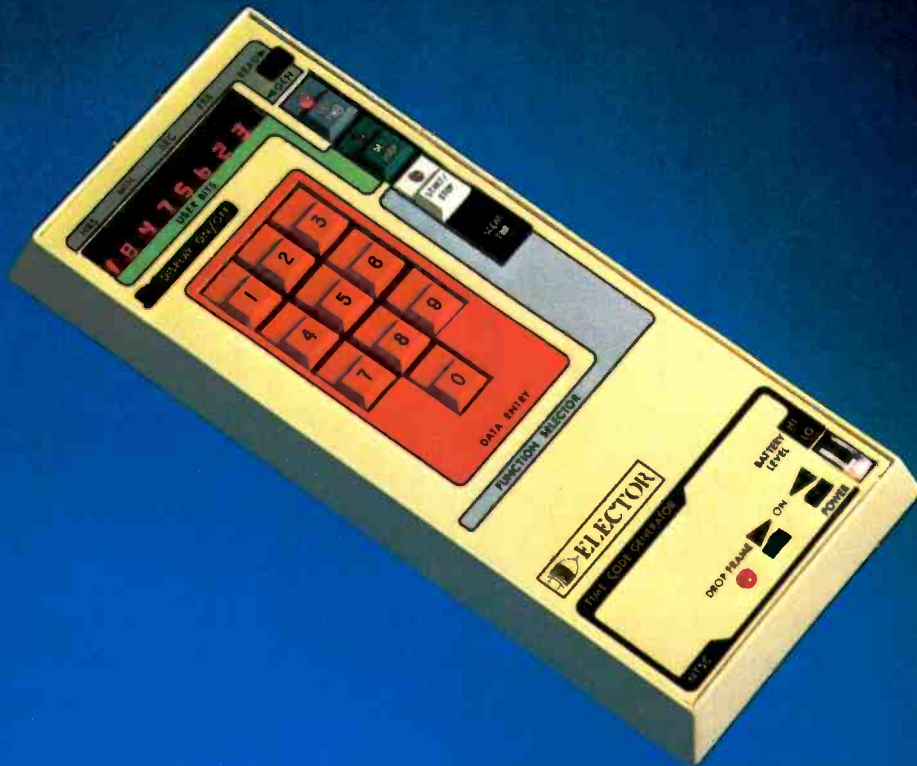

It works with you wherever you go.

The Electro TCG Mk III portable Time Code Generator creates a whole new era of video production techniques with its compact, lightweight flexibility.

Measuring only 9" long, and weighing less than three pounds, the TCG Mk III runs for up to 16 hours at a time on its rechargeable batteries.

Equipped with a belt harness carrying case, or optional desk-top stand, the TCG Mk III is equally versatile out in the field or inside the studio, utilizing the battery eliminator.

Available in either NTSC, PAL or SECAM configurations, Electro's TCG Mk III works with you wherever you go in the world. An integral play-speed Time Code Reader is available as an option.

Ask us for full details and the name of your nearest distributor.



Electro & Optical Systems Limited, 3015 Kennedy Road, Scarborough, Ontario, Canada M1V 1E7. Tel: (416) 291-4492.
Telex: 065-25431

Circle 112 on Reader Service Card

News

annual convention in 1972, a news panel, "News On Independent Stations," was included as part of the convention program.

The panel was one of the most fully attended of all the meetings at the fifth annual INTV Convention and indicated the growing interest that the majority of independent TV stations' operators are showing in developing competitive news programs in markets throughout the country.

Although only about 35 of the 106 INTV association members now have full fledged news operations complete with staffs, studio facilities, and news equipment, the number of stations prepared to make this expensive venture into the news operation area could double the current figure in the next six months, according to an official of the INTV. In fact, less than 50 percent of the independent station in the top 35 markets have full fledged news operations.

Two major reasons for this foray into new programming on the part of independents are the exceptionally fine profit years they have had in 1976-77 which, for the first time has provided them with a revenue surplus, and the overall feeling that a solid news program in competition with the network affiliates is the ultimate in helping build a sound, local, community oriented image.

INTV members attending the News Panel program were warned, however, that building a news operation from scratch was a long, hard pull, but, as Jack Matranga, President and General Manager of station KTXL-TV, Sacramento, CA., said, "It's worth every effort to build credibility and a spirit of community dedication for the independent TV station." Matranga pointed out that KTXL-TV is the only UHF independent in the country that programs an hour-long news show and that the costs had risen from about \$87,000 for the first year's budget to over \$416,000 for 1978. "I expect to lose about \$100,000 this year," said Matranga, "but in terms of image and community recognition, it's money well spent." KTXL-TV is the only UHF independent to subscribe to the ITNA News service, and this year Matranga plans to add an investigative reporting team to the staff of 17 now working full time on news at the Sacramento independent station. "Not only does our news program give us that community recognition," added Matranga, "but it definitely benefits the rest of our programming schedule."

The News on Independent Stations
continued on page 18

Number

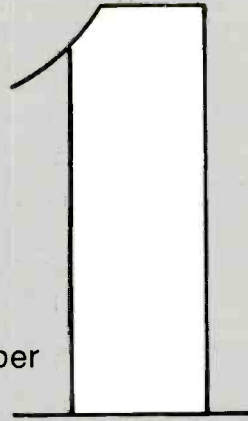

in design, performance
and features

Spotmaster[®]

5300A

MULTI-DECK

The cart machine with features competitors can't match...

FEATURES

	<i>Spotmaster</i> [®] 5300A	ITC 3D	HARRIS CC-III
Single Connector Plug-In Decks	YES	No	No
Companion Record Amplifier	YES	YES	No
Low-Voltage Solenoid	YES	No	No
Independent Azimuth Adjustment	YES	No	No
Shielding Above & Below the Head	YES	No	No
LED Service Aids	YES	No	No
Tapered Cartridge Guides	YES	No	No
Companion Audio Switcher	YES	YES	No
Do the decks lock in place to a bulkhead permitting operation with the front panel down?	YES	No	YES



Plug-in removable decks and superb electronics make this the most up-to-date monaural or stereo three deck cart machine available. Rugged machined deck, quiet air-damped solenoid, unique cartridge guidance system, drop down front panel and run lights next to each deck.

For information call or write:

BROADCAST ELECTRONICS, INC.
4100 North 24th St., Quincy, Illinois 62301
Telephone (217) 224-9600



A FILMWAYS COMPANY

News

panel was also the source of another unique effort to be launched by station wpix-TV. As outlined by Leavitt Pope, President of WPIX-TV, Inc., the New York independent station will develop daily half-hour long newscasts modeled after the network's programs and will transmit them via satellite to member stations. Each news cast will contain six commercial minutes, three of which would be sold by the local station and three by WPIX-TV for sale to national

advertisers. Stations taking the WPIX-TV news feed will pay no fee. Mr. Pope noted that the economics of satellite transmission will make such service feasible. "A half-hour transmission via landlines for each program would cost about \$3000," said Mr. Pope. "The satellite cost would be only about \$300."

The startup time for the WPIX-TV news feed will be determined by the number of stations that show an interest according to Mr. Pope. "We would need a minimum of 15 stations in the top 25 markets or 18 stations in the top

35 markets." \$3.5 million is being budgeted for the WPIX-TV news cast and Mr. Pope said that a major promotional campaign will be started within the next few weeks to promote the independent satellite transmitted newscasts.

KBMA-TV's Bob Wormington Chides Independent Operators On Lag In Earth Station Acquisition

Robert J. Wormington, president and general manager of station KBMA-TV, Kansas City, who last year urged independent TV station operators to "Go Earth Station" fast, chided the members of the INTV convention meeting in San Diego on their foot-dragging in acquiring earth stations for transmission of programming. He also noted that CATV systems are far ahead of independent TV stations in adapting their operations for satellite transmission.

During a session at the INTV convention, "How to Get From Here to There Alternatives to AT&T," Wormington noted that as of 1978 only 10 or 11 independent stations had earth stations, an increase of only two over last year. The KBMA-TV president, whose station was one of the first to utilize an earth station for satellite transmission of programming, told the INTV audience, "economy alone should dictate the importance of capability to receive satellite transmission. Acquisition of an earth station would put the independents in a perfect position to receive all of the additional programming that will be transmitted by various sources over the next few years."

Wormington cited a typical example of how much it would cost to get a program "from here to there" via satellite. Using a baseball game — average time 2½ hours — he told the audience that the cost via land lines for the transmission would run \$3185.50 via AT&T without construction or phone lines. A satellite transmission for the same time period would cost \$1687.40 for the 750 mile telecast. "Economics aside," said Mr. Wormington, "it is imperative that independent stations gear up for large amounts of programming being proposed for satellite distribution by a wide variety of program sources for the future."

Wormington's views were seconded by Ken F. Leddick, senior marketing engineer for Scientific-Atlanta, Inc., one of the largest suppliers of earth stations in the country. Mr. Leddick noted that CATV systems were showing far greater interest in constructing earth

continued on page 20



MCI JH-110A

THE BROADCAST PRODUCTION MACHINE THAT MAKES PRODUCTION FUN AGAIN.

Write or call for details:

 **PACIFIC RECORDERS AND ENGINEERING CORPORATION**
11100 ROSELLE ST., SAN DIEGO, CALIFORNIA 92121
TELEPHONE (714) 453-3255 TELEEX 695008

Circle 114 on Reader Service Card

If your quad head fails today, we'll have a replacement to you by noon tomorrow.

"If it can go wrong, it will." A guy named Murphy said that, and he was probably referring to quad VTR's. Because when you least expect, when you can least afford it, and when you don't have a backup—one of your head assemblies will probably fail.

And when it fails, you can't wait weeks for the head to be refurbished. Every hour counts. That's why Videomax developed Maxi Service. It cuts your downtime from weeks to a matter of hours.

All you do is dial our Maxi Line and tell us what head you need. We'll rush it to the airport, put it on the next plane, and you'll have the head the following day—before noon in most major cities. That's how Maxi Service works.

Head refurbishment is all we do, so we have to do it well. That's why no company works harder than we do to meet your needs. So the next time Murphy pays you a visit, put your feet up, relax, and give us a call. Sales & Service—
New York: (212) 947-8031,
Los Angeles: (213) 980-7927,
Atlanta: (404) 992-4490,

VMX® videomax®

Videomax Corporation
An Orrox Company
3303 Scott Boulevard
Santa Clara, CA 95050
(408) 988-2000
Telex: 910-338-0554



**"We move
our tails for you."
HEADS**

"Meet Max Line at
NAB booth #1000"

BROADCAST AUDIO DISTRIBUTION SYSTEMS

FROM



DA504

- Standard DA504 systems are supplied with up to six active, balanced AT310 distribution amplifiers, c/w self contained PS855 power supply.
- Each amplifier is supplied with 12 600 ohm output splits.
- Remote, D.C. or computer ramp gain control available.

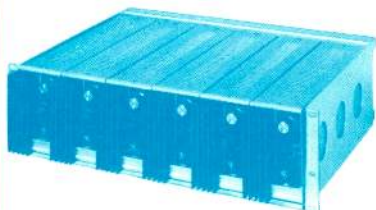

DA505

- Standard DA505 systems are supplied with up to six AM487 self powered amplifiers.
- Input and output transformer coupled with the output strappable for 4, 8, 16, 150 or 600 ohm impedance.
- Each amplifier capable of driving a maximum of 75 output splits, 600 ohm, or delivering 20W into 8 ohm load.
- Remote controlled mute circuit in each AM487.
- Front-mounted power heat sinks provide a cool interior operation.
- Larger audio distribution systems are also available.

McCURDY RADIO INDUSTRIES

Chicago (312) 640-7077, TWX 910-222-0436
New York (201) 327-0750, TWX 710-988-2254
Toronto (416) 751-6262, Telex 06-963533

Circle 116 on Reader Service Card

News

stations than their over-the-air colleagues. More than 250 CATV systems are already equipped to receive satellite-distributed programming. "And there will be 450-500 systems equipped by the end of 1978," he said. Mr. Leddick noted that the price of a 10-meter receive-only antenna was between \$150,000-160,000 while a five-meter dish, which has been approved for CATV systems, sells for about \$30,000. Cost for a receive-transmit 10-meter facility, of which there are only a few now operational, was placed at up to \$375,000.

Panel member John A. Tagliaferro, vice president for communications services, Paramount Television Distribution, saw the acquisition of earth stations by independent TV station operators as the opportunity "to lead in the use of satellites and to get a competitive advantage in the market."

Stressing the economics of satellite transmission as outlined by Worthington, Tagliaferro said "such investments could lead to creation of an independent satellite network. It would offer more and better programming, and better and bigger independent audiences. The more earth station outlets there are, the more viable becomes the prospect of an alternative network." He noted that the economics of satellite transmission from a program suppliers viewpoint is a highly important one and that, given sufficient outlets to feed, could become a major asset to the top producers.

Programs, Programs — Who's Got The Programs?

Unlike its 1977 convention, when excitement was riding high at the prospects of the "fourth" or "alternative" network becoming a fact rather than a continuing fiction, the fifth annual INTV convention held in San Diego early in February, was carried out in a cool, calm, and confident atmosphere.

With Operation Prime Time having proved itself, while the much touted "Metronet" alternative fell by the wayside, emphasis on programming at the INTV convention focused on more of the OPT mini-series and an influx of proposed new programs from varied sources such as the commercial offerings of Mobil Oil — *Ten Who Dared* and *When Havoc Struck*.

During the closing meeting of its highly successful fifth annual convention, INTV members were updated on programming prospects for the future — both good news and bad.

The bad was, according to John Ser-

continued on page 24

To hear... perchance to speak...



ay there's the rub. Or at least it used to be.

For now Beyer has come up with a headphone/microphone combination that's been designed never to rub you the wrong way.

Created to meet the stringent requirements of the broadcast industry, the Beyer DT 109 combines a hypercardioid microphone with wide, flat frequency response and a two channel high quality headphone that offers the kind of performance that has made Beyer the overwhelming choice of professionals the world over.

Together they provide excellent isolation from ambient noise, superb intelligibility, unfettered, hands-free operation and unexampled comfort.

Equally at home in the studio or the field, the DT 109 is built to withstand the rigors of hard, constant use. And in the unlikely event any part is broken or wears out, its modular construction permits on-the-spot replacement.

As for the price, it won't rub you the wrong way either.

**Another innovation
from Beyer Dynamic,
the microphone people.**

**Hammond Industries Inc.
155 Michael Drive
Syosset, N.Y. 11791**

Circle 117 on Reader Service Card

TECHNICAL DIRECTION MADE EASIER.

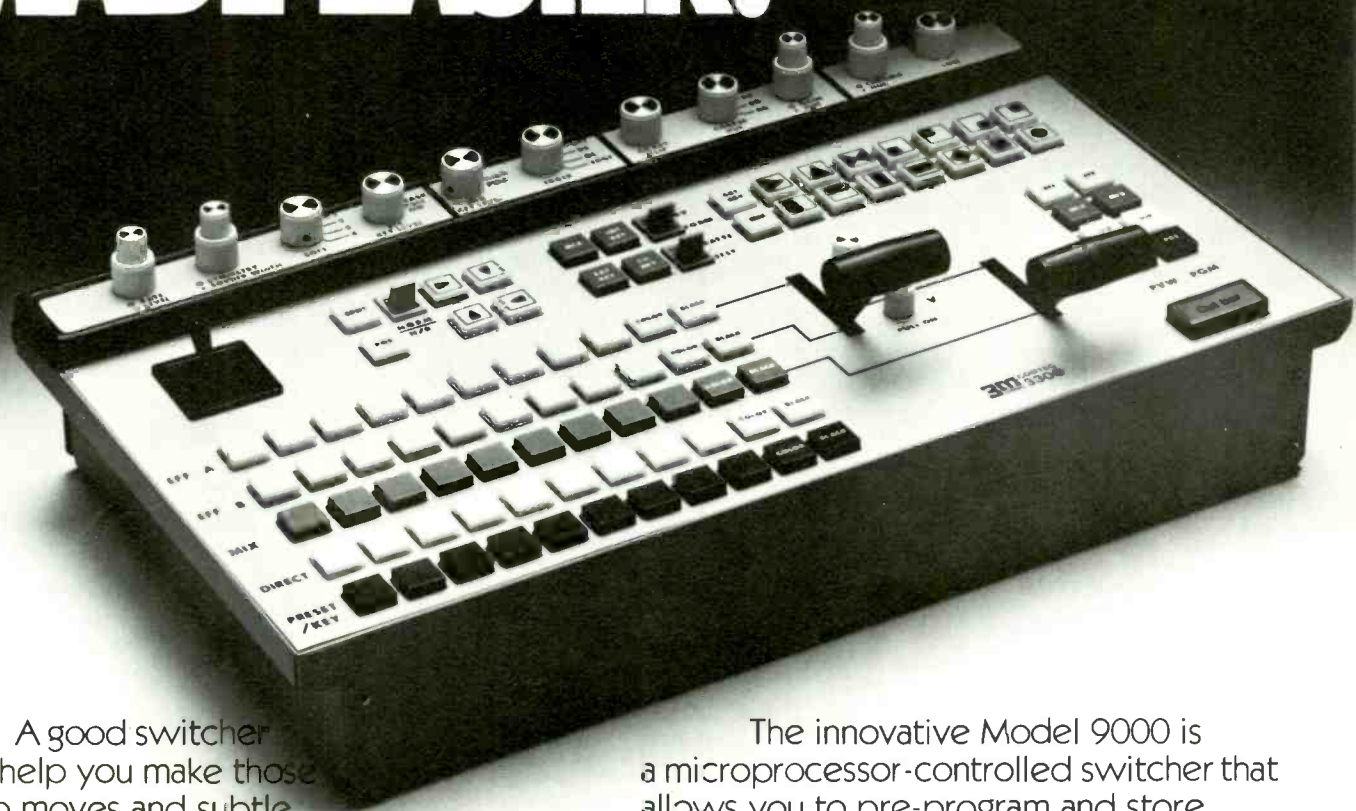

A good switcher can help you make those crisp moves and subtle effects that lift an average production right out of the ordinary. And we make a line of production switchers that pack top performance in four affordable price ranges.

Take our Model 3300, for example. It's an 11-input, 5-bus switcher offering 18 popular effects. Easy to read controls let you punch up preset wipes, dissolve to effects or key, wipe behind mask key and more. Optional internal chroma key and digital effects give you all the flexibility of far more expensive switchers.

Our mid-priced switchers, the Model 3100 and Model 1114 are low-profiled, self-contained units. The Model 3100 features 11-inputs with 3-busses and 19 patterns. The larger 1114 combines 11-inputs with 4-busses, 14 patterns, and a built-in chroma keyer. They're both built with easy to reach plug-in circuit boards.

The innovative Model 9000 is a microprocessor-controlled switcher that allows you to pre-program and store up to eight production set-ups for error-free retrieval during fast-moving productions and editing. 12-inputs, 21-effects, border wipes, and 5-busses are digitally scanned and controlled for maximum operating performance.

To find out more, just circle our reader service card number.

3M Video Systems. Watch us in action.



Model 9000

Model 1114

Model 3100

A Panasonic 3/4" direct-drive editing system this good is no surprise.

It doesn't make much sense to build a 3/4" editing system around two expensive editing recorders when one editing recorder and one less expensive player/recorder are all you really need. That's why you need the economy and direct-drive performance of Panasonic's Series 9000™ 3/4" editing system. The NV-9500 editing recorder, the economical NV-9200 player/recorder and the amazing editing controller that goes between them, the NV-A950. Together they give you the kind of performance you expect from Panasonic, along with considerable savings over comparable editing systems.

When used with the NV-9500 and NV-9200, the

NV-A950 will execute frame-by-frame insert and assembly edits, automatically. There's a five-minute memory for entry and exit points of video and audio inserts. And for quick and precise location of the exact edit points, the NV-A950 also has controls for fast play (double speed), search (one-fifth speed), slow rewind and pause. There's also a rehearsal mode that lets you run through an edit before you actually perform one.

And you'll be able to perform an edit in style. Thanks to the NV-9500 and the NV-9200. Especially since both decks give you the precision of direct-drive video head cylinders, the speed



NV-9200



NV-A950

Under \$10,000 is.

accuracy of the capstan servo system and the toughness of patented HPF™ video heads. The results: Excellent stability, low jitter, high resolution (330 lines B/W and 250 lines color) and a video S/N ratio of 45 dB.

And if performance this good from Panasonic doesn't surprise you, then neither will our kind of reliability. Like the strength, stability-of-alignment and long-term durability that our annealed aluminum die-cast chassis gives you.

There's a lot to be said about the advantages of using the NV-9500 and the NV-9200 together, but there's just as much to say when you use them separately. You can use the NV-9200 as a high-quality master recorder. Or for dubs that look almost as good as masters, use it as a high-quality dubbing deck. And with the NV-9500 editing recorder, you'll also get

frame-by-frame insert and assembly edits without tear, roll or loss of video information.

Both decks also include automatic rewind, Auto search, BNC and 8-pin connectors, Chroma level adjustments, Subcarrier and vertical sync inputs. And non-locking pushbutton controls. All in simulated wood cabinetry.

Panasonic Series 9000 3/4" editing system. If its performance doesn't surprise you, its price will. For more information, write: Panasonic Company, Video Systems Division, One Panasonic Way, Secaucus, N.J. 07094. In Canada, contact Panasonic Video Systems Department, 40 Ronson Drive, Rexdale, Ontario M9W 1B5.

Panasonic
just slightly ahead of our time.



NV-9500

Circle 119 on Reader Service Card

Visit Panasonic at NAB, Booth #417.

“If you buy a routing switcher without talking to me first, we both lose.”

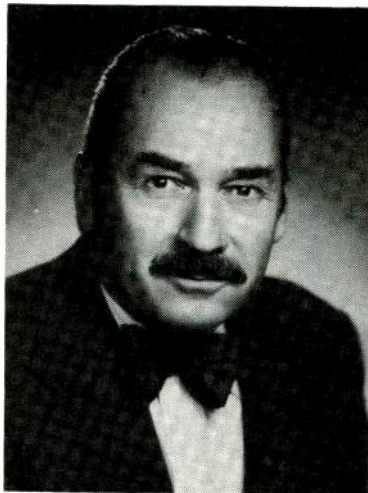

Our business—our only business—is routing switchers. We at Utah Scientific have developed a new switcher that embodies both proven design principles and state-of-the-art components.

Our switcher has a rich heritage. It is based upon the same 10 X 10 matrix building block that I conceived and developed at TeleMation. This concept, as exemplified by the TeleMation switcher, has proven to be the most cost effective in the industry and has established an excellent worldwide reputation for electrical performance and reliability. I think we have succeeded in refining this design to provide a better product for less money.

Call me for a quote or demonstration and see if you don't agree.

Lyle Keys

See us at NAB, Booth No. 1213 in the East Hall.

USUTAH SCIENTIFIC, INC.

2276 South 2700 West
Salt Lake City, Utah 84119
Phone: (801) 973-6840

Dealer and representative inquiries invited.

Circle 120 on Reader Service Card

News

rao, VP-Director, Operations and Programming, Petry Television, Inc., New York, that prices in the top markets “were 2-3 times higher than in the past for syndicated series; feature films in the top ten markets were astronomical.” Mr. Serrao also added, “There are fewer viable series coming up in the near future.”

The good news included the fact that MCA-TV was preparing three new mini-series for independent TV stations à la the successful *Testimony of Two Men*. The first, scheduled for May, is *The Bastard*; the second, scheduled for July, is *Evening in Virginia*, and the third, scheduled for September, will be *The Immigrants*.

Bill Schwartz, Vice President and General Manager, KTVU, Oakland-San Francisco, told the assembly how the infusion of such programs as *Mary Hartman, Mary Hartman, All that Glitters, Fernwood Tonight, Fernwood Forever* and other non-network offerings had provided the independents with a substantial amount of quality programming. He also noted that Paramount Television was still working on the development of a new version of *Star Trek*, which would depend on commitments from at least 50 stations around the country, 50 percent of which would be independents, and a 52-week commitment from advertisers before full production could be undertaken. “The Nixon-Frost series and *Testimony of Two Men* have proven that independents can compete given quality series,” said Schwartz. “As independents, we have to take risks and provide aggressive support to those suppliers who are trying to further our programming efforts. There is no other way.”

Risk-taking was very much a major concern of the panelists on the program session. Louis Friedland, President of MCA-TV, announced how his firm was willing to take risks, and hoped that advertisers would be equally willing to back up their cries for “alternative” programming with equitable risk-taking.

On the subject of the need for alternatives, Art Frankel, Senior Vice President, Paramount Television, outlined the fierce competition which suppliers face in order to play the “network” production and development game. “It is not a game which is ideal for delivering the best product at the best price,” he said. “On the contrary, it gives rise to a system which is inherently wasteful, arrogant, illogical, and capricious.” “But,” he added, “the suppliers will continue to fiercely compete with

continued on page 26

The Best.

New 5315/24 Console for Television
Affordable 5402 Console for Radio
Standard Consoles to 40 Channels
Custom Designed Consoles
NECAM Computer Audio Editing



Our business is sound. Sound of the highest quality and reliability, for Television and Radio. Our standard and custom consoles need no color advertising or fancy words to convince you of our quality. Neve consoles are built to last. Frame construction is of heavy gauge aluminum and steel. Most electronics are housed in metal enclosed plug-in modules for maximum RF rejection and ease of maintenance. We give you the finest reputation, reliability and performance. Call our customers. They'll tell it to you straight. Neve is the best!

Take the 20 channel Model 5305 console pictured above. This is one of the most successful sound production consoles ever built by any console supplier. From Boston to Los Angeles, from Toronto to Austin, this range of consoles is widely used by network and independent broadcast facilities. And now we are introducing the 5315/24P, an expanded version with 24 input channels, 4 auxiliaries, 4 subs and stereo output. With these and other consoles, Neve offers you a real choice to suit your requirement. Standards, modified standards or custom consoles. Give us a call or drop us a line. You'll be working with the best!

**See us at NAB
Booth #405**

Rupert Neve Incorporated, Berkshire Industrial Park, Bethel, Connecticut 06801 Tel: (203) 744-6230 Telex: 969638
Rupert Neve Incorporated, Suite 609, 6255 Sunset Blvd., Hollywood, California, 90028 Tel: (213) 465-4822
Rupert Neve of Canada, Ltd., 2717 Rena Road, Malton, Ontario L4T 3K1 Canada Tel: (416) 677-6611 Telex: 983502

 **Neve**

Circle 121 on Reader Service Card

News

each other in playing it as long as it's the only game in town. They desperately want, and need, other viable alternatives."

Mr. Frankel told the independent station delegates to the convention that he came to address them "to encourage you to do everything you can to further those alternatives." "The suppliers," he said, "stand ready, willing, and able to provide you with the best product at a fair price given those opportunities.

There will never be a better time than now," he said.

The Congressman And The Commissioner

There was little doubt about the sentiments of the delegates to the fifth annual Independent TV stations convention following the speeches of the two main guests of the convention, Representative Lionel Van Deerlin, Chairman of the House Subcommittee on Communications, and FCC Commissioner Abbott Washburn.

Congressman Van Deerlin's continuing pitch for a total rewrite of the Communications Act was greeted, for the most part, with a loud silence. There was a particularly strong reaction to a statement about "increased competition within and among the communications media which could involve substantially less regulation." To the independents operators this translated into additional cable deregulation which fills most operators with alarm. The Congressman from California also upset a number of the communications law experts in the audience as well as some of the broadcasters with a request that they by-pass their Washington lawyers and go directly to the FCC. "I like to see everyone make a good living," said Congressman Van Deerlin, "but I really wish you broadcasters didn't feel so all-fired dependent on your attorneys."

This didn't sit too well with either the attorneys or station operators. As one TV manager said, "I'm a broadcaster. I have to run a TV station. My law firm in Washington is my eyes and ears. I have to depend on them for guidance in the mounting mass of rules and regulations that emanate from Washington. I just don't have the time to run to Washington every time a problem comes up that effects our station. That's why we retain a law firm in the Capitol."

In contrast to the reaction to Congressman Van Deerlin was the reception of FCC Commissioner Abbott Washburn's remarks at the INTV luncheon the following day (Mon., Jan. 30). Commissioner Washburn told the assembled independent station operators primarily what they wanted to hear; the luncheon speech was interrupted several times with prolonged applause.

Commissioner Washburn's positive approach to the independent operator and his standing in the industry gave the independent delegates the fillip they were looking for. Citing the possibility of the Wired Nation in the future, the Commissioner said, "The Office of Telecommunications Policy in the White House may announce, as it did, that they foresee the possibility by the year 1990 of broadcast service without over-the-air signals. Don't you believe it. We are not about to adopt that system. No option like this is anywhere to be found in the Van Deerlin Subcommittee papers."

Commissioner Washburn also jabbed Congressman Van Deerlin's rewrite plans with the comment, "A total rewrite is impossible," a comment that is gaining more and more proponents in the television industry. He further delighted the assembly with a call for more regulation of cable and a

continued on page 28

INNOVATIVE TITLING GENERATORS



T-1024 SERIES



MICROSYSTEM I



T-1000A

TOMMOROW'S PRODUCTS ... TODAY

PRODUCT LINE PRICED FROM \$995.

FEATURING: MICROPROCESSOR DESIGNS, SELECTABLE FONT ENHANCEMENT, ROLL, CRAWL, VARIABLE CHARACTER HEIGHTS AND WIDTHS, DISKETTE, MEMORY SYSTEMS... WITH CONTINUING PRODUCT DEVELOPMENT FOR THE FUTURE.

SEE US AT NAB BOOTH 1210

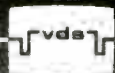

Video Data Systems

Headquarters, Hauppauge, N.Y., (516) 231-4400
Western Regional Office, Salt Lake City, Utah
(801) 363-0408

Innovative Communications

Video Data Systems, a Division of Sterling Television Presentations, Inc., Printed USA, Copyright 1977

Circle 122 on Reader Service Card

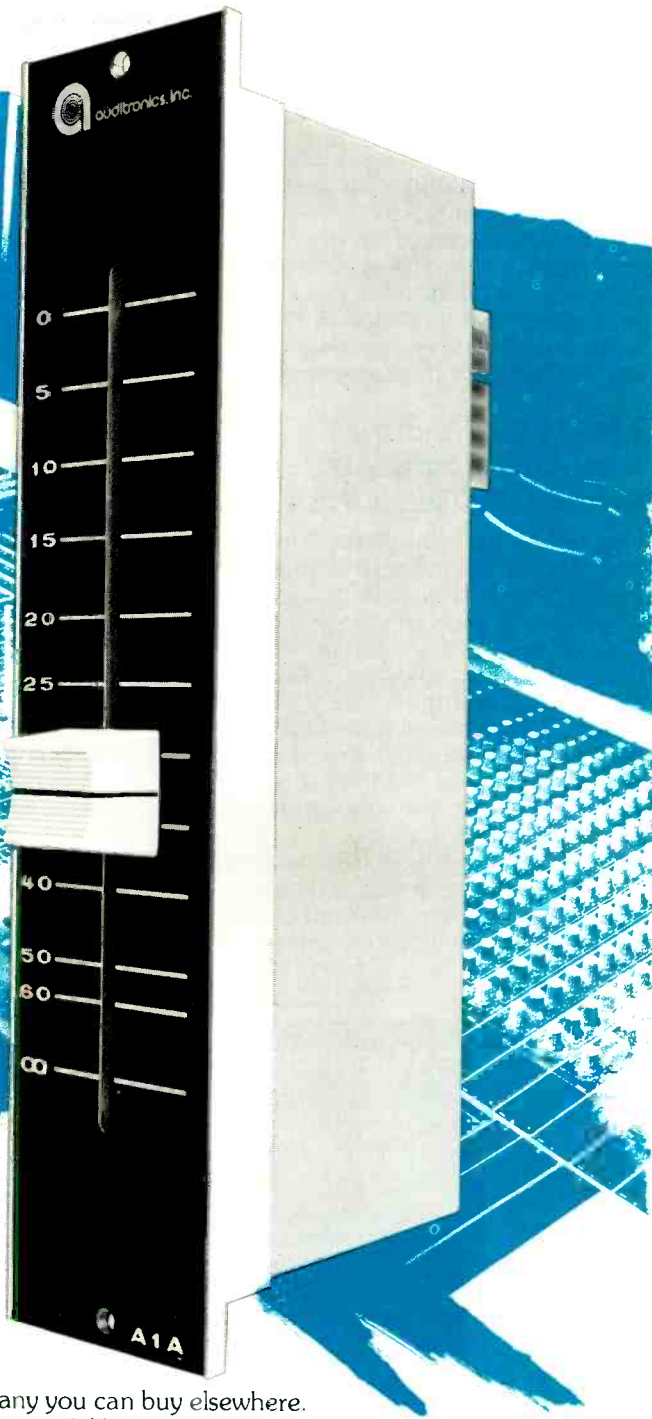

Some people buy us for our fader

because ours is better than any you can buy elsewhere. Ours has all the features you need, like smooth action, accurate tracking, long life and low noise, plus a full 85 dB attenuation. And ours is coffee proof. It's just one more reason an Auditrone mixer is a better investment for the long haul. To learn more, circle reader service number or write to us for complete information.



It's coffee proof

auditrone, inc.

3750 Old Getwell Road, Memphis, Tennessee 38118 / (901) 362-1350

Circle 123 on Reader Service Card

News

five-year license renewal process — all manna to the majority of independent TV station operators.

If the appearance of the two Washington government representatives had been rated on an applause monitor, it would have been no contest. Commissioner Washburn was a runaway winner and the darling of the Convention.

AM/FM Car Radio Manufacturing Costs Relation To Retail Prices

Most of the price difference between AM and AM/FM automobile radios is directly related to manufacturing cost, concluded a study by Booz, Allen Applied Research. A portion of the price difference, however, reflects a higher cost multiplier for AM/FM radios — the percentage markup from manufacturing to retail averages 15 percent more for an AM/FM radio than for a comparable AM only set among the radios analyzed.

The study notes that technological advances are being applied to car radios which, although expensive now, have the potential for reducing overall cost in the long run.

The Booz, Allen study was performed for the Corporation for Public Broadcasting (CPB) and the National Association of Broadcasters.

News Briefs

The National Association of Broadcasters has called on the FCC to act on **TV interference by CB transmitters**. NAB said the interference problem could be corrected by modifying transmitting equipment specifications by enforcing regulations against the use of illegal amplifiers **Exports of audiovisual products gained** during the first nine months of 1977 while imports decreased, easing the audiovisual trade deficit, according to Hope Reports. The findings, based on an analysis of U.S. Dept. of Commerce data, show that the leading export item was 16mm and 8mm film, accounting for nearly one-third of total exports. Major import product was the video cassette player/recorder J. Kenneth Moore and Arthur Kaiser of the CBS Technology Center (CTC) and Dr. William E. Glenn, Jr. a former employee of CBS Laboratories, have been granted a patent for their invention of a **Digital Noise Reduction System (DNR)** for Color Television.

The National Association of Broadcasters will hold a **Radio Programming Conference** on August 21-23, 1978, at the Hyatt Regency Hotel in downtown Chicago. Registration fee will be \$100 Price for the update service to the NAB's *Legal Guide* is \$10 (members) and \$30 (non-members). NAB has also announced the production of a series of three cassette tapes designed to **assist the broadcaster with renewal of license, ascertainment, and EEO**. Available to members only, the tapes are \$10 each, or all three for \$25. Orders and payment for tapes must be made directly to On-the-Spot Duplicators, Inc., 7309 Fort Hunt Road, Alexandria, VA 22309 **An editorial contest** for radio and television stations on the First Amendment and Restrictions on the Free Press is being sponsored by NAB. All editorials must have been broadcast by the submitting station after March 1, 1977, and must be received by NAB by March 1, 1978, in script form.

A group of local citizens has filed a **petition to deny the renewal** of the license of KVOS-TV, Bellingham, WA. Richard F. Wolfson, Executive Vice President and Chief Legal Counsel for Wometco Enterprises, Inc., owner of KVOS-TV, said he is confident the FCC will renew the license of

continued on page 33

JUST ANOTHER PRETTY FACE?

Maybe so . . . but it's what's inside that counts. . . CHARACTER is what **SC** has to offer. . . HI-RESOLUTION CHARACTER at that. . . whether you need one size or twenty-four, **SC** will give you character size selection at the press of a button.

If it's INTELLECT you're looking for. . . how about a MICROCOMPUTER. . . as a matter of fact, **SC** and its entire family of QUANTAFONT™ systems were the first microcomputer-based character generators in the industry. . . .



. . . for CHARACTER, INTELLECT and incredible PRICE vs. PERFORMANCE . . . may we introduce you? NAB BOOTH NO. 1125

**SYSTEM
CONCEPTS**

SYSTEM CONCEPTS, INC.
395 Ironwood Drive
Salt Lake City, Utah 84115
(801) 486-3833

IF YOU'RE A PERFECTIONIST YOU'VE MET YOUR MATCH

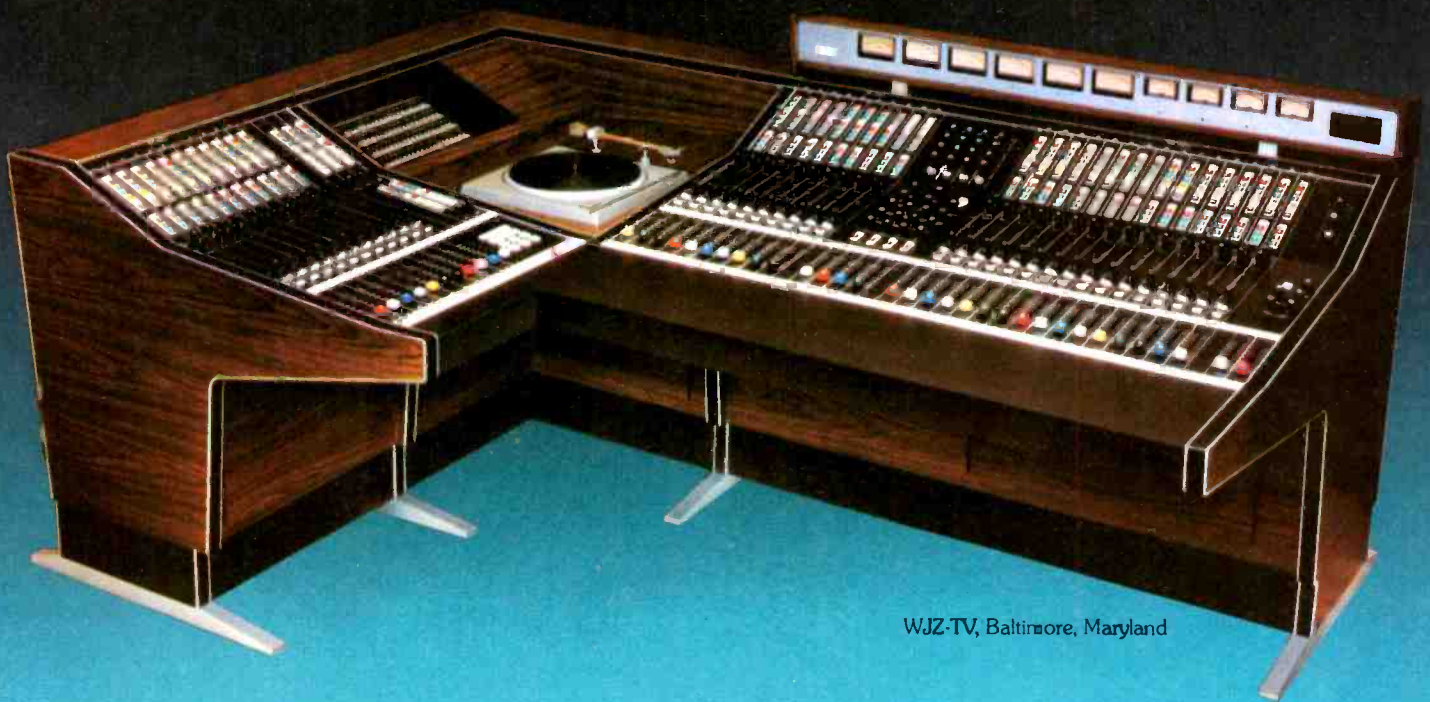

WJZ-TV, Baltimore, Maryland

If you're really hard-nosed about audio quality, you'll see our perfectionism in our equipment. We're really demanding about our engineering, manufacturing and quality control standards. Correction. Make that read "downright finicky."

We're insistent about maintaining complete in-house design and manufacturing operations and about our painstaking quality control methods. These factors help maintain our position as the innovator, the one others look to for leadership. They assure you of the finest, the most reliable and advanced audio equipment.

You'll probably want to read every word of our excellent 5-year warranty, the most comprehensive in the industry. And while you're at it ask for our customer list. We're proud of it and we think you'd be proud to have your name on it some day.

For our complete catalog contact Audio Designs and Manufacturing, Inc., 16005 Sturgeon, Roseville, Michigan 48066. Phone (313) 778-8400. TLX-23-1114.

AMPEX Distributed outside U.S.A. by Ampex International Operations, Inc.



The Audio Company

See us at booth 435.

HITACHI SATICON[®]



® U.S. Registration No. 1047050

The Tube for Beyond-ENG

The Hitachi SATICON H8397A is a small 2/3-inch tube that aims at Beyond-ENG, namely small live cameras with the following high performances features:

- High resolution — amplitude response of nominal 55% at 400TV lines in high voltage mode.
- Negligible flare — low reflection coefficient of photoconductor throughout the entire visible range.
- Well-balanced, highly sensitive spectral response — no R.G.B. tube selection required.
- Low lag — almost zero with bias light.
- Long shelf life — The SATICON can be replaced any time from storage without conditioning.



Hitachi, Ltd. Electronics Devices Group
6-2, Otemachi 2-chome, Chiyoda-ku, Tokyo 100
Telephone: Tokyo (270) 2111
Cable Address: "HITACHY" TOKYO
Telex: J22395, 22432, 24491, 26375

For information, write to: Hitachi America, Ltd.
Chicago Office, Electronics Department
2700 River Road, Des Plaines, Illinois 60018
Telephone: (312) 298-0840 Telex: 72-6353

See what the SATICON is like at Booth 815 1978 NAB in Las Vegas.

Circle 125 on Reader Service Card

News Briefs

the station Kalba Bowen Associates, Inc. has completed an in depth study assessing the **potential impact of a "separations" policy** on the cable TV industry. The study, "Separating Content from Conduit: Market Realities and Policy Options in Non-Broadcast Cable Communications," analyzes the growth of leased access services, pay TV, data communications and other cable services, and discusses the financial and regulatory impact of these developments. The report is available from Kalba Bowen Associates, Inc., 12 Arrow Street, Cambridge, MA 02138 for \$190 (prepaid). Extra copies are \$40 each.

N.V. Philips (Holland) Test & Measuring Instruments International reports **highly satisfactory trading results for 1977**, in what Philips Director Henk Bodt calls a "much more encouraging buying climate. Turnover target figures for 1977 have been surpassed in Europe and, to a much greater degree, in the U.S.," says Bodt The rapidly expanding communications industry is to be covered by a conference sponsored by several Scandinavian publishers this summer. "**Euro Comm 78**" consists of a general session plus four specialist meetings on the following: international video; computers and the media; video technology; and Mediapolis (covering social and political effects of increased electronic contact, and perhaps reduced personal contact, that might be expected to arise from improved electronic links). The conference will be held in Copenhagen, May 30-June 1, 1978. Information can be obtained from Bella Center A/S, Center Boulevard, DK-2300 Copenhagen S, Denmark.

Communications Press, Inc., has published the second in its continuing series of books on cable TV and new communications technologies. **The Cable/Broadband Communications Book 1977-1978** contains 13 chapters on in depth information written by well-known experts in each field covered. Edited by Mary Louise Hollowell, as was its predecessor *Cable Handbook 1975-1976*, the new book is available from Communications Press, Inc., 1346 Connecticut Avenue, N.W., Washington, DC 20036 for \$15.50 plus 75¢ postage and handling The National Radio Broadcasters Association is sponsoring **five one-day sales management seminars** during 1978 for sales members of member stations. The seminars will be conducted by The Welsh Company in Tulsa, OK, on April 7, June 9, August 11, and October 18.

THINKING IKEGAMI? THINK CAMERA MART.

Because we're a full-service Ikegami Dealer.

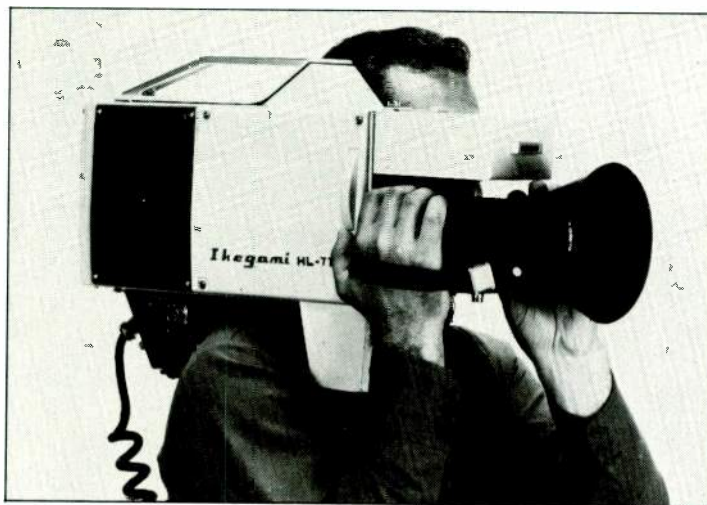

At Camera Mart, we feature the entire line of Ikegami quality products. *And we service what we sell*—with our own in-house, factory-trained technicians and factory-approved facilities. The ENG package below is just one of the many we offer, so why not talk to us about your needs . . . or come in for a demonstration.

CAMERA MART CUSTOM IKEGAMI PACKAGE

The camera: Ikegami's HL-77,* completely self-contained. High-sensitivity color in a compact, light-weight three-Plumbicon** package. All in a single low-profile 16mm-size

camera with eye-level CRT monitoring on take and playback, plus many more features you'll appreciate.

The lens: The Canon f/1.6 10-100mm zoom, for wider wide-angles and tighter tele's.

The recorder: Sony's easy-to-operate VO-3800—a 30-lb. package that gives you up to 20 minutes of NTSC color on a single U-Matic® cassette which can be edited on the 2850.

*Also available with HL-35.
**Plumbicon is a trademark of N.V. Philips



OPTIONAL ACCESSORY: "VIDEO CRASH CART"

Custom-designed to make production safer and smoother, with reduced set-up and strike time, easier transport and fatigue-free shooting. Sturdy, welded construction with 2-position handle lets you transport or operate in upright "handtruck" or horizontal "dolly" position. So it can go virtually anywhere your crew can go.

Holds camera backpack, recorder, AC adapter, cables — even extra cassettes.

RENTAL-LEASE-PURCHASE:

Pick the terms that suit your budget (and tax situation) best.



CAMERA MART

THE CAMERA MART, INC.

456 W 55th Street, New York 10019 (212) 757-6977 Telex: 1-2078
Sales • Service • Rental



SUSTAINING
MEMBER

Improve Any Video Signal.



Reduce Color Errors

Increase Picture Detail

Crispen Chroma

Reduce Video Noise by 6 DB

Microtime
1280 Blue Hills Avenue
Bloomfield, Ct. 06002
(203) 242-4242 TWX 710-425-2330

MICROTIME

Circle 127 on Reader Service Card

RADIO

PROGRAMMING & PRODUCTION FOR PROFIT

Making a Big City the Community; Putting on Drama In A Small Town

LAST MONTH THIS DEPARTMENT described seven radio stations that were exhibiting freshness in their programming. This month we describe two station managements who are also adding to the variety on the air in rather surprising ways. The first, WCCO in Minneapolis, is a highly successful big-city station. The second, WSBS in Great Barrington, Massachusetts, is a 250-watter in a country area of the Berkshires. Sheila Angus, a resident of the area, tells about an experiment at WSBS that goes sharply against the conventional wisdom about what you can and cannot do in a small market.

WCCO has something for everybody

Can a station make a go of it by treating a large city as a "community" and cultivating every major activity and interest therein? WCCO-AM, in Minneapolis, gives a strongly positive answer. It may be that Minneapolis is the limit in city size for such an operation; or perhaps the city has more "community cohesion" than most cities of comparable size. It is hard to envisage "community" programming in Chicago, Philadelphia, or Detroit, for example; but maybe somebody will come along and prove this a near-sighted view.

In any case, WCCO's General Manager Phil Lewis has built one of the widest ranging program operations in the country. Here are a few highlights. There are two early morning farm broadcasts, and reporters assigned to cover all-important agricultural meetings and shows, plus market and weather reports; all are of prime interest to the station's farm listeners, who are strong supporters of the station. Every week, there are school "teams of the week," chosen from the school sport scene to be congratulated and described on the air, with everybody's name on the program. In a discussion with *BM/E* Phil Lewis noted the station-identification power of such programs; they are, of course, standard in very small markets.

There is a similar value attached to the "Prep Parade" programs in which school bands and teenage music take the stage. For a wide demographic

sweep, Lewis uses a heavy sports program with live pickup of Minnesota Vikings football team and the Minnesota Twins baseball team games. Local college sports also get air space. The 50,000 watt signal is used to carry the sports broadcast to the neighboring states of Iowa and Nebraska.

There is comedy with such local radio personalities as the team of Boon and Erickson, and "commentator" Howard Biker. There is a very strong local news operation which covers every important event in the city with news segments aired every half hour; a team of eight reporters brings in the news. There is a full measure of cultural material, mining local sources such as the Minneapolis Symphony to draw in another sector of the audience. And as a CBS affiliate, Lewis uses CBS news and other network programs, including the *Mystery Theater and Adventure Theater*.

This is just a suggestive summary — and the programming style works. WCCO is a strong No. 1 in the 18-plus demographics, and this fact has brought in a substantial number of national advertisers in addition to very heavy time buying by local firms. The moral: If you really know your city and its citizens, and have imagination, you can make your own rules for success.

A country station takes a flyer in drama

By Sheila Angus

"If a little station like ours in a rural area can do it, other stations can," believes Jack Ryan, manager of the 250-watt WSBS in the Berkshire Mountain country of southwestern Massachusetts. He was talking about his station's recent achievement in broadcasting a live, original drama — written, performed and directed by local residents.

It was a project which Ryan had long been nursing in the back of his mind: helping to bring live drama back to radio. But he was a little afraid of how to go about it, he admits, until he got turned on by Himan Brown, (see *BM/E*, June 1977) producer of the CBS *Mystery Theater and Great Adventure Series*, who was a guest speaker at a Na-

continued on page 36

LISTEN
CAREFULLY...

that's how you'll discover
the quality in every 5
channel Audio Console
built by LPB

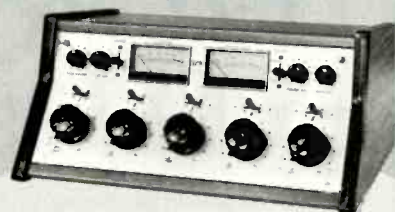

With LPB's S-12 Stereo and S-14A Mono SIGNATURE II SERIES Audio Consoles, the "small" console comes of age. Flexible, immune to RFI, quiet and reliable, these boards have been built to match the most critical studio application. Features include: step attenuators, LED peak indicators, transformer inputs and outputs, internal power supply and more.



When you need an audio console that's small in stature and has quality written all over it, listen carefully to what we have to say. Call or write today for details.

LPB[®] LPB Inc.
520 Lincoln Highway
Frazer, PA 19355
(215) 644-1123

See us at NAB Booth 508

Transmitters Love Our Modulimiter.

The Competition Will Hate Your New Sound.

The BL-40 Modulimiter is a unique automatic AM broadcast limiter, which will maximize modern transmitter performance. Whatever your format—hard rock to classical, Modulimiter will increase transmitter efficiency and extend coverage.

The BL-40's patented electro-optical attenuator provides smooth, unobtrusive, true RMS limiting. An ultra fast F.E.T. peak limiting section assures absolute protection from unwanted over modulation without peak clipping. Attack time is essentially instantaneous.

Three separate meters indicate RMS LIMITING, PEAK LIMITING AND OUTPUT LEVEL, simultaneously. All critical adjustments are behind a front security panel. A "phase optimizer" maintains most favorable signal polarity permitting up to 125% positive modulation without negative undershoot. "Its the limit" in todays broadcast limiters. UREI quality of course

Available from your UREI dealer.

UREI
QUALITY
OF COURSE

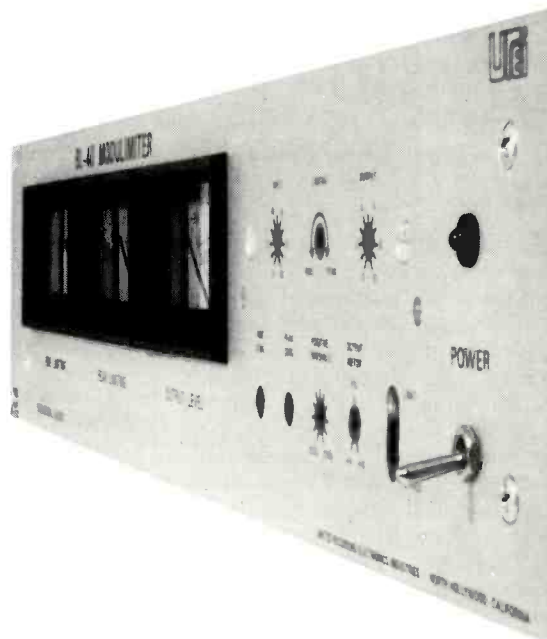

UREI

8460 San Fernando Road, Sun Valley, California 91352 (213) 767-1000

Exclusive export agent: Gotham Export Corporation, New York

Circle 128 on Reader Service Card

Radio Programming

tional Association of Broadcasters conference Ryan attended in November.

Brown told his audience, "Don't let me do all the radio drama. You people can do it. But don't take the tired, old shows. Today's language is different. You have community theater groups. Go and find them."

Ryan did. He went to The Hayloft Players, a two-year-old community theater group, and learned they would be happy to find the play, the actors, and the director. A young reporter from an area newspaper teamed up with his wife to write the play, a Christmas play entitled *A Midnight Clear*. Much local color was woven into the play to give it a special meaning for listeners. Suitable music and sound effects were found in the station's files. WSBS, a daylight-only station, scheduled the hour-long program for 12:30 on Christmas Day.

The radio station had no advertising budget for the project. The Hayloft Players did some publicity, mainly through releases to the newspapers. WSBS announced the coming broadcast a number of times, using brief taped excerpts from the play as a come-on. Ryan also got a few ads in local newspapers through trade-off arrangements.

The station did not attempt to get a sponsor for the program. "It may sound corny," said Ryan, "but I wasn't all that eager to make a buck on this. I thought of it as a fun thing for us at the station, for the performers, and for the community. I really want to encourage creative people in the towns around here to show what they can do. This station has been involved in the community for a long time in a number of ways, and this appealed to me as one more way."

And on the day the play was taped at the station, Mother Nature upstaged everybody by having a blizzard. That's a considerable problem in a mountainous area where back roads may not be cleared for some time. One actor had to travel 50 miles. Two others had to leave unexpectedly early.

"I wondered if anybody would show up in that storm," Ryan recalls, "but they were so enthusiastic nothing would stop them."

Was it a success? "That's hard to say," Ryan says candidly. "It was an experiment, we haven't done anything like it before, and I'm not sure how to evaluate it right away in terms of what we are trying to accomplish."

The station received some nice listener comments. "We enjoyed it, it was good family entertainment" . . . "We should have more of the same"

continued on page 38

quality television transmitters and transposers.



TV Transmitters and
Transposers up to 2 x 1 kW

Solid state up to 200 W in VHF
and to 100 W in UHF

7,000 equipments in service
in 75 countries
throughout the five continents.

LGT



THOMSON-CSF

LABORATOIRE GENERAL DES TELECOMMUNICATIONS
51, boulevard de la République
78400 CHATOU (FRANCE)

Distributed in U.S.A. by :

THOMSON-CSF INC.

75 Rockefeller Plaza
NEW YORK 10019 NY

Tel. (212) 977 22 00

Telex 12.5118 TCI NY

Circle 129 on Reader Service Card

See us at Thomson-CSF Inc., Booth #727

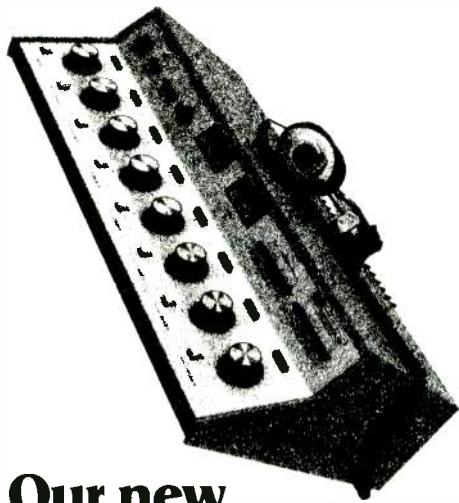

Our new stereo console does everything but cost like one.

It's the new Rockwell-Collins Mark 8 Stereo Console. You get outstanding performance at about half the cost of many ten-channel models.

Mark 8 features all plug-in construction, including switches, PC boards, attenuators and amplifiers. Plus a host of maintenance aids.

Additional features? Performance that equals consoles costing several times as much. 22 dB of head room. ± 1 -dB frequency response. $\frac{1}{4}\%$ harmonic and intermod distortion. Big 25-W monitor amps. 5-W headphone amps. Optional machine control functions for ease of operation.

The remarkable new Mark 8 Stereo Console. It looks like we just priced ourselves right into your radio station. Contact your local Rockwell-Collins man. Or Collins Broadcast Marketing, Commercial Telecommunications Group, Rockwell International, Dallas, Texas 75207. Phone 214/690-5574 or 5424.



**Rockwell
International**

...where science gets down to business

Circle 130 on Reader Service Card

Radio Programming

... "That kid who played Andy (the 12-year-old major character) was great" ... "I thought the music really added to it."

"It was a beginning," says Ryan. He's gratified that they were able to bring it off at all. The next one will be easier, he believes.

Yes, there will be a next one. Ryan has faith in the concept and is planning,

at least tentatively, to do a series of live, original plays, perhaps keyed to major holidays. He is thinking of encouraging different theater groups and different authors to contribute. A nearby high school is working on a new play for radio as part of its drama course. WSBS will take a look at that one, too, Ryan says.

"If we could do it, think how much better a larger station in a more urban area with greater resources might be able to do it," speculates Ryan. "Anyway, it's worth a try." **BM/E**

BM E's Program Marketplace

Syndicators For Radio

Century 21 Productions and Programming

2825 Valley View Lane, Dallas, TX 75234. Tel. 214-243-6721

THE MANAGEMENT OF A RADIO broadcast station *may* be able to operate largely from the local country club, with a few trusted employees and syndicated programming left to grind out the same package, old friends in the community to keep buying time, year after year.

However, in a lot of markets, probably most, alert competition soon puts the skids under any such long-term standpatism. And most station managers are, by temperament, incapable of operating that way. They want to be on or near the top, and the struggle to stay there is part of the satisfaction.

Century 21, says Dave Scott, the programming manager and one of the founders, aims particularly for the station management eager to meet competitive challenges quickly and keep the station floating high in the roughest seas. Century 21 had about 75 stations signed up when this was written (early February) and no two of them, says Scott, are exactly alike in the character of their market and competition, in the talents and desires of the management.

In order to respond to a great variety of competitive situations, Century 21 has great flexibility in program make-up. This flexibility is handy not only in the initial program set-up, but also whenever changes seem desirable; it allows the station management to act quickly to meet new challenges.

In the first and most used format, the "Z" format, there are 14 different categories of music which can be combined in hundreds of ways. After a careful market analysis and evaluation of the station's capacities, Century 21 will

make recommendations on the program mix. Scott emphasizes "recommendations;" he says that Century 21 never dictates to the station management, but rather tries to help the management reach objectives already formed, using the station management's own skills and intimate knowledge of the market.

The Z Format, for example, includes music ranging from "square," very adult contemporary, to the not-so-square, to two shades of top 40—the long list of most played, and a shorter, highly researched list of special favorites—to album-oriented rock, etc. The proportions of each style and the sequence used are worked out by Century 21 with each station management. Essential to the success of this kind of programming, says Scott, is the fact that the combinations made will always fit together neatly and attractively. This result has to do with expert selection of every number and every combination.

Scott used a good analogy: Century 21's programming is like a supply of bricks, windows, doors, floors etc. that can be fitted together into houses of different sizes and styles. But the finished product will always be harmonious.

The same kind of planning applies to Century 21's other formats. The "E-Z" is an MOR format with high-familiarity songs, more mature than many "easy 40" or "soft rock" formats. The "Super Country" includes a range of country styles so that this format can be tailored to the audience and the competition in particular markets. Similarly flexible are the Disco and Classic Gold formats.

This "program agility" came pretty directly from the experience of Scott and his associate, Mike Rice, in the early 1970's at KFMZ in Columbia,

continued on page 40

We interrupt this magazine to bring you all you need in broadcast equipment.

One call is all it takes to get anything and everything you need in broadcast equipment — from turntables to AM and FM transmitters.

Choose from Rockwell-Collins equipment plus that of close to a hundred different manufacturers. It's one-stop shopping with fourfold advantages:

1. Quality products. Our transmitters and consoles are the result of our technical excellence and single-minded dedication exclusively to the radio broadcaster for over 40 years. We've never once deviated from our goal: to make our name synonymous with quality, reliability and long life... for your benefit.

2. Broad choice of products. In addition to our own Generation 4™ FM transmitters and our all-new Power Rock 5-kW AM transmitters (the cleanest,

brightest, loudest AM in town), we carry products from the largest team of respected specialty vendors available anywhere from a single source — from ADC to UREI, with nearly a hundred other such leaders in between. If we don't have what you want, chances are we can get it for you. Fast.

3. Flexible financing arrangements. If it's under \$1000, you can use your own or your company's Master Charge. For larger orders, take your choice of time-purchase (up to 5 years) or lease plans.

4. Unbeatable customer support. Your emergency is our emergency. We're ready to respond — without delay — 24 hours a day, 365 days a year.

See the cities listed below for the representative nearest you — and call him for one-stop shopping, Rockwell-Collins style. Ask him for a copy of our new brochure, or contact: Collins Broadcast Marketing, Commercial Telecommunications Group, Rockwell International, Dallas, Texas 75207. Phone: 214/690-5424.



**Rockwell
International**

...where science gets down to business

Circle 130 on Reader Service Card

Cairo 801525 • Frankfurt (Rodgau 6 Weiskirchen) (0) 6106-4093 • Hong Kong 5-274-321 • Johannesburg 211-521
Kuala Lumpur 27283 • London 01-759 9911 • Mexico City (905) 533-1846 • Melbourne (Lilydale) (03) 726-0766 • Paris (Rungis Principal) 687-31-02
Rio de Janeiro (021) 246-3276 • Riyadh 69060 or 68324 • Rome (0) 6-862-415 • Tehran 685-180 • Toronto (416) 757-1101

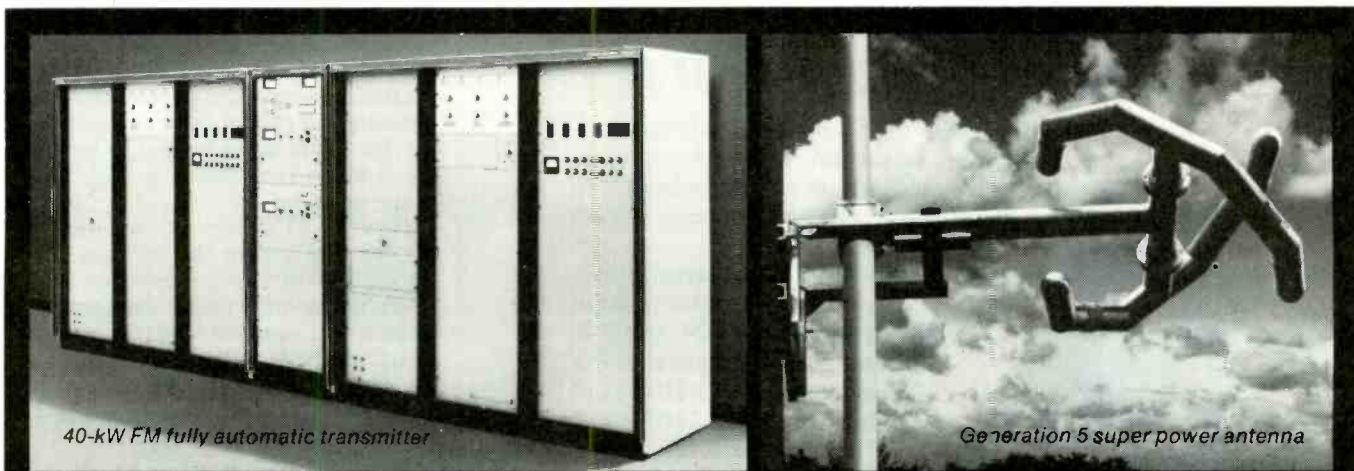

The latest words in communications: Rockwell-Collins.

For mono, stereo...AM, FM, TV...
ONLY FIDELIPAC® GIVES YOU A CHOICE

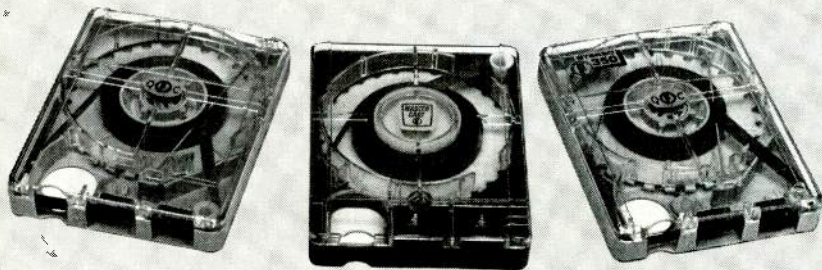

MODEL 300

The most popular NAB cartridge...performance and price make it the mono broadcaster's first choice.

MASTER CART

For the modern stereo broadcaster satisfied with nothing less than the ultimate in performance.

MODEL 350

For use in stereo machines with inadequate tape guidance. The precision is provided by adjusting the cartridge.

AND, for extended play...Fidelipac's Models 600 and 1200.
 For details, contact your Fidelipac Distributor or



FIDELIPAC®

109 Gaither Drive • Mt. Laurel, NJ 08057 • (609) 235-3511

® Trademark

See us in Las Vegas Booth 415
 Circle 131 on Reader Service Card

**the 3 WATT TRANSMITTER with
 100,000 WATT CAPABILITY**

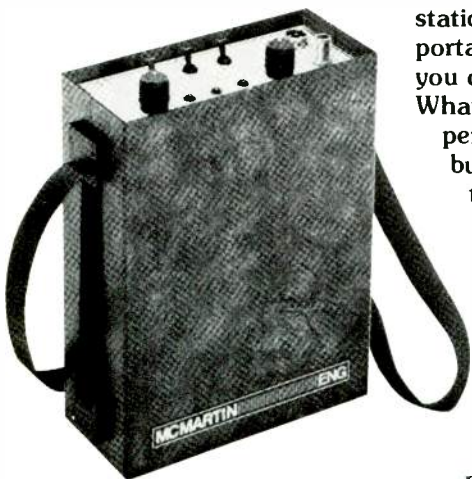

RPU-1103

When you use a remote pickup transmitter for a live feed, your station's full power is behind the portable. You'd better have a unit you can trust.

What McMartin has learned about performance and reliability from building full-power AM and FM transmitters, it has put into the "New Breed" RPU-1103 (150 MHz) and RPU-1403 (450 MHz) remote units.

- 3 watts
- Built-in compressor
- Only six pounds
- Rechargeable battery
- Line level and Mic inputs
- Exceeds all FCC requirements
- Dual frequency operation (optional)

We'd love to demonstrate our complete line of RPU equipment. (50 watt fixed or mobile also available) **Call McMartin or see us in Booth 302 at the NAB.**

MCMARTIN

4500 South 76th St • Omaha, Nebraska 68127 • (402) 331-2000 Telex 484485

Circle 132 on Reader Service Card

Radio Programming

MO (the name "Z-Format" evolved from these call letters). Scott says they were running a syndicated program and found that the competition repeatedly caught up with them. A change in the syndicator might hold off the new competitive push for a while, but eventually the competition's ability to change quickly would make things hard again.

This experience, and Scott's own liking for work with the more competitive, more active kind of station management led to the formulation of Century 21's methods. With 75 stations on the roll, the success of these methods is plainly established.

Another large part of Century 21's activity also goes back to its early days. The firm has a very large jingle production operation in its own recording studios at headquarters; the jingle was, in fact, one of the firm's first products. Jingles are personalized for each subscriber as part of the firm's regular programming package.

Another part of the package is a series of contests, also individualized, which the station can use to enlarge coverage. The contests have been widely popular with subscribers and successful in attracting new listeners.

Underlying all this activity, including the shaping of the programming for each station, is an active consultancy which starts when the opening analysis is made and continues throughout the station's relationship with the syndicator. Century 21's personnel are on constant call (as are those of most successful syndicators) to tend to large or small brush fires and help with long-range planning.

Century 21's rates are adjusted to market size and to the services contracted for. In nearly every case, says Scott, the monthly fee for the tapes, the jingles, the contests and the consultancy will be less than the pay for one DJ in the station's market.

Century 21 sends out an initial library of 75 to 82 tapes, and adds to it 15 new tapes a month. To assure maximum freshness, one of these tapes may be sent out every two or three days, making a total of about 250 ten-inch reels a year. The tapes are produced in a mastering and duplicating operation set up at Century 21's headquarters. The system was designed by Eric Small, noted audio consultant, and aims for the absolute top in audio quality. All duplication is on fresh tape, at playing speed, with elaborate control of quality.

Century 21 is, therefore, like a number of the other syndicators covered in this series, a strong force for better audio in broadcasting—in addition to the other qualities that have won success.

BM/E

WE INVITE YOU TO VISIT OUR COMPETITORS EXHIBITS.

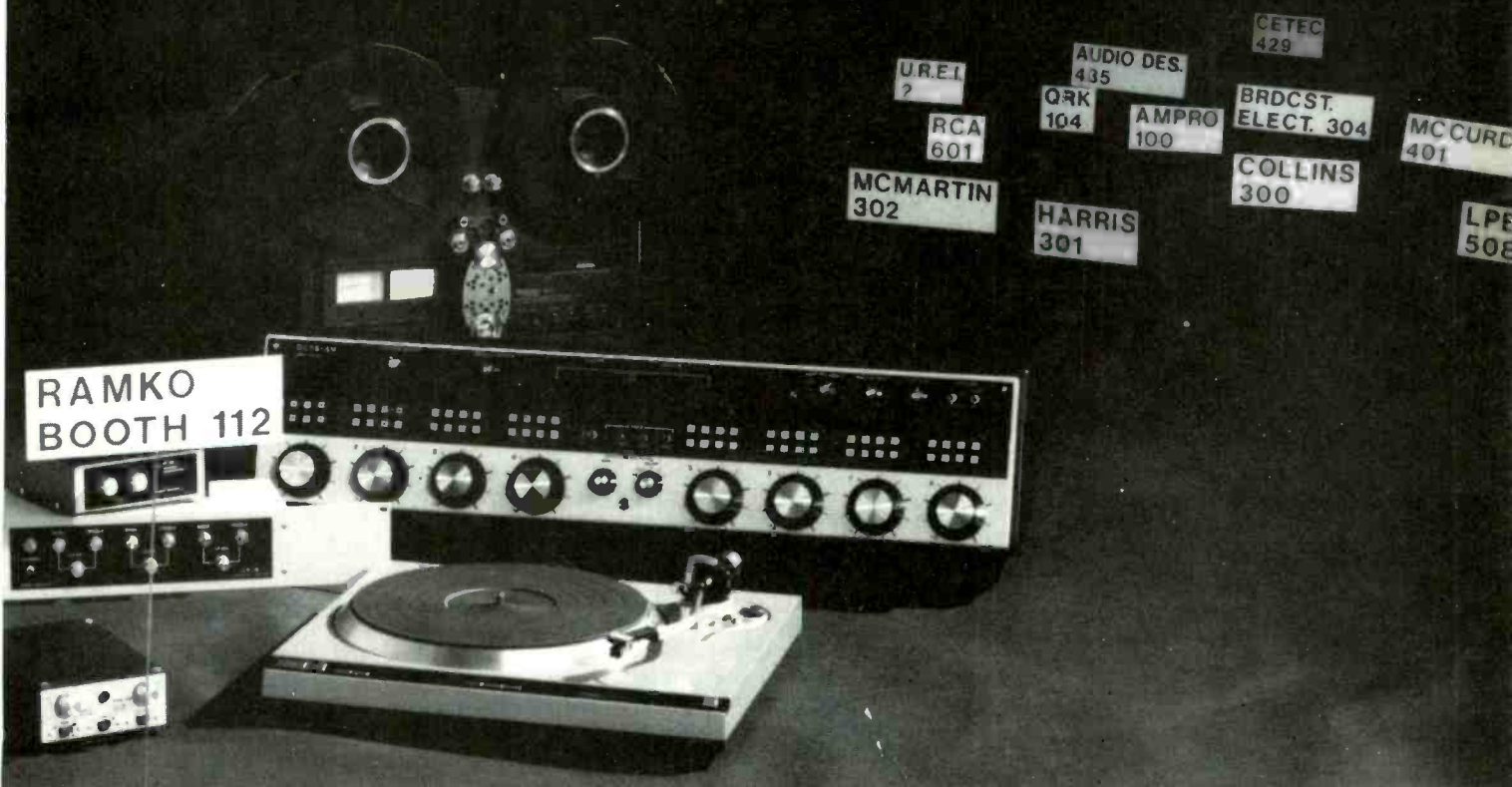

NAB offers you the opportunity to personally compare, feature for feature, dollar for dollar, broadcast quality audio equipment by all the major manufacturers. We are frankly out to show that RAMKO RESEARCH can provide you with both the most advanced technology and the best cost/performance ratio in the industry.

No matter whether you are AM, FM, mono, stereo or looking towards AM stereo we have over 150 products to fill your audio requirements. Fourteen different audio consoles, twelve audio distribution amplifiers, audio router/switchers, cart machines, a vast array line, mic and equalized preamps, the fabulous TECHNICS line of Reel/Reel and cassette rec/play units, monitor amps, turntables, monitor speakers and a host of the other studio accessories.

See us first or see them first, but visit them all. We will even give you directions. We are convinced you will immediately see why RAMKO is considered the leader in innovative audio technology and the benefits you will derive from it.

If you will not be attending the convention write or call collect for further information. You'll be money and performance ahead.
(916) 635-3600

RAMKO RESEARCH
11355-A Folsom Blvd. Rancho Cordova, California 95670

Circle 133 on Reader Service Card

TELEVISION

PROGRAMMING & PRODUCTION FOR PROFIT

Complex Hanna-Barbera Production Shows Benefit of Editing Off-Line Before Editing On-Line

By Bernard C. Laramie



Bob Heath, Hanna-Barbera Post Production Supervisor (back to camera) points to exact spot where edit is to be made. Time code information is recorded for reference.

ADVANCEMENTS AND REFINEMENTS in videotape post-production are increasing at an exciting rate. Recently, Reeves/Milestone of Hollywood was involved in a project with Hanna-Barbera Productions. Acting as both the editorial service and post-production facility, Reeves used several "state-of-the-art" editorial techniques. This carefully planned and well executed use of post-production services proved to be an excellent example of maximum usage of three complementary post-production editing systems: The Convergence ECS-1 Joystick Editor, the CMX-50 Computer Editor, and 2" Automatic Assemblies. The overall experience is one that can be of interest to producers, editors and other persons involved with videotape editing.

The Hanna-Barbera project was a children's pilot program produced for CBS Network. The show, entitled *That Yellow Bus*, was shot on location in Cincinnati, Ohio at Kings Island Park, an amusement park that utilizes Hanna-Barbera characters. Nearby, a garage set was constructed which served as the primary indoor locale—a clubhouse for the children involved. In

Bernard C. Laramie is Vice President/General Manager Reeves/Milestone Productions, Inc. Hollywood, California

addition, the show utilized an animated cartoon segment.

Because we were dealing with a children's show for morning television, a limited budget was in force. Multiple camera videotape was chosen, using three cameras and two tape machines plus a hand-held portable camera wherever necessary.

Regardless of budget restrictions, however, it makes considerable sense to do much of your preliminary editing—or your rough cut—using an off-line system. For one thing, very efficient off-line editing equipment exists for the much less expensive 3/4-in. videotape format. At Reeves/Milestone, we use three of Convergence's ECS-1 Joystick Editing Systems. We find the Joystick system to be an essential part of the approach since it is fast and accurate, permitting easy forward and reverse search with stable video throughout its speed range. Utilizing the Convergence system as the first stage of editing provides significant benefits. First, the producer and editor can reach a rough cut of the show in the shortest possible time, thereby being in a position to more reasonably plan the entire post-production process. Second, the producer can quickly test various options for scenes and segments with alternate dialogue cuts as well as various video only or audio only cuts. Third, the Convergence Joystick provides the easiest as well as the fastest method of accurately selecting the creative edit point. By having all original footage transferred to 3/4-in. cassettes with time code, it then becomes possible to create a rough cut with accurate in/out cues. We prepare a careful log including verbal descriptions of each scene along with SMPTE time code references noting in/out points (see fig. 1). Use of an off-line editing approach before getting involved in expensive sophisticated on-line systems is not that uncommon, but without careful logging of the type we do, a producer can find himself back

at square one when he walks into the CMX room.

Until the introduction of the Joystick system for off-line editing, sophisticated editing projects were almost exclusively the province of the CMX-50, 340 or similar equipment. The CMX System has been the workhorse of the industry, providing sophisticated off-line editing capability while producing a decision list and a punch tape. Once the creative decisions have been made on convenient videocassettes, the punch tape can be used for automatic assembly of the finished product on broadcast tapes.

The CMX System is outstanding but its greatest assets are also its greatest liabilities. For the majority of creative editing, it is too sophisticated. In editing, the majority of time is consumed in making the basic cuts in order to make a tremendous quantity of material work in a limited period of time. All of the sophisticated "bells and whistles" that make the CMX an excellent system are not needed during the initial creative phase.

Due to the fact that the program was a pilot of a unique format, i.e. children, on location and in the studio, animation, and in some cases puppets and animals, extensive screening and edit decision time was necessary. This, combined with the limitations of the budget itself made the obvious decision to build the show off-line on a Convergence System. We found by making the creative decisions on convenient videocassettes, the show could be constructed with maximum convenience and minimum costs. The videocassette system allows screening of original and edited materials in the office, conference room and anywhere else a videocassette machine and television can be hooked up. This convenience makes cassette editing desirable even when budgets and equipment availability permit the use of the more expensive videotape formats. Edito-

continued on page 44

American Data American Data American Data American Data American Data American Data American Data American Data American Data American Data

See us at the NAB Convention for
 a complete demonstration

Booth no. 822

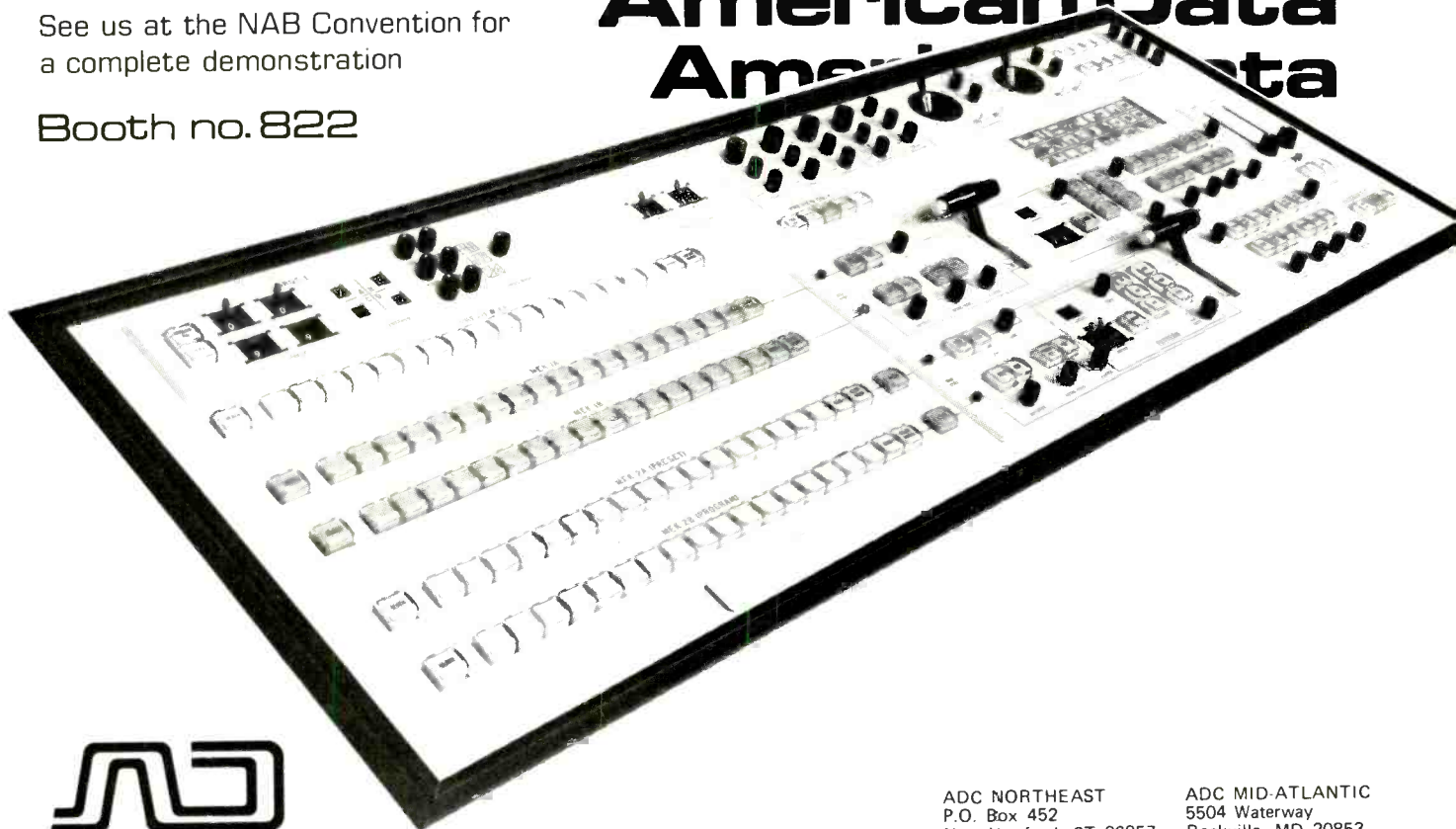

American Data
 A North American Philips Company
 Research Park • P.O. Box 5228
 Huntsville, Alabama 35805
 Telephone (205) 837-5180
 TWX 810 726-2125

ADC SOUTHEAST
 2219 Oakawana Rd., N.E.
 Atlanta, GA 30345
 (404) 633 2100

ADC MIDWEST
 P.O. Box 27324
 Indianapolis, IN 46227
 (317) 784-3000

ADC WEST
 3760 Cahuenga Blvd.
 North Hollywood, CA 91604
 (213) 760 3221

ADC NORTHEAST
 P.O. Box 452
 New Hartford, CT 06057
 (203) 379-7840

ADC MID-ATLANTIC
 5504 Waterway
 Rockville, MD 20853
 (301) 460 1454

Circle 134 on Reader Service Card

Are You As Modern As:

- CFRN-AM
- CFRN-FM
- WCAW-AM
- WERE-AM
- WGCL-FM
- WHAS-AM
- WHK-AM
- WISE-AM
- WJAC-AM
- WKTM-FM
- WLBC-AM
- WLBC-FM
- WMMS-FM
- WNCG-AM
- WRJZ-AM
- WRNO-FM
- WTIC-AM
- WTIC-FM
- WVAF-FM
- 5AA-AM
- 2CH-AM?

The first Radio Station Installation of a BAT 1700-series Computerized Business System produced its first radio logs in January, 1977. In just twelve months, these stations had all purchased similar BAT Systems. We're proud to have such a great list of clients for these powerful systems.

Why did they buy the PSI BAT 1700-series? BAT Systems do all Billing, Traffic, Accounting and Payroll. They automatically schedule. They can load automation. They can prepare the copybook. They can do a lot of jobs at once. They can handle multiple-stations. And, even though they do more, they cost less than many systems.

Check us out for your station. Call 800-426-8872 or call collect 206-733-8510. Or visit Booth 316 at the NAB!



Post Office Box 38, 1609 Broadway,
Bellingham, Washington 98225 (206) 733-8510

Circle 135 on Reader Service Card

TV Programming

Milestone Productions Incorporated
3350 Barham Boulevard
Hollywood, California 90068
Telephone (213) 851-6633

Milestone

Editing Log
 Job # _____

PROJECT TITLE: _____

NOTES: _____

EDIT #	REEL #	IN	OUT	DESCRIPTION	VIDEO IN / OUT	AUDIO IN / OUT

Milestone "Editing Log" is one key to efficient use of off-line video rough cuts. Space is provided for Edit number, Reel number, A/V identification information, a verbal description, and SMPTE time code numbers for In/Out points.

rially, most decisions that can be performed in 2" or 1" broadcast can be performed on videocassette editing systems at a savings of 50 to 85 percent. Our conclusion simply stated is that for a given editing budget, a great deal more can be accomplished off-line than on-line. It is perhaps for this reason that most prime time videotape shows from Soap to ABC's 25th Anniversary Special make extensive use of off-line editing.

Reeves/Milestone specializes exclusively in videocassette off-line editing. The facility consists of one CMX-50 and three Convergence ECS-1 Joystick Editing Systems. Using these systems together allows our editors to work quickly and without technical encumbrances to arrive at a rough cut and subsequently to develop a fine cut.

In the case of Hanna-Barbera, 17 hours of original material was honed to a 40-minute first cut in two days. After this material was reviewed by Hanna-Barbera Producer Walt DeFaria, Milestone Editor Richard Audd and "Yellow Bus" Editorial Supervisor Bob Heath, the show was refined by Heath to a 25-minute second cut in one day. At this point, the entire staff of the production had been able to analyze and restructure material for several days. This period of "Close Encounters" (of

the worst kind) with the material and the ability to try several different ways to cut any bothersome section allowed the producers to create a superior project for a reasonable budget in a reasonable amount of time.

After everyone concerned had screened the second cut, a final cassette containing all dissolves and other opticals was put together using the CMX-50. At this point, adjustments were made to get the show to exact time as well as add optical effects and create a computer printout of the time codes for each edit. The original schedule called for an automatic assembly on a CMX-300 2" System at Vidtronics in Hollywood. Because of scheduling conflicts, final assembly was done manually at Compact Video Systems in Burbank. By the time this final step was begun, all creative decisions were complete and this allowed the 350 edits in the show to be done in less than eight hours.

By using the Convergence Joystick Editing System as a keystone in the creative process, on this and other shows, we have provided well-edited shows for our clients without charging exorbitant fees for 2" machines or any other sophisticated equipment until they were sure of exactly what they wanted to do.

BM/E

How to Get Closer To FM Sound On The Standard AM Receiver

By Robert Orban

More and more, the AM broadcaster has to compete with FM sound, and the average small AM radio is a very weak weapon for the fight. The highly sophisticated audio processing of the system described here promises a large improvement in the AM sound.

INTERESTINGLY, THE FLAT FREQUENCY response specified by the FCC for AM transmission is extremely wasteful of the spectrum from an information-theory point of view. Ideally, a preemphasis complementary to the spectral density of the program material would be applied, and the carrier suppressed. Of course, in the 1930's information theory had not been developed, and the error was made. By 1947, much more was known about optimizing channel use, and the then-new FM service was standardized with a 75 microsecond preemphasis. This preemphasis complemented the spectral density of the 1947 program material quite appropriately. With this fact in mind, we realize that some high-frequency rolloff probably is desirable in AM receivers. The problem is that receiver manufacturers have gone much too far.

Many broadcasters are beginning to employ modest H-F equalization (i.e. preemphasis) in an attempt to partially counteract some of the high frequency rolloff of these narrowband radios. But experience has shown that the limitations of casual equalization are manifold. Such limitations include the introduction of stridency, severe loudness loss, sibilance splatter, "holes" punched in the program when high-energy high-frequency material actuates peak limiter gain reduction, and more.

Most of these limitations result directly from the use of wideband audio processing equipment designed to handle flat signals. This equipment falls apart aurally when processing preemphasized material. Historically, the effects are similar to those created by placing the limiter *after* preemphasis in an FM system—a standard operating procedure in FM's infancy. And the first widely-accepted solution to *that* problem (first commercialized in the early 1960's) hints at a solution for AM's current dilemma.

This solution is split-band processing. The bands can be in parallel or series. In this way, high frequencies can be limited without affecting the overall loudness of the program. The original split-band limiter was a two-band series device—today one can buy such compressor/limiters with up to eight (parallel) bands. Use of split-band processing permits very substantial improvements to be made in the sound emerging from a narrowband AM radio, and many stations are using such processing today. But if the situation were wholly satisfactory, this paper wouldn't be necessary. Unfortunately, even split-band processing runs out of gas when called upon to deal with the amount of preemphasis necessary for truly satisfactory

correction of AM receiver characteristics.

An examination of any typical receiver-response graph tells the tale. In a third-octave plot of the frequency response of a typical medium-bandwidth AM radio from antenna through loudspeaker, it can be seen to be *much* more rolled-off than the standard FM preemphasis, plotted for comparison.

Current split-band processors simply can't handle the inverse of such a curve without audible side-effects—the curve is too radical. These problems are increased by the topology of most split-band units—they attempt to perform the compression function with the multiband compressor alone. Depending on how hard the multiband compression section is driven, the frequency balance of the program can change disturbingly. If radical equalization is included *before* the multiband section, the high frequency band(s) can be driven into heavy compression while no compression at all is occurring in the lower frequencies. This can result in a "choppy" high-frequency sound, which is exaggerated by the single time-constant attack and release times characteristic of the current generation of split-band processors.

An additional problem occurs when the peak limiting function is considered. The use of optimum attack times in a multiband compression system results in an output (when all bands are recombined) which is very "spiky" when extreme preemphasis is employed. The peak-to-average ratio is very high because the multiband processor is controlling *energy* within a band—not peak levels.

Such a signal cannot be limited with a fast-attack limiter without the spikes punching "holes" in the program. The traditional solution is the use of a moderate attack time AGC amplifier followed by a clipper to catch the spikes. When extreme preemphasis is used, this approach fails because insufficient clipping is used to prevent "holes," yet the AGC/clipper combination would cause audible distortion on *some* program material if more clipping were permitted.

It would seem that we have reached an impasse. Conventional techniques can take us no further. Fortunately, by combining a systems approach to the problem with a totally new approach to the peak-limiting function, the problems relating to use of extreme preemphasis can be solved. A signal can be created which is as *loud* and *distortion-free* as moderately preemphasized signals processed by current multiband technology. Yet far more *information* can be packed into the same peak levels,

Mr. Orban is chief engineer, Orban Associates, Inc.

continued on page 46

AM Audio Processing

yielding a signal with greatly improved presence and detail on common narrowband AM receivers. By *extremely* careful psychoacoustical "tuning" of the processing, this can be accomplished without the pumping, sucking, gasping, and wheezing which all too often accompanies highly compressed AM audio. Such lack of audible "action" can *only* be achieved by tailoring each part of the system to all the other parts. The rest of this paper will discuss our new system, which we call "Optimod-AM" (TM).

At the input of the unit is a broadband-compressor to control average levels and to compensate for operator sloppiness. The input to the broadband compressor is bandlimited over a 100Hz to 11kHz range to eliminate energy which would not be reproduced by a typical AM receiver. Broadcasting out-of-band energy simply wastes loudness and sideband power. In addition, a mild pre-emphasis @6kHz to be the minimum required in any situation to preserve intelligibility. The preemphasis/bandpass filter is switch-bypassable for proofs.

The level-controlled signal is then applied to a three-stage equalizer. Equalization is continuously adjustable from flat to beyond the curve of high frequency, which we consider optimum for producing subjectively bright, crisp, present sound on a wide variety of AM radios of different bandwidths. A small bass boost and extreme high-frequency boost are employed. The high-frequency boost is shelved-off past 5kHz. The low-frequency equalizer is full-parametric; the high-frequency equalizer consists of a 5 kHz second-order equalizer with *bandwidth* control in cascade with a special 10 kHz *fourth order* equalizer in order to obtain the sharp selectivity necessary. The user can thus adjust the system response to suit his market and format, and to trade off brightness against tuning ease according to his taste.

The *Optimod-AM* equalizer is followed by a six-band parallel limiter with program-controlled attack and release times. Because of the program-controlled characteristics and 12dB/octave filter selectivity, this split-band processor can perform a frequency-dependent *limiting* function to control excess energy in any band. Because of the preceding broadband compressor, this section is not required to control *average levels*. It is particularly effective as a high-frequency limiter, and makes the extreme equalization usable. However, the output of the six-band limiter has a very high peak-to-average ratio, and would be unusable with any conventional peak limiter. We have thus developed a novel technique of peak limiting we call "Smart Clipping..."

A polarity follower is inserted before the "Smart Clipper" to optimize its performance by assuring that asymmetrical waveforms always modulate the transmitter more highly in the positive direction. A "soft switching" polarity switcher has been developed. This inverts the polarity smoothly in approximately one second. It introduces no audible side-effects with any program material; thus, the usual zero-crossing detector and/or program pause detector are unnecessary.

The "Smart Clipper" is a broadband AGC followed by a clipper. This much is conventional. However, instead of being controlled by peak, average, or RMS values, the gain of the broadband AGC is controlled by a complex psychoacoustical estimate of the *audibility of distortion* produced by the subsequent clipper. In addition, a

smoothing signal is derived which, when added to the output of the clipper, completely cancels distortion below 1.8kHz.

The distortion estimator starts by subtracting the clipper's output from its input. This signal represents distortion *added* by the clipper. Above 2kHz this distortion signal is divided into psychoacoustical "critical bands" one-third octave wide. The undistorted clipper input is divided into identical bands.

Analog divider circuits associated with each pair of bands compute the ratio between the distortion component and the undistorted component in each critical band. If the ratio in any band exceeds a threshold determined by a user-adjustable "clipping" control, the distortion is considered masked. If it does not exceed said threshold, then the gain of the AGC amplifier is reduced by feedback until the clipping has been reduced to an acceptable level.

Sometimes clipping distortion can be *audible*, but still *acceptable* (it might be perceived as a subtle timbre change, or increased brightness, for example). Another circuit estimates the acceptability of distortion, and electronically adjusts the "clipping" control on a moment-to-moment basis. We call this a "Loudness Augmentation" circuit because it permits maximum loudness (due to maximum clipping) on all program material, and also acts as an expander to restore some of the punch and dynamics lost to heavy limiting.

The combination of these "Smart Clipper" circuits typically results in 6 to 9B of linear gain reduction and 12dB of clipping on program material without objectionable distortion. Despite the extreme preemphasis, loudness is comparable to or *greater than* older systems because the "spikyness" has been entirely controlled. The program-controlled release time of the control circuit results in very smooth action despite the relatively large amounts of linear gain reduction.

The preemphasis employed has the potential for causing out-of-band interference. Therefore, an 11 kHz 30 dB/octave phase-linear lowpass filter is added at the output of the "Smart Clipper" to protect adjacent stations and comply with all FCC occupied bandwidth requirements. The filter is followed by a safety clipper to remove occasional filter overshoot and also to control excessive peaks in the 1.8 kHz distortion cancelling signal. The safety clipper is the last signal-processing device in the system; it is followed by a 10-turn output attenuator and highly phase-linear transformerless, balanced output stage to drive the audio input of the transmitter.

Provisions for possible future AM stereo transmissions have been made by the inclusion of a plug on the rear apron of the chassis which will accept an adapter system. This external chassis will be configured to process the stereo signal as eventually specified by the Commission according to its requirements—whether sum-and-difference or otherwise.

To summarize: *Optimod-AM* is a complex systems approach to preconditioning audio for the purpose of obtaining the most efficient possible use of the conventional AM radio channel—efficient in that maximum obtainable fidelity at the listener's receiver is provided, along with high loudness, high average modulation, significant increases in signal information content (resulting in improved coverage and intelligibility), and freedom from audible processing "action" and other sources of listener fatigue. Many of the techniques used are the subjects of patent applications.

BM/E



**Broadcast
Slow Motion and Slide File
Disc Recorders**

This is the same basic machine
that was used by NASA
for televising the Apollo Moon Landings,
the Jupiter Fly-bys, and
more recently the Mars-Viking Missions.

See us at NAB, booth 1131.

 **Oktel Corporation**
Campbell, California 95008
(408) 374-1811



ONE THING ABOUT THE NEWS BUSINESS: YOU NEVER GET A SECOND TAKE.

Here's a videocassette made for the people who make the news.

It's the new "Scotch"® Brand Master Broadcast U-Matic videocassette. MBU for short. The first ¾" videocassette designed specifically for tough ENG recording and the repetitive stress of editing.

We took the same high energy oxide videotape you've used for years and fused it to an incredibly strong backing. The result is a videotape that won't twist, tear or jam in the field. An unyielding videotape that won't stretch under the strain of tape editing's shuttling modes or degrade in extended stop motion.

And to protect it even under the worst conditions, "Scotch" MBU videotape comes packed inside a high impact cartridge.

Of course, "Scotch" MBU videocassettes have the same high signal-to-noise ratio and low headwear and dropout rates of our superb quad tapes.

So if you've ever worried about a good story and a videocassette breaking at the same time, record on "Scotch" Master Broadcast U-Matic videocassettes. They'll always back you up.



"Scotch" MBU Videocassettes.

"Scotch" is a registered trademark of 3M Company, St. Paul, Mn. 55101, © 1977, 3M Co.

MORE. BETTER. SOONER.

from NEC at NAB

See a full range of innovative broadcast equipment from one of the world's largest manufacturers. On display will be exciting new products like our Noise Reducer, UHF & VHF transmitters, and budget priced Dom. Sat. Receiver that should stop you in your tracks.

Also included will be sophisticated, second-generation versions of the products we introduced at NAB '77... TBC's, ENG Cameras, Frame Synchronizers. All at one exhibit, ours. Stop in and see us at booth #1009.

NEC

Nippon Electric Co., Ltd.

NEC America, Inc.

Broadcast Equipment Division

130 Martin Lane
Elk Grove Village, Illinois 60007
(312) 640-3792

Circle 137 on Reader Service Card

How An FM Station In A Small Community Built A Valuable Emergency Alert Net

by Michael J. Epler

By using the EBS two-tone alert signal to turn on special receivers in schools, businesses, industries and homes throughout the community, WWST-FM in Wooster, Ohio, has developed a service of tremendous value to the community. The system was used about 35 times in its first year to supply warnings and information in emergencies.

ALL RADIO STATIONS have an obligation to alert their listeners to local emergency conditions; virtually all stations do this so that people listening to their station know about the impending or occurring danger.

Unfortunately, however, they are alerting ONLY those people who are listening *at that time*. The great number of people whose sets are turned off have no knowledge of the emergency, and while it is true that many of them, at home or at business, are within easy earshot of their radios, they do not hear the emergency broadcast.

Charles Craig, Assistant Manager of our station, has worked diligently on this problem for a long time. He talked to members of local civil defense, law enforcement, and community leaders; all agreed that some kind of alerting system, using the local station, would be extremely useful. However, until recently there seemed no way to do it.

With the advent of the new Emergency Broadcast Tone Alert System we finally saw an opportunity to solve the problem. After almost a year of study and test, WWST-FM in Feb. 1977 inaugurated a new service for its listening audience. This community service is based on the EBS Attention Signal, the 20-second two-frequency tone which precedes all EBS Tests (see *BM/E*, Dec., 1975). Although the primary purpose of the tone is to alert other stations and attract the listener's attention to the broadcast, we also use it to turn on a battery of special receivers strategically placed in Wayne and Holmes Counties.

In Aug. 1976, when we started our search for receivers to overcome the 'radio-off situation,' we got in touch with Jack Bergman at Fixtune Electronics in New York. We knew that Fixtune had been supplying stations for about 10 years with crystal-controlled fixed frequency receivers for station promotions. We asked them to design a set which could be activated by the EBS two-tone alert signal, in exactly the same way our EBS receiver at WWST-FM is activated by the two-tone signal from our "Control Station" on the EBS net. We needed a receiver at a price that would make it affordable to schools, hospitals, etc. where budgets were already a problem.

Fixtune agreed to go ahead with the development in collaboration with George Ipolyi, Chief Design Engineer



At WWST-FM, a warning-alert receiver is inspected by (from left) Ralph Linsalata, Director of Disaster Services, Wayne County, Ohio; Mike Epler, Chief Engineer of WWST-FM; and E.B. Evans, General Manager of WWST.

for Electronic Designers, of Hauppauge, NY. About 3 months later Mr. Bergman called to tell us they had the first prototype. This was actually a modification of their basic crystal controlled FM Receiver, plus an extra stage and special decoder circuitry which turned the set on when our EBS Alert Signal was broadcast. The set remained in its stand by or mute stage at all other times.

On Jan. 11, 1977, we met Jack with his unit in the weather bureau office at the Akron Airport-Canton. This placed the receiver about 40 miles from our transmitter, in

continued on page 52

Mr. Epler is Chief Engineer, WWST-FM, Ohio

Emergency Alert Net

an area surrounded by antennas and electronic equipment of all kinds. The receiver had crystal control tuned to our frequency of 104.5mHz. The unit was placed in stand by or mute position a few minutes before our regular weekly EBS Test was to take place. When our engineer at the station hit the EBS button, the Fixtune set activated in 15 seconds and the audio came in loud and clear. Then, and only then, were we sure that we had 'the missing link' in the EBS Chain, from the button in Washington (or any other city) or from our studio for local emergencies, to the people in Wooster, Ohio, whether at home, in school, in the office, factory, hospital, mobile home park, nursing home, apartment building, etc.

The Weather Bureau personnel, too, were impressed with this demonstration. Additional tests were then made including one in the office of Ralph Linsalata, Civil Defense Director of Wayne County. In every instance the unit activated without any problem.

For several months prior to the initiation of our system, we conducted an educational campaign using on-the-air announcements and mailings to schools, hospitals, homes, business and industry, and public agencies. By April 1977 the receivers had been installed in 19 schools, 7 hospitals, 2 nursing homes, and 15 industrial plants, plus farms and homes in Wayne and Holmes Counties. Since then, additional users have been coming into the network every week and we estimate that several hundred are in service at time of writing (January 1978). In fact, as more and more receivers have been installed, public interest in our system has increased far beyond our expectations. WWST-FM has not spent any money to institute this program, and receives no financial gain from the sale of the receivers.

On this point it is worth noting that the Defense Civil Preparedness Agency, an arm of the Department of Defense (address, Washington, 20301), is prepared to help any state or local community in setting up such a warning net. The help includes technical advice, if needed, and also matching funds for purchasing the equipment, if the money is needed for installations in schools or local government offices considered essential to the operation of the net. The help does not extend to home purchasers.

Another point that needs to be made: the system works easily for us because no other broadcaster is tied in to the national EBS net through our frequency. When we activate our EBS alert, we do not activate the EBS system in another station. We get our own national alert from another city. Stations on the EBS alert chain would need some special method for differentiating national from local emergencies.

The system does not interfere in any way with our role in the national EBS net. In the *extremely* unlikely event of a national alert coming in on top of a local emergency in process, we could, of course, immediately preempt the local by an announcement to make way for the national.

As word of our network became known, we received calls from many stations all over the country asking about it, and we assume that by now other stations are building their own local networks. The key word here is LOCAL. We still, of course, broadcast weather advisories for all places within our coverage area, but we activate the system only for conditions affecting the Wayne and Holmes county area.

In order to make the system authoritative and fail-safe,

all requests for activation go to a Disaster Services Director who is a member of local government and can be reached quickly by other organizations in the community. He is responsible for checking the authenticity of the alert. The only exception to this is the local police, with whom we already have close communication lines set up; they can call us for help directly.

Since the inception of our system in January, 1978, we have used it 35 times. Thirteen of these were for heavy snow, winter storm, and blizzard warnings, two were for tornado watches, twelve for severe thunderstorm warnings, seven were flash flood watches and warnings, and one was for freezing rain.

While we realized at first that institutions, agencies and businesses would be early users of the receivers, we expected that more and more home owners would join the network, and this has proved to be true. We also expected schools, hospitals, etc., but we got a pleasant surprise from the great number of industrial plants who joined us. One local manufacturer gave warning receivers to their office staff for Christmas. The hospitals like the system because it allows them to put into effect their contingency plans for various emergencies.

We are still making over-the-air announcements and demonstrating the unit to interested groups such as the school board, rotary club, hospital staffs, and safety directors of industrial plants. We know from past experience that it is very difficult for a person to understand how the broadcast station can turn on his set, and the best and easiest way is simply to demonstrate its being done.

Another big plus for the receiver is that it automatically switches to battery operation (Nicads are included). This is of prime importance because our overhead power lines are vulnerable to falling trees in severe weather. We are also pleased with the high sensitivity, since some of the receiver locations are not ideally suited for good FM reception. We do, however, tell our listeners that they can use any equipment that will do the job.

I heartily recommend such a local warning net to any station ready to put into it the time and effort necessary to make it work. Here are some requirements:

Make it a *local* system, covering one or two counties at most. A strong selling point for users is our assurance that their receiver will trip only when something happens that affects *them*.

You need unlimited broadcast hours for effectiveness; a day-timer would be seriously hampered. By the same token, FM will generally be better than AM in smaller markets; AM may suffer from interference, serious noise in electrical storms, etc.

All procedural methods should be thought out thoroughly in advance. There must be clear rules about which events are to activate the system and which are not, which local authorities can ask for an alert, and how to verify requests for alerts. These should not be spur-of-the-moment decisions by the operator on duty. Arrangements must be made for getting information on local developments to the studio even if phone lines are down. It does not help to advise people on the net that a tornado is on the way, and then not keep them informed of its progress.

If the system is thoughtfully worked out along these lines and continuously publicized, it can greatly increase interest in the station while serving the community in a vital way. It should be undertaken not primarily, though, to improve the station's image, but to serve the community. After all, that is what radio is all about. **BM/E**



You're covering live news. Capturing a story as it unfolds. Ready for a shift in emphasis at a second's notice. In a situation like this, the last thing you can afford to be concerned with is power failure... because no news is bad news.

The revolutionary Christie Reflex 20 charger and battery give you the reliability you need, as well as provide full recharge of completely discharged battery packs in 12 to 20 minutes. Even faster recharge of partially discharged battery packs. And there's more.

90 to 97% net charging efficiency keeps the batteries cool during charge and extends battery cycle life up to 10 times that of conventional ni-cads. Patented "Negative Pulse" minimizes capacity fading (memory). Christie's unique "Trough Voltage Sensing" assures charge turn-off at precisely the right moment. To insure long life, the

Reflex 20 System battery-temperature-lockout automatically delays recharging of overheated batteries due to high current discharge. The system includes a state-of-charge indicator. The net result is the least expensive battery on a cost per cycle basis.

Contact Christie for complete information on the Reflex 20 line. For dependability in DC power supply, Christie is the source.

CHRISTIE

ELECTRIC CORP

The Source. Since 1929.

3410 West 67th Street
Los Angeles, California 90043
(213) 750-1151

From outside California, call toll-free
(800) 421-2058

TWX 910-321-3867



When every second counts, count on Christie.

The charger/battery system that gives you full recharge in 12 to 20 minutes.

(Now Shipping from Stock)

Circle 138 on Reader Service Card

Visit us at NAB Booth 1115.

IT'S GOING TO SPOIL YOU!

The **NEW MARK IX** Family of Color Cameras



SEE
THEM FOR
THE FIRST TIME
AT NAB
BOOTH 605

- Studio/Remote/Portable
- Multiple Configurations
- Standard or Triax Cable
- Low Power Consumption (400 Watts)
- 110/220 VAC or 24 VDC
- Manual or Automatic Registration/Operation
- Over 1/2 mile with Standard Cable, up to 1 mile with Triax
- Compact, Lightweight CCU
- Select from choice of view finders 1", 3" or 7"
- Selection of pick-up tubes includes Bias Light and HOP
- Remote Control Operation up to 500 ft. . . . and much more!

Marconi Electronics, Inc.

100 Stonehurst Court Northvale, New Jersey 07647 (201) 767-7250

Circle 139 on Reader Service Card

The Automated Console: One Hundred Hands For The Recording Engineer

By Albert B. Grundy

In professional recording studios the mix-down from multi-track originals to a "mix" tape would often be impossible today without console automation. Broadcast engineers, too, will need help from console automation more and more. Here is how it works, along with brief descriptions of some systems on the market.

CONSOLE AUTOMATION HAS WON a large place in professional recording simply because recording engineers can no longer manage all the knobs that would have to be turned, in real time, if they got no help from automated level control.

Broadcast engineers will use console automation more and more to help them satisfy the rising demand for sophistication in programs produced for radio. And the technique has some capabilities valuable specifically for radio and TV program production, as noted further on.

In professional recording the producer is calling for more signal processing — special effects, reverb, equalization, etc. Each of the 8 or 16 or 24 tracks must get separate treatment. All this, plus of course the basic balancing of channels and the correction of errors, rides on the mix-down; this includes what radio and television program producers call "post production."

In the past the basic balancing could be done segment by segment of the program, but naturally each segment had to be transferred to the program "mix" tape before the engineer went on to the next. Processing adjustments, for reverb, equalization, etc., were usually set at average values at the beginning of the program, and left there throughout the mix-down.

On simpler material it is still often done that way. But for most professional recording the practice is now to make frequent adjustments of processing, keyed to changes in the program. Without automation, this can mean that many adjustments have to be made in real time in very short segments of the program. No engineer has enough hands or enough attention centers in his hearing system.

Automation gets the engineer back on top of the mix-down by "remembering" every level setting he makes and the precise point in the program where he made it. Then on every subsequent run-through of any part of the multi-track original, the levels off the original are automatically adjusted to those the engineer has chosen.

He can, if he wants, concentrate on the most difficult and complex part of the job, the channel balancing for the whole program. All the levels he has chosen will be held in the automation memory, without transfer to the mix tape. Then he can back-track the original as often as he likes, adding the processing adjustments one at a time, and hearing the exact effect of each on the fully balanced

Mr. Grundy is President of the Institute of Audio Research, in New York, and also Eastern Vice President of the Audio Engineering Society.

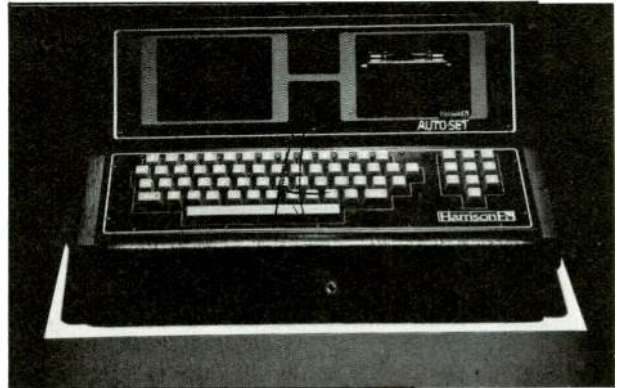

Harrison console automation system is controlled by a separate unit with ASCII keyboard and CRT for flexible management of data in memory.



Neve "Computer Assisted" mix-down system includes control panel and readout installed in right end of console; faders are operated by servos, with manual override.

program. As the processing adjustments are made they, too, are added to the memory, until the memory holds all the levels for a finished mix; then the program can be recorded on the mix tape.

Furthermore, the engineer is not locked in with any adjustment he has put into the memory; every console automation system has some method for "updating," for an instant change in any setting in the memory. For example, if a few notes in a saxophone solo sounded just

continued on page 56

The Automated Console

right after the initial balancing, but too loud after reverb was added, the engineer can pull those notes down to satisfy himself exactly, usually with the normal control for that purpose. The change is instantly "memorized."

It is clear from this that console automation makes the mix-down more creative, not more "mechanical." The engineer has much greater freedom of choice. In fact, he needs automation to learn what his choices are, which he cannot do under the pressure of multiple real-time adjustments that have to be made in a hurry, if they can be made at all.

The description so far applies to systems in which *all* adjustments are automated; but this is not necessary to get the main benefits of the technique. As already noted, the basic balancing of channels makes up the greater part of the mix-down job; this must be automated, and all systems do at least that much. The complexity of the balancing with today's recording practice can be judged from the fact that a typical three-minute piece of popular music may take as many as 300 level adjustments, if each of the 24 tracks is handled separately.

The processing adjustments are usually longer term. If the basic balancing has been automated, it is often possible to do the processing adjustments without an automation memory to hold them. This somewhat simpler system approach may appeal to broadcast engineers who believe they don't need the ultra-finish in program quality that is required in professional music recording today.

Any system that automates the basic level setting has a capability especially interesting to the broadcaster. It allows the program producer to go back and change a single element in the mix without redoing the mix. For example, he can make a program and optimize it separately for AM and FM stereo; he has to do the basic mix only once, and the automation memory will hold it while he records the two different versions. This could be applied to commercial production: the basic mix of music, etc., is set up in the memory, and turned into 10 commercials by using 10 different voice tracks. Even one phrase in a voice track can be changed. Every producer of programs for radio will think of applications for this.

After the balancing of the channels, the functions often automated are:

- Echo send, each track separately
- Echo receive, each track separately
- Channel assignment and panning
- Special effects (flanging, etc)
- Equalization

The last is the most complex and expensive to automate, and thus is least often automated. With a four-band or five-band parametric equalizer in each track, the EQ adjustments in a single piece of music may run to the thousands. All this *can* be automated; the system memory must be adequate.

To carry out the automation functions, every system must have these three main elements: (1) a device for controlling signal level in accordance with a standard

continued on page 61

LIKE EDGE NUMBERS ON FILM, ONLY BETTER. SUN TIME CODE.

The new PRO-SUN family of time code products allows you to put time code data on helical videotapes in the same manner that edge numbers are put on film. Thus, time code or user bits can be read in normal playback as well as still frame and search modes, without sacrificing the use of a longitudinal track.

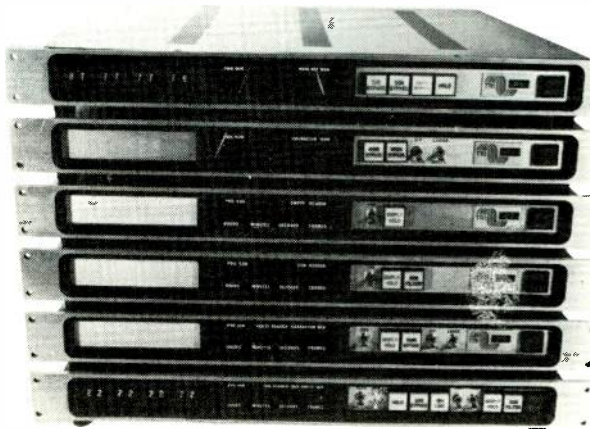

Furthermore, SUN encoded video signals can be microwaved containing time code information, thus saving time and often a generation loss if time code must be added after the original take.

A SUN/SMPTE Generator module produces both time codes for extra versatility.

A SUN Reader provides still-framed as well as normal play speed reading capabilities. A SMPTE Reader accurately reads SMPTE Code over the speed range of 1/10 to 60x normal play speed, as well as providing SMPTE code regeneration for dubbing.

Finally, a SUN Character generator displays time code or user bit data from either SUN or SMPTE readers, right on the screen where it is most needed for editing decisions.



Television Research International
1003 Elwell Ct.
Palo Alto, CA 94303
(415) 961-7475

CCA
is taking the wraps
off many surprises
April 9th at NAB '78
in Las Vegas.



See them at CCA — Booth N-307

The New CCA

CCA Electronics Corporation • Box 5500 • Cherry Hill, N.J. 08034 U.S.A. • Tel: (609) 424-1500 • Telex: 845200

Call toll-free: In U.S. 800-257-8171 • In Canada 800-261-4088 • In N.J. call collect.

Offices in Greece, Canada and Saudi Arabia

Circle 141 on Reader Service Card

Tektronix has the ANSWER

A Revolution in Television Signal Measurements... **ANSWER.**

Now you can automatically measure signal amplitude *and timing* parameters ... quickly and precisely with **ANSWER**. For example, a complete in-service NTC 7 measurement routine can be completed and recorded in less than one minute – and with $\pm 0.5\%/0.5^\circ$ worst case accuracies.

■ Future measurement requirements are easily accommodated!

Software programmability allows **ANSWER** to accommodate signal and measurement format changes or your own special requirements. You'll make a sound, long term investment with **ANSWER**.

■ ANSWER is automatic.

Ideal for continuous surveillance at remote transmitter and earth station sites. **ANSWER** requires no operator attention, thus reducing training requirements, and freeing engineering personnel for more pressing tasks!

■ Minimizes need for out-of-service system evaluation.

Performance of your system over its entire dynamic range may be easily determined in-service. **ANSWER** not only measures signal average picture level, but may be programmed to instantaneously run a complete measurement routine when a specified APL condition occurs.

■ Fast identification and warning of system faults.

ANSWER provides *two* sets of programmable limits for each measured parameter. Limits set #1 can trigger data logging; limits set #2 can initiate data logging, activate alarms, and cause executive action such as switching to a backup line.

■ High accuracy – low maintenance.

Up to 15 dB noise reduction through digital signal averaging gives improved measurement accuracy. In addition, **ANSWER's** all digital circuitry minimizes drift and extends the time between periodic recalibrations.

■ System compatibility.

Three RS232C interface ports are standard. An IEEE 488,1975 (GPIB) interface is available as an option.

There's much more to learn about the economies, reliability, and measurement accuracy **ANSWER** can offer you. Call your nearest Tektronix field engineer or circle the reader service number for a brochure with the **ANSWER**.



SEE IT AT
NAB
Booth 811

The Questions...

- Transmission Quality ?
- Legal Signals ?
- Long-Term Performance Trends ?
- Permanent Records ?

The ANSWER... facts, when you want them.

1-28-78
5:32 PM
STL OUT
WRGN-TV

IN SERVICE MEASUREMENTS

UITS

INS GAIN	-2.2	IRE
LINE TIME DIST	2.9	IRE
SHORT TIME DIST	5.0	IRE
CHROM-LUM GAIN	-6.4	%
CHROM-LUM DELAY	50.0	NS
AMP/FREQ	0.5	MHZ
	50.2	IRE
	1.0	MHZ
	49.0	IRE
	2.0	MHZ
	48.0	IRE
	3.0	MHZ
	47.5	IRE
	3.58	MHZ
	47.0	IRE
	4.2	MHZ
	46.2	IRE
LUM NON-LIN	-4.0	IRE
CHROM NON-LIN GAIN	-1.0	IRE
	-4.4	IRE
CHROM NON-LIN PHASE	4.7	DEG
DIFF GAIN	8.1	%
DIFF PHASE	4.6	DEG
CHROM-LUM XTALK	2.0	IRE
RANDOM NOISE	54.0	DB
REL BURST GAIN	-0.2	%
REL BURST PHASE	-0.7	DEG
SYNC GAIN	39.1	IRE
BURST GAIN	38.0	IRE
APL	41.0	%

TIMING

H SYNC	4.91	US
FRONT PORCH	1.79	US
SYNC-BURST END	7.79	US
SYNC-VIDEO START	9.61	US
H BLANKING	11.40	US
COLOR BURST	9.0	CYCLES
BREEZEWAY	0.56	US
EQ PULSE	2.46	US
SERRATION	4.73	US
U BLANKING	21/20.5	LINES

You can get individual measurements or complete sets of amplitude and timing measurements on-command or continuously from ANSWER. Hard copy, such as shown here, minimizes manual logging and provides a uniform, permanent record.

This sample output is one of many possible formats.

Tektronix[®]
COMMITTED TO EXCELLENCE

SEE US AT NAB IN BOOTH 916 WITH EASTMAN KODAK

Spin Physics will show you how and why our hot-pressed ferrite quad video heads with the 1000 hour warranty are your best buy.

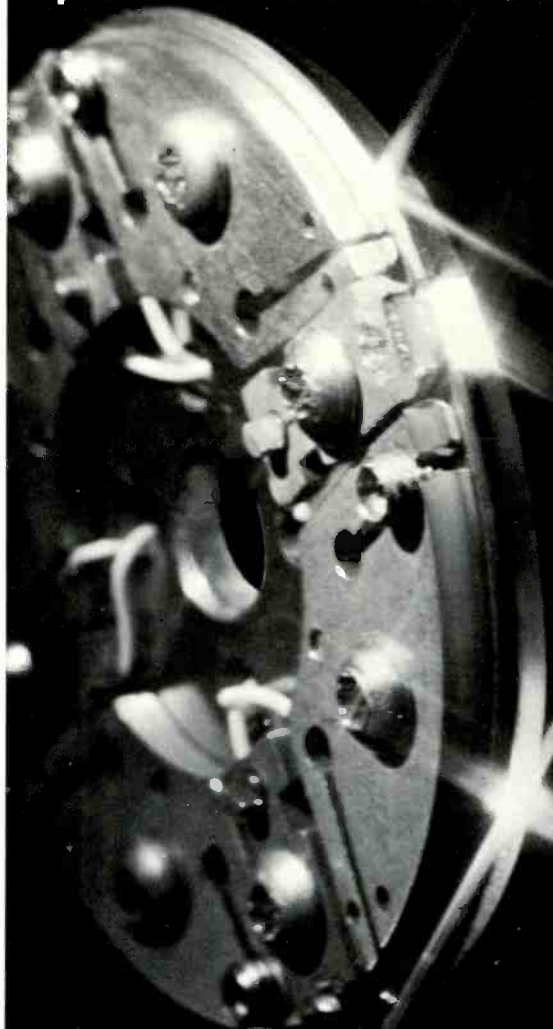

OPERATIONS MANAGEMENT. ENGINEERING. FINANCE.

Everyone gains from the long life and low cost per hour of quad panel operation with Spin Physics' unique Manganese-Zinc hot-pressed ferrite heads. Our rapidly growing list of customers bears witness to our claims of superior quad panel performance — from 3 to 5 times longer than our competition. Even if you are getting higher than average life from ordinary heads, you can expect to save from 25 to 40 per cent of panel refurbishing costs with Spin Physics' high technology ferrite heads and upgraded panel components.

THE NON-PRORATED 1000 HOUR WARRANTY for each Mark X, Mark XV or RCA High Band quad panel spells out the story of savings. The compatible broadcast quality picture that maintains its crisp clarity throughout its dramatically extended life demonstrates superior performance. The combination illustrates Spin Physics' commitment to better service for the broadcast industry.

LET US SHOW YOU MORE AT NAB or at your facility. Contact our Field Engineer who serves your region, listed below, or Gene Long, National Sales Manager, at our San Diego home office.



SPIN PHYSICS, INC.

A KODAK COMPANY

11533 Sorrento Valley Road, San Diego, California 92121

Telephone: 714-453-5410 Cable: SPINEX SANDIEGO TWX: 910-322-1737

EASTERN REGION Kent White 301-839-3218 **NORTHEAST** Ben Everett 301-730-6855
SOUTHEAST Knowlton Harrell 205-582-6572 **MIDWEST** Ray Kundrol 312-325-1009 **CENTRAL** Leroy Koonsman 214-245-1816
PACIFIC Ken Thompson 415-961-7794 **SOUTHWEST** Ed Gebble 805-964-3316 **NORTHWEST** Dave Franssens 916-332-0885
WESTERN EUROPE Bill Kroom, Putten, The Netherlands (03418) 3689 or Telex (844) 47589

Circle 143 on Reader Service Card

The Automated Console

control (fader) operation, and also with a signal from the automation memory; (2) a synchronizing and coding system for telling the memory where each item is on the tape, and for getting back to that item as required; and (3) the memory itself, including the method for getting the adjustments into the memory, and for updating the settings. These functions are carried out in different ways in the available systems, as the following summaries show. It is worth noting that all the systems aim, by differing means, for operation that fits naturally into the normal mix-down process. The recording engineer has not traded one set of difficult knob operations for another; automation keeps it fairly simple and easy.

Automated Processes, Inc., "Auto Mix"

The level control devices are "VCA Faders" (voltage-controlled amplifiers) which adjust level both with a natural fader operation and with DC voltages from the memory. They are installed in the console to replace directly the normal faders. All the control functions are DC operated, including channel assignment, echo send and receive, equalization; all (including the equalization) can be fully automated in this system.

The memory is a digital tape cartridge system, using magnetic tape carts which are regularly available from the tape manufacturers. The memory tape is synchronized to the multi-track original through the manufacturer's Mag-Link system, using one track on the multi-track for the sync code, which can be SMPTE or a similar code. The capacity of the memory is large enough to hold all adjustments, including equalization adjustments, for the most complex mix-downs; and to hold up to four or five complete mixes. The operator can put one in, try another, call back the first, or any part of it.

Operation is based on three switches on each fader panel, "write", "read", and "update". "Write" puts into the memory any adjustment made; "read" is used on playback to get the level off the multi-track original as set in the memory. With "update", the operator simply sets the fader to a new position to change any setting in the memory.

Rupert Neve NECAM

This system uses a computer to carry out many functions. Two magnetic "floppy" discs supply the memory. The computer software supplies the function directions.

One track of the multi-track original tape records the SMPTE code, and this provides the location function. The tape can be returned to any point wanted automatically. The faders in this system are servo-motor controlled, but normal hand operation overrides the servo. When the operator's hand approaches the fader, a microwave oscillator is detuned and this is used to disconnect the servo drive. Removing the hand lets the fader go back to servo control; then the faders respond to signals representing level decisions stored in the memory.

This servo system also provides for very natural updating. The operator simply pushes the fader to the new level he wants. Depending on the setting of a three-way switch on the fader panel, the new setting can be added only while the fader is touched ("normal"); or applied to all

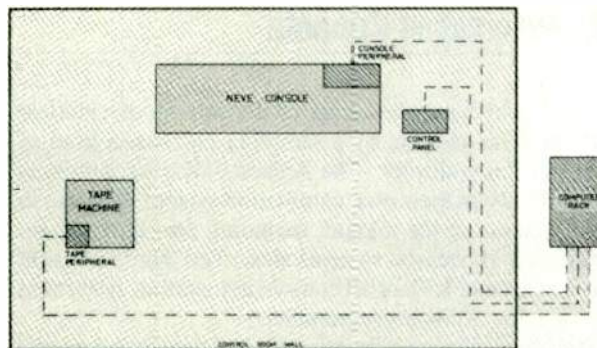

Control unit in Neve system can be separate, connected to console by card-mounted peripheral. Computer in all systems is rack-mounted anywhere.

subsequent material until a second adjustment is made ("relative"); or be applied completely outside servo control ("manual").

In addition to the special faders, the system consists of the computer, A.C.A.I. Alpha-LSI-2/20, with floppy disc memories; peripheral units incorporated into the tape machine and the console; and the control panel, in a small free-standing unit set up next to the console.

Harrison "Auto Set"

This is described by Harrison as a "system of process control," using microcomputers. It has a number of applications, including console automation. In its first form, the 864 Auto Set V-1, it is designed for Harrison 24, 32 and 32B series consoles, or any console using DC voltages as automation interface, with the Allison 64K Programmer or earlier Allison programmers.

The Auto Set system uses a complete ASCII keyboard, with CRT readout in the same unit; the whole system is in this small unit. The main difference between this system and the foregoing one, for example, is that the Auto Set functions are carried out by "data management," in the computer, rather than by specific function buttons connected to hard-wired circuits.

Harrison says that the data management, with the CRT showing the operator what he is doing and has done at all times (it can show up to 16 lines of 32 characters each) is direct and easy, and can be used after a few minutes' instructions. The operator can manipulate stored data in a wide variety of ways.

The system uses one track of the multitrack recording to store up to four independent mixes or sets of data; each set can include up to 63 console positions. The data can be applied to any console position, whatever the source selected for any other console position.

Any console function can be automated, as long as that function can be DC controlled through the proper console interface. The memory capacity is more than adequate for the most elaborate mix-down operations.

Allison Research "Memory Plus" System

This system can be used with any console; it is connected between the tape machine and the console inputs. It includes a "programmer," a system for taking either digital or analog signals representing the levels of the various tracks, and other adjustments, and turning them all into a single signal for recording in the automation

continued on page 62

The Automated Console

memory, which may be a track on the tape or other storage medium. This is done by a sampling process, a kind of time-division multiplex. The Allison 65K programmer is used not only in their own automation system, but also in other systems on the market, including the Harrison and Automated Processes systems described here. (Allison says that around 85% of all console automation systems in use have the Allison programmer.)

The programmer will work with any type of automated fader, but Allison has developed a fader with an optically encoded continuous belt, which drives an 8-bit digital up-down counter, as well as a 32-element linear LED array. The fader thus has no mechanical position; it can be operated by hand or by a signal. The setting is indicated by the LED array.

The system also includes a Central Engineering Unit, which provides *function* buttons for all the functions, with each function applied to a particular track by an access button for that track. The whole system, with the faders, central entering unit, and programmer, is marketed as the Memory Plus (trad marked) system in two packages. It will automate, says Allison, channel levels, grouping submasters, grand masters, channel solos and mutes, group solos and mutes, assignment of channels to groups, presets for all above, and has provisions for auxiliary switching. Echo, EQ, panning, and other signal process-

ing are carried out without automation.

MCI, JH-50 Automation System

This system uses a VCA connected to each fader; and for memory uses two or more tracks of the multi-track original. The faders, control buttons and LED's are in retrofit packages installable in MCI consoles; consoles can be delivered "automation ready", with these items already installed.

The system is microprocessor-based. During mix-down the system scans all the fader and mute functions, and any other automated functions, 9.8 times a second and records their levels. Thus the system follows each level change made by the operator and records it. There is a switching matrix to control as many as four tape tracks for the data recording.

Three buttons control the modes: VCA Write, VAC Update, and Mute. There is a set of the buttons for the whole console, a set for each group, a set for each I/O module and a set for each echo return circuit. The operator must learn only these three buttons to run the system. The microprocessor makes the transitions smooth from one mode to the next. For updating, the system has an automatic nulling operation: when the update button is pushed, the nulling system assigns the position of the fader to whatever level has been set for the program at that point. The operator can use any part of the fader range for updating, by moving it before using the update button.

BM/E



What do **YOU** do about **videocassette** problems?

Meet the problem-solver: **The Chyron[®]** **Cassette Cleaner & Evaluator**

Model U-1 The remarkable little machine that thoroughly cleans 3/4" videotape while it detects tape hazards that cause video dropout, poor image quality, and clogged VTR heads. Hazards like surface and edge damage, scoring, dimples, and oxide voids.

The Model U-1 does it all... **ten times faster than real time without altering the recorded signal.** Erases, too... but only when you tell it to!

Completely automatic and self-contained, the Chyron U-1 minimizes tape replacement costs, extends VTR head life, improves tape performance... at a modest price.

You can't afford to be without it because... what you don't see **can** hurt you. Call or write today.

CHYRON
CORPORATION
VIDEO PRODUCTS DIVISION

223 NEWTOWN ROAD, PLAINVIEW, NEW YORK 11803 • TELEPHONE: (516) 249-5202 • TELEX: 144522 CHYRON PLVW

See us at NAB Booth # 729.

About the Duca-Richardson Series 4000 production switcher:

“We bought two!”

**See the Series 4000
and master control
switcher in operation
at booth 1301
the 1978 NAB show.**



Listen to Herb Schubarth, V.P./Chief Engineer. KBTV, Denver...

“Combined Communications bought one for our Denver Station, KBTV, and one for our station in Phoenix, KTAR. We also bought routing and master control switchers for both stations from DRC.

“We selected the Series 4000 because of its outstanding practical features. Your choice of ten different key sources...and the ability to key in eight different places, make it a beautiful addition to our production facilities.

Also the ability to do titles and composite chroma keys over buses before entering mixed effects was a big selling feature.

“All this, plus the downstream keyer’s ability to do title keys as well as composite chroma keys. The switcher has opened a whole new world of creative possibilities for our directors.” Thanks Herb, for the kind words!

For details on the full line of DRC switchers, call or write. Carl A. Hedberg



Duca-Richardson Corporation
11465 W. 48th Ave., Wheat Ridge, CO 80033, 303/423-1300
Circle 145 on Reader Service Card



Audio-Technica introduces five new microphones... and a pleasant surprise.



AT813
Electret
Condenser
Cardioid

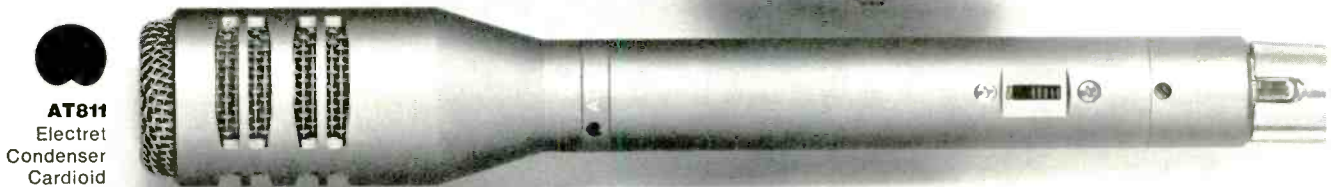

AT811
Electret
Condenser
Cardioid



AT801
Electret
Condenser
Omnidirectional

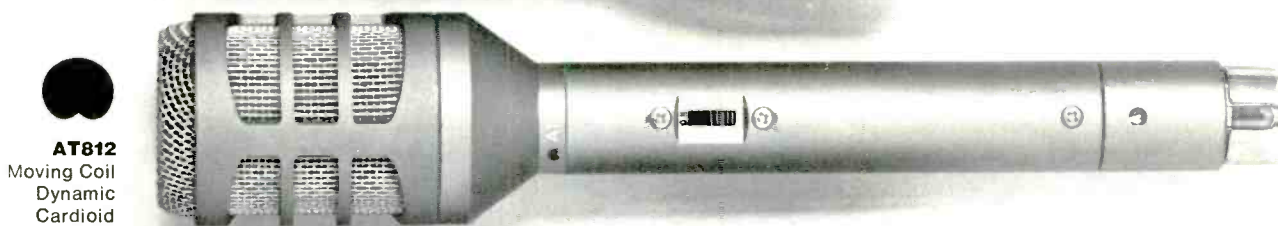

AT812
Moving Coil
Dynamic
Cardioid



AT802
Moving Coil
Dynamic
Omnidirectional

Take a close look at these new Audio-Technica microphones. Three electret condensers and two dynamics. Plus two clip-on miniature electrets (not shown). All are superbly finished. Carefully thought out in every detail. With the right "heft" and feel. Professional A3M Switchcraft output connectors, of course.

Then listen in your studio. Full-range, peak-free, clean and crisp. With

no distortion even when used close-up to high-level performers. And the balanced, phased Lo-Z (600 Ohm) output matches pro and semi-pro mixers alike.

Now for the surprise. The price. Both omnis are nationally advertised at just \$60, for either dynamic or electret condenser element. The two basic cardioids are just \$80, while the AT813

electret condenser with integral wind-screen is pegged at \$95. All complete with full one-year warranty.

Once you've seen and tried these new Audio-Technica microphones we think you'll welcome them. Not just because they cost so little...but because they do so much. Available now from your Audio-Technica Professional Products dealer.

 **audio-technica**. *Great sound, right from the start!*

AM Stereo: The FCC Needs Your Help

Read the highlight summaries in this article of two typical reports on AM stereo submitted to the FCC recently. Send in your own analysis or experiences before March 31. You may help to reduce the time for the ruling.

WHEN THE FEDERAL COMMUNICATIONS COMMISSION recently extended the cutoff date for replies in the AM stereo inquiry to March 31, it was an acknowledgement that the subject is complex and important, and that the industry is responding with a heavy volume of comment.

Two comprehensive reports recently submitted in the inquiry have been studied by *BM/E*, and they cover many of the most important questions that must be resolved. We summarize those points very briefly in the following: readers who have strong positions or information on any of them should prepare replies to the FCC, if they have not already done so. It is worth noting here that all reports sent in can be seen by any interested person at the FCC offices in Washington. This material is a public record.

Station K101 measurements and listening tests. At the time of the NRBA Convention in San Francisco in September, 1976, Motorola, at the invitation of K101, had set up their C-Quam AM stereo system for the NASC tests using the K101 AM transmitter. Under the direction of James Gabbert, president, K101 undertook a series of measurements on its own, and also invited station managers and engineers who were at the convention for listening demonstrations. In the listening tests (about 450

people participated), opinion was close to universal that the results were excellent. Nearly all listeners said that the quality was close to FM quality, and many could not believe that the audio cut off above about 6 - 7 kHz. Of the several hundred highly expert listeners, only one noted that the distortion seemed a trifle high.

The measurements were made on both closed-circuit and over-the-air transmissions. They showed, for example, envelope distortion running two to three percent at a level of 70 percent envelope modulation. Checks for undue expansion of the spectrum under various conditions of modulation were essentially negative, indicating that the system would fit into the present AM band without substantially increasing interference.

In their conclusions, K101 judged the Motorola system capable, with some minor refinements, of producing excellent quality with existing AM equipment. On the last point, they found what they called an "unexpected bonus:" it took only 30 minutes to convert the 20-year-old AM transmitter for the AM stereo broadcasts.

Office of Telecommunications, Department of Commerce, Report to FCC on AM Stereo. This mas-

continued on page 66

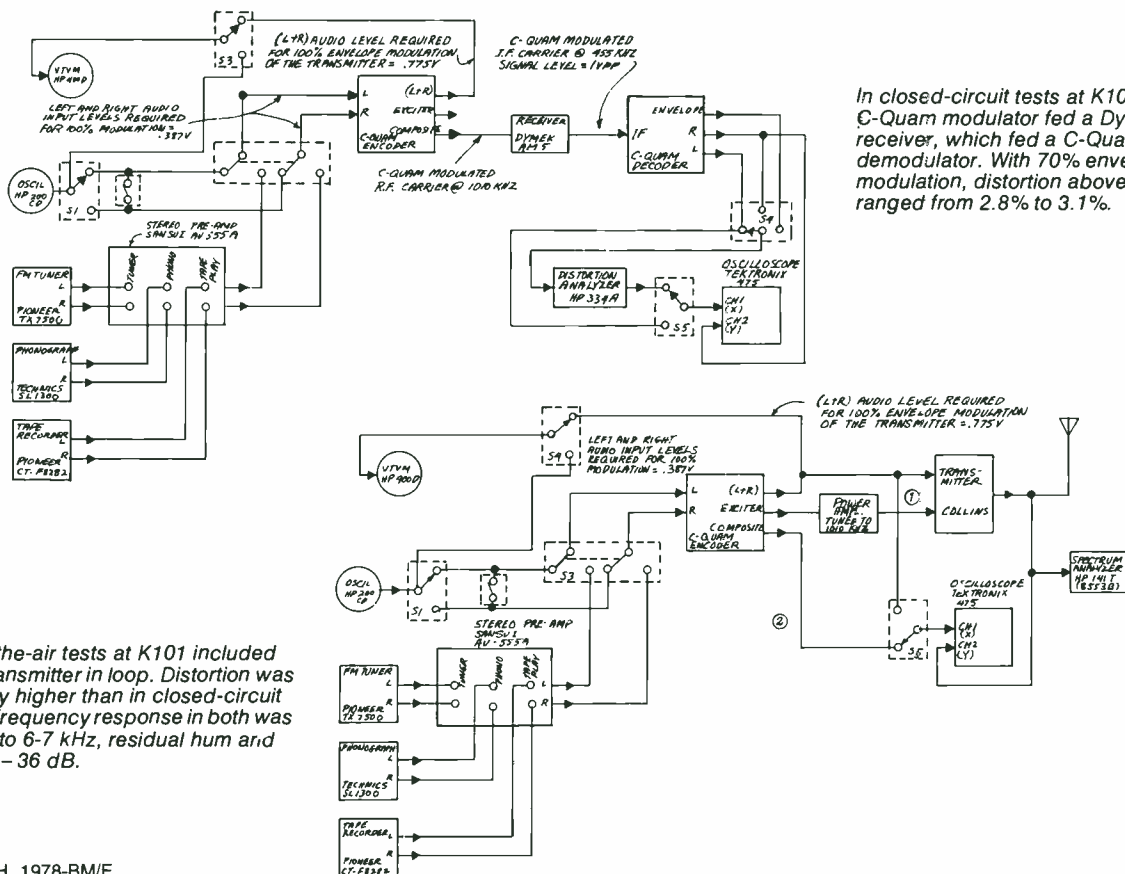

In closed-circuit tests at K101, the C-Quam modulator fed a Dymek receiver, which fed a C-Quam demodulator. With 70% envelope modulation, distortion above 100 Hz ranged from 2.8% to 3.1%.

Over-the-air tests at K101 included AM transmitter in loop. Distortion was slightly higher than in closed-circuit test. Frequency response in both was good to 6-7 kHz, residual hum and noise - 36 dB.

AM Stereo

sive report includes a general summary covering issues of overall policy, and a complete mathematical analysis of each of the proposed AM stereo systems, with theoretical distortion, sideband production, etc. for each system developed.

The Office of Telecommunications (OT) is the reconstitution of the older Office of Telecommunications Policy (OTP) which was in the Executive Office in the Nixon and earlier administrations. Although transferred to the Department of Commerce, the influence of the organization is still very large; the report will certainly get the full attention of the FCC.

OT admonishes the FCC (unnecessarily, one might believe) to be careful that AM stereo does not degrade the existing AM service with increased interference, increased distortion, reduced loudness, or changes that might reduce the number of people getting satisfactory service. The FCC and, in fact, all those proposing systems have had these objectives very much in the foreground.

OT has the excellent idea, though, that the AM stereo decision gives the FCC the chance to review the whole technical framework of AM broadcasting. The present rules, says OT, are based on the technology of the 1930's. They urgently need updating.

In the process the FCC should seek, says OT, the best balance among a number of desirable objectives: supplying the maximum number of channels consistent with acceptable service; raising audio quality; better spectrum utilization; the long-term financial health of AM radio.

The fact that increasing the bandwidth, for the additional information of stereo, means, in general, decreasing the number of stations on the air leads OT to ask for very careful long-range consideration about which objective is more important. Or should there be some trade-off for a stance in between?

OT particularly wants the FCC to take a long view because of the upcoming possibility that the International Telecommunications Union will recommend a reduction of AM spacing in Region 2 (which includes the US) from the present 10 kHz to 9 kHz. This would allow many more AM stations on the air, diversify programming, and give under-represented minorities a better shot at owning radio stations.

So, if AM stereo runs counter to this result, the FCC, says OT, must move after close study. OT is careful to say that they have not finally concluded that a 9 kHz spacing and AM stereo are mutually exclusive; but the question of whether they can lie down comfortably together must be examined thoroughly.

The OT mathematical analyses of the five systems are directed to uncovering three qualities: the distortion after demodulation by an envelope detector; the reduction in signal-to-noise when a stereo receiver is switched from mono to stereo; the relative bandwidth required when transmitting a four-tone signal. With the particular assumptions of the study in mind, the Motorola system appeared to have the lowest distortion and the lowest production of intermodulation sidebands; the increase in noise was quite low at 3 dB. However, the study admittedly is based on a single set of conditions only, and a complete evaluation would require more analysis. **BM/E**

ATS THE ONLY SURE BET IN LAS VEGAS

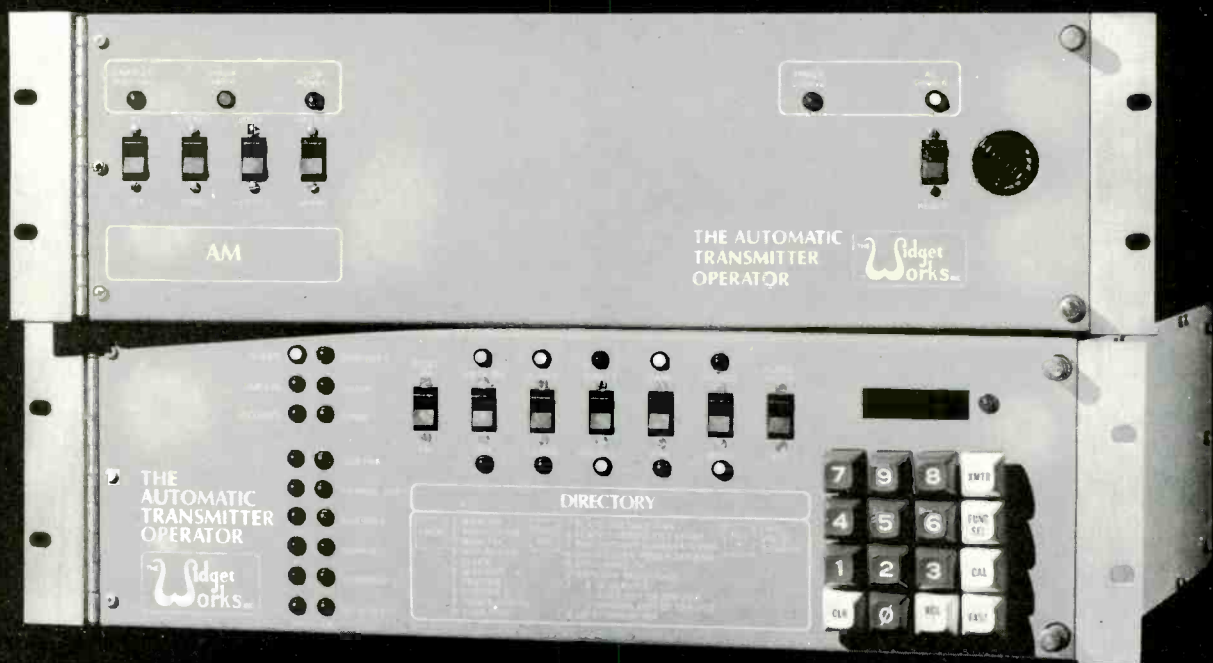

SEE THE AUTOMATIC TRANSMITTER OPERATOR AT THE N.A.B.

THE WIDGET WORKS INC. P.O. Box 79 Medina, Ohio 44256 (216) 336-7500

See Us At Booth #104

Circle 147 on Reader Service Card

Making Money With No Help From Compression

New York's WNCN shows that all-out pitch to quality can work if you do it right in the right market. The music is uncompromisingly classical. The technical quality is as high as it can be pushed today. The station puts on the air a signal with a dynamic range of 50dB, and will get it higher.

IN JUNE, 1976, THE GAF CORPORATION took over New York's WNCN with a promise to return the station to classical music. That ended a two-year storm that had buffeted the station after the previous owners, Starr Broadcasting, switched the station from its 20-year classical format to rock. WNCN had consistently lost money, so Starr had some incentive to change direction.

But New York's classical music lovers would not have it so. They did everything, short of marching into the station and taking it over, to get it back in the classical fold. Protracted petitioning to the FCC ran into a dead end when the Commission flatly decided not to intervene in format changes by station managements (see *BM/E*, "FCC Rules & Regulations," November, 1977).

Rescue came from GAF in large part because Dr. Jesse Werner, president, is a classical music lover and a hi fi buff. He had complained to Richard Sequerra, audio and broadcasting consultant and designer of loudspeakers and FM tuners, that many FM stations did not sound nearly as good as records played on his own system. Sequerra gave him a convincing summary of deficiencies in station design and operation that could lead to this discrepancy.

Consequently, when Starr's venture into rock started to crumble, Dr. Werner persuaded GAF to buy the station as an arm of the business, to rebuild it to the highest possible technical standards, and to devote it to classical music entirely. Werner engaged Sequerra to write a prospectus for a new FM plant that would be at the top of the art, and would be kept there by constant improvement.

This was not to be a fling at "public service." Although the announcement convinced New York's highly articulate classical music community that the millennium had come, it was not necessarily forever: WNCN would have to make money within some reasonable period, or face another serious change. The rebuilding was budgeted at around one million dollars.

As this is written, about one year after the rebuilt station got into regular operation, Dr. Werner's gamble has won on all fronts. The station is in the black, and the trend is clearly to more of the same. The new plant has established new high standards for FM technical quality. The classical music listener, in the surrounding tri-state area as well as in New York City itself, has adopted the station fervently — the mail is ecstatic.

Moreover, the new WNCN came along at the right time to benefit from, and participate in, the swing toward the higher audio in broadcasting. (See "Audio For The Eighties," *BM/E*, October, 1977). WNCN is now the local outlet for stereo simulcasts from Lincoln Center and from public TV station WNET. The station is beginning to function as a super-grade recording organization for live concerts chosen from the wealth of music performed



General Manager Robert Richer looks at script for on-air announcement held by operator Gordon Spencer, at main console of WNCN. Window lets lobby visitors watch operation.

in the New York area. These recordings are program material for the station (or the concert may go on the air live as the recording is made). The recordings will also be syndicated to other stations around the country, an operation now getting underway.

In addition, the station's studios will be used to put live music on the air directly, which, as every classical buff will agree, is the ultimate gift, from FM's high quality.

Mainly responsible for these successes, created under Dr. Werner's benevolent aegis, have been Robert Richer, general manager of the new station; Dick Sequerra, who, as noted, was consultant for the technical design; chief engineer, Richard Koziol, who carried out the design and actively continues to carry forward the technical quality of the station; Matt Biberfeld and David Dubal, program director and music director, respectively, who have the job of filling 24 hours, every day, with music of the quality that the station wants.

We examined the technical design first, and then the business and programming sides of the operation. Dick Sequerra told *BM/E* he aimed primarily for a signal-to-noise ratio, from input to air signal, of at least 70 dB, with vanishingly low distortion. This would allow the station to operate without any audio compression and, in turn, allow the dynamic range to be up to the expectations of the hi fi conscious audience.

The fight to ban noise and distortion started, of course, at the audio input. WNCN uses the Technics (Panasonic) SP10 Mark II turntables. Arms and pickups tend to change, since chief engineer Koziol is constantly trying to keep up with advances in this area. When *BM/E* visited him recently, he was using, with high satisfaction, the new AEG-PAE pickups and Micro-Seki arms. Preamps tend to change too; doing an excellent job on *BM/E*'s visit

continued on page 68

Until now ordinary was the best SCPC program channel you could get

The new Coastcom 411A is simply the finest SCPC program channel you can buy. Its phase lock loop detector provides network quality performance, even in adverse noise environments. The 411A is the first program channel good enough to meet the exacting specifications of National Public Radio.

A unique Coastcom stabilizer network ensures that the carrier frequency is held to within .001%. The program channel seldom needs adjusting, and because of this stability closer spacing of SCPC channels is possible. The unit can also handle low frequencies and wide deviations. And it's the only program channel that can offer up to 152-kHz wideband service with less than 1% distortion.

Whatever your application: point-to-multipoint broadcasting, direct satellite access from many locations, high speed data or FAX transmission, or other uses where quality cannot be sacrificed, move

out of the ordinary. The Coastcom 411A SCPC program channel is now the best you can get. Ask for more details today.

Coastcom

2312 Stanwell Drive Concord, California 94520
(415) 825-7500 TWX 910-481-5781



Circle 148 on Reader Service Card

Making Money

were Mark Levinson's ML-1's.

No AC power comes into the turntable assembly. All power supplies are in the bottom of a cabinet about ten feet away: the turntables themselves run on DC. The same all-DC design was applied to the main console. After checking out some available units, Sequerra and Koziol decided to build their own. They used amplifier cards from Spectra Sonics, transformers built to order, many all-out refinements in lead dress, shielding and grounding techniques. The result is that the whole audio line, through the console, has signal-to-noise ratio above 95 dB. Distortion in the line is below the residual distortion of very good test equipment.

The console has some useful operating refinements. When the fader for a turntable channel is advanced from its bottom position, it starts the table; pulling it back down stops the table. Records can be cued and left on the table until the operator needs them.

Koziol points out that an important part of the low-noise effort is keeping the number of systems between turntable and transmitter as small as possible. His audio line is a minimum operation with only the turntable preamps, the console, the telco lines, and the Optimod (with compression bypassed) on the way.

Commercials are on carts, and are all played monophonically; only a small percentage of those sent in by the ad agencies are in stereo anyway. Sequerra and Koziol say they may go to stereo ads later; at the beginning they avoided the well-known problems of stereo phase error in carts to concentrate on other crucial problems.

Every record is washed on a Keith and Monks record cleaner before going on a turntable. Every operator gets training in careful handling of the records.

The operators must get careful training in level setting too, because there is no compression anywhere in the audio line. An Optimod FM processor precedes the transmitter, with the compression turned off and set for very light limiting, as a safety measure only. Thus the modulation level depends heavily on the operator; and the modulation meter is mounted right on the console, at operating eye level.

The lack of compression does not apply on commercials. When a commercial is played, a digital control system automatically switches in the compression. When the switching system takes the line back to the turntables, the compression circuits are automatically taken out entirely to avoid any increase in the noise level.

Chief Engineer Koziol has found a useful correlation between the amount of music on a record and the recorded level. With a lot of music on the side (close groove spacing), the level is lower than it is on a short side. Koziol has worked out a series of markings for the fader strips, showing settings calibrated in terms of the total time on a recording. Each record jacket has the playing time on the front in large letters so the operator does not have to look for it in the back copy or on the record label.

This provides the operator with an initial setting. Then he must watch the peaks on the oscilloscope display of a Sequerra tuner (see page 71) and keep them below the top. A Stereo Vectorscope will be used for this purpose shortly. With the system constants as they stand, close

continued on page 71

KIRO KNOWS EXACTLY WHAT THEY WANT IN A 50 KW AM TRANSMITTER.

SO DOES CONTINENTAL ELECTRONICS!



When the fine folks in Seattle, Washington tune in KIRO they get what they want: "Newsradio 71."

A dynamic format of news, sports, commentary and all-night talk that keeps the Northwest market tuned in.

There's someone else who gets what he wants. Mr. C. R. Morris, Director of Engineering at KIRO. It's Chuck's responsibility to deliver engineering excellence, so his department took a long and careful look at the various 50 KW transmitters on the market before making the decision to purchase Continental Electronic's 317C.

"One manufacturer pointed to their unique measuring techniques. We asked Continental to test the 317C the same way." The results? Chuck says they were "as good as or even better than" the competition.

As a leader in high-power broadcasting Continental builds-in state-of-the-art performance from the start. Like high efficiency in a small space. "And I'm really impressed with how easy it is to get to the 317C for maintenance.

"With some of the problems other stations are having our decision to go along with the lower plate voltage has turned out to be a good one."

This is a result of Continental's Screen/Impedance Modulation which yields a loud 125% "without special effort."

What confirmed Chuck Morris' decision to go with the 317C? "It's Continental's track record. We've had a Continental 10 KW auxiliary for years and it's never failed us. Continental has bent over backwards to work with us and now that we have the 317C it's living up to our expectations. It just sits there and runs and runs." We salute "Newsradio 71" and KIRO's continuing

service to the Northwest. KIRO knows exactly what they want in a 50 KW AM transmitter

... so does Continental!

For information on the 317C, write Continental Electronics Mfg. Co., Box 270879, Dallas, Texas 75227.

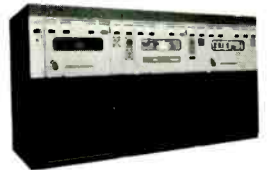

Continental Electronics



E.E.V. is no longer E.E.V. NOW IT'S **EEV, INC.!**



Klystron



Power Tetrodes



Leddicons®

EEV, INC. . . . a new and larger company with new and larger facilities for sales and service of the entire product line of English Electric Valve Company Limited, Chelmsford, England . . . imaging tubes—including the patented Coaxial Leddicon®—film/slide chain vidicons, reliable EEV orthicons . . . vacuum capacitors . . . power tetrodes . . . high efficiency klystrons and more. All, now available, from one location from the people who made the "old" E.E.V. the prime source of communications related tubes and devices world-wide. EEV, INC., Elmsford, New York—a new name for an old friend. EEV, INC. where YOUR IMAGE IS OUR BUSINESS.



EEV, INC.

7 Westchester Plaza, Elmsford, NY 10523 • 914-592-6050
In Canada: EEV CANADA, LTD., 67 Westmore Drive
Rexdale, Ontario M9V 3Y6 • 416-745-9494

A member of the GEC-English Electric Group of Companies

Circle 150 on Reader Service Card
See us at NAB Booth #605

Making Money

control of peaks to avoid serious peak limiting will lead to an average modulation level of around 18 dB, the lowest for any commercial broadcast station in the U.S.

Sequerra sums up: the station is maintaining around 17 dB of headroom, above a noise margin of 33 dB, for a total 50 dB of dynamic range. That gets the low end below the tape hiss on most top grade recordings, and close to or below the audience noise in most live converts. But WNCN is very much a project still in process. Dr. Werner, Sequerra and Koziol are actively looking for further improvement. As Sequerra puts it, they are finding many new facts in the largely uncharted territory they have occupied. They expect to put more and more of them to work as time goes on.

How does the low modulation level affect the station's coverage? Such a level would be suicide for an all-rock station in a highly competitive market. But WNCN's listeners are out for the particular music the station puts on the air and are not dial-cruising for the peppiest sound they can find.

Koziol notes that probably in far fringe areas the AFC will pull receivers away from WNCN and on to adjacent channel stations that are much stronger. But WNCN is prepared for a slight loss of audience on the fringes in order to satisfy its following in the very large New York metropolitan area. And the signal is still viable in cultural centers as far away as Princeton, NJ.

As already noted, live broadcasts will be important in the station's programming. The station's studios will also be used for recording production, eventually for other musical organizations that want to make recordings under excellent conditions.

One very large studio, about 70 by 80 feet and two stories high, is being readied for the larger musical groups. Two smaller studios are already in use. Each is "floated" from the building structure on sound-absorbent supports; air conditioning uses large volumes of air moving very slowly. Every other device is used to reduce ambient noise to extremely low levels. The smaller studios are already being tested at 15 to 18 dB of ambient noise, although the New York subway runs only six stories below. They also have movable panels on walls and ceiling to allow adjustment of the reverberation time and other acoustic characteristics to match differing musical demands.

WNCN's transmitter is in the Empire State Building, and the management has, at least for the present, decided to leave it there rather than moving to the World Trade Tower in downtown Manhattan as most TV and radio stations in the city are doing. Koziol points out that the expense of the move and the higher cost of operation in the new building would not be offset by any substantial gain in coverage.

Getting the signal with high quality intact from the WNCN studios at 47th Street and Sixth Avenue to the Empire State at 34th Street and Fifth Avenue was naturally a main concern. Sequerra and Koziol tried some microwave STL equipment, but found they lost around 6 dB of signal-to-noise ratio. After some negotiation with the telephone company, they got a pair of wideband, low-noise lines. With corrective measures by Sequerra and Koziol at the ends, these have performed somewhat better than some other parts of the system so far.



Chief Engineer Richard Koziol shows operation of main console. Large meter to right is modulation percentage; operator is responsible for maintaining proper level.



General Manager Richer shows microphones used for pickup of small musical groups in one of "live" studios. WNCN has three studios which air live music fairly often.

The two transmitters, main and standby, are both Collins 10 kW FM units, the older one (standby) being the 30-FHA, the newer one the 831F. The older transmitter, used by WNCN for a number of years before the new management took over, was substantially rebuilt to bring it nearer to the state of the art. The new one was also altered to reduce quirks that did not quite fit into Sequerra's battle plan for the station.

Other main units in the plant are: Moseley DRS-1 digital remote control for the transmitter; Belar monitors; the Sequerra tuner (rebuilt with crystal control, for 0.6 percent distortion) as an off-air monitor; Sequerra Pyramid loudspeakers for audio monitoring; DBX noise reduction, used on telco lines on remote program pickups; Dolby noise reduction, used to play back some taped programs that come in "Dolby stretched," like those from Chicago's classical station, WFMT; Studer tape recorders, both studio and portable; AKG and Neumann condenser microphones. Koziol points out their experience that *proper placement* of microphones, to get the right acoustic effect, is more important than the precise quality of the microphones, given models in the upper quality bracket.

How does General Manager Bob Richer make this supergrade transmitting plant earn its keep? The major effort has been to convince sellers of high-quality products that a classical music station has a high-quality audience. Other classical stations in the country, notably the successful WFMT in Chicago, are taking the same line — its validity is now well confirmed by research studies and demographic information (see story on WFMT in *BM/E*, September, 1977, *Broadcast Industry News*).

However, even with a valid idea, the sales program must be carried out with finesse, energy, ingenuity, and Richer has supplied all those qualities in full measure. The number of fairly regular advertisers is now not far from 200, which is a fine figure for a radio operation that is, by

continued on page 72

Automate your station breaks for under \$50,000

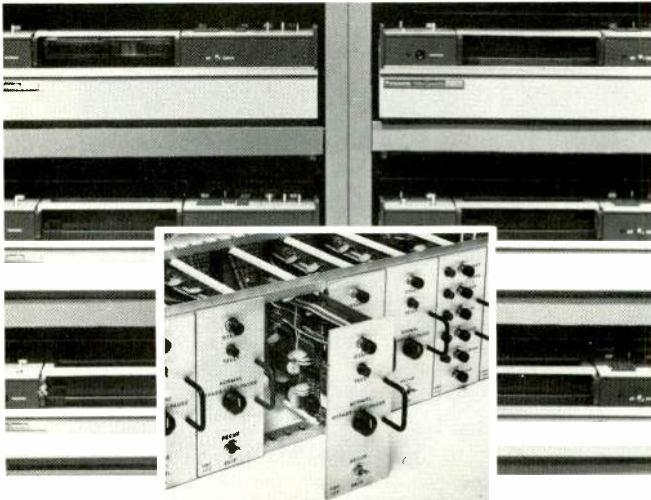

Videomedia's VMC-100 professional sequencing system

Now small and medium sized stations can afford automatic sequencing of up to six $\frac{3}{4}$ " tape machines for spot and station break play. All for about one-fifth the cost of a quad video cart machine.

Less than \$50,000 includes six tape units, switchers, TBC, waveform monitor and hardware. Smaller systems (two or more tape machines) are also available. The VMC-100 is an ideal back-up for quad video cart machines.

The system is made for pros who demand not only simplicity and precision, but virtual failsafe performance from their equipment.

To prevent loss of commercial air time, VMC-100 features individual control cards for each video machine, 100% redundant circuitry, and a by-pass capability in case any individual machine malfunctions.

Accuracy is ensured by counting control track pulses, so expensive time codes are unnecessary. A tone encoder plug-in card allows precise, automatic tone placement for tape cueing.

The VMC-100 is completely modular, expandable, and adaptable for future microprocessor control. For more information, please call or write for our free VMC-100 brochure.

Videomedia
Total Video Systems

250 North Wolfe Road, Sunnyvale, CA 94086
(408) 733-6500

Circle 151 on Reader Service Card

Making Money

choice, serving a select audience. Included is a good proportion of national advertisers — several air lines, several major oil companies, some national hi fi makers (Pioneer has sponsored a whole series of live concerts) and auto manufacturers. Also included are a large number of organizations from New York's teeming cultural scene; for them WNCN is a natural. There are also local book, record, and department stores; luxury restaurants; wine makers; hi fi dealers. The last group, Richer points out, is delighted with WNCN's signal as a means for demonstrating their top-bracket equipment; for them too, the station is a natural.

The programming is, of course, under the general direction of Bob Richer, whose conception of the station's function on the New York scene, its stance against local competition, has proved to be a winner. Richer is particularly pleased that audience surveys have shown WNCN adding growing numbers of young listeners to the expected "mature" audience. This is a good portent for WNCN's future.

The programming specifics, which include a number of elements besides pure music, are designed by Program Director Matt Biberfeld, who has shown ingenuity in devising programming ideas that enhance and enrich the listening experience in a number of ways. The day-to-day record choices are made by Music Director David Dubal, a Juilliard graduate and a performing concert pianist. He has a staff of musically-educated assistants who work with him in assembling each day's list of recordings.

The records come from a collection that now totals 15,000, to which are added a hundred or more every month. The number of live pickups is expected to grow steadily, and WNCN will get more and more "live tapes," from other stations and from concert sources of various kinds. But obviously the records must always be the main source of music.

The records are numbered as they come in, and get a card under their number, plus cross-filing cards for type of music, composer, length, etc. The management is now working on a plan for a computer to hold all this information. With the computer, the programmer will be able to call up, by pushing a few buttons, all his records of a certain length, or of a certain type, or by a certain composer, or with any combination of these or other qualities.

The computer will also save large efforts in another area — the preparation of the monthly program guide, "Keynote," distributed by the station. A month's programs, stored in advance in the computer memory, will be printed out for the magazine automatically. The magazine is a handsome, sophisticated publication with numerous articles on musicians, music, and related cultural matters, well designed to interest the station's listeners.

WNCN's story is, in specific terms, mainly interesting to stations in large cities where there may be a large enough classical music audience to support such a concentrated effort. But there is also a more general moral: one good route to radio success is all-out cultivation of a particular garden, whatever that may be. For many stations in small markets, the garden is the community as a whole, and many stations have taken that way to success.

BM/E



Central Dynamics Creator of "the Smart Switcher"

The super powerful CD-480 Video Switcher

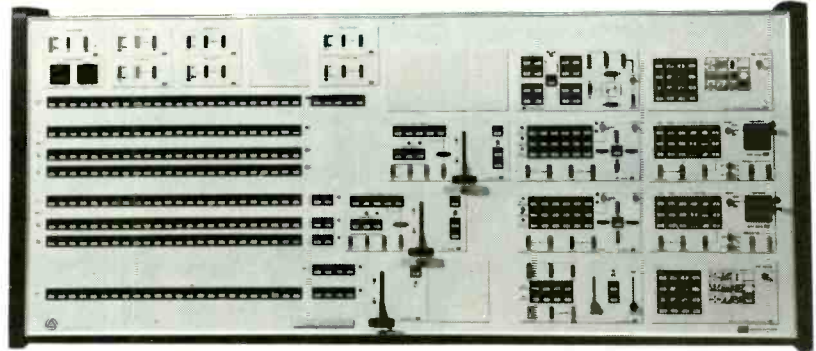

Revolutionary modular switchers with unprecedented production power. They outperform the largest conventional switchers, yet are extremely simple to operate. Their power and ease of operation are due to CDL's new Sequential Effects (SFX) Amplifier, which can cut, mix or wipe between background sources and two separate key

sources either individually or in any combination. Models with one or two SFX Amplifiers provide all the standard and optional features you need. A variety of modular accessories will continue to keep your switchers smarter than the rest as new technology develops.

The sophisticated VS-14

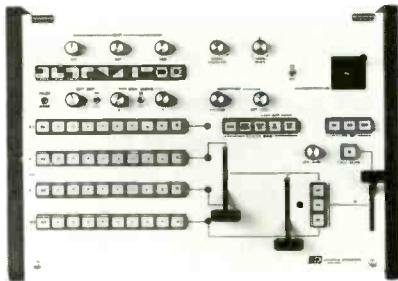

Sophisticated enough for large studio production, yet compact and inexpensive enough for small mobiles. Soft wipes and keys—even a Downstreamer keyer are standard. Self-contained and remote versions available.

The inexpensive VS-10

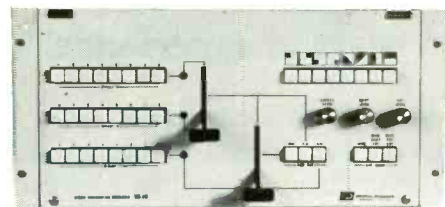

An inexpensive broadcast quality 8-input switcher that features flexibility and ease of operation. Self-contained electronics for rapid installation in ENG and other small mobiles.

Request our Short Form Catalog for a description of a complete line of video products.
Master Control Switchers • Video Tape Editors • System 100 Automation • SMPTE Time Code Generators and Readers • Video and Pulse Distribution Amplifiers • Chroma Keyers: RGB and Encoded • Processing Amplifiers • Audio/Video Routing Switchers • Pulse Assignment Systems • Machine Control Systems •



CENTRAL DYNAMICS LTD

U.S.A.
Chicago
331 West Northwest Highway,
Palatine, IL 60067
Phone—312-991-4720
TWX—910 693 4805

New York City
230 Livingston Street,
Northvale, NJ 07647
Phone—201-767-1300
TWX—710 991 9753

Los Angeles
15130 Ventura Blvd.—Suite 307,
Sherman Oaks, CA 91403
Phone—213-789-0574
TWX—910 495 1713

CANADA
Montreal
147 Hymus Blvd.,
Montreal, Quebec H9R 1G1
Phone—514-697-0811
TWX—610 422 3906

For all the video freedom you can use, get the studio camera with the outstanding picture.

That's the RCA TK-46, latest version of the most popular studio camera ever made. It incorporates a host of features introduced to the industry by RCA—successful in more than 1,500 units—the largest universe of any camera series.

Camera excellence doesn't just happen. In the TK-46, it comes from years of experience.

We planned to set a new standard for studio cameras when we introduced the original TK-44—and we succeeded. Its successor, the TK-46, still sets the standard, with features that deliver outstanding pictures. Among them: Chromacomp, the colorimetry adjustment that doesn't change picture luminance; comb filter and coring, for greatly improved signal-to-noise ratio; high efficiency prism optics for clarity and stability; scene contrast compression. And such automatic features as color balance, iris control and optional centering control.

You deserve the latest camera developments. You get them in the TK-46.

The TK-46 includes these new features: an advanced preamp that improves signal-to-noise

ratio by 3 dB; a 30° tiltable viewfinder with an 8" diagonal screen; simultaneous in/out of band aperture equalization with combing and coring—standard, of course. The control panel has been simplified, and setup controls are virtually accident-proof.

Video freedom is available now in the TK-46. And in a huge array of broadcast equipment from RCA.

Video freedom is the outstanding performance of the TK-46. It's the flexibility, features and value of our other cameras. It's everything you need for quality TV operation: antennas, transmitters, mobile vans, VTRs, telecine systems, and more.

It's all available now. Contact your RCA Representative, or write us. RCA Broadcast Systems, Building 2-2, Camden, NJ 08102.

The RCA logo, consisting of the letters "RCA" in a bold, stylized, sans-serif font.

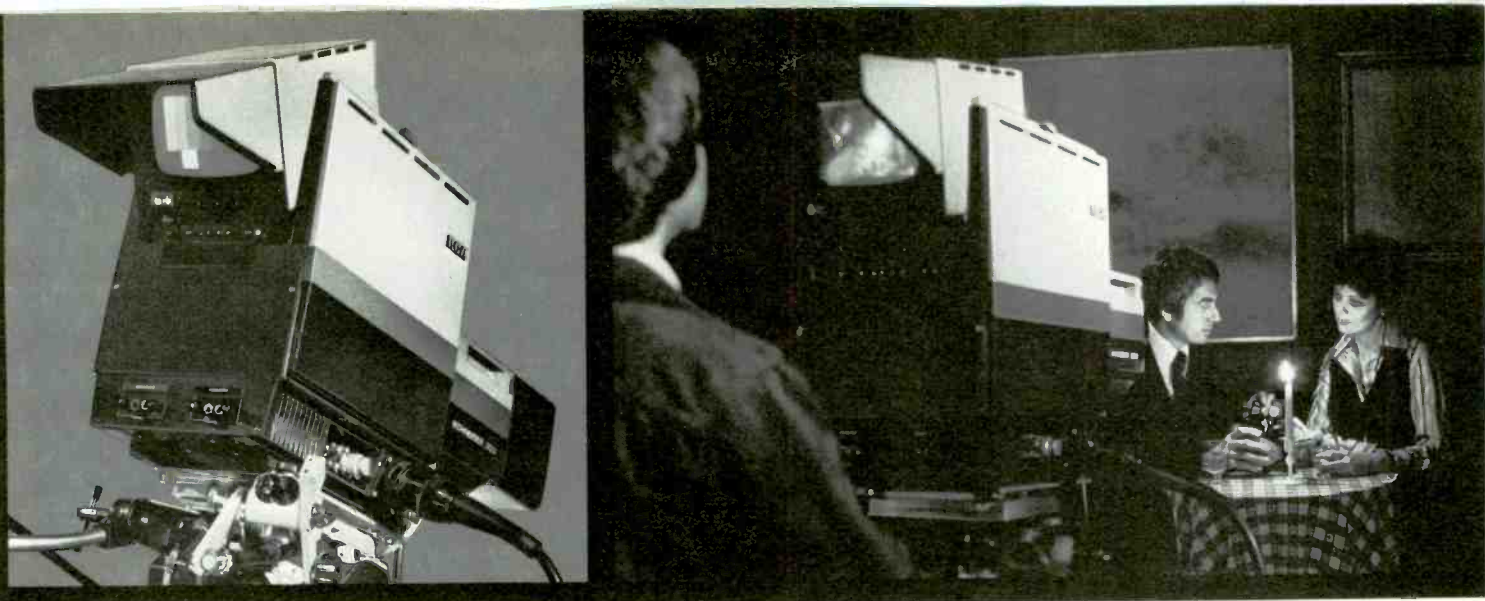

TK-46. Part of the new video freedom.

NAB Booth 1321

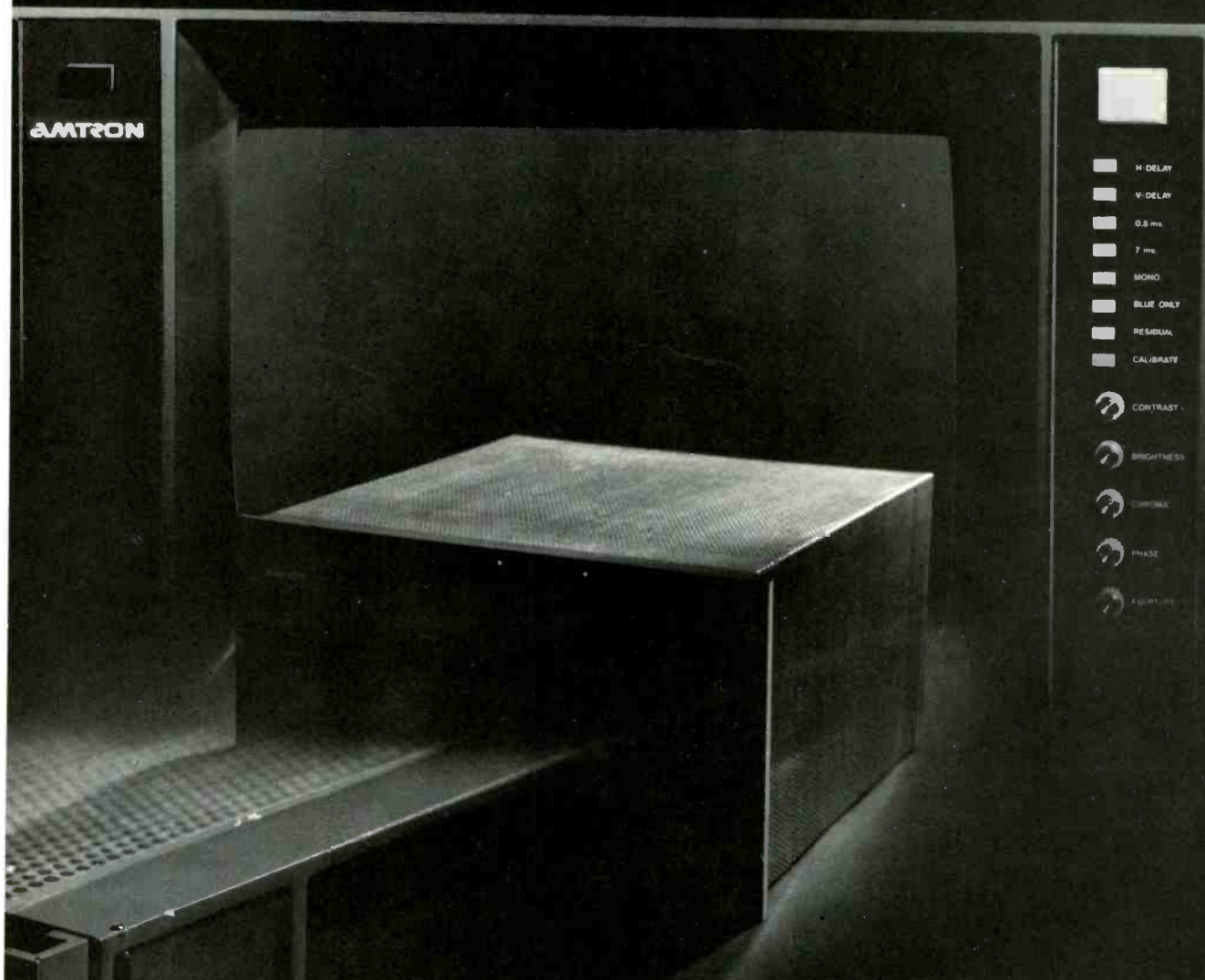

Turn on in Las Vegas.

*Wait until you see the all-new
high-resolution color broadcast
monitors from Amtron. You'll be
turned on, too.*

AMTRON

Circle 154 on Reader Service Card

AMTRON CORPORATION, APTOS, CA 95003 • (408) 688-4445 • TWX 910-598-8420

NBC Television Network Simulcast Uses New Duplex System For Audio; FM Station Participants Surprised By High Quality

Though simulcasting is not a new technique, it has always been viewed with some caution by FM stations doubtful of network audio-feed quality. The Bell duplex system is the key to this new standard of excellence.

NOT LONG AGO an FM broadcaster could, with reasonable safety, doubt the ability of any of the major television networks to bring off a simulcast program with audio quality that could meet his own station's standards. In fact, network audio quality was so notorious that when simulcasting was done, brute force methods were used such as sending radio stations copies of the program audio tape to be run simultaneously with the TV station's program signal. In other cases a network would rent high-speed audio lines from AT&T to distribute the signal to participating radio stations, but because of differences in propagation rates between the video lines and high-speed audio lines it was not uncommon for the two signals to drift out of phase and lose lip-sync. Even when, in theory, the propagation problem could be solved, the telephone company would occasionally re-route the audio, changing the physical distance from originating point to receiving point and thereby impune the synchronization. But, all that is changed — radically.

On November 17, 1977, NBC simulcast the *Neil Diamond Special: I'm Glad You're Here With Me Tonight*. The program was carried on NBC's 213 television station affiliates and a network of 21 FM stations. Twenty of the FM stations carried the program's audio in stereo. The participating FM stations reported a degree of astonishment that the quality was very good. Many were puzzled by the fact that despite the distance there was no discernable drifting from synchronization. What many of the FM stations didn't know was that NBC was using a new duplexing system supplied by the Bell System to distribute the audio.

At NBC Television Network headquarters in Rockefeller Center, New York, the video portion of the program, along with monaural soundtrack and SMPTE time code were being played back on a TR-70 quad VTR. The time code was used to sync an 8-track 3M M-79 audio recorder. The M-79 carried SMPTE time code on one track, the mixed monaural track, a discrete left channel on another track, and discrete right channel on another. The discrete left and right channels and the monaural track were repeated on the remaining tracks. As primary back-up to these air machines, another TR-70 and M-79 carried the



The simulcasting of the Neil Diamond special by NBC marked the beginning of a new era of higher quality audio in network distribution.

same material. As secondary back-up, a single Sony BVH-1000 carried the video, and used its three audio tracks to carry monaural, left and right channels. According to Bob Daniels, NBC director of Video Recording Operations, nothing extraordinary was required to bring off the show.

The NBC video/audio distribution system has long been set up to handle stereo programming. The distribution systems offer a 100 x 320 matrix with three audio crosspoints to every video crosspoint thereby providing for left, right and monaural audio signals. The rack is prewired to expand to a four audio to one video setup with the addition of more modules. In fact, the point was made that the problem of network audio feed quality has never been a matter of the in-house capabilities but rather a problem with the AT&T networking system.

Ron Gnidzejko, NBC's manager of Network Transmission and Master Control, had arranged with AT&T to purchase two video transmission facilities in parallel. The system carrying the program to the television stations was normal and used the traditional video line with a 5 kHz audio line for monaural sound. The second video facility, however, carried only the stereo audio for distribution to

continued on page 78

NBC Simulcast

the participating radio stations. At the AT&T Television Operating Center in downtown New York, the incoming stereo audio signals were modulated onto subcarriers in the second video facility.

From AT&T, the two video facilities carried the program to local telephone company test centers. There, 15 kHz lines were tapped into the test boards and run to the participating radio stations which received discrete left channel, discrete right channel and the monaural track as a back-up. In a couple of locations, the radio stations got a back-up of the monaural track from the local NBC Television affiliate.

Because of the diplexing of the audio onto a parallel video facility, the signals were assured of being transmitted along identical AT&T paths. Moreover, as the audio was carried on the same transmission medium, no propagation problems could arise. The results were a frequency response from 50-15000 kHz, and a signal-to-noise ratio in the neighborhood of minus 56 dB below program level. Distortion was less than 1 percent. This compares to the old 5 kHz system which gave a relatively flat frequency response from 50 to 5000 kHz, with a signal-to-noise ratio of minus 34 dB below program level and about 3 percent distortion. As far as headroom goes, well there wasn't any to speak of.

Hollis Duncan, chief engineer at KVIL-FM, Dallas, Texas, said that the quality of the audio his station received was "just fine." "We got real good separation with phase shift in the higher frequencies at less than 20 degrees, and at the lower frequencies below 1 kHz, no phase shift at all." KVIL-FM normally carries adult contemporary programming so the program was right down their alley. The station received numerous calls from listeners (viewers) who praised the program. Duncan admitted that he was quite leery of the quality he thought he would get from New York, but now, all fears are removed and he'd be happy to do more simulcasting. After all, said Duncan, "the quality was better than we get from our own cart machines."

Frank Raymo, assistant to the chief engineer for WMJC-FM, Detroit, said the quality was "exceptional." There were some initial problems with the Michigan Bell hook-up and some others related to the signal from New York, but NBC's extensive pre-testing of the system permitted these problems to be cleared up well before air time.

Gnidziejko had the system established the day before the program and was on the phone with each of the participating stations on Network A, which included all the stations with the exception of those on the West Coast. Being fed by an identical NBC setup in Burbank, Calif., the West Coast stations carried the program on a delayed basis. The testing consisted of tone runs, distortion measurements, and phasing. In addition, tests were run for three minutes leading into the program on the air date.

The program content, high quality, and superb cooperation between network and the stations has led to the reaction, "let's do more." There will be, no doubt, more such simulcasts. Another Neil Diamond special is in the works and the success of the system has led to talk of other stereo simulcast enterprises. An earlier stereo simulcast program of *Peter Pan* showed some of the potentials of using stereo audio for dramatic effect. Though the program was basically a musical, many of the stereo effects

enhanced the dramatic content, too, in that characters had aurally identifiable positions on the screen, and action was given an additional emphasis by its audio direction as well as video direction.

NBC corporate management has given consideration to stereo production of other types of programming but it will no doubt remain well down the road until television manufacturers begin to build stereo into their sets. Whereas a simulcast of a musical special strikes an FM station operator as a logical extension of his programming format, it is doubtful that many would easily accept the idea of carrying the audio portion of a strictly dramatic program though there undoubtedly would be exceptions if one of the networks landed a blockbuster like *Star Wars*. Before stereo in other programming becomes a reality it is likely that television stations would have to develop their own stereo capability.

Handling the Neil Diamond program presented few awkward circumstances for the FM stations that cleared the program. Usually, the stations were already programming soft rock or adult contemporary so that their particular audiences would be interested. Moreover, the show was fully sponsored by Datsun so there was no problem created in terms of local sales efforts built on the simulcast. Josh Kane, NBC Vice President of Programming, personally handled all the arrangements between the Neil Diamond production company and lined up the stereo network with local broadcasters.

The commercials that ran in the program were the only part of the show not done in stereo. The commercials were edited into the show so no switching was required. The monaural sound track of the commercials was fed not only into the monaural connections but also into the left and right channels so that the sound of the commercials was as smooth as possible. Discussions are being held to encourage the sponsors of future simulcasts to produce their commercials in stereo as well.

On January 23, all three major networks went onto the Bell diplexing system so that in just the past month the quality of network audio has taken a giant leap forward. Currently, however, the diplexing system is just carrying the monaural track modulated onto a subcarrier at 5.8 MHz. Tests with Bell Labs have shown that it is possible to generate a second audio channel on the same video line at 6.4 MHz so that stereo audio is technologically available from the television networks. This service is not as yet being offered and probably will not be until AT&T establishes a new tariff for the service.

Overall, television audio is vastly improved with the new diplexing system. The tests at Bell Labs show that with the use of a bandpass filter putting the video into a 4.5 MHz band and with the two audio channels at 6.4 MHz and 5.8 MHz an extremely flat response from 50 to 1500 kHz can be achieved. Tests are also showing that signal-to-noise is typically 60 dB below program level. This has, in fact, clearly placed the responsibility for better audio on the shoulders of television receiver manufacturers. The technology, if not the exact equipment, is already in place at many stations to deliver a top grade audio signal. Improvements in the audio chain and the transmitter could easily be made with existing equipment. At last, the chicken-and-egg argument over providing better audio for television is over. It may take time for this fact to sink in, but eventually television manufacturers will have to admit that there is a much better sound out there than their customers are able to get over current receivers. **BM/E**



Introducing a monitor with beauty and brains.

Behind the beautiful image, there's cool, calculating logic.

Logic circuits built into Conrac's new 6100 monitor represent a breakthrough in video performance.

They make it possible to enjoy all the significant advantages of a Comb Filter Separator* which provides full bandwidth capability. Even a non-professional could see the difference this state-of-the-art development makes. But to the professional, it's obvious.

So are the results of our Beam Current Feedback System. It samples each gun in the CRT and corrects color temperature to a set reference, and

maintains stability for long periods of time.

Another important feature is fully active convergence, even in corners. And there's a pullout drawer plus front access to all circuit modules.

See the Conrac 6100. It's a real beauty, and a smart buy.

Conrac Division, Conrac Corporation, 600 North Rimsdale Ave., Covina, CA 91722, (213) 966-3511



CONRAC

We're more than meets the eye.

Circle 155 on Reader Service Card

*Optional

Automated Camera Setup Comes To WLS-TV

Computerized control of camera setup reduces camera crew requirements by 20 percent and shortens routine setup time to 45 seconds per camera

LAST YEAR'S STRIKE AGAINST ABC-TV IS HISTORY. The passions and grievances are matters of public record and, by now, somewhat faded into the industry's memory bank of experience for most people on both sides. But at WLS-TV Chicago, one event of the strike period is still a part of their daily production situation.

The strike began on May 16, 1977. All of the NABET cameramen, video controllers, TD's, and other technicians walked out, leaving supervisory staff to man the station, keep it on the air, and maintain transmitted signal within limits tight enough to avoid the phone calls that always flood in when picture quality goes even slightly awry. At WLS-TV that supervisory staff consisted of Joe Kresnicka, Director of Engineering, and John Dancaster, Assistant Chief Engineer.

The studio cameras were venerable PE-250/350's, originally built by GE some ten years earlier, when they indeed reflected state-of-the-art technology. By May 1977 they were ancient by contemporary criteria, especially with respect to alignment and registration stability. So when the strike began, Kresnicka and Dancaster faced a massive problem. The station uses six studio cameras, four in the large news studio, two in another studio for live origination. Each of the cameras required an hour of setup time at the start of daily operations, a chore normally performed by the video control man of the two-man camera crews then on the station's staff. About the time of the strike WLS-TV began running live weather inserts into the *Good Morning, America* network show that they tape from 6 to 8 AM, and air at 7 to 9 AM Chicago time, so at least some of the four newsroom cameras had to be set up and run through alignment and registration functions very early each day. The other two, used for their live local show, *AM Chicago*, didn't go on the air till 9 AM. With cameras manned by sales people, and with Kresnicka and Dancaster doing camera setup mornings, then riding video and correcting for drift as best they could throughout the day for live inserts in network programming and their own news shows at 5, 6 and 10 PM, the station managed to maintain the broadcast schedules that are the base of its economic existence.

For a long time before the strike crunch, the old cameras had been unstable, requiring frequent adjustments throughout each day after initial setup, and Kresnicka and Dancaster had their hands full keeping them within acceptable limits. It was no surprise to them. Months before, Joe Kresnicka had been in touch with Julius Barnathan, President of Broadcast Operations and Engineering, ABC in New York, about the question of replacing the old cameras. They had agreed that any new cameras they'd consider should be equipped with automa-

tic, computerized setup of all daily adjustment parameters and registration functions. Submitting this requirement to several camera builders, they were met with can-do answers, but also with lead times of eighteen months to two years from all the major suppliers except Ikegami. Their HK-312 already came with an optional plug-in computer that cycles it in less than a minute per camera through white balance, black balance, flare correction, gamma correction, video gain, beam alignment, and eight registration functions.

The first five HK-312's were ordered by ABC Hollywood for use at their giant, new network facility, Studio 57. By the time the cameras were accepted, Ikegami had made 170 modifications to conform with ABC specifications. The shakedown continued with more than 50 modifications required for the six cameras at WLS-TV and the ten going to ABC-TV's New York operation. By the time WLS-TV began taking delivery on their HK-312's, "they were pretty sophisticated animals," said Kresnicka. Eleven days after the strike began, on May 27, the cameras were off-loaded from a truck and carted up to the WLS-TV floors at 190 North State Street.

Speaking of those days, Kresnicka shook his head in disbelief at the work load that Dancaster and he carried. They kept the old cameras working the best they could. And in two weeks they also unpacked, installed, cabled, fired up, checked out, and placed on line the six new cameras. On June 10 they were operational.

Five minutes after they went on the air a former employee called to congratulate them on the improved picture quality. Someone really had noticed — even if he was a former WLS insider. Gratifying as that lone call was, Kresnicka recalled, the real reason Dancaster and he performed their heroic feat was sheer desperation.

"The old cameras fell out of registration as soon as we took our hands away from them," he said. "It was almost impossible for the two of us to keep them on the air within anything but outright capture range. We had to get the new ones on line." As it turned out they were able to put them on line for 17 out of the 20 weeks of the strike, which lasted till October, and they are still on line.

At first they used the old cabling. But streaking problems motivated them to install the TV-81 minicable specified by Ikegami for the cameras. Now, with automatic pulse compensation (APC) built into the CCU's, they don't have to do anything when a camera is moved to another position with a different cable length. The cable runs are 225 feet in one studio, and no more than 275 feet in the others. They just unplug and replug the camera, turning off only power to the camera head but leaving 82

continued on page 82

See the Latest from Hitachi at NAB



Hitachi FP1020
Performance *PLUS* from a self-contained 3-Saticon ($\frac{2}{3}$ ") ENG/EFP color camera. Low power consumption, built-in vertical enhancer, plug-in PCB, auto white and black balance circuits, and much more.



Hitachi FP 3060
For professional quality pictures from a modestly priced, one-piece ENG color camera! Features new tri-electrode Saticon[®] tube, low power consumption, aluminum die cast body, tiltable and adjustable viewfinder, and an optional single coaxial power supply system.



Hitachi SK-90
Superb, broadcast quality ENG/EFP color camera (self-contained). Features 3- $\frac{2}{3}$ " Saticons with extra small prism optics, built-in ABO (Automatic Beam Optimizer) circuit, 2H Contour Corrector and Masking Amplifier, and low power consumption.

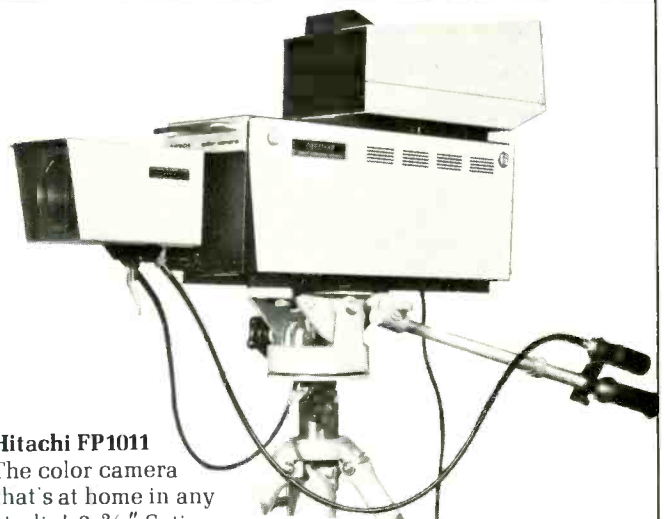

Hitachi FP1011
The color camera that's at home in any studio! 3- $\frac{2}{3}$ " Saticon tubes, multifunction RC panel, optional kit for conversion self-contained use, tiltable and detachable 7" viewfinder.

All this and a few more big surprises at the Hitachi exhibit. Don't miss it!

Booth #E-815, NAB Show.



HITACHI
Hitachi Denshi America, Ltd.
FORMERLY HITACHI SHIBADA CORP. OF AMERICA

Executive Office: 58-25 Brooklyn-Queens Expressway, Woodside, N.Y. 11377 (212) 898-1261 Offices in: Chicago (312) 344-4020, Los Angeles (213) 328-2110; Dallas (214) 233-7623; Atlanta (404) 451-9453; Denver (303) 344-3156; Seattle

Circle 156 on Reader Service Card

Automated Camera

CCU running. What with all the decabling and recabling, however, they decided to attach in-line connector adapters into which they would plug the cables rather than directly into the camera connectors themselves, thus reducing the danger of an expensive replacement of a worn or damaged connector pin or complete camera connector and consequent down time.

Each auto-setup computer can handle as many as five cameras. A push of the button on the computers (installed in the master control room) automatically programs the adjustment functions as well as the eight registration functions: H and V centering, width, height, H and V linearity, rotation, and skew. The P-18 Canon zoom lenses used on the HK-312's contain built-in test pattern projectors that come up automatically when the camera is addressed. The adjustments are handled in sequence by the computer, then double-checked. If all of them are within capture range, the procedure takes less than forty-five seconds per camera, so that the four cameras set up by computer #1 at WLS-TV are set up in less than three minutes each morning. Any time a camera is unplugged and connected to another cable at WLS-TV, the computer button is hit again for another auto-realignment check. If the camera is not in capture range (a rare occurrence according to Kresnicka), the technician need only make manual adjustments to the camera to bring it into capture range, at which point the computer finishes the job.

The consequence of the automatic setup feature, of

course, is the elimination of the need for a video control man for each camera, and it naturally became an issue in the strike. Without getting into the specifics of the settlement of the issue, Kresnicka explained what happened then and since.

"It reduced our crew requirements by about 20 percent, or four people, which took some convincing. But the cost saving from the automation in the studio enabled us to expand our mobile news operations with ENG equipment and crews," he said. "None of the former video control people were fired. They were moved laterally into other spots in the studio or into the mobile crews. And we've actually hired, oh, eighteen people since."

He also mentioned other byproduct aspects of the auto-setup feature. "Before, when the TD's were setting black level, we'd get one man's version of black — which, of course, would vary from person to person, depending on taste, and raise havoc sometimes in cuts. Now the auto-alignment does it objectively, so it's constant from camera to camera. At first the cameramen used to object to the camera's choice of black level, but gradually they began to accept it. Another thing that's interesting about the new setup is that the camera heads are almost independent of their CCU's. We can set up a CCU, then just plug in the camera head knowing that the head and the CCU will 'talk' to each other. We hit the setup computer button and in seconds they're ready to go." He did note that they're still debugging the cabling on the new cameras, but that such problems were par for any new system in the course of on-line operation the first year. After seven months of operation to date, the HK-312's are performing reliably.

BM/E

To make an impression that lasts use GE large screen TV projection

GE large screen television projectors are at work, today, presenting video information to audiences in Education, Business and the Arts.

At Universities, lectures, science demonstrations and off-campus programs are being presented in bright, color video, on screens up to 20 feet wide. At live seminars, overflow attendance is being accommodated in nearby facilities with large screen television projection.

At medical schools, surgical techniques and medical procedures are projected in images larger than life, with clarity and impact which facilitates subject retention and learning.

In addition to use at stockholder's meetings, seminars and training programs, business management also employs GE large screen television projection to present computer bank data. Coupled to computer facilities through interface equipment, it projects alpha numeric data, graphic displays and computer generated images in real time.

The GE Solid-state PJ5000 is reliable and designed to deliver projected pictures with high contrast, brightness and resolution, with simple remote control operation. Here's why:

- GE's exclusive single gun, simple optical path system generates the complete range of colors simultaneously.

No fussy alignment of three separate images.

- Single optical path provides the same color picture to everyone in the audience, regardless of his angle of view.
- Variable picture size from two to 20' wide for both large and small groups.
- Simple image changeover for front or rear screen projection, with sweep reversal switches.
- For easy set-up, internal sync and RGB Color Bar generators are provided.
- Convenient remote control unit allows picture set-up adjustments and operating control, at the projector or up to 200 feet away with the addition of an accessory control cable.
- Only power required is standard 120V/20 amp appliance outlet.
- No radiation hazard. Highest voltage used is 7,200V.
- High efficiency power conditioning circuits permit operation over a range of line voltages without affecting picture.
- Versatile projector mounting on table top or accessory rolling base. Easy to transport from one location to another.
- Compact in size and weight; projector and tilt mechanism weigh 135 pounds.

For more information call (315) 456-2562 or 456-2533 today, or write to: Video Display Equipment Operation General Electric Company Electronics Park—6-206 Syracuse, New York 13201

GE large screen
color TV projector
PJ5000

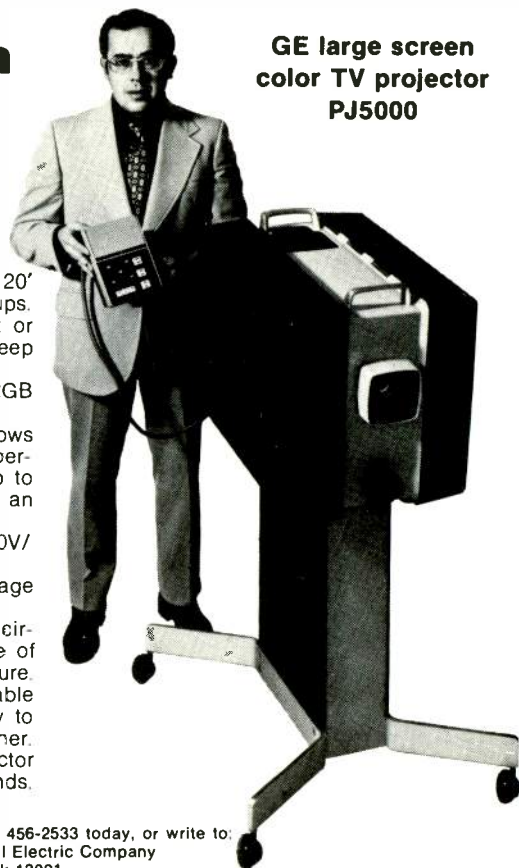

GENERAL  ELECTRIC

HITACHI SK-70

The One Camera That's Right for Both Field Production and the Studio!

The modular SK-70 converts easily from a fully equipped, self-contained color studio camera to a modified studio camera. In the field, the studio version of the SK-70 can be connected directly to a VTR with only a co-axial cable. And for hand-held portability, the camera head features a shoulder mount, an auto-iris portable zoom lens, and a 1.5" viewfinder, along with a DC and process pack. The Digital Command Unit (DCU) with up to 3000 feet of single co-axial cable strongly enhances the capability of the SK-70. Another striking option is a 22:1 zoom lens that can be used for the studio version of the SK-70 in the field.

No matter which configuration you choose from those shown in the photo and three diagrams, the Hitachi SK-70 offers the precision and reliability of three 2/3" Saticon tubes in the camera head to insure excellent picture quality, combined with all the latest advances in broadcast camera technology.

As you can see, our outstanding Hitachi SK-70 is a sound investment for broadcasters, production studios, and universities who need broadcast quality performance in a wide variety of assignments, all for the price of a single camera. We'd be pleased to arrange a demonstration of how the SK-70 can fit the following camera requirements inside or outside your TV studio, and more:

1. Fully studio-equipped

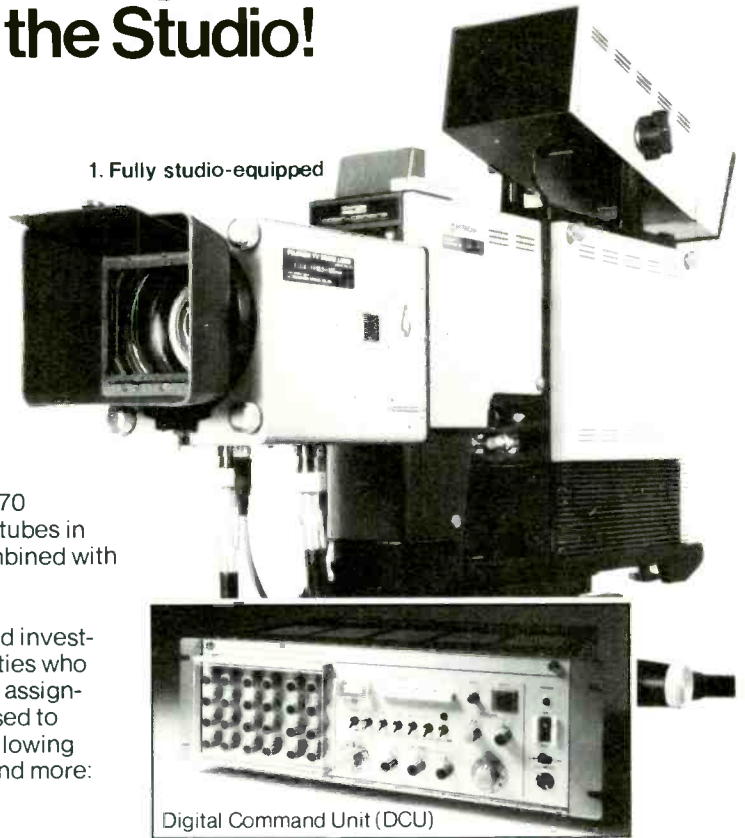

Digital Command Unit (DCU)

2. Portable Use

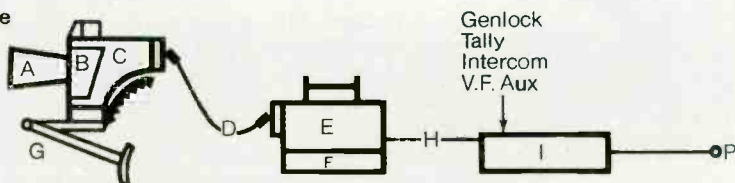

3. Field Use

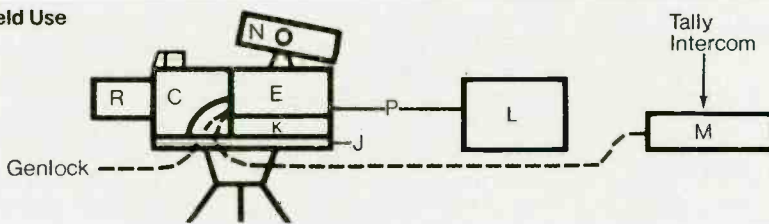

4. Modified Studio Use

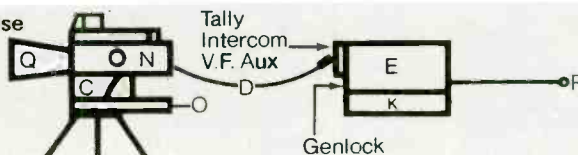

A)	Portable lens
B)	1.5" viewfinder
C)	Camera head pack
D)	Camera cable (300 ft.)
E)	Process pack
F)	D.C. pack
G)	Shoulder Mount
H)	Co-axial cable (3000 ft.)
I)	DCU
J)	Mount adapter
K)	A.C. pack
L)	VTR or FPU
M)	Operation panel
N)	5" viewfinder
O)	5" V.F. Mounting Plate
P)	Co-axial cable (video)
Q)	Portable lens w/conversion adapter
R)	Studio lens



HITACHI
Hitachi Denshi America, Ltd.
FORMERLY HITACHI SHIBADEN CORP OF AMERICA

Booth #E-815;
NAB Show

Executive Office: 58-25 Brooklyn-Queens Expressway, Woodside, N.Y. 11377 (212) 898-1261 Offices in: Chicago (312) 344-4020; Los Angeles (213) 328-2110; Dallas (214) 233-7623; Atlanta (404) 451-9453; Denver (303) 344-3156; Seattle

Circle 158 on Reader Service Card

Stored News Footage Speeded To NBC News By Computer-Assisted Microfilm Retrieval

Immediacy is a major component of TV News even when it deals with past events. This system provides rapid access to NBC's morgue



Janice Godfrey, an Archival Services staff member, reads a microfilmed abstract that explains the content of a segment of news film.

Cynthia Gagen, NBC News Archivist, mounts tape on the tape drive of the Micro 4000 mini-computer. Two 200 megabyte disc packs are used on a rotation basis and contain the NBC data base.



AT 5:30 P.M., AUGUST 1, 1977, editors of *NBC Nightly News* learned that Francis Gary Powers had been killed in a Los Angeles helicopter crash. It was only one hour before air time, and they needed news footage fast on Powers' past activities.

Powers' name was thrust before the world in 1960 when the U-2 spy plane he was piloting was shot down over Russia just before a summit conference scheduled between President Dwight D. Eisenhower and Russian Premier Nikita S. Krushchev. Powers was convicted by a Russian court of spying and sentenced to jail. The incident created an international crisis and caused cancellation of the summit conference.

Powers was released in 1963 and was a helicopter pilot for KNBC's news department in Los Angeles at the time of his death. But his national prominence merited a film report, even though time was tight.

The network news team rushed into action starting with a call to the news archival services library. Editors wanted all the film footage, scripts and background on Francis Gary Powers. The search began on one of the library's computer terminals. NBC has been using a computer-assisted microfilm retrieval (CAR) system since January to find film and videotape stories and background information to fit the needs of network news editors and producers of documentaries. The computer maintains a voluminous but easily accessible index of all the library's material, including the location of microfilmed abstracts that explain what each news clip contains. The system also tells where the film clip is located in NBC's storage facility at Fort Lee Film Storage and Service Co., just across the George Washington Bridge in Fort Lee, New Jersey. NBC has about 250 million feet of news film and thousands of hours of documentaries stored there. Fort Lee Film also maintains NBC's stock footage library.

In the case of a breaking news story, such as Powers' death, the researcher called the storage company and asked for the film, reading the storage locations from the microfilm reader-printer's screen. A local taxi cab delivered the film to NBC's studio. At the same time, printed copies of the microfilmed abstracts were given to the editors so they would know what to look for when the footage arrived.

As a result of modern microfilm and computer technology, *NBC Nightly News* viewers all over the nation that night saw 55 seconds of an obit on Powers, plus a report from the crash site by KNBC-TV, the NBC-owned station in Los Angeles. A documentary, among the footage brought from Fort Lee to NBC at Rockefeller Center, was made when Powers was exchanged for Soviet master spy

continued on page 86

First Hitachi developed the revolutionary Saticon tube. Then Hitachi designed the perfect camera for it...

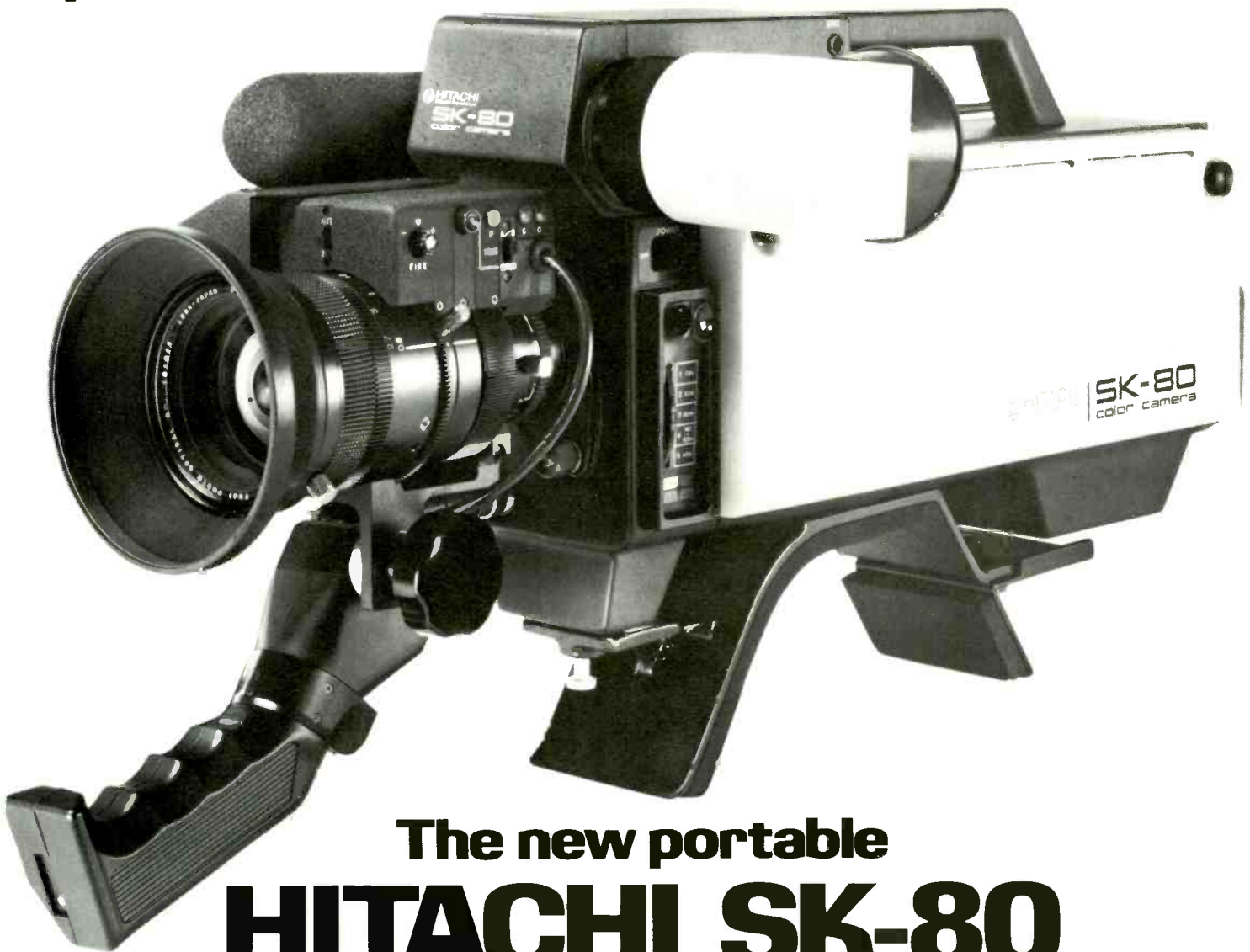

The new portable **HITACHI SK-80**

The remarkable new SK-80 has three superior $\frac{2}{3}$ " Saticons at its heart, for unexcelled image and color fidelity. Hitachi's sophisticated electronics coupled with the high resolution capability of the Saticon set a new high level of performance for a portable EFP camera under the most demanding conditions.

Moreover, the SK-80 feels and handles like a true portable should. And its 2-hour battery belt with 1-hour charge time assures you of adequate power for continuous long-term shooting when you're on location. The standard C-mount and optional Arri adapters give you the added versatility of selecting the exact lens that fits your shooting requirements.

But performance is only half the SK-80 story. A special training tape on videocassette is available with complete camera set-up and maintenance instructions, to help you keep your SK-80 making its excellent pictures. Beyond this, our six Hitachi regional offices are all staffed with qualified engineers and fully stocked with parts. They stand ready to back up our vast national network of servicing dealers.

We urge you to check out the performance features of the SK-80, as well as its low price, before specifying any other camera. Arrange a demonstration with your local Hitachi dealer or call the Hitachi regional office nearest you.



HITACHI
Hitachi Denshi America, Ltd.
FORMERLY HITACHI SHIBADEN CORP OF AMERICA

Executive Office: 58-25 Brooklyn-Queens Expressway, Woodside, N.Y. 11377 (212) 898-1261 Offices in: Chicago (312) 344-4020, Los Angeles (213) 328-2110, Dallas (214) 233-7623, Atlanta (404) 451-9453, Denver (303) 344-3156

Circle 158 on Reader Service Card

Booth E.815, NAB Show

Microfilm Retrieval

Rudolph Abel.

Power's death was one of the three occurring during a two-week period in August that were considered breaking news and required the speed of the CAR system. Word of Elvis Presley's death was received an hour and ten minutes before air time, and news of Archbishop Makarios' death in Cyprus was received at midnight, seven hours before the *Today* show. Handling the Makarios story required researchers and editors and warehouse personnel to come to work in the wee hours of the morning. Footage from Fort Lee was used on the network newscasts of all three stories. Although the CAR system gives NBC News fast access to film for news stories, when production staffs of documentaries have the luxury of time, it can provide them with the summaries and locations of every inch of film that might be remotely connected with their subjects. It can find film through Seven Search Categories.

NBC believes its system is breaking new ground in the broadcasting industry. It offers the user the following categories to search: personality, subject, place, date of event, receipt date of story, identification number, and source, an umbrella term to include reporter, cameraperson, bureau and assignment number.

"CBS has a system similar to ours," says NBC News Archivist Cynthia Gagen, "and ABC is looking into several systems. None of the networks in Canada or the United Kingdom have completely computerized film libraries, and the French national network has a printed index which may be computerized."

With no examples to follow, NBC made up its own rules as it went along.

"We tried the New York Times Index for a year," says Sigmund Bajak, Director of News Services. "Then we developed our own cataloging to fit our specific needs. But before we commit any story to our index, we let it sit for 30 days to settle. In that time, we can see the story in perspective and determine its importance. Originally, we wanted to get everything on the story down in the abstracts. But we learned that we could only record the basics."

Film clips and news videotapes are handled in essentially the same way on the CAR system. Known as "Sunshine" to the News Services department, the system consists of a Zytron Micro 400 computer with seven video display terminals, two hard copy terminals, and a Recordak Microstar reader, model PR-1, Recordak with printer, model ERG-1, and a Recordak image control keyboard, model IC-5P.

Up to 56 different items of information can be entered into the computer, which has two 200-megabyte disc packs capable of storing 400 million characters of information.

Each story is assigned a work sheet. This contains the film or tape identification number, date, title, place, reporter, cameraperson, program on which it appeared, technical information on story's length and the medium on which it was recorded, all the indexing terms needed to retrieve the story, an abstract of the story and a summary of the abstract.

The abstract not only tells what is on the film, but also the background and additional information on the story. The information can be culled from other sources, such as daily newspapers.

Abstracts on videotape stories are completed by reviewers at NBC's studios in New York. Film stories are

continued on page 90

At Last, a Cart Machine that Keeps its Cool

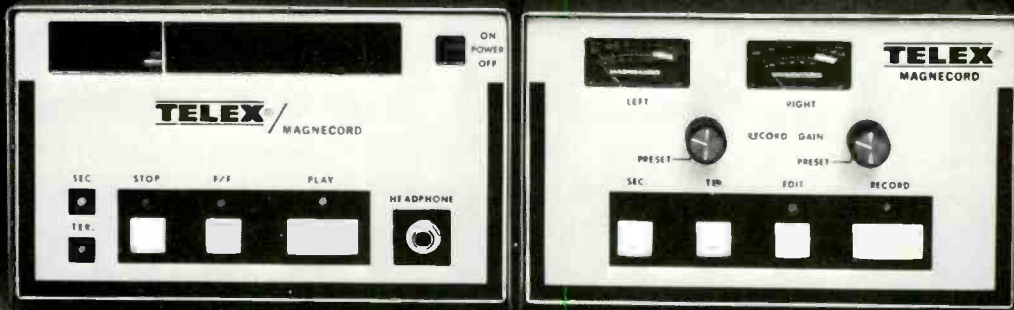

Telex/Magnecord broadcast cart machines run cool and steady. So cool no ventilation is required, so steady not even voltage or frequency fluctuations will alter their speed. Thanks to our dc servo flutter-filter drive.

The MC series offers broadcasters a host of options, including field convertability from mono to stereo or play to record and, of course, end of message, secondary/tertiary cue tones.

Designed for type A or B carts, the MC series meets all NAB specifications, offers full immunity to EMI and RFI, is remote controllable and automation compatible with CMOS digital logic. Audio muting, air damped low voltage

dc solenoid and fast forward are standard features on every MC unit.

Four broadcast cart machines to choose from in the Telex/Magnecord MC series. Running cool and steady. With a pleasant surprise—they're affordable.

For detailed information please write:

PRODUCTS OF SOUND RESEARCH
TELEX[®]
COMMUNICATIONS, INC.

9600 ALDRICH AVE. SO. • MINNEAPOLIS, MINN. 55420 U.S.A.
Europe: 22 rue de la Legion-d'honneur, 93200 St. Denis, France
Canada: Telak Electronics, Ltd., Scarborough, Ontario



'Take Me Anywhere'

That's a "no-strings" invitation from Hitachi's amazing FP3030 color camera. It's the first time a self-contained portable camera has packed so much quality into a lightweight, compact housing that, better yet, goes for such a painless price.

No wonder, then, that the FP3030 has received such an enthusiastic reception from corporations, schools and hospitals. They find it gives them unrestricted mobility in all their communications and training programs. Broadcasters also are utilizing the FP3030's unique capabilities for everything from at-the-scene news gathering to field documentary production.

The FP3030's diverse current user list reflects the camera's ability to deliver results that meet the high standards of America's top communicators...in broadcast, industry, and education. And we think that's quite an endorsement for a camera that runs less than \$5,000!

A few key features of the FP3030's design: • Easy to use. Just point and shoot. • Featherweight portability: weighs only 8½ lbs. complete. • Exclusive single Tri-Electrode Vidicon tube for registration-free color. • Internal NTSC, or external sync for multi-camera system use. • 3-way power—uses AC line, battery, or external DC (12V). • Can be used with any video tape recorder from cartridge to quad.

Your authorized Hitachi dealer will be glad to demonstrate the FP3030. Write or call for the name of your nearest dealer.



HITACHI
Hitachi Denshi America, Ltd.
FORMERLY HITACHI SHIBADEN CORP. OF AMERICA

Executive Office: 58-25 Brooklyn-Queens Expressway, Woodside, N.Y. 11377 (212) 898-1261
Offices in Chicago (312) 344-4020—Los Angeles (213) 328-2110—Dallas (214) 233-7623—
Atlanta (404) 451-8453—Denver (303) 344-3156

Booth #E-815, NAB Show

Circle 161 on Reader Service Card

FUJINON

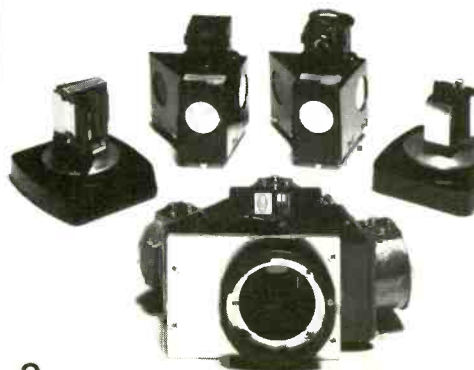

Always the best choice. Now, the first choice.

New all-in-one case gives hand held cameras studio flexibility.

Now you can take on any field or studio assignment with Fujinon's outstanding ENG-type lenses and all-in-one case. With one lens on the camera, and two in the shock and weather protected case, you're ready for anything. Case holds the lenses, cables and accessories. (A single lens case is also available.)



1. For field and close-in shots, it's

Fujinon's exclusive F/1.9 14x10 Zoom with built-in 2X extender. Flip the button and you get 20 to 280mm (that's equivalent to a 544mm on a 1 1/4" format). It's the only lens today to offer all these features. Weighs only four pounds and gives you all three servo functions: zoom, focus and iris. It also has built-in macro and back focus adjustment. M.O.D. is just 31 inches.

2. For studio and field use, it's the Fujinon 12x9 F/1.7 lens that zooms from 9 to 108 mm. The "workhorse" of the industry and the most useful lens you could use. Weighs just three pounds and gives you the same 3 servo functions as the lens above.

3. For that close or ultra wide shot, even under low light conditions, it's the Fujinon F/1.4 ultra wide 6mm lens. The only fixed focal length lens that focuses from 0-inch to infinity with better than a 70° horizontal field of view. Weighs less than 4 1/2 pounds. Manual focus, servo iris.

Fujinon BCTV lenses — fast becoming the industry standard.

Your new studio or field cameras should come equipped with Fujinon BCTV lenses. Everyday, more and more camera manufacturers, networks, stations and production companies are specifying Fujinon. Because Fujinon is visibly better. Here are some examples.

4. Close focusing wide-angle zoom . . . The widest on the market. Focus down to less than 1 foot with better than a 59° horizontal field of view.

1 1/4"	1"
10x15	10x11
f/2.8	f/2.1
15-150mm	11-110mm

5. Wide-angle high resolution zoom. M.O.D. is less than 2.5 feet for studio and field work.

1 1/4"	1"
14x17	14x13
f/2.2	f/1.6
17-240mm	13-182mm

6. Lightweight 4-range wide-angle zoom. Use the pushbutton controlled, built-in 1.5, 2, and 2.5 range extenders for up to a 40X zoom. The studio standard.

1 1/4"	1"
16x17	16x13
f/2.1	f/1.6
17-270mm	13-210mm

7. Triple-range field zoom. Built in 1.5 and 2.5 range extenders give up to a 55X zoom.

1 1/4"	1"
22x25	22x18
f/2.2	f/1.8
25-550mm	18-400mm

8. Twin-range field zoom. From 30X to 60X at the push of a button with its built in 2X range extender.

1 1/4"	1"
30x20	30x16
f/2.2	f/1.8
20-620mm	16-500mm

Servo plug in modules available for all lenses.

Fujinon Color Optical Systems — now found in virtually every new camera.

9. Beam splitters, the standard of the industry. So widely used, it would be tough to find any cameras being made today without Fujinon.

Here's what makes Fujinon better.

The best glass. It's made in platinum crucibles to eliminate impurities. The result? Japan's best known lenses use Fujinon glass.

Computer assisted design. The most modern computer systems available help Fujinon engineers design optical systems so advanced, they're changing the state of the art.

E.B.C. That's Fujinon's exclusive Electron Beam Coating. So thin, up to 11 coatings are applied creating lenses that give 99.6% light transmission. Almost perfect.

Testing. Fujinon lens testing, for example, includes resistance to humidity, shock (vibration and dropping), temperature, salt water spray. Optical Transfer and Modular Transmission Function testing are employed to measure high contrast performance.

Fujinon lenses are unexcelled for spectral transmission and flare characteristics. When it comes to color rendition and fringe transmission, especially in the extreme wide-angle position, Fujinon lenses are light years ahead.

All of which helps explain why Fujinon is fast becoming the world's leading line of lenses. And Fujinon service will keep your productions on schedule. See the differences for yourself. For more information, phone (914) 472-9800 or write:

Fujinon Optical, Inc.
672 White Plains Road
Scarsdale, N.Y. 10583



Part of the Fuji Photo Film Group

**SEE FUJINON AT THE 1978 N.A.B. CONVENTION
Booth 528 Las Vegas Convention Center, April 9-12, 1978**

Circle 162 on Reader Service Card

Microfilm Retrieval

handled by reviewers at Fort Lee Film. Completed work sheets and abstracts are entered into the computer, and data analysts in the library call them out for final verification. Once approved and validated, the information is generated into the catalog (a computer-based file) stored on disc, and is now displayable and searchable within the seven categories. The final sheets and abstracts are printed out on a hard copy terminal and are microfilmed. Generally, the library waits until it has a batch of 500 to 600 documents to microfilm at one time, which usually occurs twice a week. Microfilm is sent to Kodak for processing. There, it is mounted onto cartridges and returned to the

NBC News' 250 million feet of new film documentary and stock footage are stored at Fort Lee Film Storage and Service Co. Computer contains warehouse location as well as descriptive information.



library for indexing, that is, cross referencing the cartridge and page number with the film reference number.

In addition to using the files for its own news department, NBC also makes film available to CBS, ABC and PBS in this country and to Canadian and European networks.

"They are interested in precise reporting of American news," Miss Gagen says of the foreign networks.

For producers of films and documentaries, the computer's access to a wide range of topics increases its value.

"We get about 150 written and telephone requests a week for film and videotape," Miss Gagen says. "That might not sound like a lot, but some of those can take a long time to complete."

For example, Universal Studios has a request that could take six weeks to complete. The studio is making a film version of the novel *Loose Change* for NBC's *Big Event*, and it needs footage of events that occurred between 1961 and 1973. Topics to be covered include presidential inaugurations, assassinations, the Cuban missile crisis, Vietnam, space shots, civil rights stories and others that probably only the computer can remember.

Producers of a documentary on health, to be aired in 1978, have been looking at footage of health-care technology, Laetrile, health costs, abortion and other related topics. For a documentary on *Violence In America*, footage on a wide range of subjects was viewed.

For a "roast" of former President Gerald Ford, a new category of politicians' non-political activities was added to find footage of the former President making slips of the tongue, tripping on stairs and other faux pas.

While the computerized file is available only to NBC in New York, Miss Gagen says it may be possible for other network stations to buy their own computer terminals and make full use of the library's facilities.

BM/E

VTR IMPROVEMENT PLAN

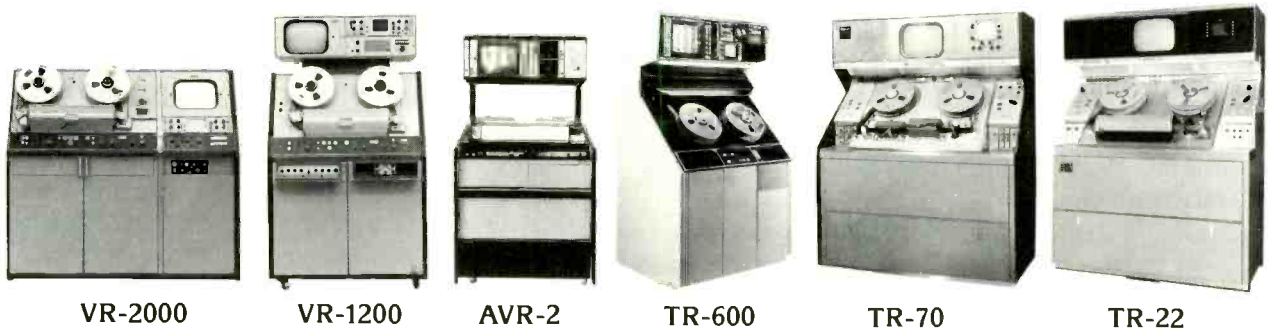

VR-2000

VR-1200

AVR-2

TR-600

TR-70

TR-22

Installation of R-MOD (reel servo modification) Provides Tangible Benefits

- Automatic Search and Cue—Saves operator time
- Automatic End-of-Tape Stop—Saves video heads
- Constant Tension Tape Handling—Saves tape
- Electronic Tape Timer—Improves accuracy
- Faster Lockup—Consistent for any reel size
- Built-in Tape Cleaner—Saves tape and heads
- Remote Control—Ready for station automation
- Faster Acceleration—Improves editing time
- Extends VTR Life—Alternative to new machines
- Intelligent Interface—Universal for all VTRs

RECORTEC, INC. 777 PALOMAR AVE., SUNNYVALE, CA 94086 TEL: (408) 735-8821 TELEX: 910 339 9367

It's A New Era For Radio And Television On The Campus

Television is not to education what it is to entertainment — not by a long shot. And radio as an instructional medium on campus or off barely exists. But a new perspective on these media as teaching tools is emerging, as the examples cited here show.

DIAL ACCESS TO ANY VIDEO TAPE course in the instructional media center is an idea that flowered briefly and withered quickly. The climate for such a technological phenomenon on most campuses is far too arid. To be sure there are oases here and there but they are the exception. Nor have college campuses been redesigned wholesale, as once envisioned, into TV lecture complexes where instructors equipped with large-size rear projection screens, remote-controlled cameras, and what not, might do multi-media extravaganzas. Many colleges which do have this capability are not fully utilized.

After a quarter of a century of television, not more than a few percent of the nation's college faculty use video. Usually those who do are found mainly in institutions where "instructional development" is heavily stressed. Radio gets used even less. Nonetheless instructional television is a viable medium and is a solid force these days. Each year a few more instructors turn to TV to become

Communications Technologies In Higher Education

In the course of our research for this issue, we perused some 22 profiles included in *Communications Technologies In Higher Education* (Communications Press, Inc., 1346 Connecticut Ave., N.W., Wash., D.C. 20036, HC \$13.95, PB \$7.95 plus 50¢ postage). All profiles were interesting and particularly so the effort of professor of English Paul Briand, SUNY, Oswego, NY, who teaches writing (among other things) through the imaginative use of three-screen multimedia presentations. In a follow-up with Richard Pfund, director of Learning Resources Center at Oswego, we got some further interesting inputs which are reported in this issue.

Other accounts of extensive use of TV at institutions of higher learning describe the 20-year old Chicago TV College, The British Open University, Outreach By Telephone at the Univ. of Wisconsin, and "the gospel of media" at Brigham Young Univ. Most fascinating, however, for perspective, were the accounts of how educational technology failed to live up to early expectations at Stephens College, Columbia, MO, and at Florida Atlanta Univ. These stories of dreams defaulted in the late sixties and early seventies are interesting but they should not be taken as the state of affairs today as many are prone to do. This issue belies old impressions but if one wants a very good summary of the effectiveness of television in higher education, *CTHE* offers it in its final chapter written by Ruth Weinstock, Educational Facilities Lab (and editor of the series) entitled "Growing Up Wise: Shaped By Lessons Of The Past, Technology Is Serving New Clients, New Needs." That chapter title is a most accurate description of what *BM/E* found in it's calls about the country.



One of the 72 individual viewing carrels at Univ. of Texas dental school.

more effective in their teaching. And as more and more adults engage in life-long learning, i.e. enrolling on continuing education programs, even radio is getting back into the act.

But what is happening today is not like what took place in the sixties when TV was necessary to reach students who couldn't fit inside overcrowded classrooms. By the mid 70's enrollments in colleges were down; now administrators and faculty are concerned with how to avoid empty seats.

Decline in enrollment means cuts in staff; and it is concern over job security that has turned some college educators to television. The instructor who gets a good rating from the student body is safer than one who does not. And since the entire student body these days has been reared on television, they are receptive to that medium being used intelligently in the classroom. So it follows that "attuned" instructors will learn how to master the medium.

But fear of losing one's job is not the official explanation for the stepped-up interest in using TV in the classroom. Nor is it fair to those universities who have indirectly promoted more utilization of TV as a consequence of a *genuine pursuit of excellence*. That is to say, on many campuses today there is a big push toward what is called Professional Development, Faculty Improvement, or Excellence Through Innovation. (See box, Faculty Development: A Big Movement). Often the measure of an improved faculty member is his or her effectiveness in the use of *instructional media* — which often means ITV.

A case in point is State University of N.Y. (SUNY) at Oswego. Oswego has been singled out by the Society of College and University Planning and Educational Facilities Laboratories as an institution where some exciting things have happened. This results from the existence

continued on page 92

Radio And TV On Campus

of a comprehensive Learning Resource Center and a program of assistance in "instructional development."

Instructional Development gets into curriculum planning (including studying instructional options available), selection of equipment and materials, and cost estimating. Faculty workshops are conducted to help in program planning and in evaluating results.

This last summer, 24 staff members attended an Instructional Development Institute. One outcome was the plan to offer last fall and this winter a radio program for credit. Subject is philosophical foundations of learning. Intended audience is public school teachers in the county.

Instructional Development at Oswego (as elsewhere) is a systematic process which tries to help educators develop the most effective and efficient programs possible. This means a variety of teaching-learning options are explored with selection based on expected learning outcomes.

A basic assumption at Oswego, according to J.R. Pfund, director of the Learning Resource Center, is that curricula should be designed "to foster the ability of each person to accentuate his own unique potential." This means curricula should be structured to accept students "where they are" and provide whatever options are necessary to take them "where they believe they should be." A learning situation should create a state of "intellectual turmoil" to stimulate further self-development.

To meet the needs of students who may not be ready for the same learning experience at the same time, the curriculum should be packaged in small modules. Varied content options should be used. Media should be picked to improve teaching-learning effectiveness but it should rec-

Faculty Development: A Big Movement Helping ITV

To fully understand the current growing interest in instructional TV and radio, one must appreciate the intensity of concern for professional or faculty development. It would probably be hard to find a college today that does not have a professional development program of some sort.

J. Richard Pfund, Learning Resources, State Univ. of N.Y., at Oswego, included in a kit of materials sent to *BM/E*, a "Selected Bibliography on Faculty Development." It includes over fifty titles, most of them dated 1974 or later. Dr. Albert B. Smith of the Univ. of Florida, publishes a newspaper on the subject, "Faculty Development and Evaluation." The Univ. of Michigan's Center for Research on Learning and Teaching puts out a newsletter which regularly comments on new resources for teaching (including ITV). The Society for Values in Higher Education sponsors Project in Institutional Renewal through Improvement in Teaching (PIRIT). Located at 1818 R St. NW, Washington D.C., 20009, PIRIT also puts out a newsletter. Its director, Dr. Harry G. Gaff, is the author of a recent book, *Toward Faculty Renewal* (Jossey-Bass). A salient theme: schools must help faculty members design effective learning experiences for students and assist in the adaption of innovative methods of instruction.

How this was done at Michigan State University and how it relates to instructional television's growth is covered cogently in a book *Commitment to Excellence, A Case Study of Educational Innovation* by Davis et al. A good survey of what is happening in various colleges is contained in a book published by the Great Plains National Instructional Library, *Media and the Adult Student: One Man's Journal* by Robert Carlyle (\$6.95 GPN, Box 80669, Lincoln, Nebraska).

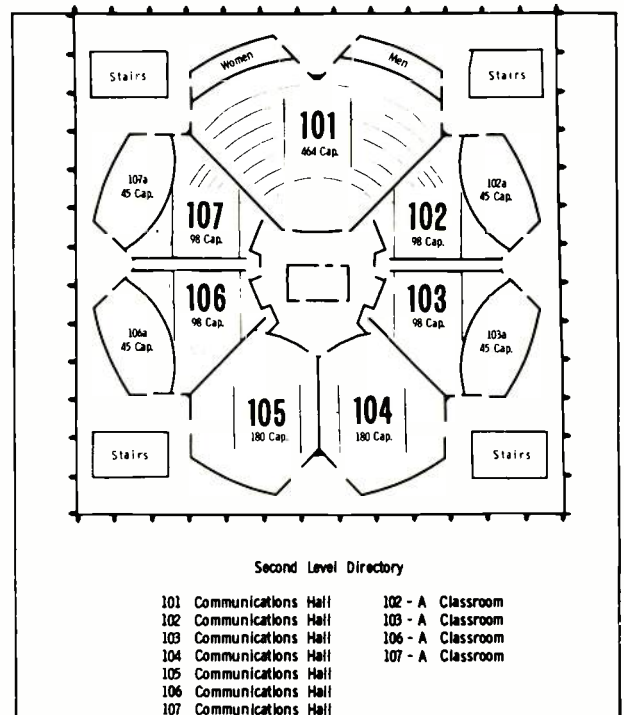

TV communications halls (equipped with slides, 16mm projectors & TV) are in upper level of Learning Resources Center.

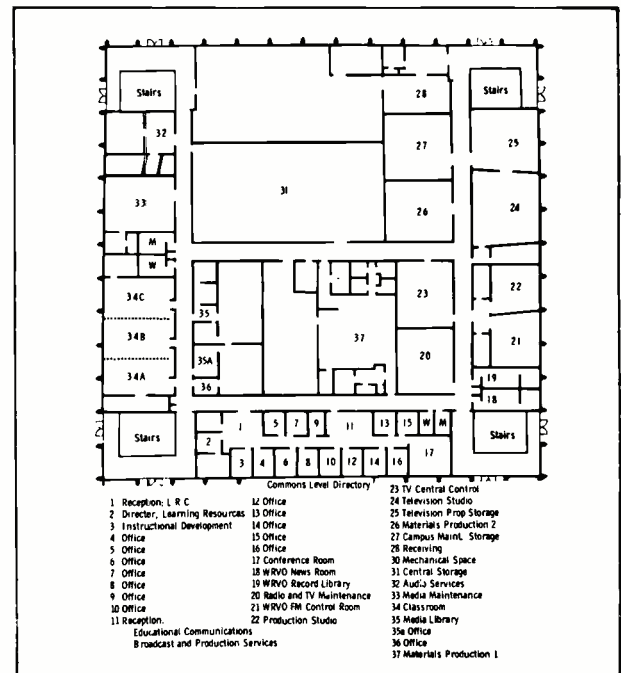

Facilities in lower level of Learning Resources Center are quite complete.

ognize that all media are not equally effective for all disciplines.

Dealing with all these criteria is a tall order — usually beyond the ability of a lone instructor. The LRC at Oswego provides help through its Campus Media Services group and its Broadcast and Production Service group in addition to the Instructional Development function. Campus Media Service provide media services for large group presentations, standard classrooms and self study. The Production and Broadcast Service includes an audio facility, a graphics department and a television studio. Part of this facility is WRVO-FM, a 7-day a week 24,000 watt

continued on page 94

For the truest picture of transmitter performance available.



The Philips TV Demodulator.

- Direct channel selection for easy shift to other RF sources
- AFC corrects for transmitter offset
- Synchronous detector for very accurate demodulation
- Automatic gain control eliminates measuring errors caused by drift of output level
- Quadrature output for incidental phase modulation
- Tight amplitude and group display profiles for very precise analysis and adjustment of transmitters and modulators
- Built-in vision rest carrier meter and sound deviation meter

If you are determined to maintain maximum control of the quality of the signal you transmit, this laboratory-quality demodulator is

an essential piece of equipment. With the proper video and audio measuring set-up to monitor not only the quality of the transmitted signal, but even the modulation depth.

We also make modulators, VITS analyzers, video signal generators and pattern generators, all with Philips' traditional respect for quality, ease-of-operation, and reliability.

For more information on what Philips can do to help you maintain signal quality, call Stuart Rauch on our toll-free Hotline number: (800) 631-7172 (New Jersey residents call collect). Or contact Philips Test & Measuring Instruments, Inc.

In the U.S.:
85 McKee Drive
Mahwah, New Jersey 07430
Tel. (201) 529-3800

In Canada:
6 Leswyn Road
Toronto, Canada M6A 1K2
Tel. (416) 789-7188



PHILIPS Test & Measuring
Instruments

PHILIPS

Circle 164 on Reader Service Card



**RANK OPTICS
TAYLOR-HOBSON**

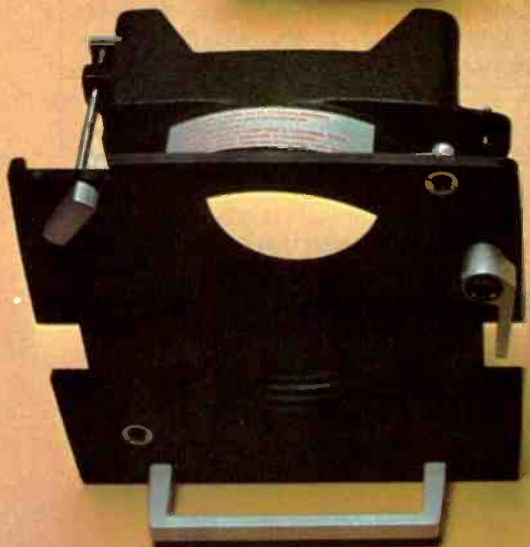

The world's most compact lens and the world's most flexible TV System—it's all in the packaging

Whether you have standard or mounted portables, or both, you set the specification for what you want to achieve and then select from three front units. The main body of the lens stays the same—focal length 13 to 728 mm. It takes only seconds to change the front for:

Wide angle (52° — 2°) copes with the studio and smaller outside broadcasts. (M.O.D.—2 ft.).

Narrow angle zeros in on those 1° shots and infinity closeups for outside broadcasts.

All purpose (44° — 1.6°) (M.O.D.—4 ft.) economy version gives you a lens of broadcast quality and performance for utility shots.

Zoom and focus modules are quickly interchangeable for both manual and servo operation.

Varotal MRL—experience the economy, the standard of quality and performance that is yours with the quick change artistry of Taylor-Hobson. Call or write for literature:

RANK PRECISION INDUSTRIES, INC.

260 North Route 303, West Nyack, N.Y. 10994,
(914) 358-4450

Circle 167 on Reader Service Card

Radio And TV On Campus

Academic Services.

The campus classroom network is 70 miles long and includes 178 rooms in 26 buildings. The network handles eleven channels. Nineteen classrooms have student talk-back circuits. Additionally, two channels of ITV courses go to student apartments off campus that are served by the local CATV company, National Cable.

During 1976 the number of regularly scheduled exclusively TV lecture courses was 72 and enrollment was 23,853 students. Television Student Credit Hours (TVSCH) defined as credits divided by class hours \times TV hours \times enrollment equalled 53,561 hours. Taking into account courses that used *some* television (scheduled) the number was 356 and student enrollment was 51,344. See Fig. 1 for more details. Comparative year end totals for six years are shown in Fig. 2. Note the big increase in courses that use at least some TV (up 89%) and the increase in production hours (34% increase).

Jorgensen reports that the centralization effort and the sharing of facilities and staff are necessary to achieving efficiency and effectiveness. This appears to be true for all

campuses where progress is being made. His comments on "What We Have Learned About ITV" (at MSU) are worth quoting in full.

Several valuable lessons have been learned over the past twenty years of applying television to the purposes of instruction and learning at MSU. Many more have yet to be learned. Although teaching and learning by television has been the subject of more research than most other innovations in education, more careful research is needed in the applications of this medium. Among the most valuable of the lessons learned at MSU is the importance of organization and direction linked to the highest academic authority in the University. The usefulness of ITV at MSU has grown because the facilities have been provided on a University-wide basis. Other institutions have permitted ITV to grow in a decentralized fashion with the result that insufficient staff and facilities have been available to produce quality instruction. Furthermore, MSU has integrated its ITV, and other media production as well, with the thrust toward instructional development and systematic design. Future needs for high quality televised instruction, on-campus as well as off-campus, will be significantly easier to meet because of these two factors.

ITV planning must be integrated with total course planning in order for the medium to contribute fully to effectiveness and efficiency. We have learned that this requirement is not easily

continued on page 98

Instructional And Public Television Facilities At Michigan State Univ.

ORIGINATION

***Erickson Hall Color Studio.** 20 x 40 ft. studio equipped with two broadcast quality color cameras (Philips PC 72), an overhead vidicon camera, two film-slide chains, audio, effects and related equipment.

***Life Sciences Building Color Studio.** a 30 ft. x 30 ft. studio equipped with two broadcast quality color cameras, (Philips PC 70), film-slide chain, audio, effects, and related equipment.

Wells Hall Lecture Auditorium. Teaching auditorium equipped with two image-orthicon monochrome cameras, (RCA TK 14), instructor-controlled overhead vidicon camera, film-slide chain, effects, amplifier, shotgun audience microphone, audio console, video monitors, P.A. system, projection and related equipment.

***WKAR-TV Color Studios.** Two studios (30 ft. x 40 ft. and 35 ft. x 40 ft.) equipped with five broadcast quality color cameras (four RCA TK 45, one RCA TK 44), film-slide chains, patio access, audio, effects and related equipment.

Mobile Unit. Van, three color cameras, one quad VTR, associated broadcast level video and audio gear designed for broadcast quality remote originations.

Portable Units. Two portable filed units with broadcast quality cameras (one Philips PCP 90, RCA TKP 45), a portable high band quadruplex recorder (Ampex VR 3000), Sony 2850 videocassette recorder and associated audio and lighting equipment. Battery or a.c. power operation possible with the PCP 90 and VR 3000.

RECORDING/EDITING

Instructional and Public Television operates ten high band color quadruplex videotape recorders (eight RCA TK 70, two TCA 600), seven monochrome (Ampex 1100 and 1000C) quadruplex recorders and a portable high band quadruplex videotape recorder (Ampex 3000). Tape rooms in two locations on campus each provide for quadruplex editing with RCA TEP units; a third location houses Sony videocassette editing equipment with remote control operation. In addition, several one-inch, half-inch and three-quarter-inch cassette helical scan recorders are available for copying and editing of recordings. A system on one-inch recorders, cameras and related audio and switching

**Four studio-control room complexes provide broadcast quality double re-entry video switching with special effects and chroma key. One is equipped with a character generator.*

equipment serve the Learning Services Experimental Classroom facility. Three hundred additional helical scan videotape recorders and camera systems are maintained for 50 University departments.

DISTRIBUTION

Campus distribution is provided by means of cable interconnection among a number of University buildings. The system carries instructional television materials into more than 200 dormitory and on-campus classrooms and laboratories in 26 buildings. The coaxial cable system handles 12 channels. An antenna receiving system makes it possible to feed these channels with any of the local television stations' signals throughout the campus network. Also, the East Lansing CATV system can feed 21 channels into the campus system.

The East Lansing CATV system carries two channels of instructional material provided by Instructional and Public Television. Courses totaling 100 hours per week are distributed through the National Cable Company to residents of the MSU married housing complex. Sixty percent of the 2400 apartments are subscribers to this CATV system. Begun as an experiment to determine problems connected with CATV off-campus distribution, the schedule fills two channels weekdays from 8:00 a.m. to 9:00 p.m.

Broadcast distribution of Instructional and Public Television materials is a function of WKAR-TV, the public television station licensed to the Board of Trustees of Michigan State University. Tapes of IPTV materials are also distributed. Through the Central Education Network and the Public Broadcasting Service, extended distribution of IPTV materials is possible.

LARGE SCREEN PROJECTION

Two television projection systems are operated by ITV (GE PJ 5000 and Advent 1000 A). The larger unit is semi-permanently located in a 533 seat auditorium equipped for projection to a 9 x 12 foot screen. The other is available for use in smaller rooms and projects on a 4 x 6 foot screen.

STAFF

Ninety full-time professionals staff Instructional and Public Television. In addition, fifty part-time student employees and interns assist the staff. IPTV is a division of Academic Services in the Office of the Provost at Michigan State University.

Radio And TV On Campus

met without mutual trust between faculty member and ITV producer. Much university teaching is a solo performance by an individual faculty member. Television, in contrast, requires a team effort and precise advance planning. It is difficult for the typical faculty member to start from the beginning in the redesign of his course. Yet television, fully and effectively used, requires redesign and recasting of traditional classroom messages into new forms. Selecting the elements which can most usefully be televised requires consideration of all the elements in the course, including the student's perceptions and competencies as well as those of the teacher. Such a redesign requires full cooperation from all members of the team and a willingness on the part of the faculty member to relinquish some of the control he has typically held and assume new roles.

Producing instructional television lessons and materials has also taught us the error of blindly adopting the styles and forms of other educational or commercial television entertainment or information programming. Instruction at the collegiate level is frequently criticized for being overly pedantic and dull. *Yet nothing is more distracting than unnecessary humor, drama or production technique* (italics added). On the other hand, clear and precise presentation of well-organized and intelligent ideas and interpretations are of themselves compelling and attract the full attention of learners in higher education. Much of the content we deal with in college instruction is abstract and verbal in nature. Such subject matter frequently requires better organization and improved presentation rather than increased visualization and production technique.

Yet good production and visualization is absolutely essential to improved instruction in other cases. Faculty members are frequently unskilled in the visualization of their instructional materials. Here the ITV producer with training and experience in

television production and instructional development must be co-equal with the faculty member in order for effective ITV to result.

Finally, we have learned that the student in today's college classroom is a product of the electronic age. He is a sophisticated viewer of television with long experience. He is quick to judge our instructional television product against the high standards of what he knows is possible with television. He has watched the world through television. He has learned much through this medium. He has been taught by all kinds of expert television teachers from Captain Kangaroo to Walter Cronkite. He has learned fully prepared and produced messages from commercials to presidential addresses. He knows TV can teach. If we're to succeed, we cannot be less professional and less creative than these other users of the television medium.

Individual Programming at Univ. of Texas

Self-directed learning is a key component of the educational program at the University of Texas, Health Science Center, Dental Branch, located in Houston. Much of this is mediated through instructional television. Quick accessibility to videotaped materials is essential for the 400 students, including 150 postgraduate students. This need is met by a 24-channel distribution system which feeds 180 different locations — 72 carrels and 108 viewing stations in laboratories and classrooms. A pushbutton telephone type intercommunication system is used by students and faculty members in requesting a tape. Houston, therefore, is one of those "oases" where dial-access, or more precisely, pushbutton-access, lives.

Director of Instruction Television, Mario J. Paoloski has provided us with a description of the system at Health
continued on page 213

THE COMPANY THAT BROUGHT YOU QUAD POLARIZED ANTENNAS FOR ENG/EJ NOW OFFERS MULTI-BAND, MULTI-CHANNEL AND EXTENDED RANGE ANTENNA SYSTEMS WITH REMOTE CONTROL CAPABILITY.

QUADS
GOLDENRODS™
SUPERQUADS™

SEE THEM
ON DISPLAY
AT NAB
BOOTH 910

nURAD, inc.

2165 Druid Park Drive
Baltimore, Md. 21211

• 301-462-1700

WRITE OR PHONE FOR
FURTHER DETAILS

VIDEOCASSETTE EDITING. MADE FOR SPEED. MADE FOR ACCURACY. MADE FOR QUALITY. MADE by JVC.

MODEL GR-50000 Receiver



CH-1 AUDIO REC LEVEL CH-2
LIMITER ON OFF



JVC INTRODUCES THE CR-8300U FULL EDITING VIDEOCASSETTE RECORDER...

FOR FASTER EDITS

Now you can significantly cut the time you spend editing 3/4U-format tapes, thanks to JVC.

The unique bi-directional search control of the CR-8300U Electronic Editing Recorder lets you fast-forward at 7 times normal speed. Reverse at 10 times normal.

And you can do it while the tape is threaded on the head. You don't have to stop to rethread.

The unique preview feature lets you pass the signal from a second source through the CR-8300U while it's playing, without erasing the tape. You'll cut down on false starts by knowing what your edit will be like.

FOR MORE ACCURATE EDITS

Accuracy is what the JVC CR-8300U is designed for.

The unique built-in Pre-Roll rewinds tape for about 4 seconds from the actual editing point, and puts the recorder in stand-by mode. When you push "Edit Start" the CR-8300U first plays back about 4 seconds of rewind program, then goes automatically into the recording mode at the edit point. You're assured of the highest accuracy.

When you assemble edit, video and audio signals are edited simultaneously. When you insert, you can edit video and either audio channel independently or in any combination. Either way, accuracy is ± 5 frames.

You want still frame and slow motion? You've got them. The forward speed can be adjusted from 0 to 1/15th normal speed. You'll always find the exact frame you want.

And the tape counter doesn't just count. It has a memory. When you know you'll want to find a particular point again you reset the counter to "000". Then when you rewind, it will automatically stop the CR-8300U right there.

No other moderately priced videocassette editor has this combination of features to give you the accuracy you're looking for.

FOR THE HIGHEST QUALITY PICTURE

But speed and accuracy are nothing without quality. And quality is what the JVC CR-8300U has most of. It has everything you need for NTSC-type color video built-in.

Automatic Phase Control and patented Color Dubbing assure generation after generation of duplicates with stable color lock and highest quality.

There's a built-in Dropout Compensator. There's a video S/N ratio

of better than 45dB (unweighted) on the Rohde & Schwarz noise meter. An audio S/N ratio of better than 45dB. Independent Audio VU Meters and Controls for both channels (which can be operated either automatically or manually) help you upgrade the quality of low-level audio recordings.

Black & white resolution is better than 320 lines; color, better than 240.

And if "flag-waving" turns you off, all you have to do is turn on the CR-8300U. The frame servo locks on the odd field, so every edit is smooth and clean.

JVC WORKS WITH YOU

JVC has worked with broadcasters and producers to give you what you want, what you really need. Speed, accuracy, quality. And the features you need to get them.

Features like an external sync input for V-locking other sources. A built-in capstan servo mechanism for jitter-free, stable tape speed. An internal time-lapse meter to make

regular maintenance easier. And a new remote-control system you can learn about by reading the next page.





AND...TO TIE IT ALL TOGETHER... THE JVC RM-83U REMOTE AUTOMATIC EDITING CONTROL UNIT.

The RM-83U completely controls two JVC CR-8300U recorders for fast and accurate insert and assemble editing.

Its two independent LED timers (indicating minutes, seconds, and tenths of seconds) can be put on "Hold," so you can precisely identify the edit point. They then return to real time. "Hold" again at the end of the edit, and you've timed the length of your insert. Both clocks memorize the edit point—for fast and accurate review, you quickly return to it by touching "Search".

Not only can you *review*, you can *preview*. A unique rehearsal editing feature lets you see your edit without putting a signal on the tape. You can be sure you've got exactly what you want, exactly where you want it. After you've previewed, both machines go back to the edit point automatically. If you like what you saw, just push "Start" and you have it.

There are many more great features, such as the automatic safety device that shuts off both recorders if a tape is left in still-frame for 10 minutes. Get all the details on both the RM-83U and the CR-8300U by writing today to the address listed on the back page.

SPECIFICATIONS OF THE CR-8300U EDITING COLOR VIDEOCASSETTE RECORDER

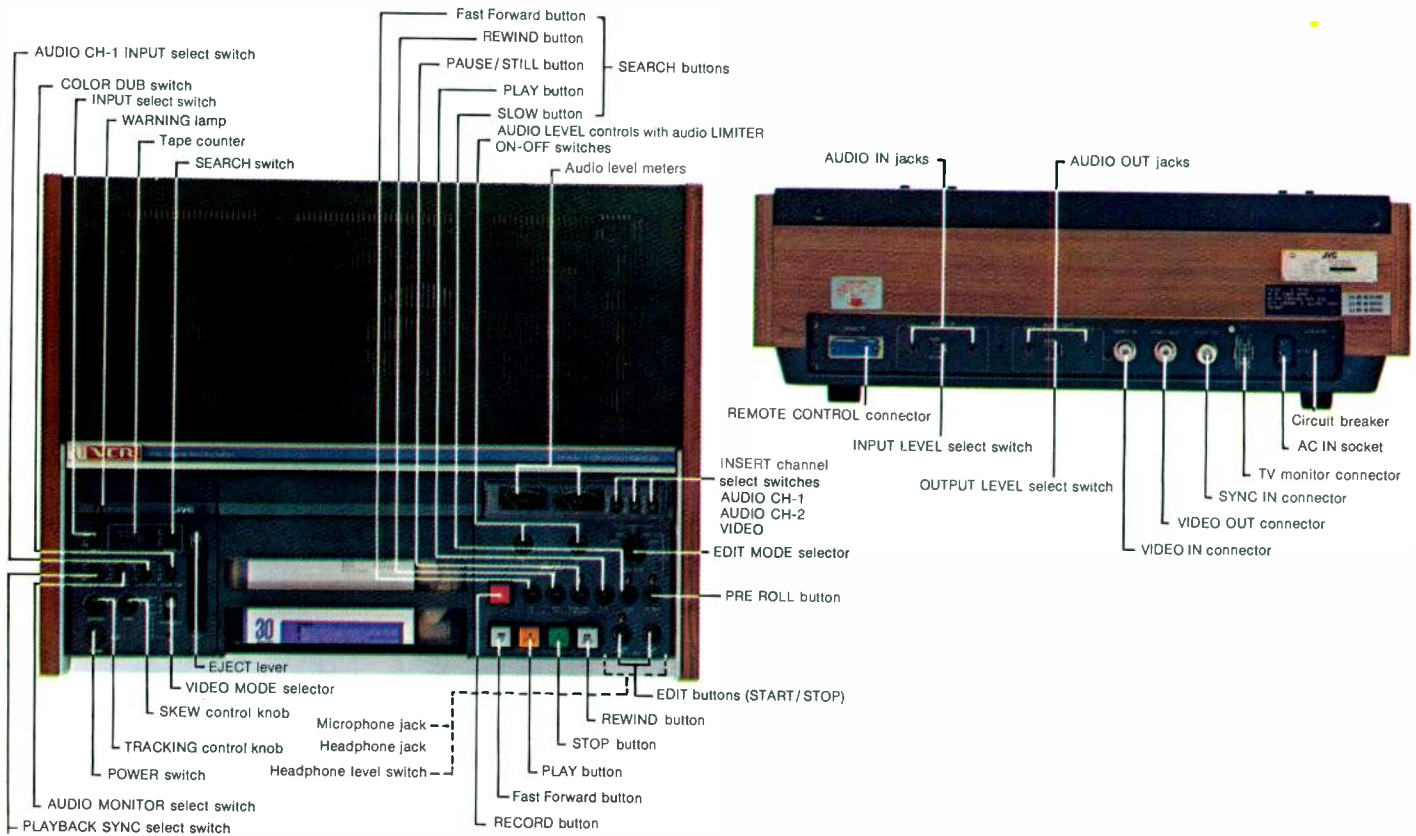

GENERAL

Video Recording System	: Rotary two-head, helical scan system
Luminance	: FM recording
Color Signal	: Converted subcarrier direct recording
Video Signal System	: NTSC-type color signal
Power Requirement	: 120 V AC, 60 Hz 120 watts
Temperature Operating	: 41°F to 104°F (5°C to 40°C)
Storage	: -4°F to 140°F (-20°C to 60°C)
Operating Position	: Horizontal only
Weight	: 67.5 lbs. (30.6 kg)
Dimensions	: 24-1/16" (W) x 7-11/16" (H) x 17-3/4" (D) (610 mm x 195 mm x 450 mm)

Tape Transport

Tape Speed	: 3-3/4 ips (95.3 mm/s)
Fast Forward Time	: Less than 6 min. for 60 min. tape
Rewind Time	: Less than 5 min. for 60 min. tape
Wow & Flutter	: Less than 0.2% RMS

Video Signals

Input	: 0.5 V to 2.0 Vp-p, 75 ohms unbalanced
Output	: 1 V p-p, 75 ohms unbalanced
Signal-to-Noise Ratio	: More than 45 dBs (Rohde & Schwarz noise meter)
Horizontal Resolution	: Color 240 lines Monochrome 320 lines

Audio Signals

Input	: Mic -70 dBs, 600 ohms unbalanced
	: Line -20/0 dBs, 10k ohms unbalanced
Line Output Level	: -20/0 dBs (600 ohms unbalanced load)
Headphone Output	: -28 dBs/-37 dBs, (8 ohms unbalanced)
Signal-to-Noise Ratio	: More than 45 dBs (@ 3% distortion level)
Frequency Response	: 80 Hz to 15 kHz

Be sure to write today to JVC for more information on the CR-8300U Electronic Editing Color Videocassette Recorder and also for a copy of JVC's new Glossary of Video Terms.

JVC

JVC INDUSTRIES COMPANY, a division of US JVC Corp., 58-75 QUEENS MIDTOWN EXPRESSWAY, MASPETH, N.Y. 11378 (212) 476-8010

For literature Circle 169 on Reader Service Card
For a demonstration Circle 170 on Reader Service Card

NAB Las Vegas: Likely To Be The Best Game In Town

Unlike some of the attractions in Las Vegas, the National Association of Broadcasters' 56th Annual Convention is a sure bet. The pay-off will come from a jackpot of new equipment.

WITH STANDARDS FOR the Type B and Type C one-inch helical scan videotape recorders a virtual certainty, and the explosion of digital technology for control, video, and audio, this year's convention and exhibit will expose eager broadcasters to the 1978 generation of broadcast equipment.

This new generation will, by and large, bear a striking family resemblance to earlier equipment but will offer a much greater degree of automation. Almost every piece of equipment in a broadcast facility, from the test bench to the transmitter, will start showing up with some sort of microprocessor capability. This is not only true of the television equipment but also for radio. Automation is being applied to audio consoles with good results (see article elsewhere in this issue). Satellite distribution, spearheaded by Mutual Broadcasting, will be another hot subject at the convention, and interest in processing, both for AM and FM, remains high. A full preview of the most talked-about radio equipment begins on page 120.

TV broadcasters are in for a bumper crop of new equipment. Cameras, VTRs, and new digital devices will lead the way. If you've read the article on the use of the Ikegami HK-312s (p. 80), you'll note that as of last year's NAB, Ikegami was the only manufacturer of computer controlled color TV cameras with automatic setup. That picture will be in for a major change this year as Toshiba enters the sweepstakes with its PK-31A automatic setup camera. RCA, according to a reliable source, will also demonstrate a new studio camera using these automatic functions. With the past few years of quiet on the studio camera front, things should be hopping this year. Though we have not been able to confirm this prediction, there may be other automatic setup cameras shown.

As our Panels of 100 survey revealed in last month's issue, interest in ENG and EFP gear is running high. Both cameras and VTRs lead in this category, and visitors looking for these products are in for a real treat. The one-inch videotape machines meeting Type C standards will be found in Sony's, Ampex's, and probably in NEC's booth. Sony has expressed confidence in its ability to begin full production of the machines shortly, and Ampex will not be far behind. One last step in the trek towards Type C standards is likely to take place at the show when Sony and Ampex exchange tapes to demonstrate the interchangeability of their format. The Sony Omega version will also be on display under the RCA label in the RCA booth. RCA will also show the BCN system with the RCA label, while Marconi will show the Sony, Type C.

Bosch-Fernseh will be taking on the Type C machines with their Type B, BCN system. The Type B standards

were published in the February issue of the SMPTE *Journal*. Type C standards are scheduled to be published in this month's *Journal*. Bosch will be showing the BCN as a more fully developed system offering many features that stem from their use of the Digital Store. The Digital Store, though available as a standalone device, gives the BCN machines flexibility in search operations for editing. Moreover, a wide array of special effects and other benefits are derived from the digital store. (For a fairly complete run down of the production and post production benefits of this digital approach, see "Digital Technology's Impact On Television Post-Production," *BM/E*, Feb. '78.) One machine in the BCN format without a competitor at this point is the BCN-5, 1-inch cassette recorder. No word has yet been received regarding the availability of the BCN-5; they've been shown only in prototype form until now.

When Type C standards were drafted, it was made clear by the SMPTE that they expected other manufacturers to get in on the product. The first new entry in the Type C category will be NEC. Two other Japanese manufacturers are expected to begin producing Type C machines in the next year but they will not present them at NAB.

While it seems clear that the new one-inch machines will have considerable impact on the quad market, there is good indication that the presence of one-inch will not greatly affect the U-type format. One-inch is likely to find itself supplanting quads in some tasks and expanding the interest in high quality remote recording. For news, however, the superior weight and size characteristics of U-type systems should keep that portion of the market in the $\frac{3}{4}$ -inch column.

The lightweight champ of the U-type format will be seen in production form at the Sony exhibit. The BVU-50 is an extremely lightweight record-only cassette VTR. Panasonic and JVC will be presenting their U-Matic machines with additional emphasis on the editing systems they have been developing over this past year. Hitachi will be showing a SV-3040, portable U-format cassette machine as an addition to their product line. In addition, you can expect these three manufacturers' machines to show up in various booths under different labels.

TRI will be showing production models of their Tri-Chroma recording U-type machines. According to TRI, Tri-Chroma recording offers far superior performance over conventionally encoded NTSC format recording methods. Essentially, Tri-Chroma records luminance and chrominance on separate FM carriers. This method is said to provide a dramatic increase of chroma signal-to-noise

continued on page 104

NAB '78 Las Vegas

ratios over conventional color under VTRs and completely eliminates differential gain and phase errors, and velocity errors. The method also has great immunity to erasure during numerous passes and greater chroma bandwidth. Color framed output is available at all times. Though Tri-Chroma has been applied to only U-format machines at this stage, it is adaptable to other format VTRs.

Quad VTRs are not down and out. RCA, though, will be the only manufacturer showing anything new in the quad format, and that will be an automation package for the TCR-100 Video Cartridge Player, according to a reliable source. The new package will improve the TCR's role in automation systems and provide random access to the carts. Previously, the TCR handled carts in a serial fashion which meant that carts had to be loaded in the desired play sequence.

ENG/EFP Cameras will be there by the score

Last year, one of the big changes in camera design was the premier of several modularly designed multi-role cameras for both ENG and EFP. This year will see more of such cameras coming from Philips, Hitachi, and Ikegami.

Ikegami will show its new HL-52, EFP camera and Hitachi will show the SK-96. The SK-96 is configured differently than the SK-70 while retaining many of the SK-70 features. It is equipped with three Saticons and will operate on a 1000 feet of multi-core cable or at up to a mile with triax.

There is a virtual cornucopia of ENG cameras. Hitachi will show production models of its SK-90 with special anti comet tailing circuitry and other modifications. They will also show the low-cost FP-3030 with an improved tube. Ikegami has a new ENG camera, the HL-79 which maintains many of the popular features of the HL-77 but in a more compact and lightweight package with lower power consumption. Both the HL-79 and the older HL-77 are now triax adaptable. Panasonic, which has not had a high end ENG camera before, will be introducing a 3-tube ENG camera this year that also features low power consumption. Bosch-Fernseh has added a camera to its line too, the new KCA-90. Sony will be showing its BVP-200 ENG camera which it first showed at the SMPTE meeting in Los Angeles, but they will also have a brand new addition, the BVP-300. Another camera, also first seen in Los Angeles at SMPTE, was the NEC manufactured MNC-71CP, from Cinema Products. This camera will be exhibited again at NAB. Toshiba will be showing two new ENG cameras, the PK-36 and PK-39. Thomson-CSF will, of course, be showing its MicroCam. But this year it's to be your show as Thomson will be relying on you to put your hands on equipment and get a feel for it yourself.

One camera that doesn't seem to have a competitor at the show is Cohur's 7410 Isocon. It's a special purpose single tube low-light level camera suitable for remote control for taping of theatrical events or other low-light situations.

Microwave for ENG: lighter, faster, better

Corresponding to broadcasters' great interest in compact, lightweight field equipment is a high degree of interest in new microwave gear. High on the list of desirable options is improved portability. Many manufacturers

KCA-90 from Bosch-Fernseh will be one of many new ENG cameras to be shown at this year's exhibition.

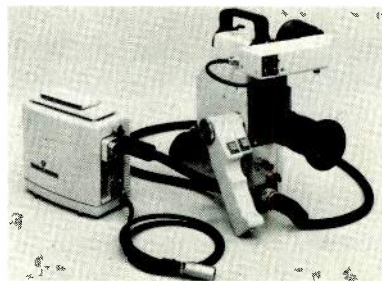
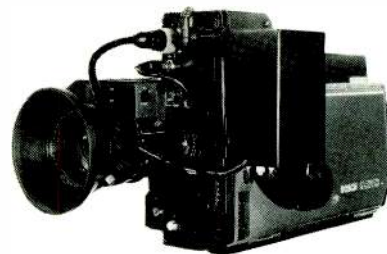

This year, Thomson-CSF will invite broadcasters to give the Microcam a "hands-on" workout. Sony Corp. was licensed to manufacture the camera last year.

are apparently responding to these needs. A new company to the broadcast industry is Tayburn Electronics of Carlsbad, CA. At this year's NAB Tayburn will premier with its steerable microwave dish approach which has been so successfully employed at KRON (see *BM/E*, January '78). The Tayburn approach is based on the use of a master controller, located at the station, which can control up to four remote antenna sites, with two antennas each. Digital techniques are applied for command and telemetry communications, and link up time is said to be consistently under one minute because of automatic sensing and directional control. The highly sensitive receiver can give an indication of transmitter operation even if the sending dish is pointed away from the receiving point.

Nurad, Inc. will be highlighting its Super Quad MC2 master control system which will also handle up to four inputs. Added to this system is a new product, the 20 QP2 Dual Channel Quad Polarized Antenna System. The new system permits simultaneous reception of two frequencies in the 2 GHz auxiliary broadcast band from any direction. Cablewave Systems, Inc. will be showing a new line of microwave parabolic antennas.

Microwave Associates says that they will introduce a new generation of portable microwave ENG products. Other manufacturers such as Farinon, TerraCom, International Microwave, and RCA have not indicated any specific new product introductions in this particular area though some related new product introductions are expected. Van Ladder, though not a microwave system manufacturer, will be showing two new carriers for microwave-equipped vans. There will be a new 34-foot telescoping tower with a cherry picker, and a new 29-foot boom for dish only.

Two companies, Wolf Coach and E-N-G Manufacturing Co., will be showing several types of vans for ENG. Wolf Coach will be showing traditional custom built vans plus a new van for multi-camera field production and will be talking about its new modular approach to custom built vans. E-N-G will be showing both vans and sedans completely equipped with remote microwave capabilities. The sedan will also have full microwave capability with a telescoping 20-foot mast. In the Comrex booth several new ENG van communications packages will be shown.

continued on page 108

SMALL NEWS FROM CANON!

It's significantly smaller than a 10X ENG zoom lens. Has wider wide angle, longer focal length, shorter M.O.D. and higher sensitivity. It's rugged enough for the most demanding ENG applications, yet sophisticated and versatile enough for EFP and many studio applications. Visit NAB Booth 918 and discover the big, small news at Canon... or contact us after the Show.

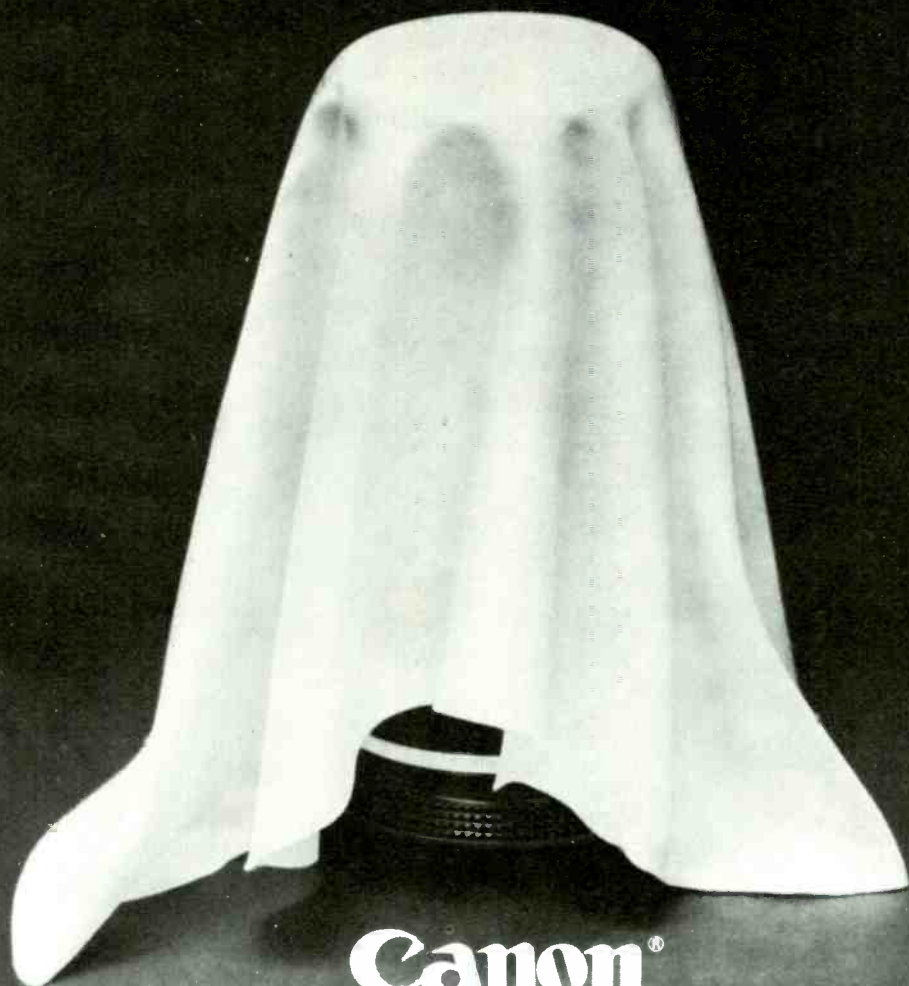

Canon®

Canon U.S.A. Inc. Head Office, 10 Nevada Drive, Lake Success, N.Y. 11040 (516) 488-6700 • 140 Industrial Drive, Elmhurst, Ill. 60126 (312) 853-3070 •
123 Paularino Avenue East, Costa Mesa, Ca. 92526 (714) 979-6000
Canon Optics & Business Machines, Canada, Ltd., 3245 American Drive, Mississauga, Ontario L4V 1B8, Can.
Canon Amsterdam N.V., Industrial Products Division De Boelelaan 8, Amsterdam, Netherlands

Circle 171 on Reader Service Card

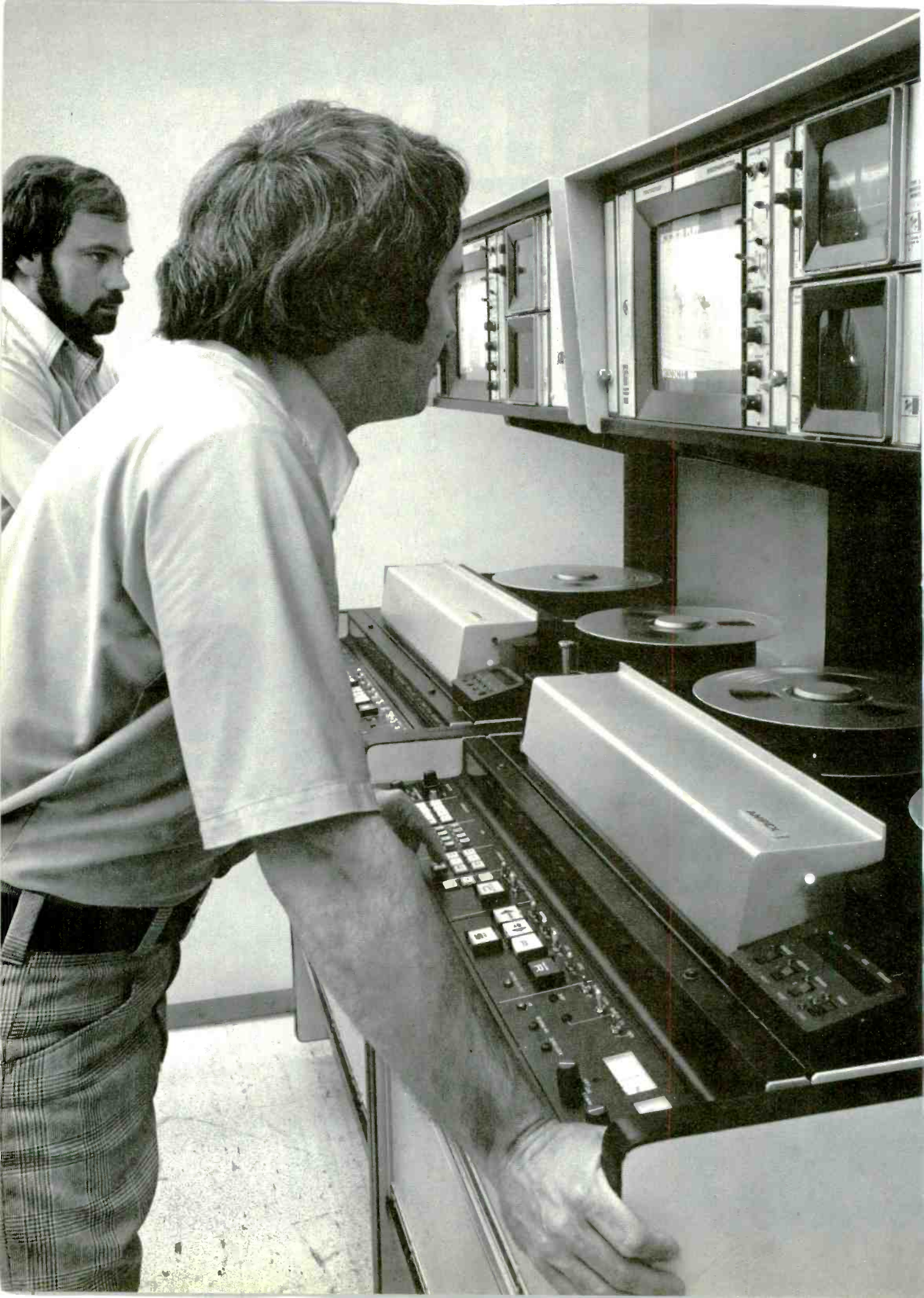

The small machine for big stations. The big machine for small stations. AVR-2.

Tell us what it has to do. There's an Ampex AVR-2 for every videotape assignment in your station.

If you already have a complete production/editing setup, you probably don't need a lot of accessories for your AVR-2. Order it with basic manual controls, and it's ready to go to work.

You might want Super High Band Pilot. It comes with optional switch selection to augment the standard High Band Color circuits, and it adds valuable depth to your multi-generation production work.

If you're just now growing into more advanced production work, then you're going to want the EC-2 Edit Controller.

This complete, sophisticated stand-up time code editing accessory can put you in command of as many as seven additional (similarly equipped) machines working in any combination of master/slave for production or multiple dubbing service.

Modular construction means an easy fit for your AVR-2, no matter where you want to use it—at a remote location, in your tape room, or out in the mobile van.

AVR-2 is the quad recorder that grows. Every accessory for this machine is available upon initial purchase or at any time in the future when you're ready. Tell us what it has to do, and we'll recommend the model that suits your needs.

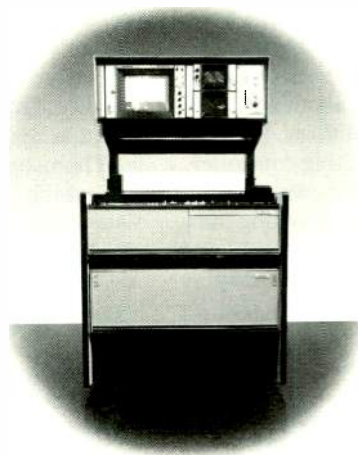

AMPEX

Circle 172 on Reader Service Card

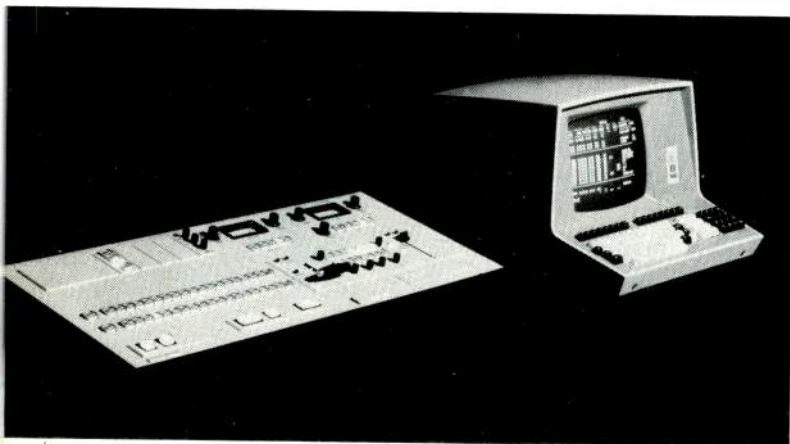

A new entry in the Technical Automation field is the American Data Corp.'s 3100 Series with ACTS.

Big year for computerized editors

CMX which has for years enjoyed a near monopoly on computerized, multi-format editors will see some competition this year. Sony will introduce a computerized editing system for its Omega one-inch machines capable of A/B rolling. CVS (Consolidated Video Systems) will also introduce a computer based editing system which will handle any format tape machine, cassette to quad.

Convergence says that it will introduce a whole new generation of its Joystick editing system though at this time we have no specific details. Sony's BVE-500A, which added variable speed search controls to its edit controller for U-type machines, will also be on display. The other major multi-format editing controller, the Data-ron 7600 series, will be present with new capabilities. Spectra-Vision will be showing a new version of its editor, the JBT-104A. Rumors also exist about new editing apparatuses from RCA, Ampex, and others. Many of these items will be ancillary to the main editing controller.

Time Code generators and readers in numerous configurations will be present. CMX will be showing new SMPTE/EBU time code generators, both portable and master. There will also be a new time code reader display from CMX. Electro & Optical Systems, Ltd. will be showing a 3-lb. SMPTE time code generator, the Mark III, that provides keyboard entry for user bits. BTX will be showing a low-cost (\$3850) Edit Code Synchronizer Model 4500 that has the ability to synchronize high quality multi-track audio recorders with VTRs.

Digital, digital, and more

Time base correctors, frame store synchronizers, fieldstore synchronizers, digital noise reducers, digital special effects, digital still stores and slow motion recorders, etc. — all will be there in record numbers. For the first time in a few years we have no information on truly new time base correctors. This may be because so many of the time base corrector manufacturers are extending the technology of their equipment to handle more complex tasks such as noise reduction and image enhancement. Moreover, the powerful field and frame synchronizers are providing infinite window time base correction an integral part of their applications.

Microtime, CVS, Sony, Digital Video Systems, NEC, MCI, RCA and others will be showing their TBCs, many

of which were introduced at last year's NAB. Some like the Microtime system promise further image enhancement while others like CVS will be showing some lower cost models. Frame synchronizers and field synchronizers will be on display in the usual booths though we have not heard of anything new to be introduced in this area.

The big story in digital special effects this year will probably grow out of improvements in systems that premiered last year. The RCA TFS-121 shown at SMPTE last month in Atlanta seemed to have many more options than the model shown at last year's NAB. The Grass Valley Group is expected to be back with the DVE package that utilizes the NEC FS-15 synchronizer. Digital Video System will undoubtedly return with its system. The DPE-5000, which last year was not seen in the Micro Consultants booth, will be there this year. The fact that several DPEs are now in use at the networks gives you some idea of how fast last year's prototype can become a fully accepted product.

Vital Industries promises a dazzling display with its "Squeezoom" special effects package which was shown in a developmental stage last year. Vital says that "Squeezoom," which offers special effects for synchronous or non-synchronous signals will be shown as a production model this year.

Thomson-CSF, which showed the Digital Noise Reducer last year, will bring it back this year with an improved operating panel and even more signal-to-noise reduction, now up to 15dB. But the concept of digital noise reduction has spread. CVS will be showing an Image Enhancer/Digital Noise Reducer and TeleMation will show the TDF-1, Digital Noise Filter. The TDF-1 will use CCD technology, and features 4fsc sampling for greater bandwidth. NEC America will also be showing something in this area, but as of this writing, all we know is that it will be digital, and it will have noise reduction characteristics. At least one other company is rumored to be prepared to enter the digital noise reduction area, but word is that they will wait until after NAB.

Thomson-CSF, in keeping with the hands-on theme of its exhibit, has invited broadcasters to bring their noisy videotapes with them and witness the improvement possible through the DNR. Still stores and slow motion recorders will be there in both digital and analog configurations. Arvin/Echo will show its new Slo-Mo which provides 20 seconds of slow motion on a disc cassette. This is an analog system as is the Eigen slow motion recorder which will have a new controller for its Color Disc Recorder.

The digital still stores will be from ADDA Corp. and Ampex. ADDA Corp., which was a new company to NAB last year, has since expanded its line to include systems with expanded still storage. The new modular systems can handle anything from 200 to 3000 stills. Several of ADDA's ESP systems have been sold now, one going to NBC where they have accomplished some pretty interesting things with it (see "SMPTE" article elsewhere in this issue).

The Ampex system has evolved to the ESS-2 and now offers some remarkable characteristics. For one thing, ESS-2 can be used as a variable speed recorder/player for slow motion in addition to its use as a still store. (Additional details on ESS-2 are contained in the "SMPTE" story elsewhere in this issue.) Moreover, the price for the basic system has come down to \$120,000

continued on page 110

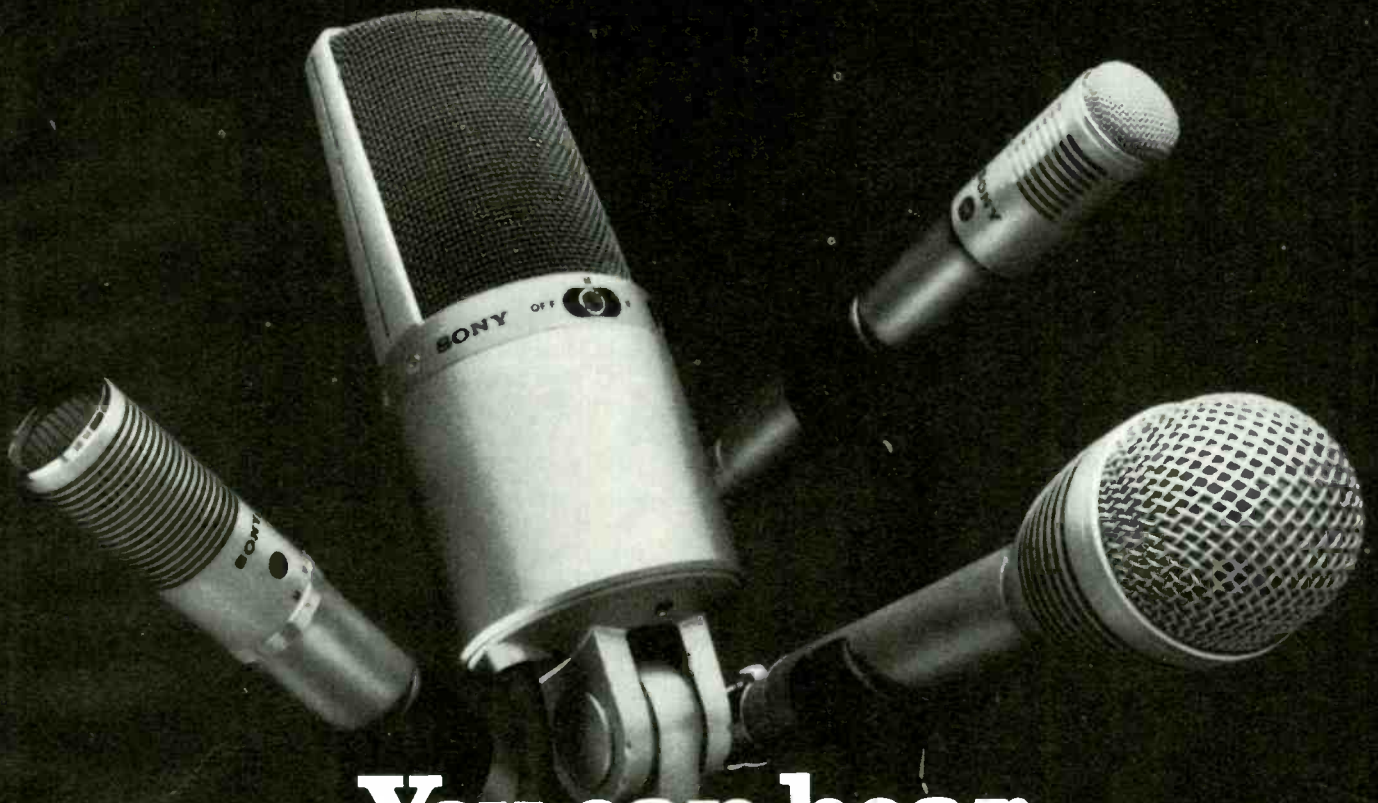

You can hear the difference because the difference is right here.

Take a look at what's taking the industry by storm. The Back Electret, another giant step forward from Sony.

Never before has it been possible for thin polyester film to be used in electret condenser microphones.

That's because polyester film, acknowledged as the best material for microphone diaphragms, just can't hold a static charge for a long duration.

But Sony's engineers have made the impossible, possible. They've found a way to adhere the electret material directly to the back plate of the microphone. By thus putting the charge on the back plate, we are able to use polyester film in the diaphragm.

The result will be obvious to your ears. Clearly superior sound quality, without particular color-

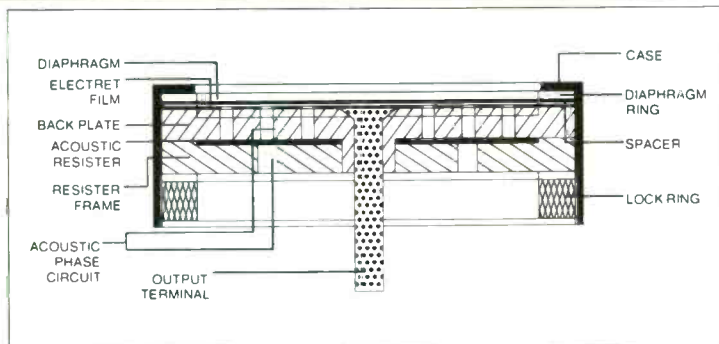

ation in the upper frequency range. The low mass diaphragm means better transient characteristics over the entire frequency range.

You can find the Back Electret in four Sony microphones: ECM-56F, \$220; ECM-65F, \$210; ECM-33F, \$165; and ECM-23F, \$100.

But you don't have to look at Back Electrets to see why Sony is ahead.

NO MATTER WHAT KIND OF MIKE YOU NEED TO GET, WE'VE GOT IT.

Sony's microphone line is thoroughly complete. It ranges from professional condenser to semi-professional to microphones for public address, vocalists, and outdoor use. There's omni and uni-directional. And we think it's big of us to make sophisticated

miniatures.

And all microphones are available with Phantom Power, battery operated, or both.

So if you need something to talk into, it makes a lot of sense to talk to Sony. Write to Sony, 714 Fifth Avenue, Dept. TK, New York, N.Y. 10019.

SONY AUDIO

Circle 173 on Reader Service Card

NAB '78 Las Vegas

from its former price at nearly \$200,000.

Bosch-Fernseh, of course, has developed its BCN one-inch videotape system for use as a slow motion recorder and still store. At the SMPTE Fall Conference in Los Angeles, BCN performed some interesting demonstrations along these lines and it can be expected that there will be more such demonstrations at NAB.

Character generators will have some changes

TeleMation, Chyron, and Vidifont (from Thomson-CSF) have all indicated that their character generator lines remain essentially unchanged though new capabilities can be expected. By NAB time, any one or all three of these manufacturers might have a wholly new system to show though this cannot be confirmed at this time. Systems Concept, however, will have the Q-X™ Merchandizer I, microcomputer based character generator/graphics system. The system, based on four microcomputers, extends the power of the Q-VI Television Production Titler system to include remote machine control of any video source to automatically switch from one source to another. Thus, with the new system it would be possible to produce a hands-off segment under the control of the automation in the character generator. One hundred-ninety two pages of text and 8000 or more individual remote machine commands can be stored on one high-speed digital cassette tape. This marks one of the first attempts by any manufacturer to take advantage of the numerous computing capabilities provided in some microcomputer based systems and use them for other tasks.

Video Data Systems will show its Computer Managed Multiple Display System, the MicroSystem I™, that has both RAM and diskette memory. 3M Corp. will show both its D8800 Graphics System and a new D-3016 character generator. The D-3016 replaces the D-3000 and offers a 16-page memory, three font styles, upper and lower case characters in variable fonts, and a 3-speed vertical roll or horizontal crawl. This is probably one of the more versatile low-cost systems, priced at \$6900. Dynasciences will also introduce a brand new Video Graphic System, the Model 9048. Laird Telemedia has also given some indication that they will have new character generators.

New Switchers in production, routing and master control

The Grass Valley Group has now added E-MEM, to its

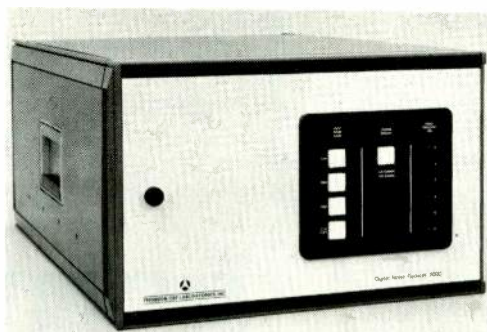

The Digital Noise Reducer from Thomson-CSF. This year other companies such as NEC, CVS, and TeleMation will be showing gear in the digital noise reduction area.

1600 series production switchers. E-MEM, Effects Memory, is another approach to simplifying the increasingly complex operations of modern production switchers. E-MEM permits the presetting of complex switching sequences for either real time production or post production. Vital Industries, which introduced PSAS (Production Switching Automation System) last year, has further simplified the system and will be showing it in Las Vegas.

The DVE (Digital Video Effects) package introduced at last year's NAB by GVG will, of course, be back and we might see some new things there. But this year, the Vital "Squeezoom" will garner a lot of attention that GVG had all to itself a year ago.

Central Dynamics will be showing off new multipattern and matrix wipe special effects in their production switchers this year. Industrial Sciences Inc. (ISI) will show its new Model 902 Video Production Switcher featuring digital control logic which allows a pattern generator to be shared so that wipe transitions can be created on either mix/effects system. The digital logic allows many more functions to be performed on, essentially, less hardware. Duca-Richardson Corp. promises both new Master Control Systems and new Production Switching Systems. Ross Video Ltd. will be showing a new Multi Level Effects video switcher, the Model 520-8A. This switcher includes two Multi Level Effects amplifiers that can accept four independent sources simultaneously. With this approach, even a quad split can be achieved without tying up any single bus. Moreover, a unique previewing system permits viewing of multi level events using the On-Air bus.

Another production switcher taking the microprocessor approach is the new Model 9000 from 3M. Microprocessors provide event memory and simplified operation. Up to eight panel setups can be stored for automatic recall during difficult production sequences. Twenty effects can be selected by a 10-key input bank thereby simplifying the operational design of the switcher. 3M, of course, has recently acquired Comtec and will be showing the Comtec line of production and routing switchers. Two Comtec models now coming from 3M are the Model 3100, with computer type momentary pushbutton switches, and the Model 3300, 5-bus, remote controlled 11 input switcher using illuminated momentary switches.

In the area of compact switchers, Dynasciences will introduce a new model, the 7400A. A new company, Centro Corp., will be showing their model MD/500 Portable Television Production System. Along similar lines is a 5 lb. production switcher for EFP from Electro & Optical Systems Ltd. This mini switcher will accept up to four color sources and can be expanded to six. It will mix, wipe, key, and wipe-key.

American Data Corp. will enter into the automated master control switching system in a big way with its new ACTS system. ACTS (Automatic Control Television Switcher) is designed as a complete line of programmable control schemes, ranging from full manual operation of the 3110/3111 Master Control Switcher, to total automatic control of machines, switching, and event scheduling from a traffic or business computer system. It takes a low-cost modular approach to automation, and American Data believes it is suitable for either the smallest or largest market station. American Data will also introduce a new Model 558-4 production switcher that uses a four channel video processor to permit the operator to perform multiple

continued on page 113

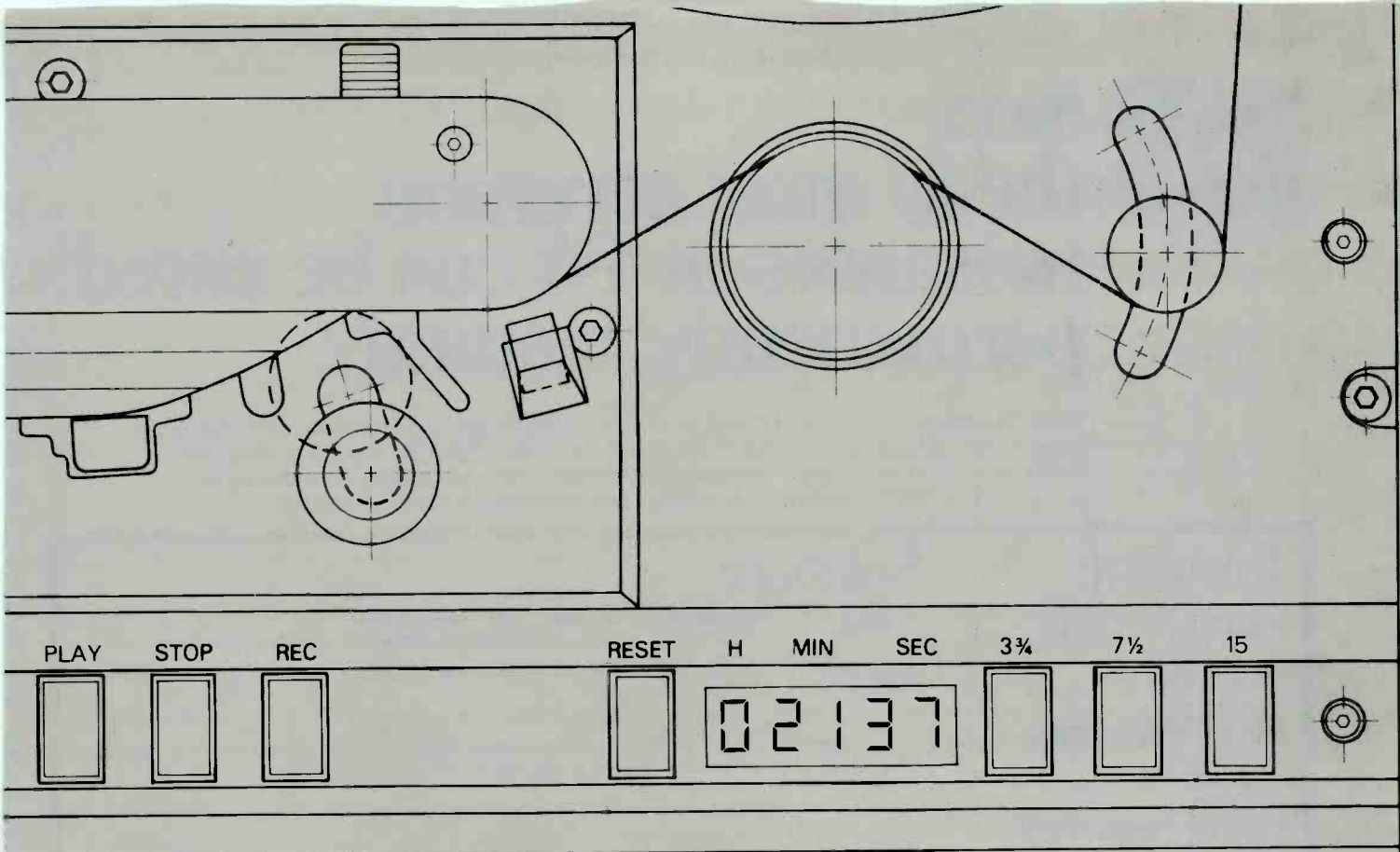

Studer B67

**It's got competitors...
but no competition!**

STUDER
B 67 TAPE RECORDER

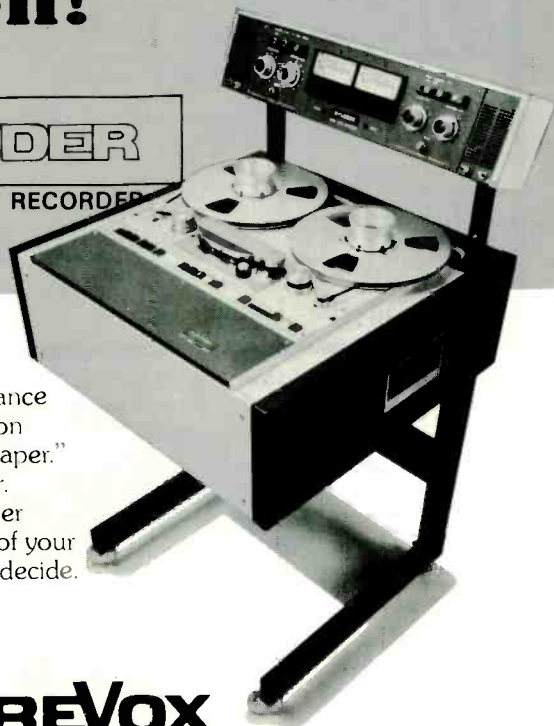

When you buy the Studer B67 tape recorder/reproducer, you get more than just one of the world's finest tape recorders.

You are buying an engineering philosophy where performance is first and there isn't any second or third. You are buying a dedication to quality seldom seen in today's world of "make 'em faster and cheaper." At Studer, one person in every seven is a quality assurance inspector.

You are buying performance that stays within spec long after lesser equipment has given up. If performance is an important part of your tape recorder buying decision, test drive the Studer B67 before you decide. You'll find the B67 is the recorder without competition.

To learn more, circle reader service number or contact:

STUDER REVOX

Circle 174 on Reader Service Card

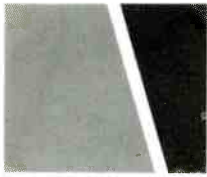

fact: the 10 most common nuisances in PA can be cured. permanently. instantly.

These 10 problem solvers in your toolbox are like 10 new tricks up your sleeve. Or 10 hours of saved time. Or money in the bank. They tailor the sound, match the lines, smooth out the peaks, fill in the valleys, make molehills out of troubleshooting mountains. Snap one in. Out go the hassles. Without soldering, or splicing, or internal equipment modifications:

Problem:	Solution:	
Input Overload	A15A	Microphone Attenuator prevents input overload. Ideal where very strong signals are applied to a microphone input.
Phasing	A15PR	Phase Reverser reverses the phase of a balanced line without modification of equipment.
Low-Frequency Noise	A15HP	High Pass Filter provides a low-frequency microphone cutoff to reduce unwanted low-frequency noises and proximity effect.
High-Frequency Noise	A15LP	Low Pass Filter provides high-frequency cutoff to reduce objectionable high-frequency noises.
Lack of Presence	A15PA	Presence Adapter adds voice-range intelligibility and extra brilliance.
Sibilance	A15RS	Response Shaper provides excellent sibilance filtering; flattens microphone response.
Line Level to Mic Input	A15LA	Line Input Adapter converts balanced low-impedance microphone input to line level input.
Matching/ Bridging/Isolating	A15BT	Bridging Transformer, a balanced unit, matches balanced or unbalanced devices of different impedances.
Troubleshooting	A15TG	Tone Generator produces a continuous 700 Hz low-impedance microphone level signal — extremely useful in setting-up and troubleshooting lines. Helps check levels, connections, mixer inputs, and cables. Allows one man to do the work of two!
Microphone Impedance Matching	A95 and A97	Series Line Transformers make it possible to connect low-impedance lines to mid- and high-impedance inputs (or vice-versa). Completely reversible. Solves problems of excessive high-frequency loss and objectionable hum.

Shown Actual Size: 114mm (4½ in.) long x 19mm (¾ in.) diameter.



Send for the free Shure brochure, AL280F



Shure Brothers Inc., 222 Hartrey Ave., Evanston, IL 60204, In Canada: A. C. Simmonds & Sons Limited
Manufacturers of high fidelity components, microphones, sound systems and related circuitry.

Circle 175 on Reader Service Card

NAB '78 Las Vegas

functions on a single mix/effect amplifier.

With the multiplication of video sources due to the ENG explosion, there is renewed interest in routing and distribution switching systems. New systems will be shown by Lenco, The Grass Valley Group, American Data, Utah Scientific, Di-Tech, Datatek, and Dynair. Many of these new systems offer new approaches to routing that result in greater reliability, more sophistication, and lower operating cost. This should be a good year to make a point of getting around to see these booths.

Audio begins to look less like poor relative

Every succeeding NAB Show sees more and more manufacturers presenting new products for television audio. This year will be no exception. Two aspects of this change are manifested by the increase both in the number of firms producing audio boards for TV and in the number and variety of tools for the post production of audio. With field production becoming more practical through the advent of high quality one-inch VTR systems, there is increasing concern about the quality of audio associated with prime-time filmed productions.

In addition to synchronizing systems like those from BTX, we are now beginning to see systems like the NECAM Computer Audio Editing system for TV sound from Rupert Neve, Inc. Again, this system takes advantage of SMPTE Time Code in the way that the society had hoped time code would be used when it was proposed. Studer ReVox America will show its Studer Tape Lock System 2000. The TLS-2000 uses SMPTE Time Code as the electrical link between the VTR and a multi-track audio recorder like the Studer A-80. It also can be used for synchronizing two multi-track audio recorders so that two eight track recorders can effectively be operated like a 14, or two 16s can be operated like a 30-track machine. One track from each audio recorder is sacrificed to time code information. In fact, any combination of multi-track machines can be operated in synchronized fashion.

Audio consoles will abound. McCurdy, long respected manufacturer of audio consoles for radio, will introduce the SS 7900 TV & Recording Console. This marks McCurdy's entrance into these markets. Audio Designs will show a new line of audio consoles using their modular approach. Ward Beck Systems can be counted on to show some of their latest work in the custom built audio console area, and word is that Cetec Audio has made some improvements to their venerable Series 20 consoles. Broadcast Electronics will also be showing new console and control room equipment for TV audio.

Transmission: from audio diplexing to transmitters, to earth stations

The TV transmitter manufacturers will be showing a good deal of new equipment. CCA says that it will have a new VHF transmitter and "several surprises." Acrodyne will show a 5 kW VHF IF diplexed transmitter as well as a 25 watt UHF solid state amplifier for IF diplexer applications. According to Acrodyne, its TT-347 transmitter uses a hybrid combined parallel amplifier stage which produces a highly reliable transmitter since loss of any single amplifying stage will still permit the transmitter to automatically remain on the air at a power level 6 dB down from the rated output.

Townsend Associates will introduce a solid state 1 kW VHF driver to replace the tube type drivers that may use as many as 56 tubes. Townsend will also have a couple of new Klystrons. Another new Klystron should be on display by Eimac, a Division of Varian Associates. Bogner Broadcast will be showing some new repeater equipment and antennas for UHF and VHF.

Harris will be introducing a 10 kW transmitter for the international market, but is also putting a good deal of emphasis on its "total" CP package. This package is said to offer a cost-saving CP facility. It will be called the BTD-100H3, 100 kW TV transmitter and CPV antenna system. It uses two BT-50H3 50 kW transmitters and a central control cabinet. This configuration will use the same floor space that is required for existing 50 kW transmitters.

Neither Collins nor RCA has as yet indicated what they will show in the transmitter line, but it is safe to presume that some development will be announced. Jampro, of course, will be there strongly pushing the CP antenna argument.

Farinon will be showing the new FM43-02 FM transmission channel system. This system diplexes television audio onto a single Bell System video facility for much higher quality audio (see "NBC Stereo" article elsewhere in this issue). The diplexing improves monaural audio and can handle stereo audio as well.

Earth station equipment will be shown by a number of manufacturers including Farinon, Andrew Corp., Scientific-Atlanta, and Moseley Associates which recently landed a big PBS contract. For additional firms showing earth station equipment see the alphabetical listing following this article.

Radio in Las Vegas: The Jammed Shelves

In last month's issue, *BM/E* reported on the Panels of 100, who told us what radio managers and engineers would be looking for in Las Vegas. With our preview of the show complete, it is clear that the managers and engineers will find all they are looking for and much more. The shelves will be jammed with state-of-the-art equipment.

Take reel-to-reel tape recorders, the top of the wanted list. At least a dozen firms will have tape recorders on display, and this includes, of course, the top makers in this country and abroad. The new machines continue the trend of the last few years, noted in earlier articles. They perform better, and at the same time are easier to use, with various kinds of automation generally available. With perhaps three years to go to general availability of the digital tape recorder — which in any case will cost several times as much as the best analog machines, for the foreseeable future — the machines in this year's show are excellent buys, some of the medium priced units performing at a level that used to be considered strictly "laboratory."

Consoles are next on the list, and again, as in all NAB shows of recent years, consoles will be super-abundant. In this area, too, quality per dollar is way, way up. The major technical trend is to automation, a subject explored in

continued on page 114

some depth in the article by A.B. Grundy in this issue. At the show Automated Processes, MCI, and Neve are demonstrating console automation, so registrants can read the article and then go right out on the floor for a direct encounter.

Audio processors are next on the list, and this interest is a response to a real technical upswing. Quality in this area has jumped dramatically in the last three or four years, starting with units for FM, but now moving into the AM area where it is sorely needed. Robert Orban describes the Optimod AM in full detail in an article in this issue, and it is demonstrated on the exhibit floor. Another new one on the floor is the Harris MSP-100A, for AM, available soon. Virtually, all other makers of up-to-date processors will be on hand, including Inovonics and Moseley, with established units.

Test equipment, always in high demand, will be on hand from Tektronics, Rhode and Schwartz, Philips, Sound Technology, and others.

New to the NAB will be the hand-held spectrum analyzers of Ivie Electronics, which have $\frac{1}{2}$ octave and full octave readings, with both LED and digital readouts, and many refinements leading to highly accurate measurement.

Microphones, next on the wanted list, are heavily represented from all the well-known sources: AKG, Beyer, Electro-Voice, Shure, Neumann, and Sony. An interesting introduction comes from Edcor, who will show the English Calrex microphone system: four capsules in a close-spaced array, with an electronic system that can combine their outputs in various ways to produce all the standard polar patterns, plus a stereo mode of special quality.

On cart players, remote pickup equipment, STL, noise reduction, AM and FM transmitters, etc. — there are similar stories and plenty of all. The higher-powered FM group gets a stalwart addition with Cetec's Model 630, a 30 kW system. There are lots of antennas, from Jampro, Harris, RCA.

AM stereo, potentially the most exciting new technology, will be somewhat quiescent, with only Harris (according to latest reports) demonstrating the process at the show. Everybody is waiting for the FCC to choose a system. A decision by the time of the show is technically possible, but seems highly unlikely.

Another new technology of great significance, though, will make a splash; satellite distribution of program material. Mutual Broadcasting, which is planning to reach all its 750 subscribers through a satellite net (see *BM/E*, January 1978), will bring a program from its Arlington, VA headquarters to an earth terminal on the convention hall, via the Westar satellite. The program will have a variety of material, and will show the 15 kHz low-noise transmission that will let Mutual into the stereo music business, along with all its other kinds of programs.

Other satellite material will appear in the booth of Scientific Atlanta, with a new earth terminal for radio only, using a 6-foot antenna. Commercial Telecommunications of Rockwell (Collins Radio) will also have satellite earth terminal equipment: details were not available before the show. Farinon will have an operating demonstration of a radio-only earth terminal set up in a van adjacent to the Convention Hall.

Automatic transmission systems will be on hand from

Harris, QEI, the Widget Works and Eric Small, but this new technology is moving quite slowly in the market. Potomac Instruments says they will have an ATS for stations with directional arrays. Eric Small's system is called "Telesis" and is computer-controlled, for FM, AM or TV with many-channel capacity for control, telemetering, and out-of-tolerance alarm.

Automation is in a flourishing state, and the established makers of automation equipment will all have comprehensive exhibits. IGM will be emphasizing their new English-operated programmers, BASIC A and BASIC B. Cetec-Schaeffer also will have a new control system that can be operated by plain English commands; it will be on display.

The many-cart machine will be represented by the Cuerac (500 carts) and the ITC 1K machine (1024 carts). The latter is still in prototype form, although much closer to operating form than the prototype shown last year by ITC. In addition, the ITC will be connected to automation systems in a number of other booths, for live demonstrations: one is IGM. Sono-Mag will bring a new programmer and programmable remote control system. A firm new to NAB, Hallikainen and Friends, promises a line of radio automation equipment.

Another new thing in automation will be Paperwork Systems' new programmer which, added to the large BAT 1750 automation system, will operate AM, FM, and TV stations all at the same time, covering both program switching and accounting. The PSI combination will be connected to switching equipment at the Grass Valley, Vital, Cetec, and Harris booths for live demonstrations.

The solid-state transmitter, the big noise two years ago, is still there but has not become a sweep. Harris has sold a large number of their 1 kW AM solid state units which will be on display again. Sintronics will have an all solid-state 1 kW AM. RCA indicated last year that their solid-state 5 kW AM would be along soon; it is still in preparation. Cetec-Sparta will also exhibit their 1 kW model.

The sharp trend to the direct-drive turntable, with highly precise electronic control of speed, gets a substantial new supporter in EMT (imported by Gotham Audio). The older EMT 930 was for years the most precisely and expensively built turntable, a machine without peer at about \$1500 each. The New EMT 950 is a direct-drive design with electronic servo control; EMT's switch acknowledges that electronics is carrying precision further than even the best mechanical design could. QRK, too, will introduce a direct-drive table; and Eric Small Associates will bring a new high-precision table.

There are many new products that will be at this year's NAB which we just could not go into categorically in the space and time available. We have tried to touch most of the highlights of the major new products in both radio and television, especially those where general trends seem to be evolving. Much more is happening in the areas of business automation, test and measurement, monitoring, lighting, telecine equipment, camera lenses, and accessories. For a more complete reference to everything new that we have information on, we strongly suggest that you consult the alphabetical listings immediately following this article. New product introductions will be boldfaced in the listings.

Besides those new products there will be some, possibly of high significance, from companies that like to keep the curtains closed until the show actually opens. They will get their due in *BM/E*'s May issue, the Show In Print.

BM/E

Frezzi **ENERGY** Belts® them all!

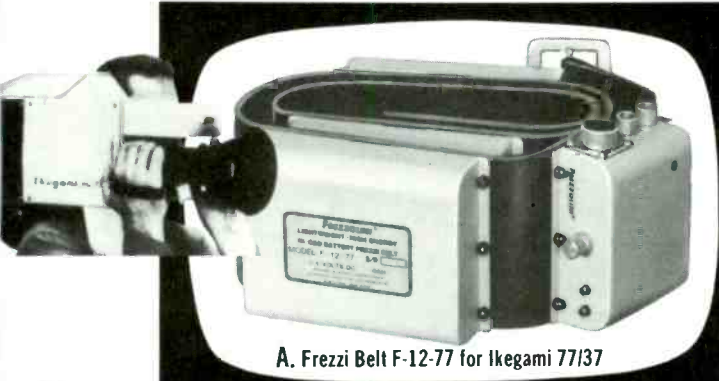

A. Frezzi Belt F-12-77 for Ikegami 77137



B. Frezzi Belt F-30 & F-30EXF for Sun Gun & Mini Pro



C. Frezzi Belt F-12P6 for RCA TK-76

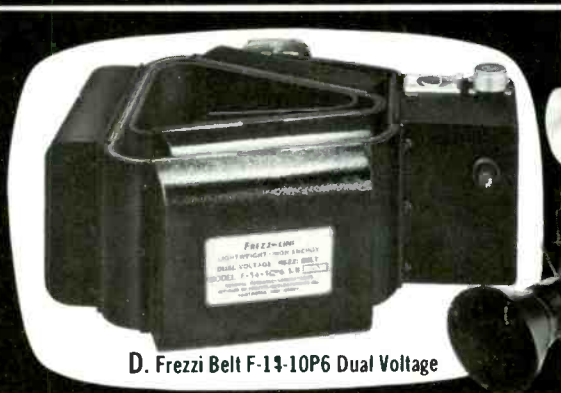

D. Frezzi Belt F-14-10P6 Dual Voltage

A. Frezzi Belt F-12-77 provides reliable power & maximum operating time for Ikegami HL-77 or 37 cameras. Totally compatible for original or replacement service.
List (USA) \$440.

C. Frezzi Belt F-12-P6 provides reliable power & maximum operating time for the RCA TK-76 camera. Totally compatible for original or replacement service.
List (USA) \$440.

Frezzi Belts/Power Packs are manufactured for Akai, Ampex, Hitachi, JVC, Philips, RCA, Sony, Thomson video equipment.

B. Frezzi Belts F-30 or F-30EXF provide reliable maximum power for 30 volt, 250 watt Sun Gun or Mini Pro or other light heads or camera systems.
F-30 (standard charge) . . . List (USA) \$485.
F-30EXF (1-hour recharge) List (USA) \$535.

D. Frezzi Belt F-14-10P6 simultaneously provides reliable maximum power for both RCA TK-76 & Frezzi FLH-100 Sun Gun or increased power for camera.
List (USA) \$585. (Other camera & light Dual Voltage Belts available).

Other Frezzi Battery Packs and Belts, single and dual Chargers, Sequencer Chargers, and Complete Systems available. In addition, we manufacture for OEM



Re-charge fully in less than 1 hour with optional Frezzi Rapid Chargers.

For information: (New Jersey 201) 427-1160 or (New York 212) 594-2294.

Frezzolini® E.N.G. support equipment.
Made in U.S.A.



Frezzolini Electronics Inc.
7 Valley St. Hawthorne, N.J. 07506 USA

Find your specific "Video Power" — Call us or write for Selector Guide.

Circle 176 on Reader Service Card

New from TeleMation

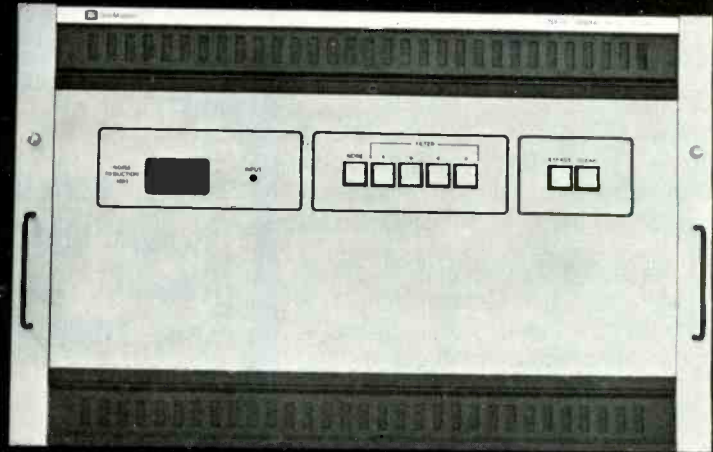
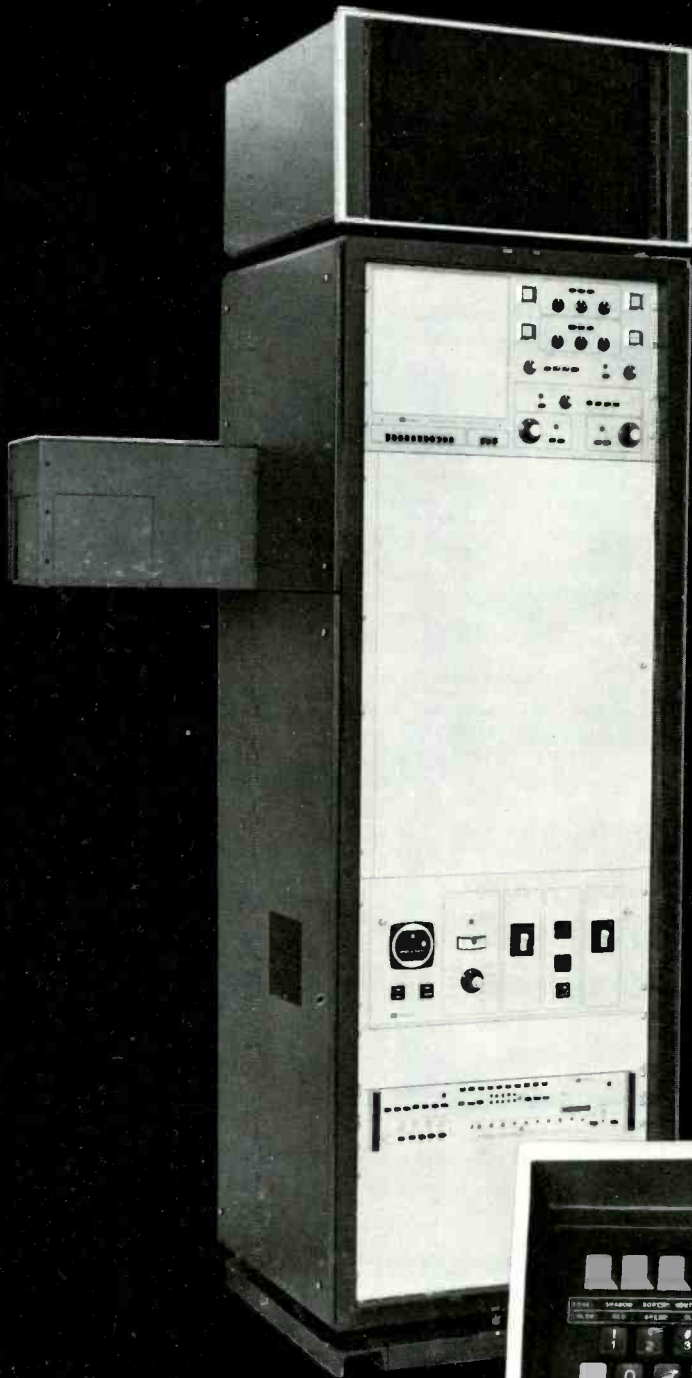

Introducing a state-of-the-art digital noise filter that costs less.

From input to output, the 8-bit TDF-1 represents an entirely new approach to digital noise reduction. At the input, we've included a full, broadcast-quality processing amplifier that completely regenerates incoming sync pulses. The TDF-1's charge-coupled device (CCD) memory offers the same high performance as RAM systems at a significantly lower cost. We've also increased the video sampling rate from three-times-subcarrier to four-times-subcarrier for greater bandwidth and resolution. And maintenance of the TDF-1 is made simple by a built-in diagnostic system.

A graphics system with off-line archival storage.

Everyone who uses an electronic graphics system has their own artistic requirements. With the new Compositor I™ memory system, each of your clients (or departments) can use the fonts they like and logos they need to create up to 999 graphics on a low-cost, removable cartridge disk. At the end of their taping session, they simply take out the cartridge and put it on the shelf. The next user (such as your news department) can then load another cartridge containing different fonts, logos, and pages and be on line in seconds. And, with the new dual disk system, you can copy directly from one cartridge to another.

What else is new with Compositor I? Fonts! More than 40 fonts are now available, including weather symbols, graph characters, and foreign fonts. And Compositor I's are now in use in PAL countries.

A microprocessor-controlled distribution switcher.

The new TVS/TAS-1000 Distribution Switcher microprocessor option can be programmed to perform salvo switches of multiple crosspoints simultaneously. Eight (or more) different salvos can be loaded into the system's memory and previewed by the operator before the live switch is executed, virtually eliminating the possibility of error. Other new control options include X-Y panels, where the source is selected with one button and the destination with another, and category-number selectors, where the input is selected by a name key (such as "VTR," "Camera," "Studio," etc.) and a number key.

A telecine camera that replaces GE units quickly and easily.

A new optics kit allows the TCF-3000 Broadcast Color Film Camera to replace GE 240 and 240-format cameras without so much as moving a projector or changing a lens. The TCF-3000 also gives you true hands-off color balance and color correction, automatically correcting poor-quality film without disturbing balance or gamma tracking of good film. This long term operational stability is made possible by unique, temperature-compensated sampling and control techniques. The TCF-3000 has several other advantages over competitive units, such as lower noise, more detail in black, and superior color separation. And a fully-remotable six-vector color corrector is available as an option.

For more information about these TeleMation products, visit booth 920 at the NAB, or, if you prefer, circle one of the numbers below. TeleMation, Inc., P.O. Box 15068, Salt Lake City, Utah 84115. Phone: (801) 972-8000.

Circle 177 on Reader Service Card for TDF-1 literature

Circle 178 on Reader Service Card for Compositor I literature

Circle 179 on Reader Service Card for TVS/TAS-1000 literature

Circle 180 on Reader Service Card for TCF-3000 literature

NAB Booth 920

New System Improves Selectivity, Linearity, of FM Reception

The McMartin Company has put into service a new selectivity and demodulation system in their SCA receivers, FM monitor tuners, and other FM receiving equipment.

Called the "Precise Tracking Decoder," the system is based on a phase-locked loop demodulator. The major aims of the change in FM receiver design were to reduce crosstalk between SCA and main channel through the improved linearity of the PLL system, while maintaining very high selectivity. The fully developed system, McMartin says, also has extremely low capture ratio, high sensitivity, improved AGC action, and improved squelch action.

The role of non-linearity in the IF filters in causing intermodulation and crosstalk in FM receivers has been recognized for a long time. McMartin points out that standard multi-pole filters that have adequate selectivity are also prone to non-linearity which is very costly to reduce. Filter

vendors are not ordinarily well equipped for the elaborate quality control necessary.

By shifting to a phase-locked loop demodulator, the design immediately has the potential for very high selectivity combined with excellent linearity. Properly used, says McMartin, it can reduce average crosstalk to the level of the noise in the SCA channel, and produce a composite stereo signal with minimum phase error, particularly at the higher frequencies from 12 KHz to 15 KHz. The method also saves the cost of the complex multi-pole filters, which are no longer required.

As described by McMartin, the main characteristics of the "Precise Tracking Decoder" are outlined in the series of diagrams and captions on this page. The block diagrams show the overall layout of the system. It has been incorporated into the McMartin products listed under the diagrams.

BM/E

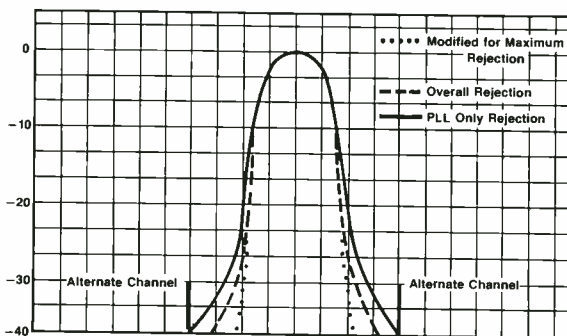

Solid line is selectivity of PLL with no external bandpass; broken line with matching transformer used in all McMartin tuners; dotted line with optional additional filter.

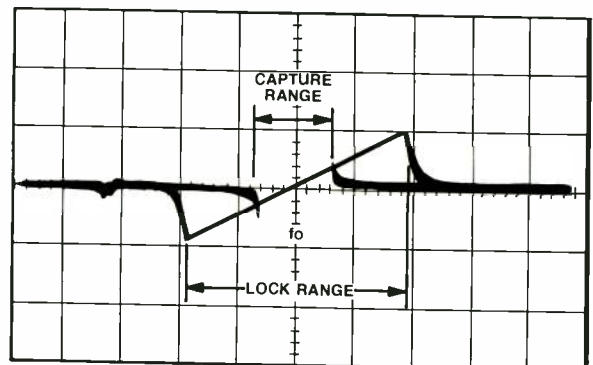

Capture range, less than 1 dB allows PLL to respond to weak signals; wider lock range minimizes multipath, allows PLL to follow original signal, reject interference.

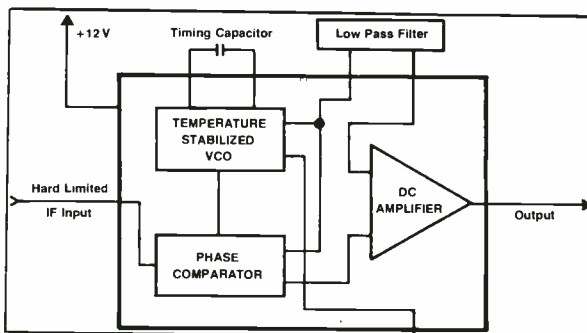

PLL block diagram shows operation. Error voltage from phase comparator, with FM input signal, forces VCO to track signal, and also becomes demodulated output. Linearity and signal/noise can be made very high.

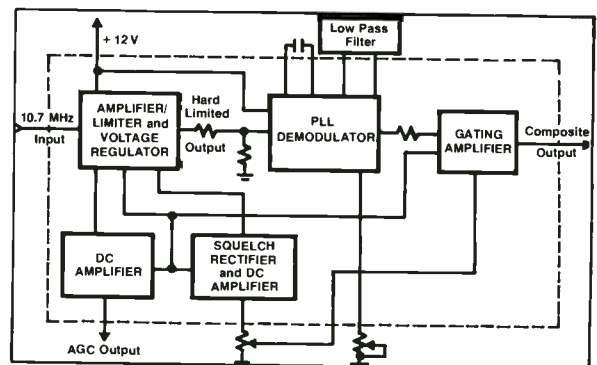

Block diagram of Precise Tracking Decoder shows how PLL is applied in receivers. Limiter normally limits on input noise. Squelch circuit produces usable voltage down to one microvolt. AGC reduces front-end gain before overload. (McMartin has pamphlet with details of circuit action.)

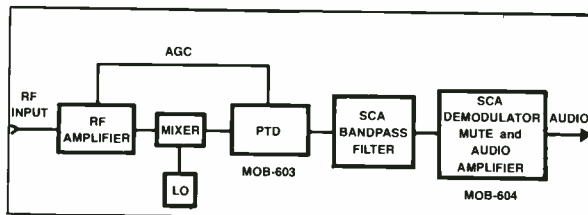

Block diagram shows receiver using PLL and new SCA demodulator. SCA is selected by 67 KHz bandpass filter. All SCA circuitry, including audio output, is on one chip.

This little box can save you
\$12,000 a year and end
station slide troubles
forever.



Lost slides. Jammed slides. Dirty slides. Upside down slides.
Out of sequence. Too slow. Too expensive.

You don't need trouble like this. Not when you can create, store, and retrieve up to 3,000 stills instantly with the ADDA Electronic Still Processor.

Create stills instantly from videotape, character generator film, slides, network feeds, and live camera. Store up to 3,000 images, electronically, on the ESP disk drives. Pre-program up to 800 stills for automatic advance at the touch of a button.

You can punch up any still within half-a-second. Freeze frames from any video source. Zoom or simulate animation. Create "stills" that look like they are moving. Fade, dissolve, and super two separate outputs through the program switcher. Full sequence editing capability lets you preview, add, delete, and skip.



Do it all while cutting slide handling and labor cost by 80%. Still handling and camera support time can be reduced to less than three hours a day. If you produce 80 new slides a week, you can save film and processing cost of \$12,000 a year.

Use the ADDA Electronic Still Processor with your existing computer, or as a stand-alone system. Either way, you'll improve still picture quality, make life easier, and save money.

Take a look for yourself. Call, write, or check our reader service number for more information and a demonstration.

1671 Dell Avenue/Campbell, California 95008/
(408) 379-1500

ADDA CORPORATION

Circle 181 on Reader Service Card

Complete Listing of Exhibitors At NAB '78, Las Vegas

The following is based on information received late January, early February. Some booth numbers may change by show time. Number in parenthesis is the exhibitor's booth number. New products are boldfaced.



Microwave will be hot at NAB with a lot of new equipment. Here, a Van Ladder 29 ft. telescoping boom is shown.

Accurate Sound Corporation (202)

Showing high speed duplicating systems for broadcast automation, including both reel-to-reel and cassette duplication.

Acrodyne Industries, Inc. (1011)

Television transmitters and translators. New **5kW VHF IF** Diplexed TV transmitter and **25 W UHF** solid state amplifier for IF diplexed applications. TT347 Series transmitters.

ADDA Corp. (524)

Electronic still processing systems, ESP-100, 200, 300. System is digital disc based offering dual channels.

Alford Manufacturing Co. (733)

Will show their line of FM, and TV antennas; RF diplexers, loads, switchers; transmission lines and line accessories; RF test equipment.

Amco Engineering Co. (441)

High-styled **cabinets and consoles** for broadcast equipment will be shown including a new line of audio-visual desks.

American Data Corp. (822)

Will show new line of audio and video distribution switchers, **Series 3900**. Also, first time introduction of **master control automation system**, ACTS and new **Model 558-4** Series of video production switcher.

American Electronic Laboratories (306)

Showing the FM-25KG transmitter; also the line of AM and FM transmitters.

Amperex Electronic Corp. (819)

New high resolution Plumbicon® tubes for EFP/ENG and electronic cinematography. **High resolution 1-in. Plumbicon, 30 mm Plumbicon. Light biased 30 mm Plumbicon and 2/3-in.**

continued on page 122

Simply Sophisticated

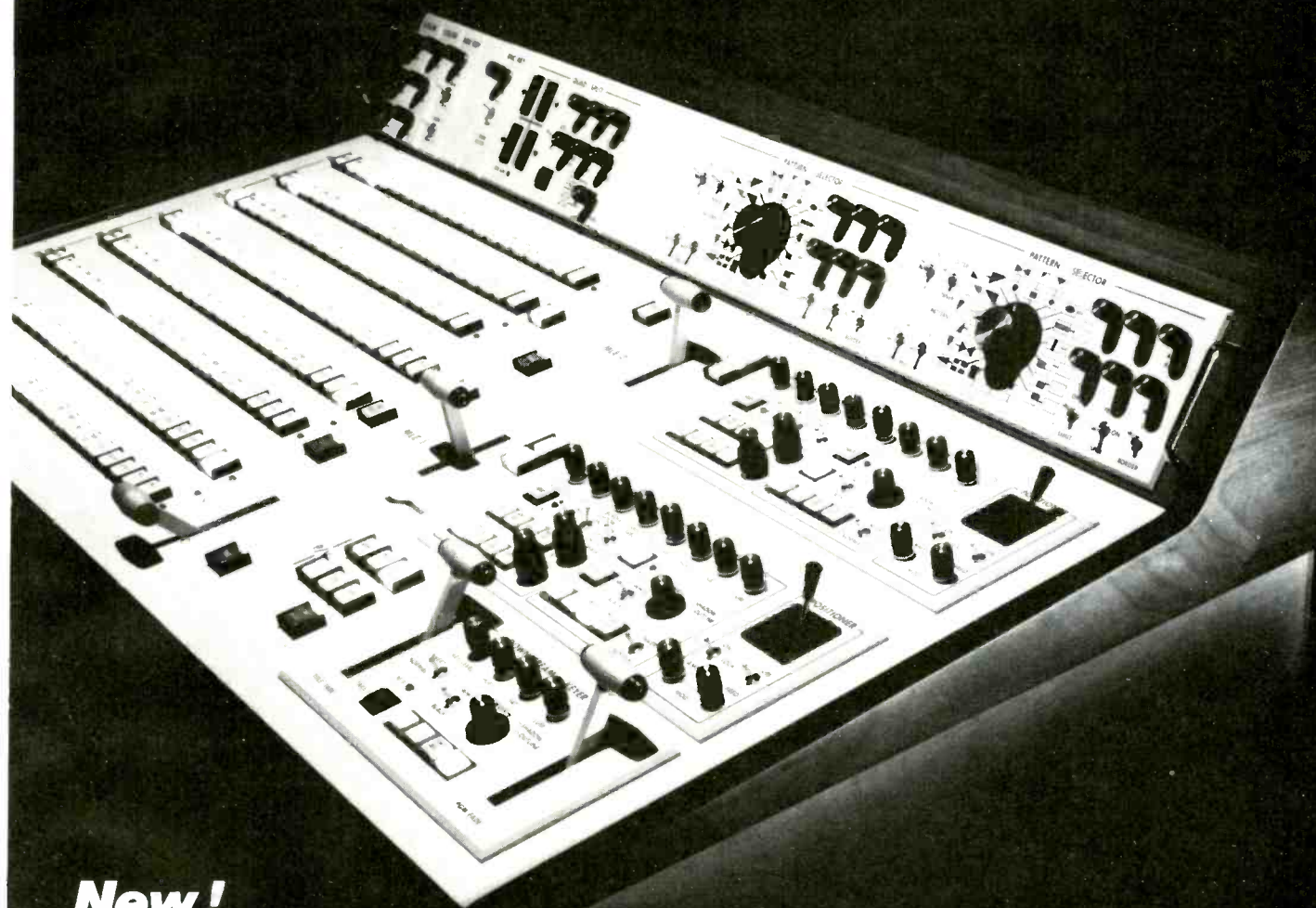

New!

ROSS 500 Series Multi Level Effects Switchers ...are

Sophisticated . . .

- Each Multi Level Effects (**MLE**) Amplifier processes 2 background and 2 key signals.
- Exclusive Transition Preview system. Complicated program transitions can be previewed with the On-Air **MLE** Amplifier.
- Rotary and Spin wipes with unique controls.
- Pattern Multiplier can be controlled with joystick.
- Video & Key inputs for a character generator.
- Auto transition & editor interfaces.
- Downstream Keyer, Master fade to black, PST/PGM Bus, Soft keys and wipes, border and background generator, RGB & Encoded chroma keyers, and up to 24 inputs... and 4 Auxiliary buses.

yet . . . Simple to Operate

- Clean, logical panel layout designed for the operator.
- Quad Split *does not* tie up a primary buss.
- One RGB Keyer accommodates 2 cameras.
- Exclusive feedback circuitry plus low power consumption keeps the electronics "rock stable" and eliminates the twiddle pots.
- Packaged as a console with turret.
- Only 46 inches long (max)...and only 14 inches for rack electronics...including all options.
- Models: 1 or 2 **MLE** Amplifiers, 16 to 24 inputs... many options...NTSC, PAL & PAL-M.

Call ■ 613-652-4689 or write, **ROSS VIDEO LTD.**
9 Iroquois Plaza, Iroquois, Ontario, Canada K0E 1K0



... at NAB
East Hall 1301B

BASIC A

is the audio control system you can afford.

BASIC A is available at a price almost any station can afford... lower than the cost of many existing systems with fewer capabilities.

This system will operate all of your existing reel-to-reel decks, Instacarts, Go-Carts, single-play units or carousels. Don't throw anything away. Just let BASIC A take over. Update peripheral equipment as you can.

Any time you want to expand, just add optional modules. You won't have to buy a whole new system to get the increased capabilities you need.

In these and other ways, BASIC A helps you control costs.

At the same time, BASIC A is, technologically, the state-of-the-art in audio control systems. It's easy to program (it understands English), gives you positive control of rotation and the consistent sound you want.

Please send for the brochure.

IGM

A Division of NTI
4041 Home Road
Bellingham, WA 98225
206-733-4567

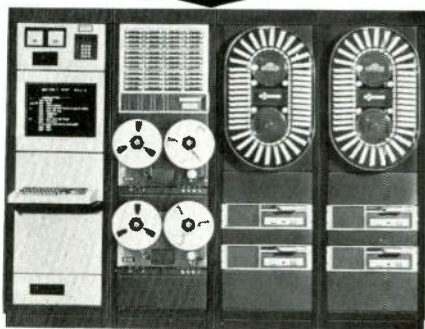

Circle 183 on Reader Service Card

NAB '78 Las Vegas

reduced flare Plumbicons will be shown. Recently introduced 1600 line resolution Plumbicon.

Ampex Corp. (603)

Highlighting Type-C 1-in. helical VTRs, VPR-2; portable version of VPR-2, VPR-20, field recorder with built in assemble editing. ESS-2, Electronic Still Store and variable speed digital recorder for slow-motion and skip field. VTRs will be shown in NTSC and PAL versions.

Ampro Broadcasting, Inc. (100)

Will introduce the Tri-Dek cartridge reproducer and the "ADDS" audio digital delay system. Also showing consoles, turntables, other cartridge player/recorders.

Amtron Corp. (1321)

Color monitors. New 8", 13" and 19" models.

Andrew Corp. (808)

Heliac coaxial cables and earth station antennas.

Anginieux Corp. of America (812)

Family of broadcast lenses including the 10X and 12X studio lenses and the 15X and 42X for studio and OB. Also the Tele 42X for sports and OB. New is the 12X studio lens.

Anixter-Mark (110)

Will show microwave antennas and accessories.

Arvin/Echo Science Corp. (1114)

Will introduce the new "Slo Mo" video disc machine. Electronic still storage.

Asaca Corp. (800)

Video sweep generator, color bar generator, envelope delay measuring set, color video noise meter, 14" high resolution monitor, 10" AC/DC color monitor, digital pattern generator, distortion meter.

Aristocart (401)

Cartridges for tape cartridge systems.

Audi-Cord Corp. (335)

Will show tape cartridge recorder/player systems; multiple cart players.

Audio Designs and Manufacturing, Inc. (435)

Modular audio consoles and components. New intercom system.

Audio Sellers (The Money Machine) (343)

Will show their music library services for radio, The Money Machine and

Music Explo. Will introduce a new country music library and "Sunday at the Memories" three-hour nostalgia program.

Auditronics, Inc. (106)

Introducing a new 18 in/four out mixing console with both VU and peak level indicators.

Automated Business Concepts (328)

New business automation system. Uses A O Smith mini computer, Mesa Two. Includes general ledger, payroll, accounting programs and other broadcast management programs.

Automated Processes Inc. (731)

Complete audio line. New intercom/audio routing system. New system uses four wire interconnect and is programmable through microprocessor control. Features broadcast quality audio.

Automation Industries, Inc. (1403)

Will show a weather radar system, with rain precipitation intensity displayed in six colors.

Beaveronics Inc. (1216)

Video equipment. Production and routing switchers. FHVAG clock and audio systems. J&D video switchers, Holland video terminations, and audio products of Audio Video Eng. Co. Humbucking coils.

Belar Electronics Laboratory (520)

Will show the complete line of broadcast monitors.

Berkey Colortran Inc. (912)

Lighting equipment. Studio suspension equipment, computerized and manual lighting control systems. New pantographs, portable control packs, computerized lighting systems, Luminaires, new key and fill lights, line of portable lighting kits. New pantograph support system will lift up to 88 lbs.

Beston Electronics Inc. (1105)

Automatic light control for all film chains. Low cost character generators.

BTX Corp. (1208)

Economical synchronizers for audio recorders and video recorders. Uses SMPTE time code. Model 4500 Edit Code Synchronizer will be shown.

Bayly Engineering Ltd./AEG-Telefunken (337)

Will introduce FM STL equipment for remote pickups; portable audio mixer; will show AM and FM transmitters, noise reduction systems, monitor speakers, antennas, microphones and accessories.

continued on page 125

**We put over
200 TV news
departments
on the spot
every day.**

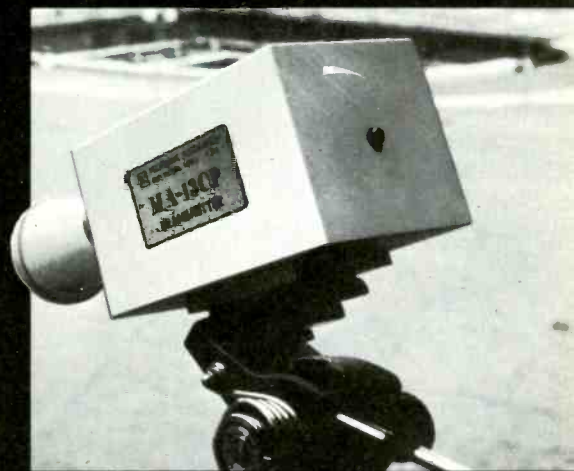

And vice versa.

Over 200 news departments nationwide rely on our microwave products in their ENG systems. In fact, ours are the most widely used microwave links in the industry.

We understand the real world of ENG. That's why our equipment is built to endure weather changes and survive the bouncing and jouncing of everyday use. We make it rugged, lightweight, dependable. And we provide service you can count on coast-to-coast.

Because we've been involved in ENG since the beginning, we can show you how to build a state of the art system for today's needs . . . and tomorrow's.

If you'd like a good combination of experience and technical expertise in ENG microwave links, be sure to include us in your planning. Microwave Associates, Communications Equipment Group, Northwest Industrial Park, Burlington, MA 01803, (617) 272-3100.

See us at NAB 78,
Booth #809

Field Sales Offices: Atlanta, GA (404) 455-3815,
Dallas, TX (214) 234-3522, Kansas City, MO (816) 891-8895,
Sunnyvale, CA (916) 339-9248, Seattle, WA (206) 232-3550,
Honolulu, HI (808) 537-3991.



**Microwave
Associates**

Circle 184 on Reader Service Card

REDUCE NOISE AND BLOWER HORSEPOWER WITH

the Quiet Ones



EIMAC's new patented ripple-fin anode tetrodes for FM transmitters are the Quiet Ones because they operate with a drastic reduction in cooling-air-flow acoustical noise emission.

Noise measurements made on the ripple-fin structure in the annoying high frequency range (6000 to 12000 Hz) show a marked noise reduction of 9 dB to 16 dB in sound pressure level over traditional anodes.

In addition, the more efficient wave-like geometry of the new structure allows vastly reduced cooling horsepower—from one-half to one-quarter as much as conventional tubes.

This new concept is the result of EIMAC's continuing upgrading of the popular 3CX and 4CX families of FM power tubes

which have already established an enviable reputation for long life and stability.

The X-2213, first member of this new tube family, also provides sufficient gain to permit the practical use of a solid state driver for a power output level of 25 kilowatts in FM service.

Traditional EIMAC quality and dependability are now available with the latest in anode cooling design and electron ballistics. For complete details on the X-2213, contact Varian, EIMAC Division, 301 Industrial Way, San Carlos, California 94070. Telephone (415) 592-1221. Or contact any of the more than 30 Varian Electron Device Group Sales Offices throughout the world.



See us at NAB, Booth #913

Circle 185 on Reader Service Card

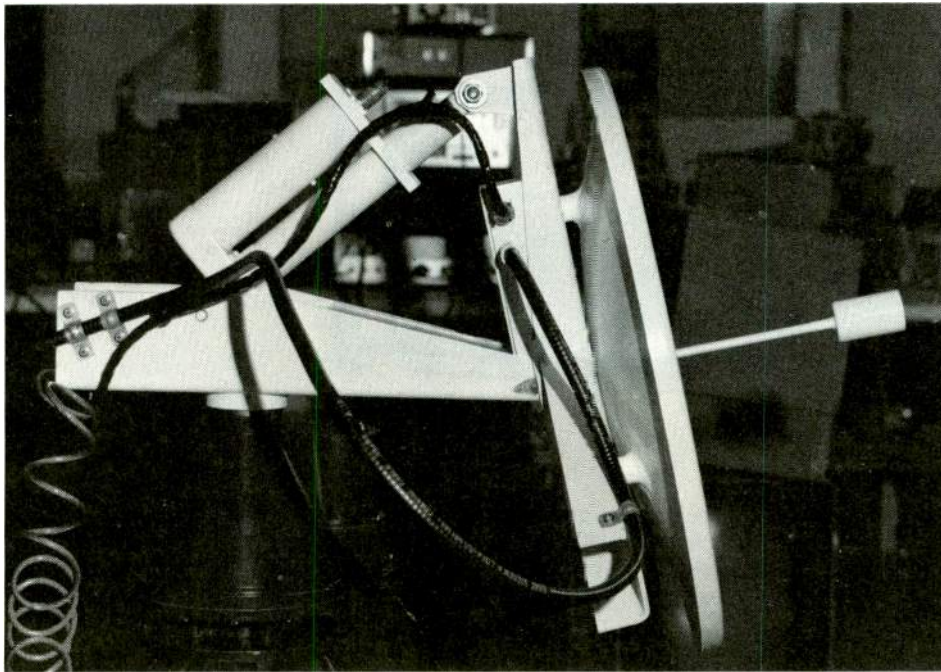

New steerable dish from Tayburn Electronics. Many manufacturers will be showing new portable gear as well.

Tayburn's Master Station will control up to two antennas on each of four sites.

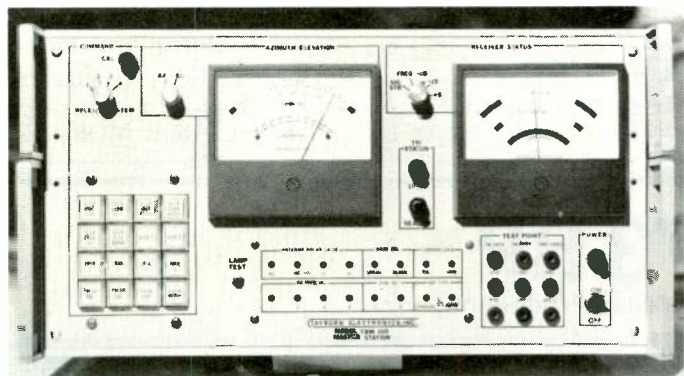

Bird Electronic Corp. (1109)

Feature attraction will be new very **low-priced coaxial loads to 40kW.** (EconoLoad RF terminations.) Also shown will be compact high-power RF loads that require no water. New also will be **digital coaxial RF calorimeter** which measures power to 80kW.

Bogner Broadcast Equipment Corp. (907-A)

Slot type VHF & UHF transmitting antennas, high power emergency antennas, MDS antennas, high and low VHF dipole transmitting antenna. New high power UHF slot transmitting antenna, convertible to CP — no premium.

Bosch Fernseh (922)

Full 1-in. videotape recording systems using Type-B SMPTE standards. Standalone Digital Store. Editing, studio recorders, field recorders, and **1-in cassette portable.** Still store and slow motion capabilities of BCN system will be demonstrated. New

KCA-90 ENG camera.

Boston Insulated Wire and Cable Co. (921)

Cable systems for TV cameras; connectors for camera cables.

Broadcast Electronics Inc. (304)

New **audio consoles, audio tape cartridge machines, and audio control equipment.** Control room audio equipment for radio and television.

Broadcast Programming International (325)

Syndicated music programs for radio, in a variety of formats.

CCA Electronics Corp. (307)

Full line of AM, FM and TV **transmitters, audio consoles, FM and TV antennas** and related accessories, including ATS equipment, audio processors, monitor speakers. Some brand new products will be introduced.

CMX Systems, Div. of Orrox Corp. (801)

Featuring expandable computer assisted videotape editing systems. Use of I², (Intelligent Interface) makes system suitable for editing on- or off-line in all VTR formats, plus slo-mo disc machines, synchronous audio recorders, and advanced switchers. New **SMPTE/EBU Master Time Code Generator, and portable time code generator. Time code reader display.**

CSI Electronics Corp. (318)

Showing AM and FM transmitters, carrier current systems, stereo and SCA generators.

Cablewave Systems Inc. (100A)

Transmission line systems will be shown. New will be **semi- and automatic dehydrator equipment and microwave parabolic antennas.**

continued on page 126



Asaca Corp.'s color video noise meter. Asaca will show several new devices in its test and measuring line this year.

California Switch and Signal Co. (313)
Will show patch panels and audio switching equipment.

The Camera Mart, Inc. (1137)
Will show video cameras and VTRs of various makes, for rent, lease, purchase.

Canon USA, Inc. (918)
New **ENG camera lens**, J13 X 9B, other lenses will be PV 25:1 or 18:1

Zoom lenses for studio cameras and **V6, 18:1, f1.6** lens suitable for single tube color cameras. Also, Scoopic 16mm film cameras.

Capitol Magnetic Products, Inc. (423)
Showing tape cartridges; master tapes for audio recording.

Cavox Stereo Productions (347)
Demonstrating syndicated radio programming in numerous formats, including Adult MOR, contemporary

MOR, Beautiful Music, Good Music, Conservative Tempo, Standard Pop, Easy Listening, Cavox Country.

Ceco Communications (404)
Transmitting and camera tubes for radio and TV will be shown.

Central Dynamics Ltd. (915)
Video production switchers, technical automation systems. New **Multipattern** and **Matrix Wipe** special effects.

373 BP

(Broadcast Production)

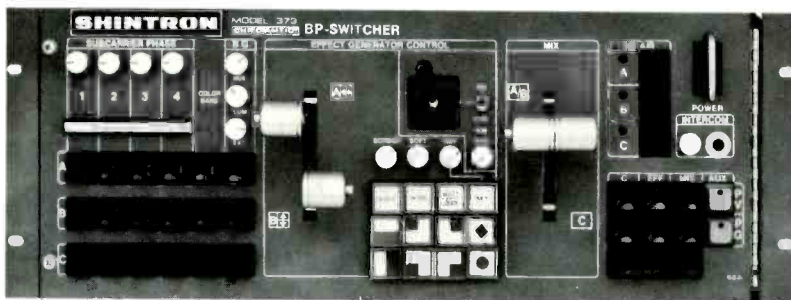

IPU

A new broadcast term is born. IPU. An IPU, integrated production unit combines a professional switcher, color sync Gen, DAs and tally/intercom in one enclosure for ENG, EFP, and just any productions. Given cameras, an IPU is a complete studio. No cabling is required. Thus reliability and super convenience. Rough it up. It's rugged. No compromise in performance. A step above a switcher in an ever compactizing chain of evolution in professional television equipment.

SHINTRON

World Wide

Cambridge, MA 02142 U.S.A.

Phone 617-491-8700 Telex 921 497

Centro Corp. (1229)
Computer assisted switching and logging system for television master control, suitable for small and medium market stations, **Centro Mark II**. Also, new **MD-500** Portable Television Production System.

Cetec Audio (429)
Part of the overall Cetec Broadcast Group exhibit. Will show Series 20 Audio Console sporting a new **meter face**.

Cetec Broadcast Group (429)
Will be emphasizing the Cetec-Schaefer **Model 7000 automation system**, controlled with plain English commands; also the transmitter line of Cetec-Sparta, including the SS1000 solid state AM transmitter, and the new **Model 630**, 30 kW FM transmitter.

Christie Electric Corp. (1115)
Will show ReFLEX-20, the burping 20 minute charger and super ni-cad battery packs. New is an **Automatic Battery Charging Sequencer**.

Chyron Corp. Video Products Div. (729)
A new model of the Chyron **Graphics and Titling generator** will be intro-

continued on page 129

DK8000 *the complete production machine...*

See us at the
NAB
Booth 1227

- Keyboard M/E programming offers remote operation in which all M/E functions (such as transition mode, time selection, pattern selection and key selection) may be quickly and efficiently entered via the keyboard.
- DK series incorporates a number of advancements including multiplexing, L.E.D. indicators and readouts.
- Predesigned to incorporate a small memory allowing storage and re-call of complex production set-ups.

Everything You Wanted In A Video Controller (...but were afraid to ask for)

Another best seller from ...

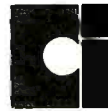

**COMPUTER IMAGE
VIDEO CONTROLLER**

A PRODUCT OF DYTEK INDUSTRIES INC.

2475 West Second Ave.
Suite 4
Denver, Colorado 80223

(303) 934-5804

Circle 137 on Reader Service Card

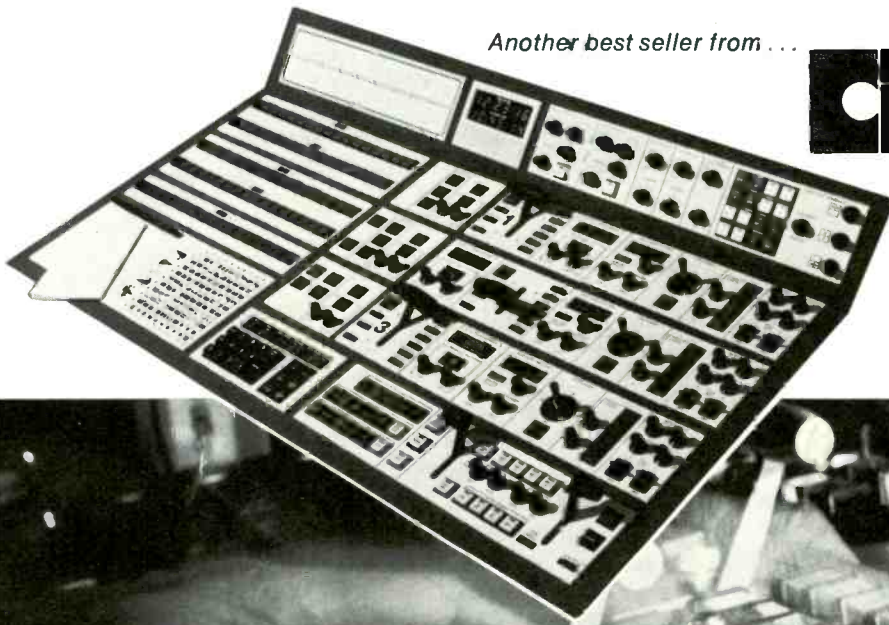

DK8/178



Until now you wouldn't consider buying a demod for \$1775.



The remarkable Scientific-Atlanta 6250 falls about \$7,000 short of the price you might normally pay for a comparable high quality demodulator. But it doesn't fall short in engineering and performance. We've sold over 300 6250 Demodulators since its introduction a year ago. In fact one group of station engineers wrote, "we are amazed at your demod's performance," after comparative bench tests against a unit close to the \$10,000 range.

Consider the specs. 100 uv input sensitivity. Video response ± 0.5 dB to 4.18 Mhz, $\pm 2.5\%$ differential gain and $\pm 1^\circ$ differential phase. With audio response ± 0.5 dB 30 Hz to 15 KHz.

Consider the features: Zero chopper capable of operation from external as well as internal command. Envelope detector with optional syn-

chronous detector. Intercarrier sound detection, also direct mode with synchronous detection option. Local or remote control of chopper on/off, envelope/synchronous detection, intercarrier/direct sound detection. Automatic switch-back to envelope mode if phaselock is lost in synchronous mode. AC operation with optional +DC standby powering. Optional powering from -DC.

Consider the organization. At the forefront of the companies who are revolutionizing world communications via satellite, Scientific-Atlanta has had to meet some of the toughest requirements for performance, reliability and economy. The results of this experience are evident in our advanced 6250 Demodulator.

For a demonstration, call Harry Banks at (404) 449-2000. Or write us.

Scientific Atlanta

Circle 188 on Reader Service Card

United States: 3845 Pleasantdale Road, Atlanta, Ga. 30340, Telephone 404-449-2000, TWX 810-706-4912, Telex 054-2898
Canada: 6511 Atlantic Drive, Mississauga, Ontario, L5T 1C8, Canada, Telephone 416-677-6555, Telex 06-983600
Europe: 1-7 Sunbury Cross Centre, Staines Road West, Sunbury on Thames, Middlesex TW16 7BB, England,
Telephone Sunbury on Thames 80751, Telex 806015

See us at NAB, Booth #1205

NAB '78 Las Vegas

Chyron Telesystems' new U-type cleaner/evaluator. Device represents a broadening of Chyron systems.

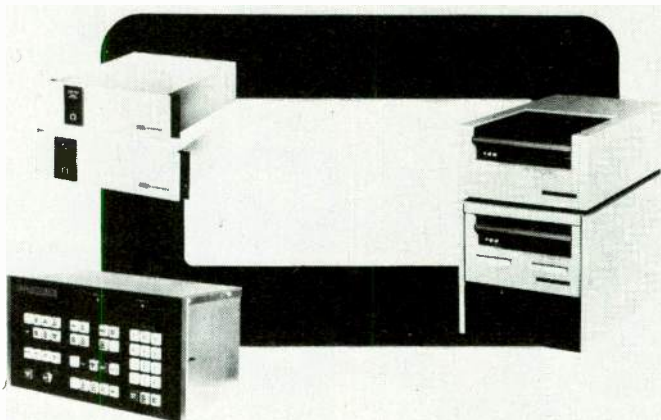

duced which contains several new and unique features. **Cassette cleaner and evaluator** for 3/4-in. videocassette tape will be shown.

Cine 60 Inc. (1002)

Will be introducing new **battery systems** including fast charging systems and new **Sun-Gun kits**. Other lighting equipment will be shown.

Cinema Products Corp. (901 E)

Line of film cameras (16mm) for news and camera stabilizing system, Steadicam. New electronic ENG camera, **MNC71CP**, a company first.

Cohu, Inc. Electronics Div. (908)

Will feature operating film island with Model 1550 telecine. **New Model 7410** single tube, special purpose, low-light level camera. Uses isocon tube.

Colorado Video, Inc. (911)

Show scan television for FM subcarrier transmission or news remotes.

Comark Industries, Inc. (1113)

Diplexers, power combiners, and RF needs.

Commercial Electronics Inc. (1102)

CEI-310 portable, modular EFP/Studio color camera.

Commercial Telecommunications Group, Rockwell International Corp. (300)

Will introduce a **new video relay microwave system**. Will demonstrate the "Power Rock" 5-kW AM transmitter, and a complete audio studio with live Mark 8 console. Also the Phase 4 exciter, other AM and FM transmitters, satellite communications equipment.



Studer's **TLS-2000 Tape Lock System**. A number of approaches to synchronizing video and audio recorders will be shown this year, indicating a renewed interest in double system production.

The **ADDA Corp.'s ESP System** will be one of several new developments in electronic still storage to be shown at NAB.

Computer Image, Div. of Dytek (1107)

Video switchers, audio and video routing switchers, **VAMCO Digital Tape Timers**, digital clocks. Featured will be the **SL6000**, **SL3000** series switching systems, and **new DK8000** series keyboard programming switcher. Also, 12 input, 1 output audio/video routing switcher.

Computer Magnetics Corp. (449)

Will show rebuilt audio and video magnetic heads, video discs, video equalizers, color correctors.

Comrex Corporation (1004)

Will introduce a **TV ENG van package**, **radio ENG repeater systems**, and the **LX line extender** for telco lines. Also showing complete line of remote pickup transmitters and receivers, wireless microphones.

continued on page 133

Look what's the "Old



**The faces are familiar...
and these engineering
updates have kept this
generation on top, year
after year:**

- New program recording and reproducing amplifiers provide less distortion, more headroom.
- +18 dBm audio output (optional).
- Improved 450 RPM capstan motor with less heat, less wow and flutter, higher reliability.
- New, long life Nortronics Duracore® heads. Ten times longer head life.
- Improved head mounting blocks provide better stability.
- Improved air-damped solenoid with Teflon® coated plunger for quieter operation.
- Motor-driven recording head azimuth control to compensate for variations in cartridges (optional).
- Self-aligning top capstan bearing in 3 Deck Reproducer.
- Improved, high-reliability meters.
- Field-selectable 600 or 15k ohms balanced audio inputs.
- Improved solid-state recorder logic control for better reliability.
- Improved tone detectors for fail-safe high-speed operation.
- Improved equalization technique on Recording Amplifier smooths high end response.
- RP Delay machine for program delay and cartridge production (optional).
- New IC Voltage Regulators with thermal and short circuit protection provide improved regulation.
- Two year warranty on parts and factory labor.

new: Faithfuls™

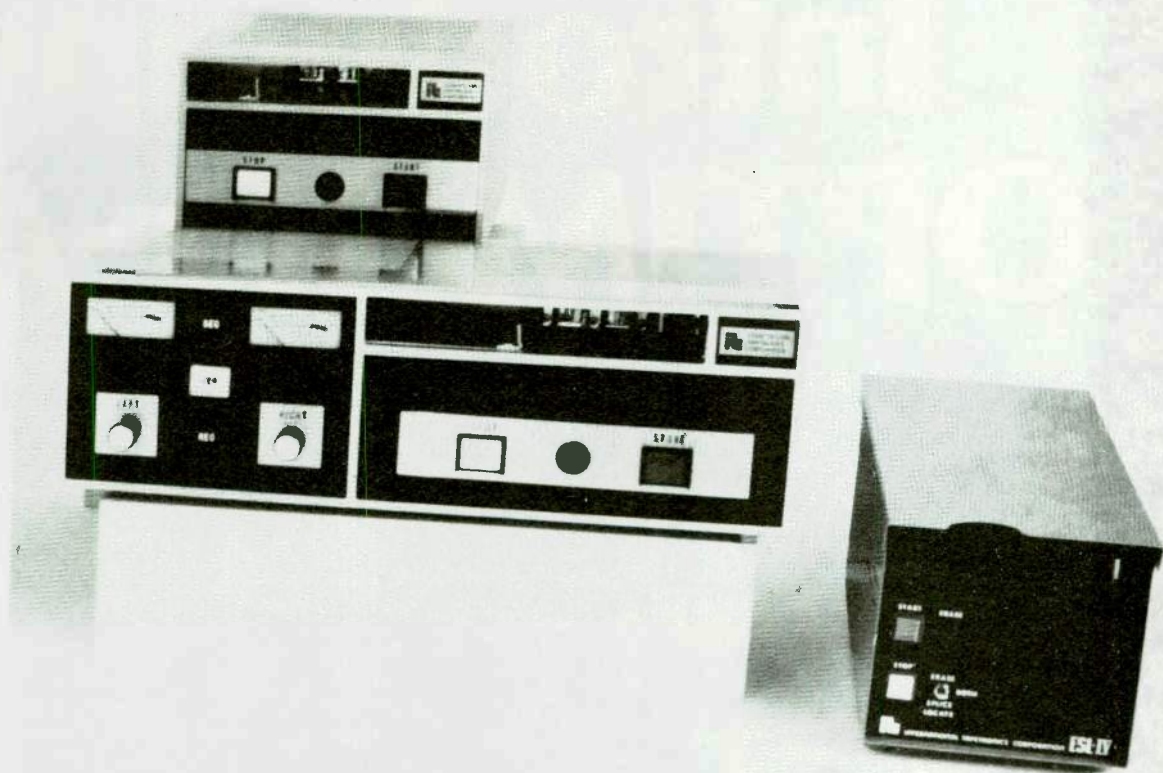
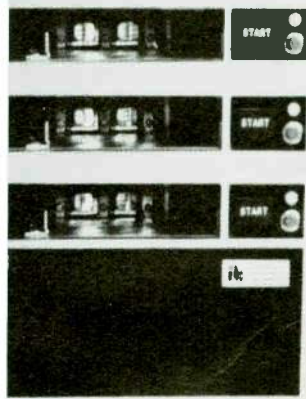

No Risk Trial Offer

Try ITC tape cartridge equipment in your own station for 30 days. If it doesn't outperform the competition, return it. No cost. No obligation. To place a trial order call us toll-free. Ask about our attractive lease-purchase plan and trade-in allowances.

**CALL TOLL-FREE
800-447-0414**

In Alaska, Hawaii or Illinois
call collect: (309) 828-1381.

it Quality
Improves With Time

**INTERNATIONAL TAPETRONICS
CORPORATION** • Bloomington, Ill. 61701

Marketed exclusively in Canada
by McCurdy Radio Industries Ltd., Toronto

Circle 189 on Reader Service Card

See The Entire ITC Product Line
BOOTH 431-1978 NAB

Orban Perfects AM Radio: Introducing OPTIMOD-AM

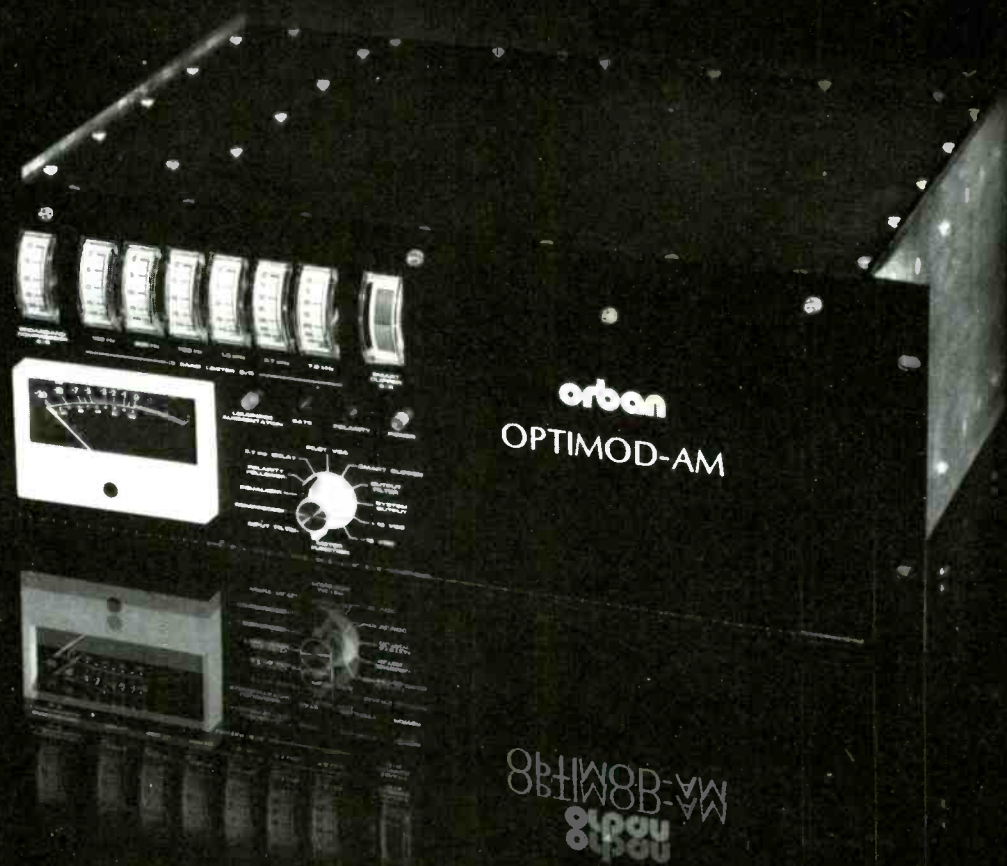

Circle 190 on Reader Service Card

Call Toll Free (800) 227-4498

Orban Associates Inc. 645 Bryant Street San Francisco, CA 94107 In California (415) 957-1067
(Hear it at NAB LAS VEGAS Booth 402.)

NAB '78 Las Vegas

Conrac Corp, Systems East Division (743)

Will be demonstrating the Eddophor television projection system.

Conrac Division, Conrac Corp. (721)

Showing line of video monitors.

Consolidated Electronic Industries (409)

Will introduce series of tape cartridge and reel-to-reel recorder/players. Also showing the Cuerac, 500-cart system for automated playback.

Consolidated Video Systems (917)

CVS time base correctors, field and frame synchronizers. Will introduce new **computer assisted editing system** suitable to 3/4-, 1-, and 2-inch VTR post production. Also, new **digital Image Enhancer/Noise Reducer** will be shown.

Continental Electronics Mfg. Co. (312)

Showing line of low and high power AM transmitters.

Convergence Corp. (1007)

Two simultaneous presentations to

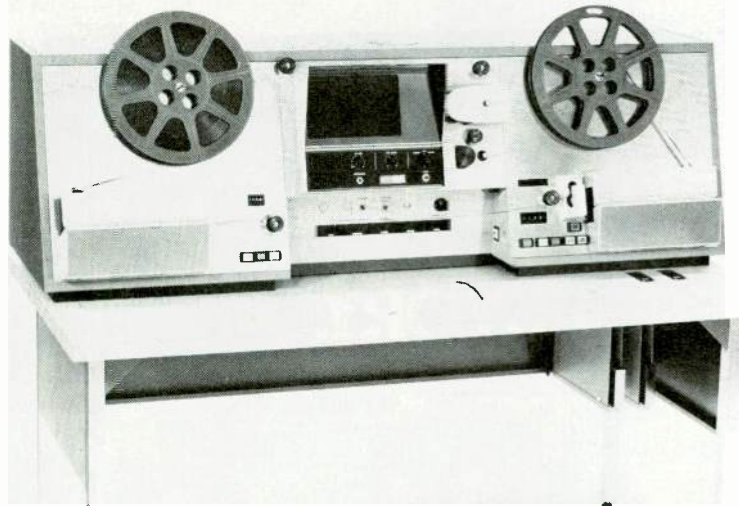

The TV 120 Film inspection/Cleaning Machine with previewing and editing, will be on display in the Research Technology exhibit.

show off videocassette editing systems. Will introduce **new series of editing control systems** and post-production equipment.

Data Communications Corp. (919)

Feature attraction will be micro BIAS system (hardware and software) along with the BIAS automatic switching interface. New will be **BIAS Account-**

ing package (AR/AP/GL/Corporate Reports) offering total automation.

Datatek Corp. (705)

Video-Audio Routing Switching System. New **SMPTE Time Code Switching System** and **SMPTE Time Code DA**. Also new **audio routing switcher**.

continued on page 135



From single camera ENG to multi camera production with 1" tape, Wolf Coach and TEC have the experience, facilities and technical capability to meet your mobile video needs.

Come see the latest in ENGINEERING — Booth 1100 at the NAB.



Wolf Coach Inc.

200 Bartlett Street
Northboro, Mass. 01532
tel. 617-393-2551
Circle 191 on Reader Service Card

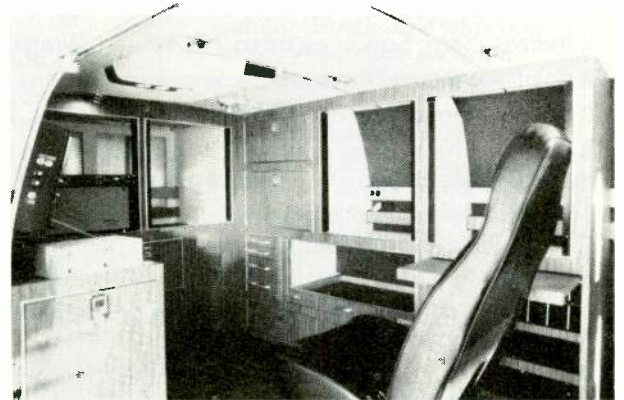

TELEVISION ENGINEERING CORPORATION
519 Rudder Rd. — Fenton, Mo. 63026
Telephone: 314/343-5605

More performance per pound for ENG from NEC.

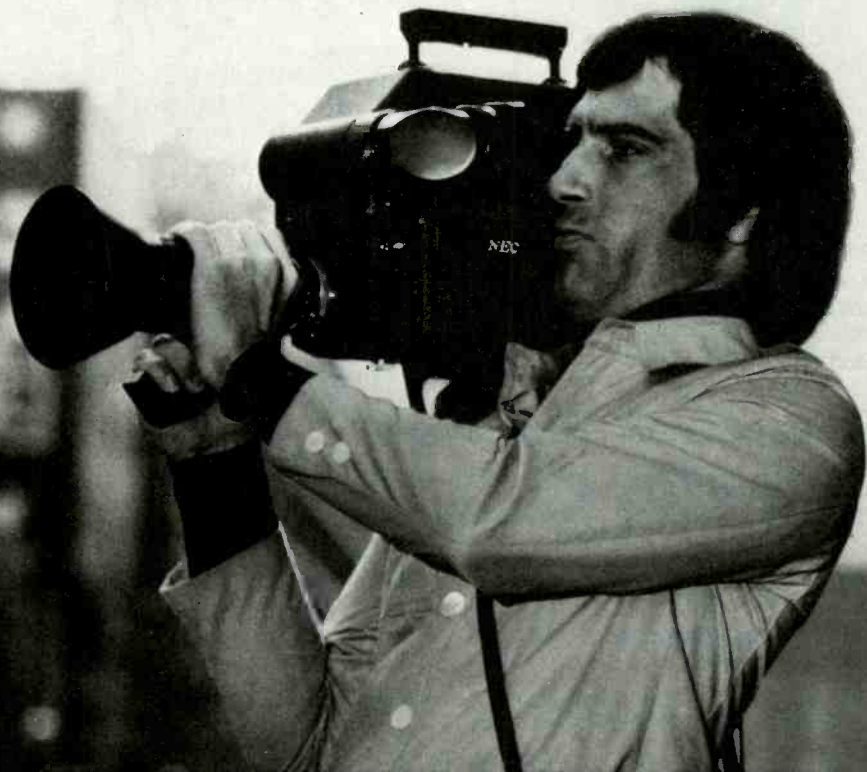

In a pinch you could use NEC's portable MNC-61A color camera in your studios. It delivers that kind of quality. Yet this field-ready, backpackless camera weighs less than 20 lbs. And the weight is evenly balanced for easy shooting from the shoulder.

Use of large-scale integration keeps power consumption at only 25 watts, so you can shoot extra hours if necessary. And you have a choice of Plumbicon* or Saticon** tubes.

To give you more flexibility, the MNC-61A is designed to take C-mount or Arri-mount lenses. Everything's been thought through to give you peak performance for every pound your cameraman carries, every dollar you spend.

It could only come from one of the world's largest and most experienced makers of broadcast equipment. And it does. That's NEC. Write or call us for details.

NEC

NEC America, Inc.

Broadcast Equipment Division
130 Martin Lane
Elk Grove Village, Illinois 60007

(312) 640-3792

Circle 196 on Reader Service Card

*N. V. Philips. **Hitachi

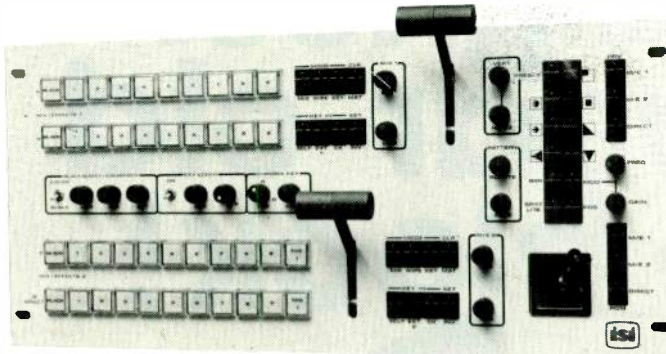

New production switchers will be in abundance in all configurations. The one above is the ISI 802.

International Tapetronics Corp. (431)

Will show the 1000-cart mass tape cart storage system; also the complete line of reel to reel and cart player/recorders. The 1K cart system will be demonstrated, and also operated by controllers in other booths.

International Video Corp. (741)

Video color cameras; color encoders; helical video tape recorders.

Ivie Electronics (1401)

Will introduce to NAB **hand-held audio spectrum analysis systems**, 1/3 octave, with digital readout; also related equipment including noise generator for acoustic measurements, harmonic distortion analyzer, others.

JVC Industries (925)

Highlight will be new **CY88DO color ENG camera**. VTRs, other cameras will be shown.

Jampro Antenna Co. (1135)

Feature attraction will be circularly polarized TV antenna. A new **CP tower top mounted antenna** will be introduced.

Jefferson Data Systems (108)

Business automation systems for broadcasters.

Kaman Sciences Corp. (445)

Shown for the first time will be the BCS "News" and "Kart" **inventory programs** and the "Films" **inventory and Amortization program** (Film Library Management System). Several "total automation" BCS systems will be shown (1100, 800, 800B, 100).

Kings Electronics (1008)

A new modular concept in **audio and video patch panels** will be shown. Line includes connectors and accessories for broadcast industry.

Kliegl Bros. (805)

Highlight will be **new features added to the Performance Memory Light-**

ing Control Console. Balancing of key, fill, base and back up lights for single or multi-studio set up possible. Up to 24 sub-groups can be controlled at any one time. A **new scintillator panel** allows special effects and creative moods. New **studio spotlight and floodlight fixtures** will be shown along with the new **HMI TV Booster** (which offers high light levels at maximum power efficiency).

Knox, Ltd. (739)

Showing character generators for video systems.

LPB Inc. (508)

Will show the new "Producer" series of **audio consoles**, as well as line of other consoles and audio equipment.

L-W International (1000)

The Athena 4000-5000 film projector systems will be highlighted. Units feature slow-motion and freeze frame projection.

Laird Telemedia, Inc. (1306)

Theme will be support systems for ENG. New products will include some **accessories for character generators**, a **dissolve slide projector**, **automatic light control** for telecines, a **dolly-up multiplexer**.

Leitch Video Inc. (1301A)

Several new products will be displayed: the **SPG 102N master sync generator**, **CBG 230N color bar generator**, **SPG 130N slave sync gen.**, **CSD 510 master clock and driver system**, **FR 601 distribution amplifier frame**.

Lenco Inc. Electronic Div. (416)

The feature attraction will be the 300 system which is a family of terminal equipment. New will be **miniature video processors**, **12x1 vertical interval bridging switcher**, **new test signal generators**. Also new will be full line of professional **b&w monitors**.

continued on page 143

Let's Talk Broadcast Equipment

HARRIS' NEW TV CYCLOTRAN SYSTEM

...with the new Harris **BTD-100H3**, 100 kW TV transmitter, and the **CPV**, CP antenna, for circularly polarized TV transmission provides a **high performance, efficient, cost-saving method** for a TV station to achieve CP.

- **Save space**—the new Harris **BTD-100H3** uses about the same space as existing 50 kW transmitters.
- **Increase reliability**—the **BTD-100H3** employs only 6 tubes and features a solid-state IFA.
- **Cut costs**—No need to change tower design with the top mount CPV. Replace your antenna, bay for bay.

talk with
the Leaders
in
Broadcast Technology
visit
Harris'
NAB Exhibit

BOOTH 301

If you are not planning to attend the NAB this year, write for full details to Harris Corporation, Broadcast Products Division, Quincy, IL 62301.



HARRIS
COMMUNICATIONS AND
INFORMATION HANDLING

Circle 198 on Reader Service Card

The toughest three-year-old on the block!

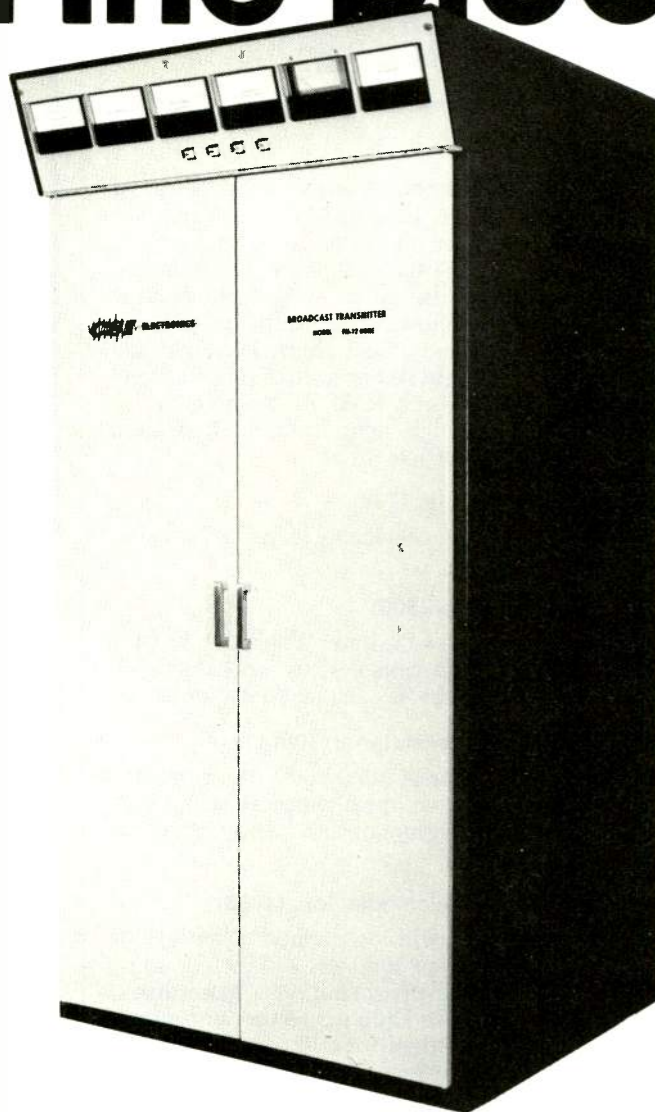

Three years ago, CSI announced a new line of AM and FM transmitters at the NAB convention in Las Vegas.

In 1978 — three years and 271 installations later we'll be back in Las Vegas with the NAB and a full line of broadcast transmitters.

Be sure to drop by Booth #318 and say Hello . . . to the toughest three-year-old on the block.

CSI ELECTRONICS INC.

3800 South Congress Street • Boynton Beach, Florida • Phone 305/732-0300 • Telex 513458

IN CANADA, contact Peter MacFarlane, CSI Electronics, Pointe Claire P. Q. Phone 514-695-8130 or 514-484-6601.

Circle 199 on Reader Service Card

NAB '78 Las Vegas

Lightning Elimination Associates (516)

Complete lightning protection systems will be shown. New products include a Tri-axial surge eliminator and high-frequency transient eliminators, (including a very high frequency transient eliminator). The surge eliminator uses new high-current inductors.

David Lint Associates (341)

Will show a number of lines of audio equipment.

Listec Corp. (700)

Several new products will be shown; the Vinten Dunlin LF (lubricated friction) pan and tilt head for small cameras — the LF dampening system eliminates backlash commonly encountered with fluid heads; the **Telecue Monitor Prompting System model 702** which can drive up to five monitors at the same time; the Richmond Sound Design **model M82B audio console**. The latter is a compact portable broadcast unit featuring monitoring, metering and cue of all channels by switch selection. Full range equalization, foldback and echo send facilities are available on all input channels.

Lowell-Light Mfg. Co. (322)

Showing line of lights for TV studios; accessories and systems.

3M Company Magnetic A/V Products Div. (807)

New **one-inch videotape**, Scotch 479, will be introduced to complement the company's total video tape capability which includes mastering tape for U-matics, 8250 high audio quad tape, others. Scotch 479 will have RF output 3dB higher than standard high density tape.

3M, Mincom Div. (807)

Among the new products are a **character generator with a 16-page memory**, the D-3016. Three font styles are available. Unit displays up to 22 characters per row, 10 rows per page. A new **TV image enhancer/decoder** with an internally-generated output (RGB) suitable for chroma key application will be introduced. A model 9000 **studio production switcher with built-in microprocessor to provide event memory** and simpler operation will be introduced. The 3M exhibit will show the full Comtec line of production and routing switchers and the D-8800 Graphics system.

MCI, Inc. (101)

Will show their full line of automated recording/remixing consoles, multi-track tape recorders, and related prod-

ucts. Will introduce some new products.

Marconi Electronics (605)

Studio and field cameras will be shown. New this year will be a portable EFP version of a **one-inch professional helical VTR**.

Marti Electronics, Inc. (314)

Will introduce a new low-cost remote control system, and an automatic relay station for radio ENG. Also showing the complete line of remote control and STL systems.

McCurdy Radio (401)

Highlight will be a new **SS7900 television and recording production console**. Full line of audio equipment will be shown including audio processors, tape recorders, carts players, turntables, reverb units, monitor speakers, audio consoles for TV, control switchers and routing switchers.

McMartin Industries, Inc. (302)

Showing their full line of AM and FM transmitters, audio consoles, remote pickup transmitters and receivers, FM relay receiver, **FM monitor receiver; SCA receivers; power amplifiers**.

Memorex, Professional A/V Products (814)

Full line of audio and videotape products for professional use. New will be **Q₂HD ¾-in. videocassettes**.

Merlin Engineering (1129)

Customized quad VTRs and accessories will be shown.

Charles Michelson, Inc. (353)

Demonstrating famous radio programs now available for syndication — *Lone Ranger, Suspense, Gunsmoke, Fibber McGee and Molly*, many others.

MICMIX Audio Products, Inc. (345)

Will introduce new **audio flanger** for production applications; audio delay line and special effects generator; **new models of reverberation chambers**. Also showing LED panel meters with peak/rms readout.

Micro Communications, Inc. (737)

Will have their line of microwave transmitting and receiving systems; ENG equipment; microwave antennas and accessories; RF filters and loads; transmission lines and components.

Micro Consultants, Inc. (1001)

Featured attractions will be the **DPE 5000 Digital Production Effects** unit and the **DSC 4000 Digital Standards Converter**. The DPE unit is designed to easily interface with any production

continued on page 145

Let's Talk Broadcast Equipment

HARRIS' TC-80 LIVE COLOR CAMERA

Now field proven...the Harris TC-80 is one of the best performing live color cameras available. The proof? More and more stations are switching to the Harris TC-80.

This top-of-the-line camera offers such state-of-the-art features as...

- Add-on Triax capability offering great flexibility.
- Low signal-to-noise ratio.
- Rapid optical filter change.

Don't miss seeing the Harris TC-80 in action at the 1978 NAB Convention. Continuous demonstrations in the Harris TV theatre.

talk with
the Leaders
in
**Broadcast
Technology**
visit
Harris'
NAB Exhibit

BOOTH 301

If you are not planning to attend the NAB this year, write for full details to Harris Corporation, Broadcast Products Division, Quincy, IL 62301.



HARRIS
COMMUNICATIONS AND
INFORMATION HANDLING

Circle 200 on Reader Service Card

TRICHROMA-UTM AND YOU...

...HAVE CLOSED THE

'generation gap'



An advanced
Color Signal
System for low
writing speed VTR's*

Created exclusively to provide 3/4-inch videocassette recorders with the higher levels of performance required for quality multigeneration work.

A profound new concept that breaks away from conventional recording systems to formulate a new dimension in video tape recording technology. A system designed to record color video signals on tape so playback is *free* from velocity errors, chroma streaking, differential gain and phase errors, taking a quantum leap over conventional systems in terms of chroma signal-to-noise ratio.

Implemented to give YOU, the serious user of 3/4-inch recorders, access to the most powerful production tool available at anywhere near the price, right in your own present facilities, using your own existing equipment.

Imagine the additional value that Trichroma-U adds to your product, giving you plenty of head room for creativity even on fifth generation, saving your masters as well as your copies from the *multipass erasures* so typical of existing systems, and adding that pleasant film-like texture to the picture so important to captivate an audience.

Trichroma-U is available now for all models of U-format VCRs, including the portable versions. Call the best distributor in your area. Chances are he's a TRI distributor. And remember, Trichroma-U becomes an integral part of your recorder allowing you to retain the use of the standard color under system for added flexibility.

It's new, it's exciting,
and U need it!

*Patents Pending

Television Research International
1003 Elwell Ct.
Palo Alto, CA 94303
(415) 961-7475

NAB '78 Las Vegas

switcher. Automatic tracking of chroma key and digital noise reduction are built-in features. The DSC 4000 converts any known television standard to any other standard and vice versa. Unit is highest quality and small in size.

Micro Control Associates, Inc. (152)
Will show their line of remote pickup, STL, and SCA subcarrier equipment.

Micro-Trak Corporation (506)
Showing line of "D-Systems", complete studio systems with audio consoles, input equipment mounted, for radio broadcast, disco, remote pickup applications.

Microtime, Inc (902)
Feature attractions, will be the 2020 Plus Total Signal Corrector, The standalone Image Plus Image Correction System, and time base correctors, the 1020 and the 1600 CCD TBC.

Microwave Associates (809)
A new generation of portable microwave ENG equipment is promised. Also new will be a satellite earth station receiver.

Minneapolis Magnetics, Inc. (133)
Magnetic tape recorder heads; replacement heads for all leading brands of tape recorder.

Mole-Richardson Co. (433)
Fresnel Condenser HMI Solar-Arc lights will be shown. Units rated at 4000-, 2500- and 1200 Watts are included. Another new product will be a 30V battery pack and super charger.

Moseley Associates (310)
Introducing their new TCS-2 telecontrol system, for independent command, telemetry and status report capabilities. Also showing AM stereo STL systems, satellite earth station remote control, audio processing equipment, remote pickup equipment.

Motorola Communications and Electronics, Inc. (308)
Will show Spectra-Tak receiver voting systems, paging systems, mobile telephone, portable-mobile communications. Shown for the first time is the "Flexar" base station.

Mutual Broadcasting System (407)
Will demonstrate satellite distribution system with earth terminal on convention hall receiving 15 kHz programming from Mutual headquarters, Arlington, VA. Will have complete run-down of news, sports, other programming.

continued on page 146

Let's Talk Broadcast Equipment

HARRIS' NEW TAPE CARTRIDGE MACHINES

Harris introduces yet another top quality tape cartridge machine to its new line...the Criterion 90-3, combining three playback decks in a single, space-saving unit.

All Criterion 90's are precision built and extremely rugged.

Rigorous computer-testing assures the very best in audio performance and reliability.

And NOW...Harris not only offers its Criterion 90 line to broadcasters at 1967 prices...but with a 30-day free trial!

Call...217/222-8200.

talk with
the Leaders
in
Broadcast Technology
visit
Harris'
NAB Exhibit

BOOTH 301

If you are not planning to attend the NAB this year, write for full details to Harris Corporation, Broadcast Products Division, Quincy, Il. 62301.



HARRIS
COMMUNICATIONS AND
INFORMATION HANDLING

Circle 203 on Reader Service Card

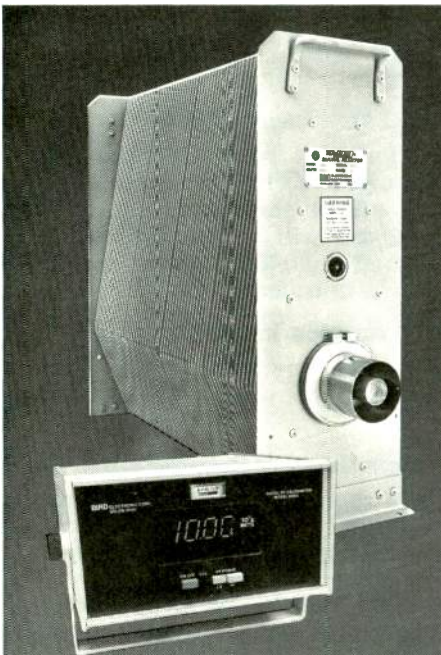

NEW
DIGITAL
CALORIMETER

NEW
WATER-COOLED
LOADS

NEW
AIR-COOLED
LOADS

NEW
THRULINE[®]
WATTMETERS

NEW
BROADCAST
CATALOG

See it all
in Las Vegas
at NAB booth 1109
or circle reader service number

BIRD

30303 Aurora Road, Cleveland (Solon) Oh 44139
Phone: (216) 248-1200 • TWX: 810-427-2687
Cable: BIRDELEC

Circle 202 on Reader Service Card

COMPLIMITER™

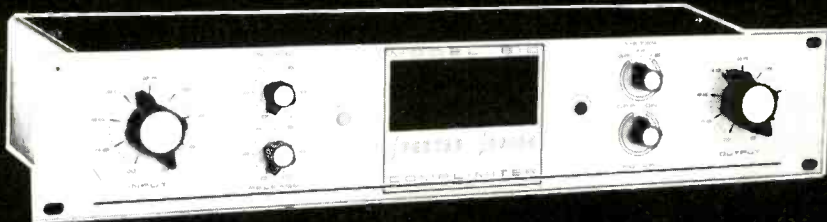

MODEL 610

Used in recording studios; disc mastering studios; sound reinforcement systems; TV, AM, FM broadcast stations to maintain a sustained average signal at a level significantly higher than that possible in conventional limiters, and with performance that is seldom attained by most linear amplifiers.

Rack mounted, solid state, new functional styling, the Model 610 is in stock for immediate shipment.

Specifications are available from:

SPECTRA SONICS

770 WALL AVENUE, OGDEN, UTAH 84404
(801) 392-7531



Circle 204 on Reader Service Card

NAB '78 Las Vegas

NEC America Inc. (1009)

Theme will be a working studio. Cameras, VTRs, frame synchronizers will be shown. Among the new products will be a noise reducer, domestic satellite receiver and UHF and VHF transmitters.

NTI America, Inc. (1600)

Are showing their digital signal generators for video, also program timers.

Nagra Magnetic Recorders, Inc. (323)

Will show line of portable recorders, including the "E" recorder designed for remote pickup for broadcasters.

Rupert Neve Inc. (405)

Big feature will be the NECAM console which offers computer audio editing for TV sound. Audio is referenced to video through use of SMPTE code. Other audio consoles, processors for radio and TV will be shown.

Nortronics, Co., Inc. (319)

Will emphasize new line of magnetic heads with "Duracore", long-life material. Also showing accessories and maintenance equipment for magnetic tape recorders.

Nudd Corp., Fred A. (351)

Models of communications towers that can be designed, fabricated, erected, and serviced will be shown.

Nurad Inc. (910)

Featured product will be the 20 QP2 Dual Channel Quad Polarised Antenna System which permits simultaneous reception of two frequencies in the 2 GHz auxiliary broadcast band from any direction.

O'Connor Engineering Labs, Inc. (1202)

Lightweight tripods and fluid heads. Featuring camera support equipment.

Oktel Corporation (1131)

Will show video disc recorders for slow motion playback.

The Olesen Co. (1309)

Will have their line of TV lights and accessories; dimmers; cycloramas.

Optek Inc. (1304)

Will exhibit their bulk erasers, head degaussers.

Orban Associates, Inc. (402)

Introducing production models of Optimod AM, audio processor. Also showing Optimod FM, and full line of Orban Parasound audio processing

continued on page 149

Beau Audio Heads.



A head is a head is a head. Except when it's a Beau Head. And the difference is price. Because at \$24.00 for mono heads and \$74.50 for stereo heads, our units are considerably less expensive than anything else on the market. But they still meet those tough NAB standards and deliver the broadcast quality performance you expect. We stock heads with no mounts, and models with threaded studs and leads, for Ampro, ATC, Beaucart, Collins, Garron, Harris/Gates, ITC, RCA, Sonogarron, Harris/Gates, ITC, RCA, Sonomag, Sparta, Spotmaster, and other popular cart machines. Where do you get them? Only from the Broadcast Products Division, UMC Electronics Co., 460 Sackett Point Road, North Haven, Connecticut 06473.

UMC

For a complete listing of all Beau Audio Heads with electrical specifications, write for our revised brochure today, or call us at (203) 288-7731.

See us at Booth #210 Las Vegas Convention Center

Circle 205 on Reader Service Card

The Audio Travel Lab



Tektronix TM 500

Here are the four basic instruments you need to check out your electronics. The precision. The versatility. The convenience. They plug in, side by side, in a **TM 515 Traveler Mainframe** that supplies their power and includes storage space for probes and cables.

The Audio Travel Lab features an **SG 502 Audio Oscillator** as a 600- Ω source of low distortion sine and square waves from 5 Hz to 500 kHz (0.035%, 20 Hz to 50 kHz). The **DC 504 5-digit Counter/Timer** provides precise display of frequency or period for cue and control tone measurements, alignment of filters, and readout of tones from test tapes and records. The **DM 502 Digital Multimeter** provides full-function ac, dc, current, temperature, and resistance readings in addition to dB measurements. The **SC 502 15 MHz Dual-trace Oscilloscope** features Enhanced Automatic Triggering, making it one of the easiest to use oscilloscopes on the market today. It readily reveals clipping and crossover distortion, transients and peak levels, rf interference, and high-frequency oscillations. Reverberation and delay measurements can be made via the

triggered capability with a tone-burst signal. A rear interface circuit board in the TM 515 Mainframe lets you interconnect the plug-in instruments for applications such as gain, loss, or response measurements—at the touch of a push-button.

The TM 515 Traveler Mainframe looks like carry-on flight luggage, but it's really an electronic instrument mainframe and power supply that operates from 48 to 60 Hz, 100 to 240 V ac with a quick-change line voltage selector. **It's designed to put lab-quality modular instruments conveniently on the road**, to make them easily movable from room to room, useable on a small surface or on end on the floor, or to be easily stashed in the corner out of the way.

Should you have special needs requiring different instrumentation, you can select from the more than 35 plug-in modular instruments of the continually growing TM 500 Product Line. For example, the AF 501 Tunable Bandpass Filter selects a narrow band of frequencies for oscilloscope observation and frequency or level measurement. The AM 502 Differential

Amplifier adds balanced input capability, and its high gain extends noise measurement floors. The sophisticated new FG 504 40 MHz Function Generator features log sweep over the 20 Hz to 20 kHz spectrum and full tone burst capability for delay measurement and transient analysis. The Product Line also includes calibration instruments, power supplies, a logic analyzer, and two sizes of blank plug-in that you may use to build in your own custom circuits. **Just pull one or more of the Audio Travel Lab plug-ins from your TM 515 and insert the appropriate instrument.**

To get full specifications, applications recommendations, and prices, send for the TM 500 Catalog. Circle the reader response number or write or call: Tektronix, Inc., P.O. Box 500, Beaverton, Oregon 97077, (503) 644-0161 ext. 5283. In Europe write: Tektronix Limited, P.O. Box 36, St. Peter Port, Guernsey, Channel Islands.

Tektronix
COMMITTED TO EXCELLENCE

Circle 206 on Reader Service Card

Nothing else
matches it for
features and
reliability

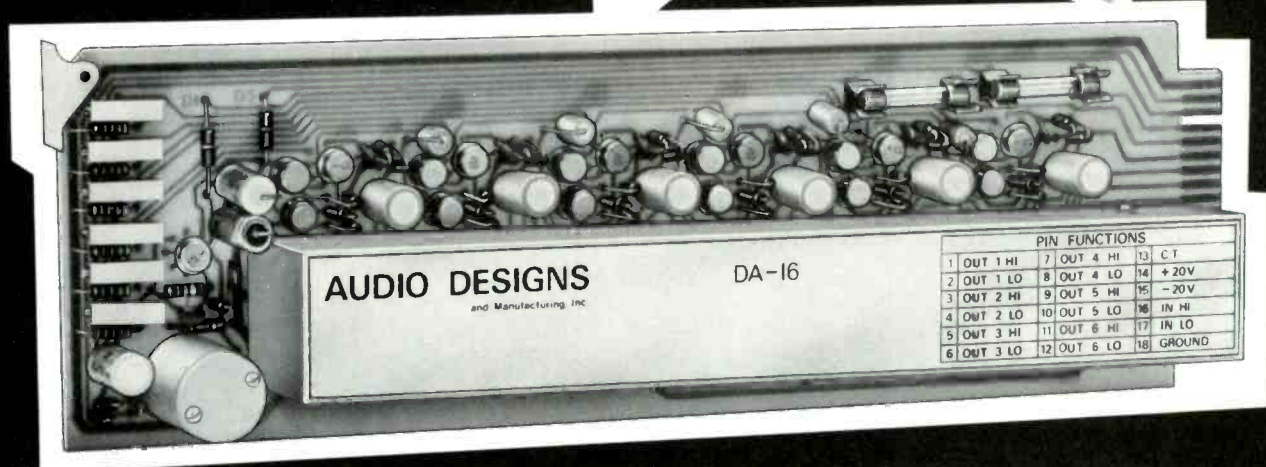
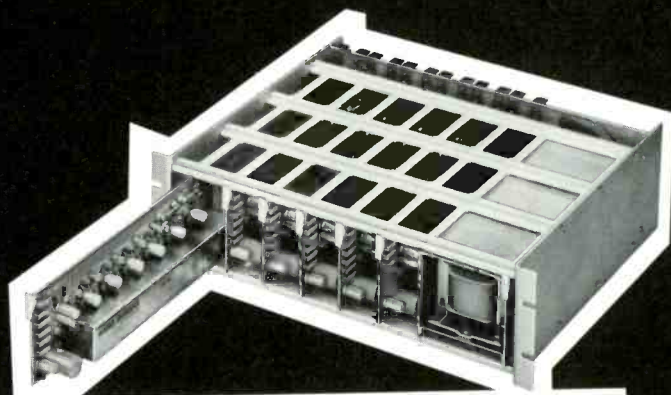

ADM's UNIQUE DA16/CH20 AUDIO DISTRIBUTION SYSTEM

The ADM® DA16 incorporates an advanced-design approach, with superb specifications. It is the ultimate in audio distribution amplifiers. Each amplifier is a one in, six output plug-in card with +24DBM input and output capability.

The input is transformer coupled, and each of the six outputs is individually transformer isolated. Amplifiers have individual front panel gain adjustments.

Noise level is ultra low, and distortion is less than .1% at +24DBM.

Up to six DA16 amplifiers can be housed in the Audio Designs® CH20 rack frame, which includes a redundant power supply with automatic change-over. Built to exacting quality standards, DA16 amplifiers offer exceptionally high reliability. For complete information write or call for specification sheet.

A COMPLETE LINE OF HIGHEST QUALITY CONSOLES AND COMPONENTS



AUDIO DESIGNS AND MANUFACTURING, INC.
16005 Sturgeon, Roseville, Michigan 48066
Phone: (313) 778-8400, Cable: AUDEX TLX-23-1114

AMPEX

DISTRIBUTED OUTSIDE U.S.A.
BY AMPEX INTERNATIONAL OPERATIONS, INC.

NAB '78 Las Vegas

units, including reverb units, parametric equalizers, stereo synthesizer, dynamic sibilance controller.

Otari Corp. (400)

The full line of audio tape recorders and duplicators.

Packaged Lighting Systems, Inc (905A)

On exhibit will be the line of lights and lighting systems for TV studios.

Pacific Recorders and Engineering (102)

Will show for the first time the new **BMX-12, console** designed specifically for broadcast use. Also showing the line of other consoles and audio processors.

Panasonic Co. (417)

Studio broadcast camera, AK-920. **Convertible ENG/Studio camera**, ENG camera features 3-tube design and low power consumption. Completely self contained (for Audio equipment see Technics Div.).

Paperwork Systems, Inc. (316)

Will introduce a new **Datapoint 6600 Processor** with 128K of internal memory; mass storage disks, will be demonstrated running BAT 1750 automation system, to operate a radio, TV station switching, plus accounting and payroll all at once. The BAT 1750 will be on line to receive data from several other booths, including Vital, Grass Valley, Cetec, Harris, and use data for billing confirmation and preparation. Also on display will be another new system, BAT 1700, for both program switching and accounting for most single stations or AM/FM radio operations. Other accessories and systems for use with BAT systems will be shown.

Phelps Dodge Communications, Co. (327)

FM antennas; transmission lines; coaxial cable.

Philips Broadcast Equipment Corp. (719)

Following the theme of "Philips, Innovative Leader in World Television," new products in UHF transmitters, VHF transmitters, and studio cameras are expected. Video 80 Modular Camera system will be shown as well as 1-in. VTRs. New **EFP camera** is also expected.

Potomac Instruments, Inc. (427)

Will introduce a new **ATS** for directional antenna arrays. Also showing line of monitoring and test equipment, including multi-test audio test system.



3M Model D-3016 Character Generator features 16-page capacity memory - four times that of its predecessor.

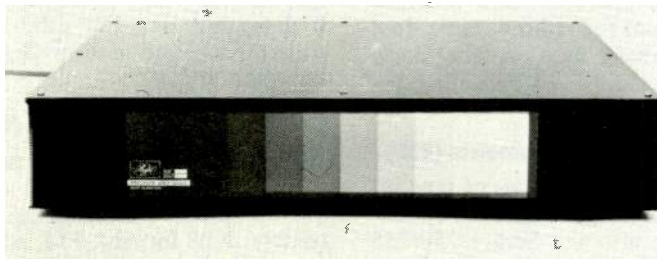

New from Telecommunications, the Color Monitor Grey Scale Reference Unit provides an accurate 6500 Kelvin rear-illuminated visual reference for adjustment of control room and technical area monitor picture white and grey scale tracking.

Power-Optics, Inc. (820)

To show remote control systems for video camera mounts; chroma key sync system.

QEI Corp. (329)

Showing a new **ATS** for FM broadcasters, Model 7775.

QRK Electronic Products Inc. (104)

Will introduce a new **direct-drive DC turntable**, the Omega audio consoles, electronic speed control, digital clock, monitor speakers. Also showing line of other turntables and audio consoles.

QSI Systems, Inc. (1500)

Timers and clock systems; video source identifier; frame counters; test monitor switchers.

Q-TV (735)

Will be showing VideoPrompter systems.

Quick-Set Inc. (1110)

Tripods, stands for video cameras; dollies, camera braces for ENG.

RCA American Communications, Inc. (707)

Satellite communications services.

RCA Broadcast Systems (601)

Full line of radio and television broadcast equipment. New **studio camera** is expected along with some innovations in TCR-100 Cartridge Player. Type-C, and Type-B SMPTE Standard 1-in. VTR systems will be shown.

RCA Electro Optics and Devices (701)

TV camera tubes; audio tapes; CCTV

cameras; test instruments; digital display devices.

Ramko Research, Inc. (112)

Will show line of components for complete audio installations, including the DC-12 and DC-38 console series, Technics turntables and other audio units.

Rank Precision Industries, Inc. (922)

Rank Cintel MK-3 Flying Spot Color Telecine, Varotal MRL (Multi-Role) Lenses. New **programmer for automatic control of telecine**, color correction and Pan Scan.

Recortec Inc. (803)

Overall attraction will be methods-products for enhancing VTR operations. New **video cassette tape evaluator** will be shown plus a new **tape cleaner for quad VTRs**. Editing equipment will be on display.

Research Technology Inc. (1006)

TV-120 Film Editing/Maintenance Console (Lipsner-Smith); Ultrasonic CF-200 MicroPerfect Film Cleaning Machine (Lipsner-Smith).

Ross Video Ltd. (1301 A)

Will show new **Model 520-8A Multi Level Effects** video switcher. Two MLE amplifiers accept 4 independent input sources simultaneously. New rotary pattern manipulator and positioner.

Rohde and Schwarz (817)

Test systems and instruments for audio and video; automated video test equipment.

continued on page 150

NAB '78 Las Vegas

Russco Electronics Mfg. Co., (200)

Will introduce new **8-channel consoles** and **variable speed turntable**; also a new **Disco mixer** and "Phonomate" preamplifier.

S.W.R. Inc. (1215)

Will have in operation new **satellite earth terminal** for radio with six-foot

Scientific-Atlanta, Inc. (1205)

Will have in operation **new satellite earth terminal** for radio with six-foot antenna; showing data on other earth terminals for radio and TV satellite distribution.

Scully Recording Instruments (305)

Will show the 280B Series of tape recorders with recently improved operating features; also the Scully 250/255 series of low-cost units for automation applications, all now in production.

Sescom, Inc. (105)

To exhibit audio amplifiers and equalizers; audio compressors and limiters. Also the News Bridge for television news conferences.

Shintron Co. Inc. (1123)

Compact special effects systems. New

encoded **Chroma Keyer**, Model 350, **Color Bar, Background Generator**, Model 383 (CB)³, **SMPTE/EBU Code Generator**, Model 607, **SMPTE/EBU Code Reader**, Model 644.

Shure Brothers, Inc. (309)

The theme of the exhibit will be "Upgrade Your Audio." New products to be shown: the **50 AC acoustic coupler** for remote pickups; the **FM59 microphone**.

Sintronic Corporation (512)

Introducing a new **solid-state direct-FM exciter**, a 1 kW solid-state AM transmitter and a new **3 kW FM transmitter**.

Eric Small and Associates (413)

Will introduce the **DP-9000 turntable**, with 300 ms start time; will show also the "Telesis," autologging, remote control, ATS for AM, FM, and TV, in an operating display.

Soll, Inc. (816)

Slide presentations of recent broadcast installations will be shown.

Sono-Mag Corporation (403)

Will have a new automation programmer and programmable remote control system. Also showing their line of automation systems for radio broad-

casting.

Sony Broadcast (1005)

Featuring production models of Type-C 1-in. **helical VTR systems**. New **computerized editing system** of 1-in. Omega VTRs. Improved BVE-500A Edit controller for BVU systems. New **BVU-50**, super compact record only VTR. Also, will show a new **ENG Camera**, the BVP-300.

Sound Technology (1308)

Will introduce a new **audio signal generator**. Also showing the line of multi-test audio test equipment.

Spectra-Vision Corp. (1315)

Videotape Editing Systems. JBT-104 BA Editor-Programmer with random access ETG time code system. Search MOD-1; Remote Control of VTR.

Stanton Magnetics (211)

Will show the new **881S pickup cartridge**, Dynaphase 35 lightweight headphones; also the 681BPS pickup for playing stampers.

Storeel Corp. (903)

Easy access modular high density storage systems will be shown.

Strand Century, Inc. (359)

To have on exhibit their line of lights
continued on page 152

You just can't duplicate our Duplicator (or our Transport)

High speed . . . low cost . . . outstanding performance,
they're all on our side.

Our 2400 Duplicator and our 2600 Transport together
provide the finest Real Time performance available, and
at a price that can't be matched.

From Original to Copies in 2 Easy Steps:

2600 Transport

Constant tension holdback extends head life and assures
speed accuracy . . . motion sense . . . spill tape edit . . . full
function remote control.

2400 Duplicator

Plug-in head assemblies for rapid format changes . . .
precision mount ferrite heads increase life at least
1,000% and stabilize alignment . . . all tape formats avail-
able . . . bin loop master . . . stereo phase error and fre-
quency response better than Real Time copies . . . auto-
cue/counter module available for programmed
production runs.

We'll Prove It

We'll be giving free demonstrations at the April NAB
show. Bring your master and we'll show you why our
name is "Accurate."

Or, write or call Brian Mason for details.



Accurate Sound Corporation

114 Fifth Avenue / Redwood City, California 94063 / (415) 365-2843

New! For heterodyne VTRs



a broadcast quality, digital TBC

It's the CVS 516, first digital TBC made and priced to give users of non-segmented, heterodyne VTRs all the proven advantages of modern digital video processing.

The CVS 516 is ideal for ENG, teleproduction, studio VTR backup and much more because it comes with features that, before, you'd find only in TBCs costing up to twice as much.

For example, correction of chroma/luminance delay problems, a 3dB chroma noise reduction, velocity compensation and color dropout compensation are standard.

So is "Gyrocomp," an exclusive, use-proven CVS memory design that easily handles severe gyroscopic distortions—without breakup.

There's also a broadcast stable, gen-lock sync generator, automatic VTR advanced sync and a built-in completely adjustable processing amplifier.

If all that's not enough, add our optional, moderately priced Image Enhancer/Noise Reducer. This plug-in card

substantially reduces luminance and chroma noise and significantly improves subjective resolution. And, to tame even the wildest instability, you can add our optional 16 line window.

Simple operation is another plus for the CVS 516. Front panel controls give you total mastery of your video signal. Each control also has a preset unity position to give you a consistent starting point for all your tapes.

All this, and more, is contained in a package that weighs only 25 pounds, is only 3½ inches high and uses only 175 watts—major advantages with today's increasing emphasis on ENG and field production.

So, to give your heterodyne productions the quality they deserve, get the one digital TBC made and priced to do the job—the CVS 516. For full details and/or a demonstration, contact your authorized CVS Distributor or CVS. And ask for our new booklet about the basics of digital time base correction. It's free.

CVS Consolidated
Video
Systems, inc.

1255 E. Arques Avenue, Sunnyvale, California 94086 (408) 737-2100 Telex: 35-2028

Circle 209 on Reader Service Card

Your TV Studio may as well be a radio station without the right lighting.

At Kliegl, we want your video to be up to par with your audio. Or even better. That's why we have a team of seasoned engineers who design studio lighting systems that meet your exact requirements.

Thanks to our experience in dealing with studio lighting, we have designed six standard TV lighting packages that meet normal needs for standard-sized studios. And since these are complete systems already engineered and in stock, ready to ship, they offer substantial savings.

So, if you don't want your viewers to turn on their radios, turn to Kliegl. For complete information on our TV packages or anything else, please write or call:

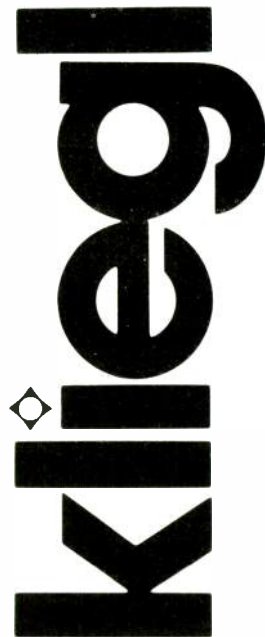

Kliegl Bros.
32-32 48th Ave
Long Island City
New York 11101
212 786-7474

See us at Booth #805, NAB Show.

Circle 210 on Reader Service Card

DOM dropout monitor

operates "on line" with your VCR or VTR to give instant warning of:

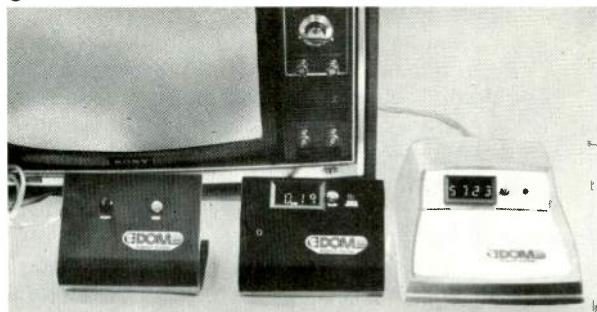

- Defective Tape • Head Clogging • VTR problems
- Loss of tracking • Poorly recorded tape

Dealer Inquiries Invited



studio tape exchange

a division of studio film exchange, inc.

6424 Santa Monica Blvd., Hollywood, CA 90038 (213) 466-8101
630 9th Ave., 8th floor, New York, N.Y. 10036 (212) 977-9330

Circle 211 on Reader Service Card

NAB '78 Las Vegas

and lighting systems for TV studios.

Studer Revox America, Inc. (114)

Will introduce the **TLS 2000 tape-lock system** for synchronizing audio-audio and audio-video machines, using SMPTE code. Also introducing the **Revox B760 broadcast monitor FM tuner**; and showing line of studio tape recorders.

Studio Tape Exchange (1212)

Will show for first time the "Omnilink," information handling device to allow rapid access to maintenance data on tape recorders; also the **DOM**, for monitoring tape and VTR, through connection to dropout compensator, to give early warning of defects.

System Concepts (1125)

Microcomputer based character generators. New **Q-X merchandiser I**, uses character generator computing capacity for automatic control of broadcast plant machines.

Taber MFG. & ENG. Co. (510)

VTR stereo audio heads. Stereo **audio conversion system for Ampex 1200 & 2000 series VTRs.**

William B. Tanner Company (349)

Will show a new **station ID package**, and describe new **station merchandising concepts**. Describing and demonstrating their syndicated music services for automated stations, production and sales promotion packages.

Tayburn Electronics (1200)

Intelligent Modem (IM) provide instant microwave for ENG systems. Master Modem, Remote Modem, Antenna System, Video Receiver, Portable Transmitter & Receiver. Will build entire system to interface with existing equipment. Extremely compact and lightweight systems will be highlighted.

Technics Div., Panasonic (419)

Will introduce a new **isolated-loop reel-to-reel recorder** designed specifically for broadcast use. Also showing line of audio products for broadcasters: turntable, amplifiers, loudspeakers.

Technology Service Corp., Development Laboratories Div. (1501)

New **Time Lapse Unit** allows automatic recording of color weather radar in TV frames onto magnetic floppy disc. Operator Recorder is digital, microprocessor control systems allows flexible operation. Also new, **Compter/Communications Interface**, allows

continued on page 154

Still manually monitoring VITS?



NEW • mi 2914A
• Tighter Specs
\$11,500
U.S. Domestic Price Only

mi has the **AUTOMATIC** answer
whether your system is **NTSC, PAL** or **SECAM**

Adaptable to all national VIT waveforms including NTC #7 and FCC, the **mi 2914A** Insertion Signal Analyzer has proven performance with broadcasters and common carriers throughout the world. For unattended operations the Analyzer interfaces directly with telemetry control systems. Combine the **mi 2914A** with the optional Limits Comparator, **mi 2915**, and the **mi 2917** Data Selector for a complete monitoring, measuring and alarm system. You can control or print out at a local or remote terminal, and, our print-out is now available in

English, French or American. As a stand alone unit, the **mi** automatic VITS Analyzer replaces Waveform Monitors, Vectorscopes, Color Gain and Delay test sets and Random Noise Measuring sets. Even the most complex VITS measurement is performed at the push of a button and the result displayed with digital accuracy on the front panel meter.

So if you are still manually monitoring VITS . . . we have the immediate solution . . . contact **mi** today for the new **mi 2914A** specifications,

mi **MARCONI INSTRUMENTS**
DIVISION OF MARCONI ELECTRONICS INC.

100 Stonehurst Court, Northvale, New Jersey 07647 • (201) 767-7250 • TWX: 710-991-9752

Circle 212 on Reader Service Card

See us at NAB, Booth # 605



"Not the loudest sound in town, but the best quality" claims WXRT, Chicago, longtime Stanton user...

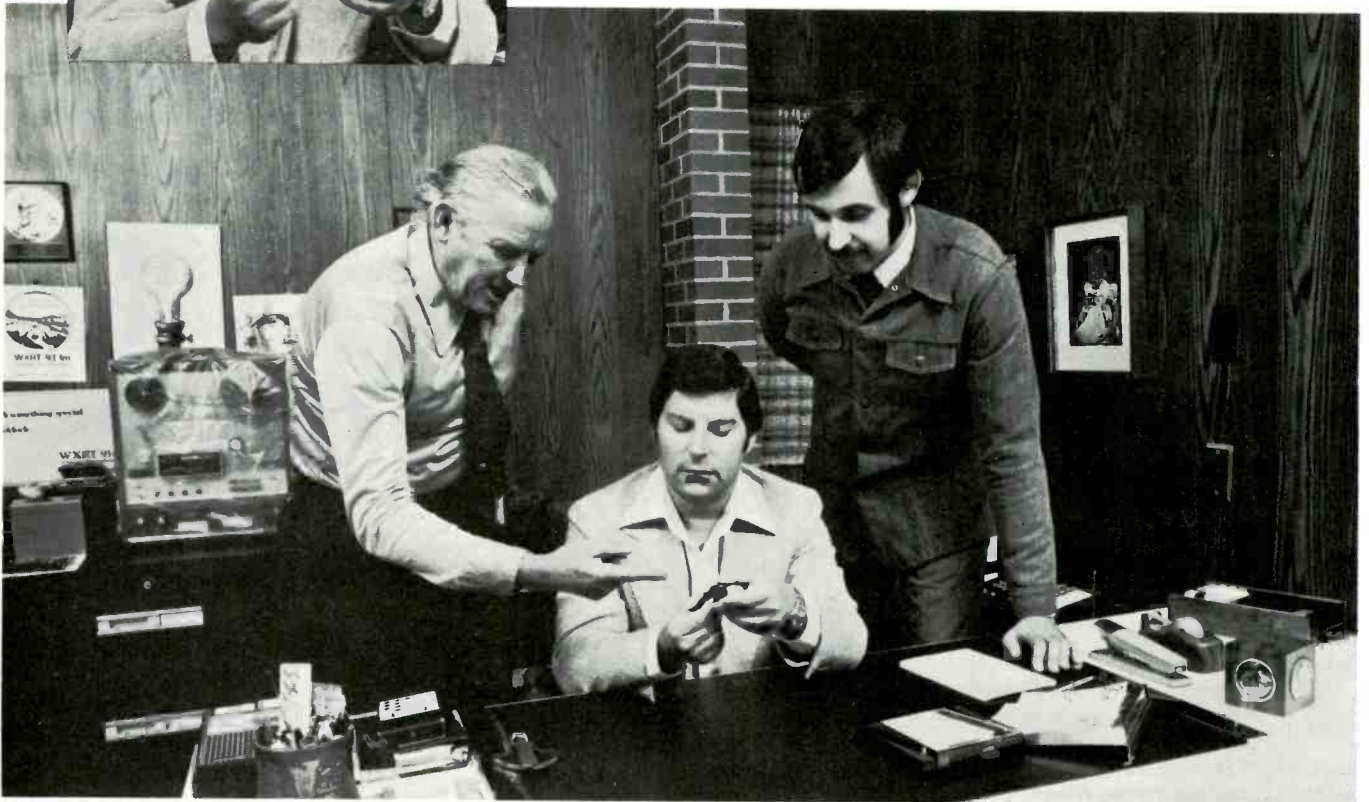

Daniel Lee, President and General Manager, discussing Stylus Replacement Policy with Howard Williams, Chief Engineer and Ken Rasek, Audio Engineer.

WXRT is a progressive rock, FM station that is unique in many ways. Its whole operation, including Administration, Sales, Engineering, Programming, Broadcasting, Transmitting (even the tower itself), is located in one place . . . a highly unusual set-up for a major market.

In a market crowded with as many radio stations as Chicagoland, the excellence of sound can make or break the station, especially a station like WXRT . . . which plays no tapes . . . has no recorded commercials . . . and goes totally with disc-to-air and live copy.

Since WXRT uses no limiters and no compression to magnify the level of their signal, their turntables and cartridges are absolutely crucial to the quality of their sound.

For over 10 years, the station has used the Stanton product in its turntables. Today, it even uses the 681 Triple-E for disc-to-air playback and, although this stylus was not designed for back-cueing, the engineers and announcers report no problem (they even use them on their AM operation, WSBC).

Leading radio stations around the nation depend on Stanton 681 Calibration series cartridges, because they offer improved tracking at *all* frequencies . . . they achieve perfectly flat frequency response to beyond 20 kHz. Its stylus assembly, even though miniaturized, possesses greater durability than had been thought possible to achieve.

Each 681 Triple-E is guaranteed to meet its specifications within exacting limits, and each one boasts the most meaningful warranty possible . . . an individual calibration test result is packed with each unit.

Whether your usage involves recording, broadcasting or home entertainment, your choice should be the choice of the professionals . . . The Stanton 681.

For further information, write to:
Stanton Magnetics, Terminal Drive,
Plainview, N.Y. 11803.

© Stanton Magnetics Inc., 1977



John Bell hands new record to Scott McConnell.



Air personality, John Bell prepares to play a record.

Visit Stanton Magnetics at the Las Vegas Convention Center at Booth #211

Circle 217 on Reader Service Card

CHOOSE YOUR ROUTE.



Model 101 — a 10 x 1 stand-alone routing switcher featuring:

- vertical interval
- illuminated push-buttons
- audio and video DA's
- audio follow
- remotability
- momentary contacts

15x Routing Switcher Series

offers unlimited possibilities:

- field expandable
- control variations
- vertical interval (optional)
- second audio channel (optional)
- three frame sizes

For more information, circle our reader service card number.

3M Video Systems.
Watch us in action.



Circle 218 on Reader Service Card

NAB '78 Las Vegas

television station music, and ID packages.

UMC Electronic Co., Beucart Division (210)

Will introduce an **automated news recording system**. Also showing the line of tape cartridge player/recorders, replacement magnetic heads.

Ultra Audio Pixtec (1133)

Will be showing new **TV waveform monitor, vectorscope, sync and pattern generator, audio console, compact audio preamplifier, and audio remote amplifier**.

Unarco-Rohn, Div. of Unarco Industries, Inc. (339)

Introducing new **solid rod towers**, three models.

Uni-Set, Div. of Kniff Woodcraft. (1311)

Studio set design modules will be shown for various stagings, studio settings, elevations.

United Press International (1121)

Will have **satellite delivery of their audio network** news through an earth terminal at the Convention Hall; also demonstrations of the broadcast data

word service, and a video terminal to show the basic elements of **electronic news handling**. In addition the regular wire service will be fed to the exhibit.

United Research Laboratory Corp. (425)

Will have for the first time the **C-5 set of solid-state conversion amplifiers**, replacing tube electronics in older tape machines. Also showing Auto-Tec tape recorders and accessories; replacement parts for many professional tape recorders.

United States Tape and Label Corp. (204)

Will show their line of bumper strips and window labels for promotional campaigns in the broadcast industry.

Utah Scientific, Inc. (1213)

New audio and video distribution switchers. New **AVS-1** features 20-in/20-out audio video switcher in a single 10½-in. chassis with choice of either BCD or party line control. Audio noise and crosstalk suitable for monaural or stereo; built in matrix refreshment memory with 24-hour battery supply. Matrix sizes for 10 X 10 to 160 X 160.

Utility Tower Company (411)

Will introduce new **insulated guy wire**

assemblies for FM antenna towers. Also will have actual tower sections 18" to 42" in length, I-beam anchors and galvanized hardware, and the Model 340L solid base insulator.

Thomas J. Valentino, Inc. (315)

Will have a new **series of sound effects** records; also showing the complete line of production and background music for all broadcast needs.

Van Ladder, Inc. (1139)

Antenna carrier and aerial ladder with antenna carrier. Model SS2900BC provides 29 foot telescoping boom. Model BC2913 provides 34 foot extension with cherry picker type bucket for camera position.

Video Aids Corp. of Colorado (1106)

Demonstration of VACC battery operated sync generator with two color cameras to show how post production can be reduced. Featuring **Model 100 ENG Edit-Aid™, No. 2. Auto Preview/Crosspulse Editor Controller** for helical VTRs.

Video Data Systems (1210)

Character generators, production titlers. New **MicroSystem I**, is a computer managed Multiple Display System. Both RAM and Diskette memory.

continued on page 160

NAB '78 Las Vegas

Videomax, Div. of Orrox (108)

Major attraction will be video head refurbishing/rebuilding capability for Ampex Mark III, Mark X, and Mark VX; RCA high band and low band heads; conversion of RCA low band to high band.

The Video Tape Co. (1108)

Video tape; post production services.

Videographix (1400)

Exhibit information not available at press time.

Video Maghetics (1220)

Refurbished video heads.

Videotek, Inc. (1117)

Will introduce a new 8" video color monitor. Also showing line of other video monitors.

Vital Industries (723)

Video production switchers, master control switchers. Production model of "Squeezezoom" digital special effects system will be shown. Features simultaneous or individual manipulation of up to 4 synchronous or non-synchronous video signals. PSAS (Production Switching Automation System) will be shown with simplified controls.



The Richmond Sound Design Model M82B Broadcast Audio Console is one of several new consoles suitable for location recording and broadcasts.

Ward-Beck Systems, Inc. (923)

Audio consoles both custom and standard design for radio and television. Suitable for both production and continuity. **Entire new line of WBS consoles for radio** — all solid state switching, control logic, modular packaging.

Western Union Telegraph Co. (905)

Communications services, Westar Satellite services.

Wilkinson Electronics, Inc. (1313)

AM/FM transmitters. Surge protectors.

Winstead Corp. (1313)

Spacing saving tape storage systems will be shown including new storage

systems and tape trucks for quad cartridges and 3/4-in. U-matic cassettes. Also editing consoles.

The Widget Works (104)

Will have their automatic transmitter operator in a production model.

Wolf Coach, Inc. (1100)

EFP and ENG vehicles. New **Modular ENG Van** package. New **EFP van** for multi-camera productions.

World Video, Inc. (904)

Professional color monitors for studio, mobile, and EFP applications. Will show a new **8" rack mount color monitor** for EFP and EJ featuring both AC and DC operation.

NEW ZOOM LENSES JOIN **COSMICAR**[®] "ES" SERIES



Perfect Your CCTV System
with COSMICAR Lenses

COSMICAR ES SERIES LENSES

- 12.5~75mm f/1.8-ES for 2/3" cameras
- 8.5mm f/1.5-ES for 2/3" cameras
- 12.5mm f/1.4-ES for 2/3" & 1" cameras
- 16mm f/1.6-ES for 2/3" cameras
- 25mm f/1.4-ES for 2/3" & 1" cameras
- 50mm f/1.8-ES for 2/3" & 1" cameras

For more information, please write:

COSMICAR COSMICAR LENS DIVISION, ASAHI PRECISION CO., LTD.
424, Higashi-Oizumi, Nerima-ku, Tokyo, Japan
Cable Address: "MOVIEKINO TOKYO"

In the USA, please call or write:

PENTAX CORPORATION
Atrium Building, 98 Cutter Mill Road, Great Neck, New York 11021
(516) 487-9800

With **AUTOMATIC IRIS**, Focal Length of 12.5~75mm and Relative Aperture of F 1.8, in two types:

Motorized Focusing and Zooming

Ideal for surveillance in security system.

Manual Focusing and Zooming

Suitable for portable cameras, but can be used also at any fixed focusing within the range of 12.5~75mm.

Smallest in sizes, Economically priced and provide Very Wide Applications.



TOTAL CAPABILITY

Cablewave offers the
Largest Selection of Coaxial
Cable FOR ALL your system
requirements

NEW! Antenna/Transmission Line Systems Catalog

Complete in every detail, total information needed to plan, specify and purchase a complete system or component, plus complete engineering data and more.



from smooth wall aluminum and corrugated copper coaxial cables in foam and air dielectric . . . to matching connectors for most standard interfaces . . . to hardware and installation accessories. All cables are jacketed for mechanical protection, and you can specify either standard or phase stabilized versions. There's a full line of field assembled matching connectors, or if you desire . . . Cablewave will provide the completed cable assembly manufactured to your specific requirements. Most of your system requirements will be available from stock . . . all are fully tested, conservatively rated and backed by our field service organization.

Whether you require a single component or a complete system, rely on the TOTAL CAPABILITY of Cablewave!

Cablewave Systems, Inc., 60 Dodge Ave., North Haven, Conn. 06473, Phone (203) 239-3311.

In Canada: LeBlance & Royle Communications Towers Ltd., 514 Chartwell Rd., Oakville, Ontario, Canada L6J 5C5 Phone (416) 844-1242.

See us at NAB — Booth #100A

Cablewave Systems

Circle 220 on Reader Service Card

angēnieux

**The Trusted Name in Quality Lenses
for every application, for every budget**

10x

FOR THE STUDIO
the most widely used lens in the world.

15x

FOR THE STUDIO AND OB
for demanding studio work and ob.

42x

FOR THE STUDIO AND OB
for ultimate flexibility.

12x

FOR THE STUDIO
for outstanding optical quality.

TELE

42x

FOR SPORTS AND OB
full screen a person 600 ft. away.

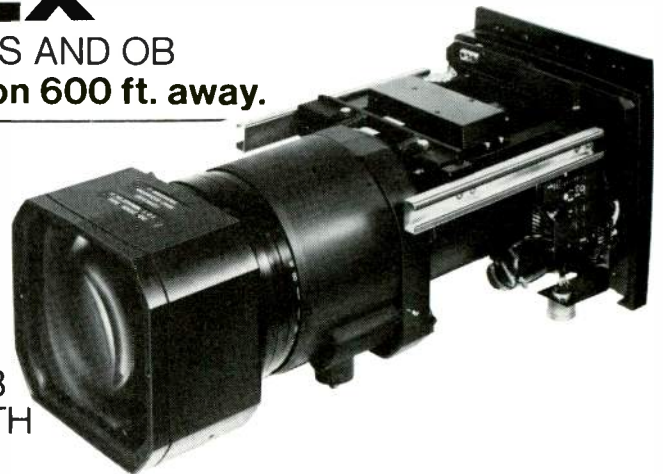
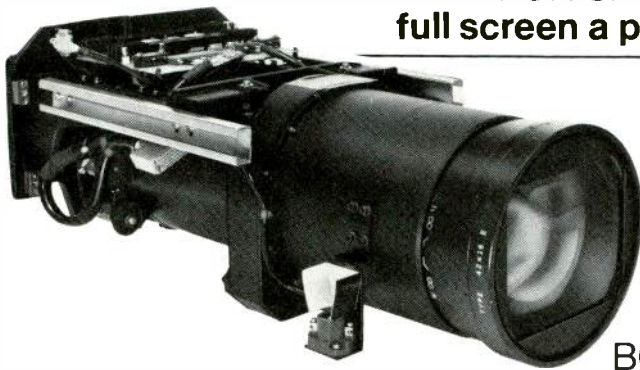

NAB
BOOTH
812

angēnieux corporation of america

1500 OCEAN AVE., BOHEMIA, NEW YORK 11716 • (516) 567-1800
13381 BEACH AVE., VENICE, CALIFORNIA 90291 • (213) 821-5080
4 HAVEN HILL SQ., AGINCOURT, ONT. M1V1M4 • (416) 291-2363

SMPTE Winter Conference Updates Industry on 1-Inch VTRs and Digital Technology

Formidable progress is being made in television technology and digital techniques, along with 1-inch tape, are leading the way.

THERE IS NO SUBJECT of more interest to broadcasters these days than videotape recorders. That very subject, coupled with a collection of papers on digital video aids for production brought engineers in droves (over 650) to the SMPTE Television Conference at Atlanta last month. Judging from the papers delivered, panel discussion, questions from the floor and speculation in the aisles, the video recorder will be in a state of ferment for some time to come.

There's no doubting that the one-inch recorders are the wave of the immediate future — all users at Atlanta gave favorable accounts of their experiences to date. The only disappointment so far is difficulty in getting completely satisfactory video tape. But whether the format will be type B, type C, or neither of these two recent SMPTE standards remains to be seen. The all-digital video recorder is now seen as a distinctive possibility. Overseas guest, John Baldwin of the IBA, predicted that the digital video recorder could be the sine qua non production tool of the early 80's. Howard Steele, now general manager of Sony's operation in Great Britain, but recently of the IBA, saw digital recorders as a necessary development if we are ever to have a video recorder that is truly "transparent." Privately, Bosch Fernseh hints that it might be ready to go into the manufacturing of digital video recorders quite early.

The all-digital recorder moved into the spotlight at Atlanta only briefly, however, and that was on the second day. The first day concentrated almost solely on reports of one-inch analog devices. It became immediately clear once the users spoke that these were the machines that would be commanding everyone's attention. The morning was dominated by manufacturers; the afternoon was given to user experiences.



Users and manufacturers discuss one-inch VTR progress. Left to right, Bill Kelly, WNEW; Henry Zahn, Bosch-Fernseh; David Fibush, Ampex (leaning back); Denny Fussell, Tricom; E. Grey Hodges, Jefferson Productions; William Connolly, CBS; Howard Steele, Sony; Joe Roizen, moderator.

During the morning sessions, both Sony and Ampex confirmed earlier reports that both would have machines capable of handling the new type C formats at the NAB convention. Will these machines be able to demonstrate tape interchangeability? This question was of prime concern. Dave Fibush of Ampex assured the audience that interchangeability would be no problem. In an overview to the session, Fred Remly, Jr., Univ. of Michigan, predicted that it is likely that other manufacturers are to join the ranks of Sony and Ampex in making type C machines. The preferred term for the type C format is no longer "non-segmented," but "continuous field." Altogether there are

five documents that describe type C, said Fibush as he described their content. (Type C specs will be published in the SMPTE *Journal* in March; type B in February.)

Since the requirement for six video heads has surprised some, Fibush outlined the reasons. The main video head contains all active picture lines plus lines 16 through 5 of the vertical interval. A second half sync head records the missing ten tracks in the vertical interval. For editing purposes, it is necessary to have flying erase heads for both. Thus, four heads are needed for these video functions. Number five is a "confidence" video head which per-

continued on page 164

SMPTE Conference

mits instant monitoring while recording. Head number six offers a confirmation that the sync track is laid down.

Since the type B format is not new, it was not described at the conference, but a digital store accessory for the type B format — which allows still store and slow motion (forward and reverse) — was described by Hans Peter Maly of Bosch Fernseh. Maly's technique is economical since component encoding rather than composite encoding is used and only every other field is stored. Details of this system can be found in *BM/E's* report of the 10th International Television Symposium, Montreux (*BM/E*, Sept. 1977, p. 40).

Two papers at the SMPTE Televi-



The Action Track picture above shows a series of balls after one was bounced on the floor and its locations stored in the tag store. The picture element behind it is a live, real-time image.

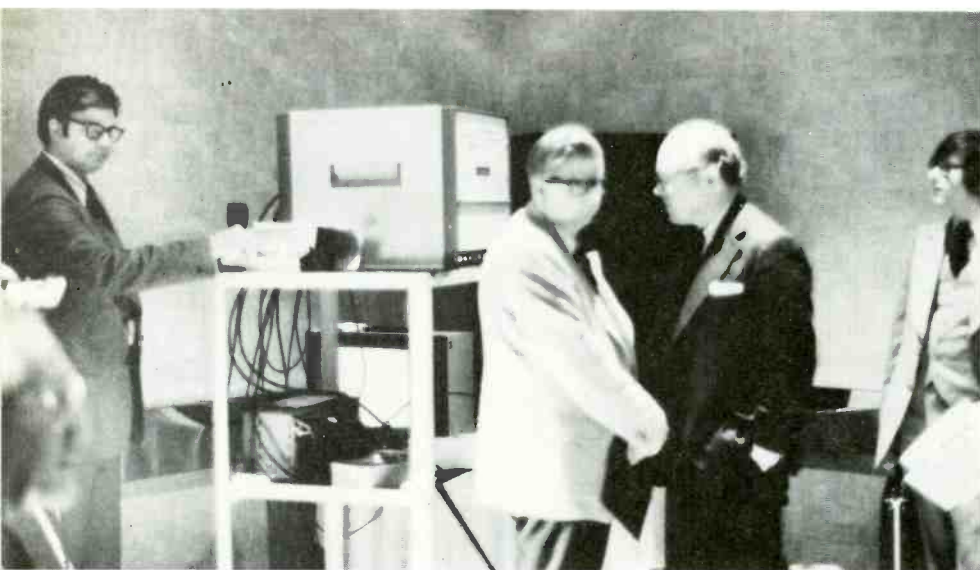

Dick Streeeter, (third from right) and Renfield McMann, (fourth from right), president of Thomson-CSF and instrumental in the development of the DNR of which Action Track is an outgrowth, observe as the device (on stand) is activated.



IBA digital recording, left, is actually half picture width at twice subcarrier frequency requiring 40 Megabit rate. Full width picture (80 Megabits) is possible at tape consumption equal to analog recorders. Vectorscope picture shows how digitalized color bars are on target.

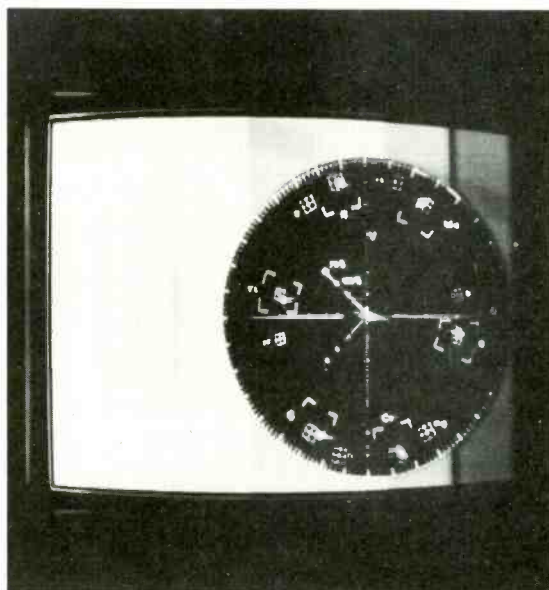

sion Conference (the 12th) described design aspects of the new one-inch machines in considerable detail. M. Morizono of Sony described the approach taken by his company in perfecting a portable one-inch unit, the BVH-500. Methods of reducing friction in the scanner and guide system were described along with the design of the tension servo system. Morizono characterized the BVH-500 as the EFP counterpart to the ENG U-matic. Dennis Ryan described mechanical design aspects of the Ampex VPR-1 concentrating on tape guidance, speed control, and tension control. Ryan stressed that the tape's "natural path" was preserved and therefore required a minimum of guidance.

User's report

Leading off in describing how one-inch machines have been performing was William Kelly, vice president, engineering, WNEW-TV. Kelly has three BCN 50's (delivered last April) and two BCN 20 portables (the first of which was delivered in June, the second in December). Kelly said he bought "performance not format," selecting the BCN after a trial experience. Since delivery of his units, Kelly has chalked up 500 hours on the studio units and 350 on the BCN 20. His only troubles have been in finding "three faulty IC's, two LED's, and two cold solder joints." Said Kelly, "My postage and freight bills for quad replacement parts cost me more."

The studio unit has been used to record and edit the nightly news feed (14 to 15 segments). Editing on the BCN units is two to four times faster than quad, according to Kelly. Portable units have been taken into the field for producing on-location talk shows, commercials (in stores), as well as ENG reports. The BCN 50's have not

continued on page 167

Looking for more than just a remote control...?

Until now, all remote controls did was extend the transmitter plant into the studio. Nothing more, and often a lot less.

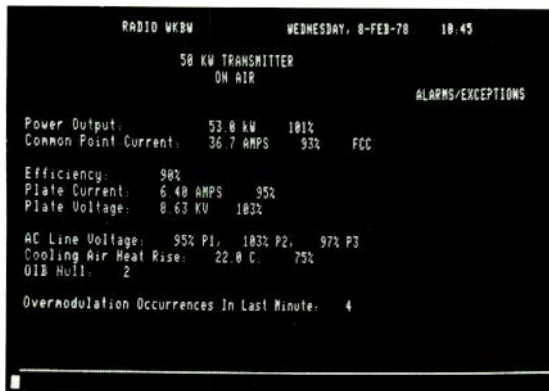

One of the selectable displays.

Today this is not enough. Good engineering management dictates improved reliability and better usage of manpower. So called "Computer" remote controls do little more than display the same old data on a CRT. The remote control contributes nothing to the reliability of the station. In fact, because of its dependence on a single telephone line or microwave link, it is often the most frequent cause of lost air time. All too often it requires more skill to interpret the display and operate a remote control than is available at the studio. Rarely is a combo DJ or a skilled master control video switch operator up to dealing with one of the current "sophisticated" remote controls.

Some stations have attempted to remedy this problem by extensively customizing an off-the-shelf remote control themselves. The cost of doing this is high, and the results often disappointing.

Available remote control systems are too complicated. There are too many different boxes, too many interconnections, too many critical adjustments.

TELESIS solves all of these problems, and many more. It does so economically and with tremendous flexibility. TELESIS is a microcomputer based system with its intelligence at the transmitter where it's needed. Instead of just extending the transmitter plant into the studio, TELESIS intelligently deals with the transmitter plant itself.

For many more details, call or write direct.

See Telesis — booth 413

Telesis is a customized, flexible system. All of the features are examples of what can be readily done, rather than limitations of what is possible.

- The system improves reliability of a transmitter plant over conventional operation because of continual, comprehensive checking of all parameters, fast response time, and self-correction of errors.
- A single Telesis system can control several transmitters. The transmitters may be in the same service or in mixed services such as AM, FM and TV.
- Virtually unlimited metering, control, and contact sensing channels at only a nominal increase in cost.
- Accessory DC amplifiers and log-linear converters are not needed.
- System allows a single command to automatically sequence procedures normally requiring many steps by the operator. Examples of this are transfer of main to standby transmitter, change of antenna pattern, and morning turn-on procedures — each requiring only a single command.
- Calculated parameters are displayed and alarmed. These include VSWR from Forward and Reflected Power, and Efficiency from Plate Current, Plate Voltage, and Power Output.
- If the normal link between studio and transmitter fails, an autodialer provides automatic, instant control line backup using regular dial-telephone circuits.
- The system interfaces directly with the Tektronix 1440 Automatic Video Corrector.
- Critical functions can be restricted to certain employees using their personal I.D. codes. For example, only a maintenance technician can reset the internal time-of-day clock.
- Comprehensive security and fire-prevention capabilities are available.
- Telesis uses non-volatile, magnetic core memory for information storage so that vital data are not lost during a power failure.



esa

Eric Small and Associates, Inc.
680 Beach Street, Suite 365
San Francisco, Calif. 94109
Telephone (415) 441-0666

micro-Q[®]

A memory lighting control system complete with 2 scene preset capability.



Strand Century's new Micro-Q is economical, compact, portable and designed to grow with you. You can buy Micro-Q with memory or, if your budget doesn't allow for it now, install the memory later by plugging it in. All it takes is a screwdriver. Micro-Q — the new modular 2 scene preset system with Independent Master, Grand Master and split dipless Crossfader, with a 200 preset memory, micro proces-



sor controlled. Micro-Q offers timed crossfades, cue insert, preview and submastering. For your newscasts, commercials or more sophisticated production, be creative with your lighting — memorize it the Micro-Q way. Ask for your new Micro-Q brochure. Strand Century leads in memory lighting control systems for the broadcast industry. At Strand Century we speak your language.



STRAND CENTURY

A COMPANY WITHIN THE RANK ORGANISATION

THEATRICAL, TV, MOTION PICTURE, ARCHITECTURAL LIGHTING AND CONTROLS.

Strand Century Inc., 5432 West 102nd Street,
Los Angeles, California, 90045, U.S.A.,
(213) 776-4600

Strand Century Inc., 20 Bushes Lane, Elmwood
Park, New Jersey, 07407 U.S.A. (201) 791-7000,
(212) 564-6910

Strand Century Limited, 6334 Viscount Road,
Mississauga, Ontario, Canada, L4V 1H3
(416) 677-7130

Circle 223 on Reader Service Card

See Micro-Q at the NAB Booth #359 in the Las Vegas Convention Center

SMPTÉ CONFERENCE

left the studio but they can be stripped and set up and running within 20 minutes.

The quality is high according to Kelly and dependability is excellent. WNEW has no qualms about sending the BCN out into the field with its least trained operators. Neither audio nor video drift when left on preset. All machines match. Kelly concluded, "We like the flexibility and we find one-inch does it better." WNEW has the Bosch Fernseh EES built-in editor and does SMPTE frame accurate edits. An interface is being built to use with CDL 200 editors.

The CBS Television Network experience was reported by William Connolly. Two editing systems employing a total of eight machines have been installed, one in Television City (Hollywood) and one in CBS Studio 51 (New York). These editing systems take full advantage of the one video field per track format to provide the editors with viewable pictures from still through thirty times normal play speed.

Another system has been installed at CBS Studio Center (Hollywood) which incorporates film production techniques with video tape post production

techniques (*BM/E*, August, p. 6). As many as five recorders can be played back with frame accurate synchronization. Operator experience with the new machines has shown them to be equal or better in performance compared to quad. The video S/N ratio stands at 49.5 dB with less than 0.2 dB drop when the tape of one machine is played on another. Thirteenth generation dubs have been made but CBS normally doesn't go beyond eight for broadcast. According to Connolly, below-the-line cost savings using the new video techniques run 30 to 40 percent. He concluded, "I think it is conceivable that we might not ever buy another quad." Later, Connolly backed off a bit, indicating that quad would be the playback interchange standard for another seven years or so. CBS might need more quads for playback.

How CBS Television Network uses continuous-field recorders in an editing system in Hollywood was described by William Nicholls. The system, using four BVH-1000's, is designed around the CMX-340X editor. To take advantage of the high shuttle speeds of the BVH-1000 (viewable picture at 30x), CBS modified its edit console panel to include a remote control "joystick" speed control knob. This single knob controls the machine in both shuttle and jog modes. There is one for each re-

coder. This feature was integrated with the CMX I²L interface.

Because SMPTE time code will not reproduce from a longitudinal track at speeds below 1/5-1/10th normal, the CBS editor inserts time code in the vertical interval of video. In this way it can be recovered during slow and freeze modes.

Denny Fussel of Tricom, a production house in Hilton Head, SC, described his experiences with three VPR-1's as replacements for IVC helicals. His new capability has landed him jobs from all three commercial networks plus PBS. Jefferson Productions' experience with BVH-1000's was described by Grey Hodges. J-P has now clocked about 350 hours on one-inch units purchased in connection with CMX editors. Hodges said it took some time to get the system to lock up as desired when making edits. The problem was landing on correct field for proper color match.

In a subsequent panel discussion on using one-inch recorders, the problem of color matching edit points came up several times. There is no sure way of landing on the proper field, but attention must be paid to the TBC and sync generator system, etc., to gain fine control over the system. Another problem is getting video tape that works. There

continued on page 168

The ultimate in easy operation -- no controls.



Fully automatic counting to 80MHz
--only \$275.00*

- Automatic triggering • Automatic input attenuation
- High 20 mV sensitivity • High stability time base
- RF measurement capability • Compact, rugged case

Designed to provide the ultimate in trouble-free operation without sacrificing accuracy or reliability. Power on/off switch and BNC connector are the only additions to the 8-digit LED display. Fully automatic operation of the PM 6661 has been achieved by replacing the usual sensitivity and attenuation controls with an automatic input attenuation circuit having a 50:1 range.

A 520 MHz version featuring PIN diode attenuation for RF measurements is available at \$645.00*

For immediate information, use our toll-free Hotline number: (800) 631-7172. (New Jersey residents please call collect.) Or contact Philips Test & Measuring Instruments, Inc.



In the U.S.: 85 McKee Drive
Mahwah, New Jersey 07430
Tel (201) 529-3800

In Canada: 6 Leswyn Road
Toronto, Canada M6A 1K2
Tel (416) 789-7188

PHILIPS

*U.S. Domestic
Prices Only.

Circle 224 on Reader Service Card

OPTICAL EFFECTS

THROUGH MICROPROCESSOR-
CONTROLLED SLIDE DISSOLVE

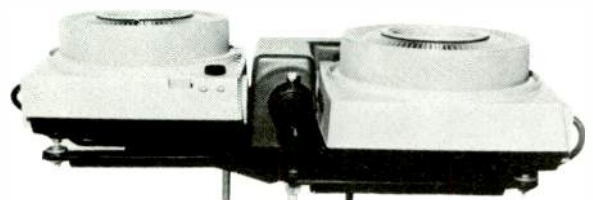

MODEL 4220
DISSOLVE PROJECTOR

- ★ STATIONARY OPTICS
- ★ ADJUSTABLE DISSOLVE RATE
- ★ SUPERIMPOSITION
- ★ EXTRA LARGE CAPACITY
- ★ AUDIO PROGRAMMABLE

FROM THE WORLD'S LARGEST SUPPLIER
OF TELECINE EQUIPMENT



LAIRD TELEMEDIA INC.
2125 SOUTH WEST TEMPLE • 801 487 6251
SALT LAKE CITY, UTAH 84115

VISIT BOOTH 1306 AT N.A.B.

Circle 225 on Reader Service Card

SMPTE CONFERENCE

have been excessive dropouts due to shedding. Current batches of tape going to Jefferson Production and WNEW suggest that the problem may be getting under control. However, another source of tape is desired.

Moderator Joe Roizen, Telegen, asked user-manufacturer panelists whether one-inch recorders made off-line editing unnecessary. The answer was, by and large, no. WNEW does on-line editing because it is staffed up that way. CBS Hollywood uses off-line approach since as many as six individuals get involved before final decisions are made. According to Connolly, the number of edits made in programming has grown 15 to 20 percent in recent years.

Chief Engineer Walt Bundy, WPHL-TV, Philadelphia, concerned that it will be some time before enough machines get into the field to permit tape interchanges, asked if a less expensive playback-only version of one-inch recorders might be made. The answer was no unless a huge demand for playback-only devices emerge. At present, manufacturers have no trouble selling their production — Ampex is producing units at a rate of one per calendar day; Bosch Fernseh has 350

BCN 50's in the field and 80 portable BCN 20's have been delivered with demand growing.

While the prognostication for one-inch recorders could not have been more bullish, there was repeated recognition at the SMPTE TV Conference that in today's world the industry can readily support special recorders for special applications. There is no need to select one recorder at the exclusion of others. As of early 1978, the one-inch recorder looks like a fine, less-expensive choice for production; quad remains the only choice for tape interchange between stations for some time. There may be another reason for quad remaining in demand; prices may come down. Manufacturers say they haven't cut prices but reports of discounts keep popping up.

Tomorrow, a digital video recorder?

If special recorders are justified for special jobs, can digital recorders be very far away? Technologically, a digital video recorder can now be made; in the face of declining prices of high speed IC's, such a recorder may be economically justified. We are closer than would have been predicted a few years ago, said Howard Steele, former IBA director of engineering. Several successful new strategies for designing digital video recorders have emerged.

Firstly, bandwidth requirements have been lessened from 106 or 141 Megabits/sec to 80 (including error bits) because it has been demonstrated that you can sample a picture at four times the color subcarrier frequency and then take it down to two times ($2F_{sc}$). Alias frequencies generated are removable with digital comb filters. The only impairment noticeable is a slight reduction in diagonal resolution, said Steele.

It is essential to get track widths down (to increase tape packing density) but this seems feasible now because of improved tracking servos. One only needs a 20 dB signal-to-noise ratio to get perfect reproduction digitally, Steele said.

If tape consumption is held low by virtue of reducing track width, then a low bit rate of 34 Megabits/sec using differential pcm coding is not so necessary. A 34 Megabit rate is dangerously low, said Steele, because if a dropout occurs, vital information is lost. The new emphasis is to use ten bit words, then split these words so that part runs a half line later. Hence, if there is dropout, it is not total.

Steele's remarks set the stage for John Baldwin's paper (delivered during the digital portion of the conference) entitled "Digital Recordings, When?" Baldwin declared that an all-digital re-

continued on page 170

The Professional's Parametric

Introducing the 622... a Parametric Equalizer with even better performance and more cost-effectiveness than its highly reliable predecessor. Improved manufacturing efficiency and state-of-the-art componentry help us provide more for less money.

We've added a host of features important to you—the professional user. The 622 now includes in/out switches for each band, balanced inputs (with transformer-balanced

"constant-Q" design by enabling 40 dB notches to be consistently obtained.

The 622 is backed by an outstanding quality control program, including the use of burned-in, hermetically-

sealed IC's, and further burn-in procedures on the entire equalizer. We know this is important to you when your equalizer doesn't fail in front of an arena audience of 5,000 people... or on the air in drivetime... or in the middle of a critical mix. This combination of unbeatable performance and quality makes the 622 the professional's choice.

Your Orban/Parasound dealer has all the details. Write us for his name and a brochure with the complete 622 story.

orban/parasound

680 Beach Street, San Francisco, CA 94109
(415) 673-4544

output optional), extensive RF protection, and the latest FET-input opamps which reduce transient intermodulation to the vanishing point and which provide THD guaranteed less than 0.025%, 20-20,000 Hz at +18 dBm output. A 115/230 volt 50-60 Hz AC power supply is now standard. A new proprietary parametric bandpass filter has been designed which virtually eliminates the effects of control wear and complements the notching capability of our

"Orban/Parasound products are manufactured by Orban Associates Inc., San Francisco, Ca."

Get the

LIVE LOOK



Rank brings new and **even better quality,** fidelity and ease of film-to-video transfer

With the new electronic scanning Flying Spot MK3B Telecine, you can expect and get superb reproduction from color or mono, positive or negative, 16 or 35 mm film, or slides—all on the same transport.

Here's a film chain with no camera, no lag, no complex optics, no intermittent projectors—not even a lamp house. It has a silent capstan drive with shuttle forward and reverse. Electronic *Cinemascope* panning handles 16 or 35 mm, full frame.

It is designed to deliver what you have always wanted in film reproduction—the immediate look of live video from film and all the quality, color, definition and contrast that you shot, or bought, with the film.

Arrange for a demonstration. Call Neil Kempt (312) 297-7720 or write

Rank Precision Industries Inc. at 411 East Jarvis Ave., Des Plaines, Ill., 60018.

Flying spot TELECINE by



RANK CINTEL

RC-178

SEE THE **LIVE
LOOK** AT NAB BOOTH 922

Circle 227 on Reader Service Card

SMPTÉ CONFERENCE

of where the card moved, the keyed image remained accurately displayed within the card's borders.

It seems clear that digital techniques have entered the scene to stay, and many of the devices that have led the advance are finding their ways into applications throughout the broadcast plant. The field store and frame store synchronizers are rapidly expanding their role in broadcasting. What began as a need to synchronize non-synchronous signals has now opened the way to an impressive variety of special effects for production switchers and led to considerable thought about how to maximize their use.

Field Stores and Frame Stores

According to a paper presented by J. Brian Matley of Micro Consultants, Inc., the breakthrough in cost and size of second generation fieldstore synchronizers now offers a solution to some of television engineering's most perplexing problems. Though the fieldstore offers some significant capabilities in the way of digital special effects, its greatest application may be its superior handling of non-synchronous video signals from any

source, microwave, non-capstan servo VTRS, etc. The transparent character of the fieldstore makes all signals, whether synchronous or non-synchronous, appear the same to the production switcher. Thus, a fieldstore with time base correction characteristics "enormously simplifies the handling of any TV signal," whether it be local or remote, and it will provide automatic detection of direct or non-phased tape recorder sources. It also can provide improved dropout compensation over conventional time base correctors since the missing video may be replaced by video from the previous field. Using the previous field is superior to using the previous line, according to the paper, since it is spatially more exact. Use of a fieldstore in this capacity eliminates the need for an advanced vertical phasing signal being fed back to the tape recorder.

One method of taking advantage of the fieldstore's capabilities has been to locate the device after the routing switcher so that any non-synchronous signal coming in may be assigned to the fieldstore prior to the production switcher input. This, of course, provides the advantage of synchronization while limiting the number of fieldstores necessary. The problem, however, is that only one signal at a time may be handled. The other approach is to pro-

vide one fieldstore for each non-synchronous signal so that all incoming signals are immediately available to the switcher.

Another promising method for achieving similar ends was discussed in a paper presented by T. Yoshida of Mainichi Broadcasting Systems, Inc. of Osaka, Japan. This paper described a new master switching system incorporating a frame synchronizer. In this system a frame synchronizer is located just before the mix effects amplifier to accept all remote signals. The system has been in operation since November 1976, and its reliability is highly rated.

According to the paper, the approach has completely abolished a conventional genlocking system; no phase adjustment is required when changing sources to the switcher; there is no "recording shock" while a program is recorded on a VTR; the system is disturbance free from gen-lock loop problems; a loss of input signal merely results in a freeze frame retained from the last signal received; and each VTR provides very stable playback through the H lock mode.

A few problems remain in this method. For one thing, a switch of the input signal to the synchronizer causes noise in one horizontal line. To prevent this phenomenon, a sync separated

continued on page 175

Broadband or discrete - a better idea either way you turn...

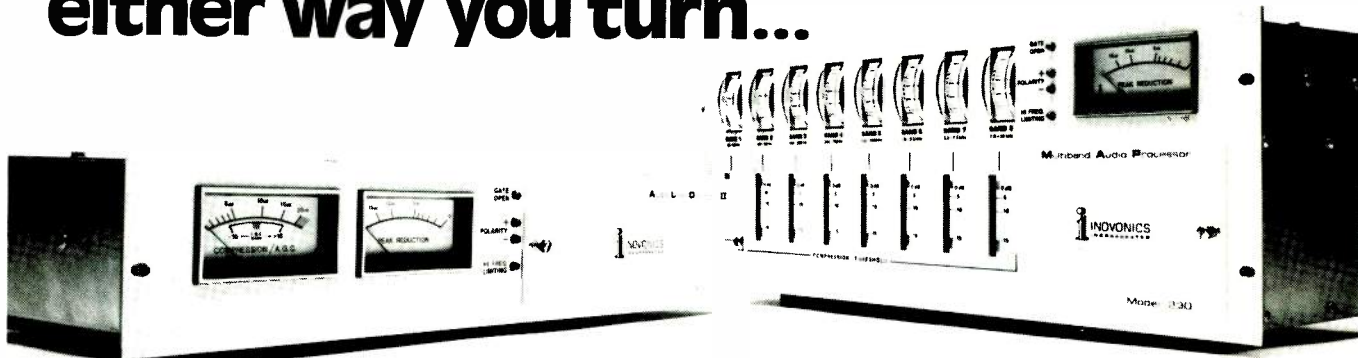

Model 221 Audio Level Optimizer II

Like it smooth? Turn to the new Model 221 Audio Level Optimizer II, the "firm but gentle" AGC/compressor/limiter.

Start with gain-riding AGC for smooth, gradual correction for input level variations. Go on to our unique auto-ratio compressor for unlimited control

over program dynamics. Then get absolute protection from over-modulation with a fast, phase-reversing peak limiter for AM and an independent high-frequency limiter for FM.

Model 221—a better idea at \$760.

Model 230 Multiband Audio Processor

Like it loud? Turn to the Model 230 Multiband Audio Processor. Make individual dynamic compression adjustments in eight independent bands. The results? Ultimate program density with a sound you have tailored. Gated expansion keeps the noise down.

For AM, the Model 230 features program-controlled phase inversion and adjustable limiting symmetry. Or switch in the separate frequency-selective limiter for FM.

Model 230—a sound idea at \$1500.

Inovonics Inc.

503-B Vandell Way
Campbell, CA 95008

Telephone
(408) 374-8300

See us at NAB Booth
#202



Circle 229 on Reader Service Card

Heard Altec's latest?

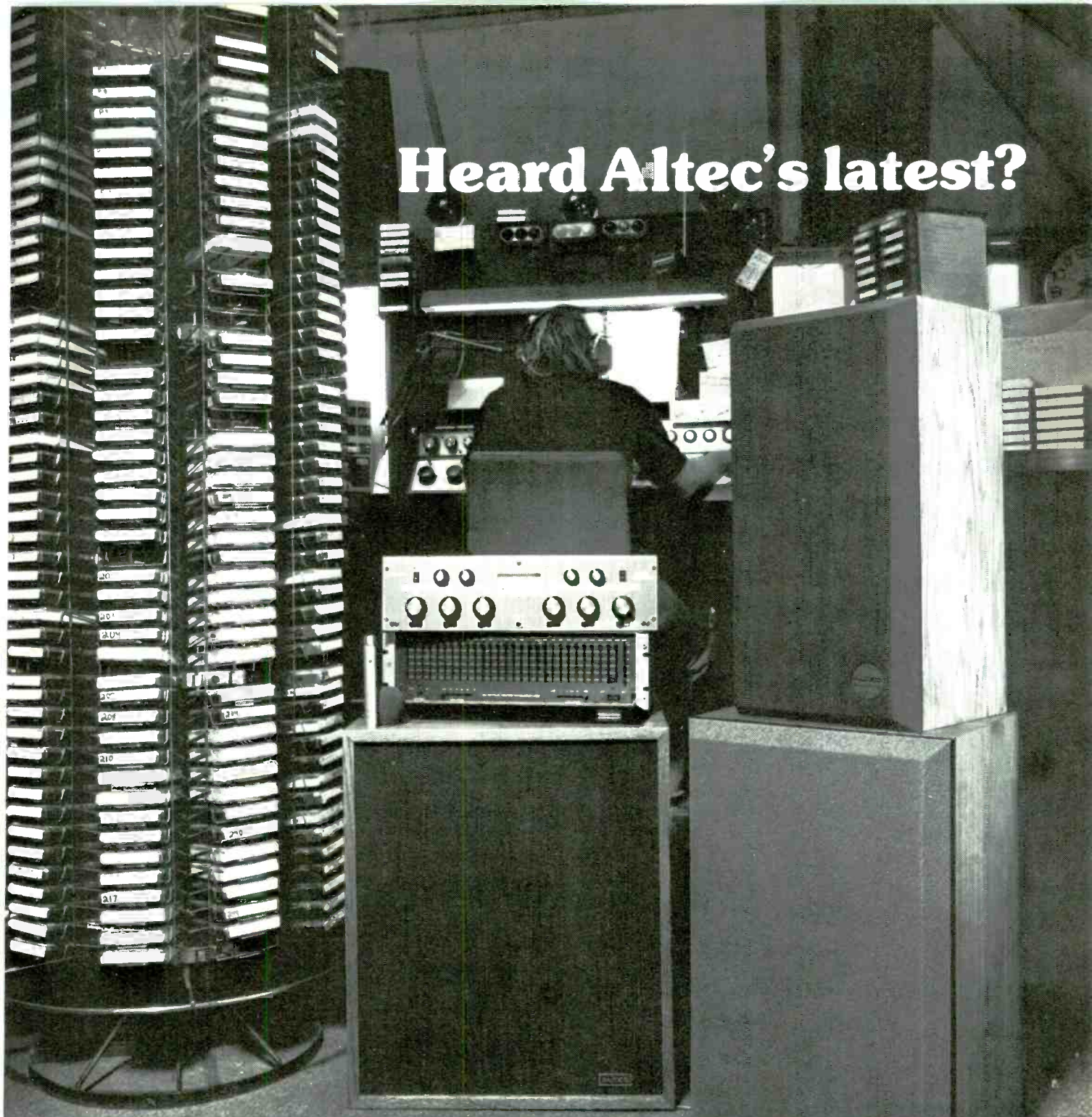

It's another dynamic performance.

We're not bragging. Building sound systems with superb dynamic performance has been our profession for over 40 years — we wouldn't settle for anything less. Straight fact.

If your profession is centered around spending long hours in a broadcast studio, you can't afford to be distracted or fatigued by poor quality audio. You've got to have the best, distortion-free equipment available. Clean. Clear. Dynamic.

At Altec, we make a wide range of top quality

sound equipment — microphones, remote mixers, equalizers, monitors — that will help make a pleasure out of your demanding profession.

For further information on how Altec can add dynamic performance to your studio's sound system, write to: Altec Sound Products Division, Commercial Sales Dept.

Location photography courtesy of KEZY Radio, Anaheim, Ca.

1515 S. Manchester Ave., Anaheim, Calif. 92803 • 714/774-2900
ALTEC CORPORATION

Circle 230 on Reader Service Card

ALTEC

the sound of experience

SMPTÉ CONFERENCE

therefore handling up to four write operations and a read operation in sequence, though at the output ports it appears that these tasks are being done simultaneously. Compression is achieved by varying the address information of incoming video while expansion (zooming) is achieved by varying the read address information from the memory.

Action Track, the new video effects device reported in last month's *BM/E*, was at least the visceral hit of the program. A live demonstration of this remarkable device got just about everyone there excited. In a paper delivered by J. Kenneth Moore of CBS Technology Center, the device was described as an outgrowth of the technology that went into the Digital Noise Reducer now manufactured by Thomson CSF.

As reported last month, CBS Action Track permits the display and/or recording of the history of moving objects in a video picture. The effect is roughly approximate to stroboscopic photography techniques. It is based on digital frame store and digital video processing techniques like those used in the DNR. A digital frame store with a digital comb filter and chroma inverter allows

input video to be compared with earlier video in a motion detector. The rate of comparison, or the stroboscopic rate, is controllable. When motion is detected, the picture elements involved will be updated and the fact of that update is stored in an auxiliary tag store. The information in the tag store will remain there until erased. In the case of a golf putt for instance, the information in the tag store is likely to consist of just the series of positions the ball was in—like a line of dots. The stationary elements of the picture continue to be displayed in real time though in fact, the whole picture can be frozen.

The information in the tag store can be made to blink or its luminance can be heightened. The stationary background can also be suppressed so that another element can be keyed in or some other color (usually black) can be entered to create striking stills.

Electronic still stores

Three methods of electronic still storage were covered in papers presented Saturday afternoon. The Ampex ESS System and the ADDA ESP system use digital techniques to store and retrieve stills while the Arvin/Echo System uses analog techniques on a flexible magnetic disc. A third method discussed was a system of using holographs to store still information for a

CATV system in Japan. While this last method offers an image capacity of 200,000 images and an access time of 0.4 seconds and takes just one second for cycle time, its application to broadcasting at this stage of development is vague.

The other systems discussed, of course, are in use at broadcast operations today. The ADDA ESP system, as discussed earlier, is in use at NBC (several other recent sales have been announced), and the Ampex ESS system is in use at CBS. The Arvin/Echo system can be found at a number of broadcast stations. ABC is a heavy user of the Arvin/Echo system and presented a paper discussing its applications in their operations.

Both Ampex and Arvin/Echo took the opportunity to discuss recent changes to their systems. Arvin/Echo has added a slow motion capability to their system and has dubbed it Slo-Mo. Slo-Mo offers up to 20 seconds of slow motion in varying speeds from freeze to real time. Images are continually recorded on the Slo-Mo disc. When the 20-second capacity of the disc has been exhausted, it goes back to the top of its cycle and begins again so that there is a continuous flow of information. When a sequence is to be played back in slow motion, a keyboard is used to enter the desired start point of the sequence and

The strong, silent type.



Just one glance at the Yamaha P-2200 power amp tells you the whole story. The case, the handles, the whole exterior relate a single, powerful message—rock-solid reliability, stability and high performance. The P-2200 is no hi-fi retread. It's designed for a wide variety of professional applications.

Strong! With 200 watts of continuous average sine wave power into 8 ohms, you've got plenty of punch to handle the high peaks essential to clean studio monitoring, as well as all-night cooking in "live" concert reinforcement or disco sound systems. (You can easily

convert it into a monaural super amp and/or 70-volt line output capability for distribution systems.)

Silent! With a 110dB S/N ratio and .05% THD from 20Hz to 20kHz, the P-2200 satisfies even the most critical ears.

How pro can you go? The P-2200's dB-calibrated input attenuators and 50dB peak reading meters are flush mounted. Inputs to each channel have XLR connectors with a parallel phone jack, plus a phase reversing switch. Speaker connectors are five-way binding posts that take wire or "banana" plugs.

There's not enough room to give you all the facts here, so send this ad along with six dollars. (Please, certified check or money order only. No cash or personal checks.) We'll send you the P-2200 operation manual filled with facts. Or better yet, see your Yamaha dealer.



YAMAHA

Musical Instrument Combo Division
6600 Orangethorpe Avenue,
Buena Park, CA 90620.
Write: P.O. Box 6600, Buena Park, CA 90622

from that start point the succeeding 20 seconds are played back.

Ampex's ESS, which began some time ago as a CBS inspired project, has developed some new and useful characteristics, one of which is its use as a slow motion recorder in addition to its use as a still store. The Ampex ESS will store up to 79,772 individual frames with 2242 frames on-line at anytime. The worst case access time to any of these slides is 70 msc. What has made the ESS-1 turn into the ESS-2, however, is largely its redesigned operation features and its new slow motion capabilities.

The paper, delivered by William Justus of Ampex, described the ESS-2 as a "digital video production system," to reflect its new capabilities. As currently configured, ESS-2 has the ability to record in real time and to play back from freeze to 60 fields per second. Since the record speed is variable too, ESS-2 can be used as a variable speed production recorder. It can do skip field for fast motion and reverse action playback as well as single frame animation.

When recording in real time, each disc can hold up to 28 seconds of information. A separate control panel has been constructed to take advantage of the machines variable speed record and playback functions. The basic price of ESS has come down to \$120,000, a

considerable decrease from when it was first introduced at about \$200,000.

The other major paper dealing with still stores was delivered by Jesse Blount of ADDA Corp. His paper largely dealt with the economics of electronic still stores and gave a clear indication that a station producing more than 80 slides a week and using 125 slides a day in its operation would find an electronic still store to be a sound capital investment.

According to a study done by Blount, a station using an electronic still store like the ESP-100 could save as much as \$30,000 in annual operating cost if the station's conventional slide handling method is now costing about \$52,000, which was the case for the typical station surveyed in Blount's 1977 survey of 175 television stations. In addition, this savings is achieved while picture quality improves and damage to valuable graphics is virtually eliminated.

With all of this activity growing out of the digital technology trend, the first paper given during the digital technology portion of the conference may well prove to be the most important. Bob Hopkins of RCA, a member of the SMPTE committee dealing with digital standards, gave an update on progress being made in establishing standards for digital television.

The SMPTE Committee on New Technology authorized the formation

of the Working Group on Digital Video Standards in January of last year. With the rapid explosion of the numbers of digital devices, the Working Group is moving as quickly as is practical toward the drafting of recommendations on digital standards. So far, the decision has been made to split the problem into two. The two problems might best be described as standards for the interfacing of black boxes, and standards for the total plant system. Thus, two working groups have been established, one for each problem.

The "black box" group has already reached a number of conclusions which might form the basis of a recommendation. For the interfacing of black boxes, the committee feels that a parallel data format should be used. It has also come down in favor of 4fsc sampling rates and an 8 bit word per sample. (As an aside, the Working Group determined that a conversion of some other sampling rate to the 4fsc seems possible.) In addition, the Working Group will recommend the use of Emitter Coupled Logic (ECL) rather than TTL. In all, eight separate recommendations have been decided upon. The Working Group on standards for the digital plant, however, has a somewhat trickier problem, and no time frame was given for when we might expect to hear their recommendations. **BM/E**

THE FAMOUS ORIGINAL REVERBERTRON



NOW LESS THAN \$600

This is the original REVERBERTRON not a substitute. Until now it has been selling for \$1148. Price Reduction is due to improved production technology.

The REVERBERTRON Model # 659-00 is designed to enhance broadcast/production or recording studio sound. It features solid state electronics in separate removable enclosures to isolate from ambient noise. Also contains high performance electro-mechanical delay lines, continuous reverb mix controls, VU metering, 3 band equalization, remote controls and selectable decay time. All in 7" of vertical rack space.

FOR COMPLETE DETAILS CALL OR
WRITE SAM JONES

ROBINS®

BROADCAST & SOUND EQUIP. CORP.
75 AUSTIN BLVD.
COMMACK, N.Y. 11725
(516) 543-5200

Circle 234 on Reader Service Card

For Tape Heads Head for TABER

At Taber you get precision work, quality results and low price ...
unmatched by any other audio head manufacturer.

We will recondition your three head assembly ... F/T \$45.00 ...
2 TRK \$60.00. Three new 2 TRK heads installed and aligned in your
AG-440B for \$254.00 ... Scully 280 at \$270.00.

Ampex VTR audio is priced at only \$385.00
for four new heads installed, or \$110.00 for
four reconditioned heads. (Add \$38.50 if
monitor post needs lapping.) RCA VTR
audio heads are available for only \$475.00.

Loaner assemblies are available.

For heads, head for Taber ... the best source
available.

Send for free brochure.

TABER Manufacturing & Engineering Company
2081 Edison Ave. • San Leandro, Ca. 94577 • (415) 635-3831

Circle 235 on Reader Service Card

INSTANTANEOUS Digital Command

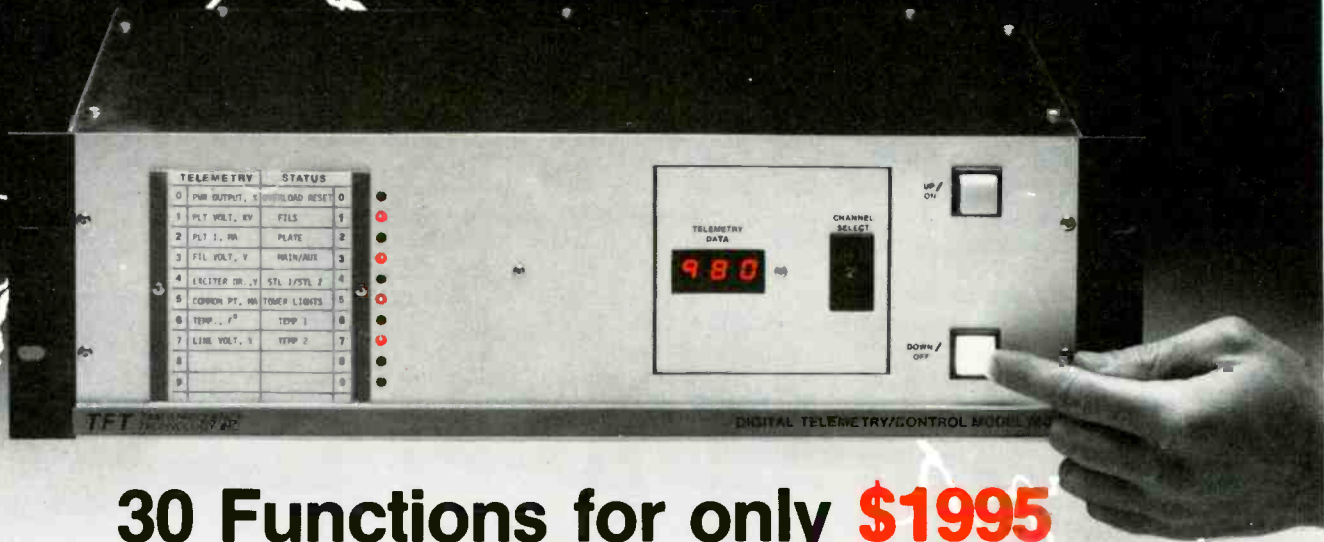

30 Functions for only \$1995

TFT Model 7601 represents a major breakthrough in remote control systems. Now, you can get 20 channels of digital command functions plus 10 channels of digital telemetry functions for less than \$2000! And it's the same high quality, reliable design that has made TFT equipment a standard in the broadcast industry. Just check this line-up of features:

DATA SECURITY ASSURED

Full command-code redundancy, *plus* odd/even parity check, makes digital data errors virtually impossible. A TFT proprietary feature. Even lightning induced noise has no effect on integrity of command functions.

INSTANTANEOUS COMMAND

Less than 0.2 second marks the time for a complete command/execute function with the new TFT high speed data modem.

ONE MAN CALIBRATION

The front panel of the Model 7601R (Remote Terminal) has a DVM and scaling potentiometers so that just one man, on-site, can perform the FCC required weekly calibration. A studio lock-out switch provides complete operator safety for on-site work.

CHOICE OF TRANSMISSION METHODS

Model 7601 interconnection can be either telephone lines or radio links which include STL, TLS or SCA.

MINIMAL SERVICE DOWNTIME

Quick-disconnect rear barrier strips allow fast removal of the 7601 from the rack without disconnecting any of the interface wiring between the remote terminal and the transmitter or alarm sampling points.

TEN OPTIONAL STATUS CHANNELS

In addition, 10 status indicator functions may be factory or field installed to provide instant status display and alarm.

The Model 7601 is just one of a full line of field-proven, reliable, fail-safe remote control systems offered by TFT. Other remote control systems designed for AM, FM and TV include the Model 7610, 120-channel digital telemetry/status/control system, the TELESCAN* auto-logging multi-channel CRT display and tolerance alarm system, and a complete line of remote control accessories. They're all available now from TFT. Call or write:

*Trademark pending

TFT TIME & FREQUENCY TECHNOLOGY INC.

3000 OLCOTT STREET, SANTA CLARA, CA 95051 (408) 246-6365 TWX No. 910-338-0584

Circle 236 on Reader Service Card

British Stage Day of Digital Broadcasting Demos

Working digital video recorder and digital audio recorder demonstrations along with noise reducer, vision mixer, and digital fiber optics transmission exhibition shown to overflowing crowds.

THE DAY IS FAST APPROACHING when digital broadcast equipment will be a logical choice over analog because of reliability, higher performance, and possibly even lower price. Sensing this trend, engineers from British broadcasting, production, and manufacturing companies turned out en masse last Jan. 26 to see the new possibilities. Through the combined efforts of the BBC, IBA, ITCA*, and British Post Office, a number of impressive demonstrations were conducted. The most difficult was a two-day-old, full-frame digital videotape recorder by the IBA which used a modified Bosch-Fernseh BCN machine as the tape transport. The pictures and sound were not yet broadcast-perfect, but the achievement was remarkable because the bandwidth used up was only 80 Megabits/sec. including error coding. SubNyquist sampling was used to get the lesser bandwidth (more on this later). While the video recorder was billed as experimental, a digital sound recorder that could be replicated was shown by the BBC. Transport and much of the electronics were produced by 3M (as shown in the U.S. by 3M at the AES last November). Other demos were a noise reducer by the BBC, a vision mixer (British parlance for a production switcher) by ITCA and IBA, and digital transmission using fiber optics by the British Post Office.

While there was no intention to focus on the day-to-day practicality of switching from analog to digital devices, it was evident that Peter Rainger of the BBC, who provided introductory comments, felt that digital systems would be ready to take over soon. He suggested that the audience ask themselves, "What steps should I take to ensure their success?"

The rate of progress toward ever more digital facilities hangs a lot on the coding schemes that will evolve. If standards can be quickly adopted — within the studio, for transmission — progress could be rapid. The problem is

in deciding what the standard should be. The essential trade-off is exchanging bandwidth for signal-to-noise ratio. "While the performance of pcm can be nearly perfect, signalling via yes/no or 1,0 basis can be dangerous," said Rainger. "If the message is received correctly, it is perfect; if it is received incorrectly, it cannot be more wrong. Pcm, when it is good, is better than competitive systems; but when it is bad, it is worse than the alternatives." While this observation might not make history as Rainger's Law, it turned out to be a prophetic statement. There were some unsuccessful demonstrations: they were simply bursts of noise. However, these, we must quickly add, were greatly offset most of the time by outstanding results.

In terms of deciding what digital codes are appropriate, Rainger, as chairman of the EBU-CCIR Working Party on digital coding, stated the problem succinctly. In Europe there has been general agreement to use *several* standard bit rates. "Therefore, said Rainger, "it is common sense for a common carrier to arrange for a convenient number of small bit streams to fit in the next larger bit stream; and the CITT have agreed on a number of different bit rates. Within this hierarchy, 2,048 kilobits per second is what concerns us today. Within this bit stream we wish to mix a number of different signals. Time division multiplex techniques will be employed, and in order to recognize the beginning of the signal (or a section of the signal), it is necessary to have a framing pattern. Thus, the bit stream must have some bits allocated for framing and other housekeeping tasks; the rest may be spent as we see fit. In an attempt to economize we wish to code the audio signal so that the package contains as much information as possible." The sound demos that followed used the Working Party recommendations.

In video, the problem is the same but there are differences which Rainger described as follows: "The television signal contains more information and a much higher bit rate is required. The development is, to some extent,



Digital audio recorder . . .



and other digital demonstrations . . .



made before overflowing crowd.

device-limited, and considerable circuit complication is necessary to achieve the required speed."

Both studio and transmission coding schemes are necessary. As *BM/E* reported after the 10th International Television Symposium, Montreux, there are two approaches to coding: deriving the digital signal either from the color components or from the composite signal. For exchanging signals between SECAM and PAL countries, coding the color component is best. But repeated coding and decoding of PAL signals introduces impairments, and PAL countries may wish to use composite PAL with their national networks. Consequently, Rainger said that it may be possible to reach an international compromise to avoid proliferation of standards. On the other hand, if there is to be rapid progress in replacing analog equipment with digital sections,

continued on page 180

*ITCA stands for Independent Television Companies Assn; IBA stands for Independent Broadcasting Authority; the BBC is, of course, the British Broadcasting Corporation.

British Digital Demos

standards are needed quite soon. One paper at the London digital techniques session dealt with transcoding between composite and separate component systems.

The first course in the "feast of events" held at IEE headquarters, Savoy Place, was the BBC noise reducer. This device was described as designed not to salvage really poor pictures but to improve average pictures. Thus, the unit is designed to be placed in the circuit before the transmitter, and left running. The challenge, said BBC engineers, was in finding a suitable method of detecting movement, and then switching off the averaging process in a controlled manner. If this is not done properly, impairment of the moving pictures due to noise can outweigh improvements.

The equipment uses a single digital picture store in a recursive mode to average the signal. The degree of noise reduction is controlled by the value of the divisor k , the unweighted noise reduction-factor being given by $10 \log_{10}(2k-1)$ dB. According to the BBC, a k value of 4 has proved to be adequate for most purposes as the subjective effect appears greater than this value would imply. The BBC felt that their unit provided more reduction of noise than did Thomson-CFS device, but that the design objectives were perhaps different.

The pulse response of the recursive filter is an exponential decay so that the effect of the filter on moving objects is similar to that of a long-persistence display phosphor with a time constant of k picture periods. Detection of movement to avoid blurring is carried out by examining picture-difference signals, element by element, at the output subtractor. When these signals immediately exceed a threshold value, the averaging process is stopped to allow the picture-difference signals to contribute to the output. The visual effect is that all stationary parts of the picture are

reduced. Where there is movement, there is noise; but the result is acceptable since moving detail tends to distract the eye from noticing noise.

In the block diagram shown, the movement detector is used to control the multiplier, thus varying the amount of noise reduction.

To gain first hand experience on how a digital switcher-mixer might be different from analog units, the ITCA decided to build a unit for comparison. The idea was to do the kind of processing that one normally encounters in a long chain. Special effects possible only through the use of digital techniques were avoided in favor of more straightforward analog effects. The kinds of effects demonstrated were cuts in blanking, cross mixing, wiping, hard and soft variable wipe edges, and fading. Chroma key is also possible.

In the U.S. it is generally assumed that the VTR is the last device to be digitalized because of the high bit rates required. Assuming 114 to 140 megabits/sec are required, digital recorders would be carnivorous consumers of video tape and expensive to operate. On the other hand, analog VTRs leave much to be desired when multiple generation recordings are required. Yet digital techniques could lead to a desired improvement in quality.

The IBA, therefore, has been anxious to find a digital solution. The goal has been to minimize tape consumption so that costs will remain in line with analog machines. In the London demonstration, John Baldwin of the IBA showed the possibilities of using bit rate reduction schemes and adapting a BCN analog recorder to the digital mode.

Essentially the scanner speed is doubled which results in a writing speed of 2000 ips. The data stream of 82 megabits/sec is switched into the two heads resulting in a density of 41 kilobits per inch. But because the track width was halved, the tape consumption remains the same as that of a conventional BCN.

The IBA approach successfully uses a sampling rate only twice the PAL

subcarrier frequency. Samples convey all of the color information of a PAL system if the phase is carefully controlled. A comb filter gets rid of unwanted components. To reduce the bit rate still further, differential pcm techniques were applied. This system has just been put together, and not all bugs were eliminated but Baldwin seemed to feel that the concept would be perfected. In the demonstration, Baldwin showed how a four times subcarrier frequency sampling signal is converted to two times color subcarrier signal, recorded, then converted back to four times, and thence to an analog PAL. Comb filter are used extensively.

Mr. A. Bellis of the BBC said the BBC/3-M audio recorder was suitable for operational use. In demonstrating the system, it was pointed out that the present signal-to-noise ratio, distortion, etc. (unnoticeable to this reporter) were not dependent on the recorder but on the parameters of the digital coding system. Specifications of the machine were given (see below); also *BM/E*, "Digital Audio," Feb. 78.

G.W. McNally of the BBC showed how the mixing of digital sound signals could be accomplished digitally. To allow for a wide range of experiments without constructing a fully-equipped mixing desk, some functions were simulated by a mini-processor. Ten sound channel inputs and six outputs were provided for signals in the 13-bit pcm serial form. Settings of 12 faders and four pots controlling other functions were digitalized. Programs can be entered via paper-tape reader. Speed of the process is such that an 89-step program can be executed in the interval between sound samples. Demonstrations showed the mixdown of several inputs to a stereo pair, spectrum shaping, test signal generation. Automated mixdown is also possible.

In a demonstration of digital sound transmitted over wire transmission lines, W.G. Simpson provided examples that had gone through 480 miles of wire. With digital transmission, length of the line is not important. New types of distortion are introduced by the coding parameters used. Two main types of codes have been developed. One type uses non-linear companding (instantaneous), while the other uses a switched-range linear companding (near-instantaneous) system. The BBC demonstrated the latter.

In a demonstration of TV distribution of fiber optics, two 69 Mbit/sec codes were multiplexed into a 139 Mbit/s stream and transmitted over fiber (1 km BICC cable). The Post Office also has installed better graded-index fiber between Martlesham and Kesgrave. J.E. Thompson of the British Post Office predicted regular optical fiber service by 1984-85. *BM/E*

BBC/3M Digital Audio Recorder Specifications

<i>Tape speed</i>	20"/sec. (50 cm/sec)
<i>Tape width</i>	1" (2.54 cm)
<i>Tape type</i>	3M 461
<i>Playing time</i>	45 mins (10%'' (26.7 cm) reel, 4500 ft.)
<i>No. of sound channels</i>	10 (only 7 fully equipped)
<i>Bandwidth</i>	30 Hz - 15 kHz
<i>"Signal/noise ratio</i>	56 - 58 dB (using CCIR Rec. 468 weighting network and a PPM; relative to zero-level line-up)
<i>Wow and flutter</i>	Zero
<i>Crosstalk between channels</i>	- 60 dB

The VTR Format of Tomorrow. While others are still talking about it... Bosch already has it: the BCN System.

BCN scanner shortens tape path, minimizes environmental and mechanical tracking error



Since the BCN was first introduced, more than 400 of these systems have been ordered from all parts of the world. More than 350 of them have been delivered and are in operation.

Simplified threading of the BCN 20

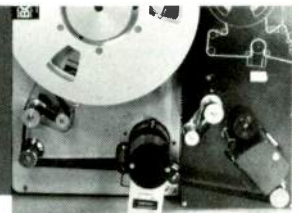

The four basic requirements placed on a new VTR format:

- Top broadcast quality for all TV standards.
- Universal applicability.
- Reel-to-reel and cassette handling.
- Adaptable to future developments.

The BCN System is not only a broadcast VTR:

It is also the electronic alternative to film. For the quality- and economy-minded industrial user, and for all professional non-broadcast applications.

The BCN System is offered by four leading manufacturers of "broadcast" equipment, and it is produced in both Europe and the USA.

The BCN System offers two different portable versions: the portable BCN 20 with a tape capacity of more than 60 minutes on one reel—and the BCN 5, the 20-min. cassette recording and play-back version. Both versions operate under all conditions with full broadcast quality. In the future, the BCN cassette version will also be used in an automatic multi-cassette VTR.



BCN 5 cassette VTR

The BCN System meets these four basic requirements for a new VTR format today: The compatible and economical BCN 1" format produced by Bosch guarantees broadcast quality in all TV standards and color systems (PAL, PAL-M, SECAM, NTSC). For all fields of telecasting and VTR applications. It is adaptable to future developments in video tape and video head technology. The segmented-field process makes purely electronic switching of writing speeds possible. As a result, the BCN is already an economical and universal VTR with a guaranteed future today.



Portable BCN 20

The BCN System features electronic editing with:

- Single-picture display*—for an unlimited time with no danger to the tape.
- Jogging*—single-picture search mode, forward and reverse.
- Slow-motion, fast-motion*—variable take-search mode. And all this with a state-of-the-art digital store.

The BCN format also offers the possibility of filing over 100,000 single pictures (for example, slides) on a 90-min. video tape with an extremely short access time to each single picture.

The BCN System is designed for both basic tape-handling methods: reel-to-reel and cassette handling in full broadcast quality, in both portable and stationary VTR's.

BCN—a format with a guaranteed future.

BOSCH FERNSEH

Robert Bosch Corporation, Fernseh Group,
279 Midland Avenue, Saddle Brook, New Jersey 07662

See us at Booth 924, NAB show, April 9-12, Las Vegas

Circle 237 on Reader Service Card

NOW THE SUPERSTICK



THE ONLY VIDEOTAPE EDITOR FOR ALL APPLICATIONS

If you're editing ENG, EFP, or Commercial Post Production – the new Convergence ECS-100 Superstick system will do your job faster, easier and better than ever before possible. With its modularity of design, the ECS-100 lets you start with a basic low cost system and expand to meet your needs for increased capability. All of this is made possible through the use of a field-proven Microprocessor and the famous Convergence human engineering.

Electronic News Gathering

Today's skilled ENG operator insists that an editor must be fast, reliable, accurate and simple to operate. The ECS-100 Superstick is that – and more. Our exclusive new low cost CUT/LAP™ Transition Programmer will put you head and shoulders above your competition. Now you can program fades and simulated dissolves from a single playback VCR without adding a switcher or TBC. The Superstick is the ENG editor of the future.

Electronic Field Production

Single camera film style producers require the flexibility and expandability that only state-of-the-art microprocessor technology provides. The Superstick's microprocessor lets you grow to command up to four VTRs with one simple control. CUT/LAP™ plus our other exclusive super features like Liplock™ Audio Pitch Control, Automatic Return to Edit, Auto Tag, and ADR (Automatic Dialogue Replacement), provide an unbeatable EFP editing combination.

Commercial Post Production

The demands of today's sophisticated post production editing world require SMPTE Time Code, A/B rolls, Special Effects, Split Edits, Multiple Source Machines, CRT Display of all edit data, and a hard copy edit decision list for auto assembly. The ECS-100 Superstick Editing System has all of these features plus Programmable Animation. More important, in the midst of all this sophistication, simple edits are still simple.

The Superstick system interfaces with a growing number of low cost videocassette recorders and – the new one inch Type "C" teleproduction VTRs – ask us for information and a demonstration. Remember...

Editing means Convergence.

See the Superstick at NAB/1007

CONVERGENCE CORPORATION

17935 SKY PARK CIRCLE, IRVINE, CA 92714
(714) 549-3146 TWX: 910-595-2573

For information Circle 238
For demonstration Circle 285

"Super-Stations" Are An Unneeded And Unwanted Threat To Local Stations," Says Jack Matranga



Jack Matranga, president of KTXL-TV, Sacramento, Calif., asks some important questions about "Super-Stations." What is the audience getting? What impact will there be on programming available to the local broadcaster? What happens to the official obligation to operate in the interest of the local audience? And finally, "Do we really need Super-Stations?"

Recently, the broadcast industry was given a jolt when it was announced at the Western Cable Television Convention that the "era of the super-station" was here and soon, thanks to a rapidly expanding technology, earth stations and satellites would be carrying additional programming to cable systems throughout the country—that such programming was "waiting in the wings, ready to be put in flight all over America."

This flowery tribute baffled me for a time. What was waiting in the wings? Further reading indicated that the first of the "Super-Stations" was WTCG-TV, Atlanta, Georgia. That Ted Turner's station was now serving some 767,000 subscribers on 107 cable systems, many of them via satellite. And that Edward Taylor, who heads up the distribution firm that transmits the WTCG-TV programming, is forecasting another 800,000 in the next six months.

I have no axe to grind with Ted Turner. Over the years he has demonstrated that he is every bit as good a broadcaster as he is a sailor; however I think it's time that the myth of the "super-station" be put into proper perspective. The charisma of the glamour terms "Earth Station" and "Satellite" has, it seems, created a state of euphoria in many cable televi-

sion operators and in some independent TV station operators. I think that they have been carried away by the romantic image of that great big eye in the sky.

First, one wonders about the audience, the subscribers to the super-stations. Is it really fair for them to be charged for what they are now receiving for free? KTXL-TV, like many other TV stations around the country now supplies programming via cable gratis. At the present time our station lists over 800,000 potential cable viewers in a 13-state area in the western part of the U.S. Other stations, particularly those with coverage in remote areas, offer similar programming to similarly large numbers of cable systems in their region, again, for free. It doesn't seem reasonable that a Pacific Coast cable system viewer should be charged for watching a program that he can watch for free on any number of cable channels just because it originates in Atlanta or Chicago.

Nor does it seem reasonable that West Coast viewers will be all that interested in watching, say, the Atlanta Braves, or any other regionally oriented program, sports, local news or otherwise. We are, after all, a regional country; what is of interest in the Northeast or South may have absolutely no interest to the people in the West or Southwest or vice versa.

This of course brings up the second important question. Given the proposition that "super-stations" are really here, what then happens to local determination? TV stations' licenses are specific about programming for the public interest and convenience in the areas they serve. Local community ascertainment is an on-going and major TV station commitment to local community service. What happens to the viability of a small market TV station surrounded by CATV systems receiving a multiplicity of top programs from several super-stations? It is not inconceivable that such local TV service might be seriously threatened in the immediate future. How would a super-station in Chicago, Atlanta, San Francisco or Los Angeles perform the public interest function of a Laramie, Sioux Falls, Fargo or other small market station whose operation it might disrupt?

A third question: Individual TV sta-

tions throughout the country now spend millions of dollars for feature film packages and top run off-network syndicated series. (KTXL-TV itself has over \$6 million invested in its film library.) Will the super-station offer better or, more important, different programming than that now available to many cable systems throughout the country from their area TV stations — for nothing? Certainly a product distributed via satellite from a super-station could be used to fill additional channels on cable systems, but the question would seem to be whether or not such additional programming, whether or not it is sports, movies or syndicated series, would be worth the fee the satellite distributors would have to charge to cover their distribution costs, when the cable audience was receiving similar programming from regional stations for free.

The programming aspects of such national distribution also pose somewhat of a Chinese puzzle. Will the program suppliers, film companies, production firms and other program sources suddenly decide that perhaps five or ten "super-station" customers are worth more than the 1500 or so customers they now have? How will the super-stations contract for the super programs they will need to interest a national audience? With such off-network series such as *Happy Days* running as high as \$45,000 in a major market, what kind of figure would be demanded for top-rated series by program suppliers — or even more interesting, what part of the "action" would the super-station operators have to part with to satisfy the program suppliers who would indeed be in the driver's seat?

I am all for additional programming material for CATV systems, particularly in those areas where available service to viewers is sparse. However, I cannot see three, four, or even six super stations solving the CATV system operators' problems of increasing their channel offerings; especially if there is to be an additional cost to the viewer. At the present time the super-station advocates say they are charging operators a "minimal" fee. How long will this fee remain minimal if the super-station becomes a reality — and

continued on page 184

Meet the AKG "Enhancers"

Professionals throughout the world are using the unique Torsional Transmission Line Principle in our big Studio Standard BX-20E. It duplicates and enhances natural reverb with a control and predictability not possible with natural "vibes."

Now the Torsional Transmission Principle is available in the first truly portable reverb. Our two-channel, studio quality BX-10E.

It lets you adjust independent decay time of 1.5, 2.5, or 3.5 seconds. There's also sep-

arate high frequency and low frequency equalization for each channel. A reverb/dry signal mix for each channel as well. Input sensitivity selection of +12, +6, -6, and -22dBm. And a stereo/mono switch.

The BX-10E uses motional feedback circuitry, so instant variation of decay time is possible during recording. You can make dynamic adjustments to a score while it is being recorded. The BX-10E features an ingenious two point pendulum suspension within an insulated case with a foam lining. You can use the BX-10E near monitors without fear of acoustic feedback or structure-borne sound and vibrations.

Despite all it has going for it, the BX-10E is only 17 x 12 x 19 inches small and weighs only 45 pounds. Visit your AKG professional dealer for a personal introduction. Or write to us.



PHILIPS AUDIO VIDEO SYSTEMS CORP
A NORTH AMERICAN PHILIPS COMPANY
91 McKee Drive, Mahwah, N.J. 07430 • (201) 529-3800



The Mark of Professional Quality... in microphones, headphones, phonocartridges, reverb units.

Speak Out

the only game in town? Add to this minimal fee the additional costs for Pay TV, Home Box Office, Special Sports and movies and other pay-as-you-watch programs the entrepreneurs have on the drawing boards in the not-too-distant future, the cost of this special television viewing may well be out of reach of the mass of people who have made TV the tremendous force that it is today. And it may very easily strike a telling economic blow to many local TV stations and their local service as programming is diverted from the many to the few!

Finally, the proposition of super-stations brings into sharp focus the exclusivity question. There are as many facets to this problem as there are suggestions for solution. The general consensus has been to "leave it to the marketplace," and the natural economic laws will eventually allocate a definitive balance.

How then do you define the "marketplace" of a super-station? Local stations, particularly local independent TV stations, have made heavy investments in feature films and syndicated series. If they are to be subjected to a flood of identical program material from the super-stations, the "marketplace" will become chaotic and the viability of many local TV stations (both affiliates and independents) will be seriously jeopardized. This will be especially true in those areas already saturated with a broad selection of signals via cable. Local cable systems will be able to offer programming, via satellite and 2 or 3 super-stations without incurring the tremendous financial risks TV stations take on as a matter of course. The specially-produced local programs — news, public affairs, community issues — and others, again, primarily in small markets, will certainly suffer.

The concept of the super-station is not new to broadcasting. There are still a number of super-radio stations, 50,000 watts, which transmit on a national basis. However, the original premise which launched these stations has long been disproved and those super-stations are now more of a curiosity and ego trip than national entities. Many of these are now little more than "local stations" with a lot of meaningless extra coverage.

I'm 100% for progress—in technology, in increased opportunities for viewers to receive as much programming material as can be digested, and for broadening the social and cultural promise of an expanding TV audience. The super-station, as presently proposed, fed via satellite into every nook and cranny of the U.S., will not add one whit to further progress in these areas.

BM/E

ADVANCE INDUSTRIES

TOWERS and accessories

COMPLETE PACKAGE SERVICE — design, manufacture, erection and maintenance.

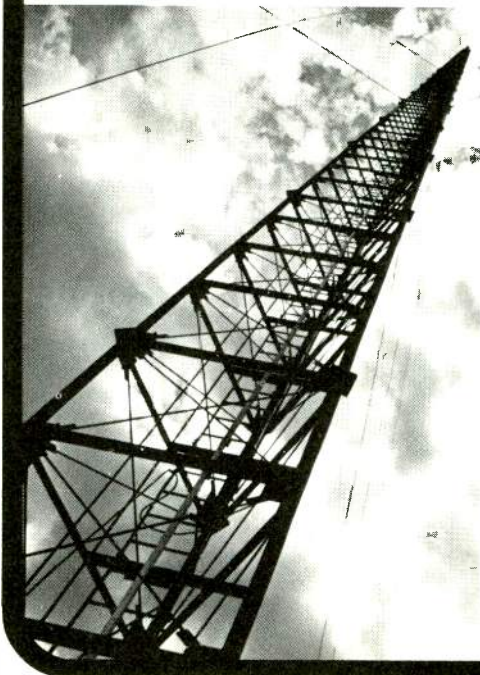

We offer the skills of our experienced engineering staff, and the facilities of our modern plant to give you the best towers and accessories.

For your new or additional facilities contact us. Let us help you plan your needs, and then offer you a turnkey package.

Call 712/252-4101 or write
ADVANCE INDUSTRIES

2307 Bridgeport Drive
Sioux City, Iowa 51102

Circle 239 on Reader Service Card

The IE-30A Audio Analysis System from IVIE

- 1/3-octave Spectrum Analyzer
- Full-octave Spectrum Analyzer
- Precision Sound Level Meter
- True RMS AC Voltmeter
- RT₆₀ (Reverberation)*
- THD (Harmonic Distortion)*

For the first time, a real time analyzer and precision sound level meter have been combined into a portable audio analyzer "system" with features and accuracies rivaling the best laboratory instruments available.

The fully digital IE-30A comes standard with a precision laboratory microphone calibrated in dB-SPL and remoteable up to several hundred feet, a test probe with two precision attenuator settings for calibrated dB μ V measurements (true rms, average or peak), nickel cadmium batteries with charger, and a hard shell, foam lined travel case.

*Using optional accessories



Other features include selectable detector responses, gated mode operation for measurement of reflections and time delay events, dual involatile memories that store or accumulate data that can be recalled to the IE-30A display up to weeks later.

The IE-30A was designed to accommodate an inexpensive new family of optional accessories. The IE-17A measures RT₆₀ (reverberation time) in 1/3-octave bands up to 99.99 seconds with 10 millisecond resolution. The IE-15A measures total harmonic distortion (THD) to less than .01%.

SPEC BRIEFS

- 1/3 octave or full octave bands 30 filters on ISO centers 25Hz to 20KHz.
- Highly selective three pole-pair filters exceed ANSI S1.11-1966 Class III, B.S. 2475-1964, DIN 45652, and IEC255-1966.
- 1/3 octave display weighted A, C or Flat.
- LED array 30 x 16. Resolutions of 1, 2 or 3 dB for display ranges up to 45dB.
- Precision SLM has *Fast, Slow, Impulse or Peak* responses with A, C or Flat filter weightings.
- 4 digit 0.1dB resolution readout with display hold mode.
- Meets requirements of:
ANSI E 1.4-1971 TYPE S1A, S1C, BS 4197-1967
DIN 43633 B1.1, B1.2 (Impulse) IEC 179-1973.
- 30 to 49 dB SPL re 20 μ N/M²
- Microphone is omnidirectional condenser Type 1 (Precision). Flat 10Hz to 20KHz.
- Signal outputs for recorders, oscilloscope displays and voice prints.



IVIE ELECTRONICS, INC.
500 West 1200 South
Orem, Utah 84057
(801) 224-1800
TELEX or TWX 910-971-5884

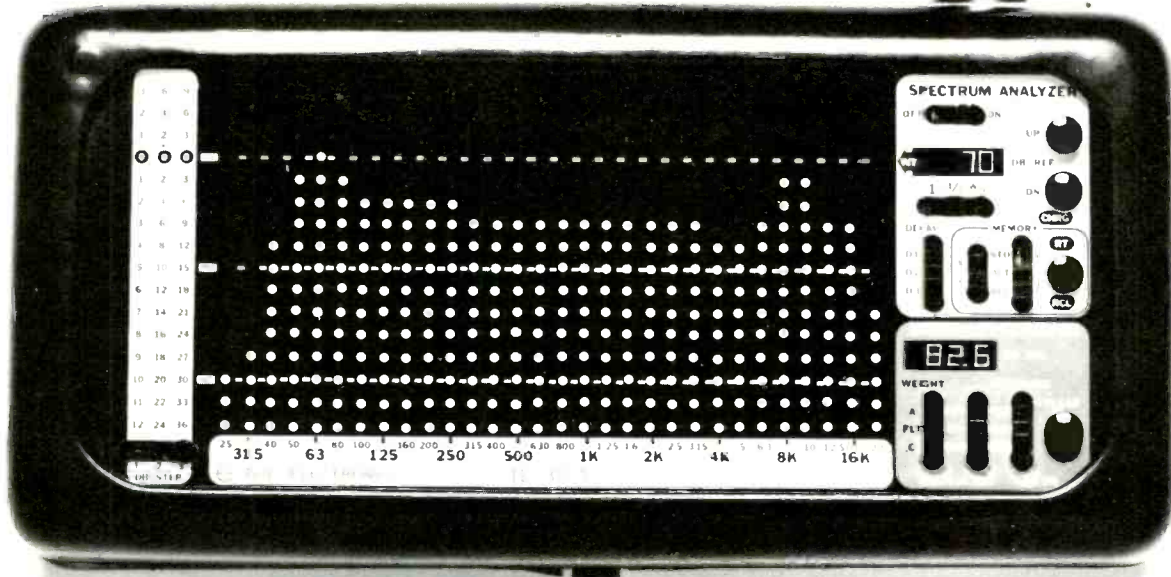

Atlanta, GA
FIDELICOM
(404) 458-3616

Syracuse, NY
DARMSTEDTER ASSOC.
(315) 638-1261

Boston, MA
V F SALES
(617) 237-6544

Chicago, IL
PAPPAS AND ASSOC.
(312) 685-2338

Cleveland, OH
PARENT COMPANY
(216) 725-8871

Dallas, TX
WYBORNY SALES
(214) 346-9657

Denver, CO
H P MARKETING
(303) 794-8367

Des Moines, IA
THE BEAMS COMPANY
(515) 255-1148

Detroit, MI
V F SALES
(313) 453-8720

Houston, TX
WYBORNY SALES
(713) 772-0961

Kansas City, KA
THE BEAMS COMPANY
(913) 631-0300

Los Angeles, CA
MARSHANK SALES
(213) 559-2591

Miami, FL
WORLD WIDE PRODUCTS
(305) 754-5475

Minneapolis, MN
KODO ASSOC.
(612) 881-1255

New York, NY
ADELMAN - PINZ
(914) 423-4747

Phoenix, AZ
MARSHANK SALES
(602) 949-9443

Portland, OR
EARL & BROWN
(503) 245-2283

St. Louis, MO
THE BEAMS COMPANY
(314) 569-1060

San Francisco, CA
MAC PHERSON SALES
(415) 937-1482

Seattle, WA
EARL & BROWN
(206) 284-1121

Washington, D.C.
SPHERE ASSOC.
(703) 471-1230

Calgary, Alberta
ESTRON INDUSTRIES
(403) 276-9621

Toronto, Ontario
THORVIN ELECTRONICS
(416) 274-1573

Montreal, Quebec
AUDESCO ELECTRONICS
(514) 288-4122

ELEVEN GREAT REASONS TO VISIT ASACA, BOOTH 800



2.



3.

1. **ASACA ACC-2000 COLOR MINI-CAM.** C-mount, excellent sensitivity, superior balance. Many standard features which are optional on others.
2. **925-C COLOR NOISE METER.** World's first instrument to measure both luminance and chrominance noise. Measures both AM and PM components of chroma noise. Already in use at major networks and manufacturers' laboratories.
3. **201 ENVELOPE DELAY MEASURING SET.** Compact, one-piece instrument measures group delay with built-in sync and blanking circuit. Already preferred by major networks. Determines sweep measurement point-by-point delay.
4. **205 VIDEO SWEEP GENERATOR.** Especially designed to adjust and maintain frequency response of U-matic VTR and 2-inch VTR. Built-in sync, colorburst switch. Easy-to-read frequency, thanks to digital meter. Accuracy and dependability enhanced by function generator.
5. **216 COLOR BAR GENERATOR.** Ideal instrument for maintenance and service of TV sets and VTRs. An economical unit that is a must for maintenance departments and repair shops.
6. **588 DIGITAL PATTERN GENERATOR.** No distortion. Excellent signal to noise ratio based on up-to-date technique. Permits all-point quality control check of TV receivers. Indispensable to manufacturers. Great for maintenance of broadcasting equipment.
7. **449 DIGITAL PATTERN GENERATOR.** Composite TV testing wave-form generator performs comprehensive testing adjustment of color monitors and receivers. Also tests black and white systems. Invaluable to manufacturers' quality control and after-market maintenance and service.
8. **846 DISTORTION MEASURING SET.** Oscillator, level meter, distortion meter and frequency counter are all in one unit. Provides accurate and easily conducted measurements of audio distortion.
9. **CMM 10-1 10-INCH COLOR MONITOR.** Compact, broadcast quality monitor operates on DC power. Ideal for station and production house on-location "shooting."
10. **CMM 14-1 14-INCH HIGH RESOLUTION COLOR MONITOR.** Compact and light-weight to permit use in vehicles and as a VTR monitor. High resolution—more than 600 TV lines.
11. **CMM 20-3 20-INCH COLOR MONITOR.** Reasonably priced master color monitor for TV stations. Stable and dependable. Look into this one.

If you are not coming to Las Vegas,
WRITE OR PHONE FOR MORE INFORMATION.

ASACA®

ASACA CORPORATION OF AMERICA
1289 Rand Road
Des Plaines, Illinois 60016
(312) 298-4380

Circle 241 on Reader Service Card

Great Ideas

The extremes in temperature often contribute to problems with the transmitter. If the building exhaust fan fails, temperatures can soar above 150 degrees quickly. The objective is then to design a device to make the building temperature readable on the remote reading meters.

Solution: The LM-3911 is a readily available temperature sensing IC, but it delivers a differential voltage. This resolved by the LM-3900 Quad Norton amplifier and it also sets the zero. The device requires +24 vdc which is often available in the relay control board. Calibration can be accomplished with the remote meter pot and the zero adjust pot.

38. Preventing Burn-Up Of Intermittent Duty Bulk Eraser.

Tom Schultz, Engineer, WGHP, High Point, NC

Problem: Prevent burn up of inter-

mittent duty bulk eraser due to power switch inadvertently being left turned on.

Solution: Install the enclosed protection circuit in the bulk eraser such that the switch which controls power to the bulk eraser also controls power to the protection circuit. When the protection circuit has had power applied for approximately one minute and 40 seconds, the sonolert emits a pulsed, audible signal warning personnel to turn off

the eraser. The 1.5 K, 1 W resistor was added across the sonolert to maintain the SCR current above the minimum latch current. If a non-pulsed sonolert is used, this resistor may be omitted provided the sonolert draws enough current to keep the signal latched on.

A new video tape bulk eraser with this circuit added was installed at WGHP-TV on November 11, 1974. The eraser and the circuit are still operational as of this date.

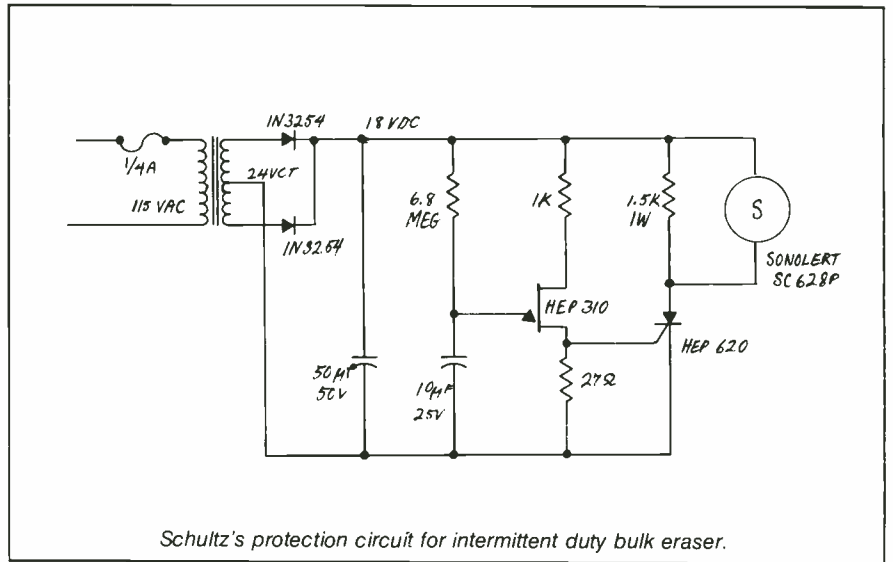

Schultz's protection circuit for intermittent duty bulk eraser.

Innovation in editing technology

That's what sets Datatron editing products apart from the competition. You already know us for our state-of-the-art Tempo 76 Editor — the first videotape editing system that combines both SMPTE Time Code and Control Track Technologies in one unit. But the innovation doesn't stop there. We've added new options to the Tempo 76 which make it even more versatile than ever:

- High-speed Peripheral Capability
- Expanded Interface Capability
- Extended Memory
- System Debug
- And More To Come!

Our Multiple Interface Unit (MIU) allows you to interface up to nine VTR's to the Tempo 76 system. With features like an optional code routing switcher and optional remote VTR selection and display, the MIU can add new dimensions to your editing capability.

We've developed new peripheral equipment too. In addition to our already large array of fully-compatible add-ons, we now offer time code generators and readers with user-defined bits, a new jam sync generator, and more.

To see these products and other new Datatron editing system developments, visit booth 1223 at the NAB Convention, April 9 thru 12 in Las Vegas. Find out why innovation makes the difference at Datatron.

datatron, inc.
 EDITING SYSTEMS DIVISION
 1562 Reynolds Avenue • Irvine, California 92714
 (714) 540-9330 • TWX 910-595-1589 • Cable RELIABLE

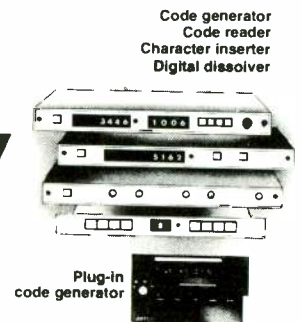

Plug-in code generator

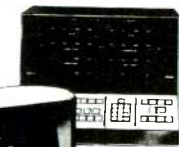

Editor-in-chief



Tempo controller

Circle 242 on Reader Service Card

39. Low Cost Clock Takes Advantage of Automation System Accuracy.

Leslie P. LeBlanc, Chief Eng., WKXL AM/FM, Concord, NH

Problem: For many years we had thought the synchronous-motor-driven electric clock was ideal for radio station control-room use. We had equipped our entire building with fifteen inch General Electric timekeepers. The accuracy of these units is fine when averaged over many days but they do drift a few seconds slow and fast during the day as the power system corrects for varying loads.

Then we automated the FM. The system we chose was the Harris SC-90. The accuracy with which this system joins network on time is phenomenal. The budget would not allow an automation control console in AM control as well as FM. Unfortunately at present Harris does not offer a clock-only accessory.

Solution: In its latest catalog, The Heath Co. offers the Model GC-1094 Electronic Clock Kit for \$49.95. The six-digit display is large enough to read at a fair distance, and being a kit, it is easy to service. The concept was to

build the Heathkit clock, and then substitute its AC line timebase with a sample taken from the automation system. The project proceeded as follows:

We obtained a GC-1094 clock and built it. While we allowed it to run for several days as a smoke test, we looked for our time-base sample in the System-90.

The crystal, in its oven, is located, along with a divider chain, on a circuit board that plugs into the larger board designated as 'Control Logic 1'. A TTL level signal at 60 Hz appears at pin 3C of this plug. For isolation precautions, we routed this signal through an unused gate and on to connection #86 where

continued on page 190

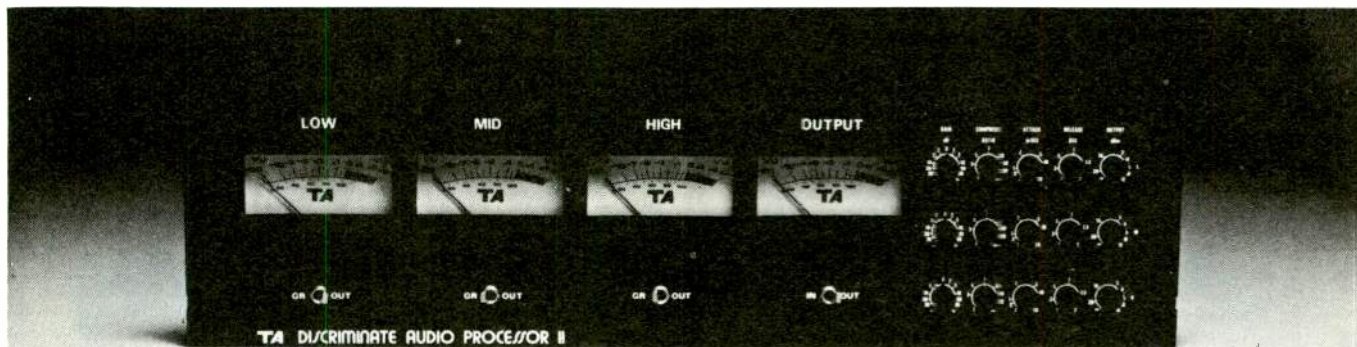
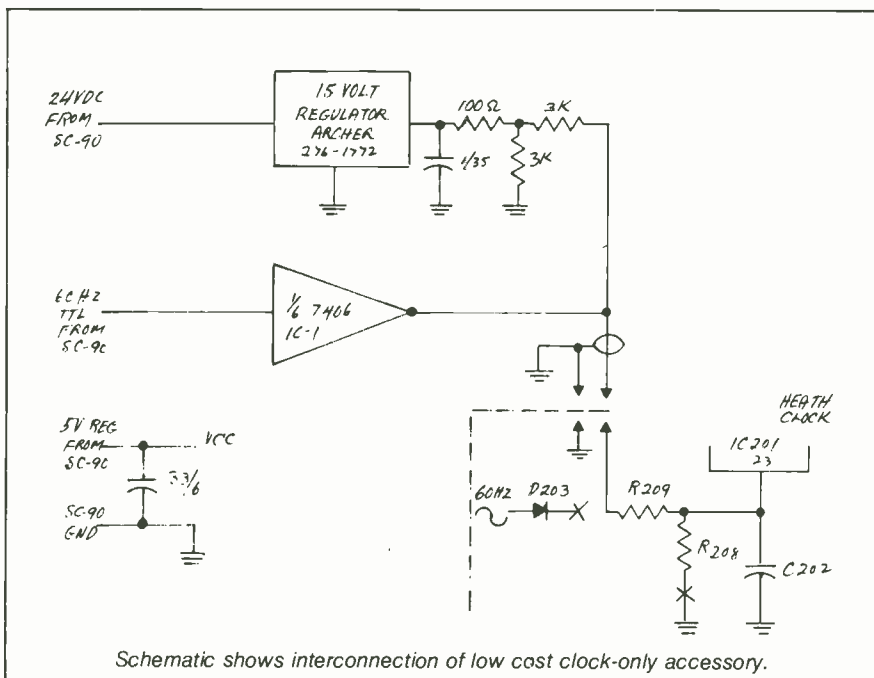

**Put our audio processor
on your station for ten days.**
Then let your audience decide if you should keep it there.

Quite simply, Track Audio makes the best audio processor available today.

That's quite a sweeping statement. But not when you consider that we back it up with the kind of independent research money can't buy — your listening audience. They'll tell you more about our sound than we can — after they've heard it on your station.

We'll send you our audio processor for a free ten day trial. If you like what you hear — from Track and from your listeners — you buy it. If not, we'll pay the freight both ways. Once you're on Track, you're on the way to a whole new sound.

Track Audio has another Sound idea.
33753 9th Ave. So. Federal Way, WA 98003 (206) 838-4460
Write or call us today.

Circle 243 on Reader Service Card

NAB—Las Vegas—Booth #326

Great Ideas

this board plugs into the 'mother-board/back-plane assembly. The spare gate was found at IC-2 pins #1 and #2. This gate is a 7404 inverter, so we will invert again before we apply the signal to the clock. Point-to-point wiring was used. We then had an accurate, 60 Hz, TTL level signal available to the outside world.

The GC-1094 clock utilizes a Mostek chip of type number MK5017PAA. Heath feeds a 60 Hz signal to the chip which is derived from a half-wave rectifier and voltage divider. The level at the chip is 14.5 volts, zero to peak.

To increase our TTL level signal to this value, the circuit shown was built on a small piece of perf board and mounted in the rear of the automation cabinet. Power was borrowed from the SC-90 supply, and the output is a replica of the crystal divider chain raised to a level of just under 15 volts.

In the Heath clock, the internal time-base is disabled by breaking the connection between D203 and R209. Our new signal is inserted at R209 and the voltage divider is disabled by lifting the grounded end of R208. The 30 foot run to the AM control-room is made with shielded pair; the shield is

grounded at the SC-90 end only.

Probably the enterprising technician can adapt this idea to most any clock and/or automation systems. Anyway, it is a delight to watch this inexpensive

little clock as it tracks the SC-90 second for second. The line-driver has five more circuits, so perhaps we can add clocks in several locations about the building.

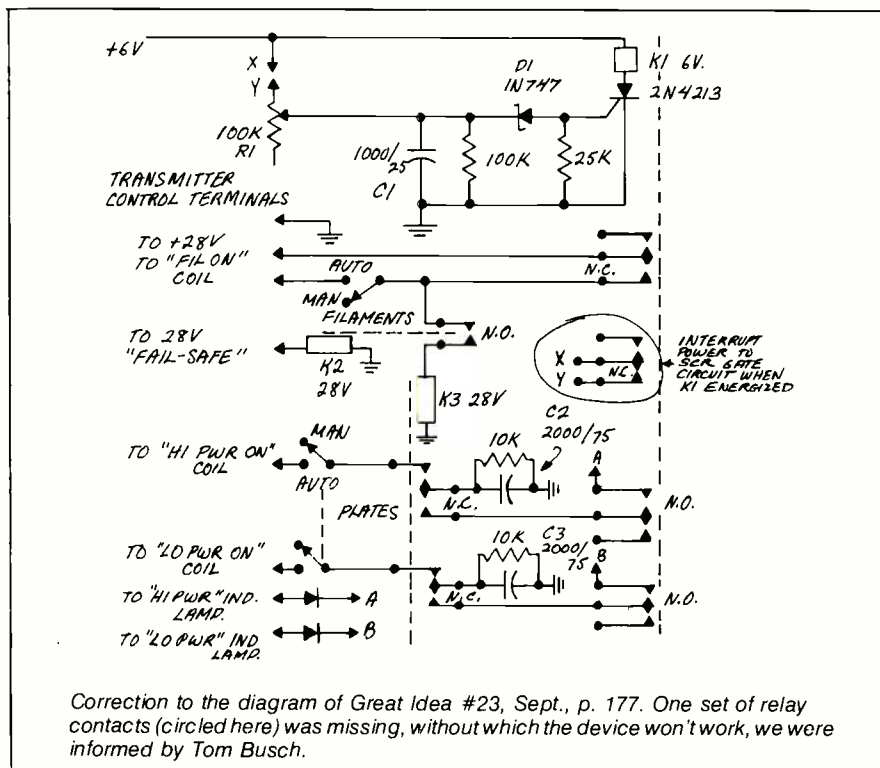

SPECTRA-VISION

CORPORATION
VIDEO EDITORS
AND

INTEGRATED VIDEOTAPE EDITING SYSTEMS



JBT-104-BA Backspacer

Patented Backspacer Editing
Time Code • Random Access • Search MOD-1
Decision Storage • Special Effects
SMART Interface for VO-2860

GENTLE HANDLING — LEAST WEAR ON RECORDER AND TAPE

- **TIME CODE RANDOM ACCESS SYSTEM**
uses SVC or SMPTE format
- **SINGLE FRAME ACCURACY**
for edits and random access retrieval
- **DECISION STORAGE**
for special effects mixing, workprints, and multiple second-generation masters
- **STEPLESS SEARCH**
in either direction on U-matic VTRs

SEE US AT NAB BOOTH #1315, ITVA BOOTH #18

Spectra-Vision Corporation

1528 Belfield Avenue
Philadelphia, PA 19141
(215) 457-6500

Circle 244 on Reader Service Card

CASES

ALL TYPES—ALL STYLES

- HEAVY DUTY A.T.A.
- FIBRE
- COVERED WOOD

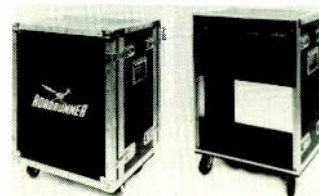

PORTABLE RACK MOUNTABLE
EQUIPMENT CASE—ATA STYLE

- STOCK DESIGNS & STYLES
- CUSTOM CASES AVAILABLE
- QUANTITIES 1 TO 1,000's

CASES, INC. OF CALIFORNIA

1745 W. 134th St.
GARDENA, CA. 90249
(213) 770-4444

SEE US AT THE N.A.B. SHOW
BOOTH 1409

Circle 245 on Reader Service Card



**You get only one
chance at a live feed.
So put a TerraCom
TCM-7 "Miniwave"
at the scene.**

The TCM-7 is the best performance ENG microwave available anywhere — and the easiest to set up and operate. Field tune to any channel. No reported failures on the first one hundred links delivered. Available in 2, 7 and 13 GHz — as well as all other bands.

That's it — fine reliability, high performance, easy to use, all bands, and tunable frequency. Best price too.



For more information or a demonstration, call Bob Boulio or Stan Sievers at TerraCom (714) 278-4100 9020 Balboa Avenue, San Diego, CA 92123

Circle 246 on Reader Service Card



LORAL Corporation

See us at NAB, Booth #1233



SEE MOSELEY ASSOCIATES • NAB BOOTH 310

Remote Control

DIGITAL

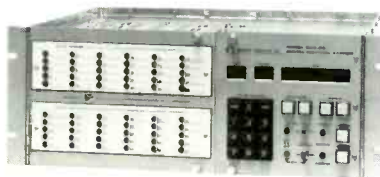

DCS-2A Control Terminal

Fully digital remote control of a distant transmitter plant is provided by the DCS-2A Digital Control System. Multiple transmitter site operation is a standard option. Provides command, telemetry, and status in groups of thirty channels. Automatic parameter logging is available.

Computer-assisted operation of the DCS-2A is another standard option, to provide a totally automated plant operation. With CRT display, thirty telemetry or status channels are displayed simultaneously. Tolerances on all telemetry channels and logging are also provided.

The Model DRS-1A Digital Remote System provides telemetry, command and status capability at an attractive price. This system is available for operation over telephone or radio interconnecting facilities. Automatic logging is provided by the companion Model DLS-1 Digital Logging System.

Aural Studio- Transmitter Links

148-174 MHz 215-240 MHz 300-330 MHz
450-470 MHz
890-960 MHz

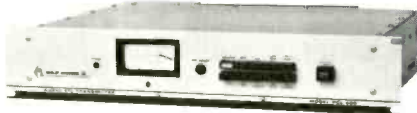

PCL-505 Transmitter

Moseley aural studio-transmitter links provide uncompromised, dependable performance — a Moseley tradition. They offer all silicon solid-state circuitry and utilize direct FM. Also, micro-stripline techniques and true modular construction are but a few of the features typical of the advanced technology used in the PCL-505 and PCL-101 series STL Systems.

For AM or FM Monaural — PCL-101 or PCL-505

For AM or FM Stereo — DUAL STL — Two monaural links conveying left and right audio

COMPOSITE STL — Stereo on a single RF carrier — the PCL-505/C — A system pioneered by Moseley!

NEW!



TCS-2 Command Terminal

Provides fully independent Command, Telemetry and Status reporting capability, as required by the FCC for AM and FM broadcast transmitter remote control. The companion Model TCS-1 provides eight independent channels of Status and Control. Two TCS-2 or TCS-1 units can be mixed for operation over a common 3 kHz radio or wire interconnection.

ANALOG REMOTE CONTROL

The Moseley TRC-15A Remote Control System provides fifteen Telemetry and thirty Command functions on telephone or radio interconnection circuits.



ESC-10 Earth Station Control System

The product of the future . . . today from Moseley Associates. Over seventy (70) Model ESC-10 Earth Station Control Systems are being supplied for use in the Public Television Satellite Interconnection System through the Commercial Telecommunications Group of Rockwell International. Remote Command, Telemetry, and Status are provided. Remote digital frequency control and universal interconnect (including automatic data access via dial-up telco), highlight the system capabilities. The ESC-10 is a standard Moseley product, and is receptive to custom requirements.

NEW!



Remote Pickup Links

Moseley offers FCC type-accepted Models RPL-3A (150 MHz band); RPL-4A and RPL-4B (450 MHz band). Also companion Models AMP-3A and AMP-4A RF Power Amplifiers.

Audio Limiter



TFL-280 Audio Limiter

Get loudness and clarity without compromise! The Moseley Associates' TFL-280 Audio Limiter precisely controls the modulation levels of FM and TV aural transmitters. FM monaural, stereo, quadraphonic, FM SCA, TV aural are all expertly processed. This frequency-conscious limiter cleanly solves the problems associated with the transmission of pre-emphasized audio, including the ringing (over modulation) produced by low-pass audio filters.

Remote FM Stereo

A combination of the Model TFL-280 Audio Limiter; SCG-9 Stereo Generator; and PCL-505/C Composite Aural Studio-Transmitter Link, provides maximum modulation capability with clarity for the remote FM stereo broadcast operator.



MOSELEY ASSOCIATES, INC.

A FLOW GENERAL COMPANY

SANTA BARBARA RESEARCH PARK, 111 CASTILIAN DRIVE • GOLETA, CA 93017
(805) 968-9621 • CABLE: MOSELEY • TELEX: 658-448

INTERPRETING THE FCC RULES & REGULATIONS

By Frederick W. Ford and Lee G. Lovett;
Pittman, Lovett, Ford and Hennessey, Washington, D.C.

Programming and Commercial Matter Proposals

MANY BROADCASTERS DO NOT REALIZE that the Commission's Rules *require* the Broadcast Bureau to refer to the full Commission for disposition a substantial number of renewal application matters relating to commercial and noncommercial programming. This can be the start of a broadcaster's nightmare of substantial legal expenses and anxiety over the possibility that the Commission will not renew broadcaster's station license.

The cliché that "an ounce of prevention is worth a pound of cure" is especially appropriate here. It is important to be aware, well in advance of license renewal, what the Broadcast Bureau will be looking for in reviewing a station's broadcast record. This is so notwithstanding the First Amendment protection afforded to a broadcaster's choice of program content. The Broadcast Bureau does not review content *per se*, but rather reviews whether the licensee's representations of what the content will be are *accurate*. The courts have not as yet barred the Commission from regulating in this peripheral area.

Programming: promise versus performance

At renewal time, an AM or FM station must complete FCC Form 303-R. Paragraph 14 requires, among other things, that the station licensee list information concerning news, public affairs and other programs (exclusive of entertainment and sports), as well as public service announcements. The information provided must include the minutes of operation and the percent of total weekly broadcast time that this programming comprises for three important categories: (1) proposal contained in the *prior* license renewal application, (2) composite week performance for the *just-completed* license period and (3) minimum proposed for *coming* license period.

Paragraph 14(b) of Form 303-R is set up in table form. Thus, the Broadcast Bureau has all the information that it needs to make an initial promise versus performance analysis. A Bureau staff attorney first reviews the "promise" (programming proposed in the last license renewal application). The analysis next focuses upon performance (i.e., the composite performance).

The Bureau will refer the renewal application to the full Commission if the Composite Week programming "varies substantially" from that proposed in the prior license renewal application. The Commission has not pinned down precisely what "varies substantially" means. It is in the best interest of a broadcaster to maintain a level of non-entertainment programming, day in and day out, that assures that Composite Week performance exceeds or roughly approximates programming promises made in the prior license renewal application.

Many broadcasters introduce a "control" procedure to make sure that it is doing so. On a regular basis, a station staff person conducts a test Composite Week performance analysis. The test should include a random sample of days occurring over at least the past several months. One test day, each, for Sunday through Saturday should be included. After that, it is a simple matter to analyze the program logs for the test Composite Week days and determine the number of hours and minutes of news, public

affairs and other programming (excluding entertainment and sports). If there is substantial variation from the promises contained in the station's last renewal application, immediate steps should be taken to remedy the shortfall. Of course, there is always a possibility that one of the test days was not representative. For instance, a Presidential press conference might have occurred, or the day might coincide with the televising of the summer or winter olympics. If this occurs, the test day should be discarded and another chosen. (Not that this is not permitted with respect to the *actual* Composite Week chosen by the Commission. If the day is not a typical one for the station, Paragraph 16 of the renewal form (Form 303-R) requires a full explanation.)

The Broadcast Bureau also looks at another measure of public service when reviewing a commercial AM or FM renewal application. If an AM or FM station's proposal for non-entertainment programming *during the coming license period* is for less than 8 percent (for AM's) and 6 percent (for FM's), it will refer the application in question directly to the full Commission to determine whether license renewal will be in the public interest. The moral for broadcasters: Keep non-entertainment programming proposals at *least* a percentage or two above the indicated minimums.¹

Whenever the renewal application of a commercial broadcast station shows a "substantial change" affecting either the entertainment or non-entertainment portion of the station's existing format, the Broadcast Bureau will refer the application to the full Commission for disposition if the substantial change (1) raises a "significant public interest question" or (2) is opposed by the listening or viewing public.²

This is a mandate to the Broadcast Bureau; it may not exercise its discretion in deciding, on its own, that the substantial changes which raise significant public interest questions are in the public interest. Therefore, it behooves broadcasters to study carefully any significant format change plan *before* it is implemented to be sure that the Commission will find the change to be in the public interest. (Of course, some broadcasters do not believe that the Commission acts constitutionally in passing upon licensee-chosen program formats. They may well be right, but may have to "bankroll" litigation to prove their point in the courts. Many stations simply do not have the money to do so.)

If a commercial AM or FM station proposes in its renewal application to broadcast an excessive amount of commercial matter per hour, the Bureau will direct the renewal application to the full Commission to determine if license renewal would be in the public interest.

Normally, broadcasters propose 18 or fewer minutes of commercial matter per hour. There are exceptions.³

continued on page 194

¹Section 0.281(a)(8)(i) of the Commission's Rules.

²Section 0.281 (a)(9) of the Commission's Rules.

³These exceptions, along with other aspects of commercial matter broadcasting, were covered in an article entitled "Advertising Time Limitations" in the February 1978 issue of BM/E.

PHILLYSTRAN®

The Tough Guys

Far surpassing steel guys in strength and durability, PHILLYSTRAN is manufactured from impregnated KEVLAR* and polyurethane. Completely non-metallic, PHILLYSTRAN eliminates electrical problems and the usual problems of RFI.

- **Non-interference**
Outstanding dielectric properties
- **Minimum Stretch**
New designs substantially reduce creep
- **Corrosion Proof**
Non-metallic construction: polyurethane jacket
- **Non-Conducting**
Outstanding insulation properties

PHILLYSTRAN . . . The Tough Guys in more ways than one.

®PHILLYSTRAN . . . proprietary resin impregnation process of Philadelphia Resins Corp.
*duPont registered trademark



manufacturers of Chockfast®, Phillystran®, Phillybond®, Wearax™

PHILLYSTRAN®

ROPES AND CABLES

PHILADELPHIA RESINS CORPORATION
20 Commerce Drive, Montgomeryville, Pa. 18936, U.S.A.
215/855-8450 • Telex: 84-6342 • Cable: PHILRES MMLL

FCC Rules & Reps

The foregoing makes clear that "substantial changes" in entertainment or non-entertainment format will often be studied by the Commission at license renewal time. A broadcaster that has instituted such substantial changes must justify them to the Commission at that time.

But, broadcasters have additional responsibilities when substantial changes occur in programming proposals or commercial matter proposals.

Proposals for future programming and commercial matter broadcasting "constitute representations on which the Commission relies."⁴ The Commission has explained numerous times that it relies upon these representations to determine whether grant of a broadcast application (be it an initial application or a renewal application) is in the public interest. Therefore, the Commission imposes upon all broadcast licensees the duty to advise the Commission whenever "substantial changes" occur in its programming and commercial matter proposals.

What constitutes a "substantial change?" The Commission answered that question enigmatically.⁵

It is not possible to define what would constitute a substantial change so that it may be applied in every case. This is a judgment to be made by the licensee in the exercise of sound discretion. It does not require that every departure from programming and commercial proposals is to be reported to the Commission. Obvious examples of the type of program format alteration which would be reported are a change in format from popular music and news to all talk or all news; or switching from an independent operation to affiliation with a network. Examples of the type of changes in commercial practices which should be reported are a station deciding as a matter of policy to increase the maximum percentage of commercial matter which it proposes to allow, or if the station determines that it is exceeding these proposed maximums approximate 10% of the time.

The station licensee must notify the Commission of the "substantial change" within 30 days. This may be done in the form of a letter. The letter should include a discussion of the reason or reasons underlying the change.

The Broadcast Bureau will review the letter and may ask the station licensee for additional information. If the Bureau determines that the change raises a substantial public interest question, additional information may be sought.

The Commission has stated that failure on its part to contact the station licensee immediately after receiving the notification letter does not indicate that the Commission has ratified the licensee's action. Indeed, the "station's performance in the public interest will be evaluated in any event at the time of next renewal." It is clear that "substantial changes" in programming and commercial matter broadcasting will be subject to Commission evaluation *either* at the time of implementation or at license renewal time.

Conclusion

Station personnel should always bear in mind that a change in the entertainment or non-entertainment portions of the station's existing format might give rise to an obligation to notify the Commission. The same applies for changes in commercial matter broadcasting policies.

For this reason, careful analysis of Commission policies in this area is necessary before implementation of any programming changes.

Similarly, the inevitable promise versus performance analysis performed by the Commission as part of a station's tri-annual license renewal is substantial reason for developing an ongoing program of periodic performance spot checks.

BM/E

⁴AM-FM Program Forms, 1 FCC 2d 439, 5RR 2d 1773 (1965) ah Para. 12.
⁵Id.

YOU NEVER HAD IT SO EASY.

The things you're asked to do! Now that people have discovered how valuable and flexible video can be, there's no limit to the things they want you to do with it. Which creates some terrific opportunities...and more than a few production problems as well. At Cine 60, we're specialists in designing new products to help you get more of the former. With less of the latter.



Take power, for instance. Our rechargeable Powerbelts mean you *can* take it with you. More ampere-hours than ever before. Evenly distributed around your waist to give you the same kind of mobility TV film cameramen have relied on for years. Our fast-charge versions are at full capacity in just one hour,

to give you more shooting and less waiting. □ For more light on the go, compact Cine 60 Sun Guns fill the bill. Color-balanced for video, they give you lots of fresnel-soft lumens in the smallest spaces. Plus wide angle and focusing, too. □ And if you prefer your Sun-Gun power packaged differently, we can give you



Cine 60 NiCad reliability in a Powerpak/Sun Gun combination. □ Our rechargeable Powerpaks are also available separately. In a variety of



sizes, voltages and capacities to power just about any-

thing you have in mind. Video. Audio. You-name-it. Just slip it on your belt or into a pocket...and go! □ While our rugged, reliable power systems take a load off your mind, we can take a load off your shoulders, as well. With a complete line of comfortable shoulder



pods and body braces that let you concentrate on what you're shooting...instead of your aching sacroiliac.

Whatever the configuration of your camera, we've got a pod to match. □ Cine 60 has a lot of other valuable

tools to make life easier for video people. Like our Snaplok, to let you snap-on, snap-off cameras and other equipment

from tripods, stands, pods, etc.—in less time

than this sentence took to read. Plus suc-

sion mounts, compact quartz lighting...

and that's just the beginning. With all

the things you're asked to do these days, it pays to have all the

help you can get. Why not call or write for our catalog today?



CINE 60

I N C O R P O R A T E D

Film Center Building/630 Ninth Avenue
New York, N.Y. 10036/Tel: (212) 586-8782

See Us At Booth #1002 — Las Vegas NAB

Circle 248 on Reader Service Card



MAGNA-TECH ELECTRONIC



High-Speed Reproducers

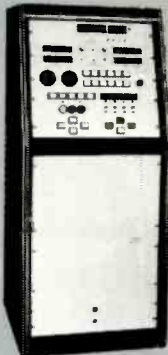

EL Console



Prism Projectors



Multi-Lok Console

MTE, The Leader, is the world's finest manufacturer of post-production sound recording and projection equipment for:

- Motion picture sound studios
- Advertising agencies
- Educational and instructional film sound facilities
- Video sound sweetening
- Screening rooms

MTE, The Leader, was the *first* to introduce:

- Noiseless pick-up insert recording (rock and roll)
- Combination 16, 35, 17.5mm Recorders and Reproducers
- Electronic Looping Systems for dialogue replacement
- High Speed Re-recording Systems
- High Speed Projectors
- "Multi-Lok", the Videotape, Film and ATR Interlock System
- Crystal controlled electronic drive Recorders and Reproducers

MTE, The Leader, is winner of two "Academy of Motion Picture Arts and Sciences" awards for Technical Achievement.

MTE, The Leader, provides complete studio engineering services and operating personnel training. Our systems engineers have over 30 years experience in all areas of film production and post-production.

MTE, The Leader, is *ready* to fulfill your needs in sound and projection equipment from a single transfer recorder to a complete re-recording facility.

The next time you have any film or video needs, discuss them with Magna-Tech first. It pays to come to

THE LEADER!

MAGNA-TECH ELECTRONIC CO., INC.

630 Ninth Avenue / New York, N.Y. 10036
Tel. (212) 586-7240 / Telex 126191 / Cables "Magtech"

Quad-Eight Electronics
11929 Vose Street
North Hollywood, California 91605
Tel. (213) 764-1516 / Telex 662446

Magna-Techtronics (Aust.) Pty. Ltd.
P.O. Box 150, Crows Nest, NSW 2064, Australia
Tel. 439-1651/3013
Telex 24655 / Cables "Magna" Sydney

BROADCAST EQUIPMENT

A few products of special interest this month are: a new FM stereo generator, with digitally synthesized modulation and a minimum-overshoot filter; a computer-based editor for all types of VTR's, which is software oriented; and a motorized mount for remote positioning of ENG antennas.

FM Stereo Generator 300

FM stereo generator is designed to drive composite STL's or the wideband input of an FM exciter. Model MS-15R uses digitally synthesized modulation, eliminating switching and balanced modulator systems. Pilot phase is automatically controlled. Separation is at least 45 dB from 30 to 15,000 Hz. The dynamic transient response filter has overshoot, with any program material, of 2½ or less, allowing for 2 to 6 dB of increased loudness, while holding transient response, separation, cross talk and intermod distortion to low levels. HARRIS CORP.

Computer-Based VTR Editor 301

Editor is designed for on-line or off-line control of all types of VTR's, including quadruplex, 1", and ¾" cassette systems. System is software oriented, leading to performance flexibility and easy customizing at small additional cost. CONSOLIDATED VIDEO SYSTEMS.

Microwave Antenna Mount 302

Antenna mount provides remote azimuth and elevation positioning for

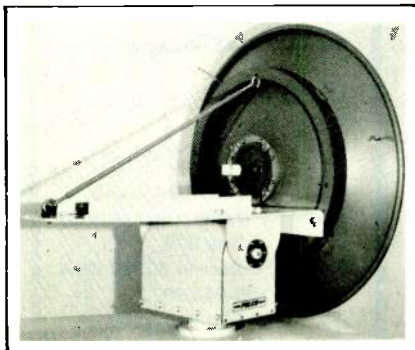

antennas up to six feet in diameter. Model AP-2500 is rated to operate in

winds of 65-70 mph, and to withstand winds of 110-115 mph. \$5,000. PELCO INDUSTRIES.

Portable VCR System 303

System consists of ½-inch video-cassette recorder and black-and-white camera. Model VT-300 VCR has pause, audio dubbing, optional still frame. Model VC-300 camera has built-in omnidirectional microphone, keyboard controls, automatic shutoff. With optical viewfinder, 16mm lens, \$1595; with added detachable 3-inch monitor, built-in speaker, \$1795; with replacement of optical viewfinder by 1½-inch electronic viewfinder, and 8:1 zoom lens, \$1895; with addition of detachable 3-inch monitor with built-in speaker to above, \$1995. AKAI.

Console Switching System 304

Two-part switching system facilitates pre-selection and buss selection on audio consoles. "Predex" system has switching module with pre-selection of up to ten incoming audio sources, and

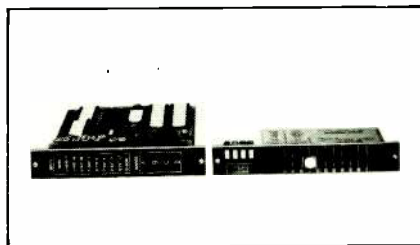

assignment of up to four program and four auxiliary busses. Also in system is an address module with fader and controls. System includes back-lit readouts, reed relay switching, DC control functions, CMOS logic. AUDIO DESIGNS AND MFG. INC.

Remote For Delay Unit 305

Microprocessor-controlled remote con-

continued on page 198

**For more information
circle bold face numbers
on reader service card.**

MODEL 525 SERIES DIGITAL MONOSCOPE SIGNAL GENERATOR

- Since the signal is generated electronically, there is no deflection distortion of the signal source itself, such as that of conventional monoscope cameras.
- The same picture quality as that of the camera is generated, DRC (Digital Rise time Controller) system.
- Single source generation system promises precise horizontal resolution.
- APC system in a constant size picture generates a perfect measurement signal.
- Built-in sync signal generator. External sync also possible.
- Grating and overscan signal can be turned ON/OFF.
- Extremely simple maintenance plug-in unit type.
- The final edition of the ultimate monoscope. Can be used with confidence for years to come.

■ MODEL 525A12 picture

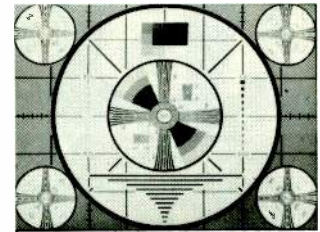

Delivered by Matsushita Electric Industry, used by RCA.

◎ Features

- With acclaimed 10-step interleaved contrast
- Generates the same pattern and picture quality up to letters as a conventional monoscope.
- Production line oriented test pattern

■ MODEL 525 A11 picture

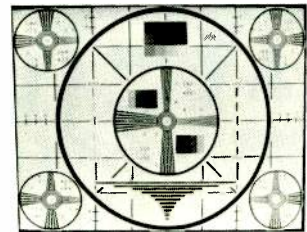

Delivered by television VTR Manufacturer, used by NASA (U.S. National Aeronautics and Space Administration).

◎ Features

- With acclaimed 10-step interleaved contrast
- 525AH generates a horizontal resolution of up to 100 lines, and is ideal for research and development.

■ Exterior view



- Video output level
1Vp-p (sync 0.3Vp-p, picture 0.7Vp-p 2 system)
- Video output impedance 75Ω
- Input/output connectors BNC
- Ambient temperature 0°C ~ +45°C
- Power requirement
100, 117, 200, 220, 240V ±10% 50/60HZ
Approx 50VA (As specified by the customer)
- SIZE (Inch) 19" (W) × 12.2" (H) × 12.6" (D)
- Weight Approx 27kg

NTI America, Inc.

1680 North Vene Street LOS ANGELES California 90028
Phone 214 462 8945

Circle 250 on Reader Service Card

ABC

What you're looking at are the different typesets now available — all together — in the new Knox Multifont Module 246.

abc

This latest option in the Knox K128 System gives you unprecedented versatility in a medium budget character generator.

ABC

The alphabets in the Multifont 246 are designed on a matrix of 1536 elements, effectively doubling the already fine resolution of the K128.

abc

In addition to these three alphabets, the Knox Multifont 246 carries a full load of math and typewriter symbols, and enough accented letters to write in 9 Western European languages.

ABC

This whole electronic type case costs just \$1200. If you're already a Knox K128 user, your present unit can be readily upgraded. Thanks to Knox engineering, the 246 Module simply inserts in the back of the K128, replacing the existing font board. Addition of a single switch on the front panel completes the change. It's really as simple as...

...well, as simple as A B C.



16021 Industrial Drive
Galthersburg, Md. 20760
(301) 840-1930

See you in Booth 739 at NAB
Circle 251 on Reader Service Card

Broadcast Equipment

trol card for Model 1745M digital delay unit plugs into unused connector in delay unit. It allows delay setting, and adds two new functions: automatic flanging with digital delay quality; new



doubling method for vocal or instrumental lines by variation of the delay in a pseudo-random manner, under microprocessor control, to avoid the mechanical quality of note-for-note doubling. Unit also provides standard IEEE interface for computer automation control. \$550.00. EVENTIDE CLOCKWORKS.

Small Stereo Mixer 306

Stereo mixer has three inputs, microphone plus any two of phono 1 and 2, line 1 and 2. Clubman One-One-M has



twin meters, rumble filter, talkover switch, crossfade, headphone output with level control. \$249.00. METEOR LIGHT AND SOUND CO.

Modular Color Camera 307

Video color camera is in four detachable sections which allow five config-

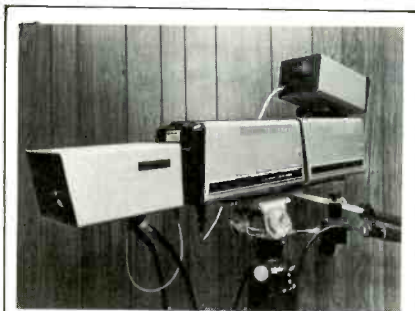

continued on page 201

Broadcasters

GET UN-HOOKED FROM
THE TELEPHONE COMPANY
— PROVIDE YOUR OWN
"PROGRAM LINES" WITH

MARTI STL



STL-8 TRANSMITTER • All Solid State • Direct FM Modulator • Modular Construction • Test Meter Built In • Proven Reliability in hundreds of installations • Unsurpassed for Dual Channel Stereo STL, Single Channel AM STL or Inter City Relay.

SPECIFICATIONS - STEREO

Stereo Cross Talk —65 DB
Noise —65 DB or less
Response ±0.5 DB 30-15000 Hz
Distortion Less than 0.5%

MARTI Electronics, Inc.
Box 661 • 1501 N. Main • Cleburne, TX 76031 • 817/645-9163

See us at Booth 314
Circle 252 on Reader Service Card

FRAME FREEZE

MS-200

- Records & plays back a single frame of video
- Uses 4" magnetic disc memory
- Holds picture indefinitely
- Compact & rugged
- \$2,000.00

cvi

Colorado Video Incorporated
Box 928
Boulder, Colorado 80302 USA
303-444-3972
TWX 910-940-3248

See us at NAB - Booth 911
Circle 253 on Reader Service Card

AUTOCUE® ASTRAL® STAGE LIGHTING CONTROL SYSTEMS

Quite simply, the best you can buy.

AUTOCUE® systems are now installed or in manufacture
for the following facilities



NBC STUDIO 4
Burbank, California

ABC STUDIO TV 59
CBS STUDIO 31
CBS STUDIO 33
CBS STUDIO 43
CBS PORTABLE
Hollywood, California

ORAL ROBERTS UNIVERSITY
Tulsa, Oklahoma

ABC STUDIO TV 1
ABC STUDIO TV 17
ABC STUDIO TV 19
New York, New York

WOLF TRAP FARM PARK
Vienna, Virginia

MEMPHIS STATE UNIVERSITY
Memphis, Tennessee

AUTOCUE® is the only memory lighting control system purchased by all three television networks for their major production studios:

If you are considering the purchase of a memory lighting control system, please call our New York or Hollywood office for an AUTOCUE® ASTRAL® demonstration. Active systems, controlling a light show, are in residence at both locations for your inspection and operation.

WEST

Skirpan Lighting
Control Corporation
1155 N. La Cienega Blvd.
Hollywood, California 90069
(213) 657-6383



EAST

Skirpan Lighting
Control Corporation
61-03 32nd Avenue
Woodside, New York 11377
(212) 274-7222

ARGENTINA 78 TELEVISORA
Buenos Aires, Argentina

Circle 254 on Reader Service Card

Glass Is Class... It Lasts & Lasts!!!

Think
Glass Bonded Ferrite...
The Jewel of Our Industry.

Update your video recorder with
Long Life Saki Audio Posts.

Ferrite heads available for all professional recorders.



Saki Magnetics

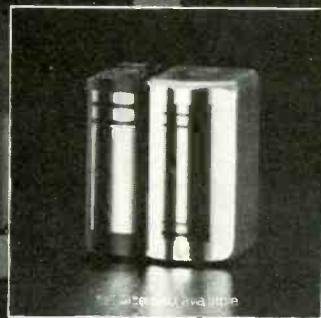

1649 12th Street • Santa Monica California 90404 • (213) 451-8611

Circle 255 on Reader Service Card

Broadcast Equipment

urations. Model XC-300U has separable C-lens mount, camera head, camera control unit, and 4.5 inch viewfinder. For ENG, viewfinder can be replaced by 1.5 inch optical viewfinder, hand grip and shoulder pad. Camera has three tubes, 3/8-inch vidicons in a single package, to eliminate mechanical registration problems; automatic iris; cable driven zoom lens with ratio 18mm to 144mm, plus a regular F/2 lens. Claimed resolution is minimum of 400 lines with 46 dB S/N ratio. Color bar generator is included. \$5995. SHARP ELECTRONICS.

NEW!

Custom 2 TURNTABLE



NOW IN STOCK

The *Custom 2* with a low Rumble of -52 db, field tested for one year, is but one of the new professional products to be introduced at the **NAB Convention** in Las Vegas April 9th... Visit our exhibit # 104 and see...

- OMEGA CONSOLE SERIES
- ALPHA AC SPEED CONTROL
- ALPHA STEREO MINI SYSTEM
- ELECTRONIC VARIABLE SPEED TURNTABLE WITH D.C. MOTOR, DIRECT DRIVE
- DIGITAL CLOCK WITH TIMER
- MONITOR I SPEAKERS



Call Toll-free (800) 344-2181
California call collect (209) 251-4213

1568 N. Sierra Vista, Fresno, CA 93703
Phone: (209) 251-4213

Circle 256 on Reader Service Card

Silicone Cooling Hose 309

Silicone-based hose carries water in cooling system for klystron tubes in high-power UHF applications. "Purosil" hose, with layers of Dow Corning silicone material, resists temperatures to 350°F, retains flexibility to -65°F. It meets specifications of MIL-H-62217/1. PUROSIL, INC.

One-Channel Limiter 310

Small limiter, for PA or live recording, has inputs for line or low-Z balanced microphone. "Mini Limiter" has one

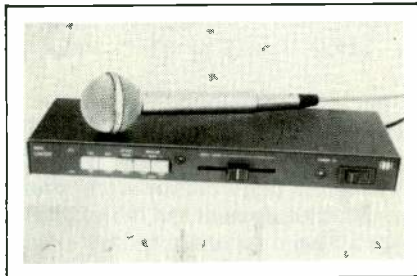

channel, level control, controls for slow or fast attack, slow or fast release. Panel LED tells when limiting above 3 dB has occurred. \$250. ALLEN AND HEATH (AUDIO-MARKETING, US DISTRIBUTOR).

Maintenance For Duplicators 311

Maintenance kits for cassette duplicators include new head cleaner developed to avoid damage to rubber, but clean efficiently. Other items optionally available are demagnetizer, lubricating oil, head alignment gauge, cassette alignment tape, spring scale. \$10.95 to \$345.00, with all options. PENTAGON INDUSTRIES.

Satellite Receiver 312

Manual frequency agility on new satellite receiver allows easy channel switchover in the field. Model SVR-462 is for receive-only service, has full



24-transponder coverage, accepting a frequency modulated video signal in
continued on page 202

ENG—FILM—EFP

DOLLY-UP OR DEDICATED

Your ENG or EFP operation certainly cannot ignore the value of film. Existing libraries of reference film, whether slides, movies or both will help tie the program together. Also remember that film is better and less expensive than ever. The 5100 system may be used in conjunction with any ENG or studio camera as well as a dedicated unit.



Photo denotes typical system.

MODEL 5100
TELECINE DIPLEXER

FROM THE WORLD'S LARGEST SUPPLIER
OF TELECINE EQUIPMENT.



LAIRD TELEMEDIA INC.

2125 SOUTH WEST TEMPLE • 801 487 6251
SALT LAKE CITY, UTAH 84115

VISIT BOOTH 1306 AT N.A.B.

Circle 257 on Reader Service Card

Broadcast Equipment

the 3700 to 4200 MHz range. Unit has phase-lock demodulation and FM threshold extension. It also includes a down converter, video processor, audio subcarrier demodulator, and power supplies. HUGHES AIRCRAFT COMPANY.

Condenser Mike Series 313

Series of condenser microphones consists of one preamp/shaft and four inter-

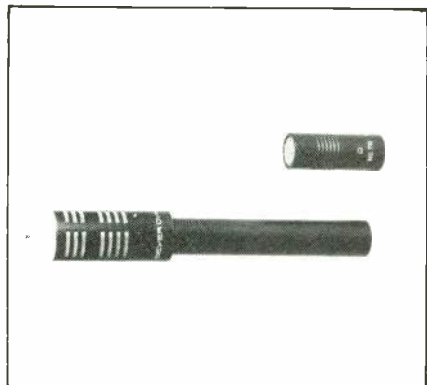

changeable head capsules. The preamp/shaft, Model HV710, and the

capsules, Models CK711-714, allow user to have either omni or cardioid pattern, with or without a windscreen. Series is 48 volt phantom powered, or can be had with optional external power supply. BEYER DYNAMIC.

A/D Video Converter 314

Analog to digital converter for video signals has 20 MHz conversion rate and 8-bit coding. Model ADC-TV is aimed at all video digital systems, including time base correctors, etc. Input range is selectable, 0 to +1V, 0 to +2V, 0 to +5V. All connections are made through 37-pin subminiature connector, plus 3mm terminated coax connector. \$1995. DATEL SYSTEMS, INC.

Surge Protector 315

Protection devices for computers, broadcast equipment and other systems have 50-nano second response to transients on power lines. "Volt-Guard" shunts energy to ground, is a passive device without moving parts. Available for wide range of power configurations, from 120-volt single phase to three-phase 550-volt Wye. SOUTHERN CONSOLIDATED CORP.

Modular Timing System 316

Series consists of modular units for six timing functions — time code generation, time code translation, parallel

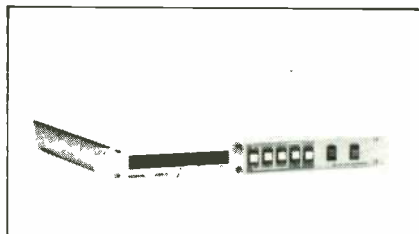

BCD, slow codes, pulse rates, and days display. Units in Model 175 series can be combined in hundreds of configurations for timing system needs. Generators and translators give choice of standard time codes. All systems have automatic advance/retard, forward/reverse on time translation, selectable internal/external clock, selectable days radix control, and other features. Basic system, under \$800. MOXON, INC.

Frequency Synthesizer 317

Five-digit synthesizer puts ECL signals continued on page 205

THE LAST WORD IN VIDEO AT NAB IS "MART."

SEE WHY AT BOOTH 1137.

Camera Mart

THE CAMERA MART, INC.
456 West 55th Street, New York 10019
(212) 757-6977/Telex: 1-2078
Sales • Service • Rental



Circle 259 on Reader Service Card

NO SPRINGS ATTACHED!

VINTEN *The Smoothest in Lightweight Heads*

DUNLIN 51 LF.

- 50 lb. capacity
- smoother than "fluid" heads
- perfectly adjustable balance without springs

PETREL 777 PANTOGRAPH

- 100 lb. capacity
- perfectly adjustable balance without springs
- available with LF dampening

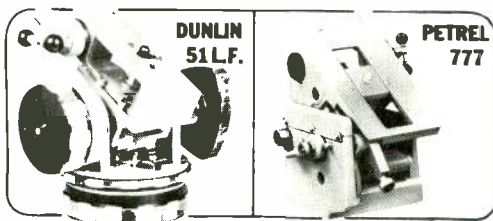

LISTEC
TELEVISION
EQUIPMENT CORP.

LISTEC
39 CAIN DRIVE, PLAINVIEW, NEW YORK 11803
(516) 694-8963 TELEX 640470
(WEST COAST)
4527 SAN FERNANDO ROAD, UNIT 1, GLENDALE,
CALIFORNIA 91204 (213) 244-0838

Booth 700 at NAB

Circle 258 on Reader Service Card

Once in a lifetime...

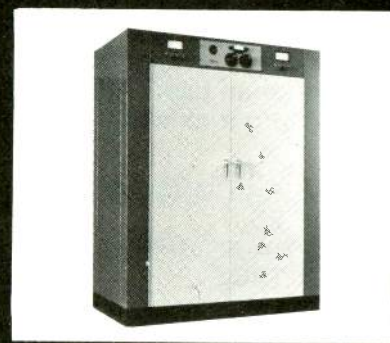

you select RF Components and Phasing Systems. If you depend on components and equipment for stability, depend on the company with a reputation for Service, Experience, and Quality Products, C.S.P.

Call or write C.S.P. for complete catalogue or quotations on COILS, CONTACTORS, and RF PHASING EQUIPMENT.

C.S.P.

203 AIRPORT ROAD
DOYLESTOWN, PA 18901

(215) 345-7386

Circle 260 on Reader Service Card

OTARI

From Otari for uncompromising recordists. MX5050-2SHD designed for peerless two-track quarter-inch masters.



It's an exception of compact recorders. Specially designed for critical professional applications from the ground up. It leaves nothing to be desired. 68dB signal-to-noise and greater-than-60dB crosstalk. Variable speed DC-servo capstan motor for less than 0.05% wow/flutter and $\pm 7\%$ pitch control. +19dBm headroom before clipping. Motion sensing control logic. Front panel edit and cue; stepless bias adjustability; built-in test and cue oscillator; all front accessible. 600 ohm, +4dBm or -10dBm fixed-level output and XLR connectors. Remote controllability for all transport functions. In short, it's a sheer professional masterpiece to produce desired 15 or 7-1/2 ips masters.

The performance and reliability have been fully proven since its original version was introduced in 1973, in more than one thousand practical applications by broadcasters, studio recordists, audio-visual professionals and musicians all over the world. For the full story of this unique and compact professional machine, ask anyone who uses it or get in contact with your nearest Otari distributor.

**Please send me details on
MX5050-2SHD**

Name _____

Company _____

Address _____

BM/E

Japan: Otari Electric Co., Ltd., 4 29-18 Minami Ogikubo, Suginami-ku, Tokyo 167, Japan U.S.A.: Otari Corporation, 981 Industrial Road, San Carlos, California 94070
Canada: Noresco Manufacturing Co., Ltd., 100 Floral Parkway, Toronto, Ontario M6L 2C5

Circle 261 on Reader Service Card

It's a very good year...



to buy Belar.

There were always lots of good reasons to buy Belar . . . now we can give you many more. Like our new automatic Stereo Monitor, shown above.

We're introducing a line of new products that will set new standards of performance in broadcast monitoring. Each piece of equipment has been Belar-engineered to remain state-of-the-art for years to come. And, of course, our monitoring systems are suitable for ATS.

Check our new equipment and see why we say this is a vintage year. Buy Belar today . . . in ten years, you'll still be thanking yourself.

- Our new **FM Modulation Monitor** features a sample-hold and absolute magnitude peak detector circuit to capture and display all the program peaks on the modulation meter.
- Our new **Digital FM Modulation Monitor** features a continuous LED display to instantaneously indicate program peaks.
- Our new **Stereo Monitor** features two sensitive auto-ranging voltmeters for simplified automatic measurement of stereo separation and crosstalk.
- Our new **SCA Monitor** features an auto-ranging voltmeter for simplified SCA measurements.
- Our new **Digital FM Frequency Monitor** includes off-frequency alarms for carrier, 19 kHz pilot, and SCA frequencies.
- Our new **FM RF Amplifier** maintains full stereo performance with the ability to select any channel.
- Our new **AMM-2 AM Modulation Monitor** features three peak lights and outputs for ATS modulation control.
- Our new **AMM-3 AM Modulation Monitor** features separate meters and four peak lights for negative and positive modulation, and also includes outputs for ATS modulation control.
- Our new **AM Frequency Monitor** includes ± 10 Hz and ± 20 Hz off-frequency alarms, and a loss-of-count alarm.
- Our new **AM RF Amplifier System** permits reliable monitoring with our new shielded loop in a field of 50 microvolts per meter.
- Our new **Automatic Power Controller** provides power correction and alarms for ATS.
- Our new **Mod-Minder** provides automatic modulation control and alarms for ATS.
- Our new **Status Alarm System** starts with two statuses and can be expanded to over 900 statuses.



BELAR ELECTRONICS LABORATORY, INC.

LANCASTER AVENUE AT DORSET, DEVON, PA. 19333 • BOX 826 • (215) 687-5550

When Accuracy Counts . . . Count on Belar

Circle 262 on Reader Service Card

Broadcast Equipment

into a 50 ohm load over the range 20 to 160 MHz, with resolution of 1 KHz. Model SL-160 has a single phase-locked loop, temperature stability of ± 1 PPM from 0 to 50°C. Options include



external BCD programming with latching for computer control sinewave output at 13 dBm into 50 ohm load. \$699. SYNTTEST CORPORATION.

Battery Charge Sequencer 318

Sequencer unit allows up to five battery packs for ENG equipment to be charged in order automatically. Battery Sequencer applies charging current to each battery pack in sequence, with ready light to show which packs have been charged. Full batteries automatically go on trickle rate. \$1995.00. FREZZOLINI ELECTRONICS INC.

Unattended TV Transmitters 319

Television transmitters of 100 watt and

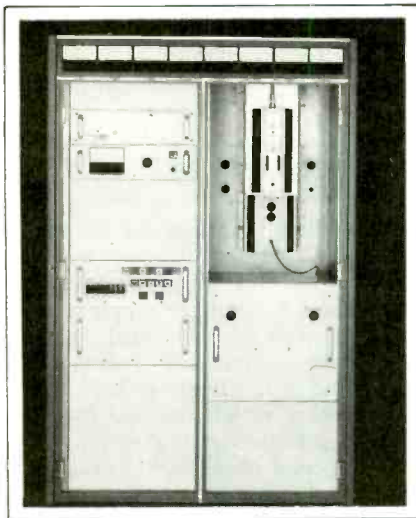

1000 watt ratings are designed for remote, unattended operation. VHF units use low-level IF modulation and quarter wave re-entrant cavities. They are aimed at automatic broadcasting, with

continued on page 206

Sintronic

AM-FM TRANSMITTERS

...give
you
something
EXTRA



See us in Las Vegas
NAB SHOW April 9-12
at Booth 512

Sintronic CORPORATION

212 WELSH POOL RD., LIONVILLE, PA 19353 (215)363-0444

Sintronic Corporation is a subsidiary of Singer Products Co., Inc.
Integrity and dependability since 1937

Circle 263 on Reader Service Card

Clear-Com

Our System is your Solution.

Your intercom must work everytime, every show. Our intercom is known for reliable communication under the most critical conditions. Portable and permanent in single or 2 channel wired systems can interconnect with existing intercoms. TV cameras or Telco lines. **No problems, just solutions from clear-com.**



Clear-Com
intercom systems

759 Harrison Street,
San Francisco, Ca 94107
(415) 989-1130



Circle 264 on Reader Service Card

Look for us at NAB

QUALITY ✓

PRICE ✓

DELIVERY ✓

THE BEST REASONS FOR SWITCHING TO—



VIDEO DELAY LINES

AUTHORIZED DEALERS

Broadcast Video Systems Ltd.,
1050 McNicoll Ave.,
AGINCOURT,
Ontario M1W 2L8
Tel. 416-497-1020

Broadcast Communications Devices Inc.,
5526 East
La Palma Avenue,
ANAHEIM,
California 92807
Tel. 714-528-9505

Listec Television Equipment Corporation,
35 Cain Dr.,
PLAINVIEW,
N.Y. 11803
Tel. 516-694-8963

Television Engineering Corporation,
519 Rudder Rd.,
FENTON, Missouri 63026
Tel. 314-343-5605

Circle 265 on Reader Service Card

Broadcast Equipment

startup and warm-up on receipt of video signal; termination on removal of signal; automatic recycling to maintain full service; full complement of controls. HOWE-YIN RESEARCH CO.

Hybrid D/A Converters

320

Microcircuit D/A converters have settling times as low as 25 ns to 0.1½ with resolution of 8 bits (Model HDS-0820) or 10 bits (HDS-1025). Volume is 0.166 cubic inch, and systems are in 24-pin DIP's. No external potentiometers are needed; output is 10 mA, which will drive transmission lines or other low-impedance loads. COMPUTER LABS, INC.

Stereo Mixer

321

Twelve-channel stereo mixer has four-band equalizer, foldback and echo send on each channel. Model "Stereo-

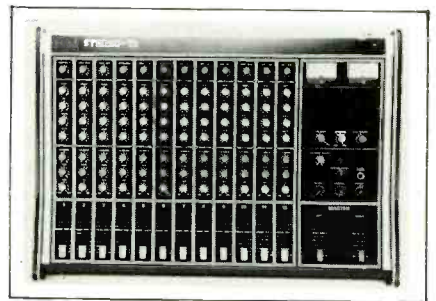

12" has optional echo effects module fitting into assembly and using CCD technology. Foldback and echo send are separately controllable from each input. Inputs are low-impedance, separately switchable to line level. H & H (UK); sold in US by AUDIO MARKETING LTD.

Arriflex-Steadicam Kit

Modification package for Steadicam "floating" camera mount allows use with the Arriflex 35BL 35mm camera. It includes a stabilizer support arm to accommodate the additional weight of the Arriflex camera, a Cinevid video-assist unit to pick up the reflex image of the Arriflex viewfinder and feed it to the Steadicam viewing monitor, and other needed changes. CINEMA PRODUCTS (c/o CHARLES J. LIPOW, 16661 VENTURA BLVD., ENCINO CA 91436)

**For more information
circle bold face numbers
on reader service card.**

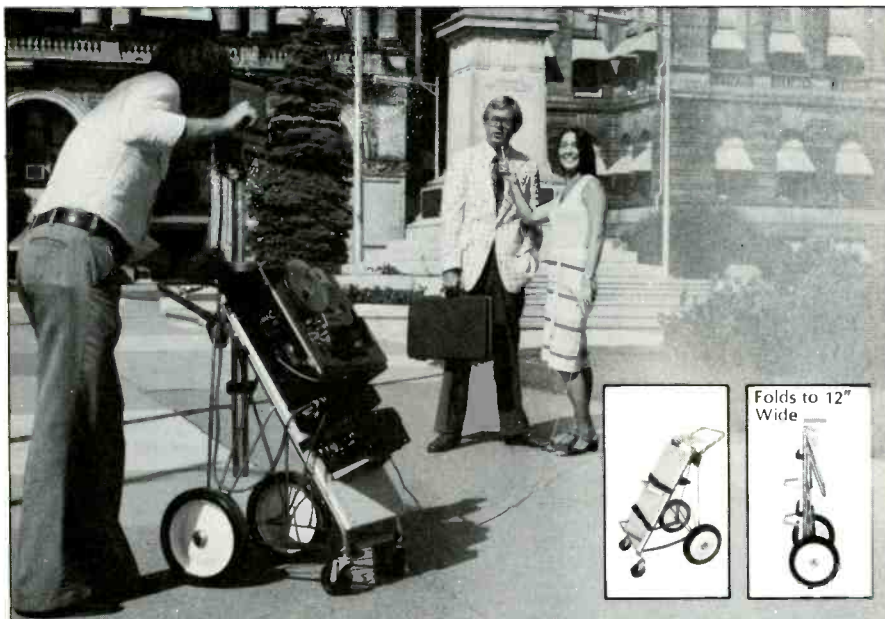

New **wheelit** ENG-1 Folding Camera Cart

Suggested Retail \$195.00

Features

- Fast, ready ENG operation
- Operate camera from cart
- Safe transportation
- 14" x 29" equipment board
- Adjustable equipment mounts for control unit, recorder, battery
- 5¾" x 14" camera platform
- Light weight, heavy duty

- 12" wheels & locking swivel casters
- Folds to only 12" width
- Elevator and universal head, optional
- Receptacle and cord reel, optional

For immediate ENG operation, Wheelit, don't pack it.

Write or Telephone for Information & Prices.

Gruber Products Co.
5254 Jackman Road
Toledo, Ohio 43613
(419) 476-7200

Circle 266 on Reader Service Card

When engineering excellence creates a more reliable design, it creates the

FM-25KG Transmitter.

A new concept in reliable design, ease of operation and maintenance—and a new high in transmitting performance.

The Model FM-25KG is a completely self-contained 25,000W FM Broadcast Transmitter, operational at any fixed frequency between 88 and 108 MHz, in monaural or stereo, and SCA mode.

Features include: Mid-Panel Metering, Automatic Re-Cycling, Remote Control Interface, VSWR Protection, Elapsed Time Indicator, Remote Control Power Adjust.

Sophisticated, reliable technology and easy maintenance too. The metering panel folds down for easy access to most major sub-assemblies.

Let Engineering Excellence be an everyday quality at your station. Contact AEL for your Broadcast Transmitter requirements.

FM: 2,500, 5,000, 10,000, 15,000, 25,000, 40,000 and 50,000 watts.

AM: 5,000, 10,000 and 50,000 watts.

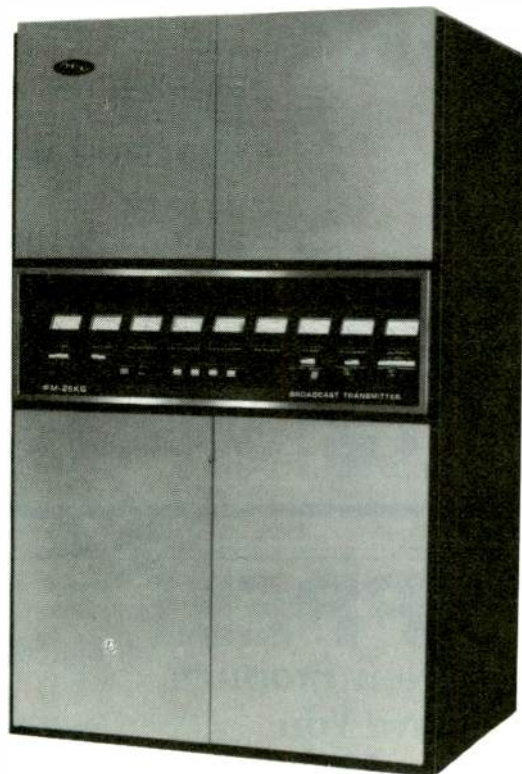

NAB/LAS VEGAS **SEE US AT THE SHOW!...**

CALL

JIM LUCY
800-523-5354
Lansdale, PA

ED HUBER
419-886-2425
Bellville, OH

BOB KELLY
617-942-0055
Boston, MA

CARL ROSECRANZ
404-492-5363
Atlanta, GA

GARRETT HASTON
915-533-8211
El Paso, TX

TOM AYE
408-738-1406
San Francisco, CA

EXHIBIT
BOOTH No. 306

Hospitality Suite
No. 1469

Las Vegas
Hilton Hotel



AMERICAN ELECTRONIC LABORATORIES, INC.

A subsidiary of AEL Industries, Inc.

P.O. Box 552, Lansdale, PA 19446 • (215) 822-2929 • TWX: 510-661-4976 Cable: AMERLAB

Circle 267 on Reader Service Card

CUERAC AT \$110 PER SLOT is less than half that of comparable systems . . .

FOR \$110 YOU GET

- Full random access of 500 carts
- Instant jock assist or
- Full automation
- Network joins
- Almost limitless expansion capability

FOR \$120 YOU GET

- All above features
- Plus TWO reel to reel
- Plus time announce

Check Us Out

SEE US AT BOOTH #409



Consolidated Electronic Industries
9721 Singleton Drive
Washington D.C. 20034
Tel. (301) 530-6080 Telex 89-8308

Circle 268 on Reader Service Card

YIPPEE!

These New Products Will Have You Jumping For Joy

★ **WM310** 5th generation Low-cost Waveform Monitor (\$750) DISPLAYS LINES, FIELDS, V-SYNC, FULL-BAND & Y-PASS MODES. INT. & EXT. SYNC. A. & B INPUTS. PORTABLE & 3-ACROSS IN RACKMOUNT. SUPERB FOR ENG TAPE EDITING & TRANSFERS.

★ **VS310** the first Low-cost NTSC Vectorscope (\$995) TRUE STUDIO-TYPE VECTOR DISPLAY PLUS A COMPLETE SERVICE SCOPE. WAVEFORM & CHROMA DISPLAYS. MATCHES WM310. CONNECTIONS FRONT AND/OR REAR.

★ **SCG396** NTSC Colorbars, Patterns & Syncgenerator (\$2,995) INCLUDES D.A.s TO FEED 4 CAMERAS, BLACKBURST OUTPUT, AUDIO TONE, GENLOCK. PORTABLE & RACKMOUNTABLE—2 ACROSS OR WITH TEST SCOPE.

★ **BAV230** U-matic Monitoring Bridge (\$695 + options) PROFESSIONALIZE YOUR VCR WITH 2-CHANNEL MONITORING (METER & SPEAKER) OF AUDIO INPUTS & OUTPUTS. CONVERT THEM TO BROADCAST-FORMAT AUDIO. MONITOR VIDEO INPUT & OUTPUT WITH (OPTIONAL) WFM AND/OR VECTORSCOPE AND COLOR OR B&W PICTURE MONITOR.

Prices, styling & specifications subject to change without notice
See all I have at booth 1133 NAB — Las Vegas & The Los Angeles Video Show.

P.O. BOX 921 • BEVERLY HILLS, CA 90213 • 213 / 276-2726



Circle 269 on Reader Service Card

Business Briefs

Communications Technology Incorporated (COMTEC) of Huntsville, Alabama, has been acquired by **3M Company**. COMTEC manufactures and markets audio and video production switchers for the broadcast and industrial/educational markets. The COMTEC facility will remain in Huntsville and continue to operate with the same management and staff The FCC has approved the transfer of control of the license of **WZZM-TV** to **Wometco Enterprises, Inc.** from West Michigan Telecasters, Inc. WZZM-TV is the ABC network affiliate serving the Grand Rapids-Kalamazoo-Muskegon, Michigan area Bo Donovan, who organized the recent meeting among radio syndicators and production firms termed the meeting "extremely productive between ourselves and the NAB and NRBA." Donovan said both organizations have assured the group that they **would give more attention to associate members.**

TM Productions, a Dallas-based broadcast services company, has filed suits against Kevin Gavin, Otis Conner, Jr. and Gavin/Conner Productions, Inc. for infringement of copyright to an original musical composition entitled "The Winning Score" and for alleged unlawful composition. Otis Conner, Jr. is an ex-employee of TM Productions. Damages sought include actual damages of \$500,000 and exemplary damages of \$1,000,000 **KPAC**, Port Arthur, Texas, has become an affiliate of the CBS Radio Network. Serving Beaumont as well as Port Arthur, KPAC was recently purchased by Clear Channel Communications, Inc., which also owns WOAI, the CBS Radio affiliate in San Antonio.

Outlet Company, national group broadcaster and retailing firm, has completed closing of its sale of WNYS-TV, Syracuse, NY, to Acquisition Corp. for \$11 million. Outlet has also announced an agreement in principle to purchase radio station **KIQQ (FM)** Los Angeles, from Cosmic Communications, Inc. for \$4.5 million. Also, Outlet has pending before the FCC an application for a construction permit for a UHF television station in Oklahoma City. The company has announced record 1977 third quarter and nine-month earnings and sales. Bruce G. Sundlun, Outlet president and chief executive officer, said third quarter sales exceeded those of the previous

continued on page 210

EXCITED?



SURE WE ARE AND HERE'S THE REASON WHY...

We Have:

New Fresnels

New Softlights

New Lighting Kits

New Pantograph Suspension Systems

New Manual Lighting Control Systems

New Memory Lighting Control Systems

All Designed to Save You Time and Money

Come See Them All At . . .

NAB Booth No. 912

**Berkey
Colortran®**

1015 Chestnut Street, Burbank,
California 91502, Tel. 213 843-1200

P. O. Box 5, Burrell Way, Thetford
Norfolk, IP24 3RB, U.K., Tel. Thetford 2484

DIVISION OF
Berkey
Photo Inc.



swintek

The Leading Name In
Cordless Microphone Systems



Transmitters small enough to be hidden almost anywhere, tiny microphones that are so unobtrusive that they probably won't even be noticed, hand-held microphones without the encumbrances of hundreds of feet of wire — that's what cordless microphone systems are all about. But there's one more factor of prime importance — reliability. If you're in television, radio or film and you want a cordless microphone system that not only offers the most advanced state-of-the-art electronics but the highest reliability rating in the industry, Swintek is the answer. There's a Swintek transmitter and receiver to fit your specific needs, no matter what your requirements. Check with us today about the greatest name in cordless microphone systems — Swintek.

alan gordon enterprises inc.

1430 N. Cahuenga Blvd., Hollywood, CA 90028
Telephone: (213) 466-3561 • (213) 985-5500
TWX: 910-321 4526 • Cable: GORDENT

Circle 270 on Reader Service Card

Business Briefs

year's comparable period by 82.2 percent with consolidated net earnings increasing 57.9 percent.

The stockholders of **Valtec Corporation**, of West Boylston, MA, and **Comm/Scope Company**, a private Catawba, NC firm, have approved the acquisition of Comm/Scope by Valtec. Comm/Scope will function as a wholly-owned subsidiary with no anticipated changes in management, operation, or location . . . **Imero Fiorentino Associates**, Consultants to the Performing Arts, will hold a Television Lighting and Staging Seminar/Workshop March 27 through 28, at WGBH studio facilities, Boston, MA. Further information can be obtained from the Education Division, Imero Fiorentino Associates, 10 West 66th St., New York 10023.

The **BIAS** (Broadcast Industry Automated System) Division of Data Communications Corp., Memphis, TN, has added stations WQAD-TV, Moline, IL and WDRB-TV, Louisville, KY, to its client list. The signing of the two stations brings the total of TV stations subscribing to the BIAS system to 182 stations . . . **MusiCues Corporation**, located in New York City, has released six new stereo discs from the Josef Weinberger Background Music Library. The new releases include "Guitar Break," "El Piano," "Flavour of the Month," "Flute Meets Harp," "More Power to Your Elbow," and "Melody All the Way."

Convergence Corporation has delivered its 1000th Joystick Editing Control System. One of the ECS-1B series, the system was installed in the department of Radio, Television and Film at Howard University in Bethesda, Maryland . . . According to the latest Nielsen Report, **KGMB-TV**, Honolulu, has maintained its dominant No. 1 position in overall programming, as well as capturing the No. 1 spot in prime time. Richard A. Weiner, General Manager of KGMB-TV said that "it makes Channel Nine one of the few CBS stations in the country to maintain its dominant No. 1 position."

Eight **Philips LDK-5** triax cameras and two Philips LDK-15 hand-held triax cameras have been delivered to ABC-TV for use with ABC's newest color TV mobile unit. The mobile unit is the latest expansion of the network's worldwide sports coverage . . . **Summit Communications, Inc.** has chosen **Scientific-Atlanta, Inc.** to supply four 5-meter satellite earth stations for Summit Communications' CATV systems in the Pacific Northwest. The first video earth terminal will be installed in the Buhl, Idaho system

VTR VIDEO PROBLEMS? WHAT'S THE TAPE TENSION?

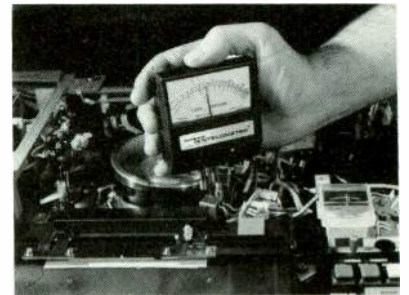

Shown measuring the critical supply tension on a Sony U-matic 2850.

TAPE EATING? FLAGGING - HOOKING? INTER CHANGEABILITY?

The **TENTELOMETER** tape tension gage can help isolate and correct these problems on your open reel and cassette video recorders by measuring dynamic tape tension. Priced from \$179 complete.

Send for your free 8 page **TENTELOMETER** instruction and application manual or call today.

TENTEL

50 Curtner Avenue, Campbell, CA 95008
(408) 377-6588

Circle 273 on Reader Service Card

NICKEL CADMIUM ENG. BATTERIES AND ONE HOUR AUTOMATIC CHARGERS



For **ALEXANDER** Nickel-Cadmium **REPLACEMENT BATTERIES** For...

**SONY (BP20) — JVC (PBP-1)
AKAI (PACK) — etc.**

CHARGERS WILL AUTOMATICALLY CHARGE IN 1 TO 4 HRS. DEPENDING ON CAPACITY . . . (SWITCHES TO TRICKLE)

Write Wire or Phone
ALEXANDER manufacturing co.
Box 1645 Mason City, Iowa 50401
Phone (515) 423-8955

Circle 274 on Reader Service Card

MARCH, 1978-BM/E

**NEW
PORTA-
BRACE
FOR SONY
DXC 1610
&
SLO 340**

**PORTA-
BRACE
"GRIP"**

**CALL US — WE CAN MEET
YOUR TRANSPORT NEEDS**

**K and H Products, Ltd.,
Main St., North Bennington
Vermont 05257 802-442-9118**

Circle 271 on Reader Service Card

STOP PLAYING DIRTY TAPES

Use the N.O.V.A. Block.
A Sapphire Tape
Cleaner.

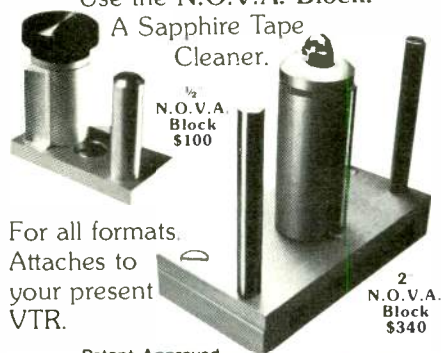

For all formats.
Attaches to
your present
VTR.

Patent Approved



Circle 275 on Reader Service Card

Does Your AM Tuner Sound Like Quality FM?



Our Dymek AM5 Does!

"Listening to a local classical-music station that carries the same programs on its AM and FM outlets, switching between the audio-output signals from an FM tuner (set to mono) and the AM 5, we found that the differences were very slight, actually comparable to those we have sometimes heard between different FM tuners. Much of the time no difference at all could be heard." . . . JULIAN HIRSCH

Reprinted with permission,
Stereo Review, August 1976

Factory Direct. Money Back Guarantee.
Rent/Own Plan. Call or write for complete
specs and details on the remarkable AM 5,
its companion piece the DA 5 antenna, and
other Dymek Products. Call toll free:

Nationwide 800/854-7769
California 800/472-1783



MK McKay Dymek Co.
111 S. College Ave., PO Box 5000
Claremont CA 91711

Circle 276 on Reader Service Card

MARCH, 1978-BM/E

Business Briefs

. . . . **Scientific-Atlanta** also has announced an agreement with Continental Satellite Corporation, under which Continental Satellite will purchase 30 satellite earth stations from the Atlanta-based communications firm. The purchased equipment includes transmitting earth stations capable of providing live programming from several stations in the U.S. **Continental Satellite Corporation** is a wholly-owned subsidiary of the Christian Broadcasting Network, Inc. (CBN), Virginia Beach, VA.

BFM Cable Communications Constructors Corp., Norwalk, CT, multiple CATV system operator, has awarded a contract to **Hughes Aircraft Company's** microwave communications products for 18 satellite video receiving terminals. BFM plans to use the new receiving terminals initially to provide its subscribers with satellite-transmitted programming from Atlanta's Channel 17, the Christian Broadcasting Network, and programming from Madison Square Garden

Fourteen additional stations have signed on for the services of **Radio Arts, Inc.** Selecting the syndicators adult MOR format, "The Entertainers," are: WAPI, Birmingham, AL; KBEA, Kansas City (Mission), KS; KRML, Monterey, CA; WIZZ, Streator, IL; WVNA, Tusculumbia, AL; WDDC (FM), Portage, WI; KNOT, Prescott, AZ; WTAZ (FM), Morton, IL; KPEL, Lafayette, LA; KFAH (FM), Alliance, NE; and KOZI, Chelen, WA. Selecting the "Easy Country" format are: KTRB, Modesto, CA; WLAX (FM), Streator, IL; and WCKC, Milton, FL.

The VCR business may be faster-growing than even the manufacturers expected. At the Consumer Electric Show in New York, Jack K. Sauter, Division Vice President, Marketing, for RCA Consumer Electronics, said that RCA's "SelectaVision" four-hour VCR is now believed to be "a very strong second" in an industry that has the potential of becoming a \$1 billion industry in less than three years. Even with an increase in shipments over the original schedule, the demand for SelectaVisions was so great in December that shortages were evident in all major markets And Sales of JVC's **Vidstar** video recorder in its first few months of U.S. availability have surpassed company forecasts too, according to JVC Marketing Vice President Richard O'Brien. Anticipated sales for 1978 are for at least 48,000 units. Both JVC and RCA have announced extensive, expanded marketing plans for 1978.

continued on page 212

Maintenance Supervisor

If you're the specialist we need, we'll provide you with:

- A starting salary of \$26,500 per year (+ over-time)
- The potential for promotion to Manager
- A stable and secure future . . . the person you're replacing is retiring after 30 years on the job.

We're a billion dollar communications organization seeking a take-charge pro capable of directing the maintenance operations for our TV/FM transmitters, microwave systems, VTR's, and associated and audio/video/digital equipment. Position will bring responsibility for supervising the work of 9 transmitter technicians, and assuring compliance with FCC engineering standards.

To qualify you should have a 1st Class FCC radio-telephone license. Your credentials should also include a knowledge of RF test techniques, TV test signals, spectrum analyzers, and associated test equipment needed to repair/troubleshoot state-of-the-art audio, video and RF systems.

Position is based in New York City. Apply by sending a resume, including salary history, to: Box 401, BM/E.

An equal opportunity employer, m/f

Business Briefs

The managers of Gould's Wil-
 ington, MA facility have purchased
 three of the product lines of the Control
 and Systems Division and formed a
 new company, **Datametrics Inc.**, to
 manufacture them. The product lines
 include pressure, vacuum and flow
 measuring systems; time code
 generators; and Trump-Ross encoders.
 Officers of the new company are Mal-
 colm Green, President; Frank C. Doda,
 Treasurer; and A.W. Siff, Secretary.
 Each will continue his present operat-
 ing function as General Manager, Con-
 troller, and Product Manager, respec-
 tively. Datametrics Inc. will continue
 manufacturing the products in the Wil-
 ington, MA location.

Wometco Home Theatre, Inc.,
 subscription television service (STV)
 operation serving the greater New York
 metropolitan area via WTVG-TV,
 Channel 68, has announced the signing
 of Box Seat Subscription Television
 and First Cine-Tel of New Jersey, Inc.,
 as new over-the-air affiliates. Wometco
 has also announced the signing of four
 more affiliated program vendors: Helf-
 ner's Antenna Service, Tele-View
 Cable TV, W.B. Heavener & Co., and
 Signal Code, Inc.

Four Stations Win BME Best Station Awards

With votes now tallied, winners of *BM/E's Best Station Award for 1977* are *WROK/WZOK, Rockford, Ill., in the AM/FM category; WCCO-FM, Minneapolis, Minn., in the FM category; WHPA, Williamsport, Pa., in the AM category; and KTIV, Sioux City, Iowa, in the TV category.*

Each of these stations will receive a plaque honoring their achievements in design, engineering, and operations.

The four winners were chosen by their peers (BM/E readers) from a group of 12 finalists. More than 20 stations were nominated for the 1977 Best Station Award Contest. Each nominee, finalist, and winner should feel special pride for having won the admiration of his fellow broadcasters.

Wanted: A special person..... for technical liaison between customers and Orban

Orban needs a person who understands the customer's problems, needs, and level of technical expertise; a person who understands the manufacturer's difficulties, requirements, designs, and processes; a person who can be diplomatic but quick to grasp the real problem and conjure an effective solution.

Thorough knowledge of AM and FM transmitters, antennas, and audio plants is required as well as an understanding of real broadcast operations. At least 1 year of experience at a radio broadcasting station is needed. The candidate must be trained as an elec-

tronic technician or have equivalent knowledge, particularly in the area of Op-Amp peculiarities. A BSEE is desirable.

Pleasant telephone style, patience, and willingness to travel to occasional trade shows are musts.

Orban is a spunky, rapidly growing maker of sophisticated audio processing equipment for broadcasters and recording studios. If you are our person, send resume or informative letter to:

Frank Santucci
Orban Associates Inc.
 645 Bryant Street
 San Francisco, CA 94107

SIMPLIFY YOUR PROMPTING with TELECUE

702 Script Drive features:

- internal video DA for multiple monitors
- self-aligning caterpillar drive for varying widths and thickness scripts
- local forward/reverse and speed control
- 2 1/2" vidicon camera
- 3 independently choked lamps for reliable lighting

Digivision Prompter features:

- high resolution compactly housed 12" monitor
- quick release mount to Vinten cam heads independent of camera
- balance achieved with an externally mounted power transformer, no balance weights or camera supports required



**LISTEC
 TELEVISION
 EQUIPMENT CORP.**

LISTEC
 39 CAIN DRIVE, PLAINVIEW, NEW YORK 11803
 (513) 694-8963 TELEX 640470
 (WEST COAST)
 4527 SAN FERNANDO ROAD, UNIT 1, GLENDALE,
 CALIFORNIA 91204 (213) 244-0838

Booth #700 at NAB Circle 279 on Reader Service Card

sound dynamics

SD-100 Transport



SHOWN
 with
 Inovonics
 Electronics

The Sound Dynamics Model SD-100 is an updated version of an old reliable tape transport. Features include sealed motor capacitors, automatic equalization switching and edit features (Optional). The SD-100 is compatible with Inovonics, MCI or Ampex 350-440 electronics. In addition, parts are interchangeable with most Ampex 350/351 in use today. Thirty days is normal delivery time.

Sound Dynamics specializes in professional broadcast equipment featuring such items as: digital clocks/timers, recorder electronics, tape heads, microwave equipment, RF monitors, microphones, limiters plus several other broadcast products!

FOR ALL YOUR BROADCAST
 NEEDS CONTACT —



(408) 926-3588

sound dynamics, inc.
 P.O. Box 32055 • San Jose, CA 95152

Circle 280 on Reader Service Card

Radio and TV on Campus

continued from page 98

Science Center.

Color TV programs are routed through the video-audio switching matrix. Video amplifiers provide level and color balance for the switched signals. Signal balance through the system allows loading of one or all subscribers to any single channel or any combination of twenty-four channels.

The switching system operates through a 12-station push button selector and a group selector switch that selects either the "A" or "B" group of players. The "A/B" selector switch controls a relay (24 PDT) that, in turn, provides one of two groups of 12 programs to the 12-station selector switch.

Subscriber "call-in" and communication to the distribution system control operator in the control distribution center is provided through a telephone handset and a lighted pushbutton adjacent to the 12-station selector switch. When a "call" button is pushed by the subscriber, a lamp flashes at the distribution center. An audible signal (chime) sounds to alert the operator. Once a call button has been pressed, the flashing annunciator lamp and audible signal will automatically continue until the operator answers. The subscriber's circuit is then released.

To order a program, the subscriber merely tells the operator the catalog number of the tape program desired. Assignment of the program to the requestee is accomplished as follows. Program videocassette player availability is indicated on a control panel in the distribution room. The control operator selects any available videocassette player by number (for example 9B) and uses two sets of "touch tone" telephone key pads to signal the videocassette player operator the requested tape program number and the player on which it is to be played. The control operator then pushes a combination of two switches (in this case

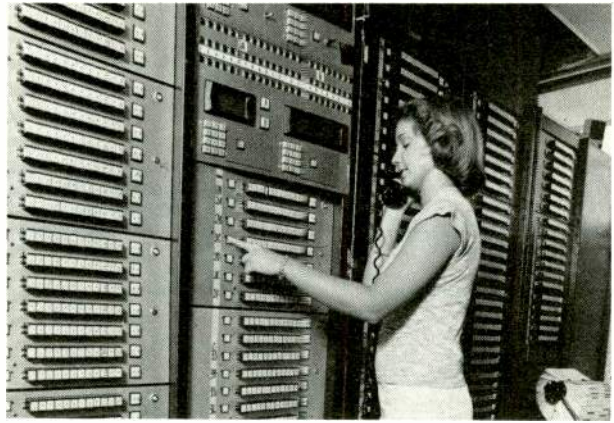

Taking a call at Univ. of Texas Health Science Center for a videotape to be played on one of 24 channels.

number "9" and the letter "B") to connect the program to the student.

In the meantime, the videocassette player operator would have switched the player status from "ready" (green light) to "busy" (red light) to prevent the player from being reassigned by the central room operator. If the videocassette player is not in operating order, this is indicated by a yellow "service" light. A subjective quality determination of any of the 24 channels may be made at the control and distribution rack or at the program rack by use of a program selector switch and color monitor. Each of the 24 channels is continuously monitored in the program room by individual monochrome video monitors and audio level meters.

There are 1258 tapes in the Dental Branch catalog, 850 of which were produced locally. Average daily requests run between 100 and 125 calls. **BM/E**

ENTER PT-1

**THE NEW MEMBER
OF THE DIGITIMER
FAMILY WITH
PRE-SETTABLE
TIME ENTRY.**



PT-1 is a production timer with just the right combination of features in a logical, compact package.

***Add the PT-1C, Circular Display Slave, and you will have a complete timing system!**

*units sold separately

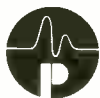

PACIFIC RECORDERS AND ENGINEERING CORPORATION
11100 ROSELLE ST., SAN DIEGO, CALIFORNIA 92121
TELEPHONE (714) 453-3255 TELEX 695008

exclusive export agent: Sierra Audio Burbank, Calif.

Circle 281 on Reader Service Card

A NEW APPROACH TO TELECINE LIGHT CONTROL THAT IS . . .

FASTER

QUIETER

SMOOTHER

and MORE EFFECTIVE.

**FROM THE WORLD'S LARGEST SUPPLIER
OF TELECINE EQUIPMENT.**

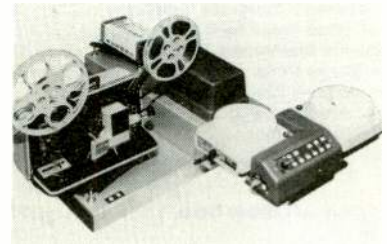

MODEL 5050
AUTOMATIC LIGHT
CONTROL

LAIRD TELEMEDIA INC.
2125 SOUTH WEST TEMPLE • 801 487 6251
SALT LAKE CITY, UTAH 84115

VISIT BOOTH 1306 AT N.A.B.

Circle 282 on Reader Service Card

Advertisers Index

Accurate Sound150
 ADDA Corp.119
 Advance Industries184
 Alexander Manufacturing Co.210
 Altec Commercial Products173
 American Data Corp.43
 American Electronic Laboratories207
 Ampex Corp.106-107
 Ampro Broadcasting Inc.8, 156
 Amtron Corp.76
 Angenieux Corp. of America162
 Asaca Corp.186
 Audio Designs & Mfg., Inc.29, 148
 Audio-Technica, U.S., Inc.64
 Audiotronics, Inc.27

Belar Electronics Lab., Inc.204
 Berkey Colortran, Inc.209
 Bird Electronics Corp.145
 Robert Bosch Corp.181
 Broadcast Electronics, Inc.17
 Broadcast Products Div.,
 UMC Electric Co.146
 Broadcast Video Systems206

Cablewave Systems161
 Camera Mart33, 202
 Canon USA Inc.105
 Cases Inc.190
 CCA Electronics Corp.57
 Central Dynamics Ltd.73
 Cetec Broadcasting Group171
 Christie Electric53
 Chyron Telesystems62, 94
 Cine 60195
 Clearcom205
 CMX3
 Coastcam68
 Colorado Video, Inc.198
 Computer Image Video Controllers
 Dytek127
 Computer Labs10
 Conrac79
 Consolidated Electronics Industries208
 Consolidated Video Systems151
 Continental Electronics Mfg. Co.69
 Convergence Corp.182
 Cosmicar Lens Div.,
 Asahi Precision Co.160
 CSI Electronics Inc.142
 CSP Inc.202

Data Communications Corp.95
 Datatek136
 Datatron Inc.188
 Digital Video SystemsCover 3
 Duca Richardson Corp.63
 Eastman Kodak Co.13
 EEV Inc.70
 Elmac, Div. Varian124
 Electro & Optical Systems16

Farinon Electric155
 Fidelipac40
 Frezzolini Electronics Inc.115
 Fujinon Optical Inc.88-89

General Electric Co., Video
 Display Equip. Operation82
 Alan Gordon Enterprises Inc.210
 Grass Valley Group5
 Gruber Products Co.206

Hallikainen & Friends157
 Hammond20
 Harris Corp.135, 137, 139, 141, 143, 145
 Hitachi Denshi American,
 Ltd.81, 83, 85, 87
 Hitachi, Ltd.32

IGM, Div. NTI122
 Ikegami Electronics Inc.15
 Inovonics, Inc.172
 International Tapetronics Corp.130-131
 Ivie Electronics185

JVC Industries Co.99-102

K&H Products210
 Kilegl Bros.152
 Knox, Ltd.198

L.G.T.—Laboratoire General
 Des Telecommunications37
 Laird Telemedia Inc.167, 201, 213
 Lestic Television Equip. Co.202, 212
 LPB Inc.35

3M/Magnetic Tape Div.48-49
 3M/Mincom-Video Products21, 159
 Magna Tech196
 Marconi Electronics54
 Marconi Instruments153
 Marti Electronics Inc.198
 McCurdy Radio Ind. Inc.Cover 2, 20
 McKay Dymek Co.211
 McMartin Industries, Inc.40
 Micro Consultants, Inc.134
 Microtime34
 Microwave Associates Inc.123
 Moseley Associates, Inc.192

NEC Broadcast Equipment Div.50, 138
 Rupert Neve25
 Nova Corp.211
 NTI America, Inc.197
 Nurad, Inc.98

Oktel47
 Orban Associates132, 212
 Otari Corp.140
 Otari Electric Co. Ltd.203

Pacific Recorders &
 Engineering Corp.18, 213
 Panasonic Matsushita Electric
 Corp.22, 23
 Paperwork Systems Inc.44
 Parasound, Inc.168
 Philadelphia Resins Corp.194
 Philips Audio Video Systems
 Corp.184
 Philips Test & Measuring
 Instruments93, 167
 Potomac Instruments14

QEI Corp.14
 QRK Electronic Products, Inc.201

Ramko Research41
 Rank Cintel169
 Rank Precision Industries Inc.96
 RCA Broadcast Systems74-75
 Recortec, Inc.90
 Robins Broadcast & Sound
 Equipment Corp.177
 Rockwell International, Collins Comm.
 Telecommunications Div.38-39
 ROH Corp.154
 Ross Video Crop.121

Saki Magnetics200
 Scientific Atlanta/Cable Div.128
 Scully Recording Instruments12
 Shlntron126
 Shure Bros., Inc.112
 Sintronic Corp.205
 Skirpan Lighting Control Corp.199
 Eric Small & Associates165
 Sony Corp. of America30-31, 109
 Sound Dynamics212
 Sound Technology11
 Spectra Sonics146
 Spectra Vision Corp.190
 Spin Physics, Inc.60
 Stanton Magnetics, Inc.158
 Strand Century, Inc.166
 Studer ReVox America, Inc.111
 Studio Tape Exchange152
 System Concepts28

Taber Mfg. & Eng. Co.177
 TA Track Audio, Inc.189
 Tektronix, Inc.58-59, 147
 Telemation, Inc.116-117
 Television Research56, 144, 175
 Telex Communications, Inc.86, 154
 Tentel210
 TerraCom191
 Thomson-CSF (DTE)174
 Thomson-CSF Labs Inc.7
 Time & Frequency Technology,
 Inc.178

Ultra Audio Pixtec208
 UMC Electronics Co., Broadcast
 Products Div.146
 UREI36
 Utah Scientific, Inc.24

Video Data Systems26
 Videomax19
 VideoMedia72
 Vital Industries9

Ward-Beck Systems Ltd.Cover 4
 Widget Works, Inc.66
 Wolf Coach133

Yamaha International Corp.176

SALES OFFICES

Broadband Information Services, Inc.

295 Madison Ave.
 New York, New York 10017

EASTERN & MIDWESTERN STATES

295 Madison Avenue
 New York, New York 10017
 212-685-5320
 Kenneth F. Luker, Jr.

WESTERN STATES

353 Sacramento Street
 Suite 600
 San Francisco, CA 94111
 415-421-7330

P.O. Box 49206
 Los Angeles, California 90049
 213-826-4543
 Art Mandell

First in a new advanced class of digital processors!

The DPS-1
by Digital Video Systems.



The DPS-1 is the new third generation Time Base Corrector conceived to operate at standards significantly higher than those previously adopted by the television industry, and born through years of dedicated research by a team of experts.

This all-digital processing system, using computer circuitry operating at four times subcarrier, adapts its parameters automatically to incoming video feeds as input sources are changed.

Features include a super-wide 32 line window, digital test signal generator, microprocessor

control, digital burst processing, and a full range of circuit board options to satisfy all operating requirements, including Frame Store.

The DPS-1 offers substantially improved production capability to both broadcasters and industrial producers. Authorized dealer and customer service representatives, strategically located throughout the United States and Canada, will be happy to demonstrate the versatility of this new advanced system to you.

Ask us for full details.



digital
video
systems

DIGITAL VIDEO SYSTEMS, 519 McNicoll Avenue, Willowdale, Ontario, Canada M2H 2C9

Telephone: (416) 499-4826

Circle 283 on Reader Service Card



AM Stereo by Ward-Beck.

Something special has happened to radio. Now, for the first time, there are operator-oriented radio consoles designed in the Ward-Beck tradition.

We take pride in introducing the new WBS R1200 and R2000 Radio Programming and Production facilities, assiduously engineered for AM and FM, assembled AM stereo ready.

Our team of engineers devoted their full attention to the new generation features included in the 1200 and 2000 systems. The quality, the performance, the singular statement of stylish simplicity, are evidence of their complete success.



WBS 2000
showing some options.



Tomorrow's Technology Today.

Ward-Beck Systems Limited, 841 Progress Avenue, Scarborough, Ontario, Canada M1H 2X4. Tel: (416) 438-6550.

Ward-Beck Systems Inc., 6900 East Camelback Road, Suite 1010, Scottsdale, Arizona 85251.