

BMIE

FOR TECHNICAL AND ENGINEERING MANAGEMENT

AN ACT III PUBLICATION

FEBRUARY 1989
\$3.00

TRENDS IN AUTOMATION



WHY DIDN'T SOMEONE THINK OF THIS BEFORE?

A FAST-PACED PRODUCTION CONSOLE

THE WHEATSTONE SP-6 AUDIO CONSOLE lets production people quickly accomplish 8 and 16-track work, yet easily handle routine transfers and dubbing operations. With its unique track monitor section it can facilitate simultaneous stereo mixdown during the multitrack bed session — almost halving typical production time cycles. Input channels are laid out just like an air console, with machine starts below the channel fader, so staff familiar with on-air consoles can quickly become comfortable in the production environment.

For those interested in more advanced techniques, the SP-6 employs a powerful talent monitor section designed to rapidly call up live mic and track combinations, making difficult punch-ins a breeze. Standard SP-6 input channel equalizers are more comprehensive than

those supplied as optional items on competing products, allowing much greater creative freedom. Input channel auxiliary send sections are designed to be the most versatile in the industry, providing 4 different auxiliary buses to allow digital delay, reverb, talent foldback, and mix-minus feeds. Stereo input channels can provide either mono or stereo effects sends. Even more, the SP-6 has 4 auxiliary effects return inputs that allow effects to be recorded on to the multitrack or sent to the monitor buses.

The SP-6 provides independent headphone, control room and studio monitor feeds, as well as stereo cue/solo. Control room and studio mute and tally functions are independently dipswitch selectable on individual input channels. Additional studio modules may be ordered to accommodate larger, multi-studio installations. The SP-6 may be configured with any combination of mono and stereo input modules, in mainframe sizes ranging from 16 to 32 or more inputs. The console is available in either an 8-track production format or a 4 stereo subgroup TV master control configuration. So why not profit from Wheatstone's experience and reputation? Call us today and learn more.



 Wheatstone® Corporation

6720 V.I.P. Parkway, Syracuse, NY 13211
Circle 100 on Reader Service Card Page 63

TEL 315-455-7740/FAX 315-454-8104

GO WITH THE WINNERS.

DYNAMAX CTR100 SERIES

*"The intelligent design
and on-air reliability of the
Dynamax CTR100 Series
give our stations a compet-
itive edge. We've purchased
about 60 machines and plan
to add more."*

*Scott Knight
President
Knight Quality Group Stations*



DYNAMAX®
BROADCAST PRODUCTS BY FIDELIPAC

Fidelipac Corporation P.O. Box 808
 Moorestown, NJ 08057 U.S.A.
609-235-3900 TELEX: 710-897-0254
 FAX: 609-235-7779



When it comes to evaluating your picture, you need the whole truth and nothing but. Monitors that show you just what you're producing. With all its beauty and all its flaws — down to the tiniest bit of noise or artifact.

You need SONY broadcast monitors. The 19-inch BVM-1910, or a 13-inch monitor, the BVM-1310 or the BVM-1315. They bring you the best possible reproduction of the actual signal. The most faithful and detailed.

Because they offer the highest resolution in their category, even at high output levels. With the BVM-1910, for example, you get a full 900 TV lines.

Add to that the best convergence and geometry you can

and nothing but



find in a broadcast monitor. Plus excellent uniformity and rock-solid color stability.

All of which we achieve by manufacturing our own CRTs.

And these monitors offer the most advanced auto-setup

option available. You can even analyze and set up other non-auto-setup monitors.

SONY[®]

But don't take our oath for it. See the BVM-1910, BVM-1310 and BVM-1315 yourself. Contact your Sony Broadcast Sales Engineer. Or call (800) 635-SONY.

Sony Communications Products Company, 1600 Queen Anne Road, Teaneck, NJ 07666. © 1989 Sony Corporation of America. Sony is a registered trademark of Sony.

BROADCAST PRODUCTS

the **SOURCE**

**A·C·E Encoders . . .
Voted 10,000 times over
as the industry standard.**

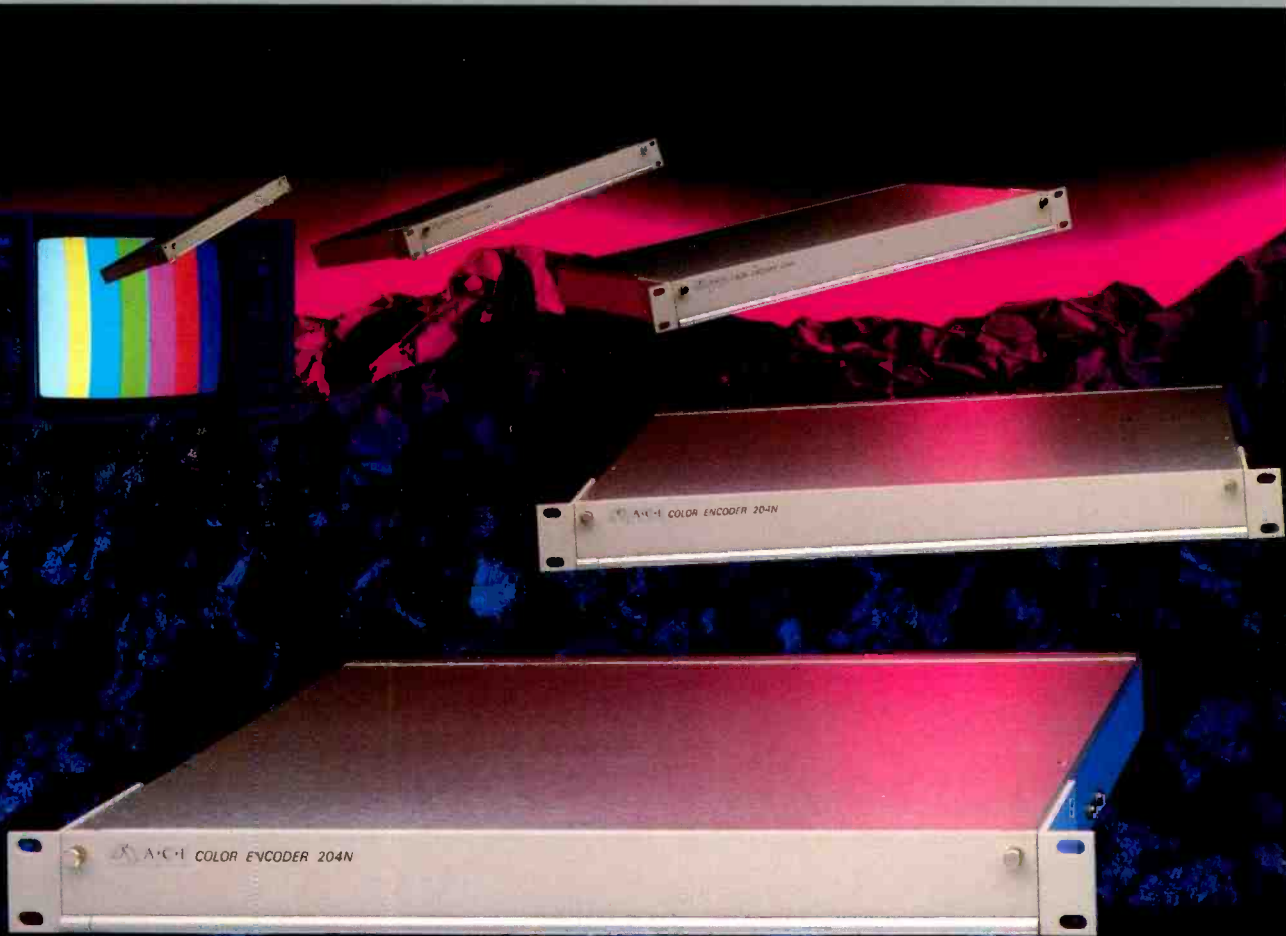

A·C·E

An encoder, which converts the RGB outputs from such sources as character generators or paint systems into composite NTSC, can be the weak link in your system. The addition of an A·C·E encoder to even an inexpensive character generator can produce excellent results.

The 204N offers stable performance and easy installation in a rugged, flexible package. The unit accepts either RGB or CAV (MII or Betacam) inputs and provides six composite outputs. The 204N even offers 32 test signals including full-field and SMPTE color bars, red field and pluge.

With over 10,000 in use worldwide, the Cox encoder is the standard of the industry. The latest version, the 204N, is now sold under the name A·C·E.

Don't compromise your graphics system with an inferior encoder. Insist on the A·C·E 204N.

The 204N Encoder from A·C·E, celebrating their 20th year in the design and manufacture of broadcast television equipment.

Available in the U.S. exclusively from Midwest Communications and backed by Midwest's nationwide service network.



One Sperti Drive
Edgewood, KY 41017
(606) 331-8990



On the cover:
"Trends in Automation"
 Cover airbrush illustration
 by Carmela Emerson.

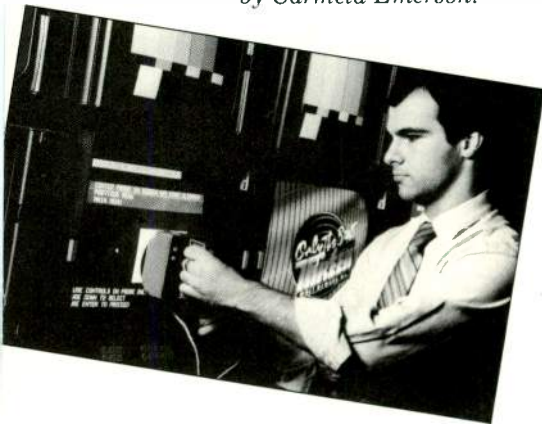

50
Monitor Benchmark

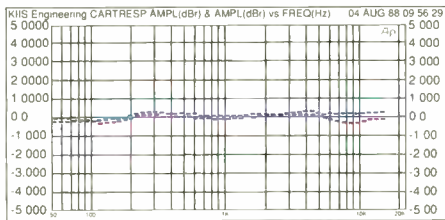

67
Automated Maintenance

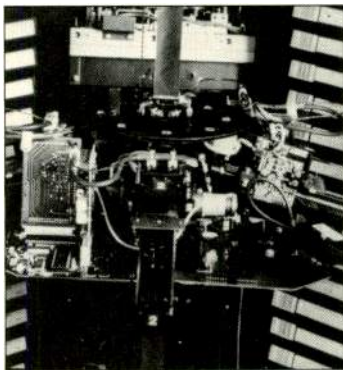

39
Cart Technology

Features

- 28 Automating the Modern Television Facility**
Automation of the master control suite can maximize a television station's efficiency and image.
- 39 Using the Modern Cart Machine for Broadcast Automation**
Will the cart machine be the core of modern television station automation?
- 44 Fiber Transmission Systems for HDTV Signals**
What's the outlook for HDTV transmission via fiber? The technology is in place, but economic and political issues still must be settled.
- 50 Product Benchmark: Barco Industries CVS Intelligent Monitor**
Second in an exclusive series: Three end-user engineers give their candid opinions of this Emmy award-winning piece of equipment.
- 55 Radio Engineering**
- 55 Radio News**
*FCC OKs Limited FM Short Spacing...
 Smulyan Named Chair for Radio '89...
 AT&T Cuts Radio Remote Service*
- 59 New Directions in Radio Automation**
Radio automation is changing radically with the introduction of digital audio and control systems. Performance is going up while costs are coming down.
- 67 Automate Your Maintenance and Performance Testing**
At KIIS in Los Angeles, an innovative preventive maintenance program spots problems before they start—while the equipment is in use.

Don't Blame The Tape!



If you aren't satisfied with the audio quality of your carts, don't blame the tape. They only sound as good as your cart machines permit.

Phase Trak 90 Cart Machines guarantee you superior production and playback quality . . . no matter what brand of tape you use.

A microprocessor-based Tape Analysis System "learns" and stores the optimal characteristics of 10 different tape formulations...Assuring you of the highest production quality.

Clean, crisp playback quality is assured with Phase Trak 90's exclusive Continuous, Non-encoded Electronic Phase Correction.*

PHASE TRAK 90™

Phase Trak 90, the most advanced cart machines on the market today, is raising the on-air standards of the industry.

Find out how you can improve your production and playback standards. Contact your Broadcast Electronics' Distributor today, or call Bob Arnold at

217-224-9600

*Patent applied for.

BE® **BROADCAST ELECTRONICS INC**

4100 N. 24th ST., P.O. BOX 3606, QUINCY, IL 62305-3606 U.S.A., PHONE (217) 224-9600, TELEX 250142, FAX (217) 224-9607

Circle 103 on Reader Service Card Page 53

BME

FOR TECHNICAL AND ENGINEERING MANAGEMENT

Group Publisher
KEVIN J. CONDON

Editor
EVA J. BLINDER

Senior Editor
BETH JACQUES

Technical Editor
JAMES A. ACKERLEY

Managing Editor
MICHAEL D. ESPINDLE

Copy Editor
PATRICK D. O'NEILL

Contributing Editor
SKIP PIZZI

Art Directors
DON KROGMAN
FRANK TAGARIELLO

Designer
RAYMOND WONG

Production Director
NICK TARTAGLIA

Assistant Production Manager
MARGOT SUYDAM

Associate Publisher
PATRICK J. MOLONEY

Southern District Sales Manager
MICHAEL S. DAHLE

Western District Sales Manager
DENICE NICHOLS

Controller
JOSEPH M. PANNULLO

Circulation Manager
JOSEPH SCHILLMOELLER

Executive Assistant
SHARON PORGES

Act III Publishing

President
PAUL DAVID SCHAEFFER

Senior Vice President,
Technical Division
KEVIN J. CONDON

Senior Vice President,
Corporate Development & Planning
MARTHA LORINI

Vice President,
Finance & Administration
SAM SCHECTER

Act III Publishing, Technical Division
295 Madison Ave., New York, NY 10017
(212) 685-5320 Telex: 64-4001

Fax: (212) 679-0919

Also publishers of:
World Broadcast News
Corporate Video Decisions



BME (ISSN 0005-3201) is published monthly by NBB Acquisitions, Inc. BME is circulated without charge to those responsible for station operation and for specifying and authorizing the purchase of equipment used in broadcast facilities in the U.S. and Canada. These facilities include AM, FM and TV broadcast stations, CATV systems, ETV stations, networks and studios, audio and video recording studios, teleproduction facilities, consultants, etc. Subscription prices to others: \$36.00 one year, \$50.00 two years. Foreign: \$50.00 one year, \$75.00 two years. Air Mail rates on request. Copyright 1989 by NBB Acquisitions, Inc., New York City. Second class postage paid New York, NY, and additional mailing offices.

POSTMASTER: send address changes to BME, P.O. Box 5056, Duluth, MN 55806.

Columns & Departments

- 11 **Viewpoint**
Challenges to the Industry
- 13 **Feedback**
Balancing Pay and Care Scales...Magic to Do?...Undocumented Features = Bugs
- 15 **Update**
Station Swapping Wins Latest Round...Pentagon Aims for HDTV...Ampex Ships D2 VTRs...IDB Buys HTN...FCC Will Modify One-To-A-Market Station Ownership
- 21 **Crosstalk: An Engineering Management Journal**
And in This Corner...Class A Power Hike Dispute Boils Over
- 23 **Tech Watch**
Rewritable Optical: Here at Last
- 74 **Compute**
A Line Stretcher for Phase Rotation
- 76 **Spectrum: The Regulatory Environment**
Changing Directionals: Fine-Tuning FM Allotment
- 81 **New Equipment**
Aston Presents New Still Store...Mathey Introduces Hybrid Audio Filter...Dynatech Unveils Surge Suppressors...Videotek Adds Line Select to Frame Sync
- 88 **Business Briefs**
SMPTE fiber study group formed
- 89 **Advertisers Index**
- 90 **Currents: A Guest Editorial**
Today's Broadcast Engineer: A Certified Professional



15
Pentagon and HDTV

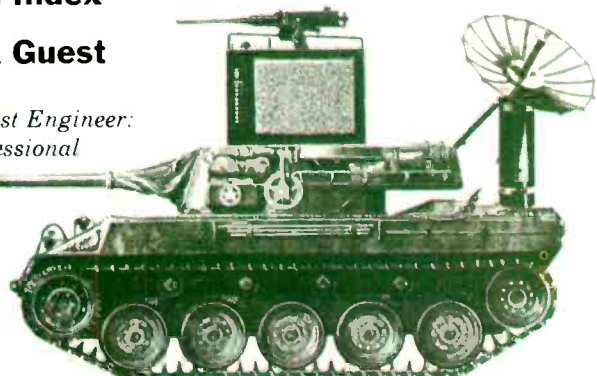

Do it yourself.

Half of doing a quality job is having the proper tools.

But when your craft is video, the tool box can get pretty heavy, and pretty expensive, before you're through. You're probably working in two or three formats at once — maybe experimenting with digital or HDTV — and they all seem to need their own separate sets of test generators. It would sure lighten the load if just one box could do it all.

We don't claim the 2021 can do **everything**... but it will give you the tools to produce any video test signal you need, in virtually any existing format. Choose from our pre-built signal sets — over 20 of them, for everything from NTSC through current HDTV standards (even PAL and SECAM) — or, for true do-it-yourselfing, build your own signals from scratch.

Because the best tools are easy to use, we've made the 2021 simple to operate. You construct signals using straightforward, menu-driven software. Store them in non-

volatile memory. Recall them instantaneously with the front-panel switch.

Ask us about the Magni 2021: the right tool for quality video craftsmanship.

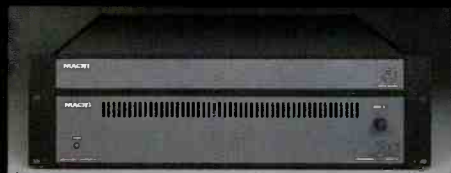

MAGNI

MAGNI SYSTEMS, INC.
9500 SW Gemini Drive
Beaverton, OR 97005 USA
(503) 626-8400
(800) 237-5964
FAX (503) 626-6225
TLX 650-2769743MCI

Magni and Magni Systems are trademarks of Magni Systems, Inc.



VIEWPOINT

The real-world pressures on the ATTC, both from within and without our industry, promise to make its act a tricky tightrope walk.



The Advanced Television Test Center stands poised, as of this writing, to begin testing the dozen-and-a-half or so proposed HDTV transmission systems. The complex task of analyzing and evaluating such a large number of proposals—similar in some ways, widely divergent in others—is a crucial and welcome step forward in this country's long, slow march toward improved television service.

Any way you look at it, the Center's work will have a profound effect on the future of broadcasting. The real-world pressures on the ATTC, both from within and without our industry, promise to make its act a tricky tightrope walk. The cable television industry, for example, is undertaking to begin its own tests of advanced television systems. Like any other business, cable has its own interests at heart—and what's good for cable may not be so good for broadcasting. Should the cable industry settle on an HDTV system before the broadcast industry has completed its testing, broadcasters could be forced to provide cable systems with signals that fit cable-designed and -decided HDTV parameters if they wish to maintain crucial cable carriage.

What about the telcos, just lying in wait to "reach out and crush someone," as many in the industry fear? Many of the regional telcos have conducted, or are about to conduct, demonstrations of their capability to deliver HDTV signals into the home over fiber optic cable. The "telco threat" will likely affect cable operators more directly than broadcasters.

A recently dealt wild card in the HDTV hand is the new-found interest of the Defense Department in this technology. Spurred by a need for less expensive high-resolution displays, the DoD is expected to release shortly a request for more information about the HDTV display technologies now under development in this country. It's still unclear what effect, if any, DoD interest will have on a choice of HDTV transmission and delivery systems. The DoD's desire for a strong U.S. consumer electronics industry, backed up by a strong U.S. semiconductor industry, may fit well with the broadcast industry's push for NTSC-compatible HDTV.

The ATTC has a difficult job ahead of it. It must keep broadcast-industry needs foremost in mind, while keeping an eye on developments in other industries. It must move quickly so that broadcasting does not lag behind other fields, while taking the time needed to thoroughly evaluate each proposal. We hope the industry and the government will keep in mind that their own best interests lie in smoothing the way toward the best possible HDTV system and avoid throwing up unneeded and hazardous obstacles. ■

A handwritten signature in blue ink that reads "Eva J. Blinder". The signature is fluid and cursive, with a long horizontal flourish extending to the right.

Eva J. Blinder
Editor

Panasonic® Pro Series Monitors.



Designed for production quality... With an eye on your budget.



Panasonic presents two very versatile, high-grade color monitors--the BT-D1910Y and the BT-M1310Y. Built for performance, these BT-Series monitors offer you the quality and reliability you've come to expect from Panasonic. Not to mention a wide array of features at an affordable price.

Our BT-Series provides you with the controls and connections necessary for studio applications--while serving a host of industrial, educational and professional video needs.

For maximum performance and versatility, both monitors offer complete, direct compatibility with the new S-VHS format--in addition to conventional signals. And video reproduction on the BT-Series is superb. As a matter of fact, the BT-M1310Y boasts a horizontal resolution of more than 560 lines, while the BT-D1910Y offers you greater than 550 lines.

What's more, each monitor provides you with a full set of front panel controls. Like Line A/B split, S-Video input connectors, Blue signal-only switch, pulse-cross circuit, preset picture off/on, comb/trap filter selectable and normal/underscan switch, just to name a few.

So when you are looking for professional quality, but still need to keep an eye on your budget, look into the Panasonic BT-Series high-grade monitors. For more information, call Panasonic Industrial Company at 1-800-553-7222. Or contact your local Panasonic Professional/Industrial Video Dealer.

Panasonic

Professional/Industrial Video

FEEDBACK

Balancing Pay and Care Scales

I just read your "Viewpoint" in the November BME (p. 13), and I couldn't agree more. In order to staff the stations of the future, broadcast management, at all levels, must begin recruiting now.

I have seen times in the past when I would get an applicant a day. Now, when an opening occurs, we have to search.

I believe the low pay scales are one of the reasons for declining technical applicants, but more so I feel that management's lack of care and understanding for technical needs and problems are more responsible. Why should a young, ambitious technician opt to be attached to a beeper for 24 hours a day and have nonexistent vacations, when he can work in computers or robotics for more money?

How many times have I heard a GM state, "Boy, that new program director really works long and hard," with no idea that the engineer opened the door when the PD arrived and was there when he left.

I don't want it to sound as if management should learn the technical side, but they shouldn't bury their heads in the sand, either.

Again, your knowledge in broadcast engineering is impressive. Keep up the good work.

Richard L. Edwards, director of engineering
Guy Gannett Broadcasting Services,
Miami, FL

Undocumented Features = Bugs

The INTERMOD.BAS program that was printed in the September "Compute" column ("Calculate Intermodulation Products," p. 82) has a couple of errors in it. The input is given as F1/F2; however, the input is parsed backwards such that the values of F1 and F2 are interchanged. To correct, modify lines

120 and 125 thus:

```
120 F1 = VAL(LEFT$(FO$,J+1))
```

```
125 F2 = VAL(RIGHT$(FO$,J-1))
```

The other error occurs in the fifth order label line. Correct lines 370 and 375 to read as follows:

```
370 PRINT "[2F1-3F2][2F1+3F2][3F1-2F2]"
```

```
375 PRINT "3F1+2F2][4F1-1F2][4F1+1F2]"
```

These changes will allow the program to run as originally intended.

Dan Stoe,
KVAL-TV
Eugene, OR

Magic to Do?

As a radio broadcast engineer, I would like to comment on the renewed effort on your part to include more articles pertaining to radio. For some time, your magazine would end up in a stack in my office, unopened, due to my lack of interest in television engineering.

It seems that over the past few months more radio articles have been published, and very comprehensive ones. I might add. Keep up the good work.

In response to your "Viewpoint" article for the November issue, I would like to add a few things. My experience is that it wasn't "mystique and glamor" that attracted young engineers. It was for a few other reasons. Amateur radio was the hobby of the day for the young technically minded, as are computers today. For these young engineers, there was a direct correlation in commercial radio. Many commercial stations started as ham stations. Secondly, people had high respect

for someone who was a broadcast engineer in those days. It was magic to most people. Today, radio and television are taken for granted. Lastly, the pay was attractive. I, and many others in the field, know of engineers that are forced to cover two or more stations to make a living. You do make mention of this last point in your article.

I think that as many of the oldtimers retire and the number of engineers in the field dwindles we will see an increase in the salary levels and also renewed interest in broadcast engineering. But we'll



have to hit a low before that happens

Thank you for making it worthwhile to receive your magazine once again.

Conrad Trautmann, chief engineer
WSYR/WYYY
Syracuse, NY

Do you have any questions, comments, or criticisms concerning what you read in BME? Any bulletins or issues you want to open up to other engineering management readers? Our letter column, Feedback, is your forum. Write to: Feedback, BME Magazine, 295 Madison Avenue, 19th Floor, New York, NY 10017.

Now, with Independent
Inner/Outer Border
Softness Control!

Prodigy™

Experience the
genius of Videotek.



You're burning the midnight oil... Final edit's due at 8 a.m. Be glad you have a Prodigy—the new switcher with more brain-power in a smaller package. Forget about old two mix/ effect systems. A reliable video switching and special effects system follows the new industry standard—multi-level effects with look-ahead preview. Much more than just another clone, Prodigy raises the standard—offering features no one else does, even on their most expensive systems. Prodigy includes stereo audio-follow-video, editor interface, effects memory and a programmable

downstream keyer. **Have it your way.** Modify Prodigy to suit your style of operation and create memorable performances. Program up to 99 events into Prodigy's 68000 microcomputer, then preview the results instantly. Ten programmable sequences link 80 on-line memory registers, and ten learned operator transitions track your actions over time. With Videotek's exclusive Times Six Plus black burst generator, system timing is virtually automatic. **Who says the grass is greener?** Equally at home in the post-production facility, newsroom or

studio—Prodigy rack-mounts in minutes and its software talks to a wide range of popular editing controllers. Get your hands on a Prodigy and let the performance begin! For more information or the name of your nearest Prodigy dealer, call Videotek today.

 **VIDEOTEK** INC.
Designed for real needs.
Priced for real budgets.

243 Shoemaker Road, Pottstown,
Pennsylvania 19464 • (215) 327-2292
TWX 710-653-0125 • FAX (215) 327-9295

UPDATE

Station Swapping Wins Latest Round....Pentagon Aims for HDTV....Ampex Ships D2 VTRs....IDB Buys HTN.... SBE Call for Papers....FCC Will Modify One-To-A-Market Station Ownership

Station Swapping Wins Latest Round

The FCC has rejected a petition to reinstate its antitrafficking rule, which formerly limited station trading by requiring licensees to hold and operate a radio or television station for a specified period before reselling. In their joint petition to the FCC, the United Church of

Christ, Action for Children's Television and the National Organization for Women asked for simple reinstatement of the antitrafficking rule and lengthening the minimum holding time for broadcast licenses.

In a split decision, Chairman Dennis Patrick and Commissioner Patricia Dennis voted against the proposal and Commissioner James Quello voted for it. The majority defended their action by saying the proposal, for the most part, "restated the same arguments made and carefully considered by the Commission when it eliminated the three-year rule in 1982." The majority further stated that the holding period "has been repeatedly evaluated and still found to be unnecessary."

Proponents of the proposal to reinstate the anti-trafficking rule remained unconvinced. United Church of Christ spokesperson Beverly Chain vowed, "We will continue the fight." Peggy Charren, president of Action for Children's Television said, "It's not surprising that a commission as narrowly focused on deregulation as this commission has vetoed yet another idea in the public interest. I expect the Bush administration to be more supportive of a regulatory agenda."



Charren: Will Bush see things her way?

in these areas, government sources say.

The Pentagon is well known for its interest in advanced video and computer graphics technologies, which have broad applications in surveillance and flight simulation activities, among other things. Because designers to date have set individual display specifications, the Pentagon hopes to achieve higher quality and less-expensive HDTV if consumer demand fuels mass production.

The Defense Advanced Research Projects Agency (DARPA) has issued requests for proposals in which it will fund \$15 million in research into advanced TV display technology and an additional

\$15 million into technology which receives high definition TV signals. The proposals are due February 19, 1989. The Pentagon has already reviewed a request from Zenith Electronics Corp. for \$15 million in funding to alter computer display technology so it can be adapted for high definition video use.

Zenith, which is the only major U.S.-owned television manufacturer, has developed what it calls a "flat (or 'high') tension mask" computer display screen. The flat-screen CRT eliminates glare and color distortion and, because it is particularly resistant to vibration and

The Pentagon has expressed interest in HDTV technologies.

Pentagon Aims for HDTV

The Department of Defense recently revealed that it plans to finance development of an advanced high-definition video

display screen. The project's secondary goal is to aid American television and semiconductor manufacturing industries and "reclaim technological leadership"

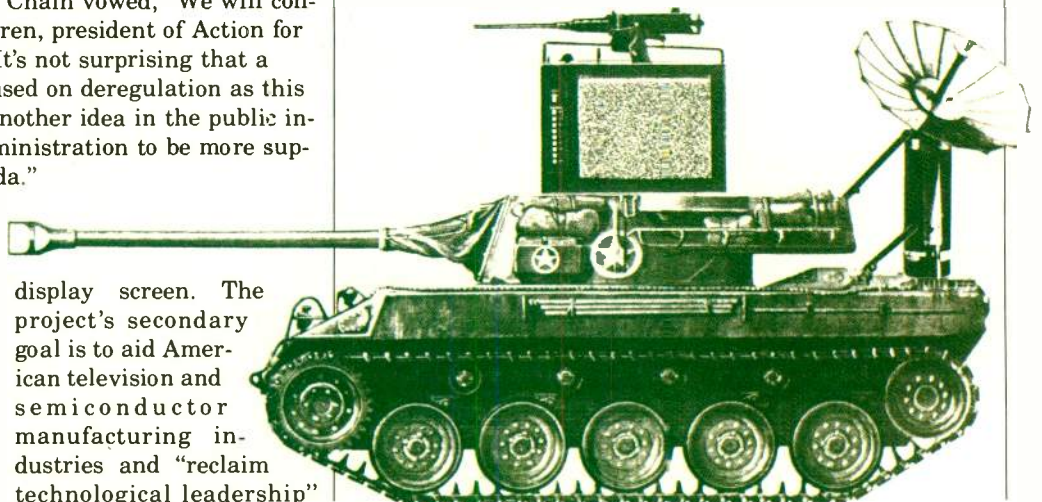

UPDATE

shock, has many applications in military field use.

Zenith is also active in advanced television (ATS) research; in September, it submitted an "eleventh hour" proposal to the FCC's ATS Advisory Committee. Called "Spectrum Compatible HDTV," Zenith's transmission proposal is based on simulcasting an enhanced digitized signal with NTSC in the 6 MHz band. (See "Crosstalk": *BME*, October 1988.) Zenith has also been the object of ongoing unfriendly shareholder activity; it was withdrawn in December.

Nothing in the formal DARPA request bars participation by foreign companies. Industry analysts say, however, another of the proposal's aims is to spur American manufacturers to better compete with Japanese HDTV development, which is the furthest along.

The Japan Broadcasting Corp. plans to deliver high definition programs based on the 1125/60 production and transmission standards by satellite to homes in Japan soon; public test transmissions were completed in September. European manufacturers are lobbying here for a different HDTV standard based on 1250/50 Hz, while NBC continues to support a third advanced television transmission standard based on 1050/59.94.

The FCC has ruled that any HDTV transmission standard used in the U.S. must be compatible with current NTSC receivers.

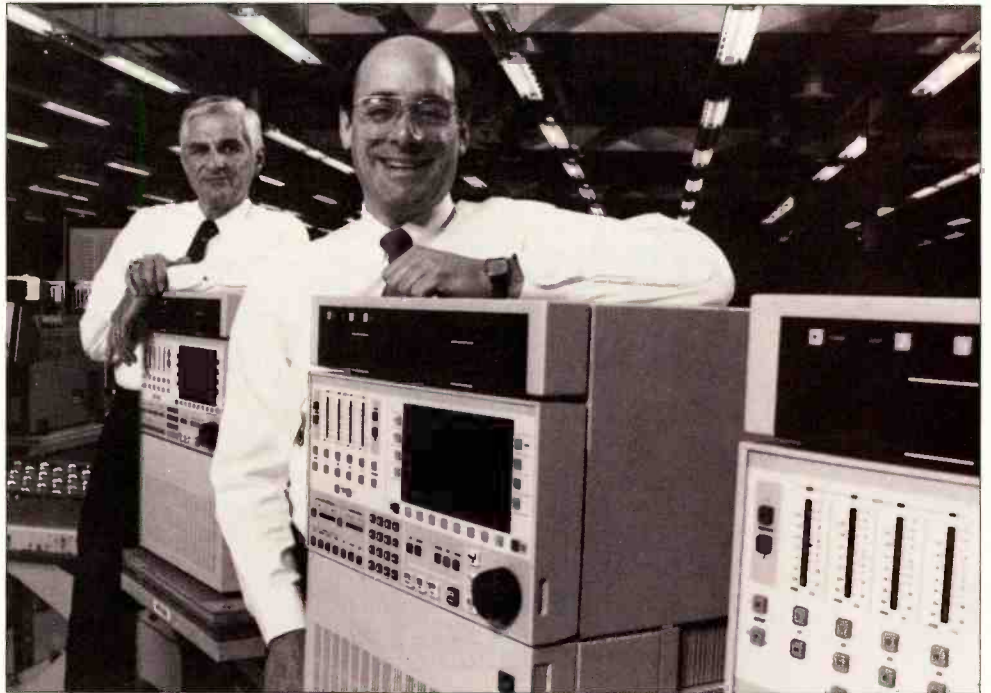

Ampex Ships D2 VTRs

The Ampex Corp. has begun shipping D-2 format composite digital studio VTRs. Customer deliveries of the company's first VPR-300s began in November 1988.

Initial orders for the format taken at the NAB in April were valued at over \$30 million, the company says. This represents 300 recorders. Contracts for an additional 100 units were received later that year. The VPR-300 is manufactured at the Ampex plant in Colorado Springs, CO.

This ruling would eliminate both Japanese and European systems from transmission here.

Next steps for HDTV receivers may leapfrog CRT technology entirely and move directly into flat panel display. Although this should not affect the adoption of either an HDTV production or

transmission standard technologically, it may impact market development decisions and hence support for a particular standard. Japanese and American manufacturers have been researching full-color liquid crystal and gas plasma flat displays for some time, to little avail. Another approach has

Ampex plant general manager Robert Hagerty (l) and Ronald Ritchie, vice president of the recording systems division, prepare to ship their first D-2 format VTRs.

been developed by FiberView Corp., Boulder, CO. Already contacted by DARPA, the company is working on a large-screen fiber-optic display. A prototype is expected within two years.

The Department of Defense has funded TV design work for more than 20 years, according to the *Wall Street Journal*.

IDB Buys HTN

IDB Communications Group, which provides satellite distribution services for television, radio and data traffic, has an-

UPDATE

nounced it will buy Hughes Television Network. Based in New York City, HTN provides domestic U.S. satellite transmission services for television programming. The company currently controls 14 transponders on four satellites and handles exclusive transmission of "away" games for major league baseball.

"This acquisition strengthens IDB's position as a provider of turnkey services for television distribution," said Peter Hartz, board member and vice president of sales and marketing for the Los Angeles, CA-based company. "It won't mean changes in how the job is done or the quality of the job that's done. It simply adds a new service we are able to provide." The move will provide "synergy" for both companies, Hartz says: previously IDB had provided ground services and uplinks to HTN transponders, while HTN provided IDB with transponder time to package to clients.

"It's a strategic fit," said Hartz, explaining that the acquisition will add capability and realize cost efficiencies which will enable the company to develop more competitive pricing packages. "We have the biggest ground fleet and they have the biggest buying power."

The move is fortuitously timed, because the company predicts consolidation in the satellite services industry. "There will be a lot of coming together of marginal players,"

Hartz said. The acquisition is especially well-timed because future shortages of transponder capacity have recently been publicized widely. Through HTN's long-term contracts on transponders, IDB can now command easier access to time that might have been scarce for

suppliers negotiating on a case-by-case basis.

There will be no management changes at HTN and president John Tagliaferro will become president of a new division of IDB. Both companies will continue to maintain key third-party vendor relationships as needed.

"It won't mean changes in quality or how the job is done," Hartz said. "It just reflects a maturation of the market."

Focusing on radio when initially founded, IDB owns and operates 14 earth stations located in Staten Island, NY in addition to Los Angeles.

FCC Will Modify One-To-A-Market Station Ownership

In a move seen as generally favorable to broadcasters, the FCC has agreed to allow exceptions to its rules against ownership of more than one station in a given market. In the top 25 markets, the Commission will "look favorably on waivers provided there are 30 separately owned and operated broadcast stations in that market," the Commission stated. It added that it would also give favorable consideration to financially troubled broadcast stations that have been dark "for a substantial period of time" or that are involved in bankruptcy proceedings.

FCC Chairman Dennis Patrick said, "The record in this proceeding overwhelming details the efficiency benefits and cost savings that accrue from joint ownership of radio and television. These efficiency benefits in turn have proven to lead to

public benefits such as increased news and informational programming, as well as more stations being able to survive on the air in an increasingly competitive environment." In a statement on the FCC action, NAB vice president and general counsel Jeff Baumann said, "Philosophically, the NAB was opposed to the imposition of the original rule [in 1970] and has favored elimination of the existing rule.

The FCC's action is a step in the right direction, and given the mood of Congress and its concern over this issue, we believe the Commission went as far as it could."

The FCC release does not specifically mention markets ranked below the top 25, but many of these markets have more than the required 30 separately owned and operated broadcast stations. Great American Broadcasting's vice president for corporate affairs, Anita Wallgren, commented, "We are awaiting release of the official report, but we plan to file a petition

for waiver in Cincinnati and Kansas City, and given the diversity of these markets, are optimistic that a waiver will be granted."

SBE Call for Papers

The Society of Broadcast Engineers is now soliciting proposed engineering papers for the 1988 Broadcast Engineering conference. It will be held October 5-8, 1989 in Kansas City, MO.

The technical conference will address hands-on needs of engineers and technical managers at radio and television stations.

Abstracts and letters of interest in serving on panel discussions must be submitted by March 31, 1989. Camera-ready manuscripts are due June 30, 1989. Send all material to conference chairman John Battison, 890 Clubview Boulevard North, Columbus, OH 43085. ■

WE'RE AS GOOD AS THEIR WORD.

"The NEC transmitter has superior reliability and stability. Breakdown is not a problem."

Bob Morgan, Chief Engineer
WCTV-TV
Tallahassee, FL

"It's got reliability and stability. There've simply been 'no bugs with the transmitter since we started. We're very satisfied, very happy."

Lacy Worrel, Chief Engineer
WMAZ
Macon, GA

"Its reliability is phenomenal. There are no moving parts in the cavity, and breakdown has not been a problem. This transmitter's been perfect. We've been amazed!"

Jim Lockerd, Chief Engineer
KSWO-TV
Lawton, OK

"We were looking for modern technology, and we liked NEC's approach. We have had no problems at all with our transmitter. Power consumption has gone way down from our older transmitter. The transmitter's very stable."

Don Luchsinger, Chief Engineer
KVOS-TV
Bellingham, WA

"We've had very, very, very few breakdowns with this system. It's been almost trouble-free. It's that reliable."

David Williams, Chief Engineer
WTVM-TV
Columbus, GA

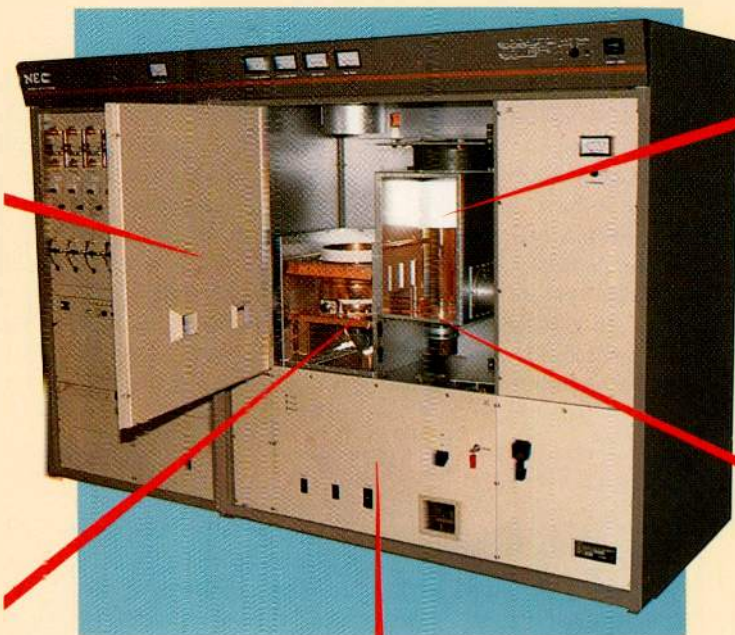

If you want a clear picture of just how good an NEC VHF transmitter is, take a look at what people who use them are saying. They're talking about reliability. Stability. Excellence in design. Low cost operation. And there's no comparison when it comes to maintenance. They require very little attention.

They're also saying that NEC people are always there when needed. With suggestions. Ideas. Answers to questions. Replacement parts. Or whatever it takes to keep a transmitter running smoothly.

What they're telling us is what we'd like to tell you. If you need a transmitter that's built to be reliable year after year, that's known for stability, and that's not power hungry, take a look at what NEC is offering. Better yet, take a user's word for it.

Here's why there's no comparison:

- 100% solid state to 10 kW; one tube to 50 kW
- Power ranges from 1 to 60 kW (parallel running) Band I, to 100 kW (parallel running) Band III
- 30% reduction in exciter parts for 50% increase in MTBF (to 30,000 hours)
- Ready for stereo without modification

- Regulated power supplies throughout transmitter (including filament of final tube)
- No finger stock in cavity
- Only two controls on cavity
- Over 20,000 hours on final tube
- All solid state aural and visual drivers

Emergency parts are available 24 hours a day, 365 days a year in Wood Dale, IL, 30 minutes from O'Hare Airport. Simply call 1-800-323-6656.

For more information about NEC transmitters, contact NEC America, Inc., Broadcast Equipment Division, 1255 Michael Drive, Wood Dale, IL 60191. Phone: 312/860-7600.



PCU-900 Series UHF Transmitters also available. Power sizes 10 kW to 240 kW (parallel running).

NEC

CROSSTALK

AN ENGINEERING MANAGEMENT JOURNAL

And In This Corner...Class A Power Hike Dispute Boils Over

And In This Corner...

As this issue of *BME* went to press, we received word that Ampex—whose Ampex Digital Optics system has a major share of the special-effects market—has filed suit against its competitor, Abekas Video Systems, for “willful and deliberate” infringement of five Ampex patents. Abekas has flatly denied any wrongdoing.

According to the Ampex suit, several Abekas products—the A52 and A53D digital special effects devices, the A62 digital disk recorder and the A42 still store—illegally use five Ampex patents. The patents protect the following techniques and devices: digitally controlled lap dissolver; high-bit-rate digital signal transmission system; video frame storage recording and reproducing apparatus; method and apparatus for digital video-signal processing; and controller for system for spacially transforming images. Ampex’s legal department would not further describe the individual patents or say which Abekas products allegedly violate which Ampex patents.

On the surface at least, Ampex appears to have a strong case simply because the three founders of Abekas—Junaid Sheik (no longer with the company), Yeshwant Kamath and Phil Bennett—all previously worked as engineers on the design team that developed the ADO and ESS still store. An Ampex spokesman said the company’s suspicions were first aroused about four years ago when Abekas introduced the A52.

“We investigated the product and determined that indeed it did infringe upon Ampex-patented inventions,”

according to the spokesman. “So, in 1986, Ampex, having confirmed to its satisfaction that an infringement had occurred, approached Abekas with an offer to license the infringed patent technology....During the course of negotiations, other patents and products were discovered to have been infringed....After two years of negotiations...Abekas refused a license agreement and said it would continue to manufacture and market those products...leaving Ampex no alternative but to seek a resolution in the courts.”

Abekas tells a somewhat different story. “Ampex offered a package of patent licenses to Abekas in 1986,” says Abekas vice president, sales and marketing, Paul G. Hansil. “We felt that their offer was not relevant because we were not using any of the technology in those patents, so we said thanks, but no thanks.” He added, “Our position really hasn’t changed since the first day we received the offer from Ampex.”

In an official statement by Abekas, company president Yeshwant Kamath said the company was “stunned” by the Ampex action. “We have always been cordial and cooperative in our relations with Ampex since our departure in 1982 to found Abekas. I am incredulous that the

A62 Digital Disk Recorder, for which our company won both an Emmy and a Monitor Award for technical excellence in 1986, now stands accused of violating Ampex patents.”

What’s behind the timing of the suit? Some industry observers speculate that Ampex may see the suit as a way to get a major cash infusion. Ampex is seeking monetary damages, which, given Abekas’s success, could prove substantial if Ampex prevails. The contestants have taken their cor-

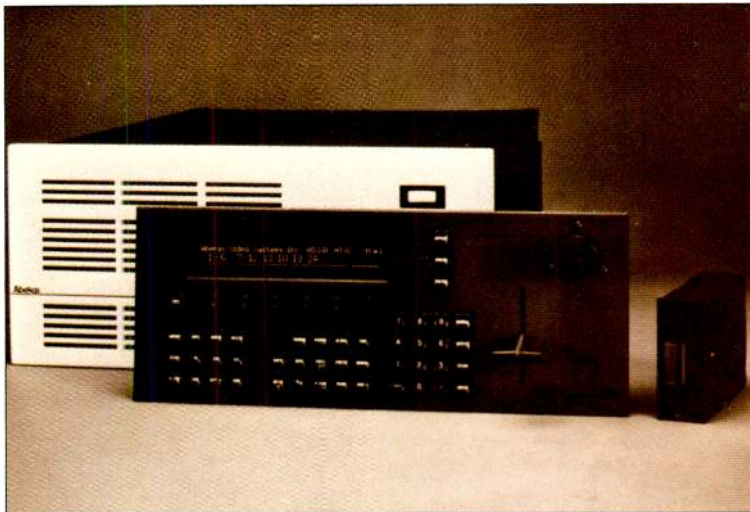

Abekas A53-D: no patent violation, says the company. Ampex's suit also names the A52, A62 and A42.

ner places and are lacing up their gloves. Whatever the outcome of this match, it should be accompanied by plenty of special effects.

Class A Power Hike Dispute Boils Over

The New Jersey Class A FM Broadcasters Association, the NAB, and a number of FMers

For Your 601 and D2 Tool Box

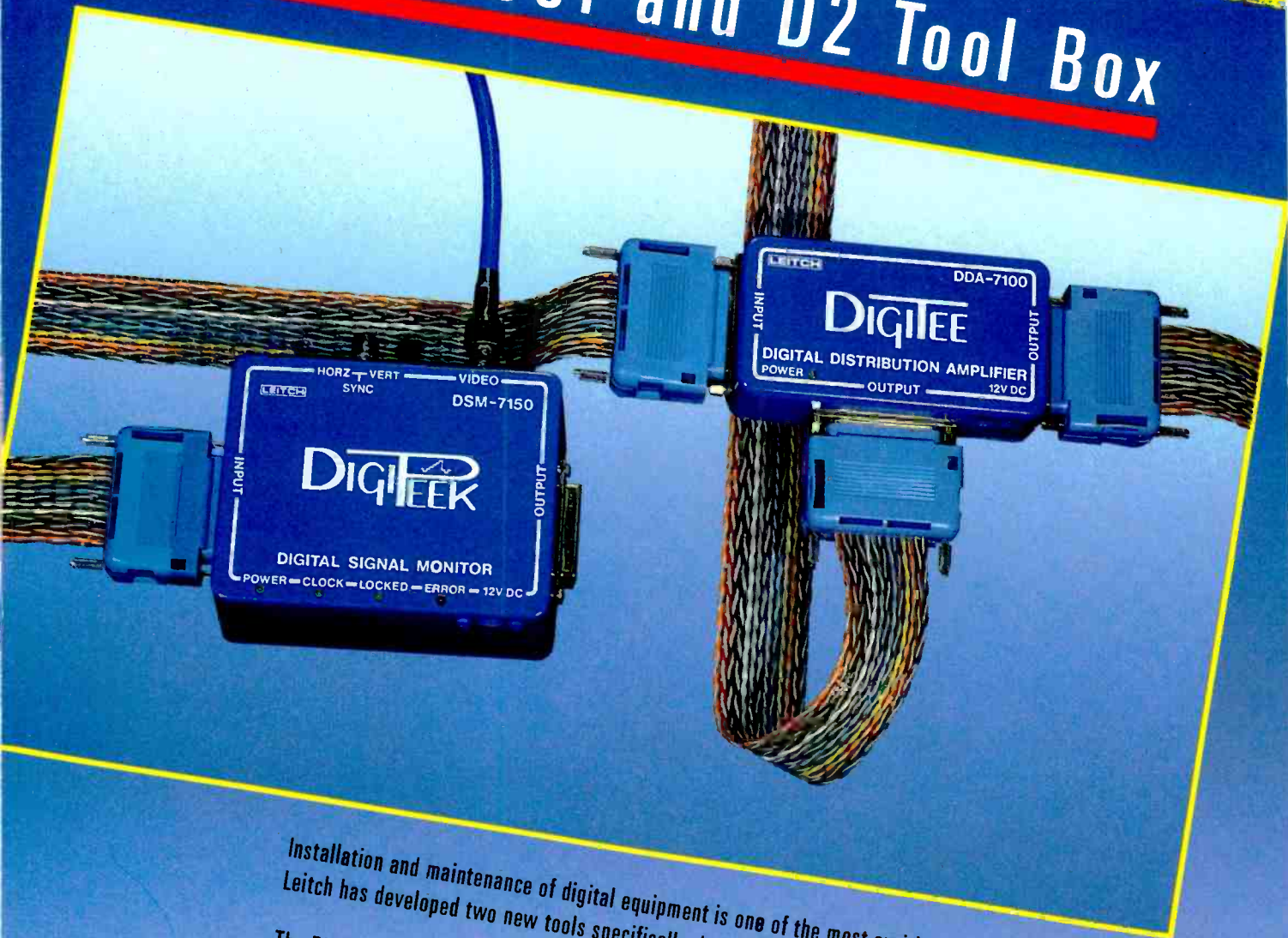

Installation and maintenance of digital equipment is one of the most exciting challenges of this decade. Leitch has developed two new tools specifically designed to simplify your digital installations.

The DigiTee provides compact signal distribution. Since, according to CCIR 601 and D2 specifications, equipment must have terminating inputs, the DigiTee provides a practical equivalent to looping inputs. The DigiTee doubles as a line amplifier for long cable runs by re-synchronizing the full 10 bit data path, yet is small enough for cable troughs.

The DigiPeek's 1 volt composite output and LEDs provides monitoring and status of the digital signal. A re-synchronized digital output permits in-circuit monitoring. The compact DigiPeek is ideally suited for trouble-shooting complex digital systems.

To keep your digital tool box up-to-date, contact your Leitch dealer.

Leitch Video of America, Inc., 825K Greenbrier Circle, Chesapeake VA 23320
Tel: (800) 231-9673 or (804) 424-7920 Fax: (804) 424-0639

Leitch Video International Inc., 10 Dyas Rd., Don Mills, Ont., Canada M3B 1V5
Tel: (800) 387-0233 Fax: (416) 445-0595 Telex: 06 986 241

LEITCH

CROSSTALK

acting independently have filed reply comments to the FCC's proposed rulemaking seeking a power increase for Class A FM stations.

The issue, which has become a bitter radio industry dispute, began in September 1987 when the New Jersey Class A association filed for an across-the-board power increase from 3 kW to 6 kW for all Class A FM stations. In response, the FCC issued a proposal in July 1988 which provides a power increase for all Class A stations that are not currently short-spaced.

A second Commission proposal—developed in response to an autumn petition by the NAB, which calls it a “compromise”—mandates increased separation between Class A stations and all other stations to accommodate

“Most of the arguments that can be made have been made, although we will establish several salient new points in our reply comments,” said Robert McAllan, president of the New Jersey association. “There’s no question that the Commission, various organizations and radio broadcasters are sympathetic to the need for a power increase, but the real argument is about who is going to get what. We strongly believe—and our proposal so states—that *all* stations must benefit.”

Not enough Class A stations would gain much from the FCC's proposal, according to the New Jersey group. About 30 per cent of the 845 Zone 1 Class A stations are short-spaced.

The NAB's proposal, which in effect

the most are least likely to get it,” McAllan says. The group further opposes any solution that mandates the use of directional antennas, according to Ken Keane of Wilner and Scheiner, counsel for the association.

While it is virtually certain that some form of power increase will be granted to Class A broadcasters, the altercation has caused a nasty rift between the NAB and some Class A FM stations. Some Class A stations have already resigned from the NAB, charging that more consideration has been given to the special interests of bigger Class B and C operations. Dissidents maintain these classes were more heavily represented on the Radio Board and FM Subcommittee, which considered the technical merits of the New Jersey proposal.

More wide-ranging is the charge that an industry trade association should not act in a manner that would not support the interests of its entire membership body.

“I believe that we need a strong trade association to represent us on issues that face us as a total industry,” says McAllan. “I further believe it is not appropriate for the NAB to get involved in intramural squabbles between association members. The FCC is the right and proper forum for that.”

The NAB replies that the Radio Board considered the New Jersey proposal in the light of its newly developed position on maintaining spectrum integrity. This position holds that no FM or AM activity should cause “significant new interference,” according to Jeff Baumann, general counsel for the Association.

“We are totally in favor of a power increase for Class A stations, but our engineering studies indicated that an across-the-board upgrade would cause significant interference,” he said.

Moreover, the Class A power upgrade should be considered as part of the bigger issue of FM spectrum allocation. “We see the FCC abandoning the concepts of mileage separation and localism in favor of a ‘demand’ system,” Baumann said. ■

New (and Old) AM Contours

Power	250 watts	1000 watts	5000 watts	50,000 watts
630 kHz	9.0 (23.5)	14 (33)	23 (46)	38 (75)
1100 kHz	5.9 (13.5)	8.6 (18)	12.5 (26)	24.5 (45)
1550 kHz	4.2 (8.9)	5.8 (12.3)	7 (17.6)	14.5 (31)

[Error is +/- 1 mile. Assumes nondirectional antenna operations at standard AM antenna efficiencies (175 mV/m/kW).]

New FM Contours

Class	Max. Facilities (ERP/HAAT, meters)	60 dBu	70dBu
A	3 kW/100m	14.8	8.4
B1	25 kW/100m	24.0	14.2
B	50 kW/150m	32.2	20.2
C2	50 kW/150m	32.2	20.2
C1	100 kW/300m	44.7	31.0
C	100 kW/600m	56.9	41.9

[Error is +/- 0.2 mile.]

Distances to both contours for AM and FM bands, following recent relaxation of FCC rules.

such an increase. Increases would only be granted on an application-by-application basis. Further, short-spaced stations would have either to use a directional antenna, relocate their transmitter or reduce antenna height. These measures are designed to prevent interference on the FM band or affecting service of other FM stations in the short-spaced direction.

creates two groups of Class A stations—those who can increase power and those who would have to take other measures to benefit—only provides a simple upgrade for about half the 2043 Class A stations operating in the U.S. Most of those are in Zone 2. The New Jersey group, most of whose members are in Zone 1, opposes this proposal, too. “Those that need help

Ready to Score Another Scoop!

Toshiba's Mt-3 Satellite Scoop System makes live coverage of fast-breaking news events routine.

This complete Ku-band system fits in 10 compact, lightweight flight cases that meet IATA carry-on baggage regulations.

Once on site, an array of proven Toshiba design advances facilitate set-up. A 1.8M parabolic antenna with a simplified 360° azimuth rotary mechanism in addition to an easy polarization, 6-segment FRP antenna reflector make set-up short and sweet.

The synthesized exciter minimizes MCPC/SCPC carrier phase noise and provides all-purpose control flexibility. And advanced microprocessor controls assure complete access with all existing international communication satellites.

Toshiba's Mt-3 Satellite Scoop System effectively takes the work and worry out of live news coverage.

The Mt-3 was developed jointly by Toshiba and CBS Engineering and Development.



Satellite Scoop System
Mt-3

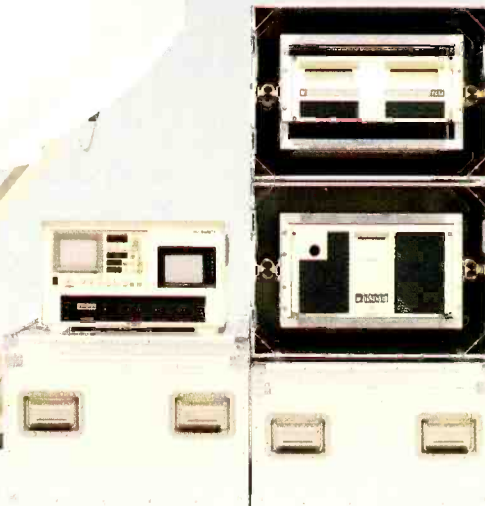

TOSHIBA

TOSHIBA CORPORATION TOKYO JAPAN

ELECTRONIC SYSTEMS DEPARTMENT

1-1, SHIBAURA 1-CHOME, MINATO-KU, TOKYO, 105, JAPAN
TELEX: J22587 TOSHIBA CABLE: TOSHIBA TOKYO PHONE: 457-3246-8

TOSHIBA AMERICA, Inc.

701 WESTCHESTER AVE., SUITE 204W, WHITE PLAINS, N.Y. 10604 TELEPHONE: (914) 949-7750/52/56/58 FACSIMILE: (914) 949-8004

Circle 123 on Reader Service Card Page 63

Rewritable Optical: Here at Last

By Beth Jacques

For the last seven years the joke in the disk drive industry has been that the optical drive is just three years away. One variant, the so-called "erasable" optical disk, has been a gleam in PC users' eyes since 1981, when 3M developed a major materials breakthrough that helped enable real-world development.

Following a frenetic year of product launches and chimerical "announcements" of independently developed technologies, the good news is that erasable optical disks and companion disk drives are now here and available for use. Related to CD-ROM (Compact Disk-Read Only Memory) and WORM (Write Once Read Many) technologies, erasable, or "rewritable," optical disks can be erased and rewritten at will over the life of the disk. (Optical disk life is currently estimated at 10 million write-erase cycles, which compares favorably to magnetic media.)

Quantities are limited, but at least six major manufacturers have created drives and disks that look like they will work. Best of all, they communicate with each other, which bodes well for agreement on an international standard. Standards for the 5¼-inch erasable optical format were, in fact, accepted by the International Standards Organization two months ago.

"We're home free from a standards point of view," exulted one industry insider, acknowledging that acceptance of a standard (the ISO agreement also includes ANSI ratification) and commercial availability of products are the two biggest hurdles facing the nascent format. Development of a standard interface will be critical for mass acceptance of the format.

For sheer number of "blue sky" technology announcements, the erasable optical disk looks to be computerland's next alchemical stone. Bold an-

nouncements were made in 1988, first of an erasable audio compact disc (CD-Thor, from Tandy, which is "at least" two years away by the company's own admission) and then from

Steve Jobs, former Apple president, who claims his NeXT PC, a much-ballyhooed "fourth-generation" personal computer, will contain Canon's erasable optical disk, and at prices which appear to contradict Canon's own reports.

"These announcements generated a lot of interest—and some confusion," said one engineering expert, pointing out that Canon's refusal to demonstrate the disk at a recent computer show indicates that, like Tandy, the technology is proprietary (and hence not compatible with a standard.) Reviewers also say they have not been able to perform hands-on work with the NeXT computer alone; a second industry expert tells *BME* categorically that the NeXT optical system disk announcement is "just a tease. When it ships, it'll ship with a hard disk."

Manufacturers who are currently supplying optical disk drives include Sony, Olympus/Ricoh and Maxtor. Erasable optical disks are currently available from Sony and 3M, although "it's just a matter of when the other shoe drops" before European giant NV Philips enters the market, says an expert. (Philips and Sony independently developed the digital audio technology that later became the industry standard Compact Disc audio format.) It is, perhaps, significant that of these companies, only 3M and Maxtor are American. Called "Tahiti"—ostensibly because if it succeeds, company engineers can retire there—the Maxtor drive offers 1 gigabyte of storage on one 5¼-inch optical disk. This is currently twice the capacity offered by Japanese companies, but that will change. It is known that "Japan, Inc." holds a "national interest" in information technology in general and optical media in particular.

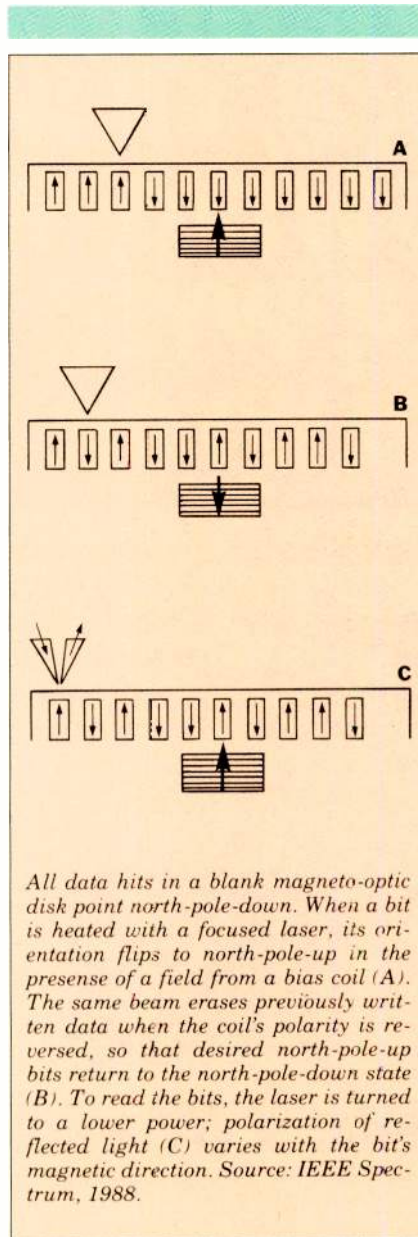

All data bits in a blank magneto-optical disk point north-pole-down. When a bit is heated with a focused laser, its orientation flips to north-pole-up in the presence of a field from a bias coil (A). The same beam erases previously written data when the coil's polarity is reversed, so that desired north-pole-up bits return to the north-pole-down state (B). To read the bits, the laser is turned to a lower power; polarization of reflected light (C) varies with the bit's magnetic direction. Source: *IEEE Spectrum*, 1988.

**CBKT, CBVT, CIVN, KAKE, KARE, KDCO
 KFVS, WGAN, WOI, KHJ, KIMO, KOA
 KOLO, KTSM, KUON, KWHY, KWWI
 KXJB, KXTV, NUSTAR, WATL, WBAI
 WDRB, WFTX, WGGB, WGME, WGN
 WGRZ, WICS, WICU, WJAC, WKBW
 WMTV, WOWT, WPBT, WBIR, WPEC
 WPTF, WPTN (2), CRAWFORD, WSYX
 WTHI, KHBS, WTVO, WVEC, WKOW
 WWAY, WWLP, WYTV, WKYT, WLOS
 NBC NEWS (2), WYOU, CNBC, WTML**

No one has installed more library management video cart systems than Odetics.

Every one of these cart machine users now enjoy a better on-air look and fewer makegoods.

Their operations have been simplified by a database management system that's so powerful, an

operator can track every cart without leaving his chair.

The Odetics library management cart system smoothly interfaces with other equipment, from traffic computers to station automation systems.

To learn more about Odetics' broad line of library management video cart systems, call us today.

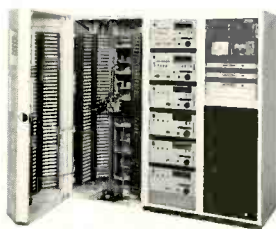

Odetics Broadcast

1515 South Manchester Avenue, Anaheim, California 92802-2907 ☎ 800-243-2001 or 714-774-2200

Director of Sales Bill Keegan ☎ 913-862-2824	Northeast Jesse Nickels ☎ 608-754-2139	Southeast Emerson Ray ☎ 813-960-0853	West Chuck Martin ☎ 818-880-4165	South Central Philip Smith ☎ 214-250-4429	Midwest Bill Boyd ☎ 612-894-2121
--	--	--	--	---	--

See Us At NAB, Booth #0711

Circle 110 on Reader Service Card Page 63

Second generation erasable optical drives and media are already in development, according to Sony. While other development announcements to date have been mostly blue smoke and mirrors, companies known to be working in the area include Sharp, Nikon, IBM, Hewlett Packard and Verbatim, a subsidiary of Eastman Kodak, which is working on 3½-inch drives. It is further expected that Korean and Chinese manufacturers will enter the market within the next two years. While such an entry stamps the erasable optical disk a true mass-market product, it is still probable that only the companies who are currently in production or far advanced in planning will eventually succeed. "Some people will tough this out regardless for strategic reasons, but this is very sophisticated and you really need to have a lot of costs behind you," said one manufacturer.

Rewritable optical media offer two major advantages which broadcasters and facility users, among others, cry out for: high capacity digital storage which can be erased and which can be removed from its operating unit. Based on magneto-optical technology, erasable disks currently hold about 600 Mbytes of information on a two-sided 5¼-inch disk or 80 Mbytes on a PC-sized 3½-inch disk. (Note, though, that current optical disk drives are single-sided only.) Applications abound, particularly in video imaging, which requires a great deal of data and is difficult to manipulate because no portable, high-capacity storage medium has hitherto been available. Initial target markets include CAD/CAM and graphics and imaging equipment, where the pressure is constant to offer higher resolution and better color definition.

Sony is targeting special applications for the technology, at least initially. When it demonstrated its 5¼-inch erasable optical disk drives and cartridges at the recent COMDEX computer show, it used them to throw up detailed color images on the screen of its NEWS workstation. First-generation

First generation data transfer time is "a problem but it will be solved."

optical drives won't replace Winchester hard disk drives, the company says, but will instead be used in new applications such as backup for central computer systems or on-line library storage systems for engineering and graphics drawings. CAD/CAM, medical imaging and high-resolution scanning and color printing applications are immediately apparent. Speedier second generation models will be "the storage medium of choice" for networked data libraries and desktop workstations, according to W. Mike Deese, vice president of Sony's U.S. optical storage system division.

Two problems plague the first-generation technology, however. Data access time is slow and not competitive with fast Winchester disks. (A 300-Mbyte 5¼-inch Winchester drive accesses data between 20 and 60 ms; the same capacity magneto-optic drive takes 40 to 60 ms.) Worse, first-generation data transfer rates for erasable optical media run at 100 kb/s, compared to 1Mb/s for magnetic media. "This is a problem," said one

manufacturer. "Everyone knows it, and it will be solved." Second-generation magneto-optic drives are expected to approach 16-30 Mbits/s for data transfer and 20 ms for data access, according to Robert Freece of Alphatronix Inc., a North Carolina company which supplies complete high end magneto-optic subsystems to computer companies. The problem arose in part, according to Freece, because erasable disks arrived before the drives, while new, did not and therefore operate essentially as modifications of current designs.

In addition to much faster access and transfer times, new developments for the technology include dramatically increased data capacity—perhaps ten times the current launch capacity of 600 Mbytes—and a 3½-inch format. Pricing, too, will be an issue: drives currently cost around \$3800 and cartridges are \$250 apiece; Canon will supply an evaluation system for \$6000 and an additional cartridge for \$200. While citing Canon-based cartridges for the NeXT computer at \$50 is considered "premature," prices for a standard 600 Mbyte erasable disk are expected to fall into that price range eventually. ■

Jacques is BME's senior editor.

Recording the Erasable Disk: How to

Data are stored on a thin film of magnetic material as a sequence of digital bits whose magnetic field is either north-pole-up (digital "1") or north-pole-down (digital "0").

All magnetic domains on a blank disk point north-pole-down. At 150 degrees C. the magnetic force ("coercivity") needed to flip a domain falls to zero and the bias field records a north-pole-up alignment.

To record an erasable disk, an infrared laser beam heats a microscopic spot on the disk to 150 degrees C. and records a digital bit. The medium cools immediately and freezes the spot's orientation. To erase, the bias magnetic field is reversed to north-pole-down—either by physically inverting the magnet or reversing the current flow through an electromagnet. The data flips and the disc can be rewritten.

Ikegami's Mini-Microwave Links Offer Video Coverage
Never Before Possible

PORTABLE MICRO



The PP-70 provides coverage from atop the Gulf & Western Building to a receiver at ground level for window-link transmission.



The PP-80 mounted atop the Verrazano Narrows Bridge provides spectacular coverage at the start of the NYC Marathon.

By miniaturizing sophisticated microwave technology, Ikegami's microwave links allow you to maximize your video coverage by reaching these hard to get to places and sending back those once impossible shots.

Recent uses of the PP-70 and PP-80 models include spectacular bridge-top shots of the start of the N.Y.C. Marathon, breathtaking mountain top shots of a major ski jump event and, up-close action in the pits of the Indianapolis 500.

SUPERIOR TECHNOLOGY MEANS VIDEO COVERAGE AT ITS BEST.

High performance, state-of-the-art technology, combined with rugged, lightweight design, are just some of the many advantages you'll discover in our mini-microwave links.

When used with the appropriate antenna, the links can transmit up to 50 miles between the event site and an OB van or relay point.

The PP-70, available in 7 or 13 GHz, (soon to be available in 2GHz) features low power consumption, a built-in frequency synthesizer with 14 channels in the 7 GHz Band and 22 channels in the 13 GHz Band, a Double

WAVE!!!

Superhetrodyne Receiver to minimize adjacent-channel interference, built-in video and audio test signal generators to simplify field operations, audible tone to insure directional alignment, and much more.

The PF-80 available in 2 or 7 GHz incorporates many of the advantages of the widely acclaimed PP-70, and adds such up-to-the-minute technologies as switchable

power (low-high), and a remote control terminal for airborne operation.

Both systems are available with a wide range of antennas and accessories.

To find out more, contact Ikegami Headquarters or your nearest Ikegami microwave sales representative.

SYSTEM FEATURES AT A GLANCE

POWER OUTPUT ● PP-70 – 120mW – 13GHz
1.2W – 7GHz

SWITCHABLE POWER OUTPUT ● PP-80 – 2GHz 3/12 watt
PP-80 – 7GHz 1/6 watt

PP-70 ● Rugged two-piece design

PP-80 ● STL applications

PP-70 & PP-80

- Quick disconnect antenna
- Plug in card design affords easy change of subcarrier frequencies and easy service
- FCC type acceptance
- Frequency agile
- Built-in LED field strength meter and beeper for easy antenna alignment
- External field strength meter capability
- Off-the-shelf availability
- Wide range of accessories available
- Ideal for IF (70MHz) repeat capability
- Small size, lightweight, make it ideal for mobile van applications
- Ideal for sporting applications

Beers Associates, 112 Turnpike Road Ste. 302, Westboro, MA 01581, 508-898-3200

R&H Associates, 2060 N.E. Coachman Road, Clearwater, FL 34625, 813-442-7505

Charles Patterson & Associates, 4815 Montclair Avenue, Charlotte, NC 28211, 704-364-5146

ComLogic Inc., 5240 E. Bromley Drive, Agoura CA 91301, 818-991-7506

Broadcast Plus, Inc., Central American Terminal, Bowmar Field, Louisville, KY 40205, 502-452-2777

Emmons Associates, Inc., 1121 Riverwood Drive, Burnsville, MN 55337, 612-890-8920

Image Marketing, PO Box 68996, Schaumburg, IL 60168, 312-885-4870

G.P. Enterprises, PO Box 912, Arlington, TX 76004-0912, 817-572-0132

The Waterford Group, 3070 Orchard City Drive, Ste 202, Campbell, CA 95008, 408-374-8450

Applied Electronics, 299 Evans Avenue, Toronto, Ontario M8Z1K2, 416-252-3761

Ikegami Electronics (USA), Inc.

37 Brook Avenue
Maywood, NJ 07607
(201) 368-9171

Ikegami

Why automate a television facility? What kind of automation system is best? These questions, which many station engineers face today, are made more complicated by the increasing number of choices in the automation field. In contrast to the situation just a few years back, today's broadcast industry offers many different options for television automation, ranging from the very simple to almost total station control. This article will explore the issues involved in automating master control in the modern station.

BY DAVID P. BIRD

Automation itself is not a new topic. Automation systems control many

suite. Perhaps no other purchase can do more for the efficiency and image of a television station. General purpose station automation systems offer many operational advantages; yet, there is probably no purchase that is put off or avoided more than the station automation system. This is due largely to the requirement of interfacing and controlling nearly everything in the broadcast facility. The magnitude and complexity of this task make specification, selection and installation of station automation an imposing task. There is also much confusion as to what television station automation can and cannot do, and what features are desirable or important.

There are few purely technical reasons to automate. The impetus to automate starts with station management and technical operations departments, with technical planning support from engineering.

The overriding reason to automate is reduction of errors. Incorrect interpretation of the printed schedule, incorrect media selection, and on-air switching errors detract from the station's image and its revenues.

Reduction of commercial errors increases sta-

tion revenues. Commercial spot errors affect station revenues in several ways. First, the revenue is lost. Second, a "make-good" is required. This means finding an acceptable position somewhere else in the schedule. Unless the schedule contains non-revenue positions, another commercial spot must be dropped. Thirdly, the revenue from the dropped spot is lost. A single commercial error results in loss of at least two revenue positions. Elimination of one or two commercial errors per week can pay for a sophisticated automation system in short order.

Switching errors are grouped into two types: operator and schedule. Operator errors are caused by misreading printed schedules or incorrect switcher source selections. Schedule errors are caused by bad program continuity or incorrectly identified me-

AUTOMATING THE MODERN TELEVISION FACILITY

AM and the majority of FM radio stations. Various forms of television facility automation have been in use during the last 10 years. The video editing controller was the first practical use of sophisticated machine and switcher automation. Cable television uses automation for multiple channel management and commercial insertion.

Most television broadcast facilities use automation to some degree. For over a decade, the Ampex ACR-25 and RCA TCR-100 video cartridge machines have been in widespread use, providing basic semi-automated operations. The new generation of video spot players, such as the Sony Betacart and Odetics cart machines, improves on the capabilities of their predecessors.

The greatest potential of facility automation lies in the master control

dia. Automation eliminates the need to search a printed schedule visually to find the next event or media. Validation of media and supervision of machine activities ensures that the correct media is available. If the system includes a spot player device, automation can confirm the presence of needed spot material.

Various levels of terminal prompts and alarm messages advise the operator of upcoming schedule requirements and alerts the operator to missing media. The timing of these messages permits operator corrective action before the schedule execution is effected. In event of equipment failure, the system must revert to a known default configuration preserving the on-air appearance.

Efficient use of technical labor and equipment is another reason to automate. Automation does not necessarily result in the reduction of labor costs. Rather, it helps the technical operator perform technical functions by reducing paperwork and the detailed review of complex schedules. With the flat commercial market of the last few years, efficient scheduling and maximum use of station technical resources are important concerns.

Various levels of facility automation exist in the modern television facility. The first step in selecting an automation system is to define the system control requirements clearly.

The simplest form of automation is switcher and machine control. This is described as configuration storage. The settings of routing switcher crosspoints and machine assignments are stored and retrieved depending on facility usage. These actions are not tied to an execution time but to the immediate needs of the facility.

The next level of automation includes execution of events based on scheduled times. These events are usually "off-line" or auxiliary control functions. Providing cuts switching and control of machines, *auxiliary schedule* events switch signal trunks, change inputs to production equip-

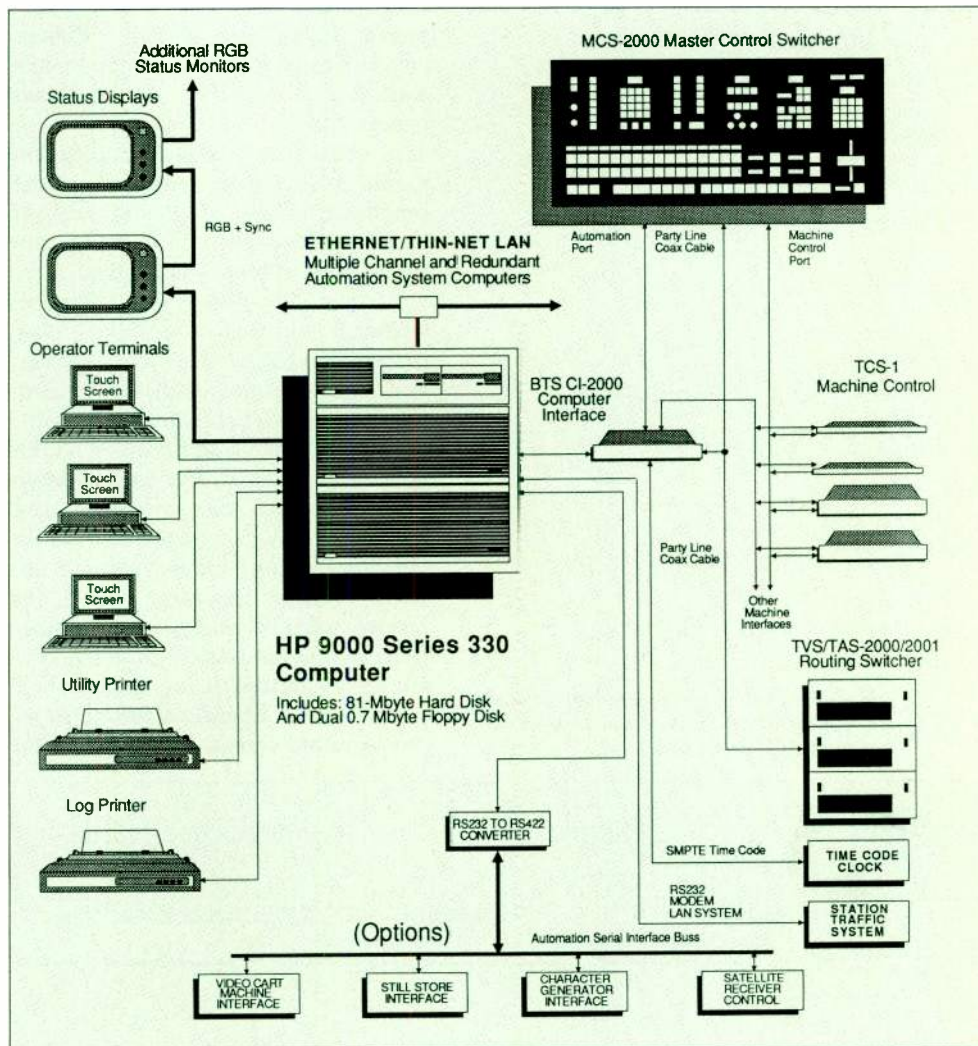

ment, assign sources to the master control switcher, and supervise scheduled recordings. Recording events may use multiple overlapping recorders and actually control external support equipment such as satellite antenna and receiver systems.

Master control or "presentation automation" includes many of the functions already mentioned, expanded to control the on-air continuity. *Main schedule* events control the signals and machines used for the master control operation. Traffic system interface, spot player support, and source transition are important features of this control level. The degree of master control switcher sup-

Typical system configuration of a full-blown master control automation system (BTS BTA-2300). An HP 9000 multiterminal computer system controls master control and routing functions, with optional interfaces to cart playback system, still store and graphics, and satellite receiver.

Automation of the master control suite can maximize a television station's efficiency and image.

The impetus to automate starts with station management and technical operations departments, with technical planning support from engineering.

port is one of the major differences between automation systems. Expansion to full-facility automation means control of all aspects of the broadcast operation.

A television station automation system must support each step in the broadcast process. Consider each of the following steps and how they apply to your current operations:

Automation system user interface. Operator terminal displays must present the required system information in an easily readable form. Effective use of color and character highlights direct the terminal user to the more important screen data. Simple and accepted use of keyboard pushbuttons coupled with touchscreen and mouse pointer devices simplify operator access to needed schedule data. System functions should not require unusual keystrokes or button sequences. System menus should identify themselves on the terminal screen and appropriate

menu functions should be easily selected.

The automation system should support multiple operator terminals. A valuable system feature supports terminal contexting. This permits a single-operator terminal to control more than one system function at a time, effectively doubling the number of terminals in a given system.

Automation video status displays. The station automation system should include a video status output distributed throughout the broadcast facility. This display contains the current schedule execution and the overall status of the automation system. System level error conditions are included on the status display. A system alarm output connected to an external alarm circuit can advise the operator of error conditions while away from the terminal.

Using the station traffic computer. Most modern broadcast facilities include a booking, billing and traffic de-

Multiple control computers can be linked via an Ethernet local area network to provide multichannel operation.

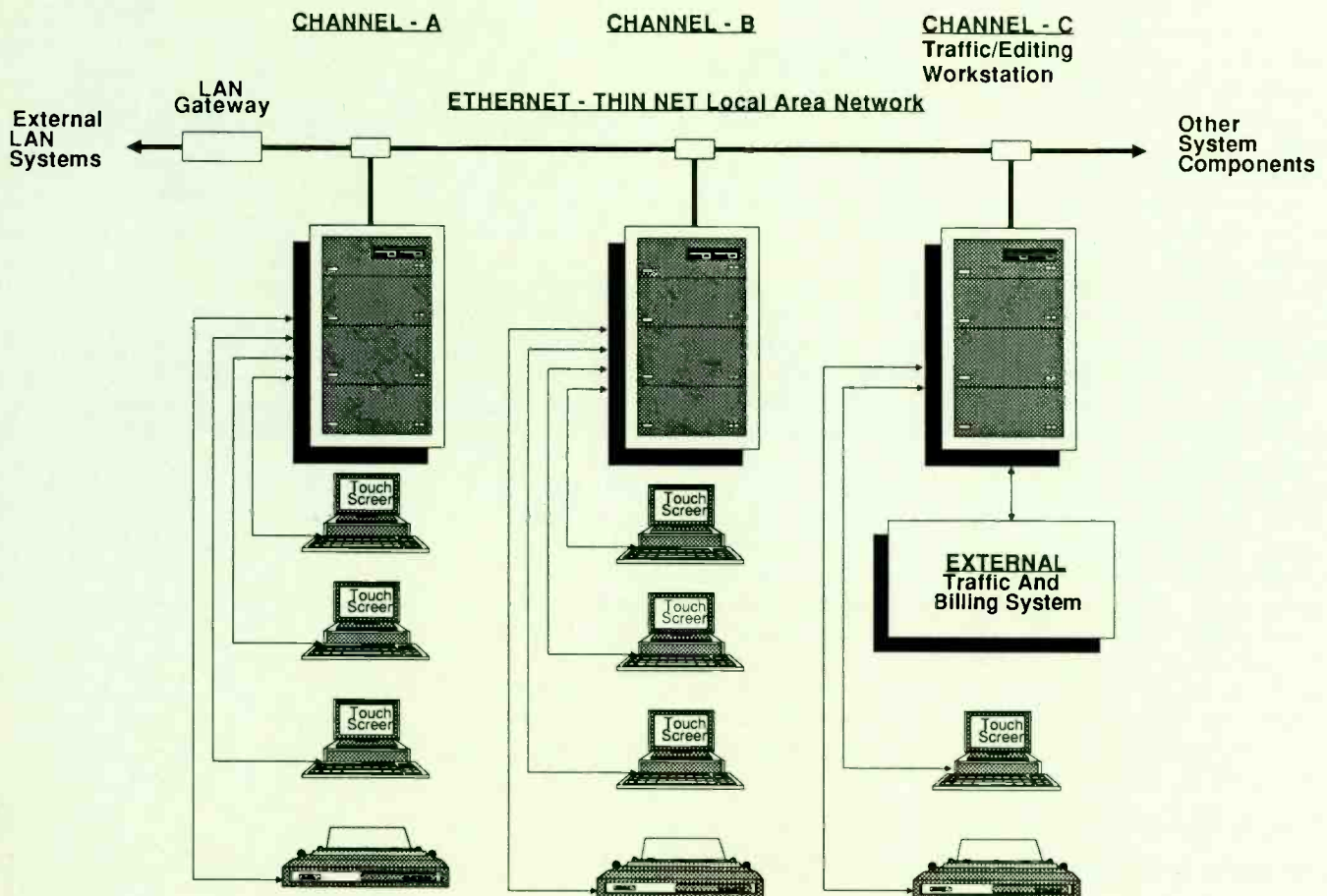

ROUTING

SYSTEMS



Wouldn't it be great if somebody built a routing switcher that could handle ALL of your switching requirements today without becoming obsolete tomorrow?

***SOMEBODY DOES.
UTAH SCIENTIFIC.***

Utah Scientific routing systems perform to the best specs in the industry. Reliability, ease of operation and long-term stability have been proven in more than 500 installations around the world.

Whether you need a simple 10x10 audio/video router, or a large, multi-level matrix to handle timecode, tally, and RS-422 control switching, Utah Scientific can provide a router configuration to meet your needs.

Controlling the router is easy with the industry's broadest selection of control panels, computer interface equipment, and automatic control systems, all of which are user reprogrammable. And, the uniquely flexible design of the Utah Scientific system ensures that you will have a router which can be easily expanded as your systems requirements change.

Call us today for more information.

Somebody does!

**US UTAH
SCIENTIFIC**

DYNATECH Broadcast Group

1685 West 2200 South, Salt Lake City, Utah 84119
(801) 973-6840 Toll-Free: 1-800-453-8782

```

A manager   Dec 15, 88      SCHED MANAGER OPERATION      15Dec88n.sch
15:22:34 00:00:58 Hold
Start      End      Tr  T Vid      Na Main NAud NAud  N Back Ba Back
Time      I C Duration T Typ S Sour Prer No Medt Sour Level N Sour No Medt Commn
15:21:38 E 00:00:30 R IV F BLK 0:05          +08.0 S          U j123 Altere
15:22:08 E 00:01:00 R V F BETA 0:02 BC b345 +06.0 L          Altere
15:22:10 E 00:00:58 R X F BETA 0:02 BC Id99 +08.0 S
E 00:03:00 X M CAM3          TUN1 +12.0 S          Audio
E 00:03:00 R V S VTR9 0:05 2 v345          S VTR2 U v345 Matte

```

THIS IS THE START OF A PROGRAM SEGMENT --- Example of a full-line comment

```

15:30:00 A 00:00:15 V S CAM1          S
15:30:15 E 00:01:00 W V S VTR1 0:05 BT v456          S
15:31:15 E 00:00:15 R X M CG-1 0:00 CG v890          S
15:31:30 E 00:00:15 X S          -- S001          S

```

```

Start      Duration Sour Dest Mach Co Tv Medt Lane Dest No Medt Lane Title
T S Time
M 15:22:45          VTR3 SAT1
M 15:23:00          DCR1 RC
M 15:23:15          VTR4 1002
M 15:23:30          DCR2 CU
M 15:23:45          VTR1 SAT2

```

```

Main Hold Take Skip 50 72 Increase Decrease Take More
SemiAuto Last Lost Next 307 90 Duration Duration Default
Nun Pad HP

```

Typical schedule manager screen of the BTA-2300, showing duration, location and status of upcoming events.

partment. The automation system should have access to the schedules generated by this department. A traffic system interface permits the transfer of schedule data and log reports directly to and from the traffic department computer, preferably with storage capability for multiple schedules and logs. Since the schedules and logs are transferred electronically, errors due to operator interpretation or keyboard entry are eliminated. Accurate logs and discrepancy reports are returned directly to the traffic computer for reconciliation and billing.

The technical interface to the station traffic system must be as simple as possible. The information interface should use industry-accepted data transfer protocols and serial interface standards. The automation system traffic routines must handle existing traffic system data formats. The automation system will convert the traffic format schedules to the required internal data formats. Extensive customization of the existing station traffic computer system is not a prerequisite to automation installation.

Editing and maintenance of program schedules. Broadcast schedules are subject to various forms of sched-

ule editing. The addition, movement, or dropping of spot positions, program changes and equipment availability require modification of the schedules received from the station traffic computer. Multiple authorized system users must be able to edit schedules and logs including schedules being executed.

The operator interface to system editors must be as simple as possible. If the editor functions like common word processors, training of system operators is simplified. Typical word processor functions such as search, search and replace, and global change are valuable editing capabilities.

The schedule editor must ensure that the data entered or modified is valid for required system operation. Validation of times, media types, and machine assignments help prevent the operator from creating a schedule error.

Further, the schedule editor should maintain a log of schedule changes. If an event is deleted or changed, the time, date, and who made the change is stored. This change record is important in tracking schedule-related errors. It can be used to trace the cause of an execution error to determine if it was caused by a hardware fault or an operator mistake.

The degree of editing capability should be limited to the requirements of each system operator. Permission levels tied to user passwords would permit full schedule editing, viewing of schedules and editing of comments, or viewing of schedules only.

Controlling schedule execution. The schedule manager functions control the actual execution of main and auxiliary schedule files. Automatic and semi-automatic modes should be included. The operator must be able to skip events to advance the schedule. The operator may define alternate or protection schedules, and easily change to the new schedules as required. The system should have the capability to automatically link to the next day's schedule. The automatic linking of schedules is important to

There is probably no purchase that is put off or avoided more by staff than the purchase of a station's automation system.



With the Master-21™ Master Control Switcher, the pressure goes off when the commercials go on.

The intelligent Master-21 Master Control Switcher will get rave reviews from a small but highly critical audience.

The people in your control room.

Thanks to the Master-21 switcher's configurable pre-set bus, you can take the guesswork out of complex set-ups by programming them in advance. And the system's RS422 Ebus port interfaces with a variety of automation systems.

The Master-21 system is a

dedicated stand-alone matrix that's loaded with high performance features. Like 16 inputs, accumulative keying, built-in stereo, and the industry's first-ever *Transition Status Display*.

There's something else intelligent about the Master-21 Master Control Switcher: the price. It's proof you don't need a

big budget to enjoy great programming.

Who knows? With the Master-21 system, you may actually enjoy watching television again.

For complete details and ordering information, contact the Grass Valley Group office nearest you.

Grass Valley Group®

A TEKTRONIX COMPANY

THE GRASS VALLEY GROUP INC.

P.O. Box 1114, Grass Valley, CA 95945 USA
Telephone (916) 478-3000
TRT: 160432

OFFICES: New York (201) 845-7988; District of Columbia (301) 622-6113; Atlanta (404) 493-1255; Chicago (219) 264-0931; Minneapolis (612) 483-2594; Dallas/Fort Worth (817) 483-7447; Los Angeles (818) 999-2303; San Francisco (415) 968-6680; GVG International Ltd. (U.K.) +44-962-843939; Grass Valley Group Asia (HK) +852-3-7396632

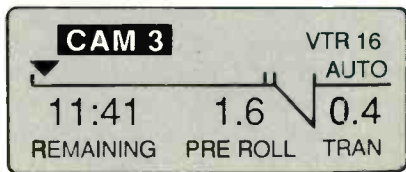

Master-21's unique Transition Status Display is one of many window inserts, that provides flexible, instant, and highly graphic access to all the information you need.

An ideal television station automation system must properly support each of the necessary steps in the broadcast process.

24-hour operation. The schedule execution must support several types of event initiations:

Absolute start times force events to start at a predetermined clock time. This start mode is used for predictable events, such as the start of programs.

Estimated start times change based on schedule continuity. If the operator changes or drops an event or places the schedule on hold, any following events should automatically adjust to reflect the new times. Estimated start times float within a program segment. Start times are adjusted up to the start time of the next absolute timed event.

A major obstacle to station automation acceptance has been handling events with unpredictable start times. Manual start times are used when such an event is scheduled, for example, a time-out in a sporting event or a network cut-in. Automation presets the next event but waits for the operator to initiate the transition. The start times of following events are adjusted to maintain schedule timing.

All switching events including operator manual intervention should be time-stamped and included in the automation system "as-aired" log. Automation time-stamped logging of external events should also be included. These external events may include important conditions such as transmitter failure, EBS alarms, or any important contact closure.

Support for commercial spot players. Video spot players and library management systems are becoming an integral part of the broadcast chain. The automation system must be able to identify spot material and generate the required event playlists. The machine playlists should immediately reflect any changes made in the current main schedule. The "as-aired" log from the spot player should be retrieved and included as a part of the automation system "as-aired" log.

Data management and schedule storage. User list utilities permit file management and system housekeeping without having to deal with a computer operating system. Printing of media pull lists, schedules and discrepancy reports should be included. Required schedule management func-

tions include file merging, copying, and backup.

System configuration and definition. The configuration of the automation system must be very flexible. The user should easily be able to configure the station automation system without costly custom programming. The system manager should include simple configuration editors which the operator uses to change and load system parameters. The user must be able to back up these important parameter files in case of system failure. The number of definable parameters should be as large as possible.

Many station automation systems use proprietary or highly customized hardware. The automation vendor must be willing and able to provide long-term system support. Support of the automation system hardware is simplified by use of standard products.

Automation system security. A sophisticated security system must be included. Definition of user and terminal permissions can control access to the various system functions and restrict the level of schedule editing permitted. The operator uses an appropriate user name and password, but must also be at a terminal with the correct system permissions. The security system should prevent unauthorized terminal access.

Full-facility television station automation is available now. The BTS/Broadcast Television Systems BTA-2300 Television Station Automation System is a general purpose automation package that meets or exceeds station automation requirements. BTA-2300 automation uses a standard Hewlett Packard computer workstation, standard BTS control hardware and software written in the "C" programming language. A number of systems in a variety of operating environments demonstrate the power of this versatile television station automation system. ■

Bird is product manager for the BTS BTA-2300 television station automation system. He has worked in television engineering for 17 years and most recently was manager of engineering for Video West, the Salt Lake City post-production facility.

Typical control terminal configurations. Disk drives provide expandable storage while mouse and trackball devices streamline input.

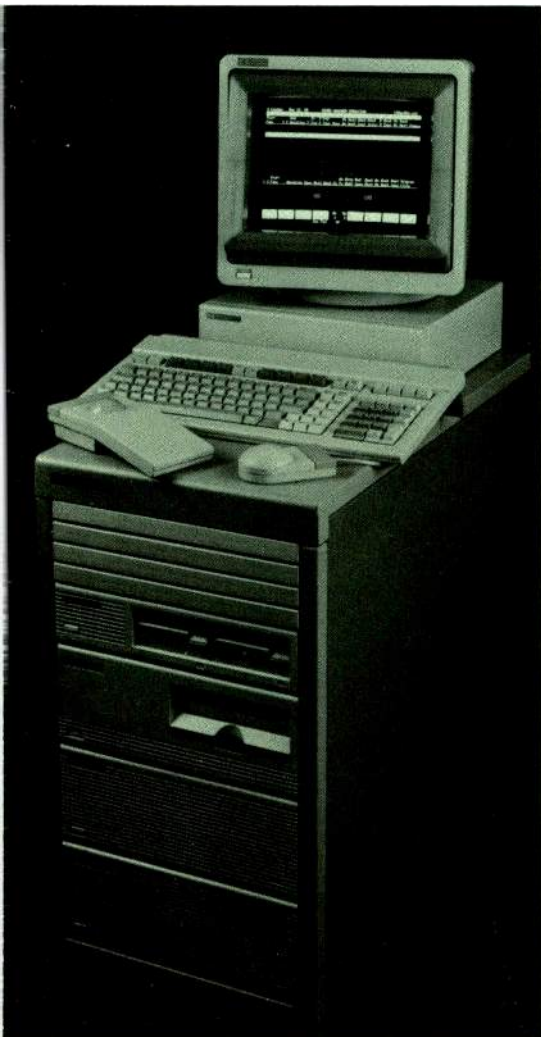

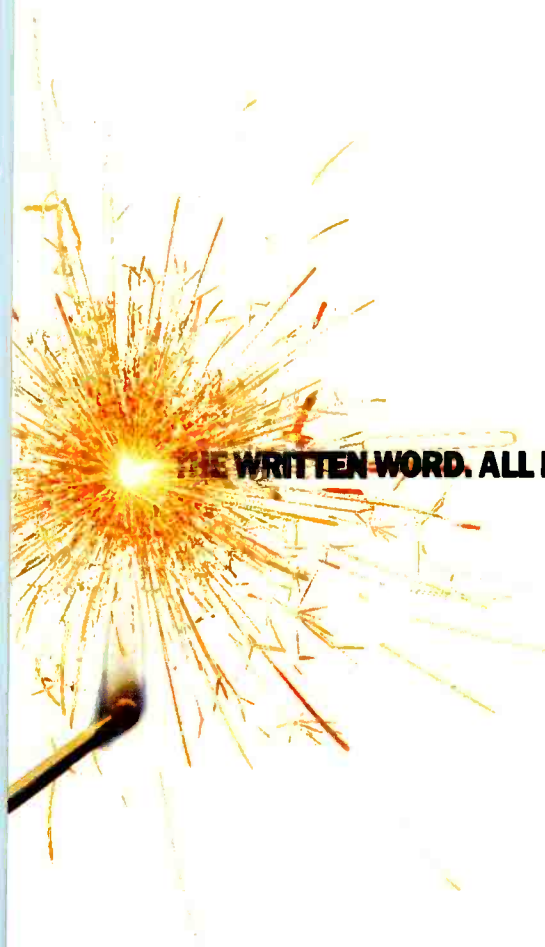

THE WRITTEN WORD. ALL ITS POWER UNDONE BY SLOW, TYPE-ONLY-ON-A-STRAIGHT-LINE,



ADD-A-SHADOW-BUT-NOT-MUCH-MORE CHARACTERLESS CHARACTER GENERATORS. UNTIL NOW. FROM THE GUYS WHO TURNED YOUR VIDEO WORLD INTO

WITH ADO® EFFECTS COMES A CHARACTER GENERATOR TO TAKE YOUR PRECONCEPTIONS OF TV TYPE AND EXPLODE THEM





ALEX.™ Truly a *lexical* character generator.
Virtually unlimited character manipulation and
real-time animation... true perspective... full antialiasing
in every mode... and easy to use, with a model for every budget...
but don't read about it... *SEE IT!* Call or write for a *free VHS*
demo tape showing the full range of dynamic effects.
You'll never be satisfied with just a character generator again!
Call your nearest Ampex sales office today.

GET YOUR HANDS ON ALEX AT NAB!

AMPEX

Atlanta (404) 491-7112 Boston (617) 932-6201 Chicago (312) 593-6000 Dallas (214) 960-1162 Los Angeles (818) 365-8627
New Jersey (201) 825-9600 (In New York (212) 947-8633) San Francisco (415) 367-2202 Washington D.C. (301) 530-8800 Canada (416) 821-8840

© Ampex Corporation 1989

USING THE MODERN CART MACHINE FOR BROADCAST AUTOMATION

The modern cart machine is beginning to redefine television station automation significantly.

This statement becomes self-evident when one considers that, until recently, station automation was generally perceived as a central computer used to switch between program sources, to preroll tape machines, to preselect still stores or special effects sequences, and to report the log as it was actually executed.

For the last few years we have indeed been hearing much about station automation. However, relatively few stations are successfully using station automation to any degree that approximates the implied promises or publicity for this technology.

With the arrival of the large, modern cart machine, there is now a very valid reason to reexamine overall station automation needs. New cart machines have large storage capacities and from four to eight tape decks, providing a huge sequential programming capability. When you add sophisticated computer control and software to that combination, you are performing many station automation functions.

To fully appreciate the potential of the modern cart machine, it is necessary to examine some of their more salient features which are already being utilized at television stations on a daily basis. An Odetics cart machine, for instance, provides the operator with keyboard control to edit a running playlist or the parameters that influence the playing of any event within a playlist. The cart machine also preserves and prints true "as-run" logs, which take into consideration most pertinent factors, including the on-air tally from the master control switcher.

Most important of all is the library management function. The cart machine maintains a database of all

Will the cart machine be the core of modern television station automation?

AS RUN LOG
Playlist MDDGORS
Page 1

Air Date	Air Time	House #	Title	ID	Box #	Time On Air	Time Remaining	VTR	Ref1	Ref2	Status
12-20-88	10:31:11	5906	RAYCOM SPORTS	BL-B108	6258	00:00:12		2			
12-20-88	10:31:24	9108	SHRINER/GERALDO	MPEC-12	11705	00:00:01	00:00:28	3			
12-20-88	10:31:27	9045	DAYTON'S 13 HOUR	06223	11589	00:00:09		4			
12-20-88	10:31:37	9010	D. COKE NINJA	06244	11519	00:00:29		5			
12-20-88	10:32:07	5804	GERALDO	BL-B108	6290	00:00:13		1			
12-20-88	10:32:20	9040	THIRTEENS	06225	11579	00:00:14		2			
12-20-88	10:32:35	9121	W.M. OF DISNEY	WATL-36	11731	00:00:20		3			
12-20-88	10:32:56	5727	D. PEPSI REMOTE	SP	5054	00:00:29		4			
12-20-88	10:33:26	5612	KITV 10 ID	SP	5023	00:00:03		5			
12-20-88	10:33:29	9073	HARLEM G.TROTTER	06226	11635	00:00:30		1			
12-20-88	10:34:00	9091	COME HOME #2	06226	11651	00:00:30		2			
12-20-88	10:34:30	5808	UFO COVER UP 1	BL-B108	6267	00:00:26		3			
12-20-88	10:34:56	5812	KIDS KLUB	BL-B108	6404	00:00:11		4			
12-20-88	10:35:07	9060	ARBY'S GIANT	06223	11609	00:00:30		5			
12-20-88	10:35:57	9107	THE BILL REPORT	MPEC-12	11703	00:00:30		1			
12-20-88	10:36:07	5911	MIAMI HEAT B.B.	BL-B108	3061	00:00:19		2			
12-20-88	10:36:27	5909	UFO COVER UP 2	BL-B108	6269	00:00:28		3			
12-20-88	10:36:55	9018	41 PROMO	06224	11535	00:00:59		4			
12-20-88	10:37:55	9030	WDIV ID	08335	3021	00:00:09		5			
12-20-88	10:38:04	9901	MCDONALDS KICK	CD	11791	00:00:29		1			
12-20-88	10:38:35	5908	UFO COVER UP 1	BL-B108	6263	00:00:26		2			
12-20-88	10:39:01	9036	CREATURE FEATURE	08335	11920	00:00:17		3			
12-20-88	10:39:18	8258	MIAMI HEAT NBA	08335	11879	00:00:20		4			
12-20-88	10:39:38	5803	WPTY SAT MOVIE	BL-B108	6264	00:00:15		5			
12-20-88	10:39:54	5612	KITV 10 ID	SP	5023	00:00:03		1			
12-20-88	10:39:57	5900	BIG MOVIE WPTY	BL-B108	11887	00:00:15		2			
12-20-88	10:40:42	5816	CRAWFORD DIAMOND	BL-B108	3058	00:00:11		3			
12-20-88		9067	PHIL	06226	11623		00:00:29	0			
12-20-88	10:40:24	9074	PELICANS SHRIMP	06226	11637	00:00:30		4			
12-20-88	10:40:54	8227	COKE OLD/GOOD		6401	00:00:40		5			
12-20-88	10:41:34	8216	HALL COKE RENT	08335	6276	00:00:30		1			
12-20-88	10:42:04	9018	41 PROMO	06224	11535	00:00:59		2			
12-20-88	10:43:04	8262	MIAMI HEAT NBA	08335	3025	00:00:20		3			
12-20-88	10:43:24	5612	KITV 10 ID	SP	5023	00:00:03		4			
12-20-88	10:43:27	8232	WMLP 35 YEARS	06CDEF6H	11914	00:00:06		5			
12-20-88	10:43:34	5805	NEWS 4 TODAY	BL-B108	11717	00:00:09		1			
12-20-88	10:43:43	5810	NEWS 2	BL-B108	3069	00:00:20		2			
12-20-88	10:44:03	9026	LP&G BLUES	06224	11551	00:00:29		3			
12-20-88	10:44:33	9013	D. APPLE CRUSH	06244	11525	00:00:29		4			
12-20-88	10:45:34	9020	HIRES ROOTBEER	06224	11539	00:00:29		5			
12-20-88	10:45:34	9138	WDRB SHORT ID	WDRB1424	11765	00:00:10		1			
12-20-88	10:45:44	5806	RAYCOM SPORTS	BL-B108	6265		00:00:12	2			
12-20-88		9137	CHEERS W/ID	WDRB-542	11763		00:00:29	0			
12-20-88		7900	CRAWFORD DIAMOND	FGH	11926		00:00:10	0			

End of As Run Log

Printout of "as-run" log records events as actually aired.

BY TIM CRABTREE AND
DAVE LEWIS

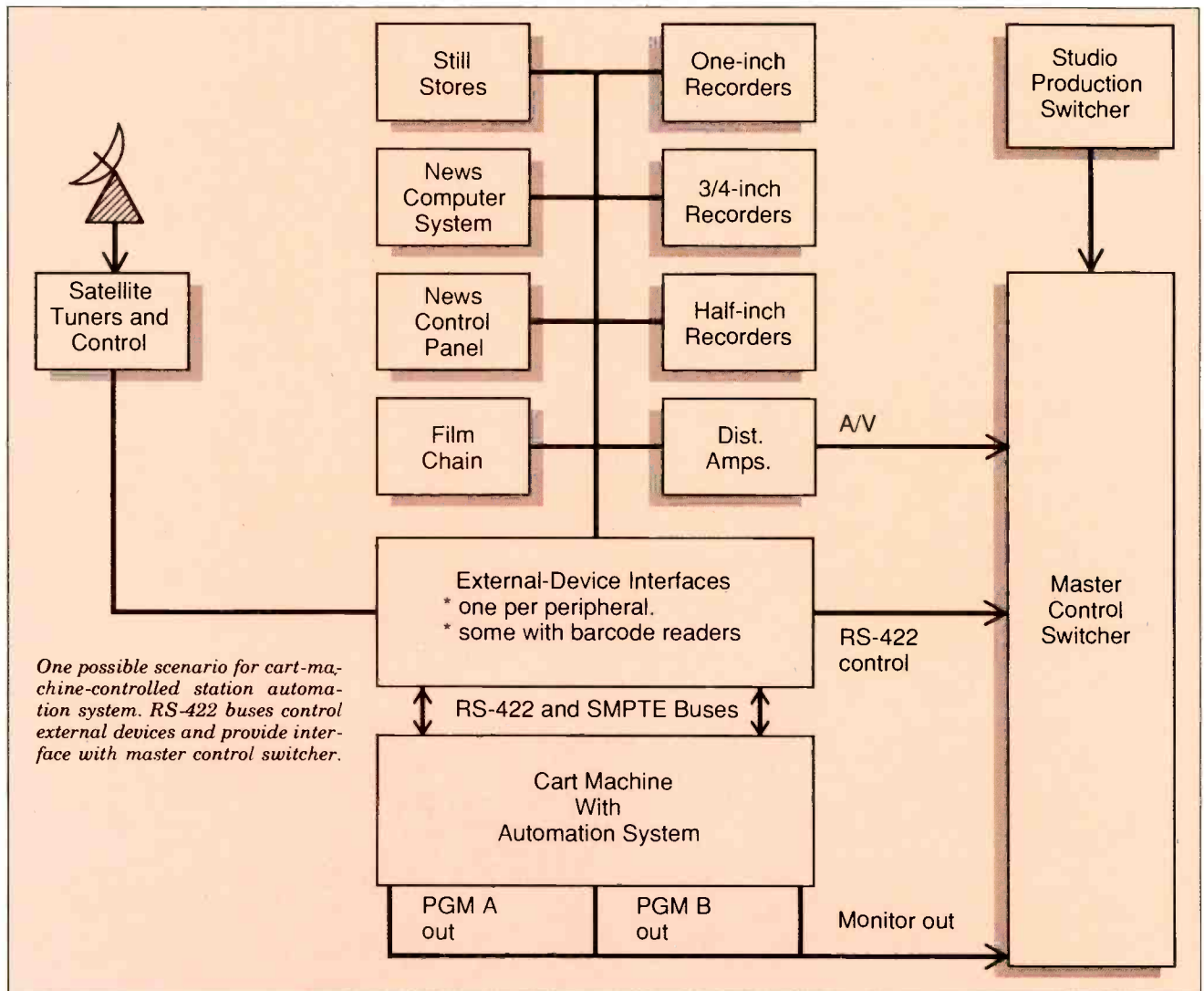

carts within the station and maintains the robotic on-line library to minimize cart handling by the operator.

This on-line library management function is often overlooked until the system goes into use. Even the largest cart machine will soon become full. If

the operator himself must choose which carts are to be taken out when new carts are added, or if the cart machine does not look ahead to see which carts should be saved, most of the labor savings potential of the system will be lost.

In addition to playing the carts within the system, most modern cart machines are now equipped to trigger external machines and to select at least one externally fed switch crosspoint to the program output.

Knowledge of a full day's schedule is imperative if the cart machine is to manage the library efficiently. Because the process of entering the cart machine playlist can be so labor-intensive, every modern cart machine should provide a means to connect the business traffic computer or the automation computer to the cart machine database for downloading the daily

schedule.

As cart machines grow in capacity and capability, automation systems that do not originate from these devices will probably duplicate several of the cart machine's functions, but will not be sophisticated enough to exploit their power fully. Indeed, with more than 75,000 lines of program code carefully timed to compensate for the physical delays and resources found in every mechanical robotic system, the modern cart machine's controlling computer cannot be easily subordinated to the automating computer.

Automation suppliers may attempt to duplicate the cart machine's control program within their master programs, but the software development effort would probably not prove to be economical. On the other hand, the cart machine's inherent power could

Most modern cart machines can trigger external machines and select at least one externally fed switch crosspoint.

be easily extended to control external program sources of a much more diverse nature.

Considering current cart machine technology, most recorded events aired by commercial stations can and should come from the cart machine. Therefore, the cart machine is the logical nucleus for station automation.

Within every cart machine, some sort of sequence controller is provided to accomplish the real-time triggering and switching of the hardware resources that are contained within the machine. The cart machine playlist or schedule employs one event line for each spot or program segment. The information in each event line is utilized by the robotic manipulator to get the proper cart loaded into a recorder or player. That same event line defines the parameters of cue point, duration of play and user bits identification to the sequence controller. The sequence controller, in proper time, rolls the machines, commands the switcher, times the play and carries on to the next event while recueing and subsequently storing the spent cart.

Odetics advocates the use of a separate, external device interface (EDI) for each peripheral as the best means for allowing the cart machine's inherent automation capabilities to control and switch nearly every other device or signal source within a station.

The introduction of external-event command lines, in addition to internal-event lines, makes it possible to have literally thousands of command types programmed in the cart machine playlist. The command types can be passed through in essentially zero time to the EDIs, where these commands can be interpreted to drive several digitally interfaced or dry contact remote controllable devices. For example, tape recorders can be directed to cue to a specific frame, and to trigger after a specific time delay. Other commands to a separate EDI will cause addressable switchers to switch to specific crosspoints at specific times, trigger still stores to be preset and preselected, and initiate production switchers to execute special effects between two sources at specified times at a predesignated rate.

The opportunities created by such a

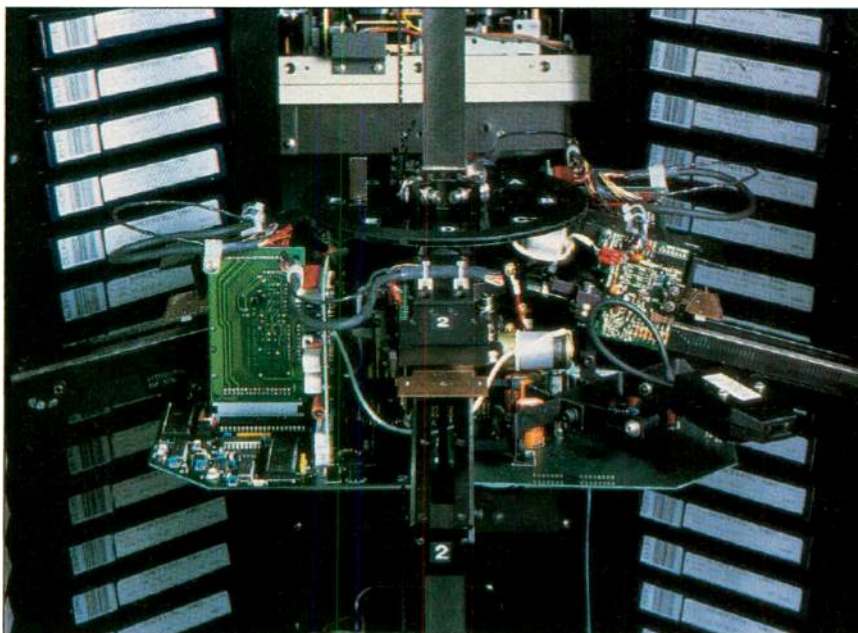

concept are limited basically by the effort required to advance-program the individual command lines to achieve the desired effects. We anticipate that future traffic systems (business computers) will evolve to include memories to store a set of production switcher commands for use between events. These commands could also be included as part of a play schedule. As such, they would get downloaded to the cart machine just as the program and spot-play schedules are today.

Even if this never transpires, a concise library of regularly used command lines, such as "Switch to network," "Preselect still store by frame number," "Switch to still store, A/B wipe," etc., can easily be stored in the cart machine automation module. This will allow automatic insertion between events in a playlist according to some presettable parameters, or for quick manual insertion by the oper-

The robotics controller of the Odetics cart machine. The robotic arm is programmed to select the proper cassette according to the information contained in the programmed playlist.

ator at the desired switch points within the traffic computer generated playlist.

Going hand-in-hand with the concept of automating a station via the cart machine is the question of how to put an entire spot and program inventory inside the robotic library. Emerging today in the cart machine field are two very different approaches to the question. One trend is toward larger cassette populations of up to 1200 units. This type of cart machine would be of expanded dimensions, taking up much floor space. This would seem to be the simpler way to satisfy the goal of more recorded material on-line. The cylindrical tower configuration of the Odetics library management cart machine, for example, lends itself well to adding one or two robotic secondary storage towers, which will increase capacity to 600 or more carts.

With 600 events on-line, recent analyses of many station logs shows that, on average, fewer than 50 carts must be loaded new each day, and at least half of those consist of new material that would have to be loaded no matter what the machine's capacity. The alternative approach is to use up the full capacity of each cassette by recording and playing more than one spot per unit. Since even the

*External-event
command lines
make it possible
to program
literally thousands of
command types into the
playlist.*

```

Local : Library verified      Playlist Loaded      89-22-86  12:06:28
                               NTSC RECORD MODE

Preroll: 4 secs
UTR #1

Time code:
Search speed: -----|+++++++
               <-REV 0 FWD->

Type:  Single  Dual  Sequential
Box #   88826   S0M   Duration
                00:00:15:00  00:00:30:00

House #: 881577
ID:      G/F
Title:   JELLO

Message: Completed

FUNCT KEYS:
F1  F2
RBC  RE Q
F3  F4
SAVE STOP
F5  F6
TC # AMI
F7  F8
PAW1 PAW2
F9  F10
EJC1 EJC2

F10 for play functions  Enter to set parameters  Exit

```

smallest cassette generally used within modern cart machines can hold at least 20 minutes of tape, storage of 20 commercial spots on a single cassette is easily accomplished, even with generous spacing for leaders and trailers. Extrapolating this concept quickly leads to the assumption that a 280-cassette cart machine could easily hold over 5000 spots.

Unfortunately, this approach presents some significant challenges that must be overcome if its benefits are to be realized. The most obvious ones are:

- Strategizing the execution of the playlist to resolve time conflicts when more than one spot for the break is stored on the same cassette.

- Managing the library to minimize the extra wear on each player incurred while shuttling the tape.

Cart machine playlists use one event line for each spot or segment. The event line informs the robotic manipulator for loading and defines parameters of cue point and duration for the sequence controller.

- When only one event exists on a cassette, that event can be parked at the optimum point to minimize cue time at the next usage. With multiple events per cassette, there can be no optimum parking point unless complex strategizing software is employed.

- Labor is required to repair a worn or damaged cassette. To avoid generation loss, multiple sources must be collected to reconstruct the entire cassette.

- The use of a recorder and one or two players to build a break cart will effectively reduce the number of machines available to execute a real-time break.

- If every break is compiled before execution, then every break will be one or more generation down and last-minute rescheduling will suffer.

Most of these problems are caused because putting multiple spots on one cassette gives those spots a relationship to each other that formerly did not exist. We have physically linked these otherwise unrelated spots and left ourselves with the new problem of making that linkage transparent to the outside world.

If we combine only material that al-

ready has some relationship, either of material content or scheduling, then most of the conflicts disappear and we are left with a very valuable and readily realizable system.

Three examples of related material come to mind:

- Program material is seldom presented as one continuous element, but rather as many shorter segments. These program segments are strongly related, as they are from the same source material and the playback order is fixed. Software power is required to track and select the proper segment at the proper time, but the conflicts mentioned earlier do not exist.

- Creating break tapes is a good way to increase the reliability of on-air playback or to free cart machine resources for other jobs, such as new production. Playing back the break tape is once again a matter of selecting the appropriate element, or group of elements, from the many recorded on the same cart. The elements, however, have a chronological relationship dictated by the program log, so conflicts do not arise.

- Many times, multiple versions of the same spot are produced—for example, 10-, 30-, and 60-second versions of a commercial, all with the same story line. The relationship between these elements would preclude playing any two of them back-to-back. The small number of elements would eliminate the need to precue the cart, since the maximum search time would be very short.

In spite of the difficulties, the advantages of multiple spots per cart are significant enough that it is still worth the time and effort to search for ways to overcome problems.

Regardless of the configuration, cabinet size, tape format or number of spots per cart, modern cart machines will continue to play an important and rapidly growing role in television station operations. With the synergism between modern cart machines and station automation systems, the trend in station automation of the future may well be rooted in the core of a cart machine. ■

Crabtree and Lewis are the director of engineering and vice president, respectively, of the Odetics Broadcast Division, Anaheim, CA.

One trend is toward larger cassette populations of up to 1200 units as a way to achieve the goal of recorded material on-line.

TV-Nikkor S15X8.5B

ENG/EFP Lens
for 2/3-inch TV Cameras

S13X9B

Nikon improves TV lens technology

- Compact, lightweight lenses for 3-CCD cameras, with the flexibility to meet any shooting requirement.
- Nikon ED (Extra-low Dispersion) glass for faithful color rendition and minimal tracking/registration errors.
- New anti-reflection coating improves spectrum transmission ratio.
- Highly advanced optical design via CAD for improved corner resolution and high, flat MTF curve.
- 15x zooming ratio – highest among standard ENG/EFP lenses (S15x8.5B).
- Minimum focal length of 8.5mm – widest among standard ENG/EFP lenses (S15x8.5B).

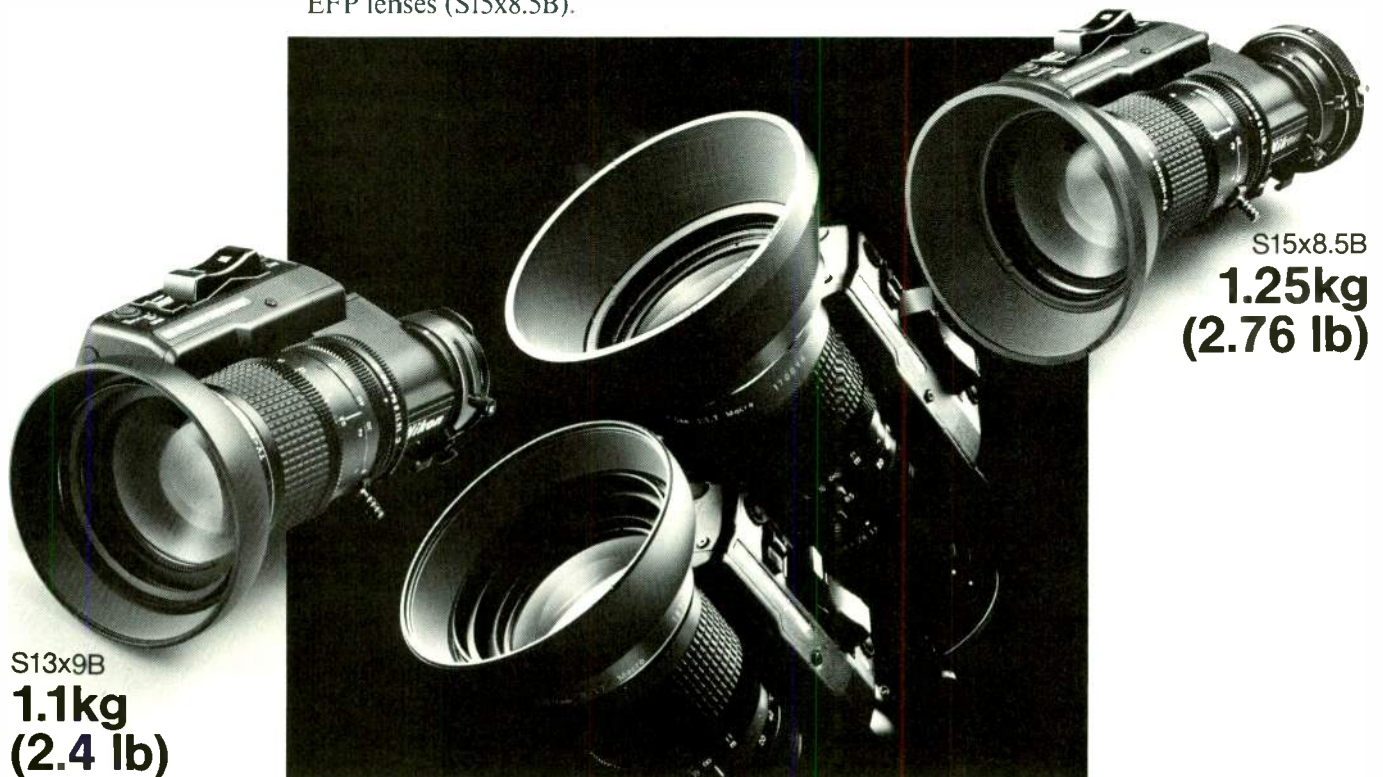

Nikon

NIKON CORPORATION

Fuji Bldg., 2-3, Marunouchi 3-chome, Chiyoda-ku, Tokyo 100 Japan

U.S.A.	© Nikon Inc. 623 Stewart Avenue, Garden City, New York 11530, U.S.A.
Canada	© Nikon Canada Inc. 1366 Aerowood Drive, Mississauga, Ontario, L4W 1C1 Canada
Europe	Nikon UK Ltd. 380 Richmond Road Kingston, Surrey KT2 5PR, UK
West Germany	Nikon GmbH Tiefenbroicher Weg 25, 4000 Düsseldorf 30, West Germany
Australia	Maxwell Optical Industries Pty Limited Unit 5, Level B, 100 Harris Street, Pyrmont, N.S.W. 2009, Australia

FIBER TRANSMISSION SYSTEMS FOR HDTV SIGNALS

What's the outlook for HDTV transmission via fiber? The technology is in place, but economic and political issues still must be settled.

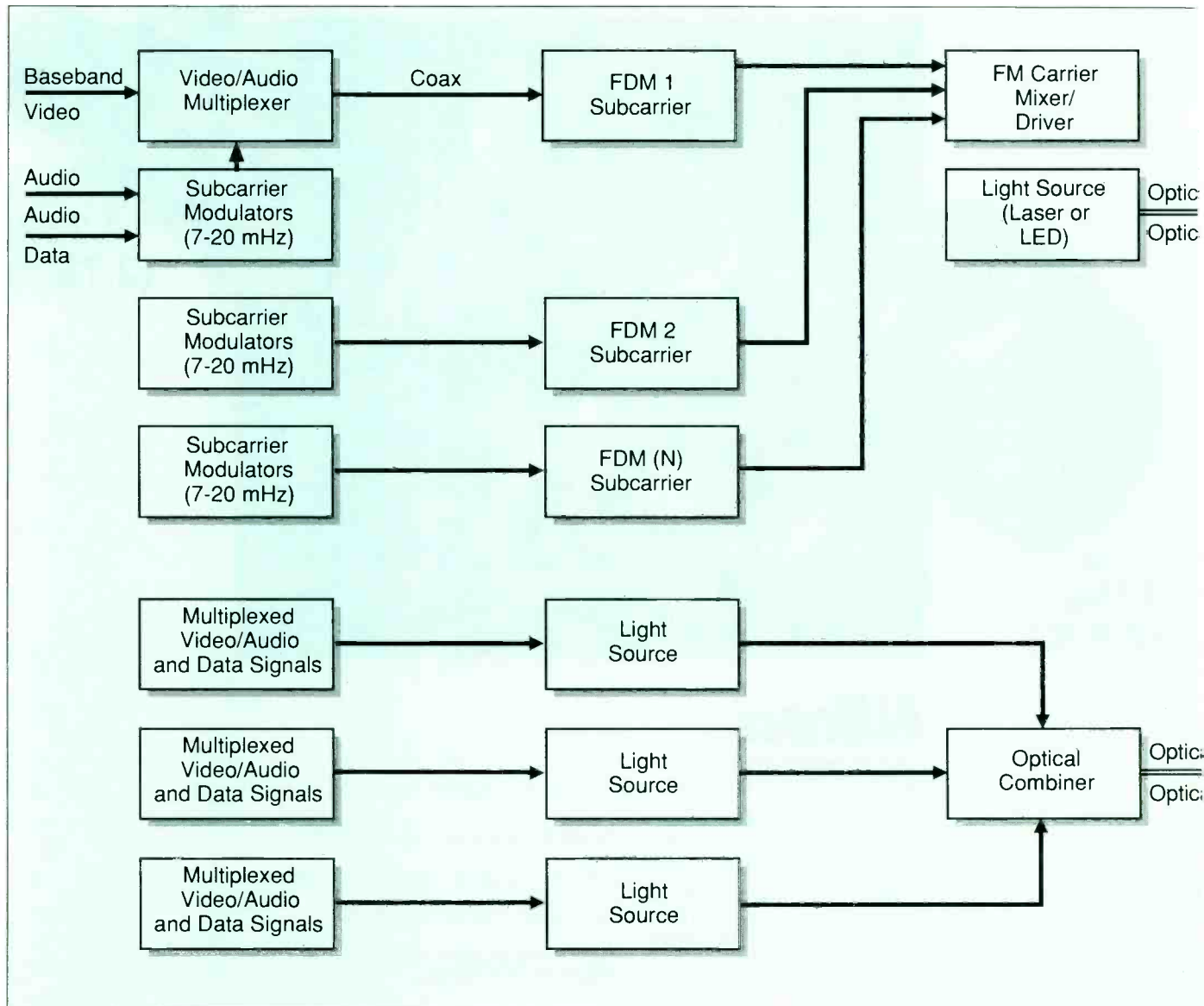

Any discussion of the pros and cons of transmitting HDTV signals via fiber optics must first define "HDTV." As of early 1989, however, that definition remains elusive. What is "HDTV"? A single-standard service delivered free via VHF/UHF stations or cable systems? A scrambled pay cable or pay-per-view service, delivered by cable or DBS? A telco-delivered service via subscriber loops? High-quality software for tape or disc rental libraries? A high-def/widescreen videotape production system, or several such systems? All of the above?

As of this writing, none of the above answers serves to define HDTV. While SMPTE has promulgated a Standards Document 240M covering the 1125/60 HDTV videotape production format produced by Sony and championed by NHK, other companies stand ready, or apparently so, to introduce systems with different specs. Standardization is even farther away on a transmission standard or standards, despite the FCC's recent rulemaking that narrowed the field ever so slightly (and the bandwidth by a much greater factor) by determining that a transmission system for the U.S. must be compatible with NTSC.

Single-mode fiber (nominal 8 to 10 micron transmissive core surrounded by 125 micron diameter reflective cladding) has been the fiber transmission medium for all community-wide HDTV delivery tests. Obviously, in comparison to the bulk of a coax cable, or even the cross-section of a 22-gauge twisted pair, fiber transmission offers enormous size and weight advantages over the media used by cable systems for multiple-channel program delivery.

Fiber is also widely acclaimed for its information-carrying capacity, routinely expressed in GHz of analog bandwidth or gigabits per second of digital transmission throughput. Another advantage is its transmission distance capability before repeater is required (photonic to electronic domain demodulation, signal conditioning and new light source intensity remodulation).

Electronic engineers tend to interpret this impressive bandwidth-distance transmission advantage of fiber over broadband coax as a somehow plug-compatible replacement. It isn't: the ultimate need for a high-quality, multiple-channel, multiple-format, broadband loop from the nearest central office (CO) to the home, carrying integrated voice, low-baud-rate home systems management data, high-speed synchronous data, graphic information services, HDTV programming, and NTSC regional news from the old VHF station now transmitting at 1 V p-p, or whatever, cannot be satisfied by the fiber transmission technologies used in these tests.

In 10 years we will consider these tests as primitive as Edison cylinder recordings—a three-fiber drop cable, for instance, in which a CO video switchboard is accessed by Touch-Tone phone to select which three television channels are to be delivered.

One analog or digitized television channel per fiber is the capability offered by today's transmission technology, if you want EIA 250B short-haul specifications (67 dB or better S/N over the original bandwidth) from the received video and audio signals.

True, several vendors offer fiber transmission systems that can carry

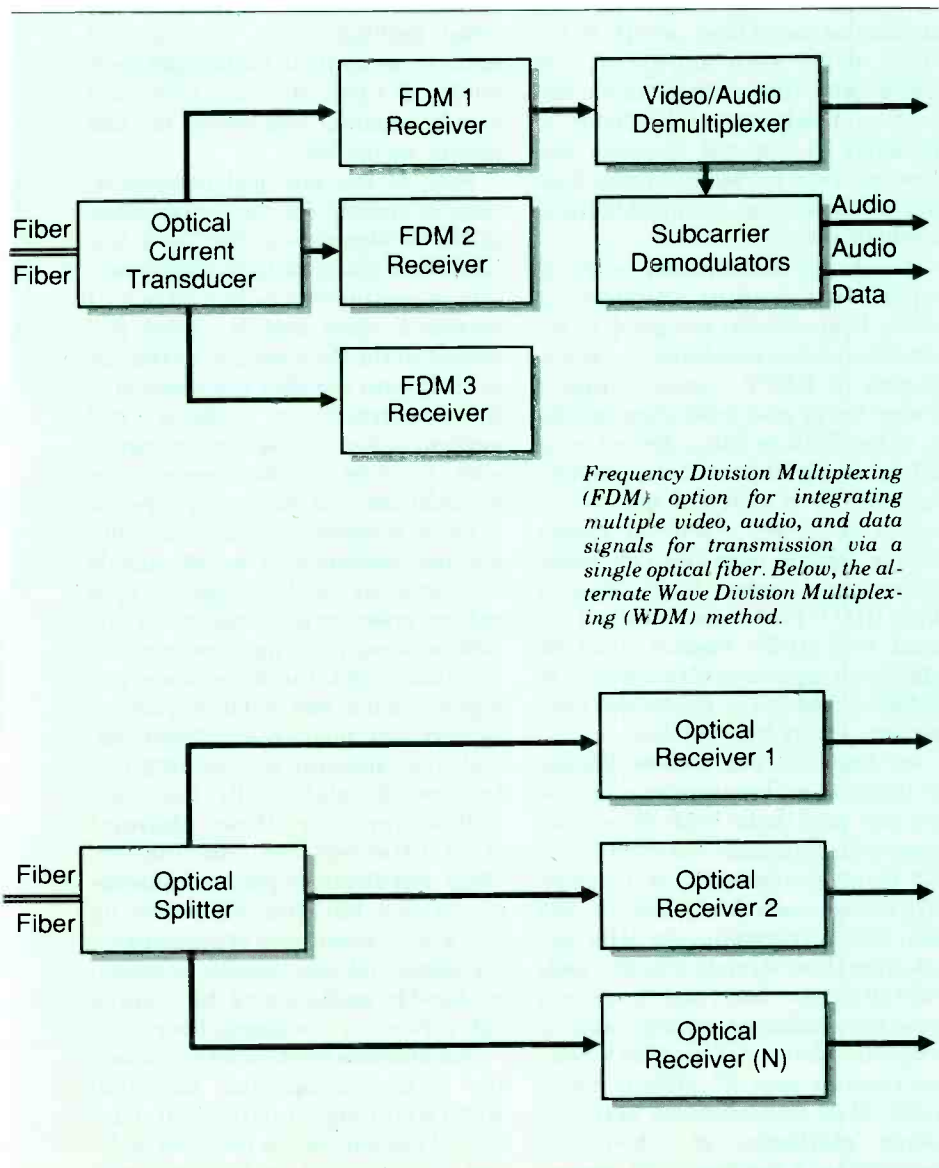

BY C. ROBERT PAULSON

up to a dozen or more full 6-MHz bandwidth television channels per fiber. Each channel is FMed onto its own subcarrier, which is added to all others to create one complex broadband voltage that intensity-modulates the transmitting light source. This is obviously a nonlinear process, since lasers have somewhat the same voltage input to light output characteristic as the familiar Edison Electric Illumination light source.

In a fiber-optic transmission system, optimum performance specifications are achieved over wide analog bandwidths or at high digital transmission rates by designing the transmitter/modulator, fiber and receiver detector/current amplifier as a matched set of components to carry one precisely conditioned signal. The fiber has incredible bandwidth-distance characteristics. The bandwidth characteristics can be controlled in the fiber manufacturing process. The limiting transmission distance is determined by a combination of the core diameter of the fiber and the spectral bandwidth of the light source. But the quality of signal received is quite rigorously limited by the nonlinearities in the electron-to-photon and photon-to-electron energy conversion (transduction) processes.

A broadband coaxial cable transmission system is conceptually quite different. The cable itself has a distance (resistive) attenuation determined by the copper conductors, and a frequency vs. attenuation characteristic determined by conductor-to-shield spacing and the dielectric. This characteristic does not change with changes in the input signal quantity of channels or the spectral bandwidths of channels. If each transmitted channel's output is confined to its assigned spectral bandwidth, and is detected and demodulated in an equally well-designed receiver, that channel's output quality will not be degraded by the presence of other channels on the cable. If, however, the entire spectrum of individual channels must be processed through broadband amplifiers (repeaters) before reaching their common destination, the result is no better and may often be worse than mixing all the signals initially into one light source driver.

As is also the case with mixing television signals for microwave or coax transmission, the best transmission results obtain from an IM (intensity modulation) transmission of a complex FM signal which is the sum of the FM signals resulting from frequency modulation of many television channels onto many subcarriers (FDM/FM/IM). But FM circuits are expensive, compared to AM. And cable systems are therefore looking at FDM/AM/IM systems to satisfy their rapidly emerging needs for "supertrunking cables" (cables in which a few fibers can carry all the channels originally transported over one coaxial circuit through many repeaters).

In any event, early 1989 seems destined to be the beginning of the first substantial use of fiber circuits in the cable television industry, for supertrunks that connect earth stations to headends, or headends to headends in regional systems, and then to feeder cables that carry bundles of channels to neighborhood breakout points.

For all the transmission technical superiority reasons enumerated above, fiber systems are going to become the exclusive solution for transmission of HDTV signals within a production or post-production facility in either RGB or luma/chroma color difference signal form. Artel Communications Corp. provided such a system at NAB '88, a 200-foot system feeding signals from the Las Vegas Convention Center East Meeting Wing HDTV Production Center to the South Hall HDTV Theater. NAB '89 will see an expansion of this system to include a feed to the Production Center from the Hilton Pavilion.

An Artel CG 203 high-resolution, RGB graphics fiber transmission system was used in the NAB '88 system, along with a modular T/R 3000 Series link for transmission of a 20-Hz to 20-kHz stereo audio feed. The CG 203 link, which transmits 100-MHz signals over three strands of multi-mode 100/140 micron fiber, was found in a sense to be technical overkill, because a transmission out of an HDTV camera requires only 27 MHz of bandwidth. Most transmissions were videotape playbacks, in which the bandwidths of the luma and chroma

channels were nominal 20 MHz and 10 MHz, respectively. Critical evaluation of the image projected from the Eidophor HDTV projector (55-MHz bandwidth) identified out-of-band noise in shadow areas, which could have been suppressed by transmission system filtering.

A cable (24 multi-mode 50/125-micron fibers) in the NAB '89 fiber trunking service will interconnect the East Hall 50-by-80-foot booth of Midwest Communications Corp. with its field production vehicle and satellite microwave system exhibit in the outdoor exhibit area adjacent to the Hilton Convention Center. It is being provided to NAB exhibitors primarily for their use in setting up one-way or two-way simultaneous feeds of "traditional" television signals (NTSC video, multiple audio, intercom and data) between their booths and their trucks of earth stations. Artel will supply terminal equipment for this service as needed.

Most of the practical demonstrations of systems for the transmission of HDTV signals via fiber have utilized three fibers for individual intensity-modulated transmission of baseband video signals. Artel pioneered in the development of this capability with the 1981 introduction of its first-generation modular and modem systems graphics transmission systems for high-resolution monochrome and RGB color signals.

These systems' interfaces are simple and adaptable to accept signals with sync on all three signals, sync only on green, or combined syncs carried on a separate input coax cable. Intensity-modulated systems are highly reliable and stable, require no routine maintenance or adjustment, and are economical, representing a total cost of substantially less than \$5000 for the three-channel transmitter/receiver combination. Their specifications permit transmission of up to 100 MHz over circuits up to 3 km. Transmission of accompanying audio and data signals is accommodated by multiplexing the required subcarriers on a separate fiber.

The ultimate solution for transporting a three-component, full-bandwidth HDTV signal and several channels of full-bandwidth program audio and intercom and production house-

keeping data will, of course, be a gigabits-per-second-speed, time-division multiplexed, serial digital system. The technology to push bits through a single-mode fiber at rates in excess of 2 Gbps, over distances of 50 km or more, is already in use in the telephone industry.

When will technology be available in terminals that take in and give back analog HDTV and audio signals, and process the signal for transportation over a few km? Within months after some affluent, entrepreneurial, "I'm gonna be first" HDTV program producer writes a rather large check. The A/D-D/A video and audio signal

transcoding hardware is also already available.

When will the first serial digital production/post-production transmission system order be placed? When it's been proved to be a cost-competitive alternative to the existing four-fiber analog transportation means.

Engineers who think like supertrunking cable systems designers may have already begun to ask, "Why can't the three video component signals and all the audios be FMed onto FMed subcarriers and modulated onto one light source?" Engineers with a grasp of the basics of fiber transmission system design are

now ready to voice another question: "Why can't the three video component signals and all the audios be wave division multiplexed (WDMed) onto different light sources of different wavelengths and optically combined for transmission on one fiber?"

One answer suffices for both questions: They can be; there are no technological breakthroughs required. A cost/benefit analysis will establish if or when either single-fiber system becomes popular, once alternative techniques have been shown to have transmission specifications equal to multiple-fiber/single-channel.

continued on page 88

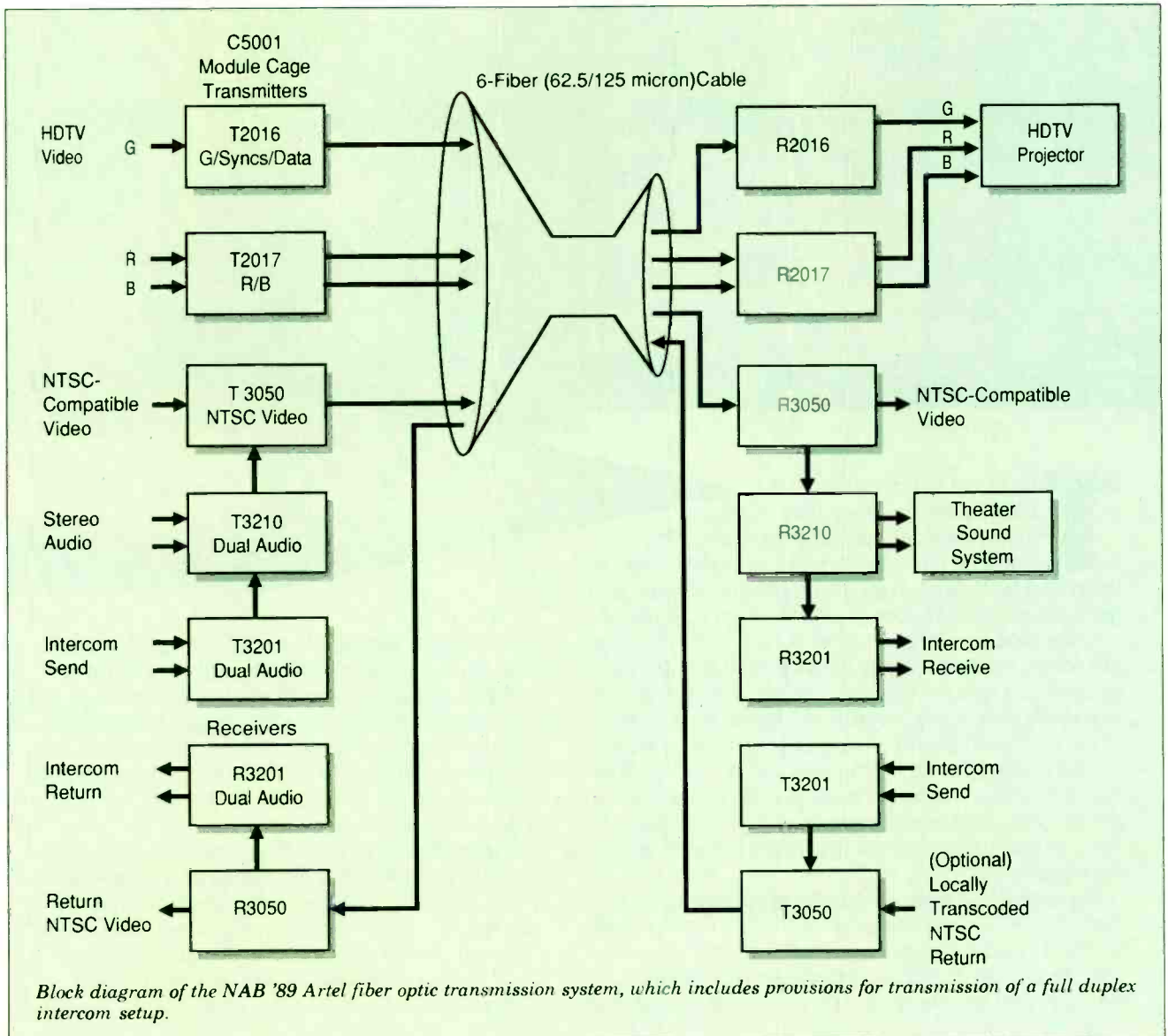

Get a sharper image...

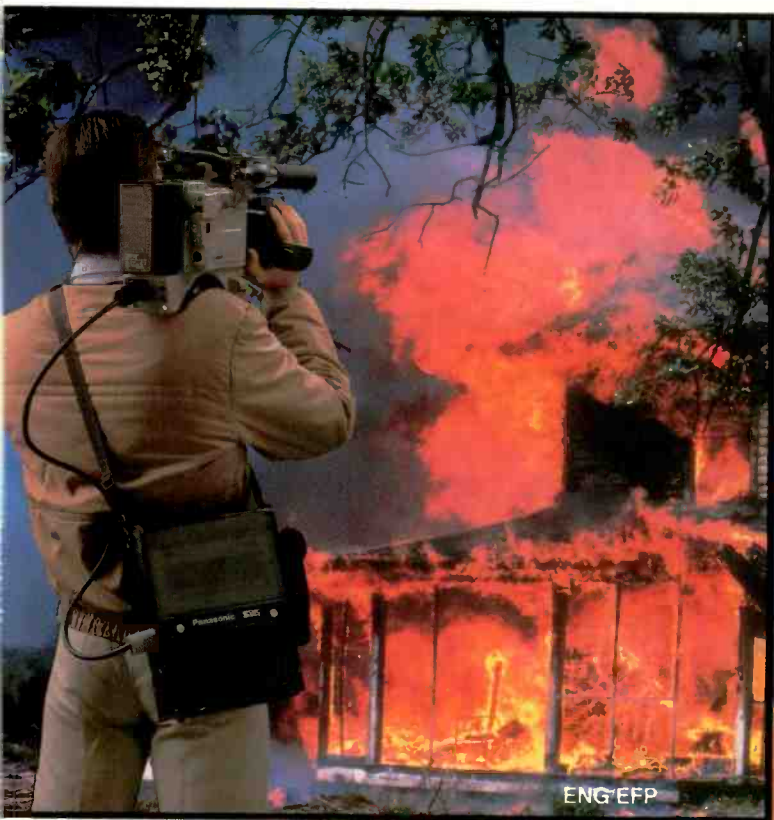

The SVHS format behind the Panasonic® Pro Series will change the way you look at half-inch recording systems. Because it delivers over 400 lines of horizontal resolution. At an affordable cost. So you can get a sharper image even as you sharpen your pencil.

In the field, the Panasonic Pro Series offers you a host of benefits existing formats fall short on. Like two hours of recording time on a single cassette with Hi-Fi audio capability. In a highly portable package. To capture more action and sound on fewer tapes. Which means you'll have less to carry in the field and on your budget. And the Pro Series easily interfaces with a variety of existing component or composite cameras and VCRs. So you can easily integrate the Pro Series in your present field operations.

For editing and post-production applications, the Pro Series takes full advantage of the SVHS format as well. With easy to use features and high performance capabilities. Such as digital framing servo circuitry to provide highly stable edits. And time code input/output facilities for frame accurate editing. The Pro Series edit-

ing VCR also features 7-pin dub capability to maintain component signal integrity throughout the system.

For studio production, Pro Series components are designed with flexible operations in mind. With VCRs and monitors outfitted for total systems application. And cameras designed for use both in the field and in the studio. To help minimize your investment without limiting your capabilities.

For duplication, Pro Series monitors and VCRs provide you with the convenience and versatility of half-inch cassettes. And the performance of SVHS. When duplicating, you can maintain excellent picture quality thru component or composite signal transfer. And dub Hi-Fi audio simultaneously with the video signal. There's even a Pro Series cassette changer to help increase the efficiency of your duplicating system.

even as you sharpen your pencil.

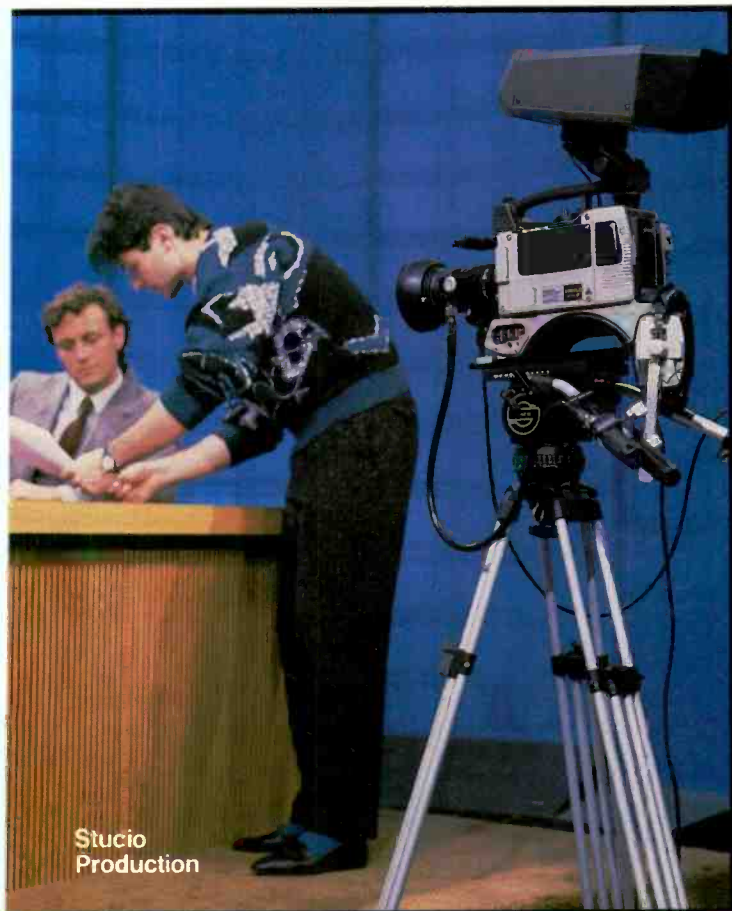

Whether it be a small or large operation.

For video network applications, the Pro Series produces high quality images on both large projection systems and small screen monitors. With features like auto repeat playback for unsupervised presentations. And the system is upwardly compatible with standard VHS. So you can continue to use your existing library of recordings without any type of conversion.

Pro Series VCRs also incorporate a number of features designed for network automation. Such as video sensor recording. So you can transmit video programs to your network locations during off-peak hours. And save on both transmission and personnel cost. You can even interface Pro Series VCRs with computers for interactive training programs.

So whether you're looking for high performance field

recording, post-production, studio, duplication or networking systems. The Panasonic Pro Series can sharpen your image while you sharpen your pencil.

For more information, call Panasonic Industrial Company at 1-800-553-7222. Or contact your local Panasonic Professional/Industrial Video dealer.



Panasonic

Professional/Industrial Video

PRODUCT BENCHMARK

PRODUCT DESCRIPTION:

The CVS Intelligent Video Monitor from Barco Industries is the first fully intelligent video monitor and the first broadcast monitor to be awarded an Emmy from the National Academy of Television Arts and Sciences. High-quality video reproduction with microprocessor control of all functions and settings provides critical viewing of original sources and evaluation of RGB or other component signals.

The unit's modular design, rather than the usual monolithic construction, with interchangeability of boards between the 14-inch CVS 37 and the 20-inch CVS 51 models greatly speeds troubleshooting and repair. Modular construction and dual analog and digital bus architecture also ensure design flexibility. Extra plug-in slots provide for options and future expansion.

Accurate color temperature alignment is accomplished using the BI light probe with built-in memory to allow storage and rapid transfer of both factory-set and user-selected automatic setups. Any CVS monitor can be aligned in two minutes and setups can be copied from one monitor to another.

Matching of contrast, brightness, saturation and hue between any number of CVS monitors is assured when identical numerical values are digitally entered. These values can also be stored in memory. The Calibrate memory provides factory installed parameters while the Preset memory stores customized values.

A closed-loop correction system which monitors the CRT guns provides stable color temperature performance regardless of picture tube aging or changing environmental conditions. Menus provide an on-screen display of all control and display parameters as well as self-explanatory assistance for fast and accurate operation. An optional remote control is also available.

USER REPORTS:

*Herb Ohlandt,
Director of Engineering,
National Video Center, New York*

We acquired our first Barco CVS monitor about 18 months ago and our most recent six months ago. We now have 16

BARCO INDUSTRIES
**CVS INTELLIGENT
VIDEO MONITOR**



*Three end-user
engineers give their candid
opinions of an Emmy
award-winning piece of equipment.*

of these new monitors, all 20-inch models, in use in new applications and also replacing old units. Two of them are located in the senior operator position, one serves in each of three TV studios as a line monitor, one is located in each of two paint box studios, one is in the Alias 3D suite, one is in each of seven edit suites and the last is in the color correction suite. All units are in service 20 hours a day, five days a week and sometimes on weekends as well.

When it comes to color temperature accuracy, the CVS has solid-as-a-rock stability. We also like the fine resolution, the extremely close color matching between monitors, the automatic color alignment using the light probe, the ease and convenience of the remote control and the very impressive reliability. There has been, in fact, just one failure of a CVS in all the time we've had them and that failure was repaired the next day. Barco's support was and is excellent. Further evidence of this support is the help

they have given and continue to give us on two special problems.

The units, as delivered, have automatic chroma control circuitry. This is undesirable from our point of view because, in our applications, we want the monitor to tell the truth at all times. Barco worked with us on the problem and came up with a modification that defeats this circuitry. The second problem concerns dot crawl. With the comb filter active, resolution is increased, which is desirable, but so is dot crawl which is undesirable. Barco is working with us to achieve better picture quality by suppressing the dot crawl.

Before deciding on the Barco, we also looked at Ikegami, Asaca and Conrac. Our conclusion was that Barco had the best collection of features, quality, and performance. The units we replaced were the 20-inch Conrac 61-42. Although the specification sheets say the Conrac has better resolution, we weren't able to distinguish the difference.

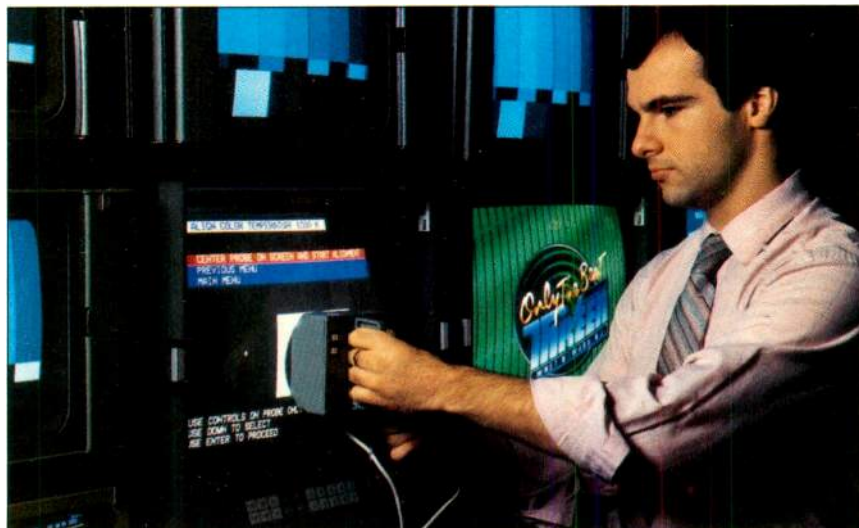

*CVS Monitors,
Models CVS
51 and CVS 37.*

The process of adjusting one of the older Conrac units was long, tedious and difficult. We had to be satisfied with only a fairly close alignment and the tendency of the unit to drift meant it wouldn't be long before we'd have to align it again.

Adjusting the CVS monitors is simpler and faster and the results are much closer to ideal. Also, once a

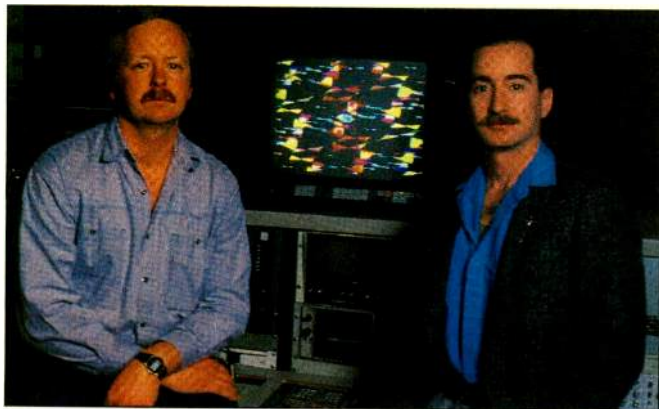

Jeff Dockendorff (left) and Jace Reiken, National Video Center.

monitor is adjusted, it doesn't drift. One engineer has the job of adjusting the monitors. Operators are excluded from attempting the adjustment procedures by the use of passwords.

The changeover to the new monitors was easy and quick. The operators required a training period of about a half an hour and the engineer responsible for calibrating the units needed several days over a period of three months. The major benefit of the changeover has been a better, more stable picture, the same on all monitors from room to room. It has been and remains a pleasure to work with Barco. We have found them to be cooperative, interested, and very helpful.

*Frank Graybill,
Chief Engineer, WNET-TV,
New York, NY.*

We purchased 10 of the 20-inch Barco CVS monitors in January, 1988 as replacements for monitors that had worn out. Five of

these units are in the master control room and the others are in each of five post-production rooms.

The units in the master control room have been in operation continuously since they were received while the units in the post-production rooms have been operating 16 hours a day, seven days a week. In all that time, the monitors have met our full expectations for reliability and performance with only one exception.

On that occasion, a high-voltage power supply failed. Barco exchanged the failed board under the warranty and had the unit back in operation in less than a day. The service was as courteous as it was prompt. We have every confidence that Barco will always be there when we need them, but the good thing is we rarely do.

Before choosing the Barco we also looked at Ikegami, Conrac, and Acaca. All of these monitors had automatic set-up, but Barco features seemed superior to those of the others, in particular the internal safe area and safe title generator.

This feature, which prevents titles from being inserted in areas of the screen where they wouldn't be seen on home receivers, saved us the cost of paying for the same feature on our character generators. In the final analysis, the Barco performed to the specifications we thought necessary, delivered within the time frame we could allow, and sold at a competitive price. It was an easy choice.

The engineers who would operate the monitors took about a week to break the habit of wanting to turn knobs. Once they became comfortable with the controls, they had no further problems. The engineers who would maintain the units took a little longer to train, but were fully able to do their jobs in just a few weeks.

The thing that pleased me was not having to listen to the usual litany of complaints about both the quality and the reliability of the monitors. The bottom line is that the CVS lives up to the expectations of the engineers and

PRODUCT BENCHMARK

*Frank Graybill,
WNET-TV.*



it doesn't create headaches for anyone. If I were asked what should be done to make it a better product, I wouldn't know how to answer.

*Michael Kaye,
VP, Director of Engineering,
Encore Video, Hollywood, CA.*

We bought our first CVS in July 1986 and have purchased nine more since that time. We acquired them as replacements for older monitors and also for new monitoring positions. Each of our two telecines utilizes the CVS-37 monitor for bridge monitoring. We have several CVS-51 monitors in use through the facility in such areas as telecine QC, tape QC, graphics and offline edit. The monitors get continuous usage 24 hours a day, seven days a week. Because Encore is a multi-standard facility, all monitors are used in both NTSC and PAL.

There have, however, been a number of problems. As originally designed, the CVS monitor's high voltage power supply was not regulated. Although Barco corrected this problem in the 20-inch model, they never bothered to correct the 14-inch model. Unfortunately, many monitor manufacturers now design these products with switching power supplies, as does Barco. This lends itself not only to higher failure rates, but also to the high susceptibility of the picture to displays of ac noise and transients.

The monitor manufacturers seldom want to admit that their reasons for implementing switching supplies in their products is one of lower cost and certainly not performance.

Another major problem to date with the CVS monitors is that their color decoders cannot be aligned to produce precise enough decoding either in PAL or NTSC formats. There always seems to be a compromise within the decoder alignments. It seems that precise decoder alignment can never be achieved without a certain margin of error internal to its design. One has to try to balance out the percentage of error to a minimum. One of the most annoying problems with the CVS series of monitors is the switching power supply noise, which displays itself as a randomly changing moire pattern. This problem has yet to be totally eliminated to the point where it can no longer be detected. The software, moreover, is cumbersome at best. The abundance of menus for the simplest of functions seriously slows down the setting-up process, and the passwords which were designed to restrict access to the menus can actually lock an operator out of the system.

We were surprised to find the results of evaluating other monitors were actually considerably worse than the results of evaluating Barco monitors. We decided that Barco's product, next to its competitors, is still the lesser of evils.

Unfortunately, we still have to go through the process of repairing new CVS monitors and/or returning them to the factory in the hope that the next factory-sent unit will have been tested and, most of all, that Barco will acknowledge and admit to some of their design or manufacturing mistakes. However, with proper high voltage regulation, proper video alignment, cleaner power supplies and less complex software, questionably needed to perform some of the simplest functions, the CVS monitor has some potential of being a decent product. ■

McCURDY PRESENTS A PLATFORM ON ECONOMICS



The stage is set for an exciting new performer. The McCurdy Series 'S' console. Affordable. Innovative. Designed to grow with you.

Here is audio engineering at its finest. A desk top "drop in" package which can be tailored for any size budget and broadcast requirement.

Inexpensive by design, the Series 'S' console provides precise audio mixing, monitoring and control. The very latest in analog and digital electronics is coupled with full electronic audio switching to assure the highest quality.

- up to 26 input mixing modules • stereo program and audition buses • telephone and cue buses • solid state audio switching
- full function digital logic control • universal module positioning • full travel Penny & Giles conductive plastic faders • separate VU housing section for customer provided equipment

As complete or as basic your budget allows, the Series 'S' offers McCurdy's unsurpassed audio quality and ultra-reliability. Simple economics with high-tech engineering. Another winning performance from McCurdy.

McCurdy

McCurdy Radio Industries

108 Carnforth Road, Toronto, Ontario Canada M4A 2L4 Tel: (416) 751-6262 Telex: 06-962533 Telefax: (416) 751-6455

1051 Clinton Street, Buffalo, New York 14206 Tel: (212) 772-0719

Circle 117 on Reader Service Card Page 63

RADIO ENGINEERING

NUMBER FIVE

SPECIAL SECTION

FEBRUARY 1989

FCC OKs Limited FM Short Spacing

In a rulemaking strongly protested by the NAB and one of its own members (Cmmr. James Quello), the FCC voted to permit limited short-spacing of FM broadcast station assignments. Handed down December 12, 1988, the new rules allow broadcasters greater flexibility selecting transmitter sites and plotting coverage.

Co-channel or adjacent channel signals must be protected from interference, according to the new rules, so short-spaced facility assignments will be contingent on the use of directional antennas. Additional interference protection can also be maintained by reducing power or antenna height, the Commission added. The new rules limit the amount of short-spacing to the separation specified for the next-smaller station class, but the FCC is imposing an additional temporary limit of five miles while it develops a streamlined applications process.

The new rules do not alter the table of FM allotments. The Commission will continue to maintain strict minimum distance separation when FM stations are allotted.

The NAB has repeatedly objected to the proposal and filed comments opposing the reduction of mileage separation between FM stations. "This is the beginning of the end, or nearly so, of FM broadcasting's reputation for quality," said NAB chairman Eddie Fritts after the rulemaking was made official.

The NAB's primary concern is that a lack of technical safeguards in the installation and operation of FM directional antennas will lead to increased interference.

The NAB further fears that authorization of the directional antennas will "inevitably" lead to a "contour" system of allocating FM stations, according to Fritts. "The FM broadcast service is far from broken; the FCC should refrain from making repairs," he said. (See "Changing Directionals: Fine-Tuning FM Allotment," p. tk, for a full analysis.)



Smulyan Named Chair for Radio '89

Jeffrey Smulyan has been named chairman of the NAB Radio '89 steering committee. He was appointed by NAB president and CEO Edward Fritts

and joint board chairman Wallace Jorgenson, executive VP of Hubbard Broadcasting. Based in Indianapolis, IN, Smulyan is president and chairman of the board of Emmis Broadcasting. Radio '89 will be held September 12-16 in New Orleans.

AT&T Cuts Radio Remote Service

The FCC has ruled to allow AT&T to discontinue its interstate domestic terrestrial audio service (DTAS). This telephone-line service is used by radio stations to relay remote pickups. Each of the

regional telephone companies offers a similar service but the AT&T service is the only one of its kind to cross regional lines.

In asking for permission to discontinue the DTAS service, AT&T cited declining revenues and underutilization of available facilities. It also cited the

fact that 40 per cent of its 111 customers used only local-access components of the service, which are available from local exchange carriers.

Opposition to the AT&T request came from the Metropolitan Broadcasting Corp. and National Public Radio. Claiming that dis-

CONTENTS

Radio News 55

New Directions
in Radio
Automation 59

Automated
Maintenance
and Testing 67

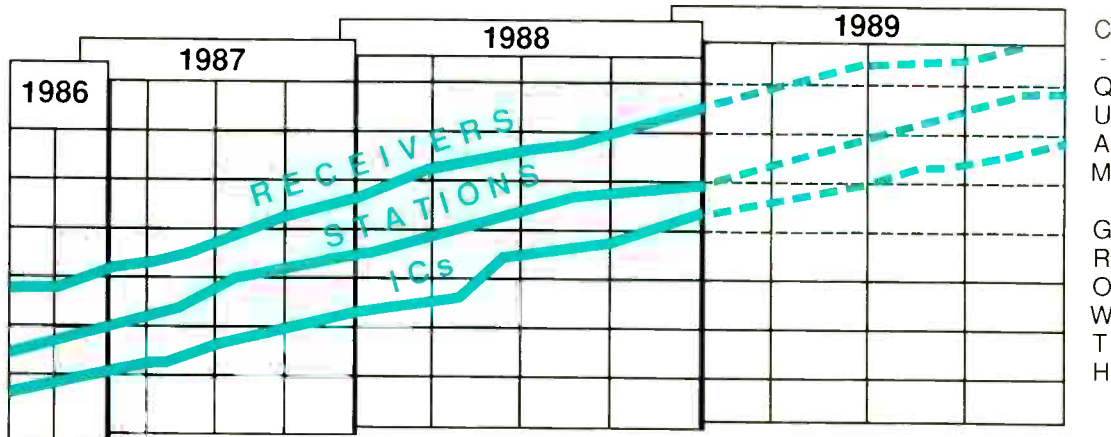

Nearly 700 radio stations worldwide have upgraded their facilities to C-QUAM-format AM stereo, according to format-developer Motorola. The company says that nearly 17 million AM stereo ICs have been shipped to receiver manufacturers to date. A new series of semiconductors making AM stereo available in personal stereo and home component systems will become available in 1989.

continuance of the service "will materially and adversely affect NPR and is prima facie inconsistent with the public interest, convenience and necessity," NPR further contended that "cost-effective, technologically comparable alternatives" to the service were not available.

The director of engineering for Metropolitan Broadcasting, Phil Harris, attended the FCC hearings. "In my opinion, if more companies had been represented at the hearings, we would have reached a more favorable agreement with AT&T," he said.

The final agreement called for Metropolitan and NPR to withdraw their petitions and for AT&T to continue to offer switching services in New York and Washington until another carrier should undertake to meet the customers' service requirements. AT&T will also

continue four interoffice channels until December 31, 1989. These are: Camp David to Washington, Atlantic City to Philadelphia, El Paso to Austin, and Chicago to New York.

One private satellite service provider, IDB Communications Group, intends to offer switching services in Washington and New York to augment the AT&T switching centers in these cities. IDB expects its own increased switching capacity will assist AT&T in the eventual discontinuance of DTAS.

Asked about the possibility that whatever companies replace AT&T in offering DTAS might raise prices, NPR assistant general counsel Karen Christensen responded, "Yes, but AT&T might also raise the price. What concerns me most is the agreement that AT&T will offer service on an individual case basis. I don't find that provision in the state-

ments AT&T has issued to its customers."

The entire matter is strictly an east coast problem. Jim Carollo, chief engineer at WGN-AM, Chi-

cago, commented, "The ruling won't affect us. Illinois Bell is continuing its equalized service and we haven't used AT&T in 10 years." ■

AM Bandwidth Rulemaking Due Soon

As the new Bush administration swings into action, the NAB says formal FCC rulemaking directing implementation of the expansion of the AM band is expected "any day now".

"No one is against this proposal. We're just waiting for the FCC to tell us how," said NAB staff engineer Stan Salek.

The proposed expansion of the AM band adds bandwidth from 1610 through 1690 kHz; TIS will move from 1610 and 530 to 1700 kHz. By international agreement, the

expanded band can begin operation July 1, 1990. The FCC hopes to have an allocation scheme in place so that it can accept applications by that date.

The NAB has consistently supported giving AM daytimer stations the first opportunity to "colonize" the expanded AM band by diplexing an expanded band transmitter onto existing towers. Power levels of up to 10 kHz are generally permitted in the expanded band.

The FCC has been supporting a national licensing option, which the NAB says will not promote public service at the local level. ■

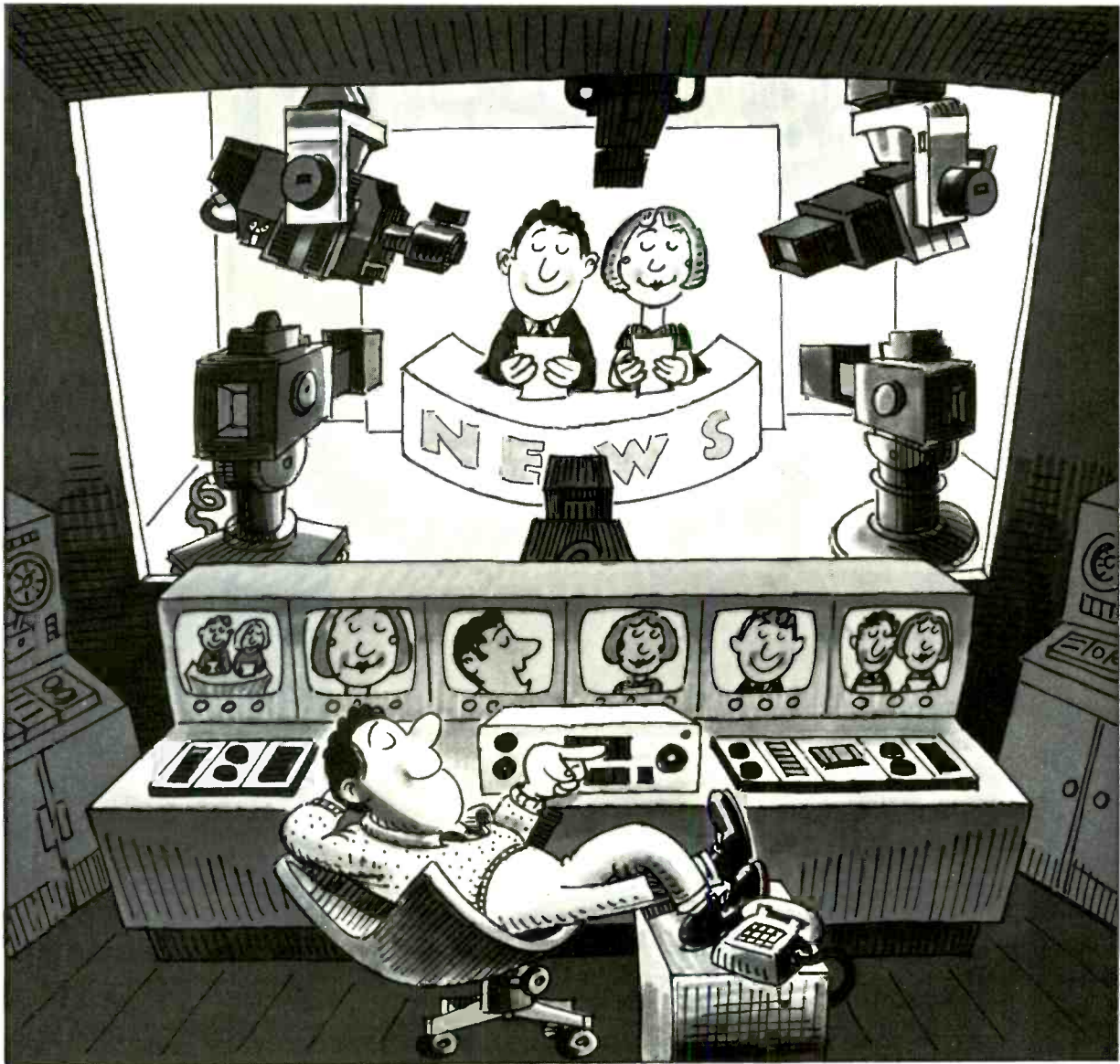

MULTIPLE CAMERAS. ONE OPERATOR.

Impossible? Not if your cameras are mounted on EPO Servo-Controlled pan and tilt heads. These extraordinary, labor-saving devices, which first found favor in legislatures where remote-controlled, unobtrusive coverage was a key factor, are now the basis for complete remote-controlled news studios.

Just look at these outstanding features:

- Up to 500 preprogrammed positions per camera, including control of iris and black levels
- Programmable fade modes that provide smooth transition from preprogrammed shots
- Ability to zoom and focus
- Unobtrusive
- Can be operated via telephone lines or microwave in a remote studio away from the main studio location
- Wide range of pan and tilt heads, for full studio cameras with teleprompters to ENG type cameras
- Wide range of control options, from panels with multiple-shot memories to simple joy stick remote controls.

It's flexible, affordable—and it's sold and serviced exclusively in the U.S.A. by A.F. Associates.

THE RADAMEC EPO REMOTE CAMERA CONTROL SYSTEMS

Your news show's bottom line will never look so good.



A.F. ASSOCIATES INC.

ADVANCED SYSTEMS AND PRODUCTS FOR THE VIDEO INDUSTRY
100 STONEHURST COURT, NORTHWALL, N.J. 07647 (201) 767-1201
IN THE WEST: 5625 ROUFFIN ROAD, SUITE 200, SAN DIEGO, CA 92123 (619) 277-0291
LEASING AVAILABLE THROUGH COMPTON CAPITAL CORP.

Circle 118 on Reader Service Card Page 63

200 LBS. SUPPORT WITH SACHTLER CONFIDENCE

WE'VE GOT IT.
INTRODUCING THE NEW VIDEO 80
AND OB-2 TRIPOD SYSTEM...

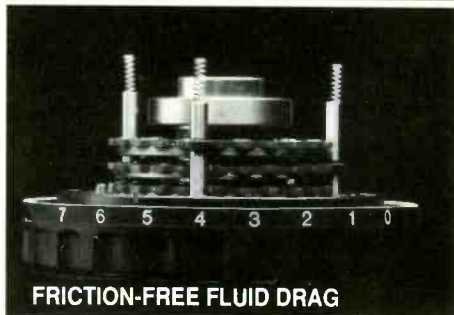

The Video 80 gives you fluid control for any camera, lens & prompter combination. With instant "dynamic" counterbalancing there are no cams to change. Our New OB-2 System gives you a range from 19" to 60" height with an optional elevation unit up to 75". The whole system is warranted for **3 years, plus** the Fluid Modules are warranted for **5 years**. The best warranty in the industry.



Eric D. Falkenberg
Executive Vice President

Call or write for information.

sachtler[®]
corporation of america



55 North Main Street
Freeport, NY 11520
Phone: (516) 867-4900
FAX: (516) 623-6844

West coast:

3316 West Victory Blvd.
Burbank, CA 91505
Phone: (818) 845-4446

Circle 119 on Reader Service Card Page 63

A lot has been going on lately in the world of radio station automation. Thanks to a few intrepid explorers, the benefits of small computers and digital audio recording have found their way into this milieu. Early development has not been without its difficulties, however, as many of the steps taken toward implementation have been through the back door.

Compared to the automation systems of the past, however, reliability, programmability, audio quality and capacity can all be improved greatly by these new devices. Among other advantages, they feature dramatically reduced space requirements and operating costs. Naturally, the potential for problems also rises commensurately due to their greater complexity. And for a system to be truly useful, it must be able to accommodate a wide range of present and future applications comfortably.

The three major players in the field right now are Systemation of Decatur, IL, Schafer Digital of La Jolla, CA and Concept Productions of Roseville, CA, each coming at the technology from a slightly different direction. Systemation's parent is a highly rated AM/FM combo in Decatur, WDW/WDZQ. Schafer Digital is the descendant of a major force in "old style" automation systems, and Concept Productions is a music syndication/programming house.

All three systems use a microcomputer as a controller to store and update programming sequences. They use digital audio recording systems of one sort or another for music storage, thereby providing high audio quality and recording density, and relatively fast access time. Here the benefits of digital audio go well beyond improved audio quality and include lower cost-per-minute of storage, quicker access and smaller physical size for hardware and software. Short duration events (spots, PSAs, IDs, etc.) are usu-

NEW DIRECTIONS IN RADIO AUTOMATION

Radio automation is changing radically with the introduction of digital audio and control systems. Performance is rising and costs are coming down.

ally handled by a hard-disk digital audio storage device, to allow true random access and instant start.

The Schafer Digital system uses the EIAJ (Electronics Industry of Japan) format pseudovideo PCM system for its music storage, which is on standard Beta format VCRs. (Pseudovideo digital systems convert a stereo audio signal into a 16-bit, 44.1 kHz-sampled datastream, then format it into a monochrome video signal that can be recorded on any VCR.) Schafer currently employs Sony PCM-601ES PCM processors and Sony SLHF-650 VCRs. Although these models were discontinued from Sony's consumer product line, Schafer has an agreement with Sony to continue to provide and service these units. For maximizing storage time, the Beta-HiFi tracks on the VCR can also be used for a second pair of stereo tracks (albeit with slightly reduced quality), thus providing twice the recording capacity on each tape. Over 10 hours of

storage per tape can be achieved using L-830 Beta cassettes at BIII speed. Schafer claims negligible interference and crosstalk between these tracks. The VCRs are slightly modified to allow hardware remote transport control, although Schafer and others are currently investigating a "less invasive" form of interface using LEDs to control the decks through their IR remote port, thus avoiding warranty violation. SMPTE timecode is used on the linear audio track of the Beta cassettes for location data.

Schafer's system uses a PC/AT-class computer for control, typically configured with a 20 or 40 MB hard drive. The PC's hard drive is used for storage of programming instructions. Optionally, a Dyaxis hard-disk digital editor/recorder with 30 minutes of stereo capacity is also used. Spots are stored on Beta cassettes and downloaded to the Dyaxis before they are needed. A typical system can be preprogrammed for up to a two-week "walkaway."

Schafer claims about a dozen systems are currently in use, including one in Amsterdam, The Netherlands,

BY SKIP PIZZI

R DAT
(Concept
Productions)



one DAT-120

=



Two analog reels*

OR



24 5-minute cassettes

Pseudovideo PCM
+ Beta HiFi™
(Schafer Digital)



one L-830
(beta III speed)

=



Ten analog reels*

OR



120 5-minute cassettes

8mm Video/
"Audio only" mode
(Systemation)



one Video8-120
(EP speed)

=



20 analog reels*

OR



240 5-minute cassettes

Storage density of three digital automation systems compared. Audio quality of digital formats is superior to analog equivalents in most cases. (Analog reel is defined as 10.5-inch reel using 1.5 mil tape at 7.5 ips, in 1/4-inch two-track stereo format.)

CHART BY NEXTWAVE PRODUCTIONS

serving audiences in 15 countries. But the Schafer system has reportedly encountered some difficulties in reliability and flexibility. In apparent

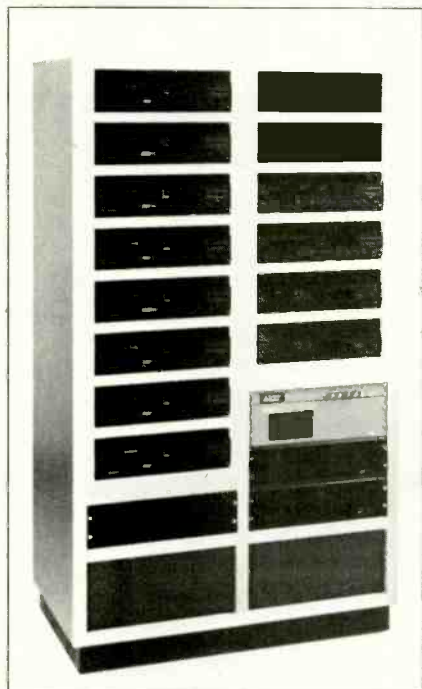

The Schafer Digital system, using eight modified Sony SLHF-650 Beta HiFi decks for music storage on the left. On the right are two more 650s for spot downloads, two Sony PCM-601EX pseudovideo digital audio processors, and a Dyaxis hard-disk recorder.

response to this, its software is being rewritten to expand its capabilities and user-friendliness. One of the beauties of such systems is the ability to correct problems and improve functioning through software changes. Such enhancements can continue to be made throughout the useful lifetime of the hardware.

The system under development by Concept Productions—the CAPS-II (Computer Assisted Programming System)—uses the R-DAT (Rotary Digital Audio Tape) format for music storage, a Turbo XT computer with 20 MB hard drive for control, and a CompuSonics hard-disk audio storage device for short-duration events. The R-DAT decks are slightly modified Sony DTC-1000 units. The standard “start ID” indexing feature of the R-DAT format is used to locate cuts. An FSK (Frequency Shift Keying) burst is recorded just ahead of every song or spot. The burst, unique to each event, serves as feedback to the controller to confirm proper programming and for generating verifiable logs from the system’s printer. It is also used as an exact cueing point and to select “startup delay time,” the programmable interval between cuts.

The R-DAT modifications again involve a hardwire remote transport control interface. This interface vio-

With tears in his eyes, one small-market GM testified that he would not be in business today were it not for his automation system.

lates the original Sony warranty, so Concept picks up warranty service on these decks. Concept has also designed an ingenious mechanical loader for the R-DAT cassettes. Operating like Sony’s Betacam Betacart, it allows up to 62 two-hour cassettes to be shuffled among 10 R-DAT players in a rack. The company plans to incorporate a new line of CompuSonics hard-disk recorders, currently in development. They are said to provide from 22 to 105 minutes of wideband stereo audio, using from 80 to 380 MB of hard-disk capacity respectively.

Concept has yet to tackle the finer points of satellite system interfacing, where music is delivered from a satellite network while spots, DJ tracks and other local elements are handled by the automation system. (Satellite

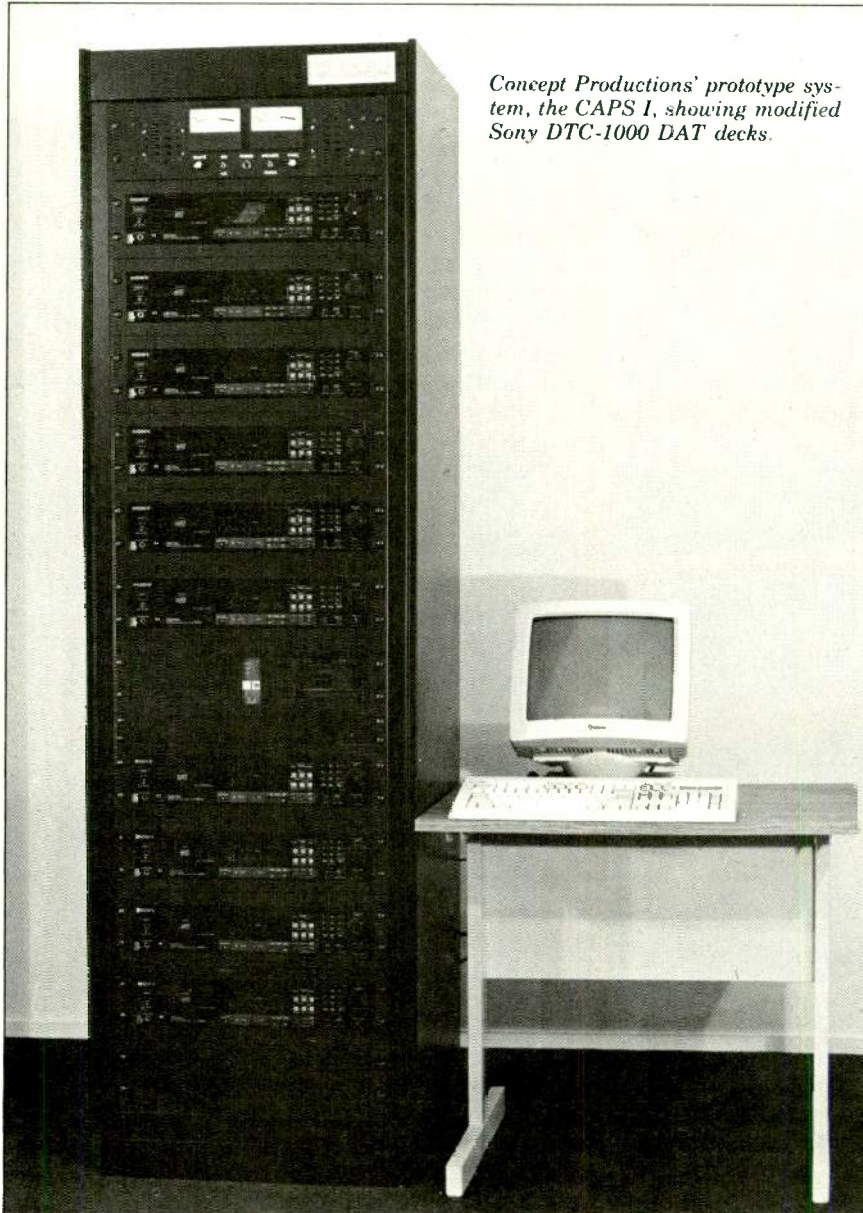

Concept Productions' prototype system, the CAPS I, showing modified Sony DTC-1000 DAT decks.

networks typically employ subsonic tones—usually 25 Hz and 35 Hz on either or both channels—to communicate with station automation systems, thereby providing six separate command possibilities to the controller.) In the meantime, the CAPS-I prototype system is currently in operation at KZXY-FM in Apple Valley, CA, where it provides music only in a live-assist configuration. Results in this limited application have been good since its installation in August 1988, but the station, and about a dozen of

Concept's other 130 programming clients, all anticipate the release of the full CAPS-2 system, scheduled for early this year.

The leader in the high-tech automation field at present seems to be Systemation, with some 450 analog and digital systems in service worldwide. The company's current digital music system uses the 8mm videocassette format in its companded eight-bit, 31.5 kHz-sampled digital audio-only mode. This format allows six stereo audio tracks to be placed

sequentially along the length of the videotape, each running the full length of the tape. With a four-hour tape length, this could provide 24 hours of music on a single 8mm videocassette, which currently costs between \$8.00 and \$10.00. Although audio quality does not match 16-bit, 44.1 kHz formats, 8mm audio exceeds the quality of many analog recorders, and certainly any that might be considered for automation systems.

Systemation uses one of the six tracks for time coding (a proprietary system using ASCII), which provides up to 20 hours of music per tape. Currently, Sony V-800 decks are used with a noninvasive control interface; original warranties remain in force. The system controller is also propri-

For a system to be truly useful, it must comfortably accommodate a wide range of applications now, and in the future.

etary—Systemation calls it the X-7D—and it is accessed for programming via a Commodore 64 or a PC. The X-7D controller allows multiuser/multitasking operation, with interface capacity for up to six computers. This allows various station personnel access to the system for simultaneous monitoring or control from their desks or, via modem, from home. The system also supports printers for logging. Up to seven days of walkaway are permitted without repeating any programming. And proprietary hard-disk recording systems are offered for short-duration events.

Systemation burns in the format of the network of choice for satellite music stations on the automation controller's defaults; the station may adjust the programming as it desires, or new defaults may be programmed (or

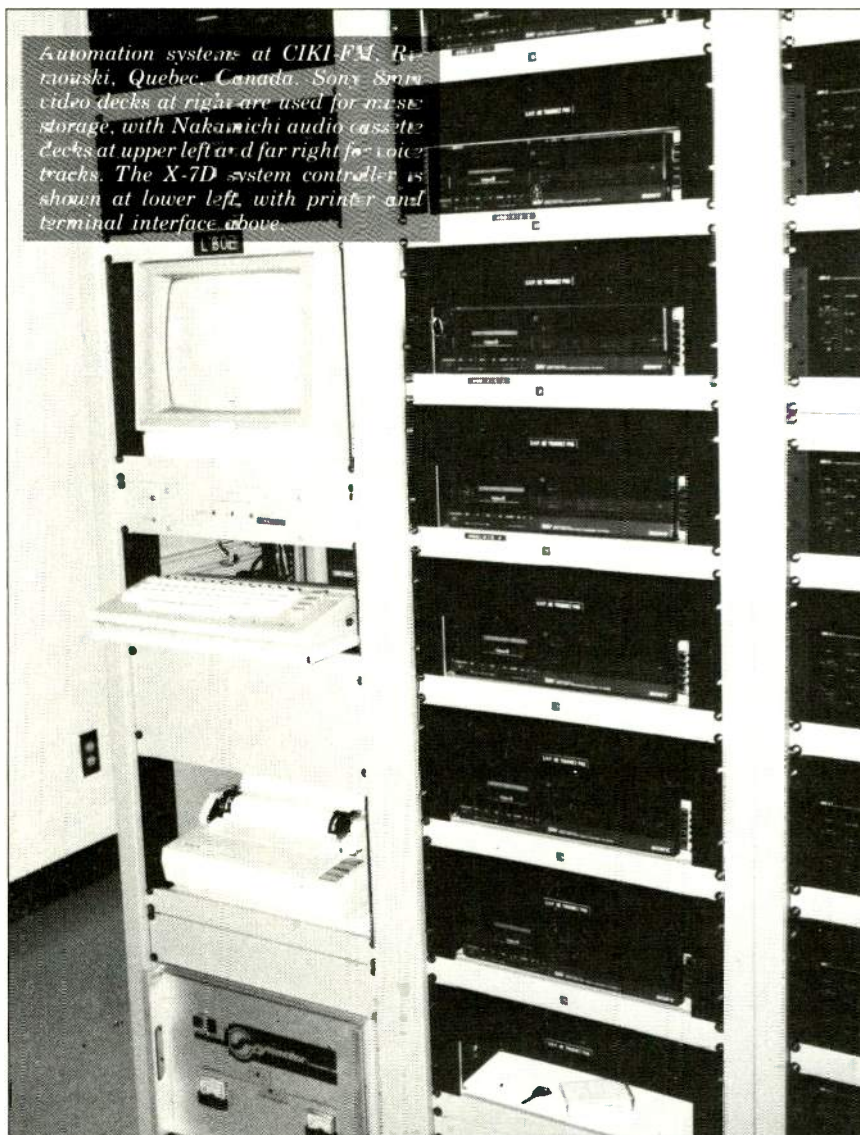

Automation systems at CIKI-FM Riverview, Quebec, Canada. Sony SMC video decks at right are used for music storage, with Nakamichi audio cassette decks at upper left and far right for voice tracks. The X-7D system controller is shown at lower left, with printer and terminal interface above.

ROM chips swapped) if the station changes networks.

A remote package for field work is also available. This enables a reporter to call the system from a Touch-Tone phone and either record a spot and program it for later airing or switch himself live onto the air. An announcer can operate the station in a similar manner during a remote broadcast. Audio from the remote site gets to the station via telco loop, RPU or dial-up while program control is operated on a separate dial-up line. Systemation's proprietary twin-duplex RPU system will also support

hosting a call-in show in this fashion.

Systemation is fortunate in its link with a built-in proving ground, station WDZ/WZQ, while its no-inventory, "soft-configurable" approach enables it to respond quickly to perceived need. A new generation of automation systems, expected to be introduced at NAB '89, will consist in part of an IBM AT controller with a 100 MB hard disk drive. In addition to running a digital music system or satellite network interface, the new system can hold a commercial log for up to one year. An operator will be able to call up any particular commercial's

script or set of notes via a touchscreen interface, while the station's music log and notes can also be preprogrammed in the database for touchscreen recall. Other functions include CRT access to a color weather radar display for a particular market accessed via dial-up from The Weather Bank in Salt Lake City. (The computer can be programmed to automatically call in for updates on an hourly or other basis.)

The system also accommodates an optional weather voice function, for either on-air or listener dial-up use. Similar to a companion sports service, an announcer's voice reading phrases and numbers necessary for a short weather forecast is digitally recorded and pieced together from a hard-disk system via a simple ASCII command stream. Although regulatory hurdles may stand in the way, the company is also developing a brief over-the-air data burst to send information to electronic signs in the listening area.

The basic approach of all these systems is to maximize human and hardware efficiency and improve listener service. While some argue that it's just another case of robotics stealing jobs or reducing a craft to pure mechanics, others counter that it's the best way to serve an audience with the limited dollars available. Systemation cites one small-market GM who testified with tears in his eyes that he would not be in business today were it not for his automation system. And—given the proper equipment—there can be creative fulfillment programming. ■

Pizzi is BME's contributing editor.

For More Information

Dick Wagner, Concept Productions, Roseville, CA (916-782-7754)
 Paul Schafer, Schafer Digital, La Jolla, CA (619 456-8000)
 Steve Bellinger, Systemation, Inc., Decatur, IL (217 423-9763)

Most broadcast engineers spend a large part of their time working in two areas: making sure equipment doesn't break, and then fixing it when it does. The first task is closely related to the second; if you don't devote enough time to preventing problems, you'll have to make time when problems appear.

The difference between broadcast engineers and most people who make their living repairing problems is that we are often under pressure to correct problems while equipment is still in use. It's sort of like changing the tire without stopping the car.

We also get to run diagnostics while the equipment is being used. That presents a real challenge because the equipment's in a studio and the test gear is in the engineering shop. Either Mohammed goes to the mountain or the mountain comes to Mohammed, but both have to come together for tests to be run. In either case, the disc jockey gets annoyed. Either we take the studio apart in front of him and whisk away his cart and tape machines, or we invade the sanctity of the on-air studio with a cartful of test gear and subject him to a bunch of test tones. He doesn't appreciate either scenario and would far rather we just left him alone. And because we would rather avoid lugging equipment around the station, we're inclined to indulge those wishes. The all-too-common result is that the equipment has to be in serious trouble before it gets the attention and care it deserves.

It needn't be this way. The recent advent of automated testing equipment not only makes it easy to save time while testing the equipment, it also lends itself to testing equipment located in another room. Distortion, frequency response and stereo phase can all be tested automatically without operator intervention. We can predict the timings of the test tones on an alignment tape and program a computer to test them as they appear.

MAKE YOUR TESTING AND DIAGNOSTICS AUTOMATIC

At KIIS in Los Angeles, an innovative preventive maintenance program spots problems before they start—while the equipment is in use.

Requirements are an automatic test system and a standard audio alignment tape. A simple test can be developed for the analyzer that will wait for the standard 700 Hz level tone at the front end of the test tape and, when it's detected, start the frequency or phase runs automatically. A set of tolerance limits decides if the equipment under test passes or fails the tests, and the performance is graphed out on a standard dot-matrix printer.

To make the testing as easy as possible, KIIS uses a feature built into the Dynamax CTR-100 series cart machines we have on the air. These have a set of infrared sensors built into the right-hand cart guide which are triggered by reflective stickers on the side of the carts we play. Our standard test cart has a special sticker

that closes a set of internal contacts. We use this to disconnect the outputs of the machine from the console. Instead, they feed a special test bus that runs from the studio into the maintenance shop. Machines without the IR sensors and shiny stickers could substitute the studio's audition bus and wire it into the shop.

The output of the test bus assessing the cart deck's performance feeds into an Audio Precision System One, a Compaq Portable computer and an Epson FX-85 printer in the KIIS shop. A special version of the Standard Tape Labs test cart performs two frequency sweep runs before the stop tone: the first set of tones tests the stereo frequency response and the second checks the playback stereo phase. Both runs take less than five minutes, during which the engineer is free to do other work. When the test cart finishes and recues, the air personality

By **MICHAEL D. CALLAGHAN**

moves it down to the next cart deck and starts it again.

Frequently the automated testing shows a machine has drifted out of tolerance. This produces a special note on the printout and the operator then decides if the machine should be taken out of service. Simple frequency response and phase adjustments are usually made with the machine still placed in the studio, while excessively worn heads, bent guides and other mechanical repairs require relocation to the workshop. After repairs are finished, the same automatic test procedure is repeated before the machine goes back into the studio.

Cumulative records are kept on each cart and tape machine. Looking through the frequency response runs reveals the results of head wear and machine aging; people who use the program come to develop a perception

about when a head should be changed as a precaution or how long it will be before phase will need adjustment. Sudden phase errors brought on by

equalization adjustments are easy to spot and correct.

Here's how the system works in detail. First, the automated testing is

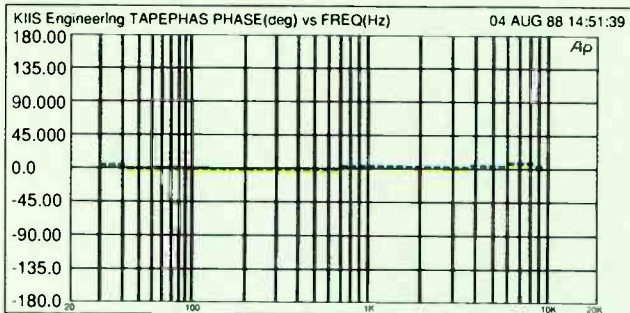
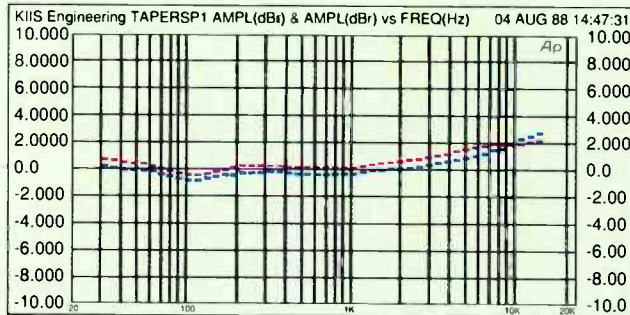

Curves on a reel-to-reel deck in the KIIS FM production studio. Test data is within limits—tape deck performs normally.

CAMERA REMOTE CONTROL THE SENSIBLE WAY

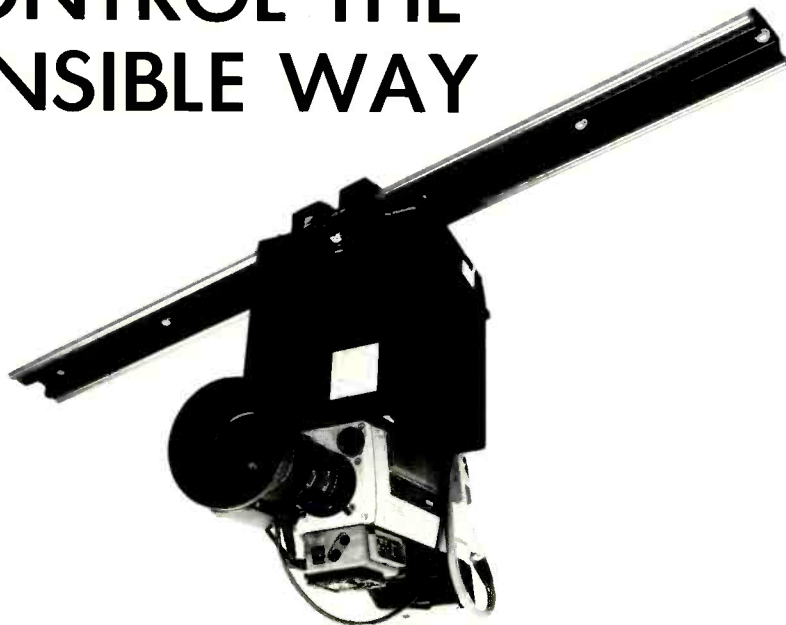

Control Pan-Tilt-Trolley-Zoom-Focus

with

- Simple Joystick Panel
- Presetable Shot Panel
- Touch Screen Panel
- Computer RS-232/242

thru

- Multicore Cable
- Twisted Pair
- Telephone Modem

Telemetrics – for over 20 years
the innovators of camera
control systems.

Circle 120 on Reader Service Card Page 63

Telemetrics

7 Valley St. Hawthorne, N.J. 07506
For Information Call (201) 423-0347

run as a procedure by the System One. This is simply a group of key-strokes that are stored as a script; they are executed as though you were sitting in front of the keyboard. Each portion of the procedure calls up a specific test that has been previously stored on the system's hard disk; after each test is completed, the procedure calls up the next test. For example, in the cart tests, the first 700 Hz tone on the tape starts the sequence and calibrates the reference level. The system waits 45 seconds while azimuth tone runs through and then starts a stereo frequency sweep. It measures the left and right channels starting at 50 Hz and working up through 12 kHz. When the 700 Hz reference tone reappears, it signals the end of the test, and the results are stored on disk. Then the stereo phase test uses the second sweep to check playback head

azimuth for each tone. When it finishes, the system prompts the operator to type in the machine's serial number and location, and the operator's initials. All this information and a corresponding pair of graphs are sent to the printer for evaluation.

The system includes some timing delays: for example, we know that on our test tape there are 22 seconds of azimuth tone between the start of the 700 Hz level tone and the beginning of the frequency response run, so we simply put a 22-second delay in the test procedure while it passes by. If we were in a production line environment, we would probably edit the test tape to get rid of it. Fortunately, things aren't so hurried here, so we can keep the azimuth tone for another test. The reel-to-reel tests work on a similar basis. There are differences in the tone placement for the two com-

mon tape speeds, however, so a pair of different procedures is used.

The computer itself is configured so the user doesn't need any knowledge of the operating system. As it is powered up, the user sees a menu asking what program he'd like to use. The first three choices relate to the System One procedure. The "Audio Precision" choice brings up a detailed menu with numerous parameter choices. This menu is for experienced operators who are comfortable working with the many options the system provides; routine equipment testing doesn't involve this option. The second and third choices, "Audio Precision Cart Deck" and "Tape Deck Tests," start the automated test sequences. Choosing "Tape Deck Tests" brings up another menu which selects machine speed. On-screen prompts guide the user through each step in

The wireless system that will never leave you speechless.

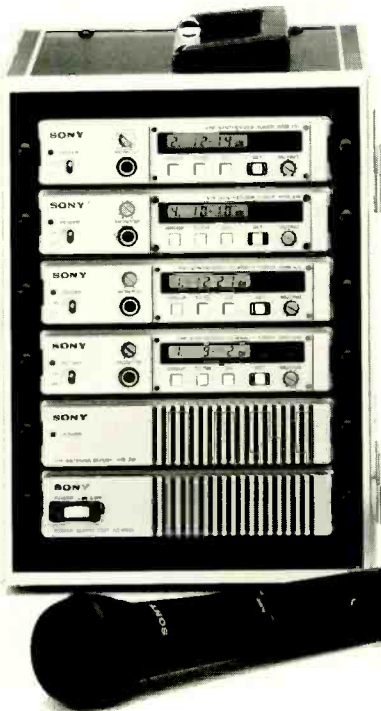

If this has ever happened to you, you weren't using a Sony VHF wireless microphone.

Rather than a mere one, two or ten channels, the Sony wireless system gives you up to 168. So no matter where you are, no matter how cluttered the airwaves, the signal will come through loud and clear. And with so many open channels to choose from, multi-microphone set ups are a snap.

For added insurance, Sony wireless arms you with true space diversity reception. Twin tuners constantly compare incoming signals for the strongest, clearest signal. Sparing you the echoes, dead spots and other horrors that plague lesser systems.

So, if you're looking for a wireless system you can have faith in—any time, any place—contact your Sony Professional Audio representative. Or call Sony at 800-635-SONY.

SONY.
Professional Audio

NOW GET THE SAME SERVICE AND EQUIPMENT ON THIS COAST...



AS YOU DO ON THIS COAST.

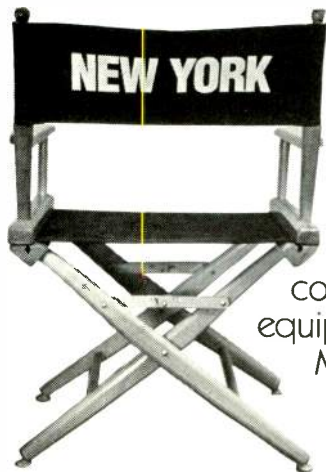

East Coast or West Coast. Now the same complete selection of sophisticated video equipment you've come to expect from Camera Mart/New York is yours to rent or buy from CMTV/Burbank, CMTV/California and CMTV/Nevada.

The same great service, too. Because with your continued support, we've been able to expand CMTV to a full-fledged West Coast operation, complete with repair and maintenance facilities.

So now you can have the best of both coasts.

We've been big in video since it was small.



CMTV Inc.

Affiliated with

The Camera Mart, Inc.

SALES • SERVICE • RENTAL

1900 W. Burbank Blvd., Burbank, CA 91506 (818) 843-6644 FAX (818) 843-2473

Headquarters/New York
456 West 55th Street, New York 10019
(212) 757-6977
Telex: 275619/FAX (212) 582-2498

Upstate/Central N.Y.
305 Vine Street, Liverpool, N.Y. 13088
(315) 457-3703 FAX (315) 457-3795

Nevada
3553 Regents Court, Las Vegas, Nevada 89121
(702) 435-9234 FAX (702) 451-3229

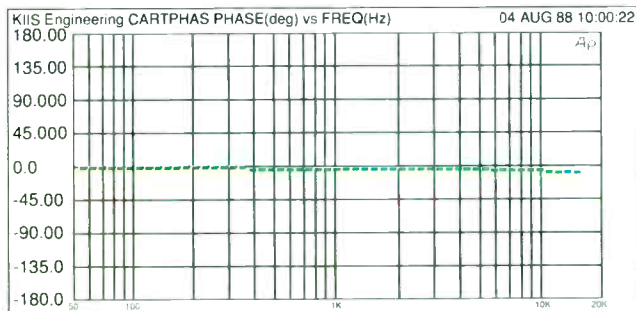
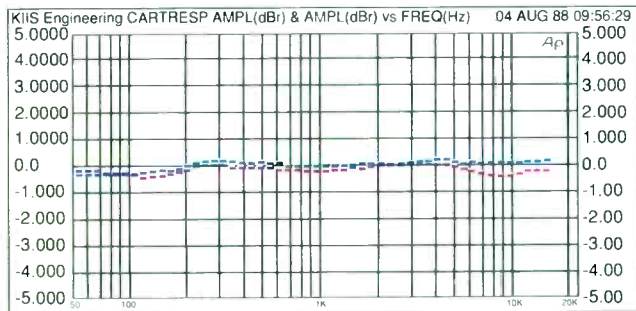
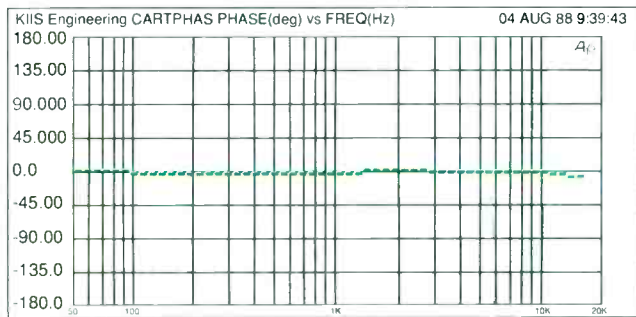
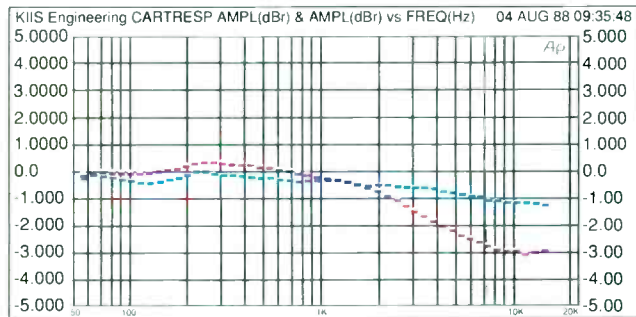

Top two charts show cart machine with a worn playback head. Although the curve looks poor, the machine is almost within manufacturer's limit: ± 2 dB. Second chart, stereo phase response. Bottom two show the same machine 30 minutes later after replacement of playback head. Response curve is flat and phase response is accurate. The KIIS system is based on the Audio Precision System One (right).

the test procedure. All the menus include a safe return to the main menu.

The equipment under test either passes or fails the performance criteria; as long as it passes, it stays in service without leaving the studio.

In conclusion, the Audio Precision System One does represent a substantial capital investment. But the return on investment and the time that is saved make it a remarkable value.



Being able to track the performance of studio tape machines this easily keeps staff comfortable and also allows better management of manpower resources and parts inventories. The ability to quickly analyze the performance of a breadboarded circuit speeds up design time and results in better performance. ■

Callaghan is chief engineer of KIIS-AM/FM, Los Angeles, CA.

Lots of people make their living repairing problems. Broadcast engineers have to do it while the equipment is in use.

IT LOOKS EVEN BETTER ON TV.

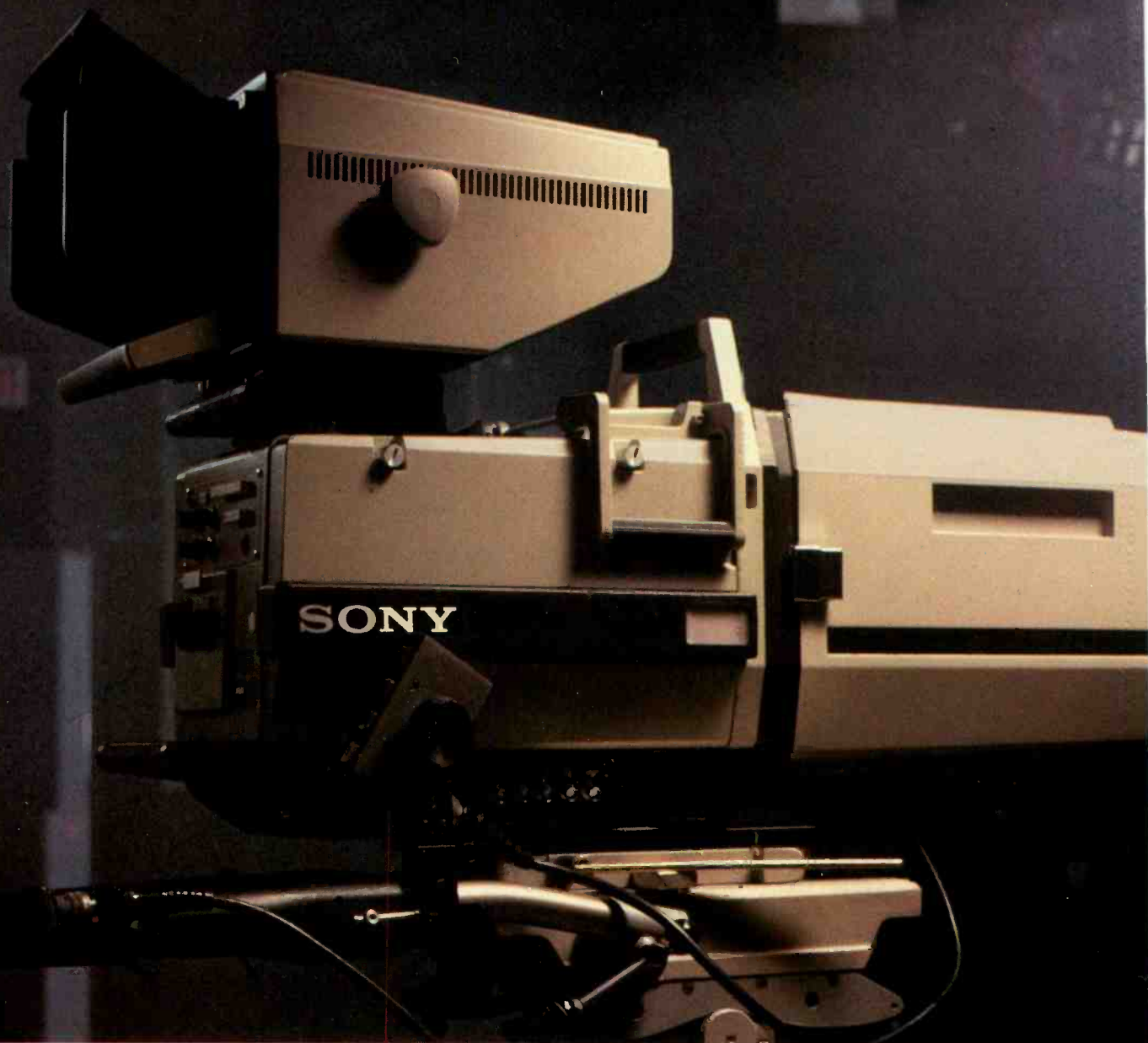

And no wonder—it's the Sony BVP-360. The best-looking studio camera on TV. And the one with the best-looking picture.

The BVP-360 offers state-of-the-art mixed-field technol-

ogy in 2/3" Plumbicon™ tubes—precise and ultra-stable geometry and registration, and more than 700 lines of resolution. The best signal-to-noise ratio. And the most accurate color reproduction. To the

darkest shadows and highest-level whites. And the widest range of light levels in between.

By design, the BVP-360 is ideally suited for studio and outdoor production. And, since the portable companion

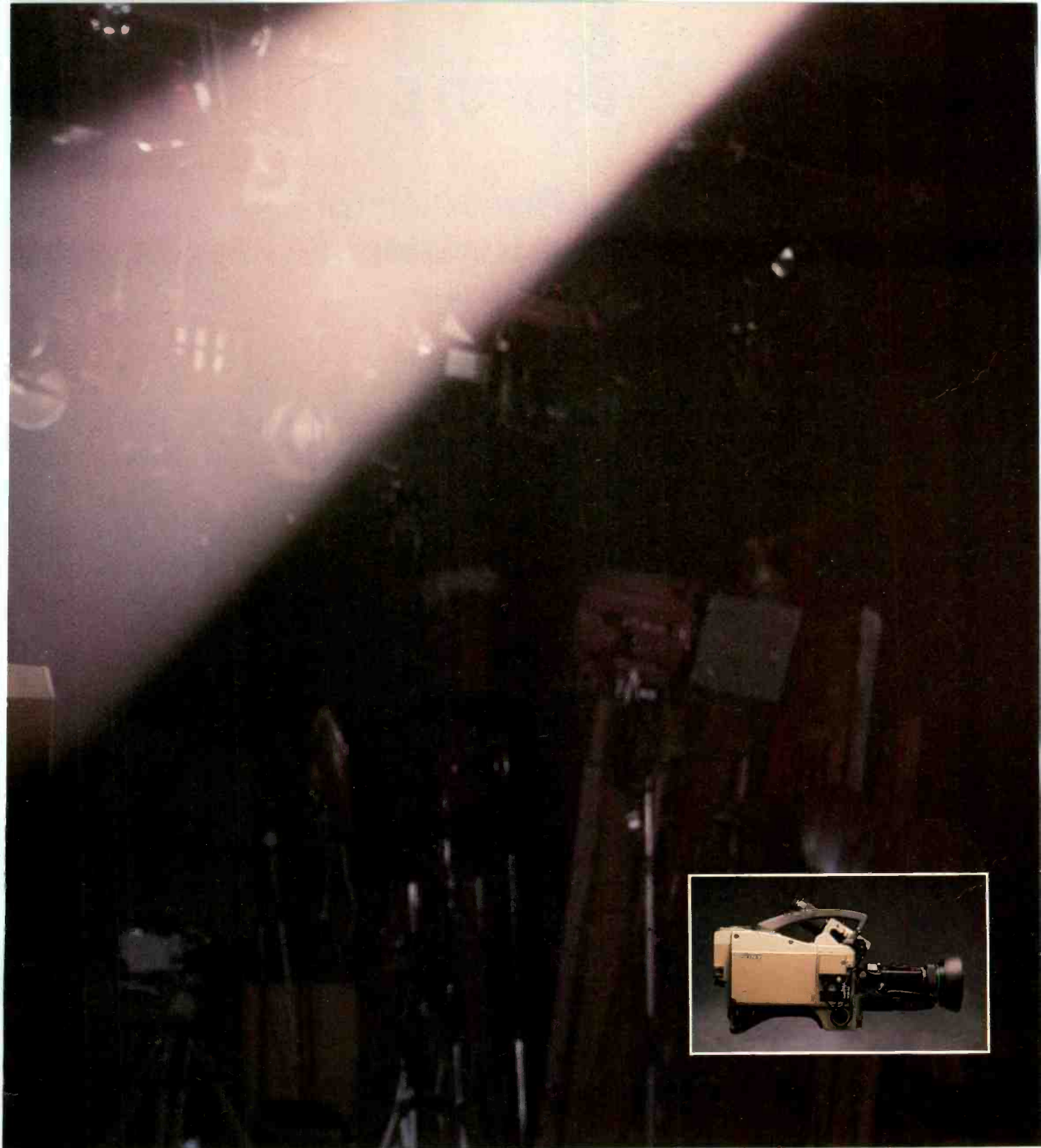

BVP-350 uses the same circuit boards and optics, its picture is exactly the same.

But most of all, the BVP-360 looks good because it's from Sony—the leader in broadcast camera sales. And

it's backed by Sony service. Our national service organization is on call 24 hours.

SONY®

Any day. Anywhere.

But see the BVP-360 for yourself. Contact your Sony Broadcast Sales Engineer. Or call Sony at (800) 635-SONY.

Sony Communications Products Company, 1600 Queen Anne Road, Teaneck, NJ 07666. ©1988 Sony Corporation of America. Sony is a registered trademark of Sony.

BROADCAST PRODUCTS

A Line Stretcher for Phase Rotation

By Ronald F. Balonis

For AM stereo the load that the antenna system gives to the transmitter can have a significant effect on the quality of a station's AM stereo sound. The magnitude of the sideband VSWR and the symmetry of the load determine, to an important extent, the amount of stereo separation and ultimate signal distortion.

In the real world, physical constraints and limitations determine what the transmission distance (phase shift) is from the transmitter to the antenna—some as actual transmission line, and some as matching networks to transform the antenna load. And, in the real world, the impedance of a broadcast antenna, or the common-point impedance, varies over the transmission band, affecting a transmitter's frequency response, amplitude linearity, and the modulation capability. It can also cause, because of frequency selectivity, IPM—Incidental Phase Modulation.

Theory says that regardless of the kind of am-

plifier circuit or the modulation method, at maximum modulation the output stage can deliver either a full peak current or a full peak voltage to the load. And, for the transmitter to deliver a voltage or a current wave to the load, free of phase modulation and identical to the input audio, the load must be a point of impedance symmetry. That is at some half-wave or odd quarter-wave point from the antenna.

There are three ways to get the load point right for the transmitter's output stage: by designing it in with a new transmission line and matching networks, by redesign of a transmission line and the matching networks, or by adding a "line stretcher" to add phase shift to reorient the impedance-versus-frequency characteristic of the load.

This month's Compute program, LSTRETCH.BAS, computes the component values for a Pi-like line



stretcher that can be used to get the overall system phase shift (transmission distance) right. It has a transformation ratio of unity, and it can have a phase shift that ranges from 90 to 270 degrees.

It's a relatively simple calculating program: Just enter the Frequency, the Impedance (a pure resistance), and the Phase shift, between 90 and 270, desired. And then it displays the values of the components for the "Line Stretcher" (see the example screen). All that's left to do is build it or adjust it.

This "line stretcher" comes from the July, 1949 Proceedings of the IRE: "Operation of AM Broad-

+ Phase Shifter or Line Stretcher Network +

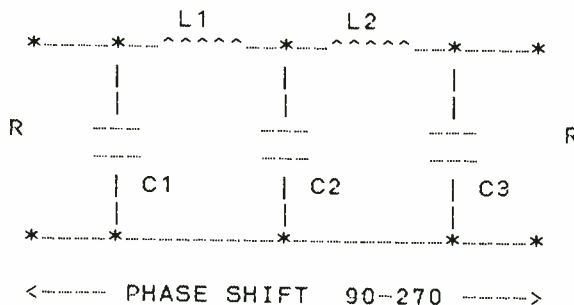

FREQ. (mHz) = 0.98 R = 100.0 PHASE SHIFT = 180.0

L1 =	100.0 ohms	16.2 uH
L2 =	100.0 ohms	16.2 uH
C1 =	100.0 ohms	1624.0 uufd
C2 =	50.0 ohms	3248.1 uufd
C3 =	100.0 ohms	1624.0 uufd ?

Demo screen for LSTRETCH.BAS.

cast Transmitters into Sharply Tuned Antenna Systems" by W. H. Doherty. In this seminal paper, Doherty describes the use of the "transmission line calculator," the Smith Chart, for improved matching of a transmitter. He explains the theoretical reasons for locating the modulation monitor, depending on the sample (current or voltage), at appropriate distances from the load. And he also explains and proves that there are also optimum transmission distances (phase shifts) between the antenna and the output stage of a transmitter—distances which allow the transmitter to produce its least distortion; distances that put a point of impedance symmetrical at the output stage of the transmitter.

Basically, the way to check on where in the ballpark a system is is to start with the +/- 10 KHz sideband impedance data (read it from the antenna and common point impedance plots). Enter that data in the program VSWR-PHR.BAS to compute the VSWR and to determine, by intuition or trial and error, the needed phase shift (multiples)—see example screens for VSWR-PHR.BAS. Then for a new system, just add up the shifts and adjust them to get the correct overall phase shift. For an old system, calculate the phase shifts (shunt reactance of matching networks determines phase shift) and add them up, then adjust them or add a line stretcher to get the correct overall phase shift. Finally trim the system, by adjusting for minimum distortion on a distortion analyzer or minimum L-R (IPM) on a stereo modulation monitor.

However, it's not as easy, or as simple, as it sounds. And, neither program is designed to do away with the need for a qualified consultant in such matters or to do away with Smith Charts and the need for complex math-

ematical methods of designing matching networks. But as computer tools, they can help you understand the reasons and the theory behind it. And they can help you maintain an "optimum" transmitter-to-antenna match for just plain good quality mono or the highest quality AM stereo. ■

Balonis is chief engineer at WILK-AM, Wilkes-Barre, PA.

```

0  'LSTRETCH.BAS  ** TRANSMISSION LINE STRETCHER **
5  'BY Ronald F. Balonis 2/20/82 & 10/7/82
10 PI=4*ATN(1):RAD=180/PI:CMX=999999999.9#
20 'Based on Fig. 7 & 8 in "Operation of AM
21 'Broadcast Transmitters into Sharply Tuned
22 'Antenna Systems" by W. H. Doherty in
23 'The Proceedings of IRE for July 1949
50 DATA "+ Phase Shifter or Line Stretcher Network +"
58 DATA ""
59 DATA "
60 DATA "          L1          L2"
61 DATA "          *-----*-----*-----*"
62 DATA "          |           |           |           |"
63 DATA "          |           |           |           |"
64 DATA "          |           |           |           |"
65 DATA "          |           |           |           |"
66 DATA "          |           |           |           |"
67 DATA "          |           |           |           |"
68 DATA "          |           |           |           |"
69 DATA "          *-----*-----*-----*"
69 DATA "          <----- PHASE SHIFT  90-270 ----->"
70 DATA "",""
71 DATA "FREQ.(mHz)= ##.##  R=#####.#  PHASE SHIFT= ###.##"
72 DATA "\ \ =#####.# ohms  #####.# \ \ "
100 CLS: '---SIGNON PROGRAM AND GET DATA
105 FOR I=1 TO 15
110  READ A$:PRINT TAB(17);A$
115 NEXT I
120 READ A$:PRINT LEFT$(A$,12);
125 INPUT FRQ$:IF FRQ$="" THEN STOP
130 FRQ=VAL(FRQ$)
135 IF FRQ<.5 OR FRQ>2! THEN RUN 0
140 '
145 LOCATE 16,1:PRINT USING LEFT$(A$,21);FRQ;
150 INPUT R$:IF R$="" THEN RUN 0
155 R=VAL(R$)
160 IF R<=0 OR R>20000 THEN RUN 0
165 '
170 LOCATE 16,1:PRINT USING LEFT$(A$,43);FRQ;R;
175 INPUT PH$:IF PH$="" THEN RUN 0
180 PH=VAL(PH$)
185 IF PH<90 OR PH>270 THEN RUN 0
190 LOCATE 16,1:PRINT USING A$;FRQ;R;PH
195 '
200 '-----THEN DISPLAY COMPONENT VALUES
205 L1=R:L2=R:LX=2*PI*FRQ:CX=LX*.000001
210 C1=1/((1-1/TAN((PH/2)/RAD))/R)
215 C2=1/(2*(1-SIN(PH/RAD)/2)/R)
220 IF ABS(C1)>CMX THEN C1=CMX
225 C3=C1
230 READ A$:PRINT
235 PRINT USING A$;"L1";L1;L1/LX;"uH"
240 PRINT USING A$;"L2";L1;L1/LX;"uH"
245 PRINT USING A$;"C1";C1;1/(CX*C1);"uufd"
250 PRINT USING A$;"C2";C2;1/(CX*C2);"uufd"
255 PRINT USING A$;"C3";C3;1/(CX*C3);"uufd"
260 INPUT ANS$:RUN 0:'---END OF PROGRAM

```

Basic code for LSTRETCH.BAS, a line stretcher for phase rotation.

Changing Directionals: Fine-Tuning FM Allotment

By Harry Cole

In December 1988, the Commission took a significant step toward what many are calling the "AM-ization" of the FM band. Abandoning its own longstanding policy, the Commission announced it would permit certain limited short-spacing of FM stations where the applicant causing the short-spacing proposes to utilize a directional antenna to protect other short-spaced station(s) from interference. We've referred to this general topic before, but the FCC's recent action warrants particular consideration.

For more than 25 years the Commission has allotted FM channels to communities based on minimum mileage separations designed to prevent any adverse interference. For purposes of the allotment process, in most instances the Commission assumes that the channel would be utilized by a station operating from the center of the community (the center of the community being, in the Commission's view, the community's main post office). If the community's center would not meet the minimum mileage separations, then the channel generally will not be allotted unless the proponent of the allotment can demonstrate that some non-short-spaced site which would permit adequate signal coverage for the community is available.

Once a channel is allotted, applicants who file for use of that channel must specify a transmitter site that also meets those minimum mileage specifications. While the Commission virtually never waives those requirements with respect to the initial channel allotment process, it has been willing to waive them to a limited degree as part of the application process. Normally such waivers have involved very small distances (*i.e.*, less than two miles). Applicants seeking a waiver must generally demonstrate that no non-short-spaced site is available and that the site proposed is the least short-spaced of all suitable sites.

One argument that has often been advanced by applicants in support of short-spacing waiver re-

quests—and which equally often has been rejected by the FCC—is the claim that the applicant will use a directional antenna to prevent adverse interference. The theory underlying such an argument is certainly logical: If the avoidance of the evils of interference is the goal of the minimum mileage separations, why should those separations be invoked against an application that proposes to avoid those very evils through the device of directionalization?

While that approach may be both theoretically and technologically sound, the Commission historically has been reluctant to take any steps that might undermine its overall FM allocation mechanism. The primary advantage of this mechanism is that it permits the Commission to assure appropriate distribution of FM channels across the country with a minimum of individualized calculation on a case-by-case basis. The FCC previously had been concerned that reliance on directionalization would require precisely the type of detailed, time-consuming review it has sought to avoid, and it had further tended to view FM directionalization as a step toward a "drop-in" approach to station allotment. This approach is similar to the current system of AM allocation, which the minimum mileage separation method was designed to avoid.

Those historical concerns appear to have been substantially alleviated. Under the December 1988 action, applicants for new or modified FM facilities will be able to specify short-spaced sites as long as their proposals include some means of protecting other stations from interference. Such means could include reduction in operating power and/or antenna height as well as directionalization. Since it is concerned about applications im-



Cole is partner in Bechtel, Borsari, Cole & Paxson, a Washington, DC-based law firm.

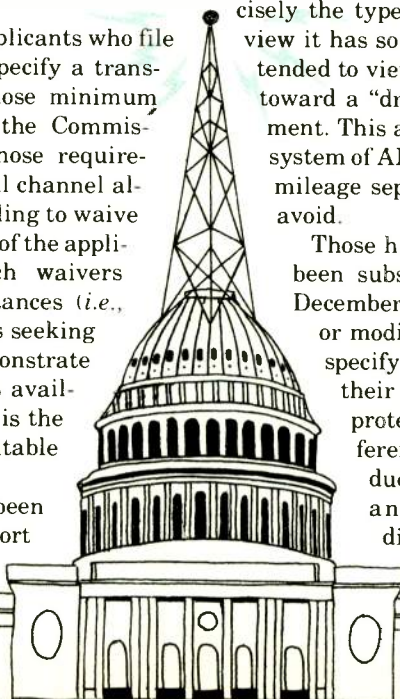

ADD IMPACT TO YOUR CLASSIFIED AD!

CLASSIFIED

HELP WANTED

The Washington DC Bureau of Conus Communications is seeking a full time Engineering Maintenance Supervisor. This person must be capable of supervising a small engineering maintenance department and must have experience in servicing Sony Betacam field equipment, and studio edit facilities. Candidates for this position should have experience in operating a wide variety of broadcast video and audio equipment, as well as the cast use of a spectrum analyzer. Experience with satellite equipment or transmitters is desirable, but not required. Individuals seeking this position must be able to work in close quarters with an active news organization, and make decisions quickly, frequently while under pressure. Salary is open, depending on qualifications. Resumes should be sent to Scott Goodfellow 1825 K Street, NW, Suite 601, Washington, DC 20006.

REGIONAL SALES MANAGER—Growing manufacturer of broadcast video products seeks two regional sales managers. Positions based in California and Chicago area. Require aggressive self-starter capable of working with minimum supervision. We offer competitive salary, excellent benefits including profit sharing. Interested individuals should send resumes with salary history and requirements to: [redacted] NY NY 10006

Transmitter Supervisor—Washington, DC station needs supervisor to perform maintenance and supervise the technical operation of XMTR facility. Requires Bachelor's Degree in Electrical Engineering, Electronic Technology or a related field. Must possess General Radio/Telephone License. RF endorsement is desirable. Three years of progressively responsible TV maintenance experience with supervisory responsibilities. Experience in maintaining VHF/UHF transmitters utilizing vapor-cooled klystron tubes. For prompt and confidential consideration, forward your resume with salary history to: Clarence Brodus, Director of Operations & Engineering, WHMM-TV, 2222 Fourth Street, N.W. Washington, D.C. 20059. We Are An Equal Opportunity Employer M/F/H.

Top fifty VHF affiliate in the Southeast seeks chief engineer. Job entails supervision of all engineering and maintenance personnel. Individual will be responsible for all technical functions. Must have SBE Certification. College graduate. Must be forward-thinking. Technologies as well as art equipment. 5-10 years experience. Salary commensurate with ability. Send resumes to: [redacted] NY NY 10006

Assistant Chief Engineer. Top Philadelphia CHR Station seeking self-motivated Ass't Chief Engineer. Studio and RF experience required. FCC General. Strong company; good benefits. Resumes to: Chief Eng, WEGX-FM, Three Bala Plaza, Suite 580E, Bala Cynwyd, PA 19004.

FOR SALE

**FOR SALE
ENTIRE FILM-TO-TAPE SUITE**
BOSCH FDL-60 w/Digital Grain Reducer, Corp. Comm. System 60 SL B2 Color Correction Computer, MAGNATECH MD-636-B4 Magnetic Reproducer w/multiple head assemblies, Two (2) Lipsner Smith CF-200 Film Cleaners, Film Editing Bench w/wires, splicers, etc. All equipment has been meticulously maintained, is fully operational and

Does your classified ad program need more impact? If so, there's a place where you can effectively advertise job openings, equipment for sale, educational opportunities...even books.

It's the classified section of Broadcast Management of Engineering. And it's where you'll reach the highest concentration of technical and engineering managers.

Take advantage of our 35,000 interested readers. Call Margot Suydam at (212) 685-5320 for classified rates and details today. And put our impact behind your classified message.

BMIE
FOR TECHNICAL AND ENGINEERING MANAGEMENT

ACT III Publishing, Technical Division, 295 Madison Avenue, New York, NY 10017 (212) 685-5320

PRIME

Technological Brilliance. Unsurpassed Performance.

SPECTRUM

posing a burden on processing staff, however, the Commission will not currently consider proposed short-spacings of more than five miles.

Relaxation relative to directional proposals in FM short-spacing situations is, however, not absolute. According to Commissioner Dennis, short-spacing will not be permitted to exceed the minimum mileage separation for the next lower class of station. Further, the interference protection levels have not been reduced and directionalization will still not be considered as part of the initial channel allotment process.

Short-term, it's likely that there will be an initial rush of short-spacing applications, particularly from existing licensees whose efforts to upgrade have been frustrated by the limited availability of suitable non-short-spaced transmitter sites. This new alternative provides more flexibility in the search for sites, so many licensees are likely to act quickly. The initial rounds of these applications are likely to be processed fairly slowly, however, as the FCC staff familiarizes it-

self with their special requirements.

Whether directionalization will accomplish its intended goal will become an important issue following the first round of successful applications. The question will then become whether short-spaced stations will encounter increased interference or whether the technology will provide the protection it is claimed to. If interference problems keep recurring, due to technical problems or the failure of directional operators to install, operate and monitor their facilities properly, the Commission may wish to think again.

Finally, if the preliminary results support the validity of directionalization as an interference-preventing mechanism, the long-term prospects point to increased use of that mechanism to permit licensees, in effect, to "drop in" stations in areas where no stations could presently be established. For station engineers reviewing potential opportunities for new stations or upgrading existing stations, considerations will now include not only channel allotments to the desired market

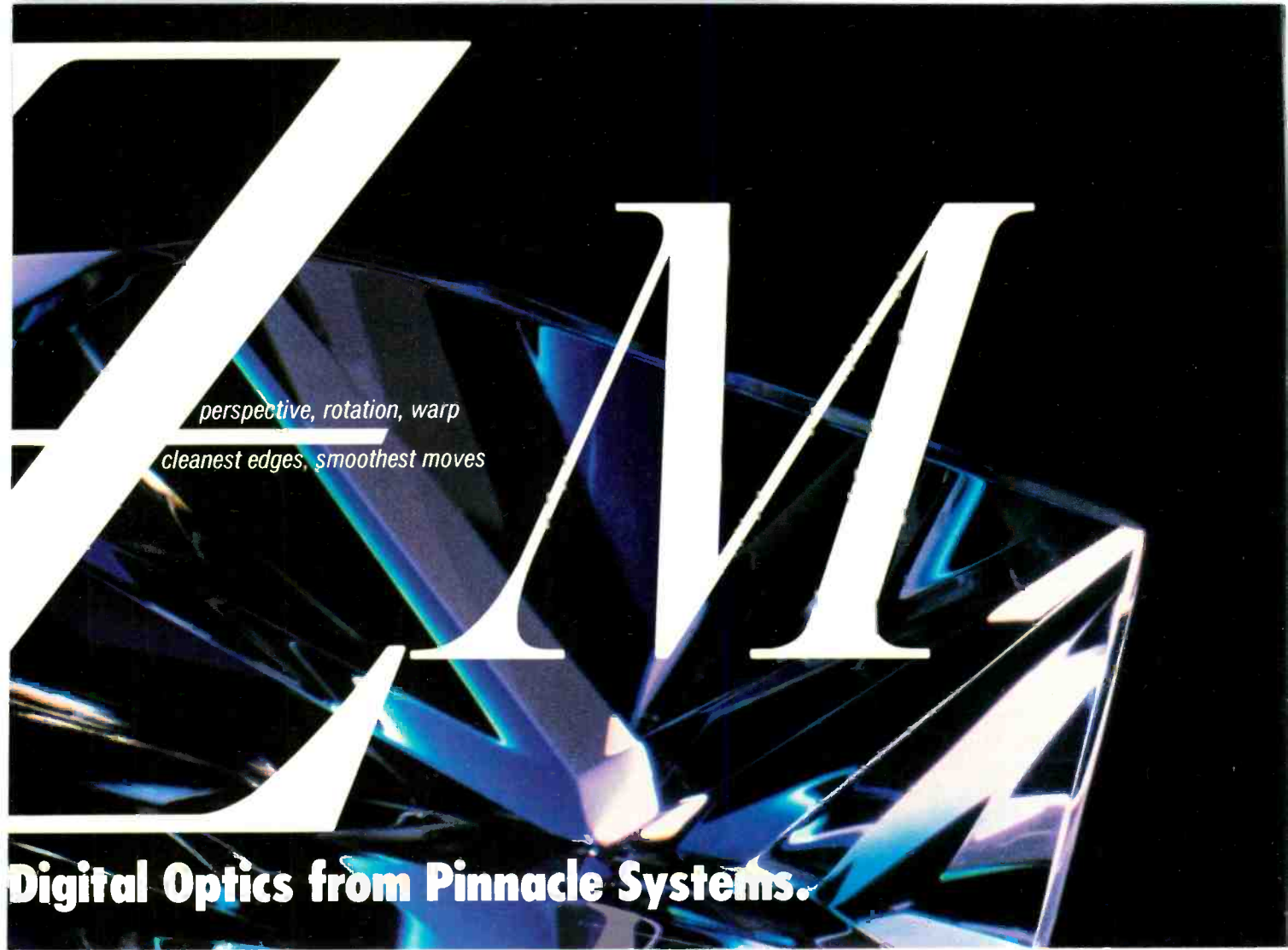

*perspective, rotation, warp
cleanest edges, smoothest moves*

Digital Optics from Pinnacle Systems.

Circle 124 on Reader Service Card Page 63

but also to nearby markets. Once established, nearby market allotments might be modified with the help of directionalization to permit service to the actual target market. Although it should still be possible to take advantage of the new flexibility, applicants taking such a multiple-step approach will have to be careful not to misrepresent their true purposes.

Where this new approach ultimately leads is to what some are calling the "AM-ization" of the FM service: A "drop-in" system of station—but not channel—allotment that will permit "shoe-horning" stations into various settings from which they would clearly have been precluded before the change. Commissioner Quello views this possibility with alarm and, in a partial dissent, noted that reliance on directionalization for the achievement of equivalent contour protection is

The new FM approach can best be deemed an effort to fine-tune the existing distribution of stations.

in many respects identical to the allocation mechanism governing the AM band.

The difficulty with such an analysis is that FM is different from AM in a number of important respects. First, FM signals have different propagation characteristics

and may be easier to control through directionalization. Second, directional FM technology may be somewhat more sophisticated than the AM technology which was first utilized decades ago.

Third, the initial allotment of FM channels across the country has already been accomplished *without* reliance on directionalization. Thus the Commission is not undertaking an initial allotment process requiring various detailed "drop-in" calculations. Rather, the new FM approach can probably best be deemed an effort by the Commission to fine-tune the existing distribution of stations. ■

SPACE TECHNOLOGY

Broadcasting, Recording, and Production Enclosures

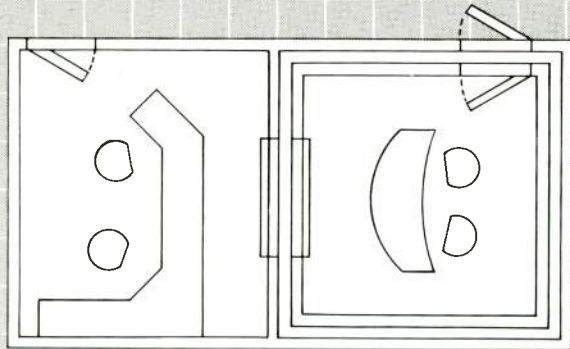

Acoustic Systems acoustically engineers prefabricated, modular designed enclosures for broadcast, recording, and production requirements. Our effective system for sound isolation is designed to meet any space requirement or configuration. The modular enclosures are capable of expansion or can be disassembled, moved, and reassembled without loss of acoustic integrity, which is guaranteed within ± 3 dB. Our systems approach includes client consultation, design, fabrication, installation, and final inspection to provide a complete customized enclosure. For consultation on broadcast, recording, or production enclosures call toll free (800) 531-5412.



415 E. St. Elmo Rd./Box 3610/Austin, TX 78764
(512) 444-1961 (800) 531-5412 TELEX 767119

THOMAS REGISTER SWEETS CATALOG 13.C

Circle 125 on Reader Service Card Page 63

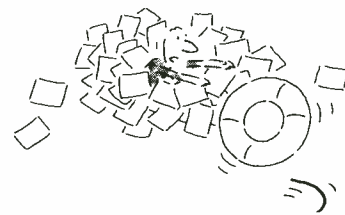

THERE ARE VOLUNTEERS TO HELP MAKE YOUR TAXES LESS TAXING.

Call the IRS and we'll direct you to the volunteers nearest you.

Do yourself a favor. File your taxes now and file accurately. If you need help understanding the recent changes in the tax laws or just need help, there are trained volunteers who can help. Call or visit your local IRS office today. And make your taxes less taxing.

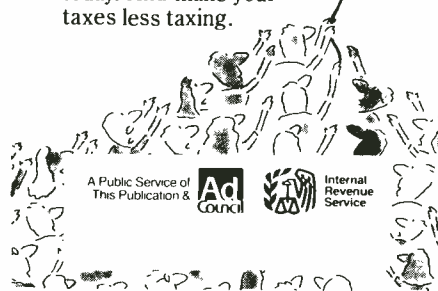

CLASSIFIED

RF SERVICE ENGINEER

One of the nation's premier telecommunications companies currently seeks an RF Service Engineer to provide customer and engineering support to sales staff and RF field service for TV transmitters.

Based in Dallas, this individual will be responsible for installing TV transmitters; checking performance and repairing RF products; answering customer inquiries; interfacing with vendors to make orders; and preparing drawings and documents. This position

requires three years of related experience and the willingness to travel 50%.

If you meet these qualifications, send your resume and salary history to: Stackig, Sanderson & White, Dept. LR, 7680 Old Springhouse Road, McLean, VA 22102. We are the advertising agency for this client, not an employment agency. No fees are involved. No phone calls please. Our client is an equal opportunity employer.

SONY BVP-150 broadcast ENG camera, 3 tube, like new, low hours, 650+ lines resolution, 57 db S/N, composite & Betacam output. \$4400.00 (305) 864-5489.

TELECOMMUNICATIONS MANAGER

Major midtown Manhattan office building seeks knowledgeable "hands-on" supervisor of multi-type telecommunications transmission center. Engineering, leasing/licensing background essential. Ability to coordinate with broadcasters, building's operational staff and technical consultants required. Submit detailed resume, salary history and requirements to: NY, NY 10017.

SALES REP SOPHISTICATED TV TEST EQUIPMENT

Good knowledge of TV signals. Min. 3 years sales experience. Involves substantial travel. Report directly to VP Sales. EOE.

Send resumes only to:



A.F. ASSOCIATES INC.
100 Stonehurst Court
Northvale, NJ 07647

EQUIPMENT

*Aston Presents New Still Store...Matthey
Introduces Hybrid Audio Filter...
Dynatech Unveils Surge Suppressors
...Videotek Adds Line Select*

Aston Presents New Still Store

Aston Electronics has an economical still store which stores key signals and features image access retrieval in under 1.5 seconds. The Wallet also includes editing output software which provides three operator-controlled automatic output sequences and the ability to accept either RGB or YUV and act as a converter between the two systems. Video sampling conforms to the CCTR 601 and 4.2.2 specifications with an internal clock frequency of 13.5 MHz. Designed for broadcasting and corporate and industrial applications, the unit comes with either one or two removable or fixed Winchester hard disk drives or a combination of both. The fixed disk stores 39 images; the removable disk stores 42 images. **Reader Service #200**

Matthey Introduces Hybrid Audio Filter

A new digital audio filter from Matthey Electronics performs to rigid specifications, is pin compatible with many existing filters, and can be easily retrofitted into new equipment. Matthey can also provide OEMs with a full designer support package. **Reader Service #201**

Dynatech Unveils Surge Suppressors

BN series Kleanline electronic filters from L.E.A. Dynatech are designed for use in critical



locations where power conditioning is required. The BN is capable of withstanding more than 1000 ANSI/IEEE Category B—3000 A, 6000 V—surges (equivalent to ten years of operation) without degrading and is UL approved. Noise filtering in all modes of operation is 70 dB. The unit comes with status annunciators, four receptacles, and six feet of cord. With a maximum energy handling capacity of 2000 joules, the BN is designed as a permanent solution to noise, electrical surges and transients. **Reader Service #202**

Videotek Adds Line Select To Frame Synchronizer

Videotek, Inc. has added line select to the VDP-8000 Frame Store/Synchronizer, which can now be programmed to view a single line of a particular field of video. This line is repeated throughout the frame in order to display a bright line select on any waveform monitor or vectorscope. The frame store/synchronizer provides jitter free lockup of noisy feeds from satellite, microwave, ENG and remote broad-

casts. Signal processing is composite 8 bits at a sampling rate of $4 \times f_{sc}$ (14.31818 MHz). Unique independent freeze field capability permits the storage of two different fields or one field without interruption of live video synchronizing. Stored images remain clear and sharp through the use of a three-line digital comb filter. Price is \$5495.

Reader Service #203

FM Systems Premieres Digital Video Voltmeter

A new hand-held, battery-operated digital video voltmeter, model VVM, from FM Systems, Inc. measures the sync pulse amplitude, white level, and overall composite video level in volts peak-to-peak or I.R.E. units on a terminated or loop-through basis. The maximum reading is 1.99 volts or 199 I.R.E. units so that with a normal 1-volt video signal, a 1 percent voltage or one I.R.E. unit level change can be measured. The Model VVM from FM Systems features portability, ease of use, accuracy and the low price of \$325.

Reader Service #204





**IF YOU NEED
SATELLITE
SERVICES,
WE'LL DO
EVERYTHING
ON EARTH
TO HELP.**

Our six Ku-band Portable Uplinks provide redundant satellite transmission from anywhere on the continent. Downlinks, too. Ku transponder time with occasional or long term leases. Teleconferencing and video production. Conus Master Control provides all necessary coordination. Just pick up the telephone, and no event is beyond your reach. Anywhere. Anytime. For more information, call Todd Hanks or Woody Hubbell, (612) 642-4679.



Conus Satellite Services
a division of Conus Communications
3415 University Avenue
Minneapolis, MN 55414

Circle 126 on reader Service Card Page 63

82 BME February 1989

EQUIPMENT

Dolby Laboratories Has New Audio Processor

Model 363 is the first unit to offer both Dolby SR spectral recording and Dolby A-type noise reduction in switchable form. This compact economical package was designed for all audio facilities including music recording, video post-production, broadcast and film. Both channels are equipped with built-in record/playback changeover capability allowing a single model 363 to serve for stereo recording applications. The two independently controlled channels are easily switched between record and playback from the front panel or under command of a tape recorder or remote control device. Internally generated signals allow quick alignment and the auto compare function can be used to verify the performance of the audio system. Independent level adjustments for the record and playback signal paths allow accurate matching of existing line levels. Either the "line in" signal or the encoded tape may be monitored while recording and either channel may be removed from the audio system for studio alignment.

Reader Service #205

Wheatstone Announces Stereo Distribution Amplifier

Model SDA-82 is a new 8-channel stereo distribution amplifier from Wheatstone Corp. It may be used in a single-input, 16-output configuration or in a stereo-input, eight stereo-output configuration. Each input and output has its own three-pin gold connector to allow load

and source changes after installation. Outputs are individually active balanced and capable of delivering +26 dBm. Sixteen individual output gain controls compensate for load dependent gain shifts. Handy signal-present LED indicators on input and output ports verify signal integrity. Dynamic range is 115 dB and typical THD is .002 percent.

Reader Service #206

Alpha Audio Offers New Automated Audio Editor

Boss/2 from Alpha Audio is a second-generation post production audio editing system offering advances in both hardware and software. Editing entirely in the digital domain, Boss/2 features simultaneous multi-protocol communication in RS-422, RS-232, SMPTE and MIDI, and the ability to talk directly to any machine that speaks Sony, Ampex, ES-

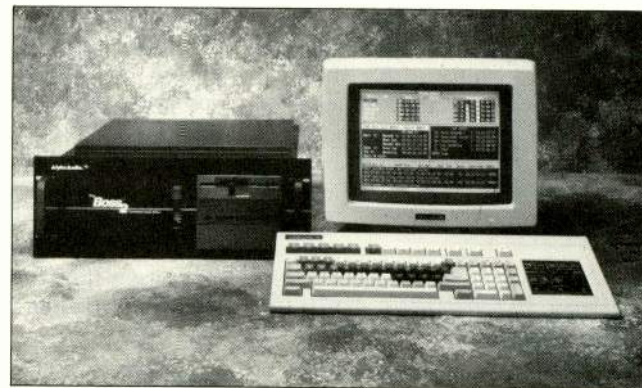

BUS or other serial protocol. When synchronizers are necessary, users may select whatever combination of brands is best for their system's specific needs.

Reader Service #207

Acrodyne Launches 25 KW UHF TV Transmitter

Acrodyne Industries has shipped the world's first 35 kW UHF television transmitter using a single-tetrode final amplifier. Designated TRU-25KVC, the system is the



GLOBAL SUPPORT FOR GLOBAL COMMUNICATIONS

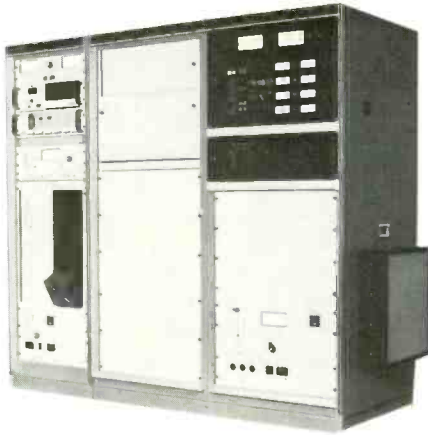

most energy-efficient 25 kW UHF transmitter available, according to the manufacturer. Incorporating class A solid-state amplifiers and ultralinear tetrodes in combined amplification service, it delivers high-quality visual, aural and rf performance. The internally diplexed approach is designed to make it a compact cost-effective transmitter suited to small TV markets and as a standby unit.

Reader Service #208

Audio/Composite Video Routing Switcher From Novadyne

Novadyne introduces the model 8x16 composite video/two-channel audio routing switcher designed to provide electronic, vertical interval switching and computer-controlled routing at a moderate cost. Unit accepts between one and eight inputs and routes them to between one and 16 outputs depending on the number of output boards on the motherboard. Front-panel LED indicators display the status of each output. The unit features internal color bars and blackburst. Price is \$9850.

Reader Service #209

Summit Audio Presents Preamplifier

A preamplifier named "Warm Interface" can be used to warm and enrich hard-edged or metallic digital signals from tape machines or signal processing equipment and to

Microprocessor Controlled Klystron High Power Amplifiers

Field-proven and recognized for wide spectrum coverage and consistent, reliable output, MCL's Microprocessor Controlled (and Standard Logic) Klystron High Power Amplifiers (SATCOM C-Band and Ku-Band) are accepted and proven by communications experts worldwide. MCL Series 10000 Klystron Amplifiers are designed to withstand variable environmental and mechanical conditions and are engineered for minimum maintenance and repair.

MCL's SATCOM Series 10000 Amplifier Systems feature a host of standard equipment and options, including:

- full microprocessor (or CMOS Logic) system control panel
- modular assembly for rapid sub-assembly access
- Motorized Channel Selectors available
- RS232, RS422, IEEE488, or Contact Remote Interfaces
- electrical/mechanical "no-step" or SCR AC line regulator drawer
- Beam Supply on casters; all other assemblies on slides
- ruggedization for transportable applications
- and more!

MCL is the leader in the field of amplifiers and allied equipment for the field of satellite communications. MCL offers a complete line of products, at competitive prices, quality-tested and proven to provide *unexcelled performance*.

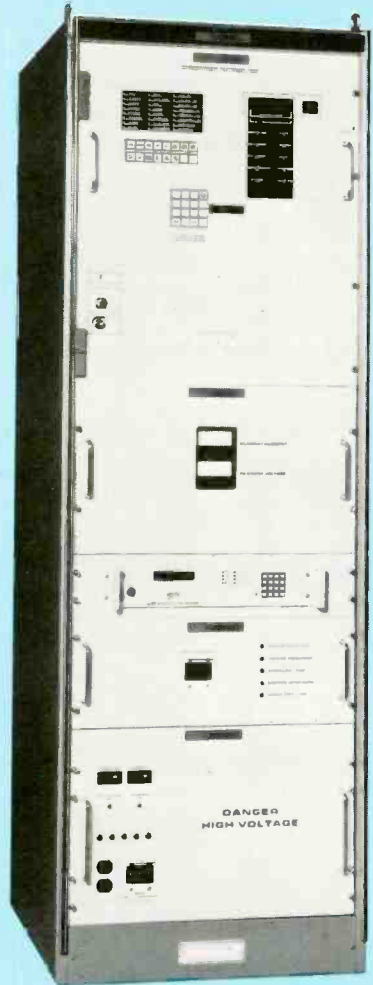

Microprocessor amplifier shown

Write or call MCL today and request your FREE copy of Brochure #1001 (Microprocessor Logic) or Brochure #9009 (Standard CMOS Logic) for details and technical specifications.



MCL

MCL, INC.
501 S. Woodcreek Road
Bolingbrook, IL 60439
312-759-9500 TWX 910-683-1899

Manufacturers of TWT and Klystron Amplifiers for Satellite Communications.
24-Hour Sales and Technical Support for Immediate Service Worldwide.

EQUIPMENT

provide level matching. Used as an interface between CD players, R-DAT recorder/players and any analog audio equipment, the "Warm Interface" controls even order harmonics to provide "tube sound." By employing vacuum tubes in circuits that affect sound quality and solid state in circuits that affect reliability, "Warm Interface" embodies the advantages of both technologies. Features include two channels, +25 dBm output, front-panel trim gain adjustment and 110 dB dynamic range. Price is \$950.
Reader Service #210

Nady Introduces Video Camera Boom Mic

Model VCM-100 from Nady Systems is a highly sensitive super-directional microphone

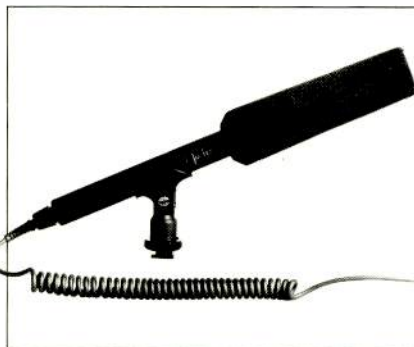

that captures even far-away sound with clarity. The super cardioid electret condenser element used in the mic combines wide frequency response with extremely low noise. Used as a replacement for the on-board mic supplied with video cameras, the unit offers the option of normal or long-distance recording. Price is \$64.95.

Reader Service #211

Harris Unveils 50 KW Digitally Modulated AM Transmitter

Model DX-50, the third and largest of a series begun in 1987, has an overall efficiency of 86 percent and provides good signal transparency with virtually no audio overshoot, tilt or ringing. A patented digital modulator consists of 128 identical rf power amplifiers and applies audio to an ultra-fast analog-to-digital converter. Digitized audio and a carrier level control signal go to the modulation encoder which controls each power amplifier. Power amplifiers turn on and off with modulation and a master rf combiner totals their output. The DX-50 modulates at 140 percent at 50 kW. Should a power amplifier fail, the "FlexPatch" ensures

★ NEW ★ AVCOM PSA-37D PORTABLE SPECTRUM ANALYZER

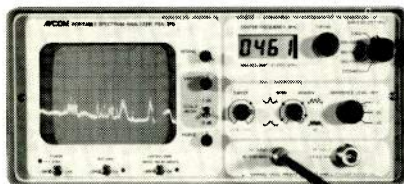

AVCOM INTRODUCES THE NEW PSA-37D PORTABLE SPECTRUM ANALYZER WITH DIGITAL FREQUENCY READOUT. AVCOM'S NEW PSA-37D Portable Spectrum Analyzer has a 4 digit front panel frequency readout and is controlled by a rotary frequency adjustment control. Frequency ranges that the PSA-37D cover are 0 to 500 MHz, 500 to 1000 MHz, 950 to 1450 MHz, 1250 to 1750 MHz and 3.7 to 4.2 GHz. The PSA-37D Portable Spectrum Analyzer is lightweight, portable, battery operated, ideal for field test situations. A built-in DC block with a +18 VDC powers LNAs and BDCs with the flip of a switch. All other performance characteristics and features are the same as the PSA-35A which has become an industry standard for satellite communications work. **\$2475**



AVCOM INTRODUCES A FULLY AGILE SINGLE CHANNEL PER CARRIER DEMODULATOR, THE SCPC-3000E, FOR VERSATILE AND ECONOMICAL RECEPTION OF SCPC SIGNALS. The SCPC-3000E Demodulator features a high-performance synthesized 50-90 MHz tuning module for maximum system versatility. Frequencies are tunable in 800 steps of 50 KHz each. Standard expansions are 3:1 and 2:1, other expander formats are available. Deemphasis is switchable between 0, 25, 50, and 75 micro-seconds. Selectable low-pass 15, 7.5, and 5 KHz audio filters are standard. AVCOM can customize the SCPC-3000E Agile SCPC Demodulator to suit specific receiver needs, contact AVCOM with your requirements. **\$1378**

AVCOM®

500 SOUTHLAKE BOULEVARD, RICHMOND, VA 23236
 Tel. (804) 794-2500 FAX (804) 794-8284 Telex 701-545

Broadcast Automation, Inc.

BAI offers a full line of products and services for automated and live-assist environments

- ▶▶▶ New and remanufactured automation controllers for SATELLITE and REEL-TO-REEL formats
- ▶▶▶ Multi-Cart Playbacks
- ▶▶▶ Reel-to-Reel Decks
- ▶▶▶ New Studio Equipment
- ▶▶▶ Installation, Training and Technical Support
- ▶▶▶ Field Service
- ▶▶▶ Lease Financing
- ▶▶▶ All systems custom designed for your requirements

Ask us about the
 New Live Assistant!

**QUALITY • VALUE
 REPUTATION**

bai
 BROADCAST AUTOMATION INC

4125 Keller Springs, Suite 122
 Dallas, Texas 75244-2012
 (214) 380-6800

continued safe operation with only a slight reduction in peak power. Twenty-eight front-panel LEDs monitor key operating stages. Modular construction with plug-in power amplifier modules affords easy servicing. **Reader Service #212**

RF Technology Premieres Microwave Systems

Offset FED semi-parabolic antenna, model RF-CEO-GL, for ENG transmit and receive, is the first of a new line of miniature microwave systems, amplifiers and antennas to be known as the Gold Line Series. This ultra-efficient antenna features high gain, low side lobe performance, low weight and windloading. Available in either dual circular or quad polarization and any frequency band from 1.7 to 8.5 GHz. **Reader Service #213**

Leitch Has Rack-Mount Computer

A wide range of standard and optional modules allows the RacPac AT computer to be configured for any application. This compact unit is only seven inches high and features space for any combination of three full-height drive units, a passive backplane with five XT slots and five AT slots, a 250-W power supply and modular design for low MTTR. Standard modules include a 286 CPU card with 1 MB of memory, a multifunction card with a serial port, a parallel port, room for 1.5 MB of

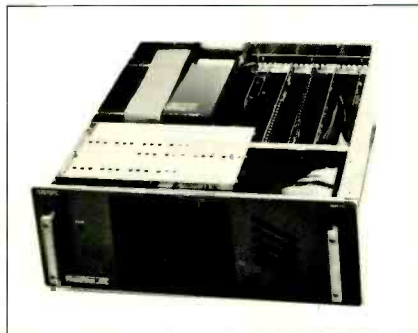

Telex Announcers Headsets Cover Every Broadcast Need Comfortably

Each unique announcing situation can require a different headset. Is there a lot of noise in the background or are you in a quiet studio? Do you want to include or eliminate the ambient noise around the announcer? Is there a need for the announcer to be able to monitor more than one sound source? What about impedance differences, or microphone audio quality.

You could probably get by with a standard "all-around" headset, but do you really want to? Similarly, you could probably find something that would "make-do" from a headset source offering only a couple of models from which to choose. But, for a complete selection, one that offers a solution to your every broadcast need, turn to Telex.

	MICROPHONE					EARPHONE					
	TYPE		ELEMENT			TYPE		ELEM OHMS			
	OMNI	N/C	UNI	DYN	COND	BIN	MONO	MAG	150	300	6000
Full Cushion	X		X	X	X	X		X	X	X	X
Light Weight	X	X			X	X	X	X	X	X	



Camera

The above chart indicates the wide variety of styles and specifications available in our announcers' headsets. Ask about our full line of camera and intercom headsets as well. Call or write to:

Telex Communications, Inc.,
9600 Aldrich Av. S., Minneapolis, MN 55420
BME 9/88



Intercom

TELEX®

EQUIPMENT

RAM, a drive controller with a 20-MB 3½" hard drive and a 1.2-MB 5¼" floppy drive and a display adapter capable of EGA, CGA, MDA, Hercules

or composite monochrome. Options include a 386 CPU card, an SCSI controller and an RS-422 adapter. Reader Service #214

Full Compression. No Depression.



If you're really depressed by the fact that broadcast quality full video compression systems *start* at \$17,000, ALTA Pictoris offers you a fresh start that will really impress you.

\$10,900. For broadcast quality infinite video compression, and so much more. Variable cropping and positioning over live background video. Colored borders. Auto zoom in and out. Dissolve. Programmable presets. GPI trigger. Digital effects that include negative video, vertical and horizontal inversion, posterization, mosaic and freeze. And spectacular 5.5 MHz, 450-line resolution video, with full 8-bit Y/C component processing.

ALTA Pictoris. Another example of ALTA's "Technology of Value" that designs a whole lot more into packages that cost a whole lot less. Call us for the dealer nearest you.



535 Race Street, San Jose, CA 95126
TEL 408/297-2582 FAX 408/297-1206



Circle 131 on Reader Service Card Page 63

86 BME February 1989

Farrtronics Announces Programmable Punch Block

Model PD250 uses punch down connectors for fast economical connecting of input feeds to the input of a distribution amplifier. A color-coded nylon cap inserts an input wire, provides strain relief, and insulates the terminal in one operation. An "AMP" 50-pin female connector is wired internally to the terminals and installed on either or both sides of the block. This connector may provide either an input or output channel, but in the case described provides the output from the block to the input of a distribution amplifier. The PD250 has 25 rows of 10 terminals, 5 for T, R, S, TN and RN inputs and 5 for T, R, S, TN and RN outputs. Reader Service #215

ESD Offers New Weather System

Environmental Satellite Data announces a new WeatherGraphix system for the television weathercaster. The new high-resolution system runs on a 386 personal computer and displays 256 colors from a palette of over 16 million. Features include the ability to time-lapse loop up to 64 frames of satellite imagery, map building, font generation, color-cycling, auto plotting, cell animation, blob animation, embossing, tilting, and air brush. WeatherGraphix also incorporates video input and multi-tasking capabilities and is able to acquire satellite and radar data and imagery.

Reader Service #216

Fortel Adds S-VHS Capability to Time Base Corrector

Model Super-Pro 110 time base corrector has been modified for S-VHS compatibility and

now includes 5.5-MHz bandwidth Y/C processing for PAL S-VHS signals. The SP-110 provides Y/C processing for S-VHS, high band U-Matic and low band U-Matic systems and HET processing for PAL composite signals. Transcoding between formats allows simultaneous signal correction and transcoding for post-production or distribution.

Reader Service #217

Edit Controllers From EECO

A new series of edit controllers features self-contained A/B roll operation, 450 to 1000 lines of non-volatile EDL memory, list management and the ability to control up to three serial or parallel ½", ¾" or 1" VTRs. The ECS-195 series controllers consist of the 195-XL edit controller, the 195+ edit controller and the 195Si edit controller. The 195-XL offers 450-event edit memory, TAG features, edit decision list (EDL) in and out, add, delete and "CleanIt." The 195+ offers all 195-XL features plus a complete list-management package including add, delete and replace with or without ripple, "JoyScrol," sequential/checkerboard auto-assembly, 409 list clean and PC-300 Editpac software. The unit offers all 195+ features plus a 1000-event edit memory.

Reader Service #218

NEC Launches Improved Definition Converter

ImageSmart, NEC model IDC-1000, improves video presentations by eliminating the common problems caused by the limitations of the current NTSC video system. ImageSmart connected between any conventional video input and the monitor eliminates "cross color," "cross luminance," "line jitter," and "video noise." ImageSmart is fully compatible with all existing video equipment and composite video computer graphics. Built-in connectors

make hook-ups simple and the unit comes with a remote control. "Line flicker" is eliminated by doubling

scanning rate. Non-interlaced system scans 525 lines every 1/60 of a second.

Reader Service #219

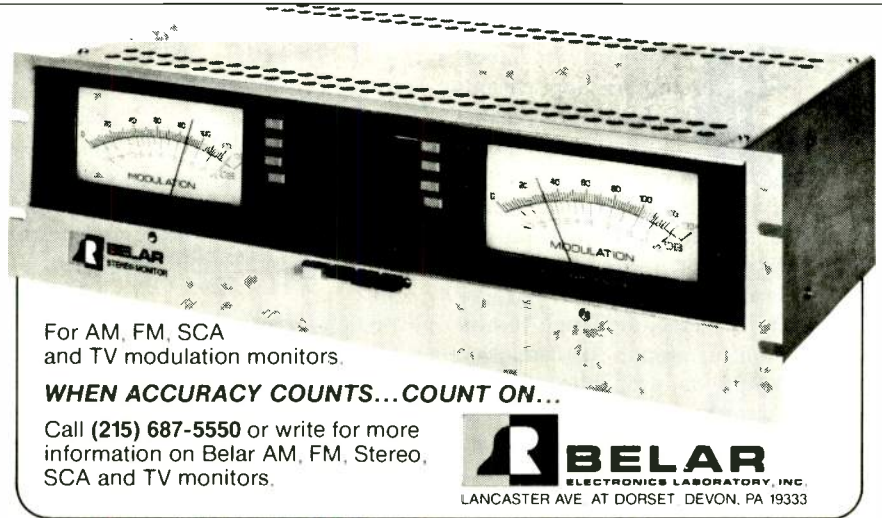

For AM, FM, SCA and TV modulation monitors.

WHEN ACCURACY COUNTS...COUNT ON...

Call (215) 687-5550 or write for more information on Belar AM, FM, Stereo, SCA and TV monitors.

BELAR
ELECTRONICS LABORATORY, INC.
LANCASTER AVE AT DORSET DEVON, PA 19333

Circle 132 on Reader Service Card Page 63

Model 9700 Video Routing Switcher

2400 Crosspoints in 9 Rack Units

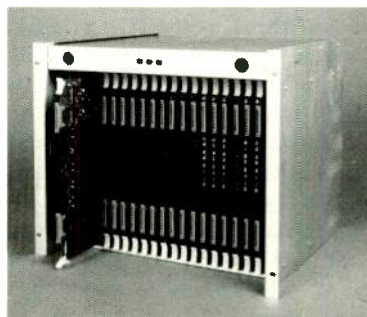

Created for medium sized applications with minimum expansion and unique input/output requirements, the 9700 Video Switcher has a capacity of up to 2400 crosspoints in any input/output configuration — and still occupies only 9 rack units. Pre-wiring of the unit can range from 20 to 120 inputs and 10 to 80 outputs to produce any custom configuration. A bandwidth exceeding 40MHz (-3dB) makes the 9700 the perfect choice for high definition and graphics applications, while incorporating one or more audio channels into the system is easily achieved by adding a 9600 or 6200 Series Audio Switcher.

IMAGE VIDEO LIMITED

705 Progress Avenue, Scarborough, Ontario, Canada M1H 2X1 Tel. (416) 438-3940 Tlx. 065-25392 Fax. (416) 438-8465
1051 Clinton Street, Buffalo, N.Y. Tel. (716) 855-2693 Tlx. 065-25392

Circle 133 on Reader Service Card Page 63

BUSINESS BRIEFS

SMPTE's **Committee on New Television Technology** has created a study group to inform its membership on applications of fiber-optic transmission technology. The fiber study group, chaired by C. Robert Paulson of **Artel Communications** (and a *BME* contributor; see p. 44), has already identified analog HDTV, high-speed digital video, and high-resolution graphics signal transmission requirements as probable areas of study. According to Paulson, "The study group will have four focuses: existing fiber-optic applications; identification and summarization of standard-setting activities; interconnection standards and practices;

and potential production, post-production, ENG, EFP, distribution, and broadcast applications for fiber optics."

Cablecaster Computer Channel Corp. has proposed a digital signal standard to the **National Cable Television Association (NCTA)** for delivery of digital audio, computer-based games and software, and interactive services over commercial cable television.

First deliveries of NEC's newest ENG camera have been logged to three station groups: Two SP-30s to **Tribune Broadcasting's** WPIX-TV, New York; three units to **Fox Broadcasting's** WNYW, New York; and camera systems to **Nationwide Communications' WATE-TV**, Knoxville, TN, and **WBAY-TV**, Green Bay,

WI....Miami's **Limelite Studios** has taken delivery of the first U.S.-installed BOSS/2 audio editing system from **Alpha Audio**. The unit is slated for sweetening duties in tandem with the facility's Sony BVH-2800 and BVU-850 VTRs, Mitsubishi X-850 and X-86 DTRs, Otari MTR-90 and MTR-20 ATRs, and a Nagra T two-track recorder....Howe Technologies Corp. (**Howetech**) has been awarded a contract from the **Armed Forces Radio and Television Service** for 31 variously configured audio consoles....**ABC and CBS** have renewed their agreements recently to continue use of **IDB Communications'** transportable uplink services for news, sports, and special events. This is CBS' third consecutive year with IDB; it's ABC's second with the service. ■

FIBER FOR HDTV

continued from page 47

The FDM approach requires specification of widely separated carrier frequencies that accommodate required deviation ratios, guardbands and harmonic interaction suppression. The WDM approach requires specification of light-source wavelengths that can be optically separated to suppress interchannel electrical interference. Each approach requires far more than a trivial technical effort in terminal design, brassboarding and testing. Quoted selling prices for these terminals will be determined far more by volume sales potential than by the cost of terminal manufacturing.

Cost savings and convenience resulting from reduction of fiber requirements from four to one, over cable runs from a few to a few thousand feet, do not yet represent a transmission circuit cost which would offset the higher costs of multiplexed transmitter/receiver pairs, both for FDM and WDM approaches. Systems representing both technologies are expected to debut at NAB '89.

Light attenuation in multi-mode and single-mode fibers is a function both of the light wavelength and the trace elements and chemical compounds intermixed with the molten silicon "sand" from which the fiber is drawn. Wavelengths around 850, 1300 and 1550 nm currently represent "windows" (defined as first, second and third, respectively) offering progressively lower light attenuation.

Engineers new to fiber-optics technology tend to relate the window wavelengths to the wavelength/frequency stability precision of identical numbers in the AM radio band. This is not the case, which is why creating either one-window or multiple-window WDM systems is more than a trivial technical exercise. A light source with a 1300 nm nominal wavelength is actually operating at a center wavelength somewhere in the vicinity of 1300, but including a spectrum of other wavelengths which may be plus and minus 30 nm removed. This fact comes as a shock to engineers who grew up believing that a laser represented a light of a single frequency.

My guess is that single-fiber FDM systems will become economically attractive well before WDM systems. But if the cost of multi-fiber cable continues to drop, there is no near-term practical reason for moving to single-fiber systems for analog FDM or WDM transmission of HDTV signals within production and post-production facilities. And since all terrestrial long-haul services are high-speed digital, only "right-priced" full-bandwidth digital TDM terminals will have any future chance of competing with satellites.

Once the programs are on the birds, DBS downlinks to 20- to 30-MHz bandwidth, "true" HDTV receivers (20- to 30-MHz bandwidth) might become technically eye-catching at the same time they're becoming economically attractive. The options are enough to cause a thinking broadcaster many sleepless nights in the next few years. ■

C. Robert Paulson is Director of Marketing Television/Graphics Systems for Artel Communications Corp. and chairs the SMPTE Study Group on Fiber Optic Technology.

ADVERTISERS INDEX

Manufacturer	Page No.	Circle No.	Manufacturer	Page No.	Circle No.	Manufacturer	Page No.	Circle No.
Acoustic Systems	81	125	Camera Mart	70	122	MCL, Inc.	83	127
ADX Systems Pty. Ltd.	89	134	Conus Communications	82	126	Midwest Corporation	6	102
AF Associates	57	118	Fidelipac Corp.	3	101	NEC America, Inc.	18	107
Alta Group, Inc.	86	131	The Grass Valley Group	33	113	Nikon Corporation	43	115
Ampex AVSD	35-38	114	Ikegami Electronics	26-27	111	Odetics	24	110
Avcom of Virginia, Inc.	84	129	Image Video Ltd.	87	133	Panasonic Industrial Co.	12	105
Belar Electronics	87	132	Leitch Video Ltd.	20	108	Panasonic Industrial Co.	48-49	116
Broadcast Electronics, Inc.	8	103	Magni Systems, Inc.	10	104	Pinnacle Systems	78-79	124
Broadcast Automation, Inc.	84	128	McCurdy Radio Industries	54	117	Sachtler Corp. of America	58	119

SALES OFFICES

295 Madison Avenue, New York, NY 10017 Telex: 64-4001

Eastern States

295 Madison Avenue
New York, New York 10017
212-685-5320
Telex: 64-4001

William P. Dey

Europe/United Kingdom

33A Station Road
North Harrow
Middlesex HA2 7SU England
(01) 427-9000
Telex: 21289
Ric Bessford

Western States

21757 Devonshire Street
Suite 3
Chatsworth, CA 91311
(818) 998-5154

Denice Nichols

Japan/Far East

5-24 Sanbancho
Chiyoda-ku, Tokyo, 102 Japan
(81-3) 234-2161 Telex: J28208
Fax: (81-3) 234-1143

Takashi Kasai

Shoichi Maruyama

Sony Broadcast Products, Inc.	4-5	-
Sony Broadcast Products, Inc.	72-73	-
Sony Pro Audio	69	121
Telemetry, Inc.	68	120
Telex Communications	85	130
3M Magnetic Media	Cov. III	135
Toshiba Corp., Broadcast Equip.	23	123
Utah Scientific	31	112
Videotek	14	106
Ward-Beck Systems Ltd.	Cov. IV	-
Wheatstone Corp.	Cov. II	100
Classified	80	-

ADx TurboLock

BEEP. BEEP. BEEP.

That's the sound the ADx-22 TurboLock high performance Audio Synchronizer/Emulator makes when it locks up. MASTER/SLAVE lock-up happens fast, accurately. *beep. beep. beep.*

Select the ATR and/or VTR models on a menu screen. The balastics of each machine is automatically calculated by the ADx-22 during set-up mode. *beep. beep. beep.*

The time code reader follows the MASTER to more than 80 times PLAY speed for fast SEARCH with SLAVE follow. Put the MASTER into PLAY and in a flash, *beep. beep. beep.*

Better yet in our performance tests, the synchronizer controlled the ATR so accurately that machine wow and flutter specs improved. Improved sound performance. Fast lock up. *beep. beep. beep.*

For more on ADx-22 and other ADx Time Code products, contact your nearest ADx Systems dealer or call ADx at 1-800-444-4 ADX.

ADx SYSTEMS, INC.

274 Madison Avenue
New York, New York 10016
TEL. 800-444-4 ADX
FAX. 212-532-0514

Today's Broadcast Engineer: A Certified Professional

By Richard Farquhar

Today's broadcast engineer can best be described as a creator, a designer, a planner, an innovator, and an organizer. Who needs today's broadcast engineers? Every facility that is looking for the best qualified person to operate and maintain its equipment needs them.

How do managers determine who will be responsible for their equipment and their engineering program? How do they ensure that they have the best person for the job? Many of them are placing their confidence in the Society of Broadcast Engineers certification program. This program has long been recognized as one way of judging the technical competence of their engineering staff.

The broadcast industry recognizes the need for the SBE-certified engineer. Is it not time for the broadcast engineer to acknowledge the value of SBE certification? Today's broadcast engineer must possess confidence and competence, and one of the best ways to attain these qualities is to become SBE certified. Since the program's introduction in 1975, the SBE has certified over 4000 persons. Why not plan on taking the examination? It is given twice a year, in June and November, and is proctored by SBE chapters throughout the United States. The SBE can make special arrangements in areas where there are no local chapters.

Engineers who currently

maintain radio, television or other related equipment have an excellent chance of passing the certification examination. This is a comprehensive examination with emphasis on practical working knowledge rather than general theory. Certification results in greater job satisfaction and is also recognized as the measure of a broadcast engineer's professional growth. In this era of tightly controlled budgets, the median salaries of SBE-certified engineers are significantly higher than the salaries of their non-certified counterparts.

Why not help the SBE celebrate its twenty-fifth anniversary by taking part in the certification program? The program has four levels of certification—Broadcast Technologist, Broadcast Engineer, Senior Broadcast Engineer and Professional Broadcast Engineer. Regardless of which level you are eligible for, once certified, you will have achieved a professional level of which you can be proud. Certification is an individual effort. It is based entirely upon your personal knowledge and skill. When will you become an SBE-certified broadcast engineer and join the ranks of the professionals? The first step is to contact your local chapter or call the national office at (317) 842-0836 for additional information. Why not take that step today? ■



Farquhar, VP of Technical Services at SOS Productions, Columbus, OH, is secretary of the SBE and a member of the SBE's National Certification Committee. He is an SBE-certified Professional Broadcast Engineer.



The people who set our standards are very tough to satisfy.



Our standards are set by our most demanding customers. And by our scientists. And by our sales and technical service representatives. And, since all of them are seeking perfection, not one of them is ready to settle for less than the best. So if the last thing you want to worry about is the tape, choose ours. We won't be satisfied until you are.

3M

Ward-Beck's Ubiquitous ST!

No matter what size the market - Chicago to Shreveport, New York to Seoul, Vancouver to Greenville - the versatility of Ward-Beck's ST Stereo Console is unsurpassed.

Flexible 24, 36 or 48 channel configurations can meet every need and fit every budget

Available features... • 4-BAND EQ • INTEGRAL ROUTING SWITCHER • CENTRAL MICROPROCESSOR CONTROLLER • PROGRAMMING KEYBOARD • ALPHA-NUMERIC DISPLAYS • PEAK MONITOR/ANNUNCIATOR • AUDIO-FOLLOW-VIDEO INTERFACE.

Talk to us! Discover how affordable Super-Quality can be!

