

THE CASH BOX

VOLUME XVI

JANUARY 15, 1955

NUMBER 17



Joni James smiles as she reads the terms of her new MGM Records contract. Seated with Joni is Charles C. Moskowitz, vice president of Loew's Inc. Standing are Harry Meyerson, A&R director of MGM, and Frank Walker, head of the diskery. Joni's first smash on MGM came a couple of years ago when she broke through with "Why Don't You Believe Me?" Since that time she has become one of the nation's top ranking singing artists. Her current disk, riding high on the charts, is "When We Come Of Age."

IS THIS A L^AFALCE?

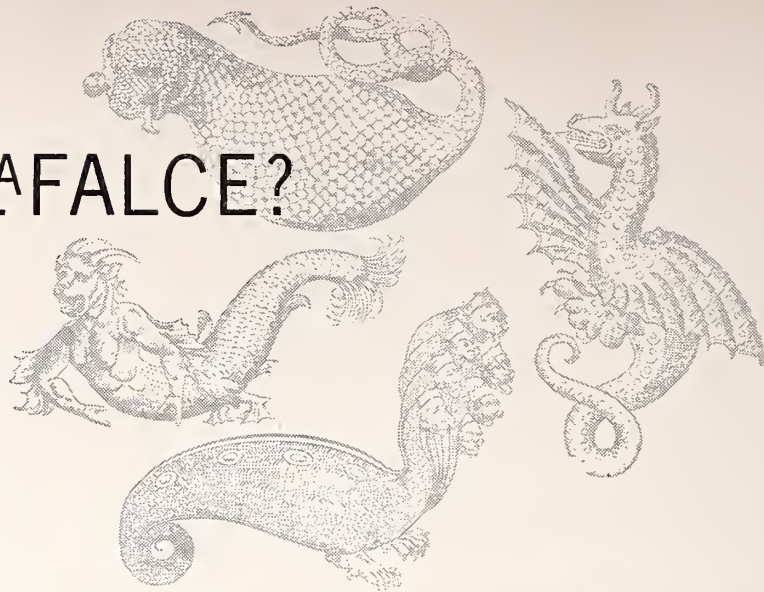

NO...THESE ARE LAFALCES (La-fal-chees)



THE 9 L^AFALCE BROTHERS

(La-fal-chee)

at their first recording session...

and it was fabulous...hear it!

THE DEVIL'S HIGHWAY

MARIA, MARIA, MARIA

20/47-5981





FOUNDED BY BILL GERSH

The Cash Box

Volume XVI Number 17

January 15, 1955

Publishers

BILL GERSH JOE ORLECK

The Cash Box Publishing Co., Inc.

26 West 47th Street, New York 36, N. Y.

(All Phones: JUdson 6-2640)

JOE ORLECK

CHICAGO OFFICE

32 West Randolph St., Chicago 1, Ill.

(All Phones: DEarborn 2-0045)

BILL GERSH

Karyl Long

HOLLYWOOD OFFICE

6272 Sunset Blvd., Hollywood, Cal.

(Phone: HOLlywood 5-1702)

CARL TAFT

NASHVILLE OFFICE

804 Church St., Nashville, Tenn.

(Phone: NASHville 5-7028)

CHARLIE LAMB

BOSTON OFFICE

137 Sutherland Rd., Boston, Mass.

(Phone: BEacon 2-7396)

GUY LIVINGSTON

LONDON OFFICE

17 Hilltop, London, N.W., England

MARCEL STELLMAN

EXECUTIVE STAFF

JOE ORLECK, Advertising Director

BOB AUSTIN, General Mgr., Music Dept.

SID PARNES, Editor-In-Chief

NORMAN ORLECK, Associate Editor

MARTY OSTROW, Associate Editor

IRA HOWARD, Associate Editor

A. MARINO, Office Manager

T. TORTOSA, Circulation

POPSIE, Staff Photographer

BRUNO DUTKOWSKY, Art Director

ADVERTISING RATES on request. All advertising closes Friday at 12 Noon preceding week of issue. Advertisements subject to approval of publishers.

SUBSCRIPTION RATES \$15 per year anywhere in the U.S.A. Special listing for jobbers and distributors at \$48 per year includes 40 word classified advertisement each week for an entire year (52 weeks) plus the full year's subscription free of charge. Airmail, First Class, as well as Special Delivery subscription rates on request. Subscription rates for all foreign countries on request.

THE CASH BOX covers the entire music industry, ranging from retail record and music stores to disk jockeys, music publishers, recording artists, record manufacturers, music composers and arrangers, radio and TV stations, and all others allied to the music industry throughout the world.

THE CASH BOX covers the entire coin machine industry all over the world. Operators, jobbers, distributors, manufacturers and suppliers of automatic music, vending, service and amusement machines are covered.

THE CASH BOX coverage extends to finance firms, loan organizations, factors, banks, and other financial institutions, expressly interested in the financing of coin machines of all kinds.

"THE CASH BOX PRICE LISTS" (a combination of The Cash Box' former 'Confidential Price Lists' and The Cash Box' former 'C. M. I. [Coin Machines Industry] Blue Book') are the one and only officially recognized price quotation guide for all new and used machines in the United States and all over the world where American made machines are used. "The Cash Box Price Lists" are an exclusive and copyrighted feature of The Cash Box. "The Cash Box Price Lists" are recognized officially by cities and states throughout the country as the "official price book of the coin machines industry." "The Cash Box Price Lists" are officially used in the settlement of estates, for buying, selling or trading of all types of coin operated equipment and are also officially recognized for taxation purposes. "The Cash Box Price Lists" are used by finance firms, factors, loan companies, bankers, and all other financial institutions to guide them in the making of loans to members of the coin machines industry. "The Cash Box Price Lists" have been legally recognized in courts in the United States, Canada, and many foreign countries. Entire business transactions and legal cases are based upon the quotations appearing in "The Cash Box Price Lists."

Copyright under the International Copyright Convention. All rights reserved by the Pan American Copyright Convention. Copyright 1955 by The Cash Box Publishing Co., Inc.

NEW ERA

If ever the record industry could confidently expect to enter upon a new, expanded prosperous era, 1955 is the year.

We start off the year by opening up the record market to millions of people who may never have bought before—this because of RCA Victor's reduction of album prices and the necessity of the record firms to bring their prices into line.

The effects of these price cuts will be felt not only in the album field, but also in the sale of singles. For people who go into stores to buy albums come into contact with all the other merchandise in the store—and contact is the first requisite for sales.

In an expanded record market, the benefits must be passed along to everyone else in the business. That includes the publishers, writers, etc.

It was only a couple of years ago that publishers and writers were worried—and with good reason—about the constantly falling sale of sheet music. Many publishers wondered how in the world they could remain in business if top hits didn't produce in sheet music what an ordinary song would have produced only a few years back. Yet today, the situation has settled down to the point where performance money fills in the gap that the decline of sheet music left open. BMI intro-

duced an entirely new concept in the computation of performances, spreading working capital throughout the entire music business and in a sense subsidizing publishers and writers who have since come through with smashes which have more than repaid the money and confidence invested. ASCAP too, in the light of changed conditions, has modernized its setup so that new writers and publishers have a greater say in the division of performance money than before.

Now in addition to the added performance money, the expansion of the record market must result in still more revenue not only for the record companies themselves, but also for the writers and publishers. We may be reaching the day when the one million seller is not the great goal. It may be two million and it's not inconceivable that it could be more. In the face of this kind of possible expansion—and it is possible—the greater benefits and profits must be felt throughout the entire industry.

So today, in this year of 1955, we may truly be entering upon a new era in the record industry. We may find within a short time that our concept of what constitutes a hit has changed drastically. And we may find also that the number of records which hits can sell far surpasses anything we can hope for today.



ALL ABOUT DISK JOCKEYS

**THE TEN RECORDS
DISK JOCKEYS PLAYED MOST THIS WEEK
PLUS THE NEXT FIVE**

A SUMMARY OF REPORTS RECEIVED FROM THE NATION'S DISC JOCKEYS

- | | |
|-----------------------------------|--|
| 1. LET ME GO, LOVER | { Joan Weber (Columbia)
Teresa Brewer (Coral)
Patti Page (Mercury) |
| 2. MR. SANDMAN | { Chordettes (Cadence)
Four Aces (Decca) |
| 3. THE NAUGHTY LADY OF SHADY LANE | { Ames Brothers (RCA Victor)
Archie Bleyer (Cadence) |
| 4. HEARTS OF STONE | Fontane Sisters (Dot) |
| 5. MAKE YOURSELF COMFORT-ABLE | Sarah Vaughan (Mercury) |
| 6. MELODY OF LOVE | { Billy Vaughn (Dot)
Four Aces (Decca)
David Carroll (Mercury) |
| 7. NO MORE | DeJohn Sisters (Epic) |
| 8. TEACH ME TONIGHT | DeCastro Sisters (Abbott) |
| 9. THAT'S ALL I WANT FROM YOU | Jaye P. Morgan (RCA Victor) |
| 10. COUNT YOUR BLESSINGS | Eddie Fisher (RCA Victor) |
| 11) SINCERELY. | |
| 12) I NEED YOU NOW. | |
| 13) DIM, DIM THE LIGHTS. | |
| 14) MAMBO ITALIANO. | |
| 15) OPEN UP YOUR HEART. | |

WNEW treated New York to a musical New Year's Eve last week as the jocks welcomed in the New Year with a night of musical fare gleaned from the tunefully rich era that ran from 1937 to World War II. Starting at 5:35 P.M. with Jerry Marshall's Make Believe Ballroom, Jerry took the listeners through the musical pleasures of 1937-38. Art Ford picked up the arm at 7:30 with the delights of 1939. At 9 Bill Williams made the 1940 survey and Lonny Starr at 10 spun through 1941. From 11:35 to 12:05 Guy Lombardo broadcast from the Hotel Roosevelt with the "sweetest music this side of heaven." "Milkman's Matinee" wrapped up the spree with music till dawn.

Pic of the week—Don Sherman (WLYN-Lynn, Mass.)—Don was one of the jocks to write a column for the March issue of Hit Parader. Don picked his five favorite records of all time and went down the line with Teresa Brewer's "Rhode Island Red Head from Pawtucket"; Guy Mitchell's "Truly, Truly Fair"; Ralph Flanagan's "Penthouse Serenade"; "How High The Moon," Les Paul and Mary Ford; and Harry James' "Ciribiribin." . . . Dick Doty (WHAM-Rochester, N. Y.) was voted the most popular radio show in upstate New York from 10:30 to 1 P.M. in a recent poll. Dick has a pretty tricky gimmick. At midnight he interviews top show people on his "Speak To The Stars" via phone conversations. Interviews are recorded and played back on the air 4/10's of one second later. Dick wants stars to call him on special Rochester phone number, "Baker 5490." He'd appreciate a collect wire advising him when you expect to call. . . .



DON SHERMAN (WLYN—Lynn, Mass.)

Bill Baer no longer at KRSD-Rapid City. He is now active at ABC affiliate KWOR-Worland, Wyoming. Bill asks record companies, artists and publicity to contact him at his new address. . . . Claude (Buddy) Young, great pro football player, will combine a sports-record spinning show for WEBB-Baltimore, Md. WEBB is a 1,000 watter and will go on the air between the 15th of February and March 1. Bentley Stecher has been named general manager. . . . Happy New Year's telegram from Lou Barile (WKAL-Utica, N. Y.). Lou sends us a telegram for every holiday on the calendar. . . . Eddie Dillon no longer with WHJB-Greensburg, Pa. Eddie is leaving for the west coast and hopes to re-locate in one of the major stations in L.A. . . . Ken Garland has taken over the "wake up" chores at WPOR-Portland, Maine, 6-9 A.M.

These are Stan Burns (WINS-New York) personal picks aired on December 31. Best Male: Frank Sinatra and Eddie Fisher; Best Female: Joe Stafford; Best Male Group: Ames Brothers; Best Female Group: Chordettes; Best Ork: Ray Anthony. . . . Neal Wallace, all nite guy at KDKA-Pittsburgh, Pa., taking a vacation from his 50,000 watts and platters. Neal will be in New York the entire week of January 18. . . . Sid Dickler, same station, home with a broken leg for the past four weeks. Sid expects to be laid up for another three weeks before he's moving around with real freedom. . . . Bob Kloss (WTRF-TV and WKWK-Radio-Wheeling, W. Va.) in New York for about one week. . . . Bob E. Lloyd (WAVZ-New Haven, Conn.) writes in nice words about Patti Page's new children's disk, "I Want To Go Skating With Willie."

Top 10 Best Selling Pop Albums

1. THE STUDENT PRINCE Mario Lanza (RCA Victor LM 1837; ERB 1837)
2. MUSIC, MARTINIS AND MEMORIES Jackie Gleason (Capitol W 509; EAP 1, 2, 3, 4-309)
3. MUSIC FOR LOVERS ONLY Jackie Gleason (Capitol H 352; EBF 352)
4. A STAR IS BORN Judy Garland (Columbia BL 1021; BA 1021)
5. WHITE CHRISTMAS Bing Crosby, Danny Kaye and Peggy Lee (Decca DL-8083; ED-819)
6. SEVEN BRIDES FOR SEVEN BROTHERS Original Cast (MGM E 244; X 244)
7. SELECTIONS FROM THE GLENN MILLER STORY Glenn Miller (RCA Victor LPT 3057; EPBT 3057)
8. DEEP IN MY HEART Original Cast (E 3153; X276)
9. THERE'S NO BUSINESS LIKE SHOW BUSINESS Original Cast (DL 8091; ED 828)
10. FANNY Original Cast (LOC 1015; EOC 1015)

"Vera Cruz"



NEW YORK—Movie star Denise Darcel, who is featured in the Gary Cooper-Burt Lancaster film "Vera Cruz", plays one of the six recordings of the title tune on the new Wurlitzer juke box in the lobby of the Capitol Theatre. The juke box features the song by Tony Martin on Victor; Richard Hayman on Mercury; Gordon Jenkins on Decca; Nelson Riddle on Capitol; Dean Parker on MGM and Spencer-Hagen ork on label X.



Special Rush Release!

Bill Darnel & Betty Clooney

with Sid Bass' orchestra

**"KO KO MO"
"SO ALL ALONE"**

X-0087 (4X-0087)

"Z" RECORDS MARK THE HITS!

a product of Radio Corporation of America

"It's What's in THE CASH BOX That Counts"

RECORD REVIEWS

ⓐ DISK & SLEEPER	ⓐ GOOD
ⓑ EXCELLENT	ⓑ FAIR
ⓒ VERY GOOD	ⓒ MEDIOCRE

THE CASH BOX DISK OF THE WEEK

"KO KO MO" (2:21)
[Meridian BMI—Forest, Haven]
"YOU'LL ALWAYS BE MY LIFETIME SWEETHEART" (2:40)
[Wizzell & Day ASCAP]
PERRY COMO
(RCA Victor 20-5994; 47-5994)



PERRY COMO

● Perry Como, whose "Home For The Holidays" turned out to be the biggest Yuletide release this year, comes up with a rhythm and blues tune on his latest release. It's an exciting and driving novelty with a good beat and is tagged "Ko Ko Mo (I Love You So)". It's Como's first waxing of an R & B item and it should be a big one. Flip is a very pretty ballad labeled "You'll Always Be My Lifetime Sweetheart". It's a delightful love song that starts as a ballad and breaks into a bounce. Watch "Ko Ko Mo". Should be the first big one in '55.

"KO KO MO" (2:32)
[Meridian BMI—Forest, Haven]
"EARTH ANGEL" (2:49)
[Dootsie Williams BMI—Curtis, Williams]
CREWCUTS
(Mercury 70529; 70529 x 45)



THE CREWCUTS

● As rhythm and blues material continues to hit big in the pop market, the Crewcuts wax two R & B tunes for their first release of the new year. The big side is a solid jump version of a real cutie called "Ko Ko Mo". It's definitely the boys' best job since "Sh-Boom" which, incidentally, also was originally an R & B tune. Coupling is a smooth reading of "Earth Angel", an R & B song that's already making it in pop. Crewcuts should share heavily in final tally. A two-sided threat. Watch both halves.

"YOU TOO CAN BE A DREAMER" (2:44)
[Mills ASCAP—Livingston, Parish]
"EVERLOVIN'" (2:15) [Tannen BMI—Sherman, Sherman]

PATTI PAGE
(Mercury 70528; 70528 x 45)



PATTI PAGE

● Patti Page, 1954's queen of song according to the juke box ops, steps into the new year with a money

earning coupling that should take off in no time flat. On one side, the song star penetratingly presents a warm and moving ballad dubbed "You Too Can Be A Dreamer." It's a precision performance by Patti of a piece of top drawer material. Excellent blending of lyrics and melody. The coupling is a driving jumper with a country air and is tagged "Everlovin'." It's a sparkling demonstration of multiple voicing by the chirp who makes multiple track waxings sound easy. Two powerful sides that show a great deal of promise for success during the early months

JUNE VALLI
(RCA Victor 20-5988; 47-5988)

ⓑ **"TELL IT TO ME AGAIN"** (3:07) [Weiss & Barry BMI—Mandel, Rotha] June Valli does a great job on this beautiful new ballad as Henri Rene sets up a big ork backdrop. Lovely song that could reach way up there.
ⓑ **"YOUNG AND FOOLISH" (2:57)** [Chappell ASCAP—Horwitt, Hague] Here, Junie waxes a wonderful love song from the forthcoming musical "Plain And Fancy." A good song that should stir up much noise too.

DORIS DAY
(Columbia 40408; 4-40408)

ⓑ **"THERE'S A RISING MOON"** (3:05) [Artists ASCAP—Webster, Fain] Doris Day comes up with a lovely romantic reading of a pretty tune from her pic with Frank Sinatra, "Young At Heart." Very warm and tender.
ⓑ **"TILL MY LOVE COMES TO ME" (3:14)** [Artists ASCAP—Webster, Heindorf] New lyrics are added to a beautiful old melody and the results are very pretty. Good love song also featured in Day-Sinatra movie.

BOB STEWART
(MGM 11902; K-11902)

ⓑ **"A MILLION STARS" (2:41)** [Mecca ASCAP—Reid] The brilliant, sincere voice of Bob Stewart is at its best as the crooner leans into a potent new love song that could establish him as a big name. Wonderful offering with loads of possibilities.
ⓒ **"YOURS FOR THE ASKING" (2:41)** [Brighton ASCAP—Dee, Danzig] Bob comes up with another inspired reading of an interesting love song. Pretty.

ROGER KING MOZIAN
(Pic 0023; 45-0023)

ⓑ **"UGH! COULD I HUG YOU" (2:20)** [Village BMI—Shayne, Regney] A real socko deck is belted out by Roger King Mozian's ork with Dee Clifford on the vocal. It's a wild Indian beat novelty that could catch like wild fire. Real commercial.
ⓒ **"STORY OF A STARRY NIGHT" (2:25)** [Mutual ASCAP—Hoffman, Curtis, Livingston] Mozian shows his wares as he beautifully fashions a soft arrangement of a classical melody on his tender trumpet. Good job.

THE INK SPOTS
(King 1429; 45-1429)

ⓒ **"THERE IS SOMETHING MISSING" (2:28)** [BMI—Kerr, Milton] Charlie Fuqua leads his Ink Spots through a soft and sentimental ballad. Familiar sound and introduction. Big lead voice.
ⓒ **"MELODY OF LOVE" (2:50)** [Presser ASCAP—Engleman] This side features the group on a mellow version of a currently high-flying hit. Poem by Mary Davies is capably recited by the bass voice.

THE MELACHRINO ORCH.
(RCA Victor 20-5980; 47-5980)

ⓑ **"THE SONG OF THE SEA" (2:25)** [Chappell ASCAP—Trindale] A very beautiful melody is excitingly fashioned by the soaring strings of the Melachrino orchestra. Big production arrangement of a lush tango. Thrilling.
ⓑ **"SUR LE PAVE" (2:50)** [Sam Fox ASCAP—Auric] The Peter Knight Singers join the Melachrino men on this atmospheric rendition of the "Pavements of Paris." Instrumental mood music at its level best.

EILEEN TODD
(Coral 61326; 9-61326)

ⓑ **"WANT ME" (2:59)** [Gil BMI—Bollinger, Marcus] Eileen Todd does a great job on a wonderful new love song that could head way up there with very little effort. Poignant delivery.
ⓑ **"TO EV'RY GIRL—TO EV'RY BOY" (3:07)** [Goday BMI—Samuels, Parker] The thrush gives her all for a dramatic item first heard some months ago. A great song that could still head up there.

MILLS BROS.
(Decca 29382; 9-29382)

ⓑ **"PAPER VALENTINE" (2:06)** [Stratton BMI—Dave Coleman] The Mills Prothers offer a new tune that sounds very much like "Paper Doll" in the delivery, melody and title. Inviting number.
ⓑ **"THE URGE" (2:41)** [Meridian BMI—Gimbel] Another familiar tune is employed for this Mills Brothers number. Cute ditty that'll please the kids. Could break out.

THE SONGSTERS
(London 1512; 45-1512)

ⓑ **"IT ISN'T RIGHT" (2:11)** [Mellin BMI—Mellin] A new vocal group called the Songsters makes an impressive debut on London with a strong ballad that could take off. Boys have a commercial sound that shows promise.
ⓒ **"BAHAMA BUGGY RIDE" (1:59)** [Love BMI—Mellin, Steggerda] The boys dish up a lyric reading of a tune previously released as an instrumental. Cute waxing.

THE JOHNSTON BROTHERS
(London 1497; 45-1497)

ⓑ **"HUBBLE BUBBLE" (2:22)** [Leeds ASCAP—Jordon, Grafton] A catchy Oriental novelty very reminiscent of "Istanbul," is cleverly treated by the Johnston Brothers who made their first strong showing with their last release, "The Bandit."
ⓑ **"NO HEART AT ALL" (2:22)** [Larrv Spier ASCAP—Kennedy, Simon] This end is a shuffle jumper handled with class by the group. Boys have some potent material here, material that could top "Bandit." Watch this one.

Crew-Cuts Double Smash!

'KO KO MO'

(I LOVE YOU SO)

AND

**'EARTH
ANGEL'**

MERCURY 70529 · 70529X45

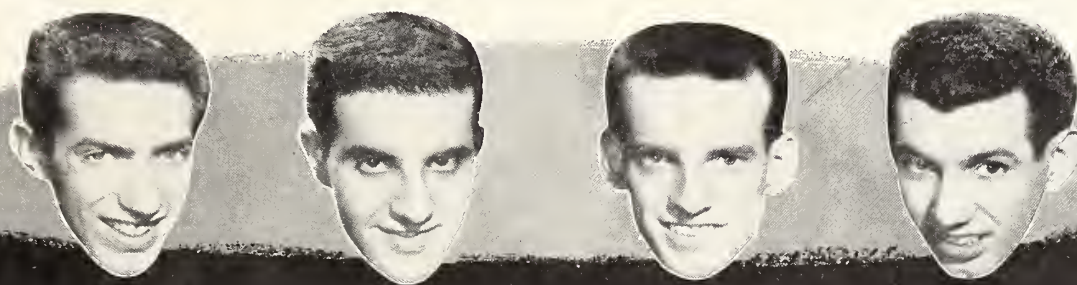

**BY THE
CREWCUTS**



NOW DELIVERING

"It's What's in THE CASH BOX That Counts"

RECORD REVIEWS

ⓐ DISK & SLEEPER	ⓐ GOOD
ⓑ EXCELLENT	ⓑ FAIR
ⓐ VERY GOOD	ⓐ MEDIOCRE

GUY LOMBARDO
(Decca 29377; 9-29377)

B+ "BLUE MIRAGE" (2:57) [B. F. Wood ASCAP—Olias, Coslow] Guy Lombardo, who usually covers hits, may very well make one with "Blue Mirage." It's an exciting and very beautiful tango handled in hit fashion. Penetrating melody that has lasting power.

C+ "GREENSLEEVES" (3:00) [P. D.] Lombardo offers a warm instrumental waltz rendition of an old favorite. Touching melody.

THE CHEERS
(Capital 3019; F-3019)

B+ "WHADAYA WANT?" (2:10) [Quintet BMI—Stoller, Leiber] The Cheers, who hit it big with "Bazoom," have a wild follow-up platter that could easily top the first success. Real exciting driver.

C+ "BERNIE'S TUNE" (2:28) [Atlantic BMI—Miller, Stoller, Leiber] Buddy Bregman sets up another good backing for the Cheer's clever reading of a cute novelty. Ok side. Top half has the goods.

GEORGE LIBERACE ORCH.
(Columbia 40413; 4-40413)

B "MADALENA" (3:09) [Rex BMI—Nacedo, Amorim] George Liberace has about a 40,000 piece ork with him as he fashions the beautiful and exciting "Madelena." Wonderful song that could still make the grade. Big production delivery.

C+ "THE STARS AND STRIPES FOREVER" (2:52) [P.D.—Sousa] The ork gives out with a big orking of a Sousa favorite. Nice job. Full sound.

BILLY FIELDS
(MGM 11917; K-11917)

B "YOUNG AND FOOLISH" (2:28) [Chappel ASCAP—Hague, Horwitt] Assisted by LeRoy Holmes ork. Billy Fields offers a big voiced rendition of a ballad from the coming musical "Plain and Fancy." Pretty ballad.

C+ "SINCERELY" (2:22) [Arc BMI—Fuqua, Freed] Billy comes up with a good male recording of an R & B tune that's currently heading to the top in the pop field too. Good coverage.

THE NOCTURNES
(MGM 11906; K-11906)

B+ "THESE ARE THE THINGS WE'LL SHARE" [Famous ASCAP—Wolfson, White, Kesle] The Nocturnes come up with an ultra-commercial side that could hit big. It's a lovely romantic number with a load of quality. Pretty. Watch it.

B "HEY, PUNCHINELLO" [Paramount ASCAP—Livingston, Evans] The boys bounce through a cute novelty from the Dean Martin-Jerry Lewis pic "Three Ring Circus." Pleaser.

THE CASE BOX

SLEEPER OF THE WEEK

"I GOTTA GO GET MY BABY" [Springfield-Four Star BMI-Rainwater] "WHAT MORE IS THERE TO SAY" (2:46) [Mellin BMI-Mellin, Frisch]

TERESA BREWER
(Coral 61339; 9-61339)



TERESA BREWER

● Little Teresa Brewer, who has developed into a consistent hit maker, takes hold of a tune that may best be classified as a folk

song and belts it out in her inimitable fashion that spells hit. It's an infectious two-tempo ditty going under the title, "I Gotta Go Get My Baby." The choruses alternate from a fast bounce to a slow lilt with a Scottish flair. Song is entirely different from the run-of-the-mill tin pan alley material and could easily break out. Miss Brewer performed the song on a network TV show which in the recent past has meant definite success for a number of tunes. Flip is a beautiful ballad called "What More Is There To Say" which the thrush reads with sincerity. It's a terrific song that, if given enough exposure, could be the bigger of the two. Wonderful coupling.

STEVE LAWRENCE
(Coral 61327; 9-61327)

B+ "KISS ME NOW" (2:27) [George Pincus ASCAP—Saxon, David] Steve Lawrence offers a cute and inviting love ditty set to a mambo and jump tempo. Good arrangement that has big possibilities.

B "HOW DO I BREAK AWAY FROM YOU" (2:55) [Vim ASCAP—Reid, Altman] Aided by a lush Dick Jacobs orking, Steve leans into very pretty love song. Crooner has loads of feeling.

THREE HARMONICAIRE
(De Luxe 2028; 45-2028)

C+ "TUXEDO JUNCTION" (2:18) [Lewis ASCAP—Dash, Johnson, Hawkins, Feyne] A great oldie is given an interesting treatment by the Three Harmonicaire. Catchy instrumentation that's real pleasing.

C+ "JAZZ PIZZICATO BOOGIE" (2:03) [Millis ASCAP—Leroy Anderson] A Leroy Anderson classic is given a catchy delivery by the boys. They have a good sound that's tailor made for the boxes.

CONNIE RUSSELL
(Capital 3020; F-3020)

C+ "GREEN FIRE" (2:39) [Robbins ASCAP—Brooks, Rozsa] The sultry voice of Connie Russell comes over with excitement as she fashions the title tune from a forthcoming MGM pic. Pretty number.

C "SNOW DREAMS" (2:46) [Fred Raphael ASCAP—Webster, Rasch] The songstress presents another heavy piece of material here. Eerie tune that doesn't have a commercial flavor.

PARIS SISTERS
(Decca 29372; 9-29372)

C+ "WHOSE ARMS ARE YOU MISSING" (3:17) [Peer Inter'l BMI—Hewitt, Davis, Hahn] The interesting sound and style of the Paris Sisters comes over well on this pretty love song with a lilt. Warm treatment.

B "OOH LA LA" [Golden State BMI—Jarvis] A cute bouncy novelty with an exciting beat, is cleverly handled by the chirps. Girls have a great vocal quality that could catch like wild fire.

NORO MORALES ORCH.
(RCA Victor 20-5976; 47-5976)

C+ "SEMILO" (2:20) [Southern ASCAP—Rico] As the Merengue begins to build as the new dance fad, Noro Morales fashions a pleasing arrangement of a tune to the new tempo. Exciting.

C+ "NOT TOO FAST" (2:14) [Peer Int'l BMI—Robles] Another pretty melody set to the same tempo.

CYRIL STAPLETON ORCH.
(London 1504; 45-1504)

B "ELEANORA" (2:15) [Odeon ASCAP—Arendo] The harpsichord takes a lead spot on this exciting instrumental item by Cyril Stapleton. Fast moving thriller that could take off.

C+ "MEXICAN MADNESS" (2:29) [Southern ASCAP—Hamilton, Earley] This side presents the ork on another fast moving instrumental with a Mexican flair. Very pretty.

MITCH MILLER ORCH.
(Columbia 40409; 4-40409)

C+ "THE SINGING LESSON" (2:36) [E. H. Morris ASCAP—Franklin] Here's something different. Mitch Miller and the chorus present a light bouncy item with a cute idea. Chorus is supposed to be taking a singing lesson. Clever.

B "FOLLOW ME" (2:17) [Hollis BMI—Engvick, Saidenberg] Mitch employs the French horns and the chorus on this cute and inviting ditty. Happy-go-lucky number that sticks with you.

THE DOOLEY SISTERS
(Tampa 2000; 2000-45)

B "KO KO MO" [BMI—Wilson, Porter, Levy] The Dooley Sisters debut on the new Tampa label with a rockin' pop rendition of a rhythm and blues item that's catching on. Solid side that could take off.

C+ "HEART THROB" [Webster BMI—Scherman] The chirps have another good commercial item in this beaty jumper. Side moves. Girls have a real good technique that comes over strongly.

DOROTHY COLLINS
(Audiobox 114; 45-114)

B+ "TWEEDLEE DEE" (2:45) [Progressive BMI—Scott] Dorothy Collins dishes up a top notch version of a rhythm and blues tune that's breaking big in pop. Dotty belts it out with a load of zest. Big reading that rocks. This one should share nicely in the final tally. Song is breaking big.

B "GET HAPPY" (2:09) [Remick ASCAP—Coehler, Arlen] This side is being released in answer to a flood of requests by Dorothy's fans after she performed the number on TV. Great job on a great standard. Number moves.

THE CASH BOX

BEST BETS

In the opinion of The Cash Box music staff, records listed below, in addition to the "Disk" and "Sleeper" Of The Week, are those most likely to achieve popularity.

- ★ "TWEEDLEE DEE" Dorothy Collins Audiobox 114; 45-114
- ★ "NO HEART AT ALL" Johnston Brothers London 1497; 45-1497
- ★ "THESE ARE THE THINGS WE'LL SHARE" Naclurnes MGM 11906; K-11906
- ★ "KISS ME NOW" Steve Lawrence Coral 61327; 9-61327
- ★ "UGH! COULD I HUG YOU" Rager King Mazian Pic 0023; 45-0023
- ★ "IT ISN'T RIGHT" Songsters London 1512; 45-1512

THE CASH BOX ROUND THE WAX CIRCLE

NEW YORK:

It looks like "Ko Ko Mo" is the next smash to come out of the Rhythm and Blues field. Already some of the top names in the recording world have cut it . . . New fathers in the music business this week include Tommy Valando,

Walt McGuire and Irving Fields . . . Mercury Records has moved its New York office to 745 Fifth Avenue

. . . A 20th anniversary party for Tommy and Jimmy Dorsey will be held on January 11. One of the highlights of the affair will be the reunion of Tommy and Jimmy and most of the performers' bandstands . . .

Jan Garber has made a deal with Freddie Large to rejoin the Garber band when it plays the Roosevelt Hotel in New Orleans . . . Eileen Todd's new Coral recording of "Want Me" was plugged by Walter Winchell last Sunday night when he held the disk up before his TV audience . . .

Wateo Records has signed Tad Bruce to a new contract which guarantees him 12 sides for 1955. At the same time, Sid Feller has been retained by Wateo to supervise, conduct and arrange for Tad's next record release in February . . .

Bill Kenny has just signed an exclusive booking contract with Joe Glazer of the Associated Booking Corporation . . . "Dixie Danny" recorded by the Matys Brothers on the Sound label has been taken over by Irving Dentsch of Southern Music. Additional recordings of the tune are being set for release . . .

The Songsters, whose first disk for London Records is "It Isn't Right," are an American group whose masters were sold to London by Bobby Mellin.



THE SONGSTERS

contract with Joe Glazer of the Associated Booking Corporation . . . "Dixie Danny" recorded by the Matys Brothers on the Sound label has been taken over by Irving Dentsch of Southern Music. Additional recordings of the tune are being set for release . . . The Songsters, whose first disk for London Records is "It Isn't Right," are an American group whose masters were sold to London by Bobby Mellin.

CHICAGO:

Hats off to WBBM-TV, this city. Station's "In Town Tonight" is fast becoming a top flight show by bringing in top record names to do the TV'er. For instance, January 11 to 13, program will star Mel Torme. On January 17, the Crew Cuts whose latest release, just out this week, is titled "Earth Angel" b/w "Kokomo." And later this month, Lou Monte is coming in expressly for this stint. Feel this deserves praise, as more programs like this could really MAKE Chicago TV . . .

RCA's Rocky Rolf reports overall reaction to Victor's price changes very favorable. . . . Bob Manning skedded for Chicago visit, plugging "My Love Song To You". . . . One of our town's top dee-jays, Bill Evans enjoyed a surprise birthday breakfast (1/4) as promotion people came around to wish him 'Happy Birthday'. . . . Birthday greetings this week also go to Chicago Theatre co-star, Julius LaRosa. Speaking of this thitter, both its stars, Julius and Kitty Kallen were hit with Chicago throat the third day of their engagement. Both are hoping they will be able to speak, much less sing, when three weeks roll by. . . .

Teresa Brewer paying one of her rare visits here, singing at the Furniture Show. Stayed in town an extra day to plug her new recording of "I Gotta Go Get My Baby," b/w "What More Is There To Say." . . . Dolores Hawkins doing likewise comes January 14. Her Epic version of "George" has really caught on. . . . Surprising to hear that after an association of three years, Ron Terry no longer telecasting for Polg Bros. . . . Eddie Matthews, free-lance promotion man with Dick LaPalm reports that Decca's Janet Brace opens at the Seville in Canada on 1/13, following a record session. . . . Brand new singing star, Ricky Denell another Chicago visitor. His Benida waxing is titled "Hurt", the R & B hit by Roy Hamilton. . . . Don Hassler happily reports tremendous reaction to Vicki Young's Capitol waxing of "Tweedlee-Dee".



JANET BRACE

Don Hassler happily reports tremendous reaction to Vicki Young's Capitol waxing of "Tweedlee-Dee".

HOLLYWOOD:

Odd coincidence behind the signing of Bobby Milano to a Capitol Records contract. When he was 13 years old Frankie Laine heard him sing and told the boy he would like to sponsor him after his schooling was finished. In 1953, when Milano was 17, Al Lerner, an accompanist, heard him sing and immediately signed the boy to a managerial contract without knowing of Laine's interest. Upon the death of Laine's longtime accompanist, Carl Fisher, Lerner was hired to take his place. Only then did Frankie Laine and Al Lerner realize that they were both interested in Milano's career. At their encouragement Milano auditioned for Capitol and was signed. The young baritone's first release "A King Or A Slave" b/w "If You Cared" is being given the full treatment from Capitol's promotion department. . . . Singer Carl Ravazza has been so successful at Charley Foy's Supper Club that he has been held over thru Jan. 16th. . . . The hit rhythm and blues tune "Kokomo" has been covered in the POP field by the Dooley Sisters on the new Tampa label. Tampa is a subsid. of Bob Scherman's Skylark label. Al Sherman, who handles the line, says that any similarity between names is purely coincidental. Al (S-h-e-r-m-a-n, that is) is planning a sales and promotion campaign for his newly-acquired Label "X" line. . . . After being held over for three consecutive week-ends at the East Side's Savoy Ballroom, Billy Warp & The Dominos received their big break when they were booked into The Hollywood Mocambo for three weeks. . . . It looks like a new career for orkster Harry James. His TV plans are fast becoming a reality. Incidentally, he's celebrating his 16th year as a bandleader. . . . Nick Therry and Mimi Martel bow in on the new SpinIt label with two excitingly different releases. Mimi renders a warm infectious reading to the old familiar tune "Trees" while Nick sings a cajun French ditty "Bougalié." Nick is also out with "Oo Wah" on the Crown label. Tune features himself as featured singer along with his own group The Nickabobs. . . . Capitol Records is eyeing pianist Joe Burton with more than a casual interest. Joe is currently appearing at Abruzzi's Sunset Strip restaurant. . . . Restaurateur Noel Clarke has changed the name of his new exclusive Palm Springs club from The Stables to The Palm Springs Ranch Club. Bistro is slated to open Jan. 14.



BOBBY MILANO

coincidental. Al (S-h-e-r-m-a-n, that is) is planning a sales and promotion campaign for his newly-acquired Label "X" line. . . . After being held over for three consecutive week-ends at the East Side's Savoy Ballroom, Billy Warp & The Dominos received their big break when they were booked into The Hollywood Mocambo for three weeks. . . . It looks like a new career for orkster Harry James. His TV plans are fast becoming a reality. Incidentally, he's celebrating his 16th year as a bandleader. . . . Nick Therry and Mimi Martel bow in on the new SpinIt label with two excitingly different releases. Mimi renders a warm infectious reading to the old familiar tune "Trees" while Nick sings a cajun French ditty "Bougalié." Nick is also out with "Oo Wah" on the Crown label. Tune features himself as featured singer along with his own group The Nickabobs. . . . Capitol Records is eyeing pianist Joe Burton with more than a casual interest. Joe is currently appearing at Abruzzi's Sunset Strip restaurant. . . . Restaurateur Noel Clarke has changed the name of his new exclusive Palm Springs club from The Stables to The Palm Springs Ranch Club. Bistro is slated to open Jan. 14.

A sensational new voice

BOBBY MILANO

A KING OR A SLAVE IF YOU CARED

CAPITOL RECORD NO. 3023



"It's What's in THE CASH BOX That Counts"

KO KO MO

BELONGS TO

COMO

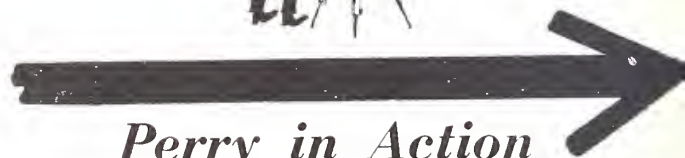

*Perry in Action
On A Great
"Rock-and-Roll"
Record*

PERRY COMO

KO KO MO

(I LOVE YOU SO)

YOU'LL ALWAYS BE MY LIFETIME SWEETHEART

20/47 5994



"New Orthophonic" High Fidelity Recordings

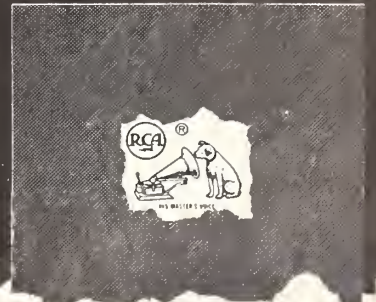
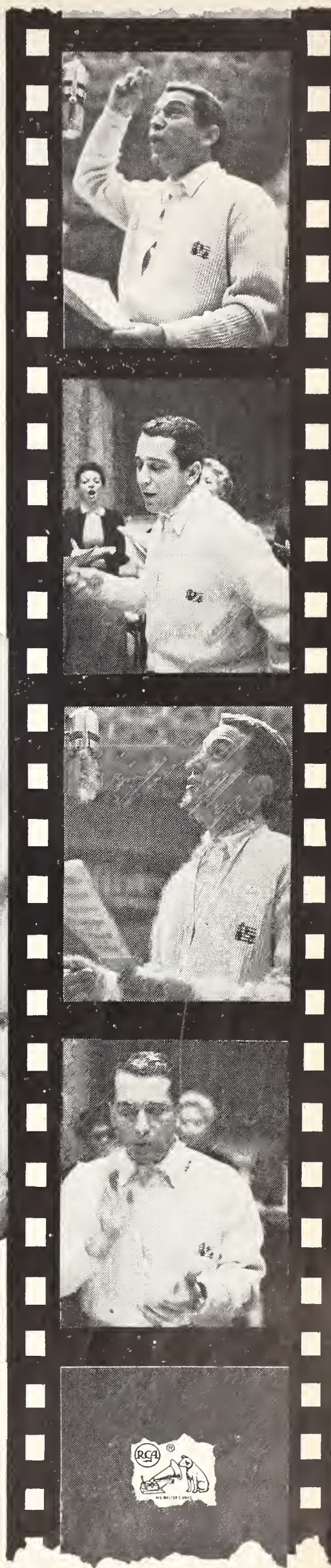

"It's What's in THE CASH BOX That Counts"

THE CASH BOX CANADIAN CAPERS

TORONTO TOPICS

Dance band records are gaining increased attention in the boxes and on the airwaves and this might be the beginning of the long-hoped-for revival that the music industry has dreamed about. Strong factors in reviving dance interest in this part of the country is the general excellence of the current flock of band names. New Year's Eve highlighted this with the Battle of the Bands presenting the **Boyd Valleau** and **Tim Wood** aggregations with **Pee Wee Russell** in from U. S. The, as ever, heavy attendance at this huge New Year's Eve event had a lot of the patrons asking for more of the same in '55. . . . The same sort of fever in the Hamilton sector was fueled by the Brant Inn's two-band booking for the holiday season of **Gav Morton and His Orchestra** and the **Kai Winding-J. J. Johnson All Stars**. . . . As we predicted a month ago, The Crewcuts holiday home coming at the Casino Theatre has the teenagers (and a surprising number of grown ups too!) lining up daily trying to get into packed houses at the Casino Theatre. This local crew cut themselves a fast path to disk and personal stardom during '54 and their local fans have the town completely "crew cut conscious." Quality Records, which presses Mercury platters in Canada "threw a terrific trade reception for the boys. Co-incidental with their home coming was the announcement of the forthcoming marriage of one of the gang, **Rudi Maugeri** to **Placeda Dee Conteen**, who is a nurse at the Allegheny General Hospital in Pittsburgh. Although the past week was highlighted by the boys at the Casino Theatre, another fast breaking record name, **Coral's Jimmie Komack** was also a strong star in the gala stage show.



CREWCUTS

Jimmie is no newcomer here having a host of friends in and out of the business that he made while appearing at **Melody Fair** here last Summer. . . . Back on the band kick—a big bow to **Moxie Whitney's Orchestra** holding over again at the swank Imperial Room of the Royal York Hotel. We hear that one of the major platter firms is mulling plans to sign the group to its label. Seems like a smart move as the group sounds as well as it looks and it is generally conceded to be one of the most beautifully presented dance aggregations in the business, highlighted by the four gorgeous gal violinists and singer, **Louise Thompson**. . . . Most of the recording names who've played these parts during past few years have become personal friends of **CBC's Bing Whittaker**, who has been a very co-operative platter spinner. They'll be interested in knowing that Bing's "Small Types Club" has snow-balled into a top live kiddie show which has been honored by a national magazine dedicated to the program. Seems like a very strong bit for some disk firm which might be interested in expanding its moppet market. . . . At the Colonial, the current attraction is the **Red Heads** and **Johnny Wyndhurst** and His Dixieland Band. This group doing right nicely and rumored to become a standard attraction at the Yonge Street Jazz spot.

MONTREAL MEMOS

The start of the New Year saw the reopening of the Seville Theatre as a variety house. Featured on their opening show was **Norman Brooks** who drew very good business. Headlining the show this week are the **Deep River Boys** who enjoy a very strong following in this part of the country. . . . Starting this week, the **El Morocco** will inaugurate a new policy of big name attractions. Their opening show will feature the well known Toronto quartet, the **Rover Boys**, **Coral** recording artists. . . . **Helene Cordet** is the current chanteuse at the Ritz Cafe. . . . **British United Press** has released its yearly compilation from a breakdown of its weekly survey of Canada's Top Ten. This survey which is based on retail record sales, illustrates that there is a variance as to the relative popularity of certain numbers. The survey showed the tunes in the following order: 1. "Little Things Mean A Lot"; 2. "Hey There"; 3. "Oh My Papa"; 4. "Sh-Boom"; 5. "Make Love To Me"; 6. "This Ole House"; 7. "Wanted"; 8. "Secret Love"; 9. "Three Coins In The Fountain"; 10. "That's Amore." . . . Held over for the 16th week at the Monterey is **Montana Hill** and his **Saddle Serenaders**.



NORMAN BROOKS

THE CASH BOX



GAIETY MUSIC SHOP New York, N. Y.

1. Naughty Lady (Ames Bros.)
2. Papa Loves Mambo (P. Como)
3. Mambo Italiano (R. Clooney)
4. Count Your Blessings (Fisher)
5. That's All I Want From You (Jaye P. Morgan)
6. Mr. Sandman (Chordettes)
7. Let Me Go, Lover (J. Weber)
8. I Need You Now (E. Fisher)
9. Teach Me Tonight (DeCastros)
10. Shake, Rattle And Roll (Bill Haley)

WALLICHS MUSIC CITY Hollywood, Calif.

1. Mr. Sandman (Chordettes)
2. Earth Angel (Penguins)
3. Naughty Lady (Ames Bros.)
4. Shake, Rattle And Roll (Bill Haley)
5. I Need Your Lovin' (Cheers)
6. Let Me Go, Lover (T. Brewer)
7. This Ole House (R. Clooney)
8. Barefoot Contessa (Hugo Winterhalter)
9. Let Me Go, Lover (J. Weber)
10. Open Up Your Heart (Cowboy Choir)

HIGH POINT RECORD SHOP Philadelphia, Pa.

1. Mr. Sandman (Chordettes)
2. Naughty Lady (Ames Bros.)
3. Count Your Blessings (Fisher)
4. Dim, Dim The Lights (Haley)
5. Hearts Of Stone (Fontanes)
6. Ling, Ting, Tong (Five Keys)
7. Melody Of Love (Four Aces)
8. Teach Me Tonight (DeCastros)
9. Let Me Go, Lover (J. Weber)
10. This Ole House (R. Clooney)

FERGUSON'S RECORD SHOP Memphis, Tenn.

1. Hearts Of Stone (Charms)
2. Shake, Rattle And Roll (Bill Haley)
3. Mr. Sandman (Four Aces)
4. That's All I Want From You (Jaye P. Morgan)
5. Let Me Go, Lover (J. Weber)
6. Hearts Of Stone (Fontanes)
7. This Ole House (R. Clooney)
8. Papa Loves Mambo (P. Como)
9. Muskrat Ramble (McGuire)
10. Naughty Lady (Ames Bros.)

STIX, BAER & FULLER St. Louis, Mo.

1. Hearts Of Stone (Fontanes)
2. Let Me Go, Lover (J. Weber)
3. Melody Of Love (B. Vaughn)
4. Dim, Dim The Lights (Haley)
5. Count Your Blessings (Fisher)
6. Hey There (R. Clooney)
7. Papa Loves Mambo (P. Como)
8. If I Give My Heart To You (Doris Day)
9. Mambo Italiano (R. Clooney)
10. ABC Boogie (Bill Haley)

THE MUSIC BOX Spokane, Wash.

1. Naughty Lady (Ames Bros.)
2. Mr. Sandman (Chordettes)
3. Hearts Of Stone (Fontanes)
4. Shake, Rattle And Roll (Bill Haley)
5. Let Me Go, Lover (T. Brewer)
6. Make Yourself Comfortable (Sarah Vaughan)
7. This Ole House (R. Clooney)
8. Dim, Dim The Lights (Haley)
9. Count Your Blessings (Fisher)
10. Earth Angel (Penguins)

MOSES MELODY SHOP Little Rock, Ark.

1. Let Me Go, Lover (J. Weber)
2. Hearts Of Stone (Fontanes)
3. Mr. Sandman (Chordettes)
4. Count Your Blessings (Fisher)
5. I Need You Now (E. Fisher)
6. Teach Me Tonight (DeCastros)
7. This Ole House (R. Clooney)
8. Hold My Hand (Don Cornell)
9. If I Give My Heart To You (Doris Day)
10. Dim, Dim The Lights (Haley)

BEN BROWN MUSIC Lynn, Mass.

1. Let Me Go, Lover (J. Weber)
2. Mr. Sandman (Chordettes)
3. Melody Of Love (B. Vaughn)
4. Make Yourself Comfortable (Sarah Vaughan)
5. Naughty Lady (Ames Bros.)
6. Dim, Dim The Lights (Haley)
7. I Love You Madly (4 Coins)
8. No More (De Johns)
9. Cara Mia (David Whitfield)
10. Earth Angel (Penguins)

LIL' PAL RECORD STORE Houston, Tex.

1. Let Me Go, Lover (T. Brewer)
2. Hearts Of Stone (Charms)
3. Naughty Lady (Ames Bros.)
4. Sincerely (McGuire)
5. Mr. Sandman (Chordettes)
6. That's All I Want From You (Jaye P. Morgan)
7. Tweedlee Dee (Lavern Baker)
8. Unsuspecting Heart (S. Gale)
9. Melody Of Love (Four Aces)
10. Papa Loves Mambo (P. Como)

MODRONA RECORD SHOP Portland, Ore.

1. Let Me Go, Lover (T. Brewer)
2. Mr. Sandman (Chordettes)
3. Naughty Lady (Ames Bros.)
4. Hearts Of Stone (Fontanes)
5. Teach Me Tonight (DeCastros)
6. I Need You Now (E. Fisher)
7. Shake, Rattle And Roll (Bill Haley)
8. Melody Of Love (Four Aces)
9. This Ole House (R. Clooney)
10. Papa Loves Mambo (P. Como)

GILCHRIST RECORD SHOP Cleveland, Ohio

1. Open Up Your Heart (Cowboy Choir)
2. Mr. Sandman (Chordettes)
3. Melody Of Love (B. Vaughn)
4. Tweedlee Dee (Lavern Baker)
5. Let Me Go, Lover (J. Weber)
6. Sincerely (McGuire)
7. Naughty Lady (Ames Bros.)
8. Earth Angel (Penguins)
9. Hearts Of Stone (Fontanes)
10. Cherry Pink And Apple Blossom White (P. Prado)

TRI-BORO RECORD EXCH. Jamaica, L. I., N. Y.

1. Earth Angel (Penguins)
2. Hearts Of Stone (Fontanes)
3. Let Me Go, Lover (Chordettes)
4. Mr. Sandman (Chordettes)
5. No More (De Johns)
6. Teach Me Tonight (DeCastros Washington)
7. Shake, Rattle And Roll (Bill Haley)
8. Dim, Dim The Lights (Haley)
9. Ling, Ting, Tong (Five Keys)
10. Melody Of Love (B. Vaughn)

MUSIC CENTER Honolulu, T. H.

1. Mr. Sandman (Chordettes)
2. Naughty Lady (Ames Bros.)
3. Hold My Hand (Don Cornell)
4. Mambo Italiano (R. Clooney)
5. Papa Loves Mambo (P. Como)
6. I Need You Now (E. Fisher)
7. Let Me Go, Lover (J. Weber)
8. Make Yourself Comfortable (Sarah Vaughan)
9. That's All I Want From You (Jaye P. Morgan)
10. Smile (Nat "King" Cole)

VAN CURLER MUSIC Albany, N. Y.

1. Mr. Sandman (Chordettes)
2. Teach Me Tonight (DeCastros)
3. Naughty Lady (Ames Bros.)
4. Let Me Go, Lover (T. Brewer)
5. Papa Loves Mambo (P. Como)
6. Make Yourself Comfortable (Sarah Vaughan)
7. Shake, Rattle And Roll (Bill Haley)
8. Tara's Theme (Paul Weston)
9. Count Your Blessings (Fisher)
10. Dim, Dim The Light (Haley)

THE RECORD ROOM Reno, Nev.

1. Mr. Sandman (Chordettes)
2. Let Me Go, Lover (J. Weber)
3. Teach Me Tonight (DeCastros)
4. Naughty Lady (Ames Bros.)
5. Shake, Rattle And Roll (Bill Haley)
6. This Ole House (R. Clooney)
7. Dim, Dim The Lights (Haley)
8. Home For The Holidays (Perry Como)
9. Papa Loves Mambo (P. Como)
10. I Need You Now (E. Fisher)

SOUND THE TRUMPETS
BEAT THE DRUMS
START THE MUSIC
HERE "SHE" COMES . . .

NICK TERRY & MIMI MARTEL
EDDIE LeBARON ORCHESTRA
CLARK BURROUGHS SINGERS

2,200 DJ Copies coming your way



"the sound of your life"

430 S. Western Avenue, Los Angeles 5, Calif.
Phone DUNKirk 8-7800

SONGWRITERS—PUBLISHERS

DEMONSTRATION RECORDS SUNG BY
RECORDING ARTIST BURT POWERS.
CALL Circle 6-7550 (ext. 464)
318 W. 51st St. New York, N. Y.

Here's The Version
You've Been Waiting For!

"TWEEDLEE DEE"
2114
DOROTHY COLLINS

AUDIVOX RECORDS
140 West 57th St., New York, N. Y.

BILL'S "T" RECORD SHOP Tulsa, Okla.

1. Hearts Of Stone (Charms)
2. Let Me Go, Lover (J. Weber)
3. Mr. Sandman (Chordettes)
4. That's All I Want From You (Jaye P. Morgan)
5. Naughty Lady (Ames Bros.)
6. Teach Me Tonight (DeCastros)
7. I Need You Now (E. Fisher)
8. I Need Your Lovin' (Cheers)
9. Sincerely (McGuire)
10. This Ole House (R. Clooney)

LOVEMAN'S INC. Birmingham, Ala.

1. Let Me Go, Lover (T. Brewer)
2. Mr. Sandman (Chordettes)
3. Hearts Of Stone (Fontanes)
4. Teach Me Tonight (DeCastros)
5. I Need Your Lovin' (Cheers)
6. Dim, Dim The Lights (Haley)
7. I Need You Now (E. Fisher)
8. Count Your Blessings (Fisher)
9. This Ole House (R. Clooney)
10. Hey There (R. Clooney)

THE GROOVE RECORD SHOP Norfolk, Va.

1. Hearts Of Stone (Fontanes)
2. That's All I Want From You (Jaye P. Morgan)
3. Let Me Go, Lover (J. Weber)
4. Naughty Lady (Ames Bros.)
5. Mr. Sandman (Chordettes)
6. Barefoot Contessa (Hugo Winterhalter)
7. Make Yourself Comfortable (Sarah Vaughan)
8. Mobile (Julius La Rosa)
9. Teach Me Tonight (DeCastros)
10. Cara Mia (David Whitfield)

THE RECORD SHOP Hartford, Conn.

1. Open Up Your Heart (Cowboy Choir)
2. Hearts Of Stone (Fontanes)
3. That's All I Want From You (Jaye P. Morgan)
4. Naughty Lady (Ames Bros.)
5. Let Me Go, Lover (T. Brewer)
6. Shake, Rattle And Roll (Bill Haley)
7. Dim, Dim The Lights (Haley)
8. Mr. Sandman (Chordettes)
9. Teach Me Tonight (DeCastros)
10. Make Yourself Comfortable (Sarah Vaughan)

ANDRE'S RECORD SHOP Lansing, Mich.

1. Mr. Sandman (Chordettes)
2. Let Me Go, Lover (T. Brewer)
3. Teach Me Tonight (DeCastros)
4. Naughty Lady (Ames Bros.)
5. Make Yourself Comfortable (Sarah Vaughan)
6. No More (De Johns)
7. Muskrat Ramble (McGuire)
8. Hearts Of Stone (Fontanes)
9. Woman's World (Four Aces)
10. Shake, Rattle And Roll (Bill Haley)

"It's What's in THE CASH BOX That Counts"

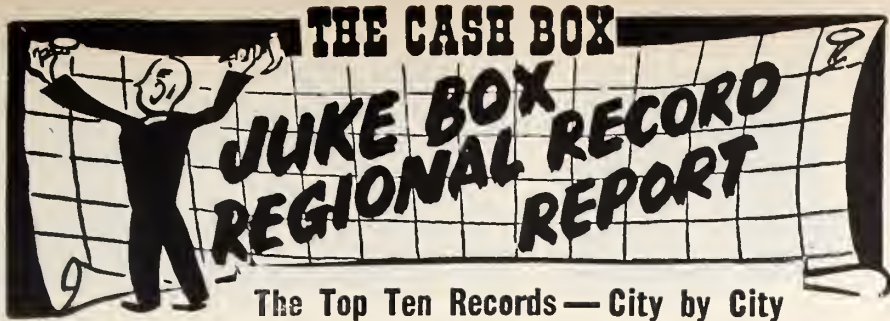

The Top Ten Records — City by City



- New York, N. Y.**
1. Mr. Sandman (Chordettes)
 2. Let Me Go, Lover (J. Weber)
 3. Naughty Lady (Ames Bros.)
 4. Teach Me Tonight (DeCastros)
 5. Make Yourself Comfortable (Sarah Vaughan)
 6. Papa Loves Mambo (P. Como)
 7. Count Your Blessings (Fisher)
 8. Mambo Italiano (R. Clooney)
 9. Dim, Dim The Lights (Haley)
 10. That's All I Want From You (Jaye P. Morgan)

- Chicago, Ill.**
1. Let Me Go, Lover (J. Weber)
 2. Mr. Sandman (Chordettes)
 3. Hearts Of Stone (Fontanes)
 4. Make Yourself Comfortable (Sarah Vaughan)
 5. That's All I Want From You (Jaye P. Morgan)
 6. Naughty Lady (Ames Bros.)
 7. Teach Me Tonight (DeCastros)
 8. Melody Of Love (Vaughn/Carroll)
 9. No More (DeJohns)
 10. Count Your Blessings (Fisher)

- Los Angeles, Calif.**
1. Mr. Sandman (Chordettes/Four Aces)
 2. Let Me Go, Lover (J. Weber)
 3. Naughty Lady (Ames Bros.)
 4. Teach Me Tonight (DeCastros)
 5. Count Your Blessings (Fisher)
 6. Papa Loves Mambo (P. Como)
 7. I Need You Now (E. Fisher)
 8. Hearts Of Stone (Fontanes)
 9. Mambo Italiano (R. Clooney)
 10. This Ole House (R. Clooney)

- Philadelphia, Pa.**
1. Let Me Go, Lover (J. Weber)
 2. Make Yourself Comfortable (Sarah Vaughan)
 3. Teach Me Tonight (DeCastros)
 4. Naughty Lady (Ames Bros.)
 5. Hearts Of Stone (Fontanes)
 6. Mr. Sandman (Chordettes)
 7. Ling, Ting, Tong (Five Keys)
 8. Papa Loves Mambo (P. Como)
 9. That's All I Want From You (Jaye P. Morgan)
 10. No More (DeJohns)

- Seattle, Wash.**
1. Let Me Go, Lover (J. Weber)
 2. Mr. Sandman (Chordettes)
 3. Naughty Lady (Ames Bros.)
 4. Dim, Dim The Lights (Haley)
 5. Earth Angel (Penguins)
 6. Count Your Blessings (Fisher)
 7. Hearts Of Stone (Fontanes)
 8. I Need You Now (E. Fisher)
 9. Papa Loves Mambo (P. Como)
 10. Teach Me Tonight (DeCastros)

- Cleveland, Ohio**
1. Melody Of Love (B. Vaughn)
 2. Open Up Your Heart (Cowboy Church Choir)
 3. Mr. Sandman (Chordettes)
 4. Let Me Go, Lover (Weber/Brewer)
 5. Naughty Lady (Ames Bros.)
 6. Sincerely (McGuire)
 7. Teach Me Tonight (DeCastros)
 8. Earth Angel (Penguins)
 9. Make Yourself Comfortable (Sarah Vaughan)
 10. No More (DeJohns)

- Baltimore, Md.**
1. Let Me Go, Lover (J. Weber)
 2. Hearts Of Stone (Fontanes)
 3. Mr. Sandman (Chordettes/Four Aces)
 4. Teach Me Tonight (DeCastros)
 5. Naughty Lady (Ames Bros.)
 6. Shake, Rattle & Roll (Haley)
 7. Papa Loves Mambo (P. Como)
 8. That's All I Want From You (Jaye P. Morgan)
 9. Count Your Blessings (Fisher)
 10. Mambo Italiano (R. Clooney)

- San Francisco, Calif.**
1. Let Me Go, Lover (J. Weber)
 2. Mr. Sandman (Chordettes)
 3. Teach Me Tonight (DeCastros)
 4. Naughty Lady (Ames Bros.)
 5. Count Your Blessings (Fisher)
 6. This Ole House (R. Clooney)
 7. I Need You Now (E. Fisher)
 8. Shake, Rattle & Roll (Haley)
 9. Papa Loves Mambo (P. Como)
 10. Make Yourself Comfortable (Sarah Vaughan)

- Atlanta, Ga.**
1. Let Me Go, Lover (Weber/Brewer)
 2. Mr. Sandman (Chordettes)
 3. Teach Me Tonight (DeCastros)
 4. Count Your Blessings (Fisher)
 5. Naughty Lady (Ames Bros.)
 6. Papa Loves Mambo (P. Como)
 7. I Need You Now (E. Fisher)
 8. This Ole House (R. Clooney)
 9. That's All I Want From You (Jaye P. Morgan)
 10. Shake, Rattle & Roll (Haley)

- Boston, Mass.**
1. Mr. Sandman (Chordettes)
 2. Hearts Of Stone (Fontanes/Charms)
 3. Make Yourself Comfortable (Sarah Vaughan)
 4. Let Me Go, Lover (J. Weber)
 5. Teach Me Tonight (DeCastros)
 6. Naughty Lady (Ames Bros./Bleyer)
 7. Melody Of Love (B. Vaughn)
 8. Dim, Dim The Lights (Haley)
 9. Papa Loves Mambo (P. Como)
 10. Sincerely (McGuire)

- Knoxville, Tenn.**
1. Hearts Of Stone (Fontanes)
 2. Mr. Sandman (Four Aces)
 3. Sincerely (McGuire)
 4. Shake, Rattle & Roll (Haley)
 5. I Need You Now (E. Fisher)
 6. Ling, Ting, Tong (Five Keys)
 7. Dim, Dim The Lights (Haley)
 8. Count Your Blessings (Fisher)
 9. That's All I Want From You (Jaye P. Morgan)
 10. Teach Me Tonight (DeCastros)

- St. Louis, Mo.**
1. Make Yourself Comfortable (Sarah Vaughan)
 2. Mr. Sandman (Chordettes)
 3. Naughty Lady (Ames Bros.)
 4. Let Me Go, Lover (J. Weber)
 5. That's All I Want From You (Jaye P. Morgan)
 6. Hearts Of Stone (Fontanes)
 7. Dim, Dim The Lights (Haley)
 8. Sincerely (McGuire)
 9. Melody Of Love (B. Vaughn)
 10. Teach Me Tonight (DeCastros)

- Kansas City, Mo.**
1. Hearts Of Stone (Fontanes)
 2. Mr. Sandman (Chordettes)
 3. Let Me Go, Lover (J. Weber)
 4. Naughty Lady (Ames Bros.)
 5. No More (DeJohns)
 6. That's All I Want From You (Jaye P. Morgan)
 7. Dim, Dim The Lights (Haley)
 8. Melody Of Love (B. Vaughn)
 9. Mobile (Julius La Rosa)
 10. Count Your Blessings (Eddie Fisher)

- Detroit, Mich.**
1. Let Me Go, Lover (J. Weber)
 2. Mr. Sandman (Chordettes)
 3. Hearts Of Stone (Fontanes)
 4. Naughty Lady (Ames Bros.)
 5. Dim, Dim The Lights (Haley)
 6. Make Yourself Comfortable (Sarah Vaughan)
 7. No More (DeJohns)
 8. Teach Me Tonight (DeCastros)
 9. That's All I Want From You (Jaye P. Morgan)
 10. I Love You Madly (4 Coins)

- Milwaukee, Wisc.**
1. Mr. Sandman (Chordettes)
 2. Let Me Go, Lover (J. Weber)
 3. Naughty Lady (Ames Bros.)
 4. Hearts Of Stone (Fontanes)
 5. Make Yourself Comfortable (Sarah Vaughan)
 6. Count Your Blessings (Eddie Fisher)
 7. Shake, Rattle & Roll (Haley)
 8. Sincerely (McGuire)
 9. No More (DeJohns)
 10. Melody Of Love (Vaughn)

- Denver, Colo.**
1. Mr. Sandman (Chordettes)
 2. Let Me Go, Lover (Weber/Brewer)
 3. Naughty Lady (Ames Bros.)
 4. I Need You Now (E. Fisher)
 5. This Ole House (R. Clooney)
 6. Papa Loves Mambo (Como)
 7. Teach Me Tonight (DeCastros)
 8. Count Your Blessings (Fisher)
 9. Shake, Rattle & Roll (Haley)
 10. Hearts Of Stone (Fontanes)

- Deadwood, S. D.**
1. Let Me Go, Lover (J. Weber)
 2. Teach Me Tonight (DeCastros)
 3. Mr. Sandman (V. Monroe)
 4. Naughty Lady (Ames Bros.)
 5. Make Yourself Comfortable (Sarah Vaughan)
 6. Mambo Italiano (R. Clooney)
 7. Count Your Blessings (Fisher)
 8. Hearts Of Stone (Fontanes)
 9. Muskrat Ramble (McGuire)
 10. I Need You Now (E. Fisher)

- Pittsburgh, Pa.**
1. Mr. Sandman (Chordettes)
 2. Let Me Go, Lover (J. Weber)
 3. Naughty Lady (Ames Bros.)
 4. Hearts Of Stone (Fontanes)
 5. Make Yourself Comfortable (Sarah Vaughan)
 6. Count Your Blessings (Fisher)
 7. Open Up Your Heart (Cowboy Church Choir)
 8. Melody Of Love (Vaughn)
 9. No More (DeJohns)
 10. Sincerely (McGuire)

- Norfolk, Va.**
1. Mr. Sandman (Four Aces/Chordettes)
 2. Let Me Go, Lover (Weber/Brewer)
 3. That's All I Want From You (Jaye P. Morgan)
 4. Hearts Of Stone (Fontanes)
 5. Naughty Lady (Ames Bros.)
 6. Teach Me Tonight (DeCastros)
 7. Papa Loves Mambo (Como)
 8. Make Yourself Comfortable (Sarah Vaughan)
 9. Count Your Blessings (Eddie Fisher)
 10. Shake, Rattle & Roll (Haley)

- New Orleans, La.**
1. Mr. Sandman (Four Aces)
 2. Let Me Go, Lover (Weber/Brewer)
 3. Naughty Lady (Ames Bros.)
 4. That's All I Want From You (Jaye P. Morgan)
 5. I Need You Now (E. Fisher)
 6. Teach Me Tonight (Stafford)
 7. Make Yourself Comfortable (Sarah Vaughan)
 8. Mambo Italiano (R. Clooney)
 9. Melody Of Love (4 Aces)
 10. Papa Loves Mambo (Como)

- Dallas, Tex.**
1. Mr. Sandman (Four Aces/Chordettes)
 2. Let Me Go, Lover (Weber/Brewer)
 3. Naughty Lady (Ames Bros.)
 4. I Need You Now (E. Fisher)
 5. Hearts Of Stone (Fontanes/Charms)
 6. Count Your Blessings (Fisher)
 7. That's All I Want From You (Jaye P. Morgan)
 8. Make Yourself Comfortable (Sarah Vaughan)
 9. Teach Me Tonight (DeCastros)
 10. Melody Of Love (4 Aces)

	Billboard	Cash Box	Variety
BELLE FROM BARCELONA (Mr. Music) DEAN MARTIN (Capitol)	Spotlight	B+ (Excellent)	Very Good
CONFUSED (American) DEAN MARTIN (Capitol)	Spotlight	C+ (Good)	Good
DON'T GO, DON'T GO, DON'T GO (Jose Ferrer) MICKI MARLO (Capitol)	76 (Good)	Best Bet	
EVER SINCE YOU WENT AWAY (Moonlight) LES ELGART (Columbia) BROTHER LEE ROY ORCH. (Epic)	74 (Good) 74 (Good)	C+ (Good)	
EVERY DAY I HAVE THE BLUES (Golden State) B. B. KING (RPM)	R & B Best Buy	Award o' the Week	
LET'S (Garlock-Sherer) JAN STRICKLAND ("X")		C+ (Good)	
THE LORD IS COUNTING ON YOU (Hamblen) THE COWBOY CHURCH SUNDAY SCHOOL (Decca)	Spotlight	Sleeper of the Week	
LOVIN' MACHINE (Stratton) BERNICE PARKS (Coral)	74 (Good)	Best Bet	
MALAGUENA (E. B. Marks) CATERINA VALENTE (Decca)	Spotlight	Sleeper of the Week	Best Bet
MAMBO FROM CHILE (Copar) CATERINA VALENTE (Decca)	Spotlight	Sleeper of the Week	Best Bet
AN OLD BEER BOTTLE (Trinity) JIMMIE KOMACK (Coral)	70 (Good)	Sleeper of the Week	
THE MARINERS (Columbia)	73 (Good)	C+ (Good)	
OPEN UP YOUR HEART (Hamblen) THE LANCERS (Coral) THE COWBOY CHURCH SUNDAY SCHOOL (Decca)	80 (Excellent) Best Buy	B (Very Good) Sure Shot	Very Good
PALSY WALSY (Gale & Gayles) GARY CROSBY (Decca)	73 (Good)	B (Very Good)	
PETITE (Regent) PERCY FAITH ORCH. (Columbia)	78 (Good)	Best Bet	
THE RIVER (Mellin) BING CROSBY (Decca)	74 (Good)	B (Very Good)	
SONG IN BLUE (Iris-Trojan) LES PAUL - MARY FORD (Capitol)	Spotlight	Disk of the Week	Best Bet
TELL IT TO ME AGAIN (Weiss-Barry) FRANK LESTER ("X")	76 (Good)	B (Very Good)	
THERE'S A LOT MORE LAYIN' DOWN (Hamblen) PHIL HARRIS (Victor)	76 (Good)	C+ (Good)	
WEDDING BELLS (Mellin) FRANK LESTER ("X")	77 (Good)	C+ (Good)	

BROADCAST MUSIC, INC. 589 FIFTH AVENUE
NEW YORK 36, N. Y.
NEW YORK • CHICAGO • HOLLYWOOD • TORONTO • MONTREAL

a Vaccine will mean Victory!
Join the **MARCH OF DIMES**
January 2 to 31

"It's What's in THE CASH BOX That Counts"

Victor Re-Signs Ames Brothers



NEW YORK—Manie Sacks, vice-president and general manager, RCA Victor Records (seated at right) signs a new five-year contract with the Ames Brothers for RCA Victor Records, while Joe Carlton, Victor's chief of Popular Artists and Repertoire (seated left) and Bill Ficks, the Ames Brothers' personal manager (seated center) look on. In less than two years of recording for RCA Victor, the four Ames' record sales have totaled nearly five million. Their first release, "You, You, You," sold over a million-and-a-half copies, and their latest hit, "Naughty Lady of Shady Lane," has already passed the 700,000 mark with sales still rising. The Ames Brothers, standing, are (left to right) Joe, Gene, Ed and Vic.

Morrison To Construct Las Vegas Mocambo

LAS VEGAS, NEVADA—Restaurateur Charlie Morrison, who owns and operates the Hollywood Mocambo, will start construction this month on the new \$5,000,000 Charlie Morrison Mocambo here.

The new spot won't be the biggest place in the world—there will be sleeping rooms for only 100 persons—but it will have the appearance of a massive private estate of French Regency architecture. Huge steps from the walk will lead to the terrace and an enormous black-and-white marble entrance hall with flying staircase of wrought iron and brass.

On either side will be the casino, one to be called "The 400" and the other will be the Rodeo Room. At the end of the hall will be the Mocambo Room to seat 250. There will be no stage, but dancing will be continuous and the finest food will be served. They plan having one top star (there will be no big chorus line) who will entertain from the dance floor.

At the back of the Mocambo Room will be an aviary (which will be much larger than the one at the Hollywood Mocambo), and two smaller restaurants to serve luncheon and informal dinners.

The upstairs will feature a miniature ballroom plus smaller rooms for

weddings, cocktail parties or dinners and two large suites.

Adjoining the patio will be an Olympic sized swimming pool, tennis courts and two units of 25 sleeping rooms with private patios. Around the pool will be cabanas with dressing rooms and showers, a bar, exclusive shops and a lunch counter. Farther back on landscaped grounds will be constructed a building of 50 suites.

Leslie Distributing Moves

NEW YORK—Lou Boorstein announced this week that his Leslie Distributing outfit, one of New York's leading One-Stop operations, will move to new and larger quarters at 639 Tenth Ave., near 45th St. as of January 10. The new quarters, right in the heart of "Coin Machine Row", will have more than double the space of the old spot. The one-stop will be completely air-conditioned and the use of up-to-date modern equipment and a modern layout will make it easier for ops to pick records. Boorstein also announced that he will provide parking space for all his customers directly across the street from the store.

Bernie Boorstein and Ralph Schechtman will manage the new set up.

THE CASH BOX



POPULAR

GEORGE GERSHWIN: PORGY AND BESS
TCHAIKOVSKY: THE QUEEN OF SPADES

Andre Kostelanetz conducting the Philharmonic-Symphony Orchestra of New York—Columbia ML-4904 (12" LP) List: \$3.98

A special non-subscription concert series which Andre Kostelanetz inaugurated with the New York Philharmonic-Symphony Orchestra at Carnegie Hall during the 1953-54 season turned out to be extremely successful. In fact, the latest performances have been complete sell-outs. Columbia offers the first in this new Kostelanetz-Philharmonic series. It features two important works by two of the best loved composers—Gershwin and Tchaikovsky. "Queen of Spades" is another in Kostelanetz's Opera-for-Orchestra series which has been so successful. LP should have a vast appeal. Gershwin and Kostelanetz are tremendous record sellers. Kostelanetz's record speaks for itself.

"MOOD FOR LOVE"—Andre Kostelanetz and his Orchestra—Columbia ML-4917 (12" LP) List: \$3.95

I'M IN THE MOOD FOR LOVE; THE SWEET SURRENDER WALTZ; APRIL IN PARIS; YOU GO TO MY HEAD; WHILE WE'RE YOUNG; ALONE TOGETHER; WHAT A DIFFERENCE A DAY MAKES.

Although Kostelanetz is a master with classics and orchestral arrangements of operas, he is still also one of the best in the mood music field. His big, stringy arrangements of standards are tough to beat. On this LP, the maestro presents eight beautiful favorites in romantic fashion. Great stuff for a cozy atmosphere.

"THE GAYLORDS SING BY REQUEST"—Mercury MG-25198 (10" LP) List: \$2.98

A KISS TO CALL MY OWN; IT; SERENADE IN THE NIGHT; FRIVOLETTE; WITHOUT A SONG; LOLA; A DOLLAR, A NICKEL AND A DIME; BLUES MY NAUGHTY SWEETY GAVE TO ME.

From among the many songs in their repertoire, the Gaylords offer eight of their most requested. And they come up with a tremendous LP that the kids'll be wild about. All of the songs except "Without A Song" are no more than a few months old. And most of these recordings have never been released. Two of the best numbers are "Lola (The Gondola Serenade)" and "Without A Song." Coupling these two on a single should mean cash in the bank for all concerned. Each number has a slightly different tempo and styling which makes the LP an exciting and very enjoyable half hour of listening.

"TIME TO DANCE with LES BROWN"—Les Brown and his band of Renown—Coral CRL-56109 (10" LP) List: \$3.00

RED SAILS IN THE SUNSET; I'LL BE AROUND; JUST WHEN WE'RE FALLING IN LOVE; MY HEART BELONGS TO DADDY; LOVE LETTERS IN THE SAND; BACK IN YOUR OWN BACK YARD; WHERE YOU ARE; I'LL NEVER CRY.

Very few bands were able to weather the storm of World War II. Les Brown's is one of the few and for a very good reason. Les plays music that people can dance to. Here with the aid of Lucy Ann Polk and Ray Sims on the vocals, Les fashions an octet of classic oldies fashioned for the hooper. The tempo is clear and inviting. Wonderful stuff for a party.

"JOSE MELIS TRIO"—MGM Records E262 (1-10" LP) List: \$2.98

"DOROTHY DONEGAN"—MGM Records E278 (1-10" LP) List: \$2.98

"VAN SMITH"—MGM Records E279 (1-10" LP) List: \$2.98

"JACK KELLY QUINTET"—MGM Records E280 (1-10" LP) List: \$2.98

A fascinating quartet of piano albums offers a variety of stylings, each a delight. Of particular distinction are the Jose Melis and Dorothy Donegan albums. Each offers lush, dreamy, exciting and colorful interpretations that serve deliciously as listening or background music. The Van Smith and Jack Kelly albums, also pleasurable albums and well worth the price for the entertainment value cut into the grooves, are not as outstanding as the first two. An investment in any or all of the above is an investment in pleasure as well as tonic for shattered nerves.

"BING CROSBY FAVORITES"—HARRY FARMER'S RHYTHM ENSEMBLE—London LB 1050 (10" LP) List: \$2.98

AN APPLE FOR THE TEACHER; PLEASE; THANKS; LOVE IS JUST AROUND THE CORNER; I'VE GOT A POKETFUL OF DREAMS; LOVE IN BLOOM; YOU KEEP COMING BACK LIKE A SONG; IT'S THE NATURAL THING TO DO.

Bing Crosby has probably outsold any two other artists as far as records are concerned, and he's probably had more million sellers than any five artists combined. Here, the Harry Farmer Rhythm Ensemble presents some of Der Bingle's favorite hits. Ensemble includes Farmer at the organ, Harry Engleman on piano, Barry Fox on the Guitar and Pete Troman on the skins. Enjoyable listening. Aimed at the adult market.

"LISTEN!"—The Hi-Lo's—Starline ST-6004 (10" LP)

FOOLS RUSH IN; WHERE ARE YOU; LITTLE WHITE LIES; JUNE IN JANUARY; SHE'S FUNNY THAT WAY; I DON'T WANT TO CRY ANYMORE; YOU BROUGHT A NEW KIND OF LOVE.

Four young men who combine their voices to create a rare blend and sing with a unique style, are the Hi-Lo's. They have a wonderful warmth in their voices and yet sing with jazz overtones. They also inject some interesting gimmicks into their recordings such as the intro on their exciting version of "Little White Lies." Good LP.

"VIENNESE WALTZES FOR DANCING"—Lawrence Welk and his Champagne Music—Coral CRL-56120 (10" LP) List: \$3.00

EMPEROR'S WALTZ; GOLD AND SILVER; WIENER BLUT; DOLORES; LIEBESFREUD; LIEBESLIED; SCHOEN ROSMARIN; CAPRICE VIENNOIS.

Lawrence Welk has a way with a European melody. He seems to bring out the true romantic quality of the tune. On this LP, the batoneer leads the group through eight of the more popular Viennese waltzes. Definitely not for youngsters. Good dance music.

CLASSICAL

JOHANNES BRAHMS—BRUNO WALTER—Columbia Masterworks SL-200 (4-12" LP)

SYMPHONY NO. 1 IN C MINOR, OP. 68; SYMPHONY NO. 2 IN D MAJOR, OP. 73; SYMPHONY NO. 3 IN F MAJOR, OP. 90; SYMPHONY NO. 4 IN E MINOR, OP. 98; VARIATIONS ON A THEME BY HAYDN, OP. 56a; TRAGIC OVERTURE, OP. 81; ACADEMIC FESTIVAL OVERTURE, OP. 80; HUNGARIAN DANCES NO. 1, 3, 10, 17.

Columbia offers a deluxe package of Bruno Walter conducting the Philharmonic Symphony Orchestra of New York through the orchestral music of Johannes Brahms. The works, listed above, and too often described, are impeccably performed. Walter brings to the classics his knowledge, genius and soul. It is a package that will bring pride to any owner. The four records are housed in a gold and black brocaded book album with bound extensive notes, pictures and drawings. Shoud prove one of the season's big money makers.

1 call puts all 9 at your service

RCA VICTOR
CUSTOM MADE RECORDS

1 The country's best equipped recording studios

2 The latest processing methods

3 The most modern pressing plants in the world

4 The industry's greatest pressing capacity

5 Design and printing of labels and sleeves

6 Album packaging

7 Bulk or drop shipment

8 Manufacture of all commercial type records

9 Plus counseling service on advertising, distribution and business problems

Pick up your phone and call the nearest RCA Victor office.

NEW YORK: JUdson 2-5011
630 Fifth Avenue, New York 20, N. Y.

CHICAGO: WHitehall 4-3215
445 No. Lake Shore Dr., Chicago 11, Ill.

HOLLYWOOD: HOLLYwood 4-5171
1016 No. Sycamore Avenue,
Hollywood 38, Cal.

custom record sales

Radio Corporation of America • RCA Victor Division

THE CASH BOX



Album Reviews

BACH CANTATAS AND ARIAS — RCA Victor LM-6023 (2-12" LP's) List: \$6.98

BACH ARIA GROUP, WILLIAM H. SCHEIDE, DIRECTOR. THE ROBERT SHAW CHORALE. EILEEN FARRELL, SOPRANO; JAN PEECE, TENOR.

A beautiful and moving high fidelity recording of Bach Cantatas and Arias. The thrilling voices of Jan Peerce and Eileen Farrell are lovingly supplemented by The Robert Shaw Chorale and the Bach Aria Group. A tender, inspiring release. Market limited to a smaller circle of music lovers.

RIMSKY KORSAKOV "La Grande Paque Russe Overture; "Capriccio Espagnol"—Mercury MG 50039 (1-12" LP) List: \$3.98

PAUL PARAY CONDUCTING THE DETROIT SYMPHONY ORCHESTRA.

Two of the most beautiful Rimsky Korsakov pieces are coupled for what should be a strong sales item. Fly in the ointment is that both pieces are well represented in the racks. However a little initiative on the part of the salesman in which he determines whether the prospect already owns a version or is perhaps the possessor of an outdated treatment, can garner ready sales. A sampling of this etching will make it hard to resist.

"LA BOUTIQUE FANTASQUE—The Philharmonic Orchestra, Robert Irving—RCA Victor LBC-1080 (1-12" LP) List: \$2.98

LA BOUTIQUE FANTASQUE, ROSSINI-RESPIGHI; SPINNING SONG AND SPRING SONG, MENDELSSOHN; MORS ET VITA; JUDEX, GOUNOD; NAILA; INTERMEZZO, DELIBES.

A Bluebird Classic. A quality production for the economy buyer. The fascinating, exciting and beautiful "La Boutique Fantasque" is a light and delicious offering. It is the kind of release that appeals to the largest segment of the classical buying public and should enjoy a healthy sale. To fill out the album the gay and lovely Mendelssohn "Spinning Song" and "Spring Song"; the stirring Mors Et Vita by Gounod and the delightful Delibes Intermezzo are included.

JAZZ

"HORN O'PLENTY"—Charlie Shavers—Bethlehem BCP 1007 (1-10" LP)

YOUNG MAN WITH A HORN; WHEN IT'S SLEEPY TIME DOWN SOUTH; AFTER YOU'VE GONE; ECHOES OF HARLEM; AND THE ANGELS SING; CIRIBIRIBIN; SALT PEANUTS.

A wonderful idea performed in a Grade-A fashion. Top trumpet star Charlie Shavers gives his interpretations of such trumpet greats as Louis Armstrong, Roy Eldridge, Cootie Williams, Ziggy Elman, Harry James and Dizzy Gillespie. On the flip, Charlie gives us Charlie Shavers. And to top it off, that familiar and relaxing voice of Al "Jazzbo" Collins tells the story. If this album doesn't become a big jazz seller, we miss our guess by a wide mark.

CLIFFORD BROWN AND MAX ROACH—EmArcy MG26043 (1-10" LP) List: \$3.85

DELILAH; PARISIAN THOROUGHFARE; DAAHOUD; JOY SPRING; DARN THAT DREAM.

Two great artists front this modern album. Clifford Brown has been making his horn brilliance known to the select jazz followers for the past year or year and one-half. Roach has been a big name on the drums for many years. The two complement each other beautifully. Supporting cast consists of Harold Land, tenor; George Morrow, bass and Richie Powell, piano.

McKINNEY'S COTTON PICKERS (Vol. 1) "X" Vault Originals LVA-3031 (1-10" LP) List: \$2.98

STOP KIDDING; PUT IT THERE; MILENBERG JOYS; NOBODY'S SWEETHEART, SOME SWEET DAY; SHIM-ME-SHA-WABBLE; IT'S TIGHT LIKE THAT; THERE'S A RAINBOW 'ROUND MY SHOULDER.

The famous McKinney's Cotton Pickers are the subject on wax in the latest "X" Vault Original series. Etchings heard in this newest historical issue covers the big band jazz in the late 1920's. Among the sidemen who are standouts are John Jesbitt on the trumpet and Don Redman on the alto sax. Will appeal to the nostalgic and collectors.

THE OSCAR PETERSON QUARTET—Album #2—Clef MG-C-168 (1-10" LP) List: \$3.85

OH, LADY BE GOOD; BODY AND SOUL.

Given the solid support of Barney Kessel, guitar; Ray Brown on the bass and Alvin Stoller; two great standards and a complete LP side for each tune to engrave his ideas, Oscar Peterson wanders up and down the keyboard with some delectable results. Peterson fans will love it.

"SONGS BY ANITA O'DAY"—Norgran MG N-30 (10" LP) List: \$3.85

ANITA'S BLUES; I COVER THE WATERFRONT; GYPSY IN MY SOUL; JUST ONE OF THOSE THINGS; I DIDN'T KNOW WHAT TIME IT WAS; MAN I LOVE; FRANKIE AND JOHNNIE.

Anita O'Day, one of jazzdom's top thrushes, gives out with her heartfelt interpretation of a handful of some of the greatest standards. Anita is at her best on this LP. The entire package has that mood music flavor since Anita is assisted by only a piano. Chirp sings like a dream. Miss O'Day is a strong seller among jazz aficionados.

FILM SOUND TRACK

"SO THIS IS PARIS"—Song hits from the sound track of the U-I film starring Tony Curtis, Gloria De Haven, Gene Nelson, Corinne Calvet and Paul Gilbert—Decca DL-5553 (10" LP) List: \$3.00

SO THIS IS PARIS; WAIT TILL PARIS SEES US; LOOKING FOR SOMEONE TO LOVE; IF YOU WERE THERE; A DAME'S A DAME; THE TWO OF US.

"So This Is Paris", the big Universal-International pic which will be opening early in '55 features a big cast including Tony Curtis, Gloria DeHaven and Gene Nelson. Decca comes up with the sound track for the flicker. This delightful, happy-go-lucky type of musical has a number of catchy songs and good ballads that the movie goer will want. Package should enjoy a healthy sale. Lots of promotion behind the LP. "So This Is Paris" and "The Two Of Us" by Miss DeHaven have been issued as a single which should in turn promote the LP.

THE CASH BOX

SURE SHOTS

The Cash Box "Sure Shots" highlight records which reports from retail dealers throughout the nation indicate are either already beginning to sell in quantity or else give every sign of doing so.

"TWEEDLEE DEE"

Lavern Baker Atlantic 1047; 45-1047
Georgia Gibbs Mercury 70517; 70517 x 45

"D-A-R-L-I-N"

Hilltoppers Dot 15318; 45-15318

"EARTH ANGEL"

Penguins Dootone 348; 45-348

"SONG IN BLUE"

Les Paul & Mary Ford Capitol 3015; F-3015

Live Talent Salute To 20th Anniversary Of Block's "Ballroom" To Aid March of Dimes

NEW YORK—A million-dollar talent salute to the 20th Anniversary of Martin Block's Make Believe Ballroom on Thursday Feb. 3 will be dedicated to the 1955 March of Dimes campaign and will be broadcast over the nationwide ABC Radio Network.

The star-spangled in-person show will originate from Manhattan Center in New York, and will climax the March of Dimes 1955 drive for funds.

The special double-decade anniversary tribute to disk jockey Block, who originated his Make Believe Ballroom show on Feb. 3, 1935, will give Block's millions of fans and hundreds of show business friends a chance to help further the fight against infantile paralysis and to wish him well on the 20th Anniversary of his musical show-case.

A treasury of top talent will sparkle in the New York March of Dimes—Martin Block salute. Block himself emcees the luminous line-up of personalities.

Julius LaRosa, The Chordettes, Teresa Brewer, Kitty Kallen, Joel Grey, the McGuire Sisters, Denise Lor, Don Cornell, the DeMarco Sisters and Jackie Gleason are but a few of the stellar names who will appear. Many more famous recording artists will be announced later.

The ABC Radio Network will carry the in-person show from 2:35 to 4 p.m., EST.

WABC-Radio in New York, Block's home-station and the ABC flagship, will carry the entire day's doings—from 2:35 to 6:45 and from 8 to 10:30 p.m., EST, while WABC-TV Channel 7 in New York will treat Block's fans to a showing of the fun-filled musical

program from 2:35 to 3:30 p.m., EST, and again from 8:00 to 8:30 p.m., EST.

Two separate shows for two different in-person audiences will be held—in the afternoon from 2:35 to 6:45 p.m., EST and again in the evening from 8 to 10:30 p.m., EST.

The entire proceeds of the double-barelled shows will be turned over to the Greater New York March of Dimes, whose annual campaign for funds begins with each new year.

Audivox Rushes Collins Disk

NEW YORK—When speed is essential, Leonard Wolf, Audivox Records, proved this week he takes a back seat to no one.

On Saturday, January 1, Dorothy Collins sang one of her numbers for the Hit Parade, the standard "Get Happy". Response from her TV audience was so immediate and overwhelming that Dorothy, Raymond Scott and Wolf decided to cut the tune immediately. As a coupler the r & b hit "Tweedle Dee" was decided upon.

Rehearsals and the session Monday. Editing through the night. Samples ready on Wednesday thirty six hours later, and on Thursday the record was shipped out nationally. Says Wolf, "I didn't sleep at all for about 48 hours."

YOUR SONG RECORDED!

by professional recording artists so it can be submitted properly to record companies, publishers or for your pleasure.

THE ONLY WAY TO SELL SONGS TODAY

Send 25c for Brochure and Info.

LANNY & GINGER GREY PRODUCTIONS
for: Adom Hats, Yonkers Raceway, Blotz, Chase National Bank, Sunoco, Rinsco, etc.
200-C East 72 St. New York City 21

EN 9-7777

Research Craft Company

Producers of

Finest Custom Record Pressings That Quality Materials and Intelligent Skill Can Offer
Any Type of Phonograph Record in Shellac • Flex • Vinylite

1037 N. Sycamore St. • Los Angeles 38, Calif. • Hollywood 5-6128

Lucky DJ



NEW HAVEN—Tiny Markle is surrounded by the McGuire Sisters (Chris, Phyllis and Dorothy) during an afternoon interview over WAVZ in New Haven prior to the girls' appearance at the TB Association 50th Anniversary Ball at The Taft Hotel. During the afternoon, Tiny also had the pleasure of talking to May Wynn and Bob Francis of the movie "The Caine Mutiny", and Eydie Gorme and Steve Lawrence of the Steve Allen TV Show.

THE CASH BOX Disk Jockey's REGIONAL RECORD REPORTS

Listings below are reprinted exactly as submitted by leading disk jockeys throughout the nation for the week ending January 8 without any changes on the part of THE CASH BOX.

Pvt. Richard Hayes
ABC, Mutual, Radio Networks
—New York, N. Y.

1. Let Me Go, Lover (J. Weber)
2. Mr. Sandman (Chordettes)
3. Teach Me Tonight (DeCastros)
4. This Ole House (R. Clooney)
5. Hold My Hand (Don Cornell)
6. Naughty Lady (Ames Bros.)
7. Funny Thing (Tony Bennett)
8. I Need You Now (E. Fisher)
9. Make Yourself Comfortable (Sarah Vaughan)
10. Finger Of Suspicion (Froman)

Joe Deane
KQV—Pittsburgh, Pa.

1. No More (DeJohns)
2. Open Up Your Heart (Cowboy Church Choir)
3. Dance Mr. Snowman, Dance (Crewcuts)
4. Home For The Holidays (Perry Como)
5. Let Me Go, Lover (J. Weber)
6. The Coo-Coo Cries (F. Weir)
7. Make Yourself Comfortable (Vaughan/Gorme & Lawrence)
8. That's All I Want From You (Jaye P. Morgan)
9. Hearts Of Stone (Fontanes)
10. Melody Of Love (D. Carroll)

Stan Burns
WINS—New York, N. Y.

1. Mr. Sandman (Chordettes)
2. Make Yourself Comfortable (Sarah Vaughan)
3. Let Me Go, Lover (Weber/Brewer/Page)
1. Naughty Lady (Bleyer/Ames Bros.)
5. Dance Mr. Snowman, Dance (Crewcuts)
6. Home For The Holidays (Perry Como)
7. Teach Me Tonight (DeCastros)
8. Cat's Whiskers (Lou Monte)
9. That's All I Want (J. Morgan)
10. Our Future Has Only Begun (Denise Lor)

Bill Burns
WQAM—Miami, Fla.

1. Hearts Of Stone (Charms)
2. Let Me Go, Lover (Brewer)
3. Naughty Lady (A. Bleyer)
4. Star Dust Mambo (R. Maltby)
5. Melody Of Love (B. Vaughn)
6. No More (DeJohns)
7. Make Yourself Comfortable (Sarah Vaughan)
8. Mr. Sandman (Chordettes)
9. Count Your Blessings (Fisher)
10. All At Once (Don Cornell)

Sam Bradley
KVLD—Kansas City, Mo.

1. Hearts Of Stone (Fontanes)
2. Let Me Go, Lover (P. Page)
3. Mr. Sandman (Chordettes)
4. Melody Of Love (F. Sinatra)
5. No More (DeJohns)
6. Naughty Lady (Ames Bros.)
7. Count Your Blessings (Fisher)
8. Dim, Dim The Lights (Haley)
9. Open Up Your Heart (Cowboy Church Choir)
10. This Ole House (R. Clooney)

Don Bell
KRNT—Des Moines, Iowa

1. Mr. Sandman (Chordettes)
2. Naughty Lady (Ames Bros.)
3. Let Me Go, Lover (T. Brewer)
4. Shake, Rattle & Roll (Haley)
5. Let Me Go, Lover (J. Weber)
6. Teach Me Tonight (DeCastros)
7. I Need You Now (E. Fisher)
8. This Ole House (R. Clooney)
9. Hearts Of Stone (Fontanes)
10. Count Your Blessings (Fisher)

Pete Ward

WCCM—Lawrence, Mass.

1. Sincerely (McGuire)
2. Naughty Lady (Ames Bros.)
3. Malaguena (Caterina Valente)
4. Hearts Of Stone (Fontanes)
5. Wabash 4-7473 (Komack)
6. No More (DeJohns)
7. Earth Angel (Penguins)
8. Dim, Dim The Lights (Haley)
9. Silk Stockings (Perry Como)
10. Melody Of Love (4 Aces)

Jim Lowe

WRR—Dallas, Tex.

1. Hearts Of Stone (Fontanes)
2. Open Up Your Heart (Cowboy Church Choir)
3. No More (DeJohns)
4. Mr. Sandman (Lancers/Chordettes)
5. I Need Your Lovin' (Cheers)
6. Melody Of Love (B. Vaughn)
7. My Own True Love (Jenkins)
8. That's What I Like (Don, Dick & Jimmy)
9. Mambo Italiano (R. Clooney)
10. Sincerely (McGuire)

Al Radka

KFRE—Fresno, Calif.

1. Let Me Go, Lover (J. Weber)
2. Naughty Lady (Ames Bros.)
3. Mr. Sandman (Chordettes)
4. Mambo Italiano (R. Clooney)
5. Make Yourself Comfortable (Sarah Vaughan)
6. That's All I Want From You (Jaye P. Morgan)
7. Teach Me Tonight (DeCastros)
8. Home For The Holidays (Perry Como)
9. All Of You (Tony Martin)
10. No More (DeJohns)

Pat Chamburs

WFLA—Tampa, Fla.

1. Unsuspecting Heart (Stevens)
2. Mr. Sandman (Chordettes)
3. Vera Cruz (Richard Hayman)
4. It's Never Too Late To Fall In Love (Pee Wee Hunt)
5. Silk Stockings (Perry Como)
6. Wind Song (Vic Damone)
7. A Whale of a Tale (Douglas)
8. Wonderful Lips (Gaylords)
9. Naughty Lady (Archie Bleyer)
10. Make Yourself Comfortable (Sarah Vaughan)

Dick Gilbert

KTYL—Phoenix, Ariz.

1. Mr. Sandman (4 Aces/Chordettes)
2. Count Your Blessings (Fisher)
3. Melody Of Love (S. Kaye)
4. All At Once (Don Cornell)
5. Where Can You Be (Martin)
6. If I Give My Heart (D. Day)
7. Mambo Italiano (R. Clooney)
8. Let Me Go, Lover (J. Weber)
9. Dream Rhapsody (Baxter)
10. On The Alamo (Norman Petty Trio)

Bill Collins

WLOX—Biloxi, Miss.

1. Hearts Of Stone (Fontanes)
2. Let Me Go, Lover (Brewer)
3. Mr. Sandman (R. Morrow)
4. I Need You Now (Fisher)
5. You, My Love (Doris Day)
6. Naughty Lady (Ames Bros.)
7. Make Yourself Comfortable (Peggy King)
8. That Was My Heart You Heard (Betty Madigan)
9. If I Give My Heart (D. Day)
10. That's All I Want (Morgan)

Mike Woloson

WNOR—Norfolk, Va.

1. Unsuspecting Heart (S. Gale)
2. My Own True Love (Johnny Desmond)
3. No More (DeJohns)
4. Hold My Hand (Don Cornell)
5. Make Yourself Comfortable (Sarah Vaughan)
6. Tara's Theme (Leroy Holmes)
7. Mobile (Julius LaRosa)
8. The Things I Didn't Do (Comor)
9. Let Me Go, Lover (J. Weber)
10. Always (Betty Madigan)

Bill Dawes

WCPO—Cincinnati, Ohio

1. Open Up Your Heart (Cowboy Church Choir)
2. Hurt (Roy Hamilton)
3. Melody Of Love (B. Vaughn)
4. Let Me Go, Lover (J. Weber)
5. Mr. Sandman (Chordettes)
6. Hearts Of Stone (Fontanes)
7. Make Yourself Comfortable (Sarah Vaughan)
8. Naughty Lady (Ames Bros.)
9. Silk Stockings (Vic Damone)
10. Dim, Dim The Lights (Haley)

Ralph Petty

WLSH—Lansford, Pa.

1. Let Me Go, Lover (T. Brewer)
2. Sure-Fire Kisses (Hill & Tubbs)
3. Mr. Sandman (Chordettes)
4. Hearts Of Stone (Fontanes)
5. Whisper (Betty Clooney)
6. Naughty Lady (Ames Bros.)
7. Sincerely (McGuire)
8. Star Dust Mambo (R. Maltby)
9. Melody Of Love (B. Vaughn)
10. No More (DeJohns)

Larry E. Jones

KTXN—Austin, Tex.

1. Mr. Sandman (4 Aces)
2. Make Yourself Comfortable (Sarah Vaughan)
3. Hold My Hand (Don Cornell)
4. If I Give My Heart (D. Day)
5. I Need You Now (E. Fisher)
6. Mambo Italiano (D. Martini)
7. Hurt (Roy Hamilton)
8. Naughty Lady (Ames Bros.)
9. Let Me Go, Lover (J. Weber)
10. Hearts Of Stone (Charms)

Ray Perkins

KIMN—Denver, Colo.

1. Mr. Sandman (Chordettes)
2. Hearts Of Stone (Fontanes)
3. Let Me Go, Lover (J. Weber)
4. Naughty Lady (Ames Bros.)
5. Teach Me Tonight (Fontanes)
6. Count Your Blessings (Fisher)
7. Papa Loves Mambo (P. Como)
8. If I Give My Heart (D. Day)
9. This Ole House (R. Clooney)
10. Melody Of Love (F. Sinatra)

Walt Gaines

WCSS—Amsterdam, N. Y.

1. Santo Natale (D. Whitfield)
2. Mambo Italiano (R. Clooney)
3. Let Me Go, Lover (J. Weber)
4. Mr. Sandman (Chordettes)
5. This Ole House (R. Clooney)
6. Count Your Blessings (Fisher)
7. Naughty Lady (Ames Bros.)
8. My Own True Love (Desmond)
9. Open Up Your Heart (Cowboy Church Choir)
10. Melody Of Love (4 Aces)

Johnny Morris

KSTP—St. Paul, Minn.

1. Let Me Go, Lover (J. Weber)
2. Mr. Sandman (Chordettes)
3. Runaround (Chuckles)
4. Teach Me Tonight (J. Brace)
5. No More (DeJohns)
6. Mobile (J. LaRosa)
7. Count Your Blessings (Fisher)
8. Naughty Lady (A. Bleyer)
9. Star Dust Mambo (R. Maltby)
10. Hearts Of Stone (Fontanes)

Wayne Stitt

WHB—Kansas City, Mo.

1. Hearts Of Stone (Fontanes)
2. Mr. Sandman (Chordettes)
3. Let Me Go, Lover (J. Weber)
4. No More (DeJohns)
5. Count Your Blessings (Fisher)
6. Naughty Lady (Ames Bros.)
7. Open Up Your Heart (Cowboy Church Choir)
8. Melody Of Love (Ink Spots)
9. Mobile (Julius LaRosa)
10. That's All I Want (J. Morgan)

Buddy Deane

WITH—Baltimore, Md.

1. Hearts Of Stone (Fontanes)
2. Let Me Go, Lover (T. Brewer)
3. Teach Me Tonight (DeCastros)
4. Dim, Dim The Lights (Haley)
5. Papa Loves Mambo (P. Como)
6. Sincerely (McGuire)
7. No More (McGuire)
8. Melody Of Love (B. Vaughn)
9. Tweedlee Dee (G. Gibbs)
10. Make Yourself Comfortable (Sarah Vaughan)

RCA Victor Opens Nashville Studio

NEW YORK—Nashville, Tenn., for a number of years the capitol of Country music in the U. S., will have its own RCA Victor recording studio in early January.

To be used for the recording of top RCA Victor Country names, the studio will also function as an RCA Victor Custom Recording Studio. In the latter capacity, the studio will become available to the many independent record companies of the area, many of which already employ the Custom record manufacturing facilities of RCA Victor.

Engineered to employ the most modern concepts of recording, the new studio will comfortably accommodate a musical organization of dance band proportions. Chief recording engineer of the new studio will be Jeff Miller, for years an engineer at RCA Victor's New York studio.

The Custom Record Sales function of the new studio will be under the supervision of G. B. Bennett, whose promotion to Manager of Custom Sales for the Nashville territory is being announced concurrently with the news of the opening of the new studio.

Bennett, until his promotion, was an RCA Victor Custom Records sales representative in the Chicago area. He held this post from 1950, the year he joined RCA Victor. Prior to his coming with RCA Victor, Bennett had many years of experience in the record field, mostly in the Orient. From 1945 until 1949 he was the Eastern India Manager for the British firm, EMI, Limited. In this post he supervised Eastern manufacture and distribution of the English Columbia label. Earlier, from 1930 until 1933, Bennett was associated in Malaya with the agency for Carl Lindstrom Company of Berlin, Germany marketing the Odeon label. The Lindstrom Company recorded native Malayan and Chinese talent and distributed the records throughout the Orient.

In his new position Bennett will, in addition to his responsibilities in Nashville, be in charge of an RCA Victor Custom Sales territory consisting of eleven states: Arkansas, Oklahoma, Texas, Tennessee, Louisiana, Mississippi, Georgia, Florida, Alabama, North Carolina and South Carolina.

A Natural Hit!

FINGER OF SUSPICION

DICKIE VALENTINE

No. 1498

LONDON

A 2 Sided HIT by THE FOUR TUNES

"I SOLD MY HEART TO THE JUNKMAN"

b/w

"GOOD NEWS"

(Chariot's Comin')
Jubilee # 5174

JUBILEE RECORD CO., Inc.
315 W. 47th St., N. Y. N. Y.

2 of the GREATEST RECORDS IN AMERICA!!

THE FONTANE SISTERS "HEARTS OF STONE"

Dot # 15265

and

BILLY VAUGHN'S

"MELODY OF LOVE"

Dot # 15247

DOT RECORDS, INC.

GALLATIN, TENNESSEE

Phone: 1600

"OUR LADY OF GUADALUPE"

b/w

"THE TEN COMMANDMENTS"

1311

TIFFANY RECORDING CO.

332 S. Michigan Ave. Chicago, Ill.



Listings below are reprinted exactly as submitted by leading disk jockeys throughout the nation for the week ending January 8 without any changes on the part of THE CASH BOX.

Stan "The Record Man" Dale
WJJD—Chicago, Ill.

1. Naughty Lady (Bleyer Ames Bros.)
2. No More (DeJohns)
3. Melody Of Love (D. Carroll)
4. There Is A Tavern In The Town (4 Aces)
5. Tweedle Dee (Young Gibbs)
6. Let Me Go, Lover (Weber Page)
7. Whisper (Betty Clooney)
8. Make Yourself Comfortable (Sarah Vaughan)
9. Hocus FOCUS (Patti Page)
10. Please Don't Break My Heart (Nick Noble)

George E. LeZotte
WAVZ—New Haven, Conn.

1. Teach Me Tonight (DeCastros)
2. Let Me Go, Lover (J. Weber)
3. Mobile (Julius LaRosa)
4. Sincerely (McGuire)
5. Dim Dim The Lights (Haley)
6. Star Dust Mambo (Maltby)
7. Hold My Hand (Don Cornell)
8. Malaguena (Catrena Valente)
9. Stars Never Cry (Applewhite)
10. Always You (Betty Madigan)

Gene Edwards
KLIF—Dallas, Tex.

1. Let Me Go, Lover (Weber Brewer)
2. Naughty Lady (Ames Bros.)
3. Make Yourself Comfortable (Sarah Vaughan)
4. Hearts Of Stone (Fontanes)
5. Mr. Sandman (4 Aces Lancers)
6. Rickety Ticky Melody (Collegians)
7. Star Dust Mambo (R. Maltby)
8. No Man Is An Island (Cornell)
9. Old Shoes (Frankie Laine)
10. Melody Of Love (Vaughn/4 Aces)

Ed Reilly
WBRY—Waterbury, Conn.

1. Hearts Of Stone (Fontanes)
2. Sincerely (McGuire)
3. Let Me Go, Lover (J. Weber)
4. No More (McGuire)
5. This Ole House (R. Clooney)
6. Melody Of Love (4 Aces Vaughn)
7. No Man Is An Island (Cornell)
8. That's All I Want From You (Jay P. Morgan)
9. Unsuspecting Heart (Stevens)
10. Make Yourself Comfortable (Sarah Vaughan)

Norman Hall
Triangle Radio Network—Boonville, Ind.

1. Mr. Sandman (Chordettes)
2. Let Me Go, Lover (J. Weber)
3. No More (DeJohns)
4. I Need You Now (E. Fisher)
5. Always You (Betty Madigan)
6. Hold My Hand (Don Cornell)
7. Teach Me Tonight (DeCastros)
8. Melody Of Love (B. Vaughn)
9. Make Yourself Comfortable (Sarah Vaughan)
10. Hearts Of Stone (Fontanes)

Jim Stanley
WGH—Norfolk, Va.

1. Let Me Go, Lover (J. Weber)
2. Mr. Sandman (Chordettes)
3. This Ole House (R. Clooney)
4. Count Your Blessings (Fisher)
5. Hearts Of Stone (Fontanes)
6. Papa Loves Mambo (P. Como)
7. Make Yourself Comfortable (Sarah Vaughan)
8. I Need You Now (E. Fisher)
9. Naughty Lady (Ames Bros.)
10. That's All I Want (J. Morgan)

Gene N. Fondren
KTHE—Taylor, Tex.

1. Mr. Sandman (Chordettes)
2. Let Me Go, Lover (J. Weber)
3. If I Give My Heart (Boswell)
4. I Need You Now (E. Fisher)
5. Teach Me Tonight (DeCastros)
6. In The Beginning (F. Laine)
7. Jacob's Ladder (4 Girls)
8. Naughty Lady (Ames Bros.)
9. Melody Of Love (4 Aces)
10. Hold My Hand (Don Cornell)

Gene Stuart
WABC—New York, N. Y.

1. Let Me Go, Lover (J. Weber)
2. No More (DeJohns)
3. That's All I Want (J. Morgan)
4. Unsuspecting Heart (Stevens)
5. Make Yourself Comfortable (Sarah Vaughan)
6. George (Dolores Hawkins)
7. Gonna Live Till I Die (Sinatra)
8. If I'm Lucky (Carmen McRae)
9. Land Of Dreams (Hugo Winterhalter)
10. Mr. Sandman (Chordettes)

Len Ross
KBMI—Henderson, Nev.

1. Mr. Sandman (Chordettes)
2. Let Me Go, Lover (S. Gale)
3. Count Your Blessings (Fisher)
4. Taras Theme (Leroy Holmes)
5. Always You (Betty Madigan)
6. Hajji Baba (Nat King Cole)
7. My Pretty Shoogah (Bennett)
8. Silk Stockings (Perry Como)
9. Naughty Lady (Archie Bleyer)
10. Mobile (Julius LaRosa)

Tom Edwards
WERE—Cleveland, Ohio

1. Melody Of Love (Vaughn/4 Aces)
2. Open Up Your Heart (Cowboy Church Choir)
3. Mr. Sandman (Chordettes)
4. Yours (Dick Contino)
5. Sincerely (McGuire)
6. Naughty Lady (Bleyer/Ames Bros.)
7. Let Me Go, Lover (Weber Brewer)
8. Teach Me Tonight (DeCastros)
9. Wedding Bells (F. Lester)
10. No More (DeJohns)

Robin Seymour
WKMh—Dearborn, Mich.

1. Hearts Of Stone (Fontanes)
2. Melody Of Love (D. Carroll)
3. Santo Natale (D. Whitfield)
4. Home For The Holidays (Perry Como)
5. Sincerely (McGuire)
6. Let Me Go, Lover (J. Weber)
7. Make Yourself Comfortable (Sarah Vaughan)
8. No Man Is An Island (Cornell)
9. Funny Thing (Tony Bennett)
10. Land Of Dreams (Hugo Winterhalter)

Tommy Riggs
WCAE—Pittsburgh, Pa.

1. Melody Of Love (D. Carroll)
2. Let Me Go, Lover (J. Weber)
3. Make Yourself Comfortable (Sarah Vaughan)
4. Hearts Of Stone (Fontanes)
5. That's All I Want From You (Jay P. Morgan)
6. No More (DeJohns)
7. Yours (Dick Contino)
8. From Nine to Five (D. Lor)
9. Sincerely (McGuire)
10. Count Your Blessings (Fisher)

Jerrie Paletta
KAYO—Seattle, Wash.

1. Earth's Angel (Penguins)
2. Let Me Go, Lover (T. Brewer)
3. Runaround (Chuckles)
4. Mr. Sandman (Chordettes)
5. It's A Woman's World (Four Aces)
6. If I Give My Heart (D. Day)
7. Hearts Of Stone (Fontanes)
8. Meod Indico (N. Fetty Trio)
9. Naughty Lady (Ames Bros.)
10. Little White Light (Lancers)

Don Sherman
WLYN—Lynn, Mass.

1. Melody Of Love (B. Vaughn)
2. Unsuspecting Heart (S. Gale)
3. Finger Of Suspicion (Froman)
4. Earth Angel (Penguins)
5. All Of You (Tony Martin)
6. Tweedle Dee (Laverne Baker)
7. Wabash 4-7473 (J. Kormack)
8. Ever Since You Went Away (Les Elgart)
9. Hearts Of Stone (Fontanes)
10. Hocus FOCUS (Patti Page)

Joe Gray—Ed Hurst
WPEN—Philadelphia, Pa.

1. No More (DeJohns)
2. I Want Eddie Fisher (Betty Johnson)
3. White Christmas (Crosby)
4. I Can't Give You Anything But You (Jackie Lee)
5. Let Me Go, Lover (Weber)
6. Make Yourself Comfortable (Sarah Vaughan)
7. Home For The Holidays (Perry Como)
8. The Last Time (Don, Dick & Jimmy)
9. Dim, Dim The Lights (Haley)
10. Tara's Theme (Leroy Holmes)

Ra'ph Phillips
WFBZ—Baltimore, Md.

1. Let Me Go, Lover (Weber)
2. Mr. Sandman (Chordettes)
3. Teach Me Tonight (DeCastros)
4. Dim, Dim The Lights (Haley)
5. Naughty Lady (Ames Bros.)
6. Hearts Of Stone (Fontanes)
7. Count Your Blessings (Fisher)
8. Mambo Italiano (R. Clooney)
9. Shake, Rattle & Roll (Haley)
10. Make Yourself Comfortable (Sarah Vaughan)

Art Preston
WSPR—Springfield, Mass.

1. Mobile (Julius LaRosa)
2. Melody Of Love (Shore & Martin)
3. Song From Desiree (Froman)
4. Old Shoes (Frankie Laine)
5. Santo Natale (D. Whitfield)
6. No More (DeJohns)
7. Make Yourself Comfortable (Sarah Vaughan)
8. My Love Song To You (Bob Manning)
9. That's What I Like (Don, Dick & Jimmy)
10. Count Your Blessings (Fisher)

Bob Larsen
WEMP—Milwaukee, Wis.

1. Open Up Your Heart (Cowboy Church Choir)
2. No More (DeJohns)
3. Melody Of Love (Four Aces)
4. Naughty Lady (Ames Bros./Bleyer)
5. Make Yourself Comfortable (Sarah Vaughan)
6. Mr. Sandman (Chordettes)
7. Mobile (Julius LaRosa)
8. Star Dust Mambo (R. Maltby)
9. Sincerely (McGuire)
10. Edward (Jill Corey)

Larry Wilson
WTIX—New Orleans, La.

1. Let Me Go, Lover (J. Weber)
2. Mr. Sandman (4 Aces)
3. Naughty Lady (Ames Bros.)
4. Ling, Ting, Tong (5 Keys)
5. Mambo Italiano (R. Clooney)
6. Make Yourself Comfortable (Sarah Vaughan)
7. Teach Me Tonight (DeCastros)
8. Melody Of Love (B. Vaughn)
9. I Want You All To Myself (Kitty Kallen)
10. Tara's Theme (Leroy Holmes)

Shel Horton
WVAM—WKMC—Saxton, Pa.

1. Melody Of Love (D. Carroll)
2. Naughty Lady (Ames Bros.)
3. Ole Pappy Time (S. Hamblen)
4. Runaround (Chuckles)
5. Mr. Sandman (Chordettes)
6. Woman's World (4 Aces)
7. Let Me Go, Lover (P. Page)
8. Blue Night (Johnny Maddox)
9. Song In Blue (Paul & Ford)
10. Teach Me Tonight (DeCastros)

Paul Cowley
WLEX—Lexington, Tex.

1. Hearts Of Stone (Fontanes)
2. Mr. Sandman (Chordettes)
3. No More (DeJohns)
4. Let Me Go, Lover (J. Weber)
5. I'm Only Human (L. Raine)
6. Melody Of Love (B. Vaughn)
7. Naughty Lady (Ames Bros.)
8. Cat's Whiskers (Lou Monte)
9. That's All I Want (J. Morgan)
10. Unsuspecting Heart (S. Gale)

Decca Adjusts Prices On LP Records

NEW YORK—Decca Records announced this week a re-adjustment in the price structure of their Long Play records.

10-inch Long Play records will have a suggested list price of \$2.98, including federal excise tax.

12-inch Long Play records will have a suggested list price of \$3.98 including federal excise tax, with the exception of a few sets which will be in the \$4.98 category, including federal excise tax.

It was also announced that all of the Long Play records will carry a 38% dealer discount from the suggested list price, including federal excise tax. There will be no return privileges on Long Play records.

There will be no changes in the price structure of Decca Extended Play records with the exception of the 3500 series which formerly was \$1.58 including federal excise tax which will now have a suggested list price of \$1.47 including federal excise tax.

All single records on both 78 and 45 rpm will retain their present suggested list price of \$.85, plus \$.04 federal excise tax. Existing dealer discounts and return privileges will be maintained.

All other records, such as children's sets, 78 rpm albums, etc., will retain their present suggested list prices, dealer discounts and return privileges.

Victor Records Marian Anderson In Met Opera Debut

NEW YORK — An all-star cast drawn from the Metropolitan Opera Association's production of "A Masked Ball," in which Marian Anderson made her Met debut last Friday, was recorded on Sunday, January 9, according to an announcement made by George R. Marek, director of artists and repertoire for RCA Victor.

"The recording of scenes from 'A Masked Ball' is one of the rare occasions when the Metropolitan Opera will be represented on records with the same cast of principals who will be heard by Metropolitan Opera audiences during the season," said Rudolph Bing, general manager of the Metropolitan.

Featured in the recording will be Miss Anderson as Ulrica; Zinka Milanov as Amelia; Leonard Warren as Renato; Jan Peerce as Riccardo; and Roberta Peters as Oscar.

"Production of this record is made possible because all of these world famed singers are exclusive RCA Victor recording artists," Marek pointed out.

The recording was conducted by Dimitri Mitropoulos, guest conductor of the Metropolitan Opera. Personnel from the Metropolitan Opera orchestra and chorus participated in the recording.

Mercury Offers 100% Exchange On LPs For 2 Months

CHICAGO—After a week's deliberation on the new price structure in the record business, Mercury Records executives this week announced that in line with their own new prices, they would offer dealers 100% exchange privilege on all packaged merchandise bought between January 5 and February 28. Art Talmadge, vice president of Mercury, said that the diskery feels the new prices will be a great incentive for the public to buy and as far as Mercury executives are concerned, they would like to see dealers stock up sufficiently to be able to take full advantage of this situation. Therefore Mercury has devised this offer designed to let dealers buy with the greatest protection. For two months, they will be able to exchange all merchandise in the same series on an even basis.

At the same time, Mercury announced its new price set-up. All 12 inch LPs in the Olympia series go from \$5.95 to \$3.98. The price to dealers will be \$2.47. 10 inch LPs will be \$2.98, \$1.85 to dealers. All EPs will be \$1.49, \$.86 to dealers. 78 rpm disks go up to \$.98. Childcraft remains at \$.98.

The discount will be 38 and 6, which brings single 45s to \$.52 and single 78s to \$.57.

There will be no return privilege on albums and a 5% return privilege on singles.

Capitol Promotes V-M Line

NEW YORK—Following a District Sales Managers meeting in Hollywood, Capitol Records announced that they will have an accelerated sales and promotional campaign centered around the V-M line which is now distributed by Capitol Records Branches.

Capitol has had the V-M line since August '53 and originally, only four Branches handled this line. The operation is now expanded to twenty-one Capitol Branches. This is the first year Capitol will have a special department to handle the V-M line. The V-M Corporation is one of the largest manufacturers of record changers in the business. This has been accomplished in a short ten years. The V-M has their home plant in Benton Harbor, Michigan.



America's Leading One Stop Record Service

LESLIE DISTRIBUTORS

NEW YORK: 639—10th AVE. (Phone PLaza 7-1977)
Cable Address: EXpoRecord, N. Y.

PITTSBURGH, PA.: 2231 FIFTH AVE.
ATLAS MUSIC BLDG. (Phone: GRant 1-9323)

HARTFORD, CONN.: 134 WINDSOR ST.
(Phone: JACKson 5-7123)

CHESS 4750-52 Cottage Grove Ave.
RECORD CORP. Chicago, 15, Illinois

HEADING FOR THE TOP!

**"I WANNA HUG YA,
KISS YA, AND
SQUEEZE YA"**

by

**BUDDY & CLAUDIA
GRIFFIN**

with the

**BUDDY GRIFFIN
ORCHESTRA**

CHESS 1586



**DANNY
OVERBEA**

sings

**"A TOAST
TO LOVERS"**

CHECKER 808

**JON
THOMAS
'A New Star'**

sings

**"RIB
TIPS"**

CHECKER 809

Checker RECORD CO.

4750-52 Cottage Grove Ave.
Chicago, 15, Illinois

HERALD Has Another!

A NEW SMASH BY
FAYE ADAMS

**"ANYTHING FOR
A FRIEND"**

444

Climbing UP UP UP
CHARLIE & RAY

"I LOVE YOU MADLY"

438

"ALL GONE"

b/w

"YOU HURT MY PRIDE"

440

URSULA REED



DOOTONE

HAS ALL THE

new BIGHTS!

EARTH ANGEL

THE PENGUINS # 348

BUICK 59

b/w

**THE
LETTER**

THE MEDALLIONS # 347
BEST SELLING LABEL
IN ALL KEY MARKETS

DOOTONE RECORDS

9512 SOUTH CENTRAL AVE. LOS ANGELES 2, CALIF.



8508 Sunset Blvd., Hollywood 46, Cal.

Two Great New Hits
For Miss Rhythm!

**"BYE BYE
YOUNG MEN"**

**"EVER SINCE MY BABY'S
BEEN GONE"**

RUTH BROWN

ATLANTIC # 1051



THE CASH BOX

in
NEW YORK CITY

in
CHICAGO

in
NEW ORLEANS

The Top Ten Tunes Netting Heaviest Play, Compiled From Reports Submitted Weekly To The Cash Box, By Leading Music Operators In New York City, Chicago and New Orleans.

1 TEACH ME TONIGHT Dinah Washington (Mercury 70497)	TEACH ME TONIGHT Dinah Washington (Mercury 70497)	LAST NIGHT Little Walter (Checker 805)
2 EARTH ANGEL Penguins (Dootone 348)	EARTH ANGEL Penguins (Dootone 348)	TWEEDLE DEE Lavern Baker (Atlantic 1047)
3 SINCERELY Moonglows (Chess 1581)	YOU UPSET ME BABY B. B. King (RPM 416)	COME BACK Ray Charles (Atlantic 1050)
4 KO-KO-MO Gene & Eunice (Combo 64)	RECONSIDER BABY Lowell Fulson (Checker 804)	RECONSIDER BABY Lowell Fulson (Checker 804)
5 TWEEDLE DEE Lavern Baker (Atlantic 1047)	LING, TING, TONG Five Keys (Capitol 2945)	THINKING OF YOU Fats Domino (Imperial 5328)
6 HURT Roy Hamilton (Epic 9086)	HEARTS OF STONE Charms (DeLuxe 6062)	SINCERELY Moonglows (Chess 1581)
7 MAKE YOURSELF COMFORTABLE Sarah Vaughan (Mercury 70469)	HURT Roy Hamilton (Epic 9086)	EARTH ANGEL Penguins (Dootone 348)
8 FOR SENTIMENTAL REASONS Rivileers (Baton 207)	SINCERELY Moonglows (Chess 1581)	HEARTS OF STONE Charms (DeLuxe 6062)
9 SINCE I FELL FOR YOU Harptones (Bruce 113)	MAKE YOURSELF COMFORTABLE Sarah Vaughan (Mercury 70469)	LING, TING, TONG Five Keys (Capitol 2945)
10 I LOVE YOU MADLY Charlie & Ray (Herald 438)	POISON IVY Willie Mabon (Chess 1580)	HURT Roy Hamilton (Epic 9086)

in
SAN FRANCISCO

in
NEWARK

in
MEMPHIS

1 RECONSIDER BABY Lowell Fulson (Checker 804)	EARTH ANGEL Penguins (Dootone 348)	HEARTS OF STONE Charms (DeLuxe 6062)
2 TEACH ME TONIGHT Dinah Washington (Mercury 70497)	SINCERELY Moonglows (Chess 1581)	TWEEDLE-DEE Lavern Baker (Atlantic 1047)
3 YOU UPSET ME BABY B. B. King (RPM 416)	TWEEDLE DEE Lavern Baker (Atlantic 1047)	LAST NIGHT Little Walter (Checker 805)
4 I'M READY Muddy Waters (Chess 1579)	HEARTS OF STONE Charms (DeLuxe 6062)	SINCERELY Moonglows (Chess 1581)
5 HURT Roy Hamilton (Epic 9086)	POISON IVY Willie Mabon (Chess 1580)	RECONSIDER BABY Lowell Fulson (Checker 804)
6 HEARTS OF STONE Charms (DeLuxe 6062)	YOU UPSET ME BABY B. B. King (RPM 416)	POISON IVY Willie Mabon (Chess 1580)
7 SINCERELY Moonglows (Chess 1581)	I NEED YOUR LOVE Pee Wee Crayton (Imperial 5321)	I LOVE YOU MADLY Charlie & Ray (Herald 438)
8 EARTH ANGEL Penguins (Dootone 348)	I LOVE YOU MADLY Charlie & Ray (Herald 438)	BABY, LET'S PLAY HOUSE Arthur Gunter (Excelllo 2047)
9 HURTS ME TO MY HEART Faye Adams (Herald 434)	BAZOOM (I NEED YOUR LOVIN') Charms (DeLuxe 6076)	OH BUT SHE DID Opals (Apollo 462)
10 MAMBO BABY Ruth Brown (Atlantic 1044)	NEVER LET ME GO Johnny Ace (Duke 132)	YOU UPSET ME BABY B. B. King (RPM 416)

"It's What's in THE CASH BOX That Counts"

THE CASH BOX



in
PHILADELPHIA

in
LOS ANGELES

in
ST. LOUIS

The Top Ten Tunes Netting Heaviest Play, Compiled From Reports Submitted Weekly To The Cash Box, By Leading Music Operators in Dollos, Los Angeles and Other Cities Listed.

- 1 **SINCERELY**
Moonglows
(Chess 1581)
- 2 **HEARTS OF STONE**
Charms
(DeLuxe 6062)
- 3 **TEACH ME TONIGHT**
Dinah Washington
(Mercury 70497)
- 4 **LING, TING, TONG**
Five Keys
(Capitol 2945)
- 5 **EARTH ANGEL**
Penguins
(Dootone 348)
- 6 **SHOO-DOO-BE-DOO**
Bobby Lester & Moonlighters
(Checker 806)
- 7 **HURT**
Roy Hamilton
(Epic 9086)
- 8 **STINGY LITTLE THING**
Midnighters
(Federal 12202)
- 9 **RECONSIDER BABY**
Lowell Fulson
(Checker 804)
- 10 **MAMBO BABY**
Ruth Brown
(Atlantic 1044)

- RECONSIDER BABY**
Lowell Fulson
(Checker 804)
- SINCERELY**
The Moonglows
(Chess 1581)
- EARTH ANGEL**
The Penguins
(Dootone 348)
- TWEEDLE-DEE**
Lavern Baker
(Atlantic 1047)
- EVERY DAY I HAVE THE BLUES**
B. B. King
(RPM 421)
- SHOO-DOO-BE-DOO**
Bobby Lester & Moonlighters
(Checker 806)
- DADDY, DADDY**
Richard Berry & The Dreamers
(Flair 1058)
- KO KO MO**
Gene & Eunice
(Combo 64)
- TEACH ME TONIGHT**
Dinah Washington
(Mercury 70497)
- PLEASE LET ME KNOW**
Five Pearls
(Aladdin 3265)

- TEACH ME TONIGHT**
Dinah Washington
(Mercury 70497)
- HEARTS OF STONE**
Charms
(DeLuxe 6062)
- RECONSIDER BABY**
Lowell Fulson
(Checker 804)
- YOU UPSET ME BABY**
B. B. King
(RPM 416)
- LAST NIGHT**
Little Walter
(Checker 805)
- EARTH ANGEL**
Penguins
(Dootone 348)
- POISON IVY**
Willie Mabon
(Chess 1579)
- SINCERELY**
Moonglows
(Chess 1581)
- TWEEDLE DEE**
Lavern Baker
(Atlantic 1047)
- BLUES ALL AROUND MY HEAD**
Memphis Slim
(United 186)

in
COLUMBIA, S. C.

in
NASHVILLE

in
SHOALS, IND.

- 1 **HEARTS OF STONE**
Charms
(DeLuxe 6062)
- 2 **YOU UPSET ME BABY**
B. B. King
(RPM 416)
- 3 **POISON IVY**
Willie Mabon
(Chess 1580)
- 4 **STINGY LITTLE THING**
Midnighters
(Federal 12202)
- 5 **SINCERELY**
Moonglows
(Chess 1581)
- 6 **MELLOW DOWN BABY**
Little Walter
(Checker 805)
- 7 **LET ME GO, LOVER**
Counts
(Dot 1235)
- 8 **MAMBO BABY**
Ruth Brown
(Atlantic 1044)
- 9 **EARTH ANGEL**
Penguins
(Dootone 348)
- 10 **THINKING OF YOU**
Fats Domino
(Imperial 5328)

- HEARTS OF STONE**
Charms
(DeLuxe 6062)
- YOU UPSET ME BABY**
B. B. King
(RPM 416)
- RECONSIDER BABY**
Lowell Fulson
(Checker 804)
- BABY, LET'S PLAY HOUSE**
Arthur Gunter
(Excello 2047)
- POISON IVY**
Willie Mabon
(Chess 1580)
- SINCERELY**
Moonglows
(Chess 1581)
- TWEEDLEE DEE**
Lavern Baker
(Atlantic 1047)
- I'M READY**
Muddy Waters
(Chess 1579)
- HURT**
Roy Hamilton
(Epic 9086)
- EVERY DAY I HAVE THE BLUES**
B. B. King
(RPM 421)

- HEARTS OF STONE**
Charms
(DeLuxe 6062)
- RECONSIDER BABY**
Lowell Fulson
(Checker 804)
- YOU UPSET ME BABY**
B. B. King
(RPM 416)
- TEACH ME TONIGHT**
Dinah Washington
(Mercury 70497)
- I'M READY**
Muddy Waters
(Chess 1579)
- LING, TING, TONG**
Five Keys
(Capitol 2945)
- HURT**
Roy Hamilton
(Epic 9086)
- MAKE YOURSELF COMFORTABLE**
Sarah Vaughan
(Mercury 70469)
- HURTS ME TO MY HEAD**
Faye Adams
(Herald 434)
- TWEEDLE DEE**
Lavern Baker
(Atlantic 1047)

Coming Up In R & B

Listed Alphabetically

- DADDY, DADDY**
Richard Berry & Dreamers
(Flair 1058)
Los Angeles
- LET ME GO, LOVER**
Counts
(Dot 1235)
Cincinnati, Columbia, Knoxville
- I'M A NATURAL BORN LOVER**
Muddy Waters
(Chess 1585)
Mobile, St. Louis, Nashville
- I NEED YOUR LOVE**
Pee Wee Crayton
(Imperial 5321)
Los Angeles, Newark
- I'VE GOT A WOMAN COME BACK**
Ray Charles
(Atlantic 1050)
Atlanta, Los Angeles, Mobile, Newark, New Orleans, Savannah, St. Louis
- PLEDGING MY LOVE**
Johnny Ace
(Duke 136)
Mobile, Dallas, Knoxville, Los Angeles, Newark, New York, Philadelphia, Savannah

Coming Up!

"DEEP FREEZE"

b/w "I'LL NEVER GET OVER YOU"
By THE ROAMERS—Savoy #1147

Still Going Strong!

"DON'T DROP IT"

WILBERT HARRISON—Savoy #1138

SAVOY RECORD CO., INC.
58 Market St., Newark, N. J.

DO YOU NEED ANY MONEY

CASH BOX—BILLBOARD
TERRITORIAL BEST SELLER
The Fabulous Joe Houston Blows

"ALL NITE LONG"

MONEY # 203

The Instrumental Of The Year
R&B — JAZZ — POP

THE TURBANS

sing

"TICK TOCK A-WOO"

b/w

"NO NO CHERRY MONEY"

Money 209

Some choice territory available
Write — Wire Your Order

MONEY RECORD SALES
4854 W. JEFFERSON BLVD.
LOS ANGELES 16, CALIF.



THE CHARMS

"LING, TING, TONG"

"BAZOOM"
DELUXE 6076

"HEARTS OF STONE"

"WHO KNOWS"
DELUXE 6062

THE MIDNIGHTERS

"STINGY LITTLE THING"

"TELL THEM"
FEDERAL 12202

THE PLATTERS

"VOO-VEE-AH-BEE"

"SHAKE IT UP MAMBO"
FEDERAL 12198

DISTRIBUTED BY
King RECORDS

A Spiritual Hit!

"I'M NOT UNEASY"

b/w

"SINNER, SIN NO MORE"

by The Dixie Humming Birds
PEACOCK # 1740

Peacock RECORDS, Inc.
2809 Erastus Street,
Houston 26, Texas

BREAKING IN DETROIT

"SWEET SUE"

THE CROWS

RAMA 50

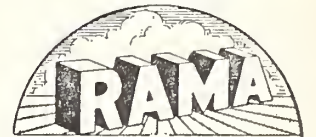

220 W. 42nd St., New York, N. Y.

Climbing Higher!

"YOU DON'T HAVE TO GO"

BY **JIMMY REED**

VEE-JAY 119

Vee-Jay RECORDS, INC.
4747 Cottage Grove Ave.
Chicago 15, Illinois

RHYTHM 'N BLUES REVIEWS

ⓐ DISK & SLEEPER	ⓐ GOOD
ⓑ EXCELLENT	ⓑ FAIR
ⓐ VERY GOOD	ⓐ MEDIOCRE

LOU MAC

(Blue Lake 108)

C+ "COME BACK LITTLE DADDY" (2:48) [Lou Mac & Bob Call] Lou Mac sings a slow rhythmic blues pleading with her man to come back. Good story and ok presentation.

C+ "HARD TO GET ALONG WITH" (2:45) [Lou Mac & Bob Call] Lou Mac is still having male woes on this deck. A slow Southern blues done with fair effect.

THE RUBIES

(Verne 103)

B "SOMEDAY" (2:16) [Mellin BMI—Brown, Parker] Sounds like an all fem group. A fast tempo bounce chanted in good style. If label can get it around could grab some sales action.

C+ "JUST YOU AND I" (2:34) [Archer] A sweet and sentimental blues ballad etched prettily. Same comments.

J. B. LENORE

(Parrot 809)

C+ "MAN WATCH YOUR WOMAN" (2:51) [Lake—Lenore] J. B. Lenore wails a slow blues chant. J. B. advises one to keep your good woman by your side. You can never tell when she might be swayed away from you.

B "MAMA TALK TO YOUR DAUGHTER" (2:43) [Lake—Lenore] Flip is a rhythmic quick beat jump energetically sung by Lenore. Engaging side that could sell well.

JON THOMAS

(Checker 809)

C+ "HI FI" (2:39) [Condor BMI] Jon Thomas and his orchestra spin a middle beat bounce instrumental with a strong sax lead. Deck has a good dance beat although the title is nothing more than just a title.

C "RIB TIPS" (2:40) [Condor BMI] S'ow tempo blues with guitar in the forefront. Ok deck.

THE MELLOWS

(Jay-Dee 797)

B+ "SMOKE FROM YOUR CIGARETTE" (2:20) [Beacon BMI—Johnson] The Mellows, featuring fem lead Lillian Leach, offer a top-notch sweet wax that should go big in the sophisticate markets. It is a mellow ballad of a sentimental nature that could follow the trend of some of its R & B sisters and grab off a big portion of pop sales.

B "PRETTY BABY, WHAT'S YOUR NAME?" (2:05) [Beacon BMI—Brown] The Mellows etch a jump on the flip and come off with a solid item. Good coupler, with "Smoke" the number one side.

THE CASH BOX

★ AWARD O' THE WEEK ★

"PLEDGING MY LOVE" (2:35)
[Lion BMI—Washington, Robey]

"NO MONEY" (2:42)
[Lion BMI—John Alexander]

JOHNNY ACE
(Duke 136)



JOHNNY ACE

● Johnny Ace, who has hit with eight successive releases, will probably have his greatest in this,

"Pledging My Love," released just prior to his untimely death, Christmas Eve. While the accident will no doubt be the cause of many sales, the etching has what it takes to hit the peak on merit alone. A lovely melody, simple and easy to remember, it will no doubt receive pop coverage. The refrain has a haunting quality that sticks with you. Can't miss. The flip, "No Money," is a rhythmic up tempo bouncer that Ace wail's effectively. However, it's a strict one-sider. "Pledging My Love" will go all the way.

"ANYTHING FOR A FRIEND" (2:44)
[Rush Music BMI—Wycal, McCrae]

"YOUR LOVE (Has My Heart Burnin')"
[Angel BMI—Scott]

FAYE ADAMS
(Herald 444)



FAYE ADAMS

● Faye Adams has a powerhouse

in "Anything For A Friend." The record is sold in the first twenty seconds. The little girl with the tremendous voice really belts this tune. Deck will prove to be one of the gal's biggest. Looks like a big R & B season ahead with this plate and the Ace item reviewed in the space above, to spearhead the sales department. The underlid, "You Love," has Faye bouncing with a zesty performance. Deck is potent, but it's "Anything For A Friend" for the big action.

SLEEPER OF THE WEEK

"UPSIDE YOUR HEAD" (2:45)
[Sophisticate BMI]

"CRAZY 'BOUT SAXAPHONE" (2:43)
[Sophisticate BMI]

BUDDY JOHNSON
(Mercury 70523)

● Buddy Johnson has a couple of good sides on his newest release, but the deck that should pull the coins is "Upside Your Head," with the mellow vocal chords of Ella Johnson providing the extra something. Ella tells of her man's fateful attractions. She ought to leave

him but she can't. Tune is an easy bouncer given the fine Johnson oik treatment. The flip, "Crazy 'Bout Saxaphone," is a fast tempo rocker on the novelty side. Ok backer-upper that will please with its novelty and dance tempo.

THE SULTANS

(Duke 135)

B "BOPPIN' WITH THE MAMBO" (2:29) [Lion BMI—The Sultans] The Sultans dish up an engaging mambo number that borrows a little from several other numbers.

B+ "WHAT MAKES ME FEEL THIS WAY" (2:43) [Lion BMI—Willie Barnes] The Sultans blend beautifully on this mellow pretty ballad. The lead is excellent. Could be a strong seller.

THE EAGLES

(Mercury 70524)

B+ "I TOLD MYSELF" (2:45) [Galvin Music BMI] A lovely romantic ballad in which the lead is stick-out. Could go both pop and R & B.

B+ "WHAT A CRAZY FEELING" (2:49) [Spiral Music BMI] Flip deck moves. A fast tempo jump that comes through in good style. Like it. Two good sides.

PEE WEE CRAYTON

(Imperial 321)

B "YOU KNOW, YEAH" (2:31) [Commodore BMI—E. Crayton] Pee Wee Crayton sings a slow blues with an effervescent treatment. Ok platter.

B+ "I NEED YOUR LOVE" (2:12) [Commodore BMI—E. Crayton] Pee Wee waxes sentimental on this side. A good etching that should sell big.

THE CRYSTALS

(DeLuxe 6077)

B "GOD ONLY KNOWS" (2:18) [Stenton BMI—Wright] The Crystals sing a s'ow ballad blues with a romantic set of lyrics. Fetching etching with lots of potential.

B "MY GIRL" (2:37) [Lois BMI—Maud Whitson] The fellows pick up the tempo on the flip deck and knock out a middle tempo bouncer. Side moves and comes through with a good sound.

BOBBY MITCHELL and The Toppers

(Imperial 791)

B "NOTHING SWEET AS YOU" (2:15) [Commodore BMI—Montgomery, Mitchell & Bartholomew] Bobby Mitchell sings a pretty blues ballad with a good degree of effectiveness. A s'ow rocking tempo with a melodic lilt.

C "I WISH I KNEW" (2:12) [Commodore BMI—Montgomery, Mitchell & Bartholomew] A similar piece of material that lacks the appeal of the top deck.

THE CASH BOX RHYTHM N' BLUES Ramblings

NEW YORK:

One of the quickest take-offs in memory is the new Johnny Ace "Pledging My Love" on Duke. While there is no doubt the tragic death of Ace is playing a big part in the surging demand for his new record, it is a coincidence (and an ironic twist) that "Pledging My Love" is also his best record. We have spoken to distributors, retail stores and juke box operators and the conversations all run the same. The gist of it being that it is Ace's biggest and the demand is far outrunning the supply. . . . Shocking news of George Goldner's father passing away only days after his mother was buried upset all of George's friends. . . . Sid Gross, Urania jazz and pop A & R, left for the west coast to make a series of TV and DJ guest appearances. Sid, a good jazz guitarist, will survey the jazz situation and speak of his experiences with his Columbia University jazz classes. Gross will be on the coast for about two weeks, then back to New York to work on his new jazz classes to be held at Carl Fisher Hall in Manhattan. . . . Herald Records really hectic with moving this week and handling three fast moving hits. The fellas are elated with the steady climb in sales of Charlie & Ray's "I Love You Madly" after a slow start. . . . And talking about slow starters—look what's happening to "Jam Up" by Tommy Ridgley on Atlantic. Released in June and now showing signs of taking off. . . . Pert Dorothy Collins makes her first release since the birth of baby girl a cover of Lavern Baker's "Tweedle Dee." Atlantic's success with r & b tunes that go pop continues to amaze. Another that bears watching for pop possibilities is Ivory Joe Hunter's "It May Sound Silly." . . . A switch is Audivox' "I Keep Crying" by the Hurricanes. In certain localities the tune is getting r & b action. . . . Irv Marcus, in discussing the new price structure, came around to the r & b 45 and 78 needs. Says Irv, "According to my experiences, when a record first breaks, the initial run should be 75%—45's and 25%—27's. That is because of the heavy preponderance of juke boxes that are using 45 mechanisms. After the initial orders, we find the swing moving steadily in favor of 78's as a good deal of the consumers are still using 78's and many radio stations have still not converted. However, each day sees less and less overall demand for the 78." Irv continued, "For the first time operators having been calling me direct on the new Johnny Ace release as they are having trouble filling their machines through the distribs. This is because the deck has taken off so fast we are temporarily behind in deliveries. In almost every case the demand from the operator is for 45's." . . . The Five Keys "Ling Ting Tong" on Capitol on both pop and r & b charts at the same time. This should do wonders for the lads booking potentialities. . . . The Five Pearls, Aladdin Records group, will appear at the Madison Ballroom, Detroit, January 14, 15 and 16. While in Detroit the "Pearls" will make a TV appearance on Ed McKenzie's show. . . . Excitement on two Atlantic items, Ray Charles' "I've Got A Woman" and "Come Back" (both sides being reported) and Lavern Baker's "Tweedle Dee." The latter is showing up so strong in pop stores that her total sales may equal or surpass Atlantic's "Sh-Boom" before it runs its string. Of course, in the r & b field, Miss Baker is miles ahead of any competitor. . . . Joel Turnero launches his "Home Boy" show on January 20 over WOV-New York. Show will be a remote from the store window of The After Hours Record Shop every day from 8 to 9 P.M. . . . Irv Marcus shooting out to Chicago to pacify some of the distribs who can't get enough of Johnny Ace's deck.



RAY CHARLES

CHICAGO:

William K. (Bill) Lawrence, formerly with Columbia Records in Pittsburgh, has been named sales and promotion manager for United Record Distribs here in Chi. . . . Nice to hear from Phil Waddell once again who reports from Detroit way that Bristoe Bryant, R&B DJ of WJLB, recently moved into his own building, complete with offices, platter lounge and studio from which he originates his Sunday morning Southland Spiritual Show. . . . Columbia Records has just released initial four sides recorded by Mahalia Jackson, which are titled as follows: "A Rusty Old Halo," b/w "Treasures Of Love." And "Walk Over God's Heaven," b/w "Jesus Met The Woman At The Well," which they've released as two singles under one cover. Mahalia set for 1/7 guest appearance on the Howard Miller CBS-TV show. . . . Len Chess, just back from Miami where he joined his family for the New Year holiday, telling us about his latest releases by some brand new artists. He is most optimistic about, "I Wanna Hug Ya, Kiss Ya, And Squeeze Ya," by Buddy and Claudia Griffin with Buddy Griffin's Ork. Len expects this one to zoom to the top of the charts. Griffins were discovered in their hometown of Norfolk, Virginia, and recording session was cut right there. . . . Jon Thomas is another newly-signed artist on the Checker label. His first release is titled, "Rib Tips." . . . From same firm comes word that Lowell Fulsom, whose "Reconsider Baby" is still riding high, is heading for Chicago from Knoxville, Tennessee, to record. . . . The Moonglows set for January 21 opening at the Apollo Theatre, Gotham. . . . It is reported that Little Walter has just been released from Mt. Sinai Hospital, this city, where he had been since Xmas morning. Seems he was rushed to the hospital a very sick man. Walter is now reported at home recuperating. . . . Lou Krevitz's "Top Ten Review of 1955," combining the talents of, The Clovers; Faye Adams; Joe Turner; Bill Doggett; The Charms; Lowell Fulsom; The Moonglows; The Moonlighters; Paul Williams and many others, set for an Eastern opening January 28. Show will then head west and is skedded for Chicago 2/5. . . . Morry Goldman of James H. Martin, Inc., called to report they are now handling the Specialty label. Morry also reports the appointment of Leslie F. Caldwell as sales rep. for R & B territory here in Chicago.



MOONGLOWS

LOS ANGELES:

While holding secret confabs as to whether to follow a new price structure which is expected to be set by the majors, all the local diskeries are all busy with a new batch of releases. . . . Al Miller, national sales manager for King Records, Cincinnati, spent several days in LA this past week. . . . The Sonny Thompson-Lula Reed package will hit Southern California January 22nd. They will appear in San Diego then move up to Los Angeles for week-end dates at The Five-Four Ballroom Jan. 27th through 29th. Their tour will include the complete Northwest. . . . Aladdin Records are shipping three potent new releases this week. They include "Please Baby Please" by The Viceroy's; "Honeysipper" with Charles Brown and "Cat Hop" by The Dodgers. . . . It was reported that a record throng of 7,000 turned out for the Louis Jordan-B. B. King show at the Oakland Auditorium recently. The package was booked by Ben Waller Enterprises. The affair broke all attendance records in the Bay area. . . . A new R & B bouncer called "The Wallflower" by Etta James and The Peaches on the Modern label is expected to break wide open throughout the area. Before the tune was released deejay Johnny Otis secured a dub and played it, just once, over the air. Record dealers and distributors were suddenly swamped with orders for the tune. . . . Irv Pinensky, former King Records branch manager in San Francisco, has gone into partnership with Gene Mandel to form their own distributing branch in the Bay area. Their offices will be located at 369 6th Street, San Francisco. The firm will be called Eric Distributing Corporation. . . . With publicist Bob Stern leaving Central Record Sales to head West Coast promotion for label "X" everyone wonders who will be next in line to take over the chores at Central. . . . Everyone mourns the passing of Johnny Ace. We wish to extend our deepest sympathies to his many relatives and friends. . . . Leo and Eddie Mesner of Aladdin Records are currently breaking into the big time with The Five Pearls "Please Let Me Know." . . . Post script on a letter written by Nick Therry to all Crown distributors: "I'm the guy who 'smiles' all through 'All I Ever Did Was Love You' . . . this cryin' stuff has got to go." . . . Imperial Records are out with 5 new releases for January. They include numbers by Smiley Lewis, Bobby Mitchell and The Toppers, Smilin' Joe, Joan Scott and a new artist, Johnny Moses. . . . Louis Jordan bowed in at the Savoy Ballroom Jan. 7th through 9th with his 1955 show and dance series. His first LA appearance in several months was marked with the usual large crowd. . . . Deejay Hunter Hancock will again stage weekly talent shows in the San Diego area starting Jan. 17th. Shows will be held at the new "Harlem 400" club. . . . Amos Milburn is back on the West Coast for dates throughout the area. He appeared at The Five-Four Ballroom Jan. 7th through 9th. . . . Ray Dobard of Music City Records, Berkeley, recently released two new sides by The Midnights. The boys belt out with "She Left Me," a driving, rhythmic tune which has great possibilities in today's market. Flip side "Cheating on Me" is a slow blues with a distinct melody. Good coupling. . . . Along with his local show, Johnny Otis now has a tape recorded hour and a half daily spot on KWBR in Oakland. . . . Many rumors have been circulated that one of the local R & B diskeries was up for sale. After inquiring around we can truthfully say that this rumor is completely false.



THE DODGERS

LOS ANGELES:

While holding secret confabs as to whether to follow a new price structure which is expected to be set by the majors, all the local diskeries are all busy with a new batch of releases. . . . Al Miller, national sales manager for King Records, Cincinnati, spent several days in LA this past week. . . . The Sonny Thompson-Lula Reed package will hit Southern California January 22nd. They will appear in San Diego then move up to Los Angeles for week-end dates at The Five-Four Ballroom Jan. 27th through 29th. Their tour will include the complete Northwest. . . . Aladdin Records are shipping three potent new releases this week. They include "Please Baby Please" by The Viceroy's; "Honeysipper" with Charles Brown and "Cat Hop" by The Dodgers. . . . It was reported that a record throng of 7,000 turned out for the Louis Jordan-B. B. King show at the Oakland Auditorium recently. The package was booked by Ben Waller Enterprises. The affair broke all attendance records in the Bay area. . . . A new R & B bouncer called "The Wallflower" by Etta James and The Peaches on the Modern label is expected to break wide open throughout the area. Before the tune was released deejay Johnny Otis secured a dub and played it, just once, over the air. Record dealers and distributors were suddenly swamped with orders for the tune. . . . Irv Pinensky, former King Records branch manager in San Francisco, has gone into partnership with Gene Mandel to form their own distributing branch in the Bay area. Their offices will be located at 369 6th Street, San Francisco. The firm will be called Eric Distributing Corporation. . . . With publicist Bob Stern leaving Central Record Sales to head West Coast promotion for label "X" everyone wonders who will be next in line to take over the chores at Central. . . . Everyone mourns the passing of Johnny Ace. We wish to extend our deepest sympathies to his many relatives and friends. . . . Leo and Eddie Mesner of Aladdin Records are currently breaking into the big time with The Five Pearls "Please Let Me Know." . . . Post script on a letter written by Nick Therry to all Crown distributors: "I'm the guy who 'smiles' all through 'All I Ever Did Was Love You' . . . this cryin' stuff has got to go." . . . Imperial Records are out with 5 new releases for January. They include numbers by Smiley Lewis, Bobby Mitchell and The Toppers, Smilin' Joe, Joan Scott and a new artist, Johnny Moses. . . . Louis Jordan bowed in at the Savoy Ballroom Jan. 7th through 9th with his 1955 show and dance series. His first LA appearance in several months was marked with the usual large crowd. . . . Deejay Hunter Hancock will again stage weekly talent shows in the San Diego area starting Jan. 17th. Shows will be held at the new "Harlem 400" club. . . . Amos Milburn is back on the West Coast for dates throughout the area. He appeared at The Five-Four Ballroom Jan. 7th through 9th. . . . Ray Dobard of Music City Records, Berkeley, recently released two new sides by The Midnights. The boys belt out with "She Left Me," a driving, rhythmic tune which has great possibilities in today's market. Flip side "Cheating on Me" is a slow blues with a distinct melody. Good coupling. . . . Along with his local show, Johnny Otis now has a tape recorded hour and a half daily spot on KWBR in Oakland. . . . Many rumors have been circulated that one of the local R & B diskeries was up for sale. After inquiring around we can truthfully say that this rumor is completely false.

Introducing a New Member of the Nashboro Family . . .

EDNA GALLMON COOKE
with a new Spiritual

"NOBODY BUT YOU LORD"

b/w

"SOMEBODY HELP ME"

NASHBORO 549

THE SKYLARKS

"CALL YOU IN THE MORNING"

b/w

"LETTER FROM JESUS"

NASHBORO 548

BLUES

BLUES

KID KING'S COMBO

"NOW LISTEN BABY" (vocal)

b/w

"THE SNEAK" (Inst.)

EXCELLO 2051

Still Ridin' High!

"BABY, LET'S PLAY HOUSE"

EXCELLO 2047

NASHBORO RECORD CO., INC.

177 3rd AVE., N.

(Phone 42-2215)

NASHVILLE, TENN.

"It's What's in THE CASH BOX That Counts"

Boston Opening



Rosen Joins Hansen & Smith

NEW YORK—It was announced this week that Bob Rosen will join the staff of Charles Hansen Music Publishing Corporation and Ethel Smith Music Corporation.

Rosen will be working directly with Charles Hansen, president, and his future assignments will cover all phases, including sales, promotion and recording. His duties begin January 10.

Plans have been made for Rosen to go to Pittsburgh and surrounding areas on January 17 to visit with disk jockeys. Upon leaving Pittsburgh he will join Ethel Smith in Cincinnati to work on her latest Decca recording "Sk-Ratch."

BOSTON—Nat "King" Cole's jam-packed opening nite at the Latin Quarter in Boston saw a complete turn-out of disk-jockeys and librarians in the area on hand. Shown glimpsing at Nat's music of his big Capitol disk hit, "Hajji Baba" with Nat is Jack McDermott and Don Sherman of WLYN at Lynn, Mass.

Dennis Day Makes N. Y. Niteclub Debut At Copa

NEW YORK—Dennis Day—a native New Yorker—will make his New York nightclub debut during a three week engagement at the Copacabana starting January 13.

For Day, singing star on the Jack Benny radio show since 1939, and star of his own weekly radio series, this will mark only the fourth night club engagement in his entire showbusiness career. During 1954 Day proved to be "a small riot" in appearances in Las Vegas, and Reno with his act. His only prior night club engagement was in 1951.

For Day, his engagement at the Copacabana marks the return of the native, since it was in this city that Day was born, on May 21, 1917, as Eugene Patrick McNulty. In fact, during his boyhood he was a choir boy at St. Patrick's Cathedral.

Soon after graduating from Manhattan College in this city, Day was signed in 1939 to replace Kenny Baker on the Jack Benny show. He has been on that show ever since, save for his time in the Navy.

For the past several years he has also been the star of NBC's Dennis Day show.

Day's supporting acts at the Copacabana will include The King Sisters and the dancing Cerneys, as well as an entirely new line of Copa girls, in new production numbers.

Million-Seller Record Club

NEW YORK—Disk jockeys and program managers interested in programming disk shows built around million-seller "gold" records will be happy to hear of an available list of almost 200 "million-sellers" on current labels that is being published by The Million-Seller Record Club in New York.

The list includes the artist, title of record, label and year of release.

Information on how to secure a copy can be obtained by writing The Million-Seller Record Club, Box 26, Ansonia Station, New York.



- 1 **HEARTS OF STONE**
Charms
(DeLuxe 6062)
- 2 **EARTH ANGEL**
Penguins
(Dootone 348)
- 3 **SINCERELY**
Moonglows
(Chess 1581)
- 4 **TEACH ME TONIGHT**
Dinah Washington
(Mercury 70497)
- 5 **RECONSIDER BABY**
Lowell Fulson
(Checker 804)
- 6 **TWEEDLE DEE**
Lavern Baker
(Atlantic 1047)
- 7 **YOU UPSET ME, BABY**
B. B. King
(RPM 416)
- 8 **HURT**
Roy Hamilton
(Epic 9086)
- 9 **LING, TING, TONG**
Five Keys
(Capitol 2945)
- 10 **POISON IVY**
Willie Mabon
(Chess 1580)
- 11 **I'M READY**
Muddy Waters
(Chess 1579)
- 12 **MAMBO BABY**
Ruth Brown
(Atlantic 1044)
- 13 **LAST NIGHT**
Little Walter
(Checker 805)
- 14 **STINGY LITTLE THING**
Midnighters
(Federal 12202)
- 15 **PLEDGING MY LOVE**
Johnny Ace
(Duke 136)

Stars Over Harlem

We are only in the second week of the new year, and already we are being treated to some of the nicest bits of commercial wax ever issued. With the late Johnny Ace's most recent "Pledging My Love" effort jumping a good distance out front as a result of his untimely passing. . . Tommy Ridgely's "Jam Up" the ideal bouncer to dance to. . . Ruth Brown and "Ever Since My Baby's Been Gone" due to explode at any moment. . . Spotted Buddy Friedlander relaxing 'neath the palms of the newly decorated Palm Cafe with personable disk-jockeys Leigh Kamman, Evelyn Robinson and raving like mad about the many, many big things that are due to come from Mercury in the very near future. . . Rose McCoy has a real nice one in "Dippin' In My Business." . . Jazz collectors just can't seem to get enough of the "Moody Mood for Blues" reading sent forth by the dynamic James Moody and crew. . . While we're on the subject of happenings on the progressive scenes of things, think this the right time to talk loud-like about the swinging sounds of Vido Musso, his whailing big toned tenor sax, the guys in the band and "Power House Boogie" B/W "Flat Top Boogie". . . George Williams busy, busy, busy preparing for his next Coral date which is to be loaded with the groovy commercial gimmicks and flavor that should make for pleasant earfuls. . . There seems to be no end to the talents of B. B. King. His "Sneakin' Around" B/W "Everyday I Have The Blues" allows the gent to show his wares. . . A short while ago we predicted the Gene & Eunice "Ko-Ko-Mo" platter to be one of the best selling items about, and already its doing just that. . . Elmore James and "Standing At The Crossroads" still growing and growing. . . A quick chat with Portem's Sam Meltzer offered us the chance to learn that all the Johnny Ace sides, both old and new were being sold with the speed of lightning. . . Irv Marcus can hardly find time for a moments rest. Energetic Irv and his busy telephone are active all hours of the night and bright filling order after order. . . Dinah Washington's latest LP entitled "After Hours With Miss D." a real touching one. . . Henry Glover hitting the uptown spots and jocks thus keeping the King precious works going 'round and 'round. . . Buddy Johnson's star male vocalist, a real smash hit with his "Lets Start All Over Again", and thats no joke.

2 NEW RELEASES

"GOING BACK TO MAMA"

"HARD-HEARTED WOMAN"

BIG WALTER HORTON

States 145

"FEELS SO FINE"

"YOU'RE GONNA CRY"

HAL BURRAGE

States 144

UNITED AND STATES RECORD CO.
5052 Cottage Grove Ave.
Chicago 15, Illinois

HERE'S A NEW ONE
... and a good one

CHARLES BROWN
"HONEY SIPPER"

ALADDIN # 3272



"Come To Me My
Little Darlin'"

by

Jan Strickland

X-0080

It's The Greatest!

COBLIN MUSIC

1587 BROADWAY, NEW YORK, N. Y.

ANNOUNCING
THE GRAND OPENING
OF

THE BAY AREAS NEWEST
DISTRIBUTOR

NOW SOLICITING NEW LINES

Irv Pinensky

ERIC DISTRIBUTING CORP.

369 6th Street, San Francisco 3, Cal.

THE CASH BOX

Country Disk Jockey
REGIONAL RECORD REPORTS



Ray Frazier's Country Junction

- WXGI—Richmond, Va.
1. If You Ain't Lovin' (Young)
 2. I Feel Better All Over (Ferlin Huskey)
 3. Hey, Where You Going (Frankie Miller)
 4. Making Believe (J. Work)
 5. Mr. Sandman (Chet Atkins)
 6. Hearts Of Stone (R. Foley)
 7. Wait A Little Longer, Please Jesus (Chester Smith)
 8. Carefree Moments (The Wilburn Bros.)
 9. Thou Shalt Not Steal (Wells)
 10. Don't Blame It All On Me (Mac Wiseman)

Sheriff Tex Davis

- WCMS—Norfolk, Va.
1. Hearts Of Stone (R. Foley)
 2. Lord Is Countin' On You (Cowboy Church Choir)
 3. Let Me Go Lover (H. Snow)
 4. Feel Better All Over (Ferlin Huskey)
 5. Are You Mine (Wright & Tall)
 6. Let Me Go, Devil (Ray)
 7. Open Up Your Heart (Cowboy Church Choir)
 8. Little Tom (Ferlin Huskey)
 9. Wait A Little Longer, Please Jesus (Chester Smith)
 10. Ole Pappy Time (Hamblen)

Joe Morris

- WOIC—Columbia, S. C.
1. More & More (W. Pierce)
 2. If You Ain't Lovin' (Young)
 3. Loose Talk (Carl Smith)
 4. If You Don't (Jimmy & Johnny)
 5. New Green Light (Hank Thompson)
 6. This Ole House (S. Hamblen)
 7. You're Not Mine Anymore (Webb Pierce)
 8. Penny Candy (Jim Reeves)
 9. Let Me Be The First (Wilburn Bros.)
 10. I've Forgotten You (Snow)

Clarence Kneeland

- WERI—WICH—Jewett City, Conn.
1. More & More (W. Pierce)
 2. Can I Say The Same About You (Tex Williams)
 3. I Don't Hurt (Hank Snow)
 4. This Ole House (S. Hamblen)
 5. This Is The Thanks (Arnold)
 6. One By One (Wells & Foley)
 7. Green Light (Thompson)
 8. Loose Talk (Carl Smith)
 9. Company's Comin' (Porter Wagoner)
 10. Courtin' In The Rain (Tyler)

Thom Hall

- WKYW—Louisville, Ky.
1. Let Me Go Lover (Snow)
 2. If You Ain't Lovin' (Young)
 3. Open Up Your Heart (Cowboy Church Choir)
 4. Let Me Be The First (Wilburn Bros.)
 5. Tomorrow I'll Cry (Davis Sisters)
 6. Downstream (Redd Stewart)
 7. Next Voice You Hear (Snow)
 8. More Than Anything (Smith)
 9. Little Tom (Ferlin Huskey)
 10. Time Goes By (M. Robbins)

Johnny Rion

- KSTL—St. Louis, Mo.
1. Let Me Go, Lover (Snow)
 2. More Than Anything (Carl Smith)
 3. Outlaw (Red Sovine)
 4. More & More (W. Pierce)
 5. Journey's End (E. Tubb)
 6. If You Ain't Lovin' (Faron Young)
 7. Lookin' Glass (Red Foley)
 8. Hillbilly Heaven (E. Dean)
 9. Close By (Bill Monroe)
 10. The Mainest Thing (Carlises)

Red Smith

- WBOK—New Orleans, La.
1. Hearts Of Stone (R. Foley)
 2. I Feel Like Crying (Fairburn)
 3. Day Dreaming (B. Dakeiman)
 4. Whispering Scandal (Locklin)
 5. That's Alright Mama (Avis Presley)
 6. I Can See An Angel (Pike)
 7. More Than Anything (Smith)
 8. If You Ain't Lovin' (Young)
 9. Thou Shalt Not Steal (Wells)
 10. Side Tracked (B. Cason)

Cousin Johnny Small

- WNLC—New London, Conn.
1. More & More (W. Pierce)
 2. I Can Read Between The Lines (Benny Martin)
 3. Sure-Fire Kisses (Hill & Tubb)
 4. If You Don't (Jimmy & Johnny)
 5. You Bet I Kissed Him (Myrna Lorrie)
 6. This Ole House (S. Hamblen)
 7. Company's Comin' (Porter Wagoner)
 8. I Don't Hurt Anymore (Hank Snow)
 9. Hillbilly Heaven (E. Dean)
 10. Seashore Blues (R. Lou)

Smokey Smith

- KRNT—Des Moines, Iowa
1. Let Me Be The First (Wilburn Bros.)
 2. The Next Voice You Hear (Hank Snow)
 3. If You Ain't Lovin' (Young)
 4. I Can Read Between The Lines (Benny Martin)
 5. Let Me Go, Lover (Snow)
 6. More Than Anything (Smith)
 7. Are You Mine (Lorrie & DeVal)
 8. Loose Talk (Carl Smith)
 9. Company's Comin' (Porter Wagoner)
 10. More & More (W. Pierce)

Wink Lewis

- KSNY—Snyder, Texas
1. More & More (W. Pierce)
 2. You're Not Mine Anymore (Webb Pierce)
 3. I Don't Hurt Anymore (Hank Snow)
 4. Singing Hills (S. Whitman)
 5. One By One (Foley & Wells)
 6. Penny Candy (Jim Reeves)
 7. Company's Comin' (Wagoner)
 8. Are You Mine (Lorrie & DeVal)
 9. What'cha Gonna Do Now (Tommy Collins)
 10. Loose Talk (Carl Smith)

Sleepyhead Cliff

- KASM—Albany, Minn.
1. More & More (W. Pierce)
 2. If You Ain't Lovin' (Young)
 3. I Can See An Angel (Pike)
 4. Loose Talk (Carl Smith)
 5. Next Voice You Hear (Snow)
 6. You're Not Mine Anymore (Webb Pierce)
 7. Good And The Bad (Arthur)
 8. Sure-Fire Kisses (Hill & Tubb)
 9. Company's Comin' (Porter Wagoner)
 10. Are You Mine (Lorrie & DeVal)

Lillie Anne

- WIRC—Hickory, N. C.
1. Wait A Little Longer, Please Jesus (Chester Smith)
 2. Are You Mine (Wright & Hall)
 3. Loose Talk (Carl Smith)
 4. Are You Mine (Lorrie & DeVal)
 5. Holding Hands (K. Lee)
 6. Hearts Of Stone (Wells)
 7. Let Me Go Lover (Snow)
 8. This Ole House (Hamblen)
 9. One By One (Wells & Foley)
 10. Green Light (Thompson)

Ed Preston

- CHML—Hamilton, Ont.
1. Loose Talk (Carl Smith)
 2. I Don't Hurt Anymore (Hank Snow)
 3. Time Goes By (M. Robbins)
 4. If You Ain't Lovin' (Young)
 5. More & More (W. Pierce)
 6. Watchmakers Waltz (Bonn)
 7. Next Voice You Hear (Snow)
 8. Little Tom (Ferlin Huskey)
 9. Kansas City Railway Blues (Wally Tranggott)
 10. Ole Pappy Time (Hamblen)

Cliff Rodgers

- WHKK—Akron, Ohio
1. Little Tom (Ferlin Huskey)
 2. Baby Doll (Skeeter Bonn)
 3. If You Ain't Lovin' (Young)
 4. Hillbilly Heaven (E. Dean)
 5. Loose Talk (Carl Smith)
 6. Let Me Go, Lover (Snow)
 7. Blue Moon Of Kentucky (Bill Monroe)
 8. Me & My Fiddle (B. Martin)
 9. This Ole House (S. Hamblen)
 10. More & More (W. Pierce)

Art Barrett

- WCMS—Norfolk, Va.
1. Blue Christmas (E. Tubb)
 2. Private Santa Claus (Arnold)
 3. Lights Are Growing Dim (Harvy June Van)
 4. Let Me Go Devil (W. Ray)
 5. Hearts Of Stone (R. Foley)
 6. I Feel Better All Over (Ferlin Huskey)
 7. Lord Is Counting On You (Cowboy Church Choir)
 8. Christmas Can't Be Far Away (Eddy Arnold)
 9. Open Up Your Heart (Cowboy Church Choir)
 10. I Want Santa Claus For Christmas (Rita Faye)

Jimmie Williams

- WNOP—Newport, Ky.
1. I Forgot To Remember Santa Claus (Sonny James)
 2. If You Ain't Lovin' (Young)
 3. Carefree Moments (Wilburn Bros.)
 4. Christmas Boogie (Davis Sisters)
 5. Loose Talk (Carl Smith)
 6. More & More (Webb Pierce)
 7. Me & My Fiddle (B. Martin)
 8. Christmas Can't Be Far Away (Eddie Arnold)
 9. Mr. Sandman (Chet Atkins)
 10. The Next Voice You Hear (Hank Snow)

Norm Hall & Tex Justus

- WBNI & WBTO—Boonville, Ind.
1. Loose Talk (Carl Smith)
 2. I'm Your Private Santa Claus (Eddy Arnold)
 3. More & More (W. Pierce)
 4. Let Me Go, Lover (Snow)
 5. Are You Mine (Wright & Tall)
 6. Take Back The Heart (Glenn)
 7. I Love You Mosty (Frizzell)
 8. Time Goes By (M. Robbins)
 9. No Fool Like Young Fool (Wade Ray)
 10. Hearts Of Stone (Foley)

Elmer Snodgrass

- WGGa—Gainesville, Ga.
1. Are You Mine (Wright & Tall)
 2. More & More (W. Pierce)
 3. If You Ain't Lovin' (Young)
 4. Loose Talk (Carl Smith)
 5. Beware Of It (Johnny & Jack)
 6. Open Up Your Heart (Cowboy Church Choir)
 7. Little Town (Ferlin Huskey)
 8. Lookin' For A Date (Tubb)
 9. Lookin' Glass (Red Foley)
 10. Never (W. & M. Tuttle)

Ramblin' Lou

- WHLD—Niagara Falls, N. Y.
1. Let Me Go Lover (Snow)
 2. Loose Talk (Carl Smith)
 3. Green Light (Thompson)
 4. I Don't Hurt (H. Snow)
 5. More & More (W. Pierce)
 6. Are You Mine (Lorrie & DeVal)
 7. One By One (Wells & Foley)
 8. Brand New Baby (Cooper)
 9. Let Me Be The First (Wilburn Bros.)
 10. Two Glasses, Joe (Tubb)

Herman Coleman

- WMGR—Bainbridge, Ga.
1. Loose Talk (Carl Smith)
 2. Little Tom (Ferlin Huskey)
 3. Don't Hurt Anymore (Snow)
 4. If You Ain't Lovin' (Young)
 5. More & More (W. Pierce)
 6. More Than Anything (Smith)
 7. I've Forgotten You (Snow)
 8. What'cha Gonna Do Now (Tommy Collins)
 9. Time Goes By (M. Robbins)
 10. Kiss Crazy Baby (Johnny & Jack)

Big Jim Hess

- WIVK—Knoxville, Tenn.
1. Hearts Of Stone (R. Wells)
 2. Everlovin' (Davis Sisters)
 3. I Love You Mosty (Frizzell)
 4. Kisses Don't Lie (Smith)
 5. More & More (W. Pierce)
 6. If You Ain't Lovin' (Young)
 7. I've Forgotten You (Snow)
 8. Angels Can't Follow (Wilson)
 9. Little Tom (Ferlin Huskey)
 10. My Son, My Son (S. Bonn)

A WINNER EVERY TIME!
CARL SMITH



"KISSES DON'T LIE" (2:39)
[Driftwood BMI—Butler, Carver]
"NO, I DON'T BELIEVE I WILL" (2:10)
[Golden West BMI—Crowe, Denny]
CARL SMITH
(Columbia 21340; 4-21340)

● Carl Smith, on the heels of a two-sided clicker, "Loose Talk" and "More Than Anything Else In The World," dishes up another pair of back to back contenders. Top portion, titled "Kisses Don't Lie," is a middle tempo heartbreaking ballad that the artist delivers in money-making fashion. Flip deck, "No, I Don't Believe I Will," is a bright, bouncy novelty flavored with Smith stylings. Both ends have the potential.

singing

TWO BIG ONES

"KISSES DON'T LIE"

and

"NO, I DON'T BELIEVE I WILL"

Columbia 21340; 4-21340

Featured on
GRAND OLE OPRY—WSM-TV

Personal Management
— HAL SMITH —
Room 202, Rice Bldg.
Madison, Tenn.

DRIFTWOOD PUBLISHING CO., INC.
NASHVILLE, TENNESSEE



TOMMY COLLINS
sings
"UNTIED"
and
"BOOB-I-LAK"
Capitol # 3017
CENTRAL SONGS, INC.
6308 Sunset Blvd.
Hollywood 28, Calif.

WATCH THIS NEW DUET!
ROB AND BOB
WEBB PIERCE **TEDDY WILBURN**
SINGING
"ONE DAY LATER"
DECCA
CEDARWOOD PUB. CO.
146 7th AVE. N., NASHVILLE, TENN.

"THE RIGHT TO LOVE"
Recorded by
Wanda Jackson
Decca # 29253
CENTRAL SONGS, INC.
6308 Sunset Blvd.
Hollywood 28, Calif.

HITTIN' THE CHARTS
FERLIN HUSKEY
SINGING
"Little Tom"
CAPITOL # 3001
TREE PUB. CO., INC.
NASHVILLE — — NEW YORK

THE SMITH BROS.
"I'M GONNA SHOUT"
CAPITOL 3013
CENTRAL SONGS, INC.
6308 Sunset Blvd., Hollywood 28, Calif.

LESTER FLATT- EARL SCRUGGS
SING
"TILL THE END OF THE WORLD ROLLS AROUND"
COLUMBIA
DRIFTWOOD MUSIC CO., INC.
NASHVILLE TENN.

Red Foley TV Show To Go Coast To Coast Via ABC

SPRINGFIELD, Mo.—The Country Music business took on new light and significance here last week when it was officially announced that Red Foley's "Ozark Jubilee" would be telecast on a coast-to-coast basis via the American Broadcasting Company.

The TV stanza is an outgrowth of the two and a half hour country music attraction, the "Ozark Jubilee" which made its advent in country music circles last July 17, headlined by Foley! Occupying the 9-10 p.m. (EST) slot every Saturday night, the show is tentatively scheduled for the networks on January 22 and will originate from Springfield. Term of the contract is for five years!

It was jointly announced by Ralph D. Foster, president of Radiozark Enterprises, and Robert A. Kintner, president of the American Broadcasting Company, that network television's first full hour country and western music show will originate from Springfield, Mo. At present, there are no facilities in Springfield to feed the entire network. However, both ABC and Radiozark officials are negotiating with the American Telephone and Telegraph Company to furnish the proper facilities to feed the show to the entire network. ABC officials estimate that one hundred stations, coast-to-coast, will carry the show from the start. Radiozark Enterprises will be producers of the show!

Bartlett Manages Whitman

SHREVEPORT, La.—Effective December 26, Ray Bartlett took over the personal management of Slim Whitman, the featured star of KWKH's Louisiana Hayride. Prior to Bartlett's tie-up with Whitman, he was an announcer on the Louisiana Hayride and had also worked for the sister station of KWKH—radio station KTHS in Little Rock, Ark.

In an interview with Bartlett, it was learned that Whitman will begin a personal appearance tour January 15, working through Texas, Louisiana and Mississippi.

Bartlett said that he plans to have the Imperial Recording artist appear on at least two major TV network shows. Whitman's latest release on Imperial is "Cattle Call" and "When I Grow Too Old To Dream."

Bartlett and Whitman will continue to operate from the city of Shreveport, home of the "Louisiana Hayride."

New Manager For Smith

NASHVILLE, Tenn.—Official announcement has been made here that Hal Smith has taken over the personal management of Carl Smith and his Tunesmiths. Hal Smith comes with Carl and his band with a thorough knowledge of the country music business. Hal Smith at one time was a musician and a regular member of Carl Smith's band. Hal later became the personal manager of Ray Price, and aligned himself with Carl on January 1, 1955!

GAC Books WLW Talent

NEW YORK—It was announced this week by the president of WLW, R. E. Dunville, that the exclusive bookings for the Crosley's Country and Western talent was assigned to the General Artist Corp. GAC has offices in five major cities in USA.

"This new arrangement opens up a tremendous field for our entertainers," Dunville said. "The popularity of our Country and Western talent has brought requests from nearly every state for personal appearances." The entire C & W roster of more than 50 artists will be represented by GAC marking the first time that both popular, country and western has ever been booked by an organization such as General Artist.

Good News In Threes

NEW YORK—Good news came to The Four Coins, newest of the vocal groups, from three separate sources this week.

Immediately after scoring a big hit at Long Island's Boulevard, where they were held over for one month, The Four Coins signed to return there for a March engagement. They then proceeded to Erie, Pa., where they broke all existing attendance records at the Calabrese Club. To top it all off, their first recording for Epic Records, "I Love You Madly", hit the charts for the first time.

THE TEN COUNTRY RECORDS DISK JOCKEYS PLAYED MOST THIS WEEK (PLUS THE NEXT FIVE)

- | | |
|------------------------------------|-------------------------------------|
| 1. LOOSE TALK | Carl Smith (Columbia) |
| 2. IF YOU AIN'T LOVIN' | Faron Young (Capitol) |
| 3. MORE AND MORE | Webb Pierce (Decca) |
| 4. LET ME GO, LOVER | Hank Snow (RCA Victor) |
| 5. ARE YOU MINE | Myrna Lorrie & Buddy DeVal (Abbott) |
| 6. THIS OLE HOUSE | Ginny Wright & Tom Tall (Fabor) |
| 7. YOU'RE NOT MINE ANY-MORE | Stuart Hamblen (RCA Victor) |
| 8. IF YOU DON'T SOMEBODY ELSE WILL | Webb Pierce (Decca) |
| 9. COMPANY'S COMIN' | Jimmy & Johnny (Chess) |
| 10. HEARTS OF STONE | Porter Wagoner (RCA Victor) |
| 11) I DON'T HURT ANYMORE. | Red Foley (Decca) |
| 12) ONE BY ONE. | |
| 13) NEW GREEN LIGHT. | |
| 14) BEWARE OF IT. | |
| 15) LITTLE TOM. | |

THE CASH BOX
Reports
THE NATION'S
BIG 10
Country
JUKE BOX TUNES

- 1 **MORE AND MORE**
Webb Pierce
(Decca 29252; 9-29252)
- 2 **LOOSE TALK**
Carl Smith
(Columbia 21317; 4-21317)
- 3 **NEW GREEN LIGHT**
Hank Thompson
(Capitol 2920; F-2920)
- 4 **I DON'T HURT ANYMORE**
Hank Snow
(RCA Victor 20-5698; 47-5698)
- 5 **ONE BY ONE**
Kitty Wells & Red Foley
(Decca 29065; 9-29065)
- 6 **IF YOU AIN'T LOVIN'**
Faron Young
(Capitol 2953; F-2953)
- 7 **IF YOU DON'T, SOMEBODY ELSE WILL**
Jimmy & Johnny
(Chess 4859; 45-4859)
Ray Price
(Columbia 21315; 4-21315)
- 8 **LET ME GO, LOVER**
Hank Snow
(RCA Victor 20-5960; 47-5960)
- 9 **THIS OLE HOUSE**
Stuart Hamblen
(RCA Victor 20-5739; 47-5739)
- 10 **COURTIN' IN THE RAIN**
T. Texas Tyler
(4 Star 1660; 45-1660)

"It's What's in THE CASH BOX That Counts"

EDDY ARNOLD CELEBRATES

HIS 10TH ANNIVERSARY

ON RCA VICTOR RECORDS

WITH THESE TWO GREAT NEW RELEASES

**I'VE BEEN THINKING
DON'T FORGET** 20/47-6000

**I ALWAYS HAVE SOMEONE TO TURN TO
IT TOOK A MIRACLE** 20/47-6001

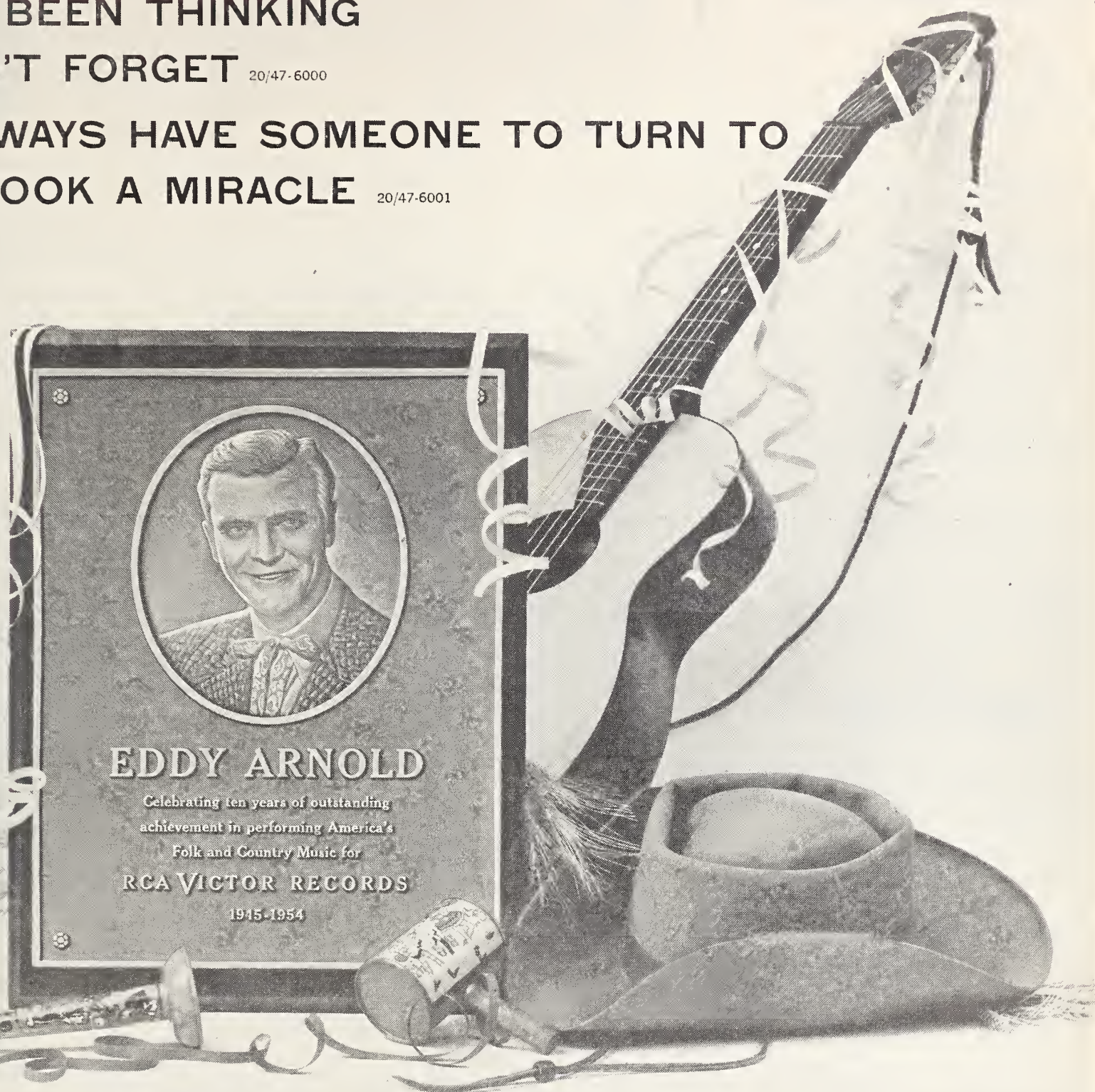

EDDY ARNOLD ALL-TIME BEST SELLERS STOCK DISPLAY SELL THESE GREAT RCA VICTOR RECORDS

This Is the Thanks I Get (for Loving You)
Hep Cat Baby . . . 20/47-5805
My Everything / Second Fling . . . 20/47-5634
I Really Don't Want to Know
I'll Never Get Over You . . . 20/47-5525
Free Home Demonstration
How's the World Treating You . . . 20/47-5305
Condemned Without Trial
Eddy's Song . . . 20/47-5108

I Wanna Play House with You
Something Old, Something New . . . 21/48-0476
There's Been a Change in Me
Tie Me to Your Apron Strings Again . . .
21/48-0412
The Lovebug Itch
A Prison Without Walls . . . 21/48-0382
Cuddle Buggin' Baby
Enclosed, One Broken Heart . . . 21/48-0342

I Couldn't Believe It Was True
It's a Sin . . . 20-2241/48-0198
I'm Throwing Rice (at the Girl I Love)
Just a Little Lovin' . . . 21-0135/48-0138
Don't Bother to Cry
I'll Hold You in My Heart . . . 20-2332/48-0030
Then I Turned and Walked Slowly Away
A Heart Full of Love . . . 20-3174/48-0025

Anytime
What a Fool I Was . . . 20-2700/48-0002
Texarkana Baby
Bouquet of Roses . . . 20-2806/48-0001
The Cattle Call / I Walk Alone . . . 20-2128
That's How Much I Love You
Chained to a Memory . . . 20-1948
Many Tears Ago
Mommy Please Stay Home with Me . . .
20-1871

WITH HIS DAUGHTER, JO ANN ARNOLD . . .
The Horse in Striped Pajamas / Why, Daddy? . . . Y / WY-492



"It's What's in THE CASH BOX That Counts"

JIMMY WORK
singing
"MAKING BELIEVE"
Dot 1221

CARL SMITH
sings
"LOOSE TALK"
COLUMBIA # 21317
CENTRAL SONGS, INC.
6308 SUNSET BLVD.
HOLLYWOOD 28 CALIF.

JIMMIE WILLIAMS
SINGS (ACORN 154)
"HEY, HEY, LITTLE DREAMBOAT"
* Note d.i.'s: Send for your 45
NOTICE
* Distributors Wanted
Write - Wire - Phone
ACORN RECORDS Inc.
(Phone Ja - 4544)
7771 Cheviot Rd., Cincinnati 24, O.

THE JORDANAIREs
"ALL THE WAY"
CAPITOL # 3022
CENTRAL SONGS, INC.
6308 Sunset Blvd.
Hollywood 28 Calif.

THE CASH BOX
THE 10 TOP Country Best Sellers

- MORE AND MORE**
Webb Pierce
(Decca 29252; 9-29252)
- LOOSE TALK**
Carl Smith
(Columbia 21317; 4-21317)
- LET ME GO, LOVER**
Hank Snow
(RCA Victor 20-5960; 47-5960)
- IF YOU AIN'T LOVIN'**
Faron Young
(Capitol 2953; F-2953)
- I DON'T HURT ANYMORE**
Hank Snow
(RCA Victor 20-5698; 47-5698)
- THIS OLE HOUSE**
Stuart Hamblen
(RCA Victor 20-5739; 47-5739)
- ONE BY ONE**
Kitty Wells & Red Foley
(Decca 29065; 9-29065)
- NEW GREEN LIGHT**
Hank Thompson
(Capitol 2920; F-2920)
- HEARTS OF STONE**
Red Foley
(Decca 29375; 9-29375)
- SURE FIRE KISSES**
Goldie Hill & Justin Tubbs
(Decca 29349; 9-29349)

Breaking For The Top In The Country Field!
"EVERLOVIN"
THE DAVIS SISTERS
RCA Victor 20/47-5966

CINCINNATI CUT-UPS

The Mid-Westerners headed by John Grigsby are being booked as "America's #1 Square Dance Units." This week the dancers are out of town for five days working the Sportsman's Show in Baltimore and Washington, D. C. In February they plan to go to Hollywood where they will be making several pictures. (More about that later) The Mid-Westerners can be seen on the Hayride each Saturday night over WLW-TV. . . Pruden has taken over the "Surprise" show on WCPO-TV in the spot that was vacated by Paul Dixon. . . Marty Roberts (Coral) played the Lyric Ball Room in Indianapolis with Goldie Hill and Dick Bland's Band. . . Audrey New and Danny Martin of the "Bill Bailey Show" seen weekdays from 2 to 3 P. M. over WLW-D were married recently. Miss Day is the featured vocalist on the show, while Martin is a member of the Villagers (Music Unit). Folks tell me Al Morgan

(Decca) of "Jealous Heart" fame was back in town over the Holidays visiting their folks in nearby KY. . . Nelson King, deejay at WCKY has been off the Jamboree for the past few nights because of illness. He is expected back to work this week. . . Bob Carroll and Little Eller Long were the guests on the Pee Wee King show Friday night. . . Crosley's Country and Western will be booked exclusively by General Artist Corp. it was announced by R. E. Dunville, president of the organization. Bookings will be on a National basis thru GAC's five offices in major cities in the U. S. A. . . Gene Masters has joined the newly organized country band at WLW.

FROM THE NEW DISC DEPARTMENT:—Tunes this week showing the most promise of becoming hits are "Making Believe" by Jimmie Work (Dot) and "Everlovin'" b/w "Tomorrow's Another Day To Cry" by the Davis Sisters (Victor).

The Cash Box
Country Reviews

DISK & SLEEPER	GOOD
EXCELLENT	FAIR
VERY GOOD	MEDIOCRE

THE CASH BOX BULLSEYE of the WEEK

"I'M GONNA FALL OUT OF LOVE WITH YOU" (2:05)
[Fairway BMI—M. E. Taylor, R. Hughes]
"IN THE JAILHOUSE NOW"
[Peer International BMI—J. Rodgers]
WEBB PIERCE
(Decca 29391; 9-29391)

● Webb Pierce had another sensational year in 1954, winning top laurels in two departments of The Cash Box Juke Box Operators Poll. The chanter had the No. 1 record in "Slowly" and also reigned as the leading male country artist. Now Pierce heads into the new year with two sides that should keep his record intact. "I'm Gonna Fall Out Of Love With You" is a potent, middle tempo lover's lament. Coupling, "In The Jailhouse Now," is a captivating, quick beat, Jimmy Rodgers tune. Both ends are winners.

TOMMY SOSEBEE
(Coral 61330; 9-61330)

B "I MAY BE LONESOME" (2:41) [Acuff-Rose BMI—V. Willis] Tommy Sosebee lends his inviting vocal stylings, to a feelingful up-tempo, sentimental item. Effective wedding of melody and lyrics.

B "SITTIN' IN THE BACKSEAT OF YOUR HEART" (2:33) [Ross Jungnickel ASCAP—R. Jorden, B. Knee] Under lid is a charming, quick beat romantic ditty. A fine coupling.

SMILEY MAXEDON
(Columbia 21337; 4-21337)

B+ "I WANT YOU" (2:11) [Ridgeway BMI—C. Adams, de Lamar] Smiley Maxedon has a gay, happy-go-lucky, romantic cutie to work with on this end. Top notch vocal on a deck that should attract a heap of coin.

C+ "OH, WHY DID I CHEAT" (2:50) [Ridgeway BMI—Payne, Maxedon] Under waxing is a slow beat weeper that the warbler sings in poignant fashion.

JIMMY LEE & JOHNNY MATHIS
(Capitol 3012; F3012)

B "DON'T FORGET TO REMEMBER" (2:00) [Jim Bulleit BMI—J. Mathis] Jimmy Lee and Johnny Mathis blend their talented chords in engaging fashion on a fetching, Latin-flavored, love piece.

B "OPEN FOR TRADE" (2:08) [Jim Bulleit BMI—J. Mathis] Jimmy Lee solos on a delectable, rhythmic ditty that should garner a heap of sales and spins.

ROLAND WILLIAMS
(Cardinal 5002; 45-5002)

B "HONKY TONK ANGEL" (2:47) [Shelter BMI—J. Morris] Roland Williams debuts in impressive fashion on a middle tempo, heartfelt piece. A warm and sincere reading on a deck that pleases.

B "BLUE LIGHTS AND BROKEN HEARTS" (2:53) [Shelter BMI—P. Paine, C. Farley] Reverse lid is an infectious, moderate beat, sentimental piece. Williams has a bright future.

HERB AND KAY
(King 1419; 45-1419)

B "SOMEBODY CRIES" (2:32) [Lois BMI—B. Barton] Herb and Kay send up a smooth vocal duet on a fast paced, tearful tune. Appealing string backing adds to the deck.

B "YOU GOT TO BITE TO CATCH ON" (2:24) [Lois BMI—B. Barton] The pair blend in polished style on a sentimental piece with a real quick beat. Two good sides.

HAL "LONE PINE"
(RCA Victor 20-5968; 47-5968)

B+ "I SHOULD HAVE SUBTRACTED" (2:25) [Trinity BMI—J. Allison, E. Tabor, M. Shelton] Hal "Lone Pine" comes through with a strong showing on a quick beat ditty with tantalizing lyrics. Solid instrumentation.

B "ADD A NAME" (2:18) [Tannen BMI—B. Carver, H. Gunter] Bottom half is a middle tempo weeper that "Lone Pine" sings with tender emotion.

JIMMY DAY
(Abbott 175; 175-45)

C+ "RIPPIN' OUT" (2:04) [Dandelion BMI—J. Day] Jimmy Day comes up with an enjoyable guitar instrumental as he slowly wends his way through this soft, melodic piece.

C+ "BLUE WIND" (1:53) [Dandelion BMI—J. Day] Flip slicing is a change of pace, bouncy ditty that Day performs in colorful style.

REX ALLEN
(Decca 29397; 9-29397)

B+ "TOMORROW'S JUST ANOTHER DAY TO CRY" (2:05) [R. F. D. ASCAP—B. Hayes, R. Allen] Rex Allen takes hold of this up-tempo weeper of a few years back and treats it to a top drawer reading. Could step out.

B+ "L-O-N-E-S-O-M-E LETTER BLUES" (2:41) [Boxer BMI—C. Walker] Flip half is a sentimental piece that moves along at a smart, rhythmic pace. A potent pairing.

CHUCK REED
(Mercury 70527; 70527x45)

B "I'M GONNA GET SOME SLEEP TONIGHT" [Milene ASCAP] The mellow chords of Chuck Reed come across in easy-on-the-ears fashion on this light-hearted, middle tempo ditty. A relaxing platter.

B "CRY LIKE A BABY" [Acuff-Rose BMI] On the lower etching Reed delivers an up-beat, sentimental item in distinctive style.

BUCK GRIFFIN
(1008; 45-1008)

B "GOING HOME, ALL ALONE" (2:51) [Lin BMI—A. C. B. Griffin] Buck Griffin takes hold of this heart rending, slow tempo ballad and delivers it with a great deal of feeling. Good material.

C "LOOKIN' FOR THE GREEN" (2:48) [Lin BMI—A. C. B. Griffin] Bottom side is a quick beat, sentimental item that Griffin vocals in coin-catching fashion.

THE CASH BOX Country Roundup

Lonzo and Oscar, comic team of Grand Ole Opry, slated for four week tour of army camps in Texas, Louisiana and Mississippi. January is always the month for beginnings, and here are some facts on big January anniversary dates for five Opry stars. On January 1, 1949, George Morgan made his first appearance on the Opry; January 11 was Goldie Hill's birthday; Marty Robbins joined the Opry on January 19, 1952; and the Wilburn Brothers joined the Opry January 8, 1954. Thanks to Bill McDaniels, public relations chief of WSM for these facts and figures! Faron Young, the Wilburn Brothers, Doyle and Teddy, and Bill Monroe teamed up for a personal appearance recently at the city auditorium in Charleston, W. Va. Recent visitors to Nashville included Ray Bartlett, now manager of Slim Whitman, Jim Halsey, and wife. Halsey manages Hank Thompson and his Brazo Valley Boys. Troy Martin music publishing rep here in Nashville says that Onie Wheeler, now recording for Columbia, was recently made an honorary Sheriff of Scott County, Missouri by Sheriff John Dennis.



MAXINE & JIM EDWARD BROWN

COUNTRY SMATTERINGS . . . The WLS singing sisters, Colleen and Donna, the Beaver Valley Sweethearts, have signed with Decca. Lon Prohut, accordion virtuoso on the Nat'l Barn Dance will record for label "X". Joe Kelly active in emceeing the Barn Dance again. Bonnie Brown, secretary for the J. E. and Maxine Brown (Fabor) Fan Club sends in a nice letter. Bonnie informs us that J. E. and Maxine are on the West Coast for their third recording session. Good to hear from you, Bonnie. Joe Lucas of Acuff-Rose says that J. D. Miller into Nashville recently cutting a session with Jimmie Newman (Dot.) Slick Norris also informed me about the Jimmie Newman session. Ralph Emory disk jockey at WSIX, Nashville, reporting news for the new Jamboree mag. Hank Thompson and his Brazos Valley Boys just completed a tour for Norm Riley through Florida, according to Hank's manager, Jim Halsey. Halsey also reports that Thompson and his group will play Frank Dailey's Meadowbrook on Jan. 17-18. On Jan. 19-20 the boys will be recording another series of transcriptions for World Transcriptions. Porter Wagoner (RCA Victor) featured artist on the "Ozark Jubilee" will do a guest spot on WSM's Grand Ole Opry, Jan. 22. Tommy Sosebee (Coral) guested on Red Foley's "Ozark Jubilee" January 8, and on January 15 Sosebee will conduct the "Jubilee" in the absence of Foley and will have as his guest the Oklahoma Wranglers (Coral). Foley will return to headline his show on Jan. 22 and will have as his guest then, Hawkshaw Hawkins (RCA Victor). Dub Allbritten, Foley's manager, reports that Pee Wee King, Goldie Hill, Ray Price and Redd Stewart were recent guests on Foley's transcribed "Red Foley Show." Ford Rush, long associated with Roy Acuff, has taken over the personal management of these Crossroads artists: Jean Shepard (Capitol), Hawkshaw Hawkins (RCA Victor), and the Foggy River Boys (Decca). Texas Tony, country music disk jockey of WMCA, New York, now out of the hospital and scheduled for some club dates!



DAVE DENNY

PREDICTION . . . watch Columbia's new country recording artist Bobby Lord. Lord has a clear, and fresh delivery vocal wise, and in our books is a sure contender for a permanent spot on the Country Roster. His first release is definitely commercial . . . watch it break through early. Tunes are titled "Why Were You Only Fooling Me" and "No More, No More, No More." Cliff Rodgers of WHKK, Akron, Ohio conducted a Hank Williams Memorial Program for January 1. So successful was the program, Cliff repeated the program the next day. The script was prepared by Thurston Moore. Ira and Charlie Louvin (Capitol) creating a mild sensation since their move into the deep south, Birmingham, Ala. and WVOK. With two shows under their belt, the boys are marking up some very good personal appearance schedules, with Harold F. Buskirk handling their bookings, and managing the group. Recently the boys inked contracts for nine days in Florida with Martha Carson, George Morgan, and have also contracted for a tour with Martha Carson and the Carlises this month. Charlie and Ira's latest Capitol release is "Satan and The Saint" and "Swing Low." Thanks fellows for the nice song folios! Speaking of song folios, take a look at the jewel just hitting the market via Hill and Range Songs on Webb Pierce. It's a song folio with sock. Pictures, story material and a good selection of the top songs recorded by Webb Pierce, and other top recording artists.



MAC WISEMAN

is the catch . . . "When I Get The Money." These are Mac Wiseman's latest on Dot! Rusty Wellington due out soon with his next Arcade waxing. Titles are "I Ain't A Tater" and "I Lost My Somebody To Somebody Else." The Lew Di Leo Agency is handling the Wellington Trio. Wink Lewis, KSNY-Snyder, Texas, tells us that his fans requested him not to play pop tunes on his country shows. Wink had programmed all the releases of "Melody Of Love" and "Let Me Go, Lover". Sheriff Tex Davis, WCMS-Norfolk, Va., reports that the Mosque Auditorium in Richmond had a real big show New Year's Day. Featured performers were Red Foley, Ernest Tubb, Deacon Andy Griffith, Midwestern Square Dancers, Jimmy Dean and the Texas Wildcats. Dave Denny, out this week with his new MGM slicing, "The Fate Of A Fallen Rose" and "I Just Can't Let You Go". Mention has been made in the past week or so of the new duet out on Decca, Rob and Bob! Their first release is "One Day Later" and "The Waltz You Saved For Me." Just in case you haven't already figured it out . . . Rob

on the new Decca duet release is Webb Pierce, and Bob is Teddy Wilburn of the Wilburn Brothers! What next! Too bad these artists can't cash in on their dual talents and play personal appearances in two sections of the country at the same time! Wade Ray comes through in fine fashion with his latest pair . . . "No Mama, No Papa" and "There's No Fool Like a Young Fool." Bill Monroe promoting his newest wax . . . "Voice From On High" and "Working On A Building". Bill Monroe has been heard on Grand Ole Opry for fifteen years. Ken Nelson, A & R topper for Capitol due in Nashville around January 24th for recording sessions! Steve Sholes of RCA Victor and Paul Cohen of Decca also reported to be in Nashville soon! Smith to manage Smith! Hal Smith, last associated with Ray Price as manager, is now managing the affairs of Carl Smith! At one time, Hal was a featured musician with the Carl Smith band!



RUSTY WELLINGTON

Bette Amos now working on the Louisiana Hayride, Shreveport, La. into Nashville for recording session enroute back to the Hayride after a holiday visit with parents! Vic McAlpin and Bondleaux Bryant, big wigs of Showcase Music, all promotion these days with six of their company's tunes being released almost at the same time. Bob Ferguson, manager of Ferlin Huskey, reports that the unit now making personal appearances via a private bus, Ferguson also informs us that the Huskey aggregation is using two advance agents on their personal appearance tours now! Hank Snow came through in fine form while guesting on the Perry Como Show from New York on Dec. 29. Slim Whitman's latest release "Cattle Call" and "When I Grow Too Old To Dream" gets some good promotional lifts as Jose Ferrer intros Whitman's new release on a small inch and a half disk which plays at 78 speed! In closing, want to thank everyone for the nice cards, letters and greetings I have received. It was good hearing from everyone!

CALIFORNIA NOTES . . . Town Hall Party, the West's big Western Extravaganza, hit the airlines from Coast on Saturday Jan. 1st over the NBC Network. The new network show will be broadcast each Saturday nite from 7:30 to 8:30 p.m., P.S.T. Lefty Frizzell guested on the show along with Town Hall Regulars Wes & Marilyn Tuttle, Johnny Bond, Tex Ritter, Joe Maphis & Rose Lee, Freddie Hart, Bonnie Sloan, Jay Stewart, Fiddlin' Kate, Texas Tiny, Quincy Snodgrass, Merle Travis, The Ranger Quartette, Tex Carman, Sandy & Alvadean Coker, Mary Lou, Betsy Gaye, and Larry & Lawrence Collins. In addition to the one hour network show Town Hall is also heard locally each Fri. nite from 9:00 to 9:30 over clear channel station KFL. On Saturday nite they present the biggest Western show on television with three hours of top entertainment over KTTV, 10 p.m. 'til 1 a.m. . . . Jim Edward and Maxine Brown came in to Hollywood for new recording dates this past week. Fabor Robison, Abbott & Fabor Records head, says that he has some tremendous material for them to record. . . . After a month's tour of Europe Jim Reeves landed in New York City January 5th. He appeared on Ed Sullivan's Toast of The Town Jan. 9th. Jim's latest Abbott release "The Wilder Your Heart Beats The Sweeter You Love" b/w "Where Does a Broken Heart Go" is starting to click nationally and looks like it may be another "Bimbo" for him. . . . The first Rex Allen Song Book, published by Hill and Range Songs, Inc., of New York, made its debut on news stands and music stores on New Year's Day. Profusely illustrated with pictures of Rex at work and at home with his family, the book contains twenty of the numbers most often requested of the cowboy singing favorite. . . . Quality Records have leased the masters on "I Dreamed of A Hillbilly Heaven" by Eddie Dean and The Frontiersmen on the new Sage and Sand label for pressing and distributing in Canada. Tune is showing up very strong and is expected to hit the best seller lists very soon. . . . Buckie Tibbs, now Mrs. Thomas Mitchell, has returned to Cliffie Stone's "Hometown Jamboree," telecast each Saturday over KTLA, after an absence of six months during which time she became a mother. Buckie had previously been with Stone for four years and returns as a permanent part of the cast.



WES & MARILYN TUTTLE



JOE MAPHIS & ROSE LEE

and his partner on record is Shirley Dale. The two turn in a top-notch duet. Watch for this pair and their recording of "A Cheap Affair." This should be a real hit for the Candy Kisses boy and Shirley! Nice title . . . "I'm Gonna Buy You A Cadillac!" . . . but the flip

NEW COUNTRY DUET
JACK TOOMBS and LUCINDA LEE
 singing
"STILL I'M YOURS"
 b/w
"IF YOU WANT ME, CATCH ME"
 EXCELLO 2048
NASHBORO RECORD CO., INC.
 177 3rd AVE. N. NASHVILLE, TENN.
 (Phone 42-2215)

PICK OF THE WEEK . . .
Billboard Best Buys:—
EDDIE DEAN
 and
 (Hy, Wayne & Hal) THE FRONTIERSMEN
"I DREAMED OF A HILLBILLY HEAVEN"
 SAGE & SAND # 180 — 180-45
SAGE AND SAND RECORDS
 5653 1/2 HOLLYWOOD BLVD. HOLLYWOOD 28, CALIFORNIA
 Phone HOLLYwood 9-1527

"It's What's in THE CASH BOX That Counts"

(HIGH FIDELITY,
OF COURSE)

Wall-o-matic

servicing
music to
millions



Seeburg
DEPENDABLE MUSIC SYSTEMS SINCE 1902
J. P. SEEBURG CORPORATION
Chicago 22, Illinois

*America's finest
and most complete
music systems*



Here and There

BOURNEMOUTH, ENGLAND—

Anyone for tennis? Coin operated, tennis, that is! The Queen's Park Tennis Club in this south coast resort area has installed floodlights in one court. Players put a shilling (14 cents) in a slot which lights up the court for 15 minutes. Additional shillings will keep the courts lighted for as long as the player desires. If the experiment is successful, more lights will be installed.

WASHINGTON, D. C.—

Statistical experts in the Federal Public Health Service report that the lowest death rate in the country's history was set for 1954. It reports that 9.2 deaths per 1,000 population in 1954 is a notable drop from 9.7 in 1953. The highest annual number of births—more than 4,000,000—was recorded.

TOLEDO, O.—

Of interest to operators throughout this area is the report that the board of directors of the Libbey-Owens-Ford Glass Company have approved a \$25,000,000 expansion program. This is in addition to the \$40,000,000 the firm spent in the past three years. Work is planned to go forward in 1955 as rapidly as engineering plans can be completed, it was said. Employment at the L-O-F plants is now at an all-time peak, and is expected to be further increased when the plant is ready for operation.

CHICAGO—

We've always understood that the pessimist and worrier walks around with a continual headache. And therefore consumes zillions of aspirin tablets. It's becoming exceedingly expensive to have these headaches, and we suggest that these people change their attitude and become optimists—and stop chewing aspirin. The price of aspirin, according to latest reports, has been advanced 10%.

HENDERSON, N. C.—

The General Electric Company has started working on a new multi-million dollar plant on its 60 acres, four miles south of this city, near East Flat Rock. In addition to the plant to house its outdoor lighting department, GE will build a \$100,000 office building. More employees—more housing—more revenue. Adds up to more coin machine locations and play.

SELL YOURSELF

"Too many, many too many, have become much, much too fat, and are now sitting back on their haunches in very comfortable and overstuffed chairs in their offices, instead of getting out in the field and selling themselves and their firms, as they used to do years ago."

The above statement was made by a well known, outstanding, and very respected leader in the industry.

He pointed to the fact that some distributors were "actually surprised" to learn about features on games which they had never "taken the time to check when the new game arrived in their quarters."

Sad, sad, but, very true.

So many, many peoples engaged in the industry have forgotten all about the fact that, to continue ahead progressively and successfully they must, at all times, continue to "sell" themselves.

What they did "years ago" won't stand up anymore.

Youth is on the march. New people are entering into this industry.

People who want to just "get ahead." People who also want to be able to sit in comfortable, overstuffed chairs, and just whisper instructions over intercom systems.

But this isn't the way the people in this field today were able to achieve those comfortable and overstuffed chairs.

And unless some of them get out of those chairs very quickly, there just won't be any comfortable, overstuffed chairs to rest their haunches in within a very short time.

There's too much progress being made by too many others in the industry. New people. New blood. Young blood.

The kind of people who aren't afraid to get out and buck wind or snow or cold or ice. The kind of people who are "fighting to make a living."

The kind of people who are willing to take "a little bit less," but, who want to build "a business" for themselves.

This is the time, when a heck of a lot of peoples in this industry had better jar themselves awake to the fact that, "things aren't as easy as they seem."

That the big moneymoon is all over. And has been over for some time now.

That this is the time to get out and "sell" themselves all over again. And, unless they do so, they just aren't going to be enjoying the kind of prosperity they basked in for some years now.

Every day someone, somewhere in the nation, is entering into the industry with the same type of spirit that a lot of the nice, fat boys who are reclining in soft, comfortable easy chairs used to have.

These are the youngsters who want to "get ahead." The kind of people who actually see a future in this business. Who like the industry. Who want to make good.

Who want to have the same kind of car and prestige and respect and living advantages and bank account a lot of guys (reclining on their haunches in soft, comfortable and overstuffed office chairs) are now enjoying.

As this noted coinman, and a lot like him have stated they realize that, unless the men once again get out and "sell" themselves, the old timers are going to be "very sorry people."

The future and progress of the nation is not based on what happened in the past but, instead, on what will come about in the future.

And unless a lot of peoples now engaged in the industry wake up from their lethargy and begin to realize that what they did "yesterday" is old and wornout and most completely decrepit in this new, atomic age then, the young men who are entering into the field, will take over all that these oldsters have built and gained.

These new men will be the new principals in the development of this industry's growth and greater prosperity for tomorrow.

Maybe, then you, too, should once again get out, just like these youngsters are getting about, learn more about exactly what the new machines can do for you.

Learn more about your locations. And, in the final sum, start to "sell yourself" and your firm all over again. The way you used to do before you began to sit in an overstuffed and over-comfortable chair.

What do you think?

N. Y. C. Licenses "Guns" For New Spots

Can be Located In Diners, Drug Stores, Restaurants, Luncheonettes, etc. No Candy Stores. Each Location Will be Inspected Prior to Approval. Ops Believe Same Locations Will Be Open For Shuffles Later On.

NEW YORK—A whole new vista for the operation of amusement machines opened in New York City this week, when the License Department informed the Associated Amusement Machine Operators of New York that the city would issue licenses for the operation of "guns" in locations where shuffle games aren't operating at this time.

Licenses would be issued for the operation of "guns" in restaurants, diners, luncheonettes, etc., at \$25. Shuffle game licenses cost \$50. The ruling calls for the operators to submit requests for licenses for each location. The license department then will

send out its inspectors to check these locations. If the location meets with the city's approval, license will be issued. The purpose of this procedure, it is stated, is to make sure that it isn't a candy store, and that it is a place where children do not congregate.

It is the belief of leading operators here that it won't be long before other approved amusement machines, as well as shuffle games, will be permitted to operate in these approved locations. If this condition arrives, it will add many thousands of locations for the operation of amusement games for local operators.

Belgian Amuse. Co., Antwerp, Celebrates Fifth Anniversary

Polak, Witsen, Groentman Attend Party



ANTWERP, BELGIUM—When Belgian Amusement Company, this city, celebrated its fifth anniversary in November, 1949, its three owners were on hand to participate in this party.

Albert Polak, Abe Witsen and Sal Groenteman, all residing in the United States, and partners of International Amusement Company and Scott-Crosse Company, Philadelphia, Pa., the well known distributing and jobbing firms, flew to Belgium for the occasion.

Polak, who managed this organization for the past three years, is now back in the United States, and the company is now managed by Armand Timmermans.

Belgian Amusement, being located here, the center of Western Europe, facilitates greatly the shipment of equipment from International and Scott-Crosse to its customers, who are located in Spain, Portugal, France, Germany, Luxembourg, Holland, Den-

AMI Model "F" Shown at Chicago Furniture Mart

CHICAGO—"Early arrivals at the Chicago Furniture Market, held during the first two weeks in January and attended by furniture people from all over the world, are delighted and enthusiastic over the new AMI Model F juke box on display," stated Bill Fitzgerald, AMI advertising and sales promotion manager.

"The Model F shown, a Firecracker Red, 120-selection machine, has been



BILL FITZGERALD

set for free play and is winning a hearty reception for its trim, functional lines and striking color as well as for its high fidelity tonal quality," he continued.

The juke box is being exhibited by the Reliance Varnish Company, prominent suppliers of finishes to the finest furniture makers. Officials of the company requested permission from AMI to display the Model "F" in their permanent exhibit rooms during the Market, feeling that AMI's cabinetry and colors gave them a splendid opportunity to demonstrate the beauty, quality and utility of their finish materials.

Arrangements to install the machine were made with Mike Spagnola, manager of Automatic Phonograph Distributing Company, AMI distributors of Chicago.

The Grand Rapids, Michigan, firm has already demonstrated its Multi-Horn Models at "High Fidelity Shows," "Sight and Sound Exhibits," "Audio Fairs" and "Restaurant Shows" in just the past few months.

"Such showings reflect credit upon the industry, greatly enhance its reputation and character, build favorable regard for automatic music and help open profitable new locations to the music operator," stated Fitzgerald.

mark, Finland, Norway, Sweden, Italy and elsewhere.

Founded in 1949, officials of Belgium boast that its original staff is still connected with the firm.

The well known American firm, International Amusement Company, in addition to shipping machines to Europe, also has considerable traffic with countries all over the world, among these being Middle East, North and South Africa, New Zealand, Japan, China (Hong Kong), and the Philippines.

All foreign inquiries and orders received at International Amusement are handled personally by either Abe Witsen or Sal Groenteman, whose intimate knowledge of the European

Cuban Music Distrib Sees Great Future Ahead

HAVANA, CUBA—"We look forward to a very great and growing future for the automatic phonograph business in Cuba," so spoke Leon Sapochnik, president of Cia. Distribuidora Internacional de Musica, S.A., this city.

Ever since entering into the "fonograf" business in Havana, Leon has seen a great many changes and just as many important developments.

"For example", as he says, "at one time we only thought of direct sales to locations. Today", he reports, "we have eliminated such sales in our organization.

"We further believe that, eventually, sales direct to the locations will be completely halted as competition becomes keener and as the phonographs become ever more electronically intricate."

Sapochnik reported that 1954 has been one of the very best years his firm has enjoyed.

He is distributor for Wurlitzer rhonos here in Cuba working with Bush Distributing Company of Miami, Florida.

Sapochnik is greatly elated over the fact that Havana's bankers are, at long last, beginning to recognize long-term paper for the music operators in Cuba.

"This", he believes, "will definitely prove of great value to all in the music field in Cuba."

He points to his continually growing organization as a definite indication of the progress which automatic music is making thruout the Island.

Vice-president and sales manager of the firm is Morris Gran. Treasurer and credit manager is Alicia Prada. Vice treasurer is Julia Rodriguez.

Secretary of the firm is Dr. Gilfredo Ortiz Calaz. Heading the legal department is Dr. Felipe Santiago Rius. Heading the mechanical department of the firm and chief mechanic is Guillermo Higuera.

The firm also has a one-stop record service for all music operators. Managers of the record and parts department is Juan Usich.

market, plus the availability of their European organization, has been responsible for the outstanding success enjoyed by this firm.

Pictured herewith are photos taken at the Belgian Amusement fifth anniversary party: TOP (l to r) The officials: Albert Polak, Sal Groenteman and Abe Witsen. BOTTOM (l to r) Armand Timmermans; Mrs. D'Hondt; Sal Groenteman; Robert Fastre; Mrs. Doussi; George Timmermans; Mrs. Thyssen; Armand Fastre; Mrs. N. Timmermans; Leonard Thyssen; Harry Doussi; Robert Fastre; Mrs. S. Doussi; Willy D'Hondt; Mrs. Albert Polak; Albert Polak; and Mrs. A. Timmermans.

EXHIBIT'S

SPORTLAND SHOOTING GALLERY

The LEADER that KEEPS 'EM COMIN' BACK FOR MORE!

All the **TARGETS** really **MOVE!**

MADE IN 4 DIFFERENT MODELS
REGULAR, MATCH SCORE AND FREEPLAY OR COMBINATION

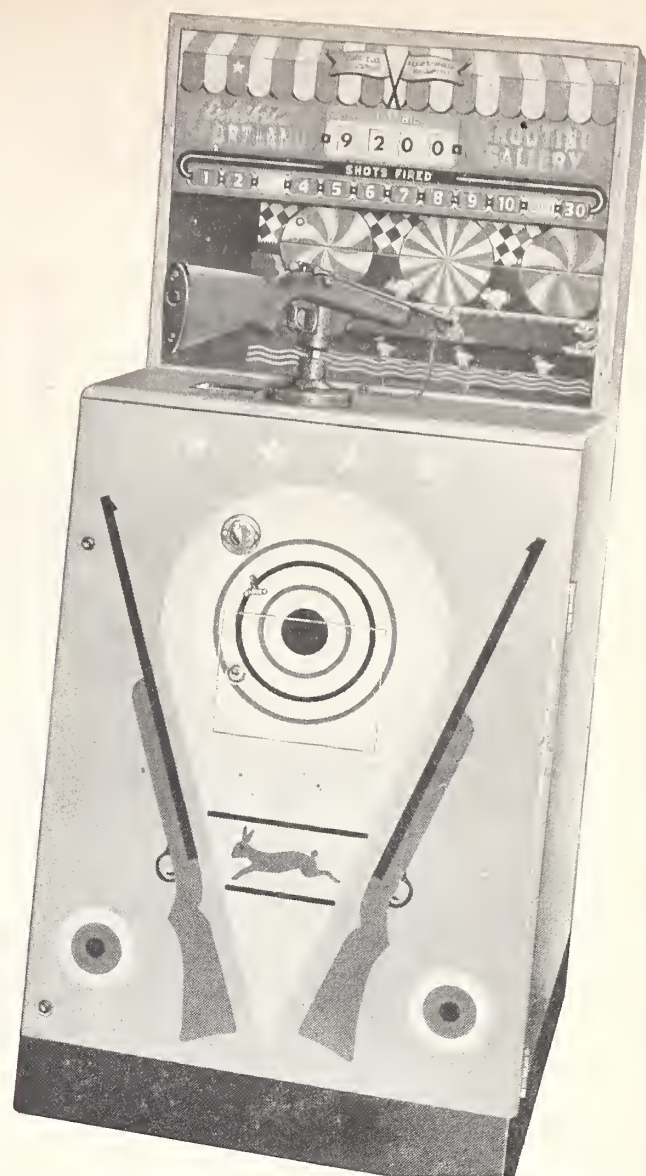

ESTABLISHED SINCE 1901

EXHIBIT SUPPLY

4218 W. LAKE STREET · CHICAGO 24, ILLINOIS

For Great Buys

Write For Our
Special Price Lists Today!

DAVID ROSEN

Exclusive AMI Dist. Ea. Pa.
855 N. BROAD STREET, PHILA. 23, PA.
PHONE-STEVENSON 2-2303

If you have
PHONOGRAPHS for sale

CALL

DAVIS

DISTRIBUTING CORPORATION

SEEBURG FACTORY DISTRIBUTORS

725 WATER STREET
SYRACUSE, NEW YORK

(Phone: 75-5194)

LATE WURLITZER
MODELS 1500 - 1550
FOREIGN AND DOMESTIC
BUYERS

WRITE WIRE CALL
FOR OUR NEW PRICES.

F. A. B. DIST. CO., INC.

1019 BARONNE STREET
NEW ORLEANS, LOUISIANA
(Phone: Canal 8123)

Cuban Op Starts Dime Play With Gottlieb's "Jumbo"

HAVANA, CUBA—Arturo G. Sterling, administrator for the Teatro Marti on the Prado here in Havana, reported:

"When Joe Mangone brought me the first Gottlieb 'Super Jumbo' pin-ball and suggested that we operate it on 10c, we practically laughed him out of our offices.

"We never believed," he continued, "that 10c play would prove successful here in Cuba.

"In fact," he says, "we were so skeptical that the first such game we received we set on the floor of our place at 5c.

"But," he comments, "we seriously thought about it and having read the stories which have appeared on 10c play in the states we decided, after some discussion, to chance a brand new Gottlieb 'Super Jumbo' on dime play and see what would happen."

According to Sterling, the results have been phenomenal, and from now on he is planning to arrange for an entire series of 10c play pin-balls as well as guns in his famed arcade here on the Prado.

He now reports, "Dime play is logical. Increased costs and expenses must somehow be equalized and since we have learned that the players are just as interested in the game at 10c play, we are planning to arrange for more 10c play machines."



Foreign, Domestic Buyers!

look at our prices!*

PHONOGRAPHS

SEEBURG M100 SELECT-O-MATIC \$565.00
SEEBURG M100A SELECT-O-MATIC 350.00

SEEBURG HIDEAWAY PACKAGE

H146M HIDEAWAY \$115.00
5 — 3-Wire 5¢ W-O-M, 20 Sel.
2 — Teardrop Speakers
WITH H147M HIDEAWAY 135.00

WURLITZER 1500 \$475.00
WURLITZER 1400 395.00
WURLITZER 1100 150.00
AMI E-120 \$625.00
AMI C 215.00
ROCK-OLA 1422, AS IS, COMPLETE \$ 49.50
ROCK-OLA 1426, AS IS, COMPLETE 55.00

WALL BOXES

SEEBURG 5¢ WIRELESS, 20 SELECTION \$ 2.50
WURLITZER 2140 6.95
WURLITZER 3020 11.50
WURLITZER 3025 5.95
PACKARD, SATIN 2.50
PACKARD CHROME 4.95

All prices subject to prior sale.

All merchandise is guaranteed. Our references: Bank of America, Dunn & Bradstreet.

R. F. Jones Co.

Exclusive distributor
J. P. Seeburg Corp.; Bally Mfg. Co.

1263 Mission St., San Francisco 3, Calif.
Klondike 2-3579

Offices in Salt Lake, Denver, Portland and Seattle. Merchandise will be shipped from office nearest you.

"It's What's in THE CASH BOX That Counts"

Mr. Juke Box Operator: This is the sign that should be on every one of your machines —

ONE DAY
During The
WEEK of JAN. 17 to 21 (inclusive)

NOTICE!

MR. COIN MACHINE OPERATOR:

Because of the problems encountered and the many lessons learned in last year's first drive for: "*A DAY OF DIMES FOR THE 'MARCH OF DIMES'*," the entire matter of donations by all in the industry has been very much simplified.

Operators need not attempt to collect from each and every individual machine the morning after the one day they choose as their "*DAY OF DIMES FOR THE 'MARCH OF DIMES'*," during the week of January 17 to January 21 inclusive but can, instead, by just making a few collections arrive at an average of what they believe are the number of dimes taken in by their machines that one day.

They can then turn this amount over to their local chapter of the "March Of Dimes" in the form of a single check as their donation for: "*A DAY OF DIMES FOR THE 'MARCH OF DIMES'*."

Remember! Every dime counts! Every single thin dime is a fighting, smashing blow at horrible, crippling, painful, killing polio.

There's not too much time left for you to arrange your "March Of Dimes" program. Start right now—and set every single one of your juke boxes—one day during the week of January 17 to 21 inclusive—to give "A Day Of Dimes For The 'March Of Dimes'," and help prevent America's children from being crippled and killed by Polio. Open your heart to this call from America's children—and at the same time take advantage of the great opportunity to build good will and better understanding for the entire music machine industry.

Phone your local chapter of the "March Of Dimes" today! Give them your name! Tell them what you're going to do! Ask for their help and guidance! Get into every single one of your locations with posters, stickers, signs and streamers!

HELP FIGHT POLIO

One Day's Collection
from this Juke Box
is being Donated to the

**MARCH OF DIMES
POLIO FUND**



Connee Boswell

"Juke Box Queen"

for

"The March of Dimes"

"It's What's in THE CASH BOX That Counts"

New!

BEST OF ALL!

IT'S A *Williams* WINNER!

SAFARI

DELUXE MODEL WITH
TRIPLE MATCH and REPLAY feature

NEW MOVING TARGETS!

MORE ANIMATION

MORE PROFITS

Easy
to move thru the smallest doorway!

Only 28 inches wide

Free-Swinging Genuine Sharp Shooting Remington Rifle

2 BONUS POINTS
added to Score for each Unit of Time under 70!

Adjustable
for Rapid-Fire Shooting at option of the operator

Convertible
to Novelty Play

CREATORS OF DEPENDABLE PLAY APPEAL
4242 W. FILLMORE ST. CHICAGO 24, ILL.

2 PANTHERS—Sharpshooting
knocks down both panthers for 2 POINTS each!

5 LEOPARDS ready to spring!
Hit each leopard for ONE POINT each!

5 LIONS good for
TEN POINTS each!

3 GORILLAS lurch out
from behind both sides and top of
mountain when any three targets are
hit consecutively. Gorillas continue
to swing into view as long as shooter
keeps on hitting 'em. Good for 20 POINTS
each. Hitting 3 Gorillas on last five shots
good for 100 POINTS each!

See your *Williams* DISTRIBUTOR!

SEEBURG M-100 B	\$575
WURLITZER 1100	195
WURLITZER 1500	475

RECONDITIONED AND REFINISHED LIKE NEW!

Terms: 1/3 Dep., Bal. C. O. D.

ATLAS MUSIC COMPANY

A Quarter Century of Service

2118 N. Western Ave., Chicago 47, Ill. ARmitage 6-5005

Washington Music Operators Form State-Wide Association

SEATTLE, WASH.—Music operators throught the state met here recently and formed the Washington Music Merchants Association.

Officers elected were Frank Counter, president; Leonard Boswell, vice president; and J. Dontos, secretary-treasurer. Elected to the Board of Directors were I. Riccetti, H. A. Christensen, L. J. Shivers and Jim Hammond. Alternates selected were Arnold Salkin and Orvall Knudtson.

George A. Miller, president of MOA (Music Operators of America), was in attendance at this meeting and acted in the capacity of the election officer and as an advisor.

Practically every music operator in Seattle was present, and every indication pointed to a successful expansion to include all throught the state.

Copyright legislation, fair trading of the music business, and 10c play were the main topics of discussion, and those present made it emphatic that dime play would be one of the first orders of the day.

Miller advised the organization he would send them immediately, copies of the California Music Merchant Association's by-laws, working rules, location contracts, membership cards, machine labels and incorporation papers. Miller is also business manager of the CMMA. He also assured them he would only be too glad to help in any manner possible.

Operators attending the meeting voted to take out individual membership in the Music Operators of America, which represents the juke box industry on a national scope.

Tony Sanders Opens Distrib Biz

DETROIT, MICH.—As of this past week, Thursday, January 6, Tony Sanders officially opened his own distributing company, Detroit Coin Machine Exchange at 10236 Grand River Avenue, this city.

Tony advised that Art Herbert continues with him as sales manager and that his two well known mechanics will also be with him to service the operators in this area.

He reports that he will, in the very near future, announce the names of the manufacturers whose lines he will handle exclusively in this area.

"We are inviting all our friends to visit with us," Tony reported, "and we are assuring them of the same close and personal service as they always received from us in the past."

Bally Service Schools

WILKES BARRE, PA.—Max Roth, Roth Novelty Company, this city, will host operators here when they gather for a Bally Service School on Monday and Tuesday, January 17 and 18. Paul Calamari, Bally service engineer will conduct the classes.

PHILADELPHIA, PA.—Bally Service engineer, Paul Calamari will conduct service sessions for customers of Scott-Crosse Company, this city, at the Scranton office on Wednesday, January 19; and at the home office of the firm in Philadelphia on Friday, January 21.

SYRACUSE, N. Y.—Al Bergman and Roy Bergman of Sheldon Sales, Inc., this city, will accompany Bob Breither, Bally service engineer, in trips to visit operators in this city, Rochester, Buffalo and other cities serviced by Sheldon for Bally. The program starts Monday, January 24. (Other Bally Service Schools—See Page 38).

It's A Darn Shame!

NEW YORK—We've watched many television programs over the past number of years, and always were thrilled when a juke box was part of the set.

In the past number of months, many more television programs have used juke boxes in tavern, restaurant and night club settings than ever before. But now your editor is not so happy over their appearances. In 99 per cent of the shows, those music machines are of pre-war vintage. With the beautiful, gorgeous, modern juke boxes available, it's a shame that the industry should be displaying these o'd fashioned machines to the millions of TV viewers. It hurts the entire industry. The 1954 and 1955 models would show the world what progress the industry has made—and make a decidedly favorable impression on the millions of people watching these shows.

BIG TOP RIFLE GALLERY BY GENCO

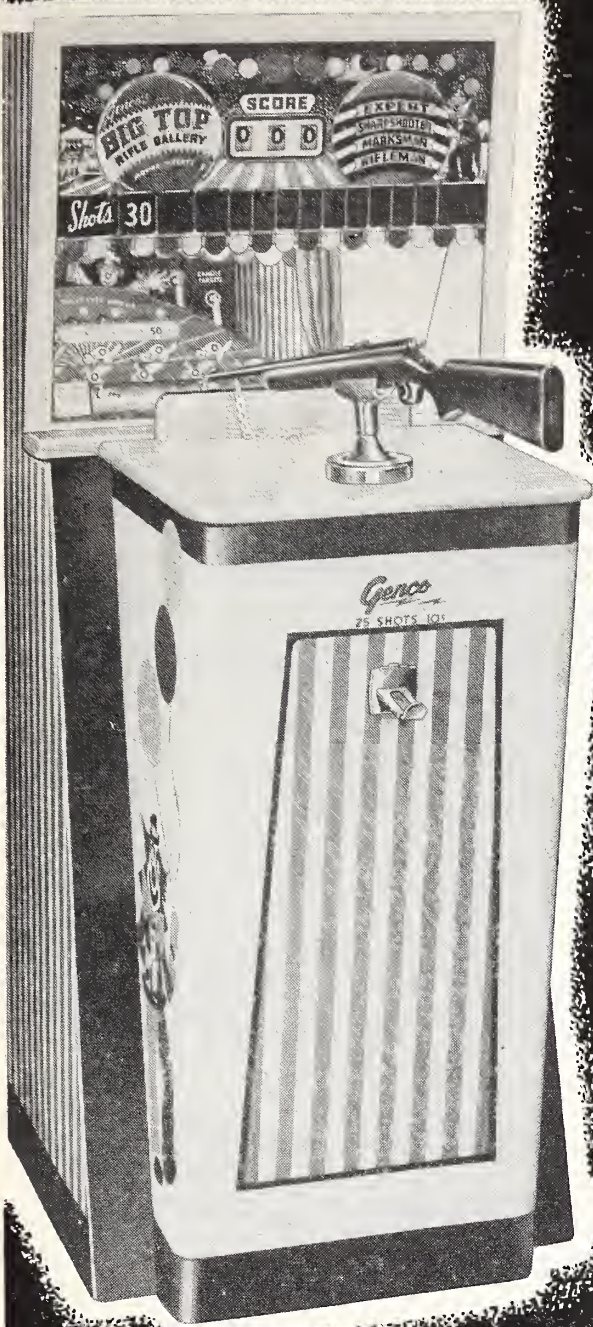

GENCO MFG. & SALES CO.
2621 North Ashland Avenue • Chicago 14, Illinois

This letter was mailed to "General's" Entire Operator List

We received our copy just before Christmas . . . an awfully nice gift and a wonderful tribute to our BIG TOP.

THANKS GENERAL!
THANKS OPERATORS EVERYWHERE!

Exclusive
Factory Distributors
for Leading Coin
Machine Manufacturers

General Vending Sales Corp.

Established 1925
237 to 245 West Biddle St., corner Howard St.
Baltimore 1, Md. VEron 4119-20 21

Dear Operator,

December, 1954

When the record of coin machine history for 1954 is written, the one highlight of the year will be the terrific record created by guns. Guns have been the most profitable new type of amusement equipment introduced in the past 5 years, and their popularity is still growing by leaps and bounds. How much bigger the craze will grow, no one knows, but at the present stage, guns are the hottest machines on the market.

But that is not to say that all guns are good. As with every successful product, there are many imitations and would-be competitive machines. And, in every such situation, discriminating purchasers find that one make stands out above all the rest. And no one will deny that the most beautiful, most original, most successful and most profitable gun ever made is Genco's BIG TOP.

- Just look at what BIG TOP gives the player, targets no other gun offers:
- 9 realistic ducks on moving endless belt - just like a real rifle range!
 - Swinging clown, moving back and forth on pendulum - flops over when hit, then resets automatically!
 - 4 realistic candles - player shoots out flame (in lights) just like a real rifle range!
 - Plus all new wild cats and birds, stationary, fall-over targets

In addition, BIG TOP is housed in a new streamlined colorful cabinet that attracts play by appearance alone. Genuine 22-caliber Savage rifle with realistic gun flash and kick; brilliantly lighted theatrical effects - all tell you why Genco BIG TOP is outplaying, outearning and outselling all others from coast to coast.

If you are not yet in the gun operating business - get in now for the biggest profits in years! And when you get in, invest your money in the TOP gun for greatest all around results - Genco's BIG TOP.

IB:beb

Yours for better operating,
GENERAL VENDING SALES CORP.



We are still 2 weeks behind in filling orders and this letter tells you why.

Trimount Annual Xmas Party



BOSTON, MASS.—Employees of Trimount Automatic Sales Corporation, this city, gathered at the Hotel Somerset for their annual Xmas party.

Seen at the table at the left are Dave Bond and Irvin Margold of Trimount, and factory representatives Sam Lewis, Genco; Ed Levin, Chicago Coin; and Ben Becker, United.

Lieberman Appts Luckman Sales Rep.

OMAHA, NEB.—Harold N. Lieberman, president of Lieberman Music Company, with offices in Minneapolis, Minn., and this city, announced this week the appointment of Bernard W. Luckman as a sales representative for the Omaha branch.

Luckman, known to all here as

"Barney," has been in the Nebraska and Iowa territory for a number of years, and enjoys the friendship of all coinmen in the area. He will soon be out covering the territory and visiting operators, it is stated.

Lieberman Music Company acts as factory distributors for many of the leading manufacturers in the industry.

NOW DELIVERING

THE **BEST** in GAMES and MUSIC

AMI Model "F" PHONO

Bally MYSTIC BOWLER

Keeney SPORTSMAN

RUNYON SALES COMPANY

Factory Representatives for:
AMI, Inc., Bally Manufacturing Co.,
J. H. Keeney & Co., Permo, Inc.

593 10th Ave., New York 18, N. Y., LO 4-1880
221 Frelinghuysen Ave., Newark 8, N. J., BI 3-8777

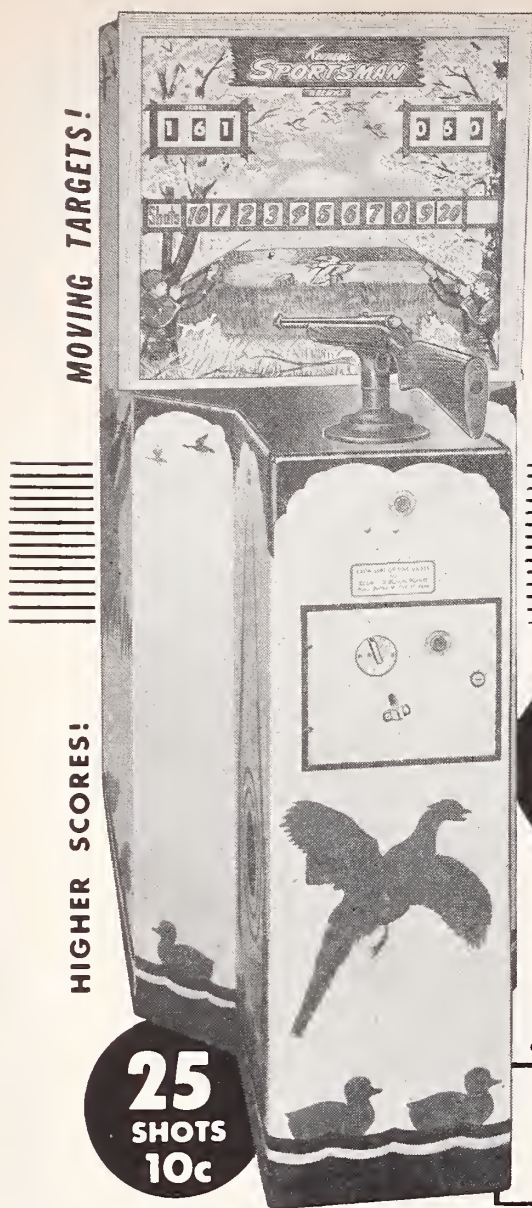

Out-Earning 'em All...

Keeney's DELUXE SPORTSMAN

NOTE NEWLY DESIGNED GUN WITHOUT CHAIN

BIG EXTRA BONUS:

New MATCH-A-SCORE "0 to 9" gives player 10-50-100-200 or 500 Award Points!

- Rabbits—Pheasants—Ducks POP-UP on mystery basis!
- Roving Targets always on-the-move in realistic 3-D colorful hunting scene!
- Slug Rejector • Standard 6 volt bulbs
- Genuine Regulation Hunting Rifle!

TIME
060

2 BONUS POINTS added to score for each unit of time under 60. Timer can be set to stop at 100-200-300-400 or 500 at option of operator.

5 DUCKS in back row 3 points each

5 PHEASANTS in center row 20 points each

5 RABBITS in first row 2 points each

IMPORTANT! This original combination of roving POP-UP TARGETS creates a brand new desire for competitive target shooting thru a true test of marksmanship.

also AVAILABLE AS *Keeney's*

SPORTSMAN

without Match Feature or Replay Button

Order KEENEY'S

Deluxe **SPORTSMAN**

Don't Delay!

SEE YOUR KEENEY DISTRIBUTOR NOW!

J. W. Keeney & CO., INC.
2600 W. FIFTIETH STREET • CHICAGO 32, ILLINOIS

FITS EVERY LOCATION!

Cuban Distrib Has Flexible Service Org

HAVANA, Cuba—Swinging from music to games, here in Havana, is a rather intricate task, in most instances.

Requirements of music operating are such that a well trained expert in both the recordings desired and the method of operation is an absolute necessity.

Therefore, when a firm can switch, from hour to hour, from its games operations and sales to music operations and sales, it has to be extremely flexible in every regard.

Such is the organization of North American Music Co., S. A. of Havana, Cuba, headed by Maynard Ross as manager.

Ross, himself, pays attention to both music and games, but, at the same time, also has a music organization behind him of native Cubans who are very well acquainted with the desires and requirements of the locations and the patrons of the locations.

Jack Delaster is manager of the firm's pinball division. Solomon Fernandez Finkelman heads the firm's sales department for both games and music. Jorge De Moya is office manager, and his three assistants are Georgina Alvarez, Isabel Nuniz and Candita Garcia. Felix Lopez heads the firm's mechanical and service departments. Milton Castillo and Gregorio Prieto are the firm's expert mechanics.

Reports Maynard Ross, "Ever since coming to Havana I have seen the automatic music and games business growing greater each year."

"As we bring in new machines, new locations continue to open up, and demand for equipment continues to grow greater from location owners thruout the entire Island.

Henry Okun Apptd. to PAL Board of Directors, Newark, N. J. Asks Local Juke Box Ops For Five Phonos

NEWARK, N. J.—Henry Okun, well known record consultant, promotion and exploitation man, for the top "names" in the record business, has been appointed a member of the Board of Directors of PAL (Police Athletic League) of Newark, N. J.

Okun, with the co-operation of The Cash Box, and the Juke operators of Newark, N. J., were the first in 1949 to start having "Juke Box Dances" in such youth centers as PAL, CYO, and others in combatting Juvenile Delinquency.

Through their efforts The Music Guild of America, donated five juke boxes to be placed in the various PAL Centers in Newark, and with the co-operation of The Cash Box and such Dee Jays as Paul Brenner, Jerry Roberts, had artists of the calibre of The Ames Brothers, Kitty Kallen, Sammy Davis, Johnny Desmond appear at the various events, held at the PAL Centers.

Mayor Leo Carlin, realizing the alarming rise in Juvenile Delinquency the past few years, decided to widen the activities of PAL, and to hold more "Get-to-gether" affairs in the Centers.

There is a desperate need for juke boxes, and records—five are needed in fact, and if they can be donated, it would make hundreds of young boys and girls happy, and be a violent and potent blow against Juvenile Delinquency.

Bally Service Schools

Runyon Sales—Hartford, Conn.

HARTFORD, Conn.—Paul Calamari, of the Bally engineering staff, will conduct the Bally Service School at the Hartford, Connecticut office of Runyon Sales Company, 181 Pleasant St., January 13, 14.

Advance reservations indicate a big turn-out of operators and servicemen for the two-day school, according to Irv Kempner and Nat Glutkin, of the Runyon organization.

"Time is short, but coinmen from the Hartford area who have not already done so, should arrange to be at the school, as Calamari will point out many ways to build up income from Bally 'Magic-Bowler', 'Mystic-Bowler', and the new in-line game, 'Big-Time', advised Kempner.

Calderon—Indianapolis, Ind.

INDIANAPOLIS, Ind. — Calderon Distributing Company, this city, will be host to the Bally Service School to be held at the Van Orman Hotel, Fort Wayne, Indiana, January 19, 20.

Classes will begin at 7:00 P. M., on both dates, and will be conducted by Bob Breither, of the Bally staff.

Al Calderon will be there, and he urges every operator and serviceman in the territory to attend. Breither will offer many new servicing tips, and answer any questions about Bally's latest games, "Magic-Bowler" and "Mystic-Bowler", and the new in-line game "Big-Time".

FOREIGN BUYERS!

It's smart to do business with THE firm that does the most for YOU.

At International Amusement and Scott-Crosse foreign buyers receive the world's most complete coin machine service. We understand how to solve your problems from personal experience... know what equipment you need to meet your particular requirements and know how to get it to you on time in perfect working condition. This is why we have satisfied customers everywhere.

CABLE for Special Price Lists.
Parts and Service Manual available.

INTERNATIONAL AMUSEMENT COMPANY

1423 SPRING GARDEN STREET
PHILADELPHIA 30, PA. (Tel. RI 6-7712)

GET PEAK PLAY with the BEST RECONDITIONED EQUIP.

ALL STAR	\$349.50
MAJOR LEAGUE	339.50
STAR SERIES	65.00
SPARK PLUG	60.00
JALOPY	60.00
HAYBURNER	50.00
SUPER PENNANT	249.50
YACHT CLUB	149.50
HI-FI	349.50
BEACH CLUB	299.50
ATLANTIC CITY	139.50
CONEY ISLAND	94.50
OLYMPIC	179.50
CASCADE	139.50

WRITE — WIRE — PHONE TODAY!
We are exclusive factory distributors for:
BALLY - WILLIAMS - ROCK-OLA

LAKE CITY AMUSE. CO.
4533 PAYNE AVE., CLEVELAND, O.
(Tel. HE 1-7577)

Another FIRST! **chicago coin's THUNDERBOLT**

NEW!...4 WAY MATCH PLAY! NEW!...EXCITING SUSPENSE FEATURE!



TWO GAMES IN ONE!

Adjustable from "Flash-O-Matic" to Advance Scoring!

FOUR DRUM SCORING!

All 4 Drums Operate to Score!

Player by Timing His Shot When Highest Score is lit on the Formica Playfield Gets as Much as 800 for a Strike in Each Frame!

LOOK!
Unbreakable PLEXI-GLASS Score Panel and Shield!

chicago coin

MACHINE COMPANY

1725 W. DIVERSEY • CHICAGO 14

chicago coin's ACTION PACKED BOWLER FIREBALL

contains all the Features of THUNDERBOLT but is played as a regular Bowler.

Western Mass. Music Guild Third Annual Xmas Party "Finest Ever"

SPRINGFIELD, MASS.—Western Massachusetts Music Guild held its third annual Christmas party on Tuesday night, December 14, at the Ivy Hotel, this city.

About seventy guests and members partook of the sumptuous meal, exchanged gifts and danced to the music of Larry Clesky and Orchestra, assisted by Mrs. Fred Mielnikowski on the bass fiddle.

Barney and Louis Blatt, Atlas Distributors (AMI distributors) and Dave Bond and Irwin Margold, Trimount Sales (Seeburg distributors) furnished liquor for the party.

Among the out-of-town guests were Abe Fish and Jimmy Tolisano of Hartford, Conn., and their wives. Other guests included Louis Blatt, Boston; Bert Thomson, Quincy; Wil-

liam Fry, Boston; Mr. and Mrs. Earl Fortin, Holyoke; Mr. and Mrs. Harry Goldenberg, Holyoke; Henry Roberge, Springfield; and Mr. and Mrs. William Beattie, South Hadley.

The entire membership of the Western Massachusetts Music Guild was on hand with the exception of a few, who were unable to attend due to illness.

"To say this party was a grand success would be putting it mildly," commented Ralph Ridgeway, president. "It was the finest social gathering ever held by this comparatively young organization, and did much to cement the friendship of operators.

Pictured below officers exchange gifts. From left to right: Ralph Ridgeway, president; George Hatzipetro, vice president; Joseph Reisner, secretary; and Fred Mielnikowski, treasurer.

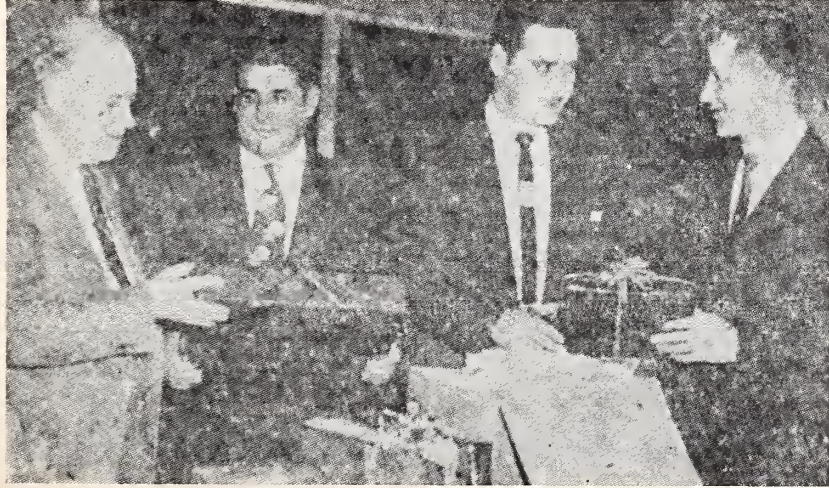

LIKE NEW
WURLITZER
Model 1500's and 1550's
PHONOGRAPHS
\$395.00

COMMERCIAL MUSIC COMPANY, INC.

1550 EDISON
DALLAS, TEXAS

Canadian Coinmen Bag Deer Limit



MONTREAL, CANADA—Canadian coinmen look over the results of a recent hunting trip. The limit per man is 5 deers, and each man bagged his five.

Romeo Laniel, Laniel Amusements, Inc., this city, distributor for some

of United States' leading manufacturers is fourth from left (holding on to a couple of deer's ears).

Jack Nelson, Bally sales manager, who sent us the picture, writes: "It takes a Bally distributor to show the way not only how to make big profits, but also how to shoot deer."

"It's What's in THE CASH BOX That Counts"



Spinning tops

Tops for everyone with
... **ROCK-OLA** Hi-Fidelity Music

Fine Hi-Fidelity music beautiful modern cabinet design
easy to read title strips plus the famous ROCK-OLA trouble-free
mechanism mean greater earnings and satisfaction
ask your routeman... he knows!

Here's what Bill Fisher of
Coin-a-Matic Music Co.
of Omaha says...

I prefer Rock-Ola phonographs to other makes because of the
minimum of maintenance required to produce the maximum
results. The appearance of the new Rock-Ola Hi-Fidelity
phonographs have made life wonderful among our locations
and the cash boxes prove it. Rock-Ola has proven to this service
man that life can be beautiful.

Bill Fisher
Bill Fisher

ROCK-OLA MANUFACTURING CORP.

THRU THE COIN CHUTE

EASTERN FLASHES

1955 started off in a big way in the big city. Operators were highly pleased with the holiday business, many stating they did better than was expected. It was thought that with a big New Year eve Friday night, Saturday would be a complete blank. However, Saturday afternoon and night turned out pretty good. Distributors on the row were all smiles, each reporting a fine flow of sales, with expectations of peak activity in the coming weeks.

The trade received its best news in a long time, when it was disclosed that the License Department would issue licenses for the operation of guns on locations. Up to now, these amusement machines weren't permitted in restaurants, diners and luncheonettes. Operators, it is now stated, can apply for licenses for these locations. The license department will then check every individual location to see that it is a proper spot. That is—not too near to schools, churches, etc. What type of patron the location serves, etc. Ops and distribs here very excited over the opportunity of broadening their operations and sales. As usual, wholesalers will continue to bring down each new machine to the license department for its approval prior to offering it to sale to operators. . . . Al Simon, Albert Simon, Inc., and his sales staff of Al D'Inzillo, Dave Lowy and Larry Feigenbaum, among the busiest on coinrow. Looks like Genco's "Big Top" gun will be in great demand, and ChiCoin's "Criss-Cross", a shuffle with a new twist, which just arrived, already finding great favor with the ops. . . . Jack Semel and son, "Happy Herbie" visit along the street. "Happy", who has been out of the coin biz for a while, taking care of his tropical fish business, back again with a games operation. He and his partner in the fish business will split up time in the store, leaving "Happy" with enough time to run his route. . . . All of the roadmen of Runyon out contacting the trade. However, biz percolating to the extent that Abe Green, Barney Sugerman and Morris Rood find it necessary to spend a number of hours visiting operators. Runyon has three items moving rapidly—AMI phonos, Bally's "Mystic Bowler" and Keeney's "Sportsman".

The Airlines Terminal Bldg., 42nd Street and 10th Ave., looks like it will be ready for operation in the Spring. The steel framework is completed. Mike Munves, just across the street, can hardly wait. "They're sure to have a couple of good restaurants there" envisioned Mike, "and we sure can use one in this neighborhood." . . . Phil Gould's (Newark arcade owner) son, Joey, was married on Saturday night, Jan. 1. The boy is in Uncle Sam's army, but expects to be released soon. . . . Harry Poole, former Wurlitzer distributor in New England, in town for a few days. Harry has spent the past few months traveling and resting. He expects to return to the coin biz in New England, but doesn't know just what he'll do as yet. . . . Bob Lutman getting ready for a Miami Beach vacation. . . . Met up with "Senator" Al Bodkin and became involved with a discussion on dime play. The "Senator", one of the country's most progressive music ops, advises he has a number of locations on dime play already, and is continuing to change over others. "No frills, no schemes, just 10c, 3 for 25c" says the "Sen." . . . Sandy Moore, Long Island op, also visiting on coinrow. He also advises he's changed over many spots to dime play, and will continue to do so as rapidly as possible. . . . Dave Stern and Bob Slifer, Seacoast Distributors, (Rock-Ola distrib) full of enthusiasm, expecting a banner 1955. . . . Nat Cohn visits his friends along the row. . . . Meyer Parkoff, Atlantic-New York Corp. (Seeburg distrib), knocks wood as he says, "We're as busy as we can be. It shouldn't be any worse at any time." . . . Dick DiCiccio, Westchester op, on the street buying. . . . Jack Wilson, Newburgh, N. Y. op, rushing from one wholesaler to another, loading up with parts and supplies. . . . Gertrude Browne, Beacon, N. Y., also makes the rounds of distribs. . . . Danny Thomas, Peekskill, N. Y. op, on the street buying. . . . Joe Young and Allie Goldberg, Young Distributing (Wurlitzer distrib), out visiting ops on Long Island, while Abe Lipsky handles the office biz. . . . Lou Dunis, Seattle, Wash., distributor, expected in N. Y. next week. He'll stop off in Chicago on his way in.

When You Enter The Cash Box "20 YEAR CLUB"

YOU ARE GETTING FULL RECOGNITION FOR THE 20 YEARS OR MORE YOU HAVE GIVEN TO THE COIN MACHINE INDUSTRY. IT IS TO YOUR COMPLETE ADVANTAGE TO JOIN The Cash Box "20 YEAR CLUB" TODAY!!

IF YOU ARE ELIGIBLE FOR MEMBERSHIP IN The Cash Box "20 YEAR CLUB," FILL OUT THIS APPLICATION AND MAIL TODAY.

Joe Orleck
THE CASH BOX
26 West 47th Street
New York 36, N. Y.

Dear Joe:

Please enter my name as a member and send me a membership card.

I have been connected with the Coin Machine Industry for 20 years or more, starting: Year Month

NAME
FIRM
ADDRESS
CITY ZONE STATE

Automatic Phono Bowling League News

CHICAGO—ABC #2 retained their first place standing by winning two games this past Monday (1/3). Results were as follows:

ABC #2 won 2 from Melody. High for ABC was Les Taylor, with 575, high for men. Vic Jaccino, Sr. was high for Melody Music with 496.

Mercury won 2 from Star Music. High for Mercury was Ralph Kick, 461. Tony Galgano was high for Star with 481.

Oomens took 2 games from Atlas Music. Johnny Oomens led his team with 523, with Carl Lat'no immediately behind with 521. Isabelle Oomens of this team was high for women with 410. Jim Wickman was high for Atlas with 535, with Mike Blumberg right behind with 534.

Decca won 3 games from Western Automatic. High for Decca (again) Frank Tutomase, 519. Bill Nyland was Western Automatic's high scorer with 424.

Coral took 3 from Paschke. Ed Walker was high man for Coral with 508. High for Paschke was Rene Gallet 528.

Coven Music took 2 games from B&B. Frank Lantz was high man for Coven with 454. Marino Pieroni was high for B&B with 463.

Gillette took 2 from ABC #1. Hank Leonarczyk led the Gillette team with 484. Len Christiansen was high for ABC #1 with 495. This makes 5 out of the last 6 games for Gillette which is the best they have done this season.

THRU THE COIN CHUTE CHICAGO CHATTER

As manufacturers, distributors and jobbers here advise, "Business started off with a boom this past Monday (January 3) and has continued on all week long." Seems that the speedy sales action, which went right thru the Holiday Season, isn't slackening off one bit, according to leaders here. And, as many now predict, looks like '55 is going to be really alive with better business for all . . . MOA's exec committee meets here at the Morrison Hotel this week, January 10, 11 and 12, to discuss the forthcoming convention. (Sure is a tough week for a meet what with the Furniture Convention on and rooms as scarce as hen's teeth). Among those expected to be present: George A. Miller, Oakland; Clint Pierce, Brodhead, Wis.; Al Denver, New York City; Martin Britz, Great Falls, Mont.; Bill Hullinger, Delphos, O.; Les Montooth, Peoria; Ray Cunliffe, Chicago; Harry Snodgrass of Albuquerque; Tom Withrow of Midland, Tex.; Jack Mulligan of Sharon, Pa.; Jim Tolisano of Hartford, Conn.; Howard Ellis of Omaha; Mel Missmer of Allentown, Pa.; Willie Blatt of Miami; Louis Ptacek of Manhattan, Kan.; Vic. Ostergren of Gary and Norm Gefke of Sioux Falls, S. D.

Nate Gottlieb, along with Sol and Alvin Gottlieb will read this here for the first time. That Cuban games operator, Arturo Sterling of the Teatro Marti, Havana, is getting dime play working in his arcade because of the success he enjoyed with his Gottlieb "Super Jumbo" which Joe Mangone of Miami convinced him to keep on 10¢ play . . . Shame to note that Chicago's music ops allowed some outfit from Wisconsin to take over the servicing and repairs of the parking meters here. Any good phono ops service organization could have handled the business. Not only profitably, but, what's even more important, as a real good will builder for the operators thruout the city. Operators in cities where there are parking meters should apply or bid for service and repairs which their expert and experienced men can do. Great and profitable public relations here . . . Jack Nelson, Bally's sales manager, advises that this was the firm's greatest year, in fact, as Jack put it, "A marvelous year. The biggest in our history." And that, dear reader, is saying but plenty when thinking back to all the great products and great years Bally has enjoyed in this industry.

Willie Blatt of Miami phoned Barney (Shugy) Sugarman of New York from his Miami office and made a date to meet Shugy here in Chicago. Shugy on his way in to see some of the manufacturers Runyon Sales represents . . . Harry Williams on his way into town, flying his own two-motored plane. Just as Chicago began to get socked in and plane flights were being cancelled . . . Ray Moloney worked so hard at the task of being Santa Claus to so many, many peoples that he came down with a severe cold and is now taking it very easy . . . Sam Stern heard some very nice reports on the latest games the firm has been producing and was tremendously encouraged with what he heard. Said Sam, "Wait'll our new products appear" . . . Rock-Ola factory a very, very busy place these days. Wayne (Brad) Bradfield has prepared a new ad program which he believes will open the way to mucho business. King Ray, sales manager, is working out new plans which should prove extremely interesting. And even tho plagued with a cold, Kurt Kluever just wouldn't stay away while all the planning for '55 was under way

Sam Wolberg in town at Chicago Coin and keeping plenty busy with telephones ringing all day long. Sam Gensburg in Miami enjoying Florida sunshine. Ed Levin put it this way, "It sure was a great year. What's more," he added, "business started off for us with a bang Monday morning." By the way, Ed's son, Arthur Levin, stranded down in Miami as the airport here in Chicago socked in . . . Sam Lewis reports that the Genco gang just can't halt producing its great gun. Orders are still being phoned and wired in from everywhere 'round the countryside . . . Johnny Casola and Al Tholke leave for Dallas to handle a service school for the operators of United products down Texasway. In the meantime, Bill DeSelm one of the happiest of the happy with this report, "Business opened up big for us right from Monday morning on." And Herb Oettinger saying nothing. He's so busy, as the year comes to its end, that he can't even find time to talk . . . Ben Becker writes in from Buffalo to advise, "Am covering New York and New England and it's just like coming home to the home folks."

The Cash Box' "20 Year Club" members now voting on what city to hold annual meet: Chicago, Miami, Las Vegas. So far there's little choice. But all suggest the meet be held in the Springtime of '55 . . . Howie Freer of Empire being troubled by that bad leg which halted his golfing this past summer, but smiling thru it all as he says, "Business is great at Empire." And Vince Shay pipes in to state, "The phones are ringing and ringing with calls from everywhere" . . . Arcade men seeking Panorams as they grow more and more scarce. Will take 'em 'as is' to just get parts for repairing their present units . . . Very beautiful card from a very swell guy, Marshall L. Wright, formerly executive assistant manager of the Ambassador Hotel, L. A., informing that he's now Manager of the new Riviera Hotel, Las Vegas, "opening soon". This is the nine story hotel built by Dave, Myer and Lew Gensburg, formerly of Genco Mfg. Co. . . . Caught in the crush of business, Roy McGinnis won't be able to leave for his Miami home until January 18. In the meantime, Paul Huebsch of the Keeney firm, yowling like everything for those sensational new drink vendors. "I've got orders this high," hollers Paul, "so where's production?"

Mickey Schaefer returns from a Canadian business tour and reports, "Greatest business we've ever done." And Stan Levin, smiling from ear to ear, says, "Guess I'll hit the road myself." . . . Paul Bennett phones to talk to us about subscriptions and winds up telling us how pleased he is with great growth of The Cash Box. (Thanks a zillion, Paul). . . . Joe Kline of busy, busy First, gets on the phone to busily comment, "Say, what's a guy gotta do to get into the Chicago Chatter column?" (Just what you did, Joe, simply phone). . . . Hear that Wally Finke broke all premium sales records this past Holiday Season. . . . Swell letter from Wilfred E. Moore of Cleve'and advising that his new 10c play kits for Packard and Buckley boxes clicking so big ops suggested he write and tell us all about them. . . . Hear that Rep. Celler (D., N. Y.) who, if our memory correctly serves us, testified in behalf of song writers and ASCAP, will be Chairman of the House Judiciary Committee this forthcoming Congressional Session. Since hearings usually held before House Judiciary Committee on phone ops vs ASCAP. . . .

LOADED with Sparkling Player Appeal!



GOTTLIEB'S
flashy, colorful



- ◆ A-B-C-D rollovers when made, lights kickout holes for replays and super high score
- ◆ Resetting Sequence Nos. 1 to 10 scores points
- ◆ Skill horseshoe spots all numbers 10 brilliantly colored diamonds in horseshoe gives terrific flash
- ◆ Special rollunders spots numbers
- ◆ Mystery rollover awards replays
- ◆ 4 Pop Bumpers
- ◆ 2 Flippers

SEE IT AT
YOUR
DISTRIBUTOR
NOW!

D. Gottlieb & Co.
1140-50 N. KOSTNER AVE. · CHICAGO 51, ILL.

EMPIRE'S JANUARY CLEARANCE!

BRAND NEW	RECONDITIONED
WMS. ALL STAR BASEBALL \$375	UNITED CASCADE SHUFFLE ALLEY \$165
GENCO 2 PLAYER BASKETBALL 345	GENCO SHUFFLE POOL 190
EXHIBIT SHOOTING GALLERY 350	GENCO MATCH POOL 275
EX. STAR SHOOTING GALLERY 375	BALLY BEACH CLUB 295
SET SHOT BASKETBALL 325	BALLY BEAUTY 235
GENCO SILVER CHEST 125	BALLY ATLANTIC CITY 135
WILLIAMS JET FIGHTER 395	WURLITZER 1015's 99

1/2 DEP., BAL. C.O.D. OR S.D.

Empire COIN MACHINE EXCHANGE
1012-14 MILWAUKEE AVE., CHICAGO 22, ILL. Phone: EVERGLADE 4-2600

CHICAGO CHATTER (Cont.)

Grand letter from John Haddock of AMI, Inc. who writes in part, " . . . the switch to dime play will be of great benefit to the juke box business." And also writes, "As the present greatly improved machines push the old clunkers out of the market, the public attitude towards our industry is bound to improve. The combination of this, with wider acceptance of dime play, should increase both gross revenue and also net income." . . . Kiddie Ride ops tremendously thrilled by reports of the continually increasing birth rate. Seems like today's mothers having more children, larger families, than 'way back when. Over 29 million kids expected to enroll in elementary schools alone this year. With over 33 million estimated enrollment for 1960.

HAPPY BIRTHDAY THIS WEEK TO: Phil Weisman, Chicago, Ill. . . . C. C. Mason, Syracuse, Ind. . . . Raymond F. Jones, San Francisco, Calif. . . . Gleason N. Stambaugh, Jr., West Palm Beach, Fla. . . . Guido J. Del Signore, Fort Edward, N. Y. . . . J. H. Sprott, Temple, Tex. . . . Benj. Sterling, Jr., Moosic, Pa. . . . Robert E. (Buster) Williams, Memphis, Tenn. . . . Wm. A. McLain, Los Angeles, Calif. . . . Charles M. Missler, Lithicum Heights, Md. . . . Sam Lewis, Chicago, Ill.

"It's What's in THE CASH BOX That Counts"

Music Installation in New Diner



PEEKSKILL, N. Y.—Runyon Sales Company, New York City, recently made an installation of AMI music equipment in the "By Pass" Diner, this city, for Max Klein, operator, which they feel is the last word in automatic music coverage.

Top photo shows, (l. to r.) Phil Kyriazis, owner; Irv (Kempy) Kempner, Runyon sales representative; Max Klein, Moder Amusement Co., operator; and Steve Stephanou, owner. Bottom picture is that of the Diner with music installation.



Guns, guns, guns—are booming throughout New England as ops report tremendous demand and enthusiastic consumer acceptance of the 10c play units. . . . "Guns are very very hot," said Irwin Margold, general manager Trimount Automatic Sales Corp. He said they are going into virgin locations, drug stores, variety stores, bowling alleys, and that ops are reaping a small bonanza with the new guns, which offer big collections. Demand for Genco's "Big Top" is growing daily thru the New England territory, Irwin said. "The enthusiastic acceptance of this gun at a 10c play indicates that the public has no hesitancy in paying 10c for good amusement equipment play. Trimount scored this week with delivery to Jordan Marsh Co., biggest department store in the region, at Boston of a specially designed portable library unit. The unit, designed by Trimount, comprises a Seeburg library unit in a steel cabinet, with a mike and speaker. Fifty feet of wire, a hand mike and attachment for a stand mike. Jordan's is using it for fashion shows and exhibitions and reported that there is a place for such equipment in every department store. Dave Bond, Trimount president, received many very favorable comments from ops throughout the country on his New Year's predictions for the coin machine business published in the Jan. 1 issue of *The Cash Box*.

As distribs along coin row in Boston closed out one of the most successful years in history, plans were being set up for bigger and better showings and activities in 1955. . . . Among those knee-deep in plans for the coming 12-months were Si Redd, owner, and Bob Jones, sales manager, Redd Distributing. Something big will be coming off here within the month. Kiddie ride biz reported holding good at Redd's. . . . Among ops visiting with Si this week were Bob Pino, Greenfield; Pete Slepchuck, Pete's Novelty, Springfield; Ralph Ridgeway, Vogue Music, Springfield; and Hal March, Brattleboro, Vt. . . . Jerry Flatto, Boston Record Distributors, visiting his father at Beth Israel Hospital where the senior Flatto recently underwent an operation. Ops visiting with Jere this week included Al Sharpe, Portland, Me.; Art Strahan, Greenfield, Mass.; Harry Walker, Newport, R. I.; and Ralph Ridgeway, Springfield. . . . Ed Ravreby making all out preparations at his World Fair for Spring kiddie ride business which is expected to be the biggest in history. Kiddie rides have mushroomed in the N. E. states this past year with installations on hotel grounds, special kiddie parks, department stores, drug stores, 5 and 10c stores, etc., and the outdoor season this year is expected to surpass all expectations in the opinion of the veteran coin distributor. Ed off on swing of New England to visit ops in preparation for the outdoor season biz. Ruth Mae Ravreby off for Manhattan week-end. Richard Mandell, sales manager for World Fair on California trek to visit his grandmother, ill in Los Angeles. Ops visiting at Ed Ravreby's World Fair and Associated Amusements this week included: Martin Oliver, Portland, Me.; Irving Taube, Manchester, N. H.; Dave Baker, Arlington, Mass.; and Connie Pocius, South Boston.



Many local operators are now in the midst of extensive expansion programs. Those who feel that there is no longer any choice territories available should remember that there are 137 cities and communities in the LA extended area which are served by the Pacific Telephone and Telegraph Company. Our expanding suburban areas will prove a valuable source of new locations during this new year.

DISTRIBUTOR DOINGS:—Business along coinrow has been rather quiet as coinmen re-adjust their activities for the new year. . . . **MINTHORNE MUSIC COMPANY:**—All the Minthorne crew have been extra busy setting up new displays and laying in new stocks of games and phonos. Frank Mencuri, who manages the branch sales offices, says that he now has a larger selection of new and used machines than he has had for several months. Ed Wisler took off for Bakersfield and San Bernardino on another of his periodic sales trips. . . . **BADGER SALES COMPANY:**—After going through the feverish Holiday rush Fred Gaunt states that he's ready for a vacation but will work and save his money with the hopes of taking off for Hawaii sometime in 1957. With several new machines on the floor that are hitting big, the Badger firm has enjoyed a steady flow of business to start off the new year right. Fred Velie, who was formerly employed in the Badger parts department, has left to take up his new post as Western Sales Representative for Wico Corporation, parts suppliers of the Coin Machine industry, Chicago. . . . **C. A. ROBINSON & CO.:**—January sales have been hyped to a new high with the introduction of United's "Bonus" Gun. Charley Robinson reports that shipments have been coming in every day and quickly moving out to locations. Operator enthusiasm on the new gun has been tremendous, he says. . . . **PAUL A. LAYMON & CO.:**—The first of the year has started off with a bang. Activity on all used phonos and games started off with a fast pace and operator acceptance on the new Bally "Magic" Bowler and "Big Times" bingos has been exceptionally good. Laymon's chief games mechanic N. G. "Red" Creswell is now at home recuperating from multiple fractures incurred from an auto accident. We all wish him a speedy recovery. . . . **SIERRA DISTRIBUTORS:**—Wayne Copeland, Ray Powers and Jack Dolan have all been in a huddle discussing new plans for '55. Popularity of the new Wurlitzer "1700" hi-fi has been increasing throughout the area and all at Sierra expect sales activity to hit a new high during the coming months ahead.

OPS JOTS:—Ben Spaulding, well known Phoenix operator, came in to take care of business and visit along the Pico strip this past week. . . . Ruth McClure came down from San Luis Obispo again this past week. . . . Ken Arnold trekked into town from Barstow. . . . Jack Neel from Riverside was also seen visiting here and there. . . . Kenneth Wolf and E. E. Peterson both drove up from San Diego to take care of business. By the way, we wish to thank Peterson for sending up those two spicy art calendars which we received in the mail. . . . Other visitors this past week included Carl Honeyman, Long Beach, and Walter Hennings, Costa Mesa. . . . Cecil Ellison, Lancaster, spent New Year's day in town. He attended the festival of roses and Rosebowl game in Pasadena. . . . Another visitor along coinrow recently was D. D. McClurg from Santa Barbara.

COINROW DOINGS:—V. Van Nattan, sales manager for Auto-Photo Company, left Jan. 5 for The Retail Industry Show at the Madison Square Garden in N. Y., Jan. 7th through 11th. He will have on display the firm's newest model "11" Auto-Photo Studio. A full production schedule has been set up on the new machine and they expect to have enough studios on hand to make deliveries early in April. Van Nattan plans to be back here at the home plant by Jan. 17th. . . . Al Shifrin has moved his business from 3518 W. Pico down to the heart of coinrow at 2704 W. Pico. He repairs and remodels all types of used games. . . . Sam Ricklin of California Music Company came up with the prize quote of the week when he said, "This is a great business. You live in hope and die in despair." . . . George Satler, manufacturer and founder of the Gaffers and Satler home appliances, thinks so much of the modern, new juke boxes which are now on the market that he rents a machine each year for his New Year's Eve party. Lee Nelson, Santa Ana operator, says that he has been furnishing Satler with a juke box each year for the past 6 years. . . . Al Weymouth, prexy of Weymouth Service Company, is now all set up in his new offices and showrooms at Pico and New Hampshire. He is the exclusive distributor for Smokeshop cigarette vendors and also handles other merchandising machines.

Last week Frank Mencuri thought he was back in Chicago when he drove into the driveway of his Garden Grove home. A thin blanket of snow covered the ground. Thinking it was quite an unusual sight for California Frank even rolled a snowball and gave it to his wife with a reminiscent gesture. . . . Doris Slater of Rusty's Tavern in Sepulveda was so interested in the coin machine business that she trekked in along coinrow just to see what makes the wheels tick in this coinbiz. Her location is serviced by one of the valley operators. . . . Received the latest issue of The California Music Merchants Association's yearly journal "News & Views." George A. Miller and his group are to be complimented on the fine job they have done in putting together this publication. It's chuck full of news and timely tips for the operators. All ops should definitely read the editorial on page 41 titled "Evils That Effect the Automatic Phonograph Business." . . . Leuenhagen's Record Bar is a quiet place again. Lovely Barbara Chandler has returned to Marysville and Mary and Kay Solle have settled down to the business at hand to start the new year right. . . . The next meeting of the California Music Merchants Association, Los Angeles Division, has been set for Feb. 15th in the Coral room of the Hotel Gaylord, it was reported by president Walt Hemple.

"THE CASH BOX" CLASSIFIED ADS

The Industry's MARKET PLACE

DURING 1954

THE CASH BOX PUBLISHED

OVER 5,280 CLASSIFIED ADS

(MORE THAN 180,000 WORDS OF COPY)

TO REACH THE INDUSTRY, USE THE INDUSTRY'S MARKET PLACE. "THE CASH BOX" CLASSIFIED ADS ARE A SUPER-MARKET OF PROFITABLE OFFERINGS AND OPPORTUNITIES. EVERYONE TRADING, BUYING OR SELLING READS "THE CASH BOX" CLASSIFIED ADS.

"THE CASH BOX" PUBLISHES MORE CLASSIFIED ADS EACH WEEK THAN ALL OTHER MAGAZINES COMBINED PUBLISH IN A MONTH

WANT

FOR SALE

CHECK OFF WHICH YOU DESIRE

CLASSIFIED AD RATE 10 CENTS PER WORD

Count every word including all words in firm name. Numbers in address count as one word. Minimum ad accepted \$1.00. CASH OR CHECK MUST ACCOMPANY ALL ORDERS FOR CLASSIFIED ADVERTISING. If cash or check is not enclosed with order your classified ad will be held for following issue pending receipt of your check or cash.

Notice to holders of "Special (\$48) Subscription": You are entitled to a free classified ad in each week's issue containing no more than 40 words, which includes your firm name, address and telephone number. All words over 40 will be charged to you at the regular rate of 10c per word. Please count words carefully.

ALL CLASSIFIED ADVERTISING CLOSES WEDNESDAY NOON AT THE CASH BOX, 26 West 47th Street, New York 36, N. Y.

Use This Convenient Form For Your Classified Ad

START HERE



FIRM _____

ADDRESS _____

CITY _____ ZONE _____ STATE _____

TELEPHONE NUMBER _____

ENCLOSE YOUR CHECK—AIRMAIL TO:

THE CASH BOX

26 WEST 47th STREET, NEW YORK 36, N. Y.

CLASSIFIED ADVERTISING SECTION

WANT

WANT—Bingos and Gottlieb 5-balls for resale. Send Prices. H & H DISTRIBUTING, 1626 3rd AVENUE, MOLINE, ILL. Tel.: 4-6703.

WANT—For resale—22 ft. Rockola—American or National Shuffleboards—Late Bingo Games—Shuffle Bowlers—Lee Mfg. Carousel. State best price and condition first letter. STANLEY AMUSEMENT COMPANY, 1523 BROADWAY, TACOMA, WASHINGTON. Tel.: BR. 3663.

WANT — Atlantic Cities \$110; Palm Springs \$325; Ice Frolics \$325; Tahiti \$195.00. Write: PENNSYLVANIA VENDING CORP., 1826 EAST CARSON STREET, PITTSBURGH 3, PENNSYLVANIA.

WANT—New and used records. Highest prices paid for 78's and 45's. No quantity too large or too small. We buy brand new LP's (33 1/3 RPM) in quantity. Write or phone. FIDELITY DISTRIBUTORS, 666 10th AVE., NEW YORK 36. Tel.: Judson 6-4568.

WANT—Phonograph records made before 1940; any quantity or dealer stock; \$150 to \$300 per thousand; will inspect if required. Some labels wanted are Brunswick; Victor; Vocalion; Paramount; Gennett; Bluebird; Champion. JACOB S. SCHNEIDER, 128 W. 66th STREET, N. Y. C.

WANT—Your used or surplus records all speeds. 45's our specialty. We buy all year round and pay top prices. No lot too large or too small. No more than 10% blues. We pay freight. BEACON SHOPS, 821 NO. MAIN STREET, PROVIDENCE, R. I. Tel.: UNion 1-7500.

WANT—A.M.I. 40 selection Hideaways—.05 & .10 W. B. and Steppers. A.M.I. E-120 phonographs. Seeburg 100 W. B. Late One Ball games. Write stating condition, number, model and prices. THE ST. THOMAS COIN SALES LTD., ST. THOMAS, ONTARIO, CANADA. Tel.: 2648.

WANT—To buy Panorams any quantity. CLEVELAND COIN MACHINE EXCHANGE, INC., 2029-35 PROSPECT AVE., CLEVELAND, OHIO. Tel.: TOWer 1-6715.

WANT—Distressed merchandise for return privileges. Purple label Capitols, Columbias, Coral, Decca, Victor, Mercury, King—78's and 45's—also L.P.'s. Please quote prices, we pay freight. C & L MUSIC CO., 11 BAYBERRY RD., FRANKLIN SQUARE, L. I., N. Y.

WANT—From all over the world! Literature on any machine that takes coins and sells anything—amusement, drinks, Bromos, fortunes, Pocket Books, cigarettes 25 2c each, aspirin at 5c each, single band-aids, newspapers. WITHAM ENTERPRISES & ASSOCIATES, 20-22 CUNNINGHAM AVENUE, GLENS FALLS, NEW YORK.

WANT—Northwestern 49's; Challengers; Pike's Peak; Kicker's and Catchers; Weigh Scales or any other penny games or equipment in Canada for resale. Will pay top prices in any quantity. Write, phone or wire. MOCHUK ENTERPRISES, 81 INDIAN ROAD, TORONTO, ONTARIO. Tel.: LO 4722.

WANT—Any quantity post-war Wurlitzer Phonographs, Models 1100, 1250, and 1400. Also Seeburg M100—78 and 45. Wire, write, or phone: BUSH DISTRIBUTING COMPANY, 286 N. W. 29th ST., MIAMI, FLORIDA.

WANT—Mills Panorams—any quantity. WESTERN DISTRIBUTORS, 3126 ELLIOTT AVE., SEATTLE, WASH. Tel.: GARfield 3585.

WANT—Bingos, late model Shuffle Alleys. For Re-sale. Send list. Have all types of amusement equipment for sale. DAVE LOWY & CO., 592 TENTH AVENUE, NEW YORK, N. Y. Tel.: CHickering 4-51 0.

WANT—Frolics, Rodeo, Circus, and Showboats, Seeburgs, Model BL's C's. FOR SALE—10 3-4-5's. Make offer. NOBRO NOVELTY COMPANY, 538 BRYANT STREET, SAN FRANCISCO 7, CALIF.

WANTED—For Cash, up to 15 Mills Panoram's. Must be in good working condition and good cabinets. Write or call: MONROE COIN MACHINE EXCHANGE, INC., 2423 PAYNE AVENUE, CLEVELAND 14, OHIO. Tel.: SUPERior 1-4600.

WANT—45 RPM Records, new or used. No quantity too large or small. Highest prices paid. Write stating quantity on hand. TONY GALGANO, GALGANO DIST. CO., 4142 W. ARMITAGE, CHICAGO 39, ILL. Tel.: DICKens 2-7060.

WANT—Tubes: 2051; 2050; 70L7; 2A4; 2A3; 5V4; 6L6; 6N7; 6L7; 6V6 metal; 6X5 metal. Will pay \$40 a hundred. Must have minimum quantity 50 of a type. Have you other types in quantity? LEWIS ELECTRONICS, 3449 NO. ELAINE PL., CHICAGO, ILL.

CLASSIFIED ADVERTISING SECTION

WANT—For Export. Quantities of the following models: Seeburg M100A; Wurlitzer 1100 and 1250. Telephone collect. DAVIS DISTRIBUTING CORP., 725 WATER ST., SYRACUSE, N. Y. Tel.: SYracuse 75-5194.

FOR SALE

FOR SALE—Spot Lites \$65.00; Beach Clubs \$250.00 TOLEDO COIN MACHINE EXCHANGE CO., 814-816 SUMMIT ST., TOLEDO, OHIO. Tel.: Adams 8621.

FOR SALE—Special. Bally Palm Springs \$299.50; Ice Frolics \$310; Hi Fis \$314.50; Frolics \$137.50; United Hawaii's \$232.50. Also novelty games, kiddie rides, etc. Let us know what you are interested in. Slightly used wooden pinball bases. \$9.00; Five or more \$8.00 each. NEW ORLEANS NOVELTY CO., 115 MAGAZINE STREET, NEW ORLEANS, LA. Tel.: Canal 8318.

FOR SALE—Hi Fi \$375; Palm Springs \$350; Beautys \$225; Frolics \$150; Spot Lights \$65; Genco Rifle Gallery \$375; Genco Sky Gummer \$175; Genco Night Fighter \$175. UNIVERSITY COIN MACHINE EXCHANGE, 858 NORTH HIGH ST., COLUMBUS 8, OHIO. Tel.: University 6900.

FOR SALE—Atlantic City \$95; Spot Lites \$60; AMI Model C \$235; AMI Model D \$325; AMI Model D-80 \$165; Seeburg 100-78 \$365; Rock-Ola Comets \$795; AMI Steppers \$19; 5/10c Boxes \$10; 5c Boxes \$5; 3020 Boxes \$15; 219 Steppers \$15; Seeburg 5/10/25c \$18. H & H MUSIC DISTRIBUTING, 1626 3rd AVE., MOLINE, ILL. Tel.: 4-6703.

FOR SALE—United Fifth Ave. \$275; United Empire \$210; United Empire converted to Fifth Ave. \$235; Williams Major League \$195; Williams Special DeLuxe Baseball \$125; Williams DeLuxe Baseball \$99. AMERICAN VENDING CO., 2684 CONEY ISLAND AVE., BROOKLYN, N. Y. Tel.: DEwey 2-9602.

FOR SALE—Genco Shuffle Pool \$195; Keeney 10 Player Team Bowler \$165; AMI D-40 \$395; AMI D-80 Chrome \$195; AMI E-120 write. Wurlitzer 1500 \$525. UNITED DISTRIBUTORS, INC., P. O. BOX 1995, 513 E. CENTRAL, WICHITA 2, KANSAS.

FOR SALE—Attention importers of AMI Juke Boxes. All late model AMI D-40's, D-80's, E-80's, E-120's, reconditioned by factory personnel. Guaranteed perfect. Lowest prices. Address inquiries to: SHELDON SALES, INC., 881 MAIN STREET, BUFFALO 3, NEW YORK. Tel.: LIncoln 9106.

FOR SALE—Hi-Speed Super Fast Shuffle board wax. 24 one-pound cans per case \$8.50 f.o.b. Dallas, Texas. Sold on money back guarantee. AMI Distributor. STATE MUSIC DISTRIBUTORS, INC., 3100 MAIN ST., DALLAS, TEXAS.

FOR SALE—Attention wholesale buyers: AMI E-80's and E-120's, like new. Contact us. Let us know your needs. COPELAND DISTRIBUTORS, 900 NORTH WESTERN, OKLAHOMA CITY, OKLAHOMA. Tel.: FO 5-3456.

FOR SALE—Can you afford 92c per week to get ahead and stay ahead of all competition? For only 92c per week you can have a 40-word ad in this section plus a free full year's (52 weeks) subscription to The Cash Box "The 'Bible' of the Coin Machine Industry." Send your Check for \$48 today plus your first 40-word ad to: THE CASH BOX, 26 W. 47th ST., NEW YORK 36, N. Y. (Phone JU 6-2640).

FOR SALE—Coin Counters, Coin Sorters, Coin Counting Combinations, Coin Changers, Coin Wrappers, Parts and Supplies. We carry a complete line of these products. GLOBE DISTRIBUTING CO., 1623 N. CALIFORNIA AVE., CHICAGO 47, ILL. Tel.: ARmitage 6-0780.

FOR SALE—Brite Lites \$65.00; Brite Spot \$85.00; Spot Lite \$75.00; Classics \$179.50; Clovers \$164.50; U-10th Fr. Stars \$125.00. ALLIED DISTRIBUTING CO., 786 MILWAUKEE AVE., CHICAGO, ILLINOIS. Tel.: Canal 6-0293-4-5.

FOR SALE—All machines 20% off high CASH BOX prices. Wurlitzer 1015, 1100, 120. Rockolas 1422, 1426. AMI Model C. Seeburgs 146, 147, 100A. Phone STerling 8-7515 or Write: DIXON DISTRIBUTING CORP., P.O. Box 2660, YOUNGSTOWN, OHIO.

FOR SALE—Records!!! 5c over wholesale, any label. Free title strips. Quick service. New accounts, token deposit with order. We also purchase surplus records new unused only. RAYMAR SALES CO., 170-21 JAMAICA AVENUE, JAMAICA 32, N. Y. Tel.: OLYmpic 8-4012, 4013.

FOR SALE—1 Chicago Coin Super Home Run 6 Player Double Coin Chute \$295; 1 Exhibit Sixshooter \$125; 2 Bright Lights \$50 each; Stars \$75; 2 Coney Island \$65 each; 1 Star Series \$60. AUTOMATIC AMUSEMENT COMPANY, 1000 PENNSYLVANIA STREET, EVANSVILLE, INDIANA. Tel.: 3-4508.

CLASSIFIED ADVERTISING SECTION

FOR SALE—Williams 6-player Baseball \$249; Williams Deluxe Baseball \$99; Genco Night Fighter \$149; Six Shooters \$79; Jet Guns \$99. Shuffle Alleys at lowest prices. Hi-Speed Shuffle Board wax—24 cans per case \$6. WEST SIDE DISTRIBUTING CORP., 612 TENTH AVENUE, NEW YORK, N. Y. Tel.: Circle 6-8464.

FOR SALE—10 cent Operators don't let profit walk out the door. Use General's Two Nickels for dime play Kits. Install in minutes. Watch Revenue increase. Samples \$3.50 each, lots of 10, \$2.95 each. GENERAL DISTRIBUTING COMPANY, 3574 HARDING STREET, CARLSBAD, CALIF. Tel.: OCeanside 5151.

FOR SALE—Used 78 and 45 RPM records. Taken right off our route. Any quantity. Write for price. NATIONAL NOVELTY CO., 183 MERRICK ROAD, MERRICK, L. I., N. Y. Tel.: FREeport 8-6770.

FOR SALE—Bally Beauties, Atlantic Cities, Beach Clubs, Dude Ranches, Palm Springs and HI-FI's, perfect condition, priced at or near lowest levels. Seeburg, AMI, Rockola and Evans Music, 78 and 45 RPM. GORDON STOUT CO., 125 N. MONTOE, PIERRE, S. D. Tel.: 4097.

FOR SALE—Genco Shuffle Pools \$275; Genco Basketballs \$399.50; Victor Hot Pops \$20; Genco Invader Guns \$259.50; Seeburg Shoot-the-Bears \$175. MILLER-NEWMARK DISTRIBUTING CO., 42 FAIRBANKS ST., N.W., GRAND RAPIDS, MICH. Phone 9-8632 and 5743 GRAND RIVER AVE., DETROIT 8, MICH. Tel.: TYler 8-2230.

FOR SALE—Premium merchandise for coin machine prizes. Over 3,000 articles carried in stock. Write for complete wholesale descriptive price list today. (Established 1932.) HASTINGS DISTRIBUTING CO., 6100 BLUEMOUND ROAD, MILWAUKEE 13, WISC. Tel.: Blucmound 8-7600.

FOR SALE—A-1 mechanical condition Wurlitzer 48 sel phonographs model 1650 @ \$475; 1400 @ \$375; 1250 @ \$239; Wurlitzer 24 sel phonographs model 1080 @ \$95; 1015 @ \$75 750 @ \$49. T & L DISTRIBUTING CO., 1663 CENTRAL PKWY., CINCINNATI 14, OHIO. Tel.: MAin 8751.

FOR SALE—All types used AMI, Wurlitzer and Seeburg equipment. Clean and shopped, or as is. Factory Distributor for Seeburg. DICKSON DISTRIBUTING CO., 631 W. CALIFORNIA, OKLAHOMA CITY, OKLA, Tel.: REgent 6-3691.

FOR SALE—ABC \$25; Brite Lites \$50; Lite A Line \$40; Broadway \$75. One-third deposit and balance C.O.D. GOLDEN GATE NOVELTY CO., 701 GOLDEN GATE AVENUE, SAN FRANCISCO 2, CALIF. Tel.: MArket 3967.

FOR SALE—Reconditioned, Like New. Yacht Club \$145; Ice Frolics \$365; Surf Clubs \$395; Bally Jets \$425; Hi Fi's converted into Beach Clubs. Write: One Serviceman with 10 thumbs. DONAN DISTRIBUTING COMPANY, 5007 N. KEDZIE, CHICAGO 25, ILL. Tel.: Juniper 8-5211.

FOR SALE—1 Seeburg Sicnm Unit, perfect condition, \$250; 2 Genco Sky Gummer, brand new; Ajax Cigarette Machines, brand new, close-out; 1 Poolette Pool Table \$50; 1 Keeney 2-Player Attachment for Shuffleboard. LIEBERMAN MUSIC COMPANY, 257 PLYMOUTH AVE. NORTH, MINNEAPOLIS, MINN.

FOR SALE—The best buy in used Bally Bingo Games. Just buy one and you will see why you pay a little more and be glad you did. Your money back if not completely satisfied. 1/3 deposit with all orders. Write or call: ALLAN SALES, INC., 937 MARKET ST., WHEELING, W. VA. Tel.: WHEELing 5472.

FOR SALE—Positively The Best. Dude Ranch \$265.00; Ice Frolics \$325.00; Palm Springs \$315.00; Surf Club \$335.00; Yacht Club \$140.00; Hi Fi \$325.00; Beauty \$190.00; Broadway \$55.00; Lite A Line \$50.00; Havana \$235.00; Rio \$225.00; Mexico \$295.00; Hawaii \$265.00. CROWN NOVELTY CO., INC., 920 HOWARD AVENUE, NEW ORLEANS, LA. Tel.: Canal 7137.

FOR SALE—Evans Constellation \$225; Shoot the Bear \$145; Keeney DeLuxe Bowler \$125; AMI A, B, C, D and a complete line of United Bingo and Shuffle Alleys. CENTRAL DISTRIBUTORS, 2315 OLIVE ST., ST. LOUIS, MISSOURI. (MAin 1-3511) or 3314 MAIN STREET, KANSAS CITY, MISSOURI (WEstport 3582).

FOR SALE—We will sell or trade all types cigarette machines (thoroughly reconditioned) Colsnac and Vendo Ice Cream Machines and Automatic Popcorn Shoppes for late model juke boxes. BRUCE MUSIC AND VENDING SERVICE, 1602 PIERRE AVENUE, SHREVEPORT, LA.

FOR SALE—To our Canadian Friends: Write for list of 5-Balls and Shuffle Alleys, low prices. Sample: United De Luxe 6-Player Shuffle Alley \$50 and Minstrel Man \$20. WESTERN DISTRIBUTORS, 1226 SW 16th AVE., PORTLAND 5, OREGON. Tel.: Atwater 7565.

FOR SALE—America's finest reconditioned phonographs and music accessories. Everyone of our reconditioned machines guaranteed beautiful condition regardless of price. Tell us what you need. Get our prices before you buy. ANGOTT DISTRIBUTING CO., INC., 2616 PURITAN AVENUE, DETROIT 21, MICH. Tel.: UNiversity 4-0773.

FOR SALE—Sensational News—12 months to pay for Kiddie Rides. Largest stock in the world of new and used Kiddie Rides. Liberal terms—Trades Accepted. REDD DISTRIBUTING COMPANY, INC., 298 LINCOLN STREET, ALLSTON 34, MASS. Tel.: ALgonquin 4-4040.

FOR SALE—Evans Jubilee \$250.00; Wurlitzer 1015's \$69.50; Wurlitzer 1250's \$250.00; United & Chicago Coin 6 Player \$59.50; Star & 10th Frame \$150.00; Olympics \$225.00. COVEN MUSIC CORP., 3181 NORTH ELSTON AVENUE, CHICAGO, ILL. Tel.: INdependence 3-2210.

CLASSIFIED ADVERTISING SECTION

FOR SALE—Rock-Ola 1436, 120 selection; 78 rpm \$425. each; Seeburg 146 \$59. each; 147M \$70.; 148ML \$98.; Wurlitzer 1080 \$65.; 1500 \$450.; AMI two E-120 \$595. each. A-1 condition. 1/3 deposit. WERTZ MUSIC SUPPLY CO., 1013 E. CARY ST., RICHMOND, VA. Tel.: 7-3021.

FOR SALE—Reconditioned ready for location. 1400 & 1450 Wurlitzers \$350. each; 1015 Wurlitzer \$79.50; E-120 AMI \$650.; E-40 AMI \$450.; C-40 AMI \$225.; Bear Gun \$150.; Exhibit Jet Gun \$125.; Genco Sky Gunner \$175. All types United Bowlers. Write: MOUNTAIN DISTRIBUTORS, 3630 DOWNING ST., DENVER, COLORADO.

FOR SALE—Just released! "I Threw Away A Diamond" (For A Worthless Piece Of Glass) featuring Hank Trotter's Happy Rangers. Dist. Att.: CROSS COUNTRY RECORDS, 229 OUTWATER LANE, GARFIELD, N.J. Tel.: PR. 9-0182.

FOR SALE—Army & Navy \$117.50; Spark Plug \$60; Jalopy \$60; Flying High \$99.50; Super Pennant \$275; Star Series \$65; Hayburner \$50; Grand Slam \$90; Cabana \$149.50; Tropic \$174.50; Beach Club \$349.50; Hifi \$465; Beauty \$240; Bright Light \$40. LAKE CITY AMUSEMENT, INC., 4533 PAYNE AVENUE, CLEVELAND 4, OHIO. Tel.: HENDERSON 1-7577.

FOR SALE—Wurlitzer Bar Boxes 2140's; Wurlitzer Wall Boxes 3020's Steppers and Master units. No reasonable offer refused. YOUNG DISTRIBUTING, INC., 599 TENTH AVENUE, NEW YORK, N. Y.

FOR SALE—Contact us before you buy. We carry all types of coin machines. Largest Central Pennsylvania distributor for United, Universal, Chicago Coin, Keeney and Bally. WILLIAMSPORT ELECTRONIC & TELEVISION CO., 233 W. 3rd STREET, WILLIAMSPORT, PA. Tel.: 2-3326 or 2-1648.

FOR SALE—Complete Arcades or a single machine. We have the largest stock of new and reconditioned Arcade Machines in the world. Also parts and supplies. Send for new illustrated catalog. MIKE MUNVES, 577 TENTH AVENUE, NEW YORK, N. Y. Tel.: CHickering 4-8628.

FOR SALE—Bally Bingo Specials; 10 Beach Clubs \$265; 5 Yacht Clubs \$160; 5 Dude Ranch \$295; 4 Palm Springs \$325; Ice Frolics \$325. Also other Bingos and Bowlers. Call or write: MICKEY ANDERSON, 314 EAST 11th STREET, ERIE, PENNSYLVANIA. Tel.: 5-7549.

FOR SALE—A.M.I. Model D-80 \$525; A.M.I. Model C \$300. W. B. DISTRIBUTORS, INC., 1012 MARKET STREET, ST. LOUIS, MISSOURI. Tel.: CENTRAL 9292.

FOR SALE—Telequiz Machines, factory reconditioned. Ready for location, \$119.50. 1/3 down, balance C.O.D. We stock all Telequiz parts, also parts and supplies for Jukes, Shuffle and Pin Games. Write for catalog. CHAMPION DISTRIBUTING CO., 3743 W. GRAND, CHICAGO, ILLINOIS.

FOR SALE—We have a large stock of reconditioned Five Balls, One Balls, Bingo and Phonos. Write for list. WESTERHAUS CORPORATION, 3726 KESSEN AVENUE, CINCINNATI, O. Tel.: MONTANA 5000-1-2.

FOR SALE—Ready for location Wurlitzer 1015, 18080 and 1400. Seeburg 146M, 147M, 148ML. Special prices on 3020, 4820 and 3W5L-56 Wall Boxes. Contact CENTURY DISTRIBUTORS INC., 1221 MAIN ST., BUFFALO 9, N. Y. Tel.: SUMMER 4938.

FOR SALE—The finest used phonographs in all our history now available for immediate sale. Get our price on any phonograph you want before you buy. UNITED, INC., 4227 WEST VLIET ST., MILWAUKEE, WIS. Tel.: WEST 3-3224.

FOR SALE—This equipment is in good working order and must be sold. Name your own price: Gottlieb's five balls; Guys & Dolls, Cyclone, Happy Go Lucky, Knockout, Hit & Run, Rose Bowl, Joker, Coronation, Happy Days, Four Stars; Genco:—Mercury; Chicago Coin:—Pin Bowler; 27 Rockola 5c Wall Boxes Straight, 22 Rockola 5-10-25c Wall Boxes, 2 Magic Glow 1428, 3 Large Rockola Speakers; Bally:—3 Turf Kings, 2 Champions, 3 Citations, 1 Jockey Special, 1 Spot Lite, 1 Frolics; 1 Chicago Coin Play Ball, 1 Chicago Coin Hockey; 1—1c Watling Fortune Teller Scale; 1—1c Mutoscope Pinching Bag; 1 H. C. Evans Skill Bowler; 1 Genco Play Ball; 3 Silver King 1c Target Guns; 1 Exhibit 1c Picture Card with stand. One-third deposit with order, balance C.O.D. TRI-STATE AMUSEMENT CO., 149 18th STREET REAR, WHEELING, W. VA. Tel.: WHEELING 649.

FOR SALE—Reconditioned Phonos—ready for location. Seeburg 146-147-148; Wurlitzer 1015; Rockola 1422-1426; AMI Wallboxes 5c-10c. Write for our low prices. MUSIC DISTRIBUTORS, INC., 213 FRANKLIN STREET, FAYETTEVILLE, N. C.

FOR SALE—Finest Bingos—factory reconditioned—like finding \$50 in your pocket. Returnable 3rd day, full refund to protect you. Palm Springs (almost new) \$395; Yacht Clubs (Improved superline frequency) \$205; Palm Beach \$140; Dude Ranch \$370; Beach Clubs \$345; Atlantic Citys \$130; Leader \$65; Coney Island \$80; Holidays (6 card) \$60; Genco 400's (percentaged right) \$65. We want Bingos. Mail your list. W. E. KENNEY MFG. CO., 5229 S. KEDZIE AVENUE, CHICAGO 32, ILL. Tel.: HEMLOCK 4-3844.

CLASSIFIED ADVERTISING SECTION

FOR SALE—Genco 2 player Basketball \$250; Genco Shuffle Pool \$125; Seeburg Coon Hunt \$450; Chicago Coin's 6 player Home Run \$250; Williams' 6 player Major League Baseball \$250; Williams' 6 player All Star Baseball \$250. RELIABLE COIN MACHINE CO., 184 WINDSOR STREET, HARTFORD, CONN. Tel.: CHapel 9-6556.

FOR SALE—Complete line of used phonographs, shuffle games, cigarette machines, all other equipment. Lowest prices. Best merchandise. One letter, wire, or phone call will convince you. Factory Representatives for United, Keeney, Bally, TARAN DISTRIBUTING, INC., 3401 N. W. 36th STREET, MIAMI 42, FLA. Tel.: 64-4864.

FOR SALE—Reconditioned phonos—ready for location: AMI A; AMI C; AMI D-40 and D-80; Rock-Ola Fireball 45 rpm; Seeburg M 100A; Wurlitzer 1500. Write for low prices. RUNYON SALES COMPANY, 593 TENTH AVE., NEW YORK, N. Y. or 221 FRELINGHUYSEN AVE., NEWARK, N. J.

FOR SALE—Coin Wrappers, Pop-Open, \$2.50 dimes only, 55c per thousand, thirty thousand to case. Fresh stock, sample mailed on request. J. ROSENFELD COMPANY, 3220 OLIVE ST., ST. LOUIS 3, MO. Tel.: OLIVE 2-2800.

FOR SALE—"Sock-The-Ock" converts "Shoot-The-Bear" into a gun that will top all others in appeal, performance, and take. A complete package \$28.00. 100 SERVICE COMPANY, 2638 OLIVE STREET, ST. LOUIS, MO. Tel.: JEFFERSON 1-6531.

FOR SALE—Wurlitzer Phonographs—Model 1500's—\$475; 1400's—\$375; 1250's—\$195; 1100's—\$175; 1015's—\$70. O'CONNOR DISTRIBUTORS, INC., 2320 WEST MAIN ST., RICHMOND 20, VA. Tel.: 84-3264.

Notice!

YOU CAN SAFELY SEND DEPOSITS TO ADVERTISERS IN "THE CASH BOX"

Your Deposit Is GUARANTEED

AS LONG as you are a paid up subscriber to 'The Cash Box', at the time you answer any advertisement that appears in 'The Cash Box', where the advertiser requires that you must send a deposit to obtain the merchandise advertised, your deposit up to \$100.00 is guaranteed by 'The Cash Box'. This is "The Cash Box' Free Deposit Insurance Plan". An exclusive and original feature of 'The Cash Box' only. Should you lose your deposit in fraudulent manner immediately write:

THE CASH BOX

26 West 47th Street, New York 36, N. Y.

FOR SALE—Clover Shuffle Alley \$125; Royal \$225; League \$325. WANT: Yankee Shuffle Alley and Bally Jets. MOHAWK SKILL GAMES COMPANY, 67 SWAGGERTOWN ROAD, SCHENECTADY 2, N. Y. Tel.: 7-2162.

FOR SALE—40 Wurlitzer 3020 Wall Boxes \$8 each; 50 Seeburg 5c 3-Wire Wall Boxes \$3 each. Beautiful equipment. 1/3 deposit, balance C.O.D., or Sight Draft. KOEPEL DISTRIBUTING CO., 629 TENTH AVE., NEW YORK, N. Y. Tel.: Circle 6-8939.

FOR SALE—All types reconditioned Coin Operated Games available at lowest prices. Write, wire, phone C. A. ROBINSON & CO., 2301 W. PICO BLVD., LOS ANGELES 6, CALIFORNIA. Tel.: DUNKIRK 3-1810.

MISCELLANEOUS

NOTICE—These 3 telephone numbers are important to you: The Cash Box, New York City, Judson 6-2640; The Cash Box, Chicago, Ill., Dearborn 2-0045; The Cash Box, Hollywood, Calif., Hollywood 5-1702.

NOTICE—Are you having trouble keeping Plexiglass clean on your juke boxes? Our Mecite does the job—16 oz. bottle \$.85. For distributor price and territory, contact MECCA SERVICE CO., 716 N. 19th ST., EAST ST. LOUIS, ILLINOIS.

NOTICE—Start The New Year Right. If you are an Operator or a Distributor and you want to purchase the finest used games, contact us for your supply. We always have a large stock of Bingo Games, Regular Five Ball Games, Arcade Equipment, etc. We welcome your inquiry. Watch our weekly ads for the red hot bargains. CROWN NOVELTY CO., INC., 920 HOWARD AVE., NEW ORLEANS, LA. Tel.: Canal 7137.

NOTICE—Bingo Operators! Stop service calls caused by balls piling up in Ball Trough. Ball guides easily installed on location in 10 minutes. Specify Bally or United Game. Four Samples \$3.00, \$8.00 per dozen. MID-WEST MUSIC SERVICE, 819 WEST 2nd ST., WICHITA, KANSAS.

NOTICE—Your Seeburg 20 selection wall boxes, wired or wireless, converted to play the first 20 (A & B Program) on all model Seeburg 100's—5 cent Box \$5.00. 5-10-25 \$15.00. Performance guaranteed. 100 SERVICE COMPANY, 2634 OLIVE ST., ST. LOUIS 3, MO. Tel.: NEWstead 6531.

NOTICE—We are exclusive national and export distributors for the new sensational home non-coin operated juke box "Jukette". Great appeal. Priced low. Write for complete information. SEACOAST DISTRIBUTORS, INC., 1200 NORTH AVE., ELIZABETH, N. J. (Tel.: Bigelow 3-3524) or 594 TENTH AVE., NEW YORK, N.Y. (Tel.: BRyant 9-4684.)

NOTICE—Louisiana & Mississippi Operators—your authorized AMI phonograph distributor is DIXIE COIN MACH. CO., 122 NO. BROAD ST., NEW ORLEANS, LA. Tel.: MAGnolia 3931.



THIS WEEK'S USED MACHINE QUOTATIONS

16th Year of Publication
797th Consecutive Week's Issue

How To Use "THE CASH BOX PRICE LISTS"

[Also known as the "C. M. I. (Coin Machine Industry) BLUE BOOK" and "The Confidential Price Lists"]

FOREWORD: Many times, wide differences appear in the quotation of high and low prices of certain equipment. Like any true reporter "The Confidential Price Lists" can only feature the market prices as they are quoted. "The Confidential Price Lists" acts exactly the same as the market quotation board at the Stock Exchange—posting the prices as they are quoted for the past week, regardless of how much they may seem to be out of line. Some prices do not change for months. "The Confidential Price Lists," rather than show no price, retain the last known quotations for such equipment so that the subscriber at least has the last known prices as a basis to work with. Prices may be very widely divergent. Someone on the West Coast may feel a certain machine worth \$150.00 whereas someone on the East Coast may think it worth but \$75.00. Of course, serial, appearance, demand, territory, quantity, and condition of equipment must be taken into consideration. (Some equipment offered by outstanding firms, having a reputation for shipping completely reconditioned machines, will be offered at higher prices than others, due to the added cost of reconditioning.) "The Confidential Price Lists" reports each quotation exactly as it is made and depends on the subscriber to make average price adjustments to fit the peculiarities of his territory.

METHOD: "The Confidential Price Lists" should be read as follows: First price listed is lowest price quoted for the week; Second price listed is highest price quoted.

FOREIGN BUYERS: To cover cost of packing, crating, shipping, etc., figure an additional \$20 to \$25 on Pin Games—and \$25 to \$30 on Phonographs.

CODE

- | | |
|-----------------------------|------------------------------------|
| 1. Prices UP | 5. No quotations Last 2 to 4 Weeks |
| 2. Prices DOWN | 6. No quotations 4 Weeks or Longer |
| 3. Prices UP and DOWN | 7. Machines Just Added |
| 4. No change from Last Week | * Great Activity |

REGARDING SELLING PRICES

IMPORTANT!

Reports received indicate that, in some cases, purchasers become upset due to the fact that they cannot, many times, buy equipment listed in the lower price brackets. Sometimes sellers of machines listed at from \$10.00 to \$25.00 ask from \$50.00 up to \$75.00 and even more for these very same machines. Purchasers of such equipment must realize that machines in the very low priced categories are much worn to be priced at these low figures. To completely recondition such machines, the reconditioner must add onto his price the cost of transportation to obtain these machines, the labor, parts and supplies needed to recondition the machines, plus the cost of cartons, crates and labor for packing and shipping of the machines, in addition to a decent profit which will, in most cases, raise the price of a \$10.00 to \$20.00 machine to anywhere from \$50.00 to \$75.00 and up. In the case of arcade and kiddie ride machines these may even be higher due to the fact that many of the parts have to be made by hand or contracted for at some machinist shop, since manufacturers of many of the old arcade machines and kiddie rides are no longer in business and it is impossible to obtain parts for reconditioning. Purchasers of such equipment should take these facts into consideration and, at the same time, should also realize that many buyers today have their own repair and reconditioning departments as well as experienced mechanics, such buyers will purchase machines "as is", at prices quoted by the trade at large, and recondition the machines themselves to meet their own operating standards.



LISTED ALPHABETICALLY

AMI

4. Model A, '46, 40 Sel., 78 RPM	129.00	165.00
4. Model B, '48, 40 Sel., 78 RPM	195.00	265.00
2* Model C, '50, 40 Sel., 78 RPM	215.00	295.00
4* Model D-40, '51, 40 Sel., 78 RPM	300.00	395.00
4* Model D-80, '51, 80 Sel., 45 RPM	450.00	525.00
4. Model E-40, '53, 40 Sel., 78 RPM	450.00	595.00
4. Model E-80, '53, 80 Sel., 45 RPM	550.00	725.00
4. Model E-120, '53, 120 Sel., 45 RPM	625.00	775.00
4. WM Wall Box	10.00	12.00
4. SM or SL Stepper	12.00	24.50

EVANS

4. Mills Constellation, '47 Model 951, 40 Sel., 78 RPM	35.00	79.50
--	-------	-------

4. Constellation, '49 Model 135, 40 Sel., 78 RPM	100.00	195.00
4. Jubilee, '52, Model 245, 40 Sel., 45 RPM	200.00	250.00
4. Century, '52, Model 2045, 100 Sel., 45 RPM	300.00	350.00

ROCK-OLA

4. 1422, '46, 20 Sel., 78 RPM	35.00	75.00
4. 1424, '46, Playmaster Hideaway, 20 Sel., 78 RPM	30.00	70.00
2. 1426, '47, 20 Sel., 78 RPM	55.00	115.00
4. 1428, '48, Magic-Glo, 20 Sel., 78 RPM	125.00	175.00
4. 1432, '50, Rocket '50-51, 50 Sel., 78 RPM	200.00	250.00
4. 1432, Same as above, Converted to 45 RPM	225.00	295.00

4. 1434, '51, Rocket '51-52, 50 Sel., 78 RPM	247.50	350.00
4. 1434, Same as above, Converted to 45 RPM	295.00	350.00
4. 1436, '52, Fireball, 120 Sel., 45 RPM	337.50	425.00
4. 1436A, '53, Fireball, 120 Sel., 45 RPM	395.00	550.00
6. 1501 Wall Box	3.00	4.50
6. 1502 Bar Box	5.00	7.50
6. 1503 Wall Box	12.50	15.00
6. 1504 Bar Box	8.50	17.50
6. 1510 Bar Box	15.50	20.00
6. 1525 Wall Box	5.00	15.00
6. 1526 Bar Box	15.00	19.50
6. 1530 Wall Box	15.00	25.00
6. 1805 Organ Speaker	24.50	29.00

SEEBURG

4. 146S, '46, Standard, 20 Sel., 78 RPM	35.00	75.00
4. 146M, '46, Master with Remote Attach., 20 Sel., 78 RPM	35.00	100.00
4. 147S, Standard, 20 Sel., 78 RPM	45.00	85.00
4. 147M, '47, Master with Remote Attach., 20 Sel., 78 RPM	49.50	95.00
4. 148S, '48, Standard, 20 Sel., 78 RPM	100.00	150.00
4. 148M, '48, Master with Remote Attach., 20 Sel., 78 RPM	75.00	150.00
4. 148ML, '48, Light Cab. Master with Remote Attach., 20 Sel., 78 RPM	98.00	159.00
2* M100A, '49, 100 Sel., 78 RPM	375.00	450.00
4* M100B, '51, 100 Sel., 45 RPM	525.00	575.00
4. M100BL, '51, 100 Sel., 45 RPM, Light Cab.	550.00	595.00

4. M100C, '53, 100 Sel., 45 RPM	650.00	685.00
4. HF100G, '54, 100 Sel., 45 RPM	725.00	825.00
4. W1-L56 Wall Box 5c	3.00	6.95
4. 3W2 Wall-a-Matic	4.25	10.00
4. W4L-56	19.50	29.00
4. 3W5-L56 Wall Box 5c, 10c, 25c	16.50	24.50
4. W6L-56 5/10/25 Wireless	16.50	24.50
4. 3W7-L-56	22.50	34.50

WURLITZER

4* 1015, '46, 24 Sel., 78 RPM	50.00	80.00
4. 1080, '46, Colonial, 24 Sel., 78 RPM	50.00	99.00
4. 1080A, '48, Colonial, 24 Sel., 78 RPM	60.00	125.00
4. 1017, '46, Hideaway, 24 Sel., 78 RPM	50.00	100.00
4* 1100, '48, 24 Sel., 78 RPM	125.00	200.00
4. 1250, '50, 48 Sel., 78 RPM	160.00	250.00
4. 1250, '50, (Same as above) Converted to 45 RPM	170.00	250.00
4. 1400, '52, 48 Sel., 78 RPM	325.00	395.00
6. 1400, '52, (Same as above) Converted to 45 RPM	325.00	400.00
4* 1500, '53, 105 Sel., 78 and 45 RPM Inter-mixed	450.00	525.00
7. 1650, '53, 48 Sel., 45 RPM	475.00	525.00
4. 2140 Wall Box	3.00	10.95
2* 3020 Wall Box	7.00	15.00
4. 3048 (Conv. of 3020)	15.00	25.00
4. 3031 Wall Box	2.95	5.00
4. 3045 Wall Box	4.00	20.00
4. 4820 Wall Box	20.00	39.50



Manufacturers and date of game's release listed. Code: (B) Bally; (CC) Chicago Coin; (Ex) Exhibit; (Ev) Evans; (Ge) Genco; (Got) Gottlieb; (Ke) Keeney; (Un) United; (Wm) Williams.

2. ABC (Un 3/51)	25.00	50.00
4. Across the Board (Un 9/52)	35.00	50.00
6. Ali Baba (Got 6/48)	15.00	25.00
6. Alice (Got 8/48)	19.50	29.50
4. All Star Basketball (Got 1/52)	20.00	39.00
6. Aquacade (Un 4/49)	10.90	25.00
4. Arabian Knights (Got. 12/53)	170.00	185.00
4. Arcade (Wm 11/51)	45.00	75.00
4. Arizona (Un 4/50)	10.00	25.00
4. Army-Navy (Wm 10/53)	69.50	117.50
1* Atlantic City (B 5/52)	110.00	145.00
6. Baby Face (Un 12/48)	10.00	20.00
6. Banjo (Ex 3/48)	10.00	20.00
4. Bank-A-Ball (Got 5/50)	15.00	25.00
6. Barnacle Bill (Got 8/48)	10.00	20.00
4. Basketball (Got 10/49)	15.00	25.00
4* Beach Club (B 2/53)	225.00	349.00
1* Beauty (B 11/52)	215.00	250.00
4. Be Bop (Ex 3/50)	10.00	20.00
6. Bermuda (CC 11/47)	15.00	20.00
4. Big Hit (CC 7/52)	35.00	50.00
6. Big Top (Ge 2/49)	10.00	20.00
6. Black Gold (Ge 3/49)	10.00	20.00
6. Blue Skies (Un 11/48)	15.00	20.00
4. Bolero (Un 12/51)	45.00	95.00
4. Bomber (CC 3/51)	20.00	25.00
4. Bone Head (Ge 11/48)	10.00	20.00
6. Boston (Wm 5/49)	15.00	29.50
4. Bowling Champ (Got 2/49)	15.00	25.00
6. Bowl League (Got 8/47)	10.00	19.50
1* Bright Lights (B 5/51)	40.00	75.00
1. Bright Spot (B 11/51)	65.00	85.00
4. Broadway (B 6/51)	49.50	75.00
4. Buffalo Bill (Got 5/50)	20.00	30.00
4. Buccaneer (Got 10/48)	10.00	25.00
6. Build Up (Ex 2/48)	10.00	15.00
4. Buttons & Bows (Got 3/49)	15.00	25.00
2* Cabana (Un 3/53)	125.00	185.00
4. Camel Caravan (Ge 6/49)	15.00	30.00
4. Campus (Ex 2/50)	15.00	20.00
4. Canasta (Ge 7/50)	25.00	34.50
4. Caravan (Wm 6/52)	35.00	75.00
6. Carnival (B 7/48)	10.00	20.00
6. Carolina (Un 3/49)	15.00	25.00
6. Caribbean (Un 3/48)	15.00	25.00
4. Champion (B 12/49)	20.00	30.00
6. Champion (CC 6/49)	15.00	20.00
4. Chinatown (Got 10/52)	65.00	95.00
4. Cinderella (Got 3/47)	10.00	25.00
6. Circus (Ex 8/48)	10.00	20.00
4. Circus (Un 8/52)	150.00	175.00
4. Citation (B 10/48)	15.00	35.00
4. C.O.D. (Wm 9/53)	85.00	125.00
4. College Daze (Got 8/49)	10.00	20.00
3* Coney Island (B 9/51)	65.00	95.00
6. Contact (Ex 10/48)	10.00	20.00
4. Control Tower (Wm 3/51)	25.00	35.00
4. Coronation (Got 11/52)	65.00	95.00
4. County Fair (Un 9/51)	30.00	45.00
6. Crazy Ball (CC 7/48)	10.00	20.00
4. Crossroads (Got 5/52)	45.00	75.00
4. Cyclone (Got 5/51)	40.00	85.00
4. Daffy Derby (Wm 8/54)	295.00	339.50
4. Daisy May (Got 7/54)	175.00	235.00
4. Dallas (Wm 2/49)	15.00	29.00
4. Dealer "21" (Wm 2/54)	145.00	175.00
4. De Icer (Wm 11/49)	20.00	39.00
6. Dew Wa Ditty (Wm 6/48)	10.00	29.50
4. Domino (Wm 5/52)	39.50	75.00
4. Double Action (Ge 1/52)	25.00	35.00
4. Double Feature (Got 12/50)	15.00	25.00
4. Dbl. Shuffle (Got 6/49)	15.00	25.00
4. Disk Jockey (Wm 11/52)	45.00	80.00

TURN TO THE "F" for the Essentials of High Fidelity

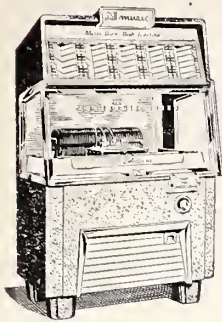

The Model "F" multiple horn system, combined with its perfectly balanced High Fidelity components, delivers music that delights the most critical listener. Every note—high, low and middle throughout the FULL RANGE—every subtle phrase and shading is heard with startling realism. Nothing is lost or added for no electronic exaggeration can intrude on this thrillingly natural music.

ESSENTIAL No. 1. Folded Bass Horn

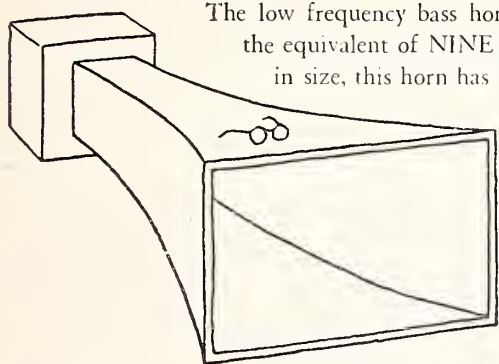

The low frequency bass horn built into the Model "F" is the equivalent of NINE 12-inch loudspeakers. Gigantic in size, this horn has room to develop low frequency vibrations and bring out the deepest notes distinctly without unpleasant "boom." The horn mouth extension at the bottom of the cabinet is almost three feet square.

ESSENTIAL No. 2. Flared Treble Horn

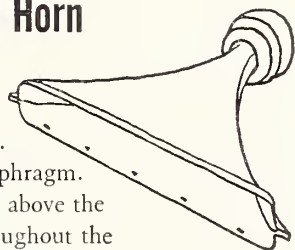

While bass speakers must be large, minute size in treble drivers gives a better response to the rapid vibrations of the higher frequencies. AMI's treble driver has but a 1-inch diameter diaphragm. The flared horn to which it is attached is located above the program panel at ear level. It delivers music throughout the room without the muffling and distortion that interfere with low placed high frequency "tweeters."

ESSENTIAL No. 3. High Output Amplifier

The new, wide range, high output amplifier provides response far beyond the audible range. It has long-life, ruggedized tubes in the early amplification stages. New, step type switch controls permit shading of "presence" and "brilliance" and also changes in volume. Acoustics can be balanced to various room properties. With its exponential horns, the Model "F" amplifier has an acoustical output that equals 50 watts with ordinary speakers. A new cross-

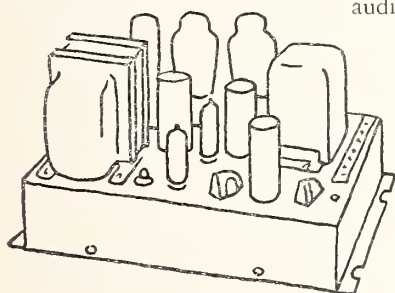

over frequency dividing network feeds lows to the bass horn, highs to the treble horn. Each horn does its own job best, meeting at the midpoint of the range with no holes in the wave pattern.

ESSENTIAL No. 4. High Fidelity Cartridge & Tone Arm

Finest for reproduction from all types of records, the General Electric variable reluctance cartridge adopted for use with the Model "F" is the standard of comparison for high fidelity cartridges. Its one single stylus may be changed in an instant. The die cast, featherweight aluminum tone arm has jewel type pivots and responds instantly to every minute variation in the record groove. Only gentle, unvarying gravity brings stylus and record together.

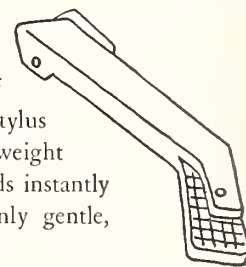

ESSENTIAL No. 5. Transcription Turntable

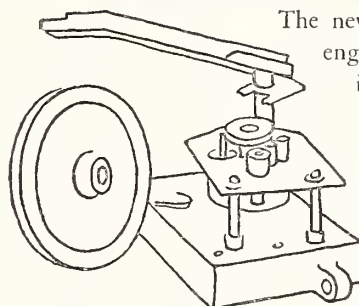

The new AMI turntable is a triumph of precision engineering. With a new sure-grip friction drive, it runs with the unvarying steadiness of costly studio transcription turntables. Records play horizontally, the same way they're recorded.

The AMI turntable has none of the Wows, Rumble or Flutter produced by ordinary turntables or unusual methods of record play.

ESSENTIAL No. 6. Dependable Mechanism

Stout heart of the Model "F" is the famed AMI multi-selection mechanism. Already world renowned for faultless performance, its many advancements and improvements in record handling, crediting and whisper-quiet operation make it the ideal mechanism for Multi-Horn High Fidelity reproduction.

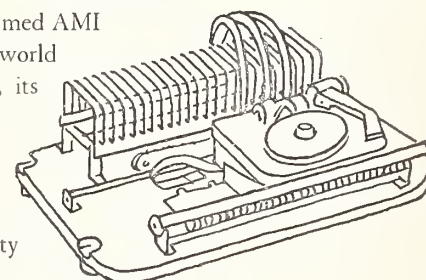

They All Add Up to Sonoramic Sound – Another AMI First!

Originator of the Automatic Selective Juke Box in 1927

AHEAD THEN – AHEAD NOW

AMI Incorporated

GENERAL OFFICES AND FACTORY: 1500 UNION AVENUE, S. E., GRAND RAPIDS 2, MICHIGAN

Licensee: Jensen Music Automates—building the IMA-AMI Juke Box sold through Oscar Siesbye A/S, 5 Palaisgade, Copenhagen K., Denmark

"It's What's in THE CASH BOX That Counts"



4. Dragonette (Got 6/54)	190.00	215.00
4. Dreamy (Wm 2/50)	15.00	25.00
1* Dude Ranch (B 9/53)	295.00	370.00
4. Eight Ball (Wm 1/52)	45.00	75.00
6. El Paso (Wm 11/48)	10.00	20.00
4. Fairway (Wm 6/53)	79.00	110.00
4. Fighting Irish (CC 11/50)	25.00	35.00
4. Five Star (Univ 5/51)	35.00	60.00
6. Floating Power (Ge 12/48)	10.00	20.00
4. Flying High (Got 2/53)	75.00	110.00
4. Flying Saucers (Ge 12/50)	15.00	30.00
6. Football (CC 8/49)	10.00	25.00
4. Four Corners (Wm 12/52)	45.00	90.00
4. Four Horsemen (Got 9/50)	30.00	40.00
4. "400" (Upright) (Ge 10/52)	55.00	75.00
4. Four Stars (Got 6/52)	50.00	95.00
4. Freshie (Wm 9/49)	15.00	29.50
4* Frolics (B 10/52)	150.00	175.00
4. Futurity (B 3/51)	60.00	95.00
4. Georgia (Wm 7/50)	19.50	35.00
6. Gin Rummy (Got 2/49)	15.00	25.00
6. Gizmo (Wm 8/48)	10.00	20.00
4. Glamour (Got 7/51)	15.00	25.00
6. Glider (Ge 8/49)	10.00	20.00
4. Globe Trotter (Got 11/51)	35.00	75.00
6. Gold Cup (B 4/48)	15.00	45.00
4. Golden Gloves (CC 7/49)	10.00	25.00
4. Golden Nugget (Upright) (Ge 2/53)	50.00	90.00
4. Gold Star (Got 8/54)	225.00	250.00
6. Gondola (Ex 5/49)	10.00	20.00
4. Grand Award (CC 1/49)	10.00	20.00
4. Grand Champion (Wm 8/53)	79.00	99.00
4. Grand Slam (Got 4/53)	65.00	135.00
6. Grand Stand (B '50)	20.00	35.00
4. Green Pastures (Got 1/54)	165.00	195.00
4. Gun Club (Wm 11/53)	95.00	125.00
4. Guys-Dolls (Got 5/53)	64.50	125.00
4. Handicap (Wm 6/52)	35.00	45.00
4. Happy Days (Got 7/52)	65.00	105.00
4. Happy-Go-Lucky (Got 3/51)	25.00	45.00
4. Harvest Moon (Got 12/48)	15.00	20.00
4. Harvest Time (Ge 9/50)	15.00	35.00
4. Harvey (Wm 5/51)	15.00	35.00
4. Havana (Un 2/54)	235.00	310.00
2* Hawaii (Un 6/54)	325.00	395.00
4. Hawaiian Beauty (Got 4/54)	180.00	210.00
4. Hayburner (Wm 6/51)	50.00	75.00
1* Hi-Fi (B 6/53)	349.50	465.00
4. Hit Parade (CC 2/51)	10.00	20.00
4. Hit & Runs (Ge 3/51)	15.00	25.00
4. Hit 'N' Run (Got 4/52)	59.50	85.00
6. Holiday (CC 12/48)	10.00	20.00
4. Holiday (Ke 12/51)	49.00	60.00
4. Hong Kong (Wm 9/51)	45.00	80.00
4. Horsefeathers (Wm 1/52)	39.50	69.50
4. Horse Shoe (Wm 12/51)	25.00	40.00
4. Hot Rods (B '49)	15.00	25.00
6. Humpty Dumpty (Got 10/47)	10.00	25.00
2* Ice-Frolics (B 1/54)	295.00	365.00
6. Jack 'N' Jill (Got 4/48)	10.00	20.00
4. Jalopy (Wm 8/51)	45.00	75.00
6. Jamboree (Ex 5/48)	10.00	20.00
4. Jeanie (Ex 6/50)	15.00	20.00
4. Jockey Club (Got 4/54)	195.00	210.00
4. Jockey Special (B 11/47)	15.00	45.00
4. Joker (Got 11/50)	15.00	25.00
4. Judy (Ex 7/50)	10.00	20.00
4. Jumping Jacks (Upright) (Ge 12/52)	35.00	90.00
4. Just 21 (Got 1/50)	10.00	24.50
4. K. C. Jones (Got 11/49)	10.00	20.00
4. King Arthur (Got 10/49)	10.00	20.00
6. King Cole (Got 5/48)	10.00	20.00
4. King Pin (CC 12/51)	30.00	69.00
4. Knockout (Got 1/51)	15.00	30.00
4. Lady Robin Hood (Got 1/48)	10.00	25.00
4. Lazy "Q" (Wm 2/54)	109.00	150.00
4. Leaders (Un 10/51)	45.00	85.00
4. Lite-A-Line (Ke 6/52)	35.00	50.00
4. Long Beach (Wm 7/52)	35.00	65.00
4. Lovely Lucy (Got 2/54)	165.00	195.00

4. Lucky Inning (Wm 5/50)	15.00	25.00
6. Lucky Star (Got 5/47)	10.00	20.00
4. Mad. Sq. Garden (Got 6/50)	24.00	49.50
6. Magic (Ex 11/48)	10.00	20.00
6. Majors '49 (CC 2/49)	15.00	25.00
4. Major League Baseball (Un 6/48)	10.00	20.00
6. Manhattan (Un 2/48)	10.00	17.50
4. Majorettes (Wm 4/52)	29.00	45.00
4. Marble Queen (Got 8/53)	95.00	150.00
6. Mardi Gras (Ge 5/48)	10.00	20.00
6. Maryland (Wm 4/49)	10.00	20.00
6. Merry Widow (Ge 6/48)	10.00	20.00
4. Mercury (Ge 3/50)	10.00	29.00
4. Mermaid (Got 6/51)	25.00	39.00
2. Mexico (Un 3/54)	295.00	400.00
4. Minstrel Man (Got 3/51)	20.00	39.00
6. Monterey (Un 5/48)	10.00	20.00
4. Moon Glow (Un 11/48)	10.00	20.00
6. Morocco (Ex 10/48)	15.00	35.00
4. Mystic Marvel (Got 3/54)	185.00	220.00
2. Nevada (Un 8/54)	395.00	425.00
4. Niagara (Got 12/51)	35.00	55.00
4. Nifty (Wm 12/50)	15.00	35.00
4. "9" Sisters (Wm 1/54)	115.00	170.00
4. Oasis (Ex 10/50)	10.00	20.00
4. Oklahoma (Un 5/49)	10.00	20.00
6. Old Faithful (Got 12/49)	15.00	25.00
4. Olympics (Wm 5/52)	45.00	75.00
4. One Two Three (Ge 10/48)	10.00	25.00
4. Palisades (Wm 7/53)	79.00	99.00
2. Palm Beach (B 7/52)	125.00	140.00
4* Palm Springs (B 11/53)	325.00	395.00
4. Paradise (Un 7/48)	10.00	20.00
4. Paratrooper (Wm 8/52)	25.00	35.00
4. Pin Bowler (CC 6/50)	10.00	20.00
6. Pinch Hitter (Un 5/49)	10.00	20.00
4. Pinky (Wm 9/50)	20.00	35.00
4. Pin Wheel (Got 11/53)	125.00	155.00
4. Play Ball (CC 1/51)	20.00	35.00
4. Playland (Ex 8/50)	10.00	20.00
6. Playtime (Ex 8/49)	10.00	20.00
4. Poker Face (Got 9/53)	125.00	150.00
6. Puddin' Head (Ge 10/48)	10.00	20.00
4. Punchy (CC 12/50)	10.00	20.00
4. Quarterback (Wm 10/49)	15.00	35.00
4. Quartet (Got 2/52)	60.00	110.00
4. Queen of Hearts (Got 12/52)	70.00	115.00
4. Quintet (Got 3/53)	79.50	135.00
4. Rag Mop (Wm 10/50)	15.00	35.00
6. Rainbow (Wm 9/48)	10.00	20.00
6. Ramona (Un 2/49)	10.00	20.00
4. Red Shoes (Un 11/50)	20.00	34.50
1. Rio (Un 11/53)	245.00	285.00
4. Rip Snorter (Ge 10/49)	10.00	20.00
4. Rocket (Ge 5/50)	20.00	39.00
4. Rockettes (Got 8/50)	25.00	49.00
4. Rodeo (Un 2/53)	135.00	185.00
6. Rondevoos (Un 5/48)	15.00	35.00
4. Rose Bowl (Got 10/51)	35.00	65.00
4. Round Up (Got 11/48)	10.00	25.00
6. St. Louis (Wm 2/49)	25.00	39.00
4. Saddle and Turf (Ev 10/53) (Club Model)	199.50	265.00
	275.00	325.00
6. Sally (CC 10/48)	10.00	20.00
6. Samba (Ex 5/48)	10.00	20.00
6. Saratoga (Wm 10/48)	10.00	20.00
4. Screamo (Wm 4/54)	150.00	185.00
6. Screwball (Ge 8/48)	10.00	20.00
4. Sea Jockeys (Wm 11/51)	24.50	50.00
6. Sea Isle (CC 11/47)	10.00	20.00
4. Select-A-Card (Got 4/50)	10.00	20.00
6. Serenade (Un 11/48)	10.00	20.00
6. Shanghai (CC 4/48)	20.00	34.50
4. Shantytown (Ex 10/49)	20.00	39.00
4. Sharpshooter (Got 5/49)	10.00	25.00
4. Shindig (Got 10/53)	120.00	150.00
4. Shoe Shoo (Wm 2/51)	19.50	29.50
6. Short Stop (Ex 7/48)	10.00	20.00
4. Shoot the Moon (Wm 11/51)	20.00	55.00
4. Show Boat (Un 1/49)	10.00	20.00
4. Show Boat (Un 12/52)	150.00	175.00
4. Silver Chest (Upright) (Ge 4/53)	50.00	95.00
4. Silver Skates (Wm 2/53)	59.00	85.00
4. Singapore (Un 11/47)	10.00	20.00
4. Skill Pool (Got 8/52)	54.50	75.00
4. Slugfest (Wm 3/52)	34.50	55.00
6. Snooks (Wm 6/51)	15.00	22.50
4. South Pacific (Ge 2/50)	20.00	39.00
4. Spark Plugs (Wm 9/51)	49.50	75.00

6. Speedway (Wm 9/48)	10.00	20.00
4. Spot Bowler (Got 10/50)	15.00	35.00
4* Spot-Lite (B 1/52)	69.50	100.00
4. Sportsman (Ge 2/51)	10.00	20.00
4. Sportsman (Wm 2/52)	30.00	35.00
4. Springtime (Ge 3/52)	20.00	34.50
6. Stage Door Canteen (Got 11/45)	10.00	20.00
6. Stardust (Un 5/48)	20.00	34.50
4. Stars (Un 6/52)	50.00	95.00
4. Starlight (Wm 3/53)	50.00	75.00
4. Steeple Chase (Un 1/52)	35.00	65.00
4. Stop & Go (Ge 3/51)	15.00	25.00
6. Stormy (Wm 1/48)	10.00	20.00
4. Struggle Buggies (Wm 12/53)	115.00	145.00
4. Summertime (Un 9/48)	15.00	25.00
4. Sunny (Wm 12/47)	10.00	20.00
2. Sunshine Park (B 12/52)	49.50	85.00
4. Super Hockey (CC 4/49)	20.00	34.50
2* Surf Club (B 3/54)	375.00	425.00
4. Sweepstakes (Wm 1/52)	75.00	95.00
4. Sweetheart (Wm 5/50)	20.00	35.00
4. Tahiti (CC 10/49)	20.00	34.50
4. Tahiti (Un 8/53)	185.00	240.00
4. Tampico (Un 6/49)	10.00	20.00
4. Telecard (Got 1/49)	10.00	25.00
6. Tennessee (Wm 2/48)	10.00	20.00
4. Thing (CC 2/51)	15.00	35.00
4. Three Feathers (Ge 5/49)	10.00	25.00

4. Three Four Five (Un 6/51)	25.00	50.00
4. Three Musketeers (Got 7/49)	15.00	35.00
6. Thrill (CC 9/48)	10.00	20.00
4. Times Square (Wm 4/53)	65.00	90.00
4. Touchdown (Un 1/52)	15.00	25.00
6. Trade Winds (Ge 3/48)	10.00	20.00
6. Treasure Chest (Ex 12/47)	10.00	20.00
6. Trinidad (CC 3/48)	10.00	20.00
6. Triple Action (Ge 1/48)	10.00	20.00
4. Triplets (Got 7/50)	15.00	29.50
4. TriScore (Ge 1/51)	20.00	39.00
6. Trophy (B 4/48)	15.00	30.00
6. Tropicana (Un 1/48)	10.00	20.00
2* Tropics (Un 7/53)	165.00	225.00
6. Tucson (Wm 1/49)	10.00	29.00
6. Tumbleweed (Ex 8/49)	15.00	35.00
4. Turf King (B 6/50)	15.00	45.00
4. Twenty Grand (Wm 12/52)	49.50	95.00
4. Utah (Un 7/49)	10.00	20.00
4. Vanities (Ex 2/47)	10.00	19.50
6. Virginia (Wm 3/48)	10.00	12.50
4. Watch My Line (Got 9/51)	15.00	35.00
4. Whizz Kids (CC 3/52)	20.00	40.00
4. Wild West (Got 8/51)	40.00	60.00
4. Winner (Univ.)	20.00	45.00
6. Wisconsin (Un 3/48)	10.00	20.00
1* Yacht Club (B 6/53)	145.00	205.00
6. Yanks (Wm 4/48)	10.00	20.00
4. Zingo (Un 10/51)	20.00	40.00



4. Bally Shuffle Bowler (9/49)	15.00	20.00
6. Bally Speed Bowler (2/50)	15.00	20.00
6. Bally Shuffle Champ (4/50)	20.00	30.00
6. Bally Hook Bowler (11/50)	20.00	45.00
6. Bally Baseball (5/51)	35.00	45.00
4. Bally Shuffle Line (7/51)	25.00	50.00
4. Bally Victory Bowler (5/54)	325.00	400.00
4. Bally Champion Bowler (5/54)	350.00	425.00
4. ChiCoin Bowling Alley (11/49)	25.00	55.00
6. ChiCoin Shuffle Baseball (4/50)	25.00	50.00
4. ChiCoin Bowling Classic (5/50)	20.00	35.00
4. ChiCoin Pin Bowler (6/50)	20.00	30.00
4. ChiCoin Trophy Bowl (7/50)	20.00	35.00
6. ChiCoin Ace Bowler, F.P. (8/50)	25.00	35.00
6. ChiCoin Pin Lite (9/50)	25.00	30.00
4. ChiCoin Horse-Shoes (5/51)	35.00	75.00
4. ChiCoin 6-Player (8/51)	45.00	95.00
4. ChiCoin 6-Player DeLuxe (5/52)	85.00	100.00
4. ChiCoin Match Bowler (6/52)	95.00	125.00
4. ChiCoin Bowl-A-Ball (10/52)	95.00	135.00
4. ChiCoin Match Bowl-A-Ball (11/52)	100.00	150.00
4. ChiCoin 10th Frame Special (12/52)	99.50	150.00
4. ChiCoin Name Bowler (1/53)	124.00	165.00
4* ChiCoin 10th Frame Double Score Bowler (3/53)	140.00	195.00
2* ChiCoin Crown (4/53)	160.00	185.00
6. ChiCoin Crown, Giant Pins (4/53)	225.00	295.00
2* ChiCoin Triple Score (6/53)	175.00	235.00
4. ChiCoin Gold Cup (7/53)	225.00	275.00
4. ChiCoin High Speed Crown (7/53)	150.00	300.00
4. ChiCoin High Speed Triple Score (8/53)	295.00	375.00
2. ChiCoin Advance (10/53)	250.00	345.00
4. ChiCoin King (10/53)	300.00	370.00

4. ChiCoin Criss Cross Bowler (12/53)	300.00	395.00
4. ChiCoin Super Frame (3/54)	300.00	395.00
7. ChiCoin Starlite (5/54)	325.00	410.00
4. Exhibit Strike (6/51)	20.00	30.00
4. Exhibit Twin Rotation (5/52)	65.00	95.00
4. Genco Bowling League (11/49)	15.00	20.00
4. Genco Baseball (5/50)	15.00	20.00
4. Genco Shuffle Target (7/51)	15.00	20.00
4. Genco 8-Player Rebound (9/51)	25.00	35.00
4* Genco Shuffle Pool (11/53)	125.00	215.00
4* Genco Match Pool (2/54)	225.00	300.00
4. Gottlieb Bowlette (3/50)	15.00	29.50
6. Keeney Pin Boy (11/49)	15.00	20.00
6. Keeney Ten Pins (1/50)	15.00	20.00
6. Keeney ABC (2/50)	15.00	20.00
6. Keeney Lucky Strike (4/50)	20.00	30.00
6. Keeney King Pin (4/50)	20.00	30.00
6. Keeney Bowling Champ (4/50)	20.00	30.00
6. Keeney Duck Pins (6/50)	20.00	30.00
4. Keeney Double Bowler (8/50)	25.00	35.00
4. Keeney League (8/50)	25.00	50.00
4. Keeney 4-Way Bowler Attachment (12/50)	40.00	75.00
4. Keeney Big League (5/51)	35	

6. Rock-Ola Shuffle Jungle (5/50)	20.00	30.00
6. United Shuffle Skill (6/49)	15.00	20.00
6. United Shuffle Alley (9/49)	15.00	20.00
6. United Super Shuffle Alley (1/50)	20.00	30.00
6. United Double Shuffle Alley (2/50)	20.00	30.00
6. United Shuffle Alley Express (3/50)	20.00	30.00
4. United Shuffle Slugger (6/50)	20.00	30.00
4. United 2-Player Express (6/50)	25.00	35.00
4. United Twin Shuffle Alley (7/50)	25.00	35.00
4. United Rebound (8/50)	30.00	39.50
4. United 4-Player Rebound (9/50)	35.00	60.00
4. United Twin Shufflecade (12/50)	35.00	60.00
4. United 5-Player (1/51)	45.00	75.00
4. United 6-Player	50.00	75.00
1. United DeLuxe 6-Player (10/51)	60.00	85.00
3* United 6-Player Super (3/52)	65.00	110.00
4. United 4-Player Official (5/52)	75.00	135.00
4. United 6-Player Star (7/52)	95.00	140.00
2* United 10th Frame Star (9/52)	100.00	150.00
4. United Manhattan 10th Frame (9/52)	125.00	150.00
4. United 10th Frame Super (10/52)	125.00	145.00

4. United Manhattan (9/52)	115.00	140.00
1* United Cascade (2/53)	139.50	175.00
4. United Clover (2/53)	125.00	175.00
4. United Liberty (2/53)	105.00	175.00
1* United Classic (6/53)	179.50	225.00
4* United Olympic (6/53)	175.00	225.00
4* United Royal (9/53)	225.00	310.00
4* United Imperial (9/53)	245.00	320.00
2* United Chief (11/53)	325.00	345.00
2* United Leader (11/53)	295.00	350.00
4* United Team (1/54)	325.00	355.00
4. United DeLuxe Team (1/54)	325.00	350.00
2. United League (1/54)	295.00	375.00
4* United Ace (Un 5/54)	375.00	425.00
2. United Rainbow (5/54)	350.00	425.00
4. United Banner (8/54)	425.00	435.00
2. United Shuffle Targette (8/54)	335.00	450.00
4. Universal Twin (1/50)	15.00	35.00
4. Universal Super Twin (3/50)	30.00	40.00
6. Universal DeLuxe Twin (10/50)	30.00	40.00
6. Universal High Score (10/50)	30.00	40.00
6. Universal Bowlomatic (3/51)	30.00	40.00
6. Williams Twin Shuffle (12/49)	20.00	34.50
6. Williams Twin Shuffle (9 1/2') (2/50)	20.00	30.00
6. Williams Bowler (9 1/2') (3/50)	25.00	30.00
4. Williams Double Header (7/50)	20.00	45.00
6. Williams 5-Player Bowler (6/51)	20.00	30.00

Manufacturers New Equipment

Products listed here are currently in production. Prices are manufacturers' list prices, F.O.B. factory.

AMI, INCORPORATED

F-120 Juke Box (Receiver included)	\$1,095.00
F-80 Juke Box (Receiver NOT included)	935.00
F-40 Juke Box (Receiver NOT included)	835.00
HS-80 Selective Hideaway	795.00
HS-120 Selective Hideaway	895.00
W-80 Wall Box	89.50
W-120 Wall Box	99.00
S-80 Receiver	60.00
S-120 Receiver	65.00
Wall Speaker	44.50
Corner Speaker	64.50
Recessed Speaker	49.50
R-167 Bargrip	12.75

AUTO-PHOTO CO.

Auto-Photo	\$2,545.00
------------	------------

BALLY MFG. CO.

Champion	\$ 795.00
Big-Time	760.00
Moon-Ride	995.00
Magic Bowler (with Match Feature)	
Model Magic-110, 10c a play	755.00
Model Magic-325, 10c a play, 3 plays for 25c	775.00
Mystic Bowler (without Match Feature)	
Model Mystic-110, 10c a play	710.00
Model Mystic-325, 10c a play, 3 plays for 25c	730.00

CHICAGO COIN

Thunderbolt Bowler (With Match Feature)	
Single Chute	\$ 750.00
Double Chute Model	770.00
Fireball Bowler (Without Match Feature)	
Single Chute	\$ 685.00
Double Chute	705.00

EXHIBIT SUPPLY

Sportland Moving Target Shooting Gallery	\$ 645.00
Junior Jet Ride	395.00
Big Bronco	997.50
Roy Rogers' Trigger	1,047.50
Rudolph The Red Nosed Reindeer	725.00
Rudolph The Red Nosed Reindeer With Music	775.00
Pete The Rabbit	725.00
Pete The Rabbit With Music	775.00
Twin Pete The Rabbit	725.00
Rawhide	725.00
Space Patrol, New Style	1,047.50
Sea Skate	1,047.50
Vacumatic Card Vendor	221.50

GENCO MFG. & SALES CO.

Big Top Rifle Gallery (With Match Score and Free Play Feature)	\$ 675.00
--	-----------

D. GOTTLIEB & CO.

Super Jumbo (With Match Score and Free Play Feature)	\$ 595.50
Diamond Lill	392.50

INTERNATIONAL MUTO. CORP.

Drive Yourself (new Drivemobile)	\$ 795.00
Photomat '54	2,150.00
3-D Art Parade, 10-show model	495.00
3-D Art Parade, 6 show model	395.00
Universal Post Card Vendor	60.00

J. H. KEENEY & CO., INC.

DeLuxe Sportsman (With Match Feature)	\$ 690.00
Sportsman (Without Match Feature)	665.00
American Bowler With Match Feature	
Single Chute	690.00
Double Chute	710.00
National Bowler Without Match Feature	
Single Chute	650.00
Double Chute	670.00
Electric Cigarette Vendor	284.50
Coin Changer Model	304.50

ROCK-OLA MFG. CORP.

Model 1446 Hi-Fi Phono, 120 Selection, 45 RPM Only	
Model 1440 "Comet Fireball" Playmaster, 120 Selection, 45 RPM Only	
Model 1442, Hi-Fi, 50 Selections, 45 RPM Only	
Model 1546 Chrome Wall Box, 120 Selections	
Model 1548, 50 Selection Wall Box	
Model 1550, 20 Selection Wall Box	
Model 1613, 8" Blonde Wall Speaker	
Model 1614, 8" Mahogany Wall Speaker	
Model 1906, Remote Volume Control	

J. P. SEEBURG CORP.

HF-100-R	
3W-1 Wall-O-Matic "100"	
MRVC-1 Master Remote Volume Control	
CVS4-8—8" Wall Speaker Ivory (Teardrop)	
CVS6-8—8" Recessed Speaker	
CVS7-12—12" Recessed Speaker	
PS6-1Z Power Supply	
ARA1-L6 Auxiliary Remote Amplifier	
AVC-1 Automatic Volume Compensator Unit	

UNITED MFG. CO.

DeLuxe Mercury Shuffle Alley (With Match Feature)	
Regular Model, 10c play	\$ 735.00
Special Model, 10c, 3 for 25c	755.00
Mercury Shuffle Alley (With Match Feature)	
Regular Model, 10c play	705.00
Special Model, 10c, 3 for 25c	725.00
De Luxe Comet Shuffle-Targette (With Match Feature)	
Regular Model, 10c play	710.00
Special Model, 10c, 3 for 25c	730.00
Comet Shuffle-Targette	
Regular Model, 10c play	685.00
Special Model, 10c, 3 for 25c	705.00
Mars Shuffle Alley (Without Match Feature)	
Single Chute	705.00
Double Chute	725.00
De Luxe Mars Shuffle Alley (With Triple Match Feature)	
Single Chute	735.00
Double Chute	755.00
Bonus Gun (Without Match Feature)	
Single Chute	690.00
Double Chute	710.00
De Luxe Bonus Gun (With Triple Match Feature)	
Single Chute	715.00
Double Chute	735.00
Tropicana	725.00

WILLIAMS MFG. CO.

Jet Fighter (Without Match or Free Play Features)	\$ 650.00
Super Jet Fighter (With Match and Free Play Features)	675.00
Lulu	389.50

THE RUDOLPH WURLITZER CO.

Model "1700" Phonograph	
Model "1600-A" Phonograph	
Model "1650-A" Phonograph	
Model 5112—12" Concealed Speaker Hi-Fi	
Model 5112—8" Wall Speaker Hi-Fi	
Model 5205 5c-10c-25c Wall Box 3 Wire (104 Selections)	
Model 5206 5c-10c-25c Wall Box 4 Wire (48 Selections)	
Model 4851 5c-10c-25c Wall Box (48 Selections)	
Model 5204 5c-10c-25c Wall Box (104 Selections)	
Model 5100 8" Speaker	
Model 5110 12" DeLuxe Speaker	



4. ABT 6 Gun Rifle Range	550.00	650.00
4. Boomerang	25.00	45.00
4. Bally Big Inning	79.50	150.00
6. Bally Bowler	20.00	30.00
6. Bally Convoy	39.50	59.50
6. Bally Defender	59.50	125.00
6. Bally Eagle Eye	39.50	49.50
4. Bally Heavy Hitter	35.00	60.00
4. Bally King Pin	20.00	35.00
6. Bally Lucky Strike	25.00	40.00
4. Bally Rapid Fire	95.00	125.00
6. Bally Sky Battle	39.50	85.00
6. Bally Torpedo	49.50	85.00
4. Bally Undersea Raider	64.50	125.00
6. Bank Ball	35.00	45.00
4. Champion Hockey	35.00	55.00
4. ChiCoin Basketball Champ	95.00	175.00
4. ChiCoin 4-Player Derby	100.00	195.00
4. ChiCoin Goalee	75.00	100.00
4. ChiCoin Hockey	55.00	75.00
4. ChiCoin Midget Skee	65.00	175.00
4. ChiCoin Pistol	75.00	95.00
6. ChiCoin Roll-A-Score	29.50	75.00
2* ChiCoin Home Run, 6 Player (3/54)	250.00	345.00
4. Edelco Pool Table	20.00	75.00
4. Evans Bat-A-Score	130.00	165.00
4. Evans Bola-Score	79.50	89.50
4. Evans Ski Roll	35.00	95.00
4. Evans Super Bomber	100.00	210.00
4. Evans Play Ball	65.00	75.00
4. Evans Ten Strike '46	20.00	65.00
4. Evans Tommy Gun	39.50	95.00
4. Exhibit Dale Gun	45.00	65.00
4. Exhibit Gun Patrol	105.00	175.00
4. Exhibit Jet Gun	99.00	195.00
4. Exhibit Space Gun	89.50	145.00
4. Exhibit Pony Express	85.00	135.00
4. Exhibit Silver Bullets	75.00	115.00
4* Exhibit Six Shooter	79.00	135.00
1. Exhibit Vitalizer	45.00	75.00
1* Exhibit Shooting Gallery	265.00	365.00
6. Groetchen Met. Typer	79.50	149.50
2* Genco Sky Gunner	120.00	175.00
4. Genco Night Fighter	149.00	225.00
4* Genco Basketball	250.00	399.50
7. Genco Rifle Gallery (6/54)	375.00	525.00
6. Irish Poker	50.00	65.00
4. Jack Rabbit	50.00	99.50
4. Jungle Joe	49.50	69.50
4. Keeney Air Raider	90.00	145.00
4. Keeney Anti Aircraft B1	15.00	35.00
4. Keeney Sub Gun	75.00	95.00
4. Keeney Texas Leaguer	25.00	50.00
4. Kirk Night Bomber	75.00	150.00
4. Lite League	49.50	99.50

4. Mills Panoram Peek	159.00	275.00
6. Mills Conv. for Panoram Peek	10.00	29.50
4. Muto. Atomic Bomber	125.00	195.00
4. Mutos. Ace Bombers	100.00	195.00
4. Mutoscope Dr. Mobile (Prewar)	95.00	195.00
4. Mutos. Fly. Saucers	90.00	160.00
4. Mutos. Phto. (Pre-War)	150.00	250.00
4. Mutos. Photomatic (DeLuxe)	350.00	595.00
4. Mustocope Silver Gloves	125.00	200.00
4. Mutoscope Sky Fighter	125.00	195.00
4. Mutos. Voice-O-Graph 35c	405.00	545.00
4. Periscope	69.50	99.50
4. QT Pool Table	65.00	85.00
4. Quizzer	60.00	95.00
6. Rockola Ten Pins HD	20.00	40.00
4. Rockola World Series	20.00	40.00
4. Scientific Baseball	35.00	75.00
4. Scientific Basketball	20.00	75.00
4. Scientific Batting Pr.	65.00	89.50
4. Scientific Pitch 'Em	145.00	185.00
4* Seeburg Bear Gun	150.00	195.00
4. Seeburg Chicken Sam.	69.50	110.00
4. Seeburg Shoot the Chute	49.50	95.00
4. Seeburg Coon Hunt	295.00	450.00
4. Set Shot Basketball	200.00	250.00
2. Telequiz	115.00	125.00
4. Un. Team Hockey	30.00	85.00
4. United Jungle Gun	350.00	425.00
4. United DeLuxe Jungle Gun	395.00	495.00
6. Western Baseball '39	75.00	95.00
6. Western Baseball '40	95.00	125.00
4. Wilcox-Gay Recordio	40.00	75.00
4. Williams All Stars	35.00	75.00
4. Williams Box Score	39.50	75.00
4. Williams Star Series	40.00	90.00
4. Williams DeLuxe World Series	40.00	90.00
4. Williams Super World Series	95.00	165.00
4. Williams Quarterback	25.00	75.00
4. Williams DeLuxe Baseball	99.50	175.00
4. Williams Pennant Baseball	175.00	250.00
4. Williams Super Pennant Baseball (1/54)	155.00	275.00
6. Williams Super Star Baseball (1/54)	325.00	395.00
4. Williams Major League Baseball (4/54)	250.00	375.00
4. Williams All Star Baseball (5/54)	250.00	350.00
4. Williams Big League Baseball (6/54)	255.00	375.00
4. Wurlitzer SkeeBall	35.00	150.00



COMING

BIG NEWS FROM WURLITZER

ON NATIONAL WURLITZER DAYS
AT YOUR WURLITZER DISTRIBUTOR
WATCH FOR DATES

That will mean
BIG MONEY
for You

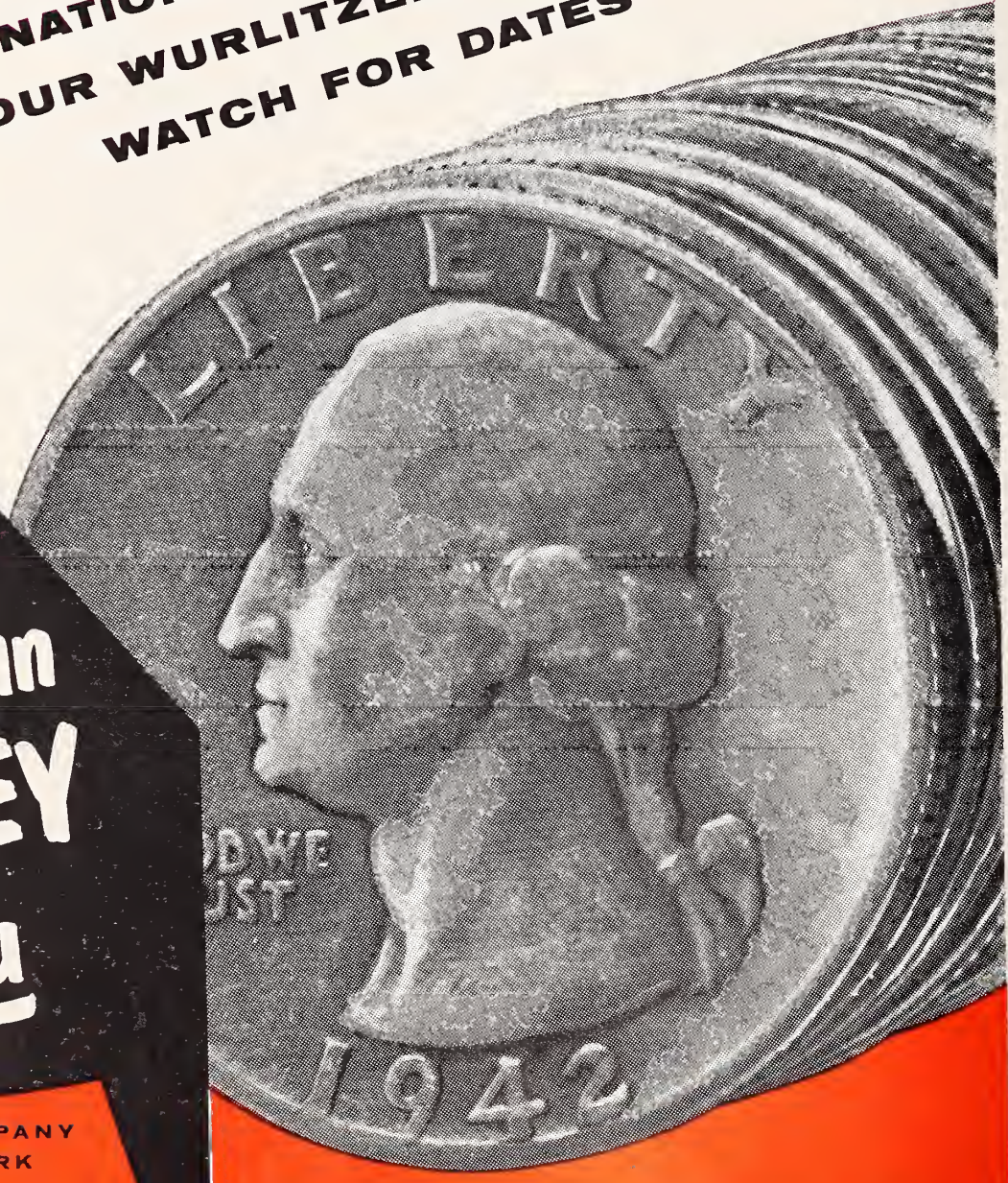

THE RUDOLPH WURLITZER COMPANY
NORTH TONAWANDA, NEW YORK
Established 1856

UNITED'S

TROPICANA

with attractive new scoring features

ROVING SPECIAL CARDS

ONE TO FOUR SPECIAL CARDS LIGHT UP ON MYSTERY BASIS

TWO BOTTOM CARDS HELD WHEN HELD PANEL IS LIT



THERE IS A UNITED GAME FOR EVERY TYPE OF LOCATION

• **6-PLAYER SHUFFLE ALLEY BOWLING GAMES**

• **COMET SHUFFLE-TARGETTE** WITH OR WITHOUT MATCH-A-SCORE EXTREMELY QUIET PLAY

• **CARNIVAL GUN** FLASHY, FAST-PLAY SHOOTING GALLERY WITH TIME BONUS SCORE

NOW AT YOUR DISTRIBUTOR

SUPER SELECTION FEATURE

EXTRA BALL
4-IN-LINE SCORES 5-IN-LINE
ADVANCE SCORE
RETURN ALL BALLS

Number Selection Feature

• 4-Corners Score

• Light-Up Spot Feature
SPOTS 5-8-15

• EXTRA BALLS
• ADVANCING SCORES
• ALL BALLS RETURN
• LATEST E-Z SERVICE FEATURES

SEE YOUR DISTRIBUTOR



UNITED MANUFACTURING COMPANY
3401 N. CALIFORNIA AVENUE, CHICAGO 18, ILLINOIS

Operators report biggest earnings ever with

Bally **BIG-TIME**

popular BEACH CLUB-VARIETY play-appeal plus

5 MAGIC-LINES

Reports from coast to coast prove the money-making power of 5 MAGIC-LINES. Get your share of the BIG-TIME profits. Get BIG-TIME at your Bally Distributor today.

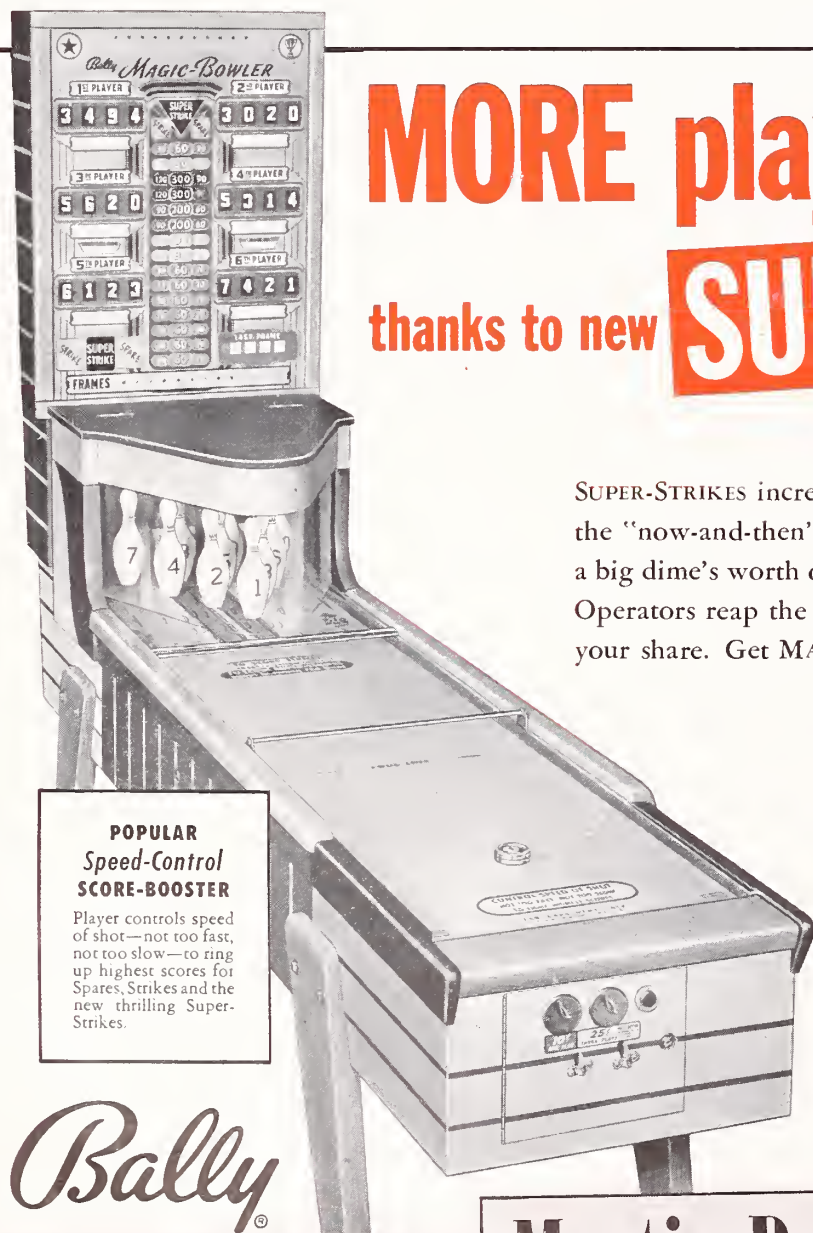
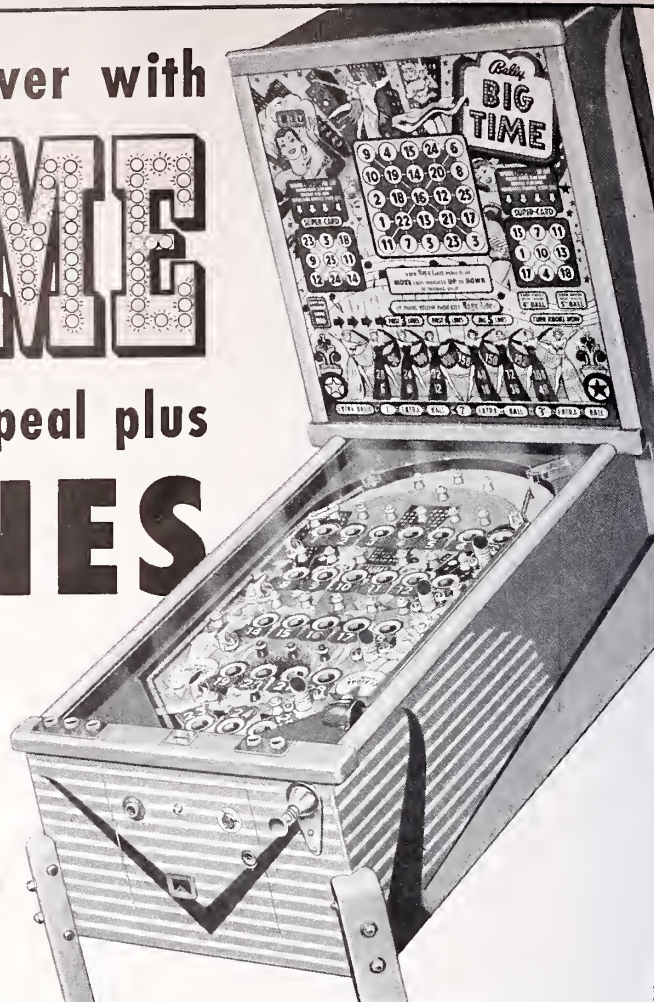

POPULAR
Speed-Control
SCORE-BOOSTER

Player controls speed of shot—not too fast, not too slow—to ring up highest scores for Spares, Strikes and the new thrilling Super-Strikes.

MORE players play MORE

thanks to new **SUPER-STRIKE** feature

SUPER-STRIKES increase earnings by attracting all types of players, from the "now-and-then" shuffler to the extra skilled regular. They all get a big dime's worth of fun playing MAGIC-BOWLER and MYSTIC-BOWLER. Operators reap the benefit in biggest bowler earnings on record. Get your share. Get MAGIC-BOWLER or MYSTIC-BOWLER now.

Bally

Magic-Bowler
WITH POPULAR MATCH-PLAY

Mystic-Bowler
WITHOUT MATCH-PLAY

CHOICE OF DIME-A-PLAY OR DIME-A-PLAY, 3 PLAYS FOR A QUARTER
POPULAR SIZE: 8 FT. BY 2 FT.



BALLY MANUFACTURING COMPANY-2640 Belmont Avenue, Chicago 18, Illinois