

GARAGE SALE ISSUE: RECORDS & CDS FOR UNDER \$6

GOLDMINE

October 19, 2001

VOL 27 • NO 21 • ISSUE 554



Goldmine

THE COLLECTORS RECORD AND COMPACT DISC MARKETPLACE



BRENDA LEE

Little Miss Dynamite packs a punch in country music

Poco

Deliverin' country-rock with nothing to hide



SPECIAL REPORT

How the Sept. 11, 2001, attack on America affected the music industry

PLUS...

- Porky Chedwick — World's first oldies DJ
- Not Lame Records — Pop-ing out all over the place

U.S. \$3.95 • CANADA \$4.95



#BXNDWUF ***AUTO** 3-DIGIT 908
 #000143160&HJ# GM FEB03 / -
 MONTY GREENLY 0451
 3740 ELM AVE # A
 LONG BEACH CA 90807-3402

Reviews

- ▶ Bill Kirchen
- ▶ John Tiltonson
- ▶ Joan Baez
- ▶ Joy Division
- ▶ Roger McGuinn
- ▶ System Of A Down



VINTAGE MEMORABILIA FOR SET SALE



- A**
- AC/DC - Block Buster Pavilion Yr. 2000 size XL Red Promo T-Shirt to gig \$25 +3
 - Aerosmith - Best Yrs. Of Our Life 2 CD picture label music & interviews \$35 +3
 - Aerosmith - Pump Jpn Box Custom CD MVCZ7 - Out of Print Sealed...\$75+5
 - Anderson Bruford Wakeman & Howe - (4) 2 CD Live Yes Music Plus Circa 1989 \$10 +3
 - Tori Amos - Promoter issued custom embroidered hooded heavy sweatshirt size XL For Under the Pink \$145 +5
 - Laser etched numbered Wooden Box Set 2 CDs Winter & Little Earthquakes No. 2 of 250..... \$125 +6
 - (9) Laser etched Single Wooden Box w/ CD \$55 +4
 - Art Deco Ashtrays - Dragon; Free standing spout type - removable cups. One-of-a-kind. Inquire for more info. Custom Painted Polaroids \$1.00
 - Audio Pro - Subwoofer w/amp & crossover Inquire.

- B**
- Beatles - The BBC tapes - The Original Masters 6 CD Set Christmas labels \$175 +4
 - No. 1 Sealed U.S. LP \$75 +3
 - (14) Magical Mystery Tour limited edition numbered Wooden Bus with CD UK release in orig. box only 1000 made \$75 +6
 - 1965 Chicago Tribune newspaper insert written by Brian Epstein on the Beatles \$50 +5
 - More rare newspaper items on Cool Rock Stuff online.com
 - (20) McCartney - Off the Ground limited edition UK Wooden Box Set with CD, Only 500 made \$60 +5
 - (3) McCartney - Deluxe Tour Book given out at 1989-90 concerts high quality \$20 +2
 - Revolver - 2 CD outtakes \$40 +3
 - Beatle Yrs. Orig. CD Hard Days Night \$20 +3
 - Beatle Yrs. Orig. Focus on Ringo \$20 +3
 - Backstreet Boys - Black XL high quality one sided concert shirt of boys \$20 +3

- Bad Company - Live 2 CD orig. band \$25 +3
- Better Than Ezra - Live 1 CD \$15 +3
- Kate Bush - (14) Red Shoes U.S. Sealed CD \$9 +2
- Rubberband Girl - Custom sleeve with litho numbered and signed by artist w/ CD \$45 +3
- Eat The Music 4 Song CD with numbered litho signed by artist in custom sleeve \$45+3
- Moments of Pleasure sealed custom box from UK \$35 +3
- (2) Very Rare UK box set A Lioness at Heart incl. 48 pg. photo book plus CD \$175 +6
- Very Rare UK Box Set Never Forever w/ photo book & CD (Different than above) \$175 +6
- Ultra Rare French 3 CD box set incl. Kick, Inside, Lionheart and Hounds sealed \$225 +6
- Shoe Box sealed heart shaped box set \$150 +5
- Jeff Beck - 1972 BBC Live Radio Show of Jeff Beck Group \$45 +3
- Anthology soft cvr. Guitar Tablature Edition All Music \$35 +3
- Black Sabbath - Remaster UK CD's sealed Vol. 4, Paranoid Masters of Reality, 1st CD self titled; Each is \$9 +2
- Ultra Rare Box Set 6 CD UK issue incl. Beads with Cross, T-shirt and first 5 releases sealed plus Greatest Hits, No. 3 of 2,000 - very high quality \$225 +6
- Shoe Box sealed heart shaped box set \$150 +5
- Jeff Beck - 1972 BBC Live Radio Show of Jeff Beck Group \$45 +3
- Anthology soft cvr. Guitar Tablature Edition All Music \$35 +3
- Black Sabbath - Remaster UK CD's sealed Vol. 4, Paranoid Masters of Reality, 1st CD self titled; Each is \$9 +2
- Ultra Rare Box Set 6 CD UK issue incl. Beads with Cross, T-shirt and first 5 releases sealed plus Greatest Hits, No. 3 of 2,000 - very high quality \$225 +6
- Shoe Box sealed heart shaped box set \$150 +5

- Blues Portrait - Historic Hardcover Custom UK book chronicling The Best of The Blues - out of print \$35 +4
- Marc Bolan - UK Hardcover Little Book - Rare \$20 +3
- David Bowie - Santa Monica 72 Live CD \$25 +3
- Bush - 2 CD Spin Session CD \$20 +3
- Brain Food - Set of 5 mounted mental exercise posters. Sold as a set only designed to feed your head. Questions? \$75 +10
- Buckingham - Original 1960's Chicago American Newspaper b&w insert \$75 +4

- C**
- Cobra - Embroidered Black Satin Jacket to Stallone movie size med. Unreal Embroidery \$100 +5
 - Harry Connick Jr. - Swingtime Rare Jpn. CD w/ obi - out of print \$25 +3
 - Camel - A Live Record 2 CD Jpn. release long out of print \$75 +4
 - Candle Box - Live 1 CD \$15 +3
 - Captain Beyond - Jpn. CD of vintage 70's release out of print \$50 +3
 - Cheap Trick - Top of the World Live 1979 Chicago Show 1 CD \$25 +3
 - Cat Stevens - 1974 Sun Times newspaper cvr. story on him \$35 +3
 - 1971 LA Show live on radio - Vintage 1 CD Rare \$40 +3
 - Chinese Lamp - Unique, heavy duty lamp, shaped like a Buddha, ornate \$300 +shipping

- Polaroids \$1.00
- The Cure - French Sealed 5 CD Coffret set only 2,500 made all picture CD's in custom box \$75 +5
- Chicago - Tour 2000 XL Concert Shirt \$25 +3
- Christmas Music - 3 CD compilation of country artists singing X-mas. Rare \$45 +3
- Collective Soul - Live 1 CD \$15 +3
- Cream - San Francisco Chronicles Import Live 1967 1 CD \$40 +4
- Tour Program w/ newspaper article of show from Chi. \$325 +4
- Eric Clapton - Timothy White 2 CD Interview & Music \$40 +3
- Milwaukee Time Live 2 CD Import \$45 +3
- The Circus Has Left Town Import Live 2 CD circa 1992 \$45 +3
- (2) Unplugged Deluxe Custom laser etched Wooden Box of Face on front UK numbered - very rare \$125 +6
- Total guitar cvr. story on Eric UK mag. June 95 w/ CD to learn to play his songs sealed \$40 +4
- (15) Reptile 313.01 promo postcard to release U.S. only \$10 +3
- Commodores - 1977 promo only ashtray to Brick House shaped like a brick. Rare \$225 +5
- Chicago Stadium - Rock glass from owner's bar w/ gold trim & Hawks logo \$75 +3

- One of a kind framed item includes:
- A. 1935 Gold Foil Book of Chicago given to A. Wirtz, his name on cover etched.
- B. Stamped 1939 postcard of stadium
- C. 2 Chicago Stadium Review magazines from 30's & 40's
- D. 1980 Front Row ticket to cancelled Led Zepplin show signed by Robt. Plant
- E. One of 8 Zenith Shields w/ Hawks & Bulls logos on TV's at each gate downstairs - very rare \$3,250 +15
- Polaroids \$1.00 Must See
- More Orig. Stadium Items Available Inquire

- D**
- Dahlquist - DQ 10 Set of 2 phased array speakers in original boxes, no stands Inquire
 - James Dean - UK Hardcover Little Book Rare \$20 +3
 - Doors - Italian Book of Poems by Morrison w/ 3 in CD of rare live Cuts sealed \$35 +3
 - Def Leppard - Illustrated Biography soft cvr \$12 +3
 - Sling sealed Jpn CD w/ obi \$28 +4
 - 2 CD Greatest Hits Vault w/ 9 song live CD in custom case UK \$25 +3
 - Deep Purple - Deluxe Boxed Set Live in Stockholm 1970 2 CD \$100 +4
 - Made in Japan Jpn CD w/ obi w/ orig. cvr \$40 +3
 - Bob Dylan - Custom Wooden Box Set Dylan Originals incl. Bootleg Series Sampler plus 4 trk. CD XPCD 137 high quality #10 numbered \$125 +6
 - Hear the document. 1966 Manchester, U.K. 2 CD, live import \$35 +3 (Other titles available - inquire)

- E**
- Gloria Estefan - 12 in mixes on CD 5 tracks Rare \$20 +4
 - The Eagles - Please come home for Christmas U.S. picture song sheet \$75 +3
 - Everclear - Live 1 CD \$15 +3

- F**
- Filter - Live 1 CD \$15 +3
 - The Firm - Sleeveless Zipper promo only shirt embroidered \$100 +3
 - Fleetwood Mac - One of 5 brass tickets given to members of Mac for Grand Opening of Rosemont Horizon on May 14, 1980 (Tusk Tour) Front is etched seat location, back is etched to Christine McVie must see - very rare \$1,500
 - UK Book by Steve Carlie soft cvr \$20 +4
 - Foo Fighters - (4) 2 CD Live in the Pit \$15 +3

- G**
- Gin Blossoms - Live 1 CD \$15 +3
 - Goo Goo Dolls - (4) Live in the Pit 2 CD \$18 +3
 - Guitar Heroes - Hardcover Book by Tobler, UK 1978 Rare \$45 +3
 - Guitar Player Book - Many artists by Guitar Player magazine 1983 soft cover \$20 +3
 - Guns & Roses - Appetite For Destruction Jpn. Boxed CD Geffen MVOZ-6 - Rare \$75 +4
 - (2) NY Ritz Gig 88 Colored Vinyl 4-45 RPM set \$45 +3
 - G & R No. 1 Comic Book \$20 +3
 - Brass Iron Gun & Rose logo signed in black marker by Steve Ashes - Cool \$40 +3
 - Illusions Box Set both CD's high quality box \$80 +6
 - Genesis - 1983 Rosemont Horizon Chicago Tour Jacket size S - Rare \$75 +5
 - Phil Collins But Seriously embroidered denim jacket Tour 90 Black size L \$90 +4

- H**
- Jimi Hendrix - Live CD - Europe 70 \$35 +4
 - Hall & Oates - 1979 Roxy LA Ticket Stub \$20 +2
 - Buddy Holly - UK Little Book Died Too Young - Rare \$20 +3

- I**
- Ice Shows, Ice Follies, Ice Capades - for listings of Ice Follies & Ice Capades orig. memorabilia from the 50's & 60's Inquire
 - Iron Maiden - Jpn. Photo History soft cvr. book by Ross Hallin high quality w/ CD - A deal at \$40 +3
 - Phantom of the Opera Deluxe Set from Dutch 1981 Show - high quality inserts \$60 +4

- J**
- Jefferson Airplane - Vintage Live CD 1967 - from 1st & 2nd LP's \$40 +3
 - Tom Jones - Deluxe UK laser etches box in wood - numbered \$60 +3
 - Judas Priest - Heavy Metal Photo Book Vol. 6 from Japan high quality \$35 +4

- K**
- Kiss - Music Life Jpn Magazine, circa 1977 cvr. story on Kiss - Rare \$75 +4
 - Music Life Jpn. Magazine circa 1978 cvr. story on Kiss \$60 +4

- L**
- Led Zepplin - 20th Anniv. Ticket to last show from 1980 at Chicago stadium. For more information check our Web site at ledzeppelinintickets.com *special Goldmine deal at \$59.00 per ticket through 10/25/01 includes numbered certificate of authenticity, special custom mat, suitable for hanging on the wall, and shrink-wrapped! \$15 +3
 - (3) Portraits Soft cvr. photo book \$15 +3
 - (5) Record Collector Magazine (Jpn.) Vol. 7 No. 9 Sept. 88 cvr. story - Rare \$40 +3
 - Record Collector Magazine UK Nov. 82 cvr. story \$25 +3
 - More info. check our website Led Zepplin Tickets.com
 - (22) BBC Rarities 7 in. 5 songs with picture sleeve Something Else unreleased song \$12 +3
 - (6) Jimmy Page Outrider Promo Custom Box w/ video & CD \$125 +5
 - Australian Connection Fanzine Vol. 1 No. 1 (1989) \$25 +3
 - 1977 Chicago Stadium ticket to show cancelled due to death of Plant's son - Aug. 3 date \$225 +4

Quality Rock & Roll Memorabilia

email-sales@ledzeppelinintickets.com

Led ZepplinTickets.com

- Page & Plant 2 CD Live in Jpn. 1994 Tour \$35 +3
- Page & Plant Shepard's Bush show 2 CD 1998 tour \$35 +3
- Carlton CD Book of Band (UK) \$25 +2
- (4) Box Set 500 only Interview Disk great picture cover \$30 +5
- HMV Zoso CD Custom Box #549 of 3,500 Sealed \$125 +5
- (4) Original Apr. 1977 unused ticket to stadium show \$200 +3

- M**
- Mamas & Papas - Original 1960's Chicago American Newspaper b&w insert \$75 +4
 - Madison Square Garden - 1967 Program to Grand Opening - wide orig. mail \$250 +5
 - Metallica - (4) 91-92 Tour Book \$20 +3
 - Cast Iron Skull Box w/ Jpn. CD one sealed #2 of 2,500 \$100 +5
 - Meat Loaf - Live 2 CD Set \$25 +3
 - Bob Marley - UK Little Book hardcvr. They Died Too Young \$20 +3
 - Photo Book \$20 +2
 - Rebel Book \$18 +3
 - Glenn Miller - UK hardcover little bk \$20 +3
 - Meat Puppets - (2) Live 1 CD - Rare \$20 +3
 - Man of LaManca - 1963 orig theatre program \$50 +3
 - Rod McKuen - About 20 orig. articles from early 70's. All for \$45 +4
 - Megadeth - (120) Inserts to Singles Jpn. Box includes postcards of each band member, Japanese book and pen set plus custom foil sticker \$25 +3
 - Skin of my Teeth limited edition box w/ 10" single \$25 +5
 - Motorhead - (6) Cast Iron Box Set of same \$60 +5
 - Mother's Finest - Orig. 1981 BBC LP w/ Ques. \$125 +5

- N**
- New Musical Express - UK Custom hard cvr book 1955-1990 \$40 +3

- P**
- Pink Floyd - (11) Animals Box Set (wooden) w/ UK CD - has pig shape - Cool Numbered Ltd. Edition - A deal at \$55 +5
 - (3) Animals UK CD sealed \$10 +2
 - (2) Atom Heart Mother sealed UK CD \$10 +2
 - Pearl Jam - Sleeveless embroidered vest to last show at Chicago Stadium 3/10/94 - has NBA basketball logo on it. Very rare Size XL \$225 +4
 - Pearl Jam - (14) Cast Iron Animal Box Set w/ cvr of CD shape w/ CD - Cool - includes CD - A deal at \$55 +5
 - River Phoenix - UK Book They Died Too Young hardcvr \$20 +3
 - Robert Plant - 1 CD Koebworth Live Concert of the Colonies 1993 \$25 +3
 - Heaven knows Ltd. Ed. Box 3 trk. 12 single, poster \$35 +5
 - Presidents of the U.S. - Rare 2 CD live Set \$20 +3
 - Pretenders - Live 1994 1 CD \$20 +3
 - Prince - Wooden Box Set #573 of 1,000 \$75 +3
 - Diamonds & Pearls Deluxe box set w/ CD No. 123 of 1,000 Wooden has pearls inside \$125 +5

- Q**
- Queen - Died Too Young, Freddie Mercury UK hardcvr little book \$20 +3
 - Custom Deluxe UK Wooden Box Greatest Hits Vol. 1, 2, (#3 of 2500) \$175 +5
 - Box Set Unseen incl. T-shirt Custom Book #211 of 2500. Nice \$75 +5
 - UK Biography Book by Judith Davis \$15 +2
 - Queen - Queen & George Michael embroidered Live 5 Promo shirt - XL Must See \$175 +5

- R**
- Rataan Table - w/4 swivel chairs unwrapped - must see, \$1,000.00. All light brown cane. Custom built! Sold as a set only Inquire
 - Shipping to be determined, based on location.
 - Rock N' Roll Promo Clothing 70's & 80's - Inquire to us available or send wants
 - Rolling Stones - 1981 WJKL The Fox Chicago Radio Station promo jacket made for Tooty You Tour - very rare - Red Size L \$275 +5
 - The Life & Times of The Stones UK hard cvr. book \$25 +3
 - For One Charlie sealed box set with Watts signature incl. from his Jazz tour \$100 +4
 - 1981 Tooty You Security Shirt - Cool - Size L \$75 +4
 - (2) Sticky Fingers custom UK zipper pack CD sealed \$25 +3
 - Rolling Stones - Behind the Buttons, Deluxe Box Set of Between the Buttons, incl. CD - custom book - high quality \$60 +5
 - Beau De Cologne Sealed 2 CD live import, Keith \$75 +3
 - 1975 orig Blacklight poster of Mick & Keith- vintage cool \$45 +6
 - Stones Biography by Dalton, soft cvr \$12 +3
 - The Stones Chronicle by Bonanno - well done \$20 +4
 - 1975 Rolling Stone Book on Stones (2) \$40 +3
 - R.E.M. - (3) Automatic For The People sealed Australian limited ed. gold CD \$20 +2
 - Jpn. sealed release of the same \$30 +3
 - Rage Against The Machine - (2) Black XL Concert T-shirt \$25 +3
 - Rush - Counterparts Tour XL Shirt, Nice, Promo \$35 +4

- S**
- Bruce Springsteen - (2) Italian Fanzine Follow That Dream w/ CD sealed \$25 +2
 - Sex Pistols - I was a Teenage Sex Pistol hardcvr UK book \$20 +2
 - Santana - Jpn. Star Box CD of Greatest Hits \$30 +3
 - Sound Garden - (4) Cast Iron Custom Box Set \$60 +3
 - The Smiths - (8) Laser etched wooden box set numbered - A deal \$60 +4
 - Steely Dan - 1975 orig Japan Promo Poster AJA Impeccably framed \$325 +15

- T**
- Tesla - Custom embroidered XL hooded purple sweatshirt logo on back very detailed \$75 +5

- U**
- U2 - War Live LP in custom box UK release 1981 show - Nice \$50 +5
 - Custom Achtung Baby Wooden Box Set w/ CD \$100 +4
 - Zoo TV Custom Box Set \$75 +5
 - Unforgettable Fire Promo only sweatshirt - Size XL \$100 +4
 - WEA embroidered collar shirt given to staff at 80's Industry Convention. Very Rare - Size L - Says U2 is No. 1 over heart \$175 +4
 - Joshua Tree promo only sweatshirt - Size L \$40 +4
 - The CD single collection Box 1 & 2 from Germany limited to 500 sold as a set only from 1981 to 1989. Vintage includes Zippo lighter. Very high quality - One set only \$350 for both +6

- V**
- Stevie Ray Vaughn - Custom 2 CD wooden laser etched box set numbered - Must see this \$125 +5

- W**
- Joe Walsh - Memphis 87 mag cvr story from local newspaper \$25 +2
 - Live 1 CD 80's show \$30 +3
 - All night long song sheet \$40 +3
 - Life's Been Good Song Sheet, U.S. \$35 +3
 - UK \$45 +3
 - The Who - 1982 Local Crew Shirt Green - Size L - Very Rare \$45 +4
 - Wingsong - The Cult Mixes \$60 +2
 - Winger - 97X promo sweatshirt - blue - size XL \$35 +3
 - Wishbone Ash - Authentic custom wooden box set 70's embroidered tour jacket size small - very rare \$175 +4
 - Frank Zappa - Shut up and Play Yer Guitar promo T-shirt \$50 +3

Metro Pulse, Inc.®

P.O. Box 759, Lombard, IL 60148

PROUD TO BE IN THE USA

1-630-932-9177

FAX 1-630-932-3422 24 Hrs.

Check out our Web site at Led Zepplin Tickets.com

Some prices negotiable, trades considered.

Number before listing denotes quantity.

Polaroids are \$1 each on any items of interest in this ad.

**In Memory of those who died in New York,
Washington D.C. & Pennsylvania
on September the 11th, 2001**

We'll never forget you!

www.elvisunlimited.com



DISC COLLECTOR



P.O. Box 4000, Parker, CO 80134
(303) 841-3000 • (303) 841-1118
FAX (303) 840-9373
*e-mail: cd@discol.com
Web site: www.discol.com
Hours: Monday thru Friday
9 a.m. to 5 p.m. Mountain Time

THE DISC COLLECTOR ADVANTAGE

- ✓ We Stock 1000's of Titles (Domestic & Import) in addition to the CDs Listed in This Ad... Don't See It or Have Questions? ...Just Ask!
- ✓ We Know Pop Music Well... From Original Recordings to Sound Quality...
- ✓ Trusted Professionals for Over 19 Years.
- ✓ Very Competitive/Low Overall Pricing.

Look! Please check out our Web site www.discol.com for up-to-the-minute new releases, super specials, reviews, and much more.

LIST #1001 Your Official Oldies Supersource! Your Blast To The Musical Past Since 1981

TOP 10 NEW RELEASE SIZZLERS

1. RICKY NELSON - THE AMERICAN DREAM... COMPLETE IMPERIAL AND VERVE RECS... '57-'62 (SUPER DELUXE 6 CD BOX & HARDBOUND BOOK) (DUE 10/20) (GERMAN) BEAR FAMILY 16196 M/S... \$134.99
2. VARIOUS ARTISTS - HARD TO FIND 45's ON CD VOL. 6 - 21 TRACKS (DUE 10/15) (US) ERIC 11512 M/S... \$14.99
3. VARIOUS ARTISTS - HARD TO FIND 45's ON CD VOL. 7 - 21 TRACKS (DUE 10/15) (US) ERIC 11513 M/S... \$14.99
4. VARIOUS ARTISTS - YA GOTTA USE BOTH EARS FOR THIS ONE (SUPER RARE NEW STEREO-50s-60s) - 20 TRACKS (EURO) TWO MIKES 001 S... \$16.99
5. VARIOUS ARTISTS - ANGEL BABY - 30 TRACKS (EURO) MR. MAESTRO 1010 M/S... \$17.99
6. BOBBY GOLDSBORO - 36 ALL TIME GREATEST HITS - (EVERY CHART HIT) (3 CD) (US) EMV/GSC 17017 M/S... \$23.99
7. TEDDY & THE PANDAS - ONCE UPON A TIME... THERE WAS - 20 TRACKS (GERMAN) CORISTINE 5125 M/S... \$17.99
8. THE WHO - INSTANT PARTY/SINGLES COLLECTION - (SUPER DELUXE 2 CD W/3 BOOKS & POSTCARDS) (UK) HIWATT M/S... \$74.99
9. NUMBREGS - #1 HIT SINGLES COLLECTION - (23-7" RED VINYL SINGLES - 45's - W/PICTURE SLEEVES) (UK) NUMBERED EDITION (US) COLLECTABLES 1031 M/S... \$89.99
10. JO-ANN CAMPBELL - THE ULTIMATE BLONDE BOMBSHELL (COMPLETE) (3 CD) 73 TKS (US) BLONDIE 1001 M/S... \$34.99



GENERAL POLICIES

- All products guaranteed as advertised and any defective will be exchanged (You pay postage one way - complete satisfaction).
- Orders shipped as soon as possible. We can only hold phone orders for 10 days, so please make prompt payment to insure getting the items you want.
- Unless you specify, out of stock product will be back ordered and your order held, otherwise funds will be given on product sold out at shipment time.
- Some titles advertised were not in stock at press time, but expected in by the time you read this ad... you might want to verify prior to sending funds.
- We reserve the right to make corrections if a typographical/pricing error occurs.
- Availability subject to prior sale.
- Hours: Monday thru Friday 9 a.m. to 5 p.m. Mountain Time.
- Phone orders and questions welcome. No collect calls.
- Mail Order only... NOT A RETAIL STORE.

PAYMENT POLICIES

- We accept VISA, MASTERCARD, DISCOVER, and AMERICAN EXPRESS in addition to personal checks and money orders (checks must clear our bank - approx. 7 days).
- No minimum order on checks and money orders. Payable to Disc Collector. All Credit Cards - MINIMUM \$15 (product only).
- Colorado residents add 4.8% sales tax. *NO C.O.D.'s*

SHIPPING POLICIES

- * 1. Parcel post \$2.95 first 2 CD's - 25 each thereafter
- * 2. UPS 2-day - Add \$3.00 to the above rate
- * 3. UPS 4-5 day first CD - 25 each thereafter
- * 4. UPS 2-day - Add \$5.00 to the above rate
- * 5. Federal Express (Air Only) - Call for rates
- * Insurance included in all orders - Please specify which preference when ordering.
- * Any additional or specific shipping requests JUST ASK!
- * Foreign - Overseas and Canada rates will be quoted.
- * IMPORTANT - Box sets count as number of items in box - example 5-CD box counts as 5 items. BOOKS count as 6 items for shipping.

*E-MAIL ORDERING When ordering by E-MAIL only credit card orders can be accepted. You must include in the body of the message, the item being ordered, price of the item, complete shipping address, and the credit card number with the expiration date. All other ordering policies apply to Electronic orders. Our Web site is secure.

Sale!

- Duke Ellington - The Duke - Complete Works 1924-1947 (40 CD box)**
750 + tracks (German) HOT PRICE!
\$139.99 \$99.99 \$69.99
- Various Artists - American Bandstand - (4 CD) 100 tracks (Holland)**
\$44.99 \$29.99 \$19.99
- Elvis Presley - Blue Suede Shoes Collection - (super deluxe 3 CD box) (US)**
\$469.99 \$369.99 \$319.99
- Various Artists - RPM Records 10th Anniversary Sampler - 25 tracks (UK)**
\$18.99 \$12.99 \$7.99
- Various Artists - Encyclopedia of Doo-Wop Box Vol. 2 - (4 CD) 100 tracks (UK)**
\$89.99 \$69.99 \$59.99
- Various Artists - String Out (instrumental diamonds '63-'71) - (2 CD)**
60 tracks (UK)
\$21.99 \$14.99 \$9.99
- Beach Boys - Studio Sessions '61-'62 - 21 tracks (UK)**
\$16.99 \$12.99 \$8.99
- Elvis Presley - The Complete Louisiana Hayride Shows - (3 CD) 35 tracks (Holland)**
\$29.99 \$21.99 \$16.99
- Procol Harum - 30th Anniversary Anthology - (3 CD) 52 tracks (UK)**
\$36.99 \$26.99 \$19.99
- John Lee Hooker - Portrait - (10 CD w/40 page booklet) (German) SUPER!**
\$89.99 \$69.99 \$44.99

BLOWOUT BLITZ...

TITLE	REGULAR PRICE	ON SPECIAL BLOWOUT!	TITLE	REGULAR PRICE	ON SPECIAL BLOWOUT!
Various Artists - 100 No. 1 Hits - (6 CD) 90 tracks (Holland)	\$69.99	\$44.99	170. SCOTT ENGL - HITS & RARITIES VOLS. 1&2 - 32 TRACKS EACH (ITALY) RSC 1002/03 M/S EACH	\$56.99	\$21.99
Dean Martin - Sings Country Favorites - (3 CD) 36 tracks (Portugal)	\$39.99	\$24.99	171. PAUL MCCARTNEY & WINGS - WINGSPAN (DELUXE ALP BOX) (UK) EMU M/S	\$139.99	\$89.99
Various Artists - Memories Of Times Square Record Shop (hot duo wop) (11 CD) (US)	\$139.99	\$89.99	172. VARIOUS ARTISTS - RADIO GOLD VOL. 4 - 31 TRACKS (UK) ACE 810 M/S	\$56.99	\$16.49
Spaniels - The Legendary - (3 CD) 69 tracks (US) w/great book	\$79.99	\$59.99	173. VARIOUS ARTISTS - DYNAMITE 1940's GROUP SOUNDS VOL. 1 - 22 TKS (GERMAN) DGS 403 301 M	\$139.99	\$16.99
Various Artists - 1000 Country & Western Songs - (5 CD box)	\$169.99	\$129.99	174. DEE DEE WARWICK - I WANT TO BE WITH YOU ('65-'73) - 26 TRACKS (UK) HIP-0 558716 S	\$139.99	\$14.49
C & W From the 50s to 80s (hits, rarities, live, etc) (Euro) WOW!	\$169.99	\$129.99	175. LONNIE MACK - FROM NASHVILLE TO MEMPHIS 26 TRACKS (UK) ACE 807 M/S	\$139.99	\$16.49
Various Artists - Sound Of The Movies (4 CD box) Approx. 800 tracks (German) (new release) HOT PRICE!	\$139.99	\$99.99	176. VARIOUS ARTISTS - MODERN RECORDS STORY 28 TRACKS (UK) ACE 784 M/S	\$139.99	\$16.49
Ringo Starr & His All Starr Band - Anthology - (3 CD) 47 tracks (Holland)	\$36.99	\$29.99	177. BETTYE SWANN - THE MONEY RECORDINGS - 24 TRACKS (UK) KENT 197 M/S	\$139.99	\$16.49
Various Artists - Entire History of Punk (Sex Pistols, Dead Kennedys, Stranglers etc.) (20 CDs) over 300 tracks w/100 page book (UK) New Release - Super Price	\$36.99	\$29.99	178. BEACH BOYS - HAWTHORNE, CA (BIRTHPLACE OF A MUSICAL LEGACY) (2 CD) 57 TKS (UK) CAPITOL 31583 M/S	\$139.99	\$23.99

1. ELVIS PRESLEY - THE WAY IT WAS (A/V DOCUMENTARY)-(DELUXE 1 CD +96 PAGE HARD BOUND BOOK) FTD STORES (DENMARK) BMG M/S... \$74.99
2. FOUR TOPS - FOUREVER/DEFINITE FOX - 85 TRACKS (US) MOTOWN 556225 M/S... \$49.99
3. JO STAFFORD - COLUMBIA HITS COLLECTION - 29 TRACKS (US) CCM 115 M/S... \$16.99
4. VARIOUS ARTISTS - THE LOVELY LADIES OF DOO-WOP (50's, 60's)-25 TKS (EURO) PAVILLION 71237 M/S... \$16.99
5. VARIOUS ARTISTS - BIRTH OF SOUL VOL. 3 - (UK) KENT M... \$16.49
6. RE-VELS - MIDNIGHT STROLL - 30 TRACKS (EURO) GRAND PRAX LX 10 M/S... \$17.99
7. ROGER MCGUINN - TREASURES FROM THE FOLK DEN (NEW RECS) - 18 TKS (US) APR CD 1046 S... \$14.99
8. CARL DOBKINS, JR. - NOW & THEN (NEW RECS/AUTOGRAPHED) - 11 TKS (US) DBW SOUND S... \$13.99
9. NOKIE EDWARDS - CARVIN' IT OUT (NEW RECS) - 11 TRACKS (EURO) SIVE! (US) LOUD NEIGHBORS 9701 S... \$13.99
10. VARIOUS ARTISTS - THE TWANG GANG (DUANE EDDY DONNIE OWENS, SANFORD CLARK) - 18 TKS (US) JAMIE 4017 M/S... \$14.99
11. HARPERS BIZARRE - 4 CATALOG TITLES (US)
 - A) FEELIN' GROOVY - SUNDAZED 6176 S... \$11.49
 - B) ANYTHING GOES - SUNDAZED 6177 S... \$11.49
 - C) THE SECRET LIFE OF... SUNDAZED 6178 S... \$11.49
 - D) HARPERS BIZARRE 4 - SUNDAZED 6179 S... \$11.49
- * ALL FOUR... \$42.99
12. THE CYRLE - RED RUBBER BALL - 19 TRACKS (US) SUNDAZED 11108 S... \$13.49
13. THE CYRLE - NEON - 20 TRACKS (US) SUNDAZED 11109 S... \$13.49
- * BOTH... \$25.99
14. THE MARMALADE - REFLECTIONS OF ANTHOLOGY - (2 CD) 46 TRACKS (UK) CASTLE 281 M/S... \$18.99
15. FREE DESIGN - THE BEST OF - 20 TRACKS (UK) CHERRY RED 194 M/S... \$16.99

16. MCGUINN CLARK HILLMAN (REMASTERED) - 13 TRACKS (US) ONE WAY 32432 S... \$12.99
17. PICKETT TWITCH - THAT SAME OLD FEELING - 27 TRACKS (UK) CASTLE 265 M/S... \$14.99
18. PERCY FAITH - THE ULTIMATE COLLECTION (3 CD) 60 TRACKS (AUSTRALIA) COLUMBIA 652000 M/S... \$18.99
19. MAMAS & PAPAS - ALL THE LEAVES ARE BROWN/GOLDEN BRA COL. 52 TKS (US) MCA 112653 M/S... \$22.99
20. BUDDY HOLLY - EP COLLECTION - (2 CD) 48 TRACKS (UK) SFM M/S... \$25.99
21. DEL SHANNON - 25 ALL TIME GREATEST HITS - (US) VARESE 66270 M/S... \$14.99
22. TONI TENNILLE - INCURABLY ROMANTIC (NEW RECS) - (US) VARESE 66284 S... \$15.49
23. THE ROLLING STONES - CHICAGO CHESS SESSIONS (SOME RARE STEREO) 20 TRACKS (EURO) PGE 005 M/S... \$18.99
24. BADFINGER - COMPLETE ASS - (2 CD) 37 TRACKS (EURO) BRILLIANT ROAD M/S... \$28.99
25. VARIOUS ARTISTS - FORGOTTEN TEEN IDOLS VOL.1/THE BOYS - 19 TKS (EURO) TEEN 101 M... \$15.99
26. VARIOUS ARTISTS - FORGOTTEN TEEN IDOLS VOL.2/THE GIRLS - 20 TKS (EURO) TEEN 102 M... \$15.99
27. VARIOUS ARTISTS - FORGOTTEN TEEN IDOLS VOL.3/BOYS & GIRLS - 20 TKS (EURO) TEEN 103 M... \$15.99
28. BRIAN WILSON - THE PET SOUNDS SYMPHONIC TOUR 2000 - (2 CD) GOLD DISCS - 41 TKS (EURO) WILD CARD 409 S... \$34.99
29. VARIOUS ARTISTS - NON STOP 90s ROCK - 18 TRACKS (US) RAZOR & TIE 189038 S... \$15.99
30. VARIOUS ARTISTS - UNDER THE INFLUENCE OF ELVIS - 31 TKS (EURO) IM 14269 M/S... \$16.99
31. DONNIE IRIS - BEST OF/MILLENNIUM COLL. - 11 TRACKS (US) MCA 112521 S... \$11.49
32. VARIOUS ARTISTS - HEY LOOK WHAT I FOUND VOLS. 10 & 11 - 27 TKS EACH (CANADA) MAVIS 4510 4511 M/S... \$14.49
- * BOTH JUST... \$27.99
33. NINO TEMPO/APRIL STEVENS - DEEP PURPLE/SING THE GAY SONGS - 24 TKS (US) COLLECTABLES 6888 M/S... \$12.99
34. THE GUESS WHO - SHAKIN' ALL OVER - 24 TRACKS (US) SUNDAZED 11113 M/S... \$13.49
35. DION - SANCTUARY/SUITE FOR LATE SUMMER 24 TRACKS (UK) ACE 792 S... \$16.49
36. ROCKY FELLERS - KILLER JOE (SCENERY RECS.) - 23 TRACKS (UK) WESTSIDE 898 M/S... \$16.99
37. SIMON & GARFUNKEL - COLUMBIA STUDIO RECS. BOX - 5 (CD W/BOOK) (US) CBS 63815 S... \$39.99

"THE STORY SERIES"

- WE MADE A SUPER PURCHASE ON 50'S & 60'S HITS. PACKAGES FROM EMU/HOLLAND... ALL FEATURE 18-25 TRACKS PER CD AND COME WITH A BONUS CD-ROM CONTAINING A BIOGRAPHY, DISCOGRAPHY & PHOTO GALLERY ON EACH ARTIST.
- INCREDIBLE PRICE! ONLY \$9.99 EACH 6 OR MORE - JUST \$8.99 EACH!**
- DEL SHANNON THE STORY
 - FRANKIE AVALON THE STORY
 - GENE PITNEY THE STORY
 - EVERLY BROTHERS THE STORY
 - JERRY LEE LEWIS THE STORY
 - JOHNNY TILLOTSON THE STORY
 - GERRY AND THE PACEMAKERS THE STORY
 - MANFRED MANN THE STORY
 - B.J. THOMAS THE STORY
 - THE SHIRELLES THE STORY
 - FATS DOMINO THE STORY
 - THE SHADOWS THE STORY
 - HELEN SHAPIRO THE STORY
 - BILLY J. KRAMER & THE DAKOTAS THE STORY
 - CILLA BLACK THE STORY
 - CHER THE STORY
 - GENE VINCENT THE STORY
 - EDDIE COCHRAN THE STORY
 - TOMMY JAMES & THE SHONDELLS THE STORY
 - JOHNNY KIDD & THE PIRATES THE STORY
 - THE KINGSTON TRIO THE STORY
 - DION AND THE BELMONTS THE STORY
 - CARL PERKINS THE STORY
 - THE CHORDETTES THE STORY
 - FABIAN THE STORY
 - RITCHEE VALENS THE STORY
 - THE VENTURES THE STORY
 - JAN & DEAN THE STORY
 - HERMAN'S HERMITS THE STORY

HOT BOX...

- | Title | Label | Mono/Stereo | Price |
|---|-------|-------------|---------|
| Elvis Presley - The Legends Collection - (2 CD) Million Dollar Quartet - 28 tracks (UK) DTK 14922 M | DK | S | \$29.99 |
| Bobby Womack - The Legends Collection/Best (2 CD) 38 tracks (UK) DTK 15422 M/S | DK | S | \$29.99 |
| Solomon Burke - If You Need Me/Rock N' Soul - 22 tracks (US) Collectables 6225 M/S | CA | S | \$8.99 |
| The Clovers - The Clovers/Dance Party - 27 tracks (US) Collectables 6218 M | CA | S | \$8.99 |
| The Drifters - Clyde McPhatter & The Drifters/Rockin' & Driftin' - 28 tracks (US) Collectables 6226 M/S | CA | S | \$8.99 |
| Ben E. King - Spanish Harlem/Don't Play That Song - 24 tracks (US) Collectables 6210 M/S | CA | S | \$8.99 |
| Ivory Joe Hunter - Ivory Joe Hunter/The Old & The New - 26 tracks (US) Collectables 6234 M/S | CA | S | \$8.99 |
| Clyde McPhatter - Love Ballads/Clyde - 21 tracks (US) Collectables 6227 M/S | CA | S | \$8.99 |
| Lavern Baker - See See Rider/Blues Ballads - 25 tracks (US) Collectables 6231 M/S | CA | S | \$8.99 |
| Lavern Baker - S/T-Lavern - 26 tracks (US) Collectables 6224 M | CA | S | \$8.99 |
| Nina Simone - Folksy Nina/Nina Simone With Strings - 20 tracks (US) Collectables 6210 M/S | CA | S | \$8.99 |
| Duane Eddy - Duane Eddy & Go/Does Bob Dylan - 26 tracks (US) Collectables 622 S | CA | S | \$8.99 |
| Paul Peterson - My Dad/Lollipop & Roses - 24 tracks (US) Collectables 6230 M/S | CA | S | \$8.99 |
| Buddy Knox - S/T - Buddy Knox & Jimmy Bowen - 23 tracks (US) Collectables 6212 M/S | CA | S | \$8.99 |
| Shelley Fabares - S/T - The Things We Did Last Summer - 22 tracks (US) Collectables 6223 S | CA | S | \$8.99 |
| Lou Christie - S/T - Lou Christie Strikes Again - 24 tracks (US) Collectables 6229 M/S | CA | S | \$8.99 |
| The Raindrops - S/T - 20 tracks (US) Collectables 6316 M/S | CA | S | \$8.99 |

107. JOHNNY BURNETTE - SINGS RARE ITEMS VOLS 1 & 2 - 20 TKS EACH (EURO) MR 6072, 73 M/S EACH... \$15.99
- * BOTH - JUST... \$30.99
108. BOBBY VINTON - TELL ME WHY/SONGS FOR LONELY NIGHTS - 24 TKS (US) COLLECTABLES 6865 S... \$13.49
109. BOBBY VINTON - MR. LONELY/COUNTRY BOY - 22 TRACKS (US) COLLECTABLES 6864 S... \$13.49
110. THE CRICKETS - TOO MUCH MONDAY MORNING - 14 TRACKS (UK) CASTLE 589 S... \$12.99
111. CONNIE FRANCIS - CONNIE SINGS BUDDY - 14 TRACKS (UK) CASTLE 262 S... \$9.99
112. TOWER OF POWER - THE VERY BEST OF - 16 TRACKS (US) RHINO 74345 S... \$11.49
113. THE CLASSICS - TILL THEN/BEST OF - 20 TRACKS (US) COLLECTABLES 6861 M/S... \$13.49
114. THE DELCLOS - BOY COULD THEY SING - 28 TRACKS (US) CRYSTAL BALL 1035 M/S... \$15.99
115. VARIOUS ARTISTS - THE PERFECT DAY/40 YEARS OF SURFER MAGAZINE(LTD.W/SET SUIT PACKAGE) (US) RIGHT STUFF 32123 M/S... \$18.99
116. BUFFALO SPRINGFIELD - BOX SET - (DELUXE 4 CD'S) 88 TRACKS (US) RHINO 74324 M/S... \$49.99
117. PIXIES THREE (60'S GIRLS) - 30 TRACKS (US) CRYSTAL BALL 1033 M/S... \$16.99
118. DAVE CLARK FIVE - HISTORY OF - (2 CD) 50 TRACKS (US) HOLLYWOOD/CCM M/S... \$24.99
119. VARIOUS ARTISTS - NUGGETS II - (DELUXE 4 CD BOX) 109 TRACKS W/100 PAGE BOOK (US) RHINO 74617 M/S... \$52.99
120. T-BONES - BOSS DRAG/BOSS DRAG AT THE BEACH (HOT ROD KINGS) - 30 TKS (GERMAN) ATM 3832 M/S... \$18.99
121. VARIOUS ARTISTS - GIRL GROUP SOUND/REDBIRD LABEL - 25 TRACKS (US) VARESE 66246 M/S... \$14.49
122. DONNIE BROOKS - GREATEST HITS '58-'68 - 34 TRACKS (AUSTRALIA) CANETAD 002 M/S... \$18.99
123. ELVIS PRESLEY - DIXIELAND ROCKS (LIVE '75) (FTD. SERIES) - 24 TKS (DENMARK) RCA S... \$27.99

ANDY'S RECORD SUPPLIES

48 Colonial Road, Providence, RI 02906; Phone, 401/421-9453; Fax, 401/421-0841

- FOREIGN ORDERS CALL OR WRITE FOR CHARGES
- CALL TO HAVE YOUR ORDER SHIPPED C.O.D.
- NO PO BOX #'S, STREET ADDRESS ONLY FOR UPS
- \$30 MINIMUM ORDER
- CHECKS MUST CLEAR



CLIP & SAVE

SINCE 1989 — QUALITY PRODUCTS, LOW PRICES & FREE SHIPPING ANYWHERE IN THE CONTINENTAL U.S.

JAPANESE RESEALABLE SLEEVES...

Direct from Japan.
The best quality protection you can get.
Crystal clear outer sleeves.
These will never fade or crack. Lifetime protection.
All come with resealable flaps
and peel-off strip on back.
Fits over jackets, sleeves, and CD jewel cases.

- LPS / LASER DISCS 100 - \$20.99; 1000 - \$145.99
- CDS 100 - \$12.99; 1000 - \$69.99
- COMIC BOOKS 100 - \$17.99; 1000 - \$119.99
- 45S, PIC SLEEVES 100 - \$15.99; 1000 - \$84.99
- DOUBLE CDS 100 - \$14.99; 1000 - \$74.99
- 10" 78 LPS 100 - \$17.99; 1000 - \$118.99
- 9 1/2 X 11 1/2 MAGAZINES. 100 - \$19.99; 1000 - \$139.99
- DVD'S **NEW** . . . 100 - \$13.99; 1000 - \$79.99

CARDBOARD JACKETS...

HEAVY-DUTY 12" ALBUM JACKETS. WHITE OR BLACK.
HIGH GLOSS. WITH OR WITHOUT HOLE
Case Price / 100 - \$49.99

HEAVY-DUTY CD WHITE JACKETS WITH HOLE.
100 - \$29.99; Case Price / 600 - \$149.99

MAILERS...

MULTI-ALBUM MAILER
Heavy duty corrugated cardboard, 200 lb test,
holds 3-20 albums.
Case Price / 100 - \$109.99

MULTI 1-10 CD MAILER
Heavy duty corrugated cardboard, 200 lb test,
holds 1 CD or up to 10 CDs in jewel cases.
Case Price / 100 - \$54.99

SPECIAL ITEMS...

CLEAR CD DISC SLEEVE
6 Mil Thick. Full front flap with white protective pad
inside.
100 - 49¢, each - 49¢; 500 - 99¢, each - 39¢;
1,000 and up, each - 34¢

SHRINK-WRAP SYSTEM
For CD's, Cassettes, and Videos. Ready to wrap
in seconds. Each \$249.99
2,000 feet of film for Cassettes \$89.00
500 feet of film for CDs \$59.00
2,000 feet of film for CDs \$93.99
2,000 feet of film for Videos \$99.00

WHITE PLASTIC DIVIDER CARDS...

- CD Jewel 6 x 7 35¢ EA.
- CD Full 6 x 14 49¢ EA.
- 45 Full 7 x 8 1/2 40¢ EA.
- 45 Slant 7 x 8 1/2 38¢ EA.
- LP Full 12 x 14 69¢ EA.
- LP Slant 12 x 14 65¢ EA.

Minimum, 50
Mix & Match Available

POLY SLEEVES • HIGHEST QUALITY...

Perfect Fitting Sleeves For Your Records & Collectibles

3 MIL THICK ALBUM SLEEVES
Fits Over Outer Album Jacket. Size, 12 3/4 x 12 3/4.
100 - \$10.99; 500 - \$39.99; Case Price / 1000 - \$65.99

4 MIL THICK ALBUM SLEEVES
Fits Over Outer Album Jacket. Size, 12 3/4 x 12 3/4.
100 - \$14.99; 500 - \$59.99; Case Price / 1000 - \$94.99

45S, EPS, PIC. SLEEVES
Size, 7 1/2 x 7 1/2 - 3 Mil Thick.
100 - \$6.99; 500 - \$19.99; Case Price / 1000 - \$31.99

78/10" LP SLEEVES
Size, 10 3/4 x 11 - 3 Mil Thick. Fits Over Outer Jacket.
100 - \$9.99; 500 - \$38.99; Case Price / 1000 - \$63.99

COMPACT DISC SLEEVES
Size, 5 x 6 With 1" Flap; 2.5 Mil Thick; Fits Over CD Disc.
100 - \$4.79; Case Price / 1000 - \$25.99

CD JEWEL CASE SLEEVES
Size, 6 x 6 With 1" Flap; 2.5 Mil Thick; Fits Over CD Jewel Case.
100 - \$4.99; Case Price / 1000 - \$26.99

LIFE MAGAZINE SLEEVES
Size, 11 x 16 With 2 1/2" Flap; 2.5 Mil Thick; Fits Old & New Issues.
100 - \$13.50; 500 - \$49.99; Case Price / 1000 - \$79.99

MAGAZINE SLEEVES
Size, 8 3/4 x 11 1/4 With 1 1/2" Flap; 3 Mil Thick.
100 - \$9.99; 500 - \$39.99; Case Price / 1000 - \$59.99

BOX SET SLEEVES
Size, 14 x 15 - 2.5 Mil Thick
100 - \$14.50; 500 - \$55.99; Case Price / 1000 - \$89.99

SHEET MUSIC SLEEVES
9 1/2 X 12 1/2; 3 Mil Thick
100 - \$9.99; 500 - \$39.99; Case Price / 1000 - \$59.99

FREE SHIPPING in the Continental U.S.

QUALITY PAPER SLEEVES...

7" WHITE WITH HOLE
100 - \$7.99; Case Price / 2400 - \$69.99

12" WHITE WITH HOLE ROUND CORNERS
100 - \$11.99; Case Price / 1000 - \$78.99

12" WHITE POLY-LINED SQUARE CORNERS
100 - \$21.99; Case Price / 500 - \$98.99; 1000 - \$169.99

JAPANESE NON-STATIC INNER SLEEVES
12" LP/LaserDisc; clear, square top with round bottom
(no hole).
100 - \$19.99; Case Price / 500 - \$84.99; 1000 - \$139.99

JAPANESE CD CLOTH SLEEVE
White (no hole) soft woven material **NEW**
100 - \$18.99; Case Price / 1000 - \$139.99

DVD BOXES...

BLACK DVD REPLACEMENT BOXES **NEW**
Case Price/100 \$49.99

CD REPLACEMENT CASES...

CD JEWEL CASE ONLY
Case Price / 200 - \$49.99; 1000 - \$219.99

CD JEWEL CASE W/TRAY
Case Price / 200 - \$73.99

SLIM LINE JEWEL CASE FOR CD SINGLES
W/BUILT-IN TRAY

Case Price / 300 - \$88.99

ULTRA SLIM CD SINGLE JEWEL CASE **NEW**
Case Price / 200 - \$69.99

ULTRA (2 CD) SLIM JEWEL CASE **NEW**
Case Price / 300 - \$119.99

ULTRA (4 CD) SLIM JEWEL CASE **NEW**
Case Price / 200 - \$139.99

DOUBLE (2 CD) JEWEL CASE W/2 TRAYS
Each (minimum 50) 99¢; Case Price / 100 - \$89.00

ALL CLEAR DOUBLE (2 CD) SLIMLINE CASE
Clear case, crystal clear tray, completely visible
throughout.

Each (minimum 50) 60¢; Case Price / 200 \$109.99

BLACK DOUBLE (2 CD) SLIMLINE CASE **NEW**
Clear case, black tray.

Each (minimum 50) 60¢; Case Price / 200 \$109.99

WHITE DOUBLE (2 CD) SLIMLINE CASE
Clear box white tray.

Each (minimum 50) 60¢; Case Price / 200 - \$109.99

3CD SLIM JEWEL CASE **NEW**
Clear Case w/Black or clear Tray

Case Price /200 \$137.99

DOUBLE SLIM UNBREAKABLE TRAY ONLY
Virtually unbreakable! Made of plastic & rubber
material and it will fit any regular jewel case.

Each (minimum 100) 35¢; Case Price / 800 \$232.00

DOUBLE SLIM TRAY ONLY **NEW**
Clear or black. Snaps into a standard jewel case.

Each (minimum 150) 35¢; Case Price / 300 \$90.99

JEWEL CASE TOP LIDS ONLY
Case Price / 200 \$35.99; 1000 - \$149.99

TRIPLE (3 CD) JEWEL CASE W/TRAYS
Each (minimum 50) 99¢; Case Price / 100 - \$89.00

QUAD (4 CD) JEWEL CASE W/TRAYS
Each (minimum 50) 99¢; Case Price / 100 - \$89.00

6 CD JEWEL CASE W/TRAYS
Each (minimum 50) \$1.19; Case Price / 100 - \$109.99

COLOR CD JEWEL CASE ONLY
Jewel Case Colors: Transparent colors of red, blue,
green, orange, or purple. Case Price / 200 - \$69.99

COLOR CD JEWEL CASE W/ COLORED TRAY
Jewel Case Colors: See above; Jewel Tray Colors:
See below. Case Price / 200 - \$83.99

COLOR CD JEWEL TRAYS
Jewel Tray Colors: red, blue, orange, crystal clear,
purple, white, green. Case Price / 400 - \$59.99

STANDARD GREY CD JEWEL TRAY
Case Price / 400 - \$44.99

CASSETTE REPLACEMENT CASES...

ALL CLEAR, OR CLEAR & BLACK
EXTRA STRONG STYRENE MATERIAL
Case Price / 400 - \$69.99; 800 - \$119.99

CLIP & SAVE

• ALL PRICES SUBJECT TO CHANGE WITHOUT NOTICE •

prices effective 1/1/01

Contents

Dedicated to the memory of Rick Whitesell

Goldmine

ISSUE 554 October 19, 2001
Vol. 27 No. 21

Courtesy of Richie Furay



14 Poco

Poco's impact on country-rock is vastly underrated. Out of the ashes of Buffalo Springfield came Poco. But a constantly shifting lineup — with a number of players ending up in the mega-selling Eagles as well as splinter groups — didn't help the cause. Yet, Poco's members did write many outstanding songs, some of which reached the Top 20. On and off for the past 30 years, if you think Poco is no longer, you better think twice. ...by George Krieger

18 Poco DISCOGRAPHY

Poco has released recordings since 1969, with the potential for more in the near future. ...by George Krieger and Tim Neely



Garage Sale ad section starts on page 43.

12 Rock Hall 2002

INDUCTION NOMINEES

The Rock And Roll Hall Of Fame induction committee has released its slate of nominees, which includes The Chantels and Jackson Browne. ...by Greg Loescher



Courtesy of Asylum Records/photo by Randa M. Michaluk/2001



Courtesy of Ed Weigle

48 PORKY CHEDWICK

The first DJ to play oldies — way back in 1948, Porky Chedwick is a legend around Pittsburgh and has been honored with an annual celebration called Porkstock. ...by Ed Weigle

PLUS...



BRENDA LEE

Courtesy of Brenda Lee



NEW RELEASES

©2001 Cathy Somardi



REISSUES

- 8 Please Mr. Postman** Letters from *Goldmine* readers and *Letter From The Editor*.
- 10 Grapevine** The Sept. 11, 2001, attacks on the U.S. and their impact on the music industry. The Rock And Roll Hall Of Fame 2002 nominees; and *Grapeleaves*.
- 12 Rare Finds** A 25¢ album nets autographs and a Beatles memento. ...Greg Loescher
- 22 Country Junction** 10 Questions for Brenda Lee by Bruce Sylvester, plus country music news and reviews.
- 26 Not Lame Records** Born out of a desire to record and distribute great pop music, Not Lame Records is one man's dream come true. ...Lee Zimmerman
- 30 New Releases** Bliss 66, Butthole Surfers, System Of A Down, Michael Nesmith and Nick Lowe tributes, Los Straitjackets, William Pears, Vigilantes Of Love, Howler and more...
- 52 Reissues** Blondie, Poco, Bob Marley & The Wailers, Jerry Garcia & David Grisman, Doc Watson, Roy Forbes and more...
- 54 25 Great Folk Albums** Here's a list with the usual suspects such as Bob Dylan and Joan Baez plus some surprises to check out. ...Bruce Sylvester

COLUMNS...

- 19 Classical Notes** Classical Classics: Beethoven's *Fifth*. ...Peter Gutmann
- 20 A Broad Abroad** A trip down memory lane — from Canada and Europe. ...Jo-Ann Greene
- 76 Five Star Cartoon** The soundtrack to Andy Warhol and Paul Morrissey's *Frankenstein*. ...Marty Winters

BUY & SELL MARKETPLACES

Unit Space Advertising	31
Garage Sale Unit Ads	43
Super Unit Space Section	46
Web Directory.....	56
Record Show Calendar	58
Retailer Directory	62
CD Showcase	65
Collector's Showcase	66
Want Lists	71
Classifieds	73

GOLDMINE INFORMATION

Subscription Information.....	77
Coming Soon to <i>Goldmine</i>	77
Advertisers Index	78
Ad Rates & Information	78

Photo credits
Cover shot ©Henry Diltz
Inset courtesy of Brenda Lee

Main office:
700 E. State Street, Iola WI 54990-0001
FAX: 715-445-4087
Telephone: 715-445-2214
E-mail: goldmine@krause.com

Visit *Goldmine's* Web site at
<http://www.goldminemag.com>

Editorial submissions: All editorial submissions as well as press releases and review copies should be sent to Greg Loescher at the Iola office. While we invite authors to submit materials for publication, due to the volume we receive, we cannot guarantee that items sent on spec will be returned or acknowledged.

Advertising should be addressed to *Goldmine's* main office in Iola or call 715-445-2214.

Subscriptions/renewals: If you would like to subscribe or renew your subscription and have a major credit card, call our toll-free number for current rates: 1-800-258-0929.

Subscription questions: Call Subscription Services, 715-445-2214, ext. 257

Subscription rates: U.S. Addresses: 13 issues (1/2 year) \$24.95; 26 issues (1 year) \$39.95; 52 issues (2 years) \$74.50; 78 issues (3 years) \$107.95.

Special Services Subscriptions: Information and rates on first class UPS and Federal Express delivery for your subscription is listed elsewhere in this issue. Or call 1-800-258-0929.

Foreign rates: Surface mail, all countries: \$49.95 for 13 issues. Airmail rates: Please call or write for current rates to your country. Or see our subscription ad elsewhere in this issue. All payments must be made in U.S. funds.

Moving? If you are moving, please include your name and new address, plus your old address, and mail it to the attention of *Goldmine*, Circulation Department, 700 E. State Street, Iola, WI 54990.

Goldmine (ISSN 1055-2685) is published bi-weekly by Krause Publications, 700 E. State St., Iola, WI 54990. Roger Case, president, Iola, WI 54945. The *Goldmine* logo is protected through trademark registration in the United States. Periodical postage paid at Iola, WI 54945 and additional mailing offices. POSTMASTER: Send address changes to *Goldmine*, 700 E. State Street, Iola, WI 54945.

No portion of the contents of *Goldmine* may be reproduced without prior permission from the publisher and pertinent author(s).

Entire contents copyright 2001 by Krause Publications, Inc.

Goldmine is printed in the U.S.A.

Please Mr. Postman

Poobah, wizard of psych, rocks at the Hall

I can't thank *Goldmine* enough for giving my band Poobah a chance to play at The Rock And Roll Hall Of Fame in Cleveland during the National Record Show (Aug. 4-5, 2001)! The buzz in my hometown has been overwhelming, with people asking me about it everywhere I go. It was such a pleasure to be involved with such a fine publication as *Goldmine*. You guys rock! I read the article about the show in The Four Freshmen issue (Sept. 21, 2001, #552) and was thrilled to be part of the news about the show. What an absolute gas it all has been for Poobah. I can't thank you enough.

— Jim Gustafson
(direct from Poobahland, Ohio!)

[Jim, my only regret is that due to a family wedding, I was unable to attend the show and hear your band play. We'll be rockin' at the Hall again next year. Hope to have you back! — Ed.]

Simon & Garfunkel reissues: it's the sound

While I wouldn't quibble with the opinions of a critic (they are, after all, just opinions), I do have to comment on the brief review by Bruce Sylvester on the recently reissued Simon & Garfunkel CDs (*Goldmine* #552, Sept. 21, 2001).

I think that Sylvester missed advising readers of the *real* importance of this series of reissues. Yes, there are a handful of bonus tracks on each, and yes, they are fairly illuminating. But why this series is so important is the sound of them. Each album has been remastered from the original master tapes, apparently for the first time in this format (the box set *Old Friends* was the first S&G release to use the recently discovered masters).

Boy, this series is an audio feast. The early albums were pleasant, but simple affairs; here, they are clear, bright and charming (as opposed to muffled on the previous CD releases). But when we get to *Bookends* and *Bridge Over Troubled Waters*, the brilliance of their production collaboration with Roy Halee had really born fruit — and these new remasters are huge, vibrant, wonderful experiences to listen to.

Hey, Bruce, you are writing to collectors — and we collectors do collect to listen and enjoy. The brilliant remastering of these classic albums is the *real* reason to buy this series, replacing our old CDs. It's a terrific job. Kudos to Sony for finally doing the right thing, and shame on you for not mentioning it.

— Gary Shaw
via e-mail

[Bruce Sylvester replies: "You have a good point about the importance of discussing remastering. Unfortunately, I had never heard the previous CD versions and so couldn't compare the new and old CDs."]

Correction

There was no byline for the Paul Thorn review in our Oct. 5, 2001, issue (#553). It was written by Michael B. Smith.

LETTER FROM THE EDITOR

Sept. 11, 2001

To all *Goldmine* readers, advertisers and music industry professionals who have lost loved ones in the hideous Sept. 11, 2001, attacks in New York, Washington and Pennsylvania, our deepest condolences.

People's emotions erupt in many different ways during a tragic time like this. For centuries, music has helped heal deep wounds in people's hearts and also roused people to take action. While America's leaders have made their statements concerning the attacks, people turn to artists to help soothe the soul. A good example is the well-done *America: A Tribute To Heroes* special aired on every major network Sept. 21. Here's my soundtrack to the situation.

For the victims — "Amazing Grace" by anyone and "In My Life" by The Beatles.

Comfort — "Bridge Over Troubled Waters" by Simon & Garfunkel.

Explanations — "Turn, Turn, Turn" by The Byrds and "Eve Of Destruction" by Barry McGuire.

Unity — "Come Together" by The Youngbloods.

Anger — "If I Had A Rocket Launcher" by Bruce Cockburn.

Forgiveness — Not possible.

Resolve — "I Won't Back Down" by Tom Petty And The Heartbreakers.

Hope — "Carry On" by Crosby, Stills Nash & Young and "We Can Work It Out" by The Beatles.

For the children — "Imagine" by John Lennon.

After watching the horrific film footage of the attacks (special thanks to ABC's news division for having the common sense to ban continual replaying of the footage), debating about whether or not a record came out in May or June, was on colored vinyl, had this or that variation, is worth more in stereo or mono — whatever — is suddenly not important at all. Human life is.

The suicide attacks bring a frightening new chapter to the ways of making war, not love. In the words of The Doors' Jim Morrison, "The future's uncertain and the enemy's always near."

May God bring justice to the perpetrators of this crime against humanity, may He take under His protection those who lost their lives and those who remain and may He have mercy on us all.

— Greg Loescher

Editor's recommendation: Put on an appropriate recording. Give your tax relief check (and more) to the Red Cross. Give blood. Pray.

Free records with stereo purchase!

Are you aware that Columbia Records in 1963 gave away record albums when a purchase of a stereo console was made? When an older friend of mine passed away some years ago, his widow gave me a brown cardboard box of record albums. The outer box is a typical cardboard brown, with black writing stating, "Lifetime Library of LP Stereo Music, A World of Entertainment for Your Listening Joy." Inside is another, more brightly colored box that was obviously intended to be used as a permanent storage box for what was a box of perhaps 50 albums.

I have 19 of the albums that were originally part of the box. Every album is either stereo or electronically reprocessed stereo. Every record cover has a big gold sticker on the cover that says "Columbia Special Archive Series." It gets better: The back cover of every record has the Columbia Special Products logo, rather than the usual Columbia logo, with a line that says "Special Archive Series." And the records read the same, too!

Most of the 19 albums I have are, uh, not too interesting, but some of them are still unopened — including Lionel Hampton's *Silver Vibes*, Meredith Wilson's *Here's Love* (by The Merrill Staton Voices), and Larry Wilcox's *Tuff Saxes And Twangy Guitars*. Oh yes, and The J.J. Johnson Quintet's *J.J. In Person* (Nat Adderley plays cornet.)

Here's what seems to be pretty interesting.

A still-sealed copy of *The Pilgrims* (the trio includes Robert Guillaume) and an open copy of *The Halifax Three* (Denny Doherty's early folk group), and, finally, The Rip Chords' *Three Window Coupe*.

Again, it's on the Columbia Special Products/Special Archives Series line. I'm not familiar with these in the collector's guides, as far as pricing, quantities made/known, etc. Perhaps I just haven't figured out where they'd be listed in the guides. Anyway, any insight would be appreciated.

— Jim Bahler
Janesville WI

[Jim, I am sure someone out there in *Goldmine* land has some thoughts on the series. If anyone does, send them to my attention at loescherg@krause.com. — Ed.]

Flamingos fan looking for articles

I'm interested in any and all articles that may have appeared in *Goldmine* over the years on The Flamingos or any of its members. Also, I was wondering if you had obituaries available on performers prior to 1999 — specifically covering members of The Flamingos who died earlier than 1999, i.e. Jake Carey, Nate Nelson, Paul Wilson, and Solly McElroy.

Finally, would it be possible to contact your R&B editor Robert Pruter by e-mail? Thank you.

— Vince Brunotts
via e-mail

[Vince, we've published a number of stories on The Flamingos over the years in the following issues: May/June 1978; April 6, 1990; May 1979 (interview with Earl Lewis); Sept. 1981 (interview with Jake and Zeke Carey); March 1978 (interview with Nate Nelson); and an obit for Nate Nelson, appearing in our Oct. 21, 1984, issue. We don't sell back issues, but you should be able to obtain them through C-Bub Productions, which stocks a healthy number of *Goldmine* back issues going way back to the early years. Check its Web site at www.cbub.com or call them at 918-585-8222 for availability and cost. As a matter of policy, we don't give out our writers' contact information, unless it is OK with them, but I have forwarded your message to Pruter. I had the pleasure of meeting Flamingo Tommy Hunt last year at The Vocal Group Hall Of Fame inductions — even sat next to him during the gala induction concert. It was his first visit back to the U.S. since he moved to England in the late '60s. — Ed.]

Where are the auction prices on Stones sleeve?

I am curious as to why you didn't include the fairly recent results of the Good Rockin' Tonight auction of an Ex 7 copy with minimum bid of \$4,000 in your article (*Goldmine* #553, Oct. 5, 2001) about The Rolling Stones' "Street Fighting Man" picture sleeve?

— Steve Arnold
via e-mail

[Steve, there is no reason for not including the results, but we didn't have them. We'll report on the results in a separate news story. Even though I listed prices in the story, I was basically going with a historical angle — how the sleeve came to be, why it's rare, how many are in existence and interesting stories about the sleeve from the few collectors who have them. — Ed.]

Arrested Vigotone owner should work for labels

Attention all those music fans who seek out and collect rare unreleased studio outtakes and live concert recordings, it's the end of the greatest producer of Beatles, Beach Boys, and Bob Dylan archival material. The owner of Vigotone CDs has been arrested and his stock confiscated. (The owner went by several nicknames. His real name is unknown at this time. — Ed.)

This person knew more about each of these bands' recording and live concert history than anyone at their respective record labels combined! No employee at a record company is given a test to show knowledge of bands on the label; the only "talent" required is a college degree and the desire to brownnose his or her boss. I know many

(Please see Please Mr. Postman page 77)

Submitting letters to *Goldmine*...

Letters to Please Mr. Postman are encouraged but cannot be responded to individually. Please keep your letter brief; it has a greater chance of being published. Send your letter to:

Please Mr. Postman/Goldmine
700 E. State Street
Iola, WI 54990
FAX: 715-445-4087
e-mail: mr_postman@krause.com

Grapevine

Music industry affected by terrorist attacks but help victims with donations

The Sept. 11, 2001, terrorist attacks on the Eastern seaboard had an effect on the music industry and record collecting hobby. Since most of the New York-based record labels are located in midtown Manhattan, they escaped any physical damage from the World Trade Center attacks, although the emotional and psychological damage will remain for a long time.

Record labels in New York closed their offices for several days, with many acting as temporary housing, providing blankets and food for stranded employees. Los Angeles-based labels such as Virgin, Rhino, Interscope, Hollywood and Capitol also temporarily closed their offices.

At press time, there were no known deaths of recording artists. However, according to *Billboard*

away all week I had to see the destruction from the New Jersey side of the river. It is worse than you can imagine. There is a large gaping hole in the New York skyline. It is still smoldering. The white smoke still covers the area and is at least — judging by the buildings still left standing — 50 stories high before it begins to disperse."

Iulucci, who spent several days attempting to get flights back to the New York area, said, "I don't believe that I'll be traveling as much anymore.

"We still can't believe that over 5,100 people died here. The others who were looking at the area still couldn't believe what they were seeing. A friend's wife, who was seven months pregnant, is listed among the missing. Life will

"We still can't believe that over 5,100 people died here.... Life will never be the same."

— record dealer Bob Iulucci

Online, several artists witnessed the devastation first-hand. Mary-Chapin Carpenter had just flown to New York to tape an episode of the new PBS series *Life 360*. She said she saw one of the planes crash into the World Trade Center. Garth Brooks, his manager, and his publicist were in midtown Manhattan on their way to meetings when they saw smoke downtown. Brooks was slated to fly to Washington, D.C., to receive ASCAP's Golden Note Award. The event was postponed.

All 30 employees of a Borders Bookstore and employees at two Sam Goody stores located in the World Trade Center complex, along with any customers, managed to escape with their lives. All three stores were completely destroyed. J&R Music World, located nearby on Park Row, was heavily damaged. Due to store closings and the mood of buyers, *Billboard* predicted sales figures for the week of the attacks will be much lower than normal — possibly the lowest ever during the SoundScan years of electronically tracking store sales.

The Vocal Group Hall Of Fame inductions, originally slated for Sept. 13 at the Hall's Sharon, Pa., museum, and The Keystone Record Collectors/Goldmine-sponsored record show at the Hall on Sept. 15, were both immediately postponed as a result of the attacks. The events have been rescheduled for Oct. 4, 2001, for the inductions and Oct. 6 for the record show.

Shipping via USPS, UPS and Fed Ex was temporarily halted by the government's grounding of all airplanes — the first time in U.S. aviation history that all planes have been grounded. Mail-order dealers and their customers should expect shipping delays due to the backlog of packages. All deliveries to a number of zip codes in lower Manhattan are either temporarily or permanently suspended. Shippers are advised to contact their delivery service to verify delivery possibilities in the affected areas.

In an e-mail message to friends and business associates sent several days after the attacks, *Goldmine* advertiser and New York record dealer Bob Iulucci wrote: "Since I was

never be the same."

New York's 2nd Saturday Record Show for Sept. 15 was cancelled. Show promoter Fred Falk said it was "too hard [for dealers and collectors] to get to the show" in light of the devastation and hampered public transportation.

Kaz Tershima of Earth Wave Records in Rohnert Park, Calif., said due to the terrorist's actions that he canceled his travel plans for setting up at the upcoming Oct. 6-7 Austin Record Convention. Whether other long-distance travelers, especially overseas collectors and dealers, alter their travel plans to the biggest record collectors show will not be known until after the show.

The National Association Of Recording Merchandisers' (NARM) 2001 Fall Conference in Florida, scheduled to run through the weekend, was canceled. Many NARM members had either just arrived in Florida for the conference or were on their way when the attacks occurred.

CMJ (*College Music Journal*) Music Marathon And Film Fest, which was to be held the weekend of Sept. 13-16 in Manhattan and Brooklyn, was rescheduled for Oct. 10-13, 2001, at the Hilton New York.

The Rock And Roll Hall Of Fame And Museum announced the postponement of the 2001 American Music Masters Program at its Cleveland museum. The weeklong tribute to legendary blues artist Bessie Smith was scheduled to take place from Sept. 24-30, 2001. No alternative date has been determined at this time.

The second annual Latin Grammy Awards — already moved from Miami to Los Angeles due to possibilities of protests by Cuban expatriates — were canceled with no makeup date announced at press time. The Emmys were canceled.

Pollstar, the concert industry's trade magazine, reported more than 2,400 concerts were planned in the U.S. through Sept. 14. According to the MTV news service, in New York,

(Please see Attacks page 23)

GRAPELEAVES

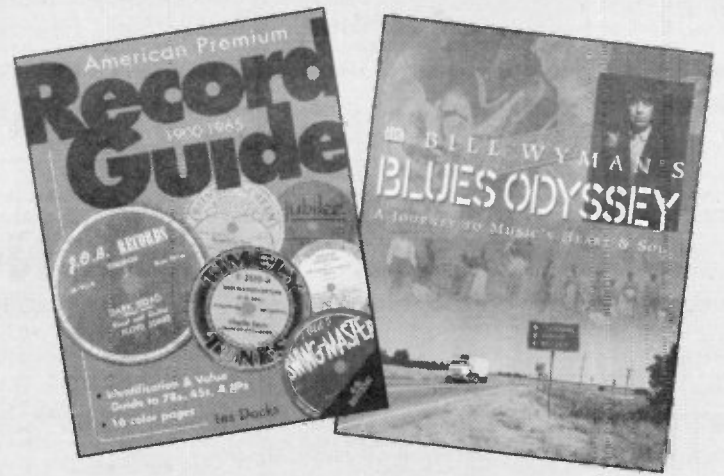

On the bookshelf: Bill Wyman's *Blues Odyssey: A Journey To Music's Heart & Soul* (DK Publishing) is a striking look in both words and pictures of the history of American and British blues. The lavish book covers everyone from early blues practitioners such as Robert Johnson, Big Bill Broonzy, and Charley Patton to contemporary players such as Bonnie Raitt, Taj Mahal, and Stevie Ray Vaughan. The former Rolling Stones bassist not only played with many blues greats over the years, but in this tome, Wyman opens up his own photo archives of 38 blues artists, personal pictures and memorabilia, telling the artists' troubled tales as well. There is also a suggested blues buying/listening list... *American Premium Record Guide 1900-1965, 6th Edition*, by Les Docks (Krause Publications) is the first update of Docks' guide since the fifth edition came out in 1997. The vastly expanded guide has gone from 500 pages to 596 pages, with more than 40,000 listings — 10,000 more than the previous edition. The guide covers blues, country western, jazz, Big Band, R&B and rock 'n' roll recordings from 1900-1965 in 78, LP, EP and 45 formats. One addition to the book is a 16-page color section that is a label identification guide ranging from Meteor, Okeh, Moxie and Oriole labels to Sun, Sunrise, Timely, Vocalion and Vee-Jay labels. Docks is a lifelong collector and has been a record dealer since 1968.

The ultimate collectible — your favorite artists' childhood home: When you have all your favorite artist's records, CDs, memorabilia, sheet music, etc., the only thing left to collect it seems is his or her childhood home. In early September, Bill Pagel of Madison, Wis., purchased Bob Dylan's boyhood home in Duluth, Minn., for \$82,000. The home was listed for \$84,900, but Pagel was the only one to place an offer with the local realtor. A short time later, on Sept. 14, Richard Osborn purchased Jimi Hendrix's family home from Hendrix's teenage years for \$33,000. Osborn placed the highest bid on an eBay auction — although there is a hitch. The white, two-bedroom home in Seattle, Wash.'s, Central Area has to be moved — and Osborn resides in Michigan. Wonder if Bags Unlimited has any storage ideas....

For couch potatoes: *American Roots Music*, a PBS special slated for airing Oct. 29 for four consecutive Mondays, features one-hour segments of rarely seen footage of America's roots music pioneers. Companion DVD, VHS and four-CD box sets as well as a single "best-of" audio disc and a coffee-table book will be released by Palm Pictures Oct. 30. The PBS series covers the early masters in folk, country, blues, gospel, western swing, bluegrass, Cajun, Zydeco, Tejano and Native

American music. The box set contains more than 75 classic recordings, and each disc matches one of the episodes. Among the artists featured both in the film and on the CDs are Lead Belly, Muddy Waters, Bob Dylan, Flaco Jimenez, Carlo Nakai, Robert Johnson, Bob Wills, Jimmie Rodgers, The Carter Family, Hank Williams, Mahalia Jackson, B.B. King, Woody Guthrie and many more. The series' theme song is performed by Ricky Skaggs, Earl Scruggs, James Cotton, and Marc Savoy... Just out



Front cover of the *American Roots Music* book.

from Music Video Distributors are *Joe Cocker — In Concert*, a 60-minute DVD with footage taken during Cocker's Organic Tour at the Oct. 15, 1996, gig at Ohne Filter TV-Studio in Baden-Baden, Germany and jazz bassist *Marcus Miller — In Concert*, taken from a June 6, 1994, concert, also done at Ohne Filter TV-Studio... Coming in November from Image Entertainment are the following videos, on DVD and VHS: Nov. 6 — *An All Star Tribute To Brian Wilson*; Nov. 13 — *Electric Light Orchestra: Zoom Tour Live*; and Nov. 20 — *Emerson, Lake And Palmer: Live At The Royal Albert Hall*.

On display: San Diego's Hard Rock Cafe just started a special exhibit of major local artists' memorabilia, on loan from the artists (or their families) for the exhibition. Running through Oct. 30, the display features items from Frankie Laine, Tom Waits, Frank Zappa, Blink-182, Michael Damian, The Locust, The Penetrators and others. It marks the first time ever a Hard Rock Cafe has focused on local bands' memorabilia.

Elvis honored again: Elvis Presley and seven others will be inducted into the Gospel Music Association's (GMA) Hall Of Fame Nov. 27, 2001, at Nashville's historic Ryman Theater. The event marks the first time in GMA's history that the inductions are open to the public.

— Greg Loescher

Courtesy of Rhino Records

Courtesy of Backstreet Records

From the Goldmine archives

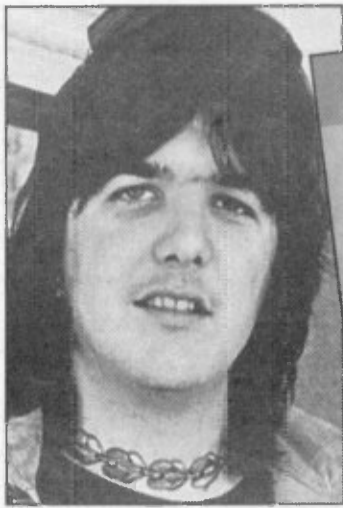

Gram Parsons

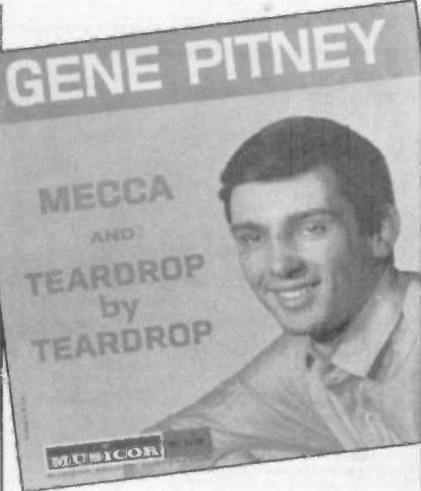

Tom Petty



Brenda Lee

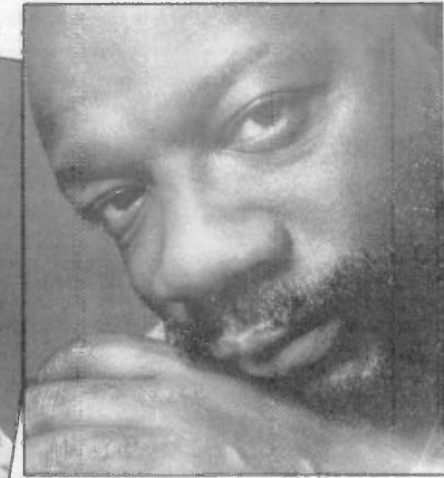

Isaac Hayes

Rock Hall unveils slate of 16 nominees for 17th annual inductions

The Rock And Roll Hall Of Fame Foundation's election process for its 17th annual inductions has begun. Nominees range from '50s R&B legends The Chantels and "Little Miss Dynamite" Brenda Lee to '60s soulman Isaac Hayes and singer/songwriter Gene Pitney to country rocker Gram Parsons and punk rockers Sex Pistols.

A band whose history is already filled with tragedy, Southern rockers Lynyrd Skynyrd's nomination is bittersweet — founding member and bassist Leon Wilkeson passed away earlier

this summer (see obituary on page 23).

The Foundation's nominating committee, composed of rock 'n' roll historians, selects nominees each year in the Performer category. Ballots, which are due Oct. 19, 2001, are then sent to an international voting body of about 1,000 rock experts. Those performers who receive the highest number of votes — and more than 50 percent of the vote — are inducted. The Foundation generally inducts five to seven performers each year.

Artists become eligible for induction 25

years after the release of their first record. Criteria for nomination to the Hall include the influence and significance of the artist's contributions to the development and perpetuation of rock 'n' roll.

In addition to the Performers category, several other categories are included in the nominations. These categories are not voted upon by the general list of voters. The special selection committee elects the inductees in the Non-performer and Early Influences categories.

Non-Performers include songwriters,

producers, DJs, record executives, journalists and other industry professionals who have had a major influence on the development of rock 'n' roll. Early Influences include artists whose music predated rock 'n' roll but who had an impact on the evolution of rock 'n' roll and inspired rock's leading artists.

A fourth category, Side Men, was introduced in 2000. It honors those musicians who have spent their career out of the spotlight, performing as backup musicians for major artists on recording sessions and in concert. Though they often play a key role in the creation of memorable music, the public rarely knows them by name. A separate committee, composed primarily of producers, selects the inductees in this category.

Information on the final inductees and the date and place of the inductions will be released by the Hall's Foundation in early November. For more information on the selection process, visit the Hall's Web site at www.rockhall.com/hof/process.asp

— Greg Loescher

From the Goldmine archives



The Dells (left) and the Ramones (right).

By Mick Rock, Dec. 1979; Courtesy of Side Records

Rare Finds

Autographs, Beatles references found in 25¢ album

Love your magazine! I don't think this record is a rare find, but I think what was inside may be.

Living in West Palm Beach, Fla., and being a new record nut, I happened to be at a thrift shop, and they were selling albums for 25¢. So I got all I could carry. When I saw The Briarwood Singers cover I knew their picture on the front was 1962-1963, because that's the year I graduated. I had to have it.

After I came home, I cleaned and put put covers on my new albums. Well, a gold-colored folder fell out. It was an info sheet on the Briarwoods, and they each had signed it. The inside said that they were the opening act for The Beatles at New York's Carnegie Hall. Could this be?

I've played the record and it's great, but the cover has some bad water marks on the bottom. I was thrilled and have no idea of any special value, if any. If anyone knows, I'm sure Goldmine's people will.

— Sandy Kight
Lantana FL

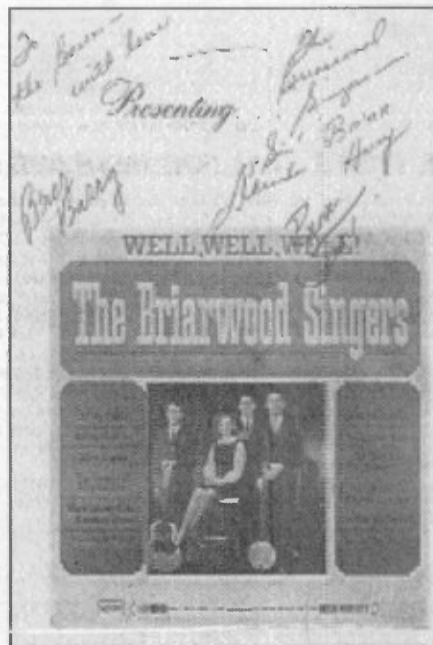

{Sandy, thanks for the story. The album itself is not worth much, even with the signed sheet. Of course, to you the sentimental value

is priceless, and it is certainly a good find for 25¢! It is unusual to find artist-signed inserts in an album of this vintage. The info sheet probably has some value, primarily because of The Beatles references. The inside copy on the flyer is interesting: "Probably the most unenviable chore in show business was given to the Briarwoods recently. That was to play Carnegie Hall with the Beatles. It's enough to give an oldtimer a scare — the thought of 2,000 screaming voices demanding 'We want The Beatles!' — and for a newcomer, or a group of newcomers, the prospect must be grim, but the four youngsters jumped at the chance and the response was fantastic." They even got a positive nod from Billboard for their performance. — Ed.]

Contributions to the Rare Finds column should be addressed to: Goldmine Rare Finds, 700 E. State Street, Iola WI 549909-0001 or e-mailed to bernardyc@krause.com. Photos or photocopies of items are welcomed, but please do not send originals. Keep on diggin'!

Rock Hall induction nominees

Listed in alphabetical order, here is the slate of 16 nominees for the 17th annual inductions:

- AC/DC
- Black Sabbath
- Jackson Browne
- The Chantels
- The Dells
- The "5" Royales
- Isaac Hayes
- Brenda Lee
- Lynyrd Skynyrd
- Gram Parsons
- Tom Petty And The Heartbreakers
- Gene Pitney
- Ramones
- Sex Pistols
- Patti Smith
- Talking Heads



Black Sabbath

OFFICIAL HOME OF CLASSIC ROCK NEW RELEASES



MASTER CARD AND VISA CUSTOMER TELEPHONE ORDER LINE

410-569-5697

HOURS MONDAY TO FRIDAY 1:00 TO 9:00 ET (10:00-6:00 PT)

LATEST ARRIVALS IMPORTS, INDEPENDENTS AND HARD TO FIND

APRIL WINE "Back to the Mansion" Myles Goodwyn and original lineup turns out their 18th album their first new one in 7 years... \$18.98
BABYS, THE "Valentine Baby" Denver concert Valentine Day 1980 includes "Every Time I Think of You... \$13.98
BEACH, REB "Masquerade" ex-Winger and Dokken guitarist new solo album, Japan only... \$17.98
BLACKMORE'S NIGHT "Fires at Midnight" new medieval classical guitar, Ltd Edition purple velvet box... \$27.98
BLUE OYSTER CULT "Tales of the Psychic Wars" (2 CD) two radio shows New York 1981... \$21.98
BROCK, TERRY "Back to Eder" vocalist of The Sign new solo album with members of The Sign... \$24.98
DARE "Belief" Thin Lizzy keyboardist Darren Wharton's band new studio their 2nd in recent years... \$14.98
DEEP PURPLE (DVD) "New Live and Rare Video Collection 1984-2000" almost all totally new... \$24.98
DEEP PURPLE (BOX) "Soundboard Series-Australasian Tour 2001" (12 CDs) six double live shows... \$16.98
DEMOB "Spaced out Monkey" NWOBHM act first new album in 10 years features original vocalist... \$17.98
EMERSON LAKE & PALMER "Original Bootleg Series from Manticore Vaults Volume 1 and Vol 2" remastered... \$16.98
EISLEY, DAVID GLEN "The Lost Tapes" unreleased recordings from the late 1980's... \$89.98
FRANK MARINO & MAHOAGANY RUSH "Eye of the Storm" guitarist first new album in 9 years... \$18.98
FUNNY MONEY Featuring STEVE WHITEMAN "Even Better Live" ex-Kix vocalist band recorded live... \$13.98
GILLAN "Live Tokyo 1978" after the Jazzy "Jan Gillan Band" disbanded the reformed lineup toured... \$17.98
GRAND FUNK "Lives" 1981 Warner Bros album first time on CD includes the song "Queen Bee"...

HUGHES, GLENN "Building the Machine" +1, new studio album with bonus track "Cosmic Spell"... \$27.98
HUGHES, GLENN "Building the Machine" no bonus, SPV USA (arrives approx Sept 25th)... \$14.98
HURRICANE "Liquifury" reformed with original vocalist Kelly Hanson and drummer Jay Schellen... \$14.98
JOSHUA "Hand is Quicker Than the Eye" "Surrender" and "M-PRE Chapter One" guitarist Joshua Perahia... \$12.98
JUDAS PRIEST "Demolition" +2, new album with Flipper Owens Ltd Edition with the studio bonus... \$17.98
KING'S X "Manic Moonlight" Missouri rockers ninth album, label states "full U.S. tour coming soon"... \$13.98
LEDS ZEPHYRUS "Captured Live" (2 CDs) reissue of their live album recorded in San Antonio 1990... \$12.98
MELIODIA "Lovelife" former Danger Danger vocalist Ted Poley's band's new release now with... \$14.98
MR. BIG "Actual Size" +1, new album bonus track "Deep Dark Secret", "reviews say fantastic most... \$27.98
MSG "One Night at Budokan" +2 (2 CDs) Special Edition 1981 album remastered on a double disc... \$13.98
RACER X "Snowball of Doom-Live at the Whiskey" new live, concert recorded in L.A. at the... \$27.98
RADIOACTIVE "Ceremony of Innocence" new project with Bobby Kimball, Fergie Frederiksen,...

SHEEHAN, BILLY "Compression" ex-Talac, David Lee Roth and Mt. big bassist new solo album... \$13.98
SILVER "Silver" Gary Bardean ex-MSG vocals, Bernie Torme guitar, Don Airey Keyboards, "reviews... \$17.98
STRATOVARIUS "Intermission" four new songs, a live track, a cover of Judas Priest, Rainbow and... \$13.98
THOMPSON, CHRIS "Worth Lie Down" former Manfred Mann vocalist new solo with guitarist Mike... \$18.98
TURNER, JOE LYNN "Slam" ex-Rainbow vocalist new solo album, "Joe chose the title he sez... \$16.98
TYGERS OF PAN TANG "Mystical" 80's British rockers new studio reviews say "very good straight... \$15.98
URIAH HEEP (BOX) "Sailing the Sea of Light", includes the live CD "Electrically Driven" plus 88 page... \$44.98
VAUGHN "Fearless" ex-Tyketto vocalist new solo album, reviews say "stronger album than his... \$15.98
WAITE, JOHN "Figure in a Landscape" former Babys vocalist new studio album, 11 tracks, Gold... \$13.98
WAITE, JOHN "Live & Rare Tracks" includes 7 live songs from a 1985 show including "Messianic... \$11.98
WESTWORLD "Live in the Fleet" +1, vocals Tony Harnell of TNT, guitar Mark Reale of Riot and... \$15.98
YES "Magnification" new album reviews say "strongest and freshest material in years different to... \$19.98

SELECTED COMING ATTRACTIONS DO NOT SEND PAYMENT YOU CAN ORDER IT NOW AND WE'LL SHIP IT TO YOU WHEN IT ARRIVES, CREDIT CARD PREORDERS ONLY - RELEASE DATES MAY CHANGE

DEEP PURPLE (BOX) "On the Road" (4 CDs) most comprehensive live collection from 1969-1993... \$47.98
DR. SIN "Shadows of Light" new with Mike Vecerra all vocals (Metal Mayhem rel 10/15)... \$13.98
GRAND FUNK "What's Funk" 1983 Atlantic album first time on CD, remastered with bonus enhanced... \$12.98
JORN "Worldchanger" vocalist of Millenium, ARK and Company of Snakes (Italy rel 10/24)... \$14.98
JOSHUA "Something to Say" guitarist new produced by Keith Olsen (MK Music USA TBA)... \$13.98
JUDAS PRIEST "Collector's Box" remastered + bonus "Sin after Sin, Stained Class, Killing Machine... \$57.98
MOTT THE HOOPLE "Two Miles from Live Heaven" (2 CD) USA tour 1971-74 (UK rel 10/15) \$19.98
MSG "Be Aware of Scorpions" +1, Jeff Martin vocals on bonus track (Japan rel 10/24)... \$27.98
OSBOURNE, OZZY "Down to Earth" +1, new bonus track "Black Sheep" (Japan rel 11/11)... \$27.98
PALPHS, MICK "It's All Good" Bad Co guitarist new solo album (Angel Air UK release 10/15)... \$13.98
RUDESS, JORDAN "Feeding the Wheel" Steve Morse, Bozzio, Petrucci, Sheehan (10/23)... \$13.98
TRANSATLANTIC "Bridge Across Forever" Portnoy and Trevasays (Metal Blade rel 10/15)... \$19.98
TROUT, WALTER (DVD) "In Concert" live show German TV, all region codes (German TBA)... \$23.98
UDO "Live from Russia" (2 CDs) former vocalist of Accept and 7 solo albums Udo Dirkschneider... \$19.98



BLUE OYSTER CULT UNRELEASED LIVE SHOWS



DARE FEATURING DARREN WHARTON



EMERSON LAKE AND PALMER LIVE BOXES



GILLAN UNRELEASED OCTOBER 1978 SHOW



GRAND FUNK "LIVES" 1981 FIRST TIME ON CD



GLENN HUGHES NEW STUDIO JAPANESE AND DOMESTIC

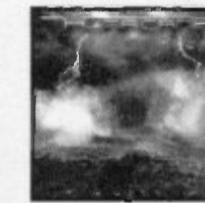

HURRICANE NEW ALBUM KELLY HANSON VOCALS

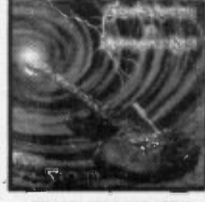

FRANK MARINO NEW CLASSIC ROCK ALBUM



GUITARIST YNNIE MOORE NEW STUDIO ALBUM



RACER X "LIVE AT THE WHISKEY" 2001 TOUR



JOE LYNN TURNER "SLAM" NEW ROCK ALBUM



VAUGHN EX-TYKETTO VOCALIST NEW SOLO ALBUM



FORMER BABYS VOCALIST JOHN WAITE NEW ALBUM



WESTWORLD WITH TONY HARNELL LIVE IN CONCERT



URIAH HEEP BOX "SAILING THE SEA OF LIGHT" CD-DVD-BOOKSET FOR FANS OF THE CURRENT LINEUP

AEROSMITH Just Push Play +2 (bonus 9 Don't Wanna Miss a Thing & Worth Let you Down?) Japan... \$13.98
ASIA Live at Budokan Tokyo 1983 (MTV broadcast first time on CD, Greg Lake lead vocals) Pilot Rec UK... \$17.98
BEAUVOIR, JEAN Bare to the Bones (Crown of Thorns vocalist solo acoustic album) 13 trks/2001/German 14.98
BLACK OAK ARKANSAS Street Party, Aunt Life Grand and Live! Mutha/1974-75/Wounded Bad USA... each 10.98
BUTCHER, JON A Long Way Home (sessions for a never released 4th Aids album + live acoustic "Wishes")... \$14.98
DBA-DERRINGER BOGHEIT AND APPICE Doing Business As (Rick, Tim, Carmine) 11 tracks/2001/German... 17.98
FASTWAY Fastway and All Fired Up (first two albums paired on one CD, remastered) 1983-84/BGO UK... 17.98
FOGHAT Rock and Roll + Energized/73-74/UK... 17.98
FOGHAT RNR Outlaws + Fuel for the City/74-75... 17.98
FOGHAT Night Shift + Live (double CDs) 76-77... 17.98
FOGHAT Tight Shoes + Girls in Chat/80-81/UK... 17.98
FOGHAT in Mood... Something Rude + Zig-Zag Walk 17.98
FORRESTER, RHETT Gone with the Wind (solo after Riot's album "Born in American") 1985/Metal Mayhem... 12.98
GEOFFDIE Singles Collection (definitive collection of their UK singles from 1970's fronted by AC/DC vocalist Brian Johnson) 18 tracks/Glam Records UK... 17.98
GLESS WHO Running Back Through Canada Live (2 CDs, original lineup live on 2000 reunion tour) Canada... 31.98

RECENT RELEASES AND LAST CHANCE TITLES CALL FOR AVAILABILITY

GUESS WHO This Time Long Ago (2 CD, 28 unreleased rare tracks with Burt Cummings) Canada... 23.98
HUGHES, GLENN (VHS) Days of Avalon and the Making of (video with behind the scenes) Pink Cloud USA... 19.98
IRON HORSE Iron Horse (Ron Keef's new band, similar to Van Zant) 11 tracks/2001/Metal Mayhem... 13.98
L.A. GUNS Man in the Moon (Phil Lewis and rest of original lineup) 10 tracks/2001/Spitfire USA... \$ALE 10.98
LEONARDO Cast Recording (vocals Steve Walsh, James LaBrie, Davey Pattison, Robert Berry) Magna Carta 13.98
MAHOAGANY RUSH Maxxon, Child of Novelty and Strange Universe (remastered 3 on double CD) 73-75/UK... 24.98
MANFRED MANN'S EARTH BAND Wired (live concert Boston 1977 remastered) 8 trks/Pilot Records UK... 17.98

MARINO, FRANK Juggernaut & The Power of Rock and Roll (81-82 albums first time on CD) Holland, each 17.98
MOUNTAIN Go for your Life (official CD debut, Leslie West and Corky Laing, remastered) 85/Axe Killer France, 15.98
NAZARETH Back to the Trenches (2 CD unreleased live tracks, 1972, 1980, 1981, 1982, 1983 and 1984, 52 page mini-book) 31 tracks/146 minutes/UK... 23.98
NOSTRADAMUS (2 CDs, vocals Glenn Hughes, Joe Lynn Turner, Jorn Lande, Goran Edman, Doogie White, Alanah Myles, Sas Jordan) 21 tracks/SPV USA... 19.98
NAZARETH TRIBUTE Another Hair of the Dog (Glenn Hughes, Doogie White, Dianna) 2001/D-line USA... 13.98
OLIVER, GRAHAM End of an Era (ex-Saxon and SOB guitarist debut solo album) 13 tracks/2001/UK... \$17.98

PARADISE Light The Fire (ex-Kick Axe vocalist George Criston & Doug Johnson ex-Loverboy) 01/German... 17.98
POISON TRIBUTE Name your Poison (2 CDs, Derek St. Holmes and vocalist of Pretty Boy Floyd, Tuff, Tiger Taltz, Cherry Street, Every Mother's Nightmare)... \$ALE 9.98
PROPHET Cycle of the Moon (reissue of second album remastered w/bonus track) 1988/2 Records UK... 15.98
RACER X Superheroes (Paul Gilbert, Jeff Martin, Scott Travis, John Aberleto) 11 tracks/2001/Z Rec UK... 15.98
ROSSINGTON COLLINS BAND This is the Way & Anytime, Anyplace, Anywhere (2 CD remaster both LPs) UK 19.98
RUNDGREN, TODD/JUTPIA A Cappella Tour (Dallas 1985) Deface the Music Tour (New Jersey 1980) Oops! Wrong Planet Tour (Chicago 1977) (Japan 2 CDs), each 32.98

SHY Brave the Storm +4 & Excess all Areas +3 (remaster with bonus tracks) 1985-1987/Zoom UK... each 17.98
TOD Below the Belt (Seattle rockers 3rd album remastered followup to "In Your Face") 1986/Metal Mayhem... 13.98
TURNER, JOE LYNN Holy Man (Al Piretti, Andy Timmons, many say his best) 13 tracks/2000/German... 17.98
URIAH HEEP Future Echoes of the Past (2 CD, live concert 1999 Germany) 22 tracks/Uriah Heep Music UK... 21.98
URIAH HEEP Acoustically Driven (unplugged live with an orchestra, December 2000) 16 tracks/UK... 19.98
URIAH HEEP (DVD) Acoustically Driven (video U.S. format for above show, sold only on band's website) UK... 21.98
URIAH HEEP Electrically Driven (full band show Astoria in London May 23, 2001) 13 tracks/UK... 19.98
VICIOUS RUMORS Sadistic Rumors (Geoff Thorpe and Ira Black) 11 tracks/2001/Penns USA... \$ALE 10.98
WAR & PEACE Light at the End of the Tunnel (Jeff Pilson vocals and bass, Reb Beach, Richie Kotzen, Paul Gilbert, John Norum guitars) 10 tracks/2001/Spitfire USA 13.98
WARRANT Under the Influence (includes two new songs and nine covers) 11 tracks/2001/Penns Rec USA... 13.98
WISHBONE ASH Live Dates 3 (Paris October 1999) 10 tracks/72 minutes/Eagle Records UK... 19.98
WOLFSBANE Lifestyles of the Broke and Obscure (2 CDs remastered both 1996 albums together "Wolfsbane and Massive Noise Injection" vocals Blaze Bayley) UK... 17.98

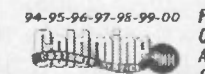

FLAT RATE SHIPPING IS \$4.50 FOR ANY SIZE SHIPMENT, MAIL ORDER CUSTOMERS INCLUDE THIS IN YOUR TOTAL. SHIPPING VIA U.S. PRIORITY MAIL DELIVERY CONFIRMED TRACKING, SHIPPED IN BOXES. ORDERS OVER \$150 INSURED FREE SMALLER ORDERS ADD \$1.50 IF DESIRED. MONEY ORDERS AND CHECKS ARE ACCEPTED, MAKE PAYABLE TO BUCCANEER RECORDS. CHECKS MAY DELAY SHIPPING UP TO 2 WEEKS. ALL ITEMS ARE NEW, UNSEALED CDS IN SLEEVES. CREDIT CARD PREORDERS ARE NOT CHARGED UNTIL MAILED TO YOU. LISTING ALTERNATE SELECTIONS IS DESIRABLE IF NOT CALLING. FOREIGN ORDERS CREDIT CARD SALES ONLY, SHIPPED VIA AIR MAIL OR GLOBAL PRIORITY. SORRY NO SPECIAL ORDERS. GOLDMINE IS PUBLISHED THREE WEEKS BEFORE THE COVER DATE, THIS AD VALID UNTIL COVER DATE OCTOBER 19, 2001. THANKS.

FAX YOUR CREDIT CARD ORDER ANYTIME 410-569-3697 MAIL ORDERS TO: BUCCANEER RECORDS P.O. BOX 1212 ABINGDON, MARYLAND 21009

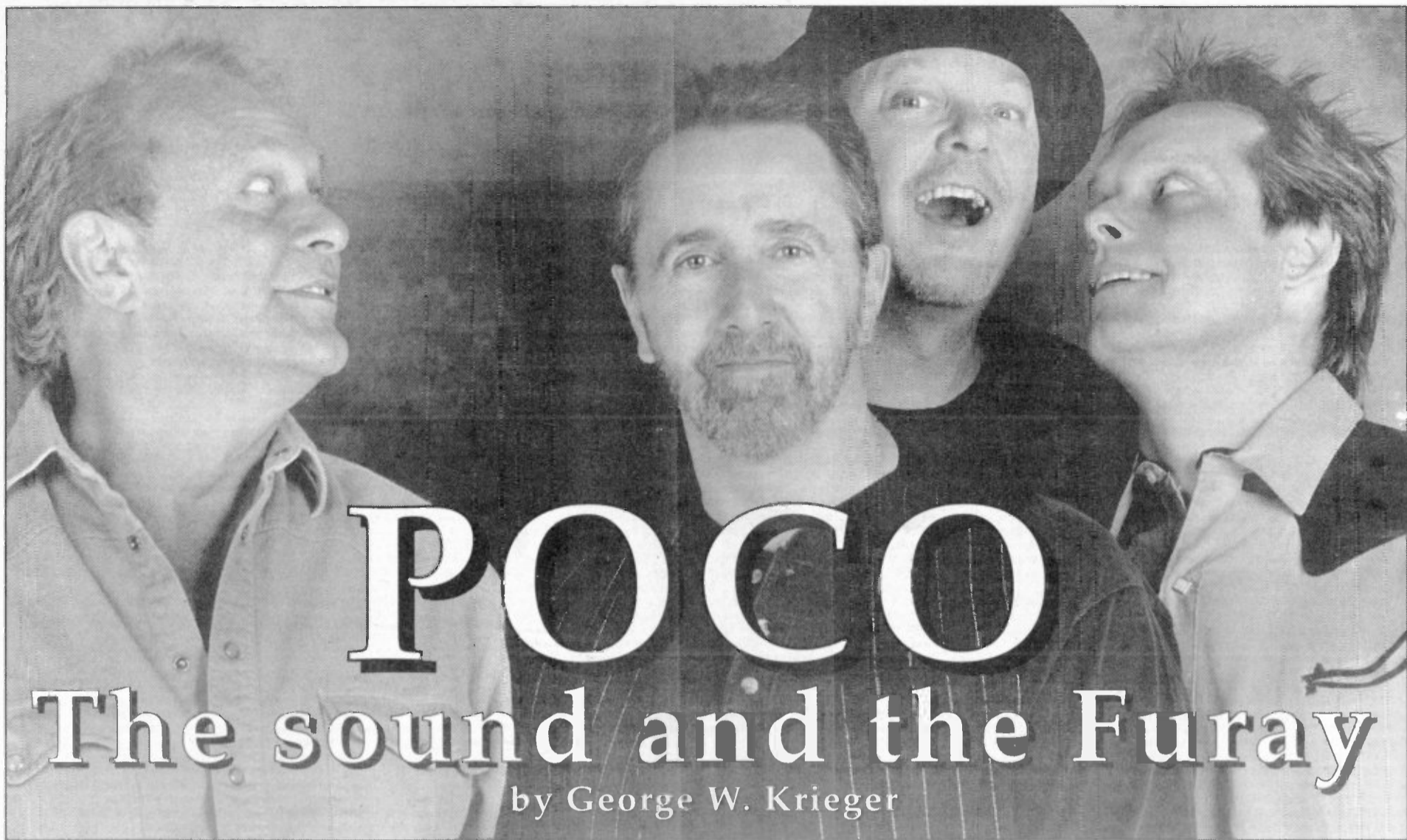

Courtesy of Rick Alter Management, Inc./by Joni Vincent

Poco, in 2000, from left are: Paul Cotton, George Grantham, Rusty Young and Jack Sundred.

A case could be made for the enshrinement of country-rock pioneer band Poco in The Rock And Roll Hall Of Fame. It will likely never happen, as an equal case could be made for their enshrinement into the Country Hall Of Fame. That is even a longer shot, even though much of what you hear today on country radio directly traces to what a bunch of longhairs were trying to do with a short-hair music form traditionally closed to them. To embrace the twang of country and western music when acts such as The Doors and Jimi Hendrix reigned wasn't a smart move commercially or politically. Country music was seen as being allied with the conservative, slicked-back pro-Vietnam War types — certainly not what hip rock musicians would be caught dead playing. Yet...

Poco has already been represented in the pages of *Goldmine* by two fine articles: Aug. 2, 1985, by Mick Skidmore and Aug. 20, 1993, by William Ruhlmann. The purpose of this article is not to rehash those pieces, but rather to color, correct and update the story. The bulk of the included information comes from separate interviews with founding members the Rev. Richie Furay, George Grantham, and Rusty Young, who are really good guys. That fact doesn't sell records, but it does make their lack of huge chart success even harder to take.

During a 21-year recording career, chart archivist Joel Whitburn shows that Poco charted 16 singles and 21 albums in *Billboard*. That's actually pretty darn impressive, but their chart placement and commercial recognition pales next to the Eagles — a band who learned from Poco's example and even took their bass players.

The story of Poco must begin with the story of Furay. Paul Richard Furay (born May 9, 1944, in Yellow Springs, Ohio) entered the world of music with The Monks, a folk trio he started while attending Otterbein College to study theater and dramatics. The details of Furay's growth as a musician are well handled in his and John Einerson's 1997 Canadian book *For What It's Worth — The Story Of The Buffalo Springfield* (Quarry Press).

Suffice it to say that Furay met a young talent in New York in the spring of '64 named Stephen Stills who would join him in the hootenanny group the Au Go-Go Singers. This act recorded one album for Roulette, *They Call Us Au Go-Go Singers*, then disbanded. Furay went to work for Pratt & Whitney but got the bug to perform again when a friend from the New York club scene (Gram Parsons) brought a copy of his band's new album to him.

"When Gram brought The Byrds' record [*Sweetheart Of The Rodeo*] to me, it stunned me," Furay told *Goldmine*. "I had never heard anything like it, and I had to get out of there so I sent a letter off to Steve [Stills]."

The story of how the principals that would form Buffalo Springfield (Furay, Stills, and Neil Young) finally got together is amazing and again, well-covered in the book about the band. Through dumb luck, this volatile group of strong individuals managed only one true hit — Stills' "For What It's Worth." While their first two albums are not country, certainly elements are present, such as Furay's "A Child's Claim To Fame." With the band splintering, producer and engineer Jim Messina (born Dec. 5, 1947 in Maywood, Calif.) was brought into the band as a replacement bassist.

Messina had previously been a guitarist playing in bands such as the Dick Dale-influenced Messina And The Jesters (check out "Yang Bu" on the GNP Crescendo CD *Bustin' Surfboards*). Messina and Furay clicked as a team and set about pulling together a final Buffalo Springfield album, *Last Time Around*. One track they worked on was titled "Kind Woman," which needed a steel guitar.

Buffalo Springfield had a roadie named Miles Thomas who had come to California with the Colorado band The Poor. To play steel on "Kind Woman" Thomas suggested his friend from Colorado band The Böenzee Cryque — Russell (Rusty) Young (born Feb. 23, 1946, in Long Beach, Calif.). Young had started playing steel guitar at age six. While The Böenzee Cryque was his first rock band, Young actually had started playing in country bands at age 12. In The Böenzee Cryque he played straight six-string guitar, as can be heard on the April 1967 Uni single "Sky Gone Grey"/"Still In Love With You Baby," a #1 hit on Denver's KIMN-AM. The unusual band name came from the Benzie-Kricke Sporting Goods company in Denver, whose sign intrigued lead singer Sam Bush (not the Sam Bush with The New Grass Revival).

On their second Uni single in June '67 "Watch The Time," Young plays a nasty-sounding steel guitar that gives the song textures foreign to most garage records of the time. The rhythm section of bassist Joe Neddo and drummer George Grantham (born Jan. 20, 1947, in Cordell, Okla.) really comes to the fore on this record. Young's steel sounds wild on the Hendrix-like "Ashbury Wednesday" on the *Psych-Out* soundtrack (Sidewalk) while the last Böenzee Cryque

single "Sightseer" (Dot records — listed under their guitarist's name, the late Malcolm Mitchell) sounds Springfield-like.

At the time Young received the call to play on "Kind Woman," he was making good money selling guitars and giving lessons at Don Edwards' Guitar City out on Denver's West Colfax Avenue, but he jumped at the opportunity.

"I didn't realize the Springfield was breaking up, but I really admired Jimmy and Richie," said Young. "I was a big fan. We all realized we had a lot in common and maybe we should see if we could put something together."

Furay and Messina knew they wanted to start a band after their experiences with Buffalo Springfield were over.

"Jimmy and I kind of connected," Furay said. "We just appreciated each other. Jim probably had more of a country vision than I did. Sight unseen we brought in Rusty and Jimmy, and I liked the way he played and said, 'There's the guy we want.' Our whole vision included vocal harmonies, and Rusty said, 'I got a drummer who can sing.'"

That singing drummer turned out to be Grantham, who was still working in Colorado (listen to the chorus of "Watch The Time" for his counterpoint vocals). That left one unfilled position — bass player. Furay toyed with the idea of a keyboard player, but auditions didn't work out with the more R&B-influenced Gregg Allman.

Auditions turned up a good candidate for bassist in Timothy B. Schmit (born Oct. 30, 1947, in Oakland, Calif.) from the Sacramento band Glad, but there were reservations at the time about his college and draft status. The bass position instead went to Randall (Randy)

Meisner (born March 8, 1946, in Scottsbluff, Neb.) who was familiar to Grantham and Young from The Poor.

Over the years, Poor leader Allan Kemp has said that "poor" pretty well summed up their economic status after leaving Denver for L.A. It should be added, however, that poor does not describe their series of 45s for York, Loma and Decca. "Once Again" is a great ballad, while "Feelin' Down" shows off Meisner's high harmonies. That Decca single, collectors should note, has "Come Back Baby" on the B-side — written by Meisner.

The five-man band was christened Pogo after the Walt Kelly comic about a possum. Their road manager loved the cartoon, and it was assumed Kelly would be flattered (like the Buffalo Springfield Steamroller Company had been previously). After the band's premiere at Doug Weston's Troubadour in L.A. (Nov. 11, 1968), the guys found that Kelly wasn't flattered; he sued. Since there was already a following for the group, it was decided to simply turn the "g" into a "c" to create Poco (which Furay said sounds better anyway). Poco means "a little" in Spanish (and in exchange for rehearsal space at The Troubadour, the band was paid "little or nothing" for evening shows).

Though A&M had some interest in the band, Poco went with Epic records in perhaps the first "sports trade" in music. Furay was still tied to the Atlantic label, which wanted Graham Nash of The Hollies (Epic) for a new supergroup being formed with David Crosby and Stills. The trade was made for a Jan. 15, 1969, signing that allowed Poco to begin recording their first album. Though there are reports of an audition for Apple Records and perhaps even an unreleased recording, none of the players interviewed for this story would confirm that.

Various stories have been reported about the falling out with bassist Meisner prior to the first album's release. What is clear is that he had wanted to attend the mixing sessions for the record but was rebuffed by Furay or Messina (who was the producer). Not feeling properly a part of the band, Meisner quit.

Interestingly enough, an attendee at The Troubadour during Poco's tenure was former teen idol Rick Nelson. Nelson was taken by this melding of rock and country and decided to put a band together called The Stone Canyon Band.

Roadie Thomas should get some sort of recognition in the creation of country-rock. Just as he had suggested Young to Furay and Messina, this time he brought members of The Poor to Nelson's attention. Drummer Pat Shanahan, guitarist Kemp and bassist Meisner were drafted from The Poor, along with a new pedal steel player, Tom Brumley, and an LP was recorded live at The Troubadour. This became the January 1970 Decca record *Rick Nelson In Concert* (DL 751620). Meisner left the band but returned for the *Rudy The Fifth* record before quitting for good to cofound the Eagles. This all happened prior to Nelson's loping countryside #6 hit "Garden Party" in 1972.

The loss of Meisner required changes to the completed Poco album. Where possible, Messina took over the bass duties and eliminated Meisner's vocals (though at times his harmonies and playing still appear). Furay said he believes that Meisner originally sang "Calico Lady," but on the released version it

Poco includes many branches of country-rock's family tree. Right: Rick Nelson's Stone Canyon Band, from left are: Allan Kemp, Randy Meisner, Rick Nelson, Pat Shanahan, and Tom Brumley. Below, right: The Poor, in this 1966 photo, includes Meisner, in the paisley shirt.

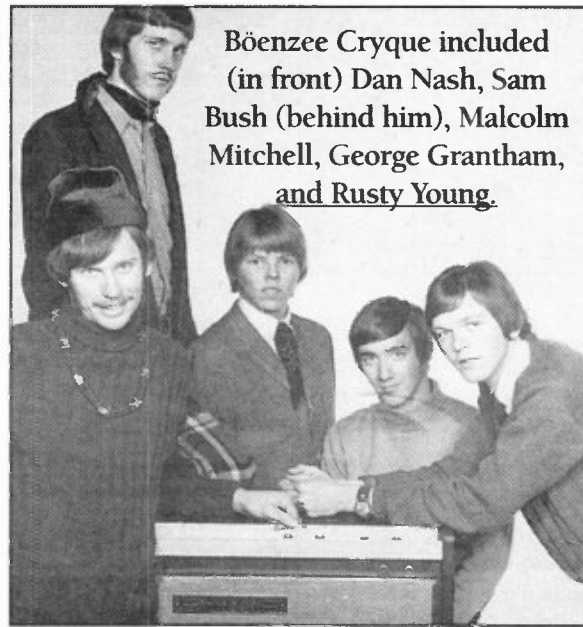

Courtesy of Beatrice Kemp

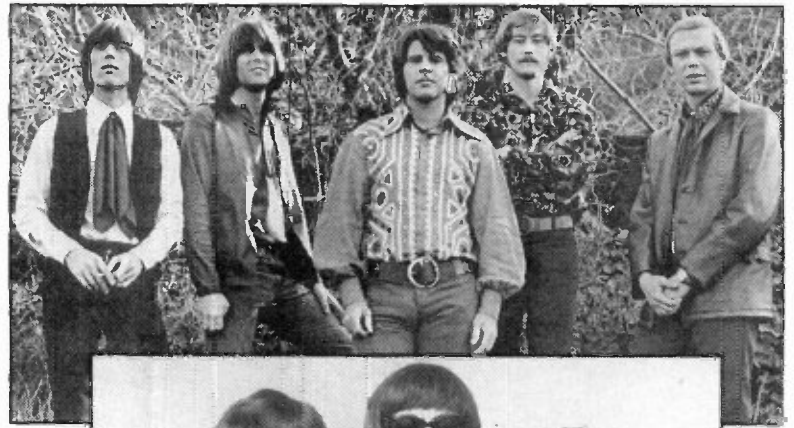

Courtesy of Beatrice Kemp

is Grantham who takes a rare lead. On the cover the picture of Meisner was replaced by a drawing of a dog.

The album *Pickin' Up The Pieces* was very much a Furay record with only one song not at least cowritten by him — the Young instrumental "Grand Junction," titled after a town on the western slope of the Colorado Rockies. A fan of Poco's, Kathy Johnson, wrote a poem about Poco that Furay set to music, becoming the LP intro "Foreword." This leads to the very "up" song, "What A Day."

The best introduction to the band, however, comes on side two with Furay's "Pickin' Up The Pieces," Poco's policy statement. "We're bringin' you back home where folks are happy, sittin', pickin' and a-grinnin'."

While its title track went nowhere, the LP did manage to chart in June 1969 as high as #63 in *Billboard*. The Parsons-led Flying Burrito Brothers charted a month sooner but only reached #164 for A&M, which had whiffed on signing Poco. While the success of Poco's debut was good, there were raised eyebrows when Crosby, Stills And Nash soared to #6 with their self-titled debut. The big country record of that summer, however, was Bob Dylan's *Nashville Skyline*, a smash at #3.

Messina didn't want to continue as bassist, so a trip to Sacramento was executed to draft Schmit, who officially joined in early '70. Back in August '69, his "Hard Luck" had been used as the flip for a non-charting, non-LP single with Furay's "My Kind Of Love" on the top side. (These songs can be found on the excellent two-CD set *The Forgotten Trail [1969-74]*, a 1990 release on Epic Legacy.)

On the next LP, titled simply *Poco*, the sound hardened a bit, which, as has been quoted many times since, was "too country for rock and too rock for country." To just get the grooves recorded, however, was a trial. Their management at the time had a tiff with label chief Clive Davis, who prevented Poco from recording until it was settled. The savior turned out to be an agent with the Creative Management Agency, David Geffen, who befriended

the guys and interceded on their behalf. While Geffen didn't take on the band's management, the back of the second LP reads: "Dedicated to David Geffen who 'Picked Up The Pieces.'"

The playing is excellent, with Young defying the tradition of country pedal steel by playing it through a Leslie cabinet and making it sound like an otherworldly organ, as he did on "Sightseer" for The Boenzee Cryque.

During the late summer of '70 *Poco* reached #58 in *Billboard*, helped along by the single "You Better Think Twice," backed with "Anyway Bye Bye." While the 45 charted at #72, Messina's finest moment with Poco deserved far better. The song careens along like a well-oiled steam engine fed by tasty bursts of Messina's James Burton-inflected licks and Schmit's pumping bass. The wind-down is preceded by Young and Grantham playing in tandem as a racing fire truck passes by. While all this flailing and picking is going on, the vocal harmonies dance around a catchy sprite of a melody. Furay's bluesy B-side was originally written for Meisner to sing.

The Gary Burden-designed cover is distinctive, with a striking Henry Diltz band photo superimposed on a Morris Ovsey drawing dominated by mountains, trees and two very large oranges. When asked about its significance, Furay replied, "I don't have a clue. I'm not a very visual guy. Somebody liked it."

Sessions for a third studio record did not progress well in July-August 1970. Messina had decided that he was the odd man out when it came to placing songs with Poco (since Furay dominated the writing), and tensions were running high in the studio. Since they were building a pretty fair following in concert (especially at colleges), perhaps the best thing would be to record shows for a live album. October shows in New York and Boston were used for the record.

When Messina decided to leave, he showed a world of class. He helped work his replacement, Paul Cotton, into the act while rooming with him on the road teaching him the songs. Furay today shows great respect for Messina.

"That was pretty upstanding for Jimmy to help get Tim established, and then when he knew he was leaving to bring Paul in. He made that transition easy."

Messina left one other treasure prior to departing, the sweetly soothing "Lullaby In September," which finally saw the light of laser on *The Forgotten Trail* CD (the song was originally a gift for Furay's wife Nancy, then expecting their first child).

Norman Paul Cotton (born Feb. 26, 1945, in Camp Rucker, Ala.) was a rock musician brought in to toughen the sound. Raised in a Chicago suburb, Cotton recorded in the early '60s with the mainly instrumental outfit The Mus-Twangs (check out their raw 45 on Smash, "Roch Lomond"/"Marie," which is very Duane Eddy-ish).

By '69 he and Kal David fronted Illinois Speed Press, who made two Columbia LPs. That band was handled by James William Guercio, who also managed the band Chicago. Chicago's bassist Peter Cetera (brother of Tim Cetera, who took over on bass in Rick Nelson's Stone Canyon Band after Meisner left) was taking steel guitar lessons from Young. Poco needed a guitarist/singer, and Cetera recommended Cotton.

February '71 found Poco with their biggest hit to date as the live record *Deliverin'* went to #26 with Furay's "C'mon" hitting #69 on the singles chart. For many, that remains the Poco L.P. It has an acoustic version of "You Better Think Twice" and reminders of the first record ("Grand Junction") and even Buffalo Springfield ("Kind Woman" and "Child's Claim To Fame"). Some of the songs appear in shortened, linked form. According to Furay, this was because as a frequent opening act they wanted to touch on as many songs as possible, so they took to arranging songs in medleys.

In fall 1971, Poco was also on the charts with two live cuts from the bloated triple LP *The First Great Rock Festivals Of The Seventies: Isle Of Wight/Atlanta Pop Festival*.

This odd pairing placed Poco next to The Allman Brothers Band and Johnny Winter

Courtesy of Richie Furay



Left: Poco in mid-1972, from left are: Richie Furay, Rusty Young, George Grantham, Paul Cotton, and Timothy B. Schmit. Below: Poco's first promo shot, from 1969.

from a July 4, 1970, sweatbox of a festival in Byron, Ga. "Kind Woman" and a steaming "Grand Junction" show the band in top form.

For the first record with Cotton, Epic paired Poco with producer Steve Cropper of Booker T. & The MG's. While the mix of a country-rock band with an R&B guitarist sounds incongruous, the result is excellent. Furay still has a hard time coming to grips with this record, as he was going through a difficult time in his marriage.

"We were spending more time on the road than at home, and I lost all concept of home. The band was my family," he recalled.

Yet, as has been proven time and again, conflict often produces great music, and the resulting record *From The Inside* is no exception. Cotton brought "Bad Weather" from the Speed Press and a tough rock sound as heard on "Railroad Days." The title song is a pretty Schmit ballad, while the lead track is a Furay/Young collaboration, the jolly "Hoe Down." Furay's "What If I Should Say I Love You" is a nice ballad with a great rock chorus, but perhaps his greatest moment in Poco is on the single "Just For Me And You," which only managed a charting of #110 in November '71. The song starts with an attractively Beatles-ish acoustic riff and lopes along like the Eagles' "Take It Easy" would six months later. History is littered with singles that went begging for airplay and were cruelly rebuffed, but that pattern continuously dogged Poco.

From The Inside managed a placement of #52 and features a set piece on the cover constructed by Johnson (she of the poem on the first LP). Furay still has the original piece hanging at home.

Home for Poco became Colorado around this time. Boulder and the areas just to the west in the foothills had become somewhat of a musical retreat, notably with Guercio building a recording studio at his Caribou ranch (which would become famous a couple of years later via Elton John's record of that name).

"We all knew we wanted to get out of L.A., as the smog was driving us nuts," said Furay. "San Francisco was our first choice, but only George bought a place [there]. After we decided to move to Boulder, I remember going up to San Francisco and here's George on a ladder painting, and we tell him that we're all on our way to Colorado. Luckily George is a pretty mellow guy, and he followed in suit. Of all the bands I've been in, Poco was certainly a family, especially when Tim and Paul were a part of the band."

A new song of Furay's debuted in concert and held the promise of the biggest success yet for Poco.

"You'd play along at one level, then everything would just go right on up to that song. I figured we'd finally got it now, so we hired Jack Richardson and Jim Mason to co-produce 'A Good Feelin' To Know' for us to release as a single."

And... nothing! For some unexplainable reason, the song that has today become one of Poco's standards never charted. An excellent album of the same name was recorded anyway, and it did chart in late '72 at #69, but Furay was devastated by the lack of success of one of his finest creations.

"I wanted to be a rock 'n' roll star like Neil and Steve and Randy and Jimmy," he said.

Indeed, '72 was a watershed year for his friends. Messina teamed up with Kenny Loggins and had a string of chart

successes as Loggins & Messina. Meisner's group the Eagles released their debut and soared to gold. Neil Young reaped the same with *Harvest*, and Stills grabbed gold with *Manassas*, while Poco kept plugging away to middling sales.

Richardson, who had produced The Guess Who, and Mason, who went to gold recording *Firefall*, crafted a superb album, *A Good Feelin' To Know*, that rivaled the Eagles step for step yet couldn't gain the same audience. Cotton's "Keeper Of The Fire," Schmit's ballad "Restrain" and Furay's angelic "Sweet Lovin'" all deserve mention. The standout is probably "Go And Say Goodbye," a Stills song from the Springfield done in a catchy style. But as a single it also tanked.

At that point Furay resolved to give up on Poco and recorded the sixth album *Crazy Eyes* as somewhat of a lame duck. In this climate, however, some great music transpired.

Cotton set the prototype for today's country with his tough guitar on "A Right Along" while Young chipped in "Fool's Gold" — an instrumental driven by banjo and former Byrd Chris Hillman's mandolin. That song, with Schmit's ballad "Here We Go Again," appeared as a non-charting single. Just months before Parsons' premature death, Furay covered one of Parsons' tunes, "Brass Buttons." The high-point of the record, however, is a nine-minute country-rock opus about Parsons that would become the title song for the album. "Crazy Eyes" benefits from a Rob Ezrin coarrangement using strings and foreshadows his work with Kiss.

Crazy Eyes actually did all right on the charts, hitting #38 in 1973, but Furay's future was already elsewhere.

"I talked to David Geffen and told him I was disappointed [with the lack of success for "A Good Feelin' To Know"]. He said, 'Let's get you together with Chris and J.D. [Souther] and have another Crosby, Stills And Nash.'"

That certainly became an epiphany moment for Young, who had previously been content to chip in the occasional instrumental and be a silent musician.

"There are two or three turning points in your life, and that was one of them for me," said Young. "That was the first day I started being a songwriter, because it was obvious that was where everything revolved around — the guys writing the songs."

In retrospect, Young fully understands Furay's leaving but has some animosity toward Geffen. "Geffen threw a lot of money at Richie to quit. I would have done the same thing [leave Poco for that money]. The only unfortunate thing was Geffen wanted Poco to stop and Richie to carry the entire audience. He threatened people."

Rather than throw in the towel, Poco continued as a four-piece and recorded *Seven*, which managed a #68 chart placement during summer '74. For the next non-charting single, Cotton's nice ballad "Faith In The Families" was paired with perhaps the best of all the Young "hoe-down" instrumentals — "Rocky Mountain Breakdown." This time around, the mandolin was handled by former member Messina with side-



man Al Garth chipping in on fiddle (never actually a band member, contrary to some reports).

A few months later, the self-titled Asylum debut by The Souther Hillman Furay Band lived up to expectations by going gold, placing as high as #11 in the charts. It spawned a medium-sized hit with the hard pop of Furay's "Fallin' In Love," a #27 charter that would not have sounded out of place on a Poco record. Indeed, the other two songs he placed on the LP would have fit Poco as well: "The Flight Of The Dove" and "Believe Me." A previously unreleased Poco version of the latter, from the *Crazy Eyes* sessions, appears on *The Forgotten Trail* CD.

The Poco version is in some ways superior to the Souther Hillman Furay Band version that is a bit tighter but perhaps is not as raw and fun. Veteran producer Richie Podolor, whom Furay credits with coming up with the stutterstep guitar intro to "Fallin' In Love," handled the radio-friendly production. Podolor had earlier been tapped by Poco for a post-Messina recording session, but Epic had rejected the results.

That all was not well in the SHF camp was evidenced by the title of their 1975 LP, *Trouble In Paradise*. Though it hit #39 that summer, the music had less energy and less Furay contribution. He was experiencing problems at home and within the band.

"Chris was the mediator trying to keep peace while J.D. and I were on opposite sides. Nancy and I had separated again, and we were looking heavily at divorce, so that second record was a real blur. Just to get me to the studio up at Caribou was a chore."

The supergroup broke up, but Furay's marriage was saved and endures.

Over in the Poco camp, three more albums had been released on two different labels. Late '74 saw *Cantamos* (Spanish for "we sing") chart at #76 with some songs reminiscent of early Poco, such as Schmit's "Bitter Blue" and Young's "All The Ways."

Cantamos has a small, square cutout on the cover, which allows a picture to show through from the inner sleeve. Epic played hardball, charging Poco for that little bit of artistry, so with their recording contract up for renewal, Poco moved over to ABC. This did not go over well with their old label, said Young.

"I have a framed letter from the head of Epic that says when

we would release a record on our new label, they would release something to compete and do their best to bury us."

This competition showed up on the charts in August 1975 when the first ABC album *Head Over Heels* was climbing to #43 while a two-record set on Epic titled *The Best Of Poco* was also moving up to #90.

Head Over Heels benefited from the lilting Schmit ballad "Keep On Tryin'," which charted at #50, their biggest hit yet and first Top 100 charter in more than five years. That this single didn't go higher is hard to explain. Indeed, pockets of the country were more open to the song, as seen by Denver's KTLK-AM pushing the song as high as #23 on its chart in early fall 1975 (the same placement as on adult radio nationally). The next single, Young's country rocker "Makin' Love," couldn't duplicate the chart placement, however. Cotton continued to hone his style on the fine "Let Me Turn Back To You." This album is notable for one more thing — Young's first recorded lead vocal, on "Us."

A month before the next ABC album, Epic released a second Poco live record to attempt, no doubt, to undermine the band's new recordings. Any questions about Epic's feelings toward Poco can be read into the cover illustration showing the flank section of a horse with the band's name stamped on the rump. While only charting at #169, *Live* is actually a pretty good record. Poco had the chops in concert to even do a hot version of "A Good Feelin' To Know" sans the song's writer. Summer '76 saw the new ABC record *Rose Of Cimarron* rise to only #89. Perhaps the non-descript cover didn't help, with no mention of the band's name or song titles and an unrecognizable picture of the band. The title track is a shuffling Young song that slowly builds to a symphonic end. As a U.S. single it only managed #94 but was a big hit elsewhere.

"That's our biggest song worldwide. It was a big hit a lot of places, including Australia," Young said. "It was covered by a lot of different people, including a German group."

One of those covers was in '81 by Emmylou Harris as the lead track to her *Cimarron* LP. An overseas single paired the Schmit/Logan ballad "Starin' At The Sky" with Cotton's "P.N.S. (When You Come Around)." "P.N.S." doesn't refer to a medical condition, but rather stands for "Paul's New Song."

That fall, Furay released his first solo record, the Asylum LP *I've Got A Reason*, which charted at #130.

"That is one of my favorite records," exclaimed Furay. "During our rehearsal time with SHE, Al Perkins [steel guitarist] had led me to the Lord, and I remember when I went in to record this, David Geffen called me in to his office. He wanted to know if I was gonna give him one of those Jesus records. I do admit that in 1976 it was probably not the most popular thing a guy in rock 'n' roll could do, making a commitment to Jesus Christ."

With this record, Furay pioneered yet another musical vision that others have taken to greater success. The rock radio sound grafted to lyrics that could be read as either the love of two people or love of God has lately come to the fore with acts such as Jars Of Clay and Michael W. Smith. The title ballad, the driving "Starlight" and the superb Poco-like rocker "Getting' Through" are among the highlights of *I've Got A Reason*.

One song deserving mention is the rocker



©Jensen Angel, Denmark

"Still Rolling Stones," which slaps at the magazine of that name. "I was fed up with *Rolling Stone* always short-changing every band I've ever been in."

A year after *Rose Of Cimarron*, Poco had a bit more success (#57) with the *Indian Summer* LP, which also spawned a #50 single in the title track. Donald Fagan of Steely Dan played synthesizers on the record in return for Schmit guesting on their records. This was the last record with Schmit. Young explained, "The Eagles made Tim an offer he obviously couldn't refuse, plus George was going through some personal things and needed to take some time off. After *Indian Summer* it was just Paul and me, and the label dropped us."

Fortunately, ABC changed its mind when Cotton and Young auditioned some new songs they intended for the next record: "Crazy Love," "Heart Of The Night" and a couple of others.

Young and Cotton auditioned a number of players for a new rhythm section but settled on two Englishmen who had worked with Leo Sayer. Charlie Harrison (born April 8, 1953, in Tamworth, Staffordshire, U.K.) was in on bass, while Steve Chapman (born Nov. 11, 1949, in London) took over the drums for Poco to record the album *Legend*. Due to their having played together previously, they were already a tight section, which gave them the advantage, Young said.

Proving that perseverance pays off, *Legend* finally rewarded Poco with gold status and a #14 placement on the charts. Young took over from Schmit writing nice ballads, as the first single "Crazy Love" went to #17 in early 1979. Cotton's "Heart Of The Night" did nearly as well at #20, but the third single, the tough rock title track by Young, only got to #103. By this point, Young was playing six-string guitar rather than steel since he felt that it was easier to sing playing that way. As a result, this LP was a move away from the country sound, yet it was the only time that Poco managed to chart in the country world, as "Crazy Love" and "Heart Of The Night" placed at #95 and #96 respectively. Go figure.

While there was a new Poco, the old Poco (at least the post-Meisner band) all made guest appearances on Furay's second solo record *Dance A Little Light*. A single of the old Drifters song "This Magic Moment" bubbled just under the Top 100 in summer '78.

In late '79 Furay released his last secular

solo LP, *I Still Have Dreams*. This album features the title track, a pleasant Poco-ish ballad that hit #39. Proving that he kept in touch with his past, this record has Souther as a guest and, intriguingly, two ex-Poco bassists (Meisner and Schmit) together on background vocals.

While producer Val Garay fashioned a slick record, including a remake of the old Young Rascals song "Lonely Too Long," solo success eluded Furay again.

"When it just didn't happen again I felt, 'Lord, what would you have me do?' and I really started to put my focus on the ministry." He had begun a home Bible study group that escalated to an organized church. "Today I am a pastor at Calvary Chapel of Boulder."

Another hot record of early '80 was an Eagles single of the Schmit song "I Can't Tell You Why," which got to #8. "It got down to a name," Young said. "If that had been a Poco record it wouldn't have been a hit, yet as an Eagles record it was. It was frustrating."

For the all-important follow-up to *Legend*, Poco released an even less country-oriented album, *Under The Gun*, which hit #46 in late summer '80.

"Boy, it was nice to finally have a hit," Young said, "and I guarantee you the motivation was to have another. Springsteen had hit, and country-rock was not seen as much of a cool thing anymore."

The sound of the time was new wave (The Knack, The Beat, The Romantics), and the look was skinny ties on skinny guys. The Searchers-like Cotton title track to *Under The Gun* fell right in line with that sound, which in retrospect may have confused some fans. Young said he also feels that MCA's decision to buy ABC hurt Poco's momentum.

"When MCA bought ABC, I think Dan never made another record because Petty refused to release his all because he gave him his own label. MCA was their enemies because they fired a lot of people."

Poco's next move may have doomed whatever momentum they still had, according to Young. "We were really upset with MCA and didn't want to be there. Since we owed them two records, we made the huge mistake of recording them really quick just to get off the label. People go out and spend money expecting to get their money's worth. We didn't give it to them with *Blue And Gray* or *Cowboys And Englishmen*, although there were some nice songs on each record."

In 1982, Furay returned to the record stores with a reissue of his *I've Got A Reason* on the Christian label Myrrh. This was followed by a new record, *Seasons Of Change*. Half of the songs are of a religious bent, while songs such as the autobiographical title track are similar to his other solo records. This is also reflected in the cover art, which shows a very Poco-looking Furay on the front with a cross next to a door on the back cover. Of the more secular songs, "Endless Flight" stands out, while the banjo gospel of "Rise Up" and the intense "Through It All" shine in the sacred realm. Poco fans who may have missed this record should look for it at their used-vinyl shops.

In 1982 Poco turned up on the double-album soundtrack to the movie *Fast Times At Ridgemont High* with the Young composition "I'll Leave It Up To You." That same year, Poco delivered a Christmas present to their remaining fans with the album *Ghost Town* on a new label, Atlantic (ironically, as it had traded away Furay to Epic at the start of this puzzle). A #195 chart placement confirmed that the last MCA album had indeed hurt Poco's career, which is a pity, as this is one of their strongest records.

Giving it one last shot, Young and Cotton released yet another solid record with 1984's *Inamorata*. Music buyers were not enamored and finally deserted Poco. This LP only hit #167, and more's the pity, as fans missed some of the band's best later-day work; indeed, Cotton's "Days Gone By" may well be his Poco high point. Of note are harmonies on "This Old Flame," "How Many Moons" and "Save A Corner Of My Heart" — a glance at the back cover shows Furay, Schmit, and Grantham lined up on vocals. Furay noted, "Rusty called and said, 'I'd like you to sing on this record.' We sang well together, though it was not a reunion yet."

With success apparently extinguished, Poco was seemingly done in 1984, and Young turned to session work in Nashville. Cotton went in search of a solo career in L.A. Messina's solo career, with the LPs *Oasis*, *Messina* and the pleasant pop of *One More Mile*, had stalled. Meisner had taken a similar dive after the Eagles with *One More Song* and *Randy Meisner* but at least spawned three chart singles from 1980-1982 (notably "Hearts On Fire" [#19]). Schmit's solo career hadn't been much healthier with the fine record *Playing It Cool* doing minor damage at #160 in 1984. Timothy B. did

better, coming in at #106. The single from that album, "Boys Night Out" reached #25 in 1987, but 1990's *Tell Me The Truth* didn't chart. Furay of course had his church work, while Grantham did some session work.

Rising like the phoenix, however, Poco had one last hurrah when in 1989 they reunited for the *Legacy* album. Furay gives Young the credit, while Young sees it the other way around. No matter the catalyst, there was new life with some caveats, as explained by Furay.

"We did have some lengthy discussions about the fact that I wanted to be careful of things," Young confirmed that those things were too hard to overcome and ultimately resulted in Furay leaving once again. "Richie has a commitment to his church, and that takes priority. I don't think we fully understood going in [to the reunion] what that meant."

At any rate, the intent to finally record as the first version of Poco (with Meisner) was a commendable idea, if ill-fated. As reunion records go, this one did pretty well, getting to #40 and spawning two hits — "Call It Love" at #18 and "Nothin' To Hide" at #39. The latter shares some similarity to Meisner's "Take It To The Limit" from his Eagles days, while the former has a catchy guitar riff but had a rocky genesis. The original lyrics were of the adult variety and caused some friction.

Furay: "If you would have heard the original lyrics, it was essentially "Call It Lust," and it wasn't Poco. We never wrote songs like that." Young mentioned, "I told them [the writers], 'I can't sing that.'"

Regarding the LP as a whole, both members also confirmed it was more of a project and an attempt by manager Allen Kovac to make Poco into Richard Marx.

Furay said, "Had we been left alone to do our own music, it would have been fine, but there were some songs on *Legacy* that didn't belong there. I hope I did stand up for the integrity of the band. I don't think Poco wanted to be known for those kind of songs."

Young, Messina, and Meisner created the album with studio players essentially. Grantham was not allowed on drums and Furay played only on his two songs, and the autobiographical "When It All Began" and the ballad "If It Wasn't For You."

Furay finally exited over objections to the video done for "Call It Love" and was replaced for the tour by a friend of Young's, Jack Sundred. Of interest is the success this record had on adult stations, as "Call It Love," "Nothin' To Hide" and "What Do People Know" got to #2, #10 and #24 respectively according to Whitburn's *Adult Contemporary* chart book ("Crazy Love" was their highest adult hit at #1 with "Heart Of the Night" at #5.)

Young said he doesn't feel the band ever got their due. "You had the Eagles, Loggins And Messina, and Poco all on one record. We're up there at Radio City Music Hall singing 'Take It To The Limit,' 'Your Mama Don't Dance' and 'Crazy Love.' It was disappointing that the critical people didn't jump on the bandwagon and go, 'This is where it all began, guys.'"

Messina, Meisner, and Young cut demos for a second LP, but labels weren't interested, and Poco was put back in mothballs.

Young's next project was to start a new band, The Sky Kings. "A friend here in Nashville, head of A&R at RCA, wanted to put together a project like a country Traveling Wilburys. We had Bill Lloyd of Foster And Lloyd, John Cowen, an amazing singer

from the New Grass Revival, and I called Pat Simmons of The Doobie Brothers since he'd written their hit 'Black Water,' which was very Poco-ish. We cut a great record, and they never released it. The head of the label left, and the new head dropped it."

With The Doobie Brothers reuniting, Simmons left The Sky Kings, who cut another record for Warner Brothers. The single "Picture Perfect" was released from the 1996 sessions, but the album never followed until Rhino Handmade resurrected it in the fall of 2000 in an expanded, 24-track version called *From Out Of The Blue* (RHM 7714).

Meisner recorded with Black Tie and returned recently with The World Classic Rockers, an aggregation of former chart-busters trying to keep their music before the public. Messina returned to his art and sporadic solo career. Grantham went back to playing drums with the likes of Ronnie McDowell. Cotton has issued two solo albums: *Changing Horses* in 1990 and *Firebird* in 2000. Schmit's latest solo album, *Feed The Fire* (Lucan 2001), came out this past May and features photography by Diltz.

Furay released a solo CD on the Calvary Chapel Music label (www.calvarymusic.org) in 1997. The players include Bush on fiddle and Young on steel guitar and Dobro. For that reason, it sounds in places like "Poco goes to church." Furay continues his ministry with occasional concerts such as a show — at a Highlands Ranch, Colo., church — that mixed new sacred songs with career highlights such as "On The Way Home," "Go And Say Goodbye" and "Pickin' Up The Pieces."

For the 2000s, the lineup of Young, Cotton, Grantham, and Sundred are out on the road and well worth fans' concert dollar. This writer took his family of four and paid \$54 total while the reconstituted Eagles wanted \$125 for one ticket — sheesh. One glorious night, July 3, 2001, Furay rejoined his old mates at Hudson Gardens in Colorado and played several songs (during a two-hour set), including a white-hot version of "A Good Feelin' To Know" that had the crowd up on their feet, roaring. The five capped the show with a heartfelt and smokin' version of Chuck Berry's "Back In The U.S.A." accompanied by fireworks. Thirty-plus years later, Poco still rocks.

Neither Furay nor Young rule out future Poco projects. Young: "Richie sent me new songs, Paul's got new songs and I've got new songs. All we need is an outlet." Furay also has a plan. "After the Hall Of Fame [Buffalo Springfield were inducted in 1997] I just got to the point that I'd really love to give it one more shot and put Poco on the map. I'd like to get the band and play all this music we did and have some guys who were Poco. I need to have a band, and he felt he couldn't [due to the Eagles] and I respect that, but I really want to give it another chance."

Restonate Poco people may still get to see their heroes on record again, as a new album is plotted for an early 2002 release (along with an official Web site, according to management).

While Poco's success pales next to their contemporaries the Eagles, frankly, so does everybody else's, since the Eagles currently have the biggest-selling album ever (27 million) with *Their Greatest Hits: 1971-1975* package. Few country-ish acts have ever done well on the pop chart, seemingly caught

Poco U.S. discography

by George Krieger and Tim Neely

Singles

Label/#	Title	Year
Epic 10501	Pickin' Up The Pieces/First Love	1969
Epic 10543	My Kind Of Love/Hard Luck	1969
Epic 10636	You Better Think Twice (edit)/Anyway Bye Bye	1970
Epic 10714	C'mon (edit)/I Guess You Made It (edit)	1971
Epic 10804	Just For Me & You (edit)/Ol' Forgiver	1971
Epic 10816	Railroad Days/You Are The One	1971
Epic 10890	A Good Feelin' To Know (edit)/Early Times (reissued in 1973)	1972
Epic 10958	Go & Say Goodbye/I Can See Everything	1973
Epic 11055	Here We Go Again/Fool's Gold	1973
Epic 11092	Magnolia (edit)/Brass Buttons	1974
Epic 11141	Faith In The Families/Rocky Mountain Breakdown	1974
Epic 50076	High & Dry (edit)/Bitter Blue	1975
ABC 12126	Keep On Tryin'/Georgia, Bind My Ties	1975
ABC 12159	Makin' Love/Flying Solo	1976
ABC 12204	Rose Of Cimarron (edit)/Tulsa Turnaround	1976
ABC 12295	Indian Summer (edit)/Me & You	1977
ABC 12439	Crazy Love/Barbados	1979
MCA 41023	Heart Of The Night/The Last Goodbye	1979
MCA 41103	Legend/Indian Summer	1979
MCA 41269	Under The Gun/Reputation (also released with picture sleeve)	1980
MCA 41326	Midnight Rain/A Fool's Paradise	1980
MCA 51034	The Everlasting Kind/ Friends in the Distance	1980
MCA 51172	Widowmaker/Down On The River Again	1981
MCA 52001	Sea Of Heartbreak/Feudin'	1982
Atlantic 7-89970	Ghost Town (edit)/High Sierra	1982
Atlantic 7-89919	Shoot For The Moon/The Midnight Rodeo	1982
Atlantic 7-89851	Break Of Hearts/Love's So Cruel	1983
Atlantic 7-89674	Days Gone By/Daylight	1984
Atlantic 7-89650	This Ole Flame/The Storm	1984
Atlantic 7-89629	Save A Corner Of Your Heart/The Storm	1984
RCA 9038	Call It Love (edit)/Lovin' You Every Minute (also released with picture sleeve)	1989
RCA 9131	Nothin' To Hide (edit)/If It Wasn't For You (also released with picture sleeve)	1989
RCA 9138	The Nature Of Love/interview (?)	1990
RCA 9138	The Nature Of Love/interview (?) (cassette single)	1990
RCA 2623	What Do People Know/When It All Began	1990
RCA 2623	What Do People Know/When It All Began (cassette single)	1990

Vinyl albums

Epic BN 26460	Pickin' Up The Pieces	1969
Epic BN 26522	Poco	1970
Epic KE/EQ 30209	Deliverin' (also released as quadrophonic)	1971
Epic KE 30753	From The Inside	1971
Epic KE 31601	A Good Feelin' To Know	1972
Epic KE/EQ 32354	Crazy Eyes (also released as quadrophonic)	1973
Epic KE/EQ 32895	Seven (also released as quadrophonic)	1974
Epic PE/PEQ 33192	Cantamos (also released as quadrophonic)	1974
ABC D-890	Head Over Heels	1975
Epic PEG 33537	The Very Best Of Poco (two LPs)	1975
Epic PE 33336	Live	1976
ABC D-946	Rose Of Cimarron	1976
ABC D-989	Indian Summer	1977
ABC AA-1099	Legend	1978
Mobile Fidelity 1-020	Legend (half-speed master)	1979
Epic JE 36210	Songs Of Paul Cotton	1979
Epic JE 36211	Songs Of Richie Furay	1979
MCA 5132	Under The Gun	1980
MCA 5227	Blue & Gray	1981
MCA 5288	Cowboys & Englishmen	1982
MCA 5363	Backtracks	1982
Atlantic 80008	Ghost Town	1982
Atlantic 80148	Inamorata	1984
RCA 9694-1-R	Legacy	1989

Compact Discs (only if number is different from above)

MCA MCAD-31019	Legend	1986
MCA MCAD-31327	Head Over Heels	1988
MCA MCAD-31334	Under the Gun	1989
MCA MCAD-31353	Indian Summer	1989
MCA MCAD-42323	Crazy Loving-The Best Of Poco 1975-1982	1989
Epic Legacy E2K 46162	The Forgotten Trail (1969-74) (two CDs)	1990
One Way 22067	Cowboys And Englishmen	1993
One Way 22068	Blue And Grey	1993
One Way 22076	Rose Of Cimarron	1993
MCA MCAD-11206	Legend (24-karat gold CD)	1995
Rhino R2-72217	Ghost Town/Inamorata (two LPs on one CD)	1995
Legacy EK 66227	Pickin' Up the Pieces (remastered with bonus track)	1995
Legacy EK 66968	Crazy Eyes (remastered)	1995
Legacy EK 66985	Seven (remastered)	1995
Sony Music Spec. Prods. A 26735	On The Country Side	1996
Hip-O HPD-40136	The Ultimate Collection	1998
Epic Legacy EK 65731	The Very Best Of Poco (remastered)	1999
MCA 088 112 224-2	The Millennium Collection	2000
One Way A 32337	Live (reissue of 1976 LP)	2000

between a rock and a country place. In that context Poco were as successful as any.

While money and fame are critical yardsticks, bands who dare to color outside of the lines are measured more by the things they leave behind. As Captain Beefheart are to the blues and Fairport Convention are to British folk, so too are Poco to country.

Due to his early death, many have anointed Parsons as the originator of the new country, yet the creation of this style of music was more a collaboration than the

creation of one player. The Monkees' Michael Nesmith deserves as much credit as Parsons but gets ignored as a one-time teenybopper idol. If the ability to create music is a superpower, than ultimately it can be said the players of Poco use their powers for good rather than evil.

In retrospect, Poco (and their like) created the new country music (which owes much to rock) as opposed to changing the pop charts.

Classical Notes

THE BEETHOVEN *FIFTH* TRANSCENDS TIME

by Peter Gutmann

Dit-dit-dit-daaaah. Talk about a great hook! Three quick Gs and a long E-flat — they just don't come any better than that. Step aside, Mick Jagger and Keith Richards — the opening of Ludwig van Beethoven's *Fifth Symphony* just could be the most memorable musical phrase of all time.

During World War II its suggestion of Morse Code became the powerful symbol of "V For Victory." GIs who didn't know Schumann from Shinola knew this was Beethoven and relished the irony of a German's music galvanizing the Allied effort to defeat the horrific murder machine that country had become.

But that's just the first five seconds. As for the rest, in nearly every poll, even of classical sophisticates, the Beethoven *Fifth* tops the list of favorites. Clearly, Beethoven crafted something powerful and universal that reverberates with ageless significance in every listener regardless of his or her depth of musical culture.

In retrospect we revere Beethoven for having ushered in the century of music that a majority of classical fans enjoy the most. While Mozart certainly was pushing in that direction (and might have broken through had he lived past 36), Beethoven's bold harmonic and structural explorations launched the Romantic era in music, in which personal feelings were no longer repressed beneath conventional form. While the *Fifth* isn't Beethoven's most innovative or influential symphony (the *Third* and *Ninth* compete for that honor), it does have a wealth of groundbreaking features: the first use of a trombone in symphonic music, variations built upon dual themes, two movements joined together, the reprise of an earlier passage in the finale and, most impressive of all, a single motif that unifies the entire work.

Beethoven reportedly called his opening "fate knocking at the door," but nowadays that's largely discredited as unreliable hearsay; as Beethoven's posthumous fame grew, many associates tried to magnify their own significance by claiming special insights. But, as befits one whose genius lay in the abstract realm of music rather than a more specific art, Beethoven didn't trivialize his creations with a single connotation. Even so, the entire work exemplifies the Romantic ideal of an expressive journey, not in the sense of telling a story but rather as an emotional catharsis.

"Fate" or not, the commanding opening figure pervades the entire work. The first movement is grim and resolute yet charged with constant conflict and energy as glimmers of hope swirl through a relentless storm. It's a miracle of construction, with all the ideas firmly grounded in that first four-note phrase — even a lyrical second theme rides atop and ultimately devolves into it. The focused intensity is relieved by a flowing set of variations, leisurely but with controlled surges of power. Next comes a resolute march built largely upon the insistent rhythm of the opening motif which descends into a hushed section of coiled tension and then explodes into the finale, an exhilarating shout of C-major triumph. In a masterstroke, Beethoven magnifies the effect by summoning again the tense portion of the third movement march and then repeating the triumphant explosion. The work ends in a breathless coda built upon variants of the opening motif to pound home the permanence of the joyous destination.

While Mozart may have written masterpieces in final form right off the top of his head, Beethoven struggled over the *Fifth* for nearly a decade. Many early ideas and sketches



found in his notebooks started out conventionally, with lengthy repetitions and standard harmonic progressions. As a great composer, Beethoven delved deeply into his material to explore and develop its full potential, and as an equally great editor, he constantly simplified and tightened it. In final form, the *Fifth* is a masterpiece not only of invention, but also of concision.

Unlike movies and novels we consider great but in which minor changes would be inconsequential, not a single note of the *Fifth* could be improved.

But please don't think of the composer who lavished so much devout care on perfecting his work as a pure soul whose rarified spirit had risen far above the venality of the

In nearly every poll, even of classical sophisticates, the Beethoven *Fifth* tops the list of favorites. Clearly, Beethoven crafted something powerful and universal that reverberates with ageless significance in every listener regardless of his or her depth of musical culture.

rest of us mere mortals. Beethoven was all too human — he contracted to sell the *Fifth* to a wealthy patron for 500 florins (a considerable sum), but after collecting the first 350 he turned around without apology or refund and sold the very same score to a publisher. But perhaps it was Beethoven's intense humanity that enabled him to write in a style that appealed to *real* people, not just aristocrats.

That, in itself, is an essential key to understanding Beethoven's lasting appeal. Two centuries ago classical music was wholly dependent upon the patronage of nobility. Public concerts were rare and established professional orchestras unknown. The *Fifth* was given its world premiere in a massive four-hour concert Dec. 28, 1808, that consisted entirely of new major Beethoven works, including his *Sixth Symphony*, *Mass In C*, *Fourth Piano Concerto* and *Choral Fantasia*. By the time the *Fifth* rolled around that night, the audience was not only too exhausted to have paid much notice but also nearly frozen, as the hall was unheated and the winter bitterly cold. With only a single rehearsal by a pick-up ensemble for the entire program of unfamiliar and difficult music, the execution was a mess. At one point, things got so tangled that Beethoven had to stop and restart, a humiliation that the shivering players repaid in their performance.

Not surprising, the world was hardly transformed by first hearing this glorious creation; as the premiere was essentially an exercise in sight-reading, notions of sensitivity and interpretive feeling were well beside the point. Nowadays, we've made up for that with a huge variety of distinctive, highly polished and deeply expressive recordings that plumb the considerable

depths of this amazingly rich work. Here are my favorites:

Although Arturo Toscanini's reputation as a classical speed demon is largely unwarranted, he does claim the fastest *Fifth* on records — a stunning concert of May 8, 1945, celebrating V-E Day (on Music & Arts CD 753). Toscanini was a fervent anti-fascist, and the overthrow of Mussolini and Hitler overpowered his usual sense of proportion to produce a hair-raising distillation of his political emotions that clocks in at a breathless 26 minutes, 45 seconds. Nearly as thrilling are his two studio recordings — a fleet and streamlined 1953 LP (BMG 60255) and a richer and more complex 1939 set of 78s (BMG 60270).

Politics also flavored the best of Wilhelm Furtwängler's readings. The first was a 1943 Berlin concert (Music & Arts 4049) in which Furtwängler's personal agony is frighteningly tangible as the vast pounding tympani and inflated dynamics of his wartime desperation battle the symphony's intrinsic indomitable spirit. (Despite suspicions of collaboration for having remained in Germany throughout the war, Furtwängler was deeply conflicted and courageously endangered himself by working within the system to save dozens of lives.) A May 1947 concert (Music & Arts 789) marked his return to active musical life after his exoneration. Proceeding from a grimly powerful opening to an ecstatic explosion of victory, it symbolizes not only Furtwängler's personal odyssey from repression to freedom but the triumph of permanent culture over temporary politics. There's also a remarkably noble 1954 Vienna studio set (EMI 69803) in which Furtwängler harnesses his former angst to animate a subtly shifting and superbly controlled overall flow.

For the opposite extreme to Toscanini, Otto Klemperer, one of the stalwarts of German tradition, stretches his *Fifths* out to a glorious 40 minutes, both in a 1959 studio record (EMI 63357) and, to even greater effect, in a magnificent 1969 concert (EMI 66865). The result is like an athlete in slow motion, with power transmuted by surreal grace. Equally spacious is Glenn Gould's playing of the Liszt piano transcription (Sony 52636), highlighted by an *Andante* of prayerful intimacy. A different sort of transcendence is achieved by Sergiu Celibidache (EMI 56521); consistent with his Zen beliefs, he strips the music of all rhetoric and presents it as a pure, radiant abstraction.

At this point you may well ask: "Does music this great really require extensive interpretation to convey its treasures?" No, it certainly doesn't, and indeed most conductors, perhaps humbled before Beethoven's genius, let the *Fifth* speak largely for itself. Among many others, Fritz Reiner (RCA 68976), Carlos Kleiber (DG 447 400), Pierre Monteux (London 443 479), and Herbert von Karajan (EMI or three remakes on DG) all present magnificent playing and a satisfying balance of energy and control, drive and repose.

A fascinating alternative is one of the "authentic instrument" renditions, which use the smaller orchestras, lower tunings, less powerful instruments and wind- and brass-heavy balances of two centuries ago in an attempt to re-create a performance that Beethoven's audiences would have recognized. It's not a mere gimmick — Beethoven wrote the *Fifth* for the purpose of being performed, with a specific sound image in mind. But rather than settling our historical curiosity, the results raise an interesting question — despite careful scholarship to emulate the original sound, they all sound so different, from the warmth, leisurely pace and subtle blend of the Hanover Band (Nimbus) to the furiously driven Orchestre Revolutionnaire et Romantique (Archive). Which of these would Beethoven have chosen as the most valid? Ironically, he might have been utterly indifferent; by the time he finished the *Fifth*, he was largely deaf and so perhaps conceived the work largely in the abstract after all!

Let's not forget the pioneers, who were raised in an era that encouraged personalized interpretation and who present a cavalcade of styles that remain fascinating and influenced all who followed. I'll survey the trailblazers on my Web site at www.classicalnotes.net/columns/fifth.html.

In reviewing several dozen *Fifths* for this column, I was struck by two realizations. First, even after such intensive and repeated exposure, I'm still as enthralled by the work as ever. Second, I've yet to hear a single record, even by an unknown orchestra and conductor, that's without interest. That, perhaps, is the strongest proof of Beethoven's genius — this is a work of limitless depth and matchless inspiration that constantly challenges and transcends personal taste and trends.

Peter Gutmann can be reached via e-mail at pg@ommlaw.com.

A Broad Abroad

SCI-FI ROCKA-PUNK-GLAM-ALOONABILLY — AND MORE!

by Jo-Ann Greene

We begin this month with a trip down a memory lane that some readers, to be honest, may not actually remember. *Roll Out The Barrel* by Terry Bradford and Sussie Arvesen (Famous Record Company, U.K.) is a hit-filled souvenir to one of the surprise smashes of the British theatrical season, a re-creation of an English music hall of the late-19th/early 20th century.

This area has already been well-documented by Bear Family's all-encompassing (but, unfortunately, sonically distressed) *On The Town Tonight* box set. There, original recordings of the era's greatest hits were reproduced from the best possible sources which, in too many cases, meant extremely hiss- and crackle-laden 78s and cylinders that are literally painful to listen to.

Although the recordings of standards such as "Down At The Old Bull And Bush," "Daisy Daisy" and "I've Got A Lovely Bunch Of Coconuts" are not performed by the original artists on *Roll Out The Barrel*, the sound and the mood remains as authentic as one could wish. Indeed, if your Anglophile tendencies reach back to Herman's Hermits and their re-creations of standards such as "Eney The Eighth" and "Leaning On A Lamp Post," *Roll Out The Barrel* will be right up your street.

Canadian bluesman Dave Goodman has a strong and devoted following across Europe, and his debut solo release, *Roadbook Rhymes* (Crosscut Records, Germany, www.crosscut.de) tells us why. Born and raised on Vancouver Island, Goodman started out loving Jimi Hendrix but playing Duke Ellington. It is this early dichotomy that still fuels his music — and that despite him abandoning electric guitar for acoustic, shortly before he began work on *Roadbook Rhymes*.

Recorded live to two-track in the studio, the 15 songs have a loose, ghostly feel to them, whether Goodman is performing alone (which he does for the majority of the set) or on those cuts where Hank Shizzoe, a second guitarist, plays, also bringing in an acoustic lap steel and even a bouzouki. Mention of Shizzoe, meanwhile, brings his own excellent album to the top of the pile. *Hank Shizzoe* (Crosscut) follows Goodman's lead into some dark and deeply personal acoustic areas, with a slightly (very slightly) country tinge thrown in on top. His version of Ned Washington and Dmitri Tiomkin's theme to *High Noon*, "Do Not Forsake Me Oh My Darling," is especially spellbinding, while Shizzoe's ability to conjure magic from seemingly every instrument he lays his hands on gives the album an almost symphonic feel, while remaining as simple and uncluttered as you could hope.

Another ace guitarist is Bill Nelson, one-time leader of cult '70s heroes Be Bop Deluxe and Red Noise but, for the past two decades, a solo artist pursuing some incredibly eclectic courses. *Simplex* (Tone Swoon, U.K., www.netcomuk.co.uk) is an album Nelson recorded during the 1980s as the soundtrack to a movie being made by the Henry Moore Foundation, examining the sculptor's work in relation to the landscape.

A series of brief but often beautifully atmospheric instrumentals, the album was originally intended for release on Nelson's own Cocteau label. It never appeared and, while a semi-bootleg edition did emerge briefly during the 1990s, a fully authorized version has long remained a Nelson collector's dream.

Its appearance today brings us 31 tracks, essentially vignettes, none much more than two minutes in length, but the overall mood is extremely self-sustaining; time passes quickly in their company. Though one does seek to find other artists with which to compare it, the journey between early analog Tangerine Dream and mid-period Mike Oldfield, with diversions via Gavin Bryars, David Bedford, and The Orb, is so vast that *Simplex* clearly cannot be so readily pigeonholed. For fans of ambient music it is a masterpiece.

From the sublime to the sweet... or, rather, a little before Sweet. *68 Was 68*, by Brian Connolly (Malibu, U.K.,

www.maliburecords.co.uk), is a nine-track compilation of the vocalist's session and studio work in the period immediately before Sweet began functioning as a recording act. It is, of course, nothing like anything you have ever heard from Connolly in the past — only one song, a demo version of the Sweet's first ever single, "Slow Motion," is even vaguely familiar.

The rest of the album catches Connolly singing what he's told to sing by whomever was masterminding the session, mainly the kind of up-tempo middle-of-the-road-type ballads that were so popular on the U.K. chart at the time. Nothing to be ashamed of there — many of the brightest stars of Britain's glam-rock era spent some time cutting similar material, often for release under their own names.

Connolly's contributions to the genre appear to have been intended more as guide vocals than final recordings and exist now only as reference tapes. Indeed, the liner notes caution that the recordings were taken from "the only available source and... lack the dynamics of modern digital sound." No matter. *68 Was 68* is an excellent collection, both entertaining and historically fascinating — the fact that it arrives at a time when Sweet collectors have been starving for something new and meaty to get their gums into only adds to its appeal.

The ever-excellent Angel Air (www.angelair.co.uk) weigh in with some remarkable reissues this month, first and foremost being *Lost World* by Zzebra. Everything you've ever read about this short-lived early '70s British band probably leaves you believing they were part of the jazz-rock community whose peregrinations often sound somewhat dated today. If that is so, then you're in for a surprise.

There are jazzy inclinations here but, as the liner notes swiftly point out, "describe Zzebra? Try Afro-rock-jazz-progressive." One simple comparison might be with Phil Manzanera's *Quiet Sun* spin-off — there is a sense of adventure the size of an interstate running through the band's musicianship. But whereas such ambition often got bogged down in the seas of self-indulgence, Zzebra never seem to lose sight of the fact that people might want to play their records rather than simply marvel at their technique. Eight studio recordings and four live cuts from a 1975 European tour catch Zzebra in audacious form, pushing *Lost World* up among the very best Angel Air releases of the year.

It's been said before, but let's say it again. What the world needs is an Atomic Rooster box set that rounds up everything that helped establish that group among the most powerful, potent and pertinent hard rock bands of the 1970s and beyond. What it doesn't need is yet another installment in the apparently never-ending, British industry-wide saga of outtakes, live cuts, oddities and latter-day reunions that have piled up around them in recent years. But first impressions of *The First Ten Explosive Years Volume Two* (Angel Air) suggest that is exactly what we've got.

A complete absence of source information leaves us totally in the dark as to when these performances were recorded or whether they've seen the light of day before. Are they from early on in those first explosive years, when the Rooster was crowing the loudest? Or do they hail from the still impressive but infinitely less volatile years at the end, when Atomic Rooster were adopted by the New Wave Of British Heavy Metal audience and ground their way around the denim and dandruff circuit, playing to an audience which, quite frankly, would have wet itself if it had encountered the original bird?

The answer is a bit of both, but with the CD paying no more regard to chronology than the sleeve pays to detail, one cannot help but feel the entire Rooster reissue project is in desperate need of a serious rethink. Angel Air have now released four Rooster CDs and, if you are looking to investigate the band, they are the ones to go for (*Live And Raw*, *Rarities* and the first volume of *10 Explosive Years* are the companions). But if you are hoping to understand the band... good luck.

With the so-called third wave of ska having apparently crashed itself out on the rocks of public apathy, it might seem an especially inopportune time to be reissuing the first two albums by Two-Tone veterans The Selecter. Both *Too Much Pressure* and *Celebrate The Bullet* appeared during 1980/81 but resurfaced — in spirit if not in fact — during the mid-1990s, as a revitalized Selecter toured the circuit, reinvigorating their old favorites even as they created some new ones. That moment seems long past now, but spinning the two reissues (both Captain Oi! — U.K., www.captainoi.com) it is not difficult to imagine it rekindling on the spot. Far from resembling the ghosts of some long-forgotten age, both albums explode with a freshness and character that has to be heard to be believed.

Too Much Pressure, the band's debut, remains the classic. Across the original vinyl's 13 songs, plus three bonus tracks drawn from contemporary 45s, The Selecter's grasp of ska as a living, breathing art form certainly exceeds the better-known Madness and UB40's efforts. "Three Minute Hero," "Missing Words" and "Too Much Pressure" are classic ska-pop songs, with vocalist Pauline Black the equal of any of the original Jamaican ska boom's best-loved chanteuses — a role call that includes legends such as Norah Dean and the singularly named Margarita, Patsy, and Naomi.

Heavily slated at the time, The Selecter's second album, *Celebrate The Bullet*, is less urgent than its predecessor, but a fresh listen reveals it to be equally dramatic. The 12-inch mix of "Train To Skaville," one of four bonus tracks, is devastating, while album cuts "(Who Likes) Facing Situations," "Washed Up And Left For Dead" and "Selling Out Your Future" aren't only excellent songs, they also offer a pigeon's-eye view on the death of the 2-Tone movement itself. Another sophomore LP that was hammered at the time but has improved with age is Penetration's *Coming Up For Air*, the successor to the hit favorite *Moving Targets*. Cut only months before the band broke apart, it vividly illustrates the conflicts that were tearing Penetration apart, as new-wave pop sensibilities battled with new-wave metal ambitions — and neither side came out on top. But listened to 20+ years on, with ears uncluttered by the petty life-stylistic rivalries that seemed so important back then, *Coming Up For Air* emerges a very strong, pounding set, high on emotion and energy alike.

Finally, Captain Oi! have also repatriated *Rev Up*, the first album by The Revillos, the freakish sci-fi rocka-punk-glam-aloonably band spun off from the much loved Rezillos. Thirteen great slabs of, indeed, revved-up pop nonsense comprise the original LP, five more fly off the end as bonus tracks, and anybody who has ever paused to wonder what would have happened if The Cramps and The B-52s had ever tried playing each other's greatest hits should grab a copy now. All the more so since the end result doesn't sound anything like you imagine it would. An amazing band release an amazing album.

Best of the rest

Front Page Review: *Mystic Soldiers* (Akarma, Italy). Another gem in Akarma's journey through producer Alan Lorber's legendary Boston Sound 1968 vaults is *Mystic Soldiers*. Front Page Review are best-remembered today for providing Boston new-wavers Nervous Eaters with frontman Steve Cataldo — here he is a decade earlier on an album that went unreleased in '68 but truly merits attention today.

Orpheus: *The Complete Orpheus* (Akarma, Italy). More Boston Sound, this time a lavish two-CD package bringing all four of Orpheus' fondly remembered albums together for the first time. Awkwardly, the first and fourth LPs share one disc, the second and third the other, thus sabotaging the opportunity to trace the group's development from pillar to post. But that aside, *The Complete Orpheus* is one of those sets that will be in with a shout for reissue of the year.

T-Bone Walker: *Back On The Scene — Texas 1966* (Indigo U.K.). Two excellent sets from the blues giant T-Bone Walker, caught in Houston and Pasadena, Texas, during 1966. Previously released as the now much-in demand *Home Cooking* album on the long-defunct Jet Stream label, it is undeniably Walker at his hottest.

WTDN: "The Beeper Song" (Mummy, U.K.). Who's The Daddy Now (WTDN for short) represents the long-awaited (but still unexpected) reunion of Carter The Unstoppable Sex Machine, with the bonus addition of lunatic chum Professor Bootle. The partnership is only temporary, and this three-track CD of "The Beeper Song" might well be their only release. So what are you waiting for?

7" PICTURE DISCS

All Records come in Clear Plastic Sleeves unless noted. Picture Insert = PI. AEROSMITH - JADED (E) SR. # d PI. \$10.00

7" SINGLES

Records have Picture Sleeves unless noted. Picture Inserts = PI. A PERFECT CIRCLE - JUDITH (E) GC. \$6.50

CD SINGLES

JIMMY PAGE & PUFF DADDY - COME WITH ME #1 & #2 (E) \$10.00@. PAGE & PLANT - THANK YOU + 2 (G) \$11.00

12" PICTURE DISCS

All Records have Clear Plastic Sleeves unless noted. Picture Insert = PI. ANTHRAX - MAKE ME LAUGH (E) \$9.00

CD SINGLES

All CDs are 5" and are in Plastic Case with Insert unless noted. Paper cover = PC, Digipack = DP. Enhanced CD-ROM Video = ROM. A PERFECT CIRCLE - JUDITH (E) \$10.00

HIP CAT RECORDS

1213 N. Elmhurst Rd. PROSPECT HEIGHTS, IL 60070 USA. (847) 537-0066 FAX # (847) 537-0069

ORDERS: Phone or Mail. Quickest delivery is by credit card phone order. SHIPPING RATES: All orders insured: UPS \$5.00 1st 2 items, 50¢ each additional item...

CD SINGLES

JIMMY PAGE & PUFF DADDY - COME WITH ME #1 & #2 (E) \$10.00@. PAGE & PLANT - THANK YOU + 2 (G) \$11.00

CDs

ARENA - BREAKFAST IN BARRIERT (E) 2-CD; Live from Amsterdam 10-17-00. ROM Documentary. \$26.00

CD SINGLES

ANTHRAX - MAKE ME LAUGH (E) \$9.00. ANTHRAX - IN MY WORLD (E) \$11.00. DAVID BOWIE - HEARTS FILTHY LESSON (E) \$12.00

Mip CAT Records & Music Videos. Logo featuring a cat's face.

CDs. PINK FLOYD - 1967 SINGLES EP (E). Original Mono Mixes of the 1st 3 Singles & B-Sides...

CDs

TORI AMOS - Y KANT TOPI READ (E) PI. \$33.00. TORI AMOS - TO VENUS AND BACK (ROM). \$33.00

PICTURE DISC LPs

TORI AMOS - Y KANT TOPI READ (E) PI. \$33.00. TORI AMOS - TO VENUS AND BACK (ROM). \$33.00

STORE HOURS

M - F, 11 am - 8:00 pm. Sat., 11 am - 7:00 pm. Sunday, Noon - 5 pm CST

Logos for MasterCard and VISA.

PAYMENT: VISA/MasterCard, Money Order, Postal Money Order or Personal Check (USA only) held to clear.

LPs

SYD BARRETT - THE MADCAP LAUGHS (E) GC. 180 Gram Audiophile Vinyl. \$27.00

LPs

SYD BARRETT - OPEL (E) 2-LP. 6 Bonus Songs. 180 Gram Audiophile Vinyl. \$28.00

LPS

ROLLING STONES - VOODOO LOUNGE TOUR SAMPLER (E) Promo. Special Non-Album Mixes & Live Songs. \$21.00

VIDEOS

TORI AMOS - SUNSHINE. Complete Concert from Ft. LAUDERDALE. \$25.00

BOOKS

ABBEY ROAD - History of the famous recording studio, prominently featuring the BEATLES, PINK FLOYD, & KATE BUSH...

CONCERT PROGRAMS

AC/DC - STIFF UPPER LIP WORLD TOUR 2000 \$12.00

Country Junction

Brenda Lee, power-lunged Little Miss Dynamite, entered the world as Brenda Mae Tarpley in an Atlanta hospital's charity ward Dec. 11, 1944. At the tender age of 10, she joined Red Foley's *Ozark Jubilee* on ABC-TV and cut her first Decca single ("Jambalaya"/"Bigelow 6-200") July 30, 1956, with a country voice that began where pop's Teresa Brewer — whom she still admires — left off. One of the youngest and tiniest rockabilly pioneers, Lee moved toward husky-voiced pop ("I Want To Be Wanted") and, as a full-grown 4-foot-11-inch adult, back to straight country ("Big Four Poster Bed").

She has just tied together her autobiography — tentatively (and appropriately) titled *Little Miss Dynamite* — with publication by Hyperion slated for early next year. Just don't expect a kiss-and-tell exposé. She has been wed to Ronnie Shacklett (who is now her manager) for 38 years. Here Brenda Lee talks to *Goldmine*.

Goldmine: Your Web site, www.brendalee.com, speaks of a gospel CD on your own label, BL Productions.

Brenda Lee: I'd always wanted to do a gospel album, and don't know why I didn't do one when I was on a record label. So I thought I'd just go in and do one. My husband and I produced *Precious Memories* ourselves, and we're proud of it. People can order it through my office [PO Box 101188, Nashville TN 37210, \$18]. It has songs I sang as a little girl in church: "Just A Closer Walk With Thee," "In The Garden," "This Little

Light Of Mine." I don't do them justice or they just weren't my type of song. I passed on "She's In Love With The Boy," Trisha Yearwood's big entry into the recording world. I passed up [The Everly Brothers'] "Bye Bye Love," [Lynn Anderson's] "I Never Promised You A Rose Garden" and [Dolly Parton's] "Here You Come Again." Kenny Rogers' "She Believes In Me" was submitted to me as "He Believes In Me." I knew they were hit records, but I didn't feel that I could do them well.

Like Brooke Shields' acting in Pretty Baby, your early records convey adult emotions you were probably too young to have actually experienced. How did you do it?

People ask me that all the time, and I swear to you I do not know. I certainly wasn't dating. As you say, I wasn't living out those experiences I was singing about. I've always loved lyrics and tried to put myself in the situation of what's going on in a song, whether I'd experienced it or not.

Growing up as your family's sole support since your father had died, did you feel that you were missing out on a normal childhood?

I didn't worry about that. My childhood was as normal as it could have been considering what I was doing. I went to public schools and had my little friends and played. The only difference was that I was working. At that age, I didn't think, "Oh, my gosh. I'm having to support my family."

I was getting to sing, and singing was what I loved to do.

Did your autobiography require a lot of legwork?

It did. I cowrote it with [music journalist] Robert Oermann and my daughter, Julie Clay. She's written *The Stars That Shine* [a collection of stories] on 12 country stars. They worked a year on the proposal before we started writing it. The book itself took a year and a half. We went to Chattanooga to interview Peanut Faircloth, the disc jockey who introduced me to Red Foley. We interviewed my family in Georgia. We did a lot of phone work interviewing people from the early days in my original band, The Casuals, and kids I went to school with for a year in California. I had gone out there to make a movie and was enrolled in Hollywood Professional School.

A lot of people say they hate writing their stories. I didn't have that experience at all. I had a great time. There'll be some things that



Courtesy of Brenda Lee

the fans don't know. I don't want to give away the story now. Some of it has to do with financial things and deranged people.

My book certainly is not a tell-all book because that hasn't been my life. It's a great music book. It goes from the '50s into this decade in terms of people I've known and what was happening musically as well as politically. I think it's very interesting because I've been blessed to have worked with people like Sophie Tucker, Judy Garland, and Jimmy Durante, and then I've worked with the rock and country people. I've had a real diversified career as far as working with different genres of artists.

Have you followed any do's and don'ts in keeping your voice in shape?

I don't smoke. I'm not a drinker. On the road, I try to get plenty of rest. I vocalize a little bit every day. I just take care of my voice and try not to abuse it.

Is it true that you tried to get Decca to sign The Beatles?

They were opening for me in Europe. I loved them. They were so talented, such good songwriters, and their look was completely different. I brought back a demo tape and picture to the powers that be at Decca, who passed on them. About six months later "I Want To Hold Your Hand" came out, and the rest is history.

What do you do for fun?

I'm probably like any other mother or grandmother. I try to spend as much time as possible with my kids and grandkids. I have a lot of friends. I'm on the National Academy Of Recording Arts And Sciences and Country Music Association boards. I've worked closely with the Country Music Hall Of Fame and Country Music Foundation. I keep busy doing music functions here in Nashville.

10 Questions For...

Brenda Lee

by Bruce Sylvester

Light Of Mine."

Which came first: the 1957 song "Dynamite" or the nickname "Little Miss Dynamite"?

I'm sure the nickname derived from the song. "Dynamite" was a big hit in Europe. When I went overseas to perform, the nickname came up over there.

The notes to your 1991 Anthology say that "Rockin' Around The Christmas Tree" took its time to become a holiday standard.

It came out in 1958, two years before my first big hits: "Sweet Nothin's" and "I'm Sorry." When they re-released it after "I'm Sorry," it started doing well and has done well ever since.

You've said that you couldn't record a song if you didn't love it. Were there hit songs you passed on because you couldn't get into them?

Oh, there've been a lot of songs that I passed on simply because I thought I could-

NEWS & NOTES

The Corncob: The Wilkinsons have signed with BNA Records. Previously, they released two albums for the now-defunct Giant Records... On the mend: Billy Ray Cyrus (knee surgery), Willie Nelson (bronchial infection), Billy Joe Shaver (angioplasty surgery), and Leona Williams (breast cancer surgery)... Carolyn Dawn Johnson captured a record-breaking five Canadian Country Music Awards: Female Artist Of The Year, Album Of The Year (*Room With A View*), Single Of The Year ("Complicated"), SOCAN Song Of The Year ("Complicated") and Chevy Truck Rising Star... A musical drama about legendary athlete Jim Thorpe, *Warrior: An American Tragedy*, premiered Sept. 27 at the Country Music Hall Of Fame museum's Ford Theatre.

New Releases/Reissues: Sept. 25: Garth Brooks, *The Magic Of Christmas* with bonus tracks (Capitol); Confederate Railroad, *Country Classics* (Atlantic); Skeeter Davis, *RCA Country Legends* (Buddha); Highway 101, *Country Classics* (Warner Archives); Kris Kristofferson, *All-Time Greatest Hits* (Varese); Dottie West, *RCA Country Legends* (Buddha); Don Williams, *The Millennium Collection, Volume 2*. Oct. 2: Gary Allan, *Alright Guy* (MCA); Béla Fleck & The Flecktones, *Perpetual Motion* (Sony Classics); George Jones, *The Rock: Stone Cold Country 2001* (Bandit, new date); Michael Martin Murphy, *Ultimate Collection* (Hip-O); Connie Smith, *Sings Her Hits* (Sony); Joe Stampley, *Somewhere Under The Rainbow* (Crittter); Tanya Tucker, *Country Classics* (EMI); Dwight Yoakam, *South Of Heaven, West Of Hell Soundtrack* (Reprise). Oct. 9: Trace Adkins, *Chrome* (Capitol); David Ball, *Amigo* (DualTone); Charlie Daniels Band, *The Live Record* (Audium); Waylon Jennings, *RCA Country Legends*; Doyle Lawson & Quicksilver, *Gospel Parade* (Sugarhill); Tim O'Brien, *Two Journeys* (Howdy Skies); Dale Watson, *Christmas Time In Texas* (Audium); Wylie & Wild West, *Paradise* (Rounder Select). Oct. 16: Pat Green, *Pat Green* (Republic). Oct. 23: Tracy Lawrence, *Tracy Lawrence* (Warner Brothers); Raul Malo, *Today* (OmTown); Reba McEntire, *Greatest Hits Vol. III* (MCA); Olivia Newton-John, *The Christmas Collection* (Hip-O); Kenny Rogers, *Live By Request* (Dreamcatcher). Oct. 30: Clint Black, *Greatest Hits II* (BNA); Joe Diffie, *In Another World* (Columbia); Collin Raye, *Can't Back Down* (Epic).

TV News: George Jones performs on CBS' *Late Night With David Letterman* on Oct. 3... *CMT Inside Fame* examines the challenges of making it in country music with rising stars Gary Allan, Keith Urban, and Andy Griggs on Oct. 7. Also on CMT: *Roots Of Country*, a six-part series that provides an inside look at the history of American country music from its beginnings in Appalachia to its evolution into a billion-dollar industry. Narrated by Kris Kristofferson, the series airs in nightly installments Oct. 8-12. In addition, Diamond Rio's video career is profiled on *CMT Personal Playback* Oct. 16... Emmylou Harris and Beth Nielsen Chapman will be part of the 2nd Annual Women Rock! Girls & Guitars breast cancer awareness concert broadcast on the Lifetime cable channel Oct. 26... Beginning Oct. 29, a four-part documentary series *American Roots Music* airs on PBS. The series will feature music by legends such as Hank Williams, Bill Monroe, The Carter Family, and Woody Guthrie. As always, check 'em out!

— Jim Bagley

On the racks

CHELY WRIGHT

Never Love You Enough
MCA Nashville (088 170 210-2)

After a few albums' worth of relative obscurity and minor chart success, Nashville songbird Chely Wright scored a #1 breakthrough with the infectious title track of her 1999 disc, *Single White Female*. Her follow-up, *Never Love You Enough*, may render additional hits, but it also includes several misses.

The high points of the set are hard to miss — catchy pop country songs loaded with sure-fire hooks such as those of the fiddle-paced toe-tapper "Horoscope" and the rollicking "Jezebel." Wright's bright voice is not long on power or remarkably expressive, but her growling delivery is more than sufficient to handle the grabby dramatics of the expansive title track. In tender circumstances she nearly speaks her lines, doing so to some effect as she drifts along with the airy pace of "While I Was Waiting."

The limits of Wright's vocal range are less disappointing than the lack of variety in her material. Forgettable romantic fluff is too plentiful on the collection, from the blustery affirmation of "For The Long Run" to the restrained longing that surfeits "Not As In Love" and the needy "Her." The sultry end of her singing suits the mood of her curious embrace of bouts of depression in "Deep Down Low." But more often she floats through insubstantial story tunes such as "Love Didn't Listen," trifles that come and go without leaving a compelling moment in their wakes.

— Thomas Kintner

(Attacks from page 10)

concerts by O-Town and Lil' Romeo were canceled, as was Nanci Griffith's Beacon Theater concert scheduled for Sept. 15. In addition, concerts by high-profile artists such as Madonna (to be held at Los Angeles' Staples Center), Black Crowes (at L.A.'s Greek Theater), Stevie Nicks (Rochester, N.Y.), The Guess Who (Pittsburgh, Pa.), Matchbox 20, Jimmy Buffett (Indianapolis), Aerosmith (Virginia Beach, Va.), Janet Jackson (Tampa), and Tool (Dayton, Oh.) were all canceled. Sting's concert from Tuscany, Italy — which was to have been broadcast over the Web — was canceled.

Major concert promoter SFX canceled all of its shows, as did Clear Channel Entertainment, the world's largest concert promoter, which operates 44 U.S. amphitheaters and holds concerts in 100 venues total.

"The decision to reschedule these events was made out of respect for the victims of this nationwide tragedy," stated Rodney Eckerman, Clear Channel's president and co-CEO.

ClearChannel has also started ClearChannel.com Relief Fund to benefit victims and their families.

In Washington, D.C., where another terrorist-hijacked plane slammed into the Pentagon, Alanis Morissette's testimony before the Copyright Arbitration Royalty Panel was canceled, as were all events at The Kennedy Center. The Washington, D.C.-based national headquarters of the Recording Industry Association of America (RIAA) and the National Association of Broadcasters (NAB) both closed early.

The R&B Foundation's Pioneer Awards 2001 originally slated for Oct. 4, 2001, at The Apollo Theater in New York was postponed until some-

ROY ORBISON

The Complete Sun Sessions
Varèse Sarabande (302 066 233 2)

Sam Phillips felt that Roy Orbison's potential had never been truly tapped at Sun Records circa 1956-1958. Yet, this superior 31-song collection provides compelling evidence that "The Big O" became a stellar rock 'n' roll vocalist and promising songwriter under Phillips' tutelage.

The Texas-born singer used a freakish youthful tenor and rapid-fire guitar runs to achieve his only Sun hit, "Ooby Dooby." However, the ominous growling of "Mean Little Mama," juvenile delinquent-noir of "Domino" and the salacious "Problem Child" showcase some of that label's hottest rockabilly performances.

Although he experimented with Johnny Cash's sound on "One More Time" and "You Tell Me," Orbison's heart was clearly into teen ballads such as "A True Love Goodbye" and "I Never Knew." Those pale in contrast to poignant demo versions of "I Give Up" and "The Clown," both of which anticipate the singer's '60s Monument Records hits.

At Sun, Orbison's releases ricocheted from ridiculous novelty rockers à la "Chicken Hearted" to haunting R&B renditions of "It's Too Late" and "Trying To Get To You." By contrast, his unreleased duet with protégé Ken Cook and demos of "Claudette" (later an Everly Brothers hit) and "Lovestruck" display a fascinating sense of artistic direction and ambition.

Boasting warm, remastered sound — though light on session details — rockabilly cats will find this smart and satisfying compilation an affordable alternative to the recent Bear Family boxed set.

— Ken Burke

time in November, contingent upon all the artists being able to show up for the new date.

To help raise funds for the victims and their families, Michael Jackson is planning a project similar to the 46-artist USA For Africa group's "We Are The World" single, which sold more than four million copies in 1985. Proceeds of that project went to help famine-stricken African nations.

The new project, "What More Can I Give?," due out sometime in October, is expected to raise \$50 million for the attack victims. Jackson wrote, produced and financed the single, which, at press time, garnered support from Carlos Santana, Britney Spears, Destiny's Child, Backstreet Boys, and NSync.

\$2 million has been donated to a fund for the families by German-based media giant Bertelsmann (BMG), which owns retailer CDNow and Napster. Sony and Vivendi Universal are also expected to announce significant contributions to the fund.

Among artists, Earth, Wind & Fire is donating \$25,000 to the American Red Cross for the New York City firefighters, police and their families. Donating at least \$10,000 from their current concerts are Janet Jackson, James Taylor, Maxwell, Lynyrd Skynyrd, Backstreet Boys, and Sade. Creed's Scott Stapp and the With Arms Wide Open Foundation announced that it will immediately donate \$50,000 to New Yorkers For Children (NYFC). The list of artists helping in some fashion goes on and on.

Of course, no amount of money can bring back the lives of those lost. But the music industry has shown — by stepping up to the mic with checkbooks in hand — it can help heal the wounds of a shattered nation.

— Greg Loescher, with contributions from Chuck Miller, Carlo Wolff, Tina Ellingson, and Pam Horvitz (NARM).

ALISON KRAUSS & UNION STATION

New Favorite
Rounder (11661-0495-2)

With a whiff of allure in her prayer-like voice, fiddler Alison Krauss brings class to bluegrass long thought unsophisticated. *New Favorite* was recorded — unlike

her previous release *Forget About It* — with her band, Union Station, once again getting equal billing. The first three songs sandwich sharp folk-country sung by guitarist Dan Timinski (George Clooney's singing voice in the slick *O Brother Where Art Thou*) between two of Krauss' smart pop numbers penned by her protégé Robert Lee Castleman, whose well-crafted ballads nicely suit her airy, understated delivery.

More sophisticated than Krauss & Union Station's prior venture (1997's *So Long So Wrong*), *New Favorite* manages to leapfrog from Krauss' to Timinski's lead vocals, from pop to hoe-down, without sounding disjointed. Multiple Grammy winner Jerry Douglas cuts dark, bluesy Dobro notes into Timinski's traditional "The Boy Who Wouldn't Hoe Corn." For a freshly written touch of old-style maudlin country, "Momma Cried" cleverly laments, "There was mourning in the evening." By the time *New Favorite* reaches its wistful close (the title track written by Gillian Welch and Dave Rawlings in a style quite unlike the songs on Welch's retro discs), Krauss has again shown that pop can bloom by an Appalachian spring.

— Bruce Sylvester



Photo by Pamela Springsteen/
Courtesy of Rounder

MARTINA McBRIDE

Greatest Hits
RCA (07863-67012-2)

For the past 10 years, Martina McBride's breathtaking soprano has been an enjoyable fixture in country music. This 18-track *Greatest Hits* offers her most successful recordings.

As this set shows, hits collections are not always the most satisfying representation of an artist's work. McBride's early hits (1992-1995) were all romps such as "My Baby Loves Me," "Life #9" and "Wild Angels." Subsequently, the first third of this chronologically arranged disc is predominantly up-tempo, with only the poignant ballad (and non-single) "Strangers" interrupting the frenetic pace ("Still Holdin' On" — her sorely missed duet with Clint Black — would have helped the balance).

The disc starts to blossom with McBride's best work from 1997's *Evolution* (her strongest release to date) and 1999's *Emotion*. The gospel-ish "A Broken Wing" and the anguish-filled "Whatever You Say" showcase McBride's impressive vocal range while "Valentine" and "Wrong Again" reveal her mastery of intimate material. "Love's The Only House" finds McBride revisiting social issues (first tackled on "Independence Day") whereas "Happy Girl" and "I Love You" capture her perky pop side.

Greatest Hits concludes with four new tracks. Among them, the power ballad "Where Would You Be" takes McBride to new depths of vulnerability, countered by the feisty "When God-Fearin' Women Get The Blues." All four make it clear that the Martina McBride musical story is far from over.

— Jim Bagley

Obituaries

Aaliyah, R&B singer and actress

Singer and actress Aaliyah, one of R&B's most promising young artists, died in a plane crash in The Bahamas Aug. 25, 2001, along with eight other passengers. She was 22.

Born Aeliyah Dani Haughton in Brooklyn, N.Y., Jan. 16, 1979, Aaliyah grew up in Detroit, Mich., where she attended the Detroit High School Of Fine And Performing Arts. At age 15 she released her debut album, *Age Ain't Nothing But A Number*, hit #18 and spawned the hit singles "Back & Forth" (#5, 1994) and "At Your Best (You Are Love)" (#6, 1994). Her next album, *One In A Million*, sold more than two million copies and reached #20 in 1996.

In 1999, Aaliyah was nominated for a Grammy award for her performance of "Are You That Somebody," a song from the film soundtrack for *Dr. Doolittle*. She was nominated again this year for "Try Again," a song featured in the movie *Romeo Must Die*, in which Aaliyah also starred. Her latest album, *Aaliyah*, debuted in July at #2 on the *Billboard* Top 200 album chart.

Aaliyah is survived by her parents, Diane and Michael Haughton, and by her brother, Rashaad.

— Russell Hall

Leon Wilkeson, Lynyrd Skynyrd bassist

Lynyrd Skynyrd bass guitarist Leon Wilkeson died in his sleep July 27, 2001, in Jacksonville, Fla. He was 49. His body was found in a Ponte Vedra Beach hotel room about 17 miles from his home, where he was taking a break from the group's current tour. He was an original member of the legendary band.

An autopsy concluded no apparent cause of death, although the results of toxicology tests are forthcoming and may take several weeks. The

autopsy did show serious lung and liver damage.

Lynyrd Skynyrd formed in Jacksonville, Fla. in the late 1960s. With hits such as "Free Bird," "Sweet Home Alabama," "Gimme Three Steps," "I Know A Little" and "Gimmie Back My Bullets," the band became a worldwide phenomenon, selling out large venues and arenas with their Southern-fried, British-influenced rock 'n' roll.

Just prior to the release of their fifth record, *Street Survivors*, on Oct. 20, 1977, the band's chartered plane crashed between gigs in Greenville, S.C., and Louisiana, resulting in the deaths of lead vocalist Ronnie Van Zant, guitarist Steve Gaines, background singer Cassie Gaines and others. Several members of the band formed The Rossington Collins Band in 1979, and then Lynyrd Skynyrd reunited in 1987 with Johnny Van Zant, Ronnie's younger brother, fronting the group. The band then suffered another tragedy when founding member Allen Collins — who had been paralyzed in an automobile wreck in 1986 — died Jan. 23, 1990, from complications while battling pneumonia.

Still performing sold-out concerts nationwide and recording, Lynyrd Skynyrd has continued the success established by its original lineup — *Lyve From Steeltown* (CMC International, 1998) was recently certified gold by the RIAA. After taking a short break after Wilkeson's death, the band returned to the road with a temporary substitute on bass, billing the affair as a "Traveling Memorial To Leon Wilkeson."

Wilkeson is survived by his father, Russell; his mother Mabel; a sister, Mary Wilkeson; and a son, Leon Wilkeson Jr.

— Michael Buffalo Smith

BAGS Unlimited INC.

FREE PHONE CALL CATALOG
1-800-767-BAGS

SEE PAGE 25 & BACK COVER FOR MORE AUDIO PROTECTION PRODUCTS

7 Canal St., Dept. A, Rochester, New York 14608-1910



http://www.bagsunlimited.com • E-mail: info@bagsunlimited.com



OUR PRICES INCLUDE SHIPPING (except where noted). States of Florida, LA, MO, MN, and all states west of the Mississippi add 10% for shipping.

45 RPM RECORD

AUDIO CASSETTE

SLEEVE	45 Poly Record Sleeves			BOX	45 Record Storage Box		
Made from High Clarity 100% Pure Virgin 2.5 mil Polyethylene							
7 1/2 x 7 1/4	7 1/2 x 7 1/4	7 1/4 x 7 1/4	7 1/4 x 7 1/4	7 3/4 x 8 3/8 x 10 1/2	7 3/4 x 8 3/4 x 15		
*No Flap	Resealable Flap	No Flap	No Flap	Holds 100 45's	Holds 150 45's		
100	\$7.65	\$11.70	\$7.20	2	\$17.00	2	
500	22.80	42.10	21.30	5	30.00	5	
1,000	37.00	73.60	32.95	10	52.50	10	
5,000	168.90	354.75	152.90	25	105.00 + Frt	25	
PCode:	S4525	S4525R	S4525S	PCode	X45100CP	PCode	X45150
*2.5 mil with FLAP add 10%. ▲Will not fit picture sleeves.							

BOX	Corrugated Audio Cassette Box	MAILER	Audio Cassette Mailer
4 1/2 x 2 3/4 x 15 1/2			
2	\$7.60		4 1/4 x 2 3/4
5	16.00		Corrugated
10	24.00	Prod. Code	10
25	49.40	MCAS1	25
50	86.85		50
Sturdy BLACK CORRUGATED BOX with 3" cover and three dividers. Holds 20 Audio Cassettes. Folds together without tape or glue.			
Holds 1 Audio Cassette. Made from sturdy 175 lb. Test white corrugated. Tape closed.			

SLEEVE	45 Poly Record Sleeves			DIVIDER	45 Divider Cards		
100% Virgin Polyethylene							
7 1/2 x 7 1/4	7 1/2 x 7 1/4	7 1/4 x 7 1/4	7 1/4 x 7 1/4	CORRUGATED	7 1/4 x 8	PLASTIC	
4 Mil	6 Mil	4 Mil	4 Mil	15	\$7.60	25	
100	\$9.60	\$14.40	25	30	11.95	50	
500	41.80	63.60	50	45	15.95	100	
1,000	67.10	100.65	75	90	27.05	500	
5,000	295.90	444.20	100	210	57.40	197.45	
PCode:	S454	S456	200	PCode	D45C	PCode	D45P
Heavy Duty/NO FLAP S774R							

CASE	Audio Cassette Case		MAILER	Audio Cassette Mailer
Single	Double/Back to Back		Qty per case	4 x 6 3/4 (Inside Dimension)
5	\$3.35	5	\$5.50	Bubble Cushioned
10	5.40	10	8.60	25
25	10.00	25	17.15	50
50	17.25	50	31.15	100
100	28.65	100	56.60	250
250	52.50	250	118.00 + Frt	500
PCode	CCAS	PCode	CCAS2	1,000
All Clear Styrene cases. Norelco Style. Qty per Case				

SLEEVE	7" Inner Sleeves			MAILER	45 Record Mailers	
100% Virgin Polyethylene						
7 x 7	Polylined	7 x 7	Poly	45 Mailer Folder	45 Mailer Box	
50	\$8.80	100	\$6.45	7 1/2 x 7 1/2	7 3/4 x 7 1/2 x 1 1/2	
100	11.80	500	19.30	10	\$10.60	10
500	48.70	1,000	30.55	25	18.70	25
1,000	80.60	5,000	146.00	50	30.40	50
3,600	152.35	No Flap		100	52.40	100
3,600	240.25 + Frt	PCode	S7P	200	99.00	200
Paper sleeve with Clear Poly lining. PC Code S451. Made from 2 mil Clear Polyethylene.						

CLEANER	Audio Cassette Head Cleaner	Labels	'J' Card
Discwasher®	Cleaning Cassette	Face Label 3 1/2 x 1 5/8	'J' Card Insert
1	\$10.90	5	\$3.40
5	50.25	10	5.60
10	95.30	25	12.20
PCode AFG1244			
Contains Cleaning Cassette, 1 oz. of cleaning fluid and 10 replacement cleaning pads. Comes Blister Packed.			

JACKET	45 RPM Jackets			FILLER	45 Mailer Filler Pads	
7 1/8 x 7 1/8 WHITE PAPERBOARD						
25	\$11.80	100	\$6.45	7 3/8 x 7 3/8	50	\$13.75
50	17.55	500	19.30	100	19.05	100
100	30.00	1,000	30.55	250	31.90	250
500	105.20 + Frt	5,000	146.00	500	51.55	500
1,000	199.80 + Frt	178.30 + Frt		1,000	97.90	1,000
PCode:	S7JH	S7J	Qty per case	Prod. Code F45		
Replace original jacket or sleeve with our Rigid White 18 pt. paperboard. Use our brown corrugated filler pads to eliminate unnecessary inner package movement while absorbing handling shock.						

SHRINK WRAP CENTER			Shrink Bags		
PCode	Sizes (in)	Suggested Uses	Price per Roll		
BSW58	5 1/2 x 8	Cassettes, CD's,	100	500	1,000
BSW710	6 5/8 x 10	Double CD Case	\$4.15	\$16.40	\$29.75
BSW1313	13 1/2 x 13 1/2	Albums, Laser Discs	6.05	24.30	43.40
			14.80	58.80	112.00

SLEEVE	7" Paper Sleeve			INSERTS	45 RPM Record Inserts	
WHITE						
50	\$7.70	\$9.50	50	\$2.00	1,000	\$64.75
100	10.80	13.50	100	5	6.50	2,000
500	34.00	38.50	500	10	11.50	5,000
1,000	61.60	70.95	1,200	25	24.50	10,000
2,000	77.95	97.35	2,400	50	37.50	25,000
4,000	124.60 + Frt	155.80 + Frt	4,800			
PCode:	S7WR	S7WM	S7GOLD	PCode ARI4510 ARI4510B		
Made from yellow, non-slip plastic. Snap-in Perfect fit. *Prices are per package of 10.						

Our Polyolefin SHRINK WRAP FILM is Archival, Super Clear, & High Gloss. Centerfold Film. It is strong, fast sealing and fast shrinking. It has superior qualities to most popular films because it has no PVC which can leach onto your work. It has approximately 10% Shrink. It is recyclable.

SLEEVE	7" Paper Sleeves			CLEANER	Record Cleaning	
Colored Paper Sleeves 7 1/8 x 7						
50	\$12.10			Discwasher® D4+™	1	\$2.00
100	16.75			1 1/4 oz.	5	6.25
500	55.25			1	\$3.00	10
1,000	101.00			3	8.25	
1,600	141.55			5	12.50	
Color code your 45 RPM Record Collection. Sleeves available in Blue, Green, Red or Yellow. SPECIFY COLOR!						

PCode	Suggested Uses	W (in)	L (ft)	Go.	Shrink Film Price per Roll			
RSF8	Cassettes, CD's, VHS	8	500	.75	1	3	5	10
RSF13	Magazines, 8 x 10 Mats, Albums, Lobby Cards, 11 x 14 Mats	13	500	.75	61.85	55.90	52.00	49.75

SLEEVE	7" Paper Sleeves			CLEANER	Record Cleaning Fluid	
"Old Style" Green						
50	\$9.90	50	\$10.20	Groovy™ Cleaner	4 oz.	
100	15.95	100	17.10	1	\$6.00	
500	51.80	500	54.70	3	16.50	
800	74.00	1,200	123.20	5	25.00	
1,600	140.40	2,400	200.90 + Frt	10	45.00	
3,200	224.40 + Frt			PCode AGC4		
Prod. Code: S7GRN						

Milwaukee Brand Heat Gun plugs into our Shrink Wrap Machines or a 120 Volt Outlet. It has High / Low Settings. The gun reaches 50 to 150 Degrees Fahrenheit. It's light weight but built for heavy duty work. Use with Shrink Wrap Bags and Shrink Film shown above.			1 year Warranty		
			Heat Gun Price per Qty.		
PCode	Description	Watts	1	3	5
AHG	Industrial Heat Gun	1200W	\$52.00	\$141.00	\$160.00

INSERT	7" Picture Sleeve Insert			CLEANER	Sponge	
.030" Thick Chipboard						
50	\$7.65	\$9.00		Record Cleaning Sponge	1	\$5.00
100	12.25	14.40		2 per pack	5	20.00
500	53.00	62.50		10	37.50	
1,000	96.15	113.50		Our super sponge is absorbant and dripless. Lint Free. Safe for vinyl.		
PCode: KCB3045 KAF2845						
Protect the corners and edges of your 7" Picture Sleeves from bending or crushing. Use Cardboard Inserts.						

CUT OFF Heat Sealers					
Use with SHRINK BAGS					
Prod. Code	Description	Watts	Length	Mil	Price
AHS4C	4" Hand Heat Sealer	400	4"	1-6	\$66.75
AHS8C	8" Hand Heat Sealer	400	8"	1-6	89.00
AHS12C	12" Hand Heat Sealer	500	12"	1-6	111.00
AHS16C	16" Hand Heat Sealer	500	16"	1-6	179.00

PLEASE CHECK BOX IF YOU HAVE ORDERED FROM US BEFORE

SIGNATURE _____ **CUSTOMER ACCOUNT #** _____

DAY PHONE () _____ **SUB TOTAL** _____

EXP. DATE _____ **NO POST OFFICE BOX NUMBERS FOR FedEx GROUND DELIVERY**

CARD No. _____ **Florida States West of the Mississippi including entire states of LA MO MN add 10% for shipping**

TOTAL _____

BAGS UNLIMITED INC., 7 CANAL ST., DEPT. A, ROCHESTER, NY 14608 (716) 436-9006 FAX: (716) 328-8526

BAGS Unlimited INC

FREE PHONE CALL CATALOG 1-800-767-BAGS

SEE PAGE 24 & BACK COVER FOR MORE AUDIO PROTECTION PRODUCTS

7 Canal St., Dept. A, Rochester, New York 14608-1910

FOR THE BEST IN CD PROTECTION

SLEEVE	Compact Disc Sleeves	CASE	Single CD Case	TRAYS	Pop-It Hub	Digi PAK	DISPLAY	Deluxe Stackable CD Rack
Made from 100% Pure Virgin Polyethylene 5 x 5 +2.5 Mil RESEALABLE FLAP No Flap 100 \$5.25 500 19.90 1,000 29.05 PCODE: SCD525 Fits directly over CD.	2.5 Mil RESEALABLE FLAP No Flap 100 \$8.80 500 37.90 1,000 63.80 PCODE: SCD525R +Add 10% for FLAP, specify when ordering!	disc® 5 \$6.90 10 10.85 25 22.00 50 38.25 100 62.35 200 94.25 400 157.10+ Frt Prod. Code CCDS Qty per case Clear Acrylic JEWEL Case with Black or Clear Tray. Specify Tray Color. 3/8" Thick Holds 1 CD and Booklet	disc® 5 \$6.90 10 10.85 25 22.00 50 38.25 100 62.35 200 94.25 400 157.10+ Frt Prod. Code CCDS Qty per case Clear Acrylic JEWEL Case with Black or Clear Tray. Specify Tray Color. 3/8" Thick Holds 1 CD and Booklet	disc® 5 \$6.90 10 10.85 25 22.00 50 38.25 100 62.35 200 94.25 400 157.10+ Frt Prod. Code CCDS Qty per case Clear Acrylic JEWEL Case with Black or Clear Tray. Specify Tray Color. 3/8" Thick Holds 1 CD and Booklet	disc® 5 \$6.90 10 10.85 25 22.00 50 38.25 100 62.35 200 94.25 400 157.10+ Frt Prod. Code CCDS Qty per case Clear Acrylic JEWEL Case with Black or Clear Tray. Specify Tray Color. 3/8" Thick Holds 1 CD and Booklet	disc® 5 \$6.90 10 10.85 25 22.00 50 38.25 100 62.35 200 94.25 400 157.10+ Frt Prod. Code CCDS Qty per case Clear Acrylic JEWEL Case with Black or Clear Tray. Specify Tray Color. 3/8" Thick Holds 1 CD and Booklet	disc® 5 \$6.90 10 10.85 25 22.00 50 38.25 100 62.35 200 94.25 400 157.10+ Frt Prod. Code CCDS Qty per case Clear Acrylic JEWEL Case with Black or Clear Tray. Specify Tray Color. 3/8" Thick Holds 1 CD and Booklet	disc® 5 \$6.90 10 10.85 25 22.00 50 38.25 100 62.35 200 94.25 400 157.10+ Frt Prod. Code CCDS Qty per case Clear Acrylic JEWEL Case with Black or Clear Tray. Specify Tray Color. 3/8" Thick Holds 1 CD and Booklet
Made from 100% Pure Virgin Polyethylene 5 3/8 x 6 +2.5 Mil RESEALABLE FLAP No Flap 100 \$5.60 500 20.25 1,000 30.80 PCODE: SCD625 Fits over Case.	2.5 Mil RESEALABLE FLAP No Flap 100 \$9.50 500 39.40 1,000 68.20 PCODE: SCD625R +Add 10% for FLAP, specify when ordering!	disc® 5 \$5.55 10 8.65 25 17.65 50 30.60 100 49.85 200 75.40 400 125.70+ Frt Prod. Code CCDSNT Qty per case Clear Acrylic Case 3/8" Thick	disc® 5 \$5.55 10 8.65 25 17.65 50 30.60 100 49.85 200 75.40 400 125.70+ Frt Prod. Code CCDSNT Qty per case Clear Acrylic Case 3/8" Thick	disc® 5 \$5.55 10 8.65 25 17.65 50 30.60 100 49.85 200 75.40 400 125.70+ Frt Prod. Code CCDSNT Qty per case Clear Acrylic Case 3/8" Thick	disc® 5 \$5.55 10 8.65 25 17.65 50 30.60 100 49.85 200 75.40 400 125.70+ Frt Prod. Code CCDSNT Qty per case Clear Acrylic Case 3/8" Thick	disc® 5 \$5.55 10 8.65 25 17.65 50 30.60 100 49.85 200 75.40 400 125.70+ Frt Prod. Code CCDSNT Qty per case Clear Acrylic Case 3/8" Thick	disc® 5 \$5.55 10 8.65 25 17.65 50 30.60 100 49.85 200 75.40 400 125.70+ Frt Prod. Code CCDSNT Qty per case Clear Acrylic Case 3/8" Thick	disc® 5 \$5.55 10 8.65 25 17.65 50 30.60 100 49.85 200 75.40 400 125.70+ Frt Prod. Code CCDSNT Qty per case Clear Acrylic Case 3/8" Thick
Made from 100% Pure Virgin Polyethylene 4 15/16 x 4 7/8 CD & Booklet 100 \$12.00 500 51.15 1,000 86.20 PCODE: SCDDPB Sleeves feature dual compartment pockets with white poly divider and 1" RESEALABLE Flap Divider separates CD from CD booklet and Tray Card. Made from durable 3 mil 100% Pure Virgin Polyethylene.	5 5/8 x 4 7/8 Also Holds Tray Card 100 \$12.70 500 54.30 1,000 91.50 PCODE: SCDDPJ +Add 10% for FLAP, specify when ordering!	disc® 5 \$6.15 10 9.70 25 19.80 50 33.10 100 65.00 Prod. Code CCDSL Qty per case Clear Acrylic Case with Built-In Tray Holds 1 CD and Booklet 1/4" Thick edge allows you to store more CD's in 1/3rd less space.	disc® 5 \$6.15 10 9.70 25 19.80 50 33.10 100 65.00 Prod. Code CCDSL Qty per case Clear Acrylic Case with Built-In Tray Holds 1 CD and Booklet 1/4" Thick edge allows you to store more CD's in 1/3rd less space.	disc® 5 \$6.15 10 9.70 25 19.80 50 33.10 100 65.00 Prod. Code CCDSL Qty per case Clear Acrylic Case with Built-In Tray Holds 1 CD and Booklet 1/4" Thick edge allows you to store more CD's in 1/3rd less space.	disc® 5 \$6.15 10 9.70 25 19.80 50 33.10 100 65.00 Prod. Code CCDSL Qty per case Clear Acrylic Case with Built-In Tray Holds 1 CD and Booklet 1/4" Thick edge allows you to store more CD's in 1/3rd less space.	disc® 5 \$6.15 10 9.70 25 19.80 50 33.10 100 65.00 Prod. Code CCDSL Qty per case Clear Acrylic Case with Built-In Tray Holds 1 CD and Booklet 1/4" Thick edge allows you to store more CD's in 1/3rd less space.	disc® 5 \$6.15 10 9.70 25 19.80 50 33.10 100 65.00 Prod. Code CCDSL Qty per case Clear Acrylic Case with Built-In Tray Holds 1 CD and Booklet 1/4" Thick edge allows you to store more CD's in 1/3rd less space.	disc® 5 \$6.15 10 9.70 25 19.80 50 33.10 100 65.00 Prod. Code CCDSL Qty per case Clear Acrylic Case with Built-In Tray Holds 1 CD and Booklet 1/4" Thick edge allows you to store more CD's in 1/3rd less space.
Made from 100% Pure Virgin Polyethylene 5 1/8 x 10 5/8 4 mil 100 \$8.90 500 34.90 1,000 63.50 PCODE: SCDGF4 Stores 1 jacketed CD and booklet one side. Tray card in the other side.	5 x 10 6 mil 100 \$12.40 500 48.35 1,000 84.05 PCODE: SCDGF6 Design allows storage of CD & Booklet in gate fold sleeve. 6 mil polyethylene insures maximum protection.	disc® 5 \$10.30 10 16.00 25 32.20 50 55.90 100 66.95 3/8" Thick Holds 2 CD's. Clear acrylic case with Black or Clear hinged flipout tray. Specify when ordering. PCODE: C2CD-HS Qty per case	disc® 5 \$7.20 10 12.35 25 25.75 50 41.20 100 53.60 3/8" Thick Holds 2 CD's. Clear acrylic standard case with hinged center black or clear tray. PCODE: C2CD-HC Qty per case	disc® 5 \$7.20 10 12.35 25 25.75 50 41.20 100 53.60 3/8" Thick Holds 2 CD's. Clear acrylic standard case with hinged center black or clear tray. PCODE: C2CD-HC Qty per case	disc® 5 \$7.20 10 12.35 25 25.75 50 41.20 100 53.60 3/8" Thick Holds 2 CD's. Clear acrylic standard case with hinged center black or clear tray. PCODE: C2CD-HC Qty per case	disc® 5 \$7.20 10 12.35 25 25.75 50 41.20 100 53.60 3/8" Thick Holds 2 CD's. Clear acrylic standard case with hinged center black or clear tray. PCODE: C2CD-HC Qty per case	disc® 5 \$7.20 10 12.35 25 25.75 50 41.20 100 53.60 3/8" Thick Holds 2 CD's. Clear acrylic standard case with hinged center black or clear tray. PCODE: C2CD-HC Qty per case	disc® 5 \$7.20 10 12.35 25 25.75 50 41.20 100 53.60 3/8" Thick Holds 2 CD's. Clear acrylic standard case with hinged center black or clear tray. PCODE: C2CD-HC Qty per case
Made from 2.5 mil 100% Pure Virgin Polyethylene INNER 4 3/4 x 4 3/4 No Flap 100 \$4.40 500 16.50 1,000 24.05 PCODE: SCD43425 Fits directly over CD for easy fit in CD Jacket.	OUTER 5 x 5 1/8 No Flap* 100 \$4.85 500 18.40 1,000 34.45 PCODE: SCD51825 Fits over CD Cardboard Jacket. *Add 10% for FLAP	disc® 5 \$10.20 10 15.80 25 31.85 50 55.35 100 90.00 200 120.00+ Frt 400 216.00+ Frt Prod. Code C2CD-CT Qty per case Holds 2 CD's, 1 tray card and booklet. Crystal Clear Case and center hinged Crystal Clear Tray come assembled. 3/8" Thick. Trays NOT sold separately.	disc® 5 \$10.20 10 15.80 25 31.85 50 55.35 100 90.00 200 120.00+ Frt 400 216.00+ Frt Prod. Code C2CD-CT Qty per case Holds 2 CD's, 1 tray card and booklet. Crystal Clear Case and center hinged Crystal Clear Tray come assembled. 3/8" Thick. Trays NOT sold separately.	disc® 5 \$10.20 10 15.80 25 31.85 50 55.35 100 90.00 200 120.00+ Frt 400 216.00+ Frt Prod. Code C2CD-CT Qty per case Holds 2 CD's, 1 tray card and booklet. Crystal Clear Case and center hinged Crystal Clear Tray come assembled. 3/8" Thick. Trays NOT sold separately.	disc® 5 \$10.20 10 15.80 25 31.85 50 55.35 100 90.00 200 120.00+ Frt 400 216.00+ Frt Prod. Code C2CD-CT Qty per case Holds 2 CD's, 1 tray card and booklet. Crystal Clear Case and center hinged Crystal Clear Tray come assembled. 3/8" Thick. Trays NOT sold separately.	disc® 5 \$10.20 10 15.80 25 31.85 50 55.35 100 90.00 200 120.00+ Frt 400 216.00+ Frt Prod. Code C2CD-CT Qty per case Holds 2 CD's, 1 tray card and booklet. Crystal Clear Case and center hinged Crystal Clear Tray come assembled. 3/8" Thick. Trays NOT sold separately.	disc® 5 \$10.20 10 15.80 25 31.85 50 55.35 100 90.00 200 120.00+ Frt 400 216.00+ Frt Prod. Code C2CD-CT Qty per case Holds 2 CD's, 1 tray card and booklet. Crystal Clear Case and center hinged Crystal Clear Tray come assembled. 3/8" Thick. Trays NOT sold separately.	disc® 5 \$10.20 10 15.80 25 31.85 50 55.35 100 90.00 200 120.00+ Frt 400 216.00+ Frt Prod. Code C2CD-CT Qty per case Holds 2 CD's, 1 tray card and booklet. Crystal Clear Case and center hinged Crystal Clear Tray come assembled. 3/8" Thick. Trays NOT sold separately.
Made from 2.5 mil 100% Pure Virgin Polyethylene 6 x 6 3/4 2.5 mil No Flap 100 \$5.90 500 21.10 1,000 31.40 PCODE: SCDDQ Keep CD Cases Scratch Free! Use our high clarity poly sleeve.	13 5/8 x 13 1/8 3 mil with Flap 50 \$8.70 100 14.90 500 68.50 PCODE: SCDBS13 Fits over Outer CD Box Set.	disc® 5 \$13.80 10 21.55 25 44.00 50 72.95 96 105.60+ Frt Prod. Code CCDD Qty per case Holds 2 CD's. Includes 2 Black OR Clear trays. Specify Tray Color.	disc® 5 \$13.80 10 21.55 25 44.00 50 72.95 96 105.60+ Frt Prod. Code CCDD Qty per case Holds 2 CD's. Includes 2 Black OR Clear trays. Specify Tray Color.	disc® 5 \$13.80 10 21.55 25 44.00 50 72.95 96 105.60+ Frt Prod. Code CCDD Qty per case Holds 2 CD's. Includes 2 Black OR Clear trays. Specify Tray Color.	disc® 5 \$13.80 10 21.55 25 44.00 50 72.95 96 105.60+ Frt Prod. Code CCDD Qty per case Holds 2 CD's. Includes 2 Black OR Clear trays. Specify Tray Color.	disc® 5 \$13.80 10 21.55 25 44.00 50 72.95 96 105.60+ Frt Prod. Code CCDD Qty per case Holds 2 CD's. Includes 2 Black OR Clear trays. Specify Tray Color.	disc® 5 \$13.80 10 21.55 25 44.00 50 72.95 96 105.60+ Frt Prod. Code CCDD Qty per case Holds 2 CD's. Includes 2 Black OR Clear trays. Specify Tray Color.	disc® 5 \$13.80 10 21.55 25 44.00 50 72.95 96 105.60+ Frt Prod. Code CCDD Qty per case Holds 2 CD's. Includes 2 Black OR Clear trays. Specify Tray Color.
Made from 16# White Paper. Fits directly over CD. 5 x 5 Paper 50 \$9.00 100 16.00 250 33.25 500 58.90 1,000 110.20 PCODE: SCDDP Emboss with 4 1/2" Mylar lined window and fold over flap. Holds 1 CD. SPECIFY COLOR WHEN ORDERING.	5 x 5 Tyvek® 50 \$14.80 100 26.10 250 54.85 500 97.20 1,000 181.85 PCODE: SCDDTHP +Add 10% for FLAP, specify when ordering!	disc® 5 \$15.75 10 27.00 25 61.25 50 112.50 Prod. Code C6CD-HC Qty per case Holds 6 CD's. Includes 1 black Center piece and 2 black Center hinged trays. Center piece and trays each hold 2 CD's back to back. CLEAR TRAYS NOW AVAILABLE.	disc® 5 \$15.75 10 27.00 25 61.25 50 112.50 Prod. Code C6CD-HC Qty per case Holds 6 CD's. Includes 1 black Center piece and 2 black Center hinged trays. Center piece and trays each hold 2 CD's back to back. CLEAR TRAYS NOW AVAILABLE.	disc® 5 \$15.75 10 27.00 25 61.25 50 112.50 Prod. Code C6CD-HC Qty per case Holds 6 CD's. Includes 1 black Center piece and 2 black Center hinged trays. Center piece and trays each hold 2 CD's back to back. CLEAR TRAYS NOW AVAILABLE.	disc® 5 \$15.75 10 27.00 25 61.25 50 112.50 Prod. Code C6CD-HC Qty per case Holds 6 CD's. Includes 1 black Center piece and 2 black Center hinged trays. Center piece and trays each hold 2 CD's back to back. CLEAR TRAYS NOW AVAILABLE.	disc® 5 \$15.75 10 27.00 25 61.25 50 112.50 Prod. Code C6CD-HC Qty per case Holds 6 CD's. Includes 1 black Center piece and 2 black Center hinged trays. Center piece and trays each hold 2 CD's back to back. CLEAR TRAYS NOW AVAILABLE.	disc® 5 \$15.75 10 27.00 25 61.25 50 112.50 Prod. Code C6CD-HC Qty per case Holds 6 CD's. Includes 1 black Center piece and 2 black Center hinged trays. Center piece and trays each hold 2 CD's back to back. CLEAR TRAYS NOW AVAILABLE.	disc® 5 \$15.75 10 27.00 25 61.25 50 112.50 Prod. Code C6CD-HC Qty per case Holds 6 CD's. Includes 1 black Center piece and 2 black Center hinged trays. Center piece and trays each hold 2 CD's back to back. CLEAR TRAYS NOW AVAILABLE.

PLEASE CHECK BOX IF YOU HAVE ORDERED FROM US BEFORE

VISA MasterCard C.O.D.

SIGNATURE _____ DAY PHONE () _____ EXP. DATE _____ CARD No. _____

NAME _____ STREET ADDRESS _____ CITY _____ STATE _____ ZIP _____

NO POST OFFICE BOX NUMBERS FOR FedEx GROUND DELIVERY

Florida, States West of the Mississippi, including entire states of LA, MO, MN add 10%

CUSTOMER ACCOUNT # _____ SUB TOTAL _____ All orders under \$25.00 add \$4.00 C.O.D. orders add \$5.50 NY State Residents add 8% TOTAL _____



© Terry Sharp

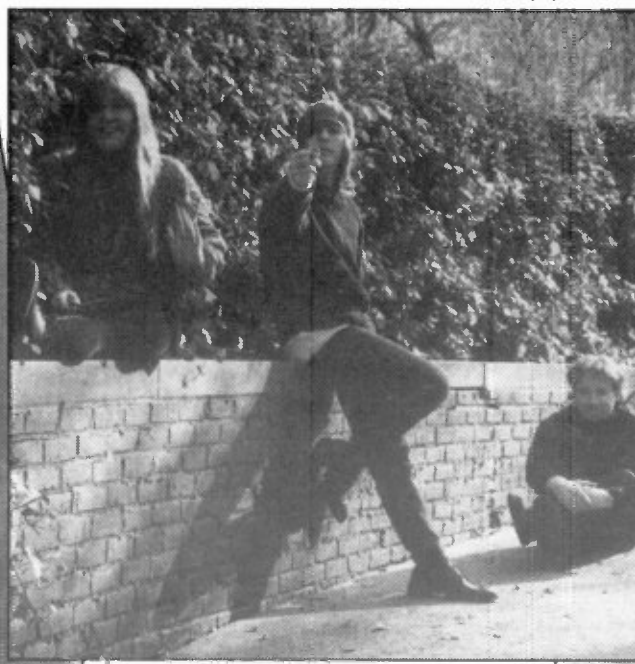

Courtesy of Not Lame



Courtesy of Not Lame

Left: Ken Sharp; center, The Rooks; right, Mark Helm.

Not Lame Records

Label's sound reflects the pinnacle of power pop

by Lee Zimmerman

Any music fans who have ever found themselves in pursuit of pure power pop know that Not Lame is the label for its most passionate partisans. Few record companies can boast such a strikingly consistent sound — Not Lame's artists bear a common allegiance to an engaging rock 'n' roll regimen rooted in the '60s and '70s. Currently, its roster is home to some of the genre's most creative combos; bands such as The Posies,

BEATLESque JELLYFISH songs blessed w/a syrupy smidge of the PUSH KINGS meets Kyle Vincent ultra-friendly doo-wop white-boy '60s soul" goes another. Whew!

"You will always hear/read me rave about anything I put out on any of the labels as they typify 'why' I do this for a living and live, breathe and see this stuff not only in my personal, but professional life," he wrote in an intro to a past catalog. "They do the hard work, I just put my money where my mouth is and try to convince the rest of you, you should too. The labels are not about 'the industry' and becoming part of it. The Not Lame Family Of Labels modus operandi are to release 'pop records for pop fans' and 'good music for good people.' Pure and simple."

He may be a fan first and foremost, but Brodeen's enthusiasm is matched by his acumen. Prior to launching his label just over five years ago, he had already garnered extensive business expertise by working at various jobs, both in and out of the music industry. Born in Boston — he still considers himself a major Red Sox fan — he majored in political science and theology at Wittenberg University in Springfield, Ohio, studied his senior year in Germany and eventually ended up in California. There he tried his hand at concert promotion, band management, record company operations, radio and music retail management throughout the mid- to late '80s. Ironically, it was his experience in the early '90s when he worked for a hair-care company that proved to be most valuable.

"I was operations VP, and it much better prepared me for running my own business," he recalled. "Without question. It greased up the skills for focusing on prudent, well-founded business principles."

Even so, after four years of running the company, Brodeen grew tired of the day-to-day regimen. "I became burned out," he admitted. "I came home from the office one day and told my wife, 'We're moving back to Colorado' — I wasn't balanced spiritually after seven years in L.A."

Brodeen quit and the move was made. "I sold everything we had — *not* my record

the label was launched in the spring of '95. Eventually, the label spawned a mail-order business, and later, a distribution company specializing in indie artists.

Initially, he recruited bands via ads in *Yellow Pills*, one of the first fanzines devoted exclusively to power pop. After sending out solicitation letters, interest began to build, eventually flooding him with eager applicants.

"I sold everything we had — *not* my record collection, though, of course. I wasn't *that* out of my mind!" — Not Lame founder Bruce Brodeen, on his move to Colorado after becoming burned out in L.A.

collection, though, of course. I wasn't *that* out of my mind!" The couple ended up in Aspen and took the only work they could find. His wife Ruth waited tables; he worked at a hotel. Despite the low-paying circumstance, the advantages clearly outweighed the challenges. For one thing, he said, "We got to ski and hike every day."

He hadn't completely forsaken his former life, however. Having experienced L.A.'s burgeoning underground pop scene, he decided he could channel some of that excitement into a start-up record label, an idea born "literally, going up a ski lift in Aspen." He financed his fledgling operation with what was left of his savings along with loans from low-interest credit cards and money borrowed from his parents.

"It was therapy, not a business idea," he insisted. "I did it for me, and it just sort of took off and I was full time in a year."

That ski run was in November 1994, and

It was "part of the dredging process," Brodeen recalled. He claims that it was "divine intervention" that led him to Michael Mazarella, whose band, The Rooks, became the first act signed under the Not Lame imprint (he recently re-released the band's debut album and early EP on a single disc). "It was music for the soul," he said, sighing.

Brodeen built the business slowly but tenaciously. Late last year, he figured Not Lame had finally "turned the corner. We're quasi-lucky," he confessed. "Each release is guaranteed to do a certain amount, guaranteed not to lose money."

The company catalog — which consists of the regular run of Not Lame Recordings, re-releases via Not Lame Archives and limited-edition discs through Not Lame Limited — currently boasts more than 50

(Please see Not Lame page 28)

There's more than one way to keep track of your records...



We suggest you try ours.

MusicTracker 1.0

- Inventory & Pricing software for Vinyl Record Collectors
- Featuring Jerry Osborne's Price Guide Data for 2001



Now only **\$39.99**

Visit us online! www.bangzoom.com
or Call us toll free! 1-800-589-7333

GLENN HUGHES

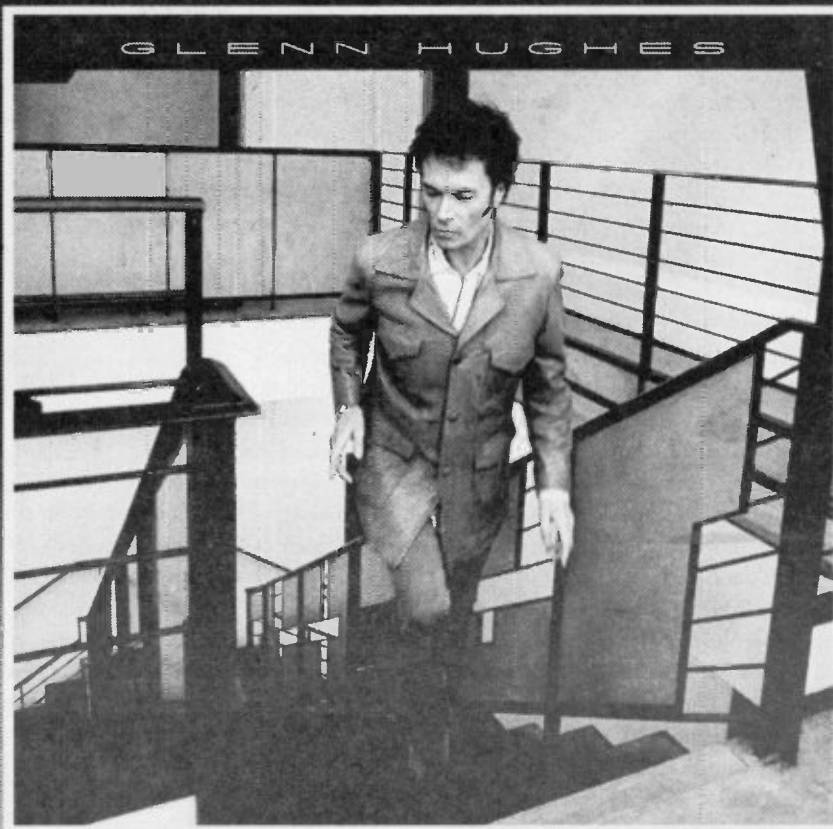

The Voice of Rock brings us

"BUILDING THE MACHINE"

a varying palette of musical styles,
where his unique voice stands
- as always - at the forefront.



OUT
SEPTEMBER
25



RECORD CLEANING PERFECTED!

Our **20th** Anniversary

Nitty Gritty offers the most affordable, efficient and hassle-free line of wet scrub/vacuum dry record cleaners available.

Clean records **Sound better, Last longer, Grade higher**
(Five models from \$282 MSRP)

DELUXE MODELS



BUDGET BALANCERS
Model 1.0 (Shown) Record Master

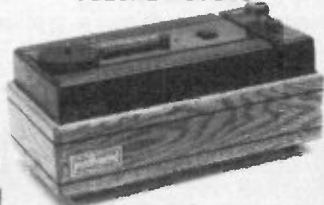

Model 2.5Fi (Shown)
Model 1.5

NITTY GRITTY
RECORD CARE PRODUCTS, INC.



ULTRA LP PRO

MINI-PRO 2

Send for **FREE** Full-Line Brochure

DEALER INQUIRIES INVITED

NITTY GRITTY, INC.

4650 Arrow Highway #F-4 • Montclair, California 91763
Tel. 909-625-5525 • Fax 909-625-5526
www.nittygrittyinc.com

"Feel the Groove!"™

(Not Lame from page 26)

offerings, with approximately 13 to 14 new entries each year. Each new project costs around \$5,000 to \$10,000, and Brodeen emphasizes that all his artists receive advances.

"A thousand to 1,500 is a first run," Brodeen explained. "What they say is true — cash flow is king. Printing less is better — 1,000 is the minimum for most pieces. You can get 500 but the price breaks don't make sense, so 1,000 is realistically it. I take it from there. Most releases sell that anyway. I promo out a few hundred, but label sales average between 900-1,500. A third of the bands will break that and fall into the 1,500-2,000 range. A handful break 2,000-3,000."

He lists The Shazam, Myracle Brah, and The Rooks as the most popular bands on the Not Lame roster, both critically and commercially. Asked how he makes the decision on which artists Not Lame will sign, Brodeen declared, "Pure gut instinct! It's what I love, and I feel a strong sense of personal connection. It's never because I think something will sell a lot — let's face it, pop does not sell a lot anyway. At the end of the day, I need to be in love with it because if it sells poorly and I lose money on it, then at least it's something that goes up on the 'mantle of pride,' something you can always look at, touch and listen to and still be connected to."

Indeed, an equal mix of cash and conviction spurs Brodeen's efforts. The oft-quoted Not Lame creed is, "Good Music For Good People!!!!" "The label is the most honest reflection of my personal tastes," he admitted. "I'm a musical pantheist. I always try to find something that's endearing and meritorious of my time in anything. But the label isn't strong enough to only keep my myopic focus. I sometimes find myself repping other bands and labels to the detriment of my own bands."

Probing into Brodeen's preferences brings some interesting insights. The Stooges' *Raw Power* was the first album he ever bought, and he admitted that he'd love to sign a "punk band with that classic sound of the '70s." He cited Big Star as his favorite band of all time and even remembers the date he first discovered them.

"It was Jan. 10, 1975. Up to that time, my favorite tune was "Bang A Gong" by T. Rex. I bought a copy of *Radio City* in Woolworths for 97 cents, and my world was never the same again." Other preferences include Tom Verlaine, Foghat, late '70s AOR, modern-day classical music ("I'm a Stravinsky freak"), aggro-folk, prog-rock from the early to mid-70s and "down and dirty rock 'n' roll." As he reels off his references, he shuffles through some old vinyl albums, looking for titles that illustrate his point. "Did you ever hear of a band called Trooper?" he asked, gazing at an album cover that caught his eye. "If you liked Bachman Turner Overdrive, you'd love these guys. Of course, if you didn't, you'd think they were just plain bad."

"I'm a fan, but I'm not an obsessive collector," Brodeen said, claiming that he freely allows friends to go through his piles of new CDs and even borrow from his personal collection without keeping tabs on who's taken what. At one point he was so pressed for cash, he sold half his albums to buy Ruth an engagement ring ("It was worth every single penny"). Of his core collection — roughly 1,500 to 2,000 pieces — he said only, "I'm a slovenly slob when it comes to collecting."

This personal tie to the music also translates to his direct relationship with Not Lame's faithful following. Because the label's releases don't offer the type of music that creates big sales in traditional retail stores, Not Lame sells most of its music through mail order.

"Sales direct to the consumer are a huge part of the mix," he explained. "Gross margins are higher for a label when you can do this, and it helps the health of the company to be able to sell a lot that way.... It's important here. Every sale matters in a most personal, bottom-line connected way."

He also admitted that heading a small company creates limitations in what he's able to do in terms of marketing and promotion. "All I need is more time in my life! I'm doing too much for one person — running three labels, distributing 2,000 plus releases. One-stopping to stores is too much for one person, and I've had my moments of breaking."

Even so, the company is making progress. From its humble beginnings in an eight-foot by 10-foot laundry room, the label progressed to a bedroom ("with a spider-infested basement to

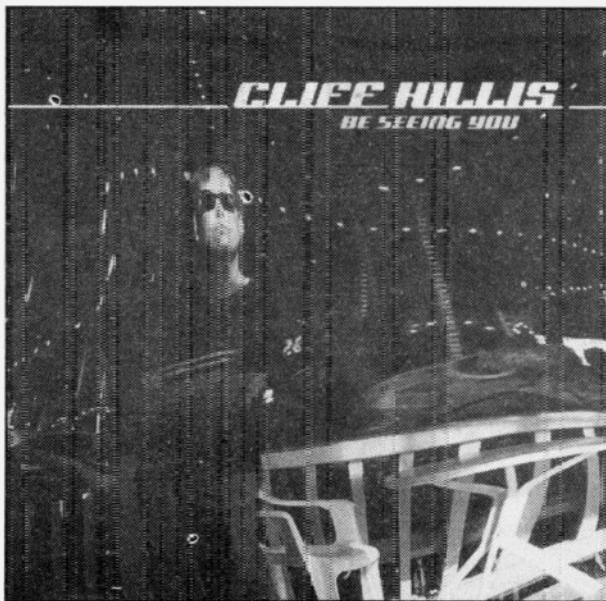

ship from") to a bigger basement ("Clean!"). Finally, in the summer of 1999, the operation was relocated to an actual 1,450-square-foot office space in Fort Collins, Colo., where Brodeen and his family now reside. Staffing is still limited to Brodeen, his recently hired assistant Nicholas Cole, part-timer Marilyn Palumbo, plus the company mascot, Townshend, "The Pop Pup." A work week can easily average 50 to 60 hours, but Brodeen isn't complaining. "There's weekend work always," he said. "Saturday night I was answering e-mail from 11 p.m. to 2 a.m., for example. It's not brutal, but the hours can get long." He's particularly vexed by the volume of e-mail. "It's oppressive — I receive 100-plus e-mails a day that require my attention and some degree of response. That's easily three to four hours [a day] of just answering e-mail before taking care of any other business."

Nevertheless, the hard work seems to be paying off; in 1999, the company's sales topped \$450,000, and last year's revenues are expected to hit \$500,000. True, not a single Not Lame artist has ever been nominated for a Grammy or any other major award, but nevertheless, the company has compiled a list of titles that rank among the best of the power pop genre. Last year saw the long-awaited release of an exhaustive four-CD set of Posies outtakes, demos and rarities. It also produced an expansive tribute to the former Byrds member, the late Gene Clark. ("I'm especially proud of that one," Brodeen boasted. "I consider it one of the best tributes ever.")

Recent releases include follow-ups for rock wunderkinds Myracle Brah and The Shazam, a third effort by former Todd Rundgren associate Powell, a new album by one-time NRBQ member Terry Anderson, a second CD from producer Michael Carpenter and a debut disc from singer/songwriter Mark Helm.

Brodeen is determined to keep building on that momentum. He relies on daily e-mail and catalog mailings every 18 months or so to reach his ever-growing database, currently numbering approximately 4,000 names. The label's revamped Web site, with improved customer-friendly features, went online in January, and Brodeen said new elements will continue to roll out.

It all boils down to Brodeen's belief that one-to-one communication is essential for the label's ultimate success. "I depend on the fans of this style of music to help grow it. Believe it or not, there are a lot of closet pop fans out in record stores willing to play and push the music, given the chance. I'm focusing more on those types and giving distributors better materials — posters and stickers, for example — to give to their record stores. We'll also offer more value-added items to go along with their orders. For example, buy two Not Lame CDs, get this free Not Lame label sampler or CD opener or sticker."

The one essential element that Brodeen keeps as his constant is credibility. He sums up his sales strategy with one word — trust.

"At this point, you really want to only sell a CD, especially from the label, to someone who is going to really dig it," he pointed out. "It's better not to sell it if they do not have a high probability of digging it. Why? Well, Not Lame wants to have customers who have a high degree of happiness with anything they purchase."

"We focus on a limited style of music. If you decided some-

thing sounded great, bought it, hated it, then, guess what? You're going to hate the majority of what's going on here, and I personally recommend those folks run away from Not Lame — not because I don't want them, but I truly don't want them to associate Not Lame's name with a consistent negative connotation. You are better off in the long term turning away from those dollars, those types of sales, and focusing on building affinity-based relationships with customers who have a probability of getting what you are doing and are going to create a win-win scenario for all participants in the transaction."

Brodeen is equally emphatic — and effusive — as he notes the importance of those descriptions that color his catalogs and e-mails. There's a big difference between hype and hyperbole, he said.

"They are meant to supply folks with as much information as possible to make the most informed decision they can and connect up that information to their own frame of relevance, musically and, additionally, further connect the process to their long-term, overall batting average of happy purchases from Not Lame and yield a high success rate on taking a chance," he mused.

"It works. It's not perfect, far from it. But compared to just reading a magazine review or whatever, it's much better. Plus, I'll be compiling customer profiles of personal tastes and trying to extend that feeling even further. At first, I'll start with the more frequent customers, though. You want to get into that classic database marketing situation and concentrate on the 80/20 rule, as it just makes better, more efficient sense."

However, even though he expresses himself in terms that sometimes make him seem as if he's pontificating, Brodeen's optimism is also tempered by the hard realities of the modern music business.

"I get a sense of accomplishment out of all this, but it is tough dealing with hundreds of musicians and artists. Sometimes you have to tell them that their music isn't appropriate for what we're doing or you have to tell them something that lowers their expectations.... Just because they're with Not Lame, it doesn't bring any guarantees. It's incumbent on the band to market and promote on their own, to have some push/pull aspect in their efforts."

As with any indie label, there are also drawbacks that come with running a company that fills a relatively narrow niche.

"With marketing to power pop fans, it's wrestling with the ubiquity of CD-R technology and the bootlegging that's become a problem," he suggested. "Folks are trading and bootlegging CDs more and not buying CDs from the indie bands and labels. This is a potential death knell for label like Not Lame. So finding new, creative ways to add value to the music is an issue that needs to be addressed and explored. We'll see what the future brings."

Actually, Brodeen does have something of a forecast. Upcoming offerings include solo sets from Not Lame veterans Scot Sax of Wanderlust and Cliff Hillis of Starbelle, a two-disc Jeff Lynne tribute and a compilation featuring unreleased tracks from all the artists on the label's roster. He also hints at a slight shift in direction, with more emphasis on rootsier singer/songwriter types as typified by the new Terry Anderson effort and the recent release from Helm, whom Brodeen describes as "other-worldly, honest, gorgeous — a cross between Elliot Smith and American Music Club's Mark Eitzel."

Whatever the outcome, Brodeen's main priority is to keep the music coming and keep having fun. "I'm blessed," he admitted. "I thank God every day."

Not Lame

Not Lame Recordings

PO Box 2266
Ft. Collins, CO 80522
Phone: 970-407-0250
Fax: 970-407-0256
Web: www.notlame.com
E-mail: popmusic@notlame.com
Promotions: Nicholas Cole
Advertising: Bruce Brodeen
Sales: Bruce Brodeen
Mail order: Yes
Catalog: Write, e-mail, fax or visit Web site
Main styles of music: Power pop, eclectic but melodically driven rock
Top artists: The Shazam, Myracle Brah, The Posies, Dwight Twilley, The Rooks

Collectables

New Release

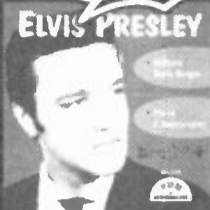

ELVIS PRESLEY #1 HIT SINGLES BOX SET!

23
7" COLORED
VINYL
SINGLES!

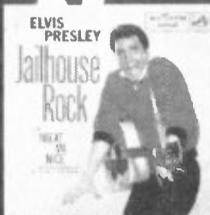
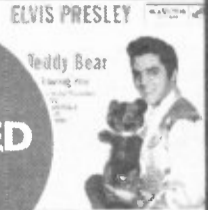

Deluxe Black Lacquered Wood Box

AUTHENTIC REPRODUCTIONS!
In Their Original Picture Sleeves
Including... **ORIGINAL SUN LABEL SINGLES**
With Limited Edition Picture Sleeves

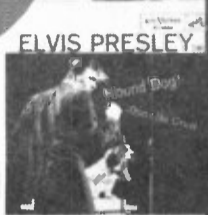
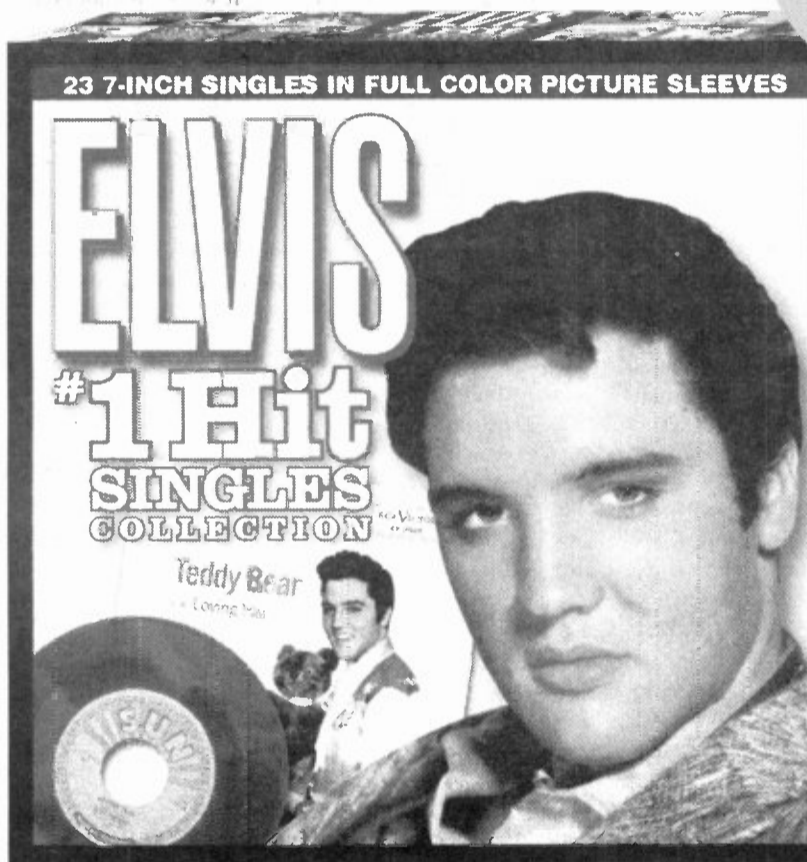

#1 SINGLES:

1. Heartbreak Hotel / I Was The One
2. I Want You, I Need You, I Love You / My Baby Left Me
3. Don't Be Cruel / Hound Dog
4. Love Me Tender / Anyway You Want Me (That's How I Will Be)
5. Too Much / Playing For Keeps
6. All Shook Up / That's When Your Heartaches Begin
7. (Let Me Be Your) Teddy Bear / Loving You
8. Jailhouse Rock / Treat Me Nice
9. Don't / I Beg Of You
10. Hard Headed Woman / Don't Ask Me Why
11. A Big Hunk O' Love / My Wish Came True
12. Stuck On You / Fame And Fortune
13. It's Now Or Never / A Mess Of Blues
14. Are You Lonesome To-night? / I Gotta Know
15. Surrender / Lonely Man
16. Good Luck Charm / Anything That's Part Of You
17. Blue Christmas / Wooden Heart
18. Suspicious Minds / You'll Think Of Me

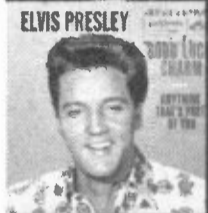

SUN® SINGLES:

19. That's All Right / Blue Moon Of Kentucky
20. Good Rockin' Tonight / I Don't Care If The Sun Don't Shine
21. Milkcow Blues Boogie / You're A Heartbreaker
22. Baby Let's Play House / I'm Left, You're Right, She's Gone
23. Mystery Train / I Forgot To Remember To Forget

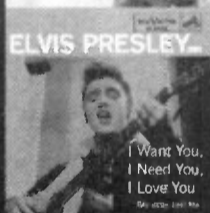
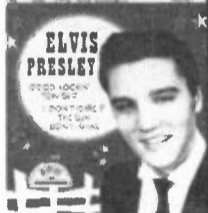

- The best-selling recording artist in history, Elvis Presley was responsible for popularizing Rock & Roll
- All of "The King's" number one 45s, with original picture sleeves on collector's colored vinyl, are featured in this limited edition, numbered, deluxe lacquered wooden box set
- All 45s in this set are pressed with the original label logos
- Presley's ground-breaking Rockabilly work on Sun Records is presented along with Presley's number one songs from RCA comprising the most important songs ever played on popular radio
- All the songs on this collection are classics including the tunes "Heartbreak Hotel," "Jailhouse Rock" and "Love Me Tender"

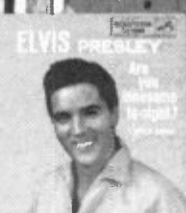
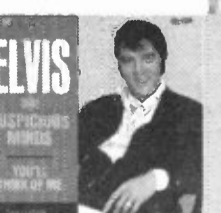
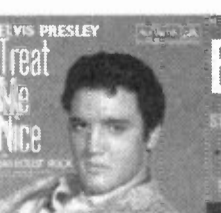
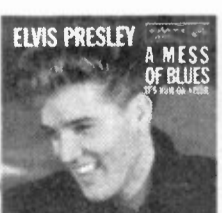
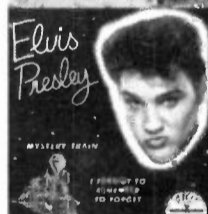
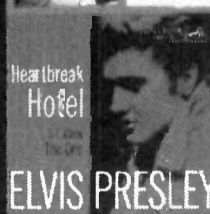
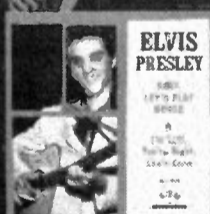
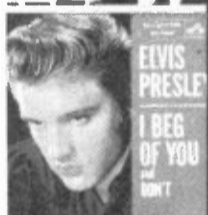

See it, sample it, buy it

www.oldies.com

COLLECTABLES RECORDS CORP.

GET A FREE CATALOG!

CALL: 800-446-8426

FAX: 610-649-0315

MAIL: P.O. BOX 35, NARBERTH, PA 19072

EMAIL: CATALOG@OLDIES.COM

New Releases



Courtesy of Hollywood Records/By Alison Dever

Butthole Surfers

BUTTHOLE SURFERS
Weird Revolution
 Hollywood/Surfdog (162269)

Three years ago, after the surprise success of 1996's "Pepper" propelled Butthole Surfers somewhat into the mainstream, the noise/punk vets were all prepared to release their follow-up album, *After The Astronaut*.

Copies were pressed, sent to the media and previewed. At the last minute, the peace between the Surfers and their record label, Capitol, broke. The band left the company and the album was never released.

Forward to 2001: The group has a new home and a new album, *Weird Revolution*, which sounds very familiar — especially to those who have heard *After The Astronaut*. It should, since eight of its 12 tracks have found their way onto *Weird Revolution*. The band returned to the studio after their Capitol debacle and re-recorded most of the album that was to succeed *Electriclarryland*. Missing pieces have been filled by, most prominently, a new collaboration between Butthole singer Gibby Haynes and Kid Rock, "Shame Of Life" (the only thing here that has even a chance of getting these guys back on the radio).

But *Weird Revolution* remains a difficult listen. Butthole Surfers have never been an easy band to embrace — gimmicky and harsh, they're at their best when their self-conscious pretenses aren't so obvious, such as on the 1985 EP *Cream Corn From The Socket Of Davis*. This retooling of a complicated album in the first place gives little justification for the revisit. There are plenty of Butthole-esque touches on *Weird Revolution* (distorted sound, skewed rhythms and megaphone shouts). Their command of the studio has matured, but there's something a bit hollow and forced about all this. Perhaps they should have just scrapped the barely there material and started from scratch.

— Michael Gallucci

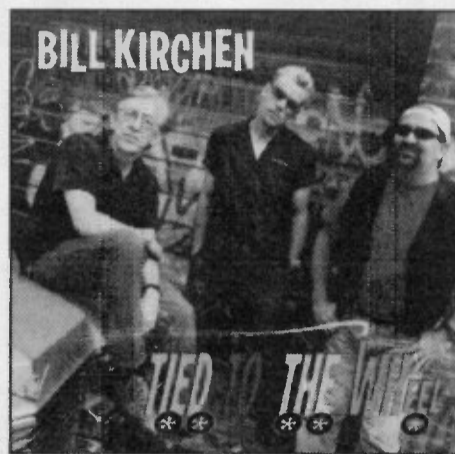

BILL KIRCHEN
Tied To The Wheel
 Hightone Records (HCD8138)

Bill Kirchen, the original picker of Commander Cody's "Hot Rod Lincoln," is still slammin' those Fenders and poppin' their strings! Kirchen continues his tasteful clean Telecaster-style pickin' with his new album *Tied To The Wheel* with Johnny Castle on bass and Jack O'Dell on drums — the rhythm section that has been with Kirchen for 10 years.

Every track sounds like a good three-piece, early '70s honky-tonk band. Although there are guest rhythm guitarists, steel guitarists, vocalists and keyboard players, the album still maintains that sparse three-piece sound.

"Truck Stop At The End Of The World" sets up the rest of the album with its opening cleanly picked guitar licks. Real country harmonies accompany "Dim Lights, Thick Smoke" as Kirchen duets with Dudley Connell.

All sorts of farm animals come to mind on the excellent instrumental "Poultry In Motion." Bob Dylan's "Just Like Tom Thumb's Blues" rocks in its own low-key manner with Kirchen's voice taking on you-know-who's phrasing and tone. The entire album has classic guitar intros, outros, solos and super lyrics.

Kirchen is currently on The Twangbanger Tour Of The USA with fellow HighTone labelmates Redd Volkaert, Dallas Wayne, and Joe Goldmark. Buy this album and check him out live!

— Guy Lee

VARIOUS ARTISTS
Labour Of Love: The Music Of Nick Lowe
 Telarc (CD-83538)

As with many other tribute albums, there's always a potpourri of musicians who sing and perform their interpretations of the artist being honored.

The combination on *Labour Of Love: The Music Of Nick Lowe* is a good cast, beginning with Dar Williams lending her vocals to "All Men Are Liars." She is backed by G.E. Smith and T-Bone Wolk (who provide the foundation for most of these songs). Graham Parker gives "The Rose Of England" a simple, down-to-earth arrangement using just an acoustic

(Please see New Releases page 41)

Indie Label Spotlight

ROGER MCGUINN
Treasures From The Folk Den
 Appleseed Records (APR CD 1046)

Having gotten his fair share of fame and fortune with The Byrds, Roger McGuinn's solo career has found him slipping further and further from the commercial spotlight. No longer content to rest on his laurels, replay the hits at his frequent appearances or contend with record company rejection, he returns to his roots with *Treasures From The Folk Den*, reprising the supporting role he played early in his career. Here he shares the spotlight with a rotating cast of his musical heroes, among them Pete Seeger, Judy Collins, Odetta, Joan Baez, and Eliza Carthy.

The songs on *Treasures From The Folk Den* are drawn from a series of downloadable offerings posted on his Web site. Inspired by McGuinn's devotion to authentic folk fare, the album emerges as a series of traditional tunes performed in a markedly bare-bones style.

In fact, the majority of the material reflects McGuinn's interest in recycling more obscure entries, which he documents in the liner notes via his enthusiastic explanations and personal observations. Resembling something of a scholarly treatise,

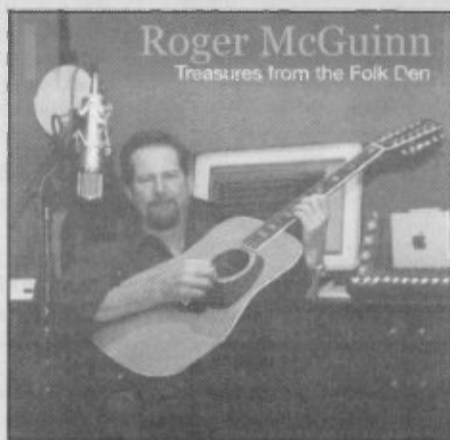

Treasures From The Folk Den's few familiar entries are limited to the traditional English ballad "Fair Nottamun Town," Woody Guthrie's "Alabama Bound," the rousing Irish drinking tune "Whiskey In The Jar" and a rudimentary remake of "John Riley," a song he recorded with The Byrds on *The Notorious Byrds Brothers* album from 1968.

However, don't expect McGuinn's usual assortment of jangly refrains and catchy choruses; these arrangements eschew commercial considerations. In the end, it's likely only true folk fanatics will appreciate the riches offered by these timeless treasures.

— Lee Zimmerman

NEW RELEASES NEWS



Just out: Austin, Texas', roots-rockers The Derailers debut on Lucky Dog Records is *Here Come The Derailers*... Boz Scaggs' first new album in more than seven years is *Dig* (Virgin)... Acid jazz kings Jamiroqui's newest is *A Funk Odyssey* (Epic)... The solo debut of Ben Folds Five's namesake is *Rockin' The Suburbs* (Epic)... Hailing from the Isle Of Man but now living in Canada, slide guitarist/singer/songwriter Harry Manx, who has recorded with Ry Cooder, just released *Dog My Cat* (NorthernBlues Music), a rootsy world/blues album that includes two sitar-laden blues rags... Dwight Twilley's latest is *The Luck* (Big Oak)... Irish rock guitar legend Rab McCullough, who shared stages with Jimi Hendrix, John Mayall, and The Small Faces in the days of the '60s British blues scene, just released *Belfast Blues* (NorthernBlues Music), dedicated to the memory of guitarist Rory Gallagher, a fellow Belfast native who passed away in 1995.

Coming up: Coming Oct. 2 from The Rembrandts is *Lost Together* (J-Bird Records), the duo's first new album since 1995's *L.P.*... Due Oct. 16 from HighTone Records is *Rhythm Room Blues*, a live compilation celebrating the 10th anniversary of Phoenix's premier blues club, The Rhythm Room. Backed by a stellar blues rhythm section, guest lead players on the 13 tracks are R.L. Burnside, The Fabulous Thunderbirds' harpist Kim Wilson, Chicago's blues piano master Henry Gray and drummer Sam Lay, Mojo Buford, Sonny Rhodes, and Nappy Brown... Due Oct. 23 is Gov't Mule's *The Deep End, Vol. 1* (ATO Records), the first in a three-part series featuring the band performing with 25 of the world's greatest bass players, including Bootsy Collins (P-Funk, James Brown), Flea (Red Hot Chili Peppers) and Phil Lesh (Grateful Dead). The series is made up of two CDs and a video. The band will be supporting the project with a fall tour. Gov't Mule's original bassist Allen Woody passed away Aug. 2000... Coming Nov. 6 is a new album from Tony Bennett, *Playin' With My Friends: Bennett Sings The Blues* (RPM Records). Bennet, who turned 75 in August, tackles blues songs and duets with the likes of Stevie Wonder, k.d. lang, Bonnie Raitt, Ray Charles, Natalie Cole, Billy Joel, B.B. King, Sheryl Crow, Diana Krall and others. Phil Ramone produced the album, whose title is the title of a song from blues great Robert Cray.

Signings: Canadian singer/songwriter Bruce Cockburn has signed a multi-album contract with Rounder Records, which includes the reissuing 18 of Cockburn's albums originally on Columbia, Gold Castle, Millennium, and True North Records from 1970-90 plus a "best of" collection with two new tracks due in early 2002 and a new album due out sometime in the fall of 2002.

— Greg Loescher

GOLDMINE UNIT SPACE ADS

WHAT ARE UNIT SPACE ADS?

Unit space ads are an affordable option for the small dealer or for the private collector who has a few items to sell. They are based on 8-1/2 x 11 sheets that you create. They are "camera ready," in other words, the ad will look in print exactly how it looks when you send it in, only smaller. We will reduce the sheets to fit the ad space. Optionally, at no extra charge we can create a heading for your ad. We will typeset your name, business name (if any), address and phone/fax numbers on your ad if you so request.

The two types of ads are:

1. Set Sale - Items are sold at the price listed.
2. Auction - Items are sold to the highest bidder.

FOR A BETTER UNIT SPACE AD . . .

1. Use white paper.
2. Have a new ribbon on your typewriter or printer; avoid low toner on a laser printer.
3. Make sure the paper is vertically oriented. We cannot publish a horizontal unit space ad unless you want the reader to turn the magazine sideways to look at it. Most readers won't bother to do that.
4. Mail it to us; don't fax it. Faxes can leave unwanted markings that make your ad hard to read.
5. **Clearly identify whether your ad is a set sale or auction.** Avoid mixing the two in the same ad; if you must, have separate sections for set-sale and auction items.
6. Include your name, address, and telephone/fax number (and when you will be available to take calls on the ad) and all ordering information, including postage and shipping fees.
7. Put your listings in a logical order. If you have several formats in the same ad (LP, CD, 45, etc.), group your items by format. You also may wish to group items by type of music. As for the listings themselves, alphabetically by artist usually works best.
8. If you have any questions on how to set up your ad, contact anyone from the *GOLDMINE* advertising staff.

SET SALE GUIDELINES FOR BUYERS

1. First, make sure you are replying to a set sale and not an auction. If an ad mentions minimum bids and deadlines, it's not a set sale.
2. Follow the advertiser's directions on how to reply. If the ad says to write first to reserve an item, do it. If the ad says that money orders only are accepted, don't write a personal check. And never send cash through the mail!
3. If you write or call to reserve an item and the advertiser still has it in stock, send your payment for the item promptly.
4. Set sale ads are "first-come, first-served," so the sooner you reply, the more likely you are to receive what you order.
5. If you receive the item and it is not as advertised, don't hesitate to complain. Reputable advertisers take complaints seriously and try to do right by the customer. But don't take advantage of this, either; complain only when you have a legitimate reason for doing so.

SET SALE GUIDELINES FOR SELLERS

1. Only advertise items you have. Because of ad deadlines, some dealers will assume they will have new material based on release dates given by record companies. In the long run, it's better to wait until you actually have an item to put it in your ad.
2. State all your policies in the ad. Examples include method of payment, whether (and at what times) you will accept telephone calls, and whether to reserve items or send money immediately.
3. Send the items promptly after they've been paid for. Federal Trade Commission regulations state that you **must** ship your items within 30 days.
4. Charge only what you pay to send the package. Or charge everyone the same amount, knowing you will lose money on large packages, but will make up for it on smaller ones. If your stated postage rates are unusually high, state why! (Insurance, special handling or packaging, etc.)
5. Take complaints seriously. An unresolved problem is usually a lost customer.

Auction Guidelines For Buyers

1. First, make sure you are replying to an auction and not a set sale.
2. Note the minimum bid, and don't bid less than that. Also, don't say "I will top all bids" unless the auction allows it and, of course, you really mean it.
3. Mail in all bids unless the ad says phone-in bids are acceptable.
4. Remember the deadline. If none is stated, then the auction closes one month from the date on the cover. For example, if the auction is in the *GOLDMINE* dated October 15, the sale closes November 15.
5. If mailing bids, allow 1-2 weeks for your bids to arrive. And after an auction ends, allow 1-2 weeks for notification. If you haven't heard 14 days after the end of an auction, assume you won nothing unless the ad says that all bidders, win or lose, would be notified.
6. **Honor all winning bids!** If you are notified that your bid has won the item, send the money for your items within a week. Bidders renegeing on their winning bids is the No. 1 complaint from those who run auction ads. If you can't honor your bid, at least have the courtesy to notify the advertiser.
7. Allow 2-4 weeks for your winnings to arrive.

AUCTION GUIDELINES FOR SELLERS

1. Set minimum bids on any item you won't sell for less. You also can set an auction-wide minimum; different minimums on different parts of the auction; or no minimums at all. Avoid "Ridiculous bids will be rejected" or similar phrases; you can't assume that everyone knows what a "ridiculous bid" is. Instead, take the time to set minimums.
2. Run an honest auction. Don't advertise items you don't have; don't artificially force bidders to bid more by claiming there's a counterbidder when there isn't one; don't overgrade your items; and sell all items that meet your published minimum and are the high bid, even if the bid is far below "book" value.
3. Notify winners within the first week after your deadline passes.
4. Send the winners their items promptly upon payment. (It's OK to wait for checks from unfamiliar customers to clear, which takes no more than a week. If it takes longer, get a new bank.) Federal Trade Commission regulations state that you **must** ship your items within 30 days.
5. Don't use your auction as a way to compile a mailing list unless you state that in your ad.
6. In sum: Treat your customers as you would want to be treated if you were the one bidding.

UNIT SPACE AD RATES

GOLDMINE has two sizes of unit space ads:

1. **Regular** - your ad is reduced to one-ninth of one of our pages.
2. **Super** - your ad is reduced to one-fourth of one of our pages.

	Regular	Super
Each unit	\$60.90	\$126.80
Full page	\$466.20	\$466.20

Contract rates are available, which earn advertisers lower rates. Call anyone on our *GOLDMINE* advertising staff for a complete rate card. 715/445-2214

RARE ALBUMS - R&B - ROCK & ROLL - SOUL - DISCO - RAP - REGGAE

Jerry Kale & Spinners(Galaxy 4893)-Twisting With The Twist/VG+
Kitty Kallen(RCA 2640)-My Coloring Book/VG+
Kalyan(MCA 2245)-Same/VG+ (Black group-1977)

Kathy Linden(Felsted 7501)-That Certain Boy/VG++ (Min Bid-\$15)
Lina(Chrysalis 1332)-Intuition/M-
Lions(Metro 300)-Twist With/VG+

George McCrae(T.K. 602)-George McCrae/VG+ or (606)-Diamond Touch/M- or (501)-Rock
Four Baby/M- or (610)-We Did It/M- or (Cat 2606)-Togetherw Gwen McCrae/S

ALLEN RADWILL 23 numbers Lane, Southampton, NJ 08088 • 609-953-5473

Hi! Welcome to our latest ad. This time we have **Import CDs and Ltd Ed. IMPORT CDs for sale.** Most are new some are used and graded. More in stock! CALL IF LOOKING FOR SOMETHING SPECIAL. Postage is \$4.00 for priority mail. USE PAYPAL! Call for details, but we're closed Mondays.

- 1) Bjork - Vespertine - UK Special Ed Cd in thick cardboard fold-out cover \$28
- 2) Bon Jovi - One Wild Night - Live '85-'01 - Ltd Ed Aust. Cd w/bonus 5 trk live in Australia disc \$ 18
- 3) Catherine Wheel - Wishville - Ltd Ed UK Cd in cardboard tri-fold digi-pak w/bonus 7 trk live disc - \$ 23
- 4) Nick Cave - Two Lectures By - Secret life of the Love Song/The Flesh Made Word-UK Cd in small book-style pack \$ 21
- 5) Cockney Rejects - Oi! Oi! Oi! - Ltd Ed UK Cd in Special Tin Cover w/postcards - 20 trks \$ 20
- 6) Deftones - Back to School - Import 8 Trk Mini Lp Cd - live/acoustic/nonLp \$18
- 7) Divine Comedy - A Secret History - Ltd Ed UK 2 Cds in 7"X7" hardcover book \$30
- 8) Divine Comedy - A Short Album About love - UK 7 Trk Cd in cardboard fold-out digi-pak \$ 18
- 9) Divine Comedy - Fin De Siecle - Ltd Ed UK Cd in cardboard fold-out cover w/lyric book & additional artwork \$ 23
- 10) Fastball - The Harsh Light of Day - Imp Cd in cardbrd digi-pak w/bonus trks \$21
- 11) Gorillaz - S/T - UK Cd w/bonus video Cd (VCD) Videos for all Songs \$28
- 12) Hellacopters - Flight Case Ep - UK Import 5 Trk Cd w/ 2 Videos in box w/woven patch \$ 15
- 13) Incubus - Make Yourself - Ltd Ed Australian Cd w/bonus 4 trk disc \$ 23
- 14) Lupine Howl - Carnivorous Lunar Activities - UK CD in box w/fold-out bklt \$21
- 15) Motorhead - We Are Motorhead - German Cd in box w/poster/sticker, photo \$21
- 16) Papa Roach - Infest - Ltd Ed Aust. Cd w/bonus disc - 3 songs/2 videos \$20
- 17) Paradise Lost - One Second - Italian Cd in Cardbrd digi-pak w/1 bonus trk \$ 23
- 18) Pink Floyd - Japanese Import Remasters - All in Cardboard Mini Lp covers w/orig mini inserts - 11 Titles - All are \$ 23 unless noted: Collection of Great Dance Songs/Animals/Atom Heart Mother / Relics/ More/ Piper/ Saucerful/ Obscured/ Middle/UmmaGummat/\$35/The Wall/\$35
- 19) Pink Floyd - Wish You Were Here-German Import Cd in mini Lp Cover w/original plastic outer sleeve \$ 21
- 20) Placebo - Black Market Music - Ltd Ed UK Cd in Digi-pak - MAY have bonus disc - It's Sealed \$ 23
- 21) Rage Against The Machine - Renegades - UK Cd w/ 2 live hidden bonus trks \$23
- 22) The Resident - German Import Reissue Cds in Cardboard fold out covers - Wormwood/ George & James / Third Reich / Icky Flux \$ 18 each
- 23) Roxy Music - Remasters - UK Cds - Country Life/ Stranded/ Siren - \$18 each
- 24) Screaming Lord Sutch - Munster Rock - Spain Cd in Cardboard fold-out cover \$15
- 25) Sepultura - Nation - UK CD in Cardboard fold-out digi-pak w/ booklet - 5 bonus trks \$ 21
- 26) Slipknot - S/T - UK Cd in cardboard fold-out digi pak w/3 bonus trks \$ 20

619 S. 4th St.
(4th between South & Bainbridge Sts.)

NOISE POLLUTION

(215) 627-7246
PHILADELPHIA, PA 19147

LET THE MUSIC PLAY SPECIALIZING IN RARE CONCERT RECORDINGS

OVER 250 TITLES FROM
STEVIE RAY VAUGHAN

Plus:
JIMI HENDRIX
LED ZEPPELIN
ROLLING STONES
AND EVERYONE ELSE
FROM AC/DC TO ZAPPA
HIGHEST QUALITY
RECORDING AND PACKAGING
\$15.00 SINGLES / \$25.00 DOUBLES
CALL FOR CD, VIDEO, & LP LISTS.
e-mail: kryway@earthlink.net
(603) 473-8618

Canadian CDs

- Frank Marino Eye Of The Storm - NEW \$14.99**
SPECIAL - Buy this CD and get free surface shipping on your entire order!
- Guess Who This Time Long Ago (2CD Rarities) \$19.99**
2 disc collection of Guess Who rarities. Tracks from TV shows, odds and ends, even covers of "Light My Fire", "Summertime Blues" as in the Blue Cheer version, "Love Is All Around" and "White Room", honest! Very very cool piece.
- Guess Who Running Back Through Canada 2 CD \$19.99**
Live album from last summers reunion tour with both Randy Bachman and Burton Cummings.
- Randy Bachman Randy Bachman Songbook \$14.99**
Randy goes back and recuts a number of his classics with his pre reunion band
Also available **Any Road \$14.99**
Merge \$13.99
Bob's Garage (live 5 song EP) \$11.99
- April Wine Back To The Mansion \$13.99**
New CD from this Classic Rock band. Will be touring this summer with new member Carl Dixon (ex Coney Hatch)
- Stampeders All Regular discs \$9.99**
All the Stampeders albums are now available: Bailly, Steamin', Platinum, Hit The Road, Backstage Pass, New Day, Rubes Dudes, From The Fire, Carrying On
- Nash The Slash Various Cds \$16.45**
Hard to find albums from this Canadian progster: Children of the Night, Thrush, Blind Windows or Nosferatu. Watch for FM Black Noise rarities coming soon!

Yes, we wholesale!

All prices are in US\$. Visa / Mastercard /US checks / Money Orders accepted.
Postage & insurance: Surface \$3.50 first, \$1.50 additional. Air Mail \$4.50 first, 2.00 each additional.
www.canadiancds.com

Spindle Records

Box 49976, 660 Eglinton Ave. E., Toronto, ON, Canada M4G 2K0
416-425-0476, 416-425-7901 FAX

ROCK N RECORDS

Set Sale: Live CD shows. CDs are mint of que status, no bootlegs here. Postage \$3.50 for 1st item, 50 cents each additional. Pre-90s-99s \$7.45 (MRT). E-mail: rocknrecords@msn.com
Payment to: Rock N Records, Wooded, Stevie R. Vaughan collection.

Artist/Title	Price
AEROSMITH 2CD Belgium 1993	\$20
AEROSMITH 2CD 1988, '87, '90	\$40
ALLMAN BROS. 2CD 75, '80, '94	\$40
ARMS Benark 4CD Roy Albert '53	\$40
BECK 2CD Boston/TOEing '98	\$40
BECK 2CD London 1998	\$40
BARENAKED LADIES 1CD	\$20
BLINK 182 1CD Anaheim '99	\$18
Bowie, David @CD Tokyo 1990	\$65
BUCKCHERRY 1CD Hollywood '99	\$38
BUSH 2CD Hollywood 1995	\$38
CARS 2CD 1984, '87	\$38
CHEMICAL BROS. 2CD Eng 1999	\$38
COLDPLAY 1CD LA	\$100
COLDPLAY 1CD Eng 2000	\$45
COLLECTIVE SOUL 2CD LA, '94	\$40
COOPER, ALICE 2CD Cal 1987	\$40
CROSBY, STILL & NASH 2CD	\$20
CUNEIFORM 1CD LA, 1987	\$20
CURT COOPER 2CD Hollywood 1995	\$40
CURE 2CD 2000	\$18
CURFMAN, SHANNON 1CD LA	\$20
CYPRESS HILL 1CD San Fran	\$45
DANZIG 1CD Hollywood 1999	\$38
DEPTONES 1CD LA, 1997	\$38
DIRE STRAITS 2CD London '78	\$40
DOOBIE BROS. 2CD San Fran. 1995	\$40
DOORS 2CD SF, March 1987	\$38
DORIS/ALICE IN CHAINS 1CD	\$38
ELTON JOHN 2CD 1973, '78 BOC	\$24
EVERCLEAN 1CD LA, 1997	\$38
EVERCLEAN 1CD LA, 1998	\$38
EVERLAST 2CD LA, 2000	\$38
FATHEAD 1CD LA, 1988	\$18
FLEETWOOD MAC 2CD Irvine '97	\$38
FOGERTY JOHN 7/8 Frampton '92 2CD	\$28
FOO FIGHTERS 2CD Quebec 2000	\$20
FU MANCHOU (L) Dope 2CD	\$35
FUN LOV CRIMINALS 1CD LA '98	\$18
GENESIS 2CD 1982, '84, '85	\$18
GOODSMACK 1CD Hollywood '99	\$18
GREENDAY 2CD	\$38
HAGGAR, S '97 Van Halen '82 2CD	\$18
(HED) P.E. 1CD LA, 1997	\$30
INCUBUS 1CD Ventura, CA '00	\$35
JETHRO TULL 2CD London '84, '91	\$40
JEWEL, 1CD 1980	\$30
KANSAS 1CD Cincinnati '86	\$55
KID ROCK 1CD LA, 1999	\$45
WOODEN ONE (Live/CD Radio Shows)	
850 KITTIE 1CD Madison, WI '00	\$20
838 KORN 2CD Indiana 2000	\$40
836 KORN 2CD O.K.C. '90 live '98	\$40
1100 LED ZEPPELIN 2CD London '71	\$40
840 LED ZEPPELIN 2CD London '80, '71	\$40
840 LIMP BIZKIT 2CD Sacramento '99	\$40
820 LIT San Francisco 1989 1CD	\$20
820 LIVE 1CD	\$18
838 LIVE 2CD Las Vegas	\$65
820 LYARD BACKHURD 2CD Atlanta '84	\$38
834 MATTHEWS, DAVE 2CD	\$38
830 MATTHEWS, DAVE 2CD Farmstead, CA	\$38
830 MILENCAAMP, JOH IN 2CD 1997	\$38
820 METALLICA 3CD Woodstock 1999	\$100
820 MINISTRY/D48 Orty 2CD Vegas '98/CA	\$45
834 MORRY 1CD England	\$18
833 MORRISON, VAN 2CD 1987, '97	\$40
838 NICKLEBACK 1CD LA, 2000	\$20
838 NICKLEBACK 1CD Hollywood 2000	\$20
838 NIRVANA 2CD Dermal, CA/BBC	\$40
840 OASIS 1CD England 1995	\$18
824 OLEANDER 1CD Pomona CA '99	\$20
820 PAGE AND PLANT 2CD New Orleans '98	\$45
818 PEARL, JAM 2CD Atlanta 1994	\$38
818 PETTY, TOM 2CD Gainesville 1993	\$38
838 PINK FLOYD 2CD RBC 1970, 1971	\$40
820 POWERMAN 5000/TOOL 2CD Vegas/CA '93	\$40
850 PRINCE 2CD Los Angeles 1993	\$38
818 QUEEN 2CD England 1970/78	\$38
828 QUEENS OF STONE AGE 1CD Eng. 1999	\$24
818 RAGE AGAINST THE MACHINE 2CD LA '98	\$38
818 RAGE AGAINST THE MACHINE P.O. 2CD	\$30
838 R.E.M. 2CD London 1995	\$38
818 RED HOT CHILI PEPPERS 1CD LA, '91	\$18
818 RED HOT CHILI PEPPERS 1CD S. Diego '91	\$18
838 ROLLING STONES 2CD New Orleans 1994	\$65
838 ROLLINS, HENRY/J.A.C. 2CD	\$28
828 SEVENTH 1999/CREEED 2CD	\$20
828 SCORPIONS 2CD Netherlands 1990	\$35
818 SH. VERCHUR 1CD Hollywood 1999	\$18
828 SMASH MOUTH, 1CD Pomona, CA 1999	\$18
830 SMASHING PUMPKINS 1CD Eng. 1995	\$18
830 SOUNDGARDEN 2CD 1989, '91	\$38
835 STR. 1CD San Diego	\$18
824 STATHIC X/Band 2CD Nevada, Calif	\$30
818 STEWART, ROD 2CD Hollywood 1998	\$35
820 STONE TEMPLE PILOTS 2CD Hollands/CA, VA	\$40
818 STYX 1CD Las Vegas 1995	\$30
818 U2 2CD London 1983	\$55
818 Young, Neil 2CD Farmstead '84, '97	\$45

ROCK N RECORDS PO Box 3777, Rapid City, SD 57709-3777
E-Mail: rocknrecords@msn.com

BREATHE DEEP...

THE MOODY BLUES

in
Higher & Higher
the Moody Blues magazine

Since 1983

Send an SASE for a brochure,
or \$20 for a 3-issue
sample set.

Higher & Higher
P.O. Box 829-G
Geneva, FL 32732
BlueLine: 407-349-BLUE
www.Moodies-Magazine.com

Interested in
**INCREDIBLY STRANGE
AND EXOTIC MUSIC?**

OUR #22 ISSUE IS HERE!

Featuring articles on RUSS MEYER,
THE RESIDENTS, VIC FLICK,
THE SINGING NUN, BRUTE FORCE,
KIDS FROM WHIDNEY HIGH,
QUINTRON, SPARKS, a centerfold
of ARTHUR FIEDLER LP COVERS,
and much, much more!

64 whopping pages of musical
mayhem and madness! For single
issues, send \$3.95 + \$1 postage
(USA & Can.), \$6 elsewhere.
To subscribe (4 issues), send \$15
(U.S.), \$20 (Canada), (Other
countries: \$30, U.S. funds only)

Dedicated to Unusual Sounds!
COOL AND STRANGE MUSIC!
Magazine

1101 Colby Ave.
Everett, WA USA 98201

CONTESTS, PICS, SOUNDS! GO TO: WWW.COOLANDSTRANGE.COM

RAOUL BJÖRKENHEIM "Apocalypse"
Raoul's energizing guitarwork has been featured with Henry Kaiser, Bill Laswell, Michael Manning, Paul Schütze and others. Apocalypse is a galvanizing work that features the power of scores of guitars, basses and percussion instruments.

CHRIS MCGREGOR'S BROTHERHOOD OF BREATH
"Travelling Somewhere"
Expatriate South African pianist Chns McGregor founded the Brotherhood in 1970. This 1973 radio concert features Mark Chang, Nick Evans, Mongezi Feza, Harry Miller, Louis Moholo, Evan Parker, Dudu Pukwana, Gary Windo & more

MIRIODOR "Mekano"
Mekano is Mindor's fifth album, and is their most impressive and entertaining work yet! Their music is a dynamic, intricate and beautifully crafted blending of rock fusion, classical, folk and avant-garde musics. - Audion (UK)

PICCHIO DAL POZZO "Camera Zimmer Rooms"
A previously unreleased studio album by one of the legends of 1970's Italian progressive rock! Recorded during their prime, this is an amazing archival find.

UNIVERS ZERO "Crawling Wind"
This reissues a very rare 12" EP that was released only in Japan. Remastered and expanded with the addition of rare and unreleased bonus material

CUNEIFORM RECORDS
P.O. BOX 8427
SILVER SPRING, MD. 20907, USA
fax (301) 589-1819

Our releases are available at fine stores.
If you are unable to find these or our previous releases
in stores, contact us for mail-order information.
Stores: email, fax or write for our direct wholesale prices.
<http://www.cuneiformrecords.com>

Attention! If you collect:
Vocal Groups • R&B • Soul • Blues
• Rockabilly • Gospel • Oldies • C&W

**ORDER OUR NEW
CATALOGUES TODAY,
THEY'RE FREE!**

Thousands of rare and obscure titles
originals • repros
45s • EPs • Pic Slvs • Paper

Rhythm RECORDINGS

P.O. Box 22372 G • San Francisco, CA 94122
Fax: 415-753-3487 • Phone: 415-753-3480 (1-5 pm PST)

Please Specify What Style Of Music You Collect

MOVING?

DON'T MISS A SINGLE ISSUE OF GOLDMINE
Let us know your new address right away. Attach an old mailing label in the space provided and print your new address where indicated.

QUESTIONS ABOUT YOUR SUBSCRIPTION?
When you write, be sure to include a label. It helps us serve you more promptly

TO SUBSCRIBE OR EXTEND YOUR SUBSCRIPTION—
Check the appropriate boxes below:

New subscription. Please allow 4-8 weeks for your first copy to be mailed.
 Renewal subscription. Please include a current address label to insure prompt and proper extension.
 1-year \$39.95. This rate limited to the U.S.A. and its Possessions. Payment enclosed Check or money order (to Goldmine) MasterCard VISA

Credit Card Number _____
Expires: Mo. _____ Yr. _____
Signature _____

Mail To: GOLDMINE, Circulation Dept.
700 E. State St., Iola, WI 54990

Name _____
Address _____
City _____
State _____ Zip _____

ATTACH LABEL HERE

(If label is not handy, print OLD address in this space)



AUDIO COLLECTIONS

PO Box 1474, Bolingbrook, IL 60440 1-630-759-2273 FAX 1-630-759-2430 E-Mail AUDIOCOLL@AOL.COM

Hours Monday through Friday 9:30 AM to 8:00 PM Central Time, Saturday 10 AM to 6 PM, closed Sundays. To place orders, call 630-759-2273 (leave order on machine). To fax orders 630-759-2430 24 hours a day. To e-mail orders AUDIOCOLL@AOL.COM. VISA, MasterCard, American Express, Money Orders, PAYPAL to AUDIOCOLL@AOL.COM. Checks allow time to clear. Perfection For Your Collection! All Original imported Euro and Japan CDs priced as marked. All are in stock and ready to ship! Use Paypal it's easy (www.Paypal.com) Shipping & Handling USA \$6.00 Priority, Overseas Global Air Rate added. No unauthorized returns. All orders shipped with High Updated Special Order Catalog. www.audiocollections.com Wonderful Selection! Thank You!

Table listing audio collections with columns for artist/album name and price. Includes entries like 'AC/DC - Back in Black', 'Aerosmith - Toys in the Attic', 'Al Green - I'm Still Here', etc.

Table listing audio collections with columns for artist/album name and price. Includes entries like 'Alicia Keys - The Diary of Alicia Keys', 'Alanis Morissette - Jagged Little Pill', 'Al Green - I'm Still Here', etc.

Table listing audio collections with columns for artist/album name and price. Includes entries like 'Alicia Keys - The Diary of Alicia Keys', 'Alanis Morissette - Jagged Little Pill', 'Al Green - I'm Still Here', etc.

Table listing audio collections with columns for artist/album name and price. Includes entries like 'Alicia Keys - The Diary of Alicia Keys', 'Alanis Morissette - Jagged Little Pill', 'Al Green - I'm Still Here', etc.

Table listing audio collections with columns for artist/album name and price. Includes entries like 'Alicia Keys - The Diary of Alicia Keys', 'Alanis Morissette - Jagged Little Pill', 'Al Green - I'm Still Here', etc.

Table listing audio collections with columns for artist/album name and price. Includes entries like 'Alicia Keys - The Diary of Alicia Keys', 'Alanis Morissette - Jagged Little Pill', 'Al Green - I'm Still Here', etc.

Table listing audio collections with columns for artist/album name and price. Includes entries like 'Alicia Keys - The Diary of Alicia Keys', 'Alanis Morissette - Jagged Little Pill', 'Al Green - I'm Still Here', etc.

Table listing audio collections with columns for artist/album name and price. Includes entries like 'Alicia Keys - The Diary of Alicia Keys', 'Alanis Morissette - Jagged Little Pill', 'Al Green - I'm Still Here', etc.

Table listing audio collections with columns for artist/album name and price. Includes entries like 'Alicia Keys - The Diary of Alicia Keys', 'Alanis Morissette - Jagged Little Pill', 'Al Green - I'm Still Here', etc.

Table listing audio collections with columns for artist/album name and price. Includes entries like 'Alicia Keys - The Diary of Alicia Keys', 'Alanis Morissette - Jagged Little Pill', 'Al Green - I'm Still Here', etc.

Table listing audio collections with columns for artist/album name and price. Includes entries like 'Alicia Keys - The Diary of Alicia Keys', 'Alanis Morissette - Jagged Little Pill', 'Al Green - I'm Still Here', etc.

Table listing audio collections with columns for artist/album name and price. Includes entries like 'Alicia Keys - The Diary of Alicia Keys', 'Alanis Morissette - Jagged Little Pill', 'Al Green - I'm Still Here', etc.

AUDIO COLLECTIONS

PO Box 1474, Bolingbrook, IL 60440 1-630-759-2273

FAX 1-630-759-2430 E-Mail AUDIOCOLL@AOL.COM

Hours Monday through Friday 9:30 AM to 8:00 PM Central Time, Saturday 10 AM to 6 PM, closed Sundays. To place orders, call 630-759-2273 (leave order on machine). To fax orders 630-759-2430 24 hours a day. To e-mail orders AUDIOCOLL@AOL.COM. VISA, MasterCard, American Express, Money Orders, PAYPAL to AUDIOCOLL@AOL.COM. Checks allow time to clear. Perfection For Your Collection! All Original imported Euro and Japan CDs priced as marked. All are in stock and ready to ship! Use Paypal it's easy (www.Paypal.com) Shipping & Handling USA \$6.00 Priority, Overseas Global Air Rate added. No unauthorized returns. All orders shipped with High Updated Special Order Catalog. www.audiocollections.com Wonderful Selection! Thank You!

(603) 629-9102

\$4.00 for shipping & handling per order, not per item (US \$6.00 outside USA)

Monday - Thursday 10:30 am - 8:00 pm Friday 10:30 am - 4:00 pm Eastern Standard Time

Visa, Mastercard, JCB Cards Diners Club, Carte Blanche Discover, Private Issue, Bravo American Express, Optima Check or Money Order



PO Box 1514 Manchester, NH 03105 USA

More titles available at: www.MetroCityRecords.com Secure On-Line Ordering

Metro CD Records

PRE-ORDER LIST COMING SOON!

Prices and availability are subject to change.

Compact Disc

Table listing CD releases including titles like 'To Power Of Three', 'Asia', 'Black Sabbath', 'Colin Blunstone', etc.

Table listing CD releases including titles like 'Small Faces', 'There Are But Four Small Faces', 'Style Council', etc.

Super Audio CD

Table listing SACD releases including titles like 'Brian Eno', 'Tangerine Dream', etc.

DVD/VHS/VCD

Table listing DVD/VHS/VCD releases including titles like 'Cheap Trick', 'Joe Cocker', etc.

Compact Disc

Table listing CD releases including titles like 'April Wine', 'Arena', 'Asia', etc.

Table listing CD releases including titles like 'AYREON', 'THE BABYS', 'PAT BENATAR', 'BLOODROCK', etc.

(603) 629-9102

\$4.00 for shipping & handling per order, not per item (US \$6.00 outside USA)

Monday - Thursday

10:30 am - 8:00 pm

Friday

10:30 am - 4:00 pm

Eastern Standard Time

VISA, Mastercard, JCB Cards, Diners Club, Carte Blanche, Discover, Private Issue, Bravo, American Express, Optima, Check or Money Order



PO Box 1514, Manchester, NH 03105, USA

More titles available at: www.MetroCityRecords.com, Secure On-Line Ordering

Metro CD Records

Table listing various music releases including EM (Canadian Prog Rock Trio), Foghat, Gamma, Genesis, and others with prices and descriptions.

Table listing releases from MARILLION, Marillion, Fish, The Outpatients, Transatlantic, and others with prices and descriptions.

Table listing releases from STACKRIDGE, Starcastle, STYX & Styx members, and others with prices and descriptions.

Quality Guides for Dedicated Collectors

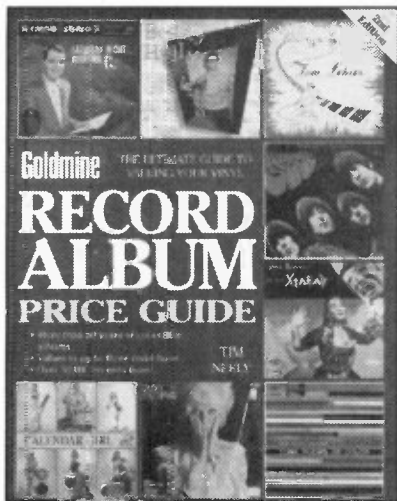

Goldmine Record Album Price Guide 2nd Edition by Tim Neely

Coverage in this comprehensive price guide includes American albums from 1948 through 2000. You will find more than 50,000 listings in up to three grades of conditions along with many photos of rare and unusual albums as well as a record label identifier section. Albums are listed alphabetically by artist and are in checklist format for easy inventory.

Softcover • 8-1/2 x 11 • 672 pages
200 b&w photos
Item# REA2 • \$24.95

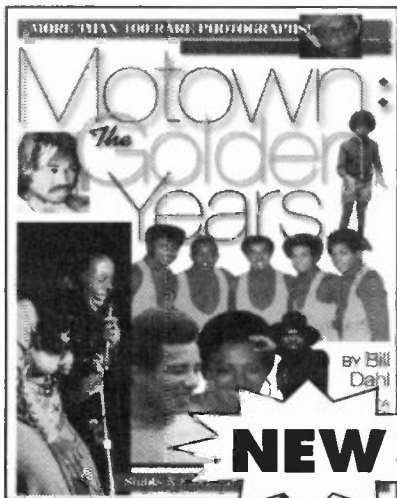

Motown: The Golden Years by Bill Dahl

Photography by Weldon A. McDougal III
Lovers of Motown, this is the book for you! Author and Motown historian Bill Dahl has expertly compiled this complete encyclopedia of groups and artists, along with information about their music, including a discography and price guide, of nearly every Motown group since 1959.

Softcover • 8-1/2 x 11 • 384 pages
200+ b&w photos
32-page color section, 50 color photos
Item# MTWN • \$24.95

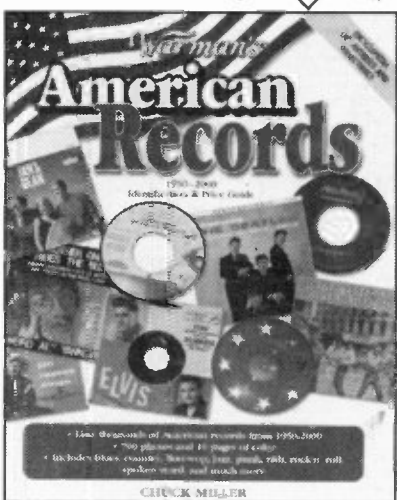

Warman's® American Records 1950-2000 Identification & Price Guide by Chuck Miller

This guide to American records released between 1950 and 2000 is perfect for any collector, beginning or seasoned. Inside you will find more than 2,000 listings for LPs, LLPs and 45s from a variety of genres, including country, heavy metal, soul, jazz and rock, among others. More than 750 photos and accurate pricing in up to three grades of condition will help you identify and value your collection.

Softcover • 8-1/2 x 11 • 352 pages
750 b&w photos • 16-page color section
Item# WAREC • \$21.95



Goldmine Standard Catalog of® American Records, 1950-1975 2nd Edition by Tim Neely

Record experts called the first edition the "best U.S. guide to American records ever published." In this second edition you'll find 150,000 listings, many of them new; updated pricing with 450,000 prices, one for each of three grades of condition; plus the most accurate information available.

Softcover • 8-1/2 x 11 • 1,296 pages
150 b&w photos
Item# REC2 • \$34.95



Goldmine Standard Catalog of® American Records, 1976-2000 by Tim Neely

Did you know that artists like Madonna, Prince, U2, REM and Garth Brooks have music available on vinyl? You will find these and more with this comprehensive price guide from Goldmine and expert author, Tim Neely. With more than 60,000 listings in three grades of condition arranged alphabetically by artist, this is the first book to cover LPs, 45s, 12-inch singles and EPs from 1976-2000.

Softcover • 8-1/2 x 11 • 608 pages
200 b&w photos
Item# AR01 • \$27.95

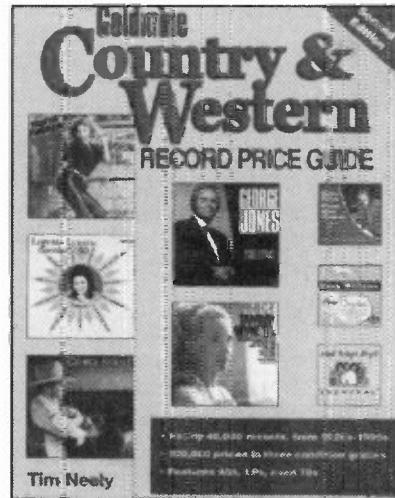

Goldmine Country & Western Record Price Guide 2nd Edition by Tim Neely

Individual listings for tens of thousands of records grace the pages of Goldmine Country-Western Record Price Guide—from 45s to LPs to selected 78s. You'll find hundreds of records not listed anywhere else plus the most current reference information available. This entirely revised edition tells you which records are available and their current market value. You'll find 40,000 listings and 120,000 prices for each of three grades of condition.

Softcover • 8-1/2 x 11 • 544 pages
100 b&w photos
Item# RCW02 • \$24.95

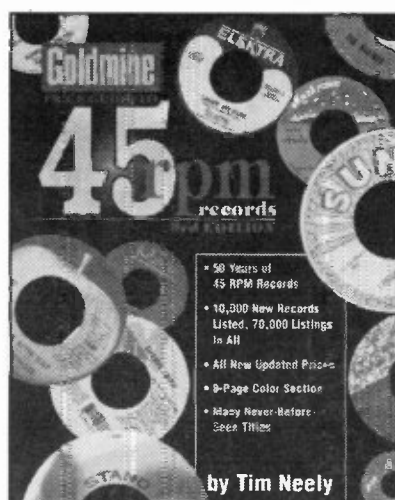

Goldmine Price Guide to 45 RPM Records 3rd Edition by Tim Neely

You'll get more record listings and current values than any other 45 RPM record price guide. Plus, more than 200 photos will help you identify and authenticate your collection. And over 70,000 RPMs, 45s, extended play singles, and picture sleeves from 1949 through 2000 are graded and priced so you'll have more than 210,000 prices to gauge your collection's value. Includes 8 pages of full-color noteworthy records and sleeves.

Softcover • 8-1/2 x 11 • 648 pages
200 b&w photos • 8-page color section
Item# R453 • \$24.95



Goldmine Jazz Album Price Guide by Tim Neely

Tim Neely, author of eight recording industry price guides, including the Standard Catalog of American Records, has authored, compiled and organized this new showcase price guide which features jazz musicians, composers and vocalists from the bebop era through to today. You'll find thousands of jazz artists - Dixieland, big band/swing, bebop, progressive, modern, fusion, and more - all featured in over 40,000 listings and priced in three grades of condition.

Softcover • 8-1/2 x 11 • 544 pages
150 b&w photos
Item# RJ04 • \$24.95

To place a credit card order or for a FREE all-product catalog call

800-258-0929 Offer R61B

M-F 7am-8pm • Sat 8am-2pm, CST

Krause Publications, Offer R61B

P.O. Box 5009, Iola, WI 54945-5009 • www.krausebooks.com

Shipping & Handling: \$4.00 first book, \$2.00 each additional. Non-US addresses \$20.95 first book, \$5.95 each additional.

Sales Tax: CA, IA, PA, TN, VA, WI residents please add appropriate sales tax.

Satisfaction Guarantee: If for any reason you are not completely satisfied with your purchase, simply return it within 14 days of receipt and receive a full refund, less shipping charges.

Goldmine

(New Releases from page 30)

guitar and his vocals. Tom Petty And His Heartbreakers rock jollily along on "Cracking Up." Petty's purposely monotone vocal performance puts a cool undercurrent on this tune.

Sleepy LaBeef's baritone voice and his Zydeco arrangement of "Half A Boy And Half A Man" will make listeners smile. "Television" is sung well by Marshall Crenshaw, who also covers Lowe's breakthrough 1980 hit "Cruel To Be Kind." I have always liked that song, and it's still a catchy tune with Crenshaw's rendition.

Bluesman Charlie Musslewhite brings out the sadness of "Faithless Love." Guy Davis, Levon Helm, and Wolk join together to give a power-trio boost to the blues-drenched "Soulful Wind." Rock and melody come together for Joe Louis Walker's interpretation of "(What's So Funny 'Bout) Peace, Love And Understanding." Funky guitar all the way!

Elvis Costello performs all the instruments on Lowe's ballad "Egypt," using his own style to redevelop the tune. With all these songs united on a single CD and performed by different artists, it doesn't make for consistent listenin'. But all the songs do have a common bond — Lowe's excellent songwriting.

— Guy Lee

VARIOUS ARTISTS

A Loose Salute To The Work Of Michael Nesmith

Dren Records (DNCD015)

After reading the expansive liner notes penned by rocker/scribe/devotee Sid Griffin, the reader will believe that Michael Nesmith a) usurped Gram Parsons as the true forebear of country-rock; b) was rock's true renaissance

man, having virtually invented MTV and the short-form video; c) helped propel the careers of Jerry Seinfeld, Garry Shandling, and Jay Leno; d) has never received his due; and e) is, in fact, the son of the woman who invented Liquid Paper® correction fluid.

Colossal claims maybe, but despite the hyperbole, Griffin is not overstating the case. Even before he became The Monkees' true musical mainstay (with all due credit to Peter Turk), Nesmith was well on his way to becoming a quiet but distinctive influence in

rock's repertoire.

Kudos aside, what matters here is the music. In that regard, *Papa Nez* does an admirable job of spotlighting 19 of Nesmith's most memorable melodies, from the hits he wrote for others to the fondly remembered tunes he penned for the Prefab Four to the equally capable but less successful offerings of his solo sojourns.

The Stone Poneys' "Different Drum" and Nitty Gritty Dirt Band's "Some Of Shelly's Blues" are easily his two best-known efforts,

bands, spin-offs and related alt-rock artists round out this extremely in-depth and engaging overview of the entire indie scene.

Drawing from the author's interviews with dozens of original band members (many of whom have never before agreed to an interview), record label honchos (representing key labels such as SubPop, SST, and Dischord), college and indie radio programmers, producers and recording engineers, DJs and journalists, Azerrad's *Our Band Could Be Your Life* is a thoroughly researched, first-hand account-filled historical narrative. It easily stands as the most comprehensive, compelling and compulsory read for indie rock fans, music historians and anyone else interested in discovering the story behind the alternative music culture of the post-punk, pre-grunge American indie underground of the '80s.

— Mark Wallgren

Book review

OUR BAND COULD BE YOUR LIFE (SCENES FROM THE AMERICAN INDIE UNDERGROUND 1981-1991)

by Michael Azerrad
Little, Brown And Company (522 pages, hardcover, \$25.95)

In his impressive new book, *Our Band Could Be Your Life (Scenes From The American Indie Underground 1981-1991)*, the revolutionary development of the American indie rock underground scene of the '80s is thoroughly scrutinized and supremely chronicled by the acclaimed author Michael Azerrad. Azerrad previously wrote the best-sellers *Come As You Are: The Story Of Nirvana* and *Screaming Life: A Chronicle Of The Seattle Music Scene*.

This tome is an absorbing volume that thoughtfully and effectively traces, in painstaking detail, the birth and fruition of this fiercely independent, alternative Ameri-

can music culture that arose from the ashes of the late-70s British punk uproar, flourished with amazing and unprecedented underground success throughout the Roland Reagan and George H. W. Bush presidencies and ultimately laid the foundation for the commercial coming-of-age of grunge rock in the early '90s.

Spotlighting a baker's dozen of the most influential indie bands of the period, the regional-based origins of the nationwide indie movement are illustrated via the exhaustive biographical sketches devoted to Black Flag, The Minutemen (Los Angeles); Big Black (Chicago); Mission Of Burma, Dinosaur Jr. (Boston); Sonic Youth (New York), Minor Threat, Fugazi (Washington D.C.); Butthole Surfers (Texas); Hüsker Dü, The Replacements (Minneapolis), Mudhoney (Seattle); and Beat Happening (in neighboring Olympia, Wash.). The criss-crossing histories of numerous other indie

conveyed, respectively, via a relatively reserved reading by Frog Holler and a far more assertive turn by The Flying Burrito Brothers' John Beland. While Nesmith's country quotient bears an overall influence, John Jorgenson's "You Just May Be The One" and Scott McKnight's "Sunny Girlfriend" spotlight his rock/pop side.

Despite a dearth of headliners here, the

(Please see New Releases page 46)

SERIOUS STORAGE

1,000 CDs in 4 sq. ft!

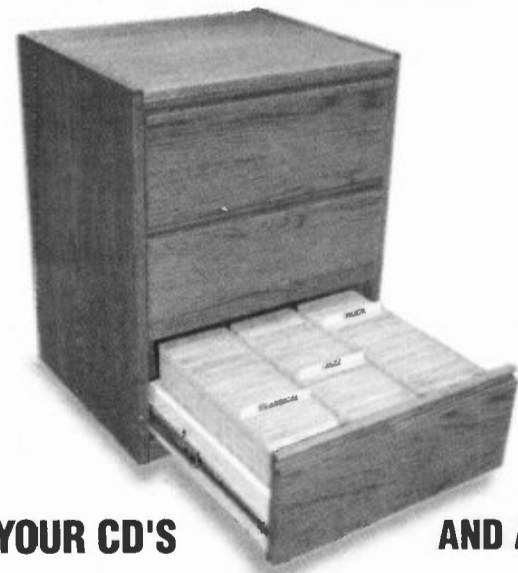

PROTECT YOUR CD'S

AND ARTWORK

And say goodbye to clutter and broken cases. The Jewelchest™ features storage for 1,000 Jewelsleeves™, the finest archival CD storage sleeve in the world.

The Jewelsleeve is a revolutionary new CD sleeve that replaces all of your fragile, bulky jewel boxes with a thin, scratch-proof poly sleeve that cannot break or tear, takes up 75% less space than a jewel box, and protects and stores EVERY PART of the CD—INCLUDING THE BOOKLET AND TRAY CARD—without folding or cutting.

Call or email for a brochure and free sample!

Jewelsleeve.com
P.O. Box 147
Nutley NJ 07110

Tel: 800/863-3312
Fax: 973/667-6644
www.jewelsleeve.com



SWINGIN' DICK'S MUSIC EMPORIUM

"Absolutely the best selection and product anywhere!"

*** Check us out at: <http://www.sdemporium.com> ***

OUR SELECTION INCLUDES (but is not limited to):

- | | |
|------------------------|------------------------------|
| • Bob Dylan | • Asia |
| • Bruce Springsteen | • Eagles & Related |
| • Chicago & Related | • Styx & Related |
| • The Doors | • Jimi Hendrix |
| • Bon Jovi | • Ratt |
| • Metallica | • Beatles & Related |
| • Def Leppard | • Genesis & Related |
| • Roadmaster | • Led Zeppelin & Related |
| • Head East | • Blue Oyster Cult & Related |
| • Prince & Related | • The Black Crowes |
| • Beach Boys & Related | • Eric Clapton |
| • Stevie Ray Vaughan | • Van Halen & Related |
| • Yes & Related | • The Who |
| • Tesla | • REO Speedwagon |

HUNDREDS MORE TITLES TO CHOOSE FROM (Including THE largest selection of '80's metal)!!

NO paper labels, NO non-printed discs! Strictly quality, professional pressings! Check our site, see what your disc(s) will look like, and judge for yourself!! Quality guaranteed!!

Online credit card processing! Quick delivery times. Log on now for details!!

<http://www.sdemporium.com>

"Come swing with us! You'll be glad you did!"

(New Releases from page 41)

bands who bear some name recognition are also the ones who deviate most from the album's distinctive down-home sound. Griffin's Western Electric add a psychedelic sensibility to their "Sweet Young Thing." The Heavy Blinkers give "Magic" a '50s finesse. On the other hand, The Mary Janes' dizzying display on "Prairie Lullaby" is spacey and surreal. Taken in tandem, they allow this loose salute to live up to its title.

— Lee Zimmerman

BLISS 66
Trip To The 13th
Epic (EK 85358)

Call me old-fashioned or a throw-back, but this reviewer enjoys bands with singers who can actually sing rather than ones who whine, grunt, growl or shout. (Isn't that why the position is called "lead singer"?)

A couple of months ago, I had the pleasure of seeing Detroit sextet Bliss 66 open a show, having never heard of them before. Recently, upon listening to *Trip To The 13th*, with the first keyboard notes of the leadoff tune, "Paramont," I was catapulted back into the concert. Now that's a memorable hook. How refreshing. The last time I saw a rock band make use of the lushness of a keyboard throughout their repertoire probably was the



Bliss 66's
Cheyenne Goff

©2001 Cathy Bernardy

last time I saw Bon Jovi. (Keyboards and grunge? Not usually. Keyboards and rap-metal? Not on your life.)

Fans of melodic rock that's making headway right now will have a difficult time getting Bliss 66's *Trip To The 13th* out of their CD players. Catchy highlights of the disc, in addition to the aforementioned lead cut, include: "Sooner Or Later," "Trip" and "Letting Go." "Crazy World" was written after lead singer Cheyenne Goff watched the news of the Columbine High School shooting.

Caution: Cranking this disc while trying to work may be counterproductive; listeners may just end up rocking out instead. Its energy is infectious. Any predictable rhymes or lines can be forgiven when one realizes that these guys are not even old enough to be served in the clubs in which they play!

Definitely check the band out live even though they are currently in a bit of a transition. As of Labor Day weekend, songwriter/lead guitarist Aaron Schossau had left the tour but still plans to write with the band. The rest of Bliss 66 are rearranging songs to perform as a quintet. Provided the band doesn't implode, the potential is there for mainstream success with the right label push. The polish (courtesy of Glen Ballard [Alanis Morissette, Dave Matthews]) and hooks are there.

— Cathy Bernardy

WILLIAM PEARS
Big Bang!
Permanent Press (PPCD 52719)

Parle vous Francais? No matter. William Pears — a band, by the way, not an individual — may be a French export, but you wouldn't know it by listening to *Big Bang!*, the fine follow-up to their self-titled 1998 debut.

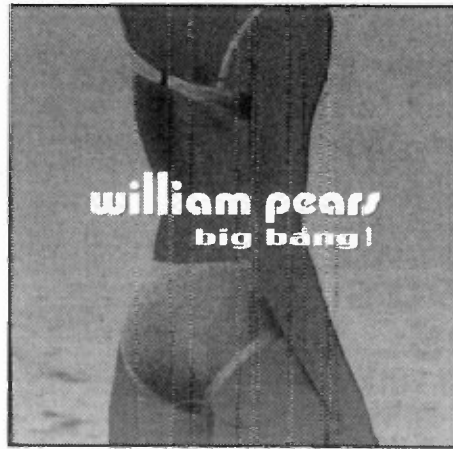

For one thing, nearly every track is sung in English. The band's Brit-rock sensibility creates comparisons that range from classic mid-60s English ensembles to more recent retro revivalists such as Squeeze and Australia's Crowded House. William Pears may be from the land of the Eiffel Tower and crepes suzette, but when positioning the Pears, it's like comparing apples to oranges. They *are* the real deal.

Without appearing phony, William Pears come by their Anglo-oriented sound easily. The shimmering ambience that permeates "Good Old Sun" sounds like vintage Yes, with singer Thierry Dubois emulating the earnest, effusive tones of Jon Anderson. The English accent that's a discernable part of his singing is especially evident on "Forever Punk," an unabashed salute to the 70s. Retro references abound, particularly on the tongue-in-cheek "Oh No (No More Of That Song)," a litany of perfect pop putdowns: "Who needs a teenage symphony/Who needs a backwards solo.../ Now is the time to let a 12-string go..."

In fact, the Pears' pop is perfect, evidenced by songs such as the title track, "Mouse And Kelly," "Easter Man" and "Je Me Venda A Qui Veut M'Entendre," the sole selection sung in French. Fresh, vibrant and irresistibly engaging, *Big Bang!* lives up to its title.

— Lee Zimmerman

SYSTEM OF A DOWN
Toxicity
American (62240)

Toxicity, the sophomore album from Ozzfest vets System Of A Down is fast, loud, and a hell of a lot more provocative than most of their peers' output. There's a heavy charge to the music — nu-metal, without a doubt but experimental where their genre pals are satisfied to stay in the same place — and one that races through the album with refreshing vitality.

Middle Eastern rhythms, Gregorian chants and complex (or at least relative to what modern metal typically offers) rhythmic structures are spaced throughout *Toxicity*. They keep it interesting lyrically, as well, getting into the minds of Charles Manson ("ATWA"), cocaine-fueled groupies ("Psycho") and a jaded big-city dweller (the title tune) — which, in fact, this Los Angeles quartet is. They even get political on "Prison Song," which, with its griping homeboy interludes, I swear is meant as some sort of parody of Fred Durst.

System Of A Down's 1998 self-titled debut was cluttered and muddy, and *Toxicity* occasionally suffers similarly. Producer Rick Rubin applies appropriate crunch, and at times it's his heavy metal thunder that sustains the album (sometimes the songs just aren't there). There's a post-goth allure to the music, which veers between black thrash and nomadic prog, and singer Serj Tankian is an appealingly dynamic frontman. Yet, there are moments of nu-metal excess, and at times it's heavy for heavy's sake. But on its core cuts (such as the slippery "Chop Suey") *Toxicity* is indeed lethal stuff.

— Michael Gallucci

(Please see New Releases page 55)

America's Best Record Rack

Your Records will be easy to organize and find, and you will never run out of space with the Original RACKIT™ Modular Record Rack system. No matter what its size, your record collection will fit in this attractive, infinitely expandable, solid oak building block system.

The portable, easy to move record rack modules hold one hundred LPs each. They are stackable up to 5 high on the Dolly. Put the Tabletop on the top rack, and you have a beautiful piece of furniture.

RACKIT storage units for all other audio/video formats and equipment are available. See www.rackittm.com for details.

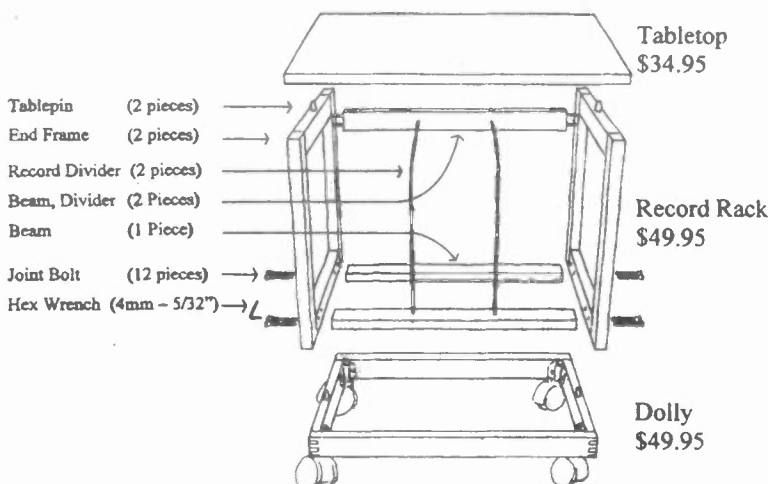

It's a great value — for as little as 50 cents a record you get convenient, space-saving storage. RACKIT is the best insurance for protecting your valuable record collection.

Factory direct to you since 1984

Place your first order today and get a free Tabletop!

Please mention Goldmine



Per Madsen Design
PO Box 882464, San Francisco CA 94188
800-821-4883 www.rackittm.com



Short Takes

When he's working his day job with the rowdy Irish insurgents Black 47, Larry Kirwan is a rocker with an antagonistic attitude. However, on *Kilroy Was Here*, Kirwan's first solo album (Gadfly 273), he slips into a meditative mode largely reminiscent of The Waterboys' compositions. With the exception of the two-part "History Of Ireland," a jaunty historical narrative, and a sterling remake of Paul Simon's "The Only Living Boy In New York," the album is defined by its rambling wordplay, free-flowing melodies and evocative anthems. (www.black47.com; Gadfly Records, Box 5231, Burlington VT 05402; 1-888-9GADFLY)... *Life On AM Radio* is an appropriate title for the sophomore set by the Canadian combo that calls itself Hennessey. Sounding like a cross between Aimee Mann and Chrissie Hynde, lead singer Pamela Brennan gives the band a radio-friendly facade, particularly on songs such as "Buddhamatic" and "Deliah" when the chorus kicks in and the band strikes a balance between the edgy and the effusive. Confident, catchy and extraordinarily engaging, Hennessey has the perfect pop posture. (www.hennessey.ca; Box 22611, 300 Coxwell Ave., Toronto Ontario M4L 2A0)... Expressive and alluring, *Shine Like It Does*, (Compass 7 4306 2) the debut album from Northeast native Eileen Rose,

is an autobiographical odyssey in song, detailing her journey from her New England roots to the old English countryside. Rose paints a series of heartfelt vignettes in an earthy, emotional style that's part folk, part country, part rock and even part retro (her "Lincoln Park" references Neil Diamond's "Sweet Caroline"). Recorded in Wales with veteran producer Jerry Boys, Rose's record reveals a confessional yet confident style that's especially evident in songs such as "Rose," "Still In The Family" and "Would You Marry Me." (www.compassrecords.com; 117 30th Ave. South, Nashville TN 37212)... *Sympatico* (Surf Road Records), Tom Freund's superb 10-song set, sounds like the work of a seasoned, sophisticated singer/songwriter. Steering between mellow, melodic alt-country compositions ("Old And In The Way," "Seat On This Train") to passionate provisos imbued with desperation ("Wake Up Call," "Do You Do"), Freund creates sinewy vibrations that frequently recall The Wallflowers in their eloquence. It's mostly the finer details that allow *Sympatico* to soar — the vibrant mandolin that kicks off "Francie," the unexpected trumpet flourishes that spark the title track — and create an experience that is memorable and mesmerizing. (www.tomfreund.com)...

— Lee Zimmerman

Porky Chedwick

Radio's most ignored pioneer and the first DJ to spin oldies

by Ed Weigle

Within the 53 years he has been Pittsburgh's "Daddio Of The Raddio," Porky Chedwick has become a radio legend, as familiar to four generations as The Pirates, Steelers, Iron City Beer and Heinz Ketchup. For the past three years, the annual "Porkstock" summer oldies festival — the only such honor ever given a DJ, living or dead — has drawn thousands to the site where Three Rivers Stadium once stood. He has hosted more than 7,000 sock hops since first spinning his 78s at social gatherings around the city's racially integrated suburbs in the 1940s. The Rock And Roll Hall Of Fame included him among its roster of legendary DJs in 1996 (although the

five weekday slot as *The Porky Chedwick Show*. With only 250 watts of power, the signal was still more than sufficient to garner Chedwick a large following. Unlike most other white R&B pioneers, Chedwick's first efforts in the fall of '48 were in broad daylight.

In Chedwick's own impoverished steelworking neighborhood, blacks and whites (as well as every ethnicity imaginable) lived side by side, secluded from much of the prejudices known beyond their tedious world. As the second of 10 children, Chedwick took it upon himself to look after the other children in his extended neighborhood family. He offered them refuge through the records he had been collecting.

"I was mainly looking for the gospel sound and down-home rhythm and blues — the songs which spoke of the problems of poor people," Chedwick recalled. "That was my music."

In the '30s and '40s, "race" or "sepia" records that were banished to stores' back shelves were often simply given to Chedwick by record store owners who couldn't sell them. "I used to have to blow the dust off them before I could play them. On the air I called them 'dusty discs,' and the Porky Chedwick sound was born!"

Chedwick's "sound" established the rich R&B-based repertoire of uniquely Pittsburgh oldies, most of which never

felt the regular kiss of a turntable stylus anywhere else on the planet. Scores of these records may have been completely forgotten because they were released only on 78 rpm discs, which, by the time radio began to embrace black records, were being phased out in favor of the more durable 45s. By 1949, when the black independent labels heard of his success with back catalog material, they inundated Chedwick with new records. He launched many recording careers and established

Once, while excitedly breaking a new record, Porky Chedwick exclaimed, "This is on fire!" Within minutes, sirens blaring, the Homestead [Pa.] fire brigade stormed the studio, responding to hundreds of phone calls from listeners insisting the station was burning down.

museum fails to tell his complete story). He's even been honored by Rep. Ron Klink on the floor of the U.S. Congress as an oldies pioneer. The importance of Chedwick's accomplishments in the dawning days of rock 'n' roll far transcends The Steel City and time itself. Still, more than half a century later, the history books continue to exclude him.

Craig "Porky" Chedwick blazed a dual trail by establishing a foundation for what fellow Caucasian and Pennsylvanian Alan Freed would call "rock and roll" four years later. Porky was the first DJ to present a program of R&B, gospel and jazz — exclusively by black artists — within earshot of a major East Coast city. The "dusty discs" he featured also made him the first bona fide oldies DJ in America. The trend he started days after launching his career at WHOD in Homestead, Pa., on Aug. 1, 1948, gave rise to a still-thriving, billion-dollar industry — including record labels and radio station formats — dedicated to meeting the demand for rock 'n' roll nostalgia. In fact, years later, when concert promoter Richard Nader organized his first rock 'n' roll revival concerts — essentially the catalyst for the '50s music craze of the 1970s — he cited his influence as none other than his hometown hero, Chedwick.

Chedwick was already a popular public address announcer at local school athletic events and a sports stringer for the newspaper in his native Homestead. He learned that a small daytime-only radio station was debuting in the suburb to present ethnic and foreign-language programming to Pittsburgh's vast immigrant blue-collar population. He was instantly granted a five-minute Saturday afternoon sports commentary program and convinced station management to allow him to play records from his own collection. His music was so well received that the sports portion was dropped and his *Masterful Rhythm, Blues And Jazz Show* was expanded to five hours, seven days a week. It finally occupied the noon to

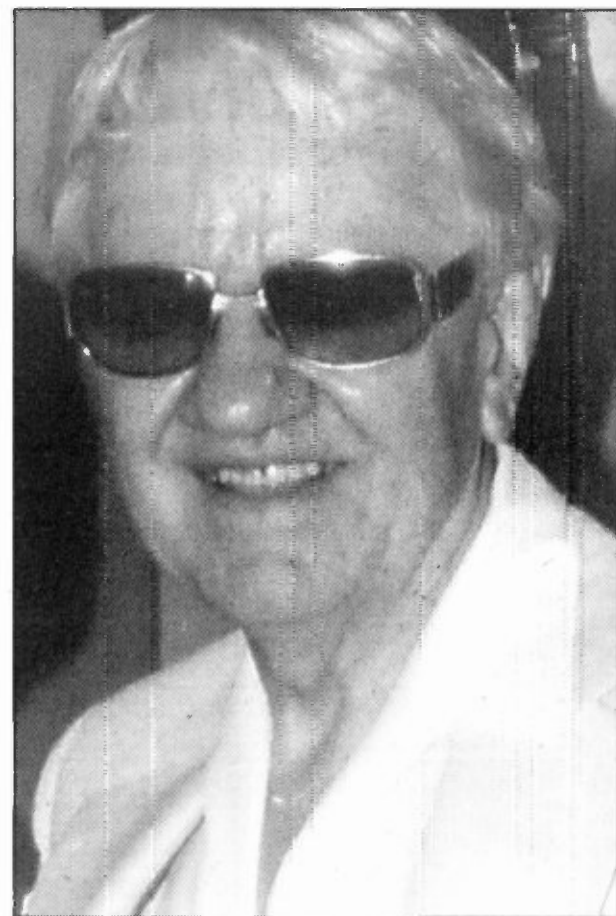

Photos courtesy of Ed Weigle

Pittsburgh as a major industry testing ground for R&B; still, oldies would always dominate his playlist. Nothing could ever make "The Bossman" play a record he wasn't confident his "movers and groovers" would "dig" — a fact that served in his defense when payola witch-hunters came knocking in 1960. From his WHOD "Spinner Sanctum," situated by the Ohio River, the sounds of Roy Brown, Wynonie Harris, Hank Ballard — and their often provocative lyrics — first regularly reached young white ears in that part of the country.

In 1956, "The Station Of Nations," WHOD, abandoned its ethnic manifest and assumed a country format, with Chedwick's show the only exception to the twang. The station became WAMO, an acronym for the rivers Allegheny, Monongehela and Ohio. Two years later, it underwent its most revolutionary change by switching from "hillbilly" to R&B, with an entirely black air staff. All except for Chedwick, that is.

Chedwick's youthful legions — most of whom thought he was black — responded to the "Pied Piper Of Platter" with such fierce loyalty that one can only look back in wonder. The fact that he didn't even have 1,000 watts behind his

(Please see Porky Chedwick page 50)

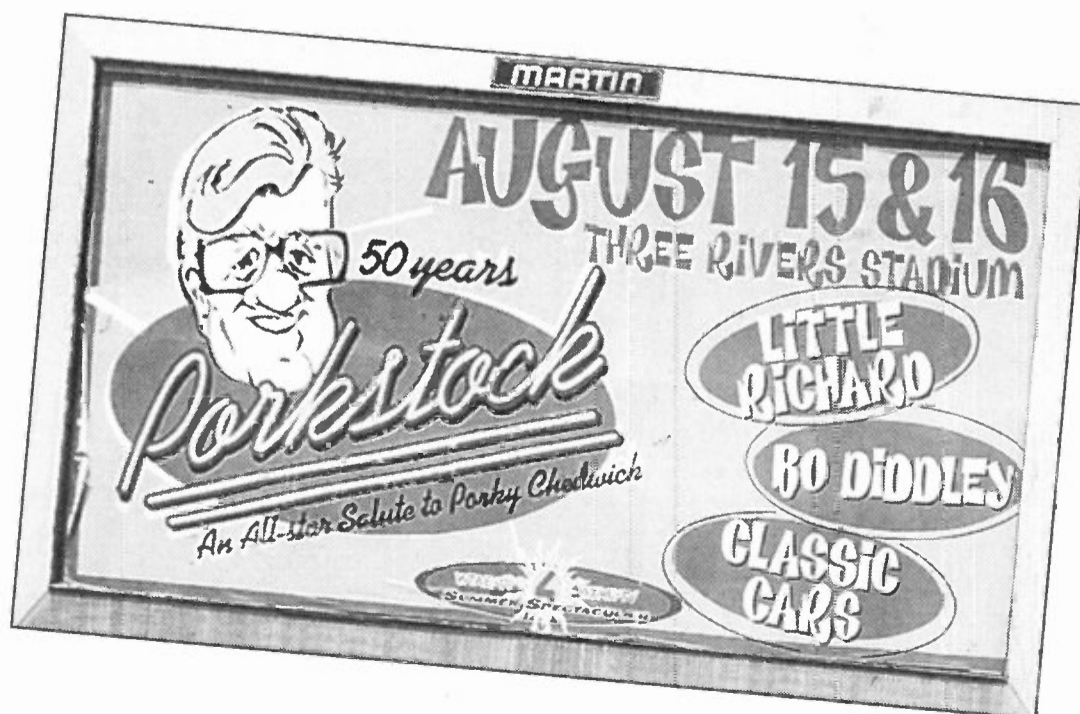

A billboard for the 1998 festival.

Photos courtesy of Ed Weigle



Fred Johnson of The MarceIs, singing "Blue Moon" at a Porkstock festival.

(Porky Chedwick from page 48)

signal until 1960 makes it all the more extraordinary. When he would open the microphone to shout over the record, "Blow your horn!" during a wailing sax solo, Pittsburgh would respond with a cacophony of car horn blasts! Once, while excitedly breaking a new record, he exclaimed, "This is

on fire!" Within minutes, sirens blaring, the Home-stead fire brigade stormed the studio, responding to hundreds of phone calls from listeners insisting the station was burning down. Police weren't amused, either, the time Chedwick told his listeners to stop whatever they were doing and start dancing. The resulting traffic mess from kids getting out of their cars to dance in tunnels and on parkways took hours to clean up. At a remote broadcast under the marquee of the Stanley Theatre in Pittsburgh in 1961, more than 10,000 kids crowded the streets, with another estimated 50,000 in transit. The resulting gridlock prompted Mayor Joseph M. Barr to personally come to the site to request an end to the broadcast.

In 1964, WAMO moved to downtown Pitts-burgh. "The Platter Pushin' Pappa" remained the top draw at the station through the end of the decade and was even named by *Esquire Magazine* as "Pittsburgh's Top DJ Of 1965." His radio presence remained constant for most of his first 40 years, including a 1972 weekend overnight stint on the legendary 1410 KQV. While critics lambasted him for corrupting kids with his "evil music," his private crusade against juvenile delinquency, alcohol and drug use earned the accolades of Sen. Estes Kefau-ver. Chedwick established youth baseball teams and even took several boys out of juvenile court and had them placed in his custody.

In spite of his kindness, fate would not reciprocate where his own family was concerned. He would lose two daughters in infancy and one of his three sons at age 16. Although Chedwick was never motivated by money, his lack of business acumen and reputation for being too kind kept him constantly at the mercy of charlatans, who absconded with most of the profits generated from the many record albums and other projects to which he lent his name and likeness.

"I made a million dollars, but I never saw it," he said, with

only a hint of regret. He never enjoyed the benefit of a six-digit salary like many better-known radio luminaries who, in fact, came on the air after him. He didn't even make union wages for most of his career. In 1991, a year after surgery to remove a large, benign brain tumor, he declared personal bankruptcy. He continues to live from sock hop to sock hop.

Chedwick moved on to several other suburban stations after leaving WAMO in 1984 — a casualty of a new era of radio, where "personality" was no more understood by young program directors than the nontraditional, regional oldies that made his show what it was. His illness in 1990 sent a shock wave through Pittsburgh, as well as a large national community of early rock 'n' roll stars, who gave a benefit concert to help pay his medical bills. Today, in spite of slightly diminished hearing and the complete uselessness of an eye first injured in a slingshot mishap when he was eight, his health is excellent. Jeannie, his wife since shortly before his illness, has admirably taken the reins of his business affairs. His return to WAMO after nearly eight years, his inclusion in The Rock And Roll Hall Of Fame and the "Porkstock" honor have together sparked a new life for the Porky Chedwick legend in Pittsburgh. He is currently heard every Saturday afternoon on WAMO, Sunday nights on WLSW-FM in Connellsville and monthly on 3WS-FM (WWSW) in Pittsburgh. Still, far too few people realize what Chedwick's trailblazing achievements have meant to a global audience.

It's the sincere hope of this writer that music history scholars will finally take a closer look at Chedwick — one the last living radio pioneers of the roots of rock 'n' roll. It is simply intolerable that a man who was one of the very first to perpetuate the music of an entire era should be one of the very last to be given credit. Without Chedwick, no popular music history book can ever be complete.

[Editor's note: Ed Weigle is operations manager for WEDJ-FM/WSYW-AM in Indianapolis and owner of WeigleVOX Productions International. He credits Chedwick with helping to start his successful voiceover career when Weigle was just 13. Weigle's voice has colored commercials and radio station imaging for 21 years.]

GOLDMINE GRADING GUIDE

VISUAL OR PLAY GRADING?

In an ideal world, every record would be played before it is graded. But the time involved makes it impractical for most dealers, and anyway, it's rare that you get a chance to hear a record before you buy through the mail. Some advertisers playgrade everything and say so. But unless otherwise noted, records are visually graded.

HOW TO GRADE

Look at everything about a record — its playing surface, its label, its edges — under a strong light. Then based on your overall impression give it a grade based on the following criteria:

Mint (M): Absolutely perfect in every way — certainly never played, possibly even still sealed. (More on still sealed under "Other considerations"). Should be used sparingly as a grade, if at all.

Near Mint (NM or M-): A nearly perfect record. Many dealers won't give a grade higher than this implying (perhaps correctly) that no record is ever truly perfect.

The record should show no obvious signs of wear. A 45 RPM or EP sleeve should have no more than the most minor defects, such as almost invisible wear or other signs of slight handling.

An LP jacket should have no creases, folds, seam splits or any other noticeable similar defect. No cut-out holes, either. And of course, the same should be true of any other inserts, such as posters, lyric sleeves and the like.

Basically, an LP in Near Mint condition looks as if you just got it home from a new record store and removed the shrink wrap.

Near Mint is the highest price listed in all *GOLDMINE* price guides. Anything that exceeds this grade, in the opinion of both buyer and seller, is worth significantly more than the highest *GOLDMINE* book value.

Very Good Plus (VG+): Generally worth 50 percent of the Near Mint value.

A Very Good Plus record will show some signs that it was played and otherwise handled by a previous owner who took good care of it.

Record surfaces may show some slight signs of wear and may have slight scuffs or very light scratches that don't affect one's listening experience. Slight warps that do not affect the sound are OK.

The label may have some ring wear or discoloration, but is should be barely noticeable. The center hole will not have been misshapen by repeated play.

Picture sleeves and LP inner sleeves will have some slight wear, lightly turned-up corners or a slight seam-split. An LP jacket may have slight signs of wear also and may be marred by a cut-out hole, indentation or corner indicating it was taken out of print and sold at a discount.

In general, if not for a couple of minor things wrong with it, this would be Near Mint. All but the most mint-crazy collectors will find a Very Good Plus record highly acceptable.

Very Good (VG): Generally worth 25 percent of the Near Mint value. Many of the defects found in a VG+ record will be more pronounced in a VG disc. Surface noise will be evident upon playing, especially in soft passages and during a song's intro and fade, but will not overpower the music otherwise. Groove wear will start to be noticeable, as will light scratches (deep enough to feel with a fingernail) that will affect the sound.

Labels may be marred by writing, or have tape or stickers (or their residue) attached. The same will be true of picture sleeves or LP covers. However, it will not have all of these problems at the same time, only two or three of them.

GOLDMINE price guides with more than one price will list Very Good as the lowest price. This, **not** the Near Mint price, should be your guide when determining how much a record is worth, as that is the price a dealer will normally pay you for a Near Mint record.

Good (G), Good Plus (G+): Generally worth 10-15 percent of the Near Mint value. Good does not mean Bad! A record in Good or Good Plus condition can be put onto a turntable and will play through without skipping. But it will have significant surface noise and scratches and visible groove wear (on a styrene record, the groove will be starting to turn white).

A jacket or sleeve will have seam splits, especially at the bottom or on the spine. Tape, writing, ring wear or other defects will start to overwhelm the object.

If it's a common item, you'll probably find another copy in better shape eventually. Pass it up. But, if it's something you've been seeking for years, and the price is right, get it... but keep looking to upgrade.

Poor (P), Fair (F): Generally worth 0-5 percent of the Near Mint price. The record is cracked, badly warped, and won't play through without skipping or repeating. The picture sleeve is water damaged, split on all three seams and heavily marred by wear and writing. The LP jacket barely keeps the LP inside it. Inner sleeves are fully seam split, crinkled and written upon.

Except for impossibly rare records otherwise unattainable, records in this condition should be bought or sold for no more than a few cents each.

OTHER CONSIDERATIONS

Most dealers give a separate grade to the record and its sleeve or cover. In an ad, a record's grade is listed first, followed by that of the sleeve or jacket.

With **Still Sealed (SS)** records, let the buyer beware, unless it's a U.S. pressing from the last 10-15 years or so. It's too easy to re-seal one. Yes, some legitimately never-opened LPs from the 1960s still exist. But if you're looking for a specific pressing, the only way you can know for sure is to open the record. Also, European imports are not factory-sealed, so if you see them advertised as sealed, someone other than the manufacturer sealed them.

A FEW NOTES ON COMPACT DISCS

In theory, a compact disc should always play-grade in at least Near Mint condition. And even the condition of generic jewel boxes and trays aren't important, as they can be replaced easily.

Unless the CD came in a special package (fold-open, fold-over, colored plastic, etc.), the two areas to check for grading are its label and its insert (booklet).

Most collector interest currently is with promotional CD's. Again, audible condition of the disc is less of a concern than the condition of its packaging and art-work and the collectibility of the artist.

Used full-length, commercial CD's generally sell for 50-75 percent of the new price. Dealers in used CD's will usually pay no more than 50 percent of that price, and often much less.

COMMON ABBREVIATIONS (not including grades)

7" - standard 45 RPM record
10" - 10-inch vinyl LP
12" - 12-inch single
bb - bb hole in cover
boot - bootleg
cc - cut corner
cd - compact disc
cd3 - 3" compact disc single
cd5 - 5" compact disc single
ce - cut-out

coh - cut-out hole
dj - disc jockey (promo)
ep - extended play 45
imp - import
lp - 12" vinyl album
m - *mono LP
nap - not affecting play
non-lp - not on full-length LP or CD
oc - original cast recording
ost - original soundtrack

pc - picture cover (12" and CD's)
pi - picture insert (CD single)
promo - promotional copy
ps - picture sleeve (45s)
quad - quadraphonic
re - reissue
ri - reissue
rpm - revolutions per minute
rw - ring wear
s - stereo LP

sl - slight
sm spl - seam split
soc - sticker on cover
sol - sticker on label
ss - still sealed
s/t - self-titled
tc - title cover (12" and CD's)
tl - title insert (CD single)
toc - tape on cover
tol - tape on label

UK - United Kingdom (British import)
US - United States (domestic pressing)
va - various artists
wlp - white label promo
woc - writing on cover
wol - writing on label
xol - "X" written on label
 *check the context, as "m" can also mean "mint"

INSURANCE

- ✓ **Collector annual rates:** \$3,000 for \$12, \$10,000 for \$32, \$25,000 for \$82, \$40,000 for \$132, \$60,000 for \$198, \$1/\$1,000 above \$60,000. Call for a no obligation collector, dealer or collector/dealer quote
- ✓ **We insure collectibles:** Records, animation art, autographs, books, bottles, ceramics, china, clothing, comics, crystal, currency, dolls, figurines, glass, maps, military/movie/political/sports/TV memorabilia, ornaments, paper, patches, pens, photos, pins, plates, postcards, posters, prints, stamps, stocks/bonds, Teddy Bears, toys, trains, and over 100 other collectibles. Call about what you collect.
- ✓ Our insurance carrier is **A.M. Best's rated A+ (Superior)**.
- ✓ **All risk coverage:** Crime, fire, flood, earthquake, hurricane, wind, tornado, natural catastrophes, breakage, travel, shows, unattended auto, auctions, consignments, worldwide mail, internet and mail order shipments worldwide by: UPS, FedEx, DHL, TNT, consignments and property of others in your care.
- ✓ Losses paid at **current replacement value**. Current retail to collectors and current wholesale to dealers.
- ✓ **A detailed inventory or professional valuation is not required.** Collectors list items over \$5,000, dealers have no inventory listing requirements.
- ✓ **VISA, MasterCard & Discover welcome.**

Collectibles Insurance Agency, P.O. Box 1200 GOLD, Westminster, MD 21158
Toll Free 1-888-837-9537, Fax 410-876-9233
E-mail: Info@Insurecollectibles.com Web site: www.collectinsure.com

ARTIST	TITLE	LABEL	\$
DAIKOKU BLD. 4F 7-8-11HISHIYUKU, SHINJUKU-KU, TOKYO 160-0023			
*POSTAGE 1-3 DISCS \$10.00; OVER 4 DISCS: ADD \$1.00 FOR EACH DISC			
*PAYMENT ONLY US \$ ON CASH OR INTERNATIONAL POSTAL MONEY ORDER			
*BEFORE YOU MAKE A PAYMENT, PLEASE CONFIRM STOCK TO US BY FAX, MAIL OR E-MAIL			
*DISCOUNT OVER 100 DISCS - 10% OFF!			
*OVER 300 DISCS - 15% OFF!			
*SEND \$3.00 FOR OUR COMPLETE CATALOG INCLUDING MANY CD TITLES.			
*AND WE CAN SEND COMPLETE CATALOG BY E-MAIL FOR FREE!!			
ANI DIFRANCO	"NOT A PRETY GIRL" <Sony Studio, NY 97+World Cafe, Sep. 20 97+Toronto, Sep. 18 93> SB sunflower		17
ASIA	"BURNING CASTLE(2CD)" <Osaka Castle Hall, Japan Dec. 9 1982>"	acqua light	40
ASIA	"MIDNIGHT SUN(2CD)" <Chicago Jun. 17 82+J.Wetton & G.Downes+inter-	view 82> aqua light	40
BEACH BOYS	"WOULDN'T IT BE NICE" DOWNUNDER 1978 <Melbourne Mar. 3	"78 w/B.Wilson+Unreleased" SB" sweet encore	20
BEACH BOYS	"SMILEY SMILE-STEREO VERSION"		22
BEACH BOYS	"WILD HONEY-STEREO VERSION"		22
BOB DYLAN	"SENSEI" <Kousei Nenkin, Hiroshima, Japan Feb. 16 1994>" home		20
BOB DYLAN	"TRUE LOVE NEEDS NO COMPANY(2CD)" <Munster, Germany Oct. 1	00+Hamburg Sep. 28 00> SB" euro boots	38
CAMEL	"NUDE IN HAMMERSMITH(2CD)" <Hammersmith Odeon,London Feb.27	1981> aqua light	31
CHEAP TRICK	"RADIO LOVER" <Unreleased songs 1992-1997>		16
CREAM	"GARDEN OF ELECTRIC DELIGHTS" <MSG, NY Nov. 2 68+L.A. Coliseum	Oct.19 68> "supersonic"	23
E.L.O.	"HOLD ON TIGHT(2CD)" <Wembley Arena, London 1982>" trystar		33
ELVIS COSTELLO	"FATAL ATTRACTIONS(2CD)" <Royalty Theatre, London Nov.	23 1986> "popmaster	32
ELVIS COSTELLO	"SUPREACTIVE LIVE" <Essen, Germany Jul. 2 78+Montreau	Jazz Fest Jul.12 80> "norria	17
ERIC CLAPTON	"KEY TO THE NEW CENTURY(2CD)" <Royal Albert Hall,London	Feb.3 2001> "a karat	31
ERIC CLAPTON	"TRAVELLING ROAD OF DRIFT(2CD)" <Royal Albert Hall,London	Feb.9 2001> "a karat	31
FIRM DOUBLE CLOSER(4CD)" <L.A. Forum Mar. 14 85+Oakland Coliseum Mar.	15 85> SB blimp		62
FLYING BURRITO BROS	"STEEL BURRITO" <Seattle Pop Fest. Jul. 27	'69+Wynona, Minnesota May '70> SB" polar bear	38
FRANK ZAPPA	"A VEGETABLE BY ANY OTHER NAME" <Copenhagen, Denmark	Nov. 21 71> "try star	20
HUMBLE PIE	"RUMBLE HUMBLE(2CD)" <Shibuya-Koukaido, Tokyo May 16	1973> "try star	30
JAPAN	"METHODS OF TIN DRUM(2CD)" <Hammersmith Odeon, London Dec. 23	1981> "combat	31
KINKS	"TWELVE INCHES" <Rarities AR. Mix, Demo, outtake, Live etc.>		16

SHAGBAG RECORDS MEMORABILIA & RARE VINYL / CD

www.shagbag.co.uk
 **ON-LINE SHOPPING** 

Rare Band & Crew Memorabilia
 from European and world wide tours.
 Itineraries, Backstage Passes, Autographs, Crew Jackets, Programmes, Posters etc. etc. + Vinyl and CDs.
Most Styles incl. Classic SXL's
 P.O. Box 1483, Sheffield, S11 9XW, UK.
 Tel: +44 (0)114 255 2116 • Fax: +44 (0)114 250 9911
 E-mail: enquiries@shagbag.co.uk

The World's Rarest Records

45's, 78's & LP's: 1930-1963





BUY

- Blues • Rhythm & Blues
- Rockabilly • Rock & Roll
- Surf • Girl Groups
- Country • Charted Hits

If you're buying or selling rare records you should contact:
JOHN TEFTELLER  **SELL**
 P. O. Box 1727, Grants Pass, OR 97528
 Ph: (541) 476-1326 FAX: (541) 476-3523

See AND Hear *The World's Rarest Records* on your computer!
 Website: www.worlds.rarest.records.tefteller.com or www.tefteller.com



Compiled by JOHN MANSHIP dealer/collector since 1969
 This is a reliable & realistic illustrated price guide

Comprehensive listing with both A & B side

Full label & release number listed

Over 10,000 titles listed, plus labels & pictures

Price Range of \$10 to \$8000

All titles that have been bootlegged are specified

The world's first RARE SOUL price guide compiled with 32 years experience

1/16 429.00
1/15 848.00

John Manship

AT LAST!! A GENUINE RARE SOUL PRICE GUIDE FOR NORTHERN SOUL/FUNK/70's/SOUL USA RELEASE 45's

Compiled by John Manship 32 Years Dealer/Collector
 This Limited Illustrated Edition Available For \$40.00
 Fully Comprehensive Listing of Both A & B Side Listed.
 All Labels & Release Numbers Noted
 All In Artists Order
 With All Titles That Have Been Bootlegged Noted.
 Limited Edition So Be Quick To Avoid Disappointment.

\$40.00 plus Shipping & Handling (\$14.00 First Class Air Mail)

All Credit Cards Accepted.

Orderline Phone: 44 1664 464526 FAX: 44 1664 464155
E-Mail: Info@raresoulman.co.uk

JOHN MANSHIP RECORDS
 45 Dalby Road, Melton Mowbray, LE13 OBG, England

VINYL TAP MAIL ORDER MUSIC

1 Minerva Works, Crossley Lane, Kirkheaton, Huddersfield, W Yorks, England HD5 0QP
 Tel: 01484 421446
 Fax: 01484 531019
 E-mail: sales@vinyltap.demon.co.uk
 Web site: <http://www.vinyltap.co.uk/>



Specializing in rare and collectable CDs, Vinyl and memorabilia
 Over 75,000 items currently in stock.

Let us know what artists / groups you collect, CDs and Vinyl or both
 Write, Phone or Fax for **FREE Lists**

<http://www.vinyltap.co.uk/>

Lists now available by e-mail - just ask Web site updated weekly

Reissues

Courtesy of Chrysalis Records © Armando GallorRetna



Blondie (from left): Frank Infante, Clem Burke, Nigel Harrison, Jimmy Destri, Debbie Harry, and Chris Stein.

BLONDIE
Blondie
Chrysalis (72435-33596-2-1)

Plastic Letters
Chrysalis (72435-33598-2-9)

Parallel Lines
Chrysalis (72435-33599-2-8)

Eat To The Beat
Chrysalis (72435-33597-2-0)

Autoamerican
Chrysalis (72435-33595-2-2)

The Hunter
Chrysalis (72435-33670-2-2)



Blondie had already etched their name firmly and deeply into the tree of rock 'n' roll prior to the release of their sixth album, *The Hunter*, in 1982, so even the substandard material and overall boring sound of that LP couldn't shake the reputation they had forged for themselves by then. From their mid-70s debut in New York as a punk band to their flirtations with pop and even disco, Blondie rode the crest of the new wave, hanging 10 and leaving their competition in the riptide. Now Chrysalis has released all six of Blondie's original albums, all remastered and beefed up with bonus tracks.

Blondie, the group's 1976 debut and one of the freshest and most original records in their catalog, is still more fun than a David Lynch film festival, with its punk anthems "X Offender" and "Rip Her To Shreds." The reissue also houses five bonus tracks, including two from their first demo, "Out In The Streets" and "Platinum Blonde," as well as the B-side "The Thin Line" and two outtake versions of "X Offender" and "In The Sun."

Plastic Letters (1977), another fine album on its own, is made even more special with the top quality remastering and the addition of tracks such as B-sides "Scenery" and "Poet's Problem," a kicking live version of "Detroit 442" and a 1975 version of what would later become the band's first #1 single, "Heart Of Glass," called "Once I Had A Love (a.k.a. The Disco Song)."

The original version of the hit "Heart Of Glass" as well as a 1978 funk version of "Once I Had A Love" — which is actu-

ally better in a lot of ways than the single — and the original Top 10 hit "One Way Or Another" all appear on the reissue of *Parallel Lines* (1978). The album also includes excellent live versions of "Hanging On The Telephone," "I Know But I Don't Know" and T. Rex's "Bang A Gong (Get It On)."

The re-release of *Eat To The Beat* (1979) of course features the #27 single "Dreaming" and the #17 title track "Eat To The Beat." In addition, there are Blondie's live cover of Johnny Cash's "Ring Of Fire" (from the movie *Roadie*) and live versions of "Die Young, Stay Pretty," The Four Tops' "Seven Rooms Of Gloom" and David Bowie's "Heroes."

Autoamerican (1980) has the distinction of yielding one of the very first commercially successful rap tunes — "Rapture," as well as the reggae hit "The Tide Is High." The reissue kicks things up a notch with the chart-topping "Call Me" from *American Gigolo*, the B-side "Suzy & Jeffrey" and the disco mix of "Rapture."

The Hunter (1982), as mentioned previously, is pretty much an embarrassment when held up the light of comparison alongside the group's five previous offerings. The album was issued to fulfill an obligation to their record company after the band's demise, and is as such pretty much filler. For the record, the reissue includes a bonus track, "War Child (Extended Mix)."

Each of the Blondie reissues comes complete with enhanced packaging and extensive liner notes written by the albums' producers Richard Gotteher and Mike Chapman. The six CDs here are "must haves" for the Blondie fan, the New York rock/Max's Kansas City/CBGB archivist or anyone who still holds a warm spot in his or her heart for Debbie Harry, so all these years later. Skip *The Hunter* and buy the other five, get yourself a beer and a burrito, pop the CDs into your stereo and eat to the beat.

It's trendy to be retro.

— Michael Buffalo Smith

REISSUES NEWS



Out now: *Mr. Dixon's Workshop* (Fuel 2000) features 18 tracks written by blues legend Willie Dixon in the '50s and '60s as done by the original artists on the Cobra, USA, Jewel, and other labels. Dixon, who produced most of the cuts also plays bass on a few. Fellow blues icons such as Otis Rush ("I Can't Quit You Baby"), Magic Sam ("Easy Baby" and "All Night Long"), Junior Wells ("Two-Headed Woman" and "She's A Sweet One"), Mickey Gilley ("My Babe"), Buddy Guy ("Sit And Cry [The Blues]"), and the late Betty Everett ("My Love"), among others. Also included, from Cobra's archives, are a piano-only demo of "My Love Will Never Die" with Dixon on vocals, followed by Rush's full-band version. Liner notes were written by *Goldmine* writer Bill Dahl... *The Fixx's Phantoms (One Way)* from 1984 has been remastered by One Way, which has also released an *Archival Edition* of The Producers' 1987 *Colectanin* album... Rounder Heritage just released Buckwheat Zydeco's *Buckwheat's Zydeco Party — Deluxe Edition*... From Universal comes *The Best Of Donnie Iris — 20th Century Masters/The Millennium Collection*, a 12-track set of early '80s new-wave songs from the solo career of Donny Iris, the former lead singer of The Jaggerz ("The Rapper") and a former member of Wild Cherry ("Play That Funky Music"). Universal has also released Squeeze's *Greatest Hits*, the only Squeeze best-of to combine their A&M tracks along with their late-80s comeback hits... Columbia just released *Alice In Chains Greatest Hits*, a 10-song set that pretty much replicates the band's 1999 *Best Of The Box* set... *The Cream — John Lee Hooker* (Fuel 2000) is a two-disc, 15-song set of the late great bluesman's repertoire... *The Very Best Of Phoebe Snow* (Columbia/Legacy) collects her best from the '70s to the '90s, including "Poetry Man," her #5 hit from 1975, and two previously unreleased live tracks from a 1977 Carnegie Hall concert

Coming soon: Due Oct. 9 from Collectables are *The Very Best Of Hank Ballard And The Midnighters*, a 25-track set that includes the original version of "The Twist," later made a mega-hit by Chubby Checker, and "Finger Poppin' Time"; *The Very Best Of The Royals And The Midnighters*, which also features Ballard and also runs 25 tracks; *The Very Best Of Little Willie John*, a 25-song album that includes the classic "Fever," covered later by Peggy Lee, The McCoys and many other artists... Also coming Oct. 9 is *Jerry Butler — The Gamble & Huff Sessions* (Universal)... *Al Jardine Family And Friends*, from Beach Boys singer Al Jardine, is due Oct. 30 from Varese Sarabande... *George Harrison's The Concert For Bangla Desh* — the first benefit album released by a major rock artist — is set for a Nov. 29 reissue. The star-studded concert was Aug. 1, 1971, at New York's Madison Square Gardens and features, among others, Ringo Starr and Jim Keltner on drums, Eric Clapton and Jesse Ed Davis on guitars, Klaus Voormann and Carl Radle on bass, Billy Preston and Leon Russell on keyboards, and members of Badfinger on acoustic guitars and percussion. One of the highlights of the concert was a last-minute appearance by Bob Dylan — his first live showing in two years. Phil Spector and Harrison were involved in the album's production. The album went gold and spent 41 weeks on the Top 200 album charts, debuting at #14 and two weeks later hitting #2, where it stayed for five weeks.

— Greg Lescier

ROY FORBES ("BIM")
Kid Full Of Dreams
Casino (LP 1007)

The Human Kind
AKA (1002)

Almost Overnight
AKA (1003)

Crazy Old Moon
AKA (1004)

Like any country, Canada has its musical secrets. There's more happening north of the border than Celine Dion, Alanis Morissette, Shania Twain or — going back a few years — Anne Murray, Gordon Lightfoot, and The Guess Who. Canada has its share of artists who toil away with little hope of breaking through to the mainstream at home or abroad. Sometimes these niche artists deserve the attention of *Goldmine's* readers.

Roy Forbes (a.k.a. Bim) has been turning out superior fare since the mid-70s. Based in Vancouver, British Columbia, Forbes has sustained a modest career that has supported him through touring, producing and songwriting for nearly 30 years. To date, Forbes' records have not exactly flooded the market: There have been 11 albums since 1975. Forbes' vocal style is quite striking; he is what the old *Seinfeld* show would have called a "high singer." Imagine the opening line to Roy Orbison's "Only The Lonely" and consider that Forbes often descends into that range.

Here is a look at four releases — his first album, from 1975, followed by the three most recent.

Kid Full Of Dreams (originally distributed in Canada by A&M) is an absolute gem. The

quality of these performances is so startlingly high one wonders how this album didn't rise to the top when it first appeared. Many of these tracks (Forbes originals) received extensive airplay in Canada, and several were released as singles. But without a solid U.S. connection, things just stalled. Tracks such as "Morning Mail," "Me And My Baby," "You Can't Expect Me To Change" and "Don't Try To Get To Sleep" simply settled into cult status north of the border.

One selection from this LP that has stayed with Forbes, even guiding much of his subsequent career, is "I'm So Lonesome I Could Cry." This vocal/acoustic slide guitar version of the Hank Williams classic exudes raw emotional power and has virtually guaranteed Forbes' reputation a quarter of a century later. To this day, he can't perform a show without it.

Although the CD *The Human Kind* sometimes sounds as if it's trying to be a country album, there is an eclectic quirkiness here that keeps things from descending into mainstream country. Granted, the source of much of the material is roots-country (Hank Williams, Bob Wills, Don Gibson, Webb Pierce, and The Carter Family), but Forbes brings his own vision to much of this music.

This keeps him distinct from the often lobotomized country charts. In fact, he is arguably least successful when he veers closest to the country mainstream and most successful when he delivers this material with a wonderfully slinky, jazzy retro feeling, as he does on "A Sweet Kind Of Love" — the album's best track. On *Not Tonight* you can hear unmistakable traces of Chris Isaak, although Forbes is quick to note that he doesn't listen to many modern records.

Almost Overnight is a landmark release in

Forbes' career. Facing the fact that music from his first four Bim albums was no longer available, Forbes took a stark vocal/acoustic guitar approach to re-recording 18 of his most-requested tracks from this period, "liberating these songs from 'out of print' hibernation," to use his words.

Bringing a minimalist approach to these 1970s/early '80s tracks makes them quite stunning, often eclipsing the impact of the originals. At the least, this CD provides a telling glimpse of Forbes in person. He is a powerful and percussive guitar player with an unmistakable bluesy edge to his work. There is also a strong melodic quality to his music, despite its relatively simple structure. Forbes talks about nailing many of these tracks in one take. I can only assume that he must have collapsed into a heap after his spectacular performance of "You Can't Expect Me To Change."

The most recent CD, *Crazy Old Moon*, is a mixed bag stylistically. While some of it seems less distinguished by Forbes' high standard, tracks such as the title tune, "No One To Talk To But The Moon" (a duet with Cindy Church) and "I Always Knew I Loved You" are more than worth the price of admission.

Like most *Goldmine* readers, Forbes is an avid record collector. His love of roots music permeates these recordings. You can use any of these albums with glee to blindfold-test your friends as well as to expand your knowledge of the lesser-known side of Canadian music. (The three AKA releases are available from Festival Distribution, 1-800-633-8282. You can visit the Roy Forbes Web site at www.festival.bc.ca/royf/.)

— Hank Davis

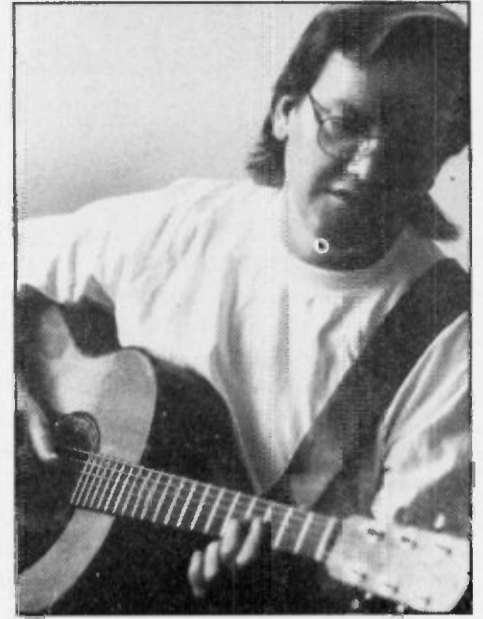

Roy Forbes

POCO

Live

One Way (A 32337)

It's April 1976. All of the U.S. is preparing for the 200th anniversary of our country some three months away. Musically, ace guitarist Peter Frampton has been surprising the competition with a huge hit live double album (*Frampton Comes Alive*) while the first and only live Beatles album is only days from release (*The Beatles At The Hollywood Bowl*).

In this climate, it does make some sense for Epic records to release the second live

(Please see Reissues page 70)

The Only Brit ever to win a Handy Award
has a new album.

peter green
splinter group

time
traders



Music That Matters
www.bluestormmusic.com



25 great folk revival albums not limited to the 1960s

by Bruce Sylvester

The '60s folk revival neither began nor ended in the '60s. It was a spirit, a renaissance, a rediscovery of ancient ballads and styles that led far beyond mere mimicry to a flowering of creativity that honored tradition but still moved forward. Like English punk (itself a folk movement), it was inextricably tied to contemporary events: the civil rights movement, Vietnam, political assassinations and, eventually, the death of the American dream in the hearts of its true believers. With that in mind, here are 25 albums that helped define the folk movement.

Odetta Sings Ballads And Blues (Tradition, 1956). The opera-trained Odetta unleashes her mighty power to boom out centuries of black pain and strength on *Odetta Sings Ballads And Blues*. Anything more than her acoustic guitar would have been superfluous beside her roars and low, low moans.

The Weavers' Reunion At Carnegie Hall (Vanguard, 1957). "When I hear America singing, The Weavers are there," Carl Sandburg said. Yet, in the ashes of McCarthyism, these buoyant pinkos — Pete Seeger, Ronnie Gilbert, Fred Hellerman, and Lee Hays — had no idea they were still popular until the sold-out show immortalized in *The Weavers' Reunion At Carnegie Hall*. After a rousing global tour in song, we get their dreamy theme, Leadbelly's "Goodnight Irene."

Joan Baez (Vanguard, 1960). Cutting to the marrow of human sorrow, the professional debut by Joan Baez, the barefoot madonna, is still arresting in its simplicity and purity. Gripping lyrics reach to Biblical times, the American frontier and the gallows-bound baby killer Mary Hamilton at a royal European court. The teenaged Baez's fatalism was overwhelming while most of America moved from Dwight Eisenhower-era complacency to John Kennedy-era idealism.

Blind Willie McTell, Last Sessions (Prestige Bluesville, 1962). Blind Willie McTell was so seeped in Georgia's Piedmont blues it hardly matters how age and alcohol had impacted the street singer's buoyant 12-string picking. It's so cleanly remastered on *Last Sessions* that you'd never guess the master tapes of this night of talk and tunes were literally fished from the trash.

Ian & Sylvia, Four Strong Winds (Vanguard, 1963). Arresting counterpoint coupled with superb and eclectic song choice on *Four Strong Winds* made Canadians Ian & Sylvia the First Couple Of Folk. "Northern hillbillies," some scoffed, apparently missing both their high drama and sadly soft romanticism. Neil Young took the title track — Ian's first recorded composition — around the world.

The Freewheelin' Bob Dylan (Columbia, 1963). The singer/writer movement burst into full flower with *The Freewheelin' Bob Dylan*. Borrowing black blues, Anglo balladry and his rambling hero Woody Guthrie's comic talking blues, the brash Dylan's second LP (the first to showcase his writing) bristles with youthful irreverence and conviction.

He'll let you be in his dream if he can be in yours. Who could have sensed that Camelot had but a few more months to live as Dylan prophesied "A Hard Rain's A-Gonna Fall"?

Peter, Paul & Mary, In The Wind (Warner, 1963). Manager/mogul Albert Grossman assembled Peter, Paul & Mary, a mellifluous, well-groomed "baby Weavers," to popularize his scruffy act Bob Dylan's songs to clean-cut folkies with sensitive ears. It worked with *In The Wind*. Simultaneously soothing and intense, "Blowin' In The Wind" became an anthem of its day.

Phil Ochs, I Ain't Marching Anymore (Elektra, 1964; now Hannibal/Rykko). The stubborn title track of Phil Ochs' *I Ain't Marching Anymore* and the self-mocking "Draft Dodger Rag" mirror the growing Vietnam conflict among young adults refusing to be mere "Links On The Chain." Poetic musical journalist Ochs offers both rage and comedy. Like his idol Bob Dylan, he saw the foibles on all sides of an issue.

Traditional Music At Newport 1964 (two volumes, Vanguard, 1965). The mass media hadn't yet obliterated our rustic, indigenous music presented at the original Newport Folk Festivals, such as sharp, fervent sacred harp singing from rural Alabama and shrill Cajun dance music from Louisiana's bayous. A few of these true originals — Doc Watson, Fred McDowell — went on to fame. Most returned to play on their porches. *Traditional Music At Newport 1964* is both raw and real!

The Byrds, Mr. Tambourine Man (Columbia, 1965). Fallen choirboy harmonies and Roger McGuinn's ringing 12-string Rickenbacker launched folk rock as the new quintet The Byrds followed the mystical (or psychedelic) Mr. Tambourine Man into a jingle-jangle morning. Mix a dash of Pete Seeger and a dollop of Beatles pop with a heap of Bob Dylan to get this Byrds album. The reissue's notes speak of "Gregorian-a-go-go radiance." Yeah.

Mimi And Richard Fariña, Reflections In A Crystal Wind (Vanguard, 1965). Joan Baez's kid sister Mimi and her wild author husband Richard Fariña spun the folk revival's most exotic fantasies while they discreetly moved toward rock in *Reflections In A Crystal Wind*. It's drenched in blood, fear and premonitions of Richard's imminent motorcycle ride to eternity.

The Fugs' First Album (Broadside and ESP, 1965; now Fantasy). "Slum goddess, gonna make her my bride!" Gee, how romantic. *The Fugs' First Album* is literary, filthy, pseudocrazy, nihilist and hilarious. Try to imagine William Blake writing for a leftist porn rag. The CD has 11 bonus tracks!

Judy Collins, In My Life (Elektra, 1966). With Joshua Rifkin's sophisticated arrangements, Judy Collins, the folk boom's chanteuse, expands her vision to art song, pop and the British invasion on *In My Life*. Powerful readings of Jacques Brel and Berthold Brecht bring subtlety to protest music, while her intense vocal caresses seduce us on newcomer Leonard Cohen's surreal "Suzanne."

Mississippi Fred McDowell, I Do Not Play No Rock 'N' Roll (Capitol, 1969). Mississippi Fred McDowell claimed *I Do Not Play No Rock 'N' Roll*. Well, he did. It's called bottleneck blues and gospel — "natch'l blues" to McDowell with the jagged notes from his steak bone sliding down his guitar strings. It's electrified and electrifying in its rustic eloquence.

Gordon Bok, A Tune For November (Folk-Legacy, 1970). Maine coast-bred Gordon Bok's sonorous bass sounds as deep as his ballads' brine on *A Tune For November's* weathered seafaring songs.

John Renbourn, The Lady And The Unicorn (Reprise, 1970; now Shanachie). Step into Henry VIII's court with the guitar's Renaissance man, John Renbourn, and friends on *The Lady And The Unicorn*. This delicate instrumental feast of medieval and early modern dance and folk tunes is even more poised than his work in *Pentangle*. Bach meets the commoners.

Steeleye Span, Parcel Of Rogues (Chrysalis, 1973; now Shanachie). England's trad folkies Steeleye Span merrily hit their rocking stride on *Parcel Of Rogues* with wonderful ballads of an ugly witch, human transfigurations, routed Scottish rebels and the licentious King George III "riding on a goosie." The clarion-voiced Maddy Prior and amplified fiddler Peter Knight steal the show.

Ralph Stanley And The Clinch Mountain Boys Play Requests (Rebel, 1975). Ralph Stanley's opening notes on "Man Of Constant Sorrow" still send chills up my spine. Hewn from the hard rocks of the Appalachian mountains, there is bluegrass at its most primitive on *Ralph Stanley And The Clinch Mountain Boys Play Requests*. Curly Ray Cline's stark fiddling perfectly fits Stanley's blood-curdling vocals as he moves into his own following elder brother Carter's death.

Old And In The Way (Round, 1975; now Grateful Dead). Serious bluegrass meets psychedelia in Jerry Garcia's brief banjo fling with mandolinist Dave Grisman, bassist John Kahn, and hillbilly jazz fiddler Vassar Clements, *Old And In The Way*. Golden tenor Pete Rowan (a Bill Monroe alum) shows his songwriting mettle on "Land Of The Navajo" and "Midnight Moonlight."

The Staple Singers, Great Day (Milestone/Fantasy, 1975). Sanctified blues, this stirring 78-minute CD, *Great Day*, is compiled from The Staple Singers' 1962-64 Riverside LPs *Hammer And Nails*, *This Land* and *This Little Light*. Chicago rhythm and religion is rooted in Pops Staples' native



Mississippi with daughter Mavis' big, earthy contralto. Booty-shaking holiness.

Richard and Linda Thompson, Pour Down Like Silver (Island, 1975; now Hannibal/Rykko). We too go "Walking Down The Streets Of Paradise" in eerie mystery and Richard Thompson's newfound Islamic faith. Dusky-voiced Linda may be the ultimate interpreter of Richard's surrealism on *Pour Down Like Silver*.

Silly Sisters (Chrysalis, 1976; now Shanachie). An all-star traditional lineup backs June Tabor (then a librarian) and Steeleye Span's Maddy Prior romping through the rich ballads of bawdy olde England on *Silly Sisters*. It's such fun you hardly notice when they're singing of small children in a Charles Dickens-ian factory.

Bothy Band, Old Hag You Have Killed Me (Mulligan, 1976; now Green Linnet). Bothy Band's *Old Hag You Have Killed Me* is Irish folk at its finest with Kevin Burke's delightful bowing and the airy soprano of Triona ni Dhomhnaill (pronounced Treena ni Donnell). Pensive ballads, sprightly reels through the mist plus "Fionnghuala" — utterly astounding wordless mouth music.

Dorothy Carter, Troubadour (Celeste, 1976). A tiny, golden-haired sprite, street performer Dorothy Carter weaves vibrant tapestries on the hammer dulcimer from melodies of France's medieval troubadours and biblical psalms on *Troubadour*. Her rippling streams of notes transcend all concepts of time.

Sweet Honey In The Rock (Flying Fish, 1976). The '60s folk boom ends and a new folk era dawns as Civil Rights veteran Bernice Johnson Reagon debuts her black women singers on the fledgling Flying Fish label with *Sweet Honey In The Rock*. With shattering intensity grounded in her father's rural Georgia church (and, farther back, Mother Africa), the a cappella ensemble offers both sweet honey and the rock of their political convictions. "Nothing lights a fire like a dream deferred." The torch is passed.

Courtesy of Yep Roc Records

(New Releases from page 46)

LOS STRAITJACKETS
Sing Along With Los Straitjackets
Yep Roc (2028)

Back a few years ago when Los Straitjackets burst onto the surf and instrumental rock scene, there were more than a few skeptics in the media who couldn't come to grips with the band's image. Mexican wrestling masks and fuzzy, twangy, surf guitar was pretty original — even in the 1990s.

Then they put out a surf instrumental version of "My Heart Will Go On," the theme from *Titanic*, performed on *Late Night With Conan O'Brien* in December 1995, and their legend began to gel. Pretty soon, even the skeptics began to warm up to Eddie Angel and the boys, who, in addition to being savvy marketing moguls, demonstrate considerable talent on their instruments of choice.

Now the Straitjackets have delivered a 13-song disc filled with nostalgic sounds of rockabilly, surf and '60s pop. Each of the tracks features a different guest vocalist, and there are some very good singers belting out the tunes here. Raúl Malo of The Mavericks and the band sound great on a version of "Black Is Black" that remains true to the sound of the 1966 original by Los Bravos. Big Sandy helps turn the Straitjackets into a rockabilly outfit, with a Spanish rendition of "Tallahassee Lassie." Sandy is the only artist to be given two slots on the record, as he shows up later with a Latin reading of Ernie K-Doe's "Mother-In-Law."

Former Paul Revere And The Raiders' lead singer Mark Lindsay belts out "Treat Her Right," and Dave Alvin blasts out a cool



The retro surf band, Los Straitjackets.

remake of The Riverias' "California Sun." El Vez, "The Spanish Elvis," rocks out on "King Creole," and X's Exene Cervenka does a phenomenal job on the country-turned-punk-pop "I'll Go Down Swinging."

Some of the other highlights include Alli-

son Moorer and Lonesome Bob on "I Ain't The One" and Nick Lowe with "Shake That Rat," and classic surf boys The Trashmen team up with Los Straitjackets for the instrumental, "A Huevo." Other guests include Mike Campbell of Tom Petty And The Heart-

breakers, The Reverend Horton Heat, and Leigh Nash of Sixpence None The Richer.

There are some down-right classic pairings on this one, and the overall project has a retro-rock sound that sticks to your psyche like a tongue to a frozen pipe. Like that tongue thing, you might not be able to remember just why you put the record into the player, but you'll be thankful to have encountered the experience. As you finally pull free, you'll be ready to do it all over again, just because.

— Michael Buffalo Smith

(Please see New Releases page 57)

Since 1995.

Siren Disc

Discount Import CDs & More.

www.sirendisc.com



SSHHH! It's Classified!

—Save **Now!**—

\$5 Off

Any Classified Ad booked for at least 5 consecutive issues

\$10 Off

Any Classified Ad booked for at least 10 consecutive issues

\$20 Off

Any Classified Ad booked for at least 20 consecutive issues

Your ads are posted free on the Internet @ www.collect.com for extra exposure at no extra charge!

PLACE YOUR Classified/Internet Ad NOW TOLL-FREE

800-942-0673

M - F 7am -7pm CST

Goldmine



Krause Publications

700 E. State St., Iola, WI 54990-0001
Phone 715-445-2214 • Fax 715-445-4087

www.krause.com

WEB DIRECTORY SHOWCASE



Call
Tina Ellingson
Ext. 334
Trevor Lauber
Ext. 322
1-888-457-2873



We deliver what music lovers want!
LOW Prices - FAST Service
A HUGE Selection of ALL Genres.
Specializing in Imports.
CDs/LPs/Collectibles/More
ImportCDS.com

www.oldies45s.com
Over 30,000 Singles for sale
Easy to Search
Priced to Sell
Volume Discounts
secure online transactions: Visa /MC
email: oldies45s@oldies45s.com

Why pay imported prices for imported CD's
www.musicselection.com
Over 1.3 million imported CD's
Compact Discs, Cassettes, Vinyl, Videos & Dvd's
Lowest prices guaranteed !!!
Shipping is still only .99 cents !!!

SLCD.com SOUTHLAND CD ONLINE
Hello from SLCD.com. Southland CD. We would like to introduce you to our collectible music Web site: www.SLCD.com. We have a large selection of collectible music available for online ordering including CDs, Records, Memorabilia & mostly anything by your favorite artists. Our vast stock consists of items from all over the world, including the U.S., U.K., Japan, Australia & Germany to name a few. SLCD.com is a user friendly Web site that is complete with an easy to use search engine & secure online ordering. We update our site on a daily basis, so check back often not to miss a thing. In addition to everything that is available to buy at SLCD.com, you can also sell to us! We pay \$ top dollar \$ for most collectible CDs, Vinyl or Memorabilia.
Check out www.SLCD.com and let the fun begin!
www.SLCD.com
www.SLCD.com

JAZZ RECORD CENTER
236 West 26 Street Phone: 212-675-4480
New York, NY 10001 Fax: 212-675-4504
New York's only specialist in out-of-print Jazz records, books, videos and periodicals.
NEW
WEB site: **www.jazzrecordcenter.com**
Web site will be a convenient way to purchase items online as well as participate in online auctions.
E-MAIL: **jazzrecordcenter@att.net**

SWEET MEMORIES
over 15,000 Rare Vinyl Records UK
101 Fratton Road, Portsmouth, Hampshire, P01 5AH, England
Telephone and Fax from USA is 011 44 23 92 837730
www.vinylrecordsuk.com
Email **nick@vinylrecordsuk.com**

www.vinylgalore.com
Where Vinyl Buyers And Sellers Meet
Sellers, list free for six months!

Memory Lane
Out-of-Print Records • Tapes • Compact Discs
1940 EAST UNIVERSITY DRIVE
TEMPE, AZ 85281
TELEPHONE (480) 968-1512
FAX (480) 921-1620
Web site: **http://www.memorylanerecords.com**
E-mail: **mlr@memorylanerecords.com**

"45" drawers, LP racks and more
Modular, stackable oak furniture holds all formats and equipment
Factory direct to you from
Per Madsen Design, 800-821-4883
Free Brochure (Please mention Goldmine)
www.rackittm.com

THE PSPOT
Music Trivia! Sixties Garage/Punk & Psychedelic Pspot. Join the fun and test your trivia knowledge. Become a part of the Pspot E-mail list of worldwide fans and collectors. The Pspot is linked with great reputable sites such as BOMP! Sundazed and Delerium. Check it out! Trivia is updated weekly.
Web site: **http://expage.com/page/garagepsych**
E-mail: **bjenkin@cvn.net**
Brian Jenkins

WWW.FULLCYRKLERECORDS.COM
Visit our online store & compare our prices. Check our monthly featured items & browse our extensive online catalogs of new CD's, new & used LP's, 45's & 78's
SPECIALIZING IN NEW CD & LP REISSUES - CLASSIC OLDIES 1920'S-80'S
Classic Rock - Psych & Garage - Progressive - Soul R&B - Blues - Country - Folk - Jazz - Audiophile - Remastered CD Reissues - Vocal Artists - Specialty - Posters - Promos
FULL CYRKLE RECORDS & COMPACT DISCS
CRYSTAL LAKE, IL
Chicagoland's premier oldies & specialty music shop for over 20 years

REDDINGTONS RARE RECORDS
One of U.K.'s oldest specialist record shops.
30 Years in the business.
Approaching 2,000,000 Records and CDs.
We've never thrown anything away - 23,000 items online and growing.
WANT LISTS ACCEPTED
www.reddingtonsrarerecords.co.uk
E-mail: **sales@reddingtonsrarerecords.co.uk**
Phone: (44) 121-643-2017

1/2 SPEEDS PROMOS
RECORDCRATE.COM
SPECIALIZING IN COLLECTABLE RECORDS
JEFF GREINDL
(630) 830-7634
IMPORTS eligreindl@aol.com 1ST PRESS

Very English and Rolling Stone
VERY ENGLISH AND ROLLING STONE
P.O. Box 7061 PHONE 717-627-2081 EST
Lancaster, PA FAX 717-627-3227
17604-7061 E-mail: **vears@lannews.infi.net**
U.S.A. Since 1977
www.veryenglish.com
(Over 5,000 Collectibles Listed)
Huge FREE!!!! Collectible / Rare Catalog containing vinyl / CDs / colored vinyl / promos / rock clothing / send a 75c stamp USA and Canada and Foreign \$2.50 stamp.
Available most weekday evenings 9:30 p.m. - midnight

www.maidenmania.com
Iron Maiden/KISS and Heavy Metal
Over 365 pages (900 plus items) of astounding rarities from all over the world from Argentina to Yugoslavia and everywhere in between. Please e-mail me at **ken@maidenmania.com** for a FREE computer catalog download. If you do not have a computer, I will be more than happy to send you a copy of each of my catalogs, but PLEASE enclose \$1 per artist per request (3 stamped IRC's for Canadian and overseas customers only) when writing to cover printed material and postage costs to:
Maiden Mania
820 Post Road, Suite 135
Scarsdale, NY 10583-5046 USA

WWW.JUSTANOTHERDREAM.COM
Just Another Dream
Home of Rare and Collectible Records, CDs, Music Videos, And Music Related Memorabilia From Around the World.
Shop for your music collectibles, 24 hrs. a day, easily and safely. We offer secure online transactions. We accept Visa and Mastercard.

MUDSHARK AUDIO
restoration * enhancement
get your LPs de-crackled!
get your tapes de-hissed!
restore & enhance your live/amateur recordings!
mudshark audio offers digital restoration services starting at \$35cdn!!
www.mudsharkaudio.com

LORAN RECORDS
Collectible Record Albums
www.loranrecords.com



SPECIALISTS IN COLLECTIBLE LP's OF ALL MUSICAL CATEGORIES
Rock • Soul • Country • Jazz • Classical • Vocals • Easy Listening
Soundtracks • Comedy • Exotic • Latin & Everything Else!
★ High Quality Records ★ Low Postal Charges
★ Free Search Service On Your Want Lists ★ Reasonable Prices
★ Fast, Friendly Service

Order By Mail → P.O. Box 1604 • Florissant, MO 63031
Order By Phone → 314-837-2649
Order By Fax → 314-921-4091
Order By E-Mail → **loranrec@aol.com**

Please Contact Us For A Free Catalog

WEB DIRECTORY SHOWCASE



Call
Tina Ellingson
Ext. 334
Trevor Lauber
Ext. 322
1-888-457-2873



**FLIP SIDE
RECORDS**

1410 Beacon Street, Brookline, Massachusetts 02446 • 617 739-8022
e-mail: flipside@flipsideweb.com

www.flipsideweb.com

Thousands of Collectibles • Reasonably Priced • All Styles • All Formats
Non-Surfers Call for or Write for printouts—
Short printouts free, \$1.00 charge for longer *Click on "Auctions" to see our eBay listings*

VINTAGE VINYL MAIL ORDER

<http://www.vvmo.com>

TOP QUALITY RARE & OUT-OF-PRINT VINYL!

BEATLES * STONES * ROCK & POP * PSYCHEDELIC
PROGRESSIVE & KRAUTROCK * JAZZ * SOUL * FOLK
WE ALSO CARRY HARD TO FIND & COLLECTABLE CD'S,
& NEW BRITISH MUSIC THE WEEK OF IT'S RELEASE IN U.K.!

MAILING ADDRESS : 925 DAVIS ST. EVANSTON, IL 60201
PH : 847-328-2899 * FAX: 847-328-2934

JOHN MANSHIP RECORDS

BUYERS & SELLERS OF SOUL since 1969

Priced Wants lists serviced

Anything to sell? Great prices offered.
Single items or Whole Collections.

Tel. (44) 1664 464526 FAX. (44) 1664 464155
E-mail: info@raresoulman.co.uk

Secure Web Site: www.raresoulman.co.uk
More Rare Soul for sale than any other site.
Over 24,000 items listed.

HEAVY METAL AND HARD ROCK

Over a decade of serving hard rock/metal fans.
5000+ titles of normalities & rare releases.

The Web's largest specialist.

Vinyl, CD's, Memorabilia.

Secure ordering with shopping cart.

www.visual-vinyl.co.uk

Celebrity Art

Artcelebs@aol.com / 610-397-1989

Features the artwork of: *Ronnie Wood,
Jerry Garcia, David Bowie, John Lennon,
Tony Bennett, Paul McCartney and more*

Visit us at: McCartneyArt.com

"HOT PLATTERS"

www.hotplatters.com

50+ searchable categories

LP's, 45's, 78's, CD's, Tapes, Books, &
Memorabilia from the 1950's - 2000's

HotPlatter@aol.com * Fax (805) 492-3682
P.O. Box 4213 * Thou. Oaks, CA 91359-1213 USA

AROUND THE WORLD MUSIC COLLECTIBLES

OFFERING MUSIC COLLECTIBLES FROM AROUND THE WORLD FOR MORE THAN A DECADE

Visit Our Web Site For Daily Updates

Also be sure to look at our last
1/2 price ad in the 9/6/01 issue.

WWW.ATWMusic.com

www.acevideoandmusic.com

Huge selection
Something for everyone, Lps, 45s
Collectable music from 1920's-now

For E-Bay's best music & auctions go to Susue



Ace Video & Music

285 Caillavet St., PO Box 1934
Biloxi, Mississippi 39533-1934 USA
228-374-0777, fax 228-374-4645
mail@acevideoandmusic.com



(New Releases from page 55)

RYAN ADAMS

Gold

Lost Highway (170235)

JAY FARRAR

Sebastopol

Artemis (751093)

Proficiency notwithstanding, Ryan Adams still has a lot of growing up to do. The former Whiskeytown member's debut solo album, *Heartbreaker*, released last year, strayed from his alt-country roots, consciously and cannily playing up the "singer/songwriter" tag. In a way, it seemed designed primarily to dispel his Whiskeytown legacy. Why then was *Pneumonia*, the final album from the band he used to lead (which sat on the shelf for more than three years), released with much fanfare earlier this year? Why also is it a more melodic piece than *Gold*, his sophomore solo record?

Mainly because Adams is aiming for things higher than the alt-country gutter. It may not be as immediately likeable and tuneful as *Pneumonia* (like *Heartbreaker*, *Gold*'s charms reveal themselves with repeated listens), but it's a better album. Adams sways all over the place, visiting Rolling Stones-y rockers and tear-stained brooders with equal aplomb. The only things Adams has in common with Otis Redding — the obvious inspiration behind the white-boy soul of "Touch, Feel & Lose" — are the quasi-funky horns and the fact that they're both Southern guys. But Adams has guts.

His conceit is in his concept: *Gold* is an American travelogue. It opens with "New York, New York" and slowly works itself across country, ending up on the West Coast for the closing "Goodnight, Hollywood Blvd."

It's an ambitious move, but one that doesn't quite pay off. Adams is too erratic a songwriter, and *Gold* is an unwieldy album (it was originally slated as a double disc but has been pared down to a 16-song, 70-minute set). Yet, there are moments of Bob Dylan-esque brilliance here. Adams' ability

to trek forward gives *Gold* its luster.

Jay Farrar, on the other hand, is content to let things be. On his debut solo album *Sebastopol*, the former Uncle Tupelo and Son Volt frontman stays on the same dusty trail on which he's traveled dutifully for the past decade. Not much here — save a synth here and there and a few worldly rhythms — breaks from the familiar pattern. Farrar still has alt-country's laziest drawl, and *Sebastopol* is drenched in faux Americana. It wallows in its very pointlessness.

— Michael Gallucci

VIGILANTES OF LOVE

Summer Shine

Compass Records (7 4320-2)

The roots-rock field is so crowded these days that it's almost impossible to keep track of the players. Still, if there's one band who deserves to be singled out from the rest of the pack, without a doubt it has to be the Vigilantes Of Love.

After a steady string of albums dating back to the early '90s, efforts that span both independent and major-label releases, the band finally hit paydirt with last year's *Audible Sigh*. Wilco and Whiskeytown may have the notoriety, but clearly the Vigilantes have come into their own as one of alt-country's most impressive up-and-coming combos.

Summer Shine confirms that assessment. Here again, the band — now trimmed to a trio — display the sheer anthemic energy and exuberance that make their music so memorable and moving. That's evident from the outset via the album opener, "You Know That," a stunning, sophisticated barn-burner of a tune fueled by its drive and determination: "Moonlight be a friend tonight/We're all wrecked on these dreams/Holding on a bit too tight/I've got splinters from these moonbeams."

It's only the first in a string of resolute rockers. "Stand Beside Me," "S.O.S.," "Puttin' Out Fires," "It's Not Bothering Me," "Making It Up As We Go Along" and the very Byrds-like "I Could Be Wrong," among them — mix craft and conviction with passion and abandon. They sweep the listener along, with an infectious energy that's all but impossible to resist. Similarly, slower songs such as "Along For The Ride," "Green Summer Lawn" and "Sailors," the eerie entry that ends the album,

reflect the introspective attitude articulated by Bill Mallone, Vigilantes Of Love singer, songwriter and all-around visionary. So chalk up another stunning set for this compelling combo. *Summer Shine* is as radiant as its title implies.

— Lee Zimmerman

HOWLER

The Mighty Field Of Vision

Howler (2001)

There's a group of musicians down Alabama way trying to make a difference by helping the down-and-out musicians around the world — folks who, for whatever the reason, have lost their money, succumbed to addiction or just need a shoulder to lean on. It is both a worthy and a noble cause. A portion of the proceeds from the sale of Howler's *The Mighty Field Of Vision* will go to benefit those in need. That alone is reason enough to buy it, but that's just one part of the picture.

The other part of the picture is the great music. Nine songs, most of which are written and sung by Stephen Foster, are accompanied by some of the best players out of Decatur and Muscle Shoals, including Ray Brand, Billy Teichmiller, John Huber, Owen Brown, Thad Usry, and Jim Nelson. Background singers — The Visionaires — include Jessica Wagner, Larry Perkins, Danny Wilder, John Huber, Rob Allen, Ray Brand, and Foster.

"Wrapped In Blue" churns a smooth groove as a blues song, with Brand dealing out some tasty guitar. The set opener "Turn It Around" smokes — a real psychedelic '60s-sounding opus. "Price Of Love," another killer tune written by Foster, trembles with some great percussion and guitar and a gospel spirit. "Too Much Seconal" (not the song by Johnny Winter of the same title) rocks along with an addictive groove. The closer, the old traditional tune "Pick A Bale Of Cotton," gets the Howler treatment complete with swampy guitar. Loads of fun.

The highlights here are a reworking of Johnny Wyker's (Sailcat) timeless "Baby Ruth," and of course, the "Mighty Field Of Vision Anthem" — a fine number that would have had Eddie Hinton smiling broadly. Somehow, as I listen to it, I can hear Hinton on the chorus. It's the vibe. It's the heart of this project that bowls me over, and at times, brings a tear to my eye while making my head bob like one of those little doggies I used to have in the back window of my '69 Barracuda. Music to bob by.

Put it on the CD player, lay up on the hood of the Chevy and howl at the moon. While you're at it, give a shout in memory of Hinton and all the other brothers and sisters who died too young. (www.idnmusic.com/howler; Stephen Foster/Howler, 1408 Highland Ave. SE #2, Huntsville AL 35801)

— Michael Buffalo Smith

(Please see New Releases page 61)

Record Shows



Please call ahead before you travel. All information listed herein is provided by the show promoters, is subject to change and is not independently verified by the Goldmine staff. Show promoters who wish to have their record and CD shows listed should mail all pertinent information at least two months in advance of the show to: Goldmine Show Calendar, 700 E. State Street, Iola, WI 54990 or FAX to 715-445-4087.

- Oct 5-14 IL, Skokie. ALS Les Turner Foundation Mammoth Music Mart, Old Orchard Ctr. I-94 at Old Orchard Rd. & Laverne. PH: 847-674-6278.
- Oct 6 CA, San Rafael. Fall Rock Swap, Masonic Hall, 1010 Loolens Pl., SH: 10am-5pm. Kris Mikkelsen, PH: 510-452-2831.
- Oct 6 MN, Minneapolis. Record Show, VFW, 2916 Lyndale Ave. S., F: \$35., A: \$2. Rich Shelton, 255 E. Kellogg St., Paul, MN 55101. PH: 651-290-2900.
- Oct 6 NY, New York. Music Memorabilia Show, Tip Top Shoe Bldg. 155 W. 72nd St., 4th Floor, SH: 10am-2pm, A: free. PH: 212-579-0689 weekdays.
- Oct 6-7 TX, Austin. Fall Record Convention, City Coliseum, 51st St. & Riverside Dr., A: \$4. Austin Record Convention, PO Box 90806, Austin, TX 78709. PH: 512-288-7288.
- Oct 6 WI, Menasha-Appleton. Record & CD Show, N8770 Fire Lane #1, near intersection State Hwy. 10 & Oneida St. at Waverly Beach, SH: 10am-4pm, T: 8', F: \$35., A: \$2. PH: 608-525-4033 or 920-954-9969.
- Oct 6 ENGLAND, Birmingham. Music Fair, Academy, Dale End, T: 6'. Rob Lythall, VIP Events, PH: 0116-224-4300 or FAX: 0116-224-4299.
- Oct 7 MA, Chelmsford. Big Ed's Record, CDs & Tapes Show, Elks Lodge, Rt. 110, SH: 10am-4pm, A: \$3. PH: 603-888-0294.
- Oct 7 MI, Southgate. Record Show, Civic Ctr. 14700 Reaume, Dix-Toledo (1 blk. N. of Eureka), SH: 10am-4pm, T: 60-8', F: \$35., A: \$3. Al Campbell, PO Box 277, Warren, MI 48090. PH: 810-759-5133 eves.
- Oct 7 NY, Utica. WOUR NY CD & Record Fair, Deerfield Vol. Fire Hall, 5476 Trenton Rd. (Exit 31 NYS T-Way), SH: 10am-5pm, T: 60-8', A: \$4. Jack Skutnik, 7 Charnel Dr., Binghamton, NY 13901. PH: 607-648-4997 or FAX: 607-648-9626.
- Oct 13 AL, Huntsville. Record & CD Show, Holiday Inn, 5903 University Dr., beside Madison Square Mall, SH: 10am-5pm, A: \$3., under 12 free. Show Logic Productions, 109 Susan Dr., Warner Robins, GA 31093. PH: 478-929-3053.
- Oct 13-14 CA, San Mateo. Bay Area Music Collectors' Expo, Expo Ctr. 2495 S. Delaware St., SH: Sat. 9am-7pm, Sun. 10am-5pm, A: \$5., \$4. seniors & children. PH: 707-942-5079.
- Oct 13-14 FL, West Palm Beach. Record & CD Show, Uptown-Downtown Outlet Mall, 5700 Okeechobee Blvd., SH: Sat. 10am-6pm, Sun. 12noon-6pm. PH: 561-844-1324 or 775-6377.
- Oct 13 IL, Hillside. Record Convention, Holiday Inn. I-290 & Wolf Rd., SH: 9am-4pm, F: \$45-\$50., A: \$3. ARC Promotions, PH: 765-646-5305 or FAX: 765-378-7706.
- Oct 13 NJ, Wayne. 2nd Sat. Record & CD Collectors Show,

- Firemen's Convention Center, Parish Dr. (N. of Rt. 46 & Rt. 80) at Rt. 23 & Rt. 202S, SH: 10am-4pm, T: 100, A: \$5., under 12 free. F. Falk, PO Box 849, Highland Lakes, NJ 07422. PH: 973-773-6067.
- Oct 13 OH, Dayton. Music Collectors' Convention, Hara Arena, 1001 Shiloh Springs Rd., SH: 10am-3pm, F: \$30. if paid one week in advance, F: \$40. thereafter, A: \$2. with coupon, \$3. without, under 12 free with adult. Alpha Records & Music, Gerald Ruark, POB 17575, Indianapolis, IN 46217. PH: 317-882-3378.
- Oct 13 ENGLAND, London. Music Fair, Electric Ballroom, Camden High St., T: 6'. Rob Lythall, VIP Events, PH: 0116-224-4300 or FAX: 0116-224-4299.
- Oct 13 ENGLAND, Wolverhampton. Music Fair, Civic Halls, North St., T: 8'. Rob Lythall, VIP Events, PH: 0116-224-4300 or FAX: 0116-224-4299.
- Oct 14 AL, Montgomery. Record & CD Show, Ramada Inn. I-85 at East Blvd., SH: 10am-5pm, A: \$3., 12 & under free. Show Logic Productions, 109 Susan Dr., Warner Robins, GA 31093. PH: 478-929-3053.
- Oct 14 MD, Columbia. 1st Annual Baltimore KISS Expo, Hilton. F: \$10. in advance, \$12. at the door. George DeCampo, 2849 Westminster St., Manchester, MD 21102. PH: 410-374-4081.
- Oct 14 MA, West Springfield. Record & CD Convention, Best Western Hotel, 1080 Riverdale Rd., SH: 9am-3pm, T: 8', F: \$40., A: \$35. Bob Belnick, PH: 413-786-1929.
- Oct 14 NE, Omaha. Record Show, 7803 Military, SH: 10am-4pm, T: 8', A: \$2. Tim, PH: 712-328-8731 or 328-2504.
- Oct 14 NY, Buffalo. Record & CD Show, Leonard VFW Post, 2450 Walden Ave., 1 mi. E. of Thruway Exit 52E, SH: 10am-4:30pm, T: 70-8', F: \$60., A: \$3. Record Baron, PH: 716-871-8722.
- Oct 14 PA, Lancaster. Pennsylvania Music Expo, Catholic H.S. Cafeteria, 650 Juliette Ave., (rear), 1 mi. S. of US Rt. 30, SH: 9am-3pm, A: free. Keystone Record Collectors, PO Box 1516, Lancaster, PA 17608. PH: 717-898-1246.
- Oct 14 ON, St. Catharines. Record & CD Show, Niagara Dome, 150 Dunkirk Rd. 20 min. N. of Buffalo, SH: 11am-4pm, T: 40-8', A: \$3. Star Records, PH: 905-682-4818.
- Oct 14 BELGIUM, Mons. Beatles RoadShow Day, Steve Holmes, 36 Brookglen Rd., Risingbrook, Stafford ST17 9DG England. PH: 0102 682008 or Mobile, PH: 07801 564622.
- Oct 14 FRANCE, Auxerre. Record Fair, (89) Centre Vaulabelle, Sagadis, Fernand Piqueras, 411 Quai Jean Jaures 71000 Macon France. PH: (33) 0385380949.
- Oct 15 ENGLAND, London. Beatles RoadShow Day, Steve Holmes, 36 Brookglen Rd., Risingbrook, Stafford ST17

- 9DG England. PH: 0102 682008 or Mobile, PH: 07801 564622.
- Oct 18 KS, Wichita. Record Convention, Holiday Inn, 5500 W. Kellogg, SH: 4pm-10pm, A: \$3. Southwest Music Promos., Bob, PH: 713-771-3939.
- Oct 19 OK, Oklahoma City. Record Convention, Travelodge, 3535 NW 39th St., SH: 4pm-10pm, A: \$3. Southwest Music Promos., Bob, PH: 713-771-3939.
- Oct 20 MI, Ann Arbor. Monster Record & CD Show, Best Western, 2900 Jackson Rd., Exit 172 off I-94, SH: 10am-4pm, T: 52-8', F: \$45., A: \$3., under 10 free. Rod Branham, PO Box 148, Chelsea, MI 48118. PH: 734-475-1006.
- Oct 20-21 NJ, Atlantic City. Atlantic City Holiday Megafair, Convention Ctr. One Ocean Way, SH: Sat. 10am-8pm, Sun. 10am-5pm, 1,600 booths. Brimfield Assoc. Inc., PO Box 1800, Ocean City, NJ 08226. PH: 800-526-2724.
- Oct 20 NY, New York City. 45 Collectors Expo, The Inn. (Formerly Days Inn) 440 W. 57th St., btw. 9th & 10th Aves., SH: 10am-4pm, T: 70, A: \$6., under 12 free. F. Falk, PO Box 643, Clifton, NJ 07012. PH: 973-773-6067.
- Oct 20 NY, New York City. Record & CD Collectors Expo, Holiday Inn. (Formerly Days Inn) 440 W. 57th St., btw. 9th & 10th Aves., SH: 10am-4pm, T: 100, A: \$6., under 12 free. F. Falk, PO Box 643, Highland Lakes, NJ 07422. PH: 973-773-6067.
- Oct 20 OK, Tulsa. Record Convention, Econo Lodge, 11620 E. Skelly at I-44, SH: 10am-4pm, A: \$3. Southwest Music Promos., Bob, PH: 713-771-3939.
- Oct 20 TN, Knoxville. Music Expo, Budget Inn of America, 323 Cedar Bluff Rd., I-75 & 40, Exit 378, SH: 10am-4pm, T: 30-6', F: \$50., A: \$2. Kevin Folkeith, PO Box 1007, Greenville, OH 45331. PH: 937-548-8364.
- Oct 20 ENGLAND, London. Music Fair, Electric Ballroom, Camden High St., T: 6'. Rob Lythall, VIP Events, PH: 0116-224-4300 or FAX: 0116-224-4299.
- Oct 20 ENGLAND, Northampton. Music Fair, Derrigate, Guildhall Rd., T: 6'. Rob Lythall, VIP Events, PH: 0116-224-4300 or FAX: 0116-224-4299.
- Oct 21 CT, North Haven. Record Convention with WPLR, Holiday Inn. I-91, Exit 12, SH: 10am-4pm, T: 72-6', F: \$60., A: \$4. Greater Promos., Ken & Alanna Sultar, PO Box 896, South Windsor, CT 06074. PH: 860-644-8044.
- Oct 21 GA, Atlanta. Record & CD Show, Ramada Inn. I-85, Exit 86, 418 Armour Dr., SH: 10am-4pm, A: \$3. Keith Alversen, PH: 770-463-2727.
- Oct 21 MD, Arbutus. Record & CD Show, Fire Hall, 5200 Southwestern Blvd., SH: 10am-4pm, T: 120-5', F: \$30., A: free. Ray or Chris Quigley, 1 Colgate Ct., Baltimore, MD 21228. PH: 410-455-0418.
- Oct 21 MO, Springfield. Record Show, Days Inn. I-44, Exit 80B, SH: 10am-4pm, T: 8', F: \$35., A: \$2. Jim Ronat, 1908 Main St., Highland, IL 62249. PH: 618-654-3049 or 417-887-9280.
- Oct 21 NJ, Edison. Music Explosion Record Show, Convention & Expo Center, at Raritan Ctr., SH: 10am-?, T: 200-8', F: \$65., A: \$6. Groovy Prods., Andy or Ira, 742 Rt. 18, E. Brunswick, NJ 08816. PH: 732-257-3888 or FAX: 732-257-2366.
- Oct 21 OH, Fairview Park. Record & CD Convention, American Legion Hall, 22001 Brookpark Rd., I-480, Exit 9 Grayton Rd., SH: 10am-4pm, A: \$3. Ted Sziag, PH: 440-884-4125.
- Oct 21 TX, Dallas. Record Convention, Radisson (formerly Clarion), 1981 N. Central Expwy. (at Campbell), SH: 10am-5pm, A: \$3. Southwest Music Promos., Bob, PH: 713-771-3939.
- Oct 21 WI, Appleton. Fox Valley Record Show, Best Western Midway Hotel, 3033 W. College Ave., SH: 9am-3pm, T: 6' & 8', F: \$30-\$35., A: \$2. Yesterdays Music, Jim, PH: 920-733-5076.
- Oct 21 ENGLAND, London International. Music Fair, Congress Centre, Great Russell St., T: 6'. Rob Lythall, VIP Events, PH: 0116-224-4300 or FAX: 0116-224-4299.
- Oct 21 FRANCE, Chalons En Champagne. Record Fair, (51) Parc Des Expositions, Sagadis, Fernand Piqueras, 411 Quai Jean Jaures 71000 Macon France. PH: (33) 0385384666 or FAX: (33) 0385380949.
- Oct 27 AZ, Tucson. Semi Annual Record Show, F.O.E. Eagles

- #180 Lounge, 1530 N. Stone, SH: 9am-4pm, A: \$3. Bob "Pepe" Galvez, 516 W. 17th St., Tucson, AZ 85701. PH: 520-628-8075.
- Oct 27-28 NC, Statesville. Records, Toys, Comics, Cards & Movie Items, Signal Hill Mall, I-77, Exit 50, SH: Sat. 10am-9pm, Sun. 1pm-6pm, T: 60, F: \$60., A: free. Mike Dentino, 820 15th Ave. Circle SE, Hickory, NC 28602. PH: 828-328-1029.
- Oct 27 ENGLAND, Peterborough. Music Fair, Town Hall, Bridge St., T: 6'. Rob Lythall, VIP Events, PH: 0116-224-4300 or FAX: 0116-224-4299.
- Oct 27 ENGLAND, Walsall. Music Fair, Town Hall, Leicester St., T: 7.5'. Rob Lythall, VIP Events, PH: 0116-224-4300 or FAX: 0116-224-4299.
- Oct 28 CA, Buena Park. Greater Orange County Monthly Record Show, Sequoia Club, 7530 Orangeflora Ave., SH: 10am-3pm, T: 135-8', F: \$50. for 1, \$95. for 2, A: \$3. Steve Brunner, PH: 626-963-9717.
- Oct 28 CT, Danbury. Record & CD Convention, Ramada Inn, Exit 8 off I-84. Trash American Style, PH: 203-792-1630.
- Oct 28 NY, Ithaca. WVB NY CD & Record Fair, Holiday Inn, 222 S. Cayuga St., SH: 10am-5pm, T: 40-8', A: \$4. Jack Skutnik, 7 Charnel Dr., Binghamton, NY 13901. PH: 607-648-4997 or FAX: 607-648-9626.
- Oct 28 NY, Massapequa. LI Record & CD Lovers Expo, American Legion, Broadway & Veterans Blvd. (at IRR, Exit 30S off Southern State), SH: 10am-3pm, T: 70, A: \$5., under 12 free. F. Falk, PO Box 849, Highland Lakes, NJ 07422. PH: 973-773-6067.
- Oct 28 VA, Richmond. Invasion of the Record Collectors Record & CD Show, Midtown Inn, 3200 W. Broad St., SH: 10am-5pm, T: 50-60', A: free. John Wood, PH: 804-796-4919 or 536-3853.
- Oct 28 WA, Seattle. Record & CD Show, Seattle Ctr. Snoqualmie Room, SH: 10am-5pm, F: \$45., A: \$3. John, PH: 425-228-3537.
- Oct 28 HOLLAND, Leiden. Beatles Collectors Show, Antonius Zalencentrum, Lange Mare 43, SH: 11am-4pm. Franck Leenheer Records, Postbus 11019, 2301 EA Leiden, Holland. PH: 31-71-5131323. Mobile: 06-23524162 or FAX: 31-71-5131220.
- Nov 2-4 NY, New York City. WFMU Spring Record Fair, Metropolitan Pavilion, 125 W. 18th St., SH: Fri. 4pm-10pm, Sat. 10am-8pm, Sun. 9am-7pm, T: 175, F: \$100., A: \$5. WFMU, Mike Lupica, PH: 201-521-1416 ext. 243.
- Nov 2-4 SPAIN, Barcelona. Record Fair, Palau Allons XIII, Fira de Barcelona, Avd. Maria Cristina, SH: Fri. 3pm-9pm, Sat & Sun. 10am-9pm. Jordi Tarda, PH: 00-34-93-97961323 or FAX: 00-34-93-7961660.
- Nov 3 IL, Hillside. Record Convention, Holiday Inn. I-290 & Wolf Rd., SH: 9am-4pm, F: \$45-\$50., A: \$3. ARC Promotions, PH: 765-646-5305 or FAX: 765-378-7706.
- Nov 3 IN, Indianapolis. Music Collectors' Convention, Quality Inn-East, 3525 N. Shadeland, SH: 10am-3pm, F: \$30. if paid one week in advance, F: \$40. thereafter, A: \$2. with coupon, \$3. without, under 12 free with adult. Alpha Records & Music, Gerald Ruark, POB 17575, Indianapolis, IN 46217. PH: 317-882-3378.
- Nov 3 NC, Greensboro. Record & CD Show, Oriental Shrine Club, 5010 High Point Rd., 2 mi. S. of I-40, SH: 10am-5pm, A: \$3., under 12 free. Show Logic Productions, 109 Susan Dr., Warner Robins, GA 31093. PH: 478-929-3053.
- Nov 3 ENGLAND, Birmingham. Music Fair, Academy, Dale End, T: 6'. Rob Lythall, VIP Events, PH: 0116-224-4300 or FAX: 0116-224-4299.
- Nov 3 ENGLAND, London. Music Fair, Electric Ballroom, Camden High St., T: 6'. Rob Lythall, VIP Events, PH: 0116-224-4300 or FAX: 0116-224-4299.
- Nov 4 CT, Waterbury. Record Collectors' Convention, Sheraton Hotel, 3580 E. Main St., SH: 9:30am-4pm, T: 8', F: \$65., A: \$4. Gorman, PH: 203-287-8923.
- Nov 4 IN, South Bend. Record & CD Collectors Show, University Area Holiday Inn, 515 Dixie Way North (IN 933), SH: 11am-5pm, T: 40-6', F: \$40., A: free. Blain, PH: 616-323-7262.
- Nov 4 MO, St. Louis. Record & CD Show, American Czech Center, Kingshighway & Landsdown, SH: 10am-4pm, F:

Final Days - October 12-14

Barenaked Ladies Kiss Meatloaf.

24th ANNUAL MAMMOTH MUSIC MART TO FIGHT LOU GEHRIG'S DISEASE.

— YOU NEVER KNOW WHAT YOU MIGHT FIND. —

October 5-14, 2001 • Event Times

Opening Night
Friday, October 5th
6PM-10PM/\$5 Donation

Opening Day
Saturday, October 6th
10AM-8PM/\$5 Donation

Sunday, October 7th
10AM-6PM

Columbus Day Hours
Monday, October 8th
12PM-9PM

Tuesday, October 9th
thru Friday, October 12th
3PM-9PM

BARGAIN WEEKEND

Saturday, October 13th
50% off products
\$5 Donation
10AM-8PM

Sunday, October 14th
50% off products+box sale
\$5 Donation
10AM-6PM

ANNUAL TENT SALE - OVER 400,000 MUSIC, ELECTRONIC AND ENTERTAINMENT PRODUCTS ON SALE

Visit Old Orchard Center in Skokie and browse through our vast selection of new and used merchandise including: CD's, Cassettes, Record Albums, DVD's, Videos, Musical Instruments, Sheet Music, Stereo Equipment and Computer Games. You'll find a lot of really great deals and support one really great cause. All proceeds benefit the Les Turner ALS Foundation in its fight against Lou Gehrig's disease.



OLD ORCHARD CENTER
1-94 at Old Orchard Road & Laverne, Skokie



For more information call **847.674.MART**

Les Turner ALS Foundation, Ltd.

\$30., A: \$2.50. Jim Ronat, 1908 Main St., Highland, IL 62249. PH: 618-654-3049 or Carl Kuelker, PH: 314-621-9121.

Nov 4 NC, Hillsborough. Record & CD Show. Daniel Boone Convention Ctr. I-85 at Exit 164. SH: 10am-5pm. A: \$3., under 12 free. Show Logic Productions, 109 Susan Dr., Warner Robins, GA 31093. PH: 478-929-3053.

Nov 4 OH, Toledo. Record Show. Sommerset Hall, 2458 Tremainsville Rd. (at Douglas & Laskey Rds.). SH: 9am-4pm. T: 8'. F: \$20., A: \$1. Bill Simmons, PH: 419-833-5040.

Nov 4 OH, Cincinnati. Music Collectors' Convention, Radisson Hotel, 11320 Chester Rd., SH: 10am-3pm. F: \$30. if paid one week in advance, F: \$40. thereafter, A: \$2. with coupon, \$3. without, under 12 free with adult. Alpha Records & Music, Gerald Ruark, POB 17575, Indianapolis, IN 46217. PH: 317-882-3378.

Nov 4 ENGLAND, Leicester. Music Fair, Aylestone Leisure Centre, Saffron Ln., T: 6'. Rob Lythall, VIP Events, PH: 0116-224-4300 or FAX: 0116-224-4299.

Nov 4 FRANCE, Epinal. Record Fair, (88) Espace Cour-Rue Gambetta, Sagadisic, Fernand Piqueras, 411 Quai Jean Jaures 71000 Macon France. PH: (33) 0385384666 or FAX: (33) 0385380949.

Nov 10 FL, Tampa. Record & CD Show, Holiday Inn Express, 4732 N. Dale Mabry Hwy., SH: 10am-4pm. A: \$1. Richard Rounds, PO Box 2716, Pinellas Park, FL 33780. PH: 727-520-8766.

Nov 10 NH, Concord. Record & CD Fair, Holiday Inn, Downtown, SH: 10am-4pm. F: \$30., A: \$1. Sound Garden, PH: 603-753-0122.

Nov 10 NJ, Wayne. 2nd Sat Record & CD Collectors Show, Firemen's Convention Center Parish Dr. (N. of Rt. 46 & Rt. 80) at Rt. 23 & Rt. 202S, SH: 10am-4pm. T: 100. A: \$5., under 12 free. F: Falk, PO Box 849, Highland Lakes, NJ 07422. PH: 973-773-6067.

Nov 10 NY, New York. Music Memorabilia Show, Tip Top Shoe Bldg, 155 W. 72nd St., 4th Floor, SH: 10am-2pm, A: free. PH: 212-579-0689 weekdays.

Nov 10 OH, Columbus. Record & Music Memorabilia Show, Veterans Memorial Hall, 300 W. Broad St., SH: 10am-4pm. T: 6'. F: \$45. ea. for 1st 2 \$40. ea. for 3 or more, A: \$4. Collector's Paradise, PO Box 261016, Columbus, OH 43226. PH: 614-261-1585.

Nov 10 ENGLAND, Norwich. Music Fair, St. Andrews Halls, St. Andrews Plain, T: 6'. Rob Lythall, VIP Events, PH: 0116-224-4300 or FAX: 0116-224-4299.

Nov 10 ENGLAND, Luton. Music Fair, Luton University, Park St., T: 6'. Rob Lythall, VIP Events, PH: 0116-224-4300 or FAX: 0116-224-4299.

Nov 11 KY, Louisville. Music Collectors' Convention, Exec. Inn, Watterson Expwy. & Fairgrounds, SH: 10am-3pm. F: \$30. one week in advance, \$40. thereafter, A: \$2. with coupon, \$3. without, under 12 free with adult. Alpha Records & Music, Gerald Ruark, POB 17575, Indianapolis, IN 46217. PH: 317-882-3378.

Nov 11 MA, Springfield. Record Convention with Rock102, Civic Ctr. 1277 Main St., SH: 10am-4pm. T: 70-8'. F: \$60., A: \$4. Greater Promos., Ken & Alanna Sultar, PO Box 896, South Windsor, CT 06074. PH: 860-644-8044.

Nov 11 MI, Roseville. Metro Detroit Record Show, VFW Hall, 25671 Gratiot (N. of 10 Mile Rd.), SH: 10am-4pm. T: 65-8'. F: \$40., A: \$3. Al Campbell, PO Box 277, Warren, MI 48090. PH: 810-759-5133 eves.

Nov 11 MI, Grand Rapids. Record & CD Collectors Show, Midway Hotel, Best Western, 4104 28th St. SW, SH: 11am-5pm. T: 50-6' & 8', F: \$40-\$45., A: \$2. Blain, PH: 616-323-7262.

Nov 11 OR, Portland. Music Expo CD & Record Convention, Holiday Inn, Columbia Conference Ctr., 8439 NE Columbia Blvd., SH: 10am-6pm. T: 6'. F: \$65., A: \$3. C-Bub Productions, 8316 N. Lombard St. #413, Portland, OR 97203. PH: 503-224-6474.

Nov 11 PA, Lancaster. Pennsylvania Music Expo, Catholic H.S. Cafeteria, 650 Juliette Ave., (rear), 1 mi. S. of US Rt. 30, SH: 9am-3pm. A: free. Keystone Record Collectors, PO Box 1516, Lancaster, PA 17608. PH: 717-898-1246.

Nov 11 PA, Pittsburgh-Monroeville. New Rock & Roll Expo, The Palace Inn, Rts. 22 & 48, SH: 10am-5pm. T: 8'. F: \$50., A: \$4. Jeff Smittle, Box 514, Muse, PA 15350. PH: 724-746-3638.

Nov 11 VA, McLean. Northern VA Record Mart, Best Western Westpark Hotel, Rt. 7 & Westpark Dr. (I-495, Exit 47), SH: 10am-4pm. T: 80. F: \$60-\$70., A: \$4. Annapolis Marketing Inc., PO Box 454, Arnold, MD 21012. PH: 410-757-6182.

Nov 11 WI, Milwaukee. Vinyl Record Show, Westwood Hotel, 201 N. Mayfair Rd. (off I-94 & Hwy 100), SH: 9am-3pm. T: 8'. F: \$35., A: \$2. Yesterdays Music, Jim, PH: 920-733-5076.

Nov 11 FRANCE, Lons Le Saunier. Record Fair, (39) Juraparc, Sagadisic, Fernand Piqueras, 411 Quai Jean Jaures 71000 Macon France. PH: (33) 0385384666 or FAX: (33) 0385380949.

Nov 16 KY, Covington. CD & Record Show, Holiday Inn Riverfront, 600 W. 3rd St., Cincinnati, OH, SH: 4pm-10pm. T: 25-6'. F: \$40., A: \$2. Rock Shop, Kevin Folkherth, PO Box 1007, Greenville, OH 45331. PH: 937-548-8364.

Nov 16 OH, Cincinnati. CD & Record Show, Holiday Inn Riverfront, 600 W. 3rd St., Covington, KY, SH: 4pm-10pm. T: 25-6'. F: \$40., A: \$2. Rock Shop, Kevin Folkherth, PO Box 1007, Greenville, OH 45331. PH: 937-548-8364.

Nov 17 KY, Lexington. CD & Record Show, Continental Inn, 801 New Circle Road NE, SH: 10am-4pm. T: 40-6'. F: \$50., A: \$2. Kevin Folkherth, PO Box 1007, Greenville, OH 45331. PH: 937-548-8364.

Nov 17 NY, New York City. Classical Music Expo, The Inn (Formerly Days Inn) 440 W. 57th St., btw 9th & 10th Aves., SH: 10am-4pm. T: 70. A: \$6., under 12 free. F: Falk, PO Box 849, Highland Lakes, NJ 07422. PH: 973-773-6067.

Nov 17 NY, New York City. Record & CD Collectors Expo, Holiday Inn (Formerly Days Inn) 440 W. 57th St., btw 9th & 10th Aves., SH: 10am-4pm. T: 100. A: \$6., under 12 free. F: Falk, PO Box 643, Highland Lakes, NJ 07422. PH: 973-773-6067.

Nov 17 ENGLAND, London. Music Fair, Electric Ballroom, Camden High St., T: 6'. Rob Lythall, VIP Events, PH: 0116-224-4300 or FAX: 0116-224-4299.

Nov 17 ENGLAND, Bristol. Music Fair, Bierkeller, The Pithay, T: 6'. Rob Lythall, VIP Events, PH: 0116-224-4300 or FAX:

0116-224-4299.

Nov 18 CA, San Francisco. Rock 'n Swap, University of San Francisco, McLaren Hall, SH: 10am-4pm. F: \$55., \$30. ea. add'l., A: \$2. KUSF, Robert Barone, 2130 Fulton St., San Francisco, CA 94117. PH: 415-386-5873.

Nov 18 IL, Hillside. Chicagoland Record Collectors Show, Holiday Inn, 4400 Frontage Rd., SH: 9am-4pm. T: 70-8', F: \$40., A: \$3. John Govi, 3045 Worcester Ln., Aurora, IL 60504. PH: 630-898-1533 eves.

Nov 18 MD, Arbutus. Record & CD Show, Fire Hall, 5200 Southwestern Blvd., SH: 10am-4pm. T: 120-5', F: \$30., A: free. Ray or Chris Quigley, 1 Colgate Ct., Baltimore, MD 21228. PH: 410-455-0418.

Nov 18 MA, Randolph. New England Record & Compact Disc Expo, Lombardo's, 6 Billings Rd., 15 min. S. of Boston next to the Holiday Inn, SH: 10am-5pm. A: \$4. Randolph Music Center, PH: 781-986-4538.

Nov 18 NY, Amityville. Record Collectors Show, American Legion Hall, Post 1015, Park Ave., SH: 9am-4pm. F: \$55. in advance, \$60. at the door, A: \$4. R. Scull, PO Box 229, Coram, NY 11727. PH: 631-331-7750 no collect calls.

Nov 18 NY, New York. Super Soul the NY City Record Convention, Gramercy Park Hotel, 2 Lexington Ave. at 21st St., SH: 10am-5pm. Record King, PH: 917-701-7089 or 506-1772.

Nov 18 NY, New York. Movie Memorabilia Convention, Hotel Pennsylvania in the Gold Ballroom, SH: 10am-7pm. The Last Moving Picture Co., 10535 Chillicothe Rd., Kirtland, OH 44094. PH: 440-256-3660 or 256-3431.

Nov 18 OH, Toledo. Glass City Record, Tape & CD Show, Knights of Columbus Hall, 4256 Secor Rd., SH: 10am-4pm. T: 8'. F: \$25., A: \$2. Stephen or Becky, PH: 419-874-1725.

Nov 18 OH, Fairview Park. Record & CD Convention, American Legion Hall, 22001 Brookpark Rd., I-480, Exit 9 Grayton

Rd., SH: 10am-4pm. A: \$3. Ted Szlag, PH: 440-884-4125.

Nov 18 PA, Scranton-Wilkes Barre. WEZX NY CD & Record Fair, The Woodlands Inn, 1073 Rt. 315 (Exit 47B, I-81 to Exit 1 off ramp), SH: 10am-5pm. T: 70-8', A: \$4. Jack Skutnik, 7 Charnel Dr., Binghamton, NY 13901. PH: 607-648-4997 or FAX: 607-648-9626.

Nov 18 TN, Nashville. CD & Record Show, Holiday Inn Select, 2613 West End Ave., SH: 10am-4pm. T: 30-6', F: \$50., A: \$2. Kevin Folkherth, PO Box 1007, Greenville, OH 45331. PH: 937-548-8364.

Nov 18 FRANCE, Montbeliard. Record Fair, (25) Centre De Congres Atria, Sagadisic, Fernand Piqueras, 411 Quai Jean Jaures 71000 Macon France. PH: (33) 0385384666 or FAX: (33) 0385380949.

Nov 18 ENGLAND, Nottingham. Beatles RoadShow Day, Steve Holmes, 36 Brookglen Rd., Risingbrook, Stafford ST17 9DG England. PH: 0102 682008 or Mobile, PH: 07801 564622.

Nov 24-25 PA, Philadelphia. 16th Annual Rock 'N' Roll Expo, Valley Forge Conv. Ctr. Exit 25 off Schuylkill Expwy., Exit 24 off PA Tpke., SH: 10am-6pm. Arc Promotions, PH: 765-646-5305.

Nov 24-25 ENGLAND, Wembley. Music Fair, Complex. Empire Way, North London. T: 6'. Rob Lythall, VIP Events, PH: 0116-224-4300 or FAX: 0116-224-4299.

Nov 25 CA, Buena Park. Greater Orange County Monthly Record Show, Sequoia Club, 7530 Orangethorpe Ave., SH: 10am-3pm. T: 135-8', F: \$50. for 1, \$95. for 2, A: \$3. Steve Brunner, PH: 626-963-9717.

Nov 25 FRANCE, Troyes. Record Fair, (10) Parc Des Expositions, Sagadisic, Fernand Piqueras, 411 Quai Jean Jaures 71000 Macon France. PH: (33) 0385384666 or FAX: (33) 0385380949.

Dec 1 IL, Hillside. Record Convention, Holiday Inn, I-290 & Wolf

Rd., SH: 9am-4pm. F: \$45-\$50., A: \$3. ARC Promotions, PH: 765-646-5305 or FAX: 765-378-7706.

Dec 1 MA, Chelmsford. Big Ed's Record, CDs & Tapes Show, Elks Lodge, Rt. 110, SH: 10am-4pm. A: \$3. PH: 603-888-0294.

Dec 1 ENGLAND, London. Music Fair, Electric Ballroom, Camden High St., T: 6'. Rob Lythall, VIP Events, PH: 0116-224-4300 or FAX: 0116-224-4299.

Dec 1 ENGLAND, Wolverhampton. Music Fair, Civic Halls, North St., T: 8'. Rob Lythall, VIP Events, PH: 0116-224-4300 or FAX: 0116-224-4299.

Dec 2 FL, Orlando. Record Show, Central FL Fairgrounds, 4603 W. Colonial Dr., SH: 10am-4pm. T: 70-8'. F: \$60., A: \$3. FL Record Collectors Association, Inc., Jeff Smith, PH: 352-331-5928 or Syd Crosby, PH: 904-454-0530.

Dec 2 PA, Allentown. Winter 2001 Lehigh Valley Music Expo, Merchants Square, 12th & Vullite Sts., SH: 10am-4pm. T: 8'. F: \$55. before Nov 25, \$65. thereafter, A: \$3. Surround Sound Prods., 801 N. Broad St., Westcosville, PA 18106. PH: 610-530-7606 or 797-7743 day of show.

Dec 2 TN, Nashville. Music Collectors' Convention, Day's Inn-Airport, Briley Pkwy., SH: 10am-3pm. F: \$30. if paid one week in advance, \$40. thereafter, A: \$2. with coupon, \$3. without, under 12 free with adult, 10am-3pm. Alpha Records & Music, Gerald Ruark, POB 17575, Indianapolis, IN 46217. PH: 317-882-3378.

Dec 2 WA, Seattle. Record & CD Show, Seattle Ctr. Snoqualmie Room, SH: 10am-5pm. F: \$45., A: \$3. John, PH: 425-228-3537.

Dec 2 WI, Appleton. Fox Valley Record Show, Best Western Midway Hotel, 3033 W. College Ave., SH: 9am-3pm. T: 6' & 8', F: \$30.-\$35., A: \$2. Yesterdays Music, Jim, PH: 920-733-5076.

Dec 2 FRANCE, Aix Les Bains. Record Fair, (73) Centre De

TAPES
★
VINYL
★
AUTOGRA
★
PHS
★
BOOKS

ARTISTS
★
VIDEOS
★
CDs
★
MAGAZINES

GROOVY PRODUCTIONS PRESENTS MUSIC EXPLOSION

**SUNDAY, OCTOBER 21, 2001 10AM
NEW JERSEY CONVENTION & EXPO CENTER
AT RARITAN CENTER, EDISON, N.J.**

**ADMISSION
\$6.00 AT THE DOOR
EARLY ADMISSION
AVAILABLE**

**PARKING FOR 2500 CARS
EASY ACCESS TO
MAJOR HIGHWAYS & AIRPORTS
ATM ON SITE
FOOD BY MERRI-MAKERS**

**CD'S - RECORDS
TAPES - VIDEOS
NEW AND USED
EQUIPMENT
RECORD LABELS
RECORDING
ARTISTS
DISTRIBUTORS
MANUFACTURERS**

**DO YOU WANT TO SELL YOUR MUSIC COLLECTION?
PROMOTE YOUR BAND? SELL YOUR EQUIPMENT?
ADVERTISE YOUR RECORD LABEL?**

FOR INFO CONTACT ANDY OR IRA AT (732) 257-3888 1-9PM

Show promoters!
Send your 2002 shows to us by Nov. 15 to have the listings included in next year's 2002 *Travel Guide*, published as a separate section in the Dec. 28, 2001-dated *Goldmine*. Extra copies will be printed for bonus distribution at shows in 2001.
Mail show information before Nov. 15 to:
Goldmine Show Calendar Listings
700 East State St.
Iola, WI 54990

"SUPER SOUL"
The New York City
Record/CD Convention

NEW LOCATION!!

SUNDAY
NOVEMBER 18th, 2001
10 A.M. - 5 P.M.
At the GRAMERCY
PARK HOTEL

2 Lexington Ave. at 21st Street
on Lexington
New York, New York 10010
Featuring N.Y.C.'s best dealers
and funkier disc jockies!!!

For More Info Call
The Record King
(917) 701-7089 or
(917) 506-1772
www.recordking117.com

 Yesterday's Music
Presents

The Fox Valley Record Show
Sunday October 21st. 9:00-3:00
At: The Best Western/Midway Hotel
3033 W. College Ave. Appleton, WI
3 Blks East of Hwy 41 on College Ave.
Setup: 7:30 Admission \$2
Tables: 6 ft. \$30; 8 ft. & 6 x 3's \$35
Clip this ad and save \$1 on Admission.
Jazz, Blues, Rock, Pop, Country, R&B,
etc. Lp's, 45's, 78's, tapes, cd's, mem.

For more information or to reserve tables
call Jim at (920) 733-5076.

Since 1995.



Siren
Disc

Discount Import CDs & More.

www.sirendisc.com

 **RAMADA INN**
418 Armour Drive
(I-85 - Exit 86)

SUNDAY, OCT. 21
10 a.m. - 4 p.m.
\$3 ADMISSION \$3

COMPACT DISCS • LPS

RARE • OLD • NEW

- IMPORTS • PROMOS • 45'S • CASSETTES
- PHOTOS • VIDEOS • POSTERS
- SOUNDTRACKS
- JAZZ • NEW WAVE • COUNTRY
- HEAVY METAL • BLUES • SOUL

PLUS OTHER MUSIC-RELATED ITEMS!

CALL 770-946-5050
FOR INFORMATION

- Congres. Sagadisc, Fernand Piqueras, 411 Quai Jean Jaures 71000 Macon France. PH: (33) 0385384666 or FAX: (33) 0385380949.
- Dec 8 MN, Minneapolis. Record Show, VFW, 2916 Lyndale Ave. S., F: \$35., A: \$2. Rich Shelton, 255 E. Kellogg St., Paul, MN 55101. PH: 651-290-2900.
- Dec 8 NJ, Wayne. 2nd Sat. Record & CD Collectors Show, Firemen's Convention Center. Parish Dr. (N. of Rt. 46 & Rt. 80) at Rt. 23 & Rt. 202S. SH: 10am-4pm. T: 100. A: \$5., under 12 free. F. Falk, PO Box 849, Highland Lakes, NJ 07422. PH: 973-773-6067.
- Dec 8 NY, New York. Music Memorabilia Show, Tip Top Shoe Bldg. 155 W. 72nd St., 4th Floor, SH: 10am-2pm. A: free. PH: 212-579-0689 weekdays.
- Dec 8 OH, Dayton. Music Collectors' Convention, Hara Arena, 1001 Shiloh Springs Rd., SH: 10am-3pm, F: \$30. if paid one week in advance, F: \$40. thereafter, A: \$2. with coupon, \$3. without, under 12 free with adult. Alpha Records & Music, Gerald Ruark, POB 17575, Indianapolis, IN 46217. PH: 317-882-3378.
- Dec 8 ENGLAND, Walsall. Music Fair, Town Hall, Leicester St., T: 7.5'. Rob Lythall, VIP Events, PH: 0116-224-4300 or FAX: 0116-224-4299.
- Dec 9 CA, Newark. Music Swap Meet, Pavilion, 6430 Thornton Ave., corner of Thornton & Cherry, SH: 9am-2pm, F: \$45. for 1, \$60. for 2, A: \$3. Charlene White, PH: 408-263-5127.
- Dec 9 CT, Waterbury. Record Collectors' Convention, Sheraton Hotel, 3580 E. Main St., SH: 9:30am-4pm, T: 8'. F: \$65., A: \$4. Gorman, PH: 203-287-8923.
- Dec 9 IN, Indianapolis. Music Collectors' Convention, Quality Inn-East, 3525 N. Shadeland, SH: 10am-3pm, F: \$30. if paid one week in advance, F: \$40. thereafter, A: \$2. with coupon, \$3. without, under 12 free with adult. Alpha Records & Music, Gerald Ruark, POB 17575, Indianapolis, IN 46217. PH: 317-882-3378.
- Dec 9 PA, Lancaster. Pennsylvania Music Expo, Catholic H S. Cafeteria, 650 Juliette Ave., (rear), 1 mi. S of US Rt. 30, SH: 9am-3pm, A: free. Keystone Record Collectors, PO Box 1516, Lancaster, PA 17608. PH: 717-898-1246.
- Dec 9 HUNGARY, Budapest. 16th International Record Fair, Petofi Csarnok Varosliget, H-1146 Budapest, Zichy Mihaly Str. 14. Lemezborze, plusz Magazine, 1300 Budapest, Pf. 129. Hungary. PH: 0036 14300990 or FAX: 0036 14300991.
- Dec 15 NY, New York City. Record & CD Collectors Expo, Holiday Inn. (Formerly Days Inn) 440 W 57th St. btw 9th & 10th Aves., SH: 10am-4pm, T: 100, A: \$6., under 12 free. F. Falk, PO Box 643, Highland Lakes, NJ 07422. PH: 973-773-6067.
- Dec 15 ENGLAND, London. Music Fair, Electric Ballroom, Camden High St., T: 6'. Rob Lythall, VIP Events, PH: 0116-224-4300 or FAX: 0116-224-4299.
- Dec 15 ENGLAND, Cardiff. Music Fair, City Hall, Cathay's Park, T: 6'. Rob Lythall, VIP Events, PH: 0116-224-4300 or FAX: 0116-224-4299.
- Dec 16 GA, Atlanta. Record & CD Show, Ramada Inn, I-85, Exit 86, 418 Armour Dr., SH: 10am-4pm, A: \$3. Keith Alverson, PH: 770-463-2727.
- Dec 16 MD, Arbutus. Record & CD Show, Fire Hall, 5200 Southwestern Blvd., SH: 10am-4pm, T: 120-5'. F: \$30., A: free. Ray or Chris Quigley, 1 Colgate Ct., Baltimore, MD 21228. PH: 410-455-0418.
- Dec 16 NY, Binghamton. WAAL NY CD & Record Fair, Heritage Country Club, 4301 Watson Blvd. (Rt. 17 W., Exit 70 N., L. at 1st light, .5 mi. on R., SH: 10am-5pm, T: 70-8'. A: \$4. Jack Skutnik, 7 Charnel Dr., Binghamton, NY 13901. PH: 607-648-4997 or FAX: 607-648-9626.
- Dec 16 OH, Toledo. Midwest Music Expo, Clarion Hotel, 3536 Secor Rd., Exit on Secor Rd. off I-475 & go S., SH: 10am-4pm, T: 60-8'. F: \$50. ea. for 1st 2, \$40. ea. thereafter, A: \$4. B-Bop Records, PO Box 2449, Toledo, OH 43606. PH: 419-535-1234.
- Dec 16 WI, Milwaukee. Record Fest, Serb Hall, 5101 W. Oklahoma Ave., SH: 10am-3pm, F: \$45.-\$55., A: \$4. Gary Mason, PH: 414-442-6060 (11am-5pm).
- Dec 16 ENGLAND, Bath. Music Fair, Sports Centre, North Parade Rd., T: 6'. Rob Lythall, VIP Events, PH: 0116-224-4300.
- Dec 22 ENGLAND, Birmingham. Music Fair, Academy, Dale End, T: 6'. Rob Lythall, VIP Events, PH: 0116-224-4300 or FAX: 0116-224-4299.
- Dec 22 ENGLAND, London. Music Fair, Electric Ballroom, Camden High St., T: 6'. Rob Lythall, VIP Events, PH: 0116-224-4300 or FAX: 0116-224-4299.
- Dec 29 NJ, Wayne. 2nd Sat. Holiday Record-CD-Tape Collectors Show, Firemen's Convention Center, Parish Dr. (N. of Rt. 46 & Rt. 80) at Rt. 23 & Rt. 202S, SH: 10am-4pm, T: 100, A: \$5., under 12 free. F. Falk, PO Box 849, Highland Lakes, NJ 07422. PH: 973-773-6067.
- Dec 29 ENGLAND, London. Music Fair, Electric Ballroom, Camden High St., T: 6'. Rob Lythall, VIP Events, PH: 0116-224-4300 or FAX: 0116-224-4299.
- Jan 5 OH, Columbus. Record & Music Memorabilia Show, Veterans Memorial Hall, 300 W. Broad St., SH: 10am-4pm, T: 6', F: \$45. ea. for 1st 2, \$40. ea. for 3 or more, A: \$4. Collector's Paradise, PO Box 261016, Columbus, OH 43226. PH: 614-261-1585.
- Jan 13 IL, Hillside. Chicagoland Record Collectors Show, Holiday Inn, 4400 Frontage Rd., SH: 9am-4pm, T: 70-8', F: \$40., A: \$3. John Govi, 3045 Worcester Ln., Aurora, IL 60504. PH: 630-898-1533 eves.
- Jan 13 FRANCE, Macon. Record Fair, (71) Centre Heritan Sagadisc, Fernand Piqueras, 411 Quai Jean Jaures 71000 Macon France. PH: (33) 0385384666 or FAX: (33) 0385380949.
- Jan 20 PA, Pittsburgh-Monroeville. New Rock & Roll Expo, The Palace Inn, Rts. 22 & 48, SH: 10am-5pm, T: 8'. F: \$50., A: \$4. Jeff Smittle, Box 514, Muse, PA 15350. PH: 724-746-3638.
- Jan 26 PA, Montgomery. Beatles Fest, Clinton Township Vol Fire Company, Rt. 54, SH: 7pm-11pm, A: \$3. \$5 couple Jimmy Stabley, PH: 570-326-4280 or Tom Staggett, PH: 570-547-6254.
- Jan 27 FRANCE, Vesoul. Record Fair, (70) Centre Parisat Sagadisc, Fernand Piqueras, 411 Quai Jean Jaures 71000 Macon France. PH: (33) 0385384666 or FAX: (33) 0385380949.
- Feb 2-3 ITALY, Milano. "Vinilmania" International Record & CD Fair, Parco Esposizioni Novogro (Milano Linate Airport) Dario Maffioli, Corso Buenos Aires 43, 20124 Milano Italy FAX: 39-029510638.
- Feb 3 OH, Toledo. Glass City Record, Tape & CD Show, Knights of Columbus Hall, 4256 Secor Rd., SH: 10am-4pm, T: 8'. F: \$25., A: \$2. Stephen or Becky, PH: 419-874-1725.
- Feb 10 FRANCE, Belfort. Record Fair, (90) Centre Congres Atria, Sagadisc, Fernand Piqueras, 411 Quai Jean Jaures 71000 Macon France. PH: (33) 0385384666 or FAX: (33) 0385380949.
- Feb 16 MA, Chelmsford. Big Ed's Record, CDs & Tapes Show, Elks Lodge, Rt. 110, SH: 10am-4pm, A: \$3. PH: 603-888-0294.
- Feb 24 CT, East Hartford. Record Convention, Pratt & Whitney Aircraft Club, 200 Clement Rd. (84 E. or W., Exit 58, 91 N., Exit 29 to Exit 91), SH: 10am-4pm, T: 90-8', F: \$45., A: \$4. Greater Promos., Ken & Alanna Sultar, PO Box 896, South Windsor, CT 06074. PH: 860-644-8044.
- Feb 24 NY, Amityville. Record Collectors Show, American Legion Hall, Post 1015, Park Ave., SH: 9am-4pm, F: \$55. in advance, \$60. at the door, A: \$4. R. Scull, PO Box 229, Coram, NY 11727. PH: 631-331-7750 no collect calls.
- Feb 24 VA, Richmond. Record & CD Show, Holiday Inn Hotel, 2000 Staples Mill Rd. (Rt. 33 E. off I-64), SH: 10am-4:30pm, T: 6', F: \$35. before Sep 10, \$45. thereafter, A: \$2.50, \$50 students & seniors, under 12 free. Stand Still Music, PH: 804-422-6772.
- Mar 9 OH, Columbus. Record & Music Memorabilia Show, Veterans Memorial Hall, 300 W. Broad St., SH: 10am-4pm, T: 6', F: \$45. ea. for 1st 2, \$40. ea. for 3 or more, A: \$4. Collector's Paradise, PH: 614-261-1585.

wfmu

Rock
Soul
Jazz
Country
Punk
R&B
Blues
Experimental
Electronica
Hip Hop
Psychadelic
Garage
International
Comedy
Rockabilly
Soundtracks
Reggae
Incredibly Strange
LPs, 45s, 78s, CDs
Posters
Videos
and much more!

FALL RECORD FAIR

November 2-3-4 2001

Metropolitan Pavilion
125 W. 18th St. (6/7 Aves.) New York City

Early admission: \$20 Fri. 4-7 PM. (Includes re-entry for entire weekend)
Regular admission: \$5 Fri. 7-10 PM and Sat./Sun. 10 AM - 7 PM

Miles and miles of the most obscure sounds from across the sonic spectrum! From vintage vinyl to the latest digitalia, the east coast's largest gathering of dealers is sure to tantalize and delight!

WFMU will broadcast LIVE from the Fair all weekend long! Stop by to search for those long-sought treasures, and be sure to check out the live bands, food, beer, and WFMU's Tchotchke Central.

WFMU 91.1 • 90.1 FM
www.wfmu.org/recfair/

\$1 off any admission with this ad! (Not to be combined with any other offer.)
for more information, call Mike at 201-521-1416 x243, or recfair@wfmu.org

BUFFALO
RECORD & COMPACT DISC
SALE

Sunday, Oct. 14th.
10 am-4:30 pm \$3 admission
AT THE **LEONARD POST V.F.W.**
2450 Walden Ave., One mile East of Exit 52E.
For more info., call The Record Baron
at (716) 871-8722.

70 Tables featuring:
Records
Compact Discs
cassettes
memorabilia
45 RPM's...
and much more!

ADMIT ONE FOR \$3 WITH THIS CARD/SUNDAY 10-5

MUSIC COLLECTORS' EXPO

- Rock
- Pop
- Jazz, Blues, etc.

Records
Posters
CDs
Memorabilia & much more

1 SHOW LEFT IN 2001:
OCTOBER 13-14

San Mateo Expo Center
Saturday, 9 7 Sunday, 10-5

Gen. Adm: \$5 (good both days)
Floor Rights Friday, 12-8 pm: \$20
INFO: 707-942-5079 or www.pmaantiqueshow.com

General admission price includes
ANTIQUE & COLLECTORS' REVIVAL
MILLIONS OF ANTIQUES & COLLECTIBLES
• COLLECTOR CAR SALE

Thanks, Northeast, for making all the previous shows sellouts!

big ED'S

RECORDS TAPES SHOW

DECEMBER 1, 2001 (SATURDAY)
10:00 AM TO 4:00 PM
CHELMSFORD ELKS LODGE
RT. 110, CHELMSFORD, MA

★ ALSO SPECIAL GIVEAWAY ★

MEMORABILIA	RHYTHM & BLUES	COLLECTABLES
SOUND TRACKS	PHOTOS	METAL
AUTOGRAPHS	ROCK 'N' ROLL	POSTERS
JAZZ	LASER DISCS	COUNTRY
VIDEOS	TOP 40	IMPORTS
ROCKABILLY	MUSIC MAGS	GARAGE

ADMISSION \$3.00 ★ EARLY BUYERS (7-9 AM) \$6.00
FREE PARKING ★ SHOW MONEY EVERY HOUR
INFO AT (603) 888-0294 ★ BIG FROGMAN@AOL.COM

SECOND SATURDAY
RECORD & CD EXPO

Saturday Oct. 13, 2001 10a - 4p
Parish Dr (@ Rt 23 & 202S)
North of Rt 80/46, Wayne, NJ

NEW YORK CITY
RECORD & CD EXPO

Saturday Oct. 20, 2001 10a - 4p
The "Inn", 440 W 57th St ptwn
9th & 10th Aves, New York City

\$1 off regular admission with this ad

INFO: 973-773-6067 or
fred@njl.com or Web:
www.showsandexpos.com

(New Releases from page 57)

ANDY WHITE
 Andy White
 Thirsty Ear (THI 57108.2)

Belfast-born singer/songwriter Andy White may not be as well-known as, say, David Gray, but that doesn't make his music any less engaging. On his 10th album in 15 years, White revisits the soft, sentimental folk-like finesse that has gained him a small but growing following in his native Ireland. By the time he waltzes his way through this superior 16-song set, it's abundantly clear that White and Gray are of one hue.

The most accurate assessment might be to liken White to the even lesser-known Boo Hewardine, another songsmith adept at wringing out emotions. Like Hewardine, White eloquently woos listeners with his beguiling melodies and effortless arrangements.

On songs such as "I Want It Straight," "What About You Babe" and "Coz I'm Free," he weaves his sweet sentiments into a wistful, reflective ambience. However, this isn't just another case of an introspective songwriter whose music is absorbed with melancholy confessionals. Songs such as "Let Me Be Free" and "Hysteria" are propelled by resilient rhythms and cool grooves. "Bodybuilder" takes a playful poke at a woman obsessed with physical fitness. "Jesus In A Cadillac" gravitates toward gospel. In "Me The Moon My Car And You," he conveys a feeling of aimless adolescence, emulating the restless longing of Springsteen's early epics. Not surprising, the lovely "Little Boy" and John Lennon's "Beautiful Boy" share similar sentiments.

Andy White is one of those albums that's

so perfectly tuned, one has to wonder why White remains so unjustly ignored. This release is nothing less than an outstanding effort from an incisive artist.

— Lee Zimmerman

FREEDY JOHNSTON
 Right Between The Promises
 Elektra (75596 26522)

Fredy Johnston is one of the finest singer/songwriters of the past decade, and *Right Between The Promises* is a diverse and consistently enjoyable collection. Johnston has long been one of the best lyricists around. Though *Right Between The Promises* is filled with his usual quirky characters and scene-setting imagery ("sunrise on the tower clock, backstreets still wet with rain"), it is the quality of Johnston's music that distinguishes his really good albums from his merely good ones.

The music on *Right Between The Promises* is consistently accomplished. "Broken Mirror" starts things off with a melodic album opener before Johnston lets 'er rip on "Waste Your Time," his best rocker in a while (he usually opts for subtle understatement over immediate excitement). A surprising cover of Edison Lighthouse's "Love Grows" is then delivered with a perfect pop pitch and without a trace of irony. Though the laid-back "That's Alright With Me" has too much of a James Taylor/West Coast-type of vibe, it's still a smoothly enjoyable listen overall.

The album really branches out on "Radio For Heartache," a sparse banjo-led story about a riverside busybody, while "Back To My Machine" is a bluesy, atmospheric and somewhat dissonant tale with Johnston's typically intriguing lyrics. Elsewhere, "Arriv-

ing On A Train" takes listeners on an especially evocative ride, and "Save Yourself, City Girl" surprises listeners with its loping shuffle beat and some pragmatic advice. Finally, "Anyone" contains an effortlessly catchy play on words before the album fades out with the appropriately dreamy "In My Dream."

Throughout this 38-minute album, Johnston adds tasteful layers of instrumentation (violin, cello, flute), but it is Johnston's easy-going vocals and inviting melodies that make this album so instantly likeable. As always, this perpetual cult artist still requires repeat plays and a devoted attention to lyrical detail for a full appreciation. But though it's not quite his best work (that honor would go to *Can You Fly* or *This Perfect World*), this thinking-man's craftsman has given his listeners a lot to chew this time out as well.

— Scott Floman

MAPLE MARS
 Welcome To Maple Mars
 Permanent Press (PPCD 52718)

Welcome To Maple Mars, the debut album from L.A. pop stalwart Rick Hromadka's latest project, Maple Mars, proves a pleasant blending of psychedelia and power pop. Hromadka has a keen ear for lyrical simplicity and a flair for adding a light touch of melodic madness and happy harmonizing to his more pointed tunes (e.g., "Souvenir"). Partner Mike Fletcher anchors each piece with superb but not overwhelming drum work, deftly balancing between Hromadka's lighter musical tendencies and heavier thematic content.

The first four songs are strong, from the inviting weirdness of the title track to the aforementioned "Souvenir." The album

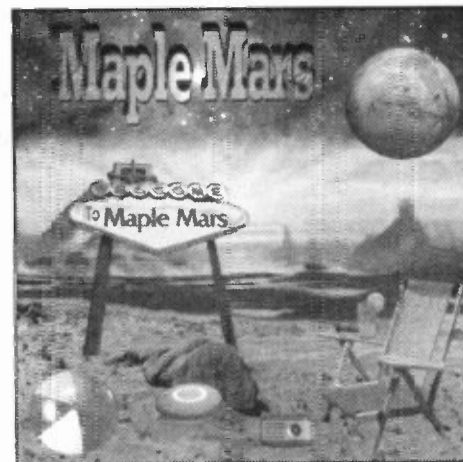

falters a bit as the tracks begin alternating between slower and faster tempos, creating a symmetry that unfortunately throws into sharp relief the weaknesses of two numbers — "When Atlas Falls" and "Afterglow." However, the kicky rocker "The Perfect Song," with its echoes of Bob Mould's *Sugar* days, and the sweet-sounding "All Brand New," about taking charge of your own life, more than compensate.

The best song in the collection is "Absolute Zero," a punchy piece with a perfect sing-along hook. The experimental noise/music soundscape "Wonderwalla" may freak out the uninitiated, but the unlisted track following it, a brief homage to Hromadka's former band, Double Naught Spies, brings it all back to Earth.

— Désirée I. Guzzetta

(Please see New Releases page 65)

New Releases on Compact Disc



- AC/DC - Boston and Bon - Boston 8/21/78 (8 tracks) plus Glasgow 1978 (3) - excellent quality recording FM broadcasts (73:38)
- AC/DC - Remastered Bees - fourteen BBC tracks 1976-79 - excellent quality FM broadcasts (70:02)
- Aerosmith - Palls Mail 1973 - Boston 1973 (9 tracks excellent FM) plus Roslyn NY 7/27/74 (5 tracks excellent soundboard) (72:31)
- Allman Brothers - Midnight Riding (2 CD) - St. Louis MO 7/23/94 - excellent quality soundboard - 12 tracks (53:58 and 57:35)
- Tori Amos - Dew Drop Inn Tour '96" - Memphis TN 4/17/96 - excellent quality soundboard recording - fourteen tracks (71:10)
- Bad Company - The Original Bad Company 1999 - Orlando FL 5/21/99 - soundboard recording - four-teen tracks (73:33)
- Beach Boys - Aloha from (Hawaii and Hollywood) - Honolulu International Center 8/25/67 (21 tracks) plus "live-in-the-studio" rehearsals at Wally Heider's Studio, Hollywood CA 9/11/67 (13) - excellent quality soundboard and studio tracks (67:41)
- Beach Boys - Smile - All the finished recordings from Brian Wilson's 1967 *Opus Magnum* with bonus tracks - 34 tracks (71:56)
- Beatles - Die Beatles in Deutschland - seven Beatles songs and support acts at the Circus-Krone-Bau in Munich 6/24/66 plus radio broadcasts and interviews - very good soundboard and excellent FM broadcasts (70:13)
- Black Sabbath - The Dead, the Bad and the Ugly - no venue information - Ronnie James Dio sings - excellent soundboard (72:54)
- Black Sabbath - Legends Unite - Costa Mesa, CA 11/15/92 w/ Rob Halford of Judas Priest - excellent audience rec. - 11 tracks (53:30)
- Black Sabbath - Live in Chicago (2 CD) - Chicago 1/19/99 - very good audience recording - eleven tracks (42:21 and 40:32)
- Black Sabbath - London to Pittsburgh - London 3/77 (four tracks) and Pittsburgh 9/27/78 (four) plus Bologna, Italy 1973 (one) - excellent FM broadcasts (69:53)
- Black Sabbath - Mass for Ian 1983 - Worcester MA 11/4/83 - very good to excellent FM broadcast - eleven tracks (71:32)
- Black Sabbath - Northern Exposure - York Stadium, Toronto, Canada 7/18/71 - excellent quality soundboard - nine tracks (65:32)
- Black Sabbath - Rocked at Reading - Reading Festival 1983 (eight tracks) plus Paris 9/30/83 (four tracks) - excellent FM broadcasts featuring Ian Gillan (63:25)
- Black Sabbath - War Pigs - Paris 12/20/70 television broadcast - excellent quality - eight tracks (52:44)
- Boston - Cleveland Rocks 1977 - Agora Ballroom, Cleveland OH 1977 - excellent quality FM broadcast - eleven tracks (59:35)
- Captain Beyond - Montreux Void - Montreux, Switzerland 9/18/71 (eight tracks) plus Miami FL 8/19/72 (ten) - good to very good audience recordings (48:22)
- Cheap Trick - Top of the World - Chicago 1979 - excellent quality FM broadcast - eight tracks (73:02)
- Deep Purple - Grand Hotel - Montreux, Switzerland 12/6-21/71 - excellent quality soundboard recording - thirteen tracks (70:08)
- Duran Duran - Rockin' the Savoy '83 - NYC 7/83 (eight tracks) plus London 1983 (three) - excellent FM broadcasts (63:49)
- Eagles - Hell Freezes Over Rehearsals (2 CD) - MTV Studios 4/26/94 - excellent quality soundboard - 23 tracks (65:41 and 70:19)
- Steve Earle and the Del McCoury Band - Mountain Stage - Huntington WV 3/77/91 - excellent FM broadcast - ten tracks (46:19)
- The Firm - Live USA 1986 - excellent quality FM radio broadcast - eleven tracks (57:44)
- Fish - There's a Guy Works Down the Chips Shop Swears He's Fish - five 1992 excellent audience recording - 8 tracks (60:37)
- Fleetwood Mac - The Last Goodbye - Seattle, WA 1/7/70 - last tour with Peter Green - very good audience recording (71:29)
- Genesis - Supper's Ready with a Little Lost Lamb (2 CD) - Lakeland, Florida 1/11/75 - excellent soundboard - 24 tracks plus one bonus (59:53 and 77:39)
- Gov't Mule - Kickin' in the House (2 CD) - House of Blues Los Angeles 9/4/97 - excellent audience - 18 tracks (61:50 & 57:05)
- Gov't Mule - Through the Roof (2 CD) - 930 Club Washington D.C. 3/10/00 - very good audience rec. - 19 tracks (68:06 & 69:21)
- Guns N' Roses - Oklahoma (2 CD) - Oklahoma 6/4/92 - excellent quality soundboard recording - 21 tracks (64:50 and 73:02)
- Jimi Hendrix - De Lane Lea Demos and Olympic Cuts - De Lane Lea Studios 1966-67 and Olympic Studios 1967-69 - very good to excellent quality recordings - fourteen tracks (70:34)
- The Jimi Hendrix Experience - First Night at the Royal Albert Hall (2 CD) - London performance 2/18/69 (six tracks) and rehearsals 2/24/69 (ten) - excellent quality soundboards (55:35 and 51:37)
- Hot Tuna - Trial By Fire - with Papa John Creach at Carnegie Hall, NYC 4/3/72 - excellent quality soundboard - 12 tracks (78:57)
- Humble Pie - On Stage 1970 - BBC 9/20/70 - very good FM broadcast - nine tracks (60:01)
- Jefferson Airplane - Flying High (2 CD) - San Francisco 9/22/72 - excellent quality soundboard - 20 tracks (70:48 and 52:20)
- Elton John - Goodbye England's Rose, Hello New York - Di's funeral, London 9/16/97 (one track); A&R, NYC 11/17/70 (6); 1968 demo (1); Live Aid, London 7/15/85 (3); London 6/30/90 (2); two others - excellent soundboards - 15 tracks total (72:21)
- Elton John - On the Beeb 1973 - London 12/22/73 - excellent quality radio broadcast - twelve tracks (74:35)
- Janis Joplin - Fillmore East 1969 - NYC 2/12/69 - excellent quality soundboard recording - ten tracks (60:06)
- Kraftwerk - Frühwerke - 1969 Organization tracks (five) plus live USA 1974 (three) plus rare singles 1974-5 (three) (76:47)
- Paul McCartney - Arizona Soundchecks 1990 (2 CD) - Sun Devil Stadium, Phoenix 4/4/90 (18 tracks) plus Cactus Club, AZ 1986 (five) excellent quality soundboards (60:19 and 47:11)
- Paul McCartney - Berkeley 1990 (2 CD) - Berkeley Stadium 4/1/90 - excellent quality soundboard - 25 tracks (61:15 and 60:37)
- Paul McCartney - Washington 1990 (2 CD) - RFK Stadium 7/4/90 - excellent quality soundboard - 24 tracks (58:36 and 60:06)
- Misfits - The 12 Inch Compilation - rare and deleted original recordings - studio quality - 31 tracks (59:14)
- Ted Nugent and the Amboy Dukes - Atlanta - Atlanta 1973 (seven tracks) plus Lubbock, TX 4/7/80 (two) - FM broadcasts (75:56)
- Pink Floyd - Live in Montreux (2 CD) - Montreux Jazz Festival 9/18-19/71 - excellent soundboard - 6 tracks (52:58 and 66:06)
- Pink Floyd - The Wall Demos - excellent quality studio recordings - 29 tracks (73:59)
- Pink Floyd - The Wall Rehearsals - Los Angeles 1/80 - excellent quality soundboard recording (19 tracks) plus two bonus (73:59)
- Radiohead - Memento for Later - recorded live for *Later with Jools* 6/9/01 (thirteen tracks) plus Warrington 2/10/00 (four) - excellent quality soundboards (79:34)
- Linda Ronstadt - The Music Shed 1975 - Lennox MA 8/26/75 - very good audience recording - seventeen tracks (72:03)
- Todd Rundgren - Puttin' on a Ritz - The Ritz, NYC 6/13/89 - excellent quality soundboard - eleven tracks (51:51)
- Bob Seger - Aragon Ballroom 1974 - Chicago 1974 - excellent quality FM broadcast - ten tracks (54:14)
- Smashing Pumpkins - The Final Show, Volume One - Chicago 12/2/00 - good audience recording - twelve tracks (65:09)
- Smashing Pumpkins - The Second to Last Gig Ever! (2 CD) - Chicago 11/29/00 - FM broadcast - 27 tracks (77:37 and 79:03)
- Steely Dan - Where Did You Get Those Shoes - *Katy Lied* outtakes (seven tracks) plus 1976 tour rehearsals (eight) - excellent quality soundboards (59:29)
- Styx - Tour for the Equinox - Toronto 4/18/76 (five tracks - excellent audience recording) plus one bonus studio mix (46:33)
- Super Tramp - Dreamers - Cleveland OH 1976 - excellent quality soundboard - twelve tracks (73:46)
- U2 - Alias the Dalton Brothers - LA Coliseum 11/18/87 - two Dalton Brothers songs plus complete U2 show (14 tracks) - excellent audience recording (73:02)
- U2 - Elevation at the Target Center (2 CD) - Minneapolis MN 5/1/01 - excellent audience recording - 23 tracks (65:13 and 64:44)
- The Who - Shakin' All Over - Fillmore East, NYC 4/5/68 plus bonus tracks - excellent quality soundboards - 13 tracks (65:28)
- The Who - They Are Alright (2 CD) - Royal Albert Hall, London 2000 with significant guest musicians (sixteen tracks) plus six bonus tracks - excellent soundboards (60:05 and 64:33)
- Frank Zappa - Thing-fish Outtakes - studio quality - 17 tracks (64:02)
- ZZ Top - Jesus Left Chicago - various American venues 1987 - excellent quality soundboards - 18 tracks (73:35)

Ordering Information: All of the above CD titles are \$18.00 per disc. Include full name and address along with a daytime and evening phone number. We accept checks and money orders (made payable to "Collector"), as well as VISA, MasterCard and American Express cards.

24 HOUR ORDER LINE: 847-465-8496

COLLECTOR

33 North Elmhurst Rd., Wheeling, IL 60090

SHIPPING:
 U.S. - \$5.00 Any Size Order, Illinois residents add additional 6.5% sales tax.
 Canada - \$6.00 for any size order.
 Overseas rates available.
 Call or e-mail for info.

STYLUS SHOWS PRESENTS
 THE LARGE 2002

ORLANDO
 MUSIC COLLECTOR'S
CONVENTION

SAT - SUN, FEB 9 - 10
 10am - 5pm

DOWNTOWN EXPO CENTRE

Zillions of LP's, CD's, 45's, 78's, DVD's &
 TONS of MEMORABILIA

DEALERS and COLLECTOR'S from Everywhere!

ADMISSION \$3 (Good for both days)
 Kids under 13 FREE w/ Adult
 Early Shopper 7am : \$15

ADVERTISED LOCALLY, STATEWIDE &
 NATIONALLY - LOTS OF PUBLIC TRAFFIC !

TABLES JUST \$60, MUST SHOW FOR BOTH DAYS, AFTER JAN. 1: \$70

RESERVE NOW FOR BEST SPACES: 301-570-5524
 STYLUS SHOWS 18127 Bowie Mill Rd., Rockville, MD 20855

www.record-shows.com

STORE DIRECTORY

The following is a list of record shops around the country arranged by state. Be sure to mention that you saw them listed in Goldmine's Store Directory. Retailers listed in bold type carry Goldmine in their stores.

ARIZONA

Memory Lane
Out-Of-Print Records ★ Tapes ★ CDs
1940 E. University Dr.
Tempe, AZ 85281
(480) 968-1512
FAX (480) 921-1620
<http://www.memorylanerecords.com>
E-Mail: mlr@memorylanerecords.com
Mail, phone, and web orders filled promptly... VISA ★ MC ★ AMEX ★ NOVUS... be sure to visit us when you're in Arizona.

ARKANSAS

Arkansas Record CD Exchange
4212 MacArthur Dr.
North Little Rock, AR 72118
(501) 753-7877
FAX (501) 758-7556
E-Mail: are@cei.net
Web: ARCD.com
11 am to 7 pm Tues.-Sat.
VISA/MC/AMEX. Your Record and CD Oasis Between Memphis and Dallas. Right on I-40 at Burns Park Exit. Thousands of 45s, LPs, CDs, CD Singles & Imports. New & Used, Buy-Sell-Trade. Send Want lists.

CALIFORNIA

Armadillo Music Records
210 E Street
Davis, CA 95616
(530) 750-2384
FAX (530) 750-2385
E-Mail: armadillomusic@mother.com
Rare, out of print and new vinyl.
New & Used CD's. Buy, Sell & Trade. Want lists welcome.
We buy collections - large or small.
Open 7 days.

Atomic Records
3812 W. Magnolia Blvd.
Burbank, CA 90026
Phone: (818) 848-7090
FAX (818) 848-1969
E-Mail: atomic1@flash.net
Specializing in rare/collectibles: Jazz - Soul - Rock - Exotica - Alternative - Childrens LPs & 45s.

Beat City Records
2090 East Main Street
Ventura, CA 93001
(805) 653-5545
Web: www.beatcityrecords.com
E-Mail: bcityrec@pacbell.net
New/Used Records, CDs & Collectibles. Import & Domestic Vinyl in Stock. Posters by Coop, Kozik & Others. We Do Mail Orders.

CD Trader
18928 Ventura Blvd.
Tarzana, CA 91356
818-705-3544
Los Angeles's best used CD store!

Earth Wave Records
Grand Opening October 1, 2000
Come visit our brand new store!
Hundreds of new arrivals daily!
219B Southwest Blvd.
Rohnert Park, CA 94928
Tel: (707) 795-1660
Fax: (707) 795-1665
<http://www.earthwaverecords.com>
E-Mail: mallstaff@vintage.com (English)
E-Mail: earthwave@home.com
* Vintage US original records from 1950's - 1990's
* Largest selection of Japanese audiophile records in the U.S.
We ship worldwide.
Dealer discounts available.

CALIFORNIA

過去7年間の皆様のご支援のお陰でこの度アースウェイレコード1号店オープンの運びとなりました。(日本語)レコードの買い付けや西海岸に遊びに来られる際は是非お立ち寄り下さい。

Goat Hill Records
1920 Harbor Blvd.
Costa Mesa, CA 92627
(949) 646-8551
Records • CDs • Collectibles •
Rarities • Rock • Jazz • Blues •
New • Used • Buy

House of Records
3328 Pico Blvd.
Santa Monica, CA 90405
(310) 450-1222
(310) 450-4525
E-Mail: info@houseofrecords.com
Web: www.houseofrecords.com
LA's oldest record store. Collectible records and used CDs. Please visit when in California.

Record Man, The
1322 El Camino Real
Redwood City, CA 94063
Phone: (650) 368-9065
Fax: (650) 368-2968
www.recordman.com
E-Mail: ARCHIVES@recordman.com
Find out why people are calling us the biggest and best record store around!!
Over 1 Million Items In Stock; LPs, 45s, EPs, Picture Discs, 78s, CDs, Cassettes and reel to reels.

Rockaway Records
2395 Glendale Blvd.
Los Angeles, CA 90039
Ph. (323) 664-3232
FAX (323) 664-0956
E-Mail: sales@rockaway.com
www.rockaway.com
LA's best collectables! Vinyl, Compact Discs, Posters and Memorabilia from the 50's to the 90's. Open 7 days, 10 a.m. - 9:30 p.m.

Rock-It-Man
55635 29 Palms Hwy.
Yucca Valley, CA 92284
Ph. 760-228-3304
FAX: 760-228-3075
Palm Springs largest selection of new & used CD's & Memorabilia.

Saturn Records
5488 College Ave.
Oakland, CA 94618
Phone: (510) 654-0335
FAX: (510) 654-4386
Fully searchable Web site with secure server for easy and safe credit card ordering: www.saturn-records.com
San Francisco Bay Area's premier collector's record store.

Streetlight Records
980 South Bascom Ave.
San Jose, CA
(888) 330-7776
939 Pacific Ave., Santa Cruz, CA
(888) 648-9201
3979 24th St., San Francisco, CA
(888) 682-3550
2350 Market St., San Francisco, CA
(888) 396-2350
www.streetlightrecords.com
Buy, Sell, Trade all kinds of CD's, LP's, Videos, DVD's and Collectibles. Secure E-store.

FLORIDA

Blue Note Records
16401 NE 15th Avenue
N. Miami Beach, FL 33162
(305) 940-3394
FAX (305) 948-3523
E-Mail: BLUENOTE@NETROX.NET
Largest selection of Jazz, Soul, Blues, 10", LPs, 34s & Rare 50s & 60s originals. Specializing in 70s & 80s originals & White Label 12".
Just opened our new Jazz store.
Phone: 305-354-4563

Offbeat Records & CD's, Inc.
937 S. State Road 7 (US 441)
Ft. Lauderdale, FL 33317
Phone: (954) 316-9084
Fax: (954) 316-9391
Web site: www.offbeatrecords.com
E-Mail: offbeatrecords@aol.com
Hours: Wed.-Sat. 11:00 a.m. - 5:00 p.m.
Sun. 12 Noon - 4 p.m.
Closed Mon. & Tues.
South Florida's coolest music collector's shop! We specialize in rare LPs, CDs, 8 tracks, reel tapes, music posters & vintage audio equipment! Please phone / fax / e-mail wants.
WE BUY COLLECTIONS!

Play It Again, Inc.
3148 W. New Haven Ave.
West Melbourne, FL 32904
(321) 724-5685
FAX: (321) 722-1215
WWW.PLAYITAGAINRECORDS.COM
E-Mail: playitagain@iu.net
Florida's best kept secret. Where dealers shop. Want list and dealers welcome.

Rock & Roll Heaven Inc.
1814 N. Orange Ave.
Orlando, FL 32804
Phone: 407-896-1952
FAX: 407-896-2130
E-Mail: rockroll@magicnet.net
Central Florida's oldest and largest source for every format and every category including books, mags, t-shirts, posters, 12's, 45's, LP's, cass, CD's, new-used, everything!

Soundsgreat! Recycled Music
853 S. Orlando Ave. (17/92)
Winter Park, FL 32789
407-599-7277
Buy • Sell • Trade all types of vinyl records Orlando area. Interstate 4 to exit #45 (Fairbanks Ave.) 1 mile east to Orlando Ave. 1 block south on right. Inside Orange Tree Antiques Mall.

Yesterday & Today Records
7902 NW 36th St., Suite 210
Miami, FL 33166
(305) 468-0311
FAX (305) 468-0313
Web site: www.vintagerecords.com
E-Mail: yandtre@aol.com
NEW LOCATION! A few minutes from Miami Airport. We carry oldies - 45s, LPs, CDs. Imports - specialize in 60s/70s, Psych/Prog Rock. Buy/Trade/Sell. Want lists welcome.

GEORGIA

Full Moon Records
1653-A McLendon Ave.
Atlanta, GA 30307
(404) 377-1919
New, Used Records, Tape, CDs.
Great Selection, Great Prices. Send us your want list!

ILLINOIS

Hi-Fi Records
2570 N. Clark St.
Chicago, IL 60614
(773) 880-1002
FAX (773) 880-1016
E-Mail: hifi@interaccess.com
Web site: www.hifirecords.com
The best vinyl selection in city. As well as many hard-to-find CD's! We Buy and Sell all types of music.

House of Music, The
2057 W. 95th St. (at Hoyne)
Chicago, IL 60643
Phone: (773) 239-4114
FAX: (773) 239-9722

Jazz-Blues-Oldies, R&B, Soul & Nostalgia. Famous for locating hard-to-find records, tapes, videos and CDs. It's our service and expertise that makes the difference. We sell imports. We ship everywhere UPS & Fed-Ex. Check our vinyl graveyard. LPs as low as \$1.00. By George! We've got it or we can get it!

Raffe's Record Riot
4350 North Cicero Ave.
Chicago, IL 60641
(773) 725-1327 - 24 hr. service
E-Mail: raffesrr@aol.com
Web site: www.raffesrecordriot.com
Open: Mon.-Sat. 11:30 a.m. - 6 p.m.;
Sunday PHONE APPOINTMENTS ONLY. Specialties, oldies, hard-to-find unusual labels. We buy collections. Want lists with orders invited. We accept VISA, MasterCard, Novus & American Express.

Remember When Records and CDs
309 W. Ogden Ave.
Westmont, IL 60559
Phone: (630) 963-1957
FAX: (630) 963-1987
E-mail: rmbwrwn@worldnet.att.net
Thousands of new & used 45s, LPs, Tapes & CDs (Imports) VISA, MasterCard, Telecheck.
Closed Sundays.

Toad Hall Books & Records
2106 Broadway
Rockford, IL 61104
FAX: (815) 226-9887
Ph: (815) 226-1259 or
(815) 399-4644
100,000 LPs, 100,000 78s, 15 rooms full of other collectibles.

INDIANA

Missing Link Records
6053 N. College Ave.
Indianapolis, IN 46220
(317) 466-1967
FAX: (317) 466-0042
Central Indiana's best vinyl selection in all genres. Don't miss us!
www.missinglinkrecords.com

IOWA

Kanesville Used Records
530 4th St.
Council Bluffs, IA 51503
(712) 328-8731
Largest selection of records in the midwest. All categories.

KENTUCKY

Pops Resale
1423-B Leestown Rd.
Lexington, KY 40511
Phone: (859) 254-7677
FAX: (859) 254-7677
Thousands of vinyl, 33/45/78 priced to sell, all genres.

Ticket To Ride Music & Memorabilia
Hwy 229-Flealand
London, KY 40741
Phone: (606) 878-0366
E-Mail: jlennon@sekybiz.net
Tons of CDs, cassettes, vinyl & all types of collectible music memorabilia. Open Sat. & Sun. 9-5, right off I-75!

MARYLAND

Crown Records
108 N. Lakewood Ave.
Baltimore, MD 21224
Phone/Fax: (410) 563-7881
E-Mail: dmilecki@maxinter.net
Rare LPs, 45s, 78s; Jazz, Soul, R&B, Rock, Country, Blues, Classical, Northern Soul 45s - Open 7 days.

Joe's Record Paradise
1300 East Gude Drive
Rockville, MD 20850
(301) 315-2235
FAX: (301) 315-2252
<http://www.joesrecordparadise.com>
E-mail: raremusic@joes-record-paradise.com
Thousands of LPs, 45s & CDs. New & used & out of print. Open 7 days, Jazz, Rock, R&B, Blues, Country. 27 Years in the business.

MASSACHUSETTS

Flip Side Records
1410 Beacon St.
Brookline, MA 02146-2771
(617) 739-8622
E-mail: flipside@flipsideweb.com
Please visit our Web site at: www.flipsideweb.com
CDs, Tapes, LPs, and 45s - New and Used - Thousands of collectibles at low prices! Send Us Your Want Lists (be specific).

Mystery Train Records
12 North Pleasant St.
Amherst, MA 01002
(413) 253-4776
MT Records@hotmail.com
Biggest selection of vinyl and used CDs in Western Mass!!

Nuggets Records
486 Commonwealth Ave.
Boston, MA 02215
(617) 536-0679
And Our Newest Location:
46 White Street
Somerville, MA
(617) 623-1001
Web site: www.nuggetsrecords.com
E-mail: nuggetsrecords@netzero.net
We buy, sell and trade records, CDs, tapes, videos, Send your want list - please be specific & include phone number.

Planet Records
54-B JFK St.
Cambridge, MA 02138
(617) 492-0693
FAX: (617) 492-0692
E-mail: planet@tiac.net
Since 1983, New England's favorite Collector's Shop. Records and compact discs. All genres.

STORE DIRECTORY

The following is a list of record shops around the country arranged by state. Be sure to mention that you saw them listed in Goldmine's Store Directory. Retailers listed in bold type carry Goldmine in their stores.

MASSACHUSETTS

Sunset Records, Etc.
1232 Wilbur Ave.
Somerset, MA 02725
(508) 678-3441
E-Mail: sunsetip@ici.net
New & Used records, CDs, cassettes, videos. We buy & sell.

MICHIGAN

PJ's Used Records
617 B Packard
Ann Arbor, MI 48104
(734) 663-3441
E-Mail: pjsrecords@mediaone.net
Buying and selling new and used products in all formats.

R.A.M.
917 W. Broadway
Muskegon, MI 49441
Established in 1983
Phone: (231) 759-0172
FAX: (231) 755-0429
E-mail: info@ramcd.com
Hours: Tuesday - Friday 11-8
Saturday 11-6
We buy and sell used CDs and DVDs. Over 15,000 in stock (Stop by and meet Stray and eBay - the store cats.)
Web site: www.ramcd.com
Over 14,000 collectible CDs, singles, LPs, 45s, books, etc. and still growing.

Vinyl Palette
310 Butler St.
Saugatuck, MI 49453
(616) 857-7664
E-Mail: vinylpal@sirus.com
Come visit us at our downtown location! Great selection of vinyl as well as new and used CDs. We also carry music DVD's. Coming on a trip? Call first for hours!

MINNESOTA

Car & Record Collector's Heaven
155 No. Snelling Ave.
St. Paul, MN 55104
(651) 645-3153
E-Mail: rbroz598@cs.com
Rock-RAB-Garage-R&B/Soul - Blues/Jazz-C&W/Pop-45/LP/CD-Domestic-Import-Car Books-Mags.
CC: VISA/MC/Disc.Card

MISSISSIPPI

Ace Video & Music
285 Caillavet St., P.O. Box 1934
Biloxi, MS 39533-1934
PH: (228) 374-0777
FAX: (228) 374-4645
E-mail: acemusic@datasync.com
www.acevideoandmusic.com
Huge inventory collectible vinyl in all categories. Mail or fax wants.

Little Big Store
P.O. Box 921, 201 E. Main St.
Raymond, MS 39154
(601) 857-8579
www.littlebigstore.com
E-Mail: bj999@aol.com
CDs, LPs, 45s, 78s, reel-to-reels, videos, memorabilia, etc. Train depot full of records & music-related stuff. Open: Wed-Sat 10 AM-5 PM

NEVADA

Big B's CDs & Records
4761 S. Maryland Pkwy.
Las Vegas, NV 89119
Phone: (702) 732-4433
FAX: (702) 795-7989
11am-8pm Mon.-Sat., 11am-7pm Sun.
E-Mail: bigbs@fnet.net
Web: Bigbsmusic.com
We stock a wide range of new and used CDs and LPs, all very organized! Dealers are welcome. Send us your want lists! THE store that locals come to shop!

Wax Trax Records, Inc.
2909 S. Decatur
Las Vegas, NV 89102
PH: (702) 362-4300
FAX: (702) 362-4340
E-Mail: waxtraxinc@aol.com
Over 1,000,000 records, CDs, cassettes & all kinds of music memorabilia. A must for the true collector. When in Vegas stop in. Also check out our new radio show THE STREET HARMONY REVUE AT: www.klav1230am.com on Mondays at 9:00 p.m. until 11:00 p.m.

NEW JERSEY

Absolute Vinyl
11 Midland Ave.
Montclair, NJ 07042
(973) 746-7775
E-Mail: absjag@aol.com
M-F 1 p.m.-8 p.m., Sat. 12 noon-5 p.m. New & Used LPs & 45s, Up to 10,000 \$1 45s & LPs always avail. Want lists accepted. Wholesale available to foreign & domestic buyers. Specialties include Soul, Jazz, Beatles & Progressive Rock.

The Album Hunter
2217 Atco Ave.
Atco, NJ 08004
PHONE: (856) 719-1515 (24 Hrs.)
FAX: (856) 719-1313 (24 Hrs.)
Great Dealer Discounts! Biggest in South Jersey in Rare Vinyl! 167+ Page Catalog Send in \$6.00 U.S.A. - \$8.00 Overseas. Thousands of Albums \$1.00-\$2.00 in Store!!

Flipside II Records
120 Wanaque Ave.
Pompton Lakes, NJ 07442
(973) 835-8448
Records, Lotsa Records. More than you need. Also 45's, CD's, Needles. Call for hours.

Hackensack Record King
303 Main Street
Hackensack, NJ 07601
Phone: (201) 488-4232
E-Mail: records123@aol.com
Visit our online auction:
http://member.aol.com/records123
45 RPM Specialists, 12", LPs & rarities on vinyl. Full line of replacement phonograph needles (stylus).

Iris Records Ltd.
114 Brunswick Street
Jersey City, NJ 07302
(bet. 1st and 2nd Streets)
Phone: (201) 217-0588
E-Mail: irisrecs@worldnet.att.net
Hours: Friday 3-9PM or by appointment
Thousands of twelve inch singles at bargain prices. Hip-hop, R&B, rock, disco, dance and more. We also carry full length soul, jazz, rock, exotica. Ten minute train ride from Manhattan. Vinyl only. No want lists, we cater to customers that like to get hands dirty.

NEW JERSEY

Izzy's Records & Compact Discs
1107 W. St. Georges Ave.
Linden, NJ 07036-5652
(908) 486-3303
E-Mail: izzmeister@aol.com
Web site: www.izzymusic.com
100,000 + LPs, CDs, 45s in stock. We buy collections - LP, CD, rock memorabilia. Buy & sell new & used LPs, CDs, 45s. Promos, imports, rarities, memorabilia. 10 Minutes from Newark Airport, 20 minutes from NYC. Great dealer prices on Jazz, Soul, R&B, 12", Rock, 50s, 60s & more. Open 7 days.

21st Century Music
15 Mount Vernon St.
Ridgefield Park, NJ 07660
Toll Free: 1-800-846-9501
(201) 641-6610
FAX: (201) 641-9309
www.21centurymusic.com
sales@21centurymusic.com
Business Hours: Mon.-Sat. 11am-6pm Specializing in 12" Singles, Dance, Rock, 12" Rap & Hip Hop, Soul LPs. Buy, Sell, Trade. Want lists accepted. All major credit cards accepted. Foreign dealers welcome. We buy DJ collections.

NEW MEXICO

Krazy Kat
9012 Central SE
Albuquerque, NM 87123
(505) 294-5644
Largest selection of music in New Mexico. LPs, 45s, CDs, Tapes, Videos, 8-Tracks. Located on Route 66.

Merlin's Record Workshop
9609 Menaul NE
Albuquerque, NM 87112
Phone: (505) 299-8031
FAX: (505) 299-0330
E-Mail: merlinsrecords@prodigy.net

NEW YORK

House of Oldies
World Headquarters for Out of Print 45s and LPs
35 Carmine St.
New York, NY 10014
(212) 243-0500
FAX: (212) 989-1697
http://www.houseofoldies.com
10 A.M.-5 P.M. Tues. thru Sat. Closed Sun. & Mon. Established in 1962 over a million 45s, 78s & LPs, R'NR, R&B, S&W, shows, S.T., Soul, Funk, Pop, Collections Bought 1950-1989 - Send or E-mail "Want Lists." #1 Oldies Shop. VISA, MC., Amex. A must when you're in NYC.

Infinity Records Ltd.
3852 Sunrise Highway
Seaford, NY 11783
(516) 221-0634
FAX: (516) 221-8901
E-mail: vinylriver@aol.com
www.infinityrecords.net
Long Island's best record collector store. Jazz, Soul, Rock, Classical, etc. Foreign dealers welcome. We buy collections.

Last Vestige Music Shop
173 Quail St.
Albany, NY 12203
(518) 432-7736
FAX: (518) 432-1812
E-Mail: info@lastvestige.com
Second hand, Out-Of-Print, CD's Records, Mailorder: lastvestige.com

NEW YORK

Mr. Cheapo CD & Record Exchange
46 Jericho Tpke.
Commack Long Island, NY 11725
(631) 543-8686
and 134 Jericho Tpke
Mineola Long Island, NY 11501
(516) 742-7670
We sell most of what's in Goldmine. Thousands of used CDs & Records in every store. Largest selection on Long Island. When you're visiting the New York area, we have 2 locations!

Off-Center Records and Collectibles
116 Bleecker St.
Utica, NY 13501
Phone/FAX: (315) 738-7651
http://www.blackdogweb.com/offcenter
E-Mail: Offcenter1@webtv.net
1,000s of LPs & Singles, Music Memorabilia 40s-90s, Books, Mags, Dolls, Tees, Plates, Figurines, CDs, Tapes, Rare & Hard-to-find items. All want lists welcome.
MC/VISA/NOVUS.

NORTH CAROLINA

Jukebox Oldies, Inc.
456 Knollwood Street
Knollwood Plaza Shopping Center
Winston-Salem, NC 27103
(336) 774-0034
Tues. - Fri 10 AM - 7 PM
Sat. Noon - 7 PM
2 blocks from Business I-40, exit 3A. Operated by a knowledgeable collector with 20 years experience. Specializing in rare 50s and 60s vinyl. Also - 70s and 80s vinyl, 45s, 78s, tapes, CDs, videos, posters music memorabilia. Rare Beatles, Buddy Holly and Elvis vinyl and memorabilia. All categories of vinyl - Rock, Country, Jazz, Blues, Big Band, Soundtracks, Comedy, Soul. Always buying good vinyl 50s and 60s collections.

Woody's Rare Records
14234 Hwy 18
(Off of Blue Ridge Pkwy.)
Laurel Springs, NC 38644
Phone: 336-359-2564
FAX: 336-359-8432
Original recordings of 30's, 40's, 50's, 60's, 70's, old country, comedy, bluegrass, soundtracks, B-bands and more. We buy, sell and trade. Open May-December (Thursday-Sunday). Send your want list or call.

OHIO

Parker's Records & Comics
1222 Suite C, Route 28
Milford, OH 45150
PH/FAX: (513) 575-3665
Mon.-Sat. 11am - 7pm
E-mail: dkparker39@fuse.net
Specializing in 50s & 60s. Over 100,000 45s & 10,000 33s. Send want lists. Accepting MasterCard/VISA & NOVUS cards.

OKLAHOMA

Gardner's Used Books Music & Comics Inc
4417 South Mingo Road
Tulsa, OK 74146
(918) 627-7323
FAX (918) 250-8828
Web site: www.gardnersbooks.com
Over 100,000 Collectibles Albums, CDs, 45s, Tapes, Music magazines, Sheet Music. We buy collections, complete stores, music memorabilia & collectibles. Open 7 days.

OKLAHOMA

Records and Stuff
1511 S. Memorial
Tulsa, OK 74112
(918) 627-1505
Web site: recordsandstuff.com
E-Mail: sales@recordsandstuff.com
Thurs-Sat 10:00 am-6:00 pm;
Sunday 11:00 am-5:00 pm, or by Appointment
Specializing in all Vinyl Selections. CD's, Cassettes, 8 Track, Books, Video Tapes, Magazines, Sheet Music, Memorabilia, Playboy Magazines, Collectible Supplies, etc.
- Buy - Sell - Trade - We Ship Worldwide

OREGON

Crossroads Music
3130 SE Hawthorne Blvd.
Portland, OR 97214
(503) 232-1767
E-Mail: xroads@xro.com
Open Mon-Thurs 11-6; Fri-Sat 11-7; Sun 12-6
Portland's largest, most complete selection of collectible records, CDs, Tapes, concert posters and music memorabilia in Co-op of 35 dealers.

2nd Avenue Records
400 S.W. 2nd Avenue
Portland, OR 97204
(503) 222-3783
FAX: (503) 287-3343
Tons of good used and new - Will travel Vancouver to San Diego to purchase collections of ANY size. ANY format.

Sonic Recollections, Inc.
2701 SE Belmont St.
Portland, OR 97214
(503) 236-3050
FAX: (503) 235-1645
E-Mail: orderdesk@sonicrec.com
Web site: http://www.sonicrec.com
Specializing in the weird and the collectible! Check Our Web Site!

PENNSYLVANIA

Attic Record Store, Inc.
513 Grant Ave
Pittsburgh, PA 15209
(412) 821-8484
FAX: (412) 821-5179
E-Mail: atticrecords@cs.comn
Astounding selection of new & used CDs, 45s, LPs & 12" singles. All categories - credit cards accepted - Expert mail order service - want lists accepted.

Flip Side Records & Coll.
Moved to: 940 Hermigate Rd.,
(Rt. 18)
Hermitage, PA 16148
PH: (724) 342-0824
FAX: (724) 342-0825
E-Mail your Wants lists:
flipsiderecords@aol.com
Web site: www.flipmail.com
Over 2,000,000 selections/All types of music/Wants lists welcome!

Mugsy's Records
212 Iron St.
Bloomsburg, PA 17815-1871
(570) 784-7134
Exit 35-A off I-80
Quality used LPs, CDs, movies (DVD & VHS), and books. New stock every week. Five minutes from Exit 35-A off I-80 Hours: Mon-Fri: Noon-8 PM; Sat: Noon-6 PM

STORE DIRECTORY

The following is a list of record shops around the country arranged by state. Be sure to mention that you saw them listed in Goldmine's Store Directory. Retailers listed in bold type carry Goldmine in their stores.

PENNSYLVANIA

Positively Records
4153 Woerner Ave.
Levittown, PA 19057
(215) 945-8063
FAX: (215) 945-0221
E-Mail: posrec@aol.com
Rare CDs/New-used-imports/10,000 used CDs. 5000 quality CDs at \$4.99 or less/open 7 days/Best Store Phila/NJ area.

Record Castle
1118 Cottman Ave.
Philadelphia, PA 19111
(215) 745-4151
Web site: www.recordcastle.com
E-Mail: info@recordcastle.com
Mon.-Sat. 1-7 p.m. (EST)
Buy/Sell records - compact discs - tapes - rock 'n roll memorabilia - thousands of records (all speeds), CD's, etc. in stock!

Record Connection
550 N. Reading Rd.
Ephrata, PA 17522
(717) 733-1641
FAX: (717) 733-1685
Visit our Web site at:
www.RecordConnectionPa.Com.
Oldies, Classic Rock, Psychedelic, Progressive, Country, Jazz, Comedy. Over 100,000 45s & albums! Compact Disc: New, Used, & imports. Directions: Located on Rte. 272, 4 miles S. of PA Turnpike (exit 21).
Open 7 days a week. M-F 10 a.m.-8 p.m.; Sat. 9 a.m.-7 p.m.; Sun. 11 a.m.-5 p.m.

Record King
The Record King - (Our Only Location!)
2113 Parkdale Ave.
Glenside, PA 19038
(215) 576-0102 (Mail & Phone orders only!)
E-Mail: therecordking@yahoo.com
Search Service - 11 a.m.-8 p.m. EST 7 days a week. SASE/IRC & collect phone # for reply.
Buy & Sell. Catalogs/lists available. 8-track \$25. Soundtrack/orig. cast \$25. All refundable w/order.
McNally's picture price guide (Soundtrack) \$29.95 + shipping, Rockin Records.
Video/DVD/Karaoke/Audio equipment sold. CDs, tapes, vinyl & adult videos. Huge assortment Country & Western, Playboy & Rolling Stone magazines. Checks/MOs pay to: J.J. Hollin only.

TENNESSEE

Val Shively-R & B Records
49 Garrett Rd.
Upper Darby, PA 19082
(1 mile from West Philadelphia)
(610) 352-2320
FAX: (610) 352-8199
11-7 EST M-Sat.
Over 4 million 45s! Also CDs, LPs, cassettes. Send want lists/mail order available. Major credit cards accepted.

TENNESSEE

Grumpy's Music & Books, Inc
3905A Hixson Pike
Chattanooga, TN 37415
(423) 874-0242
FAX: (423) 874-0286
E-Mail us at: grumpybk@aol.com
BUY • SELL • TRADE
Books • CDs • T-shirts • LPs • DVDs • Videos • Audio Books • Posters Open Mon-Sat. 10:00 a.m.-9:00 p.m.; Sun. 12:00 p.m.-6:00 p.m. We specialize in hard-to-find items.

The Great Escape
1925 Broadway
Nashville, TN 37203
(615) 327-0646
FAX: (615) 321-5568
www.duffelbag.com
E-Mail: tge@bellsouth.net
Nashville's oldest record store!
(Open for 24 years.) Thousands and thousands of collectible and bargain CDs, LPs, 45s, 78s, and tapes at low, low prices. (One of the largest selections of out-of-print records in the mid-south.) Also buying and selling: comics, videos, games, more. Voted best non-chain record store 7 years running in "The Nashville Scene." Open Mon.-Thurs. 10 a.m. - 9 p.m.; Fri-Sat. 10 a.m. - 10 p.m.; Sun. 1-6 p.m.

TENNESSEE

The Great Escape
111 N. Gallatin Rd.
Madison, TN 37115
(615) 865-8052
FAX: (615) 865-8779
www.duffelbag.com
E-Mail: tge@bellsouth.net
Thousands and thousands of collectible and bargain CDs, LPs, 45s, 78s, and tapes. (One of the largest selections of out-of-print records in the mid-south.) Also buying and selling: comics, videos, posters, memorabilia, video and computer games, gaming cards, books, toys, role-playing items, baseball cards, more. Voted best non-chain record store 7 years running in "The Nashville Scene." Open Mon.-Fri. 10 a.m.-9 p.m.; Sun 1-6 p.m.

Lost and Found Records
7315 Kingston Pike
Knoxville, TN 37919
(865) 558-9028
albumguy@email.msn.com
Buy • Sell • Trade. Records, tapes & CDs. Open 7 days a week. We have thousands of LPs

VERMONT

Mainly Music: "Where Music Lives On"
36 Main St.
Brattleboro, VT 05301
PH/FAX: (802) 257-0881
Toll Free U.S. & Canada:
877-257-0891
Southern Vermont's largest used music source! Buy, Sell, Trade: Used Rare Records, CDs, Tapes, Vintage Sheet Music, Memorabilia & Collectibles. Send want lists. Worldwide search.
Insurance and estate appraisals. Will travel.

VIRGINIA

DMS Associates
P.O. Box 724
Portsmouth, VA 23705
(757) 465-3333
FAX: (757) 465-9890
E-Mail: ddel065716@aol.com
Jazz, Blues, R&B, Soul Music Specialist. Jazz, Blues, R&B, Soul, Gospel, Music Magazines.

VIRGINIA

Safe As Milk Records
20 Kirk Ave. SW
Roanoke, VA 24011
(540) 982-7789
E-Mail:
SAFEASMILKUSA@YAHOO.COM
Mon.-Sat. 10 a.m.-9 p.m.;
Sun. 12 p.m.-6 p.m.
Want lists welcome!! New & used LPs, used CDs, tapes & 45s & videos.

WASHINGTON

Disc Connection
405 Garfield St. (1 block east of PLU)
Tacoma, WA 98446
(253) 539-5632
E-mail:
disc_connection_mail@yahoo.com
We are Tacoma's #1 location for rare Beatles memorabilia and vinyl. CASH paid for Beatles and Monkees, one item or a hundred, we buy collections. We also buy, sell and trade CD's-LP's-45's-DVD's-Laserdiscs and videotapes. Open Monday thru Friday 11am to 7pm. Open Saturday and Sunday Noon till 5pm (On Sundays please PHONE FIRST to insure we're there).

WISCONSIN

Deep Grooves
702 E. Johnson St.
Madison, WI 53703
(608) 294-5708
Rare and unusual recorded music. Specializing in: New, Used, Vintage Vinyl and Import CDs. Buy and Trade. We ship anywhere. Want Lists Welcome!

Fox Music
301 L Cotton Wood Ave.
Hartland, WI 53029
PH: (262) 367-8022
FAX: (262) 367-8043
E-Mail: foxmusic@execpc.com
Store Hours: 11:00-7:00
Thousands of rare & collectible LPs & 45s. New & used CDs/domestic & imports. We ship anywhere. We buy quality collections.

WISCONSIN

Madcity Music Exchange
600 Williamson St.
Madison, WI 53703
(608) 251-8558
FAX: (608) 251-8668
E-Mail: madcity@execpc.com
Web site: www.madcitymusic.com
Madison's vinyl source - LPs, 12", 10" 7". New CDs - Domestic & Import. Used CDs - Great Selection.

CANADA

Star Records
148 Simcoe St. South
Oshawa, Ontario, L1H 4G7 Canada
PH/FAX: (905) 723-0040
E-Mail: starrecords@altavista.com
30 minutes east of Toronto. Best vinyl selection in Canada! Over 2,000 New Vinyl LPs in stock. Imports from U.K., Italy, USA, etc. (1950s-2000) - Garage, Rockabilly, New & Old Surf, New & Old Punk Rock, Blues, Soundtracks, British New Wave. Record-related collectibles for your favorite bands available. Phone/Fax/E-mail your want lists.

FRANCE

Monster Melodies
9 Rue Des Dechargeurs
75001 Paris - France
PH: (33) 140280939
FAX: (33) 142332572
E-Mail: monster@club-internet.fr
Thousands of LPs, Singles, CD, CDs 60s-90s. Since 15 years in business. We mail everywhere.

SWEDEN

The Golden Oldies Shop
5:t Eriksgatan 96
SE-113 31 Stockholm, Sweden
PH/FAX: +46-8-32 22 40
Original singles, EPs & LPs 1955-1979, Rock & Roll, Pop, Soul, etc. Send your name and address for free catalog, or visit our Web site: www.goldenoldies.se
Company established in 1977. 24 years in business!

This section features listings for retail record stores around the world. Traveling record collectors of all types search for new stores to dig through on their vacations, business trips, etc. Advertise your establishment here, including approximately ten words of miscellaneous description, for only \$9.00 an issue. You can buy this space in increments of 13 or 26 issues, for \$117.00 or \$234.00, respectively. Send in your store name, address, phone number, and approximately ten words of description, along with your payment. If you stock GOLDMINE, we'll put your listing in boldface type.

1 year \$234.00 6 months \$117.00

Send your listing with payment to:
GOLDMINE • 700 E. State St. • Iola, WI 54990-0001 or Call 715-445-2214

Name: _____

Contact person: (This will not appear in the listing) _____

Address: _____

City: _____ State: _____ Zip: _____

Phone: _____

FAX: _____ Do you carry GOLDMINE in your store? _____

Description: _____

COMPACT DISC SHOWCASE

CD, Tape & Vinyl Storage

The RACKIT™ System

Factory direct since 1984 from
Per Madsen Design

Free brochure (mention Goldmine)

800-821-4883 or online at

www.rackitm.com

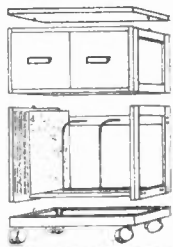

Quality CD Reissues



60s Garage/Psych - Incredibly Strange Music

To receive our catalog, send SASE
(overseas send 2 IRCs).
Dealers/Distributors/Stores,
we sell direct!

ARFI ARFI, PO Box 465, Middleborough, MA 02346
Phone/Fax: (508) 947-7323 Email: info@arfarfrecords.com
www.arfarfrecords.com

Automatically Catalog Your CDs!



CD Trustee automatically catalogs your CD collection. Quickly insert and remove each disc into your computer, then push a button to gather artist name, album title, song titles, genre and more. Takes seconds per CD. Build a database of your huge collection in a few hours, with no typing! Easily search for songs, artists, or titles. Stop buying duplicates. Prints extensive reports, along with jewel cases covers and inserts. Also handles manual entry of LPs, tapes, and other media. Only \$29.95. Download a free trial from our Web site.

Requires Microsoft Windows 95/98/ME/NT/2000/XP,
and an Internet connection (during lookup phase only).

Web site: www.base40.com

E-mail: GM@Base40.com

WWW.GPMUSICA.COM

By J. A. Gaspar & J. del Peso

MUSIC MAGAZINES FROM ALL OVER THE WORLD. SPANISH RECORDS AND CD'S.

Detailed lists on all artists, including
Spanish ones. More than 200.000
references



Secure Shop on-line



Contact us: Tirso de Molina S/N, Centre d'Empreses
Modul 9-A, 08940 Cornellà de Llobregat, Barcelona
Spain. Fax: + 34 93 475 02 36
E-mail: sales@gpmusica.com

The Ultimate STORAGE CABINET

the CUBE

by Lorentz Design

Featuring our patented
ALLSTOP STORAGE SYSTEM,
no slots, no plastic molds,
no wasted space. Full-
extension drawer
slides. Made from
high quality oak
veneers and hard-
woods. 23"H x
19 1/2"W x 17 1/2"D.
Each Cube ships
fully assembled. Stackable.

Stores
306 CD's
or any com-
bination of CD's,
DVD's, CD-ROM,
VHS, Cassettes, etc.

Call 800-933-0403 or visit www.lorentzdesign.com to order
or for a free, color brochure detailing all our disc, tape & component storage CUBES.
LDI, Inc. • P.O. Box 277 • Lanesboro, MN 55949 • Fax: 507-467-2468

101cd.com

Now over 1.6 million titles online all at discount prices. Including every UK, European, Australian and Japanese releases. UK catalogue includes budget and mid-price titles from \$7.50 (+p&h). Secure ordering, certified Bizrate Gold merchant. Plus rare records and CDs from the world's top dealers.

<http://www.101cd.com>
e-mail: sales@101cd.com

mined by a diatribe from singer David Eugene Edwards —
"Every man is evil, every man a liar..."

Edwards is key to this virulent vision. On songs such as "Brimstone Rock," the aforementioned "Fire Spirit" and "Day Of The Lords," he comes across like a mutation of Jim Morrison, Iggy Pop, and Captain Beefheart — a perverse preacher intent on driving out demons. His tireless potshots stokes 16 Horsepower with a high-octane intensity, ensuring *Hoarse* consistently stays on course.

— Lee Zimmerman

THE ALIEN KINGS

Roswell Cover-up
(Self-released)

E.T... UFO... FYI... The Alien Kings — or more precisely singer/songwriter/multi-instrumentalist/producer/ engineer (whew!) Joe Seddon — is convinced that not only does life exist on other planets, but that space aliens visit us regularly. How does he know?

As Seddon explains in the liner notes, he has had his share

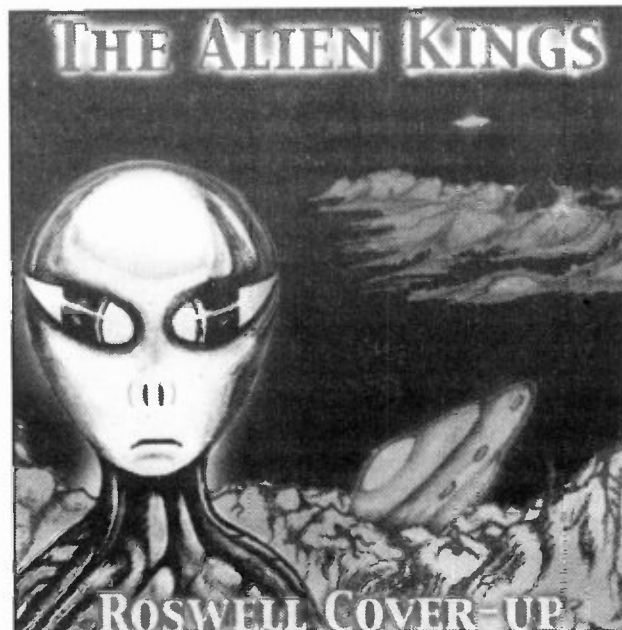

of close encounters with those proverbial gray-skinned, bug-eyed beings from other worlds. "If you've never seen a UFO or aliens, chances are you can't or won't believe... I didn't... I do." He is sure the government does too, and that they've covered up the facts since 1947 when a spaceship purportedly crashed near Roswell, N.M. The truth is out there somewhere.

As far as *Roswell Cover-up* is concerned, both the album and the assertion strain Seddon's credibility and creativity to the limit. Suffice it to say, if proving his point is left solely to his musical invention, he had better keep pointing toward the skies. Nearly every song relies on the same sort of bouncy, mid-tempo melodies that bands such as Styx and Supertramp standardized back in the early '80s.

Roswell Cover-up is mostly pleasant enough stuff and even clever on occasion. The odder entries tend to shine, such as "Madhouse In Space" (similar to what might have resulted if Arthur Brown had collaborated with Alice Cooper), the Frank Zappa-esque "World On Fire," and "Rockin' With The Alien Kings," a song that sounds like an outtake from "Rocky Horror Picture Show." But it's the title track, an accusatory narrative, that sets the standard. Set the phasers on fun.

Those drawn to its music, message or both should relate to the rest of the set. Otherwise, The Alien Kings still have something more to prove before they can score with their subjects. (www.alienkings.com)

— Lee Zimmerman

MARK McKAY

Nothing Personal

Dren Records (DNCDO17)

Mark McKay sounds vocally reminiscent of Jakob Dylan with a tinge of Chris Isaak, powered with a Blues Traveler brand and playing backwoods-y folk-rock. *Nothing Personal* is primarily guitar-based singer/songwriter fare free of crass production hooks. The acoustic guitar sounds are fresh and uncluttered, aided by some electric grit for muscle. This 11-song set was recorded live, however, it is *studio* live, without an audience, so the listener gets a rawness of a club show — minus the louts. ("Play 'Freebird!'")

With an A&R man's ear, I can say with Tom Petty honesty that I don't hear a single; but then again, there aren't many singles anymore. The most radio-friendly cuts are "Black And Blue Over You," with its late-night ambience; the mid-tempo lead cut "One Day"; and the Southern rock ode "Ninety Miles." McKay wrote every word and note of these songs, which may have benefited commercially with the intervention of a collaborator for a little more diversity here and there with a chorus or bridge.

At any rate, *Nothing Personal* is an unpretentious and sturdy outing for McKay. After a listen you can see why he has kept company with the likes of Leon Russell and the late, great Rick Danko.

— C. Brian Jasper

(New Releases from page 61)

16 HORSEPOWER

Hoarse

Checked Past (CPR 023)

In the late '90s, 16 Horsepower revved things up via three albums showcasing a Goth-rock regimen fueled by traditional Appalachian instrumentation. Taking a cue from the disturbing rumblings of post-punk combos such as X, The Cramps, and Gun Club, 16 Horsepower created an ominous, off-kilter sound that defined a new form of alt-Americana.

Hoarse launches the band's aural assault in the new century with this chilling live album that documents 16 Horsepower's turbulent tirades. It's an unnerving effort, one best epitomized by their twisted take on Creedence Clearwater Revival's "Bad Moon Rising," a song that accurately encapsulates the band's trademark gloom and doom. The album's other covers — a turbulent "Fire Spirit," Gun Club's relentless rocker, and a taut attempt at Joy Division's agonized anthem "Day Of The Lords" — say as much about the band's creepy attitude as any of their originals.

With a feeling of foreboding ricocheting through the fray, the otherwise jocular strains of banjo, accordion and even a hurdy-gurdy do little to alleviate the sinister scenario. "Black Lung" initially emulates bluegrass, but it evolves into what can only be described as a harrowing hoe-down. "Low Estate" is terse, tempestuous, fitful and frightening. Even the sprightly send-off to "Black Soul Chair" is ultimately under-

COLLECTOR'S SHOWCASE

www.rockaway.com



ROCKAWAY RECORDS 2395 Glendale Blvd. Los Angeles, CA 90039 phone: 323/664-3232 fax: 323/664-0956 email: sales@rockaway.com
Retail store open 7 days, 10 a.m. - 9:30 p.m.

Showcase ads are the most looked at in Goldmine. You may buy as many boxes as you wish for an ad, at a cost of \$38.60 per box, multiplying the \$38.60 per box required. All typesetting is done by us and included in the price.

Past & Present Rare Videos Sale by These Artists & More

John Denver	Jimmy Buffet	Debbie Harry
Toto	Elton John	Blondie
Cheap Trick	Cat Stevens	Linda Ronstadt
Sty X	ABBA	Tina Turner
Jackson Browne	Neil Diamond	Barbra Streisand
Beach Boys	Bob Seeger	Patti Smith

And many, many more!

Please send SASE & your wants & interests to
Joseph Russo
P.O. Box 2422, North Babylon, New York 11703-0422

SAN FRANCISCO
2350 MARKET
(888) 396-2350

SAN JOSE
980 S. BASCOM
(888) 330-7776

SAN FRANCISCO
3979 24TH ST
(888) 682-3550

CALL US TOLL FREE!

SANTA CRUZ
939 PACIFIC
(888) 648-9201

BUY SELL TRADE CD's LP's 45's VIDEOS LASERDISCS DVD's

www.streetlightrecords.com

NEH RECORDS

Phone: (303) 652-0199
Fax: (303) 652-2279
<http://nehrecords.com>

7915 Oxford Road
Niwot, CO 80503

Specializing in Melodic Rock
Imports, Rarities, and Classics
CDs \$14.50 - \$21.00 (all in stock). Online audio samples.

Collector Pays Cash

for Records, CDs, Coin Collections and Political Buttons.

Large collections especially welcome. Will Travel.

Collector Since 1960!

Please call Gary **203-377-3449**

ROCK N ROLL COTTON THROW BLANKETS

The Beatles - Janis Joplin - Santana
Blink 182 - Jimi Hendrix - Doors
KISS - Insane Clown Posse + More

View and order on the Web at:
www.cjcollectibles.com

CJI Collectibles * 491 Amherst St. * Nashua, NH 03063
(603) 882-0955

Also available on our Web site: Doors Lava Lamps, Rock N Roll Mugs, Lunch Boxes, much more!

RARE Hard to Find

Rare & Hard To Find will be back in the next issue! Check out our Web site for lots of new DVD's, music books, and CD's:
www.rareandhardtofind.com

MusicStack

Shop Hundreds of Record Stores at Once!

Fully Searchable

Like an online version of Goldmine

www.MusicStack.com

MusicAndVideo.com

(201) 236-9107 • Fax: (201) 236-2916

<http://www.musicandvideo.com>

One Surrey Lane

Allendale, NJ 07401

RECORDS BY MR. A

P.O. Box 27-3933
Boca Raton, FL 33427-3933

E-mail: mrarecords@adelphia.net

All records
33-1/3 vinyl
Checks or
Money Orders
\$3.00 Shipping
1st record,
each additional
\$1.00 each

PAPA JAZZ RECORD SHOPPE



Over 30,000 jazz, rock, soul, funk, punk, country, folk, blues and hip-hop LPs. Rare, new and used CDs, LPs and even tapes.

Visit us on the Web at
www.papajazz.com
or drop us a line at
2014 Greene St.
Columbia, SC 29205
(803) 256-0095

CyrCo

Collector Of Yesterday's Recordings Company

www.cyrcomusic.com

WE RECORD LP'S ONTO TAPE OR CD!!!

R&B, Big Band, Country, Easy, Folk/Ethnic, Jazz, Christmas, Classical, Rock, Soundtrack, Religious & NonMusic: Free Catalogs: (choose type)

140,000 USED RECORDS ON SALE!

Mail: CyrCo Music
3811 Leavenworth St.
Omaha, NE 68105
Ph: 402-345-8164
Fax: 520-441-2429
Email: he@cyrcomusic.com

ROCK'S HOTTEST VIDEOS

Featuring Artists From The 70s: Floyd, Who, Zeppelin, Yes, KISS, Cooper, Aerosmith, Sabbath, Angel, Bad Co.

Featuring Artists From The 80s: Accept, Badlands, Bon Jovi, Motley, Bullet Boys, Cinderella, Leppard, Guns, and all the newest.

Sensations Of The 1990s: All the current tours and of course the most perfect quality available. Over 2,000 selections listed. We've been the leader in music videos since 1983.

SEND FOR FREE CATALOG!

INTERNATIONAL TRANSFERS

P.O. Box 313, Dept. G.M., Revere, MA 02151

78's 78's 78's 78's 78's 78's 78's 78's 78's 78's 78's 78's 78's 78's 78's

FOR SALE 78 RPM ORIGINAL ROCK AND ROLL RECORDS

Hundreds of 78 RPMs - A self addressed/stamped envelope will get you all the details re: grades, prices and ordering instructions.

BIZ REED

357 Summer Street, Lynnfield, MA 01940 U.S.A.

Phone: 781/334-4805 - Fax: 781/334-2362

E-Mail: navalcom@tiac.net

NEW OLD RARE



940 N. HERMITAGE RD.
HERMITAGE, PA 16148
PH: (724) 342-0824
FAX: (724) 342-0825

RECORDS & COLLECTIBLES IN BUSINESS OVER 25 YEARS
OVER 2 MILLION RECORDS / CD'S
100,000+ LISTED ONLINE AT:

WWW.FLIPMALL.COM

Free online catalogs:

21,000+ SOUL & JAZZ ALBUMS / 25,000+ RARE 45'S / 14,000+ 12" SINGLES / 14,000+ ROCK ALBUMS / COUNTRY / POP / SURF & HOT ROD / REGGAE COUNTRY / POP / ELVIS / BEATLES / KISS / MICHAEL JACKSON

WE HAVE A HUGE SELECTION OF:

- OUT OF PRINT RECORDS
- CLASSICAL
- ETHNIC
- SOUND EFFECTS
- COUNTRY & WESTERN
- SOUNDTRACKS
- FOLK
- SOUL
- ROCK-A-BILLY
- SYMPHONY
- SURF & HOT ROD
- COMEDY
- ORIGINAL CASTS
- JAZZ
- BIG BANDS
- NOVELTY
- ROCK & ROLL
- BLUES
- RHYTHM & BLUES
- CHILDREN'S

"WANT LISTS WELCOME"

E-Mail: FlipsideRecords@aol.com

RECORD/CD LISTS (BELOW) COST REFUNDABLE WITH ORDER

\$2.50 COMPACT DISCS	\$1.00 SURF & HOT ROD	\$1.00 ELVIS PRESLEY
\$6.00 RARE 45'S (OVER 25,000)	\$1.00 KISS COLLECTIBLES	\$1.00 CLASSICAL
\$3.00 COUNTRY ALBUMS	\$6.00 SOUL/FUNK & JAZZ ALBUMS	\$2.00 LATIN 45'S/LP'S
\$5.00 ROCK ALBUMS	\$5.00 12" SINGLES (OVER)	\$1.00 POLKA 45'S/LP'S
\$1.00 BEATLES	\$1.00 REGGAE 45'S/LP'S	

COLLECTABLE LISTS AVAILABLE

COLLECTOR'S SHOWCASE

Showcase ads are the most looked at in Goldmine. You may buy as many boxes as you wish for an ad, at a cost of \$38.60 per box, multiplying the \$38.60 per box required. All typesetting is done by us and included in the price.

Record Album Frames

For: LP's - Picture Discs - 45's
All Steel - Black or Silver
Simply the best - See for yourself
Visit our secure Web site at
www.albumframes.com
Or call us toll free: 800.640.0306

CD Storage & Display

CD Poster Frames gives you quick, easy access to your Music, Game & Software CD's. Great anywhere space is limited. Put them on a wall close to your CD player or computer.
See them at our secure Web site
www.cdframes.com
Or call us toll free at: 800.640.0306

Attention Retailers

Increase your profits by selling our quality Record Album Frames & CD Poster Frames.
U.S. & Overseas distribution now available.
For Info. and wholesale pricing contact us by
E-mail: sales@albumframes.com
E-mail: sales@cdframes.com
Phone: 800.640.0306 Fax: 630.830.9009

FRENCH RECORDS & MAGAZINES
Pop, Rock, Easy...
Lists: 1 IRC per artist

DJB, 20 rue Bringier-Monnier
83640 St.-Zacharie France
Fax: +33 442 62 74 74
www.djbrecords.com

OVER 500,000 IMPORTS

Including 400,000 Track Listings
Imports From Japan, Europe, Australia & South America. CD's, Vinyl, Video & DVD's. All Categories, Fast And Reliable. All Available Online at www.musicimports.com
Not Online? Please Send Your Want List To:
MUSIC IMPORTS
757 SE 17th St. #149, Fort Lauderdale, FL 33316
954-764-3879 • FAX: 954-764-3890



Lynyrd Skynyrd
23 Feb. 92
Dusseldorf
Philippshalle NM
\$50.00

Original German Concert Posters

23 x 33
Michael S. Hoffman
1031C Margate Court
Sterling, VA 20164-5210
(703) 476-9218 (best times 7-10pm EST)
Email: swagman@mindspring.com
Posters shipped rolled in sturdy tube.
S/H \$6.50 US Insurance extra (recommended)
International/Canada customers please enquire
Orders in US Funds Only, Money Order/Cashiers Check Only!



Lynyrd Skynyrd
13 Dec. 97 Berlin
Arena NM
\$30.00

A NEW SERVICE!
If there's an artist or band you're interested in, please write/cal/email.
ANY RETURN PHONE CALLS WILL BE MADE COLLECT! ALL SALES FINAL!!
Thank you, good night!

IF IT'S OUT-OF-PRINT - OR HARD-TO-GET CHANCES ARE - I'VE GOT IT
FREE SALES LIST OUT NOW

WRITE FOR A COPY OR FAX 540-342-2471
ROANOKE'S RECORD ROOM
P.O. Box 2445, Roanoke, VA 24010
E-Mail: Roarec33@aol.com
Visit our Web site at:

<http://members.aol.com/RoaRec33/RecordAlbums>
Serving Collectors around the world since 1976.
Specializing in out-of-print 10" and 12" Rock and Pop, Jazz, Soul & Soundtrack LPs from 1949 to 1998 - Most major credit cards accepted.



"Looking For Your Lost Mind Revue"

Presents
Custom framed Posters and Autographs from the 60's and 70's
Animals to Grateful Dead to Zappa
Send for a FREE Catalog.
Dr. George
P.O. Box 23055, Santa Ana, CA 92711-3055
or call (714) 731-3424

CORRECTION!

In the following past issues of Goldmine, my telephone number was incorrect. Issues 545, 547, 548, 549, 550 & 551. Sorry for any inconvenience this may have caused you. The following posters are still available: German Concert Posters Pearl Jam 96, The Black Crowes 93 & 95, Eric Clapton 77, Stevie Ray Vaughn 86, both Queen posters 80, The Goo Goo Dolls 99, and Emmiylou Harris 00. US Concert posters The Who 96 & Eric Clapton 00, and UK Concert poster Pearl Jam 2000. If you are interested in any of the posters in these ads, please give me a call at 703-476-9218, email me at swagman@mindspring.com or write to the address below.

Original German, US, & UK Concert Posters
Michael S. Hoffman • 1031C Margate Court, Sterling, VA 20164-5210
(703) 476-9218 (best times 7-10pm EST)
Email: swagman@mindspring.com
Thank you good night!

We specialize in finding Original 50s Rhythm & Blues/Rock & Roll 45s and LPs.

Lots of original 60s material also available. Call/fax us with your wants, or send us your wish list. Send all correspondence (and PLEASE INCLUDE YOUR PHONE NUMBER) to our address below.
WE ALSO CARRY COOL, OUT-OF-PRINT CD'S



Have you read the latest ICE? Whether you have or not, the clock is definitely ticking on a healthy number of long-anticipated musical triumphs which have finally crossed over that fuzzy line into something the CDR-pigs of the world will forever be allergic to: REALITY. And just exactly what "triumphs" are we referring to? None other than new gems by old reliable faves like ELVIS COSTELLO (2 CDs of amazing demos, rehearsals and OTs for his "King Of America" LP), BOB DYLAN (the Scorpio version of "A Tree With Roots: The Genuine Basement Tapes Revisited" which, unlike any other versions that may come out, also sports incredible digi-packaging, multiple books, color inserts, etc.), THE WHO (in the spirit of "From Liekehauser To Leeds" and "Maximum BBC" comes another groundbreaking release on 2 CDs containing the complete U.K. and U.S. '60s singles collection featuring the ORIGINAL 45 mazes from the ORIGINAL, FIRST-GENERATION masters including the "lost" Shel Talmy tapes...all in super-deluxe packaging w/three books and six postcards! Also out is a 2 CD upgrade of their first-ever live performance of the complete "Tommy" in Amsterdam on 9/29/69), BRUCE SPRINGSTEEN (yes, The Boss's legendary Vietnam Vets' Benefit Concert from L.A. on 8/20/81 is now out and - as the write-up says - for the first time ever it's COMPLETE on 3 CDs and in EXCELLENT sound, along with a 2 CD SB of his 8/21/76 concert from Waterbury, CT's Palace Theater - previously unavailable anywhere), BRIAN WILSON (a 2 CD major upgrade of his complete Van Dyke Parks - conducted symphony show at the Hollywood Bowl on 9/24/00), PINK FLOYD (their entire debut show from their fall '70 U.S. tour - 9/26 - at Philly's Electric Factory on 2 CDs w/special packaging and absolutely A+ killer sound), MOTT THE HOOPLE (prev. unrlsd. SBs from the Filmore West, 7/9-10/70), ERIC CLAPTON (great SBs from Providence, R.I. on 7/10/74 and Davenport, MS on 7/27/74, LED ZEPPELIN. So now that the long wait is over, what are you waiting for? And as if we don't say it often enough (well, then again - maybe we don't!!) all of the above titles are on REAL CDs, not pukey, loser-affiliated CD-Rs. PLEASE CALL OR FAX FOR FURTHER DETAILS ON THESE RELEASES AND COUNTLESS OTHERS.

RIP IT UP! P.O. Box 142, Bloomfield, NJ 07003 • Phone (973) 743-0878 • Fax (973) 743-6316 (24 hours)
Best times to call are 10:00 AM - 4:00 PM (EST), or you can give us a try nights 10:00 - 11:30 (EST), Monday thru Friday only. Fast, reliable service.

FUN RECORDS

Germany's Largest Mail Order for Second-Hand Records and CDs.

Over 50,000 items in stock
We have the hits and rarities of the 70's, 80's and 90's.
Get our new catalogue. Send 2 IRC or \$4 for postage.

FUN RECORDS ABT. G HEGESTRASSE 29
20249 HAMBURG/GERMANY
<http://www.funrecords.de>

21st CENTURY MUSIC

YOUR #1 SOURCE FOR 12" SINGLES
DISCO • SOUL • RAP & HIP HOP • ROCK 12"
IMPORT 12" • PROMOS • SOUL ALBUMS
SEARCH SERVICE AVAILABLE • WANT LISTS ACCEPTED
BUYING DJ COLLECTIONS • VISIT US ON THE WEB
1-800-846-9501 • 201-641-6610
FAX 201-641-9309
www.21centurymusic.com
E-MAIL: SALES@21CENTURYMUSIC.COM
15 MT. VERNON STREET, RIDGEFIELD PARK, NJ 07660

Rock & Roll Autographs Hollywood Memorabilia Signed Albums

Write for Current List

Myron Ross
HEROES & LEGENDS

P.O. Box 3088 • Calabasas, CA 91372 • Phone: 818-346-9220
Web Site: www.Heroesandlegends.net

"10 Award Winning Years of Customer Service: 1990-2000"

VIDEO!

STEPHEN M. RUSSO
P.O. BOX 150/BOSTON, MA 02151-0001(M)

VHS Tapes made available on a collector-to-collector basis. Rates include priority mail postage!
Allow between 2-4 weeks for order. Overseas: Add \$5 per tape, air postage/U.S. Funds on'y.
PAL Standard videos: Add \$10 per tape. All titles offered from best available prints and elements.

\$20.00 or any 3 for \$55.00

ABC-TV 1960's MUSIC SHOWS: "American Bandstand" from 1967 with Neil Diamond, The Electric Prunes, & Tim Conway! "Where The Action Is" (9/9/66) with The Four Seasons and Jackie Paine! Both with original TV commercials! (90 minutes/B&W)

AMERICAN BANDSTAND 11TH ANNIVERSARY SHOW: As aired on ABC-TV 8/17/68 uncut with original commercials! Great clips from Philadelphia and California years! Musical guest: "The American Breed"! (1 hour/B&W)

THE GREAT 50'S/60'S ROCK: Compilation of rarely seen late 1950's-early 1960's Rock performances! Johnny Burdette Trio, Frankie Lyman & The Teen-Agers, Clovers, The Flamingos, The Platters ("The Great Pretender"), Fats Domino, LaVerne Baker, The Moonglows, Little Richard, Gene Vincent, The Diamonds ("Little Darlin'"), Shelley Fabares ("Johnny Angel"), plus Alan Freed, B.J. Thomas, and Rockabilly segments from "The Country Music Caravan"! (90 minutes/B&W-Color)

VIDEO ROCK & ROLL #7-"GARAGE BAND CLASSICS": GREAT compilation with SHIVAREE w/"Dino, Desi & Billy", James Brown, Aretha Franklin, Gerry & The Pacemakers! Followed by a selection of numbers by The Raspberries (on Mike Douglas!), Moby Grape, New Colony 6, The Kingsmen, Sir Douglas Quintet, McCoy's, Tommy James & The Shondells, Strawberry Alarm Clock, Cyrkle, Bobby Fuller 4, Blue Cheer, Standells, Syndicate of Sound, 5 Americans, The Beau Brummels, Knickerbockers, Gentrys, Love, Music Machine, Shadow of the Knight, Leaves, Outsiders, ? and The Mysterians! (Color/95 minutes.)

VIDEO ROCK & ROLL #8-"GARAGE BAND RARITIES": Another great tape with segments featuring The Guess Who, Beau Brummels, Cyrkle, Bobby Fuller 4, Remains, Kingsmen, Tony & The Tigers, We Five, Buckingham's, The Byrds, 5 Americans, Vanilla Fudge, Electric Prunes, Seeds, 1910 Fruitgum Company, Iron Butterfly, Blues Magoos, Buffalo Springfield, Strangeloves, Mitch Ryder & The Detroit Wheels, ? & The Mysterians (Color/90 minutes)

WHERE THE ACTION IS-4 SHOWS! Original ABC-TV broadcasts hosted by Paul Revere & The Raiders! Guests include Bobby Vee, Razor Edge, The Syndicate of Sound, 5 Americans, The Happening and CJ & The Runaways! Great 60's Shows! (B&W/100 minutes)

ROCK & ROLL HISTORY (GREATEST YEARS) 1950's: Great USA/British video compilation with lost/rare footage of Elvis Presley, Everly Brothers, Jerry Lee Lewis, Chordettes, Cliff Richard, Fats Domino, Buddy Holly, Paul Anka, Eddie Cochran, Vince Taylor, Chuck Berry, Carl Perkins, Lonnie Donegan, Little Richard, James Brown, Frankie Lyman, Johnny Ray, The Platters, Bo Diddley, Diamonds, Flamingos, Tommy Sands, Ritchie Valens! (Black & White/100 minutes)

AMERICAN BANDSTAND-1957: Rare find! Good quality December, 1957 show from Philly! + extras! (90 minutes/B&W)

Beatles4me.com

26-Page 2001 Beatles Catalog: \$2.00

HEIN'S RARE COLLECTIBLES

P.O. Box 179, Little Silver, NJ 07739-0179

(732) 219-1988 • FAX (732) 219-5940

**Do You Need Records
From Argentina
or South America?**

Send Want Lists to:
Casilla de Correo 237
C1000WAC Correo Central
Argentina - Ph 54-11-4774-0493
Fax 54-11-4775-1209
E-mail: kodela@datamarkets.com.ar
www.lmpportsounds.com

www.themusicseeker.com
Turntables Modified.
Custom Speakers.
Audiophile Rebuilds.
21 Cooper St.
Glens Falls, NY 12801
518-798-9140
(FAX) 518-798-5554
ON LINE

COLLECTOR'S SHOWCASE

Showcase ads are the most looked at in Goldmine. You may buy as many boxes as you wish for an ad, at a cost of \$38.60 per box, multiplying the \$38.60 per box required. All typesetting is done by us and included in the price.



We Buy Collections

Beatles On Video

Relive the excitement and hysteria that will never be seen again!
1963-Present T.V. Shows - Concerts - Specials
#1 in Quality! Guaranteed!

Free Beatles Catalog

Videos

P.O. Box 21097, Philadelphia, PA 19114

Euclid Records
7905 Big Bend Blvd.
St. Louis, MO 63119 USA

orders@euclidrecords.com

Weekly used vinyl & CD lists
Jazz, Rock, Blues, Soul, Folk, World Music, Vocals

www.euclidrecords.com

45 / LP / 12" / 78
Collectibles ... Rock / Soul / R & B / Blues / Jazz / Country / Pop / Movies & More ...

If you are buying on a regular basis, ask to be put on my mailing list. Accurate grading, reasonable prices, guaranteed to please. Specify which speeds & categories you prefer.

THE MUSIC JOINT

P.O. Box 15396, Ft. Wayne, IN 46885

1.3 Million LPs/45s - all categories!
Catalogs issued - please state areas of interest

Want lists welcomed
Collections purchased

CRAIG MOERER
Records by Mail

P.O. Box 42546-GM, Portland, OR 97242, USA
PHONE: 503-232-1735 • FAX: 503-232-1746
e-mail: cmoerer@recordsbymail.com
browsable/searchable Web site:
www.recordsbymail.com

AUTOGRAPHED GUITARS

AUTOGRAPHED GUITARS

Autographed guitars by Metallica, Red Hot Chili Peppers, Lynyrd Skynyrd, Everclear, Creed, Crosby, Stills, Nash & Young, Deftones, Slash/Guns N' Roses, Joe Cocker, Barry Manilow, 3 Doors Down, Kenny Rogers, Smashmouth, Indigo Girls, Wayne Newton, Kansas, Joan Osbourne, Third Eye Blind, B.B. King, Jethro Tull, No Doubt, Stone Temple Pilots, U2, Wallflowers, ZZ Top, Faith Hill/Tim McGraw, Bon Jovi, John Lee Hooker, Dolly Parton, Michael Bolton, Sammy Hagar, Melissa Etheridge, Police/Sting, Def Leppard, Bo Diddley, Simon & Garfunkel, Oasis, Joe Walsh, Rod Stewart
702-894-9219
www.autographedguitars.com

TOLL FREE ALBUM ONLY HOTLINE
1-800-823-4113

10 a.m.-5 p.m. Mon-Sat EST
OVER TWO MILLION RECORD ALBUMS IN STOCK
IF WE DON'T HAVE IT, WE WILL FIND IT FOR YOU

BANANAS ALL VINYL WAREHOUSE
2226 16th Ave. N.
St. Pete., FL 33713
Check out our catalog of 100,000 LP's on our new Web site:
http://musicfinder.com
E-MAIL **BANANAGRAM@AOL.COM**

ALBUM FRAMES!

Quality Brushed Aluminum Art Frames
Gold, Silver & Metallic Blue
(Black available: add \$1 more.)
Yours for less than the cost of the parts alone!



Send check or M.O. to:
Wiz Productions
10205 N. Oak Rd. W.,
Cedar Hills, UT 84062
e-mail: wizface@aol.com
www.wiz-productions.com

1 for \$10
2 for \$19
3 for \$28
4 for \$36

Postage only
\$2 per order
While Sale Lasts!
(U.S. only)
Foreign orders Inquire.

SOUTH AFRICAN PRESSINGS

MEGA 5\$ SALE

THOUSANDS AND THOUSANDS OF
SOUTH AFRICAN PRESSINGS OF ALL TYPES

ALL 5\$ EACH
E-MAIL FOR LIST **recordsrsa@imagnet.co.za.**

Karen West
P.O. Box 440, Gonubie 5256 South Africa or Fax 0027 43 7385288

* 2001 VIDEOS *

Rare Rock Concert Videos from 1963-2001
from - USA, Japan, and Europe
Best quality and service
around - guaranteed.

S.A.S.E. for list to:

VIDEOTECH
2118 Wilshire Blvd. #179
Santa Monica, CA 90403

IN YOUR FACE VIDEOS

TORI AMOS (New) Summer - U.K. - Up Close/Personal - Killer Show - Recommended	\$25.00
LIVE - (BRAND NEW) Fall - Professional - Maple Leaf - Beginning - New Songs/Covers - Great	\$27.00
GREEN DAY (New) Fall - Professional - Euzarez - Rockin'	\$25.00
TOTL (New) Fall - Maple Leaf - Right On - Brilliant	\$24.00
YES (New) Fall - Maple Leaf - Orchestra - Right On - All The Hits	\$25.00
MANDY MOORE (New) Fall - Professional - West / Hollywood - Sexy	\$23.00
STEVIE NICKS (New) Fall - NC - Solo / Mac Tunes - Very Good - Lovely	\$23.00
LYNYRD SKYNYRD (New) Fall - NC - Perfectly Screened - Southern Style - Great	\$23.00
AEROSMITH (New) Fall - Charlotte - Screened & Staged - Sensational	\$23.00
SADE (New) Summer - Northeast MD - Up Close & Personal - A Experience	\$24.00
JOURNEY (New) Summer - Northeast DE - VERY Up Close & Personal - Recommended	\$23.00
JETHRO TULL (New) Summer - Northeast - Wilkes Barre - Up Close - Wacky "The Flute"	\$25.00
ROXY MUSIC (New) Summer - Maple Leaf - Old/New - Interesting - Great Chemistry	\$22.00
QUIET RIOT / WARRANT (New) Summer - Midwest - 2 Cam Giam Slam Jam - Recommended	\$24.00
RINGO STARR W/THE ALL STARS (New) Summer - 2 Cam - Down South - Sunny - The Best	\$24.00
SUGAR RAY (New) Summer - Professional - Down South - Peaches - Sensational	\$26.00
STAND (New) Summer - Northeast - "Electrical" - In Your Face - Headliner - Justice	\$24.00
ROD STEWART (New) Summer - Maple Leaf - Up Close / Personal - Old / New - Sensational	\$26.00
IGGY POP (New) Summer - German - Festive - Rock Am Ring - Professional	\$22.00
LIMIN PARK (New) Spring/Summer - 2 Shows - Both Professional - East/West - Great	\$22.00
THE LIVING END (New) Summer - 2 Shows - 1 Aud / 1 Pro - Northeast / Maple Leaf	\$23.00
PAUL OAKENFOLD (New) Summer - Professional - Detroit - Ravers Dream - Great	\$21.00
DAVE MATTHEWS BAND (New) Summer - Professional - Maple Leaf - a "Plus"	\$25.00
ALANIS MORISSETTE (New) Summer - Rock Am Ring - Professional - German	\$23.00
PATTY SMITH (New) Summer - London - Theatrical - Clubbin - Great	\$24.00
THE CULT (New) Summer - Professional - Maple Leaf - Old / New	\$25.00
JOURNEY (New) Summer - Southern - far Heels - Perfectly Screened - Old/New - Arrival	\$25.00
STYX (New) Summer - Down South - Up Close & Personal - Sensational	\$22.00
RADIOHEAD (New) Summer - Professional - Midwest - The Best Ever - "Gorge"	\$25.00
AEROSMITH (New) Summer - LA - Wango Tango - Old/New	\$27.00
AEROSMITH (New) Summer - Maple Leaf - Up Close - Old/New	\$21.00
BACKSTREET BOYS (New) Summer - LA / West - Festive - Wango Tango - Professional	\$23.00
BEE GEES (New) Summer - Wango - Professional - Mint	\$23.00
BLACK CROWES (New) Summer - Maple Leaf - Up Close/Personal - Toronto	\$24.00
KENNY WAYNE SHEPPARD (New) Summer - NYC - w/ Double trouble	\$21.00
BLACK SABBATH (New) Summer - 3 Cam - Midwest - Recommended - All there	\$25.00
BLUES TRAVELER (New) Spring - Northeast - VA - Professional - Great	\$22.00
BON JOVI (New) Spring - Northeast - DC - Up Close/Personal - Very Good	\$23.00
CHEAP TRICK (New) Out West - Rockin' - Old/New - A Spectacle	\$24.00
CONROSION OF CONFORMITY (New) Winter '00 - Professional - "Harpos" - Great	\$22.00
DAVID USHER (New) Summer - Professional - Maple Leaf - A "Plus" - Mint	\$21.00
DEEP PURPLE (New) Summer - Sunny South - 2 Cam Jam - Good - Recommended	\$23.00
ERIC CLAPTON (New) Spring - Northeast - D.C. - Perfectly Screened - Peaceful	\$23.00
ERIC CLAPTON (Just In) Summer - NYC - #1 - Electrical & Acoustic	\$22.00
ERIC JOHNSON (New) Spring - Maple Leaf - Guitar Madness - Rockin'	\$21.00
ERYKAH BADU (New) Spring - Professional - Northeast / Big Apple	\$21.00
FEAR FACTORY (New) Summer - Northeast / Big Apple - Hard & Heavy	\$23.00
ROBERT PLANT (Just In) Summer - NYC - Good	\$21.00
G3 (New) Summer - Maple Leaf - Mind Blowing - Guitar Madness	\$24.00
G3 (Just In) Summer - Northeast - NYC - Beacon 2 tapes - Great	\$30.00
GREEN DAY (New) Summer - Maple Leaf - Good Time - Old/New - Long	\$24.00
GLENN HUGHES (New) Spring - Northeast - Clubbin - "JACK"	\$24.00
JANES ADDICTION (New) Northeast - NY - "Distinctional" - Reunion	\$23.00
JEFF BECK (New) Spring - Maple Leaf - VERY Up Close & Personal - Recommended	\$23.00
KISS (New) Spring - Ausa - Energetic - "No More Peter" - Fun	\$24.00
LYNYRD SKYNYRD (New) Summer - Maple Leaf - So Close you see beads of sweat - Great	\$24.00
MARILYN MANSON (New) Summer - Midwest - Multi Cam	\$24.00

Hey, Welcome to In Your Face Video. All Orders are shipped out A.S.A.P. Please send Checks or Money Orders to the address below made payable to "ERIC". All Videos 120 minutes or less, come on Maxell Gold Hi Grade videotapes recorded in SP in Hi Fi Stereo. Overseas and Canada please add \$3.00 for shipping charges... Thanks!!

ERIC
P.O. Box 424
Wysox, PA 18854

RARE VIDEO

ABBA	Black Crowes	Faces	Madonna	Roxette
AC/DC	Black Sabbath	Fleetwood Mac	Mick Taylor	Sabrina
Agnetha	Blondie	Freddie King	Missing Persons	Shakespeare's Sister
Albert Collins	Bo Diddley	Go Go's	Mott the Hoople	Slade
Alice Cooper	Buddy Guy	Hanoi Rocks	Muddy Waters	Sweet
Albert King	Cyndi Lauper	Ian Hunter	New York Dolls	Stevie Ray Vaughan
Allman Bros.	David Bowie	James Brown	Pat Benatar	Susanna Hoffs
Angel	Debbie Harry	Jane Wiedlin	Patti Smith	Suzi Quatro
BB King	Deep Purple	Jeff Beck	Pretenders	Suzanne Vega
Babys	Dire Straits	Johnny Thunders	Prince	T. Rex
Bad Company	Dogs D'Amour	Johnny Winter	Queen	Tori Amos
Bananarama	Duran Duran	John Lee Hooker	Ramones	Transvision Vamp
Bangles	Elvis Presley	Kate Bush	Rod Stewart	Tom Waits
Bay City Rollers	Frida	Kim Wilde	Ron Wood	+ Rare Blues
Belinda Carlisle	Eric Clapton	Lightnin' Hopkins	Rolling Stones	+ Rare 1960's

The ultimate video catalog is now available. The best quality and the best service, guaranteed. To obtain this catalog, simply send \$1.00 to:

RARE VIDEO

P.O. Box 280-005, Brooklyn, New York 11228-0005 U.S.A.
(Overseas inquiries welcome - PHL/SEACAM available). You won't be disappointed.

eRock.NET

Official Rock-n-Roll Memorabilia Auction Web site

Select from 17 exciting categories of which five specialize in vinyl records. This music site also holds a monthly drawing and gives away a \$200 auction shopping spree to one lucky winner every month.

http://www.eRock.net

MFSL WANTED



Collections of Sealed or Mint MFSL LP's & Gold & Aluminum MFSL CD's WANTED!

CALL 818-988-3313 9-5 PST
or FAX 818-988-9790

Paying BIG \$\$\$\$\$!

NEEDLES Unlimited

MANUFACTURERS IMPORTERS & EXPORTERS OF
NEEDLES CARTRIDGES & ACCESSORIES
1ST QUALITY NO GENERICS BANG & OLUFSEN
THE LARGEST INVENTORY IN THE USA
WHOLESALE AND RETAIL STEREO LP/45/78

RIVERTONE 78 RPM FOR ALL TYPES

ADC AUDIO TECHNICA STANTON PICKERING SHURE
ORTOFON BSR RIVERTONE TETRAD ACUTRAC
ASTRION ETC. EXPERT CONSULTING

TOLL FREE 1-800-662-8090

WE REBUILD & RETIP FAX 845-791-9670

E-MAIL: **rivertone@fcc.net**

WE ACCEPT VISA MASTERCARD & AMER. EXPR.
NEEDLES, P.O. BOX 161, MONTICELLO, N.Y. 12701

COLLECTOR'S SHOWCASE

Showcase ads are the most looked at in Goldmine. You may buy as many boxes as you wish for an ad, at a cost of \$38.60 per box, multiplying the \$38.60 per box required. All typesetting is done by us and included in the price.

Imports you can listen to before buying. We specialize in hard-to-find music and videos from all parts of the world. If you are seeking music or videos, you've come to the right place...

This week:
Cliff Richard, Wired For Sound, Rock 'N Roll Juvenile, I'm Nearly Famous, Scott Walker 3, Shadows Jigsaw, Canned Heat, Hallelujah, Chris Thompson, Won't Lie Down

www.musicexpress.com
retailers visit **www.allmusicwholesale.com**
since 1995 in business

POCO

Wanted: music, memorabilia, stories, anecdotes, and history on Poco and other country-rock musical aggregations. Working on future book, tribute CD and related projects on this highly influential band.

Please contact:
Stephen Bond Garvan
7919 Fairfax Court, Niwot, Colorado 80503
phone (303) 652-3489, fax (303) 652-3610
email: steve@garvanmanagement.com

TURKISH PRESSINGS GALORE!

We stock rare 78's, picture sleeve singles, LP's from Turkey and around the world! Extensive list covering picture sleeves from Beatles, Elvis, Zeppelin etc. to R&B, rock'n'roll, psych and anything you're looking for from Turkey! Please write for free list. Also watch out for our auctions at eBay as seller 'f_regalia' for superb items!

GOKHAN AYA
Akin sok., 14/7, Suadiye, Istanbul, 81070, TURKEY
tel: +90 216 369 87 74 email: gokhanaya@yahoo.com

Aether Mailorder

"Rare Psychedelic music from way back in the 20th Century." Stocking loads of labels like: Gear! Fab! Void, Rockadelic, Arf! Arf! Sundazed, Akarma, Get Back!, Shadoks, Lazarus, and many more! Mags like Ugly Things, Ptolemaic Terrascope and Crohinga Well!

ALL MAJOR CREDIT CARDS ACCEPTED
Call us **TOLL-FREE 1-888-674-5723** (orders & info)
Aether Records / PO Box 19553, Indianapolis, IN 46219
Thousands more similar titles at: www.aether-or.com

RETRIEVER MEMORABILIA SERVICES

RETRIEVER MEMORABILIA SERVICES dealing in RARE and hard to find record awards, photo's, contracts etc. for over 10 years. In our latest offering we have some VERY interesting pieces.

RETRIEVER along with Noel's agent are making the following awards available. For any information about these or any other awards in this ad please call the number below.

<p>Noel Redding's RIAA & BPI Awards for the "Experience"</p> <p>"SMASH HITS" WHITE MATTE LP AWARD</p> <p>1) "Smash Hits" RIAA White Matte SCall 2) "Ultimate Experience" RIAA Hologram CD Award SCall 3) "Cornerstones" BRITISH B.P.I. GOLD (1991) SCall 4) "Stone Free" RIAA Hologram CD Award SCall 5) "Smash Hits" RIAA Multi Plat. LP Award SCall 6) "Axis" RIAA Hologram LP Award SCall 7) "Ultimate Experience" BRITISH B.P.I. GOLD CD Award SCall 8) "Smash Hits" RARE In-House LP Award SCall 9) "Electric" RARE In-House LP Award SCall 10) Chicago "Hot Streets" RIAA G/Floater to Band Member SCall</p>	<p>RECORD AWARDS</p> <p>1) Chicago "Carnegie Hall" RIAA w/Matte RESTORED \$1,200.00 2) Black Sabbath "Sabbath" RIAA w/Matte RESTORED \$1,200.00 3) AC/DC "Highway" RIAA Plat. Floater \$750.00 4) Cream "Fresh Cream" RIAA W/M REVERSE MATTE \$3,800.00 5) Alice Cooper "I Never Cry" RARE Gold Floater 45 \$775.00 6) Faces "A Nod" RIAA W/M to Band Member SCall 7) Beatles "Revolver" RIAA w/Matte SCall 8) Stones "Exile" RIAA W/M RESTORED \$1,500.00 9) AC/DC "BLACK" RIAA Plat. Floater \$750.00</p> <p>PLUS MANY OTHER GREAT ITEMS!!!!</p>	<p>Phone: 508-872-8162 Fax: 508-872-8163 E-mail: tbeatles@aol.com</p> <p style="text-align: center;">RETRIEVER IS ALWAYS INTERESTED IN BUYING QUALITY ITEMS!!!</p>
---	--	---

(Reissues from page 53)

album by country-rockers Poco — after all, the first one (*Deliverin'*) was the biggest success they'd had on the charts up to that point (#26). What does not make sense is Epic's reason for the release at that time — allegedly to undermine the success of the second album Poco set to release in May on their new label ABC (*Rose Of Cimarron*). Whether it had any effect on chart position is hard to say, but the Epic *Live* album peaked only at #169 in its four-week run, while the ABC record hit #89 and lasted nearly four months on the charts. It's too bad that *Live* wasn't given more care since it is actually a pretty good record showcasing the four-piece band of Rusty Young, Timothy B. Schmit, George Grantham, and Paul Cotton.

Fast-forward to August 2001. Poco has just finished celebrating the 225th anniversary of our country with a fabulous fireworks-laden Colorado concert highlighted by a reunion with band founder and spiritual center Richie Furay. Frampton's album has been reissued on CD with bonus tracks, while his career has never seen the same highs as in '76-'77.

The Beatles' live album is still crying for a CD reissue (come on, Apple) while Poco's *Live* has just come out on disc. With this release, all the original Poco albums (save a few compilations) have sometime seen the light of laser. Fans will certainly want this set to add to the Poco collection. For non-fans, the question becomes, is it worth it? The answer is a qualified maybe.

In terms of quality of performance, the seven tracks showcase a band that seems to sound better in concert than on record. Heck, comparing any of the songs on the album with their studio counterparts shows a band sounding fuller and more assured on stage. Comparing the CD's sound to the old vinyl, however, reveals a surprising slight edge to the spinning black lacquer (confirmed by my two children in between 'N Sync songs). No extra songs have been added to the release either (though at least it is a budget-price CD), which is too bad since one assumes that more live songs were taped at the three '74 concert venues than were used for the album. The packaging is a straight copy of the old front (the hind quarters of a horse — a not-so-subtle comment, one assumes, of Epic's

opinion of the band) and back cover, with text so small as to be unreadable. Opening the folder reveals a restatement of the album and song titles with no notes. One Way deserves credit, however, for finally getting this album on CD.

The set starts with a three-song medley segueing from Cotton's "Blue Water" to Young's bluegrass banjo track "Fool's Gold" and hoe-down stomper "Rocky Mountain Breakdown." The next three songs are all mid-tempo Cotton workouts — "Bad Weather," "Ride The Country" and the almost progressive "Angel." Young's "High And Dry" and Schmit's "Restrain" lead to a fabulous climax on Furay's masterwork "A Good Feelin' To Know," which should have been a huge hit. (Hey, Nashville, where is that country tribute to Poco? Maybe Lonestar or Brooks And Dunn can still get Furay the hit he deserves. Heck, since Schmit is now in the Eagles it would seem he owes it to

Poco to cover this song and get it some recognition.) Even without Furay on this version, the harmonies are brilliant.

It seems like it's about time for Poco to come up with another live album to show what they can do with later hits such as "Crazy Love" and "Heart Of The Night." Until then you might want to consider *Live* for your country-rock collection. (One Way/Sony Special Products, 550 Madison Ave., New York NY 10022-3211)

— George W. Krieger

JOY DIVISION
Heartandsoul
Warner Archives/Rhino (78406) (Four CDs)

Ian Curtis' quasi-romantic legacy — he hung himself the night before his band Joy Division was to come to the U.S. for a tour — has, rightly or wrongly, inspired lots of kids to start bands, write death-obsessed poems and reconsider their lives. His haunting monotone, plus the band's numbed minor-chord backing, was post-punk before anybody knew what to call it. There was something tragic to the music even before Curtis' fateful decision in 1980: It's melancholy, depressive and cynical (which pretty much sum up the qualities of its magnum opus/swan song, "Love Will Tear Us Apart").

Heartandsoul, a four-disc box that gathers just about all the Joy Division anyone ever needs, is as obsessive about the band and its music as the band itself was. In addition to every studio recording the band released, *Heartandsoul* (which was originally released in the U.K. three years ago) is filled with live tracks, outtakes, one-off singles and BBC radio performances. Each offers something the others don't (the band was more "punk" in concert than it ever was in the studio, for example), but it ultimately comes together as a portrait of a

(Please see Reissues page 75)



Joy Division (from left): Stephen Morris, Ian Curtis, Bernard Sumner, and Peter Hook.

Goldmine

WANT LIST ADS

SAMPLE WANT LIST AD

Are you looking for a particular 45, LP or CD? Perhaps you're looking for several items to add to your collection. Now there's an inexpensive way to advertise for the music you need - the **Goldmine Want List**.

For a flat fee of \$1.00, plus 50¢ per item, you can let over **60,000 Goldmine** readers know what you're looking for!

The **Goldmine Want List** is a regular feature which will appear in every issue of **Goldmine**. Goldmine is read by the the most avid music collectors and dealers in the world. If you want it, they probably have it!

To place your wants in the **Goldmine Want List**, simply send us your name, address and phone number along with a list of the items you are looking for. Include payment with your list.* A sample listing is shown below to illustrate how the listings will appear, and how the cost for a listing is figured.

* Payment may be made in the form of Check or Money Order. We also accept MasterCard, VISA, American Express and Novus.

SAM JONES, 101 WILMETT AVE., SHADE, TEXAS 00033 (222) 445-0001
I'M LOOKING FOR THE FOLLOWING IN VG CONDITION OR BETTER:

Badfinger	Straight Up	LP	Apple SW3387
Roy Head	Roy Head and the Traits	LP	TNT 101
Dion and the Belmonts	Where or When	45	Laurie LEP-302

The cost on this listing would be \$2.50 - \$1.00 flat fee, plus \$1.50 for the items listed (3 items at 50¢ each).

Goldmine WANT LIST Order Form

MAIL TO: GOLDMINE WANT LISTS • 700 E. State St., Iola, WI 54990-0001
 715/445-2214 Fax: 715/445-4087

Name _____
 Address _____
 City _____
 State _____ Zip _____ Phone _____
 E-mail address _____

PAYMENT:

Check Money Order MasterCard VISA American Express Novus
 Credit Card # _____ Exp. Date: _____
 Signature _____
 Flat Fee **\$1.00** + _____ items @ 50¢ per listing = **TOTAL \$** _____

This line is optional and can be used to describe the condition of the items you are looking for.
FORMAT LABEL & CATALOG NUMBER

	ARTIST	RECORDING	FORMAT	LABEL & CATALOG NUMBER
Item #1	_____	_____	_____	_____
Item #2	_____	_____	_____	_____
Item #3	_____	_____	_____	_____
Item #4	_____	_____	_____	_____

Use additional sheets of paper if needed. Please type or print clearly.

Note: Due to tremendous response, *Want List Ads* will appear in the order they are received. Because of space limitations it may take several issues for your ad to appear.

GOLDMINE WANT LISTS

Looking for a particular recording? Advertise it in the Goldmine Want List section. The cost is \$1.00 flat fee, plus 50¢ per item. Use the form at the beginning of this section to list your wants. Mail the form, along with payment, to: GOLDMINE Want List, 700 E. State Street, Iola, WI 54990.

ROBERT WALKER
 • 48 Allen Street
 • East Longmeadow, MA 01028-1449
 • Phone: 413-525-6741
 • E-mail: yesmanvamp@aol.com or yessongs1234@aol.com
 I'm looking for the following titles in good condition. Call, write or e-mail. CDR's are acceptable.

ARTIST	RECORDING	FORMAT	LABEL & CATALOG NUMBER
RICK WAKEMAN	- Unleashing the tethered one, CD, Mellow records 001		
RICK WAKEMAN	- The Stage Collection, CD, NOTABLU MUSICA 949720		
RICK WAKEMAN	- Black Knights at ... , CD, Jimco records jim 0075, vendettCdva 9333 Italy		
RICK WAKEMAN	- 20th Anniversary Issue, CD, AMRWCD20		
RICK WAKEMAN	- Special Sampler, CD, JSP 0001		
RICK WAKEMAN	- After the Ball, CD, CM 2029 Japan		
YES	Recording Format Show Dates		
SUPER STAR SERIES	- CD, 2/2/92		
SUPER STAR SERIES	- CD, 11/01/93		
SUPER STAR SERIES	- CD, 11/22/99		
SUPER STAR SERIES	- CD, 12/12/99		

JOHNNY ZAPPIA
 • 1381 E. Gary Dr.
 • Chandler, AZ 85225
 • Phone: 480-917-1787

ARTIST RECORDING FORMAT LABEL & CATALOG NUMBER
 BEBOP DELUXE - Futurama, CD, EMI CDP7920742
 GILBY CLARKE - Breeze, CD, Virgin

ROB
 • 469 Carol Dr.
 • Greenwood, IN 46142
 • Phone: Rob @ 317-883-0064

WANTED TO BUY: Air Check Tapes of the following individuals and radio stations

ARTIST RECORDING FORMAT LABEL & CATALOG NUMBER
 MAJOR TOM LEWIS of WNAV out of Indianapolis
 CHRIS CONNOR of WNAV out of Indianapolis
 SCOTTY BRINK of WLS out of Chicago
 RODGER W. MORGAN of WIFE out of Indianapolis
 RANDY ROBINS of WLWX out of Indianapolis
 Looking for the Air Check Tapes on Reel to Reel or cassette! formats

ELIUD APONTE
 • 11th Street #178 Bda. Israel
 • San Juan, PR. 00917
 • Phone: 1-787-767-4028

ARTIST	RECORDING	FORMAT	LABEL & CATALOG NUMBER
RAIL	- Live 80's, VHS		
MASS (Christian band)	- Live 80's, VHS		
MICHAEL BOLTON	- Live 83-84 Tour, VHS		
KING KOBRA	- Live 85-88 Tour, VHS		
SHOOTING STAR	- Live 70-86 Tour, VHS		
SIGNAL	- Live 89 Tour, VHS		
GIOFFRIA	- Live 86 Tour, VHS		
SHY	- Live 85-86 Tour, VHS		
BALENCE	- Live 81-82 Tour, VHS		
AIR RACE	- Live 84 Tour, VHS		
CONEY HATCH	- Live 84-85 Tour, VHS		
TOUCH	- Live, VHS		

ANNEMARIE LESIAK
 • 72 Third Street
 • Dearborn Hts., MI 48127

ARTIST	RECORDING	FORMAT	LABEL & CATALOG NUMBER
PAT BENATAR	- Vinyl		
PAT BENATAR	- Tour Programs		
PAT BENATAR	- Magazines		
PAT BENATAR	- Anything!		

LARRY HORN
 • 10633 S. 41st Place
 • Phoenix, AZ 85044
 • Phone: 602-363-9515
 • E-mail: larrhorn@home.com

I am looking for the following 45's. Original U.S., Casablanca and Mercury pressings only.

ARTIST	RECORDING	FORMAT	LABEL & CATALOG NUMBER
KISS	- Strutter/Stutter, NEB0015 DJ		
KISS	- Strutter '100,000' Years, NEB001F		
KISS	- Let Me Go Rock 'N Roll/Let Me Go Rock 'N Roll, NB823 DJ		
KISS	- Let Me Go Rock 'N Roll/Hotter Than Hell, NB823		
KISS	- Rock And Roll All Nite/Rock And Roll All Nite, NB829 DJ		
KISS	- C'mon And Love Me/Getaway, NB841		
KISS	- Detroit Rock City/Beth, NB863 DJ		
KISS	- I Love It Loud/I Love It Loud, NB2365 DJ		
KISS	- Hide Your Heart/Hide Your Heart, 876-146 DJ		
KISS	- Forever/Forever, 879-716 DJ		

BILL FEENEY
 • 2210 NE 34 St.
 • Lighthouse Point, FL 33064
 • Phone: 954-783-2105
 • E-mail: barnaclebill69@hotmail.com

ARTIST	RECORDING	FORMAT	LABEL & CATALOG NUMBER
PABLO CRUISE	- Soundboard Shows, Promo Items, Posters		
BEAU BRUMMELS	- Soundboard Shows, Promo Items, Posters		
PATTY SANTOS	- Demos, Soundboard, Pictures, Posters		
STONEGROUND	- Soundboard tapes, Pictures, Promo materials, Posters		

J.J. DAVIS
 • 2618-A Battleground Ave. PMB #194
 • Greensboro, NC 27408
 • Phone: 336-370-4519

Will Pay Top Dollar For Following LP's in VG+ or better:

ARTIST	RECORDING	FORMAT	LABEL & CATALOG NUMBER
DEBBY McLATCHEY	with THE RED CLAY RAMBLERS, LP, Flying Fish?		
RELATIVELY CLEAN RIVERS	- Same , LP, Pacific PC 17601		

Will buy CD-R of "Relatively Clean Rivers", I just want to hear it -

RICHARD REID
 • 920 Chippewah Dr. A-2
 • Laurel, MS 39440
 • Phone: 601-649-4526
 • E-mail: reidr@webtv.net

ARTIST	RECORDING	FORMAT	LABEL & CATALOG NUMBER
JONNY LANG	- Live Audios, CDR's, and video wanted		
JONNY LANG	- Cover Issue of UK Mag. "Guitarist" Jan. 1999		

MICHAEL DRUCAS
 • 17 Phillips Beach Ave.
 • Swampscott, MA 01907
 • Phone: (781) 598-3936
 • E-mail: michaeldrucas@hotmail.com

Average White Band 1989-2001 wanted. If you can help please call or write. High prices paid.

ARTIST	RECORDING	FORMAT	LABEL & CATALOG NUMBER
AVERAGE WHITE BAND	- 1989-2001 Audience Tapes		
AVERAGE WHITE BAND	- 1989-2001 Video Filmed From the audience, TV appearances		

WARREN WALKER, JR.
 • 477 S. Lexington Pkwy
 • St. Paul, MN 55105
 • Phone: 651-698-3258

Looking for British and Worldwide Glam Rock

ARTIST	RECORDING	FORMAT	LABEL & CATALOG NUMBER
ANGEL	- Good Time Fanny, 7", 1974, UK		
ARROWS	- Any 7" singles 1976-1977, UK		
BLACKFOOT SUE	- Moonshine, 7", 1975		
BLACKFOOT SUE	- Never Push Your Mother, LP, 1975		
CHICOBY TIP	- 7" Singles, 1971-1973		
LYNSEY DePAUL	- Lynsey sings, LP, 1974, UK		
LYNSEY DePAUL	- Tigers and Fireflies, LP, 1979		
GAY GLITTER	- Superhero, 7", 1979		
GLITTER BAND	- Greatest Hits, LP, 1976		
GLITTER BAND	- Look What You've Been Missing, 7"		
GLITTER BAND	- Parts Match, LP, 1977, UK		
HELLO	- Hello Again, LP, German		
HELLO	- Shine On Silver Light, LP, Japan		
HELLO	- The Singles AS and BS, CD, Vol. 2 only		
HELLO	- Worldwide 7" Singles 1976-1979		
JOOK	- City and Suburban Blues, 7", 1973		
JOOK	- King Kapp, 7", 1973		
KINCADE	- Slow Down, 7", 1977, UK		
JOHN KINCADE	- Intuition, 7", 1974		
JOHN KINCADE	- One Of Those Dreams, LP		
PEARLS	- Any LP's or CD's		
READY SET GO	- "Putty", 7" 1975 UK		
ROSETTA STONE	- 7" singles, 1977-1979, UK		
ALVIN STARDUST	- Word Is Out, 7", 1976		

ERIC GREGWOLZ
 • 79 Crystal Rock Court
 • Middle Island, NY 11953
 • Phone: (631) 924-1629

ARTIST	RECORDING	FORMAT	LABEL & CATALOG NUMBER
THE ARCHIES	- This Is Love, LP, KES-110		
THE ARCHIES	- This Is Love, 45, KIRSHNER-5011		
THE ARCHIES	- Feelin' So Good (Skoopoo Doo), 45, CALENDAR-1007		
THE ARCHIES	- Jingle Jangle, 45, KIRSHNER - 5002		
THE ARCHIES	- Truck Driver, 45, CALENDAR 1006		
OLIVIA NEWTON-JOHN	- Making A Good Thing Better, Cassette, MCA		

GOLDMINE WANT LISTS

Looking for a particular recording? Advertise it in the Goldmine Want List section. The cost is \$1.00 flat fee, plus 50¢ per item. Use the form at the beginning of this section to list your wants. Mail the form, along with payment, to: GOLDMINE Want List, 700 E. State Street, Iola, WI 54990.

VINCE KIKEL
• 2886 Mason Avenue
• Port Huron, MI 48060
• E-mail: vkmk@earthlink.net
BACKSTAGE PASSES and crew shirts; 8-TRACKS sealed
ARTIST RECORDING FORMAT LABEL & CATALOG NUMBER
BEATLES - Butcher Cover paste over any condition
LYNYRD SKYNYRD - 45s LPs imports-shirts anything!

EVAN BORIS
• 6 Saint Andrews Court
• Old Westbury, NY 11568-1710
• Tel: (516) 997-4840
• Fax: (631) 234-8248
• E-mail: discdoc@bornfreefoods.com
• Web: www.bornfreefoods.com/discdoc.html
ARTIST RECORDING FORMAT LABEL & CATALOG NUMBER
CACTUS WORLD NEWS - No Shelter, CD
MODERN ROMANCE - Adventure in Clubland, CD
ROMAN HOLIDAY - Fire Me Up, CD
TUBES - Premium Gold Collection, CD
VARIOUS ARTISTS - 20 Of Another Kind, CD

MIKE SARAFIAN
• 360 W. Chevy Chase Dr. #26
• Glendale, CA 91204
• Phone: 818-241-3866
ARTIST RECORDING FORMAT LABEL & CATALOG NUMBER
BEATLES - Yesterday & Today, LP, Late 60's, Subsidiary Black Rainbow Label, L.A. Pressing

EDWARD P. REARDON, JR.
• 339 East 57th St., #1A
• New York, NY 10022
• Phone: (212) 832-9844
• E-mail: reardone@cnet.com
Mint/New in the box condition
ARTIST RECORDING FORMAT LABEL & CATALOG NUMBER
GLENN GOULD - Mozart Piano Sonatas Vol. 1, CD, CBS/Odyssey MB2K 45612 (7 copies)
BEETHOVEN - Masterpieces, 25 CD Box, Deutsche Grammophon
SAVAGE GARDEN - Truly, Madly, Deeply, CD single
JOHN COUGAR MELLENCAMP - Small Town (Acoustic), CD single

ALEX ZAMBRA
• 5644 LAWDALE
• Houston, TX 77023-3840
• Fax: 713-921-5082
No CD's or CDR's - only vinyl!!! & MINT!!!
ARTIST RECORDING FORMAT LABEL & CATALOG NUMBER
ERIC BURDON & ANIMALS - "Twain Shall Meet", LP, German, Holland pressings
ERIC BURDON & ANIMALS - "Winds of Change", LP, German & Holland pressings
STEPHEN WOLF - "The Second", LP, Dunhill stereo (sealed or MINT)
SOUNDTRACK - "From Russia With Love", LP, (ua - Liberty in MONO)
SOUNDTRACK - "The Man With The Golden Gun", (Bond film), LP (any pressing but Mint)
THE ROLLING STONES - "December's Children" in mono London or Decca
*SELLING entire CD collection incl. Rolling Stones London (UK) CD's & many mobile fidelity - write or fax for list

MICHAEL SMITH
• 3760 S. Logan Ave.
• Milwaukee, WI 53207
• E-mail: Waytogoace@cs.com
REM collector looking for the following in Very Good condition.
ARTIST RECORDING FORMAT LABEL & CATALOG NUMBER
1988-1994 Complete Fan Club Packages
Any Mexican promo vinyl
Any UK promo vinyl
Any Aussie promo vinyl
Any Japanese promo CD's, LP's, 7"
Do the Strand Live CD - (No CDR's)
TGIF Live CD - (No CDR's)
Daysleeper Japanese promo clock

DENNIS FITZPATRICK
• 1340 European Drive
• Henderson, NV 89052-4019
• Phone: 702-837-1998
• E-mail: DennisFitzpatrick@Bigfoot.com
• Fax: 702-837-1995
ARTIST RECORDING FORMAT LABEL & CATALOG NUMBER
Want used or new out of print Angel CD #49561 "The French Collection" performed by the Fred Hersch Trio.

DAVID RUBINSTEIN
• 1865 Ocean Ave., Apt. 6-H
• Brooklyn, NY 11230
• Phone: 718-253-3434
I need these 3 songs transferred on a CD separately or together.
ARTIST RECORDING FORMAT LABEL & CATALOG NUMBER
JAY BLACK - Love Is In The Air (Disco), Any, Millennium
AL KASHA - Where There's A Will There's A Way, Any, Brunswick
ELVIS PRESLEY - Softly, As I Leave You, Any, RCA

DANIEL SULLIVAN
• 5623 Laguna Quail Wy.
• Elk Grove, CA 95758
• E-mail: dandsully@aol.com
Looking For J.B. Production People. Any Band Members LP/45
ARTIST RECORDING FORMAT LABEL & CATALOG NUMBER
JAMES BROWN - UNIQUE Recordings or band members, i.e. Kay Robinson, Lee Austin, Beau Dollar, Anna King, Maceo, Fred, Marva, Leon Austin, James Crawford, etc., etc., etc.

VELPO ROBERTSON
• 205 Algiers Dr.
• Sandston, VA 23150
• Phone: 804-737-4739
• E-mail: velpo@lobe.com
ARTIST RECORDING FORMAT LABEL & CATALOG NUMBER
TOY MATINEE - s/A. LP import or U.S., near mint only
TOY MATINEE - Live at the Roxy, video
SONNY LANDRETH - Ext 103A, promo CD
SONNY LANDRETH - Outward Bound, LP import or U.S., near mint only
SONNY LANDRETH - South of I-10, LP import or U.S., near mint only
SONNY LANDRETH - any live, CD or video
SONNY LANDRETH W/JOHN HIATT AND THE GONERS, any live, CD or video

MARTYN HAMMOND
• 1 Wilbye House Lexden Park Laxden Road
• Colchester Essex CO3 3UF England
• E-mail: 106174.451@compuserve.com
Concert Tickets from Texas, New Mexico and Arizona
ARTIST RECORDING FORMAT LABEL & CATALOG NUMBER
BOWIE - concert ticket Dallas Majestic Theatre 11/11/72
BOWIE - concert ticket Houston Music Hall 11/12/72
BOWIE - concert ticket Tucson Convention Center 9/13/74
BOWIE - concert ticket Phoenix Veterans Memorial 9/14/74
BOWIE - concert ticket Phoenix Veterans Memorial 2/15/76
BOWIE - concert ticket Houston Summit 10/7-8/87
BOWIE - concert ticket Austin Frank Irwin Center 6/6/90
TIN MACHINE - concert ticket Houston Back Alley 12/10/91
BOWIE tickets from other states/countries also wanted

GARY C. HUESTED
• 1131 Piedmont Ave. NE
• Palm Bay, FL 32907
• Phone: (321) 984-2144
• E-mail: ghusted@cfl.rr.com
Serious R.E.M. collector seeking VG++ or better music and memorabilia
ARTIST RECORDING FORMAT LABEL & CATALOG NUMBER
WARNER BROS. - 14-Track (not 12) Advance CDR for Reveal
FAN CLUB - "Gardening at Night" Garden Gloves
FAN CLUB - Swiss Army Bag (Mint only)
French Near Wild Heaven Notebook
8/82 Chronic Town Press Kit
5/85 Fables Press Kit w/Photos
6/85 Fables Press Kit w/Photo
The One I Love Sheet Music (refers to Michael Stipe as "John" Stipe)
Orange Crush 3" German CD in 5" slimline jewel case w/adaptor
Stand German CD Warner Bros. 7577CD

MARK FRANKLIN
• 5345 Valley Lane East
• Columbus, Ohio 43231-3114 USA
• Phone: 614-898-5345
• New E-Mail: acdc@insight.rr.com
AC/DC WANTED: I am mainly looking for Bon Scott era (1970's) items.

ARTIST RECORDING FORMAT LABEL & CATALOG NUMBER
AC/DC: TESTPRESSINGS, ACETATES, UNUSED ARTWORK and PROOF SLEEVES
AC/DC: NEW ZEALAND 7" Singles (ANY) NEW ZEALAND CONTACTS NEEDED
AC/DC: CANADIAN 7" singles (ANY)
AC/DC: "IF YOU WANT BLOOD YOU'VE GOT IT" SPLATTER VINYL from Holland
AC/DC: PRESS KITS/PRESS PHOTOS/Archive photos
AC/DC: Magazines (1970's), especially Australian, Regional and Record Industry mags
AC/DC: Promo and magazine archive photos (Promo photo of Bon Scott sitting on floor)
AC/DC: TICKET STUBS (1970's)
AC/DC: MAGAZINES (Especially Australian, Industry and Local mags)
AC/DC: TOUR POSTERS/HANDBILLS (USA, do any 1970's exist?)
AC/DC: TOUR POSTERS/HANDBILLS (World Wide)
AC/DC: "LET THERE BE ROCK" displays, posters, tour posters, press kits
AC/DC: "LET THERE BE ROCK THE MOVIE" promo kit and ticket stubs
AC/DC: "IF YOU WANT BLOOD" displays, Promo Posters, Tour posters, press kits, etc...
AC/DC: "HIGH VOLTAGE" displays, posters, tour posters, press kits, etc...
AC/DC: "DIRTY DEEDS DONE DIRTY CHEAP" displays, posters, tour posters, tour programs
AC/DC: "POWERAGE" display stand ups, Posters, Tour posters, press kit
AC/DC: "HIGHWAY TO HELL" displays, posters, tour posters, press kits
AC/DC: "LET THERE BE ROCK" South African LP
AC/DC: "LET THERE BE ROCK" Yugoslavian 7" single with p/s
AC/DC: LET THERE BE ROCK THE MOVIE promo kit and ticket stubs
AC/DC: "HIGHWAY TO HELL" 1979 UK Sheet Music with picture cover
AC/DC: "12 Of The Best" Unissued/Unreleased Album sleeve
ROSE TATOO: Worldwide 7" singles, Memorabilia, etc...

ERIC MOORE
• E-mail: eric.n.hr.moore@intel.com
• Phone: 916-356-1618
I'm looking for the following titles n CD:
ARTIST RECORDING FORMAT LABEL & CATALOG NUMBER
PAUL MOTIAN - On Broadway, Vols. 2 or 3
TIM BERNE - Fractured Fairy Tales
VARIOUS ARTISTS - Jazz Satellites, Electrification, Vol. 1
VARIOUS ARTISTS - Oceans Of Sound
DREAM SYNDICATE - Days of Wine and Roses

TOM BERTRAND
• 235 East 13th St. 4M
• New York City, NY 10003
• Phone: (212) 673-6568
ARTIST RECORDING FORMAT LABEL & CATALOG NUMBER
BOB DYLAN - 1987 European Concert, Tour with Tom Petty-Hearbreakers Cassettes or CD
BOB DYLAN - 1981 Shot Of Love Concert Tour Cassettes or CD
BOB DYLAN - 1978 Street Legal Concert Tour Cassettes or CD

N.P. BLACKWELL
• P.O. Box 5511
• Columbia, SC 29250
• Fax: 803-254-1615
ARTIST RECORDING FORMAT LABEL & CATALOG NUMBER
THE SPIRITUALAIRES - Saint Go Marching In, 45, VJ
THE SPIRITUALAIRES - Impressing On, 45, VJ
THE SPIRITUALAIRES - Out On The, 45, VJ
THE SPIRITUALAIRES - The Last Mile of the Way, 45, VJ

DOUG LARSON
• 62 Crane St.
• Caldwell, NJ 07006
• Phone: 973-420-1349 or 973-781-2021
• Fax: 973-226-1258
• E-mail: douglars@hicom.net
PRICED WANT LIST USA (NM condition originals)

ARTIST RECORDING FORMAT LABEL & CATALOG NUMBER
AGGREGATION - Mind Odyssey (LHI) \$300
AORTA II - (Happy Tiger) \$20
BANCHIE - Thinkin' (Polydor) \$35
BEAD GAME - Welcome \$35
JOHN BERBERIAN - Any LP's \$30 each
BIT A SWEET - Hypnotic (ABC) \$25
BOHEMIAN VENDETTA - Same (Mainstream) \$125
BRAHENY, JOHN - Some Kind of Change (Pete) \$35
BREW - A Very Strange Brew \$20
CEYLEIB PEOPLE-TANYET (Vault) \$50
CHRISTOPHER - Same (Metromedia) \$150
DAVID - Another Day, Another Lifetime (VMC) \$70
DRUIDS OF STONEHENGE - Creation (UNI) \$75
ELECTRIC TOILET - Same (Nasco) \$200
EUCLID-HEAVY EQUIPMENT - (Flying Dutchman) \$150
FALLEN ANGELS - It's A Long Way Down (Roulette) \$175
FELT - Same (Nasco) \$200
FIREBIRDS - Light My Fire (Crown) \$40
FOOD - Forever Is A Dream (Capitol) \$75
FORT MUJDE MEMORIAL DUMP - Same (Mercury) \$25
FREEBORNE, THE - Peak Impressions (Monitor) \$150
GANDALF - Same (Capitol) \$150
GENTLE SOUL - Same (Epic) \$75
GRODECK WHIPPERJENNY - Same (People) \$100
GROWING CONCERN - Same (Mainstream) \$125
HEAD OVER HEELS - Same (Capitol) \$35
IMPALA SYNDROME - (Parallax) \$125
IVORY - Same (Tetragmaton) \$35
JASPER WRATH - Same (Sunflower) \$35
JODO - Guts (Decca) \$25
JULIUS VICTOR - From The Nest (AIP) \$50
KINGDOM - Same (Specialty) \$50
LANDSLIDE - Two Sided Fantasy (Capitol) \$40
MAYPOLE - Same (Colossus) \$50
MORGAN - Same (Probe) \$100
MORNING DEW - Same (Roulette) \$150
MOVING SIDEWALKS - Flash (Tantra) \$300
NOVA LOCAL - Nova 1 (Decca) \$60
ORIENT EXPRESS - Same (Mainstream) \$40
LINDA PERHACS - Parallelograms (Kapp) \$100
PLUM NELLY - Same (Capitol) \$30
PURPLE IMAGE - Same (Map City) \$60
QUEEN'S NECTARINE MACHINE - The Mystical Powers of Roving Tarol Gamble (ABC) \$25
RAINBOW PRESS - Both on Mr. G Label \$40
ROCK ISLAND - Same (Project 3) \$35
SAPPHIRE THINKERS - From Within (Hobbit) \$60
STAINED GLASS both on Capitol \$35
STONE CIRCUS - Same (Mainstream) \$100
THUNDERTREE - Same (Roulette) \$30
VELVET NIGHT - Same (Metromedia) \$75
WEST COAST WORKSHOP - The Wizard of Oz (Capitol) \$75
WESTFAUSTER - In A King's Dream (Nasco) \$75
WHALEFEATHERS - Both on Nasco \$75
WILKINSON TRI-CYCLE - Same (Date) \$30
WIZARDS FROM KANSAS - Same (Mercury) \$100
XIT - Entrance (Canyon) \$100

L. SIMMONS
• 10701 S. Eastern Ave.
• Apt. 1027
• Henderson, NV 89052
• genesimmons12@hotmail.com
WANTED: All Led Zeppelin videos and related material.

PAUL KELSO
• P.O. Box 122184
• Arlington, TX 76012
ARTIST RECORDING FORMAT LABEL & CATALOG NUMBER
BOB DYLAN - Looking to trade VHS "live" recordings
VARIOUS ARTISTS - Looking to trade VHS "Live" recordings
Your audio and video lists welcomes, VG condition or better

MICHAEL DRUCAS
• 17 Phillips Beach Ave.
• Swampscott, MA 01907
• Phone: 781-598-3936
• E-mail: michaeldrucas@hotmail.com
ARTIST RECORDING FORMAT LABEL & CATALOG NUMBER
AVERAGE WHITE BAND - 1972-1982 Wanted Desperately. If you can help, please call or write. High prices paid.
AVERAGE WHITE BAND - 1972-1982 Concerts record from the audience. Will pay \$100.00 a show
AVERAGE WHITE BAND - 1972-1982 Concert Posters
AVERAGE WHITE BAND - 1972-1982 Flyers, Handbills
AVERAGE WHITE BAND - 1972-1982 Concert Tickets
AVERAGE WHITE BAND - 1972-1982 Anyone who may have taken photos onstage, off-stage
AVERAGE WHITE BAND - 1972-1982 Autographs
AVERAGE WHITE BAND - 1972-1982 Video, Rare TV Appearances USA and Overseas

GLACIER 45 GENS
• Phone: (800) 328-0633
• E-mail: glaciardisc@hotmail.com
Limited Stock of:
ARTIST RECORDING FORMAT LABEL & CATALOG NUMBER
"Minnesota" - 1975 hit by NORTHERN LIGHTS. "Think Snow" and "Runnin"

GEORGE F. HAMPLE
• 120 Smoke Tree Court
• Gastonia, NC 28056-8700
• Phone: 704-824-7403
• E-mail: bassplayer@carolina.rr.com
ARTIST RECORDING FORMAT LABEL & CATALOG NUMBER
TRUE VALUE - Happy Holidays Vol. 24, CD
TRUE VALUE - Happy Holidays Vol. 25, CD
TRUE VALUE - Happy Holidays Vol. 28, CD
TRUE VALUE - Happy Holidays Vol. 29, CD

JOSEPH P. GIANGUZZO
• 5031 North Barton Rd.
• Lyndhurst, OH 44124
I'm looking for the following comedy CD's in Mint or Mint- condition:
ARTIST RECORDING FORMAT LABEL & CATALOG NUMBER
JEFF ALTMAN - I'll Flip You Like A Cheese Omelette, Mercury 842070
AMOS AND ANDY - Radiala CD MR 1074
LENNY BRUCE - What Was Arrested For, The Performance That Got Lenny Bruce Busted Columbia CK-30872
LENNY BRUCE - Bad Rapping Of The Marquis De Sade Blue Note 52676
BURNS AND ALLEN - Metacom 030333
RODNEY DANGERFIELD - Rappin' Rodney, RCA 60042
DOLEMITTE - Return of Dolemite, RKO 200
JIMMY DURANTE - Durante: Paron Of The Arts, Viper's Nest UN151
FIRESIGN THEATER - Nick Danger 3rd Eye: Case #666, Columbia DIS-29 Promo
FIRESIGN THEATER - The Three Faces of Al, Rhino RNCD-5812
DICKIE GOODMAN - Everything You Always Wanted To Know About Buchanan and Goodman But Forgot To Ask, STING 53238
JERRY LEWIS - Collectors, Capitol CDP 7931962
LEEROY MERCER - Huh! I'll Whoop Yer, Warhead WHD 80615
NATIONAL LAMPOON'S - The Lost Tapes Volume 2, 3, 4, Christmas, JZ Communications Co.
WINDERSPHERE AND BOOMER - The Creptation Contest, Encore 5012-2
WILDMAN STEVE - Love To Make A Ugly M.F. Laff, Ichibanich 11632
JONATHAN WINTERS - Peter And The Wolf, EMI CDC 7-499182
DAVE MASON - Certified Live, OneWay, #26078

FRANK B STEWART
• 168-43 Hillside Ave.
• Jamaica, NY 11432
• Phone: 718-523-4058 or 718-523-4646 or 718-454-4418
• Fax: 718-523-5474
• E-mail: FBStewart@aol.com
I am interested in buying the following records. Stated price is for records in New or M condition. Less if condition is below.
ARTIST RECORDING FORMAT LABEL & CATALOG NUMBER
BENNY EARL - I'm A Man/And There You Are, Jaybern 700, 100
BOBBY PARES - Gotas De Luvia (Raindrops)/Lvin With Vivian, VI 394, 250
FRED COLE - On Second Thought/A Soulful Woman, Delite, 75
JOHN LESLIE - Are You Kidding Yourself/Oh! What A Crime, LLP Records, 250
KELLY BROWN - The Right Guy/It's Your Move Now, Argo 5466, 250
MAUREEN THOMPSON - Fly Me To The Moon/Gypsy Girl, Audio Fidelity, 75
NICOLE JOSEY - La Vie C'Est Tu..., Lord, 250
NICOLE JOSEY - La Vie C'Est Tu..., Hebra 296, 250
RAY FLEMING - Talking 'Bout Love/Go On And Dance Girl, Raymar 45-1011, 250
THE FORTUNE TELLERS - From The Land Of The Blue Sky Waters/Deep In, Kapp Medallion, 75
THE GRIFFIN BROTHERS - Move It On Over/..., Dot, 75
TONY LAWRENCE - Until You Loved/That's How I Feel, Nike, 75

MICHAEL MICHAUD (Pop/Disco Specialist!)
• 83 Elliott Street
• Danvers, MA 01923-3436
• Phone: (978) 774-1716
• E-mail: m_michaud@junco.com
Pop/Disco Video "Collector" will trade 70's/80's videos (Worldwide!) Send lists on:
ARTIST RECORDING FORMAT LABEL & CATALOG NUMBER
PINK LADY! - (Mie & Kei-Japan!)
THE NOLANS! (Thanks "Girls")
AMANDA LEAR! ("Fabulous")
CELLI BEE/BUZZY BUNCH! ("It's Sad")
3 DEGREES/SHEILA! (Thanks Sheila & Staff!!!)
SILVER CONVENTION!
LIQUID GOLD!
TINA CHARLES!
AMII STEWART!
ANDREA TRUE!
PIA!
SYREETA!
ALSO WANTED: picture discs/CD's! Radio Shows/Concerts! Tour Books! Imports!
Promos! Pen Pals!

MICHAEL P. MAHON
• 41 Gleason St.
• Framingham, MA 01701-3504 USA
• Phone: (508) 877-0191
I'm looking for THE VENTURES ON JAPANESE CD's only. No replica CD's or No Cassettes. THE REAL THING!!! Any Japanese Record Dealers, or a fan of The Ventures in Japan or USA, new or used. Please let me know.
ARTIST RECORDING FORMAT LABEL & CATALOG NUMBER
THE VENTURES - Live in Box Vol. 3 (Liberty Box Set) TOCP-7826 to 7829
THE VENTURES - Melody Hits in Japan (East World) TOCT-6376
THE VENTURES - Tokyo Callin' (East World) TOCT-6378
THE VENTURES - Flying High (Inside Out) TOCP-7239
THE VENTURES - Bel Age With The Ventures Vol. 1 (Panam) (3" mini disc) CRCP-43
THE VENTURES - Bel Age With The Ventures Vol. 2 (Panam) (3" mini disc) CRCP-44
THE VENTURES - Bel Age With The Ventures Vol. 3 (Panam) (3" mini disc) CRCP-45

MARK R. SMITH
• 4618 N. I.H. 20
• Trent, TX 79561
• Phone: 915-236-6070
• E-mail: smitbm@camlott.com
3 CD Box set
ARTIST RECORDING FORMAT LABEL & CATALOG NUMBER
BOB WILLS - Encore, 3 CD Set, Liberty CDP7243-8-30275-2-1

JAY S. MURPHY
• 702 Ash St., #1101
• San Diego, CA 92101
• Phone: 858-534-4234
• E-mail: jaysmurphy@yahoo.com
Will pay \$150.00 for any of the following items!!!
ARTIST RECORDING FORMAT LABEL & CATALOG NUMBER
THE DAMNED - "Children Of The Damned", Red vinyl 7" (live), Fun Records, Cat.#fumi17
ROBERT FRIPP/LEAGUE OF GENTLEMEN - "God Save The King", Japanese CD.
EG/Virgin Japan Records, Cat.#VJD-5002
ROBERT FRIPP - "Let The Power Fall", German LP/EG/Deutsche Grammophon Records (1981)
VARIOUS ARTISTS - "Morrocco Klung Sept. 1981", Meg/Cassette, UK issue

For Great Performances Advertise In ...

if you collect it - you'll find it
COLLECTITTM
www.collectit.net

GOLDMINE CLASSIFIEDS

YOUR ALPHABETIZED INDEXED MARKETPLACE IN EVERY ISSUE OF GOLDMINE

Albums For Sale.....5000	Comedy Wanted.....5116	Girls Groups Wanted.....5216	New Wave Wanted.....5316	R&B For Sale.....5410
Albums Wanted.....5001	Compact Discs For Sale.....5117	Genesis/Gabriel/Collins.....5220	90s Rock For Sale.....5320	R&B Wanted.....5411
Alternative Rock For Sale.....5010	Compact Discs Wanted.....5118	Grateful Dead.....5225	90s Rock Wanted.....5321	Rockability For Sale.....5415
Alternative Rock Wanted.....5011	Compilation For Sale.....5120	Heavy Metal For Sale.....5230	Original Cast/Broadway.....5325	Rockability Wanted.....5416
Announcements.....5015	Compilation Wanted.....5121	Jimi Hendrix.....5231	Photographs For Sale.....5330	Search Services.....5420
Auctions.....5020	Computer Software For Sale.....5125	Imports For Sale.....5240	Photographs Wanted.....5331	70s For Sale.....5425
Audiophile For Sale.....5025	Computer Software Wanted.....5126	Imports Wanted.....5241	Picture Discs For Sale.....5335	70s Wanted.....5426
Audiophile Wanted.....5026	Country & Western For Sale.....5130	Independent Labels For Sale.....5245	Picture Discs Wanted.....5336	78s For Sale.....5430
Audio Tapes For Sale.....5030	Convention/Shows.....5135	Independent Labels Wanted.....5246	Picture Sleeves For Sale.....5340	78s Wanted.....5431
Audio Tapes Wanted.....5031	Dance Music For Sale.....5140	Michael Jackson.....5250	Picture Sleeves Wanted.....5341	Sheet Music For Sale.....5435
Autographs.....5035	Dance Music Wanted.....5141	Jazz Instrumental For Sale.....5255	Popular Vocalists For Sale.....5350	Sheet Music Wanted.....5450
Beach Boys For Sale.....5040	Dance Music Wanted.....5145	Jazz Instrumental Wanted.....5256	Popular Vocalists Wanted.....5351	Frank Sinatra For Sale.....5440
Beach Boys Wanted.....5041	Bob Dylan.....5150	Jazz Vocalists For Sale.....5260	Frank Sinatra Wanted.....5441	Frank Sinatra For Sale.....5440
Beatles For Sale.....5045	Doo-Wop For Sale.....5151	Jazz Vocalists Wanted.....5261	60s For Sale.....5445	Frank Sinatra Wanted.....5441
Beatles Wanted.....5046	Easy Listening For Sale.....5155	Jukeboxes.....5265	60s Wanted.....5446	60s For Sale.....5445
Big Bands For Sale.....5050	Easy Listening Wanted.....5156	KISS For Sale.....5270	Posters For Sale.....5355	60s Wanted.....5446
Big Bands Wanted.....5051	80s Rock For Sale.....5160	KISS Wanted.....5271	Power Pop For Sale.....5357	Soul For Sale.....5450
Bluegrass For Sale.....5055	80s Rock Wanted.....5161	Laser Discs For Sale.....5275	Power Pop Wanted.....5358	Soul Wanted.....5451
Bluegrass Wanted.....5056	World Music For Sale.....5165	Laser Discs Wanted.....5276	Elvis Presley For Sale.....5360	Soundtracks For Sale.....5455
Blues For Sale.....5060	World Music Wanted.....5166	Led Zeppelin.....5280	Elvis Presley Wanted.....5361	Soundtracks Wanted.....5456
Blues Wanted.....5061	8 Track For Sale.....5167	Madonna.....5285	Press Kits For Sale.....5365	Spoken Word For Sale.....5460
Books For Sale.....5065	8 Track Wanted.....5168	Magazines For Sale.....5290	Press Kits Wanted.....5366	Spoken Word Wanted.....5461
Books Wanted.....5070	EPs For Sale.....5171	Magazines Wanted.....5291	Prince.....5370	Bruce Springsteen.....5465
Business Opportunities.....5075	EPs Wanted.....5171	Marillion.....5293	Progressive Rock.....5373	Stereo Equipment.....5470
David Bowie.....5080	Fan Clubs.....5175	Memorabilia For Sale.....5295	Promotional Items For Sale.....5375	Storage Units.....5475
British Invasion Wanted.....5081	Fanzines.....5180	Memorabilia Wanted.....5296	Promotional Items Wanted.....5376	Barbra Streisand.....5478
British Invasion Wanted.....5081	50s Rock For Sale.....5185	Mini Discs For Sale.....5297	Psychedelic For Sale.....5380	Supplies For Sale.....5480
Kate Bush.....5085	50s Rock Wanted.....5186	Mini Discs Wanted.....5298	Psychedelic Wanted.....5381	Surf Music For Sale.....5485
Cassettes For Sale.....5087	Fleetwood Mac.....5190	Miscellaneous For Sale.....5300	Punk For Sale.....5385	Surf Music Wanted.....5486
Cassettes Wanted.....5088	Folk Music For Sale.....5195	Miscellaneous Wanted.....5301	Punk Wanted.....5386	Texas Music.....5488
Catalogs.....5090	Folk Music Wanted.....5196	Monkees.....5305	Radio Shows For Sale.....5390	Tour Programs.....5490
Christmas Music For Sale.....5095	40s Music For Sale.....5201	Moody Blues.....5307	Radio Shows Wanted.....5391	Turntable For Sale.....5495
Christmas Music Wanted.....5096	40s Music Wanted.....5201	Musical Instruments For Sale.....5310	Rap For Sale.....5395	U2.....5505
Children's Records For Sale.....5100	45s For Sale.....5205	Musical Instruments Wanted.....5311	Rap Wanted.....5396	Video Tapes For Sale.....5506
Children's Records Wanted.....5101	45s Wanted.....5206	New Age.....5312	Rock For Sale.....5412	Video Tapes Wanted.....5506
Eric Clapton.....5105	Gospel For Sale.....5211	New Orleans R&B For Sale.....5312	Rock Wanted.....5413	The Who.....5510
Classical For Sale.....5110	Gospel Wanted.....5211	New Orleans R&B Wanted.....5313	Rolling Stones For Sale.....5400	Hank Williams.....5515
Classical Wanted.....5111	Girls Groups For Sale.....5215	New Wave For Sale.....5315	Rolling Stones Wanted.....5401	Woodstock For Sale.....5517
Comedy For Sale.....5115			Reggae For Sale.....5405	Woodstock Wanted.....5518
			Reggae Wanted.....5406	Frank Zappa.....5520

Now A NETWORK OF CLASSIFIEDS!

Krause publications, the world's largest hobby & collectibles publisher, is proud to announce that every classified word ad placed in its periodicals will appear on the Internet's largest collectible classified site at www.collectit.net. In addition to reaching your target audience through Krause's periodicals, your ads will also reach thousands of collectors on the World Wide Web!

4 EASY OPTIONS TO REACH THE MOST ACTIVE MUSIC COLLECTORS FOR ONLY 40¢ PER WORD!

By Internet: Visit www.collectit.net on the internet to order with your credit card.

By Fax: Complete classified ad form, include your credit card number, expiration date, Fax to 715/445-4087.

By Mail: Complete order form, send payment by check, money order or credit card, mail to **GOLDMINE, CLASSIFIED ADVERTISING DEPT., 700 E. State St., Iola, WI 54990-0001.**

By Phone: Call 1-800-942-0673, 7 a.m. - 8 p.m. M-F. Saturday 8 a.m. - 2 p.m. Please have your credit card number and expiration date ready.

Payment must be included with all Classified Ads.

Only **40¢ Per Word**

Bold face type available (entire ad only) for only 10¢ more per word!

Frequency Discount Chart

(Consecutive Issues Only)

3-6	10%	10-12	20%
7-9	15%	13-26	25%

(Apply the appropriate frequency discount below when figuring the total cost of your classified ad.)

To order your classified ad:

- From the classified index on the following page, select the number which you want your ad to appear. Put that number in the box in the left hand corner of the order form.
- Using one word per line, write your ad EXACTLY as you want it to appear in GOLDMINE's Music Mart ad section.
- Minimum order is 25 words, or \$10.00 per ad per issue.
- Ad will run in next available issue. See deadlines on display advertising information page.

Print One Word Per Space Please use an additional sheet of paper for larger ads

Check here for entire ad in larger bold type

Classification	1	2	3	4	5
6	7	8	9	10	11
12	13	14	15	16	17
18	19	20	21	22	23
24	25	26	27	28	29
30	31	32	33	34	35

Words _____ X # of Issues _____ = Total Words _____ X 40¢ (X 50¢ for Bold Type) = \$ _____

Less Frequency Discount (See chart above) ... _____

Total Cost \$ _____

Total Amount Enclosed \$ _____

Payment:

Money Order Check

Amount Enclosed _____

MasterCard VISA Discover/Novus American Express

Credit Card # _____

Expiration Date: Month _____ Year _____

Signature _____

FOR OUR RECORDS ONLY: We must have a street address and phone number for our files before we will run your ad.

Name _____

Street Address _____

City _____ State _____ Zip _____

Daytime Phone _____

Mail to: **Goldmine** Classified Advertising • 700 East State Street Iola, WI 54990-0001 • www.collectit.net



(Reissues from page 75)

releases in the forthcoming series of Wailers remasters are even half as instructive, the art of raiding the archives will have a brand-new yardstick to be measured against. Looks like we're in for an interesting few months.

— Dave Thompson

JOAN BAEZ
Joan Baez
Vanguard (79594)

Volume Two
Vanguard (79595)

Noel
Vanguard (79596)

Kicking off Vanguard's much-anticipated realignment of the Joan Baez catalog, these three CDs represent her first, second and (oddly) seventh solo albums, each packed with bonus tracks and new liner notes, together with reproductions of the original artwork and very tasty individual slipcases.

Further installments are scheduled three months apart, and, if they maintain the quality of this trio, we have nothing to fear.

Baez burst onto the American folk scene in 1959 with a momentous performance at the Newport Folk Festival, taking the stage as a virtual unknown and running away with the headlines. Her self-titled debut album, recorded in a converted New York hotel basement the following year, repeated the feat without even breaking a sweat; her second, *Volume Two*, came 12 months after that and became Vanguard's first-ever gold record. All but overnight, Baez swept away every preconception of what the folk revival represented — and rebuilt the whole thing in her own shimmering image.

Her appeal, of course, was unmistakable — a voice of unimaginable purity, a demeanor of haunting melancholy and the ability to take the most overdone traditional ballad ("All My Trials" on her first album, "Banks Of The Ohio" on her second) and convert it into a slice of her own private mythology.

It has subsequently become rather fashionable to downplay these strengths and represent Baez (as Bob Dylan took to doing, following their romantic breakup in 1965) as little more than an empty vessel echoing the most basic elements of the folk revival. Compared to some of her later work, some of those accusations are borne out across her first albums.

But to give more than a cursory glance toward such elitist snobbery is to overlook all that Baez did bring to the folk process — popularity and romance, to be sure, but also a sequence of subtle rearrangements that were so swiftly



enshrined as "definitive" versions that Dylan himself was unable to resist them. His versions of "House Of The Rising Sun" and "Lily Of The West" both adhere to Baez's prototypes, the first recorded some months before they became acquainted, the second several years after they parted. Other artists, of course, proved equally slavish — today, only England's Fairport Convention could claim to have had a more profound influence on the traditional folk scene than Baez's first two albums.

Exquisitely remastered sound brings further dimensions to bear. The absolute silence that underpins Baez's performance is as much a part of the arrangement as the music itself, although neither vinyl nor past CD reissues truly made allowance for it. Here, the impression is of a voice literally chiming out of pitch darkness, concentrating all of the listener's attention on the mood of the song — a remarkable effect that is at its most effective, contrarily, on the least essential of the three albums.

1966's Christmas collection *Noel*, cut with a virtual orchestra of accompanists, is absorbingly lush but remains capable of transforming the grottiest hi-fi into a vast, gorgeous cathedral. The instrumental bridges that fall at regular intervals throughout (a device that is maintained within the bonus material) add further solemnity to the occasion.

All told, six new performances appear on *Noel*, including a title track whose absence from the original LP seems inexplicable. Three songs apiece, meanwhile, have been added to *Joan Baez* and *Volume Two*, all but one of which is previously unreleased and all of which, despite its long obscurity, is classic early Baez. It is, perhaps, absurd to say she'd have

sounded great simply singing her shopping list, but when two full albums of warmed-up traditional songs speed by without putting a single foot wrong, it's difficult not to get over-cited. And think — she was only going to get better.

— Dave Thompson

JOHNNY TILLOTSON
25 All-Time Greatest Hits
Varese Sarabande (302 066 210 2)

Many late-50s/early '60s teen idols have been unjustly ignored despite the depth of their contributions. One such artist is Johnny Tillotson, who, from 1958 to 1965, was a hit-making machine. Not as bluesy as Jimmy Clanton or exuberant as Bobby Vee, Tillotson displayed surprising depth as a writer and strong country leanings. All the biggest hits the Florida-born teen idol recorded for Archie Blyer's Cadence label and his post-army stint at MGM have been crisply remastered on *25 All-Time Greatest Hits*.

Tillotson's tender Neil Sedaka-range vocal stylings made him the perfect non-threatening hero for that era's pre-teen female record buyers. This approach is best exemplified by the syrupy "Dreamy Eyes," "Jimmy's Girl" and mushy remakes of "Earth Angel," "Pledging My Love" and "Funny How The Time Slips Away." Big commercial hits à la "Poetry In Motion" and "You Can Never Stop Me Loving You" smartly tapped into Frankie Avalon/Bobby Vinton boy-next-door fare. The latter haven't aged particularly well, though like much of this 25-song set, they do conjure up a certain nostalgic charm.

However, Tillotson created lasting historical impact by bringing crossover country to teenyboppers. Moreover, he wrote some of his best songs, such as "It Keeps Right On A Hurtin'," a true classic that the baby-faced star sang from the gut. The underrated "Out Of My Mind," is flat-out cry-in-your-beer country music, and his Top 10 hit "Without You" compares favorably with the dramatic heartbreak proffered by Roy Orbison and Gene Pitney. These sides still hold up and show what this artist was capable of when allowed some creative input.

For the most part, Tillotson sang other people's songs, making hits out of "Talk Back Trembling Lips" and "Heartaches By The Numbers." Scooped by James Darren on "(Theme From) Gidget," Tillotson has been playing the oldies circuit ever since. Why he didn't go country when his pop success dried up, we may never know. Bolstered with chart rankings and Brian Mansfield's fine booklet notes, *25 All-Time Greatest Hits* should please longtime fans and teen-idol buffs alike. (Order online at www.varesesarabande.com and www.johnnytillotson.com)

— Ken Burk

Five Star Record

hey Marty @ wwnet.net



THIS 1974 HORROR SPOOF (ALSO KNOWN AS "FLESH FOR FRANKENSTEIN") WAS ONE OF TWO WARHOL/MORRISSEY FILMS FROM THE SAME YEAR. THE OTHER FILM "BLOOD FOR DRACULA" (OR "ANDY WARHOL'S DRACULA") STARS MANY OF THE SAME ACTORS AND FEATURES A SUPERB CLAUDIO GIZZI SOUNDTRACK AS WELL! GIZZI'S PRIOR FILM EXPERIENCE HAD BEEN LIMITED TO ARRANGING CLASSICAL MUSIC FOR "DEATH IN VENICE" (1971) & ROMAN POLANSKI'S 1973 COMEDY "WHAT?"; BUT ACCORDING TO THE LINER NOTES HERE, MORRISSEY PICKED GIZZI TO SCORE THE FILM BECAUSE HE HADN'T WRITTEN FOR THE SCREEN, JUST AS HE OFTEN CHOSE ACTORS WHO HAD NEVER WORKED IN MOVIES BEFORE! GIZZI DELIVERED A SERIOUS, MOVING, BEAUTIFULLY ATMOSPHERIC SCORE THAT IN FACT, HAS LITTLE TO DO WITH THE ON-SCREEN LUNACY BUILT INTO THE FILM! CHOCK-FULL OF DISGUSTING GORE (SEVERED HEADS & LIMBS, QUIVERING INTERNAL ORGANS AND BEAUCOUP BLOOD) & SLEAZY SEXUAL SITUATIONS, "FRANKENSTEIN" BECAME A CULT HIT! *

* LEONARD MALTIN'S MOVIE GUIDE LISTS IT AS A "BOMB"!

ORIGINALLY RELEASED IN 3-D, "FRANKENSTEIN" WAS A MINOR HIT WHEN IT CAME OUT, DESPITE ITS "X" RATING, AND BROUGHT IN NEW FANS WITH ITS RE-RELEASE IN 1982! THAT'S WHEN I SAW IT (IN ALL ITS 3-D GLORY) WHILE ATTENDING WESTERN MICHIGAN UNIVERSITY! THAT'S ALSO THE YEAR OF RELEASE FOR THIS SOUNDTRACK LP ON THE VARESE SARABANDE LABEL! STRANGELY ENOUGH, THIS LP (ALONG WITH THE "DRACULA" SOUNDTRACK) WHEN LISTENED TO DOES NOT EVOKE THE FILM EXPERIENCE AT ALL! IT DOES SOUND LIKE SOME HORROR MOVIE SCORE, BUT IT NEVER MAKES ME REMEMBER THE MOVIE, ITSELF! AGAIN, ACCORDING TO THE LINER NOTES, MORRISSEY WAS STRIVING FOR WHAT HE CALLS "A PECULIAR KIND OF COMEDY..." WHICH CALLED FOR THE MUSIC TO "COUNTERPOINT THE ABSURDITY OF THE MATERIAL..."! RENT

THE MOVIE AND EXPERIENCE IT FOR YOURSELF! I DARE YOU! I DOUBLE DARE YOU!! I'VE ALSO SEEN THE "DRACULA" FLICK, AND I FOUND THIS ONE MUCH MORE ENTERTAINING!!



Coming to...

Goldmine



Elton John & Bernie Taupin

Elton John ruled the charts and airwaves in the '70s — including five straight multi-platinum #1 albums and seven #1 singles — and has rocked on ever since. In 1997, his "Candle In The Wind," originally a 1987 #6 tribute to Marilyn Monroe reworked for England's Princess Diana, netted him the honor of having the biggest selling single of all time. Key to his success has been songwriting partner Bernie Taupin, who has been involved in Rock And Roll Hall Of Famer John's hit-making machine since 1969. *Goldmine* interviewed Taupin about his longtime relationship with John and the songwriting process. One of the more collectible artists of the '70s, John's memorabilia and collectible records will also be explored in a separate article.

Advertisers: This is a great issue for your Elton John material, '70s rock and pop or items from any era and genre.

ISSUE DATE	AD DEADLINE	MAILING DATE	ON SALE
Nov 16	Oct 18	Oct 25	Nov 2

Advertising deadlines

DEADLINE	ISSUE DATE	MAILING DATE	ON SALE DATE
Thursday	Friday	Thursday	Friday
Oct 4	Nov 2	Oct 11	Oct 19
Oct 18	Nov 16	Oct 25	Nov 2
Nov 1	Nov 30	Nov 8	Nov 16

FOR AD INFORMATION: Call Tina Ellingson, Trevor Lauber, or Jill Ruesch at 715-445-2214. RETAILERS: To sell *GOLDMINE* in your shop at no risk, contact Bulk Sales Manager Steve Hudziak at 715-445-2214, ext. 327.

Sign up as a GOLDMINE subscriber
— get 13 issues for only \$24.95!

(U.S. addresses only; see subscription ad on this page for non-U.S. rates.)

Charge Card holders, call toll-free:
1-800-258-0929

(Please Mr. Postman from page 8)

employees of labels who have called me to ask info on projects that were assigned to them; Vigotone's work was done out of love for the music and to see that it was documented correctly. Capitol/EMI's *Beatles Anthology* series was an amateur attempt at copying Vigotone's pure-genius releases. Even John Barrett's (EMI tape librarian) cassette compilation of alternate takes and mixes was superior to EMI/Capitol's cut-and-paste outtake releases.

Apparently the Recording Industry Association Of America (RIAA) had been wanting to nail Vigotone for some time now and would spare no amount of dollars and police manpower to stop him. Now he faces many years in jail (possibly 80-100 years) and fines of \$1 million-\$25 million. Yes, your government and the RIAA (which spends the second-largest amount for lobbying politicians in Washington, D.C. — only the National Rifle Association (NRA) is outspending them) want him to spend more time on jail than a crack cocaine kingpin, terrorist bomber or child molester. Who would you rather have as a neighbor, a crack dealer, a terrorist or a child molester? I'd rather have my children get hooked on bootleg recordings than cocaine, that's for sure.

The RIAA spent close to \$1 million investigating and busting Vigotone. That amount of money would have fed a lot of broken, homeless musicians the RIAA claims to work for or paid for the musicians' health insurance. If record labels want to stop waste within their industry, they should check their own back yard. Every time a new release of a big artist comes out, all the record stores in

Hollywood are full of cut-out promos some record label staffer cashed in on his or her lunch break. Labels should check eBay for all those collectible promo items for sale under fake names.

Yes, congratulations record industry, you have taken out the most informed person in music history — or at least on Dylan, The Beatles, and The Beach Boys. Capitol should make him head of its catalog department and fire its entire staff.

— Dave Smithson
Anaheim CA

Springfield box set — "It's a crime"

Buffalo Springfield released only three albums in their short career. So why, in a four disc box set, don't we get all three complete albums? Even if their third album *Last Time Around* was "not recorded with the full involvement of its members," it is a fine album — in fact it is my favorite, and it definitely is part of the Buffalo Springfield heritage.

Although *Goldmine's* review doesn't mention this, other reviews of the box set state that the first two albums are included twice — once in mono and once in stereo. To me, it's a crime that Neil Young and Rhino chose to give us multiple versions of their favorite songs yet chose to exclude songs they could easily have found room for.

I love Buffalo Springfield, and I was looking forward to buying the boxed set. But excluding songs that I guess Neil Young didn't like and substituting duplicates — and I'm told triplicates — of songs he *did* like, just doesn't sit right with me. Maybe I'm the only one who feels this way, but I'll tape my old LPs instead.

— Sam Leandro
Willits CA

Goldmine Subscription Service

Including Special Services Subscriptions sent via UPS, 1st Class

Note: Current subscribers: when ordering any Special Service Subscription, a minimum one half year payment must be submitted. Those funds will be added to any current subscription credit and the total balance pro-rated to arrive at the number of issues due under the chosen plan. Subscribers will be notified of the resulting change in subscription duration and their new expiration date.

MasterCard, Discover or American Express orders may be phoned in by dialing 800-258-0929 and asking for Special Services.

United Parcel Service delivery subscriptions require a street address.

Clip and mail with payment to:

Goldmine

Special Services
Subscription Department

700 E. State St., Iola, WI 54990-0001

NOTE: Special Services Subscriptions are not available outside of U.S.A.

Goldmine Service	6-mo.	1-yr.	2-yr.	3-yr.
Second Class Mail (Standard Delivery 50 States)	\$24.95	\$39.95	\$74.50	\$107.95
Plain Wrapper (2nd Class Mail 50 states)	N/A	46.95	88.50	128.95
First Class Mail (in Plain Wrapper 50 states)	66.95	124.95	255.00	382.95
United Parcel Service (Regular Delivery 48 States)	75.00	140.00	N/A	N/A
United Parcel Service (2nd Day)	160.00	305.00	N/A	N/A
United Parcel Service Next Day	245.00	470.00	N/A	N/A

Foreign subscriptions including Canada and Mexico must be paid for in U.S. funds by an international money order or postal money order

Circle the rate below your country

	1/2-year	1-year
Surface mail all countries	49.95	93.95
Canada, Mexico (Air Mail)	70.95	135.00
Central America, Caribbean (Air Mail)	135.00	255.00
South America, Europe, Mediterranean Africa (Algeria, Libya, Morocco, Tunisia) (Air Mail)	135.00	255.00
Asia, Africa, Australia, all other countries (Air Mail)	135.00	255.00

Name _____ Check enclosed
 Address _____ MasterCard VISA Discover Am. Ex.
 City _____ Card # _____
 State/Zip _____ Expires Mo. _____ Yr. _____
 Signature _____

New subscription
 Renewal/Extension (please attach your mailing label)

Goldmine

Rates are subject to change.
 Circulation Dept.
 700 E. State St., Iola, WI 54990-0001 GMPTY97

Goldmine Advertisers' Index

A	E	J	P
Ace Video & Music 57	Energy 49	Jacobs, Rich 44	Papa Jazz Record Shoppe 66
Adler, Dan 74	Erock Auction 68	Jazz Record Center 56	Per Madsen Design 46, 56, 65, 75
Aether Records 71	Esprit Most Wanted 69	Jewelsleeve.com 41	PMA 60
Airwaves 74	Euclid Records 68	Joe's Record Paradise 74	Princeton Record Exchange 69
Andy's Record Supply 5		John Manship Records 51	Psychedellic State University 43
Arf! Arf! 65	F	Just Another Dream 56	
Around The World Records 57	Fab 4 Collectibles 69		R
Atlanta Record Show 60	Far West Record Sply 75		R & B Records 49
Audio Collections 35	Finbarr International 43	K	Radwill, Allen 33
Aya Gokhan 67	Fleetwood & Owen 79	Kaplan, Gary 66	Raging Belly Video 69, 75
	Flip Side Records 57	KP Adv Promotion 55	Rare & Hard To Find 66
B	Flipside Records & Collectibles 66	KP Book Promo 40	Rare Soul Man 57
B & D Record Sales 69	Full Cyrkle Records & Music 56		Raw Oldie Records, Inc. 43
Bags Unlimited 24, 25, 80	Fun Records 67	L	Record Archive Inc. 74
Banana's Records 68	Funk, Thomas 38	L.A.M. Videos 69	Record Exchange 38
Bangzoom.com 27		Last Vestige 45	Record Gems 74
Barbosa, Joey 45	G	Les Harris 47	Records And Books 3
Beebe, Ann 56	Garofalo, Peter 68	Les Turner (ALS) Foundation 58	Records Argentina 67
Better Records 68	Garvan, Stephen 70	Let It Be Records 69	Records By Mr. A 66
Big Ed's Record Shows 60	Gaspar, J.A. & J. De L. Peso 65	Let The Music Play 37	Recordsmith 38
Blue Storm Label 53	Gatefold Records 69	Loran Records 56	Reddingtons Rare Records Ltd. 56
Boo's Blast From The Past 42	GM Upcoming Issues 77	Lorentz Design 65	Reed, Biz 66
Bop Shop Records 74	Goldmine	Luth, Steve 75	Retriever Memorabilia Service 70
Brennan, Bob 74 31, 34, 44, 50, 71, 72, 73, 77, 78		Rhythm Recordings 34
Buccaneer Records 13	Green, Craig 38	M	Rip It Up! 67
	Greindl, Jeff 56	McDuffie, Jim 38	Rivertone Corp. 68
C	Groovy Productions 59	McGee, Timothy 60	Roanoke's Record Room 67, 74
C-Bub Productions 74		Memory Lane 56	Rock N Records 38
CD Trustee 65	H	Metro City Records 36, 37	Rock Of Ages 38
Celebrity Art 57	Hanna Sherif 75	Metro Pulse 2	Rockaway Records 66
CJI Collectibles 66	Hein, Gary 67	MFG 51	Ross, Scott 41
Classic Records 49	Held, Kenneth 56	Midnight Records 7	Russo, Joseph 66
Claus, Wendy 75	Heroes & Legends 67	Miller, Ken 38	Russo, Stephen 67, 75
Collectable Records 29	Higher & Higher 34	Moerer, Craig 68	
Collectibles Insurance Agency 51	Hip Cat Records 21, 75	Mud Shark Audio 56	S
Collector 61	Hoffman, Michael 67	Muller, Don 75	Safe As Milk Records 74
Continental Records 74	Hollis, Dan 75	Music Imports 67	Samuels, Gordon 75
Cool And Strange Music! 34	Hot Platters 57	Music Joint, The 68	Sandkamp, George 67
Cuneiform Records 34		Music Masters 11	Saturn Records 39
Cyrco Music 66	I	Musicstack 66	Schmid, Sam 43
	Import Record & CD's 56		Second Saturday Show 60
Disc Collector 4	In Your Face Videos 68	N	Shagbag Records 51
Discguys 74	Int'l Transfers 66	NEH Records 66	Shaheen, John 68
DJB (Devant Le Juke Box) 67	Intoxica 69	Nitty Gritty Records 27	Siren Disc 49, 55, 60
	Iuliucci, Bob 66	Noise Pollution 34	

The advertisers' index is provided as a reader service. Occasional, last-minute changes may result in ads appearing on pages other than those listed here. The publisher assumes no liability for omissions or errors.

2001 Advertising Deadlines

Deadline is 12 noon on deadline day
700 E. State St., Iola, WI 54990-0001

1-888-457-2873 • 715-445-2214 • FAX: 715-445-4087

Ad Deadline	Issue No.	Cover Date	Mailing Date	On Sale Date
Oct. 4	#555	Nov. 2	Oct. 11	Oct. 19
Oct. 18	#556	Nov. 16	Oct. 25	Nov. 2
Nov. 1	#557	Nov. 30	Nov. 8	Nov. 16
Nov. 15	#558	Dec. 14	Nov. 22	Nov. 30
Nov. 29	#559	Dec. 28	Dec. 6	Dec. 14

* Denotes Garage Sale Issue

REFERENCE FORM

COMPANY NAME _____
STREET ADDRESS _____
CITY _____ STATE _____ ZIP CODE _____

PHONE NO. _____
SOCIAL SECURITY # _____

TYPE OF BUSINESS
 CORPORATION LIMITED PARTNERSHIP
 CO PARTNERSHIP INDIVIDUAL PROPRIETOR

NO. OF YEARS ESTABLISHED _____

PRINCIPAL OWNERS - STOCKHOLDERS - PARTNERS - OFFICERS OF COMPANY

NAME _____
MAILING ADDRESS _____
CITY _____ STATE _____ ZIP CODE _____
TITLE _____

TRADE REFERENCES

NAME _____
ADDRESS _____
CITY _____ STATE _____ ZIP CODE _____
PHONE _____

BANK REFERENCE

BANK NAME _____
CITY _____ STATE _____ ZIP CODE _____
PHONE _____

BANKING OFFICIAL _____

I (we) hereby authorize Krause Publications and/or its credit agent to investigate the references herein or statements or other data obtained from me or any other person pertaining to my credit and financial responsibility. I understand that it is Krause Publications' policy to require cash in advance for all advertising until credit has been established or approved.

Further, I (we), the undersigned, will be held personally responsible and promise to pay promptly within 15 days of the billing date for all advertising debts incurred by the above named business and owing to Krause Publications.

AUTHORIZED SIGNATURE(S) OF APPLICANT(S)

Advertising Information

DISPLAY ADVERTISING:

(Cost per ad per issue; ads must run consecutively. Contract required to earn consecutive issue discounts.)

AD SIZE	WIDTH x HEIGHT	1 ISSUE	3 ISSUES	6 ISSUES	13 ISSUES	26 ISSUES
1/16 pg	2 5/16" x 3 1/4"	\$55.65	\$53.55	\$50.15	\$47.45	\$44.40
1/8 pg	4 7/8" x 3 1/4"	111.30	105.00	100.30	94.50	89.25
1/4 pg	4 7/8" x 6 1/2"	213.90	202.95	191.90	181.95	170.90
1/2 pg	4 7/8" x 13" or 10" x 6 1/2"	397.45	378.20	358.35	338.50	318.65
Jr. pg	7 7/16" x 10"	525.90	499.45	473.00	447.05	421.05
Full pg	10" x 13"	721.05	685.65	649.40	613.55	577.15

COLOR:

- A. One color and black \$190.00
- B. Full color (4-color) \$500.00
- (Plus color separation costs)
- C. Based on availability.
- D. Color is possible on any size ad.

UNIT SPACE ADVERTISING:

Unit space ads are the easiest way for you to sell records, tapes, compact discs, books, memorabilia, and any other collectibles you have for sale. Units also work well for want lists, announcements, etc. The better your unit looks when you put it together, the better it will look in GOLDMINE.

You may use any bidding deadline you wish in your advertisement. If no deadline is noted, it will be understood that the deadline will be one month from the cover date of the issue in which your ad appears.

One unit space equals one 8 1/2" x 11" typed sheet. This applies to both regular and super unit space ads.

Type your copy legibly onto 8 1/2" x 11" white sheets. We'll reduce it as is to 38% of its original size for regular units and 59% of its original size for super units. A regular unit space is one ninth of a page; a super unit space is a quarter of a page. Remember to include your ordering information, postage rates, grades, deadlines, name & address, etc., on your first unit. Do not send any partial units. There is a \$10.00 charge per photo for unit ads which contain photographs.

We will typeset your name, address and phone number at the bottom of your unit space ad for you, and a heading at the top, if you specify one. There is no extra charge for this. If you ask us not to typeset anything on your ad, we'll do nothing. Otherwise the typesetting will appear.

Do not reduce your copy before putting it on 8 1/2" x 11" format. Avoid all caps in your copy, except for headlines. Keep the copy clean. Dot matrix printers do not work well for unit ads, but if you must use one print it as dark as possible. Faxing unit space advertisement is not recommended.

Regular Unit Space Advertising Rates:

(Cost per unit, per issue; ads must run in consecutive issues. Contract required to earn consecutive issue discounts.)

1 ISSUE	3 ISSUES	6 ISSUES	13 ISSUES	26 ISSUES
\$60.90	\$57.90	\$54.60	\$52.00	\$48.60

Full page of 9 - \$466.20

Super Unit Space Advertising Rates:

(Cost per super unit, per issue; ads must run in consecutive issues. Contract required to earn consecutive issue discounts.)

1 ISSUE	3 ISSUES	6 ISSUES	13 ISSUES	26 ISSUES
\$126.80	\$120.75	\$114.20	\$108.15	\$101.85

Full page of 4 - \$466.20

COLLECTOR'S SHOWCASE:

The Collector's Showcase is a widely read advertising section in GOLDMINE. Each ad is in its own box, consisting of a space 3 1/4" wide and 1 11/16" high, or a multiple of that size. All typesetting is included in the price. We recommend no more than 14 to 15 typed or written lines per showcase box.

There are two Collector's Showcase sections available to advertisers - the Compact Disc Showcase, for those specializing in CDs; and the regular Collectors Showcase.

Showcase Advertising Rates:

(Cost per showcase box per issue; ads must run consecutively. Contract required to earn consecutive issue discounts.)

1 ISSUE	3 ISSUES	6 ISSUES	13 ISSUES	26 ISSUES
\$38.60	\$37.00	\$34.65	\$33.10	\$31.00

RETAILER DIRECTORY \$9.00 per issue

This section features listings for retail record stores around the world. Traveling record collectors of all types search for new stores to dig through on their vacations, business trips, etc. Advertise your establishment here, including ten words of miscellaneous description, for only \$9.00 an issue. You can buy this space in increments of 13 or 26 issues, for \$117.00 or \$234.00, respectively. Send in your store name, address, phone number, and ten words of description, along with your payment. If you stock GOLDMINE, we'll put your listing in boldface type.

CLASSIFIED DISPLAY:

AD SIZE	1 ISSUE	3 ISSUES	6 ISSUES	13 ISSUES	26 ISSUES
One Inch (1 1/2" x 1")	\$13.80	\$13.15	\$12.60	\$12.10	\$11.55
Two Inch (1 1/2" x 2")	26.55	25.50	23.65	22.60	21.55
Three Inch (1 1/2" x 3")	39.15	37.55	35.20	33.60	31.50

(Cost per ad; ads must run consecutively. Contract required to earn consecutive issue discounts.)

CLASSIFIED ADVERTISING:

- A. 40 cents Per Word (\$10.00 Minimum Order Per Ad Per Issue). Ad will also be included on our www.collectit.net site at no additional charge.
 - B. DISCOUNTS FOR CONSECUTIVE INSERTIONS
- | | | | |
|-----|------------------|-------|----------|
| 1-2 |No Discount | 10-12 |20% |
| 3-6 |10% | 13-26 |25% |
| 7-9 |15% | | |

ADVERTISING REQUIREMENTS: BOOTLEG POLICY

The advertiser is responsible for ensuring that advertised product conforms with national and international copyright laws. GOLDMINE magazine screens advertisements for bootleg merchandise. GOLDMINE magazine accepts no responsibility for transactions involving unauthorized product.

REFUNDS:

If delivery will take longer than 30 days from the date the seller received the order, the seller must inform the buyer and offer the buyer the option of a refund or delayed delivery.

Unless otherwise stated in the ad, the buyer has a 10-day return privilege from the time he/she receives an item from an advertiser. The buyer does not have to give a reason for a return and can demand a refund less postage costs. Advertisers must allow buyers to obtain authenticity judgments as the basis for retention provided they notify the advertiser of their intent within the applicable return privilege period.

All advertisers must provide a permanent address and telephone number before an advertisement will be run. If a post office box is used in an advertisement the advertiser must still provide a permanent address for our confidential files.

A completed reference form must be in our confidential files before any buy, sell or trade ad can be placed. See below. Minors are required to furnish a certificate of responsibility from their parents/guardian before their advertising can be accepted.

Payment must accompany an advertisement and must be in the form of a personal check drawn on a U.S., Canadian or Mexican bank; money orders; international money orders; cashier's checks; or with your VISA, MasterCard or AccessCard credit card. Send your credit card number, expiration date, and the name on the card, along with permission to charge the card for your ad, with your advertising copy.

FLEETWOOD OWEN
an eWanted company



...the world's premier auction house for entertainment memorabilia present their Autumn / Winter 2001 auction schedule.

Rock Legends, Los Angeles - October 2001

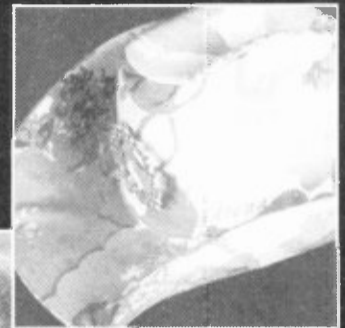

Stephen Ward Paintings from the collection of Dandy Kim (by sealed bid)
On display at the Proud Galleries, Pimlico London. 9th - 31st October 2001



Beatles For Sale, London - 27th November 2001

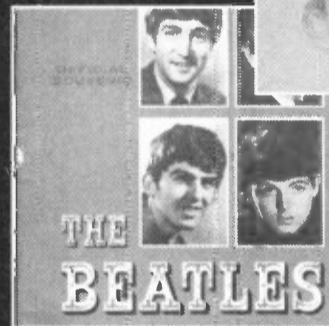

Abbey Road 70th Birthday Celebrations - 12th November 2001

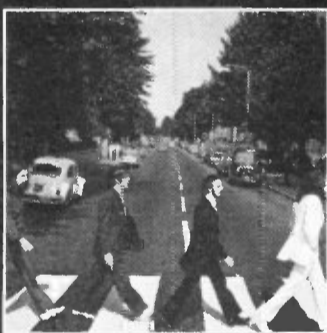

The Stuart Sutcliffe Collection
- 27th November - 7th December (by sealed bid)

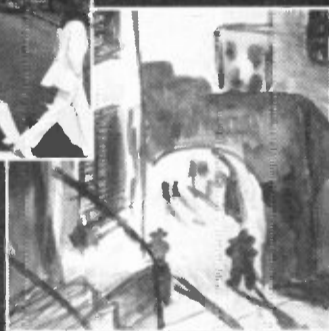

Sports Sale, London - 3rd December 2001



NOW COLLECTING FOR...
DECEMBER, JANUARY, FEBRUARY SALES

For further information, consignment details or to order a printed catalogue please

e: auctions@fleetwoodowen.com
t: +44 (0) 20 7563 5400

BAGS Unlimited

FREE PHONE CALL CATALOG
1-800-767-BAGS

SEE PAGES
24 & 25
FOR MORE
AUDIO
PROTECTION
PRODUCTS



7 Canal St., Dept. A, Rochester, New York 14608
http://www.bagsunlimited.com
E-mail: info@bagsunlimited.com



For the BEST in RECORD Collection Protection

12" LP-33 1/3 rpm / LASER DISCS

10" LP / 78 RPM

SLEEVE 3 Mil Poly Album Sleeves Made from 100% Pure Virgin Polyethylene. Fits over outer 12" LP Jacket. <table border="1"> <tr> <th>12 5/8 x 12 5/8 No Flap</th> <th>12 3/4 x 12 3/4 No Flap</th> <th>12 5/8 x 12 5/8 RESEALABLE FLAP</th> </tr> <tr> <td>100 \$11.90</td> <td>100 \$12.05</td> <td>100 \$19.70</td> </tr> <tr> <td>500 41.70</td> <td>500 43.20</td> <td>500 75.60</td> </tr> <tr> <td>1,000 72.50</td> <td>1,000 73.90</td> <td>1,000 134.40</td> </tr> <tr> <td>5,000 329.75</td> <td>5,000 336.55</td> <td>5,000 628.40</td> </tr> </table> PCODE: SLP33 SLP3 SLP33R *with FLAP add 10%.			12 5/8 x 12 5/8 No Flap	12 3/4 x 12 3/4 No Flap	12 5/8 x 12 5/8 RESEALABLE FLAP	100 \$11.90	100 \$12.05	100 \$19.70	500 41.70	500 43.20	500 75.60	1,000 72.50	1,000 73.90	1,000 134.40	5,000 329.75	5,000 336.55	5,000 628.40	MAILER LP Mailer Folder 13 x 13 Expandable <table border="1"> <tr> <td>10 \$14.85</td> <td>25 25.65</td> <td>50 39.80</td> <td>100 73.55</td> <td>200 137.45</td> <td>500 302.50 + Frt (Ships 100 wt.)</td> <td>1,000 515.75 + Frt (Ships 100 wt.)</td> </tr> </table> Made from 200 Lb. test "Bend Resistant" Brown Corrugated Material. EXPANDABLE to hold either 1-3 or 4-6 Albums.			10 \$14.85	25 25.65	50 39.80	100 73.55	200 137.45	500 302.50 + Frt (Ships 100 wt.)	1,000 515.75 + Frt (Ships 100 wt.)	DISPLAY LP/Laser Disc Display 24 x 12 X 13 1/2 <table border="1"> <tr> <td>1 \$40.00</td> <td>2 70.00</td> <td>4 120.00</td> <td>10 220.00 + Frt</td> </tr> </table> Wooden display case holds 130-140 LP's or Laser Discs. Available in walnut finish. 3 built in storage slots. STACKABLE.			1 \$40.00	2 70.00	4 120.00	10 220.00 + Frt					
12 5/8 x 12 5/8 No Flap	12 3/4 x 12 3/4 No Flap	12 5/8 x 12 5/8 RESEALABLE FLAP																																					
100 \$11.90	100 \$12.05	100 \$19.70																																					
500 41.70	500 43.20	500 75.60																																					
1,000 72.50	1,000 73.90	1,000 134.40																																					
5,000 329.75	5,000 336.55	5,000 628.40																																					
10 \$14.85	25 25.65	50 39.80	100 73.55	200 137.45	500 302.50 + Frt (Ships 100 wt.)	1,000 515.75 + Frt (Ships 100 wt.)																																	
1 \$40.00	2 70.00	4 120.00	10 220.00 + Frt																																				
SLEEVE Poly Album Sleeves 12 3/4 x 12 3/4 No Flap Made from 100% Pure Virgin Polyethylene. Fits loosely over outer 12" LP or Video Laser Disc Jackets. <table border="1"> <tr> <th>2 Mil</th> <th>4 Mil</th> <th>6 Mil</th> </tr> <tr> <td>100 \$10.75</td> <td>100 \$21.20</td> <td>100 \$31.70</td> </tr> <tr> <td>500 37.20</td> <td>500 76.20</td> <td>500 114.20</td> </tr> <tr> <td>1,000 62.10</td> <td>1,000 127.65</td> <td>1,000 191.40</td> </tr> <tr> <td>5,000 287.40</td> <td>5,000 608.00</td> <td>5,000 911.60</td> </tr> </table> PCODE: SLP2 SLP4 SLP6			2 Mil	4 Mil	6 Mil	100 \$10.75	100 \$21.20	100 \$31.70	500 37.20	500 76.20	500 114.20	1,000 62.10	1,000 127.65	1,000 191.40	5,000 287.40	5,000 608.00	5,000 911.60	MAILER Album Mailer Box-Holds 12 13 x 13 x 1 1/2 <table border="1"> <tr> <td>10 \$15.95</td> <td>25 34.10</td> <td>50 54.00</td> <td>100 97.00</td> <td>200 178.75</td> </tr> </table> Made from 200 Lb. Test Brown Corrugated Material. Foldable box with double walled edges ensures safe and "Crush Free" delivery. Holds up to 10-12 LP's in jackets.			10 \$15.95	25 34.10	50 54.00	100 97.00	200 178.75	DISPLAY Album Jacket Frame Kit Black Matte Finish <table border="1"> <tr> <td>1 \$10.00</td> <td>2 18.00</td> <td>5 39.25</td> <td>10 64.50</td> <td>25 152.50</td> <td>50 287.50</td> </tr> </table> Outside Dimension of Frame 14" x 14" PCODE: ALPJFK			1 \$10.00	2 18.00	5 39.25	10 64.50	25 152.50	50 287.50					
2 Mil	4 Mil	6 Mil																																					
100 \$10.75	100 \$21.20	100 \$31.70																																					
500 37.20	500 76.20	500 114.20																																					
1,000 62.10	1,000 127.65	1,000 191.40																																					
5,000 287.40	5,000 608.00	5,000 911.60																																					
10 \$15.95	25 34.10	50 54.00	100 97.00	200 178.75																																			
1 \$10.00	2 18.00	5 39.25	10 64.50	25 152.50	50 287.50																																		
SLEEVE Poly Box Album Sleeves 14 x 14 1/4 w/Flap Made from 100% Pure Virgin Polyethylene. 2 Mil. <table border="1"> <tr> <td>50 \$10.00</td> <td>100 16.10</td> <td>200 28.50</td> <td>500 67.20</td> <td>1,000 127.70</td> </tr> </table> Fits over outer Box Album Sets. PCODE: SBLP2			50 \$10.00	100 16.10	200 28.50	500 67.20	1,000 127.70	MAILER Album Mailer Box-Holds 20 13 x 13 x 3 <table border="1"> <tr> <td>10 \$19.20</td> <td>25 44.30</td> <td>50 71.60</td> <td>100 126.50</td> <td>200 230.70</td> </tr> </table> Made from 200 Lb. test Brown Corrugated Material. Foldable box with double walled edges ensures safe and "Crush Free" delivery for shipment of 18-20 Albums in jackets.			10 \$19.20	25 44.30	50 71.60	100 126.50	200 230.70	DISPLAY Album Art "Frame" BACK BY POPULAR DEMAND 12 1/2 x 12 1/2 x 1 1/2 <table border="1"> <tr> <td>2 \$17.00</td> <td>5 36.25</td> <td>10 60.00</td> <td>25 125.00</td> <td>50 225.00</td> </tr> </table> Clear Acrylic Frames.			2 \$17.00	5 36.25	10 60.00	25 125.00	50 225.00																
50 \$10.00	100 16.10	200 28.50	500 67.20	1,000 127.70																																			
10 \$19.20	25 44.30	50 71.60	100 126.50	200 230.70																																			
2 \$17.00	5 36.25	10 60.00	25 125.00	50 225.00																																			
SLEEVE 12" Poly/Polylined <table border="1"> <tr> <th>POLY</th> <th>POLYLINE</th> </tr> <tr> <td>100 \$11.50</td> <td>50 \$17.55</td> </tr> <tr> <td>500 42.15</td> <td>100 26.60</td> </tr> <tr> <td>1,000 74.10</td> <td>500 129.00</td> </tr> </table> Made from 100% Pure Virgin 3 Mil Polyethylene. PCODE: SLPI			POLY	POLYLINE	100 \$11.50	50 \$17.55	500 42.15	100 26.60	1,000 74.10	500 129.00	FILLER LP Mailer Filler Pads 12 5/8 x 12 5/8 <table border="1"> <tr> <td>50 \$18.15</td> <td>100 26.15</td> <td>250 50.20</td> <td>500 83.00</td> <td>1,000 124.75 + Frt</td> </tr> </table> Use our brown corrugated filler pads to eliminate unnecessary inner package movement while absorbing handling shock.			50 \$18.15	100 26.15	250 50.20	500 83.00	1,000 124.75 + Frt	CLEANER Record Cleaning System Discwasher® D4+™ Record Cleaning System Replacement Fluid Discwasher® D4+™ 1 1/4 oz. <table border="1"> <tr> <td>1 \$21.50</td> <td>3 50.25</td> <td>5 80.75</td> <td>10 145.00</td> </tr> </table> Record care system includes record cleaning pad with walnut handle. 1 1/4 oz. D4+ Fluid and DC-1 pad grooming brush.			1 \$21.50	3 50.25	5 80.75	10 145.00														
POLY	POLYLINE																																						
100 \$11.50	50 \$17.55																																						
500 42.15	100 26.60																																						
1,000 74.10	500 129.00																																						
50 \$18.15	100 26.15	250 50.20	500 83.00	1,000 124.75 + Frt																																			
1 \$21.50	3 50.25	5 80.75	10 145.00																																				
SLEEVE 12" White Paper <table border="1"> <tr> <th>Regular Weight</th> <th>Medium Weight</th> <th>Heavy Weight</th> </tr> <tr> <td>50 \$9.20</td> <td>50 \$10.20</td> <td>50 \$13.85</td> </tr> <tr> <td>100 14.65</td> <td>100 16.20</td> <td>100 22.00</td> </tr> <tr> <td>500 52.00</td> <td>500 34.50</td> <td>500 75.20</td> </tr> <tr> <td>1,000 90.10</td> <td>1,000 79.30</td> <td>1,000 108.10</td> </tr> <tr> <td>2,000 154.70</td> <td>2,000 147.10</td> <td>2,000 150.70</td> </tr> <tr> <td>4,000 248.05 + Frt</td> <td>4,000 203.30 + Frt</td> <td>4,000 160.60 + Frt</td> </tr> </table> Fits directly over 12" Record. Comes with die cut center hole.			Regular Weight	Medium Weight	Heavy Weight	50 \$9.20	50 \$10.20	50 \$13.85	100 14.65	100 16.20	100 22.00	500 52.00	500 34.50	500 75.20	1,000 90.10	1,000 79.30	1,000 108.10	2,000 154.70	2,000 147.10	2,000 150.70	4,000 248.05 + Frt	4,000 203.30 + Frt	4,000 160.60 + Frt	BOX Album Storage Box 13 X 13 X 10 1/2 <table border="1"> <tr> <td>2 \$13.60</td> <td>5 27.80</td> <td>10 43.00</td> <td>25 87.75</td> <td>50 161.70</td> <td>100 231.00 + Frt</td> </tr> </table> Store 50-65 Records. Attractive, WHITE, 275 lb. Test Corrugated cardboard storage container. Needs no tape or glue.			2 \$13.60	5 27.80	10 43.00	25 87.75	50 161.70	100 231.00 + Frt	CLEANER Record Cleaning Fluid Groovy™ Cleaner 4 oz. <table border="1"> <tr> <td>1 \$6.00</td> <td>3 16.50</td> <td>5 25.00</td> <td>10 45.00</td> </tr> </table> Bags Unlimited's own Record Cleaning Fluid. Deep cleaning. Anti-static, residue free. Pump Spray Bottle. PCODE: AGC4			1 \$6.00	3 16.50	5 25.00	10 45.00
Regular Weight	Medium Weight	Heavy Weight																																					
50 \$9.20	50 \$10.20	50 \$13.85																																					
100 14.65	100 16.20	100 22.00																																					
500 52.00	500 34.50	500 75.20																																					
1,000 90.10	1,000 79.30	1,000 108.10																																					
2,000 154.70	2,000 147.10	2,000 150.70																																					
4,000 248.05 + Frt	4,000 203.30 + Frt	4,000 160.60 + Frt																																					
2 \$13.60	5 27.80	10 43.00	25 87.75	50 161.70	100 231.00 + Frt																																		
1 \$6.00	3 16.50	5 25.00	10 45.00																																				
JACKET 12" LP Jacket 12 1/4 x 12 1/4 <table border="1"> <tr> <th>WHITE</th> <th>BLACK</th> </tr> <tr> <td>5 \$7.10</td> <td>5 \$10.35</td> </tr> <tr> <td>10 12.00</td> <td>10 17.40</td> </tr> <tr> <td>25 16.95</td> <td>25 25.60</td> </tr> <tr> <td>50 30.75</td> <td>50 45.30</td> </tr> <tr> <td>100 58.70</td> <td>100 77.00</td> </tr> <tr> <td>300 138.60 + Frt</td> <td>300 152.10 + Frt</td> </tr> </table> High Gloss Cardboard. Specify with OR without center hole. PCODE: SLPJW SLPJK			WHITE	BLACK	5 \$7.10	5 \$10.35	10 12.00	10 17.40	25 16.95	25 25.60	50 30.75	50 45.30	100 58.70	100 77.00	300 138.60 + Frt	300 152.10 + Frt	BOX Album Storage Box WHITE PLASTIC CORRUGATED 13 x 13 x 10 1/2 <table border="1"> <tr> <td>2 \$16.00</td> <td>5 35.75</td> <td>10 66.00</td> <td>25 120.00 + Frt</td> </tr> </table> A SUPERIOR Storage Box. Holds 50-60 LP's. Made from waterproof Polypropylene PLASTIC Corrugated. Acid-Free, ANTI-STAT material. UV resistant. Folds together. Super Strong. STACKABLE.			2 \$16.00	5 35.75	10 66.00	25 120.00 + Frt	CLEANER Cloth / Sponge Record Cleaning Cloth Record Cleaning Sponge <table border="1"> <tr> <td>1 \$2.00</td> <td>5 6.25</td> <td>10 10.00</td> <td>1 \$5.00</td> <td>5 20.00</td> <td>10 37.50</td> </tr> </table> Easy to use Record Cloth contains a unique Anti-Static Solution. Lubricates and protects the records as it cleans. PCODE: ASA2			1 \$2.00	5 6.25	10 10.00	1 \$5.00	5 20.00	10 37.50							
WHITE	BLACK																																						
5 \$7.10	5 \$10.35																																						
10 12.00	10 17.40																																						
25 16.95	25 25.60																																						
50 30.75	50 45.30																																						
100 58.70	100 77.00																																						
300 138.60 + Frt	300 152.10 + Frt																																						
2 \$16.00	5 35.75	10 66.00	25 120.00 + Frt																																				
1 \$2.00	5 6.25	10 10.00	1 \$5.00	5 20.00	10 37.50																																		
JACKET 12" LP Jacket 12 1/4 x 12 1/4 <table border="1"> <tr> <td>5 \$7.10</td> <td>10 12.00</td> <td>25 16.95</td> <td>50 30.75</td> <td>100 58.70</td> <td>300 138.60 + Frt</td> </tr> </table> High Gloss Cardboard. Specify with OR without center hole. PCODE: SLPJW SLPJK			5 \$7.10	10 12.00	25 16.95	50 30.75	100 58.70	300 138.60 + Frt	BOX Album Storage Box WHITE PLASTIC CORRUGATED 13 x 13 x 10 1/2 <table border="1"> <tr> <td>2 \$16.00</td> <td>5 35.75</td> <td>10 66.00</td> <td>25 120.00 + Frt</td> </tr> </table> A SUPERIOR Storage Box. Holds 50-60 LP's. Made from waterproof Polypropylene PLASTIC Corrugated. Acid-Free, ANTI-STAT material. UV resistant. Folds together. Super Strong. STACKABLE.			2 \$16.00	5 35.75	10 66.00	25 120.00 + Frt	CLEANER Cloth / Sponge Record Cleaning Cloth Record Cleaning Sponge <table border="1"> <tr> <td>1 \$2.00</td> <td>5 6.25</td> <td>10 10.00</td> <td>1 \$5.00</td> <td>5 20.00</td> <td>10 37.50</td> </tr> </table> Easy to use Record Cloth contains a unique Anti-Static Solution. Lubricates and protects the records as it cleans. PCODE: ASA2			1 \$2.00	5 6.25	10 10.00	1 \$5.00	5 20.00	10 37.50															
5 \$7.10	10 12.00	25 16.95	50 30.75	100 58.70	300 138.60 + Frt																																		
2 \$16.00	5 35.75	10 66.00	25 120.00 + Frt																																				
1 \$2.00	5 6.25	10 10.00	1 \$5.00	5 20.00	10 37.50																																		

OUR PRICES INCLUDE SHIPPING EXCEPT WHERE NOTED

PLEASE READ Money orders and orders charged to MC/VISA/AMEX are usually shipped within 2 business days. All sizes in stock at all times. Because we are manufacturers we can make many sizes of bags and backings. If you need a size not listed, please call or write for a price.

No PO Box numbers for FedEx Ground Delivery. Please send street address.

QUANTITY	MIL	PROD. CODE	DESCRIPTION	PRICE

SHIPPING & HANDLING:

▲ States of Florida, LA, MO, MN, and all states West of the Mississippi add 10% for shipping. All prices subject to change based upon current market value of raw materials. Not responsible for typographical errors. All bags have 1-1/2" flap unless otherwise noted. Alaska, Hawaii, Virgin Islands, Puerto Rico, APO, FPO, Canada & Foreign, Call or Write for Freight Price Quote.

QUANTITY	MIL	PROD. CODE	DESCRIPTION	PRICE

PLEASE CHECK APPROPRIATE BOX:
 MONEY ORDER
 CHECK ENCLOSED
 CHARGE TO MY VISA / MC / AMEX
 SEND C.O.D. ADD \$5.50

CREDIT CARD
 VISA M.C. A.M.E.X. C.O.D.

NAME	SUB TOTAL
STREET ADDRESS	All orders under \$25.00 add \$4.00
CITY STATE ZIP	C.O.D. orders add \$5.50
NO POST OFFICE BOX NUMBERS FOR FedEx GROUND DELIVERY NY State Residents add 8% Sales Tax	
▲ Florida, States West of the Mississippi, including entire states of LA, MO, MN add 10% for shipping.	
CUSTOMER ACCOUNT CODE	TOTAL