

**RARE FINDS — TWO ELVIS SUN 78s PICKED UP FOR A BUCK!**

November 16, 2001 VOL 27 • NO 23 • ISSUE 556

**GOLDMINE**

# Goldmine

THE COLLECTOR RECORD AND COMPACT DISC MARKETPLACE

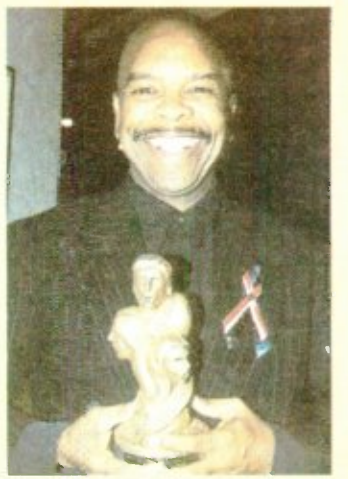

**VOCAL GROUP  
HALL OF FAME  
inducts newest  
members**



## Bernie Taupin

The man behind  
Elton John's hits

Elton John collectibles  
come with a price

Made in  
England  
**Elton  
John**

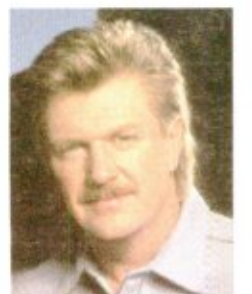
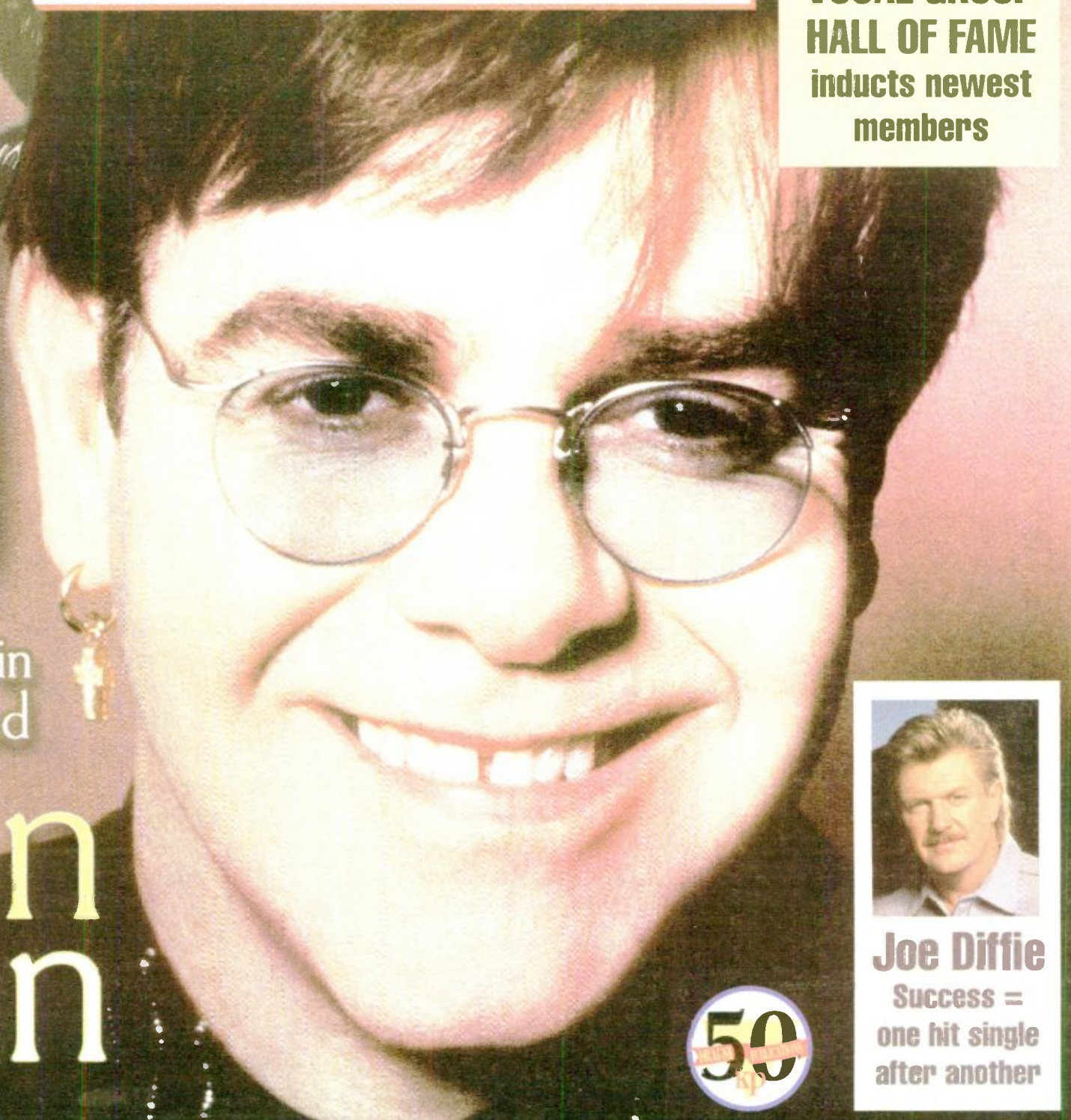

## Joe Diffie

Success =  
one hit single  
after another



1 602 485 0485

#BXNDWUF \*\*\*\*AUTO\*\* 3-DIGIT 908  
#0001431608N1# GM FEB03 / -  
MONTY GREENLY 0485 -  
3740 ELM AVE # A

LONG BEACH CA 90807-3402

U.S. \$3.95 • CANADA \$4.95



## Reviews .....

- ▶ Eric Bibb
- ▶ Buddy & Judy Miller
- ▶ Neil Diamond
- ▶ The Four Tops
- ▶ Nickelback
- ▶ The Grass Roots



**"a DY-NO-MITE set  
of music that  
grooved the hearts  
and 8-tracks of  
a generation"**

can you dig it?

# To the Soul experience

## disc ONE

1. GRAZING IN THE GRASS - The Friends Of Distinction
2. COLOR HIM FATHER - The Winstons
3. HEY THERE LONELY GIRL - Eddie Holman
4. CRUMBS OFF THE TABLE - The Glass House
5. RAINY NIGHT IN GEORGIA - Brook Benton
6. EVERYBODY IS A STAR - Sly & The Family Stone
7. GIVE ME JUST A LITTLE MORE TIME - Chairmen Of The Board
8. DIDN'T I (BLOW YOUR MIND THIS TIME) - The Delfonics
9. THE BELLS - The Originals
10. TURN BACK THE HANDS OF TIME - Tyrone Davis
11. LOVE ON A TWO-WAY STREET - The Moments
12. BAND OF GOLD - Freda Payne
13. O-O-H CHILD - The 5 Stairsteps
14. WESTBOUND #9 - The Flaming Ember
15. MAYBE - The Three Degrees
16. THE SLY, SLICK, AND THE WICKED - The Lost Generation
17. WAR - Edwin Starr
18. SOMEBODY'S BEEN SLEEPING - 100 Proof Aged In Soul
19. EXPRESS YOURSELF - Charles Wright & The Watts 103rd Street Rhythm Band
20. PRECIOUS, PRECIOUS - Jackie Moore
21. FUNKY NASSAU-PART I - The Beginning Of The End
22. GROOVE ME - King Floyd
23. I LOVE YOU FOR ALL SEASONS - The Fuzz
24. WANT ADS - Honey Cone
25. COOL AID - Paul Humphrey & His Cool Aid Chemists

## disc TWO

1. DON'T KNOCK MY LOVE-PT. I - Wilson Pickett
2. LOVE OR LET ME BE LONELY - The Friends Of Distinction
3. DEEPER & DEEPER - Freda Payne
4. PAY TO THE PIPER - Chairmen Of The Board
5. MR. BIG STUFF - Jean Knight
6. WOMEN'S LOVE RIGHTS - Laura Lee
7. WHATCHA SEE IS WHATCHA GET - Dramatics
8. BABY LET ME KISS YOU - King Floyd
9. RIGHT ON THE TIP OF MY TONGUE - Brenda & The Tabulations
10. THIN LINE BETWEEN LOVE & HATE - The Persuaders
11. HAVE YOU SEEN HER - Chi-Lites
12. THEME FROM SHAFT - Isaac Hayes
13. RESPECT YOURSELF - The Staple Singers
14. FAMILY AFFAIR - Sly & The Family Stone
15. LET'S STAY TOGETHER - Al Green
16. CLEAN UP WOMAN - Betty Wright
17. ONE MONKEY DON'T STOP NO SHOW-PART I - Honey Cone
18. DROWNING IN THE SEA OF LOVE - Joe Simon
19. AIN'T UNDERSTANDING MELLOW - Jerry Butler & Brenda Lee Eager
20. I'VE BEEN LONELY FOR SO LONG - Frederick Knight
21. SUAVECITO - Malo
22. HEARSAY - The Soul Children
23. SHE'S NOT JUST ANOTHER WOMAN - The 8th Day

## disc THREE

1. I'LL TAKE YOU THERE - The Staple Singers
2. IN THE RAIN - Dramatics
3. BETCHA BY GOLLY, WOW - The Stylistics
4. OH GIRL - Chi-Lites
5. LEAN ON ME - Bill Withers
6. I GOTCHA - Joe Tex
7. DO YOUR THING - Isaac Hayes
8. I'LL BE AROUND - Spinners
9. TOO LATE TO TURN BACK NOW - Cornelius Brothers & Sister Rose
10. (IF LOVING YOU IS WRONG) I DON'T WANT TO BE RIGHT - Luther Ingram
11. STARTING ALL OVER AGAIN - Mel & Tim
12. BACK STABBERS - O'Jays
13. YOU'RE STILL A YOUNG MAN - Tower Of Power
14. EVERYBODY PLAYS THE FOOL - The Main Ingredient
15. FREDDIE'S DEAD (THEME FROM "SUPERFLY") - Curtis Mayfield
16. I CAN SEE CLEARLY NOW - Johnny Nash
17. IF YOU DON'T KNOW ME BY NOW - Harold Melvin & The Blue Notes
18. LOVE JONES - Brighter Side Of Darkness
19. ME AND MRS. JONES - Billy Paul
20. PAPA WAS A ROLLIN' STONE - The Temptations
21. OUTA-SPACE - Billy Preston

- disc FOUR
1. COULD IT BE I'M FALLING IN LOVE - Spinners
  2. USE ME - Bill Withers
  3. LOVE TRAIN - O'Jays
  4. WHY CAN'T WE LIVE TOGETHER - Timmy Thomas
  5. AIN'T NO WOMAN (LIKE THE ONE I'VE GOT) - Four Tops
  6. I'M DOIN' FINE NOW - New York City
  7. PILLOW TALK - Sylvia
  8. SO VERY HARD TO GO - Tower Of Power
  9. NATURAL HIGH - Bloodstone
  10. LET'S GET IT ON - Marvin Gaye
  11. THAT LADY-PART I - The Isley Brothers
  12. KEEP ON TRUCKIN'-PART I - Eddie Kendricks
  13. HURTS SO GOOD - Millie Jackson
  14. MIDNIGHT TRAIN TO GEORGIA - Gladys Knight & The Pips
  15. I CAN'T STAND THE RAIN - Ann Peebles
  16. THE WORLD IS A GHETTO - War
  17. TELL HER SHE'S LOVELY - El Chicano
  18. THE LOVE I LOST-PART I - Harold Melvin & The Blue Notes
  19. CHEAPER TO KEEP HER - Johnnie Taylor
  20. SHOW AND TELL - Al Wilson
  21. LOOKIN' FOR A LOVE - Bobby Womack
  22. BE THANKFUL FOR WHAT YOU GOT - William DeVaughn
  23. JUST DON'T WANT TO BE LONELY - The Main Ingredient

- disc FIVE
1. THE PAYBACK-PART I - James Brown
  2. HOLLYWOOD SWINGING - Kool & The Gang
  3. SIDESHOW - Blue Magic
  4. ROCK THE BOAT - The Hues Corporation
  5. FINALLY GOT MYSELF TOGETHER (I'M A CHANGED MAN) - The Impressions
  6. ROCK YOUR BABY - George McCrae
  7. TELL ME SOMETHING GOOD - Rufus
  8. YES WE CAN CAN - The Pointer Sisters
  9. HANG ON IN THERE BABY - Johnny Bristol
  10. DO IT (TIL YOU'RE SATISFIED) - B.T. Express
  11. YOU LITTLE TRUSTMAKER - The Tymes
  12. LOVIN' YOU - Minnie Riperton
  13. WOMAN TO WOMAN - Shirley Brown
  14. EVERLASTING LOVE - Carl Carlton
  15. WHEN WILL I SEE YOU AGAIN - The Three Degrees
  16. PICK UP THE PIECES - AWB
  17. LADY MARMALADE - LaBelle
  18. WALKING IN RHYTHM - The Blackbyrds
  19. SUPERNATURAL THING-PART I - Ben E. King
  20. REASONS - Earth, Wind & Fire
  21. ROCKIN' - CHAIR Gwen McCrae
  22. I WANNA GET NEXT TO YOU - Rose Royce
  23. LOVE WON'T LET ME WAIT - Major Harris

- disc SIX
1. SHINING STAR - Earth, Wind & Fire
  2. EXPRESS - B.T. Express
  3. CUT THE CAKE - AWB
  4. WHY CAN'T WE BE FRIENDS? - War
  5. SO IN LOVE - Curtis Mayfield
  6. LOVE ROLLERCOASTER - Ohio Players
  7. IT ONLY TAKES A MINUTE - Tavares
  8. MOVIN' - Brass Construction
  9. KISS AND SAY GOODBYE - Manhattans
  10. YOU'LL NEVER FIND ANOTHER LOVE LIKE MINE - Lou Rawls
  11. DAZZ - Brick
  12. BEST OF MY LOVE - Emotions
  13. STRAWBERRY LETTER 23 - The Brothers Johnson
  14. FLOAT ON - The Floaters
  15. ALWAYS AND FOREVER - Heatwave
  16. (EVERY TIME I TURN AROUND) BACK IN LOVE AGAIN - L.T.D.
  17. YOU AND I - Rick James
  18. WHAT YOU WON'T DO FOR LOVE - Bobby Caldwell
  19. REUNITED - Peaches & Herb
  20. CRUISIN' - Smokey Robinson
  21. GOLDEN TOUCH - Rose Royce

**6 CDS, 136 HITS, 76-PAGE BOOK WITH IN-DEPTH LINERS,  
TRACK-BY-TRACK COMMENTARY, AND JIVE GLOSSARY.**

**RHINO**

**BORDERS** COME INSIDE:  
BOOKS, MUSIC, VIDEO, AND A CAFE

**OUT NOW IN BOXED SET SECTIONS EVERYWHERE!**



DISC UN-BOULIEVABLE PRICES COLLECTOR

P.O. Box 4000, Parker, CO 80134 (303) 841-3000 • (303) 841-1118 FAX (303) 840-9373 e-mail: cd@discol.com Web site: www.discol.com Hours: Monday thru Friday 9 a.m. to 5 p.m. Mountain Time

THE DISC COLLECTOR ADVANTAGE We Stock 1000's of Titles (Domestic & Import) in addition to the CDs Listed in This Ad... Don't See It or Have Questions? Just Ask! We Know Pop Music Well... From Original Recordings to Sound Quality... Trusted Professionals for Over 19 Years... Very Competitive/Low Overall Pricing...

Look! Please check out our Web site www.discol.com for up-to-the-minute new releases, super specials, reviews, and much more.

LIST #1101

Your Official Oldies Superstore! Your Blast To The Musical Past Since 1981



- TOP 10 NEW RELEASE SIZZLERS 1. SUNSHINE CO. - BEST OF - 22 TRACKS (DUE 11/6) (US) CCM 249 S... \$15.99 2. PLAYMATES - ULTIMATE COLLECTION - 28 TRACKS (EURO) TEEN 7110 M/S... \$18.99

- GENERAL POLICIES • All products guaranteed as advertised and any defective will be exchanged (You pay postage one way - complete satisfaction) • Orders shipped as soon as possible. We can only hold phone orders for 10 days, so please make prompt payment to insure getting the items you want.

- PAYMENT POLICIES • We accept VISA, MASTERCARD, DISCOVER, and AMERICAN EXPRESS in addition to personal checks and money orders (check must clear our bank - approx. 7 days) • No minimum order on checks and money orders... Payable to Disc Collector. All Credit Cards - MINIMUM \$15 (product only).

- 1. GRATEFUL DEAD - THE GOLDEN ROAD '65-73 - SUPER DELUXE 12CD BOX W/80 PAGE BOOK (US) RHINO 74401 M/S... \$119.99 2. VARIOUS ARTISTS - 70'S SOUL EXPERIENCE - DELUXE 6CD BOX W/BOOK 136 TKS. (US) RHINO 74346 M/S... \$84.99

- 41. ELVIS PRESLEY - THE WAY IT WAS (A/V DOCUMENTARY) - (DELUXE 1 CD + 96 PAGE HARDBOUND BOOK) FTD SERIES (DENMARK) BMG M/S... \$74.99 42. FOUR TOPS - FOUVER/DEFINITIVE CD - 85 TRACKS (US) MOTOWN 556225 M/S... \$49.99

- 178. VARIOUS ARTISTS - WASHINGTON SQUARE MEMOIRS (FOLK '50-70) - (3CD BOX) 72 TRACKS W/69 PAGE BOOK (US) RHINO 74264 M/S... \$39.99 179. GENE SIMMONS-HAUNTED HOUSE - THE COMPLETE JUMPIN' & JYRIN' (2CD) 39 TKS. (UK) HI 53 M/S... \$20.99

- 15. JIMMY CLANTON - PHILLIPS YEARS/LIVE AT GILLES' 23 TRACKS (EURO) LAZYLUK 5102 M/S... \$14.99 16. ELVIS PRESLEY - THE INTERNATIONAL EP COLLECTION - 11 EP'S W/PICURE SLEEVES (UK) ELVIS 105 M/S... \$84.99

- 98. THE DUBS - BRINGING BACK THE MAGIC (NEW SESSIONS) - 13 TRACKS (US) CANAN LAKE 01 S... \$14.99 100. VARIOUS ARTISTS - BEAT BEAT VOL. 1 (MERSEY SOUND '62-'63) (2CD) 60 TKS. (UK) SEQUEL 282 M/S... \$18.99

- 180. VARIOUS ARTISTS - ONE HIT WONDERS/LADIES CHOICE (50'S & 60'S) 29 TKS. (EURO) REGENCY 7001 M/S... \$17.99 181. VARIOUS ARTISTS - ONE HIT WONDERS/HERE COME THE GUNS (50'S & 60'S) 29 TKS. (EURO) REGENCY 7002 M/S... \$17.99

- 1. SUNSHINE CO. - BEST OF - 22 TRACKS (DUE 11/6) (US) CCM 249 S... \$15.99 2. PLAYMATES - ULTIMATE COLLECTION - 28 TRACKS (EURO) TEEN 7110 M/S... \$18.99

- 101. VARIOUS ARTISTS - BEAT BEAT VOL. 2 (MERSEY SOUND '62-'63) (2CD) 60 TKS. (UK) SEQUEL 282 M/S... \$18.99 102. VARIOUS ARTISTS - THE LOVELY LADIES OF DOO-WOP (50'S, 60'S) - 25 TKS. (EURO) PAVILLON 71237 M/S... \$16.99

- 182. INEZ & CHARLIE FOXE - MOCKINGBIRD/SUE RECS - 29 TRACKS (UK) CONNOISSEUR 103 M/S... \$15.99 183. SPENCER DAVIS GROUP - GIMME SOME LOVIN' - 20 TRACKS (US) SUNDAZED 11103 M/S... \$13.49

Sale!

Table with columns: TITLE, REGULAR PRICE, ON SPECIAL BLOWOUT! PRICE, TITLE, REGULAR PRICE, ON SPECIAL BLOWOUT! PRICE. Includes titles like Duke Ellington - The Duke - Complete Works 1924-1947 (40 CD box) and Various Artists - American Bandstand.

BLOWOUT BLITZ...

Table with columns: TITLE, REGULAR PRICE, ON SPECIAL BLOWOUT! PRICE, TITLE, REGULAR PRICE, ON SPECIAL BLOWOUT! PRICE. Includes titles like Various Artists - 100 No. 1 Hits - (6 CD) 90 tracks (Holland) and Dean Martin - Sing's Country Favorites.

HOT BOX...

Table with columns: Title, Label, Mono/Stereo, Price. Includes titles like Elvis Presley - The Legends Collection (2 CD) Million Dollar Quartet and Bobby Womack - The Legends Collection/Best (2 CD) 38 tracks.

- 110. VARIOUS ARTISTS - ONE HIT WONDERS/A GROUP EFFORT - 30 TKS. (CANADA) REGENCY 1004 M/S... \$17.99 111. VARIOUS ARTISTS - ONE HIT WONDERS/INSTRUMENTALLY YOURS - 29 TKS. (CANADA) REGENCY 1005 M/S... \$17.99

- 184. THE VENTURES - PLAYS SOUTHERN ALL STARS - 12 TRACKS (JAPAN) M&J 30053 S... \$30.99 185. CANOEY & THE KISSES - THE 81 & OTHER SOUL CLASSICS - (UK) CASTLE 116 M/S... \$14.99

"THE STORY SERIES"

WE MADE A SUPER PURCHASE ON 50'S & 60'S HITS. PACKAGES FROM EMU/HOLLAND... ALL FEATURE 18-25 TRACKS PER CD AND COME WITH A BONUS CD-ROM CONTAINING A BIOGRAPHY, DISCOGRAPHY & PHOTO GALLERY ON EACH ARTIST... INCREDIBLE PRICE! ONLY \$9.99 EACH OR MORE - JUST \$8.99 EACH!

# ANDY'S RECORD SUPPLIES

48 Colonial Road, Providence, RI 02906; Phone, 401/421-9453; Fax, 401/421-0841

- FOREIGN ORDERS CALL OR WRITE FOR CHARGES
- CALL TO HAVE YOUR ORDER SHIPPED C.O.D.
- NO PO BOX #'S, STREET ADDRESS ONLY FOR UPS
- \$30 MINIMUM ORDER
- CHECKS MUST CLEAR



CLIP & SAVE

SINCE 1989 — QUALITY PRODUCTS, LOW PRICES & FREE SHIPPING ANYWHERE IN THE CONTINENTAL U.S.

## JAPANESE RESEALABLE SLEEVES...

Direct from Japan

The best quality protection you can get.

Crystal clear outer sleeves.

These will never fade or crack. Lifetime protection.

All come with resealable flaps

and peel-off strip on back.

Fits over jackets, sleeves, and CD jewel cases.

- LPS / LASER DISCS . . . . 100 - \$20.99; 1000 - \$145.99
- CDS . . . . . 100 - \$12.99; 1000 - \$69.99
- COMIC BOOKS . . . . . 100 - \$17.99; 1000 - \$119.99
- 45S, PIC SLEEVES . . . . . 100 - \$15.99; 1000 - \$84.99
- DOUBLE CDS . . . . . 100 - \$14.99; 1000 - \$74.99
- 10" 78 LPS . . . . . 100 - \$17.99; 1000 - \$118.99
- 9 1/2 X 11 1/4 MAGAZINES. 100 - \$19.99; 1000 - \$139.99
- DVD'S . . . . . **NEW** 100 - \$13.99; 1000 - \$79.99

## CARDBOARD JACKETS...

HEAVY-DUTY 12" ALBUM JACKETS. WHITE OR BLACK. HIGH GLOSS. WITH OR WITHOUT HOLE  
Case Price / 100 - \$49.99

HEAVY-DUTY CD WHITE JACKETS WITH HOLE.  
100 - \$29.99; Case Price / 600 - \$149.99

## MAILERS...

- MULTI-ALBUM MAILER**  
Heavy duty corrugated cardboard, 200 lb test, holds 3-20 albums.  
Case Price / 100 - \$109.99
- MULTI 1-10 CD MAILER**  
Heavy duty corrugated cardboard, 200 lb test, holds 1 CD or up to 10 CDs in jewel cases.  
Case Price / 100 - \$54.99

## SPECIAL ITEMS...

- CLEAR CD DISC SLEEVE**  
6 Mil Thick. Full front flap with white protective pad inside.  
100 - 499, each - 49¢; 500 - 999, each - 39¢;  
1,000 and up, each - 34¢
- SHRINK-WRAP SYSTEM**  
For CD's, Cassettes, and Videos. Ready to wrap in seconds. Each . . . . . \$249.99  
2,000 feet of film for Cassettes . . . . . \$89.00  
500 feet of film for CDs . . . . . \$59.00  
2,000 feet of film for CDs . . . . . \$93.99  
2,000 feet of film for Videos . . . . . \$99.00

## WHITE PLASTIC DIVIDER CARDS...

- CD Jewel 6 x 7 . . . . . 35¢ EA.
- CD Full 6 x 14 . . . . . 49¢ EA.
- 45 Full 7 x 8 1/2 . . . . . 40¢ EA.
- 45 Slant 7 x 8 1/2 . . . . . 38¢ EA.
- LP Full 12 x 14 . . . . . 69¢ EA.
- LP Slant 12 x 14 . . . . . 65¢ EA.

Minimum, 50  
Mix & Match Available

## POLY SLEEVES • HIGHEST QUALITY...

Perfect Fitting Sleeves For Your Records & Collectibles

- 3 MIL THICK ALBUM SLEEVES**  
Fits Over Outer Album Jacket. Size, 12 3/4 x 12 3/4.  
100 - \$10.99; 500 - \$39.99; Case Price / 1000 - \$65.99
- 4 MIL THICK ALBUM SLEEVES**  
Fits Over Outer Album Jacket. Size, 12 3/4 x 12 3/4.  
100 - \$14.99; 500 - \$59.99; Case Price / 1000 - \$94.99
- 45S, EPS, PIC. SLEEVES**  
Size, 7 1/2 x 7 1/2. - 3 Mil Thick.  
100 - \$6.99; 500 - \$19.99; Case Price / 1000 - \$31.99
- 78/10" LP SLEEVES**  
Size, 10 3/4 x 11 - 3 Mil Thick. Fits Over Outer Jacket.  
100 - \$9.99; 500 - \$38.99; Case Price / 1000 - \$63.99
- COMPACT DISC SLEEVES**  
Size, 5 x 6 With 1" Flap; 2.5 Mil Thick; Fits Over CD Disc.  
100 - \$4.79; Case Price / 1000 - \$25.99
- CD JEWEL CASE SLEEVES**  
Size, 6 x 6 With 1" Flap; 2.5 Mil Thick; Fits Over CD Jewel Case.  
100 - \$4.99; Case Price / 1000 - \$26.99
- LIFE MAGAZINE SLEEVES**  
Size, 11 x 16 With 2 1/2" Flap; 2.5 Mil Thick; Fits Old & New Issues.  
100 - \$13.50; 500 - \$49.99; Case Price / 1000 - \$79.99
- MAGAZINE SLEEVES**  
Size, 8 3/4 x 11 1/4 With 1 1/2" Flap; 3 Mil Thick.  
100 - \$9.99; 500 - \$39.99; Case Price / 1000 - \$59.99
- BOX SET SLEEVES**  
Size, 14 x 15 - 2.5 Mil Thick  
100 - \$14.50; 500 - \$55.99; Case Price / 1000 - \$89.99
- SHEET MUSIC SLEEVES**  
9 1/2 X 12 1/2; 3 Mil Thick  
100 - \$9.99; 500 - \$39.99; Case Price / 1000 - \$59.99

## QUALITY PAPER SLEEVES...

- 7" WHITE WITH HOLE**  
100 - \$7.99; Case Price / 2400 - \$69.99
- 12" WHITE WITH HOLE ROUND CORNERS**  
100 - \$11.99; Case Price / 1000 - \$78.99
- 12" WHITE POLY-LINED SQUARE CORNERS**  
100 - \$21.99; Case Price / 500 - \$98.99; 1000 - \$169.99
- JAPANESE NON-STATIC INNER SLEEVES**  
12" LP/LaserDisc; clear, square top with round bottom (no hole).  
100 - \$19.99; Case Price / 500 - \$84.99; 1000 - \$139.99
- JAPANESE CD CLOTH SLEEVE**  
White (no hole) soft woven material **NEW**  
100 - \$18.99; Case Price / 1000 - \$139.99

## DVD BOXES...

BLACK DVD REPLACEMENT BOXES **NEW**  
Case Price/100 \$49.99

## CD REPLACEMENT CASES...

- CD JEWEL CASE ONLY**  
Case Price / 200 - \$49.99; 1000 - \$219.99
- CD JEWEL CASE W/TRAY**  
Case Price / 200 - \$73.99
- SLIM LINE JEWEL CASE FOR CD SINGLES W/BUILT-IN TRAY**  
Case Price / 300 - \$88.99
- ULTRA SLIM CD SINGLE JEWEL CASE** **NEW**  
Case Price / 200 - \$69.99
- ULTRA (2 CD) SLIM JEWEL CASE** **NEW**  
Case Price / 300 - \$119.99
- ULTRA (4 CD) SLIM JEWEL CASE** **NEW**  
Case Price / 200 - \$139.99
- DOUBLE (2 CD) JEWEL CASE W/2 TRAYS**  
Each (minimum 50) 99¢; Case Price / 100 - \$89.00
- ALL CLEAR DOUBLE (2 CD) SLIMLINE CASE**  
Clear case, crystal clear tray, completely visible throughout.  
Each (minimum 50) 60¢; Case Price / 200 \$109.99
- BLACK DOUBLE (2 CD) SLIMLINE CASE** **NEW**  
Clear case, black tray.  
Each (minimum 50) 60¢; Case Price / 200 \$109.99
- WHITE DOUBLE (2 CD) SLIMLINE CASE**  
Clear box white tray.  
Each (minimum 50) 60¢; Case Price / 200 - \$109.99
- 3CD SLIM JEWEL CASE** **NEW**  
Clear Case w/Black or clear Tray  
Case Price /200 \$137.99
- DOUBLE SLIM UNBREAKABLE TRAY ONLY** **NEW**  
Virtually unbreakable! Made of plastic & rubber material and it will fit any regular jewel case.  
Each (minimum 100) 35¢; Case Price / 800 \$232.00
- DOUBLE SLIM TRAY ONLY** **NEW**  
Clear or black. Snaps into a standard jewel case.  
Each (minimum 150) 35¢; Case Price / 300 \$90.99
- JEWEL CASE TOP LIDS ONLY**  
Case Price / 200 \$35.99; 1000 - \$149.99
- TRIPLE (3 CD) JEWEL CASE W/TRAYS**  
Each (minimum 50) 99¢; Case Price / 100 - \$89.00
- QUAD (4 CD) JEWEL CASE W/TRAYS**  
Each (minimum 50) 99¢; Case Price / 100 - \$89.00
- 6 CD JEWEL CASE W/TRAYS**  
Each (minimum 50) \$1.19; Case Price / 100 - \$109.99
- COLORED CD JEWEL CASE ONLY**  
Jewel Case Colors: Transparent colors of red, blue, green, orange, or purple. Case Price / 200 - \$69.99
- COLORED CD JEWEL CASE W/ COLORED TRAY**  
Jewel Case Colors: See above; Jewel Tray Colors: See below. Case Price / 200 - \$83.99
- COLORED CD JEWEL TRAYS**  
Jewel Tray Colors: red, blue, orange, crystal clear, purple, white, green. Case Price / 400 - \$59.99
- STANDARD GREY CD JEWEL TRAY**  
Case Price / 400 - \$44.99

## CASSETTE REPLACEMENT CASES...

ALL CLEAR, OR CLEAR & BLACK  
EXTRA STRONG STYRENE MATERIAL  
Case Price / 400 - \$69.99; 800 - \$119.99

**FREE SHIPPING** in the Continental U.S.

ALL PRICES SUBJECT TO CHANGE WITHOUT NOTICE

CLIP & SAVE

# Contents

Dedicated to the memory of Rick Whites

# Goldmine

Issue 556 November 16, 2001  
Vol. 27 No. 23

Courtesy of Lippman Entertainment



## 14 BERNIE TAUPIN

Without Bernie Taupin writing lyrics for him, it's hard to say how big of a star Elton John would have become — or whether he would have even made it in the music business. What's even more amazing is that Taupin wrote the songs independently of John, mailing or faxing John the lyrics so he could write the music to mega-hits such as "Rocket Man," "Honky Cat," "Bennie And The Jets," "Don't Let The Sun Go Down On Me" and the biggest-selling single of all time, "Candle In The Wind 1997." Taupin tells how he and his flamboyant friend share the glory of writing and recording great songs.

...by Mary Anne Cassata



Courtesy of Geffen Records

## 18 ELTON JOHN COLLECTIBLES

Forget vinyl, Elton John collectors go after his stage-worn costumes and glasses — and for big bucks too!

...by James Turano

©2001 Frank Pettis

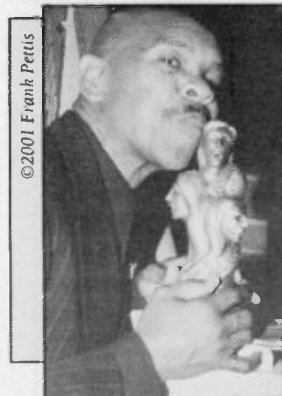

©2001 Frank Pettis

## 12 THE VOCAL GROUP HALL OF FAME INDUCTIONS

From Bubba Knight (left) of Gladys Knight & The Pips to Ross Barbour (right) of The Four Freshmen, vocal group greats picked up their HARMY awards at the Vocal Group Hall Of Fame 2001 induction ceremonies.

...by Chuck Miller



## PLUS...

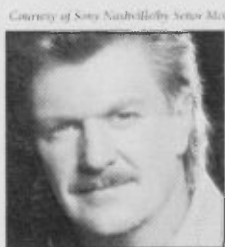

JOE DIFFIE



NEW RELEASES



REISSUES

- 8 Please Mr. Postman Letters from *Goldmine* readers and *Letter From The Editor*.
- 10 Grapevine News of Blue Storm Records and *Grapeleaves*.
- 10 Rare Finds Two Elvis Presley Sun 78s for a buck!
- 19 New Releases Elton John, Earl Scruggs And Friends, *Short Takes* and more...
- 22 Country Junction 10 Questions for Joe Diffie by Thomas Kintner, plus country music news and reviews.
- 52 Reissues Bill Wyman's Rhythm Kings, Jason Faulkner, The Jackson 5, The Kinks, Sun Records blues compilation, book reviews and more...

## COLUMNS...

- 20 A Broad Abroad What's been coming out of the vaults will delight all! ...Jo-Ann Greene
- 26 Classical Notes Francis Poulenc and his *Gloria*. ...Peter Gutmann
- 76 Five Star Cartoon *The Magic Of Ju-Ju Archie Shepp*. ...Marty Winters

## BUY & SELL MARKETPLACES

Unit Space Advertising .....	38
Super Unit Space Section .....	53
Web Directory.....	56
Record Show Calendar .....	58
Retailer Directory .....	60
CD Showcase .....	65
Collector's Showcase .....	66
Want Lists .....	71
Classifieds .....	73

## GOLDMINE INFORMATION

Subscription Information .....	77
Coming Soon to <i>Goldmine</i> .....	77
Advertisers Index .....	78
Ad Rates & Information .....	78

### Photo credits

Cover shot courtesy of Universal  
Inset of Bernie Taupin courtesy of Lippman Entertainment  
Inset of Bubba Knight ©2001 Frank Pettis  
Inset of Joe Diffie courtesy of Sony Nashville/By Señor McGuire

**Editorial submissions:** All editorial submissions as well as press releases and review copies should be sent to Greg Loescher at the Iola office. While we invite authors to submit materials for publication, due to the volume we receive, we cannot guarantee that items sent on spec will be returned or acknowledged.

**Advertising** should be addressed to *Goldmine's* main office in Iola or call 715-445-2214.

**Subscriptions/renewals:** If you would like to subscribe or renew your subscription and have a major credit card, call our toll-free number for current rates: 1-800-258-0929.

**Subscription questions:** Call Subscription Services, 715-445-2214, ext. 257.

**Subscription rates:** U.S. Addresses: 13 issues (1/2 year) \$24.95; 26 issues (1 year) \$39.95; 52 issues (2 years) \$74.50; 78 issues (3 years) \$107.95.

**Special Services Subscriptions:** Information and rates on first class UPS and Federal Express delivery for your subscription is listed elsewhere in this issue. Or call 1-800-258-0929.

**Foreign rates:** Surface mail, all countries: \$49.95 for 13 issues. Airmail rates: Please call or write for current rates to your country. Or see our subscription ad elsewhere in this issue. All payments must be made in U.S. funds.

**Moving?** If you are moving, please include your name and new address, plus your old address, and mail it to the attention of *Goldmine*, Circulation Department, 700 E. State Street, Iola, WI 54990.

*Goldmine* (ISSN 1055-2685) is published bi-weekly by Krause Publications, 700 E. State St., Iola, WI 54990. Roger Case, president, Iola, WI 54945. The *Goldmine* logo is protected through trademark registration in the United States. Periodical postage paid at Iola, WI 54945 and additional mailing offices. POSTMASTER: Send address changes to *Goldmine*, 700 E. State Street, Iola, WI 54945.

No portion of the contents of *Goldmine* may be reproduced without prior permission from the publisher and pertinent author(s).

Entire contents copyright 2001 by Krause Publications, Inc.

Goldmine is printed in the U.S.A.



# Please Mr. Postman

## Cameo/Parkway catalog deserves release

The whole, sad story as to why we cannot buy any Cameo/Parkway products (other than bootlegs, where the artists receive no royalties) should be high on your list of featured articles. Besides being an interesting read on how things got to this point, it might put a bit of pressure on Allen Klein to release the material.

— Martin Madore  
Wilmington DE

{Martin, the release of the Cameo/Parkway catalog is by far the most requested product we've received at Goldmine during the past decade. One of our writers tried getting some info out of Klein's office last spring but didn't get too far. We are in the process of getting an update (even if it's bad news) for publication in our news section shortly. We're keeping our fingers crossed we'll be hearing some good news! — Ed.}

## How can you tell when an album was released?

I hope you or someone out there can tell me how to determine the year a record was produced. Some of the records, or the cover, actually have the date on them (usually the older recordings), but most do not. Is there some way of determining the date by some of the numbers scratched on the record?

— Ernest G. Endes  
Carlsbad NM

{Goldmine price guide editor Tim Neely replies: "It varies from one record label to another. With some labels, you just have to guess. But sometimes, knowledge of codes can help you determine what year a record came out. Probably the best-documented example is for RCA recordings. RCA Victor 45s and LPs (and records they pressed for many different labels) from the early 1950s to the early 1970s have an eight-digit master number that tells you when, where and in what order that record was mastered. It's not a perfect system, as reissues with new labels can contain the same master numbers as originals if the same master is used. Through 1954, the first two digits, one a letter, the other a number, correspond to the year of mastering. For example, a 45 rpm reissue starting with "D9" would have been mastered in 1949. (The first five letters of the alphabet correspond to their numerical order.) Two more examples: A record mastered in 1951 would start with E1; one from 1954 would start with E4. But, starting in 1955, the meaning of the second digit changed, and only the first (alphabetical) digit corresponds to a year.

The complete list follows: F — 1955; G — 1956; H — 1957; J — 1958; K — 1959; L — 1960; M — 1961; N — 1962; P — 1963; R — 1964; S — 1965; T — 1966; U — 1967; W — 1968; X — 1969; Z — 1970; A — 1971; B — 1972.

Other labels' systems are more inscrutable. Most of the years of release that we have in our books are determined by external sources (new release lists, contemporary catalogs, chart debuts). The dates on the records and/or jackets can be unreliable — for example, an album might have a copyright or production date of one year but not actually get to the marketplace until the next. Labels also don't always release records in numerical order, so you can't always use that as a guide.}

## LETTER FROM THE EDITOR

### "Mr. Sandman" a real treat!

Sometimes the worst in life later on brings out some good things (although in this case, it's definitely not meant to belittle what happened). The Sept. 11, 2001, attacks on America led to the postponing of, among way to many other things to list, the Sept. 13 Vocal Group Hall Of Fame inductions. The new date was Oct. 4, so I rescheduled my flight to depart Oct. 3. On Oct. 1, I received a call from Tiffany Frank, director of the Hall. She told me that due to pressing business concerns, Jay Warner, president of National League Publishing in Los Angeles and co-emcee of the event for the previous two induction ceremonies, wouldn't be able to attend the inductions. She asked if I would be co-emcee.

Wow, it didn't take me too long to accept that gift! What an honor to be able to introduce these great artists, as well as share the stage with The Supremes' Mary Wilson, the induction ceremony's co-emcee. On the plane trip out to the Hall located in Sharon, Pa., I reminisced about my teenage years, listening to The Supremes on WLS out of Chicago. Here I was going to be on stage with one of them, and not just for a few minutes, but for the entire two-hour-plus awards ceremony!

As with previous inductions, the ceremonies were full of laughter, mixed in with some heartfelt emotion from the new inductees. I just had a much better vantage point this year. Those Lennon Sisters look a lot younger than their ages! Incredible!

The post-induction concert was a three-hour plus extravaganza that any fan of music would have enjoyed. The Marcells' bass singer Fred Johnson even dedicated "Blue Moon" to me. What an honor!

Among last year's memories during induction week at the Hall was meeting Bill

Pinkney while he was eating pie at the counter at downtown Sharon's '50s-style diner. There was no pie-eating incident at the inductions this year. Instead, after the exceptional concert, we had The Chordettes, The Pied Pipers with The Lettermen's Tony Butala, and others signing a cappella in the host hotel's lounge (there were probably other mini-concerts I missed due to the large number of artists scattered around the lounge).

Hearing "Mr. Sandman" by the original hitmakers — the first time in decades The Chordettes have sung together — was just unbelievable. One person even held up a cell phone over The Chordettes' table so some distant friend could hear the singing. Wilson grabbed a bunch of us to jump on the lounge's stage and led the entire bar in singing "God Bless America." A bunch of Michigan football fans who were in the lounge, headed to the weekend's game at Penn State, were flabbergasted by seeing — and hearing — all the artists in that room.

During the Oct. 6 record show at the Hall, The Four Freshmen's Ross Bourbaw spent some time at the Goldmine table signing autographs, and I had a nice chat with him. The Hall also started selling off some of the 1,500 albums donated by a local radio station. (I got some cool promo albums, including one on red vinyl, being sold for a buck each, 10 for \$5!)

All in all it was a great time, but some of it was by default. So I owe Jay big time — especially since he wrote the script I used!

— Greg Loescher

Editor's recommendation: Stevie Ray Vaughan And Double Trouble, *Live At Montreux, 1982 & 1985* (Epic/Legacy AE2K 86151) (Two CDs). 19 blues-rockin' slabs of live SRV — what more can you say?!

## Poco update

Goldmine published a very nice cover article on Poco (Oct. 10, 2001, #554). There was a mistake in the article. When they both lived in New York City, Gram Parsons did bring Richie Furay a Byrds album, but it was not *Sweetheart Of The Rodeo* (which would not be recorded for a few years), and Gram Parsons was not a member of The Byrds at that time. Also Poco's current bassist/ vocalist Jack Sundrud's last name is misspelled. Something that was not mentioned in the article is that Sundrud is a songwriter of country hits including a #1 hit by Ty Herndon.

— Doug Schenker  
via e-mail

## Views on Cat Stevens changed due to letter

Thank you for publishing the editorial statement from Yusuf Islam (a.k.a. Cat Stevens) in Goldmine's Nov. 2, 2001, issue (#555). As a huge Cat Stevens fan in the '70s, I stopped listening to him after he had come out and publicly supported Ayatolla Khomeini of Iran during the Iranian hostage crisis. Unfortunately it wasn't until a few months ago when I saw

Stevens on an episode of VH-1's *Behind The Music* that I learned that his comments were completely taken out of context by the media and in actuality he was not in support of everything that was going on.

After reading his editorial in Goldmine, I felt even better about what he has been doing since giving up his Cat Stevens background and devoting his life to Islam. He truly is a man of peace, and the work that he has done, especially with the children, deserves another standing ovation like he received as Cat Stevens. Thanks again for that article, and as Cat Stevens sang, "Now I've been crying lately, thinking about the world as it is. Why must we go on hating, why can't we live in bliss. 'Cause out on the edge of darkness, there rides a peace train. Oh peace train take this country, come take me home again."

— Brian Lee  
Brian Lee Records  
Norco CA

{Brian, I wasn't sure how readers would react to our publishing his comments, but I felt that since he is a major recording artist, his

thoughts should be made known in light of everything going on in the world today. I am glad it struck a positive note with you. — Ed.}

## Porky Chedwick — The Master Blaster

I would just like to commend you in regards to the article on the bossman Porky Chedwick (Goldmine #554, Oct. 19, 2001). Chedwick is not only both The Master Blaster Of The All-American Hot Wax Sounds and the Grand Wizard Of The Golden Goodies Juke Box Sounds, but he is also America's most bonified freedom metal DJ as well.

— Ted Dlugos  
Pittsburgh PA

## Neil Sedaka — Hall Of Fame bound?

Year after year we've all watched groups and artists who seemingly have little to do with rock 'n' roll (some even one-hit wonders) get inducted into the Rock And Roll Hall Of Fame. It's frustrating for many of us who can automatically name a half dozen more deserving acts right off the top of our heads, yet these acts continually get snubbed for the honor. I feel it is time for more of rock's greatest artists and hit-makers to be welcomed into the Hall where they belong, with their work to be recognized and celebrated — and done so preferably within their lifetimes. What a hollow victory was left to the family of the late, great Del Shannon a few years back. One has to wonder what a difference it may have made in his life had he been accepted in the nominations held prior to his death.

OK, let's switch gears. I'm writing about the legendary Neil Sedaka. For nearly five decades Sedaka has written hit songs. There are more references in Joel Whitburn's *Top Pop Singles* book to Sedaka than any other individual songwriter — and he even left a few of Sedaka's songs out! During those five decades, Sedaka has recorded dozens of hit records and continues to perform to sold-out audiences the world over to this day. His work has inspired the biggest names in the business, from Elvis Presley to The Beatles and from Elton John to Stevie Wonder.

Even seemingly unaffected music-makers herald his work; Randy Bachman (The Guess Who, BTO) mother once assured me her son had all of Sedaka's records. Sedaka helped change the shape of rock and expand its boundaries, introducing more intricate chord structures (as found in 1962's "Breaking Up Is Hard To Do") that were years ahead of their time and paving the way for others. He turned background vocal parts into an art, incorporating arpeggio vocal lines to counterpoint lead vocal melodies, on which he in turn

(Please see Please Mr. Postman page 77)

## Submitting letters to Goldmine...

Letters to *Please Mr. Postman* are encouraged but cannot be responded to individually. Please keep your letter brief; it has a greater chance of being published. Send your letter to:

Please Mr. Postman/Goldmine

700 E. State Street

Iola, WI 54990

FAX: 715-445-4087

e-mail: mr.postman@krause.com



#226

OFFICIAL HOME OF CLASSIC ROCK NEW RELEASES



BUCCANEER SINCE 1983

MASTER CARD AND VISA CUSTOMER TELEPHONE ORDER LINE

410-569-5697

HOURS MONDAY TO FRIDAY 1:00 TO 9:00 ET (10:00-6:00 PT)

LATEST ARRIVALS IMPORTS, INDEPENDENTS AND HARD TO FIND

APRIL WINE "Back to the Mansion" Myles Goodwyn and original lineup turns out their 18th album their first new one in 7 years. 11 tracks, Civilian Records Canada (arrived May 30th)..... \$18.98
BABYS, THE "Valentine Baby" Denver concert Valentine Day 1980 includes "Every Time I think of You, Back on My Feet Again, Head First, Midnight Rendezvous, there are some minor flaws on Looking for Love excellent sound overall", 12 tracks, Pilot Records UK (arrived July 11th)..... \$17.98
BEACH, REB "Masquerade" ex-Winger and Dokken guitarist new solo album, Japan only "reviews say the album is awesome, Reb's voice is fantastic" 11 tracks, Japan (arrived June 14th)..... \$27.98
BLACKMOOR'S NIGHT "Fires at Midnight" new medieval classical guitar, Ltd Edition purple velvet box, poster, photo cards, bonus song and video track, SPV German (arrived July 3rd, Call) \$17.98
BLUE OYSTER CULT "Tales of the Psychic Wars" (2 CD) two radio shows New York 1981 "Fire of Unknown Origin" tour + 1983 "Revolution by Night" tour, Pilot UK (arrived Sept 21st)..... \$21.98
BONNET, GRAHAM "The Day I Went Mad" vocalist 1999 solo album previously Japan only features Vivian Campbell, Slash, Bruce Knick and Tony Franklin, German (arrived Oct 17th)..... \$17.98
DAN BAIRD & THE SOFT KINGS "Redneck Savant" ex-Georgia Satellites vocalist/guitarist live in Switzerland on the band's 2000 tour, 16 tracks, German (arrives approx Oct 24th, Call)..... \$27.98
DARE "Belief" Thin Lizzy keyboardist Darren Wharton's band new studio their 2nd in recent years and fourth overall, 11 tracks, MTM Music Germany (arrived August 31st, Call for stock)..... \$16.98
DEEP PURPLE "Live at the Rotterdam Ahoy Oct. 2000" (2 CD's) orchestral show features the band performing rock songs no concerto material, Ronnie James Dio on 4 tracks including "Rainbow in the Dark" (Thames UK artist release, Buccaneer one time only, arrived Oct 17th, Call)..... \$27.98
DEEP PURPLE (BOX) "On the Road" (4 CD's) most comprehensive live collection from 1969-1993 28 tracks, 16 page fully illustrated updated booklet of the history of official live DP recordings, collector cards of all 12 band members, Connoisseur UK (arrived October 10th)..... \$47.98
DEEP PURPLE (DVD) "New Live and Rare Video Collection 1984-2000" almost all totally never seen live footage, all regions codes, 183 min 27 tracks, Thames UK (arrived July 24th)..... \$24.98
DEEP PURPLE (BOX) "Soundboard Series-Australasian Tour 2001" (12 CD's) six double live shows recorded 2001, Australia March 9th, 13 and 14th, Hong Kong the 20th and Tokyo March 24th and 25th, Tokyo shows with an 80 piece orchestra featuring Ronnie James Dio on 5 tracks, all from board tapes (due to legal complications now out of print, low copies left, Call for stock)..... \$89.98
DEMON "Spaced out Monkey" NWOBHM act first new album in 10 years features original vocalist Dave Hill "excellent reviews", Record Heaven Sweden (arrived Aug 31st, Call for stock)..... \$17.98
DOC HOLLIDAY "Song for the Outlaw Live" southern rockers 1989 live album, remastered 2 bonus tracks "Whiskey Train" and "Don't Stop Lovin Me", Holland (arrives approx Oct. 24th, Call)..... \$19.98
EISLEY, DAVID GLEN "The Lost Tapes" unreleased recordings from the late 1980's, 6 tracks are from a never released third, Giffuria album and 4 tracks from a never released second Dirty White Boy and 3 House of Lord demos, Frontiers Italy (arrived August 31st, Call for stock)..... \$14.98
FISH "Fellini Days" ex-Manitowoc vocalist new album pays homage to the Italian film director "reviews say it is melodic rock that won't disappoint" UK (arrived September 25th, Call)..... \$17.98
FRANK MARINO & MAHOOGANY RUSH "Eye of the Storm" guitarist first new album in 9 years "reviews say similar to his early style", 9 tracks 72 minutes, Canada (arrived July 13th)..... \$18.98
FRANKLIN, TONY "Brave New Tomorrow" ex-Firm and Blue Murder bassist first ever solo album, Tony handles vocalist, bass and guitar with Gregg Bissonette drums, previously Japanese only 2000 release, Buccaneer exclusive artist pressing (arrives approx October 25th, Call)..... \$13.98
FUNNY MONEY Featuring STEVE WHITEMAN "Even Better Live" ex-Knox vocalist band recorded live 2004 tour Springfield, Virginia, 10 tracks, Kavel Records (arrived Sept 14th)..... \$13.98
GILLAN "Live Tokyo 1978" after the Jazzy "Jan Gillan Band" disbanded the reformed lineup toured Japan returning to his rock roots, first time released, 12 tracks, UK (arrived Sept 21st)..... \$17.98
GRAND FUNK "What's Funk" 1983 Atlantic album first time on CD their follow-up to "Lives" and will also include a special 16 page enhanced booklet, Lissmark USA (the finished CD's have arrived awaiting the special booklets which should arrive shortly, Buccaneer exclusive, Call)..... \$13.98
GRAND FUNK "Lives" 1981 Warner album CD debut remastered, includes bonus booklet "The Making of Lives", Buccaneer exclusive, 10 tracks, Lissmark USA (arrived July 2nd, Call)..... \$12.98
HENDRIX, JIMI "Albert Hall Experience" (2 CD's) the most complete legitimate collection of music from the long lost film of the February 1969 concert, six of the tracks have just recently been unearthed for official release, this reissue corrects the poor sound and duplication of bootlegs, packaged in a slip case cover with 12 page booklet, UK (arrives approx Oct 25th, Call)..... \$19.98
HENSLEY LAWTON BAND "The Return" Ken and John and band live in concert at the UK Uriah Heep convention May 6, 2000 includes "Judy Morning, Stealin', Easy Livin', Gypsy, Free 'n' Easy and The Wizard, 15 tracks 79 min Eagle Records UK (arrived June 6th)..... \$19.98

HUGHES, GLENN "A Soulful Christmas" if you missed it last year Glenn has just repressed a 1000 copies of his successful holiday album, 12 tracks includes a stunning version of "Ave Maria", this is a Buccaneer exclusive, Pink Cloud Records USA (arrived October 12th)..... \$17.98
HUGHES, GLENN "Building the Machine" voice of rock returns with a new studio album, reviews say "a stronger performance than his previous album" SPV USA (arrived Sept 25th)..... \$14.98
HUGHES, GLENN "Building the Machine" +1 bonus track, Japan (arrived Sept 20th, Call)..... \$27.98
HURRICANE "Liquidity" reformed with original vocalist Kelly Hanson and drummer Jay Schellen reviews say "their back with a harder melodic sound" Frontiers Italy (arrived Sept 20th)..... \$14.98
JOHN "Worldchanger" vocalist Jorn Lande known for his work with bands Company of Snakes, Millennium and ARK and the Malmsteen tour of 2000 follows last years solo "Starfire" with a new album with a slightly harder edge, Frontiers Records Italy (arrives approx Oct. 25th, Call)..... \$14.98
JUDAS PRIEST "Collector's Box" (2 CD) live album 1990 San Antonio remastered bonus disc 5 tracks San Antonio 2000 includes "Immigrant Song", 21 trks, UK (arrived July 3rd, Call) \$17.98
LOUDNESS "The Soldiers Just Came Back" on their 20th anniversary the original lineup recorded live in concert March 28, 2001, 14 tracks, Japan (arrived Sept 14th, Call)..... \$29.98
MASI, ALEX "Eternal Struggle" Italian guitarist new album with vocalist Kyle Michaels, European guitar magazines say "his best album yet", German (arrived October 10th, Call)..... \$19.98
MELODICA "Lovevital" former Danger Danger vocalist Ted Poley's band's new release now with drummer Jonathan Mover and Paul Morris keyboards, "reviews say his best vocal since Danger Danger, mix of ballads & rockers" Frontiers Italy (arrived August 31st, Call)..... \$14.98
MOORE, VINNIE "Defying Gravity" guitarist new album with drummer Steve Smith keyboardist Dave Rosenthal bassist Dave LaRue, 12 tracks, Shrapnel USA (arrived August 21st)..... \$13.98
MOTT THE HOOPLE "Two Miles from Live Heaven" (2 CD's) from Mick Ralphs and Overend Watts archives comes three separate performances recorded on 1971, '73 and '74 U.S. tours plus four demos from pre-Hunter "Silence" period, 26 tracks Angel Air UK (arrived Oct. 17th, Call)..... \$19.98
MSG "Be Aware of Scorpions" guitarist Michael Schenker new album lineup Chris Logan vocals, Rev Jones Bass, Jeff Martin drums and vocals on the bonus track "Ride the Lightning" 14 tracks Nippon Japan (see "Coming Attractions" for U.S. version, arrives approx Oct 25th, Call)..... \$27.98
NAZARETH "Very Best" Eagle Rock UK release for German television, 22 tracks includes 2 new studio recordings, remastered (arrived October 5th, Call for stock)..... \$19.98
OSBOURNE, OZZY "Down to Earth" vocalist new studio album bonus track "No Place for Angels" 12 tracks, Sony Japan (arrives approx October 25th, Call for stock)..... \$27.98
PERAHIA, JOSHUA "Something to Say" guitarist known as Joshua new album produced by Keith Olsen, ex-Santana Alex Ligertwood 4 vocals, 12 tracks, MK Music USA (arrived Oct 5th) \$13.98
QUEEN TRIBUTE "Stone Cold Queen" Joe Lynn Turner, Glenn Hughes, Tommy Shaw, Jack Russell, Jeff Tate, Jack Blades, Kip Winger, The Nelsons, Robin Zander, with Jake E. Lee, Doug Meltzer, Reb Beach, previous Japan only, Shrapnel USA (arrived Sept 25th, Call)..... \$13.98
RAGER X "Snowball of Doom-Live at the Whiskey" new title, concert recorded in L.A. at the Whiskey A-Go Go May 25, 2001, 14 tracks, Japan (arrived September 14th)..... \$27.98
RADIOACTIVE "Ceremony of Innocence" new project with Bobby Kimball, Fergie Frederiksen, Joseph Williams, Fee Waybill, Jason Scheff, Mike and Steve Pocar, David Patch, David Hungate, Greg Philigrines + others, MTM Germany (arrives August 31st, Call)..... \$16.98
RALPHS, MICK "It's All Good" Bad Co. guitarist second solo album includes a live version of "Hideaway" from the Bad Co. 1999 tour, 11 tracks, Angel Air UK (arrived Oct. 19th, Call)..... \$17.98
RUDESS, JORDAN "Feeding the Wheel" keyboardist from Dream Theater and Liquid Tension new 11 track instrumental project with guitarist Steve Morse & John Petrucci, bassist Billy Sheehan and drummer Terry Bozzio, Magna Carta USA (arrives approx October 23rd, Call)..... \$13.98
SAXON "Killing Ground" (2 CD's) band's new studio album, Ltd Edition bonus disc of re-recorded best of compilation, 12 tracks +8 tracks, SPV USA (arrived Sept 28th, Call)..... \$17.98

SAXON "Killing Ground" new studio no bonus disc, SPV Germany (arrived October 5th)..... \$13.98
SCORPIONS "Taken by Force +2 and Tokyo Tapes" EMI Germany remastered reissues of 1978 studio album w/bonus tracks "Suspender Love" and live "Polar Nights", the second is the April 1978 live show from Budokah, 17 tracks (arrived September 14th, Call).....each \$16.98
SCORPIONS "Acoustica" live show Portugal Feb 2001, includes "The Zoo, Hurricane, Wind of Change, Dust in the Wind, Drive, Love of my Life" 15 tracks, German (arrived May 22nd)..... \$23.98
SEVENTH KEY "Seventh Key" Billy Greer bass/vocals with Steve Morse, Richard Williams, Phil Ehart, Steve Walsh, Mike Slamer, 11 tracks, Frontiers Italy (back in print, Call)..... \$14.98
SHANGHAI "Bombs Away" produced by James Christian, rockers 2nd album Mike Duda of WASP bass, reviews Dokken meets House of Lords' Metal Mayhem (arrived Sept 14th, Call)..... \$13.98
SHEEHAN, BILLY "Compression" ex-Talas, David Lee Roth and Mr. Big bassist new solo album, Billy handles all instrumentation and vocals, Favored Nations USA (arrived August 21st)..... \$13.98
SILVER "Silver" Gary Barden ex-MSG vocals, Bernie Torme guitar, Don Airey Keyboards, "reviews say very distinct style is excellent" 13 tracks, Point Music Germany (arrived May 23rd)..... \$17.98
THOMPSON, CHRIS "Wort Lie Down" former Manfred Mann vocalist new solo with guitarist Mike Slamer, reviews say "for fans of Steeplechase Lane", UK (arrived Sept 14th, Call)..... \$19.98
TRANSATLANTIC "Bridge Across Forever" Michael Portnoy of Dream Theater and Pete Trewavas of Madillion and Neal Morse of Spock's Beard, Metal Blade USA (arrived Oct 8th, Call)..... \$13.98
TURNER, JOE LYNN "Slam" ex-Rainbow vocalist new solo album, "Joe said his hardest album yet is anything he chose the title" 12 tracks includes Europe bonus track, German (arrived Sept 25th) \$16.98
TYGERS OF PAN TANG "Mystical" 80's British rockers new studio reviews say "very good straight ahead rock", 11 tracks, Z Records UK (arrived September 28th)..... \$15.98
URIAH HEEP (BOX) "Sailing the Sea of Light", includes the live CD "Electrically Driven" plus 88 page book of the current lineup history plus DVD documentary of the current lineup with footage of the Moscow show, sold on the band's UK website for \$49.98 (arrived Sept 12th, Call)..... \$44.98
VAUGHN "Fearless" ex-Tyketto vocalist new solo album, reviews say "stronger album than his debut", 9 tracks, Z Records UK (arrived September 7th)..... \$15.98
WAITE, JOHN "Figure in a Landscape" former Babys vocalist new studio album, 11 tracks, Gold Circle USA (arrived August 20th, Call)..... \$13.98
WAITE, JOHN "Live & Rare Tracks" includes 7 live songs from a 1985 show including "Missing You" + 5 unreleased studio tracks from "Rovers Return", One Way USA (arrived Sept 10th) \$11.98
WESTWORLD "Live in the Flesh" +1, vocals Tony Hamell of TNT guitar Mark Reale of Riot, bass Bruce Ravell of Danger Danger recorded May 2001, Z Records UK (arrived August 29th)..... \$15.98
YES "Magnification" new album reviews say "strongest and freshest material in years different to anything before" UK (No USA release until December 4th, UK arrived Sept 21st, Call)..... \$19.98

SELECTED COMING ATTRACTIONS DO NOT SEND PAYMENT YOU CAN ORDER IT NOW AND WE'LL SHIP IT TO YOU WHEN IT ARRIVES, CREDIT CARD PREORDERS ONLY - RELEASE DATES MAY CHANGE

DANDY, JIM "Ready as Hell" Black Oak vocalist reissue from 1984 (Revolver UK rel 11/13)..... \$14.98
DANDY, JIM "The Black Attack is Back" reissue from 1986 (Revolver UK release 11/13)..... \$14.98
DR. SIN "Shadows of Light" new with Mike Vescera all vocals (Metal Mayhem rel 10/26)..... \$13.98
EMERSON LAKE AND PALMER "The Show that Never Ends" (2 CD's) recorded around the world on the 1998 comeback tour, includes full band "Lucky Man" (Recall UK release 11/13)..... \$16.98
EMPIRE "Hypnotica" new project Mark Boals vocals, Don Airey keys, Neil Murray bass, Ralph Monks guitar, Anders Johansson drums (German release 11/15)..... \$19.98
GAMMA RAY "No World Order" 7th album prod by Kai Hansen (Noise USA release 11/13)..... \$13.98
GIANT "Giant III" Dan Huff reforms the late 80's band (Frontiers Italy release 10/26)..... \$14.98
MAGAGNI, MAX "Twister" Italian guitarist with Glenn Hughes vocals (1) track, Robin McAuley (2) tracks, Paul Shortino (2) tracks, Ian Paice drums (1) track (Italy release 11/5)..... \$17.98
RING OF FIRE "The Oracle" new band Mark Boals vocals, George Bellas guitar, Virgil Donati drums and Vitalij Kopřil keys (Frontiers Italy release 12/10)..... \$14.98
ST. JAMES "American Man" ex-Black n Blue vocalist Jaime (Metal Mayhem USA 11/10)..... \$13.98
MSG "Be Aware of Scorpions" Michael Schenker Group new studio album (SPV USA 11/13) \$14.98
SALAS, STEVE "Shape Shifter" funk guitarist new album (Japan release 11/7)..... \$27.98
SYMPHONY X "Live in Europe" (2 CD) prog-band 2001 tour (Century Media USA 11/13)..... \$15.98
TEN "at Beyond the World" UK melodic rockers sixth album (Frontiers Italy release 12/10)..... \$14.98
THIN LIZZY (BOX) "Vagabonds, Kings, Warriors..." 73 tracks (4 CD's) rarities "The Farmer, Cruising in the Lizzymobile, Trying a Little Harder, Song for Jim, Sisters of Mercy" (UK release 11/5) \$57.98



BLUE OYSTER CULT TWO UNRELEASED SHOWS DEEP PURPLE "ON THE ROAD" FOUR LIVE CD'S 1989-'93 GRAND FUNK "WHAT'S FUNK" FIRST TIME ON CD JIMI HENDRIX COMPLETE ALBERT HALL SHOW JORN "WORLDCHANGER" ROCK VOCALIST NEW ALBUM JUDAS PRIEST COLLECTOR'S BOX (VERY LIMITED) KING KOBRA NEW ALBUM 80'S HARD ROCK IS BACK MSG "BE AWARE OF SCORPIONS" BRAND NEW

RECENT RELEASES AND LAST CHANCE TITLES CALL FOR AVAILABILITY

AEROSMITH Just Push Play +2 (bonus "I Don't Wanna Miss a Thing & Won't Let you Down") Japan... SALE 13.98
ASIA Live at Budokan Tokyo 1983 (MTV broadcast first time on CD, Greg Lake lead vocals) Pilot Rec UK... 17.98
BEAUVOIR, JEAN Bare to the Bones (Crown of Thorns vocalist solo acoustic album) 13 trks/2001/German 14.98
BLACK OAK ARKANSAS Street Party, Airt Life Grand and Live! Mutha/1974-75/Wounded Bird USA... each 10.98
BROCK, TERRY Back to Eden (vocalist of Strangeways and recently The Sign new solo) 2001/Frontiers Italy... 14.98
BUTCHER, JON A Long Way Home (sessions for a never released 4th Ains album + live acoustic "Wishes")... 14.98
DBA-DERRINGER BOGERT AND APPICE Doing Business As (Rock Tim, Carmine) 11 tracks/2001/German... 17.98
FASTWAY Fastway and All Fired Up (first two albums based on one CD, remastered) 1983-84/BGO UK... 17.98
FOGHAT (DVD) Two Centuries of Boogie (1997) live Portland show with the original lineup) 12 songs... 14.98
FOGHAT Rock and Roll + Energized/73-74/UK... 17.98
FOGHAT RNR Outlaws + Fool for the City/74-75... 17.98
FOGHAT Night Shift + Live (double CD's) 76-77... 17.98
FOGHAT Tight Shoes + Girls to Chat/80-81/UK... 17.98
FOGHAT in Mood...Something Rude + Zig-Zag Walk 17.98
FORRESTER, RHETT Gone with the Wind (solo after Riot's album "Born in America") 1985/Metal Mayhem... 12.98
GEORDIE Singles Collection (definitive collection of their UK singles fronted by vocalist Brian Johnson)..... 17.98
GUESS WHO This Time Long Ago (2 CD, 28 unreleased rare tracks with Burl Cummings) Canada..... 23.98
HUGHES, GLENN (VHS) Days of Avalon and the Making of (Video with behind the scenes) Pink Cloud USA... 19.98
IRON HORSE Iron Horse (Ron Keef's new band, similar to Van Zant) 11 tracks/2001/Metal Mayhem..... 13.98
JOSHUA Hand is Quicker Than the Eye, Surrender, Chapter One (guitarist Joshua Perahia) 1983/85/95...each 10.98
L.A. GUNS Man in the Moon (Phil Lewis and rest of original lineup) 10 tracks/2001/Spitfire USA...SALE 10.98
LEONARDO Cast Recording (vocals Steve Walsh, James LaBrie, Davey Pattison, Robert Berry) Magna Carta 13.98
MAHOOGANY RUSH Maxxon, Child of Novelty and Strange Universe (remastered 3 on double CD) 73-75/UK... 24.98
MANFRED MANN'S EARTH BAND Wired (live concert Boston 1977 remastered) 8 trks/Pilot Records UK, 17.98
MARINO, FRANK Juggernaut & The Power of Rock and Roll (81-82 albums first time on CD) Holland, each 17.98
NAZARETH Back to the Trenches (2 CD unreleased live tracks, 1972, 1980, 1981, 1982, 1983 and 1984, 52 page mini-book) 31 tracks/146 minutes/UK... 23.98
NOSTRADAMUS (2 CD's, vocals Glenn Hughes, Joe Lynn Turner, Jorn Lande, Goran Edman, Doogie White, Alanah Myles, Sas Jordan) 21 tracks/SPV USA... 19.98
PARADISE Light The Fire (ex-Kick Axe vocalist George Crison & Doug Johnson ex-Loverboy) 01/German, 17.98
POISON TRIBUTE Name your Poison (2 CD's, Derek SL Holmes and vocalist of Pretty Boy Floyd, Tuft, Tiger Taitz, Cherry Street, Every Mother's Nightmare)....SALE \$ 9.98
PROPHET Cycle of the Moon (reissue of second album remastered w/bonus track) 1988/Z Records UK... 15.98
RAGER X Superheroes (Paul Gilbert, Jeff Marth, Scott Travis, John Alderete) 11 tracks/2001/Z Rec UK... 15.98
ROBINSON, MICK Heaven and Hell (Ian Hunter, Chrissie Hynde, David Bowie, Queen, Joe Elliott and John Mellencamp) 1994 reissue/Spitfire USA..... 9.98
ROSSINGTON COLLINS BAND This is the Way & Anytime, Anyplace, Anywhere (2 CD remaster both LP's) UK 19.98
RUNDGREN, TODD/UTOPIA A Cappella Tour (Dallas 1985) Deface the Music Tour (New Jersey 1980) Oopis Wrong Planet Tour (Chicago 1977) (Japan 2 CD's), each 32.98
SHY Brave the Storm +4 & Excess all Areas +3 (remaster with bonus tracks) 1985-1987/Zoom UK.....each 17.98
TKO Below the Belt (Seattle rockers 3rd album remastered follow-up to "In Your Face") 1986/Metal Mayhem... 13.98
URIAH HEEP Acoustically Driven (unplugged live with an orchestra, December 2000) 16 tracks/UK... 19.98
URIAH HEEP (DVD) Acoustically Driven (video U.S. format for above show, sold only on band's website) UK... 21.98
URIAH HEEP Electrically Driven (full band show Astoria in London May 23, 2001) 13 tracks/UK... 19.98
VICIOUS RUMORS Sadistic Rumors (Geoff Thorpe and Ira Black) 11 tracks/2001/Ferris USA... SALE 10.98
WAR & PEACE Light at the End of the Tunnel (Jeff Pison, Beach, Kozzen, Gilbert, Norrum) 2001/Shrapnel USA 13.98
WARRANT Under the Influence (includes two new songs and nine covers) 11 tracks/2001/Perris Rec USA... 13.98
WISHBONE ASH Live Dates 3 (Paris October 1999) 10 tracks/72 minutes/Eagle Records UK..... 19.98
WOLFSBANE Lifestyles of the Broke... (Wolfsbane and Massive Noise Injection albums together, 2 CD) UK 17.98



94-95-96-97-98-99-00 FLAT RATE SHIPPING IS \$4.50 FOR ANY SIZE SHIPMENT, MAIL ORDER CUSTOMERS INCLUDE THIS IN YOUR TOTAL. SHIPPING VIA U.S. PRIORITY MAIL DELIVERY CONFIRMED TRACKING, SHIPPED IN BOXES. ORDERS OVER \$150 INSURED FREE SMALLER ORDERS ADD \$1.50 IF DESIRED. MONEY ORDERS AND CHECKS ARE ACCEPTED, MAKE PAYABLE TO BUCCANEER RECORDS. CHECKS MAY DELAY SHIPPING UP TO 2 WEEKS. ALL ITEMS ARE NEW, UNSEALED CD'S IN SLEEVES. CREDIT CARD PREORDERS ARE NOT CHARGED UNTIL MAILED TO YOU. LISTING ALTERNATE SELECTIONS IS DESIRABLE IF NOT CALLING. FOREIGN ORDERS CREDIT CARD SALES ONLY, SHIPPED VIA AIR MAIL OR GLOBAL PRIORITY. SORRY NO SPECIAL ORDERS. GOLDMINE IS PUBLISHED THREE WEEKS BEFORE THE COVER DATE, THIS AD VALID UNTIL COVER DATE NOVEMBER 16, 2001. THANKS.

FAX YOUR CREDIT CARD ORDER ANYTIME 410-569-3697 MAIL ORDERS TO: BUCCANEER RECORDS P.O. BOX 1212 ABINGDON, MARYLAND 21009

# Grapevine

## Blue Storm Music founder a longtime record collector

Record enthusiast Arnie Goodman is the president and head of A&R of Blue Storm Music ([www.bluestormmusic.com](http://www.bluestormmusic.com)) located in New York, N.Y. Since its Jan. 1, 2001, startup, Blue Storm has so far released recordings by Spooky Tooth, Asia, Scott Holt, and Deck Heckstal-Smith, and they have a few more dandies coming up in the near future.

Goodman is a record collector with a personal collection of more than 9,000 vinyl LPs. He knows and appreciates music and is conscious of what the mature record-buying public would like to hear. On upcoming projects, he is planning on mixing veteran players with the up-and-coming ones. He also will be recording unsung heroes who have great reputations but who haven't had that chance to be marketed on a larger scale. In the past, Goodman has worked with former Rolling Stones guitarist Mick Taylor, Rory Gallagher, Cream's Jack Bruce, Clem Clemson, Leo Lyons, Savoy Brown's Kim Simmonds and many others.

Goodman is the other responsible for *The Peter Green Tribute*, *Rattlesnake Shake* and *Knights Of The Blues Table* compilations. Presently he's working with guitarist/vocalist Vince Converse and the Ten Years After rhythm section (Leo Lyons and Ric Lee) and legendary Irish guitarist Rab McCullough, whose new album *Belfast Blues* was just released. Blue Storm also just released Green's



Arnie Goodman

Courtesy of Blue Storm Music

Splinter Group's new album, *Time Traders*.

A new Taylor record has just been released and Goodman hopes to record an album based around Duke Robillard and Simmonds.

"One of things that we try to do at this label is to open the eyes of some of the buyers of people [artists] who have been overlooked," Goodman pointed out. "Like Rab McCullough — he's a great guitarist that has been overlooked for 30 years. He's 52

(Please see Blue Storm page 23)

### Rare Finds

#### Two Elvis Sun 78s picked up for a buck!

One day my wife and I were browsing at a book sale that is put on once a year. I inquired about any 45s that they might have for sale since I didn't see any out on the floor. They told me that there might be a few in the back where other donations had just been dropped off. Alas, no 45s, but there was a stack of LPs, so I took a look through them. I selected about 11 albums. Each album was for sale for \$1. My wife was still browsing, so I decided to sort through a small pile of 78s to kill some time. About halfway through the stack, I came across a rice paper sleeve. I slid the 78 out and lo and behold, an Elvis Sun 78 titled "Milkcow Blues" appeared! I slid this rare find back inside the sleeve, placed it on top of the stack of LPs I was going to purchase, paid the \$12 and walked out (on a foot of air). My wife and I sat down on the bench outside, and as we were inspecting our find, my wife said, "I think there are two records in here." Sure enough, there were two Elvis Suns. The other one was "Baby, Let's Play House." One Elvis Sun 78 for \$1 was already a mind-blowing deal, but two Elvis Suns for \$1 is heart-stopping!



We recently sold the "Baby, Let's Play House" for \$650 and the "Milkcow Blues" for \$850. Talk about the find of a century!

— Kimberly & Curtis Smith  
San Antonio TX

[Not too shabby of a find! Congrats. — Ed.]

Contributions to the Rare Finds column should be addressed to: *Goldmine Rare Finds*, 700 E. State St., Iola WI 54990-0001 or e-mailed to [bernardyc@krause.com](mailto:bernardyc@krause.com). Photos or photocopies of items are welcomed, but please do not send originals. Keep on diggin'!

### GRAPELEAVES



**On the bookshelf:** One of the hotter areas of record collecting the last few years has been in the Northern Soul area. *Manships Price Guide 2001/2: Rare Soul 45s* by John Manship (John Manship Records, U.K.) lists more than 10,000 Northern Soul, Motown, funk and group harmony records, priced in near mint minus condition. The 212-page softcover book also has a small color section featuring pictures of the two most sought-after Northern Soul labels, Shrine and Arco ([www.raresoulman.co.uk](http://www.raresoulman.co.uk); 45 Dalby Road, Melton Mowbray, Leics, LE 13 0BG England)... Speaking of Northern Soul, *Motown: The Golden Years* by Goldmine writer Bill Dahl (Krause Publications) is back from the printer. The 384-page softcover book explores the history of the venerable label from the 1950s to the early 1970s, including interviews with many of the artists and label employees who made Motown one of the biggest independent label successes of all time. Rare, previously unpublished photos — including a 32-page color section — have been supplied by former Motown promotion man Weldon A. McDougal III, who had previously founded The Larks, a Philadelphia vocal group that hit the big time in 1961 with "Unbelievable." A review of the book is forthcoming in *Goldmine*... Now available in paperback is the controversial *Lennon In America: 1971-1980, Based In Part On The Lost Lennon Diaries* by Geoffrey Giuliano. Beatles scholar Giuliano's research of Lennon's diaries portrays the struggles and triumphs of Lennon's years in America with his wife Yoko Ono, starting in 1971 until the final days leading up to his assassination outside his Dakota department in New York Dec. 8, 1980.

**For couch potatoes:** New DVDs include *Queen's Night At The Opera* (due Nov. 20 from DTS Entertainment) featuring a 5.1 surround remix of the entire album and the original music video of "Bohemian Rhapsody"; *Guided By Voices' The Who Went Home And Cried* (Music Video Distributors), a 60-minute DVD featuring the band jamming on singer Roger Pollard's back porch in their hometown of Dayton, Ohio, and also contains a nine-song bonus concert filmed at the Whiskey A Go Go in Los Angeles; and *Losing Aaliyah* (Music Video Distributors), a 60-minute documentary (without music), contains oral tributes from fans and musicians about the short life of rising R&B phenomena and actress Aaliyah, who died in a plane crash in the Bahamas Aug. 25, 2001.

**Sept. 11, 2001, benefits:** Rarely a day has gone by since Sept. 11 that there isn't news of a new fund-raising tribute concert or recording by an artist or group of artists. Among the many are Columbia's 15-track *God Bless America* collection featuring patriotic songs performed by a wide variety of top artists such as Celine Dion's version of "God Bless America," newly recorded for

this project; Frank Sinatra's "America The Beautiful"; Bob Dylan's "Blowin' In The Wind"; Pete Seeger's "This Land Is Your Land"; a previously unreleased acoustic live version of the John Mellencamp song, "Peaceful World"; and tracks by Gloria

Estefan, Simon & Garfunkel, Bill Withers, Mahalia Jackson, The Mormon Tabernacle Choir, Mariah Carey, Lee Greenwood, Bruce Springsteen, Billy Gilman, and Tramine Hawkins... Republic/Universal band

Oleander has released the single "Champion" off of their new album *Unwide*. All proceeds of the single's sales will be donated to the September 11th Fund... Twisted Sister reunites for the New York Steel benefit concert Nov. 28 at 7 p.m. at Hammerstein Ballroom in New York, N.Y., with proceeds going to survivors of the members of the New York Police and New York Fire Department who lost their lives during the rescue efforts at the World Trade Center disaster. Cohosted by WNEW-FM DJ Eddie Trunk and New York Mets superstar Mike Piazza, the hard rock concert also includes The Ace Frehley Band, Anthrax, Overkill, Sebastian Bach, and surprise guests. All of the acts on the bill reside in or are from New York or New Jersey. The original members of Twisted Sister are performing together in public for the first time in 14 years. Some of the members of Twisted Sister have close association with members of the state police, and one of the members has two relatives who worked at the World Trade Center at the time of the explosion and who survived. Tickets (\$37.50 each; \$40 day of show) can be purchased at all Ticketmaster outlets, at [www.ticketmaster.com](http://www.ticketmaster.com) and at the Hammerstein box office.

**American Bandstand celebrates 50th:** Hard to believe, but next year marks the 50th anniversary of *American Bandstand*. ABC is planning a two-hour special, hosted by former *Bandstand* host Dick Clark, highlighting performances from *Bandstand's* four decades. Clark, 71, who took over for original host Bob Horn (the show was originally called *Bob Horn's Bandstand*) in 1956, will look at some of the artists whose careers were launched nationally by the show, such as Buddy Holly, The Beach Boys, and The Jackson 5. I'll give it the planned anniversary gig a 100 — it's got a good beat, and you can dance to it.

— Greg Loescher



All photos ©2001 Frank Pettis



Clockwise from upper left: The Vogues, an ecstatic Bubba Knight of Gladys Knight & The Pips, The Miracles, The Lennon Sisters, and The Chordettes.

# Legendary vocal groups make history by reuniting for Vocal Group Hall Of Fame inductions

SHARON, Pa. — Gloria White felt her late husband's presence.

Jinny Janis searched for a pitch pipe.

Don Miller was just days removed from a hospital bed.

The Lennon Sisters avoided a chemical spill on the highway.

And all of the Lettermen's Pike brothers reunited on stage.

Such were the stories of the 2001 Vocal Group Hall Of Fame induction ceremonies, held Oct. 4, 2001, at the Hall's museum in Sharon, Pa. The induction, banquet and outdoor concert honored proponents of vocal harmony in diverse musical genres such as doo-wop, a capella, chorale, Top 40, country and traditional pop, in a ceremony devoted to the oldest of musical instruments — the human voice.

The Sept. 11, 2001, attacks on America forced The Vocal Group Hall Of Fame to reschedule its induction ceremonies and concert for Oct. 3-5. For those who attended, and for their families and friends, it was magical. Fourteen groups were inducted into the Class Of 2001, including traditional harmony pop groups such as The Lennon Sisters and The Chordettes; classic Motown groups such as Smokey Robinson & The Miracles and Gladys Knight & The Pips; and Top 40 Artists such as The Bee Gees, The Vogues, and The Oak Ridge Boys. Throughout the entire Hall of Fame week — from the golf outing to the artists' banquet, from the induction ceremonies to the post-induction concert — there was music in the air and vocal harmony on the lips.

Upon entering the host Radisson Hotel where The Vocal Group Hall Of Fame inductees were housed, one could hear the unmistakable a capella harmonies of the classic 1953 hit "Mr. Sandman." Standing in the hotel lobby, harmonizing together, were the original Chordettes — the female quartet whose stint on the Arthur Godfrey television show gave them a string of hits in the 1950s. Even though

the group sounded as fresh and clear as they had in the 1950s, Chordettes founder Jinny Janis spent most of the day searching for a pitch pipe, in case the group was asked to perform.

"Our families are probably more thrilled than we were," said Chordettes member Lynn Evans. "They haven't seen each other for over 30 years, so they were absolutely thrilled. And for me, it was a great thrill. If it had not been for Jinny Janis, who formed this group so many years ago, none of this would have happened."

The current lineup of The Pied Pipers, the vocal quartet who performed with Frank Sinatra, Tommy Dorsey, and Johnny Mercer in the 1940s, were in awe of the displays at The Vocal Group Hall Of Fame.

"The history in this building is what captures me," said Pied Pipers member Roland Michaud. "And having somebody that has the foresight to recognize the talent that's available in this business is certainly a great accomplishment."

Ross Barbour, one of the original members of The Four Freshmen, posed for photos with Freshmen family members and also in front

of The Four Freshmen statues located on the sidewalk outside of the Hall Of Fame.

"Some of the fans say, 'Oh that's very unusual to see a statue of somebody who ain't dead.' But it is a treat, what a treat. It was something. I had no expectation of ever seeing myself as a statue."

"We were here four years ago for the Freshmen reunion, and we established a display in The Vocal Group Hall Of Fame. At that time we were thinking we were inducted, and it wasn't effective at that time. Now it's effective, and we're back here to celebrate about that. It's a great honor, and we'll be proud."

*(Editor's note: Vocal groups do not need to be inducted to have a display in The Vocal Group Hall Of Fame.)*

Although Little Anthony And The Imperials were inducted as part of the Hall's Class Of 2000, none of the Imperials had been able to attend that year. The Imperials' Sammy Strain, however, did attend the ceremonies this year to accept The Imperials' induction.

"This is something special," said Strain, "because everybody started singing in a group at

one time or another — all the chicks I knew, all the guys I knew — and we'd stand on a corner. Some of us were blessed, a lot of us were blessed enough to actually make a musical contribution. I came here this year to represent Little Anthony, Clarence Collins, and Ernest Wright Jr. We love this museum, and we think it's great."

The induction ceremonies, hosted by The Supremes' Mary Wilson (1998 Vocal Group Hall Of Fame inductee) and Goldmine editor Greg Loescher (who was a last-minute replacement for music historian Jay Warner, who could not attend the rescheduled event due to pressing business matters), allowed the groups and their representatives a chance to comment about receiving the prestigious "Harmy" award — short for Harmony — which symbolizes the accomplishments each group achieved over the years.

When Bubba Knight received the Harmy award honoring Gladys Knight And The Pips, his speech was full of reverence and honor on behalf of his fellow group members.

"Gladys said to me, 'Bubba, make sure you represent us in a dignified way. Be intelligent.' So I just want to tell you all that I am so thrilled, and this is such an honor to be here in the Hall Of Fame. I've done it like the way that they asked me to do it."

Then, with a smile on his face and a twinkle in his eye, Knight continued. "Now, I'll do it my way." With that, he cheered, pumped his fists and celebrated with the hosts.

When The Miracles received their awards, original members Claudette Robinson, Pete Moore, and Bobby Rogers each expressed their thanks. Then they turned the microphone over to Gloria White, the widow of Miracles baritone Ronnie White.

"I'm kind of in a twofold position," she said at the podium. "I am enjoying the festivities just because I'm part of the era, and the



All past and present members of The Lettermen gathered together for the first time ever.

World Radio History

(Please see Vocal group winners page 19)



SHIPPING RATES: Budget: 1 CD \$2.50 (US only)  
Priority: CD's & DVD's any size order \$4.50 (US & Canada). All orders shipped Priority Mail in the US.

P.O. Box 801, Dept. 50-GM, Bellmore, NY 11710 • Credit Card Order Line: (516) 564-1613  
Fax: (516) 564-1614 • E-mail: [spinnindisc@hotmail.com](mailto:spinnindisc@hotmail.com); Web site: <http://www.spinnindisc.com>  
Hours: Mon-Fri 9AM-7PM (EST)



PAYMENT: We accept VISA - MasterCard - NOVUS  
Am Ex. Check or money order payable to Spinnin' Disc  
\*\* checks are held to clear \*\*  
New York customers add sales tax  
NO PERSONAL CHECKS FOR PREORDER TITLES

## NEW RELEASES ON COMPACT DISCS

- AKKERMAN, JAN-TABERNAKEL** First time on CD from the Focus guitarist...\$11.99
- AMERICAN BLUES-IS HERE** First time on CD featuring Dusty Hill & Frank Beard from ZZ Top...19.99
- ASHTON, GARDNER & DYKE-LET IT ROLL-LIVE!** Featuring Tony Ashton recorded in Brussels in 1971...19.99
- BLACK SABBATH-MINIATURES 1970-1978** (9CD) All their albums with Ozzy each CD is in a mini LP sleeve packaged together in a box...74.99
- BLACKMORE'S NIGHT - FIRES AT MID-NIGHT + 2** New album in a limited edition box along with a bonus track and a CD-ROM video...15.99
- BLUE OYSTER CULT-TALES FROM THE PSYCHIC WARS** (2CD) CD 1 recorded live in New York 1981 and CD 2 is from California 1983...23.99
- BLUNSTONE, COLIN-ENNISMORE** (J) Reissue of 1972 album...25.99
- BOLAN, MARC & T. REX - LIVE AT THE BOSTON GLIDERDROME** Digitally remastered edition of their live album recorded 1/15/72...15.99
- BON JOVI-ONE WILD NIGHT** (2CD) (J) Latest live album with a bonus CD...11/21 44.99
- BONNET, GRAHAM-DAY I WENT MAD** Latest album...15.99
- BROWN, IAN-MUSIC OF THE SPHERES + 2** (J) New from Stone Rose's vocalist with bonus tracks...30.99
- BUCKLEY, TIM-TIM BUCKLEY/GOODBYE & HELLO** 2 on 1 remastered...19.99
- BUTTERFIELD, PAUL BLUES BAND-BUTTERFIELD, PAUL BLUES BAND/EAST-WEST** (2CD) 2 albums on 2 CD's remastered...25.99
- CANNED HEAT-HALLELUJAH + 4** Digitally remastered digipak reissue...18.99
- CARNES, KIM-BARKING AT AIRPLANES + 3/CAFE RACERS + 3/VOYEUR + 3** Remastered reissues...EA 12.99
- CHARLTON, MANNY - STONKIN'** New album from the Nazareth member...19.99
- CRANBERRIES-WAKE UP & SMELL THE COFFEE + 3** (J) New with 3 bonus tracks...31.99
- DAVIES, DAVE-ROCK BOTTOM-LIVE** Kinks guitarist recorded live at The Bottom Line...19.99
- DEEP PURPLE - BOOTLEG SERIES 1984-2000** (12CD)...65.99
- DEEP PURPLE - IN CONCERT 1970/1972** (2CD) Reissue...16.99
- DEEP PURPLE-LIVE AT THE ROTTERDAM AHOY** (2CD) Recorded live in Rotterdam 10/30/00 Featuring Ronnie James Dio on 5 tracks. In stock for a limited time only!...27.99
- DEEP PURPLE - MK III: FINAL CONCERTS** (2CD)/SCANDINAVIAN NIGHTS (2CD) Reissues...EA. 16.99
- DEEP PURPLE-ON THE ROAD** (4CD) A great compilation of live material recorded between 1969-1993...47.99
- DEEP PURPLE-SOUNDBOARD SERIES** (12CD) Recorded live on 6 different nights from their 2001 tour...84.99
- DERRINGER, BOGERT, APPICE - DBA** New album featuring Rick Derringer, Tim Bogert, Carmine Appice...13.99
- DILLARDS-BACK PORCH BLUEGRASS /DILLARDS LIVE! ALMOST!** 2 on 1 remastered...19.99
- EDMUNDS, DAVE-ROCKPILE + 6** Reissue with bonus tracks...18.99
- FAIRPORT CONVENTION-FULL HOUSE + 4/HOUSE FULL** (LIVE) Digitally remastered reissues with bonus tracks...EA. 18.99
- FLEETWOOD MAC - SHOW-BIZ BLUES 1968-1970** (2CD) Digitally remastered compilation of previously unreleased studio jams, live tracks and alternative versions of studio tracks from 1968-1970...24.99
- FOCUS - AT THE RAINBOW/FOCUS 3/IN AND OUT OF FOCUS/MOTHER FOCUS/MOVING WAVES/SHIP OF MEMORIES/HAMBURGER CONCERTO** Reissues...EA. 14.99
- FREE - FREE + 10/TONS OF SOBS + 8/FIRE & WATER + 6** Digitally remastered reissues with bonus tracks...EA. 18.99
- GALLAGHER, RORY-LET'S GO TO WORK** (4CD) Includes the live albums 'Live In Europe', 'Irish Tour' and 'Stage Struck' plus a previously unreleased bonus live CD 'Meeting with The G-Man' recorded in Amsterdam...44.99
- GAMMA-4** Their latest studio album...15.99
- GREEN, PETER-TIME TRADERS** New album...14.99
- HACKETT, STEVE-LIVE ARCHIVE** (4CD) 4 CD set of live material...39.99
- HENSKE, JUDY-JUDY HENSKE/HIGH FLYING BIRD** (2CD) 2 albums on 2 CD's remastered...25.99
- HOT TUNA - YELLOW FEVER** Reissue of their 1975 album...16.99
- HUMBLE PIE-LIVE AT THE WHISKEY A GO GO** Recorded live in December 1969...14.99
- JEFFERSON AIRPLANE - TAKES OFF + 4/CROWN OF CREATION + 2/SURREALISTIC PILLOW + 4/VOLUNTEERS + 6** Reissues with bonus tracks...EA. 14.99
- JEWEL-THIS WAY + 1** (J) New with the bonus 'Long Slow Slide'...29.99
- KING CRIMSON-COLLECTOR'S KING CRIMSON VOL. 5** Japanese only box set featuring live material...69.99
- KING KOBRA-HOLLYWOOD TRASH** New studio album featuring Carmine Appice, C.C. Deville, Kelly Keeling, Earl Slick, Steve Fister, Mark Free, Johnny Rod and Mick Sweda...14.99
- MAGAGNI, MAX-TWISTER** Latest album from the Italian guitarist featuring guests Glenn Hughes, Paul Shortino, Robin Mc Auley plus Ian Paice playing drums on 'Highway Star'...14.99
- MALMSTEEN, YNGWIE-CONCERTO SUITE LIVE** (J) New with Yngwie and the Japan Philharmonic orchestra recorded on June 17, 2001...12/19 33.99
- MARINO, FRANK - EYE OF THE STORM** New album...19.99
- M.S.G.-BE AWARE OF SCORPIONS + 1** (J) New album with the bonus track 'Ride The Lightning'...29.99
- MINOGUE, KYLIE-FEVER + 2** (J) New with the bonus tracks, 'Good Like That' & 'Baby'...30.99
- MINOGUE, KYLIE-FEVER** New album...21.99
- MOTT THE HOOPLE-TWO MILES FROM LIVE HEAVEN** (2CD) Featuring three live shows from the U.S. in 1971, 1973 and 1974 from Mick Ralph's and Overend Watts personal archives...20.99
- MOUNTAIN - GO FOR YOUR LIFE** Digitally remastered and the first time on CD for their classic 1983 album...14.99
- NASH, GRAHAM - EARTH & SKY** Digitally remastered reissue...18.99
- NEIL, FRED-TEAR DOWN THE WALLS /BLEEKER & MACDOUGAL** 2 on 1 remastered...19.99
- NEW RIDERS OF PURPLE SAGE-GYPSY COWBOY/ADVENTURES OF...** 2 on 1 reissue...18.99
- NITZINGER-JOHN IN THE BOX + 12** (3CD) 3 CD set featuring the albums 'Nitzinger', 'One Foot In History' and 'Live Better Electrically' plus 12 bonus tracks...52.99
- NUGENT, TED (TRIBUTE) - BULLETPROOF** Tribute to the 'Motor City Madman' featuring Jani Lane, Phil Lewis, John Corabi and others!...14.99
- OCHS, PHIL ALL THE NEWS THAT S FIT TO SING/I AIN'T MARCHING ANYMORE** (2CD) 2 albums on 2 CD's remastered...25.99
- ONO, YOKO-BLUEPRINT FOR A SUNRISE + 2** (J) New album with the bonus tracks 'Yume O Moto' and 'Josei-ji Banzai'...30.00
- PAICE/ASHTON/LORD - MALICE IN WONDERLAND + 8** Reissue of their 1977 album featuring bonus material from the never completed second album...19.99
- PAXTON, TOM-RAMBLIN' BOY/AIN'T THAT NEWS 2** on 1 remastered...19.99
- PROCOL HARUM - EXOTIC BIRDS & FRUIT + 2/GRAND HOTEL + 2/PROCOL'S NINTH/SOMETHING MAGIC + 2** Digitally remastered reissues with bonus tracks on each CD...EA. 16.99
- RALPHS, MICK-IT'S ALL GOOD** New album...18.99
- RUSH, TOM-TOM RUSH/TAKE A LITTLE WALK WITH ME** (2CD) 2 albums on 2 CD's remastered...25.99
- SAVOY BROWN-RAW LIVE 'N' BLUE 1** (2CD) Featuring live material recorded in Denver 6/27/81 and studio sessions from 1980 plus the bonus track 'Run To Me'...29.99
- SCORPIONS-TOKYO TAPES/TAKEN BY FORCE + 2** Digitally remastered reissues...EA. 15.99
- SCORPIONS-ACOUSTICA** New album...23.99
- SETZER, BRIAN - IGNITION + 3** (J) With 3 bonus live tracks...29.99
- SETZER, BRIAN ORCHESTRA - LIVE IN JAPAN 2001** (J) New 21 track live album recorded 2/22/01...29.99
- SKID ROW-34 HOURS + 2** 1971 album featuring Gary Moore...19.99
- STARZ - CHERRY BABY - LIVE SUFFOLK FORUM** Recorded live recorded at the Suffolk Forum in New York on March 27th, 1978...13.99
- SUPERTRAMP-IS EVERYBODY LISTENING?** 12 live tracks from Cleveland 1976...19.99
- SYKES, JOHN - LOVELAND/20TH CENTURY/NUCLEAR COWBOY** First time on CD outside Japan...EA. 13.99
- TYGERS OF PAN TANG-MYSTICAL** New album...15.99
- TURNER, JOE LYNN-SLAM** German edition of his new album...14.99
- WOOD, ROY - STARTING UP** Digitally remastered reissue...14.99
- YES-MAGNIFICATION** New album with an earlier release...19.99
- YES - MAGNIFICATION 1** (J) new album with a bonus track...29.99

## DVD'S.

- ASIA-CLASSIC ROCK LEGENDS** Featuring the line up of John Wetton, Geoff Downes & Carl Palmer. 11 tracks total (NTSC Reg 1)...21.99
- BEE GEES - ONE FOR ALL TOUR**...35.99
- BOWIE, DAVID-GLASS SPIDER TOUR** Recorded live in Australia, 20 tracks total...34.99
- CARAVAN-CLASSIC ROCK LEGENDS** Recorded live featuring Pye Hastings, Richard & David Sinclair...21.99
- CHEAP TRICK-SILVER** DVD version of their 25th Anniversary Homecoming Concert...22.99
- CULT-PURE CULT ANTHOLOGY** Featuring 19 videos released between 1984-1995, live footage and interviews...23.99
- DEEP PURPLE-COME HELL OR HIGH WATER** Recorded live on the 'Battle Rages On' tour in England 1993...14.99
- DEEP PURPLE - NEW, LIVE & RARE A** Collection of material recorded between 1984-2000 with Ritchie Blackmore and Steve Morse (NTSC Reg 1)...24.99
- FERRY, BRIAN-LIVE IN PARIS** 16 tracks recorded live in Paris March 2000...19.99
- FOGHAT - TWO CENTURIES OF BOOGIE** Recorded live in 1998 original band...14.99
- GALLAGHER, RORY - IRISH TOUR** First time on DVD recorded live. (NTSC Reg 1)...14.99
- HELIX-S.E.X. RATED** Featuring 13 videos...24.99
- HENDRIX, JIMI - EXPERIENCE**...18.99
- URIAH HEPP-SAILING THE SEA OF LIGHT** Recorded live in concert from Sofia inn 1997. Also includes interviews...21.99
- UFO - TOO HOT TO HANDLE 'The Story of UFO'**...34.99
- UFO-LIVE MISDEMEANOR TOUR** Recorded live in London...19.99
- WISHBONE ASH-CLASSIC ROCK LEGENDS** 11 tracks recorded live in concert (NTSC Reg 1)...21.99

## BEST SELLING CATALOG TITLES

- AMERICA - HARBOR/HAT/TRICK/HEARTS/HIDEAWAY**...EA. 18.99
- BADFINGER - HEAD FIRST** (2CD)/BBC IN CONCERT 1972/73/WISH YOU WERE HERE - S/T...EA. 19.99
- BADFINGER - SAY NO MORE/AIRWAVES + 5**...EA. 14.99
- BLACK OAK ARKANSAS - LIVE! MUTHA/STREET PARTY/AIN'T LIFE GRAND/WILD BUNCH/S/T/ RAUNCH N ROLL LIVE/KEEP THE FAITH/IF AN ANGEL CAME**...EA. 13.99
- BLONDIE - EAT TO THE BEAT/PLASTIC LETTERS + 2**...EA. 19.99
- BLONDIE - HUNTER + 1** (RM)...19.99
- BLOODROCK - BLOODROCK 3/BLOODROCK LIVE/BLOODROCK U.S.A. + 1** All are on CD for the first time...EA. 10.99
- BOLIN, TOMMY SNAPSHOT** 14.99
- BOLIN, TOMMY TEASER** 16.99
- BURNING STARR S/T** Featuring Jack Starr...14.99
- CAMEL - GOD OF LIGHT LIVE 73-75**...16.99
- CAMEL - RAJAZ**...14.99
- CAMEL - THE SNOW GOOSE**...18.99
- CARAVAN-CARAVAN & NEW SYMPHONIA** Remastered reissue...18.99
- CLARKE, GILBY-RUBBER/THE HANG-OVER/99 LIVE** Reissues from the one time Guns N' Roses guitarist...EA 13.99
- DEEP PURPLE - DAYS MAY COME** Unreleased studio rehearsals with Tommy Bolin...19.99
- DEEP PURPLE - WHO DO WE + 7** (RM)...19.99
- DONOVAN OPEN ROAD** (RM)...19.99
- FREEDOM IS MORE THAN A WORD** Featuring Bobby Harrison...19.99
- HUNTER, IAN - MISSING IN ACTION** (2CD)...21.99
- IMPELLITERI - CRUNCH** (2CD)...18.99
- JADE WARRIOR - JADE WARRIOR**...23.99
- JOURNEY - ARRIVAL + 1** (J)...30.99
- LEGS DIAMOND - FIRE POWER + 2/S/T + 1/DIAMOND IS A...** + 1...EA. 18.99
- MAD RIVER - MAD RIVER/PARADISE BAR & GRILL** 2 on 1 reissue...14.99
- MARINO, FRANK-WHAT'S NEXT/JUGGERNAUT/THE POWER OF ROCK 'N' ROLL** Reissues...EA. 18.99
- NAZARETH - BACK TO THE TRENCHES LIVE** (2CD) Unreleased live material recorded between 1972 and 1984...29.99
- NESMITH, MICHAEL - NEVADA FIGHTER/TANTAMOUNT TO TREASON + 3** (RM) 2 on 1...19.99
- NESMITH, MICHAEL - AND THE HITS.../PRETTY MUCH...** 2 on 1...19.99
- NESMITH, MICHAEL - MAGNETIC SOUTH/LOOSE SALUTE + 1, 2** on 1...19.99
- QUATRO, SUZI - YOUR MAMMA/AGGROPHOBIA** 2 on 1...19.99
- QUATRO, SUZI - SUZI QUATRO/QUATRO 2** on 1...19.99
- PRESLEY, ELVIS - PRESLEY/SUN SESSIONS** (J) Each in a mini LP sleeve (out of print)...EA. 24.99
- PRICE, ALAN-THE PRICE TO PLAY** - First time on CD from the Animals member...15.99
- RODGERS, PAUL - ELECTRIC + 1** (J)...29.99
- RONDINELLI - WAR DANCE W/Ray Gillen**...12.99
- ROUGH CUTT - LIVE**...19.99
- RUNDGREN, TODD & UTOPIA - LIVE IN TOKYO '79** (2CD) (J)...34.99
- STRAWBS - LIVE AT THE CHISWICK**...21.99
- ST. HOLMES, DEREK - THEN AND NOW**...12.99
- TUBES - INFOMERCIAL: HOW TO BECOME**...18.99
- Y & T - STRUCK DOWN/YESTERDAY AND TODAY** Reissues...EA. 16.99

Check out our Web site: <http://www.spinnindisc.com> for our complete catalog and daily updated new releases.

# — Beyond Elton John Bernie Taupin

## The man behind the hits

by Mary Anne Cassata

"I want people to know that Bernie Taupin is not just Elton John's lyricist. I have much more to offer and God willing I'll prove it."

— Bernie Taupin

For more than three decades, there has been much speculated and written about Bernie Taupin and his songwriting collaboration with Elton John. In retrospect, the facts often speak louder than the words. Taupin, "The Brown Dirt Cowboy" to John's "Captain Fantastic," is one half of one of the most acclaimed songwriting teams in pop music history. Together, they have sold more than 150 million records worldwide — a staggering statistic that has earned them a rightful place alongside teams such as George and Ira Gershwin, Rogers & Hammerstein and more notably, Lennon & McCartney.

For starters, 16 of their albums have gone multiplatinum and 10 singles gold. John and Taupin ruled the international airwaves in the early to mid-70s with the string of hits that includes "Your Song," "Levon," "Daniel," "Bennie And The Jets" and "Someone Saved My Life Tonight." A few gems from the '70s that have been interpreted and recorded by more than 200 artists include songs such as "Country Comfort" and "Tiny Dancer." The most widely covered hits include "Your Song," "Daniel," "Don't Let The Sun Go Down On Me," "Candle In The Wind" (original version) and "Rocket Man."

Taupin's lyrics are recognized by some of the world's most prestigious music organizations, and he has won nearly every conceivable songwriter award. A few of his more memorable accolades, collectively with John as well as individually, include induction into the Songwriters Hall Of Fame, six Ivor Novello awards (Europe's premier songwriting honor) and the 1994 ASCAP Songwriter Of The Year honor.

The legendary lyricist is also the proud recipient of the coveted INA International Achievement Of Excellence and was inducted into the American Academy Of Achievement. Incredibly, Taupin is only the second person to receive the ASCAP Golden Word award, which honors a vastly important body of work. The first recipient was Sammy Cahn, who wrote for people such as Benny Goodman, Louis Armstrong, and Frank Sinatra, just to name a few.

While Taupin dons a plethora of career caps — singer, author and entrepreneur — he also makes sure to use his influence for the greater good. In 1992 and 1995 he produced Commitment To Life VI And VIII, events that raised more than \$8 million for AIDS Project Los Angeles. These musical benefits featured performers from all facets of the entertainment

world. Barbara Streisand, John, Liza Minelli, Garth Brooks, and Billy Joel were among the many notable celebrities.

In 1997, the hit-making duo created history again with their revised version of "Candle In The Wind," with lyrics rewritten in honor of the late Princess Diana. Aside from Taupin's lengthy partnership with John, he has continually explored his own varied interests. For starters, Taupin released two solo albums (and one of poetry) and cowrote all 10 songs on Alice Cooper's 1978 *From The Inside*. He has written #1 hits for Starship, 1985's "We Built This City," and Heart, 1986's "These Dreams," as well as a string of songs for artists such as Rod Stewart, John Waite, Melissa Manchester, Animation, The Motels and others.

Perhaps it wasn't until a few years ago that Taupin found his most comfortable "musician" voice with his own band, Farm Dogs. *Last Stand In Open Country* (1996, Discovery Records) presented a very different side of the introspective songwriter. As a lead vocalist and band leader, he prefers a more roots-oriented, acoustic sound. The Farm Dogs followed up with *Immigrant Sons* in 1998.

Bernard Joseph Taupin was born May 22, 1950. He grew up in a quiet English countryside outside of Lincolnshire. As the middle child of three sons, young Taupin was raised in a strict Catholic household (he was an altar boy) where French was often spoken as a second language.

"I was brought up in a farming community," he said of his childhood. "My father worked for the Ministry Of Agriculture. My mother was very influential in making me read good literature. She always encouraged me to write.... My grandfather was a college professor. I had a certain literary background on my mother's side of the family."

Some early boyhood sources of inspiration included *Winnie-The-Pooh*, *The Wind In The Willows* and plenty of stories from America's Old West. As Taupin grew older, his grandfather introduced him to the works of Henry Wadsworth Longfellow and other great poems of English literature such as Alfred Lord Tennyson's "Charge Of The Light Brigade" Samuel Taylor Coleridge's "Rime Of The Ancient Mariner" and Lord Thomas Babington Macaulay's "Lays Of Ancient Rome."

"I was always interested in reading English literature, writing essays and dabbling in poetry," he recalled. "I absolutely loved reading stories and long, narrative poetry. I thought to write a story and put it to music was wonderful."

A rebellious teenager, Taupin often spent idle time hanging out with his buddies in tough pool halls and rowdy pubs. At 16 he left school without much hope of a promising

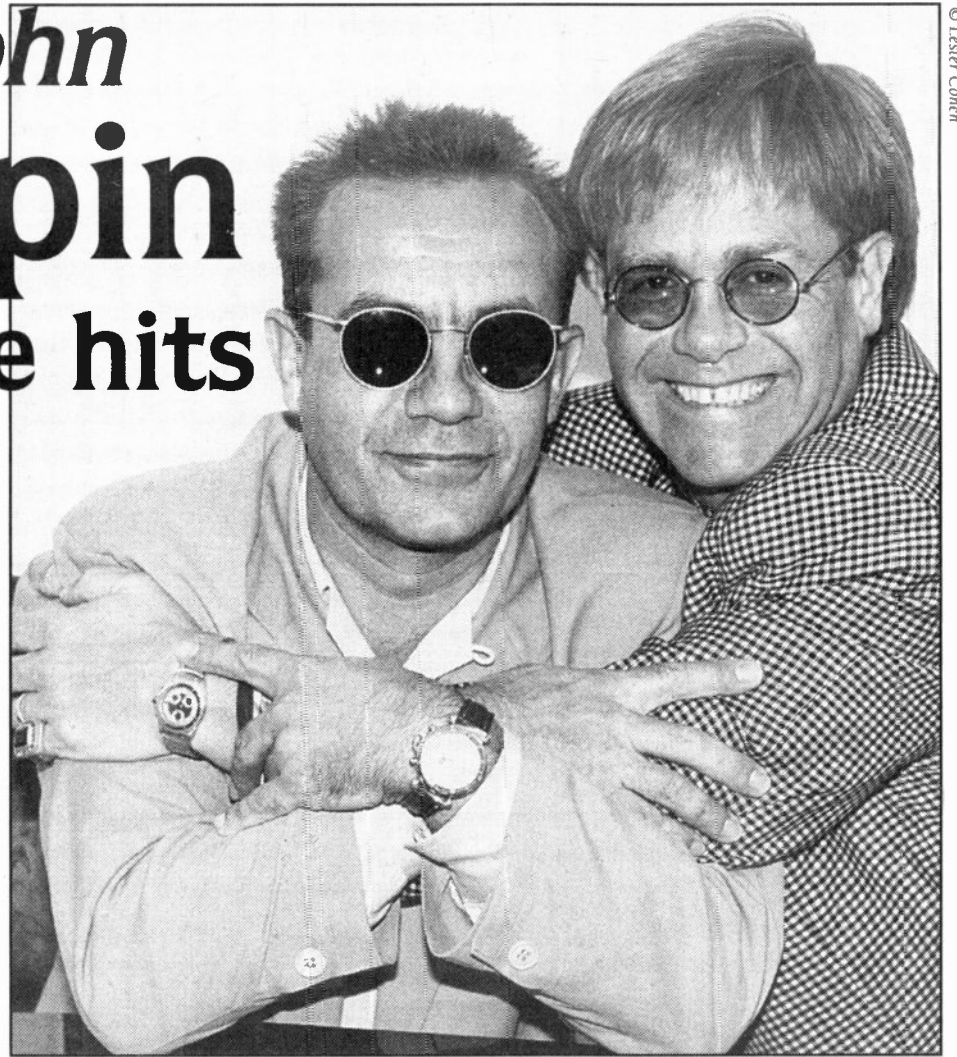

"Without Bernie Taupin there would be no Elton John," is what his musical counterpart said in 1994 when he was inducted into the Rock And Roll Hall Of Fame.

future. He became increasingly discouraged by the prospect of a farming or factory career.

"The school I went to was basically a holding tank — very overcrowded and tough," he recalled. "You had to really fight to stay alive. You can say I majored in switchblade."

His one aspiration for the future was to become a professional writer. Taupin's first job was at a Lincolnshire newspaper; however, he wasn't hired to write.

"I'll never forget it. It was a dreadful experience for me," he told *Goldmine* recently. "I worked in this dingy and dark room printing up raffle tickets and wedding invitations. I hated it.... I made about \$12 a week." After that, he ended up working on a farm in the middle of nowhere shoveling dead chickens into a furnace.

What kept the young hopeful motivated through the bleakness was his affection for literature and popular music. Taupin's earliest interest in music had been formed with the Marty Robbins classic "El Paso." As Taupin approached adolescence, interest in artists such as Woody Guthrie, Leadbelly, Brownie McGhee, Sonny Terry, and Muddy Waters soon followed.

By his late teens, rock music was leaving a profound impression on him — particularly songs by The Beatles, The Animals, and Gerry And The Pacemakers. The rock world in general intrigued the young Taupin for many reasons. Perhaps it was the free-living lifestyle more than the music itself. Dare an aspiring young songwriter from Lincolnshire dream of making a living scratching out lyrics, while most of his friends worked as farm laborers?

Then the day arrived when he spotted the

ad placed by Liberty Records in *New Musical Express* that eventually brought him and John together. "I basically answered that ad out of desperation," Taupin noted. "I honestly didn't think you could make money songwriting... I just thought, 'Well, why not? I've done everything else.'" A year later, Taupin left the quiet countryside for the big city of London. "I knew it was either sink or swim for me," he added. "I knew I had to get out if I was going to make anything out of my life."

After teaming up with Reg Dwight from Pinner who played the piano, he and Taupin started writing songs for other artists. But it wasn't until Dwight changed his name and Taupin began writing lyrics for *Elton John's* melodies that rock history was to be made.

"I honestly thought Elton and I would have some fun for a couple of years, and then I'd go home and drive a tractor. The fact that I'm still doing this today amazes me."

In 1969, John recorded one of their early collaborations, "Lady Samantha," and it became a minor hit in England. The album *Empty Sky* followed, which became their breakthrough offering.

Yearning to be known as more than a "rock lyricist," in 1971 Taupin recorded a self-titled album, where he recited his poems. John's guitarist, Davey Johnstone, and bassist, Caleb Quaye, provided impromptu music. "The poetry was written when I was about 16," he said. "It was my first shot at the spotlight. Someone suggested that I make the album, and I foolishly accepted it. I was quite naive at the time. It was all experience for me." Popular album tracks include "Birth," "To A Grandfather," "When The Heron Awakes," "La Petite

# Bernie Taupin Bibliography

*Bernie Taupin: The One Who Writes The Words For Elton John* (Knopf, 1976). Illustrated lyrics and poems.

*Elton: It's A Little Bit Funny*, (Penguin Books, 1977). Taupin-penned captions to photographer David Nutter's pictures.

*Burning Cold* (Harmony Books, 1979). Poem accompanied with artistic photographs of a nude woman.

*A Cradle Of Halos* (Aurum Press Limited, 1988). Autobiography.

*The Devil At High Noon* (Advantage Graphics, 1991). A collection of poems.

*Marilyn Monroe: Candle In The Wind*, (Pavilion 1993). Lyric to 1973 song accompanied by photographs of Monroe.

*Elton John And Bernie Taupin: The Complete Lyrics* (Hyperion, 1994). Lyrics of songs that span their entire career in alphabetical order by song title, with accompanying illustrations.

"Taupin's lyrical genius remains in his innate ability to take universal emotions and situations and describe them in thoroughly original, thoughtful and literate words and phrases."

— James Turano,  
Chicago journalist

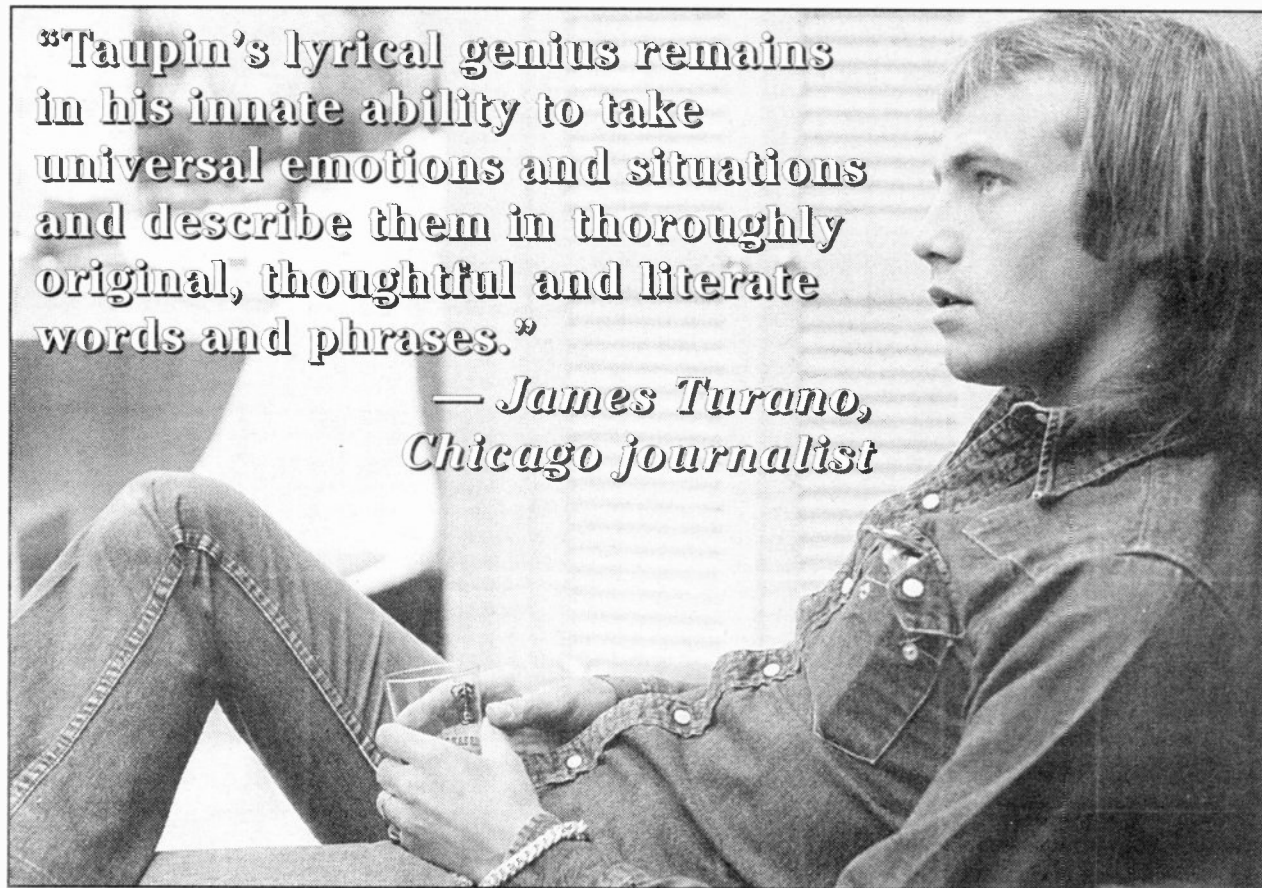

©Bob Gruen/Sir File

Marionette" and "The Visitor."

Taupin's second album — his debut as a singer — was never released, much to his relief. It was recorded for Rocket Records in the mid-70s in Canada with the help of a few friends, including Ringo Starr. The solo collection includes a few original tracks but mostly covers of country songs. Like his poetry album, Taupin wasn't satisfied with the end result.

"I was singing other people's songs," he said, frowning. "I did that album because I was too lazy to write any of songs myself. I wasn't so happy in general at the time. It was a very bad time for me. It was a bad album."

By then Taupin had certainly exceeded many of his wildest expectations since driving a tractor in rural England. Between 1972 and 1975, the John/Taupin team scored seven consecutive #1 rock albums in addition to numerous hit singles. *Captain Fantastic And The Brown Dirt Cowboy* was the first album in history ever to enter *Billboard's* album chart at the coveted #1 spot. By the mid-70s, Taupin and John were responsible for two percent of all records sold worldwide. (In 1992, the duo broke Elvis Presley's record of continuous Top 40 Hits on *Billboard's* singles chart.)

In 1976, the rock lyricist was the subject of the book *Bernie Taupin: The One Who Writes The Words For Elton John* (Knopf), which contains 114 of his song lyrics and poems. Music critics and fans alike embraced the collection. It would be nearly two decades later when Taupin followed up with the highly anticipated *Elton John And Bernie Taupin: The Complete Lyrics*.

While John's star exploded onto the rock music scene, Taupin's popularity came in at a remarkable close second. Suddenly, the introspective, nonperforming lyricist found himself (with much prompting from John) in big demand by the music media and growing public — Taupin was now pictured on the backs of album covers and inside sleeves and participated in press interviews with John, which often focused on their songwriting partnership.

Considering the large shadow John naturally cast and the overall strength of the melodies, Taupin's lyrics were often taken for granted in the mid-70s. "Early hits like 'Honky Cat' and 'Daniel' became quick, hummable hits that people knew the words to and sang along with them without really understanding them," noted James Turano, a Chicago-based journalist. "You look at much of his early work, in both the popular hit singles or the classic album tracks. You'll see great insight and creativity there. Those songs are more than just disposable pop. Taupin's lyrical genius remains in his innate ability to take universal emotions and situations and describe them in thoroughly original, thoughtful and literate words and phrases."

Having collaborated on hundreds of songs since the late '60s, the hit songwriting duo had developed what Taupin aptly described in a 1980 interview as "telepathic instinct" for each other. "We jelled so well because we both know what the other one wants. Everything always seems to fit. Elton

never says, 'This line has to go,' or 'That line has to go.' The only thing he ever says is, 'There's maybe too many verses.'"

For years, both music critics and longtime fans have contemplated as to what the secret is behind the John/Taupin partnership. John once told the press: "Bernie is very precious to me. We have the kind of a relationship that is between brothers. That's much more than being just friends. Sometimes I feel like we were once Siamese twins who then got cut clean down the middle so that each went zoom, off into the distance."

Taupin's take: "Many people write in many different ways. As most people know, the way Elton and I write is very different from the way anybody else does. We don't sit down side by side. We work very quickly because we both enjoy writing. I write the lyrics and give them to Elton, and he writes the music. Our best work comes when it's straight out, fast. It's simple. We've written everything — country, blues, reggae — not just these pure pop songs."

Since the early Dick James Music days, the magic of their collaboration has not altered much either. For example, Taupin still writes all the lyrics first and sends them off to John via fax or e-mail. "We've always worked separately," Taupin said. "I don't know any other songwriting team that does it this way, but it works for us."

In 1976, what many industry insiders viewed as something of a pop music "divorce," followed the release of the *Blue Moves* double album. To the two songwriters, it was simply a temporary separation.

"We just needed a little freedom from each other," Taupin explained to the *Los Angeles Times*. "It was never intended to be permanent. What had caused some tension for us was that he was in England, and I had moved to America [Los Angeles]. When Elton wanted to write I wasn't there to work."

It would be four years before the two men would write songs together again — John's *21 At 33* album marked the professional reunion, with Taupin penning three songs. For the next couple of years, the two continued to write together sporadically until the release of 1983's *Too Low For Zero*, where the John/Taupin team was finally once again in full force.

It was during those lost years that Taupin decided to take the plunge into other creative areas such as acting (he appeared as a musician on an episode of *The Hardy Boys*), writing screenplays and producing records for artists such as David Ackles (*American Gothic*, 1974) and The Hudson Brothers (*Rendezvous*, 1975) — none of which were the rousing successes he had anticipated. He also wrote two books, *Burning Cold*, a collaboration with Los Angeles photographer Gary Bernstein, and *Elton: It's A Little Bit Funny*, with rock shutterbug David Nutter.

Unfortunately, it happened to be a tumultuous time in the hit songwriter's life as well. Simultaneously, he experienced a

painful divorce and felt that he had hit rock bottom in his professional career. At only 26, Taupin felt completely burned out and turned off by rock 'n' roll. Worse yet, he was even questioning his own existence.

"It was such a depressing time in my life," he recalled with a shudder today. "I felt that Elton and I had gone as far as we could in our careers. There was nothing left for me to do. Considering the divorce and my disillusionment with rock 'n' roll, I was feeling real sorry for myself." Taupin had endured something of a mid-life crisis — only 15 to 20 years early. Numbled by depression, he turned to drinking and eventually was forced to face the reality of his downfall.

"I did some heavy, heavy drinking that I had to dry out," is what he told a Hollywood reporter. "I went to live in Mexico for a while. I became a recluse. I just wanted to forget rock 'n' roll because it made me a drunk and it made me lose my wife. [Taupin has married and divorced twice more since then.] I felt like a part of my life was missing."

Following his six-month Mexico retreat — largely alone and mostly catching up on 10 years of reading books he missed, Taupin returned to Los Angeles with a renewed sense of spirit. However, he still wasn't that certain about returning to the music business, until Alice Cooper, a then-recently reformed alcoholic, approached him to cowrite the 1978 *From The Inside* (Warner Bros.) album. The two men had been friends for years — drinking buddies. As Cooper tells it, they had talked about writing songs together for a long time, but drinking binges had considerably slowed down the process. When the both finally sobered up, the time was right.

"When Alice first asked me to write with him, I told him I was through with writing songs," Taupin said. "No more for me. But then I relented because I felt obligated since I had always promised to write with him but just never had the time."

Following the release of *From The Inside*, Bernie stated, "Working with Alice was a bit strange. We are both lyricists. Other people write the melodies and we wrote the lyrics, 50-50. Alice would write a line and I would write a line. He'd write a verse and I would come up with the chorus. It was such a bizarre way to write, and I'll never do it again. But I enjoyed the experience."

Cooper relished it as well. "I may be only one of the lyricists that ever collaborated with Bernie," he noted. "He was one of my blood brothers during the L.A. years." Three decades later their friendship has remained intact.

Though *From The Inside* didn't fare well with music critics, Taupin still viewed it as "clever and reasonably good." Some of the highlights include "The Quiet Room," "Jacknife Johnny" and the single, "How You Gonna See Me Now." In any case, it got Taupin feeling better about himself and getting involved in rock 'n' roll again. Perhaps he was ready

## Bernie Taupin-written songs recorded by other artists

Song	Artist	Year
"Lonnie & Josie"	Kiki Dee	1973
"Supercool"	Kiki Dee	1973
"The Last Good Man In My Life"	Kiki Dee	1974
"Hard Luck Story"	Kiki Dee	1974
"Lover Come Back To Me"	Hudson Brothers	1974
"Lonely School Year"	Hudson Brothers	1975
"The Man Who Loved To Dance"	Kiki Dee	1976
"Snow Queen"	Kiki Dee	1976
"Broken Woman"	China	1977
"Savage"	China	1977
"If I Werent So Romantic I'd Shoot You"	Derringer	1978
"Julie"	Cher	1980
"For The Working Girl"	Melissa Manchester	1980
"Never Give Up On A Dream"	Rod Stewart	1981
"Sonny"	Rod Stewart	1981
"Guess I'll Always Love You"	Rod Stewart	1982
"Johnny And Mary"	Melissa Manchester	1982
"Hey Ricky You're A Lowdown Heel"	Melissa Manchester	1983
"White Rose"	Melissa Manchester	1983
"Satisfied"	Rod Stewart	1983
"Into The Heartland"	The Motels	1984
"We Built This City"	Starship	1985
"Love Rusts"	Starship	1985
"These Dreams"	Heart	1985
"Hard Lesson To Learn"	Rod Stewart	1986
"I Engineer"	Animotion	1986
"When The Phone Stops Ringing"	Boomerang	1986
"The Burn"	Starship	1989
"Deal For Life"	John Waite	1990
"Dip Your Wings"	Peter Cetera	1992
"The Rain"	Carlene Carter	1993
"Monkey In My Dreams"	Martin Page	1994
"For Wanting You"	Marianne Faithful	1999
"Red"	The Young Dubliners	2000



The 1996 lineup of Farm Dogs, from left includes: Jim Cregan, Bernie Taupin, Dennis Tufano, and Robin Le Mesurier.

to venture back into the studio again.

In fact, it was exactly 10 years after he and John had been first catapulted into rock stardom with the *Elton John* album. The first for the newly motivated rock lyricist's musical rebirth was *He Who Rides The Tiger* (released in 1980 on Asylum Records) — a highly anticipated solo album. The lyrics were written to melodies composed by '60s ex-Buckingham's lead vocalist/guitarist Dennis Tufano. John was the guest vocalist on one of the tracks titled "Love (The Barren Desert)." Overall, *He Who Rides The Tiger* proves to be rich in passion and drama — it packs a pretty good kick in the shins too.

The songs, recorded in Los Angeles, presented a compelling new direction for Taupin, who no longer felt pigeonholed as only John's lyricist. "I was at the point where I was looking to take some risks," he explained following the release of his album. "I wanted to try singing my own lyrics. I was ready. I felt confident and was looking for new challenges."

Writing for John and writing for himself are two entirely different situations. For starters, he had more freedom and didn't have to live up to anyone's standards but his own. "I was able to say some of the things I couldn't say before, and I didn't have to force it on some other singer. Obviously, if I'm writing for Elton, I can't write songs for him that I would write for myself."

Some of his most intriguing lyrics ever are showcased on *Tiger*. A review in the *Los Angeles Times* commented: "Taupin continues his post-*Captain Fantastic* exploration in his own album, but the tone is even more troubled. In 'Approaching Armageddon,' he traces his own pop involvement including writer's block after *Blue Moves*, alcoholism and the loss of self-esteem. In 'Lover's Cross,' a wounded Taupin lashes out at romantic betrayal. Taupin exhibits his longtime fascination with people afoot of the law in 'Monkey On My Back,' writes a colorful cinema-ready tale of San Fernando Valley teenage cruising in 'Valley Nights' and attempts a Dylan-esque, post-Bicentennial statement in 'Born On The Fourth Of July.'"

Maintaining his musical and personal ties with John, Taupin still yearned to collaborate with other recording artists. Though the bulk of these efforts were with Cooper, he also wrote lyrics for Rod Stewart, country singer John Anderson, Melissa Manchester, The Motels and other artists.

Six years later came another solo offering, *Tribe*. Songs on *Tribe* are much lighter and more radio-friendly. "Friend Of

The Flag" and "Citizen Jane" were the only two singles released to radio. The latter made it onto *Billboard's* Adult Contemporary Chart. Both singles and videos received moderate airplay on VH-1 and MTV.

*Tribe* originated from Taupin's association with Martin Page, a collaboration that earlier scored two consecutive #1 singles with Starship's 1985 "We Built This City" and Heart's 1986 "These Dreams."

Regarding his '80s writing partnership with Taupin, Page told *Billboard*, "Bernie was looking to work with different influences. He had heard the song, 'Dancing In Heaven' by my band Q-Feel. The biggest thrill in my life was Bernie coming over to my house and hearing the demo to 'These Dreams' and telling me that he thought it was incredible. At that point I knew we were off to a great partnership. The greatest thing for a collaboration is to be friends, and that's what we are."

Together with Page, Taupin's goal for *Tribe* was to create songs that originated from a genuine belief in their subject matter, from the opener, "Friend Of The Flag" (a foreigner's view of life in America — Taupin has been a resident of California since 1971) — to the closing track "Desperation Train," (a tribute to unsung heroes). Other highlights include "She Sends Shivers" (an erotic duet with The Motels' Martha Davis), "Billy Fury" (John contributes backing vocals) and "The New Lone Ranger."

Like his previous effort, *Tribe* was recorded with Taupin's handpicked band. "My main concern was that the album be structured with a hungry drive for success, written in living rooms, rehearsed in basements and recorded with my own band," Taupin stated, following the album's release. "The tribe is the root of our learning in all forms of progress, including music. I'd like to think that I've returned to find something new. When people think about the word 'tribe,' they think about the Indian tribe or the African tribe. But in essence we are all [part of a] tribe."

Some of the high points of recording his second solo effort included working closely with his band, as opposed to being a lyric writer turning his work over to the recording artist.

"It was very much like a family situation for me," recalled Taupin. "I wanted to go back to a garage situation. I wanted this band element going. There was a real camaraderie born making this album. This attitude stretched onto the album. I mean, I put my whole heart and soul into making *Tribe*. So did everyone else in the band. Working together and leaning on each other gave me a tremendous confidence. The guys

were so encouraging. It was very, very special."

To coincide with the 25th anniversary of the John/Taupin songwriting partnership, the *Two Rooms* double album, video/TV documentary and hardcover book (England edition only) were released in 1991. The title was aptly named for the team's unique approach to writing lyrics and music. The high-profile project received much critical praise. Popular artists who covered John/Taupin songs include Eric Clapton ("Border Song"), Phil Collins ("Burn Down The Mission"), Tina Turner ("Bitch Is Back"), and Stewart ("Your Song"). A year later, Taupin and John made headlines worldwide again when they both received the largest songwriting advance ever in music publishing history from Warner/Chappell Music.

Those in the know will agree that the songs John sings have more to do with his musical cohort's life than his own. Two prominent examples are "Tiny Dancer" (Taupin married an American woman, Maxine Feibelman, in 1971) and "Tonight," in which he profoundly outlines the unraveling of his marriage. The words he writes are derived from his experiences, inspirations and interests. As a rule, titles usually come first, and then a few lines are knocked out before actually completing the song.

Taupin said he spends no longer than 20 minutes to a half hour writing a song. Most of his earlier works reflect upon his fascination with America. Literary figures such as Oscar Wilde, Christopher Isherwood, and Somerset Maugham have influenced his writing just as much today as 30 years ago. As for contemporary songwriters, Taupin has cited Bob Dylan, Bruce Springsteen, and Elvis Costello as a few of his favorites.

Themes often resurface on albums collaborated with John and include references to family and religion. Other lyrical imagery about farming, drinking, guns, hard living and even death reoccur. However, ambiguous love songs seem to be Taupin's speciality (particularly in the '70s and '80s). He cleverly manages to side-step love scenarios, and more often than not, his lyrics deal with gloom-and-doom relationships.

Of the hundreds of songs he's written, his two main favorites even to this day include "Candle In The Wind" (1973 version) and "Sacrifice." However, he remains reluctant to discuss specifics in songs and prefers that listeners draw their own conclusions.

Taupin's musical and personal preferences are in contrast to John's. For example, while John likes to listen to modern music,



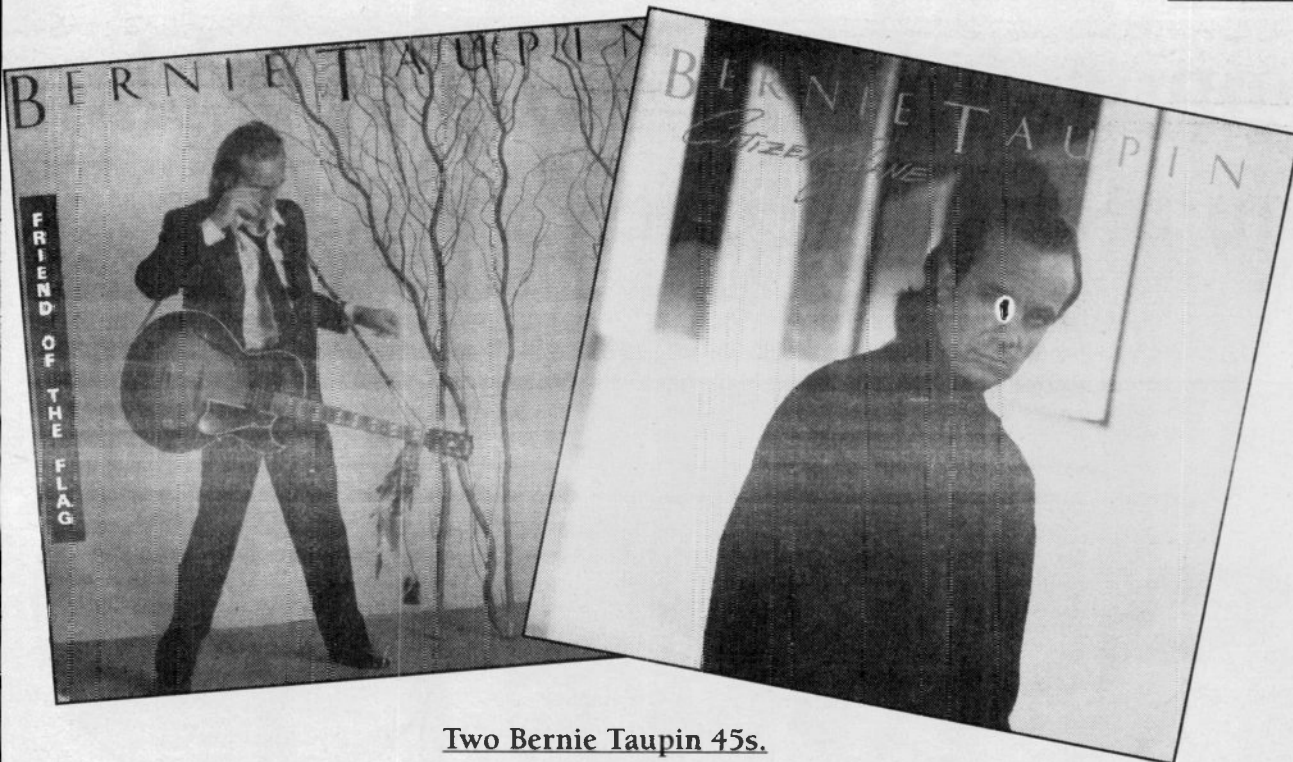

Two Bernie Taupin 45s.

## Bernie Taupin Discography

by Mary Anne Cassata

To date, Bernie Taupin has released three solo albums to which his lyrics and/or poems were set to music by musicians other than Elton John. Since 1996, he has been releasing music with his band, Farm Dogs.

45s	Label/#	A-side/B-side	Year
	RCA 5162-7-R	Friend Of The Flag/Backbone	1987
	RCA 5216-7-R	Citizen Jane/White Boys In Chains	1987

Albums	Label/#	Title	Year
	Elektra EKS-75020	Taupin (poetry)	1971
	Asylum 6E-263	He Who Rides The Tiger	1980
	RCA 5922-1-R	Tribe	1987
	RCA 6420-1-RAB	Interview Album (DJ promo)	1987



12-inch promos	Label/#	Title	Year
	RCA 6134-1-RDAA	Friend Of The Flag	1987
	RCA 6446-1-RDAA	Citizen Jane	1987

Compact disc	Label/#	Title	Year
	RCA 5922-2-R	Tribe	1987

With Farm Dogs	Label/#	Title	Year
Compact disc singles	Discovery	Beautiful	1996
	Sire 74605	Daria	1998
	Sire 7462	Foreign Window	1998

Compact discs	Label/#	Title	Year
	Discovery 77046	Last Stand In Open Country	1996
	Sire 31014	Immigrant Sons	1998

to the band's style. There is not only a wider spectrum and use of instrumentation, but the music itself seems to be much more upbeat than before." Highlights of the album include the opener, "Foreign Window," "Daria," (the only single released to radio), "Bird Of Prey" and "Whiskey In The Bathtub."

At present, Taupin is considering recording another solo album and has already completed a few songs for it. There are still plans in the works to release a third Farm Dogs effort, though a target date has not been determined. Recently, Taupin penned the title track, "Red," for the Young Dubliners' album (EMD/Higher-Octave label). The rock/pop group ranks as one of the songwriter's current favorites. He also has written a song with Matchbox 20's Rob Thomas, though it has not yet been recorded.

Taupin spends much of his time at his 30-acre Roundup Valley Ranch, where he raises and sells cutting horses, which are quarter horses specially trained to ferret out a single member of a cattle herd. His state-of-the-art ranch is considered one of the premier cutting horse facilities on the West Coast. He first got involved with cutting horses a few years ago after he attended a few shows with a friend.

As a new endeavor, he recently took up painting and had his first public showing at a trendy Los Angeles art gallery. So far, Taupin has donated a few small pieces to auctions representing different children's charities.

These days, it seems like Taupin is more involved in playing out the role of his popular "Brown Dirt Cowboy" character. But of course, it will always be the words he writes that will continue to inspire and move people.

"Taupin's lyrics have captured the hearts of music fans," noted David Sigler, of *Taupin*, the now-defunct quarterly publication of the early '90s. "Fans were always eager to learn more about him. That's why the publication strived to include rare articles and interviews and of course the less-recognizable lyrics [recorded] by other artists."

Taupin in the 21st century is still an undeniable force as both lyricist and musician. His influence grows stronger with each project he undertakes.

For more information on Bernie Taupin visit the official Farm Dogs Web site at [www.farmdogs.com](http://www.farmdogs.com)

cians Jim Cregan and Robin Le Mesurier. The group's acclaimed debut album, *Last Stand In Open Country* (Discovery Records), was written and recorded at Taupin's ranch in Southern California. The music — created in the round with Taupin supplying the lyrics — harkens back to an impressive mix of folk, blues and country. Cregan and Le Mesurier quickly applied melodies to Taupin's words, often completing as many as two songs a day.

"The whole thing about being an artist is about stretching yourself and doing the things you want to do," offered Taupin, Farm Dogs' lead vocalist. "It may have taken me a long time, but the time is right. We were reinventing ourselves." Growing up, he realized the kind of music he was listening to was simple music. "I've always gravitated towards music that was rootsy and authentic," he added. "This kind of music has stayed with me all my life... and like my life, I wanted to simplify my music and create the kind of music that really influenced me in the first place. Having made records in the past, I was always working towards that one record that I felt would be an extension of myself."

*Last Stand In Open Country* (coproduced by Farm Dogs and David Cole) comes complete with full, rich, colorful characters ranging from barflies and misfits to loose women and big-screen heroes. Strong cuts such as "Cinderella '67," "Me And My Friends," "Shameless" and the only promotional single, "Beautiful (I Don't Want To Be)," are lyrically compelling and heavy in three-part harmony. There were no singles released to radio.

Following the Farm Dogs' release, a review stated: "*Last Stand In Open Country* is an Americana album with a great grassroots/folk groove. The country/blues influence on this album is awesome, making Taupin's lyrics sing out in their unique cinematic style. His legendary storytelling abilities make the album a great start." Country singer Clint Black echoed the review, "Bernie is one of the great cowboys of pop music, both figuratively and literally."

Recording an album is a project Taupin never takes lightly, since he basically makes an album a decade. "We all had a lot of fun making this record," he noted in 1996. "We're a very light-hearted band, but we take our music very seriously. We have an identity, and that identity is to be recognized. Farm Dogs is now the most important venture in our lives."

*Last Stand In Open Country* was the first in a multi-album deal for Farm Dogs. Their follow-up effort, *Immigrant Sons* (Sire Records) was released in early 1998. This time, Taupin and company — Cregan, guitar, vocals; Le Mesurier, guitar; Tony Brock, drums; and Tad Wadhams, bass — opted for a more well-rounded sound, an acoustic rock album of sorts.

"There has been a transition already in the Farm Dog style," wrote a Los Angeles-based music publication. "*Immigrant Sons* has taken on a more full, rich sound than did *Last Stand*. Their debut album possessed a more acoustic roots feel, whereas *Immigrant Sons* adds a more musically full dimension

Taupin prefers jazz, country and more roots-oriented music. "I don't listen to anything modern at all," he stated in 1994. "But whenever I get into Elton's car he's playing stuff by these groups with initials for names, and they all use electronic percussion."

Overall, the songwriting partnership with John, which he often refers to as "a marriage," is stronger than ever. The two songwriters rarely work face-to-face (they did early on in their career) except for John's new studio album, *Songs From The West Coast*, and 1995's *Made In England*, where Taupin wrote lyrics in the recording studio instead of faxing overseas. Some John/Taupin penned songs for the new album were written in Atlanta (where John resides part time) as well as the title track to the 1999 Albert Brooks film *The Muse*.

For the millions of fans worldwide, it doesn't matter how the partnership works, just as long as it keeps going strong — hits or misses.

"Taupin gets the credit he deserves," noted former *East End Lights* publisher Tom Stanton. "Everyone knows he wrote the lyric for the best-selling song of all time ['Candle In The Wind' 1997]. But his contribution has been much more significant than that. It's tough to imagine Elton without Taupin. And Elton has said as much. He would never have been as successful without Taupin. You see that realization especially on the albums throughout the 1970s, when Taupin was given huge billing. What other lyricist regularly got such attention in the liner notes?"

Another reason why fans revere Taupin's writing is because he never ceases to challenge himself or amaze even his most ardent admirers. "Taupin has evolved as a lyricist," Stanton added. "He has never been content to simply duplicate his earlier successes. He has grown and matured. Fans find his versatility amazing. Look at his body of work. He writes about paranoia, about isolation, about renewal and aging. Our readers treasure Taupin. They love his work not only as Elton's lyricist but as a musician in his own right."

Following the tragic death of Princess Diana in August 1997, Taupin rewrote the words of the hit "Candle In The Wind" for a tribute performed by John at the funeral service in London's Westminster Abbey. It certainly came as no surprise that the heartrending song would subsequently become the biggest selling single of all time. (Even beating out Band-Aid's 1994 smash, "Do They Know It's Christmas?")

Six months later his lyric package for the song, comprised of three written, annotated and typed pages, sold for a staggering \$400,000 at a Christie's Auction held in Beverly Hills. The bidding had started at \$200,000, and the sale supported Children's Hospital. "It's beyond our wildest dreams," he expressed that night. "Children's Hospital is close to my heart, as are the lyrics to 'Candle In The Wind.' I am still amazed and astounded by what this song has achieved."

As a dedicated artist, Taupin continues to challenge himself with each new project. In 1995, he co-founded the roots-rock band Farm Dogs with longtime friends and musi-

# Elton John memorabilia most collectible, though imported 45 sleeves valuable

by James Turano

Elton John has released a plethora of product during his 30-plus year career. How collectible or valuable his recorded catalog is (42 albums alone, including his just-released *Songs From The West Coast*), as well as a varied assortment of John-related memorabilia, remains debatable.

Clearly, John is one of pop music's genuine icons, as evidenced by his statistically stratospheric record sales, dating back to the early '70s; his mantle filled with the entertainment world's most coveted statues including the Academy Award, the Grammy and the Tony; his concert attendance records; and his flamboyant personality. But unlike some of the most popularly collected acts including The Beatles, Bob Dylan, Grateful Dead, and Bruce Springsteen, it appears John is collected more based on his persona rather than the music he has made.

Although certain artifacts of historical importance or exaggerated legend owned or used by people such as Dylan, John Lennon, and Jimi Hendrix have brought thousands at auction and become high-priced collectible items, still for these and other artists, it remains their music that is of main interest to their most ardent fans or collectors. With John however, it's more the possessions than the pressings, though there are several hard-to-find, expensive recordings that the many die-hard John fans covet.

"Elton John's fan universe is huge, but it's divided into two distinct categories — the most casual of fans and the most intensely loyal," according to Alan McCormick, one of the world's most knowledgeable and foremost Elton John collectors and dealers. McCormick's England-based business, Wrap It Up, ([www.homepage.nlworld.com/EltonJohn](http://www.homepage.nlworld.com/EltonJohn)) exclusively sells John collectibles to customers around the world.

"There really isn't an in-between. There are those who may see him in concert once in a while and maybe own a couple of greatest hits compilations, and there are those who collect almost anything with his name of it. They are long-time fans and collectors with a great knowledge of and dedication and passion for all things Elton," McCormick said.

He added that within that "serious" group of fans there are several sub-groups, including those who collect only vinyl, only video, only paper goods such as programs and posters or only record industry promotional items such as album-related ashtrays, playing cards and buttons. Some fans dig down even deeper, only collecting items from a specific year or individual album.

"I know of a few collectors who, for instance,

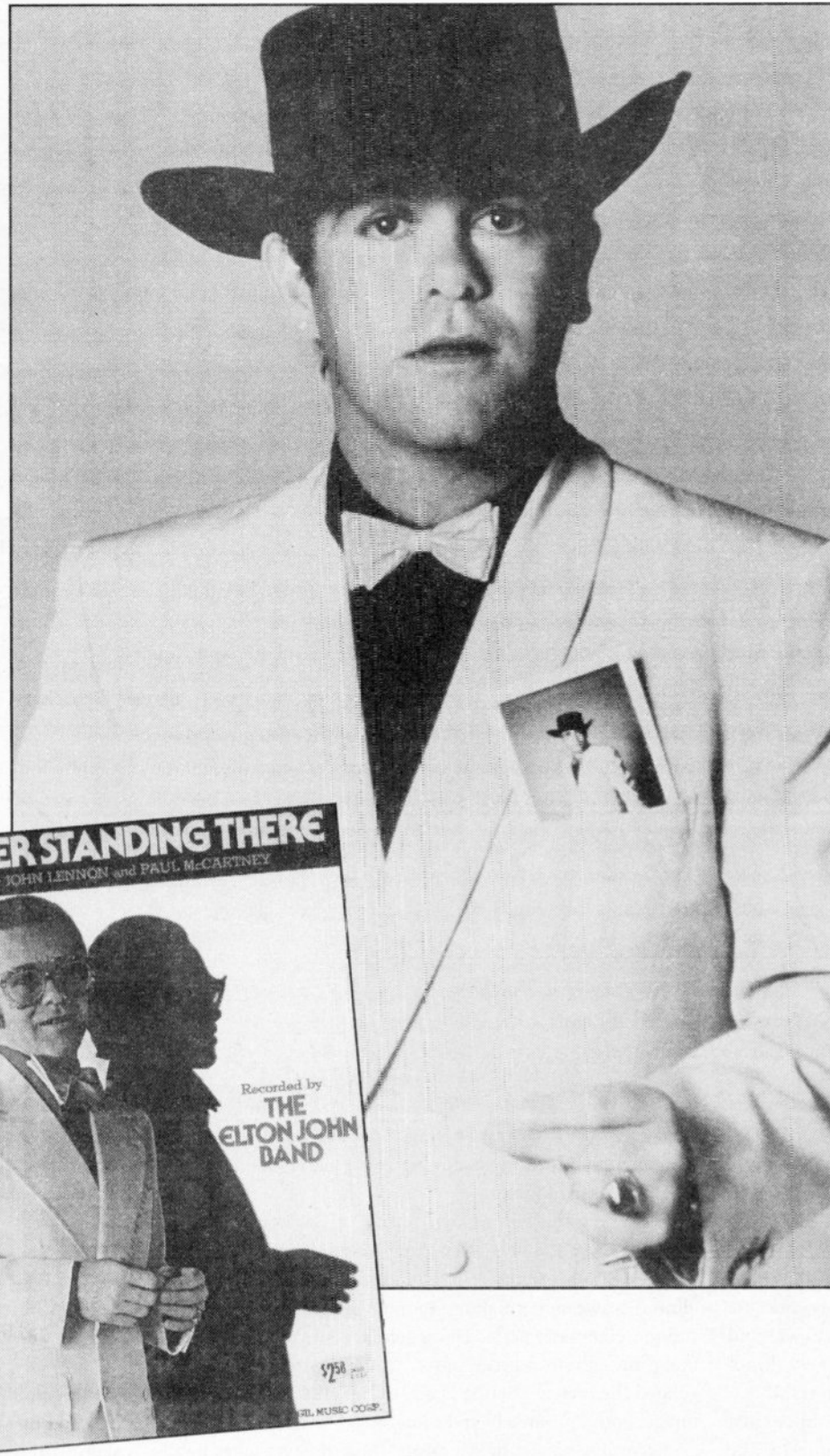

Courtesy of Geffen



A promo copy of Elton John's first single, "Lady Samantha," (DJM 70008, 1969), is listed in Tim Neely's *Standard Catalog Of American Records* with a near-mint price of \$100. The stock copy changes hands for \$300 in near-mint condition.

only collect things associated with Elton's most popular albums, *Goodbye Yellow Brick Road* and *Captain Fantastic And The Brown Dirt Cowboy*. They collect what means the most to them. There's a personal aspect to it."

McCormick said for instance, a mint condition yellow vinyl issue of the *Goodbye Yellow Brick Road* album from 1973 still can demand \$50-\$75, and a special 2,000-count limited edition, brown vinyl promo issue of *Captain Fantastic* from 1976, signed by both Elton John and his lyricist Bernie Taupin, can cost \$250 or higher.

McCormick said that several early John recordings in mint condition can garner prices from several hundred dollars to more than \$1,500, such as acetates or pressings of which very few are known to exist. McCormick said he knows of only two mono copies of John's U.K. album *Empty Sky*, for example. But it's the memorabilia associated with John's career and persona — such as the outrageous stage costumes and eyeglasses he wore during the 1970s and '80s — that most appeals to his collectors and realizes the most money in sales.

ies such a bigger-than-life personality, and even Elton John has admitted that his costumes and off-stage persona have overcome his recordings. That is reflected in what his fans want to collect. It appears they want more of what represented the 'Elton John experience' than his musical legacy," McCormick said.

When he began his exclusive Elton John business more than 13 years ago, the greatest demand from fans, especially those in the United States (who account for more than 75 percent of his business) was for vinyl 45

**"...there are some rare, historic and high-ticket Elton John items. But because those who have them are such serious Elton John collectors and fans, it's doubtful they will ever part with them, so there aren't too many floating around."**

**— Alan McCormick, Wrap It Up**

# New Releases

## NEW RELEASES NEWS

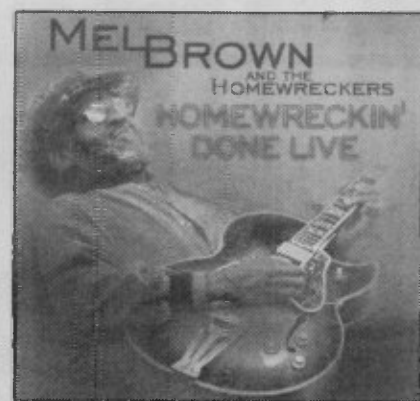

**Just out:** *Homewreckin' Done Live* (Electro Fi Records) is the new release from blues guitarist Mel Brown (a 2001 W.C. Handy Award winner) and The Homewreckers... Backing up blazing guitarist Vinnie Moore on his new *Defying Gravity* (Shrapnel) are ex-Journey drummer Steve Smith, former Dixie Dregs bassist Dave LaRue and former Rainbow keyboardist David Rosenthal.

**Coming up:** Oct. 23 is the release date for Simple Minds' *Neon Lights* (Eagle), an album of covers of some of their favorite artists' songs, including "Gloria" (Van Morrison/Them), "The Man Who Sold The World" (David Bowie), "Dancing Barefoot" (Patti Smith) and "Needle And The Damage Done" (Neil Young), among others. Simple Minds are also in the studio recording their first new album in six years, due May 2002... Carol Noonan's new release, *Big Iron*, (self-released) is due out in November... Due Dec. 4 is *Stones Raiders* (Columbia), alterna-rappers Cypress Hill's follow-up to their multiplatinum-selling (15 million worldwide) *Skull & Bones*... Victor Bailey's new release *That's Right* (ESC), originally scheduled for an Oct. 23 release, has been postponed until early 2002... England's *Motörhead*, celebrating their 25th anniversary, plan a special tour and a new release in early 2002.

**Tributes:** Out now is *Creation Dream: The Songs Of Bruce Cockburn* (True North/Rounder) by guitarist/composer Michael Occhipinti, best known as co-leader and producer of the award-winning 16-piece jazz group NOJO. Occhipinti puts a jazz spin on Canadian singer/songwriter/guitarist Cockburn's stellar output. Not only that, but Cockburn himself guests on the album, along with clarinetist Don Byron and violinist Hugh Marsh, among others. Some of the Cockburn songs on the album include "Lovers In A Dangerous Time" and "If I Had A Rocket Launcher"... *Better Than The Beatles: A Tribute To The Shaggs* (Animal World) is due Oct. 30. The Shaggs were an all-girl group made up of three sisters from Fremont, N.H., who made two eclectic "Outsider Music" albums in the late '60s and early '70s that were later discovered by music lovers and major artists (including Bonnie Raitt, Carla Bley, and Jonathon Richman) long after the band had broken up. The tribute album's title comes from Shaggs fan Frank Zappa's quote: "The Shaggs. Better than The Beatles, even today." Zappa called the band's *Philosophy Of The World* album his favorite album of all time. Artists on the tribute include Slot Racer, Ida, R. Stevie Moore (an original Shaggs fan), with liner notes written by Irwin Chusid, author of the new *Songs In The Key Of Z*, which includes The Shaggs, among other often-overlooked bands.

— Greg Loescher



those albums, and the hits kept coming.

But consider this: This is the first studio album since 1984's *Breaking Hearts* to have the sentinel drummer of the classic Elton John Band sound, Nigel Olsson, (on five tracks anyway), as well as teaming him with Davey Johnstone for those glorious backing vocal parts. Also back are Paul Buckmaster's timeless string arrangements, and of course all the songs feature high-voltage Bernie

Taupin lyrics to properly propel the Elton John melody machine like no other lyricist can, Tim Rice or no Tim Rice, respectfully. That's four big cannons of the legendary Elton John Band sound of the '70s right on the front line to begin with.

Given a second chance here is producer Patrick Leonard, who did an acceptable job on the much-overlooked *Road To Eldorado* soundtrack a couple of years ago. It sounds as though Leonard may have reviewed some of Clive Franks' tasteful production of John's late-70s/early '80s output for this material — to his advantage. Aside from so much compression used throughout the album, the producer fares OK, but he just can't approach the organic greatness of Gus Dudgeon, who

stands next to Sir George Martin on the all-time list of greatest producers in this reviewer's book.

If music fans have forgotten what those Dudgeon-produced albums sounded like, fire up 1976's *Blue Moves* and hang on — as the tropical rainforest of thrilling exotic soundscapes literally jumps out of the speakers. That's the way instruments are supposed to sound — natural. Dudgeon is an expert analyst on where individual elements fit in respective bandwidths, with wise placement of those elements within the stereo spectrum as well.

These songs would have benefited from the nuance-sensitive approach that Dudgeon — a man whose only character flaw in this life was a fall from favor upon occasion with former Elton John manager John Reid — brings to the table. Enough of this, or I'll start in on the absent percussion hurling of Ray Cooper!

*West Coast* kicks right into classic EJ mode on the first track, "Emperor's New Clothes," which would have fit nicely on 1972's *Honky Chateau*, with "Mona Lisa's And Mad Hatters" style. A good start — unaided as it were — by a stupid drum machine. "Dark Diamond" follows with a Stevie Wonder-sounding harmonica and glistening vocals headed up by Olsson and Johnstone.

More of these key ingredients surface on "Look Ma No Hands" which glides along in mid-tempo, giving way to "American Triangle." In "Triangle," Taupin handles the difficult subject matter of the brutal, senseless murder of a young gay man by two indifferent rednecks with nothing better to do. Yet he fills this steep order with his usual ease — giving John a relenting ode that mourns all three sad figures of the story, as John rises to the occasion with a compassionate and merciful performance with an albeit folklore sensibility.

The clear-cut choice for the second single, "Original Sin," is a treasure for anyone who has ever experienced losing their first true love, and whom does that not cover? A lilting melody that will go down with his best work, backed with fine self-harmonies and graceful strings from Buckmaster. Six cuts in, longtime fans get a real treat. "Birds" features a playful piano figure that echoes John's work from the 1971 *Friends* soundtrack and harks even further back to some of his Dick James demos of the 1960s (which should really be officially released).

The excellent first single, "I Want Love," sounds like a John Lennon piece from the *Plastic Ono Band* album. John's gritty dry vocal is priceless here, and the door-opening vocal hook on the chorus grabs the listener. John rocks out on the blues raver "The Wasteland," adding some extra chords in the mix for pop appeal, slightly deranged gospel backing vocals for soul and a piano solo for punch.

"Ballad Of The Boy In Red Shoes" is strong, with all the right moves as described above, harmony arrangement to die for, trickling "Madman Across The Water" mandolin and all. "Ballad" sounds like a lost song from 1973's landmark *Goodbye Yellow Brick Road*.

The 12-song set continues with "Love Her Like Me," which lyrically is a descendant of

(Please see New Releases page 32)

## Indie Label Spotlight



ERIC BIBB  
*Painting Signs*  
EarthBeat! (R2-74382)

Bluesman Eric Bibb couldn't have foreseen the tragedy of Sept. 11, 2001, when he recorded *Painting Signs*. Now its sadly hopeful lyrics offer us the comfort bygone black music knew it needed to give its people in times of deep trouble.

Like his fellow country blues revivalist Guy Davis, Bibb entered the music scene with a pedigree. Bibb is the son of '60s folk

bluesman Leon Bibb, nephew of Modern Jazz Quartet pianist John Lewis and godson of Paul Robeson.

Though he's still essentially an acoustic blues player, Bibb's palette has many shades of sepia: Jimmy Reed-based jive ("Honest I Do"), soft R&B ("Got To Do Better" with sanctified backup vocals from Linda Tillery and Emma Jean Foster) and gospel shout ("Don't Ever Let Nobody Drag Your Spirit Down" with soulman Wilson Pickett singing lead). Angels are a running theme on this album, thanks to covers of Rev. Gary Davis' "I Heard The Angels Sing" and Jimi Hendrix's piano-backed "Angel" — an apt song for the soft intimacy of Bibb's tenor.

A variant of the old folk standard "Delia" here places poor Delia's murder on Christmas day for an added touch of sorrow. Yet, where old black blues has grieved, black gospel has offered solace. Bibb does both here, seeking "Hope In A Hopeless World" (with royalties from the song's release as a single going to the American Red Cross). *Painting Signs* tells us there can indeed be hope in a hopeless world, but it's up to us to create it.

— Bruce Sylvester

# A Broad Abroad

## ATOMIC ROOSTER, ARTHUR LEE AND THE SHACK, CLIMAX BLUES BAND GET NEW LIFE FROM REISSUES

by Jo-Ann Greene

What was it that Peter Pan said? "If we all wish hard enough..."? Last month, this column bemoaned the absence of an authoritative Atomic Rooster box set. This month, we're celebrating the arrival of... well, maybe not an authoritative one, but certainly the most complete roundup of the group's first two vital years.

*Resurrection* (Akarma, Italy; www.akarmarecords.com) is a three-disc collection incorporating the band's first three albums — 1970's *Atomic Rooster* and *Death Walks Behind You*, and 1971's *In Hearing Of*, with original U.K. artwork and, for the first and third albums, bonus tracks that wrap up every note the band's first two classic incarnations released, including the "Play The Game" B-side and a Carl Palmer-era demo of the seething "VUG." There also are five tracks recorded live for the BBC in 1972 by the third Rooster lineup, featuring Chris Farlowe and highlighting songs from the band's fourth album, *Made In England*.

Even more exciting, the first album is presented in its original British form, with original bassist Nick Graham's contributions present and correct — the U.S. edition of the LP replaced his work with newly ordained Rooster John Du Cann. However, newcomer Du Cann swiftly makes his presence felt on the *Atomic Rooster* reissue, with an early demo of "Devil's Answer" appended to the end of the first album, followed (on *In Hearing Of*) by the hit take.

A 24-page booklet tells the band's story in straight, uncomplicated style, aided by some fine photos, all the lyrics and a complete discography, while the individual albums are packaged in the now-familiar "Akarmapak" sleeves, reproducing the original LP artwork. It's an excellent package and all we need now is something similar, wrapping up the rest of the band's story.

A band who has had the Akarma box set treatment already is Climax Blues Band. Now the doughty Italian label is plugging deeper into the group's catalog with the long-awaited reissue of *FM Live*, the band's first live album and first American hit. *FM Live* was recorded live in New York in 1974, originally for broadcast on WNEW-FM (hence the album's title), and it captures all the dynamism and excitement that was their onstage calling card.

Even more so than across the Climax Blues Band's studio albums, things veer between driving blues and a heavy jazz funk, but the closing six minutes of "Let's Work Together" are unequivocal boogie time, one of the punchiest renditions of the old warhorse you're ever going to hear. The audience is so enthusiastic throughout that sometimes it's hard to believe you're not in the thick of it yourself. There were an awful lot of fat, bloated, nasty things crawling around the American live landscape during the mid-1970s, but Climax Blues Band weren't one of them.

There's more blues-wailing brilliance coming from Mississippi Heat, the ever-popular Chicago blues band which has been around for 10 years now — and celebrates the fact with a Tenth Anniversary Edition of their finest album, 1999's *Handyman* (Cross Cut Records, Germany; www.crosscut.de). Repackaged in an extravagant multi-gatefold digipack with new liner notes, the album is further bolstered with two new recordings, cut last year and driving the album to over an hour in length.

If you've ever caught Mississippi Heat in concert (and heaven knows they tour enough!), you'll know exactly what to expect from *Handyman*, but it'll probably still manage to surprise you somewhere. Notices reprinted on the album sleeve describe it as "the best Chicago blues release of 1999." It's also one of the best-sounding blues albums of the decade.

Any Love fans out there? *Arthur Lee Live In Liverpool 1992* (Viper, U.K.; www.the-viper-label.co.uk) is an 11-track recounting of one of Lee's most talked-about comeback performances. Lee is accompanied by local legends The Shack, one of the finest of latter-day Liverpool bands, and performs a set that all but doubles as his greatest hits — "Alone Again Or" opens, "Daily Planet" and "Hey Joe" follow, "Orange Skies" and "Everybody's Gotta Live" wrap things up.

The sound quality on *Arthur Lee Live In Liverpool 1992* is a shade ropey in places — the gig was not recorded professionally. But it is perfectly listenable and Lee sounds fabulous. Excellent liner notes and a bonus interview from the week of the show complete a package that is as valuable, in its own way, as any bonus-track stacked remaster of the classic Love catalog. That, after all, was then. This is almost now.

Meanwhile, Viper, the most active guardians of that city's modern legacy, has also issued the first solo album by Mike

***Double Zero* is a tight, joyously melodic collection of a dozen absolutely effervescent guitar-driven pop songs. They range from "Shadow Of The Real World," a storming garage-psych rocker, to a sensational cover of Roky Erickson's "Clear Night For Love" and onto the loping "Daddy's Inside," which oddly rocks along the same rhythms as Paul Simon's "Me And Julio Down By The Schoolyard" — only better.**

Badger, a former member of another 'pool legend, The La's. *Double Zero* is a tight, joyously melodic collection of a dozen absolutely effervescent guitar-driven pop songs. They range from "Shadow Of The Real World," a storming garage-psych rocker, to a sensational cover of Roky Erickson's "Clear Night For Love" and onto the loping "Daddy's Inside," which oddly, rocks along the same rhythms as Paul Simon's "Me And Julio Down By The Schoolyard" — only better. A terrific album!

There's more masterful guitar to be found on *Caves* (Market Square, U.K.; www.themusicindex.com/marketsquare), a collection of late 1970s music by the late, lamented Ollie Halsall. As guitarist with Timebox, Patto, and Boxer, Halsall's early 1970s output has undergone something of a reinvention in recent years. This material dates from his later years, following a stint with The Glitter Band, and catches him playing all the instruments and writing all the songs.

The sleeve's warnings about the sound quality aren't really borne out by the CD itself, but even if they were, the songs themselves rise far above such concerns. Halsall is frequently eulogized for his guitar playing, but he was an excellent singer/songwriter as well. Archive demo tapes normally arrive with all manner of dire caveats attached and, of course, there's no denying that this album would have sounded better if it had been recorded in a "proper" studio. But it's a gem for all of that, and anyone with even vague interest in the less illuminated corners of Halsall's career should pay attention to *Caves*.

Another of Halsall's past associates, Kevin Ayers, also resurfaces this month. *Turn The Lights Down* (Market Square, U.K.) catches the former Soft Machinist live in London in 1995, accompanied by the delightfully named Wizards Of Twiddy. The 13-song set tracks through Ayers' entire career, from primal legends such as "Didn't Feel Lonely Till I Thought Of You" and "Stranger In Blue Suede Shoes," through "Ballad Of Mr. Snake" and "There Goes Johnny." Anyone who fears that 1995 might be some two decades too late for Ayers to be

turning out anything but workaday versions of the classics is going to be brutally surprised. "Everybody's Sometime And Some People's All The Time Blues" is taken a little too fast but retains every last nuance of its past incarnations.

Eight minutes of "Why Are We Sleeping" build as slow and sinister as you like, but the revelations appear in a lovely and extraordinarily protracted "Lady Rachel," which simply refuses to rest on any old-time laurels, and a punk-oid "Stranger In Blue Suede Shoes," which sends time itself reeling backward. There are not many Ayers live recordings available out there, but you can file *Turn The Lights Down* alongside the best of them.

Market Square has also reissued *Stroll On*, the debut album by Steve Ashley, one of the brightest lights of British folk-rock in the early 1970s. His "Spirit Of Christmas" was one of the standouts on the original *Electric Muse* four-LP box set, and the remainder of *Stroll On* lives up to the same standards. Bonus tracks include two album outtakes and an impossibly rare single from the same period, while among the guest musicians, Dave Pegg, B.J. Cole, Ashley Hutchings, Danny Thompson, and Simon Nicol are just a few of the names that leap out.

But Ashley, his voice and playing, and his spooky, thoughtful songs are the undisputed highlights and, if *Stroll On* alone isn't enough, a second Ashley album, *The Test Of Time*, compiles 17 tracks from throughout Ashley's career — infuriatingly sporadic though it has been. Three songs apiece from the albums *Stroll On*, *Speedy Return* (1975), *The Family Album* (1982) and *Mysterious Ways* (1990) are joined by three more only ever briefly available on a couple of *Demo Tapes* cassettes and two songs taped in 1998.

What's remarkable is that neither the passing of time nor the cloak of obscurity have diminished Ashley's powers in the slightest, and you come out of the closing "Over There In Paradise" as breathlessly as you entered the opening "Fire And Wine." Ashley's own liner notes suggest a new album might be on its way. Let's hope so.

Finally, Captain Oi! (www.captainoi.com) have reissued *Days In Europa*, the sophomore album by one of the most inventive of all Britain's post-punk new wave acts, The Skids. Fronted by poet Richard Jobson but powered by much of what would become Big Country (bagpipe-drenched guitars included), The Skids built upon infectious convoluted rhythms, taut and twisted melodies and some of the most memorable singles of the age.

"Masquerade," "Charade" and "Working For The Yankee Dollar" are all included here, either on the album or among the seven bonus tracks, while Captain Oi! can also be congratulated for restoring the album's original Aryan Olympian artwork, removed shortly after the original release after a journalist suggested it looked a little Nazi. The album was remixed at the same time — again, we get the original version here, as the band and producer Bill Nelson originally envisaged it.

### Best of the rest

**David Cassidy:** *Then And Now* (Universal, U.K.) — Last time around, David Cassidy revised The Partridge Family's "I Think I Love You" as a throbbing, sinister electrodance machine. It's back again, but this time, oh dear, he's playing it straight. In fact, 22 tracks include some 18 Partridge and solo classics revisited and, if you own the originals, you know exactly what they sound like.

**The Gonads:** *Schiz-Oil-Phrenia* (Captain Oi!, U.K.) — A magnificent slab of raucous punk from one of the ballsiest bands around — "Pogo Till I Die," "Surfing Rebel Psycho Pants" and "Hitler Was An 'Omo" give you some idea of what to expect.

**Graham Oliver:** *End Of An Era* (Angel Air, U.K.) — Saxon founder Oliver returns with a cracking album, highlighted not only by the single "Born To Rock 'N' Roll," but also by three sensational Jimi Hendrix covers, including one — "Sippin' Wine" — that marries Hendrix lyrics with Oliver's music. Dynamite stuff.

**Armando Piazza (Featuring Shawn Phillips):** *Suan/Naus* (Akarma, Italy) — An excellent repackaging for two much in-demand albums, unavailable since their original Italian release back in 1972. Both albums are on one CD, but the packaging reproduces all the original art.

# Holiday Releases

AVAILABLE NOW!

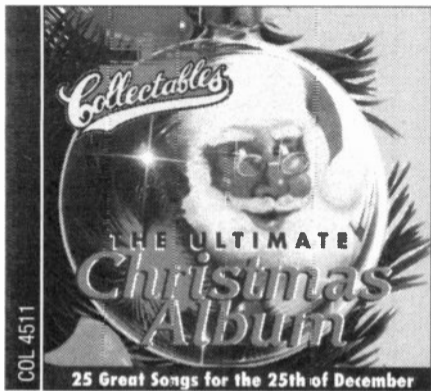

**THE ULTIMATE CHRISTMAS ALBUM Volume 1**

Highlights Include:  
 Rockin' Around The Christmas Tree Branda Lee  
 Silver Bells Diana Ross & The Supremes  
 The Chipmunk Song (Christmas Don't Be Late) The Chipmunks



**THE ULTIMATE CHRISTMAS ALBUM Volume 6**

- COL 4524
1. Last Christmas ..... Wham
  2. Santa Claus Is Coming Yo Town ..... The Beach Boys
  3. Winter Wonderland ..... Aretha Franklin
  4. White Christmas ..... Tony Bennett
  5. Frosty The Snowman ..... The Jackson Five
  6. Let It Snow! Let It Snow! Let It Snow! ..... Andy Williams
  7. Have Yourself A Merry Little Christmas ..... The O'Jays
  8. Hark! The Herald Angels Sing ..... America
  9. The Christmas Song ..... Barry Manilow
  10. The Children's Christmas Song ..... Diana Ross and The Supremes
  11. I'll Be Home For Christmas ..... Johnny Mathis
  12. Doo Wop Christmas ..... Kenny Vance And The Planotones
  13. Christmas Waltz ..... Doris Day
  14. I Believe In Father Christmas ..... Greg Lake
  15. A Night To Remember ..... Engelbert Humperdinck
  16. It Came Upon A Midnight Clear ..... Tony Orlando
  17. Happy Holiday ..... Manhattan Transfer
  18. Kissin' By the Mistletoe ..... Aretha Franklin
  19. Silver Bells ..... Andy Williams
  20. Frosty The Snowman ..... Jimmy Durante
  21. White Christmas ..... Connie Francis
  22. Come On A Sleigh Ride .. Johnny Tillotson, Freddy Cannon, & Brian Hyland
  23. Santa Claus Is Coming To Town ..... Perry Como
  24. Have Yourself A Merry Little Christmas ..... Linda Ronstadt
  25. May You Always ..... Harry Harrison

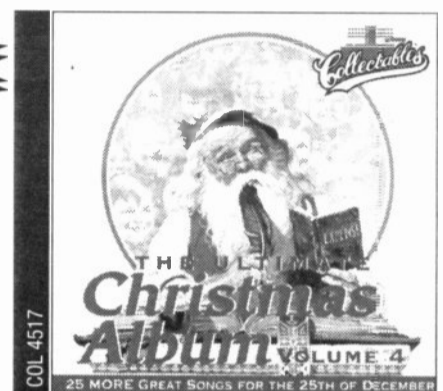

**THE ULTIMATE CHRISTMAS ALBUM Volume 4**

Highlights Include:  
 Blue Christmas Elvis Presley  
 Peace On Earth / Little Drummer Boy David Bowie & Bing Crosby  
 A Baby Just Like You John Denver



**THE ULTIMATE CHRISTMAS ALBUM Volume 2**

Highlights Include:  
 Little Saint Nick The Beach Boys  
 Give Love On Christmas Day The Jackson Five  
 It's The Most Wonderful Time Of The Year Andy Williams



**THE ULTIMATE CHRISTMAS ALBUM Volume 5**

Highlights Include:  
 Wonderful Christmastime Paul McCartney & Wings  
 Silver Bells Elvis Presley  
 Deck The Halls Nat King Cole

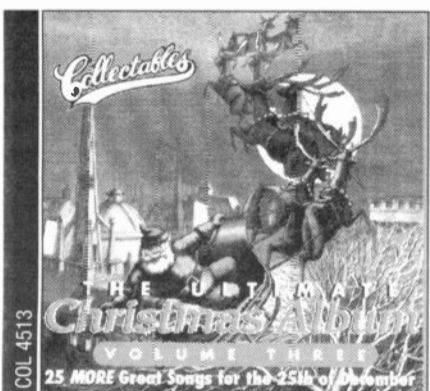

**THE ULTIMATE CHRISTMAS ALBUM Volume 3**

Highlights include:  
 The Christmas Song Nat King Cole  
 Home For The Holidays Perry Como  
 Happy Holiday Andy Williams



**THE ULTIMATE SOULFUL CHRISTMAS ALBUM**

Highlights Include:  
 Every Year, Every Christmas Luther Vandross  
 Jingle Bells Smokey Robinson And The Miracles  
 I Want To Come Home For Christmas Marvin Gaye

See it, sample it, buy it

[www.oldies.com](http://www.oldies.com)



GET A FREE CATALOG CALL: 800-446-8426 • FAX: 610-649-0315 • MAIL: P.O. BOX 35, NARBERTH, PA 19072 • EMAIL: CATALOG@OLDIES.COM

# Country Junction

On any list of successful singers in country music today, Joe Diffie has to be somewhere near the top. Possessed of a vocal range that enables him to sell hard-kicking anthems and tender ballads in equally convincing fashion, he has built his name on more than a decade's worth of successful singles, including memorable material such as "Bigger Than The Beatles" and "Ships That Don't Come In." Along the way, he has scored nine #1 hits.

The Oklahoma native is easy to root for, a down-to-earth man renowned for the charity work he does for many causes. As he prepared for the release of his new collection, *In Another World*, he took some time out to talk about a little bit of everything.

## 10 Questions For...

# Joe Diffie

by Thomas Kintner

*Your last couple of albums have seen you get back to writing some of your own songs. How does your approach to your work differ when you're the person with the pen?*

Everything is an experiment. Some come out like you want them to, and others don't. Sometimes you get in the mood and write something that's not even country-sounding or so country-sounding you're not able to use it. As a songwriter, I try to lean toward writing songs that fit my strengths, and with any luck I write in enough volume to give myself some good choices.

*You're someone who has been successful mixing country and pop conventions without selling out your sound. Where do you see the blending of pop and country headed in the future?*

That debate has been going on for years, but I just think of it as cyclical. I like the little bit of variety that we in country music have going. I don't know that we should gear ourselves toward crossing over, but I just try to do the best that I can to find the best songs for me when it comes to dividing country songs and pop songs.

*Very few artists have that philosophy but still maintain a country sound. Does anyone come to mind?*

There are a couple of guys who bear some resemblance to what I try to do. Mark Wills, Keith Urban — Trace Adkins' new CD has a few things along those lines. You have four or five producers who do the bulk of the music that you have a tendency to hear, and most of the same musicians play on their albums, so those ideas all get shared. Of course, one of my producers is Lonnie Wilson, who is one of the premier drummers in Nashville, and he plays on all of these people's sessions. We get a lot of ideas from Lonnie, which may be a reason for a lot of similarities.

*Do you worry that you're going to water down your sound by working with the same people everyone else does?*

Not at all, because I have a lot of faith in my producers, Lonnie and Don Cook. Lonnie and I have been buddies since I first moved to Nashville, and we just have a real enthusiasm for music and for trying things and doing stuff. It's just a good, comfortable feeling, but we're not blasé about it, because we're always trying to do new things, trying to be innovative.

*You have worked with many different artists throughout your career. What do you take away from those experiences?*

I can give you a specific example from when I recorded with Mary-Chapin Carpenter [on her song "Not Too Much to Ask"]. It was the first time in all the recordings I had done, other than demos, that I realized I had another part to my voice. It was a softer, kind of mellower sound. In fact, I used that same voice a lot on my Christmas CD. I did a lot of, for lack of a better term, a "Sinatra-ish" kind of thing. What's cool is that I discovered I can do it. That CD has some of what I consider my best vocal performances, especially because traditional Christmas songs are tough to sing.

*When you develop a new range like that, does it come as a surprise because you're thinking of yourself in a new way?*

Definitely, but I knew I had the capability, because I listened to Sinatra quite a bit and would sing along and think, "Y'know, that's cool. I can kind of do that stuff." I keep getting back to the Christmas album as an example, but when I was doing it, I tried doing it in a country style and some other different things. What worked the best was that style for those particular songs, so that's what I had to look at and do.

*Are you someone who worries about how new albums will be received when you've just finished them?*

Oh, absolutely! I think we all do. Sometimes you just know, like on the last CD in particular. We had about two years to look for songs, so we tried a lot of different things. After a while, there was just a certain comfort about what worked best. All of us have a little sense of insecurity about that stuff, but I think if you find the best songs, sing them as well as you can, produce them the best you can — if you really care about it and have a lot of enthusiasm for it, someone is going to like it.

*When you use your family members as a sounding board, do they ever tell you they don't like something you think is good?*

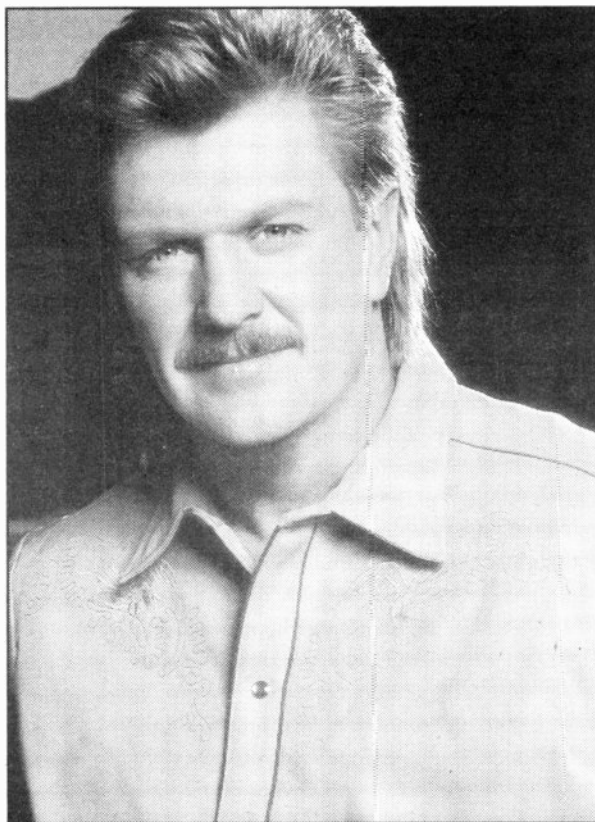

Courtesy of Sony Nashville/Sony Music

Sometimes I'm like, "Why, the audacity!" [laughs] My mother said she used to get embarrassed when I'd sing "John Deere Green." I guess when you had somebody something, you just open yourself up for it. You're usually already comfortable with their values, which is a good start. When you're in the studio with producers and musicians, the musicians aren't going to say anything bad because you're paying them, and the producers are pretty much helping you out too. Family is a pretty good outside sounding board, although I can't say I agree with them every time.

*Is a Joe Diffie album an attempt at an overall statement or more focused on the success of individual songs?*

I don't usually look at the whole album when I'm getting started. Maybe I should sometimes, but I don't approach it that way. In fact, when you search for all those individual songs, you sometimes try to have a theme, whether it's love or stories about life or whatever, but a CD kind of takes on its own life form. It's always interesting when you listen to it as a whole and see how changing the order of songs can change the feeling of a CD. A lot of thought goes into it no matter how you do it.

*What does your new disc offer that no one has heard from you before?*

Because it's me singing, the sound of it will be familiar. We have tried to step up our production techniques just a little bit. In fact some of the tracks have a pop feel, but with me singing, it sounds country. I like to think it's got a lot of versatility, just a little something for everyone.

## NEWS & NOTES

**The Corncob:** After 34 years with the label, Mercury Records has dropped Tom T. Hall from its roster... Oft-married Lorrie Morgan (five times) and Sammy Kershaw (four times) tied the knot on Sept. 29... Vince Gill and Amy Grant have arranged a holiday tour together. The tour, *A Christmas To Remember*, will start on Nov. 30 and run through Dec. 16, stopping in 13 cities... Winners at the International Bluegrass Music Association Awards included Rhonda Vincent for Entertainer and Female Vocalist Of The Year, Dan Tyminski for Male Vocalist Of The Year, and *O Brother Where Art Thou* for Album Of The Year... Dolly Parton will headline and host *Red, White & Bluegrass*, a New Year's Eve benefit concert at the Grand Ole Opry. Proceeds will go toward scholarships for children and spouses of the victims of the Sept. 11 terrorist attacks... Brad Paisley has cowritten a book based on and named after his hit "He Didn't Have To Be." In other book news, Colin Escott and Kira Florita have recently released *Hank Williams: Snapshots From The Lost Highway*, while Don Cusic's *Merle Haggard: The Lyrics* — which analyzes Haggard's colorful life through the words of his songs — comes out in November... The original members of McBride & The Ride (Terry McBride, Ray Herndon, and Billy Thomas) have reunited and are currently at work on an album... On the mend: Johnny Cash (from bronchitis).

**New Releases/Reissues:** Oct. 30: Gene Autry, *25 Texas Classics* and *25 Cowboy Classics* (both Varèse Sarabande); Deryl Dodd, *Pearl & Peps* (Lucky Dog); Rice, *Rice, Hillman & Pedersen Singing Wild (Rounder)*; Jeffrey Steele, *Somechin' In The Water* (Monument); Don Walsler, *Dare To Dream: The Best Of* (Texas Music Group). Nov. 6: Roy Acuff, *Good News According To Roy Acuff* (Audium); Robbie Fulks, *13 Hillbilly Giants* (Bloodshot); Merle Haggard, *Vol. 1: Roots* (Anti); Waylon Jennings, *RCA Country Legends* (two discs, Buddah); Danni Leigh, *Divide & Conquer* (Audium); Elvis Presley, *Country Side Of Elvis* (two discs, RCA); George Strait, *Road Less Traveled*. Nov. 13: Hoyt Axton, *Gold* (Collectables); Garth Brooks, *Scarecrow* (Capitol); Tracy Byrd, *The Millennium Collection* (MCA); Mark Chesnutt, *The Millennium Collection* (MCA); Shelby Lynne, *Love, Shelby* (Island); Willie Nelson, *The Great Divide* (Island). Nov. 20: Chet Atkins, *RCA Country Legends* (Buddah); Clint Black, *Greatest Hits II* (new date, BNA).

**TV News:** Vince Gill will once again host the *Nation's Music Association* special Nov. 7 on CBS... The CMT special *O Brother & Beyond* explores the huge success of the music from the film *O Brother Where Art Thou?*. This Nov. 3 program includes musical performances and interviews with many of the soundtrack's artists... On Nov. 4, Patty Loveless discusses her music video career on *CMT Personal Playback*... *CMT Inside Fame* profiles the private life of Travis Tritt on Nov. 5... *Austin City Limits* schedule: Mary-Chapin Carpenter and Nanci Griffith perform Nov. 3, while Brooks & Dunn and Asleep At The Wheel appear Nov. 24... Toby Keith guest stars in an episode of *Touched By An Angel* Nov. 10. As always, check 'em out!

— Jim Bagley

# On the racks

**JEFF CARSON**  
Real Life  
Curb (D2-77937)

Best-known for the 1995 hit "Not On Your Love," Jeff Carson's third outing, *Real Life* — his first album in three years — examines the small dramas that comprise lifelong romance. The Oklahoma-born, Arkansas-bred, former Louisiana police dispatcher spreads his quiet, expressive tenor over a bed of Adult Contemporary piano, strings and keyboards with splashes of steel guitar. It's a standard studio formula used by dozens of country crooners, but Carson redeems it with well-crafted material and a cohesive, observational approach.

On the title track, some radio listeners mistakenly believe that Carson is singing about the death of his character's wife. The printed lyrics — along with the current video, dispels that morbid notion while underscoring the artist's appreciation of life's transitional events. The upbeat, quasi-gospel of "Shine On" and the cute fatalism of "Divine Intervention" are further extensions of his semi-spiritual amazement.

Carson's warm, sensitive tenor brings appealing shades of self-chastisement from "What's Not To Love" and "It Wouldn't Kill Me." Nearly as effective are "Where Did I Go So Right" and "My One And Only Love," which are poignant testaments to the redemptive powers of a good woman's love. He-man hardcore traditionalists may find *Real Life* pretty drippy at times, but their wives and girlfriends will love it.

— Ken Burke

**REBA MCENTIRE**  
Greatest Hits Vol. 3: I'm A Survivor  
MCA (088 170 202-2)

The last decade or so has seen Reba McEntire emerge as a multi-media conglomerate, with music success leading to work in films, television dramas and recently, an acclaimed performance on Broadway in *Annie Get Your Gun*. Currently at work on her own sitcom, called, of course, *Reba*, this hits collection, *Greatest Hits Vol. 3: I'm A Survivor*, is a logical "breather" for the busy country queen.

Twelve of McEntire's best from the '90s are included here. The up-tempo tunes offer the most diversity, among them a reworking of the kitschy gothic classic "The Night The Lights Went Out In Georgia" and the jazzy, sassy "Take It Back." Ballads, however, remain McEntire's forte. Routine weepers such as "And Still" and "Forever Love" blossom, thanks to her expressive vocals. When paired with a great ballad — such as the AIDS saga "She Thinks His Name Was John" and the soaring Brooks & Dunn duet "If You See Him/If You See Her" — the end result is glorious.

This set also offers three new recordings. Best of the crop is a remake of the Kenny Rogers hit "Sweet Music Man," featuring gently lilting production by Alison Krauss. "I'm A Survivor" — the theme to McEntire's new sitcom — also works, while the sluggish, monotonous "Myself Without You" misses the mark completely.

Even after a third volume of hits, many of McEntire's recent singles remain unantholo-



Courtesy MCA/Ron Davis

gized, including the joyous "I'd Rather Ride Around With You," the pretty "Till You Love Me" and everything on her dud album of covers, *Starting Over*. Undoubtedly, some of these will make it onto a fourth *Greatest Hits* and/or the inevitable box set, along with — certainly — future hits. Like the title says, McEntire is a survivor.

— Jim Bagley

**HAL KETCHUM**  
Lucky Man  
Curb Records  
(78707)

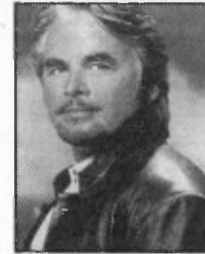

Courtesy Curb/ by Senior McGuire

If anyone in country music is primed for a comeback, it's Hal Ketchum. Six years removed from his last Top 10 hit, "Stay Forever," and clear at last from problems with substance abuse and a disease of his spinal column, Ketchum has assembled a vibrant collection of music on *Lucky Man*.

Several of the set's more energetic tunes are as difficult to resist as Ketchum's smooth vocal sound, whether they are sold by the sprightly infectiousness of "She's Something, You're Everything" or the pedal steel twang that bursts from the roadhouse-style "She's Still In Dallas." Although prone to occasional slips into deep sentimentality, his ballads — most notably the leadoff single "She Is" — are never lacking in warm sincerity.

Producer Rodney Crowell adds touches similar to those that fill his solo work, including his supple and image-rich composition, "Dreams Of Martina." He contributes to an overall sound design that manages to be bold without overloading, a sure-handed approach that allows the snare drums and peppy

response vocals of "Don't Let Go" to push along its rockabilly groove without wearing out their welcomes. Whether he fits today's country radio is anyone's guess, but Ketchum certainly sounds as good as he ever did.

— Thomas Kintner

**GARY ALLAN**  
Alright Guy  
MCA Nashville (088 170 201-2)

Gary Allan has made no secret of his general distaste for mainstream country music. His haunting 1999 single "Smoke Rings In The Dark" is reflective of the more traditional sounds this California native clearly prefers. On *Alright Guy*, Allan's bloat-free ballads such as the jazzy "Adobe Walls" and the acoustic "What Would Willie Do" (an offbeat homage to Willie Nelson) are effectively low-key, but they can't compare to the strong, memorable melodies that energize his up-tempo songs with their liberal use of fiddles and pedal steel.

*Alright Guy's* straight-talking lyrics avoid sensitive-guy pronouncements in favor of a tougher stance. They include the steely defiance of "I Don't Look Back" (the only song Allan had a hand in writing), "The Devil's Candy" (the album's highlight), in which he admits his weakness for the wild side of life, and the energized title track, which finds the singer attempting to defend his bad-boy ways: "Now maybe I'm dirty and sometimes I like to get stoned/Ain't like I'm foolin' with my intern while I'm talkin' on the phone."

Allan's deft melding of modern and classic country sounds and his insistence on doing things his way places him a cut above the competition. That's better than all right.

— Tierney Smith

(Blue Storm from page 10)

years old. He has that Belfast bluesy [approach] that we're putting out. [*Belfast Blues*] will be his first record. I'm just trying to keep this genre of music alive and give people good quality music with a history behind it. Aim it towards the fans.

"Our goal, as far as sales, is to be able to sell between 10,000 and 100,000 records of whatever we put out and try to



support the records in any which way by going to the magazines that are geared toward the fans in their genre. We have also been handing out sampler CDs."

On signing new acts, Goodman told *Goldmine*, "A lot of people are in the music business. It's [about] having something to give somebody. It's not just saying, 'Give me a job.' It's like [being in] a band. If you are going to have a successful band, you are going to have to have an audience, an audience who will buy your CDs.

"If you have no audience, you have no career. That's what a lot of bands don't realize. Like when I look to sign a band, there's a lot of great musicians out there, but very few of them have anything to sell. The name of the game is to be able to create art."

— by Guy Lee

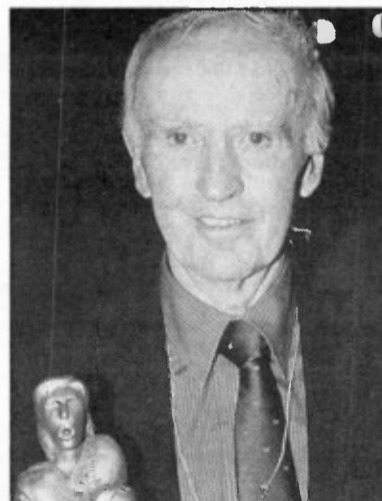

All photos ©2001 Frank Pettis

The Four Aces' Dave Mahoney; The Imperials' Sammy Strain, accepting the group's 2000 award; The Pied Pipers.

(Vocal group winners from page 12)

other has to do with the fact that many of the stories that Ron shared with me helped me to know what these guys are all about. And it deepens my love for them, because they always included me. And I know Ron is definitely smiling on us today. Thank you."

Due to prior commitments, some groups were not able to attend the ceremonies. Maurice Gibb (of The Bee Gees), Phyllis McGuire (of The McGuire Sisters), The Weavers, and The Oak Ridge Boys all sent videotaped acceptance speeches.

The last inductees to receive their HARMY awards were The Lennon Sisters. The group, whose successes on the *Lawrence Welk* and *Andy Williams* television shows made them worldwide entertainers, drove from the Lawrence Welk Champagne Theater in Bran-

son, Mo., directly to the inductions — a total of 850 miles — and arrived at the building with barely 30 minutes to spare.

"We were just so thrilled — and we have been singing 46 years — to be part of all these wonderful groups that we've grown up with that are our idols," Janet Lennon said.

"We'll take it [the award] back to the theater where we sing six days a week, two shows a day," said Mimi Lennon. "We perform at the Welk Champagne Theater in Branson, Mo., where we'll happily display this trophy. Lawrence Welk knew what to look for, and he had a lot of vocal groups on his show."

After the induction ceremony, many of the artists performed at a live outdoor concert. The concert began with Wilson's emotional rendition of "The Star Spangled Banner," which brought the cheering crowd to its feet. The Orioles, featuring original vocalist Diz Russell, performed some of their classic hits, including "Crying In

The Chapel." Accompanied by a film highlighting their career achievements, The Lennon Sisters performed a medley of their greatest and most recognizable hits (and they also left immediately after to drive back to Branson). The Memories performed a series of doo-wop classics, including their own hit "Love Bells." An all-star collaboration between The Orioles, The Marcels, and The Four Dots produced danceable versions of The Marcels' hits "Heartaches" and "Blue Moon," featuring bass singer Freddie Johnson's immortal bass line.

Although they had not performed together in public since 1972, the four original Vogues — Bill Burkette, Hugh Geyer, Don Miller, and Chuck Blasko — wowed the crowd to its feet, as the audience danced to songs such as "5 O'Clock World" and "You're The One" and cheered to "Turn Around, Look At Me."

(Please see Vocal group winners page 23)

# BAGS Unlimited INC

7 Canal St., Dept. A, Rochester, New York 14608-1910



http www.bagsunlimited.com • E-mail: info@bagsunlimited.com

**FREE** PHONE CALL CATALOG  
**1-800-767-BAGS**



SEE PAGE 25 & BACK COVER FOR MORE AUDIO PROTECTION PRODUCTS

OUR PRICES INCLUDE SHIPPING (except where noted). States of Florida, LA, MO, MN, and all states west of the Mississippi add 10% for shipping.

## 45 RPM RECORD

SLEEVE	45 Poly Record Sleeves			BOX	45 Record Storage Box		
Made from High Clarity 100% Pure Virgin 2.5 mil Polyethylene.							
	7 1/2 x 7 1/4	7 1/2 x 7 1/4	7 1/2 x 7 1/4	7 3/4 x 8 3/8 x 10 1/2	7 3/4 x 8 3/8 x 10 1/2	7 3/4 x 8 3/8 x 10 1/2	
	No Flap	Resealable Flap	No Flap	Holds 100 45's	Holds 100 45's	Holds 150 45's	
	100	\$7.65	\$11.70	2	\$17.00	2	
	500	22.80	42.10	5	30.00	5	
	1,000	37.00	73.60	10	52.50	10	
	5,000	168.90	354.75	25	105.00+ Frt	25	
				PCODE X45100CP		PCODE X45150	
				WHITE Polypropylene PLASTIC corrugated. Acid Free, Anti-Static.		White corrugated cardboard.	

SLEEVE	45 Poly Record Sleeves			DIVIDER	45 Divider Cards		
100% Virgin Polyethylene							
	7 1/2 x 7 1/4	6 Mil	4 Mil	CORRUGATED	7 1/4 x 8	PLASTIC	
	100	\$9.60	\$14.40	15	\$7.60	25	
	500	41.80	63.60	30	11.95	50	
	1,000	67.10	100.65	45	15.95	100	
	5,000	295.90	444.20	90	27.05	500	
				210	57.40	197.45	
				PCODE D45C		PCODE D45P	
				1/16" Thick Extra Strong White Corrugated.		.03 gauge White Polystyrene.	

SLEEVE	7" Inner Sleeves			MAILER	45 Record Mailers		
	7 x 7	Polylined	7 x 7 Poly	45 Mailer Folder			
	50	\$8.80	100	\$6.45	7 1/2 x 7 1/2	7 3/4 x 7 1/2 x 1 1/2	
	100	11.80	500	19.30	Holds 1-6	45 Mailer Box	
	500	48.70	1,000	30.55	10	\$10.60	
	900	80.60	5,000	146.00	25	18.70	
					50	30.40	
					100	52.40	
					200	99.00	
					400	180.50	
					PCODE M456	PCODE M4520	

JACKET	45 RPM Jackets			FILLER	45 Mailer Filler Pads		
	7 1/8 x 7 1/8	WHITE PAPERBOARD	Center Hole	7 3/8 x 7 3/8	50	\$13.75	
	25	\$11.80	\$10.30	100	19.05		
	50	17.55	15.30	250	31.90		
	100	30.00	26.10	500	51.55		
	500	105.20 + Frt	91.30 + Frt	1,000	97.90		
	1,000	199.80 + Frt	178.30 + Frt				

SLEEVE	7" Paper Sleeve			INSERTS	45 RPM Record Inserts		
	WHITE	WHITE	GOLD	*10 PACKS			
	Regular Weight	Medium Weight	Heavy Weight	1	\$2.00	1,000	\$64.75
	50	\$7.70	\$9.50	5	6.50	2,000	117.70
	100	10.80	13.50	10	11.50	5,000	268.00
	500	34.00	38.50	25	24.50	10,000	486.50
	1,000	61.60	70.95	50	37.50	25,000	1,106.25
	2,000	77.95	97.35				
	4,000	124.60 + Frt	155.80 + Frt				

SLEEVE	7" Paper Sleeves			CLEANER	Record Cleaning		
	Colored Paper Sleeves 7 1/8 x 7			Discwasher® D4+			
	Minimum order - 50 sleeves per color			1 1/4 oz.	1	\$2.00	
	50	\$12.10		5	6.25		
	100	16.75		10	10.00		
	500	55.25					
	1,000	101.00					
	1,600	141.55					

SLEEVE	7" Paper Sleeves			CLEANER	Record Cleaning Fluid		
	"Old Style" Green			Groovy™ Cleaner			
	White			4 oz.	1	\$6.00	
	50	\$9.90	50	\$10.20	3	16.50	
	100	15.95	100	17.10	5	25.00	
	500	51.80	500	54.70	10	45.00	
	800	74.00	1,200	123.20			
	1,600	140.40	2,400	200.90 + Frt			
	3,200	224.40 + Frt					

INSERT	7" Picture Sleeve Insert			CLEANER	Sponge		
	.030" Thick	7 x 7 .028" Thick	Acid Free	Record Cleaning Sponge			
	Chipboard			1	\$5.00		
	50	\$7.65	\$9.00	5	20.00		
	100	12.25	14.40	10	37.50		
	500	53.00	62.50				
	1,000	96.15	113.50				

## AUDIO CASSETTE

BOX	Corrugated Audio Cassette Box			MAILER	Audio Cassette Mailer		
	4 1/2 x 2 3/4 x 15 1/2			4 1/4 x 2 3/4 Corrugated			
	2	\$7.60		10	\$4.80		
	5	16.00		25	9.05		
	10	24.00		50	16.50		
	25	49.40		100	29.90		
	50	86.85		200	53.60		
				400	95.60		

CASE	Audio Cassette Case			MAILER	Audio Cassette Mailer		
	Single	Double/Back to Back		4 x 6 3/4 (Inside Dimension) Bubble Cushioned			
	5	\$3.35	5	\$5.50	25	\$7.10	
	10	5.40	10	8.60	50	12.95	
	25	10.00	25	17.15	100	22.00	
	50	17.25	50	31.15	250	49.30	
	100	28.65	100	56.60	500	86.10	
	250	52.50	250	118.00 + Frt			

CLEANER	Audio Cassette Head Cleaner			Labels	'J' Card		
	Discwasher® Cleaning Cassette			Face Label 3 1/2 x 1 5/8			
	1	\$10.90		5	\$3.40	'J' Card Insert	
	5	50.25		10	5.60	25	
	10	95.30		25	12.20	50	
				50	22.25	100	
				100	40.60	500	
						1,000	
						60.05	
						ACJC	

SHRINK WRAP CENTER			Shrink Bags		
PCODE	Sizes (in)	Suggested Uses	100	500	1,000
BSW58	5 1/2 x 8	Cassettes, CD's,	\$4.15	\$16.40	\$29.75
BSW710	6 5/8 x 10	Double CD Case	6.05	24.30	43.40
BSW1313	13 1/2 x 13 1/2	Albums, Laser Discs	14.80	58.80	112.00

Our Polyolefin SHRINK WRAP FILM is Archival, Super Clear, & High Gloss. Centerfold Film. It is strong, fast sealing and fast shrinking. It has superior qualities to most popular films because it has no PVC which can leach onto your work. It has approximately 10% Shrink. It is recyclable.					
PCODE	Suggested Uses	W (in)	L (ft)	Ga.	Shrink Film Price per Roll
RSF8	Cassettes, CD's, VHS	8	500	.75	1 59.00 3 \$53.55 5 \$50.00 10 \$49.00
RSF13	Magazines, 8 x 10 Mats, Albums, Lobby Cards, 11 x 14 Mats	13	500	.75	61.85 55.90 52.00 49.75

Milwaukee Brand Heat Gun plugs into our Shrink Wrap Machines or a 120 Volt Outlet. It has High / Low Settings. The gun reaches 50 to 150 Degrees Farenheit. It's light weight but built for heavy duty work. Use with Shrink Wrap Bags and Shrink Film shown above.					
PCODE	Description	Watts	1	3	5
AHG	Industrial Heat Gun	1200W	\$52.00	\$141.00	\$160.00

CUT OFF Heat Sealers Use with SHRINK BAGS					
Prod. Code	Description	Watts	Length	Mil	Price
AHS4C	4" Hand Heat Sealer	400	4"	1-6	\$66.75
AHS8C	8" Hand Heat Sealer	400	8"	1-6	89.00
AHS12C	12" Hand Heat Sealer	500	12"	1-6	111.00
AHS16C	16" Hand Heat Sealer	500	16"	1-6	179.00

Shrink Wrap System with Gun Shrink wrap 30 packages per hour.					
<ul style="list-style-type: none"> <li>System Comes With a 500 Watt Heat Gun Which Plugs into the System.</li> <li>Wraps a variety of Items (vhs, albums, magazines, CD's, DVD's, posters, etc.)</li> <li>Dispenses Rolls of Shrink Film Without Snagging.</li> <li>Use 120 Volt Outlet. NO WIRING HASSLES!</li> <li>1 Year Warranty on All Parts Except Consumables. (teflon covers, element wires, etc.)</li> <li>Easy to use. Seal one side, rotate 90°, seal second side, heat shrink!</li> <li>* Allow for approx. 10% shrink on film when choosing your system.</li> </ul>					
Product Code	Description	Application	1	2	
ASW13	13" Shrink System	CD's, DVD's, Magazines, VHS	\$250.00	\$450.00	
ASWS18	18" Shrink System	Albums, Small Mats	265.00	480.00	

PLEASE CHECK BOX IF YOU HAVE ORDERED FROM US BEFORE

**CUSTOMER ACCOUNT #** \_\_\_\_\_

**SUB TOTAL** \_\_\_\_\_

**All orders under \$25.00 add \$4.00**

**CITY** \_\_\_\_\_ **STATE** \_\_\_\_\_ **ZIP** \_\_\_\_\_

**C.O.D. orders add \$5.50**

**NO POST OFFICE BOX NUMBERS FOR FedEx GROUND DELIVERY** **NY State Residents add 8%**

**Florida States West of the Mississippi including entire states of LA MO MN add 10% for shipping**

**TOTAL** \_\_\_\_\_

BAGS UNLIMITED INC., 7 CANAL ST., DEPT. A, ROCHESTER, NY 14608 (716) 436-9006 FAX: (716) 328-8526



# BAGS Unlimited INC

## FREE PHONE CALL CATALOG 1-800-767-BAGS

7 Canal St., Dept. A, Rochester, New York 14608-1910

### FOR THE BEST IN CD PROTECTION

SEE PAGE 24 & BACK COVER FOR MORE AUDIO PROTECTION PRODUCTS

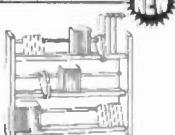
<b>SLEEVE Compact Disc Sleeves</b> Made from 100% Pure Virgin Polyethylene <b>5 x 5</b> •2.5 Mil RESEALABLE FLAP No Flap •4 Mil RESEALABLE FLAP No Flap 100 \$5.25 \$8.80 \$9.35 500 19.90 37.90 35.90 1,000 29.05 63.80 52.60 PCode: SCD525 SCD525R SCD54 Fits directly over CD. *Add 10% for FLAP, specify when ordering!	<b>CASE Single CD Case</b> <b>disc</b> 5 \$6.90 Clear Acrylic JEWEL Case with Black or Clear Tray. Specify Tray Color. 10 10.85 25 22.00 50 38.25 100 62.35 200 94.25 400 157.10+ Frt ■ Qty per case Holds 1 CD and Booklet 3/8" Thick	<b>TRAYS Pop-It Hub</b> Clear 25 \$10.00 50 17.00 100 28.40 200 46.40 400 71.40 PCode ACDTPC Clear Tray holds CD firmly in place. Disc "Pops" off center hub with one touch. Less disc stress, warping, scratching. Snaps into standard jewel case.	<b>Digi Pak</b> White or Black 5/8 x 4 7/8 x 1/4 25 \$11.75 50 19.50 100 32.45 200 53.00 400 89.40 PCode ACDDTP Digi Pak Tray holds 1 CD. Can be glued into any promotional packet. Specify color! Mix n' Match. Also holds DVD	<b>DISPLAY Deluxe Stackable CD Rack</b> 24 x 7 1/2 x 7 Prod. Code CCD52 1 \$24.00 3 66.00 5 99.00 
<b>SLEEVE CD Jewel Case Sleeves</b> Made from 100% Pure Virgin Polyethylene <b>5 3/8 x 6</b> •2.5 Mil RESEALABLE FLAP No Flap •4 Mil RESEALABLE FLAP No Flap 100 \$5.60 \$9.50 \$10.00 500 20.25 39.40 36.40 1,000 30.80 68.20 55.55 PCode: SCD625 SCD625R SCD64 Fits over Case. *Add 10% for FLAP, specify when ordering!	<b>CASE Single CD Case / No Tray</b> <b>disc</b> 5 \$5.55 Clear Acrylic Case 10 8.65 25 17.65 50 30.60 100 49.85 200 75.40 400 125.70+ Frt ■ Qty per case Holds 1 CD and Booklet 3/8" Thick	<b>TRAYS Black, Clear &amp; Colors</b> 10 \$6.25 25 9.80 50 16.25 100 27.05 200 44.20 400 70.05 PCode ACDT Clear, Black, Opaque: Blue, Red, White, Yellow, Hunter Green, Irish Green. TRANSLUCENT: Red, Green, Pink, Peach, Amber, Blue, Lavender, Fluorescent Green.	<b>DISPLAY Wooden Rack</b> 23 1/2 x 19 3/4 x 7 5/8 Prod. Code CCD150 1 \$55.00 3 148.50 6 267.30 OAK or BLACK 	
<b>SLEEVE Double Pocket CD Sleeves</b> 4 15/16 x 4 7/8 5 5/8 x 4 7/8 CD & Booklet Also Holds Tray Card 100 \$12.00 100 \$12.70 500 51.15 500 54.30 1,000 86.20 1,000 91.50 PCode: SCDDPB SCDDPJ Sleeves feature dual compartment pockets with white poly divider and 1" RESEALABLE Flap. Divider separates CD from CD booklet and Tray Card. Made from durable 3 mil 100% Pure Virgin Polyethylene.	<b>CASE Slimline CD Case</b> Clear Acrylic Case with Built-In Tray 5 \$6.15 10 9.70 25 19.80 50 33.10 100 65.00 PCode CCDSL Holds 1 CD and Booklet 1/4" Thick edge allows you to store more CD's in 1/3rd less space.	<b>TRAYS Double / Holds 2 CD's</b> Center Hinged / BLK or CLEAR Side Hinged 5 \$5.15 5 \$4.00 10 8.10 10 5.90 25 14.70 25 11.40 50 24.35 50 19.00 100 40.55 100 31.50 PCode ACDT2CD-HC PCode ACDT2D-HS Black or Clear Tray holds one CD each side. Snaps into standard CD Case. Use with Prod. Code CCDSNT or CCDD-HC.	<b>MAILER Multiple CD Jewel Cases</b> Inside Dimension: 6 1/8 x 6 1/4 x 3 1/4 10 \$12.40 25 25.85 50 47.00 100 89.50 PCode MCD8 Super double walled shipper. Ships up to 8 single CD's in their jewel cases. Made from sturdy white, corrugated cardboard.	
<b>SLEEVE Gate Fold Sleeves</b> 5 1/8 x 10 5/8 4 mil 5 x 10 6 mil Made from 100% Pure Virgin Polyethylene 100 \$8.90 100 \$12.40 500 34.90 500 48.35 1,000 63.50 1,000 84.05 PCode SCDFG4 PCode SCDFG6 Stores 1 jacketed CD and booklet one side; Tray card in the other side. Design allows storage of CD & Booklet in gate fold sleeve. 6 mil polyethylene insures maximum protection.	<b>CASE 2 CD-Compact Disc Case</b> <b>BRILLIANT BOX</b> 5 \$10.30 10 16.00 25 32.20 50 55.90 100 66.95 3/8" Thick Holds 2 CD's. Clear acrylic case with Black or Clear hinged flipout tray. Specify when ordering. PCode: C2CD-HS	<b>RETAILER Blister Pack</b> SINGLE 5 x 10 3/8 10 \$8.75 25 15.00 50 25.00 100 41.20 200 53.60 3/8" Thick Holds 2 CD's. Clear acrylic standard case with hinged center black or clear tray. PCode: C2CD-HC	<b>SLEEVE Case Logic CD Pro™ Sleeves</b> 50 \$20.35 100 33.40 250 73.80 500 134.30 1,000 255.75 5,000 1,027.45+ Frt PCode SCDDPRO Case Logic CD Pro™ Sleeve and Pocket Pages feature Pro Sleeve technology. Backing material protects CD playing surface.	
<b>SLEEVE For CD Jackets</b> Made from 2.5 mil 100% Pure Virgin Polyethylene INNER 4 3/4 x 4 3/4 No Flap OUTER 5 x 5 1/8 No Flap* 100 \$4.40 100 \$4.85 500 16.50 500 18.40 1,000 24.05 1,000 34.45 PCode: SCD43425 PCode: SCD51825 Fits directly over CD for easy fit in CD Jacket. Fits over CD Cardboard Jacket. *Add 10% for FLAP.	<b>CASE 2 CD-Compact Disc Cases</b> Clear Acrylic Case with CLEAR Tray 5 \$10.20 10 15.80 25 31.85 50 55.35 100 90.00 200 120.00+ Frt 400 216.00+ Frt PCode: C2CD-HS Holds 2 CD's, 1 tray card and booklet. Crystal Clear Case and center hinged Crystal Clear Tray come assembled. 3/8" Thick. Trays NOT sold separately.	<b>RETAILER Security Devices - ALPHA</b> Single 6 x 12 50 \$29.20 120 56.10 240 97.55 360 120.95 PCode ACD900 Natural. Holds 1 CD case.	<b>MAILER CD Jewel Case</b> 5 x 8 x 1 1/4 5 7/16 x 5 5/16 x 5 5/8 10 \$9.20 10 \$6.40 25 16.25 25 13.90 50 28.20 50 21.00 100 43.30 100 36.75 200 69.30 200 78.75 500 121.00 500 131.25 PCode MMP PCode MCD1 Made from sturdy 200 lb. Test Brown Corrugated. Made from sturdy White Corrugated.	
<b>SLEEVE Double CD / CD Boxset Sleeve</b> 6 x 6 3/4 2.5 mil No Flap 13 5/8 x 13 1/8 3 mil with Flap Made from 2.5 mil 100% Pure Virgin Polyethylene 100 \$5.90 50 \$8.70 500 21.10 100 14.90 1,000 31.40 500 68.50 PCode SCDDQ PCode SCDBS13 Keep CD Cases Scratch Free! Use our high clarity poly sleeve. Fits over Outer CD Box Set.	<b>CASE Double CD Case</b> <b>disc</b> 5 \$13.80 10 21.55 25 44.00 50 72.95 96 105.60+ Frt Prod. Code CCDD 15/16" Thick Holds 2 CD's. Includes 2 Black OR Clear trays. Specify Tray Color.	<b>RETAILER Security Devices - ALPHA</b> Hand Key Hand Held with Cable No Cable 1 \$30.00 \$6.00 3 70.00 15.00 Works with Cassettes, CD's & DVD's AFCK201 AFAK127 White with 27" steel cable and eye bolt.	<b>MAILER Multiple CD Jewel Cases</b> Inside Dimension: 6 1/8 x 5 1/8 x 5 3/16 10 \$8.00 25 15.50 50 27.55 100 52.50 PCode PXMINS-PL Ships up to 12 single CD's in their jewel cases. Made from Sturdy brown kraft, corrugated cardboard.	
<b>JACKET CD Jackets - White Paperboard</b> 4 15/16 x 5 Prod. Code SCDJW* 10 \$6.00 25 10.00 50 17.30 100 28.40 700 189.25 Die Cut one side Replace Jewel Case with our rigid paperboard jacket. *Specify Hole/NO Hole when Ordering.	<b>CASE 3 CD - Compact Disc Case</b> <b>disc</b> 5 \$10.50 10 16.50 25 35.00 50 62.50 100 98.00 200 170.00 400 240.00+ Frt PCode C3CD-HC Holds 3 CD's. Clear acrylic case includes 2 Black Snap-in trays and 1 black center piece that holds 1 CD 1 side. Snap-in trays can be Clear. SPECIFY Tray Color. Holds 2 Tray Cards.	<b>STORAGE Corrugated CD Storage Box</b> 6 x 6 x 16 1/4 Prod. Code XCD30 2 \$10.60 5 22.55 10 37.10 25 88.50 High-Tech design made from Black Corrugated Material. Three removable divider cards enable you to organize each unit to your own storage needs. Holds 25-30 CD's, 10 VHS Tapes or 100 Floppy Discs.	<b>MAILER CD Mailer - Bubble Cushioned</b> 7 x 6 1/2 (Inside) Ships 1 CD in a Jewel Case Peel Off Prod. Code MJCD 25 \$10.30 50 16.45 100 28.60 250 65.00 500 117.90 SELF SEAL!	
<b>SLEEVE CD Paper Sleeves</b> 5 x 5 Prod. Code S5W* 50 \$8.10 100 10.70 500 39.70 1,000 59.00 2,000 94.15 4,000 142.80+ Frt Die Cut one side Made from 16# White Paper. Fits directly over CD.	<b>CASE Quad CD Case</b> <b>disc</b> 5 \$13.65 10 21.15 25 43.80 50 81.15 96 138.25 PCode CCDQ 15/16" Thick Holds 4 CD's. Includes 2 Black Snap-in trays and 1 Black center-piece that holds 2 CD's back to back. Snap in trays can be Clear. Specify Tray Color.	<b>STORAGE Corrugated CD Big Box</b> 15 3/4 x 15 3/4 x 6 1/8 Prod. Code XCD100 2 \$15.30 5 34.60 10 63.90 25 145.15 Holds 100+ CD's in six equal compartments. 18 CD's per compartment. Perfect for storage, travel or display. Made from 175 lb. test White Corrugated. Comes with 3" deep cover. Order DCD56P for Dividers.	<b>MAILER White Rigid Cardboard</b> 8 x 6 Prod. Code MCDWP68 25 \$11.00 50 21.00 100 40.10 250 76.40 500 145.50 1,000 277.20 White Cardboard mailer features Peel & Stick Flap. Mails 1 CD in jewel case. Perforated flap for end user "easy open".	
<b>SLEEVE Hot Pockets - Paper / Tyvek</b> 5 x 5 Paper 5 x 5 Tyvek 50 \$9.00 50 \$14.80 100 16.00 100 26.10 250 33.25 250 54.85 500 58.90 500 97.20 1,000 110.20 1,000 181.85 White, Black, Red, Fuchsia, Orange, Lime, Blue or Green. Black, Red, Purple, Blue or Dark Green. PCode SCDDHP Envelope with 4 1/2" Mylar lined window and fold over flap. Holds 1 CD. SPECIFY COLOR WHEN ORDERING.	<b>CASE 6 CD-CD Case/Center Hinge Trays</b> 5 \$15.75 10 27.00 25 61.25 50 112.50 PCode C6CD-HC 15/16" Thick Holds 6 CD's. Includes 1 black Center piece and 2 black Center hinged trays. Center piece and trays each hold 2 CD's back to back. CLEAR TRAYS NOW AVAILABLE.	<b>DIVIDER CD/All White Polystyrene</b> 5 5/8 x 5 1/2 4 1/2 x 6 1/8 6 x 14 For CD's Stored in our CD Box XCD30. For CD's Stored with Spine Up or Out XCD100. For Long Blister Packs or Boxes. 15 \$9.30 15 \$9.40 10 \$7.90 30 13.05 30 13.40 25 18.65 45 14.60 45 15.20 50 34.30 90 24.65 90 25.85 100 62.30 210 49.70 210 52.40 250 148.05 PCode: DCDP DCD56P DBPP	<b>MAILER White Paperboard</b> 5 1/4 x 5 1/4 25 \$7.50 50 13.75 100 25.00 250 57.00 500 103.40 1,000 187.95 White Paperboard mailer features Peel & Stick Flap. Mails 1 Compact Disc and Booklet. Perforated flap for end user "easy open". Great for promotions. Does not hold CD Jewel Cases.	

PLEASE CHECK BOX IF YOU HAVE ORDERED FROM US BEFORE  
 NAME \_\_\_\_\_ STREET ADDRESS \_\_\_\_\_ CITY \_\_\_\_\_ STATE \_\_\_\_\_ ZIP \_\_\_\_\_  
 SIGNATURE \_\_\_\_\_ DAY PHONE ( ) \_\_\_\_\_ EXP. DATE \_\_\_\_\_ CARD No. \_\_\_\_\_  
 CUSTOMER ACCOUNT # \_\_\_\_\_ SUB TOTAL \_\_\_\_\_  
 All orders under \$25.00 add \$4.00  
 C.O.D. orders add \$5.50  
 NO POST OFFICE BOX NUMBERS FOR FedEx GROUND DELIVERY NY State Residents add 8%  
 Florida, States West of the Mississippi, including entire states of LA, MO, MN add 10%  
 TOTAL \_\_\_\_\_

# Classical Notes

## POULENC'S *GLORIA* — IN TUNE WITH OUR TIMES by Peter Gutmann

In times of trouble many of us turn to religion. Indeed, following the recent terrorist attacks American houses of worship are reporting a huge surge in attendance.

Nearly all the major classical composers included religious works among their significant output and left us a large body of masterpieces from which to choose for inspiration. Each reflects the fundamental artistic personality of its creator. Thus, Bach's *Cantatas* are devout reflections of the unity and ubiquity of the God who constantly guided his thoughts, Haydn's *Masses* are animated by the same lusty life-affirming vigor as his symphonies and quartets, Beethoven's *Missa Solennis* is firm and imposing, Schubert's *Masses* are lyrical and songful, Verdi's *Requiem* is stormy and operatic, Janacek's *Slavonic Mass* is fiercely nationalistic, and Stravinsky's *Mass* is lean and ascetic.

While religious sentiment infuses the work of many 20th century composers, few major works have emerged. Of those, most disdain traditional approaches and ritual for modern cynicism in order to question and test time-honored assumptions. Thus, Benjamin Britten's deeply unsettling 1962 *War Requiem* juxtaposes Latin hymns of faith with the bitter antiwar verses of Wilfred Owen, a poet killed in service near the close of World War I. Similarly, Leonard Bernstein's 1963 *Kaddish Symphony* and 1971 *Mass* challenge their respective Jewish and Catholic liturgies through characters who argue with God and ultimately emerge from the process badly shaken and with only a tenuous faith remaining.

All the more amazing, then, that late in his life Francis Poulenc (1899-1963) wrote a gorgeous, soul-affirming work that combines modern brevity and freshness with traditional creed and technique to bestow a wondrous resource for our troubled times. As with the religious masterworks of his illustrious predecessors, *Gloria* served to summarize all Poulenc had experienced and become. While it goes without saying that all composers' output reflects a combination of influences, Poulenc's were far more sweeping than most.

Poulenc was largely self-taught and thus apt to absorb a wider range of musical resources than those normally imposed by strict classical training. That, in turn, led him to become an incessant borrower of others' music, not out of laziness but out of genuine respect for music he loved. It was not as a crutch until he found his own footing but throughout his maturity as well — indeed, his final two sonatas for clarinet and oboe consciously evoke the distinctive qualities of Prokofiev and Honegger. Nearly all his work is a deft mixture of styles, suffused with ideas from Gregorian chant to burlesque.

Poulenc then studied with Ricardo Viñes, a pioneering pianist who championed the then-new work of Debussy, Ravel and others on the cutting edge of modernism. Poulenc not only developed into a fine pianist himself, but also absorbed that special feeling of delicate sensuality intrinsic to French music. His earliest works, such as the 1918 *Mouvements Perpetuels*, fully reflect this feeling, bursting with effortless melody and diffident grace. Despite Viñes' influence, though, Poulenc had no interest in sounding modern, even going so far as to write concertos for harpsichord and organ. His music generally has far more to do with preceding centuries than his own.

Poulenc's first fame (or perhaps notoriety) came with *Les Six*, a group of six rebellious young French composers

inspired by Erik Satie, who specialized in brief piano pieces whose sweet and wistful lyricism belied such bizarre titles as "Things Seen From Right To Left Without Glasses," "Limp Preludes For A Dog" and "Bureaucratic Sonata." *Les Six* rejected wispy French impressionism along with both of the alternative trends of their time — the sobriety of composers who clung to the serious (mostly German-influenced) forms of the past as well as modernists who crusaded for grating dissonance and intellectual structures that audiences couldn't understand or enjoy. Instead, their goal was light, rhythmic and functional music, grounded in popular forms and leavened with wit. Poulenc's own work in this vein culminated in *Les Mamelles de Terésias*, an absurd genre-bending satire (men spawn children when women refuse), enlivened by a dazzling musical send-up of the conventions of grand opera.

The sudden death of a close friend in 1936 plunged Poulenc back to his Catholic roots. Within a week, he had written the first of a series of austere a cappella religious works. This new profundity and gravity ultimately led to his 1957 opera *Dialogues Of The Carmelites*, which traced the transfor-

**Those who fear classical religious music as long, grim and boring, need not worry — Poulenc charges constantly ahead through a dense but joyous kaleidoscopic journey.**

mation of a young nun from an eager novice to a martyr of the French revolution. Musically, it harks back to the lyrical declamatory romanticism of Verdi but tightens the narrative by avoiding arias and other distractions and relies on atmospheric orchestral interludes to paint the shifting moods. The conclusion is one of the most chilling in all of opera, as a chorus of nuns resolutely singing a Latin hymn is gradually reduced to silence by ghastly blows of a guillotine, finally leaving the novice all alone to face the final decision of her life.

To this bewildering array of styles can be added a few constants that unify all of Poulenc's music — a fine sensitivity to the human voice (developed in an extraordinary series of song settings of surrealist poets), an amazingly fertile melodic invention, an essentially 19th century sound spiced by sudden harmonic shifts, an efficiency that constantly moves forward and avoids repetition, a lightness of touch, a sense of innocent wonder, a luminous clarity and, above all, sincere humility.

All of this infuses his *Gloria*, which is remarkable not only for its wide range of emotions, from teasing impudence to pensive reverence, but also for the sheer amount of material it packs into its 25 minutes. The very beginning announces at once its intensely human focus — to dispel any suggestion of aloofness or royalty, a majestic and exciting fanfare immediately recedes into a warmer, richly harmonized register, soft chords humanize the aura yet further and then the chorus enters by building a rising figure over swirling strings.

Those who fear classical religious music as long, grim and boring, need not worry — Poulenc charges constantly ahead through a dense but joyous kaleidoscopic journey. The fourth movement, lasting barely a minute, is woven from no fewer than a half dozen evanescent melodies. Like a well-structured pop song, it's over so fast you just want to hear it again. There's nothing intense or prolonged here — in deference to

modern attention spans, Poulenc effortlessly careers among moods of elation, wonder and contentment.

The last minute both encapsulates Poulenc's genius for seemingly effortless efficiency and exalts the depth of his surface simplicity. It's a disarmingly plain yet multi-layered and overwhelmingly effective exploration of the multiple implications of "Amen." A lush, meditative mood is broken by an "Amen" of the full chorus, followed by a sharp orchestral chord, thus forcing the traditional use of the word as marking a definitive end to prayer. But then a solo soprano glides through a loud, sinuous chant-like "Amen," wandering desperately until, at the end of her breath, she settles on a final note of doubt, ancient in sound but modern in its brash, questioning spirit. The chorus then intones a soft, lushly harmonized "Amen" of reassuring peace and eternal calm. Barely audible, the soprano suggests one more "Amen" in a bittersweet suspension of eternal unresolved mystery.

On that shimmering ambiguity the work ends. It's not only one of the most awesome moments in all of music but is brilliantly complex in all its levels of meaning. Although I've tried, words can't possibly describe the wonder of such a radiant set of events nor, for that matter, of the entire piece. One really just has to hear it.

The first recording of *Gloria* (now on EMI CD 47723) was made by the French National Radio-Television Orchestra And Chorus, conducted by Georges Pretre. Taped the day after its February 1961 European premiere and supervised by Poulenc, it's entitled to instant respect as presumably realizing the composer's intentions. Yet, while soprano Rosanna Carteri (for whom the solo part was written) sings ravishingly and while the end is sublime, the rest is weighty and earthbound, in surprising contrast to Poulenc's own headstrong and vital piano records (collected on Pearl CD 9311).

Fortunately, of the dozen recordings since then the top recommendation can go to a mid-priced release — a magnificent 1990 performance on Virgin 61843 by the Westminster Singers, City Of London Sinfonia, and soprano Catherine Dubosc, conducted by Richard Hickox — that's bright, airy, delicate (except for a slightly perfunctory end) and luminously recorded (although the deep bass is a bit unruly). Another mid-priced contender, Leonard Bernstein's 1976 release with the New York Philharmonic, Westminster Choir, and Judith Blegen (on Sony SMK 47559), is beautifully expressive and sharp, bounding with the conductor's superb sense of élan and rhythm. Unfortunately, the only budget version (on Naxos), while propulsive and raising expectations of authenticity with its French forces, smothers a decent reading beneath weird balances and a blurry (albeit 1992 digital!) recording.

One final matter — does one have to be a devout Catholic, or even Christian at all, to identify with and respond to this work? From my personal experience — no! After all, one doesn't have to want to be a paperback writer, catch a wave or paint it black to relate to rock nor, for that matter, dream of a white Christmas to enjoy pop standards. Like all great religious music, the *Gloria* delves far beneath the details of its text to ask the eternal questions and explore the universal truths that lie at the base of all human understanding. Although its specific prayer may not be personally meaningful, the music it inspired will move anyone with even a spark of religious feeling. Even if a person is not religious at all, one still has to respect the power of faith that stirred Poulenc and others before him to create such magnificently heartfelt expressions of human feeling.

Peter Gutmann can be reached via e-mail at [pg@commlaw.com](mailto:pg@commlaw.com), and his columns are archived at [www.classicalnotes.net](http://www.classicalnotes.net).



Francis Poulenc



**Bargain** And Haggle.com

There's a reason we're not called  
TakeALossAndGetOutbid.com.

Actually, we're bargainandhaggle.com, the website where people with stuff to sell connect with people who want to buy. Different from an auction site, bargainandhaggle.com lets a buyer and a seller work one-on-one. Once an item's posted and an offer's made, the parties

negotiate. The result is a relieved seller who got a fair price and a relaxed buyer who didn't have to baby-sit an auction. Which makes us wonder, Why would anyone ever choose an unpredictable online auction over a pretty predictable online sale?

conceived and created by mindpepper, LLC™



## WANTED-ORIGINAL 1960s LICENSED HIGH QUALITY BEATLES MEMORABILIA

1. GEORGE HARRISON BEAT SEAT, BY UNITREND, LTD.
2. THE BEATLE BANK...10" TALL MOLD-ED SCULPTURE WITH STICKER.
3. BINGO GAME. BY TOY WORKS.
4. BEATLES DRESS WITH LARGE BLUE MUSIC NOTES WITH BEATLE FACES.
5. DRINKING GLASS SET WITH BEATLES WEARING RED OR ORANGE COATS.
6. MAGIC SLATE, BY MERIT.
7. MAGIC TRICK, BY THE SUPREME MAGIC COMPANY.
8. RECORD RACK BY SELDOL. WITH OR WITHOUT THE END PIECES.
9. INSTRUCTION BOOKLET FOR RECORD PLAYER.
10. SHAMPOO BOX FOR INDIVIDUAL BOTTLE, BY BRONSON PRODUCTS.
11. SKATEBOARD WITH OR WITHOUT BOX, BY SURF SKATER COMPANY.
12. VASE...14" TALL CERAMIC VASE WITH BEATLE FACES AND SIGNATURES.
13. YELLOW SUBMARINE CANDLE IN TIN CONTAINER, BY CONCEPT.
14. YELLOW SUBMARINE MAGNETIC POSTER IN ORIGINAL PACKAGE.
15. YELLOW SUBMARINE DESK BLOTTER, BY A&M LEATHERLINE.
16. YELLOW SUBMARINE COLORING BOOK, BY WORLD DISTRIBUTORS.
17. YELLOW SUBMARINE PENNANT.
18. YELLOW SUBMARINE DISPLAY BOX FOR TRADING CARDS, BY ANGLO CONFECTIONARY.

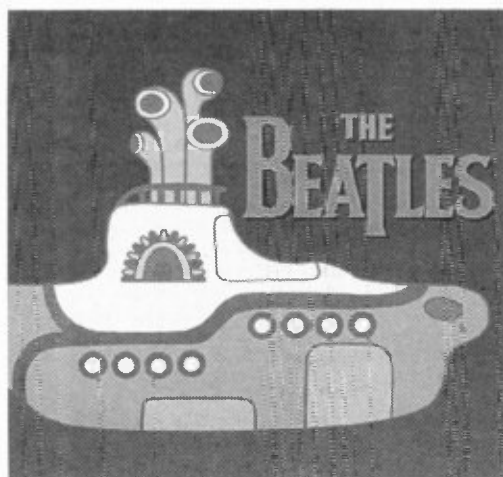

INTERESTED IN VARIOUS STORE DISPLAYS, POSTERS AND PROMOTIONAL ITEMS FOR RECORDS AND OTHER MERCHANDISE.  
ALSO INTERESTED IN VARIOUS CONCERT PROGRAMS...PLEASE CALL FOR WANTS.

WILL PAY TOP DOLLAR FOR THESE ITEMS  
DENNIS DAILEY - COLLECTOR - 308-532-8098 OR 308-534-5351 OR  
E-MAIL [condai@nque.com](mailto:condai@nque.com)

## Behind The Muse

Pop and Rock's Greatest Songwriters Talk About Their Work and Inspiration

by Bill DeMain

\$24.95

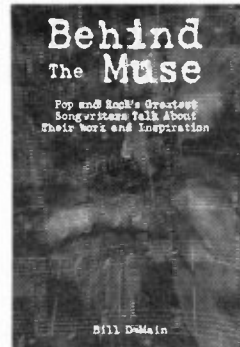

Interviews with more than 40 successful and respected songwriters, including:

- BRIAN WILSON • ROGER MCGUINN • TODD RUNDGREN  
BURT BACHARACH • MATTHEW SWEET • JOHN MELLENCAMP  
MARSHALL CRENSHAW • ANTONIO CARLOS JOBIM • DAVID BYRNE  
SMOKEY ROBINSON • DON MCLEAN • JERRY HERMAN • TIM RICE  
AIMEE MANN • JIMMY WEBB • DOLLY PARTON • BARRY GIBB  
BILLY JOEL • NICK LOWE • STEVE WINWOOD • SHERYL CROW

Also available:

**Add Some Music To Your Day: Analyzing and Enjoying the Music of the Beach Boys** \$19.95

"Dedicated fans of the Beach Boys' artistry will welcome these thoughtful writings" — Discoveries  
"Focused and provocative... a useful addition to the tsunami of Beach Boys scholarship" — Billboard

**Yesterday Once More: Memories of the Carpenters and Their Music** \$24.95

"A very compelling read" — Discoveries  
"Endlessly intriguing" — Record Collector

### Tiny Ripple Books

P.O. Box 1533  
Cranberry Township, PA 16066

[www.tinyripple.com](http://www.tinyripple.com)

Please add \$3.50 shipping;  
Pennsylvania residents add 6% sales tax.

# GOLDMINE GRADING GUIDE

### VISUAL OR PLAY GRADING?

In an ideal world, every record would be played before it is graded. But the time involved makes it impractical for most dealers, and anyway, it's rare that you get a chance to hear a record before you buy through the mail. Some advertisers playgrade everything and say so. But unless otherwise noted, records are visually graded.

### HOW TO GRADE

Look at everything about a record — its playing surface, its label, its edges — under a strong light. Then based on your overall impression give it a grade based on the following criteria:

**Mint (M):** Absolutely perfect in every way — certainly never played, possibly even still sealed. (More on still sealed under "Other considerations"). Should be used sparingly as a grade, if at all.

**Near Mint (NM or M-):** A nearly perfect record. Many dealers won't give a grade higher than this implying (perhaps correctly) that no record is ever truly perfect.

The record should show no obvious signs of wear. A 45 RPM or EP sleeve should have no more than the most minor defects, such as almost invisible wear or other signs of slight handling.

An LP jacket should have no creases, folds, seam splits or any other noticeable similar defect. No cut-out holes, either. And of course, the same should be true of any other inserts, such as posters, lyric sleeves and the like.

Basically, an LP in Near Mint condition looks as if you just got it home from a new record store and removed the shrink wrap.

Near Mint is the highest price listed in all GOLDMINE price guides. Anything that exceeds this grade, in the opinion of both buyer and seller, is worth significantly more than the highest GOLDMINE book value.

**Very Good Plus (VG+):** Generally worth 50 percent of the Near Mint value.

A Very Good Plus record will show some signs that it was played and otherwise handled by a previous owner who took good care of it.

Record surfaces may show some slight signs of wear and may have slight scuffs or very light scratches that don't affect one's listening experience. Slight warps that do not affect the sound are OK.

The label may have some ring wear or discoloration, but it should be barely noticeable. The center hole will not have been misshapen by repeated play.

Picture sleeves and LP inner sleeves will have some slight wear, lightly turned-up corners or a slight seam-split. An LP jacket may have slight signs of wear also and may be marred by a cut-out hole, indentation or corner indicating it was taken out of print and sold at a discount.

In general, if not for a couple of minor things wrong with it, this would be Near Mint. All but the most mint-crazy collectors will find a Very Good Plus record highly acceptable.

**Very Good (VG):** Generally worth 25 percent of the Near Mint value. Many of the defects found in a VG+ record will be more pronounced in a VG disc. Surface noise will be evident upon playing, especially in soft passages and during a song's intro and fade, but will not overpower the music otherwise. Groove wear will start to be noticeable, as will light scratches (deep enough to feel with a fingernail) that will affect the sound.

Labels may be marred by writing, or have tape or stickers (or their residue) attached. The same will be true of picture sleeves or LP covers. However, it will not have all of these problems at the same time, only two or three of them.

GOLDMINE price guides with more than one price will list Very Good as the lowest price. This, not the Near Mint price, should be your guide when determining how much a record is worth, as that is the price a dealer will normally pay you for a Near Mint record.

**Good (G), Good Plus (G+):** Generally worth 10-15 percent of the Near Mint value. Good does not mean Bad! A record in Good or Good Plus condition can be put onto a turntable and will play through without skipping. But it will have significant surface noise and scratches and visible groove wear (on a styrene record, the groove will be starting to turn white).

A jacket or sleeve will have seam splits, especially at the bottom or on the spine. Tape, writing, ring wear or other defects will start to overwhelm the object.

If it's a common item, you'll probably find another copy in better shape eventually. Pass it up. But, if it's something you have been seeking for years, and the price is right, get it... but keep looking to upgrade.

**Poor (P), Fair (F):** Generally worth 0-5 percent of the Near Mint price. The record is cracked, badly warped, and won't play through without skipping or repeating. The picture sleeve is water damaged, split on all three seams and heavily marred by wear and writing. The LP jacket barely keeps the LP inside it. Inner sleeves are fully seam split, crinkled and written upon.

Except for impossibly rare records otherwise unattainable, records in this condition should be bought or sold for no more than a few cents each.

### OTHER CONSIDERATIONS

Most dealers give a separate grade to the record and its sleeve or cover. In an ad, a record's grade is listed first, followed by that of the sleeve or jacket.

With **Still Sealed (SS)** records, let the buyer beware, unless it's a U.S. pressing from the last 10-15 years or so. It's too easy to re-seal one. Yes, some legitimately never-opened LPs from the 1960s still exist. But if you're looking for a specific pressing, the only way you can know for sure is to open the record. Also, European imports are not factory-sealed, so if you see them advertised as sealed, someone other than the manufacturer sealed them.

### A FEW NOTES ON COMPACT DISCS

In theory, a compact disc should always play-grade in at least Near Mint condition. And even the condition of generic jewel boxes and trays aren't important, as they can be replaced easily.

Unless the CD came in a special package (fold-open, fold-over, colored plastic, etc.), the two areas to check for grading are its label and its insert (booklet).

Most collector interest currently is with promotional CD's. Again, audible condition of the disc is less of a concern than the condition of its packaging and art-work and the collectibility of the artist.

Used full-length, commercial CD's generally sell for 50-75 percent of the new price. Dealers in used CD's will usually pay no more than 50 percent of that price, and often much less.

### COMMON ABBREVIATIONS (not including grades)

- 7" - standard 45 RPM record
- 10" - 10-inch vinyl LP
- 12" - 12-inch single
- bb - bb hole in cover
- boot - bootleg
- cc - cut corner
- cd - compact disc
- cd3 - 3" compact disc single
- cd5 - 5" compact disc single
- co - cut-out

- coh - cut-out hole
- dj - disc jockey (promo)
- ep - extended play 45
- imp - import
- lp - 12" vinyl album
- m - \*mono LP
- nap - not affecting play
- non-lp - not on full-length LP or CD
- oc - original cast recording
- ost - original soundtrack

- pc - picture cover (12" and CD's)
- pi - picture insert (CD single)
- promo - promotional copy
- ps - picture sleeve (45s)
- quad - quadraphonic
- re - reissue
- ri - reissue
- rpm - revolutions per minute
- rw - ring wear
- s - stereo LP

- sl - slight
- sm spl - seam split
- soc - sticker on cover
- sol - sticker on label
- ss - still sealed
- s/t - self-titled
- tc - title cover (12" and CD's)
- ti - title insert (CD single)
- toc - tape on cover
- tol - tape on label

- UK - United Kingdom (British import)
- US - United States (domestic pressing)
- va - various artists
- wlp - white label promo
- woc - writing on cover
- wol - writing on label
- xol - "X" written on label
- \*check the context, as "m" can also mean "mint"

# JACK WOLAK'S RARE NECESSITIES

P.O. BOX 88, NORTH SYRACUSE, NEW YORK 13212 USA  
PHONE 315-452-1355 \* FAX 315-452-5572 \* E-MAIL: INQUIRY@JACKWOLAK.COM

VISIT OUR WEB SITE FOR A COMPLETE LISTING OF OVER 20,000 ITEMS AT:

**WWW.JACKWOLAK.COM**

IF YOU DO NOT HAVE INTERNET ACCESS, LET US KNOW WHO YOU COLLECT AND WE WILL SEND YOU IN STOCK LISTS BY THOSE ARTISTS.



All items are set sale and in Mint or Near Mint condition unless noted. We accept payment by Money Order (postal preferred), Cashiers Check, Visa, MasterCard, American Express, Discover. All personal check payments are held for 14 days. New York state residents must add the appropriate sales tax. We ship thru the US Post Office/Media Mail Insured. \$4 per order up to \$50, \$5 per order up to \$100, \$7 per order up to \$200, \$8 per order up to \$300. Overseas and Canada write, call, fax, or e-mail first to reserve. Phone reservations are held for 14 days only. Phone hours are from 9 AM to 8 PM Eastern, Monday thru Friday.

### ELTON JOHN COLLECTIBLES

- JOHN, ELTON CD5, Believe +2 (2 Live) Germany, CD EP in JB, Pic Disc \$10.00
- JOHN, ELTON CD5, Believe +2 (2 Live) UK, CD EP in JB, Pic Disc, Part 1 of 2 \$10.00
- JOHN, ELTON CD5, Believe +2 (2 Live) UK, CD EP in JB, Part 2 of 2 \$10.00
- JOHN, ELTON CD5, Don't Let the Sun Go Down on Me +2, UK, CD EP in JB, 1991 Issue \$13.00
- JOHN, ELTON CD5, Easter to Walk Away +2, UK, CD EP in JB, Charic Issue \$15.00
- JOHN, ELTON CD5, Goodbye Yellow Brick Road +1, Japan, 3" CD Single in JB, 1996 Issue \$19.00
- JOHN, ELTON CD5, If the River Can Bend +3, UK, CD EP in JB, Blue Disc & Inlay \$10.00
- JOHN, ELTON CD5, Made in England +1 (Live) Australia, CD Single in PS \$9.00
- JOHN, ELTON CD5, Made in England +1 (Live) Germany, CD Single in PS \$9.00
- JOHN, ELTON CD5, Made in England +3 (2 Live) UK, CD EP in JB, Part 2 of 2 \$10.00
- JOHN, ELTON CD5, Made in England +3 (3 Live) UK, CD EP in JB, Part 1 of 2 + Cardboard Slipcase, Part 1 of 2, 3 Live Songs w/John Lennon \$11.00
- JOHN, ELTON CD5, Please +3 (3 Live) UK, CD EP in JB, Part 2 of 2 \$11.00
- JOHN, ELTON CD5, Recover Your Soul (Single Rema) +2, UK, CD EP in JB, 2 Non-LP \$11.00
- JOHN, ELTON CD5, Recover Your Soul (Single Rema) +2, UK, Enhanced CD EP in JB, 1 Non-LP, 1 Live \$12.00
- JOHN, ELTON CD5, Simple Life +2, UK, CD EP in JB, \$11.00
- JOHN, ELTON CD5, Steeping With The Past Sampler, UK, Promo CD EP in JB, 4 Songs \$45.00
- JOHN, ELTON CD5, Someday Out Of The Blue +1, US, CD Single in JB, From "The Road to Lido" \$4.00
- JOHN, ELTON CD5, Someday Out Of The Blue +3, Australia, Enhanced CD EP in PS, w/Video \$11.00
- JOHN, ELTON CD5, Something About The Way You +1, Germany, CD Single in German-Only PS, w/"I Know Why I'm in Love" \$10.00
- JOHN, ELTON CD5, Something About The Way You +2, UK, CD EP in JB, w/"Candle In The Wind 1997" \$11.00
- JOHN, ELTON CD5, The Last Song +3, UK, CD EP in JB, Part 2 of 3 from Thom Bell Sessions \$10.00
- JOHN, ELTON CD5, The Last Song +3, UK, CD EP in JB, 3 Thom Bell Produced Songs, Part 2 of 2 \$12.00
- JOHN, ELTON CD5, The One +2 (2 Non-LP), Germany, CD EP in JB \$10.00
- JOHN, ELTON CD5, The One +2 (2 Non-LP), US, CD EP in JB \$7.00
- JOHN, ELTON CD, Chartbusters Go Pop, UK, Full-length CD, No US Release, All Cover Songs From 1969 & 70, Elton Pic Disc \$15.00
- JOHN, ELTON CD, Lady Samantha, Germany, German-Only 14 Songs, w/ Mostly Non-LP B-Sides \$20.00
- JOHN, ELTON CD, Rare Masters/The E.J. Collection, US, 2 CD Promo Set, w/ 25 Tracks, 9 from "Rare Masters" on 1, 16 from "The Elton John Collection" on the Other, Excellent Item \$35.00
- JOHN, ELTON CD, Reg Dwight's Piano Songs Pop CD, UK, Full-length CD with 20 "Hits Of The Day" (All Covered Recorded When He Was Still Using His Real Name - Mic to Live 60's) \$22.00
- JOHN, ELTON CD, See Diana, Princess Of Wales In CD Section, UK, Full Length \$18.00
- JOHN, ELTON CD, Telltales Interview, UK, Interview Pic Disc CD in JB \$9.00
- JOHN, ELTON CD, The Very Best Of Elton John, Australia, 30 Tracks, 2 CD Set, No US Release \$25.00
- JOHN, ELTON CD, 7 P.D. Candle In The Wind, UK, Pic of Marilyn Monroe, Rare Picture Disc \$60.00
- JOHN, ELTON CD, 7 P.D. Empty Garden, UK, Picture Disc \$40.00
- JOHN, ELTON CD, Shape, I'm Still Standing, UK, Piano Shape \$50.00
- JOHN, ELTON CD, A Single Men LP, US, M Cover, Co \$12.00
- JOHN, ELTON CD, 7 P.D. A Single Man LP, US, Promo, Different \$45.00
- JOHN, ELTON CD, Kiss The Bride, Germany, 45 w/PS \$8.00
- JOHN, ELTON CD, Kiss The Bride, UK, 45 w/PS, Non-LP \$6.00
- JOHN, ELTON CD, Kiss The Bride +3, UK, Double 45 w/PS \$18.00
- JOHN, ELTON CD, Kiss The Bride +3, UK, Double 45 w/PS, M/M \$12.00
- JOHN, ELTON CD, Little Jeanie, UK, 45 w/PS \$8.00
- JOHN, ELTON CD, Little Jeanie, UK, 45 w/PS \$8.00
- JOHN, ELTON CD, Little Jeanie, US, Reissue 45 on Red Vinyl, B/W "Drew same Funk" \$4.00
- JOHN, ELTON CD, Lucy In The Sky With Diamonds, Germany, 45 w/PS, M/M \$16.00
- JOHN, ELTON CD, Lucy In The Sky With Diamonds, US, 45 w/PS \$12.00
- JOHN, ELTON CD, Mama Can't Buy You Love, US, 45 w/PS, M/M \$4.00
- JOHN, ELTON CD, Mama Can't Buy You Love, US, Reissue 45 on Red Vinyl, B/W "Are You Ready For" \$15.00
- JOHN, ELTON CD, Nikita, UK, 45 w/PS, Non-LP \$8.00
- JOHN, ELTON CD, Part Time Love, Japan, 45 w/PS \$8.00
- JOHN, ELTON CD, Philadelphia Freedom, Germany, 45 w/PS, Non-LP \$18.00
- JOHN, ELTON CD, Pinball Wizard, Japan, 45 w/PS, Japanese-Only PS, 33 RPM, OH-81 \$15.00
- JOHN, ELTON CD, Princess, UK, 45 w/PS \$18.00
- JOHN, ELTON CD, Princess, UK, 45 w/PS, M/M \$10.00
- JOHN, ELTON CD, Return to Paradise, Holland, 45 w/Dutch-Only PS \$15.00
- JOHN, ELTON CD, Rocket Man, Germany, 45 w/PS, German-Only PS \$20.00
- JOHN, ELTON CD, Rocket Man +2, UK, 45 EP w/PS, M/M \$12.00
- JOHN, ELTON CD, Sad Songs, US, Promo 45, 408 Verses \$6.00
- JOHN, ELTON CD, Sad Songs, US, Promo 45, Special Radio Mix, 408 Verses \$6.00
- JOHN, ELTON CD, Saturday Nights Alright For... Japan, 45 w/PS, Japanese Only PS, Canon 7Y0101, B/W "Border Song" \$15.00
- JOHN, ELTON CD, Someone Saved My Life Tonight, Germany, 45 w/PS, German-Only PS, Golden Greats Reissue, B/W "Lady Samantha" \$15.00
- JOHN, ELTON CD, Something...Candle In The Wind, US, 1997 45 w/PS + Lyric Insert \$3.00
- JOHN, ELTON CD, Special 12 Record Box (1978) UK, Ltd. Ed. Set of 12 Picture Sleeve 45's, No Box \$75.00
- JOHN, ELTON CD, Step Into Christmas, US, M/ST MP \$26.00
- JOHN, ELTON CD, Take Me To The Pilot (Live), US, 45 w/PS \$2.00
- JOHN, ELTON CD, That's Why They Call It The Blues, UK, 45 w/PS, Non-LP B-Side, Mistitled, PS (See Title) \$32.00
- JOHN, ELTON CD, The Bitch Is Back, Japan, 45 w/PS, Japanese-Only PS, M/M, WDS \$7.00
- JOHN, ELTON CD, The Bitch Is Back, UK, WLP 45 \$28.00
- JOHN, ELTON CD, The Last Song, UK, 45 w/PS \$4.00
- JOHN, ELTON CD, The Last Song, UK, 45 w/PS \$4.00
- JOHN, ELTON CD, Victim Of Love, Japan, 45 w/PS, M/M, \$8.00
- JOHN, ELTON CD, Who Wears These Shoes, UK, 45 w/PS, Non-LP B-Side \$5.00

### ELTON JOHN COLLECTIBLES

- JOHN, ELTON CD, Blue Eyes, UK, 45 w/PS, Non-LP B-Side \$8.00
- JOHN, ELTON CD, Blue Eyes, US, 45 w/PS, Non-LP B, M/WG \$3.00
- JOHN, ELTON CD, Breaking Hearts, UK, 45 w/PS, M/M, UK-Only \$9.00
- JOHN, ELTON CD, Candle In The Wind, US, 45 w/PS, Yellow PS, Live In Australia Version \$5.00
- JOHN, ELTON CD, Club At The End Of The Street, Germany, 45 w/PS, B/W Non-LP "Give Peace On A Chance" \$12.00
- JOHN, ELTON CD, Club At The End Of The Street, UK, 45 w/PS \$6.50
- JOHN, ELTON CD, Cold As Christmas, UK, 45 w/PS \$6.50
- JOHN, ELTON CD, Cocodile Rock, Japan, 45 w/Japanese Only Inlay PS \$20.00
- JOHN, ELTON CD, Cry To Heaven, Germany, 45 w/German-Only PS \$12.00
- JOHN, ELTON CD, Cry To Heaven +3 (2 Live), UK, Double 45 in JB, Gatefold PS, w/3-Song R&R Medley \$6.50
- JOHN, ELTON CD, Dear God +3, UK, Double 45 in PS \$20.00
- JOHN, ELTON CD, Don't Let the Sun Go Down on Me, UK, 45 w/PS, 1991 Issue \$6.00
- JOHN, ELTON CD, Ego, Italy, 45 w/PS \$8.00
- JOHN, ELTON CD, Ego, UK, 45 w/PS, Promo, M/M \$12.00
- JOHN, ELTON CD, Ego, US, WLP \$6.00
- JOHN, ELTON CD, Eton John's Christmas EP, UK, 45 EP w/Gatefold PS, 4 Songs (2 New), 1990 Issue \$12.00
- JOHN, ELTON CD, Eton John's Christmas EP, UK, 45 EP w/Gatefold PS, 4 Songs (2 New), M/M, 1990 Issue \$10.00
- JOHN, ELTON CD, Empty Garden, UK, 45 w/PS, Non-LP B-Side \$9.00
- JOHN, ELTON CD, Empty Garden, US, PS, M/M \$4.00
- JOHN, ELTON CD, Four From Four Eyes EP, UK, 45 EP w/PS, 4-Songs M/M \$12.00
- JOHN, ELTON CD, Friends, Japan, 45 w/Japanese Only Gatefold PS, M/M \$20.00
- JOHN, ELTON CD, Friends, US, Hard Single to Find \$5.00
- JOHN, ELTON CD, Friends +3, Japan, 45 EP w/PS + Insert, 33 RPM Compac \$32.00
- JOHN, ELTON CD, Goodbye Yellow Brick Road, Japan, 45 in Gatefold PS \$20.00
- JOHN, ELTON CD, Goodbye Yellow Brick Road, US, M/ST WLP \$10.00
- JOHN, ELTON CD, Goodbye Yellow Brick Road, US, M/ST WLP \$10.00
- JOHN, ELTON CD, Grow Some Funk Of Your Own, US, WLP 45, # in Label \$8.00
- JOHN, ELTON CD, Healing Hands, UK, 45 w/PS, EJS 19 \$6.50
- JOHN, ELTON CD, Heartache All Over The World +3, UK, Double 45 in Gatefold PS \$6.50
- JOHN, ELTON CD, Honky Cat, US, Promo 45, # on Label \$20.00
- JOHN, ELTON CD, Honky Cat, US, Reissue 45 on Green Vinyl, B/W "Harmy" \$5.00
- JOHN, ELTON CD, I Don't Wanna Go On With You, Japan, 45 w/Japanese Only PS, Promo, M/M, Inlay on PS \$8.00
- JOHN, ELTON CD, I Don't Wanna Go On With You, US, Reissue 45 on Green Vinyl, B/W "Nobody Wins" \$5.00
- JOHN, ELTON CD, I'm Still Standing, Japan, 45 w/Japanese Only PS, M/M \$10.00
- JOHN, ELTON CD, I'm Still Standing, US, M/ST Promo 45, VG \$15.00
- JOHN, ELTON CD, In Neon, US, 45 w/Non-LP B-Side, M/M \$5.00
- JOHN, ELTON CD, In Neon, US, Promo 45 \$6.00
- JOHN, ELTON CD, Island Girl, Japan, 45 w/Japanese Only PS \$20.00
- JOHN, ELTON CD, Island Girl, US, WLP 45 \$10.00
- JOHN, ELTON CD, It's Me That You Need, Japan, 45 w/Japanese Only Gatefold PS, M/M \$30.00
- JOHN, ELTON CD, J'Veux D'La Tendresse, France, 45 w/PS, Sung in French \$20.00
- JOHN, ELTON CD, J'Veux D'La Tendresse, France, 45 w/PS, Sung in French \$18.00
- JOHN, ELTON CD, Johnny B. Goode, UK, 45 w/PS, M/M, PS \$4.50
- JOHN, ELTON CD, Just Like Belgium, Germany, 45 w/German-Only PS \$12.00
- JOHN, ELTON CD, Kiss The Bride, Germany, 45 w/PS \$8.00
- JOHN, ELTON CD, Kiss The Bride, UK, 45 w/PS, Non-LP B-Side \$6.00
- JOHN, ELTON CD, Kiss The Bride +3, UK, Double 45 w/PS \$18.00
- JOHN, ELTON CD, Kiss The Bride +3, UK, Double 45 w/PS, M/M \$12.00
- JOHN, ELTON CD, Little Jeanie, UK, 45 w/PS \$8.00
- JOHN, ELTON CD, Little Jeanie, UK, 45 w/PS \$8.00
- JOHN, ELTON CD, Little Jeanie, US, Reissue 45 on Red Vinyl, B/W "Drew same Funk" \$4.00
- JOHN, ELTON CD, Lucy In The Sky With Diamonds, Germany, 45 w/PS, M/M \$16.00
- JOHN, ELTON CD, Lucy In The Sky With Diamonds, US, 45 w/PS \$12.00
- JOHN, ELTON CD, Mama Can't Buy You Love, US, 45 w/PS, M/M \$4.00
- JOHN, ELTON CD, Mama Can't Buy You Love, US, Reissue 45 on Red Vinyl, B/W "Are You Ready For" \$15.00
- JOHN, ELTON CD, Nikita, UK, 45 w/PS, Non-LP \$8.00
- JOHN, ELTON CD, Part Time Love, Japan, 45 w/PS \$8.00
- JOHN, ELTON CD, Philadelphia Freedom, Germany, 45 w/PS, Non-LP \$18.00
- JOHN, ELTON CD, Pinball Wizard, Japan, 45 w/PS, Japanese-Only PS, 33 RPM, OH-81 \$15.00
- JOHN, ELTON CD, Princess, UK, 45 w/PS \$18.00
- JOHN, ELTON CD, Princess, UK, 45 w/PS, M/M \$10.00
- JOHN, ELTON CD, Return to Paradise, Holland, 45 w/Dutch-Only PS \$15.00
- JOHN, ELTON CD, Rocket Man, Germany, 45 w/PS, German-Only PS \$20.00
- JOHN, ELTON CD, Rocket Man +2, UK, 45 EP w/PS, M/M \$12.00
- JOHN, ELTON CD, Sad Songs, US, Promo 45, 408 Verses \$6.00
- JOHN, ELTON CD, Sad Songs, US, Promo 45, Special Radio Mix, 408 Verses \$6.00
- JOHN, ELTON CD, Saturday Nights Alright For... Japan, 45 w/PS, Japanese Only PS, Canon 7Y0101, B/W "Border Song" \$15.00
- JOHN, ELTON CD, Someone Saved My Life Tonight, Germany, 45 w/PS, German-Only PS, Golden Greats Reissue, B/W "Lady Samantha" \$15.00
- JOHN, ELTON CD, Something...Candle In The Wind, US, 1997 45 w/PS + Lyric Insert \$3.00
- JOHN, ELTON CD, Special 12 Record Box (1978) UK, Ltd. Ed. Set of 12 Picture Sleeve 45's, No Box \$75.00
- JOHN, ELTON CD, Step Into Christmas, US, M/ST MP \$26.00
- JOHN, ELTON CD, Take Me To The Pilot (Live), US, 45 w/PS \$2.00
- JOHN, ELTON CD, That's Why They Call It The Blues, UK, 45 w/PS, Non-LP B-Side, Mistitled, PS (See Title) \$32.00
- JOHN, ELTON CD, The Bitch Is Back, Japan, 45 w/PS, Japanese-Only PS, M/M, WDS \$7.00
- JOHN, ELTON CD, The Bitch Is Back, UK, WLP 45 \$28.00
- JOHN, ELTON CD, The Last Song, UK, 45 w/PS \$4.00
- JOHN, ELTON CD, The Last Song, UK, 45 w/PS \$4.00
- JOHN, ELTON CD, Victim Of Love, Japan, 45 w/PS, M/M, \$8.00
- JOHN, ELTON CD, Who Wears These Shoes, UK, 45 w/PS, Non-LP B-Side \$5.00

### ELTON JOHN COLLECTIBLES

- JOHN, ELTON CD, Who Wears These Shoes, US, 45 w/PS, Non-LP B-Side, M/M \$5.00
- JOHN, ELTON CD, Who Wears These Shoes, UK, 45 w/PS \$6.00
- JOHN, ELTON CD, Who Wears These Shoes, UK, 45 w/PS, Non-LP B-Side \$6.00
- JOHN, ELTON CD, Who Wears These Shoes, UK, 45 w/PS, Live In Australia \$6.50
- JOHN, ELTON Programs, 1974 Tour, US, 28 Pgs. 9x12 1974 Tour Program \$20.00
- JOHN, ELTON Programs, 1975 Rock Of The Westies, US, 28 Pgs. 11x11 1975 "Rock Of The Westies" Tour Program \$20.00
- JOHN, ELTON Programs, European Express Tour, UK, 28 Pgs. 9x13 European Express Tour Program \$12.00
- JOHN, ELTON Programs, The Big Picture Tour, US, 32 Pgs. 9x12 "The Big Picture Tour" Program \$10.00
- JOHN, ELTON Programs, World Tour 1989-90, US, 28 Pgs. 9x13 The World Tour 1989-1990 Tour Program \$8.00
- JOHN, ELTON Misc. Rock 'N' Roll Comics, US, August 1993 Issue of Rock 'N' Roll Comics, 36 Pages \$4.00
- JOHN, ELTON Misc. Window Stickers, UK, Promo 8x8 Electrostatic Window Stickers For "The Big Picture" LP \$6.00
- JOHN, ELTON & Aretha Franklin CD5, Through The Storm, US, Promo CD Single in JB \$3.00
- JOHN, ELTON & Aretha Franklin CD5, Through The Storm +2, UK, 3" CD EP in PS \$15.00
- JOHN, ELTON & Aretha Franklin CD5, Through The Storm, US, 45 w/PS \$12.00
- JOHN, ELTON & ERIC CLAPTON CD5, Runaway Train +2, UK, CD EP in JB \$11.00
- JOHN, ELTON & ERIC CLAPTON CD5, Runaway Train, UK, 45 w/PS, Pic Label \$8.00
- JOHN, ELTON & ERIC CLAPTON Programs, 1992 UK Tour, 36 Pgs. 1992 UK Tour Program, 1/2 Clapton, 1/2 Elton \$12.00
- JOHN, ELTON & FRANCE GALL CD5, Les Aveux, France, 45 w/PS, Sung in French \$18.00
- JOHN, ELTON & KIKI DEE CD5, Don't Go Breaking My Heart, Japan, 45 w/PS + Lyric Insert \$8.00
- JOHN, ELTON & KIKI DEE CD5, Don't Go Breaking My Heart, Japan, 45 w/PS + Lyric Insert, VG + M \$4.50
- JOHN, ELTON & KIKI DEE CD5, Don't Go Breaking My Heart, UK, 45 w/PS, "Old Gold" Reissue \$40.00
- JOHN, ELTON & KIKI DEE CD5, Loving You Is Sweeter Than Ever, UK, 45 w/PS, Rimi, Rare \$12.00
- JOHN, ELTON & KIKI DEE CD5, True Love, UK, 45 w/PS, Live \$6.50
- JOHN, ELTON & LEANN RIMES CD5, Written In The Stars +1, Germany, CD Single in PS, w/Aida Album Sampler Track \$8.00
- JOHN, ELTON & LEANN RIMES CD5, Written In The Stars +2 (1 Live) UK, CD EP in JB, w/"Aida" Album Sampler Track \$8.00
- JOHN, ELTON & LEANN RIMES CD5, Written In The Stars +2 (1 Live) UK, CD EP in JB, w/Alternative Version \$8.00
- JOHN, ELTON & LEANN RIMES CD5, Written In The Stars (2 Versions) +1, US, CD Single in PS, 1 Track of Various Singles \$4.00
- JOHN, ELTON & MARCELLA DETROIT CD5, Ain't Nothing Like The Real Thing, UK, 45 w/PS \$6.00
- JOHN, ELTON & RUPAUL CD5, Don't Go Breaking My Heart, US, EP 3 Mins, Sealed \$3.00
- JOHN, ELTON & LUCIANO PAVAROTTI CD5, Live Like Heroes +3, UK, CD EP in JB, w/Studio & Live Final Versions \$10.00
- JOHN, ELTON & BONO MISC. 8x10 B&W Glossy \$1.00
- JOHN, ELTON/OTHERS CD5, Signed, Sealed, Delivered +5, UK, Original 1970 Album Records EP 2 Elton Songs, Rare \$45.00
- JOHN, ELTON/REO DWIGHT CD5, United We Stand (3 Mins) +1, UK, CD EP in JB, Pic Disc \$10.00

### COLOR VINYL 7" SINGLES

- CREEDENCE CLEARWATER REVIVAL 7", Have You Ever Seen The Rain, US, Pink Vinyl Reissue \$5.00
- CREEDENCE CLEARWATER REVIVAL 7", I Heard It Through The Grapevine, US, Pink Vinyl Reissue \$5.00
- CREEDENCE CLEARWATER REVIVAL 7", I Put A Spell On You, US, Pink Vinyl Reissue \$5.00
- CREEDENCE CLEARWATER REVIVAL 7", Lodi, US, Pink Vinyl Reissue \$5.00
- CREEDENCE CLEARWATER REVIVAL 7", Proud Mary, US, Pink Vinyl Reissue \$5.00
- CREEDENCE CLEARWATER REVIVAL 7", Run Through The Jungle, US, Pink Vinyl Reissue \$5.00
- CREEDENCE CLEARWATER REVIVAL 7", Someday Never Comes, US, Pink Vinyl Reissue \$5.00
- CREEDENCE CLEARWATER REVIVAL 7", Susie Q, US, Pink Vinyl Reissue \$5.00
- CREEDENCE CLEARWATER REVIVAL 7", Sweet Hitch Hiker, US, Pink Vinyl Reissue \$5.00
- CREEDENCE CLEARWATER REVIVAL 7", Travelin' Band, US, Pink Vinyl Reissue \$5.00
- CROWDED HOUSE 7", Not The Girl You Think You Are, UK, 45 w/Direct PS, White Vinyl, B/W Live "Better Be Home" \$6.50
- CURE 7", Interview (Care), UK, White Vinyl, Pic Label \$7.50
- CURE 7", The Real Sessions 1978 EP, UK, 45 w/PS, Purple Vinyl 4 Songs, Ltd. Ed. of 2500 \$15.00
- DAMNED 7", Gogol (Set of 4), UK, Red, Blue, Green & Yellow Vinyl 45's, All With Poster Sleeve \$24.00
- DASH RIP ROCK 7", Let's Go Smoke Some Pot, US, Purple & Blue Vinyl, Not Issued w/PS \$4.00
- DASH RIP ROCK 7", Dosed, US, 45 w/PS, Clear Vinyl (Green Tint) \$4.00
- DASHBOARD SAVIORS 7", All Before Us, 45 w/PS, Purple Vinyl \$4.00
- DEF LEPPARD 7", Have You Ever Needed Someone... France, Promo 45 w/Non-LP B Side, Yellow Vinyl, Amazing Poly \$35.00
- DEF LEPPARD 7", Have You Ever Needed Someone... France, Set of 3 45's, Each w/PS 1 Red Vinyl, 1 Yellow Vinyl, 1 Blue Vinyl \$90.00
- DICKIE 7", Silent Night, US, 45 w/PS, White Vinyl, M/M \$10.00
- DICKIE 7", Important Song, US, 45 w/PS, Original Independent "Birdcage" Label, Blue Vinyl \$7.00
- DURAN DURAN 7", A View To A Kill, UK, 45 w/Gate PS, White Vinyl \$18.00
- ECHOBELLY 7", Dark Therapy, UK, 45 w/Gate PS, Blue Vinyl \$6.00
- EDMUNDS, DAVE 7", Girls Talk, UK, Ltd. Ed. Clear Vinyl 45, w/Backing Card in Poly Sleeve \$20.00
- EDMUNDS, DAVE/ROCKVILLE 7", Wrong Way, UK, Gold Vinyl \$6.50
- EL VEZ (THE MEXICAN ELVIS) 7", Est A Bien Mamamita +2, US, 45 EP w/PS, Clear Vinyl \$8.00
- ELECTRIC LIGHT ORCHESTRA 7", Sweet Talkin' Woman, UK, 45 w/PS, Purple Vinyl, M/M \$6.00
- EURHYTHMICS 7", Would I Lie to You, UK, Red Vinyl 45 in Poly Sleeve \$10.00
- EURHYTHMICS 7", Would I Lie to You, UK, Yellow Vinyl 45 in Poly Sleeve \$12.00
- EVERLY BROTHERS 7", All I Have to Do is Dream, US, 1995 Reissue 45 on Gold Vinyl \$4.00
- EVERLY BROTHERS 7", Bird Dog, US, 1995 Reissue 45 on Gold Vinyl \$4.00
- EVERLY BROTHERS 7", Bye Bye Love, US, 1995 Reissue 45 on Gold Vinyl \$4.00
- EVERLY BROTHERS 7", Let It Be Me, US, 1995 Reissue 45 on Gold Vinyl \$4.00
- EVERLY BROTHERS 7", Til I Kissed You, US, 1995 Reissue 45 on Gold Vinyl \$4.00
- EVERLY BROTHERS 7", Wake Up Little Susie, US, 1995 Reissue 45 on Gold Vinyl \$4.00
- FAITH NO MORE 7", A Small Victory, UK, 45 w/PS # d Ltd. Ed. \$6.50
- FELICIANO, JOSE 7", Feliz Navidad, US, Red Vinyl Jukebox 45 \$3.00
- FISH 7", A Gentleman's Excuse Me, UK, Red Vinyl, 45 w/PS, Gatefold in Poly Sleeve \$12.00
- FIVE AMERICANS 7", Ignert Woman, US, Promo 45 On Gold Vinyl \$12.00
- FLUFFY 7", I Wanna Be Your Lush, UK, 45 w/PS, Pink Vinyl \$8.00
- FOGERTY/BLUE RIDGE RANGERS 7", Jambalaya, US, Red Vinyl, Live Reissue \$5.00
- FOGERTY/BLUE RIDGE RANGERS 7", Blue Morning, Blue Day, US, Blue Vinyl, M/ST Promo \$6.00
- FOX, SAMANTHA 7", Naughty Girls, UK, 45 w/PS, Pink Vinyl, w/ Backstage Pass \$12.00
- FRANKLIN, ARETHA & K. RICHARDS 7", Jumpin' Jack Flash, US, 45 w/PS, Clear Vinyl \$6.50
- GENESIS 7", Invisible Touch, UK, 45 w/Trangular Inlay PS, Clear Vinyl \$12.00
- GO GO'S 7", Our Lips Are Sealed, UK, 45 w/PS, Pink Vinyl, M/M \$35.00
- GORILLA 7", Sober, US, 45 w/PS, Grey Vinyl Sub-Pop Label \$10.00
- GRATEFUL DEAD 7", Touch Of Gray, US, 45 w/PS, Grey Vinyl \$12.00
- GREAT WHITE 7", Love Is A Lie, US, White Vinyl 45 \$4.00
- GREEN DAY 7", CeeK St. Breath, UK, 45 w/PS, Red Vinyl, Live Non-LP "I Want to Be On TV" \$6.50
- GREEN DAY 7", Warning, US, 45 w/PS on Pink Marble Vinyl with Non-LP B-Side, "Mama" + Lyric Insert, \$20.00
- GREEN, PETER 7", Slabo Day, Germany, PS, Green Vinyl \$8.00
- GUNS & ROSES 7", Since I Don't Have You, UK, 45 w/PS, Ltd. Ed. Orange Vinyl \$6.50
- HALL & OATES 7", Jingle Bell Rock, US, 45 w/PS, Promo, Green Vinyl \$4.00
- HALL & OATES 7", Jingle Bell Rock, US, 45 w/PS, Promo, Red Vinyl \$4.00
- HARRISON, GEORGE 7", My Sweet Lord (2000), US, Green Vinyl Jukebox 45 B/W "All Things Must Pass" \$4.00
- HAYES, BILL 7", Ballad Of Davy Crockett, US, 1995 Reissue 45 on Gold Vinyl \$5.00
- HENDRIX, JIMI 7", Little Drummer Boy/Silent/Auld, US, Green Vinyl 45 w/PS, Little Drummer Boy/Silent/Auld/Lang, Same Medley \$12.00
- HENDRIX, JIMI 7", Little Drummer Boy/Silent/Auld, US, Red Vinyl 45 w/PS, Little Drummer Boy/Silent/Auld/Lang, Same Medley \$12.00
- HOLLY, BUDDY 7", Heartbeat, US, Repr 45 on Orange Vinyl, 62051 \$18.00
- HOLLY, BUDDY 7", I'm Gonna Love You Too, US, Repr 45 on Orange Vinyl, Caral 1947 \$18.00
- HOLLY, BUDDY 7", Maybe Baby, US, Repr 45 on Green Vinyl, Brunswick 5053 \$18.00
- HOLLY, BUDDY 7", Rave On, US, Repr 45 on Yellow Vinyl, Caral 6985 \$18.00
- HOLLY, BUDDY 7", True Love Ways, US, Repr 45 on Orange Vinyl, w/PS Caral 6272 \$20.00
- HUNTER, IAN 7", When The Daylight Comes, UK, 45 w/Direct PS, White Vinyl \$8.00
- IRON MAIDEN 7", Out Of The Silent Planet, UK, # rd Ltd. Ed. Red Vinyl Single With Picture Labels in Hard Poly Sleeve With Backing Insert Card, Live Non-LP Version of "Aces High" on B-Side \$8.00
- IRON MAIDEN 7", The Number Of The Beast, UK, 45 w/PS, Red Vinyl, Live B-Side, M/M \$35.00
- JACKSON, JANET 7", That's The Way Love Goes, US, Red Vinyl 45, 2 Mins \$4.00

### COLOR VINYL 7" SINGLES

- JAM 7", The Butterfly Collector, US, Gold Vinyl 45 \$15.00
- JESUS AND MARY CHAIN 7", Come On, UK, 45 w/# rd Ltd. Ed. Gate PS Orange Vinyl \$7.00
- JETHRO TULL 7", A Strich In Time, UK, 45 w/PS, White Vinyl \$15.00
- JETT, JOAN 7", Coney Island Whitefish, US, 6" Square Red Flexidisc From Trouser Press Magazine \$20.00
- JETT, JOAN 7", Spinster +2 (1 Non CD), US, 45 EP w/PS, Blue Vinyl \$4.00
- KENICUS 7", I Would Fix You, UK, Clear Vinyl 45 w/Picture Label + Pic Insert \$6.00
- KISS 7", Hide Your Heart, UK, 45 w/PS, Red Vinyl \$15.00
- KISS 7", Was Made For Lovin' You, Germany, 45 w/PS, Red Vinyl \$45.00
- KISS 7", Nothin' to Lose/Love Theme From Kiss, Australia, Ultra Rare (Ltd. Jukebox Edition of 300) Clear Blue Marble Vinyl Single w/Dustbin Pic Label, A Real Party! Australian-Only \$90.00
- KISS/MIGHTY MIGHTY BOSTONS 7", Detroit Rock City, UK, 45 w/PS, Green Vinyl, Hiss on B-Side \$10.00
- KITIEE 7", Charlotte, UK, # d Ltd. Edition White Vinyl, B/W "Sittin' Here Explicit Version" \$7.00
- KORN 7", Make Me Mad, UK, Green Vinyl 45, Live B-Side, # rd Ltd. Ed. w/Backing Card \$6.00
- KORN 7", Make Me Mad, UK, Green Vinyl 45, Live B-Side, # rd Ltd. Ed. (Low Number) #0036 w/Backing Card \$15.00
- LEONN, JOHN 7", The Slog, UK, 45 w/PS, Red Vinyl \$16.00
- LEONN, JOHN 7", Happy Xmas, US, Green Vinyl Jukebox 45 \$4.00
- LEONN, JOHN 7", Just Joking, Holland, 45 w/PS, Blue Flexidisc, w/ AP Photo Fan Records Issue \$12.00
- LEONN, JOHN 7", Starting Over, US, Jukebox 45 on Blue Vinyl, B/W "Witching The Wheels" Cap 588947 \$4.00
- LEONN, JOHN 7", The KYA 1969 Peace Talk, US, Blue Vinyl 45 \$16.00
- LEONN, JOHN 7", Thin Ice, US, Jukebox 45 on Clear Vinyl, B/W "Walking On Water" Credited To "John Lennon and Yoko Ono" Cap 588957 \$4.00
- LEWIS, JERRY LEE 7", Save The Last Dance For Me, US, Promo 45, Gold Vinyl, Do! \$4.50
- LOFGREN, NILS 7", Shine Silently, UK, 45 w/PS, White Vinyl \$6.50
- LOVE, DARLENE 7", Christmas (Baby Please Come Home) UK, Blue Vinyl 45, Warner Spector Label \$6.00
- LOVE, NICKY 7", Bow, EP, Belgium, 45 EP w/PS, 4 Songs, Orange Vinyl \$15.00
- LOVE, NICKY 7", Bow, EP, Belgium, 45 EP w/PS, Yellow Vinyl \$15.00
- MADONNA 7", Live to Tell (2 Versions), Japan, 45 w/PS, White Vinyl, w/Lyric Insert \$5.00
- MADONNA 7", True Blue, US, 45 w/PS, Non-LP B-Side, Blue Vinyl \$15.00
- MARX, RICHARD 7", The Way She Loves Me, US, White Vinyl 45 w/PS, Live B-Side \$4.00
- METALLICA 7", Master Of Puppets, France, 45 w/PS, Mauve Color Vinyl, w/ Test Pressing \$40.00
- MONKES 7", 18 Great Singles Box Set, US, Ltd. Ed. Box Set, 16 Hit Pink Vinyl 45's + 8 Page Booklet \$60.00
- MONKES 7", Heart And Soul, US, 45 w/PS, Pink Vinyl \$15.00
- MOODY BLUES 7", Live, World, Germany, 45 w/PS, Blue Vinyl \$40.00
- MOODY BLUES 7", The Other Side Of Life, US, 45 w/PS, Blue Vinyl \$15.00
- MOODY BLUES 7", The Other Side Of Life, US, 45 w/PS, Promo, Blue Vinyl \$15.00
- MORPHINE 7", Honey White, UK, 45 w/PS, White Vinyl, Live B-Side \$7.50
- MOTLEY CRUE 7", Hopalong's Holiday (2 Versions), UK, Yellow Vinyl, 45 w/# rd Ltd. Ed. PS \$6.50
- MOTORHEAD 7", Iron Fist, UK, 45 w/PS, Red Vinyl, Non-LP B-Side \$12.00
- MOTORHEAD

## ALBUMS BY AMERICA'S PREMIER SONGWRITER CHIP TAYLOR

MORE THAN 100 CHART HITS IN THE LAST 40 YEARS  
From 1967's #1 WILD THING by the TROGGS  
to 2001's #1 ANGEL by SHAGGY

**HIT MAN**— Containing 13 of his best loved songs including "Wild Thing", "Angel Of the Morning", "I Can't Let Go", and "Storybook Children"

**LAST CHANCE** - critically acclaimed country-rock masterpiece

**BLACK & BLUE AMERICA** — 2001 album, a musical journey into the passions of the 1960's with guest vocalists Lucinda Williams & John Prine

**THE LIVING ROOM TAPES**—Chip's most intimate and moving album recorded in 1996

**THE LONDON SESSIONS** - 2CDs for the price of one, 26 songs including "Holy Shit"

**SEVEN DAYS IN MAY** - 1998 album featuring Rick Danko, Guy Clark, Lucinda Williams, Rodney Crowell, and Garth Hudson

All albums \$15.00. Shipping \$3.50 per order in the USA and Canada, \$6.00 overseas. Buy all six albums for \$50 and save \$25.

Credit cards, checks or money orders accepted.

Mail order or online at [www.trainwreckrecords.com](http://www.trainwreckrecords.com)

Train Wreck Records

110 Greene Street, Suite 705  
New York, NY 10012

Ernie Sands also records for TRAIN WRECK RECORDS

## RARE Hard Find

### UNIQUE AND HARD TO FIND MUSIC AT PRICES YOU CAN AFFORD

All titles as priced. Most product mint or sealed unless noted. Shipping on all orders is \$4.00 for first item and \$1.00 for each additional title (except books)  
(\$8.00 foreign airmail first item, \$2.00 for each additional). Payment with Visa, MasterCard and Am Ex accepted via mail and phone. Make checks or MO payable to Rare & Hard To Find. Send payment to:  
Al Wagenaar - Rare & Hard To Find • 1510 W Clayton Crest Ave., Milwaukee, WI 53221  
Phone 414-282-1380 (9AM - 8PM CST) • Alternate phone 414-915-4096 (if 1st line is busy)  
E-mail: [music6118@aol.com](mailto:music6118@aol.com)

Visit our Web site at: [www.RareandHardtoFind.com](http://www.RareandHardtoFind.com) Over 2000 unique collectibles from the 60's to today, including a wonderful selection of power pop, used CDs, DVDs, books and more. All items can be ordered by credit card on Web site.

- DVD/VHS TITLES**
- Alice Cooper - "The Story" Whopping 180 minutes 2 DVD set with full Pennebaker film, TV appearances, and never before seen footage from the 1987 "Raise Your Fist" tour. DVD \$29.98
  - Asia - "Classic Rock Legends" In concert at the peak of their power. DVD \$22.95
  - "American Roots Music" 2 DVD set with performances by BB King, Bob Dylan, Bessie Smith, Muddy Waters, Ernest Tubb, Kitty Wells, more. 2 DVD set \$49.95. VHS \$29.95
  - Amos, Tom - "Live NYC" VHS only. Full concert from 1997. Import from Canada. VHS \$22.95
  - Ben Folds Five - "Complete Sessions" This is the complete "West 54th" performance and the 45 minute "Spare Reels" footage, never before seen. DVD \$19.98
  - Big Brother & Holding Company - "Nine Hundred Nights" Loaded with live Janis Joplin footage. DVD \$29.95. VHS \$19.95
  - Buffalo Springfield Revisited - "Live" 1986 concert. Bruce Palmer and Dewey Martin are in the band. DVD/VHS \$18.95
  - Cheap Trick - "Silver" The 24th Anniversary concert. DVD \$23.95. VHS \$19.95
  - Chicago - "Raw, Real Artists Working" Features Chicago in rehearsal, interviews and lots of live performance. 70 minutes. VHS in stock. \$19.95. DVD version coming Nov 27. \$22.95 Order yours now.
  - Cipollina, John - "Electric Guitar Slinger" Full story with archive live footage and key interviews. VHS only. \$19.95
  - Clapton, Eric - "Live Hyde Park" Classic live show with all the hits and bonus live material not on the original version. DVD \$23.95
  - Climax Blues Band - "Live at Marquee" 1984 Full concert. DVD \$19.95
  - Cocker, Joe - "Live From Across Midnight Tour" DVD \$24.95
  - Darin, Bobby - "Mack Is Back" Pre cut version of 1973 special just months before his death. Stunning!!! DVD \$23.95. VHS \$19.95
  - Deep Purple - "Come Hell Or High Water" Classic Mark II lineup in 25th Anniv show from 1993. Over 2 hours!!! 16 songs. DVD \$16.95
  - Electric Light Orchestra - "Zoom Tour Live" Full opening tour show from Los Angeles. Over 2 hours long. All the hits and more. In stock Nov. 13. DVD \$24.95. VHS \$19.95
  - Emerson, Lake & Palmer - "Live Royal Albert Hall" 25th anniversary concert with all the key songs (Pictures, Tarkus, Lucky Man, more) in stock November 20. DVD \$24.95. VHS \$19.95
  - Emerson, Lake & Palmer - "Pictures At Exhibition" Full concert film. Includes bonus CD of concert. Import. DVD \$22.95
  - Foghat - "Two Centuries Of Boogie" Recent concert by original band. DVD \$15.95
  - Gallagher, Rory - "Irish Tour" Full concert from 1974. DVD \$15.95
  - Gillespie, Dizzy - "Live at Royal Festival Hall" Full show with guests like Arturo Sandoval and Flora Purim. Incredible show!!! DVD \$19.95. VHS \$14.95
  - Green Day - "International Super Videos" In stock Nov. 13. Order now for Priority Delivery. DVD \$24.95. VHS \$19.95
  - Guided By Voices - "The Who Went Home and Cried" In stock Nov. 20. Preorder yours for priority delivery. Live Los Angeles 1999 and rehearsals on Robert Pollard's porch along with lots more!!! DVD \$19.95
  - Hackett, Steve - "Tokyo Tapes - Live Japan" 100 minute concert. DVD \$22.95
  - Half Japanese - "Band That Would Be King" 120 min. film, loaded with live. Lots of bonus features too. DVD \$24.95. VHS \$19.95
  - Harrison, George - "Beate in Benson Illinois" Award winning docu of George visiting his sister in Benson, WI in 1963. A must for any true Beatles fan. VHS only. \$19.95
  - Hell, Richard & Voidoids - "Blank Generation" 85 min. full of live including CBGB's performance. Directed by Jill Lomelling with appearances by Andy Warhol. DVD \$24.95. VHS \$19.95
  - James, Tommy - "Live At Bitter End" All the hits in this NYC concert. Loaded with bonus features and in depth interview. DVD \$18.95
  - Living Legends Of Rock N Roll Concert in Itchycoo Park 2000 with Grand Funk, Iron Butterfly, Steppenwolf, Steppenwolf, Neilson, Firefall, Styx and more. DVD \$23.95
  - "London Rock Show" In stock Nov. 20. Preorder yours now for priority delivery. Legendary rock film with Screaming Lord Sutch, Chuck Berry, Jerry Lee Lewis, Bill Haley, Little Richard, Bo Diddley, lots more. DVD \$19.98
  - Marriott, Steve - "Live Concert 1985." Includes CD as well. DVD \$22.95
  - Mayfield, Curtis - "Germany 1990" Full show. Coming in stock Nov. 15. Order yours now for priority delivery. DVD \$19.95
  - Motorhead - "Boneshaker - Live" 25th Anniversary show at Britton. Tons of guest stars appear. Includes CD of show as well. \$28.95
  - Nesmith, Michael - "Live At The Britt" Full concert. Wonderful "Different Drum" DVD \$22.95
  - Nico - "Heroine and Underground Experience" 100 minutes. Includes two full performances... one raw electric and one acoustic. DVD \$22.95
  - Oasis - "Unauthorized Bio" UK import VHS only \$7.95
  - Oingo Boingo - "Farewell - Live" The final concert in full. Great songs and loaded with bonus features. 2 DVD set. DVD \$29.98
  - Pet Shop Boys - "Montage" In stock Nov. 20. Full concert from the "Night Life" tour 2000. DVD \$24.95. VHS \$19.95
  - Prine, John - "Live From Sessions West 54th" The full show, many unseen songs and bonus interview material. DVD \$24.95
  - Psychedelic Furs - "Live House Of Blues" All the hits from this 2000 show. DVD \$24.95. VHS \$19.95
  - Queensryche - "Live Evolution" Incredible concert from July 27, 2001 and now available on DVD. Great "Silent Lucidity" DVD \$24.95
  - Rat Pack - "True Stories of Original Kings of Cool" 2 DVD set featuring "Early Years", "Road To Vegas", "The Summit" and "Camelot and Beyond." Loaded with great footage of live material. 2 pack DVD \$19.95
  - Residents - "Icky Flx" Lots of early material. DVD \$23.95
  - Sex Pistols - "Live Dallas at the Longhorn" The first USA Pistols show back in 1978. Incredible. Full show and bonus clips. Japanese import. Very hard to locate. DVD \$38.95
  - Smashing Pumpkins - "Video Greatest Hits 1988-2000" Full compilation of videos. Lots of bonus features. In stock Nov. 20. DVD/VHS \$19.98
  - Smith, Pat - "Dancing Barefoot" Live concert. Loads of early footage. Also includes "Blank Generation" a film with live Ramones, Talking Heads, Television, Blondie, Heartbreakers and more. DVD \$22.95
  - Springssteen, Bruce - "Live in New York" 2 DVD set with lots of songs not on the HBO special. DVD \$23.98. VHS \$19.98
  - Starr, Ringo - "Best of the All Starr Band" Incredible. Frampton, Gary Brooker, Rundgren, Randy Bachman, lots more. DVD \$23.00
  - Thunders, Johnny - "Dead Or Alive" Full 1984 concert. DVD \$25.99 Also available in bonus pack with UK book "In Cold Blood" by Nina Simone with a full story on Johnny Thunders. Book/DVD \$29.99
  - U2 - "Live Rattle and Hum" 60 min. live. DVD \$18.95
  - U2 - "Acoustically Driven" Incredible acoustic set with special guest Ian Anderson. A must own for fans. DVD \$22.95
  - U2 - "Sailing The Sea Of Light" Complete show from 1997 in Sofia along with bonus interviews etc. \$22.95
  - Various - "British Invasion Returns" 2000 concert over 100 minutes with Byrds, Foundations, Peter Noone, Eric Burdon, Bill J Kramer, Searchers, Gerry & Pacemakers, Mindbenders and more. DVD \$24.98
  - Various - "Rockin The Night Away" Killer 1988 concert with live Dion, Mamas & Papas, Peter Noone, Sonny Bono, Tommy James, Jan & Dean, Donovan and more. DVD \$19.95
  - Various - "Rock Icons/Psychedelic High" Loaded with 60's Beat Club footage of Byrds, Thunderclap Newman, Moody Blues, Blue Cheer, Nice, Manfred Mann, Donovan and lots more. DVD \$14.98. VHS \$9.98
  - Various - "Rock Icons - Guitar Gods" More Beat Club live material with Jeff Beck, Johnny Winter, Duane Eddy, Eric Clapton, Mountain, Ten Years After and lots more. DVD \$14.98. VHS \$9.98
  - Various - "Rock Icons - Hard Rockin'" More live Beat Club material with Pacific Gas & Electric, Steppenwolf, MC5, Mountain, Spencer Davis Group and more. DVD \$14.98. VHS \$9.98
  - Wakeman, Rick - "Live Buenos Aires" DVD concert is 110 minute concert with English Rock Ensemble. Comes with bonus CD "Official Bootleg" of a Birmingham 1997 show. In stock Nov. 20. Order now. DVD \$23.95
  - Who - "Live Royal Albert Hall" Full show from 2000. Noel Gallagher guests. DVD \$23.95. VHS \$19.95
  - Wishbone Ash - "Classic Rock Legends" The classic Ash line up in a concert filmed in Bristol. Powell, Turner, Turner and Upton. DVD \$22.95
  - Wilson, Brian - "All Star Tribute" Incredible concert of all Brian songs with GoGo's, Jimmy Webb, Wilson Phillips, Michael Penn, Aimee Mann, David Crosby, tons more. DVD \$24.95. VHS \$19.95

KEEP IN MIND...OUR CATALOG AND WEB SITE FEATURE MORE THAN 400 MUSIC DVDS. MANY ALMOST IMPOSSIBLE TO FIND AT RETAIL.

[www.rareandhardtofind.com](http://www.rareandhardtofind.com)



# Season's Savings!

## Holiday Gift Giving Was Never So Easy!

SPECIAL 45 RPM ADVERTISING SECTION • THE 45 REVOLUTION COLUMN



GIVING POP MUSIC THE GIFT OF HARMONY

Patty Loveless  
A VOICE COMING DOWN FROM THE MOUNTAINS

Give Every Collector on Your List a Year-Long Gift Subscription to **Goldmine**—and **Save**

Give one 1-year subscription at \$39.95 and give up to 2 more gift subscriptions to your friends at just \$21.95 each!

Or, give two 1-year subscriptions at \$32.95 and take care of up to 5 people on your list at just \$19.95 each!

Send names and address to: Krause Publications, offer ABA6TB  
700 E. State Street, Iola, WI 54990-0001

Check/Money order enclosed

MC  VISA  AmEx  Discover

Card No. \_\_\_\_\_

Signature \_\_\_\_\_ exp. \_\_\_\_/\_\_\_\_/\_\_\_\_

**Phone-In Orders Call 1-800-258-0929**

Mention Offer: ABA6TB



krause publications  
700 E. State Street  
Iola, WI 54990-0001

WOED AND RHINO ATTRACTIONS present

As Seen on  
Public  
Television!

# ROCK, RHYTHM AND DOO WOP

THE  
GREATEST  
SONGS

FROM EARLY  
ROCK 'N' ROLL

66 ROCK, R&B AND DOO WOP CLASSICS ON 3 CDS, WITH HITS BY ROY ORBISON, RITCHIE VALENS, BUDDY HOLLY, LITTLE RICHARD, AND MANY MORE.



- DISC 1**
1. AT THE HOP - DANNY & THE JUNIORS
  2. TWIST AND SHOUT - THE ISLEY BROTHERS
  3. TRUE, FINE MAMA - LITTLE RICHARD
  4. LITTLE DARLIN' - THE DIAMONDS
  5. HE'S SO FINE - THE CHIFFONS
  6. EVERYDAY - BUDDY HOLLY
  7. COME GO WITH ME - THE DELL-VIKINGS
  8. REMEMBER THEM - THE BARLS
  9. A LOVER'S QUESTION - CLYDE McPHATTER
  10. RUMAROUND SUE - DION & THE BELMONTS
  11. OOHY DOOBY - ROY ORBISON AND THE KINGS
  12. THE LOCO-MOTION - LITTLE EVA
  13. PEPPERMINT TWIST-PART 1 - JOEY DEE & THE STARLITERS
  14. PALLISADES PARK - FREDDY CANNON
  15. LEADER OF THE PACK - THE SHAMMOON-LAS
  16. LET'S HANG ON! - THE 4 SEASONS
  17. DADDY'S HOME - SHEP & THE LIMELITES
  18. JOHNNY ANGEL - SHELLY FABARES
  19. CATHY'S CLOWN - THE EVERLY BROTHERS
  20. TELL HIM - THE EXCITERS
  21. SINCE I FELL FOR YOU - LENNY WELCH
  22. LAST KISS - J. FRANK WILSON & THE CAVALIERS

- DISC 2**
1. DO YOU LOVE ME - THE CONTOURS
  2. SHIMMY, SHIMMY, KO-KO-BOP - LITTLE ANTHONY & THE IMPERIALS
  3. IT'S MY PARTY - LESLEY GORE
  4. MOTHER-IN-LAW - ERNIE K-DOE
  5. COME SOFTLY TO ME - THE FLEETWOODS
  6. MY PRAYER - THE PLATTERS
  7. HONEYCOMB - JIMMIE RODGERS
  8. MACK THE KNIFE - BOBBY DARIN
  9. SEA OF LOVE - PHIL PHILLIPS WITH THE TWILIGHTS
  10. HELLO STRANGER - BARBARA LEWIS
  11. (JUST LIKE) ROMEO AND JULIET - THE REFLECTIONS
  12. THEN YOU CAN TELL ME GOODBYE - THE CASINOS
  13. MY OWN TRUE LOVE - THE DUPREES
  14. STAY - MAURICE WILLIAMS & THE ZODIACS
  15. LITTLE STAR - THE ELEGANTS
  16. I'VE TOLD EVERY LITTLE STAR - LINDA SCOTT
  17. TOSSIN' AND TURNIN' - BOBBY LEWIS
  18. THE LION SLEEPS TONIGHT - THE TOKENS
  19. TAKE GOOD CARE OF MY BABY - BOBBY VEE
  20. WILL YOU LOVE ME TOMORROW - THE SHIRELLES
  21. CARA, MIA - JAY & THE AMERICANS
  22. 1-2-3 - LEN BARRY

- DISC 3**
1. OVER AND OVER - BOBBY DAY
  2. WHAT'D I SAY (PART I) - RAY CHARLES
  3. ONCE IN AWHILE - THE CHIFFONS
  4. SEA CRUISE - FRANKIE FORD
  5. DONNA - RITCHIE VALENS
  6. THOSE OLDIES BUT GOODIES (REMIND ME OF YOU) - LITTLE CAESAR & THE ROMANS
  7. SINCE I MET YOU BABY - IVORY JOE HUNTER
  8. OVER THE MOUNTAIN, ACROSS THE SEA - JOHNNIE & JOE
  9. HE WILL BREAK YOUR HEART - JERRY BUTLER
  10. FOR YOUR LOVE - ED TOWNSEND
  11. ALL I HAVE TO DO IS DREAM - THE EVERLY BROTHERS
  12. HANDY MAN - JIMMY JONES
  13. UP ON THE ROOF - THE DRIFTERS
  14. HOLD ME, THRILL ME, KISS ME - MEL CARTER
  15. BUNNYMAY - DEL SHANNON
  16. TRAVELIN' MAN - RICKY NELSON
  17. THERE'S A MOON OUT TONIGHT - THE CAPRIS
  18. BLUE MOON - THE MARCELS
  19. STAND BY ME - BEN E. KING
  20. OUR ANNIVERSARY - SHEP & THE LIMELITES
  21. CHAPEL OF LOVE - THE DOBE CUPS
  22. WHERE WERE YOU (ON OUR WEDDING DAY?) - LLOYD PRICE

amazon.com. Amazon.com is the registered trademark of Amazon.com, Inc. Brand logo ®, use with permission.

(New Releases from page 19)

1983's "Kiss The Bride," and satisfying in that same way with a country/pop flavor. "Love Her" would make an excellent single for today's country radio market, (as would John's new version of "Country Comfort," found on *Earl Scruggs And Friends*, also reviewed in this issue). "Mansfield" is another mid-tempo tune, framed by Johnston's super-charged acoustic guitar work, (à la Pete Townshend), and the song may have worked better closer to the front of the album. Noteworthy mention: It is hard to say why another strong number, "The North Star," a U.K. B-side, wasn't added to the album's final lineup — perhaps even as a closer.

The set concludes with the melancholy

"This Train Don't Stop There Anymore," another single candidate with a strong melody, rich chord changes and open-wound lyric. "Train" chugs on under the steely majesty of a powerful, weathered vocal, delivered by the eternally gifted 54-year-old singer.

All in all, *West Coast* doesn't seek new audiences, but rather serves to reconnect longtime fans. It's an Elton John album that isn't as affected by the current pop rumblings and gadgetry as some of its predecessors have been over the last decade. In short, this is a strong album from pop music's most brilliant composer, vocalist and pianist of the past 30 years. It will stand easily among *21 At 33*, *Two Low For Zero* and *Sleeping With The Past* as one of John's most solid efforts since the 1970s.

— C. Brian Jasper

NEIL DIAMOND  
Three Chord Opera  
Columbia (CK 85500)

*Three Chord Opera*, the title of Neil Diamond's latest recording, may suggest a bare-bones affair music-wise but there's a lot more going on here than your traditional guitar/bass/drums setup.

Producers Peter Asher and Alan Lindgren have woven a rich tapestry of sound that comes across as disarmingly simple and brings out the best of even Diamond's weakest material. Diamond, who wrote all of the songs here, still goes heavy on schmaltzy sentimentality which, judging by his loyal fan base, has an enduring appeal to a certain segment of the population. But the production lifts the songs above the slick blandness that often plagues the adult contemporary genre, turning what in other hands might be humdrum fare into guilty pleasures, i.e., the



viola and cello touches on "You Are The Best Part Of Me," the lovely accordion accompaniment that highlights "My Special Someone" and the pedal steel flourishes on the record's best ballad, "Elijah's Song."

Diamond's lyrics, which lean heavily on the sunnier side of things, lack emotional

intensity — one of the ballads here is aptly named "I Believe In Happy Endings," and often the titles tell you all you need to know about the songs' content.

(Please see New Releases page 51)

Since 1995.

**Siren Disc**

Discount Import CDs & More.

[www.sirendisc.com](http://www.sirendisc.com)

★ FUNK ★ ROCK ★ PUNK ★ BREAK-INS ★ COMEDY ★ REGGAE ★ CHILDRENS ★

★ BIG BAND ★ CAJUN ★ LATIN ★ JAZZ ★ GARAGE ★ SURF ★ GOSPEL ★ INSTRUMENTALS ★

**MAIL ORDER AT ITS BEST!**

**THE LARGEST SELECTION OF 45 RPM RECORDS IN THE UNITED STATES**

MAIL OR FAX YOUR WANT LISTS TO:

**VAL SHIVELY R & B RECORDS**

Looking For Something? **TRY US!** **NO Auctions or Other GAMES!**

BOX "B" • HAVERTOWN, PA 19083

**PH: 610 / 352-2320 • FAX: 610 / 352-8199**

**Over 4 Million 45's in Stock!**

We Specialize in vocal group harmony but deal in all types of music on 45's. (original labels, promos or reissues) ALSO: CD'S • LP'S • CASSETTES • 7" PICTURE, COMPANY OR WHITE SLEEVES • 8 X 10 PHOTOS

**WAREHOUSE HRS:**  
Mon. Thru Sat.  
11:00 A.M. to 7:00 P.M.  
Closed Sunday

**Worldwide Service**

**NEW RECORDS IN EVERY DAY**

No Catalogs Available  
Send Want Lists

**WAREHOUSE ADDRESS:**

49 Garrett Road • Upper Darby, PA 19082  
(1 Mile From West Philadelphia)

**WE ACCEPT ALL MAJOR CREDIT CARDS FOR QUICK SERVICE.**

**Doing Business Since 1966 - We Buy 45 Collections**

DOO WOP ★ ROCK 'N ROLL ★ R & B ★ SOUL ★ POP ★ COUNTRY ★ BLUES

**VINYL TAP MAIL ORDER MUSIC**

1 Minerva Works, Crossley Lane, Kirkheaton, Huddersfield, W Yorks, England HD5 0QP  
Tel: 01484 421446  
Fax: 01484 531019  
E-mail: [sales@vinyltap.demon.co.uk](mailto:sales@vinyltap.demon.co.uk)  
Web site: <http://www.vinyltap.co.uk/>

**Specializing in rare and collectable CDs, Vinyl and memorabilia**

**Over 75,000 items currently in stock.**

**Let us know what artists / groups you collect, CDs and Vinyl or both Write, Phone or Fax for FREE Lists**

<http://www.vinyltap.co.uk/>

Lists now available by e-mail - just ask Web site updated weekly





Courtesy of Chuck Miller



Ross Barbour of The Four Freshmen poses next to his Freshmen statue in front of The Vocal Group Hall Of Fame.

(Vocal group winners from page 19)

Because The Vogues had been scheduled to reunite at the Sept. 13 inductions, Miller had scheduled a post-induction surgical appointment. When the inductions were rescheduled, however, Miller kept his appointment with the surgeon — and stepped out of the hospital just days before the reunited Vogues took the stage. Not only was the concert a triumph for Miller and his fellow Vogues, but it was also a chance for The Vogues' children to see their fathers perform together.

"I can remember, when I was little, my dad singing," said Kimberly Morrow, Miller's daughter. "I've always been really proud of it. As modest as he has been of it, I've been twice as proud. And now finally being here — we flew up here from Florida — and it's really neat to see everybody come together and appreciate the music and appreciate [the inducted artists] for



The Vocal Group Hall Of Fame's Class Of 2001 inductees pose with their Harmys at the Hall after the inductions.

everything they've done for music."

When The Lettermen took the stage, their concert session began with the current lineup of Donovan Tea, Darren Dowler, and original member Tony Butala. But later on, Tea and Dowler stepped aside so that original members Jim Pike and Bob Engemann could perform with Butala (all of whom wore Lettermen varsity sweaters). As more Lettermen alumni took the stage — including two of Pike's brothers, Gary and Donny, who were Lettermen in the 1970s — the audience was treated to an eight-part vocal of "Goin' Out Of My Head"/"Can't Take My Eyes Off Of You," as performed by more Lettermen than at

a homecoming pep rally. The song was a #7 hit in 1967. Letterman Butala is a native of Sharon and cofounder of The Vocal Group Hall Of Fame along with local businessman Jim Winner.

After the concert, many of the inductees and their families returned to the Radisson Hotel in nearby West Middlesex, Pa. In the intimate setting of the hotel lounge, with an audience of family members, fellow musicians and music lovers — plus some very surprised hotel guests who loved every minute of it — The Chordettes several times performed a capella renditions of their classic recordings, including "Shine" and "Mr. Sandman." As a special treat, a lucky few

heard them — and their children — singing "Lollipop" together in the hallway.

On Oct. 6, The Vocal Group Hall Of Fame, along with *Goldmine*, hosted a record and memorabilia show in the building. Visitors to the show were able to purchase new recordings by The Pied Pipers (who were on hand to sign autographs) and by Wilson, sign up as a member of E.A.M.E. (Friends Against Musical Exploitation), and purchase Vocal Group Hall Of Fame induction T-shirts and other merchandise.

At the *Goldmine* table, new music reference books published by *Goldmine* and its parent company Krause Publications, including the new hot sellers *Motown: The Golden Years* by Bill Dahl and *Warman's American Records 1950-2000: Identification And Price Guide* by this writer, were up for sale. Visitors could also receive autographs from Barbour, Robinson, and Butala.

When originally planned, the record show was to include dealers from the Keystone Record Collectors club, whose members are primarily located in eastern Pennsylvania. Due to the schedule change from the Sept. 11 attacks, dealers were unable to adjust schedules. A few had made previous plans to attend the Austin Record Convention, held the same weekend as the Hall's revised induction week.

Plans are already under way for the balloting for the next group of inductees. As with the past four years' inductions, *Goldmine* readers will be involved in the voting, with an official ballot being inserted in the magazine sometime in early 2002.

For more information on The Vocal Group Hall Of Fame, visit its Web site at [www.vocalhalloffame.com](http://www.vocalhalloffame.com).

— Chuck Miller

# a new look a new attitude

We've got a new look, new features, new services and a new attitude. A lot has changed over the last ten years. But one thing hasn't: Our devotion to everything Elton. If you think you know everything about Elton John... think again. We cover it all, with in-depth interviews, news, information and, of course, reviews of both new and not-so-new material.

Published quarterly for the past ten years, *East End Lights* is considered a must-have for all Elton fans.

Check out the web site and subscribe online, or give us a call.

Find out what you've been missing.

**eastendlights**  
the magazine for elton john fans

Phone: 417.437.1603  
[www.eastendlights.com](http://www.eastendlights.com)



Since 1995.



Siren  
Disc

Discount Import CDs & More.

[www.sirendisc.com](http://www.sirendisc.com)

# ELTON JOHN

LP'S - 45's - CD - BOX SETS - BOOKS

MANY RARITIES INCLUDING:  
• 1973/1974 Japan Tour Books  
• CD's: Live Concerts & Demos

Reggie's Goodies

4920 Bienville Ave.  
New Orleans, LA 70119  
Ph: 504-482-5151 Fax: 504-483-9025  
E-mail: [socket@bellsouth.net](mailto:socket@bellsouth.net)

There's more than one way  
to keep track of your records...



We suggest you try ours.

## MusicTracker 1.0

- Inventory & Pricing software for Vinyl Record Collectors
- Featuring Jerry Osborne's Price Guide Data for 2001



Now only **\$39.99**

Visit us online! [www.bangzoom.com](http://www.bangzoom.com)  
or Call us toll free! 1-800-589-7333

# RECORD CLEANING PERFECTED!

Our  
**20<sup>th</sup>**  
Anniversary

**Nitty Gritty** offers the most affordable, efficient and hassle-free line of wet scrub/vacuum dry record cleaners available.

Clean records **Sound better, Last longer, Grade higher**  
(Five models from \$282 MSRP)

DELUXE MODELS

BUDGET  
BALANCERS



Model 1.0 (Shown)  
Record Master



Model 2.5Fi (Shown)  
Model 1.5

**NITTY GRITTY™**



RECORD CARE PRODUCTS, INC.

ULTRA LP PRO

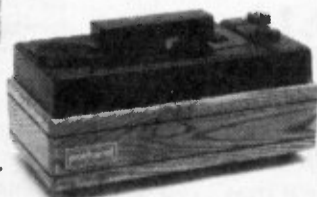

MINI-PRO 2

Send for **FREE** Full-Line Brochure  
DEALER INQUIRIES INVITED

**NITTY GRITTY, INC.**

4650 Arrow Highway #F-4 • Montclair, California 91763  
Tel. 909-625-5525 • Fax 909-625-5526  
[www.nittygrittyinc.com](http://www.nittygrittyinc.com)

**"Feel the Groove!"™**

# Greg Lake



Over 100,000 fans saw him  
and heard his legendary music  
while on tour this summer with

**Ringo Starr  
& His All Starr Band.**



His music has been a favorite on FM radio since 1969: Greg Lake, the singer, songwriter, musician and co-founder of both **King Crimson** and **Emerson, Lake & Palmer**, acclaimed solo artist, and former member of Asia. With these classic bands and on his own, he has sold over 40 million albums. Now, Greg Lake's greatest material is available in a single catalog of five CDs, including rare and never-before-released recordings. From hard to find live versions of "In The Court Of The Crimson King" and "Lucky Man" to his two classic 1980s solo studio albums (never before on CD) featuring Gary Moore, Clarence Clemmons and the members of Toto, it's all here (and not yet in stores). Discover once again the majesty and magic of the music that is....

**Greg Lake.**

Order by phone or purchase  
these titles on the

Official GREG LAKE website:

[www.greglake.com](http://www.greglake.com)

**NOW AVAILABLE:  
THE GREG LAKE  
COLLECTION  
OF CDs**

*From The Beginning: The Greg Lake Retrospective.* (Rhino 1997) All his most popular and important recordings on 2 CDs w/ 30pg. full color booklet. From King Crimson thru ELP, ELPowell and solo tracks. Loaded with hits. **\$29.95 plus s & h**

*Greg Lake.* (1981) Lake's first solo album. Available on CD the US for the first time! Featuring Gary Moore on guitar with Clarence Clemmons on sax, and the members of Toto. Digitally remastered. **\$14.95 plus s & h NOT IN STORES!**

*Manoeuvres* (1983). Lake's second solo album, available on CD the for the first time anywhere! Featuring Gary Moore on guitar with Lake's solo band. Digitally remastered. **\$14.95 plus s & h NOT IN STORES!**

*From The Underground Official Greg Lake Bootleg.* (1998) Rare Lake recordings with The Shy Limbs, The Shame, King Crimson, ELP, ELPowell, Asia and solo. These recordings are not found anywhere else! Digitally remastered. **\$19.95 plus s & h NOT IN STORES!**

*In Concert On The King Biscuit Flower Hour (Limited Edition).* (1996) Limited, numbered edition of 1981 Lake solo concert. Expanded booklet. Bonus tracks. **AUTOGRAPHED BY GREG LAKE!!! \$29.95 plus s & h**

*WORD SCULPTURES (The Greg Lake book of Lyrics).* (1998) A beautiful, limited & numbered **HARD COVER** first edition illustrated book of lyrics from his greatest songs. **AUTOGRAPHED BY GREG LAKE!!! \$49.95 plus s & h**

**Order Toll Free: 1-800-820-4068**

**International : 001- 716-454-5916**

### SilverDisc Records

Orchard Post Office, PO Box 871, SINGAPORE 812323  
 US Fax #: 1-(818) 461-1923. Email: silverdisc@aolmail.com  
 Over 1000+ titles from Japan and Europe at:  
**http://listen.to/SilverDisc**  
 See web site for more info on shipping, secured online credit card payment, cashiers check and discounts.  
 Postage: \$5.00 per set. Add \$2.00 for each additional set.  
 Over 100 Beatles, 60 Dylan, 40 Rolling Stones, 20 Clapton, N. Young, Nirvana, Floyd, WHO & more many rare titles.

Beach Boys - Archaeology (5CD Boxset)...\$110  
 Beatles - Day By Day series Vol. 1 to 21...\$44 each volume  
 Beatles - The Ultimate BBC Sessions 1962-1966 10CD Boxset...\$200  
 Beatles - The Hard Days and Nights (2CD)...\$44  
 Beatles - The Northwest Nights (2CD) Seattle and Vancouver...\$44  
 Black Crowes - Boogie With Crowes (2CD)...\$40  
 Bob Dylan - The Osaka Tapes (2CD) Japan, 7th March 2001...\$44  
 Bob Dylan - The Early Years Vol. 2 (1CD)...\$22  
 Bob Dylan - Musical Retrospective (3CD)...\$56  
 Bob Dylan - Ace Of Club (5CD Box)...\$110  
 Bob Dylan - Rock Of Ages (5CD Box)...\$110  
 Bob Dylan - Roving Gambler (2CD) Australia 25-03-2001...\$44  
 Bob Dylan & Paul Simon - Live In Denver 1999 (3CD)...\$60  
 Bruce Springsteen - Omaha (3CD)...\$60  
 Bruce Springsteen - The Lost Gems 1972-1978 (1CD)...\$22  
 Crosby, Nash & Young - Kansas City Express (1CD)...\$60  
 David Bowie - Speaking In Tongues (1CD)...\$22  
 David Bowie - Raw Moon Rehearsals (2CD)...\$44  
 David Bowie - Baton Rouge (2CD)...\$44  
 Dire Straits - Live 3CD Boxset...\$60  
 Eric Clapton - Keys to the New Century (2CD) RAM, 3rd Feb 2001...\$44  
 Eric Clapton - Change The World (2CD)...\$44  
 Eric Clapton - Bottom Dollar (2CD)...\$44  
 Eric Clapton - Blues Night (2CD)...\$44  
 Elton John & Ray Cooper - The Last Gens 1972-1978 (1CD)...\$22  
 Elton John - Final Melodies In Millennium...\$22  
 Elton John - West of the Rockies (1CD)...\$60  
 George Harrison - Long Beach (1CD)...\$22  
 George Harrison - Baton Rouge 1974 (2CD) Louisiana...\$44  
 Genesis - In & Out of Darkness (2CD)...\$44  
 Genesis - Los Angeles (1CD)...\$22  
 Genesis - Never Forget Jesus (2CD)...\$44  
 Genesis - Outvisible Side (2CD)...\$44  
 Jeff Beck - Consummate Guitar Craftsman (1CD) 18 July 2001...\$22  
 Jethro Tull - Slice of Flute Cake...\$22

Johnny Cash - The Beast In Me (1CD)...\$22  
 John Lennon Anthology - Weybridge...\$22  
 Leonard Cohen - Blossoms of Heaven, Ashes of Hell (2CD)...\$44  
 Neil Young - Between The Lines (2CD) Camden, NJ, 9 Aug 2000...\$44  
 Neil Young - Birmingham Vacation (2CD)...\$44  
 Neil Young - Rock in Rio 2001 (2CD)...\$44  
 Neil Young - The Warfield (2CD)...\$44  
 Nirvana - Eternal Legacy (KTS)...\$22  
 Nirvana - Shadow of the Sun (KTS)...\$22  
 Nirvana - Digital Nirvana...\$22  
 Nirvana - Dumb (KTS)...\$10  
 Oasis - Lost Tapes (KTS)...\$22  
 Oasis - 250,000 fans can't be Wrong (2CD)...\$44  
 Paul McCartney - Best Jobs (4CD)...\$60  
 Paul McCartney & Wings - Nashville Sessions...\$22  
 Paul McCartney - Hot Night in Charlotte (2CD)...\$44  
 Pink Floyd - LIVE 3CD Boxset...\$60  
 Pink Floyd - Dark Soundboard of Philadelphia...\$22  
 Police - Lost BBC Studio Tapes 78-79...\$22  
 Radiohead - Black Tuesday (2CD) live 11 Sept 2001...\$35  
 Radiohead - Bostonova 2001 (2CD) live 14 August 2001...\$35  
 Rolling Stones - Japan 1998 Tour (12 CD Boxset)...\$240  
 Rolling Stones - Wembley Stadium 1999 (2CD)...\$44  
 Rolling Stones - Dirty Work Outtakes (1CD)...\$22  
 Rolling Stones - We Want The Rare Stones (1CD)...\$22  
 Rolling Stones - Anthology, The Decca Years (2CD)...\$44  
 RUSH - Farewell to Frankfurt (2CD)...\$44  
 RUSH - Natural Science (1CD)...\$22  
 RUSH - Obscure Album (1CD)...\$22  
 Stevie Nicks - Naked Lunch Board...\$22  
 Stevie Ray Vaughan - Reseda S Blues...\$22  
 Stevie Ray Vaughan - Hottest Live From Exotic Honolulu (2CD)...\$44  
 STING - Rock in Rio 2001...\$22  
 STING - Sea of Silence (2CD)...\$44  
 U2 - Going Dutch 2001 (2CD) 3rd Aug 2001...\$38  
 U2 - Biesing in the Night (2CD)...\$40  
 U2 - Out of Control in Chicago (2CD)...\$40  
 Van Morrison - Moodance...\$22  
 Van Morrison - Christmas Special (2CD)...\$44  
 Who, The - Live At Leeds Complete (2CD)...\$44  
 Who, The - Secret Show 1974 (2CD) Guild Hall, UK, 22 May 1974...\$44  
 Who, The - Johnny B. Goode (2CD)...\$44  
 Who, The - We Shall Be Beneficent (2CD)...\$44  
 Who, The - Hot Fun of Summertime Blues (2CD)...\$44  
 YES - Close To Eight Progressors (1CD)...\$66  
 YES - Solo Works (2CD)...\$40

10% STOREWIDE Christmas SALE at:  
**http://listen.to/SilverDisc**

# The World's Rarest Records

45's, 78's & LP's: 1930-1963



**BUY** **SELL**

If you're buying or selling rare records you should contact:  
**JOHN TEFTELLER**  
 P. O. Box 1727, Grants Pass, OR 97528  
 Ph: (541) 476-1326 FAX: (541) 476-3523

See AND Hear *The World's Rarest Records* on your computer!  
 Website: [www.worlds.rarest.records.tefteller.com](http://www.worlds.rarest.records.tefteller.com) or [www.tefteller.com](http://www.tefteller.com)

## INSURANCE For The Collector of Records & Tapes

Your homeowners insurance is rarely enough to cover your collectibles. We've provided economical, dependable collectibles insurance since 1966.

- Sample collector rates: \$3,000 for \$12, \$10,000 for \$32, \$25,000 for \$82, \$40,000 for \$132, \$60,000 for \$198, \$1 per \$1,000 above \$60,000.
- Our insurance carrier is AM Best's rated A+ (Superior).
- We insure classic records, tapes, music memorabilia and scores of other collectibles. "One-stop" service for practically everything you collect.
- Replacement value. We use expert/professional help valuing collectible losses. Consumer friendly service: Our office handles your loss—you won't deal with a big insurer who doesn't know collectibles.
- Detailed inventory and/or professional appraisal not required. Collectors list items over \$5,000. Dealers no listing required.
- See our website (or call, fax, e-mail us) for information, including standard exclusions.

**Collectibles Insurance Agency**  
 P.O. Box 1200-GM • Westminster MD 21158  
 E-Mail: [info@insurecollectibles.com](mailto:info@insurecollectibles.com)

Call Toll Free 1 888-837-9537 • Fax: (410) 876-9233  
 More Info? Need A Rate Quote? Visit: [www.collectinsure.com](http://www.collectinsure.com)

**MFG**  
 DAIKOKU BLD. 4F 7-8-11NISHISHINJUKU, SHINJUKU-KU, TOKYO 160-0023 JAPAN  
 FAX 81-3-5330-6923 • E-mail: [mfg@pal.tok2.com](mailto:mfg@pal.tok2.com)  
 \*VISIT OUR WEB PAGE. There is complete list.  
 We renew the list as soon as new releases in our stock.  
<http://www.31.tok2.com/home/mfg/>  
 \*POSTAGE 1-3 DISCS \$10.00; OVER 4 DISCS; ADD \$1.00 FOR EACH DISC  
 \*PAYMENT ONLY US \$ ON CASH OR INTERNATIONAL POSTAL MONEY ORDER  
 \*BEFORE YOU MAKE A PAYMENT, PLEASE CONFIRM STOCK TO US BY FAX, MAIL OR E-MAIL  
 \*DISCOUNT OVER 100 DISCS - 10% OFF!  
 OVER 300 DISCS - 15% OFF!  
 \*SEND \$3.00 FOR OUR COMPLETE CATALOG INCLUDING MANY CD TITLES.  
 \*AND WE CAN SEND COMPLETE CATALOG BY E-MAIL FOR FREE!!

**BEATLES SPECIAL SALE**

ARTIST	TITLE	LABEL	\$
NIRVANA	HAPPY HALLOWEEN <Seattle 31/10/1999>	genocide	12
NIRVANA	MOIST VAGINA 1 <unknown precious live>	genocide	12
NIRVANA	OUTGECSTICIDE 2 <THE NEEDLE AND THE DAMAGE DONE>	blue moon	12
NIRVANA	OUTGECSTICIDE 3 <THE FINAL SOLUTION>	blue moon	12
NIRVANA	OUTGECSTICIDE 4 <RAPE OF THE VAULTS>	blue moon	12
NIRVANA	THE COMPLETE RADIO SESSIONS <89-91-92 RADIO>	genocide	12
NIRVANA	SYDNEY 1992 <Salinas Coeque Bay Hotel 6/2>	AD	10
OZZY OSBOURNE	CRAZY PARANOIA <Salt Lake City 18/3/1984>	SB sttp	15
PAT METHENY	GROUP A NEW PHASE OF THE GUITAR (2CD) <Bottom Line NY 1977>	SB sttp	30
PAUL McCARTNEY	NORWEGIAN NIGHT (2CD) <Norway 26/8/1989>	25	25
PAUL McCARTNEY	ROCK DEVIL ROCK <TV compilation 1999>	yellow cat	18
PAUL McCARTNEY	ROCK DEVIL ROCK VOL. 2 <live at the cavern 14/12/1999>	SB yellow cat	20
PAUL McCARTNEY	SYDNEY SOUND CHECK 1993 <6/3/1993>	killing floor	12
PAUL McCARTNEY	THE FAMILY WAY <original sound track, released in Jun '67 Instrumental, arr by G. Martin>	real boot	20
PAUL McCARTNEY & WINGS	THE AMERICAN RETURN OF THE WINGS (2CD) <Texas 3/3/1976>	30	30
PAUL McCARTNEY	I GOT STUNG <R&R Hall of FAME/Royal Albert Hall 1999>	yellow cat	18
PAUL McCARTNEY	WINGS LIVE IN GRONINGEN <GRONINGEN, HOLLAND 8/19/72>	darthdisc	20

PAUL SIMON & BRIAN WILSON MUTUAL ADMIRATION (2CD) <Greek Theatre, LA Jun. 13 '01 Paul invites Brian to his tour> sttp...\$36  
 PAUL WELER CLASSIC RADIO <BBC, London 9/11/1998> switch on...\$6  
 PAUL WELER FROM STANLEY ROAD TO ABBEY ROAD (2CD) <BBC 27/5, Abbey Road 29/5/2000>...\$30  
 PAUL WELER GLOOMY MERMAIDS (2CD) <Holland 29/10/1997> banging disc...\$20  
 PAUL WELER IN THE STUDIO; MAKING OF HELIOCENTRICK <BBC 1/4/2000> SB polar bear...\$16  
 PAUL WELER LAST GIG OF THE MILLENNIUM <Germany 4/4/1999> SB switch on...\$8  
 PAUL WELER MADE IN WALES <5/11/1997> SB dancing horse...\$8  
 PAUL WELER SOUL MAN <The Haywood Gallery 97 etc.> dancing horse...\$12  
 PAUL WELER SUMMER IN THE PARK <VICTORIA PARK 8/8/98> switch on...\$8  
 PAVEMENT ANYBODY CAN GO <BBC Session 5/1999 & Glastonbury Fest 6/1999> SB...\$5  
 PHISH DARK SIDE OF THE MOON...\$10  
 PHISH PHANTASTIC PHUCKIN' PHREAK OUT IN NASSAU (2CD) <NY 3/4/1998> SB polar bear...\$30  
 PHISH QUADROPHENIA (2CD) <Chicago 31/10/1995> sttp...\$30  
 PHISH TASTY LORELEY <Rockpalast Fest. Germany 22/6/1997> SB tendolar...\$10  
 PHISH WELCOME TO AUSTIN PHAMILY <Texas 17/7/2000 + more> SB polar bear...\$16

**NEW RELEASES**

FLYING BURRITO BROS STEEL BURRITO <Seattle Pop Fest. Jul. 27 '69 + Wyoma, Minnesota May '70> SB polar bear...\$38  
 GRATEFUL DEAD WATKINS GLEN, NY JULY 28, 1973 PT. 1 (2CD) <Daytime Show> SB polar bear...\$38  
 GRATEFUL DEAD WATKINS GLEN, NY JULY 28, 1973 PT. 2 (2CD) <Evening Show> SB polar bear...\$38  
 LIMP BIZKIT LATEST KILLER LEVEL <Rock Am Ring Fest. Germany Jun. 3 '01> SB polar bear...\$20  
 OASIS BROTHERLY LOVE: JUST BEFORE 10TH ANNIVERSARY <Denver May 17 '01> SB polar bear...\$20  
 RANDY RHOADS GUITAR SEMINAR <Private Lesson Hollywood '79 + PA Feb. 2 '82 + LA Jan. 25 '79> sttp...\$20  
 RADIOHEAD BOSTONOVA 2001 (2CD) <Suffolk Downs East Boston, MA, USA Aug. 14> head...\$35  
 DAVID LEE ROTH EAT'EM AND SMILE OUTTAKES <Demo + Radio + Finland, Jun. 26 '99> ages high...\$25  
 DEREK AND THE DOMINOS BALLROOM BRIZZ (2CD) <Pavilion, Bournemouth, UK, Aug. 18 '70> silver horse...\$46  
 RADIOHEAD BLACK TUESDAY (2CD) <Berlin, Germany Sep. 11 '01 + Verona, Italy May 30 '01> head...\$4

# Goldmine Garage Sale

SELL IT ALL!!

Save 50% off the cost of your Goldmine unit ad.

**Call: GOLDMINE ADVERTISING 888-457-2873**  
 Fax: (715) 445-4087 (attn: Display Advertising)

**SEND YOUR AD IN TODAY!**

Take advantage of this great advertising opportunity. Simply fill out the form below and mail it, along with your ad and payment, to **GOLDMINE**.

**YES!** I want to take advantage of **GOLDMINE'S** Garage Sale. I understand that in order to qualify for the 50% discount, my ad must contain items priced at \$6.00 or less exclusively.

Ads containing items priced above \$6.00 will not receive the 50% Garage Sale discount. Ads placed in conjunction with this offer cannot be used to fulfill advertising contract commitments. Goldmine reserves the right to refuse any advertising not adhering to these guidelines or our regular ad guidelines. For your convenience we accept MasterCard, VISA, American Express and Novus credit cards.

Name \_\_\_\_\_  
 Address \_\_\_\_\_  
 City \_\_\_\_\_  
 State \_\_\_\_\_ Zip \_\_\_\_\_  
 Phone \_\_\_\_\_

Number of units \_\_\_\_\_  
 (cost per unit) x 60.90 \_\_\_\_\_  
 Regular cost of ad \_\_\_\_\_  
 Less 50% discount \_\_\_\_\_  
 Cost of ad \$ \_\_\_\_\_

Credit Card # \_\_\_\_\_  
 Exp. Date \_\_\_\_\_

Goldmine 700 E. Street • Iowa, WI 54990-0001 • Visit our website at: <http://www.goldminemag.com>

World Radio History

## New Releases on Compact Disc



Allman Brothers - *Midnight Riding* (2 CD) - St. Louis, MO 7/23/94 - excellent quality soundboard - 12 tracks (53:58 and 57:35)

Bad Finger - *Hamming It Up!* - outtakes and rarities - excellent quality studio tracks and soundboards - 25 tracks (73:47)

Beatles - *All Together Now* - portable tape recorder sessions from the Beatles' chauffeur 1963-64 - very good quality recordings - 44 tracks (69:15)

Beatles - *The Alternate Abbey Road* - alternative mixes - excellent quality studio outtakes - 25 tracks (71:14)

Beatles - *The Alternate Hey Jude Album* - alternative mixes - excellent quality studio tapes - 19 tracks (73:40)

Beatles - *The Alternate Magical Mystery Tour* (2 CD) - alternative mixes - excellent quality studio outtakes - 47 tracks (74:08 and 74:00)

Beatles - *The Alternate Revolver* - alternative mixes - excellent quality studio outtakes - 26 tracks (72:05)

Beatles - *The Alternate Sgt. Pepper's Lonely Hearts Club Band* (2 CD) - alternative mixes - excellent quality studio outtakes - 34 tracks (70:55 and 66:07)

Beatles - *Another Sessions... Plus* - alternative mixes from session tapes - excellent quality - 19 tracks (57:46)

Beatles - *Arrive Without Aging* - alternative takes and rarities - excellent quality - 26 tracks (72:17)

Beatles - *Vinyl to the Core (Disc One)* - live and studio rarities - good to excellent quality recordings - 36 tracks (70:56)

Beatles - *Vinyl to the Core (Disc Two)* - live and studio rarities - good to excellent quality recordings - 35 tracks (66:58)

Beatles - *Vinyl to the Core (Disc Three)* - live and studio rarities - very good to excellent quality recordings - 31 tracks (73:01)

Bee Gees - *Live and Acoustic* - live on tour 1989-97 (sixteen tracks) plus three studio bonus tracks - excellent soundboards (69:41)

Eric Clapton - *The Rainbow Outtakes* - Rainbow Theatre, London 1/13/73 - excellent soundboard - twelve tracks (70:03)

Deep Purple - *Grand Hotel* - Montreux, Switzerland 12/6-21/71 - excellent quality soundboard recording - thirteen tracks (70:08)

Fish - *There's A Guy Works Down the Chips Shop Swears He's Fish* - live 1992 - excellent audience recording - 8 tracks (60:37)

George Harrison - *12 Arnold Grove* - "Shanghai Surprise" material, Rockline music & demos - excellent quality - 17 tracks (73:18)

George Harrison - *All Things Must Surface* (2 CD) - The Making of *All Things Must Pass*, Part II - excellent quality studio recordings - 29 tracks plus two bonus and a conversation with Hanson 2/15/01 (68:15 and 71:29)

George Harrison - *Beware of Abco!* - original *Somewhere in England* rarities - studio quality - fifteen tracks (49:59)

George Harrison - *The Making of All Things Must Pass* (3 CD) - excellent quality studio outtakes - 37 tracks of twelve songs (54:13, 53:27, and 61:46)

George Harrison - *Pirate Songs* - outtakes, demos, and alternate mixes - excellent quality recordings - 19 tracks (72:57)

George Harrison - *Through All Those Years* - unreleased Harrison songs - studio quality - twenty tracks (72:25)

George Harrison - *Through Many Years* - unreleased and rare performances from George and Ringo - sixteen tracks (50:45)

George Harrison - *A True Legend* - rare and alternative takes - excellent quality source tapes - 26 tracks (68:05)

Iron Maiden - *Brave and New in Stockholm* - Sweden 6/27/00 - excellent quality soundboard - twelve tracks plus two bonus (71:59)

Elton John and Billy Joel - *Face to Face* (2 CD) - Tokyo Dome 3/30/98 - excellent soundboard - 27 tracks (64:34 and 73:02)

Elton John - *1968* - Nick Drake Session plus Best of DJM Demos - 24 tracks (73:11)

Elton John - *Fine China* - London's Wembley Pool 11/3/77 - excellent quality soundboard - nine tracks (49:35)

Elton John - *Goodbye England's Rose, Hello New York* - Di's funeral, London 9/15/93 (one track), A&R NYC 11/17/70 (6), 1968 demo (1), Live Aid, London 7/15/84 (3), London 6/30/90 (2), two others - excellent soundboards - 15 tracks total (72:21)

Elton John - *Hammersmith Odeon 1973* (2 CD) - London 12/22/73 - excellent quality radio broadcast - 17 tracks (49:51 and 49:14)

Elton John - *On the Beeb 1973* - London 12/22/73 - excellent quality radio broadcast - twelve tracks (74:35)

Kansas - *Song for Chicago 1976* - Aragon Ballroom, Chicago 1976 - excellent quality FM broadcast - six tracks (60:23)

Matchbox 20 - *Rarities, Acoustic & Live* - excellent quality studio recordings and soundboards - sixteen tracks (65:01)

Paul McCartney - *Flaming Pies and Leftovers - Flaming Pie* (7 tracks) and *Off the Ground* (8) outtakes - studio quality (65:19)

Moby Grape - *68* - Stonybrook University NY 10/22/68 (12 tracks) plus San Francisco 12/66 (3) - excellent soundboards (72:55)

Ted Nugent - *Wild in Chippewa* (2 CD) - Chippewa, WI 1996 - very good audience recording - twelve tracks (52:44 and 42:31)

Ozzy Osbourne - *End of a Good Time* - Randy Rhoads' last performance - very good audience recording - ten tracks (49:27)

Papa Roach - *Pat-er Blatodea* - Stuttgart, Germany 2/17/01 (15 tracks) plus London 2000-01 (3) - excellent soundboards (74:27)

Placebo - *Black Libro Music* - Libro Music Hall, Vienna, Austria 4/6/01 - excellent FM broadcast - nineteen tracks (79:06)

Placebo - *B-sides & Remixes* - excellent quality studio recordings - seventeen tracks (76:09)

Iggy Pop - *Out on the Streets Again* - Queen Street, Toronto 10/93 (nine tracks) plus Lowland Paradise Fest, Holland 1993 (six) - excellent quality FM broadcasts (62:57)

Elvis Presley - *Candid Elvis On Camera* - Omaha, Nebraska 6/19/77 - *Elvis In Concert* on CBS - excellent TV broadcast (73:23)

Elvis Presley - *From the Bottom of My Heart* - alternative takes and rarities - excellent quality recordings - 29 tracks (72:36)

Elvis Presley - *From the Bottom of My Heart, Volume 2* - alternative takes and rarities - excellent quality - 23 tracks (72:36)

Elvis Presley - *Keep Following That Dream* - the complete studio session 7/2/61 - from the master tapes - 19 tracks (60:28)

Procol Harum - *Hollywood Bowl 1973* - with the Los Angeles Philharmonic Orchestra - excellent FM broadcast (63:10)

Queensryche - *eMply Unplugged* - MTV Studios rehearsal 4/27/92 - excellent quality soundboard recording - 13 tracks (73:36)

Santana - *Smoother Than Smooth* (2 CD) - Wallingford, CT 5/28/99 - excellent audience recording (74:16 and 61:46)

Savoy Brown - *Just Live* - USA tour 1972 - sourced from out of print import LP with an excellent audience recording - seven tracks (63:31)

Smashing Pumpkins - *The Final Show, Volume One* - Chicago 12/2/00 - good audience recording - twelve tracks (65:09)

Springsteen - *The Lost Masters I - Alone in Colts Neck (The Complete Nebraska Session)* - acoustic home demos 12/81 to 1/82 - excellent quality - eighteen tracks (60:00)

Springsteen - *The Lost Masters II - One Way Street (Darkness Masters Volume I)* - studio outtakes from the *Darkness On The Edge Of Town* sessions 6/77 to 8/77 - excellent quality - fifteen tracks (73:07)

Springsteen - *The Lost Masters III - Rattling the Chains (Darkness Masters Volume II)* - studio outtakes from the *Darkness On The Edge Of Town* sessions 6/77 to 9/77 - excellent quality - sixteen tracks (64:01)

Springsteen - *The Lost Masters IV - Big Expendables (Songs That Got Away)* - demos 1979 (two tracks), outtakes 1979, 1983 (two), and band rehearsals 1979 (ten) - excellent quality studio and soundboard (46:37)

Springsteen - *The Lost Masters VI - Travel In Fear (Unreleased River Masters Volume II)* - studio outtakes from *The River* sessions 1979-80 (nine tracks) plus unreleased home demos 1979 (four) - excellent quality (46:37)

Springsteen - *Where the Rivers Meet* (3 CD) - Pittsburgh, PA 9/22/84 (33 tracks) plus three bonus - excellent soundboard recordings (72:59, 73:03 and 73:57)

Traveling Wilburys - *The Complete Collection* (2 CD) - demos, both out of print albums, rarities - 41 tracks (72:47 and 76:06)

U2 - *Chicago Elevation* (2 CD) - Chicago 5/16/01 - very good audience recording - 24 tracks (64:29 and 59:40)

U2 - *Elevation at the Target Center* (2 CD) - Minneapolis, MN 5/1/01 - excellent audience recording - 23 tracks (65:13 and 64:44)

The Who - *Live 2000* (2 CD) - Shepard's Bush, London 12/29/99 - excellent soundboard - 21 tracks plus 3 bonus (71:36 and 70:30)

Frank Zappa - *Thing-fish Outtakes* - studio quality - 17 tracks (64:02)

Ordering Information: All of the above CD titles are \$18.00 per disc. Include full name and address along with a daytime and evening phone number. We accept checks and money orders (made payable to "Collector"), as well as VISA, MasterCard and American Express cards.

24-HOUR ORDER LINE: 847-465-8496

**COLLECTOR**

33 North Elmhurst Rd., Wheeling, IL 60090

SHIPPING:  
U.S. - \$5.00 Any Size Order, Illinois residents add additional 6.5% sales tax.  
Canada - \$6.00 for any size order.  
Overseas rates available.  
Call or e-mail for info.

# SWINGIN' DICK'S MUSIC EMPORIUM

"Absolutely the best selection and product anywhere!"

\*\*\* Check us out at: <http://www.sdemporium.com> \*\*\*

OUR SELECTION INCLUDES (but is not limited to):

Bob Dylan	• Asia
Bruce Springsteen	• Eagles & Related
Chicago & Related	• Styx & Related
The Doors	• Jimi Hendrix
Bon Jovi	• Ratt
Metallica	• Beatles & Related
Def Leppard	• Genesis & Related
Roadmaster	• Led Zeppelin & Related
Head East	• Blue Oyster Cult & Related
Prince & Related	• The Black Crowes
Beach Boys & Related	• Eric Clapton
Stevie Ray Vaughan	• Van Halen & Related
Yes & Related	• The Who
Tesla	• REO Speedwagon

HUNDREDS MORE TITLES TO CHOOSE FROM (including THE largest selection of '80's metal)!!

NO paper labels, NO non-printed discs! Strictly quality, professional pressings! Check our site, see what your disc(s) will look like, and judge for yourself!! Quality guaranteed!!

Online credit card processing! Quick delivery times. Log on now for details!!

<http://www.sdemporium.com>

"Come swing with us! You'll be glad you did!"

## His Song: The Musical Journey of Elton John

by Elizabeth J. Rosenthal

Billboard Books/Watson-Guptill Publications

# IN STORES NOW!



HIS SONG

The MUSICAL JOURNEY of ELTON JOHN

Elizabeth J. Rosenthal

"Engagingly informative... Will go far to lend a greater appreciation for the performer."

-Kirkus Reviews

"Elton John Fans and pop historians will love it."

-Tom Stanton, Co-author,

Rocket Man: Elton John From A To Z

"The definitive biography of Elton John."

-Jim McKay, Editor, The 22nd Row,

Elton John e-newsletter

*This is the first biography to do the Rocket Man justice...*

Go to [www.ejhissong.com](http://www.ejhissong.com) for more information!

# GOLDMINE UNIT SPACE ADS



## WHAT ARE UNIT SPACE ADS?

Unit space ads are an affordable option for the small dealer or for the private collector who has a few items to sell. They are based on 8-1/2 x 11 sheets that you create. They are "camera ready," in other words, the ad will look in print exactly how it looks when you send it in, only smaller. We will reduce the sheets to fit the ad space. Optionally, at no extra charge we can create a heading for your ad. We will typeset your name, business name (if any), address and phone/fax numbers on your ad if you so request.

The two types of ads are:

1. **Set Sale** - Items are sold at the price listed.
2. **Auction** - Items are sold to the highest bidder.

## FOR A BETTER UNIT SPACE AD . . .

1. Use white paper.
2. Have a new ribbon on your typewriter or printer; avoid low toner on a laser printer.
3. Make sure the paper is vertically oriented. We cannot publish a horizontal unit space ad unless you want the reader to turn the magazine sideways to look at it. Most readers won't bother to do that.
4. Mail it to us; don't fax it. Faxes can leave unwanted markings that make your ad hard to read.
5. **Clearly identify whether your ad is a set sale or auction.** Avoid mixing the two in the same ad; if you must, have separate sections for set-sale and auction items.
6. Include your name, address, and telephone/fax number (and when you will be available to take calls on the ad) and all ordering information, including postage and shipping fees.
7. Put your listings in a logical order. If you have several formats in the same ad (LP, CD, 45, etc.), group your items by format. You also may wish to group items by type of music. As for the listings themselves, alphabetically by artist usually works best.
8. If you have any questions on how to set up your ad, contact anyone from the *GOLDMINE* advertising staff.

## SET SALE GUIDELINES FOR BUYERS

1. First, make sure you are replying to a **set sale** and not an auction. If an ad mentions "minimum bids and deadlines, it's **not** a set sale.
2. Follow the advertiser's directions on how to reply. If the ad says to write first to reserve an item, do it. If the ad says that money orders only are accepted, don't write a personal check. And **never** send cash through the mail!
3. If you write or call to reserve an item and the advertiser still has it in stock, send your payment for the item promptly.
4. Set sale ads are "first-come, first-served," so the sooner you reply, the more likely you are to receive what you order.
5. If you receive the item and it is not as advertised, don't hesitate to complain. Reputable advertisers take complaints seriously and try to do right by the customer. But don't take advantage of this, either; complain only when you have a legitimate reason for doing so.

## SET SALE GUIDELINES FOR SELLERS

1. Only advertise items you have. Because of ad deadlines, some dealers will assume they will have new material based on release dates given by record companies. In the long run, it's better to wait until you actually have an item to put it in your ad.
2. State all your policies in the ad. Examples include method of payment, whether (and at what times) you will accept telephone calls, and whether to reserve items or send money immediately.
3. Send the items promptly after they've been paid for. Federal Trade Commission regulations state that you **must** ship your items within 30 days.
4. Charge only what you pay to send the package. Or charge everyone the same amount, knowing you will lose money on large packages, but will make up for it on smaller ones. If your stated postage rates are unusually high, state why! (Insurance, special handling or packaging, etc.)
5. Take complaints seriously. An unresolved problem is usually a lost customer.

## Auction Guidelines For Buyers

1. First, make sure you are replying to an auction and not a set sale.
2. Note the minimum bid, and don't bid less than that. Also, don't say "I will top all bids" unless the auction allows it and, of course, you really mean it.
3. Mail in all bids unless the ad says phone-in bids are acceptable.
4. Remember the deadline. If none is stated, then the auction closes one month from the date on the cover. For example, if the auction is in the *GOLDMINE* dated October 15, the sale closes November 15.
5. If mailing bids, allow 1-2 weeks for your bids to arrive. And after an auction ends, allow 1-2 weeks for notification. If you haven't heard 14 days after the end of an auction, assume you won nothing unless the ad says that all bidders, win or lose, would be notified.
6. Honor all winning bids! If you are notified that your bid has won the item, send the money for your items within a week. Bidders reneging on their winning bids is the No. 1 complaint from those who run auction ads. If you can't honor your bid, at least have the courtesy to notify the advertiser.
7. Allow 2-4 weeks for your winnings to arrive.

## AUCTION GUIDELINES FOR SELLERS

1. Set minimum bids on any item you won't sell for less. You also can set an auction-wide minimum; different minimums on different parts of the auction; or no minimums at all. Avoid "Ridiculous bids will be rejected" or similar phrases; you don't assume that everyone knows what a "ridiculous bid" is. Instead, take the time to set minimums.
2. Run an honest auction. Don't advertise items you don't have; don't artificially force bidders to bid more by claiming there's a counterbidder when there isn't one; don't overgrade your items; and sell all items that meet your published minimum and are the high bid, even if the bid is far below "book" value.
3. Notify winners within the first week after your deadline passes.
4. Send the winners their items promptly upon payment. (It's OK to wait for checks from unfamiliar customers to clear, which takes no more than a week. If it takes longer, get a new bank.) Federal Trade Commission regulations state that you **must** ship your items within 30 days.
5. Don't use your auction as a way to compile a mailing list unless you state that in your ad.
6. In sum: Treat your customers as you would want to be treated if you were the one bidding.

## UNIT SPACE AD RATES

*GOLDMINE* has two sizes of unit space ads:

1. **Regular** - your ad is reduced to one-ninth of one of our pages.
2. **Super** - your ad is reduced to one-fourth of one of our pages.

	Regular	Super
Each unit	\$60.90	\$126.80
Full page	\$466.20	\$466.20

Contract rates are available, which earn advertisers lower rates. Call anyone on our *GOLDMINE* advertising staff for a complete rate card. 715/445-2214









Above and right: Elton John belt buckles.



Right: The colored vinyl version of *Goodbye Yellow Brick Road*, which, without the autograph, changes hands for \$50-75.

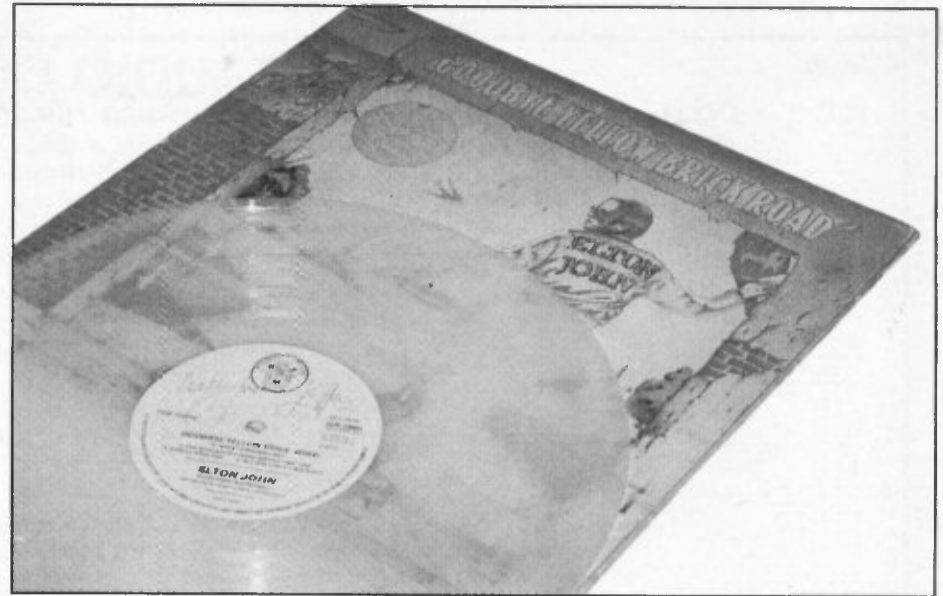

Photos courtesy James Tirano

(Elton collectibles from page 18)

singles with unique picture sleeves imported from Europe. These singles are collectible because even though in most cases, the same single and B-side was released around the world, in countries including England, Germany, France, Spain, Belgium, Italy, Holland and Portugal, each country packaged the vinyl 45 with a picture sleeve unique to that country. Many are difficult to find.

"In most cases, especially in the '70s, you'd have something like 10 different versions of the same single, because the picture sleeve differed from country to country. So, there was no different musical value, but it was the picture that made it interesting and collectible — again, his image and personality over the music," McCormick noted.

In fact, McCormick estimated that perhaps the most valuable released John recording is a vinyl Portugal-issued four-track EP from 1969 that features the first song that has the

former Reg Dwight's new moniker, Elton John. The EP includes the songs "I Can't Go On Living With You," "Here's To The Next Time," "Angel" and "Thank You For All Your Loving."

"That single can easily bring in close to \$500 based on its condition. It's very hard to find because so few were pressed, and soon after its release, it was pulled from circulation. John was just another hopeful at that time. There also is an early acetate of two songs that were never released, 'Can You See It' and 'Child,' that is extremely hard to find and that is probably worth more than \$1,000," McCormick estimated.

"Yes, there are some rare, historic and high-ticket Elton John items. But because those who have them are such serious Elton John collectors and fans, it's doubtful they will ever part with them, so there aren't too many floating around."

In 1988, John himself added to the memorabilia available to collectors. Through the auction house Sotheby's, John conducted a huge auction of his personal effects, which included many of his most identifiable stage outfits, wild

costumes and eyeglasses from the '70s and '80s, in addition to gold and platinum records, pinball machines and even jewelry.

These items attracted bids three to four times the initial bid estimates from private collectors. Some of his more outrageous stage costumes brought in an excess of \$5,000, his wildly designed prescription eyeglasses more than \$2,000, and his gold and platinum records, depending on what album or single it was, brought in between \$700 and \$1,500.

"Every so often, you can find these items posted on the online auctions, and the starting bid prices seem to be what they sold for back in 1988. Of course, depending on who is bidding, the prices could go up a bit, but I've seen these either sell for close to what they originally sold for or receive no bids at all."

"It appears the small group of collectors willing to spend big money on some of these items already have what they want," McCormick said.

Other collectible John-related items include two different

(Please see Elton collectibles page 63)

## SERIOUS STORAGE 1,000 CDs in 4 sq. ft!

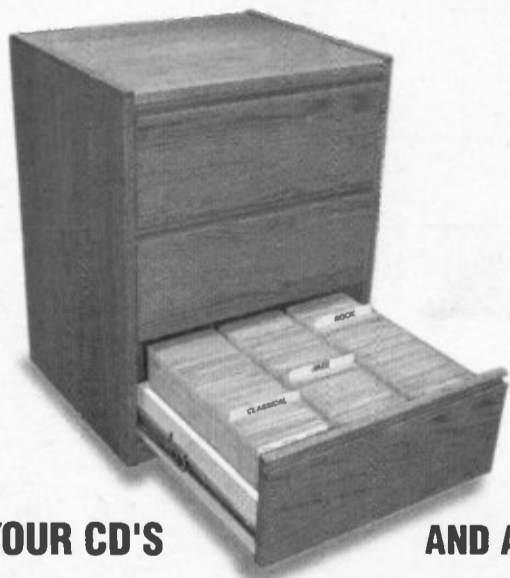

### PROTECT YOUR CD'S AND ARTWORK

And say goodbye to clutter and broken cases. The Jewelchest™ features storage for 1,000 Jewelsleeves™, the finest archival CD storage sleeve in the world.

The Jewelsleeve is a revolutionary new CD sleeve that replaces all of your fragile, bulky jewel boxes with a thin, scratch-proof poly sleeve that cannot break or tear, takes up 75% less space than a jewel box, and protects and stores EVERY PART of the CD—INCLUDING THE BOOKLET AND TRAY CARD—without folding or cutting.

Call or email for a brochure and free sample!

Jewelsleeve.com  
P.O. Box 147  
Nutley NJ 07110

Tel: 800/863-3312  
Fax: 973/667-6644  
www.jewelsleeve.com

## HISTORY. CLASS.

Street corner groups had a brief moment in the sun, roughly from 1955 to 1957, but such was the attraction of the music that a "revival" occurred almost right away. By 1961, collectors were eagerly seeking out records only three or four years old and new groups were sprouting up in cities all across the country.

The music has never died and remains strong today. Hearing the groups that "made it" and those that almost did, you will understand why.

50 Classics on 2 CDs  
25 of Doo Wop's Greatest Hits  
Plus 25 Rarities, All Making Their CD Debuts

A UNIVERSAL MUSIC COMPANY  
www.hip-o.com

BORDERS BOOKS MUSIC MOVIES CAFE



AUDIO COLLECTIONS

PO Box 1474, Bolingbrook, IL 60440 1-630-759-2273 FAX 1-630-759-2430 E-Mail AUDIOCOLL@AOL.COM

Table listing audio collections with columns for artist, title, and price. Includes handwritten annotations like 'PRINCE', 'RAGE', 'STONES', 'I MORT COB', 'RUSH', 'SANTANA', 'IMPORTS', and 'SPRINGSTEEN'.

Table listing audio collections with columns for artist, title, and price. Includes handwritten annotations like 'U2', 'STING', 'STEVIE RAY', 'Tool', 'Who', and 'NEIL YOUNG'.

!ANOTHER GREAT ROCK LP SET SALE!

!!! & WELCOME TO ANOTHER SET SALE. PRICES FOR EACH LP IS LISTED. POSTAGE FOR 1st LP IS \$4 (50 EACH XTRAL) & OVERSEAS POST IS HIGHER. GRADING IS CVR/CD & VISUAL.

"JIMMY MACK RECORDS"

105 Deer Tract Drive, Little Mountain, S.C. 29075 WEBSITE: www.jimmymackrecords.com

Advertisement for 'COOL AND STRANGE MUSIC!' magazine featuring articles on artists like The Residents, Vic Flick, and The Singing Nun. Includes a price list for subscriptions.

1960's Picture Sleeves & EPs Germany Japan etc.

SEI SALE Visual grading, sleeve 1st. Postage \$4 USA, \$6 Canada, others inquire. Phone (417)887-9280 Fax (417)890-6130 E-Mail recordsmth@worldnet.att.net Credit Cards!!!

Table listing 1960s picture sleeves and EPs with columns for artist, title, and price. Includes handwritten annotations like 'Who' and 'NEIL YOUNG'.

SOUL, DISCO & FUNK LP's

David Mendham - 1114 Commercial Street - East Weymouth, MA 02189 - (781)337-2611

Table listing soul, disco, and funk LPs with columns for artist, title, and price.

ROOTS OF ROCK 1950-60S LP SET SALE

Table listing roots of rock LPs from 1950-60s with columns for artist, title, and price.

MUSICANDVIDEO.com

(201) 236-9107 • FAX: (201) 236-2916 • http://www.musicandvideo.com

One Surrey Lane Allendale, NJ 07401



CD'S AT SPECIAL SET SALE PRICES

Table listing various music releases with columns for Artist, Title, Origin, Price, and other details. Includes entries for Aerosmith, Bon Jovi, Bruce Springsteen, and many others.



# MUSICANDVIDEO.com

(201) 236-9107 • FAX: (201) 236-2916 • <http://www.musicandvideo.com>

## One Surrey Lane Allendale, NJ 07401



Artist	Title	Format	Price	Artist	Title	Format	Price	Artist	Title	Format	Price	
ROLLING STONES	GIMME SHELTER-1968 W/INA TURNER,JEFFERSON AIRPLANE	LASER	\$55.00	VAUGHAN,STEVIE	W/DOUBLE TROUBLE LIVE FROM AUSTIN-83 MINS OUT-OF-PR	LASER	\$45.00	JOHN,ELTON	WORLD TOUR 86-87 LAMINATED BACKSTAGE PASS	PROMO	\$30.00	
ROLLING STONES	FREEDJACK W/MIKE JAGGER WIDESCREEN OUT-OF-PRINT SEAL	LASER	\$30.00	VAUGHAN,STEVIE	TRIBUTE W/ B.KING,CLAYTON,CRAYOR,JOHN,RATT,BUDDY G	LASER	\$45.00	JOHN,ELTON	LOUVER TRAM CONCERT CREW LAMINATED BACKSTAGE PA	PROMO	\$30.00	
ROLLING STONES	VIVIDOO LOUNGE-WORLD TOUR - 94 MINS OUT-OF-PR	LASER	\$45.00	VAUGHAN,STEVIE	WILD ANGEL CONCERT 1972 72 MINS OUT-OF-PRINT SEALED!!!	JAPAN	\$75.00	JOHN,ELTON	WORLD TOUR 89-90 V.P. LAMINATED BACKSTAGE PASS	PROMO	\$30.00	
ROLLING STONES	LIVE AT THE MAX-STEREO 40 34 MINS OUT-OF-PRINT SEALED	LASER	\$45.00	VAUGHAN,STEVIE	NO BRAKES LIVE-STEREO 58 MINS OUT-OF-PRINT	JAPAN	\$35.00	JOHN,ELTON	NORTH AMERICA & EUROPE 1983 TOUR BOOK	US	\$15.00	
ROSE,DIANA	VISIONS OF 6 TRACK 8"DISC RARE!!! W/ULIO GLESIAS	LASER	\$45.00	VAUGHAN,STEVIE	DIRTY,ROTTEN,FILTHY,STINKING RICH-STEREO 63 MINS	LASER	\$40.00	JOHN,ELTON	PEOPLE MAG 11/87/8 THE NEW ELTON JOHN	US	\$16.00	
RUBBER RODEO	NEED YOU NEED ME/ANYWHERE W/YOU/HARDEST THING/WEST	LASER	\$30.00	VAUGHAN,STEVIE	QUADROPHENIA W/STING,MARK WINGETT,GARY COOPER	LASER	\$35.00	JOHN,ELTON	BLUE MOGS PROMO T - SHIRT MEDIUM NEVER BEEN WORN	PROMO	\$18.00	
RUNDGREN,TODD	REDUX'92 LIVE IN JAPAN-STEREO 55 MINS OUT-OF-PRINT SEAL	LASER	\$40.00	VAUGHAN,STEVIE	THE KIDS ARE ALRIGHT-STEREO 89 MINS OUT-OF-PRINT RARE	LASER	\$45.00	JOHN,ELTON	EQUALITY SHOW 23 OCT 1994 HAND BILL ROYAL ALBERT HALL UK	US	\$5.00	
RUNDGREN,TODD	LIVE AT THE ROYAL OAK-STEREO 60 MINS OUT-OF-PRINT SEAL	LASER	\$40.00	VAUGHAN,STEVIE	THIRTY YEARS OF MAX R&B LIVE-STEREO 2 DISCS OUT-OF-PR	LASER	\$65.00	JOHN,ELTON	CASSETTE DIVIDER CARD	PROMO	\$7.50	
RUNDGREN,TODD	THE EVER POPULAR TORTURED ARTIST EFFECT-SEALED!!!	LASER	\$40.00	VAUGHAN,STEVIE	LIVE FEATURING TOMMY-2 DISCS 135 MINS OUT-OF-PRINT	LASER	\$45.00	JOHN,ELTON	LEGENDARY ROYAL ALBERT HALL CONCERT POSTER REPLIC UK	US	\$18.00	
RUNDGREN,TODD	DESKTOP COLLECTION-STEREO 32 MINS OUT-OF-PRINT SEAL	LASER	\$35.00	VAUGHAN,STEVIE	ROGER DALTRY IN GOLD JUSTICE-106 MINS SEAL-ED!!!	LASER	\$25.00	JOHN,ELTON	WHEATHER OIL 1/77/01 W/ALDO WEEBER/JANET JACKSON UK	US	\$15.00	
SANBORN,DAVID	LOVE/HAPPINESS/LIVE SIR STUDIOS NYC 41 MINS OUT-OF-PR	LASER	\$65.00	VAUGHAN,STEVIE	ROGER DALTRY IN GOLD JUSTICE-106 MINS SEAL-ED!!!	LASER	\$25.00	JOHN,ELTON	SIR PAUL WHEATHER OIL 1/77/01 WEEBER/BROSNAJAN UK	US	\$15.00	
SCORPIONS	W/TO RUSSIA W/ LORCHE STRAIVE AMBASSADEURS-488	LASER	\$40.00	VAUGHAN,STEVIE	LIVE 1975 AT Q.P.R.-MONO 88 MINS (RED COVER)	LASER	\$55.00	JOHN,ELTON	TEEN TALK PREMIERE ISSUE 11/79 PAUL THOUGHT HE WAS DY US	US	\$20.00	
SCORPIONS	W/CONANT BASIE ORCHESTRA LIVE 2/24/87 81 MINS SEALED!!!	LASER	\$45.00	VAUGHAN,STEVIE	LIVE 1975 AT Q.P.R.-MONO 88 MINS (BLUE COVER)	JAPAN	\$65.00	JOHN,ELTON	PETA'S 21ST ANIVERSARY & HUMANITARIAN AWARDS PARTY PROMO	PROMO	\$20.00	
SEX PISTOLS	WINTERLAND CONCERT-1/4/78 SAN FRANCISCO 60 MINS RARE	JAPAN	\$75.00	VAUGHAN,STEVIE	LIVE 1975 AT Q.P.R.-MONO 88 MINS (RED COVER)	JAPAN	\$65.00	JOHN,ELTON	SPECIAL PROGRAM W/PAUL STELLA	US	\$18.00	
SEX PISTOLS	GREAT R'R'N SWINDLE 104 MINS OUT-OF-PRINT SEAL	LASER	\$40.00	VAUGHAN,STEVIE	LIVE 1975 AT Q.P.R.-MONO 88 MINS (RED COVER)	JAPAN	\$65.00	JOHN,ELTON	BOOKS ALL OUT-OF-PRINT AT SPECIAL SET SALE PRICES	ORIGIN	PRICE	
SHORT,BOBBY	LIVE AT THE CARLYLE W/FRIENDS JACK LEMMON/LUCI ARNA	LASER	\$45.00	VAUGHAN,STEVIE	W/BLUES TRAVELER,SHERYL CROW,BLIND MELON, 2 DISC SET	JAPAN	\$50.00	JOHN,ELTON	SHAMELESS-HARDCOVER W/CD AND AUTOGRAPHED 304 PAGES	US	\$30.00	
SIMON,PAUL	BORN AT THE RIGHT TIME-110 MINS SEALED!!!	LASER	\$35.00	VAUGHAN,STEVIE	THE VIDEOS-74 MINS OUT-OF-PRINT EXTREMELY RARE!!!	LASER	\$65.00	JOHN,ELTON	40TH ANNUAL GRAMMY AWARDS PROGRAM BOOK 2/28/99	US	\$78.00	
SIMON,PAUL	CONCERT IN THE PARK 8/19/91 STEREO OUT-OF-PRINT RARE!	LASER	\$35.00	VAUGHAN,STEVIE	YES/YES/YES CONCERT STEREO 70 MINS OUT-OF-PRINT	LASER	\$55.00	JOHN,ELTON	W/PAUL MCCARTNEY,SHERYL CROW,HANSON R KELLY BABYFACE,	US	\$75.00	
SIMON,PAUL	SPECIAL W/ART GARFUNKEL,LEY TOWNE,IN,CHEVY CHASE SEAL	LASER	\$35.00	VAUGHAN,STEVIE	LIVE 1975 AT Q.P.R.-MONO 88 MINS (RED COVER)	JAPAN	\$65.00	JOHN,ELTON	BOE DYLAN,RADIONHEAD,ORISON,BO DIDDLE,PUFF DADDY 2004PS	US	\$15.00	
SINATRA,FRANK	W/OUT DEEP IN THE HEART-STEREO 3 VIDEOS&AUDIO TRAC	LASER	\$35.00	VAUGHAN,STEVIE	LIVE 1975 AT Q.P.R.-MONO 88 MINS (RED COVER)	JAPAN	\$65.00	JOHN,ELTON	41ST ANNUAL GRAMMY AWARDS PROGRAM BOOK 2/28/99	US	\$75.00	
SKID ROW	O SAY CAN YOU SCREAM-STEREO 108 MINS OUT-OF-PRINT RA	JAPAN	\$65.00	VAUGHAN,STEVIE	LIVE 1975 AT Q.P.R.-MONO 88 MINS (RED COVER)	JAPAN	\$65.00	JOHN,ELTON	W/CHELSEA DION,GOO GOO DOLLS,MADONNA,SHANIA TWAIN,SHERYL	US	\$15.00	
SKID ROW	ROAD NITE - PICTURE 120 MINS OUT-OF-PRINT RARE!	JAPAN	\$65.00	VAUGHAN,STEVIE	LIVE 1975 AT Q.P.R.-MONO 88 MINS (RED COVER)	JAPAN	\$65.00	JOHN,ELTON	CROW GARBADE,BACKSTREET 70YS LAURYN HILL,LDXIE CHICKS,	US	\$15.00	
SMITHS	COMPLETE PICTURE-STEREO 60 MINS OUT-OF-PRINT SEALED!!	JAPAN	\$65.00	VAUGHAN,STEVIE	LIVE 1975 AT Q.P.R.-MONO 88 MINS (RED COVER)	JAPAN	\$65.00	JOHN,ELTON	JOHNNY CASH,SAM COOKE,OTIS REDDING,SMOKEY ROBINSON,	US	\$15.00	
SONIC YOUTH	SCREAMING FIELDS OF SONIC LOVE-STEREO 60 MINS SEALED!	JAPAN	\$40.00	VAUGHAN,STEVIE	LIVE 1975 AT Q.P.R.-MONO 88 MINS (RED COVER)	JAPAN	\$65.00	JOHN,ELTON	MEL TORME,LEIBER&STOLLER,GAMBLE&HUFF 190 PAGES	US	\$75.00	
SPRINGSTEEN,BRU	VIDEO ANTHOLOGY 1978-88 STEREO 100 MINS OUT-OF-PRINT	LASER	\$40.00	VAUGHAN,STEVIE	LIVE 1975 AT Q.P.R.-MONO 88 MINS (RED COVER)	JAPAN	\$65.00	JOHN,ELTON	42ND ANNUAL GRAMMY AWARDS PROGRAM BOOK 2/23/00	US	\$75.00	
SPRINGSTEEN,BRU	BLOOD BROTHERS-90 MINS OUT-OF-PRINT SEALED!!!	LASER	\$45.00	VAUGHAN,STEVIE	LIVE 1975 AT Q.P.R.-MONO 88 MINS (RED COVER)	JAPAN	\$65.00	JOHN,ELTON	W/BACKSTREET BOYS,CHEER,RIKHY WORTHY,SANTANA,7L2 MACY	US	\$15.00	
SPRINGSTEEN,BRU	IN CONCERT - UNPLUGGED STEREO SEALED!!!	LASER	\$35.00	VAUGHAN,STEVIE	LIVE 1975 AT Q.P.R.-MONO 88 MINS (RED COVER)	JAPAN	\$65.00	JOHN,ELTON	41ST ANNUAL GRAMMY AWARDS PROGRAM BOOK 2/28/99	US	\$75.00	
STARBUCK	THE MAGIC CHRISTIAN W/BAFFINGER MUSIC RARE!!! SEALED!	LASER	\$45.00	VAUGHAN,STEVIE	LIVE 1975 AT Q.P.R.-MONO 88 MINS (RED COVER)	JAPAN	\$65.00	JOHN,ELTON	EMINEM,RADIONHEAD,PAUL SIMON,STEELEY DAN,SISQO,BEACHBOYS,	US	\$15.00	
STARBUCK	KNEE DEEP IN THE HEART-STEREO 3 VIDEOS&AUDIO TRAC	LASER	\$35.00	VAUGHAN,STEVIE	LIVE 1975 AT Q.P.R.-MONO 88 MINS (RED COVER)	JAPAN	\$65.00	JOHN,ELTON	WHO,DAVE NAVARRO,PHIL RAMON,TONY BENNETT 200 PAGES	US	\$78.00	
STEELHEART	VIDEOS-STEREO 24 MINS OUT-OF-PRINT SEALED!!!	LASER	\$45.00	VAUGHAN,STEVIE	LIVE 1975 AT Q.P.R.-MONO 88 MINS (RED COVER)	JAPAN	\$65.00	JOHN,ELTON	WINNERS IN ALL CATEGORIES	US	\$15.00	
STEWART,ROD	LAST CONCERT W/FACES & KEITH RICHARDS 69 MINS RARE!!!	JAPAN	\$75.00	VAUGHAN,STEVIE	LIVE 1975 AT Q.P.R.-MONO 88 MINS (RED COVER)	JAPAN	\$65.00	JOHN,ELTON	THE ONE SONGBOOK 72 PAGES	UK	\$20.00	
STEWART,ROD	STORYTELLER-STEREO OUT-OF-PRINT SEALED!!!	LASER	\$40.00	VAUGHAN,STEVIE	LIVE 1975 AT Q.P.R.-MONO 88 MINS (RED COVER)	JAPAN	\$65.00	JOHN,ELTON	TWO ROOMS SOFTCOVER W/PHOTOS 128 PAGES	US	\$15.00	
STING	THE VIDEOS PART 1 - STEREO 48 MINS OUT-OF-PRINT SEALED!!	LASER	\$40.00	VAUGHAN,STEVIE	LIVE 1975 AT Q.P.R.-MONO 88 MINS (RED COVER)	JAPAN	\$65.00	JOHN,ELTON	BIOGRAPHY BY PHILIP NORMAN HARDCOVER 220 PGS W/PHOTO	US	\$28.00	
STRAIT,GEORGE	PURE COUNTRY W/LESLEY ANN WARREN-WIDE-113 MINS SEAL	LASER	\$30.00	VAUGHAN,STEVIE	LIVE 1975 AT Q.P.R.-MONO 88 MINS (RED COVER)	JAPAN	\$65.00	JOHN,ELTON	VIDEO CASSETTES "" "" "" VHS VIDEO CASSETTES "" "" ""	ORIGIN	PRICE	
STREISAND,BARBR	ONE VOICE W/DUET BARRY GIBB 65 MINS OUT-OF-PRINT	LASER	\$45.00	VAUGHAN,STEVIE	LIVE 1975 AT Q.P.R.-MONO 88 MINS (RED COVER)	JAPAN	\$65.00	JOHN,ELTON	PARADISE DO YOU REMEMBER/RAIN DOWN/EDITION! PROMO VHS	PROMO	\$15.00	
STREISAND,BARBR	THE CONCERT-LIVE ARRANGEHEAD POND JULY 1994-STEREO	LASER	\$40.00	VAUGHAN,STEVIE	LIVE 1975 AT Q.P.R.-MONO 88 MINS (RED COVER)	JAPAN	\$65.00	JOHN,ELTON	LOVE AT THE GREEK H I FI STEREO 82 MINS	US	\$16.00	
SUMMER,DONNA	A HOT SUMMER NIGHT-STEREO 78 MINS 1983 COSTA MESA, CA	LASER	\$45.00	VAUGHAN,STEVIE	LIVE 1975 AT Q.P.R.-MONO 88 MINS (RED COVER)	JAPAN	\$65.00	JOHN,ELTON	SUMMER 1991 WOODS,INSPIRAL CARPET,NTALIE COLEA	PROMO	\$10.00	
TALKING HEADS	STOP MAKING SENSE-STEREO 99 MINS OUT-OF-PRINT RARE!!!	LASER	\$45.00	VAUGHAN,STEVIE	LIVE 1975 AT Q.P.R.-MONO 88 MINS (RED COVER)	JAPAN	\$65.00	JOHN,ELTON	VOL. 1-4 W/PAUL ANKA,CYRILLE,LESLEY GORE,PETER&GORDO	US	\$60.00	
TEARS FOR FEARS	SCENES FROM THE BIG CHAIR-STEREO 76 MINS RARE!!!	LASER	\$50.00	VAUGHAN,STEVIE	LIVE 1975 AT Q.P.R.-MONO 88 MINS (RED COVER)	JAPAN	\$65.00	JOHN,ELTON	FRANKIE AVALON,ELANCY SNAITRA,YARDBIRDS BYRDS,ANIMALS	US	\$30.00	
TEARS FOR FEARS	MAD WORLD/CHANGE/PALM SHELTER 87/01S 15 MINS RARE!!!	LASER	\$30.00	VAUGHAN,STEVIE	LIVE 1975 AT Q.P.R.-MONO 88 MINS (RED COVER)	JAPAN	\$65.00	JOHN,ELTON	TO RUSSIA WITH ELMC 1983 SEALED!!!	US	\$15.00	
TEARS FOR FEARS	SONING THE SEEDS-STEREO 22 MINS OUT-OF-PRINT RARE!!!	LASER	\$40.00	VAUGHAN,STEVIE	LIVE 1975 AT Q.P.R.-MONO 88 MINS (RED COVER)	JAPAN	\$65.00	JOHN,ELTON	DO IT AT IT FEELS LIKE FOR A GIRL PROMO 4:28	PROMO	\$15.00	
TESLA	LIVE'S MAKING CHANGES - 88 MINS OUT-OF-PRINT SEALED!!!	LASER	\$30.00	VAUGHAN,STEVIE	LIVE 1975 AT Q.P.R.-MONO 88 MINS (RED COVER)	JAPAN	\$65.00	JOHN,ELTON	YOU'RE THE ONE IN CONCERT FROM PARIS PROMO VHS	PROMO	\$15.00	
THREE DOG NIGHT	TIME SOUNDTRACK 1975-89 MINS OUT-OF-PRINT SEALED!!!	LASER	\$30.00	VAUGHAN,STEVIE	LIVE 1975 AT Q.P.R.-MONO 88 MINS (RED COVER)	JAPAN	\$65.00	JOHN,ELTON	IT'S ALL ABOUT TO CHANGE-STEREO 63:51 PROMO VHS	PROMO	\$12.00	
TOSH,PETER	LIVE AT THE GREEK THEATRE 8/23/83-STEREO 60 MINS SEALED	LASER	\$35.00	VAUGHAN,STEVIE	LIVE 1975 AT Q.P.R.-MONO 88 MINS (RED COVER)	JAPAN	\$65.00	JOHN,ELTON	CUTTING EDGE VOL. 1 W/ REM. ALAM. BLASTERS & MORE	US	\$15.00	
TRAVIS,RANDY	THIS IS ME-STEREO 40 MINS OUT-OF-PRINT SEALED!!!	LASER	\$35.00	VAUGHAN,STEVIE	LIVE 1975 AT Q.P.R.-MONO 88 MINS (RED COVER)	JAPAN	\$65.00	JOHN,ELTON	CHARISMA RECORDS REELS W/88 SPECIAL,TRIAU,2 IN A ROO PROMO	US	\$15.00	
TRITTS,TRAVIS	TEN FT TA BUSHU/LETTER 40 MINS OUT-OF-PRINT SEALED!!!	LASER	\$35.00	VAUGHAN,STEVIE	LIVE 1975 AT Q.P.R.-MONO 88 MINS (RED COVER)	JAPAN	\$65.00	JOHN,ELTON	ENIGMA,CHRISTY MA,COLL,FRANZER CHORUS, WORLD ON EDGE	US	\$28.00	
TURNER,TINA	PRIVATE DANCER 4 TRACK 8" DISC OUT-OF-PRINT RARE!!!	LASER	\$35.00	VAUGHAN,STEVIE	LIVE 1975 AT Q.P.R.-MONO 88 MINS (RED COVER)	JAPAN	\$65.00	JOHN,ELTON	W/ADAMSON - STEREO 81 MINS SEALED!!!	US	\$28.00	
TURNER,TINA	SIMPLY THE BEST-VIDEO COLLECTION 45 MINS OUT-OF-PRINT	LASER	\$50.00	VAUGHAN,STEVIE	LIVE 1975 AT Q.P.R.-MONO 88 MINS (RED COVER)	JAPAN	\$65.00	JOHN,ELTON	FRIENDS & RELATIVES RED FRACKERS LIVE 121 MINS PROMO VHS	PROMO	\$15.00	
TURNER,TINA	LIVE PRIVATE DANCER TOUR W/BOBBI & BRYAN ADAMS 55 MI	LASER	\$55.00	VAUGHAN,STEVIE	LIVE 1975 AT Q.P.R.-MONO 88 MINS (RED COVER)	JAPAN	\$65.00	JOHN,ELTON	SHEET MUSIC EXTREMELY RARE	SHEET MUSIC	ORIGIN	PRICE
TURNER,TINA	LIVE IN AMSTERDAM AC3-STEREO 113 MINS OUT-OF-PRINT	LASER	\$40.00	VAUGHAN,STEVIE	LIVE 1975 AT Q.P.R.-MONO 88 MINS (RED COVER)	JAPAN	\$65.00	JOHN,ELTON	SHAMELESS SHEET MUSIC W/BLBY ON THE COVER	US	\$20.00	
TURNER,TINA	BREAK EVERY RULE-STEREO 61 MINS OUT-OF-PRINT SEALED!!	LASER	\$40.00	VAUGHAN,STEVIE	LIVE 1975 AT Q.P.R.-MONO 88 MINS (RED COVER)	JAPAN	\$65.00	JOHN,ELTON	MY LIFE SHEET MUSIC W/BLBY ON THE COVER	US	\$20.00	
TURNER,TINA	STAY HUNGRY-STEREO 59 MINS EXTREMELY RARE!!!	LASER	\$150.00	VAUGHAN,STEVIE	LIVE 1975 AT Q.P.R.-MONO 88 MINS (RED COVER)	JAPAN	\$65.00	JOHN,ELTON	KEEPING THE FAITH SHEET MUSIC W/BLBY ON THE COVER	US	\$20.00	
UB40	A FAMILY AFFAIR-LIVE 6/22/91 FINSBURY PARK 90 MINS RARE!!	JAPAN	\$75.00	VAUGHAN,STEVIE	LIVE 1975 AT Q.P.R.-MONO 88 MINS (RED COVER)	JAPAN	\$65.00	JOHN,ELTON	IT'S 8'ILL R/N'R TO ME SHEET MUSIC W/BLBY ON THE COVER	US	\$20.00	
UB40	RUSSIA THE VIDEO MIX-STEREO 59 MINS OUT-OF-PRINT	LASER	\$40.00	VAUGHAN,STEVIE	LIVE 1975 AT Q.P.R.-MONO 88 MINS (RED COVER)	JAPAN	\$65.00	JOHN,ELTON	TELL HER ABOUT IT SHEET MUSIC W/BLBY ON THE COVER	US	\$20.00	
U2	RATTLE AND HUM-REMASTERED STEREO 90 MINS OUT-OF-PR	LASER	\$40.00	VAUGHAN,STEVIE	LIVE 1975 AT Q.P.R.-MONO 88 MINS (RED COVER)	JAPAN	\$65.00	JOHN,ELTON	BARY GRAND SHEET MUSIC W/BLBY & RAY ON THE COVER	US	\$15.00	
U2	ACHTUNG BABY THE VIDEOS - STEREO	LASER	\$29.00	VAUGHAN,STEVIE	LIVE 1975 AT Q.P.R.-MONO 88 MINS (RED COVER)	JAPAN	\$65.00	JOHN,ELTON	MODERN WOMAN SHEET MUSIC W/BLBY ON THE COVER	US	\$15.00	
U2	THE UNDISCOVERED COUNTRY 1982 BILLY'S ATLANTIC CITY	LASER	\$80.00	VAUGHAN,STEVIE	LIVE 1975 AT Q.P.R.-MONO 88 MINS (RED COVER)	JAPAN	\$65.00	JOHN,ELTON	N.Y STATE OF MIND SHEET MUSIC W/BLBY ON THE COVER	US	\$15.00	
U2	LIVE,RIGHT HERE,RIGHT NOW-STEREO 120 MINS OUT-OF-PRINT	LASER	\$40.00	VAUGHAN,STEVIE	LIVE 1975 AT Q.P.R.-MONO 88 MINS (RED COVER)	JAPAN	\$65.00	JOHN,ELTON	RIVER OF DREAMS SHEET MUSIC	US	\$15.00	
U2	VAN SHELTON, RICK TO BE CONTINUED-STEREO 38 MINS OUT-OF-PRINT SEALED!!!	LASER	\$25.00	VAUGHAN,STEVIE	LIVE 1975 AT Q.P.R.-MONO 88 MINS (RED COVER)	JAPAN	\$65.00	JOHN,ELTON	SHE'S ALWAYS A WOMAN SHEET MUSIC W/BLBY ON THE COVER	US	\$15.00	
VANDROSS,LUTHE	LIVE AT WEMBLEY 8/29 WORLD TOUR-STEREO 61 MINS	LASER	\$40.00	VAUGHAN,STEVIE	LIVE 1975 AT Q.P.R.-MONO 88 MINS (RED COVER)	JAPAN	\$65.00	JOHN,ELTON	YOU'RE ONLY MY WOMAN SHEET MUSIC W/BLBY ON THE COVER	US	\$15.00	
VANDROSS,LUTHE	ROCK VIDEO VOL 2 W/ELVIS,LOU REED,THOMPSON TWIN	LASER	\$35.00	VAUGHAN,STEVIE	LIVE 1975 AT Q.P.R.-MONO 88 MINS (RED COVER)	JAPAN	\$65.00	JOHN,ELTON	AND SO IT GOES SHEET MUSIC W/BLBY ON THE COVER	US	\$15.00	
VARIOUS ARTISTS	MEATLOAF,JEFFERSON STARSHIP,RODNEY DANGERFIELD,POIS	LASER	\$30.00	VAUGHAN,STEVIE	LIVE 1975 AT Q.P.R.-MONO 88 MINS (RED COVER)	JAPAN	\$65.00	JOHN,ELTON	SHE'S GOT A WAY SHEET MUSIC W/BLBY ON THE COVER	US	\$15.00	
VARIOUS ARTISTS	PARAMOUNT PICTURES PROMO SAMPLER W/INDIANA JONES,	LASER	\$30.00	VAUGHAN,STEVIE	LIVE 1975 AT Q.P.R.-MONO 88 MINS (RED COVER)	JAPAN	\$65.00	JOHN,ELTON	THE LONGEST TIME SHEET MUSIC W/BLBY ON THE COVER	US	\$15.00	
VARIOUS ARTISTS	GODFATHER,STAR TREK,GRASER,SERPICO,TOP GUN 109 MINS	LASER	\$78.00	VAUGHAN,STEVIE	LIVE 1975 AT Q.P.R.-MONO 88 MINS (RED COVER)	JAPAN	\$65.00	JOHN,ELTON	THIS WAY YOU ARE SHEET MUSIC W/BLBY ON THE COVER	US	\$15.00	
VARIOUS ARTISTS	REGGAE REFRESHERS W/BOB MARLEY,TOOTS AND MAYTALS, JAPAN	LASER	\$78.00	VAUGHAN,STEVIE	LIVE 1975 AT Q.P.R.-MONO 88 MINS (RED COVER)	JAPAN	\$65.00	JOHN,ELTON	GOODBYE YELLOW BRICK ROAD SHEET MUSIC WELTON COVE US	\$28.00		
VARIOUS ARTISTS	SILY AND ROBBIE BURNING SPEAR 49 MINS RARE!!!	LASER	\$40.00	VAUGHAN,STEVIE	LIVE 1975 AT Q.P.R.-MONO 88 MINS (RED COVER)	JAPAN	\$65.00	JOHN,ELTON	BEHIND THE SCENES SHEET MUSIC WELTON COVE US	\$28.00		
VARIOUS ARTISTS	CALL CALLING W/STEPHEN STILLS,REBECCO'S,POCCO,RYDYS JAPAN	LASER	\$60.00	VAUGHAN,STEVIE	LIVE 1975 AT Q.P.R.-MONO 88 MINS (RED COVER)	JAPAN	\$65.00	JOHN,ELTON	I SAW HER STANDING THERE SHEET MUSIC WELTON COVE US	\$20.00		
VARIOUS ARTISTS	SCOTT MACKENZIE,JAMES TAYLOR,SANTANA,NEW RIDERS,	LASER	\$60.00	VAUGHAN,STEVIE	LIVE 1975 AT Q.P.R.-MONO 88 MINS (RED COVER)	JAPAN	\$65.00	JOHN,ELTON	SACRIFICE SHEET MUSIC WELTON COVE US	\$20.00		
VARIOUS ARTISTS	SPIRIT,IT'S A BEAUTIFUL DAY 81 MINS SEALED!!!	LASER	\$60.00	VAUGHAN,STEVIE	LIVE 1975 AT Q.P.R.-MONO 88 MINS (RED COVER)	JAPAN						





# BOO'S BLAST FROM THE PAST

3875 ALBERTA PLACE • Philadelphia, PA 19154

(8:00 a.m. - 11:00 p.m.) • 215-632-0228

BOO'S BLAST FROM THE PAST 3875 ALBERTA PLACE PHILADELPHIA, PA 19154  
TELEPHONE: (215) 632-0228 (8:00 a.m. - 11:00 p.m.)  
SET SALE: All LP's & 45's are available for immediate shipment. 100% total  
satisfaction guaranteed. Prompt refund sent on anything you are  
not satisfied with or for any item that is out of stock.  
SHIPPING: U.S. CUSTOMERS: LP's: 1st Class: \$4.75 1st LP & \$1.00 for each  
additional 2 LP's.  
4th Class: \$3.50 1st LP & \$1.00 for each  
additional 2 LP's.  
45's: 1st Class: \$5.00 Any Size Order  
4th Class: \$3.50 Any Size Order  
RESERVE REQUESTS: Telephone Reserves - OK! Mail reserves - Please send SASE!!!  
TELEPHONE CREDIT CARD ORDERS - OK!!!



### CD SET SALE

ALL CD'S ARE BRAND NEW AND SEALED

## VINYL LP SET SALE

## VINYL LP SET SALE

ROLLING STONES: Sticky Fingers Virgin 47863 (180 Gram Vinyl w/Functional Zippers) SS 15.00	SOUNDTRACK: Mosquito Coast Fantasy 21005 SS 6.00
ROLLING STONES: Ballie On Main Street Virgin 47864 (180 Gram Vinyl) SS 15.00	SOUNDTRACK: The Nutty Professor SS 8.00
LINDA RONSTADT: What's New Ayluz 60260 M 8.00	SOUNDTRACK: The Players Club Heavyweight 886 (2 LP Set) SS 10.00
LINDA RONSTADT: Lush Life M 8.00	SOUNDTRACK: Rock Justice BPI 17036 SS 10.00
ROOMATES: Greatest Hits Valmor 5041 SS 11.00	SOUNDTRACK: Rush Hour Def Jam 55863 (2 LP Set) SS 10.00
JIMMY ROSSINI: Best Of Negocianal Songs M 8.00	SOUNDTRACK: Sleeping With The Enemy Columbia 46126 (UK) M 8.00
DIANA ROSS: Baby It's A Wonderful Year M 8.00	SOUNDTRACK: Soup For One Mirage 19393 M 8.00
DIANA ROSS: Diana Motown 936 M 8.00	SOUNDTRACK: Streets In Matching Def Jam 55813 (2 LP Set) SS 10.00
DIANA ROSS: Live At Caesars Palace Motown 5169 SS 8.00	SOUNDTRACK: Sunset Park East/West Columbia 46126 (UK) M 8.00
DIANA ROSS: Motown 6274 SS 8.00	SOUNDTRACK: Teachers Capitol 12371 M 8.00
DIANA ROSS: Force Behind The Power Motown 6316 SS 8.00	SOUNDTRACK: That Was That, This Is Now East Street 9903 SS 8.00
DIANA ROSS: Diana ARL 4677 M 8.00	SOUNDTRACK: Three Little Birds In Blue Hollywood 410 SS 8.00
DIANA ROSS: An Evening With Diana Ross Motown 5268 (2 LP Set) SS 12.00	SOUNDTRACK: To Wong Foo, Thanks For Every-thing Julie Newmar RCA 11231 SS 8.00
DIANA ROSS: Anthology Motown 6049 SS 12.00	SOUNDTRACK: Moe! J & Live Columbia 46294 (UK) SS 8.00
DIANA ROSS: Diane Extrem/And The Restless Motown 6177 SS 10.00	SOUNDTRACK: Mithral & I DRG 12590 SS 8.00
DIANA ROSS & Others: Poppe Me Love You Motown 15 (12" LP) M 6.00	SPINNERS: Down To Business Vols 3403 SS 6.00
ROYAL COOLES: Ring Accapella Soul Columbia 901 SS 11.00	SPINNERS: Happiness Is Being With The Detroit Spinners SS 6.00
TODD RUNDGREN: Todd Castle 177 (UK) (2 LP Set) SS 12.00	DUSTY SPRINGFIELD: A Very Fine Line Columbia 478508 (UK) SS 10.00
TODD RUNDGREN: Something/Anything? Castle 007 (2 LP Set) SS 12.00	BRUCE SPRINGSTEEN: The River Columbia 88510 (UK) (2 LP Set) SS 14.00
LEW RUSSELL: 12 State Para. 0001 SS 8.00	BRUCE SPRINGSTEEN: Greatest Hits Columbia 67060 SS 14.00
SAD CAPE: Whatever It Takes Legacy 119 (UK) SS 6.00	BRUCE SPRINGSTEEN: Lucky Town Columbia 47124 (UK) SS 10.00
SADIE: Diamond Life Records 39581 SS 8.00	STACEY Q: Hard Machine At. 18102 M 6.00
SADIE: Promise Portrait 4203 SS 8.00	LISA STANSFIELD: The 81 Remains Arista 19012 (2 LP Set) SS 12.00
SADIE: Stronger Than Pride Epic 44210 SS 8.00	EDWIN STARR: 25 Miles Dordy 940 SS 10.00
SADIE: Beat Of Epic 66686 (2 LP Set) SS 12.00	STEADY B: Let The Hustlers Play Norton Ed 274 SS 12.00
SALIS: Diamond Life Records 39581 SS 8.00	SHAKIN' STAINES: A Boogie Columbia 460126 (UK) SS 8.00
SALIS: Promise Portrait 4203 SS 8.00	SHAKIN' STAINES: The Track Years ARI 8713 SS 8.00
SALIS: Stronger Than Pride Epic 44210 SS 8.00	SHAKIN' STAINES: Turning Away Epic 6819 (12" Maxi Single) (UK) SS 8.00
SALIS: Beat Of Epic 66686 (2 LP Set) SS 12.00	BILLY STEWART: The Original Standard New Tricks Chess 8089 (UK) SS 10.00
SALIS: Diamond Life Records 39581 SS 8.00	BRUCE SPRINGSTEEN: The Ghost Of Tom Columbia 46294 (UK) SS 10.00
SALIS: Promise Portrait 4203 SS 8.00	SONNY STITT QUARTET: Same Chess 9317 SS 8.00
SALIS: Stronger Than Pride Epic 44210 SS 8.00	BILLY STRANGE: Folk Rock Hits Columbia 2016 SS 10.00
SALIS: Beat Of Epic 66686 (2 LP Set) SS 12.00	STYLISTICS: Avo 69010 SS 8.00
SALIS: Diamond Life Records 39581 SS 8.00	STYLISTICS: Avo 69010 SS 8.00
SALIS: Promise Portrait 4203 SS 8.00	STYLISTICS: Avo 69010 SS 8.00
SALIS: Stronger Than Pride Epic 44210 SS 8.00	STYLISTICS: Avo 69010 SS 8.00
SALIS: Beat Of Epic 66686 (2 LP Set) SS 12.00	STYLISTICS: Avo 69010 SS 8.00
SALIS: Diamond Life Records 39581 SS 8.00	STYLISTICS: Avo 69010 SS 8.00
SALIS: Promise Portrait 4203 SS 8.00	STYLISTICS: Avo 69010 SS 8.00
SALIS: Stronger Than Pride Epic 44210 SS 8.00	STYLISTICS: Avo 69010 SS 8.00
SALIS: Beat Of Epic 66686 (2 LP Set) SS 12.00	STYLISTICS: Avo 69010 SS 8.00
SALIS: Diamond Life Records 39581 SS 8.00	STYLISTICS: Avo 69010 SS 8.00
SALIS: Promise Portrait 4203 SS 8.00	STYLISTICS: Avo 69010 SS 8.00
SALIS: Stronger Than Pride Epic 44210 SS 8.00	STYLISTICS: Avo 69010 SS 8.00
SALIS: Beat Of Epic 66686 (2 LP Set) SS 12.00	STYLISTICS: Avo 69010 SS 8.00
SALIS: Diamond Life Records 39581 SS 8.00	STYLISTICS: Avo 69010 SS 8.00
SALIS: Promise Portrait 4203 SS 8.00	STYLISTICS: Avo 69010 SS 8.00
SALIS: Stronger Than Pride Epic 44210 SS 8.00	STYLISTICS: Avo 69010 SS 8.00
SALIS: Beat Of Epic 66686 (2 LP Set) SS 12.00	STYLISTICS: Avo 69010 SS 8.00
SALIS: Diamond Life Records 39581 SS 8.00	STYLISTICS: Avo 69010 SS 8.00
SALIS: Promise Portrait 4203 SS 8.00	STYLISTICS: Avo 69010 SS 8.00
SALIS: Stronger Than Pride Epic 44210 SS 8.00	STYLISTICS: Avo 69010 SS 8.00
SALIS: Beat Of Epic 66686 (2 LP Set) SS 12.00	STYLISTICS: Avo 69010 SS 8.00
SALIS: Diamond Life Records 39581 SS 8.00	STYLISTICS: Avo 69010 SS 8.00
SALIS: Promise Portrait 4203 SS 8.00	STYLISTICS: Avo 69010 SS 8.00
SALIS: Stronger Than Pride Epic 44210 SS 8.00	STYLISTICS: Avo 69010 SS 8.00
SALIS: Beat Of Epic 66686 (2 LP Set) SS 12.00	STYLISTICS: Avo 69010 SS 8.00
SALIS: Diamond Life Records 39581 SS 8.00	STYLISTICS: Avo 69010 SS 8.00
SALIS: Promise Portrait 4203 SS 8.00	STYLISTICS: Avo 69010 SS 8.00
SALIS: Stronger Than Pride Epic 44210 SS 8.00	STYLISTICS: Avo 69010 SS 8.00
SALIS: Beat Of Epic 66686 (2 LP Set) SS 12.00	STYLISTICS: Avo 69010 SS 8.00
SALIS: Diamond Life Records 39581 SS 8.00	STYLISTICS: Avo 69010 SS 8.00
SALIS: Promise Portrait 4203 SS 8.00	STYLISTICS: Avo 69010 SS 8.00
SALIS: Stronger Than Pride Epic 44210 SS 8.00	STYLISTICS: Avo 69010 SS 8.00
SALIS: Beat Of Epic 66686 (2 LP Set) SS 12.00	STYLISTICS: Avo 69010 SS 8.00
SALIS: Diamond Life Records 39581 SS 8.00	STYLISTICS: Avo 69010 SS 8.00
SALIS: Promise Portrait 4203 SS 8.00	STYLISTICS: Avo 69010 SS 8.00
SALIS: Stronger Than Pride Epic 44210 SS 8.00	STYLISTICS: Avo 69010 SS 8.00
SALIS: Beat Of Epic 66686 (2 LP Set) SS 12.00	STYLISTICS: Avo 69010 SS 8.00
SALIS: Diamond Life Records 39581 SS 8.00	STYLISTICS: Avo 69010 SS 8.00
SALIS: Promise Portrait 4203 SS 8.00	STYLISTICS: Avo 69010 SS 8.00
SALIS: Stronger Than Pride Epic 44210 SS 8.00	STYLISTICS: Avo 69010 SS 8.00
SALIS: Beat Of Epic 66686 (2 LP Set) SS 12.00	STYLISTICS: Avo 69010 SS 8.00
SALIS: Diamond Life Records 39581 SS 8.00	STYLISTICS: Avo 69010 SS 8.00
SALIS: Promise Portrait 4203 SS 8.00	STYLISTICS: Avo 69010 SS 8.00
SALIS: Stronger Than Pride Epic 44210 SS 8.00	STYLISTICS: Avo 69010 SS 8.00
SALIS: Beat Of Epic 66686 (2 LP Set) SS 12.00	STYLISTICS: Avo 69010 SS 8.00
SALIS: Diamond Life Records 39581 SS 8.00	STYLISTICS: Avo 69010 SS 8.00
SALIS: Promise Portrait 4203 SS 8.00	STYLISTICS: Avo 69010 SS 8.00
SALIS: Stronger Than Pride Epic 44210 SS 8.00	STYLISTICS: Avo 69010 SS 8.00
SALIS: Beat Of Epic 66686 (2 LP Set) SS 12.00	STYLISTICS: Avo 69010 SS 8.00
SALIS: Diamond Life Records 39581 SS 8.00	STYLISTICS: Avo 69010 SS 8.00
SALIS: Promise Portrait 4203 SS 8.00	STYLISTICS: Avo 69010 SS 8.00
SALIS: Stronger Than Pride Epic 44210 SS 8.00	STYLISTICS: Avo 69010 SS 8.00
SALIS: Beat Of Epic 66686 (2 LP Set) SS 12.00	STYLISTICS: Avo 69010 SS 8.00
SALIS: Diamond Life Records 39581 SS 8.00	STYLISTICS: Avo 69010 SS 8.00
SALIS: Promise Portrait 4203 SS 8.00	STYLISTICS: Avo 69010 SS 8.00
SALIS: Stronger Than Pride Epic 44210 SS 8.00	STYLISTICS: Avo 69010 SS 8.00
SALIS: Beat Of Epic 66686 (2 LP Set) SS 12.00	STYLISTICS: Avo 69010 SS 8.00
SALIS: Diamond Life Records 39581 SS 8.00	STYLISTICS: Avo 69010 SS 8.00
SALIS: Promise Portrait 4203 SS 8.00	STYLISTICS: Avo 69010 SS 8.00
SALIS: Stronger Than Pride Epic 44210 SS 8.00	STYLISTICS: Avo 69010 SS 8.00
SALIS: Beat Of Epic 66686 (2 LP Set) SS 12.00	STYLISTICS: Avo 69010 SS 8.00
SALIS: Diamond Life Records 39581 SS 8.00	STYLISTICS: Avo 69010 SS 8.00
SALIS: Promise Portrait 4203 SS 8.00	STYLISTICS: Avo 69010 SS 8.00
SALIS: Stronger Than Pride Epic 44210 SS 8.00	STYLISTICS: Avo 69010 SS 8.00
SALIS: Beat Of Epic 66686 (2 LP Set) SS 12.00	STYLISTICS: Avo 69010 SS 8.00
SALIS: Diamond Life Records 39581 SS 8.00	STYLISTICS: Avo 69010 SS 8.00
SALIS: Promise Portrait 4203 SS 8.00	STYLISTICS: Avo 69010 SS 8.00
SALIS: Stronger Than Pride Epic 44210 SS 8.00	STYLISTICS: Avo 69010 SS 8.00
SALIS: Beat Of Epic 66686 (2 LP Set) SS 12.00	STYLISTICS: Avo 69010 SS 8.00
SALIS: Diamond Life Records 39581 SS 8.00	STYLISTICS: Avo 69010 SS 8.00
SALIS: Promise Portrait 4203 SS 8.00	STYLISTICS: Avo 69010 SS 8.00
SALIS: Stronger Than Pride Epic 44210 SS 8.00	STYLISTICS: Avo 69010 SS 8.00
SALIS: Beat Of Epic 66686 (2 LP Set) SS 12.00	STYLISTICS: Avo 69010 SS 8.00
SALIS: Diamond Life Records 39581 SS 8.00	STYLISTICS: Avo 69010 SS 8.00
SALIS: Promise Portrait 4203 SS 8.00	STYLISTICS: Avo 69010 SS 8.00
SALIS: Stronger Than Pride Epic 44210 SS 8.00	STYLISTICS: Avo 69010 SS 8.00
SALIS: Beat Of Epic 66686 (2 LP Set) SS 12.00	STYLISTICS: Avo 69010 SS 8.00
SALIS: Diamond Life Records 39581 SS 8.00	STYLISTICS: Avo 69010 SS 8.00
SALIS: Promise Portrait 4203 SS 8.00	STYLISTICS: Avo 69010 SS 8.00
SALIS: Stronger Than Pride Epic 44210 SS 8.00	STYLISTICS: Avo 69010 SS 8.00
SALIS: Beat Of Epic 66686 (2 LP Set) SS 12.00	STYLISTICS: Avo 69010 SS 8.00
SALIS: Diamond Life Records 39581 SS 8.00	STYLISTICS: Avo 69010 SS 8.00
SALIS: Promise Portrait 4203 SS 8.00	STYLISTICS: Avo 69010 SS 8.00
SALIS: Stronger Than Pride Epic 44210 SS 8.00	STYLISTICS: Avo 69010 SS 8.00
SALIS: Beat Of Epic 66686 (2 LP Set) SS 12.00	STYLISTICS: Avo 69010 SS 8.00
SALIS: Diamond Life Records 39581 SS 8.00	STYLISTICS: Avo 69010 SS 8.00
SALIS: Promise Portrait 4203 SS 8.00	STYLISTICS: Avo 69010 SS 8.00
SALIS: Stronger Than Pride Epic 44210 SS 8.00	STYLISTICS: Avo 69010 SS 8.00
SALIS: Beat Of Epic 66686 (2 LP Set) SS 12.00	STYLISTICS: Avo 69010 SS 8.00
SALIS: Diamond Life Records 39581 SS 8.00	STYLISTICS: Avo 69010 SS 8.00
SALIS: Promise Portrait 4203 SS 8.00	STYLISTICS: Avo 69010 SS 8.00
SALIS: Stronger Than Pride Epic 44210 SS 8.00	STYLISTICS: Avo 69010 SS 8.00
SALIS: Beat Of Epic 66686 (2 LP Set) SS 12.00	STYLISTICS: Avo 69010 SS 8.00
SALIS: Diamond Life Records 39581 SS 8.00	STYLISTICS: Avo 69010 SS 8.00
SALIS: Promise Portrait 4203 SS 8.00	STYLISTICS: Avo 69010 SS 8.00
SALIS: Stronger Than Pride Epic 44210 SS 8.00	STYLISTICS: Avo 69010 SS 8.00
SALIS: Beat Of Epic 66686 (2 LP Set) SS 12.00	STYLISTICS: Avo 69010 SS 8.00
SALIS: Diamond Life Records 39581 SS 8.00	STYLISTICS: Avo 69010 SS 8.00
SALIS: Promise Portrait 4203 SS 8.00	STYLISTICS: Avo 69010 SS 8.00
SALIS: Stronger Than Pride Epic 44210 SS 8.00	STYLISTICS: Avo 69010 SS 8.00
SALIS: Beat Of Epic 66686 (2 LP Set) SS 12.00	STYLISTICS: Avo 69010 SS 8.00
SALIS: Diamond Life Records 39581 SS 8.00	STYLISTICS: Avo 69010 SS 8.00
SALIS: Promise Portrait 4203 SS 8.00	STYLISTICS: Avo 69010 SS 8.00
SALIS: Stronger Than Pride Epic 44210 SS 8.00	STYLISTICS: Avo 69010 SS 8.00
SALIS: Beat Of Epic 66686 (2 LP Set) SS 12.00	STYLISTICS: Avo 69010 SS 8.00
SALIS: Diamond Life Records 39581 SS 8.00	STYLISTICS: Avo 69010 SS 8.00
SALIS: Promise Portrait 4203 SS 8.00	STYLISTICS: Avo 69010 SS 8.00
SALIS: Stronger Than Pride Epic 44210 SS 8.00	STYLISTICS: Avo 69010 SS 8.00
SALIS: Beat Of Epic 66686 (2 LP Set) SS 12.00	STYLISTICS: Avo 69010 SS 8.00
SALIS: Diamond Life Records 39581 SS 8.00	STYLISTICS: Avo 69010 SS 8.00
SALIS: Promise Portrait 4203 SS 8.00	STYLISTICS: Avo 69010 SS 8.00
SALIS: Stronger Than Pride Epic 44210 SS 8.00	STYLISTICS: Avo 69010 SS 8.00
SALIS: Beat Of Epic 66686 (2 LP Set) SS 12.00	STYLISTICS: Avo 69010 SS 8.00
SALIS: Diamond Life Records 39581 SS 8.00	STYLISTICS: Avo 69010 SS 8.00
SALIS: Promise Portrait 4203 SS 8.00	STYLISTICS: Avo 69010 SS 8.00
SALIS: Stronger Than Pride Epic 44210 SS 8.00	STYLISTICS: Avo 69010 SS 8.00
SALIS: Beat Of Epic 66686 (2 LP Set) SS 12.00	STYLISTICS: Avo 69010 SS 8.00
SALIS: Diamond Life Records 39581 SS 8.00	STYLISTICS: Avo 69010 SS 8.00
SALIS: Promise Portrait 4203 SS 8.00	STYLISTICS: Avo 69010 SS 8.00
SALIS: Stronger Than Pride Epic 44210 SS 8.00	STYLISTICS: Avo 69010 SS 8.00
SALIS: Beat Of Epic 66686 (2 LP Set) SS 12.00	STYLISTICS: Avo 69010 SS 8.00
SALIS: Diamond Life Records 39581 SS 8.00	STYLISTICS: Avo 69010 SS 8.00
SALIS: Promise Portrait 4203 SS 8.00	STYLISTICS: Avo 69010 SS 8.00
SALIS: Stronger Than Pride Epic 44210 SS 8.00	STYLISTICS: Avo 69010 SS 8.00
SALIS: Beat Of Epic 66686 (2 LP Set) SS 12.00	STYLISTICS: Avo 69010 SS 8.00
SALIS: Diamond Life Records 39581 SS 8.00	STYLISTICS: Avo 69010 SS 8.00
SALIS: Promise Portrait 4203 SS 8.00	STYLISTICS: Avo 69010 SS 8.00
SALIS: Stronger Than Pride Epic 44210 SS 8.00	STYLISTICS: Avo 69010 SS 8.00
SALIS: Beat Of Epic 66686 (2 LP Set) SS 12.00	STYLISTICS: Avo 69010 SS 8.00
SALIS: Diamond Life Records 39581 SS 8.00	STYLISTICS: Avo 69010 SS 8.00
SALIS: Promise Portrait 4203 SS 8.00	STYLISTICS: Avo 69010 SS 8.00
SALIS: Stronger Than Pride Epic 44210 SS 8.00	STYLISTICS: Avo 69010 SS 8.00
SALIS: Beat Of Epic 66686 (2 LP Set) SS 12.00	STYLISTICS: Avo 69010 SS 8.00
SALIS: Diamond Life Records 39581 SS 8.00	STYLISTICS: Avo 69010 SS 8.00
SALIS: Promise Portrait 4203 SS 8.00	STYLISTICS: Avo 69010 SS 8.00
SALIS: Stronger Than Pride Epic 44210 SS 8.00	STYLISTICS: Avo 69010 SS 8.00
SALIS: Beat Of Epic 66686 (2 LP Set) SS 12.00	STYLISTICS: Avo 69010 SS 8.00
SALIS: Diamond Life Records 39581 SS 8.00	STYLISTICS: Avo 69010 SS 8.00
SALIS: Promise Portrait 4203 SS 8.00	STYLISTICS: Avo 69010 SS 8.00
SALIS: Stronger Than Pride Epic 44210 SS 8.00	STYLISTICS: Avo 69010 SS 8.00
SALIS: Beat Of Epic 66686 (2 LP Set) SS 12.00	STYLISTICS: Avo 69010 SS 8.00
SALIS: Diamond Life Records 39581 SS 8.00	STYLISTICS: Avo 69010 SS 8.00
SALIS: Promise Portrait 4203 SS 8.00	STYLISTICS: Avo 69010 SS 8.00
SALIS: Stronger Than Pride Epic 44210 SS 8.00	STYLISTICS: Avo 69010 SS 8.00
SALIS: Beat Of Epic 66686 (2 LP Set) SS 12.00	STYLISTICS: Avo 69010 SS 8.00
SALIS: Diamond Life Records 39581 SS 8.00	STYLISTICS: Avo 69010 SS 8.00
SALIS: Promise Portrait 4203 SS 8.00	STYLISTICS: Avo 69010 SS 8.00
SALIS: Stronger Than Pride Epic 44210 SS 8.00	STYLISTICS: Avo 69010 SS 8.00
SALIS: Beat Of Epic 66686 (2 LP Set) SS 12.00	STYLISTICS: Avo 69010 SS 8.00
SALIS: Diamond Life Records 39581 SS 8.00	STYLISTICS: Avo 69010 SS 8.00
SALIS: Promise Portrait 4203 SS 8.00	STYLISTICS: Avo 69010 SS 8.00
SALIS: Stronger Than Pride Epic 44210 SS 8.00	STYLISTICS: Avo 69010 SS 8.00
SALIS: Beat Of Epic 66686 (2 LP Set) SS 12.00	STYLISTICS: Avo 69010 SS 8.00
SALIS: Diamond Life Records 39581 SS 8.00	STYLISTICS: Avo 69010 SS 8.00
SALIS: Promise Portrait 4203 SS 8.00	STYLISTICS: Avo 69010 SS 8.00
SALIS: Stronger Than Pride Epic 44210 SS 8.00	STYLISTICS: Avo 69010 SS 8.00
SALIS: Beat Of Epic 66686 (2 LP Set) SS 12.00	STYLISTICS: Avo 69010 SS 8.00
SALIS: Diamond Life Records 39581 SS 8.00	STYLISTICS: Avo 69010 SS 8.00
SALIS: Promise Portrait 4203 SS 8.00	STYLISTICS: Avo 69010 SS 8.00
SALIS: Stronger Than Pride Epic 44210 SS 8.00	STYLISTICS: Avo 69010 SS 8.00
SALIS: Beat Of Epic 66686 (2 LP Set) SS 12.00	STYLISTICS: Avo 69010 SS 8.00
SALIS: Diamond Life Records 39581 SS 8.00	STYLISTICS: Avo 69010 SS 8.00
SALIS: Promise Portrait 4203 SS 8.00	STYLISTICS: Avo 69010 SS 8.00
SALIS: Stronger Than Pride Epic 44210 SS 8.00	STYLISTICS: Avo 69010 SS 8.00
SALIS: Beat Of Epic 66686 (2 LP Set) SS 12.00	STYLISTICS: Avo 69010 SS 8.00
SALIS: Diamond Life Records 39581 SS 8.00	STYLISTICS: Avo 69010 SS 8.00
SALIS: Promise Portrait 4203 SS 8.00	STYLISTICS: Avo 69010 SS 8.00
SALIS: Stronger Than Pride Epic 44210 SS 8.00	STYLISTICS: Avo 69010 SS 8.00
SALIS: Beat Of Epic 66686 (2 LP Set) SS 12.00	STYLISTICS: Avo 69010 SS 8.00
SALIS: Diamond Life Records 39581 SS 8.00	STYLISTICS: Avo 69010 SS 8.00
SALIS: Promise Portrait 4203 SS 8.00	STYLISTICS: Avo 69010 SS 8.00
SALIS: Stronger Than Pride Epic 44210 SS 8.00	STYLISTICS: Avo 69010 SS 8.00
SALIS: Beat Of Epic 66686 (2 LP Set) SS 12.00	STYLISTICS: Avo 69010 SS 8.00
SALIS: Diamond Life Records 39581 SS 8.00	STYLISTICS: Avo 69010 SS 8.00
SALIS: Promise Portrait 4203 SS 8.00	STYLISTICS: Avo 69010 SS 8.00
SALIS: Stronger Than Pride Epic 44210 SS 8.00	STYLISTICS: Avo 69010 SS 8.00
SALIS: Beat Of Epic 66686 (2 LP Set) SS 12.00	STYLISTICS: Avo 69010 SS 8.00
SALIS: Diamond Life Records 39581 SS 8.00	STYLISTICS: Avo 69010 SS 8.00
SALIS: Promise Portrait 4203 SS 8.00	STY

(603) 629-9102

\$4.00 for shipping & handling per order, not per item (US \$6.00 outside USA)

Monday - Thursday 10:30 am - 8:00 pm

Friday 10:30 am - 4:00 pm

Eastern Standard Time

Visa, Mastercard, JCB Cards Diners Club, Carte Blanche Discover, Private Issue, Bravo American Express, Optima Check or Money Order



PO Box 1514 Manchester, NH 03105 USA

More titles available at: www.MetroCityRecords.com Secure On-Line Ordering

Metro CD Records

PRE-ORDER LIST COMING SOON!

Prices and availability are subject to change.

Compact Disc

Table listing various CD releases including titles like 'Original Soundtrack + 2', 'How Dare You + 1', 'Deceptive Bends + 3', etc., with prices and formats.

Table listing various CD releases including titles like 'Queen News Of The World', 'Queen Night At The Opera', 'Queen Queen II', etc., with prices and formats.

Table listing various CD releases including titles like 'ANGEL Self-titled', 'ANGEL White Hot', 'ANGEL Helluva Band', etc., with prices and formats.

Table listing various CD releases including titles like 'PAT BENATAR Live In New Haven', 'PAT BENATAR Concert Classics', 'PAT BENATAR Greatest Hits Live (King Biscuit)', etc., with prices and formats.



(603) 629-9102

\$4.00 for shipping & handling per order, not per item (US \$6.00 outside USA)

Monday - Thursday

10:30 am - 8:00 pm

Friday

10:30 am - 4:00 pm

Eastern Standard Time

Visa, Mastercard, JCB Cards Diners Club, Carte Blanche Discover, Private Issue, Bravo American Express, Optima Check or Money Order



Metro CD Records



PO Box 1514 Manchester, NH 03105 USA

More titles available at: www.MetroCityRecords.com Secure On-Line Ordering

Ad #128

Table listing various music releases including artists like Steve Hackett, Happy The Man, Jimi Hendrix, and others, with columns for title, price, and format.

- Hi! Welcome to our latest ad. This time we have a **Cd BoxSet Sale**. Postage is \$3.50 for priority mail. Call for details, but we're closed Mondays.
- 1) Adam Ant - Antbox - 3 Cd Box w/ 27 unrised + 64 pg. bklt - UK New \$ 50
  - 2) Belle & Sebastian - 3 Singles in Box - New \$ 16
  - 3) Black Sabbath - The Singles '70 - '78-Cd Singles in mini pic slvs #4 box - \$ 30
  - 4) Buzzcocks - Beating Hearts - 2 Cds Live '78 + '79 - UK New \$ 23
  - 5) Alice Cooper - 3 for 1 - Killer/School's Out/Billion \$ Babies - Aust \$ 25
  - 6) Aleister Crowley - Satanic Verses - New 6 Cd Box of Spoken Word - \$ 33
  - 7) Cramps - 3 for 1 Box - Jungle/Bone/Songs the Lord - Aust \$ 35
  - 8) Cure - 3 for 1 Box - Pornography/Faith/Top - Aust \$ 25
  - 9) Deep Purple - 3 for 1 Box - Shades of Book of S/T - \$ 35
  - 10) The Fall - Psykick Dance Hall - UK 3 Cd Comp. Box '77 - '82 - \$ 23
  - 11) Fastball - Harsh Light of Day - UK Import 1 Cd in box w/bonus trks \$ 21
  - 12) Galaxie 500 - Ryko 4 Cd in Box w/bklt - Used but NM \$ 35
  - 13) Gothic Erotica - 6 Cd Box - Anyone who is Goth is on this - \$ 30
  - 14) Hellacopters - Flight Case - 1 Cd box - 5 Trk Cd w/ 2 videos \$ 15
  - 15) Lupine Howl (From Spiritualized) - The Carnivorous Lunar...New Cd Box \$ 30
  - 16) The Jam - Singles - '77 to '79 - 9 Cd singles in small box w/bklt \$ 50
  - 17) Kyuss - 3 for 1 - S/T/Blues for the Circus - \$ 30
  - 18) Led Zeppelin - Boxed Set - US \$ 25
  - 19) Madness - The Lot - UK 6 Cd Box w/Bklt + 24 Videos for PC \$ 50
  - 20) Magazine - Maybe It's Right - UK 3 Cd Box w/rarities, B Sides, + Peel \$ 30
  - 21) Manfred Mann - All Manner of Menn - '63 - '69 - 2 Cds in box w/bklt \$ 23
  - 22) Marillion - Singles '82 - '88 - 12 Cd singles in Box \$ 40
  - 23) Bob Marley - Songs of Freedom - Classic Box Reissued \$ 40
  - 24) Moby - Play - UK Lid Ed - 2 Cds - 2nd has B sides + rarities \$ 23
  - 25) Morrissey - Cd Singles - 10 Cd Singles in Small Box \$ 40
  - 26) New Model Army - 3 for 1 Box - Thunder/Raw Melody/Ghost of \$ 35
  - 27) Nirvana - Singles - 6 Import Cd Singles w/ B Sides + Rarities \$ 40
  - 28) Procol Harum - 30th Anniversary - UK 3 Cd set w/ rare & unrised \$ 30
  - 29) Pulp - Pulped - Their First 4 Cds - Lid to 5000 - \$ 35
  - 30) Queen - Greatest Hits 1 + 2 - US 2 Cd Set - Used, some wear on box \$ 18
  - 31) Rammstein - Mutter - German Cd in box w/poster \$ 23
  - 32) Rose Tattoo - 3 for 1 Box - S/T/Scarred/A Decade - \$ 40
  - 33) Savatage - Poets & Madmen - Lid Ed Cd in Box w/goodies \$ 18
  - 34) Silverchair - Freaky - Aust 5 Cd Box - Lots of B Sides + Live - \$ 25
  - 35) Sisters of Mercy - 3 for 1 - 1st & Last/Vision Thing/Floodland \$ 35
  - 36) Stone Roses - 10th Anniv. Ed - UK 2 Cd Box w/ bonus trks + videos \$ 30
  - 37) Bruce Springsteen - Live '75 - '85 - US 3 Cd Box w/bklt - \$ 30

619 S. 4th St. (4th between South & Bainbridge Sts.) **NOISE POLLUTION** (215) 627-7246 PHILADELPHIA, PA 19147

## Canadian CDs

**Frank Marino Eye Of The Storm - NEW \$14.99**  
SPECIAL - Buy this CD and get free surface shipping on your entire order!

**Guess Who This Time Long Ago (2CD Rarities) \$19.99**  
2 disc collection of Guess Who rarities. Tracks from TV shows, odds and ends, even covers of "Light My Fire", "Summertime Blues" as in the Blue Cheer version, "Love Is All Around" and "White Room", honest! Very very cool piece.

**Guess Who Running Back Through Canada 2 CD \$19.99**  
Live album from last summers reunion tour with both Randy Bachman and Burton Cummings.

**Randy Bachman Randy Bachman Songbook \$14.99**  
Randy goes back and recuts a number of his classics with his pre reunion band

**Also available Any Road \$14.99**  
**Merge \$13.99**  
**Bob's Garage (live 5 song EP) \$11.99**

**April Wine Back To The Mansion \$13.99**  
New CD from this Classic Rock band. Will be touring this summer with new member Carl Dixon (ex Coney Hatch)

**Stampede All Regular discs \$9.99**  
All the Stampede albums are now available: Bally, Steam'n', Platinum, Hit The Road, Backstage Pass, New Day, Rubes Dudes, From The Fire, Carrying On

**Nash The Slash Various Cds \$16.49**  
Hard to find albums from this Canadian progster: Children of the Night, Thrash, Blind Windows or Nosferatu. Watch for FM Black Noise rarities coming soon!

### Yes, we wholesale!

All prices are in US\$. Visa / Mastercard / US checks / Money Orders accepted.  
Postage & insurance: Surface \$3.50 first, \$1.50 additional Air Mail \$4.50 first, 2.00 each additional

www.canadiandocs.com

### Spindle Records

Box 49976, 660 Eglinton Ave. E., Toronto, ON, Canada M4G 2K0  
416-425-0476, 416-425-7901 FAX

## 60's - 70's Rock LP Set Sale

SET SALE OF 40+ TO 70's ROCK LP's. GRADING IS COVER/DISC, STRICT AND SATISFACTION GUARANTEED OR FULL REFUND (LESS POSTAGE). DOMESTIC PRIORITY/INSURED POSTAGE IS \$5.50 PER ORDER (17" 2 LP'S), ONE DOLLAR PER ADDITIONAL LP. PAYMENT BY MONEY ORDER, PERSONAL CHECK, OR PAYPAL. FOREIGN RATES QUOTED UPON ORDER. CALL / FAX / E-MAIL / WRITE TO RESERVE OR WITH SPECIFIC QUESTIONS.

Craig Green  
2715 67<sup>th</sup> Ct. S.W.  
Olympia, Washington 98512-7101  
(360) 956-9051  
e-mail: recordmonger@home.com

- | cover/disc  | \$\$\$   |
|---|----------|
| 1. THE BAND "Music From Big Pink" (Capitol ST 2955) '68 UK original, laminated "Flip Back" (different than US) cover  | vg+ex 20 |
| 2. BIG BROTHER AND THE HOLDING COMPANY "Same" (Mainstream) '67 original, clean  | vg+ex 15 |
| 3. BEACH BOYS "Holland" (Reprise) with 7" EP (ex. small tape tear, with insert)   | vg+ex 20 |
| 4. BEACH BOYS "Sunflower" (Reprise) g/c   | vg+ex 15 |
| 5. BROKEN GLASS "Same" (Capitol) coh. w/oc. blues rock, ex. Chicken Shack   | vg+ex 12 |
| 6. BUCKINGHAMS "Time & Changes" (Columbia) mono, with promo timing strip, w/oc  | vg+ex 12 |
| 7. JOHN CALE "Vintage Violence" (Columbia) red label, cover in shrink   | vg+ex 12 |
| 8. CAPTAIN BEEBEART "Safe As Milk" (Buddah 9063) '70, 7" issue  | vg+ex 20 |
| 9. CAPTAIN BEEBEART "Society Person" (Blue Thumb) c.g. g/c, unboxed tracks  | vg+ex 20 |
| 10. CAPTAIN BEEBEART "Spotlight Kid" (Reprise)  | vg+ex 15 |
| 11. CHRISTIE "Yellow River" (Epic)  | vg+ex 20 |
| 12. THE DOORS "Strange Days" (Elektra) brown label original   | ex 20    |
| 13. DR. JOHN "Desirefully Bizarre" (A&O)  | vg+ex 12 |
| 14. FRIEBALLS "Bottle Of Wine" (A&O) coh.   | vg+ex 12 |
| 15. FREE "At Last" (A&O) white label promo, coh   | vg+ex 12 |
| 16. HAWKWIND "Space Ritual" (UA) 2 lp, fold out poster cover, live  | ex/m 12  |
| 17. JIMI HENDRIX "Starport" (Polygram) German press, 2 lp box set, with book  | ex/m 20  |
| 18. JUCKY LUCY "Same" (A&O) g/c   | vg+ex 15 |
| 19. JOHN RAY AND THE SPARROW "Same" (Columbia) 360 sound stereo, original label, great pre-Steppenwolf material, small c  | ex/m 25  |
| 20. LOTIAR AND THE IBERIAN PEOPLE "Pretexting" (Capitol) yellow label, 70's issue, cover in shrink  | m/ex 20  |
| 21. MARY SOL "First International Puerto Rico Pop Festival" (A&O) 2 lp, c.d., with great live tracks by Allison Brothers, Cactus, Mahavishnu, BB King, Nirtinger, Geils + | vg+ex 12 |
| 22. NICO "The End" (Island) with Eno, Manzana, and John Cale, c.c.  | vg+ex 12 |
| 23. PIGFON "Same" (Disco) g/c, coh  | vg+ex 14 |
| 24. BILLY LEE RILEY "In a Lifetime" (Kama Sutra) great 1" pin, non-disc cut cover   | vg+ex 12 |
| 25. SIR DOUGLAS QUINTEZ "Together After Five" (Smash) coh, nice cover with tiny taped seal and small tear   | vg+ex 16 |
| 26. SOFT MACHINE "4" (Columbia)   | vg+ex 12 |
| 27. SOFT MACHINE "5" (Columbia) megacar   | vg+ex 8  |
| 28. SOFT MACHINE "6" (Columbia) 2 lp, 3" spine tear   | vg+ex 12 |
| 29. RICK SPRINGFIELD "Same" (Capitol) '72, coh, g/c   | ex 10    |
| 30. THE TONTO "The Boarder" (A&O) '70, Rory Gallagher   | vg+ex 18 |
| 31. THREE MEN A-BAND "Third Of A Lifetime" (Kama Sutra) great 1" pin, non-disc cut cover  | vg+ex 10 |
| 32. THOR "Same" (WB) '70, with Big Jim Sullivan   | vg+ex 10 |
| 33. THOR "Wild Thing" (Polygram) stereo, original   | ex 20    |
| 34. VAN DER GRAAF GENERATOR "Pavane Hearts" (Christmas) g/c, coh  | vg+ex 12 |
| 35. VINEGAR JILL "Same" (A&O) '72, with Robert Palmer, c.c.   | m/ex 10  |
| 36. YARDBIRDS "Liar Games" (Epic) stereo, original  | vg+ex 15 |
| 37. JESSE (LILYN) YOUNG "Together" (WB) '72, white label promo  | ex 12    |

Craig Green, 2715 67th Ct. S.W., Olympia, WA 98512-7101  
Phone/Fax: 360-956-9051 • e-mail: recordmonger@home.com

## ROCK OF AGES

Rock & Metal • Pop & Indie • Punk & New Wave

PO Box 6146, Mansfield, NG19 8SQ, England  
Tel: +44-1623-812096 Fax: +44-1623-811739

### Vinyl, CDs & Memorabilia from around the world

### Quality Items & Quality Service!

Having trouble finding that rare item?  
Look at our extensive stock - there's a good chance we have it!

Over 11,000 Rock & Heavy Rock items in stock  
Approx 5000 Magazines from around the world  
Over 750 Picture Discs - 1600 Memorabilia items available  
Over 1500 Indie titles - Over 1000 Punk items - 750 NWOBHM items  
Over 11,000 Pop & New Wave items

Plus: large selections of Glam, Goth, Prog, Jazz, Mod, Ska, Rockabilly etc!

Email: [sales@rockofages.uk.com](mailto:sales@rockofages.uk.com)  
We will email lists - just ask!

Check out our Website - 30,000 items updated weekly  
Secure online order form  
Great Images section - pics of some great items in stock  
Browse through our stock or download full catalogues  
New stock featured regularly

## www.rockofages.uk.com

### THOMAS FUNK, P.O. BOX 156, LAKE ARIZEL, PENNSYLVANIA 15408-0156

PLEASE RESERVE ITEMS & POSTAGE WILL BE EXTRA. WANT LISTS ARE WELCOME FOR RECORDS, VIDEOS, COMPACT DISCS & CASSETTE TAPES. A = ARTIST/ CV = COVER/ CC = CLIP COVER/ DH = DRILL HOLE/ DJ = DISC/ DK = DUCKY OR PROMOTIONAL COPY/ GP = GATEFOLD/ GM = GOOD MINUS/ LT = LABEL TEAR/ MM = MINT MINUS/ P = PICTURE/ SL = SLEEVE/ SM = SAW MARK CUT/ TB = TEAR ON BACK/ TP = TEAR ON FRONT/ VG = VERY GOOD/ WB = WRITING ON BACK/ WF = WRITING ON FRONT/ WOL = WRITING ON LABEL. ANY QUESTIONS PHONE/FAX 578-498-8875 NO COLLECT CALLS. E-Mail: [ThomasFunk@MSN.com](mailto:ThomasFunk@MSN.com) SET SALE

**LYLES:** End Of An Error (U.S. Moonium M-777 DJ) \$18.00  
**MADONNA:** Who's That Girl Extended Mix 4:28, Dub 5:48, White Heat LP Version 4:25 (U.S. 12" Sire 2069-2 PCV) \$15.00  
**MADONNA:** EX-YOU'RE/IN-YOUR-EYES/SENSATION: Madonna w/Hank Panky Bare Bottom 12" Mix 6:34 - Bare Bottom Single Mix 4:49, Ex-You're w/John 4:22, Loner w/Dan 4:17, Sweet Sensation w/Whisper Kane Trax 4:49 (Brazil 12" WEA 6WP 2045 DJ CV) \$35.00  
**MOON MARTIN:** Bad Case Of Love You 3:38, Cadillac Walk 3:13 (U.S. 12" Capitol SPK0-9825 DJ Color Vinyl CV) \$18.00/Escape From Domination (U.S. Capitol ST-11933) \$18.00/ (U.S. Capitol ST-11933 Test Pressing) \$25.00  
**MICHAEL MCDONOUGH:** Mega Music (U.S. Wooden Nickel WNS-1007 MM) \$16.00  
**MONTY PYTHON:** Matching The 3 Handkerchiefs (U.S. 1975 Arista AL 4039) \$20.00  
**MOOG MACHINE:** Switched On Rock (U.S. 1969 Columbia CS 9921 Stereo) \$20.00  
**RICK NELSON:** Very Best Of (U.S. United Artists UA-LA338-R) \$15.00  
**GRAMMAR PARKER & THE RUMOURS:** Local Girls 3:48 - I Want You Back (All) 3:18 (U.S. 12" Arista SP 54 DJ) \$30.00  
**ROCK FLODY:** Live At Pompeii (U.S. Laser CD Video Polygram Video Video 980 721-1 PCV) \$45.00/ Rellies (A Bizarre Collection Of Antiques & Curios) (U.S. Harvest SN-14234 Capitol Records INC. Re-issue PCV) \$15.00  
**PAULES:** Bonanova (U.S. Compact Disc 4AD/Elektra 90963-2) \$15.00/ Here Comes Your Man 3:21 - Wave Of Mutation UK Surf 2:59 - Into The White 4:41 - Bailey's Walk 2:24 (U.S. Compact Disc 4AD/Elektra 9 66694-2 PSL) \$18.00  
**ELVIS PRESLEY:** He Touched Me (U.S. 1972 RCA Victor LSP-4690 Stereo) \$25.00

**7" EPS & SINGLES:**  
**ROLLING STONES:** Heavly Tank Women 3:08 - You Can't Always Get What You Want 4:47 (Brazil 1969 London 71-6055 GM) \$16.00/ (Harvest 1969 London Records 459480) \$16.00/ Jumpin' Jack Flash 3:45 - Child Of The Moon 3:20 (France 1968 Decca Record Company Limited 79 825 Hit Parade Good PSL MM) \$35.00/ (I Can't Get No Satisfaction - Sympathy For The Devil (Harvest 1968 Decca 4617 851) \$15.00/ (U.S. Columbia Records CST-2857 DJ Stereo 12") \$15.00  
**STORIES:** (w/Michael Brown) Brother Lema 3:56 - Changin' Hava Bugan 3:35 (Japan 1973 Kama Sutra LA-1613 - KS MM PSL Sheet VG) \$35.00/ I'm Coming Home 2:37 - Memo-Stereo (U.S. 1972 Kama Sutra Records Inc. KA 545 A VG PCV) \$50.00  
**NEIL YOUNG:** Harvest Jubilee Mini-LP (U.S. 1972 Reprise Records SR 2832 Little LP's Unlimited LRP #183 Stereo ASL MM w/100 Mass 3:22 - The Needle And The Damage Done 2:48 - Heart Of Gold 3:45 - Harvest 3:33 - Alabama 4:42 \$50.00/ (Old Ways 3:02 Stereo, Same D.S. 1985 David Geffen Records Company 7-28754 - DJ Stereo) \$18.00/ (Only Love Can Break Your Heart 3:13 - Birds 1:30 (U.S. 1979 Reprise Records 0958 Stereo) \$15.00/ Sugar Mountain 5:36 - Memo - Stereo (U.S. 1977 Reprise Records RPS 1393 DJ From Decade Album) \$15.00/ Weight Of The World 3:40 Stereo - Same (U.S. 1986 David Geffen Records Company 7-28623-A DJ) \$18.00/ Wanderin' 2:57 - Payola Blues 3:08 (Canada 1983 David Geffen Records Company 92 9747 Q DJ) \$15.00  
**STONE ISLAND:** Never Stops (Hey Hey, My My Into The Black) 3:46 - Neil Young w/Rain Never Stops (My My, Hey Hey Out Of The Blue) 3:42 (Canada 1979 Reprise Records RPS 49831 Q DJ) \$15.00  
**NEIL YOUNG & THE BLUES NOTES:** Ten Men Working (Ed) 3:13 - I'm Goin' 4:09 (U.S. 1988 Reprise Records 7-27908 MM ASL MM) \$15.00  
**ZOMBIES:** She's Coming Home 2:35 - I Must Move 1:55 (U.S. 1965 Parrot 45 PAR 97477 PSL MM) \$50.00/ (U.S. Parrot 45 PAR 97477 DJ Good) \$18.00/ Tell Her No 2:05 - Leave Me Be 2:40 (U.S. 1965 Parrot 45 PAR 9723 VG PSL) \$50.00/ Tell Her No - What More Can I Do (U.S. 1965 Decca Record CO. LTD. P.12477 Memo GM) \$25.00/ Time Of The Season 3:31 - P.U. Call You Mine 2:42 (U.S. 1968 CBS 3388 GM) \$30.00

### "TEN YEARS AFTER"

Rediscover a premier band from a prime period of Rock & Roll  
A new illustrated biography and previously unreleased concert recording  
Featuring the scorching guitar of inimitable fret master ALVIN LEE

**VISUAL HISTORY** Free Street Press ISBN #0970870000  
**FILLMORE EAST 1970** EMI/Chrysalis Records 2CD set - Catalog #533297

ALVIN LEE & TEN YEARS AFTER VISUAL HISTORY by Herb Suster  
The complete Ten Years After story from the mid 60's to the present day, 192 pages with 400 rare photos from many of rock's most historic events:  
- Windsor Blues Festival, England 1968  
- Newport Jazz Festival, Rhode Island  
- Woodstock Music & Arts Festival 1969  
- Texas International Pop Festival  
- Trans-Canada / Festival Express 1970  
- 2nd Atlanta International Pop Festival  
- Randall's Island, NY Pop Festival  
- Goose Lake Park Festival, Michigan  
- Strawberry Fields Festival, Canada  
- Isle of Wight Festival, England  
- and several others....

Recorded by Jimi Hendrix studio engineer Eddie Kramer. Includes fiery, extended live versions of the timeless Ten Years After classics:  
- Love Like A Man  
- Good Morning Little School Girl  
- Working On The Road  
- 50,000 Miles Beneath My Brain  
- The Hobbit  
- I Can't Keep From Crying Sometimes  
- Randall's Island  
- Spoonful  
- I Woke Up This Morning  
- I'm Going Home  
- ...and more....

Internet orders: [www.alvinlee.com](http://www.alvinlee.com)  
or call 1-800-247-6553 (24 hours)  
also available from Amazon.com

Watch for more remastered TYA CD's with unreleased extra tracks available soon from EMI/Chrysalis

## RECORD EXCHANGE

1977 2001

JEAN HAFFNER  
RECORD EXCHANGE  
5840 HAMPTON AVE.  
ST. LOUIS, MISSOURI 63109  
INTERNET [RecordExch@aol.com](mailto:RecordExch@aol.com)

PHONE: (314) 832-2249 FAX: (314) 832-3220

Featuring one of the largest selections of USED, OUT-OF-PRINT and RARE LP's in the nation!

ROCK OLDIES JAZZ VOCALS SOUL  
CLASSICAL SOUNDTRACKS COUNTRY  
COMEDY EASY LISTENING FOLK  
SPIRITUAL and MUCH MORE

COMPLETE WORLD-WIDE MAIL ORDER

When in St. Louis, visit our two locations  
= 5840 Hampton Ave (314) 832-2249  
= 2831 Cherokee St (314) 771-0480  
DEALERS WELCOME!

## MOVING?

DON'T MISS A SINGLE ISSUE OF GOLDMINE  
Let us know your new address right away. Attach an old mailing label in the space provided and print your new address where indicated.

QUESTIONS ABOUT YOUR SUBSCRIPTION?  
When you write, be sure to include a label. It helps us serve you more promptly.

TO SUBSCRIBE OR EXTEND YOUR SUBSCRIPTION—  
Check the appropriate boxes below:  
 New subscription. Please allow 4-8 weeks for your first copy to be mailed.  
 Renewal subscription. Please include a current address label to insure prompt and proper extension.  
 1-year \$39.95. This rate limited to the U.S.A. and its Possessions.  Payment enclosed  Check or money order (to Goldmine)  MasterCard  VISA

Credit Card Number \_\_\_\_\_  
Expires: Mo. \_\_\_\_\_ Yr. \_\_\_\_\_  
Signature \_\_\_\_\_

Mail To: GOLDMINE, Circulation Dept.  
700 E. State St., Iola, WI 54990

Name \_\_\_\_\_  
Address \_\_\_\_\_  
City \_\_\_\_\_  
State \_\_\_\_\_ Zip \_\_\_\_\_

ATTACH LABEL HERE  
(If label is not handy, print OLD address in this space)

## ROCK N RECORDS

Set Sale Live CD shows. CDs are mint to que sheets, no bootlegs here. Postage \$3.50 for 1st item, 50 cents each additional. PH: 605-303-9745 (MST) E-Mail: [rocknrecords@msn.com](mailto:rocknrecords@msn.com)  
Payment to: Rock N Records, Wanted: Steve R. Vaughan collectors

Artist/Title	Price
AC/DC 2CD BBC 1978-79	\$40
AEROSMITH 2CD Belgium 1983	\$40
AEROSMITH 2CD 1986, 87, 90	\$20
ALLMAN BROS 2CD 75, 90, '94	\$18
BECK 2CD Scotland/US '95	\$45
BECK 2CD London 1998	\$38
BANCHED LADIES 2CD	\$38
BLINK 182 1CD Anaheim '99	\$38
Bowie, David @CD Tokyo 1990	\$38
BUCKCHERRY 1CD Hollywood '99	\$100
BUSH 2CD Hollywood 1995	\$45
CARS 2CD 1948, 87	\$18
CHEMICAL BROS. 1CD Eng 1999	\$20
COLDPLAY 1CD LA 2000	\$20
COLDPLAY 1CD Eng 2000	\$20
COLLECTIVE SOUL 2CD LA '94	\$40
CREDALICE IN CHAINS 2CD	\$18
CROSBY, STILL & NASH 2CD	\$38
CSN&YOUNG 2CD	\$38
CURE 2CD 2000	\$38
CYPRESS HILL 1CD San Fran	\$38
DANZIG 1CD Hollywood 1989	\$60
DEPTHE 1CD LA, 1987	\$40
DEPTHE 2CD Hollywood 1987	\$38
DIRE STRAITS 2CD London '78	\$35
DOOBIE BROS 2CD San Fran 1985	\$24
DOORS 2CD S.F. March 1987	\$38
DOPE/Alice in Chains 1CD	\$38
ELTON JOHN 2CD 1973, 75 BBC	\$38
EVERCLEAR 1CD LA, 1997	\$65
EVERCLEAR 1CD LA, 1998	\$28
EVERLAST 2CD LA, 2000	\$38
FATH NO MOORE 1CD England	\$28
FASTBALL 1CD LA, 1988	\$38
FLEETWOOD MAC 2CD Irvine '87	\$35
FOO FIGHTERS 2CD Quiver 2000	\$40
FU MANCHU @ [ ] Dope 2CD	\$18
FUN LOV CRIMINALS 1CD LA, '98	\$38
GODSMACK 1CD Hollywood '99	\$38
GREENDAY 2CD	\$35
HAGAR, S. 97) Van Halen '82 2CD	\$38
HARBOR SAMMY 2CD Onyx	\$40
(RED) P.E. 1CD LA, 1987	\$38
INCUBUS 1CD Ventura, CA '00	\$35
INCUBUS 2CD Ventura, CA '00	\$35
JETHRO TULL 2CD London '84, '91	\$45
JEWEL 1CD 1988	\$45
KANAS 1CD Cincinnati '95	\$45
KID ROCK 1CD LA, 1989	\$45
KORN 2CD Indiana 2000	\$45
LEZ ZEPPELIN 2CD London '97, '80	\$40
LIMP BIZKIT 2CD Sacramento '97	\$40
LIT San Francisco 1999 1CD	\$20
LIVE 1CD	\$18
LIVE 2CD Las Vegas	\$45
LYRICK BUYER 2CD Atlanta '94	\$38
MATTHEWS, DAVE 2CD	\$38
MATTHEWS, DAVE 2CD Farmdale Ca	\$38
MELLENKAMP, JOHN 2CD 1987	\$38
METALLICA 3CD Woodstock 1999	\$100
MINISTRY/D48 Dgy 2CD Vegas '96/CA	\$45
MONY 1CD Eng 1980	\$18
MORRISON, VAN 2CD 1987, 97	\$40
NICKLEBACK 1CD LA 2000	\$20
NICKLEBACK 1CD Hollywood 2000	\$20
NIRVANA 2CD Delmar, CA BBC	\$40
NOVEMBER 13 1CD Eng 1995	\$18
OLEANDER 1CD Pomona CA 1990	\$20
ORION 1CD Eng 1978/96	\$35
PARADE AND PLANT 2CD New Orleans '98	\$45
PEARL JAM 2CD Atlanta 1994	\$38
PETTY, TOM 2CD Gainesville 1993	\$38
PINK FLOYD 2CD BBC 1970, 1971	\$60
POWERMAN 5000/TOO, 2CD Vegas/CA '93	\$40
PRINCE 2CD Lafayette 1993	\$38
QUEEN 2CD Eng 1975/96	\$35
QUEENS OF STONE AGE 1CD Eng 1999	\$24
RAGE AGAINST THE MACHINE 2CD LA '96	\$38
RAGE AGAINST THE MACHINE A.P.O. 2CD	\$38
R.E.M. 2CD London 1995	\$38
ROLLING STONES 2CD New Orleans 1994	\$65
ROLLINS, HENRY/A.L.C. 2CD	\$28
SANTANA 2CD London Harmondsworth	\$28
SEVENDUST 1999/CREED 2CD	\$38
SCORPIONS 2CD Netherlands 1990	\$35
SEVERHEAD 1CD Hollywood 1999	\$38
SHANE MOUTH 1CD Pomona, CA 1999	\$40
SMASHING PUMPKINS 1CD Eng 1985	\$18
SOUNDGARDEN 2CD 1988, '91	\$38
STATIC X/Sland 2CD Nevada Calif	\$30
STEWART, ROO 2CD Hollywood 1998	\$35
STRIP 1CD San Diego	\$18
STONE TEMPLE PILOTS 2CD Holland/SLV	\$40
STONE TEMPLE PILOTS 2CD 2CD	\$38
STRYKER 1CD Las Vegas 1996	\$35
TANTRIC/Besuf. Creatures 2CD LA/LA	\$35
TANTRIC/Besuf. T.P. Rolling R. PA/D1	\$45
THREE DOORS DOWN 2CD Vegas '00	\$45
THREE DOORS DOWN '97	\$45
YES 2CD 1989	\$45
YES 2CD 1989	\$45
YES, Neil 2CD Pammet '84, '97	\$45

ROCK N RECORDS PO Box 3777, Rapid City, SD 57709-3777  
E-Mail: [rocknrecords@msn.com](mailto:rocknrecords@msn.com)

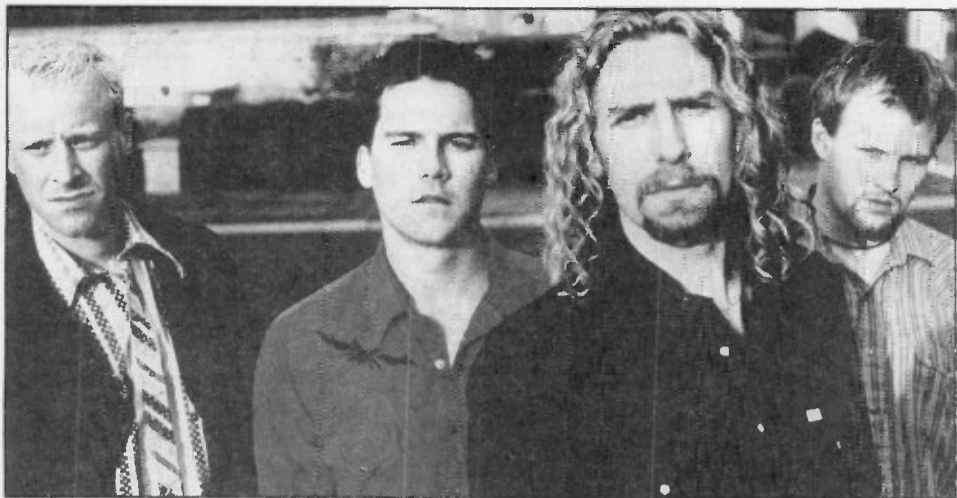

**Nickelback**

(New Releases from page 32)

Aside from the numerous romantic sentiments on display here, Diamond has written songs that convey an almost child-like delight in life's simple pleasures. In the rocker "At The Movies," it's the transportive experience of watching a good film; in "Baby Let's Drive" (propelled by some swinging horn charts), he giddily relates the joys of hitting the open road.

All told, if there's nothing on *Three Chord Opera* that can compare with Diamond's earlier classics, neither is there anything as numbingly sterile as, say, "You Don't Bring Me Flowers," which is a small but welcome achievement of sorts.

— Tierney Smith

**NICKELBACK**

Silver Side Up  
Roadrunner (618 485)

The new album from emerging Canadian rockers Nickelback, *Silver Side Up*, is great for two reasons: their driving yet melodic sound and the fact that they actually have something meaningful to say. Check out the lead track "Never Again," a distressing portrait of an abusive relationship (to serve as a wake-up call?) and "Just For." The narrator of both wants to protect women he knows from being hurt, both physically and emotionally. In "Money Bought," the viewpoint is clear — "look what your money bought/it's all that she's got/it keeps her company."

Nickelback's Roadrunner debut album last year, their first in the U.S., was *The State*, which is on the Top 200 again. Then, a person could barely turn on a rock radio station without hearing "Leader Of Men" or "Breathe," and the same is true currently with *Silver Side Up's* "How You Remind Me." But hey, if radio is going to wear out a track, at least have it

be one a person doesn't get sick of.

The song uprooted Staind's "It's Been Awhile" from the top spot on the Mainstream Rock chart, budged in front of Alien Ant Farm's heavy-duty remake of Michael Jackson's "Smooth Criminal" on the Modern Rock chart and remains there more than a month later. Nickelback also registers at #36 (Oct. 20, 2001) on the Hot 100 and #31 on the Hot 100 Airplay, and they won't be looking down anytime soon. Who says bands need a major label to succeed?

While Nickelback's homogenous sound gets a little redundant around the middle of the disc, they will only become boring if their third album shows no development at all. Nickelback are still fresh enough on the scene to keep audiences interested, especially with the big bag full of baiting riffs and hooks they carry. Close listen shows that the band has more stuff hiding in that bag than just the same old thing, as a little slide guitar playing comes out into the light on the closer, "Good Times Gone." (Also check out the cool solo on "Too Bad.") The sparse guitar on "Never Again" shows the band goes beyond cookie-cutter structure; having only the rhythm riff backing portions of the narrative makes for a rightly ominous feel indeed.

Rock fans won't go wrong to check 'em out in concert. Nickelback have just returned from Australia and are headlining gigs around the U.S.

— Cathy Bernardy

**BUDDY & JULIE MILLER**

Buddy & Julie Miller  
HighTone (HCD 8135)

With harmonies that twang like his guitar, Buddy & Julie Miller have inherited the eerie husband/wife mantle once worn by Richard and Linda Thompson and, earlier, the late Richard and Mimi Fariña. Julie wails like a hillbilly banshee on "Little Darlin'" (from her pen, not from an old Diamonds or Gladiolas 45), banging a trash can for percussion amid Buddy's nasty guitar slashes and Larry Campbell's stark fiddle bowing. Utterly lacking in guile, the innocence in her waif-like voice can turn burned and sadly knowing.

For covers, there are Richard Thompson's "Keep Your Distance" and Bob Dylan's "Wallflower" with alt-Nashville's Millers mining all the heartbroken rage of Utah Phillips' deservedly oft-recorded "Rock Salt And Nails." As Buddy's careers as producer and sideman bloomed, he understandably couldn't pen as many songs here as on his three solo albums. Thus on the Millers' debut as a duo (recorded at Dogtown Studio, which is their living room), Julie ably shoulders a heavy share of the writing burden.

For her wizened child's voice, she writes from a world of oxymorons where "forever has come to an end" (in a ballad akin to old Carter Family tracks) and "flight needs no wings." "Listen to her eyes," she begs in "That's How She Cries." "Did you dance with all your heart?" Julie asks a Columbine victim in "Rachel," a song taking on new meaning after Sept. 11's tragedies on the East Coast. In the darkness just before dawn, when folk, country and rock together bare their souls, the yearning voices are the Millers'.

— Bruce Sylvester

**EARL SCRUGGS AND FRIENDS**

Earl Scruggs And Friends  
MCA Nashville (088-170-189-2)

Admit it — you thought Earl Scruggs was dead! I honestly had the same thought. But on *Earl Scruggs And Friends*, the 77-year-old country music legend comes out to play for us for the first time in more than a decade, recording with some real heavies. Among them are the usual suspects: superstars Elton John, Don Henley, Sting, and John Fogerty, plus other fine artists such as Rosanne Cash, Melissa Etheridge, Vince Gill, and Dwight Yoakam.

So what does Scruggs have left to say musically? Plenty! His self-invented rolling style of banjo-playing — which revolutionized the

## Short Takes

When Mem Shannon was driving a taxicab in his native New Orleans just six short years ago, he knew the roads well. He has come a long way since then, but on his latest effort, *Memphis In The Morning* (Shanachie 9031), he's still hitting the highways and byways, only this time the journey is taking him from the soulful sounds of the Crescent City to the memorable music of Memphis. On the opening track, "Drowning On My Feet," Shannon recalls the stirring singing styles of renowned R&B masters such as Otis Redding, Curtis Mayfield, and Sam And Dave. The rest of his set finds him belting the blues in different hues, from the poignant narrative "Tired Arms" and the passionate "Invisible Man" to the frenzied funk of "I Smell Something" and "Shake Up The Floor." Whatever the setting, Shannon is superb. ([www.memshannon.com](http://www.memshannon.com); Adam Sloan Miasma Management, 323-663-0060)... *SmileSunset* (Mezzotint), the second solo album from Mark Mulcahy, the former leader of the creative combo known as Miracle Legion, continues the Legion's legacy by way of Mulcahy's engaging but eccentric delivery. Both soothing and satisfying, the songs sometimes take unexpected turns, but there's a rich reserve of intrigue at their core. "The Way That She Really Is," "I Just Shot Myself In The Foot Again," "Wake Up Whispering," "Resolution #1" and "A Cup Of Tea And Your Insights (From Spring Forward)" may come with awkward titles, but the eloquent execution creates a resilience that's sensuous and sublime... *Across The Milky Way* (Marina/Caroline MA53), the American debut by Scotland's David Scott (a.k.a. The Pearlfishers) is more than a mere re-creation of a '60s sound; it's a heartfelt homage to the likes of Burt Bacharach, The Beach Boys and innumerable other influences. A lush, lulling lullaby of an album, it's mellow and melodious, bolstered by billowing orchestrations, carefully crafted arrangements and a sensuous touch. Articulate, ambitious and expansive, *Across The Milky Way* is the ideal blueprint for a great pop scenario. ([info@marina.com](mailto:info@marina.com))...

— Lee Zimmerman

instrument 50 years ago — both guides and augments this host of musical characters with fire, rhythm and wisdom. This album, a gift to the country music industry, is a true joy to listen to.

The set reaches new heights with the blending and bending of musical styles. John's distinctive piano dances in time with Scruggs' banjo with grace, as John's usual stellar vocal performance kicks off the set. "Country Comfort" immediately sends the listener to a special place. Scruggs himself claims "this project was the single most enjoyable recording experience of my life" — and it shows from the first track to the last. That says it all from a man whose illustrious career now spans 60-some years.

Yoakam's "Borrowed Love" should be a single and could serve as an industry-moving experience for country music, should it decide to get "real" again. The album's producer — Scruggs' own talented son Randy — recorded things with a clean, sweet sound that shines through on every cut and is a real breath of fresh air.

So homespun and pure are these performances that even the usually melodramatic Melissa Etheridge sounds honest, and for once, relatively understated, turning in a tasteful vocal. "The Angels" is a clear call for rootsy but rockin' basics. Sting romps on "Fill Her Up," another zesty cut with the folky European influence he naturally brings to the plate.

This album is full of surprises from left-field contributions that sound unforced and uncontrived. The signature piece, "Foggy Mountain Breakdown," is the absolute best one will ever hear. The lineup includes actor/writer/comedian/fine banjo picker Steve Martin as well as Leon Russell (organ), Jerry Douglas (Dobro), Paul Shaffer (piano), Marty Stuart (mandolin), and guitar great Albert Lee.

Fogerty's timeless vocal graces "Blue Ridge Mountain Blues," and Henley nails the Johnny Cash original "Passin' Thru" with help from Cash himself. Noteworthy performances are found throughout from John Jorgenson, Stuart, and Scruggs' sons Gary and Randy as well.

In short, this may be the most exciting old-timey country music album ever made. The album is dedicated to the memory of Scruggs' youngest Steve.

— C. Brian Jasper

**Attention! If you collect:**  
Vocal Groups • R&B • Soul • Blues  
• Rockabilly • Gospel • Oldies • C&W

**ORDER OUR NEW  
CATALOGUES TODAY,  
THEY'RE FREE!**

Thousands of rare and obscure titles  
originals • repros  
45s \* EPs \* Pic Slvs \* Paper



P.O. Box 22372 G • San Francisco, CA 94122  
Fax: 415-753-3487 • Phone: 415-753-3480 (1-5 pm PST)

Please Specify What Style Of Music You Collect

# Reissues

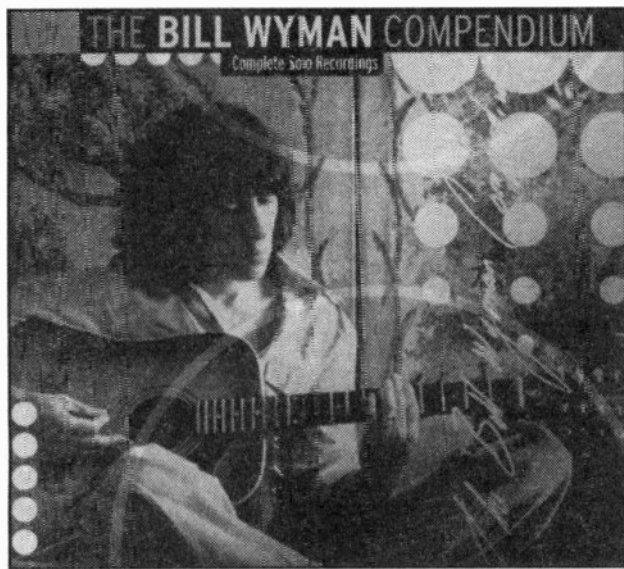

## BILL WYMAN

**The Bill Wyman Compendium: Complete Solo Recordings**  
KOCH Progressive (KOC-CD-8056) (Two CDs)

KOCH Progressive has reissued Bill Wyman's three solo albums as a twin set, *The Bill Wyman Compendium: Complete Solo Recordings*, featuring eight previously unreleased bonus tracks. The 39 selections include all 31 recordings originally issued on *Monkey Grip* (1974), *Stone Alone* (1976) and *Bill Wyman* (1982).

The first member of The Rolling Stones to issue a proper solo album, *Monkey Grip* was recorded with Dr. John, Leon Russell and a host of top session players. Much of the album bears a striking resemblance to the R&B sounds Wyman is producing with his current band, the Rhythm Kings.

*Stone Alone* rates even better, spearheaded by the single "Apache Woman." It's interesting to note that "Every Sixty Seconds" was re-recorded more than two decades later by the Rhythm Kings (on *Anyway The Wind Blows*), while "No More Foolin'" attests to Wyman's lifelong passion for R&B.

Wyman steered toward new wave with his 1981 eponymous release, commercially fueled in several countries by the Top 20 chart success of "(Si Si) Je Suis Un Rock Star." A&M Records initially declined to issue the LP in the U.S., forcing fans to scurry for imports.

Although these three albums have been sporadically reissued over the years, KOCH Progressive's slipcased edition places this material on the same domestic label as Wyman's Rhythm Kings releases. For some, Wyman's solo output represents something of an acquired taste, while for many others it is music that merely requires taste. In either case, KOCH's new double CD exquisitely fills the Wyman bill.

— Mark Wallgren

## BILL WYMAN'S RHYTHM KINGS

**Groovin'**

KOCH Progressive (KOC-CD-8286)

**Double Bill**

KOCH Progressive (KOC-CD-8287) (Two CDs)

Former Rolling Stones bassist Bill Wyman continues to spearhead his exploration of the abundant legacy of R&B, recording inspired interpretations of R&B classics spanning the 20th century while introducing several new compositions. KOCH Progressive has recently released the marvelously entertaining third and fourth Rhythm Kings albums in the U.S.

On *Groovin'*, the third collection in the Rhythm Kings' catalog of studio grooves, Wyman delivers another delicious set of pure jazz, swing and R&B, spotlighting the impressive vocal talents of Beverley Skeete and Georgie Fame along with

Gary Brooker, Albert Lee, and Adrian Byron Burns. Among the celebrated contributing musicians: Andy Fairweather-Low, Ray Cooper, and fellow ex-Rolling Stone Mick Taylor.

"Can't Get My Rest At Night," "Oh! Baby," and "I Put A Spell On You" are among *Groovin'*'s standouts. Slinky covers of the pop hits "Daydream" and the title track prove successful, while the new compositions, including Wyman's "Tomorrow Night," Georgie Fame's "Rhythm King" and the Wyman/Terry Taylor-penned "Hole In The Wall," blend in perfectly with their musical ancestors.

*Double Bill* is the newest and most engaging Rhythm Kings collection to date — it is also the most generous, offering 24 selections on this value-priced double-CD (the set retails for the price of a single-disc release).

The majority of lead vocals are shared between Fame ("I Can't Dance"), Skeete ("My Handy Man"), and Brooker ("Lonely Blue Boy"). Also, Lee, Burns, and Fairweather-Low each take a vocal turn. Wyman returns to the vocal spotlight for the first time since the Rhythm Kings' debut release on no less than three numbers, including "Brownskin Girl" and "Jellyroll Fool" (two of the album's six compositions by Wyman and his songwriting partner Terry Taylor).

As a producer, Wyman (and coproducer Taylor) continues to shine with inspired musical choices, expertly matching his talented cadre of vocalists with both vintage and fresh material. Among the guest musicians is former Beatles guitarist George Harrison, who adds his distinctive slide guitar work to a gorgeous new rendition of the classic "Love Letters."

*Double Bill* and *Groovin'* are outstanding additions to the growing stable of impeccably performed R&B and jazz recordings from Bill Wyman's Rhythm Kings. Exceptional critical reaction to The Rhythm Kings' CDs and outstanding word-of-mouth from audiences who witnessed the band's summer 2001 U.S. tour all point toward the "next big thing" on the American music scene — and deservedly so.

— Mark Wallgren

## FOUR TOPS

**Forever**

Motown/Hip-O (314 556 225-2) (Four CDs)

Since the age of three, listening to Beatles records with my much older cousin Hank, I have been drawn to music. While my tastes run the gamut, from Colin Blunstone to Collin Raye, in my book *the man was* — and continues to be — Levi Stubbs of The Four Tops. No one conveys more conviction in his voice or even comes close. When he belted out "I'll Be There," I knew he would be, and quickly.

The original Four Tops (Stubbs, Lawrence Payton, Duke Fakir, Obie Benson) performed together for 43 years — the most by original members of a pop group — and recorded more than 30 albums. As a longtime Tops collector, I was psyched by the arrival of *Forever*, the new four-disc, career-spanning (1956-1992) box set. Amid the 85 tracks, 40 are making their debut on CD. Among those, 10 were previously unreleased, four were previously unreleased in the U.S., and four more were never released on an album. While it's not perfect (what is?), it's obvious that a lot of effort went into the compiling of this deluxe retrospective.

The first disc leads off with samples of the Tops' pre-Motown work. The 1956 Chess single "Could It Be You" presents a higher-pitched Stubbs fronting a prime slice of doo-wop. Less impressive are the follow-ups: the 1960 Columbia single "Ain't That Love" and a 1962 up-tempo rendition of "Pennies From Heaven" on Riverside. The Four Tops signed with Motown in 1963, and their first album, the canceled jazz set *Breaking Through* (finally released in 1999), is represented by the ultra-smooth "Until I Met You." It's fine, but the magic doesn't begin until track five.

That recording, 1964's "Baby I Need Your Loving," was the Tops' first collaboration with the songwriting-production team of Holland-Dozier-Holland. It established a winning formula: lyrics that entail Stubbs yearning for or proclaiming his love for a girl

(Please see Reissues page 54)

## REISSUES NEWS



**Out now:** *Q: The Musical Biography Of Quincy Jones* (Rhino) is a four-CD boxed set of one of the most influential artists and producers of the 20th century. Each disc in the set focuses on an era of Jones' history, spanning 1951-1995. The first highlights his bebop, Big Band and jazz arrangements; the second showcases Jones' musical contributions in film and television; the third focuses on his "Chairman Of The Board"—producing era highlights for artists such as Aretha Franklin, Donna Summer, Lesley Gore, Paul Simon, and George Benson, among others; and the final disc delves into his star-studded solo albums such as the 1990 Grammy® Award-winning *Album Of The Year Back On The Block* and 1995's seven-time Grammy®-nominated *Q's Jook Joint...* Sundazed Records has reissued two *The Cyrkle* albums with bonus tracks, *Red Rubber Ball* (19 cuts, eight of them bonus tracks) and *Neon* (20 cuts, nine bonus); as well as *Montage*, Michael Brown's band after he left *The Left Banke*, which includes four previously unsold bonus tracks; and *The Butterfield Blues Band*, also available on 180-gram vinyl, which includes guitarists Michael Bloomfield and Elvin Bishop, blues drummer great Sam Lay, and Howlin' Wolf's rhythm section, among others... With eight Top 100 songs, three in the Top 20, Collective Soul are one of the biggest acts of the '90s. Just out is *Seven Year Itch: Greatest Hits 1994-2001* (Atlantic), a 13-track collection of the multiplatinum-selling Collective Soul's best.

**Coming soon:** Due Oct. 23 from Collectables are *Gloria Lynne — I Wish You Love — Deluxe Box Set*, a two-disc set, featuring the albums *Golden Classics*, *This Little Boy Of Mine* and *He Needs Me*, boxed in a wooden case along with the jazz vocalist's recently published 288-page autobiography, *I Wish You Love*; *Chubby Checker's The Very Best Of — The K-Tel Recordings*, a 20-song set including his smash Twist-related sides and other Checker-sung dance favorites; and *Jan & Dean — The Very Best Of The Early Years*, an 18-track collection from the duo's Dore Records output, including the Top 10 hit "Baby Talk" and charters "Clementine" and "We Go Together"... Sanctuary Records' Metal-Is subsidiary is reissuing a dozen Motörhead albums this fall, each with bonus tracks. Also in the works is a Motörhead 25th anniversary DVD, *Live At The Brighton Academy...* Ken Burns is at it again. His upcoming four-hour PBS special, *Mark Twain*, follows up his successful *Jazz* series and airs Jan. 14-15, 2002, in two two-hour segments. On Nov. 6, Columbia/Legacy will release a 29-track soundtrack CD, a combination of songs from Twain's era and more recent compositions that complement Twain's long life. Bobby Horton is well-represented on the set with 11 cuts, with Jacqueline Schwab (seven) and Fiddlin' Johnny (two) picking up most of the rest of the tracks... Due Nov. 20 from Universal are *Isley Brothers — Millennium Collection*; *Marvin Gaye & Tammi Terrell — Complete Duets* (two CDs); four from Aerosmith: *Get A Grip*, *Permanent Vacation*, *Pump* and *Young Lust — Anthology*; expanded versions of Lynyrd Skynyrd's *Pronounced Leh'nerd Skinn'nerd* and *Street Survivors*; *The Bee Gees — Their Greatest Hits*; *Buddy Guy — Millennium Collection* (Hip-O); and *Gene Watson — Ultimate Collection* (Hip-O), among others... In early 2002, EMI will reissue remastered versions of Billy Idol's *Billy Idol* and *Vital Idol* and also will release Billy Idol: *Story Tellers*.

— Greg Loescher



# LES HARRIS RECORDS



3012 Whisper Fern, San Antonio, Texas 78230 • (210) 764-3434 • FAX (210) 493-8594

LES HARRIS RECORDS 3012 WHISPER FERN, SAN ANTONIO, TEXAS 78230 Phone: 210-764-3434 FAX 210-493-8594 CELL PHONE: 210-884-3310. MASTERCARD, VISA & DISCOVER CARDS ACCEPTED. \$40 minimum on credit cards orders by phone, no limit by mail or fax. Orders are sent within 24 hours. All records are fully guaranteed with a money back refund (sorry, no refunds on postage.) I WILL NOT ACCEPT RETURNS OVER \$50 FOR CREDIT OR REFUND WITHOUT PRIOR TELEPHONE NOTIFICATION. POSTAGE is \$3.00 for first class insured. FOREIGN POSTAGE is \$20 air or \$15 surface, unless actual postage exceeds these rates, the actual postage will be charged. No refunds on orders not returned within 3 weeks of mailing. ALL RECORDS ARE M-/M- UNLESS OTHERWISE NOTED. ALWAYS SET SALE. When visiting Texas, make plans to visit my house to view over 20,000 records. ALWAYS INTERESTED IN BUYING COLLECTIONS The larger the collection the better. E-MAIL: [lharris@lesharrisrecords.com](mailto:lharris@lesharrisrecords.com) NO AUCTIONS, or any other game!

### BEATLES BUTCHER COVERS:

- BEATLES BUTCHER COVERS:
- Peel'd Stereo Nice M- \$2,000
- Unpeel'd Stereo SEALED \$3,600
- Unpeel'd Mono M- \$750
- Peel'd Stereo M- slight blemish \$1,000
- Peel'd Stereo VG \$325
- Unpeel'd Mono needs peel \$325
- Peel'd Mono VG 2/3 peel 4 tears \$250
- Peel'd Mono VG+ 5 small tears \$400
- Unpeel'd Stereo M- \$1,200
- Unpeel'd Mono VG++ \$700
- Peel'd Mono VG \$200
- RARE BEATLES ALBUMS:
- Beatles Collection 13 LP UK BOX SET
- Dark blue textured cover SEALED \$400 STEREO
- Beatles Collection 13 LP UK BOX SET
- Dark Blue textured cover M- \$200
- Revolver CAP BLK LBL orig SEALED \$300
- Magical Mystery Tour CAP blk lbi orig SEALED \$300
- Hard Days Night 2nd press St MAROON CV Sealed \$200
- Beatles VI CAP BLK LBL orig SEALED \$300
- Rubber Soul CAP BLK LBL orig SEALED \$300
- Magical Mystery Tour apple SEALED \$75
- Yesterday & Today MOCK UP Japan MINT
- Walternate cover RARE \$350
- Abbey Road FRANCE Green Vinyl M- \$100
- Abbey Road UK Green Vinyl M- \$100
- ELVIS SUN 78

### 3 DOG NIGHT It aint easy NUDE CVR \$250

- MAMAS & PAPAS If you can believe
- TOILET COVER ST M- \$300
- JOHNNY BURNETTE ROCK & ROLL 1960
- One of the rarest LPs of all times CORAL 57080
- COVER: VG+ DISC: VG plays good \$1,000
- BOB DYLAN RARE LPS
- Bob Dylan 1st LP 6 eyes lbi PROMO MINT! \$1,000
- Bob Dylan 1st LP 6 eyes lbi PROMO VG+ atkr \$250
- Bob Dylan 1st LP 6 eyes lbi STOK VG+ \$125
- Freewheelin MONO w/promo W/DJTS w/deleted songs M- \$1,500
- Freewheelin MONO w/promo no DJTS M- \$1,000
- "Mister" Bob Dylan FRANCE CBS Mono \$150
- Highway 61 ST COL 360 w/alt Bk 6 M- \$150
- COMPILATION Oxydol(soap) Presents Lets Sing Out MONO \$150
- Freewheelin ST CANADA 70s issue with Alternate song Titles!!! MINT \$225

- BOB DYLAN RAREST BOXSET
- Striptease 10 LP Box Set Black Wax \$400
- TEN OF SWORDS box set COMPLETE \$700
- ZAPPA BOX SET:
- Lather Mock up 4 lp mint \$150
- CRYSTALS RAREST LP
- Twist Uptown ELEC STEREO Philips M- \$2000

### BUDDY HOLLY/CRICKETS rarest LP

- Chirping Crickets BRUNSWICK yellow label promo
- M- cond books at \$5000 this one is M-/VG \$1,200
- IKE & TINA TURNER rarest LP:
- Soul of SUE 2001 mono SEALED \$1,000
- ZAPPA LUMPY GRAY LP:
- Mono W/ PROMO M- \$250, Yellow label Promo M- \$200
- ONE OF THE RAREST STEREO LPS:
- Dobie Gray: In Crowd CHARGER mint \$500
- RICKY NELSONS RAREST LP:
- Teen Time Verve Mono blue label \$800
- DOORS: Rarity/Mistake 1st LP
- Mono w/Gold record award VG+ \$200
- MC 5 Back in USA At Sealed \$100
- MC 5 High Time At SEALED \$200
- MC 5 High Time At W/ PRO mono \$200
- ALICE COOPER LPS
- Test Pressings: BSK 3263 no cue \$75 Goes to Hell W/ cue \$150
- SCHOOLS OUT: W/ PROMO w/party W/repport cardfl \$250
- Killer W/ calendar W/ PROMO \$100 Billion Dollar W/ PRO \$100
- ROLLING STONES: SEALED LP
- Out of our heads MONO LONDON \$200
- STRAWBERRY ALARM CLOCK
- Incense STEREO UMI SEALED ch \$100
- ZZ TOP: AMERICAN BLUES
- Do their thing UNI ST very rare M- \$150.

### RARE 45s:

- ELVIS: Plugging r/ love RCA PROMO M- rare \$250
- 7" 78: Truth about me CARDBOARD REC 1 side
- Rainbo Recs by spec permission RCA \$50
- CREAM: Anyone for tennis ATLANTIC
- 1 sided Test Pressing w/ol \$100
- HENDRIX: 4 singles pack LHM Ed Germany
- Polydor sampler from LP set 282 \$040 \$100
- JOHNNY WINTERS RAREST LP:
- Progressive Blues Experiment! SCHROEDER Stereo
- Non autographed M- ascertain on cover \$300
- ROLLING STONES: Satanic Majesties
- Ultra rare REEL to REEL tape BOXED 2 cvr M- \$250
- ZAPPA/MOTHERS Mothers ay me I K U LEMMAN
- ONLY Toilet Cover MINT Zip RARE \$275
- Ship Arriving JAPAN w/OBI and HUGE LYRIC POSTER in Japanese!!! MINT \$150
- BANANA SPLITS: We're DECCA ST WLP Sealed \$75
- JIMMY BUFFETT RAREST LP:
- Down to Earth BARNABY "DJ" SEALED \$500
- 3 DOG NIGHT RAREST:
- LP: It aint Easy W/NUDE COVER VG+ \$100
- ROLLING STONES LPS
- England's Newest Hitmakers: Mono W/Poster
- red label NICE \$300
- Songs of (NOT RARE COVER) Abkco in-store
- sampler NICE MINT COPY \$800
- ZAPPA RARE BOXSET:
- Lather (mockup) 4 LP Mint \$200
- STEVIE RAY VAUGHAN
- RAREST LP: Legend in Making
- CBS RECS Canada Only Promo Only Live 1983 MINT \$500
- BUBBLE PUZZY LP
- Gathering Promises ORIG IA SEALED \$200
- BILL HALEY 45 "5ET"
- 16 of Coates 1st 45s on DECCA, MINT \$200

### ALL NEW 45s

- MARSHALL TUCKER BM Reflections of my life LONDON DJ \$10
- MARTIN,DEAN Heard it in love song CAPR DJ MINT \$15
- MILLER,STEVE BANO Volare CAPITOL M. PROMO \$10
- MITCHELL,JOHN The Joker CAPITOL M. PROMO mint \$10
- MOBY GRAPE Living in USA CAPITOL PROMO Mint \$10
- MONKEES rel: DOLBY: Buddy Holly Trib RHM WLP \$16
- MONTEZ,CHRIS Some kinda fun MONROGRAM promo \$10
- MOODY BLUES Ride my SeeSaw DEARM DJ MINT w/alt \$15
- MOODY BLUES Tuesday Afternoon DEARM MLP antihel \$20
- MOTT THE HOOPLE All young dudes COL M. PROMO Mint \$10
- MOTT THE HOOPLE Golden age of RAR COL M. PROMO \$10
- McDANIELS,GENE Point of no return LIB DJ Mint w/alt \$12
- NELSON,RICK If you cant rock no IMP W/PS MINT \$15
- NELSON,RICK Teen Age Idol IMPERIAL M. PROMO \$20
- NELSON,RICK EP: Dont leave no IMP disc4 MINT \$12
- NELSON,RICK If you cant rock no IMP PS MINT \$12
- NELSON,RICK Garden Party DECCA DJ MINT w/alt \$15
- NEWMAN,THUNDERCLAP Something in the air THE TRACK M. PROMO \$10
- PAUL & PAULA (JILL & RAY) My Paula LE CAN M. PRO \$30
- PETERSON,PAUL My dad CALTEX M. PROMO MINT \$20
- PICKETT,BOBBY BOBS Monsters Holiday GAMPAP wlp w/PSmt \$50
- PICKETT,BOBBY BOBS Monster Rock PARROT PROMO \$12
- PICKETT,WILSON In a midnight cover ATL M. PRO mint \$20
- PRESLEY,ELVIS Devil in disguise RCA W/PS MINT \$25
- PRESLEY,ELVIS Lone legged girl RCA PS only MINT \$12
- PRESLEY,ELVIS EP: King Croelia 82 RCA W/PS nice!! \$40
- PRYCE,LLOYD KING DOUBLE L M. PROMO mint \$15
- REUNION Life in a rock RCA DJ YELLOW MAX \$15
- REVERE,P/DAVIDERS Great airplane Strio COL M. PROMO \$12
- REVERE,P/DAVIDERS red: UNKNOWN'S Melody Unknown \$15
- RIGHTEOUS BROTHERS Your o soul Verve PROMO!! \$40
- RIP CHORDS My little Cobra COL M. Paint YELLOW \$00
- RIVERS,JOHNNY Live the atomic IMPERIAL. PROMO \$10
- RIVERS,JOHNNY Under your spell again IMPERIAL MLP \$10
- RIVERS,JOHNNY Seventh sea IMPERIAL M. PRO w/SLV \$12
- RIVERS,JOHNNY California Sun RIVERA PROMO \$35
- ROLLING STONES Show a rainbow LONDON swirl lbi \$12
- ROLLING STONES Moxy Toak w/ooo LOND W/PS MINT/NT \$50
- ROLLING STONES No Tears go by LONDON Blue Swirl \$10
- ROLLING STONES Get off my cloud LONDON Blue Swirl \$10
- ROLLING STONES Street fighting LONDON Blue Swirl \$10
- ROLLING STONES Show a rainbow LONDON Blue Swirl \$10
- ROLLING STONES 19th Nervous.. LONDON Blue Swirl \$10
- ROLLING STONES Baby Toothed LONDON Blue Swirl \$10
- ROLLING STONES Satisfaction LONDON Blue Swirl \$10
- ROLLING STONES EP: Mexico JUKE Guitanoad PS ONLY \$10
- ROLLING STONES Fool to cry/Crazy BS GERMAN/PS red \$30
- ROLLING STONES If you really want to no SMASH WLP \$15
- ROBERTS You, I AMAZON LP PROMO mint \$8
- RODMEN,TODD Hello its no BEANSVILLE LP PROMO \$10
- RYDELL,BOBBY Forget Mia CAMEO W/PS nice \$12
- RYDELL,BOBBY Volare CAMEO PS ONLY nice \$8
- RYDER,HITCHCOCK/UNICE Sock it to no NEW VOICE 1 sided DJ \$35
- SHIMLEY & LEE Let good times roll MARITICK LP PRO \$20
- SILVER CONVENTION Get up & Boogie MIDLAND DJ MINT/SLV \$10
- SINON,PAUL Duncan COLUMBIA LP PROMO mint \$10
- SINATRA,FRANK & NANCY Somethin Stupid REPRISE LP PR \$8

### ALL NEW 45s

- SMITH,PATTI Gloria ARISTA LP PROMO \$15
- SMITH,WHISTLING JACK I was Kaiser Bill's DEARM LP PR \$15
- SPARKY & CHER Beautiful Story ATCO LP PROMO mint \$5
- SPARKY & OUR GANG Sunday Mornin MERCURY LP PROMO \$8
- SPINNERS If you are a kid at all PRONO mint w/alt \$15
- SPIRIT 1984 ODE M. PROMO mint \$12
- ST.PETERS,CRISPAIN You were on my mind JAMIE LP PROMnt \$5
- STEALERS WHEEL Stuck in middle with you AM M. PRO \$10
- STEVENS,APRIL Teach no tiger IMPERIAL. PROMO \$20
- STEVENS,CAT Old Schoolyard AM M. PRO MINT/SLV \$15
- SUNRAYS Still/when you're TONER MLP MINT \$12
- SYNDICATE OF SOUND Little Girl BELL LP PROMO \$20
- T.REX Bang a boom REPRISE LP. PROMO MINT \$20
- TAYLOR,JAMES How sweet it is W/ PRO MINT \$10
- TEX,JOE Hold what you've got DIAL M. PROMO \$15
- TIGERS Geeto Tiger COLPIX disc only \$20
- TRADE WINDS Mind Excursion KAMA SUTRA PROMO \$15
- TURTLES Shee y girl WHITE WMALE Promo \$15
- VEE,BOBBY EP: Mexico Don what you got W/PS LTB \$20
- VEE,BOBBY Beautiful People LIB DJ MINT \$15
- VENTURES Indian Summer UA PROMO mint \$10
- VENTURES Mokey Toak UA PROMO mint \$10
- WALKER,JR./M/STARS What does it take MOTOWN LP PROMO \$15
- WMO Long Live Rock NCA M. PRO MINT/SLV \$15
- WMO Joia Together DECCA PROMO mint/SLV \$30
- WILLIAMS,ANDY Cant got used to Los Angeles W/Pro \$25
- WILLIAMS,ANDY Days Wine & Roses COL M.P. Tollaand \$25
- WILSON,J.F/FRANK Last Kiss LE Can arenon PROMO MINT \$75
- ZAPPA,F/MOTHERS In the clinic/Montana DISCREET LP PR \$25
- ZAPPA,FRANK Valley Girl CBS LP mint orange \$10

### KARE BEATLES 45s

- BEATLES McCartney With Little Jack PRO \$25
- BEATLES Lennon Happy 7-800 W/PS DR: APPLE \$10
- BEATLES All you need is love W/PS M- MINT \$25
- BEATLES SET of 13 colorize for JUNE 04/10/10 \$10
- BEATLES Do you want to know YET JAY BLURNT \$40
- BEATLES Twist & TOLLIE Bob Yellow Label \$40
- BEATLES HARRISON Sing Dimp LP PROMO w/ol \$10
- BEATLES McCartney Wonderful: 2-nas W/Print \$10
- BEATLES EP: History a 3 1/2 bracketed nice \$50
- BEATLES 111 city instant CAP W/PS M- MINT \$100
- BEATLES 4 days w/lost CAP PS ONLY \$20
- BEATLES Mo wish you Harry VEETAT M/INT/SLV \$100
- BEATLES EP: Souvenir Tour VEETAT W/PS nice \$250
- BEATLES Day Tripper CAP W/PS M- MINT \$75
- BEATLES Yesterday CAP W/PS M- MINT \$75
- BEATLES Paperback writer W/PS M- MINT \$75
- BEATLES Girl CAP W/PS W/AFCE CLEAR REC MINT \$60
- BEATLES Modoro ans W/PS M- MINT \$75
- BEATLES Long & winding Road APPLE PS ONLY \$100
- BEATLES RINGO: You're a little APPLE W/PS \$15
- BEATLES HARRISON Bang beat APPLE mint \$5
- BEATLES Hey Jude APPLE mint \$5
- BEATLES Let it be APPLE mint \$5
- BEATLES Got back APPLE mint \$5
- BEATLES Cant buy another mint w/alt Apple \$10
- BEATLES Let it be APPLE mint w/alt Apple \$10
- BEATLES EP: Aisley a 3 VEE JAY/COOL/VE \$20
- BEATLES Let it be PICTURE DISC SEALED \$30
- BEATLES Ballad John/John W/PS M- MINT \$75
- BEATLES EP: 4 by 4 CAP \$50 \$5 \$175
- BEATLES And I love her CAP W/PS M- MINT \$100
- BEATLES And I love her CAP W/PS MINT/MINT \$150
- BEATLES EP: Souvenir of Tour 9 PICTUREDISC \$100
- BEATLES Penny Lane CAP PS ONLY M- \$75
- BEATLES Penny Lane CAP PROMO DISC M/AFACE \$30
- BEATLES W/ EATONS Sweet Music APPLE MINT \$15
- BEATLES SUNDOWN PLAYBOYS Saturd Apple MINT \$20

ELVIS 1st LP UK "Elvis Presley" HIS MASTERS VOICE mono CLP 1083 maroon lbi w/liner ULTRA RARE laminated cvr VG+/VG+ \$200

ANNETTE RARE LP Starc & College Songs DISNEYLAND 1967 MONO SEALED \$300 YARBIRDS BOX SET 7 LP Shapes of things CHARLY UK \$150

### ALL NEW 45s

- ? & MYSTERIANS Cant get enough CAMEO DJ MINT w/SLV \$40
- ABBA Take a chance on me TEST PRESSING \$8
- AEROSMITH Back in the saddle COL M. PROMO \$9
- AMERICA Doley Jane W/ PROMO mint w/alt \$10
- ANIMALS San Francisco nights HIGH DJ \$10
- ANNETTE Teenage Wedding BUENA VISTA LP/Print \$50
- BAD COMPANY Cant get enough SHAM SONG LP PROMO \$15
- BAKER,LAYERN I cried a tear ATLANTIC LP. PROMO \$16
- BALLARD,HANK & NIGHTINGERS Tuit KING LP PRO VG+ \$20
- BEACH CITY ROLLERS Honey Honey ARISTA LP. PROMO w/alt \$10
- BEACH BOYS Child of winter BROTHNER PROMO mint \$25
- BEACH BOYS Surfia USA CAP LP. PROMO mint w/SLV \$10
- BEACH BOYS Sarfia Safari/409 CAP PS ONLY rare \$75
- BEACH BOYS rel BOBBY VEE Here Today LIB PROMO \$35
- BEATLES I want to hold your CAP 5112 PSONly \$30
- BEATLES rel BOOTLES I let you hold CRES LP/Print \$25
- BELL,ARCHIE/ORELLS I cant get dancing ATL DJ MINT/SLV \$25
- BLACK SABBATH Sabbath Bloody Sabbath W/ M. PROMO \$25
- BLUE THINGS Pretty Thing-UN WUFF RECS \$25
- BOX TOPS Noo Rainbow NALA DJ MINT w/SLV \$15
- BOYCE & HART Out & About AM M. PROMO \$10
- BREAD Diary ELEKTRA LP. PROMO \$19
- BRITISH CASUALS Toy M/INT/STREAM LP. PROMO MINT \$15
- BEAMON,RUTH This little girl ATL M. PRO w/ATSLA \$40
- BROCKMAN,JACKSON Prokander ASYLUM LP. PROMO mint w/alt \$10
- BUCHANAN,ROY rel BRITISH M/ALERS Shako CAMEO DJ \$10
- CAMPBELL,GLEN Gentle on my mind CAP PROMO \$10
- CASH, GARY Good times roll ELEKTRA MLP mint \$10
- CASH,JOHNNY It aint no babe COL M. PROMO REDMAX \$25
- CASH,JOHNNY Daddy sang base COL LP. PROMO \$15
- CHEECH & CHONG Santa Claus a old lady ODE PS ONLY \$15
- CHEER Rescue Me MCA LP. PROMO MINT '74 \$10
- CHEER You better sit down hide IMPER. DJ \$8
- CHEER Dress Baby IMPERIAL. Promo \$10
- CHI-LITES Oh Girl BRUNSWICK LP. PROMO mint \$10
- CHIFFONS Sweet talkin guy LAMRIE PROMO \$20
- CHIFFONS One fine day LAURIE PROMO w/SLV \$20
- CHRISTIE,LOU Rhapsody in the rain HIGH PROMO \$15
- CLARK,GENE Echoes COLUMBIA LP. PROMO \$35
- COLLINS,JOE Soudalay Soon ELEKTRA LP. PROMO \$10
- COMPILATION END EP:Flanagoe/Chastels DJ only \$15
- COMPILATIONS EP: Atl Recca M/ALRAB-1/2/3/4 DJ/only \$15
- CREDENCE CLEARWATER Bad Mojo/Lodi FANTASY DJ \$15
- CROSBY,STILLS,MASH Suite Judy Blue Eyes ALT LP. PROMO \$10
- CROSBY/MASH Take money & Run ABC LP. PROMO mint \$10
- DARIN,BOBBY Lady Baltimore ATL 1 side Test/Press \$20
- DEEP PURPLE Black Night W/ M. PROMO mint \$15
- DEEP PURPLE Hallowhah TETRAGRAM LP. PROMO \$15
- DEEP PURPLE Lazy W/ M. PROMO mint \$12
- DEL-VETTS I call by baby STP Dumwich LP. PROMO \$25
- DEREK & DOMINOS Bell Bottom Blues ATCO LP. PROMO \$12
- DIAMOND,NEIL EP: 12 greatest hits MCA JUKE w/Sant \$25
- DIAMOND,NEIL You got to no BANG LP. PROMO mint \$20
- DOMINO,FATS My Rose cooes Fats IMPERIAL W/PC \$35
- DRAKE,CHARLIE EP: Boomerang UA LP. PROMO w/alt \$10
- DYLAN,BOB Tagled up in blue COL LP. PROMO w/SLV \$10
- DYLAN,BOB A fool such as I COL LP. PROMO \$8
- DYLAN,BOB Hozaibingo COL LP. PROMO \$8
- DYLAN,BOB Baby step crying COL LP. PROMO \$10
- DESMONN, JACKIE Put little love in heart IMP DJ/aint \$15
- EAGLES Please come home Xass ASYLUM LP/PS \$12
- EAGLES Witchy Woman ASYLUM LP. PROMO \$12

### ALL NEW 45s

- EASTBEATS Friday on my mind UA LP. PROMO w/SLV \$20
- ELEPHANTS MEMORY Hoopooes METROMEDIA PROMO \$8
- FANE,GEORGIE Got Away IMPERIAL DJ. mint \$16
- FENDER,FREDDY EP: Mexico Mestad Days PS ONLY Dot \$20
- FIREBALLS Bottle of wine ATCO WLP mint w/alt \$10
- FIREFALL Strange Way ATL DJ MINT w/SLV \$10
- FIVE AMERICANS Sound of love ABM&K DJ blood/Red \$20
- FLO & EDIE Radio Promo Spots for lat LP Re/Imp \$15
- FOUR SEASONS Ive got you under PHILIPS W/PS mint \$15
- FOUR SEASONS Working my way back PHILIPS LP/Print \$10
- FOUR SEASONS Rag Doll PHILIPS W/PS MINT \$15
- FREBERG,STAN ZEE EP: 6 spots 2 sided MINT \$100
- FREBERG,STAN ZEE EP: 6 spots 1 sided MINT \$100
- FROST,MAX/TROOPERS Shape of things to come TONER LP. PR \$15
- GARNETT,GALE Well sing in sunshine RCA M. PRO \$25
- GATES,DAVE & LEON RUSSELL Sad September 6.5-P. recatol \$45
- GATES,DAVID You had it comla DELFI LP. PROM/rae \$35
- GO-GOE B.CARLISLE I feel magic LP/Print \$10
- GOLD,ANDREW Lonely Boy ASYLUM MLP mint w/alt \$10
- GOLLIWOGS (Credence) Frigilo SCORPIO MLP VG \$50
- GOODMAN,DICKIE Bataan & his grandother/REDBIRD DJ \$20
- GORE,LESLEY You dont own no MERCURY PS only \$10
- GORE,LESLEY You dont own no MERC DJ W/PS \$25
- GORE,LESLEY Thats way boys are MERCURY WLP \$10
- GRANNY(TREME RYAN) Promo spots for her 45 MASHWOOD \$15
- GRIER,ROOSEVELT (FROTBALL) People make words ANY \$20
- GUESS WHO? Shalin all over SCPTER MLP w/SLV \$20
- HARRIS,ENNYLOU Here,there,everywhere REPR DJ MINT \$10
- HARRIS,ENNYLOU In movie on W/ DJ mint \$10
- HARRIS,ENNYLOU I dont have to tell DJ mint \$10
- HARRIS,ENNYLOU You never can toll DJ mint \$10
- HARRIS,ENNYLOU Light of Stable REPR DJ MINT W/PS \$15
- HARRIS,ENNYLOU SINGERS Oh Happy Day PAVILION LP. PR \$8
- HEART Crazy on you MUSHROOM PROMO \$10
- HOLLIES Carrie Anne EPIC W/PC SLV M-/MINT \$20
- HOLLIES On a carousel IMPERIAL W/PS \$20
- HOT CHOCOLATE Every ones a winner RAK RECS LP. PRO \$10
- HUMPERDINK,ENGLERD There goes my everything PARROT DJ \$10
- JACKSON,MICHAEL EP: Mexico Toe Young \$3 PS ONLY \$15
- JACKSON,MICHAEL EP: Mexico Toucote/Friend PS ONLY \$15
- JACKSON,MICHAEL EP: Mexico Bon & 3 PS ONLY \$15
- JACKSON,MICHAEL EP: Mexico Bon & 3 W/PS TMLW/MTW \$20
- JAM & DEAN Baby Talk DORE LP. PROMO \$20
- JEFFERSON AIRPLANE Somebody to love RCA LP. PROM/ant/SLV \$20
- JEFFERSON AIRPLANE White Rabbit RCA LP. PROMO \$20
- JEFFERSON AIRPLANE Volunteers RCA DJ W/PS \$20
- JENSEN,KRIS EP: Torture MICKROY DJonly \$80
- JOEL,BILLY Only good die young COL M. PROM/ant \$10
- JOHNSTON,BRUCE BRUCE & JERRY Take Pearl ARM WLP VG \$20
- JOH & ROBIN Oh John ABM&K DJ YELLOW M/aint \$15
- KING,ALBERT Oh Pretty Woman STAX LP. PROMO mint \$15
- KING,B.B. Thrill is gone BLUESWAY LP. PROMO \$15
- KNOX,BUDDY Mula Love RKO/TEL LP. PROMO \$20
- KRAMER,BILLY J. /DONOTAS III keep you satisfied \$15
- LANDERS,M/UREY W/oneyoon Trinidad GERMAN/NTICE PS \$25
- LALITA Sailor KAPPapJuko Box Roc w/JUKE/SLV \$25
- LONDON,TULIE Buy from Imponna(ANSWER) lbi/Print \$10
- LOS BRAYOS Bring little love PAROT DJ/aint \$15
- LOVIN SPOONFUL rel J. SEBASTIAN Shes lady K/SLV W/PS \$20
- MAGIC LANTERNS Shane Shane ATL LP. PROMO w/ATL SLV \$22
- MANFRED MANN 5 & 3 2 1 PRESTIGE their first \$20
- MANN,BARRY Best that I know how UA DJ mint \$15

CHAI,LENGERS Lloyd Thaxton goes Surfing with... VAULT 101 ST Yellow Wax \$250 FIVE KEYS THUMB COVER On stage CAPITOL MONO one of nicest live seen \$250

### LPs Newlistings

- AC/DC Power Age ATLANTIC Canada RED MAX \$50
- ALBERTS,M/LIFERS Sing Sing Singalong MONO JUBILEE \$25
- ANNETTE Golden hits NEW ZEALAND '01 dj cvr \$50
- BADFINGER Magic Christian Music W/STKR SEALED \$35
- BADFINGER Straight UP APPLE w/STKR SEALED \$60
- BEATLES Aint shee sweet ATCO mono ORIG LP/ps \$100
- BEATLES Magical Mystery MONO M-/VG+ \$100
- BEATLES MCDONALD Tour APPLE orig SEALED \$40
- BEATLES LASER DISC BOX SET: Antho. 10 discs \$125
- BEATLES HARRISON: Wondersul Music/Apple \$50
- BEATLES Abbey Road 1/2 SPEED MASTER CVR \$25
- BEATLES Set Peppers CAP MONO VG++ \$100
- BEATLES '68 MONO CAPITOL SEALED \$400
- BEATLES Revolver ST blk lbi CAP orig SEALED \$250
- BEATLES HARRISON Coc Bangladesh 3LP SEALED \$125
- BEATLES Concerto Castle ATCO M. PROMO \$20
- BELL,ARCHIE/ORELLS I cant get dancing ST ATLANTIC \$100
- BERRY,CHUCK Live at Fillmore MERC ST SEALED \$35
- BERRY,CHUCK Live Fillmore MONO MERCURY SEALED \$40
- BLUES MAGDOES Basic Conic Book MONO MERC w/COMIC \$45
- BLUES MAGDOES Basic RECS ST orig w/alt \$25
- BONIE,DAVID Peter & the Wolf RESEA/GR/Man/SLV \$20
- BROOKS,BONNIE The Haploest ERA MONO disc w/alt \$25
- BUBBLE PUZZY Gathering of prairie IA ST VG++ \$45
- BUBBLE PUZZY Gathering of prairie IA ST VG \$25
- BUFFETT,JIMMY (same) EXCELSTOR unauth? Red Cover \$50
- CAMEO HEAT Boogie with LIBERTY MONO \$50
- CHEER Backstage IMPERIAL. MONO \$30
- CLARK,GENE SONDTRACK: Chastity TEST PRESSING \$200
- CREAM 2 sides to every story RSO LP. PROMO \$25
- DEEP PURPLE 30 ans de musica MEXICO red covr \$35
- DEEP PURPLE Come taste bad LP MINT rare \$45
- DEEP PURPLE Made in Japan W/ ZLP LP. PROMO \$45
- DEEP PURPLE Harrison Coc Bangladesh 3LP SEALED \$40
- DYLAN,BOB Planet Waves ASYLUM foldback SEALED \$30
- DYLAN,BOB Bringing it all back MONO nice \$50
- DYLAN,BOB Bob Dylan COL MONO eyes lbi M-/VG \$75
- DYLAN,BOB John Wesley Harding COL MONO 300 \$75
- DYLAN,BOB Blood on the Blonds COL 360 MONO girls \$20
- DYLAN,BOB Down is flood/INT/LS DLX/MINT/SLV \$100
- DYLAN,BOB & BAND In concert Brothers of flood MINT \$60
- EDDY,DIANNE Songs of our Heritage MONO JANIE \$20
- ELECTRIC PRONES (same) MONO REPRISE LP. PROMO \$75
- ELECTRIC PRONES Underground REPRISE rare MONO \$50
- FIVE MAN ELECTRIC BAWD Goodbye US HIGH saliva cover \$25
- FLEETWOOD HAM Mystery to no REPRISE LP. PROMO \$25
- FLEETWOODS Gretchen,Gary.. MONO DOLT autograph \$45
- FOGERTY,JOHN (same) ASYLUM LP. PROMO \$25
- FOUR SEASONS 2nd Gold Vault TALMAN ORANGE MAX \$20
- HENDRIX,JIMI Elec Ladyland UK IMP w/dues POLYDOR \$100
- HENDRIX,JIMI Smash Hits REPR ST W/POSTER SEALED \$100
- HUMBLE PIE Sockin Ate LP. PROMO \$22
- JEFFERSON STARSHIP Red Octopus RCA QUAD SEALED \$50
- JOURNETHEN (J.PHILIPS/PS/MCKENZIE) mono CAP/Pro \$40
- KING CRISON In court of King.. ATL W/STKR SEALED \$45
- KINGS Kins-50 REPRISE MONO \$40
- LEWIS,ZEPPELIN Remoters 3 LP UK Import/RARE SEALED \$75
- LEWIS,GARY/PLATBYD This Diamond Ring LIB ST SEALED \$25
- LOST GENERATION Sly Slick & Miced ST BRUSH SEALED \$60
- LYNROD SKYTRD Lyndard Skyward LIVE UK '77 KORNYFONE \$100
- LYNROD SKYTRD Street Survivor MCA Flanoe SEALED \$40
- MANFRED MANN EARTH BAND (same) POLYDOR MLP SEALED \$20

### LPs Newlistings

- MANSFIELD,JAYNE Shakespearo/Tchaltovoy NGR HO SEAL \$175
- MARTINA & VANDELHAS Meet Have GORDY 907 rare STEREO \$100
- MCS Kick out Jane ELEGRA NLP. PROMO VG+ \$100
- MONKEES (Same) 1st LP MONO Colpoos SEALED \$35
- MILSSON The Polit original RCA SEALED \$25
- OUTSIDERS Time went lat no CAPITOL. MONO \$30
- PARSONS,ALAM Best of DIGITAL MASTER mint w/str \$20
- PRICE Purple Rain MEXICO levander wax \$35
- QUEEN Shoor Heart Attack ORIG ELEX SEALED \$20
- RED CRAYOLA Parable of Arable Lande MONO l/anoal \$100
- RED CRAYOLA Parable of Arable Lande IA MONO/SLV \$100
- RIVERS,JOHNNY Round ST IMPERIAL orig SEALED \$35
- ROLLING STONES Paris Bohemrales 2LP MINT Spleas \$50
- ROLLING STONES Sono Grls PROMO w/DJTS vinyl \$35
- ROLLING STONES Round PROMO w/DJTS virgia face \$35
- ROLLING STONES RADIO SHOW: Rick Jagger/Spec: 1901BDC \$30
- ROLLING STONES & MOODY WATERS Checkr/d/long/AARE \$50
- ROLLING STONES Sticly Finger 1982 RS w/Metal/zip \$16
- ROLLING STONES Mcdy July 1982 ZLP Live \$45
- ROLLING STONES Black & Blue RS W/STKR SEALED \$40
- ROLLING STONES Sono Grls W/ARREN PICTS RS SEALED \$25
- SHADOWS Shadowes Know ATL MONO orig SEALED \$100
- SINON & GARFUNKEL Bonobonds COL ST 360 orig SEALED \$30
- SINATRA,NANCY Boots REPRISE MONO SEALED \$25
- SIR DOUGLAS QUINN Live Love TEXAS RE-CORD '77 SEALED \$25
- SMITH,PATTI I never talk B.Dylan SPLIT Max/color \$100
- STEELE DAN Gold MCA ANTI/PHILE MINT \$40
- STEELE DAN Gaucho MCA ANTI/PHILE SEALED \$50
- STYX Killy was here VIRGIN VINYL SEALED \$10
- SYD Little Girl BELL rare STEREO \$75
- THE LIZZY Jailbreak MERCURY LP. PROMO \$30
- TV SOUNDTRACK Dark Shadow PHILIPS w/POSTER SEALED \$40
- THE VENTURES DOLTON W/ ZLP SEALED \$75
- YARBIRDS Five Live Tarbirds MONO COL W/orig \$100
- YES Time & a word UK w/alt ATL NUDE COVR \$25
- YOUNG,NEIL Coming home LIVE '73 VA THRO \$25
- 13TH FLOOR ELEVATOR Live ORIG IA st SEALED \$75
- 13TH FLOOR ELEVATORS Live IA orig SEALED \$75

I BUY RECORD COLLECTIONS! LPs & 45s Larger the better PHONE 210-764-3434 CELL 210-884-3310

Charles E. Null  
522 Dawson Ave.  
Rockford, IL 61107  
(815) 399-0576

Hello! And welcome to my latest Goldmine auction. Listed below are some rare 60's and 70's rock 'n roll albums. White Label Promos, (W.L.P.) Promo Boxed sets, sealed copies, 4 speeds, and stock copies. No cutouts! All open copies have been extensively graded. Special attention is given to the seams and spine of the jacket. Records have been thoroughly played to identify any hidden defects. All items are original label U.S. first pressings.  
First class (priority) postage is \$6.00 for the first album and 1.00 for each additional. Boxed set postage will be quoted upon confirmation. Insurance is extra. Cash, check or money orders are welcome.

AUCTION CLOSING ON SUNDAY, DECEMBER 2<sup>ND</sup> at 10:00 P.M. Central Time. Phone or mail bids welcomed. All mail bids must be received by Saturday, December 1<sup>ST</sup>. All initial phone bids must be placed by 12:00 noon on Saturday, December 1<sup>ST</sup>. In the event of a high demand on any item(s), I reserve the right to declare bid wars, so that all bidders have an equal opportunity to raise or pass. Any bidders who wish to participate must include a phone number where they can be reached. I will attempt to contact you if a bid war has been declared on your item(s) on Saturday afternoon, December 1<sup>ST</sup>. There is a 10% minimum overbid required after the minimum bid has been met. Minimums are listed after the grading. You may call anytime (reasonable) before 12:00 noon on Saturday, December 1<sup>ST</sup> to check on current high bids. Bidder names will not be revealed. Bid wars will commence at 1:00 p.m. central time on Saturday, December 1<sup>ST</sup>, and continue, if necessary, until 10:00 p.m. central time on Sunday, December 2<sup>ND</sup>, at which time the auction will close. If you have any questions about auction details or rules, please feel free to give me a call. You will have a prompt response.

All winners will be notified. A written confirmation will be mailed on Monday, December 3<sup>RD</sup>. All winners have 14 days after confirmation to make payment. In the event of default the next highest bidder will be notified. A 14 day, full money back, no questions asked, guarantee applies to all of these items, excluding postage. All matrix numbers and other identifying traits have been recorded for future reference.

Now, on with the auction:

- |    |                             |  |
|----|-----------------------------|--|
| 1  | Abba                        | A Collection of Hits - W.L.P. Sealed! \$50.00  |
| 2  | Abba                        | The Abba Special M-/M/M Promo Only \$75.00   |
| 3  | AC/DC                       | Live At Atlantic Studios - M-/M W.L.P. \$75.00   |
| 4  | AC/DC                       | Promo Interview Album - #PR-562 M/M W.L.P. \$50.00   |
| 5  | Aerosmith                   | The First Decade - 8LP Promo Only Boxed Set All M \$100.00   |
| 6  | Argent                      | Self Titled - Sealed! \$30.00  |
| 7  | Beatles                     | VS Four Seasons - G/VG/VG Mono With Poster \$400.00  |
| 8  | Beatles                     | 1995 - 15LP Set with cabinet - All mint LPs are sealed \$400.00  |
| 9  | Buffalo Springfield         | Self Titled - M-/M- Mono - First Pressing with "Baby Don't Scold Me" \$80.00   |
| 10 | Chicago                     | C.T.A. (1 <sup>ST</sup> LP) Mobile Fidelity - Sealed! \$75.00  |
| 11 | Eric Clapton                | Self Titled - Sealed! Original Custom Sticker (May contain rare record with alternate tracks) \$100.00   |
| 12 | Alice Cooper                | Pretties For You M-/M- In Shrink Pink label NOT censored \$100.00  |
| 13 | Alice Cooper                | Easy Action M-/M Pink Label \$75.00  |
| 14 | The Doors                   | Self Titled VG/VG/M- Rare Mono \$150.00  |
| 15 | The Doors                   | Self Titled M-/M Mobile Fidelity \$575.00  |
| 16 | Bob Dylan                   | Self Titled M-/M- First Pressing Six Eye Label Stereo \$250.00   |
| 17 | Emerson, Lake & Palmer      | Welcome Back My Friends - To The Show That Never Ends Sealed! Custom Sticker 3LP Live Set \$50.00  |
| 18 | Five Man Electrical Band    | Goodbyes & Butte Files Sealed! \$50.00   |
| 19 | Fleetwood Mac               | Rumours Sealed! Custom Sticker Rare mislabeled record with 2:16 version of "Never Goin Back" \$50.00   |
| 20 | Grass Roots                 | Where Were You When I Needed You Sealed! Mono \$75.00  |
| 21 | Grateful Dead               | Mars Hotel Sealed! \$50.00   |
| 22 | George Harrison             | All Things Must Pass Sealed! Shrink Split \$100.00   |
| 23 | George Harrison             | Concert For Bangla Desh Sealed! \$75.00  |
| 24 | Jimi Hendrix                | Electric Ladyland M-/M-/M- \$50.00   |
| 25 | Jimi Hendrix                | Cry of Love Sealed Transparent Title Sticker \$75.00   |
| 26 | Jimi Hendrix                | Cry of Love M-/M W.L.P. \$250.00   |
| 27 | Hollies                     | Heard! Heard! M-/M- Mono In Shrink \$75.00   |
| 28 | Humble Pie                  | Rockin' The Fillmore M-/M-/M- W.L.P. \$100.00  |
| 29 | Tommy James & The Shondells | Hanky Panky Sealed! Stereo \$50.00   |
| 30 | Jefferson Airplane          | Takes Off M-/M- Mono In Shrink Ten Tracks \$75.00  |
| 31 | Jethro Tull                 | Aqualung Sealed Mobile Fidelity \$75.00  |
| 32 | Billy Joel                  | Cold Spring Harbor Sealed Original \$50.00   |
| 33 | Kansas                      | Two For The Show M-/M- Promo Sampler \$30.00 (W.L.P.)  |
| 34 | King Crimson                | In The Court of The Crimson King Sealed! Record Club Issue \$50.00   |
| 35 | King Crimson                | In The Wake of Poseidon Sealed! \$40.00  |
| 36 | Kinks                       | Kink Size M-/M- Stereo In Shrink \$50.00   |
| 37 | Kinks                       | You Really Got Me Sealed! Stereo \$75.00   |
| 38 | Led Zeppelin                | II Sealed! Mobile Fidelity \$100.00  |
| 39 | Led Zeppelin                | IV M-/M- W.L.P. Stereo Promo Sticker \$250.00  |
| 40 | Led Zeppelin                | 6LP Compilation Set with Blimp! All Sealed! \$200.00   |
| 41 | Mahogany Rush               | Child of The Novelty M-/M- In Shrink \$40.00   |
| 42 | Mamas & Papas               | Eyes & Ears Sealed! Mono No toilet cover \$75.00   |
| 43 | Lee Michaels                | Carnival of Life Sealed \$50.00  |
| 44 | Monkees                     | Meet The Sealed! Stereo \$50.00 (W.L.P.)   |
| 45 | Monkees                     | Changes Sealed! Promo Copy Promo Stamped \$100.00  |
| 46 | Moody Blues                 | Promo Only Interview Set Complete! M-/M- \$100.00  |
| 47 | Van Morrison                | Live at the Roxy M-/M- Promo Only Black Vinyl \$50.00  |
| 48 | Nilsilsson                  | The True One Rare Promo Only Boxed Set Box: VG/VG Jacket: Mint! Record: Mint- All inserts Mint! \$100.00 With EXTRAS! Audio Guide Rare Promo Only 8LP Boxed set Box: Mint- All Albums Mint-To Mint! \$150.00 |
| 49 | Alan Parsons                | Official Live Bootleg M-/M- Promo Only \$50.00   |
| 50 | Tom Petty                   | Dark Side of The Moon Sealed! Mobile Fidelity \$50.00  |
| 51 | Pink Floyd                  | More M/M Original Promo Hole \$75.00   |
| 52 | Pink Floyd                  | Atom heart Mother Sealed! Mobile Fidelity \$50.00  |
| 53 | Pink Floyd                  | Self Titled Sealed! Stereo . With Poster \$75.00   |
| 54 | Procal Harum                | News of The World M-/M/M Promo Boxed Set Rare with W.L.P. record NO FAKE \$250.00  |
| 55 | Queen                       | Fresh Sealed! \$30.00  |
| 56 | Raspberries                 | Side 3 Sealed! Custom Sticker \$30.00  |
| 57 | Raspberries                 | England's Newest Hitmakers M-/M- With Poster RARE MONO "FFRR" Label \$400.00 (Sealed) is Mint except for one small corner crease   |
| 58 | Rolling Stones              | 12 X 5 M/M In Shrink RARE MONO "FFRR" label \$425.00   |
| 59 | Rolling Stones              | NOW! VG/VG/VG RARE MONO "FFRR" label \$300.00  |
| 60 | Rolling Stones              | Out of Our Heads M-/VG/VG In Shrink Custom Sticker RARE MONO "FFRR" Label Small Writing on Side 1 label \$325.00   |
| 61 | Rolling Stones              | December's Children M/M In shrink Custom Sticker-Mono First Pressing Maroon "Long Playing" label \$75.00   |
| 62 | Rolling Stones              | Got Live If You Want It M/M Mono In shrink \$75.00   |
| 63 | Rolling Stones              | Got Live If You Want It M/M Stereo In shrink Custom Sticker \$50.00  |
| 64 | Rolling Stones              | Self Titled (1 <sup>ST</sup> LP) Sealed! \$50.00   |
| 65 | Roxy Music                  | Runt M-/M- Custom Sticker RARE 12 Track First Pressing \$100.00  |
| 66 | Todd Rundgren               | Self Titled (1 <sup>ST</sup> LP) M-/M Rare W.L.P. \$50.00  |
| 67 | Rush                        | System Sealed! RARE 1 <sup>ST</sup> PRESSING "FREE PUNCHED" Promo Copy \$75.00   |
| 68 | Bob Seger                   | Self Titled (1 <sup>ST</sup> LP) Sealed! \$50.00   |
| 69 | Spirit                      | Darkness On The Edge of Town RARE PICTURE DISK - SEALED \$100.00   |
| 70 | Bruce Springsteen           | Self Titled VG/VG/M- RARE MONO W.L.P. \$125.00   |
| 71 | Steppenwolf                 | Self Titled (1 <sup>ST</sup> LP) Sealed! RARE NUDE COVER \$50.00   |
| 72 | Styx                        | Indelibly Stamped Sealed! W.L.P. Promo Sticker \$75.00 Promo Hole  |
| 73 | Supertramp                  | A Beard of Stars Sealed! With 45-Promo Hole \$50.00  |
| 74 | T Rex                       | Marc Bolin Interview Album M-/M W.L.P. \$100.00  |
| 75 | T Rex                       | Self Titled (1 <sup>ST</sup> LP) Sealed! No "One" on front cover \$50.00   |
| 76 | Three Dog Night             | It Ain't Easy Sealed!!! Original NUDE COVER! MINT!!! \$300.00  |
| 77 | Three Dog Night             | Strangers In The Night M-/M-/M- \$50.00  |
| 78 | U.F.O.                      | Self Titled Sealed! Stereo Custom Sticker \$50.00  |
| 79 | Vanilla Fudge               | Couldn't Stand the Weather M/M RARE PICTURE DISK \$100.00  |
| 80 | Stevie Ray Vaughan          | Self Titled M-/M- RARE W.L.P. "NO NAME" cover \$200.00   |
| 81 | Neil Young                  | Harvest M-/M Nautilus 1/2 speed \$100.00   |
| 82 | Neil Young                  |  |

I also have LOTS of Half Speeds at Set Sale. Mobile Fidelity, Nautilus, CBS Master Sound, A+M (Canadian), + MCA Masterphile. QUADS also. Call for Grading, Prices, and Availability. Thanks for looking!

**Charles E. Null**  
522 Dawson Ave., Rockford, IL 61107  
815-399-0576

(Reissues from page 52)

he has lost or can't have; pulsating music cut in a (high) key out of Stubbs' regular vocal range, the subsequent strain causing his pleas to sound even more dramatic; background vocals with a full, almost Phil Spector-ian resonance, thanks to the addition of Motown's resident session singers, The Andantes.

Alternate mixes of the hits follow: "Ask The Lonely" (in stereo, quite snazzy), "I Can't Help Myself" (OK, it includes background vocals on the bridge, as performed in concert), and "It's The Same Old Song" (crappy, Levi's vocals are buried). Woven in between are some previously unreleased tracks (decent, aside from the clanking clunker "Just A Little Love"). After single mixes of "Something About You" and "Wake Me Shake Me (When It's Over)" hit the spot, disc one concludes with a nice alternate version of "Brenda" (featuring Payton on lead vocals) and a weak rendition of "For Once In My Life" (recorded before Stevie Wonder's hit version).

Disc two opens with the Tops at their commercial peak (late 1966 to early 1967), leading off with the huge hits "Reach Out ("I'll Be There)," "Standing In The Shadows Of Love" and "Bernadette." A live version of "I'll Turn To Stone" follows, marred by poor sound quality. In late 1967, Holland-Dozier-Holland abruptly left Motown in a dispute over financial compensation. This prompted the label to release year-old remakes of "Walk Away Renee" and "If I Were A Carpenter" as follow-up Four Tops singles. They are proof that The Four Tops could make a hit out of practically anything.

In 1968 and 1969, other Motown writer-producers such as Ivy Jo Hunter (the poignant "Yesterday's Dreams"), Johnny Bristol (the haunting "What Is A Man"), and

Norman Whitfield (the blah "Don't Let Him Take Your Love From Me") attempted to fill the void left by Holland-Dozier-Holland's exit. None of their work with the Tops, however, penetrated the Pop or R&B Top 20 charts.

Besides the aforementioned singles and some assorted album tracks from 1966-1969, disc two also includes a pair of unique, previously unreleased collaborations: "Oh, I've Been

**This prompted the label to release year-old remakes of "Walk Away Renee" and "If I Were A Carpenter" as follow-up Four Tops singles. They are proof that The Four Tops could make a hit out of practically anything.**

Blessed" by Levi and The Vandellas (with Stubbs recording over a track that once featured Martha Reeves) and "Stranded On The Road Of Love" with Edwin Starr (The Four Tops and Starr made separate recordings — that were later merged — on the same backing tracks). Neither rises above mediocrity.

On disc three, as the '70s began, Frank Wilson had taken over as The Four Tops' producer for the landmark *Still Waters* concept album. Wilson ditched The Andantes from the background and put more emphasis on the Tops' harmonies. Payton

(Please see Reissues page 57)

## America's Best Record Rack

Your Records will be easy to organize and find, and you will never run out of space with the Original RACKIT™ Modular Record Rack system. No matter what its size, your record collection will fit in this attractive, infinitely expandable, solid oak building block system.

The portable, easy to move record rack modules hold one hundred LPs each. They are stackable up to 5 high on the Dolly. Put the Tabletop on the top rack, and you have a beautiful piece of furniture.

RACKIT storage units for all other audio/video formats and equipment are available. See [www.rackittm.com](http://www.rackittm.com) for details.

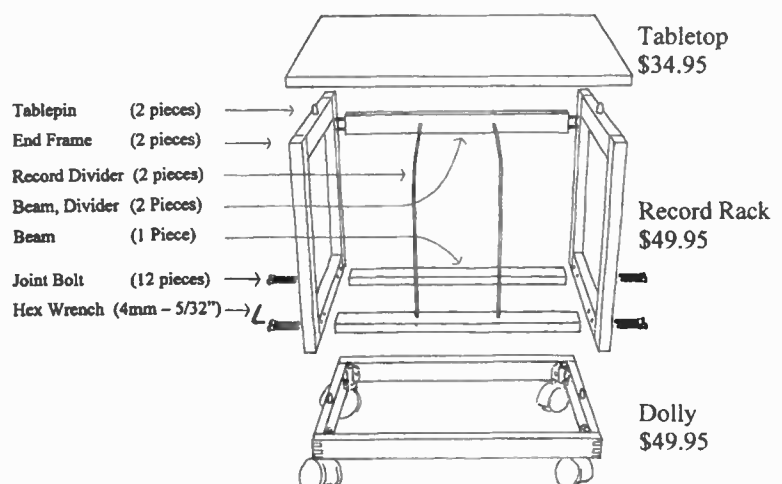

It's a great value — for as little as 50 cents a record you get convenient, space-saving storage. RACKIT is the best insurance for protecting your valuable record collection.

Factory direct to you since 1984  
Place your first order today and get a free Tabletop!  
Please mention Goldmine



Per Madsen Design  
PO Box 882464, San Francisco CA 94188  
800-821-4883 [www.rackittm.com](http://www.rackittm.com)



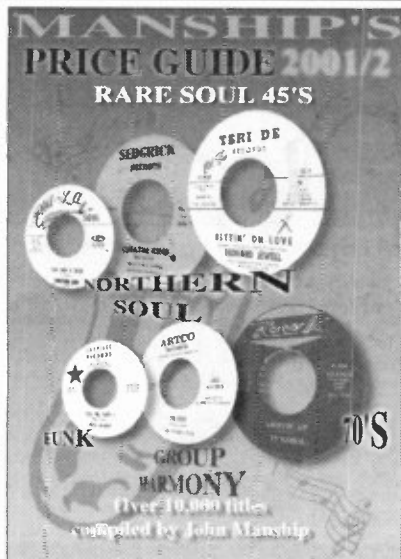

Compiled by JOHN MANSHIP  
dealer/collector since 1969  
This is a reliable & realistic illustrated  
price guide

Comprehensive listing with both A & B side

Full label & release number listed

Over 10,000 titles listed, plus labels & pictures

Price Range of \$10 to \$8000

All titles that have been Bootlegged are specified

The worlds first RARE SOUL price guide  
compiled with 32 years experience

John Manship

**AT LAST!! A GENUINE RARE SOUL PRICE GUIDE FOR NORTHERN SOUL/FUNK/70's/SOUL USA RELEASE 45's**

Compiled by John Manship 32 Years Dealer/Collector  
This Limited Illustrated Edition Available For \$40.00  
Fully Comprehensive Listing of Both A & B Side Listed.  
All Labels & Release Numbers Noted  
All In Artists Order  
With All Titles That Have Been Bootlegged Noted.  
Limited Edition So Be Quick To Avoid Disappointment.

**\$40.00 plus Shipping & Handling  
(\$14.00 First Class Air Mail)**

All Credit Cards Accepted.

Orderline Phone: 44 1664 464526 FAX: 44 1664 464155

E-Mail: [Info@raresoulman.co.uk](mailto:Info@raresoulman.co.uk)

**JOHN MANSHIP RECORDS**

45 Dalby Road, Melton Mowbray, LE13 0BG, England



**DIG Music Presents...  
Live, for the First Time!**

Stoneground



**The Last Dance**  
This Live '73 recording includes  
15 Tracks Featuring: *Butterfly*,  
*Passion Flower*, *AJax* and *Total*  
*Destruction To Your Mind!*  
DIG 103

ColdBlood  
featuring Lydia Pense



**Vintage Blood**  
Their first Live album ever!  
Recorded in 1973 and  
features the hits: *You Got*  
*Me Hummin*, *Feel So Bad*  
and *Kissin' My Love*  
DIG 104

Beau Brummels



**Live! '74**  
Featuring all 5 original  
members! 20 tracks... 10 previ-  
ously unreleased! Includes their  
hits: *Laugh Laugh*, *Just A Little*  
and *You Tell Me Why*.  
DIG 102

**\$14.99** each + \$3.00 1st Class Postage per Order

OR ANY

**3 CD's for \$40.00** (includes postage!)

DIG Music

[www.digmusiccd.com](http://www.digmusiccd.com)

[digmusic@softcom.net](mailto:digmusic@softcom.net)

916-452-4DIG

1600 Sutterville Road, Sacramento, CA 95822

**NEW  
OLD  
RARE**



THE ORIGINAL

**FLIP SIDE**

**RECORDS & COLLECTABLES**

IN BUSINESS OVER 25 YEARS

OVER 2 MILLION RECORDS/CD'S

160,000 + LISTED ONLINE AT: [WWW.FLIPMALL.COM](http://WWW.FLIPMALL.COM)

Free online catalogs:

21,000 + SOUL & JAZZ ALBUMS / 22,000 + RARE 45'S / 17,000 + 12" SINGLES / 40,000 + ROCK ALBUMS / COUNTRY / POP / SURF & HOT ROD / REGGAE COUNTRY / POP / ELVIS / BEATLES / KISS / MICHAEL JACKSON

**WE HAVE A HUGE SELECTION OF:**

- OUT OF PRINT RECORDS
- COUNTRY & WESTERN
- ROCK-A-BILLY
- ORIGINAL CASTS
- ROCK & ROLL
- CLASSICAL
- SOUND TRACKS
- SYMPHONY
- JAZZ
- BLUES
- ETHNIC
- FOLK
- SURF HOT ROD
- BIG BANDS
- RHYTHM & BLUES
- SOUND EFFECTS
- SOUL
- COMEDY
- NOVELTY
- CHILDRENS



**"WANT LISTS WELCOME"**

E-Mail: [FlipsideRecords@Aol.com](mailto:FlipsideRecords@Aol.com)

RECORD/CD LISTS (BELOW)  
COST REFUNDABLE WITH ORDER

- |                                |                           |                                  |
|--------------------------------|---------------------------|----------------------------------|
| \$2.50 COMPACT DISCS           | \$1.00 SURF & HOT ROD     | \$6.00 SOUL / FUNK & JAZZ ALBUMS |
| \$6.00 RARE 45'S (OVER 25,000) | \$1.00 KISS COLLECTIBLES  | \$5.00 12" SINGLES (OVER)        |
| \$3.50 COUNTRY ALBUMS          | \$1.00 REGGAE 45'S / LP'S | \$2.00 LATIN 45'S / LP'S         |
| \$5.00 ROCK ALBUMS             | \$1.00 ELVIS PRESLEY      | \$1.00 POLKA 45'S / LP'S         |
| \$1.00 BEATLES                 | \$1.00 CLASSICAL          |                                  |

**KOLLECTABLE LISTS AVAILABLE**



# WEB DIRECTORY SHOWCASE



Call  
Tina Ellingson  
Ext. 334  
Trevor Lauber  
Ext. 322  
1-888-457-2873

## LORAN RECORDS

Collectible  
Record Albums

[www.loranrecords.com](http://www.loranrecords.com)



### SPECIALISTS IN COLLECTIBLE LP's OF ALL MUSICAL CATEGORIES

Rock • Soul • Country • Jazz • Classical • Vocals • Easy Listening  
Soundtracks • Comedy • Exotic • Latin & Everything Else!



- ★ High Quality Records
- ★ Low Postal Charges
- ★ Reasonable Prices
- ★ Free Search Service On Your Want Lists
- ★ Fast, Friendly Service

Order By Mail → P.O. Box 1604 • Florissant, MO 63031  
Order By Phone → 314-837-2649  
Order By Fax → 314-921-4091  
Order By E-Mail → [loranrec@aol.com](mailto:loranrec@aol.com)

**Please Contact Us  
For A  
Free Catalog**



### SOUTHLAND CD ONLINE

Hello from SLCD.com, Southland CD. We would like to introduce you to our collectible music Web site: [www.SLCD.com](http://www.SLCD.com). We have a large selection of collectible music available for online ordering including CDs, Records, Memorabilia & mostly anything by your favorite artists. Our vast stock consists of items from all over the world, including the U.S., U.K., Japan, Australia & Germany to name a few. SLCD.com is a user friendly Web site that is complete with an easy to use search engine & secure online ordering. We update our site on a daily basis, so check back often not to miss a thing. In addition to everything that is available to buy at SLCD.com, you can also sell to us! We pay \$ top dollar \$ for most collectible CDs, Vinyl or Memorabilia.

Check out [www.SLCD.com](http://www.SLCD.com) and let the fun begin!  
[www.SLCD.com](http://www.SLCD.com)



Hear the Beatles with ears closed

## McCartneyArt.com

Lennon/McCartney Paintings & Lithographs  
Celebrity Art  
[Artcelebs@aol.com](mailto:Artcelebs@aol.com) 610-397-1989

## www.vinylgalore.com

Where Vinyl Buyers And Sellers Meet

*Sellers, list free for six months!*

1/2 SPEEDS

PROMOS



**RECORDCRATE.COM**  
SPECIALIZING IN COLLECTABLE RECORDS

JEFF GREINDL

(630) 830-7634

IMPORTS [eligreindl@aol.com](mailto:eligreindl@aol.com) 1ST PRESS

## Classic Rock Concert Photos.Net

Eric Clapton  
Bob Dylan  
Crosby, Stills, Nash & Young  
Grateful Dead



The Kinks

Hall of Fame Inductions  
Benefit and Tribute Concerts  
Early Influences & Legendary Bluesmen

[Britspics@aol.com](mailto:Britspics@aol.com)

## MUDSHARK AUDIO

restoration \* enhancement



get your LPs de-crackled!  
get your tapes de-hissed!



restore & enhance your live/amateur recordings!

mudshark audio offers digital restoration services starting at \$35cdn!!

[www.mudsharkaudio.com](http://www.mudsharkaudio.com)

### WWW.FULLCYRKLERECORDS.COM

Visit our online store & compare our prices. Check our monthly featured items & browse our extensive online catalogs of new CD's, new & used LP's, 45's & 78's

SPECIALIZING IN NEW CD & LP REISSUES -  
CLASSIC OLDIES 1920'S-80'S

Classic Rock - Psych & Garage - Progressive - Soul R&B - Blues -  
Country - Folk - Jazz - Audiophile - Remastered CD Reissues - Vocal Artists - Specialty - Posters - Promos

**FULL CYRKLERECORDS & COMPACT DISCS**  
CRYSTAL LAKE, IL

Chicagoland's premier oldies & specialty music shop for over 20 years



VERY ENGLISH AND ROLLING STONE  
P.O. Box 7061  
Lancaster, PA  
17604-7061  
E-mail: [vears@lannews.infri.net](mailto:vears@lannews.infri.net)  
U.S.A. Since 1977



[www.veryenglish.com](http://www.veryenglish.com)



(Over 5,000 Collectibles Listed)

Huge FREE!!!! Collectible / Rare Catalog containing vinyl / CDs / colored vinyl / promos / rock clothing / send a 75¢ stamp USA and Canada and Foreign \$2.50 stamp.

Available most weekday evenings 9:30 p.m. - midnight

## "45" drawers, LP racks and more

Modular, stackable oak furniture holds all formats and equipment

Factory direct to you from

Per Madsen Design, 800-821-4883

Free Brochure (Please mention Goldmine)

[www.rackittm.com](http://www.rackittm.com)



### www.maidenmania.com

#### Iron Maiden/KISS and Heavy Metal

Over 365 pages (900 plus items) of astounding rarities from all over the world from Argentina to Yugoslavia and everywhere in between. Please e-mail me at [ken@maidenmania.com](mailto:ken@maidenmania.com) for your FREE computer catalog download. If you do not have a computer, I will be more than happy to send you a copy of each of my catalogs, but PLEASE enclose \$1 per artist per request (3 stamped IRC's for Canadian and overseas customers only) when writing to cover printed material and postage costs to:

**Maiden Mania**

820 Post Road, Suite 135  
Scarsdale, NY 10583-5046 USA

### WWW.JUSTANOTHERDREAM.COM



Home of Rare and Collectible Records, CDs, Music Videos, And Music Related Memorabilia From Around the World.

Shop for your music collectibles, 24 hrs. a day, easily and safely. We offer secure online transactions. We accept Visa and Mastercard.

## Memory Lane

Out-of-Print Records • Tapes • Compact Discs

190 EAST UNIVERSITY DRIVE  
TEMPE, AZ 85281

TELEPHONE (480) 968-1512  
FAX (480) 921-1620

Web site: <http://www.memorylanerecords.com>  
E-mail: [mlr@memorylanerecords.com](mailto:mlr@memorylanerecords.com)



Why pay imported prices for imported CD's

### www.musicselection.com

Over 1.3 million imported CD's

Compact Discs, Cassettes, Vinyl, Videos & Dvd's  
Lowest prices guaranteed !!!  
Shipping is still only .99 cents !!!



### Long Time Gone Records

New & Used LP's & CD's Online:  
Audiophile and Otherwise

[www.recordsrevisited.com](http://www.recordsrevisited.com)

Visit us on the Web...Auction and set sale prices.  
Jazz, Folk, Rock and Blues/International Buyers Welcome!  
E-mail us: [longtimegone@att.net](mailto:longtimegone@att.net)  
Want lists accepted.

76 North Maple Ave, Suite 301, Ridgewood, NJ 07450  
Michael Phelan (201) 657-7659 Voice mail/I buy collections locally

### www.oldies45s.com

Over 30,000 Singles for sale

Easy to Search

Priced to Sell

Volume Discounts

secure online transactions: Visa /MC  
email: [oldies45s@oldies45s.com](mailto:oldies45s@oldies45s.com)

### www.acevideoandmusic.com

Huge selection  
Something for everyone, Lps, 45s  
Collectable music from 1920's-now

For E-Bay's best music & auctions go to Susue



Ace Video & Music  
285 Caillavet St., PO Box 1934  
Biloxi, Mississippi 39533-1934 USA  
228-374-0777, fax 228-374-4645  
[mail@acevideoandmusic.com](mailto:mail@acevideoandmusic.com)



### FLASHBACK COLLECTIBLES

Concert Posters, Postcards, Tickets,  
Autographs and Memorabilia

Skip & Cindy Clarke  
3307 So. College Ave., PMB 7018  
Ft. Collins, CO 80525  
(970) 224-1456

E-mail: [skipclarke@aol.com](mailto:skipclarke@aol.com)  
[www.flashbackcollectibles.com](http://www.flashbackcollectibles.com)



# WEB DIRECTORY SHOWCASE



Call  
Tina Ellingson  
Ext. 334  
Trevor Lauber  
Ext. 322  
1-888-457-2873



We deliver what music lovers want!  
**LOW Prices - FAST Service**  
A HUGE Selection of ALL Genres.  
Specializing in Imports.  
CDs/LPs/Collectibles/More  
**ImportCDS.com**

## eRock.NET

Official Rock-n-Roll Memorabilia Auction Web site

Select from 17 exciting categories of which five specialize in vinyl records. This music site also holds a monthly drawing and gives away a \$200 auction shopping spree to one lucky winner every month.

<http://www.eRock.net>

## VINTAGE VINYL MAIL ORDER

<http://www.vvmo.com>

TOP QUALITY RARE & OUT-OF-PRINT VINYL!

BEATLES \* STONES \* ROCK & POP \* PSYCHEDELIC  
PROGRESSIVE & KRAUTROCK \* JAZZ \* SOUL \* FOLK  
WE ALSO CARRY HARD TO FIND & COLLECTABLE CD'S,  
& NEW BRITISH MUSIC THE WEEK OF IT'S RELEASE IN U.K.!  
MAILING ADDRESS : 925 DAVIS ST. EVANSTON, IL 60201  
PH : 847-328-2899 \* FAX: 847-328-2934

## JOHN MANSHIP RECORDS

BUYERS & SELLERS OF SOUL since 1969

Priced Wants lists serviced  
Anything to sell? Great prices offered.  
Single items or Whole Collections.

Tel. (44) 1664 464526 FAX. (44) 1664 464155  
E-mail: [info@raresoulman.co.uk](mailto:info@raresoulman.co.uk)  
Secure Web Site: [www.raresoulman.co.uk](http://www.raresoulman.co.uk)  
More Rare Soul for sale than any other site.  
Over 24,000 items listed.

## JAZZ RECORD CENTER

236 West 26 Street Phone: 212-675-4480  
New York, NY 10001 Fax: 212-675-4504

New York's only specialist in out-of-print Jazz records,  
books, videos and periodicals.

\*\*\*NEW\*\*\*

WEB site: [www.jazzrecordcenter.com](http://www.jazzrecordcenter.com)

Web site will be a convenient way to purchase items  
online as well as participate in online auctions.

E-MAIL: [jazzrecordcenter@att.net](mailto:jazzrecordcenter@att.net)

## HEAVY METAL AND HARD ROCK

Over a decade of serving hard rock/metal fans.  
5000+ titles of normalities & rare releases.  
The Web's largest specialist.  
Vinyl, CD's, Memorabilia.  
Secure ordering with shopping cart.  
[www.visual-vinyl.co.uk](http://www.visual-vinyl.co.uk)

## AROUND THE WORLD MUSIC COLLECTIBLES

OFFERING MUSIC COLLECTIBLES FROM AROUND THE WORLD FOR MORE THAN A DECADE

visit Our Web Site For Daily Updates  
Also be sure to look at our last  
Beatles ad in the 11/2/01 issue.  
[WWW.ATWMusic.com](http://WWW.ATWMusic.com)

## CANADIAN CD'S AND VINYL

1000's of Canadian & Import titles on 12, 10 & 7 inch vinyl &  
CD's from around the world as well as many Canadian releas-  
es. Visit our constantly growing and changing Web site at:

<http://www.interlog.com/~bmens>

Mail me your wants with 2 IRC's to:

The Record Cellar

8 Anstead Crescent Ajax Ontario  
Canada L1S 3X8

Email: [bmens@interlog.com](mailto:bmens@interlog.com)

(Reissues from page 54)

was given more solo parts as well. As evidenced by the tracks "It's All In The Game" and "Still Water (Peace)"/"Still Water (Love)" — the latter recording combined as originally intended for the first time — the Tops had risen to new melodic heights.

Next up is a pair of duets with The Supremes: the soaring hit "River Deep, Mountain High," which easily surpasses the overrated Spector-produced Tina Turner version, and the so-so "I'm Glad About It." (The latter's glorious A-side, "You Gotta Have

Love In Your Heart," should have been included instead — it's available on *The Four Tops Anthology* as well as *The Supremes 40th Anniversary* box set.) They are followed by more of Wilson's well-crafted but (now) underachieving singles such as "In These Changing Times" and "(It's The Way) Nature Planned It," plus a couple of tracks recorded in England with The Moody Blues, led by the awesome "A Simple Game" (found here in its inferior original unedited mix).

During 1971-1972, the Tops received little promotional support from Motown and struggled on the charts. Frustrated, they left the label in late 1972 and signed with ABC

subsidiary Dunhill Records. Some of the Tops' best recordings from their first two Dunhill albums — produced by Dennis Lambert and Brian Potter — make up the last third of disc three. They include hits such as the urban message song "Keeper Of The Castle," the *Shaft In Africa* theme "Are You Man Enough," and the multi-format smash "Ain't No Woman (Like The One I've Got)," as well as stellar album tracks such as "Love Music" and "Main Street People." Sorely missed are the tracks "Put A Little Love Away" and "Am I My Brother's Keeper."

Disc four starts off with the Tops' remaining R&B hits at ABC/Dunhill (1974-1976),

including their funkier recording ever, "One Chain Don't Make No Frison," the stupid "Catfish" and a lively live version of "Midnight Flower" that easily tops the original. Missing is their 1978 disco hit "H.E.L.P." (the only decent track from their unrepresented 1977 and 1978 albums). Compensation comes, however, from the previously unreleased (in the U.S.) 1979 dance version of The Yardbirds' "For Your Love." It's smokin'!

In 1981 the Tops signed with Casablanca and released two of their strongest albums

(Please see Reissues page 65)

## VARIOUS ARTISTS

Living Legends Of Rock & Roll Live From Itchycoo Park  
Image Entertainment (ID0769E1DVD)

Imagine if VH-1's two highly popular television series, *Legends* and *Where Are They Now?*, materialized on the same concert stage. The result would look very much like Image Entertainment's widescreen DVD release, *Living Legends Of Rock & Roll: Live From Itchycoo Park*. The 85-minute collection is comprised of nine veteran acts performing a total of 15 selections, taped at the legendary Tennessee locale during a four-day music festival in the summer of 2000.

The rather eclectic lineup features Starship, Iron Butterfly, Rare Earth, Mark Farrow, Firefall, The Nelsons, Christopher Cross, and Styx — the latter delivering one of the show's most satisfying sets. Grabbing the spotlight is John Kay & Steppenwolf, whose signature renditions of "Magic Carpet Ride" and "Born To Be Wild" continue to thrill

audiences of all ages and register the greatest response from the crowd.

For those who grew up listening to Top 40 radio, *Living Legends Of Rock & Roll* may stir fond memories, although nearly all are bound to feel that their personal favorites are under-represented. Ultimately reflecting the very nature of the Top 40 format, this new DVD finds artists bound for *Where Are They Now?* rubbing shoulders with some true legends.

— Mark Wallgren

SAMMY HAGAR & THE WABORITAS  
Cabo Wabo Birthday Bash Tour  
Image Entertainment (ID0835MYDVD)  
(Two DVD set)

From the moment Sammy Hagar commandeers the stage — a traveling replica of his famed Cabo Wabo Cantina in Cabo San Lucas, Baja, Mexico — the Red Rocker delivers a nonstop, full-throttle, rock 'n' roll

## DVD Reviews

fiesta for his devoted legion of Redheads. Admittedly unable to drive 55, Hagar careens onto stage at 120 mph, never taking his foot off of the accelerator until his exit from the spotlight two hours later.

Be forewarned: Image Entertainment's 131-minute, double-disc DVD *Sammy Hagar & The Waboritas: Cabo Wabo Birthday Bash Tour* is not for the faint of heart. This is an all-out rock 'n' roll assault, with Hagar leading his talented ensemble — affectionately dubbed The Waboritas — through nearly two dozen signature tunes, spanning every phase of his illustrious (and notorious) career, including appropriate nods to Montrose and Van Halen.

The bonus disc features a candid, one-hour interview with Hagar, along with home video sequences lensed in Cabo, showcasing his nightclub and the local scenery. Unquestionably one of the most electrifying and enjoyable concert videos to emerge all year, this new DVD is not only for loyalists, but for

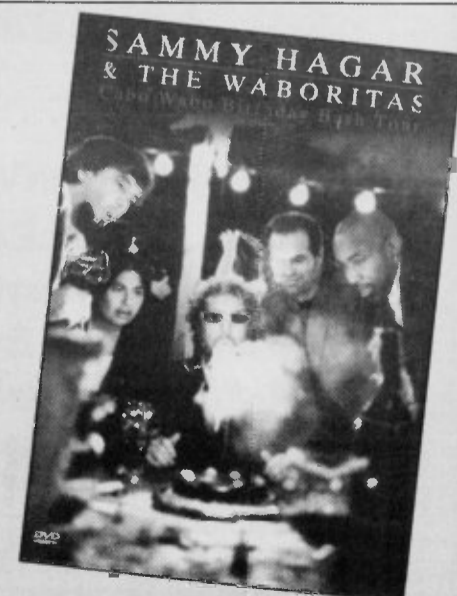

anyone wishing to experience three decades of rock history rolled into an unforgettable two-hour party. ¡Más Sammy! ¡Viva Hagar!

— Mark Wallgren

# Record Shows



Please call ahead before you travel. All information listed herein is provided by the show promoters, is subject to change and is not independently verified by the Goldmine staff. Show promoters who wish to have their record and CD shows listed should mail all pertinent information at least two months in advance of the show to: Goldmine Show Calendar, 700 E. State Street, Iola, WI 54990 or FAX to 715-445-4087.

**Nov 2-4 NY**, New York City. WFMU Spring Record Fair, Metropolitan Pavilion, 125 W. 18th St., SH: Fri. 4pm-10pm, Sat. 10am-8pm, Sun. 9am-7pm, T: 175. F: \$100., A: \$5. WFMU, Mike Lupica, PH: 201-521-1416 ext. 243.

**Nov 2-4 SPAIN**, Barcelona. Record Fair, Palau Alfons XIII, Fira de Barcelona, Avd. Maria Cristina, SH: Fri. 3pm-9pm, Sat & Sun. 10am-9pm. Jordi Tarda, PH: 00-34-937961323 or FAX: 00-34-93-7961866.

**Nov 3 IL**, Hillside. Record Convention, Holiday Inn, I-290 & Wolf Rd., SH: 9am-4pm, F: \$45-\$50., A: \$3. ARC Promotions, PH: 765-646-5305 or FAX: 765-378-7706.

**Nov 3 IN**, Indianapolis. Music Collectors' Convention, Quality Inn-East, 3525 N. Shadeland, SH: 10am-3pm, F: \$30. If paid one week in advance, F: \$40, thereafter, A: \$2, with coupon, \$3, without, under 12 free with adult. Alpha Records & Music, Gerald Ruark, POB 17575, Indianapolis, IN 46217, PH: 317-882-3378.

**Nov 3 NC**, Greensboro. Record & CD Show, Oriental Shrine Club, 5010 High Point Rd., 2 mi. S. of I-40, SH: 10am-5pm, A: \$3., under 12 free. Show Logic Productions, 109 Susan Dr., Warner Robins, GA 31093, PH: 478-929-3053.

**Nov 3 ENGLAND**, Birmingham. Music Fair, Academy, Dale End, T: 6', Rob Lythall, VIP Events, PH: 0116-224-4300 or FAX: 0116-224-4299.

**Nov 3 ENGLAND**, London. Music Fair, Electric Ballroom, Camden High St., T: 6', Rob Lythall, VIP Events, PH: 0116-224-4300 or FAX: 0116-224-4299.

**Nov 4 CT**, Waterbury. Record Collectors' Convention, Sheraton Hotel, 3590 E. Main St., SH: 9:30am-4pm, T: 8', F: \$65., A: \$4. Gorman, PH: 203-287-8923.

**Nov 4 MO**, St. Louis. Record & CD Show, American Czech Center, Kingshighway & Landsdown, SH: 10am-4pm, F: \$30., A: \$2.50. Jim Ronat, 1908 Main St., Highland, IL 62249, PH: 618-654-3049 or Carl Kuelker, PH: 314-821-9121.

**Nov 4 NC**, Hillsborough. Record & CD Show, Daniel Boone Convention Ctr., I-85 at Exit 164, SH: 10am-5pm, A: \$3., under 12 free. Show Logic Productions, 109 Susan Dr., Warner Robins, GA 31093, PH: 478-929-3053.

**Nov 4 OH**, Toledo. Record Show, Somerset Hall, 2458 Tremainsville Rd. (at Douglas & Laskey Rds.), SH: 9am-4pm, T: 8', F: \$20., A: \$1. Bill Simmons, PH: 419-833-5040.

**Nov 4 OH**, Cincinnati. Music Collectors' Convention, Radisson Hotel, 11320 Chester Rd., SH: 10am-3pm, F: \$30. If paid one week in advance, F: \$40, thereafter, A: \$2, with coupon, \$3, without, under 12 free with adult. Alpha Records & Music, Gerald Ruark, POB 17575, Indianapolis, IN 46217, PH: 317-882-3378.

**Nov 4 ON**, Hamilton. Record & CD Show, Ramada Hotel, 150 King St. E., SH: 10:30am-5pm, A: \$3. Puttin' On The Ritz, PH: 905-523-4484.

**Nov 4 ENGLAND**, Leicester. Music Fair, Aylestone Leisure Centre, Saffron Ln., T: 6'. Rob Lythall, VIP Events, PH: 0116-224-4300 or FAX: 0116-224-4299.

**Nov 4 FRANCE**, Epinal. Record Fair, (88) Espace Cour-Rue Gambetta, Sagadis, Fernand Piqueras, 411 Quai Jean Jaures 71000 Macon France. PH: (33) 0385384666 or FAX: (33) 0385380949.

**Nov 10 FL**, Tampa. Record & CD Show, Holiday Inn Express, 4732 N. Dale Mabry Hwy., SH: 10am-4pm, A: \$1. Richard Rounds, PO Box 2716, Pinellas Park, FL 33780. PH: 727-520-8766.

**Nov 10 IN**, Fort Wayne. Record & CD Show, Holiday Inn, 3330 Coliseum Blvd., just E. of the intersection of US 30 & I-69, SH: 11am-5pm, T: 40-6' & 8', F: \$40-\$45., A: \$2. Blain, PH: 616-323-7262.

**Nov 10 NH**, Concord. Record & CD Fair, Holiday Inn, Downtown, SH: 10am-4pm, F: \$30., A: \$1. Sound Garden, PH: 603-753-0122.

**Nov 10 NJ**, Wayne. 2nd Sat. Record & CD Collectors Show, Firemen's Convention Center, Parish Dr. (N. of Rt. 46 & Rt. 80) at Rt. 23 & Rt. 202S, SH: 10am-4pm, T: 100, A: \$5., under 12 free. F. Falk, PO Box 849, Highland Lakes, NJ 07422, PH: 973-773-6067.

**Nov 10 NY**, New York. Music Memorabilia Show, Tip Top Shoe Bldg, 155 W. 72nd St., 4th Floor, SH: 10am-2pm, A: free. PH: 212-579-0689 weekdays.

**Nov 10 OH**, Columbus. Record & Music Memorabilia Show, Veterans Memorial Hall, 300 W. Broad St., SH: 10am-4pm, T: 6', F: \$45. ea. for 1st 2, \$40. ea. for 3 or more, A: \$4. Collector's Paradise, PO Box 261016, Columbus, OH 43226, PH: 614-261-1585.

**Nov 10 ENGLAND**, Norwich. Music Fair, St. Andrews Halls, St. Andrews Plain, T: 6'. Rob Lythall, VIP Events, PH: 0116-224-4300 or FAX: 0116-224-4299.

**Nov 10 ENGLAND**, Luton. Music Fair, Luton University, Park St., T: 6'. Rob Lythall, VIP Events, PH: 0116-224-4300 or FAX: 0116-224-4299.

**Nov 11 KY**, Louisville. Music Collectors' Convention, Exec. Inn, Watterson Expwy. & Fairgrounds, SH: 10am-3pm, F: \$30. one week in advance, \$40, thereafter, A: \$2, with coupon, \$3, without, under 12 free with adult. Alpha Records & Music, Gerald Ruark, POB 17575, Indianapolis, IN 46217, PH: 317-882-3378.

**Nov 11 MA**, Springfield. Record Convention with Rock102, Civic Ctr. 1277 Main St., SH: 10am-4pm, T: 70-8', F: \$60., A: \$4. Greater Promos., Ken & Alanna Sultar, PO Box 896, South Windsor, CT 06074, PH: 860-644-8044.

**Nov 11 MI**, Roseville. Metro Detroit Record Show, VFW Hall, 25671 Gratiot (N. of 10 Mile Rd.), SH: 10am-4pm, T: 65-8', F: \$40., A: \$3. Al Campbell, PO Box 277, Warren, MI 48090, PH: 810-759-5133 eves.

**Nov 11 MI**, Grand Rapids. Record & CD Collectors Show, Midway Hotel, Best Western, 4104 28th St. SW, SH: 11am-5pm, T: 50-6' & 8', F: \$40-\$45., A: \$2. Blain, PH: 616-323-7262.

**Nov 11 OR**, Portland. Music Expo CD & Record Convention, Holiday Inn, Columbia Conference Ctr., 8439 NE Columbia Blvd., SH: 10am-6pm, T: 8', F: \$65., A: \$3. C-Bub Productions, 8316 N. Lombard St. #413, Portland, OR 97203, PH: 503-224-6474.

**Nov 11 PA**, Lancaster. Pennsylvania Music Expo, Catholic H.S. Cafeteria, 650 Juliette Ave., (rear), 1 mi. S. of US Rt. 30, SH: 9am-3pm, A: free. Keystone Record Collectors, PO Box 1516, Lancaster, PA 17608, PH: 717-898-1246.

**Nov 11 PA**, Pittsburgh-Monroeville. New Rock & Roll Expo, The Palace Inn, Rts. 22 & 48, SH: 10am-5pm, T: 8', F: \$50., A: \$4. Jeff Smittle, Box 514, Muse, PA 15350, PH: 724-746-3638.

**Nov 11 VA**, McLean. Northern VA Record Mart, Best Western Westpark Hotel, Rt. 7 & Westpark Dr. (I-495, Exit 47), SH: 10am-4pm, T: 80, F: \$60-\$70., A: \$4. Annapolis Marketing Inc., PO Box 454, Arnold, MD 21012, PH: 410-757-6182.

**Nov 11 WI**, Milwaukee. Vinyl Record Show, Westwood Hotel, 201 N. Mayfair Rd. (off I-94 & Hwy. 100), SH: 9am-3pm, T: 8', F: \$35., A: \$2. Yesterdays Music, Jim, PH: 920-733-5076.

**Nov 11 ON**, Guelph. Record & CD Show, Ramada Hotel, 716 Gordon St., opposite Univ. of Guelph, SH: 10:30am-5pm, A: \$3. Puttin' On The Ritz, PH: 905-523-4484.

**Nov 11 FRANCE**, Lons Le Saunier. Record Fair, (39) Juraparc, Sagadis, Fernand Piqueras, 411 Quai Jean Jaures 71000 Macon France. PH: (33) 0385384666 or FAX: (33) 0385380949.

**Nov 16 KY**, Covington. CD & Record Show, Holiday Inn Riverfront, 600 W. 3rd St., Cincinnati, OH, SH: 4pm-10pm, T: 25-6', F: \$40., A: \$2. Rock Shop, Kevin Folkert, PO Box 1007, Greenville, OH 45331, PH: 937-548-8364.

**Nov 16 OH**, Cincinnati. CD & Record Show, Holiday Inn Riverfront, 600 W. 3rd St., Covington, KY, SH: 4pm-10pm, T: 25-6', F: \$40., A: \$2. Rock Shop, Kevin Folkert, PO Box 1007, Greenville, OH 45331, PH: 937-548-8364.

**Nov 17 KY**, Lexington. CD & Record Show, Continental Inn, 801 New Circle Road NE, SH: 10am-4pm, T: 40-6', F: \$50., A: \$2. Kevin Folkert, PO Box 1007, Greenville, OH 45331, PH: 937-548-8364.

**Nov 17 NY**, New York City. Classical Music Expo, The Inn. (Formerly Days Inn) 440 W. 57th St., btw. 9th & 10th Aves., SH: 10am-4pm, T: 70, A: \$6., under 12 free. F. Falk, PO Box 849, Highland Lakes, NJ 07422, PH: 973-773-6067.

**Nov 17 NY**, New York City. Record & CD Collectors Expo, Holiday Inn. (Formerly Days Inn) 440 W. 57th St., btw. 9th & 10th Aves., SH: 10am-4pm, T: 100, A: \$6., under 12 free. F. Falk, PO Box 643, Highland Lakes, NJ 07422, PH: 973-773-6067.

**Nov 17 ENGLAND**, London. Music Fair, Electric Ballroom, Camden High St., T: 6'. Rob Lythall, VIP Events, PH: 0116-224-4300 or FAX: 0116-224-4299.

**Nov 17 ENGLAND**, Bristol. Music Fair, Bierkeller, The Pithay, T: 6'. Rob Lythall, VIP Events, PH: 0116-224-4300 or FAX: 0116-224-4299.

**Nov 18 CA**, San Francisco. Rock 'n' Swap, University of San Francisco, McLaren Hall, SH: 10am-4pm, F: \$55., \$30. ea. add'l., A: \$2. KUSF, Robert Barone, 2130 Fulton St., San Francisco, CA 94117, PH: 415-386-5873.

**Nov 18 IL**, Hillside. Chicagoand Record Collectors Show, Holiday Inn, 4400 Frontage Rd., SH: 9am-4pm, T: 70-8', F: \$40., A: \$3. John Govi, 3045 Worcester Ln., Aurora, IL 60504, PH: 630-898-1533 eves.

**Nov 18 MD**, Arbutus. Record & CD Show, Fire Hall, 5200 Southwestern Blvd., SH: 10am-4pm, T: 120-5', F: \$30., A: free. Ray or Chris Quigley, 1 Colgate Ct., Baltimore, MD 21228, PH: 410-455-0418.

**Nov 18 MA**, Randolph. New England Record & Compact Disc Expo, Lombardo's, 6 Billings Rd., 15 min. S. of Boston next to the Holiday Inn, SH: 10am-5pm, A: \$4. Randolph Music Center, PH: 781-986-4538.

**Nov 18 NY**, Amityville. Record Collectors Show, American Legion Hall, Post 1015, Park Ave., SH: 9am-4pm, F: \$55. in advance, \$60. at the door, A: \$4. R. Scull, PO Box 229, Coram, NY 11727, PH: 631-331-7750 no collect calls.

**Nov 18 NY**, New York. Supper Soul the NY City Record Convention, Gramercy Park Hotel, 2 Lexington Ave. at 21st St., SH: 10am-5pm. Record King, PH: 917-701-7089 or 506-1772.

**Nov 18 NY**, New York. Movie Memorabilia Convention, Hotel Pennsylvania in the Gold Ballroom, SH: 10am-7pm. The Last Moving Picture Co., 10535 Chillicothe Rd., Kiriland, OH 44094, PH: 440-256-3660 or 256-3431.

**Nov 18 OH**, Toledo. Glass City Record, Tape & CD Show, Knights of Columbus Hall, 4256 Secor Rd., SH: 10am-4pm, T: 8', F: \$25., A: \$2. Stephen or Becky, PH: 419-874-1725.

**Nov 18 OH**, Fairview Park. Record & CD Convention, American Legion Hall, 22001 Brookpark Rd., I-480, Exit 9 Grayton Rd., SH: 10am-4pm, A: \$3. Ted Szlag, PH: 440-884-4125.

**Nov 18 PA**, Scranton-Wilkes Barre. WEZX NY CD & Record Fair, The Woodlands Inn, 1073 Rt. 315 (Exit 47B, I-81 to Exit 1 off ramp), SH: 10am-5pm, T: 70-8', A: \$4. Jack Skutnik, 7 Charnel Dr., Binghamton, NY 13901, PH: 607-648-4997 or FAX: 607-648-9626.

**Nov 18 TN**, Nashville. CD & Record Show, Holiday Inn Select, 2613 West End Ave., SH: 10am-4pm, T: 30-6', F: \$50., A: \$2. Kevin Folkert, PO Box 1007, Greenville, OH 45331, PH: 937-548-8364.

**Nov 18 VA**, Dale City. Collector's Festival, VFW Post 1503, Minnieville Rd., SH: 10am-4pm, T: 6', F: \$30. for 1, \$45. for 2, A: \$1. PH: 703-494-9886.

**Nov 18 BC**, Vancouver. Music & Record Show, Ukrainian Centre, 3150 Ash St., off 16th Ave., 1 blk. W. of Cambie, SH: 11am-4pm, A: \$2. PH: 604-941-6204.

**Nov 18 FRANCE**, Montbellard. Record Fair, (25) Centre De Congres Atria, Sagadis, Fernand Piqueras, 411 Quai Jean Jaures 71000 Macon France. PH: (33) 0385384666 or FAX: (33) 0385380949.

**Nov 18 ENGLAND**, Nottingham. Beatles Roadshow Day, Steve Holmes, 36 Brookglen Rd., Risingbrook, Stafford ST17 9DG England, PH: 0102 682008 or Mobile, PH: 07801 564622.

**Nov 24-25 PA**, Philadelphia. 16th Annual Rock 'N' Roll Expo, Valley Forge Conv. Ctr. Exit 25 off Schuylkill Expy., Exit 24 off PA Tpke., SH: 10am-6pm. Arc Promotions, PH: 765-646-5305.

**Nov 24-25 ENGLAND**, Wembley. Music Fair, Complex. Empire Way, North London, T: 6'. Rob Lythall, VIP Events, PH: 0116-224-4300 or FAX: 0116-224-4299.

**Nov 25 CA**, Buena Park. Greater Orange County Monthly Record Show, Sequoia Club, 7530 Orangethorpe Ave., SH: 10am-3pm, T: 135-8', F: \$50. for 1, \$95. for 2, A: \$3. Steve Brunner, PH: 626-963-9717.

**Nov 25 ON**, Niagara Falls. Record & CD Show, Legion Br. #51, 5743 Valleyway, SH: 10:30am-4:30pm, A: \$3. Puttin' On The Ritz, PH: 905-523-4484.

**Nov 25 FRANCE**, Troyes. Record Fair, (10) Parc Des Expositions, Sagadis, Fernand Piqueras, 411 Quai Jean Jaures 71000 Macon France. PH: (33) 0385384666 or FAX: (33) 0385380949.

**Dec 1 IL**, Hillside. Record Convention, Holiday Inn, I-290 & Wolf Rd., SH: 9am-4pm, F: \$45-\$50., A: \$3. ARC Promotions, PH: 765-646-5305 or FAX: 765-378-7706.

**Dec 1 MA**, Chelmsford. Big Ed's Record, CDs & Tapes Show, Elks Lodge, Rt. 110, SH: 10am-4pm, A: \$3. PH: 603-888-0294.

**Dec 1 ENGLAND**, London. Music Fair, Electric Ballroom, Camden High St., T: 6'. Rob Lythall, VIP Events, PH: 0116-224-4300 or FAX: 0116-224-4299.

**Dec 1 ENGLAND**, Wolverhampton. Music Fair, Civic Halls, North St., T: 8'. Rob Lythall, VIP Events, PH: 0116-224-4300 or FAX: 0116-224-4299.

**Dec 2 FL**, Orlando. Record Show, Central FL Fairgrounds, 4603 W. Colonial Dr., SH: 10am-4pm, T: 70-8', F: \$60., A: \$3. FL Record Collectors Association, Inc., Jeff Smith, PH: 352-331-5928 or Syd Crosby, PH: 904-454-0530.

**Dec 2 PA**, Allentown. Winter 2001 Lehigh Valley Music Expo, Merchants Square, 12th & Vultee Sts., SH: 10am-4pm, T:

ARC PROMOTIONS PRESENTS...

# PHILADELPHIA

## ROCK 'N' ROLL EXPO

Saturday, November 24th & Sunday, November 25th

Dealer Set-up Friday, November 23rd

EXPO HOURS: 10AM-6PM

VALLEY FORGE CONVENTION CENTER  
SHERATON COMPLEX

King Of Prussia, Pennsylvania

Exit #25 off Schuylkill Expressway

Exit #24 off the Pennsylvania Turnpike

16TH  
ANNUAL

BUY - SELL - TRADE

COMPACT DISCS - RECORDS - POSTERS

T-SHIRTS - COLLECTIBLES and

MUSIC MEMORABILIA

OVER 250 DEALER TABLES

Admission To The Public Is Still Free!

Arc Promotions

P.O. Box 215

Chesterfield, In. 46017

Phone 765-646-5305 Fax 765-378-7706

E-mail: [arcpromos@aol.com](mailto:arcpromos@aol.com)

CO-SPONSORED BY WMMR



8', F: \$55. before Nov 25, \$65 thereafter, A: \$3. Surround Sound Prods., 801 N. Broad St., Wescosville, PA 18106. PH: 610-530-7606 or 797-7743 day of show.

Dec 2 **TN**, Nashville. Music Collectors' Convention, Day's Inn-Airport, Briley Pkwy., SH: 10am-3pm, F: \$30. if paid one week in advance, \$40. thereafter, A: \$2. with coupon, \$3. without, under 12 free with adult, 10am-3pm. Alpha Records & Music, Gerald Ruark, POB 17575, Indianapolis, IN 46217. PH: 317-882-3378

Dec 2 **WA**, Seattle. Record & CD Show, Seattle Ctr. Snoqualmie Room. SH: 10am-5pm, F: \$45., A: \$3. John. PH: 425-228-3537

Dec 2 **WI**, Appleton. Fox Valley Record Show, Best Western Midway Hotel, 3033 W College Ave., SH: 9am-3pm, T: 6' & 8'. F: \$30. \$35., A: \$2. Yesterdays Music, Jim, PH: 920-733-5076

Dec 2 **FRANCE**, Aix Les Bains. Record Fair, (73) Centre De Congres. Sagadis, Fernand Piqueras, 411 Quai Jean Jaures 71000 Macon France. PH: (33) 0385384666 or FAX: (33) 0385380949

Dec 8 **MN**, Minneapolis. Record Show, VFW, 2916 Lyndale Ave. S., F: \$35., A: \$2. Rich Shelton, 255 E. Kellogg St., Paul, MN 55101. PH: 651-290-2900

Dec 8 **NJ**, Wayne. 2nd Sat. Record & CD Collectors Show, Firemen's Convention Center, Parish Dr. (N. of Rt. 46 & Rt. 80) at Rt. 23 & Rt. 202S, SH: 10am-4pm, T: 100, A: \$5., under 12 free. F: Falk, PO Box 849, Highland Lakes, NJ 07422. PH: 973-773-6067

Dec 8 **NY**, New York. Music Memorabilia Show, Tip Top Shoe Bldg, 155 W. 72nd St., 4th Floor, SH: 10am-2pm, A: free. PH: 212-579-0689 weekdays

Dec 8 **OH**, Dayton. Music Collectors' Convention, Hara Arena, 1001 Shiloh Springs Rd., SH: 10am-3pm, F: \$30. if paid one week in advance, F: \$40. thereafter, A: \$2. with coupon, \$3. without, under 12 free with adult. Alpha Records & Music, Gerald Ruark, POB 17575, Indianapolis, IN 46217. PH: 317-882-3378

Dec 8 **ENGLAND**, Walsall. Music Fair, Town Hall, Leicester St., T: 7.5'. Rob Lythall, VIP Events, PH: 0116-224-4300 or FAX: 0116-224-4299

Dec 9 **CA**, Newark. Music Swap Meet, Pavilion, 6430 Thornton Ave., corner of Thornton & Cherry, SH: 9am-2pm, F: \$45. for 1, \$60. for 2, A: \$3. Charlene White, PH: 408-263-5127

Dec 9 **CT**, Waterbury. Record Collectors' Convention, Sheraton Hotel, 3580 E. Main St., SH: 9:30am-4pm, T: 8', F: \$65., A: \$4. Gorman, PH: 203-287-8923

Dec 9 **IN**, Indianapolis. Music Collectors' Convention, Quality Inn-East, 3525 N. Shadeland, SH: 10am-3pm, F: \$30. if paid one week in advance, F: \$40. thereafter, A: \$2. with coupon, \$3. without, under 12 free with adult. Alpha Records & Music, Gerald Ruark, POB 17575, Indianapolis, IN 46217. PH: 317-882-3378

Dec 9 **IA**, Des Moines. Record & CD Convention, Four Points Sheraton, 4800 Merle Hay Rd., SH: 10am-4pm, T: 8', F: \$40., A: \$3. Play It Again Records, PH: 608-562-6313

Dec 9 **PA**, Lancaster. Pennsylvania Music Expo, Catholic H.S. Cafeteria, 650 Juliette Ave., (rear), 1 mi. S. of US Rt. 30, SH: 9am-3pm, A: free. Keystone Record Collectors, PO Box 1516, Lancaster, PA 17608. PH: 717-898-1246

Dec 9 **HUNGARY**, Budapest. 16th International Record Fair, Petofi Csarnok Varosliget, H-1146 Budapest, Zichy Mihaly str. 14. Lemezborze, plusz Magazine, 1300 Budapest, Pf. 129. Hungary. PH: 0036 14300990 or FAX: 0036 14300991

Dec 15 **NY**, New York City. Record & CD Collectors Expo, Holiday Inn, (Formerly Days Inn) 440 W. 57th St., btw 9th & 10th Aves., SH: 10am-4pm, T: 100, A: \$6., under 12 free. F: Falk, PO Box 643, Highland Lakes, NJ 07422. PH: 973-773-6067

Dec 15 **ENGLAND**, London. Music Fair, Electric Ballroom, Camden High St., T: 6'. Rob Lythall, VIP Events, PH: 0116-224-4300 or FAX: 0116-224-4299

Dec 15 **ENGLAND**, Cardiff. Music Fair, City Hall, Cathay's Park, T: 6'. Rob Lythall, VIP Events, PH: 0116-224-4300 or FAX: 0116-224-4299

0116-224-4299

Dec 16 **GA**, Atlanta. Record & CD Show, Ramada Inn, I-85, Exit 86, 418 Armour Dr., SH: 10am-4pm, A: \$3. Keith Alverson, PH: 770-463-2727

Dec 16 **MD**, Arbutus. Record & CD Show, Fire Hall, 5200 Southwestern Blvd., SH: 10am-4pm, T: 120-5', F: \$30., A: free. Ray or Chris Quigley, 1 Colgate Ct., Baltimore, MD 21228. PH: 410-455-0418

Dec 16 **NY**, Binghamton. WAAL NY CD & Record Fair, Heritage Country Club, 4301 Watson Blvd. (Rt. 17 W., Exit 70 N., L. at 1st light, 5 mi. on R.), SH: 10am-5pm, T: 70-8', A: \$4. Jack Skutnik, 7 Charnel Dr., Binghamton, NY 13901. PH: 607-648-4997 or FAX: 607-648-9626

Dec 16 **WI**, Milwaukee. Record Fest, Serb Hall, 5101 W. Oklahoma Ave., SH: 10am-3pm, F: \$45-\$55., A: \$4. Gary Mason, PH: 414-442-6060 (11am-5pm)

Dec 16 **ENGLAND**, Bath. Music Fair, Sports Centre, North Parade Rd., T: 6'. Rob Lythall, VIP Events, PH: 0116-224-4300

Dec 22 **ENGLAND**, Birmingham. Music Fair, Academy, Dale End, T: 6'. Rob Lythall, VIP Events, PH: 0116-224-4300 or FAX: 0116-224-4299

Dec 22 **ENGLAND**, London. Music Fair, Electric Ballroom, Camden High St., T: 6'. Rob Lythall, VIP Events, PH: 0116-224-4300 or FAX: 0116-224-4299

Dec 29 **NJ**, Wayne. 2nd Sat. Holiday Record-CD-Tape Collectors Show, Firemen's Convention Center, Parish Dr. (N. of Rt. 46 & Rt. 80) at Rt. 23 & Rt. 202S, SH: 10am-4pm, T: 100, A: \$5., under 12 free. F: Falk, PO Box 849, Highland Lakes, NJ 07422. PH: 973-773-6067

Dec 29 **ENGLAND**, London. Music Fair, Electric Ballroom, Camden High St., T: 6'. Rob Lythall, VIP Events, PH: 0116-224-4300 or FAX: 0116-224-4299

Jan 5 **OH**, Columbus. Record & Music Memorabilia Show, Veterans Memorial Hall, 300 W. Broad St., SH: 10am-4pm, T: 6', F: \$45. ea. for 1st 2, \$40. ea. for 3 or more, A: \$4. Collector's Paradise, PO Box 261016, Columbus, OH 43226. PH: 614-261-1585

43226. PH: 614-261-1585

Jan 12 **NY**, New York. Music Memorabilia Show, Tip Top Shoe Bldg, 155 W. 72nd St., 4th Floor, SH: 10am-2pm, A: free. PH: 212-579-0689 weekdays

Jan 13 **IL**, Hillside. Chicagoand Record Collectors Show, Holiday Inn, 4400 Frontage Rd., SH: 9am-4pm, T: 70-8', F: \$40., A: \$3. John Govi, 3045 Worcester Ln., Aurora, IL 60504. PH: 630-998-1533 eves

Jan 13 **FRANCE**, Macon. Record Fair, (71) Centre Heritan. Sagadis, Fernand Piqueras, 411 Quai Jean Jaures 71000 Macon France. PH: (33) 0385384666 or FAX: (33) 0385380949

Jan 20 **CA**, San Francisco. Rock 'n Swap, University of San Francisco, McLaren Hall, SH: 10am-4pm, F: \$55, \$30. ea. add'l., A: \$2. KUSF, 2130 Fulton St., San Francisco, CA 94117. PH: 415-386-5873

Jan 20 **PA**, Pittsburgh-Monroeville. New Rock & Roll Expo, The Palace Inn, Rts. 22 & 48, SH: 10am-5pm, T: 8', F: \$50., A: \$4. Jeff Smittle, Box 514, Muse, PA 15350. PH: 724-746-3638

Jan 26 **PA**, Montgomery. Beatles Fest, Clinton Township Vol. Fire Company, Rt. 54, SH: 7pm-11pm, A: \$3., \$5. couple, Jimmy Stabley, PH: 570-326-4280 or Tom Staggett, PH: 570-547-6254

Jan 27 **FRANCE**, Vesoul. Record Fair, (70) Salle Parisot. Sagadis, Fernand Piqueras, 411 Quai Jean Jaures 71000 Macon France. PH: (33) 0385384666 or FAX: (33) 0385380949

Feb 1-2 **IA**, Clear Lake. Record Convention, Lake Lanes, 514 Buddy Holly Place, SH: 10am-6pm, T: 8', F: \$75-\$100. Play It Again Records, PH: 608-562-6313

Feb 2 **FL**, Tampa. Record & CD Show, Holiday Inn Express, 4732 N. Dale Mabry Hwy., SH: 10am-4pm, F: \$30., A: \$1. Richard Rounds, PO Box 2716, Pinellas Park, FL 33780. PH: 727-520-8766

Feb 2-3 **ITALY**, Milano. "Vinilmania" International Record & CD Fair, Parco Esposizioni Novegro (Milano Linate Airport), Dario Maffioli, Corso Buenos Aires 43, 20124 Milano Italy. FAX: 39-029510638

Feb 3 **OH**, Toledo. Glass City Record, Tape & CD Show, Knights of Columbus Hall, 4256 Secor Rd., SH: 10am-4pm, T: 8', F: \$25., A: \$2. Stephen or Becky, PH: 419-874-1725

Feb 9-10 **FL**, Orlando. Music Collector's Convention, Expo Ctr. 600 W. Amelia St., SH: Sat. & Sun. 10am-5pm, F: \$60. in advance, \$70. after Jan 1, A: \$3. Stylus Shows, Hal, PH: 301-570-5524

Feb 10 **OR**, Eugene. Record Show, Convention, 66 E. 6th Ave., SH: 10am-5pm, T: 100-8', F: \$45., A: \$2. Bill Finneran, PH: 541-485-7920 or FAX: 541-345-6220

Feb 10 **FRANCE**, Belfort. Record Fair, (90) Centre Congres Atria, Sagadis, Fernand Piqueras, 411 Quai Jean Jaures 71000 Macon France. PH: (33) 0385384666 or FAX: (33) 0385380949

Feb 16 **MA**, Chelmsford. Big Ed's Record, CDs & Tapes Show, Elks Lodge Rt. 110, SH: 10am-4pm, A: \$3. PH: 603-888-0294

Feb 24 **CT**, East Hartford. Record Convention, Pratt & Whitney Aircraft Club, 200 Clement Rd. (84 E. or W., Exit 58, 91 N., Exit 29 to Exit 91), SH: 10am-4pm, T: 90-6', F: \$45., A: \$4. Greater Promos, Ken & Alanna Sultar, PO Box 896, South Windsor, CT 06074. PH: 860-644-8044

Feb 24 **NY**, Amityville. Record Collectors Show, American Legion Hall, Post 1015, Park Ave., SH: 9am-4pm, F: \$55. in advance, \$60. at the door, A: \$4. R. Scull, PO Box 229, Coram, NY 11727. PH: 631-331-7750 no collect calls

Feb 24 **VA**, Richmond. Record & CD Show, Holiday Inn Hotel, 2000 Staples Mill Rd. (Rt. 33 E. off I-64), SH: 10am-4:30pm, T: 6', F: \$35. before Sep 10, \$45. thereafter, A: \$2.50, \$5.00 students & seniors, under 12 free. Stand Still Music, PH: 804-422-6772

Mar 9 **OH**, Columbus. Record & Music Memorabilia Show, Veterans Memorial Hall, 300 W. Broad St., SH: 10am-4pm, T: 6', F: \$45. ea. for 1st 2, \$40. ea. for 3 or more, A: \$4. Collector's Paradise, PH: 614-261-1585

Mar 14-17 **AZ**, Scottsdale. National Festival of the West, West-World, 16601 N. Pima Rd. PH: 602-996-4387

STYLUS SHOWS PRESENTS THE 2002

# ORLANDO

## MUSIC COLLECTOR'S CONVENTION

SAT - SUN FEB 9 - 10  
10am - 5pm

DOWNTOWN EXPO CENTRE  
NEW / OLD / RARE / COLLECTIBLE  
LPS, CDS, 33S, 45S, 78S, DVDS,  
POSTERS, MEMORABILIA

HEAVY PUBLIC ADVERTISING

EARLY BIRD TABLE SPECIAL  
SAVE 40% 'TIL NOV. 30

STYLUS SHOWS 301-570-5524  
[record-shows.com](http://record-shows.com)

Since 1995.



# Siren Disc

Discount Import CDs & More.

[www.sirendisc.com](http://www.sirendisc.com)

## Show promoters!

Send your 2002 shows to us by Nov. 15 to have the listings included in next year's 2002 *Travel Guide*, published as a separate section in the Dec. 28, 2001-dated *Goldmine*. Extra copies will be printed for bonus distribution at shows in 2001.

Mail show information before Nov. 15 to:  
Goldmine Show Calendar Listings  
700 East State St.  
Iola, WI 54990

FAIRVIEW PARK, OHIO  
GREATER CLEVELAND

# RECORD & CD SHOW

AMERICAN LEGION HALL  
22001 BROOKPARK RD.  
FAIRVIEW PARK, OHIO

NOVEMBER 18, 2001

10A.M. - 4P.M. Admission: \$3.00  
I-480 Exit #9 Grayton Rd.  
- Turn right to Brookpark Rd.  
- Turn right on Brookpark Rd. to Hall.

For more information contact:  
Lawrence Pulsic  
2930 Remsen Rd., Medina, Ohio 44256  
Voice Mail: 1-888-717-0379  
- or -  
Ted Szlag: 1-440-884-4125



NEW YORK CITY  
COLLECTOR'S  
FEST

(SAT. DEC. 15<sup>TH</sup> 2001)  
10 A.M. - 4 P.M.

\* CD'S \* RECORDS \* TAPES  
\* POSTERS \* VIDEOS  
\* MEMORABILIA \* COMICS  
\* SPORTS CARDS & MUCH MORE \*

THE HOLY CROSS SCHOOL  
332 W 43rd Street  
Btwn. 8th & 9th Ave.

**FREE ADMISSION**  
8 Ft. Dealer Tables -- \$40<sup>00</sup>  
2 for \$70<sup>00</sup>

For dealer inquiries or more information:  
Contact: Gary. Ph # 718-972-3872  
E-Mail: VideoWizards@webtv.net

"SUPER SOUL"  
The New York City  
Record/CD Convention

**NEW LOCATION!!**

**SUNDAY**  
**NOVEMBER 18th, 2001**  
**10 A.M. - 5 P.M.**

**At the GRAMERCY PARK HOTEL**

2 Lexington Ave. at 21<sup>st</sup> Street  
on Lexington  
New York, New York 10010  
Featuring N.Y.C.'s best dealers  
and funkiest disc jockies!!!

For More Info Call  
**The Record King**  
**(917) 701-7089 or**  
**(917) 506-1772**  
[www.recordking117.com](http://www.recordking117.com)

The NEXT Original  
New England  
Compact Disc &  
Record Expo  
will be held at

**LOMBARDO'S**  
6 Billings Road  
(Junction of Routes 28 and 93) Exit 5A  
In Randolph, Massachusetts

**Sunday**  
**November 18, 2001**  
**10:00 AM - 5:00 PM**

With Thousands of CD's, Records, Videos,  
Cassettes, Memorabilia & Imports  
For Information & Directions Call

**RANDOLPH MUSIC CENTER**  
**(781) 986-4538**  
From Ashmont Station take Bus #240 to Randolph  
Holiday Inn Texaco Gas Station Stop

SECOND SATURDAY  
RECORD & CD EXPO

Saturday Nov. 10, 2001 10a - 4p  
Parish Dr (@ Rt 23 & 202S)  
North of Rt 80/46, Wayne, NJ

NEW YORK CITY  
RECORD & CD EXPO

Saturday Nov. 17, 2001 10a - 4p  
The "Inn", 440 W 57th St btwn  
9th & 10th Aves, New York City

\$1 off regular admission with this ad

INFO: 973-773-6067 or  
[fred@nji.com](mailto:fred@nji.com) or Web:  
[www.showsandexpos.com](http://www.showsandexpos.com)

Thanks, Northeast, for making all the previous shows sellouts!

# big ED'S

## RECORDS TAPES SHOW

DECEMBER 1, 2001 (SATURDAY)  
10:00 AM TO 4:00 PM  
CHELMSFORD ELKS LODGE  
RT. 110, CHELMSFORD, MA

★ ALSO SPECIAL GIVEAWAY ★

MEMORABILIA	RHYTHM & BLUES	COLLECTABLES
SOUND TRACKS	PHOTOS	METAL
AUTOGRAPHS	ROCK 'N' ROLL	POSTERS
JAZZ	LASER DISCS	COUNTRY
VIDEOS	TOP 40	IMPORTS
ROCKABILLY	MUSIC MAGS	GARAGE

ADMISSION \$3.00 \* EARLY BUYERS (7-9 AM) \$6.00  
FREE PARKING \* SHOW MONEY EVERY HOUR  
INFO AT (603) 888-0294 \* BIG FROGMAN@AOL.COM

Yesterdays Music  
Presents

The Milwaukee Vinyl Record Show

Sunday Nov. 11, 2001 9:00-3:00  
The Westwood Hotel 201 N. Mayfair Rd  
Off I-94 & Hwy 100 Milwaukee, WI

Tables: 8 ft. \$35 Admission: \$2  
Bring in this ad and save \$1 on Adm.  
Vinyl LP's, 45's, etc. and memorabilia  
from the 50's 60's, 70's and 80's.

For more information call Jim at  
**(920) 733-5076**, or e-mail us at  
[ystrdymuse@hotmail.com](mailto:ystrdymuse@hotmail.com).

RECORD & CD SHOW  
ORLANDO  
SUNDAY  
DECEMBER 2, 2001

ADMISSION \$3  
10 am - 4:00 pm

Central Florida Fairgrounds  
4603 W. Colonial Drive  
3.5 Miles West of I-4 & Colonial Drive

[www.FRCAninc.com](http://www.FRCAninc.com)

FEATURING

- Memorabilia
- Imports & Rarities
- Videos, Posters, Etc.
- Collectible & Out of Print CD's & Vinyl
- 1,000's of LP's & 45's
- Record & CD Supplies
- Free Parking

Florida Record Collectors Association Inc. Member P.S.M.A.

Phone 352-331-5928 or 904-454-0530

# STORE DIRECTORY

The following is a list of record shops around the country arranged by state. Be sure to mention that you saw them listed in Goldmine's Store Directory. Retailers listed in bold type carry Goldmine in their stores.

## ARIZONA

Memory Lane  
Out-Of-Print Records ★ Tapes ★ CDs  
1940 E. University Dr.  
Tempe, AZ 85281  
(480) 968-1512  
FAX (480) 921-1620  
<http://www.memorylanerecords.com>  
E-Mail: [mlr@memorylanerecords.com](mailto:mlr@memorylanerecords.com)  
Mail, phone, and web orders filled promptly... VISA ★ MC ★ AMEX ★ NOVUS... be sure to visit us when you're in Arizona.

## ARKANSAS

Arkansas Record CD Exchange  
4212 MacArthur Dr.  
North Little Rock, AR 72118  
(501) 753-7877  
FAX (501) 758-7556  
E-Mail: [are@cei.net](mailto:are@cei.net)  
Web: ARCD.com  
11 am to 7 pm Tues.-Sat.  
VISA/MC/AMEX. Your Record and CD Oasis Between Memphis and Dallas. Right on I-40 at Burns Park Exit. Thousands of 45s, LPs, CDs, CD Singles & Imports. New & Used, Buy-Sell-Trade. Send Want lists.

## CALIFORNIA

Armadillo Music Records  
210 E Street  
Davis, CA 95616  
(530) 750-2384  
FAX (530) 750-2385  
E-Mail: [armadillomusic@mother.com](mailto:armadillomusic@mother.com)  
Rare, out of print and new vinyl. New & Used CD's. Buy, Sell & Trade. Want lists welcome. We buy collections - large or small. Open 7 days.

Atomic Records  
3812 W. Magnolia Blvd.  
Burbank, CA 90026  
Phone: (818) 848-7090  
FAX (818) 848-1969  
E-Mail: [atomic1@flash.net](mailto:atomic1@flash.net)  
Specializing in rare/collectibles: Jazz - Soul - Rock - Exotica - Alternative - Childrens LPs & 45s.

Beat City Records  
2090 East Main Street  
Ventura, CA 93001  
(805) 653-5545  
Web: [www.beatcityrecords.com](http://www.beatcityrecords.com)  
E-Mail: [bcityrec@pacbell.net](mailto:bcityrec@pacbell.net)  
New/Used Records, CDs & Collectibles. Import & Domestic Vinyl in Stock. Posters by Coop, Kozik & Others. We Do Mail Orders.

CD Trader  
18928 Ventura Blvd.  
Tarzana, CA 91356  
818-705-3544  
Los Angeles's best used CD store!

Earth Wave Records  
Grand Opening October 1, 2000  
Come visit our brand new store!  
Hundreds of new arrivals daily!  
219B Southwest Blvd.  
Rohnert Park, CA 94928  
Tel: (707) 795-1660  
Fax: (707) 795-1665  
<http://www.earthwaverecords.com>  
E-Mail: [mallstaff@vintage.com](mailto:mallstaff@vintage.com) (English)  
E-Mail: [earthwave@home.com](mailto:earthwave@home.com) (日本語)  
\* Vintage US original records from 1950's - 1990's  
\* Largest selection of Japanese audiophile records in the U.S.  
We ship worldwide.  
Dealer discounts available.

過去7年間の皆様のご支援のおかげでこの度アースウェーブレコード1号店オープンの運びとなりました。レコードの買い付けや西海岸に遊びに来られる際は是非お立ち寄り下さい。

## CALIFORNIA

Goat Hill Records  
1920 Harbor Blvd.  
Costa Mesa, CA 92627  
(949) 646-8551  
Records • CDs • Collectibles • Rarities • Rock • Jazz • Blues • New • Used • Buy

House of Records  
3328 Pico Blvd.  
Santa Monica, CA 90405  
(310) 450-1222  
(310) 450-4525  
E-Mail: [info@houseofrecords.com](mailto:info@houseofrecords.com)  
Web: [www.houseofrecords.com](http://www.houseofrecords.com)  
LA's oldest record store. Collectible records and used CDs. Please visit when in California.

Record Man, The  
1322 El Camino Real  
Redwood City, CA 94063  
Phone: (650) 368-9065  
Fax: (650) 368-2968  
[www.recordman.com](http://www.recordman.com)  
E-Mail: [ARCHIVES@recordman.com](mailto:ARCHIVES@recordman.com)  
Find out why people are calling us the biggest and best record store around!!  
Over 1 Million Items In Stock; LPs, 45s, EPs, Picture Discs, 78s, CDs, Cassettes and reel-to-reels.

Rockaway Records  
2395 Glendale Blvd.  
Los Angeles, CA 90039  
Ph. (323) 664-3232  
FAX (323) 664-0956  
E-Mail: [sales@rockaway.com](mailto:sales@rockaway.com)  
[www.rockaway.com](http://www.rockaway.com)  
LA's best collectables! Vinyl, Compact Discs, Posters and Memorabilia from the 50's to the 90's. Open 7 days, 10 a.m. - 9:30 p.m.

Rock-It-Man  
55635 29 Palms Hwy.  
Yucca Valley, CA 92284  
Ph. 760-228-3304  
FAX: 760-228-3075  
Palm Springs largest selection of new & used CD's & Memorabilia.

Saturn Records  
5488 College Ave.  
Oakland, CA 94618  
Phone: (510) 654-0335  
FAX: (510) 654-4386  
Fully searchable Web site with secure server for easy and safe credit card ordering: [www.saturn-records.com](http://www.saturn-records.com)  
San Francisco Bay Area's premier collector's record store.

Streetlight Records  
980 South Bascom Ave.  
San Jose, CA  
(888) 330-7776  
939 Pacific Ave., Santa Cruz, CA  
(888) 648-9201  
3979 24th St., San Francisco, CA  
(888) 682-3550  
2350 Market St., San Francisco, CA  
(888) 396-2350  
[www.streetlightrecords.com](http://www.streetlightrecords.com)  
Buy, Sell, Trade all kinds of CD's, LP's, Videos, DVD's and Collectibles. Secure E-store.

## FLORIDA

Blue Note Records  
16401 NE 15th Avenue  
N. Miami Beach, FL 33162  
(305) 940-3394  
FAX (305) 948-3523  
E-Mail: [BLUENOTE@NETROX.NET](mailto:BLUENOTE@NETROX.NET)  
Largest selection of Jazz, Soul, Blues, 10", LPs, 34s & Rare 50s & 60s originals. Specializing in 70s & 80s originals & White Label 12". Just opened our new Jazz store.  
Phone: 305-354-4563

## FLORIDA

Offbeat Records & CD's Inc.  
937 S. State Road 7 (US 441)  
Ft. Lauderdale, FL 33317  
Phone: (954) 316-9084  
Fax: (954) 316-9391  
Web site: [www.offbeatrecords.com](http://www.offbeatrecords.com)  
E-Mail: [offbeatrecords@aol.com](mailto:offbeatrecords@aol.com)  
Hours: Wed.-Sat. 11:00 a.m. - 5:00 p.m.  
Sun. 12 Noon - 4 p.m.  
Closed Mon. & Tues.  
South Florida's coolest music collector's shop! We specialize in rare LPs, CDs, 8 tracks, reel tapes, music posters & vintage audio equipment! Please phone / fax / e-mail wants. WE BUY COLLECTIONS!

Play It Again, Inc.  
3148 W. New Haven Ave.  
West Melbourne, FL 32904  
(321) 724-5685  
FAX: (321) 722-1215  
[WWW.PLAYITAGAINRECORDS.COM](http://WWW.PLAYITAGAINRECORDS.COM)  
E-Mail: [playitagain@iu.net](mailto:playitagain@iu.net)  
Florida's best kept secret. Where dealers shop. Want list and dealers welcome.

Rock & Roll Heaven Inc.  
1814 N. Orange Ave.  
Orlando, FL 32804  
Phone: 407-896-1952  
FAX: 407-896-2130  
E-Mail: [rockroll@magicnet.net](mailto:rockroll@magicnet.net)  
Central Florida's oldest and largest source for every format and every category including books, mags, t-shirts, posters, 12's, 45's, LP's, cass, CD's, new-used, everything!

Soundgreat! Recycled Music  
853 S. Orlando Ave. (17/92)  
Winter Park, FL 32789  
407-599-7277  
Buy • Sell • Trade all types of vinyl records Orlando area. Interstate 4 to exit #45 (Fairbanks Ave.) 1 mile east to Orlando Ave. 1 block south on right. Inside Orange Tree Antiques Mall.  
Visit Our New On-Line Store  
At: [www.tias.com/stores/sg/](http://www.tias.com/stores/sg/)

Yesterday & Today Records  
7902 NW 36th St., Suite 210  
Miami, FL 33166  
(305) 468-0311  
FAX (305) 468-0313  
Web site: [www.vintagerecords.com](http://www.vintagerecords.com)  
E-Mail: [yandtre@aol.com](mailto:yandtre@aol.com)  
NEW LOCATION! A few minutes from Miami Airport. We carry oldies - 45s, LPs, CDs. Imports - specialize in 60s/70s, Psych/Prog Rock. Buy/Trade/Sell. Want lists welcome.

## GEORGIA

Full Moon Records  
1653-A McLendon Ave.  
Atlanta, GA 30307  
(404) 377-1919  
New, Used Records, Tape, CDs.  
Great Selection, Great Prices. Send us your want list!

## ILLINOIS

Hi-Fi Records  
2570 N. Clark St.  
Chicago, IL 60614  
(773) 880-1002  
FAX (773) 880-1016  
E-Mail: [hifi@interaccess.com](mailto:hifi@interaccess.com)  
Web site: [www.hifirecords.com](http://www.hifirecords.com)  
The best vinyl selection in city. As well as many hard-to-find CD's! We Buy and Sell all types of music.

## ILLINOIS

House of Music The  
2057 W. 95th St. (at Hoyne)  
Chicago, IL 60643  
Phone: (773) 239-4114  
FAX: (773) 239-9722  
Jazz-Blues-Oldies, R&B, Soul & Nostalgia. Famous for locating hard-to-find records, tapes, videos and CDs. It's our service and expertise that makes the difference. We sell imports. We ship everywhere UPS & Fed-Ex. Check our vinyl graveyard. LPs as low as \$1.00. By George! We've got it or we can get it!

Raffe's Record Riot  
4350 North Cicero Ave.  
Chicago, IL 60641  
(773) 725-1327 - 24 hr. service  
E-Mail: [raffesr@aol.com](mailto:raffesr@aol.com)  
Web site: [www.raffesrecordriot.com](http://www.raffesrecordriot.com)  
Open: Mon.-Sat. 11:30 a.m. - 6 p.m.; Sunday PHONE APPOINTMENTS ONLY. Specialties, oldies, hard-to-find unusual labels. We buy collections. Want lists with orders invited. We accept VISA, MasterCard, Novus & American Express.

Remember When Records and CDs  
309 W. Ogden Ave.  
Westmont, IL 60559  
Phone: (630) 963-1957  
FAX: (630) 963-1987  
E-mail: [rmbrwen@worldnet.att.net](mailto:rmbrwen@worldnet.att.net)  
Thousands of new & used 45s, LPs, Tapes & CDs (Imports) VISA, MasterCard, Telecheck. Closed Sundays.

Toad Hall Books & Records  
2106 Broadway  
Rockford, IL 61104  
FAX: (815) 226-9887  
Ph: (815) 226-1259 or  
(815) 399-4644  
100,000 LPs, 100,000 78s, 15 rooms full of other collectibles.

## INDIANA

Missing Link Records  
6053 N. College Ave  
Indianapolis, IN 46220  
(317) 466-1967  
FAX: (317) 466-0042  
Central Indiana's best vinyl selection in all genres. Don't miss us! [www.missinglinkrecords.com](http://www.missinglinkrecords.com)

## IOWA

Kanesville Used Records  
530 4th St.  
Council Bluffs, IA 51503  
(712) 328-8731  
Largest selection of records in the Midwest. All categories.

## KENTUCKY

Pops Resale  
1423-B Leestown Rd.  
Lexington, KY 40511  
Phone: (859) 254-7677  
FAX: (859) 254-7677  
Thousands of vinyl, 33/45/78 priced to sell, all genres.

Ticket To Ride Music & Memorabilia  
Hwy 229-Flealand  
London, KY 40741  
Phone: (606) 878-0366  
E-Mail: [jlennon@sekybiz.net](mailto:jlennon@sekybiz.net)  
Tons of CDs, cassettes, vinyl & all types of collectible music memorabilia. Open Sat. & Sun. 9-5, right off I-75!

## MARYLAND

Crown Records  
108 N. Lakewood Ave.  
Baltimore, MD 21224  
Phone/Fax: (410) 563-7881  
E-Mail: [dmilecki@maxinter.net](mailto:dmilecki@maxinter.net)  
Rare LPs, 45s, 78s; Jazz, Soul, R&B, Rock, Country, Blues, Classical, Northern Soul 45s - Open 7 days.

Joe's Record Paradise  
1300 East Gude Drive  
Rockville, MD 20850  
(301) 315-2235  
FAX: (301) 315-2252  
<http://www.joesrecordparadise.com>  
E-mail: [raremusic@joes-record-paradise.com](mailto:raremusic@joes-record-paradise.com)  
Thousands of LPs, 45s & CDs. New & used & out of print. Open 7 days, Jazz, Rock, R&B, Blues, Country. 28 Years in the business.

## MASSACHUSETTS

Flip Side Records  
1410 Beacon St.  
Brookline, MA 02146-2771  
(617) 739-8622  
E-mail: [flipside@flipsideweb.com](mailto:flipside@flipsideweb.com)  
Please visit our Web site at: [www.flipsideweb.com](http://www.flipsideweb.com)  
CDs, Tapes, LPs, and 45s - New and Used-Thousands of collectibles at low prices! Send Us Your Want Lists (be specific).

Mystery Train Records  
12 North Pleasant St.  
Amherst, MA 01002  
(413) 253-4776  
MT Records@hotmail.com  
Biggest selection of vinyl and used CDs in Western Mass!!

Nuggets Records  
486 Commonwealth Ave.  
Boston, MA 02215  
(617) 536-0679  
And Our Newest Location:  
46 White Street  
Somerville, MA  
(617) 623-1001  
Web site: [www.nuggetsrecords.com](http://www.nuggetsrecords.com)  
E-mail: [nuggetsrecords@netzero.net](mailto:nuggetsrecords@netzero.net)  
We buy, sell and trade records, CDs, tapes, videos, Send your want list-please be specific & include phone number.

Planet Records  
54-B JFK St.  
Cambridge, MA 02138  
(617) 492-0693  
FAX: (617) 492-0692  
E-mail: [planet@tiac.net](mailto:planet@tiac.net)  
Since 1983, New England's favorite Collector's Shop. Records and compact discs. All genres.

Sunset Records, Etc.  
1232 Wilbur Ave.  
Somerset, MA 02725  
(508) 678-3441  
E-Mail: [sunsetip@ici.net](mailto:sunsetip@ici.net)  
New & Used records, CDs, cassettes, videos. We buy & sell.

## MICHIGAN

PJ's Used Records  
517 B Packard  
Ann Arbor, MI 48104  
(734) 663-3441  
E-Mail: [disrecords@medlaone.net](mailto:disrecords@medlaone.net)  
Buying and selling new and used products in all formats.

# STORE DIRECTORY

The following is a list of record shops around the country arranged by state. Be sure to mention that you saw them listed in Goldmine's Store Directory. Retailers listed in bold type carry Goldmine in their stores.

## MICHIGAN

R.A.M.  
917 W. Broadway  
Muskegon, MI 49441  
Established in 1983  
Phone: (231) 759-0172  
FAX: (231) 755-0429  
E-mail: info@ramcd.com  
Hours: Tuesday - Friday 11-8  
Saturday 11-6  
We buy and sell used CDs and DVDs. Over 15,000 in stock (Stop by and meet Stray and eBay - the store cats.)  
Web site: www.ramcd.com  
Over 14,000 collectible CDs, singles, LPs, 45s, books, etc. and still growing.

Vinyl Palette  
310 Butler St.  
Saugatuck, MI 49453  
(616) 857-7664  
E-Mail: vinylpal@sirus.com  
Come visit us at our downtown location! Great selection of vinyl as well as new and used CD's. We also carry music DVD's. Coming on a trip? Call first for hours!

## MINNESOTA

Car & Record Collector's Heaven  
155 No. Snelling Ave.  
St. Paul, MN 55104  
(651) 645-3153  
E-Mail: rbroz598@cs.com  
Rock-RAB-Garage-R&B/Soul -  
Blues/Jazz-C&W/Pop-45/LP/CD-  
Domestic-Import-Car Books-Mags.  
CC: VISA/MC/Disc.Card

## MISSISSIPPI

Ace Video & Music  
235 Caillavet St., P.O. Box 1934  
Biloxi, MS 39533-1934  
PH: (228) 374-0777  
FAX: (228) 374-4645  
E-mail: acemusic@datasync.com  
www.acevideoandmusic.com  
Huge inventory collectible vinyl in all categories. Mail or fax wants.

Little Big Store  
P.O. Box 921, 201 E. Main St.  
Raymond, MS 39154  
(601) 857-8579  
www.littlebigstore.com  
E-Mail: bj999@aol.com  
CDs, LPs, 45s, 78s, reel-to-reels,  
videos, memorabilia, etc. Train  
depot full of records & music-related  
stuff. Open: Wed-Sat 10 AM-5 PM

## NEVADA

Big B's CDs & Records  
4761 S. Maryland Pkwy.  
Las Vegas, NV 89119  
Phone: (702) 732-4433  
FAX: (702) 795-7989  
11am-8pm Mon.-Sat., 11am-7pm Sun.  
E-Mail: bigbs@fnet.net  
Web: Bigbsmusic.com  
We stock a wide range of new and used CDs and LPs, all very organized! Dealers are welcome. Send us your want lists! THE store that locals come to shop!

Wax Trax Records, Inc.  
2909 S. Decatur  
Las Vegas, NV 89102  
PH: (702) 362-4300  
FAX: (702) 362-4340  
E-Mail: waxtraxinc@aol.com  
Over 1,000,000 records, CDs, cassettes & all kinds of music memorabilia. A must for the true collector. When in Vegas stop in. Also check out our new radio show THE STREET HARMONY REVUE AT: www.klav1230am.com on Mondays at 9:00 p.m. until 11:00 p.m.

## NEW JERSEY

Absolute Vinyl  
11 Midland Ave.  
Montclair, NJ 07042  
(973) 746-7775  
E-Mail: absjag@aol.com  
M-F 1 p.m.-8 p.m., Sat. 12 noon-5 p.m. New & Used LPs & 45s, Up to 10,000 \$1 45s & LPs always avail. Want lists accepted. Wholesale available to foreign & domestic buyers. Specialties include Soul, Jazz, Beatles & Progressive Rock.

The Album Hunter  
2217 Atco Ave.  
Atco, NJ 08004  
PHONE: (856) 719-1515 (24 Hrs.)  
FAX: (856) 719-1313 (24 Hrs.)  
Great Dealer Discounts! Biggest in South Jersey in Rare Vinyl! 167+ Page Catalog Send in \$6.00 U.S.A.-\$8.00 Overseas. Thousands of Albums \$1.00-\$2.00 in Store!!

Flipside II Records  
120 Wanaque Ave.  
Pompton Lakes, NJ 07442  
(973) 835-8448  
Plenty o' vinyl, from 99¢; also 45's, CDs, needles, tapes. Call for hours.

Hackensack Record King  
303 Main Street  
Hackensack, NJ 07601  
Phone: (201) 488-4232  
E-Mail: records123@aol.com  
Visit our online auction:  
http://member.aol.com/records123  
45 RPM Specialists, 12", LPs & rarities on vinyl. Full line of replacement phonograph needles (stylus).

Iris Records Ltd.  
114 Brunswick Street  
Jersey City, NJ 07302  
(bet. 1st and 2nd Streets)  
Phone: (201) 217-0588  
E-Mail: irisrecs@worldnet.att.net  
Hours: Friday 3-9PM or by appointment  
Thousands of twelve inch singles at bargain prices. Hip-hop, R&B, rock, disco, dance and more. We also carry full length soul, jazz, rock, exotica. Ten minute train ride from Manhattan. Vinyl only. No want lists, we cater to customers that like to get hands dirty.

Izzy's Records & Compact Discs  
1107 W. St. Georges Ave.  
Linden, NJ 07036-5652  
(908) 486-3303  
E-Mail: lzzmeister@aol.com  
Web site: www.izzymusic.com  
100,000 + LPs, CDs, 45s in stock. We buy collections - LP, CD, rock memorabilia. Buy & sell new & used LPs, CDs, 45s. Promos, imports, rarities, memorabilia. 10 Minutes from Newark Airport, 20 minutes from NYC. Great dealer prices on Jazz, Soul, R&B, 12", Rock, 50s, 60s & more. Open 7 days.

21st Century Music  
15 Mount Vernon St.  
Ridgefield Park, NJ 07660  
Toll Free: 1-800-846-9501  
(201) 641-6610  
FAX: (201) 641-9309  
www.21centurymusic.com  
sales@21centurymusic.com  
Business Hours: Mon.-Sat. 11am-6pm Specializing in 12" Singles, Dance, Rock, 12" Rap & Hip Hop, Soul LPs. Buy, Sell, Trade. Want lists accepted. All major credit cards accepted. Foreign dealers welcome. We buy DJ collections.

## NEW MEXICO

Krazy Kat  
9012 Central SE  
Albuquerque, NM 87123  
(505) 294-5644  
Largest selection of music in New Mexico. LPs, 45s, CDs, Tapes, Videos, 8-Tracks. Located on Route 66.

Merlin's Record Workshop  
9609 Menaul NE  
Albuquerque, NM 87112  
Phone: (505) 299-8031  
FAX: (505) 299-0330  
E-Mail: merlinsrecords@prodigy.net

## NEW YORK

House of Oldies  
World Headquarters for Out of Print 45s and LPs  
35 Carmine St.  
New York, NY 10014  
(212) 243-0500  
FAX: (212) 989-1697  
http://www.houseofoldies.com  
10 A.M.-5 P.M. Tues. thru Sat. Closed Sun. & Mon. Established in 1962 over a million 45s, 78s & LPs, R'NR, R&B, S&W, shows, S.T., Soul, Funk, Pop, Collections Bought 1950-1989 - Send or E-mail "Want Lists." #1 Oldies Shop. VISA, MC., Amex. A must when you're in NYC.

Infinity Records Ltd.  
3852 Sunrise Highway  
Seaford, NY 11783  
(516) 221-0634  
FAX: (516) 221-8901  
E-mail: vinylriver@aol.com  
www.infinityrecords.net  
Long Island's best record collector store. Jazz, Soul, Rock, Classical, etc. Foreign dealers welcome. We buy collections.

Junkie Vinyl  
PO Box 148  
Hannacroix, NY 12087-0148  
(518) 756-9593  
E-Mail: jvinyl@msn.com  
Free mail order catalog of New Arrivals available. Newest catalog just released! Updated every 3 months. Thousands of Rare and Common LP's all types and styles of Music and Comedy. 10% discount on orders over \$50. 24 hr. voice-mail, call anytime!

Last Vestige Music Shop  
173 Quail St.  
Albany, NY 12203  
(518) 432-7736  
FAX: (518) 432-1812  
E-Mail: info@lastvestige.com  
Second hand, Out-Of-Print, CD's Records, Mailorder: lastvestige.com

Mr. Cheapo CD & Record Exchange  
46 Jericho Tpke.  
Commack Long Island, NY 11725  
(631) 543-8686  
and 134 Jericho Tpke  
Mineola Long Island, NY 11501  
(516) 742-7670  
We sell most of what's in Goldmine. Thousands of used CDs & Records in every store. Largest selection on Long Island. When you're visiting the New York area, we have 2 locations!

Off-Center Records and Collectibles  
116 Bleecker St.  
Utica, NY 13501  
Phone/FAX: (315) 738-7651  
http://www.blackdogweb.com/offcenter  
E-Mail: Offcenter1@webtv.net  
1,000s of LPs & Singles, Music Memorabilia 40s-90s, Books, Mags, Dolls, Tees, Plates, Figurines, CDs, Tapes, Rare & Hard-to-find items. All want lists welcome.  
MC/VISA/NOVUS.

## NORTH CAROLINA

Jukebox Oldies Inc  
456 Knollwood Street  
Knollwood Plaza Shopping Center  
Winston-Salem, NC 27103  
(336) 774-0034  
Tues. - Fri 10 AM - 7 PM  
Sat. Noon - 7 PM  
2 blocks from Business I-40, exit 3A. Operated by a knowledgeable collector with 20 years experience. Specializing in rare 50s and 60s vinyl. Also - 70s and 80s vinyl, 45s, 78s, tapes, CDs, videos, posters music memorabilia. Rare Beatles, Buddy Holly and Elvis vinyl and memorabilia. All categories of vinyl - Rock, Country, Jazz, Blues, Big Band, Soundtracks, Comedy, Soul. Always buying good vinyl 50s and 60s collections.

Woody's Rare Records  
14234 Hwy 18  
(Off of Blueridge Pkwy.)  
Laurel Springs, NC 38644  
Phone: 336-359-2564  
FAX: 336-359-8432  
Original recordings of 30's, 40's, 50's, 60's, 70's, old country, comedy, bluegrass, soundtracks, B-bands and more. We buy, sell and trade. Open May-December (Thursday-Sunday). Send your want list or call.

## OHIO

Parker's Records & Comics  
1222 Suite C, Route 28  
Milford, OH 45150  
PH/FAX: (513) 575-3665  
Mon.-Sat. 11am - 7pm  
E-mail: dkparker39@fuse.net  
Specializing in 50s & 60s. Over 100,000 45s & 10,000 33s. Send want lists. Accepting MasterCard/VISA & NOVUS cards.

## OKLAHOMA

Gardner's Used Books, Music & Comics, Inc.  
4417 South Mingo Road  
Tulsa, OK 74146  
(918) 627-7323  
FAX (918) 250-8828  
Web site: www.gardnersbooks.com  
Over 100,000 Collectibles Albums, CDs, 45s, Tapes, Music magazines, Sheet Music. We buy collections, complete stores, music memorabilia & collectibles. Open 7 days.

Records and Stuff  
1511 S. Memorial  
Tulsa, OK 74112  
(918) 627-1505  
Web site: recordsandstuff.com  
E-Mail: sales@recordsandstuff.com  
Thurs-Sat 10:00 am-6:00 pm;  
Sunday 11:00 am-5:00 pm, or by Appointment  
Specializing in all Vinyl Selections. CD's, Cassettes, 8 Track, Books, Video Tapes, Magazines, Sheet Music, Memorabilia, Playboy Magazines, Collectible Supplies, etc. - Buy - Sell - Trade - We Ship Worldwide

## OREGON

Crossroads Music  
3130 SE Hawthorne Blvd  
Portland, OR 97214  
(503) 232-1767  
E-Mail: xroads@xro.com  
Open Mon-Thurs 11-6; Fri-Sat 11-7; Sun 12-6  
Portland's largest, most complete selection of collectible records, CDs, Tapes, concert posters and music memorabilia in Co-op of 35 dealers.

## OREGON

2nd Avenue Records  
400 S.W. 2nd Avenue  
Portland, OR 97204  
(503) 222-3783  
FAX: (503) 287-3343  
Tons of good used and new - Will travel Vancouver to San Diego to purchase collections of ANY size. ANY format.

Sonic Recollections, Inc.  
2701 SE Belmont St.  
Portland, OR 97214  
(503) 236-3050  
FAX: (503) 235-1645  
E-Mail: orderdesk@sonicrec.com  
Web site: http://www.sonicrec.com  
Specializing in the weird and the collectible! Check Our Web Site!

## PENNSYLVANIA

Attic Record Store, Inc.  
513 Grant Ave.  
Pittsburgh, PA 15209  
(412) 821-8484  
FAX: (412) 821-5179  
E-Mail: atticrecords@cs.comn  
Astounding selection of new & used CDs, 45s, LPs & 12" singles. All categories - credit cards accepted - Expert mail order service - want lists accepted.

Flip Side Records & Coll.  
Moved to: 940 Hermigate Rd.,  
(Rt. 18)  
Hermitage, PA 16148  
PH: (724) 342-0824  
FAX: (724) 342-0825  
E-Mail your Wants lists:  
flipsiderecords@aol.com  
Web site: www.flipmall.com  
Over 2,000,000 selections/All types of music/Wants lists welcome!

Mugsy's Records  
212 Iron St.  
Bloomsburg, PA 17815-1871  
(570) 784-7134  
Exit 35-A off I-80  
Quality used LPs, CDs, movies (DVD & VHS), and books. New stock every week. Five minutes from Exit 35-A off I-80 Hours: Mon-Fri: Noon-8 PM; Sat: Noon-6 PM

Positively Records  
4153 Woerner Ave.  
Levittown, PA 19057  
(215) 945-8063  
FAX: (215) 945-0221  
E-Mail: posrec@aol.com  
Rare CDs/New-used-imports/10,000 used CDs. 5000 quality CDs at \$4.99 or less/open 7 days/Best Store Phila/NJ area.

Record Castle  
1118 Cottman Ave.  
Philadelphia, PA 19111  
(215) 745-4151  
Web site: www.recordcastle.com  
E-Mail: info@recordcastle.com  
Mon.-Sat. 1-7 p.m. (EST)  
Buy/Sell records - compact discs - tapes - rock 'n roll memorabilia - thousands of records (all speeds), CD's, etc. in stock!

# STORE DIRECTORY

The following is a list of record shops around the country arranged by state. Be sure to mention that you saw them listed in Goldmine's Store Directory. Retailers listed in bold type carry Goldmine in their stores.

## PENNSYLVANIA

**Record Connection**  
550 N. Reading Rd  
Ephrata, PA 17522  
(717) 733-1641  
FAX: (717) 733-1685  
Visit our Web site at:  
[www.RecordConnectionPa.Com](http://www.RecordConnectionPa.Com).  
Oldies, Classic Rock, Psychedelic,  
Progressive, Country, Jazz, Comedy.  
Over 100,000 45s & albums!  
Compact Disc: New, Used, &  
imports. Directions: Located on Rte.  
272, 4 miles S. of PA Turnpike  
(exit 21).  
Open 7 days a week. M-F 10 a.m.-  
8 p.m.; Sat. 9 a.m.-7 p.m.; Sun. 11  
a.m.-5 p.m.

**Record King**  
The Record King - (Our Only Location!)  
2113 Parkdale Ave.  
Glenside, PA 19038  
(215) 576-0102 (Mail & Phone orders  
only!)  
E-Mail: [therecordking@yahoo.com](mailto:therecordking@yahoo.com)  
Search Service - 11 a.m.-8 p.m. EST  
7 days a week. SASE/IRC & collect  
phone # for reply.  
Buy & Sell. Catalogs/lists available.  
8-track \$25. Soundtrack/orig. cast  
\$25. All refundable w/order.  
McNally's picture price guide  
(Soundtrack) \$29.95 + shipping,  
Rockin Records.  
Video/DVD/Karaoke/Audio equipment  
sold. CDs, tapes, vinyl & adult  
videos. Huge assortment Country &  
Western, Playboy & Rolling Stone  
magazines. Checks/MOs pay to: J.J.  
Hollin only.

**Val Shively-R & B Records**  
49 Garrett Rd.  
Upper Darby, PA 19082  
(1 mile from West Philadelphia)  
(610) 352-2320  
FAX: (610) 352-8199  
11-7 EST M-Sat.  
Over 4 million 45s! Also CDs, LPs,  
cassettes. Send want lists/mail order  
available. Major credit cards  
accepted.

## TENNESSEE

**Grumpy's Music & Books Inc**  
3905A Hixson Pike  
Chattanooga, TN 37415  
(423) 874-0242  
FAX: (423) 874-0286  
E-Mail us at: [grumpybk@aol.com](mailto:grumpybk@aol.com)  
BUY • SELL • TRADE  
Books • CDs • T-shirts • LPs •  
DVDs • Videos • Audio Books •  
Posters Open Mon-Sat. 10:00 a.m.-  
9:00 p.m.; Sun. 12:00 p.m.-6:00  
p.m. We Specialize in hard-to-find  
items.

**The Great Escape**  
1925 Broadway  
Nashville, TN 37203  
(615) 327-0646  
FAX: (615) 321-5568  
[www.duffelbag.com](http://www.duffelbag.com)  
E-Mail: [tge@bellsouth.net](mailto:tge@bellsouth.net)  
Nashville's oldest record store!  
(Open for 24 years.) Thousands and  
thousands of collectible and bargain  
CDs, LPs, 45s, 78s, and tapes at  
low, low prices. (One of the largest  
selections of out-of-print records in  
the mid-south.) Also buying and  
selling: comics, videos, games,  
more. Voted best non-chain record  
store 7 years running in "The  
Nashville Scene." Open Mon.-Thurs.  
10 a.m. - 9 p.m.; Fri-Sat. 10 a.m. -  
10 p.m.; Sun. 1-6 p.m.

**The Great Escape**  
111 N. Gallatin Rd.  
Madison, TN 37115  
(615) 865-8052  
FAX: (615) 865-8779  
[www.duffelbag.com](http://www.duffelbag.com)  
E-Mail: [tge@bellsouth.net](mailto:tge@bellsouth.net)  
Thousands and thousands of col-  
lectible and bargain CDs, LPs, 45s,  
78s, and tapes. (One of the largest  
selections of out-of-print records in  
the mid-south.) Also buying and  
selling: comics, videos, posters,  
memorabilia, video and computer  
games, gaming cards, books, toys,  
role-playing items, baseball cards,  
more. Voted best non-chain record  
store 7 years running in "The  
Nashville Scene." Open Mon.-Fri.  
10 a.m.-9 p.m.; Sun 1-6 p.m.

## TENNESSEE

**Lost and Found Records**  
7315 Kingston Pike  
Knoxville, TN 37919  
(865) 558-9028  
[albumguy@email.msn.com](mailto:albumguy@email.msn.com)  
Buy • Sell • Trade. Records, tapes &  
CDs. Open 7 days a week. We have  
thousands of LPs.

## VERMONT

**Mainly Music: "Where Music Lives On"**  
36 Main St.  
Brattleboro, VT 05301  
PH/FAX: (802) 257-0881  
Toll Free U.S. & Canada:  
877-257-0891  
Southern Vermont's largest used  
music source! Buy, Sell, Trade: Used  
Rare Records, CDs, Tapes, Vintage  
Sheet Music, Memorabilia &  
Collectibles. Send want lists.  
Worldwide search.  
*Insurance and estate appraisals.*  
*Will travel.*

## VIRGINIA

**DMS Associates**  
P.O. Box 724  
Portsmouth, VA 23705  
(757) 465-3333  
FAX: (757) 465-9890  
E-Mail: [ddel065716@aol.com](mailto:ddel065716@aol.com)  
Jazz, Blues, R&B, Soul Music  
Specialist. Jazz, Blues, R&B, Soul,  
Gospel, Music Magazines.

**Safe As Milk Records**  
20 Kirk Ave. SW  
Roanoke, VA 24011  
(540) 982-7789  
E-Mail:  
[SAFEASMILKUSA@YAHOO.COM](mailto:SAFEASMILKUSA@YAHOO.COM)  
Mon.-Sat. 10 a.m.-9 p.m.;  
Sun. 12 p.m.-6 p.m.  
Want lists welcome!! New & used  
LPs, used CDs, tapes & 45s &  
videos.

## WASHINGTON

**Disc Connection**  
405 Garfield St (1 block east of PLU)  
Tacoma, WA 98446  
(253) 539-5632  
E-mail:  
[disc\\_connection\\_mail@yahoo.com](mailto:disc_connection_mail@yahoo.com)  
We are Tacoma's #1 location for  
rare Beatles memorabilia and vinyl.  
CASH paid for Beatles and Monkees,  
one item or a hundred, we buy col-  
lections. We also buy, sell and trade  
CD's-LP's-45's-DVD's-Laserdiscs and  
videotapes. Open Monday thru  
Friday 11am to 7pm. Open Saturday  
and Sunday Noon till 5pm (On  
Sundays please PHONE FIRST to  
insure we're there).

## WISCONSIN

**Deep Grooves**  
702 E. Johnson St.  
Madison, WI 53703  
(608) 294-5708  
Rare and unusual recorded music.  
Specializing in: New, Used, Vintage  
Vinyl and Import CDs. Buy and  
Trade. We ship anywhere.  
Want Lists Welcome!

**Fox Music**  
100 E. Main St.  
Watertown, WI 53094  
Entrance on 1st St.  
PH: (920) 206-8597  
FAX: (920) 206-8641  
E-Mail: [foxmusic@execpc.com](mailto:foxmusic@execpc.com)  
Store Hours: 11:00-7:00  
Thousands of rare & collectible LPs  
& 45s. New & used CDs/domestic &  
imports. We ship anywhere. We buy  
quality collections.

**Madcity Music Exchange**  
600 Williamson St.  
Madison, WI 53703  
(608) 251-8558  
FAX: (608) 251-8668  
E-Mail: [madcity@execpc.com](mailto:madcity@execpc.com)  
Web site: [www.madcitymusic.com](http://www.madcitymusic.com)  
Madison's vinyl source - LPs, 12",  
10" 7". New CDs - Domestic &  
Import. Used CDs - Great Selection.

## CANADA

**Star Records**  
148 Simcoe St. South  
Oshawa, Ontario, L1H 4G7 Canada  
PH/FAX: (905) 723-0040  
E-Mail: [starrecords@altavista.com](mailto:starrecords@altavista.com)  
30 minutes east of Toronto. Best  
vinyl selection in Canada! Over  
2,000 New Vinyl LPs in stock.  
Imports from U.K., Italy, USA, etc.  
(1950s-2000) - Garage, Rockabilly,  
New & Old Surf, New & Old Punk  
Rock, Blues, Soundtracks, British  
New Wave. Record-related col-  
lectibles for your favorite bands  
available. Phone/Fax/E-mail your  
want lists.

## FRANCE

**Monster Melodies**  
9 Rue Des Dechargeurs  
75001 Paris - France  
PH: (33) 140280939  
FAX: (33) 142332572  
E-Mail: [monster@club-internet.fr](mailto:monster@club-internet.fr)  
Thousands of LPs, Singles, CD, CDs  
60s-90s. Since 15 years in business.  
We mail everywhere.

## SWEDEN

**The Golden Oldies Shop**  
5:t Eriksgatan 96  
SE-113 31 Stockholm, Sweden  
PH/FAX: +46-8-32 22 40  
Original singles, EPs & LPs 1955-  
1979, Rock & Roll, Pop, Soul, etc.  
Send your name and address for free  
catalog, or visit our Web site:  
[www.goldenoldies.se](http://www.goldenoldies.se)  
Company established in 1977.  
24 years in business!

This section features listings for retail record stores around the world. Traveling record collectors of all types search for new stores to dig through on their vacations, business trips, etc. Advertise your establishment here, including approximately ten words of miscellaneous description, for only \$9.00 an issue. You can buy this space in increments of 13 or 26 issues, for \$117.00 or \$234.00, respectively. Send in your store name, address, phone number, and approximately ten words of description, along with your payment. If you stock GOLDMINE, we'll put your listing in boldface type.

1 year \$234.00     6 months \$117.00

Send your listing with payment to:  
**GOLDMINE • 700 E. State St. • Iola, WI 54990-0001 or Call 715-445-2214**

Name: \_\_\_\_\_

Contact person: (This will not appear in the listing) \_\_\_\_\_

Address: \_\_\_\_\_

City: \_\_\_\_\_ State: \_\_\_\_\_ Zip: \_\_\_\_\_

Phone: \_\_\_\_\_

FAX: \_\_\_\_\_ Do you carry GOLDMINE in your store? \_\_\_\_\_

Description: \_\_\_\_\_



A pillow from the mid-70s, autographed.

(Elton collectibles from page 41)

versions of Bally's *Captain Fantastic* pinball machines. First appearing in 1976, these pinball machines took advantage of John's huge popularity at the time while promoting both his appearance as the Pinball Wizard in the film version of *Tommy* and his then-current album, *Captain Fantastic And The Brown Dirt Cowboy*. The arcade version of this pinball machine, which was designed by noted pinball artist Dave Christensen, can be found in varying degrees of condition with prices ranging from \$400-1,500. These machines are considered collectible not only by Elton John fans, but pinball machine collectors as well because it was a popular game in arcades during its time.

**Right: Elton John's stage costumes and eyeglasses, especially those from the '70s, command collectors' attention.**

Another version of Bally's *Captain Fantastic* pinball machine is more rare. A special "home version," slightly smaller than the commercially designed version that was available in department stores, features completely different artwork. This design, by artist Alan Aldridge, who designed the album's cover art, is more of an extension of the album's concept look and includes cartoon images of both John and Taupin in their "Captain and the kid" personas. Again, depending on condition, these machines can demand prices in the \$500-\$1,500 range.

McCormick said a major part of his business today is derived from special edition CDs and CD singles, mostly available in the United Kingdom or throughout Europe. For example, to promote John's new *Songs From The West Coast* album, two separate CD single versions of the album's first single, "I Want Love," were released in England only. Each version is different, including, in addition to the single, an unreleased song from the album's session, an unreleased live song from John's 2000 live album *One Night Only*, and, on one of the versions, the video for the single. "Obviously, because these are not available in the U.S., the demand is great among die-hard fans.

"But most likely, it will be that same group of loyal fans who want it. Most people in the U.S. probably don't know or even care it exists," McCormick said. "But the *real* fans do, and even at the hint of its release, I received several orders from all around the world from people wanting to know when it would be available.



Photos courtesy James Turano

"Elton John should be pleased to know his fans are a loyal bunch. He may not dominate the charts anymore, but to his die-hard fans, Elton John is a special artist. They will continue to support him no matter what. After a 30-year career, that's quite a tribute," McCormick said.

James Turano is a Chicago-based entertainment journalist and editor-in-chief of the world's leading Elton John fan magazine, *East End Lights* ([www.eastendlights.com](http://www.eastendlights.com)). He is also one of those eyeglasses and pinball machine collectors and was featured on VH-1's *Fanclub* when it spotlighted Elton John.



# SSHHH! It's Classified!

—Save **Now!**—

## \$5 Off

Any Classified Ad  
booked for at least  
5 consecutive issues

## \$10 Off

Any Classified Ad  
booked for at least  
10 consecutive issues

## \$20 Off

Any Classified Ad  
booked for at least  
20 consecutive issues

Your ads are posted free  
on the Internet @ **www.collect.com**  
for extra exposure at no extra charge!

PLACE YOUR Classified/Internet Ad NOW TOLL-FREE

# 800-942-0673

M - F 7am -7pm CST

## Goldmine



## Krause Publications

700 E. State St., Iola, WI 54990-0001  
Phone 715-445-2214 • Fax 715-445-4087  
[www.krause.com](http://www.krause.com)

# Quality Guides for Dedicated Collectors



## Goldmine Record Album Price Guide

2nd Edition

by Tim Neely

Coverage in this comprehensive price guide includes American albums from 1948 through 2000. You will find more than 50,000 listings in up to three grades of conditions along with many photos of rare and unusual albums as well as a record label identifier section. Albums are listed alphabetically by artist and are in checklist format for easy inventory.

Softcover • 8-1/2 x 11 • 672 pages

200 b&w photos

Item# REA2 • \$24.95



## Goldmine Standard Catalog of American Records, 1976-2000

by Tim Neely

Did you know that artists like Madonna, Prince, U2, REM and Garth Brooks have music available on vinyl? You will find these and more with this comprehensive price guide from Goldmine and expert author, Tim Neely. With more than 60,000 listings in three grades of condition arranged alphabetically by artist, this is the first book to cover LPs, 45s, 12-inch singles and EPs from 1976-2000.

Softcover • 8-1/2 x 11 • 608 pages

200 b&w photos

Item# AR01 • \$27.95

**NEW**



## Motown: The Golden Years

by Bill Dahl

Photography by Weldon A. McDougal III

Lovers of Motown, this is the book for you! Author and Motown historian Bill Dahl has expertly compiled this complete encyclopedia of groups and artists, along with information about their music, including a discography and price guide, of nearly every Motown group since 1959.

Softcover • 8-1/2 x 11 • 384 pages

200+ b&w photos

32-page color section, 50 color photos

Item# MTWN • \$24.95

**NEW**

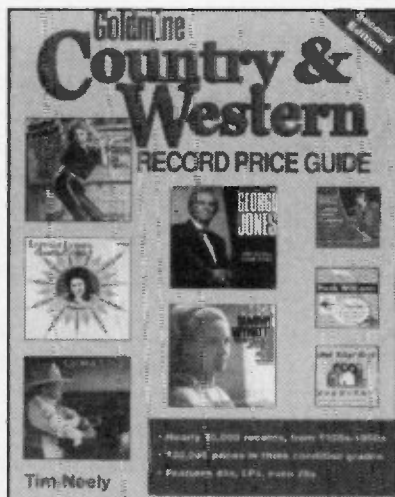

## Goldmine Country & Western Record Price Guide

2nd Edition

by Tim Neely

Individual listings for tens of thousands of records grace the pages of Goldmine Country-Western Record Price Guide—from 45s to LPs to selected 78s. You'll find hundreds of records not listed anywhere else plus the most current reference information available. This entirely revised edition tells you which records are available and their current market value. You'll find 40,000 listings and 120,000 prices for each of three grades of condition.

Softcover • 8-1/2 x 11 • 544 pages

100 b&w photos

Item# RCW02 • \$24.95



## Warman's American Records

1950-2000

Identification & Price Guide

by Chuck Miller

This guide to American records released between 1950 and 2000 is perfect for any collector, beginning or seasoned. Inside you will find more than 2,000 listings for LPs, LLPs and 45s from a variety of genres, including country, heavy metal, soul, jazz and rock, among others. More than 750 photos and accurate pricing in up to three grades of condition will help you identify and value your collection.

Softcover • 8-1/2 x 11 • 352 pages

750 b&w photos • 16-page color section

Item# WAREC • \$21.95



## Goldmine Price Guide to 45 RPM Records

3rd Edition

by Tim Neely

You'll get more record listings and current values than any other 45 RPM record price guide. Plus, more than 200 photos will help you identify and authenticate your collection. And over 70,000 RPMs, 45s, extended play singles, and picture sleeves from 1949 through 2000 are graded and priced so you'll have more than 210,000 prices to gauge your collection's value. Includes 8 pages of full-color noteworthy records and sleeves.

Softcover • 8-1/2 x 11 • 648 pages

200 b&w photos • 8-page color section

Item# R453 • \$24.95



## Goldmine Standard Catalog of American Records, 1950-1975

2nd Edition

by Tim Neely

Record experts called the first edition the "best U.S. guide to American records ever published." In this second edition you'll find 150,000 listings, many of them new; updated pricing with 450,000 prices, one for each of three grades of condition; plus the most accurate information available.

Softcover • 8-1/2 x 11 • 1,296 pages

150 b&w photos

Item# REC2 • \$34.95

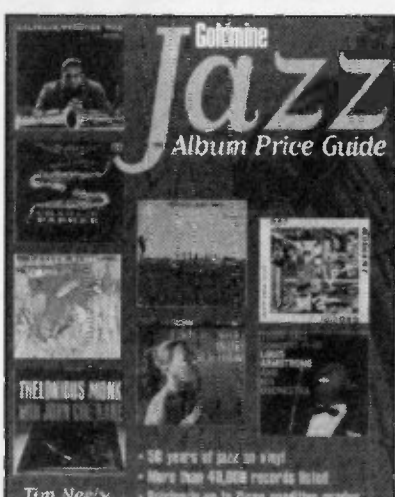

## Goldmine Jazz Album Price Guide

by Tim Neely

Tim Neely, author of eight recording industry price guides, including the Standard Catalog of American Records, has authored, compiled and organized this new showcase price guide which features jazz musicians, composers and vocalists from the bebop era through to today. You'll find thousands of jazz artists - Dixieland, big band/swing, bebop, progressive, modern, fusion, and more - all featured in over 40,000 listings and priced in three grades of condition.

Softcover • 8-1/2 x 11 • 544 pages

150 b&w photos

Item# RJ04 • \$24.95

To place a credit card order or for a FREE all-product catalog call

**800-258-0929 Offer R61B**

M-F 7am-8pm • Sat 8am-2pm, CST



Krause Publications, Offer R61B

P.O. Box 5009, Iola, WI 54945-5009 • [www.krausebooks.com](http://www.krausebooks.com)

**Shipping & Handling:** \$4.00 first book, \$2.00 each additional. Non-US addresses \$20.95 first book, \$5.95 each additional.

**Sales Tax:** CA, IA, PA, TN, VA, WI residents please add appropriate sales tax.

**Satisfaction Guarantee:** If for any reason you are not completely satisfied with your purchase, simply return it within 14 days of receipt and receive a full refund, less shipping charges.

**Goldmine**



# COMPACT DISC SHOWCASE

Showcase ads are the most looked at in Goldmine. You may buy as many boxes as you wish for an ad, at a cost of \$38.60 per box, multiplying the \$38.60 per box required. All typesetting is done by us and included in the price.

**the CUBE**  
by Lorentz Design

The Ultimate STORAGE CABINET



Featuring our patented ALLSTOP STORAGE SYSTEM, no slots, no plastic molds, no wasted space. Full-extension drawer slides. Made from high quality oak veneers and hardwoods. 23"H x 19 1/2"W x 17 1/4"D. Each Cube ships fully assembled. Stackable.

Stores 306 CD's or any combination of CD's, DVD's, CD-ROM VHS, Cassettes, etc.

Call 800-933-0403 or visit [www.lorentzdesign.com](http://www.lorentzdesign.com) to order or for a free, color brochure detailing all our disc, tape & component storage CUBES. LDI, Inc. • 5140 Clarkson St. • Denver, CO 80216 • Fax: 303-294-9705

[WWW.GPMUSICA.COM](http://WWW.GPMUSICA.COM)

By J. A. Gaspar & J. del Peso

**MUSIC MAGAZINES FROM ALL OVER THE WORLD. SPANISH RECORDS AND CD'S.**

Detailed lists on all artists, including Spanish ones. More than 200.000 references

Secure Shop on-line

Contact us: Tirso de Molina S/N, Centre d'Empreses Modul 9-A, 08940 Cornellà de Llobregat, Barcelona Spain. Fax: + 34 93 475 02 36 E-mail: [sales@gpmusica.com](mailto:sales@gpmusica.com)

**101cd.com**

Now over 1.6 million titles online all at discount prices. Including every UK, European, Australian and Japanese releases. UK catalogue includes budget and mid-price titles from \$7.50 (+p&h). Secure ordering, certified Bizrate Gold merchant. Plus rare records and CDs from the world's top dealers.

<http://www.101cd.com>  
e-mail: [sales@101cd.com](mailto:sales@101cd.com)

**CD, Tape & Vinyl Storage**

The RACKIT™ System

Factory direct since 1984 from Per Madsen Design

Free brochure (mention Goldmine) 800-821-4883 or online at [www.rackittm.com](http://www.rackittm.com)



**Automatically Catalog Your CDs!**



CD Trustee automatically catalogs your CD collection. Quickly insert and remove each disc into your computer, then push a button to gather artist name, album title, song titles, genre and more. Takes seconds per CD. Build a database of your huge collection in a few hours, with no typing! Easily search for songs, artists, or titles. Stop buying duplicates. Prints extensive reports, along with jewel cases covers and inserts. Also handles manual entry of LPs, tapes, and other media. Only \$29.95. Download a free trial from our Web site.

Requires Microsoft Windows 95/98/ME/NT/2000/XP, and an Internet connection (during lookup phase only).

**Web site: [www.base40.com](http://www.base40.com)**  
**E-mail: [GM@Base40.com](mailto:GM@Base40.com)**

**Robert Alberg Compact Disc can be ordered for \$12.00**

Send check made payable to: Robert Alberg and mail to

Robert Alberg  
503 8th Avenue, Kirkland, WA 98033

(Reissues from page 57)

ever. Unfortunately, we only get three tracks from this period: their 1981 retro smash "When She Was My Girl," a live version of the follow-up single "Tonight I'm Gonna Love You All Over" and the wedding staple "I Believe In You And Me" (Levi's performance buries Whitney Houston's hit version). Among the many choice recordings left off are the sassy *Grease 2* theme "Back To School Again" (the only redeeming component of that film) and the buoyant "Nobody's Gonna Love You Like I Do." They're available on the Tops' Polygram compilation *When She Was My Girl*.

The Tops performed a scorching medley with The Temptations on the 1983 *Motown 25* reunion special — included here — which was one of the evening's highlights. This led to the Tops re-signing with Motown for two unexciting albums, represented here by their singles "I Just Can't Walk Away" and "Sexy Ways." Also contained here are two tracks previously unreleased from their canceled 1986 Motown album *Hot Nights* (they weren't worth the wait).

A much stronger effort was their 1988 Arista album *Indestructible*, the singles of which are found here. The album's defiant title track — a duet with Smokey Robinson — returned the Tops to the Pop Top 40 chart for the first time since "When She Was My Girl" and was used as a theme for the Olympics in Seoul, Korea. The reflective Aretha Franklin duet "If Ever A Love There Was" went on to make a dent on the R&B chart, while the festive "Loco In Acapulco" hit the Top 10 in the U.K.

A classy collaboration with Grover Washington Jr. from 1992, "Till You Return To Me," and the Lawrence Payton-written "The Four Of Us" (adopted by the Four Tops as their theme song) conclude the set on a high note. Payton's death in 1997 ended the recording legacy of the original Four Tops. This collection serves as an outstanding tribute to the unparalleled harmony they shared, in and out of the recording studio.

— Jim Bagley

JASON FALKNER  
Everyone Says It's On  
Air Mail (AIRCD-026/7) (Two discs) (Japanese Import)

Necessity: The 4-Track Years  
spinART (spart90)

Jason Falkner (formerly of The Three O'Clock, Jellyfish, and The Grays), is one of the most critically lauded indie popsters of the past few years. *Everyone Says It's On* and *Necessity: The 4-Track Years* are two like-minded releases jammed with four-track demos, covers and previously unreleased tracks.

*Everyone Says It's On* is a two-disc set (a bit pricey but definitely worthwhile for the Falkner fanatic) that includes 13 demos on disc one and 11 wildly divergent covers — everything from songs by Brian Eno, The Kinks, and The Left Banke to Joni Mitchell, Magazine, and Tom Waits — on disc two. As for the home-recorded demo tracks (some of which have appeared on promos, Sub Pop singles and magazine flexi-discs), the previously unreleased "Great Big Yes," "Song For Her" and "His Train" in particular stand up to anything on his *Falkner's Presents Author Unknown* and *Can You Still Feel?* albums. Like most everything else here, they feature Falkner's dry-but-emotive vocals, rich melodies with twists and turns galore and thoughtful lyrics. Other tracks, such as the marvelously catchy "I Live" and "Revelation," are raw, early versions of cuts that appeared on Falkner's aforementioned solo records.

The covers disc was recorded by Falkner prior to his solo debut (after his departure from The Grays) and showcases his long-standing love of post-punk or "expelled art school rock," as he humorously refers to it in his liner notes. Essential Logic, The Swell Maps, The Stranglers, and The Monochrome Set (a superb version of their "Tomorrow Will Be Too Long") all get the Falkner treatment, as does Def Leppard — the frenzied take of "Photograph," with its Spinal Tap-inspired guitar solo, is a hoot.

SpinART's *Necessity: The 4-Track Years* has no cover songs, has five demos in common with the Air Mail release and is notable for the inclusion of the boppy, power poppin' "She's Not The Enemy" (originally released on an International Pop Overthrow compilation and one of Falkner's best-ever tunes) and "My Home Is Not A House," a different version of which appeared on a Yellow Pills pop compilation a few years back.

Even though the bulk of the tracks on both these releases are demos, there is a fresh, fleshed-out vitality about the songs that helps to make them quite engaging and eminently listenable, despite their humble sonic origins. Falkner fans who have been trading tapes of this material for some time should rejoice now that this fine material has officially seen the light of day. (Both releases available from [www.notlame.com](http://www.notlame.com); PO Box 2266, Ft. Collins CO 80522)

— John M. Borack

Statement of Ownership, Circulation, and Distribution

Category	Quantity	Percentage
Total Number of Copies (Net press run)	25,000	100%
Total Number of Copies (Gross press run)	25,000	100%
Printed in the United States	25,000	100%
Printed in other countries	0	0%
Total Number of Copies (Net press run) - 100%	25,000	100%
Total Number of Copies (Gross press run) - 100%	25,000	100%
Total Number of Copies (Net press run) - 100%	25,000	100%
Total Number of Copies (Gross press run) - 100%	25,000	100%

(Please see Reissues page 70)

# COLLECTOR'S SHOWCASE

Showcase ads are the most looked at in Goldmine. You may buy as many boxes as you wish for an ad, at a cost of \$38.60 per box, multiplying the \$38.60 per box required. All typesetting is done by us and included in the price.

# www.rockaway.com



ROCKAWAY RECORDS 2395 Glendale Blvd. Los Angeles, CA 90039 phone: 323/664-3232 fax: 323/664-0956 email: sales@rockaway.com  
Retail store open Mon.-Sat. 10 a.m.-9:30 p.m. • Sun. 12 Noon-8 p.m.

## THE BEATLES

### CATALOG

Not many but RARE. Over 100 rare BEATLES cds and boxset titles at:

<http://listen.to/silverdisc>

or email us at:

[silverdisc@allomail.com](mailto:silverdisc@allomail.com)

## E-commerce Web Sites

- Fully searchable database driven web sites.
- Shopping cart, secure and user updatable!
- Designed specifically for record/CD stores.

No big setup cost or contract. Just low monthly fee! Starting at \$20 / month. Call Dave 216-575-1480

[www.musicstack.com/stores](http://www.musicstack.com/stores)

## RARE REGIONAL TOP 40 SURVEY REPRODUCTIONS



TRACKING YOUR CHARTED FAVORITES SINCE 1956

(916) 315-9244 FAX (916) 315-8563

## NEEDLES Unlimited

MANUFACTURERS IMPORTERS & EXPORTERS OF NEEDLES CARTRIDGES & ACCESSORIES 1ST QUALITY NO GENERICS BANG & OLUFSEN THE LARGEST INVENTORY IN THE USA WHOLESALE AND RETAIL STEREO LP/45/78

### RIVERTONE 78 RPM FOR ALL TYPES

ADC AUDIO TECHNICA STANTON PICKERING SHURE ORTOFON BSR RIVERTONE TETRAD ACUTRAC ASTRION ETC. EXPERT CONSULTING

TOLL FREE 1-800-662-8090

WE REBUILD & RETIP FAX 845-791-9670

E-MAIL: [rivertone@fcc.net](mailto:rivertone@fcc.net)

WE ACCEPT VISA MASTERCARD & AMER. EXPR. NEEDLES, P.O. BOX 161, MONTICELLO, N.Y. 12701

## Past & Present Rare Videos

by these Artists & more

- |                  |                  |               |
|------------------|------------------|---------------|
| The Carpenters   | Dion             | Guess Who     |
| Burton Cummings  | Whitney Houston  | Oasis         |
| Gordon Lightfoot | Barbra Streisand | Cat Stevens   |
| Paul McCartney   | Blondie          | Frank Sinatra |
| Billy Joel       | Osmonds          | John Fogerty  |
| Supremes         | Bobby Darin      | Journey       |

And many more!!!

Please send SASE & your interests to:

**Joseph Russo**

P.O. Box 2422, North Babylon, New York 11703-0422

Fast Personal Service!

## gatefold records

[www.gatefoldrecords.com](http://www.gatefoldrecords.com)

- |  |                              |
|--|------------------------------|
| <b>Specializing in:</b>                      | <b>In our Cult Favorites</b> |
| Rare, Promotional & Out of Print CDs & Vinyl | Section you'll find:         |
| Imports                                      | Re-issue Vinyl & CDs         |
| Posters & Stickers                           | Imports                      |
| Videos                                       | Rare Vinyl                   |
| Memorabilia                                  | For fans of:                 |
| Specializing in 80's & 90's alternative rock | Jazz & Soundtracks           |
|  | Prog Rock & Psychedelic      |
|  | Brazilian & Latin            |
|  | Funk & Soul                  |

E-mail: [Sales@gatefoldrecords.com](mailto:Sales@gatefoldrecords.com)

Phone: 818-888-4071 • Fax: 818-888-4023

## ROCK'S HOTTEST VIDEOS

Featuring Artists From The 70s: Floyd, Who, Zeppelin, Yes, KISS, Cooper, Aerosmith, Sabbath, Angel, Bad Co.

Featuring Artists From The 80s: Accept, Badlands, Bon Jovi, Motley, Bullet Boys, Cinderella, Leppard, Guns, and all the newest.

Sensations Of The 1990s: All the current tours and of course the most perfect quality available. Over 2,000 selections listed. We've been the leader in music videos since 1983.

SEND FOR FREE CATALOG!

## INTERNATIONAL TRANSFERS

P.O. Box 313, Dept. G.M., Revere, MA 02151

## LET THE MUSIC PLAY®

1-603-473-8618 1-207-651-2790

[kryway@earthlink.net](mailto:kryway@earthlink.net)

CONCERTS \* DEMOS \* PROMOS \* IMPORTS LPs / CDs / VIDEOS / POSTERS / PHOTOS

LET ME: FILL YOUR "WANTED ITEMS LIST"; AND FILL YOUR STORE SHELVES; AND SUPPLY YOUR CUSTOMER'S WANTS & NEEDS! OVER 20 YEARS OF PRACTICE!

ALL ORDERS WILL BE MAILED WITHIN 48 HOURS!!!

I ACCEPT MONEY ORDERS, CASH & CREDIT CARDS VIA PAYPAL PERSONAL COLLECTION OF BEATLES, STONES, AND OTHERS!

AUTOGRAPHED GUITARS AUTOGRAPHED GUITARS

## AUTOGRAPHED GUITARS

Metallica, Red Hot Chili Peppers, Lynyrd Skynyrd, Everclear, Creed, Crosby, Stills, Nash & Young, Deftones, Slash/Guns N' Roses, Joe Cocker, Barry Manilow, 3 Doors Down, Kenny Rogers, Smashmouth, Indigo Girls, Wayne Newton, Kansas, Joan Osbourne, Third Eye Blind, B.B. King, Jethro Tull, No Doubt, Stone Temple Pilots, U2, Wallflowers, ZZ Top, Faith Hill/Tim McGraw, Bon Jovi, John Lee Hooker, Dolly Parton, Michael Bolton, Sammy Hagar, Melissa Etheridge, Police/Sting, Def Leppard, Bo Diddley, Simon & Garfunkel, Oasis, Joe Walsh, Rod Stewart

702-894-9219

[www.autographedguitars.com](http://www.autographedguitars.com)

## Collector Pays Cash for Records, CDs, Coin Collections and Political Buttons.

Large collections especially welcome. Will Travel.

Collector Since 1960!

Please call Gary 203-377-3449

# audiophileusa.com



Visit and bookmark our Web site now for the best in LPs & CDs. We carry a full range of new vinyl as well as a huge selection of superb condition ROCK, POP, JAZZ, FOLK, AUDIOPHILE, MOBILE FIDELITY, SOUL & FUNK & MORE. Sealed & outstanding condition LPs our specialty. We pay top dollar for your mint records - Up to \$600 for Mobile Fidelity! Not just for audiophiles! . . . . . Call toll-free 1-(877)-SPIN LPS

## COLLECTOR'S CORNER LP SET SALE

ALL RECORDS ARE GRADED COVERS/RECORDS/POSTAGE U.S.A. \$7.00 PER ORDER, AND .50 CENTS FOR EACH ADDITIONAL RECORD DUE TO POSTAL INCREASE. ALL RECORDS ARE FIRST ORIGINAL 1ST PRESS UNLESS NOTED. MONEY ORDERS SAME DAY SERVICE, CHECKS 10 DAYS. WILL HOLD FOR TWO WEEKS ONLY!

1. ANIMALS Animalization (st) M/M \$30.00
2. ANNETTE Sings Anka with photo NM/EX \$75.00
3. BASIE COUNT Sixteen men swining 2 LPS (PROMO) M/M \$35.00
4. BEACH BOYS Here comes the night 12 inch blue max single M \$20.00
5. BEATLES Happy michaelmas (sealed) \$30.00
6. BEATLES Revolver (st) shrink M/NM \$70.00
7. BEATLES Rubber soul (st) M/EX \$50.00
8. BEATLES Sgt. Peppers, L.H.C.B. (MONO) NM/EX \$175.00
9. BECK JEFF Everything you wanted to hear but were afraid to ask for (st) (PROMO) M/NM \$40.00
10. BOOMTOWN RATS a tonic for the troops (PROMO) M/M \$20.00
11. BUCKINGHAMS Made in Chicago 2 LP set C.O. (PROMO) M/M \$40.00
12. CADETS Same crown L.B. (m) (shrink) M/M \$80.00
13. CAPRIS There's a moon out again M/M \$20.00
14. CHANNEL Hey baby (m) NM/NM \$50.00
15. CLIMAX BLUES BAND A lot of bottle (PROMO) C.O. M/M \$20.00
16. COCHRAN EDDIE A legend on our time (sealed) \$25.00
17. DARIN BOBBY 25th day of December (m) (sealed) \$60.00
18. DEAL BILL+RHONDELS The best of (PROMO) NM/M \$25.00
19. DELFONICS Tell me this is a dream M/M \$25.00
20. DION Suite for late summer (PROMO) M/NM \$20.00
21. DRIFTERS Save the last dance for me (st) M/NM \$50.00
22. DRIFTERS Under the boardwalk (st) M/EX \$40.00
23. DOCKETT JIMMY Beauty + soul (sealed) \$25.00
24. EVERLY BROS. Sing (st) M/EX \$25.00
25. EVERLY BROS. Xmas with (m) (shrink) M/NM \$25.00
26. FLAMIN GROOVIES Shake some action (PROMO) M/M \$20.00
27. FLASH CADILLAC There's no face like chrome (PROMO) M/M \$20.00
28. GORE LESLEY Boys boys boys (m) (PROMO) M/EX \$30.00
29. GORE LESLEY I'll cry if I want to (PROMO) NM/NM \$40.00
30. GORE LESLEY Love love love (st) EX/M \$25.00
31. GORDON LIGHTFOOT Summer side of life (PROMO) NM/M \$25.00
32. GRIFFIN BESSIE Live at the blues festival M/M \$25.00
33. HENDRIX JIMI Are you experienced (st) NM/NM \$30.00
34. HUMBLE PIE Lost and found 2 LPS set (PROMO) NM/M \$30.00
35. JACKSONS Xmas LP M/M \$20.00
36. JAMES ELMORE I need you punch hole M/M \$40.00
37. JAMES JIMMY+VAGABONDS The new religion NM/M \$40.00
38. KAY JOHN+SPARROW Same NM/NM \$20.00
39. KEITH 98.6 Ain't gonna lie NM/M \$20.00
40. KNIGHT GLADYS+PIPS Gladys maxx 3000 (PROMO) M/M \$75.00
41. KNIGHT GLADYS+PIPS 2nd anniversary with poster (PROMO) M/M \$20.00
42. KNIGHT FREDERICK I've been lonely too for so long M/M \$15.00
43. LEWIS RAMSEY Go in' Latin (m) (sealed) \$20.00
44. LITTLE JOHN Up and down (st) NM/M \$15.00
45. NESMITH MICHAEL Nevada fighter M/M \$15.00
46. NEWTON JUICE Silver spur M/M \$15.00
47. MY BED 100 PROOF AGED IN SOUL Somebody's been sleeping in my bed (sealed) \$20.00
48. PARTRIDGE FAMILY Family Xmas card with card M/M \$25.00
49. PICKETT WILSON Mr. magic man M/M \$15.00
50. POCO Cantamos (st) (PROMO) C.O. M/M \$20.00
51. POCO Poco live (st) (PROMO) M/M \$20.00
52. POCO Seven (st) (PROMO) M/M \$20.00
53. POCO Very best 2 LP set (PROMO) M/M \$30.00
54. PRESLEY ELVIS Xmas LP LOC-1035 (m) EX/EX \$150.00
55. PRESLEY ELVIS Xmas LP Blue cover (m) M/M \$40.00
56. PRINCE FREDDIE Looking good C.O. (PROMO) M/M \$30.00
57. PRYOR SNOOKY Do it if you want to (PROMO) M/M \$30.00
58. RAINDROPS Same 5023 NM/NM \$90.00
59. REFLECTIONS Just like Romeo+Juliet (PROMO) M/NM \$200.00
60. RICHARD CLIFF Every face tells a story C.O. M/M \$15.00
61. RICHARD CLIFF Green light M/M \$15.00
62. RIVERS JOHNNY Changes (PROMO) EX/M \$20.00
63. RIVERS JOHNNY Borrowed time (PROMO) M/M \$20.00
64. RIVINGTONS Doin the bird (m) M/VG+ \$70.00
65. SAM THE SHAM+PHARAOHS Best of (st) NM/NM \$15.00
66. SINATRA NANCY Boots (st) M/M \$15.00
67. SINATRA NANCY Sugar town (m) NM/M \$15.00
68. SINATRA NANCY In London (st) M/M \$20.00
69. SPANKY+OUR GANG Change (PROMO) M/M \$25.00
70. SPENCER DAVIS GROUP Featuring S.Winwood heavies M/M \$25.00
71. SOUND OF MODIFICATION Same (st) (sealed) \$20.00
72. STEVENS CAT Back to earth (shrink) M/M \$10.00
73. TATE HOWARD Get it while you can (m) (PROMO) M/M \$40.00
74. TAYLOR JOHNNY One step beyond punch hole (shrink) M/M \$15.00
75. THOMAS PAT Jazz patterns EX/EX \$25.00
76. THREE STOOGES Xmas time M/M \$25.00
77. VEE BOBBY I remember Buddy Holly (m) M/M \$40.00
78. VEE BOBBY Xmas LP (m) (shrink) M/EX \$25.00
79. WITHERSPOON JIMMY Blues for easy livers EX/EX \$35.00
80. WITHERSPOON JIMMY Stormy Monday+other blues EX/EX \$25.00

ALEX TSOVALOS 508-752-6390

5 AETNA STREET, WORCESTER, MA 01604-4205

# COLLECTOR'S SHOWCASE

## Record Album Frames

For: LP's - Picture Discs - 45's  
All Steel - Black or Silver  
Simply the best - See for yourself  
Visit our secure Web site at  
[www.albumframes.com](http://www.albumframes.com)  
Or call us toll free: 800.640.0306

## CD Storage & Display

CD Poster Frames gives you quick, easy access to your Music, Game & Software CD's. Great anywhere space is limited. Put them on a wall close to your CD player or computer. See them at our secure Web site [www.cdframes.com](http://www.cdframes.com)  
Or call us toll free at: 800.640.0306

Showcase ads are the most looked at in Goldmine. You may buy as many boxes as you wish for an ad, at a cost of \$38.60 per box, multiplying the \$38.60 per box required. All typesetting is done by us and included in the price.

## Attention Retailers

Increase your profits by selling our quality Record Album Frames & CD Poster Frames. U.S. & Overseas distribution now available. For Info. and wholesale pricing contact us by  
E-mail: [sales@albumframes.com](mailto:sales@albumframes.com)  
E-mail: [sales@cdframes.com](mailto:sales@cdframes.com)  
Phone: 800.640.0306 Fax: 630.830.9009

## RECORD AWARDS

Janet Jackson - *Rhythm Nation* - RIAA Hologram . . . . . \$500  
Presented to Rick Krieg for the sale of 5 million  
Janet Jackson - *Rhythm Nation* - RIAA Hologram . . . . . \$500  
Presented to Rebecca Bright for the sale of 2 million. Janet's signature on the award.  
Janet Jackson - *Control* - RIAA Hologram . . . . . \$500  
Presented to Jay Macroy for the sale of 3 million.  
Janet Jackson - *Control* - British BPI Award . . . . . \$750  
Presented to Janet Jackson for the sale of 1 million  
Whitney Houston - *Whitney Houston* - RIAA Hologram . . . . . \$425  
Presented to Nancy Wilson for the sale of 1 million

Karyn White - *Karyn White* - RIAA Hologram . . . . . \$125  
Presented to Chris Landers for the sale of 1 million  
Vanessa Williams - *The Comfort Zone* - RIAA Hologram . . . . . \$125  
Gold Award presented to John Travis/KIOK  
STAND-UPS AND RARE ITEMS  
Whitney Houston - Jeans, white shirt and jacket, early shot . . . . . \$40  
Janet Jackson - *Rhythm Nation* Black Jacket and Black Pants . . . . . \$50  
Janet Jackson - Janet smiling in black shirt opened down the front, Lots of Cleavage . . . . . \$50  
Janet Jackson - Cube display from Janet Album featuring *Rolling Stone* Cover Shot . . . . . \$75

Janet Jackson - *Poetic Justice* Bus Poster used to advertise the movie on the side of the bus . . . . . \$60  
Janet Jackson - *Rhythm Nation* different than above . . . . . \$50  
Vanessa Williams - Cover shot of the *Comfort Zone* Album . . . . . \$50  
Diana Ross - Counter display for the *One Woman* CD. Diana Ross lying nude with a sheet . . . . . \$40  
Linda Ronstadt - Picture disc from *Living in the USA* album . . . . . \$16  
Linda Ronstadt - Tour book from *Cry Like a Rainstorm* album . . . . . \$25  
Natasha Kinski - Very Rare - "Natasha and the Serpent" Litho. poster . . . \$50  
Samantha Fox - Picture Discs - Interview 1, 2, 3, 4, (Nude) Hold or Holding . . . . . \$20 ea.  
Angelina Jolie - *Tomb Raider* - Giant 7' Stand-up . . . . . \$100

Posters, 12", PS 45's, available. Send long SASE (2 stamps) for list. Shipping is \$8 first item, \$4 each additional item. TO ORDER: Make M.O.'s payable to Mike Hiatt and send to the address listed. • INQUIRES: Write the address or call (618)258-1334.

MIKE HIATT 1705 Miland St., Wood River, IL 62024



**HADEN REED**  
Country Singer/Songwriter  
Singing the Old Favorite Country Classic Hits such as:  
"Tennessee Waltz"  
"Love Me Tender"  
"Merry Christmas My Love"  
"Make My Christmas"  
Plus eight others.  
Cassette Tape - \$8.95 ea.  
CDs - \$13.95 ea.  
Send to:  
**REEDSOUND, INC.**  
404 N. Gum St.  
Summerville, SC 29483

**ALWAYS BUYING LP'S FOR CASH**  
Check my Web site for HUGE wantlist and info. I am actively buying rock LP's from approximately 1965-1972, especially PROMOS, IMPORTS, CUTOUTS, sealed store & distributor stock, the larger quantity the better!  
[www.undergroundalbums.com](http://www.undergroundalbums.com)  
CHOICE SELECTION of set sale LP's: 60's Psych, Garage, Prog, Folk, Hard Rock, Soul, Jazz.  
CHECK THE WEB SITE or send for free list (4x yearly).  
**JEROME TOMKO**  
P.O. Box 303, Hebron, CT 06248-0303  
Tel: 860-228-8700/Fax: 860-228-8822 • E-mail: [Jtvinyl@aol.com](mailto:Jtvinyl@aol.com)

**Beatles On Video**  
Relive the excitement and hysteria that will never be seen again!  
1963-Present T.V. Shows - Concerts - Specials  
#1 in Quality! Guaranteed!  
**Free Beatles Catalog**  
**Videos**  
P.O. Box 21097, Philadelphia, PA 19114



**"Looking For Your Lost Mind Revue"**  
Presents  
Custom framed Posters and Autographs from the 60's and 70's  
Animals to Grateful Dead to Zappa  
Send for a FREE Catalog.  
**Dr. George**  
P.O. Box 23055, Santa Ana CA 92711 3055  
or call (714) 731-3424

**RAGING BELLY VIDEO 2000**  
Are you looking for videos on your favorite artists? Maybe the ones from when you were growing up? Look no further!  
Here are some of the artists I have on video:  
• Judas Priest • Slade • Warlock • Boston • Wasp • REO Speedwagon  
• Miles Davis • Talisman • Elvin Bishop • Heavy Load • Ramones  
• Angelwitch • The Sundays • Lynch Mob • Replacements • Tull • Television  
• Merciful Fate • Accept • Slayer • Gluffria • Iced Earth • Fire Merchants  
• Strawbs  
Send \$3.00 for postage & handling to:  
**MARC A.**  
P.O. Box 413, Farmingdale, NY 11735 U.S.A.

**FREE SET SALE CATALOGS ...**  
ALL GENRES 45 or 33LP 1940's - 1980's and SOUND TRACKS  
Approx. 20,000 each catalog  
Please specify which catalog.  
**B & D RECORD SALES, INC.**  
517 S.W. 49TH LANE, CAPE CORAL, FL 33914  
Phone: (941) 540-7559 • FAX: 941-540-4460  
Sorry due to the size of the catalogs they cannot be faxed.

**Rock & Roll Autographs Hollywood Memorabilia Signed Albums**  
Write for Current List  
**Myron Ross**  
**HEROES & LEGENDS**  
P.O. Box 9088 • Calabasas, CA 91372 • Phone: 818-346-9220  
Web Site: [www.Heroesandlegends.net](http://www.Heroesandlegends.net)

**VIDEO!**  
STEPHEN M. RUSSO  
P.O. BOX 150/BOSTON, MA 02151-001(M)  
VHS Tapes made available on a collector-to-collector basis. Rates include priority mail postage! Allow between 2-4 weeks for order. Overseas: Add \$5 per tape, air postage/U.S. Funds only. PAL Standard videos: Add \$10 per tape. All titles offered from best available prints and elements.  
**\$20.00 or any 3 for \$55.00**  
ABC-TV 1960's MUSIC SHOWS: "American Bandstand" from 1967 with Neil Diamond, The Electric Prunes, & Tim Conway! "Where The Action Is" (9/9/66) with The Four Seasons and Jackie Paine! Both with original TV commercials! (90 minutes/B&W)  
AMERICAN BANDSTAND 11TH ANNIVERSARY SHOW: As aired on ABC-TV 8/17/68 uncut with original commercials! Great clips from Philadelphia and California years! Musical guest: "The American Breed"! (1 hour/B&W)  
THE GREAT 50's/60's ROCK: Compilation of rarely seen late 1950's-early 1960's Rock performances! Johnny Burdette Trio, Frankie Lyman & The Teen-Agers, Closures, The Flamingos, The Platters ("The Great Pretender"), Fats Domino, LaVerne Baker, The Moonglows, Little Richard, Gene Vincent, The Diamonds ("Little Darlin'"), Shelley Fabares ("Johnny Angel"), plus Alan Freed, B.J. Thomas, and Rockabilly segments from "The Country Music Caravan"! (90 minutes/B&W-Color)  
VIDEO ROCK & ROLL #7-"GARAGE BAND CLASSICS": GREAT compilation with SHIVAREE w/"Dino, Desi & Billy", James Brown, Aretha Franklin, Gerry & The Pacemakers! Followed by a selection of numbers by The Raspberries (on Mike Douglas!), Moby Grape, New Colony 6, The Kingsmen, Sir Douglas Quintet, McCoy's, Tommy James & The Shondells, Strawberry Alarm Clock, Cyrkle, Bobby Fuller 4, Blue Cheer, Standells, Syndicate of Sound, 5 Americans, The Beau Brummels, Knickerbockers, Gentrys, Love, Music Machine, Shadow of the Knight, Leaves, Outsiders, ? and The Mysterians! (Color/95 minutes.)  
VIDEO ROCK & ROLL #8-"GARAGE BAND RARITIES": Another great tape with segments featuring The Guess Who, Beau Brummels, Cyrkle, Bobby Fuller 4, Remains, Kingsmen, Tony & The Tigers, We Five, Buckingham, The Byrds, 5 Americans, Vanilla Fudge, Electric Prunes, Seeds, 1910 Fruitgum Company, Iron Butterfly, Blues Magoos, Buffalo Springfield, Strangeloves, Mitch Ryder & The Detroit Wheels, ? & The Mysterians (Color/90 minutes)  
WHERE THE ACTION IS-4 SHOWS!: Original ABC-TV broadcasts hosted by Paul Revere & The Raiders! Guests include Bobby Vee, Razor Edge, The Syndicate of Sound, 5 Americans, The Happening and CJ & The Runaways! Great 60's Shows! (B&W/100 minutes)  
ROCK & ROLL HISTORY (GREATEST YEARS) 1950's: Great USA/British video compilation with lost/rare footage of Elvis Presley, Everly Brothers, Jerry Lee Lewis, Chordettes, Cliff Richard, Fats Domino, Buddy Holly, Paul Anka, Eddie Cochran, Vince Taylor, Chuck Berry, Carl Perkins, Lomax Donegan, Little Richard, James Brown, Frankie Lyman, Johnny Ray, The Platters, Bo Diddley, Diamonds, Flamingos, Tommy Sands, Ritchie Valens! (Black & White/100 minutes)  
AMERICAN BANDSTAND-1957: Rare find! Good quality December, 1957 show from Philly! + extras! (90 minutes/B&W)

**OVER 500,000 IMPORTS**  
Including 400,000 Track Listings  
Imports From Japan, Europe, Australia & South America. CD's, Vinyl, Cassette & DVD's. All Categories. Fast And Reliable. All Available Online at  
[www.musicimports.com](http://www.musicimports.com)  
Not Online? Please Send Your Want List To:  
**MUSIC IMPORTS**  
757 SE 17th St. #149, Fort Lauderdale, FL 33316  
954-764-3879 • FAX: 954-764-3890

**ALBUM FRAMES!**  
Quality Brushed Aluminum Art Frames  
Gold, Silver & Metallic Blue  
(Black available: add \$1 more.)  
Yours for less than the cost of the parts alone!  
Send check or M.O. to:  
**Wiz Productions**  
10205 N. Oak Rd. W.,  
Cedar Hills, UT 84062  
e-mail: [wizface@aol.com](mailto:wizface@aol.com)  
[www.wiz-productions.com](http://www.wiz-productions.com)  
1 for \$10  
2 for \$19  
3 for \$28  
4 for \$36  
Postage only \$2 per order  
While Sale Lasts!  
(U.S. only)  
Foreign orders inquire.

**We Buy Collections**  

**Euclid Records**  
7905 Big Bend Blvd.  
St. Louis, MO 63119 USA  
[orders@euclidrecords.com](mailto:orders@euclidrecords.com)  
Weekly used vinyl & CD lists  
Jazz, Rock, Blues, Soul, Folk, World Music, Vocals  
[www.euclidrecords.com](http://www.euclidrecords.com)

# COLLECTOR'S SHOWCASE

Showcase ads are the most looked at in Goldmine. You may buy as many boxes as you wish for an ad, at a cost of \$38.60 per box, multiplying the \$38.60 per box required. All typesetting is done by us and included in the price.



## We specialize in finding Original 50s Rhythm & Blues/Rock & Roll 45s and LPs.

Lots of original 60s material also available. Call/fax us with your wants, or send us your wish list. Send all correspondence (and PLEASE INCLUDE YOUR PHONE NUMBER) to our address below. WE ALSO CARRY COOL, OUT-OF-PRINT CDs



We just can't ask this question often enough: Are you still reading ICE? If not, then you may be missing out on important info on many great, new titles including yet another groundbreaking "G.B.S." release from BOB DYLAN that's just around the corner. Right on the heels of the now-and-hotter-than-Hell "A Tree With Roots: The Genuine Basement Tapes Revisited" comes an incredible boxed set of 9CDs containing every cover-version Zimmy performed on the Neverending Tour from 1988 to 2000! This ear-popping bonanza is loaded with prev. unrel., extremely upgraded or first-time-SB tracks in addition to several other packaging goodies including a 100-page book! And speaking of great Dylan tours, if you're really into the Rolling Thunder Revue, then you're probably wondering about that much-ballyhooed 4CD "Guam Rehearsals" release on the White Bear label, right? Well...guess what? By the way, fading VERY fast are the opportunities for all of you foot-draggers to snag those great new ones by ELVIS COSTELLO (2CDs of amazing demos, rehearsals and OTs for his "King Of America" LP), THE WHO (2CDs containing the complete U.K. and U.S. '60s singles collection featuring the ORIGINAL 45 mixes from the ORIGINAL, FIRST-GENERATION masters including the "lost" Shel Talmy tapes...all in super-deluxe packaging w/ three books and six postcards! Also the 2CD upgrade of Waterbury, CT's Palace Theater—previously unavailable anywhere), BRIAN WILSON (a 2CD major upgrade of his complete Van Dyke Paris-conducted symphonic show at the Hollywood Bowl on 9/24/00), PINK FLOYD (their entire debut show from their fall '70 U.S. tour - 8/26- at Philly's Electric Factory on 2CD w/ special packaging and absolutely A+ killer sound), MOTT THE HOOPLE (prev. unrel. SBs from the Fillmore West, 7/9-10/70), and LED ZEPPELIN (without question, the best-sounding and most complete version of their 1/11/69 Fillmore West gig to date). And as if we don't say it often enough (well, then again — maybe we don't!), all of the above titles are on REAL CDs, not those putney, loser-affiliated CD-Rs. PLEASE CALL OR FAX FOR FURTHER DETAILS ON THESE RELEASES AND COUNTLESS OTHERS.

**RIP IT UP!** P.O. Box 142, Bloomfield, NJ 07003 • Phone (973) 743-0878 • Fax (973) 743-6316 (24 hours)

Best times to call are 11:00 AM - 4:00 PM (EST), or you can give us a try nights 10:00 - 11:30 (EST), Monday thru Friday only. Fast, reliable service.



## FUN RECORDS

Germany's Largest Mail Order for Second-Hand Records and CDs.

Over 50,000 items in stock  
We have the hits and rarities of the 70's, 80's and 90's.  
Get our new catalogue, Send 2 IRC or \$4 for postage.

FUN RECORDS ABT. G HEGESTRASSE 29  
20249 HAMBURG/GERMANY  
<https://www.funrecords.de>

## BRAZILIAN RECORDS

Brazilian and International Music

All Kinds! All the Artists!  
80,000 LPs - 10,000 Singles and EPs  
From the 20's to Year 2001

- Here in Brazil, We're Issued Many More Records Than You Imagine...  
- Brazilian Pressings/Different Covers/Rock-Pop/Black Music/  
- Bossa Nova/Samba/Jazz/Soundtracks, etc., etc., etc.  
Accept VISA and American Express Cards  
VENTANIA RECORDS  
[www.ventania.com.br](http://www.ventania.com.br)  
[ventaniarec@uol.com.br](mailto:ventaniarec@uol.com.br)  
fax: 55 11 223 6734

## Do You Need Records From Argentina or South America?

Send Want Lists to:  
Casilla de Correo 287  
C1000WAC Correo Central  
Argentina - Ph 54-11-4774-0483  
Fax 54-11-4776-1209  
E-mail: [kodola@datamarkets.com.ar](mailto:kodola@datamarkets.com.ar)  
[www.importsounds.com](http://www.importsounds.com)

## RARE PERFORMANCE VIDEO

AC/DC - Back in Black - aired in Japan 1981  
AEROSMITH - New Year's Eve 1999 Osaka - aired in Japan  
BARENAKED LADIES - Intimate and Interactive 1999 - music and interview  
BON JOVI - Yokohama, Japan 1996 - perfect picture  
COUNTING CROWS - In Concerto 1994 - from Italy - rare show  
MI. We specialize in rare, hard-to-find performances from around the world. All videos are \$25.00 (includes ship. in US) shipped ASAP. Send e-mail address for list or request a copy with order. Make money order to:

**Rick**  
99B Harper Dr. • Turtle Creek, PA 15145

1.3 Million LPs/45s - all categories!  
Catalogs issued - please state areas of interest

Want lists welcomed  
Collections purchased

**CRAIG MOERER**  
Records by Mail

P.O. Box 42546-GM, Portland, OR 97242, USA  
PHONE: 503-232-1735 • FAX: 503-232-1746  
e-mail: [cmoererecordsbymail.com](mailto:cmoererecordsbymail.com)  
browsable/searchable Web site:  
[www.recordsbymail.com](http://www.recordsbymail.com)

## IN YOUR FACE VIDEOS

BRUCE SPRINGSTEEN - (Grand New) - Fall - Professional - Hometown - w/ Joan Jett & Others	\$24.00
U2 - (New) - Fall - Professional - Midwest - DANCE - Rare - Recommended - A Must	\$25.00
ELTON JOHN - (New) - Fall - Maple Leaf - Old / New - Great - Flatly - Long	\$24.00
JANES ADDICTION - (New) - Fall - Maple Leaf - Reunion - All The Hits - A Good Time	\$22.00
JOHN BON JOVI - (New) - Fall - Professional - Northeast / N. - Acoustic - Includes Other Stuff!	\$22.00
THE POLICE - (Just In) 70 - Professional - Musicians - Unbelievably MINT - Old School	\$21.00
THE CRANBERRIES - (New) - Fall - Professional - Old/New - Great - She has Hair - Wild	\$23.00
THE ALLMAN BROTHERS - Summer - Northeast - Update - A "Experience" - Trippin' - So/WB	\$25.00
DEPECHE MODE - (Just In) - Summer - Northeast PA - Did/New - Great - Recommended	\$23.99
LYNYRD SKYNYRD - Summer - Northeast - Mountain Madness - Energetic - Great	\$23.00
AEROSMITH - Fall - Out West / LA - Sensational - Old/New	\$23.00
STEVIE NICKS - Fall - Out West / LA - Screened - Shoreside - Lovely w/ Sheryl	\$24.00
JOHN McLENNAN - Fall - Maple Leaf - Did/New - "All The Hits" - Up Close	\$24.00
ERIC JOHNSON - Spring - Northeast - Ptt - Small Club - Roping Guitar - Up Close/Personal	\$24.00
TOBI AMES - (New) - Summer - U.K. - Up Close/Personal - Killer show - Recommended	\$24.00
LIVE - (Grand New) - Fall - Professional - Maple Leaf - Beginning - New Songs/Covers - Great	\$27.00
YDOL - (New) - Fall - Maple Leaf - Right On - Brilliant - Dark/Heavy	\$24.00
YBS - (New) - Fall - Maple Leaf - Orchestra - Right On - All The Hits	\$25.00
HANDY MOORE - (New) - Fall - Professional - West / Hollywood - Sexy	\$23.00
LYNYRD SKYNYRD - (New) - Fall - NC - Perfectly Screened - Southern Style - Great	\$23.00
AEROSMITH - (New) - Fall - Charlotte - Screened & Staged - Sensational	\$23.00
SADIE - (New) - Summer - Northeast MD - Up Close & Personal - A Experience	\$24.00
JOURNEY - (New) - Summer - Northeast DE - VERY Up Close & Personal - Recommended	\$23.00
JETHRO TULL - (New) - Summer - Northeast - Wilkes Barre - Up Close - Wacky - "The River"	\$25.00
RICKY MUSIC - (New) - Summer - Maple Leaf - Did/New - Intriguing - Great Chemistry	\$23.00
QUIET RIOT / WARRANT - (New) - Summer - Midwest - 2 Cam - Slam Jam - Recommended	\$24.00
RINGO STARR W/ THE ALL STARS - (New) - Summer - 2 Cam - Down South - Sunny - The Best	\$24.00
SUGAR RAY - (New) - Summer - Professional - Down South - Franches - Sensational	\$26.00
STAINED - (New) - Summer - Northeast - "Electrical" - In Your Face - Headliner - Justice	\$24.00
ROD STEWART - (New) - Summer - Maple Leaf - Up Close / Personal - Old / New - Sensational	\$26.00
IGGY POP - (New) - Summer - German - Festive - "Rock Am Ring" - Professional	\$22.00
LININ PARK - (New) - Spring/Summer - 2 Shows - Both Professional - East/West - Great	\$22.00
THE LIVING END - (New) - Summer - 2 Shows - 1 Aud / 1 Pro - Northeast / Maple Leaf	\$23.00
PAUL OAKENFOLD - (New) - Summer - Professional - Detroit - Ravers Dream - Great	\$21.00
DAVE MATTHEWS BAND - (New) - Summer - Professional - Maple Leaf - "A Plus"	\$25.00
ALANIS MORISSETTE - (New) - Summer - Rock Am Ring - Professional - German	\$23.00
PATTY SMITH - (New) - Summer - London - Theatrical - Dubious - Great	\$23.00
THE CULT - (New) - Summer - Professional - Maple Leaf - Did/New - A Spectacle	\$23.00
JOURNEY - (New) - Summer - Southern - Tar Heels - Perfectly Screened - Old/New - Arrival	\$23.00
STYX - (New) - Summer - Down South - Up Close & Personal - Sensational	\$23.00
RADIOHEAD - (New) - Summer - Professional - Midwest - The Best Ever - "Gorgy"	\$25.00
AEROSMITH - (New) - Summer - L.A. - Wango Tango - Did/New - "Goodies"	\$27.00
AEROSMITH - (New) - Summer - Maple Leaf - Up Close - Did/New	\$21.00
BACKSTREET BOYS - (New) - Summer - L.A. / West - Festive - Wango Tango - Professional	\$23.00
BEE GEES - (New) - Summer - Wango - Professional - Mint	\$25.00
BLACK CROWES - (New) - Summer - Maple Leaf - Up Close/Personal - Toronto	\$24.00
KENNY WAYNE SHEPPARD - Summer - NYC - w/ Double Trouble	\$21.00
BLACK SABBATH - (New) - Summer - 2 Cam - Midwest - Recommended - All There	\$25.99
BLUES TRAVELER - (New) - Spring - Northeast - VA - Professional - Great	\$22.00
BON JOVI - (New) - Spring - Northeast - PG - Up Close/Personal - Very Good	\$25.00
CHEAP TRICK - (New) - Summer - Professional - Maple Leaf - A Spectacle	\$24.00
CORROSION OF CONFORMITY - (New) - Winter '00 - Professional - "Hurgas" - Great	\$22.00
DEEP PURPLE - (New) - Summer - Sunny South - 2 Cam Jam - Good - Recommended	\$23.00
<b>END OF SUMMER SPECIALS</b>	
SAVATAGE - Spring - Northeast - W-Barre - Clubbin' - Night There	\$16.00
WALLFLOWERS - Summer - Northeast - Headliner - Up Close / Personal	\$18.00
BARENAKED LADIES - Spring - Northeast - W-Barre - Wacky - Great	\$16.00
MATCHBOX 20 - Spring - Northeast - W-Barre - Justice - Nice	\$16.00
A PERFECT CIRCLE - Spring - 2 Cam - Northeast - Heavy	\$16.00

Hello, Please make checks or money orders payable to: Eric  
All Overseas and Canada Orders Please add \$3.00 for S/H  
At the moment don't have a full list, so please don't ask for one.

**ERIC**  
P.O. Box 424  
Wysox, PA 18854

## LIVING AFTER MIDNITE VIDEOS

At most times, your best selection/quality amount. Include your E-mail address/phone # number.  
If you are just looking for a catalog please send \$2 (includes purchase for complete listing, info with contents and be listed)  
TORI AMOS (New) Fall/Northeast Big Apple #1 - Phenomenal - New/Old Stuff - Recommended \$27  
STAINED (New) Summer - Professional - Big East - Mint - Very Recommended \$27  
IGGY POP (New) Summer - Professional - Big East - Mint - Very Recommended \$24  
GREEN DAY (New) Summer - Professional - Big East - Mint - Very Recommended \$24  
GORSACK (New) Summer - Professional - Big East - Mint - Very Recommended \$24  
FOO FIGHTERS (New) Summer - Professional - Big East - Mint - Very Recommended \$25  
TOOL (New) Fall - Northeast Big Apple #1 - Surreal - New/Old Stuff - Marquis \$26  
BOB DYLAN (New) Summer - German - Up Close & Personal - Dark/Heavy - Great \$26  
STEVIE NICKS (New) Fall - West/Bay Area - w/Short Crow - Screened - Nice - New/Old Stuff \$24  
CHEAP TRICK (New) West/CA - Classic Set w/ Surprise - Summer - Sweet - Be There \$24  
FUJI FIST (New) Professional - Summer - Hot w/Hot Artists - (2) \$24 - New/Old Stuff - A Must \$24  
ROD STEWART (New) Winter 2001 - Professional - Big East - New/Old Stuff - Headliner - Great \$24  
AEROSMITH (New) West/Bay Area - Summer - New/Old Stuff - Fun - Nice \$24  
BLACK CROWES (New) Fall - Headliner - Northeast Big Apple #1 - New/Old Stuff - Recommended \$26  
ALANIS MORISSETTE (New) Summer - German - Professional - Nice - Mint \$25  
LININ PARK (New) Summer - Professional - German - Nice - Mint \$25  
THE CULT (New) Summer - Professional - Big East - New/Old Stuff - Headliner - Great \$24  
IRON MAIDEN (Just In) Winter 2001 - Professional - Argentina - Awesome - Wild \$24  
SUMMER BONE: FEST (New) Summer - Japanese - Professional - Mint - Features The Cult  
Marilyn Manson, Incubus & Beck  
RED HOT CHILI P'S (Just In) Winter 2001 - Professional - Smooth - High Energy - Argentinean \$24  
PATTI SMITH (New) Summer - Clubbin' - U.K. - Up Close/Personal - Killer show - Recommended \$24  
JOURNEY (New) Summer - In Your Face - Northeast - New/Old Stuff - Headliner - Great \$24  
JETHRO TULL (New) Summer - Northeast - out of this world - Pear Pan - Nice \$24  
JANET JACKSON (New) VERY HOT - Summer - Northeast Big Apple - Sexy - Awesome - A Must! \$27  
CROSBY STILLS & NASH (New) Summer - Old/New Stuff - Her 70s - Beach/Northeast - Rocks \$27  
KING CRIMSON (New) Summer - Southeast - Professional/Progressive - Up Close/Personal - Killer \$24  
STEVIE NICKS (New) Midwest - Justice - w/Short Crow - Surprising The Magic - Great \$24  
BAD RIVER (New) Summer - Spring - Northeast Big Apple - New/Old Stuff - Jewel \$24  
VAN MORRISON (Just In) Summer '01 - Professional - Club - Always - Unbel - Summer \$24  
WEEZER (New) Clubbin' - U.K. - Egypt Mt. Rush - Killer - In Your Face - Summer \$24  
BEE GEES (New) Professional - West Coast - You Know My Name - Fun - Festive - Mint \$24  
NO DOUBT (Just In) - Germany - Professional - Perfect - Mint - Rocks - Fun - Summer \$24  
LIPD (New) Spring '01 - Summer of '01 - They Rock - UK - Finally - Great CD Japan \$24  
RINGO STARR W/ THE ALL STARS BAND (New) Summer - Features - Howard Jones, Greg Lake, Stevie E, R.Hobbs (Super Tramp), Ian Hunter & more - Beachy - Up Close/Personal - Framed - Great \$28  
ROD STEWART (New) Summer - Big Apple - Soundcheck Show - In Your Face - Nice \$26  
PAT BENATAR (New) Northeast Big Apple - Summer - Beach/Northeast #1 - Screened - Alive - Sensational \$27  
BLACK SABBATH (New) (Just In) - Summer - New Song - WILD - Midwest-Rocks - Cool \$24  
BLINK-182 (New) Northeast/Beachy Mix - Summer - New Stuff - Hardcore - R.I.D. - Killer \$24  
MARIYLN MANSON (New) Summer - Northeast - headliner - Hard - shocked - AMING \$24  
STEVIE NICKS (New) w/ Short Crow - Together - Summer - Beach/Northeast - Solo/FM - J.C. - Stuff \$24  
SPINAL TAP (New) Summer - Boston - New Songs - Never Played Before Shows - Funny - Perfect \$24  
BRIAN WILSON (New) Beachy/Northeast - Summer - Special Guest - Big - Upbeat - Surf Rock \$24  
TOM PETTY (New) Summer - Beachy - Northeast - Up Close/Personal - Amazing - Recommended \$26  
A WALK DOWN ABBY ROAD Features Heart, Alan Parsons, Todd Rundgren, John Entwistle & more doing own songs/cover songs - Summer - Northeast - Killer - Awesome Set List - Great Chemistry - Recommended \$27  
R.E.M. (New) Summer - German - Professional - Very New/Old Stuff - Killer/Mint - Recommended \$26  
CHICAGO (New) Beachy - Northeast Big Apple - Summer - Rare Song Set List - Recommended \$27  
6-3 (New) Summer - Northeast - Killer - Amazing - Killer Set List - Recommended \$23 \$25  
RADIOHEAD (New) Summer - U.K. - French - Professional - More New/Old - Mint \$25  
New! Summer - Professional - German - New/Old Stuff - Mint \$26

Make Checks Payable to **L.A.M. Videos** Suite 102, 5 E. 41st St., New York, NY 10017

## RETRIEVER MEMORABILIA SERVICE

RARE RIAA AWARDS.....WHITE MATTES.....FLOATER STYL  
CONTRACTS.....NEGATIVES.....PHOTOS.....SIGNATURES

PHONE: 508-872-8162 FAX: 508-872-8163  
E-MAIL: [BEATLES196401702@YAHOO.COM](mailto:BEATLES196401702@YAHOO.COM)

RETRIEVER IS ALWAYS INTERESTED IN  
OBTAINING RARE AWARDS!!!!  
CALL US FOR AN IMMEDIATE QUOTE!!!!

## 78's 78's 78's 78's 78's 78's 78's 78's 78's 78's

**FOR SALE 78 RPM ORIGINAL  
ROCK AND ROLL RECORDS**

Hundreds of 78 RPMs - A self addressed/stamped envelope  
will get you all the details re: grades, prices and ordering  
instructions.

**BIZ REED**  
357 Summer Street, Lynnfield, MA 01940 USA  
Phone: 781/334-4805 - Fax: 781/334-2362  
E-Mail: [navatocal@tiac.net](mailto:navatocal@tiac.net)

[www.elvisunlimited.com](http://www.elvisunlimited.com)

## RARE VIDEO

ABBA	Black Crowes	Faces	Madonna	Roxette
AC/DC	Black Sabbath	Fleetwood Mac	Mick Taylor	Sabrina
Agnetha	Blondie	Freddie King	Missing Persons	Shakespear's Sister
Albert Collins	Bo Diddley	Go Go's	Mott the Hoople	Slade
Alice Cooper	Buddy Guy	Hanoi Rocks	Muddy Waters	Sweet
Albert King	Cyndi Lauper	Ian Hunter	New York Dolls	Stevie Ray Vaughan
Allman Bros.	David Bowie	James Brown	Pat Benatar	Susanna Hoffs
Angel	Debbie Harry	Jane Wiedlin	Patti Smith	Suzi Quatro
BB King	Deep Purple	Jeff Beck	Pretenders	Suzanne Vega
Babys	Dire Straits	Johnny Thunders	Prince	T. Rex
Bad Company	Dogs D'Amour	Johnny Winter	Queen	Tori Amos
Bananarama	Duran Duran	John Lee Hooker	Ramones	Transvision Vamp
Bangles	Elvis Presley	Kate Bush	Rod Stewart	Tom Waits
Bay City Rollers	Frida	Kim Wilde	Ron Wood	+ Rare Blues
Belinda Carlisle	Eric Clapton	Lightnin' Hopkins	Rolling Stones	+ Rare 1960's

The ultimate video catalog is now available. The best quality and the best service, guaranteed. To obtain this catalog, simply send \$1.00 to:

## RARE VIDEO

P.O. Box 280-005, Brooklyn, New York 11228-0005 U.S.A.  
(Overseas inquiries welcome - PHL/SEACAM available). You won't be disappointed.

# COLLECTOR'S SHOWCASE

Showcase ads are the most looked at in Goldmine. You may buy as many boxes as you wish for an ad, at a cost of \$38.60 per box, multiplying the \$38.60 per box required. All typesetting is done by us and included in the price.

## 21st CENTURY MUSIC YOUR #1 SOURCE FOR 12" SINGLES

DISCO • SOUL • R&B & HIP HOP • ROCK 12"  
IMPORT 12" • PROMOS • SOUL ALBUMS  
SEARCH SERVICE AVAILABLE • WANT LISTS ACCEPTED  
BUYING DJ COLLECTIONS • VISIT US ON THE WEB  
1-800-846-9501 • 201-641-8610  
FAX 201-641-9309

WWW.21CENTURYMUSIC.COM  
E-MAIL: SALES@21CENTURYMUSIC.COM  
15 MT. VERNON STREET, RIDGEFIELD PARK, NJ 07860

## WE BUY AND SELL NEW & USED CD's, LP's & DVD's TOP DOLLAR PAID FOR COLLECTIONS (NO COLLECTION TOO LARGE)

• 60,000 CD's • 100,000 LP's • 20,000 CD's \$4.99 OR LESS • 20,000 \$1.00 LP's!

ONE OF THE LARGEST NEW/USED & COLLECTOR SHOPS IN THE U.S.A.  
• COLLECTIBLES • R&B • OLDIES • FUNK & SOUL • HIP-HOP • IMPORTS & INDIES • JAZZ • SHOWS • SOUNDTRACKS  
• LATIN • COUNTRY • CLASSICAL • OPERA • AUDIOPHILE • ELECTRONICA • NEW RELEASES • AND MUCH MORE

### PRINCETON RECORD EXCHANGE (609) 921 0881

CALL OR WRITE FOR FREE BROCHURE & DIRECTIONS • OPEN MON - SAT 10-9, SUN 11-6  
• Friendly, Knowledgeable Staff • Discount Prices [www.prex.com](http://www.prex.com)  
20 S. TULANE ST., PRINCETON, NJ 08542 (Easy Access from N.Y.C. by Bus, Train or Car)

## HADEN REED

Country Singer/Songwriter  
His classic country CD  
(a tribute to Hank Williams Sr.)  
such songs as  
"I'm So Lonesome I Could Cry"  
"Cold, Cold Heart"  
"Blue Moon Of Kentucky"  
CD \$13.95 ea.  
Cassette Tape \$8.95 ea.  
Send to:  
**Reedsound Inc.**  
404 N. Gum St.  
Summerville, SC 29483

## \*2001 VIDEOS\*

Rare Rock Concert Videos from 1963-2001  
from - USA, Japan, and Europe.  
Best quality and service  
around - guaranteed.

S.A.S.E. for list to:  
**VIDEOTECH**  
2118 Wilshire Blvd. #179  
Santa Monica, CA 90403

## PAPA JAZZ RECORD SHOPPE



Over 30,000 jazz, rock, soul,  
funk, punk, country, folk,  
blues and hip-hop LPs. Rare,  
new and used CDs, LPs and  
even tapes.

Visit us on the Web at  
[www.papajazz.com](http://www.papajazz.com)  
or drop us a line at  
2014 Greene St.  
Columbia, SC 29205  
(803) 256-0095

# INTOXICA!

New and Collectible Vinyl

Bought - Sold - Exchanged Mail Order Available!

Send/Fax/E-mail want lists or check our Web pages.  
1 Portobello Road, London W11 1LT, ENGLAND Tel: 0207 229 8010 Fax: 0207 792 9778  
[intoxica@intoxica.co.uk](mailto:intoxica@intoxica.co.uk) [www.intoxica.co.uk](http://www.intoxica.co.uk)  
Opening times: Mon-Sat 10:30 a.m.-6:30 p.m., Sun 12 a.m.-4 p.m.  
All major credit cards accepted.

## TOLL FREE ALBUM ONLY HOTLINE 1-800-823-4113

10 a.m.-5 p.m. Mon-Sat EST  
OVER TWO MILLION RECORD ALBUMS IN STOCK  
IF WE DON'T HAVE IT, WE WILL FIND IT  
FOR YOU  
BANANAS ALL VINYL WAREHOUSE  
2226 16th Ave. N.  
St. Pete., FL 33713  
Check out our catalog of 100,000 LP's on our new Web site:  
<http://musicfinder.com>  
E-MAIL [BANANAGRAM@AOL.COM](mailto:BANANAGRAM@AOL.COM)

YOUR FINEST SOURCE OFFERING THE HIGHEST  
GRADE CONDITION OF ORIGINAL RECORDS &  
MEMORABILIA SPECIALIZING SOLELY IN

### THE BEATLES

## - FAB 4 COLLECTIBLES -

676A Ninth Avenue #105  
New York, NY 10036  
(212) 246-7409

SELL • BUY • CONSIGN

[WWW.FAB4COLLECTIBLES.COM](http://WWW.FAB4COLLECTIBLES.COM)

E-mail: [fab4collectibles-@msn.com](mailto:fab4collectibles-@msn.com)

# MFSL WANTED

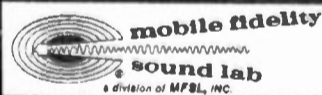

Collections of Sealed  
or Mint MFSL LP's &  
Gold & Aluminum  
MFSL CD's WANTED!

Paying  
**BIG  
\$\$\$\$\$!**  
CALL 818 988 3313 9-5 PST  
or FAX 818-988-9790

## IF IT'S OUT-OF-PRINT - OR HARD-TO-GET CHANCES ARE - I'VE GOT IT

FREE SALES LIST OUT NOW  
WRITE FOR A COPY OR FAX 540-342-2471  
**ROANOKE'S RECORD ROOM**  
P.O. Box 2445, Roanoke, VA 24010  
E-Mail: [RoaRec33@aol.com](mailto:RoaRec33@aol.com)

Visit our Web site at:  
<http://members.aol.com/RoaRec33/RecordAlbums>  
Serving Collectors around the world since 1976.  
Specializing in out-of-print 10" and 12" Rock and Pop, Jazz, Soul &  
Soundtrack LPs from 1949 to 1998 - Most major credit cards accepted.

phone/fax (525) 55 84 86 61  
sales@mexpressings.com

## mexpressings

[www.mexpressings.com](http://www.mexpressings.com)

hundreds of mexican records for sale in all formats, LP's,  
cds, promo stuff, 7" s, posters, tour passes, etc.

want lists welcome (we'll do our best!)  
puerto real 12, col. condesa c.p. 06140, mexico city, mexico

## WANTED

original 45s from the 50s & 60s - GARAGE, SURF, R&B,  
SOUL, R&R, ROCKABILLY, ETC... Will pay good prices  
for quality pieces. Interested in one 45 or entire collec-  
tion! Can consign or trade as well. Visit our Web site.  
We have over 18,000 records and misc.

[www.goldengaterecords.com](http://www.goldengaterecords.com)

Please send any lists or call/write at  
**BARRY WICKHAM**  
P.O. Box 2296, Petaluma, CA 94953  
707-765-9334

## FRENCH RECORDS & MAGAZINES

Pop, Rock, Easy...  
Lists: 1 IRC per artist



DJB, 20 rue Bringier-Monnier  
83640 St.-Zacharie France  
Fax: +33 442 62 74 74  
[www.djbrecords.com](http://www.djbrecords.com)

# Beatles4me.com

26-Page 2001 Beatles Catalog: \$2.00

## HEIN'S RARE COLLECTIBLES

P.O. Box 179, Little Silver, NJ 07739-0179  
(732) 219-1988 • FAX (732) 219-5940

## TURKISH PRESSINGS GALORE!

We stock rare 78's, picture sleeve singles, LP's from Turkey and  
around the world! Extensive list covering picture sleeves from  
Beatles, Elvis, Zeppelin etc. to R&B, rock'n'roll, psych  
and anything you're looking for from Turkey! Please write for free  
list. Also watch out for our auctions at eBay as seller 'f\_regalia'  
for superb items!

### GOKHAN AYA

Akin sok., 14/7, Suadiye, Istanbul, 81070, TURKEY  
tel: +90 216 369 87 74 email: [gokhanaya@yahoo.com](mailto:gokhanaya@yahoo.com)

## ROCK N ROLL COTTON THROW BLANKETS



The Beatles - Janis Joplin - Santana  
Blink 182 - Jimi Hendrix - Doors  
KISS - Insane Clown Posse + More  
View and order on the Web at:  
[www.cjicollectibles.com](http://www.cjicollectibles.com)

CJI Collectibles • 491 Amherst St. • Nashua, NH 03063  
(603) 882-0955  
Also available on our Web site: Doors Lava Lamps,  
Rock N Roll Mugs, Lunch Boxes, much more!

## CyrCo

Collector Of Yesterday's  
Recordings Company

[www.cyrcomusic.com](http://www.cyrcomusic.com)

WE RECORD  
LP'S ONTO  
TAPE OR  
CD!!!

R&B, Big Band,  
Country, Easy,  
Folk/Ethnic,  
Jazz, Christmas,  
Classical, Rock,  
Soundtrack,  
Religious &  
NonMusic  
Free  
Catalogs:  
(choose type)

140,000  
USED  
RECORDS ON  
SALE!

Mail: CyrCo Music  
381 T Leavenworth St.  
Omaha, NE, 68105  
Ph: 402-345-8164  
Fax: 520-441-2429  
Email: [efcyr@cyrcomusic.com](mailto:efcyr@cyrcomusic.com)

SAN FRANCISCO  
2350 MARKET  
(888) 396-2350

SAN JOSE  
880 S. BASCOM  
(888) 330-7776

SAN FRANCISCO  
3979 24TH ST  
(888) 682-3550

CALL US  
TOLL FREE!

SANTA CRUZ  
938 PACIFIC  
(888) 648-9201

## STREETLIGHT RECORDS

BUY SELL TRADE CD's LP's 45's VIDEOS LASERDISCS DVD's

[www.streetlightrecords.com](http://www.streetlightrecords.com)

# NEH RECORDS

Phone: (303) 652-0199  
Fax: (303) 652-2279  
<http://nehrecords.com>

7915 Oxford Road  
Niwot, CO 80503

## Specializing in Melodic Rock

Imports, Rarities, and Classics

CD's \$14.50 - \$21.00 (all in stock). Online audio samples.

Collectibles ... Rock / Soul / R&B / Blues / Jazz / Country / Pop / Movies & More ...

If you are buying on a regular basis, ask to be  
put on my mailing list. Accurate grading,  
reasonable prices, guaranteed to please.  
Specify which speeds & categories you prefer.

## THE MUSIC JOINT

P.O. Box 15396, Ft. Wayne, IN, 46885

# COLLECTOR'S SHOWCASE

Showcase ads are the most looked at in Goldmine. You may buy as many boxes as you wish for an ad, at a cost of \$38.60 per box, multiplying the \$38.60 per box required. All typesetting is done by us and included in the price.

## FLYING RECORDS

Box 63, 2 Lansdowne Row, London W1X 8HL UK  
 Telephone: 01144 (0207-413-9978) - answer machine in use, I will return all calls.  
 E-mail: [Flygibson@hotmail.com](mailto:Flygibson@hotmail.com)

All prices in U.S. dollars, postage included. All items EX/EX condition unless stated otherwise.  
 Payments - cash U.S. dollars registered only, I.M.O./P. Orders in U.S. dollars only, bank transfers only.

### WHO

- I'm The Face UK 7"..... \$1,000
- Who Sell Out-UK album + poster..... \$500
- Who Did It?-UK withdrawn album..... \$500
- My Generation-Extremely rare Japanese promo only album + obi + insert..... Bids

### QUEEN

- Another One Bites The Dust Columbian yellow vinyl 12"..... \$900
- Crazy Little Thing Columbian yellow vinyl 12"..... \$900
- Greatest Hits Bulgarian p/disc album..... \$1,200
- Hammer To Fall Live UK 7" sleeve..... \$350
- Seven Seas German 72 sleeve..... \$200
- Man On The Prowl v. rare Irish promo only unreleased single..... \$500
- Keep Yourself Alive v. rare Dutch 7" sleeve-VG/VG only..... \$1,500

### U2

- A Day Without Me Dutch 7" sleeve..... \$300
- Gloria Duch 7" sleeve..... \$300
- With Or Without You v. rare Japanese promo only sleeve 7"..... \$750
- I Will Follow Irish white vinyl 7"..... \$500
- Another Day Irish yellow vinyl 7"..... \$250
- Boy v. rare Japanese promo only w/drawn album..... \$1,500
- Boy v. rare Swedish blue vinyl album..... \$1,500

### PINK FLOYD

- See Emily Play Norway 7" sleeve..... \$500
- See Emily Play Japanese 7"..... \$900
- Julia Dream-Japanese 7"..... \$150
- One Of These Days-Japanese 7"..... \$200
- Relics Japanese red vinyl album..... \$300
- Japanese promo only album cow sleeve v. rare..... \$1500

### LED ZEPPELIN

- Immigrant Song Rarest Japanese promo only 7" (live on stage cover)..... \$5,000
- She Just Satisfies-UK 7" promo only..... \$700
- Best Of Thailand album (live on stage shot)..... \$600
- House Of The Holy-Korean album different cover..... \$1,000
- 1970 Original b/w image Swedish concert poster-some creasing..... \$1,000
- 2 White Matt Award presented to Richard Cole manager..... \$8,000 (photograph available)

### MADONNA

- Borderline US promo only 7" pst sleeve..... \$75
- Borderline UK p/disc..... \$75
- Crazy 4 U UK p/disc..... \$125
- Everybody UK 7" 1st single..... \$500
- Over + Over Italy 7"..... \$500
- This is Nothing But Japanese promo only album..... \$400
- Like A Virgin-Japanese p/disc album..... \$250
- Like A Virgin Hong Kong p/disc album..... \$300
- Like A Prayer v. rare Hong Kong promo 12"..... \$500
- I'm Breathless Japanese promo only CD..... \$350
- Tiffany UK promo only Tour 2001 keyring..... \$1,000

(Reissues from page 65)

### JOHN PHILLIPS

Phillips 66  
 Eagle Records (WK18854)

### DENNY DOHERTY

Waiting For A Song  
 Varèse Sarabande (302 066 230 2)

Although they managed to top the charts repeatedly while a foursome, the solo careers of the individual The Mamas And The Papas were a relative washout. With the exception of Michelle Phillips, who abandoned music for movie stardom, none of the others were able to sustain their success into the '70s. Cass Elliott was well on her way when she prematurely passed away in 1974. For their part, the two Papas — John Phillips and Denny Doherty — made only meager attempts at

## November 78 RPM

### Online Auction

November 1st to  
 Sat. November 24th

6 PM CT

One of the finest selections of 78's we've offered. With an amazing Jazz collection just in the door, not to mention our usual selection of Vocal, Pop, Country, Classical, etc. Many of the 78 sets are still sealed!

BID ONLINE AT:

[www.letitbe.com](http://www.letitbe.com)



Your Full Service Mail-order Web site

Monthly Online Auctions for  
 over three years!

All auctions end on the last  
 Saturday of the month.

1001 Nicollet Mall  
 Minneapolis, MN 55403  
[www.letitbe.com](http://www.letitbe.com) • ph 612-305-1198  
 e-mail: [letitbe@bitstream.net](mailto:letitbe@bitstream.net)

## ESPRIT MOST WANTED

We want to purchase your top quality music rarities and memorabilia

**WE WILL PAY YOU TOP DOLLARS!!**

Our lead North American buyer is Peter Fenton with over 15 years of experience purchasing your music collectibles! Discrete, knowledgeable and professional.

phone: 702-804-8872 fax: 702-804-9873

e-mail: [USEsprit@compuserve.com](mailto:USEsprit@compuserve.com)

ESPRIT MOST WANTED

9811 WEST CHARLESTON BLVD. #2-300, LAS VEGAS, NV 89117

**WE WANT TO BUY...**

VINYL: deleted, rare or promo (7" / 10" / 12" / picture discs / collectible 60's / 70's deleted LP's)

COMPACT DISCS: deleted, rare or promo (singles and/or albums, CD-Videos)

MEMORABILIA: press packs, tour books, paper goods or promo logo items or music related toys etc.

RADIO SHOWS: CD or Vinyl (Wastwood One, In The Studio, Up Close, etc. - must include cue sheets)

RECORD AWARDS: (RIAA certified gold/platinum awards in original & undamaged complete framing)

We will consider all items in at least EX condition (no visible damage or excessive wear, no scratches, tears or repairs) must include full packaging where applicable. **SEEN ITEMS IN OTHER ADVERTISERS WANTED ADVERTS? DON'T WORRY! WE WILL MATCH OR BEAT ANY REASONABLE PRICE OFFERED ELSEWHERE! SELL TO US IN COMPLETE CONFIDENCE! REASONABLE POSTAGE COSTS REIMBURSED!** Shops / wholesalers / dealers / promoters / reviewers / radio stations / DJ's - Discretion assured. Quantities wanted and encouraged. No Bootlegs or unofficial recordings or merchandise will be considered.

comeback careers. Despite several tepid tours under New Mamas & Papas moniker (with various stand-ins substituting for Cass and Michelle), Phillips and Doherty never regained the fame they knew in the band's halcyon years.

It wasn't for lack of trying, however. Shortly after the group's breakup, Phillips cut an admirable solo album, *The Wolfking Of L.A.*, which quickly sank without a trace. A second solo set for The Rolling Stones' then-fledgling label, the legendary lost album *Pay, Pack & Follow* was shelved until its posthumous release earlier this year.

Phillips fared better by farming his songs out to others — "Me And My Uncle" to the Grateful Dead, "Kokomo" cowritten with The Beach Boys, and the soundtrack for the film "The Man Who Fell To Earth," among them — but those attempts were few and far between. Then, toward the end, just prior to his passing, he completed work on *Phillips 66*, an album that ably spotlights Phillips' finesse.

Ironically, the album takes its title from the age Phillips would have been when the album was originally slated for its release. It's ironic too that the set's most revealing song, "Average Man," bears the lyrics: "I'm sixty-five, still alive/And I'm feeling fine." In reality, Phillips was very ill in his later years, so sick in fact that he was sometimes unable to stand during concerts. Coincidentally, *Phillips 66* also includes "Gram's Song," a biographical tribute to Phillips' friend and country-rock pioneer Gram Parsons. The tune effectively captures Parsons' soothing signature style via a bittersweet lament to an artist who, like Phillips, battled his demons both publicly and privately.

Despite these ominous overtones, the album boasts a surprisingly bright and breezy tone, betraying no hint of the severity of Phillips' sickness. While his voice isn't always at its strongest, his Latin-tinged remake of "California Dreaming" and sturdy take on "Me And My Uncle" fare especially well, churning with an edge, emotion and conviction that ranks with the originals.

Like *Phillips 66*, *Waiting For A Song*, Denny Doherty's second solo set following his superior debut *Whatcha Gonna Do*, bears little similarity to the music made by their classic quartet. That's

not to say he sidesteps his pop sensibilities; in fact, he takes his commercial concerns to an extreme, immersing himself in a sea of big, billowy ballads and over-the-top arrangements that radiate syrupy sentiments and excess affectations.

The high-gloss approach is typical of a '70s sound, but leaves the set sounding distantly dated. Doherty attempts to boost his standing by covering well-trod standards such as "You'll Never Know" and "You've Lost That Lovin' Feeling," but his admirable efforts add nothing new to the original rendition.

Interestingly enough, the album offers what amounted to his last attempt at a Mamas And The Papas reunion, due to the presence of Michelle Phillips and Cass Elliot, in what would be her final recordings. Even so, the unknowing listener would be hard-pressed to associate this collection with the man who voiced classics such as "Monday, Monday" or "California Dreaming." Rather, it comes across like a K-Tel collection of sappy love songs from a man who apparently felt he had to emulate others. Too bad — Doherty deserves better.

— Lee Zimmerman

### THE KINKS

#### Celluloid Heroes

KOCH/Velvel/Konk Records (VEL-CD 79734)

As The Kinks departed RCA Records, the label issued *The Kinks Greatest* — *Celluloid Heroes* in 1976, compiling a dozen tracks from the albums released between 1971 and 1974. Despite the attraction of the celebrated title tune, the LP fared poorly on the charts (not too surprising, since it contained no actual "hits") and quickly disappeared along with the band, who moved on to better days at Arista.

KOCH-Velvel's completely revamped *Celluloid Heroes* has been significantly increased to 18 tracks, featuring three selections from each of The Kinks' six RCA releases. No fewer than nine songs are brand-new to this compilation, including half a dozen songs from *Preservation Act 2* and *Schoolboys In Disgrace*, neither of which had even been represented on the original line-up.

In addition, four holdover numbers now appear in significantly lengthened edits, while three tracks no longer appear on the set at all. The result finds this new edition offering a far more balanced overview of The Kinks' RCA material — a combination of down-home blues-rock and Davies' elaborate musicals.

KOCH's new and vastly improved *Celluloid Heroes* offers both dedicated followers of the band, as well as casual fans, the welcome opportunity to sample the best of The Kinks' most underrated and misunderstood period of creativity.

— Mark Wallgren

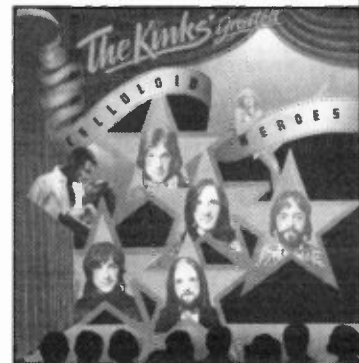

(Please see Reissues page 75)

# Goldmine

## WANT LIST ADS

### SAMPLE WANT LIST AD

SAM JONES, 101 WILMETT AVE., SHADE, TEXAS 00033 (222) 445-0001

I'M LOOKING FOR THE FOLLOWING IN VG CONDITION OR BETTER:

Badfinger	Straight Up	LP	Apple SW3387
Roy Head	Roy Head and the Traits	LP	TNT 101
Dion and the Belmonts	Where or When	45	Laurie LEP-302

The cost on this listing would be \$2.50 - \$1.00 flat fee, plus \$1.50 for the items listed (3 items at 50¢ each).

Are you looking for a particular 45, LP or CD? Perhaps you're looking for several items to add to your collection. Now there's an inexpensive way to advertise for the music you need - the *Goldmine Want List*.

For a flat fee of \$1.00, plus 50¢ per item, you can let over **60,000** *Goldmine* readers know what you're looking for!

The *Goldmine Want List* is a regular feature which will appear in every issue of *Goldmine*. *Goldmine* is read by the the most avid music collectors and dealers in the world. If you want it, they probably have it!

To place your wants in the *Goldmine Want List*, simply send us your name, address and phone number along with a list of the items you are looking for. Include payment with your list.\* A sample listing is shown below to illustrate how the listings will appear, and how the cost for a listing is figured.

\* Payment may be made in the form of Check or Money Order. We also accept MasterCard, VISA, American Express and Novus.

## Goldmine WANT LIST Order Form

MAIL TO: GOLDMINE WANT LISTS • 700 E. State St., Iola, WI 54990-0001  
715/445-2214 Fax: 715/445-4087

### PAYMENT:

Check  Money Order  MasterCard  VISA  American Express  Novus

Credit Card # \_\_\_\_\_ Exp. Date: \_\_\_\_\_

Signature \_\_\_\_\_

Flat Fee **\$1.00** + \_\_\_\_\_ items @ 50¢ per listing = **TOTAL \$** \_\_\_\_\_

*This line is optional and can be used to describe the condition of the items you are looking for.*

Name \_\_\_\_\_  
Address \_\_\_\_\_  
City \_\_\_\_\_  
State \_\_\_\_\_ Zip \_\_\_\_\_ Phone \_\_\_\_\_  
E-mail address \_\_\_\_\_

Item #	ARTIST	RECORDING	FORMAT	LABEL & CATALOG NUMBER
Item #1	_____	_____	_____	_____
Item #2	_____	_____	_____	_____
Item #3	_____	_____	_____	_____
Item #4	_____	_____	_____	_____

Use additional sheets of paper if needed. Please type or print clearly.

**Note:** Due to tremendous response, *Want List Ads* will appear in the order they are received. Because of space limitations it may take several issues for your ad to appear.

# GOLDMINE WANT LISTS

Looking for a particular recording? Advertise it in the *Goldmine Want List* section. The cost is \$1.00 flat fee, plus 50¢ per item. Use the form at the beginning of this section to list your wants. Mail the form, along with payment, to: *GOLDMINE Want List*, 700 E. State Street, Iola, WI 54990.

### DANNY AUGENSTEIN

• 219 W. Church St., Apt. #10  
• Marion, OH 43302

ARTIST RECORDING FORMAT LABEL & CATALOG NUMBER  
JEFFERSON STARSHIP - A VHS video copy of their CD: Jefferson Starship - 1999 Greatest Hits Live At The Fillmore. The liner notes of the CD said this video was produced & aired on TV Jan. 1st, 1999. I would like a complete video recording of the CD. Running time is 70 min.  
CONVOY - The soundtrack to the 1978 movie on LP, Cassette, CD.  
JOHN DENVER - Any good quality concert videos other than "The Wildlife Concert." Please tell me year & running time.

### TUGBOAT ANNIE

• 1969 Baird Road  
• McKinleyville, CA 95519  
• 707-839-4951

ARTIST RECORDING FORMAT LABEL & CATALOG NUMBER  
BOOKER T & THE MG'S - Green Onions, LP, Stax  
HARRY BELAFONTE - Marianne, LP, ?  
KENNETH MC KELLER - Sings Songs Cf The Brit. Isles, LP, London  
THE TOKENS - The Lion Sleeps Tonight, LP, ?  
MERLE TRAVIS - 16 Tons & Dark As A Dungeon, LP, Capitol 48001  
HOMER & JETHRO - I'm My Own Grndpa, LP/45, ?  
PINKARD & BOWDEN - Shake A Snake, LP/45, ?  
ORLONS - South Street & ?, LP, ?  
DOVELS - You Can't Sit Down, Bristol Stomp, Bristol  
Twistin' Annie, LP, ?

### TROY GROLLER

• 5461 San Vicente Blvd. #12  
• Los Angeles, CA 90019

ARTIST RECORDING FORMAT LABEL & CATALOG NUMBER  
JOHN HIATT - True Believer, Promo CD Sgl.  
FREDDIE MERCURY/HENDRIX/STONES - on A&E Bio. 8/00, VHS  
M. JAGGER - Private Int. from Chicago/San Fran/LA?? Film Fest. - from 98 or 99. Talks about the death of "Performance" - Director, etc.  
HENDRIX - "Revolutions" Radio Show. 9/17/90. 24 hr. from WKCR-89.9 NY. Pts. 13 & 14. Hrs 20-23.  
BLUES BROS - Conversation, 7/6/82, Radio Show. Reasonable price.  
HENDRIX - Baktabak, Picture Disc (UK)

### RICHARD ROSSI

• 5 Lyons Mall PMB #158  
• Basking Ridge, NJ 07920  
• E-Mail: martinitimerossi@aol.com

KURSAAL FLYERS - Chocs Away/The Great Artiste, CD, On The Beach - FOAMCD3  
KURSAAL FLYERS - In For A Spin, CD, Edsel, ED142  
THE RECORDS - Any Live Recording, Any Format  
XTC - When We Get To England, Any Format  
JOHN WICKS/SETH GORDON - Alan Haber's Pure Pop Broadcast of Saturday January 31, 1998  
PINK FLOYD - Shrunken Head/Relics CD or LP

### ROBERT HITTLE

• 469 Carol Dr.  
• Indianapolis, IN 46142  
• Phone: 317-883-0064

Looking for Aircheck tapes.  
ARTIST RECORDING FORMAT LABEL & CATALOG NUMBER  
MAJOR TOM LEWIS - WNAP from Indianapolis of the early 70's  
TJ BYERS - WIFE from the early 70's of Indianapolis  
J STEVENS - WIFE  
CHRIS CONNOR - WNAP  
J MICHAEL - WNAP  
RANDY ROBBINS - WXLW of Indianapolis  
LYLE DEAN - WISE of Indianapolis  
ADAM SMASHER - WNAP of Indianapolis  
I'm looking for a radio Aircheck Scout or Unscout on reel-to-reel format or cassette format. Call up at 317-883-0064.

### WILLIAM KUESTER

• 2029 Toben Drive  
• Corpus Christi, TX 78412  
• 361-985-0461  
QUEENSRYCHE - VHS Video: Mindcrime, in original box  
QUEENSRYCHE - VHS Video: Building Empires, in original box

### RICH PERRY

• 1650 163rd Avenue  
• San Leandro, CA 94578  
• Phone: 925-876-4793

I'm looking for live Van Halen shows ('78 thru '84).  
ARTIST RECORDING FORMAT LABEL & CATALOG NUMBER  
VAN HALEN - 6-19-81 Los Angeles, CA  
VAN HALEN - 7-10-81 Chicago, IL  
VAN HALEN - 7-17-82 Charlotte, NC  
VAN HALEN - 6-24-80 London, Eng.

### EVAN BORIS

• 6 Saint Andrews Court  
• Old Westbury, NY 11568-1710  
• Phone: 516-997-4840  
• FAX: 631-234-8248  
• E-Mail: discdoc@bornfreefoods.com  
• Web: www.bornfreefoods.com/discdoc.html  
ARTIST RECORDING FORMAT LABEL & CATALOG NUMBER  
CACTUS WORLD NEWS - No Shelter, CD  
TUBES - Premium Gold Collection, CD  
VARIOUS ARTISTS - 20 Of Another Kind, CD

### ERIC MOORE

• Phone: 916-356-1618  
• E-Mail: eric.n.hr.moore@intel.com  
I'm looking for the following titles in CD:  
ARTIST RECORDING FORMAT LABEL & CATALOG NUMBER  
JAZZ PASSENGERS - Best of (Crepuscule)  
JULIUS HEMPHILL - Dogon A.D. (Freedom)

# GOLDMINE WANT LISTS

Looking for a particular recording? Advertise it in the Goldmine Want List section. The cost is \$1.00 flat fee, plus 50¢ per item. Use the form at the beginning of this section to list your wants. Mail the form, along with payment, to: GOLDMINE Want List, 700 E. State Street, Iola, WI 54990.

## VINCE KIKEL

- 2886 Mason Avenue
- Port Huron, MI 48060
- E-Mail: vkmk@earthlink.net

ARTIST RECORDING FORMAT LABEL & CATALOG NUMBER  
BEATLES - Butcher Cover paste over any condition  
LYNYRD SKYNYRD - 45s LPs imports, shirts anything!  
BACKSTAGE PASSES and Crew Shirts  
SEALED & QUAD 8-TRACKS, any condition

## MARTYN HAMMOND

- 1 Wilbye House Lexden Park Lexden Road
- Colchester Essex CO3 3UF England
- E-Mail: 106174.451@compuserve.com

Concert Tickets From Oregon, Washington and Colorado.  
ARTIST RECORDING FORMAT LABEL & CATALOG NUMBER  
Bowie concert ticket Seattle Paramount Theater 11/2/72  
Bowie concert ticket Denver McNichols Arena 2/17/76  
Iggy Pop concert ticket Portland Paramount Theatre 4/4/77

Iggy Pop concert ticket Seattle Paramount Theatre 4/9/77  
Bowie concert ticket Tacoma Dome 5/21/90  
Bowie/NIN concert ticket Portland Rose Garden 10/25/95  
Bowie concert ticket Seattle Paramount Theatre 9/7/97  
Bowie tickets from other states/countries also wanted.

## ERIC MOORE

- E-Mail: eric.n.hr.moore@intel.com
- Phone: 916-356-1618

I'm looking for the following titles in CD:

ARTIST RECORDING FORMAT LABEL & CATALOG NUMBER  
PAUL MOTIAN - On Broadway, Vols. 2 or 3  
TIM BERNE - Fractured Fairy Tales  
VARIOUS ARTISTS - Jazz Satellites, Electrification, Vol. 1  
VARIOUS ARTISTS - Oceans Of Sound  
DREAM SYNDICATE - Days of Wine And Roses

## STEVE WISNER

- 49 W. 040 Route 38
- Maple Park, IL 60151
- Phone: 815-827-3504
- E-Mail: dawisner@yahoo.com

I will pay excellent prices for the following records. I will also accept tapes of these items.

ARTIST RECORDING FORMAT LABEL & CATALOG NUMBER  
BLUE MOUNTAIN EAGLE - Yellow's Dream/Marianne, 45, Atco 6770  
CORVETTES - Beware of Time/Level With Your Senses, 45, Dot 45-17283  
GOSDIN BROTHERS - You Love Me Just Enough, 45, Metromedia 0105  
IN CROWD - Never Ending Symphony/If I Knew..., 45, Viva 610  
CARL JACKSON - Dixie Train? (need B side), 45, Columbia 38-04926  
CARL JACKSON - All That's Left For Me?/, You Are The Rock?/, 45, Columbia ?  
JOE & ROSE MAPHIS - I'm Gonna Have Your Lovin'/Sippin' Pickin..., 45, Chart 5122  
LARRY MURPHY - Six White Horses/Hard To Be Friends, 45, Verve 10689  
JELLY SANDERS - Fiddlin' Country Style, LP, Global LP 1001

## MICHAEL DRUCAS

- 17 Phillips Beach Ave.
- Swampscott, MA 01907
- Phone: 781-598-3936
- E-Mail: michaeldrucas@hotmail.com

AVERAGE WHITE BAND - 1989-2001 WANTED! If you can help, please call or write. High prices paid.  
ARTIST RECORDING FORMAT LABEL & CATALOG NUMBER  
AVERAGE WHITE BAND - 1989-2001 Audience Tapes  
AVERAGE WHITE BAND - 1989-2001 Video Filmed from the audience, TV appearances.

## EDWARD P. REARDON, JR.

- 339 East 57th Street, #1A
- New York, NY 10022
- Phone: 212-832-9844
- E-Mail: reardone@coned.com

Mint/New in the Box condition  
ARTIST RECORDING FORMAT LABEL & CATALOG NUMBER  
GLENN GOULD - Mozart Piano Sonatas Vol. 1, CD, CBS/Odyssey MB2K 45612 (7 copies)  
BEETHOVEN - Masterpieces, 25-CD Box, Deutsche/Grammophon  
SAVAGE GARDEN - Truly, Madly, Deeply, CD Single  
JOHN COUGAR MELLENCAMP - Small Town (Acoustic) CD Single

## GARY C. HUESTED

- 1131 Piedmont Ave. NE
- Palm Bay, FL 32907
- Phone: 321-984-2144
- E-Mail: ghusted@cfl.rr.com

Serious R.E.M. collector seeking VG++ or better music and memorabilia:

ARTIST RECORDING FORMAT LABEL & CATALOG NUMBER  
Warner Bros. 14-track (not 12) Advance CDR for Reveal Fan Club "Gardening At Night" Garden Gloves  
Fan Club Swiss Army Bag (Mint only)  
French Near Wild Heaven Notebook  
8/82 Chronic Town Press Kit  
5/85 Fables Press Kit w/Photos  
6/85 Fables Press Kit w/Photo  
The one I Love Sheet Music (refers to Michael Stipe as "John" Stipe)  
Orange Crush 3" German CD in 5" slimline jewel case w/adaptor  
Stand German CD Warner Bros. 7577CD

## MICHAEL DRUCAS

- 17 Phillips Beach Ave.
- Swampscott, MA 01907
- Phone: 781-598-3936
- E-Mail: michaeldrucas@hotmail.com

AVERAGE WHITE BAND - 1972-1982 Wanted Desperately! If you can help, please call or write. High prices paid.  
ARTIST RECORDING FORMAT LABEL & CATALOG NUMBER  
AVERAGE WHITE BAND - 1972-1982 Concerts recorded from audience. Will pay \$100.00 a show  
AVERAGE WHITE BAND - 1972-1982 Concert Posters  
AVERAGE WHITE BAND - 1972-1982 Flyers, Handbills  
AVERAGE WHITE BAND - 1972-1982 Concert Tickets  
AVERAGE WHITE BAND - 1972-1982 Anyone who may have taken photos onstage, offstage  
AVERAGE WHITE BAND - 1972-1982 Autographs  
AVERAGE WHITE BAND - 1972-1982 Video, Rare TV Appearances USA and Overseas

## DANIEL SULLIVAN

- 5623 Laguna Quail Wy.
- Elk Grove, CA 95758
- E-Mail: dandsully@aol.com

Looking for J.B. Production People. Any Band Members LP/45

ARTIST RECORDING FORMAT LABEL & CATALOG NUMBER  
JAMES BROWN - Unique recordings or band members, i.e. Kay Robinson, Lee Austin, Beau Dollar, Anna King, Maceo, Fred, Marva, Leon Austin, James Crawford, etc., etc., etc.

## GOLDMINE

- 700 East State St.
- Iola, WI 54990
- Attn: Trevor

Serious private collector seeks the following:  
ARTIST RECORDING FORMAT LABEL & CATALOG NUMBER  
BEATLES-HENDRIX-DOORS/MORRISON-JANIS JOPLIN-STONES  
Unpublished photographs with copyright, unpublished films with copyright, color slides with copyright-only genuine material wanted-please write with details and price required. I am not interested in material on an auction basis. Strict confidentiality assured.

## L. SIMMONS

- 10701 S. Eastern Ave., Apt. 1027
  - Henderson, NV 89052
  - E-Mail: genesimmons12@hotmail.com
- WANTED: All LED ZEPPELIN videos and related material!

## TOM BERTRAND

- 235 East 13th St. 4M
- New York City, NY 10003
- Phone: (212) 673-6568

ARTIST RECORDING FORMAT LABEL & CATALOG NUMBER  
BOB DYLAN - 1987 European Concert, Tour with Tom Petty-Heartbreakers Cassettes or CD  
BOB DYLAN - 1981 Shot Of Love Concert Tour Cassettes or CD  
BOB DYLAN - 1978 Street Legal concert Tour Cassettes or CD

## GLACIER 45 GEMS

- Phone: 800-328-0633
- E-Mail: glaciardisc@hotmail.com

Limited of Stock of:  
ARTIST RECORDING FORMAT LABEL & CATALOG NUMBER  
"Minnesota" - 1975 hit by NORTHERN LIGHTS. "Think Snow" and "Runnin"

## FRANKB STEWART

- 168-43 Hillside Ave.
- Jamaica, NY 11432
- Phone: 718-523-4058 or 718-523-4646 or 718-454-4418
- Fax: 718-523-5474
- E-Mail: FBStewart@aol.com

I am interested in buying the following records. Stated price is for records in New or M- condition. Less if condition is below.

ARTIST RECORDING FORMAT LABEL & CATALOG NUMBER  
BENNY EARL - I'm A Man/And There You Are, Jaybern 700, \$100  
BOBBY PARES - Gotas De Luvia (Raindrops)/Livin With Vivian, VJ394, \$250  
FRED COLE - On Second Thought/A Souful Woman, Delite, \$75  
JOHN LESLIE - Are You Kidding Yourself?/Oh! What A Crime, LLP Records, \$250  
KELLY BROWN - The Right Guy/It's Your Move Now, Argo 5466, \$250  
MAUREEN THOMPSON - Fly Me To The Moon/Gypsy Girl, Audio Fidelity, \$75  
NICOLE JOSY - La Vita Sei Tu/..., Lord, \$250  
NICOLE JOSY - La Vie C'est Toi/..., Hebra 296, \$250  
RAY FLEMING - Talking 'Bout Love/Go On And Dance Girl, Raymar 45-1011, \$250  
THE FORTUNE TELLERS - From The Land Of The Blue Sky Waters/Deep In, Kapp Medallion, \$75  
THE GRIFFIN BROTHERS - Move It On Over/..., Dot, \$75  
TONY LAWRENCE - Until You Loved/That's How I Feel, NIKE, \$75

## JAY S. MURPHY

- 702 Ash St. #1101
- San Diego, CA 92101
- Phone: 858-534-4234
- E-Mail: jaysmurphy@yahoo.com

ARTIST RECORDING FORMAT LABEL & CATALOG NUMBER  
THE DAMNED - Children Of The Damned, Red Vinyl 7" (live), Funn Records, Cat #FUNN17  
ROBERT FRIPP/LEAGUE OF GENTLEMEN - God Save The King, Japanese CD, EG/Virgin Japan Records, Cat #VJD-5002  
ROBERT FRIPP - Let The Power Fall, German LP, EG/Deutsche Grammophon Records (1981)  
VARIOUS ARTISTS - Morrocci Klung Sept. 1981, Mag./Cassette, UK Issue

## FRANK CONTI

- 712 8th St.
- Secaucus, NJ 07094
- Phone: 201-330-9409
- E-Mail: marylee711@aol.com

ARTIST RECORDING FORMAT LABEL & CATALOG NUMBER  
TEDDY RANDAZZO - Big Wide World, LP, Colpix CP445M, SLP 445S

## MICHAEL AMIN

- 3700 Aspen Ave. NE #2L
- Albuquerque, NM 87110
- Phone: 505-256-2561
- E-Mail: mamin@twrol.com

ARTIST RECORDING FORMAT LABEL & CATALOG NUMBER  
EVERLY BROS - EB84, CD, Razor / Tie 2040  
GREGG ALLMAN - One More Try: An Anthology, CD, Polygram 529725  
DAVID CHASTAIN - Mystery Of Illusion, CD, Roadracer R09742 2  
GEORGE JONES - Sings Bob Wills, CD, Razor / Tie 2047

## JOSEPH P. GIANGUZZO

- 5031 North Barton Rd.
- Lyndhurst, OH 44124

I'm looking for the following comedy CD's in Mint or Mint-condition:

ARTIST RECORDING FORMAT LABEL & CATALOG NUMBER  
JEFF ALTMAN - I'll Flip You Like A Cheese Omelette, Mercury 842070  
AMOS AND ANDY - Radiola CD MR 1074  
LENNY BRUCE - What Was Arrested For, The Performance That Got Lenny Bruce Busted, Columbia CK-30872  
LENNY BRUCE - Bad Rapping Of The Marquis De Sade Blue Note 52676  
BURNS AND ALLEN - Metacom 030333  
RODNEY DANGERFIELD - Rappin' Rodney, RCA 60042  
DOLEMITE - Return Of Dolemite, RKD 200  
JIMMY DURANTE - Durante: Patron Of The Arts, Viper's Nest UN151  
FIRESIGN THEATER - Nick Danager 3rd Eye: Case #666, Columbia DIS-29 Promo  
FIRESIGN THEATRE - The Three Faces of AI, Rhino RNC0-5812  
DICKIE GOODMAN - Everything You Always Wanted To Know About Buchanan and Goodman But Forgot To Ask, STING 58238  
JERRY LEWIS - Collectors, Capitol CDP 7931962  
LEEROY MERCER - Huh! I'll Whoop Yer, Warhead WHD 80615  
NATIONAL LAMPOON'S - the Lost Tapes Volume 2, 3, 4, Christmas, J2 Communications Co.  
WINDERSPHERE AND BOOMER - The Creptation Contest, Encore 5012-2  
WILDMAN STEVE - Love To Make A Ugly M, F. Laff, Ichibanich 11632  
JONATHAN WINTERS - Peter And The Wolf, EMI CDC 7 499182

## MICHAEL P. MAHON

- 41 Gleason St.
- Framingham, MA 01701-3504 USA
- Phone: 508-877-0191

I'm looking for THE VENTURES on JAPANESE CD's only, no replica CD's or No Cassettes. THE REAL THING!!!! Any Japanese Record Dealers, or a fan of The Ventures in Japan or USA, new or used. Please let me know.

ARTIST RECORDING FORMAT LABEL & CATALOG NUMBER  
THE VENTURES - Live In Box Vol. 3 (Liberty Box Set) TOCP-7826 to 7829  
THE VENTURES - Melody Hits In Japan (East World) TDCT-6376  
THE VENTURES - Tokyo Callin (East World) TOCT-6378  
THE VENTURES - Flying High (Inside Out) TOCP-7239  
THE VENTURES - Bel Age With The Ventures Vol. 1 (Panam) (3 Mini Disc) CRCP-43  
THE VENTURES - Bel Age With The Ventures Vol. 2 (Panam) (3 Mini Disc) CRCP-44  
THE VENTURES - Bel Age With The Ventures Vol. 3 (Panam) (3 Mini Disc) CRCP-45  
DAVE MASON - Certified Live, Oneway, #26078



# For Great Performances Advertise In ...



## GOLDMINE CLASSIFIEDS

YOUR ALPHABETIZED INDEXED MARKETPLACE IN EVERY ISSUE OF GOLDMINE

Albums For Sale.....5000	Comedy Wanted.....5116	Girls Groups Wanted.....5216	New Wave Wanted.....5316	R&B For Sale.....5410
Albums Wanted.....5001	Compact Discs For Sale.....5117	Genesis/Gabriel/Collins.....5220	90s Rock For Sale.....5320	R&B Wanted.....5411
Alternative Rock For Sale.....5010	Compact Discs Wanted.....5118	Grateful Dead.....5225	90s Rock Wanted.....5321	Rockabilly For Sale.....5415
Alternative Rock Wanted.....5011	Compilation For Sale.....5120	Heavy Metal For Sale.....5230	Original Cast/Broadway.....5325	Rockabilly Wanted.....5416
Announcements.....5015	Compilation Wanted.....5121	Heavy Metal Wanted.....5231	Photographs For Sale.....5330	Search Services.....5420
Auctions.....5020	Computer Software For Sale.....5125	Jimi Hendrix.....5235	Photographs Wanted.....5331	70s For Sale.....5425
Audiophile For Sale.....5025	Computer Software Wanted.....5126	Imports For Sale.....5240	Picture Discs For Sale.....5335	70s Wanted.....5426
Audiophile Wanted.....5026	Convention/Shows.....5130	Imports Wanted.....5241	Picture Discs Wanted.....5336	78s For Sale.....5430
Audio Tapes For Sale.....5030	Country & Western For Sale.....5135	Independent Labels For Sale.....5245	Picture Sleeves For Sale.....5340	78s Wanted.....5431
Audio Tapes Wanted.....5031	Country & Western Wanted.....5136	Independent Labels Wanted.....5246	Picture Sleeves Wanted.....5341	Sheet Music For Sale.....5435
Autographs.....5035	Dance Music For Sale.....5140	Michael Jackson.....5250	Pink Floyd.....5345	Sheet Music Wanted.....5436
Beach Boys For Sale.....5040	Dance Music Wanted.....5141	Jazz Instrumental For Sale.....5255	Popular Vocalists For Sale.....5350	Frank Sinatra For Sale.....5440
Beach Boys Wanted.....5041	Bob Dylan.....5145	Jazz Instrumental Wanted.....5256	Popular Vocalists Wanted.....5351	Frank Sinatra Wanted.....5441
Beatles For Sale.....5045	Doo-Wop For Sale.....5150	Jazz Vocalists For Sale.....5260	Posters For Sale.....5355	60s For Sale.....5445
Beatles Wanted.....5046	Doo-Wop Wanted.....5151	Jazz Vocalists Wanted.....5261	Posters Wanted.....5356	60s Wanted.....5446
Big Bands For Sale.....5050	Easy Listening For Sale.....5155	Jukeboxes.....5265	Power Pop For Sale.....5357	Soul For Sale.....5450
Big Bands Wanted.....5051	Easy Listening Wanted.....5156	KISS For Sale.....5270	Power Pop Wanted.....5358	Soul Wanted.....5451
Bluegrass For Sale.....5055	80s Rock For Sale.....5160	KISS Wanted.....5271	Elvis Presley For Sale.....5360	Soundtracks For Sale.....5455
Bluegrass Wanted.....5056	80s Rock Wanted.....5161	Laser Discs For Sale.....5275	Elvis Presley Wanted.....5361	Soundtracks Wanted.....5456
Blues For Sale.....5060	World Music For Sale.....5165	Laser Discs Wanted.....5276	Press Kits For Sale.....5365	Spoken Word For Sale.....5460
Blues Wanted.....5061	World Music Wanted.....5166	Led Zeppelin.....5280	Press Kits Wanted.....5366	Spoken Word Wanted.....5461
Books For Sale.....5065	8 Track For Sale.....5167	Madonna.....5285	Prince.....5370	Bruce Springsteen.....5465
Books Wanted.....5066	8 Track Wanted.....5168	Magazines For Sale.....5290	Progressive Rock.....5373	Stereo Equipment.....5470
Business Opportunities.....5070	EPs For Sale.....5170	Magazines Wanted.....5291	Promotional Items For Sale.....5375	Storage Units.....5475
David Bowie.....5075	EPs Wanted.....5171	Marijuana.....5293	Promotional Items Wanted.....5376	Barbra Streisand.....5478
British Invasion For Sale.....5080	Fan Clubs.....5175	Memorabilia For Sale.....5295	Psychedelic For Sale.....5380	Supplies For Sale.....5480
British Invasion Wanted.....5081	Fanzines.....5180	Memorabilia Wanted.....5296	Psychedelic Wanted.....5381	Surf Music For Sale.....5485
Kate Bush.....5085	50s Rock For Sale.....5185	Mini Discs For Sale.....5297	Punk For Sale.....5385	Surf Music Wanted.....5486
Cassettes For Sale.....5087	50s Rock Wanted.....5186	Mini Discs Wanted.....5298	Punk Wanted.....5386	Texas Music.....5488
Cassettes Wanted.....5088	Fleetwood Mac.....5190	Miscellaneous For Sale.....5300	Radio Shows For Sale.....5390	Tour Programs.....5490
Catalogs.....5090	Folk Music For Sale.....5195	Miscellaneous Wanted.....5301	Radio Shows Wanted.....5391	Turntable For Sale.....5495
Christmas Music For Sale.....5095	Folk Music Wanted.....5196	Monkees.....5305	Rap For Sale.....5395	U2.....5500
Christmas Music Wanted.....5096	40s Music For Sale.....5200	Moody Blues.....5307	Rap Wanted.....5396	Video Tapes For Sale.....5505
Children's Records For Sale.....5100	40s Music Wanted.....5201	Musical Instruments For Sale.....5310	Rock For Sale.....5412	Video Tapes Wanted.....5506
Children's Records Wanted.....5101	45s For Sale.....5205	Musical Instruments Wanted.....5311	Rock Wanted.....5413	The Who.....5510
Eric Clapton.....5105	45s Wanted.....5206	New Age.....5314	Rolling Stones For Sale.....5400	Hank Williams.....5515
Classical For Sale.....5110	Gospel For Sale.....5210	New Orleans R&B For Sale.....5312	Rolling Stones Wanted.....5401	Woodstock For Sale.....5517
Classical Wanted.....5111	Gospel Wanted.....5211	New Orleans R&B Wanted.....5313	Reggae For Sale.....5405	Woodstock Wanted.....5518
Comedy For Sale.....5115	Girls Groups For Sale.....5215	New Wave For Sale.....5315	Reggae Wanted.....5406	Frank Zappa.....5520

### Now A NETWORK OF CLASSIFIEDS!

Krause Publications, the world's largest hobby & collectibles publisher, is proud to announce that every classified word ad placed in its periodicals will appear on the Internet's largest collectible classified site at [www.collect.com](http://www.collect.com). In addition to reaching your target audience through Krause's periodicals, your ads will also reach thousands of collectors on the World Wide Web!

only **40¢** Per Word

**Bold face type available (entire ad only) for only 10¢ more per word!**

#### 4 EASY OPTIONS TO REACH THE MOST ACTIVE MUSIC COLLECTORS FOR ONLY 40¢ PER WORD!

**By Internet:** Visit [www.collectit.net](http://www.collectit.net) on the internet to order with your credit card.

**By Fax:** Complete classified ad form, include your credit card number, expiration date, Fax to 715/445-4087.

**By Mail:** Complete order form, send payment by check, money order or credit card, mail to GOLDMINE, CLASSIFIED ADVERTISING DEPT., 700 E. State St., Iola, WI 54990-0001.

**By Phone:** Call 1-800-942-0673, 7 a.m. - 8 p.m. M-F. Saturday 8 a.m. - 2 p.m. Please have your credit card number and expiration date ready.

**Payment must be included with all Classified Ads.**

#### Frequency Discount Chart

(Consecutive Issues Only)

3-6.....10%	10-12.....20%
7-9.....15%	13-26.....25%

(Apply the appropriate frequency discount below when figuring the total cost of your classified ad.)

#### To order your classified ad:

- From the classified index on the following page, select the number which you want your ad to appear. Put that number in the box in the left hand corner of the order form.
- Using one word per line, write your ad EXACTLY as you want it to appear in GOLDMINE's Music Mart ad section.
- Minimum order is 25 words, or \$10.00 per ad per issue.
- Ad will run in next available issue. See deadlines on display advertising information page.

#### Print One Word Per Space

Please use an additional sheet of paper for larger ads

Check here for entire ad in larger bold type

Classification	1	2	3	4	5
6	7	8	9	10	11
12	13	14	15	16	17
18	19	20	21	22	23
24	25	26	27	28	29
30	31	32	33	34	35

Words \_\_\_\_\_ X # of Issues \_\_\_\_\_ = Total Words \_\_\_\_\_ X 40¢ (X 50¢ for Bold Type) = \$ \_\_\_\_\_

Less Frequency Discount (See chart above) ... \_\_\_\_\_

Total Cost \$ \_\_\_\_\_

**Total Amount Enclosed \$ \_\_\_\_\_**

#### Payment:

Money Order  Check

Amount Enclosed \_\_\_\_\_

MasterCard  VISA  Discover/Novus  American Express

Credit Card # \_\_\_\_\_

Expiration Date: Month \_\_\_\_\_ Year \_\_\_\_\_

Signature \_\_\_\_\_

**FOR OUR RECORDS ONLY:** We must have a street address and phone number for our files before we will run your ad.

Name \_\_\_\_\_

Street Address \_\_\_\_\_

City \_\_\_\_\_ State \_\_\_\_\_ Zip \_\_\_\_\_

Daytime Phone \_\_\_\_\_



Mail to: **Goldmine**

Classified Advertising • 700 East State Street  
Iola, WI 54990-0001 • [www.collect.com](http://www.collect.com)

**5000 ALBUMS FOR SALE**

**HAWAIIAN MUSIC** Sale. Discounts on LP's, 45's, 78's, tapes, CD's, videos, sheet music, sheet-music books & music books. Lists are available for most. Write to: Brian Litman, 8711 Burton Way, #305, Los Angeles, CA 90048. E-mail: hwnmusicblitman@aol.com

**PLACE YOUR AD NOW FOR THE DECEMBER 14, 2001 ISSUE OF GOLDMINE.** 1-800-942-0673.

**RELIGIOUS ORIENTED** music for sale and wanted. All types: rock, psych, garage, folk, etc. Respond to: PO Box 12777, Pittsburgh, PA 15241.

**SAN DIEGO** Local Band The Fingers EP, from 1980. Featuring Paul Kamanski, Joey Harris and Billy Thompson. Title: "The Fingers on the Radio". Fantastic condition. Covered in plastic while stored. Contact ashbyman@hotmail.com and make offer.

**SELLING 25 year 300 record collection.** 200 albums, 100 45's, 20% Beatles & Solo, 60's, 70's, 80's, Pop Rock, 80% near mint, \$2,500. 845-889-8261.

**THOUSANDS 1950'S** 1980's R&B, Soul, Pop, Jazz, Rock, 12" singles, Gospel, all types. Most in VG+ mint condition. Jerry 203-846-2636 or send wants to Jerry Records, 29 Harriet St, Norwalk, CT 06851. Also hundreds of Goldmine & Discoveries.

**1960'S-1970'S RECORDS** and CDs. \$5 each plus \$2 postage. Send orders with wantlist or send SASE for list to: Dan Giddings, PO Box 5881, Glendale, CA 91221-5881.

**IF IT'S OUT OF PRINT - OR HARD TO GET CHANCES ARE - I'VE GOT IT!** FREE SALES LISTS OUT NOW. Write For A Copy Or Fax (540) 342-2471. E-mail: [http://members@aol.com/](mailto:members@aol.com) [http://www.roadrec.com/](http://www.roadrec.com) **ROADREC'S RECORD ROOM** P.O. BOX 2445MM, Roanoke, VA 24010 Serving Collectors in The U.S. And Around The World Since 1976. Specializing in out of print 10" and 12" Rock, Pop, Jazz, Soul, & Soundtrack LPs from 1949 to 1996. Most Major Credit Cards Accepted.

**RECORD ARCHIVE** 1394 Mt. Hope Ave., Rochester, NY 14620 Phone: (716) 473-3820 FAX: (716) 473-3829 Visit our Web site! [www.recordarchive.com](http://www.recordarchive.com) E-Mail: [bobviny@aol.com](mailto:bobviny@aol.com) **VINTAGE VINYL** Over 1,000,000 Units! Want lists Accepted!

**VINYL LIVES On the Web!** <http://www.joesrecordparadise.com> Unique & Rare Rock, Jazz, R&B & Country Great prices on cool 45's, LP's, & CDs **OUR SITE IS UPDATED DAILY!** **Joe's Record Paradise** 1300 East Gude Drive Rockville, MD 20850 Ph (301) 315-2235 • Fax (301) 315-2252

**THE BOP SHOP WEB SITE!** 1000's of great condition records Visit us at [www.bopshop.com](http://www.bopshop.com) E-mail us at [bopshop@rochester.rr.com](mailto:bopshop@rochester.rr.com) **THE BOP SHOP** 274 N. Goodman St., Rochester, NY 14607 716-271-6654

Vinyl junkie cleaning up his act! No catalog yet. Send your select want lists to:

**RECORDS**  
P.O. Box 164  
Cedarhurst, NY 11516  
Fax 516-295-4370  
Check out our website - <http://earstein.com>

**5001 ALBUMS WANTED**  
ALWAYS BUYING (and selling) LPs: Nude/cheesecake, bizarre/oddball, belly dancing, electronic, and almost anything else. If it's unusual, try me! Vinyl Lives!, [buying@vinylives.com](http://www.vinylives.com), 919-846-9571.

**MOTHERS WANTED:** WLP and YLP copies of 'Freak out' and 'Absolutely Free'. Near Mint or better only. Please call Michael at 970-948-1030 or 303-477-8791 on Weekends.

1960'S-1970'S Albums wanted. Send lists with prices to: Dan Giddings, PO Box 5881, Glendale, CA 91221-5881.

**5020 AUCTIONS**

**25th Year of Continuous Record Auctions.** Send now for set sale list to: **Bob Brennan** P.O. Box 118, Elkton, FL 32033 FAX (904) 797-6294 [rbrennan427@aol.com](mailto:rbrennan427@aol.com)

**5030 AUDIO TAPES FOR SALE**

**CONCERT TAPES:** A to Z and everything in between. Send \$2 and large SASE, P.O. Box 359, Pelham, NH 03076-0359.

**HOWARD STERN** over 1000 radio shows from his 1985 NBC days to the present time. Free catalog. Michael Feinberg, 82-30 138 St., Kew Gardens, NY 11435.

**LIVE RARE** tapes 1,000+ quality hours. Rock A-Z featuring Beatles, Hendrix, Floyd, Stones, Zappa, Zeppelin. Send \$5 to: M. Piersante, 17 Fielding Circle, Mill Valley, CA 94941.

**OVER 4,600 Listings.** 114 page live rock & blues list \$2. Maxell XL II 90, \$7. Buy 6, get 1 free. BC N2939 Lemke Dr., Athens, WI 54411.

**SKYNYRD, PRETENDERS,** + many other bands, on rare audio, video and CD. Send \$2 for list or visit [www.raremusicworld.homestead.com](http://www.raremusicworld.homestead.com). Jeff B., 220 Madeleine Ave., Woonsocket, RI, 02895.

**FM CONCERTS**

Mary Chapin Carpenter, Roseanne Cash, Charlie Daniels, Guy Clark, Iris Dement, Jimmy Dale Gilmore, Nanci Griffith, Emmylou Harris, Ray Wylie Hubbard, Robert Earl Keen, Hal Ketchum, Lyle Lovett, Shelby Lynn, Marshall Tucker Band. That's just a sample

**OUR CATALOG HAS IT ALL...A TO Z** Exceptional rare concert broadcasts from around the world. Our selection, service and commitment to sound quality is unparalleled. For a free list send a SASE. To receive our amazing detailed catalog (including song titles!) send \$2 (\$3 overseas). Thank You!

**AIRWAVES** 1286 University Ave. #528-G San Diego, CA 92103

**5031 AUDIO TAPES WANTED**

**LIVE TAPES** for trade. Concert masters and low gens include: Aerosmith, Black Crowes, Sheryl Crow, Journey, KISS, Led Zeppelin, Stones, Who. Send trade lists to: Steve Jobe, 655 Britton Ave., Dayton, OH 45429.

**5035 AUTOGRAPHS**

**AUTHENTIC MUSIC,** Hollywood and television autographs, all fully guaranteed with 30 years experience. Please visit us at <http://www.WallsOfFame.com> or call 732-988-0315 for a FREE catalog.

**5045 BEATLES FOR SALE**

**Beatles4me.com**... Your #1 Beatles Source since 1977, specializing in Original Beatles Records & Memorabilia. Come visit us today! Loin's Rare Collectibles, PO Box 179, Little Silver, NJ 07739-0179. 732-219-1988, Fax 732-219-5940.

**BEATLE STUFF** Catalog: US and imports; group, solo, CDs, records, videos, books, magazines, posters, promos, toys, photos, more. Send \$1 for latest catalog. Robert Wolk, PO Box 95762, Hoffman Estates, IL 60195-0762.

**FAB FOUR** You Records has Beatles 60's collectibles, vinyls, CD's & paper goods. Also Stones, Clapton, Kinks & other British Invasion groups. For updated catalog send (5) five 34¢ stamps to: PO Box 27457, Oakland, CA 94602

**5046 BEATLES WANTED**

**ALL BEATLES** "Original" records and memorabilia wanted! Especially Butcher Cover, picture sleeves and concert ticket stubs! Gary, PO Box 179, Little Silver, NJ 07739. 732-224-8760. E-mail: [IBuyBeatles@home.com](mailto:IBuyBeatles@home.com)

**WANTED: BEATLES CONCERT** tickets, unused only, top \$\$\$ paid. Chuck 800-822-2443, 24 hours.

**5065 BOOKS FOR SALE**

**THE COMPLETE** Allman Brothers Band discography by Dean Reynolds USA \$41.95, Canada \$45, UK, Europe \$54, Australia, Asia \$55. Dean Reynolds, PO Box 709, Milford, OH 45150, USA. Full color limited edition.

**5066 BOOKS WANTED**

**SEEKING POPULAR** Music 1920-1979: A Revised Cumulation by Nat Shapiro. Write: Jerry Vogt, 141 Reservoir Dr., Boonton, NJ 07005.

**TOP PRICE** offered for "Encyclopedia of Pop, Rock and Soul" by Irwin Stambler, 1977 hardcover edition only. Sheldon Mulman, 5680 Rembrandt Ave, Apt 606, Montreal, Quebec, Canada H4W3G3.

**5070 BUSINESS OPPORTUNITIES**

**Record Store For Sale!** Be Your Own Boss! Established - Successful!

- A reputation for the best selection of LPs in this region of the state!
- Loaded with Jazz, Rock, Country, Folk, R&B, and most everything else!
- 1500 sq ft. showroom nestled in a booming downtown setting!
- Fully functional and thriving - sales have increased since opening, with another record high expected in 2001
- Full inventory LPs, CDs, 45s, Videos!
- Selling the entire store with all necessary retail equipment - cash register, stereo, computer and MORE!

For a detailed sale proposal write us at: [mastkoftrout@yahoo.com](mailto:mastkoftrout@yahoo.com) or P.O. Box 2121 Roanoke, VA 24019-2121

**5088 CASSETTES WANTED**

**OLIVIA NEWTON** John wanted. Making a Good Thing Better cassette. Any Australian cassettes. Any Japanese albums, Soul Kiss CD (Japan). If You Love Me (Let Me Know) CD US. Let Me Be There CD US. Eric Gregnoli, 79 Crystal Rock Court, Middle Island, New York 11953. No computer. Write. No phone calls please.

**5090 CATALOGS**

**FREE CATALOG** albums thousands at \$2.99 each! Jazz, Country, R&B, Pop, Big Band, and more. No junk! Foreign welcome! Jax, PO Box 1166, Ashland, OH 44805.

**FREE LIST,** set prices, primarily 1950's. Blues, R'B, R'R, etc., 45s, 78s, LPs. Collections bought. Victor Pearlin, Box 60299, Worcester, MA 01606.

**5096 CHRISTMAS MUSIC WANTED**

**RAY CONNIF** Christmas album wanted. Write: Martha Foster, RR 5, Box 315, Metamora, IL 61548.

**5117 CD'S FOR SALE**

**CD-R'S FOR SALE.** Send \$2 for complete catalog. AWalk, 1804 West Seamans Neck Rd., Seaford, NY 11783. Beatles, Clapton, Who, Eagles, many more.

**LIVE HENDRIX/ SRV/ Zeppelin** and Rory Gallagher CDs and more. For list, send \$1 to: JD's Music Memories, PO Box 784, Novato, CA 94948-0784.

**Advertise in Goldmine**

**ROOGALATOR AND DANNY ADLER GUSHA, GUSHA GUITAR R&B**

original STIFF artist EX Charlie Watts, Jack Bruce, Alexis Korner, Ian Stewart, Bo Diddley, Chuck Berry, Dr. John, T-Bone Walker, Nick Lowe, Dick Heckstall-Smith, Amos Milburn, Charles Brown, Bootsy Collins, Solomon Burke, Slims (Harpo, Memphis, Gaillard) Hookers (John, Earl) Lowell Fulson.

**PICK UP A PAIR OF EXCELLENT CD COMPILATIONS 1975-1990.5**

Roogalator "Cincinnati Fatback" Proper PRPCD7  
Danny Adler "I Better Make A Move" Proper PRPCD8  
Please contact [amazon.com](http://amazon.com) (retail) and DNA (wholesale).

**Discguys specializes in RARE and OUT OF PRINT compact discs.**

- Out of Print Compact Discs
- Rare Compact Discs
- Import Compact Discs
- Sealed Longboxes
- Compact Disc Search Service - if it was released on this planet, we can find it (Phone number required).
- Send Us Your WANT LISTS (Phone number required)

**Discguys**  
P.O. Box 491  
Charlevoix, MI 49720  
Phone Number: (231) 497-1971  
E-mail: [wefindcds2@aol.com](mailto:wefindcds2@aol.com)

**LIVE ZEPPELIN,** Hendrix plus others. Also, some domestic and imports of others. All personal stock. Send SASE for list. SAC, 1348 Canyon Side Ave, San Ramon, CA 94583.

**VINYL/CAPE REMASTERING-** Flawless sound & art. 10 years 24/7 experience. <http://worldwidemusicnetwork.com> 763-494-9222.

**5130 CONVENTIONS/SHOWS**

**SUNDAY, NOVEMBER 18, 2001.** New York, NY. New York City Movie Memorabilia Convention Hotel Pennsylvania in the Gold Ballroom 10am to 7pm. Morris Everett, Jr. The Last Moving Picture Co., 10535 Chillicothe Road, Kirtland, OH 44094. 440-256-3360/ 440-256-3431. [Lastmo@aol.com](mailto>Lastmo@aol.com) <http://www.vintagefilmposters.com>

**5140 DANCE MUSIC FOR SALE**

**DANCE ENTHUSIASTS,** DJ's and collectors. Wax Trax offers largest selection of 12" dance classics from the 70's, 80's, and 90's. Includes Disco, Hip Hop, R&B, Dance Rock, House, Techno, etc. <http://www.wax-trax.com> E-mail: [wax-trax@wax-trax.com](mailto:wax-trax@wax-trax.com) Mail: Wax Trax, 144 Fox Chase Ln, Cherry Hill, NJ 08034. Tel/Fax: 856-429-7235.

**DJ'S DISCO** 12" singles from 70's and 80's. Send \$1, (\$3 overseas), for lists or want list to: T.J. Stankard, 5300 Washington St. U503, Hollywood, FL 33021. E-mail: [discotj@aol.com](mailto:discotj@aol.com)

**12 INCH** Discodance from 80s to present, original label, we buy sale or trade! Visit: <http://www.goldrecords.it> E-mail: [goldrec@italway.it](mailto:goldrec@italway.it)

**5141 DANCE MUSIC WANTED**

**WANTED:** 12" Disco singles 1975-1995. Promos, Test Pressings, Record Pool Stock, DJ collections. Will travel for large collections. Send list: 21st Century Music, 15 Mt. Vernon St, Ridgfield Park, NJ 07660. 1-800-846-9501/ 201-641-6610.

**5145 BOB DYLAN**

**BOB DYLAN** audio, CD, video tapes; selections spanning 40 years. Rareties. Send 2 stamps for large list to: SJC, PO BOX 7096 Virginia, MN 55777.

**5190 FLEETWOOD MAC**

**FLEETWOOD MAC, Stevie Nicks,** and Sarah McLachlan memorabilia for sale. Send letter sized SASE to: Anderson Enterprises, PO Box 1011, Simi Valley, CA 93062. E-mail: [stephen8@pacbell.net](mailto:stephen8@pacbell.net)

**5195 FOLK MUSIC FOR SALE**

**FOLK SPECIALISTS.** US, UK, and Celtic Trad. Folk-Rock, Prog-Folk, Blue Grass, etc on vinyl. Send \$1 or 3 IRC's for 2 hard copy catalogues. Still Records, 6 Franklin Ct, Northampton, MA 01060. [stillrex@aol.com](mailto:stillrex@aol.com)

**5205 45'S FOR SALE**

**FREE CATALOG.** Set-Sale. Mostly 50's and 60's 45's. RAB, RR, Soul, Country, Pop. Some LP's and Magazines. Social Insect Records, 923 Baldwin, Danville, IL 61832.

**FREE 45RPM** auction list 1950's-1980's all grades. Rock, Pop, R&B, Soul, Instrumental, Folk, Motown, Surf, etc. Dave's Record Den, PO Box 360948, Strongsville, OH 44136. Fax 440-846-6048. Email: [davesrecd@aol.com](mailto:davesrecd@aol.com), <http://www.davesrecordsden.com>

**HIT PROMENADE,** Tops label 45s. Also discount disc and Tops 78s. Send for listing(s). Jim Aull, 2308 Wright Ave., Owensboro, KY 42301.

**ROCK/ ALTERNATIVE** 1970's-1990's 45's. Dealer selling out. Some titles in quantity. Business-sized SASE for list. Prefer bulk sales. DWTP, Box 5443, Kansas City, MO 64131.

**300 45'S** most 60's, 70's Soul, R&B, R&R, VG+ XF, only \$90 plus postage, insurance. Amelia Smarse, 24 N. Elm St., Westfield, MA 01085. 413-562-6735.

**Buy Below Wholesale**

From one of the world's largest inventories. Hits of the 50's, 60's, 70's and 80's - all new, quality 45 RPM records - including current reissues, imports, original pressings and discontinued collector items. Prices as low as US \$1.25 each on 90% of our stock - records selling elsewhere for up to ten times our price! Limited time offer ideal for collectors, disc-jockeys jukebox operators and dealers. Catalog listing 12,000+ records \$5.00 from Continental Records, P.O. Box 2604G, Bramalea, Ontario L6T 3S3 or download the catalog free from our web site at <http://www.gocontinental.com>

Vinyl junkie cleaning up his act! No catalog yet. Send your select want lists to:

**RECORDS**  
P.O. Box 164  
Cedarhurst, NY 11516  
Fax 516-295-4370  
Check out our website - <http://earstein.com>

**5230 HEAVY METAL FOR SALE**

**UK HEAVY** Metal 12" vinyls. Selection of top groups from 1960's onward. Mainly British and European editions including Sex Pistols, Led Zeppelin and Marillion. <http://www.vinylsrus.com>

**5235 JIMI HENDRIX**

**ALBUM** of every kind of music. Italian collector sell records 7" LP. Adv. always valid. Antonio De Spirito, Via Menghini 28, 00179 Roma Italy. Tel/Fax: 0039-6-7810837. [info@vinylmail.com](mailto:info@vinylmail.com) <http://www.vinylmail.com>

**5255 JAZZ INSTRUMENTAL FOR SALE**

**FOR SALE:** Vintage Jazz LP's. Please e-mail us at [tonygo19@aol.com](mailto:tonygo19@aol.com) or write to us at: JL, PO Box 8111, Coral Springs, FL 33075 to receive a huge list.

**5256 JAZZ INSTRUMENTAL WANTED**

**JAZZ COLLECTIONS:** Records, CD's, magazines, memorabilia. Top dollar. Ph. 314-961-8978. Fax 314-961-8206. E-mail [jazz@euclidrecords.com](mailto:jazz@euclidrecords.com) Euclid Records, 7905 Big Bend, St. Louis, MO 63119. Website <http://www.euclidrecords.com>

**5285 MADONNA**

**WANTED: COLLECTOR** of Madonna products seeks your current price list for items. Send to S. Callie, PO Box 153, Oakland, MD 21550.

**5290 MAGAZINES FOR SALE**

**ABBA** To Zappa. More cool music magazines than you can read in a lifetime. Send wantlist to: Jack Levin, 4100 N. Kenneth, Chicago, IL 60641.

**ARCHIE COMICS** for sale. \$2 each. Send SASE for list to: Dan Giddings, PO Box 5881, Glendale, CA 91221-5881.

**ARE YOU** a toy collector? TOY SHOP provides the latest toy news, in-depth features and an active buy and sell toy marketplace. Special subscription offer: 13 issues (bi-weekly) for only \$15.98! That's almost \$36 off the cover price! Call 1-800-258-0929 and mention offer ABA35V or visit our website at <http://www.toyshopmag.com>

**FOR SALE:** Movie Magazines, records, etc., list your favorite Movie Stars, TV Stars, Singers. Anna Labbate, 63 Oxholm Ave., Staten Island, NY 10301. E-mail: [ann5073@aol.com](mailto:ann5073@aol.com)

**GOLDMINE** BACK issues available. From #1 to present. Plus more than 40,000 other music magazines in stock. Contact C-Bub Productions, Box 14265, Tulsa, OK 74159. Phone: 918-585-8222. Fax: 918-585-1878. [www.cbub.com](http://www.cbub.com)

**GOLDMINE** BACK issues available. From #1 to present. Plus more than 40,000 other music magazines in stock. C-Bub Productions, Box 14265, Tulsa, OK 74159. 918-585-8222. Fax: 918-585-1878. E-mail: [mags@cbub.com](mailto:mags@cbub.com)

**INTERESTED** in Magic The Gathering or other collectible card games? SCRYE provides the latest news, in-depth strategy articles and the most respected price guide. Special subscription offer: 4 issues for only \$15.98! That's almost \$4 off the cover price! Call 1-800-258-0929 and mention offer ABA6K3 or visit our website at <http://www.scryemag.com>

**INTERESTED** in movie comics? COMICS BUYER'S GUIDE provides news and information every week to comic book readers and collectors. Special subscription offer: 14 weekly issues of CBG for only \$9.98! Call 1-800-258-0929 and mention offer ABA35U or visit our website at <http://www.comicsbuyersguide.com>

**INTERESTED** in Hot Wheels cars & models? TOY CARS & MODELS provides the latest news and information on Hot Wheels and new die cast cars & models. Special subscription offer: 6 issues (monthly) for only \$12.98! That's almost \$17 off the cover price! Call 1-800-258-0929 and mention offer ABA6K2 or visit our website at <http://www.toycarsmag.com>

**MAD MAGAZINES** for sale, 60's to present \$2 each. Send want list with order or SASE for list to: Dan Giddings, PO Box 5881, Glendale, CA 91221-5881.

**PLAYBOYS \$5** and up. Send SASE for list or send wantlist with order to: Dan Giddings, PO Box 5881, Glendale, CA 91221-5881.

**ROLLING STONE** Magazines. Best source anywhere. 1960's-present. Any article or ad located. Complete collection also available. Howard Fields (G), 25 S. First St., Bergenfield, NJ 07621, FAX/PH: 201-387-8781. Website: <http://www.rockpaper.net>

**ROLLING STONE** magazine list wish to sell all at reasonable prices. Send 3 stamps. Ed Sojka, 142 Glennon St, New Bedford, MA 02745-5238.

**TV GUIDES,** 1948-2001. Every week available. Any article located. Giant illustrated catalog, \$3. Giant illustrated newspaper "TV Guide" catalog \$3. TV Guide Specialists, Box 20-GM, Macomb, IL 61455. [oldtvguides.com](http://oldtvguides.com), 309-833-1809. VISA/MC.

**UNDERGROUND COMICS** for sale. Send SASE for list to: Dan Giddings, PO Box 5881, Glendale, CA 91221-5881.

**C-BUB'S MAGAZINE MANIA!!** The best service & selection Over 40,000 Magazines.

Circus, Cream, Guitar Mags, Hit Parade, Musician, People, Rolling Stone, Spin, Teen, Movie, Metal & Madonna.

Playboy, Penthouse, Playgirl, High Society.

Q, Mojo, Select, The Face.

#1 Source for GOLDMINE Back Issues

**WE BUY COLLECTIONS.** Send L/SASE w/Specific wants.

VISA, MC, Discover

**C-BUB PRODUCTIONS**  
Box 4567, Tulsa, OK 74159  
918-585-8222  
Fax: 918-585-1878  
[www.cbub.com](http://www.cbub.com)

**5291 MAGAZINES WANTED**

**COMPUTER MAGAZINES** wanted. Send list to: Dan Giddings, PO Box 5881, Glendale, CA 91221-5881.

**FIRST/ PREMIERE** issues only (Vol.1, #1) of US/UK music magazines/ papers in every category. Also retitled merged publications. No fanzines/ underground! "Wants" available. Grant, 5520 Maine, Concord, California 94521-4105.

**ICE, THE** CD News Authority back issues, August 1998 (#137) to June 2000 (#159). Don Schm

**5296 MEMORABILIA WANTED**

EAGLES, \*OCO, Timothy B. Schmit, Glenn Frey wanted: Photos, posters, videos, audio, magazines, anything. Karen Mott, 25 Fenwick St., Greenlawn, NY 11740. 631-261-1696. E-Mail: kimeps@aol.com

**5300 MISCELLANEOUS FOR SALE**

FREE LISTS: Old 45's Rock, Country, EZ-Listening, Low set prices 1950's-1980's Excellent cond. Quick service. D. Wilson, 602 W. Madison, Paris, IL 61944. Stamp please.

THOUSANDS OF 45s, 78s, 33s, specializing in soundtracks, country, personalities of 40's, 50's, 60's, send \$2 for refundable list. Specify speed and category. Carl Gurley Records, POB 995R, Princeton, NJ 07969.

50'S, 60'S, 70'S records. Your wants/interests (any artist, personality, type of music)? Will send free list(s). Martin, 7536 E 1050 S, Amboy IN 46911. martinrecs@com.com Web site: http://www.martinrecs.com

**5301 MISCELLANEOUS WANTED**

BASEBALL CARDS wanted. Send list Top dollar paid for collections, lots, all grades wanted. 70's to present. Send info to: Dan Giddings, PO Box 5881, Glendale, CA 91221-5881.

BEATLES LPS wanted from US & Canada. Please send price list. Thanks. Robinson, 5112 Borany Bay Village, Canal Mill, Chorley, PR6 9AF, England.

I WANT to buy Hoodies tids, sports and movie stars; Dixie premiums, sports stars and movie stars. Stan Block, 128 Cynthia Rd., Newton, MA 02159.

PEZ! PEZ! Paying \$5,000+ for certain items, premiums, ads, dispensers, anything. David Welch, PO Box 714, Murphysboro, IL 62966. 618-687-2282. pezdudef1@aol.com

**5305 MONKEYS**

AUDIO TAPE, Polly Wanna Banana, Monkey's concert in Japan, 1968. Send \$5 for tape plus \$2 postage to: Dan Giddings, PO Box 5881, Glendale, CA 91221-5881.

**5330 PHOTOGRAPHS FOR SALE**

CELEBRITY, MOVIE, Sports and TV 8X10 glossy photos. View all photos on our on-line catalog. Visit http://www.trendycollectibles.com

**5336 PICTURE DISCS WANTED**

VOGUE PICTURE records & Victor picture records wanted by collector John Jales, 324 Woodland Dr., Stevens Point, WI 54481. 715-341-6113. jcoates@coredcs.com.

**5340 PICTURE SLEEVES FOR SALE**

**PICTURE SLEEVES**  
www.  
**RECORDSLEEVES**  
.com

**5345 PINK FLOYD**

Pink Floyd Collectors Headquarters. Largest selection of merchandise and collectibles. We buy, sell and trade rare Pink Floyd items. For catalog, send \$5E SASE to address below.  
**THE WALL '80/'81 PERFORMED LIVE PHOTO BOOK**  
\$35.00 + \$5.00 Shipping  
HIP CAT RECORDS  
1213 N. Elmhurst Rd., Prospect Heights, IL 60070  
Phone: 847-537-0066

**5351 POP VOCALISTS WANTED**

**BUYING JOHNNY MATHIS!**  
(especially the cool stuff!)  
Collecting Mathis Magic/Steve C. Luth  
P.O. Box 458  
Folsom, CA 95763-0458  
SCLMUSIC@WORLDNET.ATT.NET  
Fax (916) 451-9395

**5355 POSTERS FOR SALE**

POSTERS, MEMORABILIA AC/DC, Zappa, ZZTop. Send SASE and request to: C+L Distributors, PO Box 454 East Longmeadow, MA 01028 or Email: cni20@javanel.com http://www.rockandrol-let.com

ROCK AND punk rock posters and art prints make great gifts! http://www.theshameofrockandroll.com The Shame of Rock and Roll, PO Box 151331, Dallas, TX 75315.

THE WEBSITE http://www.oneposter.com is Europe's premiere online store for music and movie posters. Thousands of promos, subways, rarities and collectible posters at unbeatable prices. All with fast worldwide dispatch - usually within 24 hours. Hundreds of new posters added to the site every week. Send free electronic postcards of our posters via e-mail to your friends. Got your own website? Why not become a Oneposter.com affiliate? We pay up to 20pc commission. For affiliate details go to http://www.oneposter.com/affiliat/

**5360 ELVIS PRESLEY FOR SALE**

ELVIS ORIGINAL Christmas album with booklet, mint condition, best offer. John Dwyer, 373 Hale St., New Brunswick, NJ 08901.

TWO "ELVIS Aron Presley" 25th Anniversary 8-LP box sets, promo "Reviewer Series", NS-3699, #02364, NM, 100 and #01200, sealed. 150 Jay Edwards, 5218 16th Ave, Meridian, MS 39305. 601-483-5586 or etahsgard@aol.com Insured shipping extra.

**5361 ELVIS PRESLEY WANTED**

ELVIS PRESLEY CD & record collector all types bought or traded 45 78 LP EP tributes, for sale. Send lists: Eddie Hammer, PO Box 836, Barteret, NJ 07008. Fax 908 353 8091.

ELVIS PRESLEY vintage items wanted. Sun records, original photography, autographs, posters, handbills and personal items. 1954-1960 preferably, top dollar paid. Bill Bryant Mgmt., 615-352-3456 fax 615-352-1922 email billbryantmgmt@yahoo.com

**ELVIS PRESLEY**  
\$100-\$20,000 offered for original film footage, MGM outtakes, private recordings, master tapes, acetates, TV kinescopes, (Roy Orbison, Pled Piper) personal belongings or wardrobe.  
562-699-8748 or 909-599-9259  
or 909-596-7109  
Ask for Hanna

**5390 RADIO SHOWS FOR SALE**

ALL NEW 2001 catalog of radio airchecks spanning the 50's thru today. Send \$1 to: Ether Madness Productions, PO Box 61, North Olmsted, OH 44070-0061 or call: 440-734-3477, leave message, thanks.

**5391 RADIO SHOWS WANTED**

OLD TIME radio wanted! Records, cassette tapes, reel-to-reels, acetates & transcription disks. Top dollar paid. Send list to: Dan Giddings, PO Box 5881, Glendale, CA 91221-5881.

**5400 ROLLING STONES FOR SALE**

GENUINE ROLLING STONES. Inket stub, Alexandria, VA 8/5/2001. Only \$4 postpaid. Evan Voita, 748 Westhills Pkwy, Baltimore, MD 21229.

**5413 ROCK WANTED**

LAZARUS PROMOTIONAL vinyl record albums, in satisfactory condition, please. Lazarus was on the Amazon, Bearsville and Midsong labels. Will pay \$10 each. Butch, 631-363-0966 after 9 AM please.

TONY CAREY wanted. Could someone please tell me what he's been up to. I don't have a computer. E.V., 85 Burton St, Bristol, RI 02809.

**5426 70'S ROCK WANTED**

AMERICA WANTED: Promotional 45's sheet music, America Halloween album on Oxygen records wanted. Also Dan Peek Write: Martha Foster, RR 5 Box 315, Metamora, IL 61548.

**5435 SHEET MUSIC FOR SALE**

I BUY and sell: Sheet Music of all kinds. Let me know what you have/want. Riseman, 2205 S. Park, Springfield, IL 62704. 217-787-2634. E-mail: riseman@riseman.com

**5455 SOUNDTRACKS FOR SALE**

SOUNDTRACKS, BROADWAY Shows, Television, Original Casts. Many rare copies. Vinyl record albums only. Catalog \$1 (refundable on first order). MJS, Box 390, Junkirk, MD 20754.

**5475 STORAGE UNITS**



"45" drawers, LP racks and more  
**The RACKIT™ System**  
(Since 1984)  
Factory direct to you from  
Per Madsen Design  
Modular stackable oak furniture  
holds all media and equipment  
Free brochure  
(Please mention Goldmine)  
800-821-4883  
www.rackit.com

**5480 SUPPLIES FOR SALE**

"If It's Worth Collecting It's Worth Protecting!"  
**JAPANESE RESEALABLE POLYPROPYLENE SLEEVES**  
(like Mylar)

Price per:	100	1,000
For 12-inch	\$20.00	\$149.00
For 10-inch	16.00	120.00
For 7-inch	14.50	102.50
For CDs	10.75	77.50

- Plus Shipping Charges
- Smaller Quantities Available
- Intermediate Prices on Quantities Between 100 and 1,000
- Other Sleeves for CDs, LPs, 45s, 78s
- Exclusive Distributor of Remington 7" Collector Albums

Call or Write for Free Price List <  
Our Sleeves Will Give You Fits  
**FAR WEST RECORD SUPPLY**  
P.O. BOX 3027  
SAN DIMAS, CA 91773  
(626) 335-5544

**5488 TEXAS MUSIC**

DOUG SAHM; Book- "Texas Tornado" \$10. CD- Doug Groove in Peace \$10. VHS- Doug-1964-1999 \$20. Rare memorabilia. Add postage. Kevin Kosub, 430 Orchard, San Antonio, TX 78220.

**5490 TOUR PROGRAMS**

VINTAGE TOUR programs, backstage passes & concert tickets. http://www.right-brain-left-brain.com Also see ebay seller.

**5505 VIDEO TAPES FOR SALE**

ADULT VIDEOS for sale \$10 to \$15. Send SASE for list to: Dan Giddings, PO Box 5881, Glendale, CA 91221-5881.

ATTENTION COLLECTORS! RARE TV and variety shows from the 50s, 60s, 70s and 80s. Please send LSASE with \$1 postage for list, or call 407-850-1049. Jim, 13926 Huntwick Drive, Orlando, FL 32837.

BANANA SPLITS on video, 2 volume set, \$10 each. Send for info to: Dan Giddings, PO Box 5881, Glendale, CA 91221-5881.

BIGGEST SELECTION A-Z video and audio. Van Halen, Bon Jovi, Police, Sting, Green Day, Alanis Morissette, LSD, Queen, U2, Slip Knot, T-Ride, too many to list. Send for free catalog. You won't be disappointed. Tony, PO Box 350-593, Brooklyn, NY 11235.

**TV Video**  
"Blast From the Past"  
Collectors of Classic Television Programs of All Kinds!  
We have a video catalog of over 22,000+ shows, check full of nostalgia, including:  
• TV Shows from the late 40's to 80's (animated/live action)  
• Aired & Unaired Pilots  
• Fantasy & Sci-Fi  
• Music Clips - many  
• Sports Items  
• 1000's of Commercials (animated/live action)  
• Shows with Original Commercials 40's to 80's  
• Promos  
• Bloopers  
• Holiday Specials  
• and Much More  
To Get Your Own Copy of Our Exclusive Catalog Collection, Please Send \$5.00 p/b to:  
D.C. Mallis  
P.O. Box 85  
Mt. Taber, NJ 07078  
(Take \$1.00 OFF with Monitor of Goldmine)

**RARE LIVE MUSIC**  
BLUES \* JAZZ \* FUSION \* ROCK  
Looking for rare, hard-to-find live music? This truly unique catalog offers the music aficionados a world class selection of live artists & is backed by excellent customer service.  
Send \$2 for our RARE VIDEO catalog  
Send \$2 for our RARE AUDIO catalog  
(Or \$3 for BOTH catalogs)  
R.W. ARCHIE  
PO Box 64944 BURLINGTON, VT 05406 USA  
International Inquiries Welcome!

**COLLECT MORE THAN MUSIC VIDEOS?**  
Get My BIG 50+ page VHS Video list of Retro-TV Classics! Sci-Fi, Mystery, Detective, Adventure, Western, Kids TV & Toons, Music, B-Movies & More! Great Selection, nice quality and timely service! Send \$3.00 to Stephen M. Russo/PO Box 150/Boston, MA 02151  
(Offered on a collector-to-collector basis.)

**"SAM'S VIDEO"**  
For Fast Service of High Quality 60's-2000 rock concerts and TV shows, from A-Z trades welcomed your list gets mine, send 4 stamps for 40-page catalog to:  
**"SAM"**  
98 Penn St.  
Pennegrove, NJ 08069-1241

**Raging Belly Video!**  
For the Best videos from 1960-2000!  
Rare videos guaranteed not to disappoint!  
"My list is like no other!!!"  
Send \$3.00 for postage & handling to:  
Marc A. P.O. Box 413  
Farmington, NY 11735 U.S.A.

CLASSIC PUNK rock and other video rarities. For complete list (free), write: Michael Loughran, 335 Broadway #21, Somerville, MA 02145. E-mail: prrdst1978@aol.com Phone 617-718-9009.

COLLECTOR'S VIDEOS: weird sci-fi, horror, fantasy, and related TV shows and animation available. List \$2. Steven Fox, PO Box 34564, Philadelphia, PA 19101.

FREE CATALOG! Hard-to-find Videos! Totally awesome selection, including classic nudist camps, foreign, restricted, uncut, much more! Discounted prices! You must be 18+. For free catalog, write: FPGO, 1974 Catherine St, #191, Montreal, Canada, H3G 2K7. E-mail: freeecat@total.net

PARTRIDGE FAMILY on videotape. Send SASE for episode list to: Dawd Giddings, PO Box 5881, Glendale, CA 91221-5881.

PEARL JAM, Tori Amos, U2, Live, Radiohead, Springsteen, Bon Jovi, Counting Crows, Oasis, R.E.M., GNR, STP, Sparden, SPumpkins, for trade. E-mail: prunes-pla1660@aol.com for list.

RARE 1950'S/60'S RnR films. RAB, R&B Doo Wop performances. Juvenile delinquent dramas. Vintage RnR on TV. Tons more! The Video Beat!, 425 Lombard St., San Francisco, CA 94133. Please visit us at: http://www.thevideobeat.com

ROCK, BLUES, Country. Collecting video since early 80's. Send artist wants. Quick response. Steve, 5957 Reach St., Philadelphia, PA 19120.

UNCUT VIDEOS of the Bizarre. Horror, Gore, adult. 4 stamps for uncensored catalog. Sign 18 or older! Bloodgore Imports, PO Box 543, Iselin, NJ 08830-0543.

SIXTIES ROCK. Everyone's source for rare and unreleased sixties and related rock videos, large SASE for extensive list. Peter Abram, 561 Staples, San Francisco, CA 94112.

VIDEO/AUDIO: Led Zeppelin, Jethro Tull, Heart, Skynyrd, Van Halen, Bad Company, Fleetwood Mac, Kiss, Eagles, Foghat, Foreigner, etc. J.A.M., PO Box 7600, Garden City, GA 31418.

**5506 VIDEO TAPES WANTED**

FOR TRADE: Beatles, Stones, Dylan, Bruce, Zep, Nirvana, Who, Queen, U2, lots more. Send audio/video lists. Ken, 304 E 20th St. #2B, NY, NY, 10003.

FOR TRADE Van Morrison rare video from around the world, 1964-2001. Excellent quality. Send lists: John, 80-40 Lefferts Blvd #3B, Kew Gardens, NY 11415.

TINA TURNER fans, looking for video tape of concert. The concert was broadcast on Dec. 4th on WCBS TV and was called Target Presents Tina Turner. Have audio/video tapes to trade. 516-317-1566.

VIDEO TAPES wanted. All specials and shows highlighting "Miami Vice", "Nash Bridges" and cast. Also Don Johnson and Philip Michael Thomas solo projects. Send inquiries to: Stacey McCann, 33 Niles Hill Rd, New London, CT 06320.

Classifieds The Key To Your Advertising Problems

(Reissues from page 70)

**JACKSON 5**  
Diana Ross Presents The Jackson 5/ABC  
Motown (440 014 380-2)

Third Album/Maybe Tomorrow  
Motown (440 014 381-2)

Goin' Back to Indiana/Lookin' Through The Windows  
Motown (440 014 382-2)

Skywriter/Get It Together  
Motown (440 014 383-2)

Dancing Machine/Moving Violation  
Motown (440 014 384-2)

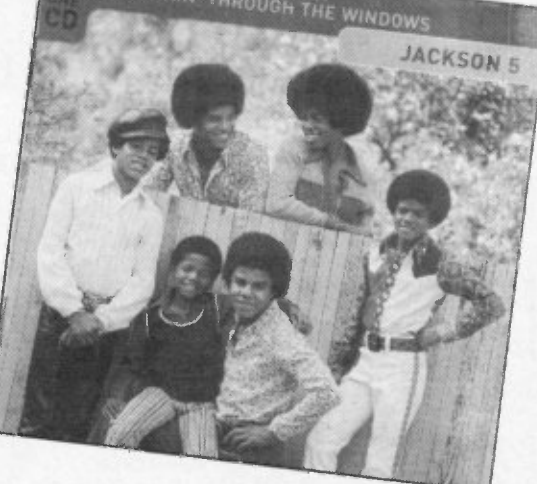

These Jackson 5 reissues should please any fan interested in the group's Motown years; each CD features two albums, digitally remastered sound and bonus tracks. They also reveal something else; though the group's early albums were the most commercially successful, the later albums may actually be the most musically interesting.

The Jackson 5 started off in a big way in 1969; their first five singles topped the Pop chart ("Santa Claus Is Comin' To Town" being the only one missing on these CDs), and their first four albums topped the R&B chart (the first three albums hitting the Top 5 on the Pop chart). The group's pop always had a soulful edge, clearly evident on hits such as "I Want Back" (Diana Ross Presents...), "ABC" and "The Love You Save" (both on ABC).

As the group's primary lead singer, Michael Jackson turns in an astonishing performance for an 11-year-old (despite that the original liner notes claim that he's 10), howling, "I may be a little fella/but my heart is big as Texas!" on "2-4-6-8" (ABC) with conviction. Diana Ross Presents... is a rawer album than the smoother ABC, but both have their highlights, including "Nobody" and "(I Know) I'm Losing You" on the former and "Don't Know Why I Love You" on the latter.

Third Album's focal points are the singles "Mama's Pearl" and the group's first classic ballad, "I'll Be There." By and large, the group opts for the mellower tone of their second album — to the point of covering "Bridge Over Troubled Water" — instead of seeking out original material. Maybe Tomorrow starts out the same way, veering close to easy-soul-listening, until the blast of "Never Can Say Goodbye" allows the band to lift off once again (the calmer title track is the

(Please see Reissues page 76)

(Reissues from page 75)

album's other single). The Latin groove of numbers such as "It's Great To Be Here" and "Honey Chile" add a welcome edge; "(We've Got) Blue Skies" even uses what sounds like a theramin.

Goin' Back To Indiana (also a great track on *Third Album*) is the weakest album of the bunch; taken from the group's TV special of the same name, numbers such as "The Day Basketball Was Saved" don't work as well without the visuals. But the group does prove to have a harder live sound on stage versus the gloss of the studio (and "Walk On" gives the group their first songwriting credit). *Lookin' Through The Windows* has two more great singles (the title track and the irresistible "Little Bitty Pretty One"). Overall, the album has a more upbeat feel, making it a pleasant toe-tapper.

The opening sound of "Skywriter," the title song and lead-off track of the group's ninth album (including 1970's *Christmas Album* and 1972's *Greatest Hits*, neither reissued in this series), reveals a newly matured Jackson 5. No longer playing the teenybopper game, they're finding their own voice, which means most of the songs tune in to a headier, funkier dance groove (just listen to "The Boogie Man," a canceled single).

Unfortunately, the album languished at #44 on the pop charts. *Get It Together* is even better, but fare worse, peaking at #100 Pop. That's especially strange considering the album contained the seeds of the group's momentary rebirth; the title track returned The Jackson 5 to the Top 30, and "Dancing Machine" just missed the top spot, peaking at #2 (#1 R&B).

"Dancing Machine" was such a success that it became the centerpiece (and title track) of the group's next album. The new version was even punchier than the original, and the rest of the album's tracks show how misguided the Motown powers were at not letting the band have more of a say in their direction.

Dance music was fast gaining in popularity, and The Jackson 5 were perfectly poised to ride the wave. Alas, it was not to be — at least at Motown. For though "I Am Love" (from *Danc-*

*ing Machine*) reached #15 pop, the vibrant "Forever Came Today" (from *Moving Violation*), stalled, incredibly, at #60. Both albums reached the Top 40, but The Jackson 5 then left Motown for Epic and greater self-sufficiency.

None of the bonus tracks are previously unreleased, but they do include rarities such as non-album B-sides and songs from compilations such as *Joyful Jukebox Music* and *Disc-O-Tech #3*. The great value of the "twofer" sets makes them the best versions of the Jackson 5's albums available today.

— Gillian G. Gaar

**THE GRASS ROOTS**

**The Best Of The Grass Roots: 20th Century Masters/The Millennium Collection**  
MCA (088 112 647-2)

For a band who placed no less than 14 Top 40 songs on the charts during AM radio's glory days, The Grass Roots had a rather inauspicious beginning. Their first single "Where Were You When I Needed You," a stinging rebuke to a fair-weather girlfriend, was a creation of L.A. contract producers/writers P.F. Sloan and Steve Barri, written to cash in on the then-prevailing folk-rock sound.

Originally sung by Sloan, the song was released under the group alias The Grass Roots — the band at that point existed in name only. Sloan eventually recruited San Francisco rock-blues band The Bedouins, and with a name change the real Grass Roots was born. Bill Fulton recorded over Sloan's vocal, but his tenure with the band was short-lived. After that initial hit, Rob Grill took over as lead singer and went on to remain the only constant in what would be an ever-changing group lineup.

The Grass Roots' hits were the product of staff writers (though the group did have a say as to how the songs should sound), and that was for the best — when they attempted to write their own material (1967's poor-selling "Feelings"), no hits were forthcoming.

The folk-rock sound of their early hits, characterized by 1967's "Let's Live For Today," an urgent declaration of personal freedom ("Let others plan their future, I'm busy lovin' you") that seemed perfectly

sued to the counterculture spirit of the times, gave way to a tougher sound by the following year. The R&B-flavored "Midnight Confessions" became the group's biggest hit, peaking at #5 on the charts.

With the exception of "Bella Linda" with its string and harp touches (a reminder of just how beautiful the best pop music can be), The Grass Roots' later hits were characterized by pounding drums and upbeat horn charts (i.e., "Heaven Knows," "Sooner Or Later"), 1972's "Two Divided By Love" would be their last Top 20 hit, peaking at #16, but by then they had already made their mark on the musical landscape.

This collection, with liner notes by Goldmine writer Bill DeYoung, easily transports us back to a more magical time when Top 40 radio still mattered.

— Tierney Smith

**VARIOUS ARTISTS**

**Sun Records — 25 Blues Classics**  
Varèse Sarabande (302 099 254 2)

When Sam Phillips recorded these remarkable blues and boogie sides during the early '50s, he was really going to school. Through trial and error, the Sun Records honcho learned how to focus on the distinctive elements that would later fuel his label's run of big country and rock 'n' roll hits.

Varèse Sarabande's *Sun Records — 25 Blues Classics* compilation focuses on blues tunes either released or intended for release on Sun, Flip or Phillips International. As a result, sessions leased to other labels featuring Howling Wolf, B.B. King and Jackie Brenston are not included. Although potent and joyous on their own merits, many of the included blues performances beg comparison to later rock 'n' roll versions.

For example: Billy "The Kid" Emerson's 1955 original of "Red Hot" plays out like a Louis Jordan cast-off compared to Billy Riley's 1957 raspy-voiced rocker. By contrast, Emerson's "When It Rains It Pours" reverberates with more plaintive feeling than either of Elvis Presley's versions.

Little Junior Parker's "Feel So Good" was redone with spirit by Sonny Burgess and



Jerry Lee Lewis, yet the original remains the ultimate statement. Parker also laid down a precise sonic blueprint for Hayden Thompson's finest moment with "Love My Baby" and crafted the eerie "Mystery Train" that Presley later transformed into quintessential driving rockabilly. However, Rufus Thomas Jr. topped the rock king on two counts — by scoring with Sun's first (albeit lawsuit-ridden) hit record, the gritty "Bear Cat (The Answer To Hound Dog)," and the original jungle-beat rendition of "Tiger Man."

Other historically important bluesmen made the trip to Phillips' Memphis Recording Studio, including a young Little Milton whose "Lookin' For My Baby" and "Somebody Told Me" betrays the influence of B.B. King. Walter Horton's vibrant harmonica work got its first exposure with "Easy," a Jimmy DeBarry-accompanied instrumental that copped its melody from Ivory Joe Hunter's "I Almost Lost My Mind."

Phillips was also wise enough to run tape on James Cotton, Pinetop Perkins, and supremely talented one-man bands such as Willie Nix and Joe Hill Louis. Striving to capture each artist's raw, youthful essence, the canny producer/engineer absorbed the seductive, rhythmic "feel" that eventually became the hallmark of his best records.

Phillips recorded dozens of other worthy performances, but this highly recommended collection provides the perfect introduction to both his label and innovative style.

— Ken Burke

Five Star Record!

© MARY WINTERS WW 2001  
lwymarty@wwnet.net

**BORN IN 1937 IN FT. LAUDERDALE, FLORIDA, ARCHIE SHEPP GREW UP IN PHILADELPHIA, WHERE HIS EARLY MUSICAL CAREER INCLUDED PLAYING R&B AS WELL AS JAZZ! IN ADDITION TO HIS MUSICAL INTERESTS, SHEPP STUDIED DRAMA & MOVED TO NYC IN THE LATE FIFTIES WITH HIS EYE ON A CAREER IN THEATRE! BUT HE WAS DRAWN TO THE JAZZ AVANT GARDE & JOINED UP WITH PIANIST CECIL TAYLOR, WITH WHOM SHEPP MADE HIS FIRST RECORDINGS! DURING HIS STAY IN THE BIG APPLE, SHEPP ALSO WORKED WITH DON CHERRY IN A GROUP HE FORMED CALLED THE NEW YORK CONTEMPORARY FIVE! HIS BIG BREAK CAME IN 1965, WHEN HE PERFORMED ON JOHN COLTRANE'S GROUND-BREAKING "ASCENSION" ALBUM! COLTRANE WAS SO IMPRESSED THAT HE USED HIS INFLUENCE TO GET SHEPP SIGNED ON AT IMPULSE! RECORDS!**

**A POET & PLAYWRIGHT AS WELL AS A MUSICIAN, SHEPP OFTEN INCORPORATES SPOKEN WORD IN HIS COMPOSITIONS! OTHER GREAT LPS: "MAMA TOO TIGHT" (1967) & "FOUR FOR TRANE" (1965)!**

☆☆☆☆☆

THE MAGIC OF JU-JU  
ARCHIE SHEPP

impulse! A 9154

**ELDER STATESMAN OF THE JAZZ AVANT GARDE, ARCHIE SHEPP RECORDED THIS LP ON IMPULSE! IN 1967! IT WAS THE HEYDAY OF THE FREE JAZZ MOVEMENT (BACK WHEN THIS MUSIC ACTUALLY FRIGHTENED & ANGERED FOLKS!) AND SHEPP WAS AT THE HEIGHT OF HIS CREATIVE POWERS! THE TITLE TRACK TAKES UP THE ENTIRETY OF SIDE ONE, AND IS EIGHTEEN-AND-A-HALF MINUTES OF FRENETIC BLOWING AND MESMERIZING PERCUSSION (SUPPLIED BY DRUMMERS BEAVER HARRIS & NORMAN CONNOR WITH EDDIE BLACKWELL, FRANK CHARLES & DENNIS CHARLES ADDING RHYTHM ON TRADITIONAL AFRICAN INSTRUMENTS)! "JU-JU" IS A WEST AFRICAN EXPRESSION THAT REFERS TO SUPERNATURAL POWERS AND MAGICAL FETISH OBJECTS OR CHARMS! SO IT'S NO SURPRISE THAT THE OVERALL FEELING OF SHEPP'S COMPOSITION IS KINDA ON THE SPOOKY SIDE! SIDE TWO FEATURES THREE MORE SHEPP ORIGINALS: THE BRIEF (LESS THAN TWO MINUTES) BUT BEAUTIFUL "YOU'RE WHAT THIS DAY IS ALL ABOUT", "SHAZAM" & "SORRY 'BOUT THAT"! ALL FEATURE SHEPP'S TRADEMARK GROWLING TENOR AND THE AFOREMENTIONED RHYTHM SECTION ALONG WITH BASSIST REGGIE WORKMAN, MARTIN BANKS (TRUMPET & FLÜGELHORN) AND MICHAEL ZNERIN (ALSO TRUMPET, TROMBONE)!**

Coming to...

# Goldmine

Courtesy Warner Bros. Records/by Jeff Katz



Prince

In the 1980s he was one of the biggest names in popular music, but by 1993 he no longer even had a name! The 1990s were an odd, turbulent and always fascinating period in the career of the Artist Formerly and Later Known As Prince. It was a decade in which he continued to record in prolific fashion, gave up life as a legendary bachelor, freed himself from his recording contract in a most unconventional manner and laid the groundwork of what some consider the music industry's future. Take a look back at stories that range from exciting to downright weird as *Goldmine* recalls the best and the worst of Prince in the 1990s. Advertisers: Cash in on one of the most collectible artists of the '80s with Prince's and other '80s artists' material — or items from any group and era.

ISSUE DATE	AD DEADLINE	MAILING DATE	ON SALE
Dec 14	Nov 15	Nov 22	Nov 30

## Advertising deadlines

DEADLINE	ISSUE DATE	MAILING DATE	ON SALE DATE
Thursday	Friday	Thursday	Friday
Nov 1	Nov 30	Nov 8	Nov 16
Nov 15	Dec 14	Nov 22	Nov 30
Nov 29	Dec 28	Dec 6	Dec 14

FOR AD INFORMATION: Call Tina Ellingson or Jill Ruesch at 715-445-2214.  
 RETAILERS: To sell *GOLDMINE* in your shop at no risk, contact Bulk Sales Manager Steve Hudziak at 715-445-2214, ext. 327.

Sign up as a **GOLDMINE** subscriber  
 — get 13 issues for only \$24.95!

(U.S. addresses only; see subscription ad on this page for non-U.S. rates.)

Charge Card holders, call toll-free:

1-800-258-0929

(Please Mr. Postman from page 8)

pioneered the technique of self-harmonization. In the '50s and early '60s, he developed a style of launching into the chorus of his refreshingly positive songs with an exciting swirl of music that would later be referred to as "the hook."

In the 1970s, Sedaka staged the one and only true individual "comeback" in rock history, a comeback that included #1 hit singles ("Bad Blood," "Laughter In The Rain"), several gold albums, TV appearances and sold-out shows. So much was the six-year success that Sedaka was actually bigger the second time around, a feat that has only been equaled in rock history by the group Aerosmith.

The 1990s brought about a third comeback in the U.K. with the hit single, "The Miracle Song" (now a wedding standard), a top-selling album, plus more TV and sold-out concerts. Approaching the new millennium, Sedaka ventured into uncharted territory again with a brilliant album, *Classically Sedaka*, consisting of classical compositions rearranged and set to his own intimate lyrics. He began performing a classical section of considerable magnitude (in addition to his '50s, '60s, '70s and '80s hits) in his live shows as well and was acclaimed by both fans all ages and critics.

I recently interviewed Sedaka for an upcoming *Goldmine* exclusive. In it he talked of exciting ideas for the future; his energy and passion for music are still boundless and fresh. For the reasons above, I'm asking for a campaign of our readers to urge the movers and shakers of The Rock And Roll Hall Of Fame to bring Neil Sedaka, a living legend, home where he belongs.

Much like his friend and fellow contemporary, Elton John, Sedaka is an amazing performer, writer and recording artist, and he remains an undiminished shining star and a triumph of human spirit. Those characteristics and more make this great

American original not only the material, but the very fabric of the Hall Of Fame itself, as well as the essence of all things rock 'n' roll.

— C. Brian Jasper  
 Somerset KY

[Readers interested in petitioning The Rock And Roll Hall Of Fame's induction committee should write to: The Rock And Roll Hall Of Fame Foundation, 1290 Avenue of the Americas, New York NY 10104. Here's a hint to help get your favorite on the ballot: Don't rant, give valid reasons as to why a particular artist should be included on the ballot. — Ed.]

My favorite band — Wishbone Ash

I was curious if *Goldmine* (the best chronicler of musical groups) has ever profiled my favorite band, Wishbone Ash? The band recently celebrated 30 years in the biz and would be a great candidate for the patented *Goldmine* treatment. Thanks,

— Richard Smith  
 League City TX

[Rick, While we've run reviews on reissues of Wishbone Ash albums, we've never done an article on the band. We'll add them to the list! — Ed.]

George Hamilton IV wanted

When will you do an article on George Hamilton IV? Why hasn't Bear Family released a second box set of his, from 1965 to now? Hamilton is still very active in country/gospel music and a true living legend.

— Phillip Paulson  
 Indianapolis IN

[Philip, I can't speak for Bear Family, although their exquisite packages take a while to put together. We'll add Hamilton to our list. — Ed.]

## Goldmine Subscription Service Including Special Services Subscriptions sent via UPS, 1st Class

**Note:** Current subscribers: when ordering any Special Service Subscription, a minimum one half year payment must be submitted. Those funds will be added to any current subscription credit and the total balance pro-rated to arrive at the number of issues due under the chosen plan. Subscribers will be notified of the resulting change in subscription duration and their new expiration date.

Regular Subscriptions are delivered via Second Class Mail to addresses in the U.S. and possessions.

**Credit card orders:** To speed the processing of your order for a Special Service Subscription, VISA,

MasterCard, Discover or American Express orders may be phoned in by dialing 800-258-0929 and asking for Special Services.

**United Parcel Service** delivery subscriptions require a street address.

Clip and mail with payment to:

## Goldmine

Special Services

Subscription Department

700 E. State St., Iola, WI 54990-0001

**NOTE:** Special Services Subscriptions are not available outside of U.S.A.

Goldmine Service	6-mo.	1-yr.	2-yr.	3-yr.
Second Class Mail (Standard Delivery 50 States)	\$24.95	\$39.95	\$74.50	\$107.95
Plain Wrapper (2nd Class Mail 50 states)	N/A	46.95	88.50	128.95
First Class Mail (in Plain Wrapper 50 states)	66.95	124.95	255.00	382.95
United Parcel Service (Regular Delivery 48 States)	75.00	140.00	N/A	N/A
United Parcel Service (2nd Day)	160.00	305.00	N/A	N/A
United Parcel Service Next Day	245.00	470.00	N/A	N/A

Foreign subscriptions including Canada and Mexico must be paid for in U.S. funds by an international money order or postal money order

### Circle the rate below your country

	1/2-year	1-year
Surface mail all countries	49.95	93.95
Canada, Mexico (Air Mail)	70.95	135.00
Central America, Caribbean (Air Mail)	135.00	255.00
South America, Europe, Mediterranean Africa (Algeria, Libya, Morocco, Tunisia) (Air Mail)	135.00	255.00
Asia, Africa, Australia, all other countries (Air Mail)	135.00	255.00

Name \_\_\_\_\_  Check enclosed  
 Address \_\_\_\_\_  MasterCard  VISA  Discover  Am. Ex.  
 City \_\_\_\_\_ Card # \_\_\_\_\_  
 State/Zip \_\_\_\_\_ Expires Mo. \_\_\_\_\_ Yr. \_\_\_\_\_  
 Signature \_\_\_\_\_

New subscription  
 Renewal/Extension (please attach your mailing label)

Rates are subject to change.

## Goldmine

Circulation Dept.

700 E. State St., Iola, WI 54990-0001 GMPY97

# Goldmine Advertisers' Index

<b>A</b>	Dig Music .....55	Hein, Gary .....69	Metro City Records.....48, 49	Record Cellar .....57	Streetlight Records .....69
Ace Video & Music .....56	Disc Collector .....4	Held, Kenneth .....56	Mexpressings .....69	Record Exchange .....50	Stylus Shows .....59
Adler, Dan .....74	Discbase CD Shop .....36, 66	Heroes & Legends .....67	MFG .....36	Record Gems .....74	Super Soul New York .....59
Airwaves .....74	Discguys .....74	Hiatt, Mike .....67	Midnight Records .....7	Record Sleeves.com.....75	Sweet Memories .....56
Alberg, Robert .....65	DJB (Devant Le Jukebox).....69	Hip Cat Records .....75	Miller, Ken .....40	Records And Books .....68	<b>T</b>
Andy's Record Supply .....5	<b>E</b>	His Song: The Musical	Mindpepper LLC Bargain &	Records Argentina .....68	Tefteller, John .....36
Arc Promotions .....58	East End Lights .....34	Journey of Elton John .....37	Haggle .....27	Recordsmith .....43	Tiny Ripple Books.....28
Around The World Records	Energy .....33	Hollis, Dan .....75	Moerer, Craig .....58	Reed, Biz .....68	TLT Productions .....59
.....57	Erock Auction .....57	<b>I</b>	Mud Shark Audio .....66	Reedsound Records.....67, 69	Tomko, Jerome .....67
Audio Collections .....42	Esprit Most Wanted .....70	Import Records & CD's.....57	Music Imports .....67	Reggie's Goodies .....34	Train Wreck Records .....30
Aya, Gokhan .....69	Euclid Records .....67	In Your Face Videos .....68	Music Joint, The .....69	Retriever Memorabilia Service	True Oldies .....66
<b>B</b>	<b>F</b>	Int'l Transfers .....66	Music Masters .....11	.....68	Tsouvalos, Alex .....66
B & D Record Sales .....67	Fab 4 Collectibles .....69	Intoxica .....69	MusicAndVideo.com .....44	Rhino Records .....3, 31, 33, 79	Turton, John .....66
Bags Unlimited .....24, 25, 80	Far West Record Sply.....75	Iuliucci, Bob .....44	Musicstack .....66	Rhythm Recordings .....51	<b>U</b>
Banana's Records .....69	Flipside Records &	<b>J</b>	<b>N</b>	Rip It Up!.....68	Universal Music Group .....41
Bangzoom.com .....35	Collectibles .....55	Jazz Record Center .....57	NEH Records .....69	Rivertone Corp. ....66	<b>V</b>
Bell, Rick .....68	Flying Records .....70	Jewelsleeve.com .....41	Nitty Gritty Records .....35	Roanoke's Record Room	Ventania Records .....68
Better Records .....69	FRCA, Inc. ....59	Joe's Record Paradise .....74	Noise Pollution .....50	.....69, 74	Very English & Rolling Stone
Big Ed's Record Shows .....59	Full Cyrkle Records & Music	John Manship Records.....55	Null, Charles.....54	Rock N Records .....50	.....40, 56
Boo's Blast From The Past .47	.....56	Just Another Dream .....56	<b>O</b>	Rock Of Ages .....50	Videos.....67
Bop Shop Records .....74	Fun Records .....68	<b>K</b>	Oldies45.com .....56	Rock Solid International .....2	Videotech .....69
Brennan, Bob .....74	Funk, Thomas.....50	Kaplan, Gary .....66	<b>P</b>	Rockaway Records .....66	Vintage Vinyl Mail Order.....57
Brito, Micheal .....56	<b>G</b>	KP Adv Promotion .30, 36, 63	Papa Jazz Record Shoppe..69	Rocky Mountain Sportscards	Vinyl Galore LLC .....56
Buccaneer Records .....9	Garofalo, Peter .....68	KP Book Promo .....64	Per Madsen Design	.....56	Vinyl Tap Mail Order Music..32
<b>C</b>	Gaspar, J.A. & J. Del Peso ..65	<b>L</b>	.....54, 56, 65, 75	Ross, Scott .....37	Visual Vinyl .....57
C-Bub Productions .....74	Gatefold Records .....66	L.A.M. Videos .....68	Phelan, Mike .....56	Russo, Joseph .....66	<b>W</b>
CD Trustee .....65	GM Upcoming Issues .....77	Last Vestige .....40	Pilato Entertainment Group	Russo, Stephen .....67, 75	W.M.I. Distribution.....56
Celebrity Art .....56	Goldmine .....28, 40, 50, 71, 73	Les Harris .....53	.....35	Safe As Milk Records .....74	Wickham, Barry .....69
CJI Collectibles .....69	Goldmine Index Page .....78	Let It Be Records .....70	Princeton Record Exchange	Samuels, Gordon .....75	Wiz Productions .....67
Collectable Records .....21	Goldmine Subscript'n .....77	Let The Music Play .....66	.....69	Sandkamp, George.....67	Wolak, Jack .....29
Collectibles Insurance Agency	Goldmine Unit Page .....38	Loran Records .....56	<b>R</b>	Saturn Records.....46	Worldwide Marketing
.....36	Goldmine Want List .....71, 72	Lorentz Design .....65	R & B Records .....32	Second Saturday Show .....59	Associates .....67
Collector .....37	Green, Craig .....50	Luth, Steve .....75	Radwill, Allen .....39	Shaheen, John .....66	<b>Y</b>
Continental Records .....74	Greindl, Jeff .....56	Lyons, Gary .....59	Raging Belly Video .....67, 75	Siren Disc .....32, 34, 59	Yesterdays Music .....59
Cool And Strange Music! .....43	Guitarist's Connection.....75	<b>M</b>	Randolph Music .....59	Southland CD .....56	101cd.com .....65
Cuneiform Records.....40	<b>H</b>	McDuffie, Jim .....43	Rare & Hard To Find.....30	Spindle Records .....50	21st Century Music.....69
Cyrco Music .....69	Hanna, Sherif .....75	Memory Lane .....56	Rare Soul Man .....57	Spinnin' Disc .....13	
<b>D</b>	Hedrich, Jack .....43	Messikian, David .....43	Record Archive Inc. ....74	Staeher, Herbert .....50	
Dailey, Dennis .....28					

The advertisers' index is provided as a reader service. Occasional, last-minute changes may result in ads appearing on pages other than those listed here. The publisher assumes no liability for omissions or errors.

### 2001 Advertising Deadlines

Deadline is 12 noon on deadline day  
700 E. State St., Iola, WI 54990-0001

1-888-457-2873 • 715-445-2214 • FAX: 715-445-4087

Ad Deadline	Issue No.	Cover Date	Mailing Date	On Sale Date
Nov. 1	#557	Nov. 30	Nov. 8	Nov. 16
Nov. 15	#558	Dec. 14	Nov. 22	Nov. 30
Nov. 29	#559	Dec. 28	Dec. 6	Dec. 14
Dec. 13	#560	Jan. 11, '02	Dec. 20	Dec. 28
Dec. 26 (Wed.)	#561	Jan. 25	Jan. 3	Jan. 12

### REFERENCE FORM

COMPANY NAME \_\_\_\_\_  
 STREET ADDRESS \_\_\_\_\_  
 CITY \_\_\_\_\_ STATE \_\_\_\_\_ ZIP CODE \_\_\_\_\_  
 PHONE NO. \_\_\_\_\_  
 SOCIAL SECURITY # \_\_\_\_\_  
 TYPE OF BUSINESS  
 CORPORATION  LIMITED PARTNERSHIP  
 CO PARTNERSHIP  INDIVIDUAL PROPRIETOR  
 NO. OF YEARS ESTABLISHED \_\_\_\_\_

### PRINCIPAL OWNERS STOCKHOLDERS PARTNERS OFFICERS OF COMPANY

NAME \_\_\_\_\_  
 MAILING ADDRESS \_\_\_\_\_  
 CITY \_\_\_\_\_ STATE \_\_\_\_\_ ZIP CODE \_\_\_\_\_  
 TITLE \_\_\_\_\_

### TRADE REFERENCES

NAME \_\_\_\_\_  
 ADDRESS \_\_\_\_\_  
 CITY \_\_\_\_\_ STATE \_\_\_\_\_ ZIP CODE \_\_\_\_\_  
 PHONE \_\_\_\_\_

### BANK REFERENCE

BANK NAME \_\_\_\_\_  
 CITY \_\_\_\_\_ STATE \_\_\_\_\_ ZIP CODE \_\_\_\_\_  
 PHONE \_\_\_\_\_

I (we) hereby authorize Krause Publications and/or its credit agent to investigate the references herein or statements or other data obtained from me or any other person pertaining to my credit and financial responsibility. I understand that it is Krause Publications' policy to require cash in advance for all advertising until credit has been established or approved.

Further, I (we), the undersigned, will be held personally responsible and promise to pay promptly within 15 days of the billing date for all advertising debts incurred by the above named business and owing to Krause Publications.

AUTHORIZED SIGNATURE(S) OF APPLICANT(S) \_\_\_\_\_

### DISPLAY ADVERTISING:

(Cost per ad per issue; ads must run consecutively. Contract required to earn consecutive issue discounts.)

AD SIZE	WIDTH x HEIGHT	1 ISSUE	3 ISSUES	6 ISSUES	13 ISSUES	26 ISSUES
1/16 pg	2 5/16" x 3 1/4"	\$55.65	\$53.55	\$50.15	\$47.45	\$44.40
1/8 pg	4 7/8" x 3 1/4"	111.30	105.00	100.30	94.50	89.25
1/4 pg	4 7/8" x 6 1/2"	213.90	202.95	191.90	181.95	170.90
1/2 pg	4 7/8" x 13" or 10" x 6 1/2"	397.45	378.20	358.35	338.50	318.65
Jr. pg	7 7/16" x 10"	525.90	499.45	473.00	447.05	421.05
Full pg	10" x 13"	721.05	685.65	649.40	613.55	577.15

### COLOR:

- A. One color and black .....\$190.00
- B. Full color (4-color) .....\$500.00
- (Plus color separation costs)
- C. Based on availability.
- D. Color is possible on any size ad.

### UNIT SPACE ADVERTISING:

Unit space ads are the easiest way for you to sell records, tapes, compact discs, books, memorabilia, and any other collectibles you have for sale. Units also work well for want lists, announcements, etc. The better your unit looks when you put it together, the better it will look in GOLDMINE.

You may use any bidding deadline you wish in your advertisement. If no deadline is noted, it will be understood that the deadline will be one month from the cover date of the issue in which your ad appears.

One unit space equals one 8 1/2" x 11" typed sheet. This applies to both regular and super unit space ads.

Type your copy legibly onto 8 1/2" x 11" white sheets. We'll reduce it as is to 38% of its original size for regular units and 59% of its original size for super units. A regular unit space is one ninth of a page; a super unit space is a quarter of a page. Remember to include your ordering information, postage rates, grades, deadlines, name & address, etc., on your first unit. Do not send any partial units. There is a \$10.00 charge per photo for unit ads which contain photographs.

We will typeset your name, address and phone number at the bottom of your unit space ad for you, and a heading at the top, if you specify one. There is no extra charge for this. If you ask us not to typeset anything on your ad, we'll do nothing. Otherwise the typesetting will appear.

Do not reduce your copy before putting it on 8 1/2" x 11" format. Avoid all caps in your copy, except for headlines. Keep the copy clean. Dot matrix printers do not work well for unit ads, but if you must use one print it as dark as possible. Faxing unit space advertisement is not recommended.

### Regular Unit Space Advertising Rates:

(Cost per unit, per issue; ads must run in consecutive issues. Contract required to earn consecutive issue discounts.)

1 ISSUE	3 ISSUES	6 ISSUES	13 ISSUES	26 ISSUES
\$60.90	\$57.90	\$54.60	\$52.00	\$48.60

Full page of 9 - \$466.20

### Super Unit Space Advertising Rates:

(Cost per super unit, per issue; ads must run in consecutive issues. Contract required to earn consecutive issue discounts.)

1 ISSUE	3 ISSUES	6 ISSUES	13 ISSUES	26 ISSUES
\$126.80	\$120.75	\$114.20	\$108.15	\$101.85

Full page of 4 - \$466.20

### COLLECTOR'S SHOWCASE:

The Collector's Showcase is a widely read advertising section in GOLDMINE. Each ad is in its own box, consisting of a space 3 1/4" wide and 1 11/16" high, or a multiple of that size. All typesetting is included in the price. We recommend no more than 14 to 15 typed or written lines per showcase box.

There are two Collector's Showcase sections available to advertisers - the Compact Disc Showcase, for those specializing in CDs; and the regular Collectors Showcase.

### Advertising Information

#### Showcase Advertising Rates:

(Cost per showcase box per issue; ads must run consecutively. Contract required to earn consecutive issue discounts.)

1 ISSUE	3 ISSUES	6 ISSUES	13 ISSUES	26 ISSUES
\$38.60	\$37.00	\$34.65	\$33.10	\$31.00

RETAILER DIRECTORY .....\$9.00 per issue

This section features listings for retail record stores around the world. Traveling record collectors of all types search for new stores to dig through on their vacations, business trips, etc. Advertise your establishment here, including ten words of miscellaneous description, for only \$9.00 an issue. You can buy this space in increments of 13 or 26 issues, for \$117.00 or \$234.00, respectively. Send in your store name, address, phone number, and ten words of description, along with your payment. If you stock GOLDMINE, we'll put your listing in boldface type.

#### CLASSIFIED DISPLAY:

AD SIZE	1 ISSUE	3 ISSUES	6 ISSUES	13 ISSUES	26 ISSUES
One Inch (1 1/2" x 1")	\$13.80	\$13.15	\$12.60	\$12.10	\$11.55
Two Inch (1 1/2" x 2")	26.55	25.50	23.65	22.60	21.55
Three Inch (1 1/2" x 3")	39.15	37.55	35.20	33.60	31.50

(Cost per ad; ads must run consecutively. Contract required to earn consecutive issue discounts.)

#### CLASSIFIED ADVERTISING:

A. 40 cents Per Word (\$10.00 Minimum Order Per Ad Per Issue). Ad will also be included on our www.collectit.net site at no additional charge.

B. DISCOUNTS FOR CONSECUTIVE INSERTIONS	
1-2	No Discount
3-6	10%
7-9	15%
10-12	20%
13-26	25%

### ADVERTISING REQUIREMENTS: BOOTLEG POLICY

The advertiser is responsible for ensuring that advertised product conforms with national and international copyright laws. GOLDMINE magazine screens advertisements for bootleg merchandise. GOLDMINE magazine accepts no responsibility for transactions involving unauthorized product.

#### REFUNDS:

If delivery will take longer than 30 days from the date the seller received the order, the seller must inform the buyer and offer the buyer the option of a refund or delayed delivery.

Unless otherwise stated in the ad, the buyer has a 10-day return privilege from the time he/she receives an item from an advertiser. The buyer does not have to give a reason for a return and can demand a refund less postage costs. Advertisers must allow buyers to obtain authenticity judgments as the basis for retention provided they notify the advertiser of their intent within the applicable return privilege period.

All advertisers must provide a permanent address and telephone number before an advertisement will be run. If a post office box is used in an advertisement the advertiser must still provide a permanent address for our confidential files.

A completed reference form must be in our confidential files before any buy, sell or trade ad can be placed. See below. Minors are required to furnish a certificate of responsibility from their parents/guardian before their advertising can be accepted.

Payment must accompany an advertisement and must be in the form of a personal check drawn on a U.S., Canadian or Mexican bank; money orders; international money orders; cashier's checks; or with your VISA, MasterCard or AccessCard credit card. Send your credit card number, expiration date, and the name on the card, along with permission to charge the card for your ad, with your advertising copy.

# GRATEFUL DEAD

## THE GOLDEN ROAD (1965 - 1973)

Weighing in at 4 lbs., this mammoth 12-CD box set contains over 15½ hours of music from the Grateful Dead's golden era. Includes all nine original Warner Bros. albums plus seven hours of previously unreleased recordings. Contains over 230 pages of liner notes & photos, plus an updated discography. Includes *Birth Of The Dead*, a new 2-CD set of pre-Warner Bros. tracks.

### BIRTH OF THE DEAD

Disc 1: The Studio Sides

#### The Autumn Sessions

1. EARLY MORNING RAIN
2. I KNOW YOU RIDER
3. MINDBENDER (CONFUSION'S PRINCE)
4. THE ONLY TIME IS NOW
5. CAUTION (DO NOT STOP ON TRACKS)
6. CAN'T COME DOWN

#### The Scorpio Sessions

7. STEALIN' (Instrumental)
8. STEALIN' (with Vocals)
9. DON'T EASE ME IN (Instrumental)
10. DON'T EASE ME IN (with Vocals)
11. YOU DON'T HAVE TO ASK
12. TASTEBUD (Instrumental)
13. TASTEBUD (with Vocals)
14. I KNOW YOU RIDER
15. COLD RAIN AND SNOW (Instrumental)
16. COLD RAIN AND SNOW (with Vocals)

#### The Hendricks Session

17. FIRE IN THE CITY - Jon Hendricks

Disc 2: The Live Sides

#### Various Live Performances

1. VIOLA LEE BLUES
2. DON'T EASE ME IN
3. PAIN IN MY HEART
4. SITTING ON TOP OF THE WORLD
5. IT'S ALL OVER NOW, BABY BLUE
6. I'M A KING BEE
7. BIG BOSS MAN
8. STANDING ON THE CORNER
9. IN THE PINES
10. NOBODY'S FAULT BUT MINE
11. NEXT TIME YOU SEE ME
12. ONE KIND FAVOR
13. HE WAS A FRIEND OF MINE
14. KEEP ROLLING BY

### THE GRATEFUL DEAD

1. THE GOLDEN ROAD (TO UNLIMITED DEVOTION)
2. BEAT IT ON DOWN THE LINE
3. GOOD MORNING LITTLE SCHOOL GIRL (Full-Length Version)
4. COLD RAIN AND SNOW
5. SITTING ON TOP OF THE WORLD (Full-Length Version)
6. CREAM PUFF WAR (Full-Length Version)
7. MORNING DEW (Full-Length Version)
8. NEW, NEW MINGLEWOOD BLUES (Full-Length Version)
9. VIOLA LEE BLUES

Bonus Material

10. ALICE D. MILLIONAIRE
11. OVERSEAS STOMP (THE LINDY)
12. TASTEBUD
13. DEATH DON'T HAVE NO MERCY
14. VIOLA LEE BLUES (Edited Version)
15. VIOLA LEE BLUES (Live)

### ANTHEM OF THE SUN

1. THAT'S IT FOR THE OTHER ONE
  - I. CRYPTICAL ENVELOPMENT
  - II. QUADLIBET FOR TENDER FEET
  - III. THE FASTER WE GO, THE ROUNDER WE GET
  - IV. WE LEAVE THE CASTLE
2. NEW POTATO CABOOSE
3. BORN CROSS-EYED
4. ALLIGATOR
5. CAUTION (DO NOT STOP ON TRACKS)

Bonus Material

6. ALLIGATOR (Live)
7. CAUTION (DO NOT STOP ON TRACKS) (Live)
8. FEEDBACK (Live)

### AOXOMOXOA

1. ST. STEPHEN
2. DUPREE'S DIAMOND BLUES
3. ROSEMARY
4. DOIN' THAT RAG
5. MOUNTAINS OF THE MOON
6. CHINA CAT SUNFLOWER
7. WHAT'S BECOME OF THE BABY
8. COSMIC CHARLIE

Bonus Material

9. CLEMENTINE JAM
10. NOBODY'S SPOONFUL JAM
11. THE ELEVEN JAM
12. COSMIC CHARLIE (Live)

### LIVE/DEAD

1. DARK STAR
2. ST. STEPHEN
3. THE ELEVEN
4. TURN ON YOUR LOVE LIGHT
5. DEATH DON'T HAVE NO MERCY
6. FEEDBACK
7. AND WE BID YOU GOODNIGHT

### WORKINGMAN'S DEAD

1. UNCLE JOHN'S BAND
2. HIGH TIME
3. DIRE WOLF
4. NEW SPEEDWAY BOOGIE
5. CUMBERLAND BLUES
6. BLACK PETER
7. EASY WIND
8. CASEY JONES

Bonus Material

9. NEW SPEEDWAY BOOGIE (Alternate Mix)
10. DIRE WOLF (Live)
11. BLACK PETER (Live)
12. EASY WIND (Live)
13. CUMBERLAND BLUES (Live)
14. MASON'S CHILDREN (Live)
15. UNCLE JOHN'S BAND (Live)

### AMERICAN BEAUTY

1. BOX OF RAIN
2. FRIEND OF THE DEVIL
3. SUGAR MAGNOLIA
4. OPERATOR
5. CANDYMAN
6. RIPPLE
7. BROKEDOWN PALACE
8. TILL THE MORNING COMES
9. ATTICS OF MY LIFE
10. TRUCKIN'

Bonus Material

11. TRUCKIN' (Single Version)
12. FRIEND OF THE DEVIL (Live)
13. CANDYMAN (Live)
14. TILL THE MORNING COMES (Live)
15. ATTICS OF MY LIFE (Live)
16. TRUCKIN' (Live)

### GRATEFUL DEAD "SKULL & ROSES"

1. BERTHA
2. MAMA TRIED
3. BIG RAILROAD BLUES
4. PLAYING IN THE BAND
5. THE OTHER ONE
6. ME & MY UNCLE
7. BIG BOSS MAN
8. ME & BOBBY McGEE
9. JOHNNY B. GOODE
10. WHARF RAT
11. NOT FADE AWAY/GOIN' DOWN THE ROAD FEELING BAD

Bonus Material

12. OH, BOY!
13. I'M A HOG FOR YOU

### EUROPE '72

Disc 1

1. CUMBERLAND BLUES
2. HE'S GONE
3. ONE MORE SATURDAY NIGHT
4. JACK STRAW
5. YOU WIN AGAIN
6. CHINA CAT SUNFLOWER
7. I KNOW YOU RIDER
8. BROWN-EYED WOMAN
9. HURTS ME TOO
10. RAMBLE ON ROSE
11. SUGAR MAGNOLIA
12. MR. CHARLIE
13. TENNESSEE JED

Bonus Material

14. THE STRANGER (TWO SOULS IN COMMUNION)

Disc 2

1. TRUCKIN'
2. EPILOGUE
3. PRELUDE
4. MORNING DEW

Bonus Material

5. LOOKS LIKE RAIN
6. GOOD LOVIN'
7. CAUTION (DO NOT STOP ON TRACKS)
8. WHO DO YOU LOVE?
9. CAUTION (DO NOT STOP ON TRACKS)
10. GOOD LOVIN'

### BEAR'S CHOICE

1. KATIE MAE
2. DARK HOLLOW
3. I'VE BEEN ALL AROUND THIS WORLD
4. WAKE UP LITTLE SUSIE
5. BLACK PETER
6. SMOKESTACK LIGHTNIN'
7. HARD TO HANDLE

Bonus Material

8. GOOD LOVIN'
9. BIG BOSS MAN
10. SMOKESTACK LIGHTNIN' (Version Two)
11. SITTING ON TOP OF THE WORLD



BORDERS  
BOOKS • MUSIC • MOVIES • CAFE



RHINO

