

BRIAN WILSON • HUGE UNPLAYED RECORDS WAREHOUSE FIND

GOLDMINE

Goldmine

December 14, 2001 VOL 27 • NO 25 • ISSUE 558

THE COLLECTORS R

THE BEST OF THE TEMPTATIONS CHRISTMAS



CHRISTMAS RECORDINGS ROUNDUP
— plenty of yuletide cheer!



EARL & RANDY SCRUGGS

Father and son fuse bluegrass with rock



Prince

A year-by-year look at his often overlooked '90s material



U.S. \$3.95 • CANADA \$4.95

#BXNDWUF *****AUTO** 3-DIGIT 908
 #0001431608N1.# GM FEB03 / -
 MONTY GREENLY 0463 -
 3740 ELM AVE # A
 LONG BEACH CA 90807-3402



0 74470 19322 7

Reviews

- ▶ Michael Jackson
- ▶ Ian & Sylvia
- ▶ Live
- ▶ Passenger
- ▶ The Who
- ▶ Sun Records compilation

ROCK SOLID INTERNATIONAL

P.O. BOX 104, DEPT. GM, PERRY HALL, MARYLAND 21128
FAX (410) 529-7972 Anytime • PHONE (410) 529-3753
Mon. to Fri. 9 am to 7:30 pm E.S.T.
Sat. 10 am to 6 pm E.S.T.



WE OFFER NEXT-DAY SERVICE ON ALL ORDERS. FedEx, UPS, or Postal Service

For charge you can call and leave your order and info. on the answering machine 24 hrs. 7 days a week!!
E-MAIL address: edm@mail.bcpl.net
ON THE WEB AT: www.rockso.com

Hello and welcome to our latest ad. All items are Mint unless otherwise noted. Many items in this ad are rare/difficult-to-find & one-of-a-kind. All items are sold on a 1st come, 1st served basis.



For your convenience and easy shopping, all 4 credit cards are accepted.



Since 1985

LOTS MORE INVENTORY ON THE WEB AT www.rockso.com

Item listing #21 of CD's, Promos, Radio Shows & More Free With Order Send \$1 for list if not ordering

Everything Is Guaranteed

***** SHIPPING RATES *** (SUBJECT TO CHANGE)**
U.S. CANADA-AIR \$4.00 1st disc., \$0.75 each additional
UK/EUROPE: \$4.00 1st disc., \$1.00 each additional
Air Mail \$8.00 1st disc., \$2.50 each additional
Sea Mail \$4.00 1st disc., \$2.00 each additional
JAPAN/AUSTRALIA: \$9.00 1st disc., \$4.00 each additional
Air Mail \$6.00 1st disc., \$3.00 each additional
Sea Mail \$6.00 1st disc., \$3.00 each additional
* Please note postage is per disc, 2LP/CD = 2 items and so on!!
* U.S. orders insurance is included in shipping
* Overseas-insurance/registered fee is \$5.00 per package
* We are not responsible for loss/damage of uninsured items!!!
METHOD OF PAYMENT: U.S. customers - check or m.o.
Outside the U.S., I.M.O. or registered letter (U.S. dollars!)
Novus, American Express, Visa & MasterCard accepted!!
**** ALLOW 3 WEEKS FOR ALL CHECKS TO CLEAR! ****

INDUSTRIAL SALES AWARDS GUARANTEED AUTHENTIC RIAA CERTIFIED UNLESS NOTED AS IN-HOUSE

LP/CD/CASSETTE FORMAT

- MEASURES 17" x 21"
- AC-DC * Razors Edge * Platinum RIAA Sales Award LP/CD/Cassette \$500.00
 - AEROSMITH * Aerosmith * Platinum RIAA Sales Award CD/LP/Cassette \$560.00
 - AEROSMITH * Get A Grip * Platinum RIAA Sales Award CD/LP/Cassette \$560.00
 - AEROSMITH * Get Your Wings * Platinum RIAA Sales Award LP/CD/Cassette \$460.00
 - AEROSMITH * Rocks * Platinum RIAA Sales Award LP/CD/Cassette \$460.00
 - (BEATLES) GEORGE HARRISON * All Thing Must Pass * LP/Cassette/CD Platinum \$650.00
 - (BEATLES) GEORGE HARRISON * Living In The Material World * LP/Cassette/CD Platinum \$850.00
 - (BEATLES) PAUL MCCARTNEY * London Town * LP/Cassette/CD Platinum \$575.00
 - (BEATLES) JOHN LENNON * Double Fantasy * LP/Cassette/CD Platinum \$800.00
 - (BEATLES) JOHN LENNON * Plastic Ono Band * LP/Cassette/CD Platinum \$900.00
 - (BEATLES) JOHN LENNON * Imagine * LP/Cassette/CD Platinum \$900.00
 - BEATLES * Meet The Beatles * Got 3 LP/Cassette/CD Platinum \$1,000.00
 - DOORS * THE DOORS * GOLD RECORD * Commemorates 3 Million Sold * #1 10/500 Autographs 3 Living Members \$280.00
 - DOORS * Morrison Hotel Award * RIAA Platinum LP/CD/Cassette Format \$560.00
 - EAGLES * Desperado Award * RIAA Platinum CD/LP/Cassette Format \$525.00
 - FLEETWOOD MAC * Mirage Award * RIAA Platinum LP/CD/Cassette Format \$575.00
 - JIMI HENDRIX * Electric Lady Lord * LP/Cassette/CD Platinum \$675.00
 - JIMI HENDRIX * Are You Experienced * LP/Cassette/CD Platinum \$650.00
 - IRON MAIDEN * No Prayer For The Dying * Platinum RIAA Sales Award CD/LP/Cassette \$560.00
 - JOEL, BILLY * The Stranger * Platinum CD/Cassette Award \$300.00
 - KISS * Crazy Nights * Platinum RIAA Sales Award CD/LP/Cassette \$560.00
 - LED ZEPPELIN * I Debut LP * LP/Cassette/CD Platinum \$650.00
 - LED ZEPPELIN * 2050 * LP/Cassette/CD Platinum \$650.00
 - LED ZEPPELIN * Physical Graffiti * LP/Cassette/CD Platinum \$750.00
 - METALLICA * And Justice For All * RIAA Platinum LP/Cassette Format \$510.00
 - NICKS, STEVIE * Rock A Little Award * RIAA Platinum LP/CD/Cassette Format \$485.00
 - PEARL JAM * Vs Award * RIAA Platinum LP/CD/Cassette Format \$510.00
 - PINK FLOYD * Dark Side Of The Moon * LP/Cassette/CD Platinum \$650.00
 - PINK FLOYD * Wish You Were Here * LP/Cassette/CD Platinum \$625.00
 - ROLLING STONES * Beggars Banquet * LP/Cassette/CD Platinum \$675.00
 - BRUCE SPRINGSTEEN * Born In The U.S.A. * LP/Cassette/CD Platinum \$525.00
 - ROLLING STONES * Steel Wheels * Platinum Award * RIAA LP/CD/Cassette Format \$560.00
 - U2 * War Option 3 * LP/Cassette/CD Platinum \$525.00
 - U2 * Unforgettable Fire * LP/Cassette/CD Platinum \$525.00
 - VAUGHAN, STEVIE RAY * Soul To Soul Award * RIAA Platinum LP/CD/Cassette Format \$545.00
 - WILLIAMS, HANK JR. * Wild Streak Gold Award * RIAA Hologram LP Format \$200.00

CD FORMAT

- MEASURES 13" x 17"
- BILLY JOEL * The Strange CD/Cassette Platinum \$350.00
 - AEROSMITH * Pandora's Box CD/Cassette Gold \$475.00
 - RUSH * 2112 CD/Cassette Platinum \$375.00
 - RUSH * Fly By Night CD/Cassette Platinum \$450.00
 - BON JOVI * Young Guns Soundtrack CD/Cassette Platinum \$375.00
 - BLACK SABBATH * Master's Of Reality CD/Cassette Platinum \$400.00
 - BLACK SABBATH * Vol 4 CD/Cassette Platinum \$400.00
 - GRATEFUL DEAD * Tour Over Europe CD/Cassette Platinum \$450.00
 - PINK FLOYD * Animals CD/Cassette Platinum \$475.00
 - METALLICA * Black Album CD/Cassette Platinum \$475.00
 - ALICE COOPER * Billion Dollar Babies CD/Cassette Platinum \$475.00
 - JETHRO TULL * Aqualung CD/Cassette Platinum \$425.00
 - DEEP PURPLE * Machine Head Platinum \$425.00
 - LYNYRD SKYNRD * 2nd Helping Platinum \$425.00
 - NIRVANA * Nevermind Platinum \$425.00
 - AC/DC * Back In Black Platinum \$425.00
 - DON HENLEY * End Of Innocence Platinum \$425.00
 - LYNYRD SKYNRD * Street Survivors Platinum \$450.00
 - QUEENSRYCHE * Empire Platinum \$425.00
 - RUSH * Permanent Waves Platinum \$475.00
 - LED ZEPPELIN * III Platinum \$500.00
 - NEIL YOUNG * After The Gold Rush Platinum \$425.00
 - MICK JAGGER * Wandering Spirit Platinum \$450.00
 - STEVIE NICKS * Street Angel Platinum \$425.00
 - ELO * On The 3rd Day Platinum \$425.00
 - JACKSON BROWN * Late For The Sky Platinum \$425.00
 - TORI AMOS * Under The Park Platinum \$425.00

CONCERT TICKETS ALL ARE MINT & COMPLETE UNLESS NOTED!

- 311 * 10-20-99 The Bottle Neck * Full Unused Ticket/Yellow, Orange, Grey & Bk \$1.25
- AC-DC * 11-28-82 Olympiahalle Munchen 3/4 Full German Ticket Stub Red-Blk & Grey \$15.00
- AC-DC * 12-11-83 * Ticket Stub 3.25" Capital Center, MD \$10.00
- ADAM, BRYAN * 2-6-88 * Ticket Stub 5" Budakon Hall, Japan \$6.00
- AEROSMITH W/GUEST SKID ROW * 1-22-90 Meadowlands Arena * Full Ticket Stub w/Name, Venue, Date Info \$7.00
- AEROSMITH-TED NUGENT * 4-10-86 Hershey Park Arena * Full Ticket Stub/Print Complete Brown & Blk \$6.00
- AEROSMITH * 1-25-94 Palacio De Los Sports * Mexico City-Full Ticket Stub - End Missing \$15.00
- AEROSMITH * 1-7-78 Jackson, MS Coliseum * Full Unused Concert Ticket Gray, Blk & White \$6.00
- AEROSMITH * 5-20-97 Sportovni Hala, Prague * Full Unused Concert Ticket-Color Pic & Log \$10.00
- AEROSMITH * 6-19-76 Jackson, MS Coliseum * Full Unused Concert Ticket - Green & Black \$6.50
- ALLMAN BROTHERS * 11-8-80 * Full Unused Ticket-Jackson, MS Coliseum \$25.00
- ALLMAN BROTHERS * 6-16-99 Sandstone Theater * Full Unused Concert Ticket Yellow & Black \$6.00
- AMERICAN MUSIC AWARDS 1982 * 1-25-82 Full Show Ticket * Ticket Has w/R.S.V.P Card For Attendance \$15.00
- AMOS, TORI * 10-13-94 Toledo, OH * Full Ticket Masonic Auditorium \$10.00

- AMOS, TORI * 7-31-96 * Full Ticket Stranahan Theater-Toledo, OH \$10.00
- ANDERSON, BUFORD, WAKEMAN * HOWE * 3-19-90 Philly Spectrum * 3/4 Full Ticket Stub/Ticketmaster Print \$6.75
- ASIA * 11-21-82 Rudi-Sedlmayer-Halle * Full Unused German Tik/Grey w/Red Print \$15.00
- B.T.O. * 9-29-74 * Ticket Stub 1.5" Baltimore Civic Center \$10.00
- BAD II-PIL-LIVE-B. MELON * 4-18-92 * Full Ticket Hammer Jacks Concert Hall \$4.00
- BAND, THE * 9-6-74 Aerosmith Opened! * Ticket Stub 3.5" Capital Center, MD \$20.00
- BANGLES * 3-23-89 Beacon Theatre * Full Ticket Stub w/Name, Venue + Date Info \$8.00
- BE-STIFF ROUTE 78 (ALLSTAR BND) * 12-20-78 The Bottom Line * Full Ticket Stub w/Names, Venue + Date Info \$6.00
- BEACH BOYS * 11-22-74 * Ticket Stub 1.5" Baltimore Civic Center \$15.00
- BEACH BOYS * 8-30-76 National Exhibition * 3/4 Full Tik Stub (\$6.00) Date, Artist Inf \$6.00
- BEATLES (PAUL MCCARTNEY) * 10-5-93 Schleyer Halle-Germany * 4"x7" Size Unused Ticket Orange & Black \$15.00
- BEATLES (PAUL MCCARTNEY) * 12-12-89 Madison Square Garden * Full Ticket Stub w/Name, Venue + Date Info \$10.00
- BEATLES (PAUL MCCARTNEY) * 9-23-93 Schleyer Halle-Germany * 4"x7" Size Unused Ticket Gold & Black \$15.00
- BEATLES (RINGO STARR) * 5-21-97 Wolf Trap * Full Unused Concert Ticket Rare! \$35.00
- BEATLES * 10-18-65 Atlanta Stadium * Full Stub From Concert VG Condition Rare \$600.00
- BEATLES * 8-18-66 Suffolk Downs * Full Unused Ticket-White Only Left!! \$100.00
- BEATLES * 8-23-66 Shea Stadium * Full Ticket w/Pic Of Beatles On Ticket! \$575.00
- BEATLES * 8-29-66 Candlestick Park, CA * Full Unused Ticket-Purple Mint! KYA 1260 \$850.00
- BLACK CROWS-LENNY KRAVITZ * 5-4-99 Sandstone Amphitheatre * Full Unused Concert Ticket Blue & Black \$6.00
- BLACK OAK ARKANSAS * 10-3-75 * Ticket Stub 3.5" Capital Center, MD \$10.00
- BLACK SABBATH * 9-6-98 Prague, Czech Republic * Full Color Laminated V.I.P Guest Pass \$16.00
- BLONDIE * 8-16-82 Merriweather Post, MD * Used Press Pass & Full Ticket Stub \$35.00
- BLOOD, SWEAT & TEARS * 11-6-70 Massey Hall * 3/4 Full Tik Stub w/Date, Venue, Artist Inf \$16.00
- BLUES TRAVELERS * 10-21-98 Gale Bullman Bldg. * Full Unused Concert Ticket Full Color \$15.00
- BON JOVI-SKID ROW * 7-12-89 * Ticket Stub 3.25" Richmond Coliseum, VA \$8.00
- BON JOVI * 6-15-96 * Full Deluxe Ticket - Hannover, Germany \$6.50
- BON JOVI * 6-23-96 * Full Deluxe Ticket - Letzigrund, Switzerland \$7.00
- BON JOVI * 9-25-87 * Ticket Stub 5" Budakon Hall Japan \$10.00
- BOSTON * 11-19-78 * Ticket Stub 3.5" Capital Center, MD \$25.00
- BOSTON * 11-27-78 * Ticket Stub 3" Princeton University, NJ \$35.00
- BOSTON * 4-5-77 * Ticket Stub 3.5" Capital Center, MD \$20.00
- BOSTON * 9-23-78 * Full Ticket-Anaheim Stadium, CA \$6.00
- BOSTON * 9-8-87 * Ticket Stub 3.25" Capital Center, MD \$20.00
- BOSTON * Oct 15 London, UK * Late 70's Ticket Stub - Rainbow Theater \$30.00
- BOWIE, DAVID * 10-23-97 Mexico City Concert * Full Unused Ticket - Earthing Tour Rare! \$35.00
- BOWIE, DAVID * 7-16-90 Nassau Coliseum * Full Ticket Stub w/Name, Venue + Date Info \$10.00
- BOWIE, DAVID * 7-18-87 * 3/4 Ticket Stub - Merriweather Post, MD \$3.50

- BOWIE, DAVID * 7-18-90 * Ticket Stub 4" Merriweather Post, MD \$25.00
- BOWIE, DAVID GUEST SQUEEZE * 8-2-87 Grants Stadium * Full Ticket Stub w/Name, Venue, + Date Info \$10.00
- C.S. & N.-BONNIE RAITT * 9-3-88 * Ticket Stub 2.5" Portland, OR \$5.00
- CAKE-BEN FOLDS FIVE * 6-2-99 Starlight Theater * Full Unused Concert Ticket-Yellow, Orange \$1.25
- CARLIN, GEORGE * 7-3-97 * Ticket Stub 3.5" Grand Ronde, OR \$3.00
- CHEAP TRICK * 1-29-89 * Ticket Stub 3.25" Patriot Center, VA \$6.00
- CHEAP TRICK * 4-17-80 Rupp Arena * Full Unused Ticket w/Blk Lettering \$8.00
- CHICAGO * 3-22-85 Maple Leaf Gardens * Full Tik Stub w/Artist, Date, Venue Info \$8.00
- CLAPTON, ERIC-ROBERT CRAY * 11-4-87 * Ticket Stub 5" Budakon Hall, Japan \$65.00
- CLAPTON, ERIC * 10-31-74 * Full Ticket 6.5" Budakon Hall, Japan \$200.00
- CLAPTON, ERIC * 11-2-74 * Full Ticket Budakon Hall, Japan \$250.00
- CLAPTON, ERIC * 7-14-74 RARE! * Ticket Stub 3.5" Capital Center, MD \$40.00
- COLLECTIVE SOUL * 6-20-99 Kahonaville, DE * Full Unused Ticket Deluxe Ticket Style \$6.00
- COMMODORES, THE * 6-14-82 Maple Leaf Gardens * Full Tik Stub w/Artist, Date, Venue Info \$8.00
- COOPER, ALICE * 4-24-75 * Ticket Stub 1.5" Baltimore Civic Center \$45.00
- COOPER, ALICE * 9-4-98 Trump Marina * Cayman Ballroom Full Ticket Stub/Print \$6.75
- COSTELLO, ELVIS * 10-28-?? * Ticket Stub 4" Tower Theater, PA \$4.00
- COUNTING CROWS-WALLFLOWERS * 7-6-97 * Full Concert Ticket Pink Knob, WI \$7.00
- COUNTING CROWS * Hammerjacks 1-29-94 * Full Ticket \$5.00
- CROW, SHERYL * 4-26-99 Hearnest Centre * Full Unused Concert Ticket \$6.50
- DANZIG * Berlin Metropol 11-22-90 * Large w/Danzig On Ticket \$10.00
- DANZIG * Hammerjacks 5-23-93 * Full Ticket \$15.00
- DEEP PURPLE * 7-1-00 Campo De Futbol Burgos * Full Unused Ticket Full Color 3"x8" Size! \$10.00
- DEEP PURPLE * Joe Louis Arena 3-11-85 * Ticket Stub 3" \$10.00
- DEF LEPPARD/KROKUS * Capital Center, MD 6-3-83 * Ticket Stub 3.5" \$15.00
- DENVER, JOHN * 4-23-71 Maple Leaf Gardens * Full Tik Stub w/Artist, Date, Venue Info \$8.00
- DEPECHE MODE * 7-5-01 Merriweather Pavilion * Complete Unused Concert Ticket Mint! \$7.00
- DIDDLEY BO * Wa. Pk Rose Garden 8-26-90 * Full Ticket \$10.00
- DIFRANCO, ANI * 4-30-99 Midland Theater * Full Unused Concert Ticket Blue & Black \$1.25
- DIMEOLA, AL PROJECT * 9-13-85 Munchen-Alabamahalle * 3"x5" Full Ticket Stub - Full Color German \$7.50
- DIO, RONNIE JAMES * Baltimore Civic Center * Full Concert Ticket \$10.00
- DIO * Baltimore Civic Center 9-18-85 * Ticket Stub 3.25" \$5.00
- DOOBIE BROTHERS * Civic Center Baltimore 4-10-74 * Ticket Stub 2.5" \$10.00
- DUKE JUPITER * Coast To Coast Baltimore * 6-13-84 Full Concert Ticket \$10.00
- DURAN DURAN * Merriweather, MD 7-13-87 * Ticket Stub 4" \$15.00
- DYLAN, BOB W/TOM PETTY * 7-21-86 Meadowlands Arena * Full Ticket Stub w/Name, Venue & Date Info \$15.00
- E L & P * Baltimore Civic Center * Late 70's Ticket Stub 2" \$10.00
- E L & P * Capital Centre 1-28-78 * Ticket Stub 3.25" \$8.00
- E L & P * Capital Centre 8-1-74 * Ticket Stub 3.5" \$8.00
- E L & P * Jackson, MS Coliseum 10-25-77 * Full Ticket \$6.50
- E L & P * University Of MD 10-22-77 * Ticket Stub 4" \$10.00

- EXTREME/DANGER DANGER * Painters Mill 12-2-90 * Ticket Stub Signed By The Bands! \$40.00
- FATS DOMINO/BUCKWHEAT ZYDECO * WA Pk Rose Garden 9-1-90 * Full Ticket \$10.00
- FILLMORE EAST * Full Unused Blank Tickets! * No Date - No Year - Just the Time Mega Rare \$250.00
- FIRM * Capital Centre 3-19-86 * Ticket Stub 3.25" \$8.00
- FIRM * Capital Centre 5-1-85 * Ticket Stub 3.5" \$8.00
- FIRM * Omaha 3-8-85 * Full Concert Ticket \$20.00
- FIXX * Norfolk, VA 3-25-89 * Ticket Stub 3.5" \$2.00
- FLEETWOOD MAC/K. LOGGINS * Capital Centre, MD 7-12-77 * Ticket Stub 3.5" \$45.00
- FLEETWOOD MAC * Capital Centre, MD 11-7-90 * Ticket Stub 4.5" \$15.00
- FLEETWOOD MAC * Capital Centre, 10-8-87 * Full Concert Ticket \$35.00
- FOGHAT/PETER FRAMPTON * Capital Centre 2-17-76 * Ticket Stub 3.25" \$15.00
- FOO FIGHTERS * Detroit State Theatre 3-30-96 * Full Ticket \$7.00
- FOREIGNER * Capital Centre, MD 9-8-78 * Ticket Stub 3.5" \$6.00
- FOREIGNER * Stranahan Theatre Toledo * 7-12-95 Full Ticket \$4.00
- FOUR PLAY * Bayou, DC 10-20-87 * Full Concert Ticket \$5.00
- GABRIEL, PETER * L.A Forum 12-15 or 12-16-86 * M- Full Ticket \$10.00
- GALLIGER II * Hammerjacks 5-26-94 * Full Ticket \$1.00
- GENE LOVES JEZEBEL * Hammerjacks 5-1-93 * Full Ticket \$4.00
- GENESIS (PETER GABRIEL) * 6-15-87 Olympiahalle Munchen * Full German Ticket w/Small Tear Red & Gold \$10.00
- GENESIS * Budokon 3-13-87 * Ticket Stub 5" \$50.00
- GILMORE, DAVID * Pine Knob 6-6-84 * Ticket Stub 3" \$15.00
- GRATEFUL DEAD * 5-10-70 Atlanta Sports Arena * Full Unused Ticket - Allmans & The Dead \$75.00
- GRATEFUL DEAD * Rainforest Gala Reception * 9-24-88 Full Ticket \$100.00
- GRATEFUL DEAD * Soldier Field Chicago 7-8-95 * Full Concert Ticket w/Hologrammed Bear \$15.00
- GRIM REAPER * Helloween * Armored Sant * Wash DC * 8-18-87 Full Concert Ticket \$5.00
- GUNS N ROSES/METALLICA * 7-29-92 Grants Stadium * Full Ticket Stub Digital Print Mint \$3.50
- GUNS N ROSES * 6-13-91 Philly Spectrum * 3/4 Full Stub Comp Ticket Blue & White! \$3.50
- GUNS N ROSES * Capital Centre 6-19-91 * Ticket Stub 4.5" \$8.00
- GUNS N ROSES * Capital Centre 6-20-91 * Ticket Stub 2.25" \$8.00
- GUNS N ROSES * Hershey, PA 6-11-91 * Ticket Stub 4.5" \$8.00
- HAGAR, SAMMY * 11-5-99 Hearnest Centre * Full Unused Concert Ticket Blue, Red & Black \$6.00
- HALL & OATES * Baltimore Civic Center 5-7-85 * Ticket Stub w/All Access Pass Used \$10.00
- HEART (NANCY WILSON) * 3-20-99 Theater Of Living Arts * Full Ticket Stub Light Blue & White! \$5.75
- HEART * 4-18-86 Meadowlands Arena * Full Ticket Stub w/Name, Venue & Date Info \$6.00
- HEART * 6-25-86 * 5"x3" Full Ticket Stub - NHK Hall, Japan \$35.00
- HEART * 9-21-85 Radio City Music Hall * Full Ticket Stub w/Name, Venue + Date Info \$8.00
- HEART * Baltimore, MD 8-9-77 * Ticket Stub 1.5" \$20.00
- HEART * Capital Centre 10-15-78 * Ticket Stub 3.25" \$6.00
- HEART * Merriweather 6-19-88 * Full Concert Ticket \$15.00
- HEART * Merriweather 9-7-87 * Ticket Stub 3.75" \$8.00
- HEART * Merriweather, MD 7-18-87 * Ticket Stub 4" \$10.00
- HEART * Patriot Center 10-18-87 * Full Ticket \$10.00

- HELIX * Bayou, DC 9-22-87 * Full Concert Ticket \$5.00
- HOOTERS * Japan 11-9-87 * Ticket Stub 5" \$10.00
- HOUSE OF PAIN * Hammerjacks 3-26-93 * Ticket Stub 3.25" \$3.00
- HOUSTON, WHITNEY * 9-19-87 Houston Summit * 3/4 Full tik Stub w/Date, Artist, Venue Info \$7.00
- INSANE CLOWN POSSE * 8-7-99 Sandstone Amphitheatre * Full Unused Concert Ticket Full Color \$6.50
- INXS * 3-25-88 Philadelphia Spectrum * 3/4 Full Ticket Stub w/Name, Venue & Date \$5.00
- IRON MAIDEN * 2-1-91 Patriot Centre, VA * 3/4 Full Used Ticket Stub Info Included! \$6.00
- IRON MAIDEN * 4-7-87 Baltimore, Arena * Full Ticket Stub w/Used Backstage Pass!! \$27.00
- IRON MAIDEN * 7-24-88 Capital Centre * Full Unused Ticket-Great For Collector's \$12.00
- JARREAU, AL * Merriweather 8-13 * Ticket Stub & 2 Passes Used \$10.00
- JEFFERSON AIRSHIP * Capital Centre 5-31-78 * Ticket Stub 3.25" \$4.00
- JEFFERSON AIRSHIP * Capital Centre 8-22-75 * Ticket Stub 3.25" \$6.00
- JETHRO TULL-STATUSQUO-NAZERETH * 7-5-86 On The Green 86 3"x6" Full Ticket Stub - Full Color + Acts!! \$10.00
- JETHRO TULL/ELP * LB Day Amphitheatre 9-28-96 * Ticket Stub 3.25" \$10.00
- JETHRO TULL * 1-22-77 Radio City Music Hall * Used Ticket Stub w/Name, Venue + Date Info \$10.00
- JETHRO TULL * 10-18-71 Madison Square Garden * End Ticket Stub w/Name, Venue + Date Info! \$20.00
- JOHN, ELTON * 11-14-92 Estadio Azteca * Mexico City - Full Ticket Stub, End Torn \$20.00
- JOHN, ELTON * 11-18-75 Mapleleaf Gardens * Full Tik Stub w/Artist, Date, Venue Info \$10.00
- JOHN, ELTON * 9-7-80 Maple Leaf Gardens * 3/4 Full Tik Stub w/Artist, Date, Venue Info \$16.00
- JONES, HOWARD * The Abyss Underground Toledo * 4-13-96 Full Ticket \$4.00
- JONES, MARTI * Wolf Trap, VA 11-20-90 * Ticket Stub 4.5" \$4.00
- JOPLIN, JANIS/JEFF BECK * Alexandria Arena 10-20-68 * Ticket Stub 1.5" \$250.00
- JOURNEY * Capital Centre, 5-8-82 * Ticket Stub 3.25" \$5.00
- JOURNEY * Capital Centre, MD 5-8-82 * Ticket Stub 3.5" \$8.00
- JOURNEY * Merriweather 8-28-81 * Ticket Stub 4" \$5.00
- JUDAS PRIEST * Baltimore Civic Center 4-11-84 * Ticket Stub 3.25" \$4.00
- JUDAS PRIEST * Capital Centre 12-9-90 * Ticket Stub 4.5" \$4.00
- KANSAS (STEVE MORSE) * 7-13-87 Theaterfabrik Allee * Full Unused German Tik w/Corner Tear! \$5.00
- KANSAS * 7-11-78 * Purple Ticket Stub - Merriweatherpost, MD \$3.50
- KANSAS * 8-16-98 * Starlight Theater * Full Unused Concert Ticket Green & White \$4.50
- KANSAS * Merriweather Post, MD 7-11-78 * Ticket Stub 1.75" \$15.00
- KING, CAROLE * 3-3-72 Maple Leaf Gardens * Full Ticket stub w/Artist, Date, Venue Info \$20.00
- KINKS, THE * 12-29-83 Roseland Arena * Complete Unused Concert Ticket Perfect M \$15.00
- KINKS, THE * 3-1-79 Wilkins Theater - Kean NJ * 3/4 Complete Tik Stub w/Name, Venue & Date \$15.00
- KISS (ACE FREHLEY) * 7-31-92 Baltimore, MD * Hammerjacks Concert Full Unused Ticket! \$7.00
- KISS-JAMES GANG & RUSH * 5-9-75 Ohio Northern University * Full Unused Ticket - Green w/Black Letters w/ Band Photo! \$150.00
- KISS * 10-13-80 Drammenshallen, Germany * Full Ticket Stub w/Band Name Complete! \$25.00
- KISS * 11-13-87 Jackson, MS Coliseum * Full Unused Ticket Blk Lettering On Red \$25.00

- KISS * 11-21-98 Philly 1st Union * Full Ticket Stub Date-Kiss-Location Vos \$3.50
- KISS * 11-27-84 Baltimore Civic Center * Full Concert Ticket Stub Brown & Black! \$6.00
- KISS * 3-18-99 Sportvni Hala Praha * Full Unused Ticket w/Band Photo - Colorful \$15.00
- KISS * 7-2-97 Geneva Arena, Switzerland * Full Ticket Stub Unique Artwork Green \$15.00
- KISS * 7-24-79 Madison Square Garden * Full Ticket Stub/Blk, Silver & Red Clean \$35.00
- KISS * Bingley Hall Stafford 10-12-84 UK Ticket Stub M- \$45.00
- KISS * Prague, Czech Republic 6-7-97 Full Concert Ticket-Full Color 3" x 7" \$20.00
- KIX * Hammerjacks 11-29-91 * Full Ticket \$2.00
- LAUPER, CYNDI * 1-8-87 Houston Music Hall * 3/4 Full Tik Stub w/Artist-Date Venue Inf \$7.00
- LAUPER, CYNDI * 5-24-93 Baltimore, MD Hammerjacks Concert Full Unused Ticket \$7.00
- LED ZEPPELIN (JOHN PAUL JONES) * 10-17-99 Theater of Living Full Ticket Stub Light Blue & White \$6.75
- LED ZEPPELIN (PAGE-PLANT) * 2-25-98 Sportovni Hala-Praha * Full Unused Concert Ticket-Beautiful MINT \$15.00
- LED ZEPPELIN (ROBERT PLANT) * 5-18-88 Meadowlands Arena, NJ * Full Ticket Stub w/Name Venue + Date Info \$10.00
- LED ZEPPELIN (THE FIRM) * 5-1-85 Capital Centre * Full Concert Ticket Stub Brown & Black! \$11.00
- LED ZEPPELIN * Chicago 11-15-80 Full Ticket from Cancelled Tour \$20.00
- LED ZEPPELIN * Joe Louis Arena IL 10-30-80 * Full Ticket For Cancelled Concert Tour \$150.00
- LITTLE FEAT * 1-3-93 Baltimore, MD * Hammerjacks Concert-Full Unused Ticket \$8.00
- LIZZY BORDEN * Bayou 12-1-87 * Full Concert Ticket \$5.00
- LOGGINS & MESSINA * Capital Centre 10-5-75 * Ticket Stub 3.5" \$3.00
- LOUDNESS/KEEL * Hammerjacks Baltimore 5-20-85 * Ticket Stub & After Show Pass \$10.00
- LOVETT, LYLE * 8-8-99 Starlight Theater * Full Unused Concert Ticket Full Color \$1.50
- LYNYRD SKYNRD * 7-1-75 Jackson, MS Coliseum * Full Unused Ticket-Beige w/Blk Lettering \$6.75
- LYNYRD SKYNRD * 7-1-75 Jackson, MS Coliseum * Full Unused Ticket-Tan w/Blk Lettering \$6.75
- LYNYRD SKYNRD * Jackson, MS 5-19-88 * Full Ticket \$6.00
- MAHOGANY RUSH (FMARINO) * Coast To Coast Balt., MD * 11-13-83 Ticket Stub 4" \$8.00
- MAHOGANY RUSH Painters Mill, MD 1-8-83 * Ticket Stub 3.25" \$6.00
- MAHOGANY RUSH * Wax Museum, Wash. DC 12-7-82 * Ticket Stub 4.5" \$5.00
- MANFRED MANN'S EARTH BAND * 3-31-83 Olympiahalle Muchen * Full Ticket w/Small Tear German Show Lge \$7.50
- MARX, RICHARD * Japan 8-13-89 * Ticket Stub 5" \$2.00
- MATCHBOX 20 * 8-23-98 Sandstone Theater * Full Unused Concert Ticket Blue & Black \$2.25
- MELLENCAMP, JOHN COUGAR * 12-8-85 Meadowlands Arena * Full Ticket Stub w/Name, Venue + Date Info \$6.00
- MELLENCAMP, JOHN COUGAR * 6-22-88 Meadowlands Arena * Full Ticket Stub w/Name, Venue + Date Info \$7.00
- MERCHANT, NATALIE * 4-13-99 Memorial Hall * Full Unused Concert Ticket \$6.00
- METALLICA * 5-25-99 Atelticky's Stadium * Full Unused Concert Ticket w/ Band Photo! \$20.00
- METALLICA * 6-14-94 Mann Music Center * 3/4 Full Ticket Stub/Ticketmaster Type \$36.75
- METHENY, PAT-GROUP * 3-20-85 Kongress Saal Museum * Full Unused German Ticket-Pink-Blk & Silver \$7.50

ROCK SOLID INTERNATIONAL

P.O. BOX 104, DEPT. GM, PERRY HALL, MARYLAND 21128
FAX (410) 529-7972 Anytime • PHONE (410) 529-3753

Mon. to Fri. 9 am to 7:30 pm E.S.T.
Sat. 10 am to 6 pm E.S.T.

For charge you can call and leave your order and info. on
the answering machine 24 hrs. 7 days a week!

E-MAIL address: edm@mail.bcpl.net

ON THE WEB AT: www.rockso.com

Hello and welcome to our latest ad. All items are Mint unless otherwise noted. Many items in this
ad are rare/difficult-to-find & one-of-a-kind. All items are sold on a 1st come, 1st served basis.

WE OFFER NEXT-DAY
SERVICE ON ALL
ORDERS. FedEx,
UPS, or Postal Service



For your convenience
and easy shopping,
all 4 credit cards
are accepted.



Since 1985

LOTS MORE INVENTORY ON THE WEB AT
www.rockso.com

Item listing #21 of CD's, Promos,
Radio Shows & More Free With Order
Send \$1 for list if not ordering

Everything is Guaranteed

SHIPPING RATES (SUBJECT TO CHANGE)

U.S. CANADA-AIR \$4.00 1st disc., \$0.75 each additional
UK/EUROPE: \$4.00 1st disc., \$1.00 each additional
Air Mail \$8.00 1st disc., \$2.50 each additional
Sea Mail \$4.00 1st disc., \$2.00 each additional
JAPAN/AUSTRALIA: \$9.00 1st disc., \$4.00 each additional
Air Mail \$6.00 1st disc., \$3.00 each additional
Sea Mail \$6.00 1st disc., \$4.00 each additional
Please note postage is per disc, 2LP/CD = 2 items and so on!!
U.S. orders insurance is included in shipping
Overseas-insurance/registered fee is \$5.00 per package
We are not responsible for loss/damage of uninsured items!!!
METHOD OF PAYMENT: U.S. customers - check or m.o.
Outside the U.S., I.M.O. or registered letter (U.S. dollars!)
Novus, American Express, Visa & MasterCard accepted!!
** ALLOW 3 WEEKS FOR ALL CHECKS TO CLEAR! **

- MILLER, STEVE LB Day Amphitheatre 7-28-89 * Ticket Stub 3.25" * \$3.00
MOLLY HATCHER THE OUTLAWS * 3-17-83 Hammerhainhalle * 3/4 Full Used German Concert Ticket NICE * \$7.50
MONEY EDDIE * Hammerjacks Baltimore 10-9-84 * Ticket Pass * \$10.00
MONEY EDDIE * Pine Knob Music Theatre * 5-25-96 Full Ticket * \$1.00
MOODY BLUES * 8-27-99 Sandstone Theater * Full Unused Ticket-Yellow, Orange, Grey & Blk * \$6.00
MOODY BLUES * Jackson, MS 5-8-79 * Full Ticket Day of Show Purple * \$6.50
MOODY BLUES Jackson, MS 5-8-79 * Full Ticket Advance Sale Yellow * \$6.50
MOTLEY CRUE * Baltimore Civic Center 8-11-85 * Ticket Stub 3.25" * \$3.00
MOTLEY CRUE * Baltimore Civic Center 8-11-85 * Ticket Stub 3.25" * \$3.00
MOTLEY CRUE * Capital Centre 12-5-89 * Ticket Stub 3.25" * \$3.00
NEW BOHEMIANS * Mosque Theatre 3-31-89 * Ticket Stub 3.25" * \$3.00
NEWTON, JUICE * Wax Museum, DC 6-24-1987 * Ticket Stub 4" * \$6.00
NICKS, STEVIE * Baltimore Civic Center 5-7-86 * Ticket Stub Vip & All Access Passes * \$50.00
NICKS, STEVIE * Baltimore Civic Center 5-7-86 * Ticket Stub 3.25" * \$10.00
NICKS, STEVIE * Jackson, MS 10-30-83 * Full Concert Ticket * \$7.50
NICKS, STEVIE * Merriweather 9-03-77 * Ticket Stub 3.75" * \$8.00
NUGENT, TED * 7-23-99 Sandstone Amphitheater * Full Unused Concert Ticket Full Color * \$2.50
OSBOURNE, OZZY * Capital Centre 2-1-84 * Ticket Stub & 2 Passes * \$25.00
OUT ON THE GREEN FESTIVAL * 7-11-87 Samstag Open Air! * Full Color Tik w/Backstage Pass! + ELP, Kansas \$25.00
PARKER, GRAHAM & (THE RUMOUR) * 5-14-79 Copacabana * Full Ticket Stub w/Name, Venue, Date Info * \$6.00
PARKER, GRAHAM & THE RUMOUR * 6-7-79 Calderone Concert Hall * Full Ticket Stub w/Name, Venue + Date Info * \$6.00
PETTY, TOM & THE HEARTBREAKERS * 12-14-82 Kongress-Saal Museum * Full Unused German Ticket-Pink-Blk + Gold! * \$15.00
PETTY, TOM & THE HEARTBREAKERS * 4-1-83 Bredan Bryne Arena * Full Ticket Stub w/Name, Venue + Date Info * \$6.00
PETTY, TOM & THE HEARTBREAKERS * 7-11-87 Garden State Arts Cntr * Complete Unused Concert Ticket Perfect! * \$10.00
PETTY, TOM (THE HEARTBREAKERS) * 6-27-80 Capitol Theater * Full Ticket Stub/Name, Venue + Date * \$7.00
POP IGGY * Hammerjacks 11-20-90 * Ticket Stub 4.25" * \$5.00
PRESLEY, ELVIS * Capital Centre 5-22-77 * Full Concert Ticket * \$200.00
PRESLEY, ELVIS * Huntington, WV Civic Center * Full Unused 9-20-77 Green w/Blk Letters * \$35.00
PRESLEY, ELVIS * Indiana St. University 9-16-77 * Full Unused Beige w/Blk Letters * \$30.00
PRINCE * Capital Centre 11-26-84 * Ticket Stub & After Show Pass * \$45.00
QUEEN/BILLY SQUIER * Capital Centre * 7-25-82 * Ticket Stub 3.25" * \$20.00
QUIET RIOT-WARRANT-SLAUGHTER * 10-30-98 MO State Fairgrounds * Full Unused Concert Ticket KLRQ Presents * \$2.50
R.E.M. * 10-6-87 Radio City Music Hall * Full Ticket Stub w/Name, Venue + Date Info * \$10.00
RAGE AGAINST THE...B. BOYS * Rhyme & Reason Tour 2000 Full Unused Ticket RFK-DC. 8-5-00 Rare! * \$7.00
RAINBOW (GIRLSCHOOL OPEN) * 11-19-82 Rudi-Sedlmayer-Halle * Full Unused German Ticket Blue-Blk + Gold * \$10.00
RAINBOW/OUTLAWS * Capital Centre 7-9-82 * Ticket Stub 3.5" * \$4.00
RAIT, BONNIE * 9-3-98 Starlight Theater * Full Unused Concert Ticket Green & Black * \$5.50

- THE WHO (ROGER DALTRY) * 7-10-98 Trump Marina * Cayman Ballroom w/Symphony-Blue + White! * \$3.75
TOTO * Kouseininki 4-29-88 * Full Ticket * \$35.00
U2 GUEST LONE JUSTICE * 5-15-87 Meadowlands Arena * Full Ticket Stub w/Name, Venue + Date Info * \$15.00
U2 * 3-18-92 Meadowlands Arena * Full Ticket Stub w/Name, Venue + Date Info * \$10.00
U2 * The Bayou, DC 3-3-80 Ticket Stub 4" 1st US Tour! * \$65.00
UGLY KID JOB * Hammerjacks 4-3-93 * Full Ticket * \$2.00
VAN HALEN * 8-1-86 Meadowlands Arena * Full Ticket Stub w/Name, Venue + Date Info * \$10.00
VAN HALEN * 9-4-81 Jackson, MS Coliseum Full Unused Ticket w/Blk Lettering-Red * \$15.00
VAN HALEN * Capital Centre 10-11-82 * Concert Ticket & Aftershow Pass Used * \$25.00
VAN HALEN * Capital Centre 10-12-82 * Concert Ticket & Aftershow Pass * \$25.00
VAN HALEN * Capital Centre 10-12-82 * Ticket Stub 3.25" * \$15.00
VAN HALEN * Largo, MD 3-25-84 * Ticket Stub & Backstage-Pass * \$30.00
VANS WARRPED TOUR '01 * Heavy Metal Band Tour * Full Unused Tickets Great Acts on Bill! * \$3.00
WALSH, JOE * 3-15-74 Capitol Theater * Used Ticket Stub w/Name, Venue + Date Info * \$7.00
WARRANT * Toledo Sports Arena 11-8-92 Full Ticket * \$4.00
WHITE ZOMBIE * Hammerjacks 11-23-93 * Full Ticket * \$7.00
WHITESNAKE & MORE * Super Rock 90 Mannheim 9-1-90 * Full Concert Ticket 3 X 7.5" * \$35.00
WHITESNAKE & OTHERS * Monsters of Rock Donnington * 8-18-90 Full Unused Concert Ticket * \$35.00
WHITESNAKE & OTHERS * Monsters of Rock Donnington * 8-18-90 Full Ticket w/Ticket Holder! * \$40.00
WHITESNAKE * Aerosmith & More * Utrecht 8-26-90 Full Ticket 7" * \$50.00
WHITESNAKE * Baltimore Arena 2-4-88 * Full Ticket & 2 Used Aftershow Passes * \$20.00
WHITESNAKE * Merriweather, MD 7-3-88 * Ticket Stub 4" * \$3.00
WHO * Pay for View Toronto * Tower Theater, PA 12-17-82 * Ticket Stub 4" Full USED Stub w/Info * \$8.00
WHO / FOR TOMMY * L.A. 8-24-89 * 2 x Ticket Stub 90% Full!! * Original Cost of Ticket \$1,000 + PASSES!! * \$250.00
WHO, THE (PETE TOWNSHEND) * 7-13-93 Beacon Theater, NY * Full Ticket Stub w/Name, Venue + Date Info \$5.00
WHO, THE (ROGER DALTRY) * 12-2-85 Capitol Theater * Complete Unused Concert Ticket Perfect! * \$10.00
WHO, THE (ROGER DALTRY) * 7-10-98 Trump Marina * Cayman Ballroom Full Ticket! Blue + White! * \$10.00
WHO, THE * 12-11-76 Maple Leaf Gardens * Full Tik Stub w/Artist,Date,Venue Info * \$8.00
WHO * Capital Centre 9-22-82 * Ticket Stub & 2 Guest Passes Used * \$50.00
WHO * Philadelphia 9-25-82 * Full Concert Ticket Pass / Comp Tickets * \$15.00
WHO * Pontiac Stadium 12-6-75 * Ticket Stub 2.5" Great Looking Stub! * \$15.00
WHO * SILVERDOME 9-30-82 * Ticket Stub 6" * \$15.00
WONDER, STEVIE * 3-13-79 Mapleleaf Gardens * Full Ticket Stub (Floor) Date,Artist Info * \$10.00
YES/PETER FRAMPTON * Capital Centre, MD 6-13-76 Ticket Stub 3.25" * \$20.00
YES * 10-17-80 Philadelphia Spectrum * Full Ticket Stub w/All Details Clear! * \$20.00
YES * 6-5-76 Jackson, MS Coliseum * Unused Full Concert Ticket Grey & White * \$5.50
YES * Capital Centre, MD 8-16-77 * Ticket Stub 3.25" * \$15.00
YES * Capital Centre, MD 9-10-78 * Ticket Stub 3.5" * \$15.00
YES * Jackson, MS Coliseum 10-8-77 * Full 7 Unused Red-Black Lettering * \$5.50

TOUR PROGRAMS FROM ALL OVER THE WORLD.

- AC-DC * 1984 World Tour Programme * 8-PAGE Programme Folds Open Into Poster! * \$20.00
AC/DC * 1982 Japanese Tour Program * 36 Page Color-B & W Mint- Condition * \$75.00
AC/DC * 1988 World Tour Programme * Blow Up Your Video Tour Programme 18 Pgs * \$8.00
AEROSMITH - HEADLINER * 1977 Reading Festival Program * 40-Pg Book w/Thin Lizzy G. Earring + Acts \$50.00
AEROSMITH * Cheap Trick, Ted Nugent & More * 4-14-79 Tangerine Bowl Concert Programme * \$125.00
AEROSMITH * Nine Lives Japanese 28-Page Full Color Tour Program * \$35.00
ARMSTRONG, LOUIS * 1962 New Zealand Tour Program * 26-Page Programme Perfect Condition! Cool * \$75.00
B.B. KING * 1976 Aussie-New Zealand Tour * 14-Page Programme Black & White Photo's! * \$65.00
BEATLES (PAUL MCCARTNEY) * 1990 Japanese Tour * 40-Page Color Program-Outstanding Photos * \$25.00
BEATLES (RINGO STARR) * Ringo & His All-Starr Band * 24 Page Color/B&W 1990 Programme * \$10.00
BEATLES * 1963 CHRISTMAS SHOW Program * Very Nice Re-print of Hard To Find Item * \$15.00
BEATLES * 1964 UK Tour Program w/Poster Fab Four Famous Card Cover! Poster Incd. * \$225.00
BEATLES * 1965 UK Tour Program * Famous Cartoon Cover w/16-Pages of Fab 4 * \$250.00
BEATLES * Australian Tour 6/64 VG + Con * 34-Page Programme Extremely Rare Book! * \$300.00
BEATLES * Help Japanese Movie Program * Original 22-Page Program Full Color * \$75.00
BLACK SABBATH * Mob Rules Tour Book * Different Cvr then the Other Bk Listed! * \$15.00
BLACK SABBATH * The Mob Rules World Tour Book * 14-Page Programme Full Color Detailed! * \$20.00
BLONDE * 1979 World Tour Programme * 22-Page Programme Full Color Book! * \$25.00
C S N & Y * Fillmore East Program 6-70 * Vol.II #29 Programme for This Show Only! * \$200.00
CANNED HEAT & OTHERS * Fillmore East Vol.1#38 Program * w/Ad's for Woodstock & Atlantic Pop Show * \$350.00
DAVIS, BETTE "IN AUSTRALIA" * 1974 "In Person & on Film" Tour * 16-Page Program for in Person Talk Tour * \$125.00
DONOVAN * 1973 New Zealand Tour Program * 10-Page Tour Program-Great Photo's Mint! * \$75.00
EMERSON, LAKE & PALMER * 1992-93 Black Moon World Tour * 18-Page Color Photograph Programme * \$9.00
GRATEFUL DEAD * 1990 European Tour * 26-Page Color Photograph Programme * \$10.00
GUNS N ROSES * 1948 Japanese Tour * 28-Page Color Photograph Programme * \$125.00
GUNS N ROSES * 1993 Use Your Illusion Tour * 30-Page Color 13 00 Photograph Programme * \$13.00

POSTERS AS LISTED

- AC-DC * 9-19 Canadian Listening Party * Poster for Ballbreaker B&W 23 x 17 w/Band Pic * \$15.00
AEROSMITH + MORE ACTS * September, October Shoreline * Full Color Poster 17"x13" Contact for Act Color Detailed! * \$35.00
AEROSMITH W/K.W.SHEPHERD * US Air Arena 1-3-98 * Promo Color Concert Poster 14 X 20" * \$20.00
ALLMAN BROTHERS * 8-89 Three Show Concert Poster Concord, Shoreline + Cal Expo 11"x18" Color * \$45.00
AMOS, TORI * Canadian Concert 10-29 * Under the Pink Tour-Photo-18x24-RARE! * \$15.00
B.B. KING-BOBBY 'BLUE' BLAND * 4-11-99 Tower Theater, PA * 13"x20" Full Color Concert Poster + Photo * \$10.00
BEATLES (JOHN LENNON) * Legends * Promo Poster on Thick Litho Like Stock * \$8.00
BEATLES (PAUL MCCARTNEY) * Run Devil Run * Promotional Poster Full Color 18"x24" * \$10.00
BEATLES * 1967-1997 Magical Mystery/Sgt. Peppers * Promo 20" Double Sided Round Poster * \$15.00
BEATLES * Anthology ABC TV Program * Full Color Promo Poster (For TV) 27"x40" * \$20.00
BEATLES * Anthology III * Full Color Promo Poster / Size 20"x30" * \$8.00
BEATLES * Anthology Their Music * Story Fiddlers Green 4-Color Concert Poster 11"x17" w/LP Pic * \$10.00

- METALLICA * 1-25-98 McNichols Arena * 4-Color Concert Poster 11"x17" w/Logo! * \$25.00
METALLICA * LOAD * Promotional Poster * \$6.00
NICKS, STEVIE * Belladonna Promotional Poster * w/Stevie Holding The White Dove! Rare * \$50.00
OSBOURNE, J-COWBOY JUNKIES * Canadian Concert Poster 4-12 * Size 18"x23" Photo of Artists B&W * \$10.00
OSBOURNE, OZZY * CNE Grandstand 7-8 Poster * 11 X 17 No Rest for Wicked Concert Tour * \$25.00
PINK FLOYD (ROGER WATERS) * 8-11-99 E-Center, New Jersey * Full Color Concert Poster-21"x13" Size! * \$20.00
QUEEN * Made in Heaven Folded * Promo Poster of LP Cover-Band at Lake Merriweather Post * Concert Poster Full Color 13"x20" Rare! * \$160.00
BUSH * Razorblade Suitcase * Promo Poster 20 X 30" * \$7.00
CHEAP TRICK * 9-12-97 Paramount Theatre * 4-Color Concert Poster 11"x17" w/Band Pic * \$15.00
CROW, SHERYL * 5-6-99 E-Center Camden, N.J. * Full Color Concert Poster Size 21"x13" * \$20.00
DANIELS, CHARLIE * 8-28-80 Merriweather Pavilion * Concert Poster Full Color 13"x20" Rare! * \$75.00
DEF LEPPARD * 8-23-96 Fiddler's Green * Color Concert Poster 17"x9" w/Band Photo! * \$25.00
DREAM THEATRE * Daytona's 5-5-98 * B & W Concert Poster 14"x23" * \$10.00
DYLAN, BOB * 6-5-99 Fillmore Auditorium * Full Color Poster 19"x13" Incredible Art * \$65.00
EARLE, STEVE * El Corazon * Promo Only Lithograph Artwork-Very Ltd! * \$10.00
EVERCLEAR-SOUL COUGHING * 3-13-99 Electric Factory * 13"x21" Full Color Concert Poster PA * \$10.00
FLEETWOOD MAC * The Dance * Promo Poster 18 X 24" Nice * \$10.00
GENE LOVE JEZEBEL * 3-29-98 Mason Jar - Arizona * 3-Color Concert Poster w/Unique Letterwk * \$10.00
GENESIS * 6-14-80 Merriweather Pavilion * Concert Poster Full Color 13"x20" Rare! * \$160.00
GRATEFUL DEAD * Fallout From The Phil Zone * Ltd.Ed. Promo Poster 17 X 22" * \$35.00
HAGAR, SAMMY * 8-31-97 Red Rocks Amphitheater Color Concert Poster w/Sammy Photo 11"x17" * \$25.00
HENDRIX, JIMI * Band of Gypsies Poster * Promo 1998 18 X 24" * \$9.00
HENDRIX, JIMI * BBC Sessions * Promo Poster 18 X 25" * \$10.00
INDIGO GIRLS * 7-17,18-97 Red Rocks * 4-Color Concert Poster 11"x17" w/Band Pic * \$15.00
JEFFERSON STARSHIP * 6-28-80 Merriweather Pavilion * Concert Poster Full Color 13"x20" Rare! * \$250.00
JOHNSON, ERIC * 4-19-96 Paramount Theater * 3-Color Concert Poster 10"x16" w/Eric Pic * \$10.00
KISS * 6-7-97 Praha Fotbalovy' Stadion * Full Color Concert Poster 32"x23" Size!! * \$25.00
KISS * 7-9-96 New Orleans Reunion * Concert Poster-Full Color 24"X16" * \$15.00
LED ZEPPELIN * 8-1-69 Santa Barbara Fairgrnds * Full Unused Ticket VG + Authentic w/Poster * \$350.00
LED ZEPPELIN * Definitive Collection Double Sided Promo Poster 24x36 * \$8.00
LIMP BIZKIT * 7-20-99 Electric Factory, PA * Full Color Concert Poster Size 21"x13" * \$20.00
MARILYN MANSON * Antichrist Superstar * Promo Poster 18 X 24 * \$8.00
MATTHEWS, DAVE * Crash 24"x18" Color Poster w/Concert Date * \$8.00
MAX WEBSTER-DICTATORS * 8-2-81 The Golden Bear * Blk & White Letter Blk Style w/Artwork * \$75.00
MEATLOAF-CHEAP TRICK * 8-6-94 Fiddlers Green 4-Color Concert Poster 11"x17" w/LP Pic * \$10.00



DISC COLLECTOR

HAPPY HOLIDAYS!
Your Official Oldies Supersource!
Your Blast To The Musical Past Since 1981

P.O. Box 4000, Parker, CO 80134
(303) 841-3000 • (303) 841-1118
FAX (303) 840-9373
*e-mail: cd@discol.com
Web site: www.discol.com
Hours: Monday thru Friday
9 a.m. to 5 p.m. Mountain Time

THE DISC COLLECTOR ADVANTAGE

- ✓ We Stock 1000's of Titles (Domestic & Import) in addition to the CDs Listed in This Ad... Don't See It or Have Questions? Just Ask!
- ✓ We Know Pop Music Well... From Original Recordings to Sound Quality.
- ✓ Trusted Professionals for Over 19 Years
- ✓ Very Competitive/Low Overall Pricing

Look! Please check our Web site www.discol.com for up-to-the-minute new releases, super specials, reviews, and much more.

LIST #1201



- #### TOP 10 NEW RELEASE SIZZLERS
1. TAB HUNTER - THE VERY BEST OF - 35 TRACKS (EURO) TEENAGER 605 M/S \$16.99
 2. THE BYRDS - THE PREFLYTE SESSIONS (PRE CBS) (2CD) 40 TRACKS (US) SUNDAZED 11116 M/S \$26.99
 3. FOUR TOPS - 4 TITLES - 2/1 - (UK) \$19.99
 - A) S/T/SECOND ALBUM - MOTOWN 359 S
 - B) ON TOP REACH OUT - MOTOWN 360 S
 - C) STILL WATERS/CHANGING TIMES - MOTOWN 362 S
 - D) YESTERDAY'S DREAMS/SOUL SPIN - MOTOWN 361 S
 4. DIOM - THE WANDERER/THEN & NOW (LAURIE, CBS, X'MAS & NEW) - (5CD) 44 TKS (US) COLLECTABLES 127 M/S \$32.99
 5. VARIOUS ARTISTS - MERCURY RECS. DOO-WOP VOLS. 1, 2, 3, 4, 5, 6 - 25/27 TKS EACH (EURO) MERCURY 5001-5006 M/S EACH \$16.99
 6. EDDIE HODGES - I'M GONNA KNOCK ON YOUR DOOR - 21 TRACKS (EURO) TEENAGER 604 M \$16.99
 7. PAPER LACE - GREATEST HITS - 16 TRACKS (EURO) MUSIC CLUB 482 M/S \$12.49
 8. SUNSHINE CO. - BEST OF - 22 TRACKS (US) CCM 249 S \$15.99
 9. JOE DOWELL - WOODEN HEART - 22 TRACKS (EURO) TEENAGE 602 M/S \$16.99
 10. CAT STEVENS - BOX SET - (4CD) 79 TRACKS W/100 PAGE BOOK (US) A&M 585285 M/S \$64.99

GENERAL POLICIES

- * All products guaranteed as advertised and any defective will be exchanged (You pay postage one way - complete satisfaction).
- * Orders shipped as soon as possible. We can only hold phone orders for 10 days, so please make prompt payment to insure getting the items you want.
- * Unless you specify, out of stock product will be back ordered and your order held, otherwise refunds will be given on product sold out at shipment time.
- * Some titles advertised were not in stock at press time, but expected in by the time you read this ad... you might want to verify prior to sending funds.
- * We reserve the right to make corrections if a typographical/pricing error occurs.
- * Availability subject to prior sale
- * Hours Monday thru Friday 9 a.m. to 5 p.m. Mountain Time
- * Phone orders and questions welcome. No collect calls
- * Mail Order only... NOT A RETAIL STORE.

PAYMENT POLICIES

- * We accept VISA, MASTERCARD, DISCOVER, and AMERICAN EXPRESS in addition to personal checks and money orders (checks must clear our bank - approx 7 days)
- * No minimum order on checks and money orders. Payable to Disc Collector. All Credit Cards - MINIMUM \$15 (product only).
- * Colorado residents add 4.8% sales tax * NO C.O.D.'s *

SHIPPING POLICIES

- * Any additional or specific shipping requests JUST ASK!
- * Foreign - Overseas and Canada rates will be quoted
- * IMPORTANT - Box sets count as number of items in box - example 5-CD box counts as 5 items BOOKS count as 6 items for shipping
- * Parcel post \$2.95 first 2 CD's - 25 each thereafter
- * PRIORITY MAIL: Add \$3.00 to the above rate
- * UPS \$4.95 first CD - 25 each thereafter
- * UPS 2-day - Add \$5.00 to the above rate
- * 3. Federal Express (Air Only) - Call for rates
- * Insurance included in all orders - Please specify which preference when ordering.

*E-MAIL ORDERING

When ordering by E-MAIL only credit card orders can be accepted. You must include, in the body of the message, the item being ordered, price of the item, complete shipping address, and the credit card number with the expiration date. All other ordering policies apply to Electronic orders. Our Web site is secure.

Sale!

- Ringo Starr & His All Starr Band - The Anthology - tours 1989-2000 - (3cd) 47 tracks (UK) below cost \$36.99 \$24.99 \$18.99
- Duke Ellington - The Duke - Complete Works - 1924-1947 (40 cd box) 750 + tracks (German) HOT PRICE! \$139.99 \$99.99 \$69.99
- Various Artists - American Bands Collection - (4cd) 100 tracks (Holland) \$44.99 \$29.99 \$19.99
- Elvis Presley - Blue Suede Shoes Collection - (super deluxe 30 cd box)(US) Below cost! \$469.99 \$369.99 \$309.99
- Crosby, Stills, Nash & Young - Carry On (Hits/Retrospective) - (2cd) 36 tracks (Australia) \$34.99 \$26.99 \$19.99
- Various Artists - Those Rock 'N' Roll Answer Songs Vols. 1&2 - 29 tracks Each (German) SR 8012, 13 M/S each \$10.99 both \$19.99
- Various Artists - Do-Wop For Dummies Vols. 1&2 - 25 & 26 tracks EACH (US) SHM 8080 9090 M/S... each \$9.99 both \$17.99
- Various Artists - RPM Records 10th Anniversary Sampler - 25 tracks (UK) \$18.99 \$12.99 \$7.99

BLOWOUT BLITZ...

- | TITLE | REGULAR PRICE | SPECIAL BLOWOUT! | TITLE | REGULAR PRICE | SPECIAL BLOWOUT! |
|--|---------------|------------------|---|---------------|------------------|
| Various Artists - Encyclopedia Of Doo-Wop Box Vol. 2 - (4cd) 100 tracks (S) | \$89.99 | \$69.99 | 156. MARKETTS - SURFIN' & STOMPIN' - 30 TRACKS (GERMAN) ATM 3830 M/S | \$15.99 | \$18.99 |
| Beach Boys - Studio Sessions '61-62 - 21 tracks (UK) | \$16.99 | \$12.99 | 157. R. DEAN TAYLOR - ESSENTIAL COLLECTION - 18 TRACKS (UK) SPECTRUM 515 S | \$12.99 | \$12.99 |
| Elvis Presley - The Complete Louisiana Hayride Shows - (3cd) 35 tracks (Holland) | \$29.99 | \$21.99 | 158. VARIOUS ARTISTS - BURGESS TREASURE/LOST GEMS FROM THE 60'S - (2CD) 40 TKS (US) CCM 222 M/S | \$25.99 | \$25.99 |
| Procol Harum - 30th Anniversary Anthology - (3cd) 52 tracks (UK) | \$36.99 | \$26.99 | 159. AMERICA - THE COMPLETE GREATEST HITS - 22 TRACKS (US) RHINO 74375 S | \$14.99 | \$14.99 |
| John Lee Hooker - Portrait - (10cd w/40 page booklet)(German) SUPER! | \$89.99 | \$69.99 | 160. BOBBY SHERMAN - HERE COMES BOBBY/WITH LOVE - 22 TRACKS (US) COLLECTABLES 6858 S | \$13.49 | \$13.49 |
| Various Artists - 100 No. 1 Hits - (6cd) 90 tracks (Holland) | \$69.99 | \$54.99 | 161. BOBBY SHERMAN - S/T/PORTRAIT OF - 23 TRACKS (US) COLLECTABLES 6859 S | \$13.49 | \$13.49 |
| Dean Martin - Sings Country Favorites - (3cd) 36 tracks (Portugal) | \$32.99 | \$21.99 | 162. OVERLANDERS - MICHELLE - 31 TRACKS (UK) PYE M/S | \$15.99 | \$15.99 |
| Various Artists - Memories Of Times Square Record Shop (hot doo wop) (11cd)(US) | \$139.99 | \$89.99 | 163. JEFFERSON - COLOUR OF LOVE + 8 - 27 TRACKS (UK) PYE M/S | \$15.99 | \$15.99 |
| Spaniels - The Legendary - (3cd) 69 tracks (US) w/great book | \$79.99 | \$59.99 | 164. BEATLES - COMPLETE BBC ANTHOLOGY 62-70 - (12 CD) 12 CD NUMBERED BOOK (UK) BEEB BT 12 BOX M/S | \$219.99 | \$219.99 |
| Various Artists - 1000 Country & Western Songs - 5/6cd box - CDW From The 50's to 80's hits, rarities, live, etc (Euro) WOW! | \$169.99 | \$119.99 | 165. RONNIE SELF - MR. FRANTIC/BOPPIN' THE BLUES - 31 TRACKS (GERMAN) HYDRA 27113 M | \$15.99 | \$15.99 |

"HOT FOR THE HOLIDAZE!!!"

1. Various Artists - Ghosts of Christmas Past - 29 tracks (UK) Mistletoe 1001 M/S \$16.99
2. The Harry Simeone Chorus - Sing We Now Of Christmas - 31 tracks (German) TCF 1105 S \$14.99
3. Jimmy Boyd - Christmas With - 10 tracks (US) CL 6270 M/S \$14.99
4. Various Artists - The Ultimate Christmas Album Vol. 6 - 25 tracks (US) Collectables 4524 M/S \$14.99
5. New Christy Minstrels - Christmas With (2 on 1) - 28 tracks (US) CCM 244 S \$16.99
6. Various Artists - The Ultimate Group Harmony Christmas Collection - 25 Tracks (Italy) Dipper 213 M/S \$16.99
7. Various Artists - Christmas - It's That Time Of The Year - 30 Tracks (Euro) Santa 001 M/S \$16.99
8. Paul & Paula - Holiday For Teens - 12 tracks (Euro.) Mistletoe 101 M/S \$14.99
9. Various Artists - Swinging Christmas - 18 tracks (US) Rhino 79998 M/S \$14.49
10. The Sheps - Give Your Heart For Christmas - 16 tracks (US) Early Bird 1004 S \$13.99
35. THE HOLLIES - RARITIES VOL. 1 '64-70 - 30 TRACKS (EURO) FEL 200 M/S \$16.99
36. CARL DOUGLAS - THE SOUL OF THE KUNG FU FIGHTER - 22 TRACKS (UK) CASTLE 18129 M/S \$13.99
37. DESMOND DEKKER - ANTHOLOGY/SRA/LITES '63-99 - 50 TRACKS (US) TROJAN 80252 M/S \$21.99
38. BOBBY VINTON - SEALED WITH A KISS/WITH LOVE - 20 TRACKS (US) COLLECTABLES 7422 S \$13.49
39. PLAYMATES - ULTIMATE COLLECTION - 28 TRACKS (EURO) TEEN 7110 M/S \$14.99
40. VARIOUS ARTISTS - TEENAGE DREAMS VOL. 12 - 30 TRACKS (GERMAN) FR 1017 M/S \$18.99
41. ELVIS PRESLEY - MEMPHIS SESSIONS (FTD SERIES) - (UK) BMG 9293 S \$28.99
42. ELLIE GREENWICH - BRILL BUILDING SOUND '58-85 - (2 CD) 56 TKS. (GERMAN) BRILLTONE 444 M/S \$28.99
43. TOKENS - GOLDEN MOMENTS OF OUR PAST/A WALK DOWN MEMORY LANE (RARITIES/COMMERCIALS) 28 TRACKS + BONUS CD (US) CRYSTAL BALL 1036 M/S \$22.99
44. TOKENS - DUM-DO-BE DUM/TONIGHT I FELL IN LOVE - 29 TRACKS (US) CRYSTAL BALL 1038 M/S \$15.99
45. LITTLE WILLIE JOHN - VERY BEST OF (NEW STEREO) - 25 TRACKS (US) COLLECTABLES 2822 M/S \$13.99
46. VOGUES - 2 CATALOG TITLES (US) A) TURN AROUND LOOK AT ME/TIL - TARAGON 1089 S \$14.99 B) MEMORIES/SING THE GOOD OLD SONGS - TARAGON 1090 S \$14.99 *BOTH \$28.99
47. GRATEFUL DEAD - THE GOLDEN ROAD '65-73 - SUPER DELUXE 12CD BOX W/80 PAGE BOOK (US) RHINO 74401 M/S \$114.99
48. VARIOUS ARTISTS - 70'S SOUL EXPERIENCE - DELUXE 6CD BOX W/BOOK 136 TKS (US) RHINO 74346 M/S \$84.99
49. VARIOUS ARTISTS - ROCK, RHYTHM & DOO-WOP - (3CD) 66 TRACKS (US) RHINO 78353 M/S \$42.99
50. VARIOUS ARTISTS - GOOD ROCKIN' TONIGHT (SUN RECORDS TRIBUTE) (US) SIRE 31165 S \$16.99
51. FRANKIE LAMINE - I BELIEVE '51-55 - (SUPER DELUXE 6CD BOX W/HARDBOUND BOOK) (GERMAN) BEAR FAMILY 16367 M/S \$134.99
52. VARIOUS ARTISTS - FRATERNITY RECORDS STORY VOL. 2 - (UK) ACE 822 M/S \$16.49
53. VARIOUS ARTISTS - SAY IT LOUD - (HISTORY OF BLACK MUSIC IN AMERICA W/100 PAGE BOOK) (DELUXE 6CD) 110 TRACKS (US) RHINO 76660 M/S \$74.99
54. SPENCER DAVIS GROUP - LIVE ANTHOLOGY '65-68 - 20 TRACKS (US) VARESE 66280 S \$14.69
55. VARIOUS ARTISTS - THEN - TOTALLY OLDIES VOL. 2 - 18 TRACKS (US) VARESE 66234 M/S \$12.99
56. HANK BALLARD - VERY BEST OF (NEW STEREO) - 25 TRACKS (US) COLLECTABLES 2828 M/S \$13.99
57. SHIRELLES - VERY BEST (HITS & RARITIES) - 34 TRACKS (EURO) BLACK TULIP 2001 M/S \$16.99
58. TONY SHERIDAN & BEAT BROTHERS - (DELUXE 2CD W/BOOK) (GERMAN) BEAR FAMILY 16447 M/S \$59.99
59. JOHN ZACHERLEY - SPOOK ALONG ZACHERLEY - (US) CCM 229 M/S \$11.99
60. JIMMY CLANTON - PHILLIPS YEARS/LIVE AT GILLEYS - 23 TRACKS (EURO) LADYLUCK 5102 M/S \$12.99
61. BLENDS MEET THE TUNEWEAVERS - 23 TRACKS (EURO) OFFICIAL 6015 M/S \$16.99
62. MELLO-KINGS - 21ST CENTURY (NEW RECS.) - 20 TRACKS (EURO) MK 101 S \$15.99
63. JERRY BUTLER - THE PHILADELPHIA SESSIONS (2/1) - 25 TRACKS (US) MERCURY 586498 S \$15.49
64. THE CASTELLS - VERY BEST OF - 20 TRACKS (US) COLLECTABLES 6851 M/S \$12.99
65. VARIOUS ARTISTS - ALADDIN & IMPERIAL VOCAL GROUP MAGIC - VOLS. 5&6 - 24 TKS. (EURO) CD-IM 9263, 9264 M EACH \$31.99
66. MAUREEN GRAY - THE VERY BEST OF - 17 TRACKS (UK) CASTLE 1002 M \$15.99
67. RAVENS - EARLY YEARS VOL. 1 - 22 TRACKS (ITALY) DIPPER 212 M \$12.99
68. THE CLICKETTES - THE VERY BEST OF - 18 TRACKS (EURO) DICE 83 M \$15.99
69. ROYALS/THE MIDWINTERS - VERY BEST OF - 25 TRACKS (US) COLLECTABLES 2828 M/S \$13.99
70. ELVIS PRESLEY - THE INTERNATIONAL EP COLLECTION - 11 EP'S W/PICTURE SLEEVES (UK) ELVIS 105 M \$84.99
71. COLIN BLUNSTONE - SAY YOU DON'T MIND - (UK) ARM 29 S \$11.99
72. BRIAN HYLAND - BRIAN'S 21 BIG ONES - (UK) CONNOISSEUR 354 M/S \$14.99
73. TOMMY ROE - TOMMY'S 22 BIG ONES - (UK) CONNOISSEUR 355 M/S \$14.99
74. DAVID CASSIDY - THEN & NOW + 1 (HITS & NEW RECS.) - (UK) UNIVERSAL TV 822 S \$25.99
75. BILLY JOEL - THE ESSENTIAL - (2CD) 36 TRACKS (US) COLUMBIA 86005 S \$22.99
76. JONATHAN KING/HEDGEHOPPERS ANONYMOUS - 24 TRACKS (US) WOUNDED BIRD 1013 M/S \$16.99
77. THE VENTURES - PLAY THE GREATEST SURFIN' HITS OF ALL TIME - (NEW) 18 TKS. (US) VARESE 066275 S \$12.99
78. RICKY NELSON - THE AMERICAN DREAM (COMPLETE IMPERIAL & VERVE RECS. '57-62) - SUPER DELUXE 6CD BOX WITH HARDBOUND BOOK (GERMAN) BEAR FAMILY 16196 M/S \$134.99
79. VARIOUS ARTISTS - HARD TO FIND 45'S ON CD VOLS. 6 & 7 - 21 TKS. EACH (US) ERIC 11512, 13 M/S EACH \$14.99
80. VARIOUS ARTISTS - YOU GOTTA USE BOTH EARS FOR THIS ONE - (SUPER RARE STEREO 50'S, 60'S) 20 TRACKS (EURO) TWO MINKS 001 S \$16.99
81. VARIOUS ARTISTS - ANGEL BABY - 30 TRACKS (EURO) MR. MAESTRO 1010 M/S \$17.99

HOT BOX...

- | Title | Label | Mono/Stereo | Price |
|---|----------------|-------------|---------|
| Various Artists - The Great Country Legends (Cash, Pline, J. Reeves, M. Haggard, K. Rogers, G. Jones, etc.) (10cd) 180 tracks (UK) Castle 902X M/S \$34.99 | Castle | 902X | \$34.99 |
| Various Artists - The Great Vocalists (F Sinatra, D. Day, D. Martin, P. Lee, P. Camo, B. Crosby, etc.) (10cd) 212 tracks (UK) Castle 901X M/S \$34.99 | Castle | 901X | \$34.99 |
| Gene Krupa - The Gene Krupa Story - (4cd) 99 tracks (UK) Proper Box 1, M/S \$27.99 | Proper Box | 1 | \$27.99 |
| Various Artists - A Whistle Stop Tour of Jasmine Country - 28 Tracks (Euro.) Jaxx CD 2, M/S \$6.99 | Jaxx CD | 2 | \$6.99 |
| Johnny Hartman - Sings Poetry in Motion - 20 tracks (UK) Castle 596, M/S \$8.99 | Castle | 596 | \$8.99 |
| Diana Ross & The Supremes - Let The Sunshine In/Cream Of The Crop - 23 tracks (UK, Motown 95882, S \$13.99 | Motown | 95882 | \$13.99 |
| The Supremes - Where Did Our Love Go?/Hear A Symphony - 24 tracks (UK, Motown 95092, S \$13.99 | Motown | 95092 | \$13.99 |
| The Supremes - Move Hits/Supremes Sing Holland - Dozier/Holland - 24 tracks (UK, Motown 95892, S \$13.99 | Motown | 95892 | \$13.99 |
| The Supremes - Love Child/Supremes A Go-Go - 24 tracks (UK, Motown 95082, S \$13.99 | Motown | 95082 | \$13.99 |
| The Supremes - A Bit Of Liverpool/TCB With The Temptations - 28 tracks (UK, Motown 96182, S \$13.99 | Motown | 96182 | \$13.99 |
| Diana Ross & The Supremes & The Temptations - Diana Ross & The Supremes Join The Temptations/Together - 11 tracks (UK, Motown 95072, S \$13.99 | Motown | 95072 | \$13.99 |
| The Temptations - Meet The Temptations/Sing Smokey - 23 tracks (UK, Motown 94432, M/S \$13.99 | Motown | 94432 | \$13.99 |
| The Temptations - Song For You/Masterpiece - 15 tracks (UK, Motown 95120, M/S \$13.99 | Motown | 95120 | \$13.99 |
| The Temptations - Psychedelic Shack/All Directions - 16 tracks (UK, Motown 94452, M/S \$13.99 | Motown | 94452 | \$13.99 |
| The Temptations - Live At The Copa/With A Lot O'Soul - 24 tracks (UK, Motown 94402, M/S \$13.99 | Motown | 94402 | \$13.99 |
| The Temptations - Cloud Nine/Puzzle People - 21 tracks (UK, Motown 94462, M/S \$13.99 | Motown | 94462 | \$13.99 |
| 93. CARL DOBKINS, JR. - NOW & THEN (NEW RECS./AUTOGRAPHED) - 11 TKS (US) DBW SOUND S \$12.99 | DBW SOUND | S | \$12.99 |
| 94. MONIE DUBOWS - CARVIN' IT OUT (NEW RECS.) - 11 TRACKS EXCLUSIVE! (US) LOUD NEIGHBORS 9701 S \$12.99 | LOUD NEIGHBORS | 9701 | \$12.99 |
| 95. VARIOUS ARTISTS - THE TWANG GANG (DUANE EDDY, DONNIE OWENS, SANFORD CLARK) - 18 TKS (US) JAMIE 4017 M/S \$14.99 | JAMIE | 4017 | \$14.99 |
| 96. HARPERS BIZARRE - 4 CATALOG TITLES (US) A) FEELIN' GROOVY - SUNDAZED 6176 S \$11.49 B) ANYTHING GOES - SUNDAZED 6177 S \$11.49 C) THE SECRET LIFE OF - SUNDAZED 6178 S \$11.49 D) HARPERS BIZARRE 4 - SUNDAZED 6179 S \$11.49 *ALL FOUR \$42.99 | SUNDAZED | 6176-79 | \$11.49 |
| 97. THE CYRILE - RED RUBBER BALL - 19 TRACKS (US) SUNDAZED 11108 S \$13.49 | SUNDAZED | 11108 | \$13.49 |
| 98. THE CYRILE - NEON - 20 TRACKS (US) SUNDAZED 11109 S \$13.49 | SUNDAZED | 11109 | \$13.49 |
| 99. THE MARMALADE - REFLECTIONS OF ANTHOLOGY - (2CD) 46 TRACKS (UK) CASTLE 281 M/S \$18.99 | CASTLE | 281 | \$18.99 |
| 100. FREE DESIGN - THE BEST OF - 20 TRACKS (UK) CHERRY RED 194 M/S \$16.99 | CHERRY RED | 194 | \$16.99 |
| 101. McGUINN CLARK & HILLMAN (REMASTERED) - 13 TRACKS (US) ONE WAY 32432 S \$12.49 | ONE WAY | 32432 | \$12.49 |
| 102. PICKETT/TITCH - THAT SAME OLD FEELING - 27 TRACKS (UK) CASTLE 265 M/S \$14.99 | CASTLE | 265 | \$14.99 |
| 103. PERCY FAITH - THE ULTIMATE COLLECTION - (3CD) 60 TRACKS (AUSTRALIA) COLUMBIA 65200 M/S \$18.99 | COLUMBIA | 65200 | \$18.99 |
| 104. MAMAS & PAPPAS - ALL THE LEAVES ARE BROWN/GOLDEN ERA COLL. 52 TKS (US) MCA 112653 M/S \$22.99 | MCA | 112653 | \$22.99 |
| 105. BUDDY HOLLY - EP COLLECTION - (2CD) 48 TRACKS (UK) SPM M/S \$14.49 | SPM | M/S | \$14.49 |

"THE STORY SERIES"

- WE MADE A SUPER PURCHASE ON 50'S & 60'S HITS. PACKAGES FROM EMV/HOLLAND... ALL FEATURE 18-25 TRACKS PER CD AND COME WITH A BONUS CD-ROM CONTAINING A BIOGRAPHY, DISCOGRAPHY & PHOTO GALLERY ON EACH ARTIST...
- INCREDIBLE PRICE! ONLY \$9.99 EACH OR MORE - JUST \$8.99 EACH!**
- | Artist | Title | Price |
|-------------------------------|-----------|--------|
| DEL SHANNON | THE STORY | \$8.99 |
| FRANKIE AVALON | THE STORY | \$8.99 |
| GENE PITNEY | THE STORY | \$8.99 |
| EVERLY BROTHERS | THE STORY | \$8.99 |
| JERRY LEE LEWIS | THE STORY | \$8.99 |
| JOHNNY TILLOTSON | THE STORY | \$8.99 |
| GERRY AND THE PACEMAKERS | THE STORY | \$8.99 |
| MANFRED MANN | THE STORY | \$8.99 |
| B. J. THOMAS | THE STORY | \$8.99 |
| THE SHIRELLES | THE STORY | \$8.99 |
| FATS DOMINO | THE STORY | \$8.99 |
| HELEN SHAPIRO | THE STORY | \$8.99 |
| BILLY J. KRAMER & THE DAKOTAS | THE STORY | \$8.99 |
| CHIL BLACK | THE STORY | \$8.99 |
| CHER | THE STORY | \$8.99 |
| GENE VINCENT | THE STORY | \$8.99 |
| EDDIE COCHRAN | THE STORY | \$8.99 |
| TOMMY JAMES & THE SHONDELLS | THE STORY | \$8.99 |
| THE KINGSTON TRIO | THE STORY | \$8.99 |
| DION AND THE BELMONTS | THE STORY | \$8.99 |
| CARL PERKINS | THE STORY | \$8.99 |
| THE CHORDETTES | THE STORY | \$8.99 |
| FABIAN | THE STORY | \$8.99 |
| RITCHIE VALENS | THE STORY | \$8.99 |
| HERMAN'S HERMITS | THE STORY | \$8.99 |

ANDY'S RECORD SUPPLIES

48 Colonial Road, Providence, RI 02906; Phone, 401/421-9453; Fax, 401/421-0841

- FOREIGN ORDERS CALL OR WRITE FOR CHARGES
- CALL TO HAVE YOUR ORDER SHIPPED C.O.D.
- NO PO BOX #'S, STREET ADDRESS ONLY FOR UPS
- \$30 MINIMUM ORDER
- CHECKS MUST CLEAR



CLIP & SAVE

SINCE 1989 — QUALITY PRODUCTS, LOW PRICES & FREE SHIPPING ANYWHERE IN THE CONTINENTAL U.S.

JAPANESE RESEALABLE SLEEVES...

Direct from Japan.
The best quality protection you can get.
Crystal clear outer sleeves.
These will never fade or crack. Lifetime protection.
All come with resealable flaps
and peel-off strip on back.
Fits over jackets, sleeves, and CD jewel cases.

- LPS / LASER DISCS 100 - \$20.99; 1000 - \$145.99
- CDS 100 - \$12.99; 1000 - \$69.99
- COMIC BOOKS 100 - \$17.99; 1000 - \$119.99
- 45S, PIC SLEEVES 100 - \$15.99; 1000 - \$84.99
- DOUBLE CDS 100 - \$14.99; 1000 - \$74.99
- 10" 78 LPS 100 - \$17.99; 1000 - \$118.99
- 9 1/2 X 11 3/4 MAGAZINES. 100 - \$19.99; 1000 - \$139.99
- DVD'S **NEW** 100 - \$13.99; 1000 - \$79.99

CARDBOARD JACKETS...

HEAVY-DUTY 12" ALBUM JACKETS. WHITE OR BLACK.
HIGH GLOSS. WITH OR WITHOUT HOLE
Case Price / 100 - \$49.99

HEAVY-DUTY CD WHITE JACKETS WITH HOLE.
100 - \$29.99; Case Price / 600 - \$149.99

MAILERS...

MULTI-ALBUM MAILER
Heavy duty corrugated cardboard, 200 lb test,
holds 3-20 albums.
Case Price / 100 - \$109.99

MULTI 1-10 CD MAILER
Heavy duty corrugated cardboard, 200 lb test,
holds 1 CD or up to 10 CDs in jewel cases.
Case Price / 100 - \$54.99

SPECIAL ITEMS...

CLEAR CD DISC SLEEVE
6 Mil Thick. Full front flap with white protective pad
inside.
100 - 499, each - 49¢; 500 - 999, each - 39¢;
1,000 and up, each - 34¢

SHRINK-WRAP SYSTEM
For CD's, Cassettes, and Videos. Ready to wrap
in seconds. Each \$249.99
2,000 feet of film for Cassettes \$89.00
500 feet of film for CDs \$59.00
2,000 feet of film for CDs \$93.99
2,000 feet of film for Videos \$99.00

WHITE PLASTIC DIVIDER CARDS...

- CD Jewel 6 x 7 35¢ EA.
 - CD Full 6 x 14 49¢ EA.
 - 45 Full 7 x 8 1/2 40¢ EA.
 - 45 Slant 7 x 8 1/2 38¢ EA.
 - LP Full 12 x 14 69¢ EA.
 - LP Slant 12 x 14 65¢ EA.
- Minimum, 50
Mix & Match Available

POLY SLEEVES • HIGHEST QUALITY...

Perfect Fitting Sleeves For Your Records & Collectibles

3 MIL THICK ALBUM SLEEVES
Fits Over Outer Album Jacket. Size, 12 3/4 x 12 3/4.
100 - \$10.99; 500 - \$39.99; Case Price / 1000 - \$65.99

4 MIL THICK ALBUM SLEEVES
Fits Over Outer Album Jacket. Size, 12 3/4 x 12 3/4.
100 - \$14.99; 500 - \$59.99; Case Price / 1000 - \$94.99

45S, EPS, PIC. SLEEVES
Size, 7 1/2 x 7 1/2. - 3 Mil Thick.
100 - \$6.99; 500 - \$19.99; Case Price / 1000 - \$31.99

78/10" LP SLEEVES
Size, 10 3/4 x 11 - 3 Mil Thick. Fits Over Outer Jacket.
100 - \$9.99; 500 - \$38.99; Case Price / 1000 - \$63.99

COMPACT DISC SLEEVES
Size, 5 x 6 With 1" Flap; 2.5 Mil Thick; Fits Over CD Disc.
100 - \$4.79; Case Price / 1000 - \$25.99

CD JEWEL CASE SLEEVES
Size, 6 x 6 With 1" Flap; 2.5 Mil Thick; Fits Over CD Jewel Case.
100 - \$4.99; Case Price / 1000 - \$26.99

LIFE MAGAZINE SLEEVES
Size, 11 x 16 With 2 1/2" Flap; 2.5 Mil Thick; Fits Old & New Issues.
100 - \$13.50; 500 - \$49.99; Case Price / 1000 - \$79.99

MAGAZINE SLEEVES
Size, 8 3/4 x 11 1/4 With 1 1/2" Flap; 3 Mil Thick.
100 - \$9.99; 500 - \$39.99; Case Price / 1000 - \$59.99

BOX SET SLEEVES
Size, 14 x 15 - 2.5 Mil Thick
100 - \$14.50; 500 - \$55.99; Case Price / 1000 - \$89.99

SHEET MUSIC SLEEVES
9 1/2 X 12 1/2; 3 Mil Thick
100 - \$9.99; 500 - \$39.99; Case Price / 1000 - \$59.99

FREE SHIPPING in the Continental U.S.

QUALITY PAPER SLEEVES...

7" WHITE WITH HOLE
100 - \$7.99; Case Price / 2400 - \$69.99

12" WHITE WITH HOLE ROUND CORNERS
100 - \$11.99; Case Price / 1000 - \$78.99

12" WHITE POLY-LINED SQUARE CORNERS
100 - \$21.99; Case Price / 500 - \$98.99; 1000 - \$169.99

JAPANESE NON-STATIC INNER SLEEVES
12" LP/LaserDisc; clear, square top with round bottom
(no hole).
100 - \$19.99; Case Price / 500 - \$84.99; 1000 - \$139.99

JAPANESE CD CLOTH SLEEVE
White (no hole) soft woven material **NEW**
100 - \$18.99; Case Price / 1000 - \$139.99

DVD BOXES...

BLACK DVD REPLACEMENT BOXES **NEW**
Case Price/100 \$49.99

CD REPLACEMENT CASES...

CD JEWEL CASE ONLY
Case Price / 200 - \$49.99; 1000 - \$219.99

CD JEWEL CASE W/TRAY
Case Price / 200 - \$73.99

SLIM LINE JEWEL CASE FOR CD SINGLES
W/BUILT-IN TRAY
Case Price / 300 - \$88.99

ULTRA SLIM CD SINGLE JEWEL CASE **NEW**
Case Price / 200 - \$69.99

ULTRA (2 CD) SLIM JEWEL CASE **NEW**
Case Price / 300 - \$119.99

ULTRA (4 CD) SLIM JEWEL CASE **NEW**
Case Price / 200 - \$139.99

DOUBLE (2 CD) JEWEL CASE W/2 TRAYS
Each (minimum 50) 99¢; Case Price / 100 - \$89.00

ALL CLEAR DOUBLE (2 CD) SLIMLINE CASE
Clear case, crystal clear tray, completely visible
throughout.

Each (minimum 50) 60¢; Case Price / 200 \$109.99

BLACK DOUBLE (2 CD) SLIMLINE CASE **NEW**
Clear case, black tray.
Each (minimum 50) 60¢; Case Price / 200 \$109.99

WHITE DOUBLE (2 CD) SLIMLINE CASE
Clear box white tray.
Each (minimum 50) 60¢; Case Price / 200 - \$109.99

3CD SLIM JEWEL CASE **NEW**
Clear Case w/Black or clear Tray
Case Price / 200 \$137.99

DOUBLE SLIM UNBREAKABLE TRAY ONLY
Virtually unbreakable! Made of plastic & rubber
material and it will fit any regular jewel case.

Each (minimum 100) 35¢; Case Price / 800 \$232.00

DOUBLE SLIM TRAY ONLY **NEW**
Clear or black. Snaps into a standard jewel case.
Each (minimum 150) 35¢; Case Price / 300 \$90.99

JEWEL CASE TOP LIDS ONLY
Case Price / 200 \$35.99; 1000 - \$149.99

TRIPLE (3 CD) JEWEL CASE W/TRAYS
Each (minimum 50) 99¢; Case Price / 100 - \$89.00

QUAD (4 CD) JEWEL CASE W/TRAYS
Each (minimum 50) 99¢; Case Price / 100 - \$89.00

6 CD JEWEL CASE W/TRAYS
Each (minimum 50) \$1.19; Case Price / 100 - \$109.99

COLORED CD JEWEL CASE ONLY
Jewel Case Colors: Transparent colors of red, blue,
green, orange, or purple. Case Price / 200 - \$69.99

COLORED CD JEWEL CASE W/ COLORED TRAY
Jewel Case Colors: See above; Jewel Tray Colors:
See below. Case Price / 200 - \$83.99

COLORED CD JEWEL TRAYS
Jewel Tray Colors: red, blue, orange, crystal clear,
purple, white, green. Case Price / 400 - \$59.99

STANDARD GREY CD JEWEL TRAY
Case Price / 400 - \$44.99

CASSETTE REPLACEMENT CASES...

ALL CLEAR, OR CLEAR & BLACK
EXTRA STRONG STYRENE MATERIAL
Case Price / 400 - \$69.99; 800 - \$119.99

• ALL PRICES SUBJECT TO CHANGE WITHOUT NOTICE •

prices effective 1/1/01

Contents

Garage Sale issue!

Records and CDs for under \$6!
Sale starts on page 48.

Dedicated to the memory of Rick Whitesell

Goldmine

ISSUE 558 Dec. 14, 2001
Vol. 27 No. 25

©NPG Records/By Steven Parke

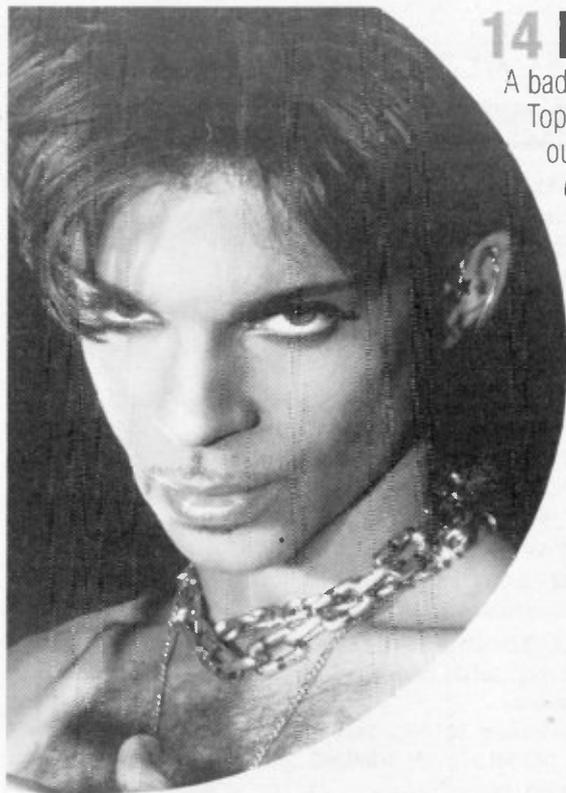

14 PRINCE

A bad renaming choice battered Prince's reputation in the '90s. Despite few hits (four Top 10s, including just one #1, compared to five #1s in the 1980s), his overlooked output from this era — 15 albums of new material — deserves a second chance. *Goldmine's* year-by-year look at Prince in the '90s reveals much about the artist's mindset and the obstacles he overcame during this time.

...by Thomas Kintner

15 PRINCE DISCOGRAPHY

With output from his major label connections as well as his own Paisley Park and NPG releases, Prince has plenty of goodies for fans to gobble up, including many 12-inch promo singles.

...by Thomas Kintner and Tim Neely



Unplayed records warehouse find!

Collectors buy 200,000 new records, mostly 45s from the late '80s—mid-90s.

...by Cathy Bernardy

See page 20

BUY & SELL MARKETPLACES

Unit Space Advertising	35
Super Unit Space Section	50
Web Directory	54
Record Show Calendar	56
Retailer Directory	60
CD Showcase	64
Collector's Showcase	65
Want Lists	71
Classifieds	73

GOLDMINE INFORMATION

Subscription Information	77
Coming Soon to <i>Goldmine</i>	77
Advertisers Index	78
Ad Rates & Information	78

Photo credits

Cover shot ©London Features/Dennis Van Tine
Inset of Earl Scruggs courtesy of MCA Nashville, by Pamela Springsteen

PUBLISHER
WAYNE YOUNGBLOOD

EDITOR
GREG LOESCHER

ASSOCIATE EDITOR
CATHY BERNARDY

R & B EDITOR
ROBERT PRUTER
(PO Box 768, ELMHURST, IL 60126)

RESEARCH DIRECTOR
TIM NEELY

ADVERTISING MANAGER
JILL RUESCH

ADVERTISING SALES
TREVOR LAUBER

ADVERTISING SALES ASSISTANT
JENNIFER PHILIPPON

Main office:

700 E. State Street, Iola WI 54990-0001

FAX: 715-445-4087

Telephone: 715-445-2214

E-mail: goldmine@krause.com

Visit *Goldmine's* Web site at
<http://www.collect.com/records>

Editorial submissions: All editorial submissions as well as press releases and review copies should be sent to Greg Loescher at the Iola office. While we invite authors to submit materials for publication, due to the volume we receive, we cannot guarantee that items sent on spec will be returned or acknowledged.

Advertising should be addressed to *Goldmine's* main office in Iola or call 715-445-2214.

Subscriptions/renewals: If you would like to subscribe or renew your subscription and have a major credit card, call our toll-free number for current rates: 1-800-258-0929.

Subscription questions: Call Subscription Services, 715-445-2214, ext. 257.

Subscription rates: U.S. Addresses: 13 issues (1/2 year) \$24.95; 26 issues (1 year) \$39.95; 52 issues (2 years) \$74.50; 78 issues (3 years) \$107.95.

Special Services Subscriptions: Information and rates on first class UPS and Federal Express delivery for your subscription is listed elsewhere in this issue. Or call 1-800-258-0929.

Foreign rates: Surface mail, all countries: \$49.95 for 13 issues. Airmail rates: Please call or write for current rates to your country. Or see our subscription ad elsewhere in this issue. All payments must be made in U.S. funds.

Moving? If you are moving, please include your name and new address, plus your old address, and mail it to the attention of *Goldmine*, Circulation Department, 700 E. State Street, Iola, WI 54990.

Goldmine (ISSN 1055-2685) is published bi-weekly by Krause Publications, 700 E. State St., Iola, WI 54990. Roger Case, president, Iola, WI 54945. The *Goldmine* logo is protected through trademark registration in the United States. Periodical postage paid at Iola, WI 54945 and additional mailing offices. POSTMASTER: Send address changes to *Goldmine*, 700 E. State Street, Iola, WI 54945.

No portion of the contents of *Goldmine* may be reproduced without prior permission from the publisher and pertinent author(s).

Entire contents copyright 2001 by Krause Publications, Inc.

Goldmine is printed in the U.S.A.

30 2001 CHRISTMAS ROUND-UP

"CDs roasting on an open fire...." There are plenty of new releases in many genres this season to bring holiday cheer to even the orneriest Grinch.

...by Tim Neely

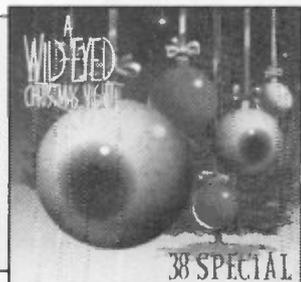

PLUS...

Courtesy of MCA Nashville/By Pamela Springsteen



EARL & RANDY SCRUGGS

Courtesy of Elektra/By Eric Van Lamsweerde & Vinoodh Matadin



NEW RELEASES

Courtesy of Rhino Records/VH-1



REISSUES

- 8 **Please Mr. Postman** Letters from *Goldmine* readers and *Letter From The Editor*.
- 10 **Grapevine** News of CMJ's "ghost" convention, Doo-Wopp Hall Of Fame, Sam The Record Man bankruptcy, obituaries and *Grapeleaves*.
- 12 **Brian Wilson** The Beach Boys' mastermind talks with *Goldmine* about the recent star-studded tribute concert in his honor and other things musical. ...*Mark Wallgren*
- 12 **Rare Finds** A \$200 45 "Found" for 10¢! ...*Greg Loescher*
- 22 **Country Junction** Eight Questions for Earl (pictured) & Randy Scruggs by Bruce Sylvester, plus country music news and reviews.
- 26 **New Releases** Björk, Passenger, Prince, Swamperella, B.B. King and more...
- 28 **Reissues** *Say It Loud! A Celebration Of Black Music In America* box set featuring Marvin Gaye and others; Big Hello; X; Chuck Berry book review; and lots more...

COLUMNS...

- 18 **Classical Notes** The emergence of American music, Dvorák's symphony *From The New World*. ...*Peter Gutmann*
- 19 **A Broad Abroad** Remarkably satisfying reissues and tributes. ...*Jo-Ann Greene*
- 76 **Five Star Cartoon** George Clinton's Funkadelic. ...*Marty Winters*

MIDNIGHT RECORDS

Box 390, Old Chelsea Station, New York, NY 10011 USA
 Phone (212) 675-2768 Oper: Mon-Fri, Sat. (Closed Sun, Mon, Wed.) • Fax 212 741 7230 • E-Mail midnightrecords@attglobal.net

Check our Web Site for the latest additions & complete listings www.midnightrecords.com

CDs • 50s: R&B, R&B, POP, BLUES

- All American R&R #1.2-New (UK CDs Fraternity Label 50s Trax) Each 15.99
- Arnold, P.P.-1st Cut-3 Bonus Cuts-(UK CD Ex Ikette 66/8 Best Of) 11.99
- Atles-Beat Of Heart-(US Amazing Blend Of Reggae Ska Blues & Pop!) 11.99
- Bluesoul Belles #1,2,3,4-New-(UK CDs w/Unre. Trax) Each 15.99
- Buffalo Bob Series-Party Date/Out For Kicks/Rockability Cuts-Each 17.99
- Carr, James-Complete Goldwax Singles-(UK CD 28 Cuts) 15.99
- Cobra & Artistic Recordings-King, B. Everett, B. Guy (UK 29 Cuts) 15.99
- Cowboy Copas-Copasetic King-StarDay 45/60-(UK CD 25 Cuts w/Unre.) 15.99
- Dion-Sanctuary-Suite For Late Summer-(UK CD 2 On 1) 15.99
- Dion-Sat Down Old Friends/You're Not Alone-(UK CD 2 On 1) 15.99
- Dion & Belmonts-EP Collection-(UK CD Hits & Rarities) 15.99
- Dion 'N' Little Kings-Live NYC '96-(UK Ace CD Legendary Concert!) 15.99
- Doo Wop/Fit Vol. 1-(UK CD From Master Tapes w/2 Unre. Cuts) 15.99
- Doo Wop: Legends Of-(UK Ace CD Ex Passions Fascinators 5 Sharks) 15.99
- Drummers-They Sing Like Angels-(UK CD 20 Cuts 5/46 Feat. R. Berry) 15.99
- Fells, Nerval-Hi Records 59/73-(UK CD 29 Prev. Overlooked Cuts) 13.99
- Foetus, Phil-Records 'Dance Party-(Euro CD 25 Best & Rare Cuts) 19.99
- Foley, Red-Chatanooga Best Of 44/58-(UK CD 25 Cuts Best & Rare) 16.99
- Fury, Buddy-EP Collection-(UK Deluxe 2CD+Book Best & Rare Sides) 24.99
- Holly, Buddy-Reminiscing-Showcase (In-Son UK CD 2 Classics) 17.99
- Hyland, Brian-Brian's 21 Big Ones-(UK CD 21 Hits & Rarities) 13.99
- Instruments, Teen Beat #105-New-(30 Cuts Ace CDs 50s+Early 60s) Each 15.99
- James, Sonny-Young Love-(UK CD 21 Cuts Best Of 56/9 Singles) 16.99
- Johnson, Syl & Jimmy-2 Better Than 1-(UK Kings/Rhythm Dymonyle) 16.99
- King Northern Soul #1,2-New-(UK Remast. King/Fed. Cuts 63/71) Each 15.99
- King, Albert-More Big Blues-(UK CD 22 Bobbin Rcds. 50's Cuts) 15.99
- MacK, Lonnie-Nashville To Memphis-(Ace CD 26 Cuts Singles+5 Unre.) 16.99
- Madness Invasion-Vol. 1-(Ltd. CD 24 Crazed Out Cuts From 50s/60s) 19.99
- Mad Cracklin' Jimmy-Blues Blasters Shuffle-(UK CD 25 Remast. 45/50) 12.99
- Modern Vocal Groups #1106-New-(UK 24 Rare 50s R&B w/Unre.) Each 15.99
- Moore, Rudy Ray-Ain't No White Xmas-(US CD XXX Rated #1 Album) 12.99
- Nashville Rock'n'Roll-(Euro CD 35 Cuts 50s Vintage R&B/Rarities) 19.99
- Nashville Rockability-(Euro CD 35 Cuts 50s Rarities) 19.99
- Nelson, Rick-Album 7+Up To You-(Finally Released!) UK CD 2 On 1 19.99
- Nelson, Rick-More Songs By Ricky-Rick Is 21-(UK CD Remast.) 16.99
- Nelson, Rick-Ricky Nelson-Bonus Trax-(Mag. CD Digipack) 17.99
- Otis, Johnny & Friends-Watts Funky-(UK CD w/2 Unre. Cuts) 15.99
- Penny, Hank-Hillbilly Be Bop-(UK CD 28 King Cuts 44/50 w/Unre.) 15.99
- R&B Anthology-Go'n' Down: Cobra & ABC/56/8-(UK CD 31 Rarities) 15.99
- R&B Dubs, Dynamite #1,2-(Euro CD 26 Cuts Each) Each 19.99
- R&B Instruments, Great-(Ace UK CD 25 Classic & Rare Cuts) 15.99
- Radio Gold #1 to 4-New-(Ace CD 30 Vintage US Trax) Each 15.99
- Rockability & Hillbilly Ram Rcds-Sharepshot High Steppers (UK 27 Cuts) 15.99
- Rockability Cuts, Them-(Ace UK CD 26 US 50s Rarities) 15.99
- Rockability Rarities #104-New-(UK CDs 30+ Mega Rarities) Each 14.99
- Roe, Tommy-Tommy's 22 Big Ones-(UK CD 22 Hits & Rarities) 13.99
- Soul Treasures, Deep-D.Godin #1,2,3-New-(UK CDs 25 Rare Cuts @) 15.99
- Soul, Northern Classics Rarities-(UK CD 24 Rare/Unre. Cuts) 15.99
- Soul, Birth Of #1,2,3-New-(UK Kent CDs 28 Trax US Soul Roots) Each 15.99
- Soul, Northern Soul Classics Rarities-(UK CD 24 Hot/Unre. Cuts) 15.99
- Southside Johnny-Party At Stone Park-(Ltd. CD S'board 76/WStars) 23.99
- Sparkletons-Complete Recordings 57/9-(Euro CD 23 Cuts) 18.99
- Sparks Records Story-(Ace CD 30 R&B Cuts 54/5) 15.99
- Stompin' #1109-(Classic Series Now On CDs Wild R&B Pounders) Each 18.99
- Teagan Dreams #1 to 12-New-(33 Trax Euro CD 50s Pop) Each 18.99
- Van, Bobby-Do What You Gotta Do-Just Today-(UK CD 2 On 1) 16.99
- Van, Bobby-Look At Me Girl-Come Back When...-(UK CD 2 On 1) 16.99
- Volk Brothers-Rock With-(US CD CD Savage N.W. R&R+Instros 59/64) 12.99
- Whitman, Slim-Yodeling-Country Songs City Hits-(UK CD 64+65 Albums) 16.99
- Wild & Frantic-(Euro CD 26 Black Rock Dubs w/Heavy Beat) 18.99

CDs • 60s & 70s

- Action-Rolled Gold-(Ltd. CD All Unre. Cuts Pre 68 Great UK Mod Psych!) 19.99
- Aerosmith-Just Sordid...-(Ltd. CD S'board Columbus Ohio 78) 27.99
- Allman Bros.-Last Serenade-(Ltd. CD Fillmore E. 6/27/71. Dfm. Date/Gig) 21.99
- Allman Brothers-Brothers In Arms-(Ltd. CD 2CD S'board Fillmore E. 7/1) 54.99
- Allman Brothers-Hour Glass-(In-Son UK CD Double Album/Early Cuts) 16.99
- Allman Brothers-Live '90-(Ltd. CD S'board 3CD Birmingham AL) 74.99
- Allman Brothers-Pittsburg 71-(Ltd. CD Soundboard!) 21.99
- American Blues Is Here-(Euro CD Great 68 TX Psych Blues Pre ZZ Top) 17.99
- Anderson, Eric-Country Changes & Things #1-2-(Euro Vanguard Albums) 17.99
- Anderson, Eric-Bouting Dream/More Hits Tin Can-(Euro CDs 68) Each 17.99
- Animals-Blues Years-(Ltd. CD US Animalism LP Version-Rare BBC) 19.99
- Animals-EP Collection-(UK CD 20 Great Cuts M. Most Produced) 17.99
- Asian Takeaways-(Euro CD 20 Cuts 60s Asian Psych Comp.) 19.99
- Atles-Beat Of Heart-(US CD Blend Of Reggae Ska Blues & Pop!) 11.99
- Atomic Rooster-1st 10 Explosive Years #1,2-(UK R&B+Unre.+Live) Each 17.99
- Atomic Rooster-Resurrection-(3CD Box 1st 3 LPs+Demos) 49.99
- Aubrey Small #1-(UK CD Excl. 71 UK Prog Folk Album+7" Cut) 21.99
- Aussie 60's Punk-It's A Kave In!(Ltd. CD 29 Wild Oz Rarities) 19.99
- Aussie 60's Devil's Children #1,2-(Ltd. CDs 28 Killer Tracks) Each 19.99
- Aussie Psych-A Forest Of-(Ltd. CD 28 Super Rarities) 19.99
- Aussie Psych-Datura Dreamtime-(Ltd. CD 25 Oz 60s Rarities) 19.99
- Autograph #1-(UK CD Excl. 68 NY Psych w/Zappa Involvement) 16.99
- Ayers, Kevin-Still Life With Guitar-(UK Super Album w/Oldfield & Co.) 16.99
- Ayers, Kevin-Turn Lights Down-(UK CD Live London '95) 16.99
- Bad Company-1st Gig Charleston-(Ltd. CD 1st Gig Ever 74 Great Sound) 21.99
- Bad Vibrations-(Euro CD 16 Mid 60s US Garage Psych Rarities) 17.99
- Badfinger-Better Days-(Ltd. CD Super Studio Outlets) 34.99
- Badfinger-Complete Ass-(Ltd. CD Ass Album+Demos+Outlets! Super!) 34.99
- Badfinger-Hammering It Up-(Ltd. CD Stereo Outlets+Live) 21.99
- Badfinger-Heavy Jelly-Like Laughs-(Ltd. CD Promo Only LP+1st Single+) 21.99
- Badfinger-Natural Gas-Been Waiting-(Ltd. CD 2x76 Soundboards) 19.99
- Banachee-Banachee-Thinkin'-(Ltd. CD 69+71 Lps Boston Psych) 19.99
- Band, The-Lost Moving Shadows-(Ltd. CD Rarities '86 Gig w/Manual) 39.99
- Band, The-L.Helm/Helm/American Son-(UK CDs) Each 15.99
- Bang-Bang-Your Bow To King-(Ltd. CDs 72 US Hard Rock) Each 19.99
- Barrett, Syd-Out Of Sight Out Of Mind-(2CD Super Studio Outlets BBC) 39.99
- Basho, Robbie-Zarthus-(Euro CD 72 Vanguard S.Bull/L.F. Type) 17.99
- Beach Boys-Rarities #1 to 8-(Dumb Angel/S.O.T./Label New Series) Each 21.99
- Beach Boys-Smile-(Ltd. CD Deep Six Version w/Original Booklet) 21.99
- Beach Boys-Today & Summer Days-(Sea Of Tunes CD Stereo+Bonus) 29.99
- Beach Boys-Unsurpassed Masters 18-(Original Sea Of Tunes CD) 29.99
- Beach Boys-Unsurpassed Masters 19/20-(Orig. Sea Of Tunes CD Sets) Each 55.00
- Beach Boys-Brian-Carr In Ocean-(2CD S'board Jones Beach 21+Bonus) 39.99
- Beach Boys-Brian-Hollywood Bow 00-(Ltd. CD 2CD Gold Pet/Bow) 54.99
- Beach Boys-Brian-Pre Show Hitters-(Ltd. Board Broadcast+Broadcast) 19.99
- Beacon 31-Union Eyes-Of-Clown Died+Come Under...+2 Cuts (3CD Box) 49.99
- Beattles-Broadcasts 3-Saturday Club-(Silent Sea 3CD 100 BBC Cuts) 89.99
- Beattles-Beat By Day #115-(Ltd. Real Yellow Dog 2CD Sets) Each 39.99
- Beattles-Every Little Thing #1,2,3-(Ltd. CDs Best Sound Rarities) Each 39.99
- Beattles-Home Tapes #1-(Silent Sea 2CD 58/62 Demos & More) 59.99
- Beattles-Home Tapes #2 #106-(Silent Sea CDs Demos 63/9) Each Vol. 21.99
- Beattles-Rock N Roll Music-(Ltd. CD Collection 1st Time On CD) 21.99
- Beattles-Sgt. Pepper's Mono Version-(Ltd. CD Monomania For Maniacs!) 19.99
- Beattles-White Sessions-(Ltd. Silent Sea 4CD 98 Demos Outlets & All!) 120.00
- Beattles-George-Making All Things #2-(Ltd. CD Video, Repro.) 39.99
- Beattles-George-Toronto 74/Nassau 74-(Ltd. CD 3CD Sets Super!) Each: 69.99
- Beattles-George-Wonderwall Mono-(Ltd. CD Fantastic Sound!) 21.99
- Beattles-George-Splitter Place 1 Love+1-(Ltd. CD) 19.99
- Beattles-John-Hushed Belts Over-(Ltd. CD Outlets Plastic One LP Band) 19.99
- Beattles-John-This Is Truth-(Ltd. CD Surround Sound Imagine/1st LP) 21.99

SHIPPING & INSURANCE: USA \$5 per order for 1-6 items; \$6 for 7-12 items. N.Y. residents add sales tax. OVERSEAS (1 item=1 CD, LPs=3 items) Canada \$5.00 for 1st item, then \$5.00 each. Europe & South America \$5.00 for 1st item, then \$1.50 each Asia & Pacific Rim \$6.00 for 1st item, then \$2.00 each. Surface rates available. First time overseas charge customers: provide a copy of your card & a recent credit card statement. Availability is limited. Specify back order, credit or refund for out-of-stock titles. Checks hold 3 weeks for clearance. Refer to our catalog for full information. Prices subject to change without notice. We often list several titles on one line followed by "each" before the price. Overized books like Tapestry and Fuzz, Acid... require extra shipping.

22nd anniversary

BEST SELECTION! BEST PRICES!

- Dion 'N' Little Kings-Live NYC '96-(UK Ace CD Legendary Concert!) 15.99
- Flour de Lys-Reflections-5 Cuts-(Ltd. CD Singles Great 60's UK Psych) 19.99
- Hillman, Chris-Tribute Concerts By The Coal Porters-(UK CD Super!) 16.99
- Love/Arthur Lee-Electrically Speaking-(UK CD 15 Cuts Live '90/2) 14.99
- Nelson, Rick-Album 7+Up To You-(Finally Released!) UK CD 2 On 1 16.99
- Orange Bicycle-Hyacinth Threads-(UK CD 67/9 UK Psych+15 Unre.) 18.99
- Punk-U Punk New Wave-Up Yours!(Big UK Book 552pp+Pix 76/82) 54.99
- V.I.P.'s-I Wanna Be Free-(Ltd. CD Complete A's&B's Pre Spooky Tooth!) 19.99

- Hillman, Chris-Tribute Concerts By The Coal Porters-(UK CD Super!) 16.99
- Hollies-Around The World Live/65/7-(Ltd. CD Awesome Soundboard!) 23.99
- Hollies-M. Rickors Years-(Ltd. CD German Old 72 LP+Blues+Unre.) 19.99
- Hollies-Rarities #1-(Ltd. CD Awesome/64/70 Demos Outlets Mega Rare) 19.99
- Hollies-What Goes Around/Rarities-(Ltd. CD 83 Rarities w/G.Nash+) 21.99
- Hot Tuna-Trial By Fire-(Ltd. CD Awesome '72 Carnegie Soundboard) 21.99
- Idle Race-BBC & Beyond-(Ltd. CD BBC+Unre. Studio+Nightriders Demos) 17.99
- Idle Wind-Flashes+2 Cuts-(Euro CD 68 Legend. Boston Psych) 21.99
- Incredible S. Band-Famous Jug Band-0 For Summer-(UK New Album) 16.99
- Incredible Sound Show #1-(UK CD Awesome UK Psych Rarities+5 Cuts) 19.99
- Incredible String Band-Mother's Day-(Ltd. CD S'board 69 Fillmore E.) 23.99
- International Harvester-Rose Marie-(Legend. 68 Swede Heavy Psych) 21.99
- Jan & Dean-More Songs For Rainy Day-(OOP Vintage Unre. Sessions) 25.99
- Jefferson Airplane-Grace-Manhole-(UK CD 1st Time On CD) 16.99
- Jellybread-(Euro CD Unre. 69 Demo Brit. Blues Savvy Brown/TYA Type) 17.99
- Joint Effort-2 Sided-2 Cuts-(Euro CD Mega Rare 71 US Psych) 21.99

OUT NOW! CATALOGUE #43

51. cash or stamps • free with order • we still carry titles listed in previous cat!
- Justification-(Ltd. CD 20 Super 60's UK Psych Trappers) 19.99
 - Kalakeke-Crawling To Lhasa+2-(Euro CD German Psych Freak) 21.99
 - Kaleidoscope-Infirnic Colours-(UK CD 20 Cuts w/4 Rare Single Sides) 16.99
 - Kenny & Kasuals-Things-Nothing-(Ltd. CD 29 Cuts 60s TX Legend!) 39.99
 - King Crimson-Chaos In Streets-(Ltd. CD Live 3/24/73 Great Sound!) 39.99
 - Kinks-BBC Sessions 64/77-(UK CD 35 Kuts! Super!) 21.99
 - Kinks-EP Box Set Vol. 2-(Ltd. UK 20s w/Worldwide Rarities!) 54.99
 - Kinks-Good Luck Charm-(Ltd. CD 60's BBC+Studio Outlets) 19.99
 - Kinks-New Great Lost-(Ltd. CD New Version w/Extra Cuts!) 19.99
 - Kinks-On Road Again-(Ltd. CD Live Tokyo Phobia Tour) 19.99
 - Kinks-Ray-What's The Frequency-(Ltd. CD Live Storyteller Tour+Bonus) 21.99
 - Kiss-Ave I S.F.-(Ltd. CD S'board August 77) 27.99
 - Klubs-Midnight Love-(UK CD w/Bonus UK Super 60's UK Psych) 21.99
 - Knight, Terry & Pack-T.K. & Pack-Reflections-(Ltd. CD Great 60's Rock!) 19.99
 - Kweskin Jug Band-Unblushing Brassness-(Euro '63 Vanguard Album) 17.99
 - Lava-Tears Are Goin'-(Euro CD Kraut Prog Rock Blues) 16.99
 - Led Zeppelin-Ottawa Sunshine-(Ltd. CD Canada 70+Maida Vale 69) 21.99
 - Led Zeppelin-Pb+(Ltd. CD Gold Disc Fillmore W69+Vancouver 70) 21.99
 - Led Zeppelin-Song Of Detroit-(Ltd. CD Killer S'board Michigan 73) 39.99
 - Lindisfarne-R.Clements-Stamping Ground-(UK Solo w/All Stars Crew!) 19.99
 - Lions-Many Sides LP+14 Cuts-(Ltd. CD Super 66 Danish R&B!) 19.99
 - Liverpool Five-Arrive-our/O/Sight+3-(Ltd. CD Great 66/7 Folk Punk!) 19.99
 - Liverpool Scene-Amarizing Adventures-Bread On Night-(123 UK 2CD) 18.99
 - Lollipop-Complete 63/7-(Ltd. CD 63/37 Swede Beat Psych Hollies Type) 39.99
 - Los Ovnis-Hippies-(CD Legend. 88 Mexican Psych Fuzz w/Bonus Cuts) 39.99
 - Love-Beat Beauty LP+Rarities-(Ltd. CD 22 Cuts w/Pre Live! Essential!) 19.99
 - Love-Lost Walk-(Ltd. CD Amazing S'board 66 Sunset Sessions+More!) 19.99
 - Love/Arthur Lee-Electrically Speaking-(UK CD 15 Cuts Live '90/2) 14.99
 - Lucifer-(Euro CD 70 Rochester NY Rarities Grand Funk Type) 17.99
 - Made In England #1,2-(Ltd. CDs Rare) 19.99
 - Great Zombies, Juniors, Ingoes, Etc) Each 19.99
 - Madness Invasion-Vol. 1-(Ltd. CD 24 Crazed Out Cuts From 50s/60s) 19.99
 - Magie Cube-(Ltd. CD Legend. Psych Comp.+17 Bonus Cuts) 19.99
 - Magie Spectacles-(Ltd. CD 28 Super Uncomp UK Freakbeat/Psych) 19.99
 - Magma-Bobino #1-(Ltd. CD Soundboard!) 24.99
 - Man-Man-2 Cuts-(Euro Repertoire CD w/2 Rarities) 16.99
 - Marie Celeste & Then Perhaps-(UK CD Remast. 71 Enchanting Folk Rarity) 21.99
 - Marmalade-Reflections Of-(UK CD 2 Ford Singles-CBS Singles) 19.99
 - Mascots-Your Mascot-Elope-(Ltd. CD Super Swede Pop Psych 65/6) 19.99
 - MC5-Sonic's Rdy. Band City Slang-(Unre. CD Remast.) 15.99
 - Meek, Joe-Crawdadly Simone-(UK CD Freakbeat Groups/Syndicates, Etc) 19.99
 - Mindbenders-Eric Bob Rick Wayne-(Ltd. CD 2nd LP+20 Cuts) 19.99
 - Moby Dick-(Euro CD Mega Rare 73 Italian Hand Zep/Sabbath Type) 17.99
 - Mod City-(UK CD 62/85 UK Mods w/8 Unre.) 16.99
 - Mod R&B Beat #47-(In Crowd-(UK RPM CD 26 UK Bands-Rare) 17.99
 - Mojo Blues-(UK CD Box Set Essential 60's UK 'Nuggets' Collection) 74.99
 - Moody Blues-Higher & Higher-(Ltd. CD 2CD Unre. Live Osaka 74) 39.99
 - Moore, Gary-Grinding Stone-(Ltd. CD Album-Skid Row BBC+Rare 70) 23.99
 - Motons-Introduction-Their Own Way+5-(Euro CD 65/6 Dutch Beat Psych) 19.99
 - Mott The Hoople 2 Miles From Heaven+(UK CD 2CD Unre. USA 71/4) 21.99
 - Mott The Hoople-Wild Side Of Life-(Ltd. CD 70 Fillmore W.+Bonus) 27.99
 - Mott:Doc Thomas Group-(Euro CD 67 Ralphs & Tippins Super!) 17.99
 - Mott:Jan Hunter-Cavern Stomp-(Ltd. CD Live Liverpool June 01) 39.99
 - Mountain-Lost Mountains Of Man-(Ltd. CD Vagrants Rehearsals+Live) 21.99
 - Move-J. Lynne-Westmountain & More-(Ltd. CD Portsmouth 73/VH2 B'cast) 21.99
 - Moving Sidewalks-Flash-5 Cuts-(Euro CD Remast. Legend. Psych) 18.99
 - Mystic Sliva-(Euro CD 72 US Psych Masterpiece In 3 Fold Digipack) 23.99
 - Nash, Graham-Arnie & Sky-(Euro CD 80 Album Remast.+Digipak) 17.99
 - Nederbeet #39-(Euro CD Box 125 Cuts 63/9 Dutch Beat Psych) 59.99
 - Newman, Randy-Political Science-(Ltd. CD Board BBC Sessions 74+Holland 82) 23.99
 - Nightcrawlers-Lite Black Eggs-Rarities-(UK Super 66 US Folk Rock!) 16.99
 - Nirvana UK-Me & My Friends/Songs Of Love-(UK CD 73 Solo+72 LP+1 Unre) 16.99
 - Norwegian #1104-(Ltd. CDs Great Mid 60's R&B Psych) Each 19.99
 - Olsen, Carla-Midnight Mission-(UK CD w/G. Clark Cooper Goldberg Etc) 16.99
 - Olson, Carl-Ring Truth-(UK CD +Mike Taylor J. Sebastian B. Goldberg) 16.99
 - Orange Bicycle-Hyacinth Threads-(UK CD 67/9 UK Psych+15 Unre.) 18.99
 - Orpheus-All 4 Albums+Bonus Cuts-(Akama 2CD 60s Boston Live Psych) 27.99
 - Otway, John-Too Much Air-(Ltd. CD Live 77+8 Sides-Rare) 19.99
 - Outiders-CO-5 Bonus Cuts-(Euro CD Dutch Psych Masterpiece!) 19.99
 - Painted Faces-Anxious Hour-(US 28 Cuts 66/8 UK Legend w/11 Unre.) 17.99
 - Parsons, Gary & Fallen Angels-Legendary Live Boston 73-(Ltd. CD) 16.99
 - Patto:O.Halsall-Caves-(UK CD All Prev. Unre. Songs) 16.99
 - Patto:TimeBox-Deram Anthology-(UK CD Complete 68 Album+Single) 17.99
 - Peppermint Trolley-(Ltd. CD Super 68 West Coast Live Psych) 19.99
 - Perfumed Garden-Vol. 1,2,3-(Ltd. CD Super 60's Psych Rarities) Each 19.99
 - Pier's Plastic Dream-(UK CD Comp. 60's UK Pop Psych Rarities) 16.99
 - Pink Floyd-British Winter Tour-(Ltd. CD Liverpool Empire Theatre 74) 27.99

CDs • ROCK '77 - '99

- Amos, Tori-Little Rarities #1,2-(Ltd. CD S'board) Each 23.99
- Atles-Beat Of Heart-(US Amazing Blend Of Reggae Ska Blues & Pop!) 11.99
- Bangles-Pat's Favourites-(Ltd. CD Soundboard Pittsburgh 86) 23.99
- Big Star-What's Goin' On/An Oop Jap Gold Disc 2+20pp Booklet) 50.00
- Big Star-What's Goin' On/An-(Booklet Super Unre. Studio Outlets 72/3) 23.99
- Chap Trick-Fuse-(US CD 69 Pre Cheap Truck+2 Earlier Cuts) 15.99
- Cash-Money Made Us Flexible-(Ltd. CD Board NY 78+Chicago 79) 21.99
- Cash-Tokyo's Burning-(Ltd. CD '82 Japan Tour) 21.99
- Cash-US Festival 83-(Ltd. CD Soundboard!) 21.99
- Cash-US Festival 83-(Ltd. CD Soundboard!) 21.99
- Coal Porters-Chris Hillman Tribute-(UK CD Ex Long Ryders!) 19.99
- Come One-hip Check-(US CD Great New Lusty Mod Garage R&B!) 12.99
- Crenshaw, Marshall-B Sides & Unreleased-(Ltd. CD 23 Cuts) 19.99
- Crippers-1 More 4 Bad Guys-(US CD Dead Boys/DMZ J. Thunders Axis!) 12.99
- Cure-Dr. Robert/M. Smith-(Ltd. CD London 77 S'board+Studio Outlets 77) 23.99
- Dictators-Dictators-(US CD 1st New Album In 20 Years! Fast Loud!) 12.99
- Dis-Dils Dis Dils-(US CD Essential 77 Punk! Studio+Unre+Live) 12.99
- Dr. Feelgood-Down At Dr. Beeb-(Ltd. CD Super Live BBC 73/8) 21.99
- Ducks Deluxe-Ducks Deluxe-Taxi To Terminal-(UK CD w/Missing Trax) 16.99
- Gov't Mule-Live Roseland NYC New Year Eve 95/6-(UK CD) 16.99
- Jam: B. Foxton-Touch Sensitive-New Bonus Cuts-(UK CD) 16.99
- Los Straightjackets-Sing Along w/-(UK M. Lindsay, El. Vez, Big Sandy...) 16.99
- Low, Nick-Radio Daze-(Ltd. CD BBC In Concert 84+Bonus Cuts) 21.99
- Lyras(pre):DMZ Live At Rat 76/93-(US CD Boston's Garage Kings) 12.99
- Material Issue-Gone But Not Forgotten+2 (Ltd. CD B Sides & Outlets) 19.99
- Material Issue Live At Gaspar's-(Ltd. CD Chicago 86) 19.99
- Modern Lovers-Songs Of-(Ltd. Board 1st Demo+70's Sessions+Live 72) 23.99
- Nomads-Up Tight-(US CD New Album+2 Cuts! Sweden's R&R Legends) 12.99
- Pilmsouls-Zero Hour-Nerves LP+Lee Solo-That's Totally Pop!-(Ltd. CD) 19.99
- Ptolemic T.#30-(UK Zine-CD Unre. Q.M.S. Soft Boys & Much More!) 9.99
- Replacements-Get Out/My Way-(Ltd. CD 84 Outlets+CBGB+Solo 82) 23.99
- Rockpile-Loud Music-(Ltd. CD Bottom Line 80+Bonus 79) 21.99
- Séquoies-Les Et Tant Ps-(CD Amazing Québec 60's Fuzz Psych Type!) 13.99
- Smiths-Sigh Here-(Ltd. CD Excl.! Rough Trade Demos 82+Bonus Cuts) 23.99
- Strokes-Melting Pot-(Ltd. CD Live Reading 01 New Stoooges/MC5 Type) 19.99
- Sympathetic Magician #2-(US CD 45 Cuts) 16.99
- Teenage Fanclub-Leston #2-(US CD Soundboard!) 21.99
- Television-Evolve-(Ltd. CD Complete Only US Performances 5/1001) 21.99
- Television-Poor Circulation-(Ltd. CD Studio 74+Max's+CBGB 74/5) 23.99
- Television-Singles & Rarities #1,2,0-(Ltd. CDs Super!) Each 19.99
- Thunders, Johnny-Such Crime-(Ltd. Board NYC 82+Canada 79+Demos) 23.99
- Waits, Tom-Dime Store Novels Vol. 1-(Very Ltd. UK CD Live Ebbs 74) 19.99

VINYL, BOOKS & MAGAZINES

- Allens Psychos & Wild Things-(US LP Only Virginia 80's Garage) 9.99
- Badfinger-Without You Book-(In Stock! Revised+Updated+CD Demos) 29.95
- Barrett, Syd-Crazy Diamonds-(UK Book New Format! Rare Pix!) 12.99
- Barrett, Syd-Random Precision-(UK Book 300pp w/Pix Recording Story) 25.99
- Byrds-Phrylie Sessions-(US 2LP 180gm.+Book) 17.99
- Dury, Ian-England's Glory Life Of-(Super UK Book 300pp.+Pix) 19.95
- Flower Pot Men-Midsummer Dreaming-(1000 Only 190gm LP Demos, Rare) 22.99
- Fuzz, Acid & Flowers-USA 64/75-(4th Ed. UK Book 548pp+Pix+Mus!) 49.99
- Instr.: Pipeline #1 to 53-New-(UK Zine 60s/90s Scene Complete) Each: 4.99
- Knaves-Live Me Alone-(US 10" Amazing 60's Chicago Garage w/2 Unre!) 8.99
- Love/Lee-Castle #1 to 20-New-(UK Zine w/Reviews, Pix, Etc) Each 11.99
- Progressive Rock Guide-Scented Gardens-(UK Book 552pp+Pix 68/80) 45.00
- Punk: UK Punk New Wave-Up Yours!(Big UK Book 552pp+Pix 76/82) 54.99
- Standells-Live Ones-(US 10" Unre. Live 66 Amazing! Incredible Fidelity!) 8.99
- Tapestry/ODelights-(3rd Ed. 728pp. 63/76 UK Beat/R&B/Psych/Prog) 59.99
- Who-In Sweden-(OOP Ltd. Big Euro Book+CD Tribute+450 Rare Pix!) 49.99
- Yardbirds/Beck's Jug Book-(Massive Euro Book 256pp.+pix 65/80) 29.99
- Zakary Thaks-Form Habt-(US LP Frenzied TX Garage Psych w/Unre) 19.99

WHEN IN NEW YORK VISIT OUR STORE: 263 West 23rd St. (between 7th & 8th Ave.) NYC Special Prices in this ad may not be valid in store.

Please Mr. Postman

The Guess Who's debt to The Yardbirds

As a longtime Guess Who fan, I was pleased to see your coverage of the band in *Goldmine* #557 (Nov. 30, 2001). I watched their recent televised concert and saw them in person this past summer.

Unfortunately, it was pitiful to read that Burton Cummings' yardstick for gauging The Guess Who's Rock And Roll Hall Of Fame credentials is positioned to assess their hit-making history to that of The Yardbirds. "We had at least as many hit records as they did," he is quoted as saying. I am embarrassed for him!

How could it be possible for a musician (famed or not) of his era not to recognize The Yardbirds for their influence? I doubt there are many of us who think The Yardbirds are in there for the number of Top 10 or Top 40 singles they placed. Cummings must be thoroughly aghast at the election to the Hall of Velvet Underground or Frank Zappa & The Mothers Of Invention and would likely argue for the admission of The 1910 Fruit Gum Company or their ilk instead.

Randy Bachman should sit Cummings down and explain to him exactly where he learned to play the guitar with the sustains, fuzztones and feedback control he uses in short-song formats such as "No Time." Then play to Cummings a couple of tunes such as "Evil-Hearted You" or "You're A Better Man Than I" (from *Having A Rave-Up*). Maybe then Cummings could see the invaluable contribution made by The Yardbirds in terms other than "popularity" or "money."

Please tell Cummings for me that the Hall Of Fame's membership consists largely of individuals who were forward-looking when they made their contribution; he should stop looking backward.

— Mike Ofiesh
Albany NY

Any info on The Guess Who's Buddha reissues?

Many thanks for The Guess Who interviews. One question I would have liked to have seen asked and answered is when Buddha will resume with The Guess Who's remastered catalog. After only four well-done discs, it has now been a full year since anything has made its way out. Although two more (*Road Food* and *Wheatfield Soul*) were alleged to be coming earlier in 2001, this was never announced on Buddha's Web page, but in *Discoveries* and *Goldmine*. Buddha never answers any e-mail I send them, although they claim to "welcome" my e-mail response.

— Eric Swedberg
Crossroads Music
Portland OR

Submitting letters to *Goldmine*...

Letters to *Please Mr Postman* are encouraged but cannot be responded to individually. Please keep your letter brief; it has a greater chance of being published. Send your letter to:

Please Mr. Postman/*Goldmine*
700 E. State Street
Iola, WI 54990
FAX: 715-445-4087

e-mail: mr.postman@krause.com
Be sure to check out *Goldmine's* question of the month at www.collect.com/records in the discussion forum.

LETTER FROM THE EDITOR

Looking ahead to better times in 2002

Terrorism on U.S. shores and a slumping economy have been the main impacts on our lives in 2001. Record collecting cannot escape these twin disasters either, as people's skittishness to travel has curtailed attendance at record shows, and economic realities have hurt both the mainstream music industry and the secondary market.

But things will definitely get better. They always have, and there is no reason not to believe America, the world and the hobby will rebound from these situations.

On the one hand, people naturally turn to music in tough times to get themselves out of a funk. This happened during both World Wars and the 1930s' Great Depression, from which jazz blossomed. Blues was born out of the angst felt by enslaved American blacks. I am certainly not suggesting that we have these events just to encourage music, but when bad things happen, music gets a rebirth.

Just about every major artist in every genre has released albums or singles or

been involved in a benefit concert pertaining to the Sept. 11, 2001, attacks. This is similar to the wave of patriotic songs written during the Civil War and World Wars. Instead of retreating, which happens with other businesses during dire times, the music industry is actually revived by such disasters, as musicians feel the need to express themselves to soothe the weary world's broken lives and hearts.

Of course, no one can really predict the future, but we have to hold out hope that things will improve. When asked what he felt would happen to the stock market in the coming year, I believe it was financier J.P. Morgan who replied simply, "It will fluctuate." That's the way it also is with the hobby's ups and downs. Here's to a better 2002.

— Greg Loescher

Editor's recommendation: Jean-Luc Ponty, *Life Enigma* (JLP 001). A solid, exhilarating effort by jazz's premier violinist.

[Our Guess Who article writer Russell Hall responds: "I just spoke with Mandy Eidgah, who is a publicity representative for Buddha. She says the possibility of reissuing *Road Food* and *Wheatfield Soul* is in discussion, but nothing has been scheduled yet. They are being considered, but right now there are no definite plans. They definitely won't be on the release schedule for the next six months."]

Gotta get these music books!

In your *Grapeleaves* column of *Goldmine* #542 (May 4, 2001) you mentioned a book

titled *Film It With Music: An Encyclopedic Guide To The American Movie Musical* by Thomas Hirschak from Greenwood Publishing. I'd love to get this book for my local public library. Can you give me some ordering information on it? I'd like similar information about Marshall Crenshaw's updated edition of his book on rock movies.

Don Schmieden
Wausau WI

[Don, you should be able to order this book, which came out last February, through your

Doo-Wopp Hall Of Fame inductions correction

In the June 15, 2001, issue (#545), *Goldmine* published an editorial and a news story featuring the Doo-Wopp Hall Of Fame of America and its founder Harvey Robbins. The editorial made reference to the staging of acts featuring famous musical groups of yesteryear but containing no original members. The editorial referred to the Hall Of Fame as constituting a new low in this practice. This statement was in error, as the acts inducted into the Hall Of Fame and who performed at the ceremony did feature original members of the groups. Likewise, the statement contained in the news story that "the induction ceremony was not a true honorarium" but merely "a concert featuring replica artists who never appeared on the original hit recordings of the groups they claim to represent" was also in error. In fact, the induction was a true honorarium with each inductee being presented with an engraved plaque and an engraved watch (see picture on page 10).

The news article also quoted a Boston DJ, Little Walter, as saying, among other things,

that Robbins had promised a museum in Providence, R.I. Although *Goldmine* accurately reported what Little Walter said, *Goldmine* did not independently corroborate it, and Robbins denies ever making such a promise. As *Goldmine* reported in 1990 and in the June 15, 2001, issue as well, Robbins has consistently stated that having a physical Hall Of Fame building is not the priority of the organization.

The editorial and news article also were in error in stating that the Hall Of Fame has no induction committee. Robbins reports that he had a 60-member nominating committee for the 2001 inductions. Finally, although *Goldmine* had been informed that Robbins had been sued by a performing artist in a New York court, a review of court pleadings proves this information to be false. *Goldmine* is unaware of any suit brought by a performing artist against Robbins. Based on these corrections, fairness dictates that we disclose that it was error to refer to the 2001 Hall Of Fame concert as fraudulent or a scam.



Goldmine #557, Nov. 30, 2001

local book store (ISBN: 0313315388) or directly from Greenwood Publishing at www.greenwood.com or 1-800-225-5800 (during regular business hours, EST). You should also be able to get Crenshaw's tome, *Hollywood Rock*, through a book store (ASIN: 0062732420) or at Amazon.com. It's great you are purchasing these books for your local library. *Goldmine* readers with unwanted music books are encouraged to donate them to local libraries. Spread the wealth! — Ed.]

Poco shoulda been huge

I really loved your issue about Poco (*Goldmine* #554; Oct. 19, 2001). The members of Poco should have walls full of gold records and songwriting awards, but it was not to be. Even though the band received only limited success themselves, it is widely known that the members of the Eagles and other more successful bands know they wouldn't be where they are had Poco never existed. Excellent issue! Even though the issue was great, I must point out a mistake in the review of Roger McGuinn's *Treasures From The Folk Den*. The song "John Riley" was on the 1966 album *Fifth Dimension* and not on the '68 album *Notorious Byrds Brothers*.

Garry L. Daniel
Knoxville TN

[Garry, glad you liked the Poco story. You are correct about "John Riley." It was "Old John Robertson" that was on *Notorious Byrds Brothers*. — Ed.]

Never mind Sex Pistols — put Kiss in Hall!

I have to put my 2¢ worth in about something. I recently saw The Rock And Roll Hall And Fame induction nominees in the Oct. 19, 2001, *Goldmine* (#554). I agree with the choices — with the exception of one: the Sex Pistols. Granted, I'm a big fan of *Never Mind The Bullocks*, but let's face it — they released one stinkin' LP (not counting the umpteen live LPs and so forth).

The band that deserves a nomination, even if they're not a critical favorite, is Kiss. Kiss has been eligible since 1999 and have obviously stood the test of time and influenced seemingly countless rock 'n' roll acts. Kiss may be indirectly responsible for a lot of bad "hair" metal acts, but they deserve respect.

(Please see Please Mr. Postman page 77)

#228

OFFICIAL HOME OF CLASSIC ROCK NEW RELEASES

BUCCANEER SINCE 1983

MASTER CARD AND VISA CUSTOMER TELEPHONE ORDER LINE

410-569-5697

HOURS MONDAY TO FRIDAY 1:00 TO 9:00 ET (10:00-6:00 PT)

LATEST ARRIVALS IMPORTS, INDEPENDENTS AND HARD TO FIND

BILLION DOLLAR BABIES "Complete Battle Axe" (3 CD) ex-Alice Cooper members Michael Bruce, Dennis Dunaway, Neal Smith 1977 Polygram album CD debut, disc 2 demos and unreleased, bonus disc 3 first 5000 is a 1977 live show, Pilot Records UK (arrived November 14th).... \$23.98
BLUE OYSTER CULT "Tales of the Psychic Wars" (2 CD) two radio shows New York 1981 "Fire of Unknown Origin" tour + 1983 "Revolution by Night" tour, Pilot UK (arrived Sept 21st)..... \$21.98
BONNET, GRAHAM "The Day I Went Mad" vocalist 1999 solo album previously Japan only features Vivian Campbell, Slash, Bruce Kulick and Tony Franklin, German (arrived Oct 17th)..... \$17.98
DAN BAIRD & THE SOFTA KINGS "Redneck Savant" ex-Georgia Satellites vocalist/guitarist live in Switzerland on the band's 2000 tour includes Satellites songs "Keep your Hands to Yourself, Myth of Love, Dan Takes 5 and Sheila" 16 tracks, German (arrived October 24th, Call)..... \$19.98
DARE "Belief" Thin Lizzy keyboardist Darren Wharton's band new studio their 2nd in recent years, 2000 release, Australia March 9th, 13 and 14th, Hong Kong the 20th and Tokyo March 24th and 25th, Tokyo shows with an 80 piece orchestra featuring Ronnie James Dio on 5 tracks, all from board tapes (due to legal complications now out of print, few copies left, Call for stock).... \$89.98
DOC HOLLIDAY "Song for the Outlaw Live" southern rockers 1989 live album, remastered 2 bonus tracks "Whiskey Train" and "Dort Stop Lovin Me", Holland (arrived Oct. 24th, Call)..... \$19.98
DR. SIN "Shadows of Light" vocalist Mike Vescera joins prog-metal band as lead vocalist, many may remember Dr. Sin opening for Malmsteen, Metal Mayhem (arrived Oct. 26th, Call)..... \$13.98
EISLEY, DAVID GLEN "The Lost Tapes" unreel. recordings 6 tracks intended for Gluffria and 4 tracks for Dirty White Boy and 3 House of Lord demos, Frontiers Italy (arrived Aug 31st, Call).... \$14.98
EMERSON LAKE & POWELL Japan Ltd Edition of the 1986 album packaged in miniature album jacket, remastered with the 2 tracks missing on the domestic CD (arrived Nov 14th, Call).... \$25.98
EMPIRE "Hypnotica" new project of guitarist Rolf Munkes with Mark Boals and Lance King of Balance of Power vocals, Don Airey keys, Neil Murray bass, Anders Johansson drums, 12 tracks, Lion Music Sweden (arrived November 7th, Call for stock)..... \$19.98
FRANKLIN, TONY "Brave New Tomorrow" ex-Firm and Blue Murder bassist first ever solo album, Tony handles vocalist, bass and guitar with Gregg Bissonette drums, previously Japanese only 2000 release, Buccaneer exclusive artist pressing (arrived October 26th, Call)..... \$13.98
FREE "Tons of Sobs" +9 "Free" +10 "Fire and Water" +6 "Paul Rodgers band first three albums from 1968-70 remastered all reissued with bonus tracks of BBC sessions and alternate versions, Island Records UK (arrived November 7th, Call for stock)..... each \$17.98
GOLDEN EARRING "Live" (2 CD's, 1977 white cover, 10 tracks) "Second Live" (2 CD's, 1981 Live cover, 14 tracks) remastered reissues, German (arrive approx November 23rd, Call).... each \$19.98
GRAND FUNK "What's Funk" 1983 Warner album CD debut remastered, includes bonus 16 page booklet, 10 tracks, Lissmark USA (arrived Oct. 25th, Buccaneer exclusive, Call)..... \$13.98
GRAND FUNK "Lives" 1981 Warner album CD debut remastered, includes bonus booklet "The Making of Lives", 10 tracks, Lissmark USA (arrived July 2nd, Buccaneer exclusive, Call) \$13.98
HACKETT, STEVE "Live Archive" (4 CD's) former Genesis guitarist all unreleased live, disc 1 and 2 24 tracks Hammersmith London 1979, disc 3 Rome 14 tracks 1981, disc 4 Grand Theatre London 14 tracks 1993, 40 page booklet, UK (arrives approx November 23rd, Call stock).... \$39.98
HELIX "Live in Buffalo" Canadian rockers captured in 1983 and released through their website for \$25, soundboard 13 tracks, Dirty Dog Records Canada (arrives approx Nov 21st, Call).... \$14.98
HENDRIX, JIMI "Albert Hall Experience" (2 CD's) the most complete legitimate collection of music from the long lost film of the February 1969 concert, six of the tracks have just recently been unearthed for official release, this reissue corrects the poor sound and duplication of bootlegs, packaged in a slip case cover with 12 page booklet, UK (arrived October 25th, Call)..... \$19.98

HENSLEY LAWTON BAND "The Return" Ken and John and band live in concert at the UK Uriah Heep convention May 6, 2000 includes "July Morning, Stealin', Easy Livin', Gypsy, Free 'n' Easy and The Wizard, 15 tracks 79 minutes, Eagle Records UK (arrived June 6th)..... \$19.98
HUGHES, GLENN "A Soulful Christmas" if you missed it last year Glenn has just repressed a 1000 copies of his successful holiday album, 12 tracks includes a stunning version of "Ave Maria", this is a Buccaneer exclusive, Pink Cloud Records USA (arrived October 12th, In stock)..... \$17.98
HUGHES, GLENN "Building the Machine" voice of rock returns with a new studio album, reviews say "a stronger performance than his previous album" SPV USA (arrived Sept 25th, Call)..... \$14.98
HUGHES, GLENN "Building the Machine" +1 bonus track, Japan (arrived Sept 20th, Call).... \$27.98
HURRICANE "Liquidity" vocalist Kelly Hanson and drummer Jay Schellen are back, reviews say "excellent melodic rock" Frontiers Italy (arrived Sept 20th, label repressing, Call for stock).... \$14.98
JORN "Worldchanger" vocalist Jorn Lande known for his work with bands The Snakes, Millennium and ARK and the Malmsteen tour of 2000 follows last years solo "Starfire" with a new album reviews say "simply great, harder edge", Frontiers Records Italy (arrived Oct. 25th, Call).... \$14.98
JUDAS PRIEST "Demolition" +2, Ltd Edition studio bonus tracks "Green Manalishi and Rapid Fire" also Priest guitar pick and sticker in black digi-pak, 15 tracks, German (arrived July 20th).... \$17.98
KING KOBRA "Hollywood Thrash" original members Carmine Appice, Johnny Rod, Mick Sweda with vocalist Kelly Keeling new studio album, guest guitar C.C. Deville, includes 2 bonus tracks with original vocalist Mark Free, 13 tracks, MTM Germany (arrived October 25th, Call).... \$16.98
KING'S X "Manic Moonlight" Missouri rockers ninth album, label states "full U.S. tour coming soon" 10 tracks, Metal Blade USA (arrived September 25th, Call for stock)..... \$13.98
LOUDNESS "Pandemonium" original lineup new studio album Ltd Edition version first shipment for the 20th Anniversary, Japan (arrives approx November 29th, Call for stock)..... \$29.98
LOUDNESS "The Soldiers Just Came Back" on their 20th anniversary the original lineup recorded live in concert March 28, 2001, 14 tracks, Japan (arrived Sept 14th, Call for stock)..... \$29.98
MAGAGNI, MAX "Twister" Italian guitarist new album vocals Glenn Hughes (1) Robin McAuley (2) and Paul Shortino (2) Ian Paice drums (1) track, Italy (arrives approx Nov 21st, Call)..... \$17.98
MASI, ALEX "Eternal Struggle" Italian guitarist new album with vocalist Kyle Michaels, Euro guitar magazines say "this best album, better than Malmsteen", German (arrived Oct 10th, Call).... \$19.98
MELODICA "Lovemela" former Danger Danger vocalist Ted Poley's band's new release now with drummer Jonathan Mover and Paul Morris keyboards, "reviews say his best vocal work since Danger Danger, mix of ballads & rockers" Frontiers Italy (arrived August 31st, Call)..... \$14.98
MOTT THE HOOPLE "Two Miles from Live Heaven" (2 CD's) from Mick Ralphs and Overend Watts archives comes three separate performances recorded on 1971, '73 and '74 U.S. tours plus four demos from pre-Hurston "Silence" period, 26 tracks Angel Air UK (arrived Oct. 17th, Call).... \$19.98
MSG "Be Aware of Scorpions" guitarist Michael Schenker new album lineup Chris Logan vocals, Rev Jones Bass, Jeff Martin drums and vocals on the bonus track "Ride the Lightning" 14 tracks Nippon Japan (arrived October 25th, Call for Stock)..... \$27.98
MSG "Be Aware of Scorpions" same as above but no bonus track, "customer feedback sez it's great, really rocks" 13 tracks, SPV Germany (arrived October 31st, Call for stock)..... \$14.98
NAZARETH "Very Best of" Eagle Rock UK release for German television, 22 tracks includes 2 new studio recordings, remastered (arrived October 5th, Call for Stock)..... \$19.98
PERAHIA, JOSHUA "Something to Say" guitarist known as Joshua new album produced by Keith Olsen, ex-Santana Alex Ligerwood 4 vocals, 12 tracks, MK Music USA (arrived Oct 5th) \$13.98
QUEEN TRIBUTE "Stone Cold Queen" Joe Lynn Turner, Glenn Hughes, Tommy Shaw, Jack Russell, Jeff Tate, Jack Blades, Kip Winger, The Nelsons, Robin Zander, with Jake E. Lee, Doug Aldrich, Reb Beach, previous Japan only, UK (arrived Sept 25th, Call)..... \$13.98
RACER X "Snowball of Doom-Live at the Whiskey" new file, concert recorded in L.A. at the Whiskey A-Go Go May 25, 2001, 14 tracks, Japan (arrived September 14th, Call)..... \$27.98
RALPHS, MICK "It's All Good" Bad Co. guitarist second solo album includes a live version of "Hideaway" from the Bad Co. 1999 tour, 11 tracks, Angel Air UK (arrived Oct. 19th, Call).... \$17.98
SALAS, STEVIE "ShapeShifter" guitarist first new album in 3 years backed up by John Alderetti and Arion Salazar, 12 tracks, Yamaha Music Japan (arrived Nov 14th, Call for stock)..... \$27.98
SAXON "Killing Ground" UK metal band new studio album reviews say "best album since the 1980's", 11 tracks, SPV Germany (arrived September 28th in stock, Limited Edition 2 CD version is now out of print a few are in stock late November Call for their availability)..... \$14.98

SCORPIONS "Taken by Force+2 and Tokyo Tapes" EMI Germany remastered reissues of 1978 studio album w/bonus tracks "Suspender Love" and live "Polar Nights", the second is the April 1978 live show from Budokah, 17 tracks (arrived September 14th, Call for stock).....each \$16.98
SCORPIONS "Acoustica" live show Portugal Feb 2001, includes "The Zoo, Humicane, Wind of Change, Dust in the Wind, Drive, Love of my Life" 15 tracks, German (arrived May 22nd).... \$23.98
SHEEHAN, BILLY "Compression" ex-Talas, David Lee Roth and Mr. Big bassist new solo album, Billy handles all instrumentation and vocals, Favored Nations USA (arrived August 21st).... \$13.98
SILENT FORCE "Infatuator" new band features ex-Royal Hunt vocalist D.C. Cooper and ex-Sinner guitarist Alex Buyrod, Massacre Germany (arrives approx Nov 23rd, Call for stock)..... \$15.98
ST. JAMES "Americanman" ex-Black 'n Blue vocalist Jaime St. James brand new band "reviews say Aerosmith meets Black 'n Blue" 11 tracks, Metal Mayhem USA (arrived Nov 15th, Call).... \$13.98
SUPERTRAMP "Is Everybody Listening?" Pilot Records UK live series comes this 1976 concert from Cleveland A&M Records archives, 12 tracks (arrived Nov 14th, Call for stock).... \$17.98
SYMPHONY X "Live on the Edge of Forever" (2 CD) New Jersey prog-rockers recorded on 2001 tour of Germany and France, over 100 minutes, Century Media USA (arrived Nov 12th, Call).... \$15.98
TEN YEARS AFTER "Live at the Filmore East" (2 CD's) Alvin Lee and the guys perform 12 songs recorded August 1970 "reviews say incredible live stars" EMI UK (Call for stock)..... \$23.98
THOMPSON, CHRIS "Wort Lie Down" former Manfred Mann vocalist new solo with guitarist Mike Slamer, reviews say "for fans of Steeltown Lane", UK (arrived Sept 14th, Call for stock).... \$19.98
TORME, BERNIE & ELECTRIC GYPSIES "Scorched Earth Live 1999-2001" former Gillan, Desperato and Silver guitarist recorded at various gigs, 9 tracks, UK (arrived Nov 14th, Call for stock).... \$16.98
TURNER, JOE LYNN "Slam" ex-Rainbow vocalist new solo album "Joe said his hardest album yet is why he chose the title" 12 tracks, MTM Germany (arrived Sept 25th, Call for stock)..... \$16.98
TYGERS OF PAN TANG "Mystical" 80's British rockers new studio reviews say "very good straight ahead rock", 11 tracks, Z Records UK (arrived September 28th, Call for stock)..... \$15.98
URIAH HEEP (BOX) "Sailing the Sea of Light", includes the live CD "Electrically Driven" plus 88 page book of the current lineup history plus DVD documentary of the current lineup with footage of the Moscow show, sold on the band's UK website for \$49.98 (arrived Sept 12th, Call for stock) \$44.98
UDO "Live from Russian" (2 CD's) former Accept vocalist with seven solo albums recorded on his Spring 2001 tour, 25 tracks packaged in mini-hardcover book, SPV Germany (due to SPV U.S. distributor going out of business German copies on order to arrive late November, Call)..... \$17.98
VAUGHN "Fearless" ex-Tyketto vocalist new solo album, reviews say "stronger album than his debut", 9 tracks, Z Records UK (arrived September 7th, Call for stock)..... \$15.98
WAITE, JOHN "Figure in a Landscape" former Babys vocalist new studio album, 11 tracks, Gold Circle USA (arrived August 20th, Call for stock)..... \$13.98
YES "Magnification" new album "reviews say strongest and freshest material in years, different to anything before" 10 tracks, Eagle Records UK (arrived September 21st, Call for stock)..... \$19.98

SELECTED COMING ATTRACTIONS DO NOT SEND PAYMENT YOU CAN ORDER IT NOW AND WE'LL SHIP IT TO YOU WHEN IT ARRIVES, CREDIT CARD PREORDERS ONLY - RELEASE DATES MAY CHANGE

DANDY, JIM "Ready as Hell" Black Oak vocalist reissue from 1984 (UK release date TBA).... \$14.98
DANDY, JIM "The Black Attack is Back" reissue from 1986 (UK release date 11/13)..... \$14.98
EMERSON LAKE AND PALMER "The Show that Never Ends" (2 CD's) recorded around the world on the 1998 comeback tour, includes full band "Lucky Man" (UK release date TBA)..... \$16.98
GIANT "Giant III" Dan Huff reforms the late 80's band (Frontiers Italy release 11/28)..... \$14.98
GILBERT, PAUL "Raw Blues Power" guitarist new album (Japan release 12/3)..... \$27.98
KOTZEN, RICHIE "Slow" guitarist new studio album (Japan release 12/19)..... \$27.98
MALMSTEEN, YNGWIE "Concerto Suite Live" recorded Tokyo June 2001 (Japan rel 12/19).... \$31.98
RING OF FIRE "The Oracle" new band Mark Boals vocals, George Bellas guitar, Virgil Donati drums and Vitalij Kuprij keys (Frontiers Italy release 12/10)..... \$14.98
TEN "Far Beyond the World" UK melodic rockers sixth album (Frontiers Italy release 12/10).... \$14.98
THIN LIZZY (BOX) "Vagabonds, Kings, Warriors, Angels" Vertigo Records UK collection of 73 tracks (4 CD's) all remastered spanning the entire rise and fall from their first single to a Grand Slam demo, includes the rarities "The Farmer, Cruising in the Lizzymobile, Trying a Little Harder, Song for Jimi and Sisters of Mercy" packaged in a book-type box (Vertigo UK release 11/26)..... \$57.98

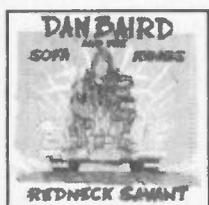

DAN BAIRD VOCALIST OF GEORGIA SATELLITES LIVE



BILLION DOLLAR BABIES LIMITED EDITION 3 CD'S



DEEP PURPLE "ON THE ROAD" FOUR LIVE CD'S 1969-93



DOC HOLLIDAY "SONG FOR THE OUTLAW" LIVE SHOW



TONY FRANKLIN EX-FIRM AND BLUE MURDER BASSIST



GRAND FUNK "WHAT'S FUNK" FIRST TIME ON CD



JIMI HENDRIX COMPLETE 1969 ALBERT HALL SHOW



GLENN HUGHES NEW 2001 STUDIO ALBUM



JORN "WORLDCHANGER" THE NEW VOICE OF ROCK



KING KOBRA WITH CARMINE APPICE RETURNS ALL NEW



MICHAEL SCHENKER NEW GERMAN COPIES JUST \$14.98



ST. JAMES NEW FROM BLACK 'N BLUE VOCALIST



JOE LYNN TURNER "SLAM" OCTOBER'S TOP SELLER



UDO THE VOICE OF ACCEPT DOUBLE LIVE 2001 TOUR



THIN LIZZY LONG AWAITED BOX SET IS COMING JUST IN TIME FOR CHRISTMAS! VERTIGO UK RELEASE DATE IS NOVEMBER 26TH PREORDER A COPY TODAY

RECENT RELEASES AND LAST CHANCE TITLES CALL FOR AVAILABILITY

AEROSMITH Just Push Play +2 (bonus "I Don't Wanna Miss a Thing & Won't Let you Down") Japan... SALE 13.98
APRIL WINE Back to the Mansion (Myles Goodwyn and original lineup 18th album) 11 tracks/2001/Canada 18.98
BABY, THE Valentine Baby (Denver concert Valentine Day 1980 includes) 12 tracks/2001/Pilot Records UK.... 17.98
BEAUVOIR, JEAN Bare to the Bones (Crown of Thorns vocalist solo acoustic album) 13 trks/2001/German 14.98
BLACK OAK ARKANSAS Street Party, Airt Life Grand and Live! Mutha/1974-75/Wounded! Bird USA..... each 10.98
BLACKMORES NIGHT Fires at Midnight (Ltd Edition box, poster, cards, bonus song +video) 2001/German.... 17.98
BUTCHER, JON A Long Way Home (sessions for a never released 4th Axis album + live acoustic "Wishes").... 14.98
DEMON Spaced out Monkey (Dave Hill & company first new album in 10 years) 11 tracks/2001/Sweden.... 17.98
DBA-DECKINGER BOGERT AND APPICE Doing Business As (F.R.I.T. Carmine) 11 tracks/2001/German.... 17.98
EMERSON LAKE & PALMER Original Bootleg Series from the Manticore Vaults Vol 1 & 2 /UK.... (CALL).... each 42.98
FASTWAY Fastway and All Fired Up (first two albums paired on one CD, remastered) 1983-84/BGO UK.... 17.98
FISH Fellini Days (ex-Marillion vocalist new 2001 melodic rock album tribute film director) 9 tracks/2001/UK.... 17.98
FOGHAT Rock and Roll + Energized/73-73/UK.... 17.98
FOGHAT RNR Outlaws + Fool for the City/74-75.... 17.98
FOGHAT Tight Shoes + Girls to Chat/80-81/UK.... 17.98
FOGHAT in Mood...Something Rude + Zig-Zag Walk 17.98
FUNNY MONEY Featuring STEVE WHITEMAN Even Better Live (ex-Knox vocalist 2001 show) 10 trks/2001/US 13.98
GEORDIE Singles Collection (definitive collection of their UK singles fronted by vocalist Brian Johnson).... 17.98
GILLAN Live Tokyo 1978 (after the jazzy IGB broke up reformed rockers first show) 12 tracks/2001/UK.... 17.98
GUESS WHO This Time Long Ago (2 CD, 28 unreleased rare tracks with Burt Cummings) Canada.... 23.98
JOSHUA Hand is Quicker Than the Eye, Surrender, Chapter One (guitarist Joshua Perahia) 1983/85/95....each 10.98
L.A. GUNS Man in the Moon (Phil Lewis and rest of original lineup) 10 tracks/2001/Spitfire USA... SALE 10.98
LEGS DIAMOND Captured Live (2 CD, remastered 1990 show with bonus disc 5 tracks 2000) 21 tracks/UK. 17.98
MAHOGANY RUSH Maxoon, Child of Novelty and Strange Universe (remastered 3 on double CD) 73-75/UK.... 24.98
MANFRED MANN'S EARTH BAND Wired (live concert Boston 1977 remastered) 8 trks/Pilot Records UK.... 17.98
MARINO, FRANK Juggernaut & The Power of Rock and Roll (81-82 albums first time on CD) Holland....each 17.98
MARINO, FRANK & MAHOGANY RUSH Eye of the Storm (first new album 10 years) 72 min/2001/Canada.... 18.98
MOORE, VINNIE "Defying Gravity" (Steve Smith, Dave Rosenthal, Dave LaRue) 12 tracks/Shrapnel USA.... 13.98
NAZARETH Back to the Trenches (2 CD unreleased live 31 tracks, 146 minutes, 52 page mini-book) UK.... 23.98
NOSTRADAMUS (2 CD's, Glenn Hughes, Joe Lynn Turner, Jorn Lande, Goran Edman, Doogie White) SPV..... 19.98
POISON TRIBUTE Name your Poison (2 CD's, Derek St. Holmes and vocalist of Pretty Boy Floyd, Tuff, Tiger Tailz, Cherry Street, Every Mother's Nightmare).... SALE \$ 9.98
RONSON, MICK Heaven and Hell (Ian Hunter, Chrissie Hynde, David Bowie, Queen, Joe Elliott and John Mellencamp) 1994 reissue/Spitfire USA.....SALE 9.98
ROSSIGNOL COLLINS BAND This is the Way & Anytime, Anyplace, Anywhere (2 CD remaster both LP's) UK 19.98
SEVENTH KEY Seventh Key (Billy Greer, Steve Morse, Steve Walsh, Mike Slamer) 11 tracks/2001/Italy.... 14.98
SHANGHAI "Bombs Away" (produced by James Christian, rockers 2nd album) 10 tracks/2001/Metal Mayhem 13.98
SHY Brave the Storm +4 (1985 second album remastered with bonus tracks) 13 tracks/2001/Zoom UK..... 17.98
SILVER Silver (features ex-MSG vocalist Gary Barden, Bernie Torme, Don Airey) 13 tracks/2001/Germany. 17.98
TKO Below the Belt (Seattle rockers 3rd album remastered followup to "In Your Face") 1986/Metal Mayhem.... 13.98
URIAH HEEP Electrically Driven (full band show Astoria in London May 23, 2001) 13 tracks/2001/UK.... 19.98
URIAH HEEP Acoustically Driven (unplugged live with an orchestra, December 2000) 16 tracks/UK..... 19.98
URIAH HEEP (DVD) Acoustically Driven (video U.S. format for above show, sold only on band's website) UK.... 21.98
VICIOUS RUMORS Sadistic Rumors (Geoff Thorpe and Ira Black) 11 tracks/2001/Perris USA.... SALE 10.98
WARRANT Under the Influence (includes two new songs and nine covers) 11 tracks/2001/Perris Rec USA.... 13.98
WESTWORLD Live in the Flesh (vocals Tony Hammell of TNT, with Mark Reale and Bruno Ravel) 14 trks/2001/UK 15.98
WISHBONE ASH Live Dates 3 (Paris October 1999) 10 tracks/72 minutes/Eagle Records UK..... 19.98
WOLFSBANE Lifesyles of the Broke... (Wolfsbane and Massive Noise Injection albums together, 2 CD) UK 17.98

94-95-96-97-98-99-00 FLAT RATE SHIPPING IS \$4.50 FOR ANY SIZE SHIPMENT, MAIL ORDER CUSTOMERS INCLUDE THIS IN YOUR TOTAL SHIPPING VIA U.S. PRIORITY MAIL DELIVERY CONFIRMED TRACKING, SHIPPED IN BOXES. ORDERS OVER \$150 INSURED FREE SMALLER ORDERS ADD \$1.50 IF DESIRED. MONEY ORDERS AND CHECKS ARE ACCEPTED, MAKE PAYABLE TO BUCCANEER RECORDS. CHECKS MAY DELAY SHIPPING UP TO 2 WEEKS. ALL ITEMS ARE NEW, UNSEALED CDS IN SLEEVES. CREDIT CARD PREORDERS ARE NOT CHARGED UNTIL MAILED TO YOU. LISTING ALTERNATE SELECTIONS IS DESIRABLE IF NOT CALLING. FOREIGN ORDERS CREDIT CARD SALES ONLY, SHIPPED VIA AIR MAIL OR GLOBAL PRIORITY. SORRY NO SPECIAL ORDERS. GOLDMINE IS PUBLISHED THREE WEEKS BEFORE THE COVER DATE, THIS AD VALID UNTIL COVER DATE DECEMBER 14, 2001, THANKS

FAX YOUR CREDIT CARD ORDER ANYTIME 410-569-3697 MAIL ORDERS TO: BUCCANEER RECORDS P.O. BOX 1212 ABINGDON, MARYLAND 21009

Grapevine

CMJ 2001: Ghost convention

NEW YORK — Those attending CMJ Music Marathon 2001 knew that attendance would drop below normal levels. After all, it had been delayed for a month because of the horrific events of Sept. 11, 2001, occurring one day before the Music Marathon was to have commenced. New Yorkers have been traumatized by the tragedy, and many people beyond the city's borders have been skittish about flying in for any reason. Indeed many West Coast-ers opted not to make the cross-country trek to this annual industry schmoozefest.

Even though one knew that things would be different, the quiet halls of the Hilton Hotel still seemed spooky. The registration

attracted approximately 50 people, which was a good showing this year.

Attendance issues aside, CMJ Music Marathon certainly wasn't lacking for events or an eclectic mix of music biz associates. The filmfest showings included *Concert For Bangladesh*, *Hedwig And The Angry Inch* and *Plaster Caster*. Music performances included Girls Against Boys, X-ecutioners, Karma To Burn, Mary Lou Lord, Eve To Adam, The Machine In The Garden, The Dillinger Escape Plan, and Kristeen Young, among hundreds of others. Numerous industry vets donated their time for Mentor Sessions, Demo (critiquing) Sessions or to offer legal

Attendees could have done cartwheels down the aisles without hitting anybody. There were so many free music magazines to give away that people were encouraged to take multiple copies.

process, which normally takes 15 to 20 minutes, was instantaneous. The normally bustling Exhibitors Hall — which featured everyone from the Dutch Pop & Rock Institute to Latinovision to Guitar Center — was very low-key. Attendees could have done cartwheels down the aisles without hitting anybody. There were so many free music magazines to give away that people were encouraged to take multiple copies. Panels averaged two or three dozen attendees, whereas many might normally have pulled in 100 people. However, the loud rock panels did well, as did the panel titled "What Is The Role Of Entertainment In Times Of National Tragedy?" Even the guest speaker event in the West Ballroom, featuring veteran jazz writer Mitch Myers interviewing Medeski, Martin And Wood drummer Billy Martin,

advice. High-profile panelists included Robert Christgau (*Village Voice*), Rebecca Rankin (VH-1), and Lee Ranaldo (Sonic Youth). The panels themselves were wide-ranging, from indie rock to hip-hop and often humorously titled: "Video Badly Maimed The Radio Star," "DIY(ODS): Do It Your Own Damn Self," "God Says No... But Loud Rock Says Yes!"

In some ways, the intimacy of the panels was heightened by the smaller number of attendees. Otonomi: media founder Michelle Ferguson cleverly exploited that idea by integrating her panelists into the audience via a classroom-style circle of chairs. This made people feel more comfortable and talkative during her panel, "World Clique: The European And Asian Music Industry Share Their

(Please see CMJ page 23)



Photos courtesy of Harvey Robbins

Left: At the Doo-Wopp Hall Of Fame inductions held in Boston April 13, 2001, Harvey Robbins (left) presents a plaque and commemorative wrist watch to Hank Ballard of Hank Ballard And The Midnighters. Right: Robbins congratulates Carlo Mastrangelo of the original Belmonts. Also shown are Fred Milano (at far right) and Angelo D'Aleo (between Robbins and Mastrangelo), both original Belmonts. The 2002 Doo-Wopp Hall Of Fame induction ceremony and concert will be held March 29, 2002, at Boston's historic Symphony Hall. For information and reservations, call 978-256-6472.

GRAPELEAVES

On the bookshelf: A *Johnny Cash Chronicle: I've Been Everywhere* by Peter Lewry (Helter Skelter) is a chronological diary of all known Cash concerts, TV appearances, recording sessions, etc., and other career highlights from his birth in 1932 right on up through 2001... *U2: The Complete Encyclopedia* by Mark Chatterton (Fire Fly) is chockful of historical info and a complete discography on this wildly popular band.

For couch potatoes: New DVDs from Music Video Distributors include the eight-track *Curtis Mayfield In Concert* and *Joe Cocker In Concert*, from a 1996 German gig... PBS will air a special on Sun Records Nov. 28, 2001 (check local listings)... A&E's *Biography* program on *Buddy Holly* airs Dec. 3 (check local listings) and is planned for video release.

Holiday record sale at ARChives: Here's a great reason to go to New York: The ARChive Of Contemporary Music is having a special Showflake 2001 holiday sale to blow out records and CDs from its bulging vaults; With 1.7 million recordings, it houses America's largest popular music collection. The nine-day ARChive benefit event, which includes new items and raffles every day, runs Dec. 8-16 with hours from 11 a.m. to 6 p.m. daily. More than 15,000 mostly pop and rock albums will be priced at \$1-\$3; collectible LPs will be selling below price guide value; with 5,000 classical CDs priced at 25¢; newly released CDs will be \$6-\$10; older CDs will go for \$1-\$5; most videos will be a buck; and new cassettes will be \$2 each, 12 for \$20. Some of the more interesting items up for sale include a rare David Bowie/Bing Crosby Christmas CD; albums signed by Bowie, John Travolta, and many others; early Beastie Boys albums and singles; music books; rare classic rock and psychedelic posters; vintage punk, new wave and classic rock LPs including hundreds of still-sealed albums (Aretha Franklin, The Troggs, The Smiths); African and world music releases; and film and Broadway soundtrack recordings. For more information, go to www.arcmusic.org or call 212-226-6967. Tell 'em *Goldmine* sent you!

Spring Austin Record Convention: The big Austin Record Convention is back this spring in its usual digs at the Palmer Auditorium, according to show promoter Doug Hanners. Due to remodeling at the Palmer, the fall 2001 show was moved across the street to the City Coliseum. The spring show will be March 15-17, 2002, with March 15 being the dealer setup and early shopper day. The show coincides with the famous South By Southwest (SXSW) music fest. For more info, go to www.austinrecords.com.

Auction action heating up: Leland's upcoming Dec. 6-7, 2001, auction includes three collections of memorabilia from The Beatles, Kiss, and Bruce Springsteen, as well as other artists' quality music-related items. The Beatles items include a large selection of tickets, press passes, programs, concert handbills and memorabilia from 64 of The Beatles' 69 U.S. concerts. Three stand-out Beatles items are a autographed copy of *Help!* (all four Beatles, plus John Lennon signed it twice), the coat Ringo Starr wore for the cover shot of *Abbey Road*, and a hand-written inventory of Lennon's wardrobe at The

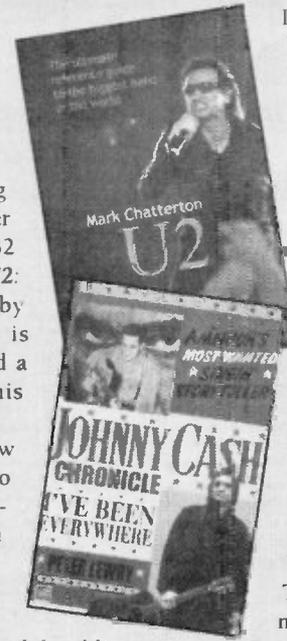

Dakota, including references to his *Sgt. Pepper's* and *Magical Mystery Tour* costumes. The Kiss lot includes hundreds of stage-used costumes and guitars, hand-written lyric books, road gear, etc., from the collections of Kiss' Gene Simmons and Paul Stanley. The Springsteen lot covers his early days in Asbury park with his high school band, The Castilles, including a copy of a 1966 *Mod Magazine*, featuring The Castilles — Springsteen's first magazine cover appearance. Other lots include an *American Bandstand* collection with autographs, etc., from Dick Clark, Ritchie Valens, Roy Orbison, The Drifters, Gene Vincent and many others and an early American popular music collection

featuring Apollo Theater handbills, 1950s advertising for Duke Ellington, Leadbelly, Miles Davis, Lavern Baker, Charlie Parker and others. For more information, go to www.lelands.com. Watch for auction results in an upcoming issue of *Goldmine*.

Sea cruise: In 1965, as a B-side to "Just A Little Bit Better," Herman's Hermits covered Frankie Ford's widely covered 1959 #14 smash, "Sea Cruise." Now Peter Noone and band are taking the song to heart, headlining a Jan. 9-17, 2002, cruise aboard the *Queen Elizabeth 2*, which departs from New York Jan. 7 for a worldwide cruise that ends in Ft. Lauderdale, Fla., April 26. Several cruising options involving the Hermits' concerts are available by contacting a local travel agent, visiting www.cunard.com or by calling 1-800-7-CUNARD.

Odds & Ends: Elvis Presley Enterprises is now running a Rick Nelson merchandising arm in conjunction with Nelson's estate. The catalog has lots of cool Nelson stuff including retro lunch boxes, T-shirts, gold record frames and more. Merchandise is available via catalog or by going to the "Shop Elvis" section at www.elvis.com, the official Presley site. In related Nelson news, the venerable Bear Family Records has produced a box set of Nelson's 1957-62 output... Gibson Guitar Corporation just purchased the assets of the Baldwin Piano & Organ Co., the largest U.S. piano maker, from GE Capital, the secured lender for Baldwin that acquired Baldwin's assets in a credit auction Oct. 15. The 140-year-old Ohio-based Baldwin markets pianos under the Baldwin, Chickering and Wurlitzer brands. Gibson's acquisition keeps the historic American piano company under U.S. ownership and brings together two of the most respected and recognizable names in the musical instrument industry. Gibson, a leader in the manufacture of fretted musical instruments since 1894, has enjoyed phenomenal growth under the current management, which purchased the company in 1986. The company's brand names include Epiphone, Kramer, Slingerland drums, Oberheim keyboards and Maestro effects, among others. The acoustic piano market is second only to the guitar market in terms of global musical instrument revenues... The Rolling Stones are discussing a possible world tour for 2002, in celebration of the 40th anniversary of the band's first performance at London's Marquee Club. Their 1998 tour cashed in at \$66.7 million for 34 concerts, and during the '90s they grossed \$751 million on ticket sales of 12 million. Vocalist Mick Jagger just released a solo LP, *Goddess In The Doorway*.

— Greg Loescher

Brian Wilson: 2001 full of good vibrations

2001 has been a remarkable year for Beach Boys founder and legendary composer Brian Wilson, who was honored with a Lifetime Achievement Award at the Grammys, successfully toured with Paul Simon, drew rave reviews for his excellent double-album, *Live At The Roxy*, and was saluted by his peers in grandiose style at Radio City Music Hall in New York — subsequently broadcast by TNT July 4, 2001.

On the eve of Image Entertainment's DVD release of *An All-Star Tribute To Brian Wilson*, the former resident of Hawthorne, Calif., shared his thoughts with *Goldmine* regarding the star-studded event held in his honor.

"I thought it was absolutely, brilliantly produced," said Wilson. "I think that the people who did my songs were all experts, and they were all great."

To be so honored by fellow songwriters of the magnitude of Paul Simon, Elton John, and Billy Joel, Wilson readily enthused, "It was a pump-up. It made me feel very, very good. I was very proud of my songs, and I'm

happy that they [chose to perform] them."

As for the rare teaming of David Crosby, Carly Simon, and Jimmy Webb, who performed a show-stopping rendition of "In My Room," Wilson was clearly moved by their exquisite three-part harmonies. "I was blown away by it. I thought it was really, really something."

Wilson readily agreed that another high-

Asked if the long-rumored *Smile* boxed set would ever see the light of day, [Brian] Wilson's answer was an emphatic, "No."

point was Vince Gill's stunning vocal on "The Warmth Of The Sun," with the country star sounding remarkably similar to Wilson's late brother, Carl. "Yeah, it was fantastic," quietly reflected Wilson, "I sure like his voice."

For all of the star power on display, perhaps no other moment meant more than when the proud father was joined on stage by his grown daughters, Carnie and Wendy (part of a reunited Wilson Phillips trio). "It was very overwhelming for me. I could have cried, it was so overwhelming."

Besides the new DVD, Wilson is equally

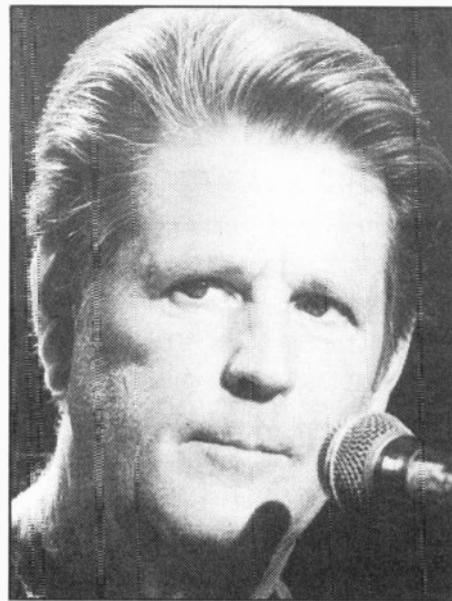

Brian Wilson

Courtesy of Brian Records/ly Tim Gaylord

pleased with his most recent solo album, *Live At The Roxy* (Oglio Records), which has enjoyed very positive critical reaction. "There were only 800 people there [at The Roxy], so it was kind of an intimate venue, and it had really good sound."

Beach Boys enthusiasts will be less than pleased to learn that Wilson has no plans to release the legendary *Smile* recordings. Asked if the long-rumored *Smile* boxed set would ever see the light of day, Wilson's answer was an emphatic, "No."

Several Wilson projects are already on tap for the new year, including a week of shows set for the Royal Albert Hall in London at the end of January 2002. However, Wilson is most excited about plans underway to record his next studio album, for which he has already written several new songs. "I hope that people will like my new rock 'n' roll album, next year."

Reportedly, Wilson is hoping to steer the record toward Phil Spector's infamous Wall Of Sound. When it was suggested that Spector be asked to produce the album, Wilson eagerly responded, "That would be dynamite, wouldn't it? I would be thrilled if Phil Spector would do it. I don't know if he would or not, but I would be thrilled if he did!"

Imagine, Wilson and Spector, together. Wouldn't it be nice? 2002 is already shaping up as another remarkable year for Brian Wilson. God only knows.

— Mark Wallgren

Brian Wilson DVD review

BRIAN WILSON & VARIOUS ARTISTS
An All-Star Tribute To Brian Wilson
Image Entertainment
(ID1276RCDVD)

Arguably the greatest American composer of the pop-rock era, Brian Wilson is honored with a 21-song retrospective of his "greatest hits" performed by a VIP guest list featuring Elton John, Billy Joel, Paul Simon, Heart, The Go Go's, Vince Gill, David Crosby, Carly Simon, Jimmy Webb, Hootie & The Blowfish's Darius Rucker, Matthew Street, Aimee Mann & Michael Penn, and a reunited Wilson Phillips, in Image Enter-



tainment's immensely enjoyable, widescreen DVD presentation of *An All-Star Tribute To Brian Wilson*.

Appropriately, the absolute highlight of this 96-minute extravaganza is the closing set from Brian Wilson himself, who cruises through rousing renditions of a handful of Beach Boys classics (including the previously unaired "Do It Again," a DVD bonus track), duets with John on "Wouldn't It Be Nice" and thoughtful conclusion with the tender, "Love And Mercy." *An All-Star Tribute To Brian Wilson* emits

extremely good vibrations and is a "must" for every Wilson fan (and who isn't?).

— Mark Wallgren

Obituaries

Smoky Dacus, early Western Swing drummer with Bob Wills

Legendary Western Swing drummer William Eschol (Smoky) Dacus died Oct. 9, 2001, in Rogers, Ark., at the Kellmark Nursing Home. He was born July 24, 1911, in Quinton, Okla., and joined Bob Wills And The Texas Playboys in early 1935.

A reading musician, he had played in Dixieland bands around the Tulsa, Okla., area when Wills asked him to join The Texas Playboys. Their recordings are some of the first in country music to use a drummer. (Jimmie Rodgers had used drums on his 1929 recordings of "Desert Blues" and "Any Old Time.") Dacus' masterful Dixieland drumming brought jazz dance rhythms to Wills' music and can be heard on many of the early Wills hits, including the original 1935-1940 versions of "Big River," "Four Or Five Times," "Maiden's Prayer," "Oozin' Daddy Blues," "San Anto-

nio Rose," "Steel Guitar Rag" and "Time Changes Everything."

His jazz influence on The Texas Playboys' sound is immeasurable and can best be heard on their 1937 Western Swing treatments of Big Band classics such as Jimmie Lunceford's "White Heat," Andy Kirk's "Dedicated To You," Fats Waller's version of Earl Hines' "Rosetta" and "Playboy Stomp," a clever rewriting of Lunceford's "Stealin' Apples." Along with jazz pianist Al Stricklin, these recordings show the incredible musicianship of The Texas Playboys. Dacus' main influence and good friend was Sonny Greer (1903-1982), Duke Ellington's legendary drummer. Dacus was replaced in February 1941 by another Dixielander, Eugene Tomlins, as Dacus was just not interested in moving to California and appearing in Wills' western movies.

(Please see Obituaries page 23)

Canada's Sam The Record Man declares bankruptcy

Sam The Record Man, once Canada's dominant record retailer, declared bankruptcy Oct. 30, 2001, owing creditors more than \$15 million. Anchored by the landmark Young Street store in downtown Toronto, the retailer was famous for deep discounts and an extensive catalog.

Founded 60 years ago by Sam Sniderman, during the mid-1980s the chain boasted 106 stores and accounted for 25 percent of music sales in Canada. In recent years, Sam The Record Man's market share had shrunk due to competition from HMV, Wal-Mart, Zellers and Internet sales. Except for 13 stores that are independently owned, the remaining 30 stores will stay open only until the end of the year in order to dispose of their assets.

— Jeff Hannusch

Rare Finds



10¢ Jimmy Stone 45 worth up to \$200

"Found"/"Mine" on the Gone label by Jimmy Stone is my best find in the 20-something years that I have been searching. That's a lot of driving throughout New England and upstate New York, stopping at every garage sale and flea market I can find. I found this record at a little flea market right next to my hometown for the unheard of price of 10¢! I don't know much about the record, only that I see it in Jerry Osborne's *Rockin' Records, 16th Edition*, with a price of \$100-\$150.

The song "Found" sounds like the beginning of Johnny Cash's "I Walked The Line" — very much like a rockabilly tune. What I think makes this record so valuable is its rockabilly appeal and the fact that it's the first issue of the Gone label. What do the readers think? Any info? I like rockabilly and was pleasantly surprised to hear this record for the first time.

— Dan Gagnon
45s Forever
Westfield MA

[Dan, cool find! According to the Standard Catalog Of American Records, 1950-1975 by Tim Neely, this 45, released in 1957, is worth \$200 in near mint condition. The same songs on the Cross Country label would be \$300 near mint. — Ed.]

Contributions to the Rare Finds column should be addressed to: *Goldmine Rare Finds*, 700 E. State St., Iola WI 54990-0001 or e-mailed to bernardyc@krause.com. Photos or photocopies of items are welcomed, but please do not send originals. Keep on diggin'!

Winners of Goldmine's British Invasion contest

The following *Goldmine* readers are winners in our British Invasion issue contest from our Aug. 24, 2001, issue. *Beatles Talkology 1 & 2* — Rich Slaughter, Suwanee, Ga.; *Goldmine's Beatles Digest* — Kevin Casey, Valparaiso, Ind., and Jeffrey Yentz, Lynchburg, Va.; Procol Harum video — Jimmie Fagan, Irving, Texas; *The True Adventures Of The Rolling Stones* book — Floyd Sullivan, Sharpsburg, N.C.; Marianne Faithfull autobiography — Peter Rigopoulos, Ashburnham, Mass.; *Nanking The Rolling Stones* book — Sherri Miller, Allentown, Pa.; *Rock's Wild Things: The Troggs Files* book — Rick Dalrymple, Ashburn, Va.; *Mick Jagger: Primitive Cool* book — George Sofranko Jr., Canfield, Ohio; *Brother Can You Spare A Rhyme: 100 Years Of Hit Songwriting* — Joseph Hyzny, Chicago, Ill.; Michael Lampert, Westfield N.J.; and Malcolm Collins, Tallahassee, Fla.; *Baby That Is Rock And Roll: American Pop, 1954-1963* — Bill Goetz, Eugene, Ore.

Be on the lookout for future *Goldmine* contests with great prizes for collectors!

VISIT US ON THE "NET" www.rockclassics.com

VISA MASTERCARD DISCOVER AMEX

Rock Classics

"LOWEST PRICES - GUARANTEED"

* "We're Back!! - Huge Pre-Christmas CLEARANCE SALE! Save 10-60%" *

NEW RELEASES

ELVIS PRESLEY

- 1. ELVIS PRESLEY: THE MOST IMPORTANT ELVIS RELEASE THIS YEAR! Due 11/15 two gorgeous studio box sets - not sold in U.S. stores!
A. ELVIS "The Unsurpassed Masters Vol. 1" 4 CD's all studio out-takes and alternate takes, most available for the first time anywhere - features over 80 trax both mono and stereo in 4 CD's, boxed, book, very limited! \$99.99
B. ELVIS "The Unsurpassed Masters Vol. 2" 3 CD's over 60 studio out-takes and alternates on 3 CD's, book, boxed - very limited \$74.99
2. V/A "ELVIS - UNDER THE INFLUENCE" - see write up under "ROCK-A-BILLY"
3. ELVIS - MEMPHIS SESSION FTD #14 in stock now! \$28.99
4. ELVIS - VINYL CLOSEOUT SALE - LIMITED TO STOCK ON HAND
A. Artist of the Century 5 LP Box Set WAS 99.99 NOW \$74.99
B. Artist of the Century 5 Color LP's WAS 109.99 NOW \$84.99
C. That's The Way It Was 5 LP Box Set WAS 99.99 NOW \$74.99
D. Peace In The Valley 5 LP Box Set WAS 99.99 NOW \$74.99
E. The Sun Singles (Black) 5 - 45's Boxed WAS 69.99 NOW \$49.99
F. The U.K. Singles 17 45's Boxed WAS 99.99 NOW \$74.99
G. The U.K. Singles 17 45's in 17 Diff. Colors WAS 99.99 NOW \$79.99
H. NEW! "I'll Be Home For Xmas" Limited Edition 10 inch LP \$19.99

ROCK AND POP NEW RELEASES

- 5. DEAN MARTIN "Evening Loves Somebody - The Reprise Years 1962-66" 6 CD's, 1 DVD Hardcover Book - Bear Family Box Set \$159.99
6. DEAN MARTIN "Lay Some Happiness On Me - Reprise and More 1966-85" 6 CD's, 1 DVD Hardcover Book-Bear Family Box Set \$159.99
7. JIMMY JONES "The Handyman Anthology" 2CD Set, 48 Trax \$24.99
PAUL N PAULA "Holiday For Teens" - Orig. LP with Bonus Trax \$16.99
8. TAB HUNTER "Very Best of" 28 Trax-All From Masters \$18.99
9. EDDIE HODGES "Gonna Knock On Your Door" 26 Trax \$18.99
10. CREEDENCE "Clearwater Revival" Box Set 6 CD's - All The Hits. Album Trax Plus 25 Prx -CCR Trax & 9 unreleased in wood-style box. Ltd. Avail. \$99.99
11. CHARLIE GRACIE "Rare & Unreleased" - Finally in stock! \$18.99
12. ROCK-A-TEENS "Woo-Hoo" - 25 Trax, all in full stereo! \$18.99
13. V/A "The High School Series" - Ultra Rare Teen Pop
A. High School Rarities 1
B. High School Rarities 2
C. High School Favorites 1
D. High School Dance 1
EA. 18.99 - BUY ALL 4 FOR \$69.99
14. V/A "God Bless America" - 25 Trax + Bonus Ending, The Cream of American Rock & Pop singing Patriotic standards \$18.99
15. HOMER & JETHRO "Country Collection" - 3 CD's, 36 trax, Ltd. Avail. SPECIAL PRICE \$17.99
16. JAN & DEAN "Very Best of the Early Years" 18 trax. \$13.99
17. CHUBBY CHECKER "The Very Best of the K-Tel Recordings" 20 trax \$13.99
18. DON HAVEN & THE HI-FI'S 14 Trax \$12.99
19. THE CASTELLS "The Very Best" 20 Trax \$12.99
20. JEWEL AIKENS "Very Best" 15 Trax \$12.99
21. BOBBY VINTON "Sealed With A Kiss/With Love" 2 on 1 \$13.99
22. HOYT AXTON "Gold" 24 trax \$13.99
23. V/A "Girl Group Gems" w/Erlene & Her Girlfriends, Donna Loren, the Blossoms, Annette & More \$14.99
24. VOGUES "Turn Around/Tell" 2 on 1 \$14.99
25. VOGUES "Memories/Sing the Oldies" \$14.99
26. DONNIE BROOKS "Mission Bells" Another new Brooks Collection, this one w/34 trax, many of which are not found on the CD released in July 01! \$18.99
27. KRIS JENSEN "Torture-The Hickory Years" 26 trax \$18.99
28. NEIL SEDAKA "Best of the Best" 2CD Set 50 Trax - most make CD debut \$29.99
29. RICKY NELSON "Album /It's Up To You" 2 LPs/1CD \$19.99
30. JOE DOWELL "Wooden Heart" 22 trax from master tape! \$18.99
31. LITTLE WILLIE JOHN "Very Best of His Stereo Masters" 25 trax \$13.99
32. V/A "Rock, Rhythm & Doo Wop" 3 CD boxed set, book, from PBS special of the same name, except these are the original masters! (Rhino) \$49.99
33. V/A "70's Soul Experience" - Deluxe 6 CD box set, book - 136 trax - a must for the collector! (Rhino) \$82.99
34. THE RUBETTES "Very Best" \$13.99
35. V/A "Juke Box Gems - Vol. 1 - Rare Ballads" 20 ultra pop and doo-wop ballads. Features Pixies, Informers, Bobbettes, Vicki Spencer, The Dolls, The Larks, more \$18.99
36. *JUKE BOX GEMS "Vol. 2" rare instrumentals, features 20 trax including Noblemen, Chuck Berry, Megatons, Sandy Nelson, Routers, Pyramids, Fireballs and more. \$18.99
Look for VOL. 3 December 2001

- 37. JONI JAMES "Merry Xmas From/Give Us This Day" 2 LPs on one CD \$15.99
38. V/A "Teenage Dreams Vol. 12" - 30 more teen pop gems!, Vol. 13 available soon! \$18.99
39. JIMMY BOYD "Christmas With" - "I Saw Mommy Kissing Santa Clause" + 11 more - 1st time on CD! \$18.99
40. HARRY SIMEONE CHORALE "Sing We Now Of Christmas" Features "Little Drummer Boy" + 11 more \$18.99
41. FATS DOMINO "After Hours" - the best of his live club dates - covers over 20 years \$16.99
42. V/A "A Tribute To Sun Records - Good Rockin' Tonight" with Paul McCartney, Jeff Beck, Tom Petty, Eric Clapton, Elton John, lots, lots more! Limited availability \$18.99
43. V/A "Botchy Sox To Stockings" Teen idols from Frankie Avalon to Everly Brothers, Terry Stafford, Fabian and lots more \$16.99
44. ROBIN LIJKE MEETS TERRY NOLAND 20 ultra rare CD debut trax \$18.99
45. THE BEATLES WITH TONY SHERIDAN 2 CD box set, with LP sized book/box \$69.99
*Available w/o box, box \$39.99
46. THE VISCOUNTS "Harlem Nocturne" - 12 rare stereo trax + 13 more - has been unavailable for 3 years! \$16.99
47. STEVE GIBSON AND THE REDCAPS "Rare Sides" All CD debuts! \$18.99
48. V/A "Riot City" - 31 trax featuring the best of the 60's Northwest: combo bands \$16.99
49. V/A "Northwest Battle of the Bands Vol. 2" Don/Goodtimes, Galaxies, Gamblers, lots more. \$16.99

- 74. JORDAN/FASCINATION & FRIENDS (Boulevards & Gothics) Most make CD debut \$18.99
75. SAFARIS "Image of a Girl" Long out of print, we found a few - very complete history of this landmark group \$19.99
76. VALENTINOS "Do It Right!" 22 trax \$18.99
77. THE TUNEWEAVERS MEET THE BLENDS - very rare stuff! 23 trax \$18.99
78. V/A "Street Corner Essentials" - 2 CD set - 40 trax - Coronets, Counts, Moonglows, more \$26.99
79. THE CASTELLS "Very Best" - 22 trax \$13.99
80. THE FEATHERS MEET THE BARONS - 26 trax from Showtime, Imperial, and Decca Vaults \$18.99
81. V/A "Dynamite Vocal Group Sounds Vol. 29" 28 trax - series will end at Volume 30 \$18.99
82. THE TOKENS "Dum Dooie Dum - Tonight I Fell In Love" 29 trax, 10 unreleased \$18.99
83. V/A "Teen Scene" - Meodders, Dovers, Chessmen, Danny Winchell - 35 trax \$18.99
84. V/A "Confidential Doo-Wop #6" Epics, C-Quing, Vibes, Covinas, Nutones, Fascinations, more - 28 trax \$18.99
85. V/A "Confidential Doo-Wop #7" 28 trax - Bo Diddley w/group, Chimes, Velvetones, Corvairs, etc. \$18.99
86. THE UNTOUCHABLES "Best Of" 28 trax - 25 make CD debut \$18.99
87. THE ROYALS MEET THE MIDNIGHTERS - 25 trax \$13.99
88. THE DEL-VIKINGS "Swingin, Singin Record Session" revised, more trax due 11/10 \$18.99
89. THE DEL-VIKINGS "They Swing, They Sing" revised, additional trax, Now due 11/10 \$18.99
90. JUKE BOX GEMS "Vol. 1 - The Ballads" - see list under "Pop & Rock" \$18.99

- 120. ROCKY FELLA'S "Killen Joe - The Scepter Sessions" \$19.99
121. ROY ORBISON "Complete Sun Sessions" 31 trax including 5 never before released alternative takes \$16.99
122. JOHNNY & THE HURRICANES "Best" 20 trax - newly remastered! \$14.99
123. DUANE EDDY "The Twangs The Thing" original LLP + 6 bonus trax \$14.99
124. THE TOKENS "Golden Moments Of Our Past" 28 CD debut trax \$18.99
125. THE TOKENS "Tonight I Fell In Love" 29 trax - lots of unreleased material \$18.99
126. V/A "Rarest Of The Rare Vol. 6" 27 ultra rare gems! \$18.99
127. V/A "Doo-Wop Confidential Vol. 3" 28 killers! All CD debut! \$18.99
128. V/A "Doo-Wop Confidential Vol. 4" 28 more gems! \$18.99
129. THE CLASSICS "Till Then - Their Very Best" \$13.99
130. THE PARAGONS "Florence - Their Best" \$13.99
131. THE CRESTS WITH JOHNNY MAESTRO "20 All-Time Classics" \$13.99
132. BOBBY DAY W/HOLLYWOOD FLAMES, BOB & EARL & JACKIE LEE \$13.99
133. V/A "The Girl Group Sound - 25 All Time Greatest" \$13.99
134. IKE TURNER W/KINGS OF RHYTHM "Sun Sessions" \$13.99
135. FRED HUGHES & HIS GROUPS - Markettes, Cymbals, Ballads, Four Rivers + Solo's \$18.99
136. REPARATA & DELRONS "Rare & Unreleased" another package from Europe - lots of trax not on July release (Evergreen) \$18.99
137. THE PLAYMATES "Ultimate Collection" (due 9/30) - 28 trax - 16 debut trax \$18.99
138. JIMMY RICKS & THE RAVENS - 18 rarities. \$18.99
139. THE FANTASTICS, THE EL-VEÑO'S, THE HEARTBREAKERS - 24 trax \$18.99
140. V/A "Schrevoport Highsteppers" 27 ultra-rare kicking trax (ACE) \$16.99
141. V/A "Them Rock-A-Billy Cats" 26 gems from Sun, Meteor, Argo & other 50's record companies (ACE) \$16.99
142. V/A "The Twang Gang" Duane Eddy, Al Casey, Sanford Clark & more \$14.99
143. V/A "Forgotten Teen Idols Vol. 1 - The Boys" 20 CD debut gems - loads of rarities \$18.99
144. V/A "Forgotten Teen Idols Vol. 2 - The Girls" companion to above \$18.99
145. V/A "Forgotten Teen Idols Vol. 3 - The Boys & Girls" more rarities \$18.99
146. JIMMY CLANTON "Philip's Years/At Gilley's Studio" 23 trax \$18.99

- 147. V/A
A. "Cruisin' 1959 W/Hunter Hancock" \$18.99
B. "Cruisin' 1960 w/Dick Biondi" \$18.99
C. "Cruisin' 1958 w/Jack Carney" \$18.99
D. "Cruisin' 1957 w/Joie Niagara" \$18.99
148. V/A "Doo-Wop 51 Live" covers recent PBS special \$16.99
Coming soon to video and DVD!
149. V/A "Modern Vocal Groups Vol. 6" last CD in series - lots of rarities \$16.99
150. V/A "Great R&B Instrumentals" 26 gems \$16.99
151. V/A "Doo-Wop Memories Vol's 5 & 6" each 28 trax, lots of CD debuts EACH \$18.99
152. V/A "Enrica & Rae Cox Groups" different from German release \$18.99
153. V/A "Lost Deep Soul Treasures #5" \$18.99

CLOSEOUTS - LIMITED TO STOCK ON HAND

- 154. DELICIOUS "Doo-Wo 1 or 2" \$8.99 Ea.
155. EMPIRE Doo-Wop \$8.99
156. GENE SIMMONS "Sun Years" \$8.99
157. GENE VINCENT "Hot Rod Gang" \$10.99
158. DOO-WOP SOUVENIRS \$8.99
159. FOUND IN THE ATTIC 1-2-3-4 \$8.99 Ea.
160. SAM HAWKINS \$8.99
161. THE VELVETS \$8.99
162. SCOTT ENGLE 2 disc set \$10.99
163. BEST OF EVEREST RECORDS \$8.99
164. GENE & EUNICE \$6.99
165. FORGOTTEN DUO'S \$6.99
166. GENE VINCENT "Lotta Lovin" \$8.99
167. MONOTONES "Bk of Love" \$8.99
168. BOBBY DARIN "It's You" \$8.99
169. JOHNNY PRESTON Stereo Hits Pk. \$8.99
170. ROY ORBISON "Dreamin" \$8.99
171. JOHNNY BURNETTE "Rarities 1" \$8.99
172. JOHNNY BURNETTE "Rarities 2" \$8.99
173. JIMMY RICKS/RAVENS \$8.99
174. SAMMY TURNER "Lavender Blue" \$8.99
175. BEST OF ENRIQA/RAE COX - 2 CD's \$10.99
176. ANN COLE "Crying" \$8.99
177. LIL RICHARD "Get Down" \$8.99
178. DOVELLS 2/1 \$8.99
179. BOBBY RYDELL 2/1's - 3 Diff. \$8.99

MAILING LIST

If you're not on our mailing list, you've missed over 300 new releases, 2 sales and multiple specials! Fax, E-mail or write & we will send you "From The Vaults" - our free monthly newsletter.

- 50. V/A "Teen Town USA Vol. 3" - 32 trax, w/Barry Davel, Jerry Fuller, Johnny Rivers, Dick Lory, Jimmy Boyd - Lots More \$16.99

NEW DOO-WOP RELEASES

- 51. DREAMERS "They Sang Like Angels" Flair, Class, Flip Rec's \$16.99
52. MERCURY "Doo-Wop Vols. 4-5-6" Available by 11/15 Each Vol. \$18.99
53. SHIRELLES "Very Best Of The Doo-Wop Sides" 34 Trax \$18.99
54. V/A "Double Blast Of Super Soul" - Sat. nite at the Apollo \$18.99
55. V/A "Christmas, It's That Time Of Year" 26 ultra doo-wop gems, all make CD debut \$18.99
56. V/A "Ultimate Doo-Wop Xmas" 24 rare doo-wop trax - 21 make CD debut. \$18.99
57. V/A "MGM Doo-Wop & Vocal Groups Vols. 1,2,3" each with 26 trax - AB make CD debut - no trax details avail. at ad time. EA. \$18.99
All 3. \$52.99
58. MELLO-KINGS "21st Century" All new recordings - 20 Trax \$15.99
59. V/A "Mercury Doo-Wop Vols. 4-5-6" 75 more killer Mercury D/W trax - All make CD debut EA. \$52.99
All 3.
60. V/A "Street Corner Romance Vol. 8" - 24 more killer Trax - w/Johnnie & Joe, Johnny Ace, Gales, Del-Knights, Esquires - Lots more \$18.99
Look for Vols. 9 & 10 by 12/15/01!
61. WILLIE MITCHELL "Soul Bag/Many Moods" 2 on 1 \$15.99
62. SPARKLETONES "Complete" 22 Trax \$18.99
63. THE ROYALS & THE MIDNIGHTERS "Very Best of" 25 Trax \$13.99
64. LITTLE WILLIE JOHN "Very Best" 25 Trax \$13.99
65. HANK BALLARD & THE MIDNIGHTERS "Very Best" \$13.99
66. CHUCK WILLIS "I Remember/King of the Stroll" 2 on 1 \$13.99
67. V/A "Doo-Wop 5 - Live" As seen on PBS \$13.99
68. TEDDY & THE PANDAS "Once Upon A Time" 20 Trax \$16.99
69. V/A "Street Corner Essentials" - 50 Doo-Wop classics on 2 CD's w/25 hits, 25 rarities - A must have! \$26.99
70. SHIRELLES "Very Best of the Hits & Rarities" 35 Trax \$18.99
71. DEL-VIKINGS "The Sing, They Swing" \$18.99
72. V/A "Best of Bullieys Records" 27 trax - El Capris, 4 Dots, Mondello's, Tricads & More \$18.99
73. ETERNALS "Today" 17 trax - all NEW \$17.99

- 91. DION "Dion & The Little Kings - Live in NYC" \$16.99
92. LEGENDS OF DOO-WOP NEW RECORDINGS \$16.99
93. FLIP RECORDS DOO-WOP VOL. 1 - includes 2 unreleased trax - no other details \$16.99
94. JOHNNY OTIS & FRIENDS "Watts Funky" \$16.99
95. GOLDWAX STORY VOL. 1 \$16.99

ROCK-A-BILLY RELEASES

- 96. STEVE GIBSON AND THE REDCAPS "Rare Sides" - All CD debut \$18.99
97. EDDIE FONTAINE "Nethin Shakin" - 1st time on CD! \$18.99
98. V/A "Candy Dolls" - an all girl kick-ass CD - Kathy Linden, Judy Warren, etc. 30 trax (B/B) \$18.99
99. V/A "Go, Cats, Go - Coast to Coast R/B Vol. 1" 30 killer trax \$18.99
100. V/A "Go, Cats, Go - Coast to Coast R/B Vol. 2" even better than Vol. 1! \$18.99
101. V/A "Skippin' Along" - 30 more B/B trax \$18.99
102. V/A "Choo-Choo-Bop" 30 more B/B trax \$18.99
103. V/A "Elvis - Under The Influence" 31 trax of Elvis-wannabes doing the King's best stuff - Pal Donner, Billy Barrx, Conway Twitty, Jody Reynolds, Virce Everett, more \$18.99

THINGS YOU MAY HAVE MISSED

- 104. V/A "Hey Look What I Found Vol. 10 & 11" Loads of rare trax, Each \$18.99
105. MARV JOHNSON "Marvelous/More Marvelous" 2 LPs on 1 CD \$13.99
106. BOBBY SHERMAN "Here Comes Bobby/With Love, Bobby" \$13.99
107. BOBBY SHERMAN "Bobby/Portrait of Bobby" \$13.99
108. BOBBY VINTON "Tel. Me Why/Songs For Lonely Nights" \$13.99
109. BOBBY VINTON "Mr. Lonely/Country Boy" \$13.99
110. V/A "Hard To Find 45's on CD Vol. 6" 21 60's trax - lots of rare stuff \$15.99
111. V/A "Hard To Find 45's on CD Vol. 7" 21 more rare 60's trax \$15.99
112. DION "Sanctuary/Suite For Late Summer" \$16.99
113. THE DOVELLS "All The Hits/You Can't Sit Down" 2 original CP LPs on 1 CD \$18.99
114. BOBBY RYDELL "Wildwood Days/Forget Him" \$18.99
115. DEE-DEE SHARP "All The Hits/All The Hits #2" \$18.99
116. THE MARKETTES "Surfin' & Stompin'" 30 kick-ass trax \$19.99
117. BRIAN HYLAND'S 21 BIG ONES \$16.99
118. TOMMY ROE'S 21 BIG ONES \$16.99
119. BOBBY RYDELL "Now & Then/Sit" \$18.99

ORDERING INFORMATION: We accept VISA, MasterCard, Discover, AMEX and personal checks. Sorry no C.O.D.s. Charge orders by phone or fax--see below. Include full charge no. and expiration date. You can also mail charge or check orders to address below. 1-2 CDs \$4.50, each additional CD \$5.00. Box sets per weight. All shipments Priority or 1st Class mail, FedEx, UPS & Express avail. on request. All sales final, defective CDs replaced w/same CD. Some items limited to stock-on-hand. Prices on imports reflect current exchange rates and are subject to change. No Catalogs

NEW: ORDER VIA E-MAIL! ROCKCLAS@MSN.COM

Secure Site - Use C.C. #/Exp. Date ORDERS ONLY - NO INQUIRIES!

ORDER LINE: (360) 769-0456 (9 A.M. - 3 P.M. PST/M-F) • FAX: (360) 769-0441

1511 E. Babydoll Rd. • Port Orchard, WA 98366

Baby, I'm still a star

Prince in the 1990s: His music and career obstacles

by Thomas Kintner

© London Features/Gie Knappes

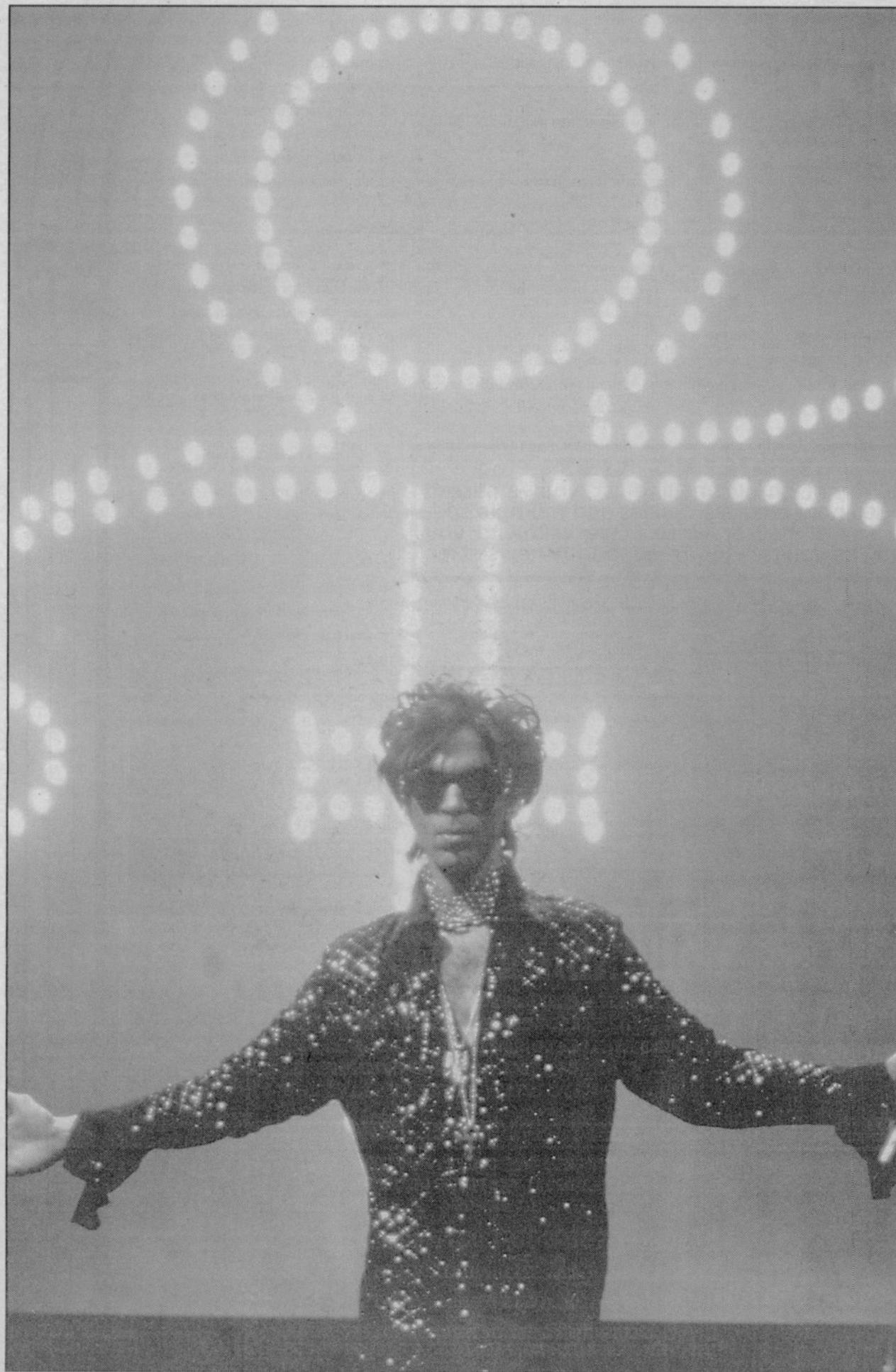

Inventory the music collection of any casual fan of iconic pop star Prince, and odds are that most of what you're going to find came out of the 1980s. That was the decade in which Prince had his biggest commercial success (a 13-million seller, the Oscar-winning soundtrack to 1984's *Purple Rain*), released what was very arguably his best album ever (1987's *Sign "O" The Times*) and made a popular comeback from several years of dwindling sales figures (the 1989 soundtrack for *Batman*). When Prince made headlines in the decade that followed, it usually had nothing to do with his continued proficiency as a musician. Simply put, in the 1980s he was one of the biggest names in the music business, but by the middle of 1993, he was best-known for not even having a name.

Although no longer the hit factory he once was, Prince continued to make interesting music throughout the 1990s, and he certainly wasn't starving his fans for choices. Over the course of the decade, no fewer than 15 discs of new material were released under his name, not to mention bonus tracks tacked onto reissues, projects he spearheaded under the names of other artists and miscellaneous tracks that popped up here and there. It was a busy time even for an artist famed for his productivity, during which each year he had something to offer.

1990

The 1990s started with Prince's popularity on the upswing, courtesy of the multi-platinum success of his *Batman* soundtrack. He looked to be in good position to string out that success as he prepared to direct his next film project, *Graffiti Bridge*, a sequel to *Purple Rain* that would already have a substantial built-in audience. However, it was clear early in the year that duplicating the first go-round's success was no sure thing, that the new film's resemblance to the Prince-directed 1986 bomb *Under The Cherry Moon* was more likely. Inside word had it that the picture was not going well, prompting Prince's backers at Warner Brothers to announce in March that reports of its unhappiness with *Graffiti Bridge*, which was still shooting in Prince's native Minneapolis, were "inaccurate."

However, something was clearly amiss. Warner Brothers responded to poor test screenings by installing its own editor to clean up the picture, a process Prince supervised as he traveled the world performing his greatest hits on the *Nude* tour from June to September. The soundtrack was released Aug. 20 as planned, but the film was delayed. When Prince returned to the United States in September, he re-shot several scenes for the final cut, which made it to theaters nationwide Nov. 2.

In the end, the negative buzz was on target. The film was just awful, and its box office was virtually nonexistent. Five weeks after it opened, it had made less than \$4.5 million, which was nowhere near *Purple Rain's* draw of almost \$70 million. Nearly a year after its release, Prince would tell *USA Today's* Edna Gundersen he was merely misunderstood, "*Graffiti Bridge* was not a failure... Maybe it will take people 30 years to get it. They trashed *The Wizard Of Oz* at first too." That comparison could be called a stretch only by the most charitable, given that Prince's film was poorly scripted, acted and directed, to the point that everything but its music sequences is almost embarrassing to watch. Suffice to say it will never be a yearly event on national television.

The soundtrack is more palatable. Featuring perfor-

mances by George Clinton and up-and-coming young singer Tevin Campbell. *Music From Graffiti Bridge* is full of flavor. The title track is horribly syrupy, but it is the exception among nicely styled tunes such as the quirky "Elephants And Flowers," the atmospheric "Joy In Repetition" and the pulsing single release "Thieves In The Temple."

The film also gave Prince occasion to reassemble The Time, the group he had put together and run from behind the scenes in the early 1980s until its breakup shortly after scoring *Purple Rain*-derived hits such as "Jungle Love" and "The Bird." After functioning as the villains of the sequel, the band released a new album called *Pandemonium*, over which Prince had considerably less control than he did over its previous incarnation. The result is a nice, if occasionally erratic, blending of the quirky cool of lead singer Morris Day, the slick production sensibilities of producer/performers Jimmy Jam and Terry Lewis and the endlessly varied electric guitar shrieks of Jesse Johnson.

Among Prince's other 1990 highlights were the announcement in July of his own fashion line (which never materialized in substantial fashion), the opening of his Minneapolis nightclub, Glam Slam and the expiration in December of his one-year contract with managers Randy Phillips and Arnold Stiefel (who were credited as producers of the *Graffiti Bridge* film along the way). That last item seemed insignificant at the time, but when Prince opted to pass on hiring new representation, essentially becoming his own manager in the process, he started down a path that would change the course of his career and his life.

1991

Prince caused a bit of a stir when he bought back the television rights to his January performance at the massive Rock In Rio II festival in Brazil, thus denying MTV the opportunity to air his performance stateside. Added to the bad publicity that had come from *Graffiti Bridge* (by then long since gone from theaters, but still remembered as a dog) and the February announcement that he was being sued by former managers Bob Cavallo, Joe Ruffalo, and Steven Fagnoli for having been a bad client, it totaled a mess that made it easy to think Prince's resurgence was an aberration. However, he was not out of comebacks yet.

Radio stations around the country were the ones who got the gifts when Prince's 33rd birthday rolled around on June 7

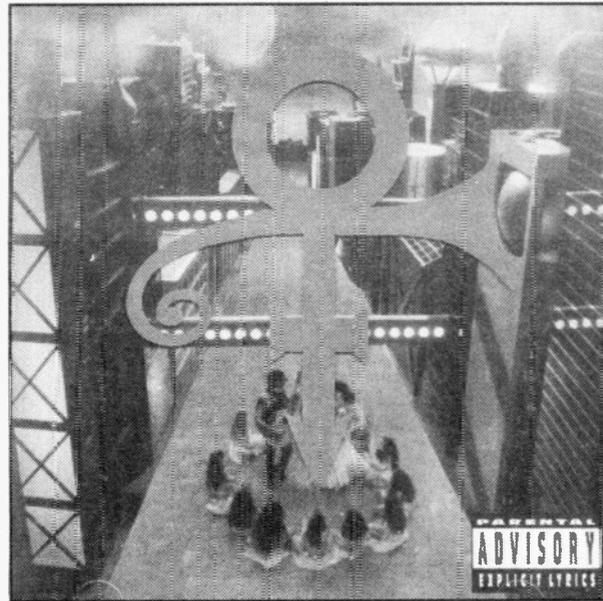

— copies of a one-sided, 12-inch record called "Gett Off." Originally intended as nothing more than a promo-only tune, it caught on quickly as a single, prompting Prince to add it to his forthcoming album and bumping the considerably weaker tune "Horny Pony" in the process. The rare original 12-inch was soon widely cherished by Prince collectors who ponied up hundreds of dollars when they could find a copy, and the song proved to be the first of several hits Prince's next album would include.

On Sept. 9, Prince previewed *Diamonds And Pearls* on *The Arsenio Hall Show*, which adopted a unique format for his visit. Patti LaBelle shared anecdotes with Hall about her friendship with Prince, which was a nice way for Prince to get some publicity without having to forgo his traditional unwillingness to talk to the media. He sang old hits and new songs including "Cream," all in front of an enthusiastic studio audience that included Sheila E., Little Richard, and M.C. Hammer.

Diamonds And Pearls made its way into stores Oct. 1. It was in many ways his most accessible album in years, a notion supported by the fact that it was his first set since *Purple Rain* to produce four Top 40 singles. The smoothly soulful "Money Don't Matter 2Night" would be the subject of two videos, one directed by Spike Lee. Both "Gett Off" and "Cream" would get deluxe treatment on maxi-single releases that took off on their featured songs' basic structures with much more than remixes.

and the album sports a thoroughly nifty hologram of Prince and two of his dancers on its cover.

Also worth mentioning in 1991 are a couple of releases by Prince-related artists. Saxophone player Eric Leeds released *Times Squared* in February, large portions of which were originally intended as the third album from Madhouse, a funk/jazz band Prince was behind and took part in. Prince's participation was hidden on Madhouse records, but he was credited for writing and performing on Leeds' album. Also in stores was an album from Prince's *Graffiti Bridge* co-star Ingrid Chavez, titled *May 19, 1992*, and consisting largely of poetry read against music backgrounds, some of which Prince composed.

1992

Support for *Diamonds And Pearls* continued well into the year, including a four-month tour that ran outside the U.S. through the end of July. Back at home, Prince got to work on new projects, including scoring and songwriting for the James Brooks musical *I'll Do Anything*. By the time the film hit theaters it was no longer a musical, and Prince's contributions went back into his vaults.

In August, Prince solidified his relationship with long-time label Warner Brothers when he extended his agreement with them for an extra six records, each with an advance of \$10 million. With added incentives, the contract had the potential to pay Prince as much as \$100 million. The deal also made Prince a vice president at the label and gave him a new sub-label of his own. It looked as if Prince's recording future was secured. However, that would soon turn out not to be the case.

In the meantime, Prince released his 14th album on Oct. 13. Titled only with the symbol of androgyny he had begun incorporating into his album graphics with *Purple Rain*, it is an often fun set that sputters in its attempt to be a concept album. Several numbers, including "7" and the raucous "The Max," are memorable, but the set is bogged down in the overblown "3 Chains O' Gold" and the rap-style lemon "The Flow." It does feature a most unlikely single, the cheerily vulgar "Sexy MF."

Prince got a nice weekend of exposure Dec. 18-19 when he appeared in a pair of specials on ABC television's *In Concert* series. The first night featured *Prince And The New Power Generation: Act I*, a documentary about the symbol album and his ensuing tour, and the second offered *The Ryde Divine*, a show built primarily on live performances.

Prince 1990s (and beyond) discography

by Thomas Kintner and Tim Neely

Regular singles

("2" is CD single, "4" is cassette single, "7" is seven-inch vinyl single)

Label/#	Title	Year
Paisley Park 19751-4/7	Thieves In The Temple/Thieves In The Temple Part II	1990
Paisley Park 19525-4/7	New Power Generation/New Power Generation (Part II)	1990
Paisley Park 19225-4/7	Gett Off/Horny Pony	1991
Paisley Park 19175-4/7	Cream/Horny Pony	1991
Paisley Park 19090-4/7	Insatiable (Edit)/I Love U In Me	1991
Paisley Park 19083-4/7	Diamonds And Pearls/X-cerpts from The songs: Thunder, Daddy Pop, Strollin', Jughead, Money Don't Matter 2Night, Push, Live 4 Love	1991
Paisley Park 19020-4/7	Money Don't Matter 2Night/Call The Law	1992
Paisley Park 18817-4/7	Sexy M.F./Strollin'	1992
Paisley Park 18707-2/4/7	My Name Is Prince/Sexy Mutha	1992
Paisley Park 18700-2/4/7	Damn U/2 Whom It May Concern	1992
Paisley Park 18824-2/4/7	7 (Album Version)/7 (Acoustic Version)	1992
Paisley Park 18583-2/4/7	The Morning Papers/Live 4 Love	1993
Paisley Park 15991-2/4/7	Cream/Gett Off [Back To Back Hits reissue]	1993
Paisley Park 15990-2/4/7	Insatiable/Diamonds And Pearls [Back To Back Hits reissue]	1993
Paisley Park 18371-2/4/7	Pink Cashmere/Soft And Wet	1993
Paisley Park 18372-2/4/7	Peach/Nothing Compares 2 U	1993
NPG BR 72514-2/4	The Most Beautiful Girl In The World/Beautiful	1994
NPG BR 72516-2	Staxowax/Sexy Staxophone And Guitar	1994
Warner Bros. 18074-2/4/7	Letitgo/Solo	1994
Warner Bros. 18012-2/4/7	Space (Universal Love Radio Remix)/(Album Version)	1994
Warner Bros. 17903-2/4/7	Purple Medley/Kirk J's B Sides Remix	1995
Warner Bros. 17811-2/4/7	Eye Hate U (Edit)/Eye Hate U (Quiet Night Mix by Eric Leeds)	1995
Warner Bros. 17715-2/4/7	Gold/Rock 'N' Roll Is Alive! (And It Lives In Minneapolis)	1995
Warner Bros. 21881-2	1999/Little Red Corvette (reissue of a reissue; first issued as a CD single with this same number In 1989)	1998

Arista 13749-2	The Greatest Romance Ever Sold (Radio Edit)	1999
	(The Adam And Eve Remix Featuring Eve)	
NPG 505-2	U Make My Sun Shine/When Will We Be Paid?	2001
NPG (no number)	Daisy Chain/Gamilah (sold only on tour)	2001
NPG (no number)	Peace/2045: Radical Man (sold only on tour)	2001
NPG (no number)	Supercute/Underneath The Cream (sold only on tour)	2001

Commercial 12-inch singles

Note: Most of these also were issued on CD and/or cassette maxi-singles with the same number		
Paisley Park 21598	Thieves In The Temple (Remix 8:03) (Thieves In The House Mix 6:50) (Temple House Dub 5:06)	1990
Paisley Park 21783	New Power Generation (Funky Weapon Remix 5:01)/T.C.'s Rap (Featuring T.C. Ellis 3:11)/Brother With A Purpose (Featuring Tony Mosley 4:18)/Gett Off (4:41)/The Lubricated Lady (2:39)/Loveleft, Lovelight (5:00)	1990
Paisley Park 40138	Gett Off (Extended Remix 8:31) (Houstyle 8:20)/Violet The Organ Grinder (4:59)/Gett Off (Flutestramental 7:26)/Gangster Glam (6:04)/Clockin' The Jizz (Instrumental 4:51)	1991
Paisley Park 40197	Cream (Album Version 4:12) (N.P.G. Mix 5:47)/Things Have Gotta Change (Tony M. Rap 3:57)/2 The Wire (Creamy Instrumental 3:13)/Get Some Solo (1:31)/Do Your Dance (KC's Remix 5:58)/Housebangers (4:23)/Q In Doubt (Instrumental 4:00)/Ethereal Mix (4:43)	1991
Paisley Park 40574	7 (Album Version 5:09) (After 6 Edit 4:20) (After 6 Long Version 5:15)/(Acoustic Version 3:54) (Album Edit 4:23)/2 Whom It May Concern (4:01)	1992
Paisley Park 40700	My Name Is Prince (12" Club Mix 8:11) (House Mix 7:18)/(Original Mix Edit 8:06) (Hard Core 12" Mix 7:55)/	1992

(Please see Discography page 16)

© 1998 Eber Roberts



1993

The first public sign that Prince was not happy with his new contract came April 27, 1993, when he released an announcement that he was retiring from studio recording. Long renowned for an insatiable work ethic that had filled his vaults

with hundreds of unreleased tracks, it had all the makings of a major announcement. It was somewhat surprising that there was little resulting panic among his fan base, but perhaps that was because no one seemed to believe he meant it.

A stranger statement came on June 7, when Prince celebrated his 35th birthday with the announcement that he was changing his name, adopting the unpronounceable symbol that had been the title of his last album (which, ironically, had led off with the track "My Name Is Prince"). Publicity that followed was almost universally negative and ended up with scribes settling on the new name "The Artist Formerly Known As Prince" and countless insulting plays on that structure.

Amid retirement and name-change chaos, the year passed as the first since 1983 that Prince had not released an album of new material. However, Warner Brothers did issue a worthwhile three-disc retrospective on Sept. 14, *The Hits/The B-Sides*. Featuring insightful liner notes by longtime Prince tour manager Alan Leeds, it was made available as two individual discs, the first being his best-known "clean" material, the second focusing on his more lascivious moments. Also available was a box set that contained both discs and a bonus disc filled with 18 of Prince's non-album B-sides, albeit in truncated form in most cases.

It was an impressive set, comprehensive in its survey of 32 hits and desirable to collectors who wanted the six new tracks it offered, not to mention the CD-quality versions of B-side tunes previously available only on vinyl and cassette.

There were other Prince/Artist doings over the course of the year as well. The Joffrey Ballet toured the country with a production called *Billboards*, which mixed ballet and modern dance in a series of pieces, all danced to the music of Prince. He even contributed new music to the process, producing a new version of his *Diamonds And Pearls* tune "Thunder" specifically for the production.

He also continued making films based on his music, putting together *The Undertaker*, which was for all intents a long-form music video that included some new tunes and featured *General Hospital* actress Vanessa Marcil. It was offered at the Artist's NPG retail store in a limited edition of 1,000 at a price of \$50. It quickly sold out. Mixing live performance and music videos, his multimedia *Glam Slam Ulysses* premiered at the Los Angeles Glam Slam Aug. 21 and included 12 new tunes (one of which, "Pope," was just about to see release as one of the bonus tracks on disc two of *The Hits*).

February saw the delayed release of the debut album by the latest of the Artist's many female protégées, the eponymously titled *Carmen Electra*. The Artist did the lion's share of the music that supported Electra, who rapped her way through tunes with plenty of attitude. Electra would not stick with music for long, going on to star in the television series *Baywatch*, pose for *Playboy*, briefly marry basketball star Dennis Rodman and become an icon of big-chested trashiness. Also out was the first album credited to Prince's backing band, The New Power Generation, titled *Goldnigga*. The Artist was behind much of its music, which was fronted on the disc by his backup rapper Tony M.

1994

There was additional evidence of the Artist's disintegrating relationship with Warner Brothers throughout the year. His personal label, Paisley Park Records, was terminated in February, eliminating his ability to easily release the projects of other artists. The move was hardly a surprise, as the label had failed to produce any real hits outside of Prince's own albums and the minor success of The Time's *Pandemonium*, which hit #18 on the Album chart.

The Artist planned to release a pair of albums at the end of the summer, following his final album as Prince with his first album under the symbol name a couple of weeks later. Warner Brothers balked at the prospect, so the only album he would release of his own choosing that year was *Come*, which came out in August and was packaged as if it were a sort of memorial service for Prince's old identity.

For fans who had followed The Artist's recent projects, *Come* is largely an exercise in review. Six of the 10 songs on the collection were part of the *Glam Slam Ulysses* lineup and the last song on the disc, "Orgasm," is little more than a guitar grind matched to a recycled recording of sexual moans by Prince's former paramour Vanity. The lead single, "Letitgo," hardly cracked the Top 40 before disappearing. Despite maxi-single releases that included seven new edits of that tune and four new versions of the second single, "Space," there was a very real feeling among Artist fans that he had just tossed out a bad album to get his label off of his back.

The Artist was clearly antsy. Shortly before the release of *Come* he issued a compilation record called *1-800-NEW-FUNK* under the aegis of his new NPG Records imprint, which featured music from compatriots such as The NPG,

(Discography from page 15)

Sexy M.F. (12" Remix 7:34)		
NPG 72514	The Most Beautiful Girl In The World/Beautiful	1994
Warner Bros. 41745	Letitgo (Caviar Radio Edit 4:49) (Cavi' Street Edit 5:02) (Instrumental 5:02) (On The Cool-Out Tip Radio Edit 4:34)/(Sherm Stick Edit 5:42) (Original Radio Edit 4:15) (Original Album Version 5:33)	1994
Warner Bros. 41833	Space (Universal Love Radio Remix 3:58) (Universal Love Funk 6:10) (Funky Radio Remix 5:41)/(Acoustic Remix 4:41) (Funky Stuff Dub 4:48)	1994
Warner Bros. 43503	Purple Medley (11:03) (Edit 3:14)/Kirk J's B Sides Remix (7:01)	1995
Warner Bros. 43592	Eye Hate U (Extended Remix 6:17) (7" Edit 4:27)/(Quiet Night Mix by Eric Leeds 3:55) (Album Version 6:07)	1995
NPG (no number) (CD)	The Truth/Don't Play Me	1997
NPG 1999	1999 (The New Master 7:09) (Rosario 1:19) (The Inevitable Mix 5:44) (Keep Steppin' 4:33)/(Rosie And Doug E. In A Deep House 6:23) (The New Master Single Edit 4:30) (Acapella 5:11) (CD single; 12-inch vinyl is promo-only on purple vinyl)	1998
Arista 13750	The Greatest Romance Ever Sold (Radio Edit Featuring Eve 4:32) (Jason Nevins Romance Beats 6:03)/(Neptunes Extended Remix Featuring Q-Tip 5:08) (Jason Nevins Remix Edit 3:36)/(Adam & Eve Remix Featuring Eve 4:30) (Album Version 5:29)/(Jason Nevins Extended Remix 6:41) (Neptunes Remix Edit Featuring Q-Tip 3:42) (two LPs)	1999
Promotional 12-inch singles		
Paisley Park PRO-A-4345	Thieves In The Temple (Album Version 3:20) (same on both sides)	1990
Paisley Park PRO-A-4515	New Power Generation (Album Version 3:15) (same on both sides)	1990
Paisley Park PRO-A-4578	New Power Generation (Funky Weapon Remix 5:01) (same on both sides)	1990
(no label) JUN 7	Gett Off (Approx: Damn Near 10 Min.)/(B-side blank)	1991
Paisley Park PRO-A-4977	Gett Off (Urge Mix) (Urge Dub) (Flutestramental)/(Thrust Mix) (Thrust Dub) (Rosie's Dub)	1991
Paisley Park PRO-A-5137	Cream (Remixes)	1991
Paisley Park PRO-A-5141	Insatiable (Edit 4:01) (Album Version 6:37)	1991
Paisley Park PRO-A-5148	Diamonds And Pearls (Edit 4:20) (Album Version 4:45)	1991
Paisley Park PRO-A-5298	Money Don't Matter 2 Night (Edit 4:11) (Album Version 4:48)	1992

Paisley Park PRO-A-5301 (no label) L-39777	Willing And Able (Edit 4:15) (Album Version 4:59)	1992
Paisley Park PRO-A-5570	Sexy MF (5:25) (same on both sides) (gold vinyl)	1992
Paisley Park PRO-A-5770	Sexy MF (5:25) (same on both sides)	1992
Paisley Park PRO-A-5890	My Name Is Prince (Edit 4:05) (6:36)	1992
Paisley Park PRO-A-5985	Damn U (Album Version 4:01) (same on both sides)	1992
Paisley Park PRO-A-5993	The Morning Papers (Album Version 3:57) (same on both sides) Pink Cashmere (Vocal Version 3:56)/(Guitar Version 3:58) (Album Version 6:12)	1993
Paisley Park PRO-A-5994	Nothing Compares 2 U (Edit 4:17) (Album Version 4:58)	1993
NPG SPRO 72516	The Most Beautiful Girl In The World (Staxowax 5:00) (Mustang Mix 6:22) (Brian's Mix 4:30)/(Beautiful 5:55) (Original Mix 4:39)	1994
Warner Bros. PRO-A-7000	Letitgo (Edit 4:17) (Album Version 5:33)	1994
Warner Bros. PRO-A-7481	Purple Medley (Edit 3:34)/(11:03)	1995
Warner Bros. PRO-A-7594	Eye Hate U (Edit 4:27) (5:58)	1995
Warner Bros. PRO-A-7941	Gold (Album Version 7:23) (Radio Edit With Guitar Solo 4:22)/(Rock 'N' Roll Is Alive! (And It Lives In Minneapolis)/Gold (Alternate Radio Mix With Guitar Solo 4:36) (gold vinyl)	1995
NPG SPRO-11672	Somebody's Somebody (Ultrafantasy Edit 3:45)/(Radio Edit 4:30) (Live Studio Mix 3:45)	1997
NPG SPRO-11698	Face Down (X-tended Rap Money Mix 4:56) (Instrumental Money Mix 3:58)/I Can't Make You Love Me (Album Version 6:38)/(A Cappella 2:21)	1997
Arista ARDP-3750	The Greatest Romance Ever Sold (Radio Edit Featuring Eve 4:32) (Jason Nevins Romance Beats 6:03)/(Neptunes Extended Remix Featuring Q-Tip 5:08) (Jason Nevins Remix Edit 3:36)/(Adam & Eve Remix Featuring Eve 4:30) (Album Version 5:29)/(Jason Nevins Extended Remix 6:41) (Neptunes Remix Edit Featuring Q-Tip 3:42) (two records)	1999
Arista ARDP-3764	The Greatest Romance Ever Sold (Album Version 5:30) (Radio Edit 4:30)/(Adam & Eve Remix Featuring Eve 4:28) (Radio Edit Featuring Eve 4:32)	1999
Arista ARDP-3783	The Greatest Romance Ever Sold — Jason Nevins Mixes (four versions)	1999

Promotional CD singles

Paisley Park PRO-CD-4305	Thieves In The Temple	1990
--------------------------	-----------------------	------

(Please see Discography page 17)

Mavis Staples, and George Clinton. It was telling of his priorities when he made a promotional appearance on the *Today* show July 12 that he performed his single from the compilation, a duet with Nona Gaye titled "Love Sign," rather than material from his soon-to-arrive Prince release.

The 1-800-NEW-FUNK set was distributed by Bellmark records, as was the Artist's independent release of a single Warner Bros. refused to issue, "The Most Beautiful Girl In The World." The song went on to become a huge hit internationally, spawning an EP of remixes and renditions by everyone from Brian Gallagher, The Artist's saxophone player at the time, to Mayte Garcia, who had been promoted from featured dancer in his stage show to the role of The Artist's girlfriend.

Warner Bros. did release a second Prince album that year when his legendary (and much-bootlegged) collection *The Black Album* hit stores in late November. The Artist was reportedly unhappy with the release of the disc, which he had pulled shortly in advance of its original Dec. 7, 1987, release date, and he later asked fans not to buy bootleg copies of it when he issued his 1988 set *Lovesexy*. *The Black Album* was put on sale for a limited time, although it remained available in stores long after its Jan. 25 off-market date while it sold through.

In May, The Artist closed a deal to set up a Glam Slam club in Miami's South Beach, taking over a building that had been a theater in the 1930s and the popular gay nightclub Paragon in more recent years. In June came the release of The Artist-themed CD-ROM *Interactive*, a game conceived as an exploration of the Artist's world (essentially a walk through a building with Artist trophies at every turn) that was perhaps most interesting for its new title track.

Later in the year came the announcement that The Artist was working on large quantities of music for the film *Showgirls* and an accompanying stage show. In the end, the movie tanked badly, the stage show never happened and just two Prince songs ("319" and "Ripogodazippa") showed up in the film although both were kept off of the movie's soundtrack release. In other film-related news, August saw the belated commercial release of the video *3 Chains O' Gold*, which strings together a dozen videos of tunes from the symbol album and some very badly acted additional material intended to add plot to the proceedings. Some of the music videos are worth watching, but there is little else to recommend it.

1995

The buzz with which his suggestive dancing with Garcia during his performance at the American Music Awards in February was greeted showed that The Artist could yet cause a stir in a conservative industry, but most talk about him still centered on his increasingly public, increasingly ugly dispute with Warner Brothers. However the conflict proceeded, The Artist still managed a productive year.

Most prominent among his 1995 releases was *The Gold Experience*, the disc originally intended for release shortly after *Come*, which hit stores Sept. 26. A joint venture between Warner Brothers and NPG Records, it included the album release of the played-out "The Most Beautiful Girl In The World," two more of the *Glam Slam Ulysses* tunes (among which was the wretched "Dolphin") and one *Showgirls* retread. Among the finer things it offers are the acoustic guitar-wrapped quirky charms of "Shy," the gutty first release "Eye Hate U" (made better as a single for having cut out an overly long middle passage) and the soaring title track. The album sold well out of the gate but faded quickly for want of a smash single, moving nearly half a million copies by the Friday of its first week in stores according to early reports but remaining close to that number a year later. By the time the century ended, the disc would be out of print.

Not nearly so well-known is the import-only, Artist-driven release of the second album credited to The New Power Generation, *Exodus*. Featuring a very different lineup than the first NPG album (including The Artist, barely hidden behind a red scarf and called "Tora Tora") and a very different funky sound, *Exodus* is perhaps the most fun of any Artist/Prince release ever. Several funny character sketches filled gaps between some of his loosest material in years, highlights among which are the rollicking "Return Of The Bump Squad" and "Get Wild" and the supple, nostalgia-free ballad "Count The Days."

Also made available as an import was Garcia's first solo album, *Child Of The Sun*. Memorable largely for its retooling of a Commodores staple to call her "mighty Mayte" in the pumping "House Of Brick (Brick House)," the album is otherwise almost entirely composed of songs written and performed by The Artist as a platform for her thin but not unappealing vocals. Unlike past projects for which he denied running things from behind the scenes, *Child Of The Sun's* packaging played up The Artist's involvement and his appear-



ance on the duet "However Much U Want," but no matter how it was marketed, it was his third-best album of the year.

Casual listeners may remember "The Purple Medley," a stitching together of many of Prince's greatest hits that got a bit of airplay in a 3:30-minute version. The full-length medley is more than 11 minutes and includes bits of everything from the B-side favorite "Erotic City" to the Sheila E. collaboration "A Love Bizarre."

Portraying it as a decision to spend as much time as possible close to his Minneapolis roots, The Artist announced in August that he was selling his home and the Glam Slam club in Los Angeles. In truth, the decision may have also been made for financial reasons, because by October the Glam Slam in Minneapolis had closed as well. The Artist got a tax refund

(Please see Prince page 41)

(Discography from page 16)

Paisley Park PRO-CD-4515	New Power Generation (Part 1 & Part 2)	1990
Paisley Park PRO-CD-4578	New Power Generation (Funky Weapon Remix)	1990
Paisley Park PRO-CD-4977	Gett Off (six versions)	1991
Paisley Park PRO-CD-4985	Cream	1991
Paisley Park PRO-CD-5148	Diamonds And Pearls (Edit) (Album Version)	1991
Paisley Park PRO-CD-5298	Money Don't Matter 2 Night (Edit) (Album Version)	1992
Paisley Park PRO-CD-5770	My Name Is Prince (Edit) (Album Version)	1992
Paisley Park PRO-CD-5890	Damn U	1992
Paisley Park PRO-CD-5981	7 (Acoustic Version 3:54)	1992
Paisley Park PRO-CD-5985	The Morning Papers	1993
Paisley Park PRO-CD-5992	Peach	1993
Paisley Park PRO-CD-5993	Pink Cashmere (three versions)	1993
Warner Bros. PRO-CD-7000	Letitgo (Edit) (Album Version)	1994
Warner Bros. PRO-CD-7204	Letitgo (six versions)	1994
Warner Bros. PRO-CD-7241	Space (five versions)	1994
Warner Bros. PRO-CD-7481	Purple Medley (Edit) (11:14 Version)	1995
Warner Bros. PRO-CD-7594	Eye Hate U (Edit) (Album Version)	1995
Warner Bros. PRO-CD-7793	Eye Hate U (Edit No Guitar Ending) (Edit) (Album Version)	1995
Warner Bros. PRO-CD-7941	Gold (four versions)/ Rock 'N' Roll Is Alive! (And It Lives In Minneapolis)	1995
Warner Bros. PRO-CD-8287	Dinner With Delores	1996
NPG DPRO-11657	Betcha By Golly Wow!	1996
NPG DPRO-11658	Emancipation CD For Retail Listening Stations (30 excerpts)	1996
NPG DPRO-11662	Somebody's Somebody (Edit) (Album Version)	1997
NPG DPRO-11664	The Holy River (Album Version) (Edit)	1997
NPG DPRO-11672	Somebody's Somebody (The Remixes) (three versions)	1997
NPG DPRO-11698	Face Down (three versions)	1997
Warner Bros. PRO-CD-9419	1999 (Edit) (LP Version)	1998
Warner Bros. PRO-CD-9933	Extraordinary	1999
Arista ARPCD-3746	The Greatest Romance Ever Sold (Radio Edit) (Call-out Hook)	1999
Arista ARPCD-3754	Rave Un2 The Joy Fantastic (6-song sampler)	1999
Arista ARPCD-3775	The Greatest Romance Ever Sold (Jason Nevins Remix Edit) (Original Radio Edit) (Call-Out Hook)	1999
Arista ARPCD-3776	The Greatest Romance Ever Sold (Neptune's Remix Edit Featuring Q-Tip) (Jason Nevins Remix Edit) (Call-Out Hook)	1999

Full-length CDs

Paisley Park 27493-2	Graffiti Bridge (also includes tracks by Tevin Campbell, The Time, Mavis Staples, and George Clinton)	1990
Paisley Park 25379-2	Diamonds And Pearls	1991
Paisley Park 45037-2	{Symbol} (Explicit)	1992
Paisley Park 45123-2	{Symbol} (Edited)	1992
Paisley Park/WB 45121-2	{Symbol} (Gold Slipcase)	1992
Paisley Park 45431-2	The Hits 1	1993
Paisley Park 45435-2	The Hits 2	1993
Paisley Park 45440-2	The Hits/The B-Sides (three CDs)	1993
NPG 71003	The Beautiful Experience (multiple remixes of "The Most Beautiful Girl In The World")	1994
Warner Bros. 45700-2	Come	1994
Warner Bros. 45793-2	The Black Album	1994
Warner Bros. 45999-2	The Gold Experience	1995
Warner Bros. 46317-2	Chaos And Disorder	1996
Warner Bros. 46239-2	Music From The Motion Picture Girl 6	1996
NPG 54982-2	Emancipation (Explicit) (three CDs)	1996
NPG 55063-2	Emancipation (Edited) (three CDs)	1996
NPG (no number)	Crystal Ball (four CDs)	1998
Warner Bros. 47522-2	The Vault...Old Friends 4 Sale	1999
Arista 07822-14624-2	Rave Un2 The Joy Fantastic	1999
NPG 78533 72000-2	Rave Un2 The Joy Fantastic (remix album, only available online)	2001
Rhino R2 74272	The Very Best Of Prince	2001
Redline 70004	The Rainbow Children	2001
Vinyl LPs		
Paisley Park 27493-1	Graffiti Bridge (also includes tracks by Tevin Campbell, The Time, Mavis Staples, And George Clinton) (two records)	1990
NPG 71003	The Beautiful Experience (multiple remixes of "The Most Beautiful Girl In The World"; issued with poster)	1994
Warner Bros. PRO-A-7270	Come (two records, promo only)	1994
Warner Bros. PRO-A-7330	The Black Album (promo only)	1994
Warner Bros. 45793	The Black Album (promo only; 1,350 copies pressed, 50 on gray marbled vinyl numbered from 001 to 050, 300 on white vinyl numbered from 051 to 350, 1,000 on peach vinyl un-numbered)	1994
Warner Bros. PRO-A-7835	The Gold Experience (promo only, gold vinyl, two records in numbered jacket)	1995
Arista 07822-14624-1	Rave Un2 The Joy Fantastic (two records)	1999

Classical Notes

A NEW WORLD SYMPHONY FROM THE OLD WORLD

by Peter Gutmann

A bizarre aftermath of Sept. 11 has been a resurgence of protest over how American influence has allegedly sullied the purity of other civilizations, depicting us as a sort of pernicious cultural kudzu overrunning and smothering the world's pristine artistic gardens. But unlike most of the other insidious and groundless propaganda claims that have burgeoned recently, to this one there's a kernel of truth.

After all, with its ready availability and massive appeal, American culture has dominated much of the last century, and its reign promises to continue. While foreign purists may have covered before incursions of Franglais and Andy Warhol soup cans, our threat to most arts hardly warranted fears of irreparable corruption. In music, though, the uniquely American developments of jazz, blues and rock surely have permanently transformed world culture. So perhaps it's worth recalling that our own roots originated overseas in the first place.

In the late 19th century, European art was roused by the same surge of nationalism that had already transformed Old World politics, as varied cultures found and proudly proclaimed their distinctive voices. But while American literature already had staked a formidable reputation, our serious music (along with painting and theater) remained mired in Old World models.

That didn't sit well with a handful of American patrons who sought to develop and project our own national character. Among them was Jeanette Thurber, wife of a wealthy New York merchant, who had founded the National Conservatory Of Music, a pioneering venture that opened its doors in 1888 to promising African-American musicians but needed strong leadership. She found it in Antonín Dvorák (1841-1904).

Influenced and inspired by his compatriot Bedrich Smetana, Dvorák had achieved great fame as an ardent champion of his beloved Czech music, fluently melding folk-tinged melodies into classical forms. But unlike Brahms, Liszt and other composers who studied folk music from an academic distance and used it as a fleeting exotic diversion, Dvorák's "Moravian Duets," "Czech Suite," "Slavonic Dances" and other cornerstones of his early fame were the very essence of his being.

Born and raised a Bohemian peasant, Dvorák never strayed far from his roots. Like the saying goes, you can take the boy out of the country, but you can't take the country out of the boy. He loved simple pleasures, was enthralled by trains and far preferred a chat with manual laborers to learned discourse. This humble man brought Czech music to the world's attention by showcasing its intrinsic appeal. He often is compared to Schubert, with whom he shared effortless melodies, spontaneous harmony and a relaxed ease, but Schubert's music wafted from Viennese taverns, while in Dvorák's you could feel the fresh rustic breeze and smell the hale country air.

Dvorák was lured to New York in 1892 with the promise of a fee 20 times his salary in Prague. Upon arrival, he enthusiastically grasped Thurber's charge. He proclaimed, "I am convinced that the future music of this country must be founded on what are called Negro melodies. These can be the foundation of a serious and original school of composition, to be developed in the United States. These beautiful and varied themes are the product of the soil. They are the folk songs of America, and your composers must turn to them." True to his word, Dvorák immersed himself in African-American music. He was particularly drawn to one of his students, Henry Burleigh, who often sang for Dvorák in his home and who later recalled that Dvorák "saturated himself in the spirit of these old tunes."

Much of his time in America was occupied by teaching and organizing performances. But above all else Dvorák was a composer, and in his first winter in New York he began to write the symphony that would become his most cherished. (It was completed that summer on vacation in Spillville, Ohio — a colony of Czech immigrants who helped assuage Dvorák's

intense homesickness.) Formally, the work fell solidly within European tradition, with a sonata-form opening, a meditative *largo* broken by restless outbursts, a lusty *scherzo* with bucolic *trios* and a vigorous, triumphant finish. In keeping with the emerging trend of cyclical form, its theme all generated from a common seminal motif and returned in the finale. But beginning with its hugely successful premiere that December, its subtitle *From The New World* generated considerable confusion over its inspiration and thematic content.

Resemblance to the atmosphere of Dvorák's prior work suggested to some commentators that the work was most heavily influenced by nostalgia for his beloved Bohemia. But assuming that Dvorák had set out to practice what he preached, others seized upon the prevalence of the syncopated rhythms, pentatonic scales and flattened sevenths of our native music to find a closer tie to America. They noted Dvorák's fascination with the "Hiawatha" legend and traced the symphony's *largo* and *scherzo* to scenes of the funeral and celebratory feast from an opera he had sketched but never pursued. They found espe-

...the uniquely American developments of jazz, blues and rock surely have permanently transformed world culture. So perhaps it's worth recalling that our own roots originated overseas in the first place.

cially significant the resemblance of a principal theme of the first movement to "Swing Low, Sweet Chariot," reportedly one of Dvorák's favorite spirituals. But such speculation has its dangers — it's hard to find much meaning in the far more striking resemblance of a motif in the finale to "Three Blind Mice." Subsequent critics who went so far as to assert that Dvorák copied his *largo* from a hymn, "Goin' Home," were chagrined to realize that the song arose only decades later when lyrics were grafted onto Dvorák's original theme.

The composer himself derided as "nonsense" claims that he used actual Indian- or African-American tunes and insisted that he only wrote "in the spirit" of native American music. In a delightful 1956 lecture, Leonard Bernstein examined each of the themes, traced their origin to French, Scottish, German, Chinese and, of course, Czech sources and concluded that the only accurate assessment was to consider the work multinational. But as New York critic James Huneker pointed out in a discerning review of the premiere, the *New World* symphony was distinctly American in the sense of being a composite, reflecting our melting-pot society. Indeed, much the same could be said for our culture generally — it's made of foreign parts but emerges from the workshop with a clear American accent.

When Dvorák returned home in 1895, he left behind a legacy even greater than Thurber had dared to dream — the very first piece of serious music that, regardless of its traditional form and disputed sources, somehow managed to embody and convey the American spirit. Wildly popular, Dvorák's *New World Symphony* served as an ambassador to legitimize American music to the rest of a dubious world and paved the way to acceptance of our 20th century cultural exports.

It seems altogether fitting that so many fine recorded performances of the *New World* were led by conductors raised in Dvorák's own Czech traditions, including Karel Ancerl, Istvan Kertesz, Raphael Kubilek, Vaclav Neumann, Libor Pesek, Joseph Suk, Vaclav Talich, and Pavel Urbanek. Most of these tend to be smooth, patient and flowing, largely devoid of intensive interpretive touches and, by letting the piece speak for itself, serve to demonstrate just how fine a work it really is.



Two of the greatest such *New Worlds* were led by Fritz Reiner and George Szell, who were born in Budapest but followed in Dvorák's footsteps and made careers in America. Both Reiner's reading with the Chicago Symphony (on RCA CD 62587) and Szell's with the Cleveland Orchestra (Sony MH2K 63151, coupled with splendid performances of Dvorák's two preceding symphonies) are played with precision and loving care, moderately paced and brim with graceful detail.

In keeping with the character of the work, more distinctive and individual interpretations come from emigrants who contributed to the richness of our music. Paul Paray, hailing from France, led the Detroit Symphony in a lean, sharp and propulsive reading that's the fastest on record (Mercury 434 317). Arturo Toscanini (Italian) with the NBC Symphony was clean and classic in the studio (BMG 60279) and more emphatic in concert (Arkadia 417). Bruno Walter (German), with the Hollywood-based Columbia Symphony, radiates a tender warmth (Sony 64484). Leopold Stokowski (English, but among the most fervent advocates of our music), was impulsive and improvisatory (even adding climactic "improvements" in his six (!) recordings, of which the most unbuttoned and thrilling was with his hand-picked American Youth Orchestra in 1940 (Music And Arts 841).

It seems especially apt that the *New World* received two of its finest performances from the most influential American-born conductor. Leonard Bernstein's 1962 reading with the New York Philharmonic (Sony 47547 or 60563) pulses with the very type of brash, idealistic enthusiasm that inspired Dvorák to have created it. (Incidentally, don't be misled by timings — Bernstein's 11-minute opening movement is every bit as swift as Toscanini's eight and a half; the difference lies in a repeat of the entire exposition rather than the tempo.) Bernstein's poignant *largo* and bounding *scherzo* lead to a massive finale, a deeply moving vision of a future filled with strength, resolve and dignity that seems especially timely. A 1986 remake (DG 427 346) is more deliberate and profoundly moving, played with great feeling by the Israel Philharmonic, an ensemble founded by Holocaust refugees who surely knew the meaning of freedom.

But analyses of art should never be so simple. Indeed, an even more striking performance generated mystery over its confusing origins and still raises intriguing questions over its pedigree. When the records first surfaced from wartime archives, they were thought to comprise a 1941 Berlin Philharmonic concert by Wilhelm Furtwängler, who had programmed this work during the war and was known for irritating his Nazi overseers by championing music of "enemy" peoples. Its 1981 release on a Swiss LP bore authentication by three musicologists and one of Furtwängler's musicians, but further research concluded that it was by the Munich Philharmonic led by Oswald Kabasta in one of his very last performances from July 1944. With seething melodrama and blazing intensity, Kabasta internalized the *New World* and transformed it into a tortured and desperate cry for a freedom he would never taste — distraught by his wartime role, he killed himself in 1946. It's an emotional roller-coaster, festering in the dank air of repression, its nazy light filtered by skepticism, its deceptively smooth transitions teasingly sarcastic.

So — a Bohemian vision of a vital and free America potently conveyed by a conflicted Nazi. Ironic, to be sure, and yet compelling proof of the universality of great music.

Peter Gutmann can be reached via e-mail at pg@commlaw.com.

A Broad Abroad

REMARKABLY SATISFYING REISSUES & TRIBUTES

by Jo-Ann Greene

It's a good time to be a Medicine Head fan. *Two Man Band* (Angel Air, U.K.) is the latest in a growing succession of vintage reissues — this time, the John Fiddler/Peter Hope Evans duo's final album together, from 1976. Recorded with the all-star backing of Tony Ashton, Charlie McCracken, and BJ Cole, among others, *Two Man Band* caught Medicine Head at a major low point in their career — out of contract and beset on all sides by legal problems.

The band's internal relationships, too, were cracking, but still the record emerged a defiantly contrary collection of rootsy, bluesy gems, opening with a lonesome whistle and rattling on down a characteristically Medicine Head-shaped track from there. Three bonus tracks round out the story, the non-album single "Me And Suzie," plus a couple of lost B-sides. One reaches the end astonished that a band that still sounded this vital, vibrant and vivacious should have felt the need to break up.

Of course, some bands never break up — or so it seems. The public at large probably hasn't thought about Savoy Brown since their peak in the early 1970s. But a full decade later, the group was still going, and *Raw Live 'N' Blue* (Akarma, Italy, www.akarmarecords.com) serves up two CDs worth of early '80s Brown-braided blues.

Disc two, a studio session from 1980, is strong, but very, very strange — thinking of Savoy Brown, one imagines them blazing through the Willie Dixon songbook, pausing to drive a tank through the Motown catalog and then getting back to work blitzing Big Bill Broonzy. One doesn't think of them sitting around playing old Smokie records and saying, "Hmmm, that's a nice little toe-tapper. Let's do it."

But two of that band's songs appear here, their own "Run To Me," and the Nicky Chinn/Michael Chapman classic "Lay Back In The Arms Of Someone." Of course, Savoy Brown don't particularly sound like Smokie, and there's nine more Kim Simmons originals to keep things down to earth. Still, it's a shock, and it is, indeed, reassuring to turn to disc one and experience the skull-crushing magnificence that was recorded live at the Rainbow Music Hall, Denver, in June 1981.

The show captures the band churning wondrously through high-energy, high-tension hits set — "Street Corner Talkin'," "Hellbound Train," "Wang Dang Doodle" and 13 minutes-plus of "Tell Mama" are highlights that you simply won't get enough of. The sound is superlative, the audience is adoring and the band teeters so delicately on the brink between assault and battery that the blues probably still hasn't got out of the hospital. A phenomenal package.

Equally unrelenting and just as well-recorded is the latest live offering from the Gillan archive. *Live Tokyo October 1978* (Angel Air, U.K.) captures the band immediately after singer Ian Gillan finally decided he was sick of playing what he called "fusion shit" and returned to the hard-metal basics for which he was renowned. A new band built around keyboard player Colin Towns crashes through a set dominated by the latest album, *Gillan*, but finds room, too, for a couple of old Deep Purple chest-beaters — "Child In Time" and "Smoke On The Water" serve up few surprises, but they sound great regardless. An excellent booklet adds to the fun.

Classic metal fans will also want to wrap their skulls around *On The Move... Plus* (Angel Air, U.K.), the long-delayed British release for a Huw Lloyd Langton solo album first issued in Sweden in 1997. The former Widowermaker/lawkwind guitarist has been working steadily but quietly throughout the last decade, recording and gigging around Britain and Scandinavia. Somehow, however, this album — the seventh of eight HLL solo albums — slipped under the radar, and turning the stereo up to full-pain threshold, it's

impossible to understand why.

As early as the opening, "Got Your Number," Langton's unmistakable guitar scythes through the mix, raising an infectious hard-riffing rocker to the unimpeachable heights that hallmark all his work, while three bonus tracks drawn from the album sessions, loose-limbed covers of "Big Boss Man," "Shame Shame Shame" and "Rollin' And Tumblin'," update the blues with brutal intent.

Tribute albums have become so much a part of the landscape these days, one really has to hunt around to find anyone worthy of honoring who hasn't already been assaulted. Then you have to hunt even further to find one that actually does justice to its victim.

People On The Highway: A Bert Jansch Encomium (Market Square, U.K. — www.marketsquarerecords.co.uk) is one such tribute. Two CDs highlight 26 contributors, ranging from folk cult favorites such as Rab Noakes, Rod Clements, Eleanor McEvoy, and Steve Ashley, through genre giants Donovan, Ralph McTell, Al Stewart, Roy Harper, and Wizz Jones and onto some genuinely unexpected young blades. Ex-Smiths guitarist Johnny Marr (with Ringo Starr's son Zak Starkey on

The sound is superlative, the audience is adoring and [Savoy Brown] teeters so delicately on the brink between assault and battery that the blues probably still hasn't got out of the hospital.

drums!) and former London Suede mainstay Bernard Butler both drop in to pay their own tribute to one of the guitar's greatest maestros, while there's an equally surprising appearance from rock 'n' roll pioneer Duffy Power.

True, a few of Jansch's best-known disciples are absent — Marianne Faithfull, Julie Felix, Anne Briggs, Gordon Giltrap and, of course, Jimmy Page have all made vital contributions to the Jansch legend over the years, as Colin Harper (author of the definitive Jansch biography, *Dazzling Stranger*) points out in his liner notes. But even without these big-name draws, everybody comes out sparkling. Maybe it's the beautiful simplicity of Jansch's music, maybe it's the genuine affection that everybody seems to feel for him. But across two full CDs, there's not a dodgy moment in earshot, not one song that you listen to and wonder what on earth was going through the contributor's skull.

Also new from Market Square is the first ever solo album by Rod Clements, best-known to readers of this column as a former member of Geordie folk-rock loonies Lindisfarne. *Stamping Ground* is a gentle, reflective album that does, indeed, remind one of the Lindisfarne heyday — catchily rocking folk songs powered by lashings of harmonium, passing Dobros, occasional autoharps and, delightfully unexpectedly, mandolin and Northumbrian pipes.

"Roads Of East Northumberland," an ode to Clements' homeland, is especially moving, with the pipes swirling with the mist and the percussion (from ex-10cc drummer Paul Burgess) thrusting through the mood like the ancient standing stones that punctuate the landscape.

Still in folky territory, Akarma's series of classic Vanguard reissues turns up a quartet of albums that, to be honest, one never really expected to find outside of the vinyl collectors market. Encased within the lavishly packaged *A Reflection On Changing Times* box set, four Country Joe McDonald albums testify to the sheer wealth of wondrous weirdness that occupied his time during the early 1970s.

Nashville held an odd fascination for Vanguard artists of the era — Eric Andersen's *A Country Dream*, best-known for

its shit-kickin' cover of "Dock Of The Bay," has also just been reissued by Akarma. But even its bizarre pastures are eclipsed by McDonald's trip into town for 1970's *Tonight I'm Singing Just For You* — the earliest album in the box.

It is joined by 1971's *Hold On It's Coming* (featuring Peter Green, among others!), the seldom-heard *War War War* collection, inspired by the poems of wartime bard Robert Service, and 1973's controversial *Paris Sessions*, featuring Country Joe's All-Star Band. All of them have their fans, but only *Tonight...*, with its growling remake of Johnny Cash's "Ring Of Fire," tends to be ranked among McDonald's finest achievements.

Listening to its successors now, however, it's clear that history has done both him and us a disservice. Divorced from the baggage of what was then his recent past and divorced too from the expectations that he was trying to dodge during this period, *A Reflection On Changing Times* is exactly what its title says. It's the sound of one of America's most crucial performers wrestling himself out of the 1960s and finding his place in the new decade's new world. He succeeds as well, and it's just a shame it's taken this many years for most people to realize that fact.

As usual with Akarma, the packaging is superlative, restoring the original LPs' original artwork and packing in a 36-page booklet of biography, discography and lyrics. Great stuff.

Another remarkably satisfying reissue brings Sons Of Champlin's *Welcome To The Dance* (Acadia, U.K., www.evangeline.co.uk) hurtling back into focus. Originally issued in 1973, the Sons' fourth album, the LP was all but overlooked even by their most devoted followers. The group had virtually disbanded back in 1971, after all, and, though a new line-up did continue marching through 1972-73 under the aegis of the Grateful Dead, few people knew what to do with them.

Certainly Columbia, who picked up both the Sons and fellow Dead-friends Copperhead (featuring John Cipollina), were baffled, releasing *Welcome To The Dance* with barely a word to the public and then doing exactly the same thing with Copperhead. Their album, too, has just been reissued by Acadia — *Copperhead* is as patchily excellent as everything Cipollina was involved with at this time. If one overlooks the fact that it does all sound just a little old-fashioned, even by 1973 standards, there's little doubt that two more nuggets of a dimly remembered past have just grabbed back some of the spotlight they deserve.

Finally this month, a quick mention for the latest volume of that most illuminating of U.K. blues fanzines, *Blues Matters!* Issue #5 is the usual weighty (120 pgs) jamboree of reviews, features and interviews, this time featuring Pete Brown, Dick Heckstall Smith, Chicken Shack, Jo-Ann Kelly, John Hammond, The Yardbirds and more. Check it out at www.bluesmatters.co.uk.

Best of the rest

BEACON STREET UNION: *State Of The Union* (Akarma, Italy). A delightful three-CD box set serves up the Boston legends Beacon Street Union's first three albums, *The Eyes Of...*, *The Clown Died In Marvin Gardens* and *Come Under Nancy's Tent*. An excellent booklet accompanies the original LP artwork and a well-designed LP-sized box.

LARRY CORYELL: *Larry Coryell/Live At The Village Gate* (Universe, Italy). Straightforward reissues of two of jazzman Larry Coryell's most provocative albums: The first is a breathtaking panorama of moods and moments highlighted by the staggering "Elementary Guitar Solo #5"; the second is a 1971 concert set featuring a remarkable rendering of Jack Bruce's "Can You Follow?"

THE FROST: *Rock And Roll Music* (Akarma, Italy). Heavy-weight vinyl re-pressing of Dick Wagner and Co's half-live second album, Motor City madness at its most virtuoso vicious.

JIMMY JONES/CHARLIE WALKER: *In The House* (Crosscut, Germany). Volume two in Crosscut's acclaimed series of live recordings from Switzerland's Lucerne Blues festival serves up a dozen songs summarized by the penultimate title — "99,000 Watts Of Soul Power!"

SONNY LANDRETH & BAYOU RHYTHM: *Down In Louisiana* (Acadia, U.K.). From 1985, it's seething gumbo from the Big Easy, courtesy of Sonny Landreth & Bayou Rhythm.

TRACY NELSON/MOTHER EARTH: *Poor Man's Paradise* (Acadia, U.K.). The long-awaited reissue for Tracy Nelson's 1973 classic, *Poor Man's Paradise*, sounds as great as it ever did.

NEWTOWN NEUROTICS: *Punk Collection* (Captain Oi, U.K.). On this 23-track roundup of rare singles and EP tracks by the Harlow New Town horrors, Ramones fans will enjoy a pair of particularly deranged cover versions.

Unplayed records warehouse find: Gould brothers purchase 200,000 records — mostly 45s — from the late '80s–mid-90s

Never accuse John Gould Jr. of dabbling. Not involved in record collecting until this past May, he currently serves as steward over more than 200,000 unplayed records, mostly 45s from the late '80s to mid-90s. It's enough records to fill a semi-trailer, front to back, top to bottom and just barely be able to close the door.

One day in May, he just happened to be out to lunch with a friend of his, who suggested that Gould tag along when he went to look at a golf shirt. While at the store, his friend said, "with a curious smile on his face" to the store owner, "Why don't you show John the record collection?" Gould said.

His curiosity piqued, he followed the man down a maze of dimly lit hallways back to the warehouse. "It was like a movie," he said. The ceiling fans rotated in slow motion, shards of light pierced the windows, and "the smell of years gone by was hanging in the air.... We turned a corner and I found myself face-to-face with a mountain.... It was kind of a dreamlike situation." The possible result of a distributor going out of business, the shrinkwrap still remained on three of the 23 pallets of at least 70 boxes apiece sent from the record labels.

"I was in awe. It was a collection of every major artist in every major category.... My brain went 'tilt.' I couldn't believe what I was looking at. I couldn't speak."

The Georgia businessman had received the records as payment of a debt a few years back. After receiving the records, the businessman had spent six weeks cataloging what was there but had to stop. Gould reported him saying, "I gave up and went back to running my business." He told Gould that he'd always wanted to do something with the records, but he eventually conceded that he would have to get rid of them in order to expand his business into the warehouse space.

Gould, a musician who on the phone with *Goldmine* found it impossible to name just one favorite band, had played keyboards in local bands in the Northeast during his teens–late 20s in the early '80s, and he still performs in a rock band at his church. ("We really praise the Lord with a lot of power and might.") At the sight of the boxes of records stacked to the rafters, all he could think was, "How can I get my hands on the funds?"

Finally he decided to call his younger brother, Tom, owner of The Gould Group, which is a human resources firm in Albany, N.Y., that places people in jobs from management and sales to engineering, finance and the cement industry. In a day or so, the collection was purchased. Tom took it on his brother's recommendation and made the business deal sight-unseen, which he said was against the recommendation of his better half. "It sounded a little out there," he admitted. However, he added that a person doesn't have to be a hobbyist to appreciate what was stored in that warehouse. "I recognize if you have something that's mint or near mint, that's something special."

Turning the pallets of boxes into orderly rows of shelves took four guys four days, eight hours per day. The almost 1,500 boxes of records are currently stored in seven shelves 25 feet long and eight feet high. Many of the boxes of 200 singles contain eight smaller boxes of 25 records apiece, though MCA boxes contain 300 singles apiece.

"I found myself in the record business so to speak," John said. "I bought the *Goldmine Price Guide To 45 RPM Records* and called Tim [Neely, the author] the next day.... 'I'd be lost in the dark in the woods without you guys. I have a nice little library of Krause Publications [titles] now.'"

Neely, author of the new *Standard Catalog Of American Records 1976-Present*, said that

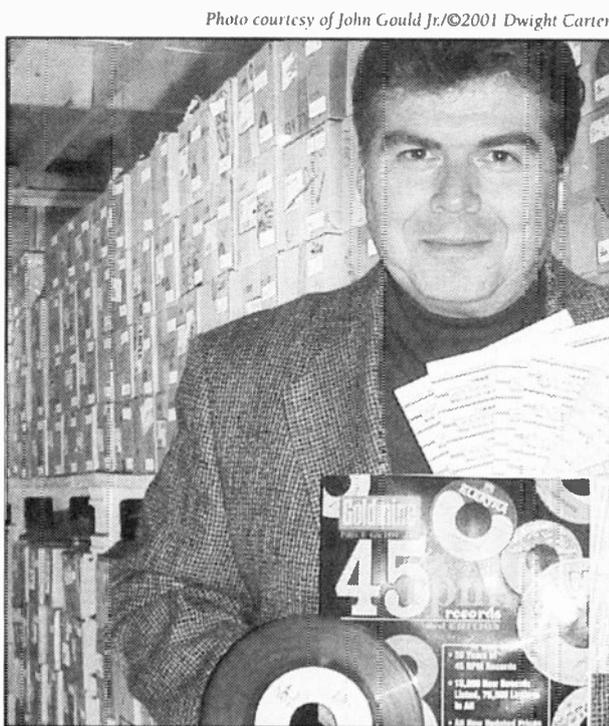

John Gould Jr., in front of one of the seven rows of records (eight feet high and 25 feet long) in his warehouse find.

the laws of supply and demand will apply to the sale of these records. Generally, the more time people put into selling a collection, the more return they will see. Warehouse finds of large quantities of single records can decrease the value of individual pieces while the stock is being sold, but he said it depends to whom the collection is being marketed.

"[The early 1990s] is a period where a lot of the general public seems to think that records 'died.' They disappeared from the Wal-Marts and Sam Goody's of the world, so as far as they knew, they disappeared entirely. Some of these items are still available from record distributors for \$2 or \$3 each. Those records that have disappeared from the distributors are the ones most likely to move.

"For most of the 1990s 45s, the price guide range is still \$3-\$4, and they might be able to get that for certain ones. Again, it depends on whether the records are still available from a regular distributor."

The Goulds' purchase includes colored vinyl, picture sleeve 45s, jukebox- only singles and reissues (complete with pages and pages of title strips), promos and even a few albums — about 10,000 or so, brand-new as well. There is a small amount of material that has been played, from the collection of a DJ (and some not played from that collection), as well as a smattering of new 45s from the late '60s and early '70s. Being singles, the material from the late '80s and early '90s could be quite collectible. That was the time when chain stores stopped stocking vinyl, and labels reduced the amount of 45s pressed for singles. Many contain B-sides or alternate mixes not found on any album or at least any vinyl album. (Sometimes bonus tracks would appear on the cassette and CD.)

"It's unique in its scope of artists, the sheer size of it and the fact that these have never been played," he said. "It's really hard to name an artist that we don't have."

The first time Tom saw the collection, "My thought was, 'It's going to take a long time to count.'"

Since the Gould brothers acquired the collection in May, it's taken an average of two people six to eight hours a day at least two days a week to count and catalog them all. That's about 800 work hours so far. John found that the initial cataloging was almost perfect, except where boxes were mislabeled. However, the spreadsheet index of the records stopped at O, and some boxes hadn't been labeled — and thus counted — at all.

"I'd call Tommy back and say, 'I found another 6,000 records [that weren't on the spreadsheet].'" Gould said. He estimated that

"Who isn't in here?"

Here's a sampling of the collection, a snapshot of the era:

Colored vinyl

Blind Melon: "No Rain"/"Tones Of Home"
Garth Brooks: "Learning To Live Again"/"Walking After Midnight"
Charlie Louvin And Roy Acuff: "The Precious Jewel"/"Buried Alive"
Paul McCartney: "C'Mon People"/"Down To The River"
The Proclaimers: "I'm Gonna Be (500 Miles)"/"Better Days"

Big country hits

Alabama: "Born Country"/"Until It Happens To You"
Garth Brooks: "The Dance"/"If Tomorrow Never Comes"
Alan Jackson: "Chattahoochee"/"Mercury Blues"
Reba McEntire: "You Lie"/"That's All She Wrote"
Restless Heart: "Bluest Eyes In Texas"/"Familiar Pain"
Randy Travis: "If I Didn't Have You"/"I Told You So"
Travis Tritt: "Can I Trust You With My Heart"/"A Hundred Years From Now"

Pop chart-toppers

Richard Marx: "Right Here Waiting"/"Wait For The Sunrise"
Milli Vanilli: "Blame It On The Rain"/"Dance With A Devil"
Mr. Big: "To Be With You"/"Green-Tinted Sixties Mind"
New Kids On The Block: "Step By Step"/"Valentine Girl"
Roxette: "The Look"/"Silver Blue"
Sir Mix-A-Lot: "Baby Got Back"/"Cake Boy"

Oh, what a great song that was

Black Crowes: "She Talks To Angels"/live video version
Tom Petty: "Runnin' Down A Dream"/"Alright For Now"
Bonnie Raitt: "Something To Talk About"/"I Can't Make You Love Me"
Stevie Ray Vaughan And Double Trouble: "The Sky Is Crying"/"Chilins Con Carne"
Whitney Houston: "The Star Spangled Banner"/"America The Beautiful"

"Hair" metal

Bon Jovi: "Bed Of Roses"/"Lay Your Hands On Me"
Guns N' Roses: "Don't Cry"/alternate version
Poison: "Unskinny Bop"/"Swamp Juice"
Slaughter: "Fly To The Angels"/"Desperately"
Warrant: "Uncle Tom's Cabin"/"Sure Feels Good To Me"

Oh, I remember that, now that you mention it

Taylor Dayne: "With Every Beat Of My Heart"/"All I Ever Wanted"
Information Society: "Think"/"Think"
Saigon Kick: "Love Is On The Way"/"All I Want"
Spin Doctors: "Little Miss Can't Be Wrong"/"Two Princes"
The Two Live Crew: "Banned In The U.S.A."/instrumental
The Simpsons: "Deep, Deep Trouble"/"Sibling Rivalry"

While many of these listed here were popular songs, collectors of particular artists or charts might be interested in some of the singles that didn't chart so high and thus weren't around stores as long, if at all.

an additional 22,000 records hadn't been represented on the spreadsheet. Based on the information on that document, three years ago the record collection had been appraised by two independent appraisers at between \$750,000-\$900,000. "We insured it for a million dollars immediately," he said.

Tom said he was also pleased to find out that the records' condition was all that the seller had said. In all his time with the records, John reported that he has only found two that were broken. Besides a little dust, there is not even a fingerprint on any of the records because any handling of them has always been with gloves.

"It's like finding an unopened vault of treasure," he said. Though he said that it's going to be difficult to let it go, it was purchased as a business venture. But how appropriate it is that a load of records might help him fund his dream of having his own recording studio.

Gould said that they are prepared to sell it in pieces over a couple of years, but for a limited time they will take offers on the entire collection, minus a slice of it (one of each 45) which they plan to donate to the Rock And Roll Hall Of Fame. They have credit card ordering set up, as well as a 1-800 number, web site: www.virginvinylclassics.com and e-mail: sales@virginvinylclassics.com.

— Cathy Bernardy

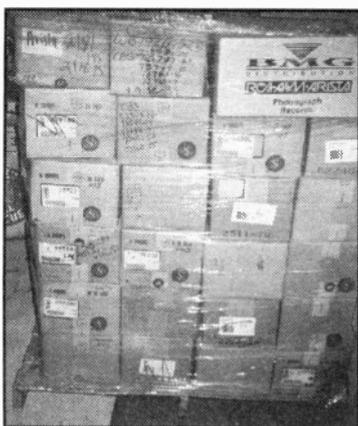

One of the three pallets shrink-wrapped for a decade.

Country Junction

At age 77, Earl Scruggs is enjoying a third career. From 1945 to 1948 in Bill Monroe's Bluegrass Boys and then, until 1969, with Lester Flatt (1912-79), he revolutionized banjo picking using the right thumb with the index and middle fingers for syncopation. In 1967, actor/director Warren Beatty raised Flatt & Scruggs' profile by making their "Foggy Mountain Breakdown" the theme to *Bonnie And Clyde*. During the '60s, they also played regularly on *The Beverly Hillbillies* television show.

Having realized from informal jams with saxman King Curtis that the banjo had roles beyond country, Scruggs bridged bluegrass and rock with sons Gary, Randy, and (now deceased) Steve in The Earl Scruggs Revue. An independent thinker, he amazed both sides of the fence by being conservative Nashville's only big name to join the Vietnam-era antiwar movement. His 1940s-1970s recordings are abundant on Mercury and Columbia (the original labels) and, through licensing, Bear Family, Collectables, County and Rounder.

In 1996, Earl survived a post-hip surgery heart attack (unlike Townes Van Zandt in '97). Now recovered, he has just released his first album in 17 years, *Earl Scruggs And Friends* (MCA Nashville). *Friends* include country's Marty Stuart, Travis Tritt, and Johnny and Roseanne Cash plus Sir Elton John and comedian/banjo pro Steve Martin. The album's producer is son Randy, whose previous credits include the AIDS fund-raiser *Red, Hot And Country*, The Nitty Gritty Dirt Band's *Will The Circle Be Unbroken, Volume 2* and Iris DeMent's *The Way I Should*.

8 Questions For...

Earl & Randy Scruggs

by Bruce Sylvester

Here Randy and soft-spoken Earl talk with *Goldmine*. It's often said that Flatt and Scruggs left Monroe's band intending to form their legendary duo. Earl revealed that isn't quite the true story.

Goldmine: *Your new album has plenty of non-country people playing on it, such as Elton John and Melissa Etheridge.*

Earl Scruggs: I like to do something different every time I do an album, and I try to get the greatest artists available.

Randy Scruggs: The Earl Scruggs Revue had performed "Country Comfort," so Elton was at the top of our list. He became the first artist to come on board. We called his office one morning to see if he'd be interested and got a call back that afternoon saying absolutely.

ES: We went to a recording studio in

Atlanta where he has a home. He said he had a box of my early recordings over in England but it didn't have an autograph, so he bought another set here for me to sign in the studio. It would be difficult to call "Country Comfort" bluegrass just because it has banjo and fiddle. Elton gave it his feel. Actually, I don't think the word *bluegrass* fits my album at all. Bluegrass isn't anything I'm ashamed of. I'm proud of it. But this isn't a bluegrass album.

RS: We didn't want just a remake of one of Dad's earlier versions of "Foggy Mountain Breakdown." We wanted to bring it freshness and collaboration. Interesting guest artists like Steve Martin, Leon Russell, and Albert Lee take part.

Did you know Steve Martin well beforehand?

RS: Steve came to many of our concerts for a while. He'd get together with Dad before sound rehearsal to study banjo with him.

ES: I've never seen anybody work harder to learn the banjo.

Earl, it's been said that for years neither you nor Flatt wanted your music called bluegrass.

ES: We didn't want our music put into categories. It wasn't even called bluegrass until the late 1950s. Before I came along, the banjo was often a part of comedy acts like Stringbean's.

Your wife's business skills are reported to have helped you hugely.

ES: I met Louise at a Grand Ole Opry show a year or so before I left Nashville for a while. At that time, I was on the road with Bill Monroe. I'd come home on weekends and see her. Then in 1948 I left Nashville and went back home where my mother lived in Shelby, N.C. I thought, "This won't work." So I proposed to her. When I left Nashville, I meant to leave the music business. I gave Bill Monroe four weeks notice, which was the standard. Lester Flatt, who was leaving Monroe about the same time, said, "Are you sure you'll be happy going back to factory work?" Then he called and asked if I wanted to do a show with him near my hometown, and we did it. That was the start of Flatt & Scruggs. Louise had a good education. She was an accountant. She started managing us in the '50s. We'd never really

Courtesy of MCA Nashville/photo by Pamela Springsteen



From left: Gary, Earl, Louise, and Randy Scruggs.

been managed before then.

RS: Her contributions are as unique as Dad's — her amazing ability to take music and represent people who play it and put them in the best light. In the '60s she booked Flatt & Scruggs at the Newport Folk Festival when no one from Nashville had been there. She introduced them to urban New York at Carnegie Hall at a time when a lot of people said, "You can't put a bluegrass band in a big city." She thought you could. She booked them at the Ash Grove in Los Angeles realizing that though it only seated 100 people, something important could happen. Paul Henning, who was writing and producing *The Beverly Hillbillies*, saw the performance and asked them to be on the show. She stood up for what she believed in.

Earl, did jamming with King Curtis broaden your musical philosophy?

ES: It sure did. We wanted to do an album together, but I was in Flatt & Scruggs then, and we never got to do it.

Your press kit says that you think that there are words to your banjo picking.

ES: I try to accent what the song is saying and let the words carry the tune. If you don't play the words to a song, it's just a bunch of hen scratchings. You're doing a lot of picking but not getting any point across.

Did you really grow up without a radio?

ES: Oh, yes. We got a battery-operated radio when I was 14 or 15. I was thrilled in North Carolina to hear something broadcast from Tennessee.

What do you two do for fun?

RS: Growing up, there was a foundation of music all the time: instruments, records. I've always felt music was an extension of my whole life. Fortunately I've been able to have a career that I love in that. Besides music, I have a daughter and wife. We spend a lot of time doing regular things together — just riding around.

ES: Music is just my entire life. I have no intention of stopping unless something bad happens to me. I grew up enjoying the banjo and music and never got over it. I hope I never will. Don't think I will.

NEWS & NOTES

The Corncob: The Warren Brothers have parted ways with BNA Records after two albums... **The Wilkinsons** — a casualty of Giant Records' closing earlier this year — have signed with the RCA Label Group... Ex-Capitol Records artist Deana Carter has a new deal with Arista Records. Meanwhile, **BlackHawk** — formerly with Arista — has signed with Columbia Records. Their debut for the label is slated for early 2002... Lari White has formed her own label: **Skinny White Girl Records**... **The Everly Brothers**, Dennis Linde, and the late **Johnny Russell** were inducted into the Nashville Songwriters Hall Of Fame... **Shania Twain's** video *The Specials* was released Nov. 20 on DVD and VHS. It features two 1999 CBS concert specials, *Winter Break* and *Come On Over*, in their entirety... **Willie Nelson** is writing a book for Random House, scheduled for a spring 2002 release... **Dolly Parton** postponed her New Year's Eve all-star bluegrass concert at Nashville's Grand Ole Opry House that was to benefit children affected by the Sept. 11 terrorist attacks (too many acts had previous engagements). Per Parton, the show will be rescheduled... On the mend: **Vern Gosdin** (from knee replacement surgery).

New Releases/Reissues: Nov. 27: **Benny Martin** — *The Big Tiger Roars Again, Pt. 2* (OMS Records). Dec. 4: *Best Of America* (patriotic songs by **Tim McGraw**, **Lee Greenwood**, **LeAnn Rimes**, etc.; Curb). Dec. 11: **Gene Autry** — *Paradise In The Moonlight* (Arpeggio Country); **Johnny Cash** — *America* (Legacy reissue of 1972 album) and *Ragged Old Flag* (Legacy reissue of 1974 album); **Rickie Simpkins** — *Don't Fret It* (Dobie Shea).

TV/Movie News: **Garth Brooks** performs an hour-long concert Nov. 28 on CBS. Brooks also contributed the music to the TNT original movie *Call Me Claus*, which premieres Dec. 2... Look for **Martina McBride** on a celebrity edition of ABC's *Who Wants To Be A Millionaire*. Air dates will be Nov. 29, Dec. 3 and 6... **Tim McGraw** will perform on the *Billboard Music Awards*, Dec. 4 on Fox... **Toby Keith** will appear on *Hollywood Squares* the week of Dec. 10... **CMT Programs:** **Waylon Jennings** sits down for a revealing conversation about his life and career on *CMT Inside Fame* on Dec. 3... The week of Dec. 10 features a five-part special on the most influential videos of the '90s on *The Big 4-0*... **Clint Black** and **Crosby, Stills, & Nash** team up on *CMT Crossroads* on Dec. 16... **Reba's** self-titled sitcom on the WB has been given a full-season commitment... A TV movie inspired by **Brad Paisley's** 1999 #1 hit, "He Didn't Have To Be," is in the works for the TBS cable channel. Paisley will have a supporting role in the movie and will also compose all of the music for it... **Wynonna Judd** has recorded the **Elvis Presley** hit "Burning Love" for *Lilo & Stitch*, an animated Disney movie to be released next summer... **Brooks & Dunn** have contributed a song, "Everyday Heroes," to the *Joshua* movie soundtrack. As always, check 'em out!

— Jim Bagley

On the racks

LYLE LOVETT
Anthology,
Volume One:
Cowboy Man
Curb MCA (088
170 234-2)



Courtesy of Curb MCA

In the mid-80s, newcomers Lyle Lovett and k.d. lang hit the charts with a quirkiness country music hadn't previously embraced. With his craggy face and Eraserhead coif, Lovett (like lang) knew how to make nonthreatening weirdness marketable. He had fresh perspectives on stock Texas images such as boots and Hereford bulls. Countless other country writers have ridden ponies, but not on their boats. This 15-track *Anthology* covers his first three albums. Two new songs show bluegrass stalwarts Sam Bush on mandolin and Stuart Duncan on fiddle shifting into Texas swing.

Though the deadpan Lovett gets the girl in enough songs to keep listeners upbeat ("I love my women, sometimes they love me"), he thrives on playing the outsider and underdog. "I went to high school. I was not popular," says country's only truck-driving character to meet German film director Wim Wenders by song's end. This retrospective's one bloodbath, "L.A. County," is so discreet that the good-time pedal steel-laced backup never hints at the denouement, as the meaning of "friend at your side" cleverly shifts back and forth from romantic to lethal.

Lovett is hardly the first to add jazz, folk and gospel to country music. It's his

outsider's stance and dryly comic intellectualism that make him unique.

— Bruce Sylvester

GARTH BROOKS
The Magic Of Christmas
Capitol (243-5-35624-2)

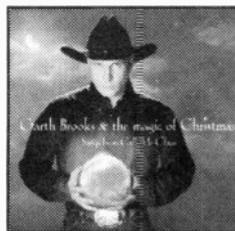

DEANA CARTER
Father Christmas Rouser (116 610 496-2)

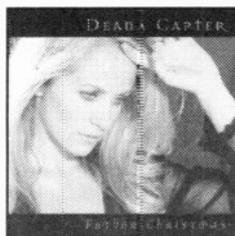

AARON TIPPIN
A December To Remember
Lyric Street (2061-65016-2)

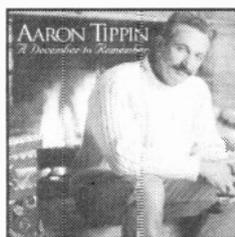

Compilations abound, but for the second year in a row, there are very few new Christmas releases by country artists. And — double bah humbug! — one of the three albums reviewed here is not even a completely new collection.

Garth Brooks' *The Magic Of Christmas* was actually released in 1999, but marketing master Brooks has re-released it with three new recordings from the TV movie *Call Me Claus*. They register two hits and a miss. The noisy opener, "Call Me Claus" is all swagger and no substance, but "Zat You Santa Claus?" strongly reprises the jazzy Louis Armstrong chestnut (on the latter, an animated Brooks is

delightfully unrecognizable). Faring best is the nativity tale "Mary Had A Little Lamb," which offers some welcome relief from Brooks' frequent histrionics. The remainder of the album is made up mostly of faithful renditions of familiar, modern Christmas classics ("Let It Snow," "Winter Wonderland," etc.). A note for those who bought the original *The Magic Of Christmas*: a CD single is also available of just the three new recordings.

Deana Carter's stripped-down rendition of "Carol Of The Bells" is one of the '90s best holiday singles. On *Father Christmas*, Carter reaches new levels of sparsedom, with the album comprised solely of her warm, clear vocals and some supple guitar work courtesy of her father, esteemed session musician Fred Carter. For the song lineup, Carter selected Christmas staples by some of her musical heroes such as Nat King Cole ("The Christmas Song") and Karen Carpenter ("Merry Christmas Darling"). What works once as a nice change of pace, however, becomes tedious by the 10th and final track, as all of these acoustic renditions start to sound the same. Folk fanatics and Carter devotees will probably enjoy this, but mainstream country listeners are apt to find it a tad boring.

Boring is one word never associated with Aaron Tippin. His *A December To Remember* effectively combines modern favorites tailor-made for his blue-collar twang such as "Jingle Bell Rock" and "Run Rudolph Run," traditional hymns such as "Away In A Manger" and "Silent Night" that showcase the lower regions of his burly baritone, plus seven great new songs, most of which are cowritten by Tippin and wife Thea. The new tunes cover a wide range of holiday-related topics, from the romp "It's A Good Thing Santa Ain't Single" (a humorous take on Santa as a gift-giving stud muffin) to the

poignant "He Said That He Was Jesus" (detailing the true story of a homeless man who claimed that he was Christ). Overall, it's a well-balanced, nicely executed collection.

— Jim Bagley

JOE DIFFIE
In Another World
Sony/Monument (ANK 85373)

Oklahoma native Joe Diffie has made his name as a country singer long on range, showing himself to be as capable of carrying tender ballads as he is of tearing up rowdy bar anthems. His performing strengths remain in evidence on *In Another World*, but his delivery throughout the collection is often more memorable than the pedestrian material it inhabits.

Diffie has a way of being convincing even when a song's lyrics are not, such as when he transforms the sentimentality of the string-filled title ballad into comfortable warmth. Similarly bland — and barely rescued — is the steel-guitar-etched bit of fluff "If I Lost Her." The pop-style country of "Live To Love Another Day" hardly registers but for its chorus hook, making it as forgettable as the puffy pledge of love "What A Way To Go."

Diffie has his finest moments when he leaves the beaten path of formula, adding a knowing playfulness to the raw-edged churn of "My Give A Damn's Busted." Other standouts include the pleasantly soft "Like A River Dreams Of Rain" and the reminiscence of a family member's funeral in "The Grandpa That I Know," which memorably offers equal parts ache and human strength. Diffie has great personality as a singer, so it's little surprise that the collection is at its best when he is put in a position to show it.

— Thomas Kintner

(Obituaries from page 12)

After leaving The Texas Playboys, Dacus took a regular day job in the aircraft industry. At the end of the war, he worked very briefly with Texas Player steel guitarist Leon McAuliffe. After working in the oil industry as a mechanic and pilot, he ran a small store in Benton County before he was convinced in 1954 to join G. Tom Thompson's radio station KAMO as a DJ.

In 1973, he recorded on the seminal Bob Wills & The Texas Playboys album *For The Last Time* (with Merle Haggard sitting in on fiddle and vocals).

In the 1984 Robert Benson/Sally Field movie *Places In The Heart* (the soundtrack is available on Varèse Sarabande Records), he accompanies Doc & Merle Watson And The Texas Playboys, including new versions of "Faded Love," "Ida Red" and "Right Or Wrong."

Survivors include two brothers, Jim and Tom. He was preceded in death by his parents, Hattie Pearl Hames and William Elmer Dacus, and the following members of the original 1935 Texas Playboys: Herman Arnsperger, Jesse Thedford Ashlock, Thomas Elmer "Tommy" Duncan, Clifton G. "Sleepy" Johnson, Thomas Caz "Son" Lansford, William Leon McAuliffe, Alton Meeks "Al" Stricklin, James Robert "Bob" Wills, and Johnnie Lee Wills.

— Eric S. LeBlanc

Dave Myers, Chicago blues musician

The distinguished and pioneering Chicago blues bass player, guitarist and singer Dave Myers died Sept. 3, 2001, at the Waterfront Terrace Nursing Center, in Chicago, Ill. He was born Oct. 30, 1926, in Byhalia, Miss., to

Mary Taylor and Amos Myers.

Dave's early mentors and teachers include Lee Cooper, Lonnie Johnson, Ernest (Little Son Joe) Lawlars, Robert Lee McCoy (a.k.a. Robert Nighthawk), Memphis Minnie, Tampa Red, Arthur "Big Boy" Spires, and John Lee (Sonny Boy) Williamson.

By the late 1940s, with Junior Wells, Louis Myers, and Fred Below Jr., he formed the nucleus of The Aces. In 1952, Little Walter (Jacobs) took Wells' place, and with The Aces, recorded for Leonard and Phil Chess at Chess Records. The Aces (billed as The Nightcaps or The Jukes) can be heard on Little Walter classics such as "Blues With A Feeling," "Mean Old World," "Off The Wall," "Oh Baby," "Sad Hours," "Tell Me Mama" and "Too Late."

Dave, his younger brother, guitarist Louis, and drummer Fred Below Jr. — collectively called The Aces — were one of the premier Chicago blues bands during the 1950s. In 1958, Dave Myers adapted his "trumping" rhythm guitar style to the Fender Precision bass and became one of the first to record Chicago blues with the electric bass. As a member of The Aces, the band recorded at least four albums in the 1970s for Black & Blue, MCM/Storyville (with Joe Carter, Johnny Drummer, and Bobby King) and Vogue (with Sammy Lawhorn and Eddie Taylor). In 1997, Black Top Records issued his only solo album, featuring Rusty Zinn, Kim Wilson, Johnny Nocturne (Firmin) and seven original selections including the title track, "You Can't Do That," and covers of songs by Fats Domino, Lowell Fulson, Little Walter, and Williamson. He can also be heard singing Lloyd Glenn's "Blue Shadows Falling," recorded at the 1977 Montreux Jazz Festival.

Other artists he recorded with, sometimes accompanied by The Aces, include Phil Alvin, Billy Boy Arnold, Carey Bell, Chuck

Berry, Lonnie Brooks, Eddie Clearwater, Arthur "Big Boy" Crudup, Willie Dixon, Buddy Guy, Earl Hooker, Howlin' Wolf, J. B. Hutto, Robert Lockwood Jr., Charlie Musselwhite, Andrew "Big Voice" Odom, Rockin' Johnny (Burgin), Jimmy Rogers, Dr. Ross, Hubert Sumlin, Sunnyland Slim, Roosevelt Sykes, Eddie Taylor, Koko Taylor, Junior Wells, and many others.

Survivors include his son, David Jr., and two sisters, Louise Porter and Nancy McCray.

— Eric S. LeBlanc

John C. Jaworowicz, songwriter/musician

John C. Jaworowicz, 49, of Jackson, Tenn., died in Nashville Oct. 28, 2001, of complications surrounding coronary heart disease. Jaworowicz founded the blues-rock band Blues Co-Op. As bass player, musician and vocalist, he managed the band through two decades of live performances plus released a CD of studio recordings on MRL Records, owned by his friend Rick Moore.

Jaworowicz formed and administered the publishing company Ort Cloud Music. An accomplished songwriter, his songs were recorded by The Allman Brothers Band, Koko Taylor, Little Milton, The Gregg Allman Band, Gov't Mule and many others.

He recently achieved popularity as a singer/songwriter in Poland, performing at several large blues festivals, and was one of the original founding members of the Nashville Blues Society. His formal education included a Bachelor Of Science in Accounting from Lambuth College in Jackson, Tenn.

The family requests that remembrances be made to the National Blues Foundation.

— Michael Buffalo Smith

(CMJ from page 10)

Plans For Global Domination." Furthermore, the regular traffic of attendees stopping in to sample panels was lower and thus made for fewer distractions. Perhaps people were more aware of making obvious entrances and exits.

Technology played a major role in many panel discussions this year, whether the topic was Internet radio, the Digital Millennium Copyright Act or Internet licensing. Ferguson's panel even talked about how Europeans are leading the way in licensing music for wireless communication devices. During "Culture Is Our Business: Music As Advertising Is Savvy Marketing, Or A Crass Sell Out?," moderated by Jeanne DaSilva, president of Vault Music Services, participants argued over the artistic integrity of licensing one's music out for commercials. Sometimes, though, the option is not always the artist's: one panelist revealed that Enya's *A Day In The Sun* has experienced a major sales boost because her music has been used on national news broadcasts covering the World Trade Center attacks. (The album has doubled its sales to quadruple platinum in two months, a fact about which she is supposedly unhappy, given the circumstances.)

Information overload aside, it was a quiet CMJ this year. But the low attendance, probably no more than 25 percent of normal levels, was not any indication of the Music Marathon's popularity or lack of importance to the industry; rather, it was the aftershock of a major event on the lives of all Americans. The festival should recover next year.

— Richard Skelly

BAGS Unlimited INC

FREE PHONE CALL CATALOG
1-800-767-BAGS

SEE PAGE 25 & BACK COVER FOR MORE AUDIO PROTECTION PRODUCTS

7 Canal St., Dept. A, Rochester, New York 14608-1910



http www.bagsunlimited.com • E-mail: info@bagsunlimited.com



OUR PRICES INCLUDE SHIPPING (except where noted). States of Florida, LA, MO, MN, and all states west of the Mississippi add 10% for shipping.

45 RPM RECORD

AUDIO CASSETTE

SLEEVE	45 Poly Record Sleeves	BOX	45 Record Storage Box	BOX	Corrugated Audio Cassette Box	MAILER	Audio Cassette Mailer
Made from High Clarity 100% Pure Virgin 2.5 mil Polyethylene.	7 1/2 x 7 1/4 *No Flap 100 \$7.65 500 \$22.80 1,000 \$37.00 5,000 \$168.90 PCode: S452S *2.5 mil with FLAP add 10%. Will not fit picture sleeves.	7 1/4 x 8 1/8 x 10 1/2 Holds 100 45's 2 \$17.00 5 30.00 10 52.50 25 105.00+ Frt PCode X45100CP WHITE Polypropylene PLASTIC corrugated. Acid Free, Anti-Static.	7 1/4 x 8 3/4 x 15 Holds 150 45's 2 \$10.60 5 21.75 10 37.70 25 74.80 PCode X45150 White corrugated cardboard.	4 1/2 x 2 1/4 x 15 1/2 2 \$7.60 5 16.00 10 24.00 25 49.40 50 86.85 Prod. Code XCAS20 Sturdy BLACK CORRUGATED BOX with 3" cover and three dividers. Holds 20 Audio Cassettes. Folds together without tape or glue.	4 1/4 x 2 1/4 Corrugated 10 \$4.80 25 9.05 50 16.50 100 29.90 200 53.60 400 95.60 Prod. Code MCAS1 Holds 1 Audio Cassette. Made from sturdy 175 lb. Test white corrugated. Tape closed.		

SLEEVE	45 Poly Record Sleeves	DIVIDER	45 Divider Cards	CASE	Audio Cassette Case	MAILER	Audio Cassette Mailer
100% Virgin Polyethylene	7 1/2 x 7 1/4 4 Mil 6 Mil 100 \$9.60 \$14.40 500 41.80 63.60 1,000 67.10 100.65 5,000 295.90 444.20 PCode: S454 S456 Heavy Duty/NO FLAP	MYLAR 4 Mil 25 \$16.40 50 26.30 75 32.85 100 38.10 PCode S455 S774R	CORRUGATED 7 1/4 x 8 15 \$7.60 30 11.95 45 15.95 90 27.05 210 57.40 PCode D45C 1/16" Thick Extra Strong White Corrugated.	PLASTIC 25 \$14.60 50 26.25 100 48.80 500 197.45 PCode D45P .03 gauge White Polystyrene.	Single Double/Back to Back 5 \$3.35 5 \$5.50 10 5.40 10 8.60 25 10.00 25 17.15 50 17.25 50 31.15 100 28.65 100 56.60 250 52.50 250 118.00+ Frt PCode CCAS PCODE CCAS2 All Clear Styrene cases. Norelco Style.	4 x 6 3/4 (Inside Dimension) Bubble Cushioned 25 \$7.10 50 12.95 100 22.00 250 49.30 500 86.10 Prod. Code MJ48 100% Recycled Kraft Exterior with recycled bubble lining. SELF SEAL FLAP! Mails 1 cassette.	

SLEEVE	7" Inner Sleeves	MAILER	45 Record Mailers	CLEANER	Audio Cassette Head Cleaner	Labels	'J' Card
50 \$8.80 100 11.80 500 48.70 900 80.60 1,800 152.35 3,600 240.25+ Frt PCode S7P Paper sleeve with Clear Poly lining	7 x 7 Poly 100 \$6.45 500 19.30 1,000 30.55 5,000 146.00 PCode S45 I Made from 2 mil Clear Polyethylene.	45 Mailer Folder 45 Mailer Box 7 1/2 x 7 1/2 7 3/4 x 7 1/2 x 1 1/2 10 \$10.60 25 18.70 50 30.40 100 52.40 200 99.00 400 180.50 PCode M456	10 \$11.80 25 20.50 50 33.55 100 57.50 200 104.55 PCode M4520	Discwasher® Cleaning Cassette 1 \$10.90 5 50.25 10 95.30 PCode AFG1244 Contains Cleaning Cassette, 1 oz. of cleaning fluid and 10 replacement cleaning pads. Comes Blister Packed.	Face Label 3 1/2 x 1 5/8 5 \$3.40 10 5.60 25 12.20 50 22.25 100 40.60 PCode LCASF 12 per sheet. Sheet size 8 1/2 x 11.	'J' Card Insert 10 \$2.15 25 5.15 50 6.95 100 12.85 500 36.05 1,000 60.05 PCode ACJC Printed one side black on white.	

JACKET	45 RPM Jackets	FILLER	45 Mailer Filler Pads	SHRINK WRAP CENTER																														
7 1/8 x 7 1/8 WHITE PAPERBOARD Center Hole No Hole 25 \$11.80 \$10.30 50 17.55 15.30 100 30.00 26.10 500 105.20+ Frt 91.30+ Frt 1,000 199.80+ Frt 178.30+ Frt PCode: S7JH S7J Replace original jacket or sleeve with our Rigid White 18 pt. paperboard.	7 3/8 x 7 3/8 50 \$13.75 100 19.05 250 31.90 500 51.55 1,000 97.90 Prod. Code F45 Use our brown corrugated filler pads to eliminate unnecessary inner package movement while absorbing handling shock.	<table border="1"> <tr> <th>PCode</th> <th>Sizes (in)</th> <th>Suggested Uses</th> <th colspan="3">Shrink Bags Price per Roll</th> </tr> <tr> <td>BSW58</td> <td>5 1/2 x 8</td> <td>Cassettes, CD's</td> <td>100</td> <td>500</td> <td>1,000</td> </tr> <tr> <td>BSW710</td> <td>6 5/8 x 10</td> <td>Double CD Case</td> <td>\$4.15</td> <td>\$16.40</td> <td>\$29.75</td> </tr> <tr> <td>BSW1313</td> <td>13 1/2 x 13 1/2</td> <td>Albums, Laser Discs</td> <td>6.05</td> <td>24.30</td> <td>43.40</td> </tr> <tr> <td></td> <td></td> <td></td> <td>14.80</td> <td>58.80</td> <td>112.00</td> </tr> </table>			PCode	Sizes (in)	Suggested Uses	Shrink Bags Price per Roll			BSW58	5 1/2 x 8	Cassettes, CD's	100	500	1,000	BSW710	6 5/8 x 10	Double CD Case	\$4.15	\$16.40	\$29.75	BSW1313	13 1/2 x 13 1/2	Albums, Laser Discs	6.05	24.30	43.40				14.80	58.80	112.00
PCode	Sizes (in)	Suggested Uses	Shrink Bags Price per Roll																															
BSW58	5 1/2 x 8	Cassettes, CD's	100	500	1,000																													
BSW710	6 5/8 x 10	Double CD Case	\$4.15	\$16.40	\$29.75																													
BSW1313	13 1/2 x 13 1/2	Albums, Laser Discs	6.05	24.30	43.40																													
			14.80	58.80	112.00																													

SLEEVE	7" Paper Sleeve	INSERTS	45 RPM Record Inserts	SHRINK FILM																												
WHITE Regular Weight Medium Weight Heavy Weight 50 \$7.70 \$9.50 50 \$9.90 100 10.80 13.50 100 15.95 500 34.00 38.50 500 52.10 1,000 61.60 70.95 1,200 106.80 2,000 77.95 97.35 2,400 196.90 4,000 124.60+ Frt 155.80+ Frt PCode: S7WR S7WM S7GOLD	*10 PACKS BULK 1 \$2.00 1,000 \$64.75 5 6.50 2,000 117.70 10 11.50 5,000 268.00 25 24.50 10,000 486.50 50 37.50 25,000 1,106.25 PCode ARI4510 ARI4510B Made from yellow, non-slip plastic. Snap-In Perfect fit. *Prices are per package of 10.	<table border="1"> <tr> <th>PCode</th> <th>Suggested Uses</th> <th>W (in)</th> <th>L (ft)</th> <th>Go.</th> <th>1</th> <th>3</th> <th>5</th> <th>10</th> </tr> <tr> <td>RSF8</td> <td>Cassettes, CD's, VHS</td> <td>8</td> <td>500</td> <td>.75</td> <td>\$59.00</td> <td>\$53.55</td> <td>\$50.00</td> <td>\$49.00</td> </tr> <tr> <td>RSF13</td> <td>Magazines, 8 x 10 Mats, Albums, Lobby Cards, 11 x 14 Mats</td> <td>13</td> <td>500</td> <td>.75</td> <td>61.85</td> <td>55.90</td> <td>52.00</td> <td>49.75</td> </tr> </table>				PCode	Suggested Uses	W (in)	L (ft)	Go.	1	3	5	10	RSF8	Cassettes, CD's, VHS	8	500	.75	\$59.00	\$53.55	\$50.00	\$49.00	RSF13	Magazines, 8 x 10 Mats, Albums, Lobby Cards, 11 x 14 Mats	13	500	.75	61.85	55.90	52.00	49.75
PCode	Suggested Uses	W (in)	L (ft)	Go.	1	3	5	10																								
RSF8	Cassettes, CD's, VHS	8	500	.75	\$59.00	\$53.55	\$50.00	\$49.00																								
RSF13	Magazines, 8 x 10 Mats, Albums, Lobby Cards, 11 x 14 Mats	13	500	.75	61.85	55.90	52.00	49.75																								

SLEEVE	7" Paper Sleeves	CLEANER	Record Cleaning	Heat Gun													
Colored Paper Sleeves 7 1/8 x 7 Minimum order - 50 sleeves per color 50 \$12.10 100 16.75 500 55.25 1,000 101.00 1,600 141.55 PCode: S45C Color code your 45 RPM Record Collection. Sleeves available in Blue, Green, Red or Yellow. SPECIFY COLOR!	Discwasher® D4+™ 1 1/4 oz. 1 \$3.00 3 8.25 5 12.50 10 22.00 PCode AFG1046 D4+™ leaves no residue. Preserves vinyl properties.	1 \$2.00 5 6.25 10 10.00 PCode ASA2 Contains a unique Anti-Static Solution. Lubricates and protects the record as it cleans.	<table border="1"> <tr> <th>PCode</th> <th>Description</th> <th>Watts</th> <th>1</th> <th>3</th> <th>5</th> </tr> <tr> <td>AHG</td> <td>Industrial Heat Gun</td> <td>1200W</td> <td>\$52.00</td> <td>\$141.00</td> <td>\$160.00</td> </tr> </table>			PCode	Description	Watts	1	3	5	AHG	Industrial Heat Gun	1200W	\$52.00	\$141.00	\$160.00
PCode	Description	Watts	1	3	5												
AHG	Industrial Heat Gun	1200W	\$52.00	\$141.00	\$160.00												

SLEEVE	7" Paper Sleeves	CLEANER	Record Cleaning Fluid	CUT OFF Heat Sealers																																
"Old Style" Green White Medium Weight Heavy Duty 50 \$9.90 50 \$10.20 100 15.95 100 17.10 500 51.80 500 54.70 800 74.00 1,200 123.20 1,600 140.40 2,400 200.90+ Frt 3,200 224.40+ Frt PCode: S7GRN	Groovy™ Cleaner 4 oz. 1 \$6.00 3 16.50 5 25.00 10 45.00 PCode AGC4 Bags Unlimited's own Record Cleaning Fluid. Deep Cleaning. Anti-Static, residue free. Pump Spray Bottle	<table border="1"> <tr> <th>Prod. Code</th> <th>Description</th> <th>Watts</th> <th>Length</th> <th>Mil</th> <th>Price</th> </tr> <tr> <td>AHS4C</td> <td>4" Hand Heat Sealer</td> <td>400</td> <td>4"</td> <td>1-6</td> <td>\$66.75</td> </tr> <tr> <td>AHS8C</td> <td>8" Hand Heat Sealer</td> <td>400</td> <td>8"</td> <td>1-6</td> <td>89.00</td> </tr> <tr> <td>AHS12C</td> <td>12" Hand Heat Sealer</td> <td>500</td> <td>12"</td> <td>1-6</td> <td>111.00</td> </tr> <tr> <td>AHS16C</td> <td>16" Hand Heat Sealer</td> <td>500</td> <td>16"</td> <td>1-6</td> <td>179.00</td> </tr> </table>					Prod. Code	Description	Watts	Length	Mil	Price	AHS4C	4" Hand Heat Sealer	400	4"	1-6	\$66.75	AHS8C	8" Hand Heat Sealer	400	8"	1-6	89.00	AHS12C	12" Hand Heat Sealer	500	12"	1-6	111.00	AHS16C	16" Hand Heat Sealer	500	16"	1-6	179.00
Prod. Code	Description	Watts	Length	Mil	Price																															
AHS4C	4" Hand Heat Sealer	400	4"	1-6	\$66.75																															
AHS8C	8" Hand Heat Sealer	400	8"	1-6	89.00																															
AHS12C	12" Hand Heat Sealer	500	12"	1-6	111.00																															
AHS16C	16" Hand Heat Sealer	500	16"	1-6	179.00																															

INSERT	7" Picture Sleeve Insert	CLEANER	Sponge	Shrink Wrap System with Gun																	
.030" Thick Chipboard 50 \$7.65 100 12.25 500 53.00 1,000 96.15 PCode: KCB3045 KAF2845 Protect the corners and edges of your 7" Picture Sleeves from bending or crushing. Use Cardboard Inserts	7 x 7 .028" Thick Acid Free 50 \$9.00 100 14.40 500 62.50 1,200 113.50 PCode: ACS2	Record Cleaning Sponge 2 per pack 1 \$5.00 5 20.00 10 37.50 Our super sponge is absorbent and dripless. Lint Free. Safe for vinyl.	<table border="1"> <tr> <th>Product Code</th> <th>Description</th> <th>Application</th> <th>1</th> <th>2</th> </tr> <tr> <td>ASW13</td> <td>13" Shrink System</td> <td>CD's, DVD's, Magazines, VHS</td> <td>\$250.00</td> <td>\$450.00</td> </tr> <tr> <td>ASWS18</td> <td>18" Shrink System</td> <td>Albums, Small Mats</td> <td>265.00</td> <td>480.00</td> </tr> </table>				Product Code	Description	Application	1	2	ASW13	13" Shrink System	CD's, DVD's, Magazines, VHS	\$250.00	\$450.00	ASWS18	18" Shrink System	Albums, Small Mats	265.00	480.00
Product Code	Description	Application	1	2																	
ASW13	13" Shrink System	CD's, DVD's, Magazines, VHS	\$250.00	\$450.00																	
ASWS18	18" Shrink System	Albums, Small Mats	265.00	480.00																	

PLEASE CHECK BOX IF YOU HAVE ORDERED FROM US BEFORE

VISA MasterCard C.O.D.

SIGNATURE _____

DAY PHONE () _____

EXP. DATE _____

CARD No _____

NAME _____

STREET ADDRESS _____

CITY _____ STATE _____ ZIP _____

NO POST OFFICE BOX NUMBERS FOR FedEx GROUND DELIVERY

Florida, States West of the Mississippi, including entire states of LA, MO, MN add 10% for shipping

CUSTOMER ACCOUNT # _____

SUB TOTAL _____

All orders under \$25.00 add \$4.00

C.O.D. orders add \$5.50

NY State Residents add 8%

TOTAL _____

BAGS Unlimited INC

FREE PHONE CALL CATALOG 1-800-767-BAGS

SEE PAGE 24 & BACK COVER FOR MORE AUDIO PROTECTION PRODUCTS

7 Canal St., Dept. A, Rochester, New York 14608-1910

FOR THE BEST IN CD PROTECTION

SLEEVE	Compact Disc Sleeves	CASE	Single CD Case	TRAYS	Pop-It Hub	Digi Pak	DISPLAY	Deluxe Stackable CD Rack
Made from 100% Pure Virgin Polyethylene 5 x 5 *2.5 Mil RESEALABLE FLAP No Flap 100 \$5.25 500 19.90 1,000 29.05 PCode: SCD525 Fits directly over CD.	2.5 Mil RESEALABLE FLAP No Flap	disc® 5 \$6.90 10 10.85 25 22.00 50 38.25 100 62.35 200 94.25 400 157.10+ Frt Prod. Code CCDS Qty per case	Clear Acrylic JEWEL Case with Black or Clear Tray. Specify Tray Color. 3/8" Thick Holds 1 CD and Booklet	Clear 25 \$10.00 50 17.00 100 28.40 200 46.40 400 71.40 PCode ACDTPC Clear Tray holds CD firmly in place. Disc "Pops" off center hub with one touch. Less disc stress, warping, scratching. Snaps into standard jewel case.	White or Black 5 3/8 x 4 7/8 x 1/4 25 \$11.75 50 19.50 100 32.45 200 53.00 400 89.40 Prod. Code ACDDTP Digi Pak Tray holds 1 CD. Can be glued into any promotional pocket. Specify color! Mix n' Match. Also holds DVD.	24 x 7 1/2 x 7 1 \$24.00 3 66.00 5 99.00 Prod. Code CCD52	Hold up to 52 CD Cases. Superior, hand crafted hardwood. Stackable racks come in oak finish or black finish. Specify when ordering.	
Made from 100% Pure Virgin Polyethylene 5 3/8 x 6 *2.5 Mil RESEALABLE FLAP No Flap 100 \$5.60 500 20.25 1,000 30.80 PCode: SCD625 Fits over Case.	2.5 Mil RESEALABLE FLAP No Flap	disc® 5 \$5.55 10 8.65 25 17.65 50 30.60 100 49.85 200 75.40 400 125.70+ Frt Prod. Code CCDSNT Qty per case	Clear Acrylic Case 3/8" Thick Holds 1 CD and Booklet	Black, Clear & Colors 10 \$6.25 25 9.80 50 16.25 100 27.05 200 44.20 400 70.05 Prod. Code ACDT Clear, Black, Opaque: Blue, Red, White, Yellow, Hunter Green, Irish Green, TRANSLUCENT: Red, Green, Pink, Peach, Amber, Blue, Lavendar, Fluorescent Green.	Mix n' Match.	23 1/2 x 19 3/4 x 7 5/8 1 \$55.00 3 148.50 6 267.30 Prod. Code CCD150 OAK or BLACK	Super Combo Storage Unit. Holds approximately 159 CD's or 96 Audio Cassettes in any combination. Solid hardwood construction. Specify OAK or BLACK finish. Assembled.	
4 15/16 x 4 7/8 CD & Booklet 100 \$12.00 500 51.15 1,000 86.20 Prod. Code SCDDPB	5 5/8 x 4 7/8 Also Holds Tray Card 100 \$12.70 500 54.30 1,000 91.50 Prod. Code SCDDPJ	disc® 5 \$6.15 10 9.70 25 19.80 50 33.10 100 65.00 Prod. Code CCDSL Qty per case	Clear Acrylic Case with Built-In Tray 3/8" Thick Holds 1 CD and Booklet 1/4" Thick edge allows you to store more CD's in 1/3rd less space.	Center Hinged / BLK or CLEAR 5 \$5.15 10 8.10 25 14.70 50 24.35 100 40.55 Prod. Code ACDT2CD-HC	Side Hinged 5 \$4.00 10 5.90 25 11.40 50 19.00 100 31.50 Prod. Code ACDT2D-HS	Multiple CD Jewel Cases Inside Dimension: 6 1/8 x 6 1/4 x 3 1/4 10 \$12.40 25 25.85 50 47.00 100 89.50 Prod. Code MCD8	Super double walled shipper. Ships up to 8 single CD's in their jewel cases. Made from sturdy white, corrugated cardboard.	
5 1/8 x 10 5/8 4 mil Made from 100% Pure Virgin Polyethylene 100 \$8.90 500 34.90 1,000 63.50 PCode SCDGF4	5 x 10 6 mil 100 \$12.40 500 48.35 1,000 84.05 PCode SCDGF6	BRILLIANT BOX® 5 \$10.30 10 16.00 25 32.20 50 55.90 100 66.95 disc® 5 \$7.20 10 12.35 25 25.75 50 41.20 100 53.60 Prod. Code C2CD-HS C2CD-HC Qty per case	2 CD-Compact Disc Case 3/8" Thick Holds 2 CD's. Clear acrylic case with Black or Clear hinged flipout tray. Specify when ordering.	Blister Pack 10 \$8.75 25 13.10 50 25.00 100 44.00 250 113.10 580 172.80+ Frt Prod. Code CBPS 10 mil Clear Plastic Hinged on bottom. Tape or Staple. Die cut hang up. Holds 1 CD Case.	5 x 10 3/8 Inside 5 \$4.00 10 5.90 25 11.40 50 19.00 100 31.50 Prod. Code ACDT2D-HS	Case Logic CD Pro™ Sleeves 50 \$20.35 100 33.40 250 73.80 500 134.30 1,000 255.75 5,000 1,027.45+ Frt 4 pockets per side. Prod. Code SCDPRO ACDPP	Case Logic CD Pro™ Sleeve and Pocket Pages feature Pro Sleeve technology. Backing material protects CD playing surface.	
Made from 2.5 mil 100% Pure Virgin Polyethylene INNER 4 3/4 x 4 3/4 No Flap OUTER 5 x 5 1/8 No Flap* 100 \$4.40 500 16.50 1,000 24.05 PCode SCD43425	5 x 5 1/8 No Flap* 100 \$4.85 500 18.40 1,000 34.45 PCode SCD51825	disc® 5 \$10.20 10 15.80 25 31.85 50 55.35 100 90.00 200 120.00+ Frt 400 216.00+ Frt Prod. Code C2CD-CT Qty per case	2 CD-Compact Disc Cases Clear Acrylic Case with CLEAR Tray 3/8" Thick Holds 2 CD's, 1 tray card and booklet. Crystal Clear Case and center hinged Crystal Clear Tray come assembled. 3/8" Thick. Trays NOT sold separately.	Security Devices - ALPHA Single 6 x 12 50 \$29.20 120 56.10 240 97.55 360 120.95 Prod. Code ACD900 Natural. Holds 1 CD case.	Double 6 x 12 x 1 50 \$46.50 100 74.40 200 124.00 300 179.55 Prod. Code ACD1800 Natural. Holds 1 Double CD Case.	CD Jewel Case 5 7/16 x 5 5/16 x 5/8 10 \$6.40 25 13.90 50 21.00 100 36.75 250 78.75 500 131.25 1,000 250.00 Prod. Code MMP MCD1 Made from sturdy White Corrugated.	CD Jewel Case Holds 1-3 CD Cases. 250 78.75 500 131.25 1,000 250.00 Prod. Code MMP MCD1 Made from sturdy White Corrugated.	
6 x 6 3/4 2.5 mil No Flap Made from 2.5 mil 100% Pure Virgin Polyethylene 100 \$5.90 500 21.10 1,000 31.40 PCode SCDDQ	13 5/8 x 13 1/8 3 mil with Flap 50 \$8.70 100 14.90 500 68.50 PCode SCDBS13	disc® 5 \$13.80 10 21.55 25 44.00 50 72.95 96 105.60+ Frt Prod. Code CCDD Qty per case	Double CD Case Clear Acrylic Case 15/16" Thick Holds 2 CD's. Includes 2 Black QB Clear trays. Specify Tray Color.	Security Devices - ALPHA Hand Held with Cable 1 \$30.00 3 70.00 Works with Cassettes, CD's & DVD's AFCK201 White with 27" steel cable and eye bolt.	Hand Key Hand Held No Cable \$6.00 15.00 AFAK127 White	Multiple CD Jewel Cases Inside Dimension: 6 1/8 x 5 1/8 x 5 3/16 10 \$8.00 25 15.50 50 27.55 100 52.50 Prod. Code PXMINS-PL	Ships up to 12 single CD's in their jewel cases. Made from Sturdy brown kraft, corrugated cardboard.	
4 15/16 x 5 Prod. Code SCDJW* Qty per case	CD Jackets - White Paperboard Die Cut one side	disc® 5 \$10.50 10 16.50 25 35.00 50 62.50 100 98.00 200 170.00 400 240.00+ Frt Prod. Code C3CD-HC Qty per case	3 CD - Compact Disc Case 15/16" Thick Holds 3 CD's. Clear acrylic case includes 2 Black Snap-in trays and 1 black center piece that holds 1 CD 1 side. Snap-in trays can be Clear. SPECIFY Tray Color. Holds 2 Tray Cards.	Corrugated CD Storage Box 6 x 6 x 16 1/4 2 \$10.60 5 22.55 10 37.10 25 88.50 Prod. Code XCD30 High-Tech design made from Black Corrugated Material. Three removable divider cards enable you to organize each unit to your own storage needs. Holds 25-30 CD's, 10 VHS Tapes or 100 Floppy Discs.	CD Mailer - Bubble Cushioned 7 x 6 1/2 (Inside) Ships 1 CD in a Jewel Case Peel Off 25 \$10.30 50 16.45 100 28.60 250 65.00 500 117.90 Prod. Code MJCD Qty per case	An economical way to ship one CD in a jewel box. 100% Recycled Kraft exterior with recycled bubble lining. Peel & Stick flap. SELF SEAL!		
5 x 5 Prod. Code S5W* Specify with or without Center Hole.	CD Paper Sleeves Die Cut one side	disc® 5 \$13.65 10 21.15 25 43.80 50 81.15 96 138.25 Prod. Code CCDD Qty per case	Quad CD Case Clear Acrylic Case 15/16" Thick Holds 4 CD's. Includes 2 Black Snap-in trays and 1 Black center-piece that holds 2 CD's back to back. Snap in trays can be Clear. Specify Tray Color.	Corrugated CD Big Box 15 3/4 x 15 3/4 x 6 1/8 2 \$15.30 5 34.60 10 63.90 25 145.15 Prod. Code XCD100 Holds 100+ CD's in six equal compartments. 18 CD's per compartment. Perfect for storage, travel or display. Made from 175 lb. test White Corrugated. Comes with 3" deep cover. Order DCD56P for Dividers.	White Rigid Cardboard 8 x 6 25 \$11.00 50 21.00 100 40.10 250 76.40 500 145.50 1,000 277.20 Prod. Code MCDWP68 Qty per case	White Cardboard mailer features Peel & Stick Flap. Mails 1 CD in jewel case. Perforated flap for end user "easy open".		
5 x 5 Paper 50 \$9.00 100 16.00 250 33.25 500 58.90 1,000 110.20 Black, Red, Fuchsia, Orange, Lime, Blue or Green. PCode SCDHP	Hot Pockets - Paper / Tyvek® Die Cut one side	disc® 5 \$15.75 10 27.00 25 61.25 50 112.50 Prod. Code C6CD-HC Qty per case	6 CD-CD Case / Center Hinge Trays 15/16" Thick Holds 6 CD's. Includes 1 black Center piece and 2 black Center hinged trays. Center piece and trays each hold 2 CD's back to back. CLEAR TRAYS NOW AVAILABLE.	CD / All White Polystyrene 5 5/8 x 5 1/2 For CD's Stored in our CD Box XCD30. 15 \$9.30 30 13.05 45 14.60 90 24.65 210 49.70 4 1/2 x 6 1/8 For CD's Stored with Spine Up or Out & XCD100. 15 \$9.40 30 13.40 45 15.20 90 25.85 210 52.40 6 x 14 For Long Blister Packs or Boxes. 10 \$7.90 25 18.65 50 34.30 100 62.30 250 148.05 PCode DCDP DCD56P DBPP	White Paperboard 5 1/4 x 5 1/4 25 \$7.50 50 13.75 100 25.00 250 57.00 500 103.40 1,000 187.95 Prod. Code MCDWP Qty / case	White Paperboard mailer features Peel & Stick Flap. Mails 1 Compact Disc and Booklet. Perforated flap for end user "easy open". Great for promotions. Does not hold CD Jewel Cases.		

PLEASE CHECK BOX IF YOU HAVE ORDERED FROM US BEFORE

NAME _____
 STREET ADDRESS _____
 CITY _____ STATE _____ ZIP _____
 NO POST OFFICE BOX NUMBERS FOR FedEx GROUND DELIVERY NY State Residents add 8%
 Florida, States West of the Mississippi, including entire states of LA, MO, MN add 10%

CUSTOMER ACCOUNT # _____
 SUB TOTAL _____
 All orders under \$25.00 add \$4.00
 C.O.D. orders add \$5.50
 NY State Residents add 8%
 Florida, States West of the Mississippi, including entire states of LA, MO, MN add 10%
 TOTAL _____

New Releases

LIVE
V
Radioactive (112 485)

Many bands have run out of ideas by the time they get to the fifth album, signified by writing clichéd songs about being rock stars and putting their picture on the cover. Or, they have gotten so deep into their own vision that they've left their audience a few albums back. On V, Live do not have these problems, though the band members do grace the cover art (just not in pretty-boy style).

The songs where the band name-checks themselves are "People Like You" and "Transmit Your Love." In the former, singer Ed Kowalczyk relates a dream that sounds like a benefit concert: "I was on a stage with Queen/Michael Stipe and Elton John/Bono and Springsteen/singing hallelujah, rock and roll is king." In the latter, the band relates that it feels as good being in front of their audience as it does to be in it: "In the name of love, we raise the roof... transmit your love to me and/silently make me whole again." No rock clichés here.

While the band's late-1999 release, the lush, crafted *Distance To Here*, has a consistent sound, on V, Live are all over the map — from rap and spoken-word to sitars, keys and strings. Guests include Tricky with a "transcendentally wicked vocal" on the first single, "Simple Creed," the video for which is on the CD, and Adam Duritz of Counting Crows, who toured with Live in a co-headlining stint during 2000. He sings the "sweetly subtle background vocal" on "Flow." This

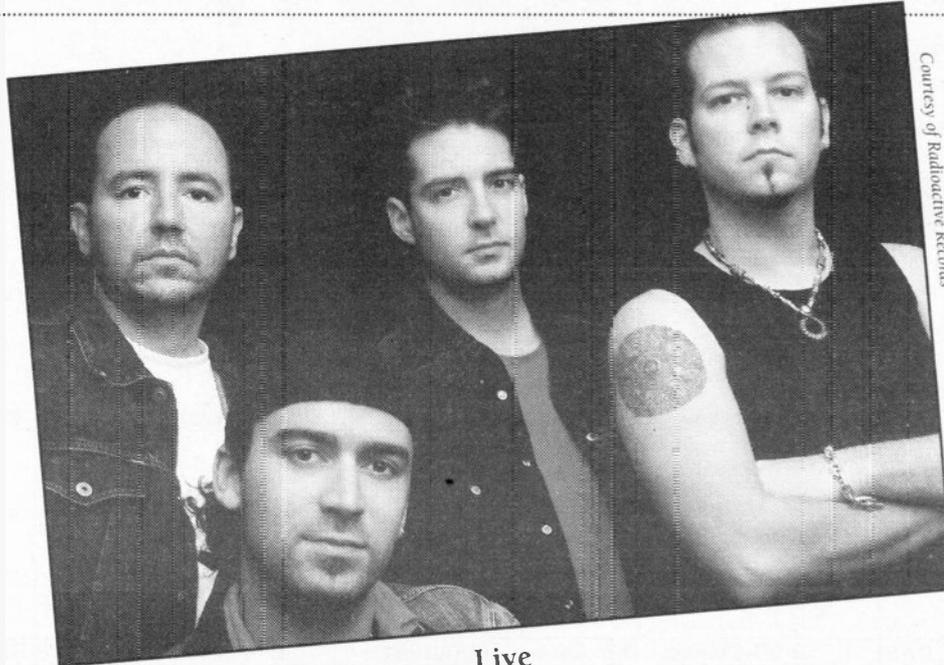

Live

reviewer admits to having been concerned that guests would make the material disjointed or would be distracting, but that is not the case.

As an unlisted bonus track, Live have included a danceable mix of "Deep Enough," (heard in the movie *The Fast And The Furious*). Whoda thunk it a decade ago, listening to *Mental Jewelry*? Only time will tell whether the spoken-word material and rappy portions of V will sound as dated as every artist's 1980 disco attempts do today. (Any Generation X-er [and probably only us] will chuckle at this insult in "Deep

Enough": "Is that a Swatch watch? Do you know what time it is?") Also danceable (even funny) is "OK."

The song currently receiving airplay is "Overcome," (which wasn't intended to be a single) which had its genesis while Kowalczyk watched CNN, he revealed on Jay Leno's *Tonight Show* a few weeks ago. The timing, sadly, is good — there is much on the album, especially that particular song, that inspires healing. V, released just a week after the Sept. 11, 2001, terrorist attacks, will never be heard in its original, intended context, however, as this country's psyche has changed much in the past few weeks. Hearing "Overcome" for the first time after the attacks is probably akin to never hearing John Lennon's "Beautiful Boy" until after Dec. 8, 1980. The song has a whole new resonance now, one that shows just how "on the pulse" Kowalczyk's sensibilities are: "the world is bleedin'/but feelin' just fine/all numb in our castle... and I am overcome."

No matter if a person's favorite Live album is the raw, driving *Secret Samadhi* or *Distance To Here*, V contains elements that will satisfy both the band's heavy rock fans ("Deep Enough," "Simple Creed") and those preferring the tunes dripping in beauty ("Call Me A Fool," "Nobody Knows"). "Forever May Not Be Long Enough" in particular contains both ends of the spectrum. Fans who heard that song in *The Mummy Returns* and procrastinated purchasing the soundtrack are now off the hook with the tune's inclusion here.

Grieving American rock fans need the new V, both as a means to help heal and also as a reminder that there are people who live by a philosophy of love. Rest assured, music fans, that not everything on the charts today is mindless, manufactured bubblegum pop drivel, angry shouting or hip-hop. (The band is touring now; www.friendsoflive.com for more info.)

— Cathy Bernardy

(Please see New Releases page 52)

Indie Label Spotlight

PASSENGER
Getting There
Curveball Records (001)

Sounding like a cross between the Grateful Dead and Earth, Wind & Fire, *Getting There*, the debut disc from Passenger, a.k.a. vocalist and multi-instrumentalist Jim Slansky, is an efficiently executed musical mix.

Slansky adheres to a basic fusion formula, one that's imbued with a host of familiar jazz and funk influences. Yet while much of the album establishes a steady groove, the subtle touches create the most indelible impressions. Listeners have to admire the fact that Slansky tackles every instrument each and every time out. Even the average overachiever would be awed by Slansky's ability to singlehandedly keep these complex arrangements solidly in sync.

Ultimately though, it's the melodies that matter most. Demonstrating a supple guitar style that brings to mind the fret finesse of Jerry Garcia, songs such as "Brand New Game," "The Golfing Song" and the mellow, melodic title tune give the album its allure. Add to that list a handful of other entries — most notably the gently swaying serenade "Howling At The Moon" and the festively



engaging "Brand New Game" — and all indications are that Passenger is heading in the right direction.

Slansky is an accomplished artist, and *Getting There* is a well-conceived showcase for his substantial skills (although the five instrumental bonus tracks verge on oversell). This Passenger is worth picking up, and once Slansky starts leaning more on his songs and less on showcasing his do-it-all attitude, sharing a ride will be even more enjoyable. (519-824-5683; www.curveballrecords.com)

— Lee Zimmerman

NEW RELEASES NEWS

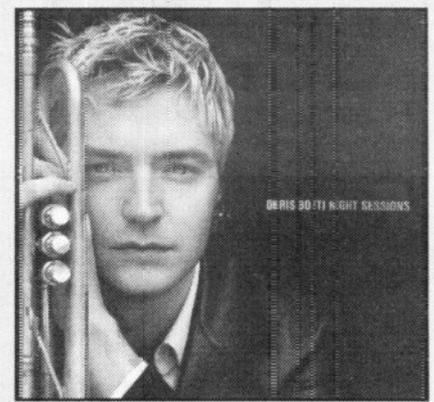

Just out: Multiplatinum-selling Salsa singing phenom Marc Anthony just released *Libre* (Sony)... Singer/songwriter Jonathan Richman just released *Her Mystery Not Of High Heels And Eye Shadow* (Vapor Records)... Jazz trumpeter Chris Botti just released *Night Sessions* (pictured above), his fourth solo album and his first album on Columbia. Among others, Botti has performed with Joni Mitchell and Natalie Merchant and joined Paul Simon's band in 1990. *Night Sessions* contains "All Would Envy," a previously unrecorded Sting song, sung here by guest vocalist Shawn Colvin... Former Little Feat members Kenny Gradney and Richie Hayward have joined up with guitarist Jimmy Herring (Allman Bros. Band, *Jazz Is Dead*, Widespread Panic, The Dixie Dregs) on their debut *Endangered Species* (Tone Center), a funk-drenched jam fest... From the new band Renaissance Illusion comes *Through The Fire* (Spiral Records). The band is made up of original Yardbirds drummer James McCarty; John Idas, bass player and lead singer with the re-formed Yardbirds; and guitarist Dzal Martin, who played on Box Of Frogs' 1984 self-titled album; along with guest backing musicians... New from the Michael Schenker Group is *Be Aware Of Scorpions* (Steamhammer)... Texas pop-folk rocker Glenn Meganck just released *Lost In Austin* (Beach Front Entertainment), his first album in more than a decade. Meganck is also known as writer JR Ripley, the author of the acclaimed Tony Kozol mystery series, whose latest installment bears the same title as this album.

Coming up: Tower Of Power guitarist Bruce Conte has just signed with Severn Records, which will soon be releasing his self-produced album, *Bullet Proof*. Among backing musicians on the album are former Tower Of Power bandmate vocalist Lenny Williams, Gavin Christopher (Rufus), and Bobby Kimball (Toto)... Austin singer/songwriter Jon Dee Graham has just released *hooray for the moon* (New West Records), with special guest appearances by Davey Faragher (Camper Van Beethoven, Cracker, John Hiatt), Mike Campbell (The Heartbreakers), and Austin Tejano artist Little Joe...

Heavy chart action: It's not enough that Pink Floyd holds the record for most consecutive weeks on the *Billboard* charts (1973's *Dark Side Of The Moon* is up to week #1,282 as of this writing, and counting), their new best-of, *Echoes*, debuted on the album chart at #2, helping to push six Floyd titles onto the Pop Catalog chart. *Dark Side* scanned more than 17,000 sales the week *Echoes* debuted. Anyone out there still need a copy?!

— Greg Loescher



Spinnin' Disc



SHIPPING RATES: Budget: 1 CD \$2.50. (US only). Priority: CD's & DVD's any size order \$4.50 (US & Canada). All orders shipped Priority Mail in the US.

P.O. Box 801, Dept. 50-GM, Bellmore, NY 11710 • Credit Card Order Line: (516) 564-1613
Fax: (516) 564-1614 • E-mail: spinnin_disc@hotmail.com; Web site: http://www.spinnindisc.com
Hours: Mon-Fri 9AM-7PM (EST)

PAYMENT: We accept VISA - MasterCard - NOVUS Am.Ex. Check or money order payable to Spinnin' Disc ** checks are held to clear ** New York customers add sales tax
NO PERSONAL CHECKS FOR PREORDER TITLES

NEW RELEASES ON COMPACT DISCS

AEROSMITH - (TRIBUTE) SWEET EMOTION Featuring Lou Gramm, Marshall Crenshaw and more \$19.99

AKKERMAN, JAN-TABERNAKEL First time on CD from the Focus guitarist..... 11.99

ALMIGHTY-PSYCHO-NARCO Brand new album 19.99

ARGUS-ARGUS First time on CD recorded in 1973 25.99

AMERICAN BLUES-IS HERE First time on CD featuring Dusty Hill & Frank Beard from ZZ Top 19.99

ASHTON, GARDNER & DYKE-LET IT ROLL-LIVE! Featuring Tony Ashton recorded in Brussels in 1971 19.99

BAIRD, DAN & THE SOFA KINGS - RED-NECK SAVANT New live album from the Georgia Satellites vocalist..... 19.99

BARNES, JIMMY - RAW + 5 new live album recorded 3/24/01 19.99

BATAAN, JOE-SUBWAY JOE/GYPSY WOMAN 2 on 1 16.99

BLACK 'N' BLUE-DEMOS REMASTERED ANTHOLOGY Digitally remastered compilation of unreleased demos 19.99

BLACK SABBATH-MINIATURES 1970-1978 (9CD) All their albums with Ozzy each CD is in a mini LP sleeve packaged together in a box 74.99

BLACKMORE'S NIGHT - FIRES AT MIDNIGHT + 2 New album in a limited edition box along with a bonus track and a CD-ROM video 15.99

BLUE, DAVID - SINGER SONGWRITER/DAVID BLUE 2 on 1 remastered 19.99

BLUNSTONE, COLIN-ENNISMORE (J) Reissue of 1972 album 25.99

BOLAN, MARC & T. REX - LIVE AT THE BOSTON GLIDERDROME Digitally remastered edition of their live album recorded 1/15/72 15.99

BUCKLEY, TIM-TIM BUCKLEY/GOODBYE & HELLO 2 on 1 remastered 19.99

BUTLER, TONY - GREAT UNKNOWN Big Country bass player 19.99

BUTTERFIELD, PAUL BLUES BAND-BUTTERFIELD, PAUL BLUES BAND/EAST-WEST (2CD) 2 albums on 2 CD's remastered 25.99

CALLENDER, BOBBY - RAINBOW + 2 1968 album 21.99

CAMEL-PARIS COLLECTION + 1 New 10 track live album 14.99

CANNED HEAT & WALTER TROUT-LIVE IN OZ Live in Australia 1981 19.99

CANNED HEAT-HALLELUJAH + 4 Digitally remastered digipak reissue 18.99

CAPALDI, JIM-LIVING ON THE OUTSIDE New album featuring guests George Harrison, Steve Winwood, Ian Paice, Gary Moore & Paul Weller 16.99

CHARLTON, MANNY - STONKIN' New album from the Nazareth member 19.99

CHER-LIVING PROOF + 1 (J) New with a bonus track 29.99

CRANBERRIES-WAKE UP & SMELL THE COFFEE +3 (J) New with 3 bonus tracks 31.99

CRAWLER - SNAKEBITE live in Denver 1978 16.99

DAVIES, DAVE-ROCK BOTTOM-LIVE Kinks guitarist recorded live at The Bottom Line 19.99

DEEP PURPLE - BOOTLEG SERIES 1984-2000 (12CD) 65.99

DEEP PURPLE - IN CONCERT 1970/1972 (2CD) Reissue 16.99

DEEP PURPLE - MK III: FINAL CONCERTS (2CD)/SCANDINAVIAN NIGHTS (2CD) Reissues EA. 16.99

DEEP PURPLE-ON THE ROAD (4CD) A great compilation of live material recorded between 1969-1993 47.99

DEEP PURPLE-SOUNDBOARD SERIES (12CD) Recorded live on 6 different nights from their 2001 tour 84.99

DERRINGER, BOGERT, APPICE - DBA New album featuring Rick Derringer, Tim Bogert, Carmine Appice 13.99

DILLARDS-BACK PORCH BLUEGRASS/DILLARDS LIVE! ALMOST! 2 on 1 remastered 19.99

DONOVAN - FAIRYTALE + 6/WHAT'S BIN DID AND WHAT'S BIN HID + 4 Reissues EA. 13.99

EDMUNDS, DAVE-ROCKPILE +6 Reissue with bonus tracks 18.99

EMERSON, LAKE, & POWELL - EMERSON, LAKE, & POWELL + 2 (J) Reissue with the bonus tracks "Locomotion" & "Vacant Possession" (Mini LP sleeve) 25.99

EMPIRE-HYPNOTICA Featuring Neil Murray, Marc Boals & Don Airy 19.99

FAIRPORT CONVENTION - FULL HOUSE + 4/HOUSE FULL (LIVE) Digitally remastered reissues EA. 18.99

FALL - ARE YOU MISSING WINNER New album 21.99

FINN, NEIL-7 WORLDS COLLIDE - LIVE Australian only live album recorded in New Zealand 2001 21.99

FIREFALL - COLORADO Recorded live 1979 15.99

FLEETWOOD MAC - SHOW-BIZ BLUES 1968-1970 (2CD) Digitally remastered compilation of previously unreleased studio jams, live tracks and alternative versions of studio tracks from 1968-1970 24.99

FLYS - FLY'S OWN/WAIKIKI BEACH REFUGEES Reissues EA. 19.99

FREE - FREE + 10/TONS OF SOBS + 8/FIRE & WATER + 6 Digitally remastered reissues with bonus tracks EA. 18.99

FRUMPY - ALL WILL BE CHANGED + 2 Reissue 19.99

GALLAGHER, RORY-LET'S GO TO WORK (4CD) Includes the live albums 'Live In Europe', 'Irish Tour' and 'Stage Struck' plus a previously unreleased bonus live CD 'Meeting with The G-Man' recorded in Amsterdam 44.99

GIBBONS, STEVE-SHORT STORIES/STAINED GLASS + 5 (2CD) Reissue with bonus tracks 31.99

GILBERT, PAUL & JIMI KIDD - RAW BLUES POWER (J) New album 29.99

GILES, GILES & FRIPP-BRONDESBURY TAPES Remastered & first time on CD 19.99

GOLDEN EARRING-CONTRABAND/ CUT/EIGHT MILES HIGH/ GOLDEN EARRING/GRAB IT FOR A SECOND/ MOON-TOWN/ON THE DOUBLE/ PRISONER OF THE NIGHT/SEVEN TEARS/ TO THE HILT/ TOGETHER Digitally remastered reissues. EA 14.99

GOLDEN EARRING-LIVE (2CD)/2ND LIVE (2CD) Digitally remastered reissues EA 19.99

GREEN, PETER-TIME TRADERS New album 14.99

HACKETT, STEVE-LIVE ARCHIVE (4CD) 4 CD set of live material 39.99

HELIX - LIVE! IN BUFFALO 1983 Brian Vollmer's own tapes 13.99

HENSKE, JUDY-JUDY HENSKE/HIGH FLYING BIRD (2CD) 2 albums on 2 CD's remastered 25.99

HOLLAND, JOOLS & HIS RHYTHM & BLUES ORCHESTRA - SMALL WORLD BIG BANG New studio album with guests Van Morrison, Eric Clapton, Paul Weller, Steve Winwood and others! 25.99

HOT TUNA - YELLOW FEVER Reissue of their 1975 album 16.99

HUMBLE PIE-LIVE AT THE WHISKEY A GO GO Recorded live in December 1969 14.99

HURST, MIKE - HOME/IN MY TIME +2 (2 on 1) Featuring guests Jon Lord, Ian Paice & Mary Hopkin 19.99

HUTCHINGS, ASHLEY - STREET CRIES New album with guests 19.99

JAGGER, MICK - GODDESS IN THE DOORWAY + 1 (J) New with the bonus track "If Things Could Be Different" and the hidden track "Goddess In The Doorway (Cocktail Version)" 31.99

JEFFERSON AIRPLANE - TAKES OFF + 4/CROWN OF CREATION + 2/SURREALISTIC PILLOW + 4/VOLUNTEERS + 6 Reissues with bonus tracks EA. 14.99

JUDAS PRIEST - COLLECTOR'S BOX (4CD) Featuring 'Sin After Sin', 'Stained Class', 'Killing Machine' & 'Unleashed In The East' which have bonus tracks on each plus a 24 page booklet and space to house the other 8 reissues...Limited copies in stock! 54.99

KING CRIMSON-COLLECTOR'S KING CRIMSON VOL. 5 Japanese only box set featuring live material 69.99

KNOPLER, DAVID - WISHBONES + 2 Dire Straits member with guests Eddi Reader, Alan Clark, Chris White, Phil Palmer and Chris Rea 19.99

LITTLE FEAT - LATE NIGHT TRUCK STOP (2 CD) Recorded live in Colorado 7/19/73 16 tracks total 19.99

LUCIFER - LUCIFER Reissue 19.99

LYNYRD SKYNYRD - TWENTY/EDGE OF FOREVER (2 CD) Two albums together in a slipcase 19.99

MAGAGNI, MAX-TWISTER Latest album from the Italian guitarist featuring guests Glenn Hughes, Paul Shortino, Robin Mc Auley plus Ian Paice playing drums on 'Highway Star' 14.99

MALMSTEEN, YNGWIE-CONCERTO SUITE LIVE (J) New with Yngwie and the Japan Philharmonic orchestra recorded on June 17, 2001...12/19 33.99

MARINO, FRANK - EYE OF THE STORM New album 19.99

MSG - BE AWARE OF SCORPIONS New album 14.99

MISUNDERSTOOD - BEFORE THE DREAM FADED reissue 19.99

MOBY DICK - MOBY DICK + 3 Rare 1973 album 19.99

MOLLY HATCHET - DEVIL'S CANYON/SILENT REIGN OF HEROES (2 CD) Two albums together in a slipcase 19.99

MOTT THE HOOPLE-TWO MILES FROM LIVE HEAVEN (2CD) Featuring three live shows from the U.S. in 1971, 1973 and 1974 from Mick Ralph's and Overend Watts personal archives 20.99

NEIL, FRED-TEAR DOWN THE WALLS /BLEEKER & MACDOUGAL 2 on 1 remastered 19.99

NENA - CHOKMAH New album 25.99

NEW RIDERS OF PURPLE SAGE-GYPSY COWBOY/ADVENTURES OF...2 on 1 reissue 18.99

NITZINGER-JOHN IN THE BOX + 12 (3CD) 3 CD set featuring the albums 'Nitzinger', 'One Foot In History' and 'Live Better Electrically' plus 12 bonus tracks 52.99

OSBOURNE, OZZY - GETS ME THROUGH 3 track single including the Japanese bonus track 'No Place For Angels' 10.99

PAXTON, TOM-RAMBLIN' BOY/AIN'T THAT NEWS 2 on 1 remastered 19.99

RALPHS, MICK-IT'S ALL GOOD New album 18.99

RABBIT - WELCOME TO AMERICA With guests Geoff Whitehorn, Snowy White & Henry Spinetti 18.99

RED CRAYOLA - PARABLE OF ARABLE LAND/GOD BLESS...2 on 1 reissue...14.99

RUSH, TOM-TOM RUSH/TAKE A LITTLE WALK WITH ME (2CD) 2 albums on 2 CD's remastered 25.99

SAVOY BROWN-RAW LIVE 'N' BLUE 1 (2CD) Featuring live material recorded in Denver 6/27/81 and studio sessions from 1980 plus the bonus track 'Run To Me' 29.99

SCORPIONS-TOKYO, TAPES/TAKEN BY FORCE + 2 Digitally remastered reissues EA. 15.99

STING - ALL THIS TIME + 1 New live album with the bonus track "Mad About You" 18.99

SUPERTRAMP-IS EVERYBODY LISTENING? 12 live tracks from Cleveland 1976 19.99

SWEET - LIVE AT THE MARQUEE/A (2CD) Two albums together in a slipcase 19.99

SYKES, JOHN - LOVELAND/20TH CENTURY/NUCLEAR COWBOY First time on CD outside Japan EA. 13.99

TEN YEARS AFTER - LIVE AT THE FILMORE EAST 1970 12 tracks recorded live 25.99

THIN LIZZY - VAGABONDS, KINGS, WARRIORS. (4CD) 4CD set covering their entire career including rarities 55.99

TORME, BERNIE/ELECTRIC GYPSIES - SCORCHED EARTH - LIVE 1999-2001 New live album recorded between 1999 & 2001 14.99

TWISTED SISTER - NEVER SAY NEVER - CLUB DAZE Vol. 2 Unreleased live tracks 14.99

TYGERS OF PAN TANG-MYSTICAL New album 15.99

UTOPIA - OBLIVION TOUR Japanese only live album 31.99

WELLER, PAUL - DAYS OF SPEED + 1 (J) New acoustic live album recorded in 2001 30.99

WILLIAMS, JOE/HARRY EDISON - TOGETHER/HAVE A GOOD TIME 2 on 1 reissue 18.99

WOOD, RONNIE - NOT FOR BEGINNERS Brand new solo album with guests Scotty Moore, DJ Fontana, Bob Dylan, Ian McLagan & many more! 16.99

WOOD, ROY - STARTING UP Digitally remastered reissue 14.99

DVD'S.

ASIA-CLASSIC ROCK LEGENDS Featuring the line up of John Wetton, Geoff Downes & Carl Palmer. 11 tracks total (NTSC Reg 1) 21.99

BAND - LIVE AT LORELEY - Recorded live at Loreley 6/23/96 36.99

BEE GEES - ONE FOR ALL TOUR 35.99

BOWIE, DAVID-GLASS SPIDER TOUR Recorded live in Australia, 20 tracks total 34.99

CARAVAN-CLASSIC ROCK LEGENDS Recorded live featuring Pye Hastings, Richard & David Sinclair 21.99

CHEAP TRICK-SILVER DVD version of their 25th Anniversary Homecoming Concert 22.99

CULT-PURE CULT ANTHOLOGY Featuring 19 videos released between 1984-1995, live footage and interviews 23.99

DEEP PURPLE-COME HELL OR HIGH WATER Recorded live on the 'Battle Rages On' tour in England 1993 14.99

DEEP PURPLE - NEW, LIVE & RARE A Collection of material recorded between 1984-2000 with Ritchie Blackmore and Steve Morse (NTSC Reg 1) 24.99

FERRY, BRIAN-LIVE IN PARIS 16 tracks recorded live in Paris March 2000 19.99

FOGHAT - TWO CENTURIES OF BOOGIE Recorded live in 1998 original band 14.99

GALLAGHER, RORY - IRISH TOUR First time on DVD recorded live. (NTSC Reg 1) 14.99

HATFIELD & THE NORTH - CLASSIC ROCK LEGENDS Recorded live for UK TV 21.99

HENDRIX, JIMI - EXPERIENCE 18.99

LINDISFARNE - CLASSIC ROCK LEGENDS Recorded live for UK TV 21.99

STRAWBS - CLASSIC ROCK LEGENDS Recorded live for UK TV 21.99

URIAH HEEP-SAILING THE SEA OF LIGHT Recorded live in concert from Sofia inn 1997. Also includes interviews 21.99

UFO - TOO HOT TO HANDLE 'The Story of UFO' 34.99

UFO-LIVE MISDEMEANOR TOUR Recorded live in London 19.99

WISHBONE ASH-CLASSIC ROCK LEGENDS 11 tracks recorded live in concert (NTSC Reg 1) 21.99

BEST SELLING CATALOG TITLES

BADFINGER - HEAD FIRST (2CD)/BBC IN CONCERT 1972/73/ WISH YOU WERE HERE - S/T EA. 19.99

BADFINGER - SAY NO MORE/AIRWAVES + 5 EA. 14.99

BELL, ERIC - LIVE TONITE...PLUS! + 3 18.99

BLACK OAK ARKANSAS - LIVE! MUTHA/STREET PARTY/AIN'T LIFE GRAND/WILD BUNCH/S/T/ RAUNCH N ROLL LIVE/KEEP THE FAITH/IF AN ANGEL CAME EA. 13.99

BLOODROCK - BLOODROCK 3/ BLOODROCK LIVE/BLOODROCK U.S.A. + 1 All are on CD for the first time EA. 10.99

BOLIN, TOMMY - SNAPSHOT 14.99

BOLIN, TOMMY - TEASER 16.99

BURNING STARR - S/T Featuring Jack Starr 14.99

CAMEL - THE SNOW GOOSE 18.99

CARAVAN-CARAVAN & NEW SYMPHONIA Remastered reissue 18.99

CHEAP TRICK - SILVER (2CD) Live with guests 22.99

DEEP PURPLE - DAYS MAY COME Unreleased studio rehearsals with Tommy Bolin 19.99

DEEP PURPLE - WHO DO WE + 7 (RM) 19.99

DONOVAN - OPEN ROAD (RM) 19.99

FREEDOM - IS MORE THAN A WORD Featuring Bobby Harrison 19.99

GROUNDHOGS - U.S. Tour '72 21.99

GROUNDHOGS - LIVE AT LEEDS '71 19.99

GROUNDHOGS - NO SURRENDER/RAZOR'S EDGE TOUR 1985 16.99

HALFORD, ROB - RESURRECTION Limited box with postcard & poster 14.99

HUNTER IAN - MISSING IN ACTION (2CD) 21.99

JADE WARRIOR - JADE WARRIOR...23.99

MAD RIVER - MAD RIVER/PARADISE BAR & GRILL 2 on 1 reissue 14.99

MAN - ENDANGERED SPECIES 19.99

MAN - LIVE AT THE PADGET ROOMS PENARTH 16.99

MANFRED MANN'S EARTH BAND - WIRED (RM) Live from Boston 1977 19.99

MARINO, FRANK-WHAT'S NEXT/JUGGERNAUT/THE POWER OF ROCK 'N' ROLL Reissues EA. 18.99

MOORE, GARY - RUN FOR COVER...17.99

MOTT THE HOOPLE - WORLD CRUISE Recordings from 1976 featuring Steve Hyams 15.99

NAZARETH-BACK TO THE TRENCHES LIVE (2CD) Unreleased live material recorded between 1972 and 1984 29.99

NESMITH, MICHAEL - NEVADA FIGHTER./TANTAMOUNT TO TREASON + 3 (RM) on 1 19.99

NESMITH, MICHAEL - AND THE HITS... /PRETTY MUCH... 2 on 1 19.99

NESMITH, MICHAEL - MAGNETIC SOUTH/ LOOSE SALUTE + 1, 2 on 1 19.99

NUGENT, TED (TRIBUTE) BULLET PROOF FEVER 14.99

PRESLEY, ELVIS - ELVIS PRESLEY (J) Mini LP sleeve (out of print) 24.99

PRICE, ALAN-THE PRICE TO PLAY - First time on CD from the Animals member 15.99

PROCOL HAREM - EXOTIC BIRDS & FRUIT + 2/GRAND HOTEL + 2/PROCOL'S NINTH/SOMETHING MAGIC + 2 Digitally remastered issues EA. 16.99

QUICK SILVER MESSENGER SERVICE - LOST GOLD & SILVER (2CD) Unreleased live and studio material 19.99

RONDINELLI - WAR DANCE W/Ray Gillen 12.99

ROUGH CUTT - LIVE 19.99

RUNDGREN, TODD & UTOPIA - LIVE IN TOKYO '79 (2CD) (J) 34.99

SAXON - POWER & THE GLORY (RM) 14.99

SETZER, BRIAN - IGNITION + 3/LIVE IN JAPAN 2001 (Latest studio and live albums EA. 29.99

STRAWBS - LIVE AT THE CHISWICK 21.99

ST. HOLMES, DEREK - THEN AND NOW 12.99

TEN - BABYLON 14.99

VIRGIN STEELE - MARRIGE OF HEAVEN AND HELL Pt. 1/MARRIGE Pt. 2/LIFE AMONG THE RUINS/NOBEL SAVAGE/AGE OF CONSENT EA. 19.99

WARLOCK - TRUE AS STEEL 14.99

Y & N - TODAY Reissues EA. 16.99

Check out our Web site: <http://www.spinnindisc.com> for our complete catalog and daily updated new releases.

Reissues

MICHAEL JACKSON
Thriller (Special Edition)
 Epic (66073)

Michael Jackson's *Thriller* revitalized the music industry in 1982-1983, revolutionized it and also defined the new MTV era. Discovering it again remastered and expanded is a lot of fun, even 42 million units and almost 20 years later. This is an album that spent 37 weeks at #1, and it's easy to see why. It's next to impossible to un-ring the bell on *Thriller* and to hear it again for the first time.

These songs and the whole concept of the biggest-selling album of all time have been embedded in our consciousness for nearly 20 years. I still remember driving around the night I first heard *Thriller's* lead single, "Billie Jean." I was knocked out; I think we all were. It was just something from a different place — that roving bass line, the eerie keyboard chords and creepy percussion posts that led the way to an amazing vocal of unprecedented lyrical subject matter. Along the way, lightning strikes in the form of strings, as the track chugs along guided by some funky, chunky rhythm guitar parts.

Sophomore albums are conventionally disappointing for many artists, especially if the debut was a large success, such as Jackson's first as an adult solo artist — 1979's *Off The Wall*. Just ask The Knack, Ace Of Base or, in more recent years, Hanson. The problems of producing a worthy follow-up album are numerous. For one thing, oftentimes an artist has accumulated material over a period of years for the debut work, (as was the case with Julian Lennon) and then instantly finds himself or herself in a jam to cash in on the initial success by quickly coming up with enough adequate material for a second album. Suddenly there's pressure from all sides: Less quiet time to reflect and write; more personal appearances, interviews and a clamoring public that wants more of the same product — only different. Imagine the task lying ahead for Jackson approaching *Thriller* after selling 10 million units of *Off The Wall*.

As with *Wall*, on *Thriller*, coproducer Quincy Jones matched Jackson's centerpiece originals, ("Billie Jean" and "Beat It") with similar smashing material from the outside. The stunning title track and the hits "P.Y.T." and "Human Nature" stood with the four Jackson originals to mark the first album to ever give birth to seven Top 10 singles — and this was when old-fashioned 45s (*They still make 'em!* — Ed.) had to sell a million copies to place in the *Billboard* Top 10. "The Girl Is Mine" — another Jackson composition — was



(Courtesy of Epic Records)

Michael Jackson

included on *Thriller* as a calculated and successful attempt to reach wider audiences.

Thriller once again paired Jackson with the graces of Paul McCartney, the biggest-selling white artist at the time, just as *Wall* had harnessed this extra strength years before with McCartney's "Girlfriend" (U.K. hit) thus broadening Jackson's base overseas. As a preface to *Thriller*, "Girl" scored a gold record to gas initial sales of the pending album as insurance. Six hits into this album — a year later — the McCartney/Jackson combo scored a #1 (not included on *Thriller*) with "Say, Say, Say." There was simply no part of the *Thriller* scenario that could go wrong from a marketing standpoint.

Then there was MTV. The new all-music video channel, then in its infancy, was under pressure to air more black artists, just as Jackson showed up with this landmark album. To be fair, when all was said and done, it was still on the strength alone of the ground-breaking videos from *Thriller*, the first of which was "Billie Jean" (reported to have cost an astounding \$40,000 to produce at the time, which is a laughable figure now of course) that earned him the air time. By the time of the excellent "Beat It," the *West Side Story*-ish video, Jackson became MTV's poster boy in no time flat, as his videos began to become special presentations and TV events in their own right. Remember, this was all unprecedented at the time.

(Please see Reissues page 64)

REISSUES NEWS



Out now: *The Buckingham's: Made In Chicago* (Acadia) is a reissue of Columbia's 1975 24-track double vinyl album that features all of their hits, except their only #1, "Kind Of A Drag"... Elektra/Rhino just released *Used Songs: The Best Of Tom Waits* (1973/1980)... Australia's Raven Records has released *Steeleye Span — Gone To Australia (On Tour 1975-1984)*, an expansion of the 1983 Australia-only LP *Gone To Australia*. It includes remixed tracks, plus several previously unreleased and rare live tracks from a 1975 concert, which had only one known — and rapidly-disintegrating — acetate left, plus a 12-page booklet with liner notes by bandmates Maddy Prior and Peter Knight... **Smashing Pumpkins** just released *Rotten Apples*, a greatest-hits package, with a twist. Their label, Virgin Records, is also releasing a limited-edition, limited-time-only double set that includes *Rotten Apples* along with *Judas O*, a follow-up to 1994's B-side filled release *Pisces Iscariot*. *Judas O* includes B-sides from the band's *Mezzanine* and *The Infinite Sadness*. *Adore* and *MACHINA* sessions... *Johnny Winter: Lone Star Shootout* (Fuel 2000) is an 11-track live set that includes guest appearances by Willie Dixon and Jimmy Reed plus extensive liner notes... **King Crimson's** two-CD live set, *Vroom Vroom* (Rykco), contains on disc one (*Vroom Vroom*) tracks from a Mexico City concert of newer material, and disc two (*On Broadway: Live In New York City*) contains Crimson material from 1981-84... *One Way* has reissued three **Kim Carnes** albums, each with three bonus tracks — *Barking At Airplanes*, *Cafe Racers* and *Voyeur*... **Misfits: Cuts From The Crypt (Collected Works 1996-2001)** (Roadrunner Records) is an enhanced-CD collection of 17 previously unreleased *Mars Attacks* demo sessions (six cuts) rarely heard B-sides and other unreleased songs plus a bonus video, *Scream*... **Ten Years After: Live At The Fillmore East** (Chrysalis/Capitol) is a two-CD set of two February 1970 concerts at **Bill Graham's Fillmore East** in New York City. The 14-track live set is all previously unreleased material, except for "Love Like A Man," a B-side to the studio version of the same song, and includes their classic "I'm Going Home" (11:57 version here), made famous at Woodstock.

Coming soon: In December, Universal is releasing new *Millennium Collection* sets for Styx, Phil Ochs, Tim Hardin, and Lionel Richie as well as *Best Of Crosby/Nash*, *Diana Ross & The Supremes — Anthology* (two CDs), *The Temptations' For Lovers Only*, and *Meat Loaf — Bat Out Of Hell II: Back Into Hell (Deluxe Edition)*... Rhino's Dec. 18 reissues include The Doobie Brothers' *The Captain & Me* (1973) and Randy Newman's *Little Criminals* (1977)... Germany's multiplatinum-selling Enigma just released *Love, Sensuality, Devotion: The Greatest Hits* featuring cuts from their four albums of the past decade... Coming soon, so get in shape, is Kiss: *The Box Set*, a five-CD, 94-track (30 previously unreleased), six-hour extravaganza housed (the deluxe edition) in a full-size, 46-by-16-by-four-inch replica guitar case with an official RIAA-certified *Kiss Alive!* gold record award and handwritten notes from the band individually printed on parchment paper. In addition to all the Kiss classics, the set contains a 120-page color book featuring track-by-track commentary from Kiss members, rare photos and a band history. Besides the deluxe version, two other less-expensive versions are available, one in a mini-guitar case and the other in a cigar box. In the past 30-plus years, Kiss has sold more than 80 million records.

— Greg Loescher

DVD Review

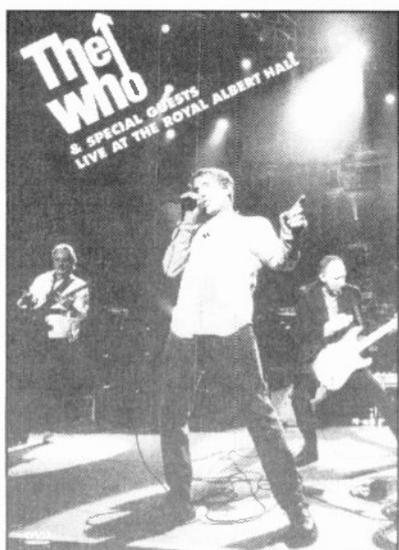

THE WHO & SPECIAL GUESTS
 Live At The Royal Albert Hall
 Image Entertainment
 (ID0659MYDVD) (Two-DVD set)

The Who definitely turn back the clock with an electrifying performance guaranteed not only to satisfy the huge expectations of "my generation," but very likely also will appeal to members of generations X and Y — given the well-chosen participation of Pearl Jam's Eddie Vedder, Paul Weller, Oasis' Noel Gallagher, Bryan Adams, Kelly Jones, and Nigel Kennedy — all on hand to pay homage to the musical legacy of one of rock 'n' roll's reigning acts.

Even though all of the guest stars turn in excellent performances, it is The Who who ultimately shine the

brightest on stage on *The Who & Special Guests: Live At The Royal Albert Hall*. The Who's Roger Daltrey, Pete Townshend, and John Entwistle — augmented by keyboardist John "Rabbit" Bundrick and drummer Zak Starkey (Ringo Starr's son) — turn in one of the most inspired and satisfying sets of their impressive career.

Image Entertainment's outstanding 14½-minute, 23-song, double-disc DVD, *The Who & Special Guests: Live At The Royal Albert Hall*, captures one of the most enduring and influential bands in the history of popular music in a superlative concert far exceeding the expectations of their critics and proving that on any given night, it is possible for rock's royalty to reclaim their crown.

— Mark Wallgren

New Releases

AVAILABLE NOW!

GREAT GROUPS

The **BEST DOO-WOP** Groups
Sing Their Original **HITS!**

7 NEW
10-CD
BOX SETS!



ONLY
\$59.95
EACH
OR ALL SEVEN
SETS FOR ONLY
\$349.95

Over **150** Songs In
Each **BOX SET!**

VOLUME 1

- THE SPANIELS
- THE FLAMINGOS
- THE DELL VIKINGS
- THE CRESTS
- THE CADILLACS
- THE ORIOLES
- LEE ANDREWS & THE HEARTS
- THE DRIFTERS
- THE HARPTONES
- THE EARLS
- EARL LEWIS & THE CHANNELS

VOLUME 2

- THE ORIOLES
- THE ELDORADOS
- THE CHARTS
- THE VALENTINES
- THE MELLOKINGS
- THE CAPRIS
- THE IMPERIALS featuring LITTLE ANTHONY
- JACKIE & THE STARLITES
- THE BOPCHORDS
- THE NUTMEGS

VOLUME 3

- THE DUBS
- THE VELVETS
- LITTLE JOE COOK & THE THRILLERS
- THE SCHOOLBOYS
- THE MONOTONES
- THE SPANIELS
- THE FLAMINGOS
- THE PARAGONS
- THE SILHOUETTES
- THE REGENTS
- THE FIVE KEYS

VOLUME 4

- THE FIVE SATINS
- THE CHANTELS
- THE WRENS
- THE FLAMINGOS
- THE PENTAGONS
- MAURICE WILLIAMS & THE ZODIACS
- CLYDE McPHATTER & THE DRIFTERS
- THE DELL VIKINGS
- THE CHIMES
- THE VIDELS
- THE SOLITAIRES

VOLUME 5

- THE FIESTAS
- SONNY TIL & THE ORIOLES
- THE IMPALAS
- LEWIS LYMON & THE TEENCHORDS
- THE KODAKS
- THE CHANTERS
- THE JAGUARS
- THE CAPRIS
- THE DUPREES
- THE FLAMINGOS
- THE HARPTONES

VOLUME 6

- THE FIVE KEYS
- THE VIBRATIONS
- THE SHELLS
- LEE ANDREWS & THE HEARTS
- THE BLUEJAYS
- THE PARADONS
- THE VOLUMES
- THE SPANIELS
- THE JESTERS
- THE RIVIERAS
- THE ELEGANTS

VOLUME 7

- THE DELLS
- THE JIVE FIVE
- THE FIVE ROYALS
- THE OLYMPICS
- THE MARATHONS
- THE AVONS
- THE TURBANS
- THE MYSTICS
- THE DRIFTERS
- THE DU DROPPERS
- THE FLAMINGOS

HIGHLIGHTS INCLUDE:

Volume 1

- THE SPANIELS Red Sails In The Sunset
- THE FLAMINGOS I Only Have Eyes For You
- THE DELL VIKING Come Go With Me

Volume 2

- THE ORIOLES It's Too Soon To Know
- THE IMPERIALS featuring LITTLE ANTHONY Tears On My Pillow
- THE NUTMEGS Story Untold

Volume 3

- THE SPANIELS Baby It's You
- THE SILHOUETTES Get A Job
- THE REGENTS Barbara Ann

Volume 4

- THE FIVE SATINS In The Still Of The Night
- CLYDE McPHATTER & THE DRIFTERS Treasure Of Love
- MAURICE WILLIAMS & THE ZODIACS Stay

Volume 5

- THE FIESTAS So Fine
- SONNY TIL & THE ORIOLES Crying In The Chapel
- THE CAPRIS There's A Moon Out Tonight

Volume 6

- THE FIVE KEYS Ling Ting Tong
- THE SHELLS Baby Oh Baby
- LEE ANDREWS & THE HEARTS Long Lonely Nights

Volume 7

- THE DELLS Oh What A Night
- THE JIVE FIVE My True Story
- THE DRIFTERS Save The Last Dance For Me

NINA'S DISCOUNT OLDIES

PHONE 1-800-336-4627 FAX 610-649-0315

For a complete listing of all products visit us at

www.oldies.com



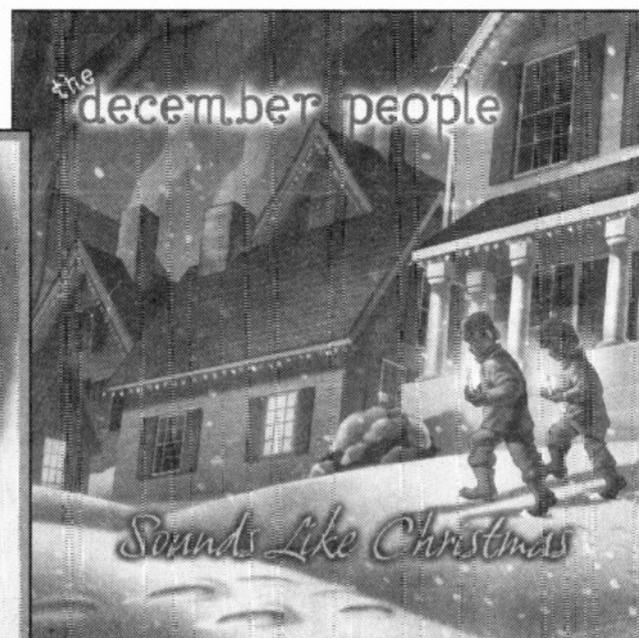

Christmas CD roundup 2001: Part one

by Tim Neely

The chestnuts are roasting, the halls have been decked, and the Christmas music is coming from the stereo. As always, the benevolent record companies of America are hoping that some of their holiday music finds its way into your collection. Also as always, they've given us plenty of new and reissued ways to do just that.

If early returns are any indication, this could be a strong year for Christmas music sales. As of the time I write this (mid-November), there are already four holiday-themed albums in the upper half of the *Billboard* album charts. They don't usually start to infiltrate the best-seller lists until mid-December.

Here's a sampling of some of the new and reissued offerings that you may or may not find in your local music emporium over the holidays. Some of these are CDs that showed up in my mail; others have been well publicized; a couple are off-the-beaten-track items from last year but worthy of your attention; still others have emerged from the bargain bins at department stores (some really cool treasures await the patient browser this year). There's even a free (almost) CD in the offing! Alphabetically by artist, with compilations at the end, here's at least one CD for not only each of the 12 days of Christmas, but also for the 52 weeks until next Christmas.

ASYLUM STREET SPANKERS: *A Christmas Spanking* (Spanks-A-Lot/Bloodshot 20702). I was almost afraid to ask. Well, I'm glad I did: Asylum Street Spankers are an Austin, Texas, band that is decidedly retro. Its members play only acoustic instruments, everything from ukulele to guitar to harmonica, and they have a blast doing so. On this CD, they put their mark on 16 holiday tunes, both traditional and new.

JOAN BAEZ: *Noel* (Vanguard 79596-2). There's no better time to listen to this sublime holiday treat, which was first issued

in 1966. It's been remastered with bonus tracks that didn't fit on the original album. Look for the "Original Master Series" banner along the left front cover. By the way, this album was arranged by then-unknown Peter Schickele, who is better known as the executor (or is that executioner?) of the musical heritage of P.D.Q. Bach.

HARRY BELAFONTE: *Christmas* (RCA 07863-68044-2). In addition to the entire contents of *To Wish You A Merry Christmas*, this CD compilation contains some other tracks Harry Belafonte recorded over the years that have a tangential relationship to the holiday.

TONY BENNETT; CHARLOTTE CHURCH; PLACIDO DOMINGO; VANESSA WILLIAMS: *Our Favorite Things* (Sony Classical SK 89468). This interesting combination of voices (two classical, one pop/jazz, one R&B/soul) was recorded live in Vienna last year. Look for the TV special based around this CD on public television this year. (Can you say "pledge drive special," boys and girls? I knew you could.)

JACKSON BERKEY: *Harpichord Carols* (Soli Deo Gloria SDG CD011). Never heard of Jackson Berkey? Well, he's the keyboard wizard on most of the Mannheim Steamroller holiday hits. He's also been a well-respected musician apart from Chip Davis' crew. Here, with help from harpist Kathy Bundock Moore, he presents 12 of his own arrangements of popular and obscure carols.

SUZY BOGGUSS: *Have Yourself A Merry Little Christmas* (Loyal Duchess LDR-0002). She's been recording one-off Christmas singles since 1989, including "Mr. Santa" and "Two-Step 'Round The Christmas Tree." At last, Bogguss has done an entire album of holiday tunes, including the original versions of those two country staples licensed from Capitol. There's also a duet with Delbert McCClinton on "Baby, It's Cold

Outside." Bogguss looks beautiful on the cover. (This is currently available only on the Internet through www.suzybogguss.com. It will be released to retail in 2002.)

TONI BRAXTON: *Snowflakes* (Arista 07822-14723-2). The R&B diva Toni Braxton, who is less prone to vocal histrionics than some of her contemporaries, wraps her vocal cords around nine mostly new holiday tunes. (There is one instrumental and, in a continuing bad trend, a remix of one of the earlier tracks on the same CD.)

GARTH BROOKS: *Call Me Claus* (Capitol Nashville 72438-77669-2). This CD single contains the three new songs that Garth Brooks recorded for his TV special of the same name. The same three songs are also on the "new" version of *The Magic Of Christmas*, replacing three others, but why buy the full-length CD again if you already have it?

THE CAMPBELL BROTHERS: *Sacred Steel For The Holidays* (Arhoolie CD 504). "Sacred steel" is an unusual tradition rooted in the African-American Pentecostal Holiness Church, also known as the House of God, Keith Dominion. The Campbell Brothers are the foremost practitioners of this steel guitar style, and their take on 11 holiday tunes is a unique listening experience.

DEANA CARTER: *Father Christmas* (Rounder 116 610 496-2). Deana Carter, the woman who gave us one of the highlights of 1990s country music, her hit "Strawberry Wine," teams up with her father, Fred Carter, who played on sessions with people ranging from Elvis Presley to the 1980s Highwaymen, for 10 holiday favorites. This album was recorded in her father's living room. Collector's note: The promo CD is on the Beyond label (BYAV-78221-2).

THE CHENILLE SISTERS: *In The Christmas Spirit* (CanToo 10005). This splendid album was the winner of the 2001 Indie Award, given out by AFIM (Association

For Independent Music) annually, in the Seasonal Music category, and it richly deserved the honor. "The All-Purpose Carol" is a must-hear; it's worthy of Dr. Demento.

PERRY COMO: *A Perry Como Christmas* (RCA 07836-68041-2). Do we really need another collection of Perry Como holiday music? When it's this well-thought out, yes we do. Compiled in consultation with George Townsend, the Canadian who maintains an outrageously comprehensive Como Web site, the 22 tracks include one previously unreleased song and others that have never been on CD, including Como's original 1950 recording of "There Is No Christmas Like A Home Christmas."

THE DECEMBER PEOPLE: *Sounds Like Christmas* (Magna Carta MA-9025-2). This album is based around an interesting concept. Assume that some of the top 1970s album-rock bands had recorded Christmas standards. What would they sound like? Here's an attempt to answer that question, with help from some of those very artists, including John Wetton (of Asia) and Steve Walsh (of Kansas). Walsh even got Kansas together in the studio to do an all-new song, "The Light," for this CD.

JOHN DENVER: *Christmas In Concert* (RCA 07863-68043-2). Recorded live at Constitution Hall in Washington, D.C., in 1996, the year before he died, this collection has most of the holiday songs John Denver recorded over the years, plus an encore of several of his most successful non-holiday hits. It's a must for the Denver fan.

DESTINY'S CHILD: *8 Days Of Christmas* (Columbia CK 86098). Looking for something really up-to-date this Christmas? This CD by the most popular female vocal group since The Supremes should do the trick. Each

(Please see Christmas 2001 page 57)

NEW
OLD
RARE



THE ORIGINAL

FLIP SIDE

940 N. HERMITAGE RD.
HERMITAGE, PA 16148
PH: (724) 342-0824
FAX: (724) 342-0825

"Just Next to
the Vocal
Group Hall of
Fame"

RECORDS & COLLECTABLES

IN BUSINESS OVER 25 YEARS

OVER 2 MILLION RECORDS / CD'S

100,000 + LISTED ONLINE AT:

WWW.FLIPMALL.COM

Free online catalogs:

21,000 + SOUL & JAZZ ALBUMS / 25,000 + RARE 45'S / 14,000 + 12" SINGLES / 14,000 + ROCK ALBUMS / COUNTRY / POP / SURF & HOT ROD / REGGAE COUNTRY / POP / ELVIS / BEATLES / KISS / MICHAEL JACKSON

WE HAVE A HUGE SELECTION OF:

- OUT OF PRINT RECORDS
- ROCK & ROLL
- JAZZ
- SURF HOT ROD
- SOUL
- COUNTRY & WESTERN
- CLASSICAL
- BLUES
- BIG BANDS
- COMEDY
- ROCK-A-BILLY
- SOUND TRACKS
- ETHNIC
- RHYTHM & BLUES
- NOVELTY
- ORIGINAL CASTS
- SYMPHONY
- FOLK
- SOUND EFFECTS
- CHILDRENS

"WANT LISTS WELCOME"

E-Mail: FlipsideRecords@aol.com

RECORD/CD LISTS (BELOW)
COST REFUNDABLE WITH ORDER

- | | |
|--------------------------------|----------------------------------|
| \$2.50 COMPACT DISCS | \$6.00 SOUL / FUNK & JAZZ ALBUMS |
| \$6.00 RARE 45'S (OVER 25,000) | \$5.00 12" SINGLES (OVER) |
| \$3.50 COUNTRY ALBUMS | \$1.00 REGGAE 45'S / LP'S |
| \$5.00 ROCK ALBUMS | \$1.00 ELVIS PRESLEY |
| \$1.00 BEATLES | \$1.00 CLASSICAL |
| \$1.00 SURF & HOT ROD | \$2.00 LATIN 45'S / LP'S |
| \$1.00 KISS COLLECTIBLES | \$1.00 POLKA 45'S / LP'S |



**KOLLECTABLE
LISTS
AVAILABLE**

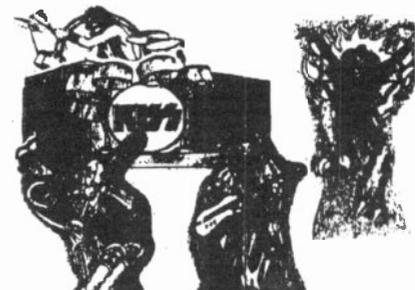

Know it all.

Let's be honest. You could find out about comics anywhere. But the information is scattered all over the place – and many so-called "experts" started collecting last Tuesday! That's why, for 30 years, the smartest people in comics read **Comics Buyer's Guide** every week!

Retailers read CBG for its:

- **High-tech market reports** on back issues, including analysis of thousands of Internet auctions!
- **Marketplace** for collectible comics. No mag has more dealer ads and want lists!
- **Long-term perspective** of comics trends. We've covered every comics boom since the 1970s!



Readers and Collectors read CBG for its:

- **In-depth reporting** on the companies, creators and comics you care about. Now with e-mail bulletins!
- **Weekly reviews** of new comic books – more than **100** each month!

- **Honest appraisals** of comics back-issue values. We cut through all the hype to get to reality!
- **Most accurate prices** for **CGC-graded** comics!
- **Convention calendar** and lists of what comics have shipped – the most comprehensive around!

Comics Creators read CBG for its:

- **Tips** on breaking in from the pros!
- **Profiles** of the greatest creators, both new and classic!
- **Timely commentary** and opinion on the state of the comics art form!

13 weekly issues for only \$9.98

800-258-0929

(All major credit cards accepted)

Mail to: Comics Buyer's Guide
 Offer: ABAGKU
 700 E. State St., Iola, WI 54990
e-mail: cbg@krause.com

COMICS BUYER'S GUIDE

It's all here.

Register for a **FREE** e-mail newsletter at www.comicsbuyersguide.com

SilverDisc Records

Orchard Post Office, PO Box 8771, SINGAPORE 912323
 US Fax #: 1-(815) 461-1923. Email: silverdisc@iol.com
 Over 1000+ titles from Japan and Europe at:
<http://listen.to/SilverDisc>
 See web site for more info on shipping, secured online credit card payment, cashiers check and discounts.
 Postage: \$5.00 per set. Add \$2.00 for each additional set.
 Over 100 Beatles, 60 Dylan, 40 Rolling Stones, 20 Clapton, N. Young, Nirvana, Floyd, WHO & more many rare titles.

- Beach Boys - Archaeology (5CD Boxset)...\$110
- Beatles - Complete 13 Albums sourced from MFSL...\$22 per CD
- Beatles - Day By Day series vol.1 to 21...\$44 each volume
- Beatles - The Ultimate BBC Sessions 1962-1990 (10CD Boxset)...\$200
- Beatles, The - Hard Days and Nights (2CD)...\$44
- Beatles, The - Northwest Nights (2CD) Seattle and Vancouver...\$44
- Black Crowes - Boogie With Crowes (2CD)...\$40
- Bob Dylan - The Osaka Tapes (2CD) Japan, 17th March 2001...\$44
- Bob Dylan - The Early Years Vol.2 (1CD)...\$22
- Bob Dylan - Musical Retrospective (3CD)...\$66
- Bob Dylan - Ace Of Club (CD Box)...\$110
- Bob Dylan - Rock Of Ages (5CD Box)...\$110
- Bob Dylan - Rolling Gambler (2CD) Australia 25-03-2001...\$44
- Bob Dylan & Paul Simon - Live in Denver 1999 (3CD)...\$60
- Bruce Springsteen - Omaha (3CD)...\$60
- Bruce Springsteen - The Lost Gongs 1972-1978 (1CD)...\$22
- Crosby, Nash & Young - Kansas City Express (3CD)...\$60
- David Bowie - Speaking in Tongues (1CD)...\$22
- David Bowie - Raw Moon Rehearsals (2CD)...\$44
- David Bowie - Baton Rouge (2CD)...\$44
- Dire Straits - Live 3CD Boxset...\$60
- Eric Clapton - 44 + Live (2CD) Norway, 5th April 1995...\$44
- Eric Clapton - Change The World (2CD)...\$44
- Eric Clapton - Slowhand Down Under (2CD) Australia, 23/11/84...\$44
- Eric Clapton - Blues Night (2CD)...\$44
- Elton John & Ray Cooper - Russian Bullete (2CD)...\$44
- Elton John - Final Melodies In Millennium...\$22
- Elton John - West of the Rockies (1CD)...\$44
- George Harrison - Long Beach (1CD) Long Beach...\$22
- George Harrison & Ringo Starr - Lost And Found (2CD)...\$44
- Genesis - In & Out Of Darkness (2CD)...\$44
- Genesis - Los Cage (1CD)...\$22
- Genesis - Never Forget Jesus (2CD)...\$44
- Genesis - Outvisible Side (2CD)...\$44
- Jeff Beck - Consummate Guitar Craftsman (1CD) 18 July 2001...\$22

- Johnny Cash - The Boast In Me (1CD)...\$22
- John Lennon Anthology - Weybridge...\$22
- Led Zepplin - Uncensored (1CD) Rare CD with Demos...\$22
- Leonard Cohen - Blossoms of Heaven, Ashes of Hell (2CD)...\$44
- Neil Young - Between The Lines (2CD) Camden, N.J. 9 Aug 2000...\$44
- Neil Young - Birmingham Vacation (2CD)...\$44
- Neil Young - Rock In Rio 2001 (2CD)...\$44
- Neil Young - The Warfield (2CD)...\$44
- Nirvana - Eternal Legacy (KTS)...\$22
- Nirvana - Shadow of the Sun (KTS)...\$22
- Nirvana - Digital Nirvana...\$22
- Nirvana - Dumb (KTS)...\$10
- Oasis - Lost Tapes (KTS)...\$22
- Oasis - 200,000 fans can't be Wrong (2CD)...\$44
- Paul McCartney - Bust Jobbus (4CD)...\$80
- Paul McCartney & Wings - Nashville Sessions...\$22
- Paul McCartney - Hot Night in Charlotte (2CD)...\$44
- Pink Floyd - LIVE 3CD Boxset...\$60
- Pink Floyd - Dark Soundboard of Philadelphia...\$22
- Pink Floyd - Concert in Modena (2CD) Modena, Italy 17/9/94...\$40
- Police - Lost BBC Studio Tapes 78-79...\$22
- Radiohead - Black Tuesday (2CD) live 11 Sept 2001...\$35
- Radiohead - Bostonova 2001 (2CD) live 14 August 2001...\$35
- Rolling Stones - Japan 1998 Tour (12 Cd Boxset)...\$240
- Rolling Stones - Wembley Stadium 1999 (2CD)...\$44
- Rolling Stones - Dirty Work Outtakes (1CD)...\$22
- Rolling Stones - We Want The Rare Stones (1CD)...\$22
- Rolling Stones - Anthology: The Decca Years (2CD)...\$44
- RUSH - Farewell to Franks (2CD)...\$44
- RUSH - Natural Science (1CD)...\$22
- RUSH - Obsolete Absalom (1CD)...\$22
- Stevie Nicks - Naked Lunch Board...\$22
- Stevie Ray Vaughan - Reseda 5 Blues...\$22
- Stevie Ray Vaughan - Hotter Live From Exotic Honolulu (2CD)...\$44
- STING - Rock In Rio 2001...\$22
- STING - Sea of Silence (2CD)...\$44
- U2 - Going Dutch 2001 (2CD) 3rd Aug 2001...\$38
- U2 - Blessing in the Night (2CD)...\$40
- U2 - Out of Control in Chicago (2CD)...\$40
- Who - The Live At Leeds Complete (2CD)...\$44
- Who - The Secret Show 1974 (2CD) Guild Hall, UK, 22 May 1974...\$44
- Who - The Johnny B Goode (2CD)...\$44
- Who - The We Shall Be Beneficient (2CD)...\$44
- Who - The Hot Fun of Summertime Blues (2CD)...\$44
- YES - Close To Eight Progressers (3CD)...\$66
- YES - Solo Works (2CD)...\$40

10% STOREWIDE Christmas SALE at:
<http://listen.to/SilverDisc>

"Once upon a time there was a little boy who asked Santa to bring him a guitar for Christmas. At that time, not even Santa knew how powerful the gift would be."

The December People / "Sounds Like Christmas" / MA-9025-2



GUEST VOCALISTS:
 Steve Walsh, John Weston, Robert Berry, Trent Gardner, Mike Baker and Jake Livgren

Exclusive track written and recorded by Kansas

Available at Progressive CD stores. Or send \$16.98 for each CD to Magna Carta. Outside the USA add \$5.00 per disc. Magna Carta, PMB 1820, 208 E. 51st St. New York, NY 10022-6500. Credit card orders can be faxed to (716) 381-0658. Email: magcart@aol.com Visit the Magna Carta website at www.magnacarta.net

There's more than one way to keep track of your records...



We suggest you try ours.

MusicTracker 1.0

- Inventory & Pricing software for Vinyl Record Collectors
- Featuring Jerry Osborne's Price Guide Data for 2001



Now only **\$39.99**

Visit us online! www.bangzoom.com
 or Call us toll free! 1-800-589-7333

Goldmine THE Beatles Digest

- Featuring
- Beatles history
 - Interviews
 - Beatles records price guide



Compiled by the editors of Goldmine magazine

Goldmine The Beatles Digest

Compiled by the Editors of Goldmine Magazine

Beatles popularity still runs high. Now discover long-lost articles on The Beatles, interviews with close associates, and stories on important figures from their history in Goldmine Beatles Digest. These stories first appeared in Goldmine, the magazine of collectible records and a respected voice in the music industry. Now they're together in one book, with 100 rarely-seen black and white photos. It's a great book for fans and an excellent resource for collectors.



Softcover • 8-1/2 x 11 • 320 pages
 100 b&w photos
 Item# GM2001 • \$19.95

To place a credit card order or for a FREE all-product catalog, call

800-258-0929 Offer RSHR

M-F, 7 am - 8 pm • Sat, 8 am - 2 pm, CST

Krause Publications, Offer RSHR

P.O. Box 5009, Iola, WI 54945-5009

www.krausebooks.com

Shipping and Handling: \$3.25 1st book; \$2 ea. add'l. Foreign orders \$20.95 1st item, \$5.95 each add'l.

Sales tax: CA, IA, IL, PA, TN, VA, WA, WI residents please add appropriate sales tax.

Satisfaction Guarantee: If for any reason you are not completely satisfied with your purchase, simply return it within 14 days and receive a full refund, less shipping.

Retailers call toll-free 888-457-2873 ext 880, M-F, 8 am - 5 pm



All the Best Records and Rockandwrapitup.org invite you to...



BE A "GOOD GUY"
Feed the Hungry!...
& get the "Good Guy Sweatshirt"
- the one you always wanted!



\$29.95 Each

Includes **\$5** donation

To feed the hungry

www.rockandwrapitup.org

Plus \$5.95 shipping & handling

Order by phone: **516 295-4367**

We Accept... **PayPal**

Order by mail: All The Best Records,

P.O. Box 164, Cedarhurst, N.Y. 11516

Specify large, x-large, xx-large



Allow 1 week delivery -

order online at www.allthebestrecords.com

POPLIFE

www.poplife-shop.de

To celebrate our **10th anniversary** we are holding our biggest auction with over **3000 incredible rarities!!!**

Here are just a few examples:

AC/DC-Dirty Deeds (schoolboy ps 45), dutch col.vinyl lp • **Marc Almond**-My Death(hard vinyl 45)
 • **Beatles**-White Album (german No. 0000044), First (orig. UK lp) • **Blur**-Parklife(japanese dj promo gimmix cd), german dbl. 12" • **Boys**-acetate 7" • **Boulevard**-Dawn Raid(orig. 45 ps) • **Maria Carey**-promo 12" box • **Charlatans**-promobox • **Cheap Trick**-japanese promo pictureshape • **Cirkus**-Cirkus One (signed original) • **Coldplay**-fierce panda 45 • **Cream**-Sunshine(german w/ promo ps) • **Cure**-The Blood (span promo 45 ps) • **Cure**-Shake Dog Shake (french promo 45 ps) • **Damned**-Love Song(german diff ps), debut lp (nzl test pressing) • **Dark Star**-Lady Of Mars (italian ps 45) • **Death In June**-State Laughter (orig. 45 ps) • **Depeche Mode**-People Are People (ltd. Nbd. 12" No.000011!) • **Descendents**-Fat E.P. (orig. new alliance 45 ps) • **Doors**-orig. gold elektra label album • **Bob Dylan**-May You Say..(german promo 7" box) • **Eloy**-german orig. gimmix cover lp • **Eno**-german ps 45s • **Flesh Eaters**-No Questions (orig. album) • **Hüsker Dü**-orig. reflex 45s • **Joe Jackson**-german sung promo 45 ps • **Joy Division**-sordide sentimental 45 • **Led Zeppelin**-german 1sided promo 45 • **Freddy Mercury**-german 8track promo cdr + presskit • **Kylie Minogue**-unique aussie col. vinyl test 12" • **Move/ELO**-etc rare ps 45's • **Paradise Lost**-In Dub (orig. 12" ps) • **Pere Ubu**-orig. hearthan 45 ps • **Plastic Penny**-Hound Dog (german 45 ps) • **Elvis Presley**-german testpressing lp, german cardsleeve promo cd ep's • **Professionals**-signed 45 • **Psychedelic Furs**-acetates • **Queen**-Seven Seas Of Rhye (german 45 ps) • **R.E.M.**-Radio Fee Europe (45 ps), promo only viewmaster • **Ramones**-signed ps • **Real Kids**-All Kindsa Girls (german 45 ps) • **Residents**-Commercial Album (german w/promo inserts) • **Rolling Stones**-orig. german decca ps singles, australian lp boxset • **Sex Pistols**-uncut coverproof, german testpressing lp • **Silverchair**-Freak (col. Vinyl test pressing) • **Siouxsie**-Israel(german diff ps) • **Smashing Pumpkins**-I Am One (orig. ltd.potential 45 ps) • **Patti Smith**-col.vinyl lp's, rare memorabilia • **Smiths**-german col.vinyl promo lp • **Status Quo**-japanese promo lp, rare german 45 ps's • **Stranglers**-Peaches(german diff ps) • **Suede**-New Generation (german promopack cd + book) • **Sweet**-Get On The Line (german 45 ps) • **David Sylvian**-Weatherbox • **Temptation**-german testpressing single • **Therapy?**-Promo only glasses! • **Tindersticks**-Unwired 45 ps • **Toad The Wet Sprocket**-Pete's Punk Song (orig. 45 g/fold) • **Tubeway Army**-blue vinyl album • **U2**-7" promo boxsets • **XTC**-12" coppermasterplate • **Yardbirds**-USA w/promo lp • **Frank Zappa**-Mothers Day (german metro ,toilet' ps)

• and many more ...

Our website is one of the biggest in Germany with over 40,000 items including many rare German 45s, 12" singles, LPs, promo CDs and memorabilia. We have a fully searchable database with both English and German versions. The auction is available online now, or for a printed version send 1 IRC (Europe) or 2 IRC (outside Europe)

Poplife • Strandstr.37 • D-24235 Wendtorf • Germany

ALBUMS BY AMERICA'S PREMIER SONGWRITER CHIP TAYLOR

*MORE THAN 100 CHART HITS IN THE LAST 40 YEARS
From 1967's #1 WILD THING by the TROGGS
to 2001's #1 ANGEL by SHAGGY*

HIT MAN— Containing 13 of his best loved songs including "Wild Thing", "Angel Of the Morning", "I Can't Let Go", and "Storybook Children"

LAST CHANCE - critically acclaimed country-rock masterpiece

BLACK & BLUE AMERICA — 2001 album , a musical journey into the passions of the 1960's with guest vocalists Lucinda Williams & John Prine

THE LIVING ROOM TAPES—Chip's most intimate and moving album recorded in 1996

THE LONDON SESSIONS - 2CDS for the price of one, 26 songs including "Holy Shit"

SEVEN DAYS IN MAY - 1998 album featuring Rick Danko, Guy Clark, Lucinda Williams, Rodney Crowell, and Garth Hudson

All albums \$15.00. Shipping \$3.50 per order in the USA and Canada, \$6.00 overseas. Buy all six albums for \$50 and save \$25.
Credit card, checks or money orders accepted.
Mail order or online at. www.trainwreckrecords.com
Train Wreck Records
110 Greene Street, Suite 705
New York, NY 10012
Evie Sands also records for TRAIN WRECK RECORDS

RECORD CLEANING PERFECTED!

Our **20th** Anniversary

Nitty Gritty offers the most affordable, efficient and hassle-free line of wet scrub/vacuum dry record cleaners available.

Clean records **Sound better, Last longer, Grade higher**
(Five models from \$282 MSRP)

DELUXE MODELS

BUDGET BALANCERS



Model 1.0 (Shown)
Record Master



Model 2.5Fi (Shown)
Model 1.5

ULTRA LP PRO

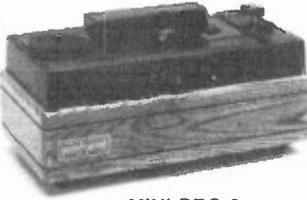

MINI-PRO 2

NITTY GRITTY
RECORD CARE PRODUCTS, INC.

Send for **FREE Full-Line Brochure**
DEALER INQUIRIES INVITED

NITTY GRITTY, INC.
4650 Arrow Highway #F-4 • Montclair, California 91763
Tel. 909-625-5525 • Fax 909-625-5526
www.nittygrittyinc.com

"Feel the Groove!"™

Goldmine

45 RPM Unit Advertising Section!

45 rpm issue—Dec. 28, 2001
Advertising Deadline—Nov. 29, 2001
Issue Mail Date—Dec. 6, 2001

1

This separate section will be devoted to 45 rpm records. All listings in an ad must be 45's.

3

Special rate for the 45 rpm unit section is \$40 per unit.

2

Special 45 section will appear in the December 28, 2001 issue of

888-457-2873

Trevor Lauber - ext. 322
Jill Ruesch - ext. 462

Fax:
715-445-4087
(attn: Display Advertising)

Your ad will be seen by over 60,000 people — more than **THREE** times more than any other music-collecting publication.

*One unit space equals one 8-1/2" x 11" typed sheet. Type your copy legibly onto 8 1/2" x 11" white sheets. A regular unit space is one-ninth of a page. Remember to include your ordering information, postage rates, grades, deadlines, name & address, etc. on your first unit. Do not send any partial units. There is a \$10.00 charge per photo for unit ads which contain photographs.

Goldmine 700 E. State Street
Iola, WI 54990-0001
Visit our web site at:
<http://www.goldminemag.com>

Take advantage of this great advertising opportunity. Simply fill out the form below and mail it, along with your ad and payment, to **GOLDMINE**.

YES!

I want to take advantage of **GOLDMINE's** 45 rpm unit issue. I understand that in order to qualify for the \$40 units my ad must contain only 45 rpm items.

Ads containing items other than 45 rpms will not receive the \$40 price. Ads placed in conjunction with this offer cannot be used to fulfill advertising contract commitments. *Goldmine* reserves the right to refuse any advertising not adhering to these guidelines or our regular ad guidelines.

For your convenience we accept MasterCard, VISA, American Express and Discover/Novus credit cards.

Credit Card # _____
Exp. Date _____
Name _____
Address _____
City _____
State _____ Zip _____
Phone _____

Number of units _____
(cost per unit) x 40.00
Cost of ad \$ _____



WHAT ARE UNIT SPACE ADS?

Unit space ads are an affordable option for the small dealer or for the private collector who has a few items to sell. They are based on 8-1/2 x 11 sheets that you create. They are "camera ready," in other words, the ad will look in print exactly how it looks when you send it in, only smaller. We will reduce the sheets to fit the ad space. Optionally, at no extra charge we can create a heading for your ad. We will typeset your name, business name (if any), address and phone/fax numbers on your ad if you so request.

The two types of ads are:

1. **Set Sale** - Items are sold at the price listed.
2. **Auction** - Items are sold to the highest bidder.

FOR A BETTER UNIT SPACE AD . . .

1. Use white paper.
2. Have a new ribbon on your typewriter or printer; avoid low toner on a laser printer.
3. Make sure the paper is vertically oriented. We cannot publish a horizontal unit space ad unless you want the reader to turn the magazine sideways to look at it. Most readers won't bother to do that.
4. Mail it to us; don't fax it. Faxes can leave unwanted markings that make your ad hard to read.
5. **Clearly identify whether your ad is a set sale or auction.** Avoid mixing the two in the same ad; if you must, have separate sections for set-sale and auction items.
6. Include your name, address, and telephone/fax number (and when you will be available to take calls on the ad) and all ordering information, including postage and shipping fees.
7. Put your listings in a logical order. If you have several formats in the same ad (LP, CD, 45, etc.), group your items by format. You also may wish to group items by type of music. As for the listings themselves, alphabetically by artist usually works best.
8. If you have any questions on how to set up your ad, contact anyone from the *GOLDMINE* advertising staff.

SET SALE GUIDELINES FOR BUYERS

1. First, make sure you are replying to a **set sale** and not an auction. If an ad mentions minimum bids and deadlines, it's **not** a set sale.
2. Follow the advertiser's directions on how to reply. If the ad says to write first to reserve an item, do it. If the ad says that money orders only are accepted, don't write a personal check. **And never send cash through the mail!**
3. If you write or call to reserve an item and the advertiser still has it in stock, send your payment for the item promptly.
4. Set sale ads are "first-come, first-served," so the sooner you reply, the more likely you are to receive what you order.
5. If you receive the item and it is not as advertised, don't hesitate to complain. Reputable advertisers take complaints seriously and try to do right by the customer. But don't take advantage of this, either; complain only when you have a legitimate reason for doing so.

SET SALE GUIDELINES FOR SELLERS

1. Only advertise items you have. Because of ad deadlines, some dealers will assume they will have new material based on release dates given by record companies. In the long run, it's better to wait until you actually have an item to put it in your ad.
2. State all your policies in the ad. Examples include method of payment, whether (and at what times) you will accept telephone calls, and whether to reserve items or send money immediately.
3. Send the items promptly after they've been paid for. Federal Trade Commission regulations state that you **must** ship your items within 30 days.
4. Charge only what you pay to send the package. Or charge everyone the same amount, knowing you will lose money on large packages, but will make up for it on smaller ones. If your stated postage rates are unusually high, state why! (Insurance, special handling or packaging, etc.)
5. Take complaints seriously. An unresolved problem is usually a lost customer.

Auction Guidelines For Buyers

1. First, make sure you are replying to an **auction** and not a set sale.
2. Note the minimum bid, and don't bid less than that. Also, don't say "I will top all bids" unless the auction allows it and, of course, you really mean it.
3. Mail in all bids unless the ad says phone-in bids are acceptable.
4. Remember the deadline. If none is stated, then the auction closes one month from the date on the cover. For example, if the auction is in the *GOLDMINE* dated October 15, the sale closes November 15.
5. If mailing bids, allow 1-2 weeks for your bids to arrive. And after an auction ends, allow 1-2 weeks for notification. If you haven't heard 14 days after the end of an auction, assume you won nothing unless the ad says that all bidders, win or lose, would be notified.
6. **Honor all winning bids!** If you are notified that your bid has won the item, send the money for your items within a week. Bidders renege on their winning bids is the No. 1 complaint from those who run auction ads. If you can't honor your bid, at least have the courtesy to notify the advertiser.
7. Allow 2-4 weeks for your winnings to arrive.

AUCTION GUIDELINES FOR SELLERS

1. Set minimum bids on any item you won't sell for less. You also can set an auction-wide minimum; different minimums on different parts of the auction; or no minimums at all. Avoid "Ridiculous bids will be rejected" or similar phrases; you can't assume that everyone knows what a "ridiculous bid" is. Instead, take the time to set minimums.
2. Run an honest auction. Don't advertise items you don't have; don't artificially force bidders to bid more by claiming there's a counterbidder when there isn't one; don't overgrade your items; and sell all items that meet your published minimum and are the high bid, even if the bid is far below "book" value.
3. Notify winners within the first week after your deadline passes.
4. Send the winners their items promptly upon payment. (It's OK to wait for checks from unfamiliar customers to clear, which takes no more than a week. If it takes longer, get a new bank.) Federal Trade Commission regulations state that you **must** ship your items within 30 days.
5. Don't use your auction as a way to compile a mailing list unless you state that in your ad.
6. In sum: Treat your customers as you would want to be treated if you were the one bidding.

UNIT SPACE AD RATES

GOLDMINE has two sizes of unit space ads:

1. **Regular** - your ad is reduced to one-ninth of one of our pages.
2. **Super** - your ad is reduced to one-fourth of one of our pages.

	Regular	Super
Each unit	\$60.90	\$126.80
Full page	\$466.20	\$466.20

Contract rates are available, which earn advertisers lower rates. Call anyone on our *GOLDMINE* advertising staff for a complete rate card. 715/445-2214

HEAVY M & BLUES - ROCKABILLY ROCK & ROLL - GARAGE - 45 RPM PT. II

Allen Radwill 23 Hunters Lane-Southampton,New Jersey 08088. Phone 609-953-5473. Minimum Bid \$4.50 per record. Call if you want to know high bid Auction ends Jan.30...

(RCA 8935)-Until Then/M- Mike Clifford(UA 489)-Close To Cathy/VG+ (Col.42226)-When We Marry/VG+...

G.L. Crockett(Four Brothers 445)-It's A Man Down There/Every Hour Every Day/VG+(65-Black) Howard Crockett(Mel-O-Dy 105)-The Spiky Haircut/Teddy Of Mine/The Big Wheel/M...

Canadian AOR

Table listing various Canadian AOR records including titles like 'Brighton Rock', 'Avalon', 'Alpha Centauri', 'Alias', 'Honeymoon Suite', 'Brian Hughes', 'Tom Cochrane', 'Teaze', 'Partland Brothers', 'Cinema Face', 'Haywire', 'Lynx', 'Korea', 'Toronto', and 'Trooper' with their respective prices.

Yes, we wholesale!

All prices are in U.S. Visa / Mastercard / US checks / Money Orders accepted. Postage & insurance: Surface \$3.50 first, \$1.50 additional Air Mail \$4.50 first, 2.50 each additional.

Spindle Records Box 49976, 660 Eglinton Ave. E., Toronto, ON, Canada M4G 2K0 416-425-0476, 416-425-7901 FAX

SET SALE - SEALED LPS

STEVE ROSS 11600 FLOWERWOOD COURT MOORPARK, CA 93021 FAX # (909) 828-4274

Hi everyone! This is a set sale of sealed LPS from the 60's and 70's. All LPS are U.S. pressings and believed to be original. Selection guaranteed. Write, fax or email to reserve records. Money orders, personal checks and cash by registered mail best accepted.

Large table listing various vinyl records with columns for artist, title, year, price, and other details.

Large advertisement for Goldmine featuring the text 'Unless an auction deadline is explicitly stated in this issue will deadline one month from the cover date of this issue' and the Goldmine logo.

Andy Jay Ondrus 616 Tunnel St., Port Huron, MI 48060 Set Sale \$5.00 Postage first LP. \$1.00 each after

- SET SALE 1. Beatles-Talk-GNW 4007-SS-\$10.00 2. Beatles-Live At The Star Club-Lingosong-2LPS-SS-\$18.00 3. Boston-Pic Disc-Epic 34188-SS-\$30.00 4. Bee Gees-Spirits Having Fun-PC Disc-\$22.00 5. Elvis-Canadian Tribute-gold wax-PCA-7065-SS-\$18.00 6. Elvis-Love Still Burns-Disc-SS-\$20.00 7. Elvis-Sun Years-1001-SS-\$10.00 8. Frog-Rock N Roll Music-Vanguard 6541-SS-\$10.00 9. Foreigner-Head Games-Atlantic 29999-SS-\$14.00 10. Frampton-Comes Alive-pink wax-2 LPS-\$24.00 11. Heart-Magazine-Pic Disc-SS-\$25.00 12. Heart-Dreamboat Annie-Pic Disc-SS-\$30.00 13. Hendrix-High Live & Dirty-red wax-SS-\$18.00 14. Herman's Hermits-Blaze-MGM 4478-SS-Cut Out-\$9.00 15. Ian Matthews-Stealing-color wax-SS-\$14.00 16. Ian Dury-Do It Your Self-with 7 single-SS-\$14.00 17. Iggy Pop-Kill City-green wax-\$14.00 18. Linda Ronstadt-Living In The U.S.A.-Pic Disc-SS-cut corner-\$20.00 19. Light House-Thoughts Of Moving On-SS-\$14.00 20. No Wave-Compilation-color wax-SS-\$14.00 21. Paul McCartney-interview-col 36687-SS-\$14.00 22. Rush-Hemisphere's-Pic Disc-SS-\$35.00 23. Rush-Byzantium-PC Disc-SS-\$32.00 24. Bad Company-Kangaroo-Rough USA2-SS-\$12.00 25. Savage Grace-1st Reprise 6399-SS-\$12.00 26. Stone 3-Mess you Disco version-12" single-SS-\$18.00 27. Stone 3-Some Girls-Original-cover-SS-\$25.00 28. Stone 3-Metamorphosis-cut corner-SS-\$15.00 29. Stone 3-Precious Stones-Pic Disc-SS-\$30.00 30. Styx-Pieces Of Eight-Pic Disc-ABM 4724-\$22.00 31. Sir Douglas-Mendocino-cut corner-SS-\$9.00 32. Spin Eric-My Mistake 12" single-SS-\$12.00 33. UK Soundwaves-wax-ABM 4667-SS-\$14.00 34. Who-Who Are You-red wax-MCA 3050-SS-\$25.00 35. Yardbirds-Shapes Of Things-2LPS-Bomb 1045-SS-\$20.00 36. Elvin Kistler-Armed Forces-with E.P.-SS-\$14.00 37. Argent-Show Of Hands-Epic 30126-SS-\$12.00 38. Gary Boyle-The Dancer-color wax-SS-\$14.00 39. Meatloaf-Bat Out Of Hell-Pic Disc-SS-\$22.00 40. Association-Windy-WB 1696-SS-\$14.00 41. Savage Grace-2 Reprise 6344-cut corner-SS-\$10.00 42. Bad Finger-Magic Christian-Apple 3364-SS-\$15.00 43. Nick Lowe-Labour Of Lust-CD 30607-SS-\$14.00 44. The Knack-Get The Knack-Capitol 511948-SS-\$12.00 45. The Cars-Candy O-Ele Semoor-SS-\$14.00 46. Ted Nugent-Weekend Warriors-Epic 35551-SS-\$14.00 47. Alice Cooper-Greatest Hits-WB 3107-SS-\$14.00 48. The Seeds-Crescendos-2023-SS-\$18.00 49. Grand Funk-Monumental Funk-SS-\$12.00 50. Deep Purple-Stromboli-WB 1974-SS-\$12.00 51. Grand Funk-Phoenix-Capitol 11069-SS-\$12.00

"TEN YEARS AFTER"

Rediscover a premier band from a prime period of Rock & Roll A new illustrated biography and previously unreleased concert recording Featuring the scorching guitar of inimitable fret master ALVIN LEE

Free Story Press ISBN 0097087000 EMI/Chrysalis Records 2CD set - Catalog #633297

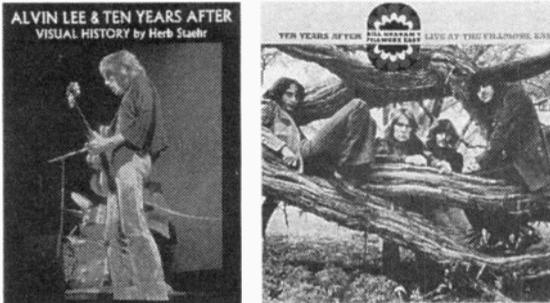

The complete Ten Years After story from the mid 60's to the present day. 192 pages with 400 rare photos from the life of every rock's most historic events:

- Windsor Blues Festival, England 1968 - Newport Jazz Festival, Rhode Island - Woodstock Music & Arts Festival 1969 - Texas International Pop Festival - 2nd Atlanta International Pop Festival - Randall's Island, NY Pop Festival - Goose Lake Park Festival, Michigan - Strawberry Fields Festival, Canada - Isle of Wight Festival, England ... and several others ...
- Love Like A Man - Good Morning Little School Girl - Working On The Road - 50,000 Miles Beneath My Brain - The Hobnob - I Can't Keep From Crying Sometimes - Help Me - Spontful - I Woke Up This Morning - I'm Going Home ... and more ...

Internet orders: AlvinLee.com or call 1-800-247-6553 (24 hours) also available from Amazon.com Watch for more remastered TPA CD's with unreleased extra tracks available soon from EMI/Chrysalis

ALLEN RADWELL

23 Hunters Lane, Southampton, NJ 08088 609-953-5473

ROCK 'N' ROLL FROM THE PAST

3875 ALBERTA PLACE • Philadelphia, PA 19154
(8:00 a.m. - 11:00 p.m.) • 215-632-0228



VINYL LP SET SALE

30'S BLAST FROM THE PAST 3875 ALBERTA PLACE PHILADELPHIA, PA 19154
TELEPHONE: (215) 632-0228 (8:00 AM - 11:00 PM)

LP SALE: All LP's & 45's are available for immediate shipment. 100% total satisfaction guaranteed. Prompt refund sent for anything you are not satisfied with or for any item that is out of stock.

SHIPPING: U.S. CUSTOMERS: LP's: 1st Class: \$4.75 1st LP & \$1.00 for each additional 2 LP's. 4th Class: \$3.50 1st LP & \$1.00 for each additional 2 LP's.

45's: 1st Class: \$5.00 Any Size Order. 4th Class: \$3.50 Any Size Order.

RESERVE REQUESTS: Telephone Reserves - OK! Mail reserves - Please send SASE!
TELEPHONE CREDIT CARD ORDERS - OK!!!
NOTE: Some of the LP's listed below are 2nd or 3rd Pressings & 1st's.

VINYL LP SET SALE

GUNS N' ROSES: The Spaghetti Incident	SS 10.00	MONTELL JORDAN: More...Def Jam 533191	SS 10.00
CHICO HAMILTON QUINTET: Deafening	SS 8.00	MONTELL JORDAN: Let's Ride Def Jam 536987	SS 8.00
HAMMER: Too Legit To Quit	SS 10.00	MARCI JOSEPH: Knockout! MLP 2009	SS 6.00
LIONEL HAMPSON ORK: Sentimental Journey	SS 6.00	JOURNEY: Raised On Radio	SS 6.00
FRANK SYLVIA BENNETT: Atlantic 81644	SS 6.00	IMI KANOZE: The Top Of The Hotsteppin'	SS 6.00
HERBIE HANCOCK: Man-Child	SS 8.00	Columbia 67056	SS 6.00
Columbia 33812	SS 8.00	K.C./SUNSHINE BAND: Game Of Love	SS 4.00
HERBIE HANCOCK: Perfect Machine	SS 8.00	Sispa 7720 (LP Maxi Single)	SS 4.00
Columbia 60025	SS 8.00	K.C./SUNSHINE BAND: TW 603	SS 8.00
HARPONES: On Sunday Afternoon - The	SS 8.00	R. KELLY: R. Live 41625 (2 LP Set)	SS 10.00
Goldener Recordings M. Hill 1098	SS 8.00	KING FLOYD: Same Columbia 9498	SS 8.00
HARPONES: Vol. 2, Great Willie Winfield	SS 11.00	OUR HEARTS: Sello 8022	SS 8.00
Relic LP 5003	SS 11.00	EARL KING: Truckload Of Lovin'	SS 8.00
EDDIE HARRIS/ELLIS MARSALIS: Homecoming	SS 8.00	SPINNA: Tomaso 295011	SS 8.00
Spindletop 105	SS 8.00	BOB KNIGHT ROX: Greatest Hits	SS 10.00
EDDIE HARRIS: The Exciting Eddie Harris	SS 12.00	Kape 1001	SS 11.00
Harc 532 (2 LP Set)	SS 12.00	GLADYS KNIGHT/PIPS: That Special Time	SS 6.00
COLEMAN HANKINS QUARTET: The Hawk Flies	SS 11.00	Of Year Columbia 460459 (UK)	SS 11.00
Riverside 12-223	SS 11.00	GLADYS KNIGHT/PIPS: Every Best Of	SS 11.00
ISAAC HAYES: Hotbel 2100	SS 10.00	Collectables 5154	SS 8.00
ISAAC HAYES: Black Moses Stax 8509	SS 10.00	JEAN KNIGHT: Mr. Big Stuff Stax 204558	SS 11.00
ISAAC HAYES: Hut Buttured Soul	SS 10.00	FRANKIE KNOX/ADEN: Welcome To	SS 8.00
Stax 4114	SS 10.00	The Real World Vinyl 40129	SS 8.00
TSAC HAYES: Truck Turner (Soundtrack)	SS 17.00	KOOL/GANG: Same De-Lite 2003	SS 10.00
Columbia 60025	SS 17.00	De-Lite 2008	SS 10.00
HEART: Magazine (PICTURE DISC)	SS 12.00	KOOL/GANG: De-Lite 2010	SS 10.00
Mushroom MRS 1-SP	SS 12.00	De-Lite 2011	SS 10.00
HEATHAVAN: Too Hot To Handle	SS 8.00	KOOL/GANG: De-Lite 2012	SS 10.00
Epic 34761	SS 8.00	De-Lite 2013	SS 10.00
HENRY'S HENRYS: Greatest Hits	SS 11.00	KOOL/GANG: Light Of Worlds	SS 10.00
ABCO 4227	SS 11.00	De-Lite 2014	SS 10.00
HI-LO'S: Harmony In Jazz CBS 14387	SS 6.00	KOOL/GANG: Split Of The Boogie	SS 10.00
AL FIP: Louisiana Man OTD 8612	SS 6.00	De-Lite 2016	SS 10.00
SILAS HOGAN: Trouble At Home	SS 8.00	KOOL/GANG: De-Lite 2017	SS 10.00
Bucella 8019	SS 8.00	De-Lite 2018	SS 10.00
HOLLIES: He Ain't Heavy, He's My Brother	SS 8.00	KOOL/GANG: De-Lite 2019	SS 10.00
Epic 26538	SS 8.00	De-Lite 2020	SS 10.00
HOLLIES: Greatest Hits Epic 32061	SS 6.00	De-Lite 2021	SS 10.00
HOLLIES: What Goes Around	SS 6.00	De-Lite 2022	SS 10.00
Atlantic 80076	SS 6.00	De-Lite 2023	SS 10.00
LALONDA HOLLOWAY: Mam Don't Papa Mam	SS 4.00	De-Lite 2024	SS 10.00
SATSON 2578 (2 LP Set)	SS 4.00	De-Lite 2025	SS 10.00
JOHN LEE HOOKER: Best Of GNP/Crescendo	SS 12.00	De-Lite 2026	SS 10.00
10007 (2 LP Set)	SS 12.00	De-Lite 2027	SS 10.00
HOOTERS: One Way Home 450 (UK)	SS 8.00	De-Lite 2028	SS 10.00
HOOTERS: One Way Home 450 (UK)	SS 8.00	De-Lite 2029	SS 10.00
Atlantic 82886	SS 8.00	De-Lite 2030	SS 10.00
LENA HORNE: Nature's Baby	SS 8.00	De-Lite 2031	SS 10.00
Buddah 6906	SS 8.00	De-Lite 2032	SS 10.00
WHITNEY HOUSTON: My Love Is Your Love	SS 6.00	De-Lite 2033	SS 10.00
Arista 19037 (2 LP Set)	SS 6.00	De-Lite 2034	SS 10.00
WHITNEY HOUSTON: Same Script, Different Cast	SS 10.00	De-Lite 2035	SS 10.00
Arista 13860 (2 LP Set)	SS 10.00	De-Lite 2036	SS 10.00
WHITNEY HOUSTON: Greatest Hits	SS 10.00	De-Lite 2037	SS 10.00
The Mack Motown 766	SS 10.00	De-Lite 2038	SS 10.00
ICE CUBE: Rap & Peace Priority 50700	SS 10.00	De-Lite 2039	SS 10.00
(2 LP Set)	SS 10.00	De-Lite 2040	SS 10.00
ICE-T: Home Invasion Rhyth Syndicate	SS 10.00	De-Lite 2041	SS 10.00
87844 (2 LP Set)	SS 10.00	De-Lite 2042	SS 10.00
IDES OF MARCH: Ideology Synthesized 5032	SS 15.00	De-Lite 2043	SS 10.00
(180 Gram Vinyl)	SS 15.00	De-Lite 2044	SS 10.00
BILLY IDOL: Rebel Yell (PICTURE DISC)	SS 6.00	De-Lite 2045	SS 10.00
Capitol 3856	SS 6.00	De-Lite 2046	SS 10.00
BILLY IDOL: An Interview With Billy Idol	SS 6.00	De-Lite 2047	SS 10.00
By Keta Heads Lip Service 021(UK)	SS 6.00	De-Lite 2048	SS 10.00
HYPOSTOGES: Rav Power Columbia	SS 8.00	De-Lite 2049	SS 10.00
32111	SS 8.00	De-Lite 2050	SS 10.00
ICUBAINS: Same (Iggy Pop's 1st Band)	SS 11.00	De-Lite 2051	SS 10.00
Norton 251	SS 11.00	De-Lite 2052	SS 10.00
INNER CITY: Do Ya (Columbia 7740)	SS 6.00	De-Lite 2053	SS 10.00
(Set Of 2-12" Maxi Singles)	SS 6.00	De-Lite 2054	SS 10.00
INTRUDERS: Super Hits Phila. Int.	SS 8.00	De-Lite 2055	SS 10.00
32131	SS 8.00	De-Lite 2056	SS 10.00
INVISIBLE MAN'S BAND: Same (All Might)	SS 10.00	De-Lite 2057	SS 10.00
Hango 9537	SS 10.00	De-Lite 2058	SS 10.00
IRON BUTTERFLY: In-A-Gadda-Da-Vida	SS 10.00	De-Lite 2059	SS 10.00
Alco 50-250	SS 10.00	De-Lite 2060	SS 10.00
ISLEY BROTHERS: Greatest Hits	SS 10.00	De-Lite 2061	SS 10.00
Thama 710	SS 10.00	De-Lite 2062	SS 10.00
ISLEY BROTHERS: Brother, Brother	SS 10.00	De-Lite 2063	SS 10.00
T-Neck TNS 3009	SS 10.00	De-Lite 2064	SS 10.00
ISLEY BROTHERS: Give	SS 10.00	De-Lite 2065	SS 10.00
T-Neck TNS 3008	SS 10.00	De-Lite 2066	SS 10.00
ISLEY BROTHERS: 3 * 3 T-Neck 32453	SS 10.00	De-Lite 2067	SS 10.00
ISLEY BROTHERS: Heat For The World	SS 8.00	De-Lite 2068	SS 10.00
T-Neck 33809	SS 8.00	De-Lite 2069	SS 10.00
ISLEY BROTHERS: Go For Your Guns	SS 8.00	De-Lite 2070	SS 10.00
Mercury 34432	SS 8.00	De-Lite 2071	SS 10.00
ISLEY BROTHERS: Minor Tears All	SS 12.00	De-Lite 2072	SS 10.00
T-Neck 36077	SS 12.00	De-Lite 2073	SS 10.00
ISLEY BROTHERS: Between The Sheets	SS 8.00	De-Lite 2074	SS 10.00
T-Neck 38674	SS 8.00	De-Lite 2075	SS 10.00
ISLEY BROTHERS: Grand Funk	SS 8.00	De-Lite 2076	SS 10.00
T-Neck 39240	SS 8.00	De-Lite 2077	SS 10.00
JERMAINE JACKSON: Feel The Fire	SS 8.00	De-Lite 2078	SS 10.00
Motown 888	SS 8.00	De-Lite 2079	SS 10.00
MICHAEL JACKSON: One In Your Life	SS 8.00	De-Lite 2080	SS 10.00
Motown 5352	SS 8.00	De-Lite 2081	SS 10.00
MICHAEL JACKSON: We're Almost There	SS 6.00	De-Lite 2082	SS 10.00
Motown 977 (12" Maxi Single) (UK)	SS 6.00	De-Lite 2083	SS 10.00
MICHAEL JACKSON: Bad Epic 40660	SS 8.00	De-Lite 2084	SS 10.00
MICHAEL JACKSON: Dangerous Epic 45400	SS 17.00	De-Lite 2085	SS 10.00
(2 LP Set)	SS 17.00	De-Lite 2086	SS 10.00
MICHAEL JACKSON: Blood On The Dance Floor	SS 17.00	De-Lite 2087	SS 10.00
Rhino 70320 (2 LP Set)	SS 17.00	De-Lite 2088	SS 10.00
MICHAEL JACKSON: History Epic 59000	SS 22.00	De-Lite 2089	SS 10.00
(3 LP Box Set)	SS 22.00	De-Lite 2090	SS 10.00
TOMMY JAMES/SHONDELIS: Anthology	SS 12.00	De-Lite 2091	SS 10.00
Rhino 70320 (2 LP Set)	SS 12.00	De-Lite 2092	SS 10.00
RICK JAMES: Throvin' Down Gordy 6005	SS 8.00	De-Lite 2093	SS 10.00
RICK JAMES: Cold Blooded Gordy 6043	SS 8.00	De-Lite 2094	SS 10.00
JANE'S ADDICTION: Nothing's Shocking	SS 12.00	De-Lite 2095	SS 10.00
WB 25727	SS 12.00	De-Lite 2096	SS 10.00
JANE'S ADDICTION: Ritual De Lo Habitual	SS 12.00	De-Lite 2097	SS 10.00
WB 25993	SS 12.00	De-Lite 2098	SS 10.00
AL JARREAU: In London WB 25331	SS 6.00	De-Lite 2099	SS 10.00
JAZZ MESSENGERS: Same Columbia 897	SS 8.00	De-Lite 2100	SS 10.00
JB'S: Food For Thought People 5601	SS 10.00	De-Lite 2101	SS 10.00
JB'S: Doing It To Death People 5603	SS 10.00	De-Lite 2102	SS 10.00
JB'S: Damn Right I Am Somebody	SS 10.00	De-Lite 2103	SS 10.00
People 6602	SS 10.00	De-Lite 2104	SS 10.00
JB'S: Breakin' Bread People 6604	SS 10.00	De-Lite 2105	SS 10.00
JB'S: Hustle With Speed People 6606	SS 10.00	De-Lite 2106	SS 10.00
JB'S: Jan 11 Disco Fever Poly 6153	SS 10.00	De-Lite 2107	SS 10.00
JEFFERSON STARSHIP: Red Octopus	SS 10.00	De-Lite 2108	SS 10.00
DCC LPZ 2036 (180 Gram Pure Virgin Vinyl)	SS 20.00	De-Lite 2109	SS 10.00
GARLAND JEFFREYS: Escape Artist Epic	SS 8.00	De-Lite 2110	SS 10.00
30693 (W/4 CD 7" LP Box)	SS 8.00	De-Lite 2111	SS 10.00
JIVE 5: Greatest Hits Betteone 5020	SS 11.00	De-Lite 2112	SS 10.00
JIVE 5: May Back Ambient Sound 801	SS 10.00	De-Lite 2113	SS 10.00
BILLY JOEL: Cold Spring Harbor	SS 8.00	De-Lite 2114	SS 10.00
Columbia 441	SS 8.00	De-Lite 2115	SS 10.00
BILLY JOEL: Songs In The Attic	SS 8.00	De-Lite 2116	SS 10.00
Columbia 37461(W/Inart)	SS 8.00	De-Lite 2117	SS 10.00
AL JOLSON: You Ain't Heard Nothin' Yet!	SS 8.00	De-Lite 2118	SS 10.00
Radio Rarities Radioli 313 LP Box	SS 8.00	De-Lite 2119	SS 10.00
GLORIA JONES: Remunited AVE 6:35	SS 8.00	De-Lite 2120	SS 10.00
JAMES JOPLIN: I Got Dem Ol' Kozmic	SS 8.00	De-Lite 2121	SS 10.00
Blues Again Name! Columbia 9913	SS 8.00	De-Lite 2122	SS 10.00
JAMES JOPLIN: Pearl 30322	SS 8.00	De-Lite 2123	SS 10.00
JAMES JOPLIN: Farewell Song	SS 8.00	De-Lite 2124	SS 10.00
Columbia 37569	SS 8.00	De-Lite 2125	SS 10.00
JAMES JOPLIN: Greatest Hits	SS 8.00	De-Lite 2126	SS 10.00
Columbia 32168	SS 8.00	De-Lite 2127	SS 10.00
JAMES JOPLIN: In Concert	SS 12.00	De-Lite 2128	SS 10.00
Columbia 31160 (2 LP Set)	SS 12.00	De-Lite 2129	SS 10.00
JAMES JOPLIN: Janis Columbia 33345	SS 12.00	De-Lite 2130	SS 10.00
REprise 2228	SS 12.00	De-Lite 2131	SS 10.00
MONTELL JORDAN: This Is How We Do It	SS 8.00	De-Lite 2132	SS 10.00
RAI 527179	SS 8.00	De-Lite 2133	SS 10.00

VINYL LP SET SALE

METHODS OF MAYHEM: Same MCA 11202	SS 8.00	PETER, PAUL & MARY: A Holiday Celebration	SS 6.00
STEVE MILLER BAND: Fly Like An Eagle	SS 15.00	Gold Castle 71316	SS 6.00
Capitol 21185 (180 Gram Vinyl)	SS 15.00	PETER, PAUL & MARY: Best Of WB 310588	SS 8.00
MIRACLES: The Miraculous Miracles	SS 10.00	TOM PETTY/HEARTBREAKERS: Southern Accents	SS 8.00
Thama 238	SS 10.00	MCA 5486	SS 8.00
MIRACLES: Greatest Hits From The Beginning	SS 17.00	P-PUNK ALL STARS: Urban Dancefloor	SS 8.00
Thama 254 (2 LP Set)	SS 17.00	Uncle Jam 19168	SS 8.00
MIRACLES/MARTIN GAY: Greatest Hits	SS 12.00	Wilson Pickett: American Soul Man	SS 8.00
Notown/Silver Eagle 10533 (3 LP Set)	SS 12.00	Motown 6244	SS 8.00
MISFITS: Die Die My Darling Plan 9 03	SS 10.00	The Final Cut	SS 8.00
MOBY GRAPES: Same Columbia 9498	SS 8.00	Columbia 36243	SS 8.00
MODERN ENGLISH: Pillow Talk VTY 2810	SS 8.00	ROBERT PLANT: Led.Ze.Int.(PICTURE DISC)	SS 6.00
EDDIE HONEY: Right Here CBS 466700K	SS 8.00	BAK 2097 (UK)	SS 6.00
MONICA: The Boy Is Mine Arista 19011	SS 12.00	POISON: Ltd.Ed.Int.(PICTURE DISC)	SS 6.00
(2 LP Set)	SS 12.00	CT 1025 (UK)	SS 6.00
MONITORS: Grazing In The Grass	SS 8.00	PRESDENTS: THE USA: II	SS 12.00
Motocity 28	SS 8.00	Columbia 67577	SS 12.00
THELONIOUS MONK QUARTET: Crisis-Crisis	SS 8.00	PRETTY THINGS: Same Morton 282	SS 12.00
Columbia CL 2038	SS 8.00	PRETTY THINGS: Get The Picture?	SS 12.00
THELONIOUS MONK QUARTET: Histerico	SS 8.00	Columbia 67577	SS 12.00
Columbia CL 2416	SS 8.00	PRETTY THINGS: Midnight To Six	SS 12.00
THELONIOUS MONK QUARTET: Monk's Dream	SS 8.00	Norton 284	SS 12.00
Columbia CS 8765	SS 8.00	CHARLY PRIDE: Best Of RCA 4223	SS 12.00
THELONIOUS MONK QUARTET: Monk's Time	SS 8.00	LLOYD PRICE: Coronado Plus	SS 12.00
Columbia CS 8984	SS 8.00	Specialty 2156	SS 12.00
THELONIOUS MONK QUARTET: Monk	SS 8.00	LLOYD PRICE: Walkin' The Track	SS 12.00
Columbia CS 9091	SS 8.00	Specialty 2163	SS 12.00
THELONIOUS MONK QUARTET: Monk Straight, No Chaser	SS 8.00	PRINCE: The Beautiful Experience	SS 6.00
Columbia CS 9451	SS 8.00	NPG 71003	SS 8.00
THELONIOUS MONK TRIO: Monk's Blues	SS 8.00	PRINCE: Rave On 2 The Joy Fantastic	SS 12.00
Columbia 9806	SS 8.00	Arista 16524 (2 LP Set)	SS 12.00
MONKEYS: Places Aquaria, Capricorn & Jones LTD. Sundazed 5048 (Blue Vinyl)	SS 11		

(Prince from page 17)

of more than \$200,000 in December after he won a fight to have Minnesota Tax Court reduce the assessed value for his Paisley Park Studios in Chanhassen from \$5 million to \$4 million, but rumors still abounded that he was having difficulty paying his bills. Whether he needed cash or not, he was still willing to miss a gig now and then — he was slated to be the musical guest on the season opener of *Saturday Night Live* in September, but he canceled on short notice.

No matter what else he managed in 1995, one of the first things The Artist accomplished was the Jan. 3 filing of a trademark for his adopted symbol with the Office Of Patent And Trademark. For the record, it is Registration #1,871,900.

1996

On Valentine's Day, The Artist married Mayte, who was 23 years old at the time. By early April, the pair would announce that the new bride was pregnant with their first child, with a due date in November. It was the last happy news he would have to offer for many months.

If anyone doubted things were falling apart between The Artist and his label, they must not have noticed the fact that he had taken to penciling the word "slave" on his face whenever he would make a public appearance. It was apparent that something was going to have to give, and in 1996 it did.

In February, many of The Artist's outside interests began shuttering. In short order came the closure of the Miami Glam Slam, NPG retail stores in Minneapolis and London, England, and the turning away of all outside business from Paisley Park Studios, which was losing money at a tremendous rate.

His music wasn't doing much better right then. He did Spike Lee a favor by agreeing to let Lee release the soundtrack for his picture *Girl 6* under the name Prince, but its mix of old and new material never caught on, struggling to get to even 100,000 in sales — a low number for Prince even in the worst of times.

A stormy ride with Warner Brothers came to an end when it at last settled an agreement to terminate The Artist's contract. Part of the deal was the July release of *Chaos And Disorder*. Billed as "the last original material recorded by [The Artist] for Warner Brothers Records," it is a simply awful record — raw, unfocused and generally boring. The minimal promotion done for the set included the release of the single "Dinner With Delores" and a few scattered appearances, including one last showcase for the word "slave" on his face when he did the *David Letterman* show in July. To know all one needs to know about the album, its accompanying artwork, which includes a photo of a heart nestled in a toilet bowl, says it all.

Possessed of freedom at long last, The Artist would take first advantage of it Nov. 19 with the release of the massive three-disc set *Emancipation*. Containing precisely three hours of new material, the set focuses heavily on songs about The Artist's hard-earned career, self-control and his new married life — in effect extolling the joys of one sort of freedom while willingly giving up another.

Released on Prince's NPG label, *Emancipation* was distributed by EMI and went double

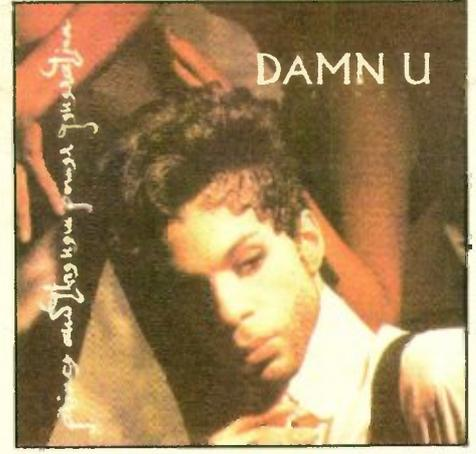
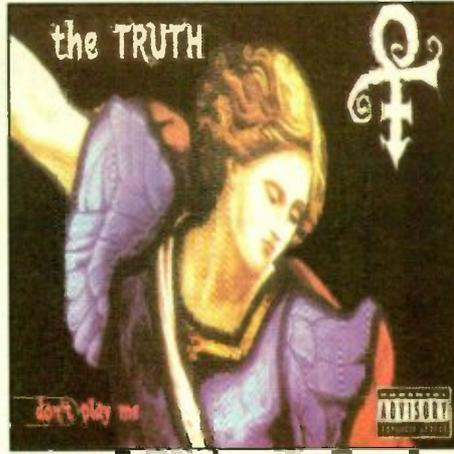
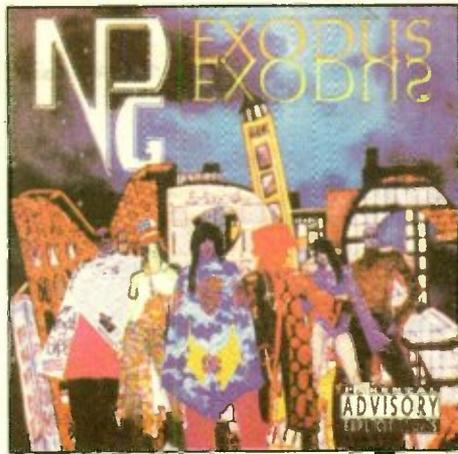

From left: NPG's *Exodus* import CD and "The Truth" single (only available on tour or by mail order), and the "Damn You" CD single sleeve.

platinum, which isn't quite as impressive as it sounds, given that each disc in the three-disc set counted as a single sale, but it still represented a giant payday for The Artist.

The music of *Emancipation* is uneven, but the package is deep enough to justify the inclusion of bits and pieces that don't work. Considering the appeals of the lavish long-form number "The Holy River," the irresistible "Sleep Around" and a sweet remake of "Betcha By Golly Wow!," it has plenty going for it.

It must have been galling for Warner Brothers' publicity people to watch The Artist promote his new record. After 15 years of making himself as inaccessible as possible, all of a sudden The Artist was willing to sit down for interviews and talk with the media. Among his more standard promotions were a live half-hour show on BET Nov. 12 and his donation of one of his yellow "cloud" electric guitars to the Smithsonian Institution's exhibit "Electrified, Amplified And Deified."

He also made a stunning appearance on the *Oprah* show Nov. 21, during which he opened up to the popular talk show host about his life and toured her around his studio playground. It was a canny move on his part. People were no longer showing interest in his music, so he sold one thing that still fascinated the world — his legendary privacy. He showed himself in the process to be as odd as people believed him to be, explaining that his closeness with Mayte was established in a previous life and proclaiming quite seriously that "recent analysis has proved that there's probably two people inside me." *Oprah* Winfrey also asked about his recently delivered child, but he avoided specifics, claiming only that it was "all good."

In truth, it wasn't. The child had been born Oct. 16 and died a week later of complications of Pfeiffer's Syndrome Type 2, a rare and deadly skull deformity. The story hit the press when Mayte's assistants, Arlene and Erlene Mojica, took it public because they had disagreed with Prince's decision to take the baby boy off of the respirator that was keeping him alive. In June of the following year, authorities completed an investigation and concluded that the baby, who was cremated Oct. 24 under the name Boy Gregory, had died of natural causes. Neither The Artist's nor Mayte's name appear on the death certificate.

1997

It was telling of the standard of proficiency expected of The Artist by his fans that he was criticized when 1997 came and went without a new collection of his music to be

found. The three discs of fresh material he had released at the tail of 1996 were a nice start to his new freedom, but after all of the times Prince had complained that he wanted to release music at a faster pace than his record company would allow, toward the end of 1997 fans were actually beginning to wonder whether anything had changed at all.

Part of the problem may have been that he announced the release of a three-CD set of vault songs to be called *Crystal Ball*, which years before had been the working title of a 1987 three-disc set that was eventually pared down to two albums and renamed *Sign "O" The Times*. It was originally stated that the album would be made available to the public by direct sale only, and fans lined up to pre-

(Please see Prince page 47)

SERIOUS STORAGE 1,000 CDs in 4 sq. ft!

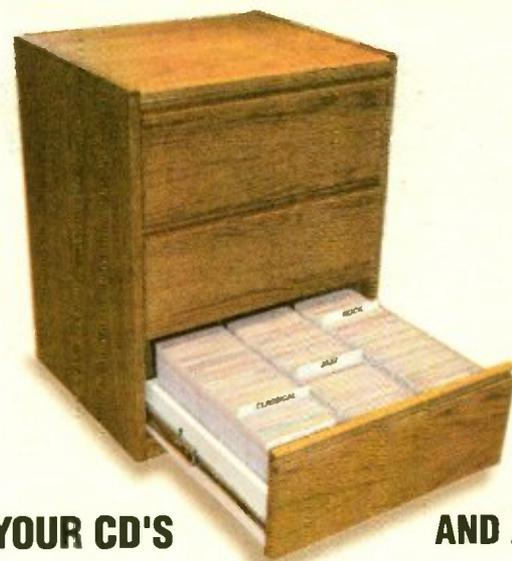

PROTECT YOUR CD'S

AND ARTWORK

And say goodbye to clutter and broken cases. The **Jewelchest™** features storage for 1,000 Jewelsleeves™, the finest archival CD storage sleeve in the world.

The Jewelsleeve is a revolutionary new CD sleeve that replaces all of your fragile, bulky jewel boxes with a thin, scratch-proof poly sleeve that cannot break or tear, takes up 75% less space than a jewel box, and protects and stores EVERY PART of the CD—INCLUDING THE BOOKLET AND TRAY CARD—without folding or cutting.

Call or email for a brochure and free sample!

Jewelsleeve.com
3949 Los Feliz Blvd. Ste. 102
Los Angeles, CA 90027

Tel: 800/863-3312
Fax: 323/663-4091
www.jewelsleeve.com

Since 1995.

**Siren
Disc**

Discount Import CDs & More.
www.sirendisc.com

(603) 629-9102

\$4.00 for shipping & handling per order, not per item (US \$6.00 outside USA)

We will be closed Dec 24 & 25 for the holiday

Monday - Thursday 10:30 am - 8:00 pm

Friday 10:30 am - 4:00 pm Eastern Standard Time

Visa, Mastercard, JCB Cards Diners Club, Carte Blanche Discover, Private Issue, Bravo American Express, Optima Check or Money Order



Metro CD Records



PO Box 1514 Manchester, NH 03105 USA

Many more items available at: www.MetroCityRecords.com Secure On-Line Ordering

Ad #130

PRE-ORDER LIST COMING SOON!

Prices and availability are subject to change.

Compact Disc

Table listing various artists and their CD releases, including titles like 'Original Soundtrack + 2', 'How Dare You + 1', 'Deceptive Bends + 3', etc.

Table listing artists and their DVD releases, including titles like 'Live Stuff Upper Lip 2000', 'Gong', 'Hatfield & The North', etc.

Compact Disc

Table listing artists and their CD releases, including titles like 'Angel', 'April Wine', 'Arena', 'Asia', 'Attention Deficit', etc.

Table listing artists and their VHS/DVD releases, including titles like 'Dream Theater', 'Transatlantic', 'Electric Light Orchestra', 'Emerson Lake & Palmer', etc.

(603) 629-9102

Monday - Thursday 10:30 am - 8:00 pm

Friday 10:30 am - 4:00 pm

Eastern Standard Time

Visa, Mastercard, JCB Cards Diners Club, Carte Blanche Discover, Private Issue, Bravo American Express, Optima Check or Money Order



Metro CD Records



PO Box 1514 Manchester, NH 03105 USA

More titles available at: www.MetroCityRecords.com

Secure On-Line Ordering

Ad #130

Table listing various music releases including Journey, Kansas, Pink Floyd, Point Blank, Porcupine Tree, Shadow Gallery, Spock's Beard, Frank Zappa, and many others. Includes columns for artist, title, format, price, and availability.

ADD-ON COLLECTIONS

PO Box 1474, Bolingbrook, IL 60440 1-630-759-2273 FAX 1-630-759-2430 E-Mail AUDIOCOLL@AOL.COM

Hours Monday through Friday 9:30 AM to 8:00 PM Central Time, Saturday 10 AM to 5 PM. To place orders, call 630-759-2273 (calling is best). To fax orders 630-759-2430 24 hours a day.

To E-mail orders AUDIOCOLL@AOL.COM. VISA, MasterCard, American Express, Money Orders, PAYPAL.COM Orders to AUDIOCOLL@AOL.COM.

Checks allow time to clear. Special orders take up to three weeks. Prices: New Lower Prices! Just In Time For The Holidays! 1 to 5 CDs, \$23.99 per CD; 6-9 CDs \$23.00 per CD; 10 and Up \$21.00 per CD. (Prices are per disc, others slightly higher.)

Use Paypal it's easy! (www.Paypal.com) Shipping & Handling USA \$6.00 Priority, Overseas Global Air Rate added if available. No unauthorized returns.

All orders shipped with Huge Updated Special Order Catalog. www.audiocollections.com, 2 catalogs on site. Incredible Selection! Order Now For The Holidays and Have A Happy Holiday! Thank You.

Main catalog table with columns for artist names, album titles, and track listings. Includes handwritten annotations like 'Deers', 'Beattles', 'Eagles', 'Izzy Striplin', 'Pink Floures', 'Munkies', 'Henry', 'Celine', 'Izzy Striplin', 'Pink Floures', 'Munkies', 'Henry', 'Celine', 'Izzy Striplin', 'Pink Floures', 'Munkies', 'Henry', 'Celine'.



SATURN RECORDS

SAN FRANCISCO BAY AREA'S PREMIER COLLECTOR'S STORE. WORLDWIDE MAIL ORDER - VISIT US ON THE INTERNET

www.saturnrecords.com



5488 COLLEGE AVE. OAKLAND, CA 94618 PHONE 510.654.0335 - FAX 510.654.4386

Order LP's directly online.

The world's largest searchable vinyl record store on the Internet.

www.saturnrecords.com

SATURN RECORDS

5488 COLLEGE AVENUE

OAKLAND, CA 94618

*To order, either use VISA/MC or AMEX by phone or mail, send payment with an SASE or access and order form...

OLDIES 7" SINGLES

Table listing Oldies 7" singles with columns for artist, title, and price.

Compact Discs

Table listing Compact Discs with columns for artist, title, and price.

Table listing various vinyl records with columns for artist, title, and price.

Table listing various vinyl records with columns for artist, title, and price.

World Radio History



MANY MORE GREAT TITLES ON OUR WEBSITE!

(Prince from page 41)

order what was promised as a limited edition. What fans did not know at the time was that The Artist was holding off the pressing of discs until such time as he had 85,000 pre-orders, a number that would ensure he would make a profit. The holiday season came and went with no news, as Artist-related Internet message boards filled up with the frustrated musings of an impatient fan base.

In the meantime, The Artist was staging his first post-freedom tour, Jam Of The Year, which would make more than \$24.6 million and check in as *Pollstar* magazine's sixth-most successful tour in 1997. Former Sly & The Family Stone bass player Larry Graham opened many of the dates along the way as fans laid down big money (ticket prices of \$100 were not uncommon on the tour of small venues) to see a show composed largely of medleys of greatest hits and just a few tunes from *Emancipation*. Mayte was nowhere to be seen in the show, as she was touring at the same time with the NPG Dance Company, a modern-style troupe that garnered generally positive reviews.

Emancipation stayed on the R&B charts well into 1997, but it was out of the Top 100 on the pop charts by early March. By then, the blitz of Artist-based promotion that had kick-started the disc's early success had come to an end, although his new accessibility remained apparent on such occasions as a cover-featured interview in the April issue of *Musician* and his appearance on the Sept. 13 season premiere of the Disney Channel's *Muppets Tonight* program, where he clowned about with the furry Bobo, who described himself as "the bear currently known as not amused." Those sorts of things were all that fans had to tide themselves over with in 1997, but that was about to change in a big way.

1998

The wait for *Crystal Ball* ended in February, but there was still controversy to be had. Direct-order customers received the three-disc *Crystal Ball*, the bonus acoustic disc *The Truth, Kamasutra* (a CD of The Artist's ballet for his wife) and a T-shirt, all for about \$50. Unfortunately, the CDs, which were originally expected to be made available only by direct order, started showing up in national chains such as Best Buy and Blockbuster Music before many direct orders were fulfilled. To make matters worse, retail ranged as low as \$30, and retail sets included a booklet telling the background behind each track that direct orders did not include (the original plan was to have all liner notes available only at an online site, www.crystalballcd.com). The retail set also included *The Truth*, so for all intents, direct order customers were paying \$30 for a CD of *Kamasutra* (which had been available from The Artist as a direct-order cassette for

months) and a T-shirt. Many were displeased.

To make matters worse, *Crystal Ball* is something of a disappointment. Of the 30 songs on its three discs of vault material, five are remixes of previously released tracks and two were previously available commercially. For someone with so much unreleased material to offer, such a large quantity of songs fans already knew was notably skimpy and unconscionable.

The collection rounds out the official release of all remaining tracks from *Glam Slam Ulysses* and the second track in the *Showgirls* film. It also includes some desirable outtakes, including its title track, "Dream Factory," "Hide The Bone" and "Crucial," all of which had been passing between fans for years on low-fidelity copies. Also interesting were experimental moments such as the Morris Day-style singing in "Cloeene Baconskin," which isn't a terribly good tune but was interesting enough to warrant inclusion. The music on *The Truth* is similarly hit or miss, ranging from an interesting acoustic version of "Welcome 2 The Dawn" to the laughable Vegan philosophizing ("No member of the animal kingdom/ Nurses past maturity") that drives the ridiculously styled "Animal Kingdom."

Although they were not exactly brimming with material, the fact that The Artist had issued five discs early in the year made it a bit of a surprise when he announced another would be coming in the fall. Calling it a disc by the NPG but showing up more clearly than he had on the group's previous pair of releases, in October, The Artist released *Newpower Soul*. The set, which is for all intents just another Artist album, relies too heavily on bland drum-machine rhythms, and has too many boring anthems along the lines of "Funky Music" and "Freaks On This Side." A couple of tunes, including "Mad Sex" and the bonus track "Wasted Kisses," stand out, but the disc was The Artist's weakest in years and perhaps of his entire career.

In addition to his own music, The Artist also issued a pair of albums by others on his NPG label and had a strong hand in both. October releases also included Chaka Khan's *Come 2 My House* and Graham Central Station's *GCS 2000*, for which Larry Graham is the driving force.

Toward the end of the year, Warner Brothers got a head start on taking advantage of its ownership of the Prince catalog by re-issuing the again-titled 1983 single "1999." Prince was reportedly not happy with the action, so he set out to do something about it.

1999

Unable to convince Warner Brothers to return the masters of his catalog to him, The Artist set out to make them obsolete. The first strike to that end came Feb. 2 with the release of the 1999: *The New Master*. Little more than a glorified



maxi-single, the EP contains seven new versions of the hit song, none of which offer much of anything to make people forget the original. Critical reaction was generally negative and the single did nothing commercially, but that didn't stop The Artist from announcing in April that he planned to

(Please see Prince page 48)

PRINCE The Very Best Of Prince Warner Brothers Records (R2 74272)

Following its nasty and very public parting of ways with Prince in 1996 after nearly two decades as his label, Warner Brothers cannot be counted on for any new Prince material going forward except reissues of the music he produced for it over that period. However, given that his greatest commercial success as an artist came during that time, that fact may not qualify as a drawback. *The Very Best Of Prince* is the second retrospective of his past work, a collection of hits culled from 1979 to 1991 that includes many fine songs but does not match the appeals of his previous greatest hits package, *The Hits/The B-Sides*.

The bonus-barron new set is composed exclusively of expected material such as the 1986 chart-topper "Kiss" and Prince's 1979 breakthrough single "I Wanna Be Your Lover," but several notable absences make it worth wondering how tunes were chosen. Top 10 hits that didn't make the cut include the relentlessly perky "Delirious" from the 1999 album, the 1985 #7 "Pop Life," and the 1987 single "I Could Never Take The Place Of Your Man."

The entire disc suffers from an odd lack of variety in the breadth of its survey, as nearly half of its 17 tunes are culled from a pair of albums that contribute four apiece — the 1991 disc *Diamonds and Pearls* and 1984's *Purple Rain* soundtrack. In the case of the latter disc, the emphasis is understandable given that it was Prince's most commercially successful album. But the inclusion of half as many *Diamonds and Pearls* tunes could have been justified to make room for cuts from the *Controversy* and *Dirty Mind* albums, neither of which is represented at all.

The comparatively minor hit "Money Don't Matter 2Night" is the only song included that was not also on the 1993 package *The Hits/The B-Sides*, which also features copious liner notes far superior to the new collection's assembly of picture sleeve photos. It is curious that neither set offers the 1989 #1 "Baidance" or its fellow *Batman* soundtrack hit "Partyman," although the new set's artwork does include a pair of pictures related to that project. If there is a reason why songs from that album are off-limits, no one has revealed it.

That mystery aside, the songs on both sets sell themselves and add up to impressive statements on the range of Prince's music and the depth of his catalog. The new collection is just fine for someone who wants to get the still-electric "When Doves Cry" and "Sign 'O' The Times" on the same disc for the lowest possible price, but *The Hits* is by far the superior package — markedly better than *The Very Best*.

— Thomas Kintner

Advertisement for Goldmine Records featuring a logo and a list of vinyl records for sale. The list includes titles like 'Texas still kicks, dudel! Boogie world-wide! LPs! & CDs!', 'Set Sale #140 All LPs are M- or sealed (ss) unless stated otherwise', and various other vinyl releases with prices and details.

Advertisement for Robert & Gloria Arredondo featuring a logo and a list of vinyl records for sale. The list includes titles like 'Texas still kicks, dudel! Boogie world-wide! LPs! & CDs!', 'Set Sale #140 All LPs are M- or sealed (ss) unless stated otherwise', and various other vinyl releases with prices and details.

Thomas Funk, P.O. Box 156, Lake Ariel, PA 18436-0156

Robert & Gloria Arredondo 4911 Manchaca Road #148, Austin, Texas 78745 • Tel: 512-447-0853

(Prince from page 17)

record new versions of his entire 17-album catalog, declaring it the end of his feud with Warner Brothers. At present no further plans for any such reissues have been made public.

It came out early in the year that The Artist's marriage to Mayte had been annulled, which was explained away as a transience of such earthbound conventions for two lovers bonding on a higher astral plane, but it was also true that rumors of jealousy on Mayte's part and possessiveness on The Artist's part were plentiful. Summing it up in one of the truly great quotes of his career, he told Paper for its June issue that he and Mayte pretended the marriage "didn't even happen." He said, "Like a lot of things in life I don't like, I pretend it isn't there and it goes away." His past managers and anyone who had ever extended him credit probably got a nice laugh out of that.

No stranger to a court of law, The Artist saw a couple of legal issues go his way as the year progressed. In June a copyright infringement lawsuit brought by Ferdinand Pickett was dismissed, ruling that even though The Artist's guitar that was shaped like his name symbol was similar to one Pickett had created, Pickett's design was derivative of The Artist's copyrighted logo in the first place. In July The Artist dropped a lawsuit he had brought against the fan magazine Uptown, following an agreement by the magazine to stop publishing

discographies of bootleg collections of his work and to stop using his symbol in its pages.

Listeners waiting for the new material The Artist was to release later in the year got something to tide them over Aug. 24 when Warner Brothers issued the last Prince album remaining in its deal — 10 songs wrapped up under the name The Vault... Old Friends 4 Sale. It features 10 tracks recorded between January 1985 and June 1994, the best of which he gave to Joe Cocker years before, "5 Women." Supported by virtually no publicity ("Extraordinary" was shipped to radio but never released commercially) and assembled as a package featuring too little music and too no liner notes to give any of it context, it was a rotten way to say goodbye, and the listeners who bought it were the biggest losers in the process.

In late August, Arista Records announced it would release The Artist's next collection of new material, titled Rave Un2 The Joy Fantastic. The label was riding high on its recent success with Santana's award-hogging Supernatural disc, and Arista head Clive Davis believed he could help The Artist with a similar revitalization, all while letting the performer keep his own masters. The disc hit stores Nov. 2, nodding to its throwback production sensibilities by crediting Prince as its producer, but The Artist as its performer. Featuring guest appearances by Ani DiFranco, No Doubt's Gwen Stefani, and Sheryl Crow on the infectious rock "Baby Knows," the disc

is long on flavor and personality.

To bring the 1990s to a close, The Artist announced a pay-per-view special to air on New Year's Eve titled Rave Un2 The Year 2000. Billed as the last time he would ever perform the song "1999," the show was taped for later broadcast on the Paisley Park soundstage and featured guest appearances by Benny Kravitz, a new incarnation of Morris Day And The Time, and Maceo Parker. Loaded with old hits and fresh energy, it was a fine reminder of the still-present strengths of one of R&B's greatest stage performers.

Although Rave Un2 The Joy Fantastic was nowhere near the commercial success that the Batman soundtrack was, the 1990s ended not on a note of slowing down, finding innovative new ways to deliver a steady stream of new music to his fans, among which was his online NPG Music Club, a pay service that would release his next album, The Rainbow Children, according to the Internet on Oct. 17, 2001 — even before the same year it would be made available in stores. But then he had also taken mercy on journalists across the land and returned to using the name Prince, which may have been his best innovation of all.

GARAGE SALE
DAVID TYSON
P.O. Box 51806, SUMMERVILLE, SC 29485
Phone (843) 821-1514 • e-mail tyson@tknology.net
Postage: \$2.75 for the 1" cd, \$5.00 for each add. cd.
Insurance: \$1.10 for each \$50 worth of merchandise
REEL-IN THE YEARS (2cd w/short
Interviews and lots of old music) \$6 ea
97-03 Carlos Santana, Bobby Keys, Steve Miller
98-18 Sting, Carlos Santana, Mike Campbell
99-25 Tracy Wright, Stephen Stills
99-31 David Bowie, Spencer Davis, Peter Frampton
99-35 Roger Glover, Jeff Beck, Christine McVie
99-41 Delbert McClinton, Roger McGuinn, Joe Cocker
99-43 Peter Townshend, Crosby & Nash, Steve Miller
99-45 Keith Moon, Joan Jett, Lou Reed, C. Hyde
99-48 Carlos Santana, Phil Collins
99-51 Mick Taylor, Robbie Robertson, David Crosby
99-55 Bill Wyman, Robin Trower, Chris Dreya
00-02 Rod Stewart, Jimmy Page, Bob Seger
00-03 Ringo Starr, Robert Kennedy clip
00-06 Boston, Robert Plant, Jon Anderson
00-08 George Harrison, Eric Clapton, Edgar Winter
00-09 R. Bachman, K. Loggins, R. Daltrey
00-10 Elton John, Glen Frey, Paul Rogers
00-12 D. Fagan, R. Davies, P. McCartney
00-13 Moody Blues, Alice Cooper, Timothy Leary
00-14 B. Buckingham, John Denmore, Rod & Woody
00-15 K. Richards, P. Townshend, Rod Stewart
00-16 Chris Hillman, Jackson Browne, C. Santana
00-18 Al Kooper, Phil Collins & Tony Banks, M. Lewisohn
00-19 Ringo Starr, Dickie Betts, Bill Wyman
00-21 Al Kooper, Mark Lewinson, Phil Collins & T. Banks
00-22 Rod Stewart, Tommy Stinson, Paul McCartney
00-23 Robbie Robertson, Ray Manzarek, Greg Allman
00-40 Mick Jagger, Bobby Womack, Chrissy Hynde
00-41 Joe Walsh, John Entwistle, Marty Balin
00-43 Peter Frampton, Jeff Beck, Peter Townshend
00-44 Don Henley, Grace Slick, Bill Wyman
00-47 Robin Trower
00-48 Ray Davies, George Harrison, Mick Fleetwood
00-49 Warren Zevon, Mark Farner, Peter Townshend
00-50 Bobbie Robertson, Crosby, Stills & Nash
00-53 Ron Wood, Rod Stewart, Peter Townshend
00-52 Elton John, Simon Kirke, Glen Frey
00-53 David Gilmour, John Mellencamp, Joe Cocker
00-54 Lynnyrd Skynyrd, Mike Daltrow, Edgar Winter
00-55 Steve Niles, Greg Allman, Joe Jackson
01-01 Paul McCartney, Peter Townshend, Mick Jagger
ARCHIVE #1 Spencer Davis, Chris Hillman, Joe Cocker
ARCHIVE #2 John Fogerty, RHCPC, Frank Zappa
ARCHIVE #3 Cal Stevens, Bob Robertson, G. Emerick
ARCHIVE #4 Warren Zevon, Mark Farner, P. Townshend
ARCHIVE #5 Ian Hunter, Ray Davies

REEL-IN THE YEARS (2cd w/short
Interviews and lots of old music) \$6 ea
ARCHIVE #6 Elton John, Glenn Frey, Paul Rogers
ARCHIVE #7 Al Kooper, Paul McCartney, Ron Wood, T. Smothers
ARCHIVE #8 Roger Eno, Mick Mitchell, Ian Anderson
OUT OF ORDER (2cd w/short interviews and
lots of new music) \$6 each
96-05 Red Hot Chili Peppers, Oasis, The Call
96-08 U2, P. No. Moby, Alice in Chains, A. Whigs
96-20 Sugar Ray, Blink 182, Silverchair, Papa Vegas
96-32 Good Goo Dolls, Filter, Verve Pipe, E. Costello
96-35 Better Than Ezra, Lamb, Remy Zero, New Radicals
96-42 Eurythmics, Barenaked Ladies, Fyis, Kravitz
96-50 Sugar Ray, Blink 182, Silverchair, Papa Vegas
96-52 Good Goo Dolls, Filter, Verve Pipe, E. Costello
96-58 Pet Shop Boys, Tonic, 311, Blink 182
99-41 Kid Rock, Powerman 5000, Live
99-42 ST. Punk, Fog Fighters, Beastie Boys, Lil' Strike 9
99-43 Rage Against the Machine, Blink 182
99-47 Creed, STP, Michael Penn, Limp Bizkit
99-48 Fiona Apple, Ray Davies, Talking Heads, Korn
99-50 R.A.T.M., Björnk, REM, Jimmie's Chicken Shack
99-51 Staind, 311, Blink 182, Hole
00-02 Black, Limp Bizkit, Staind, Lil' Fione Apple
00-04 Staind, Limp Bizkit, Replacement, S. Pumpskins
00-06 Kid Rock, Third Eye Blind, Hoobler, Incubus
00-07 Lil' F. Fog Fighters, Haircut 100, Moby, Blink 182
00-08 Okeechobee, No Doubt, Vertical Horizon, Incubus
00-10 Lil' Alimee Mann, Apollo 440, Morrissey
00-11 The Cure, 3EB, Social Distortion 99
00-12 Vertical Horizon, Blink 182, RATM, Oasis
00-13 Godsmack, Simple Minds, Korn, RHCPC
00-14 Incubus, 311, Cardigans, P.O.D., V. Horizon
00-15 Godsmack, Bush, C. Wheel, Redford
00-17 Blink 182, S. Pumpskins, Jimmie's Addition, P.O.D.
00-18 Godsmack, Simple Minds, Korn, RHCPC
00-19 STP, M. Bosstones, 5.13.13, Metallica
00-20 Incubus, Matchbox 20, Smashing Pumpkins
00-21 Godsmack, Duran Duran, Metallica, Moby
00-22 No Doubt, RATM, Richard Ashcroft, RHCPC
00-23 Godsmack, Limp Bizkit, Björnk, Kid Rock
00-24 Godsmack, Metallica, Incubus, Deftones
00-25 Korn, Radiohead, Papa Rock, Limp Bizkit
00-26 Blink 182, A. Perfect Circle, Garbage, Eminem
00-27 Deftones, Metallica, Fog Fighters, 3EB
00-28 Eve 6, Blur, Papa Rock, Moby, Skin
00-29 Dynamic Hack, Blink 182, A.P.C., dt, Toadies
00-30 Deftones, Incubus, Everclear, 3 Doors Down
00-31 Nine Inch Nails, Funk, 3 Doors Down, Eve 6
00-32 STP, Papa Rock, Metallica, Green Day, dt
00-33 Vertical Horizon, Blink 182, Deftones, Cypress Hill
00-34 3 Doors Down, Everclear, Incubus, American Pearl
00-35 Nine Inch Nails, Funk, 3 Doors Down, Eve 6
00-37 Weezer, dt, Cake, Deftones, Dandy Warhol
00-38 3 Doors Down, Temple Of The Dog, OPM, Veast
00-39 Green Day, Metallica, Deftones
00-40 Vandal SVT 71, Fog Fighters, 3 Doors Down
00-41 hrd p.a., Incubus, Beastie Boys, Deftones
00-42 Papa Rock, Jellyfish, Fuel, Coldplay 00-43 U2.
Incubus, Caviar, Frankie Goes To Hollywood 99

RARE LP'S - ONLY \$6
LIVE LP SET SALE
11/26 11/36 11/30 11/31 11/32 11/33 11/34 11/35 11/36 11/37 11/38 11/39 11/40 11/41 11/42 11/43 11/44 11/45 11/46 11/47 11/48 11/49 11/50 11/51 11/52 11/53 11/54 11/55 11/56 11/57 11/58 11/59 11/60 11/61 11/62 11/63 11/64 11/65 11/66 11/67 11/68 11/69 11/70 11/71 11/72 11/73 11/74 11/75 11/76 11/77 11/78 11/79 11/80 11/81 11/82 11/83 11/84 11/85 11/86 11/87 11/88 11/89 11/90 11/91 11/92 11/93 11/94 11/95 11/96 11/97 11/98 11/99 12/00 12/01 12/02 12/03 12/04 12/05 12/06 12/07 12/08 12/09 12/10 12/11 12/12 12/13 12/14 12/15 12/16 12/17 12/18 12/19 12/20 12/21 12/22 12/23 12/24 12/25 12/26 12/27 12/28 12/29 12/30 12/31
1. BEACH BOYS - Smile (Capitol) 7-1918, Mos Rod cov. VG+
2. BEACH BOYS - Little Deuce Coupe (Cap. 7-1998, Mos Rod cov. VG+
3. BEACH BOYS - Little Deuce Coupe (Cap. 7-1998, Mos Rod cov. VG+
4. BEACH BOYS - Little Deuce Coupe (Cap. 7-1998, Mos Rod cov. VG+
5. BEACH BOYS - Little Deuce Coupe (Cap. 7-1998, Mos Rod cov. VG+
6. BEACH BOYS - Little Deuce Coupe (Cap. 7-1998, Mos Rod cov. VG+
7. BEACH BOYS - Little Deuce Coupe (Cap. 7-1998, Mos Rod cov. VG+
8. BEACH BOYS - Little Deuce Coupe (Cap. 7-1998, Mos Rod cov. VG+
9. BEACH BOYS - Little Deuce Coupe (Cap. 7-1998, Mos Rod cov. VG+
10. BEACH BOYS - Little Deuce Coupe (Cap. 7-1998, Mos Rod cov. VG+
11. BEACH BOYS - Little Deuce Coupe (Cap. 7-1998, Mos Rod cov. VG+
12. BEACH BOYS - Little Deuce Coupe (Cap. 7-1998, Mos Rod cov. VG+
13. BEACH BOYS - Little Deuce Coupe (Cap. 7-1998, Mos Rod cov. VG+
14. BEACH BOYS - Little Deuce Coupe (Cap. 7-1998, Mos Rod cov. VG+
15. BEACH BOYS - Little Deuce Coupe (Cap. 7-1998, Mos Rod cov. VG+
16. BEACH BOYS - Little Deuce Coupe (Cap. 7-1998, Mos Rod cov. VG+
17. BEACH BOYS - Little Deuce Coupe (Cap. 7-1998, Mos Rod cov. VG+
18. BEACH BOYS - Little Deuce Coupe (Cap. 7-1998, Mos Rod cov. VG+
19. BEACH BOYS - Little Deuce Coupe (Cap. 7-1998, Mos Rod cov. VG+
20. BEACH BOYS - Little Deuce Coupe (Cap. 7-1998, Mos Rod cov. VG+
21. BEACH BOYS - Little Deuce Coupe (Cap. 7-1998, Mos Rod cov. VG+
22. BEACH BOYS - Little Deuce Coupe (Cap. 7-1998, Mos Rod cov. VG+
23. BEACH BOYS - Little Deuce Coupe (Cap. 7-1998, Mos Rod cov. VG+
24. BEACH BOYS - Little Deuce Coupe (Cap. 7-1998, Mos Rod cov. VG+
25. BEACH BOYS - Little Deuce Coupe (Cap. 7-1998, Mos Rod cov. VG+
26. BEACH BOYS - Little Deuce Coupe (Cap. 7-1998, Mos Rod cov. VG+
27. BEACH BOYS - Little Deuce Coupe (Cap. 7-1998, Mos Rod cov. VG+
28. BEACH BOYS - Little Deuce Coupe (Cap. 7-1998, Mos Rod cov. VG+
29. BEACH BOYS - Little Deuce Coupe (Cap. 7-1998, Mos Rod cov. VG+
30. BEACH BOYS - Little Deuce Coupe (Cap. 7-1998, Mos Rod cov. VG+
31. BEACH BOYS - Little Deuce Coupe (Cap. 7-1998, Mos Rod cov. VG+
32. BEACH BOYS - Little Deuce Coupe (Cap. 7-1998, Mos Rod cov. VG+
33. BEACH BOYS - Little Deuce Coupe (Cap. 7-1998, Mos Rod cov. VG+
34. BEACH BOYS - Little Deuce Coupe (Cap. 7-1998, Mos Rod cov. VG+
35. BEACH BOYS - Little Deuce Coupe (Cap. 7-1998, Mos Rod cov. VG+
36. BEACH BOYS - Little Deuce Coupe (Cap. 7-1998, Mos Rod cov. VG+
37. BEACH BOYS - Little Deuce Coupe (Cap. 7-1998, Mos Rod cov. VG+
38. BEACH BOYS - Little Deuce Coupe (Cap. 7-1998, Mos Rod cov. VG+
39. BEACH BOYS - Little Deuce Coupe (Cap. 7-1998, Mos Rod cov. VG+
40. BEACH BOYS - Little Deuce Coupe (Cap. 7-1998, Mos Rod cov. VG+
41. BEACH BOYS - Little Deuce Coupe (Cap. 7-1998, Mos Rod cov. VG+
42. BEACH BOYS - Little Deuce Coupe (Cap. 7-1998, Mos Rod cov. VG+
43. BEACH BOYS - Little Deuce Coupe (Cap. 7-1998, Mos Rod cov. VG+
44. BEACH BOYS - Little Deuce Coupe (Cap. 7-1998, Mos Rod cov. VG+
45. BEACH BOYS - Little Deuce Coupe (Cap. 7-1998, Mos Rod cov. VG+
46. BEACH BOYS - Little Deuce Coupe (Cap. 7-1998, Mos Rod cov. VG+
47. BEACH BOYS - Little Deuce Coupe (Cap. 7-1998, Mos Rod cov. VG+
48. BEACH BOYS - Little Deuce Coupe (Cap. 7-1998, Mos Rod cov. VG+
49. BEACH BOYS - Little Deuce Coupe (Cap. 7-1998, Mos Rod cov. VG+
50. BEACH BOYS - Little Deuce Coupe (Cap. 7-1998, Mos Rod cov. VG+
51. BEACH BOYS - Little Deuce Coupe (Cap. 7-1998, Mos Rod cov. VG+
52. BEACH BOYS - Little Deuce Coupe (Cap. 7-1998, Mos Rod cov. VG+
53. BEACH BOYS - Little Deuce Coupe (Cap. 7-1998, Mos Rod cov. VG+
54. BEACH BOYS - Little Deuce Coupe (Cap. 7-1998, Mos Rod cov. VG+
55. BEACH BOYS - Little Deuce Coupe (Cap. 7-1998, Mos Rod cov. VG+
56. BEACH BOYS - Little Deuce Coupe (Cap. 7-1998, Mos Rod cov. VG+
57. BEACH BOYS - Little Deuce Coupe (Cap. 7-1998, Mos Rod cov. VG+
58. BEACH BOYS - Little Deuce Coupe (Cap. 7-1998, Mos Rod cov. VG+
59. BEACH BOYS - Little Deuce Coupe (Cap. 7-1998, Mos Rod cov. VG+
60. BEACH BOYS - Little Deuce Coupe (Cap. 7-1998, Mos Rod cov. VG+
61. BEACH BOYS - Little Deuce Coupe (Cap. 7-1998, Mos Rod cov. VG+
62. BEACH BOYS - Little Deuce Coupe (Cap. 7-1998, Mos Rod cov. VG+
63. BEACH BOYS - Little Deuce Coupe (Cap. 7-1998, Mos Rod cov. VG+
64. BEACH BOYS - Little Deuce Coupe (Cap. 7-1998, Mos Rod cov. VG+
65. BEACH BOYS - Little Deuce Coupe (Cap. 7-1998, Mos Rod cov. VG+
66. BEACH BOYS - Little Deuce Coupe (Cap. 7-1998, Mos Rod cov. VG+
67. BEACH BOYS - Little Deuce Coupe (Cap. 7-1998, Mos Rod cov. VG+
68. BEACH BOYS - Little Deuce Coupe (Cap. 7-1998, Mos Rod cov. VG+
69. BEACH BOYS - Little Deuce Coupe (Cap. 7-1998, Mos Rod cov. VG+
70. BEACH BOYS - Little Deuce Coupe (Cap. 7-1998, Mos Rod cov. VG+
71. BEACH BOYS - Little Deuce Coupe (Cap. 7-1998, Mos Rod cov. VG+
72. BEACH BOYS - Little Deuce Coupe (Cap. 7-1998, Mos Rod cov. VG+
73. BEACH BOYS - Little Deuce Coupe (Cap. 7-1998, Mos Rod cov. VG+
74. BEACH BOYS - Little Deuce Coupe (Cap. 7-1998, Mos Rod cov. VG+
75. BEACH BOYS - Little Deuce Coupe (Cap. 7-1998, Mos Rod cov. VG+
76. BEACH BOYS - Little Deuce Coupe (Cap. 7-1998, Mos Rod cov. VG+
77. BEACH BOYS - Little Deuce Coupe (Cap. 7-1998, Mos Rod cov. VG+
78. BEACH BOYS - Little Deuce Coupe (Cap. 7-1998, Mos Rod cov. VG+
79. BEACH BOYS - Little Deuce Coupe (Cap. 7-1998, Mos Rod cov. VG+
80. BEACH BOYS - Little Deuce Coupe (Cap. 7-1998, Mos Rod cov. VG+
81. BEACH BOYS - Little Deuce Coupe (Cap. 7-1998, Mos Rod cov. VG+
82. BEACH BOYS - Little Deuce Coupe (Cap. 7-1998, Mos Rod cov. VG+
83. BEACH BOYS - Little Deuce Coupe (Cap. 7-1998, Mos Rod cov. VG+
84. BEACH BOYS - Little Deuce Coupe (Cap. 7-1998, Mos Rod cov. VG+
85. BEACH BOYS - Little Deuce Coupe (Cap. 7-1998, Mos Rod cov. VG+
86. BEACH BOYS - Little Deuce Coupe (Cap. 7-1998, Mos Rod cov. VG+
87. BEACH BOYS - Little Deuce Coupe (Cap. 7-1998, Mos Rod cov. VG+
88. BEACH BOYS - Little Deuce Coupe (Cap. 7-1998, Mos Rod cov. VG+
89. BEACH BOYS - Little Deuce Coupe (Cap. 7-1998, Mos Rod cov. VG+
90. BEACH BOYS - Little Deuce Coupe (Cap. 7-1998, Mos Rod cov. VG+
91. BEACH BOYS - Little Deuce Coupe (Cap. 7-1998, Mos Rod cov. VG+
92. BEACH BOYS - Little Deuce Coupe (Cap. 7-1998, Mos Rod cov. VG+
93. BEACH BOYS - Little Deuce Coupe (Cap. 7-1998, Mos Rod cov. VG+
94. BEACH BOYS - Little Deuce Coupe (Cap. 7-1998, Mos Rod cov. VG+
95. BEACH BOYS - Little Deuce Coupe (Cap. 7-1998, Mos Rod cov. VG+
96. BEACH BOYS - Little Deuce Coupe (Cap. 7-1998, Mos Rod cov. VG+
97. BEACH BOYS - Little Deuce Coupe (Cap. 7-1998, Mos Rod cov. VG+
98. BEACH BOYS - Little Deuce Coupe (Cap. 7-1998, Mos Rod cov. VG+
99. BEACH BOYS - Little Deuce Coupe (Cap. 7-1998, Mos Rod cov. VG+
100. BEACH BOYS - Little Deuce Coupe (Cap. 7-1998, Mos Rod cov. VG+
101. BEACH BOYS - Little Deuce Coupe (Cap. 7-1998, Mos Rod cov. VG+
102. BEACH BOYS - Little Deuce Coupe (Cap. 7-1998, Mos Rod cov. VG+
103. BEACH BOYS - Little Deuce Coupe (Cap. 7-1998, Mos Rod cov. VG+
104. BEACH BOYS - Little Deuce Coupe (Cap. 7-1998, Mos Rod cov. VG+
105. BEACH BOYS - Little Deuce Coupe (Cap. 7-1998, Mos Rod cov. VG+
106. BEACH BOYS - Little Deuce Coupe (Cap. 7-1998, Mos Rod cov. VG+
107. BEACH BOYS - Little Deuce Coupe (Cap. 7-1998, Mos Rod cov. VG+
108. BEACH BOYS - Little Deuce Coupe (Cap. 7-1998, Mos Rod cov. VG+
109. BEACH BOYS - Little Deuce Coupe (Cap. 7-1998, Mos Rod cov. VG+
110. BEACH BOYS - Little Deuce Coupe (Cap. 7-1998, Mos Rod cov. VG+
111. BEACH BOYS - Little Deuce Coupe (Cap. 7-1998, Mos Rod cov. VG+
112. BEACH BOYS - Little Deuce Coupe (Cap. 7-1998, Mos Rod cov. VG+
113. BEACH BOYS - Little Deuce Coupe (Cap. 7-1998, Mos Rod cov. VG+
114. BEACH BOYS - Little Deuce Coupe (Cap. 7-1998, Mos Rod cov. VG+
115. BEACH BOYS - Little Deuce Coupe (Cap. 7-1998, Mos Rod cov. VG+
116. BEACH BOYS - Little Deuce Coupe (Cap. 7-1998, Mos Rod cov. VG+
117. BEACH BOYS - Little Deuce Coupe (Cap. 7-1998, Mos Rod cov. VG+
118. BEACH BOYS - Little Deuce Coupe (Cap. 7-1998, Mos Rod cov. VG+
119. BEACH BOYS - Little Deuce Coupe (Cap. 7-1998, Mos Rod cov. VG+
120. BEACH BOYS - Little Deuce Coupe (Cap. 7-1998, Mos Rod cov. VG+
121. BEACH BOYS - Little Deuce Coupe (Cap. 7-1998, Mos Rod cov. VG+
122. BEACH BOYS - Little Deuce Coupe (Cap. 7-1998, Mos Rod cov. VG+
123. BEACH BOYS - Little Deuce Coupe (Cap. 7-1998, Mos Rod cov. VG+
124. BEACH BOYS - Little Deuce Coupe (Cap. 7-1998, Mos Rod cov. VG+
125. BEACH BOYS - Little Deuce Coupe (Cap. 7-1998, Mos Rod cov. VG+
126. BEACH BOYS - Little Deuce Coupe (Cap. 7-1998, Mos Rod cov. VG+
127. BEACH BOYS - Little Deuce Coupe (Cap. 7-1998, Mos Rod cov. VG+
128. BEACH BOYS - Little Deuce Coupe (Cap. 7-1998, Mos Rod cov. VG+
129. BEACH BOYS - Little Deuce Coupe (Cap. 7-1998, Mos Rod cov. VG+
130. BEACH BOYS - Little Deuce Coupe (Cap. 7-1998, Mos Rod cov. VG+
131. BEACH BOYS - Little Deuce Coupe (Cap. 7-1998, Mos Rod cov. VG+
132. BEACH BOYS - Little Deuce Coupe (Cap. 7-1998, Mos Rod cov. VG+
133. BEACH BOYS - Little Deuce Coupe (Cap. 7-1998, Mos Rod cov. VG+
134. BEACH BOYS - Little Deuce Coupe (Cap. 7-1998, Mos Rod cov. VG+
135. BEACH BOYS - Little Deuce Coupe (Cap. 7-1998, Mos Rod cov. VG+
136. BEACH BOYS - Little Deuce Coupe (Cap. 7-1998, Mos Rod cov. VG+
137. BEACH BOYS - Little Deuce Coupe (Cap. 7-1998, Mos Rod cov. VG+
138. BEACH BOYS - Little Deuce Coupe (Cap. 7-1998, Mos Rod cov. VG+
139. BEACH BOYS - Little Deuce Coupe (Cap. 7-1998, Mos Rod cov. VG+
140. BEACH BOYS - Little Deuce Coupe (Cap. 7-1998, Mos Rod cov. VG+
141. BEACH BOYS - Little Deuce Coupe (Cap. 7-1998, Mos Rod cov. VG+
142. BEACH BOYS - Little Deuce Coupe (Cap. 7-1998, Mos Rod cov. VG+
143. BEACH BOYS - Little Deuce Coupe (Cap. 7-1998, Mos Rod cov. VG+
144. BEACH BOYS - Little Deuce Coupe (Cap. 7-1998, Mos Rod cov. VG+
145. BEACH BOYS - Little Deuce Coupe (Cap. 7-1998, Mos Rod cov. VG+
146. BEACH BOYS - Little Deuce Coupe (Cap. 7-1998, Mos Rod cov. VG+
147. BEACH BOYS - Little Deuce Coupe (Cap. 7-1998, Mos Rod cov. VG+
148. BEACH BOYS - Little Deuce Coupe (Cap. 7-1998, Mos Rod cov. VG+
149. BEACH BOYS - Little Deuce Coupe (Cap. 7-1998, Mos Rod cov. VG+
150. BEACH BOYS - Little Deuce Coupe (Cap. 7-1998, Mos Rod cov. VG+
151. BEACH BOYS - Little Deuce Coupe (Cap. 7-1998, Mos Rod cov. VG+
152. BEACH BOYS - Little Deuce Coupe (Cap. 7-1998, Mos Rod cov. VG+
153. BEACH BOYS - Little Deuce Coupe (Cap. 7-1998, Mos Rod cov. VG+
154. BEACH BOYS - Little Deuce Coupe (Cap. 7-1998, Mos Rod cov. VG+
155. BEACH BOYS - Little Deuce Coupe (Cap. 7-1998, Mos Rod cov. VG+
156. BEACH BOYS - Little Deuce Coupe (Cap. 7-1998, Mos Rod cov. VG+
157. BEACH BOYS - Little Deuce Coupe (Cap. 7-1998, Mos Rod cov. VG+
158. BEACH BOYS - Little Deuce Coupe (Cap. 7-1998, Mos Rod cov. VG+
159. BEACH BOYS - Little Deuce Coupe (Cap. 7-1998, Mos Rod cov. VG+
160. BEACH BOYS - Little Deuce Coupe (Cap. 7-1998, Mos Rod cov. VG+
161. BEACH BOYS - Little Deuce Coupe (Cap. 7-1998, Mos Rod cov. VG+
162. BEACH BOYS - Little Deuce Coupe (Cap. 7-1998, Mos Rod cov. VG+
163. BEACH BOYS - Little Deuce Coupe (Cap. 7-1998, Mos Rod cov. VG+
164. BEACH BOYS - Little Deuce Coupe (Cap. 7-1998, Mos Rod cov. VG+
165. BEACH BOYS - Little Deuce Coupe (Cap. 7-1998, Mos Rod cov. VG+
166. BEACH BOYS - Little Deuce Coupe (Cap. 7-1998, Mos Rod cov. VG+
167. BEACH BOYS - Little Deuce Coupe (Cap. 7-1998, Mos Rod cov. VG+
168. BEACH BOYS - Little Deuce Coupe (Cap. 7-1998, Mos Rod cov. VG+
169. BEACH BOYS - Little Deuce Coupe (Cap. 7-1998, Mos Rod cov. VG+
170. BEACH BOYS - Little Deuce Coupe (Cap. 7-1998, Mos Rod cov. VG+
171. BEACH BOYS - Little Deuce Coupe (Cap. 7-1998, Mos Rod cov. VG+
172. BEACH BOYS - Little Deuce Coupe (Cap. 7-1998, Mos Rod cov. VG+
173. BEACH BOYS - Little Deuce Coupe (Cap. 7-1998, Mos Rod cov. VG+
174. BEACH BOYS - Little Deuce Coupe (Cap. 7-1998, Mos Rod cov. VG+
175. BEACH BOYS - Little Deuce Coupe (Cap. 7-1998, Mos Rod cov. VG+
176. BEACH BOYS - Little Deuce Coupe (Cap. 7-1998, Mos Rod cov. VG+
177. BEACH BOYS - Little Deuce Coupe (Cap. 7-1998, Mos Rod cov. VG+
178. BEACH BOYS - Little Deuce Coupe (Cap. 7-1998, Mos Rod cov. VG+
179. BEACH BOYS - Little Deuce Coupe (Cap. 7-1998, Mos Rod cov. VG+
180. BEACH BOYS - Little Deuce Coupe (Cap. 7-1998, Mos Rod cov. VG+
181. BEACH BOYS - Little Deuce Coupe (Cap. 7-1998, Mos Rod cov. VG+
182. BEACH BOYS - Little Deuce Coupe (Cap. 7-1998, Mos Rod cov. VG+
183. BEACH BOYS - Little Deuce Coupe (Cap. 7-1998, Mos Rod cov. VG+
184. BEACH BOYS - Little Deuce Coupe (Cap. 7-1998, Mos Rod cov. VG+
185. BEACH BOYS - Little Deuce Coupe (Cap. 7-1998, Mos Rod cov. VG+
186. BEACH BOYS - Little Deuce Coupe (Cap. 7-1998, Mos Rod cov. VG+
187. BEACH BOYS - Little Deuce Coupe (Cap. 7-1998, Mos Rod cov. VG+
188. BEACH BOYS - Little Deuce Coupe (Cap. 7-1998, Mos Rod cov. VG+
189. BEACH BOYS - Little Deuce Coupe (Cap. 7-1998, Mos Rod cov. VG+
190. BEACH BOYS - Little Deuce Coupe (Cap. 7-1998, Mos Rod cov. VG+
191. BEACH BOYS - Little Deuce Coupe (Cap. 7-1998, Mos Rod cov. VG+
192. BEACH BOYS - Little Deuce Coupe (Cap. 7-1998, Mos Rod cov. VG+
193. BEACH BOYS - Little Deuce Coupe (Cap. 7-1998, Mos Rod cov. VG+
194. BEACH BOYS - Little Deuce Coupe (Cap. 7-1998, Mos Rod cov. VG+
195. BEACH BOYS - Little Deuce Coupe (Cap. 7-1998, Mos Rod cov. VG+
196. BEACH BOYS - Little Deuce Coupe (Cap. 7-1998, Mos Rod cov. VG+
197. BEACH BOYS - Little Deuce Coupe (Cap. 7-1998, Mos Rod cov. VG+
198. BEACH BOYS - Little Deuce Coupe (Cap. 7-1998, Mos Rod cov. VG+
199. BEACH BOYS - Little Deuce Coupe (Cap. 7-1998, Mos Rod cov. VG+
200. BEACH BOYS - Little Deuce Coupe (Cap. 7-1998, Mos Rod cov. VG+
201. BEACH BOYS - Little Deuce Coupe (Cap. 7-1998, Mos Rod cov. VG+
202. BEACH BOYS - Little Deuce Coupe (Cap. 7-1998, Mos Rod cov. VG+
203. BEACH BOYS - Little Deuce Coupe (Cap. 7-1998, Mos Rod cov. VG+
204. BEACH BOYS - Little Deuce Coupe (Cap. 7-1998, Mos Rod cov. VG+
205. BEACH BOYS - Little Deuce Coupe (Cap. 7-1998, Mos Rod cov. VG+
206. BEACH BOYS - Little Deuce Coupe (Cap. 7-1998, Mos Rod cov. VG+
207. BEACH BOYS - Little Deuce Coupe (Cap. 7-1998, Mos Rod cov. VG+
208. BEACH BOYS - Little Deuce Coupe (Cap. 7-1998, Mos Rod cov. VG+
209. BEACH BOYS - Little Deuce Coupe (Cap. 7-1998, Mos Rod cov. VG+
210. BEACH BOYS - Little Deuce Coupe (Cap. 7-1998, Mos Rod cov. VG+
211. BEACH BOYS - Little Deuce Coupe (Cap. 7-1998, Mos Rod cov. VG+
212. BEACH BOYS - Little Deuce Coupe (Cap. 7-1998, Mos Rod cov. VG+
213. BEACH BOYS - Little Deuce Coupe (Cap. 7-1998, Mos Rod cov. VG+
214. BEACH BOYS - Little Deuce Coupe (Cap. 7-1998, Mos Rod cov. VG+
215. BEACH BOYS - Little Deuce Coupe (Cap. 7-1998, Mos Rod cov. VG+
216. BEACH BOYS - Little Deuce Coupe (Cap. 7-1998, Mos Rod cov. VG+
217. BEACH BOYS - Little Deuce Coupe (Cap. 7-1998, Mos Rod cov. VG+
218. BEACH BOYS - Little Deuce Coupe (Cap. 7-1998, Mos Rod cov. VG+
219. BEACH BOYS - Little Deuce Coupe (Cap. 7-1998, Mos Rod cov. VG+
220. BEACH BOYS - Little Deuce Coupe (Cap. 7-1998, Mos Rod cov. VG+
221. BEACH BOYS - Little Deuce Coupe (Cap. 7-1998, Mos Rod cov. VG+
222. BEACH BOYS - Little Deuce Coupe (Cap. 7-1998, Mos Rod cov. VG+
223. BEACH BOYS - Little Deuce Coupe (Cap. 7-1998, Mos Rod cov. VG+
224. BEACH BOYS - Little Deuce Coupe (Cap. 7-1998, Mos Rod cov. VG+
225. BEACH BOYS - Little Deuce Coupe (Cap. 7-1998, Mos Rod cov. VG+
226. BEACH BOYS - Little Deuce Coupe (Cap. 7-1998, Mos Rod cov. VG+
227. BEACH BOYS - Little Deuce Coupe (Cap. 7-1998, Mos Rod cov. VG+
228. BEACH BOYS - Little Deuce Coupe (Cap. 7-1998, Mos Rod cov. VG+
229. BEACH BOYS - Little Deuce Coupe (Cap. 7-1998, Mos Rod cov. VG+
230. BEACH BOYS - Little Deuce Coupe (Cap. 7-1998, Mos Rod cov. VG+
231. BEACH BOYS - Little Deuce Coupe (Cap. 7-1998, Mos Rod cov. VG+
232. BEACH BOYS - Little Deuce Coupe (Cap. 7-1998, Mos Rod cov. VG+
233. BEACH BOYS - Little Deuce Coupe (Cap. 7-1998, Mos Rod cov. VG+
234. BEACH BOYS - Little Deuce Coupe (Cap. 7-1998, Mos Rod cov. VG+
235. BEACH BOYS - Little Deuce Coupe (Cap. 7-1998, Mos Rod cov. VG+
236. BEACH BOYS - Little Deuce Coupe (Cap. 7-1998, Mos Rod cov. VG+
237. BEACH BOYS - Little Deuce Coupe (Cap. 7-1998, Mos Rod cov. VG+
238. BEACH BOYS - Little Deuce Coupe (Cap. 7-1998, Mos Rod cov. VG+
239. BEACH BOYS - Little Deuce Coupe (Cap. 7-1998, Mos Rod cov. VG+
240. BEACH BOYS - Little Deuce Coupe (Cap. 7-1998, Mos Rod cov. VG+
241. BEACH BOYS - Little Deuce Coupe (Cap. 7-1998, Mos Rod cov. VG+
242. BEACH BOYS - Little Deuce Coupe (Cap. 7-1998, Mos Rod cov. VG+
243. BEACH BOYS - Little Deuce Coupe (Cap. 7-1998, Mos Rod cov. VG+
244. BEACH BOYS - Little Deuce Coupe (Cap. 7-1998, Mos Rod cov. VG+
245. BEACH BOYS - Little Deuce Coupe (Cap. 7-1998, Mos Rod cov. VG+
246. BEACH BOYS - Little Deuce Coupe (Cap. 7-1998, Mos Rod cov. VG+
247. BEACH BOYS - Little Deuce Coupe (Cap. 7-1998, Mos Rod cov. VG+
248. BEACH BOYS - Little Deuce Coupe (Cap. 7-1998, Mos Rod cov. VG+
249. BEACH BOYS - Little Deuce Coupe (Cap. 7-1998, Mos Rod cov. VG+
250. BEACH BOYS - Little Deuce Coupe (Cap. 7-1998, Mos Rod cov. VG+
251. BEACH BOYS - Little Deuce Coupe (Cap. 7-1998, Mos Rod cov. VG+
252. BEACH BOYS - Little Deuce Coupe (Cap. 7-1998, Mos Rod cov. VG+
253. BEACH BOYS - Little Deuce Coupe (Cap. 7-1998, Mos Rod cov. VG+
254. BEACH BOYS - Little Deuce Coupe (Cap. 7-1998, Mos Rod cov. VG+
255. BEACH BOYS - Little Deuce Coupe (Cap. 7-1998, Mos Rod cov. VG+
256. BEACH BOYS - Little Deuce Coupe (Cap. 7-1998, Mos Rod cov. VG+
257. BEACH BOYS - Little Deuce Coupe (Cap. 7-1998, Mos Rod cov. VG+
258. BEACH BOYS - Little Deuce Coupe (Cap. 7-1998, Mos Rod cov. VG+
259. BEACH BOYS - Little Deuce Coupe (Cap. 7-1998, Mos Rod cov. VG+
260. BEACH BOYS - Little Deuce Coupe (Cap. 7-1998, Mos Rod cov. VG+
261. BEACH BOYS - Little Deuce Coupe (Cap. 7-1998, Mos Rod cov. VG+
262. BEACH BOYS - Little Deuce Coupe (Cap. 7-1998, Mos Rod cov. VG+
263. BEACH BOYS - Little Deuce Coupe (Cap. 7-1998, Mos Rod cov. VG+
264. BEACH BOYS - Little Deuce Coupe (Cap. 7-1998, Mos Rod cov. VG+
265. BEACH BOYS - Little Deuce Coupe (Cap. 7-1998, Mos Rod cov. VG+
266. BEACH BOYS - Little Deuce Coupe (Cap. 7-1998, Mos Rod cov. VG+
267. BEACH BOYS - Little Deuce Coupe (Cap. 7-1998, Mos Rod cov. VG+
268. BEACH BOYS - Little Deuce Coupe (Cap. 7-1998, Mos Rod cov. VG+
269. BEACH BOYS - Little Deuce Coupe (Cap. 7-1998, Mos Rod cov. VG+
270. BEACH BOYS - Little Deuce Coupe (Cap. 7-1998, Mos Rod cov. VG+
271. BEACH BOYS - Little Deuce Coupe (Cap. 7-1998, Mos Rod cov. VG+
272. BEACH BOYS - Little Deuce Coupe (Cap. 7-1998, Mos Rod cov. VG+

OLDIES...LP'S...45'S...OLDIES

PSYCHEDELIC STATE UNIVERSITY

psych, prog, metal, xian, blues, folk, country rock, hard rock, private press, michigan, canadian, strange music & madness

ALBUMS GRACE COVERED
ALBA-Greatness LP-GATEFOLD-SD1189-vg+
ALLMAN BROS - Eat A Peach LP-GATEFOLD-94378-vg+
PAUL ANKA - One Man Band LP-GATEFOLD-94378-vg+

1. HEARTS & FLOWERS-Now Is The Time(Capitol M)to67 psych R/g-V-g-36
2. THE GROUP-No Time Like The Present (Wiam) '70s nice Xian folk Sealed \$6
3. POINT BLANK-Second Season (Arista) '77 Southern hard rock Vg++/Vg++ \$6
4. FALLENROCK-Watch For (Capricorn Promo) poef '74 Vg++/M- \$6
5. STRAY-Houdini (Pye) ce '76 Uk hard rock, seam wear Vg++/Vg++ \$6
6. STINGRAY-St (Carrere) isofc '79 South African hard rock Vg++/M- \$6
7. STEVE MILLER BAND-Brave New World (grnCapitol)'69 gf Vg++/Vg++/\$6

136.HIV LOVECRAFT-IT (Phillips St) woc gf '67 Psych Vg++/Vg- \$6
137.JEFFERSON AIRPLANE-30 Seconds Over Winterland (Grunt) '73 M-/M-\$6
138.CHOSEN FEW-St (Rca) '69 horn rock like BS&T M/M \$6
139.THIRTY DAYS OUT-Miracle Lick (Wbc) ce '72 tiny scratch Vg++/Vg++ \$6
140.STEPHEN STILLS-St (Atlantic) noc '70 plays string Vg++/Vg++ \$6
141.RANDY STONERILL-Welcome to Paradise (Solid) '76 xian Vg++/Vg++/\$6
142.DENNY DOHERTY-Whatcha gonna do(Dunhill)'71 Country rock/M-Vg++ \$6
143.SERVANT-Shallow Water (Tunesmith) gf '79 Xian red vinyl M-/Vg++ \$6
144.ART In Whatever you can get away With(Octopus) '72 madness Vg++/Vg++/\$6
145.EMERSON LAKE & PALMER-Love Beach (Atlantic) 'm78 Sealed \$6
146.Richard Torrance & Eureka-Bell of Ball (Shelter) '75 Slide Vg++/Vg++/\$6
147.MARSHALL TUCKER BAND-Greatest Hits (Capricorn) '78 M-/Vg++ \$6
148.Bobby Bland & BB King-Together Live (Abe)noc '76 gf Vg++/Vg++ \$6
149.HOT TUNA-First Pull Up (Rca) '71 Jefferson Airplane dudes M-/M- \$6
150.ROXY-St (Elektra) dh insert Obscure rockin band Vg++/Vg++ \$6
151.COUNTRY JOE & FISH-Together (Vanguard) '68 Psych Vg++/Vg++/\$6
152.STEPPENWOLF-For Ladies Only (Dunhill) '71 gf Vg++/Vg++ \$6
153.MOUNTAIN-Best of (Columbia) '73 Rare quad: aspl Vg++/Vg++ \$6
154.SANDBIPERS-St (A&M) '67 Stereo Vg++/M- \$6
155.BABE RUTH-St (Harvest) dh '75 super UK prog rock Vg++/M- \$6
156.SIMPLE MINDS-Live in City of Light (A&M) '87 gf insert Vg++/M-/M-\$6
157.SERFS-Early Bird Cafe (Capitol)to69 '69 Latin bluesy horn fuzz Vg++/Vg++ \$6
158.COWSILLS-All Time Hits (Gold Archive) '70 'Indian Lake' Vg++/Vg++ \$6
159.ASSOCIATION-Live (Wb) Salt Lake, Utah 1970 Vg++/Vg++/ \$6
160.STARCASTLE-St (Epic) '76 prog rock Vg++/Vg++ \$6
161.VANILLA FUDGE-Rock & Roll (yellow Ato) '69 Vg++/Vg++ \$6
162.KING HARVEST-St (A&M) ce '75 sweet Canadian R&R Vg++/M- \$6
163.CHARLIE-Fight Dirty (Arista) '79 Uk rock in shrink M-/Vg++ \$6
164.DINSMORE / PAYNE (Ua) coh '73 Country rock Vg++/Vg++ \$6
165.STEVE GIBBONS BAND-Any Road (Mca) to '76 insert Vg++/Vg++/\$6
166.NEON PHILHARMONIC-The Most Confesses (Ua) '68 gf Vg++/Vg++ \$6
167.MAX DEMIAN-Take it to the Max (Rca) '79 Hard Vg++/Vg++ \$6
168.IGGY POP-Instinct (A&M) poef '88 Vg++/Vg++ \$6
169.RARE EARTH-St (Prodigal) ce '77 Soul rock on this one Vg++/M- \$6
170.FOGHAT-Girls, Chas boys to Bounce (bearville) '81 still rockin Sealed \$6
171.NEON PHILHARMONIC-St (Wb) ce '69 Serious comers. Vg++/Vg++ \$6
172.GRAPEFUL DEAD-Anthem of the 69 (Serious Wb) '68 Vg++/Vg++ \$6
173.CHARLIE-Night Train (Arista) '77 insert. Uk rock Vg++/Vg++ \$6
174.HOSEANNA (Maranatha) to gf '79 sweet various Xian Vg++/M- \$6
175.HOSEANNA (Maranatha) to gf '79 sweet various Xian Vg++/M- \$6
176.'BLUE' GENE TYRANNUS-Just for the Record (Vt) '79 Prog Sealed \$6
177.HOLD-Talking Revolution ('89 Mich private) Space rock M-/M- \$6
178.INVISIBLE INK-Lite up the Stereo ('80 Mich private) rock Sealed \$6
179.SOUND BARRIER-Total Control (Mca) poef '83 Metal Vg++/M- \$6
180.VALDY-Passport (Best of) (Canadian A&M) '80 M-/M- \$6
181.VALDY-1001 (Sloth) coh '80 good Canadian rocker M-/M \$6
182.UTOPIA-Pov (Passport) '85 'Zen Machine' M-/M- \$6
183.REZ BAND-Live Bootleg (Sparrow) insert '84 Hard xian Vg++/Vg++ \$6
184.WRABIT-Live (Mca 5268) poef '81 Canadian Hard rock Vg++/M- \$6
185.EMERSON LAKE & PALMER-Pictures At All(Coilition) '72 Vg++/Vg++/\$6
186.KGB-St (Mca) ce '76 Super star hard rock band Vg++/Vg++ \$6
187.PRETTY THINGS-Silk Torpedo (Swan song) noc '74 gf Vg++/Vg++ \$6
188.LOVIN' SPOONFUL-Very Best of (Kama Sutra) '70 in shrink M-/Vg++ \$6
189.MOM'S APPLE Pie-Ed (Brownbag)'73 horns but band cooks Vg++/Vg++ \$6
190.SMITH-A Group Called (Dunhill) '69 nr by torn shrink. Sealed \$6
191.RESURRECTION BAND-Danz (Light) '82 very hard Xian Vg++/Vg++ \$6
192.MICHAEL STANLEY BAND-North Coast (Emi) '81 ROCKS Vg++/Vg++ \$6
193.BON WOOD-Gimme some Neck (Columbia) '79 x-Garage Rocks M-/Vg++ \$6
194.HEADS of the Family-Play & Sing (Ashire) '69 garage Exploits Vg++/M/\$6
195.GARY O (Capitol) noc, coh '81 good Canadian w/ Peter Wolf M-/M- \$6
196. STARCASTLE-Real to Reel (Epic Wt Promo) isofc '78 Vg++/M- \$6
197.NOVA-Wings of Love (Arista Wt Promo) ce '77 lyrics Vg++/Vg++ \$6
198.USA ROCK (N.C.Priv) tag-ofc '87 Buzzsaw guitar retro M-/M- \$6
199.ANTHONY PHILLIPS-Wise After the Event (Passport)to68 gf Vg++/M- \$6
200.LANSING ROCK LP (Starstream) 10 local Michigan bands '82 M-/M- \$6
201.SWAMP WATER-St (Rca) '71 tape on bottom, winks-ofc Vg-/Vg- \$6
202.JIM STEINMAN-Bad for Good (Epic) coh '81 Meatloaf related Vg++/M- \$6
203.DAKOTA (Columbia Wt Promo) poef '80 good rocker Vg++/M- \$6
204.Ken Hensley-Proud Words Dusty Shell(Merc) '73 x-Urban Heep Vg++/M- \$6
205.CREDEENCE CLEARWATER-Cosmo's Factory(thick blue)to67 Vg++/M- \$6
206.PONT BLANK-Airplay (Mca) '79 southern Hard rock. M-/Vg++ \$6
207.STARZ-St (Capitol) '76 US HR metal pioneers Vg++/M- \$6
208.GRAVES OF WRATH (Capitol)to68 '87 with 60's flower sound Vg++/Vg++/\$6
209.JIMMY RYAN-Finally (Feedback) '89 balls to the wall Hard rock M/M \$6
210.ROBIN TROWER-Long Misty Days (Chrysalis) dh '76 Vg++/M- \$6
211.BOW WOW WOW-Lost of Mobeians (Rca) sm '82 'I Want Candy' M-/M- \$6
212.BOB SEGER-Smokin' O.P.'s (Palladium) no insert'72 plays well Vg++/G+\$6
213.NORTON BUFFALO-Desert Horizon (Capitol) '78 strange dupe M-/Vg++ \$6
214.TROY BEAU-ST (Rca) '78 Country rock, lyrics Vg++/Vg++ \$6
215.PIPER-Can't Wait (A&M Wht ltr Promo) ps '77 with Billy Squier Vg/M \$6
216.SAMMY HALL-Everybody has a Dream (Wc7) '70s rock M-/Vg++/\$6
217.TRILLION ST (Epic) '78 hard rock, 1 corner bent Vg++/Vg++/\$6
218.JOE COCKER-Mad Dogs & Englishmen (brownA&M) '70 double lp gf cover close to Vg++ nr. 'Lets Go Get Stoned' Vg++/Vg++/ \$6
219.STEVE WALSH-Schemer Dreamer (Kirschner) '80 x-Kansas M-/Vg++ \$6
220.AMAZING BLONDEL-Mulgrave Street (Uk Dlj) wic '74 Vg++/Vg++ \$6
221.RAY THOMAS-From Mighty Oaks (Threshold) '75 gf insert Vg++/M- \$6
222.CROSS COUNTRY (Ato) '73 gf almost like Swamp Water Vg++/M- \$6
223.ANGEL-On Earth as it is in Heaven (Casablanca)'77 no poster Vg++/Vg++ \$6
224.JEREMY MORRIS-Open Your Heart (Jam) '87 Michigan Pop M-/M/\$6
225.YOU'RE HERE at Last (New Life)'75 Meher Baha cosmic rock M-/Vg++ \$6
226.TRADEMARK-ST (Private) '73 Mich. Xian rockers Vg++/M- \$6
227.BONNIE KOLO-Hold on to me (Ovation Quad) '72 gf shrink M-/Vg++ \$6
228.KERRY LIVGREEN-Seeds of Change(Kirschner)'80 Ronnie 12 Dio Vg++/M-\$6
229.GOOD RATS-Rat City in Blue (Ratcity)cc sm '75 hard rock Vg++/Vg++ \$6
230.GARY WRIGHT-Light of Smiles (Wb) sm '77 in shrink M-/Vg++ \$6
231.BEFORE THREE O'LOCK-St (Frontier) '84 psych Vg++/M- \$6
232.REWINDING-St (Fantasy Wt ltr Promo) spfl '70 'Glad You're Here' Vg++/M- \$6
233.FOOLS GOLD-Mr.Luck (Columbia) '77 super Country rock Vg++/M- \$6
234.SPANKY & OUR GANG-Without Rhyme or Reason (Mca) '69 Vg++/M- \$6
235.GEOFFRE HARRISON-Somewhere in England (Dark horse) '81 Sealed \$6
236.PETE SEGER-Rainbow Race (Columbia) '71 demo Vg++/Vg++/\$6
237.Sutherland Bros & Quiver-Reach the Sky (Uk Cbs) wic '75 Vg++/Vg++ \$6
238.JAMES TAYLOR-St (Apple) '70 orange print usipak Vg++/Vg++ \$6
239.CONEY HATCH-St (Mca) '82 Canadian Hard rock Vg++/Vg++ \$6
240.KANSAS-Power (Mca) '86 Sealed \$6
241.DETROIT (Paramount) spfl '72 Hard rock tiny scratch Vg++/Vg++ \$6
242.PUZZLE-2nd (Motown Wt Dlj) poef '74 Prog rock Vg++/Vg++ \$6
243.W.B. & WESTERN UNION (Mpi) bio '84 Mich pop. country rock M-/M- \$6
244.NORTHERN LIGHTS (North Coast) '83 Ohio Private rock M-/M- \$6
245.HARD MEAT-Through a Window (Wbc)to67 prog hard rock Vg++/Vg++ \$6
246.BIG SUR CHOIR (Peaceable) '74 insert. Xian folk psych Vg++/M- \$6
247.OLIVER-Good Morning Starshine (Crew) '70 'Jean' Sealed \$6
248.RAM JAM-St (Epic) '77 'Black Betty' M-/Vg++ \$6
249.New Riders of P.S-Adventure of Panama Red(Columbia) '73 Vg++/Vg++ \$6
250.MAGNUM-Kingdom of Madness(JetPromo)to68 '78 Uk hr Vg++/Vg++/\$6
251.DR.HOOK & Medicine Show (Columbia) '73 'Sylvia's Mother' M-/M- \$6
252.RICHARD FURAY-Dance a Little Light (A&M) sm '78 Vg++/Vg++ \$6
253.WRABIT-Tracks (Mca) poef '82 Canadian very hard Vg++/Vg++ \$6
254.SURVIVER-St (Scotti Bros.) '79 in shrink. 1st lp M-/Vg++ \$6
255.SIMPLI-Minus-Plus (Dunhill) noc '70 spflt plays strong Vg++/Vg++ \$6
256.HENDRIX-side 1 / B.MARLEY-side 2 (Armando) Italian issue Vg++/M- \$6
257.DOBIE GRAY-Hey Day (Mca) ce '74 'So High' Sealed \$6
258.BABE RUTH-Stealin' Home (Capitol) nr '75 UK prog rock Vg++/Vg++ \$6
259.GARY MOORE-Victims of the Future (Mirajets) poef'84 Vg++/Vg++/\$6
260.MAC GAYDEN-Skyboat (Abe Wt Promo) ce '76 insert Vg++/Vg++ \$6
261.SNAFLY (Cream) '79 hard rocker band in a cool cover. Sealed \$6
262.ASYLUM CHOIR IT (Shelter) 8910 '71 Vg++/M- \$6
263.DENNIS YOST & Classics IV-Son (Liberty) ce '70 Sealed \$6
264.REDBONE-Potlach (Epic) '70 American Indian rock Vg++/Vg++ \$6
265.LAKE-IT (Columbia) '78 mighty German hard rock Vg++/Vg++ \$6
266.CROW-Music (Amaret) '69 hard rock 1st lp Vg++/Vg++ \$6
267.MOODY BLUES-Seventh Sojourn (Threshold) '72 clean '1 Vg++/Vg++ \$6
268.OUTSIDERS-Happening 'Live' (Capitol Mono) '67 Vg++/Vg++ \$6
269.NEKTA-Down to Earth (Passport) '75 gf. corner dinged Vg++/Vg++ \$6
270.FAMILY-Anyhow (Ua) ce tos '71 Live '1 Vg++/Vg++ \$6
271.BAKER GURVITZ Army-Elysian Encounter (Ato)noc '75 Vg++/Vg++/\$6

GARAGE SALE

LAURA ROTTKAMP
3 Lincoln Ave.
Lake Ronkonkoma, NY 11779
631-981-8893
E-mail: lrottkam@suffolk.lib.ny.us

>> Grading Is Cover / Record. Postage is \$3 then 50 cents per lp. **
Overseas, tell me if you want Air or Surface. Insurance is extra

>> Please make checks or MOs payable to: Dennis Serdel **
Remember to Phone, E-mail or Write to Reserve lps first

DENNIS SERDEL
339 Oakwood Lane, Perry, Michigan 48872
Ph: 517-625-7690 • psychstu@voyager.net

(New Releases from page 26)

ROD PIAZZA AND THE MIGHTY FLYERS

Beyond The Source
Tone-Cool (34047)

Wow, are these guys versatile or what? They play everything from jump blues to funk, boogie, and rockabilly — and they play it all well. A great band, underscored by the mighty vocals and smooth harp playing of Rod Piazza, The Mighty Flyers — who, incidentally, were voted Blues Band Of The Year at the W.C. Handy Awards in both 1999 and 2000 — have created another instant classic with this fabulous 14-song release.

Their cover of the old Harptones hit "High Flyin' Baby" uses some doo-wop background vocals to transform the tune into a memorable piano boogie at the capable hands of Honey Piazza. Rockabilly reigns supreme with the Flyers' updated rendition of "Shim Sham Shimmy," and they dish up some modern-sounding blues by way of "In A Wrong World" and "Twist City," both produced in Memphis by music wiz Jim Dickinson. The remainder of the album was produced by Piazza and Rick Holstrom.

As much as Piazza contributes to the music, it should be noted that guitarist Holstrom brings his own bag of mojo magic to the mix, whipping off some mighty high-flying licks on "If It Is" and especially on the instrumental groove of "Reece's Boogie." Holstrom dances his way through a wide array of styles before landing right back home in the blues with "Lovin' Daddy Blues."

Piazza pays homage to his musical influence Little Walter by way of some great



Rod Piazza

harmonica work on "Ghosting," before the album closes out with a boogie-woogie romp through "Miss Bee-llavin'."

There's a nostalgic feeling to this album, but at the same time, there is just enough modern sound mixed in to make a mighty fine musical gumbo, with just the right amount of seasoning.

— Michael Buffalo Smith

PRINCE

The Rainbow Children
NPG Records/Redline Entertainment (70004-2)

Prince went back to using his given name in 2000 after seven years of referring to himself with an unpronounceable symbol, but the artist who has returned is not exactly the Prince of the past. *The Rainbow Children*, his first collection of new material in two years, is the definition of uneven. It's a concept album that shines as his most cohesive musical package in years but falters beneath the weight of the nonsensical religious philosophizing stuffed into its lyrics.

The unity of sonic vision throughout the set is impressive, yielding a smartly produced whole that is dense and cohesive but not cluttered. Drummer John Blackwell is as important to that end as Prince, powering the dynamic jazz of the title track and the smooth calypso groove of "She Loves Me 4 Me" alike. Prince adds most of the rest of the music himself, from the blistering guitar tacked onto the rousing and angry statement on racial injustice on "Family Name" to the keyboard chitter of "1+1+1=3" copped from the dance funk of his classic B-side "Erotic City." Many songs on the collection meander past the point of being captivating, but over 70 minutes there is plenty of time for occasional diversions.

Although his melodies and still-lush falsetto vocals will draw die-hard fans in for a listen, the truth is that Prince is clearly no longer addressing those who warmly remember his lascivious past. Once gleefully vulgar, he has completely eliminated swearing from his lyrics ("Let me see you shake your pants?" From Prince?) and pushes his newly modified religious beliefs in a tale that is less a parable than a preachy soapbox turn.

The story is alternately impenetrable and dopey, done in by such ill-conceived devices as a barely decipherable narrator and a surfeit of lyrics that are not even clever. The disc comes with a sticker that declares it "controversial," but despite an engaging sound, it's too banal and conceptually muddy for anyone to bother creating any real stir about.

— Thomas Kintner

BJÖRK

Vespertine
Elektra (62653-2)

Although she's sometimes dismissed as an eccentric kook (who can forget the swan outfit at the Academy Awards?), Björk is in fact one of the most consistently creative musical talents of the last decade. After three excellent solo albums and last year's soundtrack album *Selmasongs* (which accompanied *Dancer In The Dark*, a film that she also starred in), Björk has released *Vespertine*, an album whose cover is immediately notable for the reappearance of that same dreaded swan dress!

Fortunately, Björk's taste in music is much better than her taste in clothes, and she's still one of the most remarkably distinctive singers around. Sure, her strange intonations and lyrics (example: "Who would have known that a boy like him, would have entered me lightly restoring my blisses") may still take some getting used to, but *Vespertine* is an exquisite album that's well worth getting to know.

A far cry from her earlier dance-oriented material, *Vespertine* is composed almost entirely of ballads. Granted, these hushed confessionals are sometimes slow-moving to the point of being boring, but Björk connects on an intimate

VARIOUS ARTISTS

Good Rockin' Tonight: The Legacy Of Sun Records
Sire (31165-2)

This year has seen many worthy tribute and various artists projects. *Loose Salute: A Michael Nesmith Tribute* (Dren Records); two unbeatable discs: *Earl Scruggs And Friends* (MCA Nashville); and *Timeless: A Tribute To Hank Williams* (Lost Highway Records). Now this Sire release, *Good Rockin' Tonight: The Legacy Of Sun Records*, a tribute/soundtrack to a PBS special, takes the cake. Producer and industry mogul Ahmet Ertegun has overseen an exceptional project here, calling in the biggest names in the business: Sir Paul McCartney, Sir Elton John, Bob Dylan, Eric Clapton, Tom Petty, and Led Zeppelin's Jimmy Page and Robert Plant head up the name-dropping list.

Oddly enough, the most outstanding cut here is actually a hidden bonus track, but more about that later. Most performances are respectful and true to the "Sun Sound" originals. Most notable is McCartney's "That's All Right," which features Elvis Presley's musicians, drummer D.J. Fontana and guitarist Scotty Moore. Certainly most challenging is John's all-out, near-to-the-edge version of the Jerry Lee Lewis rocker "Whole Lotta Shakin' Goin' On." Plant and Page turn in a suitably tame rockabilly job on "My Bucket's Gotta Hole In It," while Jeff Beck and The Pretenders' Chrissie Hynde tackle "Mystery Train" with lusty angst.

A significant rarity from Bob Dylan, the eclectic "Red Cadillac And A Black Moustache," shines brilliantly and would have landed perfectly on his excellent new album *Love And Theft*. Petty hits home in a less-serious way with a good-natured take on "Blue Moon Of Kentucky." Clapton gives us an impeccable vocal on "Just Walkin' In The Rain"; however, the track is marred by an annoying distraction that producer Simon Climie felt obliged to inflict on listeners on every other snare drum hit throughout the song. It is the out-of-place sound of an open-ended woodblock that makes the track sound like a horse hobbling along, and it gives the whole thing a novel feel à la "Happy Trails To You." This poor judgement ruins Clapton's heartfelt reading.

Pleasant surprises along the way include Matchbox Twenty's live version of "Lonely Weekends" and Johnny Hallyday's straight-ahead rendition of "Blue Suede Shoes." Sheryl Crow handles "Who Can The Next Fool Be" in nice order, but no one will ever touch Rusty Smith And The Amazing Rhythm Aces' masterpiece cover of that tune; they own that one.

Getting back now to the surprise centerpiece of this album: The hidden bonus track (#16) by Mandy Barnett is the real gem. This woman is an absolutely peerless country vocalist, and after you hear "You Win Again," it will leave your mouth open and your lips dry.

Songs that should've been left off *Good Rockin' Tonight*: The group Live does a cover of "I Walk The Line" that is an abomination to the institution of music itself; ditto for Kid Rock's bombastic disaster of an attempt at "Drinkin' Wine Spo-Dee-O-Dee." These people obviously have no understanding, let alone respect, for Sun Records' music.

— C. Brian Jasper

America's Best Record Rack

Your Records will be easy to organize and find, and you will never run out of space with the Original RACKIT™ Modular Record Rack system. No matter what its size, your record collection will fit in this attractive, infinitely expandable, solid oak building block system.

The portable, easy to move record rack modules hold one hundred LPs each. They are stackable up to 5 high on the Dolly. Put the Tabletop on the top rack, and you have a beautiful piece of furniture.

RACKIT storage units for all other audio/video formats and equipment are available. See www.rackit.com for details.

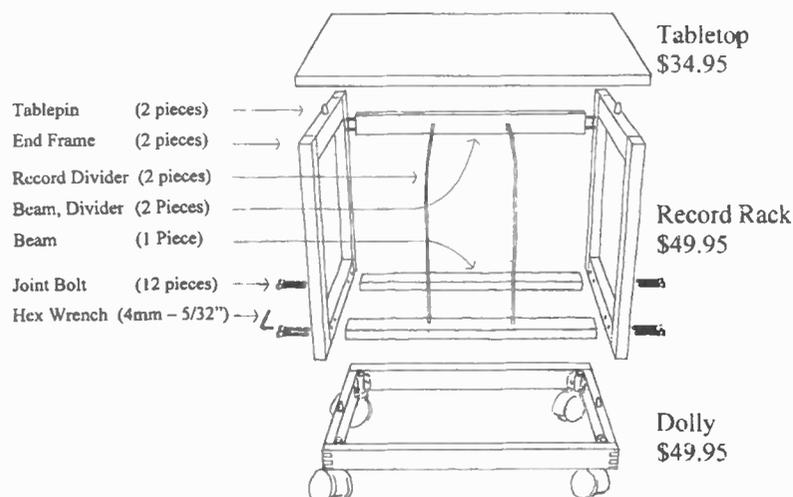

It's a great value — for as little as 50 cents a record you get convenient, space-saving storage. RACKIT is the best insurance for protecting your valuable record collection.

Factory direct to you since 1984

Place your first order today and get a free Tabletop!

Please mention Goldmine



Per Madsen Design
PO Box 882464, San Francisco CA 94188
800-821-4883 www.rackit.com



(Please see New Releases page 55)

AS HOLIDAY TIME DRAWS NEAR,
WE CAN CERTAINLY USE SOME
CHRISTMAS CHEER!
FOR A "MERRY MERRY" CHRISTMAS,
ORDER THE TOKENS
"OLDIES ARE NOW"
WHICH CONTAINS THE HOLIDAY HIT
"MERRY MERRY" AND
HAVE A ROCKIN' CHRISTMAS!
(CD INCLUDES "THE LION SLEEPS TONIGHT")
CD'S \$14.95 PLUS \$3.95 FOR S&H

MAIL ORDER TO:
B.T. PUPPY RECORDS, INC
P.O. BOX 391, MILLWOOD, NY 10546
OR www.thetokens.com
PLEASE MAKE CHECKS PAYABLE TO:
BT PUPPY RECORDS
AMEX, MC & VISA ARE ALSO ACCEPTED



HURRY!!!
BONUS!!!

IF YOU ORDER BY
DECEMBER 20,
YOU WILL RECEIVE
A BONUS CD
OF THE TOKENS VERSION OF
"THE STAR SPANGLED
BANNER" &
"GOD BLESS AMERICA"

SWINGIN' DICK'S MUSIC EMPORIUM

"Absolutely the best selection and product anywhere!"

*** Check us out at: <http://www.sdemporium.com> ***

OUR SELECTION INCLUDES (but is not limited to):

Bob Dylan	•	Asia
Bruce Springsteen	•	Eagles & Related
Chicago & Related	•	Styx & Related
The Doors	•	Jimi Hendrix
Bon Jovi	•	Ratt
Metallica	•	Beatles & Related
Def Leppard	•	Genesis & Related
Roadmaster	•	Led Zeppelin & Related
Head East	•	Blue Oyster Cult & Related
Prince & Related	•	The Black Crowes
Beach Boys & Related	•	Eric Clapton
Stevie Ray Vaughan	•	Van Halen & Related
Yes & Related	•	The Who
Tesla	•	REO Speedwagon

HUNDREDS MORE TITLES TO CHOOSE FROM (including THE largest selection of '80's metal)!!

NO paper labels, NO non-printed discs! Strictly quality, professional pressings! Check our site, see what your disc(s) will look like, and judge for yourself!! Quality guaranteed!!

Online credit card processing! Quick delivery times. Log on now for details!!

<http://www.sdemporium.com>
"Come swing with us! You'll be glad you did!"

Season's Savings!

Holiday Gift Giving Was Never So Easy!

SPECIAL 45 RPM ADVERTISING SECTION • THE 45 REVOLUTION COLUMN

October 21, 2001 VOL 27-NO 10-ISSUE 552

Goldmine

Second National Record Show
A SMASH HIT

EASY-TO-ENTER CONTEST!
Win cool gear, books, and CDs!

FACTORS

OMPAL

PLACE

The Four Freshmen

GIVING POP MUSIC THE GIFT OF HARMONY

Patty Loveless
A VOICE COMING DOWN FROM THE MOUNTAINS

Reviews

- Simon & Garfunkel
- Mickey Fitts Band
- The Dream Syndicate
- Lava/Red Bull
- Accept
- John Mellencamp

U.S. \$3.95, CANADA \$4.95

Give Every Collector on Your List a Year-Long Gift Subscription to **Goldmine**—and **Save**

Give one 1-year subscription at \$39.95 and give up to 2 more gift subscriptions to your friends at just \$21.95 each!

Or, give two 1-year subscriptions at \$32.95 and take care of up to 5 people on your list at just \$19.95 each!

Send names and address to: Krause Publications, offer ABA6TB
700 E. State Street, Iola, WI 54990-0001

Check/Money order enclosed
 MC VISA AmEx Discover

Card No. _____
Signature _____ exp. ____/____

Phone-In Orders Call 1-800-258-0929
Mention Offer: ABA6TB

krause publications
700 E. State Street
Iola, WI 54990-0001

WEB DIRECTORY SHOWCASE



Call
Goldmine
Advertising

1-888-457-2873

LORAN RECORDS

Collectible
Record Albums

www.loranrecords.com



SPECIALISTS IN COLLECTIBLE LP'S OF ALL MUSICAL CATEGORIES

Rock • Soul • Country • Jazz • Classical • Vocals • Easy Listening
Soundtracks • Comedy • Exotic • Latin & Everything Else!



- ★ High Quality Records
- ★ Low Postal Charges
- ★ Free Search Service On Your Want Lists

- ★ Reasonable Prices
- ★ Fast, Friendly Service

Order By Mail → P.O. Box 1604 • Florissant, MO 63031
Order By Phone → 314-837-2649
Order By Fax → 314-921-4091
Order By E-Mail → loranrec@aol.com

**Please Contact Us
For A
Free Catalog**

www.acevideoandmusic.com

Huge selection
Something for everyone, Lps, 45s
Collectable music from 1920's-now

For E-Bay's best music & video go to Susue



Ace Video & Music
285 Caillavet St., PO Box 1934
Biloxi, Mississippi 39533-1934 USA
228-374-0777, fax 228-374-4645
mail@acevideoandmusic.com

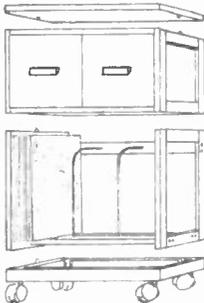

Vinyl storage and more The RACKIT™ Systems-

Made in the USA since 1984

Stackable oak furniture
holds all formats and equipment
Factory direct to you from
Per Madsen Design
Order online now at:

www.rackittm.com

SWEET MEMORIES

over 15,000 Rare Vinyl Records UK

101 Fratton Road, Portsmouth, Hampshire, PO1 5AH, England
Telephone and Fax from USA is 011 44 23 92 837730

www.vinylrecordsuk.com

Email nick@vinylrecordsuk.com

JOHN MANSHIP RECORDS

BUYERS & SELLERS OF SOUL since 1969

Priced Wants lists serviced
Anything to sell? Great prices offered.
Single items or Whole Collections.

Tel. (44) 1664 464526 FAX. (44) 1664 464155

E-mail: info@raresoulman.co.uk

Secure Web Site: www.raresoulman.co.uk

More Rare Soul for sale than any other site.
Over 24,000 items listed.



SOUTHLAND CD ONLINE

Hello from SLCD.com, Southland CD. We would like to introduce you to our collectible music Web site: www.SLCD.com. We have a large selection of collectible music available for online ordering including CDs, Records, Memorabilia & mostly anything by your favorite artists. Our vast stock consists of items from all over the world, including the U.S., U.K., Japan, Australia & Germany to name a few. SLCD.com is a user friendly Web site that is complete with an easy to use search engine & secure online ordering. We update our site on a daily basis, so check back often not to miss a thing. In addition to everything that is available to buy at SLCD.com, you can also sell to us! We pay \$ top dollar \$ for most collectible CDs, Vinyl or Memorabilia.

Check out www.SLCD.com and let the fun begin!
www.SLCD.com
www.SLCD.com



eRock.NET

Official Rock-n-Roll Memorabilia Auction Web site

Select from 17 exciting categories of which five specialize in vinyl records. This music site also holds a monthly drawing and gives away a \$200 auction shopping spree to one lucky winner every month.

<http://www.eRock.net>



We deliver what music lovers want!

LOW Prices - FAST Service

A HUGE Selection of ALL Genres.

Specializing in Imports.

CDs/LPs/Collectibles/More

ImportCDS.com

MUDSHARK AUDIO

restoration * enhancement



get your LPs de-cracked!
get your tapes de-hissed!



restore & enhance your live/amateur recordings!

mudshark audio offers digital restoration services starting at \$35cdn!!

www.mudsharkaudio.com

1/2 SPEEDS

PROMOS



RECORDCRATE.COM
SPECIALIZING IN COLLECTABLE RECORDS

JEFF GREINDL

(630) 830-7634

IMPORTS

eligreindl@aol.com

1ST PRESS

JAZZ RECORD CENTER

236 West 26 Street
New York, NY 10001

Phone: 212-675-4480
Fax: 212-675-4504

New York's only specialist in out-of-print Jazz records, books, videos and periodicals.

NEW

WEB site: www.jazzrecordcenter.com

Web site will be a convenient way to purchase items online as well as participate in online auctions.

E-MAIL: jazzrecordcenter@att.net



Long Time Gone Records

New & Used LP's & CD's Online:
Audiophile and Otherwise

www.recordsrevisited.com

Visit us on the Web ...Auction and set sale prices.

Jazz, Folk, Rock and Blues/International Buyers Welcome!

E-mail us: longtimegone@att.net

Want lists accepted.

76 North Maple Ave, Suite 301, Ridgewood, NJ 07450
Michael Phelan (201) 657-7659 Voice mail/I buy collections locally

WWW.JUSTANOTHERDREAM.COM



Home of Rare and Collectible Records, CDs, Music Videos, And Music Related Memorabilia From Around the World.

Shop for your music collectibles, 24 hrs. a day, easily and safely. We offer secure online transactions. We accept Visa and Mastercard.

www.maidenmania.com

Iron Maiden/KISS and Heavy Metal

Over 365 pages (900 plus items) of astounding rarities from all over the world from Argentina to Yugoslavia and everywhere in between. Please e-mail me at ken@maidenmania.com for your FREE computer catalog download. If you do not have a computer, I will be more than happy to send you a copy of each of my catalogs, but PLEASE enclose \$1 per artist per request (3 stamped IRC's for Canadian and overseas customers only) when writing to cover printed material and postage costs to:

Maiden Mania
820 Post Road, Suite 135
Scarsdale, NY 10583-5046 USA

World Radio History



VERY ENGLISH AND ROLLING STONE
P.O. Box 7061
Lancaster, PA
17604-7061
PHONE 717-627-2081 EST
FAX 717-627-3227
E-mail: vears@lannews.infi.net
Since 1977



www.veryenglish.com



(Over 5,000 Collectibles Listed)

Huge FREE!!!! Collectible / Rare Catalog containing vinyl / CDs / colored vinyl / promos / rock clothing / send a 75c stamp USA and Canada and Foreign \$2.50 stamp.

Available most weekday evenings 9:30 p.m. - midnight

Why pay imported prices for imported CD's
www.musicselection.com

Over 1.3 million imported CD's

Compact Discs, Cassettes, Vinyl, Videos & Dvd's
Lowest prices guaranteed !!!
Shipping is still only .99 cents !!!

HEAVY METAL AND HARD ROCK

Over a decade of serving hard rock/metal fans.
5000+ titles of normalities & rare releases.

The Web's largest specialist.

Vinyl, CD's, Memorabilia.

Secure ordering with shopping cart.

www.visual-vinyl.co.uk

WEB DIRECTORY SHOWCASE



Call
Goldmine
Advertising

1-888-457-2873

VINTAGE VINYL MAIL ORDER

<http://www.vvmo.com>

TOP QUALITY RARE & OUT-OF-PRINT VINYL!

BEATLES * STONES * ROCK & POP * PSYCHEDELIC
PROGRESSIVE & KRAUTROCK * JAZZ * SOUL * FOLK
WE ALSO CARRY HARD TO FIND & COLLECTABLE CD'S,
& NEW BRITISH MUSIC THE WEEK OF IT'S RELEASE IN U.K.!

MAILING ADDRESS : 925 DAVIS ST. EVANSTON, IL 60201
PH : 847-328-2899 * FAX: 847-328-2934



FLASHBACK COLLECTIBLES

Concert Posters, Postcards, Tickets,
Autographs and Memorabilia

Skip & Cindy Clarke
3307 So. College Ave., PMB 7018
Ft. Collins, CO 80525
(970) 224-1456

E-mail: skipclarke@aol.com
www.flashbackcollectibles.com

Memory Lane

Out-of-Print Records • Tapes • Compact Discs



1940 EAST UNIVERSITY DRIVE
TEMPE, AZ 85281

TELEPHONE (480) 968-1512
FAX (480) 921-1620

Web site: <http://www.memorylanerecords.com>
E-mail: mlr@memorylanerecords.com

www.elvisunlimited.com

www.oldies45s.com

Over 30,000 Singles for sale

Easy to Search

Priced to Sell

Volume Discounts

secure online transactions: Visa /MC

email: oldies45s@oldies45s.com

equivalents are hilarious. Consider the words to "La Queue de Tortue": "Let's go to The Turtle Tail to live on French Toast. Little one, you're criminal, and a damned little bottle..." What sweeter words were ever spoken to a loved one?

Swamperella are presently looking for a second singer who plays triangle. Gender, national origin and musical history are plainly not important. Only those with a passion for Cajun music need apply. Learn more about Swamperella online at www.swamperella.com, or buy this delightful CD directly from Festival distribution (1-800-633-8282).

— Hank Davis

(New Releases from page 52)

level on songs such as "Cocoon," on which she has never sounded so child-like and fragile. "Hidden Place," "It's Not Up To You," "Pagan Poetry," "Aurora" and "Unison" are other gorgeous highlights.

Throughout the album, Björk uses uncommon instruments such as a harp, music box, clavichord and celeste, but her songs are generally at their best when featuring lush string arrangements and the angelic voices of a backing choir. Yet programmed electronics remains her primary instrument, and though the constant electronic blips, clicks and cracks occasionally only get in the way, I can forgive Björk for her reach occasionally exceeding her grasp and for her pretensions ("Sun In My Mouth" sets music to lyrics by e.e. cummings).

The rewards of *Vespertine* far outstrip its flaws, as this ambitious album (which at times recalls Kate Bush) is a boldly beautiful departure from this always fascinating artist.

— Scott Floman

SWAMPERELLA

Swamperella
Cattail (CR 0001)

Swamperella and the group that produced it are one of the sweetest musical surprises I've encountered in years. People don't normally expect to be stopped in their tracks when walking past a noon-hour concert on a southern Ontario college campus. The endless parade of derivative rock bands from Toronto becomes pretty numbing after a while. The last thing one expects to hear is a Cajun band playing the kind of music heard in a juke joint in Lafayette some 50 years ago.

Which brings us to Swamperella. The band is unusual not just because they've taken an authentic approach to Cajun music, but also because of who they are. To use a very politically incorrect term, this is essentially a chick band. Although they've recently undergone some personnel changes, three of the four band members are female. Their backgrounds are, likewise, not what you'd expect. They perform 1,500 miles north of Cajun country, and there's not a Thibodeaux or a Doucet among them. In fact, nobody's nationality or musical pedigree in Swamperella would lead one to predict the collective passion for Cajun music that drives this group.

To be clear, when I talk about Cajun, I am not referring to the kind of hybridized, over-amplified dance music that passes for Cajun these days, simply because there's an accordion player in the group or one of the band members drove through Louisiana on his or her way to Los Angeles. This is the real thing. What these ladies lack in birthright, they more than make up for in experience. They've put in their time listening to old 78s, traveling to and playing in the right places.

Because Cajun is hardly a major force north of the border, all like-minded musicians passing through Toronto have been drawn to jam or record with this band. Swamperella has become a Cajun lightning rod.

How good is this album? At its best (which is quite often) the music is eye- and ear-opening. It comes very close to acoustic and follows some of the deepest Cajun traditions, most of which have been thrown aside by the souped-up second- and third-generation groups.

This band uses a triangle as a rhythm instrument and sometimes ends songs on the four-chord (sub-dominant, if you prefer). Not a lot of bands play songs in the key of C and end on a rollicking, big fat F chord.

Although these recordings ooze authenticity (e.g. "Barres de la Prison"), they are also joyous and danceable. Those are two essential qualities of the best Cajun music, and they are not lost here. Indeed, to their credit, Swamperella have never let their serious interest in Cajun traditions blunt the edge of their music. *Swamperella* is no PBS documentary. It's got plenty of edge and passion.

Some specifics: The first eight bars of "Ma Chere Bebe Creole" are achingly beautiful — back-porch music at its finest, assuming that one's house is located in Ville Platte or Lake Charles, La. The arrangements on tracks such as this do a fine job of contrasting the purity of the old sound with the fatter contemporary feel when the entire band joins in for the second verse.

The only song performed in English is the standout "Livin' A Lie," sung by Shelley Zubot, who has recently left the group. Her departure is a considerable loss to Swamperella, although the vocal chores are in good hands when founding member Sooz Schlanger takes the microphone. The musicianship on this album is continuously first-rate, including the percussive acoustic bass work by Dave Szigeti (also departed) and guest appearances by steel guitar player Mark Haney on three of the 15 tracks. Tracks such as "Ossun Blues" and "Sooz Blues" showcase Schlanger's fiddle playing in an old-timey style. Accordion player Peter Jellard makes a solid contribution throughout and, thankfully, continues to perform with the group.

Cajun music has always provided uncommonly melodic tunes despite the limited chord structures of its songs. The track "Bonsoir Moreau" is perfect evidence of this and easily the most haunting track on the collection. Most of the songs here reveal how different the Cajun tradition is from conventional country music. Its lyrics are almost an afterthought compared to the carefully crafted stories born in Nashville.

Although far more musical than standard 12-bar blues, Cajun songs share the tradition of improvised lyrics. Don't look for conventional A-B-A-B rhymes here. Instead, expect what amounts to free-form poetry. The enjoyable liner notes offer both the French lyrics and their English translation, to the extent that this idiomatic dialect can be translated. Some of the

B.B. KING

A Christmas Celebration Of Hope
MCA (112756)

B.B. King plays the blues like they left him long ago. They probably have. He's a legend, rich and respected among peers. No use singing the blues when you've got all that going for you. On *A Christmas Celebration Of Hope*, his first-ever holiday-themed album, King really isn't singing the blues. He's celebrating Christmas via a bunch of roasted chestnuts that go down as smoothly as a cup of eggnog.

Which means it's yet another coasting trip for King. It's a capable, likeable effort, but the casualness with which King tosses off such an urgent, lonely holiday plea such as "Please Come Home For Christmas" is a bit misplaced. He doesn't carry the longing and grief that these worn holiday perennials require. In fact, he sounds like B.B. King playing Christmas tunes.

On the joyous numbers — or even his revved-up take of "Auld Lang Syne" — it's an OK match. He celebrates "Merry Christmas Baby" with passion, and his guitar playing is fluid throughout. But one can't help but to think that *A Christmas Celebration Of Hope* (which is a charity album; proceeds will fund innovative research and compassionate patient care programs at City Of Hope children's hospitals) would have been better-served on the stage around that snowy time of year. This was recorded in New Orleans in the summertime, and the sweltering — and sometimes stifling — vibe is omnipresent. But King has been on automatic for the past couple decades anyway, so this comes as no surprise. Still, a little holiday spirit would have been nice.

— Michael Gallucci

Short Take

If Matthew Ryan sounds somewhat gloomy on his third album, appropriately named *Concussion* (Waxy Silver Records, no #), it's only because his sobering stance has marked his music from the beginning. That's not a bad thing; Ryan has an uncanny ability to reference the resilience of ordinary individuals overcome by doubt and desperation. While he mostly relies only on his guitar for these bare-boned arrangements, songs such as "Drift" and "Devastation" (featuring a guest appearance from Lucinda Williams) add a compelling edge to the drama. (info@waxysilver.com; Waxy Silver Records, PO Box 128291, Nashville TN 37212)....

— Lee Zimmerman

Record Shows



Please call ahead before you travel. All information listed herein is provided by the show promoters, is subject to change and is not independently verified by the Goldmine staff. Show promoters who wish to have their record and CD shows listed should mail all pertinent information at least two months in advance of the show to: Goldmine Show Calendar, 700 E. State Street, Iola, WI 54990 or FAX to 715-445-4087.

- Nov 30 IN, Indianapolis. New Years Eve. Fountain Square Theatre. A: \$30. in advance. \$35. at the door. PH: 765-948-3326 or FAX: 765-948-3389.
- Dec 1 IL, Hillside. Record Convention, Holiday Inn. I-290 & Wolf Rd., SH: 9am-4pm, F: \$45-\$50, A: \$3. ARC Promotions, PH: 765-646-5305 or FAX: 765-378-7706.
- Dec 1 MA, Chelmsford. Big Ed's Record, CDs & Tapes Show, Elks Lodge. Rt. 110, SH: 10am-4pm, A: \$3. PH: 603-888-0294.
- Dec 1 NJ, New Brunswick. Record & CD Show, Rutgers University, Cook Campus. Recreation Ctr., Biel Rd. (off Rt. 18), SH: 10am-3pm, T: 100, A: \$5., under 12 free. F. Falk, Rutgers Record Expo, PO Box 849, Highland Lakes, NJ 07422. PH: 973-773-6067.
- Dec 1 ENGLAND, London. Music Fair, Electric Ballroom. Camden High St., T: 6'. Rob Lythall, VIP Events, PH: 0116-224-4300 or FAX: 0116-224-4299.
- Dec 1 ENGLAND, Wolverhampton. Music Fair, Civic Halls. North St., T: 8'. Rob Lythall, VIP Events, PH: 0116-224-4300 or FAX: 0116-224-4299.
- Dec 2 FL, Orlando. Record Show, Central FL Fairgrounds, 4603 W. Colonial Dr., SH: 10am-4pm, T: 70-8', F: \$60., A: \$3. FL Record Collectors Association, Inc., Jeff Smith, PH: 352-331-5928 or Syd Crosby, PH: 904-454-0530.
- Dec 2 PA, Allentown. Winter 2001 Lehigh Valley Music Expo, Merchants Square. 12th & Vuttee Sts., SH: 10am-4pm, T: 8', F: \$55. before Nov 25, \$65. thereafter, A: \$3. Surround Sound Prods., 801 N. Broad St., Westerville, PA 18106. PH: 610-530-7606 or 797-7743 day of show.
- Dec 2 TN, Nashville. Music Collectors' Convention, Day's Inn-Airport. Briley Pkwy., SH: 10am-3pm, F: \$30. if paid one week in advance, \$40. thereafter, A: \$2. with coupon, \$3. without, under 12 free with adult. Alpha Records & Music, Gerald Ruark, POB 17575, Indianapolis, IN 46217. PH: 317-882-3378.
- Dec 2 WA, Seattle. Record & CD Show, Seattle Ctr. Snoqualmie Room. SH: 10am-5pm, F: \$45., A: \$3. John, PH: 425-228-3537.
- Dec 2 WI, Appleton. Fox Valley Record Show, Best Western Midway Hotel, 3033 W. College Ave., SH: 9am-3pm, T: 6' & 8', F: \$30-\$35., A: \$2. Yesterdays Music, Jim, PH: 920-733-5076.
- Dec 2 FRANCE, Aix Les Bains. Record Fair, (73) Centre De Congress. Sagadis, Fernand Piqueras, 411 Quai Jean Jaures 71000 Macon France. PH: (33) 0385384666 or FAX: (33) 0385380949.
- Dec 8 MN, Minneapolis. Record Show, VFW, 2916 Lyndale Ave. S., F: \$35., A: \$2. Rich Shelton, 255 E. Kellogg St., Paul, MN 55101. PH: 651-290-2900.
- Dec 8 NJ, New York. 2nd Sat. Record & CD Collectors Show, Fire-

- men's Convention Center. Parish Dr. (N. of Rt. 46 & Rt. 80) at Rt. 23 & Rt. 202S, SH: 10am-4pm, T: 100, A: \$5., under 12 free. F. Falk, PO Box 849, Highland Lakes, NJ 07422. PH: 973-773-6067.
- Dec 8 NY, New York. Music Memorabilia Show, Top Top Shoe Bldg. 155 W. 72nd St., 4th Floor, SH: 10am-2pm, A: free. PH: 212-579-0689 weekdays.
- Dec 8 OH, Dayton. Music Collectors' Convention, Hara Arena. 1001 Shiloh Springs Rd., SH: 10am-3pm, F: \$30. if paid one week in advance, F: \$40. thereafter, A: \$2. with coupon, \$3. without, under 12 free with adult. Alpha Records & Music, Gerald Ruark, POB 17575, Indianapolis, IN 46217. PH: 317-882-3378.
- Dec 8 ENGLAND, Walsall. Music Fair, Town Hall, Leicester St., T: 7.5'. Rob Lythall, VIP Events, PH: 0116-224-4300 or FAX: 0116-224-4299.
- Dec 9 CA, Newark. Music Swap Meet, Pavilion. 6430 Thornton Ave., corner of Thornton & Cherry, SH: 9am-2pm, F: \$45. for 1, \$60. for 2, A: \$3. Charlene White, PH: 408-263-5127.
- Dec 9 CT, Waterbury. Record Collectors' Convention, Sheraton Hotel. 3580 E. Main St., SH: 9:30am-4pm, T: 8', F: \$65., A: \$4. Gorman, PH: 203-287-8923.
- Dec 9 FL, Ft. Lauderdale. Record & CD Show, Airport Inn. 2440 State Road 84 (just W. of I-95), SH: 10am-4pm, A: \$2. John Miller, PH: 954-926-4545.
- Dec 9 IN, Indianapolis. Music Collectors' Convention, Quality Inn-East. 3525 N. Shadeland, SH: 10am-3pm, F: \$30. if paid one week in advance, F: \$40. thereafter, A: \$2. with coupon, \$3. without, under 12 free with adult. Alpha Records & Music, Gerald Ruark, POB 17575, Indianapolis, IN 46217. PH: 317-882-3378.
- Dec 9 PA, Lancaster. Pennsylvania Music Expo, Catholic H.S. Cafeteria. 650 Juliette Ave., (rear), 1 mi. S. of US Rt. 30, SH: 9am-3pm, A: free. Keystone Record Collectors, PO Box 1516, Lancaster, PA 17608. PH: 717-898-1246.
- Dec 9 HUNGARY, Budapest. 16th International Record Fair, Petofi Csarnok Varosiget. H-1146 Budapest, Zichy Mihaly str. 14. Lemezborze, plusz Magazine, 1300 Budapest, PH: 129. Hungary, PH: 0036 14300990 or FAX: 0036 14300991.
- Dec 15 NY, New York City. Record & CD Collectors Expo, Holiday Inn. (Formerly Days Inn) 440 W. 57th St., btw. 9th & 10th Aves., SH: 10am-4pm, T: 100, A: \$6., under 12 free. F. Falk, PO Box 643, Highland Lakes, NJ 07422. PH: 973-773-6067.
- Dec 15 ENGLAND, London. Music Fair, Electric Ballroom. Camden High St., T: 6'. Rob Lythall, VIP Events, PH: 0116-224-4300 or FAX: 0116-224-4299.
- Dec 15 ENGLAND, Cardiff. Music Fair, City Hall, Cathay's Park, T: 6'. Rob Lythall, VIP Events, PH: 0116-224-4300 or FAX: 0116-224-4299.

- Dec 16 GA, Atlanta. Record & CD Show, Ramada Inn. I-85, Exit 86, 418 Armour Dr., SH: 10am-4pm, A: \$3. Keith Alverson, PH: 770-463-2727.
- Dec 16 MD, Arbutus. Record & CD Show, Fire Hall. 5200 Southwestern Blvd., SH: 10am-4pm, T: 120-5', F: \$30., A: free. Ray or Chris Quigley, 1 Colgate Ct., Baltimore, MD 21228. PH: 410-455-0418.
- Dec 16 NY, Binghamton. WAAL NY CD & Record Fair, Heritage Country Club. 4301 Watson Blvd. (Rt. 17 W., Exit 70 N., L. at 1st light, .5 mi. on R., SH: 10am-5pm, T: 70-8', A: \$4. Jack Skutnik, 7 Charnel Dr., Binghamton, NY 13901. PH: 607-648-4997 or FAX: 607-648-9626.
- Dec 16 WI, Milwaukee. Record Fest, Serb Hall. 5101 W. Oklahoma Ave., SH: 10am-3pm, F: \$45-\$55., A: \$4. Gary Mason, PH: 414-442-6060 (11am-5pm).
- Dec 16 WI, Milwaukee. Vinyl Record Show, Best Western Midway Hotel. 1. 251 N. Mayfair Rd. (off I-94 & Hwy. 100), SH: 9am-3pm, F: \$35., A: \$2. Yesterdays Music, Jim, PH: 920-733-5076.
- Dec 16 ENGLAND, Bath. Music Fair, Sports Centre. North Parade Rd., T: 6'. Rob Lythall, VIP Events, PH: 0116-224-4300.
- Dec 21-23 NY, Monticello. Weekend Fest For Beatles Fans, Kutsher's Country Club Hotel & Resort. Catskill Mountains. International Tours & Events, PH: 203-795-4737 or FAX: 203-891-8433.
- Dec 22 ENGLAND, Birmingham. Music Fair, Academy. Dale End, T: 6'. Rob Lythall, VIP Events, PH: 0116-224-4300 or FAX: 0116-224-4299.
- Dec 22 ENGLAND, London. Music Fair, Electric Ballroom. Camden High St., T: 6'. Rob Lythall, VIP Events, PH: 0116-224-4300 or FAX: 0116-224-4299.
- Dec 29 NJ, Wayne. 2nd Sat. Holiday Record-CD-Tape Collectors Show, Firemen's Convention Center. Parish Dr. (N. of Rt. 46 & Rt. 80) at Rt. 23 & Rt. 202S, SH: 10am-4pm, T: 100, A: \$5., under 12 free. F. Falk, PO Box 849, Highland Lakes, NJ 07422. PH: 973-773-6067.
- Dec 29 ENGLAND, London. Music Fair, Electric Ballroom. Camden High St., T: 6'. Rob Lythall, VIP Events, PH: 0116-224-4300 or FAX: 0116-224-4299.
- Dec 30 IL, Rolling Meadows. Record & CD Show, Holiday Inn. Rt. 53 & Algonquin Rd., SH: 10am-3pm, F: \$50., A: \$3. Midwest CD Promos., Bill, PH: 847-459-0137.
- Jan 5 OH, Columbus. Record & Music Memorabilia Show, Veterans Memorial Hall. 300 W. Broad St., SH: 10am-4pm, T: 6', F: \$45. ea. for 1st 2, \$40. ea. for 3 or more, A: \$4. Collector's Paradise, PO Box 261016, Columbus, OH 43226. PH: 614-261-1585.
- Jan 5-7 TN, Memphis. Elvis' Birthday Con 2002, Ramada Inn SW. 1471 E. Brooks Rd. (I-55 & Brooks Rd. Exit), SH: SH: Mon. 10am-6pm, T: 6', F: \$90. ea., A: free. Soundz Good Records, Robert Alaniz, PH: 815-464-7681 or FAX: 815-464-7682.
- Jan 6 MO, St. Louis. Record & CD Show, American Czech Center. Kingshighway & Landsdown, SH: 10am-4pm, F: \$30., A: \$2.50. Jim Ronat, 1908 Main St., Highland, IL 62249. PH: 618-654-3049 or Carl, PH: 314-821-9121.
- Jan 12 NY, New York. Music Memorabilia Show, Top Top Shoe Bldg. 155 W. 72nd St., 4th Floor, SH: 10am-2pm, A: free. PH: 212-579-0689 weekdays.
- Jan 13 IL, Hillside. Chicagoland Record Collectors Show, Holiday Inn. 4400 Frontage Rd., SH: 9am-4pm, T: 70-8', F: \$40., A: \$3. John Govi, 3045 Worcester Ln., Aurora, IL 60504. PH: 630-898-1533 eves.
- Jan 13 NY, Albany. Music Lust 2002, Italian American Community Ctr. 1400 Washington Ave. Ext., SH: 10am-5pm, T: 8', F: \$55., A: \$3. Joseph Custom Tailors, 795 Madison Ave., Albany, NY 12208. PH: 518-463-4972.
- Jan 13 FRANCE, Macon. Record Fair, (71) Centre Heritan. Sagadis, Fernand Piqueras, 411 Quai Jean Jaures 71000 Macon France. PH: (33) 0385384666 or FAX: (33) 0385380949.
- Jan 20 CA, San Francisco. Rock 'n' Swap, University of San Francisco. McLaren Hall, SH: 10am-4pm, F: \$55., \$30. ea. add'l., A: \$2. KUSF, 2130 Fulton St., San Francisco, CA 94117. PH: 415-386-5873.
- Jan 20 PA, Pittsburgh-Monroeville. New Rock & Roll Expo, The Palace Inn. Rts. 22 & 48, SH: 10am-5pm, T: 8', F: \$50., A: \$4. Jeff Smitte, Box 514, Muse, PA 15350. PH: 724-746-3638.
- Jan 20 PA, Philadelphia. Philly1.com & Philadelphia Weekly, Painted Bride Art Ctr. 230 Vine St., SH: 11am-6pm. PH: 267-977-3388 or 215-514-6323.
- Jan 20 RI, North Providence. The Original RI Rock 'n' Roll Collectors Convention, K of C Hall. 1675 Douglas Pike (Rt. 7), SH: 10am-3pm, F: \$30., A: \$2. Steven "Rocky" Rothwell, 36 Spicer St., North Providence, RI 02904. PH: 401-353-9612.
- Jan 26 KY, Louisville. Music Collectors' Convention, Exec. Inn. Watterson Expwy. & Fairgrounds, SH: 10am-3pm, F: \$30. if paid one week in advance, F: \$40. thereafter, A: \$2. with coupon, \$3. without, under 12 free with adult. Alpha Records & Music, Gerald Ruark, POB 17575, Indianapolis, IN 46217. PH: 317-882-3378.
- Jan 26 PA, Montgomery. Beatles Fest, Clinton Township Vol. Fire Company. Rt. 54, SH: 7pm-11pm, A: \$3., \$5. couple. Jimmy Stabley, PH: 570-326-4280 or Tom Staggert, PH: 570-547-6254.
- Jan 27 IN, Indianapolis. Music Collectors' Convention, Quality Inn-East. 3525 N. Shadeland, SH: 10am-3pm, F: \$30. if paid one week in advance, F: \$40. thereafter, A: \$2. with coupon, \$3. without, under 12 free with adult. Alpha Records & Music, Gerald Ruark, POB 17575, Indianapolis, IN 46217. PH: 317-882-3378.
- Jan 27 WI, Milwaukee. Vinyl Record Show, Best Western Midway Hotel. 1. 251 N. Mayfair Rd. (off I-94 & Hwy. 100), SH: 9am-3pm, F: \$35., A: \$2. Yesterdays Music, Jim, PH: 920-733-5076.
- Jan 27 FRANCE, Vesoul. Record Fair, (70) Salle Parisot. Sagadis, Fernand Piqueras, 411 Quai Jean Jaures 71000 Macon France. PH: (33) 0385384666 or FAX: (33) 0385380949.
- Feb 1-2 IA, Clear Lake. Record Convention, Lake Lanes. 514 Buddy Holly Place, SH: 10am-6pm, T: 8', F: \$75-\$100. Play It Again Records, PH: 608-562-6313.
- Feb 2 FL, Tampa. Record & CD Show, Holiday Inn Express.

STYLUS SHOWS PRESENTS THE 2002

ORLANDO MUSIC COLLECTOR'S CONVENTION

SAT-SUN FEB 9-10
10AM-5PM
Early Shopper 7a Sat, 8:30a Sun

DOWNTOWN EXPO CENTRE

NEW - OLD - RARE
Out-of-Print-Collectible LPs, 45s, 78s, 12", CDs
DVDs, TAPES, MUSIC MEMORABILIA, POSTERS

FREE RECORD APPRAISAL 11-4 Sa/Su

WIN BEATLES LPS

LIVE 50's - 80's DJ

BUY 2 DEALER TABLES GET 1 MORE FREE!

ADMISSION \$3, Kids under 13 FREE
EARLY SHOPPER \$15
INFO. 301-570-5524
www.record-shows.com

NEW YORK CITY COLLECTOR'S FEST

(SAT. DEC. 15TH 2001)
10 A.M. - 4 P.M.

- * CD'S * RECORDS * TAPES
- * POSTERS * VIDEOS
- * MEMORABILIA * COMICS
- * SPORTS CARDS & MUCH MORE *

THE HOLY CROSS SCHOOL
332 W 43rd Street
Btwn. 8th & 9th Ave.

FREE ADMISSION
8 Ft. Dealer Tables - \$40⁰⁰
2 for \$70⁰⁰

For dealer inquiries or more information:
Contact: Gary. Ph # 718-972-3872
E-Mail: VideoWizards@webtv.net

RAMADA INN
418 Armour Drive
(I-85 - Exit 86)

SUNDAY, DEC. 16
10 a.m. - 4 p.m.
\$3 ADMISSION \$3

COMPACT DISCS • LPS
RARE • OLD • NEW

- IMPORTS • PROMOS • 45'S • CASSETTES
- PHOTOS • VIDEOS • POSTERS
- SOUNDTRACKS
- JAZZ • NEW WAVE • COUNTRY
- HEAVY METAL • BLUES • SOUL

PLUS OTHER MUSIC-RELATED ITEMS!

CALL 770-946-5050 FOR INFORMATION

Since 1995.



Siren Disc

Discount Import CDs & More.

www.sirendisc.com

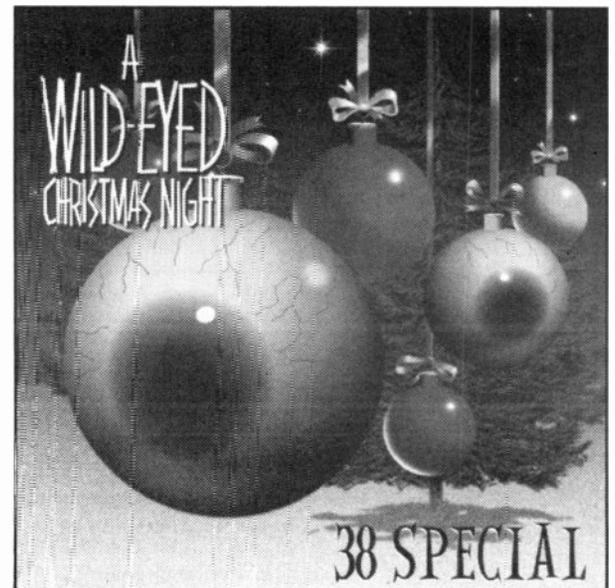
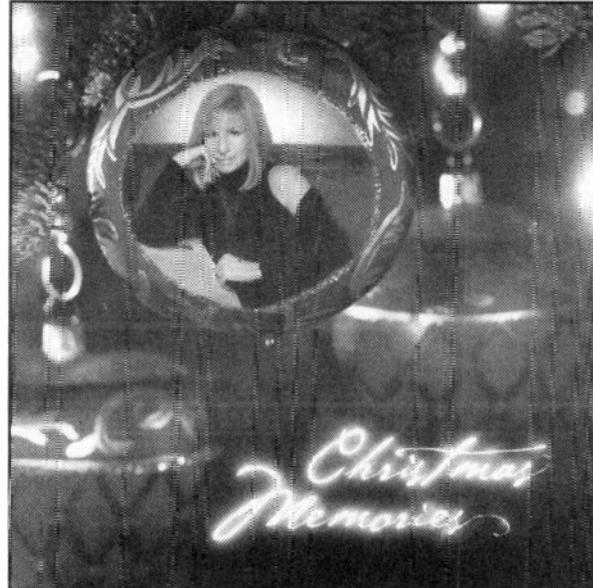
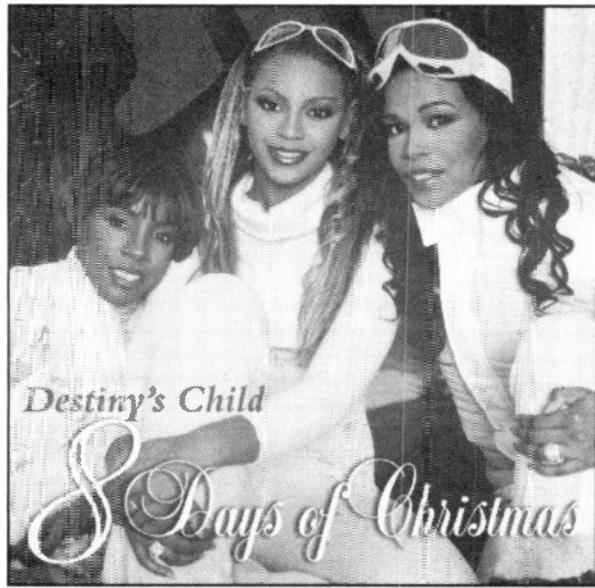

(Christmas 2001 from page 30)

of the three Destiny's Child women gets a solo turn in addition to the group harmonies. The title track appeared as a bonus on last year's "Independent Women Part 1" CD single. Collector's note: The Wal-Mart version has two bonus tracks, one of which isn't a Christmas tune (a remix of "Emotion").

AMY GRANT, VINCE GILL AND THE LONDON VOICES: *The Spirit Of Christmas* (Hallmark XPR 202-0). The 17th annual Hallmark CD features six songs by Amy Grant, including a duet on "Christmas Waltz" with her husband Vince Gill.

GLENN SCOTT LACEY AND RICK KUETHE WITH BROOKE RAMEL AND JASON JOSEPH: *My New England Town* (Fight Cloud, no number). This CD of new and traditional holiday numbers is meant to share Glenn Scott Lacey and Rick Kuethe's memories of Christmases while growing up in New England. And it's free! (OK, there's a \$4.95 shipping and handling charge. But it's still cheaper than even a used CD.) Fight Cloud is a new label in California that literally gives away its CDs, and it does so at its Web site www.fightcloud.com.

B.B. KING: *A Christmas Celebration Of Hope* (MCA 088 112 756 2). After more than 50 years of recording, one of the last remaining bluesmen of the immediate post-World War II era finally does a holiday album (though B.B. King has done singles before). Blessedly, it's lacking in "special guests."

MANNHEIM STEAMROLLER: *Christmas Extraordinaire* (American Gramophone 1225). Yet another collection of holiday cheer emerges from Chip Davis & Co., with a guest vocal by Johnny Mathis on one track. This is as close to a sure thing as it's going to get when it comes to Christmas music. Also available is a four-CD box set that contains all four regular Mannheim Steamroller holiday CDs including this one.

MICHAEL McDONALD: *In The Spirit — A Christmas Album* (MCA Nashville 088 170 230 2). Michael McDonald wraps his unique voice around 11 new and old Christmas songs, with help from guests such as Johnny Lang and James Ingram.

ANNE MURRAY: *What A Wonderful Christmas* (EMI/Chordant 72438-20335-2). This two-CD set contains tracks from all three of Anne Murray's previous Christmas collections, plus several new recordings. It

has a decent price for a two-disc set.

NEWSONG: *The Christmas Shoes Album* (Arista 10033). Last year, NewSong, a contemporary Christian group, had one of the most-played new Christmas songs with "The Christmas Shoes," which was tacked on to their then-current CD. Now the group has recorded an entire set of holiday tunes to capitalize on that success.

OLIVIA NEWTON-JOHN: *The Christmas Collection* (Hip-O 314 585 413-2). Most of the tracks on this Olivia Newton-John 12-song collection are from either her Hallmark Christmas CD of last year or from her guest appearance in a 1999 TNN special with Kenny Loggins.

JANE OLIVOR: *Songs Of The Season* (Varese Sarabande 302 066 285 2). For a time in the late 1970s, Jane Olivor was supposed to be the Next Big Thing in easy-listening circles. But after a live album in 1982, she all but vanished, not making a new recording for 18 years, until 2000. Now comes her first holiday CD, with a few quirky selections among the usual standards ("Elusive Butterfly"?).

ROCKAPELLA: *Christmas* (J-Bird 6 1746-80340-2). OK, Rockapella's *Christmas* came out in 2000. But it was a finalist for the Indie Award (independent labels' equivalent of the Grammys) in the Seasonal Music category, and you'll probably hear their Folgers commercial this holiday season again. This is a very cool collection of 12 unaccompanied tunes, including some unexpected ones (such as "You're a Mean One, Mr. Grinch").

BARBRA STREISAND: *Christmas Memories* (Columbia CK 85920). Only 34 years after Barbra Streisand's first classic Christmas album, which has never been out of print, La Barbra returns with a collection of 12 more songs. Nicely, only a handful of them are familiar. Also, she reprises her performance of the Gounod "Ave Maria" from her 1967 holiday album by performing the Schubert version of the same hymn this time. Collector's note: The version at Target has a bonus track, Streisand's rendition of "God Bless America."

THE TEMPTATIONS: *The Best Of The Temptations Christmas* (Motown 440 014 594-2). This CD collects some tracks from both of The Temptations' Christmas albums (*Christmas Card* and *Give Love At Christmas*) and adds one previously unissued recording, "O Holy Night."

THEY MIGHT BE GIANTS: *Holidayland* (Restless 01877-73756-2). This five-song EP

contains their holiday 45 of a few years back. "O Tannenbaum" (though mysteriously not the B-side "Christmas Cards") plus four others done only as They Might Be Giants can do them. How often do you encounter a remake of The Beach Boys' "Santa's Beard"?

38 SPECIAL: *A Wild-Eyed Christmas Night* (CMC International 06076-86314-2). Last year, 38 Special made a cameo appearance on Lynyrd Skynyrd's Christmas CD. Inspired by that, this year the purveyors of "Caught Up In You" and "Second Chance" take the full-length plunge with their versions of 10 holiday songs.

AARON TIPPIN: *A December To Remember* (Lyric Street 72061 65016 2). The country singer best-known for his working-class and patriotic songs has put together an unexpectedly pleasurable holiday album. New song title of the year: "It's Way Too Close To Christmas To Be This Far From You."

DR. DUKE TUMATOE: *It's Christmas (Let's Have Sex)* (J-Bird 6 1746-80360-2). This CD, from Dr. Duke Tumatoe, the former leader of the All-Star Frogs (I remember when these guys used to play gigs at the long-gone Vegetable Buddies in downtown South Bend, Ind.), is definitely not for the kids. Dr. Duke wrote eight of the 10 tunes, including the title track, "All I Want For Christmas Is To Lay Around & Love On You" and "Eat Me — I'm A Turkey."

JACI VELASQUEZ: *Christmas* (Word/Epic EK 85780). The popular Christian singer Jaci Velasquez has done seasonal tunes for compilations, but this is her first full-length holiday disc. It's mostly fairly standard stuff, but she does chirp in with The Chipmunks on a remake of "The Chipmunk Song." The CD is also available in a Spanish version (Sony Discos 84626), though I don't know whether Alvin, Theodore, and Simon also make the translation. The Chipmunks in Spanish would be quite the experience.

DALE WATSON: *Christmas Time In Texas* (Audium 8134). This 12-song set by honky-tonk hero Dale Watson was issued overseas last year but is available on an American label for 2001. It has the same tracks but completely revamped cover art. For fans of "real" country (to quote the format name), this is a must.

NANCY WILSON: *A Nancy Wilson Christmas* (MCG Jazz/Telarc MCGJ 1008). Until now, vocalist Nancy Wilson, who made a series of very successful jazz-pop albums for Capitol in the 1960s, had never done an

entire album of Christmas tunes. (She did a one-off 45, "That's What I Want For Christmas" and "What Are You Doing New Year's Eve," for Capitol in 1963.) All proceeds from the sale of this CD, which includes guests such as alumni of Dizzy Gillespie's band, Herbie Mann and Monty Alexander, goes to support the Manchester Craftsmen's Guild, a Pittsburgh, Pa., arts and learning center.

Soundtracks

Bonanza: Christmas On The Ponderosa (BMG Special Products 7551745673 2). You had to figure this "golden throats" classic, with Lorne Greene, Michael Landon, Dan Blocker, and Pernell Roberts singing various Christmas songs old and new, would eventually show up on CD. Indeed it has, with a neat picture CD and a budget price.

Prancer Returns (MCA Nashville 088 170 231 2). The soundtrack to the highly anticipated (not) sequel to *Prancer* has a strange mix of music on it — a couple of new tracks plus classics by Bing Crosby and Guy Lombardo.

Rudolph The Red-Nosed Reindeer: The Island Of Misfit Toys (Good Times 05-01960 TC). This installment in the Rudolph saga, now on video, has a soundtrack with 10 new songs, plus Tony Bennett singing "Rudolph."

Coming next issue:
Part II, Various artists
Christmas compilations

Since 1995.

Siren
Disc
Discount Import CDs & More.
www.sirendisc.com

Behind The Muse

Pop and Rock's Greatest Songwriters
Talk About Their Work and Inspiration

by Bill DeMain

\$24.95

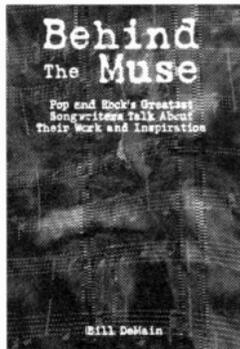

Interviews with more than 40 successful and respected songwriters, including:

- BRIAN WILSON • ROGER MCGUINN • TODD RUNDGREN
BURT BACHARACH • MATTHEW SWEET • JOHN MELLENCAMP
MARSHALL CRENSHAW • ANTONIO CARLOS JOBIM • DAVID BYRNE
SMOKEY ROBINSON • DON MCLEAN • JERRY HERMAN • TIM RICE
AIMEE MANN • JIMMY WEBB • DOLLY PARTON • BARRY GIBB
BILLY JOEL • NICK LOWE • STEVE WINWOOD • SHERYL CROW

Also available:

Add Some Music To Your Day: **\$19.95**
Analyzing and Enjoying the Music of the Beach Boys

"Dedicated fans of the Beach Boys' artistry will welcome these thoughtful writings" — Discoveries
"Focused and provocative... a useful addition to the tsunami of Beach Boys scholarship" — Billboard

Yesterday Once More: Memories of the Carpenters and Their Music **\$24.95**

"A very compelling read" — Discoveries
"Endlessly intriguing" — Record Collector

Tiny Ripple Books

P.O. Box 1533
Cranberry Township, PA 16066

www.tinyripple.com

Please add \$3.50 shipping;
Pennsylvania residents add 6% sales tax.

Woodstock Records

& Breeze Hill Records®

~Holiday CD Special~

2 for \$25 * 3 for \$35



The Sea
To The North

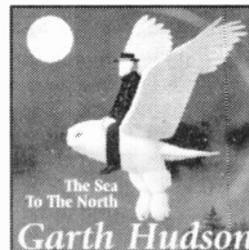

Rock 'n' Roll Hall of FAME
artist Garth Hudson
of 'THE BAND'
releases his first solo CD
Special Guests:
Levon Helm,
Prof. Louie & the Crowmatix,
Maud Hudson & Badal Roy
\$15.98

PROF. LOUIE & THE CROWMATIX
JAM



Prof. "Louie" Hurwitz
& the Crowmatix
Mike Dunn, Mike DeMicco,
Gary Burke & "Miss Marie" Spinosa
- stellar players -
This CD is full of energy & sheer
exuberance - a lively mix of blues,
jazz, boogie & rock 'n' roll
- Relix Magazine
\$13.99

Times Like These



Rock 'N' Roll Hall of Famer
Rick Danko's
last studio CD of 10 songs
Special Guests:
Garth Hudson, Levon Helm,
Prof. Louie & the Crowmatix,
Tom Malone & more
\$14.99

For CD's and merchandise
Secure online ordering by credit card
www.woodstockrecords.com
Shipping costs: USA/Canada/Mexico
\$3.50 - 1 CD plus 50¢ each additional CD

Order toll free
1-888-731-4237

Send checks to:
Woodstock Records
P. O. Box 158, Woodstock, NY 12498

GOLDMINE GRADING GUIDE

VISUAL OR PLAY GRADING?

In an ideal world, every record would be played before it is graded. But the time involved makes it impractical for most dealers, and anyway, it's rare that you get a chance to hear a record before you buy through the mail. Some advertisers playgrade everything and say so. But unless otherwise noted, records are visually graded.

HOW TO GRADE

Look at everything about a record — its playing surface, its label, its edges — under a strong light. Then based on your overall impression give it a grade based on the following criteria:

Mint (M): Absolutely perfect in every way — certainly never played, possibly even still sealed. (More on still sealed under "Other considerations"). Should be used sparingly as a grade, if at all.

Near Mint (NM or M-): A nearly perfect record. Many dealers won't give a grade higher than this implying (perhaps correctly) that no record is ever truly perfect.

The record should show no obvious signs of wear. A 45 RPM or EP sleeve should have no more than the most minor defects, such as almost invisible wear or other signs of slight handling.

An LP jacket should have no creases, folds, seam splits or any other noticeable similar defect. No cut-out holes, either. And of course, the same should be true of any other inserts, such as posters, lyric sleeves and the like.

Basically, an LP in Near Mint condition looks as if you just got it home from a new record store and removed the shrink wrap.

Near Mint is the highest price listed in all GOLDMINE price guides. Anything that exceeds this grade, in the opinion of both buyer and seller, is worth significantly more than the highest GOLDMINE book value.

Very Good Plus (VG+): Generally worth 50 percent of the Near Mint value.

A Very Good Plus record will show some signs that it was played and otherwise handled by a previous owner who took good care of it.

Record surfaces may show some slight signs of wear and may have slight scuffs or very light scratches that don't affect one's listening experience. Slight warps that do not affect the sound are OK.

The label may have some ring wear or discoloration, but is should be barely noticeable. The center hole will not have been misshapen by repeated play.

Picture sleeves and LP inner sleeves will have some slight wear, lightly turned-up corners or a slight seam-split. An LP jacket may have slight signs of wear also and may be marred by a cut-out hole, indentation or corner indicating it was taken out of print and sold at a discount.

In general, if not for a couple of minor things wrong with it, this would be Near Mint. All but the most mint-crazy collectors will find a Very Good Plus record highly acceptable.

Very Good (VG): Generally worth 25 percent of the Near Mint value. Many of the defects found in a VG+ record will be more pronounced in a VG disc. Surface noise will be evident upon playing, especially in soft passages and during a song's intro and fade, but will not overpower the music otherwise. Groove wear will start to be noticeable, as will light scratches (deep enough to feel with a fingernail) that will affect the sound.

Labels may be marred by writing, or have tape or stickers (or their residue) attached. The same will be true of picture sleeves or LP covers. However, it will not have all of these problems at the same time, only two or three of them.

GOLDMINE price guides with more than one price will list Very Good as the lowest price. This, not the Near Mint price, should be your guide when determining how much a record is worth, as that is the price a dealer will normally pay you for a Near Mint record.

Good (G), Good Plus (G+): Generally worth 10-15 percent of the Near Mint value. Good does not mean Bad! A record in Good or Good Plus condition can be put onto a turntable and will play through without skipping. But it will have significant surface noise and scratches and visible groove wear (on a styrene record, the groove will be starting to turn white).

A jacket or sleeve will have seam splits, especially at the bottom or on the spine. Tape, writing, ring wear or other defects will start to overwhelm the object.

If it's a common item, you'll probably find another copy in better shape eventually. Pass it up. But, if it's something you have been seeking for years, and the price is right, get it... but keep looking to upgrade.

COMMON ABBREVIATIONS (not including grades)

- 7" - standard 45 RPM record
- 10" - 10-inch vinyl LP
- 12" - 12-inch single
- bb - bb hole in cover
- boot - bootleg
- cc - cut corner
- cd - compact disc
- cd3 - 3" compact disc single
- cd5 - 5" compact disc single
- co - cut-out

- coh - cut-out hole
- dj - disc jockey (promo)
- ep - extended play 45
- imp - import
- lp - 12" vinyl album
- m - *mono LP
- nap - not affecting play
- non-lp - not on full-length LP or CD
- oc - original cast recording
- ost - original soundtrack

- pc - picture cover (12" and CD's)
- pi - picture insert (CD single)
- promo - promotional copy
- ps - picture sleeve (45s)
- quad - quadraphonic
- re - reissue
- ri - reissue
- rpm - revolutions per minute
- rw - ring wear
- s - stereo LP

- sl - slight
- sm spl - seam split
- soc - sticker on cover
- sol - sticker on label
- ss - still sealed
- s/t - self-titled
- tc - title cover (12" and CD's)
- ti - title insert (CD single)
- toc - tape on cover
- tol - tape on label

- UK - United Kingdom (British import)
- US - United States (domestic pressing)
- va - various artists
- wlp - white label promo
- woc - writing on cover
- wol - writing on label
- xol - "x" written on label
- *check the context, as "m" can also mean "mint"

VINYL TAP MAIL ORDER MUSIC

1 Minerva Works, Crossley Lane, Kirkheaton, Huddersfield, W Yorks, England HD5 0QP
 Tel: 01484 421446
 Fax: 01484 531019
 E-mail: sales@vinyltap.demon.co.uk
 Web site: http://www.vinyltap.co.uk/

Specializing in rare and collectable CDs, Vinyl and memorabilia
 Over 75,000 items currently in stock.

Let us know what artists / groups you collect, CDs and Vinyl or both
 Write, Phone or Fax for FREE Lists

<http://www.vinyltap.co.uk/>

Lists now available by e-mail - just ask Web site updated weekly

New Releases on Compact Disc

Barenaked Ladies - *Halos at the Tweeter* (2 CD) - Mansfield, MA 7/31/99 - excellent soundboard - 26 tracks (53:22 and 53:09)
 Beatles - *The Complete Rooftop Concert* - last public performance 1/30/69 - very good soundboard - 22 completed songs (73:46)
 Beatles - *The Peter Sellers Tapes - White Album outtakes* - very good to excellent quality studio recordings - thirteen tracks (44:17)
 Jeff Beck - *Blow Your Mind* (2 CD) - Wallingford CT 3/21/99 - excellent quality soundboard - eighteen tracks (57:45 and 45:37)
 Black Sabbath - *Eighth Star* - 1996 demo sessions with Glenn Hughes (eight tracks) plus bonus remix - excellent quality studio recordings (45:29)
 Boston - *Smokin' Long Beach* 1977 - Long Beach, CA 1977 - excellent quality soundboard recording - twelve tracks (60:26)
 Eric Clapton - *Derek & Hari Meet Michael Ellis* - Copenhagen 1970 (seven tracks) plus rarities (eleven) - soundboards and acetates (74:12)
 Def Leppard - *1979-1980* - reading Festival 8/24/80 (five tracks) plus London 10/26/79 (seven) plus BBC TV 9/15/79 (one) - excellent FM broadcasts (61:29)
 Eagles - *Wasted Time* (2 CD) - Minneapolis, MN 2/25/95 - excellent quality soundboard recording - 27 tracks (73:31 and 74:03)
 Gov't Mule - *Through the Roof* (2 CD) - 930 Club Washington, D.C. 3/10/00 - very good audience rec. - 19 tracks (68:06 & 69:21)
 Grand Funk Railroad - *Hawaiian Eyes* 1970 - Hawaii 1970 (seven tracks) plus three bonus - excellent mono AM and TV recordings (67:11)
 George Harrison - *All Things Must Surface* (2 CD) - *The Making of All Things Must Pass, Part II* - excellent quality studio recordings - 29 tracks plus two bonus and a conversation with Harrison 2/15/01 (68:15 and 71:29)
 George Harrison - *Fort Worth Express* (2 CD) - Fort Worth, TX 11/22/74 with Ravi Shankar - very good audience recording - 22 tracks (69:09 and 58:29)
 Jimi Hendrix - *Woodstock* (2 CD) - 8/18/69 (seventeen tracks) plus Shokan, NY 8/14/69 (four) and *Dick Cavett Show* 9/9/69 (three) - excellent quality soundboards (63:50 and 66:02)
 John Leo Hooker - *Wise Fool's Pub* - Chicago 1976 - excellent audience recording - eleven tracks (55:00)
 Michael Jackson - *Destination Auckland* - New Zealand 9/11/96 - excellent quality soundboard - sixteen tracks (73:26)
 Michael Jackson - *Great Duets & Unreleased Demos* - twelve duets and three demos - excellent quality studio recordings - (77:51)
 Michael Jackson - *Live and Dangerous* (2CD) - Bucharest 10/1/92 - excellent quality soundboard - 18 tracks (50:18 and 66:55)
 Michael Jackson - *Remixed Supergold* - remasters of top hits - excellent quality studio sound - eleven tracks (72:51)
 Mick Jagger & the Red Devils - *L.A. Blues* - May 1992 - excellent quality studio tracks (first two tracks flawed) - 21 tracks (71:17)
 Jamiroquai - *Legalize It* - London 6/8/97 - excellent quality soundboard recording - twelve tracks (70:03)
 Jan & Dean - *More Music for a Rainy Day* - alternates and outtakes from their 1966 LP *Save for a Rainy Day* - excellent quality studio recordings - 28 tracks (60:55)
 Jefferson Airplane - *Flying High* (2 CD) - San Francisco 9/22/72 - excellent quality soundboard - 20 tracks (70:48 and 52:20)
 Jethro Tull - *Live at the Los Angeles County Fair 2000* - very good audience recording - twelve tracks (73:37)
 Elton John and Billy Joel - *Face to Face* (2 CD) - Tokyo Dome 3/30/98 - excellent soundboard - 27 tracks (64:34 and 73:02)
 Janis Joplin - *A Combination of the Two* - Woodstock 8/16/69 (8 tracks) and Monterey 6/17/67 (5) - excellent soundboards (61:38)
 Led Zeppelin - *Legalize It* - Vienna, Austria 6/26/80 soundboard recording (67:00 and 55:13)
 Led Zeppelin - *Earl's Court* 1975 - London 5/75 - excellent quality soundboard recording - six tracks (73:18)
 Yngwie Malmsteen's *Rising Force* - Birch Hill Blitzkrieg - Old Bridge NJ 11/4/99 - very good audience recording - fourteen tracks (73:05)
 Paul McCartney - *Fabulous Trax* (4 CD) - b-sides, unreleased studio demos, soundchecks, soundtracks, bonus tracks and dance mixes - excellent quality recordings - 78 tracks (73:24, 73:12, 73:06, and 72:35)
 Paul McCartney - *Venus and Mars Outtakes* - *Venus and Mars* sessions recorded January to April 1975 - excellent quality studio source - twenty tracks (79:08)
 Van Morrison - *Inspired Evenings* (2 CD) - Beacon Theater 11/30/89 (18 tracks) plus *The Point* 12/17/95 and seven more bonus tracks - excellent soundboard recordings (68:01 and 72:10)
 Pink Floyd - *The Knebworth Tales '90* - Knebworth, Hertfordshire, UK 6/30/90 - excellent quality (56:37)
 Elvis Presley - *Bringin' the House Down* - Chicago Stadium 10/15/76 - excellent quality soundboard - 26 tracks (56:17)

Prince - *Glam Slam Boogie '95* (2 CD) - Glam Slam East, Miami 6/9/95 plus *White Room Sessions* bonus tracks (70:21 & 72:32)
 Prince - *Paris Affair* - Paris, France 1987 - excellent quality soundboard recording - fifteen tracks (78:18)
 Prince - *Tokyo 1990* - live from the 1990 Japanese tour - excellent quality soundboard recording - ten tracks (58:51)
 Prince - *Welcome 2 the Beautiful Experience* - live at Paisley Park 2/13/94 - excellent quality soundboard - eleven tracks (51:40)
 Radiohead - *Grant Park* (2 CD) - Hutchinson Field, Chicago 8/11/00 - very good audience recording - 24 tracks (69:37 and 57:22)
 Scorpions - *Captured Alive* - Berlin 1991 - excellent quality soundboard - fifteen tracks (70:37)
 Bob Seger - *Ultra Rare Trax, Volume One* - demos and alternates - excellent quality studio outtakes - eighteen tracks (73:34)
 Bob Seger - *Ultra Rare Trax, Volume Two* - studio and live rarities - excellent quality outtakes and soundboard - 21 tracks (69:41)
 Frank Sinatra - *The Lost London Concert* - first show 11/16/70 - excellent quality soundboard - fifteen tracks (55:40)
 Frank Sinatra and Sammy Davis, Jr. - *North Country Concert* - Minneapolis 3/22/88 - excellent quality soundboard - seven Sammy tracks, nine Frank tracks plus a 17-track duet medley (68:56)
 Smashing Pumpkins - *The Second to Last Gig Ever!* (2 CD) - Chicago 11/29/00 - FM broadcast - 27 tracks (77:37 and 79:03)
 Britney Spears - *Rock in Rio 2001* - Rio de Janeiro, Brazil 1/18/01 - excellent soundboard - 13 tracks - backstage cursing! (60:19)
 Springsteen - *The Genuine Tracks 1972-1976* (4 CD) - outtakes and rarities - excellent quality (75:43, 76:40, 75:06, and 74:14)
 Springsteen - *The Lost Masters I - One Way Street* (*Darkness Masters Volume I*) - studio outtakes from the *Darkness on the Edge of Town* sessions 6/7/72 to 8/77 - excellent quality - fifteen tracks (73:07)
 Springsteen - *The Lost Masters III - Rattling the Chains* (*Darkness Masters Volume III*) - studio outtakes from the *Darkness on the Edge of Town* sessions 6/7/72 to 9/77 - excellent quality - sixteen tracks (64:01)
 Springsteen - *The Lost Masters V - Heaven's Dawn* (*Unreleased River Masters Volume I*) - studio outtakes from *The River* sessions 1979 (fourteen tracks) plus *Meadowlands* soundcheck 1981 (one) - excellent quality (53:07)
 Springsteen - *The Lost Masters VII - Stockton Boy* (*Solo Masters Volume I*) - unreleased home demos 1979 to 1981 - excellent quality - 26 tracks (44:34)
 Springsteen - *The Lost Masters IX - Love is a Gun* (*Solo Masters Volume III*) - unreleased home demos early 1979 - excellent quality - 24 tracks (55:03)
 Springsteen - *The Lost Masters X - Jesse James & the Wages of Sin* (*Solo Masters Volume IV*) - unreleased home demos 1983 - 26 tracks - excellent quality (61:23)
 Springsteen - *The Lost Masters XVIII - Hollywood Hills Garage Tapes III* - solo studio outtakes from *Born in the USA* 1/83 plus 5/83 - excellent quality - sixteen tracks (48:28)
 Springsteen - *The Lost Masters XIX - Born in the U.S.A. Rare Masters* - studio outtakes from *Born in the USA* 11/83 plus 5/83 - excellent quality - thirteen tracks (59:03)
 Springsteen - *Winterland Night* (3 CD) - San Francisco 12/15/78 - excellent soundboard - 30 + 6 tracks (72:45, 73:41, and 72:52)
 Ringo Starr - *Can't Fight Lightning* - alternate takes and remues - excellent quality studio recordings - 21 tracks (73:02)
 U2 - *The Ultimate 7" and 12" Collection* (Part I through VII) - excellent soundboards and studio recordings - seven CD's for only \$110.00
 U2 - *United Center* (2 CD) - Chicago 5/15/01 - excellent soundboard recording - 24 tracks (61:41 and 66:54)
 UFO - *Where There's a Pete, There's a Way* - BBC 1974 (four tracks), 1976 (six), and 1977 (three) plus Italy 1974 (two), LA 1975 (two) - very good to excellent quality recordings (74:31)
 Frank Zappa and Captain Beefheart - *An Evening With...* 1975 radio broadcast with songs from 1963-1975 - 21 tracks (67:39)

Ordering Information: All of the above CD titles are \$18.00 per disc. Include full name and address along with a daytime and evening phone number. We accept checks and money orders (made payable to "Collector"), as well as VISA, MasterCard and American Express cards.

24-HOUR ORDER LINE: 847-465-8496
COLLECTOR
 33 North Elmhurst Rd., Wheeling, IL 60090

SHIPPING: U.S. - \$5.00 Any Size Order, Illinois residents add additional 6.5% sales tax. Canada - \$6.00 for any size order. Overseas rates available. Call or e-mail for info.

SSHHH! It's Classified!

—Save **Now!**—

\$5 Off

Any Classified Ad booked for at least 5 consecutive issues

\$10 Off

Any Classified Ad booked for at least 10 consecutive issues

\$20 Off

Any Classified Ad booked for at least 20 consecutive issues

Your ads are posted free on the Internet @ www.collect.com for extra exposure at no extra charge!

PLACE YOUR Classified/Internet Ad NOW TOLL-FREE
800-942-0673
 M - F 7am -7pm CST

Krause Publications
 700 E. State St., Iola, WI 54990-0001
 Phone 715-445-2214 • Fax 715-445-4087
www.krause.com

World Radio History

STORE DIRECTORY

The following is a list of record shops around the country arranged by state. Be sure to mention that you saw them listed in Goldmine's Store Directory. Retailers listed in bold type carry Goldmine in their stores.

ARIZONA

Memory Lane
Out-Of-Print Records ★ Tapes ★ CDs
1940 E. University Dr.
Tempe, AZ 85281
(480) 968-1512
FAX (480) 921-1620
<http://www.memorylanerecords.com>
E-Mail: mlr@memorylanerecords.com
Mail, phone, and web orders filled promptly... VISA ★ MC ★ AMEX ★ NOVUS... be sure to visit us when you're in Arizona.

ARKANSAS

Arkansas Record CD Exchange
4212 MacArthur Dr.
North Little Rock, AR 72118
(501) 753-7877
FAX (501) 758-7556
E-Mail: are@cei.net
Web: ARCD.com
11 am to 7 pm Tues.-Sat.
VISA/MC/AMEX. Your Record and CD Oasis Between Memphis and Dallas. Right on I-40 at Burns Park Exit. Thousands of 45s, LPs, CDs, CD Singles & Imports. New & Used, Buy-Sell-Trade. Send Want lists.

Blue Meannie Music
2080 Harrison St. Ste. D
Batesville, AR 72501
Phone: (870) 698-9234
Fax: (870) 698-9778
E-Mail: info@bluemeannie.com
www.bluemeannie.com
We have a wide selection of import 45's, EP's & LP's. We have over 12,000 import 45's & EP's with picture sleeves in stock. From the 50's to the present. Been doing mail order since 1973. Open 7 days a week. Mon.-Sat. 10:00 - 7:00 & Sun. 1:00 - 6:00.

CALIFORNIA

Atomic Records
3812 W Magnolia Blvd
Burbank, CA 90026
Phone: (818) 848-7090
FAX (818) 848-1969
E-Mail: atomic1@flash.net
Specializing in rare/collectibles: Jazz - Soul - Rock - Exotica - Alternative - Childrens LPs & 45s.

Beat City Records
2090 East Main Street
Ventura, CA 93001
(805) 653-5545
Web: www.beatcityrecords.com
E-Mail: bcityrec@pacbell.net
New/Used Records, CDs & Collectibles. Import & Domestic Vinyl in Stock. Posters by Coop, Kozik & Others. We Do Mail Orders.

CD Trader
18928 Ventura Blvd.
Tarzana, CA 91356
818-705-3544
Los Angeles's best used CD store!

Earth Wave Records
Grand Opening October 1, 2000
Come visit our brand new store!
Hundreds of new arrivals daily!
219B Southwest Blvd.
Rohnert Park, CA 94928
Tel: (707) 795-1660
Fax: (707) 795-1665
<http://www.earthwaverecords.com>
E-Mail: mallstaff@vintage.com (English)
E-Mail: earthwave@home.com (日本語)
* Vintage US original records from 1950's - 1990's
* Largest selection of Japanese audiophile records in the U.S.
We ship worldwide.
Dealer discounts available.

過去7年間の皆様のご支援のお陰でこの度アースウェーブレコード1号店オープンの運びとなりました。レコードの買い付けや西海岸に遊びに来られる際は是非お立ち寄り下さい。

CALIFORNIA

Goat Hill Records
1920 Harbor Blvd.
Costa Mesa, CA 92627
(949) 646-8551
Records • CDs • Collectibles • Rarities • Rock • Jazz • Blues • New • Used • Buy

House of Records
3328 Pico Blvd.
Santa Monica, CA 90405
(310) 450-1222
(310) 450-4525
E-Mail: info@houseofrecords.com
Web: www.houseofrecords.com
LA's oldest record store. Collectible records and used CDs. Please visit when in California.

Record Man, The
1322 El Camino Real
Redwood City, CA 94063
Phone: (650) 368-9065
Fax: (650) 368-2968
www.recordman.com
E-Mail: ARCHIVES@recordman.com
Find out why people are calling us the biggest and best record store around!!
Over 1 Million Items In Stock; LPs, 45s, EPs, Picture Discs, 78s, CDs, Cassettes and reel-to-reels.

Rockaway Records
2395 Glendale Blvd.
Los Angeles, CA 90039
Ph. (323) 664-3232
FAX (323) 664-0956
E-Mail: sales@rockaway.com
www.rockaway.com
LA's best collectables! Vinyl, Compact Discs, Posters and Memorabilia from the 50's to the 90's. Open 7 days, 10 a.m. - 9:30 p.m.

Rock-It-Man
55635 29 Palms Hwy.
Yucca Valley, CA 92284
Ph. 760-228-3304
FAX: 760-228-3075
Palm Springs largest selection of new & used CD's & Memorabilia.

Saturn Records
5488 College Ave.
Oakland, CA 94618
Phone: (510) 654-0335
FAX: (510) 654-4386
Fully searchable Web site with secure server for easy and safe credit card ordering: www.saturn-records.com
San Francisco Bay Area's premier collector's record store.

Streetlight Records
980 South Bascom Ave.
San Jose, CA
(888) 330-7776
939 Pacific Ave., Santa Cruz, CA
(888) 648-9201
3979 24th St., San Francisco, CA
(888) 682-3550
2350 Market St., San Francisco, CA
(888) 396-2350
www.streetlightrecords.com
Buy, Sell, Trade all kinds of CD's, LP's, Videos, DVD's and Collectibles. Secure E-store.

DELAWARE

Yorklyn Records
Contact Glyn Short at
374 Springhouse Lane
Hockessin, DE 19707, USA
for free priced and graded lists by genre
E-Mail: gdimshort@erols.com
Fax: (302) 234-1754
Tel: (302) 234-2031
All types of records bought and sold.

FLORIDA

Blue Note Records
16401 NE 15th Avenue
N. Miami Beach, FL 33162
(305) 940-3394
FAX (305) 948-3523
E-Mail: BLUENOTE@NETROX.NET
Largest selection of Jazz, Soul, Blues, 10", LPs, 34s & Rare 50s & 60s originals. Specializing in 70s & 80s originals & White Label 12". Just opened our new Jazz store.
Phone: 305-354-4563

Offbeat Records & CD's, Inc.
937 S. State Road 7 (US 441)
Ft. Lauderdale, FL 33317
Phone: (954) 316-9084
Fax: (954) 316-9391
Web site: www.offbeatrecords.com
E-Mail: offbeatrecords@aol.com
Hours: Wed.-Sat. 11:00 a.m. - 5:00 p.m.
Sun. 12 Noon - 4 p.m.
Closed Mon. & Tues.
South Florida's coolest music collector's shop! We specialize in rare LPs, CDs, 8 tracks, reel tapes, music posters & vintage audio equipment! Please phone / fax / e-mail wants. WE BUY COLLECTIONS!

Play It Again, Inc.
3148 W. New Haven Ave.
West Melbourne, FL 32904
(321) 724-5685
FAX: (321) 722-1215
WWW.PLAYITAGAINRECORDS.COM
E-Mail: playitagain@iu.net
Florida's best kept secret. Where dealers shop. Want list and dealers welcome.

Rock & Roll Heaven Inc.
1814 N. Orange Ave.
Orlando, FL 32804
Phone: 407-896-1952
FAX: 407-896-2130
E-Mail: rockroll@magicnet.net
Central Florida's oldest and largest source for every format and every category including books, mags, t-shirts, posters, 12's, 45's, LP's, cass, CD's, new-used, everything!

Soundsgreat! Recycled Music
853 S. Orlando Ave. (17/92)
Winter Park, FL 32789
407-599-7277
Buy • Sell • Trade all types of vinyl records Orlando area. Interstate 4 to exit #45 (Fairbanks Ave.) 1 mile east to Orlando Ave. 1 block south on right. Inside Orange Tree Antiques Mall.
Visit Our New On-Line Store
At: www.tias.com/stores/sgr

Yesterday & Today Records
7902 NW 36th St., Suite 210
Miami, FL 33166
(305) 468-0311
FAX (305) 468-0313
Web site: www.vintagerecords.com
E-Mail: yandtrece@aol.com
NEW LOCATION! A few minutes from Miami Airport. We carry oldies - 45s, LPs, CDs. Imports - specialize in 60s/70s, Psych/Prog Rock. Buy/Trade/Sell. Want lists welcome.

GEORGIA

Full Moon Records
1653-A McLendon Ave.
Atlanta, GA 30307
(404) 377-1919
New, Used Records, Tape, CDs.
Great Selection, Great Prices. Send us your want list!

ILLINOIS

Hi-Fi Records
2570 N. Clark St.
Chicago, IL 60614
(773) 880-1002
FAX (773) 880-1016
E-Mail: hifi@interaccess.com
Web site: www.hifirecords.com
The best vinyl selection in city. As well as many hard-to-find CD's! We Buy and Sell all types of music.

House of Music, The
2057 W. 95th St. (at Hoyne)
Chicago, IL 60643
Phone: (773) 239-4114
FAX: (773) 239-9722
Jazz-Blues-Oldies, R&B, Soul & Nostalgia. Famous for locating hard-to-find records, tapes, videos and CDs. It's our service and expertise that makes the difference. We sell imports. We ship everywhere UPS & Fed-Ex. Check our vinyl graveyard. LPs as low as \$1.00. By George! We've got it or we can get it!

Raffe's Record Riot
4350 North Cicero Ave.
Chicago, IL 60641
(773) 725-1327 - 24 hr. service
E-Mail: raffesrr@aol.com
Web site: www.raffesrecordriot.com
Open: Mon.-Sat. 11:30 a.m. - 6 p.m.; Sunday PHONE APPOINTMENTS ONLY. Specialties, oldies, hard-to-find unusual labels. We buy collections. Want lists with orders invited. We accept VISA, MasterCard, Novus & American Express.

Remember When Records and CDs
309 W. Ogden Ave.
Westmont, IL 60559
Phone: (630) 963-1957
FAX: (630) 963-1987
E-mail: rmbwren@worldnet.att.net
Thousands of new & used 45s, LPs, Tapes & CDs (Imports) VISA, MasterCard, Telecheck.
Closed Sundays.

Toad Hall Books & Records
2106 Broadway
Rockford, IL 61104
FAX: (815) 226-9887
Ph: (815) 226-1259 or
(815) 399-4644
100,000 LPs, 100,000 78s, 15 rooms full of other collectibles.

INDIANA

Missing Link Records
6053 N. College Ave.
Indianapolis, IN 46220
(317) 466-1967
FAX: (317) 466-0042
Central Indiana's best vinyl selection in all genres. Don't miss us!
www.missinglinkrecords.com

IOWA

Kanesville Used Records
530 4th St.
Council Bluffs, IA 51503
(712) 328-8731
Largest selection of records in the Midwest. All categories.

KENTUCKY

Pops Resale
1423-B Leestown Rd.
Lexington, KY 40511
Phone: (859) 254-7677
FAX: (859) 254-7677
10's of thousands of 33/45/78's, all genres, priced to sell. Want lists accepted

Ticket To Ride Music & Memorabilia
Hwy 229-Flealand
London, KY 40741
Phone: (606) 878-0366
E-Mail: jlennon@sekybiz.net
Tons of CDs, cassettes, vinyl & all types of collectible music memorabilia. Open Sat. & Sun. 9-5, right off I-75!

MARYLAND

Crown Records
108 N. Lakewood Ave.
Baltimore, MD 21224
Phone: (410) 563-7881
E-Mail: dmilecki@maxinter.net
Rare LPs, 45s, 78s; Jazz, Soul, R&B, Rock, Country, Blues, Classical, Northern Soul 45s - Open 7 days 9-9.

Joe's Record Paradise
1300 East Gude Drive
Rockville, MD 20850
(301) 315-2235
FAX: (301) 313-2252
<http://www.joesrecordparadise.com>
E-mail: raremusic@joes-record-paradise.com
Thousands of LPs, 45s & CDs. New & used & out of print. Open 7 days, Jazz, Rock, R&B, Blues, Country. 28 Years in the business.

MASSACHUSETTS

Flip Side Records
1410 Beacon St.
Brookline, MA 02146-2771
(617) 739-8622
E-mail: flipside@flipsideweb.com
Please visit our Web site at: www.flipsideweb.com
CDs, Tapes, LPs, and 45s - New and Used-Thousands of collectibles at low prices! Send Us Your Want Lists (be specific).

Mystery Train Records
12 North Pleasant St.
Amherst, MA 01002
(413) 253-4776
Email: mysterytrn@rcn.com
MT Records@hotmail.com
Biggest selection of vinyl and used CDs in Western Mass!!

Nuggets Records
486 Commonwealth Ave.
Boston, MA 02215
(617) 536-0679
And Our Newest Location:
46 White Street
Somerville, MA
(617) 623-1001
Web site: www.nuggetsrecords.com
E-mail: nuggetsrecords@netzero.net
We buy, sell and trade records, CDs, tapes, videos, Send your want list-please be specific & include phone number.

Planet Records
54-B JFK St.
Cambridge, MA 02138
(617) 492-0693
FAX: (617) 492-0692
E-mail: planet@tiac.net
Since 1983, New England's favorite Collector's Shop. Records and compact discs. All genres.

STORE DIRECTORY

The following is a list of record shops around the country arranged by state. Be sure to mention that you saw them listed in Goldmine's Store Directory. Retailers listed in bold type carry Goldmine in their stores.

MASSACHUSETTS

Sunset Records Etc.
1232 Wilbur Ave.
Somerset, MA 02725
(508) 678-3441
E-Mail: sunsetlp@ici.net
New & Used records, CDs,
cassettes, videos. We buy & sell.

MICHIGAN

PJ's Used Records
617 B Packard
Ann Arbor, MI 48104
(734) 663-3441
E-Mail: pjsrecords@mediaone.net
Buying and selling new and used
products in all formats.

R.A.M.
917 W. Broadway
Muskegon, MI 49441
Established in 1983
Phone: (231) 759-0172
FAX: (231) 755-0429
E-mail: info@ramcd.com
Hours: Tuesday - Friday 11-8
Saturday 11-6
We buy and sell used CDs and
DVDs. Over 15,000 in stock (Stop
by and meet Stray and eBay - the
store cats.)
Web site: www.ramcd.com
Over 14,000 collectible CDs, singles,
LPs, 45s, books, etc. and still growing.

Vinyl Palette
310 Butler St.
Saugatuck, MI 49453
(616) 857-7664
E-Mail: vinylpal@sirus.com
Come visit us at our downtown loca-
tion! Great selection of vinyl as well
as new and used CD's. We also carry
music DVD's. Coming on a trip? Call
first for hours!

MINNESOTA

Car & Record Collector's Heaven
155 No. Snelling Ave.
St. Paul, MN 55104
(651) 645-3153
E-Mail: rbroz598@cs.com
Rock-RAB-Garage-R&B/Soul -
Blues/Jazz-C&W/Pop-45/LP/CD-
Domestic-Import-Car Books-Mags.
CC: VISA/MC/Disc.Card

MISSISSIPPI

Ace Video & Music
285 Caillavet St., P.O. Box 1934
Biloxi, MS 39533-1934
PH: (228) 374-0777
FAX: (228) 374-4645
E-mail: acemusic@datasync.com
www.acevideoandmusic.com
Huge inventory collectible vinyl in all
categories. Mail or fax wants.

Little Big Store
P.O. Box 921, 201 E. Main St.
Raymond, MS 39154
(601) 857-8579
www.littlebigstore.com
E-Mail: bj999@aol.com
CDs, LPs, 45s, 78s, reel-to-reels,
videos, memorabilia, etc. Train
depot full of records & music-related
stuff. Open: Wed-Sat 10 AM-5 PM

NEVADA

Big B's CDs & Records
4761 S. Maryland Pkwy.
Las Vegas, NV 89119
Phone: (702) 732-4433
FAX: (702) 795-7989
11am-8pm Mon.-Sat., 11am-7pm Sun.
E-Mail: bigbs@fnet.net
Web: Bigbsmusic.com
We stock a wide range of new and
used CDs and LPs, all very organ-
ized! Dealers are welcome. Send us
your want lists! THE store that
locals come to shop!

Wax Trax Records, Inc.
2909 S. Decatur
Las Vegas, NV 89102
PH: (702) 362-4300
FAX: (702) 362-4340
E-Mail: waxtraxinc@aol.com
Over 1,000,000 records, CDs, cas-
settes & all kinds of music memora-
biliana. A must for the true collector.
When in Vegas stop in. Also check
out our new radio show THE
STREET HARMONY REVUE AT:
www.klav1230am.com on Mondays
at 9:00 p.m. until 11:00 p.m.

NEW JERSEY

Absolute Vinyl
11 Midland Ave.
Montclair, NJ 07042
(973) 746-7775
E-Mail: absjag@aol.com
M-F 1 p.m.-8 p.m., Sat. 12 noon-5
p.m. New & Used LPs & 45s, Up to
10,000 \$1 45s & LPs always avail.
Want lists accepted. Wholesale avail-
able to foreign & domestic buyers.
Specialties include Soul, Jazz,
Beatles & Progressive Rock.

The Album Hunter
2217 Atco. Ave.
Atco, NJ 08004
PHONE: (856) 719-1515 (24 Hrs.)
FAX: (856) 719-1313 (24 Hrs.)
Great Dealer Discounts! Biggest in
South Jersey in Rare Vinyl! 167+
Page Catalog Send in \$6.00 U.S.A.-
\$8.00 Overseas. Thousands of
Albums \$1.00-\$2.00 in Store!!

Flipside II Records
120 Wanaque Ave.
Pompton Lakes, NJ 07442
(973) 835-8448
Plenty o' vinyl, from 99¢; also 45's,
CDs, needles, tapes. Call for hours.

Iris Records Ltd.
114 Brunswick Street
Jersey City, NJ 07302
(bet. 1st and 2nd Streets)
Phone: (201) 217-0588
E-Mail: irisrecs@worldnet.att.net
Hours: Friday 3-9PM or by
appointment
Thousands of twelve inch singles at
bargain prices. Hip-hop, R&B, rock,
disco, dance and more. We also
carry full length soul, jazz, rock,
exotica. Ten minute train ride from
Manhattan. Vinyl only. No want lists,
we cater to customers that like to get
hands dirty.

Izzy's Records & Compact Discs
1107 W. St. Georges Ave.
Linden, NJ 07036-5652
(908) 486-3303
E-Mail: lzzmeister@aol.com
Web site: www.izzymusic.com
100,000 + LPs, CDs, 45s in stock.
We buy collections - LP, CD, rock
memorabilia. Buy & sell new & used
LPs, CDs, 45s. Promos, imports,
rarities, memorabilia. 10 Minutes
from Newark Airport, 20 minutes
from NYC. Great dealer prices on
Jazz, Soul, R&B, 12", Rock, 50s,
60s & more. Open 7 days.

NEW JERSEY

21st Century Music
15 Mount Vernon St.
Ridgefield Park, NJ 07660
Toll Free: 1-800-846-9501
(201) 641-6610
FAX: (201) 641-9309
www.21centurymusic.com
sales@21centurymusic.com
Business Hours: Mon.-Sat. 11am-
6pm Specializing in 12" Singles,
Dance, Rock, 12" Rap & Hip Hop,
Soul LPs. Buy, Sell, Trade. Want
lists accepted. All major credit cards
accepted. Foreign dealers welcome.
We buy DJ collections.

NEW MEXICO

Krazy Kat
9012 Central SE
Albuquerque, NM 87123
(505) 294-5644
Largest selection of music in New
Mexico. LPs, 45s, CDs, Tapes, Videos,
8-Tracks. Located on Route 66.

Merlin's Record Workshop
9609 Menaul NE
Albuquerque, NM 87112
Phone: (505) 299-8031
FAX: (505) 299-0330
E-Mail: merlinsrecords@prodigy.net

NEW YORK

House of Oldies
World Headquarters for Out of Print
45s and LPs
35 Carmine St.
New York, NY 10014
(212) 243-0500
FAX: (212) 989-1697
http://www.houseofoldies.com
10 A.M.-5 P.M. Tues. thru Sat.
Closed Sun. & Mon. Established in
1962 over a million 45s, 78s & LPs,
R'NR, R&B, S&W, shows, S.T., Soul,
Funk, Pop, Collections Bought 1950-
1989 - Send or E-mail "Want Lists."
#1 Oldies Shop. VISA, MC., Amex.
A must when you're in NYC.

Infinity Records Ltd.
3852 Sunrise Highway
Seaford, NY 11783
(516) 221-0634
FAX: (516) 221-8901
E-mail: vinylriver@aol.com
www.infinityrecords.net
Long Island's best record collector
store. Jazz, Soul, Rock, Classical,
etc. Foreign dealers welcome. We
buy collections.

Junkie Vinyl
PO Box 148
Hannacroix, NY 12087-0148
(518) 756-9593
E-Mail: jvinyl@msn.com
Free mail order catalog of New
Arrivals available. Newest catalog
just released! Updated every 3
months. Thousands of Rare and
Common LP's all types and styles of
Music and Comedy. 10% discount
on orders over \$50. 24 hr. voice-
mail, call anytime!

Last Vestige Music Shop
173 Quail St.
Albany, NY 12203
(518) 432-7736
FAX: (518) 432-1812
E-Mail: info@lastvestige.com
Second hand, Out-Of-Print, CD's
Records, Mailorder: lastvestige.com

NEW YORK

Mr. Cheapo CD & Record Exchange
46 Jericho Tpke.
Commack Long Island, NY 11725
(631) 543-8686
and 134 Jericho Tpke
Mineola Long Island, NY 11501
(516) 742-7670
We sell most of what's in Goldmine.
Thousands of used CDs & Records
in every store. Largest selection on
Long Island. When you're visiting
the New York area, we have 2 loca-
tions!

Off-Center Records and Collectibles
116 Bleeker St.
Utica, NY 13501
Phone/FAX: (315) 738-7651
http://www.blackdogweb.com/offcenter
E-Mail: Offcenter1@webtv.net
1,000s of LPs & Singles, Music
Memorabilia 40s-90s, Books, Mags,
Dolls, Tees, Plates, Figurines, CDs,
Tapes, Rare & Hard-to-find items. All
want lists welcome.
MC/VISA/NOVUS.

NORTH CAROLINA

Jukebox Oldies, Inc.
456 Knollwood Street
Knollwood Plaza Shopping Center
Winston-Salem, NC 27103
(336) 774-0034
Tues. - Fri 10 AM - 7 PM
Sat. Noon - 7 PM
2 blocks from Business I-40, exit 3A.
Operated by a knowledgeable collec-
tor with 20 years experience.
Specializing in rare 50s and 60s
vinyl. Also - 70s and 80s vinyl, 45s,
78s, tapes, CDs, videos, posters
music memorabilia. Rare Beatles,
Buddy Holly and Elvis vinyl and mem-
orabilia. All categories of vinyl - Rock,
Country, Jazz, Blues, Big Band,
Soundtracks, Comedy, Soul. Always
buying good vinyl 50s and 60s collec-
tions.

OHIO

Parker's Records & Comics
1222 Suite C, Route 28
Milford, OH 45150
PH/FAX: (513) 575-3665
Mon.-Sat. 11am - 7pm
E-mail: dkparker39@fuse.net
Specializing in 50s & 60s. Over
100,000 45s & 10,000 33s. Send
want lists. Accepting
MasterCard/VISA & NOVUS cards.

OKLAHOMA

Gardner's Used Books, Music &
Comics, Inc.
4417 South Mingo Road
Tulsa, OK 74146
(918) 627-7323
FAX (918) 250-8828
Web site: www.gardnersbooks.com
Over 100,000 Collectibles Albums,
CDs, 45s, Tapes, Music magazines,
Sheet Music. We buy collections,
complete stores, music memorabilia
& collectibles. Open 7 days.

OKLAHOMA

Records and Stuff
1511 S. Memorial
Tulsa, OK 74112
(918) 627-1505
Web site: recordsandstuff.com
E-Mail: sales@recordsandstuff.com
Thurs-Sat 10:00 am-6:00 pm; Sunday
11:00 am-5:00 pm, or by
Appointment Specializing in all Vinyl
Selections. CD's, Cassettes, 8 Track,
Books, Video Tapes, Magazines,
Sheet Music, Memorabilia, Playboy
Magazines, Collectible Supplies, etc.
- Buy - Sell - Trade - We Ship
Worldwide

OREGON

Crossroads Music
3130 SE Hawthorne Blvd.
Portland, OR 97214
(503) 232-1767
E-Mail: xroads@xro.com
Open Mon-Thurs 11-6; Fri-Sat 11-7;
Sun 12-6
Portland's largest, most complete
selection of collectible records, CDs,
Tapes, concert posters and music
memorabilia in Co-op of 35 dealers.

2nd Avenue Records
400 S.W. 2nd Avenue
Portland, OR 97204
(503) 222-3783
FAX: (503) 287-3343
Tons of good used and new - Will
travel Vancouver to San Diego to
purchase collections of ANY size.
ANY format.

Sonic Recollections, Inc.
2701 SE Belmont St.
Portland, OR 97214
(503) 236-3050
FAX: (503) 235-1645
E-Mail: orderdesk@sonicrec.com
Web site: http://www.sonicrec.com
Specializing in the weird and the
collectible! Check Our Web Site!

PENNSYLVANIA

Attic Record Store Inc.
513 Grant Ave
Pittsburgh, PA 15209
(412) 821-8484
FAX: (412) 821-5179
E-Mail: atticrecords@cs.com
Astounding selection of new & used
CDs, 45s, LPs & 12" singles. All cat-
egories - credit cards accepted -
Expert mail order service -
want lists accepted.

Flip Side Records & Coll.
Moved to: 940 Hermigate Rd.,
(Rt. 18)
Hermitage, PA 16148
PH: (724) 342-0824
FAX: (724) 342-0825
E-Mail your Wants lists:
flipsiderecords@aol.com
Web site: www.flipmall.com
Over 2,000,000 selections/All types
of music/Wants lists welcome!

Mugsy's Records
212 Iron St.
Bloomsburg, PA 17815-1871
(570) 784-7134
Exit 35-A off I-80
Quality used LPs, CDs, movies (DVD
& VHS), and books. New stock
every week. Five minutes from Exit
35-A off I-80 Hours: Mon-Fri: Noon-
8 PM; Sat: Noon-6 PM

Musical Energi
59 North Main St.
Wilkes-Barre, PA 18701
Phone/Fax (570) 829-2929
www.musicalenergi.com
E-mail: questions@musicalenergi.com
Northeast Pennsylvania's biggest and
best used record store. Buy & Sell
records, CD's tapes, video, books
and DVD's. Open 7 days a week.

STORE DIRECTORY

The following is a list of record shops around the country arranged by state. Be sure to mention that you saw them listed in Goldmine's Store Directory. Retailers listed in bold type carry Goldmine in their stores.

<p>PENNSYLVANIA</p> <p>Positively Records 4153 Woerner Ave. Levittown, PA 19057 (215) 945-8063 FAX: (215) 945-0221 E-Mail: posrec@aol.com Rare CDs/New-used-imports/10,000 used CDs. 5000 quality CDs at \$4.99 or less/open 7 days/Best Store Phila/NJ area.</p> <p>Record Castle 1118 Cottman Ave. Philadelphia, PA 19111 (215) 745-4151 Web site: www.recordcastle.com E-Mail: info@recordcastle.com Mon.-Sat. 1-7 p.m. (EST) Buy/Sell records - compact discs - tapes - rock 'n roll memorabilia - thousands of records (all speeds), CDs, etc. in stock!</p> <p>Record Connection 550 N. Reading Rd. Ephrata, PA 17522 (717) 733-1641 FAX: (717) 733-1685 Visit our Web site at: www.RecordConnectionPa.Com. Oldies, Classic Rock, Psychedelic, Progressive, Country, Jazz, Comedy. Over 100,000 45s & albums! Compact Disc: New, Used, & imports. Directions: Located on Rte. 272, 4 miles S. of PA Turnpike (exit 21). Open 7 days a week. M-F 10 a.m.-8 p.m.; Sat. 9 a.m.-7 p.m.; Sun. 11 a.m.-5 p.m.</p> <p>Record King The Record King - (Our Only Location!) 2113 Parkdale Ave. Glenside, PA 19038 (215) 576-0102 (Mail & Phone orders only!) E-Mail: therecordking@yahoo.com Search Service - 11 a.m.-8 p.m. EST 7 days a week. SASE/IRC & collect phone # for reply. Buy & Sell. Catalogs/lists available. 8-track \$25. Soundtrack/orig. cast \$25. All refundable w/order. McNally's picture price guide (Soundtrack) \$29.95 + shipping, Rockin Records. Video/DVD/Karaoke/Audio equipment sold. CDs, tapes, vinyl & adult videos. Huge assortment Country & Western, Playboy & Rolling Stone magazines. Checks/MOs pay to: J.J. Hollin only.</p>	<p>PENNSYLVANIA</p> <p>Val Shively R & B Records 49 Garrett Rd. Upper Darby, PA 19082 (1 mile from West Philadelphia) (610) 352-2320 FAX: (610) 352-8199 11-7 EST M-Sat. Over 4 million 45s! Also CDs, LPs, cassettes. Send want lists/mail order available. Major credit cards accepted.</p> <p>TENNESSEE</p> <p>Grumpy's Music & Books, Inc 3905A Hixson Pike Chattanooga, TN 37415 (423) 874-0242 FAX: (423) 874-0286 E-Mail us at: grumpybk@aol.com BUY • SELL • TRADE Books • CDs • T-shirts • LPs • DVDs • Videos • Audio Books • Posters Open Mon-Sat. 10:00 a.m.-9:00 p.m.; Sun. 12:00 p.m.-6:00 p.m. We Specialize in hard-to-find items.</p> <p>The Great Escape 1925 Broadway Nashville, TN 37203 (615) 327-0646 FAX: (615) 321-5568 www.duffelbag.com E-Mail: tge@bellsouth.net Nashville's oldest record store! (Open for 24 years.) Thousands and thousands of collectible and bargain CDs, LPs, 45s, 78s, and tapes at low, low prices. (One of the largest selections of out-of-print records in the mid-south.) Also buying and selling: comics, videos, games, more. Voted best non-chain record store 7 years running in "The Nashville Scene." Open Mon.-Thurs. 10 a.m. - 9 p.m.; Fri-Sat. 10 a.m. - 10 p.m.; Sun. 1-6 p.m.</p>	<p>TENNESSEE</p> <p>The Great Escape 111 N. Gallatin Rd. Madison, TN 37115 (615) 865-8052 FAX: (615) 865-8779 www.duffelbag.com E-Mail: tge@bellsouth.net Thousands and thousands of collectible and bargain CDs, LPs, 45s, 78s, and tapes. (One of the largest selections of out-of-print records in the mid-south.) Also buying and selling: comics, videos, posters, memorabilia, video and computer games, gaming cards, books, toys, role-playing items, baseball cards, more. Voted best non-chain record store 7 years running in "The Nashville Scene." Open Mon.-Fri. 10 a.m.-9 p.m.; Sun 1-6 p.m.</p> <p>Lost and Found Records 7315 Kingston Pike Knoxville, TN 37919 (865) 558-9028 alburguy@email.msn.com Buy • Sell • Trade. Records, tapes & CDs. Open 7 days a week. We have thousands of LPs.</p> <p>VERMONT</p> <p>Mainly Music: "Where Music Lives On" 36 Main St. Brattleboro, VT 05301 PH/FAX: (802) 257-0881 Toll Free U.S. & Canada: 877-257-0891 Southern Vermont's largest used music source! Buy, Sell, Trade: Used Rare Records, CDs, Tapes, Vintage Sheet Music, Memorabilia & Collectibles. Send want lists. Worldwide search. Insurance and estate appraisals. Will travel.</p> <p>VIRGINIA</p> <p>DMS Associates P.O. Box 724 Portsmouth, VA 23705 (757) 465-3333 FAX: (757) 465-9890 E-Mail: ddel065716@aol.com Jazz, Blues, R&B, Soul Music Specialist. Jazz, Blues, R&B, Soul, Gospel, Music Magazines.</p>	<p>VIRGINIA</p> <p>Safe As Milk Records 20 Kirk Ave. SW Roanoke, VA 24011 (540) 982-7789 E-Mail: SAFEASMILKUSA@YAHOO.COM Mon.-Sat. 10 a.m.-9 p.m.; Sun. 12 p.m.-6 p.m. Want lists welcome!! New & used LPs, used CDs, tapes & 45s & videos.</p> <p>WASHINGTON</p> <p>Disc Connection 405 Garfield St. (1 block east of PLU) Tacoma, WA 98446 (253) 539-5632 E-mail: disc_connection_mail@yahoo.com We are Tacoma's #1 location for rare Beatles memorabilia and vinyl. CASH paid for Beatles and Monkees, one item or a hundred, we buy collections. We also buy, sell and trade CD's-LP's-45's-DVD's-Laserdiscs and videotapes. Open Monday thru Friday 11am to 7pm. Open Saturday and Sunday Noon till 5pm (On Sundays please PHONE FIRST to insure we're there).</p> <p>WISCONSIN</p> <p>Deep Grooves 702 E. Johnson St. Madison, WI 53703 (608) 294-5708 Rare and unusual recorded music. Specializing in: New, Used, Vintage Vinyl and Import CDs. Buy and Trade. We ship anywhere. Want Lists Welcome!</p> <p>Fox Music 100 E. Main St. Watertown, WI 53094 Entrance on 1st St. PH: (920) 206-8597 FAX: (920) 206-8641 E-Mail: foxmusic@execpc.com Store Hours: 11:00-7:00 Thousands of rare & collectible LPs & 45s. New & used CDs/domestic & imports. We ship anywhere. We buy quality collections.</p>	<p>WISCONSIN</p> <p>Madcity Music Exchange 600 Williamson St. Madison, WI 53703 (608) 251-8558 FAX: (608) 251-8668 E-Mail: madcity@execpc.com Web site: www.madcitymusic.com Madison's vinyl source - LPs, 12", 10" 7". New CDs - Domestic & Import. Used CDs - Great Selection.</p> <p>CANADA</p> <p>Star Records 148 Simcoe St. South Oshawa, Ontario, L1H 4G7 Canada PH/FAX: (905) 723-0040 E-Mail: starrecords@altavista.com 30 minutes east of Toronto. Best vinyl selection in Canada! Over 2,000 New Vinyl LPs in stock. Imports from U.K., Italy, USA, etc. (1950s-2000) - Garage, Rockabilly, New & Old Surf, New & Old Punk Rock, Blues, Soundtracks, British New Wave. Record-related collectibles for your favorite bands available. Phone/Fax/E-mail your want lists.</p> <p>FRANCE</p> <p>Monster Melodies 9 Rue Des Dechargeurs 75001 Paris - France PH: (33) 140280939 FAX: (33) 142332572 E-Mail: monster@club-internet.fr Thousands of LPs, Singles, CD, CDs 60s-90s. Since 15 years in business. We mail everywhere.</p> <p>SWEDEN</p> <p>The Golden Oldies Shop 5:t Eriksgatan 96 SE-113 31 Stockholm, Sweden PH/FAX: +46-8-32 22 40 Original singles, EPs & LPs 1955-1979, Rock & Roll, Pop, Soul, etc. Send your name and address for free catalog, or visit our Web site: www.goldenoldies.se Company established in 1977. 24 years in business!</p>
--	--	--	---	---

This section features listings for retail record stores around the world. Traveling record collectors of all types search for new stores to dig through on their vacations, business trips, etc. Advertise your establishment here, including approximately ten words of miscellaneous description, for only \$9.00 an issue. You can buy this space in increments of 13 or 26 issues, for \$117.00 or \$234.00, respectively. Send in your store name, address, phone number, and approximately ten words of description, along with your payment. If you stock GOLDMINE, we'll put your listing in boldface type.

1 year \$234.00 6 months \$117.00

Send your listing with payment to:
GOLDMINE • 700 E. State St. • Iola, WI 54990-0001 or Call 715-445-2214

Name: _____

Contact person: (This will not appear in the listing) _____

Address: _____

City: _____ State: _____ Zip: _____

Phone: _____

FAX: _____ Do you carry GOLDMINE in your store? _____

Description: _____

INSURANCE For The Collector of Records & Tapes

Your homeowners insurance is rarely enough to cover your collectibles. We've provided economical, dependable collectibles insurance since 1966.

- Sample collector rates: \$3,000 for \$12, \$10,000 for \$32, \$25,000 for \$82, \$40,000 for \$132, \$60,000 for \$198, \$1 per \$1,000 above \$60,000.
- Our insurance carrier is AM Best's rated A+ (Superior).
- We insure classic records, tapes, music memorabilia and scores of other collectibles. "One-stop" service for practically everything you collect.
- Replacement value. We use expert/professional help valuing collectible losses. Consumer friendly service: Our office handles your loss—you won't deal with a big insurer who doesn't know collectibles.
- Detailed inventory and/or professional appraisal not required. Collectors list items over \$5,000, dealers no listing required.
- See our website (or call, fax, e-mail us) for information, including standard exclusions.

Collectibles Insurance Agency

P.O. Box 1200-GM • Westminster MD 21158
E-Mail: info@insurecollectibles.com

See the online application and rate quote forms on our website!

Call Toll Free: 1-888-837-9537 • Fax: (410) 876-9233

More Info? Need A Rate Quote? Visit: www.collectinsure.com

MFJ
DAIKOKU BLD. 4F 7-8-11NISHISHIMAJUKI, SHIMAJUKI-KU, TOKYO 160-0023 JAPAN
FAX: 81-3-5338-8223 • E-mail: mfj@pal.tok2.com
*VISIT OUR WEB PAGE. There is complete list.
We renew the list as soon as new releases in our stock.
<http://www31.tok2.com/home/mfj/>
*POSTAGE 1-3 DISCS \$10.00; OVER 4 DISCS, ADD \$1.00 FOR EACH DISC
*PAYMENT ONLY US \$ ON CASH OR INTERNATIONAL POSTAL MONEY ORDER
*BEFORE YOU MAKE A PAYMENT, PLEASE CONFIRM STOCK TO US BY FAX, MAIL OR E-MAIL
*DISCOUNT OVER 100 DISCS - 10% OFF!
*OVER 300 DISCS - 15% OFF!
*SEND \$3.00 FOR OUR COMPLETE CATALOG INCLUDING MANY CD TITLES.
*AND WE CAN SEND COMPLETE CATALOG BY E-MAIL FOR FREE!!

ARTIST	TITLE	LABEL	\$	
QUEEN	"ROCK IT TO THE BOWL"	Milton Keynes 5/6/1982	dancing horse	10
QUEEN	"FUGUE AND SCANDAL"			8
QUEEN	"SEVEN SEAS OF TSUMAGOI"	(2CD) <Irumagoe, Shizuoka, Japan Apr '9 1975>	sweet	35
QUEENSRYCHE	"DISEASE IS RAMPANT"	(1CD-R) <Buffalo, NY March 1989>		10
QUEENSRYCHE	"PHILOSOPHY OF LIFE"	(2CD) (PROMISEDLAND TOUR 95)		17
R.E.M.	"ALL FOR ONE"	c-BBC radio theatre 25/10/1998	polar bear	7
R.E.M.	"BUY THE SKY SELL THE SKY"	<Yokohama, 10/11/1984>	dirty 13	7
R.E.M.	"NEW TEST SURPRISE"	<GERMANY 2/11/1998>	SB polar bear	7
R.E.M.	"LP FOR IT"	<Holland 6/11/1998, MTV etc.>	switch on	7
RADIOHEAD	"HOW LONG TO APPER SINCE THE FIRST NIGHT"	(2CD) <Italy 2/6/2000 + T York acoustic>	stp	30
RADIOHEAD	"L'PATED EXPERIMENTATION"	(2CD) <Am Ring Fest, Germany Jun '01 + Covers + Div A Friday Demo Apr '91>	SB wonder boy	38
RADIOHEAD	"BOSTONOVA 2001"	(2CD) <Suffolk Downs East Boston, MA, USA Aug '14>	head	35
RADIOHEAD	"BLACK TUESDAY"	(2CD) <Berlin, Germany Sep '11 '01 + Verona, Italy May 30 '01>	head	34
RAGE AGAINST THE MACHINE	"BORN OF A BROKEN MAN"	<LA 5/11/1999>	SB wonder boy	14
RAGE AGAINST THE MACHINE	"EVIL MACHINE"	<Columbia 15/8/97>	genocide	7
RAGE AGAINST THE MACHINE	"NO SHELTER"	<Dusseldorf 4/2/2000>	SB wonder boy	16

RAGE AGAINST THE MACHINE	"RAGE AGAINST COACHELLO"	<CA 10/10/1999>	SB wonder boy	15	
RAINBOW	"INSPIRED KNEEL DOWN"	(2CD) <Fukuoka, Japan, 17/10/1982>	* neptune	20	
RAINBOW	"JAPAN TOUR 1984 (2CD)"	<Budcan 14/3/1984>		25	
RAINBOW	"LONG LIVE THREE KINGS"	(2CD-R) <Nagoya, Japan 11/1/1978>	AD	22	
RAINBOW	"OH, DARIN"	(2CD-R) <Osaka, Japan 20/1/1978>	AD	22	
RAINBOW	"ON LINE"	(1CD-R) <MILANO 9-5/1980>	SB	20	
RAINBOW	"ON STAGE SPECIAL ISSUE"	<different versions, etc.>		10	
RAINBOW	"PARISIAN MASQUE/RODE"	(2CD) <PARIS 31/10/1995>		24	
RAINBOW	"POWER LIVE BETWEEN THE EYES"	<8/1982 TEXAS>	SB stp	12	
RAINBOW	"RISE OVER CHICAGO"	(1CD-R) <12/10/79>		10	
RAINBOW	"RITCHE BOWS TO GERMANY"	(10CD) <GERMANY 1985>		80	
RAINBOW	"WILL YOU STILL LOVE MY ANTHEM?"	(2CD-R) <Osaka, Japan 15/5/1980>		22	
RANDY RHOADS	"GUITAR SEMINAR"	<Private Lesson Hollywood '79 + Greensburg, PA Feb. '82 + Whisky A-Go-Go, LA, Jan. 25 '76>	stp	20	
RASCALS	"GROOVIN' ON THE TRIBE"	<live compilations 1966-1988>	SB tendolar	10	
RASPBERRIES	"BERRY BERRY GOOD!!"	<LIVE 1973, 1974, 1998>		12	
RAY DAVIS	"20TH CENTURY MAN"	<VARIOUS LIVE 90-97>		7	
RECORDS	"TELEVISION GENERATION"	<KY 9/8/1979, studios 9/7/1980, etc.>		14	
RED HOT CHILI PEPPERS	"06/02/99"	<Hamburg>	SB	10	
RED HOT CHILI PEPPERS	"ANTHONY'S PENIS"	(2CD) <LA 17/3/1985>	stp	28	
RED HOT CHILI PEPPERS	"GIVE THE DAFT AWAY"	<Toronto 10/8/1999>	SB	14	
REDD KROSS	"CROSSING THE REDD SE"	<compilations>	SB tendolar	10	
REF	"AFTER GLOW"	<Germany + London 4, 5/1999>	SB	10	
REF	"SPEEDWAGON"	"KEEP ON MOVING YOU"	<Budokan 29/9/1981>	SB fire power	4
RICHIE SAMBORA	"MADE FROM OSAKA"	<Osaka, Japan Jun. 15, 1988>	SB head	17	
RITCHIE SAMBORA	"BOW DOWN"	"THE ARSBER"	(2CD-R) <Tokyo 14/8/1998>	AD	22
ROBERT PLANT	"29 PALMS AND 1 PLANT"	<Amsterdam, Paradiso Dec. 13 '93 + Later With Jools Holland BBC>	hammerack	5	
ROBERT PLANT	"IN THE MOONLIGHT"	(2CD) <BRIGHTON DEC. 17 '83>	mdas touch	15	
ROBERT PLANT	"MIDWINTER GUY MOMENTS"	(2CD) <Tokyo, Jpn, 16/2/84 etc.>	image quality	14	
ROBERT PLANT	"OTHER ARMS"	(2CD) <New Castle, Austr. Feb. 8 '84>	SB	12	
ROD STEWART	"ONE OF THE EDYS"	<5-38 ENGLAND>	dancing horse	8	
ROD STEWART	"RED LIGHT RESTRICT"	<budokan 12/5/1982>	SB fire power	5	
ROGER DALTRY	"ORCHESTRA TOMMY"	<1973>	party line	5	
ROGER WATERS	"IN THE FLESH"	(2CD) <Milwaukee 2/7/1999>	stp	20	



Lynn Carey Roars Back, indeed!

Available exclusively from Music Unlimited
Featuring an amazing 21 tracks, including nine previously unreleased Mama Lion songs, plus bonus tracks!
Produced by Lynn Carey Executive Producer: Paul Surdin
day or night, order on-line at: www.surdin.com



The World's Rarest Records

45's, 78's & LP's: 1930-1963

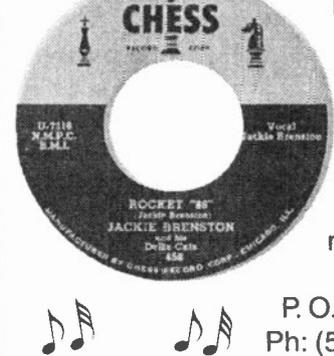

- Blues • Rhythm & Blues
- Rockabilly • Rock & Roll
- Surf • Girl Groups
- Country • Charted Hits

If you're buying or selling rare records you should contact:

JOHN TEFTELLER

P. O. Box 1727, Grants Pass, OR 97528
Ph: (541) 476-1326 FAX: (541) 476-3523



See AND Hear The World's Rarest Records on your computer!
Website: www.worlds.rarest.records.tefteller.com or www.tefteller.com

RARE Hard to Find

UNIQUE AND HARD TO FIND MUSIC AT PRICES YOU CAN AFFORD

All titles as priced. Most product mint or sealed unless noted. Shipping on all orders is \$4.00 for first item and \$1.00 for each additional title (except books) (\$8.00 foreign airmail first item, \$2.00 for each additional). Payment with Visa, MasterCard and Am Ex accepted via mail and phone. Make checks or MO payable to Rare & Hard to Find. Send payment to: Al Wagenaar - Rare & Hard to Find • 1510 W Clayton Crest Ave., Milwaukee, WI 53221 Phone 414-282-1380 (9AM - 8PM CST) • Alternate phone 414-915-4096 (if 1st line is busy) E-mail: music56118@aol.com

Visit our Web site at: www.rareandhardtofind.com Over 2000 unique collectibles from the 60's to today, including a wonderful selection of power pop, used CDs, DVDs, books and more. All items can be ordered by credit card on Web site.

- 1) Alice Cooper - "The Story" Whopping 180 minutes. 2 DVD set with full Pennebaker film. TV appearances, and never before seen footage from the 1967 "Raise Your Fist" tour. \$29.98
- 2) Abba - "Thank You Abba" This is a import VCD that plays on all DVD players. Full story of the band with rare live TV and loads more VCD. \$29.95
- 3) Asis - "Classic Rock Legends" in concert at their peak of their power. DVD. \$22.95
- 4) Arrms, Iggy - "Live NYC" VHS only Full concert from 1997. Imported from Canada. VHS \$22.95
- 5) Beatles - "Help" Deleted, but we have a few on DVD \$29.95
- 6) Beatles - "Beatles Story - Lifetime Biography" As shown on the Lifetime Network. Spans life of band. DVD \$16.95
- 7) BeeGees - "Nepel Road - Life & Times" This is an import VCD that plays on all DVD players. In depth career spanning bio loaded with many rare early performances. VCD \$29.95
- 8) Ben Folds Five - "Complete Sessions" This is the complete "West 54th" performance and the 45 minute "Spare Reels" footage, never before seen. DVD \$19.98
- 9) Big Brother & Holding Company - "Nine Hundred Nights" Loaded with live Janis Joplin footage. DVD \$23.95 VHS \$19.95
- 10) Buffalo Springfield Revisited - "Live" 1986 concert. Bruce Palmer and Dewey Martin are in the band. DVD/VHS \$18.95
- 11) Carrack, Paul - "In Concert" 18 songs in this 2000 concert. Full import with loads of bonus features. DVD \$28.95 VHS \$19.95
- 12) Cheap Trick - "Silver" The 25th Anniversary concert. DVD \$23.95, VHS \$19.95
- 13) Chicago - "Raw, Real Artists Working" Features Chicago in rehearsal, interviews and lots of live performance. 70 minutes. DVD \$22.95, VHS \$19.95
- 14) Espinoza, John - "Electric Guitar Slinger" Full story with archive live footage and key interviews. VHS only \$19.95
- 15) Clapton, Eric - "Live Hyde Park" Classic live show with all the hits and bonus live material not on the original version. DVD \$29.95
- 16) Climax Blues Band - "Live at Marquee" 1984 full concert. DVD \$19.95
- 17) Cochler, Joe - "Live From Across Midnight Tour" DVD \$24.95
- 18) Cult - "Pure Cult" Live and video on this Anthology that spans 1984 to 1995. Loaded with bonus interviews and live. DVD \$29.95
- 19) Cure - "In Orange" 2 VCD import that plays on all DVD players. Live concert from 1986 with 26 songs. Not available in any other format. VCD \$29.95
- 20) Darin, Bobby - "Mack Is Back" Fre cut version of a 9 1/2 special just months before his death. Starring 11 VHS \$23.95 VHS \$19.95
- 21) Deep Purple - "Come Hell Or High Water" Classic "Mark II" lineup in 25th Anniversary show from 1993. Over 2 hours!! 16 songs DVD \$16.95
- 22) Electric Light Orchestra - "Zoom Tour Live" Full concert tour show from Los Angeles. Over 2 hours long. All the hits and more. In stock Nov. 13. DVD \$24.94, VHS \$19.95
- 23) Elliott, Ramblin Jack - "Songs and Guitar" Jack and Arlo Guthrie tour thru the history of folk music. VHS only \$29.95
- 24) Emerson, Lake & Palmer - "Live Royal Albert Hall" 25th anniversary concert with all the key songs (Pictures, Larkus, Lucky Man, more) DVD \$24.95, VHS \$19.95
- 25) Emerson, Lake & Palmer - "Pictures At Exhibition" Full concert film. Includes bonus CD of concert. Import. DVD \$29.95
- 26) Foghat - "Two Centuries Of Boogie" Recent concert by original band. DVD \$15.95
- 27) Gallacher, Rory - "Irish Tour" Full concert from 1974. DVD \$19.95
- 28) Gillan, Ian - "Classic Rock Legends" Ian's greatest hits live from throughout his career. DVD \$23.95
- 29) Gilesie, Dizzy - "Live at Royal Festival Hall" Full show with guests like Arturo Sandoval and Flora Purim. Incredible show!! DVD \$19.95, VHS \$14.95
- 30) Greer Day - "International Super Videos" DVD \$29.95 VHS \$19.95
- 31) Groopies - "Classic R&R film from late 60's with performances by ten years after. Joe Cochler, Spooky Tooth and Jerry Reid. DVD \$28.95
- 32) Guided By Voices - "The Who Went Home and Cried" Live Los Angeles 1999 and reissues on Robert Poljanec arch alone with lots more!! DVD \$19.95
- 33) Hackert, Steve - "Tokyo Japes - Live Japan" 100 minute concert. DVD \$29.95
- 34) Hanson, George - "Beatie in Benson Illinois" Award winning docu of George visiting his sister in Benson Ill in 1963. A must for any true Beatles fan. VHS only \$19.95
- 35) Hell, Richard & Wagners - "Blank Generation" 85 min full of live including CBGB's performance. Directed by Ulli Lommel with appearances by Andy Warhol. DVD \$24.95, VHS \$19.95
- 36) Hopkins, Lightnin' - "Rare Performances 1960-1965" Collection of very rare live material. Priceless!! DVD \$24.95
- 37) Jackson, Joe - "Live in Tokyo" Live 1988 Japan concert. DVD \$19.98
- 38) James, Tommy - "Live At Bitter End" All the hits in this NYC concert. Loaded with bonus features and in depth interview. DVD \$18.95
- 39) John, Elton - "Goodbye Yellow Brick Road" The studio album with all involved in the LP and great live and in the studio footage never seen before. DVD \$24.95, VHS \$19.95
- 40) Judas Priest - "British Steel" - Classic Albums. All the people involved in the LP are interviewed and you get live and in studio footage never seen before. DVD \$19.95, VHS \$14.95
- 41) Living Legends Of Rock N Roll" Concert in Rhythmic Park 2001 with Grand Funk, Iron Butterfly, Starship, Steppenwolf, Nelson, Firefall, Styx and more. DVD \$23.95
- 42) "London Rock show" - Legendary rock film with Screaming Lord Sutch, Chuck Berry, Jerry Lee Lewis, Jill Haley, Little Richard, Bo Diddley, lots more. DVD \$19.98
- 43) Merritt, Steve - "Live Concert 1985. Includes CD as well. DVD \$22.95
- 44) Rayfield, Curtis - "Germany 1990" Full show coming in stock Nov 15. Order yours now for priority delivery. DVD \$19.95
- 45) Motorhead - "Boneshaker - Live" 25th Anniversary show at Brighton. Lots of guest stars appear. Includes 100 minute DVD \$29.95
- 46) Nesmith, Michael - "Live At The Brits" Full concert. Wonderful "Different Drum" DVD \$29.95
- 47) Nico - "Herone and Underground Experience" 100 minute. Includes two full performances... one raw electric and one acoustic. DVD \$22.95
- 48) Nugent, Ted - "Spirit Of The Wild 3 Pack" VHS only. All 3 of Ted's hunting videos with live acoustic and electric performances. Out of print. 3 pak VHS \$29.95 (\$5.00 shipping)
- 49) Oasis - "Unauthorized Bio" UK import 3HS only \$7.95
- 50) Campi Bonzo - "Farwell" Live - The final concert in full. Great songs and loaded with bonus features. 2 DVD set. DVD \$29.98
- 51) Fast Shop Boys - "Montage" Full concert from the "Light Live" Tour 2000. DVD \$24.95, VHS \$19.95
- 52) Fasthead - "Roseland New York" This is a 2 VCD import that plays on all DVD players. Live 19 songs concert from 1997. VCD \$37.95
- 53) Foghat - "Two Centuries Of Boogie" Recent concert by original band. DVD \$15.95
- 54) Pane, John - "Live From Sessions West 54th" The full show, many unseen songs and bonus interview material. DVD \$24.95
- 55) Psychedelic Furs - "Live House Of Blues" All the hits live from this 2000 show. DVD \$24.95 VHS \$19.95
- 56) Queensryche - "Live Evolution" Incredible concert from July 27, 2001 and now available on DVD. Great "Silent Lucy" DVD. \$29.95
- 57) Residents - "Icky Flx" Lots of early material. DVD \$29.95
- 58) Six Pistols - "Live Dallas at the Longhorn" The first USA Pistols show back in 1978. Incredible. Full show and bonus clips. Japanese import. Very hard to locate. DVD \$38.95
- 59) Smashing Pumpkins - "Video Greatest Hits 1988-2000" Full compilation of videos. Lots of bonus features. DVD/VHS \$19.98
- 60) Smith, Patti - "Dancing Barefoot" Live concert. Loads of early footage. Also includes "Blank Generation" a film with live Ramones, Talking Heads, Television, Blondie, Heartbreakers and more. DVD \$22.95
- 61) Springsteen, Bruce - "Live in New York" 2 DVD set with lots of songs not on the HBO special. DVD \$24.98, VHS \$19.98
- 62) Starr, Ringo - "Best of The All Starr Band" Incredible Frampton, Gary Brooker, Rundgren, Randy Bachman, lots more. DVD \$23.95
- 63) Thunders, Johnny - "Dead Or Alive" Full 1984 concert. DVD \$25.99 Also available in bonus pack with UK book "In Cold Blood" by Nina Simone with a full story on Johnny Thunders. Book/DVD \$29.99
- 64) UFO - "Live Misdemeanor Tour" 60 min live. DVD \$18.95
- 65) Unah Heep - "Acoustically Driven" Incredible acoustic set with special guest Ian Anderson. A must own for fans. DVD \$22.95
- 66) Unah Heep - "Sailing The Sea Of Light" Complete show from 1997 in Sofia along with bonus interviews etc. \$22.95
- 67) Vanous - "British Invasion Returns" 2000 concert over 100 minutes with Troggs, Foundations, Peter Noone, Eric Burdon, Bill J Kramer, Searchers, Gerry & Pacemakers, Mindbenders and more. DVD \$24.98
- 68) Vanous - "Rockin The Night Away" Killer 1988 concert with live Don, Mamas & Papas, Peter Noone, Sonny Bono, Tommy James, Jan & Dean, Donovan and more. DVD \$19.95
- 69) Vanous - "Rock Icons/Psychedelic High" Loaded with '60's Beat Club footage of Byrds, Thunderclap Newman, Moody Blues, Blue Cheer, Nice, Manfred Mann, Donovan and lots more. DVD \$14.98 VHS \$9.98
- 70) Vanous - "Rock Icons - Guitar Gods" More Beat Club live material with Jeff Beck, Johnny Winter, Duane Eddy, Eric Clapton, Mountain, ten years after and lots more. DVD \$14.98, VHS \$9.98
- 71) Vanous - "Rock Icons - Hard Rockin'" More live Beat Club material with Pacific Gas & Electric, Steppenwolf, M.C.S, Mountain, Spencer Davis Group and more. DVD \$14.98, VHS \$9.98
- 72) Wakeman, Rick - "Live Buenos Aires" DVD concert is 110 minute concert with English Rock Ensemble. Comes with bonus CD "Official Bootleg" of a Birmingham 1997 show. DVD \$29.98
- 73) Who - "Live Royal Albert Hall" Full show from 2000. Noel Gallagher guests. DVD \$23.95 VHS \$19.95
- 74) Wishbone Ash - "Classic Rock Legends" The classic Ash line up in a concert filmed in Bristol. Powell, Turner, Turner and Upton. DVD \$22.95
- 75) Wilson, Brian - "All Star Tribute" Incredible concert of all Brian songs with GoGo's, Jimmy Webb, Wilson Phillips, Michael Penn, Aimee Mann, David Crosby, tons more. DVD \$24.94, VHS \$19.95

KEEP IN MIND...OUR CATALOG AND WEB SITE FEATURE MORE THAN 400 MUSIC DVDS, MANY ALMOST IMPOSSIBLE TO FIND AT RETAIL.

www.rareandhardtofind.com

MAIL ORDER AT ITS BEST!
THE LARGEST SELECTION OF 45 RPM RECORDS IN THE UNITED STATES

MAIL OR FAX YOUR WANT LISTS TO:
VAL SHIVELY R & B RECORDS
BOX "B" • HAVERTOWN, PA 19083
PH: 610 / 352-2320 • FAX: 610 / 352-8199

Over 4 Million 45's in Stock!

We Specialize in vocal group harmony but deal in all types of music on 45's. (original labels, promos or reissues) ALSO: CD'S • LP'S • CASSETTES • 7" PICTURE, COMPANY OR WHITE SLEEVES • 8 X 10 PHOTOS

Worldwide Service
NEW RECORDS IN EVERY DAY
No Catalogs Available
Send Want Lists

WAREHOUSE ADDRESS:
49 Garrett Road • Upper Darby, PA 19082
(1 Mile From West Philadelphia)

WAREHOUSE HRS:
Mon. Thru Sat.
1P.00 A.M. to 7.00 P.M.
Closed Sunday

WE ACCEPT ALL MAJOR CREDIT CARDS FOR QUICK SERVICE.
Doing Business Since 1966 - We Buy 45 Collections

DOO WOP • ROCK 'N ROLL • R & B • SOUL • POP • COUNTRY • BLUES

World Radio History

COMPACT DISC SHOWCASE

Showcase ads are the most looked at in Goldmine. You may buy as many boxes as you wish for an ad, at a cost of \$38.60 per box, multiplying the \$38.60 per box required. All typesetting is done by us and included in the price.

Automatically Catalog Your CDs!



CD Trustee automatically catalogs your CD collection. Quickly insert and remove each disc into your computer, then push a button to gather artist name, album title, song titles, genre and more. Takes seconds per CD. Build a database of your huge collection in a few hours, with no typing! Easily search for songs, artists, or titles. Stop buying duplicates. Prints extensive reports, along with jewel cases covers and inserts. Also handles manual entry of LPs, tapes, and other media. Only \$29.95. Download a free trial from our Web site.

Requires Microsoft Windows 95/98/ME/NT/2000/XP, and an Internet connection (during lookup phase only).

Web site: www.base40.com
E-mail: GM@Base40.com

WWW.GPMUSICA.COM

By J.A. Gaspar & J. del Peso

MUSIC MAGAZINES FROM ALL OVER THE WORLD. SPANISH RECORDS AND CD'S.

Detailed lists on all artists, including Spanish ones. More than 200.000 references



Secure Shop on-line



Contact us: Tirso de Molina S/N, Centre d'Empreses Modul 9-A, 08940 Cornellà de Llobregat, Barcelona Spain. Fax: + 34 93 475 02 36
E-mail: sales@gpmusica.com

CD, Tape & Vinyl Storage

The RACKIT™ System

Factory direct since 1984 from

Per Madsen Design

Free brochure (mention Goldmine)

800-821-4883 or online at

www.rackit.com



101cd.com

Now over 1.6 million titles online all at discount prices. Including every UK, European, Australian and Japanese releases. UK catalogue includes budget and mid-price titles from \$7.50 (+p&h). Secure ordering, certified Bizrate Gold merchant. Plus rare records and CDs from the world's top dealers.

<http://www.101cd.com>
e-mail: sales@101cd.com

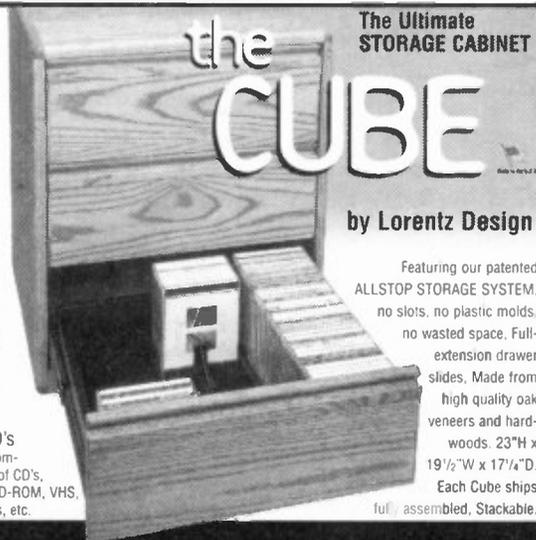

The Ultimate STORAGE CABINET

the CUBE

by Lorentz Design

Featuring our patented ALLSTOP STORAGE SYSTEM. no slots, no plastic molds, no wasted space. Full-extension drawer slides. Made from high quality oak veneers and hardwoods. 23"H x 19 1/2"W x 17 1/4"D. Each Cube ships fully assembled. Stackable.

Stores 306 CD's or any combination of CD's, DVD's, CD-ROM, VHS, Cassettes, etc.

Call 800-933-0403 or visit www.lorentzdesign.com to order or for a free, color brochure detailing all our disc, tape & component storage CUBES. LDI, Inc. • 5140 Clarkson St. • Denver, CO 80216 • Fax: 303-294-9705

FREE WORLDWIDE SHIPPING!
RARE, LIVE & COLLECTABLE CD'S!
BUY 3 AND GET 1 FREE!
Metallica, Tool, Slipknot, Black Sabbath, Ozzy Osbourne, Iron Maiden, KISS, Nine Inch Nails, Marilyn Manson, Incubus, Deftones, Motley Crue, Radiohead, U2, The Smiths and a lot more!
[HTTP://WWW.CDLIVE.COM.PA](http://www.cdlive.com.pa)

MICHAEL JACKSON
Bad (Special Edition)
Epic (EK 66072)

Can you fathom this scenario?: You write, coproduce and record an album containing five #1 songs that goes on to sell 16 million copies, and it is still labeled by critics as a "disappointment?" That's what happened with *Bad*, Michael Jackson's 1987 follow-up to *Thriller*.

The pressure was enormous on Jackson during the five years he worked on *Bad*. Quite simply, how does one follow the best-selling album of all-time? Producer Quincy Jones pushed Jackson for the first time to write the set's entire lineup. Prior to this, Michael's compositions — brilliant though they were — hadn't accounted for even half of the tracks on his *Off The Wall* or *Thriller* smashes.

Even though in actuality the final set did go outside for two compositions, Jackson had written a total of 33 songs for the project. Still, as a result, *Bad* ended up with more "filler" than "thriller," as songs such as "Speed Demon," "Liberian Girl" and "Just Good Friends" attest. As for the rest, even though absent a bonafide centerpiece on the level of "Billie Jean" or "Beat It," *Bad* is a still a solid effort. Like its predecessor *Thriller*, *Bad* contained seven hit singles. Overlooked for an eighth hit was the album's excellent closer, "Leave Me Alone."

The bonus material on this special edition reissue is considerable. Included here are *Bad* leftovers "Street Walker" and "Fly Away" as well as a Spanish version of "I Just Can't Stop Loving You." The stomping "Street Walker" was a narrow miss for the final album's line-up according to producer Jones, as Jackson really wanted it included. A conference ensued where upon the final listening Jones persuaded the artist to stick with "Another Part Of Me" instead. "Fly Away" is a pleasant love ballad with a nice arrangement and beautiful hook; it must have been a difficult decision to leave that one behind as well.

This reissue is particularly well-timed, as a rare Jackson cover, this time in the form of *Bad* track "Smooth Criminal" recorded by Alien Ant Farm has been on the charts at the time of this writing.

— C. Brian Jasper

— C. Brian Jasper

BIG HELLO
Apples And Oranges
Break-Up! (B-U! 020)

Take *The Apple Album* and *The Orange Album*, put 'em together, and whaddya got? Why, *Apples And Oranges*, of course, a 27-song compendium of the first two albums by Big Hello, the Illinois pop-rock powerhouse led by super-sassy vocalist Chloe F. Orwell and madman drummer Brad Elvis.

In addition to two full-length records, *Apples And Oranges* also contains a few rarities: There are a cookin' cover of the Jimmy Webb classic "Up, Up And Away" and a punk-pop joyride called "Cynical Girl," originally available only on a vinyl EP. There are also four short soundbites that were originally intended for inclusion on *The Orange Album*.

Big Hello's sound falls somewhere in between good-natured (and loud) power pop — tips of the top to The Beatles, Blondie, and Cheap Trick abound — and current female-fronted acts such as No Doubt.

Orwell's voice is by turns kittenish, sexy, powerful and angry, adding emotional depth to the strong tunes, penned by Elvis and Orwell separately. Among the many pinnacles reached here are the bubblegum stomper "Boys Can Be Dumb" (it's got "alternative smash" written all over it), the power-chord fiesta "If You Don't Stop You're Crying" (which channels Cheap Trick circa "He's A Whore") and "Today Will Be Yesterday Tomorrow," a ballsy rocker.

Another reason to savor *Apples And Oranges* is Elvis' drumming, which is absolutely peerless, plain and simple (especially live). His all-over-the-kit style is solid as hell without coming off as overtly flashy, and he couldn't be prided off the backbeat with a crane on numbers such as "O'Canada" or "Cynical Girl."

Since releasing *The Apple Album* and *The Orange Album* in 1998 and 2000, Big Hello have replaced their lead guitarist and bass player. These departures promise to change the band's overall sound a bit, and it will be interesting to see the direction in which they go from here. Still, *Apples And Oranges* is a chronicle of a rock group poised for greatness and ready to strike. (Available at www.notlame.com, PO Box 2266, Ft. Collins CO 80522; or at www.bighello.net)

— John M. Borack



Big Hello

(Reissues from page 28)

Part of the *Thriller* legend too is Jackson's famous Moonwalk, which debuted in May 1983 on the *Motown Anniversary Show*. Don't give me that Johnny Carson "Camel Walk" business. No one had ever done anything like this. The world gasped as Jackson slid across the stage backward, as if aboard some hidden conveyor belt on the floor. The next day everyone was trying to do it. By now, everyone has seen the Moonwalk so much from onlookers-turned-impersonators that we may have forgotten the unbelievable footage from the Motown show.

The extras and bonus tracks are worthy inclusions on this special edition too. Here we get not only the E.T. storybook song "Someone In The Dark" (first time on CD, but also a keen explanation from Quincy Jones as to how it served as a new starting point helping Jackson get to *Thriller*. For years fans and critics alike have speculated on just where Jackson's songwriting ends and Jones' production begins; the proof of Jackson's songwriting prowess is definitely in the pudding, as a home demo here shows how well-formed from a songwriting aspect "Billie Jean" was right from the start. There's a fascinating eaves-dropping session on Jackson and Vincent Price during the title song recitation, as well as an unfinished master of "Carousel," an unreleased outtake from the *Thriller* sessions. Relistening to *Thriller* kinda makes me want to do the Moonwalk again.

COLLECTOR'S SHOWCASE

Showcase ads are the most looked at in Goldmine. You may buy as many boxes as you wish for an ad, at a cost of \$38.60 per box, multiplying the \$38.60 per box required. All typesetting is done by us and included in the price.

Record Album Frames

For: LP's - Picture Discs - 45's
All Steel - Black or Silver
Simply the best - See for yourself
Visit our secure Web site at
www.albumframes.com
Or call us toll free: 800.640.0306

CD Storage & Display

CD Poster Frames gives you quick, easy access to your Music, Game & Software CD's. Great anywhere space is limited. Put them on a wall close to your CD player or computer. See them at our secure Web site www.cdframes.com
Or call us toll free at: 800.640.0306

Attention Retailers

Increase your profits by selling our quality Record Album Frames & CD Poster Frames. U.S. & Overseas distribution now available. For Info. and wholesale pricing contact us by
E-mail: sales@albumframes.com
E-mail: sales@cdframes.com
Phone: 800.640.0306 Fax: 630.830.9009

We specialize in finding Original 50s Rhythm & Blues/Rock & Roll 45s and LPs.

Lots of original 60s material also available. Call/fax us with your wants, or send us your wish list. Send all correspondence (and PLEASE INCLUDE YOUR PHONE NUMBER) to our address below.
WE ALSO CARRY COOL, OUT-OF-PRINT CD'S



Are you still reading ICE Newsletter? If not, then you're missing out on vital info on many of the best new titles now available -- including the newest groundbreaking entry in the classic "G.B.S." series from BOB DYLAN. Right on the heels of "A Tree With Roots" is "The Genuine Neverending Tour Covers Collection, 1988-2000". This is an absolutely incredible boxed set of 9 CD's containing every single cover-version (except for just one) that Zimmy performed during the title tour's time frame! This masterpiece is loaded with prev. unrels., extremely upgraded or first-time-S tracks in addition to several other packaging bonuses highlighted by two books totalling 100 pages! And speaking of great Dylan tours, if you're really into the Rolling Thunder Revue, then you probably would like to get your paws on that much-praised 4CD "Guam Rehearsals" release on the White Bear label, right? Well...guess what? Plenty of other new winners also out from FLEETWOOD MAC (at long last, two separate, great-quality alternate/outtake/demo-version releases of their "Rumours" and "Tusk" LPs), BILLY JOEL (the same great alternate/outtake/demo treatment for his "Glass Houses" LP), ELVIS PRESLEY, JIMI HENDRIX (finally, the definitive release of his legendary star-studded Newport Pop Festival shows from June 20 & 22, 1969 -- both complete, perfect SBs on 3CDs) and all of the new Doberman Rites from NEIL YOUNG, U2, and SOUTHSIDE JOHNNY. And attention all slowpokes: ESSENTIALLY SOLD OUT (i.e., barely still around) are the new ones by ELVIS COSTELLO (2CDs of amazing demos, rehearsals and OTs for his "King Of America" LP) and THE WHO (2CDs containing the complete U.K. and U.S. '60s singles collection featuring the ORIGINAL 45 mixes from the ORIGINAL, FIRST-GENERATION masters including the "lost" She Tally tapes... all in super-deluxe packaging w/three books and six postcards!) And still available for now -- are the latest hot ones by BRUCE SPRINGSTEEN (including The Boss's legendary Vietnam Vets' Benefit Concert from L.A. on 8/20/81 on 3CDs but now for the first time ever COMPLETE and in EXCELLENT sound. Also, the new ICE-touted "Live In Tempe, 1980": a near perfect-sounding CD-only gem which quite frankly, blows away the old E-Street label's release of ("Heart & Soul"). And, since we can never say it often enough: All of the above titles -- except where noted -- are on REAL CD's, not those pukky, scraggyard quality, loose-affiliated CD-Rs. PLEASE CALL, FAX OR E-MAIL US FOR FURTHER DETAILS ON THESE RELEASES AND COUNTLESS OTHERS.

RIP IT UP! P.O. Box 142, Bloomfield, NJ 07003 • Phone (973) 743-0878 • Fax (973) 743-6316 (24 hours) • E-MAIL US AT: thedevismusic@home.com
Best times to call are 10:00 AM - 4:00 PM (EST), or you can give us a try nights 10:00 - 11:30 (EST), Monday thru Friday only. Fast, reliable service.



1.3 Million LPs/45s - all categories!
Catalogs issued - please state areas of interest
Want lists welcomed
Collections purchased



CRAIG MOERER
Records by Mail

P.O. Box 42546-GM, Portland, OR 97242, USA
PHONE: 503 232 1735 • FAX: 503 232 1746
e-mail: cmoerer@recordsbymail.com
browseable/searchable Web site:
www.recordsbymail.com

"JIMMY MACK RECORDS"

BUY.....SELL.....TRADE

Fax: (803) 345-6010 or E-mail: JMack48@aol.com

105 Deer Tract Drive
Little Mountain, S.C. 29075

NEW WEB SITE:

www.jimmymackrecords.com

Do You Need Records From Argentina or South America?



Send Want Lists to:
Casilla de Correo 237
C1000WAC Correo Central
Argentina - Ph 54-11-4774-0493
Fax 54-11-4775-1209
E-mail: kodela@datamarkets.com.ar
www.limportsounds.com

45 / LP / 12" / 78
Collectibles ... Rock / Soul / R&B / Blues / Jazz / Country / Pop / Movies & More ...

If you are buying on a regular basis, ask to be put on my mailing list. Accurate grading, reasonable prices, guaranteed to please. Specify which speeds & categories you prefer.

THE MUSIC JOINT

P.O. Box 15396, Ft. Wayne, IN 46885

VIDEO WIZARD

Specializing in
Hard-To-Find Movies, &
Rare Concert Videos

www.videowizards.com
P.O. Box 5536, New York, NY 10185-5536
718-972-3872

ROCK N ROLL COTTON THROW BLANKETS



The Beatles - Janis Joplin - Santana
Blink 182 - Jimi Hendrix - Doors
KISS - Insane Clown Posse + More
View and order on the Web at:
www.cjcollectibles.com

CJI Collectibles • 491 Amherst St. • Nashua, NH 03063
(603) 882-0955
Also available on our Web site: Doors Lava Lamps, Rock N Roll Mugs, Lunch Boxes, much more!

SAN FRANCISCO
2350 MARKET
(888) 396-2350

SAN JOSE
960 S. BASCOM
(888) 330-7776

STREETLIGHT RECORDS

SAN FRANCISCO
3979 24TH ST
(888) 682-3550

SANTA CRUZ
939 PACIFIC
(888) 648-9201

CALL US TOLL FREE!

BUY SELL TRADE CD's LP's 45's VIDEOS LASERDISCS DVD's
www.streetlightrecords.com

ROCK'S HOTTEST VIDEOS

Featuring Artists From The 70s: Floyd, Who, Zeppelin, Yes, KISS, Cooper, Aerosmith, Sabbath, Angel, Bad Co.
Featuring Artists From The 80s: Accept, Badlands, Bon Jovi, Motley, Bullet Boys, Cinderella, Leppard, Guns, and all the newest.
Sensations Of The 1990s: All the current tours and of course the most perfect quality available. Over 2,000 selections listed. We've been the leader in music videos since 1983.

SEND FOR FREE CATALOG!

INTERNATIONAL TRANSFERS
P.O. Box 313, Dept. G.M., Revere, MA 02151

ALWAYS BUYING LP'S FOR CASH

Check my Web site for HUGE wantlist and info. I am actively buying rock LP's from approximately 1965-1972, especially PROMOS, IMPORTS, CUTOUTS, sealed store & distributor stock, the larger quantity the better!
www.undergroundalbums.com
CHOICE SELECTION of set sale LP's: 60's Psych. Garage, Prog, Folk, Hard Rock, Soul, Jazz.
CHECK THE WEB SITE or send for free list (4x yearly).

JEROME TOMKO

P.O. Box 303, Hebron, CT 06248-0303
Tel: 860-228-8700/Fax: 860-228-8822 • E-mail: jtjviny@aol.com

IF IT'S OUT-OF-PRINT - OR HARD-TO-GET CHANCES ARE - I'VE GOT IT

FREE SALES LIST OUT NOW
WRITE FOR A COPY OR FAX (540) 342-2471

ROANOKE'S RECORD ROOM
P.O. Box 2445, Roanoke, VA 24010

Visit our online catalog @
<http://members@aol.com/RoaRec33/RecordAlbums>
Or email your request to RoaRec33@aol.com
Serving Collectors around the world since 1976.

Specializing in out-of-print 10" and 12" Rock and Pop, Jazz, Soul & Soundtrack LPs from 1949 to 2001 - Most major credit cards accepted.

ESPRIT MOST WANTED

We want to purchase your top quality music rarities and memorabilia
WE WILL PAY YOU TOP DOLLARS!!
Our lead North American buyer is Peter Fenton with over 15 years of experience purchasing your music collectibles! Discrete, knowledgeable and professional.
phone: 702-804-9872 fax: 702-804-9873
e-mail: USEsprit@compuserve.com
ESPRIT MOST WANTED
9811 WEST CHARLESTON BLVD. #2-300, LAS VEGAS, NV 89117
WE WANT TO BUY...
VINYL: deleted, rare or promo (7" / 10" / 12" / picture discs / collectible 60's / 70's deleted LP's)
COMPACT DISCS: deleted, rare or promo (singles and/or albums, CD-Videos)
MEMORABILIA: press packs, tour books, paper goods or promo logo items or music related toys etc.
RADIO SHOWS: CD or Vinyl (Westwood One, In The Studio, Up Close, etc. - must include cue sheets)
RECORD AWARDS: (RIAA certified gold/platinum awards in original & undamaged complete framing)
We will consider all items in at least EX condition (no visible damage or excessive wear, no scratches, tears or repairs) must include full packaging where applicable.
SEEK ITEMS IN OTHER ADVERTISERS WANTED ADVERTS? DON'T WORRY! WE WILL MATCH OR BEAT ANY REASONABLE PRICE OFFERED ELSEWHERE! SELL TO US IN COMPLETE CONFIDENCE! REASONABLE POSTAGE COSTS REIMBURSED!
Shops / wholesalers / dealers / promoters / reviewers / radio stations / DJ's - Discretion assured. Quantities wanted and encouraged.
No Bootlegs or unofficial recordings or merchandise will be considered.

OVER 500,000 IMPORTS Including 400,000 Track Listings

Imports From Japan, Europe, Australia & South America. CD's, Vinyl, Video & DVD's. All Categories, Fast And Reliable. All Available Online at
www.musicimports.com
Not Online? Please Send Your Want List To:
MUSIC IMPORTS
757 SE 17th St. #149, Fort Lauderdale, FL 33316
954-764-3879 • FAX: 954-764-3890

audiophileusa.com



Visit and bookmark our Web site now for the best in LPs & CDs. We carry a full range of new vinyl as well as a huge selection of superb condition ROCK, POP, JAZZ, FOLK, AUDIOPHILE, MOBILE FIDELITY, SOUL & FUNK & MORE. Sealed & outstanding condition LPs our specialty. We pay top dollar for your mint records - Up to \$600 for Mobile Fidelity! Not just for audiophiles! Call toll-free 1-(877)-SPIN LPS

COLLECTOR'S SHOWCASE

Showcase ads are the most looked at in Goldmine. You may buy as many boxes as you wish for an ad, at a cost of \$38.60 per box, multiplying the \$38.60 per box required. All typesetting is done by us and included in the price.

COLLECTOR'S CORNER LP SET SALE

ALL RECORDS ARE GRADED COVERS/RECORDS/POSTAGE U.S.A. \$7.00 PER ORDER, AND .50 CENTS FOR EACH ADDITIONAL RECORD DUE TO POSTAGE INCREASE. ALL RECORDS ARE FIRST ORIGINAL 1ST PRESS UNLESS NOTED. MONEY ORDERS SAME DAY SERVICE. CHECKS 10 DAYS. WILL HOLD FOR TWO WEEKS!

1. BARRY + TAMERLANES I wonder what she's doing tonight (m) (PROMO) NM/NM \$125.00
2. BEATLES At Shea Stadium Described by erupting fans M/M \$50.00
3. BEATLES Collectors items Cap. SPRO-9463 (PROMO) M/M \$100.00
4. BEATLES 1962-1966-1967-1970 (SEALED) both \$100.00
5. BEATLES Sunshine superman boot MINT \$40.00
6. BEATLES White LP White vinyl M/M \$55.00
7. BENTON BROOK Endlessly (st) M/M \$20.00
8. BERRY CHUCK In London (m) NM/NM \$25.00
9. BUTTERFIELD P. BLUES BAND Best of 2 LP set (PROMO) EX/EX \$30.00
10. BYRDS Younger than yesterday (m) promo sticker EX/EX \$40.00
11. CARRIS There's a moon out tonight (sealed) \$25.00
12. CARPENTERS Xmas LP (shrink) M/M \$15.00
13. COOK SAM The man who invented soul (st) (sealed) \$30.00
14. DIDDLEY BO Boss man (m) NM/M \$30.00
15. DIXIE CUPS Best of red vinyl (sealed) \$25.00
16. DONOVAN Essence to essence (PROMO) NM/M \$30.00
17. EVERLY BROS. Gone gone gone (m) EX/EX \$25.00
18. FLOYD EDDIE Knock on wood (st) M/M \$80.00
19. FOUR 4 SEASONS Xmas LP (st) shrink M/M \$30.00
20. GERRY + PACEMAKERS Ferry cross the mersey (m) M/M \$40.00
21. GERRY + PACEMAKERS I'll be there (st) NM/M \$30.00
22. HOGAN SILAS Trouble (st) M/M \$30.00
23. HOLLY BUDDY + CRICKETS Same (st) CRL 75745 small tape sims EX/EX \$60.00
24. KERSHAW DOUG Alive+pickin (PROMO) M/M \$20.00
25. KING CRIMSON Larks tongues in Aspen CO M/M \$15.00
26. KING PINS It won't be this way always M/EX \$150.00
27. LABELLE PATTI + BLUEBELLES Xmas LP NM/EX \$40.00
28. LENNON JOHN AND YOKO ONO Happy Xmas war is over 12 inch white vinyl (PROMO) NO. 856/of 2000 M/M \$125.00
29. LITTLE BEAVER Party down (st) M/M \$20.00
30. MAD LADS, THE in action (m) M/M \$50.00
31. MAMA CASS ELLIOTT Make your own kind of music (sealed) \$25.00
32. MANFRED MANN Album (st) EX/EX \$20.00
33. MANFRED MANN Mighty Quinn (st) NM/NM \$25.00
34. MANFRED MANN My little red book of winners (m) (PROMO) M/M \$75.00
35. MARMALADES Reflections on my life (st) NM/M \$25.00
36. MASON DAVE Split coconut (st) C.O. (PROMO) M/M \$20.00
37. MARVELETTES The return of (st) (PROMO) NM/M \$40.00
38. McGUINN ROGER Cardiff rose (st) (PROMO) M/M \$20.00
39. MERCER MABEL Midnight (m) M/M \$35.00
40. MILES BUDDY Expressway to your skull (PROMO) M/M \$25.00
41. MIRACLES A pocket full of miracles (st) (sealed) \$30.00
42. MITCHUM ROBERT Sings (st) NM/M \$25.00
43. MOONGLOWS Collectors show case Vol. 11 (sealed) \$50.00
44. NASHVILLE TEENS Tobacco road (m) EX/NM \$60.00
45. NAZARETH Exercises (PROMO) M/M \$15.00
46. O JAYS Family reunion (PROMO) M/M \$15.00
47. OSMOND BROS Xmas LP (st) EX/EX \$15.00
48. PAUL + PAULA We go together (m) M/EX \$20.00
49. PAUL + PAULA Holiday for teens (m) M/EX \$20.00
50. PARTRIDGE FAMILY Bulletin board C.O. (sealed) \$20.00
51. PETER PAUL + MARY In the wind EX/EX \$15.00
52. PINK FLOYD The division bell (sealed) \$20.00
53. PLATTERS In the still of the night (st) M/M \$15.00
54. PLATTERS Reflections (m) M/M \$20.00
55. PLATTERS Xmas with (st) M/M \$35.00
56. POPPY FAMILY Which way you goin Billy (st) NM/M \$40.00
57. PRICE LLOYD The exciting (m) M/M \$35.00
58. REVERE PAUL + RAIDERS Just like us (m) (PROMO) M/M \$50.00
59. REVERE PAUL + RAIDERS Here they come (m) (PROMO) M/M \$50.00
60. REVERE PAUL + RAIDERS Midnight ride (m) (PROMO) M/M \$50.00
61. RICHARDS CLIFF It's all in the game (m) M/M \$15.00
62. ROCK-A-TEENS Woo-hoo (m) EX/EX \$80.00
63. RYDELL BOBBY At the copa (m) (shrink) M/M \$15.00
64. SINATRA NANCY Nancy (st) (shrink) M/M \$20.00
65. SPRINGFIELD DUSTY Oooweee (st) (shrink) M/M \$25.00
66. SPRINGFIELD DUSTY Something special 2 LP set M/M \$20.00
67. STARR RINGO Beaucoups of blues (st) M/M \$15.00
68. STORM GALE Sentimental me (m) M/M \$25.00
69. SUPREMES Xmas LP (st) NM/M \$25.00
70. TAYLOR TED You can dig it EX/EX \$20.00
71. TEMPTATIONS Sing smookey (st) M/EX \$25.00
72. TEMPTATIONS Xmas card (st) M/M \$20.00
73. TEN YEARS AFTER Cricklewood green with poster NM/NM \$30.00
74. TEN YEARS AFTER Sssh (st) with poster EX/EX \$30.00
75. TEN YEARS AFTER Stonedhenge PROMO Sticker (st) EX/EX \$20.00
76. ULTIMATE SPINACH Same (st) EX/EX \$20.00
77. VALENS RICHIE Best of Replica M/M \$20.00
78. VALENS RICHIE Same guest star L.B. shrink M/M \$20.00
79. VENTURES Same Batman theme (m) M/M \$15.00
80. YARDBIRDS Greatest hits white vinyl GERM. (st) M/M \$40.00

ALEX TSOVALOS
508-752-6390

5 AETNA STREET, WORCESTER, MA 01604-4205

Stay on Top of Your Music Collection

With **MUSICmate**

The music cataloging programs that does the work for you

• Add value to your music collection.

• Virtually eliminate the need to enter data by importing music selections from a database of over 200,000 music titles.

• Download Free Demo From Web

Just \$39.95



WEB INFO WWW.PWRDATA.COM OR CALL 877.797.3281 TOLL FREE

Past & Present Present Rare Videos by these Artists & more

- | | | |
|-----------------|-------------------|---------------|
| George Harrison | Ringo & All Stars | Aerosmith |
| Phish | Van Morrison | Bob Seger |
| Rush | Rolling Stones | Jack Bruce |
| Little Feat | Princ | Foghat |
| Tempest After | Elton John | Tom Petty |
| Miles Davis | Beach Boys | Todd Rundgren |
- any many more!!

Please send SASE & your interests to:

Joseph Russo

P.O. Box 2422, North Babylon, New York 11703-0422

Fast, Personal Service!

MusicAndVideo.com

(201) 236-9107 • Fax: (201) 236-2916

<http://www.musicandvideo.com>



One Surrey Lane

Allendale, NJ 07401

Collector Pays Cash for Records, CDs, Coin Collections and Political Buttons.

Large collections especially welcome. Will Travel.

Collector Since 1960!

Please call Gary 203-377-3449

Collector's CD

Over 1000++ rare titles from AC/DC, ABB, Beach Boys, Beatles, Jeeb, Dylan, Springsteen, Elton, Clapton, Genesis, N.Young, Nirvana, Oasis, Townsend, Floyd, Radiohead, Stones, Rush, SRV, U2, Who, Yes & many many more.

For more info, visit our website at:

<http://listen.to/SilverDisc>

email: silverdisc@allomail.com

FREE SET SALE CATALOGS ...

ALL GENRES 45 or 33LP 1940's - 1980's and SOUND TRACKS

Approx. 20,000 each catalog
Please specify which catalog.

B & D RECORD SALES, INC.

517 S.W. 49TH LANE, CAPE CORAL, FL 33914
Phone: (941) 540-7559 • FAX: 941-540-4460

Sorry due to the size of the catalogs they cannot be faxed.

78's 78's 78's 78's 78's 78's 78's 78's 78's 78's

FOR SALE 78 RPM ORIGINAL ROCK AND ROLL RECORDS

Hundreds of 78 RPMs -- A self addressed/stamped envelope will get you all the details re: grades, prices and ordering instructions.

BIZ REED

357 Summer Street, Lynnfield, MA 01940 U.S.A

Phone: 781/334-4805 - Fax: 781/334-2362

E-Mail: navulcom@tiac.net

TURKISH PRESSINGS GALORE!

We stock rare 78's, picture sleeve singles, LP's from Turkey and around the world! Extensive list covering picture sleeves from Beatles, Elvis, Zeppelin etc. to R&B, rock 'n' roll, psych and anything you're looking for from Turkey! Please write for free list. Also watch out for our auctions at eBay as seller 'Lregalia' for superb items!

GOKHAN AYA

Akin sok.. 14/7. Suadiye, Istanbul. 81070, TURKEY
tel: +90 216 369 87 74 email: gokhanaya@yahoo.com

Aether Mailorder

"Rare Psychedelic music from way back in the 20th Century."

NEW SHADOKS titles! NEW WORLD IN SOUND titles!

Call TOLL FREE and ask about anything you're

looking for that's Psychedelic related on LP or CD.

ALL MAJOR CREDIT CARDS ACCEPTED

Call us TOLL-FREE 1-888-674-5723 (orders & info)

Aether Records / PO Box 19553 Indianapolis, IN 46219

Thousands more similar titles at: www.aether-or.com

DIGITALAGE VIDEO

ALL are High Quality! VHS = \$20.00/ DVD = \$30.00.

Add \$5.00 for shipping overseas. Catalog = \$2.00

AEROSMITH	2001	DVD	OR	VHS
JOE WALSH	2001	DVD	OR	VHS
STYX	2001	DVD	OR	VHS
PAT BENATAR	2001	DVD	OR	VHS
CHEAP TRICK	2001	DVD	OR	VHS
ELTON JOHN	2001	DVD	OR	VHS
ROBBY KRIEGER (THE DOORS)	2001	DVD	OR	VHS
GRAND FUNK RAILROAD	2001	DVD	OR	VHS
AC/DC	2001	DVD	OR	VHS
U2	2001	DVD	OR	VHS
GO GO'S	2001 Reunion	DVD	OR	VHS
PANTERA	2001	DVD	OR	VHS
DON McLEAN	2001	DVD	OR	VHS
STAINED	2001	DVD	OR	VHS
STONE TEMPLE PILOTS	2001	DVD	OR	VHS
JANES ADDICTION	2001	DVD	OR	VHS
MOODY BLUES	2001	DVD	OR	VHS
ERIC CLAPTON	2001	DVD	OR	VHS
IGGY POP	2001	DVD	OR	VHS
POISON	2001	DVD	OR	VHS
WARRANT	2001	DVD	OR	VHS
DEEP PURPLE	2001	DVD	OR	VHS
BLACK CROWES	2001	DVD	OR	VHS
OASIS	2001	DVD	OR	VHS
THE JOHN ENTWISTLE BAND	2001	DVD	OR	VHS
DEPECHE MODE	2001	DVD	OR	VHS
THE DAVE MATTHEWS BAND	2001	DVD	OR	VHS
THE MONKEES	2001	DVD	OR	VHS
RINGO STARR & HIS ALLSTARRS	2001	DVD	OR	VHS
MADONNA	2001	DVD	OR	VHS
STEVIE NICKS	2001	DVD	OR	VHS
TOOL	2001	DVD	OR	VHS

Money Orders payable to Marc **Marc S.**
PO Box 245132, Pembroke Pines, FL 33024
E-mail: Zip2orb@cs.com for catalog

RAGING BELLY VIDEO 2000

Are you looking for videos on your favorite artists? Maybe the ones from when you were growing up? Look no further!

Here are some of the artists I have on video:

- Judas Priest • Slade • Warlock • Boston • Wasp • REO Speedwagon
- Miles Davis • Tailsman • Elvin Bishop • Heavy Load • Ramones
- Angelwitch • The Sundays • Lynch Mob • Replacements • Tull • Television
- Mercyful Fate • Accept • Slayer • Giuffria • Iced Earth • Fire Merchants
- Strawbs

Send \$3.00 for postage & handling to:

MARC A.

P.O. Box 413, Farmingdale, NY 11735 U.S.A.

Beatles4me.com

26-Page 2001 Beatles Catalog: \$2.00

HEIN'S RARE COLLECTIBLES

P.O. Box 179, Little Silver, NJ 07739-0179

(732) 219 1988 • FAX (732) 219-5940

December 45 RPM/EP Online Auction

December 1st to Saturday, December 29th

6 PM CT

Another fine selection of 45's and EP's, with many musical genres.

There are quite a few oddities and DJ copies as well. There's something for everyone!

Let It Be Records

1001 Nicollet Mall, Minneapolis, MN 55403

(612) 339-7439

letitbe@bitstream.net • www.letitbe.com

COLLECTOR'S SHOWCASE

Showcase ads are the most looked at in Goldmine. You may buy as many boxes as you wish for an ad, at a cost of \$38.60 per box, multiplying the \$38.60 per box required. All typesetting is done by us and included in the price.

LIVING AFTER MIDNITE VIDEOS

If you are just looking for a catalog please send \$2 (refundable w/ purchase) for complete listings. Order with confidence and be happy!

AEROSMITH (New) Fall - 2nd Leg - Big Apple/Ground Zero - Intense - New/Very Old Stuff - Sold Out
BOB DYLAN (New) Looking Fine - Fall - Ground Zero - New/Old Stuff - Just Spectacular - A Must! - \$27
ROLLING STONES (Just In) - Clubbin' 97 - Pre Tour - Pro Shot - Rare - Midwest - Simply Perfect - \$26
QUEENSRYCHE (New) Rippin' - A 20 Year Celebration - Tour Finale - Fall/Big Apple - MINT - \$26
ELVIS COSTELLO (New) Fall - Rare w/ Wings Jazz/Orchestra Band - New Different Stuff - Fantastic - \$26
THE CULT (New) - Big Apple - Combination (2 Shows) New/Classic Stuff - Pro Too! - Recommended - \$26
BACKSTREET BOYS (New) Fall - Way Up North - Nice - Flashy - Make Young Girls Scream - \$26
IRON MAIDEN/ROB HALFORD (New) Fall - Pro Shot - Crystal Mint - Perfect Sounding Video - Summer 00 - \$26

N.J. CONCERT FOR PEACE 4 Fall - Professional - Springsteen/Bon Jovi/Jean Jett/Smithereen/Elvis Presley Band & other N.J. artists - Mint (2 Tapes) - \$35 or combo \$25

STEVIE NICKS (New) Fall - Solo - Fantastic - Up Close/Personal - Southern Charm \$26
BEASTIE BOYS (New) Fall - Big Apple - Fall - Benefit - High Energy - Amazing! \$26
RAY DAVIES (New) Northeast - Solo - Story of Kings - In Your Face - Awesome \$26
BLACK CROWES (New) Fall - 2nd Wind - New/Old Headliner - Earth Rattling - Sweet \$26
NO DOUBT (New) Northeast - New/Old Stuff - Very Hot - Fall/Brand New - Mint \$20
LEONIE (New) Summer 99 - Professional - French - Rare - Mint - Recommended \$25
NEIL DIAMOND (New) Northeast - Fall - New/Old Stuff - Right There - Very Nice \$26
GOVT. MULE (New) Northeast - Miller Jam - Fall - PA - Lots of Action - Smoking \$26
ELTON JOHN (New) Way Up North - Ave - Fall - Brand New/Old Stuff - Screened - Nice \$27
FANTOMAS (New) Northeast - New/Old Stuff - Greener - Fall - Nice \$20
TORI AMO (New) Fall/Northeast Big Apple #1 - Phenomenal - New/Old Stuff - Recommended \$27
NEIL DIAMOND (New) Northeast Big Apple #2 - Amazing - New/Old Stuff - Recommended \$27
JANES ADDICTION (New) Fall/Classic Set - Clubby Foot - Wild - Up Close/Personal - N.I. Killer \$26
NEIL DIAMOND (New) Fall/Partytime - Cheesesteak City - Crazy As Show - Nice \$26
GOVT. MULE (New) Summer - Professional - Biz. Fest. - Mint - Very Recommended \$25
S.T.P. (New) Summer - Professional - Biz. Fest. - Mint - Very Recommended \$25
STAINED (New) Summer - Professional - Biz. Fest. - Mint - Very Recommended \$25
IGGY POP (New) Summer - Professional - Biz. Fest. - Mint - Very Recommended \$25
GREENDAY (New) Summer - Professional - Biz. Fest. - Mint - Very Recommended \$25
GOODSMACK (New) Summer - Professional - Biz. Fest. - Mint - Very Recommended \$25
FOO FIGHTERS (New) Summer - Professional - Biz. Fest. - Mint - Very Recommended \$25
TOOL (New) Fall - Northeast/Big Apple #2 - Surreal - New/Old Stuff - Marvelous \$26
 (New) Northwest/PA - Fall - Up Close & Personal - Dark/Heavy - Great \$26
 (New) Big Apple/Northeast #1 - Headliner/Sold Out - Fall - Nice \$26

BOB DYLAN (New) Summer - German - Up Close & Personal - Very Good - Fantastic/Recommended \$26
STEVIE NICKS (New) Fall - West/Bay Area - w/ Sheryl Crow - Screened - Nice - New/Old Stuff \$26
CHEAP TRICK (New) West/Co. - Classic Set w/ Surprise - Summer - Sweet - Be There \$26
FUJI FEST (New) Professional - Summer - Mint w/ Neil Young - OASIS - P. Smith - New Order - A. Morrison \$26
ROD STEWART (New) Way Up North/Ave - Long Run - Summer - Tapdancing - Nice \$27
NEIL DIAMOND (New) Summer - German - Up Close & Personal - Very Good - Fantastic/Recommended \$26
BLACK CROWES (New) Fall - Headliner - Northeast/Big Apple #1 - New/Old Stuff - Recommended \$26
 (New) Northeast #2 - Fall - Headliner - Killer Show - Awesome Up Close/Personal \$26
ALANIS MORISSETTE (New) Summer - German - Professional - Nice - Mint \$25
LINKIN PARK (New) Summer - Professional - German - Nice - Mint \$25
THE CULT (Just In) Winter 2000 - Professional - New/Old Stuff - Headliner - Great \$26
SUMMER SONIC FEST (New) Summer - Japanese - Professional - Mint - Features the Cult, Marilyn Manson, Incubus & Beck

PATTI SMITH (New) Summer - CLUBBIN' - UK - up close/Personal - Killer show - Recommended \$26
JOURNEY (New) Summer - In Your Face - Northeast - New/Old Stuff - Fantastic \$26
JETHRO TULL (New) Summer - Northeast - Oddball - Very Good - Fantastic/Recommended \$26
JAHET JACKSON (New) VERY HOT - Summer - Northeast/Big Apple - Sexy - Awesome - A Must! \$27
CROSBY, STILLS & NASH (New) Summer - Old/New Stuff - They're On - Beachy/Northeast - Protike \$27
KING CRIMSON (New) Summer - Southeast - Precision/Progression - Up Close/Personal - Killer \$26
STEVIE NICKS (New) Midwest - Summer - w/ Sheryl Crow - Spring/Up The Magic - Great \$26
SABRE (New) Summer - West Coast - Now/Classic Stuff - Sweet \$26
VAN MORRISON (Just In) Summer 00 - Professional - Irish - Bluesy - Upbeat - Sweet \$28
BEE GEES (New) Professional - West Coast - You Know All Songs - Fun - Festive - Mint \$24
LED ZEPPELIN (Just In) Summer of '75 - Very Rare - UK - Finally - Great (2 Tapes) \$36
RINGO STARR (New) Summer - Up Close & Personal - Features - Howard Jones, Greg Lake, Sheila E. R. Hudson (Super Tramp), Ian Hunter & more - Beachy - Up Close/Personal - Framed - Great \$28
ROD STEWART (New) Summer - Beachy/Northeast #1 - Screened - Alive - Sensational \$27
 (New) Hot/Bothered - Summer - Beachy/Northeast #2 - Energetic - Up Close - Great \$27
BLACK SABBATH (New) Ozie - UK #1 - Summer - New Song - WILD - Mudfest/Tubes - CD01 \$26
SPINAL TAP (New) Summer - Banana - New Songs - Never Played Before! Songs - Funny - Perfect \$26

Make Checks Payable to Kevin / L.A.M. Videos Suite 102, 5 E. 41st St., New York, NY 10017

WE BUY AND SELL NEW & USED CD's, LP's & DVD's TOP DOLLAR PAID FOR COLLECTIONS (NO COLLECTION TOO LARGE)

• 60,000 CD's • 100,000 LP's • 20,000 CD's \$4.99 or Less • 20,000 \$1.00 LP's!

ONE OF THE LARGEST NEW/USED & COLLECTOR SHOPS IN THE U.S.A.
• COLLECTIBLES • ROCK • OLDIES • FUNK & SOUL • HIP-HOP • IMPORTS & INDIES • JAZZ • SHOWS • SOUNDTRACKS
• LATIN • COUNTRY • CLASSICAL • OPERA • AUDIOPHILE • ELECTRONICA • NEW RELEASES • AND MUCH MORE

PRINCETON RECORD EXCHANGE (609) 921 0881

CALL OR WRITE FOR FREE BROCHURE & DIRECTIONS • OPEN MON - SAT 10-9 SUN 11-6

• Friendly Knowledgeable Staff • Discount Prices WWW.PRX.COM

20 S TULANE ST PRINCETON NJ 08542 (Easy Access from N.Y.C. by Bus Train or Car)

ALBUM FRAMES!

Quality Brushed Aluminum Art Frames
Gold, Silver & Metallic Blue
(Black available: add \$1 more.)
Yours for less than the cost of the parts alone!

Send check or M.O. to:
Wiz Productions
10205 N. Oak Rd. W.,
Cedar Hills, UT 84062
e-mail: wiface@aol.com
www.wiz-productions.com

1 for \$10
2 for \$19
3 for \$28
4 for \$36

Postage only
\$2 per order
While Sale Lasts!
(U.S. only)
Foreign orders inquire.

21st CENTURY MUSIC

YOUR #1 SOURCE FOR
12" SINGLES

DISCO • SOUL • RAP & HIP HOP • ROCK 12"
IMPORT 12" PROMOS • SOUL ALBUMS
SEARCH SERVICE AVAILABLE • WANT LISTS ACCEPTED
BUYING DJ COLLECTIONS • VISIT US ON THE WEB
1-800-846-9501 • 201-641-6610
FAX 201-641-9309

WWW.21CENTURYMUSIC.COM
E-MAIL: SALES@21CENTURYMUSIC.COM
15 MT. VERNON STREET, RIDGEFIELD PARK, NJ 07660



Collector Of Yesterday's
Recordings Company

www.cyrcomusic.com

140,000
USED
RECORDS ON
SALE!

WE RECORD
LP'S ONTO
TAPE OR
CD!!!

R&B, Big Band,
Country, Easy,
Folk/Ethnic,
Jazz, Christmas,
Classical, Rock,
SoundTrack,
Religious &
NonMusic
Free
Catalogs:
(choose type)

Mail: CyrCo Music
3811 Leavenworth St.
Omaha, NE 68105
Ph: 402-345-8164
Fax: 520-441-2429
Email: jefcyr@cyrcomusic.com

RETRIEVER MEMORABILIA SERVICES

RARE RIAA AWARDS.....WHITE MATTES.....FLOATER STYLE
CONTRACTS.....NEGATIVES.....PHOTOS.....SIGNATURES

PHONE: 508-872-8162 FAX: 508-872-8163
E-MAIL: BEATLES196401702@YAHOO.COM

RETRIEVER IS ALWAYS INTERESTED IN
OBTAINING RARE AWARDS!!!!
CALL US FOR AN IMMEDIATE QUOTE!!!!

PAPA JAZZ RECORD SHOPPE

Over 30,000 jazz, rock, soul,
funk, punk, country, folk,
blues and hip-hop LPs. Rare,
new and used CDs, LPs and
even tapes.

Visit us on the Web at
www.papajazz.com
or drop us a line at
2314 Greene St.
Columbia, SC 29205
(803) 256-0095

NEEDLES Unlimited

MANUFACTURERS IMPORTERS & EXPORTERS OF
NEEDLES CARTRIDGES & ACCESSORIES
1ST QUALITY NO GENERICS BANG & OLUFSEN
THE LARGEST INVENTORY IN THE USA
WHOLESALE AND RETAIL STEREO LP/45/78

RIVERTONE 78 RPM FOR ALL TYPES

ADC AUDIO TECHNICA STANTON PICKERING SHURE
ORTOFON BSR RIVERTONE TETRAD ACUTRAC
ASTRON ETC. EXPERT CONSULTING

TOLL FREE 1-800-662-8090

WE REBUILD & RETIP FAX 845-791-9670

E-MAIL: rivertone@fcc.net

WE ACCEPT VISA MASTERCARD & AMER. EXPR
NEEDLES, P.O. BOX 161, MONTICELLO, N.Y. 12701

Supreme



Legacy

A DIVISION OF MARY WILSON ENTERPRISES, INC.
GREAT GIFTS FOR EVERYONE!!!

LIMITED EDITION COLLECTIBLES

- * Tee Shirts * Tote Bags
- * Postcards * Mousepads
- * Lapel Pins * Key Chains
- *** and More ***

www.supreme-legacy.com

OR

www.marywilson.com



We Buy Collections

World Radio History

LET THE MUSIC PLAY®

(603) 473-8618 krwvay@earthlink.net (207) 651-2790

Specializing in STEVIE RAY VAUGHN concerts

SELLING: IRON MAIDEN / KISS LP COLLECTION

Rare concerts by just about everyone

WANTED BADLY: ANY recordings by

IKE EVERYLY or MOSE REGOR

TANGERINE DREAM Collection For Sale

- LP's - CD's - 7"
- Presskits - Tourbooks
- Movie Posters - more...

Please e-mail for list:

redshift1138@yahoo.com

FUN RECORDS

Germany's Largest Mail Order for
Second-Hand Records and CDs.

Over 50,000 items in stock

We have the hits and rarities of the 70's, 80's and 90's.
Get our new catalogue. Send 2 IRC or \$4 for postage.

FUN RECORDS ABT. G HEGESTRASSE 29

20249 HAMBURG/GERMANY

http://www.funrecords.de

Euclid Records

7905 Big Bend Blvd.

St. Louis, MO 63119 USA

orders@euclidrecords.com

Weekly used vinyl & CD lists

Jazz, Rock, Blues, Soul, Folk, World Music, Vocals

www.euclidrecords.com

COLLECTOR'S SHOWCASE

Showcase ads are the most looked at in Goldmine. You may buy as many boxes as you wish for an ad, at a cost of \$38.60 per box, multiplying the \$38.60 per box required. All typesetting is done by us and included in the price.

RARE VIDEO

- | | | | | |
|------------------|---------------|-------------------|-----------------|---------------------|
| ABBA | Black Crowes | Faces | Madonna | Roxette |
| AC/DC | Black Sabbath | Fleetwood Mac | Mick Taylor | Sabrina |
| Agnetha | Blondie | Freddie King | Missing Persons | Shakespear's Sister |
| Albert Collins | Bo Diddley | Go Go's | Mott the Hoople | Slade |
| Alice Cooper | Buddy Guy | Hanoi Rocks | Muddy Waters | Sweet |
| Albert King | Cyndi Lauper | Ian Hunter | New York Dolls | Stevie Ray Vaughan |
| Allman Bros. | David Bowie | James Brown | Pat Benatar | Susanna Hoffs |
| Angel | Debbie Harry | Jane Wiedlin | Patti Smith | Suzi Quatro |
| BB King | Deep Purple | Jeff Beck | Pretenders | Suzanne Vega |
| Babys | Dire Straits | Johnny Thunders | Prince | T. Rex |
| Bad Company | Dogs D'Amour | Johnny Winter | Queen | Tori Amos |
| Bananarama | Duran Duran | John Lee Hooker | Ramones | Transvision Vamp |
| Bangles | Elvis Presley | Kate Bush | Rod Stewart | Tom Waits |
| Bay City Rollers | Frida | Kim Wilde | Ron Wood | + Rare Blues |
| Belinda Carlisle | Eric Clapton | Lightnin' Hopkins | Rolling Stones | + Rare 1960's |

The ultimate video catalog is now available. The best quality and the best service, guaranteed. To obtain this catalog, simply send \$1.00 to:

RARE VIDEO
P.O. Box 280-005, Brooklyn, New York 11228-0005 U.S.A.
(Overseas inquiries welcome - PHL/SEACAM available). You won't be disappointed.

RARE PERFORMANCE VIDEO

LED ZEPPELIN Earth Court, England 5/24/75. This set contains 2 videos with 3 hours of music. This version just surfaced and is much cleaner than other versions that are available.
U2 1981 Ritz Club, New York. This video was filmed from a single camera by the band before they hit live road for the tour. Very rare and unique, 70 mins.
U2 Rock Pop Show 1984. Taped to support Unforgettable Fire album. 60 mins.
U2 Rattle and Hum Outtakes 1987 Vol. 1, outtake footage from the film, 90 mins.
U2 Madison Sq. Garden 6/17/01 - GREAT SHOW, 120 mins.
PLUS We just received 2 more videos from the Rock in Rio shows.
REM 1/13/01. Most of the REM performance was cut from the show. This is the Entire Performance from Brazil. 95 mins.
BRITNEY SPEARS 1/18/01. PRO shot for the Britney show, up close and on stage, 70 mins.
HI - We specialize in rare, hard to find performances from around the world.
 Videos are \$25 each or 2 for \$40 (includes ship. in US) shipped quick.
 Money order only to Rick:
 99B Harger Dr., Turtle Creek, PA 15145
 Send E-mail address for list, included with order. THANKS!

2001 VIDEOS

Rare Rock Concert Videos from 1963-2001 from - USA, Japan, and Europe.
 Best quality and service around - guaranteed.

S.A.S.E. for list to:

VIDEOTECH
 2118 Wilshire Blvd. #179
 Santa Monica, CA 90403

AUTOGRAPHED GUITARS

AUTOGRAPHED GUITARS

Metallica, Red Hot Chili Peppers, Lynyrd Skynyrd, Everclear, Creed, Crosby, Stills, Nash & Young, Deftones, Slash/Guns N' Roses, Joe Cocker, Barry Manilow, 3 Doors Down, Kenny Rogers, Smashmouth, Indigo Girls, Wayne Newton, Kansas, Joan Osbourne, Third Eye Blind, B.B. King, Jethro Tull, No Doubt, Stone Temple Pilots, U2, Wallflowers, ZZ Top, Faith Hill/Tim McGraw, Bon Jovi, John Lee Hooker, Dolly Parton, Michael Bolton, Sammy Hagar, Melissa Etheridge, Police/Sting, Def Leppard, Bo Diddley, Simon & Garfunkel, Oasis, Joe Walsh, Rod Stewart
702-894-9219
www.autographedguitars.com

AUTOGRAPHED GUITARS

FRENCH RECORDS & MAGAZINES



Pop, Rock, Easy...
 Lists: 1 IRC per artist

DJB, 20 rue Bringier-Monnier
 83640 St.-Zacharie France
 Fax: +33 442 62 74 74
www.djbrecords.com



LA's BEST COLLECTIBLES & USED
COMPACT DISCS - LP's - 45's - DVDS - VIDEOS - POSTERS - BOOKS - MAGAZINES MEMORABILIA AND LOTS MORE!

ROCKAWAY RECORDS
 2395 GLENDALE BLVD.
 LOS ANGELES, CA 90039

OPEN 7 DAYS
MON.-SAT. 10-9:30 • SUN. 12-8
PH 323-664-3232
FAX 323-664-0956
EMAIL: sales@rockaway.com
www.rockaway.com

INTOXICA!

New and Collectible Vinyl
 Bought - Sold - Exchanged Mail Order Available!
 Send/Fax/E-mail want lists or check our Web pages.
 231 Portobello Road, London W11 1LT, ENGLAND Tel: 0207 229 8010 Fax: 0207 792 9778
 intoxica@intoxica.co.uk www.intoxica.co.uk
 Opening times: Mon-Sat 10:30 a.m.-6:30 p.m., Sun 12 a.m.-4 p.m.
 All major credit cards accepted.

gatefold records

www.gatefoldrecords.com

Specializing in:
 Rare, Promotional & Out of Print CDs & Vinyl
 Imports
 Posters & Stickers
 Videos
 Memorabilia
 Specializing in 80's & 90's alternative rock

In our Cult Favorites Section you'll find:
 Re-issue Vinyl & CDs
 Imports
 Rare Vinyl
 For fans of:
 Jazz & Soundtracks
 Prog Rock & Psychedelic
 Brazilian & Latin
 Funk & Soul

E-mail: Sales@gatefoldrecords.com
Phone: 818-888-4071 • Fax: 818-888-4023

MFSL WANTED

Collections of Sealed or Mint MFSL LP's & Gold & Aluminum MFSL CD's WANTED!
Paying BIG \$\$\$\$\$!

mobile fidelity sound lab
 a division of MFSL, INC.

CALL 818-988-3313 9-5 PST
or FAX 818-988-9790

Rare Experimental ELVIS PICTURE DISCS and *Other Artists Found After 20 Years

Plus 100's of sealed LPs, cassettes, 8-tracks & 45s.
 *Other artists include Waylon Jennings, Bonnie Tyler, Hall & Oates, Rod Stewart, Willie Nelson, Debbie Peters, Jefferson Airplane, John Denver, Alice Cooper, Dolly Parton, KISS & more.
SEND \$5 U.S. \$7 Foreign for our 8-PAGE COLOR CATALOG with over 60 pictures AND separate 8-PAGE PRICE & INFORMATION GUIDE to:
Bob & Donna Ruggieri
 734 Calle Pecos, Thousand Oaks, CA 91360
 (805) 498-2775 • (805) 498-2769 fax.
 Web site: **www.elvispicdiscs.com**

TOLL FREE ALBUM ONLY HOTLINE 1-800-823-4113

10 a.m.-5 p.m. Mon-Sat EST
OVER TWO MILLION RECORD ALBUMS IN STOCK
IF WE DON'T HAVE IT, WE WILL FIND IT FOR YOU
BANANAS ALL VINYL WAREHOUSE
 2226 16th Ave. N.
 St. Pete., FL 33713
 Check out our catalog of 100,000 LP's on our new Web site:
<http://musicfinder.com>
E-MAIL BANANAGRAM@AOL.COM

Rock & Roll Autographs Hollywood Memorabilia Signed Albums

Write for Current List
Myron Ross
HEROES & LEGENDS
 P.O. Box 9088 • Calabasas, CA 91372 • Phone: 818-346-9220
 Web Site: **www.HeroesandLegends.net**

RARE REGIONAL TOP 40 SURVEY REPRODUCTIONS

TRACKING YOUR CHARTED FAVORITES SINCE 1956
(916) 315-9244 FAX (916) 315-8563

VIDEO!

STEPHEN M. RUSSO
 P.O. BOX 150/BOSTON, MA 02151-0001(M)
 VHS Tapes made available on a collector-to-collector basis. Rates include priority mail postage!
 Allow between 2-4 weeks for order. Overseas: Add \$5 per tape, air postage U.S. Funds only.
 PAL Standard videos. Add \$10 per tape. All titles offered from best available prints and elements
\$20.00 or any 3 for \$55.00

ABC-TV 1960's MUSIC SHOWS: "American Bandstand" from 1967 with Neil Diamond, The Electric Prunes, & Tim Conway! "Where The Action Is" (9/9/66) with The Four Seasons and Jackie Paine! Both with original TV commercials! (90 minutes B&W)
AMERICAN BANDSTAND 11TH ANNIVERSARY SHOW: As aired on ABC-TV 8/17/68 uncut with original commercials! Great clips from Philadelphia and California years! Musical guest: "The American Breed"! (1 hour B&W)
THE GREAT 50's/60's ROCK: Compilation of rarely seen late 1950's-early 1960's Rock performances! Johnny Burdette Trio, Frankie Lyman & The Teen-Agers, Clovers, The Flamingos, The Platters ("The Great Pretender"), Fats Domino, LaVerne Baker, The Moonglows, Little Richard, Gene Vincent, The Diamonds ("Little Darlin'"), Shelley Fabares ("Johnny Angel"), plus Alan Freed, B.J. Thomas, and Rockabilly segments from "The Country Music Caravan"! (90 minutes B&W-Color)
VIDEO ROCK & ROLL #7-"GARAGE BAND CLASSICS": GREAT compilation with SHIVAREE w/"Dino, Desi & Billy", James Brown, Aretha Franklin, Gerry & The Pacemakers! Followed by a selection of numbers by The Raspberries (on Mike Douglas!), Moby Grape, New Colony 6, The Kingsmen, Sir Douglas Quintet, McCoy's, Tommy James & The Shondells, Strawberry Alarm Clock, Cyrkle, Bobby Fuller 4, Blue Cheer, Standells, Syndicate of Sound, 5 Americans, The Beau Brummels, Knickerbockers, Gentrys, Love, Music Machine, Shadow of the Knight, Leaves, Outsiders, ? and The Mysterians! (Color 95 minutes.)
VIDEO ROCK & ROLL #8-"GARAGE BAND RARITIES": Another great tape with segments featuring The Guess Who, Beau Brummels, Cyrkle, Bobby Fuller 4, Remains, Kingsmen, Tony & The Tigers, We Five, Buckingham's, The Byrds, 5 Americans, Vanilla Fudge, Electric Prunes, Seeds, 1910 Fruitgum Company, Iron Butterfly, Blues Magoos, Buffalo Springfield, Strangeloves, Mitch Ryder & The Detroit Wheels, ? & The Mysterians (Color 90 minutes)
WHERE THE ACTION IS-4 SHOWS! Original ABC-TV broadcasts hosted by Paul Revere & The Raiders! Guests include Bobby Vee, Razor Edge, The Syndicate of Sound, 5 Americans, The Happening and CJ & The Runaways! Great 60's Shows! (B&W/100 minutes)
ROCK & ROLL HISTORY (GREATEST YEARS) 1950's: Great USA/ British video compilation with lost rare footage of Elvis Presley, Everly Brothers, Jerry Lee Lewis, Chordettes, Cliff Richard, Fats Domino, Buddy Holly, Paul Anka, Eddie Cochran, Vince Taylor, Chuck Berry, Carl Perkins, Lonnie Donegan, Little Richard, James Brown, Frankie Lyman, Johnny Ray, The Platters, Bo Diddley, Diamonds, Flamingos, Tommy Sands, Ritchie Valens! (Black & White 100 minutes)
AMERICAN BANDSTAND-1957: Rare find! Good quality December, 1957 show from Philly! + extras! (90 minutes B&W)

COLLECTOR'S SHOWCASE

PINK FLOYD / SYD BARRETT

Extremely rare private collection of the rarest records and memorabilia in the world, including promos, unreleased demos, unreleased acetates, unpublished photos, artwork, record awards, original concert posters, very early flyers, handwritten material, and personal effects. Serious Collectors inquire by email @

Borderlineart80@hotmail.com

ClassicRockConcertPhotos.net

Eric Clapton		Hall of Fame Inductions
Bob Dylan		Benefit and Tribute Concerts
Crosby, Stills, Nash & Young		Early Influences & Legendary Bluesmen
Grateful Dead		
		Britspics@aol.com

If You're in the New York City area December 15th be sure to visit us at the Record & CD Collectors Expo at the Holiday Inn located at 440 W. 57th St.



"Looking For Your Lost Mind Revue"

Presents

Custom framed Posters and Autographs from the 60's and 70's Animals to Grateful Dead to Zappa
Send for a FREE Catalog.

Dr. George

P.O. Box 23055, Santa Ana, CA 92711-3055
or call (714) 731-3424

RARE HIGH QUALITY VIDEO

All Titles Only \$20 Each
Super Holiday Special: Buy 2, Get 1 Free!
Overseas add \$6 per video
All titles proshot unless noted (AUD)

LUTHER ALLISON: Montreal 1997, 110 min.
ALLMAN BROS: 9/70 Fillmore/Love Valley, 55 min.
BEBOP DELUXE: '75-'77 TV compilation, 110 min.
JEFF BECK: 3/16/01 Toronto (aud) + '74 UK TV, 110 min.
JACK BRUCE: 1971 "Swing In" documentary + 1993 CREAM reunion Eric/Jack/Ginger, 45 min.
ROY BUCHANAN: 1971 US TV documentary, mint 90 min.
ROY BUCHANAN: 1985 Hamburg, Germany, 75 min.
ERLCLAPTON: UK '87 w/BUDDY GUY + '97 Switzerland w/LEGENDS! 50 min.
STANLEY CLARKE: Switzerland 1980, 60 min.
JOHN COLTRANE: Germany '61/France '65, 50 min.
LARRY CORYELL/BILLY COBHAM: Germany '97, 60 min.
MILES DAVIS: 4/82 London, UK 90 min.
RONNIE EARL: Switzerland '97/Germany '96, 80 min.
ROBBEN FORD: Germany '97/Japan '00, 75 min.
GOVT MULE: Macon, GA '94 (1st show ever) (aud), 110 min.
PETER GREEN: '96 UK TV/98 Germany, 90 min.
PETER GREEN: U.K. TV '97 + 10/96 France (aud), 110 min.
RANDY HANSEN/BUDDY MILES: Italy 1997, 80 min.
HUMBLE PIE: 1972/73 TV compilation, 80 min.
ALBERT KING: 1987 Toronto (aud), exclusive, classic! 90 min.
FREDDIE KING: N.C. '72/Switzerland '71, 75 min.
MARK KNOPFLER: 5/01 Toronto (aud), 130 min.
LITTLE FEAT: 1977 London, UK w/MICK TAYLOR, 80 min.
MAGIC SLIM: 1988 Italy, 60 min.
MAHAVISHNU ORCHESTRA: London '72/NY '73, 45 min.
MAHAVISHNU ORCHESTRA: Munich '72/USA '73, 60 min.
FRANK MARINO/MAHOGANY RUSH: '75-'83 comp., 110 min.
FRANK MARINO: 7/98 Ottawa, 80 min.
BOB MARLEY/WAILERS: Zimbabwe '80, 45 min.
THELONIOUS MONK: Copenhagen '71, 60 min.
GARY MOORE: Switzerland 1990 & 1997, 85 min.
SCOTTY MOORE/D.J. FONTANA: Hempstead, UK '93, 90 min.
JOB PASS: 1992 Trier, Germany, 55 min.
JEAN LUC PONTY: 1972 & 1993 Germany 75 min.
RETURN TO FOREVER: Germany '74 w/BILL CONNORS! 45 min.
OTIS RUSH: Brazil 1997, 105 min.
SHAKTI: 1977 French TV documentary + '00 Germany, 80 min.
THIN LIZZY: London '73/Australia '79 w/GARY MOORE, 85 min.
JIMMIE VAUGHAN: Argentina '94/Finland '99, 80 min.
STEVIE RAY VAUGHAN: 12/83 Washington, DC/Germany '86, 75 min.
WEATHER REPORT: 7/76 Switzerland, 75 min.
WEATHER REPORT: 9/78 Offenbach, Germany, 130 min.
TONY WILLIAMS: Switzerland 7/71/Germany '89, 70 min.
JOHNNY WINTER: Essen, Germany 4/21/79 rare "Part II", 60 min.

Money Orders Only Payable to:

Robert W.

P.O. Box 64944, Burlington, VT USA 05406
Add \$1 per video for extra high grade tape.

Showcase ads are the most looked at in Goldmine. You may buy as many boxes as you wish for an ad, at a cost of \$38.60 per box, multiplying the \$38.60 per box required. All typesetting is done by us and included in the price.

WANTED

original 45s from the 50s & 60s - GARAGE, SURF, R&B, SOUL, R&R, ROCKABILLY, ETC... Will pay good prices for quality pieces. Interested in one 45 or entire collection! Can consign or trade as well. Visit our Web site. We have over 18,000 records and misc.

www.goldengaterecords.com

Please send any lists or call/write at

BARRY WICKHAM

P.O. Box 2796, Petaluma, CA 94953
707-765-9334

Though X went on to release a number of other albums, these three releases form the core of the group's catalog and make a good case for why X is one of the most important independent bands of the early '80s.

— Gillian G. Gaar

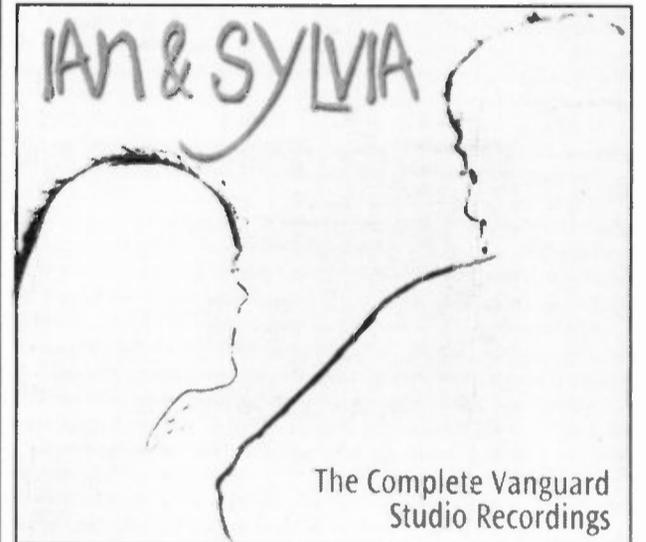

IAN & SYLVIA
The Complete Vanguard Studio Recordings
Vanguard (196-99-2)

Approaching the American folk boom of the early 1960s from a date several decades after it peaked, it's astonishing just how deeply entrenched certain truths have become. Doomed poet tragedy marks Richard and Mimi Fariña as brilliant, association ensures Joan Baez will never be forgotten. Guthrie blood keeps the Arlo boy in motorsickles, and Bob Dylan, of course, is self-perpetuating.

But Ian Tyson and Sylvia Fricker have never been granted much attention, and one doesn't have to look far to find out why. Too self-contained, too self-assured, they arrived in America with their proficiency already a fact of life, honed by years playing 'round the Canadian folk circuit. There was no chance to watch them learning to fly, no sense of seeing them grow with their audience. They simply were.

"Were what?" one might suspiciously ask. They were beautiful, they were brilliant, they looked great and they dressed dead Mod with a capital D.

Fricker had bangs to die for, and Tyson perfected the no collar/skinny-tie/drainpipe trousers look a full 20 years before new wave picked it up. But, as Fricker now reflects, "We never attracted the crazies like Dylan did. We had a romantic image with college couples, who identified with us."

At one point, only Peter, Paul And Mary were selling more records than Ian & Sylvia, and that says it all.

But then you listen to those records, and you realize just what we've been missing all these years. *The Complete Vanguard Studio Recordings* is exactly that, a four-CD box set that rounds up all seven of the dynamic duo's albums then adds a couple of

Bonus tracks include a previously unreleased rough mix of the band's first single, "Adult Books," a previously unreleased rehearsal of "Cyrano De Berger's Back" (both tracks showing a reggae influence) and a previously unreleased demo of "I'm Coming Over," among other tracks.

Though *Wild Gift* opens with another blast of Zoom's rockabilly licks, the album has noticeably smoother production in contrast to the rawness of *Los Angeles* — just compare *Gift's* version of "Adult Books" with the rough mix on the *Los Angeles* CD. Doe's and Exene's voices meld together better as well. A song such as "White Girl" even has a slow, dreaminess about it that may not be exactly punk but shows the group wasn't about to get caught in any musical ruts. The seven bonus tracks (the most on any of these reissues) include the flip side of the band's first single, the edgy "We're Desperate"; a rough and ready, previously unreleased live version of "Back 2 The Base"; and a great rehearsal take of "Heater," previously on the *Beyond and Back X* anthology.

Under The Big Black Sun shows the band displaying an increasing confidence — one might subtitle the album *X Grows Up*. The music is undeniably more pop than punk. Though "How I (Learned My Lesson)" conjures up the X of old, songs such as the title track and "Riding With Mary" are surprisingly catchy, as is "Dancing With Tears In My Eyes," a cover of a Leadbelly song from the '40s; "Real Child Of Hell" is pure power-pop. The CD's bonus tracks include two previously unreleased cuts, a live version of "Lesson" and an instrumental version of "Because I Do," preceded by a brief excerpt of Exene warbling "El Paso." Singles and a live track round out the mix.

Reissues from page 64)

Los Angeles
Slash/Rhino (R2 74370)

Wild Gift
Slash/Rhino (R2 74371)

Under The Big Black Sun
Elektra/Rhino (R2 74372)

Los Angeles punkers X have finally received the CD reissue treatment, each of three releases featuring remastered sound and a generous number of bonus tracks. The band's debut, *Los Angeles*, originally released in 1980, remains the group's most incendiary work. From the buzzsaw attack of Billy Zoom's guitar on the opener, "Your Phone's Off The Hook," to the final notes of "The World's A Mess; It's In My Kiss," the band barely stops to take a breath, as guitar, bass and drums hurtle over each in their rush to get through each song.

Of course, lots of punk bands of the era adopted the same technique; what made X stand out was their level of skill (particularly Zoom and drummer D.J. Bonebrake's work), and the unique, dissonant harmonizing between bassist John Doe and singer Exene. Producer and former Doors keyboardist Ray Manzarek (who produced X's first four albums) adds organ and synthesizer to some tracks, though interesting to note, not the group's zany cover of The Doors' "Soul Kitchen."

Special Holiday Offer From Goldmine

FREE SHIPPING



Goldmine Standard Catalog of American Records, 1976 to Present
by Tim Neely

Did you know that artists like Madonna, Prince, U2, REM and Garth Brooks have music available on vinyl? You will find these and more with this comprehensive price guide from Goldmine and expert author, Tim Neely. With more than 60,000 listings in three grades of condition arranged alphabetically by artist, this is the first book to cover LPs, 45s, 12-inch singles and EPs from 1976-2000.

Softcover • 8-1/2 x 11 • 672 pages
200 b&w photos
Item# AR01 • \$27.95



Goldmine Standard Catalog of American Records, 1950-1975
2nd Edition
by Tim Neely

Record experts called the first edition the "best U.S. guide to American records ever published." In this second edition you'll find 150,000 listings, many of them new; updated pricing with 450,000 prices, one for each of three grades of condition; plus the most accurate information available.

Softcover • 8-1/2 x 11 • 1,296 pages
150 b&w photos
Item# REC2 • \$34.95



American Premium Record Guide, 1900-1965
6th Edition
by Les Docks

Here it is record collectors, the updated and expanded version of the authoritative guide to collecting your favorite vintage records. In this comprehensive price guide you will find more than 7,500 artists from all music genres, including big band, blues, jazz, country/western and rock, and more than 30,000 values for collectible 78s, 45s and LPs recorded from 1900 to 1965.

Softcover • 8-1/2 x 11 • 592 pages
1,800 b&w photos • 16-page color section
Item# ARG06 • \$27.95



Goldmine Jazz Album Price Guide
by Tim Neely

Tim Neely, author of eight recording industry price guides, including the Standard Catalog of American Records, has authored, compiled and organized this new showcase price guide which features jazz musicians, composers and vocalists from the bebop era through to today. You'll find thousands of jazz artists - Dixieland, big band/swing, bebop, progressive, modern, fusion, and more - all featured in over 40,000 listings and priced in three grades of condition.

Softcover • 8-1/2 x 11 • 544 pages
150 b&w photos
Item# RJ04 • \$24.95



Warman's American Records, 1950-2000 Identification & Price Guide
by Chuck Miller

This guide to American records released between 1950 and 2000 is perfect for any collector, beginning or seasoned. Inside you will find more than 2,000 listings for LPs, LLPs and 45s from a variety of genres, including country, heavy metal, soul, jazz and rock, among others. More than 750 photos and accurate pricing in up to three grades of condition will help you identify and value your collection.

Softcover • 8-1/2 x 11 • 352 pages
750 b&w photos • 16-page color section
Item# WAREC • \$21.95

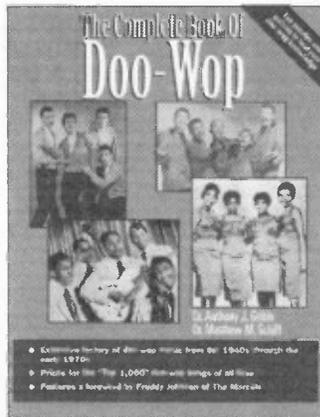

The Complete Book of Doo-Wop
by Dr. Anthony J. Gribin & Dr. Matthew M. Schiff

This book transports you back to nostalgic times of hanging out with friends at the malt shop, dances at the hop, and first romances and makes you want to scan the radio in the hopes of hearing a song by Dion & the Belmonts, the Chiffons or Little Anthony & the Imperials. An extensive history of doo-wop from 1950 through the early 1970s is given, along with 150 photos, 64 sheet-music covers and prices for 1,000 top doo-wop records.

Softcover • 8-1/2 x 11 • 496 pages
150 b&w photos
Item# DWRB • \$24.95

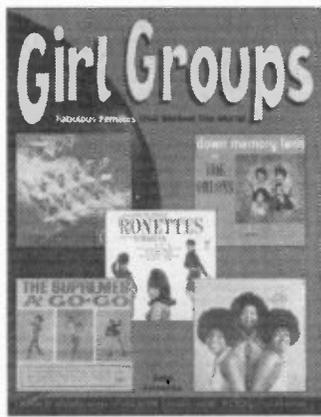

Girl Groups
Fabulous Females That Rocked The World
by John Clemente

If you love girl groups from the 1950s to the 1980s, such as the Supremes and the Go-Gos, this is a must-have book. The top 60 girl groups of rock 'n' roll and rhythm 'n' blues are profiled with complete discographies and more than 150 photos. All girl group enthusiasts and music lovers in general will benefit from the biographical information and discography included in this book.

Softcover • 8-1/2 x 11 • 280 pages
180 b&w photos
Item# OFD • \$19.95

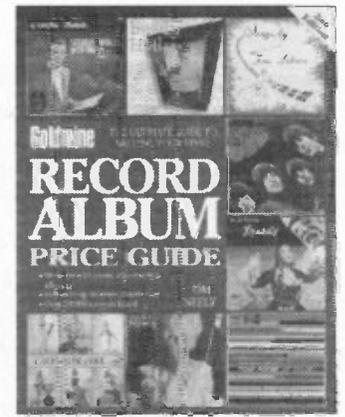

Goldmine Record Album Price Guide
2nd Edition
by Tim Neely

Coverage in this comprehensive price guide includes American albums from 1948 through 2000. You will find more than 60,000 listings in up to three grades of conditions along with many photos of rare and unusual albums as well as a record label identifier section. Albums are listed alphabetically by artist and are in checklist format for easy inventory.

Softcover • 8-1/2 x 11 • 672 pages
200 b&w photos
Item# REA2 • \$24.95

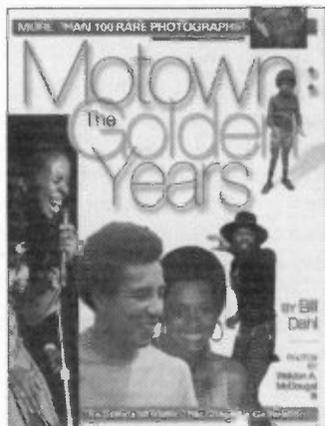

Motown: The Golden Years
Photography by Weldon A. McDougal III

Lovers of Motown, this is the book for you! Author and Motown historian Bill Dahl has expertly compiled this complete encyclopedia of nearly every Motown group and artist since 1959, along with information about their music.

Softcover • 8-1/2 x 11
384 pages
200+ b&w photos
32-page color section,
50 color photos
Item# MTWN • \$24.95

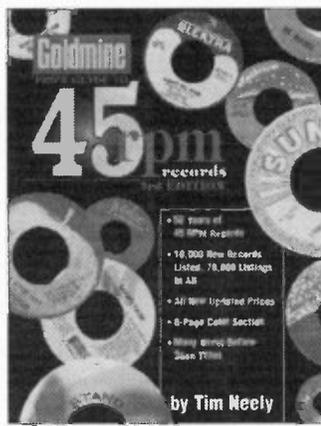

Goldmine Price Guide to 45 RPM Records
3rd Edition
by Tim Neely

You'll get more record listings and current values than any other 45 RPM record price guide. Plus, more than 200 photos will help you identify and authenticate your collection. And over 70,000 RPMs, 45s, extended play singles, and picture sleeves from 1949 through 2000 are graded and priced so you'll have more than 210,000 prices to gauge your collection's value. Includes 8 pages of full-color noteworthy records and sleeves.

Softcover • 8-1/2 x 11
648 pages
200 b&w photos
8-page color section
Item# R453 • \$24.95

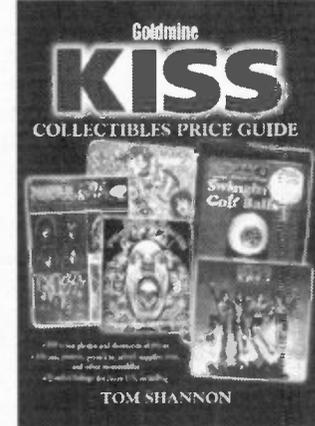

Goldmine KISS Collectibles Price Guide
by Tom Shannon

KISS is still one of the hottest bands in the world today and the most collectible musical group, next to Elvis and the Beatles. This book, featuring 2,000 listings and 500 color photos of the band's merchandise, offers detailed listings for every U.S. recording, as well as a large number of foreign releases. There are also detailed listings of more than 250 licensed products produced from 1974-1998, from action figures, Beanie's and die-cast cars, to Halloween costumes, posters and videos.

Softcover • 8-1/4 x 10-7/8
176 pages
500 color photos
Item# KISS • \$24.95

To order call

800-258-0929

Offer R71R

M-F 7am - 8pm • Sat 8am - 2pm, CST



Goldmine

Krause Publications, Offer R71R
P.O. Box 5009, Iola WI 54945-5009
www.krausebooks.com

Shipping & Handling: Free shipping & handling through December 31, 2001 to all U.S. addresses. Standard shipping only. Non-US addresses \$20.95 first book, \$5.95 each additional.

Sales Tax: CA, IA, IL, PA, TN, VA. WI residents please add appropriate sales tax.

Satisfaction Guarantee: If for any reason you are not completely satisfied with your purchase, simply return it within 14 days of receipt and receive a full refund, less shipping charges.

Goldmine

WANT LIST ADS

SAMPLE WANT LIST AD

SAM JONES, 101 WILMETT AVE., SHADE, TEXAS 00033 (222) 445-0001

I'M LOOKING FOR THE FOLLOWING IN VG CONDITION OR BETTER:

Badfinger	Straight Up	LP	Apple SW3387
Roy Head	Roy Head and the Traits	LP	TNT 101
Dion and the Belmots	Where or When	45	Laurie LEP-302

The cost on this listing would be \$2.50 - \$1.00 flat fee, plus \$1.50 for the items listed (3 items at 50¢ each).

Are you looking for a particular 45, LP or CD? Perhaps you're looking for several items to add to your collection. Now there's an inexpensive way to advertise for the music you need - the **Goldmine Want List**.

For a flat fee of \$1.00, plus 50¢ per item, you can let over **60,000** Goldmine readers know what you're looking for!

The **Goldmine Want List** is a regular feature which will appear in every issue of **Goldmine**. Goldmine is read by the the most avid music collectors and dealers in the world. If you want it, they probably have it!

To place your wants in the **Goldmine Want List**, simply send us your name, address and phone number along with a list of the items you are looking for. Include payment with your list.* A sample listing is shown below to illustrate how the listings will appear, and how the cost for a listing is figured.

* Payment may be made in the form of Check or Money Order. We also accept MasterCard, VISA, American Express and Novus.

Goldmine WANT LIST Order Form

MAIL TO: GOLDMINE WANT LISTS • 700 E. State St., Iola, WI 54990-0001
715/445-2214 Fax: 715/445-4087

PAYMENT:

Check Money Order MasterCard VISA American Express Novus

Credit Card # _____ Exp. Date: _____

Signature _____

Flat Fee **\$1.00** + _____ items @ 50¢ per listing = **TOTAL \$** _____

This line is optional and can be used to describe the condition of the items you are looking for.
FORMAT LABEL & CATALOG NUMBER

Name _____
Address _____
City _____
State _____ Zip _____ Phone _____
E-mail address _____

	ARTIST	RECORDING	FORMAT	LABEL & CATALOG NUMBER
Item #1	_____	_____	_____	_____
Item #2	_____	_____	_____	_____
Item #3	_____	_____	_____	_____
Item #4	_____	_____	_____	_____

Use additional sheets of paper if needed. Please type or print clearly.

Note: Due to tremendous response, *Want List Ads* will appear in the order they are received. Because of space limitations it may take several issues for your ad to appear.

GOLDMINE WANT LISTS

Looking for a particular recording? Advertise it in the Goldmine Want List section. The cost is \$1.00 flat fee, plus 50¢ per item. Use the form at the beginning of this section to list your wants. Mail the form, along with payment, to: GOLDMINE Want List, 700 E. State Street, Iola, WI 54990.

J. L. EDWARDS
• 4953 Whichard Road
• Greenville, NC 27834
• Phone: 252-752-6816
I would like video copies of the last three games of the 2001 American League Division Series between Oakland and the New York Yankees. If anyone has these last three games (games 3, 4 and 5) on tape and can make and send me copies (SP), please write or call. Will reimburse the sender with blank tapes and stamps.
ARTIST RECORDING FORMAT LABEL & CATALOG NUMBER
NEW YORK YANKEES - Games 3, 4 and 5 of ALDS (Oakland in NY) VHS

DAN HARVEY
• 4540 River St.
• Willoughby, OH 44094
• Phone: 440-552-3443
• E-mail: Vinyljunkie58@hotmail.com
I am looking for G, G+, VG, VG+ and NM recordings
ARTIST RECORDING FORMAT LABEL & CATALOG NUMBER
EDDIE GRANT - Electric Avenue. LP
SINNY PUPPY - Any. LP
SNEAKER PIMPS - Any. LP
MARTIN DENNY - Any. LP

MARVIN FADER
• 3130 Brighton, 6 Street Apt. IN
• Brooklyn, NY 11235
• Phone: 718-935-2261
ARTIST RECORDING FORMAT LABEL & CATALOG NUMBER
CHUCK BERRY - Rockin' at the Hops. CD. Chess CHD-9259
ESQUERITA - Capital Collectors Series. CD
VARIOUS ARTISTS - Wrinkles. CD. Chess CHD-9293

TOM BERTRAND
• 235 East 13th St. 4M
• New York City, NY 10003
• Phone: (212) 673-6568
ARTIST RECORDING FORMAT LABEL & CATALOG NUMBER
DIANA ROSS - Everything Is Everything CD/Cassette/Vinyl. Motown Records
DIANA ROSS - Music/Videos/Interviews. CD/Cassette/Video

CURTIS RIGHTOR
• 2919 Brinke Wy #18
• Louisville, KY 40218
ARTIST RECORDING FORMAT LABEL & CATALOG NUMBER
VARIOUS ARTISTS - We Wish You A Merry Christmas, cassette or 8-track. Natural Resources NR-4011C
REDBONE - Message From A Drum, cassette. Epic ET-30815
GENE PITNEY - Country Side Of 8-Track Musicor/I.T.C.C. M8-3104
PAT BOONE - Originals (Double Play). 8-Track, ABC/GRT 8022-301H
WAYLON JENNINGS - Hangin' On. 8-track, RCA P85-13918
SHIRELLES - Very Best Of. 8-track. Scepter Citation Series. 1802
BOB CREWE GENERATION - Music To Watch Girls By. 8-track. DynoVoice, DV8-9003
ROGER MILLER - Whistle Strp. 45. Buena Vista 493
LOUIS ARMSTRONG - When You Wish Upon A Star. 45. Buena Vista 489
BOBBY GOLDSBORO - These Are The Best Times. 45. Buena Vista 561
(Will not accept phone calls)

MICHAEL DRUCAS
• 17 Phillips Beach Ave.
• Swampscott, MA 01907
• Phone: 781-598-3936
• E-mail: michaeldrucas@hotmail.com
AVERAGE WHITE BAND - 1972-1982 Wanted Desperately! If you can help, please call or write. High prices paid
ARTIST RECORDING FORMAT LABEL & CATALOG NUMBER
AVERAGE WHITE BAND - 1972-1982 Concerts recorded from audience. Will pay \$100.00 a show
AVERAGE WHITE BAND - 1972-1982 Concert Posters
AVERAGE WHITE BAND - 1972-1982 Flyers. Handbills
AVERAGE WHITE BAND - 1972-1982 Concert Tickets
AVERAGE WHITE BAND - 1972-1982 Anyone who may have taken photos onstage, offstage
AVERAGE WHITE BAND - 1972-1982 Autographs
AVERAGE WHITE BAND - 1972-1982 Video, Rare TV Appearances, USA and Overseas

DEAN HANSON
• 34922 150th St. NE,
• Goodridge, MN 56725
ARTIST RECORDING FORMAT LABEL & CATALOG NUMBER
TOMMY FOGERTY & BLUE VELVETS (CCR) - Yes You Did/Now You're Not Mine, any format
GROUCHO MARX - The King and The Chorus Girl, 1937 movie (c-rotate)

DAVID E. MILLER
• 100 E. James #6
• Columbus, WI 53925
• Phone: 920-623-3401
These items must be in very good condition or better
ARTIST RECORDING FORMAT LABEL & CATALOG NUMBER
JANET JACKSON - Janet 2 CD Box Set. CD (book), Virgin Record America Inc. 7243-8-39195-2-9
JANET JACKSON - If, American Commercial Release. CD single w/p's Virgin Records America, Inc.
JANET JACKSON - You, U.S. Promo. CD single w/p's Virgin Records America Inc.
JANET JACKSON - Ask for more UK Pepsi Promo CD single w/p's Virgin Records

IAN ZUKSWERT
• P.O. Box 611
• Broadalbin, NY 12025
• E-mail: ianzukswert@hotmail.com
ARTIST RECORDING FORMAT LABEL & CATALOG NUMBER
PETER CETERA - World Falling Down. LP. WEA
CONNELLS - Ring. LP. 45 s. IVT. Blackpark Demon
DON AND THE CHEVELLS - Inner Limits/The Only Girl. 45 RPM. Speedway 1000
EXCEPTION - Any. any. Flair. Quill
FOUR SEASONS - Helicon. CD
INFINITY PLUS THREE - Setting Yesterday Free. LP
MR. MISTER - Pull. any
DAVID PATON - No Ties No Strings. 45. EMI 5063
THE RED HOUSE - any. 45s. SBK. Capitol, Etc.
SOCIAL DISTORTION - I Wa: Wrong. 45
THEZE FEW - Dynamite. 45. Blacknight 901
FRANKIE VALLI AND FOUR SEASONS - Whatever You Say. 45. WB K16107

MELVIN CARLTON UPTON JR.
• 11914 Leeila Avenue / Apt #1A
• Cleveland, OH 44135-4714
• Fax: 216-671-7338 (Anytime after 6PM EST/3PM California Time)
Vintage Soul/R&B Album Wantlist
* All of the following items listed are in the 33 1/3 LP format
* All albums must be immaculate and in 100% pristine condition and completely free and devoid of any scratches, scuffs or defects (LPs must be sealed, Mint or Mint Minus)
* All albums must be original and domestic (no imports or re-issues or re-prints)
ARTIST RECORDING FORMAT LABEL & CATALOG NUMBER
DEXTER WANSEL - Life On Mars. Philadelphia International PZ 34079, 1976
THE ISLEY BROTHERS - Get Into Something - T-Neck TNS-3006, 1970
LEROY HUTSON - Love Oh Love - Curtom CRS-8017/1973
LEROY HUTSON - Hutson. Curtom/Warner Brothers CU 5002, 1975
LEROY HUTSON - Feel The Spirit. Curtom. Warner Brothers CU 5010, 1976
LEROY HUTSON - Hutson II - Curtom. Warner Brothers CU5011, 1976
LEROY HUTSON - Closer To The Source - Curtom. Warner Brothers CU5018, 1977
THE EMOTIONS - Untouched, Volt VOS-6015, 1971
MAZE featuring FRANKIE BEVERLY - Inspiration. Capitol ST-11912, 1979
ROY AYERS & UBIQUITY - Change Up The Groove. Polydor PD6032, 1974
LEON HAYWOOD - Here To Stay. 20th Century T-411, 1973
LEON HAYWOOD - Come And Get Yourself Some. 20th Century T-476, 1975

SCOTT MONTGOMERY
• 111 Cherry Hill Road
• Carmel, NY 10512
• Phone: 914-773-1550 ext 253
• E-mail: monts@rcn.com
Vinyl LPs wanted, prefer VG or better condition - will pay up to price listed
ARTIST RECORDING FORMAT LABEL & CATALOG NUMBER
FAIRFIELD FOUR - Bells Are Tolling (Old Town or Athens press) WP \$55
FROSTY THE SNOWMAN - TV soundtrack w/Durante (MGM 4733) WP \$25
ELTON JOHN - I Get A Little Bit Lonely LP (Appy) WP \$45
MAROON - the Funky Record (Arb or other label) WP \$30
PAMELO MOUNK'A - Propulsion! (Sonic - French Imp) \$100
JIM RICHARDS - Sings for You LP (label?) WP \$25
SCHNAPPSIE - The Dachshund LP (Brunswick CS-7002) WP \$35

GOLDMINE WANT LISTS

Looking for a particular recording? Advertise it in the Goldmine Want List section. The cost is \$1.00 flat fee, plus 50¢ per item. Use the form at the beginning of this section to list your wants. Mail the form, along with payment, to: GOLDMINE Want List, 700 E. State Street, Iola, WI 54990.

GARY C. HUESTED
 • 1131 Piedmont Ave. NE
 • Palm Bay, FL 32907
 • Phone: 321-984-2144
 • E-Mail: ghuested@cfl.rr.com
 Serious R.E.M. collector seeking VG+ or better music and memorabilia:
ARTIST RECORDING FORMAT LABEL & CATALOG NUMBER
 Dead Letter Office advance promo cassette US or UK
 Documenting REM: 1983-1987 IRS 14U Canada cassette
 Fables of the Reconstruction UK CD (w/"Green Grow the RushED")
 Murrur US Cassette ("There She Goes Again" on insert)
 REM Singles Collected PTS 2039 Japan cassette
 Orange Crush 3" German CD in 5" slimline jewel case w/adaptor
 Stand German CD Warner Bros. 7577CD
 Chronic Town 12" EP Canada (gargoyle label)
 Green 12" LP Japan (w/obi)
 Dead Letter Office 12" LP Japan (w/obi)

KERRY FAMIGLETTI
 • 23 LaMaras Ave.
 • Glen Cove, NY 11542
 • Phone: 516-676-6623
ARTIST RECORDING FORMAT LABEL & CATALOG NUMBER
 STEVIE RAY VAUGHAN - Looking for souvenir hats, shirts, vests, etc.

EVAN BORIS
 • 6 Saint Andrews Court
 • Old Westbury, NY 11568-1710
 • Phone: 516-997-4840
 • Fax: 631-234-8248
 • E-Mail: discdoc@bornfreefoods.com
 • Web: www.discdoc.net
ARTIST RECORDING FORMAT LABEL & CATALOG NUMBER
 CACTUS WORLD NEWS, No Shelter, CD
 TUBES, Premium Gold Collection, CD
 VARIOUS ARTISTS, 20 Of Another Kind, CD

JOSEPH P. GIANGUZZO
 • 5031 North Barton Rd.
 • Lyndhurst, OH 44124
 I'm looking for the following comedy CD in Mint or Mint- condition:
ARTIST RECORDING FORMAT LABEL & CATALOG NUMBER
 DAVE MASON - Certified Live, Oneway, #26078

STEVE WISNER
 • 49 W. 040 Route 38
 • Maple Park, IL 60151
 • Phone: 815-827-3504
 • E-mail: dawisner@yahoo.com
 I will pay excellent prices for the following records. I will also accept tapes of these items.
ARTIST RECORDING FORMAT LABEL & CATALOG NUMBER
 BLUE MOUNTAIN EAGLE, Atco 6770, Yellow's Dream/Marianne, 45s
 CORVETTES, Dot 45-17283, Beware of Time/Level With Your Senses 45s
 GOSDIN BROTHERS, Metromedia 0105, You Love Me Just Enough, 45s
 IN CROWD, Viva 610, Never Ending Symphony/If I Knew..., 45s
 CARL JACKSON, Columbia 38-04926, Dixie Train? (need B side), 45s
 CARL JACKSON, Columbia ?, All That's Left For Me?, 45s
 CARL JACKSON, Columbia ?, You Are The Rock?, 45s
 JOE & ROSE MAPHIS, Chart 5122, I'm Gonna Have Your Lovin'/Sippin' Pickin' 45s
 LARRY MURRAY, Verve 10689, Six White Horses/Hard To Be Friends, 45s
 JELLY SANDERS, Global LP 1001, Fiddlin' Country Style LP

MICHAEL DRUCAS
 • 17 Phillips Beach Ave.
 • Swampscott, MA 01907
 • Phone: (781) 598-3936
 • E-mail: michaeldrucas@hotmail.com
 Average White Band 1989-2001 wanted if you can help please call or write. High prices paid.
ARTIST RECORDING FORMAT LABEL & CATALOG NUMBER
 AVERAGE WHITE BAND, 1989-2001, Audience Tapes
 AVERAGE WHITE BAND, 1989-2001, Video Filmed from the Audience.
 TV appearances.

ERIC MOORE
 • E-mail: eric.n.hr.moore@intel.com
 • Phone: 916-356-1618
 I'm looking for the following titles in CD:
ARTIST RECORDING FORMAT LABEL & CATALOG NUMBER
 PAUL MOTIAN - On Broadway, Vols. 2 or 3
 TIM BERNE - Fractured Fairy Tales
 VARIOUS ARTISTS - Jazz Satellites, Electrification, Vol. 1
 VARIOUS ARTISTS - Oceans Of Sound
 DREAM SYNDICATE - Days of Wine And Roses

L. SIMMONS
 • 10701 S. Eastern Ave.
 • Apt. 1027
 • Henderson, NV 89052
 • genesimmons12@hotmail.com
 Wanted: All Led Zeppelin videos and related material.

DANIEL SULLIVAN
 • 5623 Laguna Quail Wy.
 • Elk Grove, CA 95758
 • E-mail: dandsully@aol.com
 Looking For J.B. Production People. Any Band Members LP/45
ARTIST RECORDING FORMAT LABEL & CATALOG NUMBER
 JAMES BROWN - UNIQUE Recordings or band members, i.e. Kay Robinson, Lee Austin, Beau Dollar, Anna King, Maceo, Fred, Marva, Leon Austin, James Crawford, etc., etc., etc.

GLACIER 45 GEMS
 • Phone: (800) 328-0633
 • E-mail: glacierdisc@hotmail.com
 Limited of Stock of:
ARTIST RECORDING FORMAT LABEL & CATALOG NUMBER
 "Minnesota" - 1975 hit by NORTHERN LIGHTS. "Think Snow" and "Runnin'"

JAY S. MURPHY
 • 702 Ash St. #1101
 • San Diego, CA 92101
 • Phone: 858-534-4234
 • E-mail: jaysmurphy@yahoo.com
 Will pay \$150.00 for any of the following items!!!
ARTIST RECORDING FORMAT LABEL & CATALOG NUMBER
 THE DAMNED "Children of the Damned", Red Vinyl 7" (live), Funn Records, cat # funn17
 ROBERT FRIPP/LEAGUE OF GENTLEMEN "God Save the King", Japanese CD, EG/Virgin Japan Records, cat# VJD-5002
 ROBERT FRIPP "Let the Power Fall", German LP, EG/Deutsche Grammophon Records (1981)
 VARIOUS ARTISTS "Morrocci Klung Sept 1981", Mag/Cassette, UK issue

ERIC MOORE
 • E-mail: eric.n.hr.moore@intel.com
 • Phone: 916-356-1618
 I'm looking for the following titles in CD
ARTIST RECORDING FORMAT LABEL & CATALOG NUMBER
 JAZZ PASSENGERS: Best of (Crepuscule)
 JULIUS HEMPHILL: Dogon A.D. (Freedom)

VINCE KIKEL
 • 2886 Mason Ave
 • Port Huron, MI 48060
 • E-mail: vkmk@earthlink.net
ARTIST RECORDING FORMAT LABEL & CATALOG NUMBER
 BEATLES - Butcher Cover paste over any condition
 LYNRYD SKYNYRD - 45s LPs imports, shirts anything!
 BACKSTAGE PASSES and crew shirts
 SEALED & QUAD 8-TRACKS, any condition

FRANK CONTI
 • 712 8th St.
 • Secaucus, NJ 07094
 • Phone: 201-330-9409
 • E-mail: Marylee711@aol.com
ARTIST RECORDING FORMAT LABEL & CATALOG NUMBER
 TEDDY RANDAZZO, Big Wide World, LP, Colpix CP445m SLP4455

TROY AND GAYESHIA GROLLER
 • 5461 San Vicente Blvd. #12
 • Los Angeles, CA 90019
ARTIST RECORDING FORMAT LABEL & CATALOG NUMBER
 JOHN HIATT - True Believer, Promo CD Sgl.
 FREDDIE MERCURY/HENDRIX/STONES, on A&E Bio., 8/00. VHS
 M. JAGGER, Private Int. from Chicago/San Fran/LA?? Film Fest. from 98 or 99. Talks about the Death of "Performance" - Director. etc.
 HENDRIX - "Revolutions", radio show, 9/17/90. 24 Hr. from WKCR-89.9 NY, Pts. 13 & 14, Hrs 20-23
 BLUES BROS., "Conversation", 7/6/82, Radio show, reasonable price
 HENDRIX, "Baktabak" Picture Disc. (UK)

MARTYN HAMMOND
 • 1 Wilbye House Lexden Park Lexden Road
 • Colchester Essex CO3 3UF England
 • E-mail: 106174.451@compuserve.com
 Concert Tickets from Canada Wanted
ARTIST RECORDING FORMAT LABEL & CATALOG NUMBER
 Bowie concert ticket Montreal Forum 6/14/74
 Bowie concert ticket Ottawa Civic Center 6/15/74
 Bowie concert ticket Toronto O'Keefe Auditorium 6/16/74
 Bowie concert ticket Montreal Forum 2/25/76
 Iggy Pop concert ticket Montreal Le Plateau Theatre 3/13/77
 Iggy Pop concert ticket Vancouver Gardens 4/7/77
 Bowie concert ticket Ottawa Civic Center 5/2/78
 Bowie concert ticket Montreal Forum 7/13/83
 Bowie concert ticket Vancouver PNE Coliseum 9/11/83
 Bowie concert ticket Calgary Saddledome 3/13/90
 Tim Machine concert ticket Montreal Le Brique 12/1-2/91
 Bowie concert ticket Toronto Warehouse Docks 9/27/97
 David Bowie tickets from other countries also wanted

MIKE MANAIGE
 • 5947 Red Pine Blvd.
 • White Bear Twp., MN 55110
 I'm looking for the following records in MINT or MINT MINUS condition for under \$10.00.
ARTIST RECORDING FORMAT LABEL & CATALOG NUMBER
 BLACK SABBATH, Cross Purposes (1994), CD IRS
 DENVER, BOISE & JOHNSON, Take Me To Tomorrow, 45 RPM, Reprise 0695
 GOLLIWOGS, Pre-Creedence, LP or CD Fantasy F-9474
 MITCHELL TRIO, Alive, LP, Reprise 6354
 POPPY FAMILY, Which Way Are You Going Billy?, LP London, PS-674
 FEMALE PEN PALS WANTED - For conversing about our music hobby

BROOKS
 • 191 Mass St. Apt. #3
 • Philmont, NY 12565
ARTIST RECORDING FORMAT LABEL & CATALOG NUMBER
 GREAT WHITE, My, My, My, Video
 GREAT WHITE, Call It Rock n' Roll, Video
 GREAT WHITE, Unplugged, video

SAL J. ANGERAME
 • 50 1/2 Maple Street
 • Oneonta, NY 13820
 • Phone: 607-431-9846
ARTIST RECORDING FORMAT LABEL & CATALOG NUMBER
 Soundtrack to TV Special of the 1960's "Frosty the Snowman"
 All records by JOHN WESLEY SHIPP on 45s and 33 1/3s
 All Soap Opera Christmas albums
 TODD BRIDGES, 33 1/3s and 45s
 BILL HUFSEIGS, 33 1/3s and 45s
 KEN MEEREIS, 33 1/3s and 45s
 MICHAEL W. SMITH'S CHRISTMAS, on vinyl, CD or cassette
 A Soap Opera Christmas on CD and all other Soap Opera Christmas albums on vinyl

BILL PEYSER
 • P.O. Box 641154
 • San Francisco, CA 94164
 LPs needed, STEREO ONLY, all records and covers M or very strong M-.
ARTIST RECORDING FORMAT LABEL & CATALOG NUMBER
 ALLMAN BROS. - The Allman Brothers Band (Atco, not Capricorn)
 ANGELS - A Halo to You
 ARS NOVA - Ars Nova
 ASTRONAUTS - Surfin' with the Astronauts
 ASTRONAUTS - The Astronauts Orbit Kampus
 BAEZ, JOAN - In Concert, Part 2 (1st edition, not 2nd, black lbi)
 BAEZ, JOAN - Farewell, Angelina (orange lbi)
 BEATLES - Something New (orig. Capitol lbi)
 BUCKLEY, TIM - Starsailor
 CANNIBAL/HEADHUNTERS - Land of 1,000 Dances (Date or Rampart)
 DINO, DESI & BILLY - Memories Are Made Of This
 DOORS - The Soft Parade (orig. big E lbi)
 EVERLY BROS. - Both Sides of an Evening (gold lbi)
 FIREBALLS - Torquay
 FLEETWOODS - The Best of the Oldies
 FOURTH WAY - Werewolf
 GORE, LESLEY - Sings of Mixed-Up Hearts
 GORE, LESLEY - My Town, My Guy & Me
 HENDRIX, JIMI - Axis Bold As Love (3-color lbi)
 JOSIE/PUSSYCATS - Josie & The Pussycats
 KEYMEN - Dance with Dick Clark
 KEYMEN - Dance with Dick Clark, Volume 2
 LOTHAR/HAND PEOPLE - Space Hymn
 MANN, MANFRED - My Little Red Book of Winners
 MAYALL, JOHN - A Hard Road
 NOVA LOCAL - Nova 1
 POPPIES - Lullaby of Love
 REDPATH, JEAN - Scottish Ballad Book
 REDPATH, JEAN - Songs of Love, Lilt & Laughter
 SANTANA - Abraxas (360 Sound lbi)
 SHADOWFAX - Watercourse Way (Passport)
 STANDELLS - Dirty Water
 THREE MIDNITERS - Thee Midniters
 THREE MIDNITERS - Love Special Delivery
 TURTLES - It Ain't Me Babe

MIKE SARAFIAN
 • 360 W. Chevy Chase Dr. #26
 • Glendale, CA 91204
 • Phone: 818-241-3866
ARTIST RECORDING FORMAT LABEL & CATALOG NUMBER
 BEATLES - Yesterday & Today, LP, Late 60s, Subsidiary Black Rainbow Label, L.A. Pressing
MIKE SWORDS
 • 809 South St. Apt #8
 • Elgin, IL 60123
 • E-mail address: Swords999@hotmail.com
ARTIST RECORDING FORMAT LABEL & CATALOG NUMBER
 ALICE COOPER: Wanted Dragontown Promo Items
 LIVE TAPES TO TRADE: Alice, Todd, Patti, Iggy, X, Lou, Steve Wynn/Dream Syndicate. Memorabilia wanted also

DEAN HANSON
 • 34922 150th St. NE
 • Goodridge, MN 56725
ARTIST RECORDING FORMAT LABEL & CATALOG NUMBER
 VELVETS (CCR) 45 was a 1962 Bay Area-Only release. Please help me finish my collections! Thanks!
 TOMMY FOGERTY & BLUE VELVETS: "Yes You Did/Now You're Not Mine", any format
 MARX BROS.: 1956 NBC special "Inside Beverly Hills", video

TED MYERS
 • 7305 St. Rt. 753 Lot 4
 • Hillsboro, OH 45133
 • Phone: 937-365-1277
 VHS must be good sound and picture everything else good to excellent
ARTIST RECORDING FORMAT LABEL & CATALOG NUMBER
 OLIVIA NEWTON JOHN, Memorabilia and live concerts 73 thru 77, VHS (90 min. or more)
 BILL COSBY - Memorabilia hats/caps, posters, plus
 QUARTERFLASH - Memorabilia hats/caps, posters, plus
 LINDA RONSTADT - Memorabilia and live (69 thru 82) shows, VHS (90 min. or more)
 STEVEN WRIGHT - Memorabilia hats/caps, posters, plus
 I LOVE LUCY - (Any stuff)
 MR. BEAN - Memorabilia and Bean the Movie Poster

MICHAEL TURNER
 • 7 Rosewood Avenue
 • Burnham-On-Sea
 • Somerset
 • TA8 1HD
 • England
 • Phone: +44 (0) 1278 783519
 • E-mail: MTurner217@aol.com
ARTIST RECORDING FORMAT LABEL & CATALOG NUMBER
 NEIL SEDAKA - Christmas & New Year Greetings From RCA*, 45 (*radio adverts), RCA SP-45-128
 NEIL SEDAKA - Find Yourself a Star*, 45 (*radio adverts), Rad 72-1
 NEIL SEDAKA - Giving's Not So Hard to Do*, 45 (*radio adverts), United Way
 NEIL SEDAKA - Don't Go/Come Back Jo (with the Tokens), 45, Melba 1956
 NEIL SEDAKA - Amour Perdu/Oui, Nous Serons Des Copains, 45 (French Canada), Atlantic 1968
 NEIL SEDAKA - Nora, Foreign Legions "Worldwide Lyric Search" (Sedaka one of several jugs), LP, N.Y. Music NYM-5
 Sedaka Compositions nor recorded by Neil and by R. Grossman for example:
 Laverne Baker, Saddler
 The Cardinals, The End Of The Story, Atlantic 1103
 GENE PITNEY - Faithful Our Love/Classical Rock n' Roll, (Jamie & Jane duets), 45, Decca a-30934 1959
 GENE PITNEY - Run, Run Roadrunner, (Music or promo, stereo), 45, MUS1474 1968
 GENE PITNEY - LPs It's Country Time Again (with George Jones - stereo, black label), Musicor 1965
 GENE PITNEY - She's A Heartbreaker, (promo, stereo), LP, Musicor 1968
 Vintage Gold Pack of Hits, Vol. 1, 3, 4 (various artists, alt. version of: Darlin' Corey, Ain't Ya Comin', Silver Bracelets, Run, Run Roadrunner, Rags To Riches), Vintage
 45s Pitney compositions not recorded by Gene for example:
 BUZZ CLIFFORD - Magic Circle, Columbia 42290, 45 same # for 33 1962
 NOBELLS? - Searchin' For My Love/Crying Over You, Mar 101 1962
 If possible, records to be in at least EX condition.

TED HOLLAND
 • P.O. Box 336
 • Cornelius, NC 28031
ARTIST RECORDING FORMAT LABEL & CATALOG NUMBER
 VARIOUS - Coming Attractions, CD/LP, Avanti 1013
 VARIOUS - Avanti Hall of Fame, CD/LP, Avanti 1003
 VARIOUS - Southern Soul Vol 1, CD/LP, Paula 9014
 VARIOUS - Wild Women Do Get the Blues, CD/LP, Ichiban 1190

JOE HAWKINS
 • 4322 Brittany Dr.
 • Ellicott City, MD 21043
ARTIST RECORDING FORMAT LABEL & CATALOG NUMBER
 ALICE COOPER - Complete Video Transfer, "The Story" DVD, 180 minutes
 ALICE COOPER - 2001 Tour Videos

BROOKS
 • 191 Main St. Apt #3
 • Philmont, NY 12565
ARTIST RECORDING FORMAT LABEL & CATALOG NUMBER
 GREAT WHITE - Hooked (?), Video
 GREAT WHITE - Live in London, Video (?)
 GREAT WHITE - Footage of Headbangers Ball hosted by Jack Russell and Great White on video

MICHAEL P. MAHON
 • 41 Gleason St.
 • Framingham, MA 01701-3504
 • Phone: 508-877-0191
 I'm looking for THE VENTURES on JAPANESE CDs only no replica CDs, or no cassettes. THE REAL THING!!! Any Japanese Record Dealers, or a fan of The Ventures in Japan, or USA, new or used. Please let me know.
ARTIST RECORDING FORMAT LABEL & CATALOG NUMBER
 THE VENTURES - Melody Hits in Japan (East World) TOCT-6376
 THE VENTURES - Tokyo Callin (East World) TOCT-6378
 THE VENTURES - Bel Age with The Ventures Vol 1 (Panam) CRDP-43 (3" mini disc)
 THE VENTURES - Bel Age with The Ventures Vol 2 (Panam) CRDP-44 (3" mini disc)
 THE VENTURES - Bel Age with The Ventures Vol 3 (Panam) CRDP-45 (3" mini disc)

GREG CLARK
 • P.O. Box 3388
 • Kent, WA 98032
 • Phone: (206) 662-2444
 • E-mail: stirrupz@hotmail.com
ARTIST RECORDING FORMAT LABEL & CATALOG NUMBER
 KAYAK - Phantom of the Night, LP Picture Disk, JKS-7039
 NED DOHENY - Ned Doheny (1st), CD (Japan), WEA (1993)
 BENNY MARBONES - Never Run, Never Hide, CD, Mercury
 COWBOY - Best of (A Different Time), CD, Polydor 1984

For Great Performances Advertise In ...



GOLDMINE CLASSIFIEDS

YOUR ALPHABETIZED INDEXED MARKETPLACE IN EVERY ISSUE OF GOLDMINE

Albums For Sale	5000	Comedy Wanted	5116	Girls Groups Wanted	5216	New Wave Wanted	5316	R&B For Sale	5410
Albums Wanted	5001	Compact Discs For Sale	5117	Genesis/Gabriel/Collins	5220	90s Rock For Sale	5320	R&B Wanted	5411
Alternative Rock For Sale	5010	Compact Discs Wanted	5118	Grateful Dead	5225	90s Rock Wanted	5321	Rockability For Sale	5415
Alternative Rock Wanted	5011	Compilation For Sale	5120	Heavy Metal For Sale	5230	Original Cast/Broadway	5325	Rockability Wanted	5416
Announcements	5015	Compilation Wanted	5121	Heavy Metal Wanted	5231	Photographs For Sale	5330	Search Services	5420
Auctions	5020	Computer Software For Sale	5125	Jimi Hendrix	5235	Photographs Wanted	5331	70s For Sale	5425
Audiophile For Sale	5025	Computer Software Wanted	5126	Imports For Sale	5240	Picture Discs For Sale	5335	70s Wanted	5426
Audiophile Wanted	5026	Convention/Shows	5130	Imports Wanted	5241	Picture Discs Wanted	5336	78s For Sale	5430
Audio Tapes For Sale	5030	Country & Western For Sale	5135	Independent Labels For Sale	5245	Picture Sleeves For Sale	5340	78s Wanted	5431
Audio Tapes Wanted	5031	Country & Western Wanted	5136	Independent Labels Wanted	5246	Picture Sleeves Wanted	5341	Sheet Music For Sale	5435
Autographs	5035	Dance Music For Sale	5140	Michael Jackson	5250	Pinik Floyd	5345	Sheet Music Wanted	5436
Beach Boys For Sale	5040	Dance Music Wanted	5141	Jazz Instrumental For Sale	5255	Popular Vocalists For Sale	5350	Frank Sinatra For Sale	5440
Beach Boys Wanted	5041	Bob Dylan	5145	Jazz Instrumental Wanted	5256	Popular Vocalists Wanted	5351	Frank Sinatra Wanted	5441
Beatles For Sale	5045	Doo-Wop For Sale	5150	Jazz Vocalists For Sale	5260	Posters For Sale	5355	60s For Sale	5445
Beatles Wanted	5046	Doo-Wop Wanted	5151	Jazz Vocalists Wanted	5261	Posters Wanted	5356	60s Wanted	5446
Big Bands For Sale	5050	Easy Listening For Sale	5155	Jukeboxes	5265	Power Pop For Sale	5357	Soul For Sale	5450
Big Bands Wanted	5051	Easy Listening Wanted	5156	KISS For Sale	5270	Power Pop Wanted	5358	Soul Wanted	5451
Bluegrass For Sale	5055	80s Rock For Sale	5160	KISS Wanted	5271	Elvis Presley For Sale	5360	Soundtracks For Sale	5455
Bluegrass Wanted	5056	80s Rock Wanted	5161	Laser Discs For Sale	5275	Elvis Presley Wanted	5361	Soundtracks Wanted	5456
Blues For Sale	5060	World Music For Sale	5165	Laser Discs Wanted	5276	Press Kits For Sale	5365	Spoken Word For Sale	5460
Blues Wanted	5061	World Music Wanted	5166	Led Zeppelin	5280	Press Kits Wanted	5366	Spoken Word Wanted	5461
Books For Sale	5065	8 Track For Sale	5167	Madonna	5285	Prince	5370	Bruce Springsteen	5465
Books Wanted	5066	8 Track Wanted	5168	Magazines For Sale	5290	Progressive Rock	5373	Stereo Equipment	5470
Business Opportunities	5070	EPs For Sale	5170	Magazines Wanted	5291	Promotional Items For Sale	5375	Storage Units	5475
David Bowie	5075	EPs Wanted	5171	Marillion	5293	Promotional Items Wanted	5376	Barbra Streisand	5478
British Invasion For Sale	5080	Fan Clubs	5175	Memorabilia For Sale	5295	Psychedelic For Sale	5380	Supplies For Sale	5480
British Invasion Wanted	5081	Fanzines	5180	Memorabilia Wanted	5296	Psychedelic Wanted	5381	Surf Music For Sale	5485
Kate Bush	5085	50s Rock For Sale	5185	Mini Discs For Sale	5297	Punk For Sale	5385	Surf Music Wanted	5486
Cassettes For Sale	5087	50s Rock Wanted	5186	Mini Discs Wanted	5298	Punk Wanted	5386	Texas Music	5488
Cassettes Wanted	5088	Fleetwood Mac	5190	Miscellaneous For Sale	5300	Radio Shows For Sale	5390	Tour Programs	5490
Catalogs	5090	Folk Music For Sale	5195	Miscellaneous Wanted	5301	Radio Shows Wanted	5391	Turntable For Sale	5495
Christmas Music For Sale	5095	Folk Music Wanted	5196	Monkees	5305	Rap For Sale	5395	U2	5500
Christmas Music Wanted	5096	40s Music For Sale	5200	Moody Blues	5307	Rap Wanted	5396	Video Tapes For Sale	5505
Children's Records For Sale	5100	40s Music Wanted	5201	Musical Instruments For Sale	5310	Rock For Sale	5412	Video Tapes Wanted	5506
Children's Records Wanted	5101	45s For Sale	5205	Musical Instruments Wanted	5311	Rock Wanted	5413	The Who	5510
Eric Clapton	5105	45s Wanted	5206	New Age	5314	Rolling Stones For Sale	5400	Hank Williams	5515
Classical For Sale	5110	Gospel For Sale	5210	New Orleans R&B For Sale	5312	Rolling Stones Wanted	5401	Woodstock For Sale	5517
Classical Wanted	5111	Gospel Wanted	5211	New Orleans R&B Wanted	5313	Reggae For Sale	5405	Woodstock Wanted	5518
Comedy For Sale	5115	Girls Groups For Sale	5215	New Wave For Sale	5315	Reggae Wanted	5406	Frank Zappa	5520

Now A NETWORK OF CLASSIFIEDS!
 Krause publications, the world's largest hobby & collectibles publisher, is proud to announce that every classified word ad placed in its periodicals will appear on the Internet's largest collectible classified site at www.collect.com. In addition to reaching your target audience through Krause's periodicals, your ads will also reach thousands of collectors on the World Wide Web!

only
40¢ Per Word

Bold face type available (entire ad only) for only 10¢ more per word!

4 EASY OPTIONS TO REACH THE MOST ACTIVE MUSIC COLLECTORS FOR ONLY 40¢ PER WORD!

- By Internet:** Visit www.collect.com on the internet to order with your credit card.
- By Fax:** Complete classified ad form, include your credit card number, expiration date, Fax to 715/445-4087.
- By Mail:** Complete order form, send payment by check, money order or credit card, mail to **GOLDMINE, CLASSIFIED ADVERTISING DEPT., 700 E. State St., Iola, WI 54990-0001.**
- By Phone:** Call 1-800-942-0673, 7 a.m. - 8 p.m. M-F. Saturday 8 a.m. - 2 p.m. Please have your credit card number and expiration date ready.

Payment must be included with all Classified Ads.

3-6	10%	10-12	20%
7-9	15%	13-26	25%

(Apply the appropriate frequency discount below when figuring the total cost of your classified ad.)

- To order your classified ad:**
- From the classified index on the following page, select the number which you want your ad to appear. Put that number in the box in the left hand corner of the order form.
 - Using one word per line, write your ad EXACTLY as you want it to appear in GOLDMINE's Music Mart ad section.
 - Minimum order is 25 words, or \$10.00 per ad per issue.
 - Ad will run in next available issue. See deadlines on display advertising information page.

Print One Word Per Space *Please use an additional sheet of paper for larger ads* **Check here for entire ad in larger bold type**

Classification	1	2	3	4	5
6	7	8	9	10	11
12	13	14	15	16	17
18	19	20	21	22	23
24	25	26	27	28	29
30	31	32	33	34	35

Words _____ X # of Issues _____ = Total Words _____ X 40¢ (X 50¢ for Bold Type) = \$ _____
 (25 word minimum) Less Frequency Discount (See chart above) ...

Total Cost \$ _____ **Total Amount Enclosed \$ _____**

Payment:
 Money Order Check
 Amount Enclosed _____
 MasterCard VISA Discover/Novus American Express
 Credit Card # _____
 Expiration Date: Month _____ Year _____
 Signature _____

FOR OUR RECORDS ONLY: We must have a street address and phone number for our files before we will run your ad.
 Name _____
 Street Address _____
 City _____ State _____ Zip _____
 Daytime Phone _____



Mail to: Goldmine Classified Advertising • 700 East State Street Iola, WI 54990-0001 • www.collect.com

5000 ALBUMS FOR SALE

FOR SALE: Hundreds LPs 1950-80s starting \$2.99. Visit our website: <http://www.members.home.net/sandunenp> E-mail: sandunenp@home.com

OVER 10,000 vinyl records for sale. All 12" LP's. Rare and out of print. Beatles, dance, 70's, promo's and white label, Top 40, picture disc's. No cut outs, many still sealed and in Mint condition. Albums date from 1950-1997. I would like to sell the entire collection, but will consider select offers. Serious Offers Only. \$25,000 minimum bid. Brian Grosnickle, 12 Britten Cr, Bella Vista, AR 72717

PLACE YOUR AD NOW FOR THE JANUARY 11, 2002 ISSUE OF GOLDMINE. 1-800-942-0673.

RELIGIOUS ORIENTED music for sale and wanted. All types: rock, psych., garage, folk, etc. Respond to: PO Box 12777, Pittsburgh, PA 15241.

SELLING 25 year 300 record collection. 200 albums, 100 45's, 20% Beatles & Solo, 60's, 70's, 80's, Pop Rock, 80% near mint, \$2,500. 845-889-8261.

THOUSANDS 1950's 1980's R&B, Soul, Pop, Jazz, Rock, 12" singles, Gospel, all types. Most in VG+ mint condition. Jerry 203-846-2636 or send wants to Jerry Records, 29 Harriet St, Norwalk, CT 06851. Also hundreds of Goldmine & Discoveries.

1960's-1970's RECORDS and CDs. \$5 each plus \$2 postage. Send orders with wantlist or send SASE for list to: Dan Giddings, PO Box 5881, Glendale, CA 91221-5881.

THE BOP SHOP WEB SITE!

1000's of great condition records
Visit us at www.bopshop.com
E-mail us at bopshop@rochester.rr.com
THE BOP SHOP
274 N. Goodman St., Rochester, NY 14607
716-271-6654

IF IT'S OUT OF PRINT - OR HARD TO GET CHANGES ARE - I'VE GOT IT!
FREE SALES LISTS OUT NOW!
Write For A Copy Or Fax (540) 342-2471
Visit our on-line catalog @
<http://members.aol.com/RosRec33/RecordAlbums>
or email your request to: RosRec33@aol.com
ROANOKES RECORD ROOM
P.O. Box 2445MM, Roanoke, VA 24016
Serving Collectors in The U.S. And Around The World Since 1974. Specializing in out of print 10" and 12" Rock, Pop, Jazz, Soul, & Soundtrack LPs from 1949 to 2001. Most Major Credit Cards Accepted

RECORD ARCHIVE
1394 Mt. Hope Ave., Rochester, NY 14620
Phone: (716) 473-3820
Fax: (716) 473-3829
Visit our Web site
www.recordarchive.com
E-mail: bobvinyl@mindex.com
VINTAGE VINYL
Over 1,000,000 Units!
Want Lists Accepted!

VINYL LIVES On the Web!
<http://www.joesrecordparadise.com>
Unique & Rare Rock, Jazz, R&B & Country
Great prices on cool 45's, LP's, & CD's
OUR SITE IS UPDATED DAILY!
Joe's Record Paradise
1300 East Guide Drive
Rockville, MD 20850
Ph (301) 315-2235 • FAX (301) 315-2252

Vinyl junkie cleaning up his act!
No catalog yet.
Send your select want lists to:

RECORDS
P.O. Box 164
Cedarhurst, NY 11516
Fax 516-295-4370
Check out our Web site - <http://earstein.com>

5001 ALBUMS WANTED

ALWAYS BUYING (and selling) LPs: Nude/cheesecake, bizarre/oddball, belly dancing, electronic, and almost anything else. If it's unusual, try me! Vinyl Lives!, www.vinylives.com, 919-846-9571.

I WILL pay excellent prices for the following records, if they match my interest. The Blossoms "Things Are Changing" Luciecita and Julio Angel "Things Are Changing", Akihiko Matsumoto Tokyo, Japan e-mail: sociulifeista@mac.com

MOTHERS WANTED: WLP and YLP copies of 'Freak out' and 'Absolutely Free'. Near Mint or better only. Please call Michael at 970-948-1030 or 303-477-8791 on Weekends.

1960's-1970's Albums wanted. Send lists with prices to: Dan Giddings, PO Box 5881, Glendale, CA 91221-5881.

5020 AUCTIONS

25th Year of Continuous Record Auctions.
Send now for set sale list to:
Bob Brennan
P.O. Box 118, Elkton, FL 32033
FAX (904) 797-6294
rbrennan427@aol.com

5030 AUDIO TAPES FOR SALE

CONCERT TAPES: A to Z and everything in between. Send \$2 and large SASE, P.O. Box 359, Pelham, NH 03076-0359.

HOWARD STERN over 1000 radio shows from his 1985 NBC days to the present time. Free catalog. Michael Feinberg, 82-30 138 St., Kew Gardens, NY 11435.

LIVE RARE tapes 1,000+ quality hours. Rock A-Z featuring Beatles, Hendrix, Floyd, Stones, Zappa, Zeppelin. Send \$5 to: M. Piersante, 17 Fielding Circle, Mill Valley, CA 94941.

OVER 4,600 Listings, 114 page live rock + blues list \$2. Maxell XL II 90, \$7. Buy 6, get 1 free. BC N2939 Lemke Dr., Athens, WI 54411.

FM CONCERTS

Bad Religion, Breeders, Clash, Cramps, Dinosaur Jr., Faith No More, Green Day, PJ Harvey, Hole, Jesus Jones, Killing Joke, Neda, Atomic Dustbin, Nirvana, Pearl Jam, Ramones, Sonic Youth, Sugar, Thrill Kill Cult, White Zombie
That's just a sample!

OUR CATALOG HAS IT ALL... A TO Z

Exceptional rare concert broadcasts from around the world. Our selection, service and commitment to sound quality is unparalleled. For a free list send a S.A.S.E. to receive our amazing detailed catalog (including song titles!) send \$2 (\$3 overseas).

Thank you! 
AIRWAVES
1286 University Ave. #528-G
San Diego, CA 92103

5035 AUTOGRAPHS

AUTHENTIC MUSIC, Hollywood and television autographs, all fully guaranteed with 30 years experience. Please visit us at <http://www.WallsOfFame.com> or call 732-988-0315 for a FREE catalog.

5041 BEACH BOYS WANTED

BACK IN The 1960's, were you a member of the (Official) Beach Boys fan club? If so, please write to me and tell me what the club was like. Randy Erdman, 7413 Red Oak Lane, Charlotte, NC 28226.

5045 BEATLES FOR SALE

Beatles4me.com... Your #1 Beatles Source since 1977, specializing in Original Beatles Records & Memorabilia. Come visit us today! Hein's Rare Collectibles, PO Box 179, Little Silver, NJ 07739-0179. 732-219-1988. Fax 732-219-5940.

BEATLE STUFF Catalog: US and imports; group, solo, CDs, records, videos, books, magazines, posters, promos, toys, photos, more. Send \$1 for latest catalog. Robert Wolk, PO Box 95762, Hoffman Estates, IL 60195-0762.

FAB FOUR You Records has Beatles 60's collectibles, vinyls, CD's & paper goods. Also Stones, Clapton, Kinks & other British Invasion groups. For updated catalog send (5) five 34U stamps to: PO Box 27457, Oakland, CA 94602

TRANSFER YOUR vinyl to CD-R! Only \$10 per album or C-60 cassette, postpaid (U.S.). (Originals returned with CD.) E. Strauss, PO Box 29048-0048, Chicago, IL 60629.

5046 BEATLES WANTED

ALL BEATLES "Original" records and memorabilia wanted! Especially Butcher Cover, picture sleeves and concert ticket stubs! Gary, PO Box 179, Little Silver, NJ 07739. 732-224-8760. E-mail: 1BuyBeatles@home.com

WANTED: BEATLES CONCERT tickets, unused only, top \$\$\$ paid. Chuck 800-822-2443, 24 hours.

WANTED: BEATLES Pepperland on Secret Trax, original only. Call John 202-255-0512.

5060 BLUES FOR SALE

PLUS SOUL, Jazz, Gospel, more: on CDs, cassettes, videos! Reviews, ads, links, more. New titles every other week!
<http://www.musicandthings.com>

5065 BOOKS FOR SALE

THE COMPLETE Allman Brothers Band Discography by Dean Reynolds USA \$41.95, Canada \$45, UK, Europe \$54, Australia, Asia \$55., Dean Reynolds, PO Box 709, Milford, OH 45150, USA. Full color limited edition.

5066 BOOKS WANTED

SEEKING POPULAR Music 1920-1979: A Revised Cumulation by Nat Shapiro. Write: Jerry Vogt, 141 Reservoir Dr., Boonton, NJ 07005.

5070 BUSINESS OPPORTUNITIES**Record Store For Sale!**
Be Your Own Boss!
Established - Successful!

- ▶ A reputation for the best selection of LPs in this region of the state!
 - ▶ Loaded with Jazz, Rock, Country, Folk, R&B, and most everything else!
 - ▶ 1500 sq ft. showroom nestled in a booming downtown setting!
 - ▶ Fully functional and thriving - sales have increased since opening, with another record high expected in 2001
 - ▶ Full inventory LPs, CDs, 45s, Videos!
 - ▶ Selling the entire store with all necessary retail equipment - cash register, stereo, computer and MORE!
- For a detailed sale proposal write us at:
mashofrout@yahoo.com
or P.O. Box 2121 Roanoke, VA 24019-2121

5088 CASSETTES WANTED

OLIVIA NEWTON John wanted. Making a Good Thing Better cassette. Any Australian cassettes. Any Japanese albums, Soul Kiss CD (Japan). If You Love Me (Let Me Know) CD US. Let Me Be There CD US. Eric Gregoni, 79 Crystal Rock Court, Middle Island, New York 11953. No computer. Write. No phone calls please.

5090 CATALOGS

FREE CATALOG albums thousands at \$2.99 each! Jazz, Country, R&B, Pop, Big Band, and more. No junk! Foreign welcome! Jax, PO Box 1166, Ashland, OH 44805.

FREE LIST, set prices, primarily 1950's. Blues, R'B, R'R, etc., 45s, 78s, LPs. Collections bought, Victor Pearl, Box 60299, Worcester, MA 01606.

5096 CHRISTMAS MUSIC WANTED

WANTED: "JINGLE Bells (Laughing all the Way)" by St. Nick. (Warner Bros. 45 49877) from 1981. Mike Hutchison, 14181 Natalie Rd., Prior Lake, MN 55372.

5117 CD'S FOR SALE

BLOODROCK KEYBOARD player Steve Hill. New C.D. featuring Warren Ham on vocals is now available. To order visit: steviehill.com

CDBO.COM 200,000 one of a kind CDs. Mention ad for \$5 off first order.

CD-R'S FOR SALE. Send \$2 for complete catalog. AWalk, 1804 West Seams Neck Rd., Seaford, NY 11783. Beatles, Clapton, Who, Eagles, many more.

LIVE HENDRIX/ SRV/ Zeppelin and Rory Gallagher CDs and more. For list, send \$1 to: JD's Music Memories, PO Box 784, Novato, CA 94948-0784.

VINYL/CAPE REMASTERING- Flawless sound & art. 10 years 24/7 experience. <http://worldwidemusicnetwork.com> 763-494-9222.

ROOGALATOR AND DANNY ADLER GUSHA. GUSHA GUITAR R&B

original STIFF artist EX Charlie Watts, Jack Bruce, Alexis Korner, Ian Stewart, Bo Diddley, Chuck Berry, Dr. John, F-Bone Walker, Nick Lowe, Dick Heckstall-Smith, Amos Milburn, Charles Brown, Bootsy Collins, Solomon Burke, Slims (Harpo, Memphis, Gaillard) Hookers (John, Earl) Lowell Fulson.
PICK UP A PAIR OF EXCELLENT CD COMPILATIONS 1975-1990.
Roogalator "Cincinnati Fatback" Proper PRPC07
Danny Adler "I Better Make A Move" Proper PRPC08
Please contact amazon.com (retail) and DNA (wholesale).

Discguys specializes in RARE and OUT OF PRINT compact discs.

- Out of Print Compact Discs
 - Rare Compact Discs
 - Import Compact Discs
 - Sealed Longboxes
 - Compact Disc Search
- Service - if it was released on this planet, we can find it (Phone number required).
- Send Us Your WANT LISTS (Phone number required)

Discguys
P.O. Box 491
Charlevoix, MI 49720
Phone Number: (231) 547-1971
E-mail: wefindcds2@aol.com

5120 COMPILATIONS FOR SALE

NOW AVAILABLE Gary Edwards latest double CD- Life Is A Song- 42 love songs from 1969-2000. \$12.99 + \$3 S&H. PO Box 1449, Windermere, FL 34786.

5135 COUNTRY FOR SALE

FREE LIST, most \$4 each, also some rare albums and EPS and memorabilia. Please specify artist wanted. R.C.O., 7801 88th Ave #111, Pleasant Prairie, WI 54148-1909.

5140 DANCE MUSIC FOR SALE

DANCE ENTHUSIASTS, DJ's and collectors. Wax Trax offers largest selection of 12" dance classics from the 70's, 80's, and 90's. Includes Disco, Hip Hop, R&B, Dance Rock, House, Techno, etc. <http://www.wax-trax.com> E-mail: wax-trax@wax-trax.com Mail: Wax Trax, 144 Fox Chase Ln., Cherry Hill, NJ 08034. Tel/Fax: 856-429-7235.

DJ'S DISCO 12" singles from 70's and 80's. Send \$1. (\$3 overseas), for lists or want list to: T.J. Stankard, 5300 Washington St. U503, Hollywood, FL 33021. E-mail: discotj@aol.com

12 INCH Discodance from 80s to present. original label, we buy sale or trade! Visit: <http://www.goldrecords.it> E-mail: goldrec@italway.it

5141 DANCE MUSIC WANTED

WANTED: 12" Disco singles 1975-1995. Promos, Test Pressings, Record Pool Stock, DJ collections. Will travel for large collections. Send list: 21st Century Music, 15 Mt. Vernon St, Ridgefield Park, NJ 07660. 1-800-846-9501/ 201-641-6610

5145 BOB DYLAN

BOB DYLAN audio, CD, video tapes: selections spanning 40 years. Rareties. Send 2 stamps for large list to: SJC, PO BOX 7096 Virginia, MN 55777.

5190 FLEETWOOD MAC

FLEETWOOD MAC, Stevie Nicks, and Sarah McLachlan memorabilia for sale. Send letter sized SASE to: Anderson Enterprises, PO Box 1011, Simi Valley, CA 93062. E-mail: stephen8@pacbell.net

5205 45'S FOR SALE

FREE CATALOG. Set-Sale. Mostly 50's and 60's 45's. RAB, RR, Soul, Country, Pop. Some LP's and Magazines. Social Insect Records, 923 Baldwin, Danville, IL 61832.

FREE 45RPM auction list 1950's-1980's all grades, Rock, Pop, R&B, Soul, Instrumental, Folk, Motown, Surf, etc. Dave's Record Den, PO Box 360948, Strongsville, OH 44136. Fax 440-846-6048. Email: davesrecd@aol.com, <http://www.davesrecordden.com>.

SELLING COLLECTION OF 670 singles, 1950's to 1980's. Some promos & picture sleeves. \$100 plus postage. For list: e-mail slstier@yahoo.com or write Stu Stier, 3022 North Central Drive, Chandler, AZ 85224.

50,000 45'S for sale from 1940's to early 90's. Classical, country, rock. Must buy as complete lot. \$5,000. 937-365-1395.

Buy Below Wholesale

From one of the world's largest inventories. Hits of the 50's, 60's, 70's and 80's - all new, quality 45 RPM records - including current reissues, imports, original pressings and discontinued collector items. Prices as low as US \$1.25 each on 90% of our stock - records selling elsewhere for up to ten times our price! Limited time offer ideal for collectors, disc-jockeys juke-box operators and dealers. Catalog listing 12,000+ records \$5.00 from Continental Records, P.O. Box 2804G, Bramalea, Ontario L6T 3S3 or download the catalog free from our web site at <http://www.gocontinental.com>

Vinyl junkie cleaning up his act!
No catalog yet.
Send your select want lists to:

RECORDS
P.O. Box 164
Cedarhurst, NY 11516
Fax 516-295-4370
Check out our Web site - <http://earstein.com>

5230 HEAVY METAL FOR SALE

UK HEAVY Metal 12" vinyls. Selection of top groups from 1960's onward. Mainly British and European editions including Sex Pistols, Led Zeppelin and Marillion. <http://www.vinylsrus.com>

5250 MICHAEL JACKSON

MICHAEL AND The Jacksons for sale. Have cassettes, CD's and LP's. For list please write to: Anna Iverson, 917 West 2nd Str., Redfield, SD 57469.

5255 JAZZ INSTRUMENTAL FOR SALE

RARE JAZZ AND VOCALS for both set sale and auction. Free list. Good Sounds, PO Box 023268, Brooklyn, NY 11202-0665. 718-624-4718.

5256 JAZZ INSTRUMENTAL WANTED

JAZZ COLLECTIONS: Records, CD's, magazines, memorabilia, Top dollar. Ph. 314-961-8978, Fax 314-961-8206. E-mail jazz@euclidrecords.com Euclid Records, 7905 Big Bend, St. Louis, MO 63119. Website <http://www.euclidrecords.com>

5270 KISS FOR SALE

ALBUM OF every kind of music. Italian collector sell records 7" LP. Adv. always valid. Antonio De Spirito, Via Menghini 28, 00179 Roma Italy. Tel/Fax: 0039-6-7810837. info@vinylmail.com <http://www.vinylmail.com>

5285 MADONNA

MADONNA 1985, Virgin tour book, new, \$50 pp. Also books, magazines, CDs, records. Send want list: Bill Shepherd, Box 352, Church Hill, TN 37642. 423-357-3753.

WANTED: COLLECTOR of Madonna products seeks your current price list for items. Send to S. Callie, PO Box 153, Oakland, MD 21550.

5290 MAGAZINES FOR SALE

ABBA TO Zappa. More cool music magazines than you can read in a lifetime. Send wantlist to: Jack Levin, 4100 N. Kenneth, Chicago, IL 60641.

ARCHIE COMICS for sale. \$2 each. Send SASE for list to: Dan Giddings, PO Box 5881, Glendale, CA 91221-5881.

ARE YOU a toy collector? TOY SHOP provides the latest toy news, in-depth features and an active buy and sell marketplace. Special subscription offer: 13 issues (\$36 weekly) for only \$15.98! That's almost (b/w off the cover price! Call 1-800-258-0929 and mention offer ABA35V or visit our website at <http://www.toyshopmag.com>

BRITISH MAGAZINES/ rock books, 70's onwards: Sounds, MNE, Melody Maker, History of Rock, VOX, Raw, etc. Write: Dorothy Hebbes, 8 Penns Lane, Colshill, Birmingham, B461BA, England.

FOR SALE: Movie Magazines, records, etc., list your favorite Movie Stars, TV Stars, Singers. Anna Labbate, 63 Oxholm Ave., Staten Island, NY 10301. E-mail: ann5073@aol.com

INTERESTED IN Magic The Gathering or other collectible card games? SCRYE provides the latest news, in-depth strategy articles and the most respected price guide. Special subscription offer: 4 issues for only \$15.98! That's almost \$4 off the cover price! Call 1-800-258-0929 and mention offer ABA6K3 or visit our website at <http://www.scryemag.com>

INTERESTED IN comics? COMICS BUYER'S GUIDE provides news and information every week to comic book readers and collectors. Special subscription offer: 14 weekly issues of CBG for only \$9.98! Call 1-800-258-0929 and mention offer ABA35U or visit our website at <http://www.comicsbuyersguide.com>

INTERESTED in Hot Wheels cars & models? TOY CARS & MODELS provides the latest news and information on Hot Wheels and new die cast cars & models. Special subscription offer: 6 issues (monthly) for only \$12.98! That's almost \$17 off the cover price! Call 1-800-258-0929 and mention offer ABA6K2 or visit our website at <http://www.toycarsmag.com>

MAD MAGAZINES for sale, 60's to present \$2 each. Send want list with order or SASE for list to: Dan Giddings, PO Box 5881, Glendale, CA 91221-5881.

PLAYBOYS \$5 and up. Send SASE for list or send wantlist with order to: Dan Giddings, PO Box 5881, Glendale, CA 91221-5881.

ROLLING STONE Magazines. Best source anywhere, 1960's-present. Any article or ad located. Complete collection also available. Howard Fields (G), 25 S. First St., Bergenfield, NJ 07621, FAX/PH: 201-387-8781. Website: <http://www.rockpaper.net>

TV GUIDES, 1948-2001. Every week available. Any article located. Giant illustrated catalog, \$3. Giant illustrated newspaper "TV Guide" catalog \$3. TV Guide Specialists, Box 20-GM, Macomb, IL 61455. oldvguides.com, 309-833-1809. VISA/MC.

UNDERGROUND COMICS for sale. Send SASE for list to: Dan Giddings, PO Box 5881, Glendale, CA 91221-5881.

C-BUB'S MAGAZINE MANIA!!

The best service & selection
Over 40,000 Magazines.

Circus, Creem, Guitar Mags, Hit Parader, Musician, People, Rolling Stone, Spin, Teen, Movie, Metal & Madonna.

Playboy, Penthouse, Playgirl, High Society, Q, Mojo, Select, The Face.

#1 Source for GOLDMINE Back Issues

WE BUY COLLECTIONS.

Send L/SASE w/Specific wants.
VISA, MC, Discover

C-BUB PRODUCTIONS

Box 4567, Tulsa, OK 74159
918-585-8222
Fax: 918-585-1878
www.cbub.com

5291 MAGAZINES WANTED

COMPUTER MAGAZINES wanted. Send list to: Dan Giddings, PO Box 5881, Glendale, CA 91221-5881.

FIRST/PREMIERE issues only (Vol. 1, #1) of US/UK music magazines/ papers in every category. Also refitted merged publications. No fanzines/ underground! "Wants" available. Grant, 5520 Maine, Concord, California 94521-4105.

ICE, THE CD News Authority back issues, August 1998 (#137) to June 2000 (#159). Don Schmedden

5296 MEMORABILIA WANTED

EAGLES, POCCO, Timothy B. Schmit, Glenn Frey wanted. Photos, posters, videos, audio, magazines, anything. Karen Mott, 25 Fenwick St., Greenlawn, NY 11740. 631-261-1686. E-Mail: kimeps@aol.com

5300 MISCELLANEOUS FOR SALE

THOUSANDS OF 45s, 78s, 33s, specializing in soundtracks, country personalities of 40's, 50's, 60's, send \$2 for refundable list. Specialty speed and category. Cari Gurfey Records, POB 995R, Princeton, NC 27569.

VERY LARGE quantity of 45's and albums for sale. All 50's and 60's covering Elvis, Beatles, Rock, Country, Classical, comedy Folk etc. All categories many rarities and one offs. Send priced wants to: carolek@cknight64@tscnet.co.uk

5301 MISCELLANEOUS WANTED

BASEBALL CARDS wanted. Send list. Top dollar paid for collections, lots, all grades wanted. 70's to present. Send info to: Dan Giddings, PG Box 5881, Glendale, CA 91221-5881.

I WANT to buy Hoodies lids, sports and movie stars. Dixie premiums, sports stars and movie stars. Stan Block, 128 Cynthia Rd., Newton, MA 02159.

PEZ! PEZ! Paying \$5,000+ for certain items, premiums, ads, dispensers, anything. David Welch, PO Box 714, Murphysboro, IL 62966. 618-687-2282. pezduke1@aol.com

5305 MONKEES

AUDIO TAPE, Polly Wanna Banana. Monkee's concert in Japan, 1968. Send \$5 for tape plus \$2 postage to: Dan Giddings, PO Box 5881, Glendale, CA 91221-5881.

5330 PHOTOGRAPHS FOR SALE

CELEBRITY, MOVIE Sports and TV. 8x10 glossy photos. View all photos on our on-line catalog. Visit: <http://www.trendycollectibles.com>

5336 PICTURE DISCS WANTED

VOGUE PICTURE records & Victor picture records wanted by collector John Coates, 324 Woodland Dr., Stevens Point, WI 54481. 715-341-6113. jcoates@coredcs.com

5340 PICTURE SLEEVES FOR SALE

PICTURE SLEEVES
www.RECORDSLEEVES.com

5345 PINK FLOYD

Pink Floyd Collectors Headquarters. Largest selection of merchandise and collectibles. We buy, sell and trade rare Pink Floyd items. For catalog, send 55¢ SASE to address below.
THE WALL '80/'81 PERFORMED LIVE PHOTO BOOK
\$35.00 + \$5.00 Shipping
HIP CAT RECORDS
1213 N. Elmhurst Rd., Prospect Heights, IL 60070
Phone: 847-537-0066

5351 POP VOCALISTS WANTED

BUYING JOHNNY MATHIS! (especially the cool stuff!) Collecting Mathis Magic/Steve C. Luth P.O. Box 458 Folsom, CA 95763-0458 SCLMUSIC@WORLDNET.ATT.NET Fax (916) 451-9395

5355 POSTERS FOR SALE

POSTERS, MEMORABILIA AC/DC, Asia to Zapta, ZZTop. Send SASE and request to: C+L Distributors, PO Box 454, East Longmeadow, MA 01028 or Email: cn20@javanet.com <http://www.rockandrol-letc.com>

THE WEBSITE <http://www.oneposter.com> is Europe's premiere online store for music and movie posters. Thousands of promos, subways, rarities and collectible posters at unbeatable prices. All with fast worldwide dispatch—usually within 24 hours. Hundreds of new posters added to the site every week. Send free electronic postcards of our posters via e-mail to your friends. Got your own website? Why not become a Oneposter.com affiliate? We pay up to 20pc commission. For affiliate details go to http://www.oneposter.com/affi_liate/

5360 ELVIS PRESLEY FOR SALE

EDDIE FADAL'S ELVIS PRESLEY Memorabilia collection silent auction Saturday January 5, 2002 Waco Convention Center, Texas Room, 10:00 AM to 5:00 PM photographs, records, videos, posters, Elvis' personal items & more, reasonable bids, door prizes, many low priced items & grab bags. Something for everybody. No checks allowed.

1 ONLY Elvis Presley autograph received from him Feb. 1957 at the Knickerbocker Hotel parking lot, Hollywood, CA along with picture of him and myself shaking hands. Submit offers: mlweis@telusplanet.net Lawrence 403-239-6828

5361 ELVIS PRESLEY WANTED

ELVIS PRESLEY vintage items wanted. Sun records original photographs autographs posters and his personal items. 1954-1960 preferably, top dollar paid. Bill Bryant Mgmt., 615-352-3456 fax 615-352-1922 email: billbryantmgmt@yahoo.com

5391 RADIO SHOWS WANTED

OLD TIME radio wanted! Records, cassette tapes, reel-to-reels, acetates & transcription disks. Top dollar paid. Send list to: Dan Giddings, PO Box 5881, Glendale, CA 91221-5881.

5400 ROLLING STONES FOR SALE

FOR SALE Rolling Stones Backstage Pass Set—combination of 1,950 stones passes (satin passes and tour laminates in set). Passes are from four (4) different tours. Serious and interested buyers "only", e-mail me at: tourpasses@cs.com if interested.

5435 SHEET MUSIC FOR SALE

I BUY and sell Sheet Music of all kinds. Let me know what you have/want. Riseman, 2205 S. Park Springfield, IL 62704 217-787-2k34 E-mail: riseman@riseman.com

5455 SOUNDTRACKS FOR SALE

SOUNDTRACKS, BROADWAY Shows, Television, Original Casts. Many rare copies. Vinyl record albums only. Catalog \$1 (refundable on first order). MJS, Box 390, Dunkirk, MD 20754

5475 STORAGE UNITS



"45" drawers, LP racks and more
The RACKIT™ System (Since 1984)
Factory direct to you from Per Madsen Design
Modular stackable oak furniture holds all media and equipment
Free brochure (Please mention Goldmine)
800-821-4883
www.rackit.com

5480 SUPPLIES FOR SALE

"IF IT'S WORTH COLLECTING IT'S WORTH PROTECTING!"
JAPANESE RESEALABLE POLYPROPYLENE SLEEVES (like Mylar)

Price per:	100	1,000
For 12-inch	\$20.00	\$149.00
For 10-inch	16.00	120.00
For 7-inch	14.50	102.50
For CDs	10.75	77.50

- Plus Shipping Charges
- Smaller Quantities Available
- Intermediate Prices on Quantities Between 100 and 1,000
- Other Sleeves for CDs, LPs, 45s, 78s
- Exclusive Distributor of Remington 7" Collector Albums

Call or Write for Free Price List
Our Sleeves Will Give You Fits
FAR WEST RECORD SUPPLY
P.O. BOX 3027
SAN DIMAS, CA 91773
(626) 335-5544

5488 TEXAS MUSIC

DOUG SAHM; Book- "Texas Tornado" \$10 CD- Doug- Groove in Peace \$10. VHS- Doug- 1964-1999 \$20. Rare memorabilia. Add postage. Kevin Kosub, 430 Orchard, San Antonio, TX 78220

5490 TOUR PROGRAMS

VINTAGE TOUR programs, backstage passes & concert tickets. <http://www.rightbrain-leftbrain.com> Also see ebay seller.

5505 VIDEO TAPES FOR SALE

ADULT VIDEOS for sale \$10 to \$15. Send SAS for list to: Dan Giddings, PO Box 5881, Glendale, CA 91221-5881.

BANANA SPLITS on video, 2 volume set, \$10 each. Send for info to: Dan Giddings, PO Box 5881, Glendale, CA 91221-5881.

BIGGEST SELECTION A-Z video and audio Van Halen, Bon Jovi, Police, Sting, Green Day, Alanis Morissette, LSD, Queen, U2, Slip Knot, T-Ride, too many to list. Send for free catalog. You won't be disappointed. Tony, PO Box 350-593, Brooklyn, NY 11235

COLLECTOR'S VIDEOS: weird sci-fi, horror, fantasy, and related TV shows and animation available. List \$2. Steven Fox, PO Box 34564, Philadelphia, PA 19101.

FREE CATALOG! Hard-to-find Videos! Totally awesome selection, including classic nudist camps, foreign, restricted, uncut, much more! Discounted prices! You must be 18+. For free catalog, write: FPGO, 1974 Catherine St., #191, Montreal, Canada, H3G 2K7. E-mail: freecat@total.net

HOT LESBIAN and other adult videos plus rock videos, CD's and tapes. \$6-\$13. Send SASE for list. Brian, 27 Lindstrom Dr., Hillsborough, NJ 08844.

PARTRIDGE FAMILY on videotape. Send SASE for episode list to: Dan Giddings, PO Box 5881, Glendale, CA 91221-5881.

PEARL JAM, Tori Amos, U2, Live, Radiohead, Springsteen, Bon Jovi, Counting Crows, Oasis, R.E.M., GNR, STP, Sgarden, SPumpkins, for trade. E-mail: prunes-plat66@aol.com for list.

RARE 1950'S/60'S RnR films, RAB, R&B Doo Wop performances. Juvenile delinquent dramas. Vintage RnR on TV. Tons more! The Video Beat!, 425 Lombard St., San Francisco, CA 94133. Please visit us at: <http://www.thevideobeat.com>

UNCUT VIDEOS of the Bizarre, Horror, Gore, adult. 4 stamps for uncensored catalog. Sign 18 or older! Bloodgore Imports, PO Box 543, Iselin, NJ 08830-0543.

SIXTIES ROCK. Everyone's source for rare and unreleased sixties and related rock videos, large SASE for extensive list. Peter Abram, 561 Staples, San Francisco, CA 94112.

VIDEO/ AUDIO: Led Zeppelin, Jethro Tull, Heart, Skynyrd, Van Halen, Bad Company, Fleetwood Mac, Kiss, Eagles, Foghat, Foreigner, etc. J.A.M., PO Box 7600, Garden City, GA 31418.

"SAM'S VIDEO"
For Fast Service of High Quality 60's-2000 rock concerts and TV shows, from A-Z trades welcomed your list gets mine, send 4 stamps for 40-page catalog to:
"SAM"
98 Penn St.
Pennsgrove, NJ 08069-1241

Raging Belly Video!
For the Best videos from 1960-2000!
Rare videos guaranteed not to disappoint!
"My list is like no other!!!"
Send \$3.00 for postage & handling to:
Marc A. P.O. Box 413
Farmington, NY 11735 U.S.A.

COLLECT MORE THAN MUSIC VIDEOS?
Get My BIG 50+ page VHS Video list of Retro-TV Classics! Sci-fi, Mystery, Detective, Adventure, Western, Kids TV & Toons, Music, B-Movies & More! Great Selection, nice quality and timely service!
Send \$3.00 to Stephen M. Russo
P.O. Box 150/Boston, MA 02151.
(Offered on a collector-to-collector basis.)

TU Video
"Blast From the Past"
Collectors of Classic Television Programs of All Kinds!
We have a video catalog of over 22,000+ shows chock full of nostalgia, including:
• TV Shows from the late 40's to 80's (animated/live action)
• Aired & Unaired Pilots
• Fantasy & Sci-Fi
• Music Clips - many
• Sports Items
• 1000's of Commercials (animated/live action)
• Shows with Original Commercials 40's to 80's
• Promos
• Bloopers
• Holiday Specials
• and Much More
To Get Your Own Copy of Our Exclusive Catalog Collection, Please Send \$5.00 p/a to:
D.E. Miller
P.O. Box 65
Mt. Taber, NJ 07878
(Take \$1.00 OFF with Mention of Goldmine)

5506 VIDEO TAPES WANTED

FOR TRADE: Beatles, Stones, Dylan, Bruce Zep, Nirvana, Who, Queen, U2. Lots more. Send audio/video lists. Ken, 304 E 20th St #2G, NY, NY, 10003

(Reissues from page 69)

bonus tracks — an alternate take of "Rocks And Gravel," previously available on the *Best Of The Vanguard Years* compilation, and the lovely "Je T'aime Marielle."

From start (1963's eponymous debut) to finish (1968's *Nashville*), it's a staggering repertoire. It's no secret that the strongest songs are those on which the two voices entwine — less well-known is the fact that their taste in covers and traditional arrangements reinventions is equaled on every album by their own compositions. From *Ian And Sylvia*, "Rocks And Gravel" and "Old Blue" have both ascended to that rarified strata where they are all but folk staples regardless of authorship, while the later albums are equally rewardingly pocked with moments of staggering self-defined beauty. Tyson's "Four Strong Winds," the title cut from their sophomore album, is only the best known; Fricker's "You Were On My Mind" (from *Northern Journey*) is simply the best.

Of the covers, their treatment of Dylan's "Tomorrow Is A Long Time" is all but definitive, while Gordon Lightfoot's "Early Morning Rain," Joni Mitchell's "Circle Game" and Phil Ochs' "Changes" reinvented the authors' own personal visions with such profound

power that the originals themselves sound like covers by comparison.

Only toward the end of the box do things falter, although even the final album in this sequence, *Nashville* (named, of course, for its prevalent mood), is simply making the same mistake as a lot of other folk warriors were making at the time. But still there are highlights — Fricker's interpretation of Dylan's "This Wheel's On Fire" at least tries to pursue Julie Driscoll's genre-smashing interpretation toward perfection, while Tyson's "Taking Care Of Business" effortlessly anticipates the country-rock boom of a few years hence.

Included in the package, a lavishly illustrated booklet tells the duo's full story, while the sound quality is exemplary. Indeed, regardless of what you think you know about Ian & Sylvia, this package is going to rewrite most of it. When the Folk Gods assess the essential reissues of the year, *The Complete Vanguard Studio Recordings* is going to be high among the highlights.

— Dave Thompson

(Please see Reissues page 76)

Chuck Berry Book Review

LONG DISTANCE INFORMATION
CHUCK BERRY'S RECORDED LEGACY
by Fred Rothwell
Music Mentor Books (351 pages, soft-cover) (<http://go.to/musicmentor>)

Long Distance Information: Chuck Berry's Recorded Legacy contains just about everything you ever wanted to know about Chuck Berry, but were afraid to ask (or didn't know where to look)! A member of both The Rock And Roll Hall Of Fame (1986) and the M.C. Handy Awards' Blues Hall Of Fame (1985), Berryites know fully well how important his

(his August 1954 recording with Joe Alexander And The Cubans) to Session 93 (a live concert recording in August 1998). The many indexes refer to these session numbers. As much as possible, complete listings of session personnel are included, and each song is evaluated, and when appropriate, it is noted which songs by other artists influenced Berry's songwriting.

Most of the entries include details about the cover versions of Berry's songs, lending credence to his fame (and fortune) and to the songs that have made him immortal. You'll find out the true (and not the usual

Even if he has a cynical attitude, is uncooperative and, let's face it, not your best live performer (it doesn't help that he rarely rehearses), this book is essential reading for his many fans.

Chess recordings were.

Some of us may even argue that his Chess recordings between 1955 and 1966 were his only important recordings. In *Long Distance Information*, author Fred Rothwell — in all his honesty (and humor) — lays it down exactly as he hears it. The book's title refers not only to a lyric contained in the Chuck Berry song "Memphis Tennessee," but also to how Rothwell approached this music ("through headphones whilst reclining on a velvet chaise longue"). In some ways, the title also refers to the guitarists, songs and singers that influenced Berry. All of this information is interwoven into the text.

The music is described in standard discographical order, beginning with Session 1

untrue) stories behind songs such as "Maybellene," "Rock At The Philharmonic," "Run Rudolph Run" and many others. He also discusses the claims that pianist Johnnie Johnson has on some of Berry's songs. Regrettably, Berry's early drummer Ebbie Hardy is no longer alive (he died in 1983) to resolve some of the discographical questions.

Even if he has a cynical attitude, is uncooperative and, let's face it, not your best live performer (it doesn't help that he rarely rehearses), this book is essential reading for his many fans. His songs were some of first to speak directly to American teenagers.

— Eric S. LeBlanc

(Reissues from page 75)

VARIOUS ARTISTS

The Long Road To Freedom: An Anthology Of Black Music
Buddha (7-4465-99756-2) (Five CDs)

Say It Loud! A Celebration Of Black Music In America
Rhino (R2 76660) (Six CDs)

Say It Loud! Soundtrack From The Documentary Series
Rhino (R2 76786)

"Social and political hypocrisy, abandoned-love pain, and the high cost of being not just Black, not just American, but of being *human* has been spelled out in grooves, words, and breathtaking riffs," read the liner notes to the six-CD *Say It Loud! A Celebration Of Black Music In America*.

Released almost simultaneously, the six-CD *Say It Loud!* and the five-CD *The Long Road To Freedom: An Anthology Of Black Music* present — mostly in music — black Americans' painful trek down freedom's highway. Where *Long Road* breathes refinement, *Say It Loud!* grows loud and in-your-face by the time it has gone from Scott Joplin's 1916 ragtime to Run D.M.C. and Ice-T's rap.

Harry Belafonte (whose *Calypso* was the first-ever gold LP) brilliantly masterminded *Long Road*, which languished unissued in RCA's vaults for decades until BMG (which now owns RCA) discovered it and released it out on BMG's oldies imprint, Buddha. Taped from 1961 to 1971 — crucial years for African-Americans — it chronicles centuries of blackness through fresh studio sessions rather than field recordings or delving into RCA's rich black archives.

Divided into 10 "chapters" (*Roots, Country Moods, City Moods, Slave Christmas* and so on), starting with *Mother Africa*, it's intentionally smooth aurally — 10 Belafonte vocals mark its tone. Sonny Terry And Brownie McGhee's provide relatively genteel Piedmont blues, not stark Delta blues. Gloria Lynne's "Fare Thee Well, Oh Honey" gets a supper-club piano backup instead of a juke-joint setting. A field shout receives an elegant chorale arrangement by the late Leonard de Paur. Fusing African beats and Catholic hymns, Creole church music — not rollicking zydeco — represents Louisiana's blacks.

Say It Loud! cuts a wider path with its jazz, blues, R&B, soul, Motown, disco, hip-hop and rap, all birthed in blackness, intermixed with words from Booker T. Washington, Jackie Robinson, W.E.B. Du Bois, Malcolm X and others. "Ole Man River" by Paul Robeson (Belafonte's predecessor as a black singer fighting for his people) has lines Robeson later dropped because they stereotype blacks. Belafonte sings his 1956 "Day-O (Banana Boat Song)."



Courtesy of Atlantic Records

Otis Redding

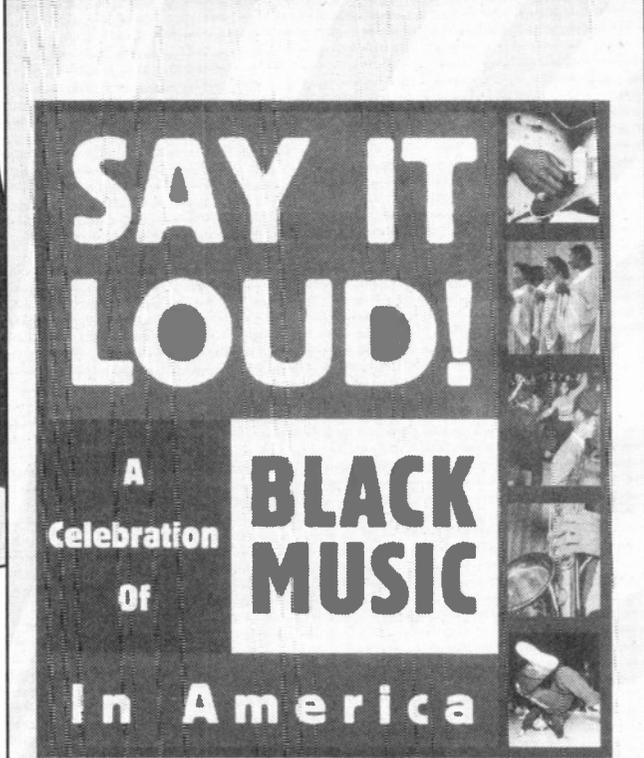

Classically-trained Marian Anderson and Odetta, as well as church-trained Aretha Franklin, are present. Including young Sam Cooke's heavenly gospel, not his later crossover pop, is sensitive. From Billie Holiday's "Strange Fruit" to The Staple Singers' "Respect Yourself" and Diana Ross' "Love Child," Rhino's box is a plea for — a demand for, as Franklin shouts — "Respect." Its strong essays make this point with fewer polemics than the scholarly hardbound book accompanying *Long Road*.

Rhino's adequately remastered 108-song set appears in conjunction with VH-1's series *Say It Loud! Say It Loud! Soundtrack From The Documentary Series*, a 20-track single-CD, has 12 songs not in the box — for example, Marvin Gaye's carnal "Let's Get It On" rather than his sadly philosophical "What's Going On" (which, like others in the box, transcends specific political struggles).

Does Lena Horne's 1942 line "Stormy weather, keeps raining all the time" subtly refer to social questions? Sly & The Family Stone's 1969 "Don't Call Me Nigger, Whitey" obviously does. But hope is found in both boxes: the freedom to, if nothing else, as NWA say, "Express Yourself."

— Bruce Sylvester



Ruth Brown

Five Star Record MASTERY WINNERS WWW 2001

IT'S PROBABLY NO SECRET BY NOW THAT I LOVE THE FUNK! AND NOBODY STRETCHES THE BOUNDARIES OF FUNK AS FAR AS THE MIGHTY GEORGE CLINTON! SINCE THE '70'S HE HAS BEEN THE PRE-EMINENT PURVEYOR OF WHAT HAS BECOME KNOWN AS PSYCHEDELIC FUNK... HENCE THE NAME: "FUNKADELIC"! THE MUSIC OFTEN COMBINES SCORCHING GUITAR RIFFS WITH DRIVING PERCUSSION, SOUND EFFECTS & SOMETIMES SILLY LYRICS TO FORM GEORGE'S INSTANTLY RECOGNIZABLE BRAND OF FUNK/ROCK! A PROLIFIC PRODUCER, AS WELL AS WRITER/PERFORMER, CLINTON HAS BEEN RESPONSIBLE FOR BRINGING NUMEROUS MUSICIANS THROUGH THE FUNKADELIC UNIVERSE AND HELPING TO LAUNCH THEIR SOLO CAREERS! KEYBOARD PLAYERS "JUNIE" MORRISON & BERNIE WORRELL BOTH SPENT TIME IN CLINTON'S BAND (VARIOUSLY KNOWN AS FUNKADELIC, PARLIAMENT OR P-FUNK) AND BASSIST BOOTSY COLLINS SPUN OFF HIS GROUP, BOOTSY'S RUBBER BAND, AFTER A STINT WITH GEORGE! OTHER CLINTON-PRODUCED ARTISTS INCLUDE THE RED HOT CHILI PEPPERS & THOMAS DOLBY!



"MAGGOT BRAIN" IS ONE OF GEORGE'S EARLIEST (AND BEST) FUNK/ROCK LP'S! RELEASED IN 1970 ON THE WESTBOUND LABEL, IT RUNS THE GAMUT FROM THE HAUNTING TITLE TRACK WHICH FEATURES A LENGTHY, BEAUTIFUL GUITAR SOLO BY EDDIE HAZEL TO THE FOLKY, DOO-WOP INSPIRED "CAN YOU GET TO THAT"! ALSO OF NOTE: THE ROCKIN' "HIT IT AND QUIT IT"! I HAVE TWO COPIES OF THIS LP... THE ONE I USUALLY PLAY IS A RE-ISSUE FROM THE EIGHTIES, BUT THIS ONE IS AN ORIGINAL (SOMEWHAT SCUFFED & WORN) WITH A TERRIFIC GATEFOLD COVER!

GEORGE OLINTON WAS BORN IN KANNAPPOUS, NC IN 1940, AND STARTED HIS MUSICAL CAREER DURING THE '50'S IN A VOCAL GROUP CALLED THE PARLIAMENTS, WORKING OUT OF NEWARK, NJ! SEVERAL LINE-UP CHANGES AND OVER A DECADE LATER, THE PARLIAMENTS SCORED THEIR FIRST HIT IN 1967 WITH "I WANNA TESTIFY"! A FEW YEARS LATER, CLINTON WAS LEGALLY BARRED FROM USING THE PARLIAMENT NAME AND FUNKADELIC WAS BORN! FROM THE SEVENTIES ON, CLINTON SPENT HIS MOST PRODUCTIVE YEARS WORKING OUT OF DETROIT, PRODUCING & RECORDING OVER FIFTY ALBUMS! "FLASHLIGHT" & "ATOMIC DOG" ARE PERENNIAL DANCE HALL FAVORITES AND P-FUNK IS REGULARLY SAMPLED BY RAP ARTISTS TOO NUMEROUS TO NAME!

Coming to...

Goldmine

Courtesy of RCA

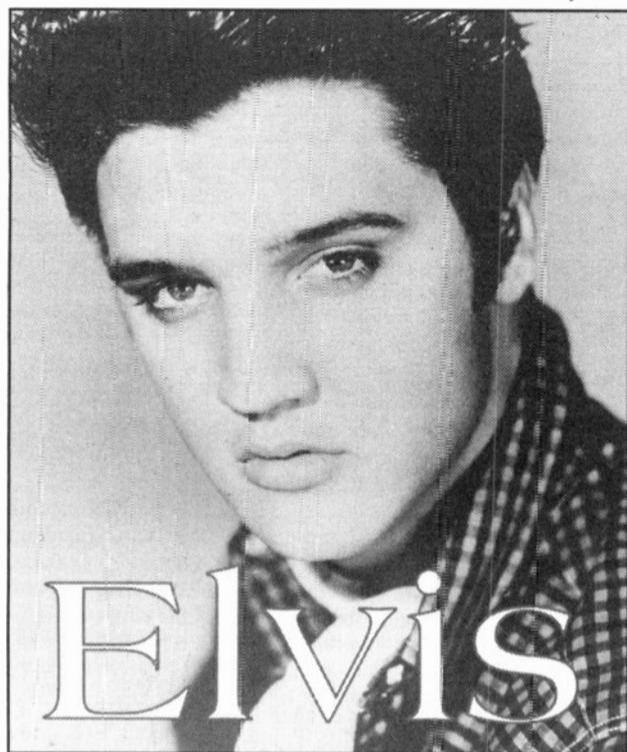

The King Of Rock 'N' Roll would have been 67 in 2002, and although he passed away nearly 25 years ago, Elvis Presley is just as vital as ever and still at the top of the collecting world. In *Goldmine's* annual Elvis celebration, we'll be taking a look at the making of "Good Rockin' Tonight," Elvis sites around the country, Sun Records and lots more. In addition, our *Country Junction* section will feature a Willie Nelson interview.

Advertisers: Take advantage of *Goldmine's* active readership and the added magazine sales of this special Elvis issue. Advertise your Elvis and rock 'n' roll items as well as items from every genre and era. Reserve your ad space today.

ISSUE DATE	AD DEADLINE	MAILING DATE	ON SALE
Jan 11, 2002	Dec 13	Dec 20	Dec 28

Advertising deadlines

DEADLINE	ISSUE DATE	MAILING DATE	ON SALE DATE
Thursday	Friday	Thursday	Friday
Nov 29	Dec 28	Dec 11	Dec 14
Dec 13	Jan 11, 2002	Dec 20	Dec 28
Dec 27	Jan 25, 2002	Jan 3, 2002	Jan 11, 2002

FOR AD INFORMATION: Call Trevor Lauber or Jill Ruesch at 715-445-2214.
 RETAILERS: To sell *GOLDMINE* in your shop at no risk, contact Bulk Sales Manager Steve Hudziak at 715-445-2214, ext. 327.

Sign up as a GOLDMINE subscriber
 — get 13 issues for only \$24.95!

(U.S. addresses only; see subscription ad on this page for non-U.S. rates.)

Charge Card holders, call toll-free:

1-800-258-0929

(Please Mr. Postman from page 8)

I also feel Cheap Trick should be nominated in 2002 (their five-star debut LP, *In Color*, was released in 1977), but for some reason, I doubt that will happen. If someone as middle of the road as Billy Joel (who's a lightweight — let's face facts!) can be in the Rock Hall, Kiss certainly can be! Oh well, you can't please everyone! Keep up the good work guys. I'm a longtime reader of *Goldmine*, my #1 source for music and collecting.

— Ken Vail Jr.
 Kalamazoo MI

(Ken, you bring up valuable points concerning Kiss' inclusion into the Rock Hall. Only time will tell if they ever make it to the Rock Hall's altar or will be perennial bridesmaids such as Chicago, The Moody Blues and others. — Ed.)

Is guitarist Bill House in the house?

I was wondering if *Goldmine* knows whatever became of guitarist Bill House. He played on a couple of David Cassidy albums. I contacted a guy with the same name on MP3's Web site, but he said he's not who I'm looking for. Any help you can provide would be appreciated.

— Dennis Dwyer
 Bridgewater NJ

(Dennis, according to Cassidy's publicist, House is currently touring with him. — Ed.)

So many article requests, so little space

I have been a subscriber to your great and unique magazine for many years and a dedicated reader of it years before this. I drove out of my way many miles to get my copy every two weeks. I just wanted to say thanks again for the many great articles on many great and favorite artists of mine over the

years. No one writes them like your writers, and I love all the useful information and ads.

Here is a list of a few artists that I hope you will look at and decide to do a cover story on. You may have done some of these years ago and I didn't know it, but I sure would appreciate it: Blue Cheer, Bubble Puppy, Captain Beyond, Canned Heat, James Gang (Joe Walsh), Journey, Lynyrd Skynyrd (again), Diana Ross And The Supremes, The Temptations, Sly & The Family Stone (a history), Uriah Heep, War.

A big thank you for stories in the past on these favorites of mine. The Allman Brothers, Blue Oyster Cult — where else would I read about this great band? CSNY (great story, from the early '90s), The Dorsey Brothers (Big Band), Jefferson Airplane (great articles on one of the '60s greatest) Likewise, Quicksilver Messenger Service, Renaissance (a fantastic progressive band with the great Annie Haslam on vocals), SRC (classic heavy rock band from Detroit), Barbra Streisand, and Deep Purple.

Thanks again. I don't like to see *Goldmine* shrink in size as it has over the past year or so. If there are some factors on this you cannot help, then maybe you can fill in the gaps with more articles. Just the same, keep up the quality work. Thanks, and long live the LP!

P.S. What did happen with the new studio LP by Renaissance? You wrote about in January 1999.

— Dave Wallace
 Avon IN

(Dave, thanks for the thanks! We'll work on your list. The economy hasn't been kind to many businesses, us included, but it will get better! According to Goldmine writer Geof O'Keefe, who follows the band, Renaissance's reunion album Tuscany came out in Japan late 2000 and in Europe this summer. No U.S. release is scheduled, so get the imports! — Ed.)

Goldmine Subscription Service

Including Special Services Subscriptions sent via UPS, 1st Class

Note: Current subscribers: when ordering any Special Service Subscription, a minimum one half year payment must be submitted. Those funds will be added to any current subscription credit and the total balance pro-rated to arrive at the number of issues due under the chosen plan. Subscribers will be notified of the resulting change in subscription duration and their new expiration date.

Regular Subscriptions are delivered via Second Class Mail to addresses in the U.S. and possessions.

Credit card orders: To speed the processing of your order for a Special Service Subscription, VISA,

MasterCard, Discover or American Express orders may be phoned in by dialing 800-258-0929 and asking for Special Services.

United Parcel Service delivery subscriptions require a street address.

Clip and mail with payment to:

Goldmine

Special Services
 Subscription Department

700 E. State St., Iola, WI 54990-0001

NOTE: Special Services Subscriptions are not available outside of U.S.A.

Goldmine Service	6-mo.	1-yr.	2-yr.	3-yr.
Second Class Mail (Standard Delivery 50 States)	\$24.95	\$39.95	\$74.50	\$107.95
Plain Wrapper (2nd Class Mail 50 states)	N/A	46.95	88.50	128.95
First Class Mail (in Plain Wrapper 50 states)	66.95	124.95	255.00	382.95
United Parcel Service (Regular Delivery 48 States)	75.00	140.00	N/A	N/A
United Parcel Service (2nd Day)	160.00	305.00	N/A	N/A
United Parcel Service Next Day	245.00	470.00	N/A	N/A

Foreign subscriptions including Canada and Mexico must be paid for in U.S. funds by an international money order or postal money order

Circle the rate below your country

	1/2-year	1-year
Surface mail all countries	49.95	93.95
Canada, Mexico (Air Mail)	70.95	135.95
Central America, Caribbean (Air Mail)	135.00	255.95
South America, Europe, Mediterranean Africa (Algeria, Libya, Morocco, Tunisia) (Air Mail)	135.00	255.95
Asia, Africa, Australia, all other countries (Air Mail)	135.00	255.95

Name _____ Check enclosed
 Address _____ MasterCard VISA Discover Am. Exp.
 City _____ Card # _____
 State/Zip _____ Expires Mo. _____ Yr. _____
 Signature _____

New subscription
 Renewal/Extension (please attach your mailing label)

Goldmine Rates are subject to change.
 Circulation Dept.
 700 E. State St., Iola, WI 54990-0001 GMPTY97

Goldmine Advertisers' Index

A	Cuneiform Records38	Gubala Richard38	McDuffie, Jim65	Rare & Hard To Find63	Shaheen, John68
Ace Video & Music40, 54	Cyrco Music67	Guitarist's Connection69	Memory Lane55	Rare Soul Man54	Siren Disc.....41, 56, 57
Adler, Dan74	D	Hein, Gary66	Metro City Records ..42, 43	Record Archive Inc.74	Southland CD.....54
Aether Records66	Digitalage Video66	Held, Kenneth.....54	MFG63	Record Exchange.....38	Spindle Records.....37
Airwaves74	Disc Collector4	Heroes & Legends68	Midnight Records7	Record Gems.....33, 74	Spinnin' Disc.....27
Andy's Record Supply5	Dischase CD Shop.....33, 66	Hip Cat Records.....75	Moerer, Craig65	Record Sleeves.com75	Staeher, Herbert.....37
Arredondo, Roberto47	Discguys.....74	Hollis, Dan75	Moffitt, Stephen67	Records and Books55	Streetlight Records.....65
Atlanta Record Show56	DJB (Devant Le Juke Box)68	I	Mud Shark Audio54	Records Argentina65	Stylus Shows LLC56
Audio Collections44	E	Import Record & CD's54	MusicAndVideo.com.....66	Recordsmith45	Supreme Legacy (TM)67
Aya, Gokhan.....66	Erock Auction54	Int'l Transfers65	Music Imports.....65	Reed, Biz66	Sweet Memories54
B	Esprit Most Wanted65	Intoxica68	Music Joint, The65	Retriever Memorabilia	T
B & D Record Sales.....66	Euclid Records67	Iuliucci, Bob66	Music Masters11	Service.....67	Tefteller, John63
B.T. Puppy Inc.53	F	J	Music Unlimited63	Rhythm Recordings45	Tiny Ripple Books58
Bags Unlimited...24, 25, 80	Fab 4 Collectibles.....67	Jazz Record Center54	N	Rip It Up!65	Tomko, Jerome.....65
Banana's Records68	Far West Record Sply75	Jewelsleeve.com41	Nitty Gritty Records34	Rivertone Corp.67	Train Wreck Records34
Bangzoom.com33	Finest Record Store79	Joe's Record Paradise74	Noise Pollution45	Roanoke's Record Room	True Oldies68
Bell, Rick68	Flipside Records & Collectibles.....31	Just Another Dream54	O65, 74	Tsouvalos, Alex66
Better Records68	Flying Records69	K	Oldies45.com55	Rock Classics.....13	Turton, John65
Binkowski, Rick48	Fun Records.....67	Kaplan, Gary66	Ondrus, Andy Jay.....37	Rock N Records.....45	Tyson, David.....48
Bonhams21	Funk, Thomas47	KP Adv Promotion	P	Rock Of Ages45	V
Boo's Blast From The Past39	G32, 34, 53, 59	Papa Jazz Record Shoppe	Rock Solid International	Very English & Rolling
.....39	Garofalo, Peter68	KP Book Promo70672, 3	Stone54
Bop Shop Records.....74	Gaspar, J.A. 7 J. DelPeso	L	Per Madsen Design	Rockaway Records.....68	Videotech68
Breeze Hill Productions ..5864	L.A.M. Videos6752, 54, 64, 75	Rocky Mountain	Vintage Vinyl Mail Order
Brennan, Bob74	Gatefold Records68	Last Vestige38	Phelan, Mike.....54	Sportscards5555
Brito, Michael69	Gianetti, Frank48	Les Harris50	Poplife.....34	Ross, Scott.....53	Vinyl Galore LLC54
Buccaneer Records9	GM Upcoming Issues.....77	Let It Be Records66	Powerdata Computer Corp.	Ross, Steve37	Vinyl Tap Mail Order Music
C	Goldmine37, 48, 58, 71, 73	Let The Music Play.....6766	Rottkamp, Laura.....4959
C-Bub Productions74	Goldmine Index Page.....78	Loran Records54	Princeton Record	Ruggieri, Bob & Donna ..68	Visual Vinyl.....54
CD64	Goldmine Subscript'n.....77	Lorentz Design64	Exchange67	Rumble, Danny.....37	Vitek, Stan48
CD Trustee64	Goldmine Unit Page.....35	Luth, Steve75	Psychedelic State	Russo, Joseph66	W
CJI Collectibles.....65	Goldmine Want List ..71, 72	Lyons, Gary56, 65	University49	Russo, Stephen68, 75	W.M.I. Distribution54
Collectable Records29	Greindl, Jeff54	M	R	Safe As Milk Reocdrd.....74	Wickham, Barry69
Collectibles Insurance Agency.....63		Magna Carta Records33	R & B Records63	Samuels, Gordon75	Wiz Productions67
Collector59			Radwill, Allen36	Sandkamp, George69	Worldwide Marketing Associates65
Continental Records.....74			Raging Belly Video....66, 75	Saturn Records46	

The advertisers' index is provided as a reader service. Occasional, last-minute changes may result in ads appearing on pages other than those listed here. The publisher assumes no liability for omissions or errors.

2001 Advertising Deadlines

Deadline is 12 noon on deadline day
700 E. State St., Iola, WI 54990-0001

1-888-457-2873 • 715-445-2214 • FAX: 715-445-4087

Ad Deadline	Issue No.	Cover Date	Mailing Date	On Sale Date
Nov. 29	#559	Dec. 28	Dec. 6	Dec. 14
Dec. 13	#560	Jan. 11, '02	Dec. 20	Dec. 28
Dec. 26 (Wed.)	#561	Jan. 25	Jan. 3	Jan. 12
Jan. 10 '02	#562	Feb. 8	Jan. 17	Jan. 25
Jan. 24 '02	#563	Feb. 22	Jan. 31	Feb. 8

REFERENCE FORM

COMPANY NAME _____
 STREET ADDRESS _____
 CITY _____ STATE _____ ZIP CODE _____
 PHONE NO. _____
 SOCIAL SECURITY # _____
 TYPE OF BUSINESS _____
 CORPORATION LIMITED PARTNERSHIP
 CO PARTNERSHIP INDIVIDUAL PROPRIETOR
 NO. OF YEARS ESTABLISHED _____

PRINCIPAL OWNERS - STOCKHOLDERS - PARTNERS - OFFICERS OF COMPANY

NAME _____
 MAILING ADDRESS _____
 CITY _____ STATE _____ ZIP CODE _____
 TITLE _____

TRADE REFERENCES

NAME _____
 ADDRESS _____
 CITY _____ STATE _____ ZIP CODE _____
 PHONE _____

BANK REFERENCE

BANK NAME _____
 CITY _____ STATE _____ ZIP CODE _____
 PHONE _____
 BANKING OFFICIAL _____

I (we) hereby authorize Krause Publications and/or its credit agent to investigate the references herein or statements or other data obtained from me or any other person pertaining to my credit and financial responsibility. I understand that it is Krause Publications' policy to require cash in advance for all advertising until credit has been established or approved.

Further, I (we), the undersigned, will be held personally responsible and promise to pay promptly within 15 days of the billing date for all advertising debts incurred by the above named business and owing to Krause Publications.

AUTHORIZED SIGNATURE(S) OF APPLICANT(S) _____

Advertising Information

DISPLAY ADVERTISING:

(Cost per ad per issue; ads must run consecutively. Contract required to earn consecutive issue discounts.)

AD SIZE	WIDTH x HEIGHT	1 ISSUE	3 ISSUES	6 ISSUES	13 ISSUES	26 ISSUES
1/16 pg	2 5/16"x3 1/4"	\$55.65	\$53.55	\$50.15	\$47.45	\$44.40
1/8 pg	4 7/8"x3 1/4"	111.30	105.00	100.30	94.50	89.25
1/4 pg	4 7/8"x6 1/2"	213.90	202.95	191.90	181.95	170.90
1/2 pg	4 7/8"x13" or 10"x6 1/2"	397.45	378.20	358.35	338.50	318.65
Jr. pg	7 7/16"x10"	525.90	499.45	473.00	447.05	421.05
Full pg	10"x13"	721.05	685.65	649.40	613.55	577.15

COLOR:

- A. One color and black\$190.00
- B. Full color (4-color)\$500.00
(Plus color separation costs)
- C. Based on availability.
- D. Color is possible on any size ad.

UNIT SPACE ADVERTISING:

Unit space ads are the easiest way for you to sell records, tapes, compact discs, books, memorabilia, and any other collectibles you have for sale. Units also work well for want lists, announcements, etc. The better your unit looks when you put it together, the better it will look in GOLDMINE.

You may use any bidding deadline you wish in your advertisement. If no deadline is noted, it will be understood that the deadline will be one month from the cover date of the issue in which your ad appears.

One unit space equals one 8 1/2" x 11" typed sheet. This applies to both regular and super unit space ads.

Type your copy legibly onto 8 1/2" x 11" white sheets. We'll reduce it as is to 38% of its original size for regular units and 59% of its original size for super units. A regular unit space is one ninth of a page; a super unit space is a quarter of a page. Remember to include your ordering information, postage rates, grades, deadlines, name & address, etc., on your first unit. **Do not send any partial units.** There is a \$10.00 charge per photo for unit ads which contain photographs.

We will typeset your name, address and phone number at the bottom of your unit space ad for you, and a heading at the top, if you specify one. There is no extra charge for this. If you ask us not to typeset anything on your ad, we'll do nothing. Otherwise the typesetting will appear.

Do not reduce your copy before putting it on 8 1/2" x 11" format. Avoid all caps in your copy, except for headlines. Keep the copy clean. Dot matrix printers do not work well for unit ads, but if you must use one print it as dark as possible. Faxing unit space advertisement is not recommended.

Regular Unit Space Advertising Rates:

(Cost per unit, per issue; ads must run in consecutive issues. Contract required to earn consecutive issue discounts.)

1 ISSUE	3 ISSUES	6 ISSUES	13 ISSUES	26 ISSUES
\$60.90	\$57.90	\$54.60	\$52.00	\$48.60

Full page of 9 - \$466.20

Super Unit Space Advertising Rates:

(Cost per super unit, per issue; ads must run in consecutive issues. Contract required to earn consecutive issue discounts.)

1 ISSUE	3 ISSUES	6 ISSUES	13 ISSUES	26 ISSUES
\$126.80	\$120.75	\$114.20	\$108.15	\$101.85

Full page of 4 - \$466.20

COLLECTOR'S SHOWCASE:

The Collector's Showcase is a widely read advertising section in GOLDMINE. Each ad is in its own box, consisting of a space 3 1/4" wide and 1 11/16" high, or a multiple of that size. All typesetting is included in the price. We recommend no more than 14 to 15 typed or written lines per showcase box.

There are two Collector's Showcase sections available to advertisers - the Compact Disc Showcase, for those specializing in CDs; and the regular Collectors Showcase.

Showcase Advertising Rates:

(Cost per showcase box per issue; ads must run consecutively. Contract required to earn consecutive issue discounts.)

1 ISSUE	3 ISSUES	6 ISSUES	13 ISSUES	26 ISSUES
\$38.60	\$37.00	\$34.65	\$33.10	\$31.00

RETAILER DIRECTORY\$9.00 per issue

This section features listings for retail record stores around the world. Traveling record collectors of all types search for new stores to dig through on their vacations, business trips, etc. Advertise your establishment here, including ten words of miscellaneous description, for only \$9.00 an issue. You can buy this space in increments of 13 or 26 issues, for \$117.00 or \$234.00, respectively. Send in your store name, address, phone number, and ten words of description, along with your payment. If you stock GOLDMINE, we'll put your listing in boldface type.

CLASSIFIED DISPLAY:

AD SIZE	1 ISSUE	3 ISSUES	6 ISSUES	13 ISSUES	26 ISSUES
One Inch (1 1/2" x 1")	\$13.80	\$13.15	\$12.60	\$12.10	\$11.55
Two Inch (1 1/2" x 2")	26.55	25.50	23.65	22.60	21.55
Three Inch (1 1/2" x 3")	39.15	37.55	35.20	33.60	31.50

(Cost per ad; ads must run consecutively. Contract required to earn consecutive issue discounts.)

CLASSIFIED ADVERTISING:

- A. 40 cents Per Word (\$10.00 Minimum Order Per Ad Per Issue). Ad will also be included on our www.collectit.net site at no additional charge.
 - B. DISCOUNTS FOR CONSECUTIVE INSERTIONS
- | | | | |
|-----|-------------|-------|-----|
| 1-2 | No Discount | 10-12 | 20% |
| 3-6 | 10% | 13-26 | 25% |
| 7-9 | 15% | | |

ADVERTISING REQUIREMENTS: BOOTLEG POLICY

The advertiser is responsible for ensuring that advertised product conforms with national and international copyright laws. GOLDMINE magazine screens advertisements for bootleg merchandise. GOLDMINE magazine accepts no responsibility for transactions involving unauthorized product.

REFUNDS:

If delivery will take longer than 30 days from the date the seller received the order, the seller must inform the buyer and offer the buyer the option of a refund or delayed delivery.

Unless otherwise stated in the ad, the buyer has a 10-day return privilege from the time he/she receives an item from an advertiser. The buyer does not have to give a reason for a return and can demand a refund less postage costs. Advertisers must allow buyers to obtain authenticity judgments as the basis for retention provided they notify the advertiser of their intent within the applicable return privilege period.

All advertisers must provide a permanent address and telephone number before an advertisement will be run. If a post office box is used in an advertisement the advertiser must still provide a permanent address for our confidential files.

A completed reference form must be in our confidential files before any buy, sell or trade ad can be placed. See below. Minors are required to furnish a certificate of responsibility from their parents/guardian before their advertising can be accepted.

Payment must accompany an advertisement and must be in the form of a personal check drawn on a U.S., Canadian or Mexican bank; money orders; international money orders; cashier's checks; or with your VISA, MasterCard or AccessCard credit card. Send your credit card number, expiration date, and the name on the card, along with permission to charge the card for your ad, with your advertising copy.

