

# INTERNATIONAL Musician

AND RECORDING WORLD

DECEMBER 1978 50p

CHASE MUSICIANS  
SUPPLEMENT INSIDE



## Al DiMeola

**Aynsley Dunbar**  
**Charlie Byrd**

**Strangler Jean Jacques Burnel**  
**Crusader Wilton Felder**  
**Crawler's Rabbit Bundrick**

TESTS: PEAVEY T60 GUITAR • ARIA 7-STRING CLASSIC  
SCORPION SYNTH • ROLAND MP600 ELECTRIC PIANO  
AMPEG VT22 COMBO

The World of  DiMarzio



*Inside!*



# Kramer™

SOLID BODY ELECTRIC GUITARS AND BASSES

Sole U.K. distributors:  
BRODR JORGENSEN (U.K.) LTD.,  
GREAT WEST TRADING ESTATE,  
983 GREAT WEST ROAD,  
BRENTFORD,  
MIDDX. TW8 9DN.  
TELEX 888 941.

# Chingford ORGAN STUDIOS does it again.

COS gives you a chance to own the fantastic

## WURLITZER EP 200A ELECTRIC PIANO

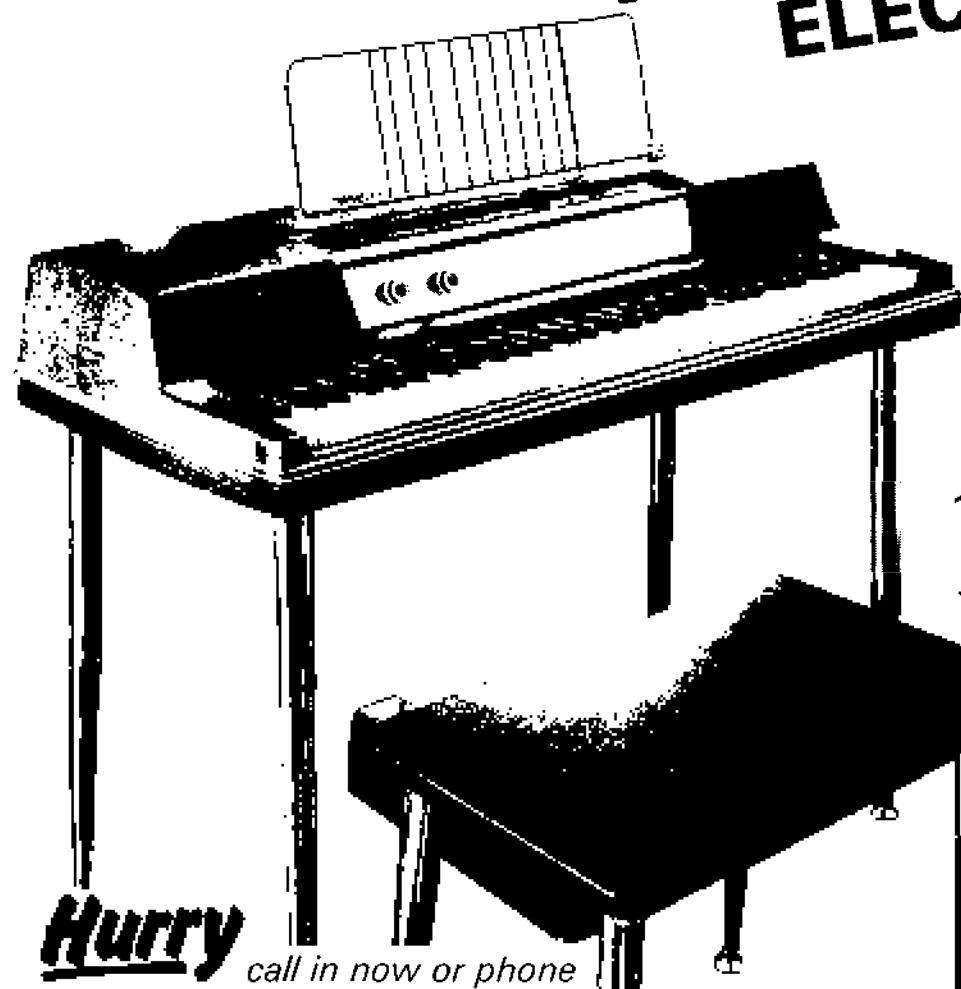

**Hurry** call in now or phone

For only  
**£499**  
inc VAT

12 MONTHS GUARANTEE

There's no hidden charges, no tricks, just COS value, we'll still give you our expert advice, and we have

**EXCELLENT  
FINANCE FACILITIES**

**GROUP GEAR SHOP**



**CHINGFORD  
ORGAN STUDIOS LTD**

242 Chingford Mount Rd, London E4

Tel: 01-524-1446/7/8

Deposit	£99
36 monthly payments	£15.94
Total H.P. price	£674.84
List price	£713

# Contents

Editorial Director Ray Hammond  
Advertisement Director Richard Desmond  
Promotion Director Malcolm Green  
Executive Director Alan Marcuson

## UK

Editor Jeff Pike  
Assistant Editor David Lawrenson  
Features Editor Eamonn Percival  
Supplements Editor Sean Hogben  
Copywriter Adam Sweeting  
Editorial Assistant Hervé Corre

Art Director Mervyn King  
Assistant Art Director Chris May  
Artists

Fiona Beecham, Tom Fawcett,  
Beverley Barrett, Marjorie Westwater

## Type Compositors

Janice Brown, Maureen Morton

Photographer Keith Bernstein

Production Manager Andrea Beerman  
Production Assistant Jennet Ward

## Consultants

Robin Lumley  
Mark A Sawicki M.Sc.(Eng).  
C.Eng., M.IEE, MAES.  
Stephen Delfr MIMIT  
Dave Mattacks  
Ken Dibble MIOA  
Alan Holmes  
Dave Simmons  
Tony Hymas

## ADVERTISING

Assistant Advertising Manager Allan Andersson  
Advertising Art Director Rick Alexander

## USA

Editor Bill Stephen  
General Manager Julius Graifman  
Assistant General Manager Maurisa Solomon  
Contributing Editors  
Jon Tiven,  
Gary Graifman,  
Steve Rosen

## LONDON

International Musician and Recording World is published monthly by Cover Publications Ltd., Grosvenor House, 141-143 Drury Lane, London WC2B 3TE. TEL: X No. 24676. TELEPHONE 01 379 6342, 01 379 6917. Distributed in Great Britain by Independent Magazines Ltd., Bridge House, 181 Queen Victoria Street, London EC4V 4DD. Tel: 01 248 3482 (10 lines). Printed by Carlisle Web Offset, Carlisle, Cumbria, England. International Musician & Recording World is a trade mark of Cover Publications Ltd. All rights reserved. Cover Publications Ltd., 1978. Whilst every care is taken in the publication of the magazine, the publishers cannot be held responsible for any results arising from the contents thereof. Subscriptions, 12 months only: UK £10.50. Worldwide (surface mail) £12.00. US (includes 12 issues, shipping charges to New York, NY and mailing costs from NY) \$20. Second class postage paid at New York, NY and at additional mailing offices. Air mail rates Europe £17.00. S. America and S. Africa £25.00. Australia and Japan £31.00.

## NEW YORK

Executive Offices  
The Gull and Western Building, 15 Columbus Circle NY 10023, USA. Tel: (212) 586 5417.  
Editorial & Advertisement Offices  
277 Old Nyack Turnpike, PO Box 414, Spring Valley, New York, NY 10977 USA. Tel: (914) 356 6797, Telex 131566  
POSTMASTER: If undelivered, please send form 3579 to International Musician and Recording World, PO Box 414, Spring Valley, New York 10977

## MONTREAL

Ian Cronley, 4770 DuChesnel Street, Chomedey, Laval, Quebec H7W 1X3, Canada.  
Tel: (514) 681 9135

Sole International Distribution Agents  
Gordon Gotch (Canada) Ltd., 55 York Street,  
Toronto, Ontario M5J 1S4, Canada.  
Gordon & Gotch (Australia) Ltd., Melbourne,  
Sydney, Brisbane, Adelaide, Perth,  
Gordon & Gotch (NZ) Ltd., Wellington,  
Auckland, Christchurch, Dunedin.  
Central News Agency Ltd., South Africa.

## SPECIAL FEATURES

**100 The Musician's Survival Guide**  
A comprehensive guide to the music business, covering everything from contracts to royalties.

**101 The Musician's Survival Guide**  
A comprehensive guide to the music business, covering everything from contracts to royalties.

**102 The Musician's Survival Guide**  
A comprehensive guide to the music business, covering everything from contracts to royalties.

**103 The Musician's Survival Guide**  
A comprehensive guide to the music business, covering everything from contracts to royalties.

**104 The Musician's Survival Guide**  
A comprehensive guide to the music business, covering everything from contracts to royalties.

**105 The Musician's Survival Guide**  
A comprehensive guide to the music business, covering everything from contracts to royalties.

**106 The Musician's Survival Guide**  
A comprehensive guide to the music business, covering everything from contracts to royalties.

**107 The Musician's Survival Guide**  
A comprehensive guide to the music business, covering everything from contracts to royalties.

**108 The Musician's Survival Guide**  
A comprehensive guide to the music business, covering everything from contracts to royalties.

**109 The Musician's Survival Guide**  
A comprehensive guide to the music business, covering everything from contracts to royalties.

**110 The Musician's Survival Guide**  
A comprehensive guide to the music business, covering everything from contracts to royalties.



**111 The Musician's Survival Guide**  
A comprehensive guide to the music business, covering everything from contracts to royalties.

**112 The Musician's Survival Guide**  
A comprehensive guide to the music business, covering everything from contracts to royalties.

**113 The Musician's Survival Guide**  
A comprehensive guide to the music business, covering everything from contracts to royalties.

**114 The Musician's Survival Guide**  
A comprehensive guide to the music business, covering everything from contracts to royalties.

**115 The Musician's Survival Guide**  
A comprehensive guide to the music business, covering everything from contracts to royalties.

**116 The Musician's Survival Guide**  
A comprehensive guide to the music business, covering everything from contracts to royalties.

**117 The Musician's Survival Guide**  
A comprehensive guide to the music business, covering everything from contracts to royalties.

**118 The Musician's Survival Guide**  
A comprehensive guide to the music business, covering everything from contracts to royalties.

**119 The Musician's Survival Guide**  
A comprehensive guide to the music business, covering everything from contracts to royalties.

**120 The Musician's Survival Guide**  
A comprehensive guide to the music business, covering everything from contracts to royalties.



## REGULAR FEATURES

**8 Letters**  
IM's regular agony column, where musicians give vent to their feelings.

**16 Buzz**  
A busy little feature which keeps growing and growing.

**82 Playing -- Simon Phillips**  
That nimble young drummer makes a welcome appearance in the playing section with a few tips from the top.

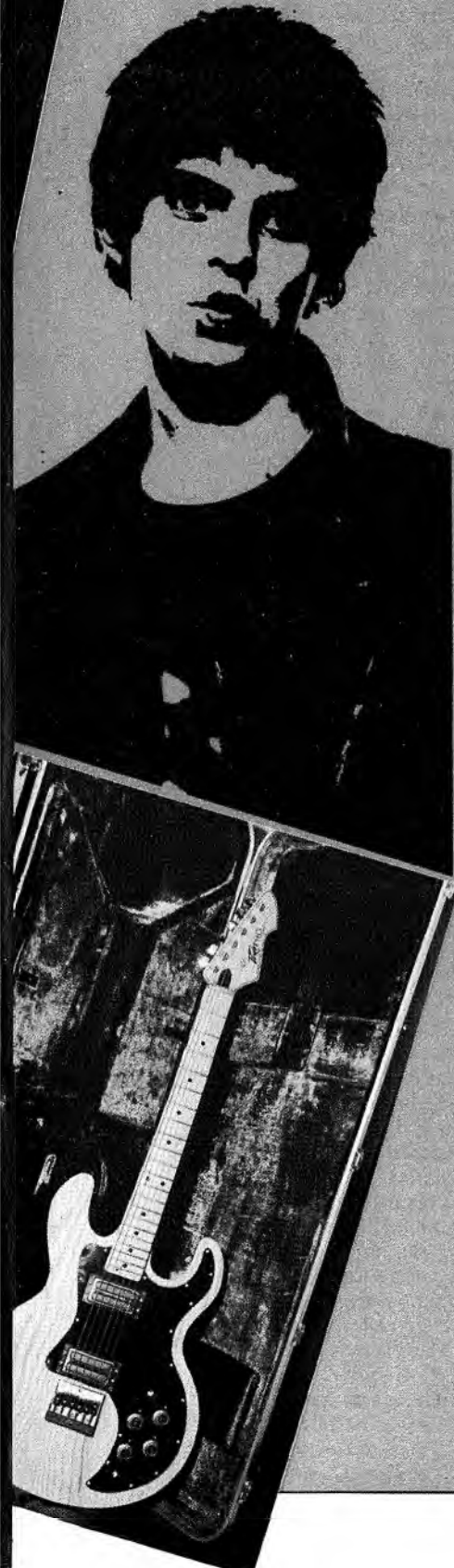

### 116 Albums

If you can't find anything you like in this month's four pages of album reviews, there's just no hope for you.

### 126 Steel Works

Part Four of Dave Hayward's still appealing steel appeal.

### 134 Guitar Workshop

Stephen Delft discusses screening guitars against electrical interference.

### 173 Meet Your Engineer

We may be running out of puns for this feature but we're certainly not running out of engineers.

### 178 Studio of the Month

IM paces the Mersey Beat and tracks down Liverpool's brand new 24-track studio, Amazon.

### 198 Understanding Synthesizers: 7

Further mysteries unravelled by Tony Horsman.

### 206 Small Things

More pearls of wisdom from Stephen Delft.

### 225 Ad Index

## TEST SECTION

#### 46 DELFT'S GUITARCHECK

As the new Peavey T60 electric guitar is unveiled, Stephen goes behind the gloss to bring the inevitable in-depth report.

#### 48 DELFT'S GUITARCHECK II

In Round Two, Stephen spars with a seven-string Aria.

#### 53 HYMAS' KEYBOARDCHECK

Meet and greet our new keyboard analyst Tony Hymas as he gives his expert opinion on a new Roland electric piano.

#### 56 SAWICKI'S SOUNDCHECK

It may be good enough for the Stones, but is it good enough for IM readers? Mark takes his screwdriver to a classy Ampeg combo.

#### 60 DIBBLE'S SPEAKERCHECK

Amid growing concern over the cobalt crisis, Ken Dibble tests some 15" units from all over the world and gives his verdict.

#### 77 SIMMONS' SYNTHCHECK

Dave Simmons makes a welcome return to the test section with a report on an all-British synthesizer, the Scorpion.

#### 78 ROBERTS' DRUMCHECK

Henry heaves himself behind a new Ludwig six-ply kit.

## EDITORIAL

What? December already? Time for your favourite music magazine to take breath and reflect on yet another successful year. 1978 has been a year of change and expansion for IM. A new editor, luxurious new premises in London's glittering West End, lots of new ideas. And, early next year, a whole new edition, too. For on both sides of the Atlantic, dedicated IM staff are toiling night and day to produce the first issue of our USA edition, to be launched in Los Angeles in January.

Meanwhile, what of the last issue of 1978? Casting aside all false modesty, we're not ashamed to claim that the magazine you hold in your hands covers the music scene wider and deeper than ever. Just look at the interview features, for instance — two guitarists, a bass player, a drummer, a keyboardist, a horn player and a producer. What more could you ask? (Sorry, roadies, we'll get round to you soon.)

You'll notice, too, that the Buzz feature is expanding. We aim to build it into the busiest, newsiest round-up of what's what in any music magazine. You can help by letting us know if you hear of anything you think will interest fellow musicians.

Take it from us, folks. International Musician is getting even better all the time.



VOL. 4 NO. 12  
DECEMBER 1978 (UK)  
JANUARY 1979 (USA)

## Ill above board

Dear Sir: May I use your columns to put a possible misunderstanding cleared in the excellent article on "Landscape" in your October issue. One paragraph of the article could conceivably be read to give the impression that the use of Vitavox equipment by the group might have prevented their winning of the 1976 Vitavox Live Sound Award. However, due to their success in the Award and to giving the pair of Thunderbolt loudspeakers which are presented to the winners, the group did not use Vitavox equipment and it was purely the group's skill and musical expertise which earned them the votes of an independent panel of judges.

Entries for the 1979 Live Sound Award are now being invited and groups would like to be reassured that the use of Vitavox sound equipment is certainly a condition of entry.

Neil Young,  
Joint Managing Director,  
Vitavox Ltd.

*We welcome your comments, criticisms and queries. Write to: Letters, International Musician, Grosvenor House, 141-143 Drury Lane, London WC2 5TE. If you have a question you'd like answered by one of our consultants, write to the same address but mark the envelope "Stephen Delft", "Mark Sawicki", etc.*

putting the other DiMarzio in the bass position. Do you think this would be wise? What sound would I get? Does anybody else have the same set-up? I use a Marshall master volume 100 watt set-up. I would like a Thin Lizzy style sound but more versatile. Thanks for the greatest, most comprehensive mag of all time! (Lick, lick.)

Stephen Murtagh,  
Belfast.

*Stephen Delft replies: Sorry, most years produced good and no-so-good Strats. If you mean whether or not your guitar is a valuable/collectable one, I would say, yes. It depends on the quality and condition of the particular instrument. If you want to add a PAF pickup, I would suggest*



## Fast Nicotine (cont.)

Dear Sir: Thank goodness that I am not the only musician/vocalist who dislikes cigarette smoke. I heartily agree with Colin Slater's letter in the November issue. It is most unpleasant, not to mention unhealthy, to be enveloped in a greasy smoke screen while performing. Musicians invariably seem to get chain smokers sitting close to the stage so that the smoke drifts up, causing us dry throats and watering eyes, also contaminating our clothes and equipment with the stench of burnt tobacco.

How can we give our best under these conditions?

C.F. Colwell,  
Droxford,  
Hants.

## Pickup switch

Dear Sir: I recently bought a second-hand Fender Stratocaster. It is a 1969 model. Was that a good year for Strats? Has a DiMarzio "fatstrat" pickup in the bridge position. I was thinking of putting a DiMarzio PAF in the treble position and

doesn't make any more noise than the average splice so give it a try.

P. White,  
Malvern,  
Bucks.

## Cash flow

Dear Sir: After reading Mark Dellow's letter in your September issue, I felt I should write to clear up some questions about us American bands. Mark Dellow said that as a matter of curiosity he'd like to know what kind of wages we get.

I am a keyboard player (female) and, by the way, I resent the reference to female singers made by Jack Fallon in the "Going abroad" article. If a band member was involved with the girl, so what? That should be secondary to a professional attitude about your career. In the States, an attitude like that would put you quickly out of work).

I also sing lead and back-up in a four-piece rock band based out of Boston and the New England area. I've been playing clubs and such for 12 years, since I was 13. Believe me, the club scene here is crazy as far as quality determining wages. It doesn't always! There are hundreds of schmaltzy, talentless bands all over the area playing in ritzy lounges for the older crowd, making cartloads of money. There are also many excellent, but uncommercially appealing bands who are starving.

Rock'n'roll here is big business on the regional level. The band I'm in now has really made a name for itself here. We play three 50-minute sets a night in a club, and usually do one or two long sets if we're doing a college, or a back-up for a name band (we recently opened for City Boy, who we think are tremendous).

For a one-night gig at a large college or university, we get around \$1500. Less known bands with smaller drawing power can get upwards of \$500 if they have the equipment to cut the room. Club gigs of a six-night duration can get us \$3500-\$4000 at the bigger places (with a seating capacity of 800 or more). There are quite a few rock clubs here that pay \$1500 a week (five or six nights) and up.

Pay is often determined by how many people you can be expected to pull into a place. The way most bands start making money on this level is to get a good solid, well-paced programme of familiar music. Top 40 bands are in great demand and if they have some sort of show or are well-dressed and have some promotional materials, they can make fantastic money.

Here, the competition for rock bands is stiff. Frequently the band with more and/or better equipment will get more than a musically better band. You might be great, but if you don't keep an audience coming in and drinking, you can be sure you'll never be hired back again. Conversely, if you make money for the club, you'll get hired back for more ▶▶

*putting it at the fingerboard end. The nearest sound to what you describe that I have heard recently came from an Aria LC550 VS with gold fittings and covered pickups. Pickups are not the only factor in guitar sound so you should try this guitar, or perhaps ask Aria if they could spare one of these pickups. Thank you for your comments - we try to be comprehensive and reliable.*

## Superjoint

Dear Sir: There must be many people like myself who own tape echo machines and who have spliced their own replacement tapes only to find the joint coming apart after only a few hours' use. A friend of mine suggested using Superglue and I tried a few test tapes to see if it worked.

After glueing several yards of tape to my fingers, I finally evolved a method that worked. Just cut the tape half an inch longer than the loop length, apply a small spot of Superglue and make an overlap joint between a quarter and half an inch long. Press the joint firmly and, if you haven't glued it or yourself to the table, you will have a long-life echo tape. I made 10 a few weeks ago and the first one is still going strong. Also, the joint



**Ludwig<sup>®</sup>**

We're playing together again.

Buddy Rich is playing Ludwig drums. And, we're telling drummers everywhere with 4-color ads and posters. Because when the greatest name in drums gets together with the greatest drummer, everyone should hear about it!

# Letters

money. Of course, this can mean that a technically horrid band can be super-popular with club-goers and so make lots of money. This could explain how punk music is in existence. However, in my opinion, the less said, the better.

There's so much more to all this, but I hope I've given an adequate description of the club scene here that may interest your readers.

Linda Chase,  
Boston,  
Mass.

## Oops

Dear Sir: I am a student, recently arrived to study here for a year from America and have since had the pleasure of running into your magazine. I would like to call your attention to a mistake that I noted in your November 1978 issue. On page 6 you have incorrectly captioned a picture of Runaway Lita Ford as being that of Joan Jett, or else, having seen them three times in the States, I have been totally confused! Either way, I enjoy your magazine and look forward to it each month.

Seth Foster,  
London, SW7

You're quite right, Seth. Just to put the record straight, and to decorate this page with yet another sexist pic of a gorgeous Runaway, we're happy to bring you the real Joan Jett. ▼



## Corporal punishment

Dear Sir: As a poor serviceman, I would like to see more information on how to get the best from cheap equipment. I own a cheap Les Paul copy, a 20 watt amp, a Coloursound wah-wah pedal, an Ibanez will agree that this is not the best selection of equipment gathered under one roof. The problem is that all music shops that I know of will not give credit (HP) to servicemen below the rank of sergeant. I think that this is nothing short of disgusting.

Servicemen have their money paid into the bank and (with the help of a short letter to the CO) can have any amount of money deducted from their pay to pay off any unpaid bills. We are paid every month, not as some musicians, so I believe that the excuse of us not paying will apply only to a very few.

G.A. White MRCPA, IMLS,  
RAF (H) Ely, Cambs.

## Vox valves

Dear Sirs: Perhaps your good selves or your correspondents could help me with a somewhat baffling problem with an old Vox AC-30. I own a second-hand, rather ancient AC-30 top – a "bass" or single tone control model, as my prime musical interest is centred around early Beatles era music. Quite often the "Vib/Trem" oscillation dies away while in use, reverting to the straight sound.

CBS-Arbiter kindly sent me a copy of the only circuit diagram they had and I investigated with the normal musician's limited electronic knowledge. Both my own and an associate's AC-30 top contain different valves and his do not even correspond with the diagram. Mine contains all ECC 83 small valves while my friend's contains one ECC 82 – but the positions differ. Also, on the AC-30s and AC-50s I've seen, a grey capacitor has been slung across the back of the oscillator valve in what looks like a subsequent modification. Some of the ECC 83s work for at least part of the time in the Vib/Trem oscillator but others won't even start up. Incidentally, the pre-set depth control has no effect, it was de-activated by removing the wiper some time ago. Can you throw some light on this?

P. Harley,  
Stallingborough,  
Sth. Humberside

Mark Sawicki replies: To get the appropriate circuit diagram for this amp, I suggest you write to Vox Sound Ltd., Shoeburyness, Essex. I am sure they will send what is necessary. I recommend that you use high quality ECC 83s (don't use any Russian rubbish). Should your Tremelo/Vibrato circuit still not work properly the best thing you can do, since

you have only limited knowledge of electronics, is to contact Vox and see if they will take it back for repairs.

## Wiring inquiry

Dear Sir: Having followed Stephen Delft's excellent articles on building a solid guitar, I feel sure he will be able to advise me on some modifications that I wish to make to my Fender Strat. As you know, the Strat has three pickups and a three-position switch which selects any of the three pickups. I wish to modify this set-up without changing the outward appearance of the guitar (i.e. no addition of switches).

I would like to re-wire the three position switch to obtain the following results: 1, switch in front (nearest neck) position brings in front (neck) pickup and middle pickup. 2, Switch in middle position brings in all three pickups. 3, Switch in rear (bridge) position brings in only the bridge pickup. I intend to leave the present tone and volume controls unaltered. I would be much obliged for any help you can give me with the re-wiring.

K. Foxcroft,  
Willington,  
Crook, Co. Durham

Stephen Delft replies: I don't think that what you want to do is possible with the standard switch. I regret that I cannot design a "one-off" circuit for you at the moment. If you can obtain a more complex switch which looks the same on the outside, the job is possible. I suggest that you contact Roka in Endell Street, London WC2, or perhaps CBS-Arbiter, though I feel they may not be able to help much in this particular case. The switching can be done more easily with a bank of three push-button switches.

We're still receiving numerous letters concerning Stephen Delft's "Build a Solid Guitar" series. Alas, we can no longer send back issues of IM containing these articles – we've simply sold out of most of them – but we can supply immaculate photocopies, at £1 per article. Plans of the guitar's neck and body are also available at £1.50 each. Send your cheque or postal order, payable to Cover Publications Ltd., to Ann Mear, International Musician, Grosvenor House, 141-143 Drury Lane, London WC2 5TE.

Readers who would like the whole "Build a Solid" series – all 21 parts – might be interested to learn that it will reappear in full in the new USA edition of International Musician, which launches early next year. Subscriptions will be available, so watch this space for further details.



# Just what the world doesn't need. Another 15" loudspeaker.

How many 15" loudspeakers have you listened to lately?

Every major manufacturer seems to have one nowadays. Some of these companies have been producing them for years. And understandably some of them have produced loudspeakers of the highest quality. Loudspeakers you would be proud to use and recommend.

With all this competition around it would take a very special speaker to break into the current market.

That's where we come in. We've been making quite good speakers for some years now. First came the 12" drive unit. Originally designed by us to cope with the same problems that confront traditional 15" units but in a more compact package. Sensible enough it seemed to impress groups like Supertramp and Tangerine Dream. And give them that little extra others have never achieved.

Impressive enough to beat the entire field which included many of the big name American models in the recent International Musician awards.

Then came the 9" drive unit. Smaller again, while others were trying to be bigger, and designed especially to give more power than most of the bigger units.

Over the years our reputation has gradually been built up through technical excellence and now we are ready to give you our latest offering. A new 15".

We applied the same design criteria as with the 12". The same advanced cone technology has given us the same lower distortion characteristics. The same advanced voice coil technology has given us even greater power handling. Our uncompromising approach to materials and tolerances has given us even greater efficiency.

So if you're thinking. What does the world need with another 15" loudspeaker, we think we might just have the answer.



## AE

Acoustic Engineers, Pier House Laundry Strand-on-the-Green  
London W1. Telephone 01-995 3654

© Attribution to the Retail Trade: Mick Johnson (musician) tel. 01-753 2151. Represented  
internationally by: Australia: Robert Wardman tel. 51-446098. Canada: Guy Beresford  
tel. 416-261-3340. Denmark: Paul Sørensen tel. 45-267500. Germany: Bernd Kahl  
tel. 49-521-42110. Sweden: Göran Malmberg tel. 08-140 00. Switzerland: Tony Parker  
tel. 01-254362. USA: Kenny Berger tel. 017-3352573.

# *The fifteen inch speaker.*

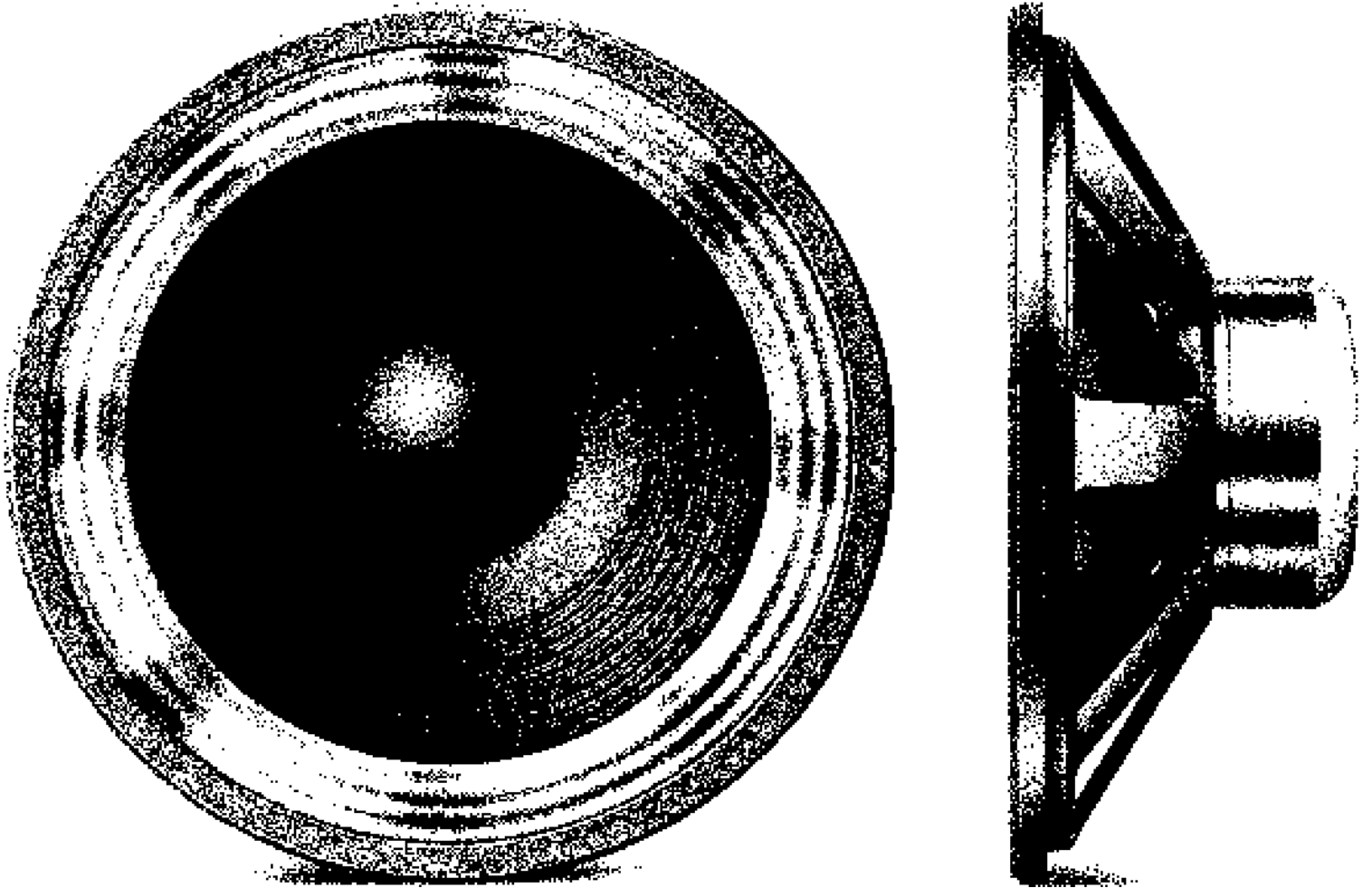

*Which ever way you look at it,  
it's the best value for money.*

What you want from a bass speaker is deep, rich sound. Sound you can almost feel rather than hear. Sound that's pure and undistorted.

That's the starting point we used when we designed our 15 inch bass speaker.

And it's also what we achieved.

As well as a remarkable level of economy that enables us to sell it at a bargain price.

Send now for full details and test reports.

Deep down, you'll be glad you did.

From the people who know.

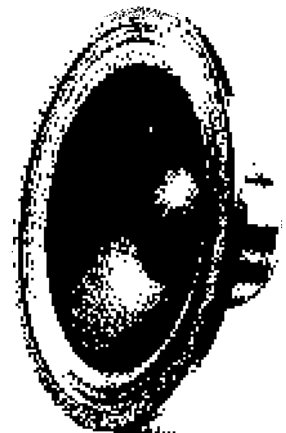

**RCF**  
**Coveman Ltd**

Dunchurch Trading Estate, London Road, Dunchurch, Rugby CV23 9LL. Telephone: Rugby 815020.

# A message from Jim Marshall to club musicians

“ You’ve been asking me for some time now for a Marshall twin channel reverb combo designed specially for club work. Your requests and the ideas of many top musicians in the UK and USA, plus Marshall’s expertise, have led to this exciting development.

This new 100W valve combo has a clean, bright sound – very different from the famous Marshall rock amps. It’s ideal for Country and Jazz artists and anyone playing the club and pub circuit.

It’s not often that I step into the spotlight to talk about Marshall amps but I’m very proud of this new combo. Try it soon at your local music store – I’m sure you’ll be impressed – I am! ”



## The Marshall 4140-

Twin Channel Combo with valve pre-amp and power amp. Built in Hammond Reverb. Twin 12" 80 Watt Speakers specially made for this combo. Minimum power output 100 Watts RMS. Brown Oak leather cloth and straw coloured speaker fret. 26 1/4" wide 9 1/2" deep 24" high excluding castors. Weight 36 kilos. Brown Oak cover included.

## The Club & Country Combo

Each channel has individual volume, treble middle and bass controls. Master volume control over both channels. Bright and Boost switches on channel one. Footswitch included for reverb and boost. Channel two (flat response) suitable for acoustic guitar pickups or microphone. Operates on 120/240 Volts AC 40/60 Cycles.

Rear panel has Europlug mains socket (lead provided), stereo socket for footswitch and two speaker output jacks. Selectors for mains voltage and impedance.

Please send me more information about this new Marshall Club/Country Combo

Name \_\_\_\_\_

Address \_\_\_\_\_

Rose-Morris & Co., Ltd

32-34, Gordon House Road, London NW5 1NE Tel: 01-267 5151

M4140 9781M

**Rose-Morris**  
*Marshall*

# How to get fat sounds from a thin wallet.

Today's keyboard player demands a degree of reliability and musical capability that only a few synthesiser manufacturers worldwide can provide.

Korg not only lead the world in up-to-date technology and performance, but do so at prices you won't believe!

Every Korg instrument incorporates the very latest developments in electronic design and a continuous research programme builds in increasing reliability, unvarying performance and the newest electronic sounds. Their absolute tuning stability is a byword amongst professional keyboard players.

The five world-beating models shown here, each with its own unique range of facilities, each with a mouth-watering price tag, are just a few of the range available now. They give you a hint of what is to follow. Try them at your Korg dealer now!



## KORG 800 DV

You can't get better value for money than two in one, and that is just what the 800 DV is! Comparison with other makes will show you that the 800 DV has more facilities at a lower price., in some cases by hundreds of pounds.

- \* Four independent sound sources.
- \* Two independent VCOs.
- \* Four VCFs.
- \* Six modulators.
- \* Duophonic.
- \* Auto delayed vibrato.
- \* Auto pitch bend.
- \* Recommended retail price. - £835!



## MINI KORG 700s

Brilliant design gives you extreme versatility and amazing ease of operation. Unsurpassed note stability and a price under £500 that beats all rival models means you've got to check out the 700s. quickly.

- \* Two VCOs.
- \* Three LFOs.
- \* Two noise sources.
- \* Recommended retail price. - £499!
- \* Two VCFs.
- \* Auto delayed vibrato.
- \* Auto pitch bend.

## KORG 770

Another astonishing Korg synth, combining professional design with a low price. A versatile reliable instrument which is lower priced than any rival yet the 770 offers much more!

- \* Two VCOs.
- \* Two LFOs.
- \* Two noise sources.
- \* Recommended retail price. - £475!
- \* Delayed vibrato.
- \* Auto pitch bend.
- \* Two VCFs.

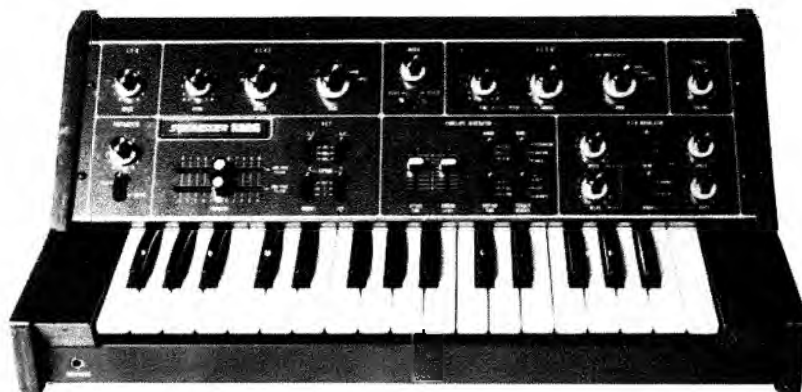

## KORG POLY 1000

Superb sound from a design which provides a wide range of keyboard tone colours. Check out the 1000 for an instrument that makes beautiful music and then compare the price for this pro. musician's instrument with other keyboards. You'll find it's the best value in polyphonic synthesisers.

- \* Truly Polyphonic.
- \* Sixty VCOs.
- \* Sixty ADSRs.
- \* Sixty VCAs.
- \* 8 Presets.

- \* Two modulators.

\* Recommended price.

- £875!

## KORG POLY 2000

Undoubtedly the finest string synth available! A superb, beautifully engineered instrument, with a high degree of variability and like the rest of the Korg range, it beats other comparable keyboard instruments for a combination of price and quality. Try it today!

- \* Fully Polyphonic.
- \* 8 mixable presets.
- \* 144 VCOs.
- \* 3 notes per key.
- \* 48 VCAs.
- \* 48 ADSRs.
- \* 3 modulators.
- \* Built in studio quality phasing.
- \* Separate control of bass /treble, attack and sustain.
- \* Recommended retail price. - £995!



Please send me more information about Korg synthesisers.

Name \_\_\_\_\_

Address \_\_\_\_\_

Rose Morris & Co., Ltd. 32-34, Gordon House Road, London NW5 1NE Tel: 01-267 5151

IM1178K

**Rose-Morris**  
**KORG**

# J & C SOUND SYSTEMS

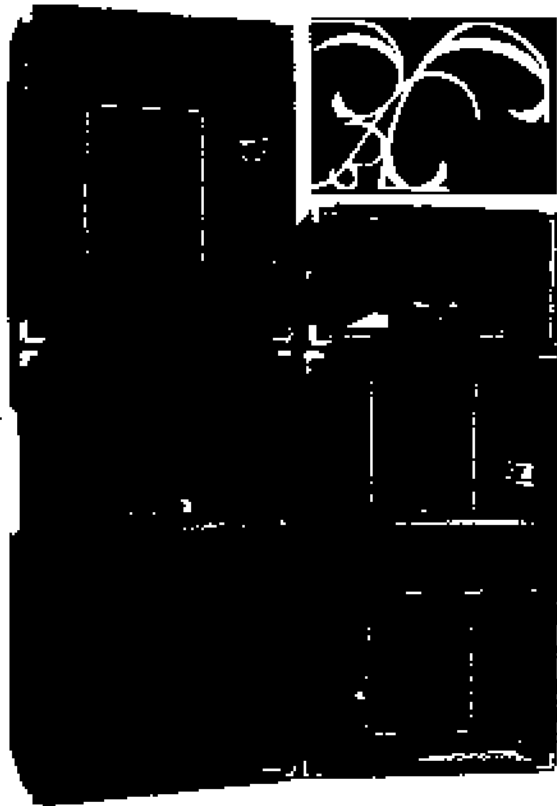

Many other sound equipment companies specialise in amplifiers and then, as an afterthought, they buy in mass produced cabinets

We make all our own cabinets ourselves at our own premises, and we have always specialised in speaker enclosures.

When we started J&C Sound Systems resolved to provide the highest quality and best sound reproduction speaker cabinets available but at prices that musicians can afford.

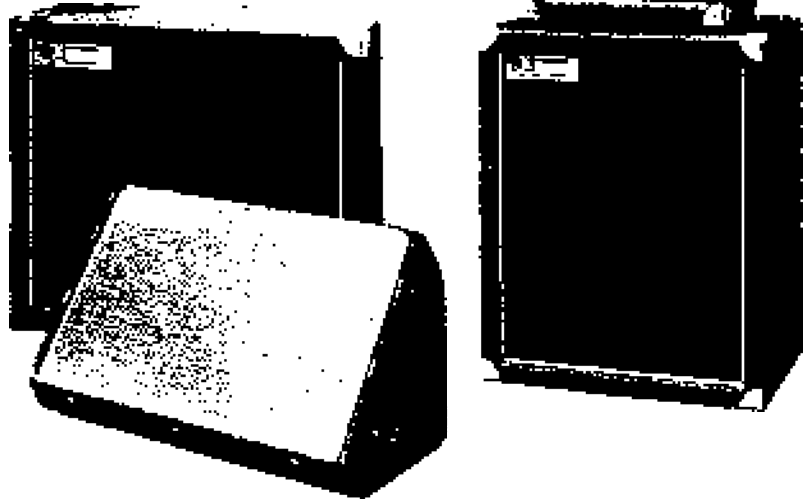

## THE SOUND THAT EXCELS

LISTEN AND SEE



DROP IN AT OUR DEALER FOR A DEMO AND CONVINCE YOURSELF

BANGOR	SOUND CENTRE	(0248) 53320
BLACKBURN	E.D. BROWN (ORGANS) LTD.	(0254) 54681
BRADFORD	SOFISCODISC	(0274) 661405
CANNOCK	MUSIC STOP	(05435) 77768
CANTERBURY	KENNARDS & SONS LTD.	(0227) 60331
CARDIFF	PETER NOBLE (LLANISHEN)	(0222) 753911
COVENTRY	COVENTRY MUSIC	(0203) 58571
CREWE	CUSTOM AMPLIFICATION	(0270) 4779
DONCASTER	MUSIC GROUND	(0302) 843037
FLEET	KINGFISHER MUSIC CO.	(02514) 21210
GRAVESEND	GIG CENTRE	(0474) 66766
HEMEL H'STEAD	FREE'N'EASY MUSIC	(0442) 59659
IPSWICH	SOUNDWISE	(0473) 53386
KENDAL	E.D. BROWN (ORGANS) LTD.	(0539) 24212
LANCASTER	HOBBS MUSIC	(0524) 60740
LEEDS	KITCHENS	(0532) 446341
LEEDS	J. SCHEERER & SONS	(0532) 449592
LOWESTOFT	MORLINGS	(0502) 65491
MANCHESTER	A.1. MUSIC	(061 236) 0340
MIDDLESBRO'	HAMILTONS	(0642) 247314
NELSON	E.D. BROWN (ORGANS) LTD.	(0282) 65976
NEWCASTLE	ROCK CITY	(0632) 24175
NORWICH	COOKES BAND INSTRUMENTS	(0603) 23563
OXFORD	FREE'N'EASY MUSIC	(0865) 721411
SCUNTHORPE	JOHN'S MUSIC SHOP	(0724) 3800
SUNDERLAND	WHITE SOUND	(0783) 78058
SWINDON	SWINDON GUITAR CENTRE	(0793) 22650
WOLVERHAMPTON	MUSIC STOP	(0902) 29352

J&C SOUND SYSTEMS, NILE ROAD, ILKLEY, WEST YORKSHIRE LS29 9DX. TEL: (0943) 608011

Mr J and Mr C (alias Steve Jones and Terry Crook) would like to wish musicians and music dealers world-wide a very happy Christmas and a Prosperous New Year.

**ITA**  
THE ONE STOP SHOP

**PRICE GUARANTEE**

Our prices are rock bottom. If you find lower we refund difference.

**PART EXCHANGE**

**FINANCE HIRE**



**A234OSXH**  
3¾+7½  
or  
7½+15



**A334OSX**  
7½+15



**A334OS INDUSTRIAL**  
LOW NOISE INDUSTRIAL VERSION  
7½+15

**TEAC**



**8 TRACK**

CONSOLE £2040



±50% Varispeed servo control  
Low noise. Full sel sync  
£1990  
Portable

**COMPRESSOR LIMITER**

£250

VARIABLE SLOPE AUTO RELEASE. A must for accomplished recording engineers

**ITAM**



3¾+7½



7½+15



15+30



VARIABLE SPEEDS



3¾+7½+15

**REVOX**  
OVER 400 VERSIONS

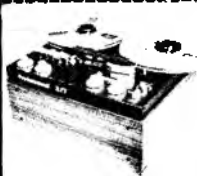

**3.77**  
BEST SELLING STEREO RECORDER WITH 3 SPEEDS  
3¾+7½+15  
MOTION SENSING

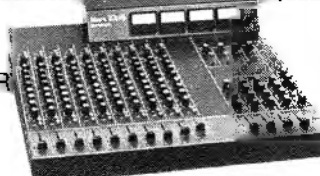

NEW 10-4 4-limiters, direct outputs, remix, A-B monitoring, PFL, comprehensive patching. £790.00

**ITAM**



**MULTI ECHO**

**SLIDER ECHO**

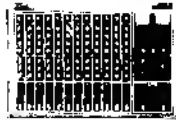

12in-2out

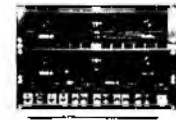

**S500-D POWER AMP** 500 Watts

**H+H**  
THE MUSICIAN'S CHOICE



**8 TRACK MODEL 5** 8in-4out **MODEL 3** 8in-4out **MODEL 2** 6in-4out

**TASCAM**  
FOR THE PRO USER



**SD12** 12 in 2 out



**PRODUCTION MIXER**



**MODULAR** 16x8

**ALLEN + HEATH**



STEREO £465

THE FINEST STEREO ECHO UNIT FROM U.S.A. ANTI-TWANG LIMITERS, BANDWIDTH CONTROL. STRICTLY PROFESSIONAL UNIT.

**ORBAN**

**3M - AGFA - AKG - TRIDENT - AUDIO DESIGN - OTARI - AMPEX -**



CURRENT DUMPER

**QUAD**

CONTACT:  
JIM NELSON  
01-724 2498

ALL PRICES WITHOUT VAT

**ITA**

1-7 Harewood Avenue  
Marylebone Road  
London NW1

Easy parking by Marylebone Station



# Buzz

## What's happening in the music biz

### New Exec Direc

IM is pleased to welcome Alan Marcuson to the board of Cover Publications. He takes up his appointment as Executive Director with effect from December 1st, 1978, with special responsibilities for developing markets for advertising and circulation of IM and our sister magazine, Home Organist & Leisure Music.

Before joining us, Alan spent 14 years as a marketing executive with companies in the music industry, the last four of them as International Sales Director for British Music Strings in Cardiff. He says: "I'm very excited at the prospect of directing growth of such successful titles as International Musician and Home Organist. I believe we can build the magazines into a unique international force." Hear hear. Welcome aboard, Alan.



### Three to watch

A somewhat unusual new trio from London have already caused a critical stir at the Battersea Jazz Festival and the Birmingham Arts Lab. Gary Smith (guitar), Rauf Galip (bass) and Bill Stratton (drums) work together under the name Acne and produce music which one critic has boldly described as "punk jazz".

If that sounds a bit too bizarre to be true, then try this review from "Black Echoes": "Young, acute aggressive, fluid playing in the true expression of jazz." And that's not all. After their Battersea gig, Donald Atkins described Gary Smith in "The Guardian" as "the star soloist of the festival." Obviously a band to watch.

### Going down a bomb

We can't help feeling that it's taking a bit of a chance to call a Belfast band the Detonators. At the very least, they run the risk of being identified as a punk rock ensemble. But these Detonators tell us that they play "fast and furious R'n'B", which

includes a lot of their own material, plus songs by the Stones, the Rods, Dr. Feelgood, etc.

The line-up is Howard Ingram (bass/lead vocals), Colin Gourley (rhythm guitar), Paul McIwaine (lead guitar/vocals) and Stephen Mulree (drums). They recently signed to George Doherty's Rip Off label and contribute two tracks to a compilation album, "Belfast Rocks". They're hoping to have a single out in the New Year and look forward to working in England. Meantime, anyone interested in managing or booking the Detonators should ring Barry (Belfast 59660) or Stephen (Belfast 658988).

### Swedish sound

Musicians about to tour Sweden will be pleased to know that a first-rate PA and lighting hire service, based in Stockholm, is on hand to fill their sound reinforcement needs.

Sound Side at 32 Götgaten, Stockholm, has the largest lighting system in Sweden available for hire, as well as concert PAs, stage amplifiers and all sorts of instruments. They are associated with the EMA-Telstar booking agency and management company and have provided equipment for Talking Heads, Mink De Ville, Sarah Vaughan and 999 tours of Sweden.

"Many bands find it cheaper to come here with just their instruments and hire back line and PA amplification for their tours," says British-born Roger Pincott, Sound Side manager and former professional musician. "The EMA-Telstar agency have their own roadies and tour managers and we provide the sound technicians." Roger, once bass player for the Nashville Teens, went to Stockholm on a gig in 1972, stayed to manage the Sound Side retail shop and has seen the group gear business boom in the past five years.

He says Sound Side provide extensive service and repair work for their customers and can furnish most kinds of spares for drummers, guitarists and keyboard players. Sound Side do their own amp repairs as well as building mixers, power amps and cabinets.

### Bring back the Bison?

Anybody got an old Burns guitar? More to the point, has anyone got any interesting stories to tell or snippets of information about early Burns guitars and amps? If so, Paul Day would like to hear from you. He's preparing a book on Jim Burns, his guitars and possibly his amps — which is a natural extension of Paul's hobby, since he collects and sometimes buys, sells and exchanges old Burns instruments. Burns fanciers should write to Paul at Sound Investments, 19 Forde Road Newton Abbott, Devon.

Meanwhile the man himself, Jim Burns, called in to see IM's guitar consultant, Stephen Delft, last month. Stephen reports that Jim is very enthusiastic about the idea of re-starting production of the old Burns Bison guitar, although he has no definite plans for the future. We have a strong hunch that a lot of guitarists would be pleased to see one of Britain's most respected makers turning out guitars again.



**Son rising**  
Sister Sins are a band with an impressive pedigree, led by drummer/bassist/bassist Peter Davies, the line-up also include guitarist Chris West (formerly with Stormy Tamashai) and Marcus Sullivan (ex-Window) and keyboard player David Sams (ex-Heron). The line-up is completed by Don Stewart on sax and flute and by Peter Stratton on bass.

The band draw their inspiration from Sun Ra (hence their name), and Tony Williams Lifetime. Most of their success so far has been on the Continent where they have appeared at jazz festivals in Paris and Cologne. They are currently working through a while British record companies which





## Thank you, Goodnight

"A pop/rock group with the innate ability to stun audiences." That's how they modestly describe themselves. And "An R 'n' B/pop fusion, strong on melody, hard on beat." Getting the picture? They are a four-piece band called Samuel Goodnight, and they've been playing together nearly two years.

Samuel Goodnight is also the name of the lead vocalist (actually, we know his real name, but we're not telling). Graham Douglas plays guitar and sings, Gary Finch plays bass and the cryptically named N.J.L. is the drummer who's "hard on the beat". They work in and around London and for more information you should contact Blue Inc Records Ltd., on 01-723 6561.

## Music Hall

Outstanding practitioners of the guitar and other fretted instruments can now stand by to achieve immortality in the new Gibson Hall of Fame. The project, inaugurated by Norlin Music Inc., will enrol artists into the Hall in recognition of their contribution to music, and while it is stipulated that the players should be associated with Gibson instruments, the nomination list is not restricted to Gibson endorsers.

The selection for enrolment will be in the hands of a board of directors and International Musician is honoured to have been offered a voting seat on the board. IM's Editorial Director, Ray Hammond will attend the inaugural meeting in Anaheim, California, in January. Initially 18 artists will be voted into the Hall of Fame and every year four more will receive the accolade. Each artist will receive an award commemorating his enrolment and a permanent record of the members will be on display at the Gibson plants in Kalamazoo and Nashville.

## Country gentlemen

The four lads pictured lounging in the sun in front of a quaint thatched cottage are, appropriately enough, called Honeysuckle Dew. They're a country rock band

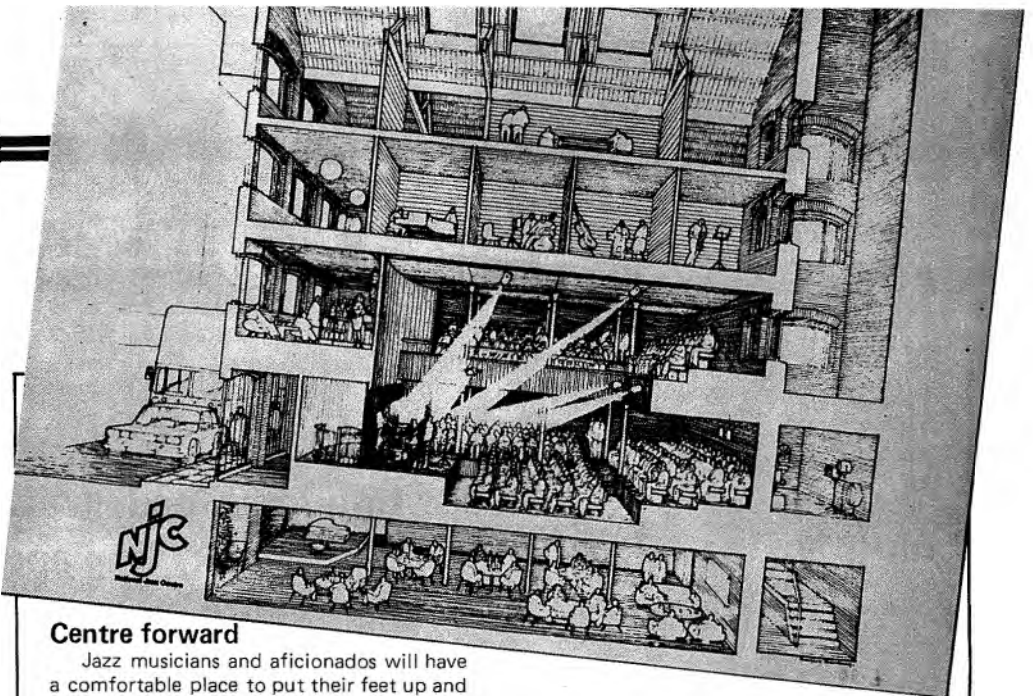

## Centre forward

Jazz musicians and aficionados will have a comfortable place to put their feet up and get an earful when the National Jazz Centre opens in London's Covent Garden. Just out of the planning stages, the Centre will occupy a suitably mellow three-storey warehouse building in Floral Street, which is being drastically converted to house a 290-seat auditorium, a 150-capacity clubroom for informal performances and spacious rehearsal rooms on the second floor. Bars, lounges and a comprehensive library will be at the disposal of visiting musicians.

The Jazz Centre Society has grown rapidly since its 1968 inception. From an initial series of concerts at the Notre Dame Hall in London they have grown to promote

international artists at the South Bank while building a solid programme of club presentations. A centre opened in Manchester in 1976 and another is presently being set up in Birmingham. The Jazz Centre Society runs a two-week summer school in London, issues a reference book called "Jazz Now" and also "Jazz Film Guide". A growing membership of 2,300 ensures the financial viability of this limited company and registered charity. If you want to know more, drop into the Jazz Centre Society HQ, 35 Great Russell Street, London WC1 or call 01-580 8532.



whose music — "from Emmylou Harris to Poco" — is winning them a following in clubs and colleges throughout Essex, Hertfordshire and Kent.

The band consists of Roger Gee (lead guitar/vocals), Chris Wren (lead guitar/vocals), Graham Ansbridge (bass/vocals) and Paul Davies (drums). They make full use of the twin lead guitars and three singers, with a load of tight vocal and instrumental harmonies.

Roger and Chris have had six of their original songs published and hope to include them on the band's forthcoming album. Honeysuckle Dew can be contacted at Gee Up Management, on 01-989 6202.

*Readers with news items for these pages — especially fax, pix and info on new and interesting bands should write to Buzz, International Musician, Grosvenor House, 141-143 Drury Lane, London WC2B 5TE.*

## Stolen Instruments File

This is IM's Police 5 spot, where we try to reunite ripped-off musos with their lost loved-ones. Two Fenders to look out for this month...

First, a Precision bass, black with a white scratchplate and maple neck, serial No. 639788. Distinguishing features: no chrome covers, top machine head slightly bent, felt between neck and body to improve action. It was stolen, together with its black hard case, from a flat in Bromley, Kent, on October 19th. Information, please, to Pete Ferris, 62 Plaistow Lane, Bromley, or to Bromley CID on 01-464 4315.

Secondly, a 1963 Stratocaster, serial No. L07577. Body: varnished natural wood. Neck: curly, bird's eye maple fingerboard with Gibson-type frets. Heads: Mini-Schallers. When stolen, it was in its original tan-coloured Fender case. The ex-owner, K. McDougall, admits that his Strat was actually ripped off nearly two years ago, but he hasn't given up hope, especially as a friend's 1952 Telecaster stolen at the same time turned up recently in a music shop in Guildford. If you notice a Strat that fits the description, you can make K. McDougall a happy man by calling him on 041-339 3966, or writing to 34 Montague Street, Glasgow.

Let us know if you lose an instrument to villains, burglars, highwaymen or hijackers — but be sure to inform the police and/or insurance company first. The other rules of the game are: instruments only, please. No amps, mixers, etc. Only instruments stolen in the UK can be considered. And we're afraid we can only feature gear stolen from individuals. We simply don't have space to cover thefts from dealers — though dealers can help us by looking out for the instruments we describe.

# Honky-Tonk Drum Store

## Now Open!

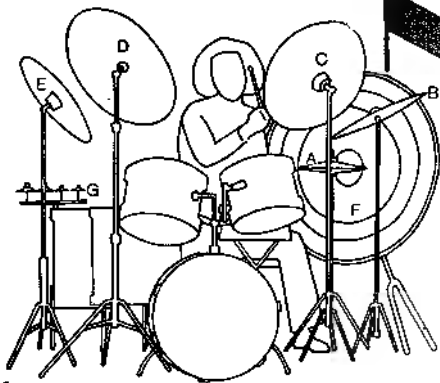

at  
333, London Road, (A13)  
Hadleigh, Essex, England.  
with

**THE LARGEST SELECTION OF DRUMS IN ESSEX!**  
(Opposite our main shops at 300 - 302, London Rd.)

### PAISTE PERCUSSION CENTRE

404 14" Hi Hats	E34
" 16" Crash	E25
" 18" Medium	E30
" 20" Ride	E40
505 14" Hi Hats	E49
" 16" C.R.	E32
" 18" C.R.	E39
" 20" C.R.	E49
2002 11" Splash	E43
" 14" Hi Hats	E76
" 14" Heavy H/Hats	E80
" 14" S/Edge	E128
" 16" C.M.R.	E49
" 18" C.M.R.	E59
" 20" C.M.R.	E73
" 18" China	E85
" 20" China	E108
602 14" Hi Hats	E98
" 14" S/Edge	E128
" 16" C.M.R.	E62
" 18" C.M.R.	E75
" 20" C.M.R.	E94
" 22" C.M.R.	E120
" 18" Flat Ride	E85
S.C. 18" Dark Ride	E80
" Gong	E15
" 13"	E37
" 16"	E41
" 20"	E80

### LUDWIG "A" DEALER

Power Factory Kit, 9-drums + Stands, Black	E995
Rock Machine, 5-Big Drums and Stands, Stainless Steel	E795
Big Beat Kit, 5-Drums + Stands, Black	E745
Super Big Beat 5-Drums + Stands, Yellow	E795
Speed King Pedals	E39
Ghost B.D. Pedals	E45
Atlas Hi-Hat Pedals	E49
Atlas S. Drum Stands	E38
Atlas Cymbal Stands	E34
Atlas Boom Stands	E49

### TAMA STAR DEALER

Billy Cobham Kit, 5-Big Drums, Stands, Platina	E645
Imperial Star 5-Drums, Stands, Black	E595
Spartan B.D. Pedal	E39
" Hi Hat Pedal	E39
" S.D. Stand	E35
" Cymbal Stand	E32
" Boom Stand	E39
Titan B.D. Pedal	E32
" Hi Hat Pedal	E39
" S.D. Stand	E33
" Cymbal Stand	E29
" Boom Stand	E37

### PEARL AGENT

Thunderking Kit, 5-Drums, Stands, Silver	E495
Professional B.D. Pedal	E29
" Hi-Hat "	E35
" S.D. Stand	E18
" Cymbal Stand	E19
" Boom "	E29
Timbales, Stand, Cowbell (P.R.)	E99

### PREMIER DRUM STORE

D717, 7-Drums, Brown-Cream Custom Finish	E495
--	------

As before, with stands	E645
24", 14", 15", 18", 6 1/2", Snare, Black	E395
5-Big Drums, finished in Custom Metallic Copper	E425
S/H 5-Drums, Black	E195
S/H 4-Drums, Black	E145
S/H Recording Kit	E139
252 B.D. Pedals	E35
Tri-Lok Hi-Hat Pedals	E35
" S.D. Stands	E25
" Cymbal Stands	E23
" Boom Stands	E32
Lok-Fast Hi-Hat Pedals	E25
" S.D. Stands	E20
" Cymbal Stands	E18
" Boom Stands	E25

### MAXWIN STOCKISTS

Stage 805 Kit	E275
" 705 "	E245
" 504 "	E225
8" x 10" + Stand	E45
12" x 13" + Stand	E65
14" x 16" + Stand	E95
Maxwin Timbales (pr.)	E65

### ROGERS DRUMHOUSE

Londoner Five Kit, Memriloc Fittings + Stands	E625
Greater Londoner V Big, Sizes, Memriloc, Stands	E675
Supreme B.D. Pedals	E55
Supreme Hi-Hat Pedals	E55
Memriloc S.D. Stands	E39
" Cymbal Stands	E32
" Boom "	E48

### OTHER DRUMS AND ACCESSORIES

Fibes, 5 Black Drums	E495
Staccato, 6 White Drums	E695
Gretsch 4 Drum Kit	E325
S/H Gretsch, 5 Drums	E365
S/H Gretsch, 4, Rosewood	E325
Yamaha, 5 Drum Kit	E395
S/H Yamaha, 4 Drum Kit	E159
S/H Hondo Congas (pr.)	E65
S/H Small Conga (Hondo)	E45
S/H Natal Congas (pr.)	E135
Premier 2000 Snare, 5"	E79
" 2003 Snare, 6 1/2"	E85
Pearl 6 1/2" Brass Snare	E89
Rogers Dynatronic 5" Snare	E110
" 6 1/2" Snare	E125
Gretsch 5" Snare Drum	E95
Ludwig Supraphonic 5" Snare	E95
" 6" Snare	E98
" Supersensitive 5" Snare	E149
" 6 1/2" Snare	E155
" Black Beauty Snare	E175
Olympic Cymbal Stand	E8
Maxwin	E7
Synare 3 Drum Synth.	E159
A. Zildjian B" Splash	E21
" 14" Hi-Hats	E89
" 16" Crash	E45
" 18" C.M.R.	E59
" 20" C.M.R.	E69
" 22" C.M.R.	E85

### NEW BASS GUITARS

Musicman Stingray	E349
Kramer 450 B.	E395

Kramer (Di Marzio) 4000	E495
Rickenbacker 4001	E425
Fender Precisions	E249
" " + M/N	E279
" Jazz	E310
" " + M/N	E340
" " Antingua	E335
" Mustang	E175
" Musicmaster, L/Hand	E125
Gibson R.D. Artiste	E425
Hondo "Rickenbacker" Copy	E98
" " Precision" Copy	E79
Kay Bass, Cherry	E35

### SECONDHAND BASSES

Fender Precision	E185
Fender Jazz Bass	E235
" Jazz + M/N	E245
1965 Rickenbacker	E295
Gibson EB3 Bass	E225
" Grabher III	E198
Hayman Bass, Long Scale	E110
Columbus Jazz Bass	E75
Avon Jazz Bass	E69
Columbus EB3 Copy	E59
Antoria Tele Bass	E45

### NEW GUITARS

Gibson R.D. Standard	E395
" L.P. Deluxes	E415
" L.P. '55'	E425
" L.P. Customs	E489
" L.P. Pro-Deluxes	E525
Rickenbacker 6-String	E245
" 12-String	E425
Yamaha S.G. 500	E335
" S.G. 1000	E465
" S.G. 2000	E495
" S.F. 700	E275
" S.C. 1000	E325
Ovation Preacher	E325
Musicman Stingray II	E345
Kramer 450 G	E345
" DM2 1000	E425
" DM2 3000	E395
Travis Bean, Black	E395
Ibanez 2617 Artist	E325
" 2619 "	E375
Fender Telecasters	E229
" Tele + M/N	E259
" Stratocaster	E279
" Strat. + Trem.	E289

### SECONDHAND GUITARS

Gibson L/P "55"	E325
" L/P Custom	E375
" 330, 1960	E295
Fender Strat. 1958	E195
" Strat. as new	E235
Gretsch Broadcaster II	E295
" Country Club	E325
Antoria 175 Copy	E165
Ibanez L.P. '55' pr.	E169
Hoyer Telecaster	E95
Arbiter T.V. Model	E75
Shaftesbury L.P. Deluxe	E125
Aria Pro II, Stratocaster	E129
Framus Stratocaster	E85
Framus Semi-Acoustic	E35

### KEYBOARDS

Yamaha CP30 Piano	E750
-------------------	------

Fender Rhodes '73	E675
Wurlitzer Pianos	E545
Armon Electric Piano	E295
Crumar, Touch Sensitive	E295
Vox Electric Piano	E235
Elgam Piano, Stand	E139
Roland String Synth.	E495
Solina String Synth.	E525
Korg Poly 1000	E645
" Mini 700-S	E375
" Mico-Synth.	E325
Roland SH 2000 Synth.	E595
Synthetone SX 2000 Synth.	E199
Yamaha C.S.60 Synth.	E1,599
S/H Farfisa Pro-Piano	E245
S/H Pianotone	E125

### AMPLIFICATION

OMEC 150 Standard	E125
" " Graphic	E139
" " Effects	E179
" " Bass Cab	E125
" " Gtr. Cab.	E135
Peavey Backstage 30	E85
" Classic Combo	E235
" Pacer	E169
Phoenix Amp + Cab	E285
Roland G.A. 120 Combo	P.O.A.
" G.A. 60 "	P.O.A.
" G.B. 50 "	P.O.A.
Vox AC30 Solid-State	E125
Vox AC30 Valve	E210
Yamaha Bass 50 Combo	E225
Carlsbro Stingray Combo	E225
Ampex V140 Combo	E395
" V2 Stack	E595
Maine 200w. Top	E189
" Arnie Top	E189
" Alex Bin	E225
" 4 x 12 Cab	E175
" 70 watt Combo	E179
" 120w. Combo	E295
Intermusic Combos	P.O.A.
Marshall 50w Tops	E159
" 100w Tops	E195
" 120w Cabs	E169
" 8 x 10 Cabs	E165
" 50w Combos	E255
" 100w Combos	E345
" 30w Combos	E159
" Country Combos	E385
" Rock Combos	E295
Musicman 112 Combos	E345
Fender Pro Reverb.	E295
" Twin-Reverb.	E345
" Super Reverb.	E295
" Bassman 70	E175
" " 135	E225
Custom Trucker Lead	E89
" Bass	E95
S/H Vox AC30	E95
S/H Twin Reverb.	E285
S/H H/H V.S. Amp	E139
S/H H/H 2 x 15 Cab	E125
S/H Acoustic 135 Combo	E275
S/H Fender Bassman 50	E125
S/H Orange 2 x 15 Bin	E185
S/H Yamaha 100 Combo	E195
S/H Arbiter 50w. Combo	E125
S/H S.A.A.S. Altex Cab	E125

P.O.A. Price on application, please phone for quotation. All prices include VAT  
HP, ACCESS and BARCLAYCARD Welcome. Mail order and fast air freight service anywhere in the world.

**SOUTHEND (0702) 553647**

# If Rolls Royce could build pedals they would be Morleys . . .

**peerless in performance; incomparable for reliability.**

From concept through execution all 15 Morley models were engineered to excel and built to endure.

First off, we eliminated the three most common causes of pedal failure — pots, gears, and batteries — and replaced them with printed circuits, optoelectronics, and heavy duty industrial grade cords for AC power. Then we protected it all by entombing it in a structural steel chassis designed to withstand any kind of kicking around or road abuse that occurs.

Stomping on Morley's steel chassis is a lot more re-assuring than having just a "pretty toy" underfoot that's going to collapse at the high point of your act. But that's not all.

Pros pick Morley because our studio quality signal to noise ratios let their audiences hear everything they're capable of getting out of their instruments. Whatever your instrument you can rely on perfect response. Whatever sounds you're after — notes fleeting through the inner labyrinths and sanctums of your mind — are delivered to the ears of your audience with your expression and individuality preserved intact — through Morley. Here's why you can count on it.

Every pedal that makes it through production undergoes 33 on-line inspections before you ever get to put your foot on it. Like Rolls, when we deliver we make sure you get reliability that guarantees peak performance gig after gig after gig after . . .

Finally, if Rolls and Morley look bulky or boxy to you that's opinion. But, if your career depends on the best, then you can't rely on anything less than Morley. That's fact. Just eyeball the pedals of virtually every chart-rated group. You'll focus on Morley.

## the Morley Pro-Flanger (PFL)

The ultimate flanging machine. No unit under \$1000. matches its performance for quietness, broad band pass and versatility in producing new sounds. The Morley competitive edge further includes:

- harmonic emphasis control to regulate the amount of signal to be re-circulated.
- in "Automatic" position the pedal presets any selected sweep from .1 second to once every 25 seconds.
- in non-automatic position the sweep varies with the movement of your foot.
- indicator lamp indicates when you are in the flanging position and also oscillates at the flanging rate when on "Automatic."

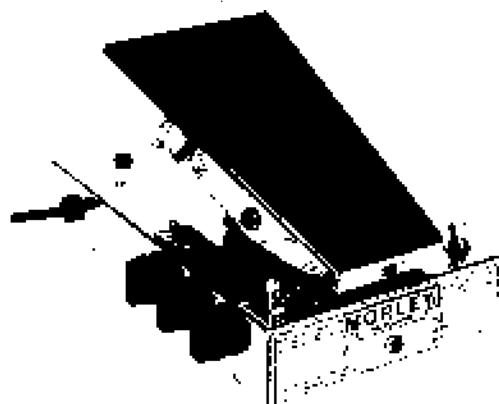

FREE catalog upon request from your dealer

**MORLEY** Inc. • 1000 Park Ave. • Fort Lauderdale, FL 33305

NAME \_\_\_\_\_

STREET \_\_\_\_\_

CITY \_\_\_\_\_ STATE \_\_\_\_\_ ZIP \_\_\_\_\_

**we build them failsafe because your career depends on  
it and so does ours.**



**"The  
ELECTRO-VOICE  
EVM 15L has the lowest  
effective resonance,  
the lowest distortion and  
by far the  
smoothest  
response."**

(Dibble's Speaker Check)

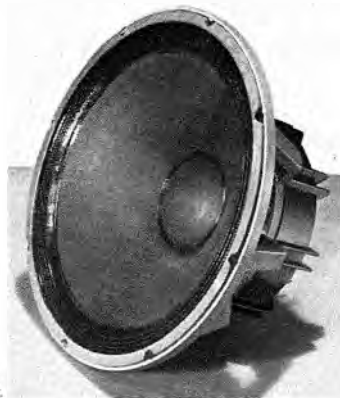

Instead of boasting of our loudspeakers we suggest you listen to Ken Dibble, the well-known expert and author of Speaker Check.

In the International Musician he says of the EVM 15L among others:

"Considering its unusually smooth frequency response curve, this unit would be ideal as the bass section of a large PA rig or as a bass instrument reproducer... this is certainly a very fine loudspeaker indeed."

Of the EVM 18B his opinion in Speaker Check is no less enthusiastic:

"From a performance aspect it is faultless. The sensitivity of 101 db is very good indeed..."

It thus appears once more that ELECTRO-VOICE loudspeakers set the standard.



ELECTRO-VOICE  
sets the standard in loudspeakers.

Send to: Electro-Voice Division  
Gulton Europe Ltd.  
Maple Works  
Old Shoreham Road  
**Hove BN3 7 EY**

# Al DiMeola

dedicated to his craft



**W**hat can you say about a guitarist who began his career with Chick Corea in *Return to Forever* at the age of 19, and by the time he had reached 23 had recorded three top-selling solo albums?

The story of Al DiMeola's success reads like a musician's fairytale, yet his achievements are those of a dedicated artist who has spent many hours working at his craft. At 24, DiMeola is one of the most exciting talents around and is poised to enter the league of guitar giants.

In a music world where guitarists abound, finding a true original is an increasingly daunting task. The number of players who have an instantly recognisable sound can be counted on one hand, so anyone like DiMeola who strives for something different deserves to command some attention.

Al's background and career has not followed the usual course of a rock musician's apprenticeship. Born of Italian parents, he was raised in Bergenfield, New Jersey, and after showing an early interest in music was bought a cheap \$20 acoustic to learn on.

"I went for lessons to a jazz guitarist called Robert Aslanian, and studied theory and sight reading. He showed me different styles and I was learning jazz standards at the age of eight. Lessons were one thing and very important, but it wasn't necessarily what I

## DAVID LAWRENSON meets a young man with a big future

liked at the time. When I was away from that on my own I used to listen to Elvis Presley, the Ventures and the Beatles, stuff like that.

"I got an electric guitar a year or two later. I liked the sound of the electric guitar and wanted one from the beginning but my parents wanted to see

if I would develop before they spent any money. The guitar at that time, the beginning of the Sixties, was new, very fresh sounding, and the Ventures had a very strong effect on me. My teacher was a total virtuoso – the best – but I really liked pop music."

In his teens, when Al wanted to get into bands, he came across a rather unusual problem. He found that his style wasn't acceptable to the groups he wanted to play in. In fact, if anything, he was too good. "In the beginning I didn't know what kind of style it was, all I knew was that I wanted to play in rock and roll bands. I never really got accepted because of the way I played, using all my fingers, playing scales instead of only licks, so I was very frustrated.

"It wasn't that I was a purist at all, it was a combination of styles. In the Sixties a combination of any kind of music didn't make it – it was only rock and roll, or only jazz, or only classical. Fusion was not accepted. The progressive thing wasn't ►►

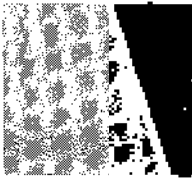

# fact: the 702 stage monitor cuts through!



**Made for you.** The 702 was designed from scratch after a careful analysis of on-stage performance requirements — Shure tested it on stage, and Shure refined it on stage. Here's what we found:

**You need . . .** Clear, clean sound from your stage monitor without extra bass, and with smooth, high-end dispersion. You must hear yourself . . . above the super-amplified instruments, above the brass.

You want a monitor that cuts through! We've solved the problems, so you hear YOU — no more and no less. Where innovation was necessary, our engineers rose to the challenge. For example, the 702's unique tweeter array with three tweeters mounted in a concave, cross-firing arrangement dramatically



It's compatible with voltage — or current — source amplifiers, and is highly efficient. Handles 50 watts continuous at 16 ohms. The Model 702 Monitor is a necessary part of your act. Put it up front and you'll like what you hear.

increases high-end dispersion. This array eliminates high frequency beaming commonly found with single and double flush-mounted tweeters. This means more freedom of movement for you on stage.

**You also get . . .**

**Super Intelligibility.** Shaped response — boosted mid-range, controlled bass rolloff. Lets vocals cut through on stage.

**Super Output.** 114 dB sound pressure level at four feet (1.2m) with only 50 watts.

**Exceptionally Wide Dispersion.** 90° horizontal, 110° vertical dispersion for broad stage coverage.

**"Roadie" Proof.** 5/8" plywood, corner protectors, rubber feet. Built to last.

**Stage Versatility.** Close-up (30°) or long-throw (60°) set up positions. Great for both roomy and confined stage areas.

**Portability . . . Looks.** All these features in a fine-looking, low profile, and lightweight cabinet.

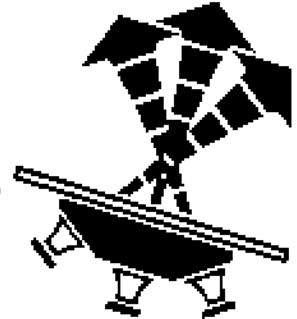

Unique "wide-angle" concave tweeter array — cuts through on-stage volume, eliminates "beaming" on-axis and muddy sound off-axis.

702 Frequency Response Curve — with enhanced mid-range for outstanding intelligibility.

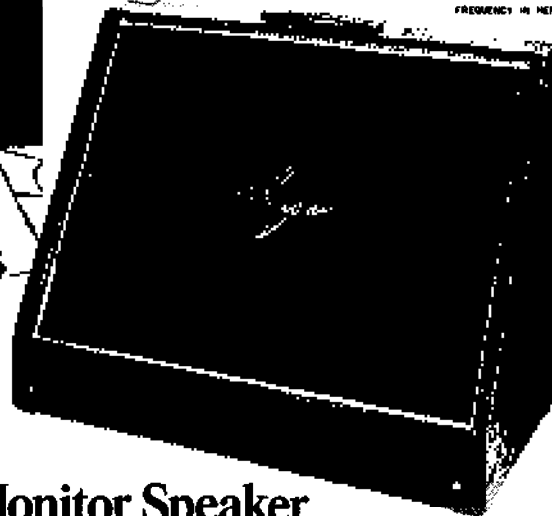
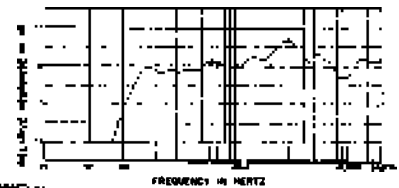

**Shure 702 Monitor Speaker**



**Sound of the Professionals.**

Shure Electronics Limited, Eccleston Road, Maidstone ME15 6AU—Telephone: Maidstone (0622) 59881



# Al DiMeola

"You get the best sustain from a Les Paul, I feel. With the weight of it, that solid wood, you get more balls out of the sound. Forget it if you want to play nice clean chords, it's not the guitar for it. A Stratocaster's much better for that sort of thing, but for what I do the majority of the time the Les Paul's the guitar – for live work.

"When I'm making my records, for any solo that requires a good amount of technique, a Les Paul will be there. Playing chords of any kind, I'd rather use a Stratocaster or some other kind of guitar unless it's a power chord thing like that Who sound of Pete Townshend, smashing chords, which I like. So there are different guitars for different sections, different moods. I normally don't change that much, it's either the Strat, which is an old 1958 model, or the Les Paul – that's all.

"I have tried an Alembic, but it's too clean a sound for me. It doesn't have the weight of a Les Paul, it may be good for chords but not for getting that nice, round sustain – not distortion, just good sustain. You have to also find a good Les Paul, one that sustains naturally. There are some that die out too soon and it's just not right. The old Les Pauls seem to be better somehow.

"I'm always changing the volume settings on the guitar but never the tone settings, I change tone by only moving the volume control. If you're mixing treble with bass and you take a little bit of the bass volume off, then you have more treble, it's like a tone control."

As for amplification, Al remains faithful to the tried and trusted Marshalls. Although these amps became synonymous with heavy rock of the Sixties and early Seventies, they are capable of giving the clean, powerful sound he's looking for.

"I use Marshall 100 watt heads and 4 x 12" cabinets, two or three of each depending on the size of the hall. I'm satisfied with Marshall, not perfectly, but they're the closest to what I want. I don't know if it'll ever be perfect because my standards are way up there.

"You can get a very clean sound from a Marshall depending on how you have your tone settings on your guitar and amp. When I turn down I have a clean sound, when I turn up I have all the sustain in the world. It's just the way you set your instrument, what kind of pick-ups you use and what combination. It's very personal.

"That's what I look for, because I don't want just sustain. There are certain parts where I want to get a clean staccato sound rather than distortion, but the problem with Marshall, as with any other amplifiers, is that they don't last. They don't make equipment that will sustain heavy touring, so this [London] being the last date of the tour, my heads are in serious trouble. They badly need doctoring. I had custom work done on the heads anyway, and I wasn't getting the sound I normally get when they are working properly.

"I've done a 20-date tour of Europe and the amps worked phenomenally on every date, but London wasn't up to my standard – they need to be worked on. I play full up and those amps are really screaming. I love it loud, the louder the better, you're able to feel it.

"Drummers want to feel their bass drum, bass players want to feel their bass, well I've got the same concept. When I listen to a record I don't like just hearing the guitar, I want to feel it, feel each note and that's a whole other concept. When a guitarist plays a phrase that's fast, you should hear every note."

To most of today's guitarists, effects pedals have become a way of life. At the very least there is ►►

happening yet, it was only in the Seventies that it started to. That's why I say that the music I do is rock of the Eighties to be accepted on a large scale."

Despite these problems, Al's career received an enormous boost when he encountered Larry Coryell prior to his enrolling at the Berklee School of Music in 1971. Subsequent jamming with Coryell gave him the encouragement to perform and he joined up with keyboard/percussionist Barry Miles.

Chick Corea heard a tape of Al with the band and when Bill Connors quit Return to Forever, Chick called him up and offered him the gig. After only two days of rehearsing the guitarist made his debut with the band at Carnegie Hall and received a standing ovation.

During his two years with Return to Forever, Al's stature as a musician grew steadily. By the time the band stopped working in 1976, he had already made an enormous contribution to their music and even released his first solo album. Two more solo ventures firmly established him as a highly successful performer in his own right, and a major new talent.

He is a guitarist first and foremost, with very definite ideas on the tools of his trade. "The first electric guitar I had was Japanese and I had a Danelectro practice amp with a 10" speaker. I graduated to a bigger model with a reverb unit, piggy-back head and a 12" speaker which was great.

"After that I bought a Guild Starfire, which was a very popular guitar in the middle and late Sixties. That was a dream come true – my first really good guitar. After that I bought a 1971 Les Paul. It is black and called a Custom, but it was also custom made. Originally it was wired in stereo, had a Bigsby arm on it and a couple of other devices. I had it changed when I joined Return to Forever, I had it changed back to just mono because I didn't need stereo – it was ridiculous. I also had the Bigsby taken off, I didn't need that piece of junk.

"About a year later I bought a 1966 Les Paul which I had painted white. That's the one on the cover of the 'Casino' album, and I used it for about two and a half years. Then when I was making 'Casino' I found this 1958 Les Paul sunburst, which is the one I'm using now.

"I have the original pickup on the bass end and a DiMarzio PAF on the treble end. I find this is much better than using two DiMarzios because the original pickup has a smooth tone, not a jagged distortion sustain tone, it's a nice round sustain, mellower. That combination with the treble pickup, which is hot, gives a nice blend. It's not the only thing that gives me my sound, but the pickups are responsible for a large part of it."

His playing is characterised by a clean, clear sustain which he calls an "overdrive" sound. This is the sound he has been striving for since he joined Return to Forever, which owes nothing to distortion. A good Les Paul is vital to this sound, as Al explains:

# A NEW WAVE OF PEDAL POWER

The latest additions to the ever-increasing range of **COLORSOUND** effects



## GIGSTER

The Gigster pedal is a self contained rhythm unit — battery operated, it just plugs into most amplifiers. Up to ten different rhythms are available, including Bossa-Nova, Bossa-Rock, Swing, Waltz-Rock, etc.

## THE V.C.F. UNIT

V.C.F. voltage control filter is triggered by the signal from the Guitar, the harder you play the more effect. A variety of interesting sounds include a staccato, a wah wah type and a funky 'shaft' tone.

## DIPHTHONG

A new sound for Bass Guitar. The Dipthong is the first in a series developed for the Bassist. The device is triggered by a signal from the Bass or Guitar. It has three controls — Overdriver, Speed Depth, Filter Bias. Vowel sounds based on E—OO—AR can be produced in varying degrees.

## FLANGER

The new Flanger produces sounds which are out of this world. The unit features automatic double tracking which gives all the usual flanging sounds, but with superb quality. With a total of four controls regulating speed, depth of sweep filter quality and ADT, the possibilities of this new unit are virtually limitless.

## THE PHAZEX UNIT

Wide variety of effects including a rotating speaker type sound. A new reactance control enables the unit to scan the Phase circuit producing an arpeggio effect.

## VOCALIZER

This is the unit that simply 'speaks for itself' the Vocalizer goes one step beyond the voice box. By merely pressing down the pedal it produces all the vowel sounds AEIOU. The

resonance control enables the player to get a totally different set of vowel sounds and so opens up a whole new world of effects.

## WAH FUZZ SWELL

4 different effects. Wah Wah, Fuzz Swell, Wah Fuzz and swell pedal.

## OVERDRIVER

Gives an extra 'Boost' to an instrument which can overdrive to the extent of producing distortion.

# COLORSOUND

TRY THIS NEW WAVE OF PEDALS NOW OR WRITE FOR DETAILS



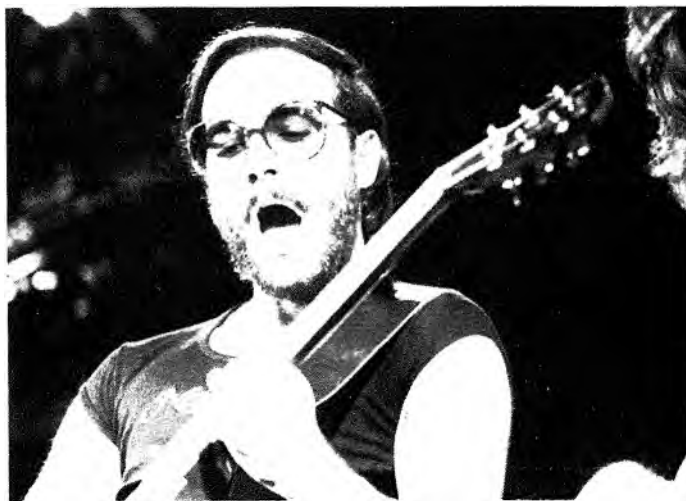

# Al DiMeola

current ones just suit him best at the moment.

Despite being a formally trained musician, with the hours of practising that it entails, Al has no set pattern of practice. "I don't time it, I just pick up the guitar whenever I feel like it. I'm the type of player who will pick it up for 15 minutes, put it down for 10 and go and do something else and then go back to it for half an hour. So in a whole day I may practice for five hours and not even realise it.

"Whenever I'm frustrated or bored I'll pick it up, or if there's something in particular I want to practise. As for sitting for four hours solid to practise, I rarely do that. I did when I went to music school, for eight to 10 hours a day, but I will be going into that kind of woodshedding next year, when I'll maybe set aside six hours a day."

With his background and love of Latin music, perhaps that is an area where he would feel more satisfied. "I play classical guitar, but I don't think I'd ever only want to do one kind of music. If you play classical music, you'd only be playing to a classical audience, just like if you only play jazz guitar you're playing to a jazz audience. I'm playing a mixture of music, I've been brought up with these different kinds and I don't want to only do one, I'd feel unfulfilled. If I could live other lives then maybe I'd like to be a classical guitarist because I'd feel great aesthetically, practising classical music every day."

Yet what he plays today is far removed from the world of the classical musician and it would seem difficult to reconcile the two areas. Al believes he has incorporated his formal training with jazz guitar and his Latin influences to produce a totally original sound for his own original type of music.

He explains: "The most important instrument to rock music is the guitar. It's up front now, and there is more concentration on dynamics with the use of power. Energy and emotion are very important to rock fans, but I also know what the ingredients are other than rock. It's a combination which includes very heavy classical from Latin, with a blending of jazz harmony and jazz lines.

"The mixing of the styles is no real problem for me. I guess it must be very hard for a player who never had any theory training or can't read music and doesn't know what he is playing when he plays it. It is a problem for him to play any other kind of music. What I do know is that I've learned my instrument and I'll always keep learning, but I've learned it to the point where I know what I'm doing, but I don't think about it when I'm doing it. I'm feeling it, but if I had to analyse it I could do. I couldn't play what I'm playing now without formal training, nobody could."

His tastes in music reflect his combination of styles and influences, and range from early pop and rock music through to classical players. "I like the overall sound of particular groups, but I never listened to guitarists. I listen to classical guitar, people like Segovia and Julian Bream, but way back it was groups that had an effect.

"Jimmi Hendrix didn't really influence me. I never really understood why people freaked out over his guitar playing or even Eric Clapton's, but I really liked them in the context of what they were doing to music. I listened to their records the whole time. If I had to name anyone I listen to now, it would be a classical composer, although I listen to someone like Chick Corea a lot."

When you look back over his career and the work he is doing now, it is still difficult to believe that they are the accomplishments of a musician who is just 24. If the next four years are anything like the last four, then the future for Al DiMeola really knows no bounds.

usually a phaser or a wah-wah pedal lurking around somewhere, perhaps for use just on one or two numbers. But for Al DiMeola effects are strictly out. He uses nothing but his guitar and amplifier, and intends to keep it that way.

"I like effects, but they don't make any that work. They always break and when they break I get mad. Most of them are made very cheaply. One night they work great and the next night, for some damn reason, they are too noisy or something and mess up during a tune so you've got to unplug everything - I don't need it. I don't need that because I can create effects with my hands, and I like the sound of the guitar. There's no sense in making it sound like a Moog, you confuse an audience.

"If I could get something reliable, I would like to use an octave divider, one of those that gives a fifth or a third or something. But the less effects you use, the better sound you will have, the more sustain and the thicker the sound. A lot of people use that stuff to get more sustain, but I don't need it.

"Phase shifters, they're not the best. When they put out a good phase shifter I may use it. The best phase shifter sound is the studio phase shifter sound where you have two machines together slightly out of synch. That gives you the full effect of the phase - those little devices only give about one tenth of that effect. There's no reason why some genius can't come up with a box, even if it's the size of a Marshall bottom. When that happens, fine, I'll try it out.

"I've spent many hours, many days and many weeks trying out effects that people have said, 'This is the best man, you ought to try it'. But it don't sound that great to me. It really has to impress me. I'd rather not use anything than use something that's going to be gimmicky. One night it works great and the next it don't. It's a pain in the ass, I don't need it."

Al's set includes a section on acoustic guitar, something which is also featured strongly on his albums. It is in this acoustic field that his Latin and classical influences really shine through. On stage he uses an Ovation acoustic electric guitar which he is quite satisfied with. "It's good enough, I don't know any better acoustic guitar playing-wise, or action-wise. The sound projects very well.

"It's not the deepest sound you can get on a guitar, but the problem with a guitar like a Gibson or Martin is that though they have the best tone, the old ones especially, you can't play them. They're not made for my type of playing, they're made for chords, folk guitar playing. It is hard to situate your hands on those necks. I prefer Ovation."

As far as choice of strings is concerned, he's not constantly trying out different permutations and new makes. He uses Ernie Ball Super Slinky on his electrics and Guild on the acoustics - but feels there's little to choose between strings anyway. His

# SCHECTER GUITAR RESEARCH



**our parts go on and on...**

DISTRIBUTED BY:



**ISA**

INTERNATIONAL SALES ASSOCIATES

POST OFFICE BOX 9783 NORTH HOLLYWOOD, CA 91609 (213) 782-3202

For Our All New Complete 20 Page Catalog Send One Dollar For Postage & Handling. See Your Dealer Or Guitar Repair Shop.

# SCHECTER GUITAR RESEARCH

## THE SCHECTER STORY

Several years ago David Schecter arrived in Los Angeles from Boston. Getting work in a small guitar repair shop in Hollywood, Schecter began to formalize his ideas on pickups, while custom winding and repairing guitars for practically every major artist in the L.A. Market. Through word of mouth it gradually became evident that Schecter was producing some of the best pickups available, and musicians who heard his work began to search him out.

In those early days David could be very difficult to find. When pressures became to great, he would just pack up suddenly and disappear. He would usually return within a reasonable time with new ideas in mind and a desire to continue his work.

It was under dismal conditions that David survived those first couple years in Los Angeles. Living in his car or a friends garage, he kept his life simple.

It wasn't until early 1976, that Schecter finally joined up with two friends and the plans for **Schecter Guitar Research** were made. His reputation was already allowing enough business so David could rent a small shop in Van Nuys, California. With each custom hand-wound pickup and skillfully repaired instrument, **Schecter Guitar Research** built up a following that spread across the country.

Schecter came up with a design which he called the 'Tapped Pickup'. It had two coils in a continuous series. The first or inside coil faithfully reproduces that original Fender sound so the purist wasn't giving up any-

thing. The second coil works as an extension for power increase, but with a basic difference from other replacement pickups, it retained those crisp highs. This was really essential because so many musicians loved their old Fender instruments, but wanted more variations and color, not to mention higher output.

From the moment Schecter and his associates realized the demand for their products, David set about designing efficient means of production without sacrificing any quality. Working day and night for months on end, Schecter actually lived in the middle of his production facility. Virtually every piece of equipment in his shop was rebuilt, modified or designed by David. His abilities were endless. He built, within a matter of weeks, a sophisticated coil winding machine with innovations geared to insuring the consistency of each pickup.

While all of this growing was going on, David's associates Shel Horlick and Herschel Blankenship began to make plans for selling and getting the SGR products to musicians around the world. The end result was the formalizing of **International Sales Associates [ISA]**, which would be the exclusive sales and distribution company for **Schecter Guitar Research**.

As time continued on, Schecter expanded at a furious rate with David creating new ideas and products, almost on a daily basis. The 'Tapped Pickup Assembly' became a sophisticated product geared to professional musicians which literally opened up endless tone possibilities for Fender

Guitars. Some of the biggest names in the music business became **Schecter** enthusiasts and used the products religiously.

It wasn't long before the phone was ringing off the wall and demand for other **Schecter** products was being made. Pickguards, Jackplates, Knobs, Bridges... the list goes on and on, all being made with David's touch and design. The beautiful exotic wooden bodies and necks finalized the reality and it became obvious to everyone that you could order and build a completely custom instrument from **Schecter Guitar Research Parts**.

Like quite a few other companies in the music business, **Schecter Guitar Research** has gone from poverty to prosperity in a very short time.

With over 400 items in the **Schecter** line, the company has grown and become quite an interesting place. Every employee is a musician and skilled technician. New products continue to pop up regularly and David is still right in the middle of it, checking on each part, teaching and training every employee the **Schecter Quality**.

The outlook is bright for this young company and with the possibility of a completely new guitar design in the near future **Schecter Guitar Research** is a company to keep your eyes on.

★ ★ ★

Written By:  
Charles Simmons

EXCERPTS FROM  
**UpBeatDaily**

DISTRIBUTED BY:



# ISA

INTERNATIONAL SALES ASSOCIATES

POST OFFICE BOX 9783 NORTH HOLLYWOOD, CA 91609 (213) 782-3202

For Our All New Complete 20 Page Catalog Send One Dollar For Postage & Handling See Your Dealer Or Guitar Repair Shop.

# SM 200-The H.H. Mixer and Stereo

This is the answer to the creative soundman's problems - two one-hundred-watt power amps teamed up with a fully specified six channel mixer. The new HH sound machine, the SM 200, is packed with every conceivable control feature: Volume, Bass, Treble, Reverb/Echo, Stereo Pan, 3-way Monitor Switch, and an Input Selector switch on each channel. Separate Master volume faders for left and right outputs with output level meters, Monitor output volume, and Auxiliary input channel, keep everything under control.

## SPECIAL FEATURES

### Two Hundred Watts Stereo Power

Two 100 Watt r.m.s. power amplifiers at less than 0.2% distortion.

### Reverb

Built-in Accutronics reverb unit, with individual reverb send controls.

### Graphic Equalizer

Seven band active graphic equalizer for infinite tone control.

### Input Selection

A 3-way input switch selects optimum matching and equalization for Microphones, (High or Low impedance), Instrument-guitar bass or keyboard, Ceramic record player pick-ups, or audio line input.

### Stereo-Pan

Pan control enables a true stereo image to be created, particularly when echo or reverb is added.

### Illuminated V.U. Meters

Illuminated V.U. Meters show output programme levels.

### Monitor Facilities

Comprehensive monitor facilities include: Pre-off-Post channel and Auxiliary monitor switches - separate monitor mix with monitor volume control.

### Headphone Output

Stereo headphone socket, can also be used to drive a separate monitor amplifier.

### Tape Record Outputs

Stereo tape recorder output sockets facilitate recordings on to tape.

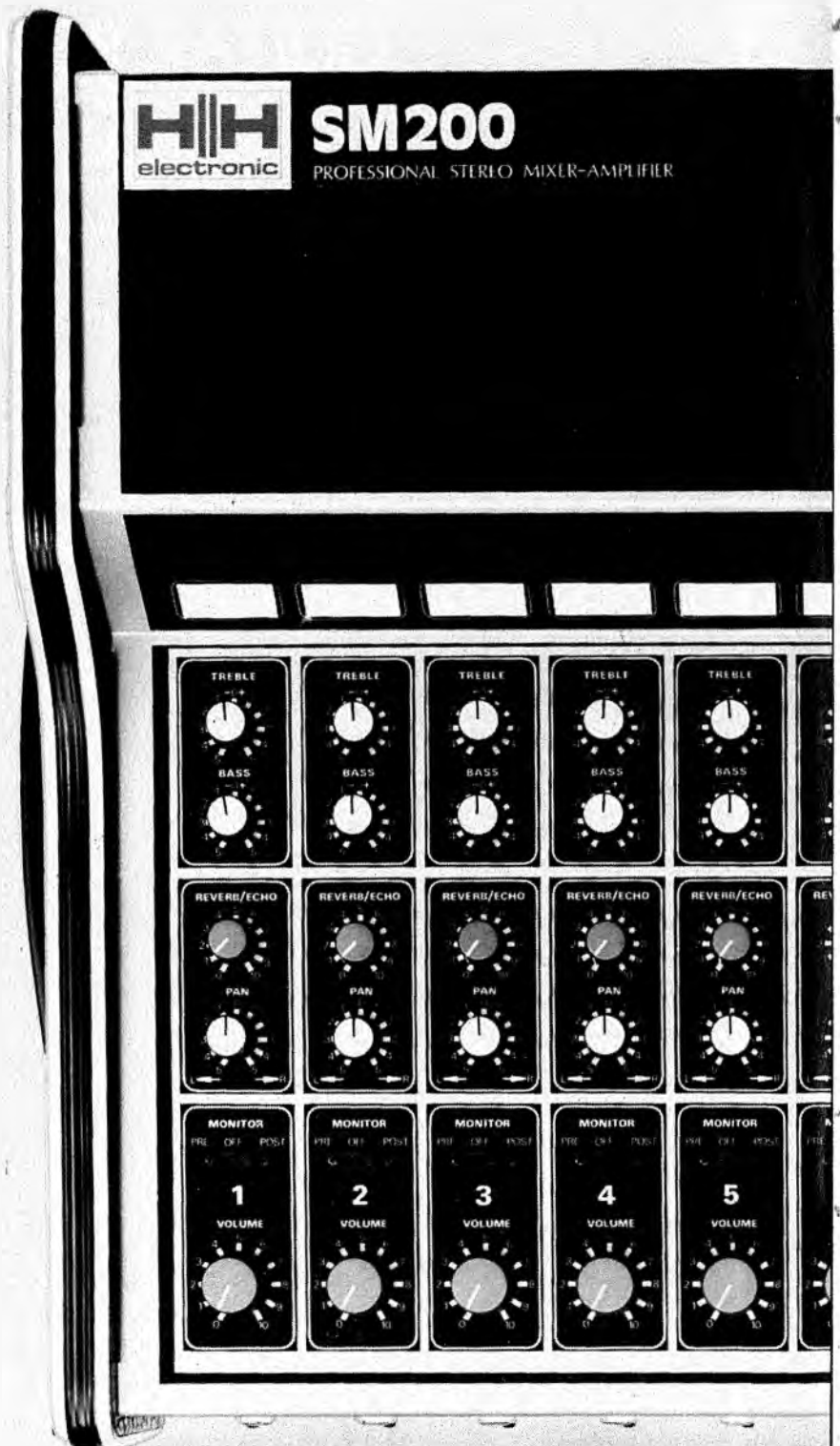

For that Special Sound  
everything in one unit

# Sound Special

## Amps in one unit

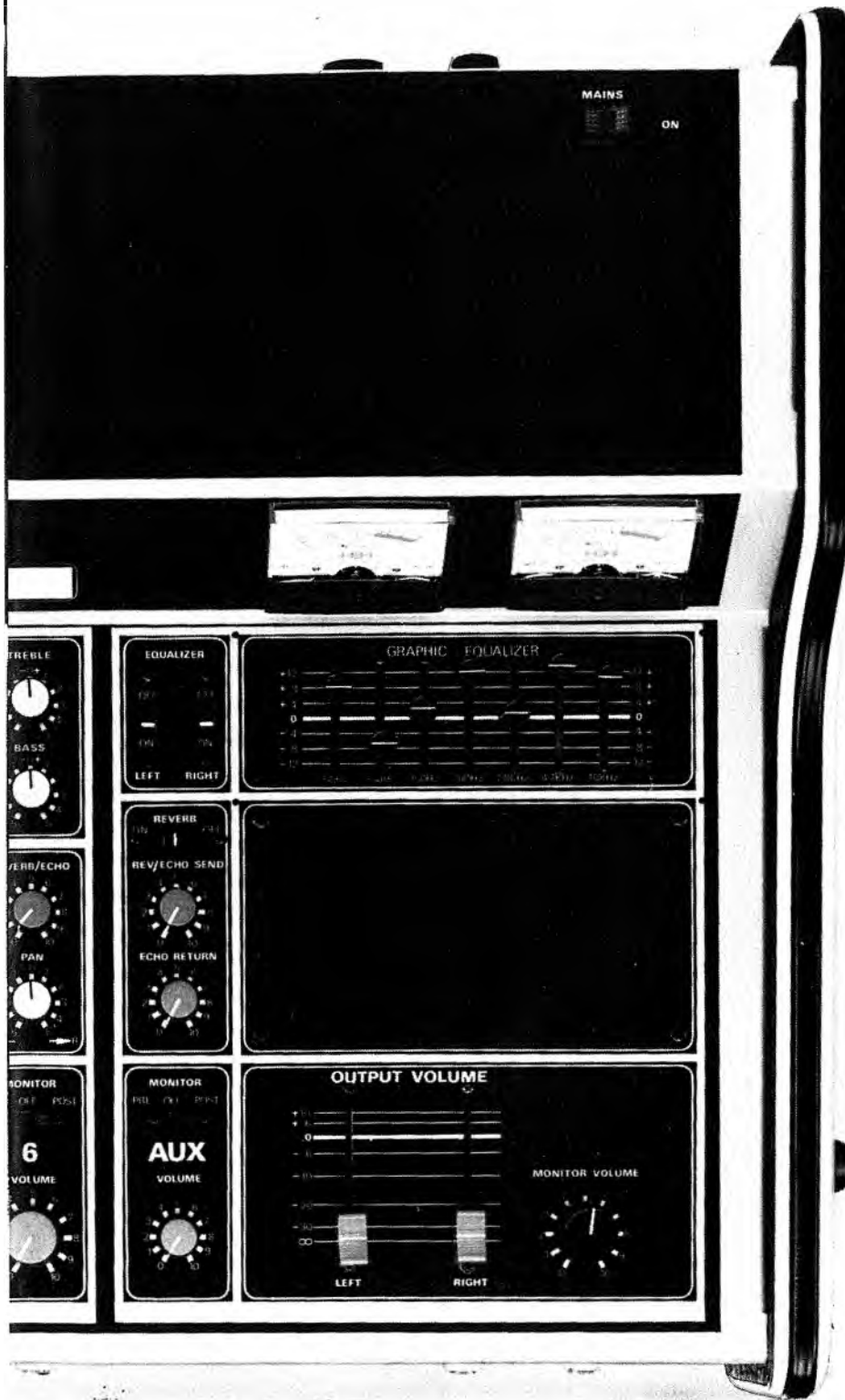

### ACCESSORIES:

#### Digital Effects Module (D.E.M.)

The remarkable HH D.E.M. simply plugs into the SM 200 and adds wonderful sound effects at a push of a button.

#### Echo

A wide selection of echo sound with variable delay times and repeat combinations.

#### A.D.T.

Automatic double tracking essential for today's vocals.

#### Reverb

Great reverb sound for adding the extra dimension to sound.

#### Flanging

Adds whirling spatial dimensions by means of a controlled pitch change.

Free yourself of the disadvantages of external effects units with all the inconvenience of connections, mains power leads, etc.

### Plug in the HH D.E.M.

#### Mixer Tripod Stand

The convenience of having your mixer at the right height for easy control is afforded by the fold-up portable HH Mixer stand. The stand fixes to the unit in seconds and folds up to a small size for easy transport.

#### Vinyl Carrying case

The vinyl case is sturdily made from hardboard padded with foam and covered with tough waterproof vinyl material for full protection in portable application.

The SM 200 is the most versatile and effective sound machine that HH has ever produced. It forms a control centre/power house for a wide variety of sound set-ups, including:

- Sound Reinforcement P.A. system
- Keyboard mixer/amp
- Stereo guitar amplifier/effects unit
- Club installation sound system

with the convenience of  
it it is the H.H. SM200

PLEASE SEND ME INFORMATION ON  
THE HH SM 200

NAME .....

ADDRESS .....

.....

.....

TEL No.....



HH Electronic  
Viking Way, Bar Hill, Cambridge CB3 0EJ  
Telephone: Crafts HH (0954) 81140  
Telex: 617515 HH ELEC G



# JEAN JACQUES

puts the boot in..



The punk division of new wave music has always been renowned for its controversy and violence. No group to emerge in Britain in the past five years has faced violence and created controversy like the Stranglers.

Jean Jacques Burnel, their karate-kicking bassist, is infamous for his contempt of everything but his motorbike, his karate and the three other Stranglers. Yet the Stranglers' songs and Burnel's confident lead-like bass playing have set them above the cacophony of their hundreds of new wave contemporaries.

Burnel is in Japan now, studying for his karate black belt. The Stranglers have taken five months' holiday and JJ was off to record the last track and do some mixing of his solo album when IM collared him. In the stream of consciousness that followed came *Euroman*, karate and Burnel's musical *raison d'être*.

Criticism of new wave bands and their players

came quickly from every section of the music business, from the pin-striped denizens of multinationals' boardrooms to Joe Publican who "wouldn't put a band like that" in his pub. The most biting and often true criticism that new wavers face from other musicians is that they are "unprofessional", they are not good musicians and they don't even try to be better.

Burnel has an answer to peer group criticism: "They are totally patronising. These session men don't know nothing. They don't cause any ripples, man. They should shut up and do something. They should play gigs in pubs and small clubs and get spat upon, have fights and do something."

"I don't know whether a band's energy is proportionate to the amount of aggravation they suffer because I've only been in one band. But we had a lot of hassles, we had a lot of fights. The first gig we ever had, in 1974, they hit the guy who was mixing our three channels. The crowd didn't like what we were playing. In the end, the mark of an artist is how far he is willing to go to prove he is right."

It was not for art's sake that Jean faced this aggravation when the Stranglers first got rolling. He says: "I wasn't into music before. Hugh (Cornwell, the Stranglers' guitarist) turned me on to records. I was just a greaser riding around on bikes. For years before I met Hugh I never went to gigs, I listened to Radio 1 as much as anything else. I wasn't a rock fan."

"I met Hugh and he said, 'Start a band'. I said OK. I'll give up my job and start a band. It was more fun than the van-driving job I had at the time. It certainly wasn't lucrative. I had to sell my motorbike. At the time it was an adventure. The only means of expression I had then was karate."

Hugh Cornwell taught Burnel the riff to "Toulouse Street" and Jean claims everything since then he has taught himself. He couldn't play bass before he joined the Stranglers, only nylon-string guitar. Technique, sound and set-up were of the least importance but therein lies the secret to Burnel's cutting bass sound.

"It's simple man, just straight through the amp. The original sound I had was because I had just bought this bass from Hugh for £35 - a Fender Precision. I've got two Precisions. It was just coincidence that it was that one because he played bass before. He gave it to me. We started the group that way."

"I had a transformer amp, like a train transformer amp converted, then I had a 100 watt amp with Baker speakers, then I got an actual bass set-up, a Marshall amp."

"I then got a notion of the sound I wanted. I gave the Marshall up because of too many problems. Now I use a Hiwatt. I wanted the sound that I got from the first bass, it was great. I

...on session men, the media, the record companies - but happily not on IM's Sean Hogben

got it with the Marshall stack when we first went into the studio; I tried the Hiwatt with two speaker cabinets, with 4 x 15s and 4 x 12s and it was just right. Then I had to look around for a spare bass because the first one was getting battered.

"I had to play literally hundreds of Precisions to get one which sounded just the same. I found one that sounded better. It had the same topky sound as the first one with the set-up I had, but it was louder, more powerful with more distortion. Now I have those two basses. I only use that set-up, just with what is on the dials.

"The two sounds that I've got, the barracuda sound and the topky sound I get from using roundwound strings - Rotosounds - and heavy picks. The sounds are not gimmicks. It's the speakers I use, the amp - I guess a combination of all those things. Guitars, I've tried lots of other Fender Precisions but never been able to get it right. Just lucky, I guess. Roundwound strings are really good. Except they go off when they get gobbed on, after a couple of gigs they get really shitty. I used to break a lot, especially bass C every third or fourth gig."

If Burnel's equipment set up sounds simple, the Stranglers' song-writing process is basic. Though Jean said he would work out every note in a planned album if he had the time, the Stranglers "just play it."

He says: "You've got to have the intent worked out in the first place. There are four members of the band so there are four people who write songs 'cause they all play on it. Four people write one song. It depends on the first person who stops lying around. There are so many different ways of writing a song, you must know that. Sometimes you compose it while whistling along a street, if you've got a riff, you can hear something and vary it, you know, do a rip off. Other times you've got a lyric line good enough to put down. With us, we always credit the four, even when the drummer puts his drums on it he's in. All that shit about having one or two members of the band and the rest on wages is not on. I don't think that's a real band. If not everyone is writing, there is no dynamism, it's just a gig.

"I'm not analytical about what I write. I just put it down. If it feels good, it feels good and if it doesn't, I scrap it. I don't analyse failures, for this type of music we never do that, we haven't done it yet. With the Stranglers, if a song is suggested and we can't get off on it in half an hour, we drop it straight away. We've lost a lot of good songs that way."

The Burnel-Cornwell connection is crucial to the Stranglers' future, says Jean, but it doesn't stop there. All Stranglers are important to him.

"If I wasn't in the Stranglers I wouldn't be doing this interview. My relationship with the three others is

extremely important. I have the utmost respect for them. Unlike other people who reckon it is necessary for a group of artists who work together to hate each other, I can't see that. Yes, despite the exterior, within the Stranglers things are very harmonious. When one of us gets done, the others get kicked too. If I go into a fight, Jet is there straight away."

Fights, violence and abuse have lead the Stranglers to "commercial suicide", as Jean put it. "We've gone over the top, totally. Commercially, we've gone over the top. How many bands, when they are given a 40 minute television slot (on BBC's 'Rock Goes To College' series), blow it?"

Answer: only the brave and the stupid. Says Jean: "I think that's what we are, brave and stupid. And irresponsible. But we owe it to ourselves to be brave, stupid and irresponsible. Every real artist, musician or rock and roller, owes it to himself to not have obligations to commercial interests like that. Otherwise, we are doing what all the other bands are doing. We always take risks. What other band would give away 100,000 singles then release three weeks later, as we did with our last single? That was out of our own pocket.

"We've taken so much stick from the media that we can get away with anything. We've got no obligations to anyone, man, not even to you. We've never been anyone's blue-eyed boys. It's not the sort of situation we'd realised we'd be in but we can't lose from it, can we? We can't be hated or more disliked by the media than we are already. So we might as



well relish the fact. We are not obliged to anyone. The only people we are obliged to are the ones who come to see our gigs, who pay to see us play. That's an obligation."

Despite the Stranglers' anti-social behaviour, they still enjoy the embrace of a record company, United Artists. Of their record company, Jean says: "There have been some bad goings on. For a few months, they messed up our release dates, they've messed up our artwork. They were bringing out records without sleeves, they brought out 'Peaches' without a sleeve because they put artwork on it that they thought should go with a new record. We wouldn't have it, so they scrapped 30,000. That's why 'Peaches' and 'Go Buddy Go' had no picture sleeve. We thought we had a fair contract at the time. Now, well, it's all relative. I think it's great that you can play in a band, get arrested and have a laugh at other people's expense. Doing what I do. That is a luxury in itself. On the other hand I've found out that what we've got is a very poor deal compared to other people."

Jean thinks being able to afford a motorbike and a trip to Japan "on a half-priced flight" is luxury. Life would go on if it all blew up tomorrow.

"Euroman is still here. Euroman is not that easily destroyed, it's not something that concerns you if it all packs up tomorrow. It will just be another interview for you."

Euroman is not newspeak, it is the title of Burnel's first solo album. "It is totally different from Stranglers-type music," he says, "but it's a good new direction, a way of us extending ourselves. We're not boring ourselves or the people listening."

He will probably do some gigs with it, "with a few friends, or the Stranglers doing my solo album." Burnel claims that the Stranglers are four very complementary egos. They are not struggling to survive but he won't say whether they have a future. "We don't want to reach our own level of incompetence. When we start getting boring we'll change it. We're that together. That's a claim but no-one will refute that. I know about the technical limits you can reach. In the early days we played two-minute songs because that was about all we could muster. I can see over three albums we've got much better. I don't know what will happen in the future."

Now Burnel has flown off to "the most important thing in my life", far from rock and roll's madding crowd. He said: "Life is too short to dissipate energy. That's why in our first break for four years I'm going to get my black belt. I want to teach, I want to teach people karate. I have four dojos to look at next week, I'll pick the one that suits me best. I've got a small room with just a rattan mat. I'll live in it by myself for five months. Or I can try."

**if you care  
about sound...**

**we care about  
you**

**IT TAKES A LOT OF TECHNICAL KNOW-HOW  
AND PRACTICAL EXPERIENCE TO BUILD A  
SUCCESSFUL SOUND SYSTEM.  
OTHERS MAKE WILD CLAIMS  
WE HAVE THE TRACK RECORD**

**MANY, MANY PEOPLE HAVE SOUGHT OUR SERVICES INCLUDING:**

**THE ACTORS  
THE CLASH  
CO CO  
THE EXILE  
FISCHER Z**

**GENGHIS KHAN  
GRAND HOTEL  
HENRY COW  
JOHN MOLE (Colosseum II)  
THE LOOK**

**THE ONLY ONES  
PORTSMOUTH POLYTECHNIC  
ROBIN TROWER  
ROY CASTLE  
THE RUBETTES**

**STEEL PULSE  
SUSIE QUATRO  
WHEATLEY TAVERNS  
YEOVIL COLLEGE**

**SO IF YOU REALLY CARE ABOUT YOUR SOUND, DO YOURSELF A FAVOUR AND INVEST IN A 12½p S A E  
(Overseas 2 International reply coupons) FOR YOUR FREE COMPREHENSIVE PA & LIVE SOUND CATALOGUE  
FULL DEMONSTRATION FACILITIES EXPORT ENQUIRIES WELCOME**

**soundwave**

**66 Victoria Rd, Romford, Essex, England  
Telephone: Romford (0708) 25919**

**EUROPE'S LEADING SUPPLIERS OF PA & LIVE SOUND EQUIPMENT**

**PLEASE SEND ME MY FREE CATALOGUE  
I ENCLOSE A 12½p S A E**  
NAME \_\_\_\_\_  
ADDRESS \_\_\_\_\_  
LM



# HIT THE ROAD.



This is the HIT, WLM's portable combo organ weighing no more than some 70 kgs.



Its sturdy, though elegant cabinet easily withstands the rough life on the road.



The HIT folds open unbelievably quickly, in just ten seconds.



Then you just start playing. And what a sound you've hit! Purely magnificent!



The HIT sound also contains consonants, not just vowels, which means an exciting and pleasing sound impression.



A light touch of your finger enable you to use seven fixed sound combinations.



And you just go on enjoying the distinctive sine-wave sound and the easiness of controlling it with the drawbars.



The HIT also folds neatly back after you've finished. Ready, steady, go!

Meet the HIT, WLM's impressive organ. Mail this coupon for our new brochure giving full details about the distinctive WLM Sound Concept.

Name \_\_\_\_\_

Address \_\_\_\_\_  
 \_\_\_\_\_  
 \_\_\_\_\_

Representative in the U.K.: Richard Brown Distributors, The Minster, Harbridges Lane, Long Buckby, Northants, England. • USA: UNICORD Inc. 75 Frost Street, Westbury, New York 11590. • Australia: The Music Distillery, 503 Pittwater Rd. Brookvale N.S.W.



Manufacturer: WLM-organ Oy, SF-03600 Karkkila, Finland

# Premier's new range of outfits.

## 1 POWER.



PREMIER RESONATOR is the only outfit with double shells to boost volume, giving natural studio sound and superb cut through power.

## 2 RANGE.



PREMIER ELITE, a new name for the best selling outfits around. A vast range of options and thousands of set ups to choose from.

## 3 TONE.



PREMIER SOUNDWAVE is a totally new range of outfits fitted with single tension drums for the free vibrant sound many drummers prefer.

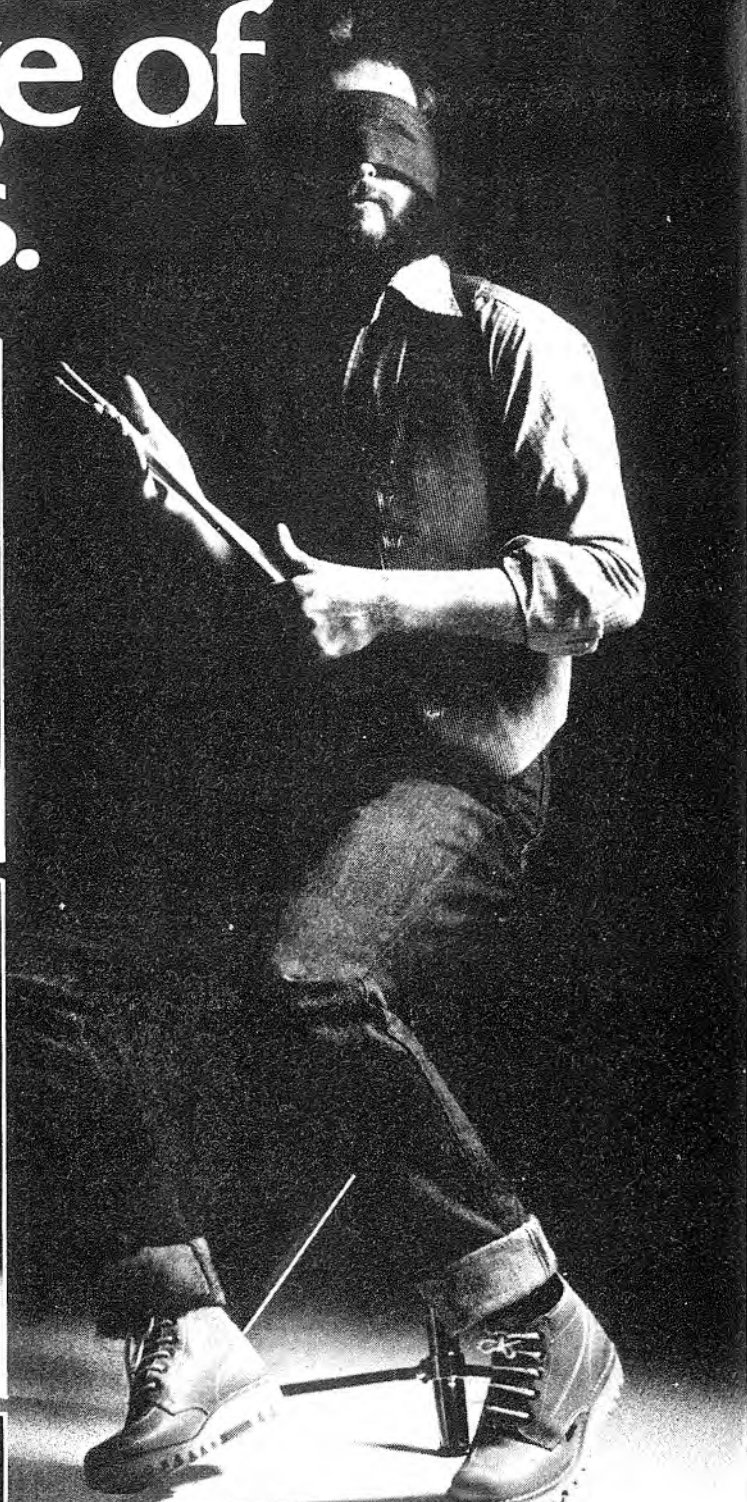

You've got to feel  
the difference before  
you can see it.

***Premier***

**1st IN PERCUSSION**

The Premier Drum Co. Ltd., Blaby Rd., Wigston, Leicester LE8 2DF.

# In the light of experience

The Clavinet and the Pianet  
are two of the legends of the  
keyboard world.

Now Hohner have used all their experience with these  
instruments to put them together as a single instrument with a 'split personality'.

The new Clavinet-Pianet Duo.

The Duo gives a range of five full octaves and, incredibly, you can play  
Clavinet with Pianet bass, Pianet with Clavinet bass or a combination  
of Clavinet and Pianet with Pianet bass. You can play Clavinet and Pianet at the  
same time over the whole length of the keyboard, or use damper sound on the  
Clav. whilst playing Pianet. You can even switch back and forth between

Clavinet and Pianet by a simple touch of a foot pedal!

The combinations are almost endless, the sound is sensational.

That's why in the light of THEIR experience both Jan Schellhaas of Camel and  
Brian Chatton of John Miles Band have chosen the Duo, and Duncan Mackay has  
already taken the Duo to the USA with 10cc.

Give the Clavinet-Pianet Duo the benefit of your experience.

Contact your Hohner dealer for a demonstration of this unique new keyboard.

## THE NEW CLAVINET-PIANET DUO



**HOHNER**

M. Hohner Ltd., 39/45 Coldharbour Lane, London SE5 9NR. Telephone: 01-733 4411/4

ALAN HOLMES talks to a former player who has worked with the same band for 27 years

# WILTON FELDER, Crusader

There are a lot of those jazz bass players who have a reputation like an elite college. They're very sensitive about who joins their band and they expect standards to always be in their repertoire. Wilton is one of the few saxophonists who have yet to relax the limits of their repertoire. The Crusaders, his first and only band, are both a reflection of Felder's professional career and a reflection of his school days ago. Formed in a Houston high school 27 years ago by drummer Sid Hepper, the Crusaders went from jazz-funk beginnings to become a pillar in the music

superstructure that has sprung from those roots. They have had six consecutive charting entries on the number one of the jazz charts, crossing over to top 40 pop charts at the same time. They have found the wide and profitable appeal of a session man in more than 200 gold-selling albums. Above all, this is the pride of the fellow musician who respects the individual members of the band as creative craftsmen and inventors of new sounds in instrumental music.

Now Wilton Felder, bass and Wayne Henderson, the Crusaders' core of Sid Hepper, pianist Joe Sample and saxophonist/bassist Milton "Felder" are constantly on the road in America and Europe. They Sample's album "Rainbow Seeker" received wide acclaim and now Felder's solo album "We All Have A Star" has just appeared.

Felder has these words to say to *Rolling Stone* about his art and his bandmates:



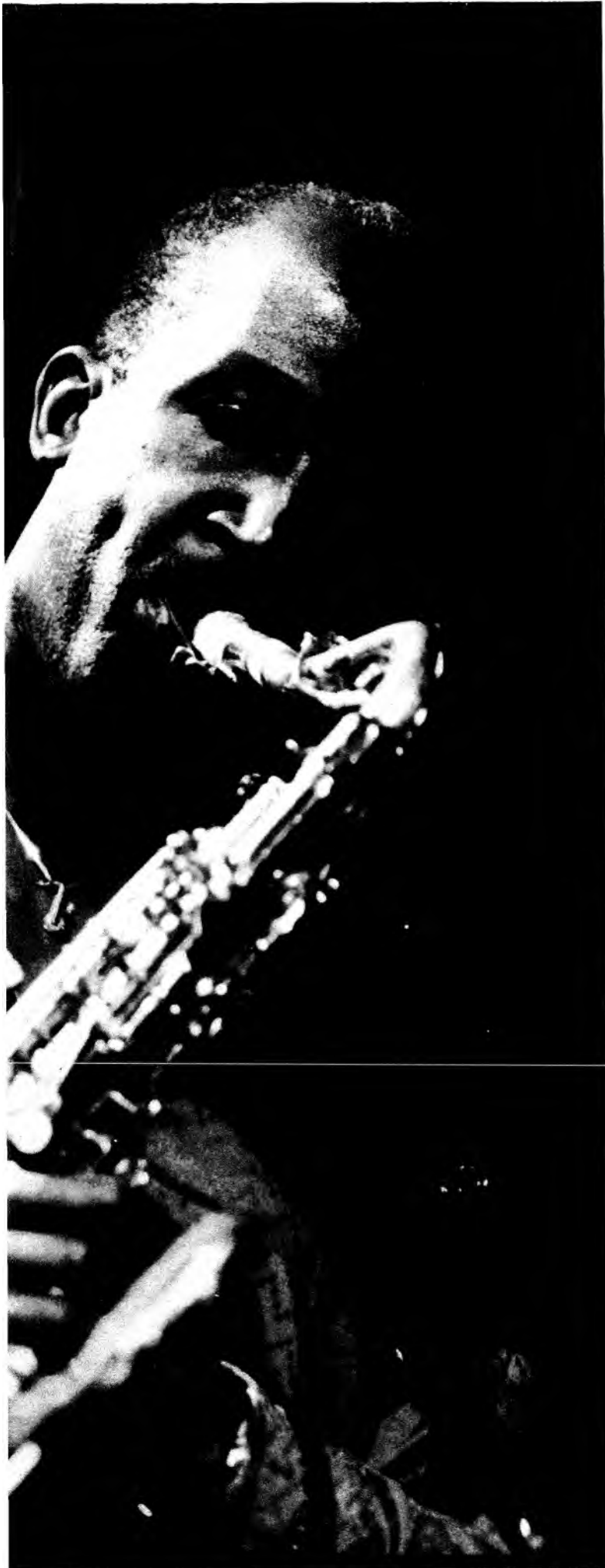

*How did you first get into playing?*

I have a brother who use to play. I saw him play when I was about eight years of age. I became interested after I saw him and he gave me my first horn, a Holton alto. I picked it up and began to play it so I joined the Junior High School band. That's where I met Stix Hooper, the leader of the Crusaders. He invited me to play in the band he was starting and it continued from there. So I must have been about nine when I first started playing, and I was about 10 or 11 when we got together. That means I've been with the Crusaders for 27 years.

*Was the band always called the Crusaders?*

We went through various name changes. The only one that stayed for a while was the Modern Jazz Sextet, when we were in Senior High School in Houston, Texas. When we got our first record contract in California in 1960, we'd work jazz. That's when we came up with the name Jazz Crusaders because we wanted a name that signified what we were trying to do. The name seemed to indicate we weren't so concerned about having one individual out front because we recognised the strength of a unit. We came up with Jazz Crusaders and it's now down to just the Crusaders.

*When you were learning sax, were there any things that made a big difference to you – when you said, "Ah, now I understand it"?*

I can't remember any particular discoveries that I made that were outstanding. I did notice myself improving and becoming more familiar with the instrument, in different ways to approach things. The biggest discovery I made was that I had in me the ability to create – that was the most outstanding discovery.

*How did you relate to the sound of the instrument?*

I don't think that when I started sound even came into the picture. It was just fun and I wasn't critical or analytical about the music. In later years as I progressed I recognised the need to have "a sound".

*When did you switch from alto to tenor?*

I switched to tenor when the group ended up with six players. Hubert Laws was playing alto and flute and there wasn't any sense in having two alto players, so I switched to tenor. In Texas, where rhythm and blues is quite popular, all the bands had tenor players who would solo more than alto players. I had my father buy me a tenor. My first one was a 1955 Selmer. The tenor I have now is a King Super 20.

*How did you sort out a mouthpiece?*

I just played the stock mouthpieces until I became familiar with metal mouthpieces. I checked with other guys and found what they were playing. I noticed certain guys had bigger sounds so I tried the Otto Link but it didn't do for me. I liked the ease of getting the horn over but it wasn't strong enough to project over the guitarist, so I tried a Berg Larsen. It allowed me to play loud and compete with the guitarist so I stayed with the Berg Larsen. I still use it but the one I use now is a 105/0 with a medium reed. I used to play a 130/0 but I was killing myself. I even played with a number five reed for a bigger sound but that was overworking myself. Later, as I progressed, I could get the sound I wanted without a bigger opening and stronger reed.

*How did you develop your harmonic register?*

Mostly from hearing and listening to other guys playing. I bought method books that showed fingering and talked to other guys about how to do it and experimenting – that's about it. I bought a book by a guy named Armstrong in Texas quite a few years ago. ▶▶



*"I would rather hear someone else play soprano than me"*

►► *How long did it take you to develop control of the whole harmonic range?*

I can't really put it into a period of time. I practised it for a year or so to find out what I could do with it and then to decide what I wanted to do with it. Knowing where it is and what to do with it are two different things as far as I'm concerned.

*It's a very characteristics part of your playing, these harmonic things that you throw in.*

I don't think about it when I'm doing it. When I play, I try not to analyse what I'm playing as opposed to what I'm feeling at the moment of playing.

*I noticed you seem to have come back to alto.*

Alto is one of favourite saxophones. I feel a certain freeness about alto that I don't seem to have on tenor. When I'm playing alto, it feels like the weights have been lifted off my shoulders. When I put the tenor in my hands, it controls me rather than me controlling it.

*What alto and mouthpiece do you use?*

I haven't really found one that I'm satisfied with. I don't know the name of the one I'm playing now. I'm playing an alto with a stock mouthpiece because I haven't really played it long enough to settle in to a mouthpiece.

*How about soprano?*

I am playing soprano more than I have before because I think other saxophones are good as a variation and needed for certain things. But I don't "think" soprano. I'm getting used to it now but I don't think I'll play it an extreme amount because it's not me. I'm not happy with the sound I have on soprano, I would rather hear someone else play soprano than me. I have two, a Yanagasawa and a Selmer. I use a Selmer mouthpiece. The Yanagasawa is Japanese and a very good instrument. I like its rich warm sound – I play it for variety.

*What is the electronic attachment you use?*

That is a Maestro unit. I have a Maestro phaser, a couple of flangers and a Mutron hooked up to it. I have some other electronics for special effects on songs but I don't play them often. I still prefer the natural sound of the saxophone to the electronic sound but I do want to stay apace of what is going on. There may be some way I can use it in conjunction with the band. For example, on our last album "Images" I used electronics with melodies and as another extension to make a different sound on the album.

*I got one of your albums in 1967 when you were the Jazz Crusaders and your style seemed to be more like Coltrane in those days.*

I think that Coltrane has had an influence on my life. I can't think of too many saxophonists that Coltrane hasn't influenced in one way or another. I think 'Trane began and mastered an era – a sound and a feel that will last forever. When Coltrane gained his popularity, it was an advancement period for the way

of playing. It was to everyone's benefit to at least find out how it is done. I think that for every form of music that I hear, it is beneficial for me to find out what it is, to understand it, not necessarily to copy it but see if there is anything about it that will spark my creativity. Listening to Coltrane naturally influenced me but I hope I've been able to express *me* through it. *Your style has evolved from playing a lot of notes to something much more basic. You leave a lot of notes out now that you used to put in.*

Each piece of music calls for a way of playing. If you are playing with a straight-ahead jazz feel, I would be inclined to play more notes. That feel says it's time to show technique and play more notes. The way in which we play right now does not call for that many notes. I'm more concerned now about what I'm playing, how I'm playing it and how it is coming across, rather than how many notes I'm playing.

*It's nice that you just play what's required and stick right to the basics.*

I hope that's what I'm doing, at least that is my way of thinking. Each time I play a song, I'm trying to feel what is coming to me at the moment. There was a time when I played for playing – like showing off on the horn. After hearing other guys play and seeing their maturity, older guys like Ben Webster and Lester Young, then Miles, I began to appreciate something about their playing that I hadn't grasped. That was, they could either play a lot of notes or a few notes, but in either case the feeling is there. I switched my way of thinking and freed myself to go with what I feel more than what I know will work. I don't mean to sacrifice technique because I think it is very valid. You can only play what you are able to play. Speed is valid and is needed, I would like to be able to increase my speed on the instrument. If the moment calls for me to rip through something, I want to be able to do that. If it calls for being slowed down and to pick out certain notes, I want to have the maturity to be able to pick out which are the right notes.

*You can learn that from a lot of playing.*

Each person has to mature and grow. We all play what we relate to and it will be different for each guy that plays.

*Do you find it hard to play a bass part to a solo you will be playing on sax later?*

It is difficult. You just know there is a space to play sax and you have to play the bass line with the same attitude. If excitement is needed, you have to do that so when the solo goes on, it will be there.

*Was Wayne Henderson playing the lives? He was in the band then wasn't he?*

Everybody did their solos live except for me – I couldn't play both instruments at the same time.

*He did the tune parts, did he?*

He would play the melody so everyone would have an idea what it would be then we'd come back and do it



together. He would play his solo live, like everybody else, except me, so there would be that feeling of everyone playing live.

*Did you have some problems in replacing yourself and getting a bass player to play live?*

Yes. There's a difference here again. You can get a studio musician to come in and play notes but it's different when you have the feeling being played. Steely Dan has a certain feel and not everybody can feel that. That's why you see on their records that they used this or that player or went through four drummers until they found the right one for a particular song. It's the same way with us. I've played with Joe and Stix for so long that when they go in a certain direction I can tell where they're going before they go. Someone else who comes into the group without that experience may not know all the different styles that we do. When it happens, they will be lost and not know what to do.

There's a tendency, too, among bass players to go with the groove, or at times for players not to realise what is making some piece of music feel good. Joe is only able to play his piano part because I'm playing this. Now Joe's piano part might feel so good it makes me want to go with him but if I go with him the feeling is lost because his part was played as a counterpoint to mine. Quite a few musicians have yet to realise that we look at ourselves as five musicians playing off one another and the songs and what is happening is like a puzzle being put together. It doesn't matter what you play as long as you're mindful of what the other guy is playing, realising that what the other guy is playing may change at any moment and go somewhere else. When he changes, you might have to adjust yours or hold yours while everyone else adjusts. It's those things that take years of playing together and the majority of bass players that we've played with had no idea about it. Therefore it became necessary for me to step in and play bass.

*I noticed you played bass on Marvin Gaye's album, "Let's Get It On".*

Yes, I've been doing some studio work on bass with a lot of different people.

*Do you find you do more sessions on bass than sax for other people?*

Yes. That's deliberate. I refuse to play sax for anybody else. My sound is the sound of the Crusaders. It's special and I think it should be reserved for the Crusaders. For me to play sax on somebody else's album and spread it around would dilute the Crusaders. If anyone wants to hear me, for whatever talent I may have or whatever causes people to listen to me, I would like them to come and hear the group to hear me. I deliberately do not accept dates on saxophone.

*Do you just put the songs down in a spontaneous way, get them together in the studio?*

The only thing that is put together, worked out, is the melody. We have an idea of what goes where but what happens in the inside of the song as we are recording it is what we look forward to in the studio.

*Do you use any special techniques in the recording?*

It's no particularly special technique but we know what we want. We've worked with a particular engineer, Rick Pekkonen, quite often and he knows what we should sound like. It's a matter of relating to him. We'll put something down and go inside and listen and if it's not what we want we'll say "let's make an adjustment here" until we come up with what we want. We also recognise his ability to hear and suggest. Whoever has the idea that is the best thing going at the time, we'll go with him.

*When Wayne Henderson left, why didn't you get another trombone player?*

Simply because it would no longer be the Crusaders. The Crusaders are a sound and they are also the individuals. The Crusaders are six guys, Stix Hooper, Joe Sample, Hubert Laws, Wayne Henderson, a guy by the name of Henry Wilson and myself. To bring someone in from the outside, no matter how great a musician he was, he could not know the 25 years of experience that we've lived through and felt, to come in and replace Wayne. The sound of the group within which we grew up is just inherent in us.

*Do you have personal methods for practice?*

I probably should but I don't. My method for practice right now is really to become stronger so that I can physically play the instrument better and be able to get the instrument over better. I'm trying to free my mind of all that I know and not play what I know. If I can't play what I know, I'm forced to create.

*When you say physically strong, do you mean from blowing the horn or strong from lifting weights?*

Strong from lifting weights, of having my hands free to do what I want them to do. I think I have reached the point now where I am at another level of practice. My hands have been on automatic pilot and now I've got to take them off automatic pilot and say "I've got control of you again." What I want them to do now is contrary to what they've been doing for the past few years.

*That's a nice point. I think everyone needs to check himself when he just plays the same old licks.*

That is the most boring thing in the world to me, playing the same old licks. I can think of only one musician who I have always respected because he is always fresh — a saxophonist named Wayne Shorter. It seems he's always creative whenever I hear him, always playing in harmony with what is around him. He plays the song. I think that it is important for musicians to play the song and to feel what the song is saying and what it should be. That's what I'm trying to do.

*Do you have plans for a solo album?*

I have already recorded a solo album. I understand it has just been shipped here, it's called "We All Have A Star". It should be released in the UK pretty soon.

*How do you see the Crusaders of the future?*

I see them progressing, ever striving to be at the focal point of what is going on in music, honest and sincere in what we do, striving to be creative and always mindful of showing deep appreciation to our audiences, those that come and see us or those who just listen. We greatly appreciate the privilege of having something to contribute musically, so we try to keep and make available the highest quality possible.

## Perfectly Balanced Strings

Our new *perfectly balanced* acoustic bass strings, with their unique hexagon cores, are not only considered the finest in the world, but they were also designed in conjunction with the top acoustic artists to be versatile for use with any type of music.

That's why Ron Carter, Downbeat Reader Poll's No. 1 bass player, prefers La Bella's *perfectly balanced* strings.

You can hear Ron Carter play these strings on his new hit album, Ron Carter Quartet—"Piccolo"—Milestone M55004. They come in two types: flat metal wound "Deep Talkin' Bass #7700" and nylon tape wound "Deep Talkin' Bass #7710"; and available from piccolo bass to full size bass. No matter what style you play, our new *perfectly balanced* acoustic bass strings are right for your music. E. & O. Mari, Inc., 68-01 23rd Avenue, Long Island City, N.Y. 11105.

**Ron Carter uses  
the best strings  
in the world.**



**E&O  
Mari**





# electro-harmonix

27 WEST 23RD STREET, NEW YORK, N.Y. 10010 (212) 741-1770

## ALL NEW STATE-OF-THE-ART PRODUCTS

DIAL (212) 741-1797, (212) 741-1799, AND (212) 242-7799  
FOR THREE DIFFERENT AUTOMATIC DEMONSTRATIONS



### THE \$5,000 SOUND

Now the amazing musical speech of the vocoders used on recordings like Electric Light Orchestra's "Mr. Blue Sky" and the Sergeant Pepper's Lonely Hearts Club Band soundtrack can be obtained for incredibly less than the \$5-20,000 it has previously cost. The Electro-Harmonix VOCODER modulates voice input with an instrument signal using two matched sets of 14 finely-tuned active filters covering the vocal range. The result is the same clearly intelligible effect of the gold-plated units. With our VOCODER, mike, and organ or synthesizer, you can achieve huge choral sounds. Or you can experience the greatest talking guitar you've ever heard—with no tubes, pedals, or wiring headaches. Any wide-range instrument with a VOCODER can transpose voice into any key.

Joining the EH-200 SLAVE AMP as the first in a series of rack-mounting audio processors, the VOCODER shares the same imposing styling, exacting design, and top-quality components. While a natural for the small to medium-sized studio, the E-H VOCODER at last brings vocal processing potential to the performing environment. You must hear this cost engineering breakthrough to believe that such fantastic sound is available for so little! Call our demonstration line (212-741-1799) today!



### ULTIMATE ECHO WITH CHORUS

The response to our Economy and Deluxe Memory Man solid-state analog echo/delay lines has been tumultuous. Musicians all over the world have found these compact, foot-switchable units the answer to their needs for a highly versatile, zero-maintenance device. Now we are proud to introduce two companion models with even greater audio quality and added CHORUS capability.

The MEMORY MAN Echo/Chorus of course retains widely flexible delay, repeat, and blending functions for infinitely repeatable arpeggios, "slapback" echo, vocal doubling, "bathub" reverb, and more. But it sparkles with greatly improved S/N ratio and distortion specs and better frequency response. The Chorus is pre-set for optimum fullness and musical tone.

The MEMORY MAN DELUXE Echo/Chorus/Vibrato has all the features of the standard Deluxe model, including companding circuitry and input clipping control for immaculately clean sound. The specifications for distortion and bandwidth on the standard Deluxe have been pulled up to spectacular levels on the Echo/Chorus also. In addition to variable Chorus, wide-range true Vibrato is available.

Our Memory Men have always been the ultimate in affordable analog delay. Now the Memory Men with Chorus are more ultimate!



### TUBE AMP OVERDRIVE

Ever since the more efficient and reliable transistor amps began replacing tube models, guitarists have been trying to recapture the gutsy voice of scorching vacuum tubes. Now HOT TUBES finally restores the complete range of tube characteristics: the full-bodied vitality rich in even harmonics; the smoking, infinite sustain; and the slicing attack presence. The snap and juiciness are preserved at all settings from mellowest to most piercing. Excited reactions to HOT TUBES have included, "It's a Mesa Boogie in a box!"



### MINI-MIXER

The ultra-compact Electro-Harmonix MINI-MIXER provides just the features needed by the club band or home recordist. Four individually mixable, high impedance inputs allow good power transfer for all microphones, with more than enough gain to compensate between different mike outputs. Also perfect for a precise and variable blend of multiple accessories. The Input and Master Volume controls are high-grade, smooth and quiet slide pots. Yet the MINI-MIXER is available at leading music stores for the usual rock-bottom Electro-Harmonix prices!



### FULL DOUBLE TRACKING EFFECT

Studio-style doubling and slapback echo perfected for performance! The FULL DOUBLE TRACKING EFFECT is clean, quiet and responsive with a wide range of instrument or voice signals. Doubles parts for greater fullness. Opens up the acoustics of small clubs. Repeats can be tailored with selection of 50 or 100 millisecond delay and blending of delayed and original signal.



### POWER WITH PURITY

The Electro-Harmonix 200 Watt SLAVE AMP provides the solution to nearly every power amplification requirement. Its highly innovative tetramodal operation, switching between A, AB, B, and C amplifier classes, allows the amp to be extraordinarily light, compact, efficient, and economical for its power output—200 watts rms and 375 watts peak for clean reproduction of the loudest musical transients. The SLAVE's non-sparing, complementary symmetry design creates true high fidelity characteristics, and the complete protective circuitry makes the amp virtually immune to electrical damage. The SLAVE can be driven from PA mixers, monitor stands, hi-fi preamps, and even the power output of instrument amps (i.e., the external speaker jack), thus preserving the warm responsiveness of these lower power amps. Housed in a sleek, strikingly original chassis, the SLAVE AMP is truly the universal power amplifier.

#### SPECIFICATIONS

POWER (to 4 ohm load): 200 watts rms, 375 watts peak  
FREQUENCY RESPONSE: 40 Hz-20kHz ± 3dB  
HARMONIC DISTORTION: Less than 0.2%  
SIGNAL TO NOISE RATIO: 90 dB  
INPUT SENSITIVITY (for full power output): 1.0 vrms

### THE MICRO-SYNTHESIZER

The MICRO-SYNTHESIZER creates many of today's most popular lead synthesizer voicings at a fraction of the normal cost for such capabilities. In addition, it is a powerful processor of basic guitar sound. Its four voices—Guitar, Octave above, Sub-Octave, and Distortion—are completely independent and continuously mixable. The MICRO-SYNTHESIZER modifies these signals with envelope control for "bowed" and "blown" sound, and with particularly potent filtering featuring highly variable sweep options—the key to exact synthesizer simulation. The sweep can be de-selected for variable frequency filtering, and the Resonance control sets the sharpness and boost of the filter.

The Trigger slider permits exact adjustment to individual playing style, and also creates the possibility of playing lead lines with filtering against softer unfiltered chords. Moreover, a special preamp gain trim can be calibrated by the user for perfect matching to any pick-up output. Steel guitar, organ, and violin simulations (detailed in the instructions) are just a few of the multitude of possible effects. The introduction of the MICRO-SYNTHESIZER means that, without mortgaging your home or surrounding yourself with a wall of electronics, you can rise above the inherent limitations of guitar to broader horizons of sound.



### BASS POWER

Now there's BASSBALLS, an accessory designed especially for bass guitar—created to explode the bass into the bigger sonic dimensions enjoyed by the lead guitarist. BASSBALL's two sweeping, dynamic filters, responding sensitively to attack variations, are critically tuned to the deep, masculine vocal resonances. And no bass with any amp has ever had so much rich, harmonic power. The bass player with the macho of BASSBALLS is like Clint Eastwood with a 357 Magnum. You know people are going to pay attention! P.S. Paul McCartney bought the first one!



### FIRST FUNKY RHYTHM BOX

A trap set in a package scarcely larger than a pocket calculator! Large Scale Integration makes it possible at an unheard-of price. The RHYTHM 12 offers a full dozen patterns, all realistically and dynamically voiced. The Rock patterns, especially, throb with a cooking groove never before produced by a rhythm unit. Also featured are Latin, Reggae, and ¾ beats. The unique Start/Stop touchpad always brings in the rhythm selected at the top of the beat. Wide range Volume and Tempo controls are included, and high output level ensures good volume with the smallest amps.

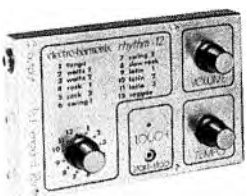

### ELECTRONIC METRONOME

The Electro-Harmonix ELECTRONIC METRONOME is an extremely compact, easy to use (plugs into any amp) timekeeping device which features both a greater tempo range than is generally available in a metronome, and a choice between a crisp click or a deep thump. Digital IC precision for less than the cost of a mechanical metronome!



# TOMORROWS

# Ibanez®

While most guitar companies are resting on their past accomplishments, there's a new name in guitars that has set its sights on the future — Ibanez. At Ibanez, it is our philosophy that guitarists should be able to enjoy the latest advancements in the guitarmaking art, without spending an exorbitant amount of money. We achieve this through a close relationship with many musicians, professional, amateur and in between, and by choosing features of honest value, not fad or flash. From this philosophy come the guitars on these pages — they're tomorrow's guitars as we see them today.

## TRI-SOUND



Background: The top of the line Musician MC-500 — the ultimate solid body. The carved exotic wood body is a wonder to behold. The two Super 88 Tri-Sound pickups and EQ Tone System are a marvel to play. The Tri-Sound switches allow you to select either pickup as a humbucking, single coil, or reverse phased humbucking in any one of 15 combinations. The EQ Tone System gives you  $\pm 15$  db of gain in three frequency bands plus an overall boost of  $\pm 15$  db for nearly any sound you can imagine. This is a guitar you simply have to try.

The new Musician Series showcases our latest advancements. The maple and walnut neck runs the entire length of the instrument for rigidity and sustain. With optional extras like Super 88 Tri-Sound pickups and the exclusive Ibanez EQ Tone System, the Musician is the most versatile electronic guitar you can buy.

# NAME IN GUITARS



## SURE-GRIP KNOBS

The Ibanez Sure-Grip knobs feature a special contour and a ribbed rubber insert for no-slip performance even the going gets hot and sweaty.

## GIBRALTAR BRIDGE AND TAILPIECE

After adjusting, the bridge and tailpiece can be locked rocksolid to the body for consistency of intonation and sustain.



The Ibanez Iceman is rock and roll. The bold body shape and Super 80 pickups make the Iceman hot in both looks and sound. Available in mahogany, maple or ash, the Iceman gives you more rock per buck than any guitar in its class.

The Concert Series is new and better balanced update of traditional concepts in a reasonably priced package. The body is mahogany with a carved rock maple top for great sustaining power and brilliance. The Super 80 pickups combine with the body construction to produce a bright, clear tone, rich in upper harmonics.



The Ibanez Performer Series offers a wide selection of features and finishes at a moderate cost. The Performers feature our famous Super 70 pickups and the Ibanez Gibraltar lock-down bridge for starters and are available with Tri-Sound pickups and carved maple tops.

For a catalogue of the 1978 Ibanez electrics, clip this coupon and send 20p to:  
Summerfield Saltmeadows Road, Gateshead, NE8 3AJ

Name

Address

City

# Hondo

comes

# ALIVE



with

# DiMarzio®



HDDCS



HDFS-3N



HDFP-2

You know the sound you're looking for. Whether you want bright piercing highs, a powerful midrange, or soft mellow tones, the HONDO/DiMARZIO guitars and basses deliver. They come alive with the sound versatility and power you should demand in a guitar at any price — and the price you pay for a HONDO/DiMARZIO could be your most pleasant surprise. Models from \$235.95 to \$349.95 (suggested list).

*International*  
Music Corporation

P.O. BOX 2344 FORT WORTH, TEXAS 76113

# Celestion Horns give your systems ahead start

Celestion Horns are top quality, precision manufactured loudspeakers. They offer reliable backing for heavy duty systems, especially those using Celestion cone speakers, and give maximum performance for prolonged periods without deterioration.

## **MH1000**

A 25 watts horn with a great reputation reflected in its use in a variety of equipment around the world.

## **Hi Cel.**

Is a variation on the MH1000 theme, using two of those units on a specially designed casting, giving a 50 watts system handling capacity.

## **MH500**

This cast horn is available with single or twin throats, accepting Celestion DC25, DC50 and DC100 drive units. Using the twin throat with two DC100 units, a power handling capacity of 200 watts is available.

Principal distributors to the trade:

A. C. Farnell Ltd., Sheffield, England. Norman Rose (Electrical) Ltd., London, Birmingham, Manchester, England. Lugton & Co. Ltd., London, England.

**Celestion**



**Rola Celestion Limited,**  
Ditton Works, Foxhall Road, Ipswich,  
Suffolk IP3 8JP, England.  
Tel: Ipswich (0473) 73131.  
Cables: Voicecoil Ipswich. Telex: 98365.



# Guitarcheck

**Aria A80-7**  
**£288 inc VAT**

Generally speaking, most instruments come to me for review on loan. Occasionally, I review instruments of various ages as they pass through my workshop, either because they are not easily available in new condition, or because I feel it may be interesting to see how well, or poorly, they are standing up to reasonable wear and tear. This instrument arrived on the pages of IM by a different route. I saw it at the Trade Show and bought it for myself. It later occurred to me that if I found it interesting, perhaps other people might also be interested. It was offered for sale along with other production guitars, and although more instruments of this model are available, I suspect this one may be a prototype, or possibly one sample from a very limited first production batch. It seems to have been the only one in the country at the time I bought it; also there is no serial number written in the appropriate space on the label. I had a word with Shiro Arai, of Aria, who confirmed that this seven-string guitar was a new development for his company. If it is successful, he also plans to introduce eight-string and possibly nine-string versions.

Classical guitars with additional strings have been around for some time. For example, there is a photograph of José Lopategui playing

---

*Stephen Delft is a maker and repairer of guitars and other instruments, and a member of the Institute of Musical Instrument Technology. He is also a capable performer on the guitar.*

what appears to be a 10-string guitar in the back of the new Daniel Mari classical guitar string packet. I believe I have also seen a photograph of Narciso Yepes playing a guitar with 10 strings. The classical guitar has almost been standardised as a six-string instrument but there have been several experiments with alternative stringings, and there are also the early precedents of the Russian seven-string guitar and, of course, the members of the lute family.

As far as I can ascertain, most experiments so far with extra strings on classical guitars have concentrated on adding these strings to the bass end. I have no exact information on the tuning, but D and/or B or B-flat below the usual bottom E would seem to be useful possibilities. This assumes that the standard tuning for the upper strings is retained. The Aria A 80-7 was fitted with what appeared to be a set of medium-heavy single-course lute strings, or half a set of double-course strings, if you prefer it that way. (I know the top string on a lute is single, but many sets of lute strings sensibly include two of everything). I questioned Mr. Arai about this, and was told that although the instrument would accept other strings and tunings, it was intended for lute strings, and lute music. I suspect that hands, principles and charred copies of IM will be thrown in the air at the next AGM of the Lute Society and I suppose I would have to agree. A guitar with six strings, eight strings, or even eight pairs and

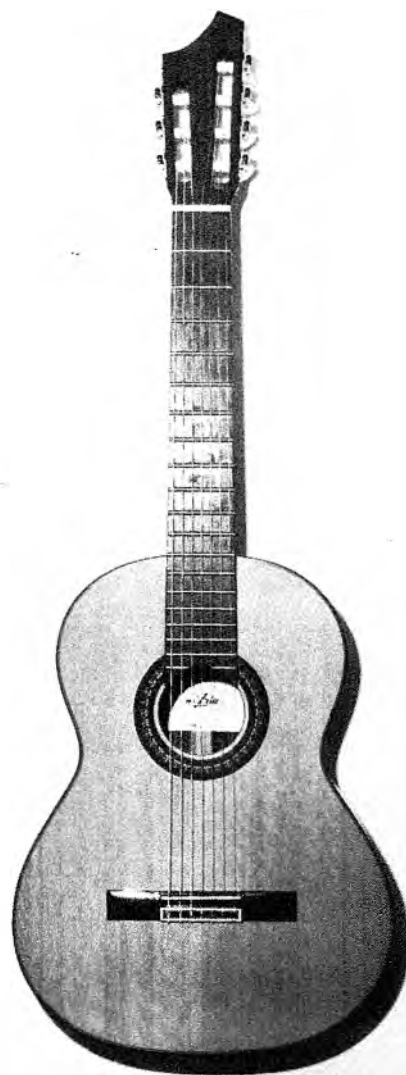
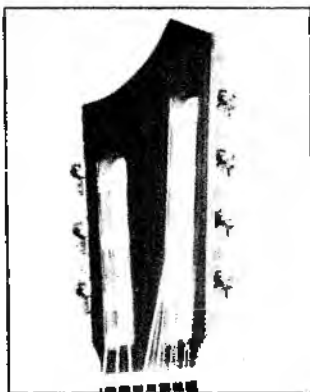

a single, is not a lute. One might as well perform music written for any early square piano on a modern grand. Of course, many people do just that, and although it is better to hear the music on a modern instrument than not to hear it at all, I still prefer pieces composed on old instruments to be played on old instruments. However, many classical guitarists who play using their fingernails have difficulty with the double stringing of lutes, and it may be more sensible for them to play lute pieces on a single-strung instrument.

**A**lthough lute tunings vary, g', d', a, f, c, G, F or D seems fairly representative for a seven-course instrument, and works well with the strings supplied with the Aria. It may seem very different from guitar tuning at first sight, but it is roughly equivalent to a standard guitar with an extra high 'a' string on top, and the whole instrument then dropped in pitch by two semitones. Ignoring intervals between strings, fingering and simple chord shapes are just about the same as on guitar. I have used this tuning on various instruments for many years, and in some ways I find it more useful than the standard guitar tuning.

The Aria A80-7, apart from its extra string, is a fairly good example of a Japanese classical guitar in the range above about £150 and below the cost (and quality) of the sort of guitar which comes from an internationally-famous small maker and usually costs more than £500 wherever it is made. The back and sides are of laminated construction, made wholly or partly of rosewood veneers. The soundboard appears to be a light-coloured cedar and is solid, not laminated. It carries inside one of the more complex modern strutting patterns which has recently appeared inside production guitars from Spain and Japan. One could make some interesting speculations on the speed with which fashions in internal construction spread throughout the world. I cannot say whether this particular soundboard strutting gives any particular tonal advantage, but my own A80-7 seems to be playing in very nicely. It still seems a bit weak and reedy on the fourth string (in this case, the thickest plain nylon string) but all other strings have a pleasant tone and remarkable volume. Apart from the fourth, there is a gradual transition between the "reedy" basses and the sweeter and "flutey" treble strings, which I personally find very pleasing.

The neck appears to be mahogany: it is fairly thick (and of course, wider than usual) and nicely shaped in the "rectangular" rather than "crescent" style. I like necks with almost a flat on the back, although I believe some players find them rather bulky and prefer more of a crescent shape. I think that the sort of guitarist who is going to pay £288 for a distinctly non-standard instrument can safely be left to decide whether he likes the neck.

There are three features which the A80-7 seems to have inherited from its six-string Japanese brothers. First, the inlays around the body edges appear to be plastic. Secondly, these are not improved in appearance by the yellow tint which has been applied to most of the guitar in, or under, the lacquer. Thirdly, the front face of the rosewood fingerboard has

been stained black, presumably in a simulation of ebony. All three of these features are fairly common on production classical guitars of various makes.

My sample of this guitar was supplied nicely adjusted and plays acceptably in tune with the maker's strings. These are of good quality, and do not yet require replacement, but I would expect the guitar to perform just as well with similar strings of other makes. Spare strings could be a bit of a problem, as most sets of lute strings are thin and operate under low tension. This is appropriate for a lightly-built lute strung with pairs of strings, but such strings may not be suitable for this review instrument. I have a smaller eight-string instrument with a similar tuning, and I rely on a stock of La Bella medium gauge strings bought some years ago. I don't know whether these are still available. At the time, La Bella supplied several gauges of lute strings but the labelling was ambiguous and I believe the gauges changed at one point. I am sure Gigsville, the UK importers, would be happy to arrange a supply of spare strings from Aria, if necessary. Alternatively a set of low or medium tension guitar strings with a lute top g' should work.

### Conclusion

Overall, I am rather impressed with this instrument. The few cosmetic features which displease me are found in most Japanese production guitars, and they have no bearing on tone, playability or reliability. It is neatly made and accurately adjusted, and it has given me much pleasure and some new musical ideas. It should be of interest to guitarists who would like to play some lute music (especially from tablature) but who do not get on with lutes or their rather different playing techniques, or who do not wish to buy or transport both a guitar and a lute. Alternatively, you could consider it as an extended classical guitar, and tune and string it almost any way you wish. One possibility would require a standard set of classical guitar strings with a duplicated A or E string fitted between the usual positions of fifth and sixth, and tuned to G. It is a versatile instrument, and an interesting one.

For anyone wishing to experiment with tunings: on a scale of 657mm, a La Bella light lute 1st string will probably break just above g-sharp. This means that it will work tuned to g and still have a small safety margin. If you try to tune it to a it will either break or have an impossibly small safety margin. Thinner strings will not help. The limitation is the relatively long string length.

#### Measurements on Aria A80-7

Scale length 657mm

String spacing at bridge 64mm (53mm between strings 1 and 6)

Fingerboard width at nut 56/57mm

Depth of neck/fingerboard at first fret 24mm

Depth of neck/fingerboard at ninth fret 24.5mm

Action as supplied 4.5mm treble/5mm bass (This could easily be lowered to 3.5/4mm by adjustment to the bridge saddle, if required)

# Guitarcheck

Peavey T60  
£292.08 inc VAT

Peavey have apparently spent several years developing this guitar before they offered any for sale. Even then, they made only small quantities and sent them to areas whose climates are known to be unkind to musical instruments. Only when the first instruments had survived this test were larger batches made for general distribution. I appreciate this sort of caution, and I think if Peavey are intending their new guitar to have a reputation for reliability, they are going the right way about it.

I was told some time ago that the new Peavey guitars and basses were being made largely with the help of computer-controlled machines. I appreciate that many electronic equipment firms are using such equipment, but there is a difference between wiring circuit boards and making guitars out of a material as variable as natural timber. I must admit that I was quite prepared to be asked to review some sort of technological monster. I was very pleased that, although the methods of production may be space-age, the instrument itself is a simple, attractive and fairly conventional guitar.

It works well because its design is appropriate for its intended function, and because it is accurately made. In spite of what one hears about carbon fibres and tungsten carbide frets, the conventional sort of guitar construction still works very well if it is made properly. The trouble is that not many of them *are* made properly. Obviously I cannot be certain that every Peavey guitar will be as good as this one, but I do know that my sample was taken at random from a production batch and is certainly a very nice instrument.

Of course the artistic design of the guitar is modern and original and the electrical system includes one or two things like coil taps and a phase switch which have become rather popular on de-luxe or specially-made guitars.

However, there is nothing gimmicky about the basic construction and you are not going to need a 20-page instruction manual to tell you how to play it.

The T60 has a two-part maple neck finished in clear gloss, and an ash body with a grain-enhanced hard, matt finish. Unless you have your heart set on a shiny guitar, this really is one of the most sensible ways to treat ash. The result looks pretty and feels nice to the touch. There is no separate fingerboard on the neck: it is formed from the front of the neck in the same way as on some Fender guitars.

The truss rod seems to have been installed before the two halves of the neck/fingerboard were glued together, and the adjustment end includes a neck-tilt adjustment. Such arrangements are usually even less rigid than the standard bolt-on neck joint. But this neck seems to be fastened on solidly. I am reluctant to take it apart to find out how it is done, because I strongly feel that such things should be left alone once they are set correctly. The instruction book does explain that the height adjustments at the bridge should be used only to set the "curve" of the string heights to suit the fingerboard and to adjust *relative* action heights. It is recommended that the neck tilt adjustment is used for any large alterations in action height. This is not the way most guitarists would raise or lower the action on a guitar, but I would suggest that you follow the makers' advice.

The machine heads are one of the less common "mini" patterns from the Japanese Gotch Gut company. They seem a bit loose without the strings, but they work very smoothly with the strings fitted and under tension. The bridge and string supports appear to be cast Mazak alloy or something similar with a heavy chrome plating. This is entirely satisfactory for the heavy bridge base, but it may not be so good for the bit which supports the strings. With some makes of guitar, the plating wears through quite quickly and the string tone and sustain begin to deteriorate. Plating onto die-casting alloy is far from easy. I suppose the long-term performance of these string supports will depend on the care, processes and materials with which they have been plated. Time will tell, but I would have rather more faith in stainless steel or heavy nickel plate on cast iron or hard brass.

As with some other recent guitars, the back edge by the head shows a solid-looking thread and a brass nut of adequate dimensions. Once again, it is a well-tryed arrangement, with some slight modifications for greater efficiency. The final test is to find out whether the neck is stable and easily adjusted to suit different string gauges. In this case, the neck seems to be stable so far; it *is* easily adjusted, but it does not seem to *need* any adjustment for the normal range of lightish electric string gauges. This is coming very close to an ideal electric guitar neck. In addition, there is something rather strange about the shaping of the neck and fingerboard. It *looks* like a standard maple neck/fingerboard but it feels more comfortable than usual. I have fairly thick fingertips and I am usually happier with a relatively wide fingerboard. This one is about 43mm wide at the nut, which is within the usual range of about 41 to 43mm for electric guitars, but I definitely felt that my fingers had more freedom of movement than usual on similar instruments. There is no magic to this. It must be a result of the shape of the fingerboard and the back of the neck, but it is certainly a very clever bit of work. I felt that I should ask for another opinion on this neck, so

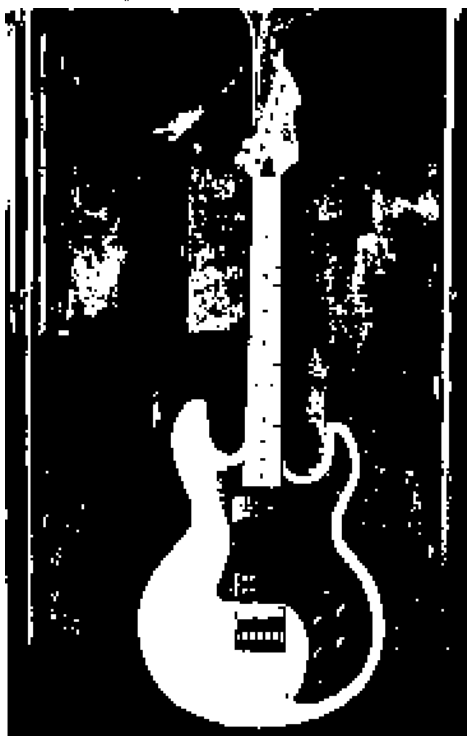
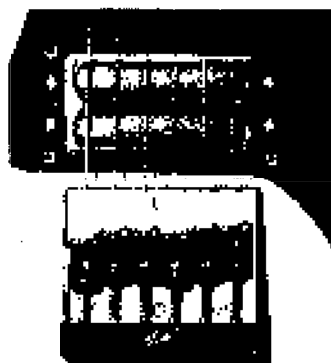



I offered the guitar to one of my most discerning customers, who also said that it was very comfortable. Now, he has thin fingers and small hands, and usually likes very thin and narrow necks. Between the two of us, it would appear that this guitar is likely to suit most sizes of hands.

The neck is bolted to the body, and although this can result in an uncertain fixing, in this sample I cannot move the joint at all by hand pressure. This is surprising, because the neck joint assembly is raised and can be used as a hand rest when playing near the bridge. For this purpose, I would like it better without the relatively sharp corners.

One nice touch is that the strap button by the cutaway is counterbored into the curved wood surface so that it fits properly. These strap hangers take a lot of wear, and this is typical of the detailed thought which has gone into this guitar.

**T**he electrical system is fairly straightforward. Peavey claim that it is unique and that a patent has been applied for. It is a good and useful system, but it is not unique. Different parts of the Peavey system have been in use for some time on other guitars, and in the instructions provided with certain replacement pickups. I have used these features myself on occasions over at least the last five years, and I am sure I am not alone in this respect. However, this in no way criticises the quality or versatility of the T60 guitar. The internal cavity is thoroughly screened with metal foil, and only high-quality components have been used.

There is a miniature 3-way selector switch, a phase change-over switch and each pickup has volume and tone controls. Between settings 7 and 10 on each tone control, one coil on the appropriate pickup is steadily faded out, giving a sort of "variable coil-tap" effect. This extends the treble range of the pickup and control combination, although between settings 8 and 10 the pickup is rather more susceptible to induced hum. At these settings, pickup hum is now worse than on guitars with single-coil pickup units, and the additional tone range should really be considered as an extra. You still have normal hum-cancelling operation, and practically the full range of tones between settings 7 and 1 on each tone control. When both pickups are switched on, the phase change-over switch operates in the usual way, allowing for a hollow sound when the volume controls are balanced against each other correctly, and intermediate tones when one pickup is set louder than the other one.

When the treble pickup is selected, and the tone control is in the "enhanced treble" range, between about 8½ and 10, there is a slight change in brightness of the tone as the phase switch is operated, probably because it changes the position of the dominant coil in the pickup. The effect is similar to that of moving the bridge pickup a little nearer to the bridge:

there is a slight change in the balance of harmonics. It is not very obvious when put straight through an amp with average settings, but it could be more noticeable if you normally use treble boost on the amp, or an effect such as a phaser or flanger.

On the subject of electrical details, both the volume controls have compensating circuitry so that the tone quality remains fairly constant as the controls are turned down. As stated in the instructions, best results are usually obtained with the volume controls fully up, but this is not always possible, and the compensation certainly helps.

### Conclusion

This is an accurately and solidly made guitar, with a very good neck and fingerboard. The overall tone is, on average, brighter, warmer and less "muddly" than one usually expects from modern American solid guitars with humbucking pickups. It has a fairly simple control layout combined with a relatively wide tonal range, and it seems a useful sort of instrument that is likely to please a wide range of players.

It is important to note that the price includes a good, tough fitted case, and that the combination of guitar and case is surprisingly small and light enough to carry about easily. All decent American guitars are expensive compared with UK musicians' wages, but relatively speaking, this guitar offers outstanding quality and comfort in playing for the price asked. (One would expect to pay that price *without* a case.) The guitar's sustain beats almost anything else I have tried for legato playing.

On the debit side, I prefer electric guitars "voiced" with a bit more middle, and if it was mine, I would file the corners off the bridge base. Also, that deep double cutaway is effectively not quite as deep as it looks. Behind part of it is the neck joint, and the end of that also has sharp corners. The body obviously has to end somewhere, but couldn't it be rounded over a bit?

The switches on this guitar are undoubtedly of high quality, but their operating levers have relatively sharp corners and similar switches can be broken fairly easily if the levers are forced sideways. I would prefer stronger and shorter operating levers, either rounded or with soft plastic covers to protect the side of the player's hands.

#### Measurements on Peavey T60 guitar

Scale length 650mm  
String spacing at bridge 54mm  
String spacing at nut 34mm  
Fingerboard width at nut 42.5mm  
Depth of neck at 1st fret 18mm  
Depth of neck at 12th fret 22mm  
Depth of neck at 15th fret 27mm  
Action as supplied 1.5mm treble/2mm bass

# frumf®

**it sounds new — it looks new,  
we make no comparisons,  
but from acclamation so far,  
you won't be dissappointed.**

**200watt bass amp head**



**another part of a complete  
range of band gear,  
with your frumf man now.**

**200b £140 (ex vat)**

Please send me further details of your new range

Name

Address

Soundous Laboratories Ltd, 91 Ewell Rd, Surbiton,  
Surrey, England. Telephone: 01-399 3392/3/4.  
Telex: 8951073.

SWITCHCRAFT  
HELPS YOU  
MAKE THE

# RIGHT ONNECTION



Fas-Disconnect

Audio Adapter

**Big Ugly—A Tough Guitar/Audio Plug.** An extra-rugged 2-conductor, 1/4" dia. finger phone plug for demanding jobs everywhere... amplified instruments, audio equipment in broadcasting, sound stage, open-air, etc. Easy solder connections. Conical tip to mate with 2-conductor phone jacks.

**Silent-Plug™ Stops Loudspeaker Blasting/Squawking.** One-piece finger stands up against extra tough use. Strong heavy nickel-plated, 2-piece metal handle. Easy-to-wire. Disconnecting plug from instrument closes switch and shorts out amplifier input. Loudspeakers stay quiet.

**Audio Adapters For Quick, Easy Mike Changeovers.** Series 399F adapters easily mate with standard Switchcraft "Q-G" audio connectors from 3- and/or 4-pin/contact threaded-coupling microphone connectors.

**Q-G Shorting Plugs Minimize Hum/Noise Pickup.** Switchcraft plugs connect directly to female audio receptacles to "short-out" unterminated microphone input circuitry. Protects receptacles, too. Brass housing; molded, high-input thermosetting plastic insert insulation.

**Fas-Disconnect "Q-G" Audio Cord Plugs.** Provides instant disconnect... just pull plug straight out. New series A(\*)FD mate provides excellent electrical and mechanical reliability. Choice of 3, 4, 5, 6, and 7-contact styles.

These are just five of the hundreds of Switchcraft audio plugs, jacks and connectors. Call or write us for details on the full-line of Switchcraft Audio Components. Ask for our **FREE CATALOG.** Direct all inquiries to Switchcraft's International Sales Representative:

Atlas Electronics Limited  
50 Wingold Avenue  
Toronto, Ont., Canada M6B1P7  
Phone (416) 781-6174  
Telex No.: 065-24140



Silent-Plug™

Big Ugly

Q-G Shorting Plug

**SWITCHCRAFT**  
INC.

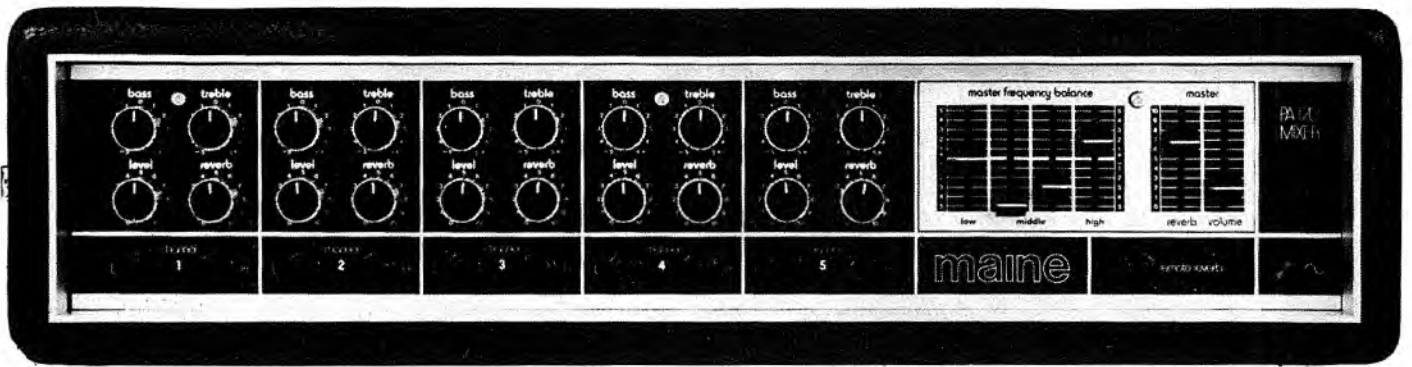

**200  
WATTS**

**5**

**YEAR  
GUARANTEE**

**RELIABLE**

Please send me the information.

Name \_\_\_\_\_

Address \_\_\_\_\_

\_\_\_\_\_

IM 12/78 **maine**

Maine Electronics Ltd, Maine House, 193 Rickmansworth Road, Watford, Hertfordshire, England WD1 7JH. Tel. Watford 45388 and 43567

# Keyboardcheck

**Roland MP600**  
**Electric Piano**  
**£655.67 incVAT**

The Roland MP600 is a compact electric piano, well finished – as you might expect from these makers – and pleasing to look at, i.e. no garish colours. It is easy to lift and has a convenient flat top for putting your synth or whatever on, or even writing reviews.

This review sample came with its own stand (for £76 extra), which is a very sturdy contraption and difficult to push over unless you are really trying. There was also a flight case (£85 extra) which was light but gave the impression of long-term fragility. I wouldn't be too worried about the stand, as I see this instrument as part of a stack resting on the organ or some other piece of hardware. Having said that, if you are looking for a competitively priced electric piano to form the basis of a keyboard set-up, you should certainly try one of these out.

The keyboard has a compass of five octaves and a minor third running from E (two octaves and a sixth below middle C) up to G (two octaves and a fifth above it). To the left of the keyboard is a Volume control and tone selectors in the form of sliders – I for "mellow piano", II for "bright piano" and III for "clavichord". To the right of these is another slider for decay time. When set on '0' the effect is similar to the mute on a clavinet. When set on '4' or '5', the result is similar to conventional piano decay. N.B. Don't confuse the term "decay" with release – the note will only sound as long as you depress it.

*Tony Hymas is a keyboard player with a wealth of experience in rock, jazz and classical music. He has played in groups ranging from the Jack Bruce Band to the London Symphony Orchestra, and is in great demand for session work.*

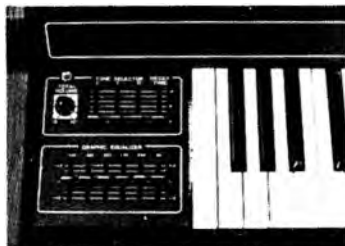

Sustain is taken care of by a foot pedal (cable connected to the rear) which you can place where you like. In passing, I would like to mention that it is a well-made foot pedal giving the impression that it won't start squeaking or falling to bits at inopportune moments.

Below the tone selectors is a six-band graphic equalizer (100,300,600Hz, 1.2, 2.5 and 5kHz) with  $\pm$  variation of 12dB. All these controls are within easy reach of your left hand. At the back of the instrument is the on/off switch, a stereo headphone jack, the output jack with a switch for high or low output, the foot pedal jack and a tuning knob which, when set at centre, gives you A440 but when rotated produces a variation of nearly a quarter-tone each way. It's a shame that this is not within easier reach because you could use it for good effect and I don't just mean keeping in tune with the rest of the band.

What is it like to play? Well, the keyboard feels great, though I would dispute the maker's claim that it is exactly like playing a "traditional piano". It's a bit lighter than that, chaps. I suppose that no amount of weighting can compensate for the absence of a piano action. Never mind – the keys depress just as far and you can really dig into it if you want, make it sing (traditional piano virtues these) and play as staccato or legato as you like. In other words, it is touch-sensitive and feels chunky and solid under the fingers.

How does it sound? Starting with all the controls flat and with just Tone Selector I ("mellow piano") faded in, you get a sound that to my ears is a bit bland. Start messing around with the EQ and things immediately get more interesting. Plug in a flanger and a volume pedal and you'll get some nice string effects. The volume pedal is essential because there is no slow attack facility. Anyway, it's a piano not a synthesizer and the only pianos I can think of offhand which have the slow attack are those that have had beer poured over them.

Selector II is, as you might expect, a brighter version of I and the same remarks apply. Selector III has a very thin quality and is best used in combination with the other two. Of course, you can mix the three selectors together as you wish. One that I really liked was with I half in, II all the way in and III out altogether. With some judicious phasing and some lightly-struck high chords you can get those harmonic chords that guitarists (bless them) so like to lay on us. If you want a sound reminiscent of a clavinet – easy! Reinststate number III, boost the low-mid EQ and add some I and II. OK, it doesn't sound *exactly* like a clavinet, but it's a good sound with a personality of its own.

And that about sums it up. There are a lot of keyboards around that, no matter what you do to them, will always remain faceless wonders. This one has a bit of character – by experimenting, there are plenty of interesting textures to be found – far more than I could go into in the space of one review. It's easy to come to terms with and I enjoyed the limited amount of time I had with it.

Both as a basic instrument or as an ancillary in a larger set-up, it is well worth a good hard look and, bearing in mind that you can shop around, it seems to me to be good value.

Tony Hymas

## PEARL "SG" SERIES GUITAR & BASS AMPLIFIERS.

"SG" Series... A line of compact guitar amplifiers of highest quality at low cost.

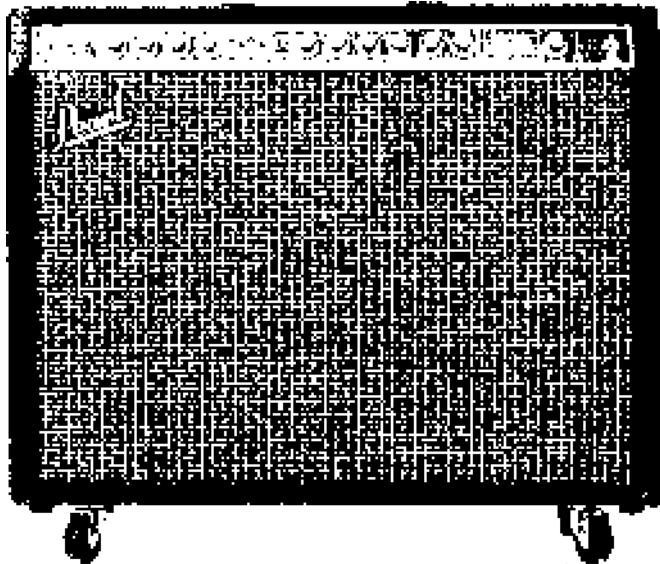

The star of the "SG" series, with 100W power and original distortion effect.

This system employs a newly developed CNF circuit. The CNF circuit produces sounds which could not be achieved with previous transistor amplifiers. It provides clear tone quality — just like tube sound. Furthermore, the distortion depth can be controlled as desired with the over-drive circuit and by employing FET.

#### SPECIFICATIONS

OUTPUT: 100W RMS, 200W Music Power  
 SPEAKER: 30cm x 2, P30-50CT  
 SEMICONDUCTOR: 13 Transistors, 5 FET, 8 Diodes  
 CONSUMING POWER: 250W  
 DIMENSIONS: H525 x W670 x D250mm  
 WEIGHT: 22kg  
 ACCESSORIES: Foot Switch, Vinyl Cover

**SG-101**



Pearl's newest compact amplifier (also suitable for use with headphones).

This amplifier embodies the best qualities of high-class guitar amplifiers in an extremely compact format. A special feature is the built-in hard distortion effect.

#### SPECIFICATIONS

OUTPUT: 30W RMS, 60W Music Power  
 SPEAKER: 30cm x 1, P30-35L  
 CONTROLS: Volume, Treble, Bass, Distortion  
 SEMICONDUCTOR: 8 Transistors, 7 Diodes  
 CONSUMING POWER: 50W  
 DIMENSIONS: H411 x W362 x D160mm  
 WEIGHT: 8kg  
 ACCESSORIES: Vinyl Cover

**SG-031**

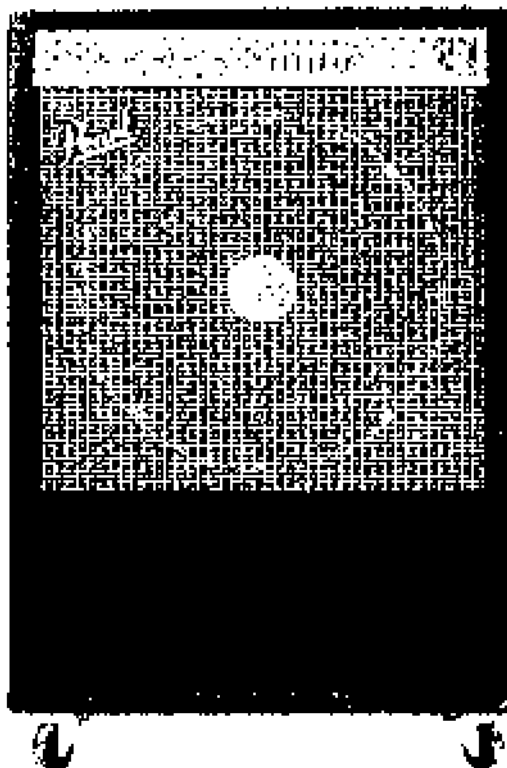

New CNF circuit in a 100W bass amplifier mounted with a 15in speaker

The special CNF circuit built into this amplifier opens up many new possibilities. The new and exclusive 15in bass speaker offers impressive low frequency response coupled with superb high frequency performance. The speaker is of the back-loaded horn type.

#### SPECIFICATIONS

OUTPUT: 100W RMS, 200W Music Power  
 SPEAKER: 38cm x 1, P38-100B  
 CONTROLS: Volume, Treble, Middle, Bass, Equalizer Bright  
 SEMICONDUCTOR: 10 Transistors, 2 FET, 4 IC, 7 Diodes  
 CONSUMING POWER: 250W  
 DIMENSIONS: H820 x W535 x D335mm  
 WEIGHT: 33.5kg  
 ACCESSORIES: Vinyl Cover

**SG-101B**



# VARI SET SYSTEM

Many different settings are instantly possible  
Designed for the professional drummer

Because drummers have many different requirements, Pearl has developed some very special accessories. The new tom-tom holders feature the VARI system. Very precise adjustments as well as full-range movements in all directions can be achieved. Using the lock-stopper, the unit is exceptionally stable and there is absolutely no vibration of the tom-tom. Once set, the system will always smoothly re-set.



• TWIN TOM-TOM HOLDER

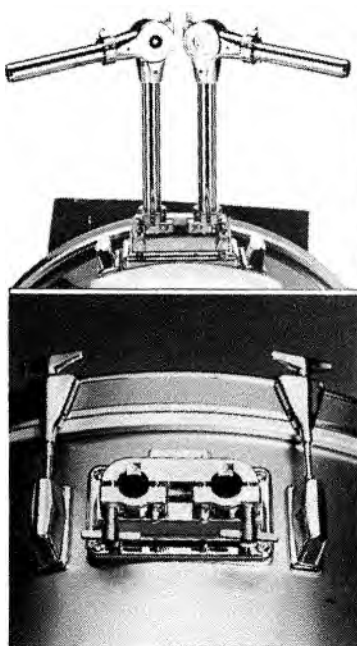

• TRIPLE TOM-TOMS

VARI System twin tom-tom holder  
Adaptor  
VARI System single tom-tom holder

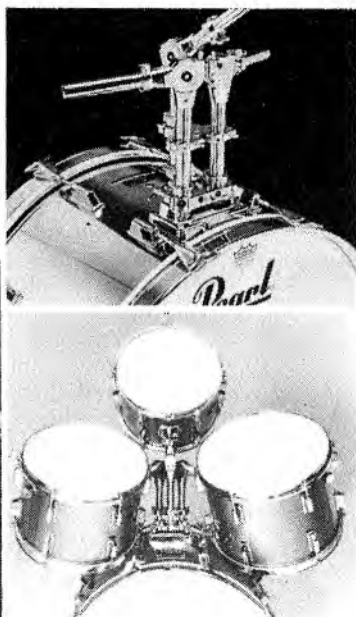

• TWIN TOM-TOM HOLDER WITH  
UNIQUE CONCERT  
TOM-TOM HOLDER

VARI System twin tom-tom holder  
Adaptor  
Concert tom-tom holder

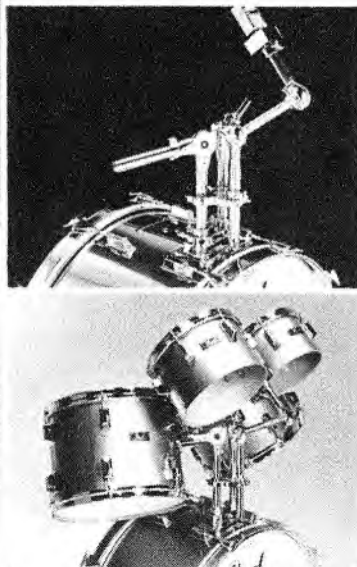

• TWIN TOM-TOM HOLDER WITH  
CYMBAL HOLDER

VARI System twin tom-tom holder  
Adaptor  
Cymbal short boom holder



The adaptor of the VARI system and the stand in the New Pro 900 series comply with the same standard. With only a few stands, many Tom-Tom units and cymbals can be set up in a compact arrangement.

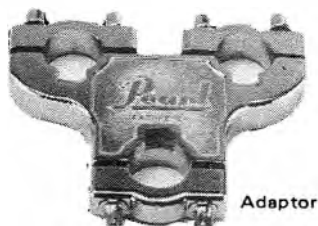

Adaptor

*Pearl*<sup>®</sup>  
**DRUMS**  
The Driving Force

# Soundcheck

Ampeg VT22  
combo amp  
£485.76 + VAT

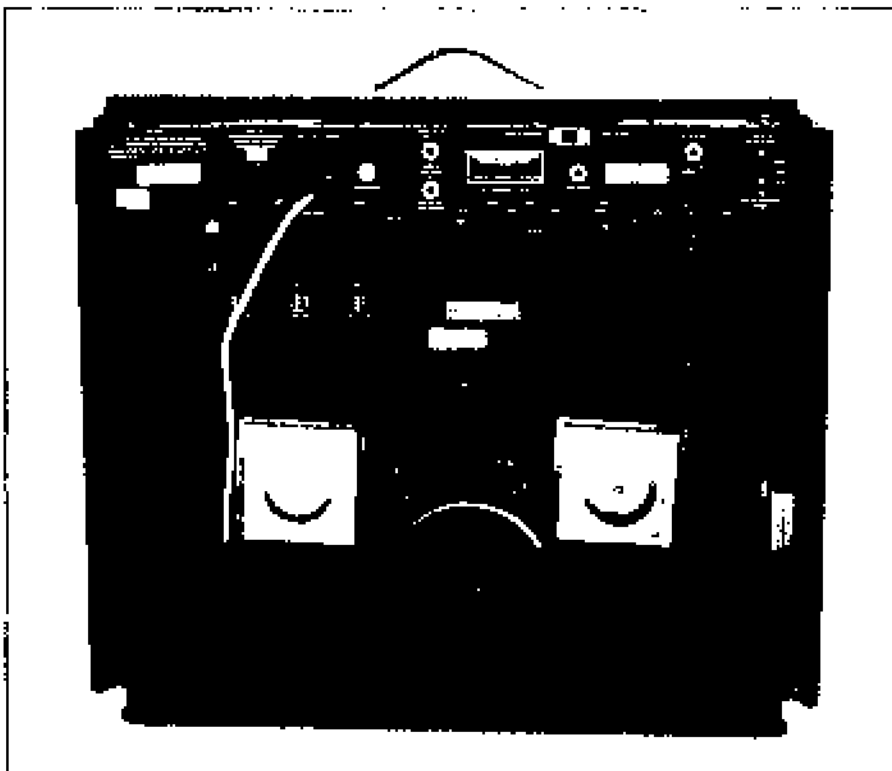
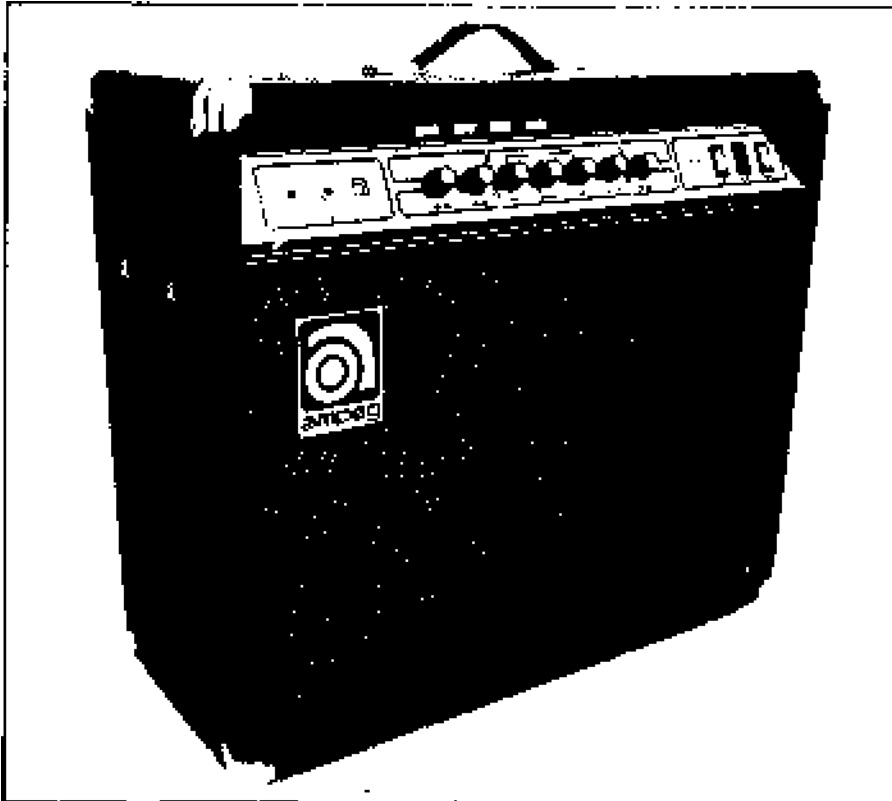
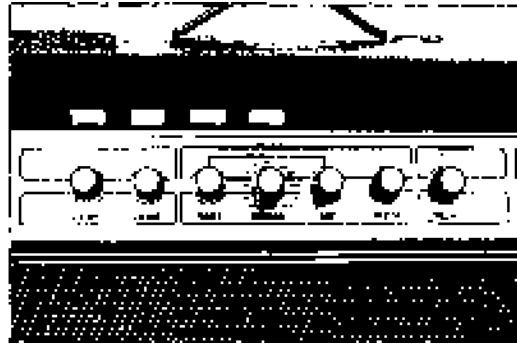

## Introduction

The Ampeg company is a division of Magnavox in Elkhart, Indiana, USA, an area well-known for manufacturing musical instruments and associated equipment.

The VT22 combination amplifier is basically an all-valve design, recommended by the manufacturers as a multi-purpose amplifier system. Considering the range of tone controls, together with the reverb and sustain (distortion) facility and a power output of 100 watts (see spec. table), this is a reasonable claim. However, the unit does not have an infinite baffle speaker design, which is bound to limit its response performance for bass guitar.

## Construction

The VT22 combo is basically as compact as most 100 watt designs on the market having overall dimensions of 26" (W) by 23" (H) by 11" (D). However, for all this, it seems to be a lot heavier than many other models, weighing in at around 40Kg (88lb). Although it is sturdier than other models, it is rather heavy to carry and we would recommend a quick Bull-worker course to prospective VT22 users!

The amplifier cabinet is constructed from 3/4" plywood and all the corner joints have been dovetailed. The whole enclosure is covered in a good quality black PVC material and all corners are protected with chromed corner caps. The handle is a standard type of strap handle of reasonable quality. Whether or not it will stand the test of time considering the weight of this unit remains to be seen. There are no recessed handles at the side of the unit.

The front panel of the amplifier section is clearly laid out and the silver and black knobs contrast well with the silver brushed aluminium finish of the fascia panel. The speaker enclosure is covered by an attractive grille cloth which is easily removable. Two 12" Altec speakers with 2" aluminium voice coils and 40oz. ceramic magnets are wired up in parallel.

On the control panel, there are two 1/4" jack sockets, two rotary volume controls and a range of tone controls, which give a little more than the average. As well as Bass, Middle and Treble, the Middle control incorporates a three-position switch for 300Hz, 1KHz and 3KHz. There is also a two-position Ultra-Hi switch plus Reverb and Distortion controls which can be operated by a small footswitch supplied with the amplifier. The mains and standby switches, a common feature on valve amps, are also on the front panel and they each have a small red indicator lamp.

The rear panel is very straightforward, housing two 1/4" speaker jack outlets, a pre-amp output signal jack and a power amplifier input jack. An impedance selector for 2, 4 and 8 ohms operation is also incorporated on a slide switch. A mains cable of approximately two metres in length is supplied wired into the amplifier and there are a couple of brackets at the back to house the cable.

The internal construction of the amplifier section is robust as the main chassis section has been constructed from 1/16" thick steel sheet. A lot of care has been taken in the magnetic screening in order to achieve RF rejection and the standard of workmanship and quality of components used is high. This is an all-valve



design, as we mentioned in the introduction, and uses four 7027A's in the output stage and seven other small valves type 12AU7, 12AX7, 12DW7, 6CG7 and 6K11 in the rest of the circuit. Ampeg have obviously paid a lot of attention to the design, layout and construction of the unit as it has approval from two safety standard authorities, the Underwriters Laboratory and the Canadian Standards Authority. This is, of course, an excellent recommendation for the amplifier from the safety point of view.

As an all round performer, the amplifier meets all the specifications claimed by the manufacturers and for those thirsting for more power, Ampeg offer a performance conversion kit consisting of four 6550 valves for the output stage together with the retainers. This apparently cranks the power up to 130 watts at 3% total harmonic distortion. The conversion has to be done at authorised Ampeg service centres though, and we would advise non-technical users to leave well alone. A vinyl cover also comes as an extra which is common to many American amplifiers. This may seem odd to UK musicians as nearly all home market amps are supplied with vinyl covers as standard.

We tried the amplifier with several guitars and a Godwyn 444P organ and found the

power handling excellent and the tonal range and quality extremely good. We compared the VT22 with a solid state combo which we had in our test room and found a remarkable difference when trying both amps out with the organ. The VT22 gave a much richer, fuller sound than the solid-state combo and, in this instance, we much preferred the valve amp sound. The reverb in particular was full and quite clean on the VT22.

### Conclusion

The Ampeg VT22 performs well, right up to specification in fact, and gives the deep, full sound characteristic of a valve amp. Unlike many valve amps, the power delivery is relatively distortion-free which also makes it an acceptable amp for keyboard players. The overall engineering standard is high and small details like their reverb spring locking device gives it the edge over some other makes.

Considering the fairly high price of the amplifier, my criticism would be the absence of castors, recessed handles – and a free vinyl cover. However, as always, sound quality is the main criteria at the end of the day and, in this respect, the VT22 is up with the best.

Mark Sawicki

PARAMETER	RESULT	TEST CONDITION	COMMENTS
Specific power output Watts RMS Ref 1KHz	126.56 w RMS 85.15 w RMS 76.56 w RMS	Onset of clipping into 4 ohms Onset of clipping into 8 ohms Onset of clipping into 16 ohms	Manufacturer claims: power output: 100w RMS minimum continuous at less than 3% total harmonic distortion into 2, 4, 8 ohm load over 20-20,000Hz bandwidth
Total harmonic distortion (THD) Ref. 4 ohms dummy load, 1KHz	1.23% 1.09% 0.98% 0.75% 0.92% 1.05%	@ 100w RMS @ 80w RMS @ 60w RMS @ 30w RMS @ 10w RMS @ 3w RMS	Smooth overload characteristics provided by valve type pre-amplifier (distortion circuit) & power output stage. Valve complement: four 7027A, three 12DX7, one 12AU7, one 12DW7, one 6CG7, one 6K11.
Input sensitivity in mV RMS for 100w RMS (20V RMS)	13.2mV RMS 14.5mV RMS	Input No.1 Ref. 1KHz/4 ohms, Input No.2 tone controls flat	Manufacturer claims: Channel 1 and 2 input impedance is 5.6M-ohms and input sensitivity is 11mV RMS for full power
"Slave in" jack sensitivity	Approx. 0.22v RMS	Ref. 100w power output – 1KHz	Useful, quite high for US designed and built equipment: still very welcome in Europe
"Pre-amp out" jack impedance	Approx. 10 Kohms	Ref. 1KHz	Satisfactory
Tone controls range	±12dB ±12dB ±20dB	Treble @ 4KHz Bass @ 40Hz Midrange @ 300Hz, 1KHz, 3KHz	Symmetrical and quite effective. For all tone controls measurements, Ultra Hi switch is in off position. Midrange has three-position switch.
"Ultra Hi" switch range	+12dB	Ref. 8KHz	Ultra Hi provides additional boost of the initial presence frequency. Dependent on volume control position.
Signal/noise ratio	Approx. 80dB	Tone control – flat, below full power level	Good
Frequency response	Approx. ±1.2dB	Ref. 20Hz-20KHz	Very good
Capacitance load test	OK	2µF/nonelectrolytic caps. + 4 ohms dummy load	Small overshoot observed
Short circuit test	30 seconds	Short circuit at full drive, tone controls – max	No ill effects, worked perfectly when short was removed, however anodes of 7027A go "red" hot quickly
Open circuit stability test	OK	Volume – max, tone controls – max, Ultra Hi switch – on, dummy load – removed	Quite good stability margin bearing in mind "valve design"

# MAKE '79 A GOOD YEAR WITH LEECH AMPLIFICATION

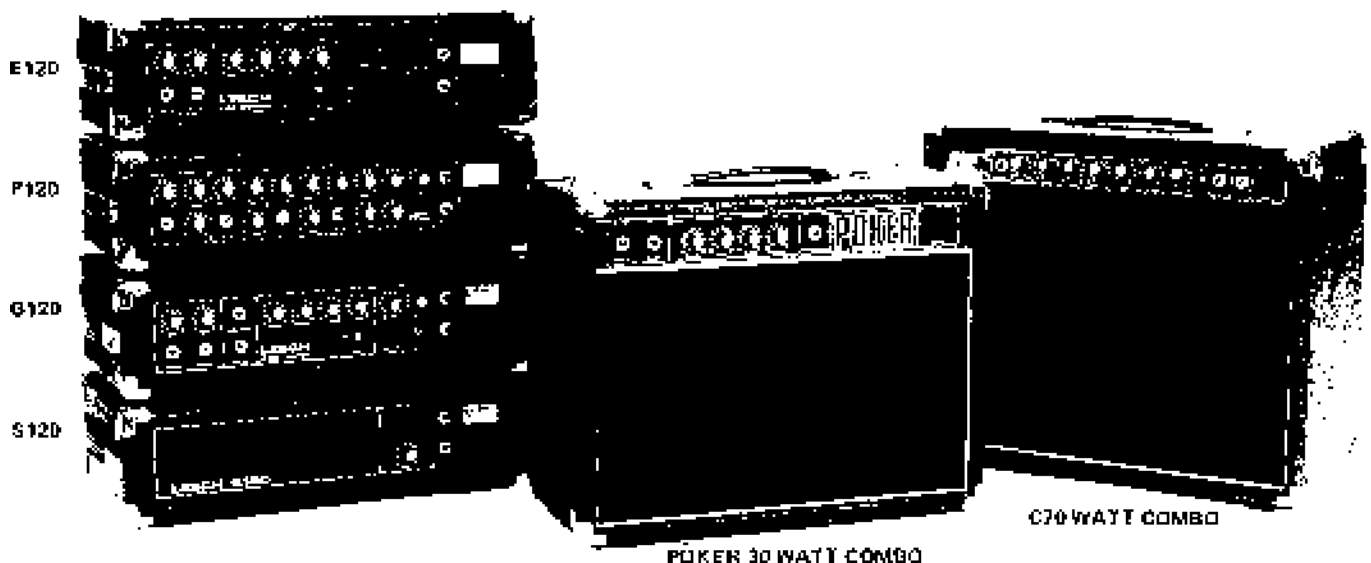

## LEECH MUSICAL SERVICES LTD.

Unit 1, Knutsford Industrial Estate, Parkgate Lane, Knutsford, Cheshire WA16 5DX. Tel: Knutsford 54641.

# Birth of the two-track masterpiece. Otari MX5050-B2.

The new Otari two-track machine is designed for discriminating recordists. Built with inside-out improvements over our long succession of compact professional recorders. With built-in operation ease and better serviceability. With fidelity, reliability and professional functions indispensable for every critical application you have in mind.

DC-servo direct drive for minimum wow/flutter and speed deviation. With  $\pm 7\%$  pitch control and foolproof IC motion-sensing control logic. Optional remote control for all transport and mode functions. Maximum 30dBm input and 600 ohm +4dBm or  $-10$ dBm switch-over output with XLR connectors. Front-panel edit and cue, test oscillator, stepless bias and IEC or NAB equalization. Full professional four heads with extra quarter-track playback. And it's designed for both vertical and horizontal operation.

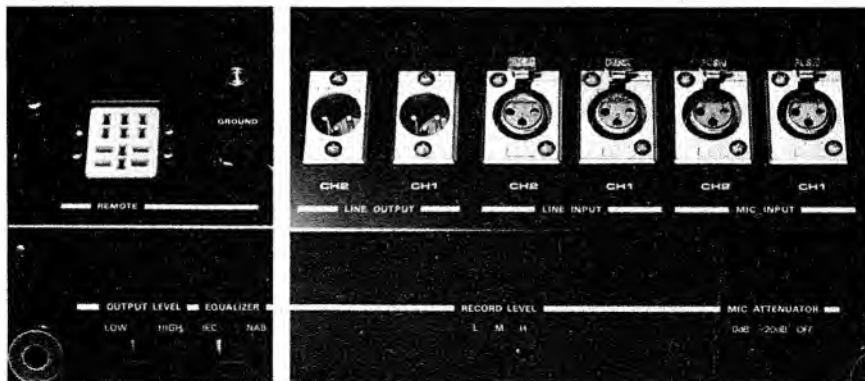

Resultant performance: smooth punch-in/punch-out mastering at 63dB S/N, 55dB crosstalk and 70dB erase with 30Hz - 20kHz ( $\pm 2$ dB) response. It's the latest and wisest choice for your quality 15/7-1/2 ips masters. For the full story about the new generation recorder/reproducer, contact your nearest Otari distributor and see why we call it the masterpiece.

## OTARI

U.K.: Industrial Tape Applications, London  
Phone: 724 2497  
France: Reditec, Paris Phone: 300-9630  
West Germany: Peter Strüven GmbH, Hamburg  
Phone: 801028/29  
Belgium: Trans European Music S.A., Brussels  
Phone: 569 1823  
Italy: Exhibo Italiana S.R.L., Monza Phone: (039) 360021  
Switzerland: Audio Bauer AG, Zurich Phone: 643230  
Australia: Klarion Enterprises Proprietary Ltd.,  
South Melbourne Phone: 613801  
Japan: Otari Electric Co., Ltd., 4-29-18 Minami Ogikubo,  
Suginami-ku, Tokyo 167, Japan

# SPEAKERCHECK

BY KEN DIBBLE

This month, we have another varied collection of loudspeakers from both "standard" and "special" categories, this time 15" units intended for use as musical instrument loudspeakers or as part of a PA stack. The samples submitted come from Germany, Italy, Spain and the USA, as well as three units from the UK. Among the home-grown units are the long promised, long awaited 15" range from ATC, who have established themselves among the leading manufacturers of high performance loudspeakers in just four short years. Noticeably absent from our tests are the new loudspeaker units from Rola Celestion and HH Acoustics, the new loudspeaker manufacturing offshoot of HH Electronics, but perhaps we can look forward to putting these through their paces a little later on, as I am frequently being asked why we have not yet reviewed these products.

There have been one or two interesting developments in the Stateside speaker business recently, in that two of the major American manufacturers have published new price lists showing actual *reductions* in recommended retail prices! Both JBL and Electrovoice have reduced a wide cross-section of their musical and professional products by between 10 and 20 per cent, with the result that the JBL K120 12" lead instrument unit now costs only £3 more than the ATC PA/75, while the Electrovoice EVM/12 is a few pounds cheaper than the ATC. It is amazing that while most loudspeaker prices of this type are soaring due to the cobalt crisis which we discussed last month, the American manufacturers, despite freight costs and import duty, can actually bring their prices down. The justification offered is simply that they are now selling more over here and can therefore pass the benefits of this on to the consumer. I must admit that this is a trend that I am very pleased to see, and as regular followers of the Speakercheck series will know, the very high prices of the big name American loudspeakers has been a favourite gripe of mine in

the past. However, I cannot help wondering just how long this can continue, before the American manufacturers feel the bite of the cobalt price escalation, and prices start an upward trend once more. I think that if I were contemplating the purchase of up-market loudspeakers, I would be negotiating my deal now, as I really cannot see any likelihood of anything but increases over the next few months, unless there is a rapid solution to the political situations on the African continent.

As the samples started arriving for this month's tests — the ATC Bass Long Coil unit, rated at 200 watts, the JBL K140, and Isophon PS 385/200, both with programme ratings of 300 watts, it became apparent that we would run out of amplifier power for the full power sine wave tests and that the HH TPA-100D we have used hitherto would no longer be adequate. The TPA-100D is my own property, and as soon as I mentioned my predicament to Mike Harrison, Managing Director of HH Electronics, I was immediately offered one of the new HH S500 amplifiers on an extended loan basis, despite the fact that S500s are at present in short supply. This is most appreciated, and we can now power Bohm loudspeakers submitted for test with up to 640 watts, which, I would hope, will be adequate for the time being. As with the TPA, the new amplifier was set up and checked against specification to ensure that the results recorded during our tests are directly attributable to the loudspeaker under test, and not to shortcomings with the driving amplifier. Throughout the tests, we monitor the amplifier output signal on an oscilloscope as an additional precaution.

I suppose that if we were to exclude the Richard Allan HD15/P, we could attempt a league table this month, as all the remaining six loudspeakers come well within our "special" category. Not that the Richard Allan unit should be dismissed so lightly, for, as the results table shows, it has almost the specifica-

tion of a "special" category loudspeaker — except that it costs just £46!

There can be little doubt that the best set of results were again returned by the two ATC 15" units, but at almost £180 these are, for the time being at any rate, very, very expensive. The Isophon too showed itself to be capable of outstanding performance, but at £130 is still on the expensive side. The JBL K140, at £124, is specifically intended for use as a bass instrument reproducer and certainly performed in a manner which we have come to expect from JBL, its lower sensitivity being an intentional sacrifice in order to achieve the necessary "guts" at the very low frequencies. Although not specifically marketed for this purpose, the RCF L15P/06 came up with an almost identical performance to the K140 at some £24 cheaper, around the £100 mark. The Spanish-made DAS MI-400 also gave a good account of itself and is nicely made but alternative units, of at least equal performance, can be obtained at similar, if not lower, prices, and that do not suffer from the peculiarities of the DAS design. Without exception, all the units tested gave a good account of themselves, but I think that the RCF L15P/06, for its application, at the current price, must offer the best value on today's market. The professional will undoubtedly go for the performance benefits of the ATC units, and probably write off the cost against the taxman!

If all goes according to plan, the January 'Speakercheck' will feature compression drive units as separate components and, depending upon the number of manufacturers who participate in this, it could well go over into the February issue as well. Following on from this, we plan to evaluate horn flares as separate components, and then to go on to testing complete loudspeaker systems — such as the Bose 800 system, the Electrovoice Eliminator, the Shure SR system, the little Goodmans DB50, etc.

## RICHARD ALLAN HD15/P RRP incl. VAT £46.15

Parameter	Manufacturer's Rating	Test Result
Power	100 w RMS	Confirmed at 100w RMS sine wave
Distortion	Not stated	3% at 100w as above
Sensitivity	100dB @ 1w @ 1m	98dB @ 1w @ 1m averaged between 300Hz and 3KHz
Resonance	85Hz free air	100Hz in 90ltr IB enclosure
Impedance	8 ohms nominal	8-40 ohms (upper figure estimated)
Useful freq response	Graph given	60Hz-4.5KHz @ -20dB — see graph

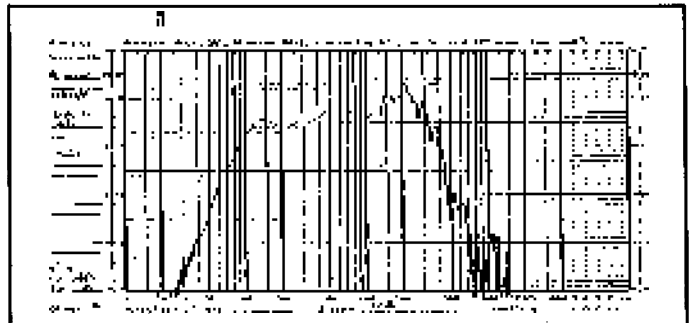

This is another of the new range of musical instrument loudspeakers from this British manufacturer. It is built on a new, four-spoked, cast alloy chassis of adequate rigidity and strength, and has been re-designed to permit front or rear mounting, with gaskets supplied for both. Termination is by means of a pair of colour-coded screw terminals and a fairly large ceramic magnet is fitted which, as cobalt is not an ingredient, should ensure some price stability. A deep, particularly stiff, ribbed cone is carried by a low compliance, plasticised paper suspension, and a composite paper centre dome is employed. The whole unit, finished in matt black, has a nice, substantial 'feel' to it for a 'standard' category loudspeaker, and is readily identified by the unusual mounting lugs attached to the front rim, and by the bright red felt front gasket.

Its performance can only be described as excellent, especially so at this price. As the result table above shows, it easily confirmed the maker's power rating at just 3 per cent distortion and returned a very good sensitivity for a 'standard' unit, along with an adequate frequency response.

If the HD12 and HD15 series units we have so far tested are anything like indicative of Richard Allan's new product range aimed specifically at the professional and musical end of the market, then I for one welcome the re-emergence of this old established family business into the limelight, and look forward to seeing a lot more Richard Allan loudspeakers on the road.

## JBL K 140

RRP, incl. VAT £124.20



Parameter	Manufacturer's Rating	Test Result
Power	150w Cont. RMS 300w Cont. Prog.	Confirmed at 150w and 300w. RMS sine wave
Distortion	Not stated	3% @ 150w and 300w as above
Sensitivity	98dB @ 1w @ 1m	98dB @ 1w @ 1m averaged between 300Hz and 3KHz
Resonance	30Hz free air	60Hz in 90ltr 1B enclosure
Impedance	8 ohms nominal	8-40 ohms (upper figure estimated)
Useful freq response	40Hz-2.5KHz unqualified	40Hz-5KHz @ -20dB -- see graph

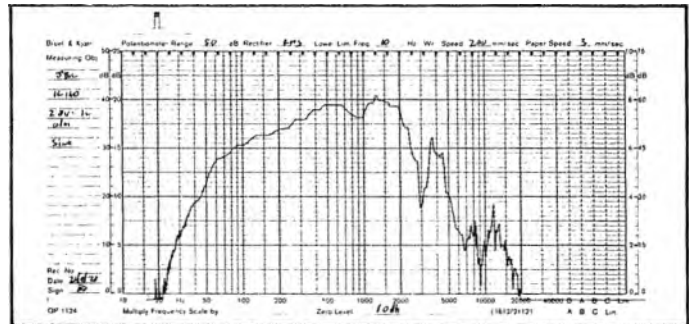

This is yet another superbly made and immaculately finished product from this leading American maker. It is of substantial proportions and is intended for use as a bass instrument reproducer. The unit is built on a well braced, cast alloy chassis of the shallow pattern and is fitted with a large Alnico type magnet which does rely on cobalt for its manufacture. An unusually heavy cone assembly is carried by a treated cambric front suspension of medium compliance and a dural centre dome is fitted. The delivery includes mounting hardware, a rubber 'O' ring to facilitate front mounting and a full installation/operating manual, and the JBL 5 year Professional Products Warranty applies. The lowish sensitivity figure — which exactly confirms the maker's specifications — is due to

the heavy cone fitted to ensure faithful reproduction of the bass frequencies and to minimise any likelihood of cone break up. At the makers' invitation, we carried out a sine-wave power test at the full 300 watts programme rating, and as the results table shows, there was so little increase in distortion, that without going to decimal points of a per cent, we had to publish a constant figure.

A very nice unit indeed for a specific application, and if JBL can hold these prices in the face of rocketing magnet prices now being reflected in the price lists of their competition, this will not be an excessively expensive loudspeaker — which hitherto has been JBL's main problem in selling in the UK.

## RCF L15P/06 Retail price, incl. VAT around £100



Parameter	Manufacturer's Ratings	Test Result
Power	150w	Confirmed at 150w RMS sine wave
Distortion	Not stated	3% @ 150w as above
Sensitivity	Not stated	98dB @ 1w @ 1m averaged between 300Hz and 3KHz
Resonance	Not stated	60Hz in 90ltr 1B enclosure
Impedance	8 ohms nominal	8-40 ohms (upper figure estimated)
Useful freq. response		50Hz-4.5KHz @ -20dB -- see graph

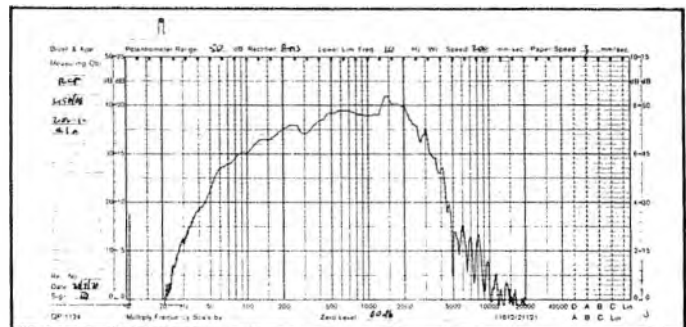

Apart from the fact that this loudspeaker is fitted with a composite paper centre dome and that a differently formed cambric suspension is employed, the L15P/06 would seem to be an almost exact replica of the JBL K140. A comparison of the results table for the two loudspeakers will show that the similarity is not only confined to visual aspects, as almost identical figures were obtained. Comparing the two response curves, it can be seen that while the JBL has the edge in low frequency energy, the RCF does not suffer from the sizeable dip exhibited by the JBL at 3KHz. OK, so the JBL standard of finish and presentation is noticeably better, and the RCF has only solder tags for termination instead of the nice spring-retaining terminals fitted by JBL. If you want to pay for such refinements, OK, but look at the results,

and look at the manufacturing quality of L15P/06, and decide for yourself if it is not virtually equal. Although a 300 watt programme rating is not claimed for the L15P/06, we were invited to subject our sample to the same tests as were applied to the K140, and the unit withstood this gruelling 300 watt test without excessive distortion. Remember, however, that this is only a short term test and must not be taken to imply that the loudspeaker will handle 300w as a rated power! A very nice loudspeaker indeed, and in keeping with the quality and performance we have come to expect from RCF and at a sensible price for the moment, but the magnet is based on cobalt and one cannot expect this price to hold for long. ▶▶

## ISOPHON PS 385/200

RRP incl. VAT £140.28

Parameter	Manufacturer's Rating	Test Result
Power	*Musical load capacity, 300w Nominal load capacity to DIN, 200w.	Confirmed at 200w RMS sine wave
Distortion	Not stated	3% @ 200w as above
Sensitivity	Not stated	100dB @ 1w @ 1m averaged between 300Hz and 3KHz
Resonance	50Hz unqualified	110Hz in 90ltr 1B enclosure
Impedance	8 ohms nominal	5.5 - 30 ohms
Useful freq response	50Hz-5KHz. Graph given	55Hz-4.7KHz @ -20dB - see graph

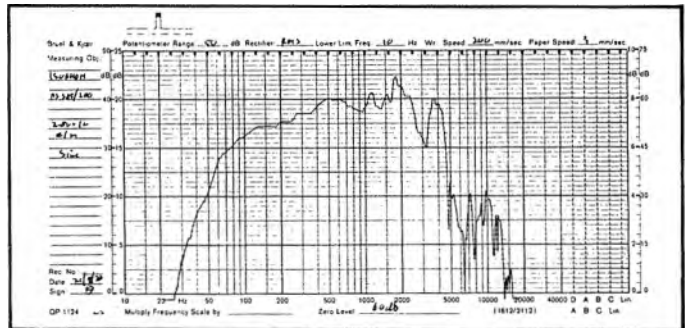

Although fabricated from pressed steel sections, this chassis is of a very substantial nature. The pressed sections are of a generous gauge of metal, and the whole assembly is well braced and is well able to carry and hold in alignment the heavy magnetic structure fitted to this unit. It is an eight spoked, shallow pattern chassis of the JBL/RCF general form and is fitted with a thick felt gasket for conventional mounting. A curved profile cone with paper composition dome is self-suspended, with doped, corrugated ribs formed into the edge of the paper cone itself. A black crackle stove enamel finish to the chassis and cadmium plated magnet gives an unassuming look of functional quality to this loudspeaker, which came bolted to a fibrous panel, inside a particularly substantial cardboard box.

As the table shows, the unit returned a very good set of results, with good sensitivity and confirmation of the maker's power rating at just 3

per cent distortion. We did in fact try a re-test at a gruelling 300 watts RMS just to evaluate the maker's 300 watt musical rating, and although distortion increased rapidly to 6 per cent, and showed other evidence of self-limiting, the unit withstood this punishment without complaint.

Altogether, a rather nice unit from a German manufacturer not as yet very active in the UK market. It is certainly at the upper end of the price scale but from its performance and high power handling capability, this is probably justified. However, whereas a musician is usually prepared to pay these prices for a loudspeaker with a JBL or ATC label at the back, Isophon have not as yet established that market respectability necessary to command top prices in the UK. This is especially so while JBL, Electrovoice and RCF are holding their prices at the present level.

## DAS MI-400

RRP, incl. VAT £97.36

Parameter	Manufacturer's Rating	Test Result
Power	*140w	Confirmed at 140w RMS sine wave
Distortion	Not stated	5% at 140w as above
Sensitivity	*99dB @ 1w @ 1m	97dB @ 1w @ 1m averaged between 300Hz and 3KHz
Resonance	Not stated	80Hz in 90ltr 1B enclosure
Impedance	8 ohms	4.5-19 ohms
Useful freq. response	45Hz-8KHz unqualified	50Hz-5KHz @ -20dB - see graph

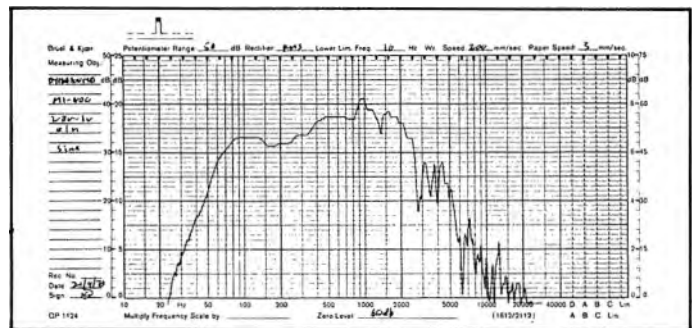

\*Manufacturer's rating measured using band limited pink noise, 30Hz - 1KHz, with unit mounted in 'recommended enclosure'. However, this 'recommended enclosure' is not specified in the manufacturer's literature.

This loudspeaker is built on a larger version of the chassis used for the DAS MI-300 reviewed last month. Not only has the size of the chassis been increased, but also the strength, resulting in a particularly sturdy unit. Although suitable for front loading or for conventional mounting, a felt gasket is fitted only to the front rim and no gasket is provided to facilitate front loading. One major problem, however, is that the basket casting is of a non-standard size and cannot be front mounted into a standard diameter cut-out, and further, the eight mounting holes are not equally spaced and are on a larger than usual pitch circle diameter. If this loudspeaker is to be mounted into a cabinet specially built for it, then these matters are of little consequence, but if it is to be used as a replacement unit in up-grading a standard cabinet, then you can expect problems. The overall standard of finish and manufacture is very good indeed and again, has notable similarities to JBL engineering. It generally performed well, with an

adequate frequency response and an acceptable distortion figure at full rated power, although sensitivity is on the low side for a unit of this type and price. The impedance figures are a little worrying, however, with a low of just 4.5 ohms. I would suggest that this is unacceptably low to qualify for an 8 ohm rating, and could result in the unit being overdriven at low frequencies. I cannot make a great deal of sense from the maker's own methods of arriving at their specification figures as published. From our results, I would expect this unit to be good for a 100/150 watt power rating and would assess a nominal impedance of about 6 ohms. It is not at all a bad unit, but some conformity with standard practices would, I suggest, be to their own, as well as to the user's, advantage. The publishing of the instruction booklet in English, instead of Spanish, would be a further advantage if the company expect to make any serious inroads into the UK market.

**ATC PA100-375 Std.**  
Ser. No. 000001

**RRP, incl. VAT £178.20**



Parameter	Manufacturer's Rating	Test Result
<b>Power</b>	100w nominal 150w maximum	Confirmed at 100w and 150w RMS sine wave
<b>Distortion</b>	Not stated	3% @ 100w and 150w as above
<b>Sensitivity</b>	Not stated	102dB @ 1w @ 1m averaged between 300Hz and 3KHz
<b>Resonance</b>	55Hz free air	75Hz in 90ltr IB enclosure
<b>Impedance</b>	8 ohms nominal	7.17 ohms
<b>Useful freq response</b>	up to 5KHz	55Hz-6KHz @ -20dB — see graph

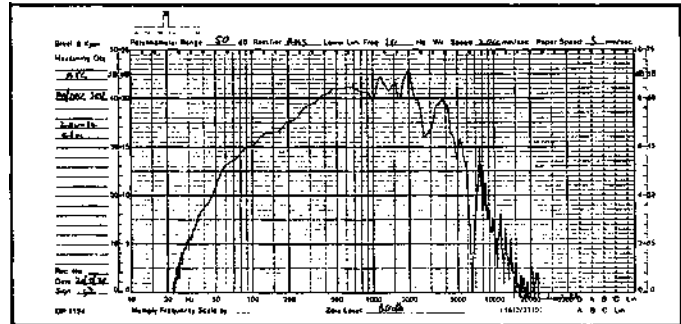

**ATC PA100-375 Bass Long Coil**  
Ser. No. 000008

**RRP, incl. VAT £178.20**



Parameter	Manufacturer's Rating	Test Result
<b>Power</b>	100w nominal 200w maximum	Confirmed at 100w and 200w RMS sine wave
<b>Distortion</b>	Not stated	1% @ 100w; 2% @ 200w as above
<b>Sensitivity</b>	Not stated	97dB @ 1w @ 1m averaged between 300Hz and 3KHz
<b>Resonance</b>	35Hz free air	65Hz in 90ltr IB enclosure
<b>Impedance</b>	8 ohms nominal	9.40 ohms (upper figure estimated)
<b>Useful freq. response</b>	up to 3KHz	45Hz-4.5KHz @ -20dB — see graph

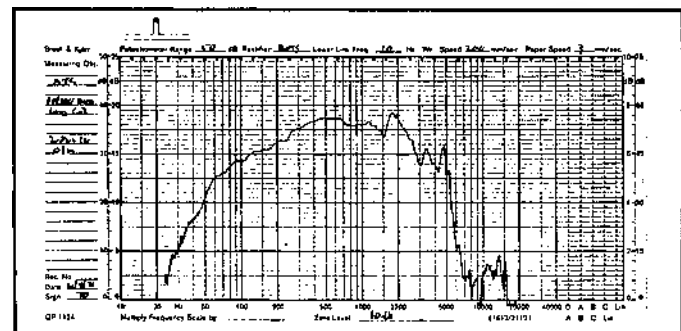

These two loudspeakers are the long awaited 15" additions to the ATC catalogue, and after the excellent results obtained with the PA75-314 Std., 12" model in our Speakercheck review in the March '78 issue, I must admit to some enthusiasm at the prospect of putting the new 15" units through their paces. Both units are built on an identical, eight spoked, cast alloy chassis that looks to be extraordinarily similar to the chassis used for the Goodmans Audiomax 15AX which we reviewed last April. It is of a substantial and well braced design and visually, I would suggest that its lineage would not need to be traced back very far before, yet again, JBL original engineering crept into the picture. Both loudspeakers are fitted with large Alnico magnets within a cast iron 'pot' and the whole unit is finished in a matt black paint over a rough cast surface. Underdome venting is achieved by the usual rear port arrangement and termination is by means of a pair of colour-coded, plastic, spring-retaining terminals. A solid cork front gasket is fitted, and a kit of mounting hardware is included in the delivery. These models have a solid and functional feel to them, if somewhat utilitarian in presentation.

The cone assembly fitted to the Std. model is very light, with a stiff, treated paper front suspension and a dural centre dome. The Bass Long Coil version is fitted with a heavier, textured cone and a more compliant rubber or neoprene roll type surround to give a free, but controlled, extended cone movement to facilitate the reproduction of the low frequencies for which this particular unit is designed. It is because of this extended cone travel that a special long voice coil is fitted — in order that the coil can remain in the magnetic field during the whole of its travel, and therefore allow the unit to remain linear under high levels of drive.

A study of the results tables will show that both units returned a creditable set of figures under test. The Std. model exhibited excep-

tional sensitivity at 102dB and a usefully wide frequency response for a 15" unit, while due to the increased cone mass, the Bass Long Coil version showed a considerable improvement in low frequency energy, but at the expense of some 5dB in sensitivity. Both loudspeakers showed exceptionally low distortion at the makers 'nominal' power rating, and on a re-test at the 'maximum' rating, only small increases became apparent, although due to the inadequate cabinet loading employed for the Bass Long Coil model, this particular unit showed large peaks of both second and third harmonic distortion at the lower frequencies. At the makers' invitation, and due to its low distortion at its rated power, we subjected the Std. model to a 300 watt RMS sine wave test, and although the unit withstood this punishment for the duration of the test, we found upon inspection that the voice coil had seized up inside the air gap — even so, the coil itself had not burned out.

From these results, there can be little doubt that Bill Woodman, ATC's design engineer, has done it again. These loudspeakers are without doubt up among the very best of their type and all credit must go to this small, privately owned British manufacturer. However, while the superb 12" range have until now enjoyed a vast price advantage over their American competition, the escalating price of cobalt and the price reduction by certain American manufacturers, has put an end to this, and ATC, due to their small size, are unfortunately among the first to be affected. At £178.20, these loudspeakers are expensive indeed, costing more than their JBL counterparts. These products are certainly as good as JBL, and in some instances better, but I cannot help but think that ATC will have to sell hard at these prices, or else sit back and wait for the rest of the market to face the same problems and for prices to catch up — as they undoubtedly will.

# HESSY'S MUSIC CENTRE NOTICE BOARD

## THIS MONTH'S SPECIAL OFFER

M/A 100 P/A  
system complete  
with pair 2x12  
cabs & shure  
mike only **£299**

WILL THE PERSON  
RESPONSIBLE FOR  
LEAVING LADIES  
BRIEFS IN GENTS  
KINDLY RETURN

## Memo from the MD

Remember! we will match or better any  
genuine advertised price on current equipment  
ex-stock.

*B. M. Shwa*

## GUITARS

Check all prices on our  
range of guitars as you  
know our stock rooms  
are bulging.

Fender and Gibson at up  
to 35% discount.

New range of copies in  
stock some with demarzio  
pick-ups-up to 50% off  
prices from only £99  
Electric Guitars from £27  
Jumbo Guitars from only £27

## Christmas Party

## sound effects

INCLUDING  
Electro-Harmonix  
UP TO 50% OFF

A Small selection of New and Part-ex  
bargains in our show rooms now.

Fender Strat	£175
Gibson S.G.	£275
Hagstrom Swede	£295
John Birch guitars	£295
Fender Tele	£145
Grech Anniversary	£199
Premier Drum Kit	£199
Maxium 5 drum Kit	£185
H/H Combo	£150
M/A 100	£145
Stagg 100w amp.	£185
Wem Copycat	£65
ARP AXXE together with big brother	£499
Vox piano	£125
Roland piano	£299
Rhodes Piano	£599
Korg Synthesizer	£275
Fender Bass	£99
Precision Bass	£165
Godwin S.C. 100 P	£699
Elka X55	£899
Diamond 800	£299
plus loads of effect units (Electro Harmonix Etc.,)	

STAFF OUTING.  
\*NOTE BACK SEATS  
RESERVED FOR PETER.

WILL OUR BUYER  
ARTIST NOT  
NOT SPELT  
WAY.

PLEASE RETURN  
THE MD'S  
FUNCTION REPAIR  
OUTFIT NOW!  
HE'S GOT A

**FREE T-SHIRTS**  
TO EVERY CUSTOMER  
bringing in International  
musician ad and  
spending over £5

**HESSY'S MUSIC CENTRE 62 Stanley St. Liverpool 051 236 1418**



# PARK

Bigger and Better  
This is not always true.  
Have you tried the PARK 100W P.A.?  
The new link between artist and audience.



MODEL 1219 4ch 100W P.A.  
ONLY £281.50 complete.

.....  
SEND COUPON FOR DETAILS

NAME .....

ADDRESS .....

.....  
.....  
.....  
CLEEARTONE M.I. LTD.  
7 DAWSON ROAD, MOUNT FARM  
MILTON KEYNES. MK1 1LH.  
0908 71662.

## Introducing ... The Chrom Basic ... the package with a difference.

■ The **Chrom Basic** is an integrated system which can be purchased complete and ready for immediate use on the road, and yet also allows you to choose the components from our specially selected range that best suit your particular requirements and budget.

■ The **Chrom Basic** is designed to be easy to set up, simple to operate and portable, yet has a performance comparable to the most expensive professional systems.

■ We have chosen as our basic low cost mixer the **RSD 12/2b**, which is available in 12 or 16 channel format and have manufactured a simple 16 channel stagebox and line system to perfectly complement the desk. For more advanced systems a **Kelsey Acoustics 20/4/2** and 20 channel stagebox and line system is also available. Both desks are modified for fully balanced operation and are supplied with a specially designed flight case.

■ All our amplifiers are built into heavy-duty flightcases and are supplied with balanced inputs to match our line systems. A range of amplification from **Turner, RSD** and **Yamaha** has been chosen to provide the power for the system. Additionally, for the most demanding applications, we can supply state of the art amplifiers by **Amcron** and **BGW**.

■ To provide high quality foldback on stage, we have designed a wedge monitor using an **ATC 12"** bass/low-mid unit augmented by a horn loaded compression driver above 2KHz. The high frequency response has been especially shaped to enhance vocal projection under conditions of high ambient noise.

■ To complete the system, we have a horn loaded, full range bin based on the **JBL 4560** design. When fitted with **JBL** or **Gauss** bass drivers and an integral **JBL** high frequency unit this bin is extremely efficient and is capable of a very clean response at high sound levels. As an alternative we can provide an **RCF** loaded system, which performs remarkably well at a much lower cost.

■ For more powerful systems we have a range of professional quality components from which a modular PA system can be constructed. For more information on these do contact us and look out for our next ad.

■ We have various examples of the 'Basic' available for hire to allow the system to demonstrate its capabilities under real working conditions at your next live performance.

**chrom audio**  
The Powerhouse • 300-320 Acton Lane  
Chiswick • London W4 • (01) 995 4712

# THUNDERCHILD

## SYNTHESIZERS

If you haven't visited Chappell's new Group Gear Centre at 52 Maddox Street, London W1, then you have missed something. We have a range of keyboards, guitars and amps that is unequalled in the U.K. - and they are all at competitive prices, whether you pay by cash or H.P.

The new THUNDERCHILD synthesizer (as featured on Jeff Wayne's musical version of "The War of the Worlds") is **EXCLUSIVE** to Chappell and on permanent demonstration. We can't put all the specifications down in this ad, but take our word for it, that, at £550 for a 2 v.c.o. synth, with internal monitor speaker this is the best value on the market.



**THUNDERCHILD 5Z3540**  
**Jwm**  
 Electronics

Come and compare the **THUNDERCHILD** with its competition, side by side only at Chappell.

We also have the amazing second generation of 'KORG' synthesizers:

MS 10	£250.00
MS 20	£425.00
Sequencer	£350.00
Vocoder	£785.00

The complete range of Roland synths, Yamahas, the new Oberheim OB1 programmable synth., ARP, Hohner keyboards, CP 70B electric portable grand piano - they're all waiting for you to try them.

**Remember: Our amazing January Sale starts Wednesday, 27th December. See our Melody Maker 1/2 page ads. for clearance lines and special buys.**

Ed, Jack, Ian, Pete, Terry and Miles would like to thank all I.M. readers for reading their bible every month, and to everyone who has made 1978 the year that put Chappell at the top - including Genesis, Status Quo, Tom Robinson, Leo Sayer, John Lord, Hi-Tension, Kandidate, Jeff Dexter and Alphapha, Neo, Andy Mackay, Chas and Dave, Gerard Kenny, Richard Harvey, Viola Wills, Cliff Richard Band, everyone we should not have forgotten and all our friends in Scotland!



**chappell**  
 Tel: 01-629.7600

**London's musical department store**

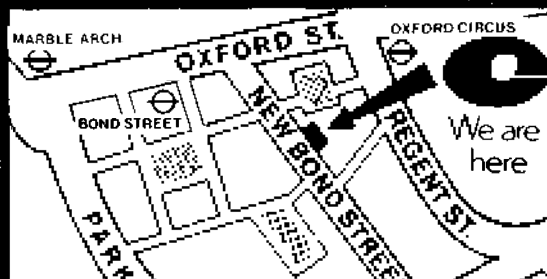

50 New Bond Street, 9.30-6 Mon-Fri, 9.30-5 Sat. (Free parking in Bond Street, after 1.30 Sats)

# Fender SOUNDHOUSE

18A SOHO SQUARE, LONDON W1. TEL: 01-434 1365

## NOT JUST THE FINEST SHOWROOM, BUT.....

a place for a really good deal.

The Fender Soundhouse in London's Soho Square is a phenomenon of the music business. All facets of music come together here and when you call in to talk about Fender, Rogers, Rhodes, Vox, Auto-Tune or Gemeinhardt you'll get expert advice that only the CBS UK headquarters are qualified to give.

The Soundhouse is located easily if you miss the time when those poor office workers are rushing backwards and forwards.

When you call in at the Soundhouse you can spend time. You'll never be hurried and you can take advantage of a few coffees to talk over any plans you may have for your musical equipment.

Remember when you're coming to CBS, you're coming to the heart of the distribution network for Fender, Rogers, Rhodes, Vox, Auto-Tune and Gemeinhardt in Britain. If they don't know the answers there, they're not worth knowing!



### THE CENTRE OF CBS OPERATIONS IN THE UK

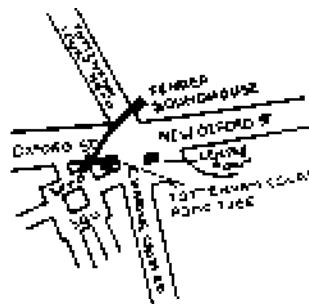

SEE HOW EASY IT IS TO GET TO THE FENDER SOUNDHOUSE. THE MIGHTY CBS ORGANISATION HAS ITS HEADQUARTERS HERE AND WHETHER YOUR MAIN PURPOSE FOR CALLING IS RECORDS OR TELEVISION (OR MUSICAL INSTRUMENTS) THE SOUNDHOUSE IS THERE TO SOLVE YOUR PHYSICAL PROBLEMS IN MUSIC.

### The Fender Soundhouse for Gemeinhardt flutes

If you want to find out about the best range of flutes in the world you'll just have to take yourself off to the Fender Soundhouse in Soho Square, where the Gemeinhardt Flute Centre is situated. Here you'll find the complete range displayed and, what's more important, you'll be given the chance to take as much time as you need to try them and find out which model is right for you.

Previously only "individually imported" instruments were available. Now CBS/Arbiter have solved that problem by bringing to Britain CBS's very own range of Gemeinhardt flutes and piccolos. Available in solid silver and gold plate (as well as silver plate) these instruments represent the ultimate. The entire range may be seen, tried and purchased at the Fender Soundhouse in Soho Square.



I am interested in (Please tick)

- |   |  |
|---|--|
| <input type="checkbox"/> Fender Guitars                   | <input type="checkbox"/> Auto-Tune Drums   |
| <input type="checkbox"/> Rogers Drums                     | <input type="checkbox"/> Fender Amplifiers |
| <input type="checkbox"/> Rhodes Pianos                    | <input type="checkbox"/> Vox Amplifiers    |
| <input type="checkbox"/> Gemeinhardt Piccolos and Flutes. |  |

Please send me further literature.

Name .....

Address .....

Send To Fender Soundhouse, 18a Soho Square, London W1.  
Or Phone 01-434 1365

The London  
Synthesiser  
Centre



Buy Direct &  
Save Money  
Tel. 01-387-7449

# CHASE MUSICIANS

## We have



### Micromoog

Variable rather than preset synth with famous fat Moog sound. Ribbon for pitch bending and sample and hold. Frequency knob sweeps oscillator pitch through eight octave range. Modulation wheel controls vibrato, trills, pitch bending, wah wah and wave shaping.

### Polymoog Keyboard

Fourteen programmed voices available through a touch sensitive keyboard. Individual VCF and VCA for each key allows unrestricted polyphonic playing. Eight octave range, ribbon pitch control and sustain, trigger mode and volume control with optional Polypedal.

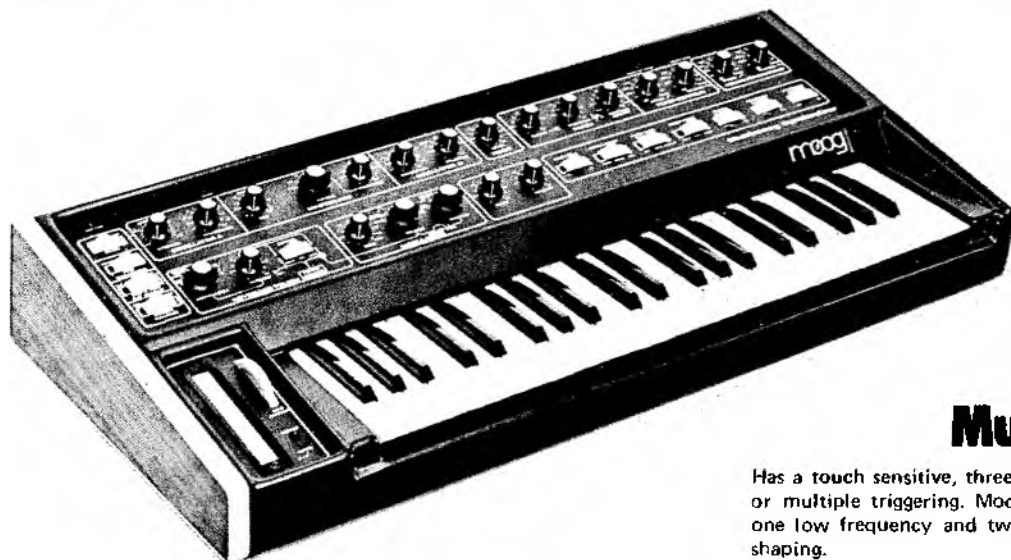

### Multimoog

Has a touch sensitive, three and a half octave keyboard with single or multiple triggering. Modulation wheel, pitch ribbon controller, one low frequency and two audio oscillators. Fully variable wave shaping.

# CHASE MUSICIANS



# Buy Direct & Save Money

Tel. 01-387-7449

# — MOOG MOGULS them all!

### FREE MOOG DEMONSTRATION

Roy Goudie will demonstrate the products on Thursday, December 7, 1978. The display is open from 1pm, formal show begins at 7.30pm. Refreshments are available. The Society Suite, Hotel New Ambassador, Upper Woburn Place, London, WC1.



## Minimoog

Three tone oscillators with separate octave clickers, wave form selectors and volume controls. Separate on/off switches, oscillators two and three have separate tuning controls. Sine wave for harmonic distortion and white/pink noise generator. New drift free oscillators. Can be programmed.

## Taurus Pedal Synthesiser

Two oscillators create three preset voices with one voice fully programmable. Electronic preset selectors. Five octave range with ultra-stable oscillator design, less than 0.18% long term drift.



## Polymoog

Polyphonic chip technology puts one VCA, two wave shapes, one VCF and envelope generator under each key. Almost any function can be adjusted by slider or button. Variable keyboard dynamics and ribbon pitch controller. Acoustic or electronic intonation. Optional expression pedal controller for varying volume, sustain, filter, pitch or modulation. Advance studio systems available.

The London Synthesiser Centre, 22 Chalton Street, off Euston Road, London NW1.

# The London Synthesiser Centre



# Buy Direct & Save Money

Tel. 01-387-7449

## Electronic Pianos

# CALL CHASE



**CP-70B Electric Grand**  
Keys 73 (E<sub>1</sub>-e<sub>4</sub>)  
Effects Controls Bass, Middle, Treble, Tremolo Speed and Depth.



## String Synthesiser



**SS-30 Strings**  
Keys 49 (C-c<sub>3</sub>)  
Tone Selectors  
Violin Part, Viola, Violin I, Violin II, Attack, Cello Part, Cello I, Cello II, Attack, Volume Control, Orchestra Selectors.



**CP-20 Piano**  
Keys 61 (f<sub>1</sub>-f<sub>3</sub>)  
Piano I, Piano II, Harpsichord I, Harpsichord II, Tremolo Controls, Speed, Intensity.



**CP-30 Piano**  
Keys 76 (E<sub>1</sub>-g<sub>4</sub>)  
Tone Selectors: Ch1-4, Ch2-4  
Effects Controls: Pitch, Decay, Tremolo Speed, Intensity, Bass, Treble.

## SEND THIS COUPON FOR INFORMATION

<p>Please check appropriate box</p> <p><input type="checkbox"/> Yamaha Synths</p> <p><input type="checkbox"/> Yamaha Electric Pianos</p> <p><input type="checkbox"/> Yamaha Strings</p> <p><input type="checkbox"/> Yamaha Amps</p> <p>Other .....</p>	<p>Enclosed is £1 for a T-shirt/ £3 for a sweat shirt.</p> <p><input type="checkbox"/> Small</p> <p><input type="checkbox"/> Medium    <input type="checkbox"/> Large</p>	<p><i>Dear Chase Musicians</i> <i>22 Chalton Street, off Euston Road, London NW1.</i></p> <p>Please send me details on items checked. ....</p> <p>Name .....</p> <p>Address .....</p>
--	---	---

# CHASE MUSICIANS



# Buy Direct & Save Money

Tel. 01-387-7449

# FOR YAMAHA

### FREE YAMAHA DEMONSTRATION

Dave Bristow will demonstrate the products on Monday, December 11, 1978. The display will open at 1pm, formal show commences at 7.30pm. Refreshments available. The Society Suite, Hotel New Ambassador, Upper Woburn Place, London, NW1.



#### CS-80 Synthesiser

Polyphonic (8 notes x 2ch)  
Keys 61 (C-c4)  
Tone Selectors: ch. 1-II, ch 2-II  
Programmable Section Levers: 24 x 2,  
Memory Banks: 4  
Effects Controls: Ring Modulator,  
Touch Response, Sub Oscillator,  
Sustain, Portamento/Glissando,  
Slide Controller, Resonance,  
Brilliance, Keyboard Controls,  
Tremolo/Chorus, Feet Selectors



#### CS 50 Synthesiser

Polyphonic (4 notes x 1 ch)  
Keys 49 (c - c4)  
Tone Selectors: 13  
Programmable Section Levers: 20  
Effects Controls: Ring Modulator,  
Touch Response, Sub Oscillator,  
Sustain, Portamento/Glissando,  
Resonance, Brilliance,  
Transposition Selectors



#### CS-60 Synthesiser

Polyphonic (8 notes x 1 ch)  
Keys 61 (C - c4)  
Tone Selectors: 20  
Memory Bank: 1  
Effects Controls: Ring Modulator,  
Touch Response, Sub Oscillator,  
Sustain, Portamento/Glissando,  
Slide Controller, Resonance,  
Brilliance, Keyboard Controls,  
Transposition Selectors



#### CS-10 Synthesiser

Monophonic  
Keys 37 (c-c3)  
VCO, VCF, VCA,  
Trigger Selector (external/single/multi)  
LFO, Noise Generator



#### CS-30 Synthesiser

Monophonic  
Keys 44 (F - c3)  
VCO-1, VCO-2, VCF-1, VCF-2,  
VCA-1, VCA-2  
Ring Modulator,  
Sequencer,  
Envelope Generators,  
EG-1, EG-2, EG-3  
LFO

★ RRP £360, Our price £299 ★  
★★★★★★★★★★★★★

The London Synthesiser Centre, 22 Chalton Street, off Euston Road, London NW1.

**The London  
Synthesiser  
Centre**



**Buy Direct &  
Save Money**  
Tel. 01-387-7449

# A FEW BARGAINS WITH



**Roland S101 System**  
RRP £552. Our price £399.

**SPECIAL: Solina  
String Ensemble**  
RRP £629. Our price £499



**Roland GR/GS 550  
Guitar and Synth**  
RRP £1701. Our Price £1150.

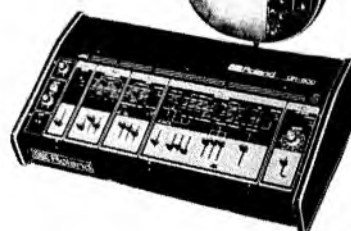

**Elka 490**  
RRP £368. Our price £285



**Elka 610**  
RRP £607. Our price £470.

## DISCOUNT PRICES

EMS	
SYNTHI E . . . . .	399
HI FLI . . . . .	445
VCS 3 . . . . .	895
VOCODER . . . . .	1799

ELKA	
SOLOIST SYNTH . . . . .	295
ELVINS ELEC PIANO TS53 . . . . .	325

KORG	
BASS SYNTH . . . . .	299
770 SYNTH . . . . .	360
700S SYNTHS. . . . .	375
800 DV SYNTH. . . . .	675
POLY I. . . . .	675
POLY II . . . . .	695
PS 3300 SYNTH . . . . .	3995

HOHNER	
KI PIANO . . . . .	240
K4 STRINGS . . . . .	290
CLAVINET D6 . . . . .	399
K2 STRINGS & PIANOS. . . . .	465

ROLAND	
SH 3A SYNTH. . . . .	395
PKP KITTEN . . . . .	430



# CHASE MUSICIANS



# Buy Direct & Save Money

Tel. 01-387-7449

## OUR COMPLIMENTS



Elvins TS55 Touch Sensitive  
Electric Piano  
RRP £510. Our price £345



Hohner Pianet T  
RRP £368. Our price £245



Korg Preset  
RRP £575, Our price £399



Roland SH-1000  
Shop soiled  
RRP £675. Our price £399.

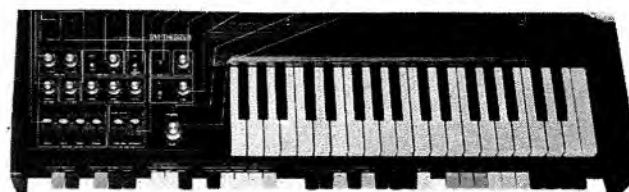

### ALSO IN STOCK

**ARP:** Axse, Sequencer, Pro DGX, Odyssey, Omni Mk I, Omni Mk II, Avatar, "2600"

**KORG:** MS10, MS20 Synthesisers, VC10 Vocoder and SQ10 Sequencer.

**MOOG:** Polymoog, Minimoog, Micromoog, Taurus pedals, the new Multimoog and Polymoog Keyboard.

**OBERHEIM:** OBI, Two voice and four voice Synthesisers with programmers.

**ROLAND:** SH1 & SH7 Synthesisers, RS202 Strings EP30 Pianos, effects pedals, echo machines and combo amplifiers.

**YAMAHA:** CS80, CS60 and CS50 polyphonic Synths, CS10, CS30 and CS30L monophonic Synths, SS30 String Machines, CP20, CP30 pianos and CP70B electric grand.

**The London Synthesiser Centre, 22 Chalton Street, off Euston Road, London NW1.**

The London  
Amplification  
Centre



Buy Direct &  
Save Money  
Tel. 01-388-4094

# HUGE DISCOUNTS ON COMBOS!

## UP TO 50 WATTS

### CARLSBRO

WASP	10w
HORNET	35w
SCORPION	35w

### CUSTOM SOUND

TRUCKER STD.	45w
TRUCKER DUO	45w
TRUCKER BASS	45w

### MARSHALL

2 x 12 TRANS	30w
2 x 12 M/V VALVE	50w

### PEAVEY

BACKSTAGE	17w
PACER	45w
CLASSIC	50w

TNT	50w
-----	-----

### ROLAND

GA 30	30w
-------	-----

## 60 TO 100 WATTS

STINGRAY	100w
----------	------

STINGRAY BASS	100w
---------------	------

### LAB SERIES

L5 2 x 12	100w
L7 4 x 10	100w
L9 1 x 15	100w

### MARSHALL

2 x 12 TRANSLEAD	100w
4 x 12 BASS	100w
4 x 12 LEAD	100w
2 x 12 M/V VALVE	100w

### MUSIC MAN

2 x 10	65w
1 x 12	65w
2 x 12	65w

### ORANGE

GRAPHIC O/DRIVE	80w
GRAPHIC O/D REVERB	80w

### ROLAND

JC60	60w
JC80	60w
GA60	60w

### YAMAHA

G100B 2 x 12	100w
G100 2 x 12	100w
G100 1 x 15	100w
G100 4 x 10	100w
B100 1 x 15	100w

## OVER 100 WATTS

### MUSIC MAN

2 x 10	130w
2 x 12	130w
4 x 10	130w

### ORANGE

GRAPHIC O/DRIVE	120w
GRAPHIC O/D REVERB	120w

### PEAVEY

DEUCE	120w
ARTIST	120w
MACE	160w
LTD	200w
SESSION	200w

### ROLAND

JA120	120w
JC120	120w
JC160	160w

# PLUS: A COMPREHENSIVE RANGE OF CABINETS AND HEADS

### BOSE

800 AMP	550w
800 Speakers	270w
802 Speakers	270w

### CARLSBRO

FULL RANGE FLARE	
CAB	120w
FLARE CAB 2 x 12	120w
HORN PAIR 2 x 12	120w
M130 SLAVE	130w
MARLIN HEAD	130w
STINGRAY BASS HEAD	150w
STINGRAY SUPERHEAD	150w
CAB 4 x 12	200w

### CUSTOM SOUND

CS700A MIXER AMP	150w
GS700K KEYS AMP	150w
706 GRAPHIC BASS	150w
TRUCKER PA	150w
7215 BASS CAB	200w
7412 4 x 12	200w
7 MPH HORN UNIT	

### LAB SERIES

L4 HEAD	200w
L4 CAB 2 x 15	200w
L11 HEAD	250w
L11 CAB 4 x 12	200w

### MARSHALL

M/V VALVE HEAD	50w
M/V VALVE HEAD	100w
LEAD/BASS HEAD	100w
SLAVE	100w
CAB 4 x 12	100w
ALL PURPOSE CAB 2x12	100w

### MUSIC MAN

REVERB HEAD	65w
HEAD	130w
212 RH CAB	130w
412 B3 CAB	130w

### ORANGE

GRAPHIC HEAD	120w
GRAPHIC O/D HEAD	120w

CAB 4 x 12	120w
2 x 12 HORNS	

### PEAVEY

CENTURY HEAD	100w
MUSICIAN HEAD	200w
412F 2 x 12 CAB	200w
T300 HIGH	FREQ.PROJ.

### YAMAHA

G100 LEAD HEAD	100w
B100 BASS HEAD	100w
EM120 MIXER AMP	100w
A4115H SELF POWERED	
CAB	100w
EM160 MIXER AMP	150w

# PLUS: A WIDE RANGE OF MM MIXERS

# -AND MANY MORE

Barclaycard, Access,  
H.P. Facilities  
And Mail Order  
Available

The London Amplification Centre  
88 Chalton Street  
off Euston Road  
London NW1  
01-388 4094

OPEN MON-SAT  
10am - 6pm  
Two minutes walk from  
Euston/Kings Cross Stations

**CHASE  
MUSICIANS**



**Buy Direct &  
Save Money**  
Tel. 01-387-7449

**The London Synthesiser Centre**  
22 Chalton Street  
off Euston Road  
London NW1  
01-387 7449

**The London Amplification Centre**  
88 Chalton Street  
off Euston Road  
London NW1  
01-388 4094

# Mail Order Service

Your choice of Chase Musicians' wide range of amps and synths can be mail ordered. We will supply them through our rapid export delivery service.

## Our prices are the lowest

Synthesizers by: ARP, CAT, Crumar, Elka, Elvins, EMS, Fender Rhodes, Hohner, Korg, Logan, Moog, Multivox, Oberheim, Prophet, Roland, Solina, Wasp, Wurlitzer, Yamaha.

Amplification by: Bose, Carlsbro, Custom Sound, H/H, Intermusic, LAB, Laney, MM, Music Man, Orange, Omac, Peavey, Redmere, Roland, Yamaha.

(subject to stock availability.)

*Dear Chase Musicians*  
22 Chalton Street, off Euston Road, London NW1.

Please send me details on .....

Name .....

Address .....

*Dear Chase Musicians*  
22 Chalton Street, off Euston Road, London NW1.

Enclosed is £1 for a T-shirt/£3 for a sweat shirt.

T-shirt/sweat shirt

Small     Medium     Large

Name .....

Address .....

# Who Are We?



John Entwistle, Percy Jones, John Perry, John Gustafson... through the specialist services of design engineer and custom guitar builder Wal, these eminent and accomplished bass players became involved with us in the development of a totally new range of professional guitars.

From the beginning, our aim at Electric Wood was to produce the ultimate instrument, an instrument in fact that professional bass players would be proud to own.

We believe that this unique team work has produced the most objective instrument design.

For full information on the new range of Wal Pro Bass guitars, write to the sole distributors of Wal Guitars.

---

**Barratts of Manchester Ltd.,**  
652 Chester Road,  
Old Trafford,  
Manchester M16 0RX.  
Tel: 061-872 0713

THE *Wal*

PRO BASS

**A New Beginning**

# Synthcheck

## The Scorpion £595 inc VAT

The Scorpion is being advertised as the first British lead line synthesizer. It is not the first British synthesizer by any means but, as far as I know, it is the only one that has been introduced to compete with the smaller stage synthesizers like the Micro Moog, Arp Axse, etc.

It is a simple to understand, easy to operate synth, aimed at the person who has been frightened off using a variable synthesizer because of his/her lack of understanding of synth jargon and technical terms. (The owner's manual contains information on not only how to operate the synthesizer, but also how the different parts of the synthesizer affect the final sound.)

The unit has been designed for one-handed operation, so pitch bend knobs, etc. are missing, although this is compensated for by the keyboard being touch-sensitive and the inclusion of a vibrato delay circuit. The front panel and controls are positioned along the back of the 3½ octave (F to C) keyboard and most controls can be reached by the hand which is actually playing the keyboard.

### Variable Controls

There are two voltage-controlled oscillators that are both capable of producing four waveforms: triangle – a soft flute-like sound; sawtooth – brassy; square wave – hollow, clarinet-like; and pulse – nasal.

The different waveforms are indicated by the usual graphic presentation and are routed to the filter via a four-position switch. Two tuning controls are provided for each oscillator. One is a four-position switch – 32', 16', 8', 4' for VCO 1; 16', 8', 4', 2' for VCO 2. The other is a variable which alters the pitch of the oscillator from minus a tone to plus a seventh from concert pitch. The output from each oscillator is fed via a single mix slider to the filter, which is the usual low-pass type with variable controls for cut-off frequency and resonance. It has its own envelope shaper that can supply two types of envelope – Attack/Decay, used for percussive envelopes and Attack/Release. The attack and release times can be varied from instant to about six seconds.

The signal from VCO 2 can be switched into the control input of the filter, which produces interesting distortion and ring modulation effects. The output from the filter is then fed to a voltage-controlled amplifier, which also has its own envelope shaper, similar to that of the filter.

### Modulation and Keyboard Touch Sensor

A single LFO (low frequency oscillator) is supplied, which gives a sine wave output. This can be routed to the filter, voltage-controlled amplifier or oscillators. The speed of the LFO is adjustable, as is the delay time. The LFO can be brought into play either continuously, after the delay period or when the keyboard is pressed hard (using the touch sensor). The touch sensor can also be used to bend the pitch of the oscillator sharp by an interval set by the bend sensitivity control.

When the keyboard is pressed (bringing the touch sensor into play), the whole keyboard moves down. This, to my mind, is one of the best types of touch sensor I have seen as, when you are playing, you "feel" a mechanical link between pressure and pitch.

### Pre-Sets

As well as the variable controls already described, there are eight pre-set sounds which can be instantly selected by a press of the appropriate button.

The pre-sets are: Synth 1, 2 and 3, Trumpet, Clarinet, Flute, Oboe and Violin. The only problem with the pre-set controls is that one has to remember to switch the footage switches on the oscillators to the appropriate pitch for the instrument (as the footage is not "remembered" by the pre-sets) – i.e. the flute pre-set sounds wrong if played at 32'.

### Sounds

The synthesizer I was given to review performed well with no evidence of drift, I was particularly impressed by the sound of the instrument. It sounded a lot like a Mini-Moog (which can't be bad). The pre-set sounds were full and rich and reasonably realistic, and the sounds chosen seem to be the most useful when you are limited to eight.

### Conclusion

The Scorpion is a good lead line synthesizer that should appeal to the first-time buyer. I must admit to being a bit doubtful about the appearance and finish of the unit that I reviewed, especially when it is in competition with the American and Japanese synthesizers which have such good presentation. But the recommended retail price of £595 is very reasonable for the sound this synthesizer makes.

Dave Simmons

*Dave Simmons is a musician and a technician. His musical background grew from learning piano and organ as a child to playing the massive synthesizer part in David Bedford's "Odyssey". His technical training in practical and theoretical electronics has led him to become a partner in a highly specialised company undertaking all types of synthesizer modification and servicing.*

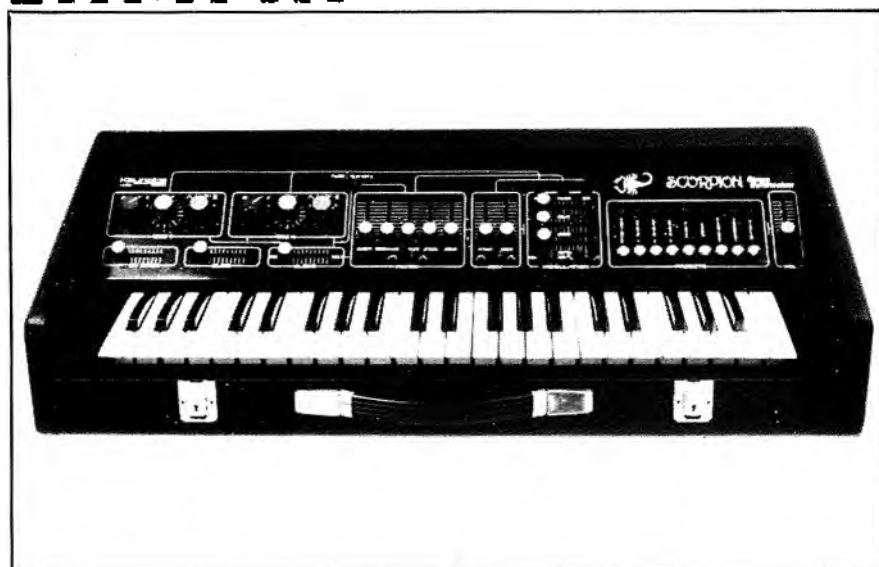

# Drumcheck

## Ludwig 'Big Beat' 6-ply kit £792 inc.VAT

Nowadays, I'm reliably informed by Rose-Morris, the British importers, the only Ludwig sets brought across the Atlantic have the new six-ply maple shell construction. Prior to '77 Bill Ludwig's drums boasted a bent three-ply shell with glue-rings.

Gretsch have until now been the only manufacturers making genuine six-ply shells, albeit only for their bass drums and some of their floor-standing tom-toms. The other American manufacturers still make their products with the glue-rings which Ludwig have now discarded. All Ludwig drums are now maple shelled (even the mahogany ones are only face-veneered) and made with twin plies, but jointed and these pairs of joints are staggered around the circumference. This, of course makes the shell stronger since it has not one six-ply joint but three two-ply joints.

### BASS DRUM

Big Beat has a 22" x 14" drum. (There are now some bass drums with extra-depth shells available called Power B.D., which are a couple of inches deeper and have two pairs of spurs.) This one has 20 nut-boxes (casings), pressed steel double claws and cast curved "T" handled timpani-type tuners. It also has Ludwig's retractable, fixed curve, square section spurs with sharp points on them which seem to do the job of stopping forward movements very well. These 1/2" square section spurs are now filled with the new plastic, hand-sized tension knobs, which are in reality large plastic wing bolts. The drum uses solid rock maple hoops, in this case inlaid with black plastic (Cortex).

I played the bass drum first with both heads on and it sounded nice and meaty. A good full-bodied tone but somehow (for me) a little old-fashioned. Mind you, once I had taken off the front head, it really came to life. I didn't have a head with me with a hole cut out of it to try on the drum but I'm sure had I put it on and replaced the hoop and the claws and tuners it would have had an even more ballsy sound. The drum comes with Ludwig's usual felt-strip damper which did its job unobtrusively.

### TOM-TOMS

This set has the smallest double-headed tom-toms with it, viz. 12" x 8" and 13" x 9", plus the 16" x 16" floor tom, all of course complete with six-ply shells.

The 12" drum has 12 square-headed tensioners per drum, as has the 13", while the 16" floor tom has eight per head. The rims are Ludwig's traditional triple-flange type which serve to brighten the sound. All the tom-toms nowadays have the same size nut-boxes as fitted to the bass drum, which for my money is a worthwhile standardisation. These nut-boxes are all padded inside with a piece of foam wedged between the spring and the outside of the casing. This foam very effectively stops the springs and tensioner inserts from rattling or "singing" in sympathy with any note which is emanating from any instrument around it. All the toms have thicker-than-usual spring-steel dampers, which work inside the drum on the underside of the batter head. These dampers are operated on a thread with a large knurled thumb-screw.

I played all the tom-toms double headed at first and their sound was good and clear, with lots of tonal definition and strong penetration. However, I did the same head removal experiment with the smaller drums as I had with the bass drum and reached the same conclusion: without the sympathetic heads, the tom-toms for me suddenly came to life and were somehow more throaty. I suppose one could say they had a brasher sound, with a louder tone at least at source - but they would not have the penetration afforded by the sympathetically resonating bottom head. I think it speaks volumes for the six-ply shell that it sounds as good as it does single-headed.

### SNARE DRUM

The snare drum supplied with the Big Beat set is the world-famous Supraphonic 400. This is the drum which transcends all different styles of music, from heavy rock (for which I feel it is the definitive drum) to Sixties modern jazz Joe Morello-style and for all those other styles and sounds inbetween. The 400 metal-shell was first introduced in the sixties but Ludwig have in fact been making a 10-lug metal-shell snare drum since 1911.

Anyway, for those of you unfamiliar with the 400 (where have you been?) I'll tell you something about it. It has a beautifully made one-piece, seamless shell, whose edges are bent over (flanged) at 45° into the drum (inverse). There's a strengthening bead in the middle which is a concave indentation around the circumference. This serves to stop the shell from buckling out of shape. Ludwig's tasteful Imperial nut-boxes, of which the 400 uses 10 double-ended ones, seem to be the same now as they were on the 1932 Ludwig and Ludwig snare drum I bought in New York many moons ago. There are of course a pair of triple-flange pressed-steel hoops, which contribute a great deal to the bright cutting quality of the drum. (I once replaced these hoops with some cast Gretsch-type hoops and the difference was quite marked - the sound became much darker and more suitable for recording.) The snare strainer is the part-cast, cam-action adjustable P85, to which the 18-strand metal snares are cord-attached. It's a single-end throw-off and its butt end (the P32) serves just to hold the other end of the snares. The 400 no longer has an actual snare bed (indentation in which the snare sits in the shell) but nowadays has a gradual decrease in shell depth for about 2 1/2" or so each side of the centre of the snare mechanism positions.

By the way, there is of course a substantial (by every other company's standards) spring-steel felt-pad damper which operates internally under the batter head. This is activated by a large chrome thumb-screw and means you can now have any damper strength. (The dampers on the tom-toms have also been changed to this more effective thumb-screw type.)

So what does it sound like? Well, it's everything the catalogue claims: "Instantly responsive over the whole head, crisp, clear, powerful and fast." The one important thing the catalogue doesn't say in so many words is that it's also very loud! It comes with the standard Ludwig coated heads (more of these later) but I prefer it with the centre dot head.



## ACCESSORIES

The Big Beat outfit comes with Ludwig's newish line of stands called Hercules. All are constructed from very wide-bore tubing and all have bent tubular-steel tripod legs with massive rubber feet. These feet are no longer like the walking-stick bottoms which only touches on a very small area but instead are angled at the bottom where they "sit" on the ground and so give a much larger contact area, so there's less chance of slipping and sliding.

All of the stands have extra wide tripod bases on them and, to judge from the ones I saw, it would be a very unfortunate drummer indeed who managed to persuade one to fall over. All the stands too have very large plastic height arrest screws called hand-size knobs, which really do allow you to put some torque on them (even the cymbal angle adjustment has one of these). We also say hello again to the old die-cast, top-of-tube clamps. I personally preferred the old pressed-steel clamps which maintained pressure all around the tube, as opposed to the cast variety which grip at only one position by pressing *into* the tube.

The set comes with two Hercules cymbal stands which are three-section large-diameter tubes with wide-spreading tubular steel tripod legs with the aforementioned large rubber feet. The stands have four or the new plastic hand-size "T" knobs, one for the cast ratchet filter and one to regularise the spread of the legs. I notice in the Ludwig '80 catalogue that you can buy a 10" extension tube to give extra height to any of your stands. I haven't quite sussed how it works – but it must work, or it wouldn't be in the catalogue. By the way, the stand has an extra-length, extra-thick rod from the filter upwards to contain the cymbal.

There is, of course, a Hercules hi-hat stand with tubular tripod legs and thick down tubes. It seems to be the same specification as the old Big Beat stand with a centre pull and an adjustable expansion spring. There's a pair of spurs, one under the heel plate (it has a two-piece cast foot-plate) and one adjustable one in the bottom of the twin-post assembly/framework. There's a brand new (to me) top cymbal clutch, with a large wing-nut on the bottom, a sensible new oval oversized locking nut on top and a "stronger-than-before-looking" height adjustment "T" bolt arrester. The other locking screws on the stand are the hand-sized plastic wing-nuts. The centre pull action is joined as before to the pedal itself by a very strong link made of a substance called Lexan, which I personally have never seen broken. Although the Hercules is not as mammoth as some of its competitors, it does the same job and has a smooth, positive action.

The snare drum stand is more or less the same as the famous Atlas, but with tubular tripod legs instead of the flat steel. It's basically the old "Buck Rogers" stand with an adjustable basket-type drum retaining action.

Ludwig's bass drum mounted double tom-tom holder has been around for years. Thousands of drummers must have given it their seal of approval over the past 10 years or so. In common with some other manufacturer's products I feel that the female holder casting is not positioned close enough

to the front of the bass drum. This enables the twin tom-toms to be mounted close enough together for easy play, but not too close to the snare drum. Most drummers appears to want to play the tom-toms close together yet still positioned over the centre of the bass drum. The top of the holder has two right-angle rod arms at the top which locate into Ludwig's cast block tom-tom mounting bracket which is fitted with an eyebolt to retain these angle rods and arrest them. (These blocks are fitted to the floor tom-tom as holders for their bent steel legs.) The stand itself works well once set up, and now boasts a new innovation to arrest its height adjustment – one of the new hand-size knobs. This is good because you now don't need to use the eminently losable hexagonal box spanner every time you dismantle your drum set.

The Speed King foot pedal: much has been written before about this famous pedal but I feel such a good pedal could stand a little more praise. It was first manufactured in 1937 and for those of you who don't know it, it's an adjustable twin compression spring model with a reversible one- or two-piece cast foot-plate and a beautiful feel. It has a metal connecting link whose strength is, I feel, the pedal's weakness. Because this piece of pressed steel is so strong other parts of the pedal, like the cast footplate, or the cast rocker assembly which retains the beater have the tendency to fracture. Anyway, the Speed King is the easiest pedal around to use and takes no time at all to get used to.

## HEADS

All toms have 1000 Db Ludwig Silver Dots on the batter sides and standard 750 white coated on their bottoms. The bass drum has 1000 Db on both sides but a Silver Dot on the back-side. I don't think it's generally realised that head with the spots in their centres are stronger because they are double-thickness there. Ludwig now produce heads with white dots, which rumour has it are even stronger and more rigid than the Silver Dot variety. The Company's heads are no longer made from Thermolene but are not created from Mylar, the material Remo makes his from. The Ludwigs are however crimped into the "U" shaped channel, while Remo's have lots of small holes around the perimeter which the epoxy resin used to glue them runs into and around.

To sum up, the Ludwig six-ply set is everything I had expected it to be. Without splitting hairs, I can find nothing to criticise in its sound or its appearance. The set I saw was covered in Black Cortex, which is evidently one of their best selling finishes. I say one of their best because the most in demand and therefore most difficult to get one is the natural maple wood. The interiors of the drums were absolutely perfect, not a blemish on them. (I understand they are hand-sealed after their final coat of varnish.) The stands, too, are great as, with a couple of reservations, are the pedals. I would hazard a guess that these Ludwig six-ply shell drums are going to be with us for a long time.

Henry Roberts



# ADD ON A CAMBER

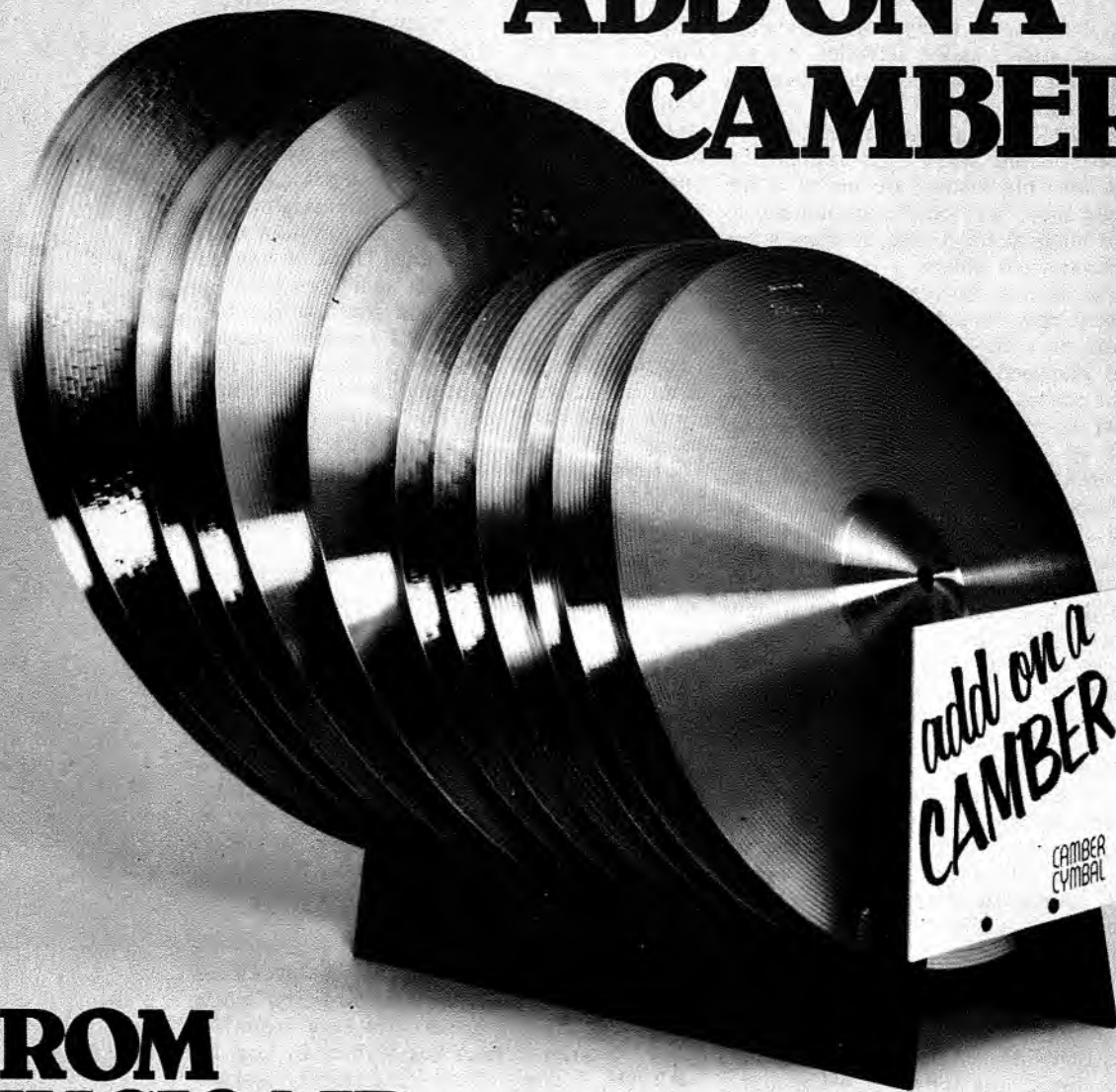

## FROM MUSICAID

Add Camber brilliance to your drumming. Add the "zing" that's lacking with a cymbal by Camber.

These exciting new cymbals are made with great care in USA and you'll find a cymbal to match your style in any Camber dealer.

For his address and a free copy of "How to Choose a Cymbal" return the form below to Camber's UK distributors, Musicaid.

HOW  
TO CHOOSE  
A CYMBAL

---

SEND FOR YOUR FREE BOOKLET 'HOW TO CHOOSE A CYMBAL'

NAME \_\_\_\_\_

ADDRESS \_\_\_\_\_

Send to MUSICAID, 176 Hatfield Road, St. Albans, Herts.



# SEE HOW MUCH YOU CAN STILL BUY FOR £53\*

Not one, but two inputs!

Three tone controls: treble, middle, bass

The loudness switch. Turn the amp full up for maximum overdrive and sustain, use the switch to keep the same sound at low volume.

This headphone socket automatically cuts the loudspeaker out when you plug in a pair of cans.

Don't let the price fool you. This "cheap" amp uses a 10in. Celestion speaker. Hard to believe isn't it?

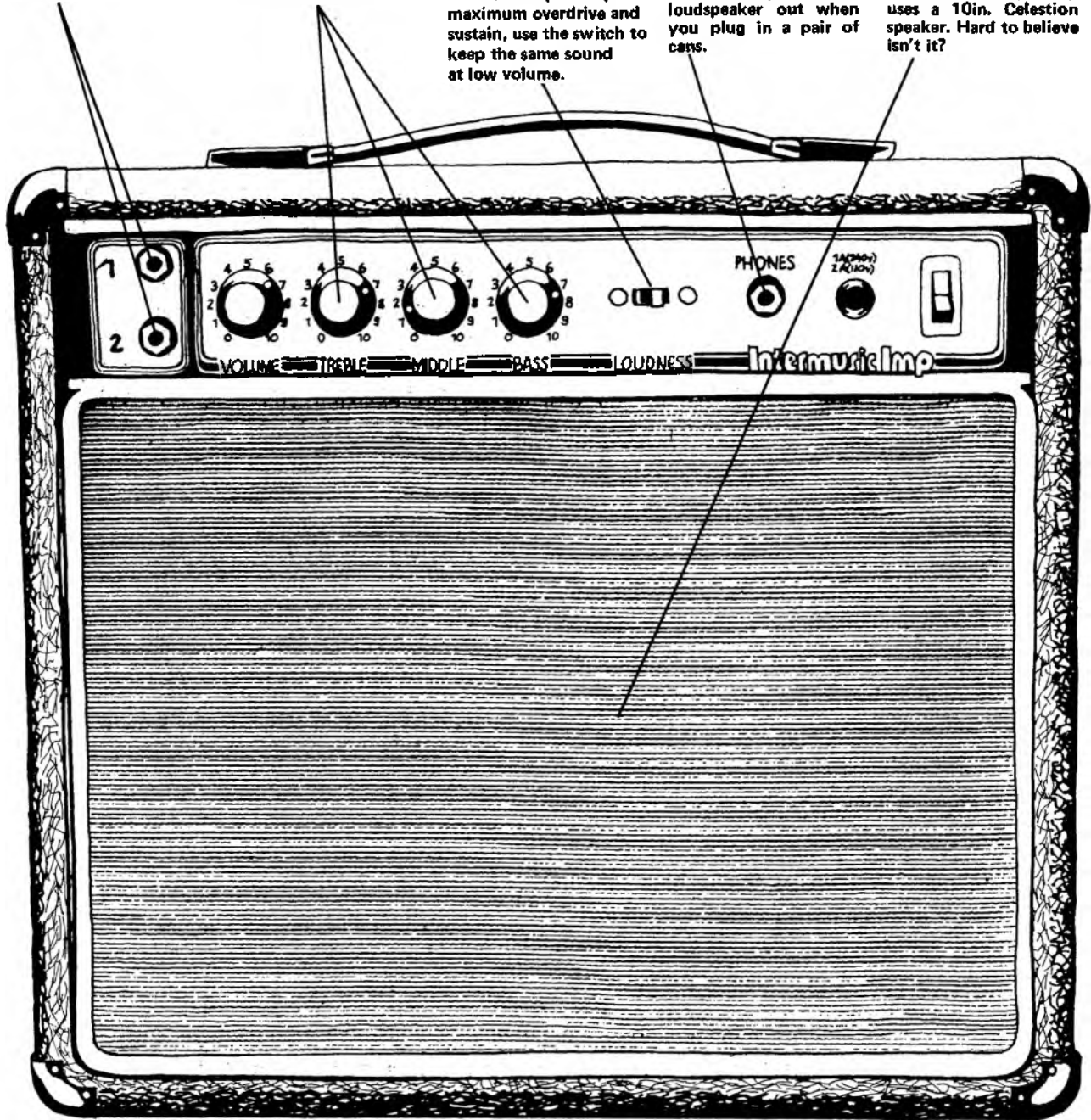

The Intermusic Imp is a 15 watt rehearsal amp which delivers like a stage amp. The same circuits used in producing the tone of the big Intermusics are used here, the only difference is the size and the price.

In a cynical world there's little enough to make you

believe in other people. But all this for just £53\* must tell you a lot about the Intermusic team. By now you should have got the word about the fantastic Intermusic reliability. So for the studio, the routing session or the bedroom, Intermusic has it.

**Intermusic**  
is Musical Value!

PA:CE Ltd., Kneesworth Street, Royston, Herts.  
Canadian Distributor:—  
Northern Audio Musical Enterprises, 953 Fraser Drive,  
Burlington, Ontario L7 L4X8, Canada.

\*Exclusive of VAT

## Make your drums work for you

### INTRODUCTION

I am really knocked out by the many recent exciting developments in drum design. I find this innovative attitude very encouraging as I am constantly in search of new sounds and ideas in the field of percussion. I hope to devote at least one future article to these new developments as it now seems that because of this inspiring approach by various manufacturers, the drum kit is fast approaching its zenith and has become more prominent than ever before. However, in this article I am going to deal with the basics of how drums can be applied to various playing situations, trying to be as helpful as I can, particularly to drummers who are fairly new to the scene.

As with the drum kit, sound equipment is rapidly becoming more and more technologically advanced. It can sometimes be baffling for the musician to retain his own individual sound -- hence I will endeavour to talk about, and try to clarify, certain situations he is likely to encounter.

### Live Sound

First, I will deal with the sound of drums in a live context, and before bringing in PA systems, microphones, monitors, etc., I would like to talk about natural sounds.

OK. So you are set up on stage in a big hall. You have a bass stack to your left, a guitar stack to your right, and keyboards somewhere else. You have no mikes, so you have to be able to project the sound of your drums to the audience.

First, if you have a double-headed kit, you will find that it is basically an excellent projector of sound to your own ears while you are playing, although it does not project so well to the people listening in front of you. A two-headed bass drum generally produces a more boomy sound -- but tuned with care, it can be made to sound extremely deep and rich -- and of course it will always be audible to you when playing as the sound is kicked back by the front head. Also, the less dampening you employ the louder the volume will be, the more dampening, the quieter the sound.

When no dampening is used during the soundcheck or warm-up, the bass drum can sound a bit offensive, but come the gig, you will be glad you left

it free of tape and foam, because with all those people in front of you soaking up those unwanted tones, you will have a nice healthy thwack down there.

Tom-toms with two heads produce a full, tonally good sound which can be varied to your own personal preference by careful tuning. Again, take care with dampening for the same reasons which apply to the bass drum. Double-headed tom-toms again supply you with a pretty good natural monitor system, as the sound is projected back up and around the drum, but great importance must be placed on the natural balance of the kit -- don't drown out the tom-toms with your favourite crash cymbal or whatever. Try to make the kit sound like a total instrument rather than a few drums and cymbals put together at random.

With single-headed kits there is a little problem. Our portable monitor system is no longer there to such a great extent because, with the bottom head gone from the tom-toms and the front head removed from the bass drum, the sound just ain't gonna hang around! I find the disadvantage of single heads is that there is no "kick-back" when the drum is struck, because most of the sound is projecting out of the front of the drum only. However, this is offset by the fact that all the sound is shooting straight out of the front to where the eager audience lies in wait. Obviously, the degree of projection depends on how you set up. The tom-toms really need to be angled to some extent so that the open end is facing the front, together with the bass drum.

Again, take care with the dampen-

ing. Single heads will generally have less tone, they produce more of a flat sound and, without the front head on the bass drum, it will have lost its deep, rich tone. The only way to make up for this is to dampen the playing head. This will also thicken up the sound as well as reducing the "boom".

So far, I have talked only of single and double-headed drums which, being of traditional design, tend not to project too well in a large hall unmiked.

### Projection

This is where the newer, revolutionary drums like North and Staccato really come into their own. They project so well and, because of their shape, you can set them how you like -- which is great if you do not like playing on tom-toms set at an angle. This also applies to sound reflectors like the Ludwig design or the Remo type. Another important factor for projection is the type of shell used, whether it be glass fibre, Plexiglass, wood, metal or even recycled paper -- each of these materials has different qualities concerning the projection of sound. Also, different types of wood, different thicknesses of shells, types of head used and different ways of tuning affect the degree of sound projection.

However, even with all the different types of drums mentioned above, you just ain't gonna be heard in a big hall -- not when you are battling with those two skyscrapers (the guitar stacks) looming either side of you! They are also directed at the front of the stage so if you are unamplified, you're going to sound very tiny. So what do we do about this? I'll tell you next month.

*Simon Phillips*



Simon Phillips, one of Britain's busiest session drummers, has worked on albums by David Coverdale, Gordon Giltrap, Art Garfunkel, Dave Greenslade, Roger Glover, Judas Priest and Jeremy Spencer, among

many others. He has also toured and recorded with Phil Manzanera's 801 and the Jack Bruce Band, and is currently working with a band fronted by Jeff Beck and Stanley Clarke.

# More Than Great Specs, Great Ideas.

For the past three years we've been telling you about the benefits of using graphic equalizers, now we've made it even easier to appreciate them. Introducing the MXR Dual Fifteen and Thirty-One Band Equalizers. Two equalizers designed with the imagination and understanding to solve your toughest equalization problems. Designed for use in either studios or sound reinforcement situations, our new eqs offer features not previously available at any price.

The Dual Fifteen Band Eq features two channels of equalization with the bands set two-thirds of an octave apart. By breaking the frequencies down further than conventional octave equalizers, you now have the flexibility to contour your music with much greater selectivity. As most musical information occurs in the midrange, this is where you need even more definition, and the Dual Fifteen Band Eq gives you six bands of contour in this area rather than the usual four. In addition, each channel has its own level control.

The Thirty-One Band Eq divides the frequency spectrum even further. A single channel unit, the Thirty-One Band features frequency bands set one-third of an octave apart, generally regarded to be the optimum amount of resolution.

When used in conjunction with any PA system, our equalizers can make a bad environment sound good, and a good performance sound great. Unlike parametric equalizers, the frequency response change is immediate and easily visible, so that when you shape a response curve you know what it's going to sound like.

Both units feature a range of -12 to +12 decibels on each band, standard 19" rack mount, and the rugged construction you always get with an MXR product. Both units also feature phone plug input/output connections, (the Thirty-One Band also features Cannon type XLRs), high slew rate (7V/microsecond), and incredibly low noise (better than -90 dBm). But not only do we offer great specifications, we produce great ideas... you wouldn't expect any less from us.

Allantex Music Ltd., 16 High Street,  
Graveley, Herts., England, (0438) 50113

**MXR** Professional  
Products Group

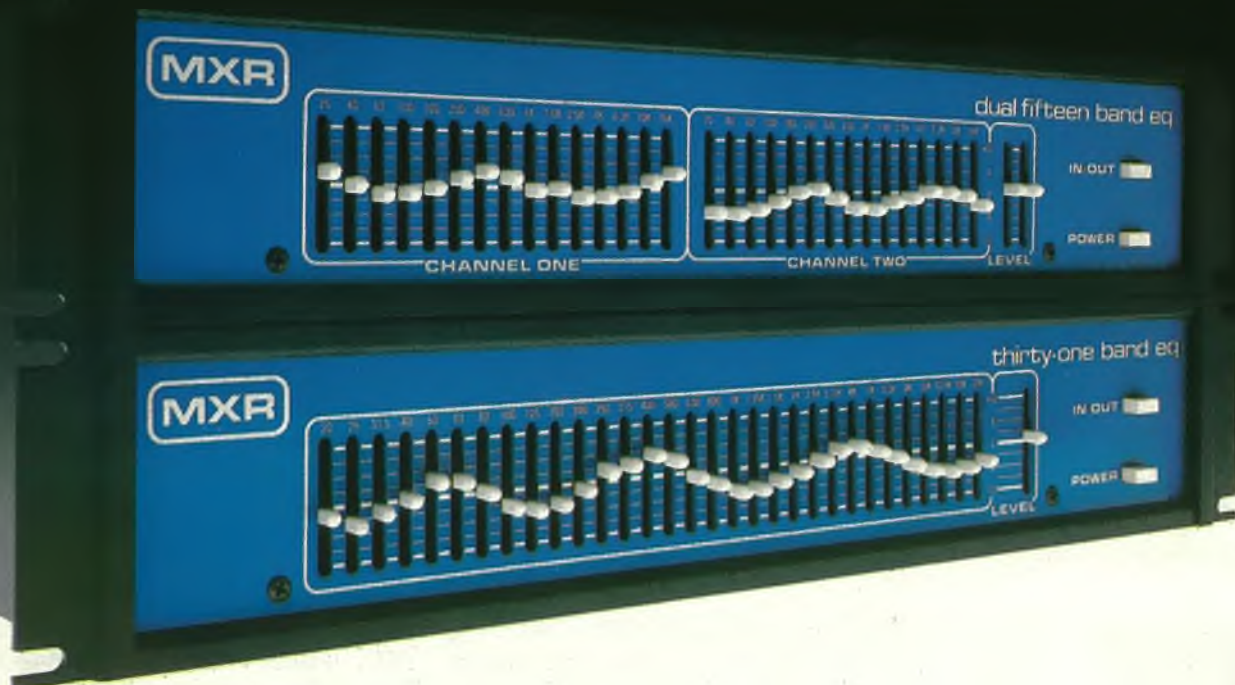

# REW Professional

*We Will Beat Any Genuine Advertised Price*

## Europe's Largest Suppliers of Studio

### EQUALIZERS SOUNDCRAFTSMEN

Graphic EQ's.  
SAE Parametric EQ's.  
JVC SEA 10 (2 x 5 Band),  
SEA20 (2 x 7 Band)  
TECHNICS SH9010 (2 x 5  
Band), SH9090 (1 x 10 Band)  
MXR (1 x 5 Band), (1 x 10  
Band), (2 x 10 Band)  
MM-Pace (2 x Band), SR271  
(1 x 27 Band)

### REVOX

Incredible stocks at  
ridiculous prices!



A77, B77, A700 Off the Shelf.  
High speed, low speed, vari-  
pitch + all accessories!  
Ring us now for the lowest price.

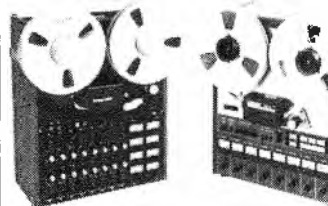

### 8 TRACKS 1/2" or 1"

Both Tascam and Brenell  
Recorders in stock for immediate  
delivery.  
Plus complete range of 8 Track  
ancillaries.

### LONDON LOUDSPEAKER CENTRE



### Hundreds of speaker chassis in stock!

Main agents for  
CELESTION, GOODMAN'S,  
JBL, TANNOY, ELECTRO-  
VOICE, FANE, GAUSS, ALTEC,  
KEF. ATC. CERVIN-VEGA

CELESTION G12 50 STD 12" 50 watt	£20.00
CELESTION G12 50 Aluminium Dome 12" 50 watt	£21.00
CELESTION G18C Bass 18" 100 watt	£44.50
CELESTION Powercell 12" 100 watt	£47.00
CELESTION Powercell 15" 125 watt	£53.90
CELESTION MH1000 Horn 25 watt	£14.00
Plus all other Celestion Models in stock	
GOODMANS 12P STD 12" 50 watt	£18.00
GOODMANS 12PD Disco 12" 50 watt	£20.00
GOODMANS 12PG Lead 12" 50 watt	£19.00
GOODMANS Hifax 50HX Horn 50 watt	£18.00
ATC PA75 Standard 12"	£78.30
ATC PA75 Bass 12"	£81.00

### JBL

REW are the West End's  
JBL Distributors. Large  
stocks at lowest prices.

TANNOY HPD 385A 15" 85 watt	£112.85
TANNOY HPD 315A 12" 60 watt	£85.90
TANNOY HPD 295A 10" 50 watt	£85.90
All models, dual-concentric full range inc. crossover	
GAUSS 12" all models 12" 150 watt	£105.00
GAUSS 15" all models 15" 200 watt	£129.95
GAUSS 18" all models 18" 200 watt	£155.00
FANE POP 50H, 50 watt 12" Bass Speaker	£13.60
FANE POP 70, 70 watt 12" General purpose	£23.95
FANE POP 150, 150 watt 18" Bass Speaker	£47.55
FANE 80L, 80 watt 12" Lead Guitar Speaker	£20.60
FANE 80B, 80 watt 12" Bass Guitar Speaker	£21.55
CRESCENDO 12-150 watt General purpose Speaker	£71.95
CRESCENDO Colossus 200 watt 15" Bass Speaker	£86.40
CRESCENDO Colossus 200 watt 18" Bass Speaker	£92.00

### Just Arrived -

New HH Chassis speakers. Call now for details. All speakers  
carry full manufacturer's guarantee. All prices include VAT.  
Carriage extra. 12" - F1, 15" - C2, 18" - C3. Horns - £1.50

### MICS—OVER 500 ALWAYS IN STOCK!

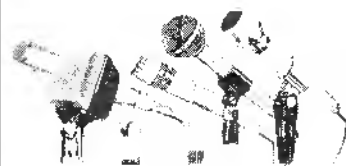

AKG We carry every model  
inc. capacitors  
BEYER Most dynamic + ribbons.  
CALREC 600 Range.  
SENNHEISER Large stocks.  
SONY All models.  
NAKAMICHI All models.  
E.V. Selected range.  
SHURE Very large range.  
NEUMANN All popular  
models.  
+ Cables, Transformers, Stands,  
Connectors & Clips, Windshields,  
etc.

### CANNON XLR'S ANY QUANTITY—SAME PRICE

XLR-3-11C	£1.39 + VAT
XLR-3-12C	£1.06 + VAT
XLR-3-31C	£1.85 + VAT
XLR-3-32C	£1.06 + VAT

### AMPLIFIERS

HH S500D, TPA, All stage  
amplifiers.  
SAE From 2 x 50 watts to  
2 x 400 watts RMS.  
QUAD 405, 303, 50E usually  
in stock.  
JPS A fantastic range of budget  
studio amps.  
AMCRON DC 300A, D150A,  
D60. Trade prices.

**SPECIAL  
OFFER**  
**AMCRON D150A**  
£311 + VAT Few only

### TEAC A3340S

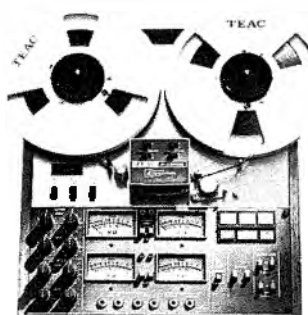

4-channel recorder.  
Symul-sinc. 10 1/2" reels,  
7 1/2 + 15 ips.  
**NOW BACK IN STOCK**  
Prices on application

### MIXERS

The widest range under one  
roof!

From £35-£2500.  
Mixers in stock:  
SOUNDCRAFT 16/2, 12/2,  
12/4 Series II.  
HH 16/2, 12/2.  
MM All models.  
TEAC-TASCAM Models  
1, 2, 3, 5 + Accessories.  
CANARY 10/2, 10/4.  
HILL 16/2, 10/2.  
SONY MX8, MX510, MX650.  
PLUS ALLEN & HEATH,  
JVC, UHER, EAGLE, etc.

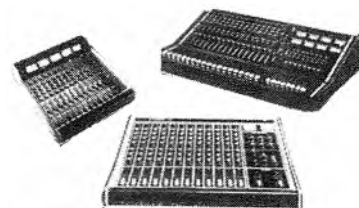

Plus Echoe's, Phasers, Flangers,  
Limiters, Noise Reducers,  
Expanders, Mix-Downs, Mic  
Stands, Cable Drums, Disco  
Gear, Chassis Speakers, Studio  
Monitors, Headphones, Demags,  
Splicers, etc.

# REW

PRO-AUDIO & DISCO: 146 Charing Cross Road, WC2 01-836 2372  
VIDEO & HI-FI: 114-116 Charing Cross Road, WC2. Hi-Fi 01-240 3386 Video 01-240 3066  
TAX-FREE EXPORT & EXPRESS MAIL ORDER: REW House, 10-12 High Street,  
Colliers Wood, SW19. 01-540 9684 ● Also at 230 Tottenham Court Road, W.1.

# The Professional Everything Store

# Audio Established 1948

**Largest Stocks Lowest Prices!!**

## & Stage Equipment

### WEST-END **HH** CENTRE

We carry the most comprehensive stock of HH in the centre of London. Just arrived in stock are the

New Concert P.A. System

New Unit PA System



New SM200 2 x 100 watt mixer amp  
New Digital Multi-Echo

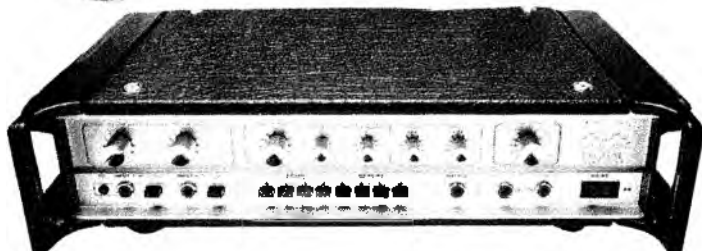

New PRO100, PRO150, PRO200 Speakers  
New HH Chassis Speakers

*All models on demonstration or display*

**Open 9.30 am — 6 pm — 6 days a week**  
**Just walk in — 95% of advertised gear available off the shelf**

Payment by: Cash, Barclaycard, Access, American Express, Diners, HP (Instant credit possible)

**THE LOW PRICE HOT LINE 01-836 2372**

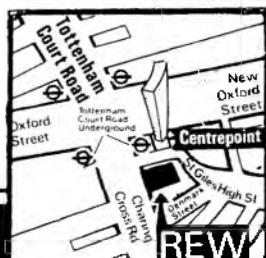

**NEAREST TUBE STATION**  
**TOTTENHAM COURT ROAD UNDERGROUND**

# They look good on paper and sound even better...

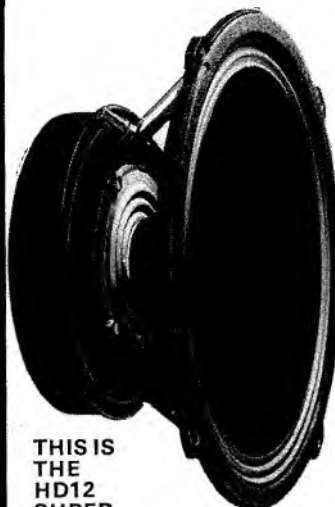

Now we offer 8 fabulous units to put even **MORE MUSCLE IN YOUR MUSIC!**

THIS IS THE HD12 SUPER

Unit	Chassis	Weight Kgs	Power Handling RMS Watts	Sensitivity 1W/1kHz/1m	Flux Density TESLA
HD8	8"	2.6	50	93	1.3
HD10	10"	2.7	50	94	1.3
HD12	12"	4.6	100	96	1.4
HD12P	12"	4.6	100	99	1.4
HD12 Super	12"	6.8	100	99	1.6
HD12P Super	12"	6.8	100	101	1.6
HD15	15"	7.30	100	96	1.6
HD15P	15"	7.30	100	100	1.6

*All Units available in 8 or 15 OHM Impedance: Front or Rear Mounting; Single or Twin Cones*

## Richard Allan FOR A SOUND SYSTEM

Please send me further information on the above units, plus a list of Richard Allan stockists in my area.  
Richard Allan Radio Ltd, Bradford Road, Gomersal Cleckheaton BD19 4AZ, Yorkshire, England.  
Tel: Cleckheaton (0274) 872442  
Telex: 51311 Relays G Cables: 'ACOUSTICS' Bradford

Name .....  
Address .....

IM 12/78

TRADE ENQUIRIES INVITED

# RABBIT'S TALE

The name John Bundrick probably won't mean much to most of the music world – but chances are a keyboards player called Rabbit will. Over the last seven or eight years John "Rabbit" Bundrick has become one of the busiest session musicians on the British scene, although he is now a permanent member of the band Crawler.

Rabbit first came to the attention of the British public following the first break-up of Free in 1971. He joined Paul Kossoff and Simon Kirke, together with bass player Tetsu, to record the album "Kossoff, Kirke, Tetsu And Rabbit". When Free reformed for the "Heartbreaker" album, Rabbit became their keyboards player.

A couple of solo albums followed, sandwiched between some heavy session work which gained him a considerable reputation. His playing, on both piano and organ, is a combination of power and feel that fits in exactly with the music being created in the Seventies.

Seeing his name on so many British albums over the last few years, one could be forgiven for thinking that Rabbit was a native of these shores. But although he has been based in Britain since 1970, he is a Texan boy through and through – which explains the strong country and western influences in certain Crawler material.

He's a lively, effervescent character whose enthusiasm and energy for music hasn't been blunted by countless sessions and continuous gigging. Rabbit still has his idols and still gets a tremendous kick out of working with musicians he respects and admires.

His musical career began at the age of seven, deep in the heart of Texas, when his parents bought him a new "toy" – a piano. "I started playing piano when I was seven and I quite enjoyed it. The only hassle was taking classical lessons. I like classical music, but I didn't want to play it because there was no soul in it. I took classical lessons for three years but then realised that I was ignoring my country and western background. After three years of the classical lessons, a guy named Floyd Kramer came into the country and western market and he was a piano player. It sounded good, more to the heart, so I bought

all his records and used to sit at the piano and work out his style. I used to spend eight or nine hours a day learning to play from the records. I didn't know there were books on how to play like somebody.

"From then on, it was country music for a few years, but eventually that wasn't enough. I started listening to blues and then around 1968 there were people like Traffic and Hendrix around and I went to LA to experience the whole thing for the first time. I heard all this music coming from England, you could see all the emotion coming out, so it was heavy rock music from then."

Rabbit's path to Britain was by no means straightforward. In fact he came here via Sweden. He had been playing sessions in Houston around 1968 when Johnny Nash came into town looking for musicians. Rabbit worked with him and Nash asked him several times to join him. Eventually, Nash ended up in Stockholm writing music for a film and sent Rabbit an air ticket.

"While I was in Stockholm with Nash I had a friend named Rebop Kwaaku Baah. He went to England to join Traffic and said he'd let me know if there was a gig going there. At that time Free had broken up and Kossoff, Kirke and Tetsu were getting together. They asked Rebop if he knew a keyboard player and he played them some of my demo tapes. They said, 'OK bring him over.' So the next day I was in England and went straight into the studio to do the 'Kossoff, Kirke, Tetsu, Rabbit' thing.

"When that folded, Rodgers came back on the scene to do the 'Heartbreaker' album, so I was a full-time member of Free for an album and about three tours. After that folded, I was stuck with nothing to do. The engineer at Island, Richard Digby-Smith, said that there was a lot of time at night in the studios and I could come in and do some demos. Gradually they started to take form and he played the stuff to Muff Winwood who liked it and that became the 'Broken Arrows' album.

"Anyway, Island were impressed and so they asked me to do another album but they wanted me to get



musicians to do the actual tracks because 'Arrows' was all overdubbing. I'd been working with Nash again by this time and the bass player and drummer who are now in Crawler were too. We were in New York and that's where I did the 'Dark Saloon' album, in between time when we weren't working with Nash."

Rabbit was then due to work on his third solo album when he got a call from Eric Burden who had heard "Broken Arrows" and wanted to work with him. Rabbit's third album wasn't going too well so he joined Burden and went touring the States.

By the time he returned to Britain, the bass player and drummer had joined up with Paul Kossoff in the first Back Street Crawler band. Although they did have a keyboards player, he wasn't working out too well so Rabbit was offered the gig. After

---

By David Lawrenson



the death of Kossoff, the band got a new guitarist and became simply Crawler.

From starting out as a piano player, Rabbit soon realised that to play the type of music he wanted – powerful rock – he needed to get into organ. “Probably the first organ I ever owned was a Farfisa. That must have been around 1965-66. The thing eventually blew up on stage. I started playing Hammond in about 1968.

“At that time only the rich kids owned Hammonds and my first cost me \$600. I had been looking through the paper and saw a B3 Hammond for \$600 – it must have cost \$3,000. It was sitting in some rich people’s house. They wanted to buy some other kind of furniture and the Hammond was in the way, they just wanted to get rid of it.

“It was a very old one because it

didn’t have any of the things that modern Hammonds have. It didn’t have vibrato buttons or percussion buttons, just drawbars. It also didn’t have Leslie’s, it had a tone chamber cabinet. I immediately got a cheap Leslie and hooked it up and it was a gutsy Hammond even though it could only make drawbar sounds. If you turned it up it was just like a power-house.

“By that time I was just using Hammond on stage, because it was fashionable to play Hammond then. There were no synthesizers. It was fun, too, because with just one instrument you could put everything into it whereas now, I have to actually think which one to play because there are so many damn keyboards.”

Rabbit admits to not being a technical expert when it comes to his equipment and finds it

hard to keep up with the constant changes in effects and amplification. He is fortunate in having his own roadie, Jeff Perran, to look after all the gear, make sure that everything is working and ensure the sound is good no matter what the venue may be.

Jeff has been with Rabbit for about 18 months, and is well qualified to explain the set-up. He says: “The gear is still changing, but at the moment we have a Yamaha electric grand, a Yamaha YC45D organ and a Hammond 100. It’s not standard; it has been worked on. Similarly, the Leslie’s aren’t standard – they’re really loud.

“The amps have been changing too. Here in Britain we’re using a Fender Twin hooked up to an HH 2 x 15 for Rabbit’s monitors. Normally, for America, we use a three-way ▶▶

# IT'S NO SECRET The Unbelievable Laney Sound

Dear E.M.C.

I am what you would call a very beginning Guitar Player and at the age of 24 it's a hell of a time to begin. I figured that at this age it would be harder to learn to play the guitar so I would need extra incentive. I saved up and bought what I consider one of the best R & R guitars: a Les Paul Custom (Black, Left Handed) Now, I'll never need another guitar! Like my guitar, I would like to have an amp that I wouldn't have to upgrade. (But maybe add a couple more)

I have always liked the sound of Marshall and Orange but they just don't compare to that unbelievable Laney sound. I would love to get my hands on one but the problem is, how?

Since Black Sabbath is the only group that I have ever seen use Laney, and since I have never seen any literature in a magazine about your product, I'm hoping that they are not made exclusively for Black Sabbath. If so I'm S.O.L.

All kidding aside, I would appreciate knowing any little detail about Laney amps, that you could give me. The number of speakers in the cabinet, speaker size, number of watts and most helpful would be the weight. When Black Sabbath comes down next month I'd like to see if I could carry one on my back !!! Sure!

I appreciate your help very much and I hope to hear from you.

Sincerely,  
Mark Rochow.

1809 N. A St. Apt. 4.  
Lake Worth, Florida  
USA 33460.

## BLACK SABBATH

If you would like further information  
please contact -  
Electronic Manufacturing (Sales) Ltd.,  
Devonshire House, High Street,  
Deritend, Birmingham B12 0LP.  
Tel. 021-772 7145/3669.  
Telex: 336409 Fiesta.





system crossed over, that's a 2 x 12 bin, a 1 x 15, then a midrange driver and two tweeters. That's three separate cabinets driven off two Crowns, parametric equaliser and JBL crossover – but that's too loud for the places we play in Britain.”

Rabbit does not play synthesizers, which is somewhat unusual for a top keyboards player these days. The explanation is simply that he doesn't like synths and prefers to work with just what he's got. “I don't want to be known as a synthesizer player. It's probably an inner guilt complex at not being able to play the thing, so it makes me stress the basics more.”

“The more basic the thing is, with a little hint of something extra, that's what I like. What we have been doing is keeping the basic instrument and using effects on that, rather than going for something completely different with a synth. Basically, we're simulating a synthesizer thing because with this Yamaha organ and effects we can get sounds that regular audiences wouldn't know whether they were a synthesizer or what.”

“Effects, that's where we get our synthesizer sound from. The Yamaha's got a ribbon on it and we run it through flangers and stuff like that. The piano runs through an MXR 100 phaser and a compressor, and the Yamaha runs through a Space Echo. In fact, every keyboard runs through the Space Echo. We have this mixing board so that at any time we can put echo on something. We use an Electro Harmonix flanger on the Yamaha, and have the phasers and flangers patched in but it's all very basic.”

“I'm afraid of synthesizers because everybody uses them. If you play them badly, you'll get a name for not being a good synthesizer player. You really have to own a synth to learn how to use one. I've done a lot of sessions where they've wanted keyboards, and they've brought out this huge synth and said, ‘OK keyboards player – use it!’”

“If I owned one, I'd probably learn how to use it, but right now I'm not that bothered. Still, it probably limits the kind and amount of work I do because I suppose some people won't hire me. People who want basic rock and roll piano, just plain basic solidness, come to me. If they want synthesizer stuff they go to other people.”

“I've tried synths and it's embarrassing. The only time I can use one at all is if it's for my own music and I'm the only one in the studio. On the last Crawler album we did, I was going to use an Oberheim. There were people there to programme it, but even they



*Crawler's current line-up, with Rabbit second from right.*

didn't get it together. When we did get a sound out of it, it was false, so instead I went back to the basics and effects.”

Despite his reluctance to dabble in synths, Rabbit is still much in demand as a session player. In fact, he has spent as much of his career doing sessions as on the road with a band. He began his session career at home in Texas and admits that it was something that he just fell into.

“I was the king of the hillbilly sessions in Houston at that time. Everybody used me on their sessions. They'd say, ‘Hey, that kid knows how to play like Floyd Kramer, let's get him on the session.’ One thing that helped was when I started writing my own songs. They were not country and western orientated, they were more long-haired and a bit of smoke, so that made me search out musicians who had a harder core than country music. That's when I progressed from the innocent, yet not so innocent, country and western music, from quiet piano playing into loud organ playing.”

“When I came to Europe I was very lucky. Free must have helped me out there because as soon as I was in Free everyone wanted to know who Ronnie Lane and that was great. happening but all these sessions kept coming in and they were getting better and better.”

“For example, I got a chance to work with Pete Townshend and Ronnie Lane and that was great. Then I was going to do the last Who album ‘Who Are You’. I'd done the rehearsals and I got on really well with them. After the rehearsal I went out

and was so excited that I got drunk and ended up breaking my hand so I couldn't do the album. But at least they had accepted me.”

The list of people that Rabbit has played with over the last few years includes Joan Armatrading, the Sutherland Brothers, Bob Marley, Toots and the Maytals, John Martin, Claire Hammill, Johnny Nash and Frankie Miller. He literally cannot remember the countless sessions he's done but you can find yourself sitting in a pub with him and a tune will come on the radio. He'll pause and say ‘Hey, I'm on this!’ which is exactly what happened during the interview.

He admits that the sessions aren't quite so plentiful these days, and is very honest about the reasons. “I don't know the real answer, but a lot of it could be my drinking. Then again, some of it could be that they're worried about the Musicians' Union jumping on them for hiring someone from the States.”

“It might also be that there are a lot of new up and coming players, plus in England they're not exactly doing the kind of music that we used to do a few years ago. I don't want to know about punk, but they're flooding the studios. The people I used to work with are either in the States or not really working much.”

“I did get tired of doing sessions and got to the point where I would actually disagree. In the early days I'd do anything, but it started to hurt and I started getting in the way of producers and stuff. Now, there's only a few people I work with that I respect – and I stay out of their way.”

# ROSS

T.M.

Made in U.S.A.

EXCLUSIVE WORLDWIDE DISTRIBUTION  
Musical Merchandise Suppliers  
P.O. Box 424  
Lake Geneva, WI. 53147

EXCLUSIVE UNITED KINGDOM DISTRIBUTOR  
Trevor Daniels & Co.  
65 Langdale Road  
Dunstable, Beds. LU6 3BX



£72.00



£98.00



£175.00



£88



£32



£42



£52

all prices include VAT

# Straight-Ahead or Crossover Jazz!

## Guild X-500.

One of Guild's original hand-made acoustic electrics, improved and refined to state-of-the-art perfection over the years.

Today's X-500 has wide frets on a curved ebony fingerboard, humbucking pick-ups, and the famous "harp" tailpiece.

The deep 17"x21" body has an especially fine spruce top with curly maple sides and back, in sunburst or blonde. The sound? You've got to hear it to believe.

Options available:

- DiMarzio pick-ups.
- Stereo wiring.
- Left-handed.

# Guild

MADE IN U.S.A.



Phones: (201) 351-3002 • (212) 227-5390.  
Telex: 138711. A Division of Arnet, Inc.

Guild Guitars, P.O. Box 203,  
Elizabeth, New Jersey 07207.

Send Electrics Catalog B8634-A.

Name \_\_\_\_\_ Age \_\_\_\_\_

Address \_\_\_\_\_

City \_\_\_\_\_

State \_\_\_\_\_ Zip \_\_\_\_\_

My Dealer/City \_\_\_\_\_

In the U.K. send large S.A.E. to:  
Guild Guitars (UK) Ltd.,  
151 Portland Road, Hove East Sussex BN3 5QJ.

# Kimbara

*Exclusive New Models*

*an exciting new world of sound for every electric guitarist . . .*



181/V



182/Y

***Sustain • Distortion • Auto-Wah • Phase Shifter • Power Boost all compactly built into each instrument and conveniently to hand, no need for additional pedals. Ask your dealer for a demonstration now.***



FLETCHER COPPOCK & NEWMAN LTD  
MORLEY ROAD TONBRIDGE KENT TN9 1RA

Name \_\_\_\_\_

Address \_\_\_\_\_

Ref: **IM-Kim**

**Ask your dealer now for details  
or write to us for literature.**

**Martin Drew with Ronnie Scott and  
Oscar Peterson demand the best.  
Martin Drew chose Sonor because only  
the best is good enough.**

**When only the  
best is good enough**

**SONOR**

Sole UK distributors: M. Hohner Ltd.,  
39-45 Coldharbour Lane,  
London SE5 9NR,  
Tel. No. 01-733 4411 Telex No. 24224.

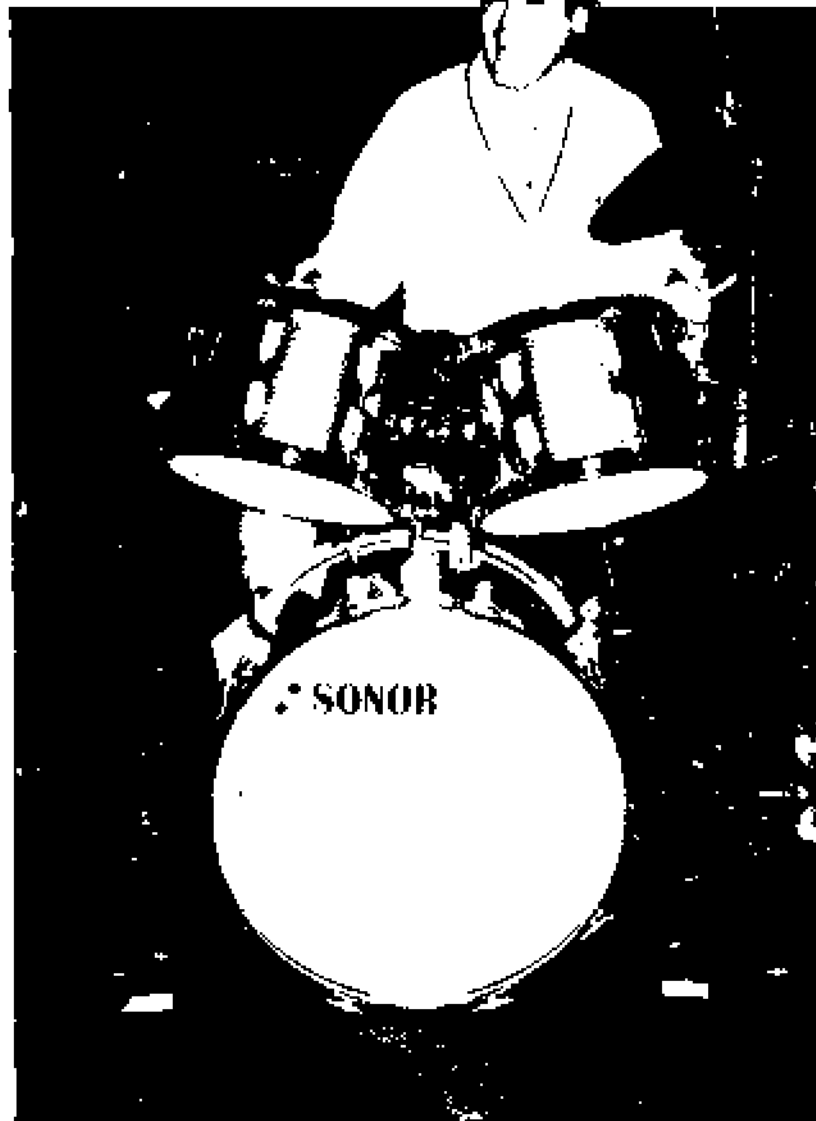

To M. Hohner Ltd.,  
39-45 Coldharbour Lane,  
London SE5 9NR.

*Please send me the  
Sonor illustrated  
brochure and the  
complete list of Sonor  
key dealers.*

Name \_\_\_\_\_

Address \_\_\_\_\_  
\_\_\_\_\_  
\_\_\_\_\_

IM 12/78

# The classical jazz of CHARLIE BYRD

By Jeff Pike

If you try to list on your fingers the guitarists who have successfully played jazz on the classical guitar, you'll run out of names before you run out of fingers. There's Bill Harris, Earl Klugh, the Brazilian Baden Powell, Julian Bream (in private, at least), and a sprinkling of others. If you try to list the guitarists who have made a full-time career out of nylon-strung jazz, with dozens of albums and international tours to their name, the list is even shorter. It begins and ends with Charlie Byrd.

Byrd first came to the notice of British fans in the early Sixties, when his best-selling album "Jazz Samba", with tenor saxist Stan Getz, launched the Bossa Nova boom on an unsuspecting world. The subtle blend of Brazilian rhythms and jazz improvisation was something quite new and established Byrd beyond question as a world-class instrumentalist. But his musical roots stretch back much further than that. In fact, the Bossa Nova explosion was only one phase of a career that has swung in very different directions at different times.

Phase One was a steady but unremarkable development from musical schoolboy in Suffolk, Virginia, to professional jazz guitarist in New York. Charlie first picked on a guitar at the age of nine, taught by his mandolin-playing father. His first professional gig was with a local dance band and he went on to tour Europe with a US Army show band (a tour which took in Paris, where Charlie met and jammed with Django Reinhardt). After leaving the Army, he settled in New York and played orthodox, plectrum-style electric guitar with a number of jazz groups.

Charlie recalls that period in the Forties: "I listened to Django as much as anyone. I also listened to Charlie Christian a lot and went through a period playing with groups who liked that style. But I never had the ear or the inclination to really copy anyone. I found that tedious and uninteresting. When I was just a kid, the first Django record I ever heard, I said I'm going to learn that improvised solo. So I sat down and I got about halfway through it. For a good 15 years of my life, I remembered half that solo — it was 'Some Of These Days'. I found it as boring as hell to play.

"I think that you can learn from other people's solos, but my approach to, say, Charlie Christian, when I played with groups who wanted that style from me, was to try to emulate the feeling and the phrasing and the sound, rather than playing his exact ideas."

So far, so good. But around 1950, Charlie Byrd discovered the classical guitar. End of Phase One. Phase Two involved his moving to Washington, DC, studying classical guitar with Sophocles Papas — and virtually giving up jazz completely. "I gave it up in that I stopped doing any serious work, work that *involved* me. I did a lot of teaching, I worked in theatre pit bands, did



a few sessions — all things that didn't involve a commitment on my part. Strictly for the money. I didn't want to be with a jazz group that was *serious* about jazz. My head was into the classical guitar and I didn't want anything to interfere with that."

Perhaps surprisingly, it didn't even occur to him at first how his new discovery could be applied to jazz. "I became very engrossed in the classical guitar, its heritage and its literature. That intrigued me so much, I really didn't give a lot of thought about what I might do with it. After a few years, I was playing small classical concerts, in art galleries and music clubs and stuff like that. I was realistic enough to see that a full-blown concert career wasn't much of a possibility, but I thought that, through teaching and some playing, I could make a living at it. It only occurred to me later to apply this to popular music and jazz. I don't know why I didn't think of it before . . ."

It was a string of happy coincidences that launched Phase Three of the Charlie Byrd story. One was his first experiments at arranging popular songs for the classical guitar. "I'd done eight or 10 tunes, Richard Rogers songs, Cole Porter songs and so on, and I'd even made a demo tape to take round to anyone who might be interested." But he didn't have to bother. Around the same time, he received a glowing review for a gig he had played on electric guitar ("strictly for money") in a Washington club. The review was read by a producer for Savoy Records, who promptly called Charlie up.

"It was almost uncanny," he says, "in that someone calls me and asks if I'd like to make a record at exactly the time I had something in mind that I would like to record. If he'd called me three months before, I wouldn't have known what to do. So the idea came to me and I never had to promote it, I never had to go round and knock on anybody's door and say would you be interested?"

The resulting album — standard tunes played in jazz arrangements on classical guitar — didn't exactly sell a million, but it attracted a welter of glowing press reviews. (And the following year, on the strength of that record, Charlie won the New Star

The Great Guitars (l to r):  
Charlie Byrd, Barney Kessel  
and Herb Ellis



award in the Critics' Poll in "Downbeat".) He started playing jazz more seriously, injecting more and more numbers on classical guitar into his set. Then came two more strokes of luck which confirmed the course his career would take: a residency at a prestigious Washington jazz club and a weekly television show for a local station.

In the mid-Fifties, his reputation spread from the East Coast throughout the States, thanks to tours with his trio (guitar, bass and drums) and a series of albums that ranged from interesting to impressive. He was constantly expanding his musical limits, discovering more and more things a jazz player can do on the nylon-strung guitar but never diverging far from the strict classical approach to fingering. "My starting-point is a classical technique, but the emphasis is in a different place. In an improvised solo you don't have to be so concerned about tone as you do in certain kinds of classical pieces. And there are some techniques, like bending strings and sliding on to notes, that are typical of jazz, which I wouldn't employ in classical music. I sometimes do that Chet Atkins thing with the thumb and finger — which is also part of the old lute technique — but that's only for certain effects. Basically, if I play a scale-type passage, I use the regular classic apoyando technique."

Then came Phase Four — the Bossa Nova experiment, which was successful beyond his wildest imaginings. It grew out of a tour by the trio to South America, where Charlie became captivated by Brazilian rhythms and melodies. Although the boom dwindled, as booms will, and Bossa Nova today means little more than a strict-tempo routine on "Come Dancing", Charlie hasn't lost his love for the Brazilian samba. His set invariably includes a tune or two by composers like Antonio Carlos Jobim and Joao Gilberto. It usually includes a few straight classical pieces, too.

He explains: "I don't play too much classical music in my programme — maybe 15 to 20 minutes in each set, a total of half an hour or so every night. I usually include something baroque — a couple of Bach pieces or Vivaldi — and probably something Spanish. Villa-Lobos perhaps, if I'm in that kind of mood. I don't try to stick to the 'popular classics', like 'Jesu Joy Of Man's Desiring'."

Most of his public playing today is in the trio context — "We do a lot of clubs, some concerts, colleges, whatever comes along" — but a few years ago, Charlie found himself playing in yet another area, a sort of jazz Mini-Hall of Fame. It was an Australian impresario's idea to bring together three of the world's finest guitar players, Charlie, Barney Kessel and Herb Ellis. Charlie recalls: "That first tour wasn't just a success with audiences, it seemed to have a chemistry that caught on. We enjoyed working out some charts and playing



### "Most of my time is spent trying to do what I do better"

together, and that was contagious to the audience. They seemed to sense how much fun we were having so we decided to keep it together on a part-time basis."

Now, nearly five years later, the formidable threesome still tour together three or four times a year, under the rather grand title *The Great Guitars*. Each of the trio takes his solo spots, but most of the time two or three of them are in action together — which causes all sorts of difficulties, since Charlie's classical sound has to be balanced against Ellis and Kessel's more regular electric guitars. On their recent British tour, he compromised by using an Ovation Classic acoustic electric. It still wasn't easy: "The inherent problem with the instrumentation is matching the amplifiers to the situation you're in. It's an ungodly problem, an insoluble problem. Even when we carry our own amplifiers, which we didn't on this tour, no amplifier works good in every situation. In one size hall you get just what you want, then you move on to somewhere larger or smaller and there are terrific adjustments to be made."

It might seem that with three such capable soloists on stage at the same time, there would be problems knowing just *what* to play. Not, apparently, so. "How to voice things for three guitars, that's never been a problem. The first arrangements that we did, most of them by Barney, weren't written down at all. He just had them in his head and we kinda came up with things that worked. We learned a lot in the process, and we're still learning, but by now we know a lot of things that do work well. For instance, sometimes the difference in timbre between my guitar and the other two allows me to do things like play a harmony part above them, the same way a clarinet can play a harmony line above the trumpet in a Dixieland band without distracting from where the melody is.

"When we put our minds to it, we can still find new things for three guitars to do

together. It still has a lot of possibilities we haven't tried. To be honest, I don't think we work at it hard enough. We had planned to do some creative work on this tour, but we've been so busy that nobody's got the energy left. We did discuss some basic ideas, but what we lack is the time to sit down and work on things. We all live in different places: Barney is in Europe as much as he is in the US, Herb lives in Los Angeles and I live on the East Coast. Three people playing together couldn't be much farther apart than that!"

When it comes to working on his own technique, Charlie is much more disciplined — as befits a serious musician who once studied under Segovia. "I practise every day. I always have a guitar by me. I guess I could lay off for a while and then have some time to practise. Even on a tour like this, with all the playing, because I'm not practising every day I can feel the deterioration of technique."

And what form does this dedicated practice take? "I do maybe 20 per cent of whatever time I have on what you might call callisthenic practice, which might be scales, hammers and snaps, sometimes even apoyando on open strings, just basic exercises. That kind of thing I like to do for half an hour or 45 minutes, or if I'm doing a really good day's practice, maybe an hour of that. Then it will be pieces. I usually have some classical pieces that I'm working on at different stages, some that I'm trying to get back under my fingers, some that I've just started working on."

His continual efforts to improve on a technique which would more than satisfy most of us are matched by a continual struggle to get his personal sound on to record. In common with most acoustic players, he feels he's never got it quite right. "It's a problem for every classical guitarist and it's an even bigger problem when you're faced with having to balance it with other instruments. I don't know if it will ever be resolved. I've tried recording in lots of different ways. It's not just the way the guitar is miked, it's the different room, the different acoustics . . . I've done two recordings direct to disc and in some ways that's very good — the presence and everything. But it's very hard to do because you have to do all those tracks without stopping to retune, and you can't turn the pages of the music."

The quest continues. After a career that has taken so many sharp changes of direction, you wouldn't be surprised to find Charlie Byrd launching on a new course any day now. But he insists he knows where he's heading. "I think I've bitten off a hell of a chunk for myself, to do what I do already. So I don't feel in any great need of finding another completely new direction to go. No, I'm very content with what I'm doing. Most of my time is spent trying to do what I do better."

# Built the way your customers say "they" don't build them anymore...

**and, in many ways,  
we make them even  
better!**

- No gimmicks, no shortcuts — just the finest instruments we can build. Power-Forged, aluminum "T-neck" (pat. pending) and ebonol fingerboard guarantees no warping or twisting. Select wood inlays in the back of our neck combine the strength of forged aluminum with the warmth of wood for playing ease and comfort.
- Kramer guitars feature Schaller machines positioned to let you tune into perfect pitch quickly and easily.
- All Kramer bodies are made with fancy-grade figured maple and American black walnut, and are finished with our brilliant DIAMOND-COAT (TM) that both protects and enhances.
- Kramer pickups have an extremely strong magnetic field to achieve excellent response with low distortion, low noise and great sustain. Along with our tonal network, it is possible to get the sound of virtually any other guitar or Kramer's own great sound.
- Our adjustable bridge enables an artist to correct and set the action and intonation of his instrument. Speed knobs are standard on all models.
- Aluminum nut enhances sustain and will not crack or break. Zero fret design guarantees every Kramer guitar the best action possible and assures open string intonation accuracy by eliminating the wrong point of contact through nut wear.
- Custom-tooled aluminum and stainless steel are used for all inlays, hardware, nuts, bridges and cover plates. All models have adjustable pickups and precision body contouring designed to make every artist completely comfortable with his instrument.

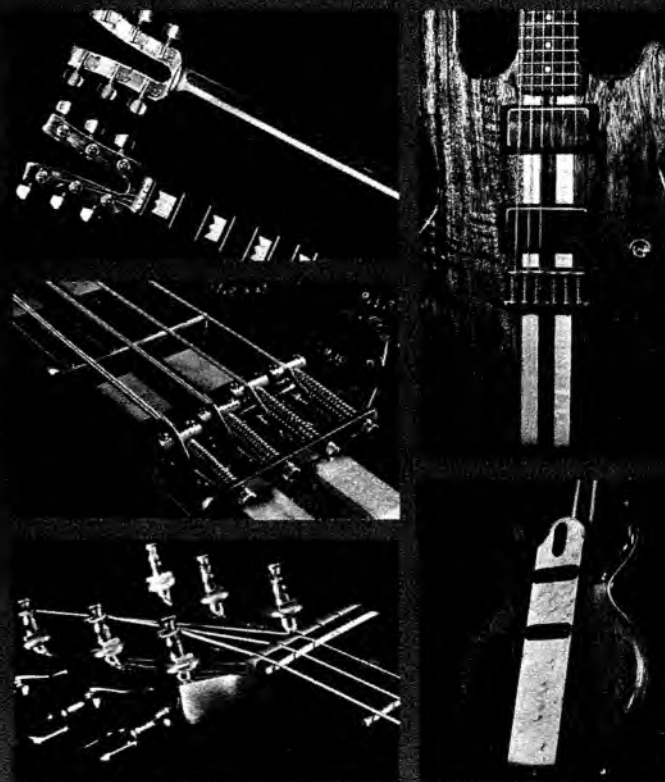

At Kramer, we have one purpose, one goal: to offer the serious musician a quality instrument in demand for surpassing those on the market, at a reasonable price. No other fretted instrument manufactured for ability, the versatility of sound, the quality of electronics, the precise intonation, the amazing sustain and a clean, functional design. Ask well-known artists like Dave Hope of Kansas, Toy Caldwell of Marshall Tucker, Hank Williams Jr., The Lenny White Group, The Oak Ridge Boys and many more.

Each of our eight models goes through numerous inspections at every stage of manufacturing, the last being a trained professional playing each instrument to check out every detail before it leaves our plant. And we back each model with Kramer's solid warranty.

Machines never replace people at Kramer! Each instrument is virtually handmade with the pride of old world luthiers, coupled with technologies and advances of today. Kramer is not 'just another guitar', but a hard worked dream of many people to achieve the ultimate in guitar manufacturing.

At Kramer, quality is not just a word.  
It's a must!



# Kramer



For information contact:  
**BKL International Distributing**

1111 Green Grove Road • Neptune, New Jersey 07753  
201-922-8600



# **THEATRE PROJECTS**

10 Longacre, London WC2. Tel: 01-240 5411

## **SYSTEMS & COMPONENTS FROM**

**ALTEC** & **STAGESOUND**



**STOP PRESS** – Visit the Theatre Projects new shop,  
10/16 Mercer Street, London WC2.  
Professional Trade & Export enquiries to Mike Ingram 01-240 5411

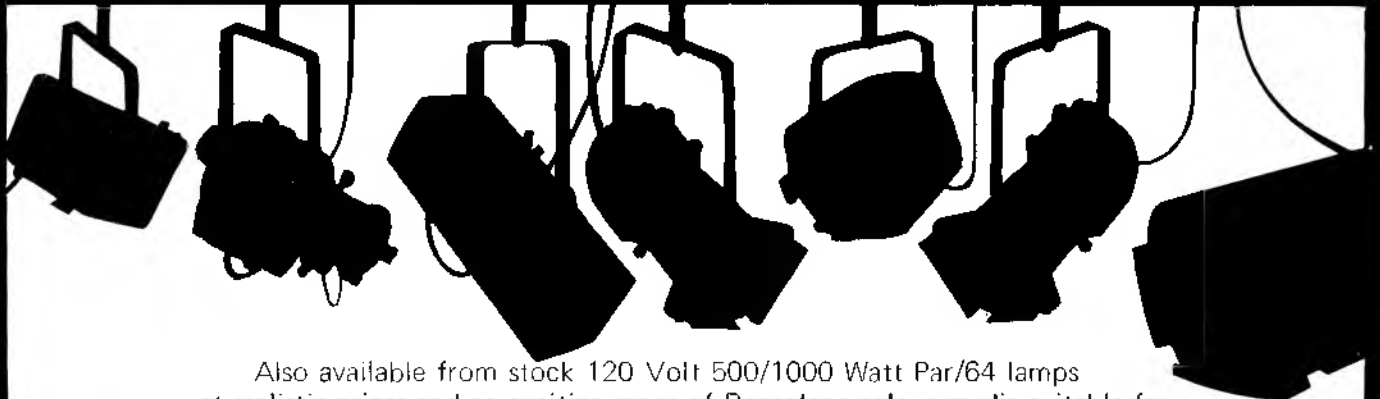

Also available from stock 120 Volt 500/1000 Watt Par/64 lamps at realistic prices and an exciting range of Roscofene colour media suitable for Par/64 lighting units together with any other applications your ingenuity can devise. Naturally, we also keep a range of theatre lighting equipment.

# 'Play Me A Rainbow'

Pick up the Roland Guitar synthesizer and let your heart sing! Open up a new world of creative possibilities: Be a brass section, be a string section, be a bass guitar – all at the same time!

Roland gives you music. Bend a note, the synth bends with you, throw a switch for infinite sustain, split the output through three separate amps so your sound fills the stage like an orchestra. Never has a single instrument offered so much. "Play Me A Rainbow On A Roland Guitar Synthesizer".



Roland

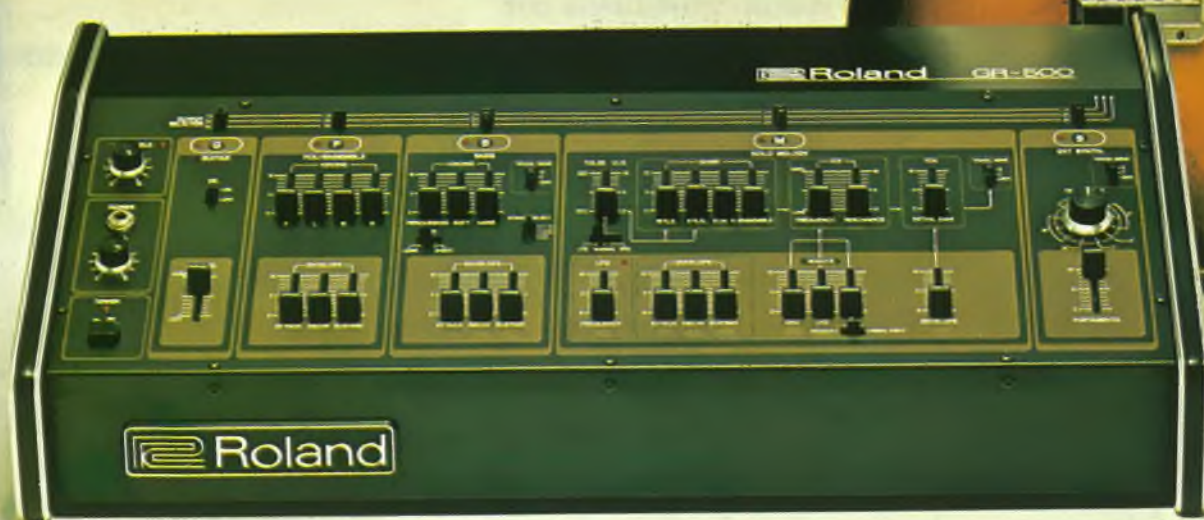

Brodr Jorgensen (UK) Ltd., Great West Trading Estate, 983 Great West Road, Brentford, Middx. TW8 9DN.  
Telephone 01-568 4578 Telex 888941 Chamcom London.



# "When I'm with Kustom, I have no problems."

Mixing it up with Red Roe, of the "Midnight Special".

**When did you start with Midnight Special?**

I was in on it from the beginning. I'm the only original engineer left on the show.

**In fact you and producer Burt Sugarman are the only originals still with the show. What keeps it going on?**

Burt's a down-to-earth cat who's got a whale of a TV show. I guess you could call it a success because there's a lot more people who care, from our end of it, than they do on other shows. People seem to pump out more. We do a lot together and we kinda keep each other loose.

**The music ties all of you together?**

Music is a helluva outlet. I really get pumped up on the show. It's cookin' on the natch, it really is.

**Cookin' on the natch??**

Natural high . . . it's the only way to go.

**You've been using Kustom PA and mixing equipment on Midnight Special for three or four years now.**

**Any problems?**

Technical problems? No. As a matter of fact, I'm a firm believer that Kustom does kick. It's good. And when it's good, you don't have to worry about it.



Red mixes sound for the Midnight Special with a Kustom SRM XX 24 in, 8 out. Stage set-up includes 8 each MF 1212 cabinets and MF 1012 horns, 4 XII Bi-Amp Slaves, and 8 sets of III Monitor Systems.



**How about your Kustom mixer?**

This is one helluva board. As a matter of fact, it's a better board than the main mixer on the show. That mixer was made for television and this board is made for music. It gives me what I need.

**Did you ever use Kustom equipment before you came to the Midnight Special?**

Oh yeah . . . in Texas . . . Oklahoma . . . back when I was a roadie . . . a go-fer in several of the PA houses in some of the towns I worked in.

**Back in Kustom's roll and pleat days?**

Yeah, Tijuana tuck 'n roll!

**Are there any features you especially like about Kustom?**

Sure, all of them . . . and that's the truth.

**Is the music on Midnight Special your own kind of music?**

I just like music. I love all kinds. Music speaks the language of the heart. All music does, but to me I understand country music more than I would understand Prokofiev or Tchaikovsky. I don't feel out of place listening to the Juilliard String Quartet or the Oklahoma Symphony or any of that jazz. It's just that I'd rather kick back with a cup of coffee and listen to a country western group any day.

**You have to deal with a lot of different personalities on the show — the groups, the hosts, and so forth. How do you manage it?**

When I let people know where I come from, that makes it a lot easier. As long as I'm honest with myself, that's all that counts. I say hello to myself every



morning. I have a sign over my mirror that says if I can't smile at this person, I can't smile at anybody.

**But handling the sound for a show like Midnight Special is a great deal of responsibility. . .**

It depends on how you look at it. I'm just a person who was put in a position, that's all. I'm a Group 2 engineer, like the guys down on the floor. I just kinda roll with the flow, that's all.



When sound is everything. . .

Chanute, Kansas 66720

DISTRIBUTED IN ENGLAND BY TREVOR DANIELS & CO.  
65 LANGDALE ROAD DUNSTABLE  
BEDS LU6 3BX TEL. 0582-600053

# DRIVERS WANTED FOR A.S.S. RADIAL HORNS

A.S.S. horns are designed to provide optimum loading for all good compression drivers producing a wide, even sound dispersion in the horizontal and vertical planes at high pressure levels. The material used in the construction of the horn is a fibreglass derivative which exhibits extremely non-resonant properties over the audio frequency spectrum. Using this material it was possible to produce a flare rate best able to give the smooth response and wide dispersion characteristics required. The 'peaky' response generally associated with horns has been totally eliminated making this unit ideal for mid to high frequency reproduction in low or high power P.A. systems.

The horn is available in three versions:  
TRF 570/S - 1 - inch threaded throat  
TRF 570.1 - one inch throat for plate mounting drivers  
TRF 570.2 - two inch throat for plate mounting drivers

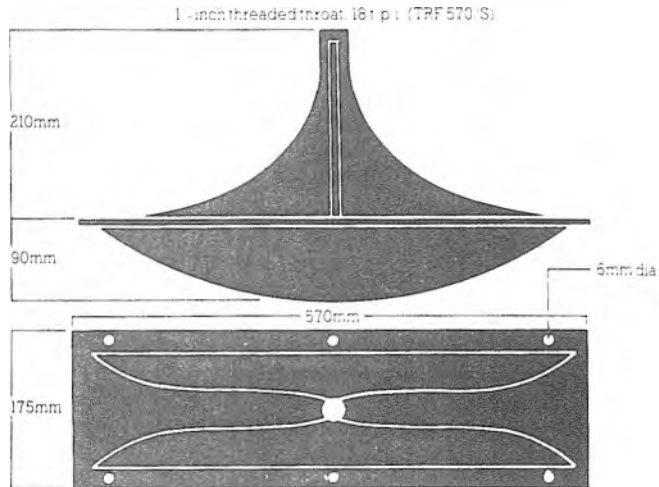

H403 - two inch throat for plate mounting drivers  
Adaptors are available for one inch plate mounting and 1 1/2 inch threaded drivers

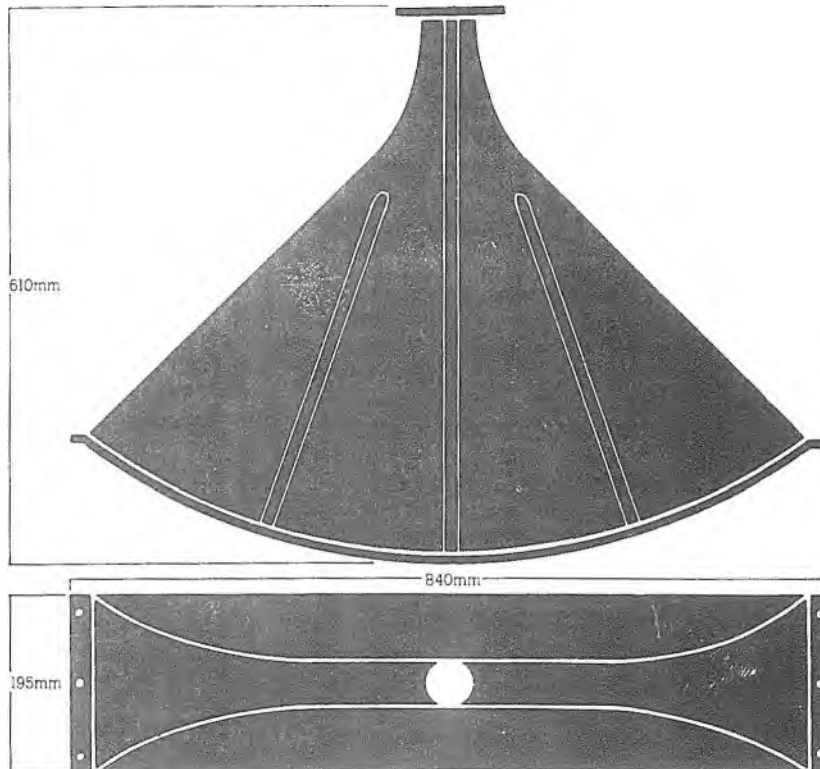

ASS Radial Horns are distributed by:

*Mick  
Johnson  
& Music*

277 Putney Bridge Road London SW15 England  
Telephone 01 788 3491

# LOGAN

## LINE UP THEIR PROFESSIONALS

String  
Orchestra  
**£570**



T 242  
RAM  
**£690**



Already famous throughout the Music World for their reproduction of String Orchestral effects, Logan have created a range of professional keyboards designed by specialists for use by the most discerning of musicians.

Just look at the specification of the fabulous Caravelle T 249 Portable with its built-in String Melody, host of flute and orchestral voices, comprehensive Synthesis, Piano & Percussion section, intermixable rhythm patterns — to name only a few basic features — **Unbeatable Value at £1,490 R.R.P.**

Why not ask your local Dealer NOW about the Logan Professionals or write to us for more information.



Caravelle  
T 249  
**£1,490**

*Recommended  
retail prices  
including VAT*

Piano  
String Synths  
**£750**

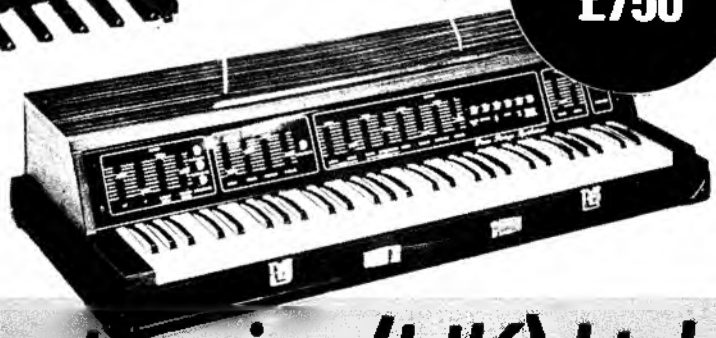

## Logan Electronics (UK) Ltd

John M. Edgar, Managing Director, Logan Electronics (U.K.) Ltd.,  
Unit 3, Queensway Industrial Estate, New Milton, Hants. BH25 5NN  
Tel: (0425) 618220 Telex: 965649 Teleca G.

# THE LATEST FROM THE GREATEST



Pro-line 815 – from Leslie, the leaders in speakers. It pumps out 215 watts RMS of Discrete Quadrasonic Amplification but there's nothing discreet about this one – there's quality in the sound and it hits you. Hearing is believing but how's this for a whole bunch of features:

- Solid state, 2 channel bass-reflex speaker system.
- Stationary channel has a specially treated 15" woofer for pedal and bass tones and three matched 6x9's at front and sides for a wide spread of mid-range and treble frequencies.
- Sound in Motion rotary channel has 2 rotors.
- High compression treble driver and rotary horn for the upper range.
- Newly designed Rotosonic drum for the lower range.
- 4 separate volume controls and treble response sliders; create your own response curve!
- The 4 amplifiers virtually eliminate pedal keyboard intermodulation "garble" to give a superb, clean top-quality sound.

So go along to your Leslie dealer for a try out and he'll take you through the whole bit.

**PRO LINE**  **815**  
**Leslie**  
SPEAKERS

Details from: LESLIE SPEAKER DIVISION  
Boosey & Hawkes (Electrosonics) Ltd.,  
4 Brick Knoll Park, Ashley Road, St. Albans,  
Herts AL1 5NX.

*A member of the Boosey & Hawkes group*



# AYNSLEY DUNBAR



Aynsley Dunbar is a frequent choice as the "drummer's drummer". In a career spanning nearly 20 years he has played almost every type of music, showing amazing technique and unusual sensitivity. Dunbar began playing in his early teens, working in local groups in his hometown, Liverpool. His first professional job was with the Mojoes, a Liverpool band who had a Mersey Beat era hit with "Everything's Alright". Late in the Sixties, Dunbar replaced Mickey Waller in John Mayall's Bluesbreakers to record "Hard Road" with one of Mayall's finest line-ups — Dunbar, John McVie, Mayall and Peter Green. He went straight from the Bluesbreakers to form his own band, Retaliation, with guitarist John Moreshead, bassist Alex Dmochowski and singer Victor Brox, who doubled on keyboards with Tommy Eyre.

**STEVE ROSEN**  
talks to one  
of Britain's  
most successful  
exports

A brass-powered band called Blue Whale was Dunbar's short-lived successor to Retaliation, then he went into Frank Zappa's Mothers of Invention. Dunbar recorded four albums with the Mothers and later toured with two other Mothers graduates, Flo and Eddie. Aynsley worked with Lou Reed and recorded with David Bowie before forming Journey. Journey is a San Francisco-based band that includes Dunbar, Ross Valory on bass, Gregg Rolie playing keyboards, Neil Schon on guitar and Steve Perry singing. They are all very experienced musicians. Valory played with the Steve Miller Band, Perry worked with Tim Bogert and both Schon and Rolie were members of Santana. Journey have enjoyed great success in the US. IM caught up with Aynsley Dunbar in San Francisco and he told his story from the beginning. ►►

# AYNSLEY DUNBAR

*What kind of musicians influenced you?*

Everybody did. When I started playing drums, I was about 13 and there were a lot of rock shows on TV. I used to watch the drummers and I started to think that maybe drumming could be interesting. I started to get a few drums together and continued adding piece by piece, until I had a full kit. I used to go to a drum instructor after school who taught me a lot. I'd buy Gene Krupa and Buddy Rich albums and play along with them for practice. I used to listen to anybody who was interesting. Those kind of drummers did very "musical" fills. Buddy Rich did a tacky kind of music, Max Roach was avant garde and I used to love Elvin Jones' rhythm patterns.

*At what point did you start playing with other people?*

When I was 15, I started out with my own trio and later joined some other bands working around, doing small gigs. I was more practised than most other people playing in Liverpool at the time so I came on the scene like a professional when most of them were pretty amateurish in their styles.

*Did you know Lennon and McCartney in those early days?*

Not until I started going to a club called The Blue Angel. I used to play in a trio there occasionally. Ringo Starr and those guys used to come down there and I got to know them. Later on, I moved down to London and got to know them there. Then, later on of course, I did "200 Motels" with Ringo and one side of Lennon's "New York" album.

*You nearly joined Zeppelin at one point.*

Well, what happened was that, after I left Beck, Peter Grant asked me if I wanted to do the last Yardbirds tour of America. I had already formed Retaliation and told him I had my own band and couldn't really do it. He said "Well, Jimmy Page wants to do something on his own afterwards" and I said "Well, I'd love to do it but really I have three other people depending on me for work." It was my sense of everybody else's well-being which I should have forgotten, because he then formed Zeppelin! I could have been with ELP as well. It always happens as soon as I start a group, I get offered a job in another band. I'd been working with Retaliation for two or three months when the ELP offer came. The band would have been upset but what I should have done is taken the offer.

*When you went pro with the Mojos, what kit were you using?*

I had a German Trixon kit with a pear-shaped bass drum. Later on, I got a Ludwig kit.

*Were you still playing a Ludwig kit with Retaliation?*

Yes I used Ludwig all the way up until I joined Zappa.

*How did that come about?*

I was playing with Retaliation at a big outdoor festival and Zappa was doing the announcing. A friend of mine brought him over to the stage where we were playing, and asked if he could sit in. I said "sure" and he sat in on a couple of songs. Afterwards, he came back and told me I could make a lot of money being a session man in LA but, again, I was still being mother to the band and felt I couldn't do it. Later on, when I was with Blue Whale, I went down to the Speakeasy one night and there was a

message on the door for me saying Zappa was there and he wanted to talk to me. He asked me to join Hot Rats and I turned it down but, within a week, I had changed my mind. I spoke to the guys in Blue Whale and said "Whatever I think, I've passed up too many gigs to be passing up this one." So Zappa "imported" me over and I joined Hot Rats and later the Mothers and continued playing with him until '72. After that, I was with Flo and Eddie and did the Alice Cooper tours in Europe and the States.

*How did you get together with Bowie?*

After the Flo and Eddie gig, I did a Lou Reed album and Bowie asked me to do his last night with the Spiders at Hammersmith Odeon when, coincidentally, Beck also played. I wanted to do it but Lou wouldn't let me because he said we were going to do a session. He called the session just so I couldn't go and do the Bowie gig because there was some kind of bad feeling between him and Bowie. I joined Bowie later on but the only reason I stayed with him for six months was because I was being paid to do nothing. I was just travelling between LA, France and London. I had an apartment in London and a house and car in LA and I was going across to Paris to do "Pinups" and "Diamond Dogs". Eventually Bowie invited me on a holiday to Rome and I went over there and spent two days with him but it was so depressing I had to leave. I went back to LA for a while and later went to London to start another Bowie album. It was around Christmas time and Tony Defries handed me a nine sentence piece of paper, asked me to sign it and called it a contract. I said "I'm sorry, I can't sign this because it's all for you and nothing for me." He said "If you can't sign it, then we'll have to split up our situation" and I said "That's fine with me, I'll be on the next plane home tomorrow." That was when I went back to LA and started with Journey. I liked the music, it was progressive and I'd been playing dead simple for so long.

*What kind of drummer do you consider yourself?*

A rock drummer. I like playing jazz but I'd rather play progressive rock because there's more feel to it.

*What makes an Aynsley Dunbar solo different from a John Bonham solo?*

I'll leave that for everybody else to tell me. I think it's down to technique. Also, I notice a lot of people leave when John Bonham plays and most people listen when I play.

*Do you like the sound of John Bonham's snare on record?*

Yeah, and his bass. I think he uses both heads on the bass drum because it gives you a bigger, thicker sound, but it doesn't travel or cut on stage. I have a hole cut in my front bass drum head. It actually cuts the bass sound out on stage, it's more of a click, but it makes the sound travel.

*How would you describe your technique?*

A lot of times, it's just instant feel. I don't have to sit there and work things out — it just happens. A lot of drummers get so stuck on having to learn a basic pattern of a song that they don't feel it, it's not natural. I may play a quick fill instead of a quarter note if that's the way I feel.

*So might you play a song differently on two nights?*

Yeah. Maybe the fills more than anything else and some of the rides for the solo. Most





of the background behind the vocals will be the same so the vocalist knows what's going on. But, even then, the fills will be different.

*How important is the bass player?*

I'd say he's very important. I was noticing the other night Ross (Valory, Journey's bassist) had a new amplifier and I can hear him a lot cleaner on stage. Without a solid bass player, forget it.

*Do you think in all the different bands you've played, your style has changed each time?*

Yeah, it all depends on what music I'm playing. If you're playing one session which is rock and roll, you're not going to play jazz on it. And on the other hand, if you've got a great technique you don't want to show it playing rock and roll. I listened to Fleetwood Mac a lot, just so I could get a simple, straightforward and effective beat. Just to hear what was selling. That's important. To play rock and roll you have to be simple. You can't leave the people in the background. If a musician says something is fantastic, the album is not going to sell. Basically that's where it's at. But if the public says an album is fantastic, then you're on the right road.

*Is there recorded work you've done which you think stands out?*

I don't know. I don't think about that kind of thing. I liked Nils Lofgren's first album and "Cry Tough" as well.

*Would you like to do a drummer's album?*

I will do one sometime in the future.

*What about people like Billy Cobham and Tony Williams, do they influence you?*

I listen to Tony Williams a hell of a lot. Billy Cobham has just come on in the last few years. But I like them all. I hate to have to say I listen to anybody so much that I would know when I'm hearing them. But I think I would know Billy if I heard him because he has his own style. My idea is not to follow anybody to the extent of copying him, so I listen to a lot of different people. I never listen to one thing too much. I don't sit down and learn anybody's licks, I just do it all by ear. If I did that, I'd play just like everybody else and I don't want to do

that. If you get stuck on one drummer you start sounding like him.

*Do you practise?*

All the time. I practise as much as I can although I don't practise every day. You fall into too much of a rut if you do that.

*What kinds of things do you practise?*

Co-ordination between my hands and my feet. I'm writing a book right now on double bass drum technique, because there are no books out there that help with that. Helping to co-ordinate the mind between the hands and the feet so you can play left foot and right hand together. It means a lot in soloing. It also means a lot during the song because you can roll with the bass drums while you're playing a straight beat on top. You don't have to depend on the right foot leading with the downbeat.

*How long have you been playing double bass drums?*

About 2½ years. The band needed something more driving and more solid because we play a lot louder on stage than most bands do. We try and get the same focus of sound as we would if we were playing in a small club.

*Was it difficult to work in a second bass drum?*

Well, I'm still learning after 2½ years. My left foot will never be as good as my right foot but it'll be there. It's getting more accurate every day. I can play paradiddles on it and other things like that. There's really not too many people who do much with double bass drums. Ginger Baker might have been the one guy who could have tried but even he didn't — he got stuck in his old-fashioned routine. He plays better solos on a single bass drum than he did with two. I used to see him playing a small drum kit when he was with Graham Bond.

*What set-up are you using?*

The bass drums are 24" with 8", 10", 12" and 14" tom-toms across the bass drums. The floor toms are 16" and 18" and the snare is 14" x 6½". The drums are all Ludwigs but the bass pedals are Pearl. I use a Rogers hi-hat and the hi-hat cymbals are Zildjian. On my left, I have a Paiste 22"

crash ride, second left there's a Zildjian 22" swish cymbal, then a Zildjian 18" crash and a Paiste 22" heavy ride. Above my 22", I have a Paiste 20" Chinese inverted cymbal.

*Do you use the same set-up in the studio as you do on stage?*

Yeah. They usually like the snare drum to be sloppier so it gets a bigger sound and spreads more.

*Do you use the light ends of your sticks?*

Yeah, but I'll invert them on some real heavy passage. I'll invert the left so I get more of a solid sound. It's better to use matched ends or else you're going to get a heavier sound on one side.

*How are your drums miked?*

I have two Sennheisers across the top picking up overhead and an 88 in the centre which is the overhead mike for the whole kit. I have Beyer 201 mikes under all the tom-toms, a Shure 87 on the snare drum, a Beyer on the hi-hat and RE 20's on the bass drum.

On stage, I have two 18" speakers behind me driven by one side of a 400 watt Phase Linear and two 15" speakers behind me driven by the other side of the Phase Linear. I have a 60 watt amplifier to drive my horns for the highs. I also have a Yamaha mixing board and a parametric equalizer. The overall cost is about \$10,000.

*Do you use any special effects on the drums?*

Yeah, there's a harmonizer on one part of the drum solo and sometimes there's a phase.

*What dictates you using a certain drum for a part?*

Again, what sounds right.

*Do synthesized drums interest you at all?*

Yeah, they do. I wish somebody would offer me some because they're one of those weird things I have to try out.

*Do you tune your own drums?*

Yeah, but I don't tune them to a piano or anything like that. Then, you're limiting yourself. You might be clashing on some songs. The drums cannot be too musical or else they lose their value.

# JUST A MINUTE

is all it takes to load a complete string orchestra



The Logan String Melody II at £549 r.r.p. incl. V.A.T. is designed to fit on the top of most organ cabinets. Featuring Split Keyboard - Sliders for Violin, Viola, Cello and Bass - Attack and Sustain controls - 5 settings including Organ, Accordion and pre-set Orchestra - the Melody II is reputed to produce the most authentic string sounds available today. No wonder it is one of the most sought after machines on the market.



U.K. TRADE DISTRIBUTORS

**hornby skewes**



## Introducing our new stereo power amplifier the Studiomaster 800c

- Entirely new circuitry produces ultra-low distortion even at high frequencies and low load impedances.
- Led displays indicate when amp is clipping, improperly loaded, short circuited or there is insufficient ventilation.
- Fully protected against improper loads, short circuits and overheating.
- Special circuitry disconnects the speakers in the event of any malfunction.
- Forced air cooling, modular construction.
- Inputs and outputs on front panel.
- 500 watts per channel into 2 $\Omega$ .

For further details and full specification write to:—

*Studiomaster Ltd*

Home Farm, Northall, Dunstable, Beds. Tel: Eaton Bray (0525) 221331

For further details contact your local dealer or write to us:  
 name \_\_\_\_\_  
 address \_\_\_\_\_

# GERRY COTT

'BOOMTOWN RATS'

On stage with his

*Aria* PRO II PE 1000

Gerry says, 'In my opinion the PE 1000 is the best guitar on the market BAR NONE'

'RAT TRAP'

Gone SILVER

'A TONIC FOR THE TROOPS'

Gone GOLD

on ENSIGN RECORDS

CONGRATULATIONS FELLAS

Pic by  
Fin Costello

GIGSVILLE

South Drive, Phoenix Way,  
Heston, Middx. Tel 01-897 3792

PLEASE SEND BROCHURES ABOUT ARIA PRO II GUITARS AT PRICES MEDICALLY APPROVED TO PREVENT HERNIA OF THE WALLET.

Name.....

Address.....

I enclose 25 pence

I.M.12

# Guitar Forum

The guitar world is changing and keeping pace with technological advances. Once upon a time, everyone played either a Gibson or a Fender. Now you are just as likely to find the stars playing Ibanez or Alembic or a custom-built instrument. Today there are far more guitars available than ever, in all price brackets, while pickups have undergone a revolution over the last few years.

To examine the current state of play in the guitar world, IM gathered together a cross-section of the people involved - musicians, distributors and a guitar maker - to air their views. The discussion raised some thorny old problems and some interesting new ones.

In the musicians' corner we had top session player Alan Parker, a master of his craft who tasted the limelight with Blue Mink but who is most at home playing in the studio or writing music for TV and films. Alongside Alan was Midge Ure, a former member of Scottish pop band Slik, who now fronts the Rich Kids and is a guitarist of real energy and verve.

Roger Hains, representing Norlin, the UK distributors of Gibson, and Tom Charlton from Summerfield's, the Ibanez distributors, put their points of view and answered questions both as guitarists and traders. Stephen Delft, IM's guitar consultant and a highly respected instrument maker, formed a vital and informative link between the two sides.

We began by asking the two professional musicians which instruments they use. Alan kicks off...



Midge Ure

Alan Parker

**AP:** I'm a bit of a collector - I've got 38 guitars in all - so I tend to chop and change a bit. But the three electric guitars I usually carry around with me are a 1958 Gibson Birdland, a '58-'59 Les Paul Special and a '59 Strat. The two Gibsons have got the old black Alnico pickups, which to my ears give the best scope of sound, especially for recording. There are some excellent new pickups around, like DiMarzios, and I've tried them. I've fitted them on some other Les Pauls I've had but they just don't sound right to my ears.

I've got a couple of very nice old Les Paul Standards, which are great for certain things but not so good for other things. The work I've been doing lately has involved a lot of disco stuff, so I pull out a couple of instruments to cope with that style of playing. For that, I find the Birdland is excellent, and also the old Strat. Strangely enough, I also use the Birdland for a lot of heavy rock. Because of the

characteristics of the semi-acoustic body, you can get some very good controllable sustains and harmonics and feedback. Obviously, for stage work it would be harder to control but in the studio it's excellent, gives a very good sound.

**RH:** Do you think there's going to be a move towards rock players using semi-acoustics?

**AP:** I wouldn't be surprised. Look at Ted Nugent.

**TC:** I can't see that there will be a general move in that direction.

**AP:** No, but there's no getting away from it: it's a totally different sound. There's no way you can get that sound from a solid. Apart from some Fenders, I don't think you can get a good funky sound from any solid guitar either. But if you use the old Birdland with both pickups and adjust your amp a little, you can▶▶



Roger Hains

get a recording sound that is very clean and thin, tending towards a Fender sound, which you can't with a Les Paul with humbuckers.

**RH:** Can't you get it with a Les Paul with P90 pickups?

**AP:** Not quite the same.

**IM:** Midge, you don't play a lot of funky disco music do you? What guitars do you use on the road?

**MU:** I've gone through a lot of stuff in the past. The way I work is totally different from sessions and I don't need a lot of guitars. Basically, I need two - my main guitar and a spare for when I bust strings. My main guitar is a Yamaha SG2000, which I've had for about a year and a half. I got it just before they came on the market here. I love it dearly. It's a beautifully made guitar, it's perfect in every way for me. The thing I couldn't get used to at first was the slightly wider fretboard, because I'd been used to playing Gibsons, but that was only a matter of time. I love the sound of it. You get amazing sustain out of it but it's a very controllable guitar. It seems to react perfectly to whatever you put into it.

**IM:** What's your second guitar?

**MU:** My second guitar was stolen last week! It was a hand-built guitar, made for me by a guy in Glasgow. Pure self-indulgence. I'm at a loss now to know what to use for a second guitar, because I'm very happy with the Yamaha.

**IM:** A lot of musicians, including Alan, it seems, still maintain that an old electric guitar is likely to be better than a new one...

**AP:** I must be honest, I have one of the new Gibsons, an LSS with the new humbuckers. The



Midge Ure

guitar itself I think is beautiful. It plays nicely and has an incredible neck - but I just cannot stand the pickups.

These new humbuckers, on metres or on scopes they're supposed to have more range, more this and more that. But to my ear, the sound is nothing like what it should be. Although it may be a much better pickup technically, it doesn't give me the sound I would expect. So I always go back to the old guitars, which give me the sound I want.

**TC:** I think that's all pie in the sky. People say, "Ah, that's a '52 Fender so it's got to be good." It's just as easy to find a 1978 guitar that's perfect in every detail - maybe you won't like the sound but that's subjective, that's up to you.

**SD:** If there are a significant number of musicians who happen to like the subjective effect of the sound of certain early pickups,

and granted that their construction is fairly primitive and should be easy to reproduce, why are they not being reproduced? More to the point, why aren't the people who made them before making them again?

**RH:** As we're talking about Les Pauls, let's look at the range. There's the Artisan, the Custom, a three-pickup Custom, the Standard, the Deluxe, the Pro Deluxe with P90s, which should equate in sound to the early Les Pauls... there's a large range of Les Pauls, all with different characteristics.

**SD:** Agreed. But does any of them have the same characteristics as the particular sort of black, two-pickup, ebony-fingerboarded Les Paul which is rather in demand at the moment?

**TC:** But you know, Stephen, that some pickups out of a certain batch, made under the old conditions, come through better than others. It's no good saying, "1954 Les Pauls are the end, because every one I've played is great." Let's say they made 500 that year. Four hundred of them were duff, so guys hacked them up and eventually they got thrown in the dustbin. The other 100 are the best ones. They're the ones that survive.

**RH:** If you accept that Gibson produce guitars to a factory standard, and all the guitars that come out of Kalamazoo or Nashville are set to that standard, then you must accept that along those lines there will be an occasional marriage of wood, strings, pickups that makes an absolutely superb guitar. In 20 or 30 years' time, that one will still survive and still be superb, while the others will still be factory standard guitars.

**SD:** It's loaded even more against you, in that some of the ones which are nearly as good



Stephen Delft

will have been sent to repairers or improvers and worked on until they are of a higher standard, which falsifies the apparent myth of all old guitars being good ones. If you've paid a lot of money for an old guitar and it's not good, the first thing you're likely to do with it is take it to someone who will make it better. You're not going to stand there with a guitar that won't play and say, "But it must be good - I spent 2,000 dollars on it." That then becomes another one of "They don't make them like they used to." The truth is, they didn't make it like that to start with.

If the problem with reproducing old pickups is unstable magnets, I would raise an interesting paradox. The two best sounding Gibsons I've heard both have magnets so weak that it's difficult to tell there's a magnet there. The characteristic which I like about them is maintained when the pickup is transferred to another guitar of reasonable quality, so at least a large part of it comes from the pickup. They both also give the subjective impression of having unusually sensitive and loud pickups, in spite of the fact that the magnets, as magnets, are practically useless. Now, when one notices that producers of new and improved pickups go on at some length about their higher-powered and hotter magnets, while the best pickups I've ever heard have the worst magnets I've ever come across, it suggests either that high-powered magnets are not desirable for high-output pickups, or at least that they're not essential, or even necessary. I have a suspicion that some of the much-loved old Gibson humbucking pickups have actually improved in practical usability as the magnets have deteriorated. It might even be worthwhile to look at ways of putting worse magnets in, if they would be stable at the lower level.

**TC:** I think you're going into the realms of fantasy there.

**SD:** Well, when I can prove it, I'll put it in print. But I'm beginning to see enough examples that it's beginning to convince me. To put it at its simplest, I wonder if the claimed advantages of modern pickups are necessarily advantages.

**RH:** But what do you want from modern pickups?

**MU:** It's an indefinable quality. You just know when it sounds right. You can't say that it's got more this or more that. It's just something that's there.

**IM:** Have you spent a lot of time trying different pickups on your guitars?

**MU:** No, I've never really been into chopping and changing pickups. The guitars that I've had, I had because I liked the guitar - I didn't want to change anything. They were mostly Gibsons and I'd keep them for a while and either they'd get stolen or I'd trade them in for something else. I've never liked bastardising them, pulling them apart and sticking on various bits and pieces.

**AP:** One thing does amaze me, and I'm not a technical man at all. Would it not be a simple task for Gibson to buy a couple of their old guitars, instruments which you know people know are good and analyse them?

**RH:** Yes, that we can do.

**AP:** Have you done it?

**RH:** Well, for instance, when people said they wanted P90s put back on a Les Paul, we issued the Pro Deluxe, with P90s on it. Now, did that sound appeal to the number of people who told us we ought to do it?

**SD:** Did it sound like the guitar that it looked like?

**RH:** A lot of people said yes, a lot of people said no.

**TC:** Don't forget, anything that was made to the old standard in the Fifties, if they made it the same today it would be a lot more expensive.

**SD:** Would it not be better, then, to make it clear that the instruments which look the same are not going to be the same?

**TC:** It's being very honest. Whether it's good business sense, I don't know...

**AP:** It might be a minority of the buying public, but even so it's a large minority that go in and buy old instruments. But why do they go for them? There must be a reason. It's not just that they love old guitars.

**TC:** I think a lot of it is myth. The guy believes that a certain old... whatever it may be is going to be good. Once he's bought it, he's stuck with it. He finds he's bought a stumer. So he takes it to a guy like Stephen and says, "I've just spent 400 quid on this and it's terrible. Make it work, will you?" So he fixes it and the guy uses it. Then he suddenly says, "I did a great thing when I bought that."

**SD:** Fifteen hours' work can make quite an improvement to most guitars.

**TC:** Anything that comes out of a factory today can be improved upon, one way or another. It's just whether you can afford to have it improved.

**AP:** That's a sad fact...

**TC:** It isn't sad, because the prices you are being charged are relative to the instrument as it stands.

**AP:** Exactly. What I was going to say was that it's sad that one could almost get the duplication of what a lot of people are after - except that, because there's a slight price difference between, for instance, different types of timbers, they'll go for the cheaper timber because it's a factory situation.

**TC:** Take that one step further. If you're really knocked out by whatever particular guitar it is you've been looking for, I'm quite sure that given the time and money someone like Stephen could make you one. Whether you could afford it is something else.

**SD:** That's one thing that removes the pressure from the manufacturers to produce precise duplicates. Some of the people who would be in a position of importance, because they're respected musicians, who would perhaps lean on a manufacturer and say, "I want one of these and I want it *exactly* like that" find an easier course of action by finding an independent maker, because he can supply exactly what they want with less hassle. It's still very expensive.

**RH:** If we took this to its ultimate conclusion and produced guitars "like we used to", you'd end up with hollow-necked guitars, as they were originally built by Gibson.

**MU:** Why did Gibson stop production of Juniors? Especially in today's market, the kids don't have that much money. You must be losing trade to the Japanese in that price range, because kids used to be able to buy a guitar for £150 that was a good guitar. For the standard they were at, it was great.

**RH:** Yes, but a Junior would be slightly more than £150 now. The Junior was withdrawn through lack of demand.

**MU:** That was quite a while ago.

**RH:** That's right. Again, the Melody Maker was stopped through lack of demand, then we reintroduced it and it didn't sell as well as we would have liked. Now the Marauder is the bottom of the Gibson range and that now retails at £249.

**MU:** But the Marauder hasn't got the sound that any other Gibson has. It doesn't have the sustain or the attack. For the price of production of a Marauder, you've got to be able to produce an SG Junior or a Les Paul Junior. Because most of the people I know basically look for one good sound, and once they've got that sound they don't need to change it. They don't need two pickups.

**RH:** If we had enough demand...

**MU:** I think the demand would be there if the kids knew they could get a guitar with one pickup. Now they can't buy a one-pickup guitar unless it's a Japanese copy. They can't even buy an original Japanese guitar with one pickup now. So you're paying for the extra pickup and the extra electronics, and a nice scratchplate and a bit of purfling... whereas the Juniors were very basic but they sounded great. Surely a guitar like that could be made to sell for £250.



# MEET LEO

## MUSIC MAN

## FENDER

# COMPETITION

Open to all purchasers\* of Music Man amplifiers and instruments until April 1979, the winner to receive an all expenses paid trip to California during June 1979 to meet Leo Fender, designer of the Sabre and Stingray guitar and bass, and visit the Music Man factory plus tours of Hollywood, Los Angeles, Disneyland and other nearby attractions. (\*UK and Eire residents only).



### NEW 65 & 100

### WATT SERIES COMBO

### AMPLIFIERS FROM

### £350-AVAILABLE

### NOW AT YOUR DEALER!

Complete this coupon with your name and address and forward with large stamped addressed envelope to receive the latest Music Man brochure.

Name .....

Address .....

Send to: Strings and Things Ltd., 20 Chartwell Road, Lancing, Sussex BN15 8TV.



**SD:** I'm interested to hear you, as a working and well-known musician, say you would have a single-pickup guitar, because I've suggested it to manufacturers and they've told me it's impossible to sell a guitar without two pickups.

**MU:** With the stuff that I'm playing right now, I very rarely use the bass pickup. It's modern high-energy rock and roll music — and it really doesn't matter which pickup you're on. I prefer the treble one because it gives the bite and attack that I like. I'm sure if my bass pickup broke down, I wouldn't even get it replaced, except for the fact that I sometimes use it in the studio. A lot of today's new musicians are only interested in that one sound. And for a second guitar, for me, I only want something to get me by for a number while someone's changing a string for me. I don't need a guitar that's got three pickups, mother of pearl down the fretboard, gold-plated machine heads . . . I want a functional instrument that will play OK and stay in tune.

**RH:** Are you saying that we've reached too great a degree of sophistication?

**MU:** I think so. I think you're trying to give them too much for the money. Although the kids are new musicians, they know what sound they want to get and I think that if you cut out all the elaboration and give them a good, basic instrument, the way the Juniors used to be, you'd find a good market for it.

**SD:** We've been talking about American guitars a lot but we have here a representative of Japanese guitar importing company, and Midge is obviously very happy with his guitar from another Japanese importer. Alan, do you have any opinions on Oriental guitars?

**AP:** I've never tried Yamahas. I've tried an Ibanez, the new Artist with a built-in pre-amp, and I was amazed by it. The electronic side of it, the power boost and so on, I found better to operate than the Gibson RD.

**TC:** It's a very easy guitar to operate. Ibanez learned about that a year or so ago when we made a guitar for another company to be used in conjunction with a synthesizer. I would say it's still the best of the synthesized guitars. But for the average guitar player, it's over his head — there's just too much electronic junk to handle.

**AP:** It's taking a time for guitar players to get to grips with guitar synths. I was around when keyboard synths first came out. At first, keyboard players didn't have a clue. It took a lot of good players a long while to get to grips with them. Now the same thing is happening with guitar synths. Guitar players have never had to set up or programme synthesizers. Suddenly they have to think "How do I get a sound out of this thing?"

**TC:** I think most of them are too far into their instrument to want to know how to do that. There's probably five per cent who would persevere and make a success of it. It's the same as some established players who will not use foot pedals, they will not persevere. But I've heard Chuck Wayne, who's been playing for ever, he handles most of the pedals so well it's unbelievable. He uses them for jazz and all sorts of things.

**MU:** I really don't know if I like the idea of electronics built into the guitar. As a performer on stage, you wouldn't use half the stuff that was there. It's more important to be running from one side of the stage to the other because

you're entertaining 4,000 people than it is to fiddle around with the effects on your guitar. You can get any of those effects as pedals if you want them.

**IM:** Do you use any effects on stage?

**MU:** None at all now. Sometimes I use some in the studio, usually on the desk after the track has been recorded. I find I don't need any on stage. A couple of years ago, when I used a guitar that didn't give me the sustain I wanted, I used an overdrive pedal to give me sustain. I used to use Big Muff fuzz boxes, which tended to break down quite a lot, and I had a Cry Baby wah-wah which I bought second-hand about 12 years ago and it's still going strong.

**AP:** I'm like Midge, I prefer not to use effects. I like to get a guitar that has the sound I want and use it straight. If I need effects, the only ones I use generally are a phaser, the MXR envelope builder — I prefer that to any wah-wah pedal — and a flanger now and again. I used to use a fuzz, but I prefer not to. The only one I liked was a pedal steel fuzz by Sho-Bud, which is a knockout, a lovely quality fuzz, and it goes well with any guitar.

**MU:** I'd like to use an ADT unit. I think I'd use that on the road. I haven't tried enough of them yet.

**SD:** I'd like to hear one that actually sounds like double-tracking and not like an ADT box.

**AP:** The only one that comes almost close to it is a studio thing, the Marshall Time Modulator. As well as your constant pitch, it gives you a separate feed from two variable pitches, so you can create tracks with a slightly different pitch from your original, and they also vary slightly — which is what real double-tracking is all about. It's very effective.

**IM:** We haven't talked about acoustics at all. Do you professionals play acoustic guitar much?

**MU:** I've got an acoustic but I wouldn't say I play it. I just use it in the studio sometimes for chord work. It's an Ovation Balladeer, which I've had for about four years.

**AP:** I play quite a bit. I carry around with me a Martin D28 and a Guild F50. I've got a few Martins but this particular D28 is ideal for recording. It's a very middley sound. There's not an awful lot of bottom, not a lot of top. The Guild has a much broader sound and it's a good solo instrument. If I know I'm going into a session which will be just a couple of guitars, I use the Guild. But it would be lost if I played it with a group, so that's when the Martin is useful.

**IM:** What's the market trend with acoustics?

**RH:** I think people have tended to lay low on the expensive acoustics recently. I really don't know why that is. There was a big change in the acoustic market when Ovations arrived. The old-style acoustics with the broad range of sound, as Alan described, have tended to die off.

**TC:** I'm impressed by Ovations — not so much because of their volume but because, to my ears, they resemble the old Maccaferri. They have a cutting power that so many modern acoustics don't have. The sustain isn't what you'd expect perhaps from an acoustic guitar, but it does come through.

**AP:** To get back to the question of old guitars compared to new, do you think today's



Tom Charlton

Gibson acoustics are as good as the old ones?

**RH:** I think that when the new ones have been played in and have had time to age, they will be as good as the old ones.

**TC:** I always used to believe that, about guitars having to mature before they sounded at their best, until I met Jimmy D'Acquisto, who proved it all wrong. That guy can produce a guitar and you can play it the next day and make it sound like something that was made 30 years ago. And if you don't like the sound, you can take it back to him. He takes the back off and does whatever's necessary — and then it does sound how you want it. Visiting his workshop was a revelation to me, because I honestly believed that if you wanted a 1950 jazz sound you had to buy a 1950 guitar. But he can make you a guitar that will sound like anything from 1930 onwards. You just tell him what you want it to sound like and he makes it to sound to order.

**RH:** Of course, you're talking about one-off guitars —

**TC:** Yes, but it can be done. Of course, for Gibson to make a guitar like that, they would have to charge Jimmy D'Acquisto prices.

**SD:** What's so unusual about that? If that's the price for the job, why should Gibson charge any less?

**TC:** Exactly. But people do seem to feel that if you're a big concern and you're turning out thousands of guitars, you must be cheaper than a one-off guitar maker. When you're talking about instruments of this quality, that isn't necessarily so.

**IM:** After everything that's been said today, Midge, do you think that the music trade, as regards guitars, is on the side of musicians? Are things looking healthy?

**MU:** I think it's getting healthier all the time. Especially now that Gibson are lowering their prices at the bottom end of their range, to compete with the Japanese makers — who have already got low prices. It's looking good for young musicians, buying their first or second guitar. Now they can go and buy a good guitar for £100, which is a great instrument to start on. When I started, I had to buy a dilapidated old Watkins Rapier, which just didn't have the class of the £50 Japanese copy that I've still got. So things are looking good.

# acoustic

## Nobody is ever sorry



# Acoustic

## they bought the best.

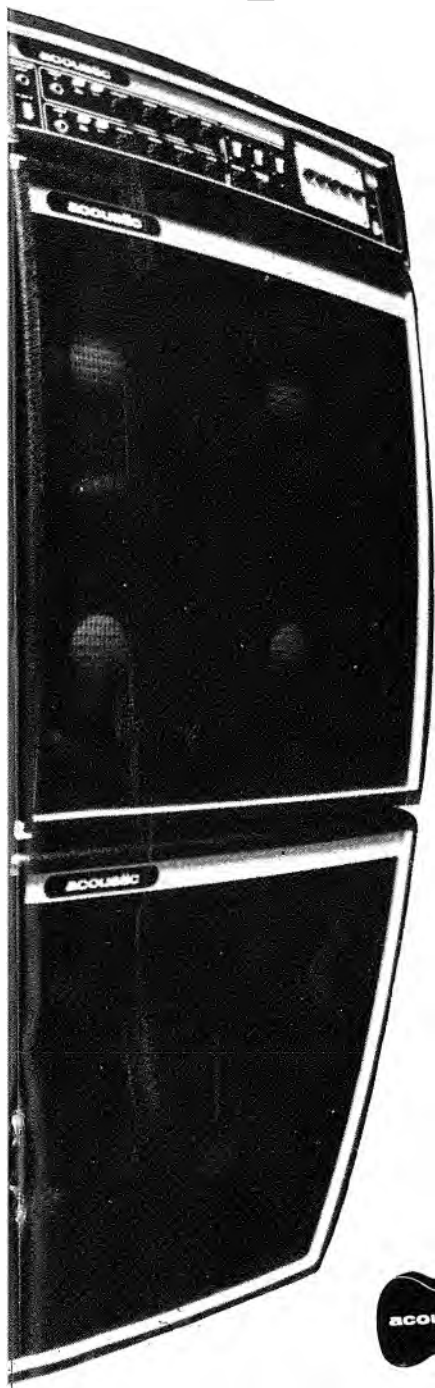

We are proud to present the new line of Acoustic amplifier products. More than ever before we believe there is an Acoustic amplifier that is right for you. Once you hear them, we're sure you'll agree.

Acoustic has always maintained a reputation of reliability and dependable performance. The final success of any product is how well it stands up in use, and the integrity of the companies behind the product. In these areas Acoustic is second to none.

Now for the first time in the U.K. you can see a full range of Acoustic products at the following hand picked dealers.

### Available in the U.K. only at:~

Aberdeen: Middleton Music Ltd., 105-109 Holburn Street.-0224 54512.

Barnsley: Kitchens of Barnsley, 33 Peel Street.-0226 5867.

Bedford: Mr. Music, 18 St. John's Street.-0234 50861.

Belfast: M. Crymble Ltd., Dublin Road.-0232 26818.

Birkenhead: Rushworths Music House, Grange Road.-051-647 7723.

Bradford: Kitchens of Bradford, 26 North Parade.-0274 23577.

Cardiff: Sound Centre, 9 St. John's Square.-0222 34018.

Chester: Rushworths Music House, 48 Eastgate.-0244 25252.

Edinburgh: Grant Music, 53-53a Home Street.-031-228 1704.

Hemel Hempstead: Mr. Music, 24 Bridge Street.-0442 61812.

Kent: Unisound, 48 High Street, Chatham.-0634 44068.

Leeds: Kitchens of Leeds, 26 Queen Victoria Street.-0532 446341.

Liverpool: Rushworths Music House, 42-46 Whitechapel.-051-709 9071.

London NW6: Unisound, 213 Kilburn High Road.-01-624 3900.

Loughborough: Loughborough Music Centre, 18 The Rushes.  
-0509 30398 or 218020.

W. Midlands: Modern Music, 30 Castle Hill, Dudley.-0384 55293.

Newcastle Upon Tyne: Kitchens of Newcastle, Higham House,  
New Bridge Street.-0632 22965.

Newport: Sound Centre, 107 Commercial Street.-0633 66814.

Southport: Rushworths Music House, 42 Eastbank.-0704 40383.

Tredegar: Sound Centre, 91 Queen Street.-049-525 2203.



### The protection department.

Every Acoustic Amplifier carries a full 12 month parts and labour guarantee.

# Albums

Richard Wright

Brian Eno

Neil Young

Fabulous Poodles

Third World

Leon Russell

David Townshend

Frank Zappa

Richard Wright

*Wet Dreams* (Harvest)

I suppose you can't really blame members of lethargic supergroups for making solo albums. After all, working for the Pink Floyd is not exactly a full-time job these days and Rick Wright presumably had to do *something* to stave off terminal boredom. But after listening to this solo effort, I can't help feeling that he might find a more profitable way of passing the time. Like being chairman of a football club or making raffia mats.

First impressions suggest that we're in for something grand and pretentious. (Why is he suddenly calling himself Richard? What's the point of the slick, meaningless Hipnosis sleeve?) But he avoids that pitfall with music that is predictable and trivial. Perhaps it would have been a more satisfying album if he had tried to be a little grander. The Floyd can often pull it off, so why not their keyboard player? Instead, he's plumped for a set of undemanding, unremarkable and utterly forgettable numbers, competently played by some well-respected musicians: Wright on keyboards, Mel Collins (saxes and flute), Snowy White (guitars), Larry Steele (bass) and Reg Isadore (drums).

It's all quite harmless stuff, but I still wonder why they bothered. Hip easy-listening background music for a party I'd rather not be at.

Jeff Pike

*Recorded at Super Bear Studios, France, January-February 1978. Produced by Richard Wright and engineered by John Etchells.*

Brian Eno

*Music For Films* (Polydor)

Brian Eno first came to prominence as the ideas man behind Roxy Music, after which he returned to his original interests in experimental sound and recording techniques. Recently, he has returned to the limelight through his collaboration with David Bowie on the "Low" and "Heroes" albums, and his production work for Talking Heads and Devo.

This new album, as the title suggests, is a collection of instrumental pieces which have been used in various films, television and theatre productions. Its content is something like the instrumental passages on Bowie's recent albums, rather than the more experimental side of Eno's work issued on his own label — the aptly-titled Obscure Records.

Each individual piece is inconsequential, but they

*Fabulous Poodles: enjoyable*



do combine over the whole album to create a haunting and reflective atmosphere. Possibly the most successful item is "From The Same Hill" in which a strikingly recorded acoustic guitar slices through lush Mellotrons.

For an artist who is usually associated with the so-called avant garde, the basic construction of "Music For Films" is conventional. The melodies remain unexplored and there is virtually no thematic development except on the three-part "Sparrowfall". This would only be expected if the pieces were written as functional background for other productions, but in fact they were written prior to their incorporation in other settings.

Nevertheless, the simplicity, brevity and attractiveness of these little pieces make this Eno's most accessible album to date and as such might serve as a useful introduction to more experimental instrumentation and recording techniques for those who are just discovering that there is more to modern music than discos and guitar solos.

David Lawrenson

*No recording details available.*

Neil Young

*Comes A Time* (Reprise)

"Comes A Time" is Neil Young's most carefully textured album for quite a while. "American Stars And Bars" offered the mighty "Like A Hurricane" amongst a bizarre collection of red-eyed cowboy ballads and songs from various past sessions. "Comes A Time" is much more cohesive, again refers back to Young's folk and country roots, and despite the cast of thousands listed on the sleeve, is generally sparse, and laced with carefully arranged strings.

When Young is on form, which is most of the time, his music has something of the plainsman's spirit about it. The opening "Goin' Back" (not the Goffin/King tune) has it here, in a pastoral, dreamy way. Young's recurrent theme of search for some sort of romantic ideal achieves one of its best-ever expressions here, with Nicolette Larson's floating harmony perfectly suited.

"Peace Of Mind" makes subtle use of strings to suggest its title, but again it's the idea of search that's the real point of the song. The raucous "Motorcycle Mama" finds Neil in his dirtiest electric mood, blasting out the most basic licks while Nicolette Larson unleashes some raunchy vocal work. "Look Out For My Love" features Crazy Horse in a strange piece with a doomy chord sequence, haunted harmonies and tearing electric guitar.

If you prefer Neil Young running amok with Crazy Horse, "Comes A Time" isn't it. But it's a thoughtful album with some vintage moments.

Adam Sweeting

*Produced by Neil Young, Ben Keith, Tim Mulligan and David Briggs. Recorded in London, Florida, California and Tennessee.*

Fabulous Poodles

*Unsuitable* (Pye)

Things seems to be going just right for the Fabulous Poodles now. They recently signed a new management deal with Yes mentor Brian Lane and are currently headlining a British tour. Their debut album, "Fabulous Poodles", was produced by John Entwistle and was highly acclaimed. This time, Muff Winwood sat in the producer's chair and the result is a highly enjoyable and thoroughly entertaining album.

The Poodles — Tony de Meur (vocals/guitar), Ritchie C. Robertson (bass/vocals), Bryn Burrows (drums) and Bobby Valentino (violin) — write their own material and, almost without exception, it's hilarious. Their musicianship isn't anything to write home about, nor is it meant to be. The lyrical content

is the real focus.

Songs range from straightforward pop songs like the opener "Mirror Star" to the black humour of "Topless Gogo", the sad tale of a gogo dancer who, after a road accident, ends up as a "headless, topless torso".

"Chicago Boxcar" is a song about a hairstyle, strangely enough, with a nice early R&B feel to the backing even down to an authentic-sounding harmonica passage. "Toytown People" is another standout track with an "oompah" rhythm and, lyrically, is a parody of the "plastic people in little boxes" line of thought.

The thing about this kind of record is that I'm not sure how many repeated listenings it would stand as it's mainly the lyrics that carry the material . . . then again, I still listen to "The Blood Donor".

Eamonn Percival.

*Produced by Muff Winwood. Engineered by Howard Kilgour. Recorded at Basing Street Studios.*

### Third World

#### *Journey To Addis (Island)*

A few months ago Third World had a hit with "Now That We Found Love" which was a brilliant mixture of reggae and soul. "Journey To Addis" is the album from which that song was taken, and proves every bit as refreshing and exciting as the single.

Third World are a six-piece Jamaican band who have worked long and hard, particularly in America, bringing reggae to the attention of new audiences. In the process they have absorbed the influences of American music, as witnessed by their Gamble and Huff written hit, and produced a sound which is original and infectious.

Overall, an excellent easy listening album which creates a great atmosphere and feeling. Third World would probably be labelled crossover artists, which should in no way detract from their abilities in making reggae a more accessible music form.

David Lawrenson

*Recorded and mixed at Compass Point Studios, Nassau. Engineers: Alex Sadkin, Steve Stanley and Jack Nuber. Produced by Alex Sadkin and Third World.*

### Leon Russell

#### *Americana (Paradise)*

The title of this album rouses the suspicion that there might be some sort of concept in the offing here. Listening to it does little to dispel or confirm this notion, largely because Russell's singing throughout is so lacklustre that he might well have been ironing or reading railway timetables while making this record.

Most of the tracks are indistinguishable from one another. They are often made up of the sort of melodic phrases which are half-remembered from some hinterland of the psyche, and have been reassembled for no immediately apparent reason on this disc.

Adam Sweeting

*Produced by Leon Russell. Recorded at Paradise Studios.*

### David Townshend

#### *Making Up The Number (Mercury)*

You may be forgiven for not having heard of David Townshend. His only claim to fame was writing the excellent "Miss You Nights" and this is his debut album, a culmination of three years' work featuring some fine songs and some excellent musicians.

The first track is a beautiful song called "Time Is

No Support" and features just organ and piano backing. It has a really haunting melody and dramatic chord changes. A strange opener for a debut album but very effective.

Townshend is as good a singer as he is a writer, particularly on the slower "Far Side Of The Bay" where he also provides all the vocal backing. This cut is further enhanced by Richard Hewson's beautiful string, horn and flute arrangement.

The very excellent BJ Cole appears playing pedal steel on "We Are Reflections", along with luminaries such as Mike Giles (drums) and Ray Russel (guitar) while the hymn-like chorus is strengthened by the voices of Vicki Brown, Helen Chappelle and Lisa Strike.

Personally, I would have liked to have heard his version of "Miss You Nights", but nevertheless the material here is very strong and the album seems a good pointer to the future for David Townshend.

Eamonn Percival

*Produced by Robin Cable. Engineered by Steve Holroyd. Recorded at Marquee and Air Studios.*

### Frank Zappa

#### *Studio Tan (Discreet)*

Uncle Frank goes secretive. For some reason, he has chosen not to tell us who plays with him on this album. (In fact, the very ugly sleeve carries more information about who designed it than about the who, where and when of the recording within.) Perhaps this is intended to concentrate our minds on to listening to the music without any preconceptions, which is rather a pity because it's the worst thing Frank has recorded in recent years.

Not that it's bad. Just nowhere near the amazingly high standards he sometimes hits. I happen to like Zappa's songs and admire his guitar playing. And there isn't half enough of either here. Side One consists of a long fable, a monologue with music, all about Gregger Peccary ("a little pig with a white collar that usually hangs around between Texas and Paraguay"). The story is not very interesting, not very funny and if there is a moral, it was so subtle or so obvious that I missed it. Frank narrates in two voices: his oily leering one and a speeded up version of the same, which sounds like a Smurf on Mandies. The music is disjointed, full of startling time changes and odd instrumentation, and ultimately very frustrating because it never gets anywhere. It's like listening to a ▶▶

Frank Zappa secretive

Neil Young thoughtful



# Albums

Barry Manilow

Van Morrison

Andy Mackay

Dick Haymes

Alessi

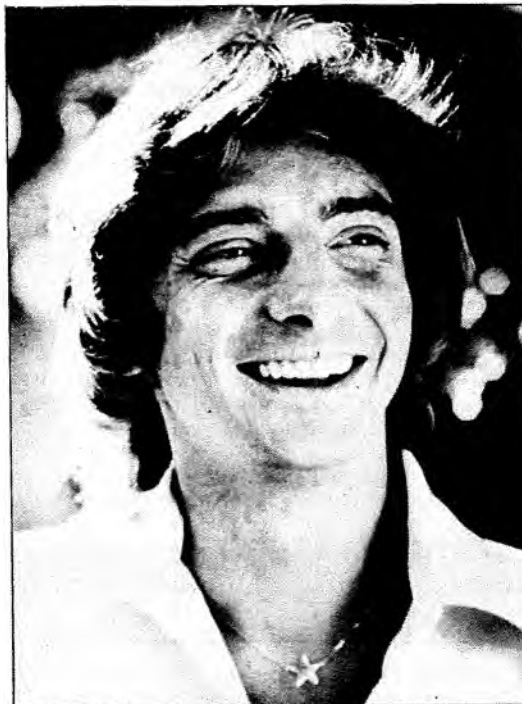

Barry Manilow: poignant

Tom and Jerry soundtrack without being able to see the cartoon.

Side Two has one song on it and a couple of lengthy instrumentals. The latter are both clever – cleverly constructed and cleverly played – but fundamentally hollow. Good guitar by Frank on one of them and stirring piano by somebody on the other, but not much else to write home about. Which leaves the song, "Let Me Take You To The Beach". It's a delicious teenage ditty, as the title implies, full of off-pitch Beach Boys falsetto vocalising and corny guitar licks. Lovely. But not worth buying the album for.

Jeff Pike

## Barry Manilow

### *Even Now* (Arista)

With almost monotonous regularity it seems that the USA can throw up solo MOR artists who are able to sell millions of albums, go on to make the inevitable TV specials and become international superstars. In recent years there has been Neil Diamond, John Denver, etc. and this year's model seems to have come in the shape of Barry Manilow.

His road to fame came via his association with Bette Midler when he became her musical director, arranger and pianist. Hits with songs like "Mandy" and "I Write The Songs" followed and a new star was born. However, despite all the razamattaz that surrounds such artists, the "Even Now" album shows Manilow to be one of genuine talent.

His particular forte is in writing lush, poignant ballads of which there are an abundance on this album, but he staves off the schmaltz thanks to some interesting techniques and good singing. For example, he whistles the introduction to "Can't Smile Without You" which proves a simple but effective ploy, and begins "I Just Want To Be The One In Your Life" near the top of his vocal range before descending into the full song.

"Copacabana" is the hit which veers away from his ballad formula and proves that he can write good up-tempo pop songs. Manilow's voice throughout is excellent, displaying a range and a clarity which is hard to beat.

David Lawrenson

Recorded at A&M Studios, Hollywood, California.  
Produced by Ron Dante and Barry Manilow.

## Van Morrison

### *Wavelength* (Warner Bros.)

Several of Van Morrison's album are among my all-time favourites but now that he has passed through his period of transition I find I'm no longer on his wavelength.

"Wavelength" is the title of Van's latest, a sonorous but soporific album that seems to make massive concessions to either record company, the US easy listening market or someone else's taste.

Though the roll call of sidemen is strong, including guitarist Bobby Tench, keyboard player Peter Bardens and the Band's own Garth Hudson, a lot of Morrison's vocal and composing power seems lost in a morass of bland arrangements and final mix. Morrison takes the production credit and so the responsibility for the clever but essentially insubstantial songs on "Wavelength".

Two tunes are this album's saving grace. "Venice USA" has a simple bass line and tickling percussion that give it an infectious rhythm, perfect backing for Garth Hudson's accordion part and Van's most expressive vocal. The album's best track by far is "Hungry For Your Love", it features teamed bass and keyboard chord work that ring in the listener's head. Stand out guitar bridges and an accented staccato vocal delivery warmly reminded me of the Morrison of old.

Sean Hogben

Produced by Van Morrison.

Engineered and mixed by Mick Glossop.

Recorded at the Manor and Shangri-La Studios.

## Andy Mackay

### *Contradiction* (Bronze)

This is the second solo album from former Roxy Music sax player Andy Mackay, and reflects a visit he made to China earlier this year. Andy has proved the most versatile of all the members of his old band since its demise, particularly in his writings for television.

Now with "Resolving Contradictions" he is breaking new ground by incorporating heavy Chinese influences and in some cases marrying together traditional tunes with Western instrumentation. It would be easy to dismiss such a concept as gimmicky, but with a musician of the calibre and professionalism of Mackay nothing could be further from the truth.

The album is purely instrumental, but is never dull or samey thanks to an imaginative use of instruments and a wide variety of material. "Trumpets On The Mountains Off To Work 'Unreal City'" is a typical cut. It begins with a quiet mediæval tune with a minimum of percussion and moves into a full-blown orchestral piece with a good change of tempo before picking out a Japanese melody on violin.

By far my favourite track is "A Song Of Friendship (The Renmin Hotel)" which was the only song that Andy actually wrote while in China. It is a haunting, simple tune picked out on what appears to be flute with an acoustic guitar. Strings and bass are gradually introduced with another flute to produce a stunning and effective little song.

The final result is an album which is a refreshing change from mainstream rock, although it is still accessible to rock fans. The overall concept doesn't work on every track, but that is only to be expected when an artist attempts something so adventurous – the places where it does work are excellent.

David Lawrenson

Recorded at Basing Street and Sawmills Recording Studios. Mixed at Roundhouse Studios. Engineered by Phil Brown. Produced by Andy Mackay.

## Dick Haymes

### *Rain Or Shine* (Capitol)

There's something touchingly familiar about Dick Haymes' life story... a string of gold discs, then a fall from favour, tax problems, hassles with the US immigration authorities, a broken marriage, the agonising drift into obscurity...

It all happened a quarter of a century ago. In 1955, after five years without a hit, Haymes was rescued by Capitol Records, who were then aiming for world domination on the ballad front - they already had Sinatra and Nat "King" Cole on their books. The result was this album, recorded at a time when albums were still novelties and now released unedited for the first time in Britain. It contains 14 warm ballads, sung in a relaxed, controlled style that very nearly rivals Sinatra's. No doubt about it, this chap was good. Honest, unpretentious, romantic vocalising, the way they used to like it. He was popular, too. The Capitol contract gave him a few more deserved hits before the final slide into the crooner's oblivion. If you can't remember just how big Dick Haymes was, ask your dad. Better still, ask your mum.

Jeff Pike

No recording details available.

## Alessi

### *Driftin'* (A&M)

Alas, the Alessi brothers seem to be playing safe nowadays. If, like me, you enjoyed their debut album and first two singles, this album will come as a disappointment. This time round, with few exceptions, the material is a cross between mundane MOR and even more mundane disco. The brothers' high vocals and Gene Page's string arrangements make it sound like The Bee Gees meet Barry White, especially on "Dancing In The Halls Of Love" and the awful title track.

There is, however, an exceptionally good song called "Rainbows Go On For Ever", which appears on Side One. It's the kind of song the Alessi brothers do best and all I'm waiting for is a whole album of quality material like this.

The generally poor standard of songs is saved by the superb musicianship on the album. The personnel changes from track to track but musicians including Steve Porcaro, Seals and Crofts and Richie Havens all appear. The backing throughout is faultless and if you want to hear a really tight rhythm section, look no further than a track called "Believer" with Ed Greene and Ave Laboriel on drums and bass respectively.

Producer Louie Shelton also adds some nice guitar parts on various tracks and is especially interesting on "You're Out Of Love" where the sound is considerably beefed up with a nice, gutsy guitar.

The sad thing about the way Alessi records are going now is that, although I dislike the material, there is no doubt that they can write good pop songs and are also good singers. Further, their use of harmonies is excellent, particularly the background vocals, but they can't seem to come up with consistently good albums.

Eamonn Percival

Produced by Louie Shelton. Engineered by Joseph Bogan. Recorded at Dawnbreaker Studio, San Fernando, California.

## SHORT CUTS

**Trevor Rabin:** *Trevor Rabin* (Chrysalis)

A debut album from a budding Todd Rundgren in that Mr. Rabin sings and plays everything himself with

the exception of drums. Actually, that's the only real similarity between the two. Rabin favours a much heavier approach. His songs are fairly predictable, his singing good and his guitar playing excellent. It's almost melodic heavy metal and is well executed, although the overall sound is a bit "muddy". EP

**Gordon Giltrap:** *Fear Of The Dark* (Electric)

The third of Giltrap's "orchestrated" albums, this one is a further step beyond his now near-forgotten "folkie" tag. Without doubt, Giltrap is a fine acoustic guitarist, although I don't rate him too highly on electric, and this album is well produced. The material is enjoyable but I can't help feeling the parts are greater than the whole. EP

**Ian Gomm:** *Summer Holiday* (Albion)

Ex-Brinsley Schwarz man's first solo album on a new label and very good it is too. Gomm has got the knack of writing good, no-nonsense pop songs down to a fine art. Particularly interesting is his version of Lennon-McCartney's "You Can't Do That" in which, for some strange reason, he misses out the middle eight! Nice debut, well worth checking out. EP

**The Swinging Blue Jeans:** *Best Of* (EMI)

Yes, it's all here - "Hippy Hippy Shake", "Good Golly Miss Molly" and lots more. Some other rock standards don't fare too well on the album but it's worth buying for their best two singles, "You're No Good" and "Don't Make Me Over", both of which are included on this excellent compilation. EP

**Beach Boys:** *M.I.U. Album* (Warner Bros.)

This is the most disappointing album I have ever heard in my life. How can Brian Wilson & Co. write such appalling teeny songs as this in 1978? Nostalgia aside, not one of these cuts can even compare with "Surfer Girl" or "Little Deuce Coupe". To be avoided. EP

**Booker T. Jones:** *Try And Love Again* (A&M)

Over recent years the organist/leader of the MGs has diversified his talents, arranging and producing for a variety of artists. This album features him as a vocalist and is apparently aimed at the MOR market. Cover versions of such classics as "I Was Made To Love Her" and "Ain't That Peculiar" don't really work, but the two self-penned numbers show him as a writer of promise. DL

**Elton John:** *A Single Man* (Rocket)

Without doubt, the most brilliant and creative album little Reg has released in the last two years. And the only one. The new wordsmith, Gary Osborne, doesn't make much difference: his lyrics look slightly better than Taupin's written down, sound slightly worse when sung. Elton plays himself. If you like him, you'll like this. JP

**Ike Isaacs:** *The Latin Guitars of Ike Isaacs* (Dansan)

A specialist album, for folks who are into strict-tempo ballroom dancing. But interesting, nevertheless, for the skill with which Ike creates a huge variety of sounds from a combo that is basically various guitars plus rhythm section. JP

**Kingfish:** *Trident* (Jet Records)

Sadly lacklustre West Coast choogle in the Doobies vein. Lead guitarist Michael O'Neill stands out with his consistently driving playing, and also sings a bit like Eagle Don Henley. Otherwise it's very difficult to take seriously lyrics like "Movin' down the highway with my guitar in my hand." File under lost innocence. AS

Alessi: mundane



# TAKE THE MELODY LINE

The Melody Guitar range from Italy represents all that is best in European instrument design. Exceptional tone, sustain and stability. Attractive, durable finishes. Melody prices are traditionally middle-bracket but recent new models move the name significantly up-market. When you're looking at guitars have a good look at the Melody range.

CLASSICS	STEEL STRUNG	12-STRING	ELECTRICS
	About	About	About
M420	£32.00	M1600 Folk £39.00	M1200 £51.00
M450	£38.00	M500 £47.00	M1250EL £62.00
M460	£48.00	M525EL £59.00	M1300 £63.00
M470	£59.00	M630 Sunburst £66.00	M1400 £64.00
M480	£67.00	M650 Black £68.00	M1430 Sunburst £78.00
-		M700 Tawny £58.00	M1450 Black £80.00
-		M800 £52.00	
-		M800EL £64.00	
-		Rondo £128.00	
-		Rondo EL £145.00	
			M6000 SG £90.00
			M5300 Strat £106.00
			M6200 £99.00
			M6300 LP £110.00
			M6600 Bass £112.00
			M5000 £110.00

## MELODY—SIMPLY GREAT MUSIC MAKERS

Information and stockists from sole distributors:—

### RICHARD BROWN DISTRIBUTION

The Minster, Harbidges Lane, Long Buckby, Northants.  
Tel: Long Buckby (0327) 842677.



# A LEGEND IN AMERICA!! A RUMOUR OVERSEAS...

THERE IS A COMPANY THAT SELLS THE VERY FINEST FRETTED INSTRUMENTS  
EVER MADE

They sell:

Gibson Mandolins: 1900-1950  
Gibson Mastertone Banjos: 1925-1939  
C.F. Martin Guitars: 1850-1969  
Pre-War Gibson Guitars  
. . . And Banjos by turn-of-the-century  
companies like A.C. Fairbanks, S.S.  
Stewart, Vega, Cole's, Orpheum,  
Washburn, Paramount, Bacon & Day,  
Epiphone.

They Publish a Free Illustrated Stock and Price List  
And they Ship Instruments everywhere — All over the World.

THEIR NAME?

**mandolin bros. Ltd.**

"The largest Bluegrass Store"

629 FOREST AVENUE, STATEN ISLAND, NEW YORK 10310 USA.  
Telephone: 212 981-3226

They sell:

New C.F. Martin Guitars  
New Ovation Guitars  
New Guild Guitars  
New Dobro Guitars  
New Gibson Mastertone Banjos





# FREEDMANS THE KEY TO A GREAT DEAL!

## SYNTHESISERS

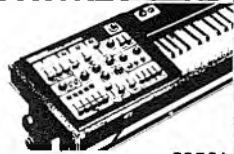

POLYMOOG	£2581
MINIMODG	£936
MICROMOOG	£449
ROLAND SH3A	£369
SH5	£749
KORG	
POLYPHONIC	£595
700S	£385
770	£385
CRUMAR	
POLYSYNTH	£595
JEN SYNTHTONE	£175

## BASS PEDALS



BOOGIE-BASS £125

## PRESET SYNTHESISERS



SH2000	£595
KORG PRESET	£420
KORG MICRO	£229
ELKA SOLIST	£310

## ELECTRIC PIANOS



ELVIN PIANO	£316
ROLAND TOP	£565
NP700 BOTTOM	£295
TOTAL	£860
ROAD RUNNER	£219
RHODES	
STAGE 73	£549

## RHYTHM UNITS

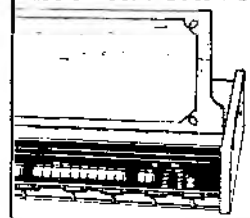

ROLAND TR33	£129
ROLAND TR55	£175
ROLAND TR66	£195
ROLAND TR77	£256
KORG 120P	£195
MINI POPS	£ 84
ALTAI	£ 64

## STRING SYNTHESISERS

ROLAND	
RS 202	£495
CRUMAR	
MULTIMAN	£550

## THE BIG MUSIC STORE



## PRO ORGANS

WLM	£1075
ELKA X 705	£2285
ELKA	
CONCORDE	£1295

Get into **FREEDMANS** -Fast! all prices include VAT

627-631, High Road, Leytonstone, E.11 01-539-0288

# CODA MUSIC

THE LARGEST STOCK OF DRUM KITS IN YORKSHIRE.

Agents for: **LUDWIG** and Slingerland

Large stocks of the following kits:

Gretsch  
Rogers  
Beverley  
Tama  
Premier

Musical Instruments · Sales · Hire · Tuition · Repairs  
Recording and Video Studios

28, Churchbank, Bradford  
Tel: Bradford (0274) 307433

# Boogie Bass

## Self Generating Bass Pedalboard

- PLUGS INTO ANY AMPLIFIER
- 16' AND 8' PITCH
- SINGLE TUNING CONTROL
- VARIABLE SUSTAIN
- ULTRA COMPACT TO FIT UNDER ELECTRIC PIANOS
- CAN BE USED WITH ORGANS + GUITARS + PIANO ACCORDIONS + SYNTHESIZERS

7 DAY MONEY-BACK HOME TRIAL SEND TODAY  
**£125**  
INCLUDING V.A.T. POST & PACKING

TRADE ENQUIRIES WELCOME!



**FREEDMANS** MAKE CHEQUE PAYABLE TO FREEDMANS:-  
629, High Road, Leytonstone, E.11 01-539-0288

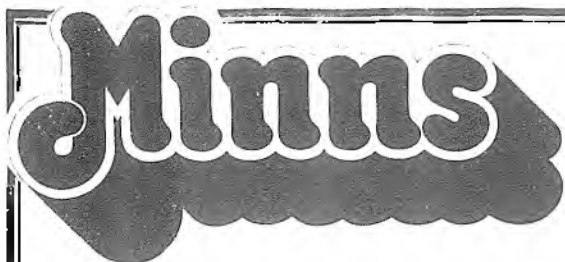

**Distributors Limited**

**U.K. AND EXPORT DISTRIBUTORS  
TO THE MUSIC TRADE  
387/389 LINCOLN ROAD, PETERBOROUGH  
ENGLAND PE1 2PF. Tel: (0733) 61357, 60256, 61830**

Retailers — don't get left in the dark, make contact with our bright sparks, guaranteed to illuminate you in all aspects of lighting.

**Britain's leading effects lighting from Pulsar and Zero 88 — Always ex-stock**

*Also available ex-stock products from: —*

**BULGIN & CO. LTD.  
CLIFF ELECTRONIC COMPONENTS LTD.  
ELECTRO-VOICE  
F.A.L. (East Anglia Only)  
FANFACOUSTICS LTD.  
LE MAITRE  
OPTIKINETICS  
TURNER MICROPHONES  
PETER & NICHOLAS ENGINEERING CO. LTD.**

**PLUTO ELECTRONICS  
PLAYSAFES  
THEATRICAL AND PROJECTION LAMPS AND  
BULBS FROM A VARIETY OF MANUFACTURERS  
RANK ALDIS  
RANK STRAND  
RE-AN PRODUCTS LTD.  
SOUNDOUT (Midlands & Wales only)  
TO NAME BUT A FEW**

Great selection of sheet music  
and accessories

**HIGHEST  
P/Ex**

# BIGGEST CHOICE

## at the right prices

plus... the best after-sales service in the business

We pay  
Top Cash Prices  
For Used  
Instruments and  
Amplification

Ampl	Peavey Electric Combo	E258	FAL 50w Bass Combo	E105	Yamaha SG 1500	E425	Cimar Strat.	E115
N/H M4 100	E200 Peavey TNT BASS COMBO	E189	FAL 100w Combo	E169	Yamaha SF 1000	E375	Antares Strat. used	E95
N/H DC212	E118 Peavey Backstage 30 Combo	E95	FAL 50w Combo	E125	Yamaha SF 500	E225	Rickenbacker 480	E195
N/H Pro 100	E128 Peavey Standard P.A.	E225	Furlax 50w Combo, used	E150	Ibanez FA 400 Super 400	E482	Ibanez Silver Series Tele	E139
N/H Pro 150	E159 Custom Sound Trucker P.A. & reverb	E189	H-watt 50w Combo, used	E99	Ibanez Artist Acoustic	E288	Mondo Les Paul	E81
N/H Pro 200	E189 Custom Sound Trucker cab and horn	E75	Roost 50w Combo, new	E145	Ibanez Musician In sound pickup	E268	Kanga S.G. used	E65
N/H 115 bins, used	E85 Custom Sound Trucker Combo	E95	Roost 100w Valve Head, new	E180	Ibanez Les Paul	E175	Vox 12 string electric	E55
N/H VS Musician Combo	E245 Custom Sound Trucker Bass Combo, 100w	E150	Orange 120w Valve, used	E180	Quira B301	E255	Sheepold Magytrador, used	E135
N/H VS Musician Combo	E761 Custom Sound CS100A as new	E95	Orange 120w Valve, used	E85	Quira B301	E255	Sunbo S.G. Custom	E59
N/H 412 Cab, new style	E189	E95	Carthage Scorpion Combo and Rob, used	E185	Quira S600	E255	Gibson Les Paul	E35
N/H 125 Cab	E214	E75	Harrell 100w 2x10 Combo	E750	Musman Synter, used	E140	Arp Avatar Guitar Synthesizer	E999
N/H Bass Combo	E275	E145	Musman 100w Combo, new	E550	Musman Syntray 1	E195	O VATIONS	
N/H Bass Combo, new style	E267	E475	Sound City 50w P.A., used	E375	Shergold Marauder	E225	Mattis	E245 E199
N/H VS Musician, new	E114	E135	Wam P.A. 100, used	E50	Shergold Marathon Bass, used	E110	Glen Campbell 12 string	E650 E450
N/H VS Bass, top	E147	E159	Wam P.A. 100, used	E45	Fender Telecaster Bass, used	E275	Ralinder	E395 E299
N/H VS Musician Combo, as new	E225	E150	Carthage Min. Bass, used, pair	E750	Fender Mustang Bass, new	E265	Electric Folklore	E588 E660
N/H VS Bass Combo, as new	E275	E248	FAL Bins, each (new)	E120	Fender Jazz Bass, used	E265	Logan	E475 E375
N/H Studio 50	E145	E65	FAL 12 into 2 Mixer, new	E270	Fender Musicmaster, new	E275	Case available	
N/H Studio 50 New Style	E160	E100	Moin 100 Combo, new	E250	Fender Precision, new	E275	KFYRDARDS	
N/H Organ Mute Echo	E264	E399	Marshall 100w Amp, new	E210	Fender Strat. s.w. and trem., new	E375	Vox S1man Consonance, used	E150
N/H 12 into 2 Mixer	E371	E951	Marshall 1x15 Combo, used	E345	Fender Strat. m/m and trem., new	E150	Falco V.P.P. 255, used	E399
N/H 16 into 2 Mixer	E209	E95	Marshall 4x12, or	E150	Fender Mustang Guitar, new	E275	Keynote Consort, used	E455
N/H SM200 Mixer Amp	E530	E110	Marshall 4x12, neo slope and straight	E110	Practise Amps from	E275	ARP Odyssey, used	E545
N/H Echo for Mixers	E295	E110	Marshall 100w M.V., as new	E110	Ampl 100	E275	Workites SP200, new	E588
N/H 12 into 2 Mixer	E159	E150	Marshall 50w M.V., as new	E120	Xelly 100	E375	Hohner Planet T, new	E215
N/H 16 into 2 Mixer	E228	E150	Marshall 100w M.V., new	E150	Selmer T & B 100	E375	King Microport, new	E295
N/H AP350	E228	E150	Marshall 50w M.V., new	E150	Ampl 100	E375	King Poly I, new	E695
Intermusic Combo reverb and phasing	E213	E213	Marshall 50w M.V., used	E150	Ampl 100	E375	King 700, new	E395
Mono 100 Amp, used	E236	E236	Marshall 1x12 Powercell Cab 100w	E150	Ampl 100	E375	Korg Armit, new	E395
Mono PA200	E110	E110	Marshall 1x12 Powercell Cab 100w	E150	Ampl 100	E375	Art Ace, new	E795
Mono 115 Cab	E189	E189	Marshall 1x15 and Horn Cab	E150	Ampl 100	E375	Art tone XS, used	E795
Mono 200 Head & Reverb	E189	E189	Marshall 4x12, used	E150	Ampl 100	E375	Roland SMD, used	E345
Peavey Picco	E185	E185	Marshall 4x12, used	E150	Ampl 100	E375		
Peavey Decca Combo	E348	E348	Marshall 4x12, used	E150	Ampl 100	E375		
Peavey Artist Combo	E347	E347	Marshall 4x12, used	E150	Ampl 100	E375		

\* 100's second bargains  
ALL GEAR  
GUARANTEED

\* Surrey's biggest H/H  
dealer

\* Instant credit up to  
£500

\* Barclaycard/Access

\* High speed mail order  
Export service



**SURREY'S LIVELIEST Music Store**

14-16 High Street, Aldershot, Surrey. Tel: Weybridge (0932) 40139/54877 Telex: 24256 Aftay G  
96 High St., Esher, Surrey. Tel. Esher 66195 Pianos. 85 High St., Esher. Tel: Esher 66195



## Still the best.

That's our opinion and we're sticking to it. We haven't seen or come to think of it, haven't heard anything to compare with our Master Rack System. This 1000 watt triamped monitor or p/a system is the most compact available. Yet its size does not sacrifice power, power that bands demand and require. Of course we realise you'll want to form your own opinion that's only natural so give us a ring and we'll arrange a demonstration that will show you why it's the best.

# Westmill

West Mill Road, Colinton, Edinburgh. 031-441 7926.  
AGENTS FOR: A. T. C. TURNER RSD in Scotland.

# ALAN'S Music Centre

ANNOUNCE THAT THEIR  
PROFESSIONAL GROUP GEAR  
BASEMENT IS OPEN

STOCKS INCLUDE:  
GIBSON, GUILD, FENDER, IBANEZ,  
HAGSTROM, OVATION

PREMIER, PEARL, TAMA

CUSTOM SOUND, MARSHALL PEAVEY  
ARP, HH, ORANGE, PHOENIX

7 KETTERING ROAD, ABINGTON SQUARE  
NORTHAMPTON 0604 31129

# Chandler GUITARS ACTIVE GUITAR ELECTRONICS

FOR THE FIRST TIME IN THE UK A RANGE OF  
PRE-AMPS AND EQ UNITS FOR INSTALLATION INTO  
YOUR OWN INSTRUMENT.

THINK OF THE ADVANTAGES: MASSIVE  
INCREASES IN VOLUME; TREBLE AND BASS  
CONTROLS WHICH REALLY BOOST AND CUT GIVING  
TONAL CONTROL UNHEARD OF WITH CONVEN-  
TIONAL GUITAR CIRCUITRY; LOW IMPEDANCE  
OUTPUT FOR CRYSTAL CLEAR TREBLE AND NO  
SIGNAL LOSSES FROM GUITAR LEAD CAPACITANCE;  
MICRO CIRCUITS WILL FIT INSIDE ALMOST ANY  
GUITAR.

- C.1. Volume booster. Gives a weak guitar roaring power; gives basses punch and clarity. £19.50.
- C.2. Custom version of above allows for equalised output from two pickups of unequal strength. £32.00.
- C.3. The tone system. Massive volume boost and treble and bass boost and cut in one miniaturised unit. £32.00.
- C.4. Especially for bass guitarists. With this unit you can choose the frequencies you boost as well as how much you boost them! Will drive a power amp on its own. EPOA
- C.5. The ultimate tone system. Two sophisticated equalisers in one package to give mixing desk type tone shaping in your own guitar. EPOA

All units supplied with wiring instructions and necessary hardware. Send SAE for our full range of parts.

CHANDLERS GUITARS  
199 SANDYCOMBE ROAD  
KEW, RICHMOND, SURREY  
TEL: 01-940 5874

MM ARIA MEGA RSD CUSTOM SOUND

To all our Customers  
and our Suppliers

"WE WISH YOU A MERRY CHRISTMAS

AND

HAPPY NEW GEAR!"

from

  
at 106, SCHOOL STREET,  
WOLVERHAMPTON. TEL: 0902 29352

PEAVEY ALLEN & HEATH CARLSBORO

MARSHALL  
PARK  
RCF  
GAUSS

FRUNT  
ATC  
ALTEC  
TRAYNOR

# Schaller machine heads

How can you tell a high-quality machine head? Look at what brand machine head the leading guitar manufacturers are using on their top line guitars. We're sure you will find that Schaller makes them.

The Schaller reputation has been built on creative engineering, closer tolerance, care in handling, better buffing, and a high-quality chrome finish that is a good reflection of our name.

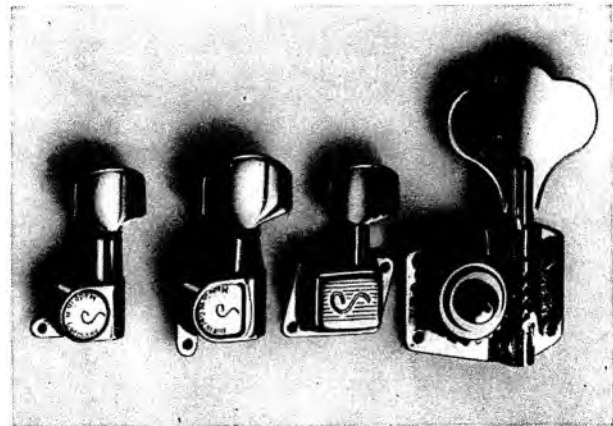

Schaller Electronic Pfingstingstrasse 2, 8501 Feucht, West Germany

## Rex Bogue

**THE  
"BALZ"**

Is ideally suited for use with normal magnetic pickups and Piezo electric. This basic pre-amp does not change the sound of the instrument, only amplifies and drastically improves signal to noise ratio, attacks transients, frequency response, by isolating the pick-up from the capacitance of the cord, and overall sound quality. Output is low impedance and will drive a set of headphones. With your normal amp it will give you "The Bals" and much wanted sustain at much lower levels, and, with a power amp, very clean stereo sound. You can also go direct to any board.

"The Bals" is recommended for any 2 control guitar or bass such as Telecaster, F, Ibanez Les Paul Junior, etc and will also fit all others.

**"BALZ"  
GALORE**

Can be used to achieve an extremely clean sound, will, when turned up, delivers the most sought after overdrive and sustain characteristics yet obtainable with any device mounted directly in the guitar. Balz Galore offers limitless control over sound characteristics, with active treble and bass circuitry. Unlike conventional tone controls, Balz Galore gives enormous boost and cut of the treble and bass frequencies, so you can really dial in Your Sound.

If you own a Stratocaster, Les Paul, Explorer, L5S, or any 3 or 4 control guitar, this is the model for you, and it is the same one you've seen and heard on the Rex Bogue Guitars we've become famous for. If you don't have \$3,000 for a Rex Bogue Guitar, the "Balz" Galore at under \$100 is a nice!

**"BALZ"  
DELUXE**

Offers the ultimate in onboard electronics with selectable frequency ranges for the treble and bass tone circuitry. You can boost or cut at four selectable frequency ranges, two for treble and two for bass giving intense upper and harmonic snap and driving bass simultaneously, or for that matter, any sound you like. For the bassist, the clearest, most powerful sound to be enjoyed.

The "Balz" deluxe is installed in every bass we build without exception. Because its sound is what bass players have been looking for, for years. Once you hear it, you'll never be without "Balz" deluxe. The "Balz" deluxe is ideal for guitarists seeking the ultimate fidelity & clean sound.

The three electronic packages offered, "THE BALZ", "BALZ GALORE" and the "BALZ DELUXE" are designed to fit any guitar you own, with any type of sound you wish, from a sweet and clean sound to the most awesome power and sustain you could possibly imagine. We offer all models in kit form, which includes assembled "BALZ" of your choice, and instructions, intended for repair shops, dealers, or electronically inclined guitarists or fully assembled, complete with all parts fully wired and ready to install.

In addition to our line of electronics, we will also be offering a complete line of pickups to directly replace and update all humbucking and Fender types. We maintain a full repair and custom facility, which includes our line of guitars that we build on custom order only.

### GUITARS ELECTRONICS

ASK YOUR LOCAL MUSIC DEALER IF HE HAS "BALZ". IF HE DOESN'T, WE DO!...  
REX BOGUE GUITARS P.O. BOX 751 SAN GABRIEL CA 91778 PHONE (213) 571-1970

for \$1.25 prove  
to yourself  
the sounds  
in your brain  
can really come  
out your fingers...

with  
the Energy

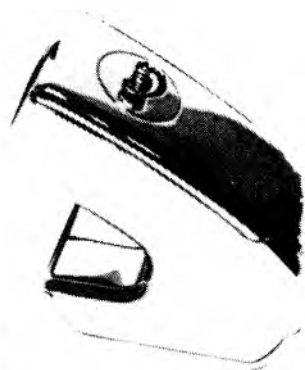

price: \$125.00

Widen your creativity with this hand held electronic bow for guitars that gives you a virtually unlimited sustain plus a range of new sound effects — cello, oboe, violin, flute, bass, etc. — even a synthesizer.

With it, discover dynamics and harmonics that tantalize your talent. We have a demo tape to end tapes. If you're good — really good — and dedicated maybe you'll be able to match it. Send for it today. Right now. We know you'll want your own EBOW after you hear the tape.

manufactured by Heat Sound Products  
distributed exclusively by

### MORLEY

6855 Vineland Ave.  
No. Hollywood, Ca. 91605

- Send me the tape & free information  
Here is my check, money order — \$125.
- Send me free information only.



NAME \_\_\_\_\_  
STREET \_\_\_\_\_  
CITY \_\_\_\_\_ STATE \_\_\_\_\_ ZIP \_\_\_\_\_

# STEEL WORKS

by Dave Hayward

## PART 4

### More about tuning

If you have applied the tuning procedure which I outlined in the last article, you'll be starting to find your way around the instrument in terms of how each string is related to the others. In this respect, it is a very useful exercise to carry out, but it is not the ideal way to tune a pedal steel guitar. When you place the bar at a particular position on a string in order to give you the note for another string, how do you know it's placed *exactly* where it should be? The answer is — you don't! On a normal guitar, you can hold a string down on to the fret and you know it's the right note because the fret can't move (assuming, of course, that the instrument is accurately fretted and you don't bend the string) but on a steel you have to rely on a certain amount of judgement to achieve correct pitch. There are several reasons.

First, the fret markings on a steel are only meant as a guide and they do vary in accuracy from one instrument to another. Second, from where you are sitting at the steel, it's unlikely that your head is exactly above the fret position, and as the strings are maybe half an inch away from the neck, you have to allow for the parallax effect when lining the bar up with the required mark. Also, it can be difficult, because of the thickness of the bar itself, to see where the mark is once you've placed the bar over it! And lastly, probably the biggest factor of all, experience, or rather the lack of it. The bar moves so easily along the strings that, while concentrating on other things like which string to pick, volume and pedal operation, the player allows the bar to wander slightly from where it should be. Later on, we'll look at how to improve this, one of the basic faults with beginners. But for now, let's examine a method of tuning which completely avoids all the pitfalls I've just mentioned.

### Tuning with harmonics

I don't propose to go into a long dissertation on harmonics. I shall assume you know the theory already. The fact is, a steel guitar lends itself very well to the use of harmonics due to its high sustain (and I mean true sustain, not the electronic variety produced by fuzz, distortion, etc.), clear sound, pickup sensitivity and so on. Therefore, it is a fairly easy matter to produce harmonics for tuning purposes on the open strings. I find the easiest way is to lightly touch the string in the appropriate place with a finger of the left hand, then pick the string with either finger or thumbpick of the right hand while lifting your finger off.

After a little practice, you'll be able to produce nice clean harmonics on a number of positions. When you've become reasonably at home with the technique, I suggest you try the following

tuning method. The bar is not required for this, incidentally.

### Fourth string

Start by getting the fourth string correctly pitched to E with a tuning fork or whatever means you use.

### Eighth string

'Harmonic' the fourth string at the twelfth fret position, and the eighth string at the fifth fret position, and adjust the eighth string until the notes match. You'll find it's not too difficult to get the two strings ringing at the same time. The advantage of this is that, being very high-pitched pure notes, the ear is easily able to detect the most minute difference between them in the form of a "beat", and so it becomes a very accurate way of tuning.

### Fifth string

'Harmonic' the fourth string at the seventh fret and the fifth string at the fifth fret and adjust the fifth string to match.

### Tenth string

'Harmonic' the eighth string at the seventh fret and the tenth string at the fifth fret, and adjust the tenth string to match.

### Sixth string

'Harmonic' the eighth string at either the fourth or ninth fret whichever is the loudest (they both produce the same note), then 'harmonic' the sixth string at the fifth fret and match the two by adjusting the sixth string.

### Third string

'Harmonic' the fourth string at either the fourth or ninth fret and then 'harmonic' the third string at the fifth fret and match the two by adjusting the third string.

### First string

'Harmonic' the fifth string at the seventh fret and the first string at the twelfth fret and adjust the first string to match.

### Seventh string

'Harmonic' the tenth string at the seventh fret and the seventh string at the twelfth, and adjust the seventh string to match.

### Ninth string

'Harmonic' the ninth string at the fourth or ninth fret and the seventh string at the fifth fret, then match the two by adjusting the ninth string.

### Second string

'Harmonic' the fifth string at the fourth or ninth fret, then harmonic the second string at the fifth fret, and match the two by adjusting the second string.

### Pedalled notes

That takes care of the open string notes; now for the pedalled notes. Don't forget, by the way, that on some instruments you may have to tune the pedals first and then the open strings as I explained in the last article. If this is the case, you'll have to do it in a different order to the way I've written it. The relationships between the strings still remain the same.

### Pedal A

Depress the pedal. 'Harmonic' the first string at the seventh fret and the fifth string at the fifth fret, then make the necessary adjustment to the fifth string to make the two notes the same. (Remember, depending on the type of action your steel has, you will have to make this and the other pedalled note adjustments either at the machine heads or at the pedal adjusters on the endplate). This pedal also raises the tenth string by the same amount as the fifth, and as they are an octave apart you can 'harmonic' the tenth string at the fifth fret and the fifth string at the twelfth fret (with the pedal still held down) and adjust the tenth string to match the fifth. As with all pedal adjustments, 'pump' the pedal a few times and check that it is still in tune and then re-adjust if necessary.

### Pedal B

Depress the pedal. 'Harmonic' the fourth string at the fifth fret and the third string at the seventh fret, and adjust the third string to match. The sixth string is tuned an octave below the third and this pedal raises it to the same extent, so, 'harmonic' the third string at the twelfth fret and the sixth string at the fifth fret and adjust the sixth string to match.

### Pedal C

Depress the pedal. 'Harmonic' both the fourth string and the first string at the twelfth fret and adjust the fourth string to match the first. The fifth string raise on this pedal probably won't need adjustment because it's the same as the same as the raise on Pedal A. However, if you do need to check it, do it like this: with Pedal C still held down, 'harmonic' the fourth string at the seventh fret and the fifth string at the fifth fret and match the two notes by adjusting the fifth string.

### Knee Lever

Hold the knee lever over. If the knee lever on your steel lowers the fourth and eighth strings, 'harmonic' both the fourth and second strings at the twelfth fret and match and notes by adjusting the fourth string. The eighth string is an octave below this so, with the lever still held over, 'harmonic' the fourth string at the twelfth fret and the eighth string at the fifth fret and match these two by adjusting the eighth string.

If the knee lever lowers the second string on your steel, 'harmonic' the ninth string at the fifth fret and the second

string at the twelfth fret (with the lever held over) and match the two notes by adjusting the second string.

This lever may, in some cases, also lower the eighth string in which case hold it over and 'harmonic' the tenth string at the fourth or ninth fret whichever is loudest, and the eighth string at the fifth fret and adjust the eighth string to make the two notes match.

Getting your instrument in tune accurately is very important as a small error can make a lot of difference to the way it sounds. The pedal steel is such a complex instrument that there are almost unlimited numbers of slightly differing tuning procedures. By using harmonics alone, the notes of many combinations of strings can be compared and checked.

Personally, I use a system of harmonics not much different to the one I've just outlined. I suggest you experiment until you find the method that comes easiest using the procedure I covered in the last article, and this month's, as a basis.

### More major chords

Up to now, we have examined ways of playing some major chords using either no pedals or A and B pedals together. As a recap, Example A shows some of the C chords we've seen so far.

But you don't have to stick to these shapes alone. For example, Example B shows nine more C chords.

They're obviously just made up from the same chords but using a wider "grip". You'll find they sound fuller and, I think,

more interesting. There are other inversions too, and to complete the picture, Example C shows yet more C major chords, this time using the knee lever or B pedal alone.

So far I've used C major chords to illustrate many of the positions in which any one major chord can be played. From this, it's an easy matter to work out where to play other major chords by simply moving the bar up or down the strings to another position. For example, take any one of the C major chords shown, move the bar up and it becomes C sharp major; up one more fret and it becomes D major, etc. If you refer to the last article you will see how we arrive at the F and G chords.

All right, so you now have the means to play any major chord. I don't suggest you slog away and learn every one by heart immediately. Fix as many in your mind as you can remember easily (about six or eight variations of the same chord at a time) but spread them over the whole length of the neck. If you do this for C, F and G, you should soon be able to start making up your own sequences similar to the ones I gave in the last article.

1										
2										
3			3B			B			15B	
4		3	3			8		8	15	15
5		3A	3A	3A		8		8	15A	15A
6	3B	3B	3B		8	8	8	15B	15B	15B
7										
8	3	3			8	8		15	15	
9										
10	3A				8			15A		

Example A

1										
2										
3		3B	3B		8	8		15B	15B	
4	3			8				15		
5		3A	3A		8	8		15A	15A	
6	3B			8				15B		
7						8				
8		3							15	
9										
10	3A	3A		8	8			15A	15A	

Example B

1			1			13				
2			1			13				
3										
4										
5		1	1			13	13			
6								10B	22B	
7	1	1		13	13			10	22	
8	1L	1L		13L	13L					
9								10	22	
10	1			13						

Example C

1										
2										
3								8		
4								8	8	
5	3	3	10A	8	8	8A	8	8A		
6	3	3	10B	8B	8	8	8	8		
7										
8	3	3	10	8L	8	8				
9										
10										

1
2
3
4

Example D

1										
2										
3						8	8			
4		8	8	8L	8A	8	8			
5	B	8A	8A	8	8	8A	8A	1	3	
6	B	8	8B	8B			8B	1	3	
7										
8	B						B	1	3	
9										
10										

C
Am
F
G7
C
Am
F
F
G7

Example E

### Minor and seventh chords

Obviously the use of pedal steel is by no means limited to just major chords. It's when you start to build up other chords that the instrument really starts to come into its own. For instance, try the change 1 in Example D.

The G note on the eighth string is dropped to F on string nine, modifying the G major chord to G7th. Change 2 gives the same chord progression but using different inversions. Change 3 shows how, by using Pedal A, a 6th chord can be produced from a major, in this case C. For most purposes on steel, a C6th chord is the same, and is interchangeable with, A minor so, in effect, you have two chords for the price of one in this case.

The same thing applies at all the other fret positions of course. Thus, as before, if you move the C6th chord in change 3 down to the seventh fret position you have B6th etc. Change 4 is just another way of producing the C to C6th change.

It doesn't take a genius to realise that, so far, if you put together some of the chords we've covered, you come up with that good old corny four-chord sequence, C, A minor, F, G7th. Corny it may be, but it does start to give you an insight into how chords fit together on pedal steel. Example E shows a couple of ways of playing the sequence: an easy one first, then a slightly more difficult one. You'll find there are plenty more ways if you experiment.



# THE STEEL MILL

ZB custom

FOR EMMONS AND ZB CUSTOM GUITARS



STEEL GUITARS,  
STEEL GUITAR ALBUMS  
and all other Steel accessories

★  
plus a large stock of  
STRINGS, AMPS, TUTORS

★  
For further information contact  
us direct at:

THE STEEL MILL,  
2 UPPER FANT RD. MAIDSTONE, KENT. (Tel: 673355)

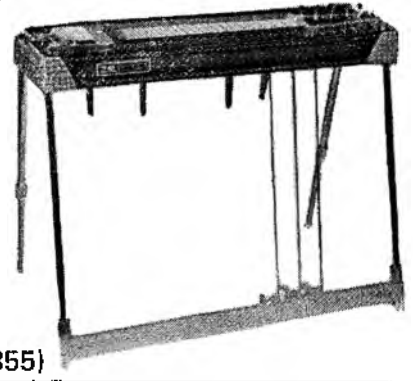

## NORTH LONDON GROUP GEAR

809/811 High Road, Tottenham N.17.  
(Near White Hart Lane)  
Telephone: 01-808 0388/9214

(NORTH LONDON ORGAN STUDIOS)

(Run by Musicians for Musicians)

WE ARE PROUD TO ANNOUNCE THE ARRIVAL SHORTLY FROM U.S.A. of

### SIERRA Pedal Steel Guitars



SIERRA  
"PROFESSIONAL"  
MODELS

SSO-10, 5 PEDALS 4 KNEELEVERS EXTRA PICKUP & CASE £775  
SSO-12, 5 PEDALS 4 KNEELEVERS EXTRA PICKUP & CASE £895  
SSO-14, 6 PEDALS 5 KNEELEVERS EXTRA PICKUP & CASE £1150

For more details phone 01-808 0388/9214  
or call in for demonstration by MICK BYRNE  
our Steel Guitar Specialist.

We also stock wide range of Guitars/Amps/Drums  
Electronic Organs and Keyboards, Sheet music.

#### SIERRA EXCLUSIVES AND FEATURES

##### Modular Quick Change Pickups

- The artist can get the sound he wants. They also can be changed—quickly—for different sounds.
- Truly a feature that pros, as well as beginners, will desire.
- It is exclusively on "Sierra". Interchangeable pickups!! Unique.

##### Folding Legs and Quick Disconnect Linkage

- This feature—alone—can reduce set-up time by 50%.
- All steel players appreciate the reduced set-up time and the rock solid stance.
- It is exclusive on "Sierra".

##### High Strength Aluminium Construction

- This feature gives maximum rigidity, yet is light in weight.
- The solid body design eliminates detuning from frame distortion.
- Construction is of extruded aluminium, not sand castings. Even small parts such as pedals. The result—extremely strong components.
- All aluminium is anodized with a special bright dip for lasting beauty and hardness.

##### Solid Maple Decks and Necks

- Handcrafted, individually fit, hard maple decks and necks are bonded to the aluminium to produce true sounds. Decks and necks are then covered with top quality formica, handcrafted for a precision quality fit.

##### Most Advanced Changer Mechanism

- Rod driven, double raise and double lower standard
- Universal linkage, allowing artist to change his set-up without factory redo.
- All rods are polished, ground stainless steel.

GEARS!! Real "Groovers"—of course!

We are sole importers

Trade enquiries welcome

GUITARS AMPS DRUMS ETC. ALSO  
AVAILABLE FROM OUR BRANCH  
J 60 MUSIC BAR LTD.,  
439 HIGH ST. NORTH,  
MANOR PARK E.12.  
TELEPHONE: 472-4690/5107

## Premier

Abgestimmte Schlagzeug- und  
Trommelsätze erhältlich von:

Chas. E. Foote Ltd.,  
17 Golden Square, London W.1.  
Tel. 01-437 1811.

MERRY  
CHRISTMAS  
AND A  
HAPPY  
NEW  
YEAR

FROM  
KEITH  
HAND  
MUSICAL  
SUPPLIES

219 Walmersley Road, Bury,  
Lancashire. BL9 6RU. Tel: 061 764 1792/3



# THE 8 HOUR 6 IN 2 OUT

PROKIT 62 is a stereo mixer designed for professional PA and recording applications. Gain, treble, bass, folback, echo and pan are featured on each channel. Slide level faders are used for inputs and main outputs. Echo returns and VU meters feature on the outputs.

PROKIT can be built in about 8 hours with the minimum of tools, following the comprehensive 32 page assembly and fault finding manual.

Phone or write for the 12 page illustrated leaflet.

Exclusively from ;

TURNKEY.  
8, East Barnet Road  
NEW BARNET  
Herts EN4 8RW  
01-440 9221

REW.  
146 Charing Cross Rd  
LONDON WC2  
01-836 2372

Kit £99-95  
Assd. £149-95

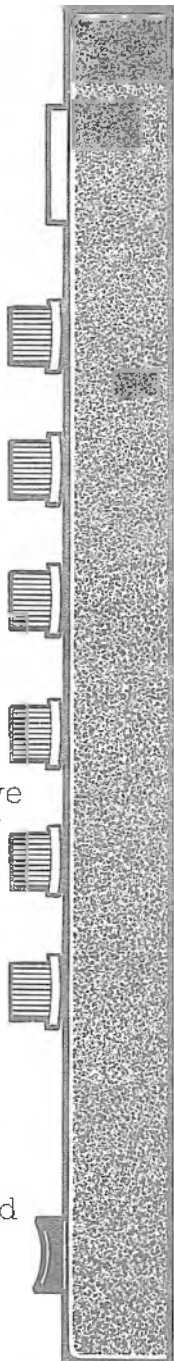

# tough & tiny

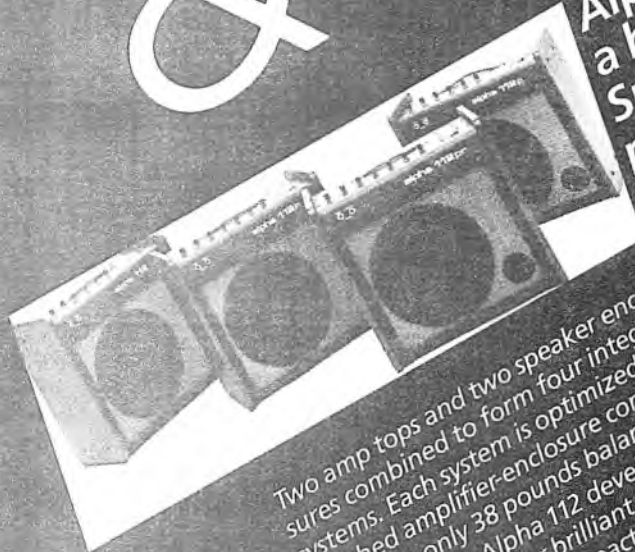

Alpha 112.  
a balance of  
Sunn quality,  
portability  
& power.

Two amp tops and two speaker enclosures combined to form four integrated systems. Each system is optimized as a matched amplifier-enclosure combination. Weighing only 38 pounds balanced at the handle, an Alpha 112 develops 50 watts RMS to deliver brilliant, high volume sound from its compact package. With one of the most sophisticated tone control circuits you'll find in any amplifier, this system can produce the most colorful variation of sounds you'll ever need. Best of all the Alpha 112 series is priced from \$299 to \$359. Stop by your Sunn Sound Dealer and get one to go.

**sunn**   
Sunn Musical Equipment Company  
a Hartzell Corporation Company  
Amburn Industrial Park  
Tualatin, Oregon 97062

# SIGMA SOUND ENTERPRISES

Rear Of 128 HARTLEY ROAD, RADFORD, NOTTINGHAM

# Introduce



ICE BLUE STUDIOS

## The **EX231**

Stereo Electronic Crossover

2way / 3way switchable  
300Hz & 3KHz

AVAILABLE NOW DIRECT FROM S.S.E.  
OR THEIR APPOINTED STOCKISTS  
R.R.P. £125 plus VAT

# THE LAST WORD IN GUITAR DESIGN THE B.C. RICH BICH

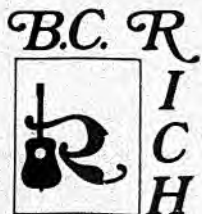

4770 VALLEY BOULEVARD • SUITE 121 • LOS ANGELES, CA. 90032 •

At B.C. Rich we know what guitar playing and building is all about and we understand the concept of craftsmanship. We build each guitar by hand because that's the way it should be. We do not believe that machines are any replacement for pride in craftsmanship.

Play with a BICH and see what it's like to play with the BEST.

# WHO SAYS TOTAL TUBE AMPS AREN'T THE BEST?

And here are 15 good reasons why.



- Hi Low gain pre-amp control switch
- Two volume and master controls
- Pull Gain
- Pull Bright
- RMS Setting — 60/100
- Ohm Selection Switch — 4/8
- Total Tube Amplification
- 6 Band Graphic EQ
- Overdrive distortion at low volume, regardless of player's loudness
- Foot channel Selector — to select distortion or clarify
- Individually hand wired
- Available in black or white tolex, or ZEBRA WOOD
- Speaker Options: Gauss, Electro Voice, Altec, JBL, or ATC
- 3 Spring Hammond Reverb
- PRICE: See your local Mitchell dealer and be pleasantly surprised! Or call us direct.

#### EUROPEAN DISTRIBUTORS

HAGSTROM MUSIKK A/S,  
NADDERUDV 63,  
N-1347 HOSLE, NORWAY.

T. CROWLEY & SONS LTD.,  
29 MAC CURTAIN STREET,  
CORK, IRELAND.

SEE AND HEAR THE PRO 100 AT YOUR LOCAL MITCHELL SPEAKER DEALER  
AND HEAR WHY WE THINK IT'S THE BEST!

## MITCHELL SPEAKER ©.

2906 Rubidoux Blvd. Riverside, CA. 92509

For catalog send \$1.00



**Sound Equipment Ltd.** Unit 3 Carlton Court Grainger Road Southend-on-Sea Essex SS2 5BZ England Tel: 0702 613232



## *Frankfurt with star casting*

500 exhibitors from 23 different countries await you at the world's most important music fair for international business with instruments, accessories and pieces of music.

**Wind, string, plucked and keyboard instruments. Accordions and harmonicas. Electronic instruments. Amplifiers, microphones, loudspeakers, parts and accessories. Music publishers.**



**International  
Trade Fair for  
Musical Instruments**  
4.3. - 8.3.1979

Fair admission tickets (advance sale at reduced rates) information and travel tips are available from:  
**Collins & Endres, 36, Sackville Street,  
London W1X 1DB,  
Telephone: 01-734 0543, Telex: LOP G LDN 262236**

**NEW EXCITING 64-PAGE**

# GUITAR

and AMPLIFIER, DISCO  
and LIGHTING

**FREE  
CATALOGUE**

Hot off the press comes this new BELL Catalogue. Packed with exciting instruments and profusely illustrated with actual photographs. It contains absolutely the latest — model after model of all types and makes of Guitars, Pick-ups, Amplifiers, Echo Units, Microphones, Accessories, Disco Units, etc. Wonderful cash bargains or easy terms.

CALL OR WRITE  
FOR YOUR  
**FREE**  
GUITAR CATALOGUE  
TODAY!

**BELL'S**

MUSICAL INSTRUMENTS LTD.  
Dept. 87 157/159 EWELL ROAD  
SURBITON, SURREY KT6 6AR

Callers Welcome.  
Phone 01-399 1166.  
Open all day Saturday.



## It can be a rough business.

For the guitarist, but also for his equipment. Take guitar amplifiers. They get quite a hammering on the road, and they need tough components to stand up to it.

The M-OV KT77 Beam Tetrode Valve does just that. It has strengthened components in its construction for extra durability. It is built to withstand rough handling and perform brilliantly.

Many leading manufacturers are finding out for themselves with the KT77 right now.

If you'd like to join them, get in touch with M-OV for technical data and details of worldwide distribution.



**M-OV**  
A MEMBER OF THE GEC GROUP

GEC

S 665

THE M-O VALVE CO LTD, HAMMERSMITH, LONDON, ENGLAND W6 7PE.  
TELEPHONE 01-603 3431. TELEX 23435. GRAMS THERMIONIC LONDON

## Richie Furay picks with the best of 'em: D'Angelico Guitar Strings.



When you're a top, professional folk rock guitarist like Richie Furay, you've got one thing in mind: making good music. For over ten years, Richie has insisted on the consistent quality of D'Angelico Guitar Strings. He just won't accept substitutes. In his book, D'Angelico Guitar Strings are the tops. And he ought to know.

Hear Richie Furay on *Asylum Records*.

*D'Angelico*  
NEW YORK

The Ultimate in Strings and Picks, none finer... perfect for pickin'.  
D'Merle Guitars, Inc., P.O. Box 153, Huntington Station, New York 11746.  
D'Merle successor to D'Angelico, New York.

# Guitar Workshop

*We have had to defer Stephen Delft's promised analysis of pickups for a month or two as we have not yet received sample pickups from some of the more interesting manufacturers. Meanwhile, Stephen discusses screening guitars against electrical interference*

Many elderly electric guitars suffer from excessive pickup of electrical interference from such sources as mains electrical wiring or lighting supply cables when an "electronic" dimmer board is in use. Although some makes of guitar have shown considerable improvements in the internal screening of their more recent models, it is still possible to find recently-made electric guitars, from various countries, in which the screening around internal wiring and/or internal components is inadequate for modern on-stage conditions. There are other instruments which appear to be effectively screened against electrical interference under most circumstances, but which may exhibit problems under the more critical listening conditions of studio work, or at the occasional large and important concert. This last factor is not just perversity: large and important concerts tend to involve larger and more complicated lighting systems, and unless you are very fortunate in your choice of engineers and equipment, this is likely to increase the level of electrical interference on and around the stage.

I don't wish to aim unfair criticism at the makers of modern solid-state lighting boards. The more recent models for switching very high-power lighting generate considerably less radiated electrical interference from equipment and cables than was sometimes found in earlier models. But it is very difficult to provide adequate suppression on some tens or hundreds of kilowatts of electric lighting power, whatever form of control is used. In any case, very few musicians have enough time, knowledge and executive authority to specify exactly what form of lighting and power distribution shall be used at each and every concert.

There is also the possibility of interference from nearby private or public-service radio transmitters. If your audio equipment picks up radio transmissions, it is probably a good idea to have it checked and if necessary "RF-proofed" by an engineer with experience in this sort of work. However, you are certainly going to make the problem worse with any amplifier if you attempt to play a poorly-screened electric guitar anywhere near a high-power radio transmitter.

In either of these cases, I feel that the simplest and probably the most economic solution is to ensure that all the electrical parts of your guitar(s) are adequately screened, and of course to use only high quality jack leads, which are known to

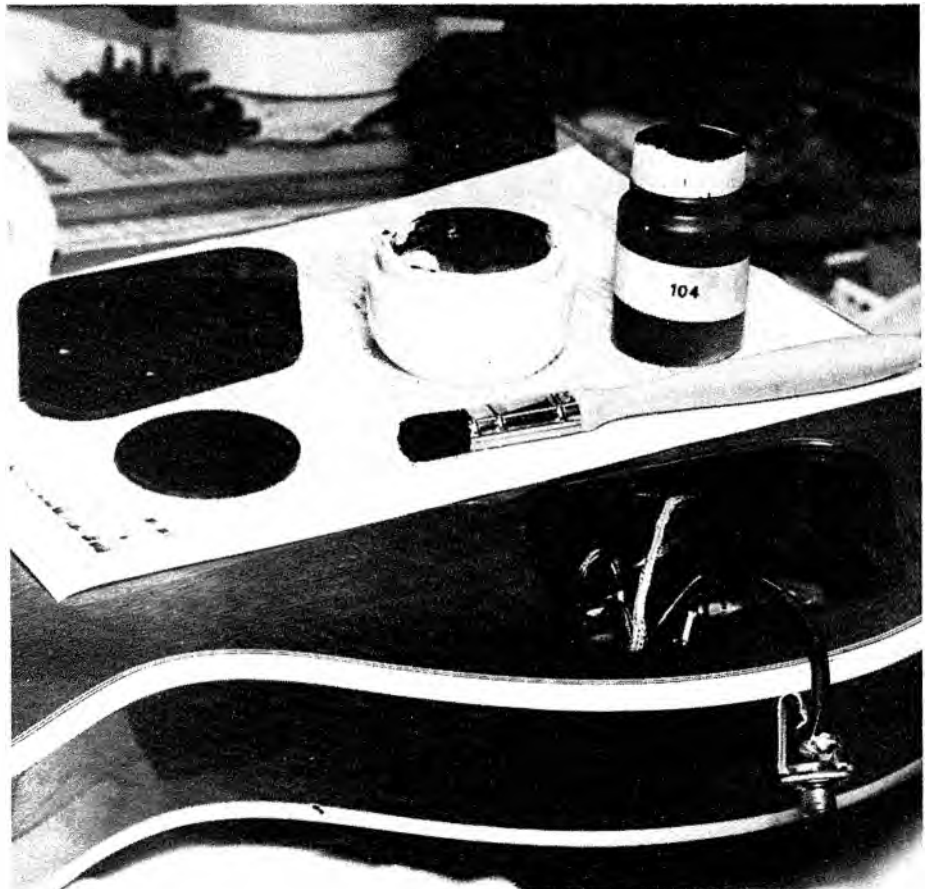

*All you need for a screening job*

have adequate internal shielding. There is little point in screening the guitar and then using poorly-screened cables. For the benefit of American readers, I think we may consider the terms "screening" and "shielding" to be interchangeable. Some of the better audio cables come from an American company and are therefore described by the makers as "shielded cable". English manufacturers often describe their similar products as "screened cable". In either case, quality and performance are usually roughly in proportion to price. Readers in Britain will probably find that some of the best screened and most durable audio cables come from the American Belden company. They are also relatively expensive. If any British manufacturer can provide a sample of home-produced cable of comparable quality, I shall be happy to give them some support. I have nothing against Belden. In my experience, they do an excellent job, but we do process rubber and plastic in Britain and we do make copper wire, and it only requires someone to put them together in the right proportions to make a really good stomp-proof, noiseless cable for guitarists. What about it BICC, Permantoid, and the rest?

You can not easily make your own screened cable, but if you can take a guitar apart and put it back together without damaging it, you can do your

own screening job. The first thing you should do is find out whether the instrument already has adequate screening. If it has, you are unlikely to make any real improvement and you should start chasing your interference troubles elsewhere.

Most guitars have access to the internal wiring in one of two ways. The first type, of which the Gibson Les Paul is typical, has one or more rear access panels, which may easily be removed for inspection without disturbing any other parts of the instruments. If all the body cavities are lined with metal foil or pressed metal shells, and any connections between these cavities are made with screened cables, leave well alone. If you are certain the guitar has a screening problem, look for any obvious broken wires, for instance around the jack socket, and otherwise take the instrument to a competent repairman.

If you have in the past removed the metal covers over the pickups, and your interference problems date from this time, you probably have your answer. Put the lids back, or accept the consequences of leaving them off. Some guitars screen the cavity containing the volume and tone controls, but not the one containing the selector switch. Also some instruments have screening applied to the guitar body or the back panel(s) but not both. You need screening on body and

back panels. (The only exception I can think of concerns some Gibson guitars which have a second metal shell screwed down over the controls and wiring. This arrangement completely encloses the controls and no further screening of this area is needed.)

The back panels are usually of some sort of plastic, and may be lined with metal foil or with a silvery paint. Either of these is effective as long as the panels make contact with some part of the body screening when they are screwed in place. If there is a firm contact, you will not make any improvement by over-tightening the panel fixing screws. This is likely to split the panel, or strip the thread in the holes in the body.

Some guitars are screened internally, but with conductive paint, not metal sheet or foil. This may be the colour of silver, or tarnished silver, or it may look like ordinary matt-black paint. Unfortunately, I have seen a few guitars painted inside with *real* matt-black paint, which has no conductive properties at all. It can be very difficult to tell the difference by inspection. Any electronics serviceman or engineer who has a high-range resistance meter should be able to tell in seconds whether your black paint is conductive or not. If it reads somewhere between 1k and 1Meg between two test probes about 25mm/1" apart, it is conductive enough. (The resistance is not critical, but this should give your friendly engineer a rough idea of the range to look for.) If the paint appears to be non-conductive, assume it is not screening paint. See later for suppliers and application methods.

Another common sort of electric guitar construction has all, or most, of the electric bits and wiring mounted on a removable front panel or scratchplate. One typical example would be the Fender Stratocaster. Access to this requires removal of the strings, and taping-down of any bridge or tailpiece bits which may fall off or slip out of place without the string tension. After this you will probably need to remove between 10 and 20 screws around the edge of the panel, and perhaps also some in the centre which hold down fittings such as covers or hand rests on top of the panel. In the case of Fender guitars, and possibly others, screws immediately at each end of the pickups are for pickup height adjustment and should not be unscrewed. They are attached to the panel, not to the guitar body. You should now be able to lift up the front panel slowly and gently.

If there is a separate panel for the controls, as on a Telecaster, or if the jack socket is separate from the main panel, there will be wires joining the socket and/or panels and these may pass through tunnels in the guitar body. There should be enough spare wire inside to allow you to lift up any one panel at a time and

gently place it upside-down beside the hole in the body. But take care: sometimes there is not enough slack in the inter-connecting wires to allow this without the risk of breaking something. Move each panel slowly and check that you are not straining any of the wires. If the wires are obviously too short, or if you see untidy joints covered with tape in the internal wires, someone has probably been in there before you. It might be all right. On the other hand, if the joints are a bit doubtful, any disturbance may stop the guitar working altogether. It is probably most sensible to put everything back carefully and have the guitar professionally checked — unless you fancy taking on a comprehensive fault-finding and re-wiring job.

If you see clean, neat wiring and enough spare wire to allow you to move things about a bit, continue. On this sort of guitar, it is common to find that the only screening precaution consists of a bit of foil stuck to the underside of the panel. On old instruments, you may find a thin metal sheet, roughly the same shape as the front panel/scratchplate. This is better, but it still leaves some room for improvement. On Fender-type guitars it is unusual to find any screening around the body cavities. It is also normal to find the internal connections to the pickups made with ordinary, unscreened twin wires. Although I appreciate that the pickups on such guitars are usually of the single-coil, unscreened, non-humbucking variety and that this places a limitation on the success of interference-proofing, I still find a significant improvement from screening the wiring and controls properly, and I think it is well worth the effort.

If you can also undertake the much trickier job of screening the pickups, or find someone to do it for you, you can gain a further improvement in hum and noise levels. This is not in my opinion a DIY job for the average musician. In Britain ask Kent Armstrong; in America ask Stars Guitars or Seymour Duncan. There are, no doubt, others who can do the same work without spoiling the pickup or changing its characteristics. Humbucking pickups with metal covers are already screened. Humbucking pickups without covers are usually partially screened by the choice of winding directions and by the earthing of the magnet poles and base plate.

As most of the replacement humbuckers widely advertised are constructed in this way, and they seem to be generally acceptable, one must assume that this degree of screening is a pickups unit is good enough for most people, most of the time. This does not necessarily mean that a pickup intended to have a metal cover will be satisfactory without it. Some are; some are not. Pickups of the same make but from different production

batches may react differently to the removal of their metal covers. In general, I would advise that you leave pickup alterations to pickup specialists. (I may in the future describe some pickup modifications, but they all require great care and dexterity, and they are entirely at the owner's risk.)

There is a third sort of guitar construction, found in hollow and semi-hollow electric guitars. One example would be the Gibson 335. It is quite easy to get the wiring out of one of these, if you are sufficiently determined — and very difficult to replace it. Also, the wiring on some of these instruments has begun to perish and any attempt to disturb the screened cables may involve a complete rewiring job. Only a few, older instruments are affected in this way, but even with wiring in good condition, replacing it all in the body is not a pleasant job. Leave this sort of guitar to professional repairers. Fortunately, a large proportion of these semi-hollow instruments had and still have, good internal screening arrangements, and are unlikely to need any improvement in this respect.

If you have followed this so far, you should have decided by now whether there would be any advantage in putting more extensive screening in your guitar. If you think there would be an advantage in this, various methods are open to you. One involves glue and aluminium kitchen foil. Another method uses self-adhesive copper foil. This is less messy and allows soldered joints without difficulty. Unfortunately, I do not know of a supplier in England. All screening methods have some disadvantages but self-adhesive copper foil is useful stuff to have if one is involved in making or repairing electric guitars.

The third method uses conductive paints, often called screening paints. Conductive paint with an organic solvent base is available from Stars Guitars in America. It is certainly a very good and useful product, but I prefer a British-made, water-based conductive paint called Condec 104. This does not give off unpleasant fumes, and does not appear to damage guitar lacquer if it is wiped off fairly quickly. It is also relatively inexpensive. If you send your name and address and postal order for £2.30 (no cheques please) to: Electrolube Ltd., Blakes Road, Wargrave, Berkshire, RG10 8AW, (England) requesting 50ml of Condec 104, they will send you enough paint to treat several guitars. Larger quantities are available to industrial and professional users.

This is the screening method I would recommend, particularly for amateur use. You will need the paint before you start work, so I shall continue this in next month's issue. The only other tool you need will be a cheap household paint brush about 15mm or 5/8 inch wide. —

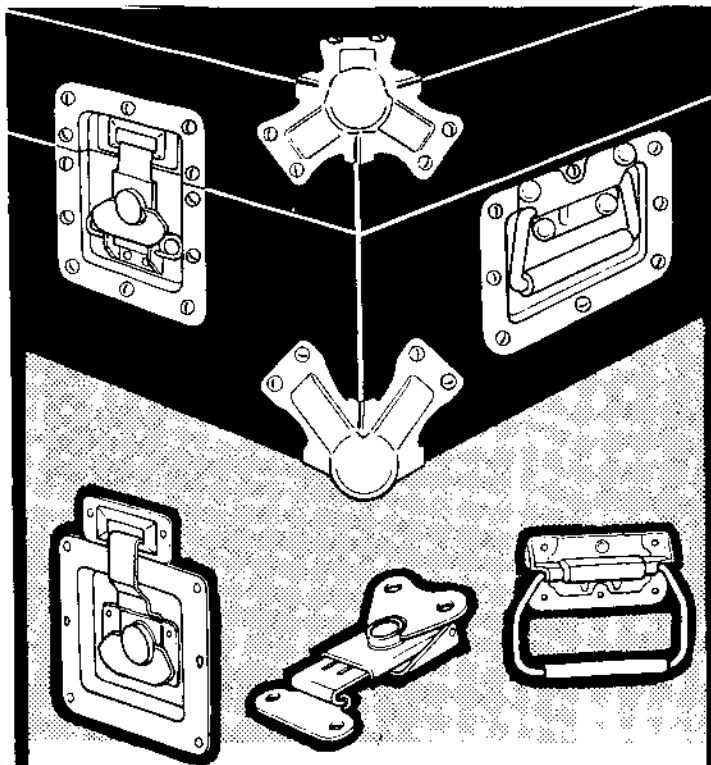

Protex quick-release latches, handles, corner pieces and fasteners are used by some of the world's leading manufacturers because they are just right for the job.

**protex** FASTENERS LTD.

Arrow Road, Redditch, Worcs. Tel: Redditch 63231

# SOUND SHOP

MAYORALTY HOUSE,  
NORTH QUAY,  
DROGHEDA,  
EIRE.

TEL. DROGHEDA 7473

WE ARE THE MAIN

## Wurlitzer Organ

STOCKISTS IN EIRE

A COMPLETE RANGE OF  
MUSICAL INSTRUMENTS,  
AMPLIFIERS, P.A. SYSTEMS,  
AND PERCUSSION ALWAYS  
IN STOCK.

WE ALSO CARRY OUT REPAIRS  
ON ALL MUSICAL EQUIPMENT  
INCLUDING BRASS INSTRUMENTS.

## PERFORMERANCE PERFORMERANCE PERFORMERANCE

Malatchi Electronic Systems, Inc. introduces the Performer Mixers for Sound Reinforcement and Recording.



### STEREO

- Master Section
- Effects Send
- REVERB With Pan
- Effects Return / Pan
- Monitor With Aux. Level
- Stereo LED OUTPUT METERS
- Seven Band Graphic Equalizer
- Left & Right Masters W. Aux. Inputs

### STANDARD

- Master Section
- Seven Band Graphic Equalizer
- LED Output Level Meters
- Electronic Crossover
- Effect Controls
- Input Attenuator
- Channel Patching
- Two Effects Buses
- LED Overload Indicator
- Internal Reverberation
- Independent Monitor Send
- Four Band Graphic Equalizer
- Balanced Mic and Line Inputs

Available in six, twelve, eighteen and twenty-four standard and stereo.  
• International Inquiries Welcome

**MALATCHI  
ELECTRONIC  
SYSTEMS**

1369 C WEST BYERS DENVER, CO 80223 (303) 722-5775

## DeArmond Pick a Pickup that picks up your sound!

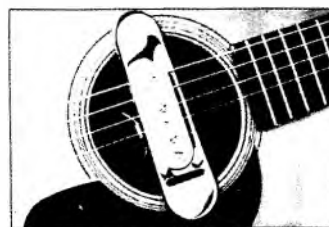

**Model 210**  
Full rich tones from individually adjustable 1/8" alnico magnets. Advanced coil design for maximum pickup power. Fingertip volume control. Try one... today!

**Model 3010**  
Piezoelectric transducer with sound transmitting diaphragm. No pre-amp needed, thus no pre-amp noise! Simple to attach, small enough to be installed inside. DeArmond designed it for you!

**Model 220**  
Tripod mount humbucking pickup cancels extraneous electrical interference, operates hum free. Pole pieces adjust individually, thumb wheel provides convenient volume control. Adjusts to openings 3 1/2" x 4 1/2" dia. in steel string guitars. A humbucking favorite!

Not Shown, Ask to see them at your favorite musical instrument dealer!

**Model RHCB—Flat Top Pickup.**  
Each string has its own magnet, preset for balanced output. High output possible without feedback. It's in our catalog!

**Model 800—Nylon String Flat Top Pickup.**  
Magnetic type contact pickup. Easy to attach and remove. Fingertip volume control. Available now!

**Model 1100—Arch Top Pickup.**  
Tone and volume control, plus rhythm switch for instant change from solo to rhythm. String output individually adjustable. Coil structure provides minimum distortion-free output.

**Model 1200—12 String Flat Top Pickup.**  
Fingertip volume control. Easy to attach and remove!



Model 3010

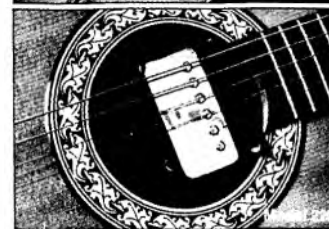

Model 220

DeArmond, Inc. 1702 Airport Highway/Toledo, Ohio 43609/U.S.A.





## Guitars and Amplifiers

Calling all Midlanders. No need to "go down the smoke" for a fantastic selection of Fender guitars and HH amplification. Pay us a visit or ring Miles. Not before 10 a.m. in case he has a late gig.

Credit facilities



Part exchanges

### DORMANS

NORMANS (BURTON-ON-TRENT) LTD.

1 Lichfield Street, Burton-on-Trent, Staffs.  
Telephone Burton (0283) 61528 or 42401.



## DRUMS

Premier main agent • Ludwig Percussion Centre  
Sonor main dealer

Now showing in the Drum Room:

From the U.K. — Premier

From the States — Ludwig

From Germany — Sonor

Plus many more kits and accessories. Pay us a visit or phone Norman Willey.

Part exchanges  
and credit  
facilities



Ask about our  
percussion hire  
service

### DORMANS

NORMANS (BURTON-ON-TRENT) LTD.

1 Lichfield Street, Burton-on-Trent, Staffs.  
Telephone Burton (0283) 61528 or 42401.

# FBT ELETTRONICA

THE LARGEST MANUFACTURERS OF AMPLIFIERS, AND P.A. SYSTEMS IN ITALY

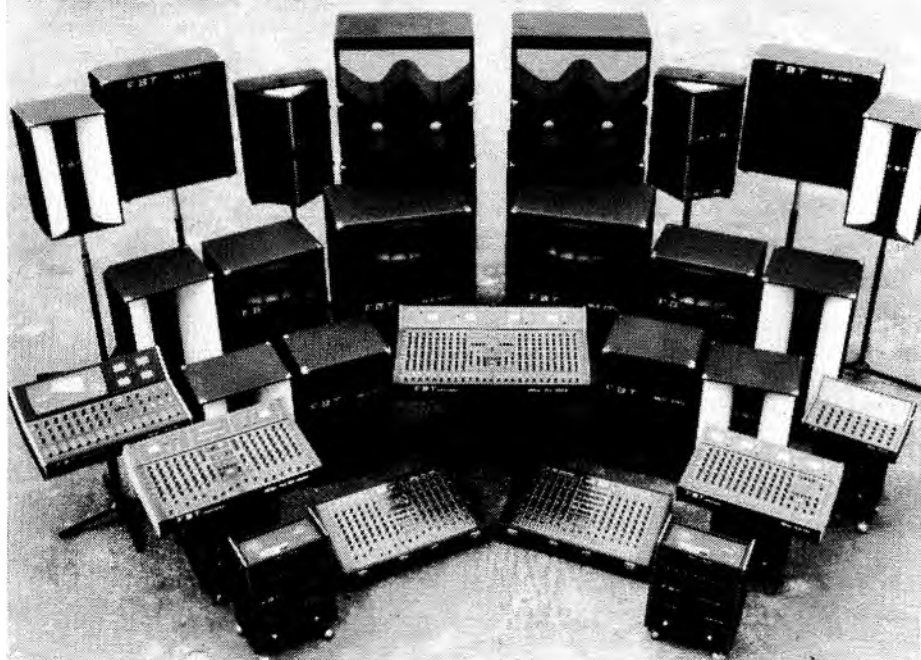

DISTRIBUTED IN ENGLAND BY  
THE CHAIRMAN  
33 Old Compton Street  
LONDON, W.1. Tel: 01-439 1842/3  
Telex 298803

To: The Chairman 33 Old Compton Street London, W.1. England

Please send me details of FBT products

NAME .....

ADDRESS .....

.....

**Don't choose  
one of these for our sound.  
Choose one for yours.**

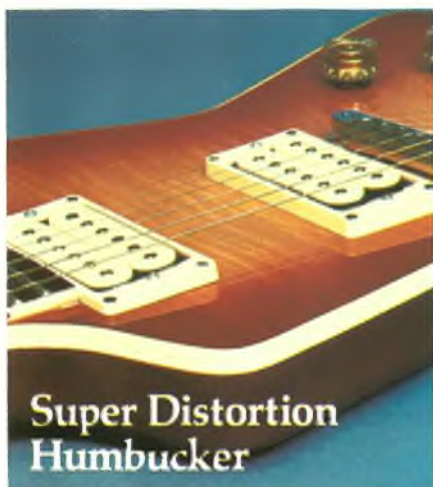

**Super Distortion  
Humbucker**

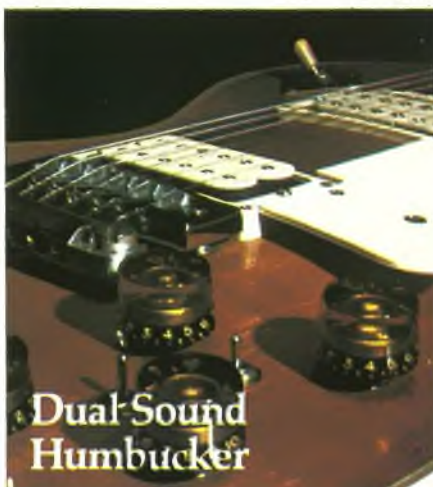

**Dual Sound  
Humbucker**

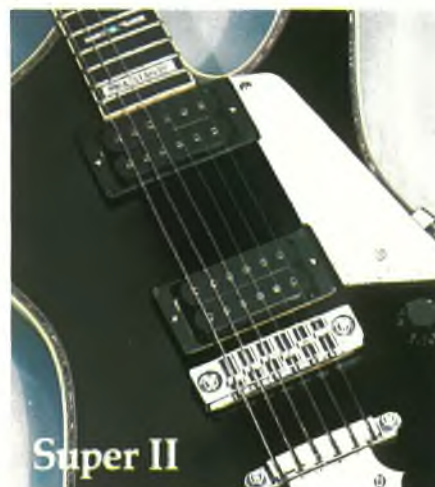

**Super II**

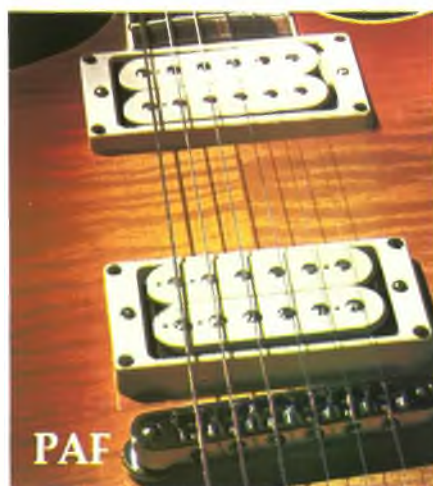

**PAF**

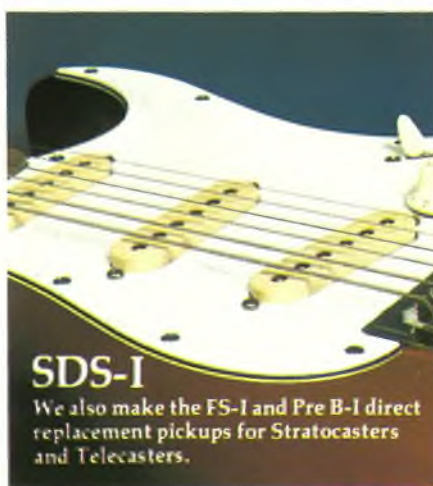

**SDS-I**  
We also make the FS-I and Pre B-I direct  
replacement pickups for Stratocasters  
and Telecasters.

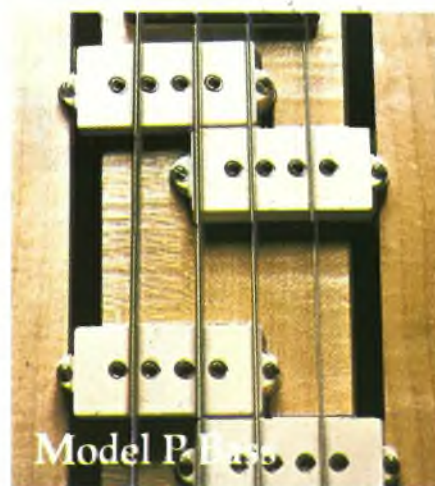

**Model P**



**Model I Bass**

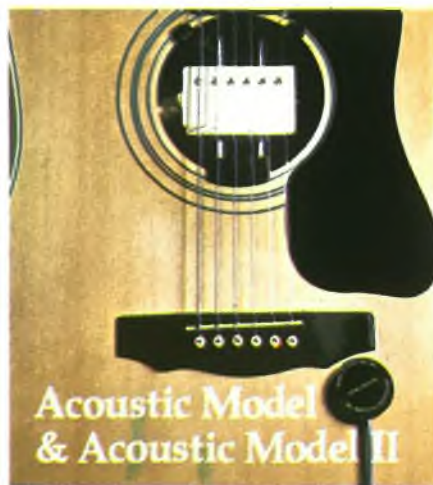

**Acoustic Model  
& Acoustic Model II**

*For a full color catalog  
on all our fine pickups,  
send 75¢. Also, if you'd  
like a poster of this ad,  
send \$1.00 to cover  
postage and handling.*



**DiMarzio**  
Musical Instrument Pickups, Inc.

1388 Richmond Terrace  
Staten Island, N.Y. 10310  
(212) 981-9286



# The sound of the 50's moves into the 80's.

The classic sound captured by the DiMarzio PAF has never grown old. The PAF still can create new dimensions in sound, which is why it is used by some of the leading innovators of tomorrow's music. Just listen to Alan Holdsworth on the new UK album on Epic records. Check out the PAF. Tomorrow is only a day away.



photo: Michael Halsband

For a color catalog, send 75¢ to:



**DiMarzio**  
Musical Instrument Pickups, Inc.

1388 Richmond Terrace  
Staten Island, NY 10310  
(212) 981-0286

# ADAM HALL (SUPPLIES)

**THE MAN OF MANY PARTS HAS IT** flares—feet—locks—hinges—piezos—trim—catches—castors—fasteners—connectors—corners coverings—frontcloths—handles—grilles flight case edgings, locations & fittings

send 2x9p stamps to ADAM HALL  
Unit 3 Carlton Court, Grainer Rd,  
Southend on Sea, Essex.

**NOW OPEN!**

## STAGE ONE MUSIC CENTRE

14 SEBERT ROAD, LONDON, E.7.

Musical Instrument Retailers  
**PLUS**  
Luxury 8 and 4 Track Recording Studios  
(formerly penthouse)

Special Opening Offers on Instruments and Studio Rates!

RING NOW 01-534 5472  
(24 hours)

**Celestion** 

Retail & Trade from:

**ADAM HALL**



**Celestion** 

Celestion: power speakers, powercel range, horn drivers, tweeters, now available from Adam Hall Supplies Ltd.

Unit 3 Carlton Court, Grainer Rd, Southend on Sea, Essex.

(0702 613292)

# BILLY COBBHAM & FRIENDS

**REMO** USA

Weather King and CS Black Dot drum heads

REMO, INC. 12804 RAYMER ST., NO HOLLYWOOD, CA 91605 U.S.A.

# The Performing Right Society

BY ALAN HOLMES

Taking  
Care of  
Business

Part  
10

Whenever a song is composed, a copyright exists. That copyright is the property of the writer unless he gives a music publisher the right to administer that copyright. If he assigns the song to the publisher, they become partners in the copyright. The Copyright Act of 1956 states that a performer may not publicly perform the song without the permission of the copyright owner. But it is obviously impossible for everyone who performs a song to ring up the composer and ask for his permission even to play down at the local pub. If he wanted to play 30 songs, he would have to spend all day on the telephone — and not just to Britain.

So the Performing Right Society Ltd. makes agreements on behalf of the copyright owners with all broadcasting companies, clubs, discotheques, public houses — in fact, any areas where music is performed publicly. Even in a private club, royalties are due to the composers of the music. So every place of performance, be it a pub, concert hall, disco or cafe,

requires a PRS license (see below). If someone does not have a license, he is infringing the rights of either the publisher or the composer and could be taken to court and sued. The performance does not have to be live: it can be by any mechanical means, record player, tape recorder, radio or television set.

Almost all music in popular demand is in copyright, which lasts for the lifetime of the composer and for 50 years after his death — in practice around 75 years. The initial term is 28 years and the renewal term 47 years.

A music, singing and dancing license in the case of a public house does not give any band or the publican the right to perform any copyright music at their premises without the correct PRS license. Although you do not now need a Post Office license for your radio, this does not mean you may use it to make copyright music audible to the public, in the same way that holding a television license does not authorise you to use your set to make copyright music audible to the public, for instance in a hotel, a private club or anywhere where they have a television lounge. The PRS employs full-time licensing representatives to license premises for the performance of copyright music in public. The total income for the year 1977 for all PRS sources was £24,895,226, so the sums involved are substantial.

*We asked a representative exactly what the Society is.*

An association of composers, authors and publishers of musical works which was established in 1914 to administer on behalf of its members certain rights granted under the copyright legislation. It is limited by guarantee, has no share capital and is non profit-making. The members elect a general council of 12 composers and 12 publishers who decide the policies for the administration of the society and appoint the management to carry out these policies.

Members are divided into three main categories: a provisional member, whose minimum qualification is one work or works which have been used in such a way as to make it worthwhile collecting the royalties, normally by recording (or, in the case of a publisher, 10 works). They have a right to receive from the society reports and accounts only.

The next grade up is the associate member, who after one year's provisional membership receives £150 for a writer or £750 for a publisher in PRS earnings, earned over a period not exceeding three years. Associate members are entitled to attend general meetings and have one vote on a show of hands in each poll.

A full member has to have PRS earnings of £1,000 for a writer or £5,000 for a publisher in each of two

## PRS Public Performance Tariffs

There are more than 40 standard tariffs governing the Society's charges for public performance of copyright music. They cover every conceivable place where live or recorded music might be performed, from clubs to circuses, airports to amusement arcades, bingo clubs to handstands in the park. Here are some of the more important tariffs (rates are exclusive of VAT).

### CLUBS

#### Live performances

1. If the licensee's annual expenditure on music is £2,000 or more 2% of such expenditure is payable to the PRS.
2. Otherwise, performances are charged for at fixed rates, based on the average number of days' performances per week — e.g. £20 per annum for three days per week.

#### Recorded music (e.g. discos)

1. 50p per 100 persons per day if there is no live music.
2. 25p per 100 persons per day if there is also live music.

### PUBLIC HOUSES

#### Live performances

1. If the licensee's annual expenditure on musical entertainment is £2,000 or more, a percentage of this expenditure: 2% of the first £17,500, 1.5% of any additional expenditure.
2. Otherwise, based on number of days' performance per week — e.g. £25 per annum for three nights a week.

### VILLAGE & URBAN HALLS

1. Dances, concerts, socials etc. at which music constitutes a major part: 30p per 100 persons (seating) or 50 persons (dancing).

2. Other entertainments where music is only incidental: 15p per 100 (seating) or 50 (dancing).

### HOTELS, BOARDING HOUSES & GUEST HOUSES

1. Where entertainment is restricted to residents: 31.5p per day for each 15 bedrooms.
2. Dances, dinner dances, banquets, etc.: £1.25 per day per 100 persons attending.

### JUKE BOXES

A basic annual rate of £3 per juke box, with reductions on a sliding scale to operators who hire out three or more juke boxes.

If that seems complex, remember that's only a few of the 40-odd tariffs. There are also rates for industrial premises, railway stations, football grounds, funfairs, ice rinks, hairdressing salons...

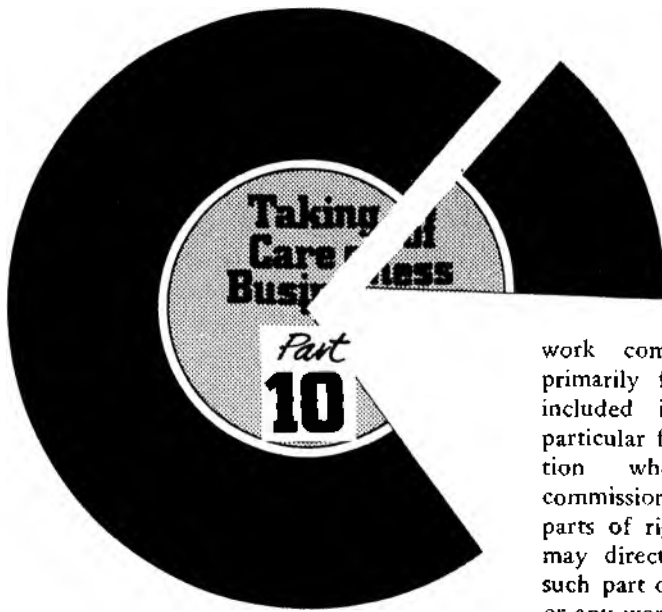

out of any three consecutive years. In addition to the associate member's rights, they have a supplementary 10 votes on each poll, plus a further 10 votes in certain special circumstances. In the case of someone having a very large success, with annual PRS earnings of 10 times the full membership minimum in each of the preceding two years, they will be eligible for their 10 extra votes. The Society is run by a board of directors elected by the members and this is done by a voting system with the number of votes proportioned as described.

**What does it do?**

The Society collects and distributes the public performance, broadcasting and diffusion royalties on behalf of the composers and publishers, whether they are members of the Society or members of affiliated societies throughout the world.

The rights administered by the Society are: *the performing right*, in the case of writer members only; *the film synchronization right* in every

work composed by the member primarily for the purpose of being included in the soundtrack of a particular film or films in contemplation when such work was commissioned; *other rights* or such parts of rights as the general council may direct for the whole world or such part or parts of the whole world or any work or parts of works, present or future, in which the member is the writer, publisher or proprietor.

Performing right means, in relation to a musical work, the right to do or authorise other persons to perform the work in public, to broadcast it or to cause it to be transmitted to subscribers in a diffusion service. These rights exist under the laws relating to copyright. The society groups its royalties into two categories, broadcast royalties and general performance royalties. Each of these categories is then broken down into distribution pools relating to the specific sources of performance or broadcasting. For example, UK broadcasting royalties are divided into four pools: BBC radio, BBC television, commercial radio and commercial television. UK and Irish general performance royalties are sub-divided into a number of different pools: films, cinemas, background music, tapes, live performances, recorded performances, serious performances and public reception and broadcasts. Broadcasting royalties and general performance royalties collected in the PRS overseas

territories and in territories such as India and Hong Kong, where the local societies still rely on PRS to distribute their royalties, are not normally kept separate but are distributed again under one code for each territory. Those territories are at present Africa, Asia, the Western Hemisphere and the Mediterranean.

The PRS obtains programme returns from broadcasters and other music users, which give details of all the music that has been broadcast or publically performed by persons or organisations licensed by the PRS. Broadcasting stations in the United Kingdom and the Irish Republic submit complete returns of all music used, showing every piece of music broadcast on all channels. In the overseas or agency territories the returns from the broadcasting stations are not always complete. The smaller stations, in particular, may supply only sample returns and sometimes none at all.

In the case of music users other than broadcasting stations — hotels, dance halls, juke boxes — it is not practical to require complete returns to be submitted. Even if they were obtained, the cost of analysing them would consume so much of the royalties collected that there would be little left to distribute. Programme returns are therefore only obtained from a limited section of general music users (*on the programme form illustrated left*).

The volume of programme returns which are actually received by the PRS is enormous. The BBC's returns alone amount to over 1,200 foolscap sheets of information every week. A large proportion of these returns is now supplied on computer tape. The programme material thus received is analysed by the PRS so as to identify all musical works which have been broadcast or publically performed and in which a PRS member or a member of one of the affiliated societies has an interest as a composer, lyric writer or publisher. The actual programme material is augmented in special cases by other data which reflects contemporary patterns in music use, such as the current single and album record charts. Because of the volume of all this material it is necessary in some cases to analyse the returns on a sample basis.

Each of the works identified as a

PROGRAMME DETAILS

**THE PERFORMING RIGHT SOCIETY LTD**  
IN ASSOCIATION WITH COMPOSERS AND PUBLISHERS OF MUSIC

100 BERNERS STREET, LONDON, W1P 8AA Telephone 01-4003366  
 100 BERNERS STREET, LONDON, W1P 8AA Performance copyright, SEPTEMBER 1976

Name of performer **EMPIRE ROOMS**  
 Address **SMINTON RD, LINCOLN, Lincs**  
 Name of entertainment **DANCE**  
 Name of performance **DANCE BAND AND VOCALIST**

NOTE: Performer must pay on the form of ALL MUSIC WHICH IS PERFORMED OR IS TRANSMITTED, OTHERWISE BY ANY MEANS, IN ANY TERRITORY, UNDER ANY RIGHTS, IN ANY PROGRAMME, WHICH MAY BE COVERED BY THIS SOCIETY'S RIGHTS. ALL THE MUSIC WHICH IS PERFORMED OR TRANSMITTED MUST BE IDENTIFIED ON THE FORM BY THE NAME OF EACH WORK.

DATE LISTED	TITLE OF WORK PERFORMED	DESCRIPTION (e.g. Song, Dance, Song, Dance, etc.)	NO. OF PERFORMANCES	COMPOSER (Surname first)	PUBLISHER (if known)	ARRANGER (if known)
	HUSTLE	WALTZ	2	MCCOY, V	WARNER BROS.	
	ANYTHING GOES	DANCE SONG	1	PORTER, COLE	CHAPPELL	
	STRING OF PEARLS	DANCE SONG	1	GRAY, J/BELANGE, E	CHAPPELL	
	I ONLY HAVE EYES FOR YOU	DANCE SONG	1	WARREN, H/DUBINS, AL	FELDMAN	
	FIVE FOOT TWO EYES OF BLUE	DANCE SONG	1	HENDERSON, R	F D HUNTER	
	DAYS OF WINE AND ROSES	SONG	1	WAINWRIGHT, H/BERCE, P	WARNER BROS.	
	SMILE	SONG	2	CHAPLIN, C	BOURNE	
	RHINESTONE COWBOY	WALTZ	2	WEISS, LARRY	ARD. BEECHWOOD	
	AT LAST	DANCE SONG	1	WARREN, H/SOARDEN, M	G H MUSIC	
	ONCE IN A WHILE	SONG	1	EDWARDS, M/OREN, G	BIG THREE MUSIC	
	BIMBO	DANCE SONG	1	MORGAN, C/SWAPPER, H	BURLINGTON	
	DA DOO RON RON	DANCE SONG	1	SPEER, G/FRANKY, J GREENNICH, C	CARLIN MUSIC	

Signed **S Miller**

**SUPPLY OF FORMS**  
 Free additional supplies of the form shown here are available from the Society upon request. Simply write or telephone.

**ANY OTHER QUERIES?**  
 Again, we are at telephone 01-4003366. We shall also be pleased to arrange for one of the Society's Representatives to call should you wish to discuss a particular matter in detail. We thank you for your attention.

result of this analysis then receives a points credit, the amount of which depends upon the duration of the work, the number of times the work has been broadcast or publically performed, and sometimes other factors. The total number of points in the distribution is then divided into the revenue so as to establish the case value of the points and consequently of each performance.

The cash credits for each work are then allocated to the member or members interested in the work, the composer, the lyric writer and the publisher, according to the terms of the contracts between them (but subject to the PRS rules which stipulate that the publisher may never receive more than 50 per cent of the total royalties distributed by the Society). If a member's total credits amount to less than £3, the Society regards this as uneconomic and will not make payments.

The revenue is distributed in a number of sections, each concerned with the distribution of the license fee obtained from a particular and usually fairly important licensee, for example the BBC, the independent television contractors and the operators of juke boxes. There is little possibility or justification for establishing information to distinguish one performance or use of the work from another. All the works are treated as equal within that section and it is the number of performances which determines the different earnings of the different works.

*How much are the respective sums per performance for radio, television and concerts?*

The Society does not normally charge royalties on a per work basis. As you can imagine, the administration costs involved would be vast. Instead, it issues annual licenses to the radio and television stations, as well as to the owners and manager of concert halls, clubs, etc. where the music is performed. The royalty is paid according to a series of tariffs which have been calculated and take into account the different circumstances in which the music is performed. Most tariffs have been agreed with the National Association representing the types of music owners to whom they apply.

*What would the average royalties be*

*for a Number One hit?*

It will vary according to length of time the work is at the top of the charts. However, a rough average in the UK is £8,000 – £10,000, which is divided between the composer, author and publisher of the work. On the other hand, if the work is a Number One hit in the United States it could earn as much as £50,000. It is very difficult to estimate what the average might be.

*Should all bands fill in performing right forms, even at pubs?*

The Society's policy is not to ask for programme returns to be completed by performers at every single premises to which it issues a license. Only a sample of premises are asked for returns. It would be impossible to analyse and credit the results of so many forms and the administration expenses of doing so would consume a disproportionate share of the royalties which have been collected. However, where performers are given a form to fill in, it really does make a tremendous difference to the composers and publishers if those forms are returned to the PRS accurately and legibly completed. These sample returns are used as a basis for the distribution of the general performance royalties.

These returns should be, in the case of regular entertainment, sent in at the end of every month. If it is a long-running entertainment, a tour, the same form will do providing the programme remains the same. The Society accepts from tour promoters details of all the music to be performed, together with a list of dates and this provides the basis for the composers' royalties. The returns are not required in the case of wedding receptions, church services, occasional voluntary piano performances given by performers in public houses who are normally the worse for wear and music from radio receivers and television sets, which are covered by a separate license. The Society obviously does not require returns for performances given by mechanical means because these are covered by the MCPS (see last month's IM) or traditional music, that is folk songs or music of over-75 years ago). It is sometimes regarded as being out of copyright, but much traditional music is specially arranged

and just because it seems to have been around for a long time, it does not necessarily mean that it is not copyright. The chances are that somebody somewhere owns it so it is best to still list this in the return to the Society and see if there is a royalty payable.

*How long does it take for the royalty to be paid?*

This depends on where the performance has taken place. If it is a public performance in a country controlled by an affiliated society, it could be as long as two years. This is because royalties are normally collected by societies on an annual basis and then analysed according to the programme returns. The PRS distributes quarterly. In October and April, broadcasting royalties are distributed and in December and July, public performance and foreign royalties are paid out.

*What happens to performing fees paid by the BBC for songs by writers who are not in the PRS?*

The Society license to the BBC covers all the works in the repertoire of the Society, including works by writers who are not members but which are in the catalogues of publisher members. Writers who are not members of the PRS and who have not assigned their copyright to a PRS publisher are of course perfectly entitled to negotiate a royalty on an individual basis with the BBC.

*If they join the PRS after their song has had a number of broadcast performances, will they get the money sent to the PRS by the BBC?*

Strictly speaking, until a member has assigned his rights to the Society, the Society is not in a position to collect royalties for the composer and therefore he must negotiate directly with the broadcasting organisation which has played his music.

*How does a songwriter join?*

The only requirement for a songwriter to join the PRS is that one song or a number of songs are performed or recorded in such a way as the royalties will be worth collecting. The songwriter can write to the PRS, whose offices are at 29-33 Berners Street, London, W1P 4AA. Or telephone 01-580 5544 and ask for the Registrations Department. They will send a membership form and all the necessary information required to join. =====

# RAC

## PROFESSIONAL SOUND EQUIPMENT FOR STUDIOS AND PA.

Need a Limiter/Compressor?

What about our **RAC LIM2 Unit**.

Has all the usual facilities ratio, threshold, attack, release, gain, etc. Unit can be used on its own or in a 19" rack frame so that other rack units can be added later. The price is reasonable too!

contact Martin Bennett,  
Rugby Automation Consultants  
19 Freemantle Road, RUGBY Tel. 0788 810877

# Rhenc Series

exotic wood bodies for  
the discriminating  
guitarist

crafted from fine Walnut and Hard Rock Maple

exclusively by

# Kharna Bodies

Dept. MR  
P. O. Box 82  
W. Hempstead, N.Y. 11552  
U. S. A.  
(516) 489-2038

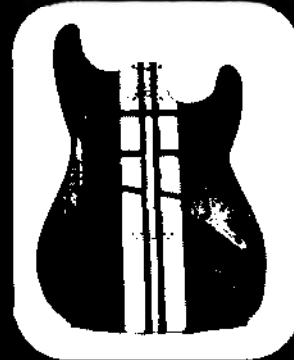

send 50c for info

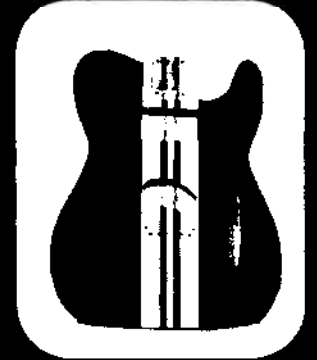

Dealer Inquiries

## Real Audio Transparency Unconditionally Guaranteed for 5 years

### DX 700

### DX 350

### DX 140

POWER:

DX700-800w (4ohms + 4 ohms) Rated R.M.S. Continuous.  
1300w (2 ohms + 2 ohms) MAX R.M.S. Continuous.

DX350-400w (4ohms + 4 ohms) Rated R.M.S. Continuous.  
650w (2 ohms + 2 ohms) MAX R.M.S. Continuous.

DX140-160w (8 ohms + 8 ohms) Rated R.M.S. Continuous.  
260w (4 ohms + 4 ohms) MAX R.M.S. Continuous.

PERFORMANCE:

THD less than 0.005% rated output, 1KHz;  
less than 0.04% at all levels up to  
rated output 20Hz-20KHz.

IMD less than 0.02% at all levels up to rated  
output, SMPTE 60Hz: 7kHz/4:1.



# hill

Ron Blechner, Sound Reinforcement, 6 Lillie Yard, 9 Lillie Road, London SW6 1UD, England. (01)- 381 3446

Peter Moody, Studio/Broadcast, 15 Greenfield Close, Stapleford, Cambridge.  
Shelford (02204) 2060. Cambridge (0223) 62392.

Malcolm Hill Associates, Head Office, Hollingbourne House, Hollingbourne, Kent, England. (062780)- 556



## The NOVATRON



### For the sounds of

REAL Strings, REAL Brass, REAL Choirs etc, etc.  
NOT Simulated – NOT Generated – NOT Synthesized

**BUT – THE REAL THING**

Novatrons are now fitted with:

- Rock steady non-temperature sensitive speed control.
- Improved amplifier signal-to-noise ratio.
- Noise gate.

A SELECTION OF 40 TAPE SETS ARE AVAILABLE  
CURRENT MODELS

Single Manual Model 400SM (in black or white)

Double Manual Mark 5 (in black vynide)

#### READERS IN USA PLEASE NOTE

We are pleased to announce that a distributor for the East Coast of USA has now been appointed to whom all enquiries should be addressed. Their name and address is: Plateau Electronics Inc., 928 Broadway, 7th Floor, New York, NY 10010. Telephone: 212 673 4205.

#### STREETLY ELECTRONICS LTD.

338 ALDRIDGE ROAD, STREETLY, SUTTON COLDFIELD,  
B74 2DT, WEST MIDLANDS, UNITED KINGDOM

Telephone: 021 353 3171

Telex: 338024 Bircom G (Prefix all messages STREL)



## MUSIC CIRCLE LIMITED

MUSIC AMPLIFICATION  
ACCESSORIES  
KEYBOARDS  
82 Dame Street and  
11/3 Parliament Street,  
Dublin. Phone: 774280 or  
774959/774671

Ireland's leading music store  
covers an area of more than 6000 sq ft.

*Stockists for most  
leading manufactures*

ORGANS • GUITARS • AMPLIFIERS  
DRUMS • BOOKS

**CHECK US OUT FIRST FOR THE  
BEST IN GEAR AND PRICES**

BEST CREDIT TERMS AVAILABLE  
TRADE INS WELCOME



### Gherson Guitars

Hand made in Italy

### Eccleshall Guitars

Hand made in London

### Gordon Smith Guitars

Hand made in Manchester

### Gaffa Tape

The best and the cheapest

### Prostix & Regal Prostix

The best in drumsticks

### Eccleshall Strings

Guaged, Electric, Acoustic, Bass

### Hide Guitar Straps

For the 'Leather Freaks'

### Guitar Cases & Bags

All shapes and sizes

### Microphone Stands

Lightweight and heavy duty

## Agencies for Northern England and Scotland

#### Including:

Percussion Services - Remo Heads, Rototoms and  
lots of drum bits. Wing Music - Rickenbaker,  
Resounder, Invader Speakers. Scotland only -  
Gigsville, Aria Guitars etc. Gretsch Guitars and  
Drums, Coloursound, Eurotec.



For Trade Enquiries or Brochures  
please write to:  
219 Walmersley Road, Bury, Lancs.  
BL9 6RU. Tel: 061-764 1792/3.



# *Aria Pro II* ELECTRIC GUITARS **PE-1000**

UK distributor: Gigsville Limited, NMT House, Phoenix Way, Cranford Lane, Heston, Middlesex.  
USA distributor: Music Distributors, Inc., 3400 Darby Avenue, Charlotte, N.C. 28216.  
Canada distributor: Great West Imports Ltd., 788 Beatty Street, Vancouver, B.C.  
Canada Music Supply Limited, 8660 Jeanne-Mance, Montreal, Quebec.

(ILLUSTRATED PE1000)  
(Send 25p for Catalogue)

# It's All Happening At Highway Manchester

**HIGHWAY HOUSE**

**3 FLOORS FOR THE**

**BEST VALUE  
IN MUSICAL  
INSTRUMENTS**

**GREAT SERVICE  
GREAT DEALS**

**ADD GUITAR  
SYNTHESISER  
Now on Demo!**

COME TO  
WHERE  
THE TOP  
PROS  
SHOP

**WALL TO WALL  
GUITARS inc.**  
GIBSON, FENDER, ARIA  
GUILD, OLI, Ibanez, GRANT, CMI  
PLUS MANY  
USED NAME  
GUITARS

**SPARES TO  
FIT MOST GUITARS**  
Pickups, Pieces, Bridges  
Machines, Nuts, Frets  
Tailpieces etc.

E BALL  
GIBSON  
PICATO  
ROTSOUND  
GUILD  
EARTHWOOD  
MARTIN  
ETC  
ETC

**FAST  
H.P. SERVICE**  
Vast selection of  
Guitar strings

**FIRST CLASS  
GUITAR REPAIRS**

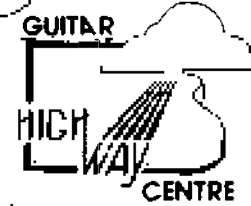

**WE FEELZE  
MOST PRICES**

**UNRIVALLABLE  
SELECTION OF  
EFFECTS**

NINE QUARTERS THE BEST AT A PRICE FOR

NINE QUARTERS THE BEST AT A PRICE FOR

**LARGEST SELECTION IN THE NORTH**

**GOOD REPAIR SERVICE  
HIRE SERVICE**

**RSD, RCF, EV  
ATC, GAUSS, HILL**

**DISC LIGHTS &  
ACCESSORIES**

**Drop INTO  
OUR AMP  
ROOM**  
GORS  
Combo Amps  
P.A. Amps  
Slave Amps  
Most Leading  
Makes

**CUSTOM  
BUILT CABS**

**PA  
HIGHWAY  
CENTRE**

**GIGANTIC STOCK  
AMPS INC.  
MARSHALL  
PEAVEY  
BOSS  
HIWATT  
ORANGE  
ROCK**

**MIXERS FULL  
RANGE**

**UP TO 2000 WATTS PA HIRE**

061-833-0328 — 061 833 0328 — 061-833-0328

**PERSONALISED STICKS & KITS**  
CHOICE OF SEVERAL  
DRUM SYNTHS  
FOR SALE OR HIRE

**COME IN FOR  
A QUICK  
BANG!**

**FREE T-Shirt,  
Badges**  
MANY 000 DRUMS  
IN STOCK

**LOADS OF  
STANDS  
NEW AND USED**

**FAST H.P. SERVICE**

**DELIVERED FREE**  
THE NORTH'S  
LARGEST  
DRUM  
CENTRE

**FULL RANGE  
L.P. PERCUSSION**

**OCTABANS**  
**GONGS**  
**TAM TAMS**  
**BELLS**  
6"-30"

**TAMA  
BEST  
AVAILABLE**

**MAX WILK  
GERTSCH  
LUDWIG  
REMO**

**DRUM  
HIGHWAY  
CENTRE**

**LOADS OF  
STANDS  
NEW AND USED**

**FAST H.P. SERVICE**

**MANY, MANY MORE  
EVERYTHING YOU COULDN'T GET, HERE**

# Muir Music

FOR THE  
**MUSICIAN IN MANCHESTER**  
TOP QUALITY EQUIPMENT AT THE BEST PRICES

ROLAND AND KRAMER MAIN AGENTS

A COMPREHENSIVE RANGE OF THE NEW ROLAND BOSS COMPACT EFFECTS PEDALS, GA ROCK AMPS AND EXCELLENT ROLAND JC CHORUS AMPS ALWAYS IN STOCK. ALSO THE FANTASTIC KRAMER GUITARS AND BASSES ARE NOW AVAILABLE.

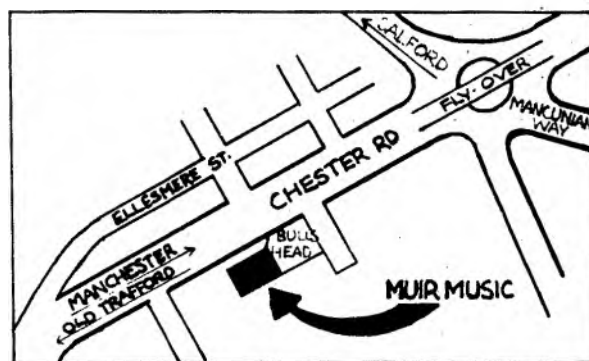

**Muir Music** 289 Chester Road, Manchester 15. Tel: 061 8341532

and at

## Revolution Studios

### Quality 8-Track Recording

Studio use of amps, guitars and keyboards free of charge

Call at Revolution Studios for demonstrations of Roland heavy artillery! — The guitar synthesizer, VK9 organ, JP4 poly synth

Also the Kramer range including the new DMZ series

**Revolution Studios** 11 Church Road, Cheadle Hulme, Cheshire.

Tel: 061 485 8942

# SHELDON ORGANS

79 SMALLBROOK, QUEENSWAY, BIRMINGHAM  
TEL: (021)-6432985

## Midlands Largest Stockists Of Roland Keyboards



The New Jupiter R.R.P.



MP 600 R.R.P.



ROLAND MP 700 PIANO, complete with amp.	RRP £1500	OUR PRICE £950!
ROLAND SH 2000 Synthesizer	RRP £ 799	OUR PRICE £699!
ROLAND SH 3A	RRP £ 690	OUR PRICE £530!
ROLAND String Synthesizers 202	RRP £ 675	OUR PRICE £520!
ROLAND Revo 150 Organ Cab.	RRP £ 999	OUR PRICE £799!
ROLAND JC 120 Combo Amp.	RRP £ 463	OUR PRICE £399!
ROLAND SPACE ECHO 201	RRP £ 449	OUR PRICE £360!

ROLAND EP 20 PIANOS (2 only!) OUR PRICE £329!

AND

ALL AVAILABLE CASH OR H.P. (LOW DEPOSIT)

PHONE PETE OR RAY FOR DETAILS AND OUR PRICES  
ON ANY OTHER GEAR YOU'RE  
LOOKING FOR!

# ALL AS ADVERTISED ON ATV!

# THE ELECTRIC



Wal with some of his early Pro Bass prototypes

A modern fairy tale with a happy ending, told by PHILLIP PAUL

**T**HERE must be many milkmen, dustmen, railwaymen and even one or two local councillors who have dreamt of stardom via the rock and roll route of Northern Clubs.

Now bitter for them to look back at what might have been, and reflect, perhaps, on what they have become. But most of them had their dream and lost it.

Happily that's not the case with Ian Waller – Wal to his friends and just about everyone else. He had two dreams. The other was to build the world's best bass.

"When I think back to old days, to the hours whiled away in the Barratts of Manchester shop on a Saturday afternoon, it's a shame to think that that personal involvement and friendship between the musicians and the dealer has faded somewhat. Musical instruments are for musicians. If they don't feel this vibe, no-one else will."

Coming up through the beat boom of

the early Sixties, Wal had his taste of public acclaim playing alongside groups like the Hollies and the Beatles. On his own stomping ground, the group he was with, the Wallers, was as much a crowd-puller as these subsequently eminent bands, and in fact went on to become Herman's Hermits after Wal left.

His day came and went. Like a lot of others, his dream gradually dissolved into a cloud of almost-successes and occasional studio sorties. But he still nurtured his other ambition. He wanted to build a bass guitar which would appeal to players who swore by Gibson or Fender or Gretsch. In other words, the world's most versatile bass instrument, with no corners cut and no compromises.

Why a bass guitar? First, because Wal plays bass himself. Secondly, because he feels that over the years the bass guitarist has had a raw deal in comparison to the six-string guitarist, in the area of

instrument development. "Lots of manufacturers seem to think that a bass guitar is just an extra long guitar with four strings. Sure it is, just like the cello is an extra long violin. But you try sticking a cello under your chin!"

In other words, every instrument must be considered individually and as subjectively as the musician demands, and Wal thought that until recently, no-one had even approached the innovative excellence of Leo Fender's first Precision basses.

Over the years, Wal, a compulsive designer with infectiously enthusiastic personality, has been into just about everything – guitar building, electrical engineering, electronics, advertising, production management and session playing. It was his father, a skilled wood craftsman, who first fired his interest in guitar building and Wal maintains to this day that it's the memory of his dad and his endless search for self-satisfaction that gives him his inspiration. Between them, they made a series of guitars and related equipment. Perhaps the crowning glory was an acoustic bass guitar, a giant of an instrument, eventually bought by George Harrison.

But it wasn't until he met top session man John Perry in 1974 that Wal began to see the possibilities for turning his dream bass into reality. They met at Farmyard rehearsal rooms in Little Chalfont, Buckinghamshire, home of ex-Peddlers drummer Trevor Morais. Morais, having split from the Peddlers to play music which was more in line with his personal preferences, was putting together the first Quantum Jump album with Perry, guitarist Mark Warner and keyboardist and producer Rupert Hine.

Perry, who had also recently left his own band, Caravan, fell into conversation with Wal as they worked not only on the album, but also at building the studio it was to be recorded in. "That was a magic summer," says Wal. "Inseparable friendships were formed and we all had great fun. Somehow, through the encouragement and collective loyalty of those friends, we've all managed to realise our own personal dreams."

Wal and John naturally talked about guitars, and it transpired that John had lots of ideas of his own about a bass guitar he'd never been able to buy. Wal immediately set to work building what became the first prototype for Electric Wood's new Pro Bass. It was three-quarter scale – Perry's preference – with a long scale performance.

The bass itself was very impressive, but even more impressive was the reaction from outsiders. "John Perry's bass" became almost a catchword in London studios. Wherever Perry had a session, the bass became a talking point, with

# WOOD STORY

engineers, tape ops and producers. Equally gratifying was the response of other musicians and it was a short step from the one-off model – which quickly made Perry's other instruments redundant – to a decision to make more.

Then one day, when John returned to his car, parked outside a studio, he was devastated to find it had been stolen. He eventually recovered the car and all the contents – except the bass (Serial No. W1111). The event was a milestone. Perry, having lost his beloved prototype, decided to invest with Wal in the production of a limited edition of 10 guitars which through necessity were built one at a time.

Over the next 12 months Wal and John attended concerts, visited studios and generally talked to engineers and musicians, trying to find the common denominators that would produce an instrument to please everyone. "We decided that every single component we put into it would be the very best we could find," says Wal. "If it wasn't good enough, we'd make it ourselves."

The consequence of that ambition is that the Schaller machine heads and the strings are the only parts not made by Electric Wood.

Above all, however, it was the decision to allow the musicians themselves to choose what they wanted and didn't want, and put forward their own design ideas, that set the course for future success.

Wal says: "I've been pretty lucky with my work in that I've been able to make friends with many very accomplished musicians. They loved getting involved with our project and some great, original design ideas emerged. The company exists today because everyone who contributed and bought one of our instruments became a spokesman for us, helping to spread the word."

The concept of Electric Wood had been born.

In April 1977, Wal moved into a workshop off London's Oxford Street, and set about completing the first batch of 10 instruments. Electric Wood Ltd. was formed as a company with Wal and John as directors, together with a management team to handle financial affairs.

It seems a long way from a first floor room in London to 2,500 square feet of factory in High Wycombe – and, in truth, there were times when it looked like Wal would never make the trip. But the fact is that a lot has happened very quickly for Electric Wood. Inevitably, there were periods of depression, sheer boredom and financial problems but as Wal points out, "At last I felt as though I was contributing something really worthwhile to the business which had given me so much pleasure for 17 years. And I was

thoroughly happy doing it."

The nature of the set-up meant that Wal could do no favours. His first 10 basses were all bought and paid for – some even in advance by those who were keen to see the project reach conclusion. The result was two three-quarter scale instruments and eight long-scale. Electric Wood kept one of each and John Perry, naturally, was the recipient of the other, first finished three-quarter model (JP1112). Serial number JG1112 adorns the first long-scale bass, which belongs to John Gustafson. "Gus" had been a great pal to Wal since the old Liverpool/Manchester rock days and was also one of his favourite bassists. Now with the Ian Gillan Band, Gus was able to offer invaluable advice, assistance and enthusiasm to the project and did so gladly. Wal returned the compliment by dedicating the long-scale bass to Gus. It became known as the J.G. Custom Bass. Other recipients of these early models were Pete Zorn, sessioner and bassist with the Barbara Dickson Band, Pete Hurley of Lone Star, Jack Brand (Meal Ticket), Phil Knight, Barry Johnson (Nova) and Alec Konstandinos (Demis Roussos's producer).

Within a year Wal's basses had been used in 26 London studios without one complaint being received. Engineers were astonished at an instrument which needed no studio balancing or equalisation.

---

**"One day I'll make products that you'll be proud to sell"**

---

Still working solo, but able to buy machinery and make more refinements, Wal set to work on two more batches of 15 instruments each. By now he was having to take in freelance electronic design work in order to keep body and soul together and it was becoming increasingly apparent that John Perry's involvement was conflicting with his main interests in music. His enthusiasm, encouragement and knowledge of the bass instrument had been, and still are, an essential spark to Electric Wood, but now he decided to lessen his obligations and resigned his directorship. He still retains shares in the company.

Enter Pete Stevens, the present partner in Electric Wood. Pete "The Fish", as he is known to all who had ever visited Farmyard rehearsal rooms or worked with the Rolling Stones Mobile Studio, is an amiable character and had formed an inseparable friendship with Wal back in that "magic" summer of '74 at Farmyard.

With a wife and two children to

support, Pete was not able to become involved full-time but he became an invaluable right arm to Wal. Together they kept Electric Wood going and succeeded in finishing the new 30 instruments and attracting even more prestige.

Back in Manchester, during his group days, Wal spent a lot of time in Barratt's music shop. He recalls telling Adrian Barratt, whose father owned the shop at the time: "One day I'll make products that you'll be proud to sell."

Hans Christian Anderson could hardly have come up with a better scenario for a happy ending.

In company with John Perry, Wal visited the 1977 BMI Trade Fair at the Russell Hotel. He looked up his old friend, Adrian Barratt, who in the meantime had built up a big wholesale operation with brass and woodwind. He had also recently taken on the Hofner franchise and was ready to add other lines.

He was immediately impressed with the Wal bass and was ready to talk business even though, at that point, it could not be mass-produced. "The last thing we said to him," recalls Wal, "was that next year we would have 30 per cent of his exhibition space at the BMI Show." Yet another fairytale prediction that came true at the 1978 Fair.

Back to the drawing board again for Wal, who had to come up with a design which could be mass-produced without detracting from or compromising the instrument. He also wanted a more versatile design which would allow the player to choose just the facilities he or she desired. The result, after several months and trips between Manchester and London, is that Barratt has guaranteed distribution on an open-ended, worldwide basis, and Wal is at last approaching his dream.

Which brings us back to a factory in High Wycombe, where Wal and Pete (now full-time with Electric Wood, and managing to support his wife and two children) are busily at work producing in quantity, for the first time, the newly named Wal Pro Bass, which will retail in a range from £340 to £570. Delivery to Barratts is due in January 1979.

If your pocket stretches to that kind of money, you'll be in illustrious company. Not only the eminent bassists mentioned so far but also Percy Jones, John Entwistle, Mick Taylor, John Glascock of Jethro Tull and Manhattan Transfer's MD and bass player, Mike Schnoebelen, have given their own valuable contributions to the Pro Bass and have ensured a prominent future for Wal and Electric Wood.

You will have also helped to see a 20-year-old dream come true. And maybe you'll live happily ever after.



HOFNER 494

£132



HOFNER 457E2

£229



HOFNER S5E

£345



HOFNER A2L

£477



HOFNER A2HL

£511



HOFNER S7B

£276



HOFNER VIOLIN BASS

£186



HOFNER 4912

£197

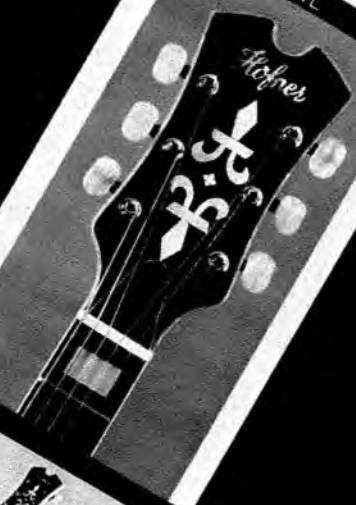

# Hofner

FOR FURTHER DETAILS OF THE HOFNER RANGE  
CONTACT SOLE U.K. DISTRIBUTOR

BARRATTS OF MANCHESTER LTD.  
WHOLESALE DIVISION  
652 CHESTER ROAD  
MANCHESTER M16 ORX  
061- 872 0713  
OR YOUR LOCAL MUSIC DEALER



**THE**  
**Zildjian**  
**BAZAAR**



Zildjians have been making cymbals for centuries. Their cast bronze cymbals are found the world over in the hands of those who must have quality and perfection of sound and strength. And, for years, people have been collecting Zildjian souvenirs . . .

Bazaar is going to make it easier. Here is a selection of some of the very popular Zildjian mementoes, and some new ones.

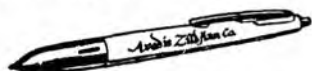

1. Zildjian lighter by Zippo, U.S.A. The 'one-zip' wind proof lighter comes with the unique Zippo guarantee. Brushed stainless steel finish complete with Zildjian trademark engraved black and gold.  
£2.50 + 18p P&P

2. Zildjian steel tape measure, inches and centimeters, by 'Park Avenue' U.S.A. Gold metal with black Zildjian trademark. Complete with makers guarantee.  
£1.00 + 18p P&P



5. 'Ritepoint' retractable black felt marker. Red casing with black writing 'Avedis Zildjian Co.'  
75p + 18p P&P



9. Zildjian all-purpose T-shirt. Size: small, medium and large. White trademark printed on black shirt.  
£2.50 + 35p P&P

8. Zildjian baseball shirt. White with red ¾ length arms and red neck band. Zildjian trademark in black. Sizes: small, medium and large. £3.50 + 35p P&P

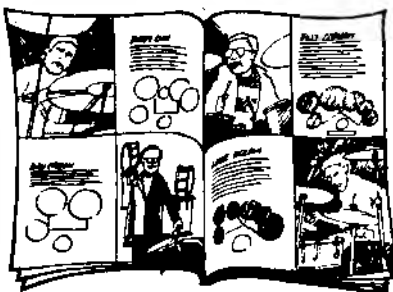

4. The Zildjian book of cymbal set-ups of famous drummers. Printed in brilliant colours with action photos and cymbal set-up diagrams of rock, jazz, studio and big band poll winners.  
50p + 18p P&P



10. Satin banner. Contrasting white on black screen print. Billy Cobham, Buddy Rich or Louis Bellson. Hanging banner pole and tassels. Size 20" x 27"  
£ 2.00 + 35p P&P

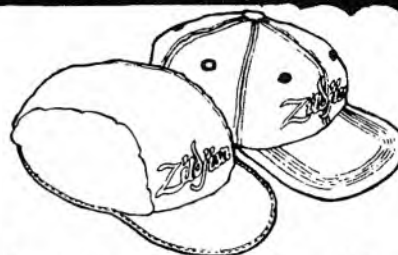

3. American sports cap of a very high quality, for all weather, for always. The Zildjian logo is machine embroidered in white writing on navy blue cap.  
£5.00 + 18p P&P

7. Zildjian all-purpose cotton drill cap - one size fits all. Yellow writing on black.  
£1.50 + 18p P&P



11. Deluxe cymbal bag, custom-made for Zildjian. Simulated leather with smart black handles and fittings. Zildjian trademark printed in gold. Double nylon stitched for long life.  
£9.00 + 75p P&P

12. Zildjian key-tag. Bronze alloy cymbal replica bearing Zildjian trademark. 75p + 18p P&P

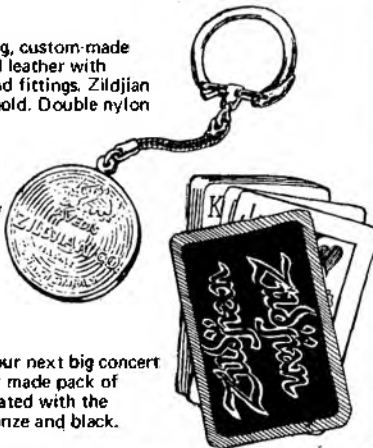

13. Relax before your next big concert with this beautifully made pack of playing cards, decorated with the Zildjian name in bronze and black.  
95p + 18p P&P

Please send me the following:

Quantity	Ref. No.	Item	Price	Total

Please enter total postage and packing:

I enclose cheque/postal order for

Name: \_\_\_\_\_

Address: \_\_\_\_\_

Post this coupon to: Zildjian, BCM 989, London WC1V 6XX

in favour of Zildjian

ADVERTISEMENT

# FREE 'N' EASY MUSIC

HEMEL HEMPSTEAD BRANCH, 57 HIGH STREET  
HEMEL HEMPSTEAD. TELEPHONE HEMEL HEMPSTEAD 59659

OXFORD BRANCH, CHAPEL WAY, BOTLEY.  
TELEPHONE OXFORD 721411

It's been really difficult to get the old brain together for this months - SAGA, and the delightful Andrea of I.M. obviously still cares as she rings us daily for copy, well here it is at last.

The Free 'N' Easy on Wheels van has been busy of late - famous driver Reg has now discovered that England extends further north than Luton. We have at last found a use for all the smashed up cars which Roger our well known accident blackspot, keeps putting our way, under the team managership of our very own Stuart. Free 'N' Easy now has its own bang-up racing team - the drivers all want a mention, so here goes, they are Jeremy, Kevin and Allan. We understand that they are in the process of forming a band, and we can only hope that their playing is better than their driving!

Don Ellis has begun to train for the next World Cup and also

intends to represent Hemel Hempstead in the next Olympic Games. He tells us that sales of Ludwig drums has been good this past month, and is very enthusiastic about a second hand six drum Rogers kit which has just come in.

For the rest of the staff John Prieg has had trouble coping. Eds band has just come back from their tour of Bikini Atoll, and now with the world at their feet intend to go on a Jubilee tour of Melton Mowbray. Roger smiled on November 9th - or at least so rumour has 'it, which Reg and Stuart are denying all rumours.

Some of you may have noticed that a new name appeared in these columns last month - to wit the lovely Margaret. This good lady has joined us recently and when canvassing for the Tory Party permits has been known to work for us in the Free 'N' Easy on Wheels Department making sure that all

goods are despatched on time. Why not chat her up on Aylesbury 28555 and tell her your sob story - you never know she may even arrange credit for you.

In response to his many fans Den has finally decided to emerge from the shadows. He will do this every Saturday at Hemel Hempstead. Signed photos and autographs etc., are not available yet as he is still learning to write.

On the equipment front a large consignment of Marshall gear has arrived as we have noticed a great demand of late for this perenial equipment. We have also received another consignment of the Yamaha Super Flighter series of guitars. These are truly amazing and well worth the try.

Unfortunately poor Andrea has got a touch of writers cramp so we have decided to fill the rest of the space up with a photograph. OOOOh my brain hurts!



# The CP-30 for £750.

(INCLUDING VAT)

# There must be a catch.\*

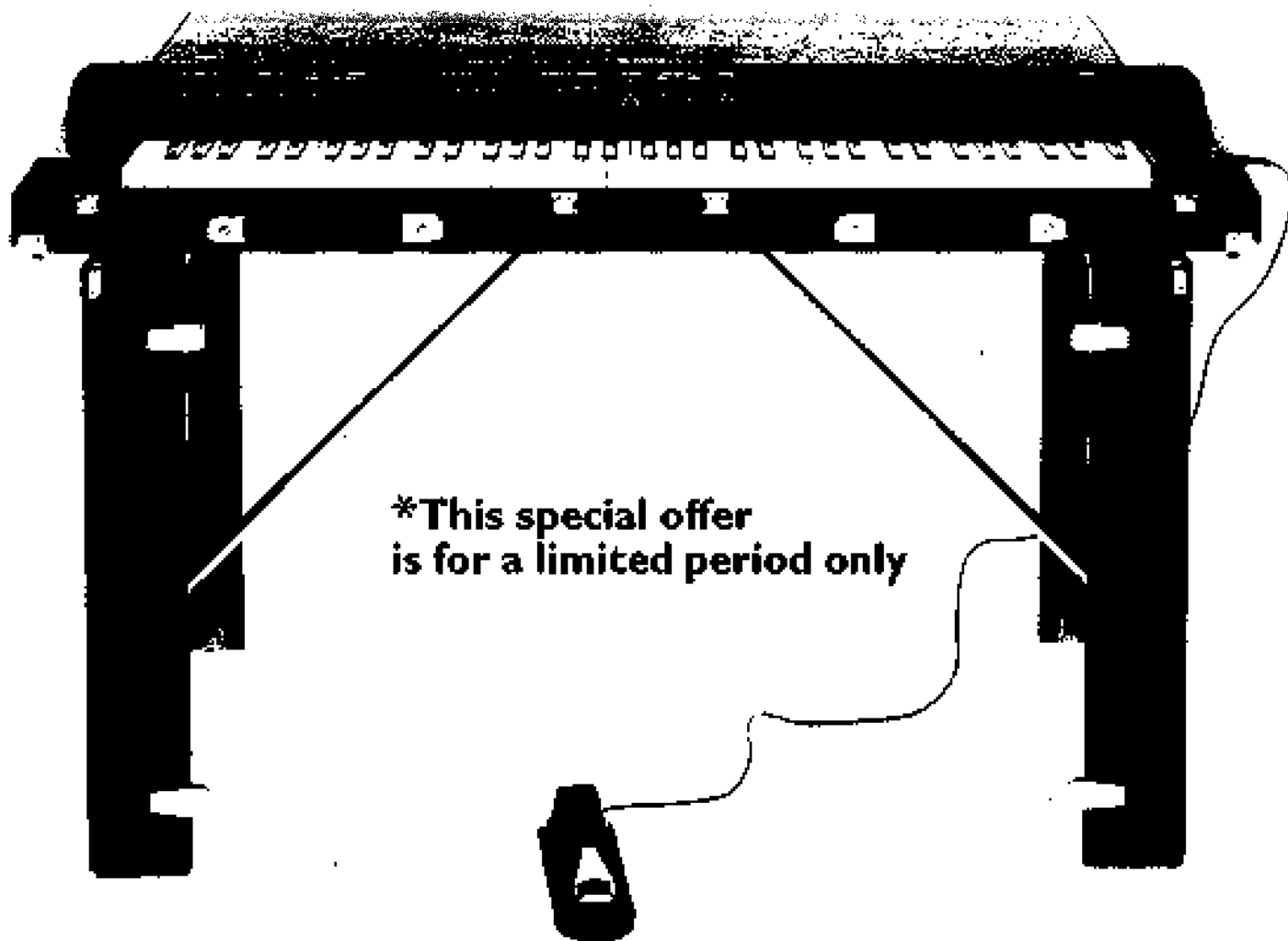

**\*This special offer  
is for a limited period only**

## Available from these Yamaha Pro Centres...

**Andertons Modern Music,**  
5 Stoke Fields,  
Guildford,  
Surrey.  
Tel: 0483 38214

**Argents Keyboard Centre,**  
20 Denmark Street,  
London.  
Tel: 01-240 0084

**Cambridge Rock,**  
44 Newnham Road,  
Cambridge.

**Carlsbro Sound Centre,**  
182/184 Chesterfield Road North,  
Mansfield,  
Nottinghamshire.  
Tel: 26976

**Carlsbro Sound Centre,**  
13 Berkley Precinct,  
Eccleshall Road,  
Sheffield.  
Tel: 0742 663862

**Chappel & Co,**  
52 Maddox Street,  
London W1A 2RB.  
Tel: 01-629 7600

**Coventry Music Centre,**  
3/4 Whitefriars Street,  
Coventry.  
Tel: 0203 58571

**E. D. Brown,**  
51/52 Friar Gate,  
Preston,  
Lancashire.  
Tel: 51403

**E. D. Brown,**  
108/110 Highgate,  
Kendal, Cumbria.  
Tel: 0539 24212

**E. D. Brown,**  
55 Darwin Street,  
Blackburn,  
Lancashire.

**James Grant Music,**  
53 Home Street,  
Edinburgh,  
Scotland.  
Tel: 031-228 1704

**Hessy's,**  
62 Stanley Street,  
Liverpool.  
Tel: 051-236 1418

**Honky Tonk Music,**  
302 London Road,  
Hadleigh,  
Essex.  
Tel: 0702 553647

**Kitchens,**  
27/31 Queen Victoria Street,  
Leeds 1,  
W. Yorkshire  
Tel: 0532 446341

**London Synthesizer Centre**  
22 Chalton Street,  
(off Euston Road)  
London.  
Tel: 01-387 7449

**McCormack,**  
33 Bath Street,  
Glasgow,  
Scotland.  
Tel: 041-332 6644

**Eddie Moors Music Centre,**  
679 Christchurch Road,  
Boscombe,  
Bournemouth,  
Hants.  
Tel: 0202 35135

**Rock City Music,**  
48 Cloth Market,  
Newcastle-upon-Tyne.

**Sound Pad Music Centre,**  
64 London Road,  
Leicester.  
Tel: 0533 20760

**White Sound,**  
3 Albion Place,  
Sunderland,  
Tyne & Wear.  
Tel: 0783 78058

**Woodroffes,**  
58a Dale End,  
Birmingham.  
Tel: 021-236 4992



# YAMAHA

Craftsmen to the world's  
musicians since 1887.

# MM ELECTRONICS

MP 175/8, 12, 16 into 2: Hi-lo inputs, 4 band EQ, Echo & Foldback controls, Vu meters, Optional PFL & PPI, Multipin, Balancing transformers.

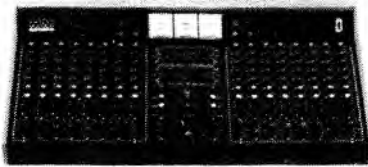
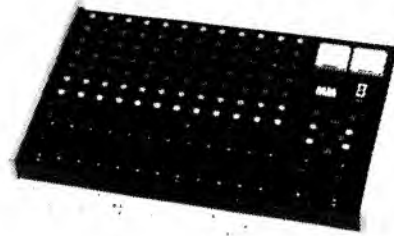

MP 185 & 285 "Super 16": same features as MP 175, plus built-in 2 way Crossover, 7 band stereo graphic equaliser, and PPI and PFL.

MP 175/8, 12, 16, 20 into 4 mixers offering the same facilities as the 2 track models but including switchable routing, talkback and limiters as standard. Ideal for Teacs, Otaris, etc.

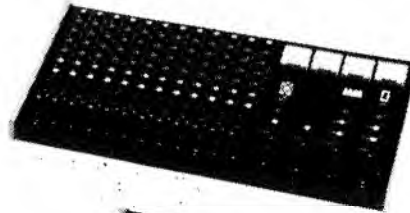

MP 275. A Flightcase housed 12 into 2 mixer. All features as for MP 175 series but bass control frequency is at 50hz. Mains Toroidal power supply. XLR connectors as standard.



19" Rack mounting units

- EP 122 & 123, 2 & 3 way electronic crossovers
- EP 127 7 band stereo graphic equaliser
- EP 130 Bass Bin Filter
- EP 141 Compressor/Limiter
- AP 360 200/200 watt Stereo power amplifier

Options on all the MM range of mixers:- PFL, PPI, Balancing transformers, Multipin connectors and multi core systems, Talkback, Flightcases.



INTERMUSIC IMP — 15 watt practice amp with 3 band EQ, loudness switch, headphone socket and 10" Celestion speaker.

## Intermusic

INTERMUSIC 120 WATT COMBO. 'Clean' and 'dirty' channels, each with 3 band EQ, 2 x 12 Combo available (100w rating), optional reverb, flightcase housed, Bright switch, master presence & volume, built-in phaser and optional reverb. Also available in Head form.



INTERMUSIC 50 watt COMBO single channel 50 watt version of the above, complete with phaser & flightcase.

The REDMERE is an amplifier of a very advanced design offering:- 3 characteristic sounds: Graphic, Reverb, Flanger, Compressor/Sustain, Chorus, Noisegate, Touch-Sensitive Switches, D.I. Socket, Programmable Footswitch. 200 watts: Available in combo or head configuration

## REDMERE

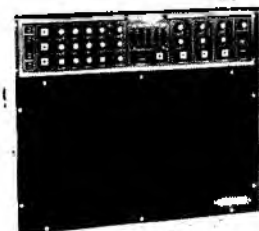

PACE Ltd  
Kneesworth Street  
Royston Herts SG8 5AQ  
Tel Royston 45214

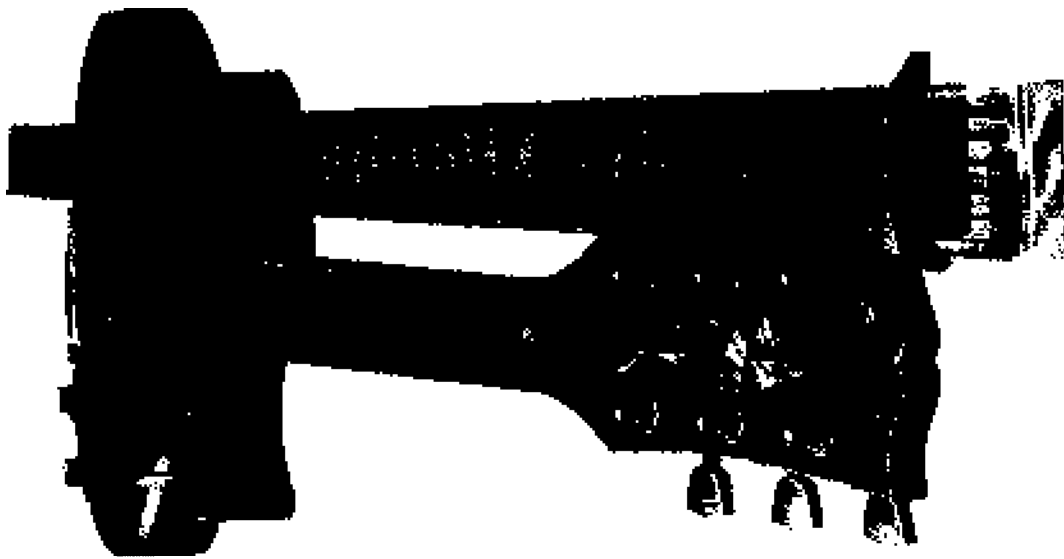

# Guitar strings deserve to be straight.

Until now, all guitar strings came coiled up in square envelopes. Unfortunately, coiling a sensitive, finely wound guitar string can bend and damage the precision windings, making the string sound less than perfect. Nashville Straights, the first guitar strings sold straight, are made of the finest nickel and bronze alloys. Inside this long,

rigid package, the string set is hermetically sealed in plastic to prevent oxidation and promote brilliance and long life. String up a set of Nashville Straights and hear the difference. They're resonant, uncrashy, loud and together. If your dealer doesn't have them yet, write us. Dept. IM, 1234 Sherman Ave., Evanston, Ill. 60202.

We give it to you straight.

## NASHVILLE STRAIGHTS

ACOUSTIC, ELECTRIC AND BASS GUITAR STRINGS

Available through George Higl Co., Wiedenzhausenerst 8, 8061 Orthofen, West Germany; Strings & Things, 20 Chartwell Rd., Lancing, West Sussex, Great Britain; Music House of New Zealand, 203 Hobson St., Auckland, New Zealand; Camac, 44850 Ligne, Mouzeil, France, and other fine distributors.

# TRANSCENDENT 2000 SYNTHESIZER KIT

FROM BRITAIN'S LEADING ELECTONIC KIT SUPPLIER



Complete Kit £196 includes Filter sweep footpedal, VAT and securicor delivery.

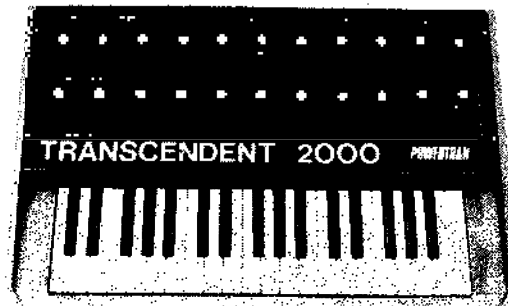

Filter Sweep Footpedal

Live performance synthesizer designed by consultant Tim Orr (formerly synthesizer designer for EMS Ltd) and featured as a constructional article in *Electronics Today International*. The TRANSCENDENT 2000 is a 3 octave instrument transposable 2 octaves up or down with portamento, pitch bending, a VCO with shape modulation a versatile VCF with both low and high pass outputs and a separate dynamic sweep control, a noise generator and an ADSR envelope shaper. There is also a slow oscillator and a new pitch detector amongst its many features!

Kit includes fully finished metalwork, solid teak cabinet and really is complete right down to the last nut and bolt! Virtually everything is on one circuit board and construction is so simple it can be built easily in a few evenings by almost anyone capable of neat soldering! When finished you will possess a synthesizer comparable in performance and quality with ready built units advertised in this magazine for sale between £500 and £700!

Please send me . . . . . Transcendent 2000 Kits/further-information.

I enclose my cheque for £ . . . . .

NAME . . . . .

ADDRESS . . . . .

. . . . .

. . . . .

### MONEY BACK GUARANTEE!

If you are not completely satisfied with your Powertran Kit, return it within 10 days in its original condition and your money will be fully refunded.

If you want to save £2.50 carriage charge, come and pick up your kit from our Sales Counter - open Monday to Thursday 9am-4.30pm (you can also look over a built up example of this and other kits).

Powertran Electronics, Portway Industrial Estate, Andover, Hants. SP10 3MM. Tel: Andover (0264) 64455.

# SOUND -SIDE-

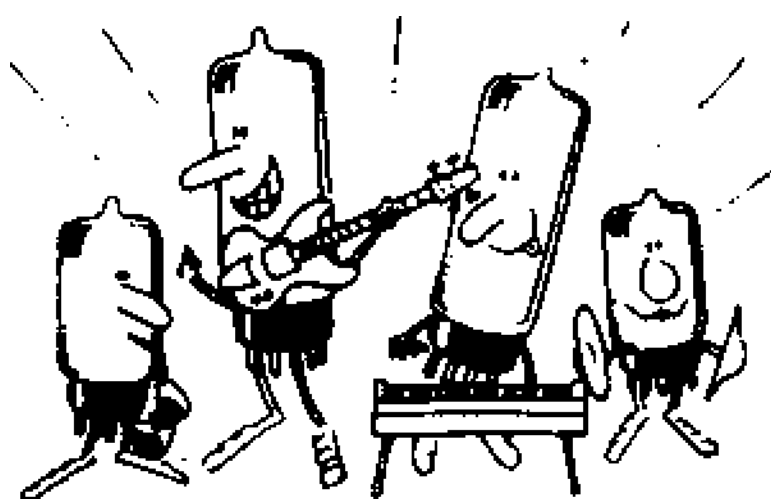

## Orkester- anläggningar

- Uthyrning
- Försäljning
- Service

Götgatan 32 • Stockholm • Telefon 08-421520, 436093



## BARNET MM CENTRE

FULL RANGE OF M.M. MIXERS, POWER AMPS, RACK MOUNTING EQUIPMENT, FULLY GUARANTEED AT COMPETITIVE PRICES.  
eg MP175 12:2 £229.

### TRY US FIRST!

8:2's, 12:2's, 16:2's, Super 16's, AP 360 Power amps  
E.O.'s, Cross-overs, Multiwave, - Full back up service.



**DiMarzio**  
MAIL ORDER

S.D.H.B.	£21.50	Mod. I Bass	£32.50
Dual Sound	£23.00	Acoustic II	£32.50
P.A.F.	£21.50	JAZZ Bass	- Available soon!
Super II	£19.50	Mounting ring	
Fat Strat	£17.00	Black/Cream	
PRE B.S.	£17.00	Long/Short	.45
S.D.S.I.	£19.50	Hardware Kits	
P. Bass	£24.50	Long/Short	.50
		5 position Strat	
		Switch	£1.75
		Pots 250K & 500K	95

**SUPER DEAL!** Buy any two Humbuckers and get two complete mounting kits **FREE OF CHARGE!**

**ALSO FREE** - to all DiMarzio customers - a complete 'How To Rewire Your Axe' Info sheet with lots of useful tips on pick up reworking!

**BUY WITH CONFIDENCE. WE ARE MM SPECIALISTS!**



TELEPHONE CREDIT CARD SALES - IMMEDIATE DISPATCH  
P.N., M.P., MAIL ORDER, VAN FREE DELIVERY  
OPEN 6 DAYS 9am - 6pm



SPECIAL LATE NIGHTS MONDAY and THURSDAY till 8pm

**powers your performance!**  
SAI Ltd, Regent St, Gropoll, Luton.  
0257-791645/791163

## Full Range of



**Professional PA equipment**

**NOW IN STOCK!**

Custom-built PA systems, full range of Mixers, Slaves & Racks in stock

SAI are just off the M6, Junction 27

**ACCESS, BARCLAYCARD & HFC TRUST FINANCE**  
mags, coffee, easy parking, servicing, exchange.

Late openings Mon & Wed till 8pm



amplification available at Stateside prices direct to you

model 114 guitar amplifier 50 Watts RMS 2-10" speakers	£260
model 116 bass amplifier 75 Watts RMS 1-15" speaker	£250
model 124 guitar amplifier 100 Watts RMS 4-10" speakers	£399
model 125 guitar amplifier 100 Watts RMS 2-12" speakers	£385
model 126 bass amplifier 100 Watts RMS 1-15" speaker	£385
model 220 bass amplifier 160 Watts RMS	£285
model 230 guitar amplifier 160 Watts RMS	£325
model 320 bass amplifier 300 Watts RMS	£395
model 330 guitar amplifier 300 Watts RMS	£445
model 402 enclosure 2-15" speakers	£225
model 403 enclosure 4-12" speakers	£250
model 406 enclosure 2-15" speakers	£295
model 407 enclosure 2-15" speakers, 1-mid horn	£295
model 408 enclosure 4-15" speakers	£429

ALL PRICES INCLUDE VAT

**Kingfisher**

20 Kings Road, Fleet, Hants.  
Tel: 02514 21210

Everything new and secondhand for the modern musician. Give us a ring for the best prices. Barclaycard/Access/H.P. welcome.

SUDBURY MUSIC  
52 North Street,  
Sudbury, Suffolk,  
Tel: (0787) 76003

# SUDBURY MUSIC

OPENING SOON  
497 London Road  
Sheffield

## NEW PEARL & ROGERS KITS AT LOWEST PRICES ANYWHERE!

Including stands, pedals etc.  
Pearl Powermate (5) black, white,  
chrome or blue. . . . .£410  
Pearl Four diemsnion (7) white . . . . .£520  
Pearl Rock Kits (5) black, white,  
deep ocean . . . . .£485  
Pearl Dynafamily (12) seamless  
blue acrylic. . . . .£800  
Pearl Powermate (5) yellow tinted  
acrylic. . . . .£500  
Pearl 11 drum clear acrylic. . . . .£790  
Rogers Gtr Londoner (5). . . . .£585  
Rogers Londoner (7). . . . .£730  
Autotune concert showman (9) . . . . .£599

## BASSES

Precisions R/N. . . . .£235  
Precisions M/N . . . . .£250  
Jazz R/N. . . . .£280  
Jazz M/N. . . . .£295  
Rickenbackers 4001 . . . . .£350  
Gibson Grabber + case . . . . .£250  
Gibson G3 + case . . . . .£260  
Gibson RD Artist + case . . . . .£399  
Gibson Ripper + case . . . . .£325  
Gibson EB3 + case . . . . .£399

## NEW ACOUSTIC BARGAINS BELOW HALF PRICE

Gibson MK 81 + case nat or S/B . . . . .£240  
Gibson MK 72 + case nat or S/B . . . . .£235  
Gibson J50 nat . . . . .£299  
Gibson Dove + case S/B . . . . .£460  
Gibson B50 12 string . . . . .£385  
Guild F30 . . . . .£255  
Fylde Falstaff . . . . .P.O.A.  
Fylde Goodfellow. . . . .P.O.A.  
Fylde Orsino. . . . .P.O.A.  
Fylde Sir Toby acoustic Bass + case . . . . .P.O.A.

## NEW GIBSON ELECTRICS

SG Specials . . . . .£260  
ES 335 + case . . . . .£499  
LP Customs + case . . . . .£450  
LP Deluxe + case. . . . .£410  
SG Customs+ case. . . . .£395  
RD Artists + case . . . . .£499  
SI + case . . . . .£266  
Marauder customs + case. . . . .£280  
Marauders + case . . . . .£260

## NEW FENDERS

Strats R/N . . . . .£250  
Strats R/N + trem. . . . .£280  
Strats M/N . . . . .£270  
Strats M/N + trem. . . . .£299  
Teles R/N . . . . .£225  
Teles M/N . . . . .£245

## NEW GIBSONS ONE OFF SPECIALS! UNIQUE!

Les Paul Custom Walnut + case . . . . .£550  
Les Paul Deluxe walnut + case. . . . .£500  
Les Paul Deluxe ebony + case . . . . .£500  
SG Standard ebony + case . . . . .£450

## AMPLIFICATION

Guaranteed lowest prices in U.K. for Marshall,  
Peavey, LAB Series, MM, Intermusic plus Bell  
electrolab effects.

## KEYBOARDS

Massive discounts on ARP, Rhodes and Korg.

NOW IN STOCK THE NEW GIBSON PAUL

FREE DELIVERY IN U.K. AND EUROPE



# WELSON

## Christmas Greetings From Woods Of Bolton



Sole U.K. Distributor

# WOODS (PIANOS & ORGANS) LTD.

15/17 Manchester Road, Bolton. Telephone: 0204 27171/ 2



# Forth Valley Music



SCOTLAND'S LEADING MUSIC SPECIALISTS  
79-93 CADZOW STREET,  
HAMILTON

Tel: Hamilton 28448

and at

(Head office)  
3-7 COW WYND,  
FALKIRK

Tel: Falkirk 31477



We hold virtually every major franchise, besides holding the SOLE Scottish agency for KAWAI organs and MOOG Synthesizers (we stock the ENTIRE MOOG range).

Besides which we have agencies for: Orange, H/H, Maine, Peavey, Custom Sound, Canary, Sonor, Premier, Maxwin, Pearl, Tama, Farfisa, Thomas, Lowrey, Wurlitzer, Crumar, Cavendish, Marshall, Carlsbro, Hohner, Roland products etc. etc.

Yes -- whether it's organs, pianos, electric or acoustic guitars, synthesizers, amplifiers, drums or accordians, we can offer you a selection that is probably one of the best ANYWHERE.

For instance, we have all guitars up to £1000 price-range including the Gibson Anniversary, the COMPLETE range of Fender guitars and Fender-Rhodes pianos, Kawai organs, and Kawai guitars, Ovation guitars, Farfisa synth-accordians and Marshall amplification. Plus Roto-Tom drums and over 250 organs in stock in our warehouse! In fact -- everything a musician could ever wish for!

But it's not only instruments and amplification -- we have huge stocks of sheet music, all spares, accessories, a full range of Disco and lighting equipment, practise kits and of course a full repair service. Need we say more?

Forth Valley Music offer a full after-sales service and full tuition facilities ('phone our Head Office at Falkirk for details) from people who believe in giving you courtesy and professional service.

WHY NOT VISIT US NOW?

BARCLAYCARD. ACCESS. EQUIPMENT HIRE FACILITIES.  
TRADE-IN ENQUIRIES WELCOMED  
SERVICE. REPAIRS. TUITION

On the Isle of Wight, the ONLY place you'll  
get it is at

## RYDE GUITAR CENTRE

RICKENBACKER – we mean of course  
plus Hagstrom, Gibson, Ovation, Aria,  
Shergold, Dobro, Antoria, Carlsbro, Randall,  
Peavey, Marshall, Laney, & Music Man.

SO – If you're on the Island, make for RYDE  
IF NOT – hover over NOW and see Phil.



3 MELVILLE STREET, RYDE, ISLE OF WIGHT  
(Phone: Ryde (0983) 62262)



# SOUNDWISE

27-29 Norwich Rd., Ipswich (0473) 53856



We wish all our customers  
Merry Christmas and a Happy  
New Year.



## Kenilworth Music Supplies Ltd.

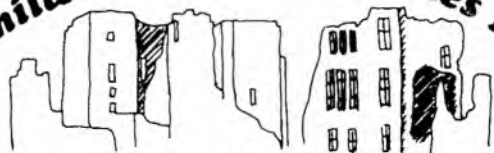

for  
GUITARS, AMPLIFICATION, SHEET MUSIC,  
ACCESSORIES AND MUCH, MUCH MORE!  
also  
ORGAN AND GUITAR TUITION

Free parking • Access • Credit Facilities  
Hire Purchase • Part Exchange

**KENILWORTH MUSIC**  
47 Spring Lane, Kenilworth, Warwickshire.  
Telephone: (0926) 544931

## BLACKPOOL SOUND CENTRE

7 COOKSON STREET,  
BLACKPOOL  
(Tel: 0253 25544)

Wish all Customers

# MERRY XMAS

and a Happy 1979!

## Farnsworth Music



**powerhouse**



*Marshall*



134 Radford Boulevard, Nottingham. Tel. (0602) 76516  
Lots of Guitars, Amplification & Keyboards.

Open 6 Days  
10am – 6pm

## THE MUSIC BOX AND SOUND SENSE

26 PROSPECT ST, BRIDLINGTON, E. YORKS.  
Telephone: 0262 70366



## PEAVEY POWER HOUSE

GUITARS, AMPS, GROUP GEAR, RECORDS  
ALL MUSICAL REQUIREMENTS

9 Chapel Street, Bridlington, E. Yorks.  
Telephone: 0262 70366

All types of electric organs and sheet music

**DISTANCE NO OBJECT –  
WE DELIVER ANYWHERE**

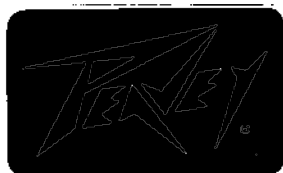

# PRODUCT INFORMATION AND DEALER DIRECTORY DECEMBER 1978

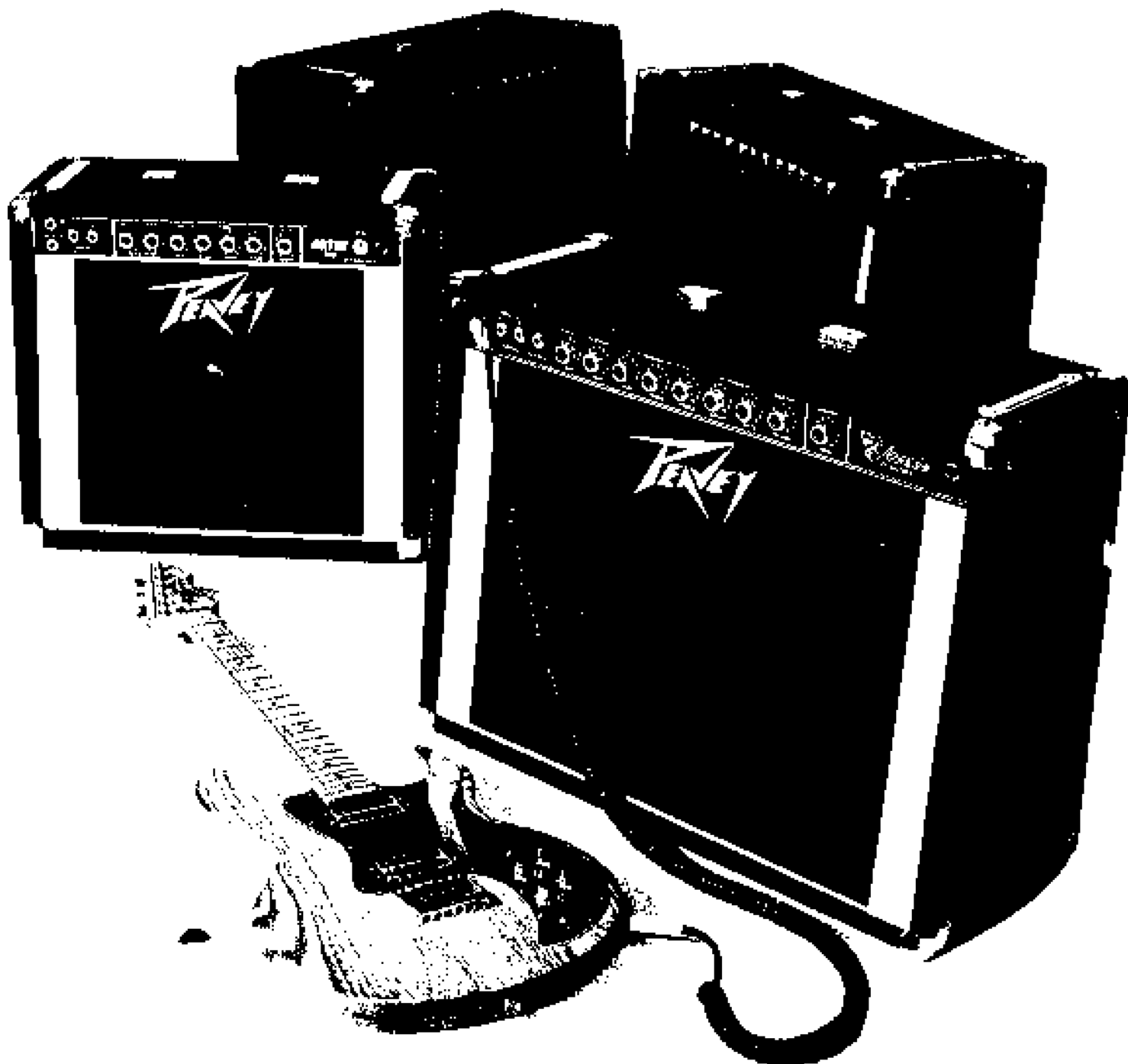

---

PEAVEY PRODUCTS ARE DISTRIBUTED IN THE U.K. AND IRELAND BY:  
PEAVEY ELECTRONICS (U.K.) LTD.,  
UNIT 8, NEW ROAD, RIDGEWOOD, UCKFIELD, SUSSEX TN22 5SX.

---

## PEAVEY DEALERS



A.B.C. MUSIC  
ADDLESTONE, SURREY



ALLEN'S MUSIC  
GREAT YARMOUTH, NORFOLK



BELL MUSICAL  
SURBITON, SURREY



CARLSBRO SOUND CTR.  
MANSFIELD, NOTTS



CUSTOM AMPLIFICATION  
CREWE, CHESHIRE



GIGSOUND  
LONDON SW17



J.S.G.  
BINGLEY, YORKS



J. RAFTERY  
GALWAY, EIRE

# THE PEAVEY GUITAR-

The most significant event since Hartley Peavey made his first amp . . .

T-60  
T-40

The new Peavey T-60 Guitar and T-40 Bass represent years of research and design by a combined staff of skilled craftsmen, engineers and musicians dedicated to the creation of extraordinarily high quality instruments for the serious performer. We have accomplished many construction

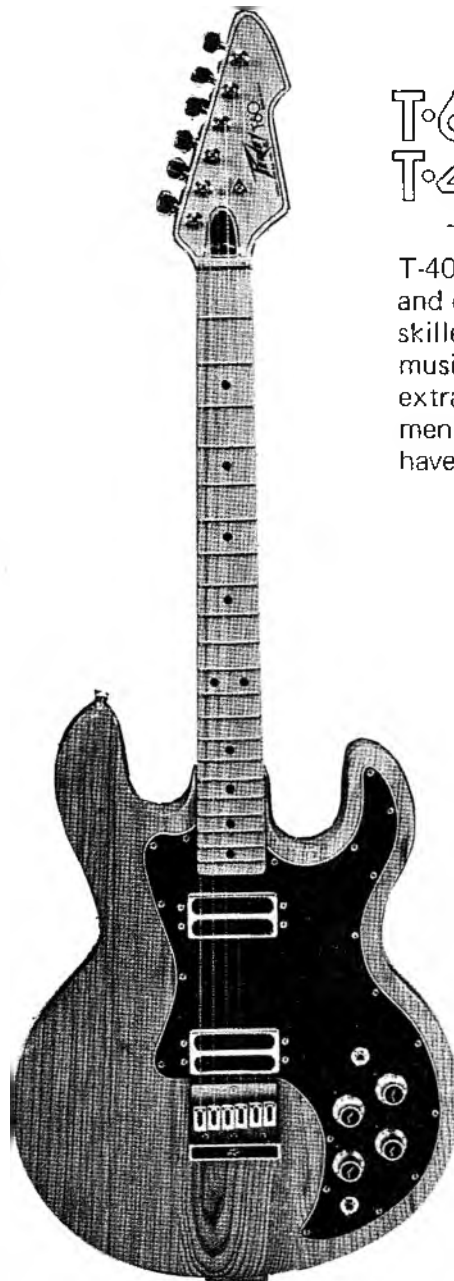

T60 GUITAR

and design innovations and have improved on many of the features of competing units that have enjoyed acceptance on the concert stage and in recording studios. This approach has led to a series of versatile and dependable instruments that are among the very best available, regardless of price.

WE REGRET THAT INITIAL  
SUPPLIES OF THESE FINE  
GUITARS WILL BE VERY  
LIMITED

CHECK YOUR LOCAL  
DEALER FOR FULL  
DETAILS

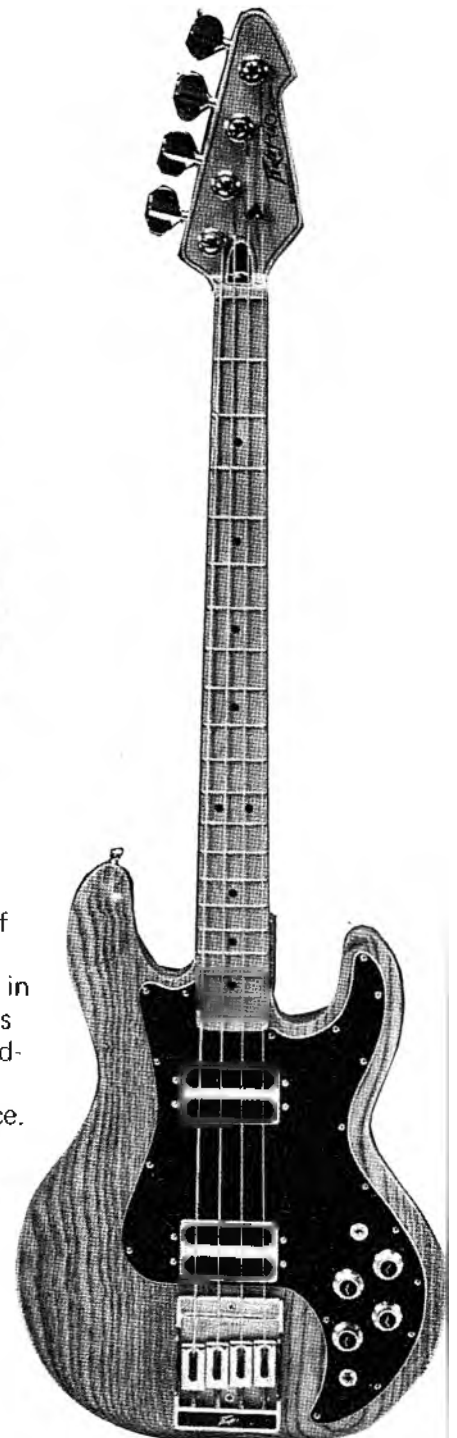

T40 BASS

# VT series....

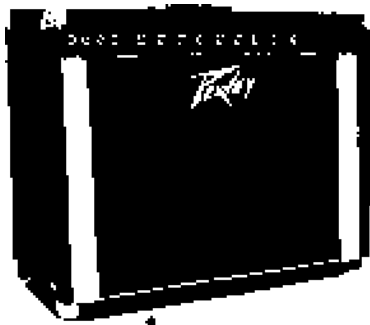

VT CLASSIC

being accomplished by the remote footswitch (supplied). The Normal channel features a more mellow type of response and is especially suited to playing styles featuring heavy distortion and sustain. The Effects channel is somewhat brighter and includes a variable middle control: Super sustain, harmonic distortion, smooth overload and tonal variations that are impossible with the ordinary two-channel system can be created with the Automix feature, all with a flick of the footswitch without ever having to take your hands from the guitar.

The Classic, Deuce and Mace feature a new type of phasor built into the unit. Because of this unique phase circuitry, these amps are able to achieve an extremely wide range of phasing effects, from very subtle



VT ARTIST

of preamp out/power amp in jacks have been included on the rear panel of the VT Series amplifiers. With this versatile patching facility, many interesting effects can be created using delay lines, noise gates, etc. to further enhance the flexibility of the system.

Combined with Peavey's excellent choice of speaker options and extension enclosures, the VT Series represent the most outstanding value in professional tube amps on the market for today's serious musician.

The new Peavey VT Series amplifiers represent our latest designs to provide the guitarist with the right blend of features, power, tonality and ruggedness to handle any performing requirement. Many new innovations in circuitry have been designed into these units providing simpler and more effective operation than previous configurations. The tremendous flexibility of the preamplification circuitry is complemented by the durability of the system and the smooth harmonic characteristics of the vacuum tube (valve) power amplifier.

These new amplifiers are basically two-channel units with two distinctly different sounds. Our Automix feature enables either or both of the channels to be used, with selection

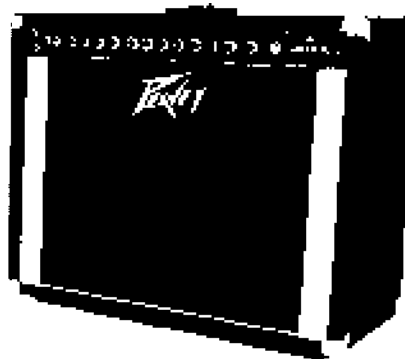

VT DEUCE

colourations to deep "swooshing" phasing sounds. We have designed a new oscillator that is capable of modulating the phase effect from slow, barely perceptible rates through the normal rates of conventional phasers, up through rates associated with traditional tremolo/vibrato circuits extending to the range of rotating speaker systems. The tremendous range of the phase colour and rate controls interact to yield what we think is the best phase circuit available either as an accessory or built into any amp to date.

The reverb follows the phaser circuitry and is also controllable from the remote footswitch. Our new design utilizes an entirely different type of reverb unit and drive circuitry producing an extremely deep reverb sound. To allow "in line" patching of various accessories, a system

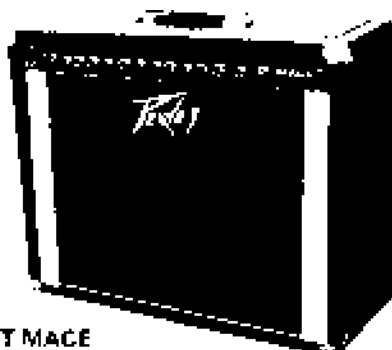

VT MACE

## PEAVEY DEALERS



RUMBELOWS  
READING, BERKS



ST. GILES MUSIC  
LONDON WC2



SOUNDWAVE  
ROMFORD, ESSEX



S.E. ENTERTAINMENTS  
LONDON SE13



SPIDER SOUND  
LIVERPOOL, MERSEYSIDE



STRINGS MUSIC  
KIRKCALDY, SCOTLAND



SUDBURY MUSIC  
SUDBURY, SUFFOLK



CHAS. TAPHOUSE  
OXFORD

# PROFESSIONAL

## CS-800 Power Amplifiers

- 400 Watts RMS per channel @ .05% THD into 4 Ohms – 5 Hz to 60 kHz
- LED clipping indicators on each channel
- Level control each channel
- 3 parallel inputs per channel on back panel
- One additional input per channel on front panel for convenience
- Forced air cooling (with two-speed fan)
- 18 gauge steel chassis with 1/8" thick steel front structural plate
- Total of 24 output transistors for reliability
- Overload protection circuitry
- Crowbar speaker protection
- Capability of being transformer balanced (with PL-2 plug-in module)
- Capability of being converted to a biamp (with PL-3, PL-4 and PL-5 electronic crossover modules)
- Capability of being converted to a biamp with special equalization for certain speaker systems such as Peavey SP-1 when PL-5 is used
- Capability of patching electronically crossed over low pass and high pass signals out to other amplifiers without purchasing additional crossover modules
- Capability of patching full range signal out to other amplifiers while in biamp mode



- Capability of being bridged to convert stereo operation into mono for an 800-Watt slave into 8 Ohms
- Two speaker outputs per channel – one phone jack and one set of binding posts



## CS-200 / CS-400 Power Amplifiers

The Peavey CS-200 and CS-400 Commercial Series power amplifiers are designed for durability in demanding sound reinforcement situations and for quality of performance and frequency response required in studio and home applications.

The CS-200 and CS-400 are of the standard 19" rack mount configuration and are packaged with structural qualities to withstand the most demanding road use. The basic structural package is held together by a 1/8" thick steel plate, immediately behind the front panel with 1/4" diameter machine screws securing transformers to the chassis.

The CS-200 is a single channel amplifier capable of delivering 200 Watts RMS into a 4-Ohm load. The CS-400 is a dual channel amplifier with each channel capable of delivering 200 Watts RMS into a 4-Ohm load.

Both amplifiers are equipped with internal fans which are controlled by manual switches with slow and fast positions. The fans may be switched completely off for light-duty applications such as home stereo, etc.



## SP-1

The SP-1 is a two-way system with Model 22 Driver coupled to the MF-1 horn on the high and crossing over at 500 Hz to a 15" cone speaker in a folded horn enclosure.

## FH-1

The FH-1 is identical to the SP-1's folded horn woofer which, along with the MF1-X forms a complete SP-1. It can be used with other high ends and in multiples to increase the low frequency projection of a P.A.

## MF1-X

The MF1-X is identical to the high end of the SP-1, MF-1 horn, 22 driver and crossover. It can be utilized in a number of ways: coupled to a FH-1, it forms a two-piece SP-1; wired in parallel with other speaker systems, it provides extra high end; or, using the internal 500 Hz crossover matched to a low frequency speaker that compares in efficiency and sensitivity. The MF1-X delivers large amounts of acoustic power from a small package.



WHOLMES MUSIC

CROYDON, SURREY



CACOPHONY

LONDON W3



CHASE MUSICIANS

LONDON NW1



DUCK, SON & PINKER

BATH, AVON

# PEAVEY

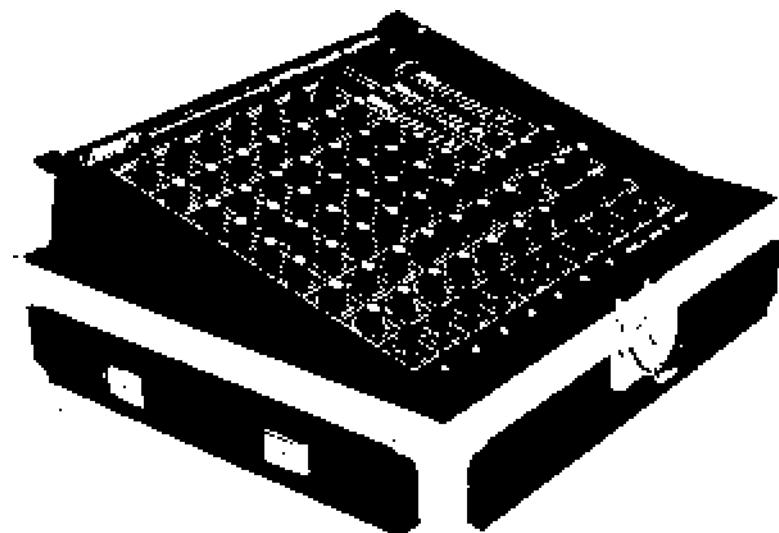

## MARK 2 MIXERS

7 CHANNEL 19" RACK MOUNT OR 8, 12, 16, AND 24 CHANNEL CONSOLES

- LED overload indicator each channel
- Pre monitor send each channel
- 4-band EQ each channel
- Stereo pan each channel
- LED ladder displays on Main and Sum (40.0 dB range)
- Stereo headphones selectable on Main and Sum
- Transformer balanced inputs and outputs
- +20.0 dBm levels at all outputs
- Easy access to all busses

### SPECIFICATIONS

#### Inputs.

Low Z, High Z, microphone inputs:  
Access to all busses: Main A, Main B, Monitor, and Effects.

#### Mic input:

Mic Impedance: Low Z: 200.0 Ohms  
Nominal Input Level: -40.0 dB (10.0 mV)  
Minimum Input Level: -80.0 dB (0.10 mV)  
Maximum Input Level: -10.0 dB (0.30 Volts)

#### Line and HI Z Mic Input:

Line Impedance: Greater than 20.0 K Ohms  
Nominal Input Level: -20.0 dB (0.10 Volts)  
Minimum Input Level: -60.0 dB (1.0 mV)  
Maximum Input Level: +10.0 dB (3.0 Volts)

#### Main Outputs:

Load Impedance: 600.0 Ohms, balanced and unbalanced.  
Nominal Output Level: +4.0 dB (1.2 Volts)  
Maximum Output Level: +20.0 dB (8.0 Volts)

#### Monitor Output:

Load Impedance: 600.0 Ohms, unbalanced  
Nominal Output Level: +4.0 dB (1.2 Volts)  
Maximum Output Level: +20.0 dB (8.0 Volts)

#### Sum Output:

Load Impedance: 600.0 Ohms, balanced and unbalanced.  
Nominal Output Level: +4.0 dB (1.2 Volts)  
Maximum Output Level: +20.0 dB (8.0 Volts)

#### Headphones:

Load Impedance: 4.0 Ohms – 50.0 Ohms  
Maximum Output Level: 0.50 Watt

#### Frequency Response:

30.0 Hz – 20.0 kHz,  $\pm 2.0$  dB

#### Equivalent Input Noise:

0.60 micro-Volts or - 125 dBV.  
200.0 Ohm source impedance.

#### Equalization:

High Mid and Low Mid: Peak and dip type,  
 $\pm 15.0$  dB continuously variable  
High and Low Frequency: Shelving type,  
 $\pm 15.0$  dB continuously variable  
Frequencies:  
Low: 100 Hz  
Low Mid: 500 Hz  
High Mid: 5.0 kHz  
High: 15.0 kHz

#### Crosstalk:

Greater than 60.0 dB (at 1.0 kHz)

#### Overall Distortion:

Less than 0.3% THD (Mic input to output)

#### Fader Attenuation:

Greater than 60.0 dB

#### Send Data:

Preamp direct send level: Nominal Output –  
5.0 Volts into 1.0 K Ohms or higher

#### Buss Input, Sub-mix Input:

Input Impedance: Greater than 22.0 K Ohms  
Nominal Level: -4.0 dB (0.50 Volts)



REGENT MUSIC

ST. HELIER, JERSEY



REA SOUND

STEWARTSTOWN,  
N. IRELAND



R. & H. RICHART

CÔSHAM, HANTS



WESTSIDE MUSIC

SOMERSET

# PEAVEY prices

EFFECTIVE DECEMBER 1978



CHAPPELL MUSIC

LONDON W1



HOUSE OF CLYDESDALE

SCOTLAND



UNISOUND

LONDON NW6



DICK MIDDLETON

GUILDFORD, SURREY

## COMBINATION AMPLIFIERS

			Suggested Selling Price excluding VAT	VAT Rate
BS30	BACKSTAGE	17 watts 1 x 10"	£ 92.25	12%
TK0	TK0	40 watts 1 x 12" bass unit	£147.25	12%
P112	PACER	45 watts 1 x 12" with reverb	£170.50	8%
TNT	TNT	45 watts 1 x 15" bass unit	£209.25	8%
CL212	CLASSIC	80 watts 7 x 12" with reverb + AUTOMIX	£259.65	8%
CL410	CLASSIC	90 watts 4 x 10" with reverb + AUTOMIX	£310.00	8%
D212	DEUCE	120 watts 2 x 12" with reverb + AUTOMIX	£360.50	8%
D212BW	DEUCE	ditto with Black Widow Speakers	£449.50	8%
A112BW	ARTIST	120 watts 1 x 12" Black Widow with reverb + AUTOMIX	£360.50	8%
A115BW	ARTIST	120 watts 1 x 15" Black Widow speaker	£395.25	8%
C115BW	COMBO	130 watts 1 x 15" Black Widow Bass Unit	£333.25	8%
M212	MACE	160 watts 2 x 12" with reverb + AUTOMIX	£449.50	8%
M212BW	MACE	ditto with Black Widow Speakers	£503.75	8%
SN115	SESSION	200 watts 1 x 15" Black Widow	£503.75	8%
LTD115	LTD	200 watts 1 x 15" Black Widow	£503.75	8%
		Cover for PACER, ARTIST and LTD	£ 11.25	8%
		Cover for other Combination Amps	£ 14.45	8%

## INSTRUMENT AMPLIFIER HEADS

CY	CENTURY	100 watts All purpose	£166.65	8%
SAP	STANDARD	130 watts All purpose + reverb + AUTOMIX	£224.75	8%
B	BASS	200 watts with Equalization + AUTOMIX	£286.75	8%
M	MUSICIAN	200 watts with EQ + effects + AUTOMIX	£313.90	8%
MA	MACE	160 watts with reverb (valve) + AUTOMIX	£313.90	8%
SN	SESSION	200 watts with reverb	£279.00	8%
		Covers for Instrument Amps	£ 7.30	8%

## INSTRUMENT SPEAKER ENCLOSURES

115	1 x 15"	4 Ohms	£127.87	8%
115BW	1 x 15" Black Widow	4 Ohms	£182.15	8%
212	2 x 12"	4 Ohms	£195.00	8%
412S	4 x 12" Stackable	4 Ohms	£209.25	8%
412M	4 x 12"	2 Ohms	£232.50	8%
412F	4 x 12"	4 Ohms	£232.50	8%
FH1	1 x 15" Folded Horn Bin	8 Ohms	£186.00	8%
215	2 x 15"	4 Ohms	£197.65	8%
215BW	2 x 15" Black Widow	4 Ohms	£310.00	8%
610	6 x 10"	4 Ohms	£209.25	8%
1510T	2 x 15" + 2 x 10" + 2 Tweeters	4 Ohms	£279.00	8%
B10	8 x 10"	4 Ohms	£348.75	8%
SP1	1 x 15" + Radial Horn Spider Bin	8 Ohms	£372.00	8%
		Cover for: 115, 212, 610	£ 14.45	8%
		Cover for: 412S, 412M, 412F, 215	£ 16.15	8%
		Cover for: 810, 1510T	£ 20.10	8%

## INSTRUMENTS

T-60	Guitar with case	£259.63	12%
T-40	Bass Guitar with case	£259.63	12%

## PUBLIC ADDRESS AMPLIFIERS AND SLAVES

PA100/112PT	PA 100	45 watts system complete	£255.75	8%
PA100	PA100	45 watts PA Combo Amplifier	£174.40	8%
PA200	PA200	100 watts 8 inputs amplifier	£205.40	8%
SPA	STANDARD	130 watts 8 inputs amplifier	£224.75	8%
XR600	XR600	200 watts/300 watts mixer amplifier	£360.40	8%
XR600FC	XR600	ditto in flight case	£395.25	8%
PA700S	PA700S	Stereo mixer amp 120 watts per channel	£558.00	8%
PA1000S	PA1000S	Stereo mixer amp 200 watts per channel	£736.25	8%
260B	260 BOOSTER	130 watts slave	£170.50	8%
260S	260 STEREO BOOSTER	120 watts per channel stereo slave	£259.65	8%
400B	400 BOOSTER	200 watts slave	£240.25	8%
800B	800 BOOSTER	400 watts slave	£333.25	8%
		Cover for 800B	£ 9.60	8%
		Covers for all other units except PA700S, PA1000S and PA100	£ 7.30	8%

## POWER AMPLIFIERS AND ACCESSORIES

CS200	CS200	POWER AMP Mono 200 watts	£251.90	8%
CS400	CS400	POWER AMP Stereo 200 watts/channel	£369.40	8%
CS800	CS800	POWER AMP Stereo 400 watts/channel	£480.50	8%

## MARK 2 MIXERS

MR-7	RACK MOUNT 7 CHANNEL STEREO	£503.75	8%
MC-8	8 CHANNEL STEREO CONSOLE	£612.25	8%
MC-12	12 CHANNEL STEREO CONSOLE	£880.25	8%
MC-16	16 CHANNEL STEREO CONSOLE	£1077.25	8%
MC-24	24 CHANNEL STEREO CONSOLE	£1433.75	8%
KM-4	Keyboard Mixer	£251.90	8%

## PUBLIC ADDRESS SPEAKER ENCLOSURES

112PT	1 x 12" + 1 Tweeter Column	Each	£ 81.40	8%
210	2 x 10" Column	"	£ 81.40	8%
410	4 x 10" Column	"	£116.25	8%
1210TS	1 x 12" + 1 x 10" + 3 x Tweeters Column	"	£135.65	8%
1210T	2 x 12" + 2 x 10" + 3 x Tweeters Column	"	£178.25	8%
C15TS	"Continental" 1 x 15" Black Widow + 2 Tweeters	"	£217.00	8%
1510T	2 x 15" + 2 x 10" + 3 x Tweeters Cabinet	"	£271.25	8%
115HT	1 x 15" + Hyperbolic Horn 12 x Tweeters Vocal Projector	"	£217.00	8%
215HT	2 x 15" + 2 Hyperbolic Horns + 2 x Tweeters Vocal Projector	"	£333.25	8%
SP1	SPIDER BIN 1 x 15" + Radial Horn Theatre Type Enclosure	"	£372.00	8%
FH1	1 x 15" Folded Horn Bin Section of SP1	"	£186.00	8%
MF1-X	Radial Spider Horn Section of SP1	"	£224.75	8%
T300	BANK of 3 TWEETERS	"	£ 58.15	8%
T12	RADIAL BANK of 12 TWEETERS	"	£166.65	8%
	Cover for 112PT, 210, 1210TS	"	£ 12.05	8%
	Cover for 410, 1210T, 115HT, T12	"	£ 16.15	8%
	Cover for 1510T, 215HT	"	£ 20.40	8%

## ANCILLIARY PUBLIC ADDRESS EQUIPMENT

MO	MONITOR Amplifier 130 watts with Graphic EQ	Each	£185.00	8%
112TS	MONITOR WEDGE CABINET 1 x 12" + 2 Tweeters	"	£135.65	8%
212TS	MONITOR WEDGE CABINET 2 x 12" + 2 Tweeters	"	£158.90	8%
22	SPIDER 22 High Efficiency Horn Driver	"	£ 73.65	8%
A1	ADAPTOR for above	"	£ 7.75	8%
A2	DITTO	"	£ 11.65	8%
A3	DITTO	"	£13.95	8%
22DK	SPIDER 22 Driver Diaphragm Kit	"	£ 27.15	8%
PBH	PEAVEY BALL MICROPHONE High Impedance	"	£ 62.00	12%
PBL	PEAVEY BALL MICROPHONE Low Impedance	"	£ 62.00	12%



# BLACK WIDOW

## PREMIUM LOUD-SPEAKER PROGRAMME

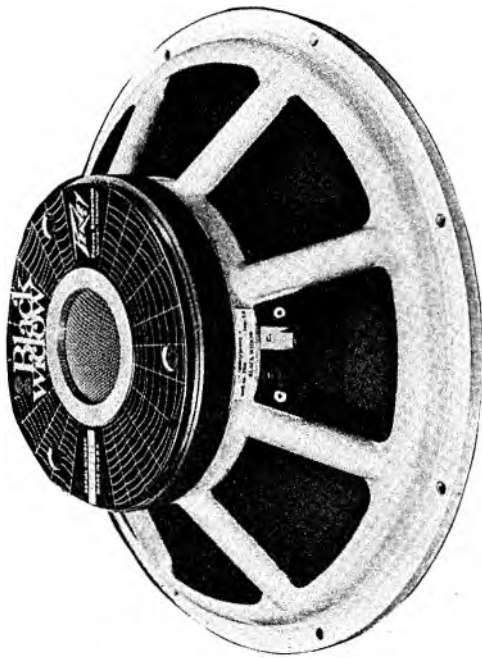

The design and development of our Black Widow speakers is the direct result of our commitment at Peavey to produce products of the highest quality to fill the needs of our customers.

The Black Widows are manufactured at our plant facility in Meridian, Mississippi and are tested by a team of highly trained and dedicated employees. Our transducer design and manufacturing is done in a modern, well equipped, and efficient facility, employing advanced techniques to insure uniform and dependable performance and quality. Every speaker (NOT ONE OUT OF TEN) is subjected to exhaustive power tests, curving and finally extensive listening tests to insure our Black Widows are of the highest quality available.

The new Peavey Black Widow speaker features:

- One-piece aluminium coil form and dome which reduces mass, improves heat transfer and increases structural rigidity.
- Field replaceable cone/basket assembly.
- Venting of inside of dome through the magnet structure, assuring the

absence of air noises at high SPL and unmatched cooling of the voice coil area.

- Easy access terminations for assembly ease in tight applications.
- Four-inch (4") diameter voice coil, edge-wound with flat wire for better efficiency.
- Rugged cast aluminium frame.

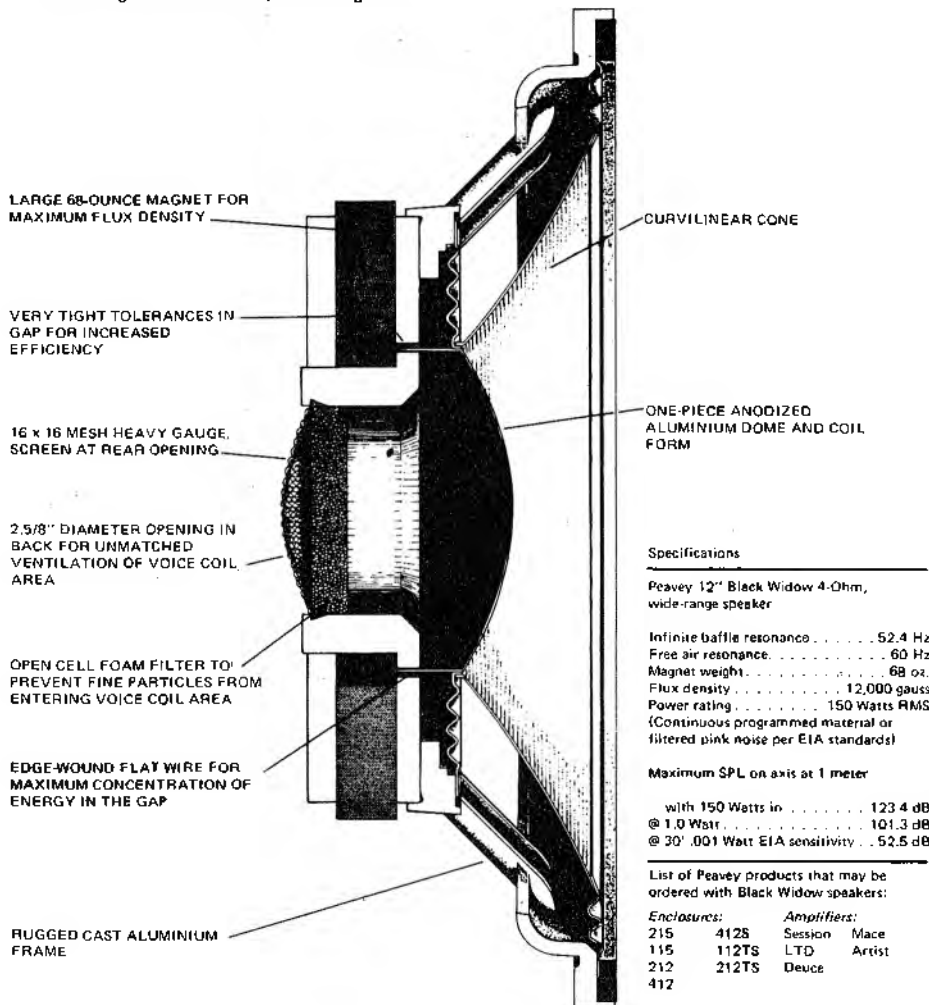

### Specifications

Peavey 12" Black Widow 4-Ohm, wide-range speaker

Infinite baffle resonance . . . . . 52.4 Hz  
 Free air resonance . . . . . 60 Hz  
 Magnet weight . . . . . 68 oz.  
 Flux density . . . . . 12,000 gauss  
 Power rating . . . . . 150 Watts RMS  
 (Continuous programmed material or filtered pink noise per EIA standards)

### Maximum SPL on axis at 1 meter

with 150 Watts in . . . . . 123.4 dB  
 @ 1.0 Watt . . . . . 101.3 dB  
 @ 30' .001 Watt EIA sensitivity . . . 52.5 dB

List of Peavey products that may be ordered with Black Widow speakers:

Enclosures:	Amplifiers:
215	412S Session Mace
115	112TS LTD Artist
212	212TS Deuce
412	



McCORMACKS

GLASGOW, SCOTLAND



ROCKBOTTOM

CROYDON, SURREY



MUSIC CITY

LONDON W1



BROADWAY MUSIC

WORHTING, SUSSEX



## powerhouse ..... there's one near you!

A.1. MUSIC - MANCHESTER  
A.B.C. MUSIC - ADDESTONE, SURREY  
ALLENS - GREAT YARMOUTH, NORFOLK  
ANDERTONS - GUILDFORD, SURREY  
ASSEMBLY MUSIC - BATH, AVON  
AXE MUSIC - COLCHESTER, ESSEX  
A. BALAAM - IPSWICH, SUFFOLK  
BARRATTS - MANCHESTER  
BECKETTS - SOUTHAMPTON, HANTS  
JOHN BEEBY - LONDON N8  
BEES MUSIC - POULDTON-LE-FYLDE, LANCS.  
BELL MUSICAL - SURBITON, SURREY  
BENNETTS - PORTSMOUTH, HANTS  
BIGGLES - BRISTOL, AVON  
BIRDS - BEXHILL, E. SUSSEX  
BLACKPOOL SOUND GR - BLACKPOOL, LANCS.  
PETER BONNER - EASTBOURNE, E. SUSSEX  
BOOGIE MUSIC - LONDON WC2  
BRADLEY'S MUSIC - GLASGOW, SCOTLAND  
BROADWAY MUSIC - WORTHING, W. SUSSEX  
CACOPHONY - LONDON W3  
CAMBRIDGE ROCK - CAMBRIDGE  
CARLSBRO - MANSFIELD, NOTTS.  
CARLSBRO - SHEFFIELD, YORKS.  
PAT CHAPMAN - SIDCUP, KENT  
CHAPPELL - LONDON W1  
CHARNLEYS - WISHAW, SCOTLAND  
CHASE MUSICIANS - LONDON NW6  
CHICHESTER MUSIC CENTRE - CHICHESTER, W. SUSSEX  
CITY ELECTRONICS - WEMBLEY, MIDDX.  
CLARKES - NEWRY, N. IRELAND  
CLINKSCALES - MELROSE, SCOTLAND  
CODA MUSIC - BRADFORD, YORKS.  
COOKES - NORWICH, NORFOLK  
COUNTERPOINT - STEVENAGE, HERTS.  
COVENTRY MUSIC CENTRE - COVENTRY  
CRANES MUSIC WREXHAM, N. WALES  
CRANES MUSIC - AYR, SCOTLAND  
T. CROWLEY - CORK, EIRE  
CUSTOM AMPLIFICATION - CREWE, CHESHIRE  
DAWSONS - WARRINGTON, CHESHIRE  
STEPHEN DELFT - LONDON E1  
DUCK, SON & PINKER - BATH, AVON  
E.S. ELECTRONICS - MAIDSTONE, KENT  
E.S.S. - BARNET, HERTS.  
F.D.H. - LONDON WC2  
J.T. FORBES - DUNDEE, SCOTLAND  
J.T. FORBES - EDINBURGH, SCOTLAND  
J.T. FORBES - GLASGOW, SCOTLAND  
LEN FROBISHER - DUMFRIES, SCOTLAND  
GAMLIN PIANOS - CARDIFF, S. WALES  
TIM GENTLE - LEIGH, ESSEX  
GIG SOUNDS - LONDON SW17  
J. GRANT - EDINBURGH, SCOTLAND  
GREENHALGH'S - EXETER, DEVON  
GUITAR CENTRE - LANGLEY, BUCKS  
HAMILTON MUSIC CENTRE - HAMILTON, SCOTLAND  
FRANK HESSY - LIVERPOOL, MERSEYSIDE  
HICKIES - READING, BERKS  
HIGHWAY MUSIC - MANCHESTER  
JOHN HOLMES - SWINDON  
C.E. HUDSON - CHESTERFIELD  
H.W. MUSIC - NEWPORT, GWENT  
J.60 MUSIC BAR - LONDON E12  
JONES & CROSSLAND - BIRMINGHAM  
J.S.G. - BINGLEY, YORKS  
KENNARDS - ASHFORD, KENT  
KENNARDS - CANTERBURY, KENT  
KENILWORTH MUSIC - KENILWORTH, WARKS  
JOHN KING - KINGSTON, SURREY  
KINGFISHER - FLEET, HANTS  
R.S. KITCHEN - BRADFORD, YORKS  
R.S. KITCHEN - LEEDS, YORKS  
LARGS - ABERDEEN, SCOTLAND  
LARGS - AYR, SCOTLAND  
LARGS - DUNDEE, SCOTLAND  
LARGS - KIRKCALDY, SCOTLAND  
LARGS - GLASGOW, SCOTLAND  
LARGS - EDINBURGH, SCOTLAND  
LARGS - FIFE, SCOTLAND  
LUTON MUSIC CENTRE - LUTON, BEDS  
MAGNUM SOUND - WISHAW, SCOTLAND  
MEAN MACHINE - DARLINGTON, CO. DURHAM  
DICK MIDDLETON - GUILDFORD, SURREY  
C. BRUCE MILLER - ABERDEEN, SCOTLAND  
C. BRUCE MILLER - INVERNESS, SCOTLAND  
MR. MUSIC - BEDFORD  
MODERN MUSIC - DUDLEY, W. MIDLANDS  
MODERN MUSIC - NEWTOWNAROS, N. IRELAND  
JIM MOORE - HORNCHURCH, ESSEX  
EDDIE MOORS - BOURNEMOUTH, DORSET  
MUIR MUSIC - MANCHESTER  
MUSICAL SOUNDS - SHEFFIELD, YORKS  
MUSIC BOX - TAMWORTH, STAFFS.  
MUSIC GROUND - DONCASTER, YORKS  
MUSIC HOUSE - PETERBOROUGH  
MUSICIANS' WORKSHOP - FALMOUTH, CORNWALL  
McCORMACKS - GLASGOW, SCOTLAND  
BILLY McEWAN - MAUCHLINE, SCOTLAND  
NEWTONE MUSIC - NEWTON-LE-WILLOWS  
PETER NOBLE - LLANISHEN, S. WALES  
J. AND P. O'DONNELL - IPSWICH, SUFFOLK  
ORGAN LOFT - HUDDERSFIELD, YORKS  
PALL MALL MUSIC - CHORLEY, LANCS  
PIONEER SALES - ROMFORD, ESSEX  
MAURICE PLACQUET - LONDON W12  
PLUG INN - LIVERPOOL, MERSEYSIDE  
PROFESSIONAL MUSIC SERVICES - GRIMSBY, S. HUMBERSIDE  
J. RAFTERY & SON - GALWAY, EIRE  
NOEL RANDALL - WEXFORD, EIRE  
R.B. MUSICAL - FORFAR, SCOTLAND  
REA SOUND - STEWARTSTOWN, N. IRELAND  
REGENT MUSIC - ST. HELIER, JERSEY  
REGENT MUSIC - ST. PETER PORT, GUERNSEY  
RENO'S - MANCHESTER  
RHYTHM HOUSE - STOCKPORT, GTR. MANCHESTER  
R. & H. RICHART - COSHAM, HANTS  
ROCKBOTTOM - CROYDON, SURREY  
ROCK CITY - NEWCASTLE  
ROCK SHOP - DUDLEY, W. MIDLANDS  
RUMBELAWS - READING, BERKS  
RUSHWORTHS - LIVERPOOL, MERSEYSIDE  
ST. GILES MUSIC - LONDON WC2  
SALOP MUSIC CENTRE - SHREWSBURY, SALOP  
JOHN SAVAGE - KINGS LYNN, NORFOLK  
SCHEERERS - LEEDS, YORKS  
SHARON MUSIC - TUNBRIDGE WELLS, KENT  
SIGHT & SOUND - SPENNYMORE, CO. DURHAM  
GORDON SIMPSON - EDINBURGH, SCOTLAND  
SOCODI - CANTERBURY, KENT  
SOUND CENTRE - COVENTRY  
SOUND GEAR - GREAT YARMOUTH, NORFOLK  
SOUND PAD - LEICESTER  
SOUNDS - LONDON W1  
SOUNDS GREAT - CHEADLE, CHESHIRE  
SOUND SHOP - DROGHEDA, EIRE  
SOUNDWAVE - ROMFORD, ESSEX  
SOUTH EASTERN ENTERTAINMENTS - LONDON SE13  
SOUTHERN MUSICAL - HOVE, E. SUSSEX  
SPIDER SOUND - LIVERPOOL, MERSEYSIDE  
SESSION MUSIC - BALLYMENA, N. IRELAND  
SESSION MUSIC - BELFAST, N. IRELAND  
SESSION MUSIC - LONDON DERRY, N. IRELAND  
STEPHENS MUSICAL - LEEDS, YORKS  
STRINGS MUSIC - KIRKCALDY, SCOTLAND  
STUDIO MUSIC - CARLISLE, CUMBRIA  
SUDBURY MUSIC - SUDBURY, SUFFOLK  
CHAS TAPHOUSE - OXFORD  
TELECOMMS - PORTSMOUTH, HANTS  
TELFORD MUSIC - SHREWSBURY, SALOP  
WM. THOMSON - AYR, SCOTLAND  
WM. THOMSON - GLASGOW, SCOTLAND  
WM. THOMSON - KILMARNOCK, SCOTLAND  
WM. THOMSON - HAMILTON, SCOTLAND  
UNISOUND - LONDON NW6  
UNISOUND - LONDON SE15  
UNISOUND - CHATHAM, KENT  
VARSITY MUSIC - EDINBURGH, SCOTLAND  
BERT VEALE - NEATH, GLAM  
VIKING VISION - LERWICK, SCOTLAND  
VOLUME ONE - HARROW, MIDDX.  
WESTERN ROCK - PLYMOUTH, DEVON  
WESTSIDE MUSIC - BRIDGEWATER, SOMERSET  
WESTSIDE MUSIC - YEOVIL, SOMERSET  
WHITE CUSTOM SOUND - SUNDERLAND, TYNE AND WEAR  
WHOLMES - CROYDON, SURREY  
WILKIES - PERTH, SCOTLAND  
WILKINSONS - AIRDRIE, SCOTLAND  
WILSON - LEEDS, YORKS  
WISHERS - DERBY  
WOODROFFES - BIRMINGHAM  
WOODS - BOLTON, LANCS.  
YARDLEYS - BIRMINGHAM

PEAVEY PRODUCTS ARE DISTRIBUTED IN THE U.K. AND IRELAND BY:  
PEAVEY ELECTRONICS (U.K.) LTD.,  
UNIT 8, NEW ROAD, RIDGEWOOD, UCKFIELD, SUSSEX TN22 5SX.

# GOOD NEWS FOR CHRISTIAN MUSIC

A registered Interdenominational Christian Charity  
spreading the Gospel by Modern Media



4 REGENCY MEWS SILVERDALE ROAD EASTBOURNE  
SUSSEX BN20 7AB ENGLAND TEL EASTBOURNE (0323) 26134

Please phone for more details

## AUDIOGENIC STUDIOS

All our engineers have had national releases.

- 8 track 1" with noise reduction
- 16/8 custom desk
- Flanger, ADT Equalisers, Compressors, Expanders
- Microphones include AKG, Beyer, Shure, Neumann
- Mix down onto A700
- Revox for echoes and copies
- Master room reverb
- Tannoy/Quad monitoring
- Schiedmayer grand piano
- Solina string synthesizer
- Fender & Vox amps
- Relaxation room
- Comfy surroundings

All for under £99 per day  
For bookings call David Smithson  
Reading (0734) 595647  
34-36 Crown Street, Reading, Berks.  
CASSETTE DUPLICATION

*"Well, it's only a  
demo, innit...?"*

If you're happy to record demos that  
sound like demos, fine. If not, ring Rowan  
Laxton or Peter Dunkley – and never  
waste a cent again.

**studio G**

145 Wardour Street, W1. Tel: 734 5784

# Bird Sound Studios

Situated at Warwick, 20 miles south of Birmingham

## NOW 16 TRACK!

Visit our new purpose built studio in its own grounds.

Run by professionals for professionals.

Facilities also available, 8 track and complete  
custom pressing including artwork.

Rates: 16 track . . . £18.00 per hour

8 track . . . £12.00 per hour

+ £2 per hour overtime.

Special rates for block bookings and night sessions.

Several instruments available (no charge).

So for a friendly atmosphere with no hassles visit us or ring us on  
Warwick (0926) 45123/4

4 Welton Road,  
Wedgnoek, Warwick CV34 5YA.



Be Original man -  
Celebrate Xmas in August  
and yule really sleigh 'em.

Many thanks to all our clients and  
a merry Christmas to everyone.

15% reduction on published  
STUDIO GUIDE prices  
during December.  
Tel 051-708-0006

# August Sound Studios

16. BENSON STREET, LIVERPOOL L12ST

# RIG RAG SOUND STUDIOS

8 Track Studio  
For list of ancillary equipment  
telephone 0532 633717  
12 Kirkdale Avenue, Leeds.  
P.S. We also own the Off-Licence next door!

".... we're at the centre of things ...."

FIND OUT ABOUT....



**millstream recording studio**  
vernon place, cheltenham, glos., phone (0242) 43243



Used and  
recommended by  
ALVIN STARDUST,  
CLIFFORD T. WARD  
and other  
named artists

## ROCK RECORDINGS.

The professional  
one inch 8 track  
studio at a rate  
you'll find hard  
to beat.

For the musician who cares about  
quality and an atmosphere of  
friendliness (no charge). Consider  
these features-Allen & Heath,  
Leavers-Rich, Tanoy, Revox's, Teac,  
Cas dup, Shure, AKG etc.  
Piano, Drums and Booth,  
Amplification, Guitars etc.  
Session Musician. Demo Rates:  
Day & Evenings till 10:30pm  
£6 per hour. Weekends & after  
10:30pm £8 per hour.  
Mastering £10 & £12 per hour

# ROCK



Anglo House  
Worcester Road  
Stourport on Severn  
Worcestershire  
Tel: (std 02993)  
77626

## Meet Your Engineer

### Tony Robins, Rook Studios, Stockport

Multi-instrumentalist Tony Robins has been a musician for 18 years. Three years ago he became involved with mobile recording, from which he started Rook Studios about six months ago.

Rook is an eight-track with an Allen and Heath desk, a Leavers Rich one-inch eight-track machine and additional Revox equipment. The studio is fitted with Tannoy monitoring and Shure and AKG microphones. Results at Rook are good enough to attract such artists as Clifford T. Ward and Alvin Stardust, while jingles, demos and tapes for dancers have been recorded there.

Tony Robins is assisted at Rook by Terry Butcher, and Terry's technical expertise complements Tony's musician's know-how. The studio can also offer tape-to-disc facilities, and plans in the pipeline include setting up a record label, Rook Records.

### Rowan Laxton, Studio G, London

Studio G, in London's Wardour Street, is a well established studio. John Gale began there 15 years ago, recording voice-overs and effects for pirate radio stations. The studio is managed by Rowan Laxton, a graduate of Colchester Institute's music faculty. Rowan was made manager last Christmas and spends most of his time at the board recording radio and television jingles and voice-overs.

He wants to record more bands and often brings out carefully mixed demos for multi-instrumental recordings, putting a skeleton of instruments down on a Neve desk, Studer ¼-inch machines and Otari eight-track. Mikes are by Neumann and AKG and EMT reverb and a harmoniser are available.

Studio G has produced tapes for Glydri, Slipstream and Tonight while many television ads feature music recorded at Studio G for their widely-circulated tape service, Library Music.

### John Acock, Millstream Studios, Cheltenham

Millstream Studios, nestling quietly by the Cheltenham water that gives its name, evolved from a disused pottery studio that folk-rocker Dik Cadbury bought last year.

Engineer John Acock has been there since its inception, after eight years with London's De Lane Lea Studios. John helped freelance studio designer Roger Paton fit and equip the 16-track studio that will soon be up-graded to 24 tracks. He was taken on at De Lane Lea's Kingsway studios as a tape operator in 1969, working with Martin Birch to record Deep Purple and the Jeremy Spencer era Fleetwood Mac. A spell at their Soho operation recording orchestral works for films preceded his move to the Wembley Music Centre where he worked on Stackridge, Steve Hackett, Showaddywaddy and the last MC5 sessions.

Millstream is a warm studio where local folk-rock acts record and John has engineered and produced Tights there for Cherry Red Records. The studio boasts a 16-track desk by Solid State Logic in the US "in line"

form, Scully Transport recorder, A77 Revox varispeed and B62 two-track stereo recorders. Audio and Design provided the Scamp rack with noise gates, time shaper flanging and a compact limiter/expander. An EMS delay unit will be installed soon.

### David Smyth, Wizard Sound, Belfast

David Smyth's 16-track Wizard Sound studio started as a four-track demo studio. David is a musician who has played professionally and semi-pro for nine years.

David has been impressed by effect of the new wave in Northern Ireland. He wholeheartedly approves of the attitude among young musicians who don't want to be technical experts, but just want to play. As a result, he has made a real effort to give new bands the chance to make records.

The Undertones recorded their sizeable hit "Teenage Kicks" at Wizard. They started out on Teri Hooley's Good Vibrations label, with which David Smyth works closely, and have now signed to Sire. David charged the band a rock-bottom fee for their use of the studio, and has undoubtedly given their career a big boost.

John Peel has played a number of acts who use Wizard on his radio show, including Stiff Little Fingers, Outcasts and Victim. David Smyth is grateful for the publicity, but fears that Wizard's days may be numbered. He's thinking of moving to new premises in London.

### Dave Snead, Bird Sound Studio, Warwick

Dave Snead, a former professional guitarist, worked as a part-time sound engineer for bands and as an electronics engineer with Lucas Aerospace before becoming a full-time recording engineer at Breaker studios, in Birmingham.

Dave's knowledge of electronics meant that he was able to build much of the equipment at Breaker, and when he joined Bird Sound his expertise was again put to good use. He built Bird Sound's 24-channel desk which is based roughly on a Neve design. He also converted the studio's EMI BTR 4 recorder to take two-inch tape, and it will

be able to handle 16-track recording soon.

Dave Snead is building a stereo plate for the studio, and has already devised his own Digital Delay unit. Equipment not built by Dave at Bird Sound includes Tannoy monitors and microphones by Calrec, AKG, Beyer, Shure and Neumann.

### Peter Walters, Coachhouse Studios, London

Coachhouse deals mainly with artists from Ice Records who, as reggae regulars will know, number Eddy Grant among their directors. Peter Walters, who used to work at The Workhouse studios, found it quite a revelation to be recording bass-heavy reggae and soul music by such acts as The Equals and The Pioneers after working with light pop music.

Coachhouse is currently changing over from 16- to 24-track. A new Spectrasonics desk is being installed along with a Lyrec machine. Tannoy corner cabinets are used for studio monitoring, and Peter Walters finds their bass-loaded sound ideal for the music he records.

Peter currently does a lot of co-production work, and hopes to move into full-time production. He enjoys the scope afforded by reggae, especially when engineering dub tracks, where the engineer is free to experiment with reverb, repeat echo and other devices.

### Mike Robson, Ric Rac Studios, Leeds

Studios come in all shapes and sizes, and Ric Rac is what used to be a bakery. Mike Robson, a professional musician with many years of experience, started Ric Rac in collaboration with Alan Young.

The studio is currently eight-track. Mike wants to add all the necessary extras to the studio before expanding to 16-track, and he's already well on the way to doing just that. Ric Rac has quad Tannoy monitoring, Master Room reverb, and a Scamp rack of noise gates and compressing/limiting equipment.

The majority of Ric Rac users are groups, for example The Squares, signed to Squire Records, and The Sneakers, who have clinched a deal with Phonogram. Ric Rac also handle mastering jobs for custom pressings.

Mike Robson, a hi-fi enthusiast who began recording with a Teac machine for his own use, says that there is room for expansion on the current premises, but a new building will probably be necessary.

Tony Robins of Rook

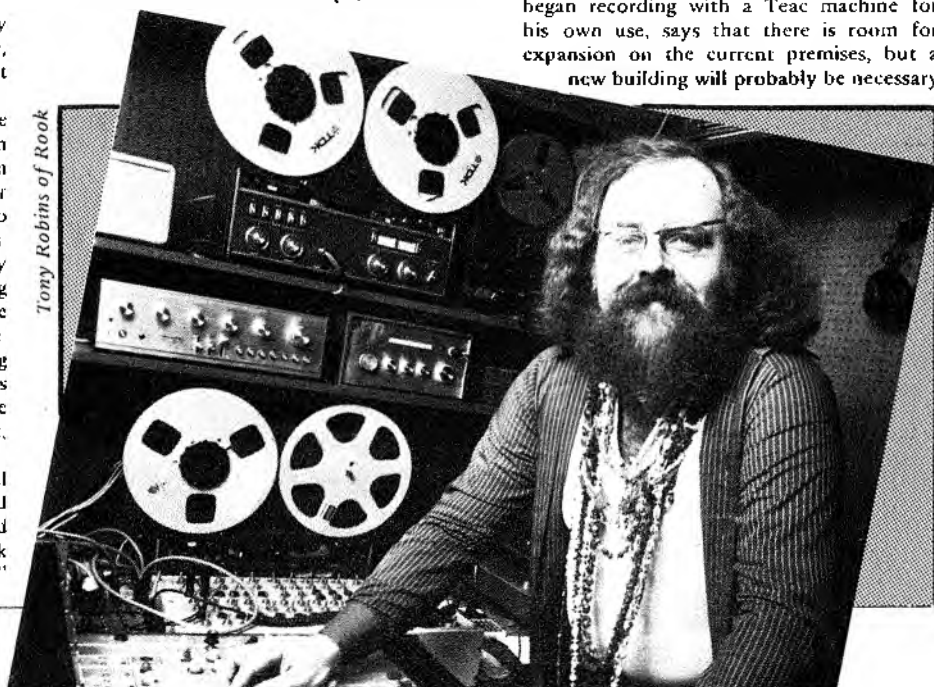

# NOT ONLY AN EQUALISER

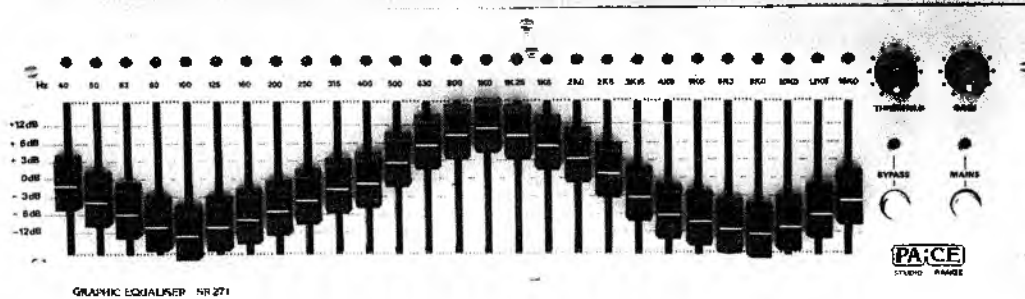

## BUT ALSO

ACOUSTIC SPECTRUM INDICATION  
ACOUSTIC FEEDBACK INDICATION

The PA:CE Studio range of graphic equalisers represent the technical solution to the equalisation requirements of users in the field of professional recording and sound reinforcement system. They provide uncompromising performance and reliability through state of the art circuitry incorporating ultra-linear gyrators and the unique "current sourced filtering monitoring technique" (pat pend).

The twenty seven bands provide third octave equalisation at the ISO standard frequencies, giving calibra-

ted cut and boost characteristics via smooth operating 60mm faders. They may be noiselessly switched in and out of the circuit, even during live use, and signal level within each band is continuously monitored by means of variable threshold LED monitoring circuits. These circuits are exceptional in that they provide monitoring at no expense to the noise and distortion characteristics of the filters and give an invaluable indication of acoustic feedback, or system response.

**PA:CE**  
STUDIO RANGE

PA:CE STUDIO EQUIPMENT LTD  
32 TRESHAM ROAD, ORTON SOUTHGATE,  
PETERBOROUGH, CAMBS. tel (0733) 234340

## Studio services, speakers and things...

*Studios couldn't operate and bands couldn't perform without the many auxiliary companies who develop, make and service all manner of vital equipment. This month, IM takes a look at three of them.*

### County Recording Service

County Recording Service started in business over 20 years ago. John Martin has been at the helm right from the beginning, and moved into disc-cutting after training as a watchmaker. He points out that the skills necessary in watchmaking come in very useful when dealing with the high-precision equipment used in disc-cutting.

Although County Recording Service is not a well-known name, this small company has pioneered a remarkable and as yet largely ignored breakthrough in disc-cutting equipment. According to John Martin, his company makes the only stereo disc-cutting head manufactured in Britain. Even more remarkable is the fact that this product costs about half as much as existing European and American competition while offering a comparable performance.

The disc-cutter was developed jointly by John Martin and his original partner, Eric Elliott. Eric died before the project came to fruition, but carried out all the basic electronic design work before his death. John is now assisted by electronics engineer and designer David Wright.

The disc-cutter now perfected by County Recording is smaller and more efficient than its competitors. This is because John and his helpers eliminated the need for negative feedback coils from the design. Though a technical breakthrough in disc-cutting, this has also proved to be something of a disadvantage when it comes down to persuading customers to buy the cutter, because negative feedback has become an established part of the design of other disc-cutting equipment. The task now facing County is to persuade a cautious industry that their product is a marked step forward.

County Recording Service are additionally involved in the manufacture of disc-cutting sapphires, which they export all over the world. In the early Seventies, the company built and operated its own pressing plant, which is no longer in operation. The disc-cutter itself has been used to cut records like Ronco's Horse Racing disc, which allows for a number of

different outcomes to the race. Records of this type have been cut by County for export to Japan, Norway and the USA.

It would be a great pity to see the work done at County Recording Service go to waste. The company's address is London Road, Binfield, Bracknell, Berkshire.

### Studio Equipment Services

If you've ever been to the Department of Transport's building in Acton to apply for a Heavy Goods Vehicle licence, you were probably too overawed to notice that the PA mixer in that establishment was designed and built by Studio Equipment Services. It's worth reflecting that there's, a whole variety of applications for sound equipment that often go unnoticed. Studio Equipment Services have built themselves a very solid reputation for providing sophisticated equipment for all kinds of different purposes, and at least equally importantly, for providing a thorough and knowledgeable back-up service.

Studio Equipment Services is now three years old. It was started by Ian Downs and Trevor Taylor; Ian is the electronics expert, while Trevor is primarily concerned with the sales side of the company. The range of customers who come to SES is bewildering. A cursory glance through Ian Downs' account book reveals Government Departments, Colleges and Universities, professional studios including Berwick Street, DJM and AIR, as well as bands such as Yes and even Marks and Spencers.

It's not easy to describe SES briefly, since every job they do is treated on its own merits. They act as dealers for certain makes of equipment, for example Allen and Heath, Revox, Brenell and Otari. They have recently brought into stock Dynacord's digital reverb system, the DRS 78, which looks like being a winner.

Specialist jobs undertaken by SES have included a lot of work for radio stations and voice recording studios. In fact, they built a speech studio from scratch for BRZ Productions, mainly for recording commercials. To deal with the special requirements of voice recording, the mixer in the studio has four stereo line inputs as well as five mono inputs. Comprehensive monitoring, pre-fade listen and talkback facilities have been incorporated into the studio, which is up to IBA broadcasting standards.

Radio is another field in which SES have found a ready market for their expertise, having supplied equipment to local stations as well as to hospital and community radio. The company supply and service cartridge machines for radio use, as well as building mixers, which they did for a hospital radio station in Stanmore.

Although only a small company, SES handles a lot of export work. "Anywhere from the Orkneys to Egypt," as Ian Downs puts it. This sounds like a hazardous undertaking, but SES minimise the risks by unpacking, testing and, if necessary, re-aligning all the equipment they supply. This goes for both new and second-hand equipment, used gear being supplied with SES's own guarantee.

In the complex world of sound recording, it's reassuring to know that there is a company like SES who are both willing and qualified to offer a professional service.

### Johnson and Jones

The name Johnson and Jones derives from the Radio and TV Repairs firm taken over after the last war by Douglas Wearn. Work undertaken by Douglas in the early days of his company included installing Philips sound equipment in Fleet Air Arm bases, after which he moved into trade work, such as putting speakers into televisions and radiograms.

Nowadays, Johnson and Jones specialise in customising work on loudspeakers. They deal with a large number of individual customers, and have also handled work for the Small Faces and the sound equipment hire company, Ground Control.

The work carried out by the company can be a specific customising job requested by a client, or it can involve repairing speakers which have blown or suffered other damage.

All the work at Johnson and Jones is carried out by hand. Coils are made to measure, and are wound onto spun aluminium formers, a development devised by the company. The wire used for coils is treated with a heat-resistant enamel and is then wound in with a heat-resisting adhesive. The company do take on some hi-fi work, but do not yet feel well enough equipped to advertise for work in this field. They also work on numerous 18" speakers used by reggae bands, which are subjected to heavy bass frequencies. Johnson and Jones is very much a family business, being run by Douglas with the help of his three sons. The company is now situated at 66 Dalston Lane, London E8.

# Amazon Studios

## LIVERPOOL



Two Studios – 24 track & 8 track facilities  
(with tie-lines between both Control Rooms)

– A Studio complex offering the very best in recording  
with Relaxation/Games Room, Kitchen & Shower facilities

### STUDIO 24

- \* Air Conditioned Studio and Control Room
- \* AMEK M3000 28 into 24 mixing console (Quad/automation ready/parametric EQ)
- \* Compressor limiters – Meyer noise gates/Allison Research Gain Brain/Urie LA4's/Urie 1176's/A&D Compex/Coghlan Audio's/Klark Technik 27 band graphic EQ's.
- \* Dolby noise reduction
- \* Lockwood Universal Major monitors/Crown DC300A
- \* E.M.T. stereo plate & Master "C" series stereo reverb
- \* Lyrec 24-track recorder with autolocate & tape position controller
- \* MCI mastering machines
- \* A.M.S. microprocessor controlled Digital delay system/A.M.S. Phaser

- \* 5 x 26 channel stereo headphone mixers in Studio
- \* 3 recording areas: Main studio area 75M<sup>2</sup> (800 sq. ft.)/Isolated "hard room"/Vocal overdub booth
- \* Steinway Concert Grand Piano (9')
- \* Hammond C3 & Leslie Cabinet
- \* Any instrument hired at client's request
- \* Parking for at least 30 vehicles, with easy loading

### STUDIO 8

- \* AMAZON's well established 8-track studio has recently been extensively refurbished and re-equipped
- \* MCI 110A 8-track 1" recorder with remote
- \* AMEK 16 into 8 desk
- \* Ampex Stereo machines
- \* Quad Power amps/Tannoy Golds monitoring
- \* Orban Parasound reverb
- \* A.M.S. Stereo Phaser
- \* "In-Studio" headphone mixers
- \* Tie lines to Studio 24
- \* 600 sq. ft. Studio



Amazon Recording Studios, I.S.D., Stopgate Lane, Simonswood, Liverpool L33 4YA.  
Phone 051 546 6444/0434 for a full colour brochure.



## Studio of the Month



### Amazon

Liverpool may not be the most beautiful city in Britain, but when it comes to music its place in history seems assured. Despite the wealth of talent that has emerged from the 'Pool over the years, when it comes to actually making records, the bands have often found it necessary to leave the city and make the long trek down to London. But now, thanks to an enterprising local lad called Jeremy Lewis, all that is about to change. Jeremy is responsible for Liverpool's first 24-track studio, believed to be only the second of its kind in the North of England.

Amazon Studios opened a few years ago as a result of Jeremy's interest in music and subsequent hobby. He explains: "I'd always been interested in music and played in various local bands. I'd built myself a small studio in the basement of the house where I was living. It was really only for my own songwriting. I was due to go to university about that time, but decided that I wanted to get into recording instead."

He began looking around for suitable premises in which to continue expanding his recording work and came across a place called Liverpool Sound Enterprises at Simonswood, on the outskirts of Liverpool. The studio was a simple two-track affair and the equipment quite ancient, although they did have "a weird, converted eight-track" which hadn't been used. Jeremy took the gamble and the risk eventually began to pay off.

"The first two years, we functioned as an eight-track with rather difficult equipment. Eventually we re-equipped and got a good reputation for our sound. Things went so well that we decided to go for the big one.

"We found that all the people who were using the eight-track, people like the Real Thing, Liverpool Express, Marseilles, Supercharge, all the recording acts in the area, needed proper master recording. They would work out ideas and write songs on our eight-track and then go down to London to record. We thought that that was a bit ridiculous so we decided to do it here."

He realised that it wouldn't be enough to just build a straightforward 24-track studio that was merely adequate. Jeremy set out to create one which was at least as good as, if not better than, any 24-track in the country. He knew it had to be something better, particularly if he was to compete with London studios.

To begin with, he wanted an original design so he set to work on it himself: "What usually happens is that you get consultants in, pay them a lot of money

and they come up with a studio design. We didn't do that because, apart from not having the money, we didn't like the idea of a Westlake/Eastlake type of approach. An architect friend and myself spent about a year visiting studios, attending lectures and reading all the right books until we eventually came up with a design. It was only then that we gave it to a consultant who did a lot of the acoustic windows, doors, etc., and he came up with a few modifications. It has worked extremely well because we've ended up with something which is as good as anywhere but, in its own way, it unusual.

"There's a proper hard room that opens out into the studio rather than just one live area. Certainly, the sounds we can get if we want to use that live facility are quite unusual because we can go from 0.4 seconds reverb, a tight sound in the studio proper, to two seconds just through an opening."

Amazon is certainly a studio with character and has its own particular atmosphere which will suit musicians looking for something a little different. The actual studio hardware is of the highest quality and bears comparison with anything you're likely to find in a British studio.

A new Amek M3000 console has just been installed, which is a 28-into-24 desk with comprehensive parametric EQ, VCA faders and VCA echo facilities on all channels. The desk is also capable of being updated to 36-into-32. The monitoring comprises a Crown DC300A/Lockwood/Tannoy system and other equipment includes a Lyrec TR532 24-track, Klark Technic 27-band graphic equalisers, Meyer noise gates and Allison Gain Brains. The studio also offers a Steinway concert grand piano and a Hammond C3 free of charge, and any other instrument or amplifier can be hired on request.

One added feature of the Amazon set-up is the provision of five 26-channel headphone mixers, which enable each musician to have his own stereo headphone mix. This facility is also available in the thriving eight-track studio, which is a separate unit and as big as many 24-track studios you find around.

The chief engineer at Amazon is Phil Ault who spent six years at Basing Street working with such acts as 10cc, the Wailers and Joan Armatrading before moving back to his native Liverpool to help set up the studio. Geoff Higgins and Frazer Henry are the two other engineers while maintenance engineer Peter Duncan and Jeremy's personal assistant Anne Bersin complete the personnel.

The complex is entirely self-contained with its own kitchen and shower facilities, a relaxation/games room and ample free parking. Amazon is handily placed for the M62 and M57 motorways, which connect to the M6. It's a path which will be trodden by many musicians in search of the "Liverpool sound".

# Coach House Recording Studios

81A Osbaldestone Road  
London N16 6NP  
Tel: 01-806 3252/5



16-track mixing & recording  
£25 per hour

Overtime, 7 days a week,  
After 6.00p.m. -- an extra £5.00 per hour

After 12.00p.m. -- an additional £5.00 per hour

Saturday & Sunday -- Minimum £30.00 per hour

RESIDENT ENGINEERS:  
PETER WALTERS    RON TELMAQUE

Come to Coachhouse where you'll hear  
the hottest sounds on the coolest label in town.

## AXE MUSIC

16 MERSEA ROAD, COLCHESTER, ESSEX.

COLCHESTER 65652  
ONLY 20 MINUTES  
FROM HARWICH

WE ARE HERE

FOR  
FENDER, GIBSON,  
MARSHALL, MAINE,  
YAMAHA, IBANEZ,  
ORANGE  
VOX, GUILD M.M.  
AND MANY MORE

LOWEST POSSIBLE PRICE

COLCHESTER  
(0206) 65652

POP IN AT COFFEE TIME

FELIXTOWE

COLCHESTER

HARWICH -- NORTH  
SEA

## HAVE YOU BEEN

HANDLED  
WITH CARE AT

# QUEST

When you're ready for the best in 8-Track recording  
Phone: Luton 414297 (24 hour answering service)  
721 WINDMILL ROAD, LUTON, BEDS.

## HUMBUCKER MUSIC CENTRE

124c Green Lane Road Leicester  
(769318)

*The Specialist in NEW and  
SECONDHAND Equipment  
All Accessories carried.*

Agents for Mood, Marshall & Laney

●  
Manufacturers of P.A. Bins

●  
P.A. Systems installed

●  
We buy gear for cash

●  
P.X. welcome.

●  
Finance available.

# These are the dealers...



**Rock City,**  
48, Cloth Market, Newcastle-on-Tyne.  
*Mike Forster* Tel: 0632-24175  
**Kingfisher Music Co.,**  
20, Kings Road, Fleet, Hants.  
*Cathy Fisher* Tel: 02514-21210  
**Chappell & Co.,**  
50, New Bond Street, London W.1.  
*Edmund Jones* Tel: 01-629 7600  
**Julians Retail Instruments Ltd.,**  
2, Churchill Road, London N.W.2.  
*Gordon Graham* Tel: 01-459 7294  
**W.J. Taylor (Music) Ltd.,**  
126/130, Hawthorne Road, Kingstanding,  
Birmingham B44 8QA.  
*Graham Cook* Tel: 021-382 1312  
**Peter Noble (Llanishen) Ltd.,**  
11, Station Road, Llanishen,  
Cardiff CF4 5LS.  
*Ed Noble* Tel: 0222-753911  
**P.M.S.,**  
145, Clouds Hill Road, St. George,  
Bristol BS5 7LH.  
*Michael Gregory* Tel: 0272 555694  
**Rod Argent,**  
Denmark Street, London W.C.2.  
*Mel Wesson* Tel: 01-240 0084  
**London Synthesiser Centre,**  
22, Chalton Street, Off Euston Road,  
London N.W.1.  
*Pammi* Tel: 01-387 7449 01-363 0440

**Session Music,**  
73/75, Broughshane Street,  
Ballymena, N.Ireland.  
*Robin Shannon* Tel: 0266-41792  
**Sound Pad,**  
64, London Road, Leicester.  
*Graham Pell* Tel: 0533-20760  
**Treasure Music,**  
86, Bridge Street, Peterborough.  
*Roy Neil* Tel: 0733-60508  
**Eddie Moors,**  
679, Christchurch Road,  
Boscombe, Bournemouth.  
*Eddie Moors Jnr.* Tel: 0202-35135

**Forth Valley Music,**  
3-7, Cow Wynd, Falkirk.  
*Norman MacLeod* Tel: 0324-31477  
**Kitchens,**  
27-31, Queen Victoria Street, Leeds.  
*Michael Cooper* Tel: 0532-446341  
**Treasure Music,**  
20, Allhallowes, Bedford.  
*Roy Neil* Tel: 0733-60508  
**Carlsbro Sound Centre,**  
182-184, Chesterfield Road North,  
Mansfield.  
*Nick Atkinson* Tel: 0623-26976  
**Tower Music,**  
46-48, Topping Street, Blackpool.  
*Dave Lee* Tel: 0253-27359

# These are the deals...

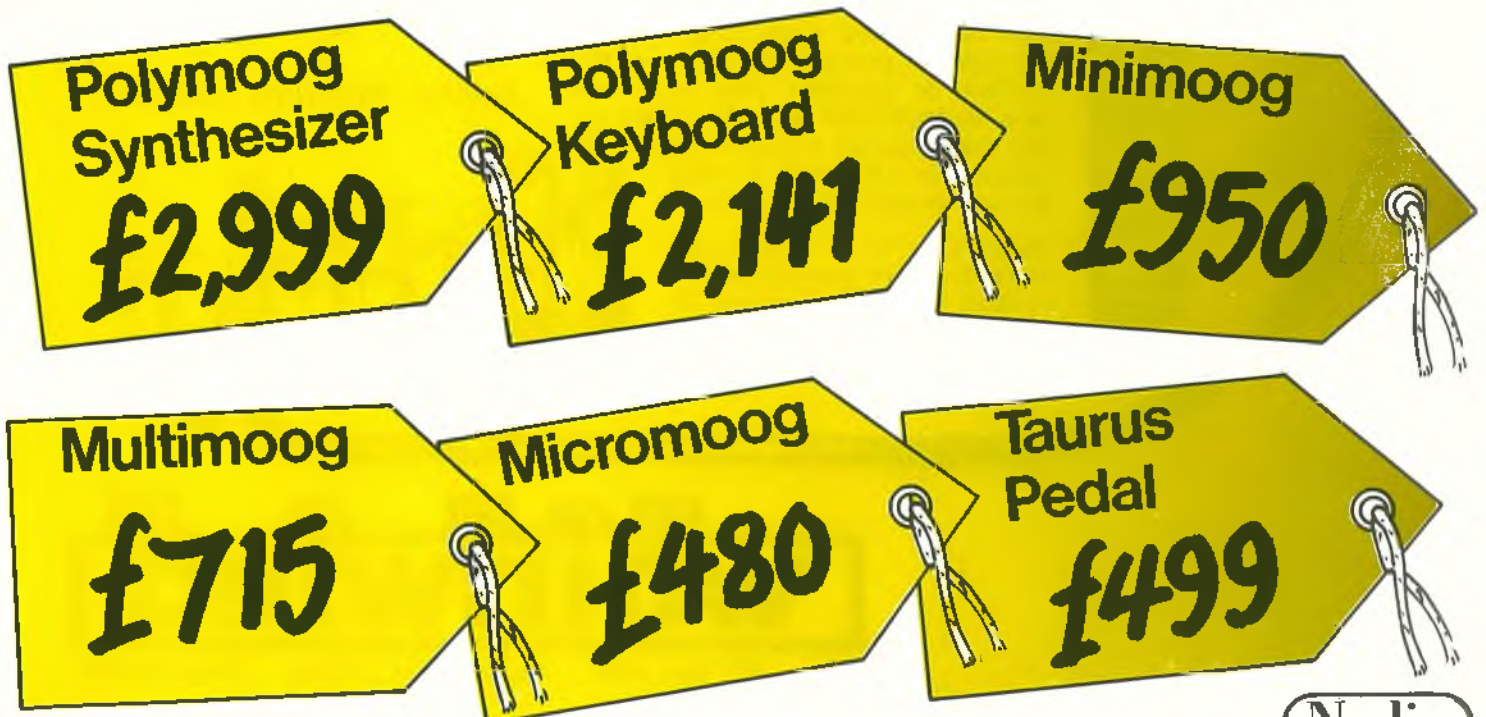

**moog**® the power and the glory  
SYNTHESIZERS \*recommended retail price

another quality product from **Norlin**  
Norlin Music (UK) Ltd Woolpack Lane  
Braintree, Essex.  
Telephone: (0376) 21911

# A Tip from the Experts

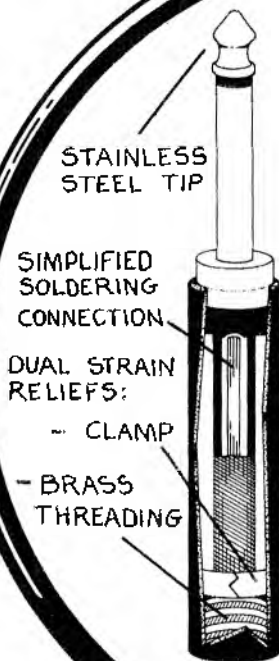

For years, everybody thought that connectors were about as basic as you could get—so nobody improved them. Then along came Whirlwind. We recognized the musicians' needs for high-quality, rugged and noiseless cords that *lived up* to their guarantees, and so we started designing our own cords, having them manufactured by Belden, and selling them to you.

Now our designers have recognized another need in connectors that no one has bothered to think about before —  $\frac{1}{4}$ " phone plugs. We went beyond the "standard," constructing a plug that exceeds the positive contact properties of the "military" or "computer" plug, by using a new, stainless-steel diamond-shaped tip, and then designed a tougher strain relief system and outer shell, to make the plug virtually indestructible.

We call it the Tip. It's a phone plug that's designed from scratch to combine the most secure strain re-

lief available with a reliable contact-making diamond-shaped tip.

The Tip looks just like a "military" plug, with a high-impact, shatterproof black housing, and brass body—but its stainless steel tip is an instant giveaway. A double strain-relief system and simplified soldering arrangement complete the picture, to provide you with the most secure phone plug there is.

The Tip—sure it's not big; but we got big by caring about the little things. Only at authorized Whirlwind dealers.

Another Whirlwind exclusive.

**the tip**  
Pat. Pending  T.M.

# whirlwind

P.O. Box 1075 • Rochester, N.Y. 14603 • (716) 663-8820

# The Producers:6

## BRUCE WELCH

In 1958, at the legendary Two I's coffee bar in Soho, a young singer called Cliff Richard was fronting a four-piece pop group called the Drifters. Later that year, Cliff and the Drifters had a huge hit with "Move It". The following year, the group — Hank B. Marvin (lead guitar), Bruce Welch (rhythm), Tony Meehan (drums) and Jet Harris (bass) — changed their name to the Shadows, to avoid confusion with the American soul group. Also in 1960, they had a Number One hit with their first record without Cliff, "Apache". From 1960 until 1968, when they broke up, the Shadows had 25 hit singles and toured the world many times.

Marvin and Welch came together again in the early Seventies, teaming up with Australian guitarist/vocalist John Farrar. Under the name Marvin, Welch and Farrar, they recorded two superb albums for EMI. Marvin and Farrar recorded a further album together before the Shadows re-formed in 1975.

In 1976, Bruce Welch produced Cliff's "I'm Nearly Famous", an album which certified Cliff as "cool". Welch had collected together an excellent set of songs and a superb group of musicians, and the resulting album caused many double-takes from many former Cliff critics. Welch also produced the follow-up "Every Face Tells A Story" and Cliff's latest, "Green Light". Eamonn Percival spoke to Bruce Welch a week after he celebrated 20 years as a professional musician.

Bruce's first involvement with production was in the early Seventies when, with John Farrar, he co-produced a string of hits for Olivia Newton John, his girlfriend at the time.

He recalls: "The first session we produced for Olivia was 'If Not For You', which became a big hit. Then we went on to do things like 'Banks Of The Ohio' and 'What Is Life'. John is now in America and still produces her. That was the start of my producing and I learnt a lot from John. He hadn't produced before either but he was the real musician out of the two of us. The thrill of getting a hit with our first production job was fantastic."

Bruce's next step into production



came with the formation of Marvin, Welch and Farrar. The three produced the two albums they recorded under that name and, later, when the Shadows re-formed, it was again a group production effort. From then on, production was "a natural thing" for Bruce and led up to his producing Cliff. Along the way, he found time to produce an album for the Sutherland Brothers and Quiver which he described as "not very successful".

"In 1975, Peter Gormley, our manager, virtually said that whoever came up with the best songs for Cliff's next album could have a shot at producing him. Up until then, Cliff had only had a couple of producers — Norrie Paramor for years and Dave Mackay for about two years. At the time, he was doing all those Eurovision-type songs and I came up with 'Miss You Nights', 'Devil Woman' and 'I Can't Ask For Any More Than You'. Those three songs were the first ones we did for the album."

Part of Bruce's job as Cliff's producer is to find suitable material for albums and singles — and few would disagree with his choice for "Famous". But he admits it isn't easy.

"Good songs really are hard to find but I think we came up with a good batch. I have to wade through lots of submitted songs because I get lots sent to me from publishers. I sit down and listen to all the cassettes and acetates. They come from all over the place. Terry Britten, who was Cliff's guitarist, wrote 'Devil Woman' and they had the song for about nine months before I heard it. They hadn't done it, I suppose because it was so different from the stuff Cliff was doing at the time. He was doing all that really bland MOR stuff. I found 'Miss You Nights' by accident. I was given a cassette of a batch of songs by David Townshend and I didn't like the one that I was supposed to be listening to, but the third song on the tape was 'Miss You Nights' and I liked it immediately."

The album was critically acclaimed as a breakthrough for Cliff Richard. The material was very different from his standard fodder and the backing on most of the tracks were a definite "group" sound, quite the opposite of his previous middle-of-the-road orchestral arrangements.

"I was just trying to get Cliff a bit ▶▶

# SR20 and SR28

## MIXING BUSINESS WITH PLEASURE

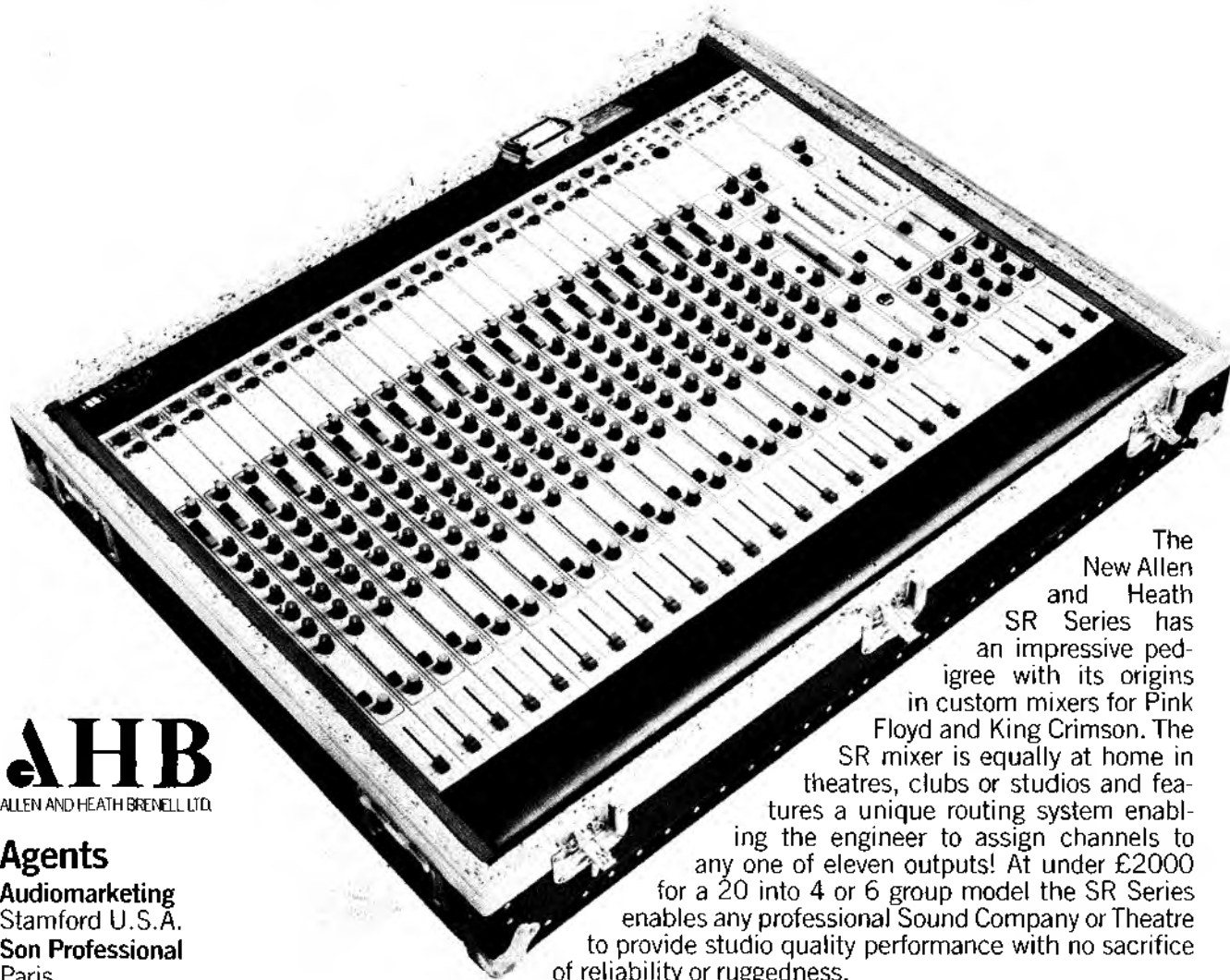

The New Allen and Heath SR Series has an impressive pedigree with its origins in custom mixers for Pink Floyd and King Crimson. The SR mixer is equally at home in theatres, clubs or studios and features a unique routing system enabling the engineer to assign channels to any one of eleven outputs! At under £2000 for a 20 into 4 or 6 group model the SR Series enables any professional Sound Company or Theatre to provide studio quality performance with no sacrifice of reliability or ruggedness.

**AHB**  
ALLEN AND HEATH BRENNELL LTD.

### Agents

**Audiomarketing**  
Stamford U.S.A.

**Son Professional**  
Paris

**Intersonic**  
Stockholm

**Fading**  
Madrid

**Studio Sound**  
Frankfurt

**S.E.D.**  
Brussels

**Sun Music**  
Denmark

**Audiolab Hellas**  
Greece

**Peter Bollen**  
Eindhoven

**Texim**  
Italy

**Lastron**  
South Africa

- Fully modular construction allows any format up to 28 inputs per frame.
- 8 routing busses to groups and masters.
- 3 auxiliary busses for foldback and effects.
- 10 echo returns for multiple effects mixing.
- Integral stage communications system.
- Built-in oscillator with frequency sweeping.
- Sweep frequency equalization as standard.
- Phantom power as standard.
- Heavy Duty external power supply.
- XLR transformer balanced microphone inputs with low noise preamplifier.
- LED Peak reading meters with stereo monitoring.
- Comprehensive headphone monitoring system.
- Military spec multipin connector as standard.
- +18dBm output head room.
- P & G fader option.
- Solo (PFL) of all desk functions.
- Special dual frame option for 40 or 48 inputs.
- Heavy duty flight case (as shown).

ALLEN AND HEATH BRENNELL LTD. PEMBROKE HOUSE, CAMPSBOURNE ROAD, LONDON, N.8

# The Producers:6

## BRUCE WELCH

more contemporary really. I think Cliff would admit this as well — he'd become a bit blasé about recording. As far as I was concerned, he was getting away from what he started out as — a record star. He was getting into the all-round entertainer thing which is a trap we all can fall into.

"I wanted him to get back into being interested in records. From what I can gather, he just used to come in and put the voice down. The tracks were all recorded beforehand and he'd come in and put two or three vocal tracks on in the same night. If a session was booked from seven until 10, he would book a dinner date for nine! But not now. He loves it, he's always at the backing track sessions and joins in on the harmonies and it's great. It brings a spark back in the studio because we all throw ideas around. We just have chord sheets and the rest happens in the studio. Doing 'I'm Nearly Famous' was a good kick up the arse and that was good for him.

"Nowadays, though the song publishers are very helpful, I still get people sending me the Eurovision-type stuff. I'm blessed in as much as people like Terry Britten and Alan Tarney are mates and they also write good stuff. They'll often be in the studio and start messing around with something that sounds good, so I tell them to go and finish it off. I usually get about 30 songs together and then we whittle it down to about 15. Then there are always two or three that won't work out for some reason or other. We have lots of songs still hanging around like that that we may re-work and eventually use.

"If a song has got something then I'll keep it. We recorded 'Every Face Tells a Story' for the 'Famous' album and I scrapped it because I didn't like it. We re-recorded it later and it became the title track of the follow-up album. With songs, I think they should grab you first time. Let's face it, the punters don't listen to a song three or four times before they decide they like it or not. I know some songs grow on you but I tend to be very instant. It doesn't have to be madly commercial but there's got to be something in it."

With Cliff Richard albums, Bruce always works with engineers Tony Clarke and Peter Vince, and always records at EMI's Abbey Road studios.

"Tony and Peter are two really top guys and Abbey Road is a good studio. It may not look as modern or as groovy as a lot of places but it's got a

good sound. I use Studios 2 and 3 and always seem to get a good sound. They haven't got every modern aid on tap like most of the big studios — it's a bit like EMI Records where you get everything a year later. We've been EMI artists for 20 years now and it's always been the same but I really like it.

"The thing is, I don't know a lot about the technical side of producing. I don't fiddle with the board at all. Obviously, the balance is what I want to hear and I just do it by ear. Whether it's so many decibels at so many kilohertz, I don't understand all that.

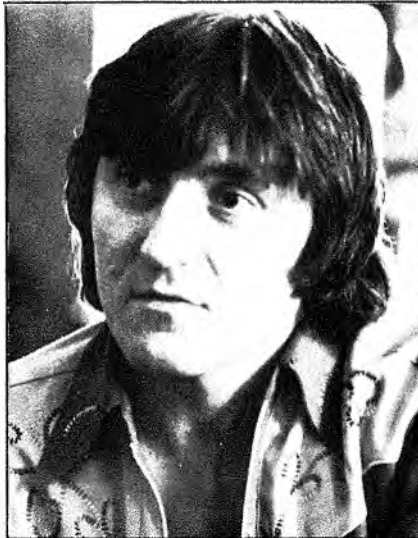

That's why it's so important to work with good engineers and we all work well together — there's no moodies and that's great. You know, when you're trying to create something, I don't think there's a lot of room for prima donnas. I often think of people like Gus Dudgeon and Alan Parsons — I would have liked to have been an engineer-turned-producer because then you know exactly how to get what you want. Sometimes you go into a strange studio with someone you don't know and you feel a bit helpless because you've only got your ears. I'd like to have done the engineering side of it for that reason."

With such an amazing background, I wondered why Bruce had never thought of getting into production before 1970.

"Well, I think the producer thing now is really a product of the Seventies. Before, it was people like George Martin, Norrie Paramor, Ron Richards that were the men in power. By power, I mean that they were the staff producers at the major labels like EMI, Decca, Pye and Philips in those days. They were always older men, they had already been in the business for about 20 years and we were

the young upstarts. It was also a different kind of job being a producer in those days. There's a lot more music around now and also a lot more record labels. The producer now is all-powerful. Some companies won't sign an act now without a producer of note because they don't want to waste their money. They don't want the kids going into the studio for three weeks and coming out with nothing. Really, the staff producer thing now has gone out of the window — unless it's middle-of-the-road."

Bruce's current project is the mixing and editing of tapes from the recent London Palladium shows, which will eventually come out as a live album early next year.

"I'm wading through lots of tape at the moment to see what we can use. It's obviously got to be tarted up a little bit — everybody does that. I don't know of any live albums that are straight live stuff. Tricks of the trade, we call them. I've been listening to a lot of other live albums to see what other producers have done, because it's the first time I've done an album with applause and chat. I've been doing things like trying to pick out the best applause! What went well and what didn't and snipping out bits here and there."

Bruce Welch has had his fair share of ups and down in 20 years but is still very much in love with the music business. Whatever he's doing, he puts his all into it. He is also, at times, disarmingly modest. He claims he almost wanted to give up playing guitar when he heard John Farrar for the first time and he claims he felt like giving up writing songs when he heard "Hotel California". He's also equally modest about his capabilities as a producer.

"I'm not an expert producer but I think I have good ears. You've got to have good ears to find the right songs. If you're producing people who don't write, it's all down to the producer to find the songs, then you have to do the obvious things like booking the studio and keeping the costs within the budget and just generally holding it together.

"The thing about being a producer is that if the record's a hit, it's the artist who's right and if it's a flop, it's always the producer who's wrong! I love doing it though. I love the whole business. I always think about the people stuck in factories and how awful it is and we're in a profession where we're lucky enough to do what we love doing and get paid for it."

# superb sound



**RB-120-115**  
120 Watt RMS Bass Amp

**RG-120-212**  
120 Watt RMS Guitar Amp

If you haven't tried a Randall Guitar or Bass Amp do yourself a favor and try one — compare it to any other amplifier. Treat yourself to the greatest sound around.

We produce amplifiers of all types, from 30 watts RMS to 500 watts RMS, P.A. mixers, electronic cross overs, rack mounted equipment, speaker enclosures and many effects items and accessories.

***Randall*** RANDALL INSTRUMENTS, INC.  
1132 DURYEA, IRVINE, CALIF. 92705  
P.O. BOX 10936, SANTA ANA, CALIF. 92711





## Five Good Reasons to Make Altec Lansing Your Choice for Sound Equipment.

We at Altec Lansing know what you need from your equipment. Great sound, sure, but even more than that you need dependability. Night-after-night performance that you can count on.

To make sure that you get everything you need out of our equipment, we put some of the best brains in the industry into every product we make. Designers, engineers and technicians. All working to fill your needs in professional, high-quality sound products.

Altec Lansing. The dependable performers for over forty years. And our people won't have it any other way.

For further information on Altec's new line of portable sound reinforcement speaker systems, contact the Altec Lansing office nearest you:

#### Europe

Altec Sound Products, Ltd.  
17 Park Place  
Stevenage, Hertfordshire  
SG1 1DU, England  
Tel: 0438-3241  
Telex: 825495

#### U.S.A.

Altec Lansing International  
1515 S. Manchester Ave.  
Anaheim, Calif. 92803  
Tel: (714) 774-2900  
Telex: 655415

#### Canada

Altec Lansing of Canada, Ltd.  
151 Carlingview Drive, No. 5  
Rexdale, Ontario  
Canada M9W 5E7  
Tel: (416) 675-1177  
Telex: 06-96 634



*The dependable performers from Altec Lansing.*



Altec Lansing International  
1515 S. Manchester Ave., Anaheim, CA 92803  
ALTEC CORPORATION

# AREVOLUTION HEARI

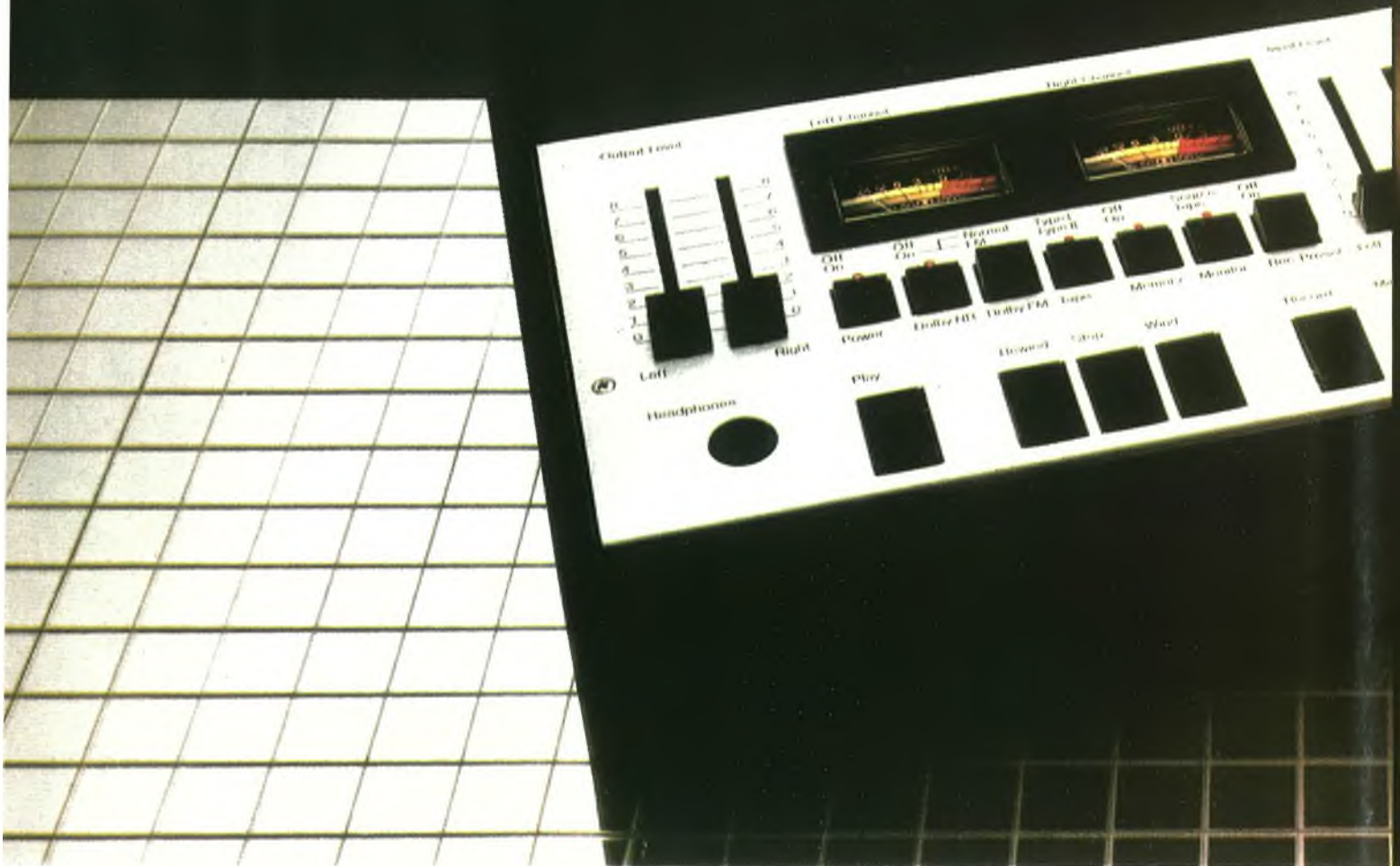

Tandberg's revolutionary Actilinear\* system, as in the new TCD 340A cassette deck and TD 20A reel-to-reel system, gives you superior recording quality comparable with that of any other current recording technology.

**Why the TCD 340A is the finest cassette deck you can buy.**

*From AUDIO magazine, July 1978.*

"With the development of the new recording system we have left behind and abandoned any form of compromise solution. The new design philosophy is based on the optimization of modules, that is, the whole chain is divided into natural functions, and each function by itself is realized as a module. Hence, a solution is obtained which is optimum on all points at the same time as a system is realized which is more amenable to adjustment to new types of magnetic tape."

Dr. Hermann Lia, Senior Engineer Dept. of Magnetic Research and Development at Tandberg.

Improvements compared to conventional

designs can be summarized as follows:

- 1.** More headroom in the recording amplifier (an improvement greater than 18dB), resulting in improved dynamic range.
- 2.** The recording circuitry operates at a Lower voltage level and will, therefore, give less intermodulation because of slew-rate limitations.
- 3.** An improved electrical separation between oscillator and recording amplifier which gives less interference with the oscillator.
- 4.** Substantially greater possibilities of adjusting the recording to new high-coercivity tapes such as the new metal particle tapes.

The Actilinear system is unique. It belongs solely to Tandberg, and world-wide patents have been taken out. Only Tandberg's Actilinear system will give you the cleaner, more realistic sound you get with a signal reserve of up to 20dB.

# ONARY NEW NG AID.

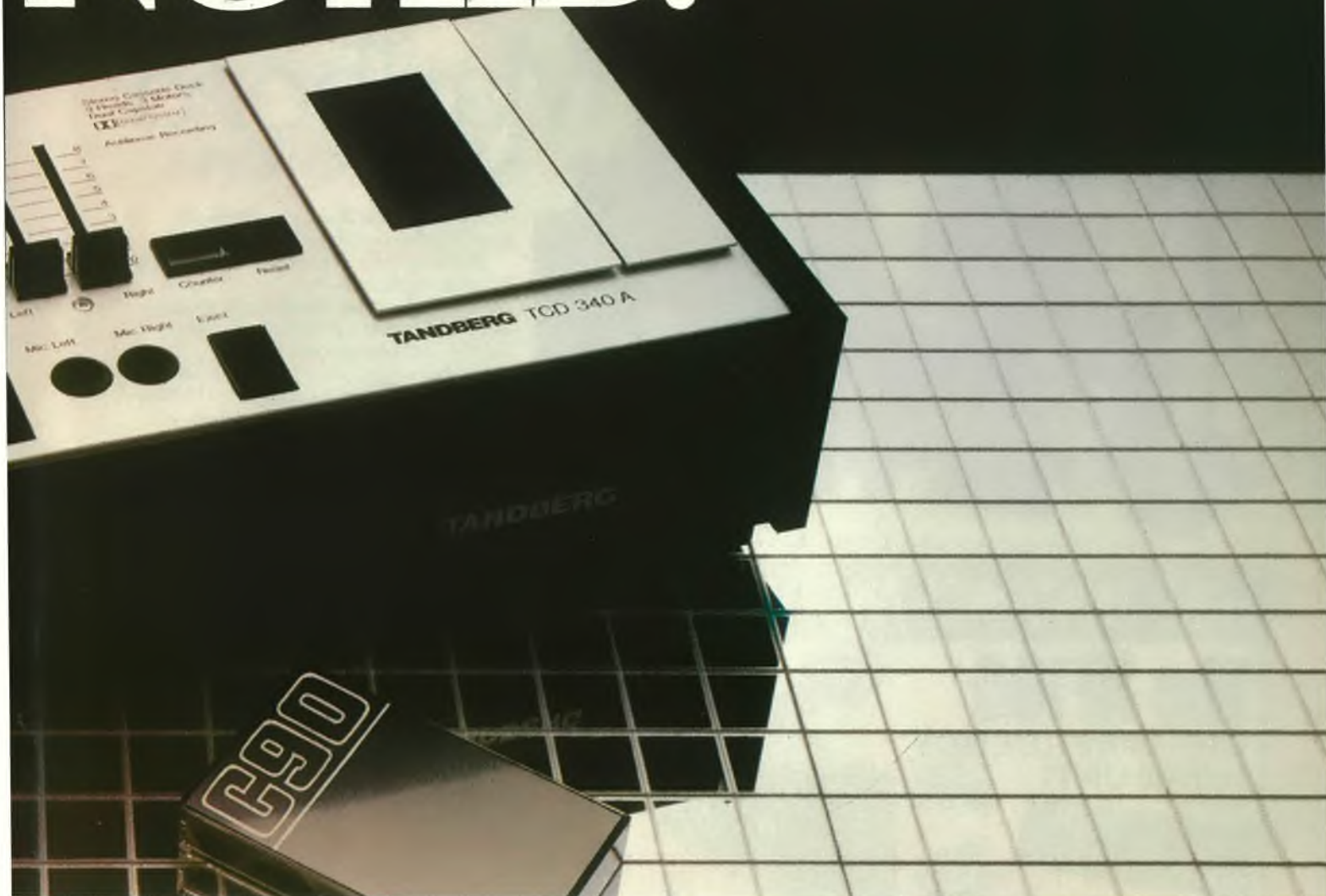

*Today's machine for tomorrow's tapes.*  
Cassette technology is surging ahead.  
Completely new high-coercivity tapes have already



been announced (metallic tapes) and should be on the market soon. Only the new Tandberg Actilinear

TCD 340A cassette deck, of machines already on the market, can be adapted to use these tapes.

Tandberg's equipment has, traditionally, been aimed almost exclusively at the serious home recording enthusiast; to use the word in its proper sense for once, the amateur - the 'lover'. The development of the Actilinear recording system has made the term even less meaningful: professional recording studios are already using Tandberg cassette and reel-to-reel decks at major recording sessions. We just try to make the finest recording equipment we possibly can.

For more detailed information on the new Tandberg Actilinear system and the whole hi-fi range, write to us at:

## TANDBERG

Tandberg (UK) Limited, 81 Kirkstall Road,  
Leeds LS3 1HR. Tel: (0532) 35111. \*Patents pending.

# We build equipment for musicians building careers.



Amps & Sound Systems from \$95 to \$550, Microphones from \$19 to \$132 (sugg. retail).

# Marlboro

SOUND WORKS

If you're serious about your music, it's time to get serious about your equipment.

Marlboro offers a complete line of amplifiers, sound systems, professional quality microphones, and speaker components, specially designed to cover a wide range of playing abilities...and paying abilities.

So whether you're just getting into music or just getting out on the road, test a Marlboro. After all, when you're building a career, you have to start with a sound foundation.

Send for our free catalog.

a division of  
Musical Instrument Corporation of America  
Dept. C, 170 Eileen Way, Syosset, N.Y. 11791

## FANE ANNOUNCE ANOTHER OUTSTANDING DEVELOPMENT

### The HF100

**HIGH FREQUENCY  
HORN UNIT**  
with a

Average  
Sensitivity  
104 d/b

**LIFETIME  
GUARANTEE**

Also  
available

**OVER 60**

**BASIC MODEL CHASSIS SPEAKERS**

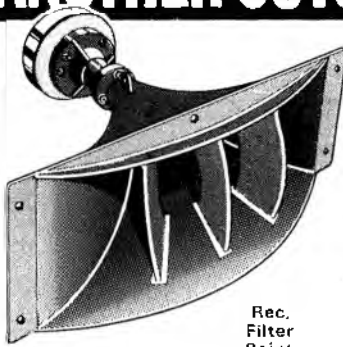

Rec Retail Price  
inc. V.A.T.

**DRIVE  
UNIT  
FLARED  
HORN**     **£33.00**

**FOR OUR ENGINEERS'  
ANSWER TO THE BEST  
WE COULD FIND**

**COMPARE THE HF100  
CURVE WITH THAT OF  
ANY SIMILAR UNIT  
currently available**

Rec.  
Filter  
Point

**USEFUL FREQUENCY  
RESPONSE**

1 KHz - 15 KHz  
**HORN CUT-OFF** 400 Hz  
**AVERAGE SOUND  
PRESSURE LEVEL**  
at 1 metre for 1 watt input  
104 db.

**INPUT IMPEDANCE**  
8 - 15 ohms

**POWER RATING**  
with 1,200 Hz Filter 100 watts

**DIMENSIONS**  
Drive Unit: Diam. 6" (Thread 1 1/2")  
Height overall 3.375"  
Horn Flare: Overall width 17"  
Overall height 8.7"

**WEIGHTS:**

Drive Unit 10lbs (4.5 Kg)  
Horn 8lb 4oz (3.9 Kg)

**'CROSS-OVERS'**

**HPX3A** High Pass Filter  
1200 Hz

**HPX3B** Low Pass Filter to be  
used only with HPX3A  
where FULL cross-  
over at 1,200 Hz is  
required.

Rec. Retail Price     **£3.25** each  
inc. V.A.T.

**FANE HF100**  
HORN AND DRIVE  
UNIT ASSEMBLY

8 - 15 ohms  
1 DIV. = 2.5 db

Measured for 1 watt input  
at 1 metre under anechoic  
conditions.

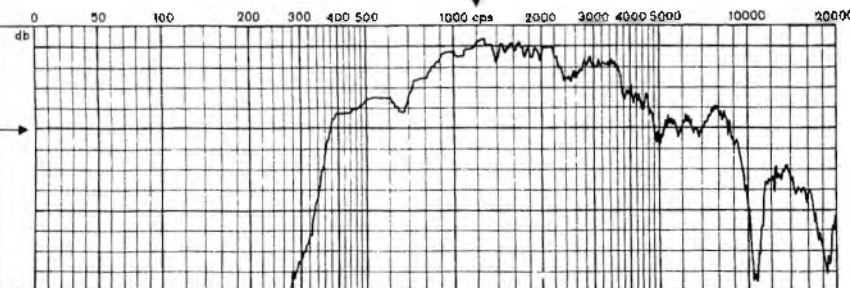

Manufacturers & Export Enquires to: **FANE ACOUSTICS LTD.**, Hick Lane, Batley, Yorkshire

Tel: 947 6431 Telex: Chamcom  
Hudds. 51458 for Fane

# FANE

**LEADING SUPPLIERS OF  
HIGH POWER SPEAKERS  
to the U.K. MUSIC INDUSTRY**

# THE SYNTHESIZER MAY BE A PRODUCT OF THE SPACE AGE BUT THIS ONE IS ALSO DOWN-TO-EARTH!

The variable synthesizer has finally released the keyboard musician to become a major creative force in contemporary music through its vast range of tonal possibilities, but the Scorpion with its carefully researched blend of live performance features, stands alone (among instruments littered with knobs and riddled with gimmicks) as the supreme example of straightforward musical engineering.

The most important thing you'll notice about the Scorpion is its understandable layout, designed to follow the natural progression of thoughts and ideas which form the basis of musical expression.

Apart from being easy to understand, the Scorpion is also very easy to play... you can be in full control and still have one hand free to play other instruments in your multi keyboard set-up thanks to features like keyboard pressure pitch bend, delayed modulation and the fact that the major variable controls are grouped within comfortable reach of the playing hand.

The Scorpion is really two synthesizers in one! As a variable synthesizer its 2 oscillators and full range of smooth-action controls give the freedom to experiment and the power to express music through your own ideas. Alternatively, at the touch of an electronic switch pad you can instantly and silently select one of the 8 accurately voiced presets.

The sounds which are so obviously important to today's top keyboard musicians are embodied in the Scorpion — we've simply made it easier for you to get them out!

## SCORPION Stage Synthesizer

— NOW GET LOST  
IN THE MUSIC —  
NOT THE CONTROLS!

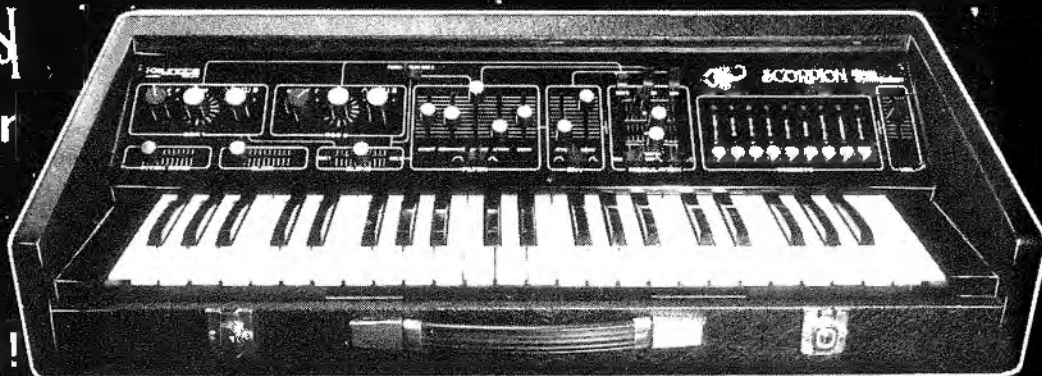

Keynote Musical Instruments Ltd., Head Office & Showroom: 563 High Road, Chiswick, London W.4. Tel: 01-994 2689

To an extent that no other stereo power amp in its price range can equal, the Peavey CS-400 is a totally versatile amplifier.

The CS-400 offers many features in terms of operation, engineering, and concept never before available.

Up front, the CS-400 features a rugged 5.25" x 19" rack mountable chassis with a steel reinforced, die cast panel for beauty and protection. LED overload indicators, level controls, line outputs, high temperature indicator, and lighted mains switch add to the amp's clean, functional design.

Inside, the CS-400 is an uncompromising fusion of modern, solid-state technology and quality components. 200 Watts per channel into 4 Ohms, less than 0.1% total harmonic distortion, with an extremely wide frequency response (+0, -1 dB 5 Hz to 40 kHz @ 1w, 4 Ohms) make some pretty impressive specs.

But there's a lot more to the CS-400 than raw power and impressive specs. What really makes the CS-400 so special is its versatile back panel and patching system that enable such accessories as input transformers,

crossover networks, and bi-amping possibilities using small interchangeable plug-in modules. With the CS-400's plug-in module system, our engineers have created a method to *fully utilize* all the performance capability of the amplifier.

Without this unique patch panel, our CS-400 would just be another great amplifier. With it, it'll be another standard for power amplifiers.

Get all the details at one of our selected audio dealers. He'll show you why incredible values are *still* a reality at Peavey.

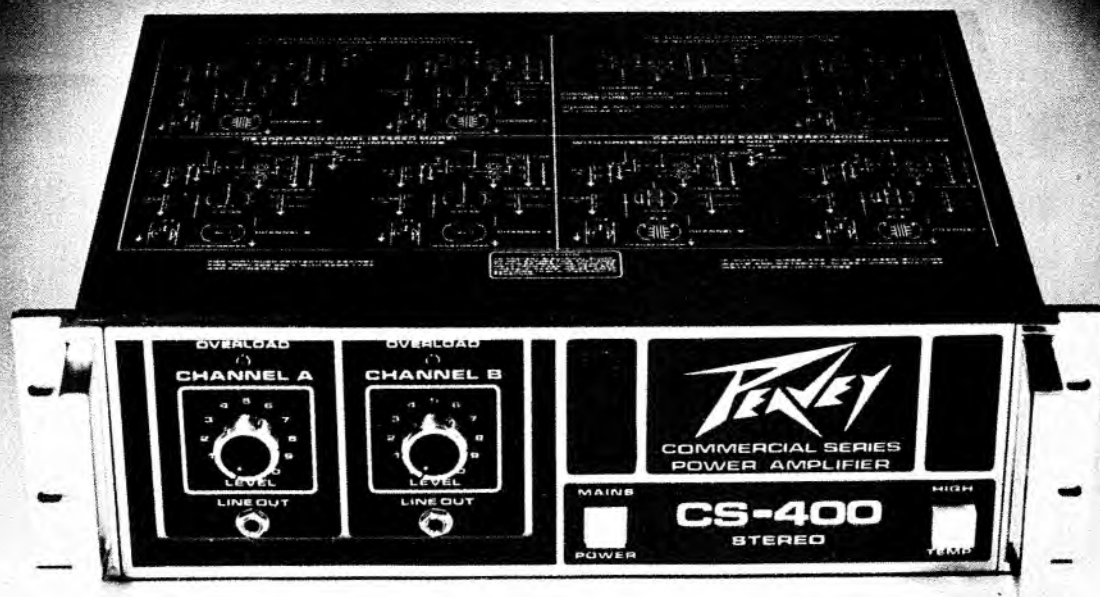

# The Peavey CS-400

**Power @ Clipping:**  
(1.0% THD, 1.0 kHz, 120 VAC Line)  
260 Watts RMS into 4 Ohms

**Total Harmonic Distortion:**  
Less than 0.1% from 20 mW to 200 Watts RMS  
20 Hz to 20 kHz into 4 Ohms, typically below 4 Ohms



**Intermodulation Distortion:**  
Less than 0.1% from 10 mW to 200 Watts RMS  
into 4 Ohms, typically below .05%

**Frequency Response:**  
+0, -1 dB, 5 Hz to 40 kHz (1 Watt, 4 Ohms)

© 1978 Peavey Electronics Corp. Meridian, Mississippi 39301

# CRUMAR<sup>®</sup>

*sound design for the creative musician*

## organizer T1

61 notes keyboard.  
9 Flute Harmonics drawbars  
4 organ Presets.  
9 Percussions + 2 special percussive effects  
(which add 2 different Key-click sounds).  
Percussion Decay and Volume controls.

Synthesizer Bass Section, operating  
on the first 24 notes (C - B) with Mode  
(Sustain/Percussive) - Footages  
(16' - 8' - 4') - Decay - Range - Resonance  
and Volume controls.

Modulation: Vibrato Depth - Tremolo Depth  
Vibrato and Tremolo Speed control.  
Pitch Bending: which gives the player  
a frequency transposition of 1/2 tone  
up or down.  
Weight: 25 Kg. (55 Lbs.)  
Dimension: cm. 97x45x20 (38"x17"x7")



## organizer T2

2 x 61 keyboards  
Upper Manual: 9 Flute Harmonics drawbars  
4 organ Presets  
9 Percussions + 2 special percussive effects  
(which add 2 different key-click sounds).  
Percussion Decay and Volume controls.  
Sustain - Auto Sustain +  
Sustain Length control.  
Lower Manual: 9 Flute Harmonics  
drawbars - 4 Organ Presets.

Synthesizer Bass Section operating  
on the first 24 notes of Lower Manual  
with Mode (Sustain/Percussive) -  
Footages (16' - 8' - 4') - Decay - Range  
Resonance and Volume controls.  
Modulation: Vibrato Depth - Tremolo  
Depth - Vibrato and Tremolo Speed control.  
Pitch Bending: which gives the player  
a frequency transposition of 1/2 tone  
up or down.

Pedal Board Unit: 18 notes, operating by  
means of the same Bass Section  
controls.  
Weight: Kg. 43 (Lbs. 94.6)  
Dimension: cm 106x57x25 (41"x22"x10")

DISTRIBUTED IN ENGLAND BY TREVOR DANIELS & CO.  
65 LANGDALE ROAD DUNSTABLE  
BEDS LU6 3BX TEL. 0582 - 600053





“tour first class”

For well over a decade Acoustic has been the choice of top touring bands. Why? Two big reasons, **PERFORMANCE & RELIABILITY**. Take the new Model 320/408 Concert Bass System, two channels for A/B switching or play them stereo. Acoustic's Graphic EQ is now footswitchable for added versatility. And, we've built our largest power section ever and designed the revolutionary 408 Bass Enclosure to match it. The 408's four powerful 15" bass drivers in Acoustic's unique

"Dual-Axis Bass Drive System" delivers twice the output of it's legendary predecessor, the Model 371. Or experience the incredible new Model 330/403 Lead Stack featuring Graphic EQ, Reverb, and Master Volume which can be assigned to either of the channels. As always Acoustic has used only the finest materials and construction techniques, and we continue to offer our exclusive Lifetime Protection Plan. So compare our performance, rely on our quality, and Tour First Class....

nobody was ever sorry

**acoustic**

... they bought the best.

professional sound equipment



# WHY DON'T YOU PUT YOUR GIG UP IN LIGHTS WITH PULSAR?

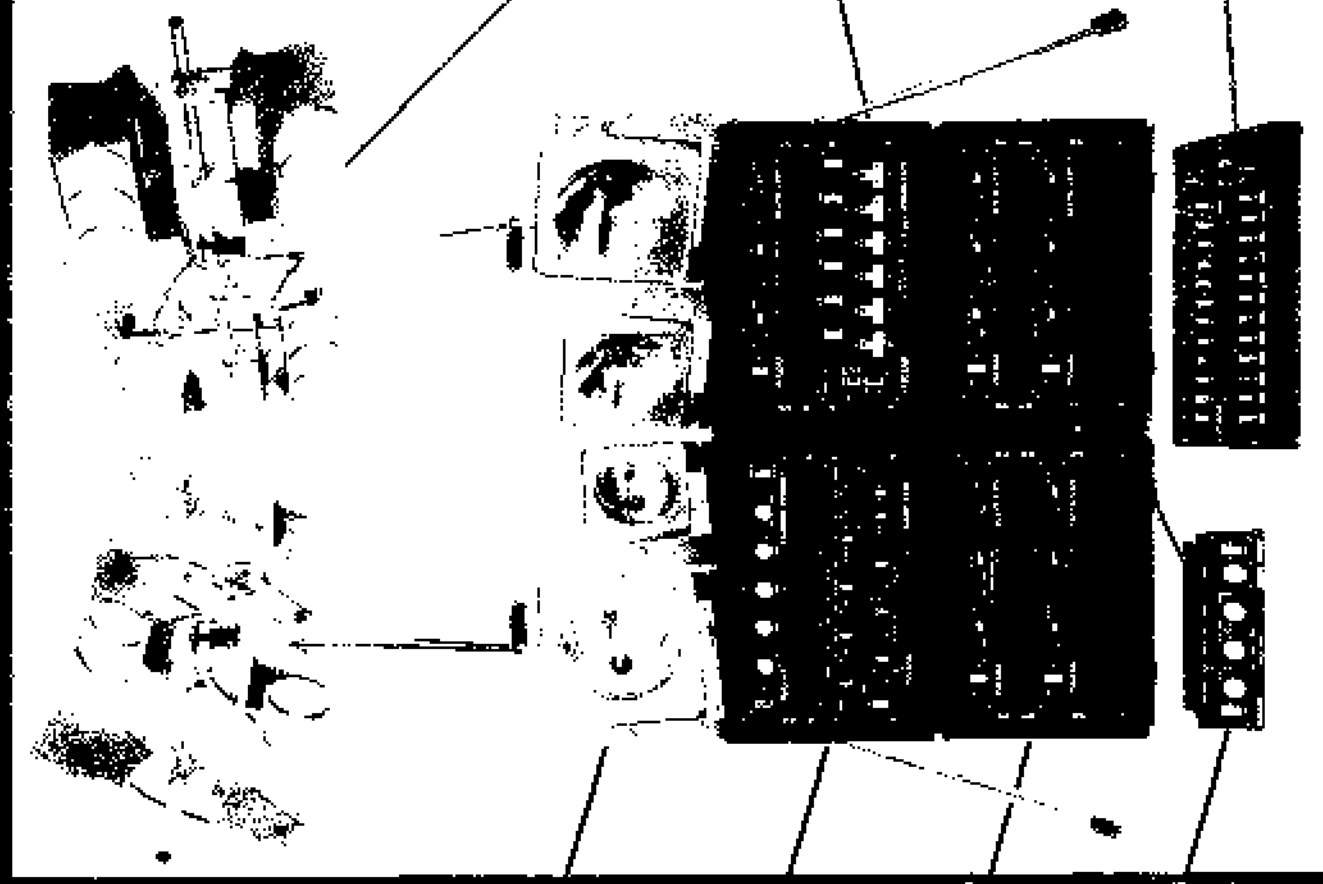

*Strobes*

*Modulator*

*Slave Units*

*Zero 3000  
Sound to Light*

*Trispots*

*12 Kw  
Dimmer Pack*

*12 Channel  
Control Desk*

We produce the finest range of stage lighting control systems available, that will give your gig the ultimate professional touch. A great deal of thought went into making our control systems easy to operate and all of our units shown above can be simply linked together to create exciting sounds to light effects.

Pulsar really does offer you something extra.



**CONTRER'S THE LIGHTING  
PROFESSIONALS USE!**

Pulsar Light of Cambridge Limited  
Hemley Road, Cambridge, CB1 3EA  
Tel. (0223) 667398



In their search for perfection, Yamaha constructed and tested hundreds of prototype drum kits, listened to opinions, then formed their own before arriving at the right techniques and materials which form the basis of a revolutionary new drum collection.

The result of their labours is a completely interchangeable drum system comprising two drum types, the YD9000 and 7000 series, making every kit unique. As varied as the sounds they make are the colours of the kits, two standard with others available on request.

It's been a hard slog, but nothing beautiful comes easy.

 **YAMAHA**  
Craftsmen to the world's  
musicians since 1887.

*Kemble/Yamaha, Mount Avenue, Bletchley, Milton Keynes Telephone 0908 71771*

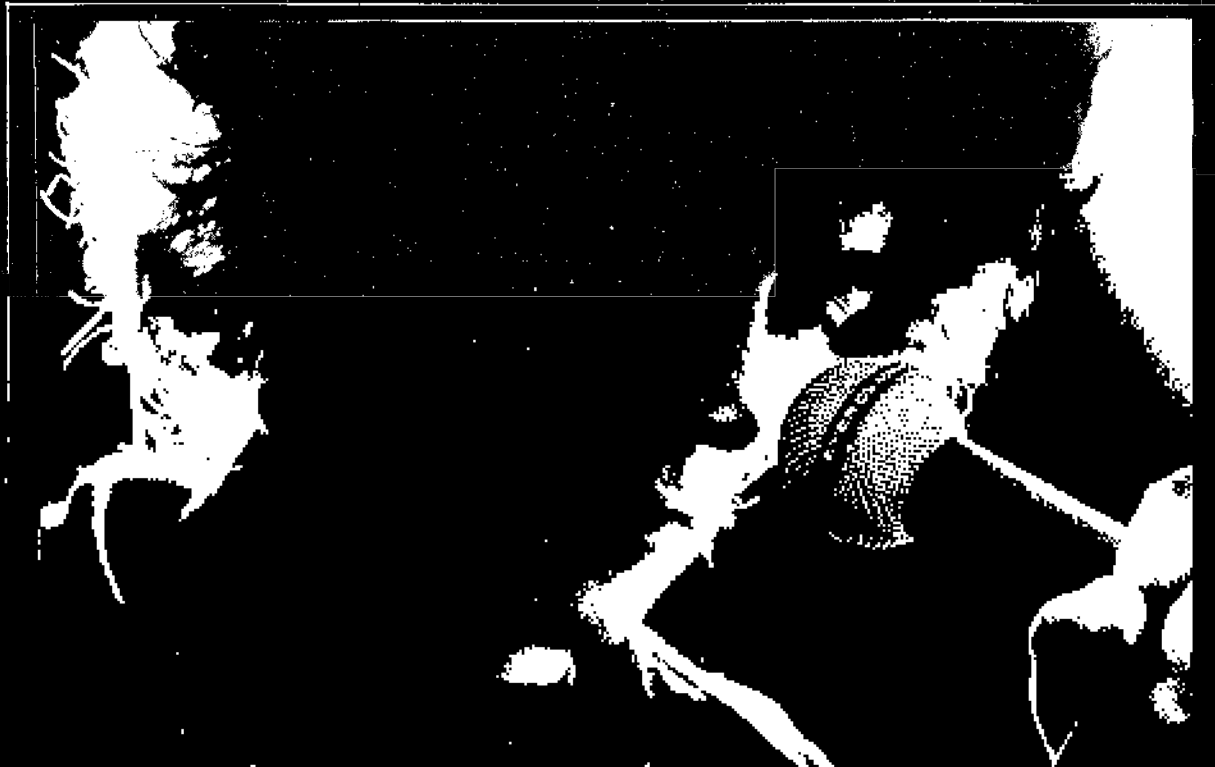

The microphone is the most important link for most singers. They will gladly spend hundreds of pounds on amplification, but far too little consideration goes into the choice of their microphones. The mike is where the whole sound starts, get that right and everything else follows. Get that wrong and you can have a £10,000 P.A. system and your sound will still be bad.

The new Beyer Dynamic M260NS (illustrated) has been designed with you in mind — a four stage filter for close operating performers, a high stability protection basket, an easy to operate on/off switch. Complete with accessories and carry case. Beyer Dynamic is just about the oldest and most experienced mike company in the business, but the design and marketing team is young enough to know just what today's music needs. That's how Beyer Dynamic mikes can improve the chain — then it is up to you!

Ask your Beyer Dynamic dealer for a demonstration. Send now for our 1977/78 brochure, illustrating the full range of microphones, headphones, infra-red listening systems, etc.

## THE NEW MOST IMPORTANT Link

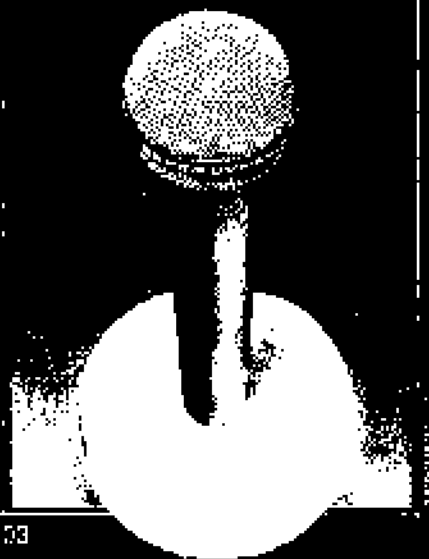

**BEYER DYNAMIC**

1 Clair Road, Haywards Heath, Sussex. Tel: 01253

To Beyer Dynamic, 1 Clair Road, Haywards Heath, Sussex.

Please rush me details of the Beyer Dynamic microphones/headphones/infra-red listening system etc.

Name \_\_\_\_\_ Address \_\_\_\_\_

\_\_\_\_\_

\_\_\_\_\_



**KORG Guitar Tuner  
GT-6**

**See The  
Correct Pitch**

The days of guess work in guitar tuning are over. Whether you play a classical, folk or electric guitar, the compact, battery-operated KORG Guitar Tuner GT-6 permits visual tuning of individual strings and is also adaptable to string bass.

This scientifically-designed tuning instrument assures optimum precision in pitch measurement. Why be less than sure

when the GT-6 can give you increased confidence in your playing. Open-string pitch readings can be taken directly through built-in microphone. Can also be inserted between electric guitar and amp to hear pitch while tuning, and if you don't need to hear the sound, you can see correct pitch in silence. Why guess? KORG Guitar Tuner GT-6 can give you the correct pitch, simply and precisely.

**KORG Tuning Standard WT-10A**  
(Elder Brother of GT-6)



**KORG Guitar Tuner  
GT-6 Specifications**

**NOTES** E(82.41 Hz) A(110.00 Hz)  
D(146.83 Hz) G(196.00 Hz)  
B(246.94 Hz) E(329.63 Hz) MEASUREMENT RANGE 2-octaves above and 1-octave below each position.  
**ACCURACY** ±3 cents **DIMENSIONS** 143(D) × 86(W) × 43(H) mm  
**WEIGHT** 275 grm **BATTERY** 006P 9V x1



ERIKSON MUSIC REG'D. 7750 Trans Canada Hwy. St. Laurent, Que., H4T1A5, CANADA  
GAMME 17, Rue Laperous, 93500 Pantin, FRANCE  
G. MEYER KG. 3550 Marburg 1 WEST GERMANY  
MILESTONE B.V. Energieweg 36 Vlaardingen, HOLLAND  
ROSE MORRIS & CO. LTD. 32, Gordon House Road, London NW5 1NE ENGLAND  
UNICORD, INC. 75 Frost Street, Westbury, New York, N.Y. 11590 USA  
KEIO ELECTRONIC LABORATORY CORP., Tokyo, Japan

**JBL PROFESSIONAL DEALERS  
IN THE U.K.**



**FORMULA SOUND  
LIMITED**

FORMULA SOUND LIMITED  
3 Waterloo Road  
Stockport Cheshire  
Telephone 061-480 3781

**GRAHAMS**

Graham's Electrical  
86/88 Pentonville Road  
London N1  
Telephone 01-837 4412



P. A. Hire & Sales  
Unit F New Crescent Works  
Nicol Road  
London NW10 9AX  
Telephone 01-961 3295

**SIGMA SOUND ENTERPRISES**

Rear of Works  
128 Hartley Road  
Radford  
Nottingham  
Telephone 73306

**soundwave**

66 Victoria Road  
Romford  
Essex  
Telephone 0708 25919

**REW**

REW Audio Visual  
126 Charing Cross Rd.  
London WC2  
Telephone 01-836 2372/7851



PROFESSIONAL AUDIO SYSTEMS  
50 Dennington Park Road  
West Hampstead  
London NW6  
Tel. 01-435 0532

For further information contact  
Harman (Audio) U.K. Ltd.

St. John's Road  
Tylers Green  
High Wycombe  
Bucks HP10 8HR  
Telephone  
0494-815221



**GET IT ALL**

# 200,000 PEOPLE. ONE SPEAKER.

Go to almost any major outdoor rock concert and you'll find three things. Lots of music. Lots of people. And lots of JBL.

Those giant towers of sound, some containing as many as 1200 loudspeakers, require the very finest equipment. And that's why JBL is used more than any other brand for large, outdoor events.

Of course, if you've got a slightly smaller sound requirement—say a board room, discotheque,

church or recording studio—we can handle that, too. With the same famous JBL integrity.

We've been making components and electronics for quality sound reinforcement systems for over 30 years now.

And we've gotten quite good at it.

Call or write us. We'll send you information on our full line of products, and put you in touch with your JBL Engineered Sound Systems Contractor.



**JBL**  
GET IT ALL.

James B. Lansing Sound, Inc. / Professional Division, 8500 Balboa Boulevard, Northridge, California, U.S.A.

# UNDERSTANDING SYNTHESIZERS

## Introduction

Last month I explained how the continuous oscillations produced by the synthesizer's audio-oscillators (VCOs) are split up into discrete notes by the voltage-controlled amplifier (VCA). This is a very important concept, so I am going to go over this point again before describing the VCA and ADSR module (envelope generator) in more detail.

Have a look at Fig. 1, and imagine that no key is depressed on the synthesizer keyboard. The VCO is oscillating and its voltage waveform is reaching the audio input of the VCA. The keyboard gate pulse is not present, so the output of the ADSR module is zero. Because this output is controlling the VCA gain, the VCA is effectively switched off and prevents the VCO's signal from reaching the power amplifier. Now, suppose a key was pressed down, then released. The keyboard voltage would change immediately to its new value and stay there (held by the keyboard memory). The keyboard would also produce a keyboard gate pulse which would stay "high" only as long as the key was depressed. This pulse would "trigger" the ADSR module, producing the ADSR waveform (shown in Fig. 1) once only. This waveform would increase the gain (amplification: see Part 6) of the VCA, and the VCO's signal would reach the power amplifier and speaker as long as the key was held down. So by their combined efforts the keyboard gate pulse, the ADSR module and the VCA would produce a discrete "note" from the continuous train of oscillations generated by the VCO.

## Dynamics

You might well be wondering why we need an ADSR module at all. If the keyboard gate pulse was fed direct to the control voltage input of the VCA, wouldn't that have the same effect? The answer is yes, it certainly would work, but it wouldn't sound too good. Every note would start very suddenly (with an audible "click"), because the keyboard gate pulse takes virtually no time at all (perhaps 1 millionth of a second — or 1 microsecond) to go from zero to its high level. While the key was held down, the VCA gain would be constant (the loudness of the note would not change) then very suddenly, when the key was released, the note would stop.

In reality, no note just suddenly starts and then stops dead. Within the duration of a note played on any acoustic instru-

ment a number of "phases" can be identified, and the loudness (and actually the tone quality) of the note varies throughout the phases. "Dynamics" is a general term used to describe variations in loudness, either over long time intervals (such as the duration of a composition) or short time intervals (such as the duration of one note). The ADSR module produces these short-term dynamics by generating a voltage waveform which varies in amplitude while a key is depressed (see Fig. 1), continuously altering the gain of the VCA as it does so.

## AR Module

The bare minimum of control over note dynamics is provided by a module known as an "AR module" (AR stands for Attack-Release) and although it is not as versatile as the ADSR module described below, it acts as a useful introduction to the latter.

In an AR module two *times* are under the player's control. Have a look at Fig. 2, which shows the voltage waveform produced at the AR module's output. The first is the attack time which determines how long the waveform takes to reach its highest value. Having reached a maximum (say 10 volts as shown), the voltage does not change until the key is released. The second time interval which is under the player's control is the release time, which is the time it takes the waveform to fall to zero after the key is released. In terms of the "phases"

referred to earlier, this waveform has an "attack phase", a "sustain phase" (within which the AR module produces a fixed voltage) and a "release phase". In practical terms, the attack and release phases may be anything from 1/1000th second (1 millisecond) to 10 seconds long, depending on the settings of the "A" and "R" sliders on the synthesizer front panel.

Fig. 3 shows various AR waveforms which might be used in synthesizing instrumental sounds. Note that if a key is released *before* the end of the attack phase, the AR waveform does not reach its peak value.

## ADSR Module

Whereas an AR waveform has three phases, the ADSR module generates a waveform with four phases (Attack-Decay-Sustain-Release) and in addition provides manual control over the voltage which will be maintained as long as the key is held down.

The ADSR waveform is shown in Fig. 4. The new phase is called the "decay phase" which follows immediately after the attack phase, and the new "S" control, active in the sustain phase, is called the sustain level (see Fig. 4). It is very important to realise that the "A", "D" and "R" sliders control *times* (the durations of the attack, decay and release phases) but that the "S" slider controls the *voltage level* during the sustain phase (the duration of the sustain phase of

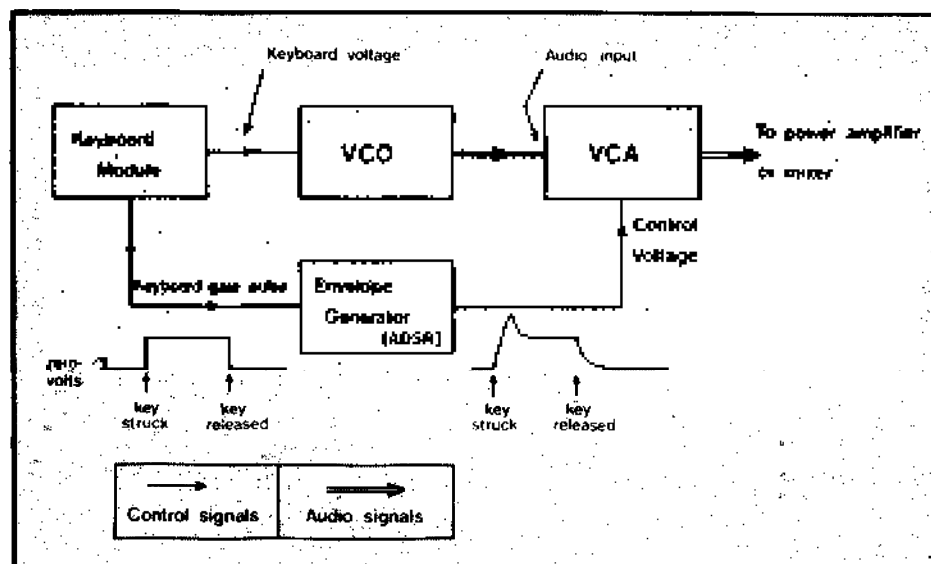

Fig. 1 A basic synthesizer. Every time a note is struck on the keyboard, the keyboard gate pulse triggers the ADSR module (envelope generator) which in turn produces an output which smoothly increases then decreases the gain of the VCA.

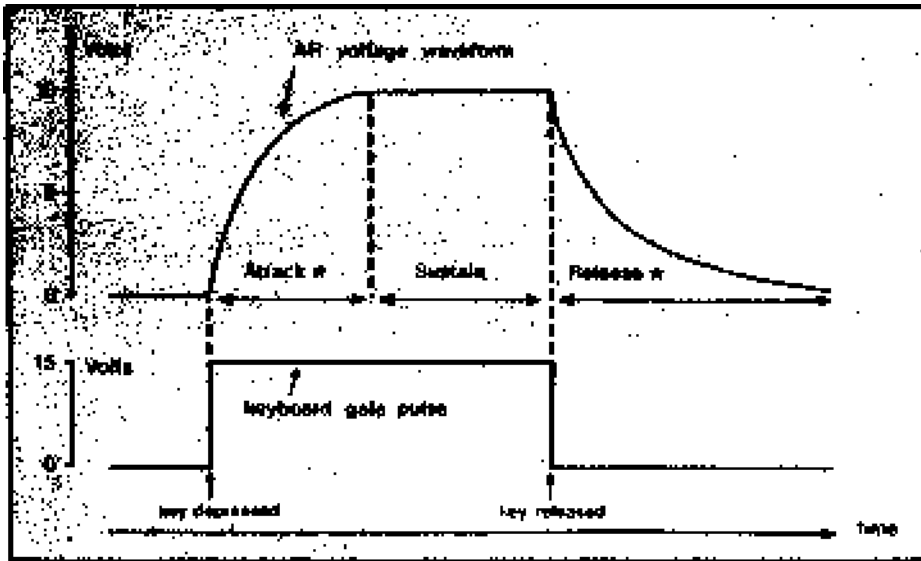

Fig. 2 Voltage waveform produced by an AR module showing the attack, sustain and release phases. The attack and release times (\*) can be varied.

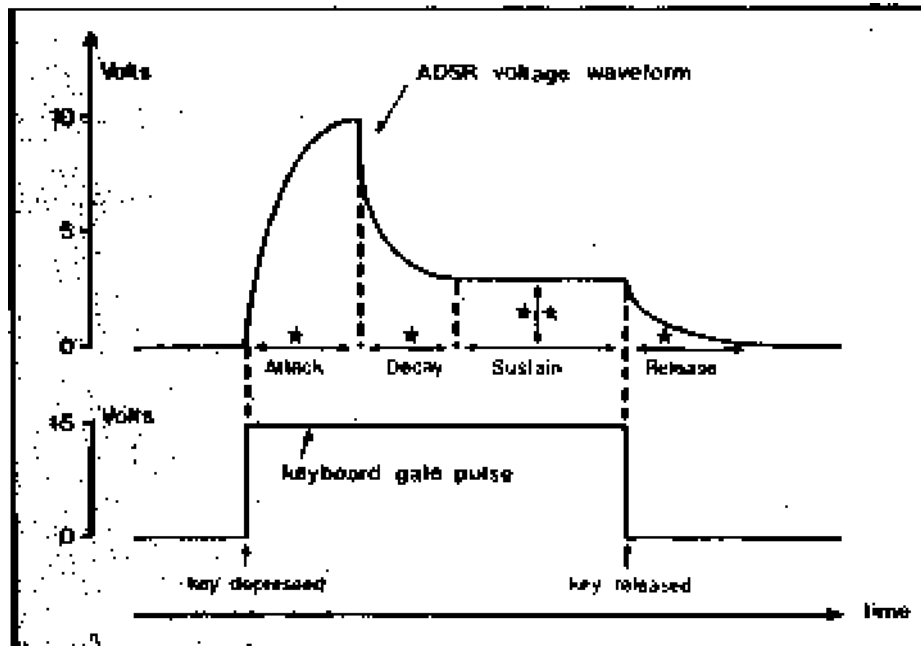

Fig. 4 Voltage waveform produced by an ADSR module showing the attack, decay, sustain and release phases. The attack, decay and release times (\*) and the sustain level (\*\*) can be varied.

course varies from note to note).

At first all this may seem confusing, particularly so because the usual design of ADSR sliders produces a misleading pattern which bears little resemblance to the resulting ADSR waveform. However, the sounds synthesized by an ADSR/VCA combination are much more interesting and varied than those produced by an AR/VCA combination. One of the main reasons for this lies in the ability of the ADSR modules to produce a "spike" during its attack and decay phases (see Fig. 5) before it settles to its sustain level. This feature enables percussive sounds to be generated and also (when used with the filter) enables "attack transients" to be generated if the attack and decay times are very short. These very fast changes in

loudness and sound quality which occur at the start of a note are extremely important in determining the perceived sound quality even during a long sustain phase. We remember what happens at the start of a sound and attach great importance to the attack transients, even though the attack and decay phases may together represent only a very small fraction of the total duration of the sound.

#### VCA Module

You are already familiar with the general idea of how a voltage-controlled amplifier works; the higher the control voltage the greater the amplification (or gain) of the amplifier. In Part 4, I showed a diagram in which the frequency of a

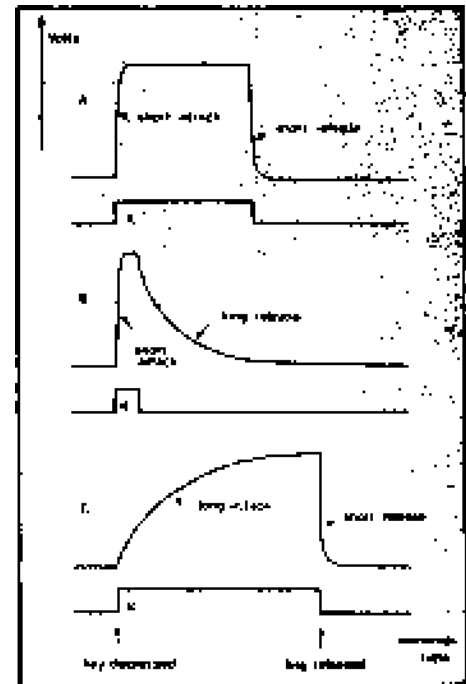

Fig. 5 Examples of AR waveforms with keyboard gate pulses (K). (a) Short attack and release times: produces a rather dry sound, like an electronic organ (without reverberation). (b) Short attack and long release times: tapping the keys so that the sustain phase is short produces pleasant sounds which die away slowly. (c) Long attack and short release times: produces an unusual effects, the sound taking a long time to grow to its maximum loudness, then suddenly disappearing.

VCO was related to the control voltage – usually for each 1 volt step in control voltage the pitch of the oscillator moves one octave. In the same way it is possible to show how the VCA gain changes with its control voltage, as in Fig. 6. For the particular VCA illustrated there, the VCA amplification increases by about 0.1 for each 1 volt increase in control voltage.

The control voltage which reaches the heart of the VCA module is actually the sum of control voltages from a number of possible sources, analogous to the control voltage mixing shown for the VCO in Part 5. Fig. 7 illustrates this idea with control voltages coming from the ADSR module, LFO and a slider called "Hold" or "Initial Gain". The slider (amplitude control) between the ADSR and the VCA simply controls the overall amplitude of the ADSR waveform, and effectively acts as a synthesizer volume control. The Hold or Initial Gain slider presents an adjustable voltage which again is added to the ADSR waveform. With this control at any position other than zero, the VCA always lets some audio signal through; the VCO waveform is never completely blocked and all notes are held indefinitely.

The slider between the LFO and the VCA alters the amount of LFO waveform▶▶

# EVERYBODY'S GETTING BEHIND BGW

## Even Crown and Yamaha



	POWER* @ 8 OHMS	HEATSINKS, COOLING SYSTEM, TOTAL # OF OUTPUT TRANSISTORS	SPEAKER PROTECTION	MAINS (AC) PROTECTION	CONSTRUCTION DESIGN	TURN-ON DELAY	CIRCUITRY	T.H.D.	PRICE**	YEAR INTRODUCED		
BGW 750 B/C	225 Watts/ch.	360 Watts/ch	20	Forced air cooling for 2 massive removable modules	Active arc-interrupting circuitry	Front panel magnetic circuit breaker	Modular all Teflon wiring	Relay operated transient delay circuitry	Full complimentary	0.02%	\$ 999 — Model 750C \$1099 — Model 750B	1978
CROWN DC300A	155 Watts/ch.	NO FTC RATING	16	Passive airflow only	None provided	Rear panel fuse only	Hard-wired, non-modular	None	Quasi-complimentary	Not specified*	\$ 919 ***	1974
YAMAHA P2200	200 Watts/ch.	NO FTC RATING	12	Passive airflow only	None provided	Rear panel fuse only	Hard-wired, non-modular	None	Full complimentary	Not specified*	\$1095	1976

Here they are — The big guns of professional amplification: The respected Crown DC300A, The cosmetically impressive Yamaha P2200, And BGW's new, no-nonsense 750B/C.

Top of-the-line professional power amplifiers from the industry's most respected manufacturers. All boasting impressive reputations. All costing about \$1,000.

The table reveals the specifications.\* You decide which one is best.

### THE RELIABILITY FACTOR

Above all else, professional musicians and audio engineers want to know two things about their power amplifiers: How dependably they function under extreme conditions, and how well they interface with other components.

BGW's new 750 Series amplifiers have taken the lead in both areas. Twenty (20) output transistors as opposed to Crown's 16 and Yamaha's 12 provide a Safe Operating Area unmatched by either the DC300A or the P2200. While both Crown and Yamaha rely on passive "convection" cooling, the extensive heat sinks on BGW's pro amps are cooled by forced air for reliable, continuous performance even on the hottest outdoor concert stages. Unique new arc-interrupting circuitry protects speakers — not just the

amplifiers themselves — from catastrophic DC offset.

Like all BGW amplifiers, the 750B and C feature modular construction and front-panel circuit-breakers rather than hard wiring and cumbersome rear-panel fuses. The result: Maintenance is easier both onstage and in the studio — when time and tempers can be very short.

### CLARITY AND PRESENCE

Now that audible Harmonic and Intermodulation Distortion have been all but eliminated from professional power amplifiers, Transient Intermodulation Distortion (TIM) has become important. Neither Crown nor Yamaha specifies TIM levels whereas BGW's 750's Series are published with the greatest of pride. The 750B and C consequently produce clearer, warmer, and more open sound.

Pros will also appreciate another BGW exclusive: A delay circuit that eliminates all transient "thumps" when the 750B and C are activated. Neither Crown nor Yamaha has anything like it.

### POWER

This is where BGW really leaves the competition behind. While the Crown DC300A and the Yamaha P2200 are rated at

155 and 200 watts, respectively, BGW's 750B/C delivers a full 225 watts per channel into 8 ohms,\*\* leaving the competition behind entirely at 4 ohms, with a whopping 360 watts. Only BGW has FTC rated 4 ohm power specifications.

Both the DC300A and the P2200 are good power amplifiers by conventional standards. But real recording pros don't deal with convention.

They get behind BGW.  
Because the competition already is.

\*Based on manufacturers' published specifications and prices available 7/1/78.

\*\*BGW 750B/C FTC Specification: 225 watts minimum sine wave continuous average power output per channel with both channels driving 8 ohm loads over a power band from 20Hz to 20KHz. The maximum Total Harmonic Distortion at any power level from 250 milliwatts to 225 watts shall be no more than 0.1%.

\*\*\* Includes optional HMB-7 Handles (\$20.00, not shown)



Get Behind Us!

BGW Systems, INC.  
13130 S. Yukon Avenue  
Hawthorne, California 90250  
In Canada: Omnimedia Corp., 9653 Cote de Lesse  
Dorval, Quebec H9P 1A3



# UNDERSTANDING SYNTHESIZERS

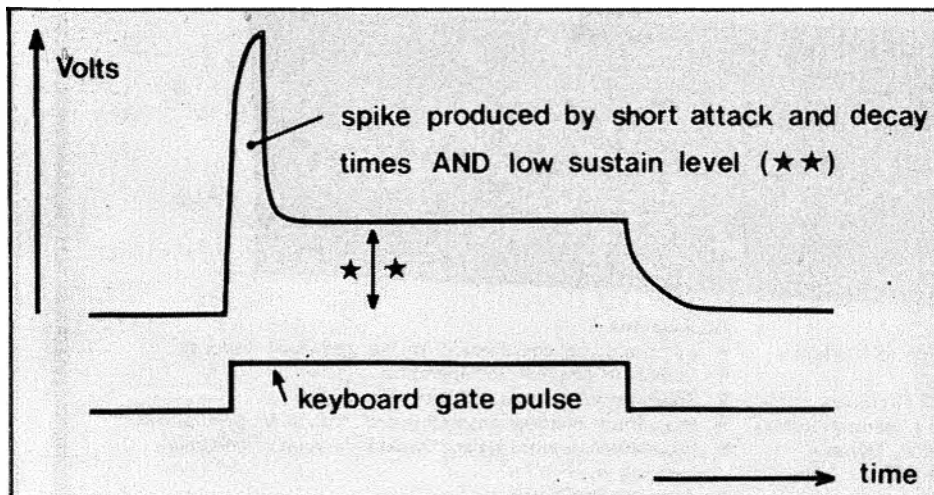

Fig. 5 ADSR waveform with short attack and decay times and low sustain level, used for synthesizing percussive sounds.

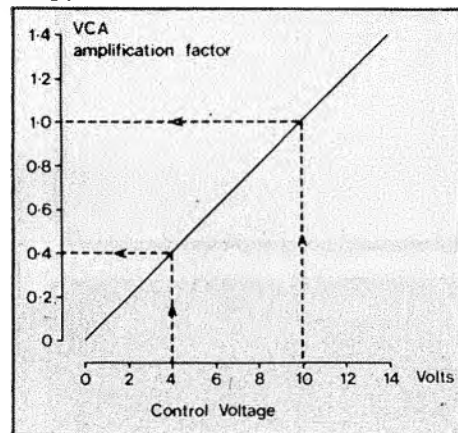

Fig. 6 Graph showing how the amplification of a VCA varies with control voltage. When the control voltage is 10 volts the gain (amplification factor) of this VCA is one (i.e. the output amplitude equals the input amplitude). At lower voltages the gain is proportionally less; e.g. if the control voltage is 4 volts, the output is only four tenths (0.4) of the input.

added to the ADSR waveform for the production of the tremolo effect (see Part 2). In synthesizers with only one VCA and without a ring modulator, adding the LFO's output to the ADSR waveform is the only way tremolo can be produced. However, tremolo is much better produced using two VCAs in series (one after the other) or using the ring modulator as I will be describing later in the series.

## LFO trigger for the ADSR module

There is an effect well known to organists as "repeat percussion" in which a rapid series of discrete notes of the same pitch is produced as long as a key is held down. The effect is used for imitating, for example, strummed mandolin, banjo, xylophone and marimba sounds. At first sight it might seem that

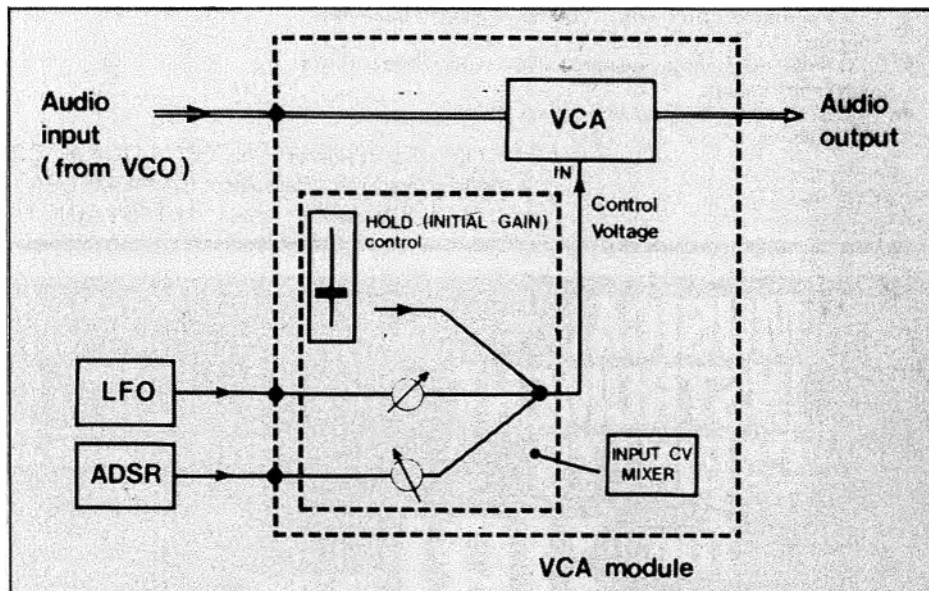

Fig. 7 Schematic diagram of a VCA module showing the control voltage mixer receiving inputs from the ADSR and LFO modules via amplitude controls and from the HOLD or INITIAL GAIN control

adding the sawtooth or square wave outputs of the LFO to the ADSR waveform (in the VCA's control voltage mixer) would produce this repeating effect. However with a little thought you will realise that even when the ADSR's waveform had decayed to zero, the LFO's waveform would periodically cause the VCA to pass on the VCO's signal – the train of notes would never stop.

The way synthesizer designers have got round this problem is fairly simple: They provide a switch which routes the square waveform of the LFO to the input of the ADSR module (instead of the keyboard gate pulse). Every time the LFO waveform goes from zero to its maximum (see Fig. 8), the ADSR is triggered. There is one proviso, which is that repeated triggering is allowed only when the keyboard gate pulse is present

— i.e. when a key is depressed. From the player's point of view, while a key is held down a repeated chain of notes is produced with a repetition rate governed by the LFO frequency control. In this situation the ADSR controls determine the characteristics of every note in the chain, so some care is needed in setting up the ADSR. If the LFO is set at a relatively high frequency (say 10 Hz) and the attack time is long, the results will be disappointing, if not inaudible!

Next month I will be introducing the voltage-controlled filter (VCF) and showing how the ADSR waveform can be used to vary the tone quality during a note as well as the amplitude.

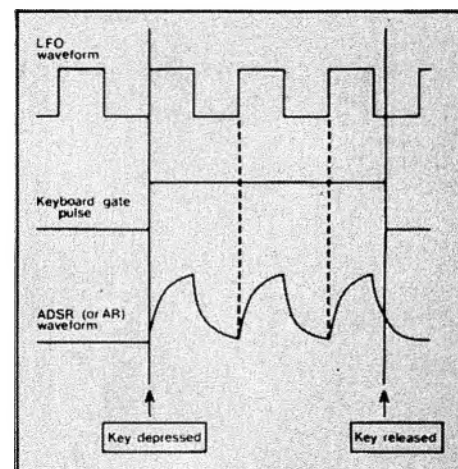

Fig. 8 Production of repeated notes by using the LFO's square waveform to trigger the ADSR module. The repeated triggering only occurs when the keyboard gate pulse is present i.e. a key is depressed.

# adi 1500

## automatic graphic equaliser



### Features

- Fast, simple, and extremely accurate equalisation to  $\pm 0.75$ db using easy-to-read red and green LED indicators
- Economical self-contained Auto-EQ (pat pend.) circuitry
- Double-tuned, minimal phase-shift, monolithic IC saturation-free active filters on standard ISO centres (leaves older "gyrator" design undesirable due to distortion and saturation)
- Low-noise with super-wide dynamic range
- Precision pink-noise generator
- Time-delay circuit for noiseless operation
- Full spectrum controls with  $\pm 12$ dB boost and cut input level controls
- Low-noise, hydraulically-damped, silver-contact slide controls with centre detent
- Highest quality ADI deign with rugged 19" rack mount construction

### Applications

- Environmental equalisation for flat frequency response
- Utmost in simplicity of operation
- Speediest solution to feedback elimination
- Programme material processing and frequency optimisation
- Programme monitoring and visual indication of feedback frequencies
- Acoustic level balancing
- Elimination of all peripheral test gear

AUDIO DEVELOPMENTS INTERNATIONAL CORP.  
644 Emerson St., Palo Alto, CA 94301 USA  
tel: (415) 321-3035 telex: 470 464 ADIC UI

## MUSICAL INSTRUMENT CABINETS

for **JBL** SPEAKERS

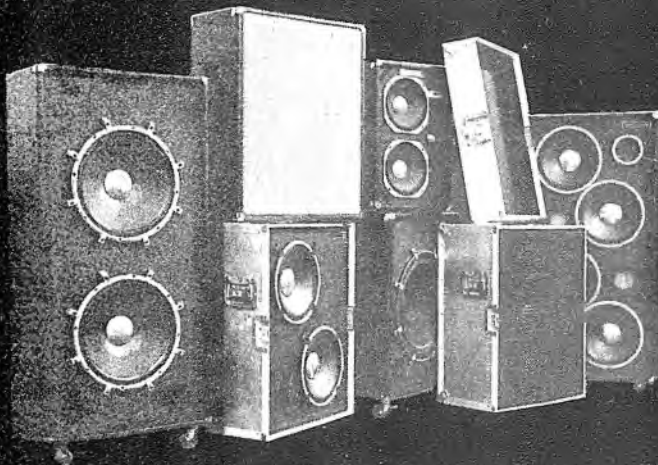

- **CABINETS AVAILABLE:**  
2 x 10; 1 x 12; 2 x 12; 4 x 12; 1 x 15;  
2 x 15; 1 x 18; 2 x 18.
- All cabinets available with Heavy Duty Vinyl covering or Aluminium clad flight case with lid.
- All cabinets may be fitted with optional high frequency units to extend the frequency range to 12 or 15KHz utilizing a 3KHz passive crossover.

### W-HORN FOR JBL K151 18" DRIVER

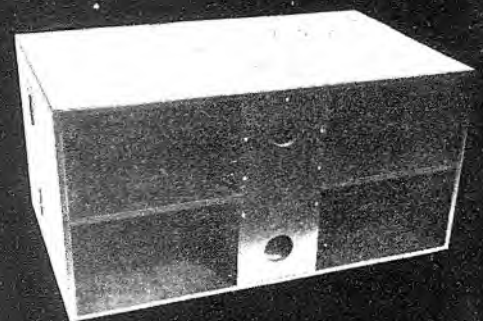

Manufactured to JBL specifications  
under licence.

TRADE  
ENQUIRIES  
INVITED

FOR FURTHER DETAILS CONTACT

**A R WILMSHURST LTD**

66 VICTORIA ROAD-ROMFORD-ESSEX-ENGLAND  
TELEPHONE: ROMFORD (0708) 25919

# SENNHEISER

*profipower* = the

*musicians*

*microphone*

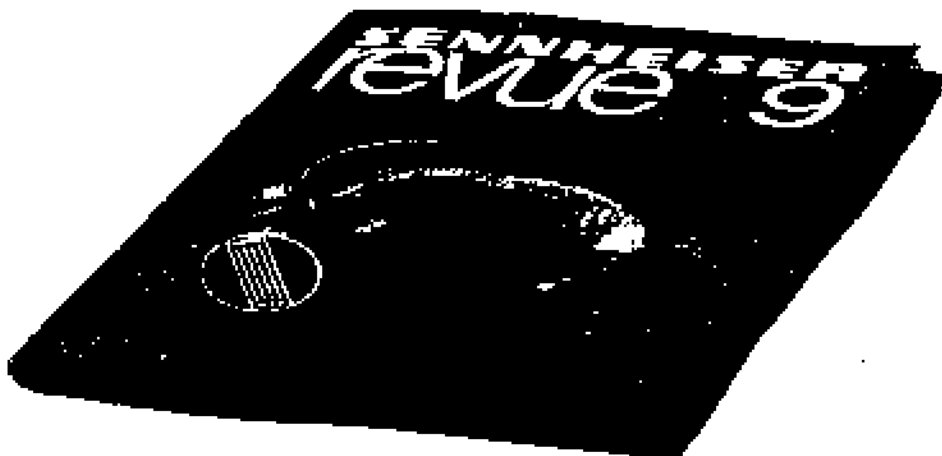

This newly developed microphone is Sennheiser's answer to many of the problems performers of popular music encounter. Considerable efforts were necessary to find the best solution for the various demands put by professional musicians. The result was "profipower" – beyond doubt a microphone in a class of its own.

To find out more about this exciting new development and the full range of Sennheiser microphones, complete the coupon below. We will then send you a free copy of the recently published Micro Revue 9 – a 124 page catalogue packed full of information on all Sennheiser products.

**Hayden Laboratories Limited**



HAYDEN HOUSE, CHURCHFIELD ROAD,  
CHALFONT ST. PETER, BUCKS, SL9 9EW  
Telephone: Gerrards Cross (02813) 88447

Please send me a free copy of the Sennheiser Micro Revue 9  
Name .....  
Address .....

Code 1111778

# CANARY

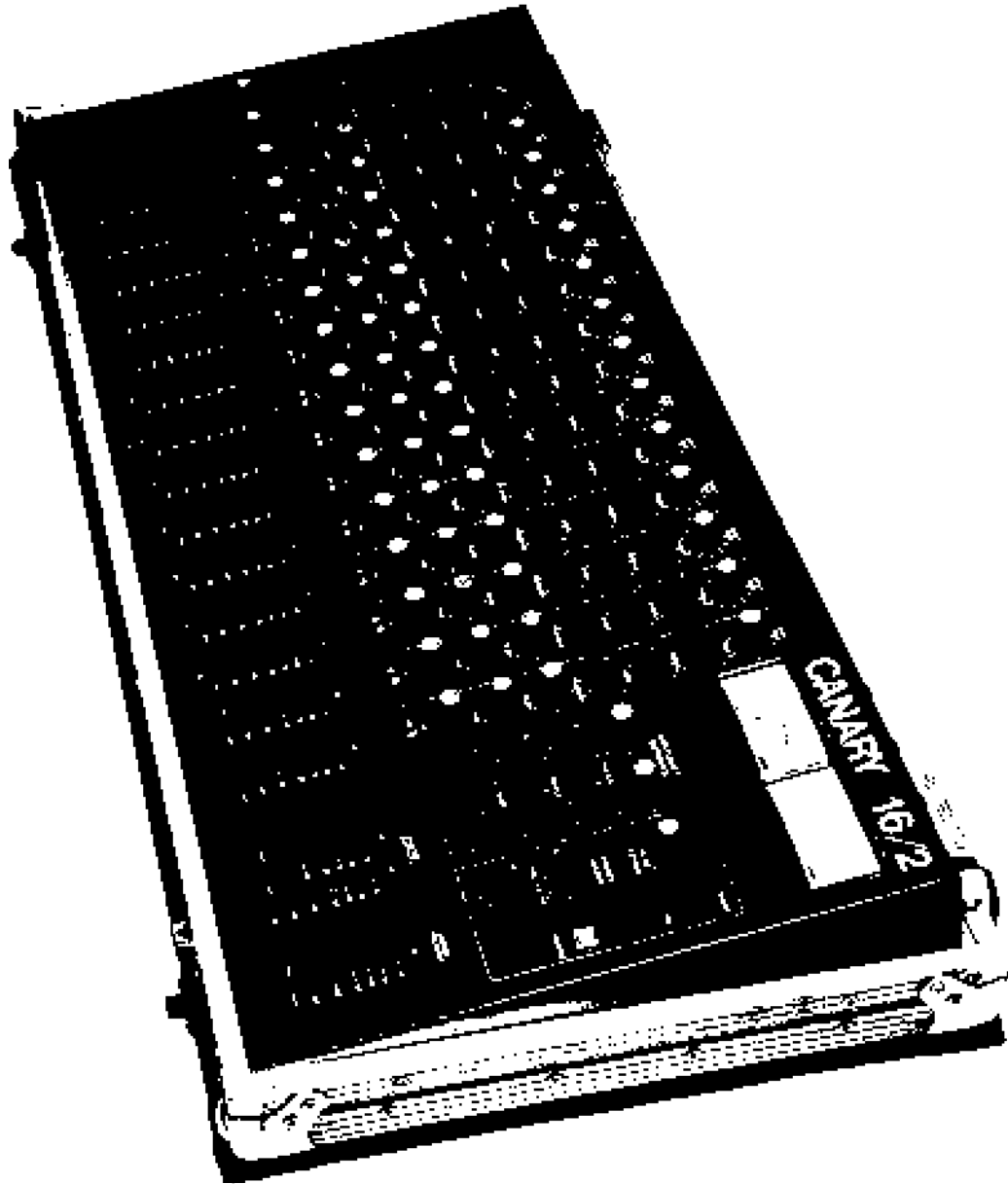

## CANARY TAKES FLIGHT

“MIX IT WITH CANARY”

Manufactured by:  
**Canary Mixing Desks Ltd:** 17 West Hill, Wandsworth, London SW18 1RB England · Telephone: 01-870 7722  
Cables and Telegrams: Canarymix Wandsworth SW18

Distributed by:  
**Mick Johnson Music:** 277 Putney Bridge Road, London SW15 · Telephone: 01-788 3491

# Small Things

## Stephen Delft ruminates on exhibitions...

I understand that the British Annual Music Trade Show is scheduled for London's Olympia next year and is to be open to the public on certain days. I am entirely in favour of public exhibitions of musical instruments and ancillary equipment, if they are properly organised and well presented. As the range of products is now so much greater than any one shop could possibly hold in stock, it seems an excellent idea to exhibit everyone's new products in the same place at the same time.

However, I am *not* in favour of combining public and trade exhibitions. In particular, I do not relish the prospect of entertaining overseas visitors under the conditions which have prevailed during other public exhibitions at Olympia. The official daily publication of this year's Trade Show gave me the clear impression that the wholesalers and importers had indicated their support for the move to Olympia by booking exhibition space. As I see it, with the new venue already decided and the dearth of alternative exhibition sites (for a "fringe" show)

adjacent to Olympia, they had little alternative. I have not been able to ascertain whether, or to what extent, the wishes of retailers have been taken into account in this matter.

The other point which I find disturbing is that a variety of factors seem to indicate that the proposed move may seriously restrict the activities of some of the present "fringe" exhibitors who are not members of the appropriate trade associations.

I have no doubt that this is in the interests of the relevant associations, and it may also be in the interests of the music publication which is reported to be sponsoring the exhibition, but I am not at all sure that it is in the interests of our readers and of musicians in general. I invite the organisers of next year's show to issue a clear statement, indicating that they will also be willing to grant adequate exhibition space to companies who are in the music business but not members of any association. I believe this to be in the public interest – and, for better or worse, this is now a public show.

## ... and pins down bridge problems on acoustics

Most people who have anything to do with steel-string acoustic guitars have, at some time, been faced with a bridge pin which refuses to come out. Occasionally this is caused by the end-winding of the string (or the silk lapping over it) being rather wider than usual, but it can also be the result of badly fitted or bent bridge pins. I have also seen new guitars in which the bridge holes were too small for the pins supplied. In this case, any attempt to force the pins down into place will certainly make them difficult to remove, and will probably also crack the bridge after a few months. I prefer to fit smaller pins or ream out the holes to a more suitable size. This requires a tapered reamer to suit the pin, and not all pins are the same. It is also possible to split the bridge while enlarging the holes. Unfortunately, engineers' taper-pin reamers do not have the right taper for the majority of Japanese and American plastic pins, and the Swiss reamers which *do* fit are expensive. It is probably cheaper to have the job done by a competent repairman.

Most commercially made guitars have round holes in the bridge, and are supplied with grooved plastic bridge pins, to allow clearance for the thickness of the string. Bridge pins are *not* supposed to hold in the string ends by a wedge-fit, although some of them do seem to work this way (and sooner or later fly out into the audience). The pin only needs to be just tight enough to hold *itself* in place. The

string is (or should be) held in, because the pin is longer than the hole through the bridge, and so projects inside the guitar. When the newly fitted string is tightened, the ball-end pulls up against the *side* of the pin, not the end, and so does not try to lift the pin out. Occasionally the ball-end will hook over the end of the pin. If the pins are correctly fitted and not too tight, the pin will rise up as you tension the string, and warn you of this. Usually it is only necessary to slacken the string, remove the pin and start again, keeping a slight tension on the string by hand while inserting the pin. If a pin is a very tight fit in its hole, it can sometimes support the string tension on to the *end* of the pin, but it is almost certain to fly out at some later time.

For the usual bridge pin system to work reliably, it is necessary that when the pin is in the hole, there is just enough clearance for the string, but not too much. As the moulded, grooved plastic pins are usually all the same size in a set of six, and as strings are different sizes, this represents a compromise solution. It is common to find grooves in the pins which are not really big enough for the heavier strings, combined with pins which taper more steeply than the sides of the hole and have relatively thin ends. This works well enough when everything is new, but after a few years of use, the pins become kinked and increasingly difficult to remove. The obvious and

cheap solution is to fit new pins. In many cases, a new set of pins every two years is all that is needed. However, if old or badly-fitting pins have encouraged the string ball-ends to wear away the underside of the bridge holes, you are likely to find the strings jammed in place as well as the pins, and you will have great difficulty shifting either of them.

If your guitar is new, or not too badly worn, and you want to make string changing easier and more reliable, I would suggest you consider the alternative system of hard *wooden* bridge pins, with the necessary string clearance cut in the sides of the *holes*. If this is done well, it works reliably and for a long time, without further attention. If done badly, it may make matters worse. If you have a valuable instrument, take it to a repair establishment which has a good reputation for delicate repair work on old and/or valuable instruments. It is much better to have this job done right first time, and it is very difficult to correct errors. It should not cost very much, and you may find that strings will settle into tune faster as well. For best results, you must state exactly which gauge of strings you intend to use, and keep to this in future. You will be able to use thinner strings, but if you decide to change to a heavier gauge, or to strings with padded, silk-lapped ends, take the guitar back and have the shop readjust the slots to fit.

Meanwhile, for those who don't want to go to this trouble and expense, here is a useful tip for removing jammed pins. First, slacken the string and try to push the end further *into* the bridge, while lifting up the pin. If this does not work, take an old teaspoon (preferably not one from a set) and file a half-round nick in the end of the bowl, so that it will just fit under the head of the pin. You now have a sort of lever which should get the pin out.

Put the slotted end under the head of the pin, rest the bowl of the spoon on the bridge, and press gently down on the handle, while pushing the end of the string into the hole as before. The shape of the spoon bowl gives good leverage, and reduces the chances of marking the bridge. This usually works, with only gentle down-pressure on the spoon handle. If the pin is still stuck, don't try to tear it out. You have reached the limits of what can be done safely. Take the guitar to a repair shop. If it is essential to change a string on the spot, it is sometimes possible to work the whole string through, into the guitar and out through the soundhole. If this does not loosen the pin, a new string can be fitted from the inside in the same way. Although this is inconvenient, it will probably hold reliably until you can have the pin freed. Unless you have no other possibility, don't try to hammer a pin in or out, and don't try to drill out a jammed pin. In either case you are likely to damage the bridge.

# Levin

## MASTER GUITARS are hand-made of solid, rare woods.

Levin guitars are made by master craftsmen, guitar makers who know the art of charming the sound out of the wood. You benefit from this combination of master artisans and the use of solid, rare woods.

They are the secret of how real Levin guitars are made.

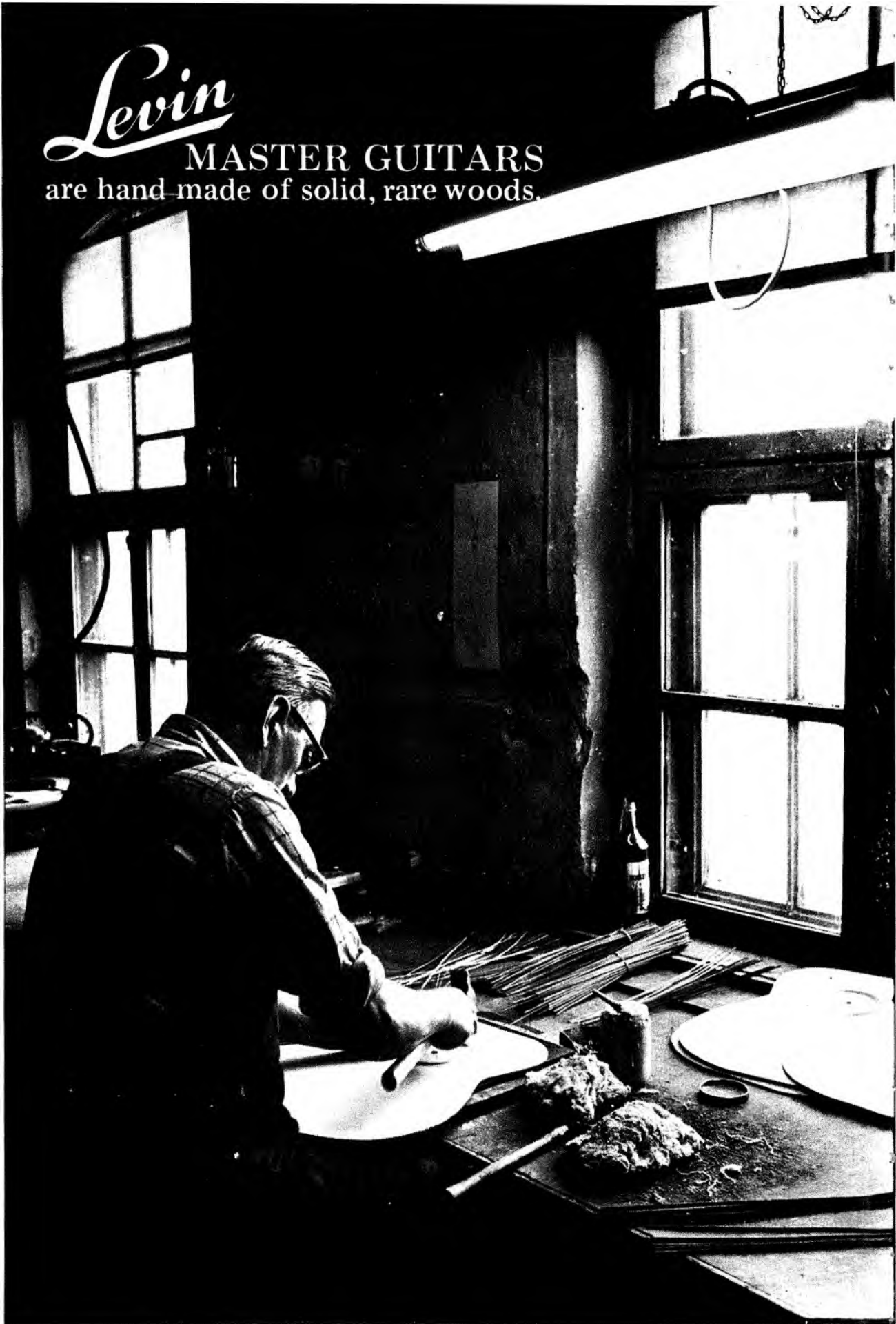

LEVIN  
BOX 8968,  
S-402 74,  
GOTEBORG,  
SWEDEN.  
Head Office for  
The CF Martin  
European  
Organisation.

For further information on Martin guitars, Levin guitars, Sigma guitars and Fibes drums, please contact:  
**THE C.F. MARTIN ORGANISATION IN THE UK:**  
Kinchyle, Church Lane, Great Holland, Essex.

Name .....

Address .....



Each 802 speaker is capable of handling 300 watts RMS with a much improved efficiency.

There was a time when you could tell how powerful a speaker was just by looking at it.

If it was big and heavy it was powerful.

But not any more. With the new Bose 802.

The 802 is something of a landmark in the music world.

It's small.

But with an awful lot of power packed into its neat little frame.

Instead of one there are eight drivers. And because Bose speakers are renowned for it, you can imagine the bass is exceptional.

On the 802's it's been extended even further to handle the wild edges of any group's repertoire.

While the treble is clean way up to the top of the audible spectrum.

With every pair of Bose 802

speakers there's an active equaliser which ensures a flat power spectrum is radiated across the entire audible range.

And being small doesn't mean being fragile. The new 802 is built to be virtually indestructible.

The cabinet has been redesigned. So it looks as dramatic as it sounds.

And the price? Just £555 a pair plus VAT. Not much when it comes to putting muscle where it belongs. On stage instead of on your roadies.

If you'd like to know more about Bose speakers, get in touch with us now.

Bose (UK) Limited, Trinity Trading Estate, Sittingbourne, Kent, ME10 2PD.

Telephone Sittingbourne (0795) 75341/5.

**BOSE**

Better sound through research.

## ARE YOUR SPEAKERS BUILDING UP YOUR ROADIES INSTEAD OF YOUR REPUTATION?

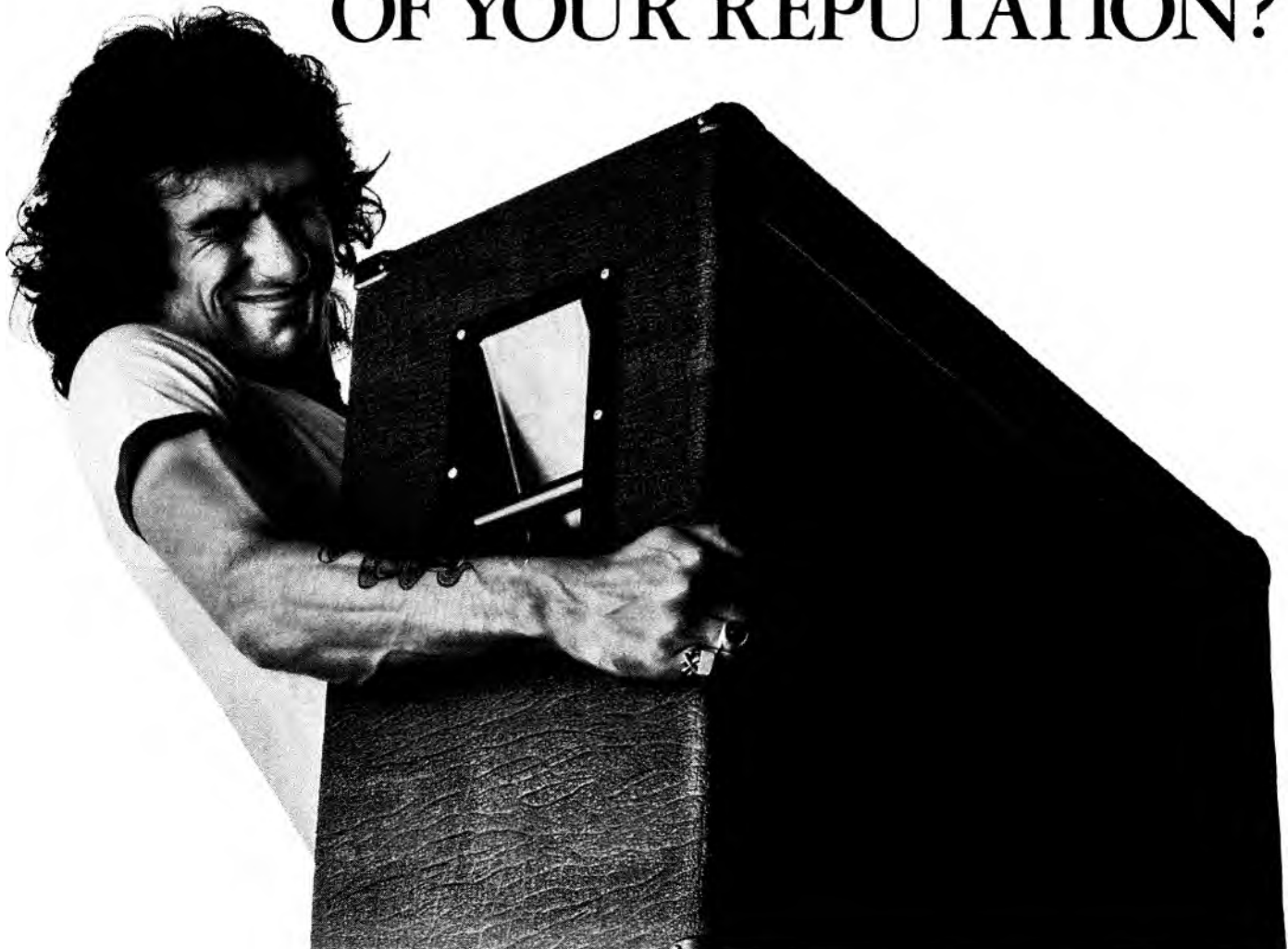

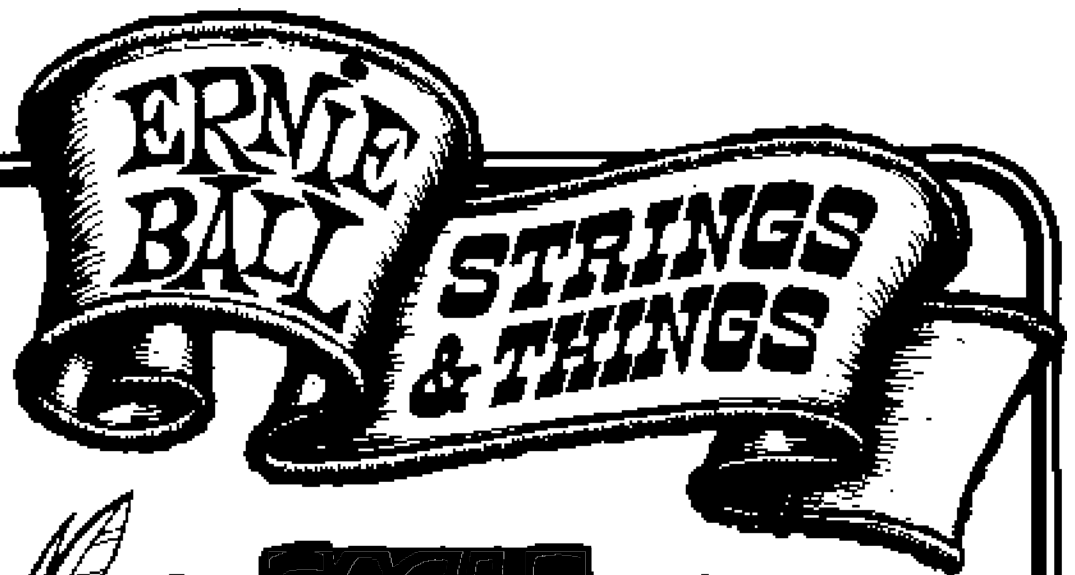

**EAGLE K'NEAGLE**



# LORD BALL

WANTS YOU TO HAVE A FREE COPY OF EAGLETOONS NUMBER ONE WITH YOUR NEXT PURCHASE OF ERNIE BALL/ERNESTO PALLA/EARTHWOOD STRINGS TO MEET EAGLE K'NEAGLE AND FRIENDS AND READ THE EPIC "HOMEMADE JAM" CARTOON STORY WHICH FEATURES THE BALLEAGLE FAMILY. GET A COPY TODAY!



**SELF-STYLED SUPER-STUD SALESBIRD, STUDENT OF SCREW-UPS & SILLY STUNTS**

# eagletoons™

AT YOUR LOCAL STORE NOW!



# The Trucker Show

Hear the fantastic quality, experience the rugged reliability of the compact Trucker P.A. system from Custom Sound. The star attraction could be you.

You just won't believe the Trucker P.A. amp. Terrific sound, great facilities and a price that's too good to be true! Just compare what you get; 100 watts RMS of power; 4 channels, each with 2 inputs, volume, bass and treble; master volume; master presence; built-in reverb with master control.

All this, not for £200 as you'd expect but for under £150!!

Available without reverb for less than £130!

But don't take our word for it—hearing is believing so check it out at your nearest Custom Sound dealer.

Designed to provide a compact but effective P.A. loudspeaker enclosure, the Trucker Cab is ideal where space is tight, like small clubs and pubs. It's easy to set up—and pack up in a hurry too, especially if you have to fit all your gear into a car.

With 60 watts of power handling each—120 watts the pair—you get massive volume from the 12" speaker and horn with a wide, even range of response.

The Trucker P.A. amp, Trucker Cabs and Stands, a superb "no bother" system at a ridiculously low price for such quality and specification.



Just mail the coupon and we'll send you details of the whole Trucker range and the 700 series from Custom Sound. PLUS a free pen and news of our T-shirt offer.

Custom Sound Solid State Technology Ltd.,  
Arthur Street, Oswestry, Shropshire SY11 1JN.  
Telephone: (0691) 59201

NAME \_\_\_\_\_

ADDRESS \_\_\_\_\_

\_\_\_\_\_

\_\_\_\_\_

**CUSTOM SOUND**

PROFESSIONAL SOUND EQUIPMENT

# Express yourself with

# *Antoria*

guitars.



Please send more information on *Antoria* electric guitars

Name \_\_\_\_\_

Address \_\_\_\_\_

\_\_\_\_\_

\_\_\_\_\_

IM 12 7B

*Antoria*

electric guitars

Distributed by



JAMES T. COPPOCK (LEEDS) LTD  
Royds Lane Leeds LS12 6LJ England

# SATUR ELECTRICAL SERVICES

Primary Distributors of **Electro-Voice®**  
products for the North and Midlands.



**Electro-Voice®** professional systems.

Why not send in the coupon and get detailed particulars on Electro-voice microphones, loudspeakers, loudspeaker systems and other individual components?

Please forward details of Electro-Voice products.

Name .....

Address .....

Send to S.E.S. Howard House, Butterthwaite Lane, Ecclesfield, Sheffield. Tel: 07415 64585

# WINDOWS OF NEWCASTLE

ONE OF THE NORTH EAST'S LEADING  
GUITAR CENTRES  
WHERE YOU CAN TRY OUT  
FOR YOURSELF THE WONDERFUL  
RANGE OF

*Fylde Acoustic Guitars*

THESE GUITARS ARE MANUFACTURED  
IN BRITAIN TO THE HIGHEST STANDARD  
FOR DISCERNING MUSICIANS

- SECOND HAND GEAR ● TOP PART EXCHANGE ALLOWANCES ● H.P. FINANCE BY OURSELVES (RING US FOR A QUOTE) ● THE STAFF ARE EXPERT, FRIENDLY AND EFFICIENT ● AN AFTER SALES SERVICE SECOND TO NONE

# WINDOWS OF THE ARCADE

1/7 Central Arcade (by Grey's Monument)  
Newcastle upon Tyne. Tel: 21356

Music, Musical Instruments, Hi Fi, Television, Records & Cassettes

# LANGDONS ELECTRIC MUSIC



## SPECIAL OFFER ON GIBSON GUITARS

Gibson Marauder	£299 + vat
Gibson The Paul	£299 + vat
Gibson S1	£299 + vat
Gibson Ripper Bass	£299 + vat
Gibson Les Paul Custom	£450 + vat
Gibson Les Paul Deluxe	£450 + vat

ALL WITH  
GIBSON FITTED CASES  
Plus full stocks of H/H, Maine,  
Carlsbro, Marshall, Fender,  
Peavey, etc.

We are  
PEARL franchised dealers

Great news for Drummers  
**THE DRUM CELLAR**  
opening in the New Year

Call in and see us  
27 Victoria Street,  
Wolverhampton.  
Tel: (0902) 27251.

BRISTOL'S OWN



GET IT ALL.

COMES  
TO



## THE SOUTH-WEST

WE ARE PLEASED TO ANNOUNCE THAT WE  
ARE NOW THE FRANCHISED DEALERS FOR ALL  
JBL PRODUCTS IN THE SOUTH WEST.

Speaker Chassis	H.F. Drivers	
K110 10" £ 87	2420 H.F. DRIVER UNIT	£160
K120 12" £100	2440 H.F. DRIVER UNIT	£250
K130 13" £110	2461 H.F. DRIVER UNIT	£140
K140 15" £115	2470 H.F. DRIVER UNIT	£160
K151 18" £215	2482 H.F. DRIVER UNIT	£270
2220 15" £125	2402 SLOT RADIATOR	£ 80
	2405 BULLET	£ 85
Horn Flares	Lens Units	
2345 Radial horn £130	2301 Perforated plate lens	£ 48
2350 Radial horn £180	2390 Crinkle plate lens	£140
	2395 36" Slant plate lens	£260

All prices are excluding V.A.T. at 18%

RECONE KITS NOW AVAILABLE OR RECONE  
SERVICE FOR MOST OF THE POPULAR RANGE.  
FULL RANGE OF A.T.C. SPEAKERS STOCKED  
ALSO ALL QUALITY P.A. COMPONENTS.

BIGGLES MUSIC, 85 West Street, Old Market,  
Bristol 0272 562147

# whomes music

	Rec. Price	Our Price
<b>HAGSTROM GUITARS</b>		
Jimmy	£365	£299
Viking	£285	£199
Swede Bass	£350	£299
Scandi (6 string)	£299	£225
Scandi (left handed)	£350	£299
<b>GUILD</b>		
D50	£505	£429
D55	£614	£499
F50	£590	£490
F212	£453	£380
<b>OVATION</b>		
Magnum Bass with case	£615	£410
Preacher	£450	£350
Viper (shop soiled)	£396	£299

**NOW IN STOCK!**  
**YAMAHA ELECTRIC GRAND**  
**OUR PRICE £2,300**

Whomes Music Ltd.,  
292 High Street, Croydon, Surrey.  
Phone: 01-686 2708  
Open between 10am - 6pm Closed all day Wednesday

# FREE 'N' EASY MUSIC

100 HIGH STREET, AYLESBURY. TELEPHONE AYLESBURY 28555

## FREE 'N' EASY ON WHEELS

This service has been running now for a year, with customers throughout England, Scotland and Wales. We offer you the opportunity to try out, in the comfort of your own home, the gear of your own choice. Just telephone Margaret at the above number and tell her what gear you are interested in. Send us the £10 for delivery, and Reg our famous ex-milk roundsman will make an appointment to deliver the gear, to your house, for you to try before handing over the readies.

Alternatively if you want credit facilities let Margaret know when you telephone, and she will arrange for this to be fixed up before Reg arrives

We can give credit up to 3 years

	deposit	Weekly over 2 years			
<b>ELECTRIC GUITARS</b>			<b>DRUM KITS</b>		
Kramer 350G	£45	£4.75	Rogers 6 drum (S/H)	£75	£8.45
Kramer 450G	£55	£5.65	Premier 717 black	£75	£7.95
Aria PE1000	£35	£3.60	Premier 3304 Chrome	£60	£6.55
Gibson Les Paul Standard	£55	£6.20	Ludwig Big Beat Yellow		
Gibson SG Standard	£50	£5.55	Matrix	£90	£10.10
Rickenbacker 360 12 string	£55	£6.05	<b>GUITAR AMPS</b>		
Rickenbacker 320 (S/H)	£30	£3.35	Music Man 212 65W Combo	£55	£6.20
Rickenbacker 4001 Bass (L/H)	£55	£5.70	Roland JC120 Combo	£55	£5.65
Guild M80	£45	£5.05	Roland JC60 Combo	£40	£4.45
Guild S100 (L/H)	£30	£3.20	Maine 120w Musician Combo	£35	£3.80
Shergold Masquerader Custom 12 string	£20	£2.25	Traynor YGM3 25w Combo	£20	£1.70
Shergold Masquerader Custom (L/H)	£20	£2.25	Carlsbro Stingray Super Combo	£30	£3.00
Shergold Meteor de luxe (L/H)	£20	£2.00	Carlsbro Stingray Top	£20	£2.00
Yamaha SF500 with case	£30	£3.18	Orange overdrive amp	£21	£2.36
Yamaha SF700 with case	£35	£3.64	Marshall 100w Master Vol. Top	£25	£2.70
Yamaha SF1000 with case	£40	£4.19	Marshall 120w 4x12 Cab	£20	£2.20
<b>ACOUSTIC GUITARS</b>			<b>P.A.</b>		
Ovation Glen Cambell	£45	£4.95	Maine 200w P.A. Amp	£30	£3.48
Ovation Balladeer	£35	£3.95	Maine 2x12 (with horns) Cols	£31	£3.49
Ovation Electric Matrix	£35	£3.70	Other P.A. Equipment in stock, Traynor, MM, Stagesound, Altec, Carlsbro.		
Ovation Electric Country Artist	£50	£5.65	<b>KEYBOARDS</b>		
Applause Electric	£20	£2.20	Yamaha CS60	£190	£21.40
			Roland SH2000	£80	£8.90
			Roland SH3A	£70	£7.75
			Roland SH5	£110	£11.90
			Other keyboards in stock, ARP, Octave, Korg.		

To: Free 'n' Easy, 100 High Street, Aylesbury, Bucks.

Please send me my free Free 'n' Easy T shirt and sticker along with my order for a.....  
I enclose a cheque to the value of.....  
which includes a charge of £10 for delivery. I require/  
do not require credit (delete where applicable).

Small  
Medium  
Large

Name .....

Address .....

Telephone No. ....



OFFICIAL  
STOCKISTS

# Giannini

GUITARS  
&  
CRAVIOLAS

LONDON  
WC2 G. Scarth, 55 Charing Cross Road  
WC2 F.D. & H. Music, 138 Charing Cross Road  
E11 Freedmans, Leytonstone  
SE6 Music House Three, Catford  
SE13 S.E. Entertainments Ltd., Lewisham  
BATH Westside Music Centre, 4 Railway Street  
BEVERLEY Music Centre, 14 Norwood  
BEXHILL Bird Music, 9 Sackville Road  
BLACKBURN Reidy's House of Music, 9-13 Penny Street  
BLETCHLEY Marshall Music, 146/148 Queensway  
BOGNOR REGIS A. Olby & Son, High Street  
BOURNEMOUTH Music Centre, Old Christchurch Road  
BOURNEMOUTH Don Strike, 16 Westbourne Arcade  
BRADFORD Vallances, Arndale House  
BRADFORD J. Woods, 28 Sunbridge Road  
BRIDGWATER Westside Music Centre, 7 Fore Street  
BRIDLINGTON The Music Box, Chapel Street  
BRISTOL Churchill & Son Ltd., 66 Park Street  
BRISTOL Duck, Son & Pinker, 8-9 The Arcade  
BRISTOL Professional Music Services, St. George  
CAMBRIDGE Ken Stevens, 11 Sussex Street  
CARLISLE J.P. Dias, 149 Hotchergate  
CRAWLEY L. & H. Cloake, 34 The Boulevard  
CRAYFORD Curromusic, 13 Princesses Parade  
CROYDON Croydon Music Studios, 40 Station Road  
CROYDON Potters Music, 7 South End  
DEWSBURY C. J. Auty, 12-24 The Arcade  
DONCASTER Professional Music Centre, Nether Hall Road  
DURHAM Musicore, 88 North Road  
ENFIELD Organ & Music Centre, 1 St. Onge Parade  
GILLINGHAM (Kent) Simpsons Music Studio, Watling Street  
GRAVESEND The Music Shop, 39 Harmer Street

HITCHIN Hermitage Organ Centre, 35 Hermitage Road  
KNARESBOROUGH Photo Musica, 11 Castlegate  
LEEDS R.S.C., 16 County Arcade  
LEEDS J. Scheerer, 8 Merriion Centre  
LEICESTER Brees Record Shop, Churchgate  
LEWES Cornelius Editions, 29 Lansdowne Place  
MAIDSTONE Sharon Music, 65 High Street  
NORTHAMPTON South Midlands Co-op Socy.  
NORWICH Cookes Band Instruments, St. Benedicts Street  
PETERBOROUGH Peterborough Music Shop, Broadway  
RAINFHAM (Kent) Home Entertainments, 8 Station Road  
READING Norman Hackett, Bristol & West Arcade  
READING Hickie & Hickie, 153 Friar Street  
SEVEN KINGS (Hilford) Cliff Owen, 673 High Road  
SHEFFIELD Hudson & Son, 131 The Moor  
SIDCUP Pat Chapman, 33 Sidcup Hill  
SOUTHAMPTON Jim Becketts Music, 2/3 Gibbs Road  
SOUTHEND-ON-SEA Mandela Pianos, 15 Queens Road  
SOUTH SHIELDS Music Maker, Westoe  
STAMFORD (Lincs) Music Shop, St. Mary's Hill  
SWINDON Duck Son & Pinker, Millford Street  
TAMWORTH The Music Box, 35a Lower Gun Gate  
TUNBRIDGE WELLS The Music Centre, 3 Vale Road  
WELLING Allan Billington, 172 Park View Road  
WESTON-SUPER-MARE Worle Music Centre, Worle  
WORTHING Approximate Music, 244 Ham Road  
WORTHING Broadway Music, Brighton Road  
YEOVIL Westside Music Centre, 7 Vicarage Road  
SCOTLAND  
GLASGOW Wm. Thompson & Sons Ltd.  
AIRDRIE Wilkinson Music Centre  
KILMARNOCK Mike Gill Organs  
PERTH Wilkies Music House



SOLE TRADE DISTRIBUTORS:  
PETER LEIGH MUSICAL INST. LTD.  
13 WATERSIDE  
CRAYFORD  
KENT

## BUZZ MUSIC CAN YOU SPARE A NOTE OR TWO FOR OXFAM?

Your notes are helping people to enjoy good music. Can you spare a different note to help those who never enjoy a proper meal?

400 million people in the world are seriously undernourished. The money we raise is used to help them to help themselves in over 80 countries throughout the world.

Wouldn't you like to help!

Send whatever you can afford to:—

OXFAM  
ROOM No. IMM  
274 BANBURY ROAD  
OXFORD

*This space was generously donated to Oxfam by Buzz Music.*



BUZZ MUSIC  
65 Widemarsh Street  
Hereford.  
Telephone: (0432) 55961

## Looking for a PA Quote

GROUND CONTROL  
MAURICE PLACQUET  
ENTEC.  
R.G. JOHN  
EURO ELECTRO SOUND  
T.F. ELECTRO SOUND  
H.B.  
WESTMILL AUDIO  
GIGGLES.  
STAGE SHOWS  
SOUND WAVES  
HAROLD SMAR  
WHALE AUDIO  
JOHN PETER  
BRITANIA REV  
WARD SOUND  
DESCENDO  
DOMINIC SERVICE  
JOHN MOORE SOUND EQUIPMENT  
ORANGE  
KELSEY ACCOUNTS  
E.S.E. HIRE  
SSE P.A. HIRE

P.A. HIRE COMPANY.  
COLAC.

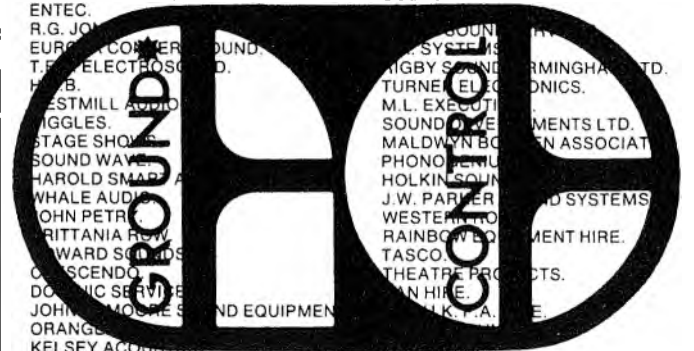

'ITS A LONG LIST'  
SO START SENSIBLY  
PUT **GROUND CONTROL** AT THE TOP  
WE GET PLEASURE FROM SUPPLYING  
YOU WITH THE BEST SOUND

### GROUND CONTROL

7/9, WOOD CLOSE LONDON E2. 01-739 1448.

AND

27, RUE PRINCIPALE, PIA SUACRE, DELLE, FRANCE. 84-36-13-28.

## Sound Logic

# SOUNDS INTERNATIONAL

RETAILERS OF HIGH QUALITY MUSICAL INSTRUMENTS

Sounds International are the main stockists for Professional Amplification Systems in the South West. Get the very best quality at a very realistic price.

Roy and Kim will be happy to quietly discuss your amplification problems.

Sounds International give a full guarantee on all their equipment. There are generous Part Exchange Terms. Access/Barclaycard are accepted. There are Mail Order facilities. Instant credit up to £500 available.

Ask for Roy in Bath.

**SOUNDS INTERNATIONAL**  
 RETAILERS OF HIGH QUALITY MUSICAL INSTRUMENTS  
 28 Westgate Street, Bath, Avon. Tel: (0225) 64056

Ask for Kim in Frome.

**SOUNDS INTERNATIONAL**  
 RETAILERS OF HIGH QUALITY MUSICAL INSTRUMENTS  
 5 Bath Street, Frome, Somerset. Tel: (0373) 2083

## THE FINEST AUDIO CABLES BUILT: PERIOD!



COIL GUITAR CABLES NOT SHOWN

COMPLETELY HAND-MADE IN THE U.S.A. USING BELDEN CABLE AND SWITCHCRAFT PLUGS  
 — EUROPEAN DISTRIBUTOR ENQUIRIES WELCOME —  
 SEND FOR FREE CATALOGUE

**CONQUEST SOUND COMPANY**  
 15523 S. 70TH CT.  
 ORLAND PARK, ILLINOIS, U.S.A. 60462  
 312-429-1770

DON'T LET THE BEAUTIFUL WORKMANSHIP OF OUR CABLES FOOL YOU...  
 THE PERFORMANCE IS EVEN BETTER...

So many people have been saying nice things about Flame Amps. that we decided it was time to tell the world about us.

*They say they look good* - but then so do many other amps (mainly of foreign origin).

*They say they are reliable* - now this is a thing that doesn't apply to many amplifiers (of any origin).

*They say the price is very competitive* - we are trying to help the musicians make a living.

However the most complimentary thing they are saying is that *Flame Amps sound good* (hours of hard work and patience, changing components until we find exactly the sound we want).



If you would like to know about all the good things Flame can offer you, then call into your local Flame dealer (there is normally only one in each town) he will be happy to give you any information you need. If you prefer, then complete the coupon and we will send you a catalogue, price list and details of your nearest Flame dealer.

**OVERSEAS DISTRIBUTORS WANTED FOR MOST COUNTRIES**

FOR MORE INFORMATION, SEND THIS COUPON TO:  
**FLAME AMPLIFICATION**, 100 Eastbank St, Southport,  
 Merseyside, England PR8 1EF.

Name .....

Address .....

# SHARMA<sup>®</sup> ORGAN SPEAKERS

British made throughout

## HOME ORGANIST RANGE

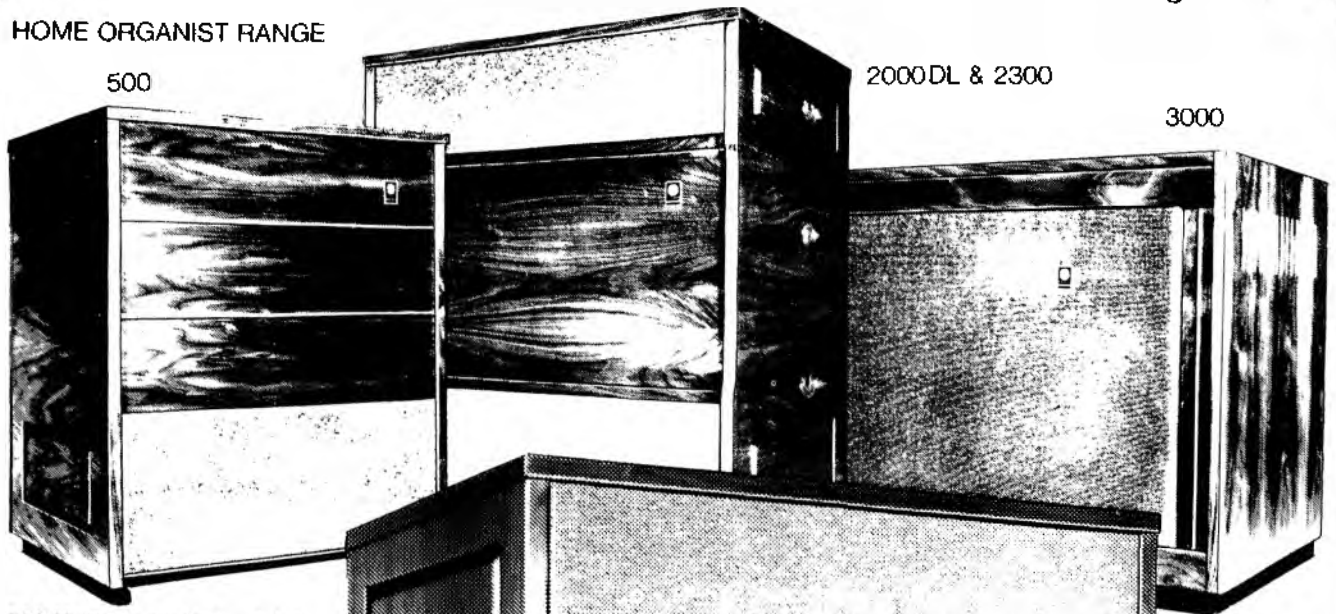

**500 Majestic music in miniature.**  
Has been created with the home in mind.  
Lending beauty to any decor yet discreetly unobtrusive.

**SHARMETTE Inexpensive luxury.**  
A scaled-down version of the famous 2000 de-luxe, big in every way except price.

**2000DL For the discriminating musician.**  
Established the world over as a standard par excellence.

**2300 Multi-channel magic**  
Is specially designed for twin channel organs, one channel for straight voices, the other handling chorale and tremolo tones.

**3000 The ultimate in perfection.**  
Has three channel output, each channel is entirely separate, with the speakers acoustically placed to give unique sounds without interchannel interference.  
"Truly Sharma Sound Around."

SHARMETTE

## PROFESSIONAL RANGE

**Sounds of the 80's.**  
A must for the professional organist.  
Incorporating tomorrows modern sounds, today, with chorale and fast tremulant, plus extra outputs, brilliance, ease of transportation, hard wearing vinyl finished cabinets, concealed handles, aluminium fittings and castors.

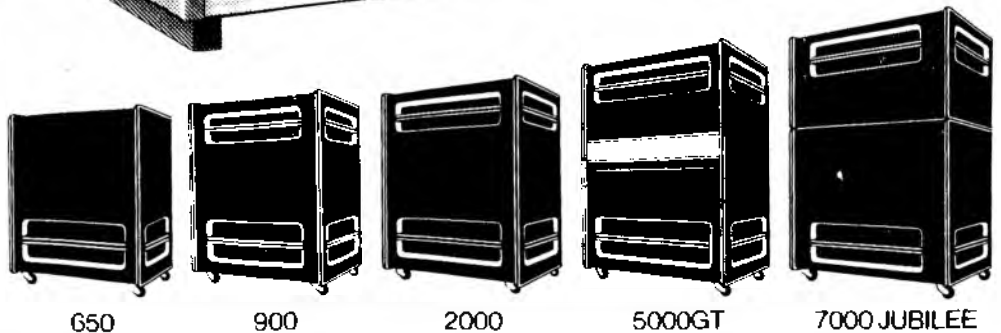

650

900

2000

5000GT

7000 JUBILEE



Sound Around

SEND FOR A FREE BROCHURE ON OUR COMPLETE RANGE

## KEITH HITCHCOCK & CO

THE MILL 1379 LINCOLN ROAD WERRINGTON PETERBOROUGH  
TEL (0733) 71913 CABLES HITCHCOCK PETERBOROUGH



# DEALER GUIDE

## AVON

**ASSEMBLY MUSIC**  
25 Claverton Buildings, Widcombe, Bath.  
0225 22894  
12 The Promenade Gloucester Road,  
Bristol.  
0272 425245  
EC, IR, MA, RS Spec. ERS, EK, G, A, D, B,  
W.  
H. Ac. SFI, PA, PSG, S/Hnd, M, RC, CB  
Premier, Traynor, Sonor, Carlsbro, Gibson  
Tama.

## BEDFORDSHIRE

**BEDFORD MUSICAL INDUSTRIES**  
58 Midland Road, Bedford.  
0234 58142  
EC, IR, G, A, D, S, S/Hnd, MA, RS, Spec.  
ER, L, H, M, RC, PA, CB, Di.

**BOOGALOO BASEMENT**  
17 Bridge St., Leighton Buzzard, Beds.  
05253 66622  
G, A, D, B, W, S, Dr, R, S, Gibson Star  
Dealer

**MILTON KEYNES MUSIC LTD**  
17 Bridge St., Leighton Buzzard, Beds.  
05253 66622  
ER, RCn, O, IR, SYN, G, A, D, S, S/Hnd  
MA, RS, ERS, EK, K, B, W, L, H, T, M, RC,  
SM, PA, Di.

**MR MUSIC**  
St. John Street, Bedford.  
Bedford 50861/2  
A, EC, O, IR, SYN, G, D, S, S/Hnd RS, K,  
ERS, EK, B, W, L, H, Ac, SFI, SM, PA,  
PSG, CB, Di.

**LUTON MUSIC CENTRE Ltd.**  
114 Leagrave Road, Luton, Beds  
Tel: Luton 26826  
Part Exchange Credit and Cash  
G, K, A, D, S, W, S, & EC, O, IR, SYN, S/Hnd,  
MA, RS, Spec, ERS, EK, L, H, Ac, S, FI, T, M,  
RC, SM, PA, PSG, CB.

## BERKSHIRE

**RUMBELOWS MUSIC**  
138/141 Friar Street, Reading.  
Reading 55361  
EC, O, SYN, G, A, D, S, S/Hnd, RS, SPEC.  
ERS, EK, K, L, AC, T, M, SM, PA, Di.

## BIRMINGHAM

**MICHAEL PECK-THE SHEET MUSIC SPECIALISTS**  
1478 Pershore Road, Sturchley,  
Birmingham B30  
Tel: 021 458 6460  
K, EK, Syn, RS, S, ERS, S/Hnd, A, G, S  
(Gibson, Rotosound Spec.) T, D, K, G, A, C  
SM, PA.

**YARDLEYS**  
Snow Hill, Birmingham.  
21 Colmore Row, Birmingham B3  
021 235 7441  
G, A, D, B, W, S, Di, PA, RS

**JONES & CROSSLAND LTD.**  
6-8 Smallbrook, Queensway, Birmingham.  
021 643 4655/6/7  
CB, RCn, O, IR, SYN, G, A, D, S, S/Hnd  
RS, ERS, EK, B, W, Ac, M, SM, PA.

**Woodroffes**  
**Drumland**  
A Division of Woodroffes

## BRISTOL

**BIGGLES MUSIC**  
85 West Street, Old Market Bristol  
0272 552147  
A, G, S, RCn, IR, S, Hnd, MA, RS,  
ERS, EK, M, PA, CB, T, HP & PX.

**BROWNS OF BRISTOL**  
5 Union Street, Bristol.  
0272 23646  
Wern Copycat EC, RC, IR, G, A, (MA Custom  
Sound) D, (Premier MA) S, S/Hnd, RS, ERS,  
B, (MA Conn), W, SFI, (Mandolins,  
bouzouki), M, PA.

## BUCKINGHAMSHIRE

**HAMMOND MUSIC & ORGAN CENTRE**  
43a Buckingham St., Aylesbury, Bucks.  
0296 3131  
G, A, D, K, B, W, S, EC, Di, L, Ac, Syn  
RS, EK, SM, RC.

**ORGAN WISE LTD.**  
48 Aylesbury Street, Bletchley, Milton  
Keynes  
0908 70955  
O, K, Spec. RES, EK, S, A, G, SYN, IR, EC, B  
W, Ac, T, M, RC, SM, PA, CB

**YEOMAN MUSIC LTD.**  
33 Cambridge Street, Aylesbury, Bucks  
Aylesbury 85549  
O, W, K, Ac, SFI, T, M, RC, SM, ERS, EK,  
G, A, S, CB, MA, S/Hnd.

## CAMBRIDGESHIRE

**CAMBRIDGE ROCK**  
44 Newnham Road, Cambridge.  
0223 65093  
EC, RCn, IR, G, A, S, S/Hnd, MA, RS,  
ERS, H, M, RC, PA, CB, PA.

**DRUM AND GUITAR CENTRE**  
4 Norfolk Street, Cambridge  
0223-64410  
D, G, A, ERS, EC, S.

## CHESHIRE

**CUSTOM AMPLIFICATION**  
45 Nantwich Road, Crewe  
0270 4778  
46 Hope Street, Hanley  
Stoke-on-Trent  
0272 266897  
G, A, D, K, S, Di, L.

**THE ORGAN CENTRE**  
(J, G, Flattly & C.R. Durrant)  
26 Edleston Road, Crewe.  
G, A, D, K, B, W, S, P, M.

**JONES MUSIC STORE**  
5 Queen Victoria St., Macclesfield.  
0625 22677  
G, A, D, K, W, S, B.

**RUMBELOWS-STROTHERS**  
Coronation Bldgs., Wallasey Rd., Wallasey  
051 638 3622/9871  
G, A, D, K, W, S.

## CLEVELAND

**CLEVELAND MUSIC**  
19-21 Cleveland Sq., Middlesborough.  
0642 210889  
G, A, D, K, S, Di, ERS, S/Hnd Fender,  
S/House

## COVENTRY

**COVENTRY MUSIC CENTRE**  
3-4 Whitefriars St., Coventry  
0203 58571  
(EC, RCn, O.) Syn, G, A, D, S, S/Hnd, MA,  
RS, Spec. ERS, EK, K, B, L, H, T, M, RC, SM,  
PA, CB, Di.

## CORNWALL

**WEST COUNTRY MUSIC**  
New Bridge Street, Truro, Cornwall.  
Truro 78501  
EC, O, IR, SYN, G, A, D, S, S/Hnd  
MA, EK, B, W, M, SM.

## CUMBRIA

**J.P. DIAS (CARLISLE) LTD**  
149-153 Botchergate, Carlisle  
0228 22369/28700  
EC, O, Syn, G, A, D, K, B, W, S, Di,  
Ac, PA, RS, ERS, EK, T, M, S, M, P.

**NORTHERN SOUNDS**  
41 Jane Street, Workington  
0900 4797  
113 Duke Street, Barrow-in-Furness  
0229 27100

G, A, D, K, RS, T, M, SM, Di, SYN, B, M, RC,  
EC, RCn, CB, MA, MAINE

## DEVON

**MOSS MUSIC**  
5 Allalland Street, Bideford, North Devon  
Bideford 5994  
G, A, O, RS, ERS, B, W, T, S, SM, MA,  
SYN, S/Hnd M, PSG.

**MUSIC MARQUEE**  
47 Notte St., Plymouth PL1 2AG  
0752 63559  
G, A, D, K, Di, L, RS.

**O. NICKLINS & SONS LTD.**  
45 High Street, Barnstable, Devon  
0271-2005  
A, K, G, W, S, S/Hnd, SM, D, RS.

**THE DAVID VANE MUSIC CENTRE**  
47 Exeter Rd., Exmouth, Devon  
03952 75246  
A, O, D, Di, S/Hnd, S, M, ERS,  
Spec, G, T, G, K

## DORSET

**COAST MUSIC**  
296 Cranbury Road,  
Bournemouth BH20 2ZB  
Specialist American Dealers  
A, D, S, W, A, R, S, P, A, C, B, S, Hnd

**JOHN ZIMMERMAN**  
GLOUCESTER

**Ray's**  
21-23 Broad Street, Gloucester  
01452 34111  
Specialist American Dealers  
A, D, S, W, A, R, S, P, A, C, B, S, Hnd

## HAMPSHIRE

**BECKETTS MUSIC**  
2/3 Gibbs Road,  
(Side of ABC Cinema),  
Southampton  
0703 24827  
G, A, D, S, S/Hnd, RS, B, W, Ac, M, SM.

**TELECOMMS**  
189 London Road, North End, Portsmouth  
0705 60036  
S/Hnd, MA, RS, EK, K, I, R, SYN,  
G, A, D, S, M, PA, Di.

**U-NAME-IT**  
8 Arundel Way,  
Arundel Street,  
Portsmouth, Hants  
Portsmouth 21165  
Everything music at super discount

**Kingfisher Music Company**  
20 Kings Rd, Fleet, Hampshire  
02514  
G, A, EK, P, A, S/Hnd, EC, CB, O, RC, SM, P,  
RS, ERS, SFI, E, Fender, Soundhouse, Gibson  
Star Dealer Syn, IR, M, A, S, L, H, PSG, M, P,  
CB.

## HEREFORD

**BUZZ MUSIC**  
65 Widemarsh St., Hereford  
0432 55961  
G, A, S, S/Hnd, RS, H, PA, M,  
EC, MA, Maine, Altac, MM, Artek.

**HEREFORD SOUND CENTRE LTD**  
7 Bridge St., Hereford  
Hereford 58550  
EC, G, A, D, S, S/Hnd, MA, P, RS, Spec.  
L, H, M, PA, Di.

## HERTFORDSHIRE

**HERMITAGE ORGAN CENTRE LTD.**  
35-37 Hermitage Road, Hitchin, Herts.  
Hitchin 59925  
O, G, D, EC, RCn, IR, SYN, A, S, S/Hnd  
MA, RS, Spec. ERS, EK, K, B, W, L, T,  
M, RC, SM, PA, Di.

**MR MUSIC**  
24 Bridge Street, Hemel Hempstead, Herts.  
Herts 81812/3  
A, EC, O, IR, SYN, G, D, S, S/Hnd, RS, K,  
ERS, EK, B, W, L, H, Ac, SFI, SM, PA,  
PSG, CB, Di.

**Ware Music Ltd**  
3 Baldock St., Ware, Herts. 0920-5939  
G, A, K, EK, B, W, S, T, M, RC, SM, P, ERS, O,  
S/hnd

## HUMBERSIDE

**JOHNNY PAT'S MUSIC PLACE**  
188 Holderness Road,  
Hull HU9 2EA  
Hull 23762  
New & SFI Group Gear Plus  
Repair Service - Main Agents

## REPUBLIC OF EIRE

**AUDIO INTERNATIONAL LTD.** IRISH AGENTS FOR  
**BOSE**  
and  
**Submerge**  
18 Fleet Street, Dublin, 0001/730011,  
A, EC, O, IR, SYN, G, A, D, S, S/Hnd, MA, RS, Spec.  
ER, L, H, M, RC, PA, CB, Di.

**THE BAND CENTRE**  
9 Harcourt Road, Dublin 2  
0001 75 2663  
G, A, K, PA, Spec, M, PA

## NORTHERN IRELAND

**CRYMLES (IRELAND)**  
67 71 Dublin Street Belfast  
0237 26818  
G, A, D, K, B, W, S, Di, Ac, RS, SM.

**Evans Musical**  
11-13 The Arcade, Newtownards, Co. Down  
11-13 The Arcade, Newtownards, Co. Down  
0183 51292  
EC, IR, SYN, G, A, D, S, S/Hnd, RS,  
ERS, B, W, L, Ac, T, M, RC  
SM, PA, PSG, CB, Di.

**SESSION MUSIC**  
(Sports and Music NI Ltd)  
73-75 Broughshane Street, Ballymena  
0266 41792  
81-93 York Street, Belfast.  
0232 38502  
Session Music, 169 Spencer Road,  
Londonderry  
0504 46796  
G, A, D, K, PA, S, PSG, M, ERS, MA, W,  
Ac, T.

## ISLE OF MAN

**ISLAND MUSIC CENTRE**  
2 Market Hill, Ramsey.  
0624-813688  
52 Duke St., Douglas  
0624 6752  
O, SYN, G, A, D, S, P, x, RS, SFI, T, M  
JVC, Spec, SM, PA, Di. Sole Agents: Lowry  
Thomas, Welson, Wurllitzer O. Service,  
Educ Records.

## KENT

**PAT CHAPMAN**  
31-33 Sidcup Hill, Sidcup, Kent  
01-300 3938/9668  
EC, SYN, G, A, D, S, S/Hnd, MA, RS, CB,  
Spec, ERS, K, B, W, Ac, SFI, M, RC, SM.

**Drumland Percussion**  
71 Leavelle Street, Dartford  
01474 28448

**KENNARDS**  
86-88 Northgate Canterbury, Kent  
0227 60131  
EC, O, IR, SYN, G, A, D, S, Hnd, RS, Spec, ERS,  
EK, K, B, W, L, H, Ac, T, M, RC, SM, PA, D  
24-hour answer phone service

**KENNARDS**  
10 New Kent, Ashford Kent  
0233 23226  
O, Syn, G, A, D, S, Hnd, EK, K, B, W, T, M, SM, PA

**MOSS MUSIC LTD.**  
67 Canterbury St., Gillingham  
Medway (0634) 576381  
G, A, D, S, RS, ERS, PA, B, W, T, M, Di.

**PEPPER MUSIC**  
86 Northdown Road, Margate  
0843 23205  
G, A, D, PA, RS, PA Hire

**WING MUSIC**  
15-15A London Road, Bromley, Kent  
01-464-3190  
EC, RCn, O, IR, SYN, G, A, D, S, SYN, MA,  
RS, Spec, ERS, EK, K, L, H, M, RC, PA, CB, Di.

## LANCASHIRE

**BARRATTS**  
1 Meadow Street, Preston  
0772 55628  
IR, SYN, RS, ERS, EK, G, A, D, B, W,  
S, Di, L, H, PA, M, P.

**FLAME AMPLIFICATION**  
100 Eastbank St., Southport Lancs  
0704 37050  
G, A, EC, RCW, S, Di, L, PA, S/Hnd  
M, RC, CB for Cab's and PA Systems

**HOBBS MUSIC**

3/5/7 Mary Street, Lancaster  
Lancaster G0740  
EC, O, IR, Syn G, A, D, S, S/Hnd, MA,  
RS, ERS, EK, K, B, W, L, H, Ac,  
SFI, M, RC, SM, PA, CB, Di  
HW AUDIO  
174 St Georges Rd., Bolton BL2 1RA  
0204 385199  
PA, Di, L, MA, A, M, CB, H, RS.

**PALL MALL MUSIC**

58 Pall Mall, Chorley, Lancs.  
025 72 71124  
G, A, S, Di, EK, M, P, A, S/Hnd, ERS, CB



**SAI**  
Regent St Showrooms,  
Regent St., Coppull,  
Chorley, Lancs  
0257 791846  
G, A, D, Di, L, PA, RS

**TOWNSEND MUSIC**

35 Church Street, Great Harwood, Nr  
Blackburn  
Tel. 0254 896694  
Percussion specialists DiMa, Premier,  
Ludwig, Beverley, Tama, Olympic, Hoshino  
Hamma, Slingerland, Maxwin, Rogers)  
S/Hnd, RS, Ins, M, A, Class, G, Elec, G, T, by  
arr.

**WOODS PIANOS & ORGANS**

1a-b Manchester Rd., Burnley  
0282 33709  
SYN, G, A, D, K, B, W, S, Ac, PA, RS,  
ERS, EK, M, RC, SM, T, EC, O,  
IR, S/Hnd, P

**WOODS PIANOS & ORGANS**

84 Church St Preston  
0772 52865  
SYN, G, A, D, K, B, W, S, Ac, PA, RS, ERS,  
EK, M, RC, SM, T, EC, O, IR, S/Hnd, P

**WOODS PIANOS & ORGANS**

15-17 Manchester Rd., Bolton  
0204 27171  
SYN, G, A, D, K, B, W, S, Ac, PA, RS, ERS,  
EK, M, RC, SM, T, EC, O, IR, S/Hnd, P

**LEEDS****KEYBOARDS of LEEDS**

54-58 The Hedrows, for all musical instruments  
Leeds Tel: 0532 468939 Tuition for most instruments  
251 Otley Road, for pianos, organs,  
Teeth Ln. piano-tuning & direct music  
Tel: 0532-788166 Yamaha Music School  
G, A, S, Di, Syn, G, A, S/Hnd, MA, Yamaha, Farfisa, Clonax,  
RS, Spec, ERS, EK, L, Ac, T, SM

**SCHEERERS**

8 Merrian Centre, Leeds 2  
0532 449592  
G, EC, A, WB, S, D, ERS, RS, HH Agents

**STEPHENS MUSICAL**

70 New Briggate, Leeds LS1  
0532 34710

**LEICESTERSHIRE****CENTRAL MUSIC LTD.**

12 New Bond Street, Leicester  
0533 538681  
EC, O, R, IR, RS, EK, K, ERS, F, A, D, B  
W, Di, S/Hnd, T.

**CUSACK'SUSIC**

33 Braunstone Gate,  
Leicester  
0533 548517  
CB, PA, G, A, ERS, Di, H  
**HUMBUCKER MUSIC CENTRE.**  
124C, Green Lane Road, Leicester  
0533 769318  
EC, O, IR, SYN, G, A, S, S/Hnd, MA (Laney)  
RS, Spec, ERS, EK, K, L, H, Ac, (TBass) M,  
RC, PA, CB, Di (Manufacturers of Sound to  
Light, P.A. Speakers and Bins)

**LOUGHBOROUGH MUSIC CENTRE.**

18 The Rushes, Loughborough, Leicester.  
0509 30398  
EC, O, IR, SYN, G, A, D, S, S/Hnd, MA, RS  
ERS, EK, K, B, W, L, H, Ac, T, M, SM, Di

**SUPERMOUSE MUSIC.**

233 Melton Road, Leicester  
0533 63830  
IR, SYN, G, A, D, S, S/Hnd, MA, RS, Spec,  
ERS, EK, K, B, L, H, T, M, RC, SM, PA, CB,  
Di

**LIVERPOOL****HESSY'S  
MUSIC CENTRE**

62 Stanley St., Liverpool 1  
051-236-1418  
G, A, D, K, B, W, Di, L, RS.

**LONDON**

**J.V. BOURDON LTD.**  
21-22 High Street, Shoreditch, London E1  
01 247-8063  
(500 yds from Liverpool Street Station)  
G, A, D, S, S/Hnd, RS, B, W, M, RC.

**CACOPHONY**

110 Churchfield Road, Acton W 3.  
(01) 993 2910  
EC, G, A, D, S, S/Hnd, MA, Elec, Guitar, RS  
ERS, Peavey, Traynor, Marshall, Spec, M,  
RC, Electric Guitar + Amplification, CB.

**CITY OF LONDON MUSIC STORE.**

17 Eldon Street, E.C. 2.  
01 588-4649  
EC, SYN, G, A, D, S, S/Hnd, B, W, Ac, SFI,  
PSG, RS, ERS, M, SM (Albums) PA

**STEPHEN DELFT**

242 Cable Street, E1  
01 790 7028  
G, A, SFI, CB, 24 Hrs, RS

**FD & H MUSIC**

138 - 140 Charing Cross Road, London  
WC2H 0LD  
Tel: 01 836 4766  
EC, Syn, G, A, S, S/Hnd, MA (HH, Marne,  
Ibanez, Peavey, Music Man, Guild, Gibson,  
Electroharmonic) RS, Spec, ERS, EK, K, B  
W, SFI, T, M, RC, SM, PA, PSG, Di

**GRANGEWOOD ORGANS (J&O)**

445/7 High Street, North, Manor Park,  
London E12  
01 472-5107/4690  
EC, SYN, D, S, S/Hnd, MA, RS, ERS, EK, K,  
L, T, M, PA, Di, Spec, A, O, G

**HENRITS DRUM STORE**

112 - 114 Wardour Street,  
London W1  
01 734 7121  
All makes of percussion and accessories  
supplied usually from stock or certainly in  
order

*Holiday Music LTD.*  
EC, RCW, G, A, S, Syn, MA, RS, ERS, M, RC, PA, CB,  
SFI, HND, T, TONS, LONDON E11 Tel: 01-928-2466

**LONDON  
SYNTHESISER  
CENTRE**  
72 Chalfon Street,  
London NW1  
01 367 7149  
EC, O, IR, Syn, G, A, S/Hnd, MA, RS, Spec, Syn,  
=RS, EK, K, H, T, M, RC, PA, CB.

**macari's**  
MACARI'S LTD  
122 Charing Cross Road, WC2  
01 836 9149  
G, E, K, Ac, SM, RS.  
MACARI'S MUSICAL EXCHANGE  
102 Charing Cross Road, WC2  
01 836 2856  
A, PA, Di, RS.

**MAURICE PLACQUET**  
358-360 Uxbridge Rd., Shepherds Bush,  
London W12  
01 749 1204/0859  
G, A, D, B, W, S, Ac, PA, RS, P

**MUSIC HOUSE (S E ENT)**  
375-377 Lewisham High St., SE13  
01 690 2205  
G, A, D, K, S, Di, L, PA, RS, Spec.

**PRO-DRUM PRODUCTS**  
112 - 114 Wardour Street,  
London W1  
01 437 1836  
Distributors of stackable fibre glass concert  
tom toms and the drumstore multi purpose  
drum key. Call John Vernon any time

**SESSION MUSIC LTD.**  
163 Mitcham Rd., Tooting SW17  
01 872 3413  
G, A, D, S, S/Hnd, RS, ERS, L, M, SM,  
PA, Di

**DAVE SIMMS MUSIC CENTRE**  
1-5 The Grove, Ealing W5  
01 560 0520  
Spec, G, A, PA, S/Hnd, Di, L, D.

**SOUNDS**

124 Shaftesbury Ave, London W1  
01 437 2458  
G, A, D, EC, S, S/Hnd.

**ST. GILES MUSIC  
CENTRE**

18-20, St. Giles Street, London WC2E 7HJ Tel: 01 436 2889-7559-4080  
G, A, D, B, W, RS, M, RC, SM, PA, CB, Di, SFI, T, M, SM

**THE SUPREME DRUM COMPANY**

206 Forest Road, Walthamstow, London  
E17  
Tel: 01 520 3873  
43 The Broadway, Stratford, London E15  
Tel: 01 534 1680  
Acrylic Drums Manufacturer, 3 Ply-Birch  
Shell 6" - 24" Full Recovering Service

**TOP GEAR**

5 Denmark Street, WC2H 8LP  
01 240 2118  
Spec, G, A, D, PA, EC, Ac, CB, M, RC,  
P, MA, RS, PSG, S/Hnd.

**WESTERN MUSIC CO. LTD.**

50 The Broadway, Wimbledon SW19  
01 540 0494  
O Syn, G, A, D, S, S/Hnd, MA (Lowrey,  
Farfisa, Yamaha), SPEC (Keyboards), ERS  
EK, K, B, W, AC, SFI, T, M, SM

**WESTERN MUSIC CO. LTD.**

130-132 King St.,  
Hammersmith W6.  
01 748 6824  
O Syn, G, A, D, S, S/Hnd, MA (Lowrey,  
Farfisa, Yamaha), SPEC (Keyboards), ERS  
EK, K, B, W, AC, SFI, T, M, SM.

**MANCHESTER**

**AL.MUSIC**  
88 OXFORD STREET, MANCHESTER 1  
061 236 0240  
SYN, G, A, D, K, EC, RCW, D, RS, ERS, S,  
EK, Di, SFI, PA, S/Hnd, M, RC, P, CB, SM,  
MAIN AGENTS - OMEGA 1, HUNROLAND,  
MUSHMAN, PROJECT LIGHTING, MARTIN GUITARS,  
PEARL, LAMPS, STRAMP, CITRONIC DISCOS  
Contact - Graham and Anne for personal service

**BARRATTS**

8a Oxford Street, Manchester M15 0A  
061 236 0542  
IR, RS, B, W, H, SM.

**BARRATTS**

72-74 Oxford Street, Manchester  
061 236 0052  
IR, SYN, RS, ERS, EK, G, A, D, K, Di,  
L, H, SFI, PSG, P.

**MIDDLESEX****BAND CENTRE**

53 Bell Road, Hounslow, Middlesex.  
Tel: 01 570 7821  
(Only 4 miles from London Airport)  
G, A, S, S/Hnd, Spec, ERS, EK, K, H, M, PA,  
CB

**NEWCASTLE-UPON-TYNE****BARRATTS**

158 Newbridge St., Newcastle-upon-Tyne.  
0632 22331  
IR, SYN, RS, ERS, EK, G, A, D, B, W, S,  
Di, L, H, PA, M, P.

**LEWIS MUSIC**

16 Bedduburn Road, Jarrow  
Jarrow 897784  
D, P, Sp, MAP, SCB,  
EC, G, A, S/Hnd, RS, H, T, M, R, C, PA.

**ROCK CITY**

48 Cloth Market, Newcastle-upon-Tyne.  
Newcastle-upon-Tyne 78058  
G, A, D, EC, RCN, IR, O, SYN, S, MA, RS,  
ERS, EK, B, W, L, H, M, SM, CB, Di

**NORFOLK**

**Cookes Band  
Instruments**  
18 St. Benedicts Street, Norwich. 0533 4026  
G, A, D, S, S/Hnd, RS, ERS, EK, K, B, W, PA, M

**NORWICH SOUND SYSTEMS**

80 Prince of Wales Road, Norwich  
Norwich 611989  
H, E, RS, RS, S/Hnd, S, D, A, G, SYN,  
EC, Di, PSG, AC, PA, M, MA, Traynor Pearl  
Gibson, Star Dealer, Yamaha and Disco  
Sound (in MA)

**JOHN SAVAGE MUSIC CENTRE**

71, 72 Norfolk Street, Kings Lynn, Norfolk  
0553 4026  
G, A, D, S, SM, S/Hnd, EC, SYN, RS, T

**JACK WHITE ORGANS**

48-50 St. Benedicts Street, Norwich  
0603 613678  
Pro. Keyboard Centre

**NORTHAMPTONSHIRE**

**PETER GRAY**  
212 Wellington Road, Northampton.  
0604 31211  
EK, RC, PA, CB, Port O, IR, (B & H Scheme), G,  
B, W, L, A, D, S, S/Hnd, RS, MA-Ludwig,  
Sonor, B & H Rental.

**NOTTINGHAMSHIRE**

**JACK BRENTNALL**  
Premier Music House,  
3 Market Street,  
Nottingham  
0602 47166  
G, A, EC, IR, D, S, RS, B, ERS, W.

**CLEMENTS' PIANOS LTD.**

21-23 Derby Road, Nottingham.  
0602 47912  
G, A, D, P, B, W, S, SM, RS.

**HARDY SMITH MUSIC CENTRE**

2a Outram St., Sutton-in-Ashfield, Notts.  
Mansfield 56242  
G, A, D, K, B, W, S, RS, SM.

**Farnsworth  
Music** 134 Radford Boulevard  
Nottingham 06021 76516  
Syn, G, A, S, S/Hnd, RS, ERS, K, D, W, H, T,  
M, SM, PA.

**SCOTLAND**

**BRADLEYS MUSIC LTD.**  
69a West Regent St., Glasgow.  
041 332 1830  
EC, RCN, MA, RS, Spec, G, A, D, B, S,  
PA, S/Hnd, T, M, P.

**Charnley**  
117 Main Street, Wotho  
06883 73097 G, A, D, K, B, W, S, RS

**FVM** FORTH VALLEY MUSIC  
37 Cow Wynd, Falkirk  
Tel: 012241 31473  
EC, O, SYN, G, A, D, S, ERS, EK, K,  
Ac, M, PA.

**JERRY ALLEN MUSIC**  
25 Titchfield Street, Kilmarnock  
0563 28450  
G, A, D, K, Di.

**C. B. MILLER & CO. LTD.**  
2 Queensgate Arcade, Inverness, Scotland.  
Inverness 33374  
G, A, D, S, EC, O, IR, S/Hnd, RS, ERS, EK, K,  
B, W, Di, M, T, Ac.

**THE MUSIC BOX**  
7-9 Whitburn Road, Bathgate.  
0506 52893  
G, A, D, K, B, W, S, RS, SM.

**NORTHERN MUSIC**  
58 Church Street, Inverness, Scotland.  
0463 221833  
EC, O, SYN, G, A, D, S, S/Hnd, MA (Custom  
sound, Lowrey) RS, Spec (Guitars), ERS, EK,  
K, Ac, SFI, T, PA, PSG, Di.

**WILKINSON'S MUSIC.**  
71 Stirling Street, Airdrie.  
02366 60873  
G, (Yamaha, Ibanez, Antoria, Hagstrom,  
Gibson, Fender) EC, O, MA, (WEM,  
Carlsbro, Marshall etc.), J, D, (Tama)  
S, S/Hnd, A, SM, PA, M, ERS, EK, B,  
W, AC, SFI, T arranged.

**SHROPSHIRE**

**THE  
GEAR CELLAR  
at SWANS**  
69 Market, Shrewsbury, Tel: 58264  
O, Syn, G, A, D, S, PA, EK, K, B, W, SM, PSG

**KEYBOARD INSTRUMENTS**, 13 Tower  
Street, Ludlow. Tel: Ludlow 2993.  
EC, O, Syn, G, A, S, S/Hnd, MA (Peavey,  
Kawai), RS, Keyboard Spec, ERS, EK, K, B,  
W, AC, SKF, M, RC, SM, PA

**SALOP MUSIC CENTRE**  
Unit 1, Town Walls, Shrewsbury  
0743 64111  
EC, IR, SYN, G, A, D, S, S/Hnd, MA,  
RS, Spec, ERS, EK, K, B, W, L, H, T, SFI,  
M, SM, PA, CB, Di.

**STAFFORDSHIRE**

**THE ABBEY MUSIC CO.**  
5-6 Market Place, Burton on Trent  
0283 68404  
G, A, K, B, W, RS, T, Spec, D

**JOHNSONS MUSIC CENTRE**  
37 Station Street,  
Burton-on-Trent, Staffs  
0283-44535  
Brass and woodwind Parade band  
equipment.

**LANGDONS ELECTRIC MUSIC**  
27 Victoria Street, Wolverhampton  
0902 27251  
Ec. RCn. Syn. G. A. D. S. S/Hnd. RS. ERS. L.  
PA. D. Gibson Star dealer. Maine Custom  
USA. Custom amplification.

**NORMANS MUSICAL INSTRUMENTS LTD.**  
1 Lichfield St., Burton-on-Trent.  
0283 42401/61528  
G. A. D. K. B. W. S. R. S. Gibson Star Dealer  
H/H. Boosey & Hawkes, Premier. SM  
Pianos.

**SUFFOLK**

**MORLINGS LTD**  
House of Music,  
149-151 London Road North,  
Lowestoft, Suffolk  
Lowestoft, 05491-713143  
EC. O. IR. SYN. G. A. D. S. S/Hnd MA.  
RS. ERS. K. B. W. L. H. AC. SFI. SM.  
P. SG. DI.

**SURREY**

**ABC MUSIC**  
14/16 High Street, Addlestone, Surrey  
0932 40139/54897  
96 High Street, Esher  
78 66436  
EC. RCn. O. IR. Syn G. A. D. S. S/Hnd.  
MA. RS. Spec. ERS. EK. K. B. W. L. H.  
Ac. SFI. T. M. RC. SM. PA. PSG. CB. Di

**CROYDON MUSIC STUDIOS**  
40 Station Road, West Croydon, Surrey  
01 688 0628  
G. A. D. S. S/Hnd RS. B. W. Ac SFI.  
M. SM. MA. (Premier, MXR)

**JOHN KING SOUNDS**  
8 Richmond Road, Kingston  
01 546-9100/9124  
O. IR. SYN. G. A. D. S. S/Hnd. MA (HH) RS  
Spec. EK. B. W. L. H. Ac. T. M. RC. PA. Di

**DICK MIDDLETON MUSICAL  
INSTRUMENTS.**  
51 Quarry Street, Guildford.  
0483 34537  
EC. O. IR. SYN. G. A. D. S. S/Hnd RS. ERS.  
EK. K. H. Ac. SFI. M. RC. PA. PSG. CB

**DOWN UNDER** KEYBOARD  
HARMONY  
82 High Street,  
Redhill, Surrey,  
91 68821  
EC. RCn. O. IR. Syn. G. A. D. S. S/Hnd. MA. RS.  
Spec. ER. EK. K. B. W. L. H. SFI. T. M. RC. SM.  
PA. CB. Di.

**brockbottom**  
14 London Road, West Croydon, Surrey. 01 688 1987  
Ac. SFI. T. M. RC. SM. PA. PSG. CB

**WESTERN MUSIC CO LTD**  
53-59 High Street Croydon,  
01 688 1246  
O. Syn. G. A. D. S. S/Hnd. (Lowery, Farfisa,  
Yamaha) SPEC (Keyboards) ERS. EK. K. B.  
W. AC. SFI. T. M. SM.

**WESTERN MUSIC CO. LTD.**  
125 High Street, Sutton, Surrey.  
01 661 1167  
O. Syn. G. A. D. S. S/Hnd. MA. (Lowery,  
Farfisa, Yamaha) SPEC (Keyboards) ERS.  
EK. K. B. W. AC. SFI. T. M. SM

**SUSSEX**

**CASSMUSIC**  
29 South Street, Eastbourne, Sussex.  
0323 37273  
EC. G. A. D. S. S/Hnd. MA. RS. Spec. ERS.  
EK. K. B. W. SFI. M. RC. SM. PA. CB.

**Hastings sound**  
37 Kings Road, St Leonards-on-Sea  
0424 428970 G. A. D. S. S/Hnd RS.

**SOUTHERN MUSIC**  
34 Waterloo Street,  
Hove, Sussex.  
0273 733387/774536  
EC. RCn. IR. Syn. G. A. S. S/Hnd MA. RS.  
Spec. (G. A.) ERS. EK. L. H. SFI. M. RC.  
PA. CB. Di.

**SHOREHAM  
MUSIC CENTRE**  
20 High Street, Shoreham-by-Sea, Sussex  
Phone: 0434 3442  
EC. O. IR. Syn. G. A. D. S. S/Hnd MA. RS. Spec. ERS.  
EK. K. B. W. L. H. SFI. M. RC. SM. PA.

**TYNESIDE**

**ROCK CITY MUSIC CO**  
48 CLOTHMARKET NEWCASTLE  
Tel: (0632) 24175  
THE NORTH'S BEST  
FOR GUITARS, AMPS & CABS  
KEYBOARDS, EFFECTS, DISCO,  
PERCUSSION, REPAIRS,  
Mail Order, H.P. Available.

**WHITE SOUND  
EQUIPMENT**  
3 Albion Place,  
Sunderland, Tyne & Wear 0783 78058  
Spec. RS. EC. O. IR. Syn. G. A. D. S. S/Hnd.  
ERS. EK. K. B. W. L. H. SFI. M. RC. SM.  
PA. PSG. CB. Di. MA. (Peavey, Marshall, Pearl,  
Amcor, Carlsbro, Fender, Rodgers, Ludwig,  
DJ Electronics, SAI, Gibson, Music Man).

**TYNE AND WEAR**

**LEWIS MUSIC**  
16 Bedeburn Road, Jarrow, Tyne and Wear  
0632 897784  
G. D. Spec. MA. Premier. Rogers Tama,  
Orange, Synair, Beverley Greisch. S/Hnd  
RS. ERS. S. T. M. RC. Drum Recovering and  
Customising. CB

**WALES**

**MUSIC STUDIO**  
15 Bridge Street, Carmarthen, Dyfed,  
Wales.  
0267 7759  
O. G. S. S/Hnd MA. Viscount. RS. EK. AC. T.  
SM.

**JOHN HAM**  
75-76 Mansel St., Swansea, Wales  
0792 50968  
G. A. D. K. B. W. Di. RS. SM. Tape Demo  
Gear

**MUSIC CENTRE ABERDARE**  
13c Canon Street, Aberdare, Mid  
Glamorgan.  
Aberdare 074141  
O. G. A. RS. S. SM. M. K. SYN. ERS.

**PETER NOBLE LTD.**  
11 Station Road, Llanishen, Cardiff  
0222 753911  
EC. SYN. G. K. B. D. P. W. S. Di. L. S/Hnd  
M. Spec. PA. ERS.  
Yamaha and Pearl pro centre.

**RHYL SOUND CENTRE**  
25 Vale Road, Rhyl, Nth. Wales  
Rhyl 51436  
G. A. RS. Di. E. O. SYN. D. S. S/Hnd.  
ERS. K. EK. L. M. SM.

**SOUND CENTRE**  
129 High Street, Bangor  
0248 53320  
A. Di. L. RS. SFI. H. SM. Spec. G. D. O.

**SOUNDWAVE MUSIC CENTRE**  
51 Gwent Square, Cwmbran, Gwent,  
Wales.  
06333 2501  
SFI. T. M. RC. SM. PA. CB. Di. EC. O. IR.  
SYN. G. A. D. S. S/Hnd. RS. ERS. EK. B.  
H. Ac. MA. Music Man, Gibson Star Dealer,  
John Birch.

**BERT VEALE (MUSICAL) LTD.**  
8 New St., Neath, Glam.  
Neath 2825  
EC. RCn. O. SYN. MA. RS. MA. RS. Spec  
EK. G. A. D. K. B. W. S. Di. L. Ac. SFI. PA.  
PSG. S/Hnd T. M. SM. P.

**WILTSHIRE**

**Mitchell Music  
& Electronics**  
2 Queen St., Swindon,  
Wilt. 0753 21912  
EC. H. S. Syn. EK. RS. RCn. SM. G. A. D. K. E. C. Di. MA. Gibson Star Dealer  
L. PSG. S/Hnd. Spec. ERS.

**WARWICKSHIRE**

**BUZZ STOP**  
24 Regent Street,  
Leamington Spa, Warwickshire  
01926 32281  
O. Syn. G. A. D. S. S/Hnd. RS. EK. K. B. W.  
L. Ac. M. SM. Di.

**CENTERSOUND**  
11 Castle Street, Rugby, Warwickshire.  
0788 74566  
RCn. O. IR. S6n. G. A. D. S. S/Hnd MA.  
RS. ERS. EK. L. H. M. RC. SM. PA. Di.

**S. A. RENTON LIMITED**  
25 High Street, Leamington Spa,  
Warwickshire.  
Tel: Leamington 26703  
G. A. S. S/Hnd. RS. W. SFI. M. SM. Early  
Hand made Inst

**WORCESTERSHIRE**

**MALVERN MUSIC**  
19 Abbey Road, Malvern, Worcs  
Malvern (06845) 5567  
**WORCESTER MUSIC CENTRE.**  
75 Bull Entry, Worcester  
Worcester (0905) 20279  
EC. O. G. A. D. S. S/Hnd MA. Fender,  
Gibson, Premier, Yamaha RS. Spec. ERS.  
EK. K. L. H. T. M. SM. PA. Di.

**ROCK SHOP**  
201-203 Stourbridge Road, Holly Hall,  
Dudley  
Tel: 0384 74700  
EC. Syn. IR. G. A. Dr. Str. S/Hnd MA  
Carlsbro MM, Randall Arja Marshall  
Peavey, Yamaha Fender, Ludwig Pearl  
Gibson Star Dealer Tama Sonor Custom  
Sound, Roland Rosetti Hohner CMI  
Hagstrom, Antoria ARP EMI Music ERS  
EK. K. L. H. (Br. W. Ac. to order) SFI. T. M.  
RC. CB. (PSG to order) PA. Di.

**YORKSHIRE**

**ALBERT HIND**  
16-18 Waterhouse Street, Halifax, Yorks  
0422 53879  
A. G. P. O. D. S. W. SM.

**JIGSAW SOUND CENTRE**  
2 Station Road,  
Ossett, W. Yorks  
(0924) 277981  
Fender, Gibson, Vox, Carlsbro, Orange,  
WEM, Custom, Pearl, Rogers, Area agents  
for MM equipment.

**J.S.G. MUSICAL SERVICES**  
180, Main St., Huddersfield, West Yorkshire  
0474 519411  
EC. H.  
M. A. Custom, Eastern, South, Musical Man  
Drum Repair.

**★ STUDIO GUIDE ★**

**BEDFORDSHIRE**

**PIPER SOUND STUDIOS**  
50 Cheapside, Luton Beds.  
0582 605875/27195/26693  
8T £8 p/h 16T 10 p/h incl. tape Cap 10 R-R  
C-D, DBX, Comps/Lims Sm, ff, CP, Ac/ba, I.  
A. Ampex Mastering Echo Plates, TV  
**QUEST STUDIO**  
721 Windmill Road, Luton, Bedfordshire.  
0582 414297/36960  
8T Cap 8, from £6.00 p/h. p/d ba. D. ff. R-R,  
CP, R-C, Dc, Ba, d-t, Piano, M.S. Ac. ba. SM.  
Eventide effects

**ROLLING THUNDER STUDIO**  
21A Bridge Street, Leighton Buzzard, Beds  
05253 71622  
16 Track Master Recording Studio £12 p/h

**BIRMINGHAM**

**GROSVENOR RECORDING STUDIO**  
(Hollick & Taylor Recording Co)  
15 Grosvenor Road, Handsworthwood,  
Birmingham B20 3NP  
021 356 9636  
Studio 1 16T Cap 35, £27 p/h  
Studio 2 2T Cap 10, £18 p/h  
Studio 2 16T Cap 35, £34 p/h  
ff. R-R. CP. Ka RC. Dc. d-t. M.S. fcf. SM

**ZELLA RECORDING STUDIOS**  
Walker Hall, Ampton Road, Edgbaston,  
Birmingham B15 2UJ  
021 455 0645  
8T £15 p/h (10am-10pm after 10pm and  
Sundays £20 p/h) Cap 35 ff. R-R. R-C. R-  
C. d-t. CP. Ka (Bechstein, Chappell baby-  
grand) DC. OTC. M. S. SM. ba

**BRISTOL**

**MUSHROOM STUDIOS**  
18 West Mail, Clifton, Bristol.  
0272 35994  
8T £10.50 p/h Cap 17. R-R-C-Cr CP DBX D  
Ka Disc Pressing, Accommodation 6  
bedrooms, self catering  
**SOUND CONCEPTION**  
85 Ashley Road, Montpelier, Bristol 6  
0272 554721  
8T £9p/h. £75p/d. Cap 10. ff. R-R. R-C. d-t.  
CP. Ka. (Bechstein Grand Piano) SM.

**KEYBOARDS**  
54-58 The Headrow, Leeds  
251 Otley Road, Leeds 16  
0532 468939  
O. H. SYN. A. MA. Yamaha Farfisa Crumar  
RS. Spec ERS. EK. E. Acc T SM

**MUSIC GROUND**  
Station Road, Stainford, Doncaster, South  
Yorkshire  
0302 843037  
EC. RCn. O. Syn. MA. RS. G&A Spec  
ERS. EX. D. K. PSG. S/Hnd. T. M. RC. P

**PROFESSIONAL MUSIC CENTRE**  
13 Netherhall Rd., Doncaster  
0302 68157  
G. A. B. W. K. T.  
EC. RCn. O. IR. Syn. D. S. S/Hnd MA.  
RS. Spec. Organs perc. ERS. EK  
M. H. RC. PA.

**KEY FOR DEALER GUIDE**

EC	Echo Chamber
RCn	Re-Coning
O	Organs
IR	Instrument Rental
SYN	Synthesizers
G	Guitars
A	Amplifiers
D	Drums
S	Strings
S/Hnd	Second Hand
MA	Main Agents
RS	Repair Service
Spec	Specialists
ERS	Electronic Repairs
EK	Electric Keyboards
K	Keyboards
B	Brass
W	Woodwind
L	Lighting
H	Hire
Ac	Accordions
SFI	Special Fretted Inst
T	Tuition
M	Mikes
RC	Reconditioning
SM	Sheet Music
PA	Public Address
PSG	Pedal Steel Guitars
CB	Custom Building
Di	Disco

**BUCKINGHAMSHIRE**

**MAURICE PLACQUET**  
Pinewood Ltd., Pinewood Film Studio,  
Pinewood Road, Iwer, Bucks.  
0753 654 571/0753 651 700  
Cap 60 when touring ring Iwer 654571 for  
the following, Rehearsals, Sound  
Recordings, Promotional Filming.  
Instruments available including  
amplification, PA System, Steinway Grand  
Piano Hammond 83 & C3 Organs Ac/ba,  
Sm.

**CAMBRIDGESHIRE**

**SPACEWARD RECORDING STUDIOS**  
19 Victoria Street Cambridge  
0223 64263 24 hours  
16T from £99 p/d f9 p/h 2T £6 75 p/h D  
ff. R-R. R-C. C-C. CP. Ka. Dc. d-t. no OTC  
Ac. SM production, arrangement, location  
and live recording and PA in Europe ba.  
**CHESHIRE**

**STRAWBERRY RECORDING STUDIO (UK)  
LTD.**  
3 Waterloo Rd., Stockport Cheshire.  
061 480 9711  
24T £30 p/h 16T £35 p/h 8T £18 p/h, 2T  
Stereo & Mono £15 p/h Cap 35, ff. D. R-R.  
R-C.

**COVENTRY**

**HORIZON STUDIOS**  
Now 16T The rates are applicable for 16T  
and for 8T.  
Horizon House, Coventry CV3 6OS  
0203 21000  
16T £19 p/h 8T £14 p/h 4T £10 p/h 2T £6  
p/h Cap 20 Dc/ba R-R-C Ka SM/ba Special  
rate day bookings.

**DEVON**

**WEST OF ENGLAND SOUND LTD.**  
14 Swan St., Torquay, Devon  
080428 278  
Studio 1 8T £8 p/h Cap 30  
Studio 2 8T £8 p/h Cap 10  
R-R-C-Cr CP Pro PA Equipment for hire.

## GLOUCESTERSHIRE

**MILLSTREAM RECORDING STUDIOS**  
Vernon Place, Cheltenham  
Tel: 0242 43243  
16T £16.00/no OTC Cap 6 mus; £160  
p/d; D: R-R, R-C, Cf, Ka, M.S. SM, ba.  
AC, ba.  
**WINDRUSH RECORDING STUDIO**  
(Between Oxford and Gloucester)  
High Street, Bourn-on-the-Water,  
Gloucestershire  
0451 20172  
4T £4.00 p/h £35.00 p/d Cap 7, R-R, R-C,  
d-t, CP (K A G D ba) Ac, ba, M.S. SM, ba

## HEREFORD

**CHAPEL LANE STUDIOS**  
Hampton Bishop, Hereford  
0432 73430/65198  
16T £20 p/h 8T £12 p/h Cap up to 15  
musicians if R-R, R-C. No OTC CP, MS.  
Good AC, ba, all SM, ba, bass, drums, guitars,  
etc. Use of instr. Steinberg Rugged Ruger,  
drums, Fender amps, String synth, etc.

## Huddersfield

**SEPTEMBER SOUND STUDIOS**  
38 Knowl Road, Golcar, Huddersfield,  
HD7 4AN  
0484-658995, 8  
16T, Cap 45 £15.00 p/h, p/d ba D, R-R, R-  
C, R-C, ba CP, M.S. vs Ac, ba, SM, ba, Oba,  
Ka, Drums

## N. HUMBERSIDE

**FAIRVIEW MUSIC**  
Willerby, Hull, N. Humberside  
0482 653116  
8T £8.50 p/h p/d neg. Cap 10, R-R, CP,  
Ka, R-C, d-t, M.S. SM.

## KENT

**ESCAPE STUDIOS**  
Island Farm, Edgerton, Kent  
023 376259  
16T £350 p/d Cap 10 D, Ac

**INDEPENDENT RECORDING STUDIOS**  
39 Harmer Street, Gravesend, Kent,  
0474-656887  
8T Cap 20 From £10 p/h or £70 p/d.  
D, All if R-R, CP, Kba, (Grand Upright String  
Synth) Dc, No OTC, M.S. SM, (all types) by  
arr. Acc by arr. Food and drink available on  
premises.

## LIVERPOOL

**AMAZON RECORDING STUDIO,**  
Music House, 1 S.D. Stopgate Lane,  
Simonswood, Liverpool 33  
051-545 6444/0434  
8T, Cap 20 £10 p/h R-R, CP, Ka, R-C, Dc, d-  
t, OTC, £12 p/h M.S. Ac/ba, SM.  
24T Cap 30 £35 p/h D, R-R, CP, Ka, R-C,  
d-t, OTC £38 p/h Ac/ba, SM.  
Steinway Concert Piano, Hammond C3.

**AUGUST SOUND STUDIOS**  
16 Benson Street, Liverpool 1,  
051 708 0005  
16T p/d neg. 8T £10.50 £86 p/d (inc spool  
& tape) Cap 8, R-R, R-C, CP, Ka,  
(Bechstein Piano, Hammond organ, Moog  
Synth.) NO OTC, M.S. AC, ba, SM.

## LONDON

**ABBNEY ROAD STUDIOS (EMI)**  
3 Abbey Road, St John's Wood, NW8 9AY  
01 285-1161  
24T £48 p/h 16T £46 p/h 8 or 4T £44 p/h  
2T £42 p/d neg Cap 120 if R-R, R-C, Cp,  
Ka, DC (Playback Lacquers) d-t, OTC,  
M.S. (Custom Disc Pressing, Electronic  
process, Mono to Stereo, 2 Mobile  
recording units operating in any country).

**ALVIC STUDIO**  
13 All Saints Road, Wimbledon, SW19  
01-542 5695  
4T Cap 8 £6.00 p/h, R-R, R-C, R-C, CP  
Piano, M.S. SM, ba, Drums, Amps

**ANEMONE SOUND FACILITIES LTD.**  
D'Arblay House, 10 Poland Street, London  
W1V 3DE  
01 439 9511/2  
8T rates negotiable Cap 10 KA Synthesiser  
and amps, D & DBX CP R-R, C-D, D & DBX  
M.S. cassette high-speed duplication.

**BASING ST & ISLAND MOBILE STUDIOS**  
8-10 Basing St., London W11,  
01 229 1229  
Studio 1 24T £48 p/h up to 6pm, £55 p/h  
after 6pm, weekends and holidays. Cap 80  
Studio 2 24T £48 p/h up to 6pm £55 p/h  
after 6pm, weekends and holidays. Cap 20  
Island Mobile: 24T and 16T £500 p/d  
R-R, C-Cr £10 p/h D, OTC.

**BERWICK STREET RECORDINGS**  
8 Berwick Street, London W1  
01-734 1888/5750  
24T Cap 16 £40 p/h D, R-R, CP, Ka, R-C,  
t, M.S.

**B.T.W. RECORDING STUDIO**  
125 Myddleton Road, Wood Green,  
London N22,  
01-888 6855  
4T Cap 10 £6.50 p/h R-R, Ka, d-t, M.S.  
SM

**CBS RECORDING STUDIO**  
31-37 Whitefield St., London W1  
01 635 3434  
Studio 1 £52 p/h 24T Cap 75  
Studio 2 £52 p/h 24T Cap 25 & automated  
desk  
Studio 3 £49 p/h 24T Cap 12  
DC, R-R, C-Cr, D All studios multi-track

**CENTRAL RECORDERS LTD**  
9 Denmark Street, London WC2H 8LP  
01-836 8061  
24T Cap 20 £32 p/h D, R-R, CP, Ka, R-C,  
d-t, OTC £5 p/h, M.S. Ac/ba, SM

**CHALK FARM STUDIOS,**  
1A Belmont Street, London NW1  
01 485 5798  
16T Cap 15 £18 p/h, D, TF, R-R, CP, Ka,  
R-C, DC, D-T, OTC £3 p/h, M.S. SM

**DECIBEL STUDIOS**  
19 Stamford Hill, London N15  
01 802-7868  
24T £27 p/h, p/d neg. Cap 20, D, R-R, CP,  
Ka (Yamaha Grand and Synth), R-C, d-t, Q, OTC, £2,  
M.S. fcf Ac, ba, SM.

**ELEPHANT RECORDING STUDIOS**  
181A Long Lane, London SE 1  
01 403-3505  
8T £6 + £5 1" Tape hire, £30 per 6 hours,  
Cap 8, if (Brenell 8 track - Revox 2T, R-R,  
Cp, Ka, (Piano, Organ), R-C, OTC (after  
11pm £2.00 p/h) M.S. SM, ba

**FOREST STUDIO**  
189 Hainault Road, Leytonstone, E11  
01 558 3344  
24T £18 p/h 16T £16 p/h 8T £10 p/h  
(Block Bookings - more than 10hrs. neg) if  
R-R, R-C, Cap 25, CP, Ka, (2 Organs,  
Synthesizers, Pipe Organ, Piano etc., DC,  
ba, NO OTC, M.S. AC, SM

**FREE RANGE STUDIO**  
22 Tavistock Street, London WC2  
01-836 7608  
16T £15 p/h neg p/d Cap 30 if R-R, CP, Ka  
(Grand Piano) No OTC, MS fcf VS, SM

**GOOSEBERRY STUDIOS**  
19 Gerrard Street, London W1  
01-437 6255, 01-734 2257  
16T £16 p/h (discounts available on sliding  
scale), 8T £13 p/h Cap 8 D, R-R, CP, Ka,  
Hammond L100, Roland SH2000, Fender,  
Rhodes) R-C, d-t, OTC, M.S. SM, ba

**R.G. JONES**  
Beulah Road, Wimbledon SW19  
01 540 9881  
24T £40 p/h 16T £35 p/h Cap 40 R-R, C-D  
OTC, Studio 2 Stereo only £7 p/h.

**KINGSWAY RECORDERS LTD.**  
129 Kingsway, London WC2  
01 242 7245  
24T £38 p/h Cap 35  
16T £34 p/h Dc, ba D

**KPM STUDIOS**  
21 Denmark Street, WC2,  
01 836 6699  
18 Track £28 p/h, Cap 18 Copyshop  
£12 p/h

**MARGRITTE MUSIC**  
15 Holloway Lane, Harmondsworth, West  
Drayton,  
01 897 9670  
16T £20 p/h 8T £10 p/h, Cap 12  
DC/ba, if, DBX, SM, Ka, R-R, C all rates  
negotiable Fender, Marshall and more  
available

**MAJESTIC RECORDING STUDIO**  
146 Clapham High St., London SW4  
01 622 1228/9  
24T £34 p/h Cap 50 R-R, C, DBX, CP, OTC £5  
p/h

**MARQUEE STUDIOS**  
10 Richmond Mews, Dean Street, W1,  
437 6731/2  
24T/16T £44 p/h p/d neg. Cap 35, D, R-R,  
R-C, d-t, CP, Ka (Steinway) £8p/h OTC,  
MS, S. (Remix & Studio with MC1 500  
series automated consoles. Live recording  
facilities to adjoining Marquee Club).

**MILNER SOUND LTD**  
117c Fulham Road, London SW3  
01 589 6477  
8T Cap 14 £14 p/h R-R, CP, Ka, R-C, DC,  
d-t, M.S.

**PATHWAY STUDIOS**  
2A Grosvenor Avenue, London N5  
01 359 0970  
8T £8 p/h, Cap 6, R-R, CP, R-C, d-t

**RADIO LUXEMBOURG STUDIOS**  
38 Hertford Street, W1,  
01 493 6961  
Studio 1 8T £14 p/h, Cap 8, D, R-R, R-C,  
R-Cr, d-t, CP, Ka (Steinway grand, ARP  
2600 Synth) OTC, £4 p/h, (6.00am -  
9.30pm Weekends & Bank Holidays) M.S.  
SM, ba.  
Studio 2 Self op £12 p/h, Radio productions  
and commercials.

**RAMPART ENTERPRISES LTD.**  
115 Thessaly Road, London SW8  
01 720 0566  
Cap 40 8am-12noon 12T & 24T £30 p/h,  
12noon-6pm 16T £35 p/h 24T £40 p/h  
6pm-8am next day flat rate w/ends Bank  
Hols, 16T £40 p/h 24T £45 p/h £12 p/h  
editing copying D & DBX Bosenrdorfer,  
Rhodes, Hammond B3 Q M S, R-R, R-C,  
R-C, R-Cr, d-t, SM, ba

**REDWOOD RECORDING STUDIOS**  
15 Neals Yard, WC2,  
01 240 0568  
8T £18 p/h, Cap 8, R-R, R-C, R-Cr, d-t, CP,  
Ka, (Rhodes, ARP Odyssey, Roland String  
Synth, Daneman Piano) Q, OTC (+25% of  
hourly rate) M.S. SM

**REGENT SOUND STUDIOS**  
4 Denmark St., London WC2  
01 836 6769  
16T £16 p/h Cap 20 R-R, C OTC, Sound  
Techniques Desk 18 x 16

**RIVERSIDE RECORDINGS**  
78 Church Path, Fletcher Road, Chiswick,  
London W4  
01 994 3142  
16T £16 p/h Reductions on block bookings  
8T £14 p/h, OTC £2 p/h, R-R, CP, Kba, R-  
C, R-C, d-t 8T Mobile Bechstein Session  
Musicians

**ROCK STAR RECORDING STUDIO**  
63 Charlotte Street, London W1  
01-637 0999  
16T £16 p/h Cap 15 D, R-R (Revox,  
Ampex) R-C No OTC, M.S. AC, ba, SM  
(Drummers, Guitarists)

**ROX BOX STUDIO**  
92 Devonshire Road, Chiswick, W4  
01 570 7821  
4T £5 p/h p/d neg Cap 7 if R-R, R-C, CP,  
M.S. SM, ba (Fender, Marshall, HH, Amps)  
Rehearsal Studios £2.00 p/h

**STAGE ONE STUDIO**  
14 Sebert Road, Forest Gate, London E7  
01 534 5472  
8 Track £9.50 p/h 4 Track £6.50 p/h,  
Cap 10, R-R, R-C, R-Cr, D-T, CP, Ka, DC, M.  
S. AC, SM.  
**STUDIO G**  
145 Wardour Street, London W1  
Tel: (01) 734 5784/5572  
8T £18 p/h, no OTC (eves and weekends),  
Cap 12 R-R, R-C, R-Cr, D-T, CP, Ka,  
Clavinet, Yamaha Synth, Bechstein pno,  
Elka string machine, M.S. Neve Desk,  
Studer, m/m Neumann, AKG, Shure M, EMT  
Reverb, Studer 8-T

**SARM STUDIOS**  
Osborn Hse., 9-13 Osborn St., London E1  
247 1311  
24T £42 p/h 16T £42 p/h RECORDING &  
mixing Cap 30 R-R, C-Cr, D, Oba (NO OTC)

**SAV STUDIOS**  
34 Crickwood Broadway, NW2  
01 450 4455  
8T (17) £16 p/h Cap 5, DBX, if, R-R, R-C, R-  
C, d-t, CP, Ka (Piano) DC, OTC, M.S. SM

**THE SOUND SUITE RECORDING STUDIOS,**  
92 Camden Mews, London NW1  
01-485 4881  
16T £16 15 p/h 8T £10 p/h, 15% discount  
for settlement within 10 days if R-R, R-C,  
d-t, CP, S. No OTC, JBL monitoring (graphic  
equalised), SM, ba Master room Fender,  
Rhodes Suitcase 88, Tama drumkit, Fender  
Jazz bass, Grand piano.

**THEATRE PROJECTS SERVICES LTD.**  
11-13 Neals Yard, Monmouth St., London  
WC2  
01 836 1168  
Studio A 8T £12 p/h and piano Cap 15  
(demo tape)  
Studio B M.S. £12 p/h Cap 6 (voice overs)  
R-R, C OTC.

**UNDERHILL STUDIO**  
178 Newcross Road, London SE14  
01-639 3090  
16T £25 p/h Block bookings neg. Cap 25  
(30RPS), R-R, R-C, CP, Ka (grand pianos,  
string machine, Mellotron) d-t, No OTC,  
M.S. SM

## MANCHESTER

**ARROW SOUNDS LTD.**  
6-10 Jacksons Row, Manchester 2  
061 833 9417/832 8457  
24T £35 p/h £225 p/d 16T Cap 35 £25  
p/h p/d ba, D, R-R, CP, R-C, R-Cr, d-t, Ka, O,  
OTC, after 9.00pm MS, SM

**PLUTO STUDIOS**  
36 Granby Row, Manchester 1  
061-228 2022  
16T £28 p/h 8T £25 p/h Cap 35, R-R, CP,  
R-C, d-t

## MIDDLESEX

**LANE STUDIO**  
87 Deans Lane, Edgware, Middlesex,  
01 959 6369  
4T £4 p/h, 2T £2 p/h, Cap 8, R-R, R-C, ba,  
M.S. SM /ba NO OTC, (Drums & Guitars  
available. No extra charge).

**VILLAGE WAY STUDIO**  
228 Imperial Drive, Rayners Lane,  
North Harrow,  
01-868 2073  
16T £18 p/h fully Dolby R-R, R-C, No  
OTC, +S, CP, Overdubbing, Bechstein,  
Summerfield grand Roland SM by  
arrangement Scamp rack

## NOTTINGHAMSHIRE

**RAINBOW SOUND LTD.**  
Pearson Buildings, 26/28 St. James Street,  
Nottingham,  
0602 41 2749  
8T £9 50 p/h, p/d, ba, Cap 6 R-R, R-C, Ka,  
d-t, No OTC, M.S. Ac, ba, SM, ba, Rock  
specialists

**SIN CITY MUSIC OF NONPONEX LTD.**  
c/o Fiat 1, 1 Shirley Road, Mapperley Park,  
Nottingham  
0602 624666  
4T £4.50 p/h £39 p/d Cap 8 R-R, R-C,  
D-T, M.S., Ka, DBX, AC, SM & DC, ba,  
Various instruments and amplification both  
available and/or by arrangement. Fully  
Professional Recording Equipment and  
Accessories.

## OXFORDSHIRE

**MANOR STUDIO**  
Shipton Manor, Shipton-on-Cherwell,  
Kidlington, Oxford,  
08675 2128  
24T £800 per day, Quad, Cap 20, D  
Accommodation: 8 bedrooms & resident  
chef

## PORTSMOUTH

**TELECOMMS RECORDING STUDIOS**  
189 London Road, North End, Portsmouth  
0705 60036  
8T £9.00 p/h £48 p/d Cap 8 R-R, CP,  
(Cassette + 1/4") Ka (Rhodes, ARP OMNI,  
Korg, Preset, Cat) R-C, R-Cr, d-t, M.S. Ac,  
ba, SM.

## SCOTLAND

**CRAIGHILL RECORDING STUDIOS**  
68 Craighill Road, Edinburgh, EH6 4RL,  
031 552 3685  
16T £22 p/h, p/d neg, D, R-R, R-C, CP,  
Ka, (Steinway grand, Hifen organ) d-t, Q,  
OTC (+25% on basic after 6.00pm of  
Saturdays and Sundays), M.S. SM, ba, Ac,  
ba, (8T Mobile available, Prices on request.)

**SIROCCO STUDIO**

1 Glencairn Square, Kilmarnock, Ayrshire.  
0563 36377  
8T 6-8 Cap. £6 p/h. p/d special rates: ff. R-  
C. R-R. CP. Ka. No OTC. SM always  
available. Ac. ba. M. S. Dynacord effects.

**SURREY****RIDGE FARM (MOBILE RECORDING STUDIO)**

Capel, Nr. Dorking, Surrey  
0306 711202  
£40 p/d. No OTC (Steinway Grand, Gibson  
Les Paul) 60' x 22' AC (12 Persons. £12 p/d.  
p/p. 3 meals per day. £6 p/d per person self  
catering). Block Bookings Neg.

**SURREY SOUND STUDIO**

70 Kingston Road, Leatherhead.  
53 79444  
MC1 24T £25 p/h. £250 p/d. (12hrs). 16T  
£22.50 p/h. Automated CAP 40 No OTC. 4  
to 8/16 R-R. R-C. CP. Grand Piano other K  
by prior arrangement. d-t. MS. AC. ba. SM.  
Any Catering Facilities.

**E. SUSSEX****BLUEBELL STUDIOS**

Bluebell Farm East Sussex.  
058083 635  
16T £15 p/h. (Over 10hrs £10 p/h.) Cap 5 ft.  
R-R. R-C. R-Cr. d-t. Cp. Ka. NO OTC M. S.  
SM ba.

**W. SUSSEX****OBIDEC RECORDING STUDIOS.**

Dorvic Building, Quarry Lane, Chichester,  
West Sussex.  
0243 83265  
8T £8 p/h £65 p/d (10 hr.) £250 p/wk. Cap  
16 ft. R-R-R-C d-t CP. M. S. Ka  
Dc/Ac/Sm/ba.

**TYNE & WEAR****IMPULSE RECORDING STUDIO**

71 High Street East, Wallsend NE28 7RJ  
Tyne & Wear  
0632 624999  
8T Cap 25 £12 p/h DBX ff R-R CP Ka R-C d-t  
OTC SM

**MORTON SOUND.**

13-15 Carlisle Square,  
Newcastle-upon-Tyne.  
0632 26902  
8T £5 p/h Cap 10 DC R-R-C R.

**WALES****BBC WALES**

Stacey Road Studio, c/o Broadcasting  
House, LLantrisant Road, Cardiff.  
Tel: 0222 493053  
16T £20 p/h. 8T £10 p/h. (Block bookings  
neg.) CAP 40. D. ff. R-R. R-C. d-L. CP. Ka  
(Schstein Baby Grand, Yamaha Electric  
Piano, Poland String Synth. Drum Kit,  
Electric Organ). Q/ba. OTC + 25%. M.S. fct.  
VS. AC/ba. SM. (Also 22T facility available).

**FOEL STUDIO LTD**

Foel, Llanfair Ceareinion Powys Wales  
093 882 756573  
16T Cap 10 £175 p/d ff. R-R. CP. Ka. R-C.  
Dc. M. S. AC/ba. SM.

**ROCKFIELD STUDIOS**

Amberley Court, Rockfield Rd., Monmouth  
0600 2449/3625  
Studios 1 & 2, 24 T. 40 Channel Custom  
Built Mixer, Natural Acoustic Echo Room,  
Auxiliary equip. to cover all eventualities.  
ALSO Acoustically insulated Rehearsal  
Studio in 10 Bedroom country house. 1½  
miles of fishing available. ALL prices on  
application only.

**WARWICKSHIRE****BIRD SOUND STUDIOS**

Wedgcock Industrial Estate, Warwick.  
0926-45123/4  
8T £12 p/h Cap. 20 DC/ba. R-R.-C DBX  
OTC £14 p/h

**WORCESTERSHIRE****THE OLD SMITHY RECORDING STUDIO**

The Old Smithy,  
1 Post Office Lane, Kempsey, Worcester.  
0905 820566  
16T £20 p/h p/d/ba. Cap. 35 D. ff. R-R-R-C  
Dc. CP. Ka. No OTC. M.S. VS. Ac. SM

**ROOK MUSIC**

Anglo House, Worcester Road, Stourport-  
on-Severn.  
Tel: 029 93 77626  
8T £10 p/h. Cap 15. ff. R-R R-C. CP. t-d. M.  
S. SM.

**W. YORKSHIRE****LEADER SOUND**

209 Rochdale Road, Greetland, Halifax, W.  
Yorks  
04227 6161  
8T £75 p/d Cap 8 D. DBX. R-R. R-C. CP. Ka  
(Piano). Dc ba. M.S. Ac. SM ba.

**SOUND COMMUNICATION (PUBLISHERS) LTD.**

Dewsbury, W. Yorkshire.  
0924 469436  
Loop-bin cassette copying and R-R copying.  
Dolby A & D facilities. Blank cassettes of  
any length supplied.

**KEY FOR STUDIO GUIDE**

T	Track
Cap	Capacity
p/h	per hour
p/d	per day
D	Dolby
tf	Transfer facilities
R-R	Reel to Reel
CP	Copying
tba	to be advised
Ka	Keyboards available
R-C	Reel to Cassette
R-Cr	Reel to Cartridge
Dc	Disc Cutting
d-t	Disc to tape
Q	Quad
OTC	Overtime charge
M	Mono
S	Stereo
fcf	Fully coated film
VS	Video Studio
AC	Accommodation
ba	by arrangement
SM	Session Musicians

**KEY FOR HIRE COMPANIES**

ME	Musical Equipment
T & C	Transport & Crew
RhR	Rehearsal Rooms
SL	Stage Lighting
Sc	Security
Di	Disco
CM	Channel Mixer
CTM	Concert Tour Management
PA	Public Address
ST	Storage
R	Repairs

**Loughborough Music Hire**

18 The Rushes, Loughborough

0509 35390

88, 12 C. HARRIS DR. CH. WA. C. 238



**A. C. LIGHTING**  
57 The Crescent, Totteridge, High  
Wycombe, Bucks.  
For enquiries please ring 06285 28522  
SL. T & C. Di. CM. PA. Mr Leggett.

**ACME P. A. HIRE**  
Willow Bank, Leeds Road. Otley, Yorkshire.  
08434 2261  
P.A. 1,000 watts. T&C 16 CM. Di

**ANDROMEDA SOUND SYSTEMS (IRELAND)**  
1 Thirlmere Gardens, Belfast, BT1 5SEF  
0232 772491  
Pa. SL. CTM. Sc. T & C ME. R

**BAN MANAGEMENT**  
89/97 St. John Street, EC1 M4AB  
01 253 9410  
ME. T & C. RhR. SL. Ba. St. R. CM. (24 or 16)  
P. A.

**CASCADE MUSIC & HIRE**  
42-44 Upper Tooting Road,  
Tooting, SW17  
01 672 3997  
ME. T&C. ba. SL. Sc. Di. CM. PA.

**CERWIN VEGA UK**  
281 Balmoral Drive, Hayes, Middlesex.  
01 573 1566  
ME. T & C. CM. P. A.

**COLAC SOUND & LIGHTING EQUIPMENT RENTALS.**  
212 Carlisle Lane, London SE1 7LH  
261-1705  
Midas Martin PA System SL, T&C

**COUNTERPOINT STEVENAGE**  
5, Queensway, Stevenage, Herts.  
Stevenage 50815 Day  
Hitchin 35717 Evenings only  
ME. Di. CM. PA.  
Full repair service. Not evenings.

**C.P. HIRE,**  
Pier House, Strand on the Green, Chiswick,  
London W4  
01-994-7135  
Flight Case Hire & Staging Hire

**CUSACK'S MUSIC,**  
33 Braunstone Gate, Leicester.  
0533 548517  
ME. SL. Di. CM. PA. Competitive Rates

**EUROPA CONCERT SYSTEMS EUROPA CONCERT SOUND LTD.**  
11A Sharpleshall Street, London NW1  
01 586 3848  
PA Mixers. T & C CTM.

**H. W. AUDIO**  
156 Bradshawgate, Bolton, BL2 1BA.  
0204 26639  
D.I.Y. or T & C. Instrument Amps. P.A. and  
Di. S.L. and Di. L.

**JULIAN'S S. I. R. LTD.**  
2 Churchill Road, London NW2.  
459 7294/5  
M.E. Demo room, repair workshop

**KELSEY ACOUSTIC HIRE**  
1 Alfa Place, London W11.  
01 721 1046  
ME. T & C CM. CTM. PA.

**MAURICE PLACQUET HIRE**  
69 Jeddo Rd., London W12.  
01 749 3232  
PA. ME. T & C. RhR. Di. Cm. CTM.

**MITREX**  
951 Oldham Road, Newton Heath,  
Manchester M10 6FE  
061-205 8093  
ME. T + C Di. 12 CM. PA 2 miles from city  
centre

**MUSCLE MUSIC**  
74 Great Suffolk Street, London SE1.  
01 633 0065  
ME. T & C. RhR. SL. CM. CTM. PA. ST. R.

**THE P. A. COMPANY**  
7-9 Market Road, London N7  
01-607 0087/8  
ME. PA. T & C. RhR. Sc. CM. Spec in Yamaha  
Equip.

**PILEDRIIVER EQUIPMENT HIRE**  
11 Harrison Gardens, Edinburgh 11.  
031 337 1071  
ME. T & C. SL. Di. PA. 16T Chhannel Mixer  
Frunt. MM. Rose Morris.

**P.S.H.**  
Block 6/8, The Avon Trading Estate,  
Avonmore Road, West Kensington, London  
W.4.  
01-603 4438  
Zoot Horn PA to 4000W. Backline ME.  
Storage. RhR. T & C.

**RED UK PA HIRE**  
Coolderry, Rising Lane, Lapworth, Solihull,  
Warwickshire.  
05643 2860  
Enquiries to Mark Robbins  
ME. T & C. CM. CTM. PA. ST.

**RIG HIRE**  
20A Russell Parade, Golders Green Road,  
London NW11  
01-458 5807  
T + C. SL. ba 30 into 8CM (Main Desk). 20  
into 6 Monitoring PA.

**STANDISH LIGHT & SOUND HIRE CO.**  
358 Preston Rd, Standish, Wigan.  
0257 421603  
PA to 3,000 Watts Di. T & C. SL

**SUTTON MUSIC CENTRE**  
64 Haddon Road, Sutton.  
01 642 2838  
G. A. D. B. W. S. SM. RS. H. Di.

**TELECOMMS**  
189 London Road, North End, Portsmouth,  
Hants.  
Portsmouth 60036 Ask for Mike.  
ME. Di. T&C. PA. CM.

**WHALE AUDIO VISUAL**  
20 Belmont Park Road, Maidenhead, Berks.  
0628 21696  
Hill-Martin 20 CM. PA. 38Kilowatt SL. T &  
C. Di.

**WIGWAM ACOUSTICS**  
St Annes House, Rye, Ryeport Avenue,  
Heywood, Lancashire.  
0706 68766 Contact Mike Spratt  
ME. T & C. SL. 24 CM. CTM. R PA to 5000  
Watts.

# ★ CLASSIFIED ★

SONGWRITERS

ACCESSORIES

## SONGWRITERS

Songwriter Magazine explains copyright, royalties, publishing etc. and interviews famous songwriters. Free copy from

INTERNATIONAL SONGWRITERS ASSOCIATION LTD (IMRW), Limerick City, Ireland

MANUFACTURERS AIDS & GUITAR PATENTS

## GUITAR MAKERS:

Our 1978 catalogue includes everything for the professional and Amateur Luthier. Spruce and Cedar, Rosewood, Maple, Ebony, Walnut, Ash, Etc. Also Pearl, Abalone, Ivory Sheet plastics, Truss Rods, Bindings, Glues and Finishes.

NEW: Reproduction Solid Bodies in Ash, Maple and Alder - ideal for repairs

NEW: Largest range of Banjo, Mandolin parts outside USA

Send today! 50p postal order appreciated to: Strings 'N' Things, 63 Far Gosford Street, Coventry CV1 5DZ.

## ROKA ACOUSTIC SERVICES

AMPLIFIER Repairs & Servicing to all leading makes. Modifying and Customising GUITAR Repairs, Retrets, Resprays, Re-winds to Pick ups, Setting up, Covering Acoustic BRIDGES Tuning and Repairing, Lightening Action, Fitting Piezops, etc. Full range of Accessories and Spares for the above always available. Flight Cases Custom Made. 57 Endell Street, London W1 2H SA. Tel: 01 240 2610. Open 10-6 weekdays, 10-4 Saturdays.

## Windsor Music



Guitars, Amplifiers, P.A. & Accessories NEW & USED

Hire Department



DARVILLE HOUSE, OXFORD ROAD, WINDSOR, BERKS. (off Peascod St.) 66 989

PROCESSES: PRODUCTION, RECORDING, MIXING, MASTERING, MUSIC VIDEO, MUSIC VIDEO PRODUCTION, MUSIC VIDEO EDITING, MUSIC VIDEO POST PRODUCTION

PRO WORKSHOP AND MOBILE SERVICE FACILITIES buy and sell second hand Studio equipment collection delivery SALES & SERVICE to studios, broadcasting, education and government departments, everything for the Producer EXPORT FACILITIES

studio equipment services Ltd

THE STUDIO SHOP, Oxgate Farm, Coles Green Road, London NW2 7LY, Ring 01 452 1979



For all your RECORD MANUFACTURING and SLEEVE DESIGN/PRINT requirements, tel: 01 388 5771



DISC CUTTING Stereo/Mono Masters and Demos cut on our Scully lathe with ME/76/Juk Cutterhead. Masters sent to any pressing plant. Free helpful advice regarding pressing and record production. SAE for details to: COUNTY RECORDING SERVICE London Rd. Binfield, Bracknell Berks. Tel: Bracknell (0344) 54935 DOLBY A, DOLBY B AND DBX NOISE REDUCTION

D.I.Y. RECORDS AND CASSETTES 133, Park Road Blackpool FY1 4ET Enq: (0253) 23095. (Studio)



SRT RECORD MANUFACTURING 01-446 3218

Top quality Pressing 12-inch and 7-inch Also Sleeve Printing, Mastering, etc., provided to pressing customers.

Cassette manufacturing



## AERCO PRODUCTIONS LIMITED

The Professional Record Pressing Service. Send S.A.E. or ring Aercopro Productions Ltd., 27 Chobham Road, Woking, Surrey. 04862-64032

## RECORD & TAPE EXCHANGE

LP's and Tapes of every kind bought, sold and exchanged. 40 Notting Hill Gate, London W 11, 28 Pembridge Road, Notting Hill Gate, W 11, 90 Gulsea Road, Sharnahat, Bush W 12. TELEPHONE 01 49 2930

## CHRIS Eccleshall GUITARS

Established Hand Builders of the finest acoustic and electrical guitars, mandolins and dulcimers

17c-18b, Station Parade, Uxbridge Road, Ealing Common, London W.5. Tel: 01-992 4741. 020-488 6860

## D.I.Y. Cabinet Makers

Give your cabs the professional finish with

### HAMILTONS CABINET FITTINGS

Get our fully illustrated catalogue now. Vynides, Fret Cloths, Handles, Feet, Adhesive, Paint, Catches, Castors, Edging, Trim, Connectors, Switches... The lot! Huge Stock - Fast Service

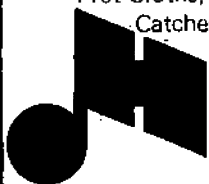

Write or Ring

HAMILTONS OF TEESIDE 26 Newport Road, Middlesborough, Cleveland. (0642) 247314

Standard range £350-£650.



Fine handmade acoustic steel string guitars.

Custom instruments also made to your requirements.

Enq: George Lowden, 6a High St., Bangor, Co. Down, N. Ireland. Tel: (0247) 62981.

## RECORDS

## INSURANCE

# schiedrecht

THE COMPANY WITH THE SPECIALISED KNOWLEDGE OF THE MUSICAL INDUSTRIES REQUIREMENTS

## IMPORT-EXPORT

WORLD WIDE SHIPMENTS BY LAND-SEA OR AIR

FULL INSURANCE COVERAGE UNDERTAKEN THROUGH LLOYDS OF LONDON

Phone

## schiedrecht

Shipping & Transport (Immingham) Ltd., Ashley House, Ferry Terminal, The Dock, Felixstowe, Suffolk. Tel: 03942-74343/4. Telex: 987546

★ **CLASSIFIED** ★

To advertise in the classified section  
Telephone: 01-388 2011

# Sowter Transformers

WITH 37 YEARS' EXPERIENCE  
we have the expertise to design and manufacture  
ANY TYPE OF AUDIO TRANSFORMER  
AT THE RIGHT PRICE

Whilst we specialise in every kind of transformer for audio control desks and mixers demands are increasing for **LOUDSPEAKER TRANSFORMERS** and **100 VOLT LINE AUDIO OUTPUT TRANSFORMERS** FOR MOST KINDS OF **AMPLIFIERS FROM 30 WATTS TO 500 WATTS OR MORE.** We can also supply multi-output transformers for **COLUMN LOUDSPEAKERS.** A recent tendency is the demand for **OUTPUT TRANSFORMERS FOR ULTRA LINEAR AMPLIFIERS** using **KT 88** and **KT 66 BEAM TETRODES** and for these we have standard designs with exceptional performance.

We call your attention to our very successful **MICROPHONE SPLITTER TRANSFORMER** type 4079 with a high impedance 200 ohm primary and two 200 ohm secondaries. It will handle up to 2.3 volts rms at 30 Hz and has a frequency response of plus/minus 1/2dB from 20 Hz to 20 KHz. It is contained in a Mumetal Can 33 mm diam x 37 mm high and **WORKING DETAILS OF THE CONSTRUCTION OF A SPLITTER ARE AVAILABLE ON REQUEST.**

We will supply single transformers, or any quantity, with short delivery times and, without obligation on your part, will quote price and exact dispatch on receipt of your requirements.

## E.A. Sowter Ltd.

Manufacturers and Designers,  
P.O. Box 36 IPSWICH IP1 2EG  
ENGLAND. Tel: Ipswich (0473) 52794 & 219390

### REPAIRS

### FOR SALE

**Eddie Ryan**  
DRUM RENOVATIONS  
5 Langley Street, Covent Garden,  
London WC2. Tel: 836 4941



Best sounding drums made. Made from finest selected beech and mahogany (not plywood)  
Own design not boxes, legs, spurs, etc. Sizes from 6 in. to 26 in.  
Drums recovered and repaired by experts  
All work guaranteed - no job too small

**TOOTLEBUG**  
FOR  
**WOODWIND & BRASS**  
BUGS  
OCTAVE DIVIDERS

**A.R. TOOTEEL**  
9 Mendip Close  
ST. ALBANS  
HERTS  
Tel: 60525

**SPEAKERS**

**QUALITY**

**SPEAKER**

**REPAIRS**

**JOHNSON & JONES**  
66 Dalston Lane, London E8 3AH  
Phone 01 254 9331

*JBL ALTEC ELECTRO VOICE GAUSS FENDER RCF KEF VOIT  
GOODMAN CELESTION FANE PEERLESS ELAC WHARFEDALE RICHARD ALLEN EMINENCE BAKER LEAK*

Individual Customizing service  
for Power Rating - Frequency  
and Performance.

**ANDY'S**  
**GUITAR WORKSHOP**  
Secondhand guitars guaranteed  
1 year  
Fast professional repairs and  
resprays  
27 DENMARK ST., WC2  
Tel: 01-836 0899  
Open 10am 7pm inc. Saturdays

**PERCUSSION  
& DRUM  
ACCESSORIES**

**PRACTICE  
DRUM KIT**

WHY HAVE NOISE PROBLEMS?  
5 drum complete practice units. Excellent  
drumkit feel. Fully adjustable - £48 Send  
stamp to: Bill Sanders, 84 Cornwall Ave.,  
Southall, Middx. Personal attention  
01-578-2909 (evenings)  
**SOLD DIRECT EST. 1973**

### REHEARSAL STUDIOS

**EAR**  
**REHEARSAL STUDIOS**  
**HOLLAND PARK**  
Fully equipped AKG Turner  
JBL PA. Full backline included.  
Keyboards. Acoustics etc.  
Excellent access parking.  
**01-727 2900**

### MISCELLANEOUS

**FREE-LANCE**

*State of the Art for the Artist*

BOOKS by John Ameral (Berklee Instructor)  
1. Lead Sheets and 12 guitar licks  
2. Pentatonic Scale  
3. Jazz Rock Fusion Impassioned  
with chordage  
4. 1200 riffs  
5. 1000 riffs  
6. 1000 riffs  
7. 1000 riffs  
8. 1000 riffs  
9. 1000 riffs  
10. 1000 riffs  
11. 1000 riffs  
12. 1000 riffs  
**\$6 EACH**

**COMPLETE ALBUM TRANSCRIPTIONS \$20 EACH**  
Jazz  
Rock  
Blues  
Funk  
Soul

**TYM MACHINE - \$50**  
Analog Digital Effects Reverb  
Delay Chorus

**HOCKEY PUCK - \$50**  
Analog Digital Effects Reverb  
Delay Chorus

Free-lance Music, 18 Haviland, Boston 02115.  
617-536-9494

**Hereford Sound Centre Ltd.**  
7 Bridge Street, Hereford. Tel: 58550  
EC: G.A.D.S. S/H/and. P.R.S. Spec.  
L.H.M. PA. DiMa. II/II. WRM.  
Custom Sound. Carlsbro etc.

### AIDS

**PRECISION GUITAR TUNING**

with the **NEW DIOTUNER MODEL G2 ELECTRONIC STROBE**

Suitable for both electric and acoustic guitars (including bass models). **Direct input allows on-stage tuning.** Purpose designed instrument gives quick **precision tuning of octaves** and open strings.

Model G2 has an accuracy better than 1/100th of a semitone and costs only **£59 (inc. VAT) plus 50p p&p.**  
As reviewed in "I.M." August 1978, page 206.  
Send for details or c/w to

**A. M. MARSHALL**  
3 Doughty Street, LONDON, W.C.1  
Telephone: 01-405 9966

**EASYSTREET STUDIOS**

Has two very comfortable rehearsal rooms, plus 4 track recording facilities; equipment hire per hour. P.A. inclusive with room and free refreshments.  
Tel: 01-739 1451

**CONTACT THE EXPERTS**  
for service on Revox, Neal Ferrograph, Uher & Tanberg

Photo Acoustics Ltd., 255A St Albans Road, Watford Tel Watford 32006  
The Studio, Sherrington. Tel Newport Pagnell 610625

**BRAGGER STUDIOS**  
Central London  
Large Rehearsal Studios  
P.A. available - storage  
Easy access and parking  
From £2.00 per hour  
**01-231 3200**  
**WHARF MUSIC**

**R & C MUSIC**  
41 Malvern Road, Orpington,  
Kent. Tel: 231 3200  
3 kw upwards: 30 channels.  
Full tour management facilities  
available.

**Fake Books & Music**  
**FREE Big Catalog**

Jazz-Pop-Improvising-Combs, etc.  
Greatest & Biggest Collection of  
Best Music Books Ever Published.  
Write: Box 66-E,  
New York, N.Y., USA.

City of London Music Store  
Music Books, Instruments,  
Strings, Spares & Accessories.  
**SUPER SELECTION**  
Send large SAE for your free list  
to  
City of London Music Store  
Mailback Music Dept IM  
17 Eldon Street, London EC2

### BOOKS & CATALOGUES

## RECORDING STUDIOS

**BIRD SOUND STUDIOS**  
Tel: Warwick (0926) 45123/4

16- and 8-track Studios plus  
Custom Pressing & Artwork  
Enquiries to:  
4 Welton Road, Wedgcock,  
Warwick CV34 5YA or ring  
Warwick (0926) 45123/4.

**ZIPPERMOBILE RECORDING STUDIO**  
London NW3

Contact Jeffrey (01)-435 3076  
(01)-637 9977

**GET TAPED ANYWHERE**  
- 16 TRACK  
£9.50 per hr. (min charge  
£47.50) & 10 hrs @ £76.

Percussion recording of superior  
quality.

Write:  
Percussion Dept. RW,  
P.O. Box 88,  
Palsades Park,  
N.J. 07650,  
U.S.A.

**ICC STUDIOS**  
International Christian Communications  
& Regency Mews, Silverdale Road,  
Eastbourne, Sussex BN20 7AB, England  
Tel: (0323) 26134

**STUDIO 1** 16 track **Studio 2** 8 track  
High Quality, Fully Equipped Studios  
Fully Qualified Engineers Available  
Professional musicians on call. All facilities  
Accommodation in an Artist Flat  
can be arranged.

**ALLAN-GORDON**  
**STUDIOS**

**WALTHAMSTOW**  
Special weekday 10-6 and Saturday  
evenings £4.50. Weekend 10-6 £7.50  
Evenings 6.30-11.00 £6.00. FULLY  
EQUIPPED room available at approx-  
imately double the above rates.  
01.520 3706/8642

## CUSTOM BUILDING

**Petep Cook**

*by reputation the best.*  
Custom Built Guitars, Bases  
and Flight Cases  
Repairs, Resprays, Refrets,  
P.V. Rewinds, Circuit Repairs  
and Modifications.  
Tel: 01-998 3101.

**JOHN ANDREWS**

Handcrafted acoustic guitars  
made to personal specification.  
Flamenco, Classical, Folk and  
Acoustic Bass  
Repairs and customising  
undertaken.  
Inlay work a speciality.  
Studio:  
(rear of) 30 Croham Road,  
South Croydon CR2 7BA  
Tel: 01-680 0940  
(home) 01-689 2017

# ★ CLASSIFIED ★

## LOUDSPEAKERS

## WANTED

### LOUDSPEAKERS AT DISCOUNT PRICES

	RRP	Inclusive G.W.O.
ATC 9"	£ 86.40	£69.95
ATC 12"	£ 97.20	£79.95
ATC 15"	£178.20	£139.95

Isophon Panorama Slant plate  
Lents Unit £33.50 RRP-£29.95  
inc. CWO. Also Motorola 100w  
Piezo Horn Tweeters. Needs no  
crossover. Special offer £6 each.

**Scotsound Amplification**  
5 Bedwyn Close, Swindon, Wilts  
Tel: (0793) 30854

### WANTED FOR CASH

All Keyboards, Guitars,  
Amplification, Mics and  
Pedals. Collection arranged.  
Top Cash Offers at  
Sound Exchange,  
296 High Street,  
Sutton, Surrey.  
Tel: 01-643 6420



WE'VE JUST HAD  
A FIRE!

So we've got DRUMS,  
AMPS, FENDERS,  
GIBSONS, ACOUSTIC  
GUITARS, ROLAND  
SYNTHS etc. SMOKE  
DAMAGED ONLY!

AT GREATLY REDUCED PRICES. CALL OR PHONE NOW  
(0234) 50861

**MR MUSIC, 7 ST. JOHNS STREET,  
BEDFORD.**



# Sounds like a good thing

Complete range of RCF  
loudspeakers, horns  
and drivers available from:

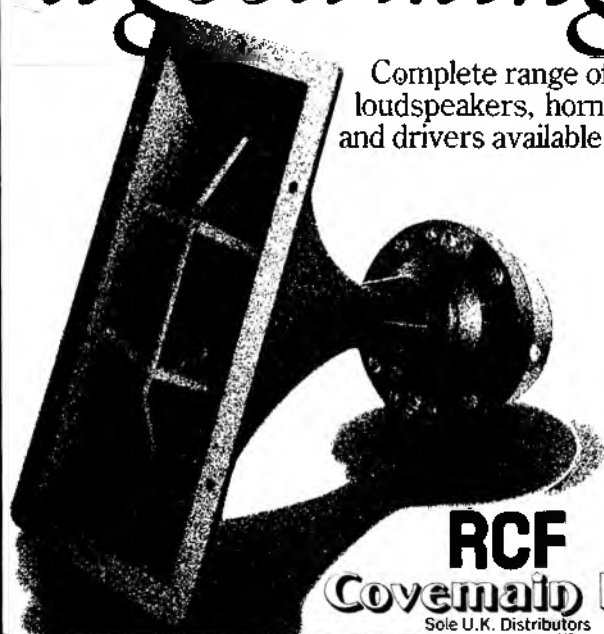

**RCF**  
**Covema Ltd**  
Sole U.K. Distributors

**BAIRD ELECTRONICS,**  
10 CANNING STREET  
BELFAST.  
TEL: 749358

## Bind your copies of

**INTERNATIONAL MUSICIAN  
& RECORDING WORLD**  
as you receive them in the  
**EASIBINDER**

Sturdily made in Blue Rexalon with the  
title blocked in Gold on the spine.  
The EASIBINDER will hold 12 issues  
and opens flat for easy reference. Copies  
can be removed and replaced with ease.



PRICE £3.05 each inclusive. Overseas postage 25p extra.  
(Please allow 3/4 weeks for fulfilment of order).

Order Form:  
for INTERNATIONAL MUSICIAN & RECORDING WORLD Binders  
To EASIBIND LTD., 4 Uxbridge Street, London, W8 7SZ

I enclose P.O./Cheque Value ..... for ..... binders

NAME .....

ADDRESS .....

..... DATE .....



# SEND THIS PAGE BACK

This page can be used for competition entry, Readers Survey, and our Readers Service. Use the bottom coupon to get more information about catalogues and price lists. Tick the advertiser you require information from, state which instrument you play, and return the coupon to Cover Publications Ltd., Grosvenor House, 141-143 Drury Lane, London WC2.

ABC Music . . . . .	122	DiMarzio . . . . .	138-139,	Kustom . . . . .	99	Remo . . . . .	140
Achille Roma . . . . .	M21		24 page insert	Laney . . . . .	88	REW . . . . .	84-85
Acoustic Control . . . . .	192	D'Merle . . . . .	133	Langdons . . . . .	212	B.C. Rich . . . . .	130
Acoustic Kingfisher . . . . .	159	Drumland Percussion . . . . .	M16	Leech . . . . .	58	Ric Rac . . . . .	172
ADI . . . . .	202	Dublin Drum Centre . . . . .	M20	Peter Legh . . . . .	214	Rock City . . . . .	M22
Alans Music Centre . . . . .	124	Electro Harmonix . . . . .	41	Levin . . . . .	207	Rola Celestion . . . . .	45
Richard Allen . . . . .	85	Electrovoice . . . . .	20	Eric Lindsay . . . . .	M16	Rook Music . . . . .	172
Allen & Heath . . . . .	182	Elvins . . . . .	M10	Logan . . . . .	101	Roost . . . . .	132
Altec . . . . .	185	Ess . . . . .	149	Ludwig . . . . .	7	Rose-Morris . . . . .	M15
Amazon . . . . .	176	Eurotronic . . . . .	M9	Macaris . . . . .	24	Rose-Morris-Korg . . . . .	12-13
Rod Argent . . . . .	M12	Fane . . . . .	188	Maine . . . . .	52	Rose-Morris-Marshall . . . . .	11
Aria . . . . .	146	Farnsworth . . . . .	162	Malatchi . . . . .	136	RSD . . . . .	107
ATC . . . . .	9	FBT . . . . .	137	Mandolin Brothers . . . . .	120	Ryde Guitar . . . . .	162
Audiogenic . . . . .	171	Flame . . . . .	215	E & O Mari . . . . .	40	SAI . . . . .	159
August Sound . . . . .	172	Fletcher, Coppock		C.F. Martin . . . . .	159,226	Schaller . . . . .	125
Avedis Zildjian . . . . .	153	& Newman . . . . .	92,OBC	Mary's Music . . . . .	M20	SES . . . . .	211
Axe . . . . .	178	Forth Valley . . . . .	161	Mean Machine . . . . .	M16	Session Music . . . . .	M21
Ernie Ball . . . . .	208	Michael Foley . . . . .	M23	MICA . . . . .	188	Sheldon . . . . .	149
Barratts . . . . .	76,152,M22	Freedmans . . . . .	121,M20	Millgate . . . . .	172	Shure . . . . .	22
Bell . . . . .	133	Free 'N' Easy . . . . .	154,213	Minns . . . . .	122	Sonor . . . . .	93
Bennets . . . . .	M14	Fretted Industries . . . . .	157	Mitchell Speakers . . . . .	131	Soundout . . . . .	50
Beyer Dynamic . . . . .	195	GEC . . . . .	133	MM . . . . .	156	Soundpad . . . . .	M4
BGW . . . . .	200	Gigsville . . . . .	108	Morley . . . . .	19,125	Soundside . . . . .	158
Biggles . . . . .	212	Peter Gray . . . . .	M14	Muir Music . . . . .	148	Sounds International . . . . .	215
Bird Brothers . . . . .	226	Ground Control . . . . .	214	Musicaid . . . . .	80	Sound Shop . . . . .	136
Birdsound . . . . .	171	Guild . . . . .	91,M9	Musical Merchandising . . . . .	90	Soundwise . . . . .	162
BKL . . . . .	96	Adam Hall . . . . .	140	Music Circle . . . . .	145	Soundwave . . . . .	32
Blackpool Sound Centre . . . . .	162	Keith Hand . . . . .	128,145	Music Ground . . . . .	M6	SSE . . . . .	130
Rex Boque . . . . .	125	Harmon . . . . .	196	Music Man . . . . .	112,IBC	Stage One . . . . .	140
Boosey & Hawkes . . . . .	102	Hayden Labs . . . . .	203	Music Stop . . . . .	124	Stateside . . . . .	M2
Bose . . . . .	206	Frank Hesy . . . . .	64,M23	MXR . . . . .	83	Steel Mill . . . . .	128
Bradleys . . . . .	M14	H/H . . . . .	28-29	Newtone Music Centre . . . . .	M16	Streety . . . . .	145
Brodr Jorgensen . . . . .	98,M9,IFC	Highway . . . . .	147	Norlin . . . . .	179,M8	Strings . . . . .	M23
Richard Brown . . . . .	120	Malcolm Hill . . . . .	144	Normans . . . . .	137	Studio G . . . . .	171
Buzz . . . . .	214	Keith Hitchcock . . . . .	216	North London . . . . .	128	Sudbury Music Centre . . . . .	160
CBS/Arbiter . . . . .	67	Hohner . . . . .	35	Nova . . . . .	226	Summerfield . . . . .	42-43
Chappell . . . . .	66	Honky Tonk . . . . .	18	Olson . . . . .	M14	Sunn . . . . .	129
Chas E. Foote . . . . .	128,M20	Hornby Skewes . . . . .	106	Otari . . . . .	59	Switchcraft . . . . .	51
Chase Musicians . . . . .	68,75	Humbucker . . . . .	178	Pace . . . . .	174	Tandberg . . . . .	186-187
Chandler . . . . .	124	ICC . . . . .	171	Peak . . . . .	M10	Theatre Projects . . . . .	97
Chingford . . . . .	3	Intermusic . . . . .	81	Packleader . . . . .	M8	The Music Box . . . . .	162
Chrom Audio . . . . .	65	International Music Corp. . . . .	44	Pearl . . . . .	54-55	Total Percussion Centre . . . . .	M21
Coach House . . . . .	178	International Sales Assoc. . . . .	26-27	Peavey U.K. . . . .	163-170	Townsend . . . . .	M22
Coda . . . . .	121	ITA . . . . .	15	Peavey USA . . . . .	190	Turnkey . . . . .	129
Collins & Endres . . . . .	132	JBL . . . . .	197	Percussion . . . . .	M23	Vitavox . . . . .	M10
Conquest . . . . .	215	J & C Sound Systems . . . . .	14	Picton . . . . .	M22	Westmill Audio . . . . .	123
Cookes Band Centre . . . . .	M16	Mick Johnson . . . . .	100,204	Powertran . . . . .	157	Whirlwind . . . . .	180
J.T. Coppack . . . . .	210	Keio . . . . .	196	Premier . . . . .	34	Whomes . . . . .	212
Covermaine . . . . .	10	Kennards . . . . .	M21	Protex Fastners . . . . .	136	WLM . . . . .	33
Coventry Music Centre . . . . .	M22	Kennilworth . . . . .	162	Pulsar . . . . .	193	A.R. Wilmhurst . . . . .	202
Crumar . . . . .	191	Keyboard Harmony . . . . .	M14	Quest . . . . .	178	Wilson Musical Supplies . . . . .	M20
Custom Sound . . . . .	209	Keynote . . . . .	189	RAC . . . . .	144	J.G. Windows . . . . .	212
Trevor Daniels . . . . .	M8	Kharma Bodies . . . . .	144	Raftery & Sons . . . . .	M21	Woods . . . . .	160
De Armond . . . . .	136	Kitchens . . . . .	114-115	Randall . . . . .	184	Yamaha . . . . .	155,194,M8

## READERS SERVICE FORM

Name ..... Address .....

.....



**Spirit of 56 Bandstand**  
 as reviewed in International Musician  
 Available now direct from the manufacturer  
 at wholesale prices:-

**PLEASE WRITE FOR YOUR FREE CATALOGUE  
 TRADE ENQUIRIES WELCOME**

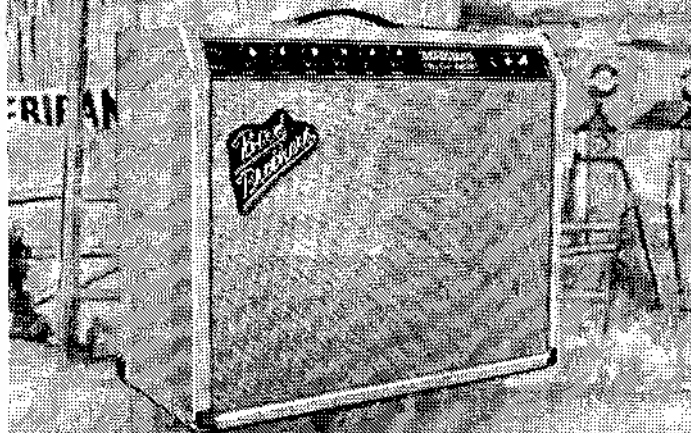

22/24 ST. MARYS GATE, ROCHDALE OL16 1DZ, ROCHDALE 524483

# RICO

Reeds

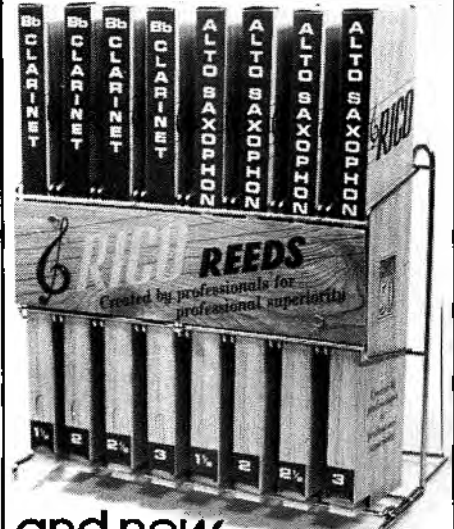

and now...  
**THE NEW  
 RICO PADS**



**NOVA**  
 REED CORPORATION

P.O. Box 661  
 Sun Valley, California 91352, U.S.A.

Contact Your Rico Distributor  
 For Rico Pads and Rico Reeds.  
 U.K. Exclusive Distributors:  
 Boosey & Hawkes, Ltd.  
 Rose-Morris & Co., Ltd.



**MARTIN STRINGS  
 AND ACCESSORIES**

# Introducing The All New SABRE™ Guitar!

## Body

- Light-weight, contoured body for perfect balance and tireless playing.
- Volume control located for convenient operation by picking hand.
- Fast-action pickup lever switch is positioned for operation during course of picking motion.
- Wide cutaway for easy access to 22nd fret.
- Body finishes available: Natural, Sunburst, Walnut, Black and White.

## Neck

- One-piece rock maple construction.
- 25½" scale with 22 frets.
- Available with flat 12" radius fingerboard (Sabre I) or oval 7½" radius fingerboard (Sabre II). Sabre I has jumbo frets, Sabre II has standard frets.
- Rock-hard Melamine nut for long wear and precision notching.
- Patented flat truss rod which allows more strength while providing thin neck size (800/1000ths inches front to back).
- Neck tilt adjustment for adjustable angle without the use of shims.
- Head designed so that strings pull straight across nut.
- Patented Music Man tuning keys (manufactured by H. Schaller). Tapered string post forces strings to lie flat against head for improved tension over nut.

## Pickups

- Two humbucking pickups with 12-¼" magnets.
- Narrow pickup design provides increased picking space between pickups.
- The two pickups are each of individual sizes so that magnets are positioned directly beneath each string. There is no volume loss when string is bent away from magnet.
- Pickups are vertically adjustable for perfect tone balance.

## Electronics

- Internal micro-powered pre-amp for long battery life (one to three years).
- Pre-amp provides low impedance output. Tone is unaffected by long cords or low-volume control settings.
- Separate bass and treble tone controls provide both boost and cut.
- Bright switch conveniently adds additional highs at the player's fingertips.
- Phase reversal switch for pickups works in any position of lever switch. Instant out-of-phase operation can be obtained even though the lever switch is not in the two-pickup position.

## Bridge

- Heavy cast bridge provides excellent sustain without the need of a heavy body.
- Strings pull through from inserts in rear of body, then through bridge casing, resulting in rigid, vibration-free assembly.
- Bridge casting provides recessed well for six individual bridge saddles.
- Bridge saddles are made of stainless steel to resist corrosion and ensure long life.
- Each bridge saddle has two vertical height adjustment screws and one horizontal octave adjustment screw. All screws are recessed within bridge saddle avoiding interference with picking and muting styles.

## Basic Design

The Sabre guitar is the end result of 30 years' research and development of solid-body electric instruments. Experience and knowledge gained from creating new designs these many years have been applied to the perfection of the all-new Sabre. You can't appreciate it until you play it. Visit your Music Man dealer today!

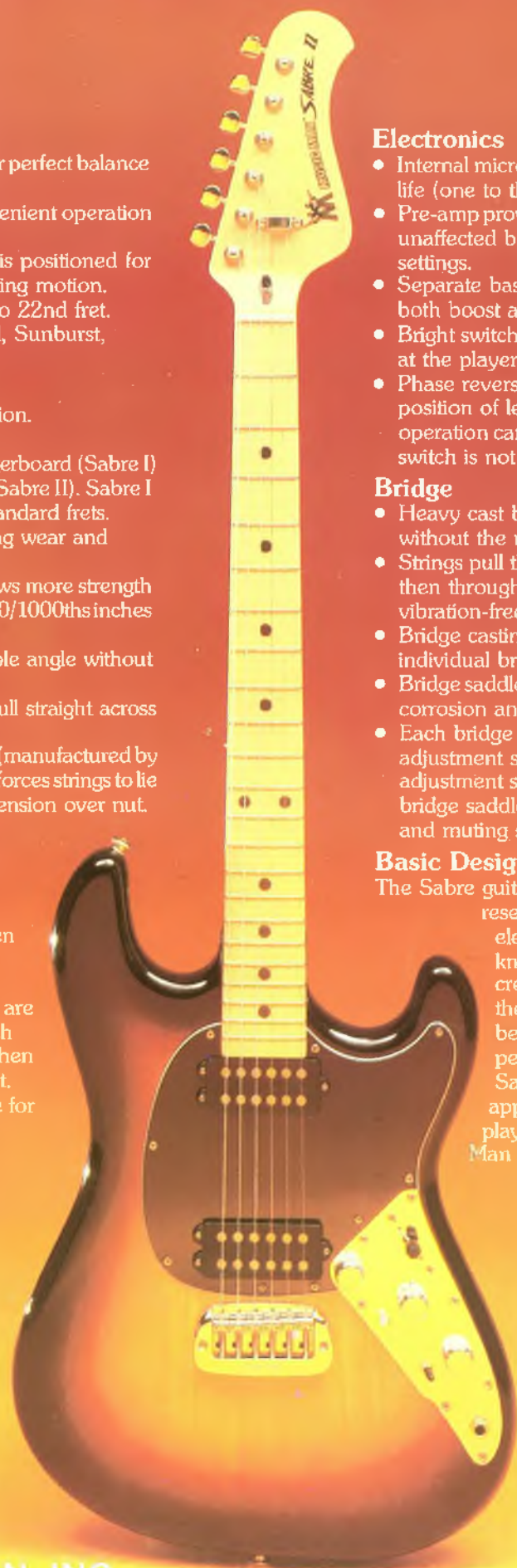

**MUSIC MAN, INC.**

*The experience people.*

P.O. Box 4589  
Anaheim, CA 92803  
Telex 892-397

*UK and Eire Distributors*  
Music Man Division  
STRINGS & THINGS Ltd, 20 Chartwell Rd.  
Churchill Industrial Estate  
Lancing, W. Sussex BN15 8TU

Super Swede' has arrived

A Swedish Superlative in a class of its own



Write now for illustrated details . . .

**F c n**  
music

FLETCHER COPPOCK & NEWMAN LTD  
MORLEY ROAD TONBRIDGE KENT TN91RA

Name \_\_\_\_\_

Address \_\_\_\_\_

Ref: \_\_\_\_\_

*Hagstrom*