

HOW TO GET A GIG WITH ALANIS MORISSETTE

MUSICIAN

OCTOBER 1995 \$2.95

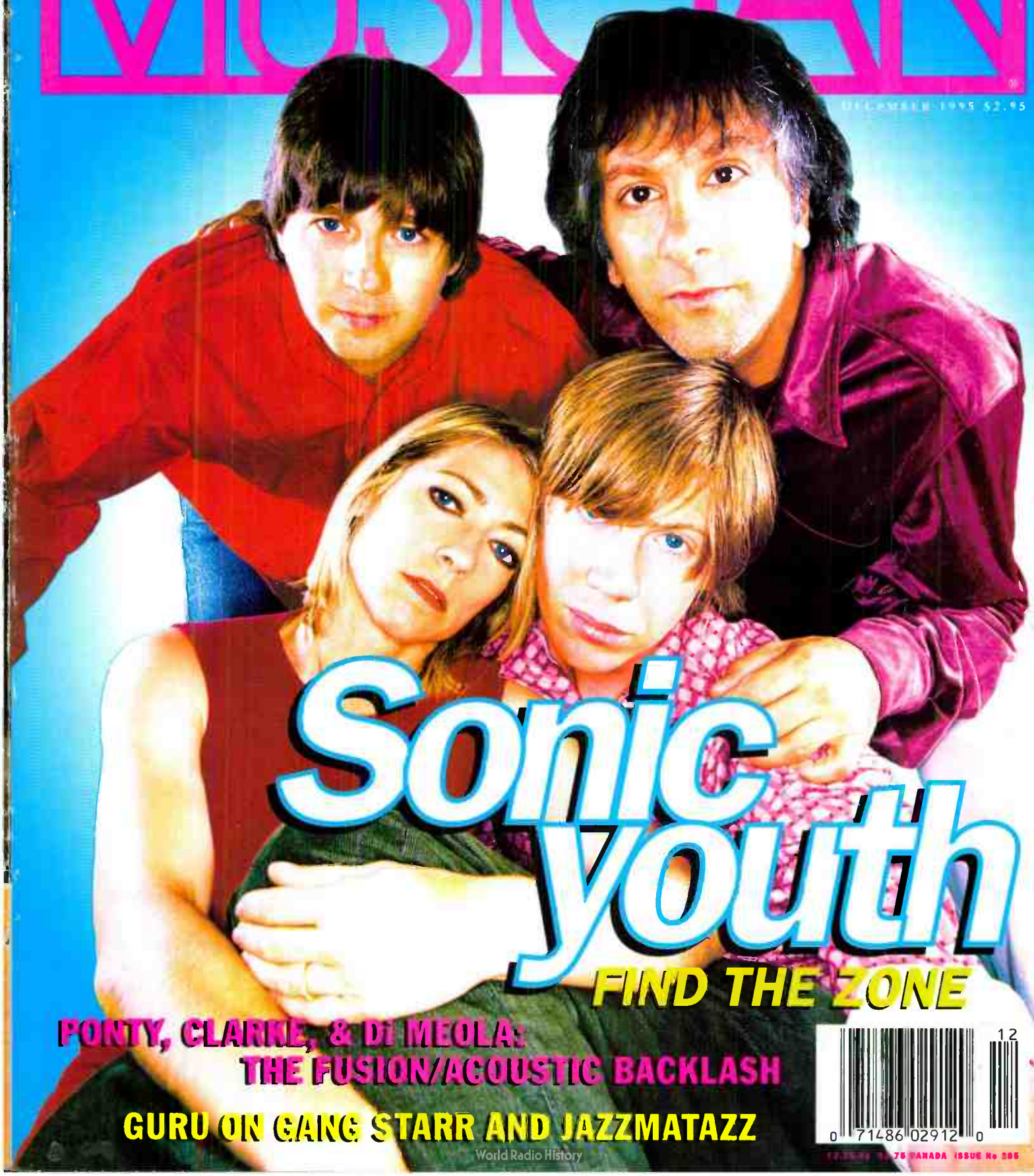

Sonic Youth

FIND THE ZONE

**PONTY, CLARKE, & DI MEOLA:
THE FUSION/ACOUSTIC BACKLASH**

GURU ON GANG STARR AND JAZZMATAZZ



Twin Sons of Different Mothers

Finally...
fingerstyle guitars
for fingerstyle players

If you're a serious fingerstyle player you'll want to add one or both of these twins to your collection. They look a lot alike, but the Ovation Folklore and Country Artist are different guitars in several important ways.

The Folklore is the steel string guitar made especially for fingerstyle players. The fingerboard is slightly wider and a little bit flatter than usual, making fingerstyle patterns and inversions easier to play.

The slotted headstock puts a little more down pressure on the nut, helping the pitch stability when you really start laying into it.

THE OVATION
COUNTRY ARTIST

The Country Artist is the nylon string guitar for steel string players. In this case, the neck is narrower than a classic guitar—1 7/8"—exactly the same width as the Folklore. The neck is also considerably thinner than a classic, making it far more comfortable for players accustomed to steel strings.

Both instruments feature a mid-depth body, 5-piece maple and mahogany neck, 21-fret ebony fingerboard, inlaid rosette and special design Ovation pickup and OP-24 electronics. Give the twins a try at your Authorized Ovation Dealer today.

THE OVATION
FOLKLORE

THE 1 7/8" NECK WIDTH IS A BIT WIDER THAN A TRADITIONAL STEEL STRING AND A BIT NARROWER THAN A TRADITIONAL CLASSIC.



Ovation®

Ovation Instruments, PO Box 507, Bloomfield, CT 06002



REACH FOR IT!

An incredible performance keyboard controller is out there for you.

The world is full of wonderful sounds, and you can put them at your fingertips with the Fatar Studio Series MIDI keyboard controllers! Since feel is such an important consideration when purchasing a keyboard controller, Fatar, the world's largest keyboard manufacturer, has designed their latest models with a remarkable touch of the keys that mimics the feel of the best synthesizers right through to the authentic feel of a traditional acoustic piano.

Fatar has a full range of keyboards that have a multitude of playing features for every musician from

the beginner to the pro, to the multi-media computer user, **starting at only \$199.95**. The synth actions are light and responsive without a hint of sponginess. The hammer-actions on the 88-note controllers are rated the best in the business.

Fatar's natural dynamics are due to response curves that have been refined with the help of some of today's top leading players. The possibilities are limitless. So reach for a Fatar Studio controller at your nearest music store and witness the alternative way of control. *Play it! Enjoy it! Feel the music!*

FATAR[®]
MIDI CONTROLLERS

Exclusively Distributed in the U.S.A. by

MUSIC INDUSTRIES CORP.

99 Tulip Avenue, Floral Park, NY 11001 • (516) 352-4110 • FAX: (516) 352-0754

Roland Corporation U.S., 7200 Dominion Circle, Los Angeles, CA 90040 (213) 685-5141 Roland Canada Music Ltd., 5460 Parkwood Way, Richmond, B.C. V6V 2M4 (604) 270-6626. COMPUSERVE: GO ROLAND

Breaking the rules of windmilling,
the lead guitarist creates a weather system
never before seen in Nova Scotia.

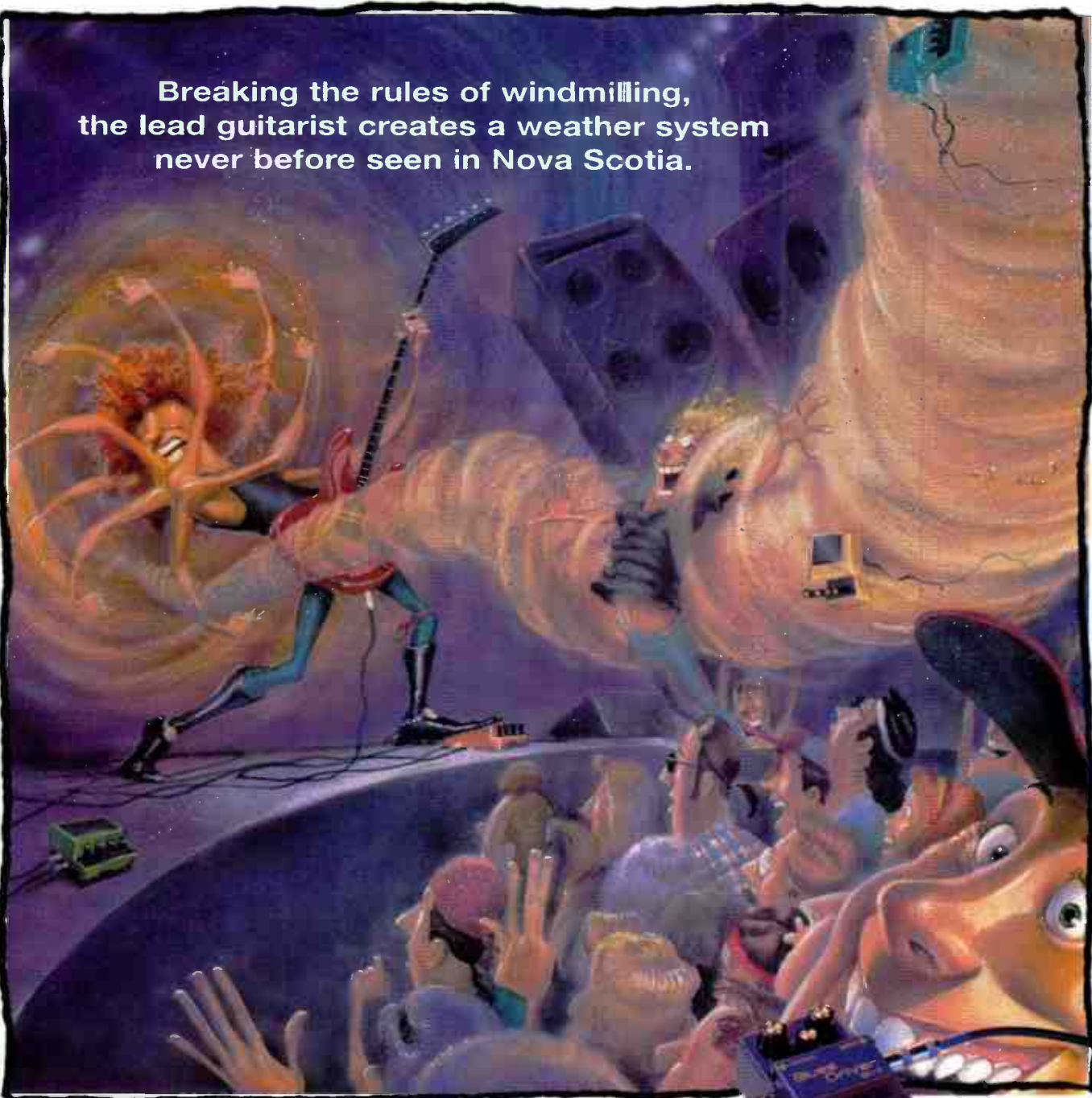

Some rules you don't break. Others you stomp, hack and shred to unrecognizable bits. That, my friend, is what BOSS pedals and Rock & Roll are for. With effects pedals like the **BD-2 Blues Driver**, **HR-2 Harmonist** and **DD-5 Digital Delay** no one will ever tell you where to get off again. Except us. We'll tell you to go to your BOSS dealer and get off on all our pedals. Instant gratification almost never felt so good.

BOSS[®]
Break Some Rules



World Radio History

CONTENTS

MUSICIAN MAGAZINE

DECEMBER 1993 • ISSUE NO. 269

9 FRONTMAN: GURU
Putting the Matazz in Jazz. BY NATHAN BRACKETT

14 ROUGH MIX
Better Than Ezra writes "Good"; Mike Watt skips rehearsal; Jordan Rudess of the Dregs tackles tough time signatures; and Poe talks her way into a record deal.

34 ONLINE RADIO
Tune in, turn on and place your music on the computer-based 'Networks of the future. BY LESLIE J. BOCK

44 SONIC YOUTH
After headlining Lollapalooza and recording a killer new album, Sonic Youth are in a different zone. BY MAC RANDALL

60 RITE OF STRINGS: LIFE AFTER FUSION
Jean-Luc Ponty, Al Di Meola, and Stanley Clarke find new life in the acoustic arena. BY ROBERT L. DOERSCHUK

68 FAST FORWARD
Fender's new DG acoustic series, Nady's E03 in-ear wireless system, Peavey's Q431F equalizer, portable practice spaces from WhisperRoom, and shiny phono plugs from Switchcraft.

74 KEYBOARD AMPS
Give your synth the headroom it deserves with this selection of keyboard amplifiers. BY JULIAN COLBECK

78 BOOT UP THE GROOVE
How your computer can help you rock harder in rehearsals and get ready to kick it with your band onstage. BY NICK DIDKOVSKY

82 MATT FINK'S HOME STUDIO
The artist formerly known as Dr. Fink has gone from banging keys with Prince to producing incredible simulations for K-TEL. And he does it all at home. BY TED GREENWALD

87 RECORDS
Emmylou Harris mines the heartbreak mother lode with Daniel Lanois; Red Hot Chili Peppers tone down the funk; Medicine goes down easy; Keith Jarrett goes back to the Blue Note.
DEPARTMENTS: Masthead, 10; Letters, 12; Reader Service, 94

98 BARENIDE
If you haven't forgotten these milestone dates in rock history, try harder. BY MARK ROWLAND



22 HOW TO GIG WITH ALANIS MORISSETTE

Plus the perils of Gatorade, toejam, and old boyfriends.
BY CHARLES M. YOUNG

In From The Storm



09026-68223-2/4

THE MUSIC OF **JIMI HENDRIX**

FEATURING GUEST PERFORMANCES BY **STING · JOHN McLAUGHLIN · CARLOS SANTANA · STANLEY CLARKE · COREY GLOVER · BRIAN MAY · TONY WILLIAMS · ROBBEN FORD · BILLY COX · STEVE LUKATHER · TOOTS THIELEMANS · NOEL REDDING · BUDDY MILES · HIRAM BULLOCK · ERIC SCHENKMAN · STEVE VAI**

PRODUCED AND ENGINEERED BY **EDDIE KRAMER**

EXECUTIVE PRODUCER **STEVE VINING**

DIAL 800-989-MUSIC
(code #106)
TO HEAR In From The Storm

VISIT RCA Victor ON THE INTERNET
<http://www.rcaVictor.com>



AVAILABLE AT

TO ORDER BY PHONE...

1-800 ASK

TOWER

RECORDS · VIDEO · BOOKS

...OR FOR STORE LOCATIONS.

In From The Storm

SWEEPSTAKES

Commemorating
the musical
genius of
Jimi Hendrix

ENTER TO WIN

The
Jimi Hendrix
Flying V Guitar
from
Gibson USA

ENTER TO WIN
THE JIMI HENDRIX
FLYING V GUITAR
FROM GIBSON USA

Name: _____

Address: _____

City: _____ State: _____ Zip: _____

Daytime Telephone# (_____) _____

No purchase necessary. All entries must be postmarked by midnight, January 12th. BMG Music and Gibson USA, and their affiliates, subsidiaries, agencies, and the directors, officers, employees and agents of all of them assume no liability or responsibility for any damage, loss or injury resulting from or arising out of the acceptance or use of any prize. All winners are chosen by random drawing. Employees of BMG Music or Gibson USA, their affiliates, subsidiaries, agencies, and family members are not eligible for this sweepstakes. Winners will be picked on January 19 and notified by January 31, 1996. RCA Victor and Musician Magazine are not responsible for lost, delayed or misdirected entries. Odds of winning are dependent upon the number of entries received. There are no substitutions, transfers or redemptions for cash prizes. Void where prohibited by law. All federal, state and local laws and regulations apply. For a list of winners, send a self-addressed stamped envelope to address below after January 31, 1996. Only residents of the United States and its possessions are eligible. Entries must be sent to:

RCA Victor - Musician Magazine
In From the Storm Sweepstakes
1540 Broadway - Dept. IFS - 40th Floor
New York, NY 10036

Gibson
USA

Denon congratulates RCA Victor on their new release
"In From the Storm"

Trmk(s) (R) Registered Marca(s) Registrada(s) General Electric Company,
USA, except BMG logo (R) BMG Music (c) 1995 BMG Music

World Radio History

David Byrne. Many Stories.

One Microphone: Shure Beta 87.

SHURE



SHURE BROTHERS INC. EVANSTON, IL 1-800-25-SHURE. THE SOUND OF PROFESSIONALS...WORLDWIDE™

World Radio History

FRONTMAN

Jazzmatazz II: A New Reality is your second Jazzmatazz project. Aside from not working with DJ Premier, how does working on a Jazzmatazz album differ from doing a Gang Starr record?

For me, the concept for Jazzmatazz was to actually meet and work with these guys we sample a lot, like Ruben Wilson. A Tribe Called Quest sample some of his stuff. The guys from the first album, [Donald] Byrd and Roy Ayers, have been sampled a lot. And on the new album, Freddie Hubbard and Ramsey Lewis, and of course Bernard Purdie. The key for me was to get them into the studio and to jam to some hip-hop, 'cause I had a feeling they would want to. They're getting sampled, they're getting royalty checks from us reworking their material, so why wouldn't they want to do something with one of us live in the studio? That was the initial thing, and I also wanted to work with some vocalists.

You've stressed that this is a hip-hop album.

'Cause that's what it is. I'm a hip-hop artist. Some of the critics, I think they missed the point about that. Like Branford Marsalis' *Buckshot LeFonque* is a jazz record, not a hip-hop record. He's a jazz artist. I'm using some jazz elements, these guys are jamming with me, but it's still not a jazz record.

But there are some songs on Buckshot LeFonque and Jazzmatazz that are at least in the same ballpark. Where do you draw the line and say "This is a jazz record" or "This is a rap record"?

Just because I got jazz cats jamming with me doesn't mean that it should be viewed as a jazz record. I don't know. It's somewhere in between. But I don't think

I should be subject to someone trying to analyze it as a jazz record. It's music, that's all. Sometimes when you get too technical you miss the point.

What does this kind of crossover accomplish?

One thing that it's definitely doing is bringing people together. We played with [Marsalis] in Europe at a lot of jazz festivals. If they didn't have groups like us and Jamiroquai that are bringing in the younger crowd, they'd be phasing out. So they need our input, and they want our input.

Tell me about performing the album live.

It's dope. It takes it to another level. We press up instrumentals for every track, so we'll have an instrumental album on wax just like Gang Starr, and then we add the live elements to that. So Bernard will be playing drums, and the instrumental track is playing on the turntable. With a Gang Starr show, everything is pretty much regimented. With this, I can do two verses and then let somebody solo instead of doing all three verses. There's room for improvisation.

What does A New Reality mean in the album title?

**"When you
get too
technical,
you miss
the point."**

GURU

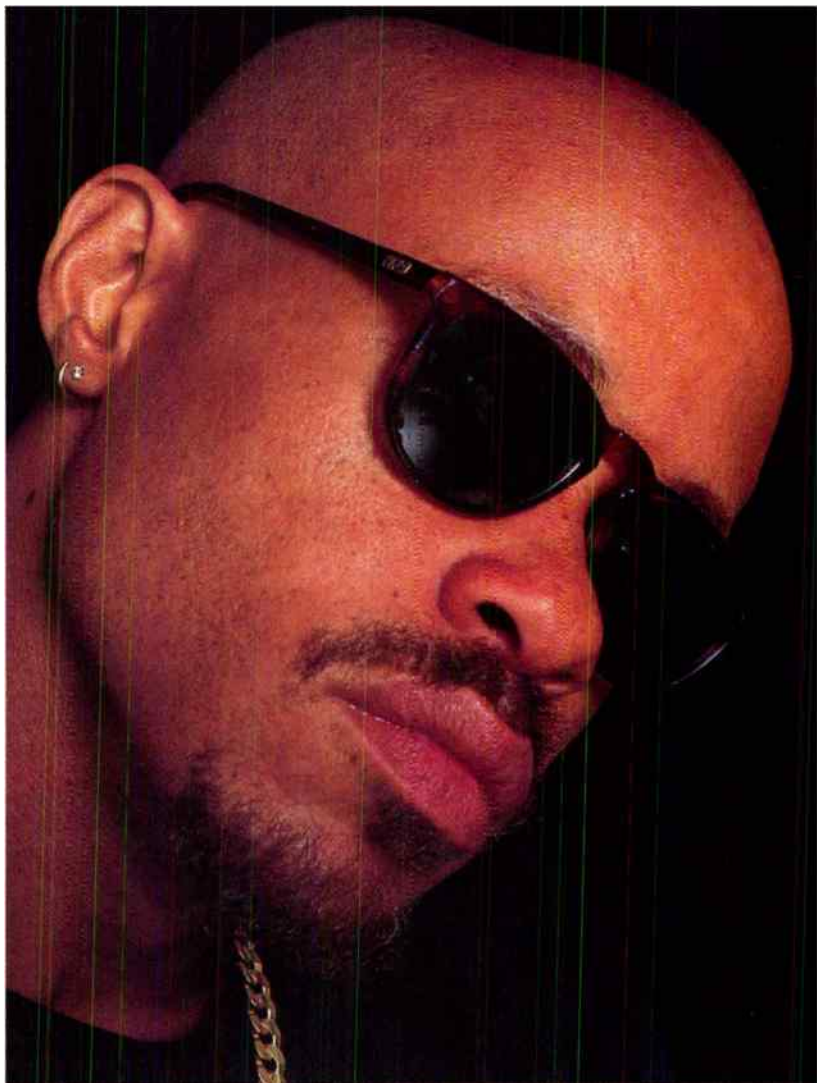

When I say "a new reality," I mean, back in the day, if I was skipping school or whatever, and one of my mother's friends saw me and my friends hanging out in the station or something, she's going to come over, say something, tell my friends that she

knows their mothers too, and that she's going to call them at work and let 'em know that we didn't go to school. Nowadays, that element is gone. Everybody's just living for now. Young people look to the rappers for guidance. On "Looking Through Darkness" I said something like, "Many children get the wrong message from clowns that walk around/Hopelessly lost thinking that they're the boss/They're in a daze, while dope MCs don't get the front page."

This album was your second collaboration with trumpet player Donald Byrd. Is he something of a mentor to you?

Most definitely. When I first called him he was saying things like, "Yes! This is what I wanted to do! I'm so glad you're doing this!" Byrd is someone I can talk to about the whole correlation between jazz and hip-hop. I can ask him stuff like what it was like between artists when he was coming up. Musically, he teaches me things about structure in songs and arranging. He's given me a lot of confidence to go on and do what I believe in. His attitude is like, "If these people don't get it, fuck 'em." And he's 60-odd years old telling me shit like that! 'Cause he believes in it. —NATHAN BRACKETT

Hear the generations of jazz roar together.



Dave Brubeck Young Lions & Old Tigers

"To have a song written for me by one of the world's greatest composers was the ultimate honor." —Christian McBride

"Dave Brubeck plays and composes his music with the wisdom and patience of an elder, yet with the passion and innocence of a youngster." —Joshua Redman

"I've been an enormous fan of Dave's playing and composing, and it's been both a thrill and an honor for me to play on this record." —Michael Brecker

"His enthusiasm and power as a musician was a thrill to experience." —Joe Lovano

Dave Brubeck hosts three generations of modern jazzmen premiering Brubeck's new tunes written especially for their expressions. Hear spectacular solos from Michael Brecker, Ronnie Buttacavoli, Roy Hargrove, Jon Hendricks, Joe Lovano, Christian McBride, James Moody, Gerry Mulligan, Joshua Redman, and George Shearing. The mingling on this recording symbolizes what jazz has always been about—passing the tradition down to future generations.



To order by phone, call J&R MusicWorld 800-221-8180.
For your free copy of Telarc's full-color catalog, call 800-801-5810.

© 1995 Derry Music Co.

MUSICIAN

ROBERT L. DOERSCHUK
editor

MARK ROWLAND
executive editor

ROBIN LEE MALIK
art director

KEITH POWERS
managing editor

MAC RANDALL
senior editor

LESLIE J. BOCK
typesetter

JULIAN COLBECK • J.D. CONSIDINE
DAVE DIMARTINO • DAN FORTE
VIC GARBARINI • ELYSA GARDNER • JIM MACNIE
RICK MATTINGLY • EMILE MENASCHE
MATT RESNICOFF • CHIP STERN • TIMOTHY WHITE
CHARLES M. YOUNG • ION YOUNG
contributing editors

PAUL SACKSMAN
publisher

GARY KRASNER
executive publisher

ANDY MYERS
national advertising manager

GREGG HURWITZ
west coast advertising manager

DEVLIN SHERLOCK
promotion director

DANIEL GINGOLD
office manager

JOAN MASELLA
circulation director

JAMIE ROBERTS
circulation assistant

JEFF SERRETTE
(800) 223-7524
classified

JOSH TULMAN
ANDREW M. SOLIN
interns

KAREN OERTLEY
group publisher

ADVERTISING/EDITORIAL
1515 BROADWAY, 11TH FLOOR
NEW YORK, NY 10036
(212) 536-5208 (PHONE)
(212) 536-6616 (FAX)

GORDON BAIRD
SAM HOLDSWORTH
founders



Billboard Music Group

HOWARD LANDER
president

MUSICIAN (USPS 431-910) is published monthly by BPI COMMUNICATIONS, INC., 1515 Broadway, New York, NY 10036. © 1995 by BPI COMMUNICATIONS, INC., all rights reserved. Second-class postage paid at NEW YORK, NY and additional mailing offices. POSTMASTER: Send address changes to MUSICIAN, PO BOX 1923, MARION, OH 43305. Subscriptions are \$19.97 per year, \$34.97 for two years, \$52.97 for three years. Canada and foreign add \$12 per year, U.S. funds only. Subscription orders can be sent to MUSICIAN, PO BOX 1923, MARION, OH 43305. For subscriber services and information call 1-800-745-8922 in the continental U.S. and 614-382-3322 elsewhere. Current and back issues are available on microfilm from University Microfilms Intl., 300 N. Zeeb Road, Ann Arbor, MI 48106. Chairman & CEO Gerald S. Hobbs, President Arthur F. Kingsbury, Executive Vice Presidents John B. Babcock Jr., Robert J. Dowling, Martin R. Feely, Howard Lander, Senior Vice Presidents Georgina Challis, Paul Curran, Ann Haire, Rosalee Lovett, Vice President Glenn Heffernan. All titles, logos, trademarks, service marks, copyrights and other intellectual property rights are used under license from VNU Business Press Syndication International BV. Attention Retailers: To carry *Musician* in your store, call Eastern News Distributors Customer Service at 1-800-221-3148, or write: *Musician* Dealer Dept., c/o Eastern News Distributors, 2020 Superior St., Sandusky, OH 44870.

MEMBER: AUDIT BUREAU OF CIRCULATION
PRINTED IN U.S.A.

Where Does Your Passport Take You?

"I'm always touring, so I have to do a lot of writing and arranging while I'm on the road. I had to find transcription software that was easy, quick, accurate and had professional looking results. Encore is that product."

"Encore has really made my life a whole lot calmer. I can quickly add a new string section to an arrangement, extract the parts and give it to the musicians in plenty of time for rehearsal. When I bought my computer I purchased two things along with it, a different notation program and aspirin. Now that I'm using Encore I don't need the aspirin!"

Charles Floyd works as Natalie Cole's musical director, is a guest conductor for many symphonies, including the Boston Pops, along with being an outstanding composer, classical pianist, recording artist and choral director.

Encore 4 has established itself as the professional standard for composing, arranging and publishing music.

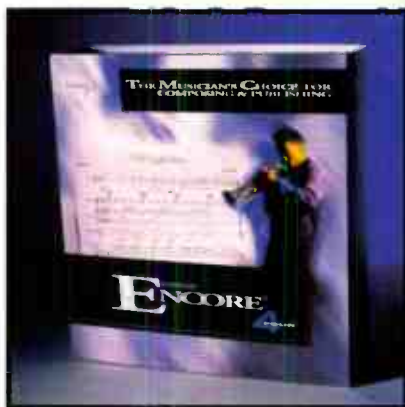

Why waste your time with anything else.

Get Encore today wherever fine music software is sold

Call (415) 726-0280 for a dealer near you.

Passport Brings Out The Musician In You.

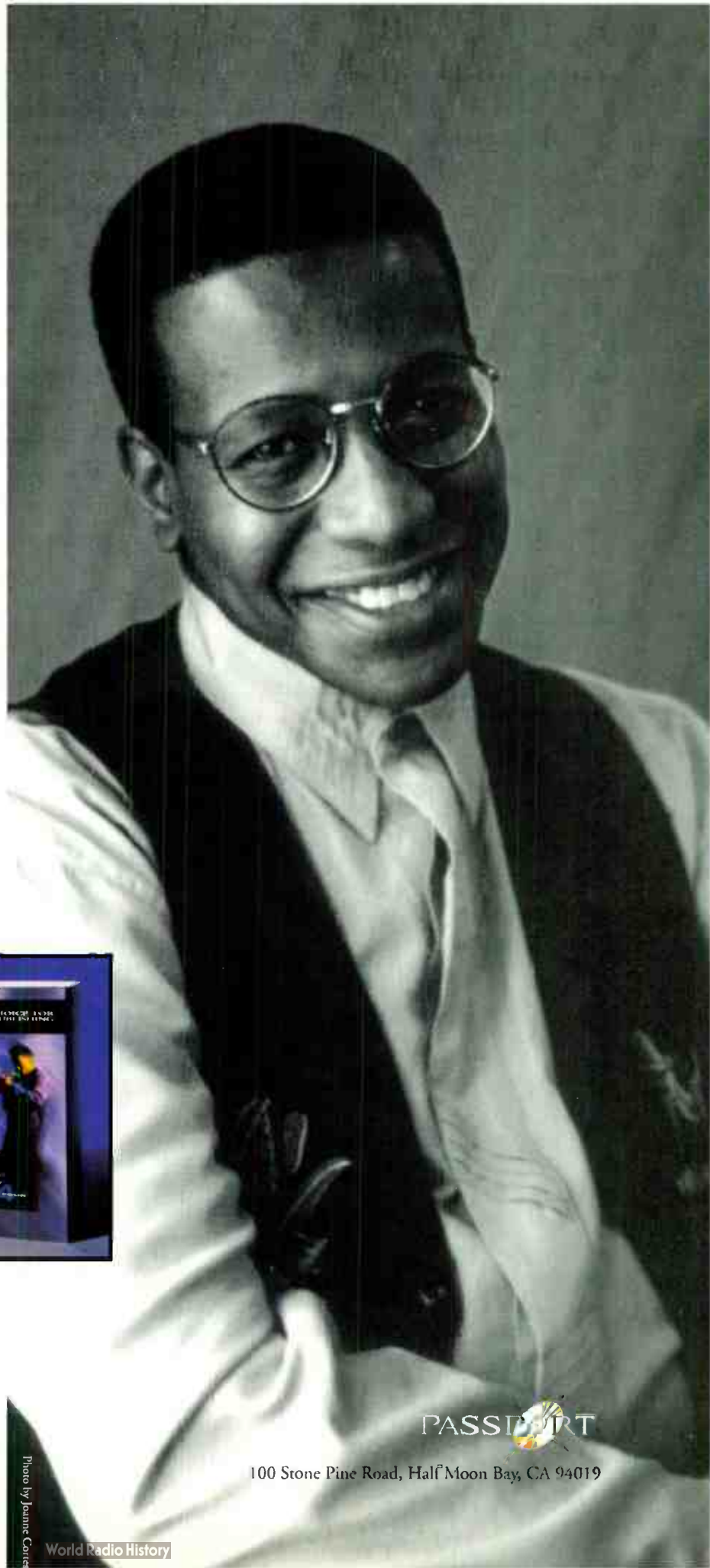

Photo by Joanne Corcoran

World Radio History

PASSPORT

100 Stone Pine Road, Half Moon Bay, CA 94019

LETTERS

PAT'S BACK

About eight years ago, I started reading your mag. At the time, I was a serious jazzhead and your mag carried the best up-and-coming jazz players. Later, as I became more interested in the alternative thing, your coverage of bands like the dB's, R.E.M., Hoodoo Gurus, the Police, Joe Jackson, etc. was exceptional and quite welcomed. I then started reading another mag and had to give up my subscription to *Musician*.

After reading the very insightful interview with Pat Metheny (who I must say I am not particularly a fan of anymore), I was glad I renewed my subscription. Pat had a lot of good things to say to musicians of any genre, reminding me of why I play in the first place.

Rkuhnsjr@aol.com

Regarding Pat Metheny's refusal to speak to *Musician* until a "living jazz musician appeared on the cover," wasn't Miles Davis on the cover before he died? In a yellow shirt, as I recall, with a black vest and a hat.

Travis Hartnett

Indeed, Miles did grace our cover back in May '89. Pat must've missed it.—Ed.

DEAR CHARLES

I've never heard Oasis, and after reading Charles M. Young's infomercial (Sept. '95), I hope I never do. There are plenty of English journalists who rub middle-class Americans' faces in dirt—why should we accept their bands?

*Christopher Davis
Forest Hills, NY*

I am not faulting Mr. Young's skills as an interviewer, but I am faulting your publication on covering another corporate hard sell. These guys were so over-hyped as "the new Beatles" that it brought another article to memory: Remember "Can Jesus Jones Save Rock 'n' Roll?" I can't believe that so much time and money are wasted on these packaged attitudes. As far as the term "lads" goes, would a real "lad" be more interested in drugs than naked women? Give me *Elastica* anyway.

*Paul Seegers
earthsea69@aol.com*

After reading Charles M. Young's stuff for so many

years, including the recent features on Oasis and Collective Soul, I often wondered about his obsession with God. Then the answer came: He's a PK! This makes sense. Only a PK could title an article "Tom Petty Is Sorta Like God and Sorta Like Us and Other Theological Insights," and make it work. Sorta makes you wonder what mighta happened if Lester Bangs had been Born Again.

*Mike Russo
Doylestown, PA*

It saddened me to learn that Ed Roland of Collective Soul spent all those years growing up in church and came away with little more than the

I saw one letter in your September issue that was so ridiculous I couldn't resist writing in response. Ron Yarnell wrote in saying that "punk is the purest form of libertarian capitalism in the music industry." The only thing I can say to that is "Enjoy your acid." The term "libertarian capitalism" is an oxymoron. He may be right that the "prank" the Dead Kennedys pulled at the 1984 Republican Convention doesn't really mean much today, but I think the point was that there aren't many bands today that would tell Newt Gingrich where to stick it. They're all too busy trying to make their first million. As far as his belief that "punk nostalgians are copycatting their Boomer elders in bragging about social pseudo-accomplishments that do not matter in the real world," that well may be, but I saw no evidence of it in that article. It's guys like him that prove that Prozac and computers don't mix.

*Charles O'Lanahan
Oliver Springs, TN*

need to publicly distance himself and his music from Christianity. Then again, I can understand his concern. Your magazine and others do tend to label Christians as "wackos" on a semi-regular basis. In fact, later in the same issue, your review of Lenny Kravitz's new album kindly warned readers about its potentially offensive gospel lyrics. For centuries, faith in God has provided a wellspring of inspiration for musicians. It would be nice to see you acknowledge that without trying to hammer Christianity into one of the prevailing negative stereotypes.

*Anthony DeBarros
Hyde Park, CA*

JULIUS

Chip Stern's appreciation of the life and music of Julius Hemphill (Sept. '95) was a fitting (and touching) tribute. Hemphill's contributions to the creative music of this century are great, but his "be my own person" attitude often struck too many people (read "mainstream critics and reviewers") the wrong way.

Everytime I saw him live the audience—no matter what size—was spellbound. I had the privilege to hear the Sextet play the music for Bill T. Jones' "Last Supper...": Messrs. Hemphill, Ehrlich, White, Grubbs, Furnace, and Carter nearly upstaged the dance troupe's fine performance. Strong writing like Chip Stern's reminds me just why I send in my check to this magazine every year, but—damn—do creative musicians have to die to get back into your pages?

*Richard B. Kamins
Middletown, CT*

RE-VIEWED

Because the illustrious Dave DiMartino began his review of the Apartments' new album (Aug. '95) with "The very best album I've heard in too many years," followed by raves comparing it to Van Morrison's masterwork *Astral Weeks*, I ran out

to buy it.

My disappointment was profound. I was stunned at what DiMartino could see in this lame whine fest awash in amateur-hour poetry, meandering (major

7ths *forever*), sloppy music, and oh-so-precious, half-whispered vocals. I know songwriters who could, as a joke, make this up as they went along. Hey Dave, want to hear my new song—"Gimme My \$15.98 Plus Tax Back, Jack"?

*Charles Horton
Nashville, TN*

Send letters to: Musician, 1515 Broadway, New York, NY 10036. Send E-mail letters to the editor, subscription inquiries and other messages to musician.mag@sonicnet.com. E-mail addresses will be printed unless requested otherwise.

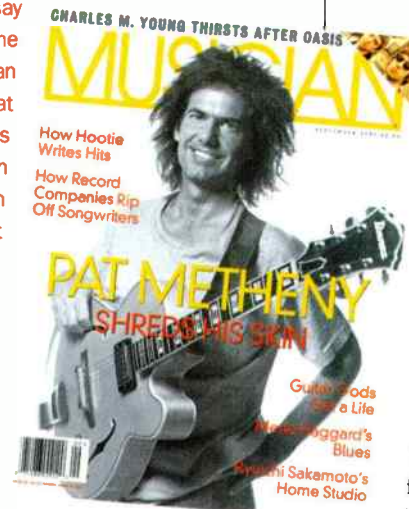

You know how good John Hiatt's always been...



...now take it one step further.

The new album featuring the first single "Cry Love," plus collaborations with special guests Bonnie Raitt and The Jayhawks.

"Walk On has the weight and depth of a classic-in-waiting."
-MUSICIAN



 PRODUCED BY DON SMITH FOR MOONDOG PRODUCTIONS
EXECUTIVE PRODUCERS: TIM DEVINE AND GARY GERSH

©1995 CAPITOL RECORDS, INC.



JOSEPH CULTICE

How We Wrote That Hit Song

by Better Than Ezra, composers of "Good"

KEVIN GRIFFIN (guitar/vocals): Most of our songs start out on acoustic guitar. I've always felt if a song doesn't work on acoustic guitar, then it has a pretty shaky foundation. But "Good" was actually written in '91. It started off as a bassline hummed into a Walkman while driving up to Oxford, Mississippi.

And, if it's not apparent, we were listening to a lot of Pixies at the time—*Doolittle*, actually. That record influenced so many people—Kurt Cobain *must've* been thinking Pixies when he wrote "Smells Like Teen Spirit." The Pixies were the first band with that formula of really in-your-face tons of guitar breaking down to just drum and bassline, and they would use those dynamics to build a really good song. Meanwhile, we had come from the R.E.M. mold of constant chords. So for me, the challenge with "Good" was to write a song that used only four chords and incorporated the ideas from what we'd been listening to, to use those dynamics to make transitions that give the illusion of different chords and different melodies. That song is the same four chords played over and over. The only thing we do is a key change: During the bridge we go up a whole step at the solo. So there were a couple of things about that song that were

real conscious: Using dynamics and writing a simple, four-chord song. A simple, upbeat, uptempo song is the hardest song to write. Most musicians will tell you that slow songs, ballads, are easier to write. But writing a fast, uptempo song with conviction and honesty without sounding contrived is the hardest thing to do. Certainly, that's true for *this* band and for most musicians I know.

Lyricaly, I don't know *where* the "uh-ho" came from. People think it was conscious, but it was really just lack of lyrics! I had to sing something. It's weird though, because the "uh-ho" part was never the catchy part to me, but now it's become the part that everyone remembers. I'm famous for the ability to—nothing to brag about—make up lyrics on the fly. Especially with some of the cover songs we play—I never know the real lyrics. So, with songs like "Good" or "In The Blood," I'll have an idea of what the theme of the song

is. After a while, I'll have a phrase or a couple of phrases or word groups that I know are gonna fit in the finished lyrics. So the good thing about coming up with lyrics by singing 'em live is that they tend to fit rhythmically because I'm forced to sing something to the rhythm of the song, as opposed to sitting down and writing lyrics, then trying to write a song around them.

"Good" was really just a melody to start. The thing is, if a song doesn't have a melody that draws you in the first few times you hear it, then it doesn't matter *how* good your lyrics are.

You have to understand that the listener wants to hear something that *catches* them. The melody brings you in and makes you love the song, and then the lyrics take it to the next level. People are drawn to songs, I think, in a superficial way sometimes, just like we're drawn to people. You can be attracted to someone because they're good-looking but if, after you spend some time with them, you find there's no personality or anything interesting about them, your interest fades. Hopefully the lyrics make you stick around.

—Dev Sherlock

ROU



Why I Practice and Actors Rehearse

by Mike Watt, bassist, *Minutemen*, *FIREHOSE*, *Dos*

When I'm either alone or together with my people going through the tunes, I call it *practice* and not *rehearsal*. Actors rehearse, I practice the songs. I do not play the role of bass player—I am the bass player! I do not have to rehearse my role as bass player but rather I have to practice the tunes for the upcoming gig. I actually have to pluck the bridge cables the bass uses for string and not perform mime. *Practice* is not *rehearsal*. The wages of this lazy thinking lead me to the defense of my craft.

By lazy thinking I'm talking about riding with the cliché, cooking up the angle, tying in the bullshit, anteing up the bonus-hype—trying to sell something for what it ain't, in simple words. They got jerks saying, "Got to go *rehearse*" so they can somehow see themselves as players in the great rock



JAY BLAESSING

dream and not as operators of god's engines, learning the way they work. Engines make sound, be it bass, throat, stomp, jug . . . whatever! Sounds are created and dealt with, not that "lights, camera, action!" shit. I mean, that's fine for pictures and theater, but we're talking about wailing out fucking music! Gigs are spontaneous when genuine.

Practice for the gig, but don't give in and try to *rehearse* it—let the gods roll the fucking dice!

The lazy thinkers embody the pure spirit of the crap artist. They will try to talk you into salt after selling you canker sores. They won't let you *practice* medicine and maybe heal them sores. No, they'd rather have you rehearse your role as Christ, and after buying their salt ('cause salt is hip this week), cake it up and rub it into your sores. Forget about if it feels right or natural, because what you're here for is to *rehearse* the great drama! You're no longer free to *practice* for your gig.

Once they divorce you from your reality, you have nothing left but the role they have for you, born of their lazy thinking, fresh from the cookie cutter. People, defend yourself first with language. Don't let them pigeonhole you—reserve the right to define yourself! *Practice* playing music and don't give in and try to rehearse it. At least wonder about the implications.

JGH MIX

NEW SIGNING

ARTIST: POE
DEBUT ALBUM: HELLO
LABEL: MODERN/ATLANTIC
RELEASE DATE: OCT. 10

Anyone who has been banging fists and head against the gates of opportunity can tell you that there are no guarantees in this business. You can prepare a killer demo, shop it 'til you drop, hire a label president's cousin as your P.R. consultant, and still wind up playing for neighborhood change.

What is the secret? What does it take to pop the lock on that gate? Talent and luck, sure. But there's more: If we learn from the lesson of Poe, sometimes just being yourself is what it takes to get the break you deserve.

For years, the New York-born songwriter, singer, and former street performer played music without giving a thought to making a career out of it. Making music was, for her, almost as natural and personal as breathing. Where other kids organized their views of the world by keeping diaries, Poe wrote songs, beginning at age eight with a precocious

paean to a teacher who had made her stand out in the hall: "I hate my teacher/She's a bitch."

"It was," Poe recalls with a grin, "my first revolutionary folk song."

During her junior high school years, Poe and her family lived in Utah, where she was one of six non-Mormons among 1600 students. Music was even more of a refuge there, with its base still rooted in the lyrics but its melodic content growing under the influence of Charles Mingus and other jazz artists. By the time she left home at age 16, "music had become an obsession. Not just something I did; it was the one thing I could hold onto. If you lose the people you depend on for your identity, it's like you've lost your witnesses, like your parents or the people who know who you are. At that point, my songs became my witnesses. I can look back at this song, whether it's [cont'd on next page]

JANE WELLS - LOCATION: CARPENTER ARMS HOTEL

ROUGH MIX

[cont'd from page 15] good or bad, and know who I was and where I came from."

Following a few years as an English major at Princeton, Poe reunited with her father during his last days in L.A. His death left her at a crossroads at which fate took her hand. "I went outside, and a T-shirt had blown up on my balcony. It said, 'Detroit, Michigan,' which is where this producer I knew lived. So I called up this producer, and when he answered the phone I heard my tape playing in the background. I said I wanted to come to Detroit and write some songs with him, and he said, 'Great!'"

Armed with new material and tapes from Detroit, burdened with her father's medical bills, Poe contacted talent manager Scott Ross, a friend of a friend of her mother's in L.A. Impressed by her tapes, Ross called a friend, Paul Fishkin, head of the Modern label. As a favor to Ross, Fishkin agreed to meet with Poe even though he had not yet heard her tapes.

Their encounter took place in Fishkin's office. "I really didn't know what I was doing," Poe admits. "But I walked in, and he was sitting on the floor, with piles of papers everywhere. The place was a disaster, with picture frames scattered all over. He was very much an absent-minded professor type, one of these guys who scratches his head and says, 'Oh, yeah. Hi. Sit down.' He started fumbling for his glasses, and we ended up just getting into a conversation about metaphysical things, life in general—nothing to do with music at all."

As Fishkin remembers it, "I was struck by her presence. I know it sounds a little corny, but that's what happened. It was just a vibe, but as we started talking, everything from that [cont'd on page 40]



RON ARIYAMA

PRIVATE LESSON

FASCINATING RHYTHMS

BY JORDAN RUDESS, DIXIE DREGS KEYBOARDIST

Take a deep breath. Prepare to enter the world of rhythmic freedom. You've been living in 4/4 time way too long and I'm holding your ticket out! The following exercises allow you to internalize different rhythms by involving your full physicality. I find this is the most effective way of learning rhythm.

First, tap a slow, steady quarter note with your foot, around 100 BPM. Now, while maintaining your foot, let's try a South Indian vocal technique called Solkattu. Sing straight eighth notes against the quarter with the syllables Ta Ka Di Mi (pronounced Ta Ka Dee Mee). Let's add a slight challenge to this. Clap your hands after every third syllable (dotted quarters). If at any point you feel too challenged, slow down.

Ex. 1: Ta Ka Di Mi Ta Ka Di Mi
 Foot Foot Foot Foot
 Clap Clap Clap

Move your dotted-quarter clapping rhythm now to either your left hand or your right. Tap it out. With your [cont'd on page 41]

♩ = 120

FOURS

SEVENS

THREES

Purchase In '95 And
Receive 6-Year Warranty!

Totally Cool.

PowerLight Amplifiers from QSC are cool to the core.

They're possibly the best sounding amps that QSC makes. *Exactly what you want from your power source:* wide, dynamic range with crystalline highs, full, round mid-range and a very fat but clean low end. PowerLight amps are extremely efficient. They'll drive your speakers better than they've been driven before. Even at 2 ohm loads.

PowerLight Amps also sound great because of *what you won't hear*—rattle and hum. These amps have remarkably low distortion due to improved output circuitry. And the noise typically associated with transformers is completely absent.

These are the only light amps that won't interfere with your wireless mics. *No static and no loss*

of radio signal. PowerLight Amps meet all RFI and FCC requirements in the U.S. and EMC requirements in Europe.

PowerLight Amps run very cool, even when the performance is very hot...even in the middle of summer. The high aspect ratio aluminum heat sink was designed with the maximum possible surface area to absorb and dissipate heat aggressively. Variable speed fans blow it away on demand. (And signal muting kicks in when things get extreme to prevent shutdown.)

PowerLight Amplifiers from QSC—the best sounding, most advanced package of power technology available. And, at a cool 18 pounds, you can put them wherever you need them without sweat. And that's cool. So, pick some up from your QSC Dealer. When you purchase throughout 1995, you'll receive QSC's extended warranty at no additional cost, for a total of six years coverage.* Call QSC for more information at 714-754-6175.

QSC[®]
A U D I O

LOAD IMPEDENCE	PowerLight 1.0	PowerLight 1.4	PowerLight 1.8
2 OHM [†]	500 Watts	700 Watts	900 Watts
4 OHM ^{**}	300 Watts	500 Watts	700 Watts

[†] 1 kHz, 1% THD, TYPICAL. ^{**} 20 Hz to 20 kHz, 0.1% THD

*If you purchase PowerLight Amplifiers by 12/31/95 you will receive QSC's 3-Year Extended Warranty in addition to the 3-Year Standard Warranty.

PowerLight is a trademark and QSC is a registered trademark of QSC Audio Products, Inc. 1675 MacArthur Blvd., Costa Mesa, CA 92626-1468 (714) 754-6175 FAX (714) 754-6174



TALENT

THE PRESIDENTS OF THE UNITED STATES OF AMERICA

The Presidents of . . . make up for their moniker with punchy pop songs about felines, arachnids and peaches. The Seattle trio uses peculiar instrumentation—two- and three-stringed guitars and portable drums-in-a-suitcase—to gleefully exploit rock tradition.

“Our record is full of rock clichés,” says “bassitarist” Chris Ballew, “but we have a certain irony. There’s something about playing two and three strings where we can blast off and do whatever we want. For us, that means quoting our influences.”

As former members of Love Battery, Beck’s band and Super-group (with Mark Sandman of Morphine), the Presidents show few stylistic ruts. “Kitty” bears a sparse grunge brand and “Lump” is pure Kinks, while “Naked and Famous” describes “30-foot Smurfs” through the spirit of Grand Funk. “‘Naked’ is about the depressing Los Angeles entertainment industry,” explains “guitbassist” Dave Dederer. “The first time I came here the billboards were crazy. Everyone was barely clothed. I was shocked.”

The Presidents stand out as positive thinkers in today’s angst-ridden climate. “I always hate those songs that say, ‘You are so messed up, you are bad,’ like Henry Rollins,” says drummer Jason Finn. “It just amplifies the problem.”

So what’s the solution to the mystery of their wordy name?

“It’s the longest title we could think of,” says Dederer. “And it’s the highest office in the land, occupied by the dorkiest guy.”—Ken Micallef



KAREN MASON

THE PRESIDENTS OF THE UNITED STATES OF AMERICA

SQUIRREL NUT ZIPPERS

Chapel Hill’s Squirrel Nut Zippers may strike you as yet another gang of kitsch-mongers, cranking out the same bachelor pad music made famous by Combustible Edison and Royal Crown Revue. But the Zippers’ musical roots extend far beyond the lounge lizard-era fifties into the decidedly un-hip “hot jazz” of the twenties and thirties. As the frisky original compositions on their Mammoth debut *The Inevitable Squirrel Nut Zippers* indicate, vintage jazz isn’t just a temporary stylistic detour. “We like to have fun, but we don’t constantly have a smirk on our faces,” says vocalist and guitarist Tom Maxwell, who helms the band

IT'S NEVER BEEN SO EA

INTRODUCING THE TUBE FEX MIDI TUBE GUITAR PREAMP



THE MIDI PROGRAMMABLE TUBE PREAMP

- ▶ The preamp uses two 12AX7 tubes running at their full rated 250 volts, which is what they’re supposed to run at to get the best tube sounds. Compare to other preamps that run their tubes as low as 4 volts!
- ▶ When the tube preamp is first in an FX chain, the input signal goes directly to the tubes without first going through analog-to-digital conversion for the best possible tone.
- ▶ Our innovative data wheel knob interface lets you change and store tube preamp patch settings in real time. The 11 LED lights around each knob indicate patch settings and changes. And a button selects the 4 tube modes, Clean, Crunch, Lead, and Ultra, with storable changes. Very easy! Very cool!
- ▶ The tube preamp can be used simultaneously with either of the two available digital distortions, one in each channel, for incredible widening of your sound. Add chorus or detune and delay for extra impact.



BEAU HUNKS

and Duke Ellington—brought them together. “This music taps into every generation,” says Maxwell. “You combine the four-to-the-bar swing beat—which rock certainly has no claim on—and add those syncopated rhythms, and you can’t beat that off with a stick. It’s killer.”—Marc Weingarten

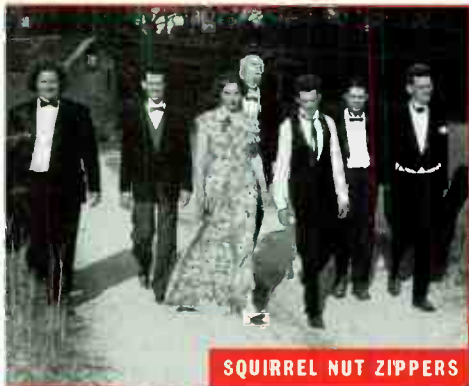

SQUIRREL NUT ZIPPERS

Bill Monroe and the Stanley Brothers in the 4th grade.”

Mathus and Maxwell both toiled in various rock bands until their passion for jazz’s holy trinity—Fats Waller, Louis Armstrong

along with guitarist Jim Mathus. For Mathus, roots music is bred in the bone—he was reared in a family of musicians. “My dad was a banjo player, and all of my cousins and uncles played, too,” says Mathus. “Every Saturday night, the family would get together for bluegrass jams. I was playing

BEAU HUNKS

A musicologist’s worst nightmare? It’s probably what happened to Dutch ensemble Beau Hunks. The group spent two years recreating compositions by LeRoy Shield from the only apparently surviving source: fuzzy soundtracks to 1930s comedies starring the likes of the Little Rascals and Laurel & Hardy. Only after they’d finished recording did the original sheet music start tuning up.

Far from being dismayed, Beau Hunks researcher Piet Schreuders is excited about his recent discovery of handwritten Shield scores. “The funny thing was, it looked very much like the parts Beau Hunks had transcribed from the recordings.”

You couldn’t ask for better proof of the band’s musical scholarship. Named after a Laurel & Hardy short, Beau Hunks are (in Schreuders’ phrase) a “documentary orchestra” of freelance musicians who get together for specific projects. [cont’d on page 76]

SY TO SOUND SO GOOD!

MP AND 24-BIT DIGITAL STEREO EFFECTS PROCESSOR.

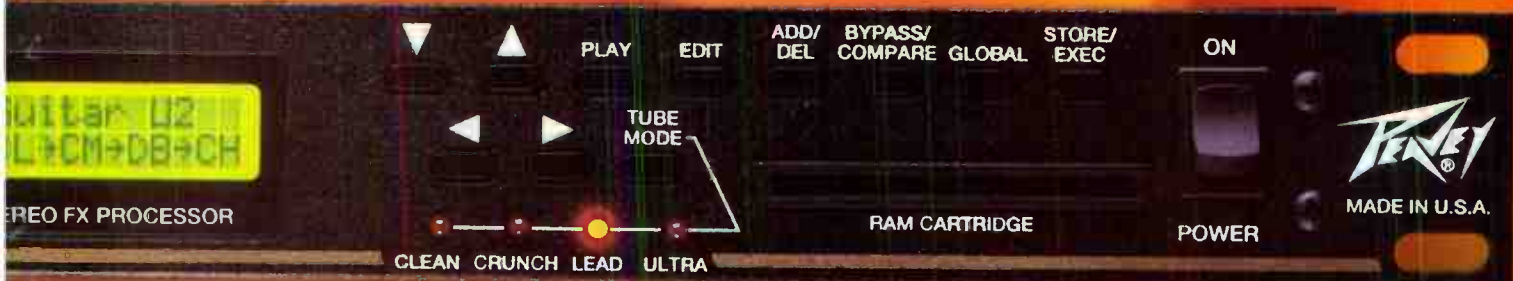

THE 24-BIT DIGITAL STEREO EFFECTS PROCESSOR

- ▶ The processor already has expanded memory so you don’t have to buy anything extra.
- ▶ 128 user and 128 factory presets, and a RAM card slot for saving or transferring 128 additional patches.
- ▶ 37 FX types like stereo tremolo, 2 pitch shifters, 8 reverbs, 3 delays, 5 EQs, compression, chorus, auto pan, wah splitter, and more. Plus unrestricted algorithm modifying/FX placement including preamp.
- ▶ The clip LED is assignable to any location in an algorithm, not just three or four points.
- ▶ The speaker simulator has various cabinet emulations, but the Tube Fex is so recording-friendly it isn’t needed to get great direct-to-board sound using the balanced stereo XLR direct outs.
- ▶ Programmable FX loop with both stereo sends and returns.
- ▶ Global master pre and postgains and EQ controlled by knob or button with super-wide gain ranges.
- ▶ Chromatic tuner with programmable mute.

The MONITOR Magazine is a publication filled with the latest information musicians want to know. To receive 4 issues for only \$5 (price good in U.S.A. only) send check or money order to: Monitor Magazine, Peavey Electronics, 711A Street, Meridian, MS 39301 (601) 483-5365 • Fax: 486-4278 • 1995

World Radio History





We
didn't
make
it
this
way
to
look
cool.

HEAT IS THE NUMBER ONE ENEMY of all speakers. Cranking the sound can absolutely cook a speaker unless it has an effective cooling system. That's one reason the new Eon system looks so radically different.

To keep its powered speakers cool, we've developed an advanced Thermomaster™ heat management system unlike any other in the world. While most speakers have a number of small mechanisms to keep the internal components from overheating, Eon utilizes a solid die-cast aluminum baffle to cool the entire speaker. As you crank the sound, this unique baffle acts as a sponge to draw heat away from internal components preventing any kind of a meltdown.

What's more, tuned ports are built right into the Eon baffle. Most speakers use ports as air vents to allow hot air to escape. But Eon's tuned ports go further. They're equipped with heat dissipating aluminum

We
made
it
this
way
to
stay
cool.



finns that take advantage of the speaker's natural "breathing" motion to soak up and get rid of additional heat. In the bi-amped powered speakers, these ports are located just below the heat generating amps. So you can work these lightweight, powerful speakers as hard as you like and they won't toast.

In fact, the Eon heat management system is so efficient, the more you crank the speakers the better the cooling system works. That's what makes the whole system so incredibly cool to use. And pretty amazing to look at, too.



H A Harman International Company

S O U N D T H A T C A R R I E S

JBL Professional, 8500 Balboa Blvd., Northridge, CA 91329

World Radio History

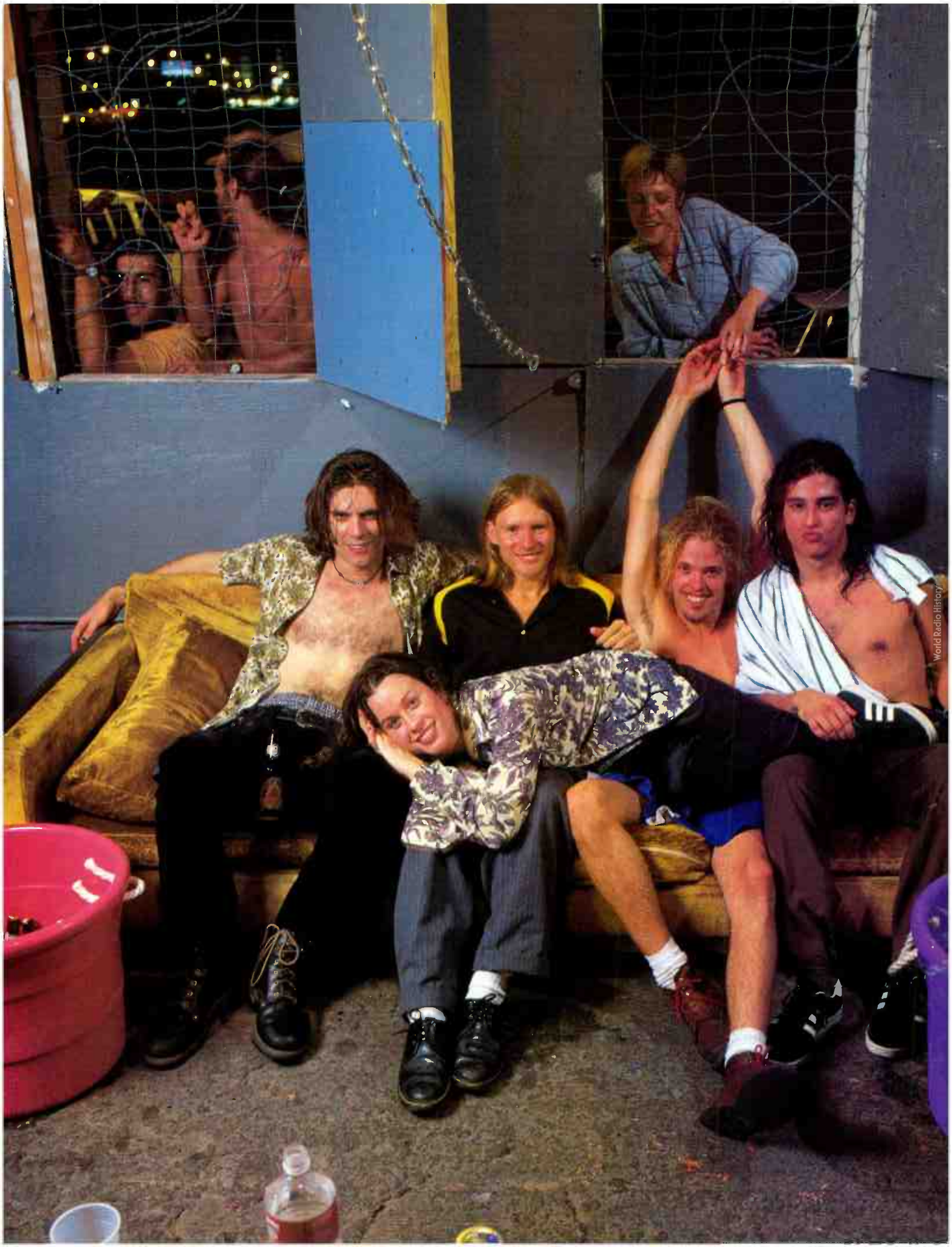



Behind
every good

PHOTOGRAPHS BY WYATT MCSPADEN
BY CHARLES M. YOUNG

Woman

TAYLOR HAWKINS HAS never taken a nap. That's what he says, and I believe him, as he's sitting there on his bed at the Austin Ramada Inn, wearing shorts and nothing else, with his knees folded into his chest, yanking on his toes with enough energy to fuel 143 clinically certifiable cases of Attention Deficit Disorder. Several bottles of cold remedies flicker in the light of a science fiction movie on the tube. A boom box in the bathroom thunders with the Foo Fighters. Dirty clothes are strewn everywhere on everything, like some anti-rock terrorist from the Christian Coalition blew a load of grapes through his suitcase.

"High school band teachers, man, they're all dicks," says Taylor, interrupting his foot fidgets just long enough to cough into his right hand, which is, by now, a roiling cesspool of toejam and streptococ-

there is a

Band

TAKING THE BUS TO THE
BIG TIME WITH
ALANIS MORISSETTE



[My band] had to be great musicians. But they also had to have great spirits.

they didn't have to do a demo or any industry showcases. Then they took an offramp to obscurity. The A&R person who signed them got replaced, and the record company recommended a manager who Jesse felt wasn't all that interested in the band. They started to record, and the music wasn't making anyone happy.

Jesse was dating a woman at the time who had once dated Anthony Kiedis of

the Red Hot Chili Peppers. Anthony dropped by one night and was impressed with some coolest-hits-of-funk tapes that Jesse had compiled. Soon he was checking out Jesse's guitar skills as Mother Tongue played local clubs. Then it was announced that Arik Marshall, the latest of several hundred Chili Pepper guitarists, was leaving the band. Jesse figured he'd give it a shot.

"I'd been a fan of theirs since I was fifteen or so," coughs Jesse in the hotel room

next to Taylor's. "I figured it was the opportunity of a lifetime just to jam with them, even if they've kind of had their day. I just went in, set up my shit, and we barely talked for a minute. We played for three hours, and it was really cool."

The next day, Kiedis and Flea offered him the job at lunch. He considered his decision for a week, then finally accepted on the grounds that Mother Tongue was deteriorating and seemed to want him only to deprive the Peppers. *Rolling Stone* published his picture; everyone told him he was going to be rich. But the rehearsals didn't quite click, and the prospect of learning a back catalog of songs he'd outgrown emotionally left him uninspired. After two months, the Peppers fired him (before he'd signed a contract) for Dave Navarro, who had probably been their first choice all along.

He followed up guitar vacancies in several bands (LSD, Faith No More), but nothing felt right until somebody at Warner Bros. called with news of an audition to back this singer/songwriter. "They took a Polaroid picture of me, which was pretty funny. I set

GO

ZERO to GO

AND NEVER MISS A BEAT!



A Volume Pedal On The Neck!



Ask Your Dealer

7th String

7th String represents the next step in access to your music. It has been designed to bring artistic expression out from under your feet and put it back where it belongs...at your fingertips!

NO MORE FOOT PEDALS!

ACCESS TREMOLO RIGHT FROM YOUR GUITAR!

Sound Ethix Corporation, 3087 12th Street, P.O. Box 667, Riverside, CA 92502, (909)274-3747, FAX(909)784-1559

up and Alanis came in. She just walked up and introduced herself. Taylor was the first drummer, and they liked what we did. It was weird how fast we blended. Taylor and I are from exactly the same school of rock 'n' roll. I used to think there were all these hard rules, things you had to have in order to be a good band. But that's obviously bullshit. I know it's her name on the album and the marquee, but this feels like a band, not the Alanis Morissette road project."

What was Jesse thinking as he auditioned for Alanis? "I was thinking, 'I'm gonna get this gig.' With the Peppers, I didn't really care if I got the job, but I knew they were going to ask. This time I had to get it no matter what. I didn't even ask about money. I just liked playing with her. That was the main thing. And at the time I was working at a veterinary clinic in Malibu, vaccinating dogs. It couldn't possibly get worse than that."

"JOHN PAUL JONES. Everyone calls me that," coughs Chris Chaney, taking the rubber band off his ponytail. Fine and straight, his hair flops down to his shoul-

ders and curves out. With his body curled over a bass, he does bear a striking resemblance to Jones. Sort of a cross between Jones and a mystified ferret. Various flu remedies and a well-thumbed copy of *Body Reflexology: Healing at Your Fingertips* testify to the relentless march of the Toejam and Streptococcus Pestilence.

After high school in San Francisco and a brief stint at junior college, Chaney decided that he had reached his limit at playing bass by ear. He wanted to know the why as well as the what of the basslines he was picking off albums by everyone from Coltrane to Rush. So he packed up for Boston and the Berklee College of Music.

"It was definitely a jazz snob scene," Chaney says before blowing his nose. "I learned a lot academically. But no one can really teach music. They can teach fundamentals, but music is what's within you: your upbringing, your emotions, what you've listened to."

Perceiving Boston as full of great players with few opportunities, Chaney packed up for Los Angeles a few credits short of graduation. He moved in with his old friend

Gary Novak, Chick Corea's drummer, and sold gasoline coupons door to door. He also started making connections by teaching bass and doing every gig that came along. One day he auditioned for both Seal and Alanis Morissette.

"The stage thing just wasn't happening with Seal. The problem was how to emulate the album without actually having a symphony, so it was mostly him singing to a computer disc. With Alanis everyone is live, and it's different every night. When I first heard her tape for the audition, I was amazed how each tune has its own personality. It all sounded so original. You can't just audition people and get that. Something magical has to happen. It's not interchangeable hired guns. The audition was for a band, not a gig."

"EVERYONE HAS TO learn his own lessons on survival," says Nick Lashley. At 31 he's the grandfather of the group, and the only member who isn't sick. There are almost no clues of human habitation in his room: a slight rumple in the bedspread, a discreet little pile of CDs on his desk. Nick



Self-titled album.
Includes the songs
"You're My World" and
"Luminous Flesh Giants."
Produced by
Glyn Johns.
To sample Joe's music,
call (718) 398-2160.
code #4409.

R
RELATIVITY

©1995 Relativity Recordings, Inc.

JOE SATRIANI

not even thinking about it. If you write something from your own unconscious, it's not that hard to get back to that place. If somebody wrote a script for me, it would be more challenging to get to that place."

So you want to spend that much time thinking about perfidious former boyfriends?

"As I've come to terms with certain things, the songs take on different emotions for me. I've stopped feeling guilty because of how mean I was being. I realized this record for me is not about revenge, whether 'You Oughta Know' or

'Right Through You.' Those songs were written for the sake of release, and it's made me more peaceful than I've ever been."

Isn't there an element of personal triumph to it, in the sense that you're rich and famous now and the people you're writing about aren't?

"Not at all. External success is entirely separate from personal success. And I was as responsible for that situation as he was. I was overly dependent. My self-esteem was entirely in his hands and I went along with everything."

So it's good you're out of it.

"That's how I see it now. I'm glad that happened. I needed it. That's what people don't necessarily know."

Alanis grew up in Ottawa and went to Catholic school, which she hated and sings about in "Forgiven." At the same time, she was pursuing a pop career as sort of the Canadian version of Tiffany or Debbie Gibson. She had a publishing deal at the age of fourteen and released two albums: *Alanis* in 1991 and *Now Is the Time* in 1992. She now views most of her earlier music as "compromised" and rages about it in "Right Through You" on the current album. By comparison, *Jagged Little Pill*, which Alanis created largely through a collaborative songwriting process with Glen Ballard, was an experience bordering on the spiritual.

"I didn't know what the word meant until I started working on this album. I just had a void in that part of my life. But there were too many unanswerable things that happened throughout the writing for me not to start believing in a higher power. The more songs I write, the more I believe it. Sometimes I want to hide under the bed, it's so scary. My palms are sweating. I'll read it back, but I don't remember writing it. Where does it come from? Eighty percent of the album is the original demos with vocals done in one or two takes. I'd listen to it and not even know who's singing. Glen and I would just look at each other."

You must have been thinking about personal compatibility as well as musical skills when you picked your band.

"Definitely. I knew what to look for because I'd been in certain creative relationships that weren't positive, where somebody had a dark karma, or where people were controlling and cruel. I just vowed I wouldn't spend any more time with people like that. I auditioned about fifty people. They had to be great musicians, because some of the chord changes aren't straight-ahead rock 'n' roll. But they also had to have great spirits. At the auditions, I was trusting my intuition a lot. They turned out to be even better musically and spiritually than I expected. We've become a mutual admiration society."

Do you plan to write with them?

"I want to try it. I just remember how long it took me to find the compatibility I had with Glen. I'd be an idiot to think that just because I get along with someone I'd necessarily have that creative magic. There

Holiday Rapping

*'Twas the night before Christmas,
And all round the block,
People were jamming
To Donny's hard rock,*

*The children were jumping
Up and down on their beds,
Laughing and singing
And banging their heads.*

*When from his guitar
there arose such a clatter;
The music had stopped:
Don's strings were in tatters.*

*Then a small sleigh appeared
With a fat dude in red,
And D'Addario Tune-Up Kits
Piled high in his sled.*

*He came down Don's chimney
And said, "Take your pick:
Phosphor Bronze or XLs
To continue your licks."*

*"There's a peg winder," Santa said
"With two sets of strings,
And the cloth with this polish
Adds shine to your things."*

*St. Nick then leaned over
And said in Don's ear,
"You should change your strings
More than once every year."*

*And I heard him exclaim
As he rode fast away,
"Keep your guitar in good shape,
You'll be famous one day!"*

Both the electric and the acoustic Tune-Up Kits include: 2 sets of strings, 1 peg winder, 6 guitar picks, 1 polishing cloth and 1 bottle of guitar polish.



Season's Greetings from **D'Addario**[®]
Farmingdale, NY 11735 USA

are a million elements that have to be in place for that to happen. But I look forward to trying it out."

There's a line in "Not the Actor": "I don't want to be adored for what I merely represent to you." Ever talk to your boss Madonna about image vs. reality vs. personal relationships?

"So weird you'd ask that, because I was just thinking of her. And I thought, 'If anyone could understand that, it would be Madonna.' I feel for her, in her position."

The next time you go with a guy, he's going to worry you'll demolish him on your next album.

"Yeah. When I have sex with a guy now, I worry that if I scratch my nails on his back, he'll think of 'You Oughta Know.' I'm never going to write another song like that." Pause. "Well, I can't promise that." Well-enunciated laugh.

WE DRIVE TO Dallas the next day in a van. The album having exploded long before anyone expected, they don't have a tour bus and are traveling at a level of luxury that should earn them some of that "indie cred" that Taylor doesn't give a rat's ass about. Taylor's in the front seat, listening to Jeff Buckley on his Discman, playing air drums, grunting at the good parts, and every three minutes coughing a fine sputum spray of Toejam and Streptococcus Pestilence into the air conditioning. Alanis sits in the second seat, listening to her complete collection of albums by Joni Mitchell (a recent discovery). The rest of the band is packed into the third and fourth seats. Stuff is piled everywhere.

When we make a pitstop at a roadside market, Alanis wants to know what everyone in her band is eating. Then she wants to smell everyone's Gatorade. Not taste it. Smell it. I didn't ask why. Then she wants to know what I'm eating. Referring to my twenty-ounce Diet Pepsi, she says, "I thought we agreed you were quitting caffeine."

"Nah. We agreed I was thinking about quitting caffeine for about the four millionth time."

"Well, I think you should write your article alone, without any crutches," she says.

Which is really annoying.

But I forgive her that night at Trees, a small, massively oversold club. It's a great show. Taylor does his funkified Keith Moon thing, Jesse does his funkified Pete Townshend rhythm thing, Chris does his

jazzified John Paul Jones bass thing, and Nick takes care of the David Gilmour spacey bluesy lead thing. Alanis does her Joni Mitchell possessed by Satan thing. The band is the second coming of Jane's Addiction. The crowd screams along with a whole lot more than just "You Oughta Know," a sure omen that the album has a long future on the charts.

Later I end up talking to Salena Copeland, seventeen, who's the yearbook editor at Pleasant Grove High School in Texarkana. "Her music applies to me, and it

applies to everyone everywhere," says Salena. "Every single song applies to your life."

"Everyone everywhere? She seems pretty angry about some of the men she's been involved with."

"Yes! They're all assholes! And they deserve to die!"

And Salena proceeds to tell me a very sad story about this boy who lied to her and left her for an older, married woman. But it's not nearly so sad as my flying back to New York and coming down with the Toejam and Streptococcus Pestilence three days later. ❧



DAVID BOWIE 1. OUTSIDE

featuring
"The Hearts Filthy Lesson"
Produced by David Bowie and Brian Eno



Virgin

©1995 David Bowie under exclusive license in the U.S.A. and Canada to Virgin Records America, Inc.

IT'S UNLEASHED MORE CREATIVITY THAN

The Mackie CR-1604 16x2 mic/line mixer is getting dangerously close to becoming a pro audio classic.

Not because it has the most mic inputs, knobs, buses or switches — others have long since topped us for sheer numbers of doo-dads and thingamabobs.

No, the CR-1604 has ended up in so many studios and on so many stages because it sounds good. And because it's downright easy to use.

More than any other component, your mixer is the focal point of all your creative efforts.

If it's complicated to operate, you've just erected a frustrating barrier between you and your music. If it's noisy, everything that's recorded will be noisy, too.

When you're looking for an affordable, compact mixer that's good enough to regularly record complete albums and prime-time TV soundtracks, call us toll-free (M-F 8:00 AM to 5PM PT).

You'll talk to a real person who'll send you our 40-page color tabloid complete with a 16-page hook-up and applications guide.

Then start exercising your musical creativity with the mixer that's becoming a classic for all the right reasons.

EXTREMELY RUDE. BLINKING SOLO LIGHT.

Sounds like a minor detail until some night at 2AM when you can't figure out why there's no sound coming out of your monitors.

BEEFY HEADPHONE AMP WITH SEPARATE VOLUME FADER.

Instead of the usual wimpy amp, the CR-1604 has a separate, high-gain headphone amplifier section with enough gain to drive any brand of headphone to shock volume levels that will satisfy even a drummer. Also has more than enough gain to drive any monitor amplifier.

INSIDE: QUALITY COMPONENTS

like double-sided, through-hole plated fiberglass circuit boards with solid brass stand-offs, gold-plated interconnects and sealed rotary potentiometers that resist dust & liquid contamination.

BEST RFI PROTECTION OF ANY COMPACT MIXER.

No matter how quiet a mixer's internal circuitry is, it can be sabotaged by external radio frequency interference. RFI is created by broadcast stations, cell phones, computers and even that expensive radio-controlled car your kid got for Christmas. RFI gets into a mixer via the input jacks where it uses the internal circuit traces as miniature antennas to produce noise ranging from a low-level hiss to actual, audible voices and music.

The CR-1604's 1/4" jacks use a shunting capacitor to stop RFI before the main circuit traces.

Instead, RFI is re-routed back through the metal jack body and washer, then dissipated via the mixer's outer chassis.

XLR inputs are likewise protected from RFI via ferrite beads.

Next time you see a mixer with plastic 1/4" jacks, remember what you just learned.

DUAL PURPOSE METERING SYSTEM.

Besides showing main L/R output level, the LED ladders are used to establish input levels. Set a channel fader at Unity, press the channel's SOLO button and set input trim level. This approach achieves very high headroom and low noise at the same time. Plus you have 20dB MORE GAIN above Unity.

INSTANT HANDS-ON-ACCESS

to constant power pan controls, musical 3-band equalization, ALT 3/4 extra stereo bus, stereo in-place solo, seven high gain Aux sends per channel (via four controls) and four high gain stereo Aux returns (20dB more gain above Unity).

MULTI-WAY CONVERTIBLE PHYSICAL DESIGN.

The CR-1604's rotatable input pod lets you conserve space in a road rack or spread out in a project studio.

Change from a 7-rack-space mixer with jacks to back (A) to a tabletop design with jacks to top (B) in minutes. Add our optional RotoPod bracket (C) and rotate inputs and outputs to the same plane as the mixer's controls (a favorite for small SR set-ups).

Any of these conversions takes just minutes with a Phillips-head screwdriver. And our XLR10 10-mic-preamp expander can be added in any of the configurations.

NOT VISIBLE BUT VERY IMPORTANT: THE MACKIE MIX HEADROOM DIFFERENCE.

Nobody uses just one channel of a mixer (although most headroom specs are stated that way). In any mixer, the mix amp stage combines signals from ALL inputs at once. If it overloads, you can't back off the master fader because it comes AFTER the the mix amp. So audible distortion results when the mix amp gets bogged down with multiple hot inputs. Mackie's unique mix amp architecture provides as much as twice the mix headroom of conventional designs. No wonder it's a favorite of top electronic percussionists.

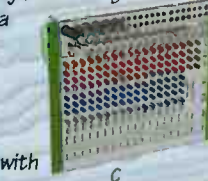
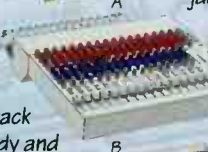

ANY OTHER COMPACT MIXER.

ULTRA-LOW NOISE. When you compare noise specs, look for the one that counts: all 16 channels up at Unity Gain — not one channel at Unity gain. No other compact mixer beats the CR-1604 when it comes to low noise floor.

MULTI-FUNCTION AUX SEND SYSTEM WITH LOADS OF GAIN. AUX 1 on each channel can be used either for effects (post-fader/pre-EQ) or switched to monitor sends for stage monitor or headphone cue signal (pre-fader/pre-EQ). AUXs 2 thru 6 are post-fader/post EQ. AUX 3 and 4 knobs can be shifted to AUX 5 and 6 at the touch of a button.

MUSICAL 3-BAND EQUALIZATION. The CR-1604 redefined equalization points for compact mixers: 12kHz Hi EQ (instead of 10kHz) for more sizzle and less aural fatigue, 2.5kHz Mid (vs. 1kHz) for better control of vocals and instrumental harmonics, and 80Hz Lo EQ (instead of 100Hz.) for more depth and less "bonk." Others have copied these EQ points, but none have successfully emulated our quality equalization circuitry. It costs us more, but the result is zero

phase distortion and a sweeter, more musical sound. It's another reason that the CR-1604 is a favorite of TV and film soundtrack scorers.

LEGENDARY MICROPHONE

PREAMPS. Instead of sixteen "acceptable" integrated circuit microphone preamps, the CR-1604 features six big-console-quality preamps...the same mic preamp design that's on our acclaimed B•Bus consoles. You get tremendous headroom and bandwidth with less noise and distortion. If your particular application requires more mic inputs, simply add our XLR10 10-Mic-Preamp Expander. Both it and the CR-1604's internal mic preamps have real and verifiable specs of -129.5 dBm E.I.N., 300,000Hz bandwidth and 0.005% THD. No wonder several of the world's top microphone manufacturers use Mackie Designs CR-1604s to demo their finest condenser mics at trade shows.

INPUTS AND OUTPUTS AT PROFESSIONAL — NOT HOBBYIST — SIGNAL LEVELS. The CR-1604 operates internally at industry-standard +4dBu levels to help reduce noise. But it can also handle the weaker -10dBV levels found on some digital multitrack machines and other equipment.

¹This is no idle boast. Consider these tours for starters: Madonna, Rolling Stones, Boyz II Men, Whitney Houston, INXS, Janet Jackson, Peter Gabriel, Bette Midler, Bruce Springsteen, Paula Abdul and Moody Blues. Mention in this list denotes usage by band members or tour techs and in no way constitutes an endorsement by the artists mentioned.

²More fine print: Mention in this ad denotes usage as reported to Mackie Designs and in no way denotes endorsement by the artist, program or production company listed.

Split monitor configurable for easy 8-track digital tracking & mixdown

Used on more superstar world tours in the last three years than all other compact mixer brands combined¹

Legendary studio-quality discrete microphone preamps

Used by members of the Tonight Show band, David Letterman band, Conan D'Brien band, Saturday Night Live Band²

Expandable with XLR10 Mic Preamp Expander & Mixer active combiner

Used by Fox Television Sports for Monday Night Football on-field sound²

Built-like-a-tank physical construction (it's too darned homely to be fragile)

Used for sound design and incidental musical scoring on the world's most popular TV show

Special mix amp architecture for twice the mixdown headroom of other designs

THE PERFECT MATCH FOR ADATS, 8A-88s AND HARD DISK RECORDING SYSTEMS. We'd dearly love for you to buy one of our B•Bus in-line consoles, but the CR-1604 makes a very effective 8-track recording mixer. The CR-1604's first eight channels have post-fader channel inserts (channel access). This VERY important feature is found on few other compact mixers. It lets you create a "split console" so that you can simultaneously track on eight channels and monitor/mixdown on eight more.

EXPANDABILITY If you add a second or third digital multitrack, you can use one or two additional CR-1604s with our MixerMixer active combiner. It lets you run 32 or 48 channels without having to "cascade" the mixers.

MACKIE™

16220 Wood-Red Road NE • Woodinville • WA • 98072 ☎ 800/898-3211 ☎ 206/487-4337
mackie.com • Outside the US, ☎ 206/487-4333 • Represented in Canada by S.F. Marketing ☎ 800/363-8855

World Radio History



BY
LESLIE J. BOCK

CATCH THE WAVE OF THE FUTURE

IMAGINE
being able to access your favorite
radio program online from anywhere in the world,
live, without delay, with FM quality sound or better. Or how
about having your indie band heard by a global audience of millions
of listeners—all potential purchasers of your music. Or maybe you want
to set up your own independent station on the 'Net. You can do all this, and
more, today via online radio. And with analysts predicting the number of homes

ONLINE RADIO

equipped with computers and modems growing to 34 million by 1998, this is just
the beginning. ♦“By the year 2000, online radio will be commonplace. There’ll be

BROADCASTING ON A COMPUTER NEAR YOU

AM, FM and online—each with its own revenue source and programming
mix,” claims Michael Rau, president of Radio Data Group, a subsidiary of
EZ Communications whose 21 radio stations will all provide Inter-
net access by year’s end. And Howard Gordon, president
of the Arroyo Grande, CA-based Xing Technolo-
gy, makers of StreamWorks, the revo-
lutionary



ILLUSTRATION
BY FRANCISCO CARERAS



Give Musician—The Ultimate **BOX** Set

A new issue in the mailbox every month!

And with each gift subscription, you and your recipients will automatically be eligible to win a portable CD player and 5 great CD box sets!

Musician Holiday Gift Certificate

Send my Musician gift subscriptions to the following and let us know if we've won a CD player and 5 great CD box sets!

My 1st gift only \$19.97

Name _____

Address _____

City/State/Zip _____

Additional gifts just \$14.97 each

Name _____

Address _____

City/State/Zip _____

We'll send holiday gift announcement cards to you as soon as we receive your order. Please add \$12 per subscription outside the US.

My Name _____

Address _____

City/State/Zip _____

Enter my own subscription at this low rate! New Renew

Payment Bill me later

Charge my Mastercard Visa Amex

Signature _____

Card# _____

Expiration Date _____

Drawing void where prohibited.

XM501 -

SPECIAL 200TH

Give the gift of a Musician subscription this holiday season and you and your recipients will automatically be eligible to win a portable CD player and 5 mega box sets from The Velvet Underground, Steve Winwood, John Coltrane, Elvis Costello and Bob Dylan!

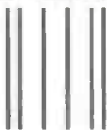

BUSINESS REPLY MAIL

FIRST CLASS MAIL PERMIT #663 MARION OH

POSTAGE WILL BE PAID BY ADDRESSEE

MUSICIAN

SUBSCRIPTION DEPARTMENT
PO BOX 1923
MARION OH 43306-2023

NO POSTAGE
NECESSARY IF
MAILED
IN THE
UNITED STATES

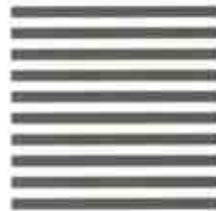



real-time audio software, says, "We expect to have over 100 radio stations on the Internet with live and on-demand broadcasting by the end of 1995." To fully grasp where online radio is headed over the next five years, consider the technological advances driving the medium. Advances in online radio software technology virtually happen "overnight."

Companies such as Seattle-based Progressive Networks, creators of RealAudio, and Xing Technology are running neck-and-neck for the latest breakthroughs.

The Internet's first 24-hour online radio station, Radio HK, developed by Hajjar/Kaufman Advertising's New Media Lab, debuted this past February, with a playlist devoted entirely to the music of independent bands. At first it took 25 minutes for every 5 minutes of audio downloaded off the 'Net using a 14.4 kilobit-per-second modem (the common modem at the time, an arduous process), which gave you extremely poor sound quality to boot. But then a few weeks later, the breakthrough technology of RealAudio enabled you to use your computer, modem and a voice-grade telephone line to browse, select and play back audio on-demand—in other words, immediately. This technology was based on a streaming process that sent compressed data at regular intervals so that it could be received, decompressed and assembled in a timely fashion. Although the sound quality at playback was strictly AM, it was an advance over the slow process of downloading.

In April, Radio HK began using RealAudio. As a result, 'Net browsers could easily access prerecorded programs from the server—not as with traditional radio, at time of broadcast, but "on-demand." Despite the obvious benefits to the listener, some advertisers squirmed at the concept of radio transmitted through a computer: the idea was too new, the audience still too small, the risk too great. "It's not economical for radio stations to go global now . . . there's no money in it," noted Phyllis Stark, managing editor of *Country Airplay Monitor*. They could not yet fathom online radio's potential for an avid listenership, alternative programming and advertising revenue. What was needed was real-time delivery of audio and better sound quality for people to be convinced. So the advertising community held back and waited for the next breakthrough in compression technology. And overnight it came. It was called StreamWorks.

StreamWorks is a product designed to provide real-time delivery of high-quality audio (and video) live and on-demand. It works by mimicking actual radio broadcasting through advanced compression techniques and the use of larger bandwidths. The basic foundation of StreamWorks is the concept of



Due to our worldwide exposure over Radio HK, we were invited to be a part of a limited-edition CD-ROM in Germany," says vocalist/bass player Allen Lorry of the San Francisco-based rock band, Riots of Boredom. "We also got a booking agent in Holland," he continues. "And when we toured England, people who came to see us told us they came because they listen to us online." Lorry's advice to indie bands: "Do it; get online now. It's the way to go."

"streaming media," which delivers both live and on-demand audio in real time without having to download audio files to local disk drives. Users can hear audio while it is being transmitted instead of waiting for a file transfer to take place.

StreamWorks technology allows online radio stations to perform live broadcasts on a global scale and provides the listener with FM quality sound or better by expanding bandwidth capabilities. "It's a matter of how much you want to pay the telephone company for the line," explains Eric Redemann, vice president of Xing Technology. "For example," he continues, "if you have a 14.4k modem, you can get 8k mono sound; if you have a 28.8k modem—fast becoming the standard—you can get 22k mono sound, which is better than AM but not FM sound. If you have an ISDN (Integrated Services Digital Network) phone line—available now in most cities and probably all by the year 2000—at 56k per second, you can get 22k stereo or 44k mono sound, which is good quality. Some time soon, we anticipate getting the full CD quality sound of 44k stereo."

Expect at some point in the next few years to have stereo sound capability from your computers. But as far as what else the "techies" have in store for us in the beginning of the 21st century, they're not talking—the competition is too fierce.

LESS THAN A year after Radio HK went online, many broadcast radio stations now proliferate in cyberspace. Radio HK boasts a listenership of 55,000 and expects this to grow immensely after it launches live radio by the beginning of 1996, complete with a disc jockey, new programming and broadcasting to a worldwide audience.

"It isn't the ability to broadcast live as much as it is the ability to have huge numbers of simultaneous listeners," says Norman Hajjar, president of Radio HK. "More listeners interest advertisers and bring revenue, which in turn pays for DJs and better forms of pro-



Twenty-five year veteran of the indie music scene Robert Danziger from the Los Angeles-based band Danz/Beat says, "After having my music played over online radio, I received many inquiries from listeners including one from a music industry person who offered to do promotion for me." And he feels that online radio has much promise for the future, "I think that in 5-10 years it will be the preferred medium of distribution."

ACCESS RADIO HK

Here's how to access Radio HK. Through a PC, it's best to use a 486/33 SX computer or better with Microsoft Windows 3.1x, a sound-card with a Windows sound device driver and a Winsock-compliant TCP/IP protocol stack.

Through a Mac, it's best to use a MacTCP, system 7.0 or newer, Sound Manager 3.0 and a Mac with a 68020, 68030, 68040 or PowerPC processor.

gramming." Radio HK still seeks indie bands to play on their shows—something regular broadcast radio will not do, even online. By the year 2000, Radio HK expects to be completely live and store their programming on the server. With live radio and storage of programs combined, online listeners enjoy the best of both options.

Why do radio stations deem it necessary to go online at all? After all radio can be listened to anywhere, mostly by people who are doing other things. But that's exactly the point—if you're working at your computer, why not tune in through your computer? "If people are spending more time with their computers, radio needs to be there," explains Michael Rau. Now with technology providing the live audio on-demand capability for radio as it is actually occurring, radio stations are beginning to notice the future prospects of this new medium.

"I'm very excited and optimistic about the future of online radio," says Daryl O'Neal, operations manager of KUTZ radio in Austin, Texas. He imagines people in offices, especially those whose employers do not allow radios on desks, tuning into KUTZ through their computers and continuing to do their work while simultaneously listening to his station. "We've just boosted the actual capacity of our station to reach a wider audience." We all know what that means—more revenue for programming.

O'Neal is getting involved with interactive radio as well. His version incorporates images of listeners "driving in their cars [who] hear an advertisement, press a button on the radio, get a coupon right on the spot coming out of the radio, drive to their nearest retailer and purchase the product. I fully expect this by the year 2010 in all automobiles and it's

THINK DRUMS THINK REMO THINK DRUMS THINK REMO THINK DRUMS TH

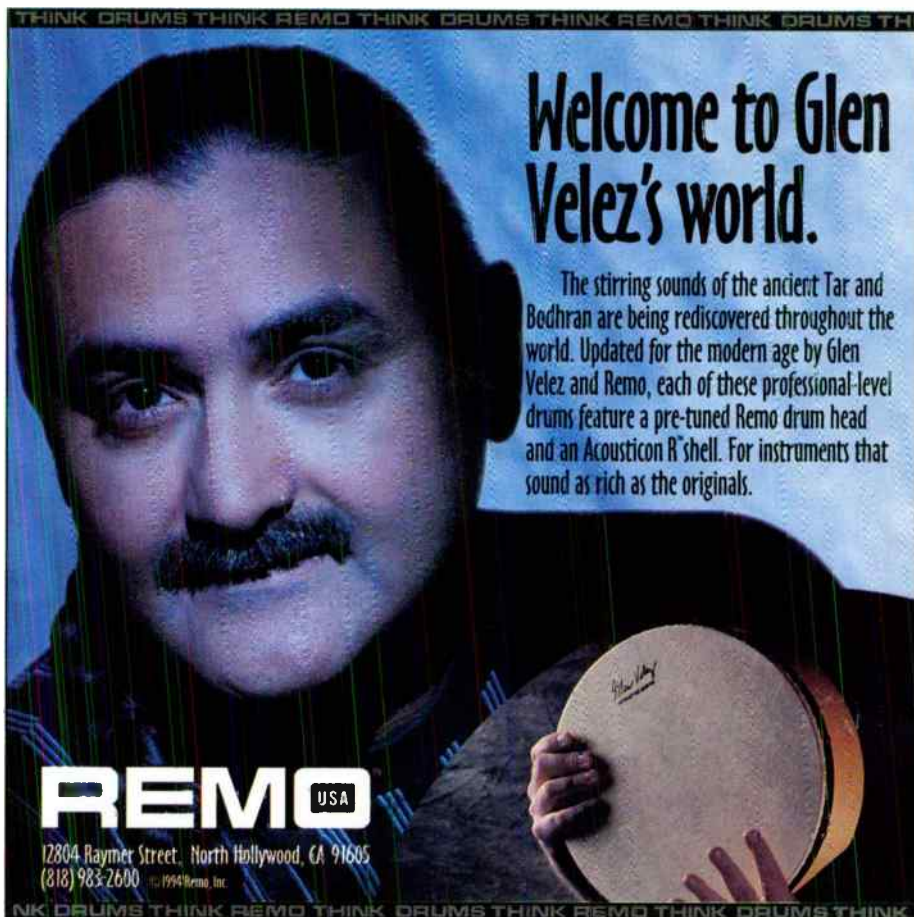

Welcome to Glen Velez's world.

The stirring sounds of the ancient Tar and Bodhran are being rediscovered throughout the world. Updated for the modern age by Glen Velez and Remo, each of these professional-level drums feature a pre-tuned Remo drum head and an Acousticon R shell. For instruments that sound as rich as the originals.

REMO USA

12804 Raymer Street, North Hollywood, CA 91605
(818) 983-2600 © 1994 Remo, Inc.

THINK DRUMS THINK REMO THINK DRUMS THINK REMO THINK DRUMS THINK

"...one of contemporary music's most committed innovators, transforming an unusually constrictive artistic base -- the three-minute radio-friendly pop song -- into cosmic territory." *The Village Voice*

"If you listen closely to these brilliant reinterpretations of his old songs, you'll know everything you need to about the elusive Mr. Wilson ... one of the most enigmatic and endearing characters of these times." *Don Was, Producer*

BRIAN WILSON

"I JUST WASN'T MADE FOR THESE TIMES"



© 1995 MCA Records MCAK/D-11270

MUSIC FROM THE ACCLAIMED DOCUMENTARY
ON KARAMBOLAGE/MCA CD'S AND CASSETTES

KARAMBOLAGE MCA

SURF THE NET, GET AMPED: http://www.mca.com/mca_records

a tribute to john lennon
WORKING CLASS HERO

featuring

RED HOT CHILI PEPPERS

MAD SEASON

CANDLEBOX

BLUES TRAVELER

SCREAMING TREES

THE MINUS 5

THE MAGNIFICENT BASTARDS

FLAMING LIPS

SUPER 8

CHEAP TRICK

COLLECTIVE SOUL

SPONGE

TOAD THE WET SPROCKET

MARY CHAPIN CARPENTER

GEORGE CLINTON

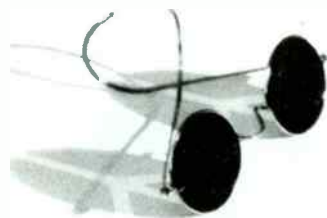

available on Hollywood Records
Compact Discs and Cassettes.



©1995 Hollywood Records

Fifty percent of artist royalties, producer royalties, and of Hollywood Records' net profits from this album will be used to establish a dedicated fund administered by The Humane Society of the United States that will be used for proactive programs conducting, promoting and furthering spay and neuter efforts for cats and dogs.



actually happening in Japan right now." Of course cars need to be equipped with digital radios for this to be effective. But, according to the automakers in Detroit all American cars will offer digital radios within the next ten years, thereby making interactive radio a reality in the United States.

Over the past year, record companies as well as record retailers have been offering consumers the capability to purchase music online through their respective websites. Look for this to be a profitable experience for online radio stations, too. Norman Hajar plans to take his program, *The Indie Listening Jukebox*, which now allows listeners to select specific songs or put together playlists of songs in any sequence, into the 21st century by offering a "credit card validation component" at the bottom of the computer screen so music may be purchased on the spot. Indie bands in particular can appreciate the possibilities of being heard and selling their wares this way. Long a fixture in record stores, this listen-before-you-buy option is expected to have a monumental impact. And once the global audience has access to this purchasing power too, the opportunities for indie and alternative bands will be greater still.

Broadcast radio stations remain skeptical. For example, Ted Edwards, program director of WNEW-FM in New York City, feels that "the great thing about [broadcast] radio is that you can take it anywhere without lugging around a computer." Edwards suggests that people who sit in front of a computer for fun "should get a life." As of

It's ironic that such an impersonal medium as the computer has gotten us more personally involved with our fans," notes Michael Hearst of the Richmond, Virginia-based band Fashion Central. "We've been contacted by listeners from all over the world—even Bosnia—who've heard our music," he continues. "The Internet easily let's us keep in touch with our fans and let's them know what we're doing."

this writing, WNEW-FM still only provides a website for its listeners with a calendar of events, station programming information, concert updates, etc. You probably shouldn't hold your breath waiting for them to broadcast online.

On the other side of the shore (figuratively and literally) are those who remain optimistic about online radio and its future possibilities of amassing a worldwide audience. "People who are listening locally are very excited about being a part of an international community," claims Norman Hajar, whose Radio HK broadcasts to all 50 states as well as 40 countries. The whole world has opened up to radio stations for alternative programming formats, new listeners and advertisers, where stations can now target programming to reach specific demographics wherever they might be located. Radio is clearly moving past the local level. But trying to get stations to speak freely about their future programming concepts was like asking the "techies" about future innovations—they, too, are not divulging any secrets now.

So what will the listener's life be like in the brave new world of online radio? Let's say you're in England and you're homesick for the lovely voice of Howard Stern. Get yourself to the nearest computer and access the show online. Oops, you forgot about the time difference and when you tried to access the show it was already over. No problem. Go to the station's server and access it there where it was stored just for people like you.

What about satellite radio, whose reach

already stretches overseas? Well, you can't get satellite radio through a computer. And once the broadcast is over, if you've missed it, you have no way of accessing it.

More importantly for bands in search of new forums for their music, overseas audiences are already lining up. WPLJ in New York City broadcast a simulcast satellite transmission of its show to London this past August: *Billboard* described the show as a huge success. So when KPIG in Monterey, California became the first 24-hour broadcast radio station to broadcast online this past summer, it came as no surprise. They're using StreamWorks to extend their reach and other stations are doing the same: WBAZ in Baltimore, KWBR and KKAL in San Luis Obispo, California, and EZ Communication-owned Seattle stations KMPS and KZOK are just a sampling of radio stations now providing alternate options for

ONLINE OPPORTUNITIES FOR INDIE MUSICIANS

Indie bands can send tapes, DATs, CDs or anything else to:

▶ **RADIO HK**

Hajjar/Kaufman New Media Lab
310 Washington Blvd, Ste 1
Marina Del Rey, CA 90292
Phone: 310/305-8128
World Wide Web:
<http://www.radio.com/radio>

▶ **TECHNOLOGY**

Progressive Networks
(makers of RealAudio)
616 First Avenue, Ste 701
Seattle, WA 98104
206/223-8221
Fax: 206/223-8221
e-mail: info@prognets.com
World Wide Web:
<http://www.realaudio.com>

Xing Technology
(makers of StreamWorks)
1540 West Brand St
Arroyo Grande, CA 93420
805/473-0147
Fax: 805/473-0147
e-mail: hgordon@xingtech.com
World Wide Web:
<http://www.xingtech.com>

THINK SOUND THINK REMO THINK SOUND THINK REMO THINK SOUND THINK



Aaron Comess has a head for drums.

Lots of heads. For his Spin Doctors' sound Aaron uses coated Ambassadors® for his tom batters, and clear Ambassadors® for his tom bottoms. His bass drum gets a clear Powerstroke® 3. His snare has a coated Ambassador® on the batter and a clear one on the bottom.



REMO USA

12804 Faymer Street, North Hollywood, CA 91605
(818) 983-2600 www.remo.com

THINK SOUND THINK REMO THINK SOUND THINK REMO THINK SOUND THINK

IT TOOK 10 FINGERS, 12 STRINGS, 15 YEARS AND 1 EXTRAORDINARY NIGHT TO MAKE THIS ALBUM. BUT ALL YOU NEED TO ENJOY IT ARE 2 EARS AND A SLIGHTLY TWISTED FUNNY BONE.

LEO KOTTKE LIVE

NOW EXPERIENCE THE LEGENDARY MASTER AT THE PEAK OF HIS PLAYFUL POWERS - AWESOME INSTRUMENTAL ARTISTRY AND SNEAKY, SARDONIC WIT CAPTURED IN CONTEXT...LIVE.

TO PREVIEW SELECTIONS FROM THIS RELEASE, PLEASE CALL: (212) 333-HITS X24305



A DIVISION OF PRIVATE MUSIC.
© 1995 Private Inc.

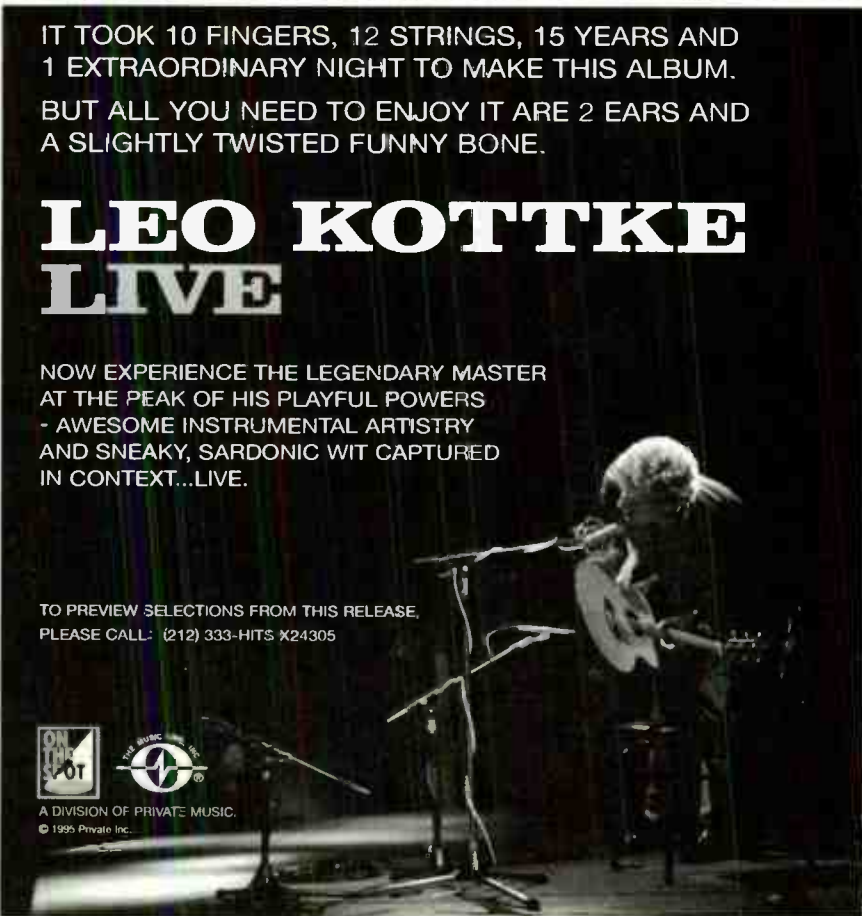

their listeners.

One thing is certain: Traveling the world on the information superhighway expands opportunities for programmers, bands, advertisers and listeners. And as each day brings new technological advances, you can be sure online radio will remain an integral part of broadcast communication into the 21st century and beyond. "We're in the middle of this new revolution," notes Daryl O'Neal. "If you sit back, it's going to run you over."

POE

[cont'd from page 16] moment only reinforced the feeling that there was something special here, that she was really bright, that she had a lot of depth, character, and real talent. We started talking about books, and then we got into her influences and how she evolved her own music. It was wonderful."

Their meeting was scheduled to last for ten minutes, but much more time than that elapsed before they even got around to

playing her tape. Interestingly, both Poe and Fishkin described themselves as "nervous" as she popped her cassette into his machine. The first cut was "Hello," now the opening title on her album, done entirely by Poe on her E-mu EPS sampler. "I was just praying that the music would be great," says Fishkin, "because I knew that if the music was on the money, all the other stuff was already there. What I got right off the bat was her voice, which was really distinctive, and the lyrics. I got a sense of her ideas in the jazzy, hip-hoppy stuff this particular tape emphasized, although I was also intrigued by some of her ballads. I didn't have to hear a lot to know that everything I was hoping for and sensed from talking to her was there on the tape."

For Fishkin, Poe was an especially rare find. He admits to signing far fewer new acts than most A&R executives; his preference is to wait for a truly rare artist and then nurture them over a long stretch of time. "The advantage of working with a small company like Modern is that I can give extra attention to each artist, but I can also deliver the large company distribution of Atlantic. It's a lot easier for a large company to sign a new act just from a demo or from hearing the band live. They don't worry so much about how complete the person is, because they have to have a larger talent flow. They have to fill that pipeline. So even if a band's a one-hit wonder, that's okay. They can afford that, even though history shows that the big fat money deals fall on their face faster than deals that are based on chemistry, understanding, and teamwork.

"The truth is, I have gotten tapes that sounded good, but when I've met the artists, I just sensed that something was missing, that they're just imitating what's happening. They sound good. They even sound like a hit. But if they start talking about images and packaging being everything, or when somebody says, 'We have this tape, but if you want us to change the music a little, whatever you want us to do, we'll do,' that's the kiss of death for me."

Poe concurs. "It's not about being friendly; it's about being absolutely yourself. People like the guys from Alice In Chains are not nice and easy, but they are real. So if you're looking for a label deal, the best thing I can say is to not try to sell yourself; the best sales pitch is to say, 'Here is who I am, this is what I do, and this is what I



What's Inside
the new album by
Joan Armatrading

Featuring
Shapes and Sizes
Everyday Boy
Back on the Road

to hear "What's Inside"
dial 1-800-989-MUSIC
(code #114)

FOR TOUR DATES
<http://www.rcavictor.com>



74321-27269-2/4

Available Now At



Tmk(s) (R) Registered. Marca(s) Registrada(s) General Electric Company, USA, except BMG logo (R) BMG Music (c) 1995 BMG Music

would like to do.” —Robert L. Doerschuk

Plans are being made for Poe to launch a national tour early next year.

RUDESS

[cont'd from page 16] free hand, start tapping half notes after every fourth syllable. If you're like me, your tap will be more like a good slap on the thigh. Don't shy away from the rhythm. Get down inside it. When you're secure with these patterns, try this little twist. Change the vocal syllables to groups of three while maintaining the eighth-note rhythm. Try singing Ta Ki Ta Ta Ki Ta against the other patterns. Once you've mastered these rhythms, hopping on one foot while whistling Dixie in 7/8 and clapping in 5/8 will be a piece of cake.

Let's incorporate some pitches now and check out my custom composed musical moment entitled "End The Hypnosis." Example 2 uses a looping bar of 7/8 as its foundation, but has divisions of threes and fours against it. On your instrument, play the "sevens" first. Seven can be felt in many different ways. The most common division is four followed by three - 1 2 3 4 - 1 2 3 or Ta Ka Di Mi - Ta Ka Ta.

As you play the "sevens," tap straight quarters with your foot. You should see that every two measures the downbeat comes together. Putting 4/4 against 7/8 is a cool rhythmic twist that can easily be applied to your own tunes. Next, incorporate the top line of "fours" (half notes). Maintain the foot in quarters while playing the "sevens" and sing or play the "fours." Notice how after four bars the "fours" and the "sevens" start in sync again. If you're ready for the next challenge, change only your foot so it's tapping three quarters followed by an eighth.

For the capper, let's check out the bottom line of "threes." First, tap straight quarters with your foot and play or tap the "threes." Now add the "fours" to the mix with your voice. Finally, play the line of "sevens" if you have any body parts left. O.K., switch! The "threes" go to the foot, the straight quarters to the hand. When you're ready, sing the "sevens" in Solkattu, play the "fours" and tap or play the "threes" while your foot keeps the quarter. Now scratch your head and wonder. If you've gotten this far without pausing, please contact me about playing on my next project.

THINK DRUMS THINK REMO THINK DRUMS THINK REMO THINK DRUMS TH



Sit in on Russ McKinnon's set.

Customize your own Remo Mastertouch® set, or have Russ—An 18 x 22" bass, 8 x 8", 9 x 10" and 10 x 12" toms, a 14 x 16" floor tom and a 5.5 x 13" snare. Custom finish.

Russ uses Powerstroke™ 3 heads for snare and bass (dot on the snare). Clear Emperor® tom batters and clear Ambassador® tom bottoms.

REMO USA

12804 Raymer Street, North Hollywood, CA 91605
(818) 983-2600 © 1994 Remo, Inc.

THINK DRUMS THINK REMO THINK DRUMS THINK REMO THINK DRUMS THINK

TONY LEVIN WORLD DIARY



From the renowned bass and Stick player with Peter Gabriel and King Crimson - a unique project recorded around the world and featuring some of the world's most fascinating players:

- Shankar** - double violin, vocals
- Ayub Ogada** - nyatiti, vocals
- Brian Yamakoshi** - koto
- Bendik** - tenor, soprano sax
- Bill Bruford** - electronic drums
- Nexus** - percussion ensemble
- Levon Minassian** - doudouk
- Manu Katche** - drums
- Jerry Marotta** - taos drums

Available **only** from
Papa Bear Records

VISA or MC **800 688-2227**

Or send \$15 + \$2.50 p&h
(New York State +\$1.44) to:
Papa Bear Records
P.O. Box 498M
Woodstock, NY 12498
PBearRec@AOL.com



The package is a three panel plastic-free container with inserts for the CD and an 18 page diary booklet. Tony Levin's photos are featured throughout.

Gregg Rubin, Engineer
After several platinum
and gold CDs, and an
Emmy, he has an ear
for sound.

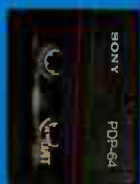

He listens. Half the year in the studio. The other half on the road as a live sound mixer. For Gregg Rubin the challenge is to capture the immediacy of music. After hundreds of live performances and countless hours in the studio, he knows what music really sounds like. What goes in his ear is what gets laid down on Sony Digital Audio Recording Media.

"It doesn't matter if a performance is great if the tape you're recording it on, isn't. That's why I trust Sony DAT tape for my live and 2-track masters. In the studio, I prefer Sony DASH tape. It's so precise, and I can punch as many times as I want without compromising the quality of the recording. And for live multi-track recording, I've discovered the DARS series for 8mm MDMS — it's performed flawlessly. The bottom line is that I know everything I'm putting down is safe — so the sound I hear the day of the recording is exactly the sound I hear the day of the mix."

Whether you're working in the control room, on location or in your basement, make the most of every note. Sony Digital Audio. After all, sound that inspires is not a luxury, it's a necessity. For a brochure call 1-800-955-SONY.

SONY

Converting the industry bit by bit.SM

© 1995 Sony Electronics Inc. All rights reserved. Reproduction in whole or in part without Sony's written permission is prohibited. Sony and Converting the industry bit by bit are trademarks of Sony.

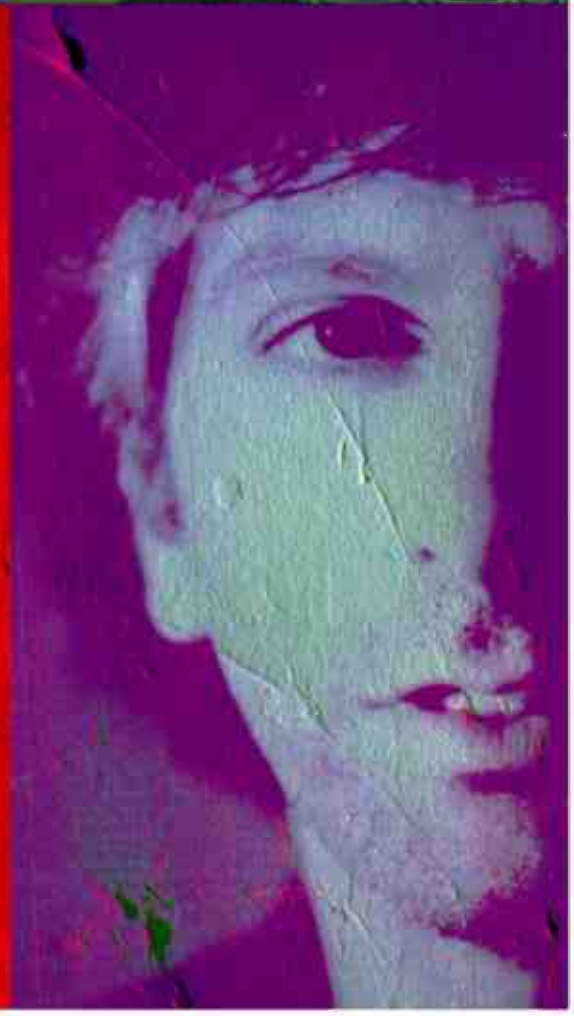
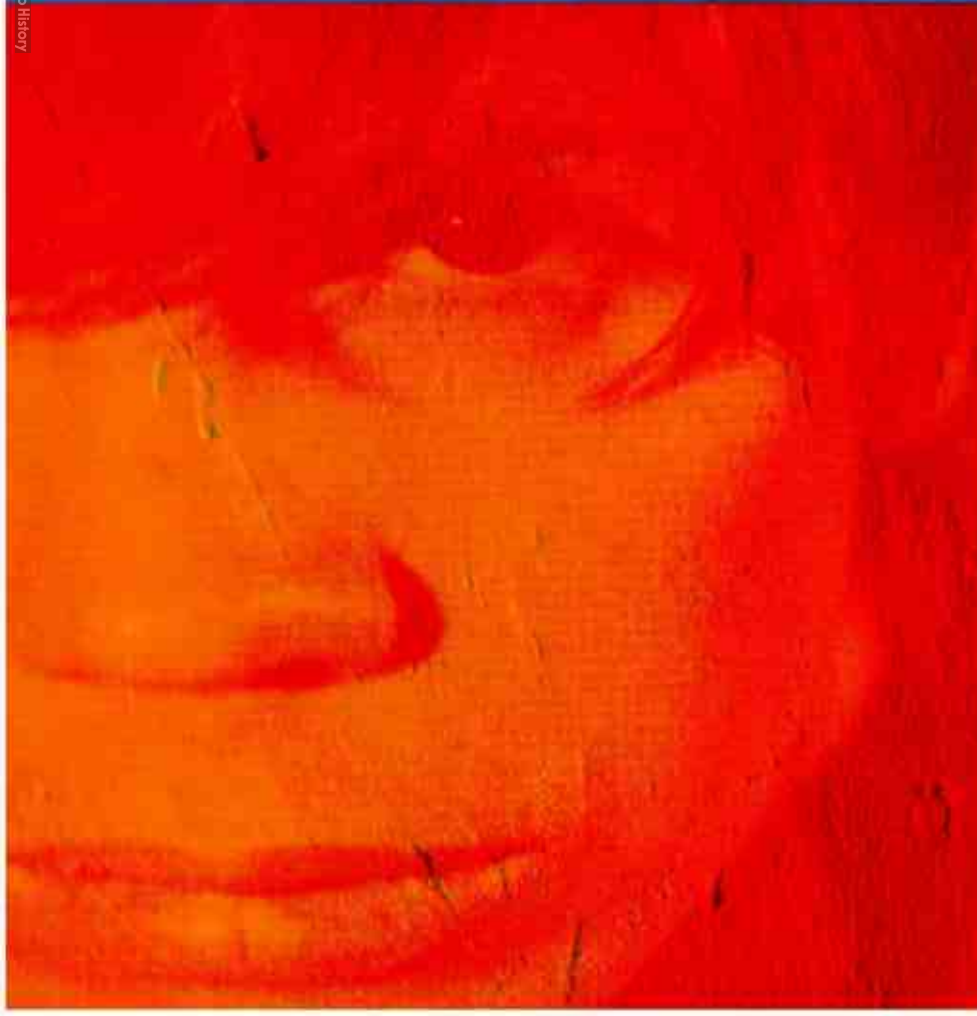
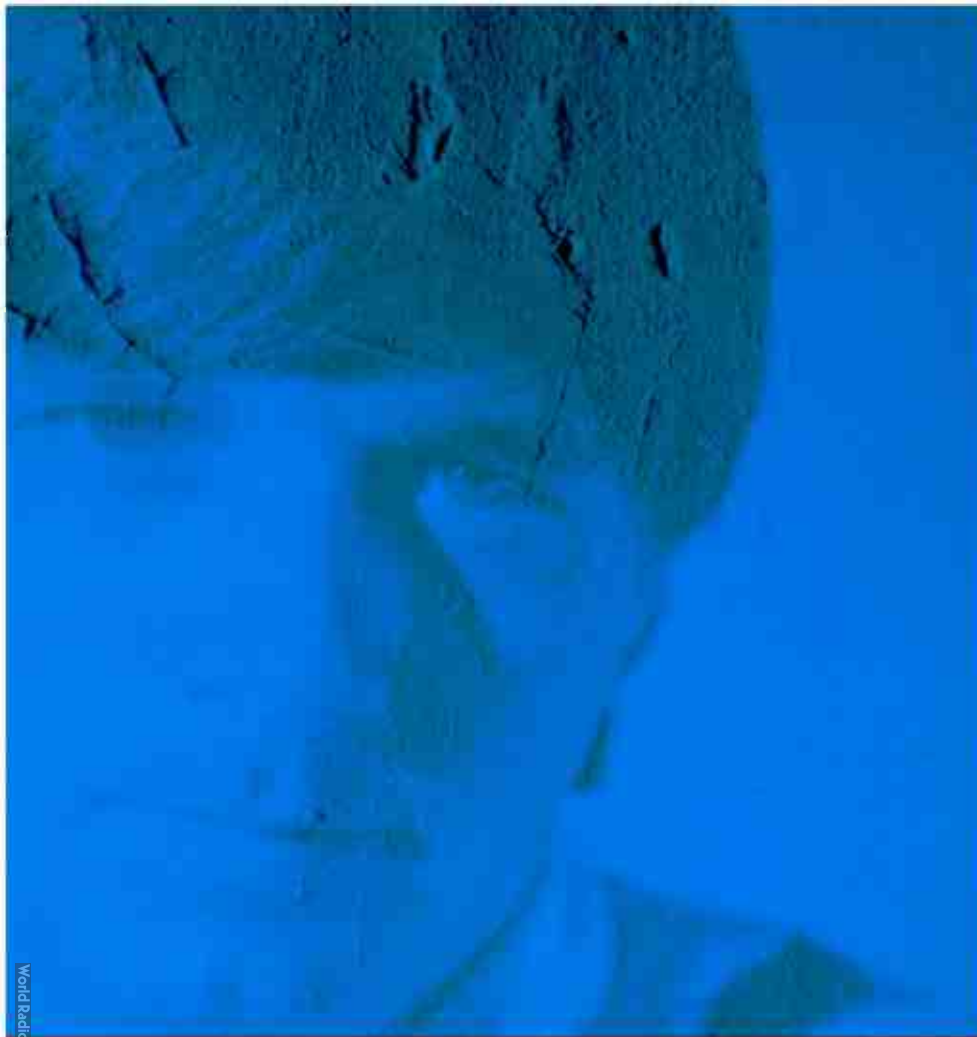

Sonic Youth
take the
Lollapalooza
caravan
to The Zone.

The
Importance
of
being

By
Mac Randall
Photographs by
Jill Greenberg

LET'S GO BACK to 1987. Sonic Youth's newest album, its second on the SST label, was *Sister*. Song number two on side one was called "(I Got A) Catholic Block." If you know the song, take a moment to remember the first time you heard it and what it felt like. If you don't know it, read no further. Run immediately to the nearest compact disc emporium and purchase a copy of the splendid DGC reissue, then run back home and slap it on. Make sure you're comfortably seated. Ready?

This is the first sound you should hear: the hum and buzz of electric current, as Thurston Moore and Lee Ranaldo plug, unplug and replugin their cables into their guitars. Once a complete connection is made, the open strings are left ringing for a few seconds. Tuned to some incomprehensible interval, they produce overtones that summon images of windowpanes breaking or funeral bells tolling. Clearly, something very, very scary is about to happen.

And here it comes. Steve Shelley launches an inside-out drum pattern that sounds like the chattering of a haunted assembly line. The song's central riff quickly follows. Menacingly catchy, it's delivered by a clean guitar with plenty of bite. Thurston's voice takes up the theme; his pitch is shaky, his tone a bit bratty, his commitment undeniable. Kim Gordon's bass rumbles in at the same time, heavy and distorted. Although the riff's tonal center is F#, Gordon hangs on a roaring C#, giving the song an ambiguity and tension that isn't relieved for the whole time Thurston sings. After the singing's over, the band



fretboard. Slowly, the slide inches downward as the band comes back in, playing one of the earlier sequences at half-speed. An acoustic guitar moves to the fore; the mood is pensive, unsettled. The song ends abruptly, but the guitars are left to ring once more.

Three minutes and twenty-five seconds is all it takes, 3:25 full of power and invention. The sound is disconcertingly strange yet at the same time familiar; writer Alec Foege has called it "tomorrow's music recorded yesterday." Go back and listen

again. There isn't much else to say. This is why Sonic Youth matters.

Of course, the song doesn't have to be "Catholic Block." It could be just about any song on any one of their albums, from 1983's *Confusion is Sex* to the just-released *Washing Machine*. For this is perhaps the most remarkable thing about Sonic Youth: They've always mattered. Born in Manhattan amid the wreckage of punk and No Wave, they've worked diligently to combine the two, arranging thrash tunes like avant-garde composers, going for the perfect mix of intellect and instinct. Every album has been a progression in that quest, a

"Lollapalooza doesn't cater to people for whom music is a priority."

further step forward. They've never stopped reaching, and they've never sounded like anyone else.

Considering the length and consistency with which this band has dominated the underground, it's only fitting that they were the headliners of Lollapalooza 1995, bringing the true alternative gospel to a new gang of kids. They didn't get there by being popular or selling lots of records; their career has been the ultimate slow climb. They've hardly made any concessions to the marketplace, and *Washing Machine*—a dazzling collection which gives the holy '80s trinity of *Evol*, *Sister* and *Daydream Nation* a run for its money—suggests that they aren't going to cozy up to the mainstream any more than they already have. Sonic Youth made it to Lollapalooza through the sheer depth of their influence and importance. Just try and imagine the last 15 years in American music without them.

Great athletes and great improvisers sometimes talk about getting into a "zone," a metaphysical place where mind and body work together without effort, where everything happens just as it should. Think of Michael Jordan draining an off-balance three-

pulverizes several more hot riffs in swift succession, ending with a brief breakdown into pure noise. Moore returns to the mike with the immortal words: "I got a Catholic block/Do you like to fuck/I got a Catholic block/I guess I'm out of luck," and the band explodes again. Left behind at the end of this last burst is one rapidly picked guitar, a slide perched beyond its



Greatness runs in the family

Great sound, features, reliability, and good looks, all shared by three families of S.R. loudspeakers from Fender Pro Audio.

From the largest Tour Series concert array, to an SPL Series stack in a club, to a pair of Artist Series speakers on stands, the family resemblance runs deep.

By intention, all are designed to give your audience the power, emotion, and subtlety of your performance, through an open sonic window that doesn't color your sound and won't wimp out when the heat is on.

Hear for yourself what mere pictures and words can't begin to tell. Listen to them today at your nearest Fender Pro Audio dealer - but be forewarned: some of that greatness just might follow you home!

Shown, front to rear:
Artist Series 110-ELC, SPL Series
1225 Mk. II, and Tour Series 2912's
and 118's subwoofers.

Tour Series concert rig courtesy of
Spectrum Audio.

For more information, send \$2.00 postage and handling to Loudspeakers, c/o Fender Pro
Audio, 7975 N. Hayden Rd., Scottsdale, AZ 85258. ©1995, F.M.I.C.
(602) 596-9690. <http://www.fender.com>

World Radio History

Fender®

ELECTRONICS

PLAYERS OF THE WORLD



UNITE

The new **K2500 Series** is Kurzweil's most powerful **sampling synthesizer**, featuring their acclaimed **V.A.S.T.[®]** technology. Available in **rack-mount, 76-note semi-weighted** and **88-note fully weighted** versions, the **K2500** is truly a **Production Station**. Its spectacular new soundscape, advanced synthesis and sampling, sequencing and stunning effects help you take a project from concept to completion without ever leaving the **K2500** environment. Plus, the **K2500 Series** interfaces with your external gear via **SCSI, analog and digital inputs/outputs**.

K2500 Options

- **DMTi Digital Multitrack Interface**
- **KDFX 8-bus Digital Effects**
- **Sampling with 'sample while play'**
- **Soundblocks: Stereo Grand Piano, Orchestral & Contemporary ROM**
- **Program Memory Expansion**

- **Rack-mount, 76 and 88-note versions**
- **True 48-note polyphony**
- **Up to 1.256 MB program memory**
- **Up to 128 MB sample RAM/28 MB internal ROM**
- **User upgradable software**
- **32-track sequencer with full event editing**
- **Full digital and analog interfacing**
- **Two ribbon controllers and 8 sliders – all assignable**
- **Extensive upgradability**

Trademarks and registered trademarks are the property of their respective owners.

World Radio History



K2500 R/S rack-mount versions also available.

SEIZE THE MEANS OF PRODUCTION.

The K2500: A Revolution in the Making.

The **K2500**

features a brand new soundset of

200 programs and 100 setups: 8 MB of Kurzweil's most spectacular sounds. Plus, it comes with a disk containing over 1,000 more of Kurzweil's finest programs. With optional soundblocks – *Orchestral* and *Contemporary ROM* and the new *Stereo Grand Piano* – the **K2500 Series expands to 28 MB of internal ROM sound.**

Interfaces with
Alesis ADAT[®],
Tascam[®]
DA-88
& AES/EBU
via the DMTi
Option.



76
88

The K2500 Series: Kurzweil's most powerful instruments ever. They integrate state-of-the-art synthesis, sampling, effects, sequencing, advanced file management, true 48-note polyphony and V.A.S.T. processing plus much more in one instrument. Your musical revolution begins with a single step. Seize the power. Play the K2500 Series at your local Kurzweil Authorized Dealer.

Get a Free Copy of the "Players of the World" poster at your Authorized Kurzweil Dealer.

KURZWEIL

Music Systems

Kurzweil is a product line of Young Chang

PURE INSPIRATION

pointer and shrugging his shoulders in disbelief, or John Coltrane floating over the rhythm of Tyner, Garrison and Jones, each phrase following the one before with unconscious ease—that's The Zone. And that's what Sonic Youth have found on *Washing Machine*. Their trademark blend of rock-solid riffs, winsome melodies, freaky noise and subtle group improv is now seamless. When the Youth play, their music seems to breathe of its own accord, as if it were generating itself. And it's been doing so in front of big festival crowds all summer long. Not a bad time to find your Zone.

Lollapalooza '95 ended at the Shoreline Amphitheatre near San Francisco, homeland of the Grateful Dead, nine days after the passing of Jerry Garcia. We spoke to Thurston, Lee, Kim and Steve two weeks later for a summary of recent events, and Garcia's name kept coming up. Surprising? A little at first. But look closer and you may find that when it comes to fundamentals, the Youth and the Dead are not so far removed from one another. Read on.

KIM GORDON and Thurston Moore had a baby in 1994. For that reason, their band didn't do a lot. Which meant solo projects galore. "Between the four of us, we must have put out 10 or 12 things in the last year and a half," says Lee Ranaldo. "Doing all that weird solo stuff freshened us up and brought something back to the group." Lee worked with downtown dudes like Michael Morley and William Hooker, while Thurston put out a solo album called *Psychic Hearts*, and Kim played in Free Kitten, in which she plays guitar rather than bass, a piece of information that will soon become significant.

Once the band had reconvened, their first big decision was to record somewhere other than New York City, something Sonic Youth had never done before. Several colleagues—Jon Spencer, the Breeders, Guided by Voices—were, in Lee's words, "talking up the vibe" of Easley Studios in Memphis. "That studio was built by the Bar-Kays in the '70s, and it has that same feel that you get from seeing old pictures of, say, the Beach Boys in those studios they worked at in the '60s. It was built from the ground up as a studio, not shoved into a loft space like most New York studios."

"We were into spending little money," Thurston says. "And Easley was a little-money studio."

The funky new surroundings were further enlivened by the pronounced lack of a producer. Butch Vig was involved with the Youth's last two albums, *Experimental Jet Set, Trash and No Star* (1994) and *Dirty* (1992), while Ron Saint Germain worked on 1990's *Goo*. This time, the band felt like going it alone. "This was the first record we've done on Geffen where the fewest possible people were involved," says Ranaldo. "It was just the four of us making decisions. Usually when you're putting a record together,

somebody's always hovering over your shoulder. But this time the record company never even asked for demos."

By the time the band hit Memphis, their new material was pretty well developed, having been fine-tuned on an eight-track reel-to-reel in the band's Manhattan practice space. (Two pieces on the final album, "Panty Lies" and the opening section of "No Queen Blues," are taken directly from those New York demo tapes, as the band felt too much stu-

"We didn't play standard changes; we didn't use standard tuning."



dio polishing could ruin them.) The one song there aren't any demos of, "The Diamond Sea," was written just before the sessions began. Steve describes it as "the closest thing to a spontaneous song that we did."

But spontaneity is present to some degree in all the tracks on *Washing Machine*. Songs frequently veer off in unforeseen directions rather than sticking to one set plan. Shelley puts the approach in historical context. "I felt *Experimental* had *Sister*-like tendencies. It was a bunch of snappy songs. This one's going into *Daydream Nation* territory, with extrapolations and extended codas. When we were in

the studio, we'd finish the bulk of a song and then something else would happen, so we'd keep the tape going. That happened a lot. I guess it's something you don't want to do on every album, or else you're going to be known as that band that goes on for another five minutes after the song's done. But when the time comes, it's interesting to play with it."

You can hear just how interesting it is on the album's churning nine-and-a-half-minute title track, which starts out riff-based, fades into noise, jams out, then returns to more noise of an almost majestic nature. "'Washing Machine' came out of riffs that I had," Kim says, "but I never said to the guys, 'Here's a song.' It evolved gradually. We were more into letting the music go where it felt like going

Affordable 24 & 32-channel mixers for no-compromise sound on the road and in the studio.

Aux Send Masters with individual Solo switches.

L/R LED meters display main outputs or output of Solo bus, allowing quick and highly accurate level setting by soloing a channel & adjusting its trim.

Stereo Aux Return 1 & 2 also have additional **TO AUX SEND 1-2 controls** for returning effects to the stage monitors.

Tape Return adjusts tape level.

Global Aux Return Solo.

Aux Return 4 can also be assigned to Submaster Buses 1 & 2 or 3 & 4.

Solo Level control.

Solo Mode switch selects mono Pre-fader (PFL) or stereo In-Place (also known as After Fader Listen, or AFL) modes. LEDs indicate when aux or submix buses are being soloed.

Air — ultra-high peaking EQ on each bus. See explanation at right.

Talkback section has level control and switches for assigning talkback to **Main Mix** (for announcing over the main PA or for slating during recording) or **Aux 1-2** (for yelling at musicians via stage or headphone monitor sends).

Submaster bus L/R Assign switches.

Phones/Control Room Level Control.

Tape Return to Phones/Control Room routes tape playback to monitor system and meters — great for live recording or monitoring mixdowns.

Tape Return to Master routes tape playback to main L/R while disconnecting all other inputs to the mains. This lets you play a tape or CD during set breaks without losing channel & submaster settings.

60mm log-taper Submaster faders with Pan controls and L/R Assign switches.

60mm log-taper stereo L/R Mix fader.

"Amazing! Our SR24-4 replaces a British-made console. The SR24-4 has the same features and sounds great at 1/3 the price! It's a tank!"

We decided to start out with this direct quote from an SR Series owner because our new consoles seem to defy logic. How can you get this much mixer for so little money? (In fact, the source of this quote, J.C. of Rocky Mount, NC, actually asked his dealer "What's missing?" after hearing the SR24-4's \$1599 retail price.)

Nothing is missing. Economies of materials and manufacturing — plus the usual Mackie fanaticism — have made it possible to offer the U.S.-made SR Series at prices that set new standards for 4-bus mixer value.

The only consoles with factory AIR.

All four submaster buses have a new equalization feature we call "AIR." Derived in part from 8-Bus parametric circuitry, AIR is a peaking EQ that gently acts on the very highest treble octaves. To quote our florid

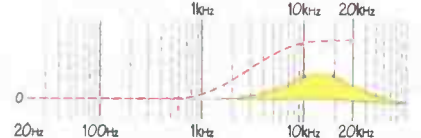

manual writer. "AIR is a smooth, broad hill of shiny hyper-treble centered at 16kHz, with gossamer skirts extending as low as 12kHz and wafting as high as 20kHz."

In more down-to-earth terms, AIR adds detail and fidelity to the high end — especially with

Produce your next CD on it, too.

It's no secret that the SR24-4 and SR32-4 have a wealth of live sound mixing features. But these are also the first affordable SR consoles with the sound quality necessary for professional digital or analog recording. That's not surprising, considering our SR Series has the same sonic characteristics and

Double-bussing means that the mixer's four buses feed TWO outputs each. For example, Sub 1 is connected to Sub Outputs 1 and 5. This way, you can feed all eight inputs of a digital multitrack recorder from just four submix bus outputs without having to constantly repatch. Simply select a track by putting the multitrack digital or analog deck into Record Ready. No additional patching is necessary.

"Headroom, headroom, headroom."

We couldn't resist another SR Series

where other mixers fall down. When a mix amp overloads, it causes mucho audible



distortion. The SR24-4 and 32-4 employ negative gain mix amplifier architecture that gives you twice the headroom, even when all 24 or 32 channels are carrying sizzling-hot signals.

Musical sweet midrange EQ.

All sweepable mids are not the same. If the bandwidth is too narrow, midrange becomes unnatural and not very useful except in extreme corrective cases. At 1.5 octaves (Q=0.9), SR Series' midrange bandwidth is almost TWICE as wide as our competitors'. It sounds natural and musical at its extremes (100Hz & 8kHz) ... and anywhere in between.

Why compromise any longer?

Are you putting up with an ancient hand-me-down console? Are you settling for a cheap, noisy mixer that overloads when you look at it cross-eyed? Or are you just tired of having to book time at a studio when you want to do some serious recording?

Band... club... church... school... no matter what your application, the SR24-4 and SR32-4 are designed to make you sound better and mix more creatively.

Call us toll-free for more information and our 20-page hook-up guide. Or better yet, visit your nearest Mackie Designs dealer soon. The SR Series is shipping in quantity right now.

Trim control with wide range of gain (for weak inputs) and attenuation (no need for a pad on hot line inputs).

6 mono aux sends per channel, all accessible at any time. 15 extra dB of gain past Unity.

Aux Sends 1 & 2 (pre-fader).

Aux Sends 3 & 4 are normally post-fader (for effects), but can be switched to pre-fader (for monitor or headphone sends).

Pre/Post switch for Aux Sends 3 & 4.

Aux Sends 5 & 6 (post-fader).

4-band equalization on last two (stereo) channels;

3-band equalization with swept mids on mono channels;

12kHz Hi shelving EQ, ±15dB.

Sweepable mid EQ on Channels 1-20 (SR24-4) or Channels 1-28 (SR32-4). Sweeps from 100Hz to 8kHz, ±15dB. Fixed 3kHz **Hi Mid** peaking & 800Hz **Lo Mid** peaking EQ on last two channels.

80Hz Lo shelving EQ, ±15dB.

When paired up with Lo shelving EQ 18dB/oct. **Lo Cut** at 75Hz (mono chs.) lets you use Lo EQ on vocals by cutting stage rumble and mic thumps.

Overload LED.

-20dB Signal Present LED.

Constant loudness **Pan control.**

Mute switch.

LED lights for mute, blinks for solo.

Solo button, PFL or AFL depending on Solo Mode switch position.

Submix & Main Mix Bus Assign switches.

60mm faders with 8-Bus log taper & long life.



sound systems that use horns and compression drivers. Yet its effect is far more subtle and musically pleasing on an overall mix (or submix) than Hi shelving EQ (red line in the drawing at left). As one user put it, "AIR breathes life into the whole live mix."

Balanced inputs & outputs throughout.

Balanced lines eliminate hum and keep signals strong, even through extremely long cable runs. Until now, there's been a simple rule of thumb: Expensive mixers were balanced, affordable mixers couldn't afford the luxury. On the SR24-4 and 32-4, every input and output — including all six aux sends — is balanced.

"...most significant is the large degree of flexibility while retaining ease of use. Typically these two factors are at odds — the more something does, the harder it is to make it do what you want. Not so with the SR24-4. Things are laid out very logically, making operation very intuitive."

J.H. Kathleen, GA

Because we're hearing it a lot. Like the 8-Bus Series, our new SR consoles have awesome headroom. First, in the studio-grade mic preamplifiers. Then in the mix amps where all channel and bus signals are combined. More than anywhere else, this is

"I've been waiting for an affordable, quality 24-channel console to be born. My wait is over. Great features and really useful EQ. Life is beautiful."

J.R. Bergenfield, NJ

"The SR24-4 mixing console surpasses its competitors in features and price. Bless everyone at Mackie!"

D.C. House of Dreams (a band), San Antonio, TX

"Engineer friends can't believe what you've packed into this unit."

A.A. Montreal, Canada

Meticulously built by mixer fanatics in Woodinville, Washington U.S.A.

"Wow! What a great stage mixer. Easy to use, perfect size for club bands. Great features for recording, also."

W.T. Port Angeles, WA

Global phantom power switch for condenser microphones. Bal. 1/4" TRS main outputs. Main inserts.

Double headphone outputs. "Double-bussed" submaster outputs. Control Room outputs.

Talk-back microphone input so you don't have to tie up a mixer channel. RCA-type tape inputs & outputs.

Mono main output with output level control. Balanced XLR main L/R outputs.

8-Bus-style, high-headroom/low-noise microphone preamps. 28 on the SR32-4; 20 on the SR24-4. All have -129.5 dBm E.I.N., ultra-wide bandwidth and 0.005% distortion.

Balanced or unbalanced line input. Channel insert.

Not showable, but built-in: Extremely high **Radio Frequency Interference** rejection.

SR SERIES SPECIFICATIONS

Noise (20Hz to 20kHz bandwidth. Line inputs to Main L/R outputs, all channels assigned, panned L/R):
 Working S/N: -90dBV
 Master fader down, Ch. gains down: -94.7dBu
 Master fader @ unity, Ch. gains down: -87.4dBu
 Master fader @ unity, Ch. gains @ unity: -83.5dBu

Total Harmonic Distortion (1kHz @ +14dBu 20Hz-20kHz Channel input):
 Any output: below 0.005%

Crosstalk (1kHz @ 0dBu, 20Hz to 20kHz bandwidth, channel in to Main Left outputs):
 Channel fader down, chs. 2-24 at Unity: -90dB
 Channel muted, chs. 2-24 at Unity: -88.7dB

Frequency Response (any input to any output):
 20Hz to 60kHz: +0/-1dB
 20Hz to 100kHz: +0/-3dB

Maximum Levels
 Mic preamp input: +14dBu
 All other inputs: +22dBu

Maximum Levels
 Balanced XLR outputs: +28dBu
 All other outputs: +22dBu

Impedances
 Mic preamp input: 1.5kohms
 All other inputs: >10kohms
 All outputs: 120 ohms per line

Equalization
 Lo EQ Shelving: 80Hz ±15dB
 Mid EQ(mono chs.) Peak: 100-8kHz ±15dB
 Mid EQ(stereo chs.) Peak: 3kHz & 800Hz ±15dB
 Hi EQ Shelving: 12kHz ±15dB

Microphone Preamp E.I.N.
 (150ohms terminated, max gain): -129.5dBm
 Mic input, shorted 20Hz-20kHz: -136dBV

Power Requirements
 60 watts

Weight
 SR24-4: 31 lbs. (14 kg)

5.75" x 30" x 19"
 (146 x 781 x 483mm)
Dimensions (HxWxD)
 5.75" x 39.25" x 19"
 (146 x 997 x 483mm)

"The sound quality and ease of use are second to none!"
 R.H. Wayne, MI

"SR24-4 rules! Received it on Friday, pulled it out of the box Friday night and recorded a band's 3-song demo on it that night. The EQ and preamps are amazing."
 K.O., East Petersburg, PA

SR32-4 32x4x2 Audio Mixing console \$2199*

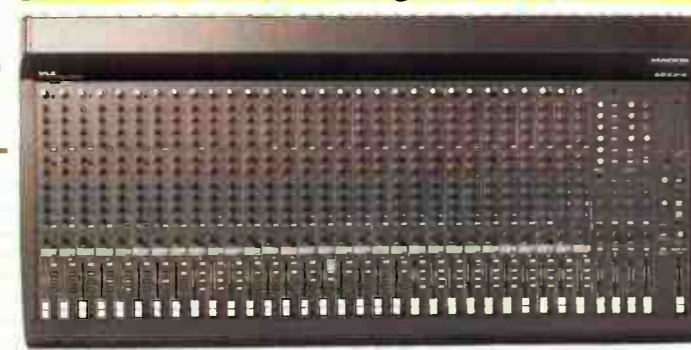

SR24-4 24x4x2 Audio Mixing console \$1599*



SR32-4
 40.7 lbs (18.3kg)
Dimensions (HxWxD)
 *Suggested U.S. retail price. Higher in Canada.

Introducing Mackie Designs' new SR Series 24 & 32 channel live sound mixers. 8-Bus console features and sound quality starting at just \$1599* suggested retail.



*Expecting a "catch"? There isn't one. This is Mackie's Suggested U.S. Retail Price for our 24-channel SR24-4 complete with factory air, dealer prep and licensing (but not tax where applicable). Your mileage may vary. Always fasten your seatbelt.

4 buses, 6 aux sends, PFL/AFL, swept mids & hi-headroom mic preamps in a road-rugged console that's also quiet enough for studio recording.

Life is full of compromises. But now your mixer doesn't have to be one of them. For little more than you'd spend on a cheap, noisy "PA" mixer, you can own a full-featured live sound console that's equally at home in the recording studio.

Only Mackie Designs can make a claim like that. But then, consider the SR Series' distinguished heritage.

A direct descendant of the acclaimed 8-Bus console series.

Our new SR24-4 and SR32-4 mixers share much of the electronic design and features that have made our 8-Bus consoles an industry standard. They have the same VLZ (Very Low Impedance) circuitry that minimizes internal noise and crosstalk. SR Series mixers have the same high-headroom mic preamps, faders with the same precision logarithmic taper — even the ultra-responsive -20dB Signal Present LED sensing architecture found in the 8-Bus.

Designed by live mixing veterans.

Greg Mackie defined the rock 'n' roll PA mixer at TAPCO over twenty years ago. To this day, he still spends time mixing live sound. So do a lot of other Mackoids (among our employees are members of over a dozen local bands). As with the 8-Bus, we built the features WE'VE always wanted into the SR Series — while keeping in mind that most

bands, clubs or churches or home project studios don't always have big bucks to spend for a pricey mixer.

SR24-4 & 32-4: Packed with stuff.

We included extremely handy features like effects foldback to stage monitors, tape

alter level settings during a gig.

Built like a tank.

Finally, we road-tested, drop-tested and drop-kicked SR24-4 and 32-4

prototypes to make sure that they could withstand the rigors of touring. They did. Because both models include:



playback routing to main left/right bus (other inputs are muted so that you can play music during a set break without having to change your bus and channel fader setting)... and a new kind of high-frequency EQ we call "AIR." We

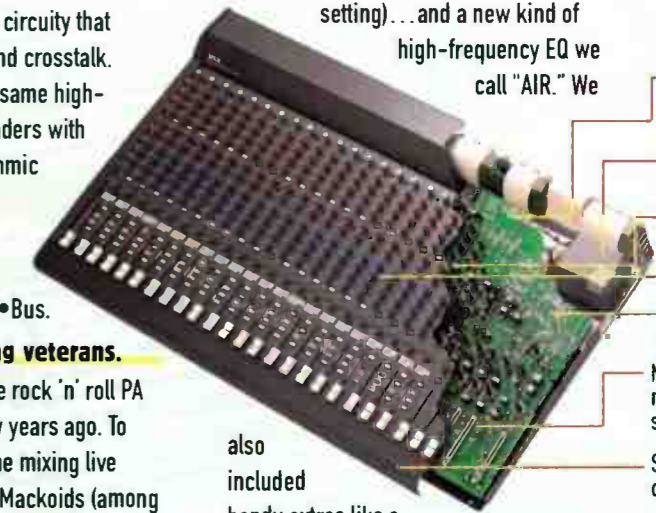

- Double-sided, thru-hole-plated fiberglass circuit boards
- Beefy, well-secured internal power supply
- Impact-resistant knob and circuit board configuration
- Sealed rotary controls
- Ultra-reliable surface mount circuitry in critical areas
- New long-wearing, wiper material derived from automotive sensor technology.
- Solid steel monocoque main chassis

also included handy extras like a separate rear mic input for talkback so that you don't tie up a mixer channel. And TWO headphone jacks — on the back so that headphone cords can't catch on faders and

Bottom line: there's never been a console value like the SR Series. Read on to prove it...

Typical SR Series mixer stereo PA hook-up

32 or 24 mic & line inputs not shown so that the drawing would fit in this insert. See our new 20-page Application guide for more, larger SR Series diagrams.

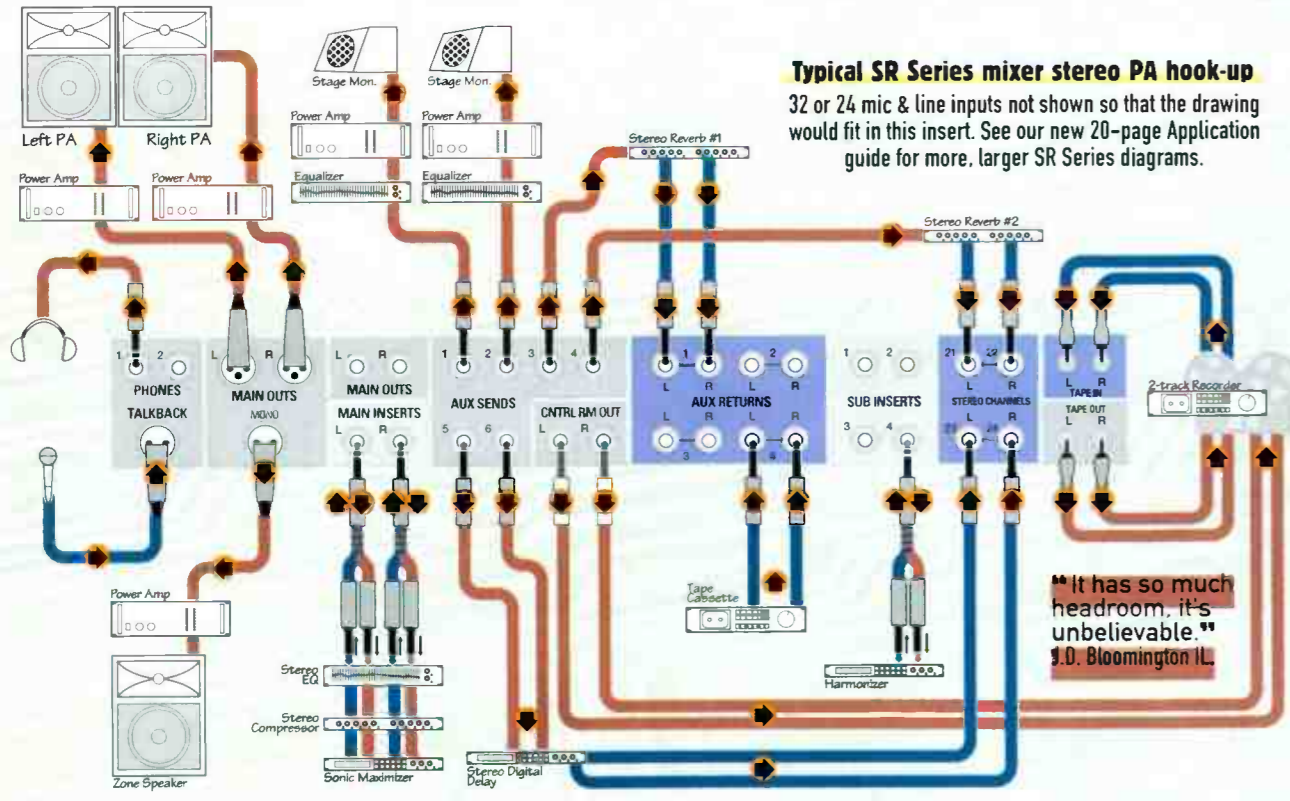

"It has so much headroom, it's unbelievable!"
 J.D. Bloomington, IL



16220 Woodinville-Redmond Rd. NE Woodinville WA 98072 USA
 Phone toll-free 800/898-3211 FAX 206/487-4337 E-Mail mackie.com
 Represented in Canada by SF Marketing Phone toll-free 800/363-8855

©1995 Mackie Designs all rights reserved. Specifications subject to change without notice. Always fasten your seatbelt when mixing and avoid playing too much speed metal dulcimer music during set breaks.



Go To Your Room



Actually, with the powerful reverb algorithms in the Alesis Q2™, you can go to any room you want.

Q2 has the power to take your music to shimmering halls, bright chambers, dark caverns, or anywhere your creativity leads you. There's 300 carefully-designed reverbs, delays, EQ, pitch and special effects that provide the high-end professional processing you need without breaking the bank.

But the best reason to use a Q2 is the incredible flexibility it gives you to create your own space. Because the place where the music sounds the best – the room to be in – might be the room you call your own.



"I love the Q2. I'm using it in the show every night."

— Robert Scovill, 3 Time TEC Award Winner (Sound Reinforcement Engineer)

"I love that Q2. We're using the hell out of it."

— Ray Benson (Asleep At The Wheel), Multiple Grammy® Winner

"Q2 is the presetter's fantasy and the tweaker's dream."

— Francis Buckley, Top Independent Dance/Pop Engineer

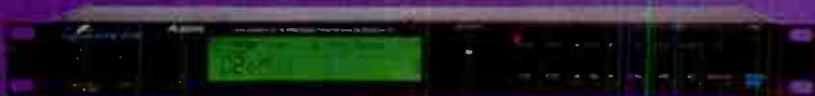

Q2.0

- Stereo or Independent Dual-Channel Operation
- 100 Preset And 200 User-Editable Programs
- Octal Processing™—Up to Eight Effects At Once, In Any Order
- 24-Bit Internal Processing; 18-Bit D/A Converters; 48kHz Sampling Rate
- +4dBu Balanced and -10dBV Unbalanced Operation
- ADAT® Optical Digital I/O
- Custom LCD Graphic User Interface with Virtual Patch Cables
- **NEW!** Version 2.0 Software Now Features Up To 5 Seconds Of Sampling, Plus Overdrive, Surround Encoding, Triggered Pan with Doppler and More!

Alesis Corporation, 3630 Hollywood Avenue, Los Angeles, CA 90028, 310-841-2272, www.alesis.com, alesis1.usa.com

World Radio History



than we were on *Experimental*.”

The trend toward more straightforward and concise material that marked Sonic Youth's previous albums for Geffen hasn't exactly been reversed on *Washing Machine*, but it's been subverted; the album's epic closer, "The Diamond Sea," features a tune as winning as anything they've done in the '90s, but it sprawls on for nearly 20 mind-expanding minutes. Extended pieces are nothing new for the Youth, but between "Diamond Sea," "Washing Machine" and the 18-minute

"Elegy For All the Dead Rock Stars" on Thurston's *Psychic Hearts*, 1995 has proven to be a year without precedent in the song duration department.

LISTENING TO *Washing Machine* and *Experimental* back to back, it's hard not to feel that the songs on the new album sound more like the product of a real group. "It's true," says Shelley. "Definitely on *Experimental*, Thurston presented his ideas to the band in more finished shape than usual. He'd say, 'Play along with me

Bird. Trane. Jimi. Jaco.

The Great Ones
Always Give Us
Reason To Celebrate

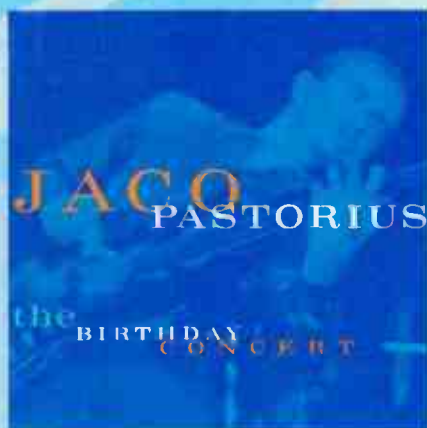

JACO THE BIRTHDAY CONCERT

Recorded at his 30th birthday concert, December, 1981
featuring the Word Of Mouth Orchestra
with Michael Brecker, Bob Mintzer,
Peter Erskine, Don Alias, et al.

Now in paperback:
Jaco: The Extraordinary And Tragic Life Of Jaco Pastorius
By Bill Milkowski

Warner Bros. Jazz on the Internet JazzSpace: <http://www.jazznlb.com/JAZZ/ABjazz.htm>

© 1995 Warner Bros. Records Inc.

WASHING MACHINES

THURSTON MOORE's favorite guitars are still Fender Jaguars and Jazzmasters. "It's because they're long," he explains. "I'm a big guy, and I like long necks. But I'll play anything except a Steinbrenner [*sic*]." The intense wind sound toward the end of "Washing Machine" is courtesy of Thurston's Mu-Tron wah/vol pedal. (Thurston rolls the word "wah/vol" around in his mouth like a piece of caramel.) As for amps: "I absolutely do not favor one amp over another. I don't even know what I use. I've told my guitar tech to black out the brand names so I don't know what I'm playing through."

LEE RANALDO is a bit more gear-conscious. First among his guitars is a mid-'70s Gibson Les Paul Custom. "It's been through a lot; when we went on tour with Neil Young in '91, the headstock broke three or four times and Neil's tech had to glue it back together." Next are four mid-'70s Fender Telecaster Deluxes, each with two humbuckers. Three aluminum-necked Travis Beans, an early-'80s Fender Strat bought just this summer, and a Gibson RD-1 round out the electric collection, along with several more Jaguars and Jazzmasters.

Pedals include a Realtube distortion, DOD two-second sampling delay, Maestro ring modulator ("Turn it on and you're instantly in outer space"), t.c. electronics phase shifter, and Lee's personal fave, an old pinkish-purple Ibanez analog delay. It all goes through a Fender setup Ranaldo acquired just before recording *Experimental*, consisting of a 100-watt Tonemaster head, 4x12 and 2x12 cabinets, and a separate reverb unit. "The Tonemaster's great, because it's simple—one volume knob, not five fucking gain controls." And it's all-tube. Big surprise, huh?

KIM GORDON doesn't believe in carrying around a lot of guitars. Her main six-string is a mid-'70s Gibson Special, and her main four-string is a '66 Fender P-Bass. Both go through a bass amp which she chooses not to identify. "I'm not getting any endorsements," she says with a sly grin, "so just call it a no-name brand." All three guitarists use Ernie Ball strings, bought in bulk in gauges between .014 and .056.

STEVE SHELLEY's main Sonic Youth kit is a Brady, with 5½x14 snare; 12x12, 14x14, and 16x16 toms; and a 22" bass drum. But he's also got older Gretsch and Ludwig kits. "The Brady is the biggest, the most involved, the most '80s rock," he says. Cymbals are Zildjian, sticks ProMark 5As.

on this and see what happens,' instead of just bringing in some chords and having us work on them for several weeks. This time, because Thurston had just done a solo record, he didn't come in with a lot of pre-conceived ideas, so we had to get together as a group and come up with material."

Much of that material was designed to be played by three guitars. For the majority of the sessions, Kim put down her bass and played six-string, as she did earlier with Free Kitten. "It was shocking when we started mixing," Lee recalls, "because when you mix, you always look for the bottom end, and it just wasn't there. But we got used to it."

Getting used to the absence of bass isn't that hard. Kim's detuned Gibson still covers the lows, and the sheer density of the three-guitar arrangements ensures that the music's got plenty of heft. There is something of a historical precedent to this: Basslines were more often felt than heard on the Youth's old albums anyway. "That's because we didn't know how to make records that well back then," Thurston comments. "You could say the same thing about the drums on a lot of those earlier albums," Shelley pipes up. "The rhythm section as a whole has suffered through the years on our records. But we're doing better."

Speaking of drums, Steve's parts are uniformly scintillating on *Washing Machine*. "Junkie's Promise" is particularly effective. The force of the opening guitar riff leads you to expect a fast beat, but when Shelley enters, it's with a creepy, staggering rhythm that drags behind the rest of the band. When asked about it, Steve simply says, "Well, it's a creepy song."

The two most striking features on the new album are prominent guitar solos and smooth vocal harmonies. Most bands use both as a matter of course, but for Sonic Youth to employ them is nothing short of revolutionary. "Stuff like that has always happened," Lee says of his upfront leads on "No Queen Blues" and "Junkie's Promise." "But I think we're allowing it to sit in the mix the way a lead guitar does more now. It used to be a scary thing to think you had a lead guitar on a song. We never wanted to get into that. I always admired Television because Richard Lloyd's and Tom Verlaine's roles were never clearly defined; in the same way, we liked it that neither Thurston nor I was the lead or rhythm guitarist. But now we're just going according

to the song's dictates."

Not all the lead parts are Lee's. The crazy bends on "Washing Machine" are Thurston's. "That's my big rock solo," he says with just a touch of sarcasm.

As with guitar solos, backing vocals have been heard before on Sonic Youth songs; Kim and Thurston sing together on *Sister's* "Cotton Crown" and Lee accompanies himself on *Go's* "Mote." But the warmth and ease of the group harmonies on "Unwind" and "Saucer-Like" is unprecedented. "I like singing with Lee,"

Thurston says. "His sense of pitch is very defined, whereas mine and Kim's are not. So it's risky for either one of us to sing with him, because we're going to be wherever we are. But when we do 'Unwind' and I hear him sing along with me, it's like this flashlight guiding me. I only wish I had a better ear."

With its lush guitar backdrop and delicate melody, "Unwind" has got to be the prettiest song this band's ever done, and "Saucer-Like" and the first part of "Diamond Sea" aren't far behind. "We've

The Art of the Trio



Bill Frisell appears courtesy of Novusach Records.

BILL FRISELL/ KERMIT DRISCOLL/JOEY BARON Live BCD 79504

Bill Frisell's first live album features his long-standing trio recorded at a creative peak during their 1991 European tour in Sovile, Spain. A captivating performance, distinguished by impeccable musicianship, sparkling solos and excellent sound quality.

"It was a concert which transmitted an energy and an emotional and hypnotic capacity that all music lovers look for in live music, regardless of genre." —*ABC, Spain*

"Frisell is without a doubt the single most important guitarist in jazz, a genius who is going to have the kind of influence on the instrument Jimi Hendrix and Wes Montgomery had before him." —*Seattle Times*

CLUSONE TRIO



CLUSONE TRIO I Am An Indian BCD 79505

The Clusone Trio -- Michael Moore on saxophone and clarinet, cellist Ernst Reijseger, and drummer Han Bennink -- has for years been among Europe's most compelling jazz groups. Individually, they are three great virtuosos; as an ensemble, their interplay comes close to telepathy. Ferocious swing, tender lyricism and daring sonic excursions mix effortlessly.

GRAMAVISION

In stores now or order toll free at 1-800-2-GRAM.
Write for free catalogue.
Gramavision Records Label
Oakland Park, 27 Songwriters Ct., Seattle WA 98107
E-mail: gramavision@jrytaf.com
World Wide Web: <http://www.gramavision.com>

Now available on CD from the Gramavision catalog.

BILLY HART *Oshumaf* (with Bradford Marsalis, Steve Coleman, Bill Frisell, Arvo Part, Bone Marrow) BCD 79506

BOB MOSES *Visit With The Great Spirit* BCD 79507

ANTHONY DAVIS *Egis* BCD 79508

BOBBY PREVITE *Pushing The Envelope* BCD 79509

always had pretty songs," Lee says, "but 'Unwind' is special. It reminds me of some Spanish guitar line." By the way, the tweaking sound in the middle of that song is Thurston running a slide up and down the strings of his Fender. "It's right over the pickup, so the sound kind of gets canceled out," he explains.

The guitarists weren't the only ones making funny noises. Steve Shelley got into the act, too. At the end of "No Queen Blues," what sounds like the clattering of a cheap drum machine is actually Steve bang-

ing on a cracked cymbal resting on a pair of congas. "Sometimes I'm hitting the cymbal, sometimes the congas. The cymbal's getting muted by the congas, so it almost sounds gated, but in an organic way."

Ask any bandmember what accounts for *Washing Machine's* more open sound, and chances are the relaxed Memphis recording environment will be near the top of the list. "It's just different down there," Steve says. "The air is different. And we were in a different frame of mind, not trying to over-achieve or going too long each day."

"Making a record in New York is more difficult," Ranaldo says, "because people always know where to find you. In Memphis we were more removed. And the town's so steeped in music. We went to this old juke joint in Mississippi. It's Sunday night, you drive down these dark roads for an hour and out in the middle of this insane darkness there's a little jumpin' shack and all the cars parked on the side of the road. You go in there and it's like stepping into 1945. A group of old black guys playing the most authentic-sounding lowdown blues, people doing these suggestive dances. It's amazing that something like that still exists today."

The scene inspired Sonic Youth to create its very first stage set, which debuted at Lollapalooza: a facsimile of—what else?—the battered plaster of a juke joint wall. "We've never done anything as cheesy as having a backdrop before, and we were uncomfortable about it at first," Lee says, "but we got used to the theatrical aspect of it after a while, and it worked great."

"THE FACT that we were headlining Lollapalooza was perverse," says Thurston Moore over a late breakfast at Jerry's on Prince Street in SoHo. "We're not a superstar band, more like a recognized brand name. But the way it's been set up is that the real headliner isn't the last band. The second-to-last band is the heavy celebrity band that all the kids want to see. Maybe the people who are seriously into what's out there in weirdville would stay for Sonic Youth, but the MTV generation for the most part wants to see Courtney say, 'Fuck you,' then go home."

Kim Gordon, sitting next to Thurston, adds, "I think most of the people who left were jock types anyway, so that was kind of good."

"Second to last is a good spot on any package tour," Steve Shelley agrees, "but I don't think that would be true for every year. If Neil Young had played after Hole, people wouldn't have had the same attitude. But that suited us fine. People are leaving all day; it's a weird thing, but you've got to psych yourself into it and say, 'We're playing to more people than we would on our own.' For a lot of people, it was their first concert ever, and if they made it all the way from Jesus Lizard to Sonic Youth, what a first concert they had. You know, the first concert I ever saw was



B R I A N
E N O

&

J A H

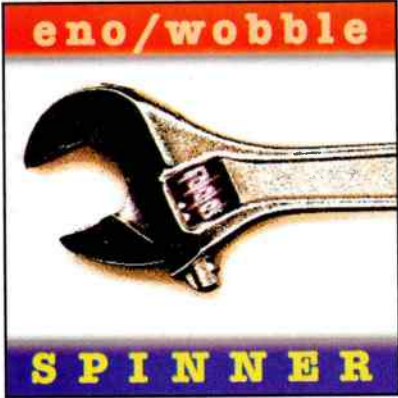

W O B B L E

For his new album *Eno* has enlisted *Jah Wobble*, Britain's foremost master of deep dub, to transform his exotic electronica into mesmerizing new rhythmic shapes.

for mail order info call: Backroads Music 800-767-4748
Echodisc 800-321-ECHO
check out the Caroline Records Web Site <http://www.caroline.com>



© 1995 CAROLINE RECORDS INC.

ELO and Heart at Pontiac Silverdome. This was such a cooler experience.”

ELO and Heart?

“Yeah, ELO had just come out with *Out of the Blue*, the one with the spaceship on the cover. That was a huge record. But I lost interest in them later when they stopped sounding like the Beatles.”

Back to Lollapalooza. Thurston: “Amphitheatres don’t really foster audience energy. A lot of kids don’t know about getting reserved seating, so they’re stuck all the way up on top of the hill.”

Kim: “Either that or they don’t want to pay the money.”

Thurston: “Yeah. Beck referred to it as a ‘reverse mosh pit.’ All through the day, you’d see all these empty seats up front and people sitting reading their programs . . . and way up there are the moshers. And a bunch of kids straining to see the bands. But they can’t get down there. That was the most stupid thing about the whole tour: putting these high-energy club bands in an environment made for James Taylor.”

Kim: “Halfway through the tour, though, we worked something out with the security guards to let people come down, and that made a huge difference. It was so much more fun.”

Thurston: “Lollapalooza doesn’t really cater to people for whom music is a priority. It’s more like Spinal Tap playing the theme park.”

Kim: “Some of the kids are so young. It’s shocking.”

And, as Steve points out, “They know very little about us. Maybe they’ve seen one of our videos on *Beavis and Butt-head*.”

Considering the makeup of the crowd, playing several songs each night from an album that hadn’t been released yet made a kind of sense. But there was still something subversive about it. Which, for this band, was completely appropriate.

Lollapalooza was the occasion for another band first. For the first time on a major tour, the band was joined by a real sonic youth, one Coco Hayley Gordon Moore, aged 14 months. Thurston and Kim seem to be adjusting reasonably well to their new role as parents on the road. (Having a full-time nanny certainly helps.) “It can be exhausting sometimes,” Kim says, “because she changes all the time. But it’s gone pretty well so far.”

“She’s part of the road crew,” Thurston says nonchalantly. “And she pulls her

weight. You know, there’s a lot of downtime on a big tour, so it’s great having a baby around to keep everybody entertained. And she’s got a good temperament; she’s not a squawking brat.” He pauses and smiles. “Not yet. She’s learning, though.”

“I THINK, in a way, *Washing Machine* is a preface to Jerry Garcia’s passing.” So reads a quote attributed to Thurston in Geffen’s latest Sonic Youth press bio. Confronted with the statement, Thurston at first denies saying it, then fesses up: “It was me being flip. The key words are ‘in a way.’”

“But at the same time,” Kim interjects, “some nights after he died, you couldn’t help but think about him.”

Thurston pauses. “I never listened to Jerry Garcia’s music that much,” he says, “but I’ve always liked him as a player. And his whole approach to being a celebrity was inspirational.”

“Totally non-sensational,” Kim adds. “Even as a drug user, he was just not in the media’s eye at all.”

“You know,” Thurston continues, “if you listen to Sonic Youth next to the Grateful Dead, they’re completely different animals. But there does seem to be some elemental thing we do that’s relative to them.”

“The songs are different every night,” Kim suggests. “And we sort of jam.”

“We jam,” Thurston counters with authority. “It was interesting that Jerry died two weeks before we ended the tour, and all that time we were heading toward San Francisco. No, not interesting. It was very heavy.”

Similarly heavy is *Washing Machine*’s untitled ninth song. A brief instrumental piece, it was originally the coda to the disc’s opener, “Becuz.” For purposes of making an accessible first track, the end of the song was cut out and reinserted later in the album sequence. Listen to the shimmering guitar tones and vast waves of reverb, and see just how easy it is to think: Fillmore West 1968.

“WE WON’T work much on new material for the next year probably,” says Steve Shelley, “but when we get done touring, we’ll finally get back to the basement or wherever and start throwing things around and rolling tape. Because we’ve got the eight-track now, we tend to record more. It’s a big part of our writing process, and it



Play this book loud.

Robert Palmer, the acclaimed *New York Times* and *Rolling Stone* rock critic, celebrates the history of Rock & Roll in a book as inventive, unsettling and infectious as the music itself.

This companion volume to the new PBS series explores rock’s complex roots and branchings—from blues and gospel to reggae, punk and rap. For those who’ve ever rocked, and for those who still rock on, *Rock & Roll: An Unruly History* salutes you.

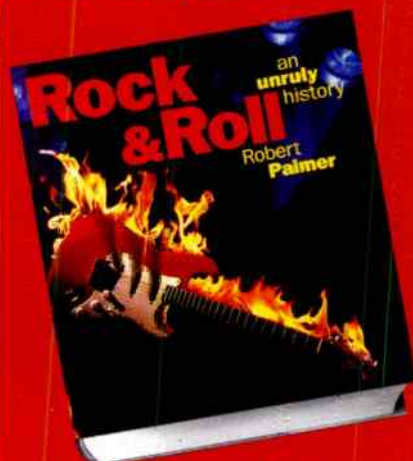

Harmony Books
A Division of The Crown Publishing Group

AT BOOKSTORES EVERYWHERE

lets us attack things more experimentally, like, 'What if I don't turn up this track?' It's a lot easier than when we just had a little cassette player with a built-in mike. Trying to hear what the bassline is on *those* kind of tapes can be tough."

Lee Ranaldo describes how the Youth's division of songwriting labor works. "Thurston generally brings in more riff-oriented stuff, I bring in more chord changes, and Kim brings in more weird note patterns. But since almost everything this time came out of tumbling jams, it's

harder to discern who came up with what. We don't do lyrics until the music's all written, so nobody comes in with a riff and two verses. It's dealt with at first on a purely musical level." Lyrics are tackled by whoever sings the song.

The sounds of instruments other than guitars are often inspirations in the writing process. "We give parts names according to what they sound like," Lee says. "It might be a gong or an Albert Ayler sax line. I'm completely into bell sounds, I've got a big collection of them on tape."

Another major inspiration, of course, is the tuning of the guitar. It's generally believed that Thurston and Lee's apprenticeship with composer/alterer Glenn Branca was what set Sonic Youth on the path of mangled tunage, but Lee points out that his retuning experiences began much earlier, when he was still a teenager in Long Island. "An older cousin of mine taught me a few. Open E was immediately great; even if you were a novice, you could play a couple of trills and sound amazing. And so many people in rock use them—the Velvets, Neil Young, Joni Mitchell, Keith Richards, never mind the bottleneck blues players—that it never seemed like a foreign thing. When Thurston and I started playing with Glenn, that just recontextualized it in a conceptual way."

Sonic Youth's 1981 self-titled debut EP is all in normal tuning; nothing has been since. "Part of that was because some of the guitars we had sounded shitty in normal tuning," Lee says, "so it was better to use them just as tone generators rather than instruments to play C chords on. In retrospect, I think the luckiest thing that happened to us is that all through the '80s, while the 'revival of the guitar band' was going on and you had all those Long Ryders-type bands coming out, we were exempt from standard rock chord changes because we didn't play in standard tuning. In those days, you'd put on a record and there'd be a couple of cool songs, and all the rest of the record would sound just like those two songs. Whereas we could switch guitars and completely change the tonality. We always had this broader palette to work with."

Ranaldo says he never thinks up tunings in advance, but simply arrives at them through instinct. "I'll be hanging around strumming and just turn the pegs until I get a nice sonority happening. The same thing happens when we're rehearsing. If Thurston's playing an interesting riff, I'll pick up a guitar that's close to the tuning he's in and then start modifying it until something resonates—the two of us hardly ever play in the same tuning at the same time anymore. From there, it's a question of figuring out fingering positions. Unlike the way someone like Branca would work, it's always ears first, never concept first."

"I only use four different tunings in Sonic Youth," Thurston reveals. "For my

COLIN
JAMES
BAD HABITS

The new album featuring
SAVIOUR

"One of the best blues-rock guitarists to emerge in recent years, with dazzling, cocksure technique, a flair for dynamics, and enough humor to stand clichés on their heads."

- ROLLING STONE

Produced, engineered and mixed by Chris Kimsey

On Elektra compact discs and cassettes.
World Wide Web: <http://www.elektra.com>

©1995 Elektra Entertainment Group, a division of Warner Communications Inc. A Time Warner Company.

solo stuff, I use a fifth tuning and just about everything's in that. But it isn't even my tuning. I stole it from Pavement."

One of the longest-lasting of Thurston's four classic tunings—heard previously on *Bad Moon Rising's* "Death Valley '69" and *Goo's* "Kool Thing"—appears again on "Washing Machine." Two pairs of F#s make up the bottom, the first pair an octave below the second. E (a whole step below the second pair of F#s) and B (in normal tuning the 2nd open string, here the 1st) round it out. On the same song, Lee's tuned to A-F#-E-F#-E-B, a more complex and lower-sounding version of Thurston's tuning, without the unisons. (The low A should be the same pitch as an open A on bass.) "The new tunings on this record were mainly variations on earlier ones," Lee claims. "I have trouble remembering them all, because the roadies tune the guitars now and it's not ingrained in my head anymore." Luckily, each guitar's tuning is written on the back of the headstock.

"If we're in a rehearsal situation," Ranaldo says, "and somebody starts playing first, the others will ask, 'Which guitar are you using?' Just so we have an idea whether it's centered around Gs or Fs or whatever. It's a little less random than it once was, but it's still pretty fucking random. And now that Kim's involved on guitar, it's created more sound chaos because she's in a specific different tuning too, where before she was playing a normally tuned bass."

Kim uses one tuning consistently, the same one she uses with Free Kitten, but unlike her bandmates, she declines to divulge it. Even Lee doesn't know what it is. "I think it's got some Cs and Gs in it" is his only comment. Kim's one hint: "A lot of the strings are very loose."

LEE RANALDO is sitting in his new apartment, within firing range of New York's City Hall. The room's full of boxes; he moved in just before Lollapalooza started and didn't have time to get set up. The unpacking may still have to wait. Sonic Youth are going to Europe next week for two concerts, one in Barcelona and one in Paris, and Lee is preparing to go to Morocco for the first time. The Master Musicians of Jajouka are on the stereo, and a documentary featuring writer Paul Bowles commenting on Moroccan culture is rolling on the VCR.

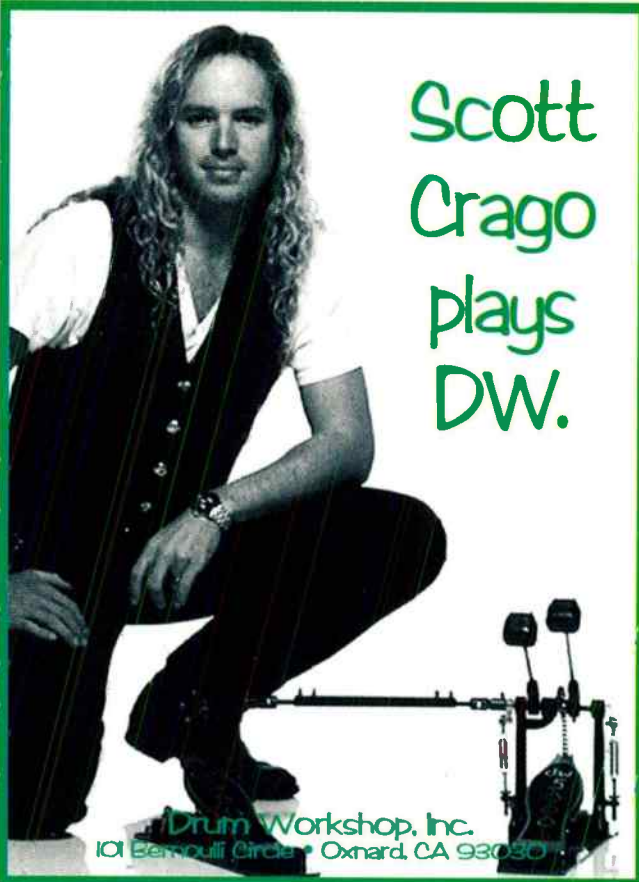

Scott
Crago
plays
DW.

Drum Workshop, Inc.
101 Bearpaw Circle • Oxnard, CA 93030

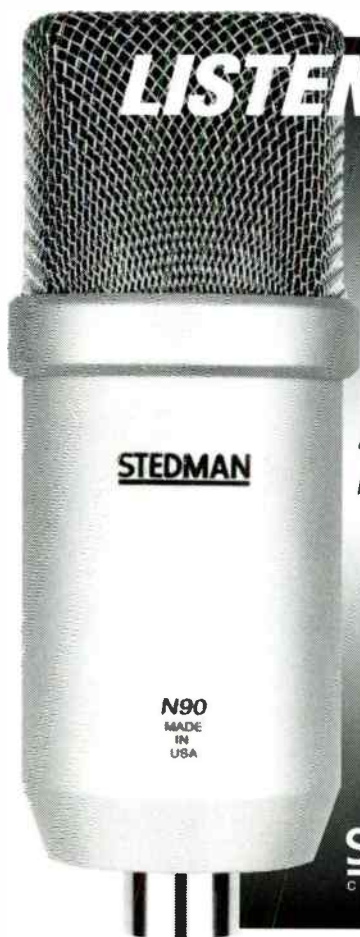

LISTEN CAREFULLY...

You're about to hear what two users are saying about the Stedman N90 studio microphone . . .

"I love the N90 for vocals. It has something happening in the high end that I actually prefer over my expensive tube mics."
Danny Wilde, The Rembrandts

"I used to use 57's to mike my AC 30, but the N90 brings out so many more nuances, it's incredible."
Phil Solem, The Rembrandts

Hear *The Rembrandts* and the N90 on their new CD titled "LP" on Warner-East/West

If you like what you hear or see . . .

Ask your dealer or call us today!

1-800-873-0544

STEDMAN
CORPORATION

4167 Stedman Dr
Richland MI 49083
Phone 616-629-5930 • Fax 616-629-4149

Of all the members of Sonic Youth, Ranaldo seems the most pleased with *Washing Machine*. "It's probably my favorite album since *Daydream Nation*. It's sprawling in the way *Daydream* was. After that record, we got more tight-fisted about recording. It was good experience, but it's great now to say, 'We won't retake each guitar part ten times until every note is fixed.' There's bum notes all over this record, stuff that's out of tune. But it's useless to worry about that. We're going for something more immediate.

"I don't know what was going on when we made the last record, but there are more songs on it where we came up with one riff and made a song out of it than we've ever done. Some of them work, some don't."

(Thurston, on the contrary, stands defiantly behind the Sonics' last album. "I think *Experimental*'s got a great feel to it. The problem people had with it was that it wasn't noisy. They said, 'This isn't experimental.' But what's experimental? Anyone can make a fucking racket.")

Had the band felt a need to make their songs more accessible once they'd signed

with Geffen? "Certainly with *Goo* and *Dirty*, we were trying to make records that were more produced, more rock-sounding," Lee answers, "but it wasn't completely conscious. Some of that came from hanging out with Nirvana and Mudhoney. Those bands would come out and rock from first song to last. It was inspiring, and it made us want to play that way. But looking back on that period, there was another side to us that was more delicate, less balls to the wall, that was getting lost in the attempt to keep up with these full-on garage-rock bands. With this record, we've come back to that side."

Lee reveals that the names of Neu!, Can and other '70s German progressive bands kept coming up during the Easley sessions. "I also started telling people what we were doing now sounded like Pink Floyd. It was a joke at first." The very "Interstellar Overdrive"-like middle sections of "Washing Machine" and "The Diamond Sea" suggest that the joke was based in fact, as does the Syd Barrett boxed set prominently displayed next to Ranaldo's stereo.

Another drug-tormented '60s icon soon

makes his way into the conversation. "I'm sorry I didn't get to Haight Street to see the memorials," says Lee. "That last week of the tour, though, it was definitely hanging over. We dedicated 'Diamond Sea' to Garcia just about every night. I wrote a piece about it in my tour journal, because the Dead definitely meant something to me. I guess what I liked about them has some kind of confluence with what we do. It's not in the way we play, but in the fact that both bands had a lot of open playing sections where you knew you were going to start here and eventually get there, and the way that you got there was left up to the musicians. With the Dead, there were long stretches where you weren't listening to pop songs. You were listening to people playing music. And that's what we've tried to be about too."

The talk turns to how Sonic Youth had been asked to do Lollapalooza before, but not as headliners. "We wouldn't have agreed to do it this time either if we weren't on top of the bill," Lee says. "That's not because we feel we're the best. It's just hard for this music to exist in the daylight hours.

From Guitarist

Angel Romero

The *Ultimate* Mix of
World, Pop, Latin
and Jazz

REMEMBERING
THE FUTURE



To order call
1-800-888-8574



09026-68268-2/4

A lot of bands get sold short because of that. And because the light show was expanded this year, we really needed the darkness. We had backdrops and weird constructed lights, and that made a difference. I've got a video of the last show that I haven't seen yet. Want to check it out?"

A couple minutes later, we're in the midst of the Shoreline concert. Three big spheres hanging from the ceiling contain banks of strobe lights. One chain of lights is against the back wall (the one that looks like it belongs in a juke joint); another string of lights is out front, plus moving lights on the sides. Occasionally Lee comments on the proceedings: "Here's the part where I change guitars," "Wish I could remember what the tuning on that Les Paul was." Gradually, the comments become more fanlike as for the first time, the performer sees the show from the vantage point of the audience. "We never saw any of this onstage," he remarks with a smile. As the lights flash wildly back and forth during "Diamond Sea," Ranaldo goes quiet. "Wow," he says. "Psychedelic."

"IT'S LIKE getting married," says Lee Ranaldo about Sonic Youth. "There's something about what we can do together that's further confirmed by the solo things we do. We've built a language up over a long period, and it's great to step on stage with 10 or 15 years of dialogue behind you. Everybody knows the point we're starting from and where we could go. Sometimes that's a hindrance, but most times it's freedom." Sounds almost like something Jerry Garcia might say, doesn't it?

All right, all right, so you're getting tired of these crazy references to the Dead and how you're supposed to think they've got something in common with Sonic Youth. Obviously, it's unfair to both the Youth and the Dead to draw too close a parallel. Sonic Youth's music rarely sounds as happy or laid-back as the Dead's can. They don't have an extended family following them around the country. They don't often wear tie-dyed clothes. And the underground scene in which they toiled throughout the '80s has little to do with the counterculture that embraced Garcia; it's so much less optimistic, so much more fragmented, so hard to easily understand.

Yet the temptation to connect still lingers. For different as the details may be,

the aesthetic core of these two great American bands lies in the same uncharted region, the same Zone, if you will. Could it be that a child of Lower Manhattan in the dark Reagan/Bush days is the true inheritor of the Haight-Ashbury spirit?

In at least one sense, the answer is yes. Remember that Lee said the Dead were never about pop songs, they were about people playing music. Likewise, Sonic Youth have never been about pop songs. They've never been about No Wave or punk or rock 'n' roll, either, even though

all of these have been important in their development. Like the Dead, they are about people playing music.

Thurston Moore puts it this way: "I like playing in a rock band, but I don't have a purist ideal about rock 'n' roll. I would never want to feel that I or Sonic Youth would have to prove ourselves as an authentic rock 'n' roll band. That's silly. We started out wanting to play rock 'n' roll, that's our basis. But we're getting away from that. And the more we get away from it, the better." 



JACK BRUCE
MONKJACK

JACK BRUCE
MONKJACK

Just Jack and his piano, with a little Bernie Worrell on the side. New songs plus new arrangements of classics from *Songs For A Tailor* and *Harmony Row*. The tastiest third of cream rises to the top.



MICK KARN
the tooth mother

MICK KARN
THE TOOTH MOTHER

Advanced sonic mutations from Japan's seminal bassist. Mick Karn plays Klein basses.

CMP DISCOVERIES. Produced by David Torn



WES MARTIN
3 POUND UNIVERSE

Former New Bohemian songs of death, imperialism, love and holism. With friends Matt Chamberlain and Brad Messer (Critic's Buggie) CMP 1009



ANDY RINEHART
JASDF'S CHORD

With guests Mick Karn, David Torn and Kurt Wirtman. "might be the best progressive rock album of [this year], perhaps the entire decade." Jazz CMP 1003



DAVID TORN
TRIPPING OVER GOD

Torn's benchmark solo work. In case you missed it, "makes you wonder if this was the direction Jimi Hendrix would have embarked upon if he were still alive." CD Review. David Torn trips exclusively through Klein guitars, Rivera amps and Lexicon digital effects processors. CMP 1007

lexicon RIVERA

CMP RECORDS

U.S. Office: CMP Records Inc., 530 North Third Street, Minneapolis, MN 55401, USA
Distributed in USA by Passport: 1-800-334-3394, in Canada by Fusion III: 514-738-4600

Life

BY ROBERT L. DOERSCHE

PHOTOGRAPHS

BY RAPHAEL

FUCHS

NOT SO LONG AGO, THEY WERE part of the vanguard: hotshots schooled on Miles and fueled on rock. They played faster than their forefathers, and hipper than the proto-metal bands that provided the concert path. Old-timers fled before their screeching solos, clearing the way for what promised to be a revolution of a scale unseen in jazz since bebop. These were the giants of fusion, the young studs of the '70s. The future was theirs, and it was loud.

But now, on a drizzly August day, three icons from that rapidly receding era gather in a New York rehearsal studio. It's quiet here at S.I.R. The walls are black, the air conditioning a subliminal whisper. The guys look like throwbacks to a gentler time, a time even pre-dating jazz, when electricity was a rumor and music a chamber delicacy. On the far left, Jean-Luc Ponty, a pioneer on the electric violin, cradles a beautiful instrument crafted 200 years ago in Italy; its sound is sweet and full, unfettered by amplification. Next to Ponty, Stanley Clarke plays a century-old German flatback bass; the gleam of its auburn

After



Jean-Luc Ponty, S

FUSION

U K



Stanley Clarke, & Al Di Meola Unplugged & Proud of it

finish reflects in the glasses balanced at the tip of Clarke's nose.

And to the right, Al Di Meola sits with his Ovation behind a couple of stompboxes and MIDI pedals; these, and the rack behind him, are the only reminders of the position he shares with his colleagues as a master of high-energy electric jazz. His guitar parts, except when enhanced by a bit of the Blopipi sound on his Roland module, are as fully acoustic as Django's.

For the time being, this trio has pulled the plug and gone back to its pre-technological roots. Their eponymous album, *The Rite of Strings* (Gai Suber, dist. by IRS), celebrates the texture and nuance of acoustic music. Through original compositions, ranging from the riff-oriented "Morocco" to Di Meola's intricate "Chilean Pipe Song," they revive the Hot Club's seductive timbres but enhance them with a bracing virtuosity, imagination, and a fine-tuned sense of interplay.

It's as far as you can get from the distorted, echo-drenched lines Ponty wove with Frank Zappa, the Mahavishnu Orchestra, and his own bands. Yet his acoustic work draws from the same postbop well that's nourished him since the '60s. Di Meola's playing is more reflective than the hyper-ventilated bursts of his prodigy period with Return To Forever; the chops surface now and again, but one recognizes Di Meola's personality now more through ideas than sheer speed. And Clarke's astonishing command of the upright bass mixes the free-ranging electric style he helped invent in RTF with traces of his totems on acoustic, Charles Mingus and Ron Carter.

Now they're wrapping up a read-through of one of their tunes. With eyes glued to their scores, they build to a big finish. Clarke breaks up, his long arms stretched toward imaginary footlights: "We can't play it that way. It sounds like . . . the Fifth Dimension."

Di Meola and Ponty back up and work through an interactive passage. It feels a little ragged, and all three begin talking about how to fix it.

Clarke, holding up his hands to stop the music: "Guys, right here is where you need to . . ."

Di Meola cuts in: "Remember that up-tempo thing we did here?"

"Lemme hear what you're doing," Clarke says. He listens to Ponty and Di Meola again, shaking his head. "Those chords are not right. Shouldn't Al have played a G chord?"

Squinting at the music, Di Meola asks, "Isn't that an E there?" Silence ensues as Clarke and Di Meola decipher the text. Then Ponty, to no one in particular, sighs: "How did we do it on the album?"

That's precisely what we were wondering too. During a break, we sat down for drinks (Canadian Club for Ponty, Snapple for Di Meola, fruit juice for Clarke) and an hour or so of talk about what *Rite Of Strings* means to survivors of the fusion experiment.

MUSICIAN: *So how did the idea of doing Rite Of Strings come up?*

CLARKE: Al called me. But we'd been fooling around with the idea for the past five or six years, mainly because Al and I had all these bills. We were broke!

DI MEOLA: Actually, we did it for Lenny. [laughter] We thought, "Let's go do some gigs for [ex-RTF drummer] Lenny White." And we got some money for him. . . . We didn't give it to him, but we got it.

CLARKE: We spent a lot of time trying to figure out how we were going to play together.

DI MEOLA: It had to be the right concept. Stanley was always open-minded to doing something, especially acoustically. It was too obvious to do electric, too close to RTF. This way, going acoustic, would be more interesting.

MUSICIAN: *Obviously you overdub yourself a lot on the album, so that you can play over your own guitar comp.*

DI MEOLA: But sometimes I like to just play a solo against the bass.

MUSICIAN: *How do you handle overdubbed passages onstage?*

DI MEOLA: It's not easy. I just kind of make it work.

MUSICIAN: *Al's acoustic guitar is MIDIed. Did you ever consider going a step or two further toward the electric realm on this gig?*

DI MEOLA: Not really. So much of what we've



Di Meola: "Doing what we do is very courageous."

done over the years has been electric. Especially Jean-Luc. I haven't heard him that much in the acoustic format, so I thought it would be great for him to do something in this context.

MUSICIAN: *How much shedding did you have to do to get back the technique you needed to make the switch from electric to acoustic violin?*

PONTY: Technically, there is no difference between the two. The electric violin is exactly the same size as the acoustic, as far as the fingerboard is concerned. The only difference is that on the electric you don't control 100 percent of the dynamics, because it's going through amplification. An electric violin is really just a normal violin that's being amplified. In fact, I've always practiced at home on the acoustic violin and played electric with my groups, and I've never had problems switching from one to the other. Transferring my playing was only a mental question, because I grew up studying classical music, so as soon as I would pick up a classical instrument and hear that sound, it was difficult

Why We Put More Care Into Our Strings Than Many Companies Put Into Their Guitars.

C. F. Martin's
String Inspector,
Barry Thompson

No matter how innovative its design or how meticulously it is crafted, a guitar is *only* as good as the strings that power it.

Strings are critical to a guitar's tone. They literally "drive" the soundboard, working together with the bridge and the delicately shaved braces. They also greatly affect playability. A carefully gauged and balanced set of strings greatly enhances the player's style and technique. Because they are so important, we make all Martin[®] and Martin Marquis[®] strings ourselves, in the very same facility where we build Martin guitars. And like our guitars, each string is made slowly, carefully, using only premium materials.

Great guitars deserve great strings. Don't settle for less.

We don't.



Martin Strings
A Necessity. Not An Accessory.™

For More Information Call Us Toll Free: 1 (800) 633-2060.

© 1998 C. F. Martin & Co., Inc., Nazareth, PA.

for me to play bebop, jazz/rock, or another form of music on it. That's why, when Al called me to do this trio, at first I wasn't all that sure that I wanted to play purely acoustic. Indeed, I had never really played the way I do, with my own style, on the acoustic.

CLARKE: It's different on the bass. The physics of playing electric and acoustic is completely different in terms of finger position. On the electric bass, the whole step is this. [Indicates first and third fingers] On the acoustic bass, it's this. [Indicates first and fourth fingers]

Di MEOLA: But you can play almost everything on the acoustic bass.

CLARKE: I can play more on the acoustic bass, believe it or not, than I can on the electric bass. With the electric bass, you can get away with more theatrics, or, let's be honest, more bullshit. I've spent a lot of time on the acoustic bass, and I wish I could play some of the lines that I play on the acoustic when I'm playing electric.

MUSICIAN: *There's just one section of one tune on the album where we hear a traditional walking bassline. Why didn't that sort of thing work elsewhere with these tunes?*

CLARKE: When it comes to walking basslines, the one ingredient that makes it great is the ride cymbal. If you don't have that, you can't do it for too long. The amount of time we did it on the record was just about right. Now, I can get away with that when I'm playing with Jean-Luc, because he's a throwback to the '50s; he's really got that bebop thing down. If we play a duet on some old bebop stuff, I can get into playing that way a long time,

Clarke: "My problem [with the Wynton Marsalis movement]—there's no integrity."

because he's got that thing.

MUSICIAN: *How do you arrange for rhythm in a group that has no drums?*

Di MEOLA: A lot of that comes from absorbing what's been around in the Latin world. I grew up listening to a lot of Latin music. Then my collaboration with Paco [de Lucia] got me into flamenco and South American music. There are so many varieties of rhythm there, and it's all about the ability to play off the clave, which is the time. There's no need



for a percussionist or a drummer to define it. When you play off the clave, the clave never moves. You just sense that the time never moves, and you play against that.

MUSICIAN: *There are songs throughout the album where the bass establishes the pulse. "Renaissance," for instance, has a pretty tight bassline. But on other tunes Stanley lays down the rhythm more loosely. What dictates when you hang onto a riff and when you can stretch a bit?*

CLARKE: It's instinct.



Di MEOLA: And maturity.

CLARKE: But it's also the composition. For instance, in "Renaissance," once you finish the intro, the flow of the piece is for the most part linear. But then you take Al's piece, "Chilean Pipes," which isn't linear. It's almost like classical music: It has three movements, and even within those movements it's not linear, so some of my bass playing is broken up in pieces.

PONTY: We're basi-

cally playing in three different meters. We can't rely on what we hear. We have to know the parts.

MUSICIAN: *You all came up from the fusion era. How has the public perception of what you can do changed since then?*

Di MEOLA: The public is really different because of radio. The Wave format came in and softened things up. They play music that's a lot more smooth. The ratings have gone up, and I see more musicians who come from a tradition of really playing get mixed out of that format. A lot of what they're programming would still work well with some of the stuff we're doing, but it boils down to business. That's too bad, because many of the people who work at these stations love what we do. They're fans, but they're not allowed to program us. That's how it's changed, and it's drastic. People aren't getting to hear what we're doing, so what we have is our die-hard fans.

PONTY: There was a gap in time, before the Wave, when a kind of music stopped being played on the radio. In the '70s, there were many open-minded program directors, and all of us got

KEITH JARRETT AT THE BLUE NOTE

The Complete Recordings

6 CD Set

Saturday June 4th, 1994 1st Set

Single CD or Cassette



ECM

also available

**"EVERY
NEW NOTE
SOUNDS
LIKE
A DISCOVERY"**

New York Times
June 6, 1994

to hear, call:

1-800-989-MUSIC code 131

World Radio History

HÄNDEL
—
SUITES
FOR
KEYBOARD
—
KEITH
JARRETT

ECM NEW SERIES

played on what they called progressive rock stations. I remember that there were at least two or three rock stations in L.A. that played Miles Davis, Mahavishnu, or Billy Cobham between Pink Floyd and the Rolling Stones. Then big corporations started buying radio stations, and program consultants started to be hired. That's when it got narrowed down to a very strict list. It was in 1979 that this happened to me.

MUSICIAN: *Isn't there another side to this picture? Jan Hammer's latest album opens*

with a major seventh chord on a Rhodes piano. Obviously he was trying to make a more radio-friendly product than he had done in the past. But once he got his more mellow stuff on the air, maybe he'd be able to start slipping more aggressive material on as well.

DI MEOLA: I have a different view of it. Doing what we do is very courageous. When we started off with RTF, and when Jean-Luc was beginning with his own music, that was going against the grain. Man, there was no way we were going to

STRINGS AND THINGS

For the Rite of Strings album and tour, AL Di MEOLA's main guitar is an Ovation Custom Legend with a standard Ovation pickup. A Hermanos classical and Taylor 12-string also made it onto the record; the latter was "borrowed from Rod Stewart's guitar player, who just happened to be in the next room at the time." For synth sounds, it's the Roland GR-1 module, fed by a GK-2 pickup attached to the Ovation. Al's rack includes a Lexicon 200 digital reverb, t.c. electronics 1210 spatial expander and stereo chorus/flanger, a Mackie Micro Series 1202 12-channel mike/line mixer to keep things in order, and an ETA PD10 conditioner/power distributor for current stability. Also in the chain are a Demeter VTMP 2A preamp, Roland DD-3 digital delay and an Aguilar on/off pedal. His steel strings are .012-gauge Guilds.

STANLEY CLARKE plays a "flatback bass by an anonymous dead German." Bought on the street for \$200, it was Clarke's first upright, and it's still his first choice for gigs. "I've also got a 300-year-old Italian bass," he says, "but I had it restored and it's just too nice to take on the road. You could buy a small house with that bass." A Fishman transducer is Clarke's ticket to amplification; for rehearsals, it ran into a 350-watt Hartke MOS FET 3500 and Hartke XL Series 410 cabinet. Thomastik Spirocores are Stanley's favorite wire.

JEAN-LUC PONTY's customary Zeta electric five-string comes out only for a brief solo spot during Rite of Strings performances. For most of the show, Ponty uses an acoustic violin made in France in 1870, picked up by an L.R. Baggs. On the album, Ponty went with a 1790 Cheruti. "An unbelievable instrument. I've had it for 12 years. I used it mostly to practice at home, but this was my chance to use it for one entire album, completely acoustically." In Jean-Luc's rack you'll find a Lexicon LXP-1 and LXP-5, complete with MRC MIDI remote controller, a Furman PL-8 power conditioner and another Mackie Micro Series 1202. Ponty has a large collection of 19th-century French bows, but the bow he's favoring these days is new, a Spiccato made of carbon fiber. "It's made by an excellent young bowmaker in France named Roland. The advantage is that it's not affected by changes in temperature or humidity. Also, you can regulate the tension with a little key, which is unique." We wanted to ask Jean-Luc what strings he uses, but Clarke came up with the answer first: "Dead cat." To which Di Meola added, "But not his dead cat."

LOUD & CLEAR



SM-610 with ring processing & shuntless boost



SL-610 for mixer input insert point

FBX-SOLO: Your Personal Feedback Controller

Let's make this loud & clear: You want more gain? Increased clarity? Automatic feedback control? Want to save some money? Sabine has the answer: the new FBX-SOLO.

How It Works:

- Precisely detects feedback frequency
- Places super-narrow (1/10 octave) digital filter directly on feedback
- Sets filter just deep enough to remove feedback

What You Get:

- More gain before feedback
- Increased signal clarity — SOLO removes only the feedback, not your sound
- Fast, accurate, real-time automatic feedback control

Use the SOLO for:

- Any feedback-prone mic
- Especially good for wireless mics
- Acoustic/electric guitars
- Add another mic input to your mixer with the SM-610



The FBX-SOLO. No other audio device gives you this much gain, clarity, and control for this low price. It's like having your

own personal sound engineer and adding a more powerful amplifier, for a lot less money. Make your sound loud & clear — ask for a demo of the Sabine FBX-SOLO.

PATENTED - MADE IN USA

Ask yours or the distributor for more information.
4637 N.W. 36th Street
Gainesville, FL 32608 USA
Tel: (800) 371-1825
Tel: (352) 371-1444
Fax: Back Product Info (904) 371-2544

SABINETM
ADAPTIVE AUDIO

FBX and FBX Feedback Extremator are registered trademarks of Sabine, Inc. and are the brand names of a line of automatic feedback controllers. Covered by U.S. Patent No. 5,245,665. Other patents pending.

SLM610m-08-02-95

Give MUSICIAN This Holiday Season



And you could win a portable CD player and 5 great box sets from
John Coltrane
The Velvet Underground
Steve Winwood
Elvis Costello
Bob Dylan

Musician Holiday Gift Certificate

Send my Musician gift subscriptions to the following and let us know if we've won a CD player and 5 great CD box sets!

My 1st gift only \$19.97

Name _____

Address _____

City/State/Zip _____

Additional gifts just \$14.97 each

Name _____

Address _____

City/State/Zip _____

We'll send holiday gift announcement cards to you as soon as we receive your order. Please add \$12 per subscription outside the US.

My Name _____

Address _____

City/State/Zip _____

Enter my own subscription at this low rate! New Renew
 Payment Bill me later
Charge my Mastercard Visa Amex

Signature _____

Card# _____

Expiration Date _____

Drawing void where prohibited. Recycled Paper XM502 Z

Musician Holiday Gift Certificate

Send my Musician gift subscriptions to the following and let us know if we've won a CD player and 5 great CD box sets!

My 1st gift only \$19.97

Name _____

Address _____

City/State/Zip _____

Additional gifts just \$14.97 each

Name _____

Address _____

City/State/Zip _____

We'll send holiday gift announcement cards to you as soon as we receive your order. Please add \$12 per subscription outside the US.

My Name _____

Address _____

City/State/Zip _____

Enter my own subscription at this low rate! New Renew
 Payment Bill me later
Charge my Mastercard Visa Amex

Signature _____

Card# _____

Expiration Date _____

Drawing void where prohibited. Recycled Paper XM503 Y



BUSINESS REPLY MAIL

FIRST CLASS MAIL PERMIT #663 MARION OH

POSTAGE WILL BE PAID BY ADDRESSEE

MUSICIAN

SUBSCRIPTION DEPARTMENT
PO BOX 1923
MARION OH 43306-2023



NO POSTAGE
NECESSARY IF
MAILED
IN THE
UNITED STATES



BUSINESS REPLY MAIL

FIRST CLASS MAIL PERMIT #663 MARION OH

POSTAGE WILL BE PAID BY ADDRESSEE

MUSICIAN

SUBSCRIPTION DEPARTMENT
PO BOX 1923
MARION OH 43306-2023



NO POSTAGE
NECESSARY IF
MAILED
IN THE
UNITED STATES

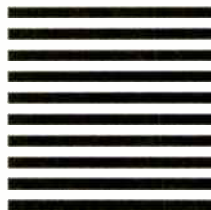

**Give
MUSICIAN**

The Ultimate box set



*And you and your
gift recipients will
automatically be eligible
to win a portable
CD player and
5 mega CD box sets!*

get on the radio. We just did the most exciting stuff we could possibly do. But then people started to find out that there was this new, exciting thing happening. So my feeling is that if Jan, with his tremendous talent, went *against* the grain, he'd probably sell more records, because people would be talking.

MUSICIAN: *Even today?*

Di MEOLA: Today.

CLARKE: Well, I don't know about that.

Di MEOLA: Jan's record didn't sell.

CLARKE: But listen to this. Al is correct when he says that when we first came out, we got literally no airplay. But we had a couple of things that a lot of groups don't have right now. First of all, our band was unique. We did something that no one else did. Number two, we had a mission. We went out and played a shitload of gigs, as long as we could play. Man, we were crazed. Nowadays, because radio has gotten so commercialized, the idea of being a musician has become commercialized.

MUSICIAN: *Because who becomes musicians now?*

CLARKE: Exactly. I guarantee that if a group came along, a young group that was doing some new shit — excuse my French — and they had a mission behind them . . .

PONTY: Leave the French out of this. [laughs]

CLARKE: I don't care what the Wave says. If they say, "We're not gonna play it," who gives a shit?

Di MEOLA: On the other hand, if Weather Report got back together, if Joe got back with Wayne, and the compositions are strong, it don't matter about radio. Look at a guy like Yanni. He gets no radio, and he sells millions of records. I'm not saying that you think, "I'm gonna go against radio," but you should think about the music.

MUSICIAN: *Isn't it an act of faith to say that the times are right for young bands to shake things up as RTF once did? What we're hearing is still the Wave, on ever-shrinking playlists.*

Di MEOLA: There's only the hope.

PONTY: It's true that this is not the best time to want to be original, if you want to get a record contract. But it's also a question of generations. You see these young musicians playing bebop like classical interpreters. They're learning to play the music of the past.

CLARKE: You're absolutely right. Wynton

Marsalis spearheaded this new wave of young musicians. My problem with these guys is that the press comes onto them like they're doing something new. Forget it! There's no integrity there. It's just copying something.

MUSICIAN: *Maybe these younger musicians just need some time to become less derivative.*

Di MEOLA: They need more time to adjust their attitudes.

CLARKE: I also think it's a question of character. Maybe I'm being stuck-up about it, but I believe it takes more effort and a little more courage to be an original. Jean-Luc is an original. Al's an original. Jeff Beck is an original. Carlos Santana is an original. B. B. King is an original. That's what I look for. I love those kinds of musicians.

Di MEOLA: A lot of these guys like Wynton are very good players, but when they first emerged it was as part of a movement against fusion. Then a very interesting thing happened: All the labels began weeding out a lot of the guys who had been selling hundreds of thousands of records, and they moved the new faction in to take their place, largely due to the fact that you could sign these young hard bop lions for next to no money. It was like when rap started: You could make a rap record for almost no money, sell 50,000 copies, and make a fortune.

MUSICIAN: *The young players talk about having to go back to the roots of jazz to pick up on what players of your generation neglected. The idea is that you guys somehow missed what came before Miles Davis.*

CLARKE: How do they know that? How the fuck do they know? Excuse my German. How can someone say Jean-Luc missed bebop? Forget it. I have a lot of passion on this subject, because it's bullshit. I would come back to those musicians and say, "How do I know you're not unoriginal? How do I know that maybe you woke up one day and realized you had nothing to say? Is that why you just go get these records and copy them?"

MUSICIAN: *So what are you going to do about it?*

CLARKE: I'll tell you what. I'm putting a new record label together, and I'm getting ready to change distributors because I want to sign some of these younger acts I hate and make money off of them.

[laughs]

Got Any HEMP?



Introducing our full line of Gig Bags made from nature's strongest and most versatile fiber.

For a Third Planet Dealer near you call
800-727-8805

Third Planet by Brandon International
Irwindale, California

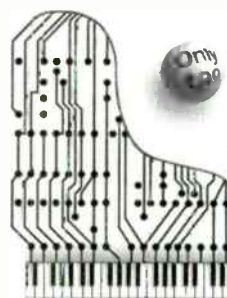

PianoScan.

Introducing PianoScan, the affordable way to scan sheet music into your computer. PianoScan is identical in every way to its big brother,

MIDISCAN for Windows 2.1; except it is designed to process piano, solo and duet scores (up to 2 staves per system). Use the built-in image editor to remove vocal lines from song books and you've got instant karaoke arrangements. Just \$99!

Free Demo On-line:
CompuServe: Go MIDISCAN
<http://www.musitek.com>
<ftp://fishnet.net>incoming.fdr>

Call about our low-cost scanner bundles

800-676-8055



410 Bryant Cir. Ste. K, Ojai, CA 93023
TEL: 805-646-8051 / FAX: 805-646-8099

FAST

FORWARD

NADY E03

Since this month's gear spread already included flying plugs and a big box on wheels, we thought we'd add a few antennae to round everything off. Nady obliged us with the E03 personal in-ear monitor wireless system (\$329.95), which consists of a 300-foot-range transmitter and bodypack receivers equipped with earbuds. The E03 provides a customized listening environment anywhere in a venue, with more focused sound than floor monitors. ♦ Nady, 6701 Bay St., Emeryville, CA 94608; voice (510) 652-2411, fax (510) 652-5075.

PEAVEY Q431F

The Constant Q filters of Peavey's Q431F 31-band monographic equalizer ensure that slider adjustments don't affect adjacent frequency band levels. Another nifty feature of the unit is an automatic feedback locating system. When feedback occurs, an LED is automatically lit over the slider controlling the offending frequency. Not bad for \$299. ♦ Peavey, 711 A St., Meridian, MS 39301; voice (601) 483-5365, fax (601) 486-1278.

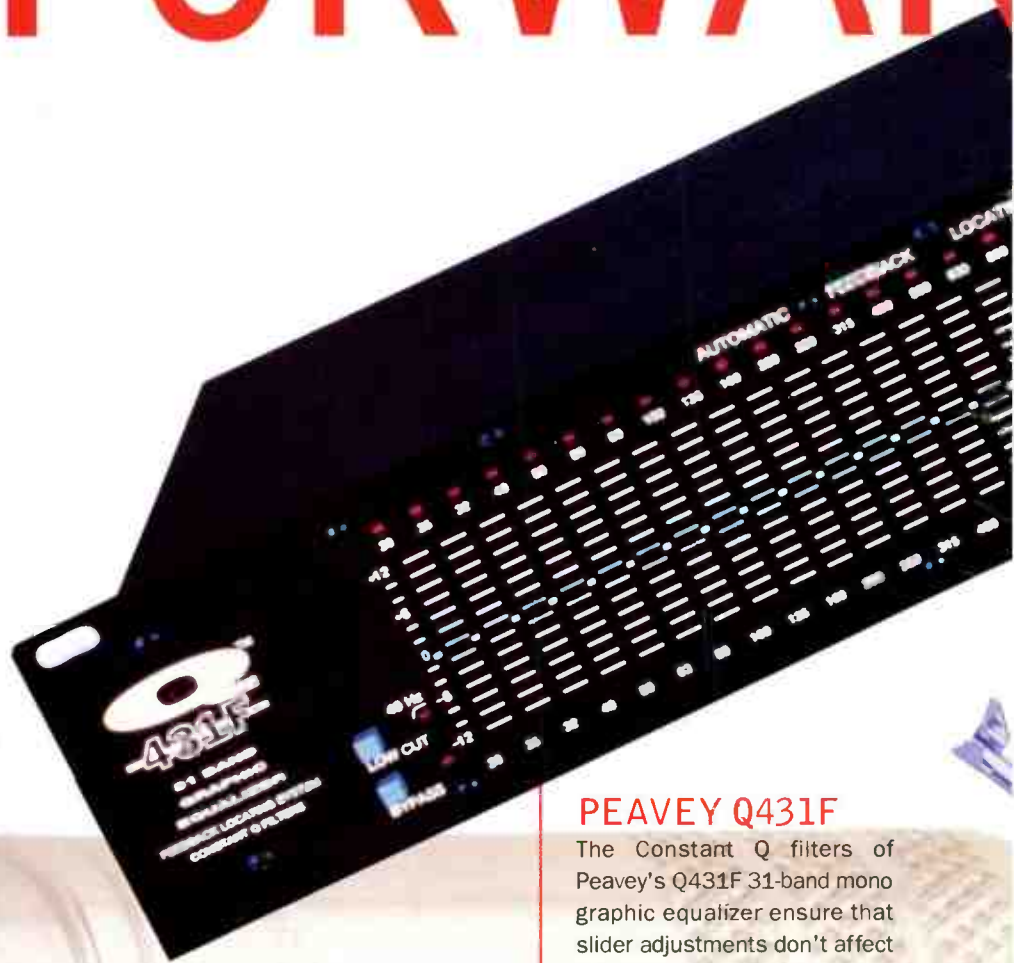



SWITCHCRAFT PLUGS

If you're in the market for heavy-duty phono plugs, look no further than Switchcraft's 3502 series, which was designed with instruments and home recording equally in mind. The 3502A features a nickel handle and nickel plug; the 3502AAU's got a nickel handle and gold plug; our fave, the 3502ABAU, has a cool black handle/gold plug combination. Prices are \$2-\$3, depending on quantity. Buy a bunch. ♦ Switchcraft, 5555 N. Elston Ave., Chicago, IL 60630; voice (312) 792-2700, fax (312) 792-2129.



WHISPERROOM BIG BOX

No, that's not what the company calls it, but that's what it is. There's more to this particular box than first glance may reveal, though; we've actually got a portable sound-proofed practice space here, complete with vent system. If your neighbors are less than tolerant, this may be the way to go. Two sizes are available, and prices start at \$1395. ♦ WhisperRoom, 116 S. Sugar Hollow Rd., Morristown, TN 37813; voice (615) 585-5827, fax (615) 585-5831.

FENDER DG-22CE NAT

Fender's new DG line of acoustic guitars includes over 30 models ranging in price from \$149 to \$989. The DG-22CE NAT pictured here (\$649) is a cutaway acoustic-electric with flame maple top, back and sides, natural finish, rosewood fingerboard, and Fishman Matrix electronics. It's also the only truly normal-looking piece of gear we could find this month. ♦ Fender, 7975 N. Hayden Rd., Ste. C-100, Scottsdale, AZ 85258; voice (602) 596-9690, fax (602) 596-1386.



NEW TOYS & NEW TOOLS

GUITARS & BASSES

Alvarez expands its 5220CEQ Artist Series of cutaway acoustic/electrics with two new models in vintage sunburst and cherry finishes. Both models have a spruce top, mahogany back and sides, Venetian cutaway, rosewood fingerboard, and Alvarez 500 pickup and EQ. Also from Alvarez is the 4075 five-string acoustic bass guitar. The additional low B string's tension is accommodated by heavier bracing, and the neck is narrower than most five-strings for better playability. The 4075's pickup system doubles the amount of piezo crystals in the bridge for better tracking of that pesky low string. ♦ **The Ultra Tone** is the latest guitar model co-designed by George Lynch and **ESP**. It features an offset double cutaway body design and three-per-side ESP Eclipse headstock shape. The maple body is finished in black with a black pearl pickguard, stop tailpiece and tune-o-matic bridge. Electronics include three Seymour Duncan Mini-Humbuckers, a five-way pickup selector switch and push-pull pots to split the pickups to single coil mode. ♦ **Citron's** CS1 features a quilted maple top, bolt-on mahogany neck and ebony fingerboard. Hardware includes Steinberger locking gearless tuners and Wilkinson Convertible tremolo. All three pickups use Alnico V magnets; the neck pickup is wound with one gauge of wire, the middle one with two gauges, and the bridge pickup with another combination of two gauges. ♦ **Alvarez**, 1400 Ferguson Ave., St. Louis, MO 63133; voice (314) 727-4512, fax (314) 727-8929. ♦ **ESP**, 7561 Sunset Blvd., Hollywood, CA 90046; voice (213) 969-0877, fax (213) 969-9335. ♦ **Citron**, 282 Chestnut Hill Rd., Woodstock, NY 12498; voice (914) 679-7138, fax (914) 679-3221.

KEYBOARDS & MIDI

Ensoniq's ASR-88 is an 88-key, weighted-action version of their ASR-10 sampling keyboard offering complete sampling workstation capabilities to the musician who desires a true piano touch. 16 MB RAM, a SCSI interface, damper-style foot switch and double-speed CD-ROM drive, and two CD-ROM sound disks are included with the ASR-88. Features include stereo sampling, 62 effects algorithms, 16-track sequencing, 2 tracks of audio recording, up to eight outputs, and an extensive library of sounds on floppy disk and CD-ROM. ♦ **Housed in a**

sturdy, cast aluminum box, and measuring in at 3 1/2" x 4 1/2", **Tech 21's** MIDI Mouse is a compact, portable and user-friendly MIDI footcontroller. It's also the only MIDI footcontroller available that is operable with a 9V battery. 128 patches are accessible on any of the 15 selectable MIDI channels. ♦ **Ensoniq**, 155 Great Valley Pkwy., Malvern, PA 19355; voice (610) 647-3930, fax (610) 647-8908. ♦ **Tech 21**, 1600 Broadway, New York, NY 10019; voice (212) 315-1116, fax (212) 315-0825.

AMPS & SPEAKERS

Bedrock's 22-watt Royale Deluxe combo (pictured) houses a single 100-watt speaker in a 1/2-cabinet. The two-tone vinyl coverings are trimmed with gold string piping, nickel-plated corners and a white gloss enamel faceplate. Each Royale is powered by a pair of premium 6V6s with a 5Y3 rectifier tube and two 12AX7s, yielding sustain at even moderate levels. ♦ **The new 60-watt JTM60 all-tube range from Marshall** is available in four different models—the 1x12 JTM612, the 3x10 JTM610, the 1x15 JTM615 and the JTM622 2x12. The JTM60's circuit relies on three 12AX7s in its preamp stage, plus one 12AX7 and two EL34s in its power section. Two channels, normal and boost, have independent controls for volume, bass, middle, treble and reverb. The back panel houses a master presence control, two effect loops (series and parallel) and a DI output, which is switchable between speaker emulated (pre-power amp) and non-emulated (post-power amp) signals. ♦ **Bedrock**, 1600 Concord St., Framingham, MA 01701; voice (508) 877-4055, fax (508) 877-4125. ♦ **Marshall**, 89 Frost St., Westbury, NY 11590; voice (516) 333-9100, fax (516) 333-9108.

MIKES & MIXERS

Electro-Voice introduces its new R-Series wireless microphone and instrument systems. Eight configurations are available: handheld, lavalier, headset and instrument cable transmitters, matched up with either diversity or non-diversity receivers. The handheld transmitter contains a high-performance N/D157B microphone element and ergonomically contoured ABS handle. It also offers separate on/off and mute switches to reduce the chance of unintentional interruption during use. The headset sys-

tem includes a high-output, unidirectional condenser microphone, while the lavalier system features an omnidirectional condenser microphone. All three bodypack transmitters provide a two-color LED readout and oversize on/mute/off switch. ♦ **GeneralMusic's** PickPad compact mixer is an ideal choice for desktop music applications and multimedia presentations. Weighing only 3.3 lbs with a convenient transport handle, the PickPad has six mono and two stereo channels. Each mono channel features a double input (line and mike) with phone jack and XLR connectors, gain control, equalizer (high and low), aux send, pan control, peak LED and rotary fader. Its stereo input channels and master section allow easy interfacing with any audio/video or multimedia device. ♦ **Electro-Voice**, 600 Cecil St., Buchanan, MI 49107; voice (616) 695-6831, fax (616) 695-1304. ♦ **GeneralMusic**, 1164 Tower Lane, Bensenville, IL 60106; voice (708) 766-8230, fax (708) 766-8281.

SOFTWARE & HARDWARE

WS Designs' Presto! The Solo Solution makes it easy for Windows users with CD-ROM drives to learn songs and solos from any audio CD. With Presto!, musicians can click an on-screen button at the beginning of each phrase or measure that they'd like to learn. This creates "loop points" for the CD. Presto! then plays back each phrase or measure repeatedly, until the musician can play along with it. Convenient sliders allow the user to subdivide each loop in order to isolate portions as short as a single note or chord. ♦ **Mark of the Unicorn** has released a version of its FreeStyle program for Windows. FreeStyle combines composition-based trackless sequencing with instant music notation. ♦ **Voyetra Technologies' Digital Orchestrator Plus** is an inexpensive but powerful MIDI/digital audio sequencer for Windows. The software allows digital audio to be seamlessly edited and synchronized with MIDI tracks. Capacity for digital tracks is limited only by a user's hardware. Full drag and drop digital audio editing features such as cut, copy, paste and merge are also provided, permitting the layering of tracks to make space for additional recording. ♦ **WS Designs**, P.O. Box 75, Jacksonville, OR 97530; voice (503) 770-0310, fax (503) 899-1857. ♦ **Mark of the Unicorn**, 1280 Massachusetts

assurance standard. No wonder N/DYM® Series III microphones offer the best sensitivity, highest output and the widest frequency response of any microphone in its class.

Electro-Voice N/DYM® Series III microphones are built at our factory in Sevierville, TN, the first professional audio manufacturing facility to receive the prestigious ISO 9002 certification — the world's foremost quality

Electro-Voice, Inc., a MARB IV company

640 Cecil St., Buchanan, MI 49107 616/695-6851 800/234-6851 Canada: 615/382-2141

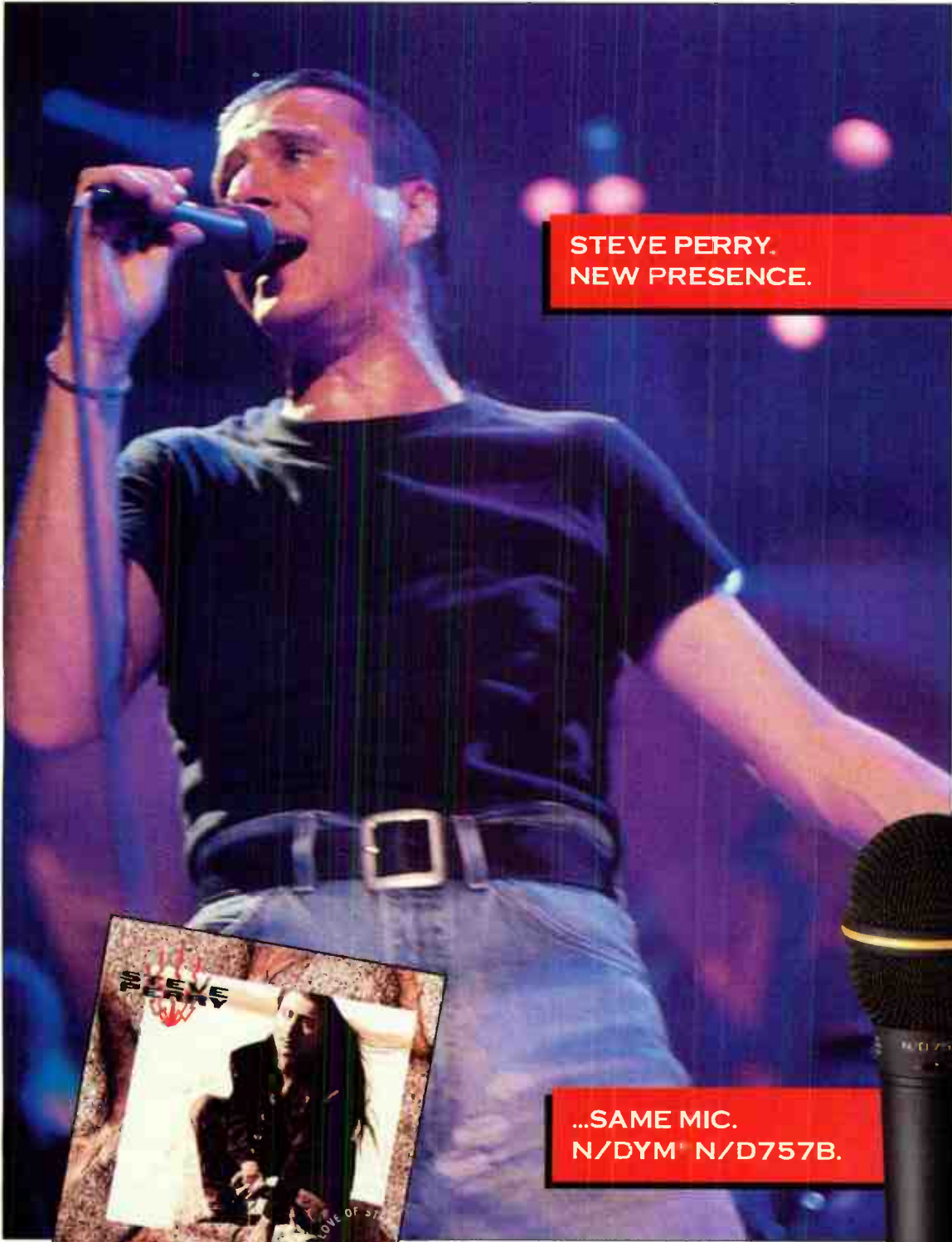

**STEVE PERRY.
NEW PRESENCE.**



"For the Love of Strange Medicine" — Columbia #CK44287

**...SAME MIC.
N/DYM® N/D757B.**



N/DYM® III — Clarity and Power Defined.

Ave., Cambridge, MA 02138; voice (617) 576-2760, fax (617) 576-3609. ♦ *Voyetra Technologies*, 5 Odell Plaza, Yonkers, NY 10701; voice (914) 966-0600, fax (914) 966-1102.

SIGNAL PROCESSORS

DigiTech's New Studio Quad digital signal processor features four completely independent inputs and outputs for paramount flexibility. Driven by DigiTech's S-DISC technology, the Studio Quad's extensive input/output routing abilities allow it to perform duties previously requiring four separate signal processing

devices. With 128 presets and room for 128 more user-defined settings, the Studio Quad also features automatic input leveling, real-time dynamic parameter modifiers, full MIDI implementation and multi-function effect modules. Also new from DigiTech is the RPM-1 vacuum-tube rotary speaker emulator and the TSR-6 true stereo effects processor, which provides 99 factory programs such as stereo reverbs, multi-tap delays, chorus, flange, tremolo, detune and parametric EQ. ♦ *DigiTech*, 8760 S. Sandy Parkway, Sandy, UT 84070; voice (801) 566-8919, fax (801) 566-7005.

RECORDING & PLAYBACK

Yamaha's latest four-track cassette recorders are the MT4X and MT50. Each channel of the MT4X includes three-band EQ, two aux sends, mike or line capability. Three-point auto-locate dbx noise reduction, pitch control and auto-punch with rehearse are among the other features, while a sync switch allows for synchronization with external MIDI drum machines and sequencers. The MT50 includes four mike/line inputs, a four-channel mixing section, two-band EQ, aux send, LED level meter, pan control and level fader, and dbx noise reduction. ♦ *Yamaha*, 6600 Orangethorpe Ave., Buena Park, CA 90620; voice (714) 522-9011, fax (714) 522-9832.

DRUMS & PERCUSSION

Zildjian's Zil-Bel special effects bells, cast from the same bronze alloy as Zildjian's cymbals, are ideal for special accents. Primus' Tim "Herb" Alexander was involved in the design process. Zil-Bells are available in two sizes, 6" and 7 1/2".

♦ **UFIP's** new Class Series of cymbals includes rides (18" to 22"), available in light, medium and heavy weights; hi-hats (10" to 15") in a choice of regular, heavy, wave or fusion types; splashes (10" to 13") and Fast Chinas (14" to 20"); and high, medium or low (8" to 20"), general-purpose cymbals which can be used on the drumset or in numerous concert and ethnic percussion situations. ♦ *Zildjian*, 22 Longwater Dr., Norwell, MA 02061; voice (617) 871-2200, fax (617) 871-3984. ♦ *UFIP*, 101 Bernoulli Cir., Oxnard, CA 93030; voice (805) 485-6999, fax (805) 485-1334.

SOUNDWARE

Tran Tracks' MULTIMIDI collections of MIDI-sequence backing tracks are reproductions of original recordings, capturing the performance and feel of work by artists such as Gloria Estefan and Frank Sinatra. MULTIMIDI sequences come as MIDIFiles on a 3.5" disk and work under DOS, Windows, any MIDIFile playback unit or keyboard sequencer that reads MIDIFiles. (Mac is available upon request.) ♦ *Steve Gadd DrumScores*, produced by Jason Miles in association with **Q Up Arts** and **Ensoniq**, is a CD-audio and CD-ROM library of loops, performances and selected drum hits by Gadd. Performances include "Perfectly Laid-Back Beat," "Blazing Brush Samba," and "In the Pocket." ♦ *Tran Tracks*, 350 Fifth Ave., New York, NY 10118; voice (201) 383-6691, fax (201) 383-0797. ♦ *Q Up Arts*, P.O. Box 686, Sandy, UT 84091; voice (800) 454-4563, fax (801) 944-9677.

Take Music. Seriously.

If you want to attend the college where careers in contemporary music begin, learn your craft one-on-one from a faculty of outstanding music professionals, study where some of the finest musicians you know have studied; if you want to play with some of the world's best players, gain invaluable experience and contacts, and if you are ready to take music as seriously as we do, apply to Berklee.

Call Berklee College of Music: 1-800-421-0084, ext. 8748 or return this coupon for admissions information about our Bachelor's Degree and Professional Diploma Programs.

Berklee College of Music
Office of Admissions, Dept. 8748
1140 Boylston Street, Boston, MA 02215

Name _____

Street _____

City _____ State _____ Zip _____ Country _____

Telephone _____ Instrument _____

(Please indicate "voice" if applicable.)

Berklee
COLLEGE OF MUSIC

It's where you go.



© Berklee College of Music, 1995

Making cool sounds. That's pretty

much the purpose of all multi-effects processors, and a task that the Sony HR-MP5 executes extremely well. It all starts with our dual-effects block architecture. Each block boasts both an effect and an equalizer. These can be used at the same time to create the exact sound you want, with your



quality that's better than expected for the price... smooth reverbs, digital clarity but with a warmth that sounds distinctly undigital.**

Yes, the Sony HR-MP5. It's versatile, convenient, affordable, and great sounding. In conclusion, allow us to leave you with some quotes from Keyboard Magazine, who wrote, "...clean

GET GREAT RECORDING EFFECTS WITHOUT BANGING YOUR HEAD AGAINST THE WALL.



OF COURSE, WE COULD MAKE THAT SOUND PRETTY COOL AS WELL.

choice of a serial, parallel, or dual mono configuration. Throw in the fact that each preset can be programmed with a different configuration, and it all spells one magical word: versatility.

With the HR-MP5, you get an abundant variety of effects, 51 in all. These include Delay, Chorus, Flange,

Pitch Shift, Reverb, and Dynamic Filtering. Add to the menu 100 pre-programmed and 100 user-definable presets, and it's easy to see that the HR-MP5 has a fully stocked effects buffet.

But don't just take our word for it, listen to what the experts are saying. Such as EQ Magazine, "Sound

and smooth presets... the display is big, bright and packed with information... friendly, easy-to-understand icons at every turn... this user interface is one of the best we've seen, ...A+ for Sony.**

What more can we say? For more information, call 1-800-635-SONY, ext. MP5.

SONY

©1995 Sony Electronics Inc. All rights reserved. Reproduction in whole or in part without written permission is prohibited. Sony is a trademark of Sony.

**EQ, August 1994. **Greg Rule, Keyboard Magazine, April 1995.

World Radio History

COMBO THIS

KEYBOARD AMPLIFICATION is potentially about as interesting a subject as air and gas filtering. Sure, someone has to do it, but do we really have to talk about it? Hot air and gas filtering is just what we need to do when it comes to keyboard amplification, though, because this particular MI realm is a bluffer's paradise, a Grade A service station on the erroneous information superhighway.

For the record: Amplification does not take place in hermetically sealed environments but in rooms of different shapes and sizes. Due to the instrument's nature, keyboard amplification has to account for the highest highs, lowest lows, and everything in between. Add in a customer base that includes both classically trained pianists and headcase rockers, and no one answer is going to be obvious, never mind right.

Often it pays to go simple, and things don't come much simpler than the Barbetta Sona 32C Pro (\$899). Barbetta is a small California company whose keyboard combos have been the favored weapon for top professionals for several years. Plain on the outside, the Sona 32C Pro houses a bi-amped active speaker design (two separate amplifiers for its 15" woofer and 3x7" tweeter), and delivers as crisp and punchy a sound as is decently possible from a combo.

To call this amp "minimalist" is putting it mildly; there are no controls whatsoever in front. At the back are just four line-level input jacks plus a single low-impedance mike input, global EQ comprising bass, mid, and treble, an effects loop, and a mono line out jack. Hookup can either be from individual instruments to individual inputs, each of which has its own gain control, or via a sub-mixer whose output can be fed into a single input. The effects loop allows you to physically patch in your trusty Quadverb, but levels will have to be set on the effects unit itself. Simple it may be, but the Barbetta reeks of design by someone with ears. The power rating is 160W, which, because of the quality, is sufficient for all but the noisiest of stages.

Yorkville's 300K (\$1149) is an unusual design in that it provides stereo amplification within a single cabinet. Two 10" Eminence speakers

and RCF high-definition tweeters are driven by 150-180W per channel amplification. There are five input channels, and lots of plug-in options such as mike input on two channels, two effects loops, a CD input, and tape out phonos that send a combined line-level signal to a DAT or cassette machine, very useful for pre-production or rehearsals. The 300K is both powerful and flexible, even if it doesn't take in the whole shooting match with internal effects. Each input channel has its own volume pot, though, plus bass and treble EQ, and a single knob that sends that channel's signal progressively onto one of the effects loops (left to EFX 1, right to EFX 2). Getting a lively stereo keyboard sound on stage is tricky; if you place cabinets too far apart, the impact is lost. Providing a stereo system in one enclosure, as Yorkville does, goes a long way towards solving the problem.

Crate, part of the giant St. Louis Music conglomerate, has long

championed the cause of keyboard amplification, and its KX range spans from the practice amp-sized KX-15 (\$150) to the beefy 160-watt KX-160 (\$800). The latter offers a solution to another thorny performance dilemma: amp positioning, which is critical, especially on a tight stage. By means of a

rod you can screw into the back, the KX-160 can be tilted, thus throwing the sound upwards. Other extras include built-in spring reverb (not the greatest but useful), and the rarely seen but very sensible built-in limiting, from which almost all keyboards benefit in a live setting. (Either by themselves or en masse, keyboards cover such a wide frequency range that it's easy for sounds to get lost; limiting tightens a sound up, makes it more defined.) The combo also offers a global seven-band graphic EQ. In addition, two of its four input channels have individual treble and bass tone controls. The KX-160 may not have the pure sound quality of the Barbetta, but it's a sturdily built all-in-one unit.

Keyboard amps may not be that exciting, but the best ones can sure punch up your sound.

BY JULIAN COLBECK



From top:
Yorkville's 300K,
Crate's KX-160, and
Barbetta's Sona 32



Why do top performers demand Audix® OM-Series Mics?

The Red Hot Chili Peppers

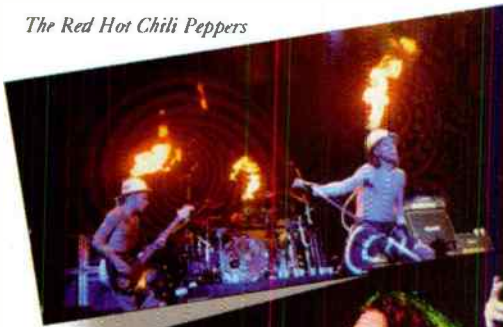

Bruce Springsteen

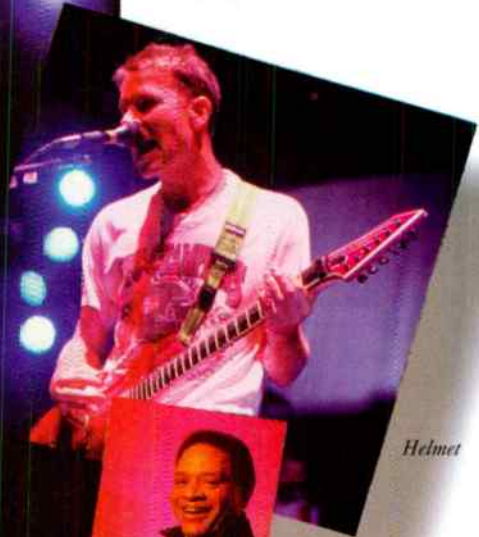

Helmet

The Breeders

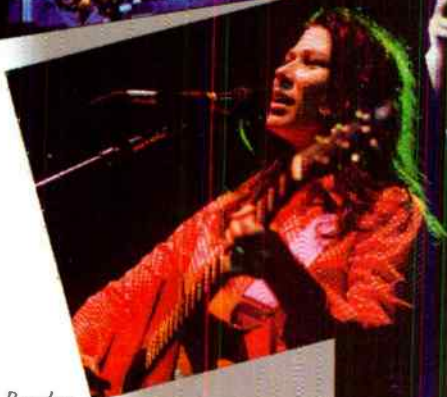

Bonnie Raitt



Al Jarreau



The performance.

Performance is everything. And our Audix OM-3™, OM-5™ and OM-7™ are the best performing mics... at any price.

Leading technology. Our exclusive VLM (Very Low Mass) diaphragm is made of a remarkably strong, yet thin and lightweight composite Mylar®. Its lightness allows phenomenal response and quick reaction to acoustic impulses. The results are unmatched levels of resolution, rejection and gain before feedback.

Top quality. Audix makes the highest quality mics in the industry. From our rugged, electronically applied "e-coat" finish, to our durable, gold XLR connector, and high-tech, precision tooling—every element of every OM-Series mic meets the most demanding performance standards. It's why we can offer a lifetime warranty on OM-Series parts.

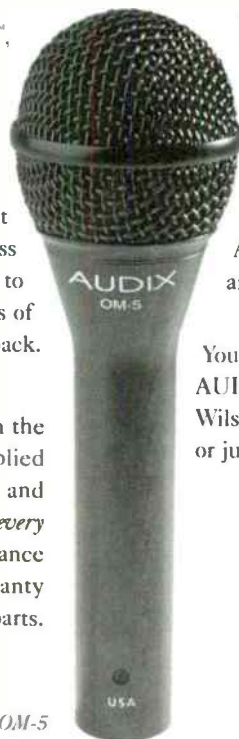

The OM-5

But don't just take our word. Go ahead. Shop around. Look for a mic as good as the OM-3™, OM-5™ or OM-7™. You'll be comparing them to mics costing much more. And frankly, no matter how much you spend, you won't find a better mic... just ask the pros!

Ask your dealer to demo the Audix OM-3™, OM-5™ and OM-7™. You won't be disappointed.

You can write to us at:
AUDIX, 29103 SW Kinsman Road,
Wilsonville, OR 97070; fax us at (714) 588-8172;
or just call **1-800-966-8261**

Don't buy a mic without trying an Audix.

AUDIX®

© Audix Corporation, 1995. All rights reserved. Audix, the Audix logo, OM3, OM5 and OM7 are trademarks of Audix Corporation. Other trademarks are the property of their respective owners.

Two units in this spotlight have been around for ten years or more. Peavey's four-input KB-300 (\$599) offers built-in automatic limiting and built-in reverb for each channel. It comes in a large cabinet, with a single 15" Scorpion Plus woofer and one CDH high-frequency horn. (If your application inclines towards the bass end, you might want the Black Widow speaker option, which adds \$50 onto the price of the unit.) Add in decent EQ controls, plus separate and useful RCA record outputs in addition to a line-level output jack, and you've got a well-

tooled unit that offers a lot for the money. But like the Crate, the KB-300 doesn't compare with the Barbetta or Yorkville for raw sound quality. It's also monstrously heavy, weighing in at 80 lbs.

The second oldie is Roland's classic JC-120 (\$1095). The JC wasn't designed for keyboards, but keyboard players have long tapped into its smooth and sexy chorus-injectable system. Both input channels feature three-band EQ and separate gain. Global effects are reverb, vibrato (speed and depth variable), and the all-conquering Roland cho-

♦ **Barbetta**, 5301 N. Commerce Ave., Moorpark, CA 93021; voice (805) 529-3607, fax (805) 529-0659. ♦ **Crate**, St. Louis Music, 1400 Ferguson Ave., St. Louis, MO 63133; voice (314) 727-4512, fax (314) 727-8929. ♦ **Fender**, 7975 N. Hayden Rd., Scottsdale, AZ 85258; voice (602) 596-9690, fax (602) 596-9948. ♦ **Peavey**, 711 A St., Meridian, MS 39301; voice (601) 483-5355, fax (601) 486-1278. ♦ **Roland**, 7200 Dominion Cir., Los Angeles, CA 90040-3696; voice (213) 685-5141, (213) 722-0911. ♦ **Yorkville**, 4625 Witmer Industrial Estate, Niagara Falls, NY 14305; voice (716) 297-2920, fax (716) 297-3689.

rus. Rated at a healthy 120 watts, the JC-120 is immensely powerful, delivering sound of rare punch if unashamedly colored quality. Retro hounds who have just sleuthed down a bargain Fender Rhodes need look no further.

That said, for marquee consistency, Fender itself also has a range of keyboard combos. The KXR 200 (\$800) is another heavyweight at 88 lbs., though the cabinet glides about on casters and has side-carrying handles. Four individual input channels come complete with three-band EQ, gain, effects send, and reverb send controls. The cabinet houses one 15" Fender Special Design woofer plus a Dual piezo horn. Fender, which also produces the somewhat underspecified KXR 100 (same size but less punch), is taking a good middle ground here between sound quality and features. This is a flexible unit, with channel inserts as well as a global effects loop, built-in reverb, and one channel (number 4) that customizes input impedance and EQ calibration for vocals. Rated at 200 watts, the KXR 200 is no shrinking violet. 🎸

BEAU HUNKS

[cont'd from page 19] Besides Shield, they've also recorded music by cult favorite Raymond Scott. Next Beau Hunks will investigate cartoon scores and the jazz-tinged orchestral pieces of Ferde Grofé.

This work is fun but serious. "The most recent sessions were very emotional," Schreuders says, "because we keep comparing to the original tracks. The string section had a very long discussion over just two bars in a particular piece. They couldn't agree how many violins were there, and they had to play it over and over. It's very motivated."

—Scott Isler

We realize
that not
everyone
can afford
their own
radio
station...

...and that's why CMCI designed the **Oracle Jr.** to be the affordable alternative to purchasing your own private radio station.

The monitor mix feeds directly to the performer's earpieces in crisp, clean **STEREO**. Choose from **100 transmit channels!** Then listen as high quality audio takes the place of damagingly loud stage volumes and annoying feedback.

THE RESULT?

A superior performance with less ear fatigue and less voice fatigue! Best of all, the complete **Oracle Jr.**

Wireless Monitoring System sells for under a thousand dollars. So you

don't need to pay for an entire radio station. All you really need is the affordable, truly cost-effective Oracle Jr. from CMCI.



CMCI
Circuits Maximus Company, Inc.

Manufactured exclusively by Circuits Maximus Co. Inc.
9017B Mendenhall Ct. Columbia MD 21045

For sales or dealer information call: **800-381-7972** / fax 410-381-5025

MUSICIAN SAMPLE THE FUTURE



A
LITTLE ON
THE CD SIDE

ALL NEW RELEASES

- JOHN HIATT
- SON VOLT
- HOLLY COLE
- EMMYLOU HARRIS
- FABULOUS THUNDERBIRDS
- PATTY LARWIN
- FRANCIS DUNNERY
- BROOKLYN FUNK ESSENTIALS
- MARCUS HUMMON
- STACY DEAN CAMPBELL
- SAL'S BIRDLAND
- VINCE CONVERSE/ INNES SIBUN
- CAROLYN WONDERLAND & THE IMPERIAL MONKEYS
- SUGAR BLUE
- WILLY PORTER
- NICHOLAS LENS
- DEAD CITY RADIO
- ANGEL ROMERO
- RANDY ROOS

A LITTLE ON THE CD SIDE VOLUME 19

9 FULL LENGTH TRACKS FOR \$3.99

Musician Magazine's New Music Sampler

19 is the lucky number! Volume 19 of A Little On The CD Side contains 19 brand new songs from 19 diverse and exciting artists, complete with extensive liner notes—all for just \$3.99 (even less if you subscribe). Order now and hear tomorrow's releases today!

Please send me _____ copies of **A Little On the CD Side Volume 19**.
Enclosed is \$3.99 per disc (\$5.99 foreign-US funds only).

Or Please enter my **5-CD subscription** to CD Side (a new volume every 3 months).
Enclosed is \$18 per subscription (\$30 foreign-US funds only).
Start subscription with _____ Vol 17 _____ Vol 18 _____ Vol 19.

Please include appropriate sales tax in CA, DC, IL, MA, NJ, TH, PA VA, OH, CAN. Thanks.

*Note: All prices include shipping. If the volume you requested is sold out, your subscription will begin with next available volume. Please allow 4 weeks delivery.

Send check/money order to: **MUSICIAN CD SIDE**, PO Box 99100, Collingswood, NJ 08108

Name _____

Address _____

City _____ State _____ Zip _____

World Radio History

ALSO AVAILABLE . . .

Volume 17

FEATURING: PJ Harvey, Pat Metheny Group, Wilco, Joan Osborne, Steve Morse Band, Del Amitri, Sonia Dada, Jann Arden and 5 more!

Volume 18

FEATURING: Catherine Wheel, Paul Weller, Never The Bride, A.J. Croce, Memphis Horns, Eleven, Charlie Sexton and 11 more!

GETTING IT TIGHT

DOCTOR NERVE is a seven-piece band that plays devilishly difficult music with searing rock 'n' roll confidence. As the band's composer, I used to have a problem. The music I write is pretty psychotic stuff. But it's supposed to rock hard, not sound hard. Somehow we had to come up with a system that would put us in technical control of our material. After some experimenting, I came up with something that works. Call it CAR—computer assisted rehearsal.

The computer and MIDI setup I've got at home helps both me and the band as a whole overcome any technical hurdles. First I'll record computer-performed versions of new pieces onto tape and give bandmembers the tape along with printed scores. Then we get the new tunes into our blood by using the computer to play difficult parts over and over. Here's how it all works.

In my personal studio, I've got an Amiga 3000 computer with a MIDI interface, a Kawai K1m MIDI sound module, an Alesis HR16 drum machine, and an Alesis Quadraverb GT for my guitar, all patched into a Tascam 8-channel mixing board. The stereo system this hooks into is loud enough to keep up with the Doctor Nerve horns when they come over for a sectional rehearsal, and can get up to neighbor-threatening volumes when we do a rhythm sectional. My equipment list is modest by modern production standards, but remember, I'm not using it to produce final recordings—it's a setup geared toward composition and rehearsal. The techniques I'll be describing can be used on any computer with a MIDI sequencer that allows

you to do such rudimentary operations as cycling a section of a composition continuously, muting tracks, and representing music in common music notation.

First, some background on how I compose for Doctor Nerve. My compositions are arranged in music software called Deluxe Music 2.0. The software displays a screen that looks like normal sheet music. I typically compose in a combination of three ways. I can punch notes and rhythms directly into Deluxe Music with a mouse. Alternatively, I can play a MIDI guitar live into my own program RiffGrabber, which properly notates my performance and sends it to Deluxe Music's staves. Finally, some of my compositions are generated by software I write in a language called HMSL (Hierarchical Music Specification Language). Whether new material is punched in note by note, played in live, or algorithmically generated, I tend to favor technically challenging music. So it's helpful to have it appear on the screen in common music notation, performable by a virtual MIDI band that performs it flawlessly and uniformly every time. This allows me to make compositional decisions that are removed from the difficulties of performance.

As a tool for practicing alone, I find the computer invaluable as a kind of tireless expert instructor. The computer is happy to play parts repeatedly until I get them into my ears, my brain, and finally my fingers. Deluxe Music can cycle any range of measures, and as a little graphic bonus, it'll flash the notes as they go by. Looks pretty silly when you're watching simple music, but it sure is

enlightening when complexity starts to go off the deep end. Some of my pieces are software-generated compositions that don't care much about how hard they are for human beings to play. I spend long practice hours in front of the computer with my guitar strapped on, playing along with tough licks until I master them. Woodshedding this way brings my performance up to par very effectively. By listening and watching the music, really weird material can get into your cytoplasm and stop feeling weird. A very healthy musical experience!

The added advantage of working out with a computer is that it acts like a "smart metronome." It can be slowed down to help you work out hard parts just like a normal metronome, but unlike a metronome, it can change time signatures. The example on the next page shows a passage that changes meters from 6/8 to 5/16, then to 3/4. These are the opening measures of "Little Jonny Stinkypants," recorded by Doctor Nerve on our new CD *Skin*. Practicing this passage with a traditional metronome would require you to set the



One of downtown Manhattan's top composers polishes his chops through Computer Assisted Rehearsal.

BY NICK DIDKOVSKY





At Soundcheck Studios, Rehearsal is Serious Business.



Left to right: Bob "Norton" Thompson, owner and president of Soundcheck, Inc., Katy Jennings and Trey Follis, sound engineers and Toni Thompson, controller and vice president.

Before performing for thousands of screaming fans, many top touring musicians fine-tune their acts at Soundcheck, Inc. in Nashville, the world's largest rehearsal facility under one roof. To the people at Soundcheck, simulating a realistic concert environment, including state-of-the-art sound support, is a top priority.

That's why they use Audio-Technica microphones.

"The A-T mics are truly incredible," says owner Bob "Norton" Thompson. "Everyone loves their sound. Plus, they take all the abuse we dish out and keep right on performing, rehearsal after rehearsal."



Audio-Technica is serious about making reliable, high-performance microphones for stage and studio use. So if your sound is serious business to you, call, write or fax.

Audio-Technica U.S., Inc.,
1221 Commerce Drive, Stow, Ohio 44224
(216) 686-2600 Fax: (216) 686-0719



audio-technica®

metronome to click all the 16th notes, since the odd 5/16 bar would throw off an eighth-note or quarter-note pulse. At the indicated tempo, that would mean setting your metronome for 352 clicks per minute! Even if your metronome went that high, you'd probably have a nervous breakdown playing along with something that fast.

Maybe my favorite musical thing to do with the computer is setting up grooves from Nerve tunes and practicing my guitar solos. I played along with the groove in "Little Jonny" for countless hours and my "rhythm section" never got tired. After recording numerous solos on cassette, it was helpful to listen back critically. I discovered completely different ways of approaching this solo, settling finally on the one I found most alluring.

The computer can also be used to enhance the personal practice time of Nerve's other members. In addition to cassettes and scores of new tunes, we can share the music files themselves. Two members of Nerve have Amigas and Deluxe Music, so I can just send them disks with the new pieces. Others have IBM-compatible PCs and their own MIDI gear. For them, I convert my pieces to standard MIDI files with my program Deluxe MIDI Converter, and zap these files over to their machines either via modem or disk. Then they can use and abuse the tunes all they want at home.

As a tool for ensemble rehearsals, the computer offers a lot of benefits. When the Nerve horns come over to my studio, it's great to have the "full band" represented with the MIDI/computer marriage. If a new tune is

especially tough, the live horns might play along with the full virtual ensemble for a while. After that I can mute the MIDI horns, and let the live musicians fly on their own. Since they're all hot players to begin with, this locks them into the tune quickly. Trouble spots are easily isolated, cycled, and nailed down.

Just for fun, we might mute other MIDI instruments as well, changing the "onstage mix" to unpredictable combinations. This not only breaks listening habits (like relying too much on another musician's line for your cue), but prepares us for the "sound system from hell" that is encountered at least once every tour: the one where the monitor mix changes unpredictably between soundcheck and the show.

Of course, the computer is not the solution to every rehearsal problem. The virtual rhythm section I solo over will never get excited by anything I play, and so will never lead me to new places like live musicians do. And no MIDI synthesizer or drum machine can hope to duplicate what Nerve's lunatic musicians do with their instruments. Non-portability is another limitation; the computer's helpful as long as musicians can come over to my place, but we don't work with it when the full band goes to a professional rehearsal studio. Conceivably, I could bring MIDI files anywhere that had a MIDI setup, but I'd expect that to be more trouble than it's worth. Spending valuable rehearsal time selecting synthesizer voices, setting monitor levels, etc. wouldn't be wise. And frankly, by the time we're in the studio for a full rehearsal, I don't want the computer around

anymore—it's time to crank up and play, not stare at a screen!

So who besides Doctor Nerve would benefit from adding a computer to their rehearsal environment? First, any composer who wants to explore treacherous musical ground and make it as easy as possible to embrace difficult material. Also, improvisers who want to delve into new realms of soloing will find the computer to be helpful as a tireless, highly indulgent backup band. Finally, any musician who wants to add unspeakably strange new chops to his or her personal arsenal will find that a computer helps lock in superhuman rhythms and intervallic leaps like nothing else. The faster you can leap over technical hurdles, the faster you can get to the creative substance of music-making. ♪

◆ Doctor Nerve's *Skin* is distributed by Cunciform Records, P.O. Box 8427, Silver Spring, MD 20907, E-mail: cunciway@aol.com. ◆ Hierarchical Music Specification Language (for the Mac and Amiga) is distributed by Frog Peak Music, P.O. Box 1052, Lebanon, NH 03766. ◆ RiffGrabber and Deluxe MIDI Converter for the Amiga are distributed by Nerveware, 118 East 93rd Street, Suite 9C, New York, NY 10128, E-mail:72250.3313@compuserve.com. ◆ Deluxe Music 2.0 is a registered trademark of Electronic Arts. Amiga is a registered trademark of Amiga Technologies, a division of ESCOM, GmbH.

♩=88

Soprano Saxophone

Tenor Horn

Bass Clarinet

Guitar

Drum Set

Little Jonny Stinkypants, meas. 1 - 4, copyright 1995, Didkovsky/ Punos Music (BMI)

ARE YOU THE BEST UNSIGNED BAND IN THE COUNTRY?



THE ONE, THE ONLY, THE ORIGINAL... MUSICIAN MAGAZINE BEST UNSIGNED BAND COMPETITION 1996

Get ready for MUSICIAN's 1996 BEST UNSIGNED BAND Competition. Here's the chance to get your music heard and compete for the title of Best Unsigned Band in the country!



STEVE WINWOOD



STONE GOSSARD



JULIANA HATFIELD



JIMMY JAM



PAT METHENY

Tapes will be reviewed by our panel of editors and music writers. Winners will be chosen by our panel of all-star judges, including Steve Winwood, Pearl Jam's Stone Gossard, Juliana Hatfield, Jimmy Jam, Pat Metheny and more to be announced soon.

Semi-finalists will be announced in future issues of Musician. Winners will appear on Musician's "Best of the B.U.B.s" CD (serviced to all indie and major label A&R departments and major media outlets) and be featured in Musician Magazine. They will also receive copies of the CD for their own promotional efforts. Top placing artists will receive a selection of equipment from JBL Professional and the all new EON Series of portable PA products. Read the rules, fill out your entry form, and send the tunes you want the world to hear.

No purchase necessary. All entries must be received by December 31, 1995. Entrants must not be signed to a recording contract. Artists retain all rights to their material, however tapes cannot be returned. If chosen, artist is responsible for final mix to appear on CD. All decisions are final. Employees of Musician Magazine, JBL Professional and Disc Makers are not eligible. Void where prohibited.

OFFICIAL ENTRY FORM

Band Name _____

Contact Name _____

Address _____

City, State, Zip _____

Telephone _____

WHAT YOU NEED TO SEND:

- 1) Entry Form
- 2) 2-song cassette (original material only)
- 3) Name/address of each musician in your band or who plays on your tape.
- 4) Processing fee \$17.50 (check/ money order)

Send to Musician/ B.U.B., 1515 Broadway, 15th Floor, New York, NY, 10036. Deadline for entries: December 31, 1995.



PHOTOGRAPH BY JAY BLANKENBERG

MATT FIN



World Radio History

© 2007

13
25
17
18
19
20
21

15
15
50
44
45
39

14

2
40
41
26
42
43
39
37
38

K'S HOME STUDIO



YOU MIGHT think that Matt Fink, after a dozen years as Prince's first-call keyboard player, would have stepped off the purple rainbow into a pot of gold, if not platinum. As the last surviving member of the Revolution, the artist formerly known as Dr. Fink had persevered through the departures of drummer Bobby Z, Wendy & Lisa, and other would-be splinter acts—and watched as their subsequent careers failed to reach critical velocity. “It was scary,” he confides. “The Prince connection didn't seem to help much.”

Undaunted, Fink left the band in 1990 to try his hand at producing. Unfortunately, as he quickly learned, labels expect to see more on a producer's résumé than a stint as sideman to music's most notorious

control freak. “They didn't trust me,” he recalls. “They said, ‘You've got to get some experience.’” It looked like a classic record-biz Catch-22 until Fink ran into an old friend who had recently taken a job with none other than K-TEL Records—you know, the people who single-handedly funded late-night TV throughout the '70s by hawking cheesy compilation albums: “The original hits! By the original artists!”

A dozen albums later, Fink is still busy cranking out K-TEL classics. “They say, ‘Oh, boy, vampires are in, let's do a vampire album!’ That kind of thing,” he explains. Some, like *The Wedding Album*, are letter-perfect remakes of Top Forty hits. Others, such as *Horror Movie Madness*, feature his own compositions, which tread a line

BY TED GREENWALD

PHOTOGRAPH BY JAY BLAKESBERG

HOME STUDIO
PRESENTED BY
THE MUSICIANS
INSTITUTE

MII
MUSICIANS INSTITUTE

between film score and new age. And, with the recent remodelling of his home studio, he records them soup-to-nuts in the basement of his suburban Minnesota house.

"I'm only 16-track **Tascam DA-88** 1," he says sheepishly. A bank of **ProCo** patch bays 2 route signals to a **D&R Dayner** 35-channel mixer 3, which he insists is too small. "It's not an in-line console," he points out, "so you can only put one instrument through one channel at a time. The DA-88s alone take

up 16." Monitoring through **Yamaha NS-10s** 4 and **Westlake BBSM 8s** 5 powered by custom **Dan Kennedy** amps 6 with a **BGW 150** 7 for the headphone cue, he mixes to **Sony PCM 2700A DAT** 8, **Panasonic SV3700 DAT** 9, and **Yamaha C-300** cassette decks 10 with an **Onkyo Integra DX-320** CD player 11 on hand for reference.

Fink's arsenal of synths and samplers is sufficient to have produced the entire *Music of the Vampires* via "virtual tracks": MIDI tracks

sequenced, rather than recorded, on a **Macintosh IICI** computer 12 and **MOTU Performer 4.2** software with a **MOTU MIDI Time Piece** 13 for MIDI routing and sync. Controlled by a **Yamaha KX88** master keyboard 14, it's a diverse rig: an **E-mu Proformance** piano module 15, **Akai S1000 HD** sampler 16, **E-mu Proteus 2** for orchestral sounds 17, **Korg Wavestation SR** 18, **Roland JD-990** 19, **Kurzweil K2000R** 20, **Yamaha TG77** 21, vintage **Minimoog** 22 (modernized via a **Roland MPU-101** MIDI-to-voltage converter), **E-mu Emax** sampler 23, and **Ensoniq VFX SD** synth 24.

Although he can fit a full rhythm section in the live room (visible through the window behind the mixer), he only recently purchased enough mikes to record live drums. Usually he drives an **Alesis D4** drum module 25 and a **Roland R5** by pounding on a **Roland SPD-11** pad. *Tribute to the Beatles*, the Fab Four soundalike that launched Fink's producing career, boasts production that is virtually indistinguishable from George Martin's. Take the guitar behind "Lucy in the Sky with Diamonds." "That's a real guitar through an **Alesis Quadraverb** 26 Leslie simulator program. I've found high-end effects necessary for a number of applications. My two **API 5502** stereo EQs 27 have such a sweet sound, much better than the EQ in my board. I use **Audio Logic MT-44** 28 and **440** 29 gates for noisy keyboards and guitars. The **Lexicon 300** reverb 30 is my best one, and the **Sony D7** delay 31 is really clean.

"As long as you have a really good reverb for vocals and a high-quality delay, you don't need any more," Fink advises. But, of course, he does have more: a gaggle of preamps including a **Summit TPA-200** 32, **Dan Kennedy** custom 33, and **API 3124** 34; a **Tube Tech PE 1B** equalizer 35; two **Urei LA-4** compressors 36 plus a **dbx 160X** 37 and two **dbx 160XTs** 38; two **Drawmer M500** dynamics processors 39; a bunch of multi-effects, including a **Lexicon PCM-70** 40 and **Yamaha SPX1000** 41, **SPX900** 42, and **SPX 90** 43; and **Eventide H3000 SE** 44 and **AMS DMX 15-80-S** 45 harmonizers.

"And you should have at least one high-end mike, like a **Neumann U87** or an **AKG 414**," he adds. "I know how hard it is to afford stuff like that, but it'll make anyone's project studio sound that much better." ☛

The Original Revolution

Equitek E-200

Introduced in 1989, as the Equitek II, the first microphone under a \$1000.00 featuring:

- State of the art servo head amplifier, eliminating coupling capacitors phase anomalies and feedthrough distortion.
- High SPL capabilities (148dB), providing tremendous ballistic integrity
- Non capacitive 20dB pad
- Proprietary H-frame internal shock mount, isolating capsules from most vibrations
- High fidelity audio reproduction

.....CAD created a revolution in the microphone industry by redefining high end performance and great value. With continual enhancements the E-200 has established a bench mark which remains to be equaled or excelled.

Every hour of every day, in thousands of project and world class studios around the world, Cad Equitek servo-condenser microphones continue to provide a unique level of performance, with a unparalleled return on investment.



Also available in matched pairs.



E-200 Shown with optional ZM-1 Shock Mount

Join the Revolution!



For a CAD dealer near you call: 1•800•726•9266

a division of CFI Audio, Inc. 341 Harbor St. Conneaut, OH. 44030
Phone (216) 593•1111 Fax (216) 593•5395

Imagine what a place like this could do for your music!

From supercharged summer courses, to the most exciting degree programs anywhere, Musicians Institute is a place where you can live your dreams!

You'll study your style of music with a collection of the world's best teachers and meet with top name recording artists. Funk, Blues, Jazz, Rock, Alternative, Folk, Fusion, Country, Latin, R&B, Classical & more... it's ALL here for you!

We also focus on songwriting and music business, to get your career off and flying.

Our graduates and visiting faculty are performing in some of the most successful bands on the planet...

Want to learn more?
Write or call for a
FREE CATALOG
on the world's most innovative
music school!

1-800-255-PLAY

MII

MUSICIANS INSTITUTE



BACK FOR THE HOLIDAYS

THE CHIEFTAINS

THE BELLS OF DUBLIN

and

- Jackson Browne
 - Marianne Faithfull
 - Rickie Lee Jones
 - Nanci Griffith
 - Elvis Costello
- and many others



09026-60824-2*4

Available now at



VISIT THE CHIEFTAINS ON <http://www.irish.com>

World Radio History
Tm(s) (R) Registered. Marca(s) Registradas. General Electric Company, USA, except BMG logo. (R) BMG Music. (c) 1993 BMG Music

Blue Kentucky Woman

THERE HAVE BEEN SOME illustrious milestones in the career of country thrush Emmylou Harris—1977's rustic *Luxury Liner*; her down-home hoedown *Blue Kentucky Girl* in 1980; *The Ballad of Sally Rose*, a stunning autobiographical piece from 1985 that payed homage to her earliest mentor, the late Gram Parsons. But nothing, repeat, nothing in Harris' catalog prepares a listener for the leap she takes with the real soundscapeist Daniel Lanois on her bold and brilliant new *Wrecking Ball*. The U2 of Nashville songbirds meets the U2 of producers—like a Reese's Peanut Butter Cup, it's one of those great conceptual ideas that makes you wonder why it didn't happen sooner. With snare-hushed brushstrokes (fittingly, U2's Larry Mullen, Jr.

EMMYLOU HARRIS

Wrecking Ball

(ASYLUM)

provides most of the drum tracks), Lanois maps out the softer borders to sonnets from Neil Young, Steve Earle, Lucinda Williams and his own textural tour de force, "Where Will I Be," while Harris nudges her vocals gingerly into place as if completing a complex jigsaw puzzle. The mix is breathtaking to behold.

Know that certain summery smell of noonday sun beating down on urban concrete, know that all's right-with-the-world aroma you might get for a few minutes on the right day, and then it's gone? There are moments on *Wrecking Ball* that approximate such fleeting epiphany. On Lanois' working-class parable "Blackhawk," acoustic guitars, played muted and gentle by Harris



BILLY NAME

STERLING MORRISON 1942-1995

STERLING MORRISON WAS one of the prime architects of modern rock 'n' roll, and very few people know it. As guitarist—with Lou Reed—in the Velvet Underground, he helped shape entire genres of music and influence countless musicians long after that band dissolved. But working with Reed, John Cale and Moe Tucker, Sterling usually stayed in the shadows.

Musically, at least. Philosophically, Morrison's avid intellect lay at the heart of the Velvet Underground and what they accomplished. He could defend the band against any and all detractors—as he often recalled, there were more than enough of those—and he helped formulate the VU's formidable take-no-prisoners stance. In a time of peace, love and misunderstanding, the Velvets were alone in viewing life from the opposite angle. More importantly, they never backed down—not once. Much of that can be credited to the mental muscle of Sterling Morrison.

After the band's breakup, Morrison moved to Austin in 1971, pursuing a Ph.D. in the University of Texas' English department. I met him there in 1975 quite accidentally, and convinced him to join our bar band, the Bizarros. It took about one song to realize what a powerful presence Sterling cut on guitar. His playing was at once adventurous and precise. In some ways, Sterling was as much a student of the guitar as he was of English lit (Chaucer, to be exact). He practiced constantly, never tiring of running

through chord changes and pinpointed lead runs, almost absentmindedly strumming away while the Bizarros would try to figure out what we were doing.

It was also during the later '70s that Morrison began working on tugboats in the Houston Ship Channel. Around the same time he received his doctorate in medieval studies, he earned his captain's license.

When the Velvet Underground reunited in Paris in 1990 for an Andy Warhol art retrospective, watching Morrison play "Heroin" with his former bandmates was like seeing a circle completed. Twenty years of distance and various recriminations were forgotten, washed away by the simple force of that one song. A full European tour and live album three years later gave the group the last laugh, proving that they were much more than a figment of the media's imagination.

Sterling once told me the two things to remember about him were that he was "no aging hippie, because I never was a hippie. And nobody can ever say I sold out, because I never did." True enough. Sterling had an amazing mind and a fearless heart. When he died August 30th in Poughkeepsie, New York of non-Hodgkin's lymphoma, the day after he turned 53, he did so knowing that his early rock 'n' roll endeavors had changed the music he loved so much forever.

World Radio History —Bill Bentley



GERARD MALANGA

Lanois, amble into Malcolm Burn's shuffling piano/bass/tambourine rhythm and—after a quiet electric bridge—the piece ascends to a velvety crescendo. Harris' voice, tinkling like a chandelier and cracking with emotion, suggests the resonance of two lovers trying desperately to make sense of their factory environments. Neil Young's title track (to which Young himself contributes fluttery vocal harmonies) conveys the aura of a smalltown romance. In Harris' hands, Lucinda Williams' suicide-is-pointless elegy "Sweet Old World" slows to a pace that lets the heartache of loss sink in (with Williams strumming along in the background). And when Harris moans, "But I recall all those nights down in Mexico/One place I may never go in my life again" in Steve Earle's fragile "Goodbye," the breakup hidden between the lines bobs to the surface. Earle adds his acoustic to that ballad as well, but Lanois' electric reverb dominates, with passages that practically howl in empathic pain. Traditional instruments are put to good use as well, especially on Gillian Welch's lilting "Orphan Girl," where a mandolin/dulcimer interplay from Lanois sets Harris back into a simple country frame she knows by heart. "Waltz Across Texas Tonight," a track she co-wrote with old bandmate Rodney Crowell, creates a similarly twangy scenario.

But *Wrecking Ball* isn't "country music," not by a long shot. It's EnamyLou Harris testing herself, pushing her voice to new interpretive limits, getting deeper inside her material than she's previously dared. From the roots-conscious sounds of her past, you may have thought you had her pegged. After *Wrecking Ball*, you can toss all those notions straight into the hickory wind.

—Tom Lanham

RED HOT CHILI PEPPERS

One Hot Minute

(WARNER BROS.)

STOUT-HEARTED WARRIORS that they are, the Red Hot Chili Peppers have not grown complacent with success, judging from the existential restlessness of *One Hot Minute*. This dense, ambitious album has flaws, but a lack of commitment isn't one of them: Anthony Kiedis and company stalk Truth and Beauty with an obsessive yearning Iggy Pop would admire. Indeed, Kiedis'



HOUSE PARTY

What Are You Listening to Lately?



KEITH EMERSON

1. Cairo, The Gates of Eden
2. Buzz Tonic, Arcade Babies
3. English Chamber Orch., Benjamin Britten's Simple Symphony & Young Person's Guide to the Orchestra
4. McCoy Tyner, Big Band
5. Ralph Moore w/ Benny Green, Who It Is You Are



STEVE HACKETT

1. Scott Walker, Tilt
2. Buffy St. Marie, Eliminations
3. Paul Weller, Stanley Road
4. Miles Davis, Bitches Brew
5. The Beatles, Revolver

BILL BRUFORD

1. Max Roach Double Quartet, Easy Winners
2. Alice In Chains, Dirt
3. Keith Jarrett, My Song
4. Ali Farka Toure w/ Ry Cooder, Talking Timbuktu
5. Frank Sinatra, Songs for Swingin' Lovers



invocation of the Ig on "Coffee Shop" is fitting, since the old man pioneered the Peppers' strategy of seeking spiritual fulfillment through corporeal excess.

Eager to prove themselves enlightened party animals, the dudes celebrate the inner self, strolling in quest of meaning on the drolly laid-back "Walkabout," and recalling youthful indiscretions in the furious "Deep Kick," concluding philosophically that it's better to sin than to not live at all. Tilting at

intolerance, Kiedis blasts organized religion on "Shallow Be Thy Game," coolly baits a "homophobic redneck dick" in "Pea," and advocates nothing less than the Golden Rule with "One Big Mob." Righteous!

However charismatic their portrayal of idealistic renegades, the lads are less persuasive in strictly musical terms. While Jane's Addiction refugee Dave Navarro (the Peppers' 37th guitarist) has moments of flashy brilliance, his playing often lacks warmth. Meanwhile, Rick Rubin's detail-oriented production emphasizes individuals rather than the group; the sizzling title track is one of the few times the quartet hits a collective groove.

Stronger material would render other complaints moot. Hard tunes tend to be eruptions of noise rather than genuine songs, although they've wisely given up trying to play genuine funk, at least. Taking a cue from the breakthrough hit "Under the Bridge," appealing sweet 'n' sour ballads such as "Tearjerker" and "Transcending" suggest a mellower brand of profundity may be the wisest course.

From superior taste in influences to savvy videos to general intangibles of image, the Chili Peppers' renown may owe more to peripherals than to the music itself. On the positive side, Kiedis and crew obviously feel a responsibility to do right by their audience, given the inspirational bent of *One Hot*



RED HOT CHILI PEPPERS

NIELS VAN IPEREN

Snake Your Hips
IT'S "GROOVE ELATION" TIME!
Snap Your Fingers

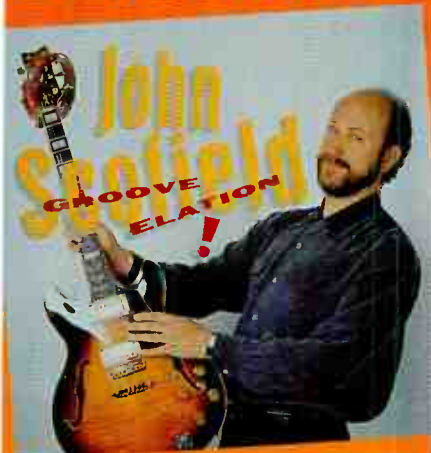

Guitarist JOHN SCOFIELD lays deep in the cut and serves up his best disc ever. Funky, slinky and full of wit, Scofield takes jazz into a wild new direction on GROOVE ELATION.

With LARRY GOLDINGS on organ
DENNIS IRWIN on bass
IDRIS MUHAMMAD on drums



To order product from the Blue Note catalog please call 1 800 217-7732



ALL NEW 1996 COLOR GUIDE
MAJOR RELEASE QUALITY SINCE 1969
WE WROTE THE BOOK
CUSTOM CD'S & CASSETTES



•Hassle Free Money Back Guarantee
 •No Charge Reference CD's & Cassettes
 •At Your Service Priority Delivery

Call for our

1996

Color Catalog Toll Free

1-800-463-9493

24 hours



WORLD RECORDS GROUP

908 Niagara Falls Blvd.
 North Tonawanda, N.Y. 14120-0260
 Phone 1-800-463-9493
 E Mail 75323.2172 @ campuserve.com

WhisperRoom INC.
 Practice Rooms



PRACTICE MAKES PERFECT

Includes: stationary floor, fan-powered ventilation system, and cable passage plug.

Available in two sizes.

Tel: 615-585-5827 Fax: 615-585-5831

116 S. Sugar Hollow Rd.
 Morristown, TN 37813 USA

Minute and relative absence of star arrogance. Such good intentions make everything else easier to take. —Jon Young

WAYNE SHORTER

High Life

(VERVE)

ORNETTE COLEMAN & PRIME TIME

Tone Dialing

(VERVE)

THOUGH THEY'VE TRAVELED IN DIFFERENT CIRCLES, Wayne Shorter and Ornette Coleman have more in common than we might think. Around the turn of the '60s, Coleman was defining a new shape of jazz to come, while, a few years later, Shorter was busy working his own redefinitions on the sidelines, injecting a juicy enigma into Miles Davis' group and Weather Report. Both have had syncopated discographies, with long gaps.

Now, after a seven-year absence from the shelves, and having settled into their sixties, each has assembled a new album to rank among their finest work to date. Coleman's *Tone Dialing*, from his electric Prime Time group (with a recording of his acoustic group in the hopper), is the first showing of his music since he was lavished with a MacArthur Grant last year. Shorter's *High Life*, a remarkably supple and secretly grandiose project which wears its complexities with grace, fulfills the lingering promise left by his last great solo album, *Native Dancer*, of twenty years ago.

Shorter's solo projects of the last decade have been unfailingly ambitious in conception, with mixed results in execution. Here, producer Marcus Miller brings a clear, open mind to the

task of coaxing the beauty that lurks in Shorter's pretzel logic. These tunes don't so much serve as pretty song form vessels—Shorter is the sole soloist, on both soprano and tenor—as they are immaculately stylized, atmospheric essays which evolve and mutate before our ears, with strings and horn parts tastefully lining the way. A sly infectiousness imbues tunes such as "Children of the Night" and "On the Milky Way Express," pushing pop-funk-jazz to a lofty plane, while the title cut and "Pandora Awakened" examine new ways of organizing ideas and defining structural development.

With Coleman's album, too, process and organizational reinvention are the keys. Like Shorter, Ornette happily embraces electric tools of the trade, with two electric guitars, bass, and very plugged keyboards. But Coleman resists the temptation of single-vantage-point grooves and that old spinal wallop of a fixed backbeat. His harmolodic theory mashes together serialist notions with proto-jazz ideas about collective improv, resulting in a deceptive anarchy of layered harmony and rhythm. On *Tone Dialing*, Coleman rings up other genres from rambling mumble funk ("O.A.C.") and island music jubilation ("Guadalupe") to a rap-flecked pop tune ("Search for Life") and even a harmolodized Bach prelude. But no one could mistake this for anything but Ornette Coleman music. Call it avant-garde, call it a folk funk thing, or both: It's good, soothing news from the cutting edge.

And bless their probing hearts and minds. The services of these gentle subversives have never been more welcome now than in the middling, transitional jazz simmer of the mid-'90s.

—Josef Woodard





MAVERICKS

MEDICINE

Her Highness

(AMERICAN)

IN THE LATE '80S, SUCH BANDS AS MY BLOODY Valentine, Slowdive and Ride created droning palettes that suggested ancient ruins tumbling over slow-motion waterfalls. Guitars showered reams of feedback like fireworks while disembodied voices rose heavenward and drums contorted rhythm in dub-infected loops. Like the bombed-out Gothic architecture that adorns the CD jacket of *Her Highness*, Medicine make resounding music that dredges this sonic past. The results are often beautiful.

Principal songwriter Brad Laner masks shivering melodies in covers of white noise and textured guitars, injecting just enough surprise to keep it from all bogging down in layers of mire. "All Good Things," a textbook drone piece, hovers methodically until a Beach Boys-styled choir illuminates its mix. Drummer Jim Goodall plays an unusual second line groove under the undulating strings of "Candy Candy," turning its cool trance shower upside down. On "Farther Dub" Medicine do Can, adding Frippish guitar jabs to a percolating snare drum rhythm. There's even a dash of unplugged: The prettiest track here, "Seen the Light Alone," blends acoustic guitar with crisscrossing violas and Laner's sweet vocals, to rapturous effect.

With MBV in exile and Mercury Rev busily repeating themselves, Medicine has the oceanic bliss field all to itself. But if *Her Highness* is any indication of the band's future, they might consider framing their dreamy songs in more minimal settings.

— Ken Micallef

THE MAVERICKS

Music For All Occasions

(MCA)

THERE'S SOMETHING VAGUELY RUSTIC AND reassuring about the Mavericks' retro approach to contemporary country music, like looking at a perfectly maintained '57 Chevy or some old black and white kinescope. The Mavericks seem to hail from another era, a time of honkytonks and one-night stands, church picnics and county fairs, when the modern country juggernaut was just a gleam in Chet Atkins' eye.

The classic verities of their sound are somehow more western than country, blossoming like desert flowers in the bordertowns and dives that stretch from Waco to Bakersfield. The mournful shuffles of "Foolish Heart" (with its close-voiced female chorus) and "One Step Away" (with its keening pedal steel breaks) manage to suggest something of contemporary playlists while hearkening back to country music's roots. However, "Here Comes the Rain," with its grand Frankie Laine gestures and bell-like 12-string accompaniment, begins to hint at the Mavericks' classic instrumental touch and the power in Raul Malo's archetypal vocal stylings. On "Missing You" his voice takes on some of the fragile yearning of early Roy Orbison over a dreamy Latin backdrop, while the Tex-Mex celebration of "All You Ever Do Is Bring Me Down" (featuring Flaco Jimenez's dancing accordion and some tasty instrumental breaks) brings out a twangy, boyish quality to his tale of a flighty lover.

But then, with every song Malo reveals an aspect of his range. The jazzy '50s stylings of "My Secret Flame" offer a perfect setting for his low-key, bluesy crooning, while "The Writing On the Wall" moves from pinched confessionals to throaty exhortations. The soulful sentiment and jumpin' jive of "Loving You" and "If Only You Knew" seem like

Eliane Elias



Alone With Her Genius

Now you can discover what jazz musicians have known for a long time....Eliane Elias is one of the most brilliant pianists in music today. On her first jazz solo outing she serves notice that she is a player beyond peer.

Five brilliant solo recordings and three duets with Herbie Hancock make this the jazz piano release of the year!

Solos and Duets



Recorded without overdubs

THE BLUE NOTE

To order product from the Blue Note catalog please call 1-800-217-7732

nods to vintage Elvis, while Malo's trembling vibrato and broken yodels on "I'm Not Gonna Cry For You" signify what is most special about his muse. A lovely cover of "Something Stupid" with Trisha Yearwood seems both a canny nod to radio programmers and an evocation of his band's south-of-the-border élan. All in all, *Music For All Occasions* refines the Mavericks' sound while reaching out to casual listeners, and I can't think of a country band more deserving of having their cake and eating it, too. — Chip Stern

LUTHER ALLISON

Blue Streak

(ALLIGATOR)

IF EVER A BLUESMAN HAS IMPROVED WITH AGE, it is Luther Allison. A protégé of such guitar slingers as Freddie King and Magic Sam on Chicago's West Side, Allison showed much promise when he came up in the late '60s. But, after a bright but half-finished Delmark debut, *Love Me Mama*, he gravitated towards the showboating messiness of Buddy Guy at his worst, and exhibited a sometimes excruciating

fondness for Hendrix-style extroversion. A godawful album incongruously released by Motown in the early '70s pretty much buried Allison for all except the ballroom-rock faithful.

Following a familiar route, Allison emigrated to Europe, and it's apparent that the change in musical climate and the passage of time has been good for his muse. His 1994 Alligator debut *Soul Fixin' Man* unveiled a more dedicated practitioner of the blues; on *Blue Streak*, Allison leaves rock stylings further behind and displays an emotional and instrumental weight largely lacking in his earlier work. Backed by a brawny, dense band, he's admirably direct on vocals, and his guitar work, in the classic West Side manner, displays plenty of sizzle and snap. On a couple of tracks here, he evokes his little-remembered debt to Hound Dog Taylor with slide performances that are highly individualistic in tone and structure.

If Allison exhibits a great weakness, it's as a writer. Some of his attempts at "socially conscious" blues, like "Big City" and "Move From the 'Hood'" (both co-written with guitarist James Solberg), make one wince. He's at his best with no-nonsense, tradition-based material; singing, playing and writing all come together on his sketch of a troublesome wine-drinking woman, "Cherry Red Wine," which has its roots in blues themes as old as time.

If Allison can hone his pen to a finer point, Buddy Guy-style veneration may arrive for him in short order. For now, *Blue Streak* is a flawed but compelling chapter in the story of a musician still reaching his mature flowering.

— Chris Morris

KEITH JARRETT

At the Blue Note

(ECM)

THERE WERE LINES AROUND THE BLOCK LAST year when Keith Jarrett, Gary Peacock and Jack DeJohnette played at the Blue Note in New York. This was no surprise: Catching Jarrett's trio at any venue smaller than Carnegie Hall is a rare opportunity. Those who made it were treated to an hour or so of transcendent performance by three musicians whose group sets the standard for standards. Multiply that by six and you've got this six-CD document of three nights at the Blue Note. It's a gourmet feast—which, when you think about it, is almost an oxymoron. Listen in small doses; it goes down better.

Jarrett's sensibility—and producer Manfred Eicher's understanding of it—defines the trio's



"Refreshing and Original" - Music Connection

"Cutting and Aggressive" - BAM Magazine

"They're Dramatic, Passionate Rock Alternative. Different!" - RIP Magazine



Look for their first full-length album in September!

CD distributed & promoted by Radio & Retail - 213-876-7027

Call ABC Management for band information - 818-932-1488

ET CETERA

RANDY WESTON

Tanjah

(VERVE)

CONSIDERING HIS STATURE as a composer and a player, pianist Randy Weston has recorded precious few albums. An important chapter in Weston's long-running collaboration with the brilliant arranger/trombonist Melba Liston, this classic but long out-of-print 1973 recording features a large ensemble with such luminaries as Ernie Royal, Budd Johnson, Al Grey and Ron Carter. Like his mentor Thelonious Monk, Weston continually revisits his own compositions, bringing years of studying African music to bear on his signature tunes "Hi-Fly," "In Memory Of" and "Little Niles." The two unreleased takes of "Sweat Meat," which feature some pungent blowing by the underrated alto saxophonist Norris Turney, are an added treat.

—Andrew Gilbert

BEN WEBSTER

Music for Loving:

Ben Webster with Strings

(VERVE)

ONE OF TENOR saxophonist Ben Webster's nicknames was the Brute, due to his size and occasionally fearsome temperament. His sound, however, was uniquely lush and sensuous, especially on ballads. With music from three entire albums (originally released in the mid-'50s on impresario Norman Granz's Norgran and Clef labels) plus alternate takes and unreleased tracks, this two-CD set contains a generous helping of Webster's long unavailable sessions with strings, as well as a strings album by Duke Ellington's great baritone saxophonist Harry Carney. Most of the arrangements are by Ralph Burns and Billy Strayhorn, whose chart for "Chelsea Bridge" is so unspeakably beautiful it alone justifies purchasing the set. Not that the other tracks decline much from this standard; these are some of the finest horn-backed-by-strings sessions ever recorded, featuring a felicitous pairing of melodically gifted soloists and arrangers who understood how to complement two of

jazz's most lyrical players. —Andrew Gilbert

MASTER MUSICIANS OF JAJOUKA

Brian Jones Presents the

Pipes of Pan at Jajouka

(POINT MUSIC)

THE ECSTATIC PIPING of Morocco's Jajouka musicians was little known to Westerners when Brian Jones entered the Rif Mountains in 1968 and heard Pan's true song for the first time. Since Jones' documentary album was released in 1971, many have made the trek: Ornette Coleman utilized the Jajoukans on his seminal *Dancing in Your Head*, the post-Jones Rolling Stones wove the musicians into their "Continental Drift," and the peripatetic Bill Laswell made his own field recordings with Bachir Attar's musical tribe. Jones' original album, despite some minimal studio chicanery, maintains its unearthly power; the Master Musicians' screeching, unearthly sound makes the presence of the goat-god Bou Jeloud hypnotically palpable.

—Chris Morris

OTIS RUSH

So Many Roads—Live in Concert

(DELMARK)

BLUES SINGER-GUITARIST Rush has always tended to be an enigmatic, erratic and frustrating live performer, so this 1975 Tokyo concert performance, originally released by Trio in Japan and later issued in the U.S. by Delmark, was an unexpected delight, and remains so two decades later. Heard in a lean quartet format, backed by a strong band that included Jimmy Johnson on rhythm guitar, Rush is at his jazziest, twirling out clotted, unpredictable licks hither and yon. His straining, impassioned singing is in near-top form as well. I heard Rush play the standard set here, comprising favorite covers like "Gambler's Blues" and such distinctive originals as "All Your Love," many times in the early '70s. He seldom performed them with the lush instrumental fervor and vocal authority he exudes here. —Chris Morris

MIDISCAN[®]

FOR WINDOWS

With MIDISCAN Version 2.1, scanning, recognition, printing and MIDI playback are fully integrated into one

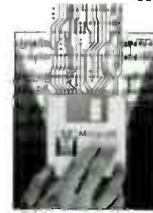

easy-to-use music scanning package. New features include:

- 25%-50% increase in speed and accuracy.

- TWIN scanner driver.
- Improved notation editor.
- GM-compatible sequencer.

Works great with FAX modems too. Now it's as simple as Scan & Play... and with

Home Studio free, MIDISCAN is an outstanding value at \$299.

Includes
Cakewalk
home studio
FREE!

Call about our low-cost scanner bundles.

800-676-8055



410 Bryant Cir. Ste. K, Ojai, CA 93023
TEL: 805-646-8051 / FAX: 805-646-8099

MIDI SEQUENCES

**MORE
HOT LICKS
IN EVERY
BYTE!**



If you want faithful reproduction and unparalleled accuracy in MIDI programming, then you want the live-music sound of TRAN TRACKS MIDI Sequences.

With TRAN TRACKS you get quality service, great prices and a large selection of popular songs. We support all computer formats and most dedicated sequencers.

Experience the MIDIGROOVE™ — It's "music-friendly!"

Call today and play tomorrow.
5 songs or more only \$10.00 each.

ORDER LINE

1-800-473-0797

Fax (201) 383-0797

Technical Support

(201) 383-6691

Canadian Orders

1-800-488-6248

350 Fifth Ave. #3304

New York, NY 10118



TRAN TRACKS

MIDI SEQUENCES

AUSTRALIA - Rhythmic Bites • 61-2-948-4025

UK - Audio Awareness • 0181-598-8081

CANADA - Kaysound • 514-633-8877

GERMANY - M3C • 49-30-785-6066

method. First, they interpret by conventional rules: Play the head, play solos, toss a few fours back and forth, recap the head. More importantly, they let the melody guide them: Where most bands build their solos on a rhythm groove, Jarrett constructs a *melodic* groove, from which the rhythm grows. DeJohnette plays circles in the Elvin Jones tradition, light cymbal brushwork and snare taps all around the beat. He stands back even when Peacock walks on bass, consenting at times to play dotted eighths on the ride cymbal but avoiding pat-

terns that would fall neatly into groups of four. With all these cymbal whispers and free bass parts swirling around, most pianists would be tempted to compensate by playing aggressively, filling in the holes. Not Jarrett: He prefers to join his band in floating above, rather than digging into, a groove.

In fact, Jarrett goes to extremes to preserve the trio's ephemeral feel. On "Lover Man," taken at exquisitely slow tempo, he spells out the theme, arranging each note like curios on a shelf, with the bridge played an octave up. Pea-

cock's spare but steady bass and DeJohnette's vaporous brushing enhance the weightlessness of his line. At other times, Jarrett pushes his agenda to extremes. If the point of playing standards is to celebrate the tune, he can be accused of following his ideas far from the changes and to the edge of affectation. Halfway through a twenty-minute rendition of "You Don't Know What Love Is," DeJohnette's overlong hand-drum exercise transports the pianist into a filigree-ridden imitation of Arabic modes and wind instru-

A Dozen Projects, One Microphone!



Vocals, acoustic and electric guitar, piano, tom toms, snare, cymbals and oh yes... even kick drums. This uniquely designed condenser microphone features a servo head amplifier delivering unparalleled transparency and sonic performance, allowing you a level of flexibility not available from any other microphone.

... and all this flexible performance can be yours at a price making owning a dozen a wonderful possibility.

Also available in matched pairs.



The incredible Equitek E-100
Microphone from CAD....Who Else!



For an authorized CAD dealer near you call!
1 800 726-9266

a division of CTI Audio, Inc. 341 Harbor St. Conneaut, OH. 44030

A D I N D E X

ABG Mgt.—1107 S Mountain Ave, Monrovia, CA 91016 (818) 932-1488	92
Audio-Technica—1221 Commerce Dr., Stow, OH 44224 (216) 686-2600	51
Audix—PO Box 248, Lake Forest, CA 92630 (800) 966-8261 x600	65
Berklee College of Music—1140 Boylston St., Boston, MA 02215 (617) 266-1400	72
Brandon International—5459 Second St, Irwindale, CA 91706 (818) 337-4160	76
CAD—341 Harbor St., Conneaut, OH 44030 (800) 762- 9266	84, 94
CMCI—9017 B Mendenhall Ct, Columbia, MD 21045 (800) 381-7972	76
D'Addario—595 Smith St., Farmingdale, NY 11735 (516) 391-5400	30
Drum Workshop—101 Bernoulli Cir, Oxnard, CA 93030 (805) 485-6999	57
Electro-Voice—600 Cecil St., Buchanan, MI 49107 (616) 695-6831	71
Fatar c/a Music Industries—99 Tulip Ave., Floral Park, NY 11001 (516) 352-4110	3
Fender—7975 North Hayden Rd., Scottsdale, AZ 85258 (602) 596-9690	47
JBL—8500 Balboa Blvd., Northridge, CA 91329 (818) 893- 8411	20-21
Kurzweil—13336 Alondra Blvd., Cerritos, CA 90703-2245 (310) 926-3200	48-49
Lexicon, Inc.—100 Beaver St., Waltham, MA 02154 (617) 891-6790	25
Mackie Designs, Inc.—16220 Wood-Red Rd. N.E., Woodinville, WA 98072 (800) 898-3211	32-33
Martin Guitar Co.—510 Sycamore St., Box 329, Nazareth, PA 18064 (610) 759-2837	63
Musicians Institute—1655 McCadden Pl., Hollywood, CA 90028 (213) 402-1384	85
Musitek—410 Bryant Circle, Ojai, CA 93023 (805) 646- 8051	67, 93
Neumann—P.O. Box 987, Old Lyme, CT 06371 (203) 434- 9190	99
Ovation—P.O. Box 507, Bloomfield, CT 06002 (203) 243- 7941	C2
Passport—100 Stone Pine Rd., Half Moon Bay, CA 94019 (415) 726-0280	22
Peavey—711 A St., Meridian, MS 39301 (601) 483-5365	18-19
QSC—1675 MacArthur Blvd., Costa Mesa, CA 92626 (714) 754-6195	27
Remo—12804 Raymer St., North Hollywood, CA 91605 (818) 983-2600	41, 47, 49
Roland/Boss—7200 Dominion Circle, Los Angeles, CA 90040 (213) 685-5141	4
Sabine—4637 NW Sixth St., Gainesville, FL 32609 (904) 371-3829	66
Shure Brothers Inc.—222 Hartrey Ave., Evanston, IL 60202 (708) 866-2200	8
Sony Business and Professional Products Group—3 Paragon Dr., Montvale, NJ 07645 (800) 365-SONY	42-43, 77
Stedman Corp—1167 Stedman Dr., Richland, MI 49038 (616) 629-5930	57
Sound Ethix—P.O. Box 667, Riverside, CA 92502 (909) 274- 3747	26
Switchcraft—5555 N. Elston Ave., Chicago, IL 60630 (312) 792-2700	75
Tran Tracks—350 Fifth Ave., #3304, New York, NY 10118 (201) 383-6691	93
Whisper Room—116 S. Sugar Hill Rd., Morristown, TN 37813 (615) 585-5827	90
World Records Group—908 Niagara Falls Blvd., North Tonawanda, NY 14120-2060 (800) 263-9493 Fax (800) 530-0216	90
Yamaha—6600 Orangethorpe Ave., Buena Park, CA 90620 (714) 522-9011	100

ment conventions. Its derivative motivation is especially odd for Jarrett, a conspicuous critic of world music. The crowd likes it, though, and responds with a two-minute ovation, all of it faithfully preserved on disc.

More often, Jarrett's distensions of written material spellbind. He begins "Autumn Leaves" with a wondrous improvisation, built on sturdy harmonic movement that peaks in a gorgeous ascent of triadic voicings. Later, in the same tune, with DeJohnette taking control of the beat, Jarrett fixates on a droning fifth. As on "You Don't Know What Love Is," the effect seems contrived—until he brings the opening theme in over the fifth,

which is transformed into the tonic note. This is classic Jarrett: He demands time to create a context in which even a trivial device can assume greater meaning.

And when working solo, Jarrett can astonish. No one can turn a simple ballad reading into the kind of masterpiece he creates here on "In the Wee Small Hours." With its Coplandesque harmonies, quietly restless second-inversion chords, avoidance of blue notes, and the finest rubato in jazz piano, this is Jarrett at the peak of his poetic strength. One could call this performance affected too, but only after the hush of a crowd that knows a miracle when they hear it.

—Robert L. Doerschuk

SHORT TAKES

BY J. D. CONSIDINE

GLORIA ESTEFAN

Abriendo Puertas

(EPIC)

AFTER PAYING tribute to her Cuban heritage with *Mi Tierra*, Estefan has expanded her musical world view to include nearly the whole of Latin America. That means everything from Dominican merengues to Peruvian marineras, and though it may be tempting to sneer at the gimmick, it's hard to ignore the strength of the performances. Though the ballads remain an obvious focus, Estefan's rhythmic sense is stronger than ever. Simply put, this is some of the best music she's ever made.

AC/DC

Ballbreaker

(EASTWEST)

BRIAN JOHNSON has been singing throat-searing boasts like "Let's Get It Up" and "Sink the Pink" for so long it's tempting to wonder which will give out first, his vocal cords or his prostate. Both are in reasonable shape here (just check "Hard As a Rock"), but it's Angus Young who comes off as the album's true hero. It helps that Rick Rubin's lean, mean production makes the most of the central riffs in "Cover You in Oil" and "Caught with Your Pants Down," but it's the sly, inventive playing Angus provides for "Hail Caesar" and "Whiskey on the Rocks" that keeps AC/DC current.

BROOKLYN FUNK ESSENTIALS

Cool and Steady and Easy

(GROOVETOWN/RCA)

REMEMBER THE jazz-funk experiments of the '70s, when Norman Connors had hit singles and Lonnie Liston Smith got played in discos? These guys do. Even better, they understand what that aesthetic was about. Rather than just flesh out a few retro grooves with bop-inflected horn solos, the BFE crew goes for true fusion, spiking "The Creator Has a Master Plan" with dancehall riddims and bringing a real sense of swing to the samples and loops that fuel "Bop Hop."

PIZZICATO FIVE

The Sound Of Music By Pizzicato Five

(MATADOR)

WITH MUSIC this soulful and infectious, the only thing standing between the P-5 and stardom is that they sing in Japanese. Fortunately, this album goes a long way toward overcoming that obstacle, adding more English to the mix without watering down the music's flavor. That makes the maddeningly catchy "Happy/Sad" much easier to sing along with, while the intra-verse chatter in "If I Were a Groupie" is infinitely easier to follow. Still, the heart of the P-5's sound is its giddy, grab-bag blend of '60s pop, '70s soul, and '90s alterna-chic. That needs no translation.

SOME BLUES RECORDS
ARE FOR BLUES FANS ...



SOME BLUES RECORDS ARE
FOR EVERYBODY...

hello everybody

Joe **louis**
walker
blues of the month club



Produced by Steve Cropper and
Joe Louis Walker

"Contemporary blues' finest guitarist."
GUITAR WORLD

"The most exciting and challenging blues
performer of the 1990's."
THE SAN DIEGO UNION-TRIBUNE

Joe Louis Walker picks Gibson
Gibson
USA

© 1995 Polygram/PolyGram S.A. France
Verve Interactive: <http://www.jazzonline.com/JAZZ/verve.htm>

MUSICIAN CLASSIFIED HOTLINE

TOLL FREE

800-223-7524

Need an ad fast?
 Call Jeff Serrette.
 In NY State (212) 536-5174
 Outside NY St. (800) 223-7524

COUPON

HOW TO ORDER AN AD
REGULAR CLASSIFIED (ads without borders): 20 word minimum. \$2.90 per word, minimum \$59 per insertion.
CLASSIFIED DISPLAY (all ads with borders): 1x/1" \$163 per, 6x/1" \$152 per, 12x/1" \$142 per.
BOLD FACE CAPS: First line, additional \$20.
MUSICIAN BOX NUMBER: Add \$4 per insertion for handling.
PAYMENT MUST BE ENCLOSED with your ad. Send to Musician Classified, Jeff Serrette, 1515 Broadway, NY, NY 10036.
DEADLINE: Two months prior to date of publication.
ALL AD CANCELLATIONS MUST BE IN WRITING AND MAILED TO THE MUSICIAN CLASSIFIED DEPARTMENT.
FAX YOUR AD TODAY (212) 536-5055

CATEGORIES: Please mark category desired.
 Accessories Books/Publications Computers
 Employment For Sale Instruction Instruments
 Miscellaneous Musicians Records & Tapes
 Services Software Songwriters Talent Video

Your Name _____
 Company _____
 Address _____
 City _____ State _____ Zip _____
 Telephone _____

Please fill in the information below if you want to charge the cost of your classified advertising.
 American Express Visa MasterCard

Credit Card # _____
 Exp. Date _____ Bank # _____
 Your Signature _____

Publisher has the right to refuse all mail order retailer ads that might conflict with Musician dealers.

ACCESSORIES

SINGERS! REMOVE VOCALS
 (Unlimited, Low Cost, Instantly Available Background Music from Original Standard Recordings) Does Everything Karaoke does... Better and gives you the Thompson Vocal Eliminator™ Free Brochure & Demo Tape.
 LT Sound Dept MD
 988 LT Parkway
 Lithonia, GA 30058
 24 Hour Demo/Info Request Line (404) 482-2485 • Ext 20
 When You Want Something Better Than Karaoke!



FACTORY DIRECT CASES

Call now for our catalogue or quote:

Radio Products, Inc.
 1-800-645-1707
 (516) 567-1181 (NY)
 (516) 567-1590 (fax)



Custom or stock sizes: our prices can't be beat

REMOVE VOCALS from music—Tanco Voice Decoder—\$79.95. Fully guaranteed. Call (813) 847-9319 for prerecorded demo/ordering information.

BOOKS/PUBLICATIONS

VINTAGE INSTRUMENT CATALOG. Call or write for our monthly catalog of over 1,000 new, used, and vintage instruments. We BUY, SELL, TRADE, and ship worldwide. Written APPRAISALS available, \$20 per instrument. GRUHN GUITARS, 400 Broadway, Nashville, TN 37203 (615) 256-2033, 255-2021 FAX.



A special gift for special occasions. Hauntingly beautiful prose and poetry by a young, gifted artist whose spiritual presence will live on through his words. These treasured writings will delight readers of all ages.

“James G. Weber—HIS PROSE AND POETRY” and “SIMPLY LOVE POEMS” by James G. Weber.

\$19.95 each or \$37.50 for the two-book set. To order, send check or money order to Jim's World, PO Box 354, Saddle River, NJ 07458. Allow 4-6 weeks for delivery.

EMPLOYMENT

MUSICIANS NATIONAL REFERRAL—Professional musicians seeking bands—bands seeking professional musicians. Bands register free. Call now for information. 1 (800) 366-4447.

MUSICIANS CONTACT SERVICE, ESTABLISHED 26 years in Los Angeles, excellent reputation, inexpensive. Jobs updated daily on hotline. Call (818) 347-8888, 24 hours.

INSTRUCTION

ATTENTION: KEYBOARDISTS. Beginners to pros. FREE Report reveals how to sound like your favorite keyboardists on recordings. (800) 548-5601 24 Hrs. FREE Recorded Message.

INSTRUCTION

ALTERNATE TUNINGS FOR BASS. An exploration of unique fretboard configurations. (manuscript version only) \$7.95, shipping included. Panmedia International, Box A3914, Chicago, IL 60690

BE A RECORDING ENGINEER
TRAIN AT HOME with AWA
 Easy Home-Study practical training in Multi-track Recording. Join our successful working graduates or build your own studio. Diploma, Job Placement, & More.
 FREE INFORMATION:
 Audio Institute of America
 2258-A Union St., Suite H, San Francisco, CA 94123



Recording Engineer Radio Announcer

ON THE JOB TRAINING
 IN MAJOR LOCAL RECORDING STUDIOS/RADIO STATIONS

Part time, nights, weekends. No experience required. Free brochure and recording tells how.
 1-800-295-4433

WANTED: TRAINEE FOR RECORDING ENGINEER

On the job training at major studio IN YOUR AREA. Keep present job, no experience required. Train around your own schedule.

THE RECORDING EXPERIENCE

Call. 1-800-795-5750

INSTRUMENTS

SUBSCRIBE NOW to our monthly listing of used and vintage guitars, with hundreds of quality instruments for players and collectors at down-to-earth prices. \$12.00/year (\$25.00 overseas). Current issue free on request. ELDERLY INSTRUMENTS 1100 N. Washington, POB 14210-EA5, Lansing, MI 48901 (517) 372-7890.

RECORDS TAPES CD S

TOP DOLLAR PAID FOR CD & LP COLLECTIONS Rock, Classical, Jazz, More. 130,000 titles in stock. PRINCETON RECORD EXCHANGE, 20 Tulane St., Princeton, NJ 08542 (609) 921-0881.

RARE ROCK CONCERTS ON CASSETTE. Hundreds of artists 1960s - 1990s. (Catalog \$1.00). Airwaves, Box 639005-168M, San Diego, CA 92130.

FOR SALE

STUDIOFOAM™!
 We're your #1 source for the world's best sound absorbents, barriers & accessories. Clients: AT&T, NASA, Sony, Warner Bros., Ford, 20th Cent. Fox, NPR, Univ. Studios, US Gov't, Shure, etc. Don't waste good gear on a lousy room. Call today for great deals!
1-800-95-WEDGE
 USAFoam • Fax 317-842-2760



MUSICIANS

RELEASE YOUR OWN CDs!
 500 CDs and 500 Cassettes only \$2,590 with B&W inserts
 • FREE Graphic Design • Ready In 3 Weeks
 • Major Label Quality • Money Back Guarantee
DISC MAKERS
 1-800-468-9353
 Call today for our FREE full color catalog
 Outside USA (215) 232-4140 • FAX (215) 236-7163



MISCELLANEOUS

SINGERS! REMOVE VOCALS
 (Unlimited, Low Cost, Instantly Available Background Music from the Original Recording!) Does Everything Karaoke does... Better and gives you the Thompson Vocal Eliminator™ Call for Free Brochure & Demo Tape.
 LT Sound Dept MD 2 7988 LT Parkway
 Lithonia, GA 30058
 24 Hour Demo/Info Request Line (404) 482-2485 • Ext 202
 When You Want Something Better Than Karaoke!

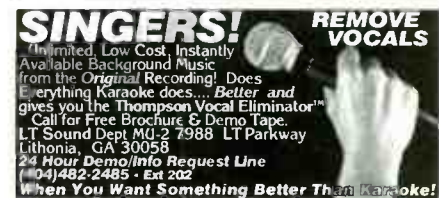

SERVICES

PLUG PRODUCTIONS—CD cassette and vinyl manufacturing and distribution in U.S. and overseas. Sampler \$4.00 (803) 750-5391, 273 Chippewa Drive, Columbia, SC 29210.
 Put that tape on CD! Only \$25... Call or Write for a free brochure. POS, PO Box 328, Goleta, CA 93116 (805) 685-5428.

SERVICES

**FOR COMPLETE COMPACT DISC,
CASSETTE & RECORD MANUFACTURING**

QCA (800) 859-8401

QCA, INC. • 2832 SPRING GROVE AVE. • CINCINNATI, OH 45225
(513) 681-8400 • FAX (513) 681-3777

CD'S .85
each based on 1,000

Way-To-Go! Music 1654 Cahuenga, L.A. CA90028
(213) 466-1661 tel (213) 466-7230 fax

Audiomation
Lowest Prices
CD & Cassette Manufacturing
1-800-375-2060

**Producing Your Own CD
Shouldn't Make You Scream**
your music is a masterpiece...our prices are a steal.

500 CDs and \$2195
with B&W Inserts complete

design • duplication • mastering
call for our FREE brochure!

1-800-916-9900
(714) 241-8801 • Fax: (714) 241-0951

The Record Factory

DUPLICATION
COMPACT DISC
AUDIO/VIDEO CASSETTE
CD ROM
NOW FEATURING THE
MAX
THE LATEST IN DIGITAL
CASSETTE BIN TECHNOLOGY
FROM GAUSS.

WMG, INC.
WORLD MEDIA GROUP
8472 Brookville Road
Indianapolis, Indiana 46236
317/353-1113 Fax 317/353-0750
Internet wmg@indy.net

Member of **NAAM NAIAD**

WAVE
Complete CD packages!
Retail ready including full color inserts.

Bar-codes, CD-Rom, CD-R, Mastering, Design and Film services available.	300	500	1,000
	CD's \$975	\$1075	\$1637
	Cassettes \$396	\$506	\$752

1-800-928-3310
World Audio Video Enterprises

SERVICES

**INCREDIBLE COMPACT DISC
& CASSETTE PACKAGES**

TOLL FREE 1-800-835-1362

LIMITED TIME OFFER! 500 cds: \$1099.00

CD package includes: color 1 panel booklet, color CD label, all
mastering, jewel box, shrink wrapping, graphic insertion

Our everyday Low Price: 1000 cds: \$1649.00

American Clients: No Tax... No Duty... No Problem!

\$1.45/cd package price!

Includes: jewel box, graphics insertion, 2 color cd label

HEALEYdisc

**MEDIAWORKS
INTERNATIONAL, INC.**
1719 WEST END AVE, STE 100E
NASHVILLE, TN 37203

**The one you
need to call!**

Compact Discs, Cassettes, and Vinyl Disc Manufacturing,
Graphics, Printing, and Packaging.
Best Quality • Competitive Pricing • Fastest Turnaround Time
Call (615) 327-9114

MASTERING • MANUFACTURING • PRINTING

DIGI-ROM™

FOR COMPACT DISCS • CD-ROM
REAL TIME & HIGH SPEED AUDIO CASSETTES

COMPLETE PACKAGES • COMPETITIVE PRICING
GRAPHIC DESIGN STUDIO • PERSONALIZED
EXPERT SERVICE • FAST TURN-AROUND



CALL (800) 815-3444
(212) 730-2111



130 WEST 42ND STREET • NEW YORK, NY 10036

**DIGITAL
DOMAIN™** **CD & CD-ROM Manufacturing**
309 E. 90 St. - B, NY, NY 10128
(800)344-4361 (212)369-2932

THE BEST CD MASTERING...
Unsurpassed mastering quality by Bob Katz.
Custom hardware and software, 128x Oversampling
20-Bit A to D, Unique Digital Processors, Sonic Solutions
Editing, Tube and Solid State Analog Recorders.
**CD Mastering is an art. Levels, fades, equalization,
spacing... everything is important to you add to us.**

CD REPLICATION...
1000 CDs at \$1.55 w/Jewel Box, Shrink, Insertion.
2500 at \$1.50. Glass Mastering Free with 2500+ CDs.

CD BOOKLET PRINTING...
1000 4-Panel Booklets, Full-Color Outside & Tray Card,
B&W Inside, Full-Color at \$0.37. Graphic Artist on staff
...COSTS LESS!

SERVICES

**3703
THIRTIETH**

MASTERING _____ REPLICATION _____
PRINTING _____ COMPLETE PACKAGING _____
GRAPHIC DESIGN STUDIO _____ POSTERS _____
PERSONALIZED EXPERT SERVICE _____

TOTAL CD, CD-ROM & CASSETTE

**The Power
of Excellence™**

212 - 333 - 5953

330 WEST 58TH ST. NEW YORK, N.Y. 10019

PRODUCTION

TALENT

NATIONWIDE TALENT SEARCH '95

**SEEKING: ★ BANDS ★ ARTISTS
★ ACTS ★ SONGWRITERS**

★ All types of original music considered.
★ FREE Promotion & exposure if you qualify.
★ NOT a contest! This is a career-launching opportunity.

Send a cassette of your music with name,
address, phone & best time to contact to:

RODELL RECORDS
P.O. Box 93457-M • Hollywood, CA 90093

TAPES

NOW! YOU CAN CHOOSE!
TDK PRO SA BULK

CUSTOM LOADED HIGH BIAS (TYPE II) CASSETTES
UNLABELLED AND UNBORN • MICHELLE CLEAR 5-SCREW SHELLS • CUSTOM LENGTHS AVAILABLE

Length	C-10	C-20	C-30	C-45	C-60	C-70	C-80	C-90
Price	\$0.31	\$0.37	\$0.44	\$0.49	\$0.55	\$0.61	\$0.68	\$0.75

MAXELL XLI BULK

CUSTOM LOADED CHROME HIGH BIAS (TYPE II) CASSETTES
UNLABELLED AND UNBORN • MICHELLE CLEAR 5-SCREW SHELLS • CUSTOM LENGTHS AVAILABLE

Length	C-15	C-30	C-45	C-60	C-75	C-90
Price	\$0.32	\$0.37	\$0.52	\$0.54	\$0.59	\$0.78

PREMIUM FOUNDED-EDGE ALL CLEAR NORELCO BOXES > \$0.13 each
10 up or 12 up Cassette Label for Laser/ink Jet Printers \$0.30 per sheet (white)
\$0.34 per sheet (gloss) call for additional Cassette Insert Cards (I-Cards)
\$4 ea \$0.30 per sheet (white) \$0.34 per sheet (gloss)

**CALL FOR
FREE
LINE
AV
CATALOG**

**SEE
MINIMUM
PRODUCT
ORDER**

NOW! RECORDING SYSTEMS, INC.
32 WEST 30TH STREET 5TH FLOOR, NEW YORK, NY 10018
Telephone: 212-788-7800 • 800-850-3570 • Fax: 212-788-6740

MASTER DISTRIBUTORS of:
3M • AMPEX • BASF • CENCO • DIC • FUJI • MAXELL • BION* • TDK • TELEX
AND SERVICE, MAINT. MORE.
We Accept VISA • MasterCard • American Express or UPS COD Cash Only

SONGWRITERS

SONGWRITER PRODUCTS IDEAS NECESSITIES!
Contracts, Copyrights, Books, Business Forms, Record Co./Radio
Directories, 8x10s, Labels, J-Cards, Musical Gifts, Jewelry, Clothing,
Accessories. *Catalog \$1.00. *SPIN 345 Sprucewood, #MU, Lake
Mary, FL 32746-5917 (407) 321-3702.

Order the
1996
**MUSICIANS GUIDE
TO TOURING
AND
PROMOTION**

for details see page 77



HAPPY ANNIVERSARY

1992 marked the 25th anniversary of the Beatles' *Sgt. Pepper* album. 1994 marked the 25th anniversary of Woodstock. This year, we're told, it's the 10th anniversary of Live Aid. Seems like nary a month goes by without tribute being paid to some illustrious date in rock history. But in the process, other profound but less, uh, prestigious anniversaries seem to get overlooked. So, in the spirit of '95, let us now genuflect before the altar of a few cherished memories...

- 1990** - 5th anniversary of the Elton John concert inaugurating the Trump Taj Mahal casino resort in Atlantic City.
- 1984** - 11th anniversary of Grace Jones co-starring with Arnold Schwarzenegger in *Conan the Barbarian*.
- 1980** - 15th anniversary of the breakup between Adam and the original Ants.
- 1977** - 18th anniversary of the formation of the Village People.
- 1990** - 5th anniversary of the first U.S. tour by Wilson Phillips.
- 1986** - 9th anniversary of the premiere of the Prince movie *Under the Cherry Moon*.

- 1965** - 30th anniversary of Paul Revere and the Raiders appearing as the house band on Dick Clark's *Where The Action Is*.
- 1981** - 14th anniversary of MTV's first ever live stereo broadcast, featuring REO Speedwagon.
- 1974** - 21st anniversary of the marriage between Gregg Allman and Cher.
- 1978** - 17th anniversary of *Sgt. Pepper's Lonely Hearts Club Band*—the movie.

—Mark Rowland

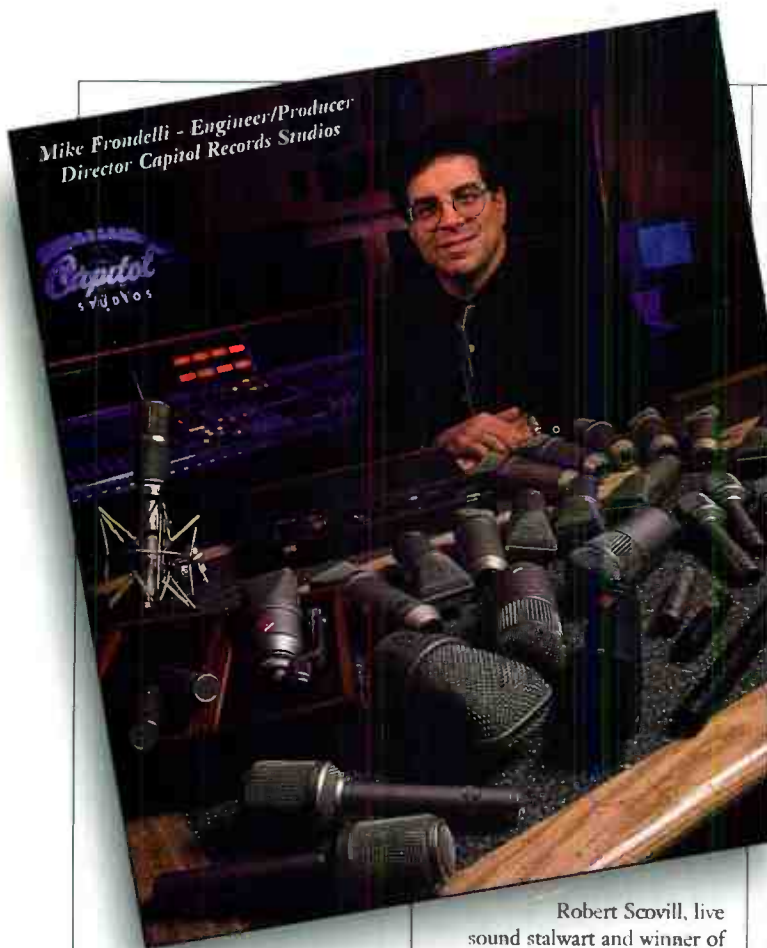

Mike Frondelli - Engineer/Producer
Director Capitol Records Studios

**TWO PROS
WHO KNOW
GREAT SOUND.**

**TWO MICS THAT
MAKE THEM
VERY HAPPY.**

Mike Frondelli, Director of Capitol Records Studios, has a connoisseur's mic locker, including more than 50 Neumann mics dating back to the 1940's. Newest in the collection? The mic Mike calls "the working man's Neumann," the TLM 193. Because it sounds so good in so many applications, Frondelli recommends the TLM 193 as "the one mic to have" for Capitol acts setting up project studios.

The TLM 193 is a stripped down, cardioid-only version of our famous TLM 170. It provides oodles of headroom, has virtually no self-noise, and can immediately give your project studio that professional sound (particularly on vocals) that you've been missing. (By the way, the TLM 193 has become our biggest seller.) It carries a retail price of less than \$1500.



TLM 193

Robert Scovill, live sound stalwart and winner of three TEC awards for Live Sound Excellence, knows a great microphone when he hears one. He has toured as the front-of-house mixer with bands like

Rush, Def Leppard and most recently

Tom Petty.

"I am using the new KM 184 both out on tour and at MusiCanvas." (Robert's studio in Scottsdale.)

"The KM 184 carries all of the Neumann signatures, and I have had great success on a wide variety of sources, from the subtleties of violin to the extremes of distorted guitar."

The KM 184 is perfect for instruments of all kinds, and excels at overhead drum miking and capturing the elusive acoustic guitar. For professional quality at less than \$700 each, a stereo pair of KM 184s can easily be a part of ANY studio.

Let's face it. While Neumann mics have a stellar reputation for rich, opulent sound, they are not the lowest priced mics around. Why? Because we have to ensure that our microphones satisfy even the most demanding engineers in hyper-critical recording environments. But, we *have* found a way to take a few of the bells and whistles off a couple of our mics and still give you that big (HUGE) studio sound on a project studio budget.

The bottom line is this: before you go dropping big cash on outboard gear trying to make your studio sound good, consider the most important part of the signal path, your microphones. The only way to get great sound *out* of your studio is to *capture* great sound. And no other microphone captures sound as well as Neumann... not even close.

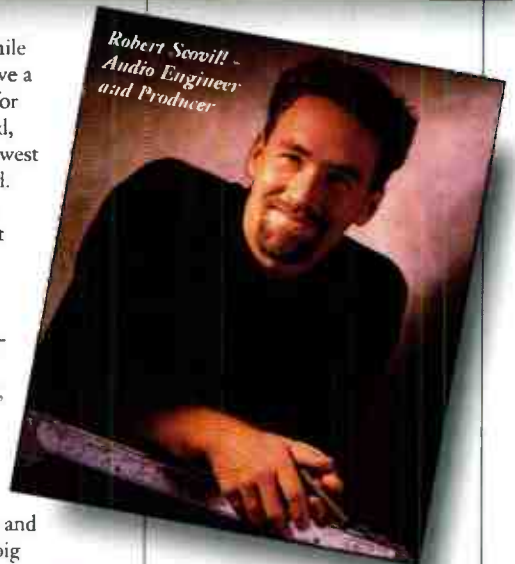

Robert Scovill -
Audio Engineer
and Producer



KM 184



Neumann USA

6 Vista Drive, PO Box 987
Old Lyme, CT 06371
Tel: 203-434-5220 Fax: 203-434-3148

In Canada: 221 LaBrosse Ave.,
Pte-Claire, PQ H9R 1A3
Tel: 514-426-3013 • Fax: 514-426-3953



WHEN YOU HOLD
A FINE HANDCRAFTED
GUITAR, YOU FEEL
A RICH APPRECIATION
FOR ITS AGED WOOD.
A PROFOUND RESPECT
FOR THE LUTHIER
WHO SPENT MONTHS
CRAFTING IT.

AND A DEEP
SADNESS, KNOWING
THERE'S NOT A
SNOWBALL'S CHANCE
YOU'LL EVER BE ABLE
TO AFFORD IT.

DON'T DESPAIR. YAMAHA LW HANDCRAFTEDS WON'T BREAK YOUR HEART OR YOUR BUDGET. STARTING AT \$599,* THEY OFFER CRAFTSMANSHIP YOU'D EXPECT FROM GUITARS COSTING TWICE AS MUCH. LIKE SOLID SPRUCE TOPS. FINE GRAINED WOOD. SCALLOPED BRACING. AND PRECISION FRETWORK.

BUT THE MOST IMPORTANT THING IS HOW BEAUTIFULLY THEY PLAY. AND THAT, YOU NEED TO HEAR FOR YOURSELF. STOP BY A YAMAHA HANDCRAFTED DEALER AND TEST PLAY AN LW. AS FAR AS WE KNOW, THAT DOESN'T COST A CENT.

FOR THE DEALER NEAREST YOU, CALL 800-879-1131, EXT. 430.

YAMAHA

*MSRP ©1995 Yamaha Corp. of America. Guitar Products, P.O. Box 6600, Buena Park, CA 90622-6600. (714)522-9011