

audiocraft

OCTOBER 1956

THE HOW-TO-DO IT MAGAZINE OF HOME SOUND REPRODUCTION

35 CENTS

THIS MONTH

First of a series on using transistors in audio applications.

Simple chart method of design for stable feedback amplifiers.

Electrostatic speakers and their effect on equipment design.

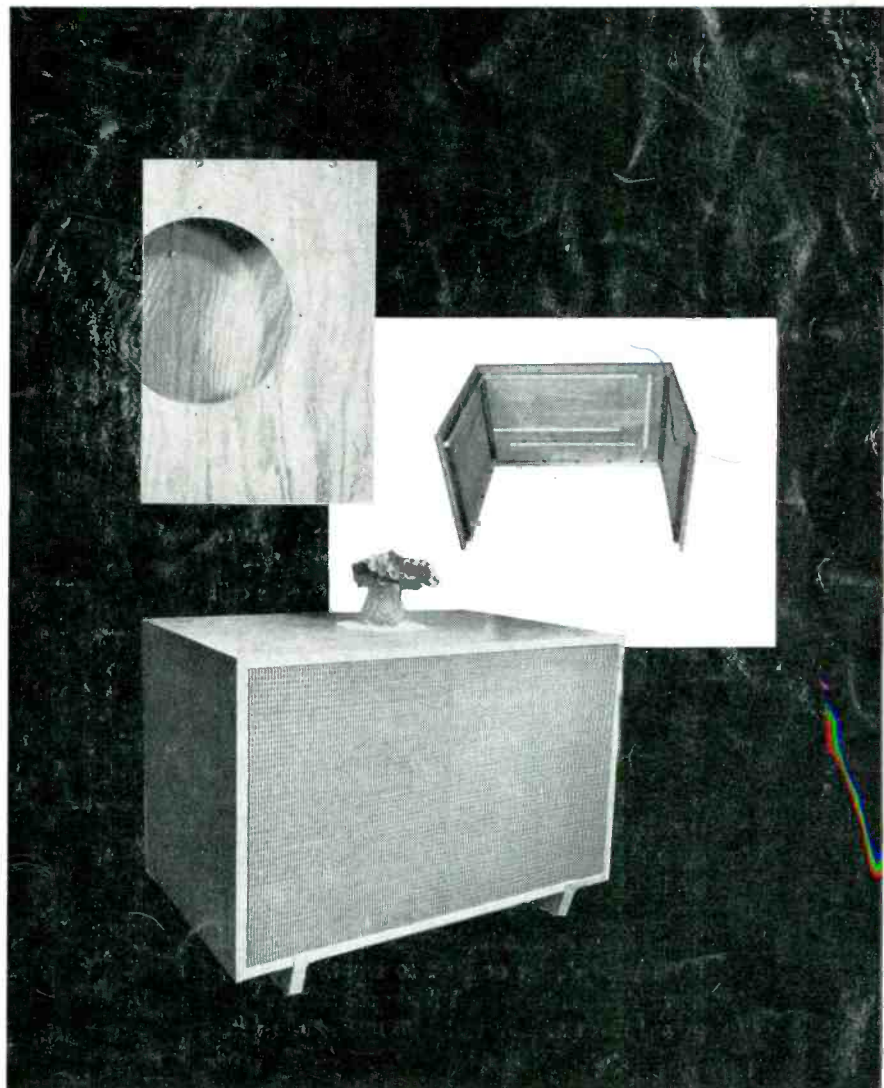

THE ACOUSTI-MAGIC ENCLOSURE

Here, in kit form, is a loudspeaker enclosure designed to give good results with any driver. This issue features an article on its construction, with our test results and an evaluation of performance.

Excitingly new

"LIVING SOUND" IS YOURS TO ENJOY
WITH NORELCO *F.R.S.*

FULL RESONANCE TWIN-CONE SPEAKERS

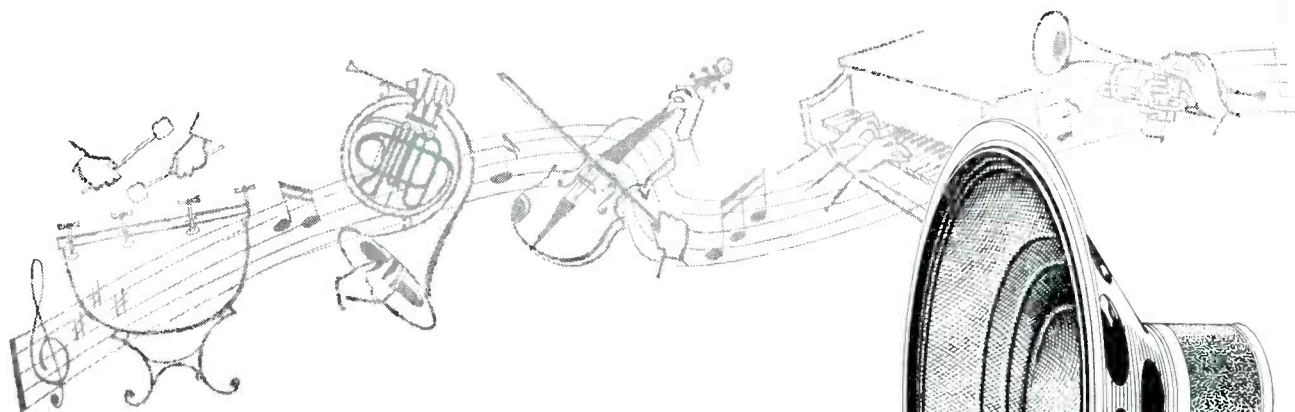

High fidelity and tonal qualities associated with expensive multi-unit speaker systems— are similarly produced with new Norelco FRS Twin-Cone Speakers.

Norelco's exclusive Twin Cones are made from specially selected and matched materials— operated from the same magnet and voice coil —some covering an extremely wide range up to 20,000 c/s. Norelco's twin-cones are always in phase and operate in harmony—providing the same degree of efficiency under all conditions.

Unequaled manufacturing precision and quality is inherent in all Norelco speakers. All component materials—including magnets, wire and even cone materials—are manufactured and assembled by Philips to suit a specific speaker design.

Many sizes in standard impedances are available from your dealer or send to Dept. M10 today for more details. Norelco FRS speakers are priced from \$59.98 to \$9.90 audiophile net.

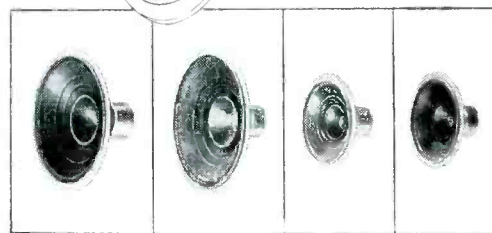

Add to...and improve any sound system
with *Norelco*

*FULL RESONANCE SPEAKERS



NORTH AMERICAN PHILIPS CO., INC., 100 East 42nd Street, New York 17, N. Y.

UNUSUAL RECORDINGS

for the Discriminating **Hi-Fi** Record Collector

AUDIO FIDELITY RECORDS presents

Studies in HIGH FIDELITY sound



THE DUKES OF DIXIELAND

You have to Hear It to Believe It!

Hot trumpets, cool clarinets, low-down trombones and a big fat tuba in the most exciting performance of true New Orleans Dixie ever recorded! The "MOST" in Hi-Fidelity... you've got to Hear It to Believe It!

AUDIO FIDELITY AFLP 1823
12-in. \$5.95

CHA CHA CHA

Here, for the first time, superbly recorded in Hi-Fidelity, is the pulsating tropical magic of the foremost Cha Cha orchestra in the world... Pedro Garcia, his Del Prado Orchestra and the captivating Latin beat of the Cha Cha Cha Complete with illustrated dance instructions.

AUDIO FIDELITY AFLP 1810
12-in. \$5.95

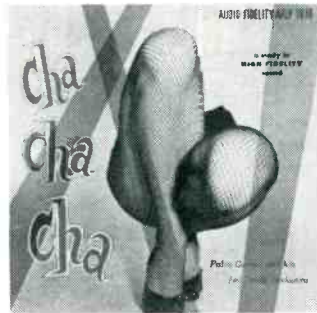

PLAZA DE TOROS—La Fiesta Brava Vol. 2

Music of the Bullfight Ring

Again the "Banda Taurina", of the Plaza Mexico, presents, in brilliant Hi-Fidelity, traditional music of another afternoon at the bullfights. Complete with portfolio of full-color reproductions of bullfight paintings by world-famous artists, suitable for framing.

AUDIO FIDELITY AFLP 1817
12-in. \$5.95



THE BRAVE BULLS!—La Fiesta Brava

Music of the Bullfight Ring

Featuring the "Banda Taurina" of the Plaza Mexico world's largest bullfight arena. A Hi-Fi presentation of an afternoon at the bullfights. Complete with book of 24 full color Bullfight Poster Reproductions, "brilliant engineering" —HIGH FIDELITY MAGAZINE.

AUDIO FIDELITY AFLP 1801
12-in. \$5.95



PATACHOU

Songs from Her Hit Shows

All the vibrance and warmth of this famous French personality is brought to life in this magnificent new Hi-Fidelity recording. Patachou sings your favorites: Le Fiacre; Paris, C'est une Blonde; Autumn Leaves; Sous Le Ciel de Paris; etc.

AUDIO FIDELITY AFLP 1814
12-in. \$5.95



ACCORDION DE PARIS

Jo Basile & Orchestra

Mysterious, romantic, French cafe music that wraps you in rhythms now passionate... now gay... with that enchanting nostalgic Paris magic. Brilliantly recorded in true High Fidelity.

AUDIO FIDELITY AFLP 1815
12-in. \$5.95



BAWDY Songs and BACKROOM BALLADS

Oscar Brand, noted balladeer sings: Folk-Americana often heard but never recorded. Rollicking songs for people with lusty appetites and strong musical tastes.

Vol. 1—AUDIO FIDELITY AFLP 1906
12-in. \$5.95

Vol. 2—AUDIO FIDELITY AFLP 1806
12-in. \$5.95

Vol. 3—AUDIO FIDELITY AFLP 1824
12-in. \$5.95



FIESTA EN MEXICO

Mariachis

Miguel Dias

A rich, colorful variety of traditional rhythmic music that expresses the heart and soul of Mexico. Played by authentic Mexican Mariachi Musicians... recorded in magnificent hi-fidelity sound. Features: Jarabe Tapatio; Guadalajara; El Rancho Grande; etc.

AUDIO FIDELITY AFLP 1816
12-in. \$5.95

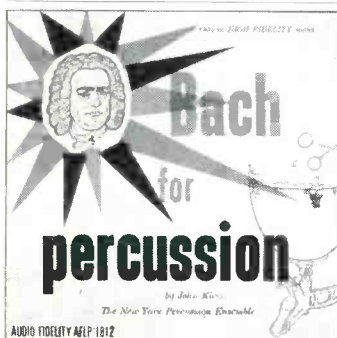

NEW !!! on AUDIO FIDELITY RECORDS for the FIRST TIME !!! BACH TRANSCRIBED FOR PERCUSSION

The most exciting, original and powerful percussion work yet.

- Tocata and Fugue in D Minor
- "Great" Fugue in G Minor
- Tocata in F Major
- Fugue in C Major

AUDIO FIDELITY AFLP 1812
12-in. \$5.95

NEW OCTOBER RELEASES

- CHA CHA CHA, Salamanca Orch. AFLP 1813 12-in. \$5.95
- TROMBONE Davis Shuman Trombonist Concerto with Orch. — Serly AFLP 1811 12-in. \$5.95
- TORERO — La Fiesta Brava, Vol. 3 AFLP 1818 12-in. \$5.95
- FIESTA EN ESPANA, Flamenco Guitar AFLP 1819 12-in. \$5.95
- GRAILVILLE SINGS, Music of Advent & Christmas AFLP 1820 12-in. \$5.95
- ACCORDIONISTE DE FRANCE, Jo Basile & Orch. AFLP 1821 12-in. \$5.95
- ROME... WITH LOVE! Italian Accordion AFLP 1822 12-in. \$5.95

other studies in HIGH FIDELITY sound on AUDIO FIDELITY

- TALBOT BROS. of BERMUDA, Vol. 2 AFLP 903 10-in. \$4.00
- TALBOT BROS., Vol. 3 AFLP 1807 12-in. \$5.95
- TRINIDAD STEEL BAND AFLP 1809 12-in. \$5.95
- LORD INVADER: CALYPSO AFLP 1808 12-in. \$5.95
- MERRY GO ROUND MUSIC AFLP 901 10-in. \$4.00
- DRUMS OF THE CARIBBEAN AFLP 902 10-in. \$4.00
- CIRCUS CALLOPE MUSIC AFLP 904 10-in. \$4.00
- MERENGUES AFLP 905 10-in. \$4.00
- MARIMBA MAMBO Y CHA CHA CHA AFLP 1802 12-in. \$5.95
- KATHERINE DUNHAM, DRUMS OF CUBA-HAITI-BRAZIL AFLP 1803 12-in. \$5.95

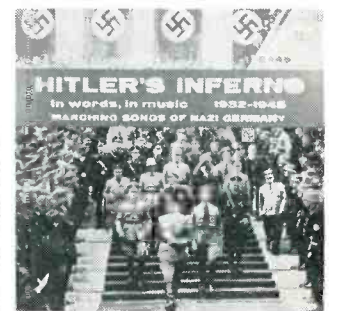

HITLER'S INFERNO

In Words and Music, 1933 to 1945 Storm Troopers singing HORST WESSEL LIED and other marching songs. Hitler's Speeches, Goebbels' Speeches, Nuremberg War Crimes Trial. A startling and shocking documentary production.

NEVER BEFORE HEARD IN THE UNITED STATES!
AUDIO RARITIES LPA 2445 12-in. \$5.95

These records are available at your favorite Audio or Record Shop

WRITE FOR FREE CATALOGS

Nationally distributed by
DAUNTLESS INTERNATIONAL

750 TENTH AVE.
NEW YORK 19, N. Y.

BUILD YOUR OWN FINE Jensen HI-FI SPEAKER SYSTEM

COMPLETE KITS NOW AVAILABLE—EVERYTHING YOU NEED
NO SAWING . . . NO DRILLING . . . NO WOOD FINISHING . . . NO SOLDERING

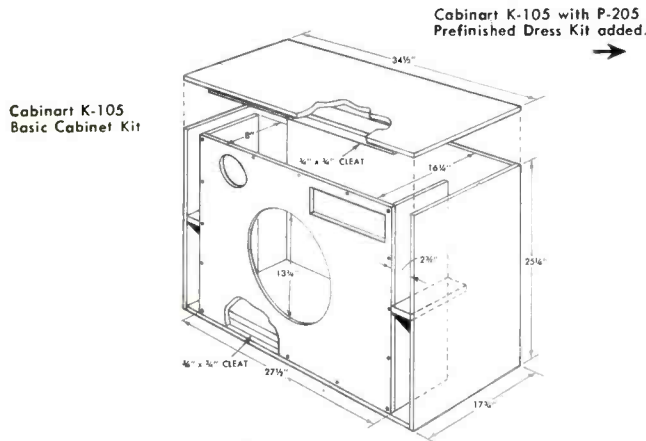

- YOU SAVE UP TO \$252.50*
 - YOU DON'T HAVE TO BE A TECHNICIAN
 - YOU DON'T NEED A WORKSHOP
 - YOU DON'T HAVE TO BE A FURNITURE FINISHER
- *Compared with factory-built Jensen Imperial reproducer

The proud owner of the Jensen 3-way hi-fi speaker system illustrated assembled the handsome low boy cabinet in a few hours *in his living room* with no tools except a screwdriver, pliers and a stapler. No cutting, sawing, or soldering. And the wood finishing? He just wiped off the finger prints, for the beautiful genuine selected hardwood was factory pre-finished and rubbed by professional finishers. Best of all, *he saved nearly \$100* compared with cost of the equivalent factory-built speaker system.

You can have the fun and satisfaction of building your own Jensen speaker system with size and performance ranging all the way from the diminutive, economical Duette up to the big incomparable Imperial at savings which will stretch your hi-fi equipment budget. Jensen and Cabinart with their specialized skills have collaborated to make this easy and trouble-free. Everything you need is furnished.

Jensen Speaker units are matched components, carefully pretested, with the smooth, balanced, wide-range performance for which Jensen factory-made reproducers are famous. Cabinart Cabinet Kits were designed by Jensen to give the best possible acoustic performance with Jensen Loudspeaker Kits; each is carefully coordinated with the recommended Jensen Loudspeaker Kit for correct loading of the low frequency channel ("woofer"). Wood pieces are accurately cut and drilled, with all cut-outs provided. Hardware, cleats and glue are included with complete instructions for easy assembly. If you like, you can start with the Basic Cabinet Kit of your choice, add the Prefinished Dress Kit later.

Here's your way to finest hi-fi speaker performance at least cost! Ask your dealer, or write now.

System Type	"Woofer" Size	Equivalent Jensen Reproducer	Jensen Speaker Kit		Type	Cabinart Cabinet Kits			
			Model	Price		Basic Cabinet Kit	Price	Dress Kit†	Price
3-Way	15"	Imperial	KT-31	\$184.50	Corner* Horn	K-101	\$89.00	P-201	\$54.00
3-Way	15"	Triplex	KT-32	169.50	Corner* Bass-Ultraflex	K-103	48.00	P-203	39.00
3-Way	15"	Triplex	KT-32	169.50	Low Boy Bass-Ultraflex	K-105	48.00	P-205	39.00
2-Way†	15"	—	KT-21	99.50	Corner* Bass-Ultraflex	K-103	48.00	P-203	39.00
2-Way†	15"	—	KT-21	99.50	Low Boy Bass-Ultraflex	K-105	48.00	P-205	39.00
2-Way†	12"	Concerto	KT-22	73.00	Corner* Bass-Ultraflex	K-107	39.00	P-207	36.00
2-Way†	12"	Concerto	KT-22	73.00	Low Boy Bass-Ultraflex	K-109	39.00	P-209	36.00
2-Way†	8"	Contemporary	KDU-10	24.75	Corner* Bass-Ultraflex	K-111	23.00	P-211	25.00
2-Way	8"	Duette Treasure Chest	KDU-10	24.75	Duette	K-113	18.00	P-213	21.00

* Gives excellent results against sidewall. Bass-Ultraflex is a Jensen trademark.
† Cabinet provides for expansion to 3-way system at any time with Jensen KTX-1 Range Extender Supertweeter Kit, price \$43.75.
‡ Available in Mahogany or Korina Blonde.

For information about Jensen Speaker Kits write:

Jensen
MANUFACTURING COMPANY
Division of The Muter Company
6601 SOUTH LARAMIE, CHICAGO 38, ILLINOIS
In Canada: Copper Wire Products Co., Ltd.

For information about Cabinart Cabinet Kits write:

CABINART

The Pioneers in High Fidelity Radio Furniture

A Division of G & H Wood Products Co., Inc.
99 North 11th Street, Brooklyn 11, N. Y.

October 1956

Volume 1 Number 12

audiocraft

THE HOW-TO-DO-IT MAGAZINE OF HOME SOUND REPRODUCTION

This month brings to a close our first year of publication. Altogether, we consider it a successful year. Our editorial direction has been stabilized, and our content expanded, in response to suggestions from subscribers. Our subscription list has climbed steadily from the beginning; now, advertising space is also increasing. We're grateful to both readers and advertisers for their support during this period—and will do our utmost to make AUDIOCRAFT ever more useful to them in years to come.

The issue is notable for at least two other reasons: it is the largest we have ever published, and it contains the first of Paul Penfield's monumental series of articles on using transistors in audio circuits. To whet your appetite for what will come in this series, the outline follows:

- 1: Transistor Action.
- 2: Other Transistor Types.
- 3: Junction Transistor Characteristics.
- 4: Biasing the Transistor.
- 5: Parameters and Small-Signal Equivalent Circuits.
- 6: Single-Stage Design and Coupling.
- 7: Input Circuits.
- 8: Intermediate Stage Circuits.
- 9: Power Transistor Characteristics.
- 10: Power Stage Circuits.
- 11: Distortion.
- 12: Feedback.
- 13: Miscellaneous Circuits.
- 14: Transistorized Construction.
- 15: Transistor Components.
- 16: Audio Transistor Specifications.

CHARLES FOWLER, *Publisher*

ROY F. ALLISON, *Editor*

FRANK R. WRIGHT, *Managing Editor*

ELEANORE B. WRIGHT,
Editorial Assistant

ROY LINDSTROM, *Art Director*

ELEANOR GILCHRIST, *Art Assistant*

FRANCES A. NEWBURY, *Manager,
Book Division*

Contributing Editors

R. D. DARRELL

J. GORDON HOLT

JOSEPH MARSHALL

WARREN B. SYER, *Business Manager*

ARTHUR J. GRIFFIN, *Circulation
Manager*

Advertising

Main Office — Claire Eddings, The Publishing House, Great Barrington, Mass. Telephone: Great Barrington 1300.
Chicago — John R. Rutherford & Associates, Inc., 230 East Ohio St. Telephone: Whitehall 4-6715.
Los Angeles — Brand & Brand, Inc., 6314 San Vicente Blvd. Telephone: Webster 8-3971.

The Grounded Ear, by Joseph Marshall	4
<i>What's new and significant in sound reproduction.</i>	
Audionews	6
Tips for the Woodcrafter, by George Bowe	10
<i>This issue: The jointer.</i>	
Sound Servicing, by Irving M. Fried	12
<i>This issue: What not to service.</i>	
Tape News and Views, by J. Gordon Holt	14
<i>This issue: Low-impedance microphone lines.</i>	
Readers' Forum	17
Editorial	17
Transistors in Audio Circuits, by Paul Penfield, Jr.	18
<i>Part 1: Transistor action.</i>	
The Acousti-Magic Enclosure	22
<i>An AUDIOCRAFT kit report.</i>	
Listening for Quality, by Joseph Marshall	24
<i>Part 2: Treble response; definition.</i>	
Designing Your Own Amplifier, by Norman H. Crowhurst ..	27
<i>Part 5: Feedback amplifier design.</i>	
Loudspeakers and Enclosures, by George L. Augspurger ..	31
<i>Part 3: Resonant enclosures.</i>	
Basic Electronics, by Roy F. Allison	34
<i>Chapter XI: Inductance in AC circuits.</i>	
Sound-Fanciers' Guide, by R. D. Darrell	36
<i>Reviews of exceptional disc and tape records.</i>	
Audio Aids	40
The Rumble Seat	46
Symbols and Abbreviations	54
Advertising Index	56

Audiocraft Magazine is published monthly by Audiocom, Inc., at Great Barrington, Mass. Telephone: Great Barrington 1300. Editorial, publication, and circulation offices at: The Publishing House, Great Barrington, Mass. Subscriptions: \$4.00 per year in the United States and Canada. Single copies: 35 cents each. Editorial contributions will be welcomed by the editor. Payment for articles accepted will be arranged prior to publication. Unsolicited manuscripts should be accompanied by return postage. Entered as second-class matter October 1, 1955, at the post office, Great Barrington, Mass., under the act of March 3, 1879. Additional entry at the post office, Pittsfield, Mass. Printed in the U. S. A. by the Ben Franklin Press, Pittsfield, Mass. Copyright 1956 by Audiocom, Inc. The cover design and contents of Audiocraft Magazine are fully protected by copyrights and must not be reproduced in any manner.

The Grounded Ear



by Joseph Marshall

Electrostatic Loudspeakers

The coming year may well go down in hi-fi history as the year in which electrostatic speakers began to offer electromagnetic speakers serious competition. True, we have had electrostatic *tweeters* for about two years now, but they are not yet being produced and sold in great enough quantities to be a serious factor in the total market. Now, the promised arrival of electrostatic speakers which cover the full range pre-sages both more rapid development and exploitation of the principle and much wider acceptance by the listener.

By far the most interesting (possibly because it has been widely publicized) and promising development is the system developed by Peter Walker of the British Acoustical Manufacturing Company, whose Quad amplifiers have enjoyed a fine reputation here as well as abroad. This electrostatic speaker covers the range from 40 to 14,000 cps and, so we are told, will actually go up to 20 Kc in the production model to come. Its performance is reported to be phenomenally good and unprecedentedly free of coloration. It is expected to sell for somewhere between \$150 and \$200. Purportedly, the range could be extended downward at the bass end with a considerable increase in size. In other words, we have here the first commercial electrostatic speaker system capable of covering the entire audible range and requiring no additional motor-driven units.

Although Mr. Walker, who has apparently achieved what nobody else has come close to doing, is not giving out the secret which makes this performance possible, it is a safe bet that whether he shares his secrets or not, others will achieve similar results, and that we will soon have the opportunity to choose between several types of full-range electrostatic speakers. This will have an impact which the electrostatic tweeter alone could not hope to manage; for, while the virtues of the electrostatic design are great in tweeters, the tweeter range does not determine alone the realism of high-fidelity reproduction. On the other hand, if the full-range electrostatic speakers do, in fact, possess their theoretical virtues, they will offer

the promise of so great an improvement in the middle and bass ranges that they cannot help winning great acceptance.

The electrostatic tweeter is an electrically driven mechanical device, like the ordinary diaphragm speaker. The difference is that in the electrostatic speaker there is one less link in the chain of mechanical transducers. In conventional electromagnetic speakers the electrical energy first actuates a motor which, in turn, drives the diaphragm that moves the air. In the electrostatic speaker the electrostatic field, changing with variations in the electrical stimulus, produces the diaphragm movement without any intermediary devices. Elimination of the intermediate motor reduces some of the nonlinearities which characterize the diaphragm speaker.

The relatively large cone of the diaphragm speaker is driven from a single point; unless the cone is made so stiff that it responds as a rigid piston, the single-point drive produces unequal movements of different sections of the cone at different frequencies. On the other hand, if it is so stiff that it radiates as a pure piston, it is almost



impossible for it to respond with equal linearity to all frequencies and it becomes a narrow-range radiator. Thus, it is extremely difficult and probably impossible to design a motor-driven cone speaker which is completely linear throughout the entire audible range, and this has led to systems with two or more separate cones, each designed to be linear over only a portion of the range. This, in turn, has brought on other difficulties, chiefly those of obtaining good balance between the various sections of the system, of achieving complete homogeneity of sound, of avoiding reproduction coloration at various points in the range covered, and, finally, of maintaining an illusion that the entire spectrum is originating in the same place.

In contrast, the diaphragm of the

electrostatic speaker is driven uniformly over its entire area and should, theoretically, be equally linear at all frequencies within its range. There exists the possibility of a *single* radiator covering the whole spectrum; this should eliminate or minimize the difficulties listed for multirange electromagnetic systems, and lead to reproduction that should be much more homogeneous in every respect.

Finally, and this is very important, the motor-driven speaker diaphragm has a relatively great mass. It has, therefore, high inertia which leads to serious problems of starting torque and overshoot damping. It takes considerable force to start the large mass of the cone and its drive mechanism moving, and it takes a high amount of damping to prevent the momentum acquired by that large mass, once under way, from exceeding the movement called for by the stimulating signal. On the other hand, the electrostatic speaker has very little mass; it requires much less damping and the damping is easier to apply. Indeed, in present versions the damping is provided electrically by making the diaphragm work against strong electrostatic fields established on both sides of the diaphragm by the so-called "bias" voltage. Even the present electrostatic systems, then, which are pioneer efforts, approach ideal damping and therefore should have much lower hangover and less coloration of the sound.

Now these are theoretical advantages. Despite the highly favorable initial reports, it remains to be seen how closely the actual wide-range systems approach the theoretical ideals, and how long it will take them to achieve a perfection sufficient to indicate a clear-cut superiority over present diaphragm speakers—which, in many cases, are so good that the average listener will be hard put to discern any improvement.

Meanwhile, putting aside speculation on the fate of conventional speakers and whether the electrostatic will replace them entirely, I am intrigued by the effect the growing use of electrostatic speakers is likely to have on the design of amplifiers and other components.

To begin, let me point out the possibility that the use of electrostatic speakers with many present amplifiers

may lead to trouble. Electrostatic speakers represent a capacitive load, while electromagnetic speakers represent a primarily inductive load. Amplifiers with high feedback factors are likely to behave quite differently with a capacitive load than with an inductive one. Very few amplifiers can stand capacitive loads of more than .05 μ fd, and most will go off into oscillation at supersonic frequencies with a much lower capacitance. Even if there is no outright oscillation, the ringing may become severe. Addition of an electrostatic tweeter, or replacement of an electromagnetic system with a full-range electrostatic, may accordingly necessitate adjustment of the feedback loop; I would be careful to check loop stability when adding an electrostatic speaker.

This need not pose any problem at all, however, with amplifiers designed specifically for use with electrostatic speakers; in fact, the use of electrostatic speakers provides considerable hope for better amplifiers. For one thing, being better damped, electrostatic speakers will not require so much damping by feedback, or none at all. For another, electrostatic speakers are high-voltage, high-impedance devices, while electromagnetic speakers are low-voltage, high-current, low-impedance devices. Electrostatic speakers may make the use of output transformers unnecessary. Although this would be tough on manufacturers of output transformers, it would greatly simplify the design, construction, and cost of amplifiers; good output transformers are not only expensive and difficult to produce, but even the best of them limit the amount of stable feedback that can be used. At present, even the Walker speaker comes with a coupling transformer for use with conventional amplifiers, but, unless I'm very wrong, there will come a day of amplifiers with resistance or impedance coupling direct to electrostatic speakers.

So far, electrostatic speakers, whether tweeters or full range, have been designed as direct radiators. It does not necessarily follow that all electrostatic speakers in the future will be direct radiators. Once the problem of making electrostatic speakers work at all is solved, I expect to see a great deal of experimentation in adapting electrostatic drivers to horns and other forms of indirect radiators, as well as suppressing or using more effectively the back radiation of balanced electrostatic speakers. That back radiation is probably going to cause trouble in some locations unless it is controlled in one way or another.

I see in the coming of the electrostatic speaker not only a serious challenge to the cone speaker, but also a stimulus to development of a high-fidelity art along unfamiliar roads.

Save Money BUILD YOUR OWN Hi-Fi

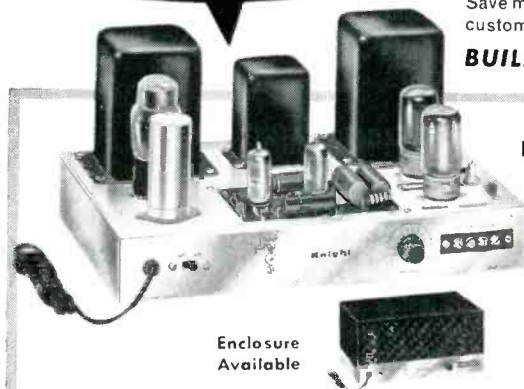

Enclosure Available

get custom quality at low cost in
**ALLIED'S own HIGH FIDELITY
knight-kits**

KNIGHT-KITS give you the last word in HI-FI design, performance and value...and they're easy to build from crystal-clear manuals featuring "Step-and-Chek" assembly. Save money—get true Hi-Fi quality with these custom-designed KNIGHT-KITS.

BUILD THE BEST... AND SAVE!

knight-kit LINEAR DELUXE 25-WATT BASIC HI-FI AMPLIFIER KIT

Model S-755 **\$44.50**

Williamson-type Circuit
Printed Circuit Board
Chrome Plated Chassis

Designed to satisfy the most critical listener. Intended for use with tuners incorporating built-in preamp or with separate preamp. Uses latest Williamson-type circuit. Has potted, matched transformers. Output: Maximum, 45 watts; undistorted, 25 watts. Frequency response: ± 0.5 db, 10 to 120,000 cps, measured at 20 watts. Harmonic distortion is only 0.15% right up to 30 watts. Intermodulation is only 0.27% at 17 watts and only .5% at 20 watts, using 60 cps and 7 kc, 1:4 ratio. Hum level is 85 db below rated output. Output impedance, 4, 8, 16 ohms. Uses two 12AU7's, two 5881's, and a 5V4G. Printed circuit is utilized in voltage amplifier and phase inverter stages. Has output tube balancing control, variable damping control, and on-off switch. Handsome chrome-plated chassis, 14" x 9" x 2". Overall height, 7". Complete with all parts, tubes and construction manual. Shpg. wt., 27 lbs.

Model S-755. Basic 25-watt Hi-Fi Linear-Deluxe Amplifier Kit. Net **\$44.50**
S-759. Metal enclosure for above amplifier. Black finish. Shpg. wt., 3 1/2 lbs. Net **\$4.25**

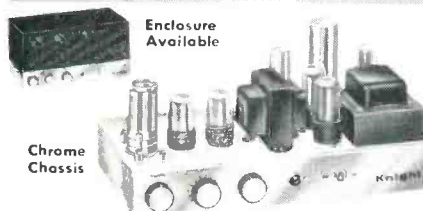

Chrome Chassis

Enclosure Available

knight-kit 10-WATT HI-FI AMPLIFIER KIT

Model S-753 Famous for wide response and smooth reproduction at low cost. Only 0.5 volt drives amplifier to full output. Response: ± 1 db, 30-20,000 cps at 10 watts. Harmonic distortion less than 0.5% at 10 watts. Intermodulation is less than 1.5% at full output. Controls: On-off volume, bass, treble. Input for crystal phono or tuner. Chrome-plated chassis is punched to take preamp kit (see below) for magnetic cartridges. Matches 8 ohm speakers. Shpg. wt., 14 lbs. Complete; ready to build.

Model S-753. Amplifier Kit. Net **\$23.50**
Model S-235. Preamp Kit for above. Net **\$3.10**
S-757. Enclosure for above. Net **\$3.95**

ALL PRICES NET F.O.B. CHICAGO



Enclosure Available

Chrome Chassis

knight-kit 20-WATT HI-FI AMPLIFIER KIT

Model S-750 True Hi-Fi for less! Response, ± 1 db, 20 to 20,000 cps at 20 watts. Distortion, 1% at 20 watts. Hum and noise level: Tuner input, 90 db below 20 watts; magnetic phono, 72 db below 20 watts. Sensitivity: Tuner input, 0.6 volt for 20 watts output; magnetic phono, .007 volts. 4 inputs: Magnetic phono, microphone, crystal phono or recorder, and tuner. Controls: Bass, Treble, Volume, Selector with compensation positions for 78 and LP records. Handsome chrome-plated chassis. Shpg. wt., 23 lbs. Complete; ready to build.

Model S-750. 20-Watt Kit. Net **\$35.75**
S-752. Chrome control panel. Net **\$1.40**
S-758. Enclosure for above. Net **\$4.15**

ORDER FROM

ALLIED RADIO

America's Hi-Fi Center

ALLIED RADIO CORP., Dept. 89-K6
100 N. Western Ave., Chicago 80, Ill.

OUR
36th
YEAR

FREE

ALLIED'S
1957
CATALOG

Send for this 356-page value-packed catalog covering everything in Electronics. Complete sections featuring world's largest selection of Hi-Fi components and music systems, many more famous KNIGHT-KITS, recorders, P.A. systems, Amateur gear, parts, tubes, tools and books. Send for your FREE copy today.

Ship the following: _____ \$_____ enclosed

Send me your FREE 1957 ALLIED 356-Page Catalog

Name _____

Address _____

City _____ Zone _____ State _____



Audionews

NEW STROMBERG-CARLSON LINE

Stromberg-Carlson, a division of General Dynamics Corporation, is offering a complete new line of *Custom Four Hundred* high-fidelity components and cabinets for fall delivery.

A new style note has been introduced for all amplifiers in the line — a bonded vinyl case in tan, flecked with brown, which offers a linenlike finish guaranteed against mars, burns, or stains.

Some of the items in the new line, and their specifications as supplied by the manufacturer, are:

The *Model AR-411* amplifier: 10 watts at less than 1% total harmonic distortion; peak power-handling capacity to 15 watts; frequency response of 15 to 25,000



Stromberg-Carlson AR-411 amplifier.

cps; hum and noise level 80 db below rated output with controls at listening level; bass control provides 15 db boost and 15 db droop at 50 cps; treble control provides 10 db boost and 15 db cut at 10,000 cps. The unit has four inputs: magnetic phono, radio tuner, tape, and auxiliary. Output taps are for 4, 8, and 16 ohms. Dimensions are 3½ in. high by 13 in. wide by 7 in. deep.



AR-419 amplifier.

The *Model AR-419* amplifier: a peak power-handling capacity of 40 watts, with less than 1% total harmonic distortion at 20 watts; frequency response of 15 to 25,000 cps; hum and noise level 80 db below rated output with controls at listening level; bass control provides 15 db boost and 15 db droop at 50 cps; treble control provides 10 db boost and

15 db cut at 10,000 cps. The unit has four inputs: magnetic phono, radio tuner, tape, and auxiliary. Output taps are for 4, 8, and 16 ohms, and there is a

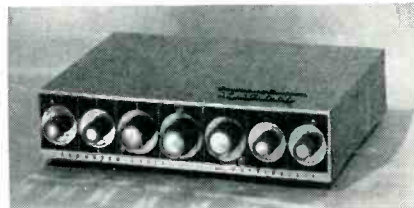

AE-426 preamp-control unit.

tape-output jack. Dimensions are 4¾ in. high by 14 in. wide by 9½ in. deep.

The *Model AE-426* preamplifier: frequency response of 10 to 100,000 cps \pm 1 db; bass control provides 15 db boost and 15 db droop at 50 cps; treble control provides 15 db boost and 15 db cut at 10,000 cps; brilliance control provides sharp treble cutoff; continuously variable turnover and de-emphasis controls for magnetic phono output. The unit is AC operated with DC on the tube filaments, and is equipped with tape output and input jacks. Dimensions are 3 in. high by 14 in. wide by 8 in. deep.

The *Model AP-428* power amplifier: peak power-handling capacity is 50 watts; frequency response is 10 to 32,000 cps; hum level is better than 80 db below rated output; output voltage regulated within 2 db variation from no output to full load; distortion is less

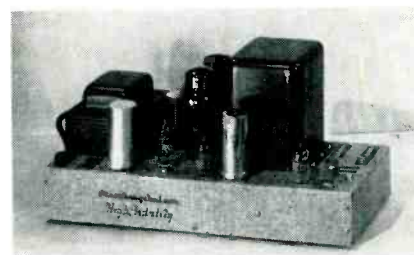

AP-428 power amplifier.

than 2% at 25 watts, and well under 1% at 20 watts output. The unit has 4-, 8-, 16-, 150-, and 600-ohm output taps, and 8-VU output taps for tape recorders. Dimensions are 8¾ in. high by 16 in. wide by 7 in. deep.

The *Model SR-402* radio tuner: frequency response on FM from 20 to 20,000 cps with less than 1% total harmonic distortion; temperature-compensated oscillator circuits prevent drift

on both FM and AM; sensitivity is 1.5 μ v for 20 db quieting. The unit has a two-position selectivity control on AM, and automatic frequency control is provided on FM. Dimensions are 5¾ in. high by 12¾ in. wide by 9¾ in. deep.

The *Model SR-403* radio tuner: frequency response on FM is 30 to 15,000 cps; sensitivity on FM is 10 μ v for 30 db quieting; loud room-volume harmonic distortion is 1%. Oscillator circuits are temperature compensated to prevent FM and AM drifting. The unit has outputs for audio amplifier and tape recorder,

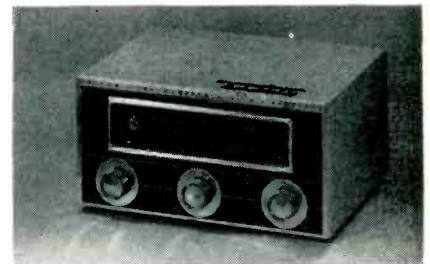

SR-402 FM-AM tuner.

and meets all FCC requirements for spurious radiation. Dimensions are 6 in. high by 12 in. wide by 9 in. deep.

The *Model SR-406* radio receiver: peak power output is 32 watts; total harmonic distortion at 20 watts is 1%; sensitivity is 5 μ v for 30 db quieting on FM. The unit meets all FCC requirements for spurious radiation. It has microphone, crystal phono, magnetic phono, and auxiliary inputs; and tape recorder output jack and output taps for 4, 8, and 16 ohms. Bass control provides 15 db boost and 10 db droop at 50 cps. Treble control provides 10 db boost and 15 db cut at 10,000 cps. Dimensions



SR-403 FM-AM tuner.

are 8 in. high by 16 in. wide by 13 in. deep.

The *Model SR-407* radio receiver: peak power output is 15 watts; total harmonic distortion is 1% at loud room

volume; sensitivity is 8 μ v for 30 db quieting on FM. Bass control provides 10 db boost and 15 db droop at 50 cps. Treble control provides 15 db boost and 10 db cut at 10,000 cps. The unit has a tape-recorder output jack and meets all



SR-406 FM-AM receiver.

FCC requirements for spurious radiation. Output taps are for 4, 8, and 16 ohms. Dimensions are 6 $\frac{3}{4}$ in. high by 13 $\frac{3}{8}$ in. wide by 9 $\frac{1}{16}$ in. deep.

The Model RF-460 8-inch speaker: frequency response of 50 to 13,000 cps; power-handling capacity of 12 watts of program material. Heavy Alnico V magnet provides high flux density in gap.

The Model RF-465 15-inch speaker is a coaxial speaker with Omega M-Voice Ring horn-loaded 2 $\frac{1}{2}$ -inch tweeter and separate 15-inch low-frequency woofer with moisture-resistant cone. Frequency



SR-407 FM-AM receiver.

response is 30 to 20,000 cps; power-handling capacity is 35 watts of program material. Angle of coverage is better than 90°. A brilliance control provides variable control of high-frequency response. Total magnetic flux at voice coils is 20,000 gauss.

The Model RF-466 15-inch speaker is a coaxial speaker which will handle 32 watts of program material. Frequency



ECC equipment cabinet.

response is 30 to 15,000 cps. Angle of coverage is better than 100°. The 15-inch low-frequency cone is moisture resistant and has a 2-inch voice coil and 20-oz. Alnico V magnet. The 3-inch high-frequency unit has a $\frac{3}{4}$ -inch voice coil and a 1 $\frac{3}{4}$ -oz. Alnico V magnet.

The Model ECC equipment cabinet is provided with special, pre-cut panels designed to accommodate any Stromberg-Carlson receiver or tuner/amplifier/record-changer combination. The carefully selected cherry woods and veneers are satin finished in a natural cherry tone. The doors are of solid cherry. A lift lid permits ready access to the phono compartment. Dimensions of the cabinet are 32 $\frac{1}{4}$ in. high by 33 $\frac{3}{4}$ in. wide by 16 $\frac{3}{4}$ in. deep.

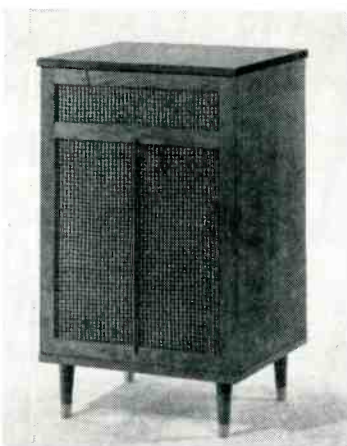

SCC loudspeaker enclosure.

The Model SCC speaker cabinet is finished to match the Model ECC equipment cabinet. The speaker enclosure is designed to accommodate any Stromberg-Carlson 8- or 12-inch high-fidelity speaker. Dimensions of the Model SCC speaker cabinet are 32 $\frac{1}{2}$ in. high by 20 in. wide by 16 $\frac{3}{4}$ in. deep.

BRENELL 3-SPEED TAPE DECK

The Brenell Mark IV, recently introduced by Fenton Company, supersedes the former Mark II tape deck, and is said to incorporate many improvements over its predecessor. The Mark IV is available with either a pair of upper-track

monaural heads (1 R/P and 1 Erase), four pressure pads, and mounting holes for two additional heads as the Model BREN IV; or with four staggered stereo heads already mounted (one pair upper

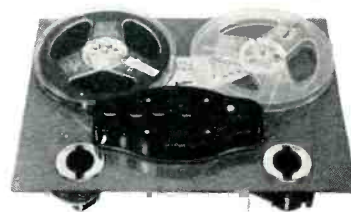

Brenell-Fenton Mark IV tape deck.

and one pair lower track) as Model BREN IV/B. The BREN IV is priced at \$96.50 audiophile net, and the BREN IV/B is priced at \$114.50 audiophile net. The recordist may start with the monaural deck and later obtain additional heads which are available at \$9.50 each for conversion to stereo or sound-on-sound recording.

The Mark IV has three independent motors (capstan, feed, and take-up), and instantaneous mechanical braking. All braking, switching, and pinch-roller operations are positively interlocked in

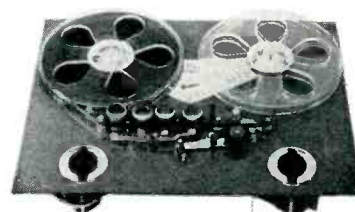

Mark IV with head cover removed.

two control knobs: the left for FAST FORWARD and REWIND; the right for RECORD/PLAYBACK and OFF.

The novel speed-selection mechanism consists of a precision-ground capstan and a 2:1 ratio screw-on sleeve permitting either 3 $\frac{3}{4}$ and 7 $\frac{1}{2}$, or 7 $\frac{1}{2}$ and 15-ips operation. To operate on either of these selections, the rubber belt can be placed either on the slow or fast grooves of the double-stepped flywheel and motor pulley assembly.

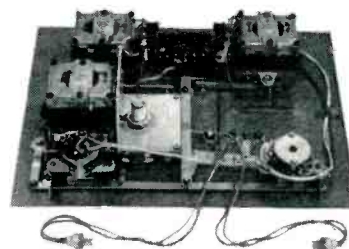

Three-motor drive section of Mark IV.

The Brenell Hi-Fi heads are mu-metal shielded to eliminate 60-cps hum and meet all NARTB requirements. According to the manufacturer, wow and flutter are less than 0.2%, and frequency response is 50 to 12,000 cps at 7 $\frac{1}{2}$ ips, and 30 to 15,000 cps at 15 ips.

For more information about any of the products mentioned in Audio-news, we suggest that you make use of the Product Information Cards bound in at the back of the magazine. Simply fill out the card, giving the name of the product in which you're interested, the manufacturer's name, and the page reference. Be sure to put down your name and address too. Send the cards to us and we'll send them along to the manufacturers. Use this service; save postage and the trouble of making individual inquiries to a number of different addresses.

Fine High-Fidelity is for you too . . .



You can enjoy savings without sacrificing quality—if you “build-it-yourself” and eliminate labor charges; and if you buy direct from the manufacturer and eliminate extra profit.

Here's what you get:

High-fidelity amplifiers, tuners, and speakers that you *assemble yourself*, from the step-by-step instructions furnished. You get, top-quality parts at lower cost through Heath mass purchasing power. You get the equivalent of systems costing approximately twice the Heathkit price.



MODEL BC-1

MATCHING CABINETS

The Heathkit AM tuner, FM tuner, and preamplifier kits may be stacked one on the other to form a compact “master control” for your hi-fi system.

BC-1

FM-3A

WA-P2



MODEL WA-P2

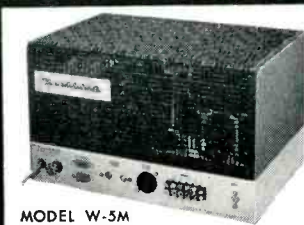

MODEL W-3M

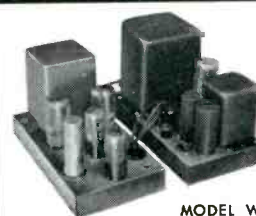

MODEL W-3M



MODEL FM-3A

HERE'S WHY A Heathkit[®] IS FUN TO BUILD:

Instructions are *complete*, and our amazing step-by-step method, tied-in with large pictorial illustrations, guide the beginner through each stage of assembly. If you can follow directions you can succeed, and can build high-fidelity equipment you will be proud to show off to your family and friends.



Here's the proof:

Thousands of Heathkits have been built at home by people just like yourself, and you should treat yourself to this same experience by dealing with the world's largest manufacturer of top-quality electronic kits for home and industry.

Heathkit Model FM-3A High Fidelity FM Tuner Kit

Features A.G.C., and stabilized, temperature-compensated oscillator. Ten uv sensitivity for 20 DB of quieting. Covers standard FM band from 88 to 108 mc. Ratio detector for efficient hi-fi performance. Power supply built in. Illuminated slide rule dial. Pre-aligned coils and front end tuning unit.

\$269.5*
(With Cabinet)
Shpg. Wt. 7 Lbs.

Heathkit Model BC-1 Broadband AM Tuner Kit

Special AM tuner circuit features broad band width, high sensitivity and good selectivity. Employs special detector for minimum signal distortion. Covers 550 to 1600 kc. RF and IF coils pre-aligned. Power supply is built in.

\$269.5*
(With Cabinet)
Shpg. Wt. 8 Lbs.

Heathkit Model WA-P2 High Fidelity Preamplifier Kit

Provides 5 inputs, each with individual level controls. Tone controls provide 18 DB boost and 12 DB cut at 50 CPS and 15 DB boost and 20 DB cut at 15,000 CPS. Features four-position turnover and roll-off controls. Derives operating power from the main amplifier, requiring only 6.3 VAC at 1 a. and 300 VDC at 10 ma.

\$217.5*
(With Cabinet)
Shpg. Wt. 7 Lbs.

Heathkit Model W-5M Advanced-Design High Fidelity Amplifier Kit

This 25-watt unit is our finest high-fidelity amplifier. Employs KT-66 output tubes and a Peerless output transformer. Frequency response ± 1 DB from 5 to 160,000 CPS at one watt. Harmonic distortion less than 1% at 25 watts, and 1M distortion less than 1% at 20 watts. Hum and noise are 99 DB below 25 watts. Output impedance is 4, 8 or 16 ohms. Must be heard to be fully appreciated.

\$597.5
Shpg. Wt. 31 Lbs.
Express Only

MODEL W-5: Consists of Model W-5M above plus Model WA-P2 preamplifier. **\$81.50*** Shpg. Wt. 38 Lbs. Express only

Heathkit Model W-3M Dual-Chassis High Fidelity Amplifier Kit

This 20-watt Williamson Type amplifier employs the famous Acrosound Model TO-300 "ultra linear" output transformer and uses 5881 output tubes. Two-chassis construction provides additional flexibility in mounting. Frequency response is ± 1 DB from 6 CPS to 150 kc at 1 watt. Harmonic distortion only 1% at 21 watts, and 1M distortion only 1.3% at 20 watts. Output impedance is 4, 8 or 16 ohms. Hum and noise are 88 DB below 20 watts.

\$497.5
Shpg. Wt. 29 Lbs.
Express only

MODEL W-3: Consists of Model W-3M above plus Model WA-P2 preamplifier. **\$71.50*** Shpg. Wt. 37 Lbs. Express only

HEATHKIT SPEAKER SYSTEM KITS

These speaker systems are a very vocal demonstration of what can be done with high-quality speakers in enclosures that are designed especially to receive them. Notice, too, that these two enclosures are designed to work together, as your high-fidelity system expands.

Heathkit Model SS-1 High Fidelity Speaker System Kit

Employing two Jensen speakers, the Model SS-1 covers 50 to 12,000 CPS within ± 5 DB. It can fulfill your present needs, and still provide for future expansion through use of the SS-1B. Cross-over frequency is 1600 CPS and the system is rated at 25 watts. Impedance is 16 ohms. Cabinet is a ducted-port bass-reflex type, and is most attractively styled. Kit includes all components, pre-cut and pre-drilled, for assembly.



\$399.5
Shpg. Wt. 30 Lbs.

Heathkit Model SS-1B Range Extending Speaker System Kit

This range extending unit uses a 15" woofer and a super-tweeter to cover 35 to 600 CPS and 4000 to 16,000 CPS. Used with the Model SS-1, it completes the audio spectrum for combined coverage of 35 to 16,000 CPS within ± 5 DB. Made of top-quality furniture-grade plywood. All parts are pre-cut and pre-drilled, ready for assembly and the finish of your choice. Components for cross-over circuit included with kit. Power rating is 35 watts, impedance is 16 ohms.

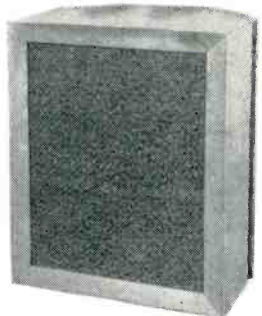

\$999.5
Shpg. Wt. 80 Lbs.

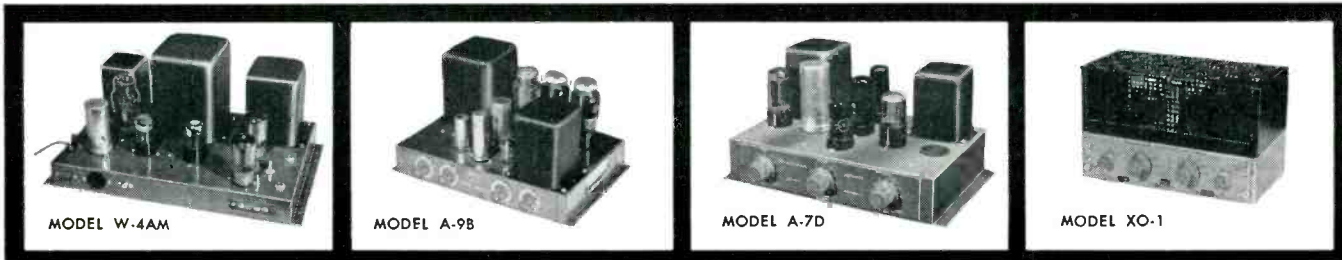

Heathkit Model W-4AM Single-Chassis High Fidelity Amplifier Kit

The 20-watt Model W-4AM Williamson type amplifier combines high performance with economy. Employs special-design output transformer by Chicago Standard, and 5881 output tubes. Frequency response is ± 1 DB from 10 CPS to 100 kc at 1 watt. Harmonic distortion only 1.5%, and 1M distortion only 2.7% at this same level. Output impedance 4, 8 or 16 ohms. Hum and noise 95 DB below 20 watts.

\$397.5
Shpg. Wt. 28 Lbs.

MODEL W-4A: Consists of Model W-4AM above plus Model WA-P2 preamplifier. **\$61.50*** Shpg. Wt. 35 Lbs. Express only

Heathkit Model A-9B 20-Watt High Fidelity Amplifier Kit

Features full 20 watt output using push-pull 6L6 tubes. Built-in pre-amplifier provides four separate inputs. Separate bass and treble tone controls provided, and output transformer is tapped at 4, 8, 16 and 500 ohms. Designed for home use, but also fine for public address work. Response is ± 1 DB from 20 to 20,000 CPS. Harmonic distortion less than 1% at 3 DB below rated output.

\$355.0
Shpg. Wt. 23 Lbs.

Heathkit Model A-7D 7-Watt High Fidelity Amplifier Kit

Qualifies for high-fidelity even though more limited in power than other Heathkit models. Frequency response is $\pm 1\frac{1}{2}$ DB from 20 to 20,000 CPS. Push-pull output, and separate bass and treble tone controls.

\$186.5*
Shpg. Wt. 10 Lbs.

MODEL A-7E: Same, except that a 12SL7 permits preamplification, two inputs, RIAA compensation, and extra gain. **\$20.35*** Shpg. Wt. 10 Lbs.

Heathkit Model XO-1 Electronic Cross-Over Kit

Separates high and low frequencies electronically, so they may be fed to separate amplifiers and separate speakers. Selectable cross-over frequencies are 100, 200, 400, 700, 1200, 2000, and 35,000 CPS. Separate level control for high and low frequency channels. Minimizes inter-modulation distortion. Attenuation is 12 DB per octave. Handles unlimited power.

\$189.5
Shpg. Wt. 6 Lbs.

*Price includes 10% Fed. Excise tax where applicable.

HOW TO ORDER:

It's simple—just identify the kit you desire by its model number and send your order to the address listed below. Or, if you would rather budget your purchase, send for details of the HEATH TIME-PAYMENT PLAN!

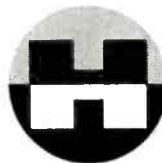

HEATH COMPANY

A Subsidiary of Daystrom, Inc.

BENTON HARBOR 18, MICHIGAN



HEATH COMPANY A Subsidiary of Daystrom, Inc.

BENTON HARBOR 18, MICHIGAN

Please send Free HEATHKIT catalog.

Name _____

Address _____

City & Zone _____ State _____

TIPS FOR THE WOODCRAFTER

by George Bowe

Basic Power Tools, Part V

ONE of the busiest power tools in today's cabinet shop is the jointer, whose basic function is planing or smoothing wood. It gets its name from the purpose for which it was primarily designed—squaring and smoothing edges of boards to make perfect joints when glued together. Although planing edges, ends, and surfaces is still its most common operation, the jointer can deliver many other cuts such as rabbets, bevels, chamfers, tenons, and tapers.

The jointer (Fig. 1) is an outgrowth of the hand plane, inverted and with the plane iron replaced by a rapidly rotating cutterhead containing three or more blades which shear off bits of wood and leave an extremely smooth surface. Unlike the hand plane, the bed of the jointer is divided into two separate tables—the front or infeed table and the rear or outfeed table. In many jointers both tables can be raised or lowered; in others only the front table is adjustable, the rear table being stationary. In use, the position of the front table is determined by the depth of the cut to be made, while the rear table, which is usually set level with the blades, supports the newly planed portion of the wood as it leaves the knives.

The fence, which guides the work as

it is being fed through the machine, can be tilted to a 45° angle either way for bevel cuts. The fence is higher than that of a circular saw to facilitate handling of wider stock without danger of tipping sidewise. Incidentally, *danger* is a word to keep in mind always when operating a jointer; it can be the most

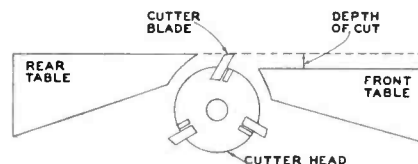

Fig. 2. Board is pushed toward the left.

dangerous machine in the shop. Use the guard—don't remove it except when necessary for certain cuts such as rabbets and some tapers. The guard can be taken off all too easily, but, regardless of your practice with other machines, this is one tool you must learn to operate with a guard.

Rear Table Adjustment

The most important adjustment on the jointer is that of the rear table in relation to the cutterhead. To perform accurately, the rear table must be exactly level with the knives in the cutterhead, as shown in Fig. 2. If the rear table is higher than the

knives, the work will be cut on a taper; if the rear table is lower than the knives, the work will be uneven and gouged at the end of the cut. Once the alignment is set perfectly with the blades, the rear table is locked in position and is not touched again until further adjustment is required after sharpening the knives or after the table has been lowered for chamfering or some other special operation.

The setting of each blade at the proper height can be accomplished by using a straightedge at least 10 in.

Courtesy Rockwell Mfg. Co., Delta Power Tool Div.

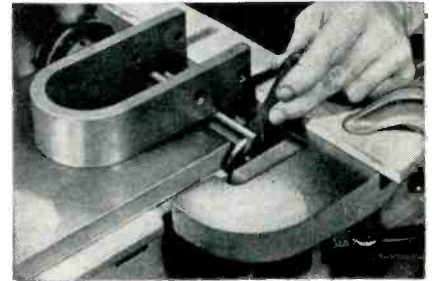
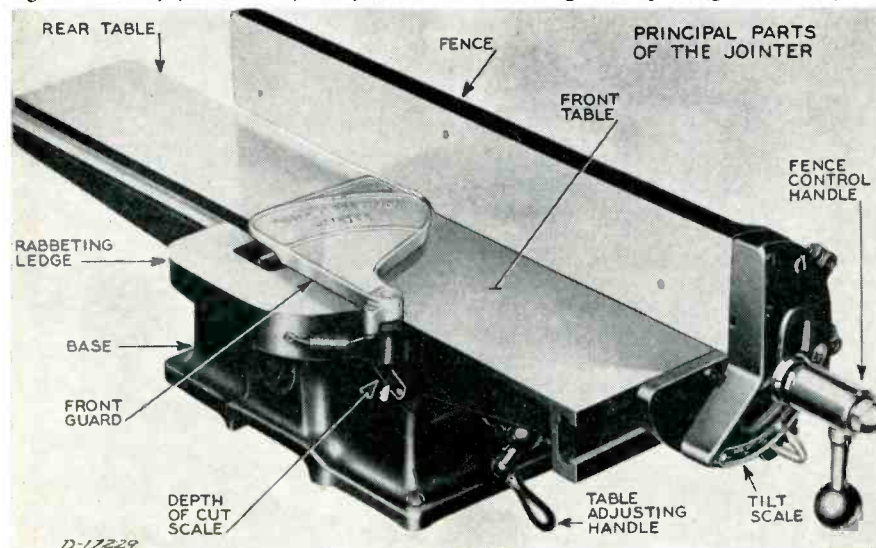

Fig. 3. Using a magnet to adjust blades.

long, or with a magnet. If a straightedge is used, place it near one edge of the rear table, overlapping the cutter head. Raise the end of the blade until its cutting edge touches the straightedge. Move the straightedge to the other side of the table and raise that end of the knife until the cutting edge touches. Turn the locking screws slightly to secure the adjustment and then rotate the cutterhead slowly by hand to check the setting. If properly set, the cutting edges will barely touch the straightedge and will not move it nor raise it. Use the same procedure to set the other blades and, turning the cutterhead slowly by hand, check all three blades before a final tightening. Even after the locking screws are tightened, it is a good idea to test the setting again before operating the machine.

Using a strong magnet instead of a straightedge simplifies the setting of the jointer blades (Fig. 3). The magnet is placed on the rear table extending over the cutterhead opening, gripping each blade and holding it accurately in position until it is fastened. After each knife has been set and locked tightly in

Fig. 1. Primary functions of the jointer are smoothing and squaring board surfaces.



Courtesy Rockwell Mfg. Co., Delta Power Tool Div.

Courtesy Rockwell Mfg. Co., Delta Power Tool Div.

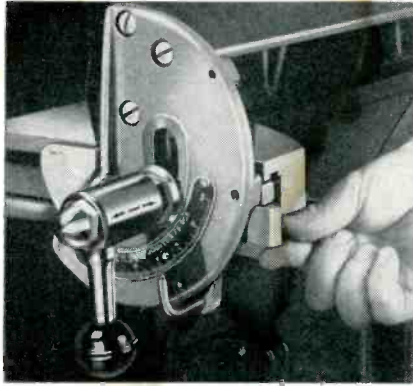

Courtesy Atlas Press Co.

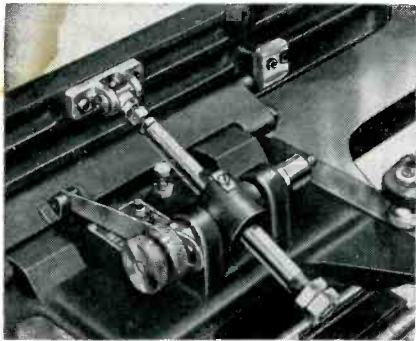

Fig. 4. Tilt mechanisms for the jointer fence: Delta (top) and Atlas (bottom).

the cutterhead, check the setting for accuracy by starting the machine and pushing a piece of scrap wood slowly over the knives. It should slide smoothly over the surface of the rear table, meeting the table level perfectly without being above it or below it and without bumping the edge.

Adjusting the Fence

The fence of a jointer must be adjusted to hairline perfection to insure doing the best work. While proper adjustment is made at the factory, continued use of the machine makes eventual readjustment necessary. Start by setting the fence exactly perpendicular to the table, using a try square for this purpose. Then set the adjustable pointer to zero on the tilt scale. If the pointer has automatic stops for zero and 45° positions, check to see if they are now in alignment with the tilt scale and adjust them if necessary. Various devices on the fence-tilting mechanism permit flexibility of setting for the desired angle and position on the table (Fig. 4).

Jointing an Edge

Planing the edge of a board is the simplest and most common operation of a jointer (Fig. 5). Approximately 1/8 in. or less should be removed in any one pass over of the cutterhead. The fence is the principal means of guiding the stock and should be set carefully at right angles to the table. The stock

Continued on page 44

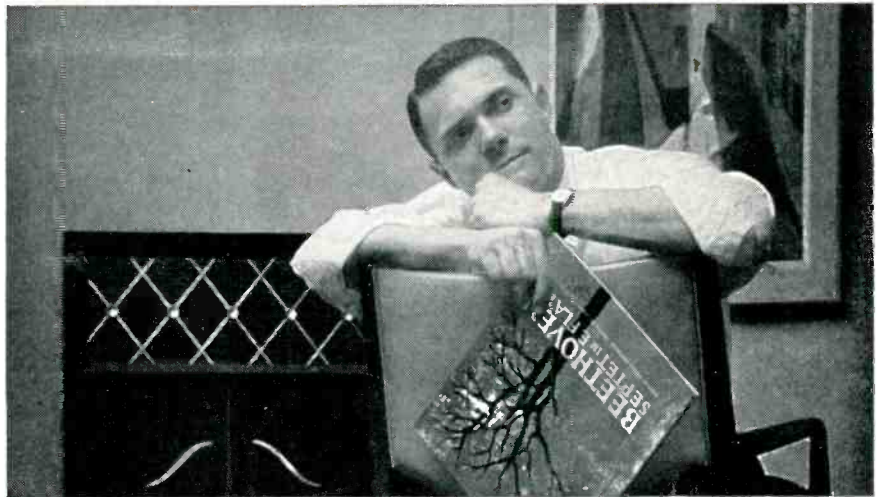

Only planned high fidelity can give you true high fidelity!

Putting together a hi-fi system for your home *can be simple*—and it probably will cost a lot less than you think! Here at MusiCraft we offer the kind of information and guidance that will help you get started right and avoid mistakes.

As you may know, possible combinations of components are practically

limitless. We're happy to help you choose what will best suit your home and your budget. You can start small and add as you wish.

Stop in at MusiCraft soon or write us for further information. Let us help you plan the *kind* of high fidelity system that will give you *true* high fidelity.

Send your name and address if you would like to be on our mailing list for our announcements. Would you like a free copy of "Understanding High Fidelity"?



If you want to "build-it-yourself" and save—MusiCraft has a complete line of component parts in stock. The step-by-step directions are easy to follow—and you can feel free to call on us for any technical assistance you may need.

MusiCraft

48 East Oak Street • Chicago 11, Illinois • Delaware 7-4150

Lowest Prices • Largest Component Selections • Complete Custom Installation Service



SOUND SERVICING

by Irving M. Fried



What Not to Service

A general series on home servicing of high-fidelity equipment is hardly complete without mention of several units which can play important parts in a complete installation: such units as AM, FM, and TV tuners, and the tape recorder.

These have not been mentioned before because, in my experience, they are potentially the most troublesome units with which the home enthusiast must deal. The maintenance of tape recorders in the home, difficult as it is, has been capably dealt with elsewhere in this publication. Which leaves tuners, and therein lies a problem—because I can only tell you that these are units you should not try to service, unless you have the equivalent of a service laboratory and the knowledge to use it properly.

Many tuners of all sorts are brought to me for repair every year, and the service bills on most of them are increased because the owners tried to fix them beforehand. Let me illustrate.

There is the man who walks in carrying his precious FM tuner, which is several years old and obviously falling apart. He wants the tube that will make it work again; it was perfect until the night before, and it must be only a tube. On casual inspection it appears that he has been playing with the little screws accessible through holes in the tops of the IF cans—the trimmers—and most

of them are now mangled beyond repair. It is also apparent that several tubes have been replaced at various times, always without the minor touchups that are required for best performance in tuners.

This gentleman, whether he is willing to face realities or not, has let himself in for a stiff repair bill. The following service work must be done on his tuner:

1) The high-voltage supply must be gone over. You can't align a tuner unless the B+ is within manufacturer's specifications.

2) All tubes must be checked and replaced with ones that will function properly in each particular location. For instance, a tube may work in one socket location, and be useless in another; only a real alignment can tell which tubes they are.

3) Complete alignment, from scratch—a process that, properly carried out, can take several hours.

Next illustration: someone brings in an expensive AM-FM tuner of which he is very proud. It seems that the tuner had been worked over by a friend in the physics lab at the university, who knew all about these things. Or he had taken it to the corner radio shop. Well, it was working again, but he noticed a slight noise at times.

Quick inspection reveals that, again, the little trimmers have all been turned in various directions. There are signs of tube changes. Underneath, someone has been resoldering connections,

probing at wires, and trying anything on general principles. This man, too, is in for a rude surprise, when he learns the size of the estimated bill.

Next illustration: someone arrives with an inexpensive tuner which he just bought as a "bargain". He explains carefully to you that it must be perfect, since it came in a sealed carton; he simply wants the tube that will make it separate stations, and doesn't want to take the time to get it where he bought the tuner. You can imagine his surprise when he is told that the unit is completely out of alignment, and needs factory rebuilding.

These cases are described merely to illustrate how troublesome tuners of all sorts can be, particularly if they have never been properly tested prior to sale, or if well-meaning amateurs have disturbed the delicate balance of adjustments.

In other words, the best way for you to service your tuner is to return it to the factory, or bring it to responsible experts who will stand behind their work. Why should this be so, when other parts of the home music system can be worked on at home? And why is a tuner more critical than a radio or TV set, which radio servicemen fix with no trouble?

First, the high-fidelity tuner is a delicate complex of wires, capacitors, resistors, and other parts. In certain parts of the circuit movement of a critical component as little as 1/32 in. can put the set out of alignment and render it completely unstable or insensitive. Adjustments are so many, and so unpredictable in aural effect, that proper test instruments are absolutely necessary to make them.

Second, a malfunctioning tuner is much more obvious than the poorly operating radio or TV set—at least by the standards of the owner, who expects the tuner to give high-quality results rather than just a picture of some sort, or a noise of some sort.

Therefore, tuner repair, if it is to be satisfactory, must be done by an expert. He can, for instance, determine rapidly that a tuner may not be sensitive because of original construction defects, and advise you not to waste your money on repair work. The expert will be careful just how he probes around in the wiring underneath, and just what tubes he interchanges. He will be honest, and tell the man with

Continued on page 55



It's not bad, but wait'll you get a load of this!



IF you want the finest... it's Fleetwood Custom Television

Fleetwood is the professional's television system. Its picture is clear and bright like those seen on TV Network monitors... also made by Fleetwood.

Designed to the custom standards of your hi-fi equipment, Fleetwood supplies audio power for a speaker and has *separate high fidelity audio outputs* to connect with your sound system.

Fleetwood is available with full electronic remote controlled tuning. Tuner may be operated 40 feet or more from the picture chassis. Both remote (2 chassis) and non-remote Fleetwoods will operate 21, 24 or 27-inch rectangular picture tubes. Tuner in Super Cascode type and is readily adapted to UHF. Four I.F. stages provide four megacycle band width. Your Fleetwood can be housed in many ways... in a bookcase, built into a wall, in a room divider... or the way it

makes a hit with your wife,



in a Fleetwood cabinet. This beautifully designed, modern cabinet comes unfinished in kit form. All glueing and sanding are done by the factory. You can assemble it easily and quickly with a screw driver.

The Fleetwood cabinet is made of sturdy three-quarter inch plywood. Edges of the top have been turned so that the top grain continues across the edge giving a fine furniture appearance.

Fleetwood chassis — remote or non-remote — side mounts on a removable board.

A free booklet of installation ideas will be sent on request.

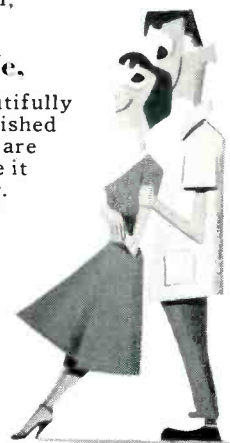

Fleetwood®

Custom television crafted by CONRAC, INC.

Department G, Glendora, California

Conrac is the Canadian name for Fleetwood • Export Division: Frazar & Hansen, Ltd., 301 Clay St., San Francisco, California • ©Conrac, Inc., 1956

T A P E

NEWS & VIEWS

by J. Gordon Holt

TO anyone who has always used a high-impedance microphone and has obtained excellent results with it from all kinds of program material, the additional expense involved in "going to low impedance" may make it seem completely idiotic.

"Why," he is likely to ask, "would anyone in his right mind spend from \$10 to \$50 in addition to the cost of his microphone, just so he can run the mike cable at low impedance?"

There are probably three good reasons why people use low-impedance mikes with nonprofessional equipment, and these reasons happen to be the same ones which prompt professional users to standardize on low-impedance microphones.

First, and perhaps most important, is the matter of flexibility. A low-impedance microphone can be used with several hundred feet of interconnecting cable between it and the recorder without either signal losses or severe hum pickup. A high-impedance mike, though, will have serious hum interference if long cables are used with it, and the higher the impedance, the worse will be the hum. Also, the higher the impedance of a dynamic or condenser microphone, the greater will be the high-frequency loss for a given length of cable. Taking 25,000 ohms as a typical high-impedance value, a cable 60 ft. long will drop the response at 10,000 cps by more than 10 db—a definitely audible loss.

Crystal microphones, though, do not behave in this fashion because they are purely capacitive to begin with. When the output of a crystal microphone is shunted by the additional capacitance of a long interconnecting cable, the cable simply forms a frequency-insensitive voltage-dividing capacitance with the microphone, reducing the output over the entire frequency range. So far as response is concerned, a crystal microphone should perform much better than a high-impedance dynamic when both are used with very long cables. Unfortunately, though, the higher impedance of the crystal type makes it more susceptible to hum pickup in the cable, so it boils down to a matter of personal taste—whether you find hum more or less offensive than high-frequency loss.

So much for hum and losses; let's

consider another angle: quality. In the low-to-medium price range, competitive microphones are likely to be comparable in quality whether they are supplied for low or high impedance. But in the top-quality brackets (where most of us can't afford to dabble around anyway), the best microphones also happen to be low-impedance units. This is not because lo-Z mikes are inherently of better quality than hi-Z ones, but simply because professional mikes are made for professional users, all of whom prefer to use low-impedance circuits for the reasons mentioned earlier.

Professional tape recorders are invariably supplied with low-impedance microphone inputs; nonprofessional equipment, rarely; and strictly home-entertainment types, never. The main reason for this is economic; it costs much more to equip a recorder with a lo-Z mike and input-matching transformer, and the less ambitious a given recorder may be, the more competition it has in its own price field. To a recordist who simply wants a machine to preserve baby's first bubbling attempts at self-expression, the addi-



tional cost of a low-impedance microphone and input transformer would be just cause for him to choose a different recorder that was less expensive. But to someone who uses his recorder for musical or more ambitious speech recording purposes, the ability to get a high-quality signal through a long mike cable is a definite advantage, and if he intends to do much recording on location, he should either own low-impedance equipment or should convert his recorder to lo-Z.

This conversion involves providing a 50- to 500-ohm impedance from the microphone, and the addition of another matching transformer at the recorder's input, to match this impedance to the input preamplifier tube's high-impedance grid.

If the microphone is presently a hi-Z unit, a hi-Z-to-line matching transformer will be required at the microphone end of the chain. This transformer can be located conveniently at the

end of the mike's integral output cable (as long as this is short enough to prevent losses in itself). Then the cable between the mike and recorder must be three-conductor, with two inner conductors and the shield. The inner conductors carry the signal and are balanced with respect to the cable shield, thus tending to cancel any slight hum that might be picked up in the cable. At the other end of the cable, just before the recorder's input jack, the second matching transformer must be inserted, with its primary winding strapped to match the secondary impedance of the first transformer.

These transformers should, needless to say, be of the highest quality that one's finances will stand. Several very good units are available which can be connected in series with the cable by means of interconnecting plugs, thus greatly simplifying their installation. More ambitious types (at higher prices) are designed for chassis mounting, and may be either attached to the recorder itself, or allowed to sit out in the open with the cables taped to their cases to prevent bending and twisting at the soldered connections.

If the microphone that is to be used happens to be a lo-Z type, or if the purchase of a lo-Z mike is planned in the near future, this will materially reduce the cost of converting to low impedance, since it is only necessary to buy one transformer for use at the recorder end of the cable.

The impedance of the input-transformer primary should, as before, exactly match the nominal output impedance of the microphone, otherwise response linearity will suffer. Also, the input transformer at the recorder may have to be oriented with respect to the recorder to reduce hum pickup to a minimum. Strong AC magnetic fields are radiated from recorder motors and power transformers, and if some care is not taken to orient the input transformer correctly, this field may induce appreciable hum into it. Highly shielded input transformers will reduce this interference materially, but it may still be necessary to orient them for lowest hum.

When connecting an input transformer to the recorder's input jack the existing grid resistor in the recorder should be clipped out of circuit, if its

resistance is less than 1 megohm. Most input transformers (and microphones) are designed for use into an unloaded grid, and an additional resistive load will often roll down the high-frequency end.

On the other hand, a few microphones, notably some condenser types, do require resistive termination at either the primary or secondary of the input transformer. Where this is so, the termination should be added at the microphone rather than in the recorder, so that the input termination will still be correct for other microphones.

All this is likely to cost some money, no matter how simple is the complete conversion. But the expense is well worth while in terms of the improved sound quality obtainable in location pickups. The difference between hi-Z and lo-Z through long cables is immediately noticeable on all but the most unashamedly lo-fi tape recorders, and may well make the difference between a good recording and a mediocre one.

Two More Microphones

Several months ago I made some favorable comments about a moderately priced, high-quality ribbon microphone, the Fenton B&O-50. Since then, two more have come along that are definitely worth attention.

The less expensive of the two, the Reslo Celeste, is a British ribbon unit that also, by chance, happens to be distributed by the Fenton Company. It is quite small, as quality ribbon units go, and has several unusual if not unique features. It is the only ribbon microphone I know of with replaceable "ribbon cartridges". The ribbon is mounted on a frame of Bakelite which can be removed easily and replaced with another, should anything happen to the original one. There's no denying the value of this, because even though it may be a fairly easy task for one with steady hands and steel nerves to replace the ribbon in a typical velocity mike, it is practically impossible to adjust the tension of the ribbon to its optimum value without the use of precision measuring instruments. The frequency response, then, is likely to be subtly changed each time the ribbon is replaced. The replaceable ribbon assembly in the Reslo eliminates this possibility. Really ingenious, and I don't see why no one did it long ago.

The mike itself is equipped with an on-off switch at the bottom of the case, and its directivity is essentially the typical velocity bidirectional (figure-8) pattern. I say "essentially" because the Celeste microphone has provision for the addition of internal baffling pads which modify the polar pattern and/or the frequency response. More about these in a moment.

Continued on page 51

NOW HEAR THIS!

Stereophonic Sound

WITH NEW *Bell* 3-SPEED TAPE RECORDER

AND ... YOU NEED NOTHING ELSE EXCEPT YOUR RADIO, TV OR AMPLIFIER

Bell, famous name in Hi-Fidelity, offers plenty that's new and STEREO too, in this inexpensive, easy-to-operate Tape Recorder.

- **TRUE FIDELITY**
... 30-12,000 cycles
- **THREE SPEEDS**
... 7½, 3¾, 1½ ips
- **DUAL TRACK RECORDING**
... Monaural only
- **PLUS STEREO PLAYBACK**
... staggered (offset) heads
- **RECORDED STEREO TAPE**
... with each recorder
- **ALL FOR ONLY \$189.95**
... slightly more in West



Model BT-76

Bell's new BT-76 Tape Recorder is masterfully engineered, ruggedly built and handsomely cased, with outstanding features usually found only on expensive professional equipment. As a recorder, or when used for either Monaural or Stereophonic playback, it is a magnificent instrument. Its staggered (offset) heads feed

equalized, pre-amplified signals from Head #1 into Recorder Amplifier, from Head #2 into any Radio, TV, or other amplifier system equipped with phono input (connecting cable furnished), guaranteeing true Stereophonic Sound. Now being demonstrated at leading Department Stores and Hi-Fidelity Dealers. Now hear it now!

OTHER BELL TAPE RECORDERS AS LOW AS \$139.95

MODEL BTK-1—Conversion Kit—To add Stereophonic Playback to any RT-75 when desired. Includes second head, pre-amp, hardware, simple instructions. **\$16.95**

MODEL RT-75—Tape Recorder—Same as BT-76, above, identical appearance and operation but without Stereophonic playback. **\$174.95**

MODEL RT-88—Tape Recorder—Two speeds, Piano-Key controls, three separate motors, True Fidelity, Dual Track Recording, Lightweight. **\$139.95**

Prices shown subject to change; are slightly higher West of the Rockies.

BELL SOUND SYSTEMS, Inc.
A SUBSIDIARY OF THOMPSON PRODUCTS, INC.
557 MARION ROAD COLUMBUS 7, OHIO

Bell Tape Recorders are sold by leading Department Stores and High Fidelity Sound Dealers everywhere. Write . . . we'll send you complete literature and your nearest dealers' name.



COMING

To Your City . . .

HIGH FIDELITY



SHOWS

SEE and HEAR the latest in HIGH FIDELITY from leading high fidelity manufacturers . . .

Don't miss these free public showings of Hi-Fi Equipment . . . from the most economical units for the budget-minded to spectacular home music theatres . . . compare and enjoy them all.

*Complete Hi-Fi Systems and Components

*Amplifiers — Pre Amplifiers — FM-AM Tuners — Turntables and Record Changers — Phono Cartridges — Microphones — Music Control Centers — Speakers.

*Speaker Enclosures and Equipment Cabinets — Finished and Assembled or Do-It-Yourself Kits.

THREE FULL DAYS OF CONTINUOUS DEMONSTRATIONS FROM 1.P.M. TO 10.P.M. FOR EACH SHOW

ADMISSION FREE

IN 1956:

MIAMI — October 12, 13, 14 — McAllister Hotel
NEW ORLEANS — October 25, 26, 27 — Roosevelt Hotel
DALLAS — November 16, 17, 18 — Adolphus Hotel
ST. LOUIS — November 23, 24, 25 — Statler Hotel

IN 1957:

MILWAUKEE — January 4, 5, 6
MINNEAPOLIS — January 18, 19, 20
SEATTLE — February 1, 2, 3
PORTLAND — February 15, 16, 17
KANSAS CITY — March 1, 2, 3
OMAHA — March 15, 16, 17
DENVER — March 29, 30, 31
SALT LAKE CITY — April 5, 6, 7
PITTSBURGH — April 19, 20, 21
CLEVELAND — April 26, 27, 28
DETROIT — May 3, 4, 5

YOUR LOCAL
NEWSPAPERS
AND RADIO STATIONS
WILL CARRY
ANNOUNCEMENTS
OF THE LOCATION
OF THESE SHOWS

Free Recorded Hi-Fi Concerts every hour on the hour during these shows.

RIGO Enterprises Inc. 500 N. Dearborn, Chicago 10, Ill.

Readers' Forum



Gentlemen:

Re "Audio Aids", July 1956 [p. 29], "Hi-Fi Sound From TV". Mr. McConnaughey's suggestion is not wholly practical in TV sets using the 6T8 triple diode, hi-mu triode tube as first audio amplifier, discriminator, and AGC delay. It is easy to see that removal of this tube from its socket will result in no sound (discriminator disabled) as well as impairment of AGC operation.

It would be practical to tap from the grid connection of this tube, leaving it in its socket, but the use of this high-impedance audio output would permit only approximately 1 ft. of the usual 100 μmfd /ft. audio cable before resulting in a 6-db-per-octave rolloff starting near 10,000 cps. (This restriction also applies to Mr. McConnaughey's method.)

The elegant technique would be to convert the first audio stage to a cathode follower, whose low output impedance would permit a longer cable run.

I have also found a good reason for the very small coupling capacitors in the audio circuit of my TV (it has little response below 140 cps): a hi-fi tap ahead of the first audio stage discloses much 60-cps hum. Also, a condenser across the output transformer limits high-frequency response. This TV just wasn't designed for hi-fi.

J. F. Brady
Rochester, N. Y.

A circuit for adding a hi-fi output jack to any low-cost "package" tape recorder was described on page 83 of AUDIO-CRAFT for January, 1956. This circuit will operate satisfactorily with any commercial radio or TV set, provided 1) the set has a power transformer with an isolated primary winding, 2) the filaments are not in series across the power line, and 3) a 0.5- μfd 400-volt capacitor is connected in series with the 15-K dropping resistor in the take-off network. — ED.

Gentlemen:

In his article on the construction of a miniature signal injector (July 1956), Rufus P. Turner mentions possible difficulties with shattering and broken taps in working Lucite. These troubles can be overcome very easily by placing a drop of kerosene or other light oil on the work where a hole is to be drilled or tapped. Small cracks radiating from

Continued on page 56

EDITORIAL

WITH interest in (and addiction to) high-fidelity sound still growing as fast as ever, the hi-fi equipment market has now reached a substantial dollar volume and will certainly increase quite considerably before leveling off. As a matter of fact, there is no indication that it will level off for many years yet. A natural consequence of this rapid growth is spirited competition among equipment manufacturers to get and keep what they consider their rightful shares of the market. New firms enter the race faster than they can be tripped up by established concerns. To stay in business and retain or advance their positions, manufacturers in this field must be—and are—as clever and resourceful a group as any you'll find. Their design and development engineers are dedicated to producing the most value for the least money, and are far above average in brilliance and ingenuity.

All this is to the benefit of us, the consumers. We are offered an ever-expanding variety of high-quality products to choose from, in both finished and kit form. The speed of technical progress is almost unbelievable; we have far better products at lower prices than we had before.

Still, it seems to us that there are several areas of development that aren't receiving the attention they deserve. First on our list is pickup cartridges. We admit that pickup design is an extraordinarily complex affair, and that the performance of any pickup is limited by the precision that can be obtained at a reasonable price in the manufacturing process. But everyone uses a pickup cartridge, and we should think that the potential market would be incentive enough for someone to come up with an LP cartridge that would have very high compliance, so that the low-frequency resonance in an average arm would occur below the audible range; very low effective moving mass, so that the high-frequency resonance would occur above the audible range; good damping of both resonances; smooth response and low distortion everywhere between the resonances; a damping material that would not stiffen, work out of place, or otherwise deteriorate for a reasonable length of time; reasonably high vertical compliance and insensitivity to vertical stylus motion; an easily replaceable stylus; mechanical ruggedness, stability, and simplicity; moderately high output; low sensitivity to hum fields; fairly low impedance; low tracking force; and a price (with

diamond stylus) below \$35. Some cartridges meet most of these specifications, but we don't know of a single one that meets them all—even if the price limitation is deleted.

Next on the most wanted list is an intelligently engineered medium-price tape recorder; one that has semiprofessional quality potential, and a few necessary professional conveniences, in the \$300 to \$400 price range. Among the essential features we would list separate record and playback heads, and separate record and playback amplifiers; a motor used only for capstan drive, which means at least two motors (preferably three); line and low-impedance microphone inputs; a VU meter driven by its own individual tube section, *not* simply bridged across the signal line; provision for NARTB reels; and operation at 7½ and 15 ips. Electrical and other mechanical specifications should be, at 7½ ips, at least high enough to assure results as good as those obtainable from the best LP's played with the best equipment. At 15 ips they should be proportionally higher. Extreme portability would be desirable but not essential; power amplifiers and monitor speakers aren't necessary at all. Hotcakes would sell like this recorder.

Then, for the do-it-yourselfers, a truly high-quality tape transport mechanism (possibly with a built-in bias and erase oscillator), and instructions for building a suitable electronics section, could command a price of \$400 easily. The buyer would know that its performance could approach that of the best professional equipment as closely as his electronics skill permitted.

Since more and more enthusiasts are turning to two-channel power amplification, with frequency division immediately following the preamp-control unit, this would seem an appropriate time to market an ultrahigh-quality, fairly high-power dual-channel power amplifier. This should have level-control adjustments for each channel and a built-in, variable-frequency dividing network. It ought to cost less than two standard full-range power amplifiers of the same power rating and comparable performance, because the output transformers could be designed specifically for the limited ranges each would have to handle.

We could go on if we had more space, but we've illustrated our point. There is still plenty of room in this industry for any manufacturer who will find out what people want and then make it. It's as simple as that. — R.A.

TRANSISTORS *in Audio Circuits*

by PAUL PENFIELD, JR.

I: Transistor Action

Introduction

Amplification is really the heart of electronics. Before the invention of the audion, the original triode, there was no means of electronic amplification — telephone conversations were limited to a few hundred miles, and wireless range was limited by the practical size of spark-gap transmitters.

Amplification is merely the control of a large amount of power, from a power source of some sort, by means of a small amount of "signal" power. Literally hundreds of mechanical, acoustical, optical, and electrical amplifiers are known. Electronic amplifiers are the most important in our civilization because of the ease of connecting electric circuits of all types, and of transporting electric energy over long distances at low cost.

Electronics has grown up with the vacuum tube as its chief amplifying device. However, several other electronic devices which will amplify are

known to science. Engineers are always on the lookout for cheaper, lighter, smaller, more efficient, more faithful, and more reliable amplifiers. The transistor excels the vacuum tube in *every one* of these important categories, with only minor exceptions. Within a few years the transistor will be the chief amplifying device in use commercially.

What will the transistor mean to you? Well, that depends on who you are. If you're the average citizen, you'll have transistorized consumer goods in large quantities soon. The little transistor portable radios available now are nothing in comparison. And look for a cheaper price, too, on the familiar electronic gadgets you use.

If you're an engineer in electronics, you've already run across transistors in your work. (If not, ask your boss why not.) If you're a hi-fi enthusiast, you can expect transistorized hi-fi gear soon, fully as good as present vacuum-tube gear. If you're an experimenter or an amateur, it's about time you started

playing around with transistors. They're a lot of fun.

But whatever your interest, you cannot ignore transistors, since they are here to stay in all fields of electronics and audio. And since you cannot profitably ignore transistors, you might as well learn about them. The series starting in this issue is intended for you — to make you familiar with the transistor as a physical device, as a circuit element, and as a useful gadget.

TRANSISTOR action is a convenient name for the physical theory of operation of junction transistors. It may not be immediately apparent why a series on transistor audio circuits should bother describing the theory of a transistor at all. Why not merely take the published characteristics of any given transistor type, and build all necessary circuits around them? Extremely useful results follow, as we will see later, from considering the transistor as an unknown linear circuit element, described completely and fully by its terminal volt-ampere characteristics. So why bother with transistor action?

The answer is easy: a knowledge of transistor action gives the circuit designer an intuitive feeling for how and why the transistor acts in a given circuit. It enables him to avoid misapplying his circuit theory, by stressing the nonlinear nature of the transistor; and it also enables him to use transistors in more varied and more useful ways. So a knowledge of the physics of transistor action is necessary for the circuit designer and experimenter, as well as the person who makes the transistors. In this installment we will limit the discussion to junction devices only.

Transistor Materials

Transistors are made from materials known as *semiconductors*. These are not, as the name suggests, merely compromises between a conductor and an insulator. Rather, this class has con-

Fig. 1. Arrangement of atoms in a crystal of germanium. Each of four electrons in every atom's outer ring is coupled by covalent bond to one electron of other atom.

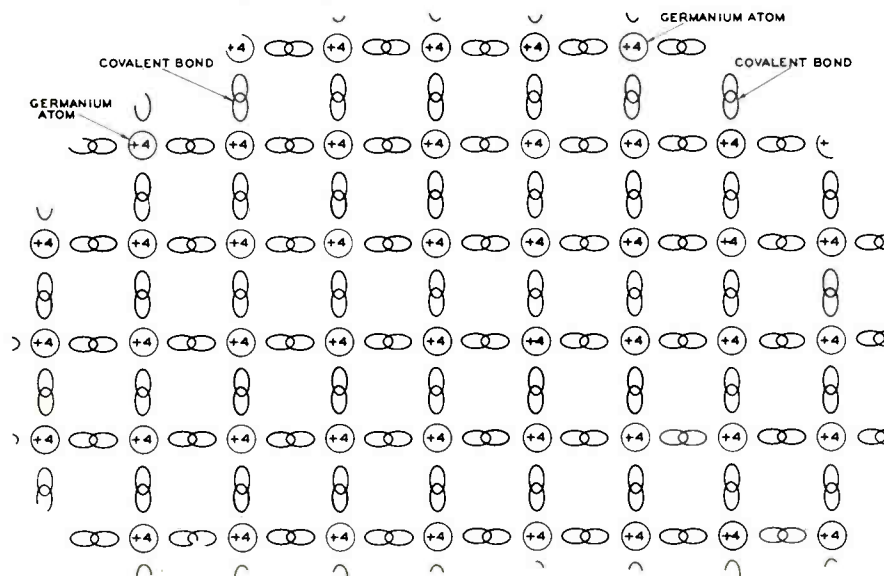

ductivity properties which are quite unusual, and it is just these unusual properties that make possible the transistor.

Germanium, the most popular transistor semiconductor, can be grown by special techniques in the form of a large single crystal: a large chunk of material in which row upon row of germanium atoms are arranged in a perfectly regular fashion. This three-dimensional array of atoms is called the *lattice*. It is known that each germanium atom neighbors four other atoms; how this is done in three dimensions is a bit complex, but it can conveniently be represented by a diagram in two dimensions, such as Fig. 1.

A single atom of germanium can be visualized as consisting of a small, dense cloud of particles known as the *nucleus*, charged slightly positive, surrounded by rings of small electrons some distance away from the nucleus, each with a small negative charge. In the outer ring are four electrons. The atom as a whole is uncharged.

The reason that germanium forms a lattice such that each atom has only four close neighbors should be apparent from Fig. 1. Each of the four outer-ring electrons from a given atom combines with an electron from a neighboring atom to form a very stable combination known as a *covalent bond*. Each atom now has, effectively, the eight outer-ring electrons which produce maximum stability. Because the covalent bonds in this condition are quite strong.

Note well Fig. 1. It shows a few rows and columns of a representation of the three-dimensional crystal lattice. Each germanium nucleus which, in combination with the inner-ring electrons, has a charge of plus four, is surrounded by four other similar germanium nuclei.

Fig. 2. When heat or light breaks some covalent bonds in pure, intrinsic (*i*-type) germanium, a few holes and electrons are formed that drift around in the crystal.

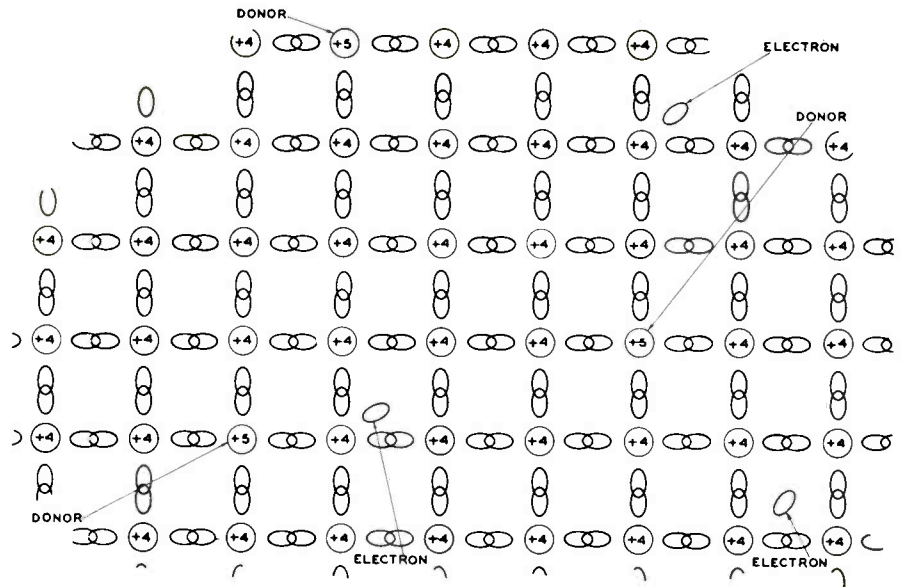
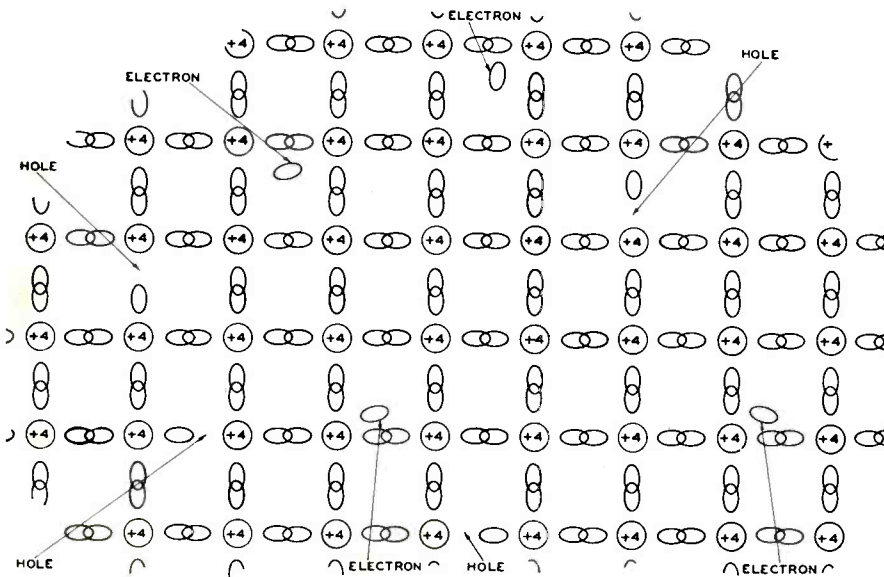

Fig. 4. Adding traces of a donor—an element having five outer-ring electrons—produces an *n*-type germanium crystal having far more free electrons than holes.

All free electrons are taken up by the covalent bonds, leaving none extra.

This is a very simple picture. On the surface it also looks somewhat uninteresting, because it is so regular and perfect. But for pure germanium the regular pattern of things can be broken up in a number of ways.

First, at room temperature, some of the covalent bonds will be broken. That



Fig. 3. A crystal of *i*-type germanium forms heat- and light-sensitive resistor.

is, some electron which should be in a bond isn't, but rather is floating around the crystal somewhere. This situation, shown in Fig. 2, means that a few bonds lack an electron. A covalent bond in this condition is known as a *hole*, and can itself move around the crystal, just as the excess electron can. It does this by having an electron from

a neighboring bond jump into the hole, thus forming a new hole the next bond over. The effect of the hole's motion is that a hole can be considered, for all practical purposes, as merely a positively charged particle similar to the excess electron.

If a hole and an electron come close enough together, they will recombine, leaving nothing behind. Normally, in a given crystal, as many recombine each second as are formed. Electron-hole pairs are formed by temperature—remember that, from an atom's point of view, temperature is merely a measure of how much agitation and vibration there is going on in the lattice. When an electron is bounced out of a bond,



Fig. 5. In *n*-type germanium the current carriers are mostly negative electrons.

we say that an electron-hole pair has been formed.

A second way the nice, orderly array of a perfect lattice can be broken up is by means of light. Light striking a pure germanium crystal will create electron-hole pairs just as temperature does. Practical photocells are made utilizing this effect.

When a germanium crystal is pure, and the only current carriers (holes and electrons) present and free to move are caused by temperature or light, the germanium is known as *intrinsic* germanium, or *i*-type. The resistance of a piece of *i*-type germanium depends on the temperature; at high temperatures, more current carriers are formed, so current can flow. This makes the resistance less. At very low temperatures, the resistance is very high, because of the lack of current carriers. The resistance also varies with illumination. A chunk of *i*-type germanium with a lead at

each end (such as is shown in Fig. 3) forms a practical photocell, whose resistance decreases with increasing illumination.

Impurities

So much for pure germanium. By far more interesting properties are given by very, very minute quantities of impurities added to the germanium lattice in certain ways.

Fig. 4 shows what is known as *n-type* germanium. Notice that it looks exactly like *i-type*, except for a few atoms which are not germanium but some other substance, and for the same number of excess electrons wandering about the crystal. Fig. 4 is very much exaggerated—normally, impurities in the neighborhood of one part per hundred million are quite noticeable. The impurity used is called a *donor*, because substituting one atom of it for one germanium atom donates an extra electron to the crystal. Such materials as phosphorus, antimony, bismuth, and arsenic are suitable as donors; each of these has five loose electrons instead of four, and an extra positive charge on the nucleus to balance things up.

Notice from Fig. 4 that current carriers in the form of electrons have been introduced into the crystal, without any corresponding holes. If a piece of *n-type* germanium is fitted with a couple of leads, as shown in Fig. 5, it will conduct current primarily by electron flow. Since here we are considering so-called conventional current, the flow of electrons will be in the opposite direction to the direction of current.* This is of course because electrons are negatively charged.

The resistance of this piece of *n-type* germanium will be a measure of the concentration of the impurities—that is, just how dense the donors are in the structure. And it will, at least at low temperatures, be virtually independent of the temperature. At high temperatures, though, so many thermally caused electron-hole pairs are formed that the effect of the few impurity carriers is lost, and the resistance drops with increasing temperature. The material is now said to be *intrinsic* again.

Similarly, *p-type* germanium may be formed by an exactly reverse process.

*Mr. Penfield chooses to use the conventional concept of current—that of positive charge flow—rather than that of electron flow. In his words: "The whole argument for electron current direction seems to me to rest on the fact that charge is carried in metallic circuits and vacuum tubes by electrons. Technicians and engineers have not often run into cases where positive particles carry charge to form current. The transistor is, of course, such a case—holes as well as electrons carry current. There is, therefore, no advantage to considering electron direction here. With the growing importance of solid-state devices, the need for considering electronic direction will diminish, and almost certainly, if any unanimity is reached, it will be with conventional current."

In this series of articles, therefore, current will be assumed to flow from the positive to the negative terminal in the external circuit of any voltage source. AUDIOCRAFT will, with this exception, continue to refer to current as electron flow.

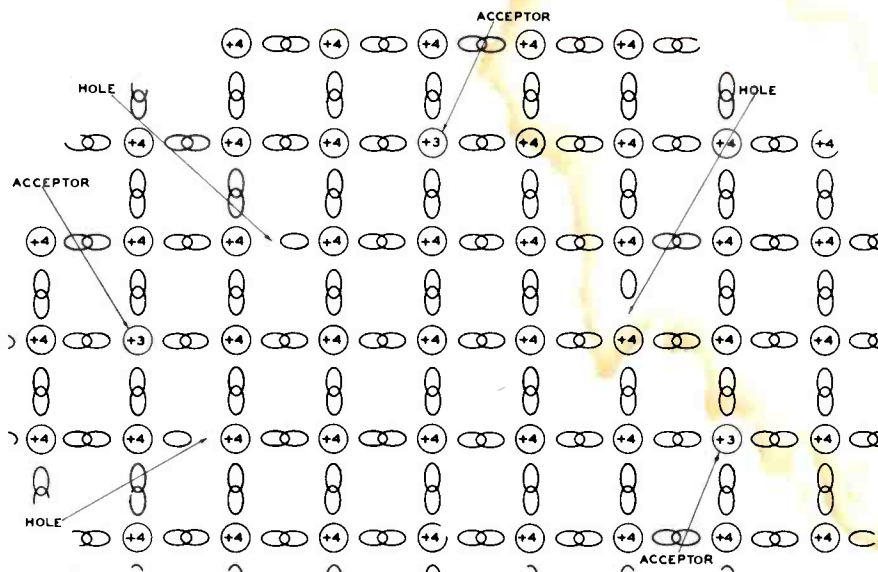

Fig. 6. If trace of acceptor element, having three outer-ring electrons, is added to crystal, *p-type* germanium is formed. Current carriers are mostly positive holes.

Fig. 6 shows *p-type* germanium which has been contaminated with *acceptor* impurities, so called because each atom of the material accepts an extra electron from the lattice, leaving it short an electron. Typical acceptors are indium, aluminum, gallium, and boron—metals with three free electrons.

The effect of having an acceptor atom substituted for a germanium atom is the introduction of a number of holes without any excess electrons. If a piece of *p-type* germanium is fitted with two leads, as in Fig. 7, the resistance will



Fig. 7. Conduction by hole flow occurs in direction of conventional current.

be a measure of the number of acceptor atoms introduced, and will be roughly independent of temperature. Of course, at high enough temperatures, *intrinsic* conduction will again take over, and the resistance will drop further.

In Fig. 7, conduction is primarily by means of positively charged holes. Since the direction of conventional current is taken to be the same as the direction positive charge moves, current direction coincides with the way holes actually move.

Table 1 shows the important properties of all three basic types of germanium, arranged for easy comparison. It may be useful in what follows to refer back to this table when necessary.

TABLE 1

	<i>n-type</i>	<i>p-type</i>	<i>i-type</i>
Impurity	Donors	Acceptors	None
Charge on Impurity	Plus	Minus	
Carriers	Electrons	Holes	Both
Charge on Carriers	Minus	Plus	

So far we have discussed some of the properties of *i-type*, *n-type*, and *p-type* germanium. Also we have talked about the effect of light and temperature on germanium; both tend to form electron-hole pairs.

Junctions and Rectification

Useful devices can be made by placing different types of germanium next to

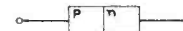

Fig. 8. *p-n* junction forms crystal diode. each other. For example, consider Fig. 8, which shows a crystal diode. Half is *n-type*, and half *p-type* germanium. The surface between the two regions is known as a *p-n* junction. Its properties are very important.

Suppose our *p-n* junction device is connected to a battery of the polarity shown in Fig. 9. In that case, the positive terminal of the battery will try to attract electrons and repel holes. Since it is connected to the *n-region*, it will

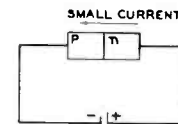

Fig. 9. Very little current flows when a *p-n* junction diode is reverse-biased.

attract the electrons out of this side of the crystal; the negative terminal of the battery will sweep the other side clean of holes. The result is that the battery current is quite small, and the device (which is just a common junction diode) is said to be *biased in reverse*.

Of course a small amount of current, known as *leakage current*, does flow.

This is caused both by electron-hole pairs formed near the junction and by surface effects, which we won't go into here. The amount of current is determined by the rate of creation of these electron-hole pairs, which is itself a measure of the temperature of the junction. So, as is well known, the reverse leakage current of a germanium diode is strongly temperature-dependent. In addition, if the junction is illuminated, light-caused carrier pairs will be formed and will enable a current to flow. When a small amount of

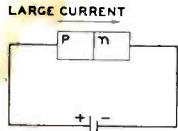

Fig. 10. Forward bias gives high current.

light strikes the crystal near the junction, an electron is thrown out of a bond somewhere, forming thereby a carrier pair—a hole and an electron. The electron drifts off toward the n-region under the action of the battery, and the holes goes the other way.

By using this *photo current* properly, a reversely biased junction diode can be made into a small, cheap, efficient photocell.

Now consider the same diode, only with the battery terminals reversed. Fig. 10 tells the story. The positive terminal of the battery repels holes from the end of the p-region where it is connected, and similarly electrons are repelled away from the n-type end. The result is that they are pushed toward each other, and so come together and recombine somewhere in the center of the diode. These, of course, are replenished by more carriers from the battery—electrons from the wire connecting the battery to the n-region, and holes from the electrons leaving the p-region at the battery end. Current continues to flow

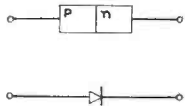

Fig. 11. Symbol for crystal diode points in the direction of easy current flow.

so long as the battery is connected, and the voltage drop across the diode is rather small. In this condition, the diode is said to be biased in the forward direction.

Fig. 11 shows the standard symbol for a diode. The direction of the arrow is the same as the direction of easy current flow. Try to push current back against the arrow, and you run into trouble. But try to push current with the arrow, and you're in business. Conventional current direction (plus to minus) is assumed, of course.

A device selective of current direc-

tion, like this, is called a *rectifier*. Junction diodes are in wide use as rectifiers, in everything from TV sets down to massive industrial power control circuits.

In summary on diodes, then, a large current can flow through a diode in one direction: the forward direction. When the battery is reversed, however, very little current flows, because the region close to the junction lacks current carriers. What current does flow may be thermally caused (leakage current), light caused (photo current), or caused by any mechanism which can inject carriers in the region near the junction. We will soon see that it is not too hard to inject carriers electrically into such a region from elsewhere, and this is the basis of transistor action.

Junction Transistors

Consider the arrangement shown in Fig. 12. Here we have what appears to be two junction diodes, placed back to back. The middle n-region is quite thin—only a few thousandths of an inch thick. Let's see how, in general terms, such a device can be made useful.

Suppose, as in Fig. 13, we bias the right-hand junction in reverse, so that little or no current flows. Now we

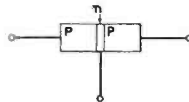

Fig. 12. Transistor has two junctions of dissimilar types of germanium crystals. Here merely a diode—what current does flow must come from one of three sources, as we saw a few paragraphs ago:

- (1) Thermal agitation producing leakage; or
- (2) Photocurrent caused by junction illumination; or
- (3) Injection of current carriers into the region of the junction from another source.

Transistor action is based on the last method of obtaining current through that right-hand reversely-biased junction. The left-hand junction is biased forward, and it performs the function of delivering carriers to the region of the reversely biased right-hand junction.

As you may have guessed, Fig. 12 is really a p-n-p junction transistor. It is a p-n-p transistor because that is the way the various regions are arranged, starting on the left. The left-hand terminal is the emitter; its function is to emit current carriers into the middle portion, which is known as the base. The right-hand portion, which collects these carriers, is appropriately known as the collector. Referring again to Fig. 13, let's see how the p-n-p junction transistor works.

Battery B_1 is connected between the collector and the base in such manner that the collector junction (on the

right) is reversely biased. The only collector current that flows now is caused by thermally generated carrier pairs created close to the collector junction, and so long as the collector voltage is

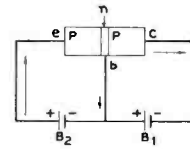

Fig. 13. Normal current flow and biases.

more than a few tenths of a volt, *this current will be independent of the collector voltage.*

Now the emitter is hooked up to a battery in such a way that the left-hand junction is biased forward. (The reader should be able to verify in his own mind that the polarities of the two batteries in Fig. 13 are correct to bias this p-n-p transistor.) Current flows through this junction between the emitter and the base. If the transistor is made properly, almost all this current will be in the form of holes from the emitter, very little as electrons from the base. These injected holes will travel right through the base into the collector, if the base thickness is small. Very few will recombine with electrons in the base.

Neglecting secondary effects, this is transistor action. And here is all there is to it—a control of current through a reversely biased junction by means of injecting current carriers from a third electrode (the emitter).

Lots of material has been written complicating the matter, but in its simplest form transistor action is very easy to understand. If the reader has got this far understanding what was said, he understands transistor action. He may not see immediately how and why this sort of action is useful, but he un-

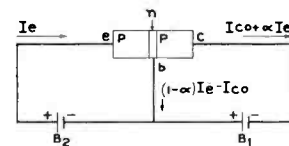

Fig. 14. Transistor currents stated in terms of leakage and emitter currents.

derstands the basic physics of transistors.

Going back to Fig. 13, consider the collector junction reversely biased, and the emitter junction conducting. Now in fact not all the emitter current flows right through the base into the collector; a few of the holes injected into the base will recombine with electrons there. These recombinations account for a small base current which must flow because of the emitter current. Let us say that out of every 50 holes coming from the emitter 49 reach the collector

Continued on page 42



PHOTOS BY SYER

The Acousti-Magic Enclosure

An AUDIOCRAFT kit report.

BECAUSE a loudspeaker's performance is so closely related to the enclosure in which it is used, an enclosure is often designed specifically for one speaker or one type of speaker. Such an enclosure may be quite unsuitable for another speaker. Still, loudspeakers are being improved constantly, just as other audio components are, and they are being bought to replace older models; further, people buy more expensive speakers to replace budget models they started with. They are not anxious to buy new enclosures along with the new speakers, but very often they have to.

A manufacturer of kit enclosures, particularly when he does not supply loudspeakers to go with them, is accordingly in a difficult position. If he markets a rear-loading horn, for instance, it won't work well with bass-heavy speakers; a bass-reflex enclosure must be

Fig. 1. A cutaway view of Acousti-Magic.

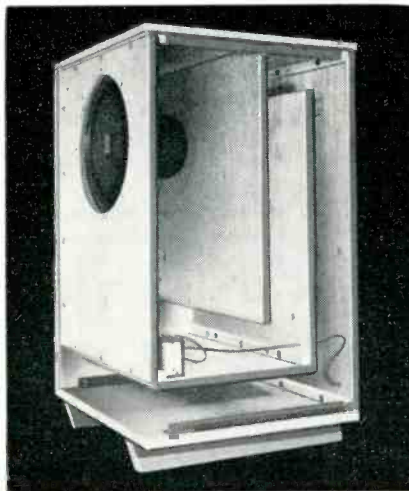

tuned to the speaker for good results; an infinite-baffle enclosure is fine, but only with speakers having low resonance frequencies. The ideal enclosure kit is one that will work well with any loudspeaker, so that it can be used with anyone's present speaker and with any other that he is likely to buy later. This is why Acoustical Development Corporation chose the acoustical labyrinth design for its Acousti-Magic enclosure kit.

The acoustical labyrinth, developed originally by Stromberg-Carlson, utilizes the broadly tuned antiresonance of a closed quarter-wave air column to damp loudspeaker cone motion at its natural bass resonance frequency. Center frequency of the column resonance occurs at about 35 cps; if this is below the speaker's free-air resonance frequency—and it will be in most cases—the speaker resonance will actually be lowered slightly, improving the bass response. A cutaway diagram of the Acousti-Magic construction is given in Fig. 1.

The labyrinth also forces the back wave of the speaker to travel 120 in. before it reaches the front of the cone. This is a half-wave length at 56.5 cps, and it produces bass augmentation in a fairly broad range around that frequency. Since the labyrinthine column walls are heavily lined with thick felt, frequencies much higher than that are trapped and absorbed, so that they cannot get through to produce cancellation.

Acousti-Magic kits are available in oak at \$64.75 and in mahogany at \$59.75. These prices include cut, sanded, and ready-to-finish top, bottom, and side panels in the chosen veneer ply-

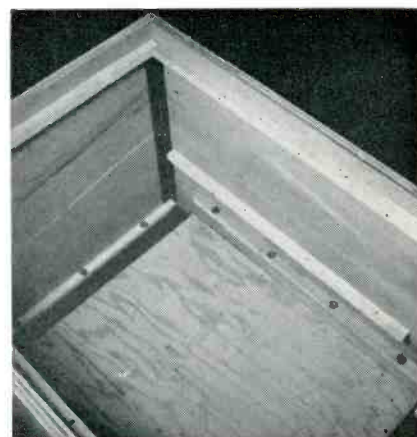

Sides are assembled with steel braces.

wood; matching hardwood base members, also sanded and ready to finish; internal baffle boards, cut to size and drilled; steel angles with which joints of the top, bottom, and sides are secured internally; a speaker mounting board cut to size and drilled, and with speaker holes cut to fit your speaker components; nuts, bolts, and screws as required, with some to spare; strips of adhesive-backed veneer to cover the plywood edge grain; a snap-in grille-cloth frame with grille cloth installed; a squeeze-bottle of glue; felt cut to the required lengths; a can of calking putty; and an elaborate, well-illustrated assembly manual with step-by-step instructions.

All wood parts are high-quality plywood $\frac{3}{4}$ in. thick—except for the two base pieces, which are of solid hardwood $1\frac{1}{8}$ in. thick. Screw cleats are already installed on all pieces, and all screw holes are drilled. Standard wood screws are not used; instead, the long truss-head machine screws supplied are



A front view with two baffles in place.

turned into T-nuts that are already installed on the screw cleats. The only exceptions are at the joints of the top, bottom, and side panels, where short machine screws driven into preinstalled anchor nuts hold the internal steel angle braces; and during attachment of the base pieces, for which small standard wood screws driven into drilled holes are used. The truss-head machine screws and T-nuts are the cleverest idea in kit construction I've yet encountered: they are very much easier for the builder to use, and are far more secure than wood screws.

Four sides of the enclosure are suitable for finishing, and the base pieces can be installed either on a long side or a short one. Inner edges of the base pieces are covered with thin strips of plastic material, so that they will not scratch the finished surface. At the front of each base piece is attached a brass lip that fits over the front edge of the cabinet and is screwed into place between the bottom panel and the grille-cloth frame; at the back, each base piece is secured by screwing a piece of thin plywood to its back edge, and then screwing this to the back panel. Thus the enclosure can be used with the long or the short dimension horizontal, and since installation of the base to any panel does not mar its finish, the low-boy installation can be changed to high-boy (or *vice versa*) as desired.

Construction Notes

Lock-miter joints are used for the outside panels; these fitted perfectly, as did every other panel. Alignment of screw-holes with nuts was made easily in every case. It wasn't even necessary to trim the felt. The result of such precision is that it is literally possible to assemble this enclosure with nothing more than a medium-sized screw driver and a tack hammer. (The hammer and a supply of 1/2-inch carpet tacks are needed to fasten the felt to the inner panels.)

The manufacturer suggests that the enclosure be completely assembled without glue first, for a two-week trial period. If there is any cause for dissatisfaction, it may be returned during this period for a full refund—a roll of packaging tape is even included for re-packing the kit! This is certainly an unusual guarantee, but we doubt that there will be many who take advantage of it. In any case, we recommend also that a trial assembly be made before any permanent bonds are made with glue; the illustrations are perfectly clear, all the panels are marked, and the instructions are rather complete, but it is always possible to make a mistake. You don't have to install the felt during this trial run either. It should take about an hour extra for this, but it will be time well spent. Photographs illustrating this article (with the exception of that showing the enclosure after finishing) were taken during our trial assembly.

Following are some notes we made as we went along. Most would be ob-



Same construction stage, seen from back.

vious to the builder on some reflection, but listing them may save him a little time.

Step 5. Baffle number 3 (marked B-3) is inserted between the glue blocks at the very edges of the side panels and the second set forward—not above the second set. It is positioned with the small odd hole (that for the speaker lead) at the bottom and to the right, viewed from above.

Step 7. The piece of felt referred to here is the one 18 in. long.

Step 8. Use the 80-inch length of felt here.

Step 11. Since our avocations do not include window glazing, we found it difficult to apply the calking putty—it stuck to our fingers much better than to the joints we were trying to calk. We were finally able to do it by kneading the compound between our palms until it was very warm; then, holding

a ball of this by-now limp and oozy stuff in the fingers of one hand, forcing it into the joint with the middle finger in a continuous motion along the intersection of the panels. We believe that other non-glaziers will do better with the rope putty that is used for sealing cracks in old houses, such as Mortite, or with a calking gun.

Step 13. The 70-inch piece of felt should be used.

Step 14. Keep baffle number 2 jammed as far as it will go toward the top panel while tightening the first screws on each side. This will make it easier to secure an air-tight seal.

Steps 20 and 21. It may be easier to change the order of these steps, particularly if you haven't a long speaker lead. Also, when attaching the speaker lead to the back panel, use the 1 1/2-inch screws—not the 2-inch ones. You'll need those later to attach the base pieces.

Step 24. When applying the wood-tape edging, cut the strips ever so slightly too long. We found that they shrank about 1/64 in. when they were ironed into place, possibly from being dehydrated by the heat.

Total assembly time, including the trial run, was 5 hours.

To finish the enclosure you'll need some flat black paint and a brush for it, in addition to your other finishing materials. The paint is applied to the speaker panel and to other exposed surfaces behind the grille cloth, so that they will not be visible through the cloth. Don't forget to paint the heads of the screws that will hold the speaker panel in place, if you elect to paint the panel before installation. We did; they gleamed brightly; we had to remove the grille frame later and paint the screws.

Our kit was in oak, and it was beautifully grained. We used a finishing kit from Yield House, consisting of

Continued on page 50

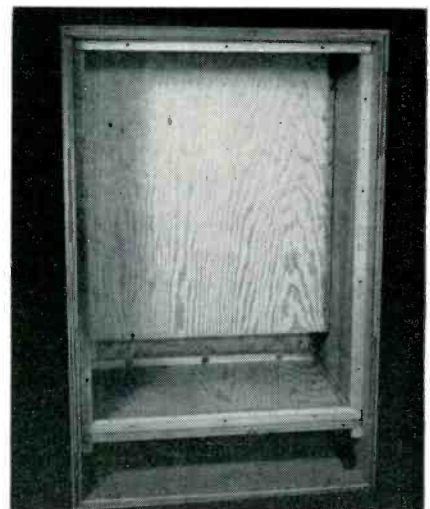

Third internal baffle is now installed.

LISTENING FOR QUALITY

by JOSEPH MARSHALL

Treble Response

Distortion can fool the ear at the high end of the frequency range just as it does at the low end. In fact, the inexperienced listener almost invariably mistakes distortion for good high-frequency response; it takes considerable experience before one is able to tell the difference immediately. Distortion can increase the apparent volume of sound at the high end and even extend, in some cases, the apparent bandwidth. Take, for example, a recording which cuts off at 10,000 cps; play it back on a system with high distortion, and you obtain a whole spectrum of sounds above 10,000 cps. What makes it especially difficult not to be fooled by this effect is the fact that the sounds above 8,000 cps resemble squeaks, chirps, hisses, and other noises more than musical tones. Accordingly, it takes a musically knowledgeable ear to distinguish between what we might call a natural sound above 10,000 cps and a purely artificial one produced by distortion.

When a distorting system emits a lot of high-pitched sounds, then, it is natural to conclude that the system has a wide bandwidth. And so, in fact, it does; for if it could not reproduce the sounds above 10,000 cps, whether they might be natural or the products of distortion, we could not hear them at all. Therefore, one possible test for wide treble response, especially in loudspeakers, is to generate a lot of distortion (or emphasize it by extreme treble boosting) and listen for the products of distortion. In this respect, those demonstrations at audio shows in which the treble is turned up do have a certain value, however painful they may be to the critical ear.

Clearly, it isn't how much treble but the quality of the treble you hear which is indicative of the quality of a system. An additional difficulty in judging treble response is that the treble response of the human ear varies with the individual and with age. Young ears can detect frequencies up to 20,000

cps and even beyond, but the response of most mature ears slopes off severely beyond 12,000 cps and cuts off entirely at some point beyond this. Moreover, the curve of any individual's hearing apparently may vary to some degree from day to day. Obviously, before attempting to judge the response of a system, one should determine, at least roughly, the response of one's own ears. Given an amplifier with a speaker system which covers the spectrum uniformly to some point between 15 and 20 Kc, the ear's sensitivity can be established roughly by listening to the reproduction of an audio generator as it is swept slowly from 10 to 20 Kc at a fairly constant volume level, and marking the point at which the signal seems to die out completely.

It is a simple matter with almost any normal ear to establish response up to around 10,000 cps. Voices provide excellent material for testing response between 5,000 and 10,000 cps because the sibilants which accompany such sounds as that of the consonant "s" and the combinations "sh" and "ch", the explosive hiss which accompanies the letters "t" and "d", and many other sounds incidental to speaking, fall into the range between 5,000 and 10,000 cps. The wider and flatter the bandwidth of a system the more natural the voices will seem.

The best musical test material for treble bandwidth is provided by the high-pitched percussives—the triangle, castanets, bells, celeste, cymbals, brushed trap drums, and so on; there is no lack today of recordings containing such material. But the mere fact that one can hear the sounds of these instruments is not very significant today. If this were the only criterion, it would weed out only the cheap table-model radios and phonographs. Every so-called high-fidelity system, even the cheapest mass production job, has sufficient bandwidth to reproduce most of the components of such sounds. The real quality of the treble response, particularly the flatness above 10,000 cps, has to be judged rather indirectly.

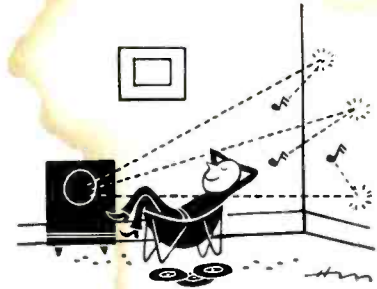

Assuming that you hear all these instruments, the first criterion of quality is cleanness. Such instruments as the triangle, the metal bars or tubes of the xylophone, celeste, and glockenspiel are precisely tuned. The tone is established by their physical dimensions and this can be adjusted precisely by grinding or polishing. For that reason, and because the resonant elements are homogeneous, the harmonic structure of these instruments is usually relatively precise. Therefore, the tone of a good triangle or celeste is clean and pure as compared, for example, with that of a horn in which the quality of the tone is determined by several variables, including the precision of the playing and the intensity of the wind, and which has a much more complicated harmonic structure. Indeed, the tones of the triangle, bells, and celeste are among the purest in an orchestra.

You can verify this for yourself if you take a fine water goblet and strike it with a knife or fork. Whatever the value of the tone in the musical scale, you will note that it is nicely clean and pleasant. On a poor system with a wide bandwidth but high distortion, or a peaked response curve, the sounds of the bells, triangles, and celeste are not clean. They are surrounded by sharp whiskery spikes of sound, a fuzziness, and a rather unpleasant jangle. On the other hand, on a system in which the treble slopes severely beyond 10,000 cps, the tone is dull, lacking luster and brilliance, just as if the glass had been damped lightly with a finger. The natural tones of triangles, bells and similar instruments are much less strident than those we hear in most hi-fi demonstrations. Stridency is the result either of frequency distortion by overboosting, which changes the harmonic structure and emphasizes the high-order harmonics; or peaked response, which also alters the original harmonic amplitude relationship; or of harmonic and/or intermodulation distortion, which adds components to the sound that not only change the harmonic pattern but depart entirely from the harmonic scale. When

listening to the highs of triangles and bells, then, listen for a brilliant tone but a clean one, without fuzziness or stridency.

In today's high-fidelity systems, the flatness of response above 10,000 cps is best determined by transient response and definition. The most easily available transients are those produced by hand clapping, finger snapping, tap dancing, heel clicking, etc. Recordings of Spanish flamencos provide excellent examples. The transient sounds are single pulses, not periodic wave forms. They may have a slight echo from room reverberation, but invariably they are single, sharp pulses of sound. The drumming of snare drums, temple blocks, and wood blocks also provides excellent transients of this type. These are usually series of pulses and, especially when the bursts are rapid, provide an excellent test. Again the sharper and more distinct the individual blows, the better the transient response; therefore, the flatter the response in the treble end (see also the section on transient response, to follow).

We have paid little attention to the middle-range response because with modern hi-fi equipment it can be presumed to be quite flat, and any departures from flatness in this region will affect the naturalness which we shall consider later.

Distortion

Low distortion is without doubt the most important single quality of a hi-fi system. Our success in producing equipment without significant distortion accounts very largely for the acceptance today of high fidelity, just as the relatively high distortion of older equipment accounted for the resistance to it. As we have seen, distortion, or lack of it, plays a large part in determining an acceptable bass and treble response. It has equally important effects on definition, transient response, naturalness, and fatigue factor.

In most of today's quality equipment the total distortion at normal listening levels in the home, including that contributed by the loudspeakers, seldom exceeds 2 or 3% average. Few ears are skilled and sensitive enough to distinguish *directly as distortion* values below the 3% point and, in consequence, it is quite unsafe to depend on the ear below that point. If you listened for distortion *as such*, the system with 1/4% might well sound very much the same as one with 3%. Yet the difference in over-all quality may be very marked, as evidenced in greater naturalness or better definition. Listening tests for audible distortion will eliminate only the poorest equipment. Certainly, if there is any audible distortion at all, you can pretty safely assume that something is wrong.

The best test for low-level distortion (not quite sufficient to hear, but suspected) is to listen to so-called dissonant modern music or progressive jazz. Very little of this music is really dissonant in the musical sense; it merely flirts with dissonance. The composer experiments, as it were, with very subtle harmonies to see how close he can come to outright dissonance without actually producing it. Aaron Copland is especially clever in this cliff-hanging performance. Although the result is very different from the rather mellow harmonies of Beethoven (which were considered dissonant in his day), analysis shows that most of it fits into the subtler forms of harmonic patterns. Whatever one may think of it as music, it does provide excellent tests for distortion because, if the harmonic pattern as written is modified even slightly by distortion, it will be unpleasantly dissonant. Almost any of Copland's music is excellent for this purpose, particularly *El Salón México*. On a system with insignificant distortion the sound, though never mellow, is interesting and not unpleasant; but on a system with considerable distortion the subtle harmonies are transformed into harsh, strident dissonances, unpleasant and even painful.

Progressive jazz flirts with dissonance even more outrageously and not infrequently is seduced by it. The high-fidelity recordings of such jazz therefore offer some delicate tests of distortion. It is significant that recorded progressive jazz did not achieve any real popularity until recording techniques and reproducing equipment were improved sufficiently to reproduce it without adding to the dissonance.

There is one kind of distortion which is likely to be all too evident even on superb systems—that produced by an overdriven phonograph pickup. This can be recognized by the fact that it is invariably accompanied by equally audible needle chatter. Fortunately,

broadcasts. Standards of the broadcast and recording industries (once the highest in the audio field), although they are being improved, are far behind those of high-fidelity reproducing equipment. It is well to make sure, therefore, that the distortion one hears is not on the record. This can usually be verified simply by reducing the volume level—if distortion disappears or is less evident, the fault is most probably in the amplifiers or speakers. Try also other records which develop the same loudness; if these have less or no distortion, the chances are that the first record is to blame.

Definition

A sound system with good definition will permit distinction among the fine details of sound, individual components of a chord, the individual instruments of an orchestra, or voices of a choir. A system with poor definition will blend or fuse the individual elements into a single indistinct sound. Low distortion, of course, is essential for good definition. Every information system including the ear has a limit of resolution—it can discern so many elements and no more. If the individual elements are compounded or multiplied by distortion, they become too numerous to be resolved. Transient response and freedom from generated transients such as hangover, ringing, and motorboating are also extremely important. A little hangover, for example, can reduce the definition of a system very seriously.

Because definition is a function of so many qualities, tests for definition provide one of the best and most severe checks of over-all quality. In fact, if I were limited to a single test, the definition test would be the one I would choose; and the difference between superb and merely good systems is almost invariably a difference in definition. Until recently it was not conclusive because recordings themselves

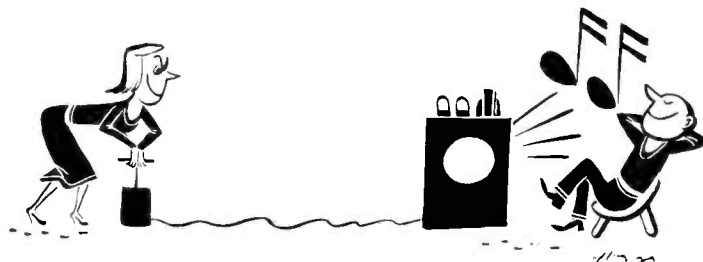

these units have been improved in their ability to track highly modulated grooves.

As a matter of fact, phonograph reproduction even when the best pickups and records are used is almost certain to have at least 5% IM (equivalent to between 1 and 2% harmonic) on the average peaks and more on the extremes. Most of this is on the record. The same is likely to be true of radio

had such poor definition that almost any playback system was superior. But most of today's good-quality recordings have excellent definition and some furnish material for really critical tests.

A favorite passage for testing definition is the final movement of Copland's *Third Symphony*. The opening is a fanfare played by drums and brasses. The fanfare is typically Copland; the harmonies of the horns playing to-

gether are exquisitely sophisticated. The brasses are punctuated by drums and tympani whose amplitudes rise as the fanfare develops. On a fine system it is possible to distinguish the separate horns, and almost to count them. The fanfare never resolves into anything even remotely resembling a single tone, or even the complex single tone of the mutant stops of an organ. The music should sound rather as a comb looks; that is, the separate tones of each instrument and the individual character of each instrument should be audible, just as the teeth on a comb are visible.

The complex counterpoint of Bach and some modern composers also provides tests of definition. It should be possible to follow each voice in the counterpoint and to distinguish between all of them. Unison choirs of similar instruments are very good also; the idea is to distinguish the blend into its component individuals.

Actually, tests of definition are simple and clear. By and large a system either has it or it hasn't. If it has, it will be clean, bright, and full of wonderful detail; if it hasn't, it simply will not be comfortable to listen to over the long run, regardless of how much bass or how much high-high response it has. The critical point for definition is in the bass end because it is here that the transient stability is likely to be poorest. Since most bass tones have a relatively high amplitude, they are most likely to trigger a system into hangover or outright instability, and thus degrade the definition.

Transient Response; Stability

Transient response has two aspects. On the one hand it involves the ability to reproduce transients or transientlike wave forms without modifying them. On the other hand, it involves freedom from generating transients within the system. Strictly speaking, a transient is a nonrecurrent and unsymmetrical phenomenon. Still strictly speaking, pure transients are as rare in nature as pure sine waves; most sound waves are mixtures or complex forms containing both periodic and transient components. Thus, the blow of a hammer on a block of wood produces a sound which is *largely* a transient, but not entirely so. Both the material of which the hammer is made and the wood have natural resonances and these, when excited, produce a sound which has both periodicity and symmetry, and this sound is added to the single burst of transient sound produced by the meeting of wood and hammer.

On the other hand, music which is predominantly periodic and symmetrical also has transient components. The characteristic features of transients are these:

(1) The sound reaches its peak in

an extremely short interval. The sound of the hammer blow may take only a few microseconds to build up from nothing to its peak amplitude. The frequency involved is extremely low, yet the reproducing system must be capable of handling very short time constants to reproduce the leading edge of the wave form. That means that it must possess good high-frequency response. The leading edge of a transient may be so steep that only a system capable of reproducing a 20,000-cps sine wave without modification has a short enough time constant to reproduce it.

(2) The frequency or recurrence rate of transients is extremely low. As a matter of fact, strictly defined, a transient has no recurrence rate and therefore no frequency. What we might call "audio transients" usually have a recurrence rate which falls somewhere between zero and some fraction or number of cycles per second. Perfect reproduction would therefore require a low-frequency response which approaches zero cps. The actual transient



should not be confused with the sound which accompanies it and which may have a fundamental frequency anywhere within the audible range or above it; this sound is a companion and a result of the transient but it is not the transient itself and entire.

Clearly, what we want in an amplifying system is the ability to reproduce faithfully the transients which accompany the music or generate noise incidental to the music. What we *don't* want is to have these transients generate any other kind of noises as they pass through the system. Each is extremely difficult to achieve and both simultaneously are almost impossible. And we have to compromise for the best possible *reproduction* of transients with the least possible generation of sound by the transients in passing through the system. A system of infinite bandwidth and complete flatness with no internal resonances of any kind would have a perfect transient response. Since high-fidelity systems, even the very best, have finite bandwidth and, as yet, cannot avoid resonance somewhere in the chain, their transient response cannot be perfect. Fortunately, the transient response of the ear is by no means perfect either; so long as the transient response of the

system is substantially better than that of the ear, the ear will probably not be able to recognize the small deformations of the reproducing system. Even this, however, is a large order and one which few, if any, systems can really fill.

A little reflection will indicate that testing transient response need not be as complicated as this explanation. The perfect transient would have instantaneous rise and instantaneous discharge time. No electronic, much less mechanical system, can have such rise and discharge time. Therefore, the leading and final edges and the top will have some tilt; but the more perfect the system, the less the tilt. It is clear that the shorter the rise and decay times, the greater the number of such transients per second or minute the system can reproduce cleanly and distinctly. Therefore, one excellent test is to feed the reproducing system with pulses of increasing rapidity or frequency and determine the point at which the pulses blend into each other instead of remaining distinct.

A rapidly rolled snare drum provides just about the closest equivalent in music to rapid pulses and, therefore, represents an excellent test of transient response. The better the system in this respect, the more clearly the separate rebounding blows of stick on drum will be evident. Another similar phenomenon is the sound of piano keys hitting bottom when they are rapidly trilled at the treble end. Beethoven's *Emperor* concerto provides many opportunities for the production of such rapid pulses, and many recordings preserve them with good enough transient quality to provide a fair test. Castanets also produce a rapid series of sharp pulses approaching the limit of the ear in their frequency rate. In all these cases, the more distinctly the most rapid series of such pulselike sounds are reproduced, the better the transient response.

The other condition for accurate reproduction of transients is that the audio system must not be triggered by the transient into producing accompanying or resulting transients in the form of thumps, hangover, ringing, blocking, or even momentary motorboating. Because transients usually have very high amplitudes well calculated to stimulate some portion of the reproducing system into a howl of protest, this is even more difficult to achieve. The instability usually occurs at one extreme or the other of the frequency response, simply because it is at the extremes that sound systems are most nonlinear and sometimes resonant. And the effects are most noticeable at the low-frequency end when it is excited by high transientlike bursts of bass tones, such as

Continued on page 53



Designing Your Own Amplifier

by Norman H. Crowhurst

Part V: Feedback Amplifiers

THERE are so many matters to consider in the design of a feedback amplifier that discussion of them will get rather confusing unless we use a practical amplifier for illustration. In this article let us work with the schematic diagram in Fig. 1, which shows the outline of a circuit with the components identified by numbers, and complete the design of this feedback amplifier step by step, filling in the values as we determine them. In this way we shall be sure to cover the practical problems that have to be solved.

A good feedback amplifier cannot be obtained by designing a reasonably good amplifier and then adding feedback for good measure. This approach, believe it or not, can sometimes produce an amplifier with greater distortion than one that does not employ feedback. The first thing to do is to go through the amplifier, starting at the output, and calculate the operating conditions for the tubes and the maximum levels they will handle, incorporating or allowing for feedback as we go.

Output Stage

Let's assume that we are designing a good 20-watt amplifier. For self-biased 6L6's in the output stage, the tube data manual shows the following tabulation of operating conditions for 24 watts output, with an optimum load of 9,000 ohms.

6L6's IN CLASS AB₁
(Values for 2 Tubes)

	Zero Signal	Maximum Signal
Plate voltage	360 v	360 v
Plate current	88 ma	100 ma
Screen voltage	270 v	270 v
Cathode resistor	250 Ω	250 Ω
Load	9 K	9 K
Power output	—	24 w
Harmonic dist.	—	4 %

We will assume that we shall use such an output circuit. That sets the cathode bias resistor, R17, at 250 ohms.

This 24 watts in the plate circuit will

be mean or average maximum watts, so the peak value will be twice this, or 48 watts. The formula $W = V^2/R$ can be altered to the form $V = \sqrt{WR}$, to determine the peak maximum-signal voltage across the primary winding of the output transformer. This is $\sqrt{48 \times 9,000}$ or 650. Then there will be a peak voltage of 325 volts on each half of the primary. We shall need this figure presently to calculate the inner feedback loop values of R15 and R16.

Next we move back to the grid circuit of the output stage. The total cathode current of the two 6L6's at maximum output is just under 120 ma. This current, in the 250-ohm bias resistor, will produce a bias of 29 volts at maxi-

prove convenient, because the feedback places extra demands on the paraphase action, as we shall see in a moment.

Using a plate-load resistor of 100 K, with a cathode resistor of 2.2 K and a plate supply of 250 volts at the junction of the three resistors R12, R13, and R14, will give a gain of approximately 13. These values will produce 3.7 volts bias with 1.7 ma plate current. The plate current of two tubes will be 3.4 ma and the drop in the common resistor, R14, will be 110 volts, from 360 to 250. This means that R14 should be about 33 K.

Now we must digress a moment to consider the voltages involved in the inner feedback loop. The purpose of this loop is to reduce the plate resistance

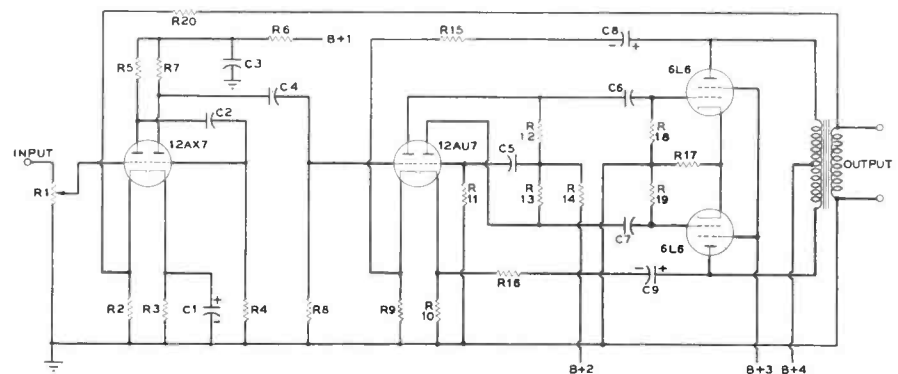

imum signal; which means the peak drive to each grid for maximum output also needs to be 29 volts.

Drive Stage; Inner Loop

The 12AU7 tube, shown in the drive stage, is similar to the 6SN7 except that it happens to be of the miniature type. In the article on the design of phase inverters it was found that a floating paraphase circuit could quite successfully provide a drive of about 29 volts to each output tube grid with a plate supply of 250 volts. We can obtain a good safety margin here by utilizing the plate supply for the 6L6's for the B+ to the 12AU7 tube, which is 360 volts. This will

Fig 1. Schematic for a feedback amplifier, whose design is developed in the text. The inner feedback loop uses components C8, C9, R9, R10, R15 and R16. Over-all feedback loop uses R2 and R20.

of the output stage to a point at which variations in output load impedance will not cause appreciable changes in the outer-loop feedback, thereby improving stability under varying load conditions. The plate resistance of the tubes is not listed, because it varies widely over the operating distance of the load line. A good estimate, however, would be that its average value throughout a signal cycle will not vary much more than

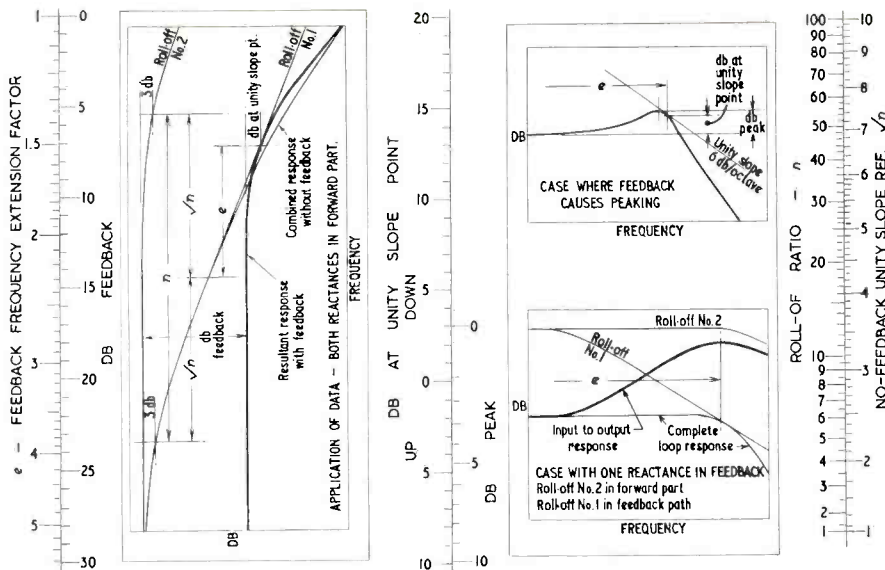

Fig. 2. This alignment chart is useful for computing the performance of feedback loops over two stages, or using two reactances contributing to rolloff at each end of the response. Use of a straight-edge across the scales gives all the information necessary to evaluate either low-frequency or high-frequency response. Diagrams show significance of quantities for high-frequency rolloffs.

about five times the optimum load resistance. Thus, if we can reduce this effective ratio by 5:1, using the inner loop, a change of load impedance from optimum value to open circuit will only change the outer-loop feedback by a 2:1 factor. This is an economic point to choose: further reduction will make unreasonable demands on the drive stage that will not produce commensurate advantage in the outer-loop stability; less reduction will sacrifice much in potential outer-loop stability.

Having settled that we need a 5:1 gain reduction by this inner loop, we can figure values and voltages. A gain of 13 from grid to plate of 12AU7 means that its grid-to-cathode swing has to be $29/13 = 2.2$ volts approximately. To reduce gain by 5:1, the grid-to-ground voltage must be $5 \times 2.2 = 11$ volts, while the cathode-to-ground voltage will be the difference, 8.8 volts. To get 8.8 volts across the cathode resistors, R9 and R10, from the 325 volts on the output tube plates, the feedback resistors R15 and R16 must be $2.2 \text{ K} \times 325/8.8 = 81 \text{ K}$. The nearest preferred value is 82 K, which will be close enough.

A voltage of 325 across a resistance of 82 K works out to almost 1 watt peak dissipation, so 1-watt resistors should be used. This indicates that these feedback resistors will absorb about 1 watt of available output, so if the output transformer is reasonably good, there should still be 20 watts left at the secondary.

The left-hand half of the 12AU7

will get its 11 volts grid-to-ground drive from the previous stage, but the right-hand half gets it from the floating paraphase junction.

The junction of the three plate resistors coupled to the grid of the second half of the 12AU7 by C5 has to produce a swing of 11 volts to match that of the first half; this must be produced by having the plate current swing of the first half greater than that of the second half by a sufficient amount to produce 11 volts swing in R14.

With our assumed plate-load resistors, 100 K, and a plate swing of 29 volts, each tube should have a swing of about 0.35 ma. To get a swing of 11 volts across the 33-K resistor R14, we need a difference in swing of 0.33 ma. If we choose values such that the average swing is 0.35 ma, and the difference in swing is 0.33 ma, we will need a swing of 0.52 ma on the first half tube and 0.18 ma on the second half tube. This you can figure by algebra or by any method you prefer.

The first, or left-hand, half of the 12AU7 must produce 29 — 11 volts across R12, because the 11 volts is in phase with this output; the current swing is 0.52 ma, so R12 should be $18/0.52 = 35 \text{ K}$. 33 K at 5% would be near enough. For the right-hand half, the current swing is to be 0.18 ma; the voltage swing, $29 + 11 = 40$ volts, so R13 must be $40/0.18 = 220 \text{ K}$. This will provide equal drive for both output grids. The operating conditions of the two halves of the 12AU7 will differ slightly, but any residual differences can now be taken care of by feedback, using close-tolerance values for resistors R9, R10, R15, and R16.

Thus we have now calculated the important values associated with the 12AU7 and 6L6 tubes. The grid resistors, R18 and R19, can be 330 K. This will be an approximate compromise between shunting down the 12AU7 too much and providing too high a resistance in the grid circuits of the 6L6 tube. The grid resistor, R11, can be 1 MΩ, to avoid shunting to any appreciable extent the 11 volts provided by the difference current. We shall consider R8 in the design of the 12AX7 amplifier stage.

First Stage; Over-all Feedback

Turning to the 12AX7 data we find that, with a plate resistor of 100 K, a plate-supply voltage of 180 volts, and the following grid resistor of 470 K, each tube section gives a gain of 52 and a peak output of 32 volts. Since we require only a peak of 11 volts, this gives a margin of approximately 3:1; distortion should be well down even before feedback is applied. The cathode resistor recommended with the following grid resistor of 470 K is 2,200 ohms. This data was obtained from the RCA tube manual. Similar information

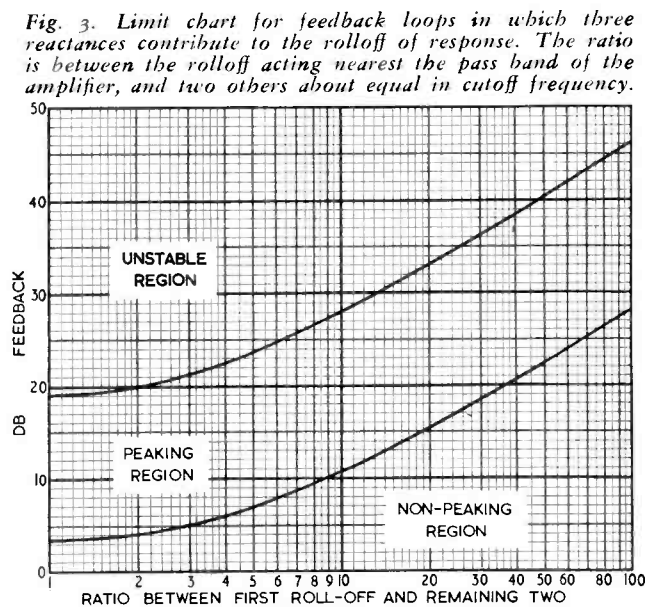

Fig. 3. Limit chart for feedback loops in which three reactances contribute to the rolloff of response. The ratio is between the rolloff acting nearest the pass band of the amplifier, and two others about equal in cutoff frequency.

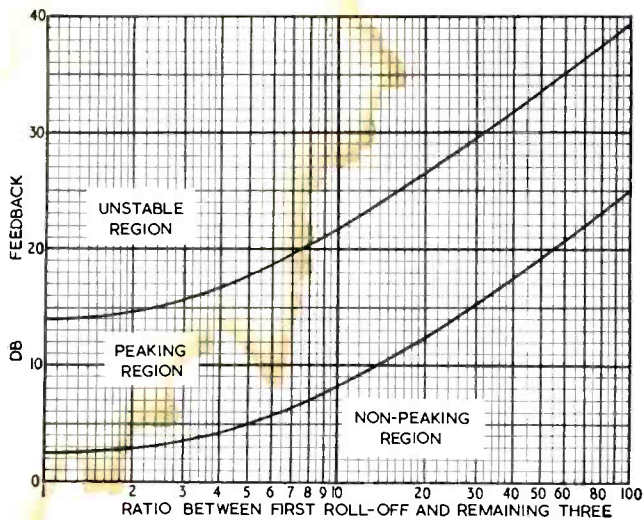

Fig. 4. Limit chart for feedback loops in which four reactances contribute to the rolloff at one end of the response.

could be obtained from any other manual, although the figures may differ a little, or data could be based on published curves as described in earlier articles.

Two stages, each giving a gain of 52, will produce a total over-all gain of about 2,700. If the output from these stages is to be 11 volts, the input must be about 4 mv.

We would like to end up with a damping factor of about 10. Therefore we must use about 20 db over-all feedback, which will reduce the gain by a ratio of 10:1 and increase the damping factor, at present approximately unity, by 10 times. This means that we will need to supply a signal of 36 mv peak across R2 from the secondary of the output transformer.

Assuming the output transformer is designed to match from 9,000 ohms to 16 ohms, the simplest way of calculating the voltage that should appear on its secondary is to figure out what voltage gives 20 watts across 16 ohms. This is 40 watts, since we are working in peak voltages, so the voltage will be $\sqrt{40 \times 16} = 25$ volts, approximately. Again working by voltage ratio, if we have 36 mv across 2.2 K ohms, R20 will need to be $25,000/36 \times 2.2 \text{ K} = 1.5 \text{ M}\Omega$.

This has given us all the resistance values in the circuit except R6, which we will consider later.

We now know that the amplifier will be driven to full output by an input of 40 mv peak, which is about 28 mv RMS. This is quite a convenient input, because it will produce full output on some low-level inputs. We might want to use a preamp, however, in which case 28 mv would be too small an input: most preamps have a normal output in the region of 1 volt. To take care of this we can insert a preset gain control

R1, for which a suitable value would be 250 K.

Low-Frequency Response of Inner Loop

Now we must tackle the question of suitable values of coupling and other capacitors. This is where the stability criterion and response factors of the feedback arrangement become important.

First we take the short-loop feedback; this includes, at the low-frequency end, the coupling capacitors C6 and C7 in the feedback loop. There are then two sets of reactor elements in this feedback loop. We want to keep the response of this section as flat as possible, and roll it off fairly sharply at the end of a band somewhat wider than the response band we ultimately require.

The charts in Fig. 2 are useful in the design of two-stage coupling arrangements with feedback. They give the response around the loop when the feedback is closed. To avoid any possibility of transient effects, the response should be not less than 6 db down on the scale on the left-hand side of the center line.

We are using a feedback ratio of 5:1, which represents 14 db. Aligning these two points, 14 db at the left, with 6 db in the center, we find that the rolloff ratio on the right-hand scale has to be almost 20. If C8 and C9 were not in the feedback loop—that is, if the output were taken across resistors R15 and R16 directly—then the rolloff would be 6 db down at a frequency determined by dividing the midway frequency, between the rolloffs given by C6 and C7 and their associated reactances, by the factor 2.24 (found on the left-hand side of the left-hand scale, opposite 14 db).

But C8 and C9 are in the feedback loop, and their reactance is included in series with the resistances R15 and R16 in determining the output voltage. So, if the low-frequency rolloff provided by C8 and C9 is 20 times that provided by

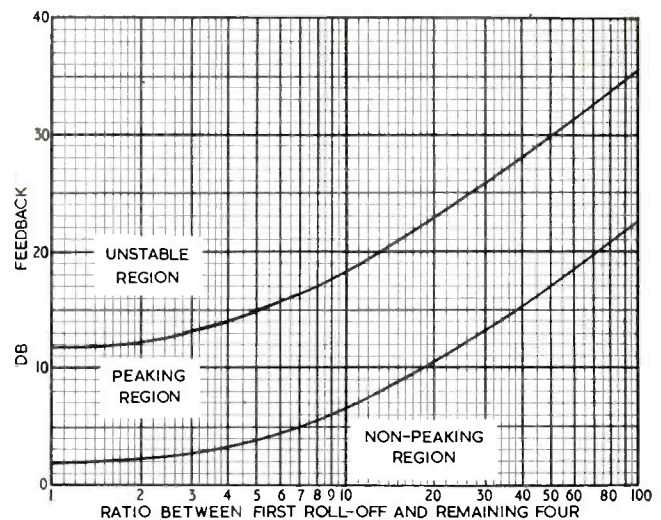

Fig. 5. Limit chart for feedback loops in which five reactances contribute to the rolloff at one end of the response.

C6 and C7, the resultant loop response would be about 6 db down at a frequency 2.24 times that of the rolloff at C6 and C7. But at this frequency the reactance of C8 and C9 would be about 9.5 times the resistance values of R15 and R16, which means there would be a boost of almost 20 db, added to the loss of 6 db, producing a resultant peak of about 14 db at this frequency.

To avoid this effect it is necessary to have the rolloff provided by C8 and C9 operate at a frequency lower than that provided by C6 and C7. Then we shall be perfectly safe, and the effective rolloff frequency will be much lower than that without feedback. Therefore, we pick values of C6 and C7 to give a rolloff at 20 cps. With R18 and R19 at 330 K, the reactance of C6 and C7 should be somewhere around 330 K at 20 cps. A suitable capacitor value is .025 μfd .

Now we need a value for C8 and C9 that will roll off at 1/20th of this frequency, or at 1 cps. The reactance required is 82 K; a capacitor to give a reactance of 82 K at 1 cps is 2 μfd . Small tubular electrolytics can be obtained with a capacitance of 2 μfd at a working voltage of 450 volts. These should be quite satisfactory for C8 and C9. The signal-voltage swing at this point is 325 volts peak, so any leakage current is not likely to introduce noticeable noise in the circuit. The 14 db of feedback over this output loop will reduce the effective rolloff point of C6 and C7 by a ratio of 5:1, so that now the rolloff of these two stages will be 3 db at about 4 cps.

To avoid unbalance, or phase shifts at the low-frequency end, C5 should roll off well below 4 cps in conjunction with the 1-M Ω grid resistor. A 0.25- μfd capacitor gives a reactance of 1 M Ω at about 0.65 cps. This should be quite

satisfactory for this position in the circuit.

High-Frequency Response of Inner Loop

The high-frequency end is not so simple to evaluate in exact terms. We can only make a guess at it. The plate resistance of the 12AU7 is listed at 7,700 ohms. This will be from each plate to ground, and the capacitance shunting this resistance will be that of the stray wiring including the coupling capacitors C6 and C7, which are quite small physically, and the grid input capacitance of the 6L6's. This should not add to more than about 50 $\mu\mu\text{fd}$ altogether, which has a reactance of 7,700 ohms at about 400 Kc.

To comply with the no-transient-distortion condition previously specified, we need to have a 20:1 ratio in high-frequency rolloff frequencies. In the output circuit, the 6L6 has a plate-to-plate load resistance of 9,000 ohms, which takes the form of 2,250 ohms from each plate to ground. The plate resistance will be about 10 times this value, or 22,500 ohms per tube. Assuming the amplifier is correctly loaded with its 9,000 ohms plate-to-plate, the impedance at each plate will be about 2,000 ohms to ground, or 8,000 ohms plate-to-plate. This should then be bypassed with a capacitor that will give a rolloff at 20 Kc. At 20 Kc a reactance of 8,000 ohms would be given by a .001- μfd capacitor, connected across the primary of the output transformer.

Without feedback this would give a rolloff of 3 db at 20 Kc. The effect of the feedback, with the staggered roll-

Now we can proceed to determine the circuit constants for the rest of the amplifier to suit the 20 db feedback applied over-all.

The reactances contributing to low-frequency rolloff are the coupling capacitor C2, the coupling capacitor C4, the pair of coupling capacitors already considered, C6 and C7, and the primary inductance of the output transformer. Thus the main feedback loop has four reactance stages that contribute to low-frequency rolloff. This means we can use the limit chart of Fig. 4 to determine the ratio of rolloff frequencies to be used (Figs. 3 and 5 are similar charts for three and five reactance stages, respectively). These charts give the ratio by which one cutoff frequency should be nearer the pass band of the amplifier than the remaining ones, in order to determine the criterion of stability and also the point at which peaking begins to occur.

If we can make one of the RC networks have a rolloff frequency about 50 times higher than the remaining three, we shall almost avoid peaking completely, and have a very good stability margin. As we have already made the output end of the amplifier look like an arrangement with a rolloff at 4 cps, we can proceed to make the rest of the amplifier look like this and arrange for one capacitor to roll off at 200 cps.

The primary inductance of the output transformer should not show a loss of more than 3 db at 4 cps at low levels, if it is not to distort at 20 cps, because pentode tubes run into distortion quite quickly with elliptical loads. If a high-quality output transformer is being used to avoid this distortion, the inductance

feedback provided is 20 db, so this will extend the rolloff downwards, by a factor of 10:1, to 20 cps. The rolloff at 20 cps will be considerably sharpened by the fact that it is not a single reactance rolloff, but that by now the other three reactances around the loop are contributing. It is a good feature to have a sharp rolloff below 20 cps to filter out hum and other undesirable effects.

The 12AX7 stage will give an output of 32 volts peak successfully. The signal handled by the first tube section is normally only 52×4 mv peak, a little more than 200 mv. When the feedback disappears, because of the reactance of C2 at 20 cps, the voltage swing at the plate of the first half of the 12AX7 will rise to about 10 times this value, or a little over 2 volts, which is still well within the voltage-handling margin of the tube.

We can see now why C2 is the best place to put the smaller coupling capacitor. If C4 were used for this extra rolloff purpose, the signal amplitude at the plate of the second half of the 12AX7 would also be multiplied by 10 times at the bottom end of the frequency band, and there is not enough margin to allow for this. The signal there is already 11 volts peak; 10 times this would raise the signal to 110 volts peak, which the 12AX7 should certainly not be expected to deliver.

High-Frequency Response, Outer Loop

Applying the same reasoning to the high-frequency rolloff, there are four high-impedance points that will be shunted by different capacitance values: the first and second plates of the 12AX7, each plate of the 12AU7, which is in push-pull, and the plates of the 6L6's, also in push-pull.

The effective rolloffs of the last two have been modified by the inner-loop feedback arrangement so that both are effectively at 190 Kc. The plate resistance of the 12AX7 is quoted at 62.5 K, but for a higher operating level than is used here. An estimate of 100 K should be safe for this condition. The total capacitance in the grid circuit of the first 12AU7, with 14 db feedback effective, should not be more than about 10 $\mu\mu\text{fd}$, which has a reactance of 100 K at about 160 Kc. This is reasonably consistent with the pattern so far.

Applying the same method as that used at the low-frequency end, the plate circuit of the first half of the 12AX7 should have a rolloff at about 1/50th of 160 Kc (taking the lower figure), or 3.2 Kc. A capacitor to give a reactance of 100 K at 3.2 Kc is 500 $\mu\mu\text{fd}$; this we put across the second-stage grid resistor. With 20 db feedback

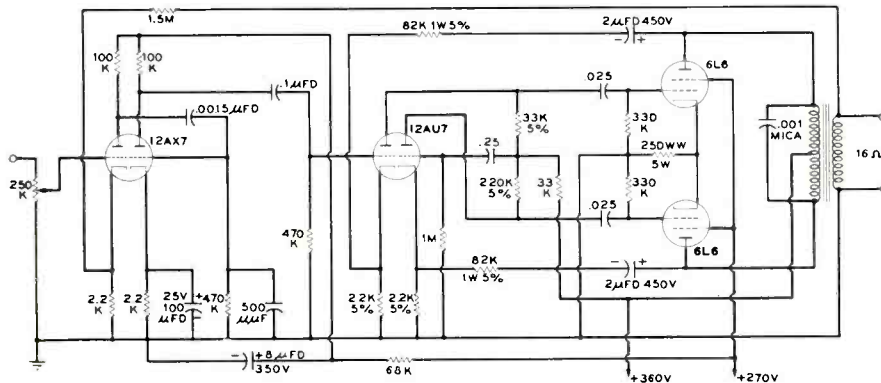

Fig. 6. The complete amplifier circuit, with circuit values and voltages shown.

off arrangement, is to increase the rolloff frequency to about 9.5 times 20 Kc for 6 db loss, or 190 Kc. There will then be no detectable loss at 20 Kc.

Low-Frequency Response, Outer Loop

We have the last two stages designed, complete with feedback, to give rolloffs of 3 db at 4 cps and 6 db at 190 Kc.

of the transformer should be satisfactory.

It remains to set the rolloff provided by C4 at 4 cps also; a value of .08 μfd will provide a slight margin for error in tolerance.

Finally, we utilize C2 to provide the earlier rolloff at 200 cps. C2 should then be .0015 μfd , which gives a reactance of 520 K at 200 cps, again allowing a slight margin for tolerance error.

Does not this mean the entire amplifier will now roll off at 200 cps? The

Continued on page 45

by George L. Augspurger

and

LOUDSPEAKERS ENCLOSURES

III: Resonant Enclosures

IN the preceding articles in this series we have dealt with such terms as stiffness and mass in rather offhand fashion, but to understand the action of tuned cavity enclosures it is essential to have a clear picture of the analogy between electrical, acoustical, and mechanical elements. Before getting in any deeper, then, let's review a few basic electro-acoustic concepts.

We learned in high school physics that any object has mass, and that mass is associated with inertia. The greater the mass, the more force is required to speed it up or slow it down: witness the emphasis on "horsepower-to-weight ratio" in automobile advertising. In

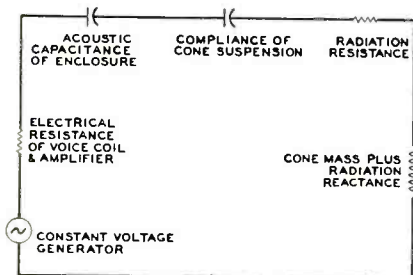

Fig. 1. Equivalent low-frequency circuit of loudspeaker mounted in an enclosure.

electronic circuits a similar quality—inductance—is found in inductors, which oppose any change in the current flowing through them; and in acoustic systems, the analogous property is called *inertance*.

Another function of certain mechanical, electrical, and acoustical elements is that of storing energy. Mechanical energy can be stored in a spring while it is held compressed—energy increases while the spring is being compressed, and decreases if the spring is allowed to expand. Most of us would call this attribute "springiness", but the term is too ambiguous for use in physics; is a stiff, heavy spring more or less springy than a light, supple one, for example? Consequently the term "stiffness" is used, which is clear enough,

or, better yet, *compliance*. Compliance is the obverse of stiffness, and has the advantage of being directly analogous with capacitance. Electrical capacitance is a measure of the ability of charged

Fig. 2. Apparatus for demonstrating the effects of resonance.

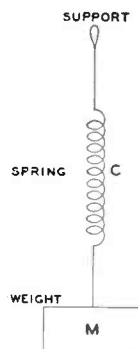

plates to store electrical energy, and acoustical capacitance is associated with the "springy" properties of compressed gas.

Resistance in electrical circuits is directly associated with friction in mechanical systems. But in acoustics we have two types of resistance: fluid resistance, or *viscosity*, and *radiation resistance*. Of all the terms mentioned, radiation resistance is the only one which has to do with the production of sound waves. If all the power fed to a loudspeaker could be dissipated in radiation resistance, the speaker would be 100% efficient and a five-watt amplifier would shake the Hollywood Bowl.

Now let's see how these analogies apply to a simple loudspeaker in an enclosed baffle, such as that described in last month's article. At low frequencies, the air inside the cabinet is being alternately compressed and rarefied by the action of the speaker cone. The air behaves as an acoustic capacitance whose value is proportional to the volume of the enclosure. An additional capacitive element is the cone suspension of the speaker. The compliance of the cone suspension plus the acoustic capacitance of the enclosure

act like two electrical capacitors in series: the total compliance is less than that of either suspension or air volume alone.

The mass of the cone and the air it moves is effectively in series with the combined capacitance of the suspension and enclosed air, to form a simple resonant system. The resonance is damped by a resistance composed of friction in the cone suspension, viscosity losses between the cone and surrounding air, and radiation resistance associated with the sound waves being produced. Also in series is the electrical resistance of the circuit. Fig. 1 is the electrical representation of an enclosed-cabinet loudspeaker at low frequencies (from Langford-Smith's *Radiotron Designer's Handbook*).

This all seems quite elementary, and when I suggest the following experiment you may feel that your intelligence is being insulted. Farfetched as it appears, however, all this is leading up to the problem of bass-reflex enclosure design. Most people are quite willing to believe that a reflex system works; they may even be able to manipulate the mathematics which prove that it works; but they are at a loss to supply any convincing physical explanation of why it *should* work. If

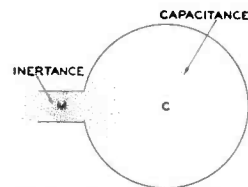

Fig. 3. Elements of acoustic resonance.

you will string along with my kindergarten physics experiments I will try to demonstrate this.

Let us consider a certain mass fastened to a spring, as in Fig. 2. If the upper end of the spring is held stationary, this forms a simple resonant system whose frequency of oscillation depends on the mass of the weight and the

compliance of the spring. The system is clearly analogous to an enclosed-cabinet loudspeaker system (neglecting the resistances and electrical characteristics of the speaker) and it is also

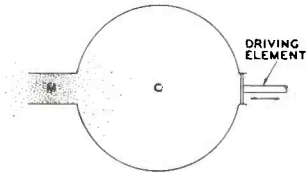

Fig. 4. Resonant cavity with excitation.

analogous to a Helmholtz resonator. Fig. 3 shows such a resonant chamber in which the enclosed air volume supplies the acoustic capacitance, and the mass of the air in the tube acts as inductance.

I suggest you find a spring and weight for yourself to be convinced that the next step really works (I used a pair of scissors and a long rubber band). If you hold the spring from the top and move it up and down very slowly, the weight will follow the

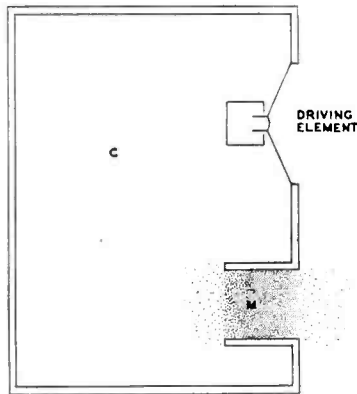

Fig. 5. Reflex enclosure is a resonator.

movement of your hand quite closely. But if you joggle the spring rapidly, it will expand and compress while the weight remains stationary. In the first instance, the frequency is so low that the inertia of the weight is negligible; movement is transmitted through the spring and duplicated by the weight *in phase* with the driving element

(you). In the second, the frequency is high enough that the reactance of the spring is virtually zero compared to that of the weight, so virtually no movement is transmitted at all.

Hold the top of the spring immobile for a moment and note the resonant frequency of the spring and weight. If you now jog your hand at precisely that frequency, only a small motion on your part will keep the weight bouncing up and down with considerable amplitude—nothing surprising in that. But you will notice that your hand (the driving element) and the weight (the driven element) are moving in *opposite directions*; they are precisely 180° out of phase.

The same thing happens if we introduce a diaphragm into a Helmholtz resonator to drive it at its resonant frequency (Fig. 4). The diaphragm (driving element) and the mass of air in the duct (driven element) move in opposite directions to sustain oscillation at resonance. Notice also that so long as introduction of a driving element does not change the volume of the chamber, it has no effect on the resonant frequency of the system. The size, mass, shape, or suspension of the driving element may influence whatever is moving it, but they will not change the action of the Helmholtz chamber.

At frequencies above and below chamber resonance, the acoustic chamber will also behave in a way similar to our mechanical representation. Below resonance the inductance of the air in the duct ceases to be important, and the air moves in phase with the diaphragm; the chamber no longer exists, so far as the diaphragm is concerned. At frequencies higher than resonance the air in the duct hardly moves at all and the diaphragm is effectively pumping into and out of an infinite baffle.

In practice, as can be verified with your scissors and rubber band, these changes take place in the space of two octaves. Thus, if the natural resonance

of such a system is 50 cps, at 25 cps the enclosure offers practically no load at all to the diaphragm, while at 100 cps it acts as if it were totally enclosed.

If this acoustic circuit is redrawn so that both driving and driven elements are on the same side, it takes the form of a conventional bass-reflex speaker cabinet (Fig. 5). The speaker cone is the driving element and the air in the duct is the driven element. At the resonance frequency of the enclosure the phase of the speaker back wave is reversed as it issues from the port, and is *in phase* with the front wave so far as the surrounding air is affected. The back wave of the speaker has been successfully added to its front radiation at this frequency.

One more experiment with the mechanical representation. If you dunk

Courtesy Pro-Plane Sound Systems, Inc.

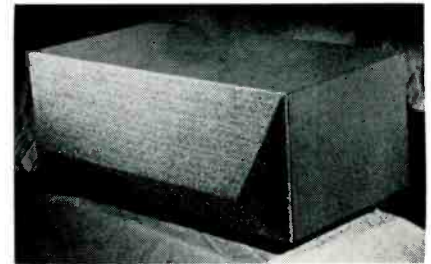

Fig. 8. A Pro-Plane ducted-port system.

the weight of your model in water and set it oscillating again, the amplitude of the movements will be much less and they will die out much sooner. The viscosity of the liquid changes some of the energy to heat, and more work has to be expended to keep the thing going. In a Helmholtz resonator acoustic resistance is supplied both by the viscosity of the air in the duct and the radiation resistance at the mouth of the vent. The driving element has no effect on the damping of the resonant chamber. It will be well to remember the following:

1) The frequency of resonance and degree of acoustical damping in a resonant chamber are independent of the

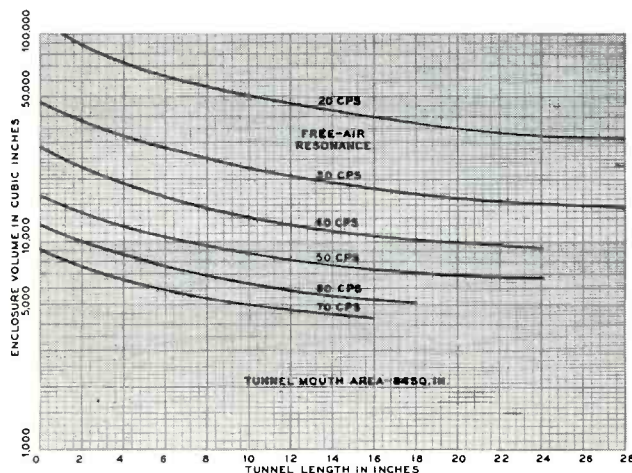
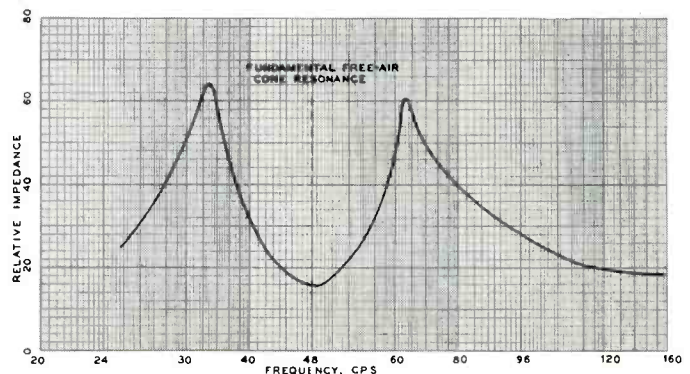

Fig. 6, left. Design chart for ducted-port reflex enclosures.

Fig. 7, below. Impedance curve for properly tuned bass reflex.



Courtesy Jensen Mfg. Co.



Fig. 9. Bass Ultraflex system by Jensen.

driving element. If a Helmholtz chamber booms without a speaker driving it, it will continue to boom once the speaker is added. The speaker cannot damp the resonant chamber.

2) The resonant chamber, on the other hand, *does* damp the speaker. At resonance the enclosure supplies a purely resistive load to the speaker, and the cone must overcome both its own radiation resistance and that encountered by the mouth of the port. If the areas of the speaker cone and reflex port are equal, at system resonance the speaker cone area is effectively *more* than doubled. This is true because the amplitude of air movement in the duct is much greater than that of the speaker cone.

Since the action of the resonant chamber is not affected by its driver, you may wonder why any attention is paid to matching the speaker and enclosure. The answer is to be found in the second statement: at its resonance point the enclosure damps the speaker; by designing the cabinet so that its acoustic resonance is at the same frequency as the speaker's cone resonance, several advantages are gained. Whereas in an infinite baffle the cone excursions are greatest at resonance, in a properly tuned bass-reflex system they are very small at this frequency because the cone is loaded by the high acoustic resistance of the enclosure; therefore, distortion is reduced. Both sides of the cone contribute to the acoustic output, and bass response at the resonance frequency is about 3 db higher than from the same speaker in an infinite baffle. The speaker cone is highly damped, distortion is lowered, and transient response is improved.

These are advantages generally claimed for the matched bass-reflex design. The bit about transient response deserves a little comment, however. It is true enough that the ability of the

speaker cone to follow transients is improved with the damping offered by a reflex cabinet—but this damping is effective over a range of a little less than an octave, and the acoustic boom of the Helmholtz chamber is still there—no amount of matching will remove it. The only way to damp the acoustic resonance of the enclosure, if it is objectionable, is to add viscous resistance. I say *if* it is objectionable because the majority of listeners prefer the "live" quality of boomy bass so long as they are assured by the salesman that it isn't there.

The resonance frequency of a Helmholtz chamber can be changed either by varying the volume of the enclosure (acoustic capacitance) or the size of the duct (inertance). The area of the mouth of the port is generally chosen to equal the cone area of the speaker, since this seems to give best results. Fig. 6 is a chart showing the relationship between duct length and enclosure volume, for several cone resonance frequencies, in a cabinet designed to be used with a 12-inch speaker.* Note that

Courtesy Altec Lansing Corp.

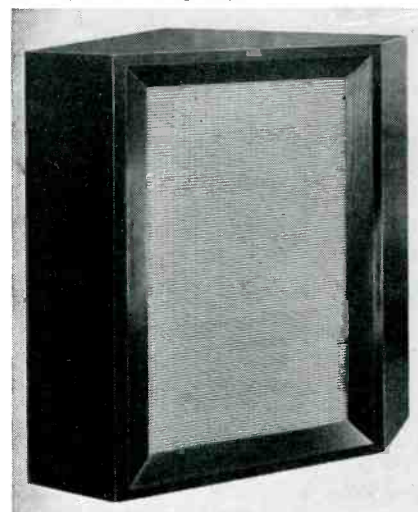

Fig. 10. Altec Lansing reflex enclosure.

when computing cabinet volume the space occupied by the speaker must be subtracted. A 12-inch driver normally reduces cabinet volume by 600 to 700 cu. in.

It is difficult to imagine what supplies the acoustic inertance in an ordinary bass-reflex cabinet which has no duct, but simply a rectangular port cut in the front panel. In this case the effective duct length is *not* the thickness of the wood. A sort of "lump" of air extending for some distance on each side of the port moves as a unit, and it is this lump which supplies the necessary inertance. Determining the resonance frequency of such a cabinet is largely empirical, as some experimenters have found out after tangling with gas laws and Bessel

* From the *Radio Designer's Handbook*. Data supplied by Goodmans Loudspeakers.

functions. The best idea is to make the port area adjustable with some sort of sliding panel, and then tune the enclosure to the speaker. Ducted enclosures can be tuned by making the cabinet resonate at a frequency lower than that desired and then throwing in blocks of wood to reduce the volume until best results are obtained.

Reflex cabinets are tuned most easily by running impedance curves with the system assembled. Using a measuring setup such as that described in the preceding article these curves can be run quickly. Since speaker impedance below 500 cps is almost pure motional impedance, the curve gives a direct indication of relative cone amplitude, and the system is tuned correctly when a dip in impedance occurs exactly at the resonance frequency of the speaker. The fundamental resonance of the speaker should be checked first in free air after being used for awhile; don't assume that the manufacturer's specification is accurate, because cone resonance frequency cannot be controlled precisely and is likely to change significantly during a break-in period.

A speaker mounted in a vented enclosure will have a bass-impedance curve similar to that in Fig. 7. When the acoustic resonance of the cabinet is properly matched to the speaker, the dip between the two impedance peaks should occur at the free-air resonance frequency of the speaker cone and the two peaks should be symmetrically spaced on each side. The peaks will vary in amplitude depending on the dimensions of the cabinet, but for best results they should not differ by more than two or three db.

For a given port area a ducted enclosure can be built into a smaller cabinet than the plain vented variety. A limit is reached at the point where the duct incremental volume is larger than the accompanying reduction in cabinet volume. Furthermore, the duct must be kept fairly short because it behaves as a tuned pipe at frequencies whose wave

Continued on page 47

Courtesy James B. Lansing Sound

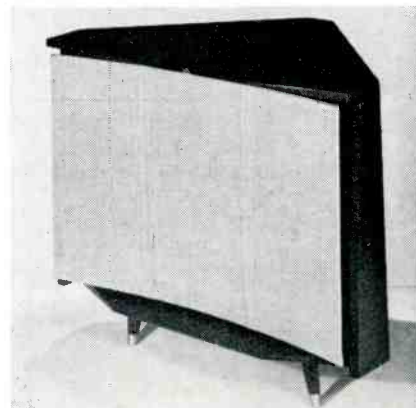
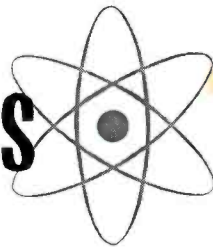

Fig. 11. The James B. Lansing "Jordan".

BASIC ELECTRONICS



by Roy F. Allison

XI: Inductance in AC circuits

IT WAS demonstrated in Chapter VI* of this series that a changing value of current in an induction coil produces an opposing voltage in the coil — a voltage of self-induction — that acts to limit whatever change in current is occurring. This voltage can be expressed in the equation

$$e = -L \frac{di}{dt}$$

where L is the coil inductance in henries, di/dt is the rate of change of current in amperes per second at any

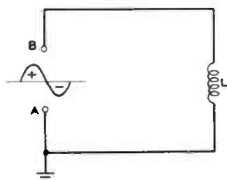

Fig. 1. AC sine waves applied to choke.

given instant, and e is the voltage at the same instant acting in opposition to the current change; e is in volts, of course.

Referring still to Chapter VI, it will be recalled that this opposing voltage prevented an instantaneous change in circuit current when the source voltage was suddenly applied or removed. Rather, the current assumed its new value in a sluggish fashion; its terminal value was reached some time after the source voltage change occurred.

Now, assume that instead of DC pulses we apply a sine wave of voltage to an inductor, as shown in Fig. 1. This will be applied between terminals A and B, with A as the reference terminal. During the first part of the sine-wave cycle, B rises from zero voltage with respect to A to a maximum positive value, then decreases through zero to a maximum negative value, and rises to zero again. We have drawn only one cycle, but it will be understood that this process repeats itself over and over again, at a rate determined by the sine wave's frequency. What will be the current in this circuit?

We know already that the current follows changes in applied voltage at some time interval, so that we can reasonably expect the current wave form to look like a delayed replica of the applied voltage wave form — provided that a single fre-

quency is involved. A pure sine wave is, as we have seen in the preceding chapter, a single frequency. Further, we know that the rate of change of current will be directly proportional to the magnitude of the applied voltage. This must be so because the opposing voltage set up by the coil is proportional to the rate of current change within it, and this same opposing voltage has to be equal to the applied voltage — the coil is connected directly across the source.

The applied voltage wave form is drawn enlarged in Fig. 2. We have reasoned that 1) the current wave form will be a sine wave also; 2) it will be displaced somewhere to the right of the voltage wave form, because it will occur later in time; and 3) its rate of change will be everywhere proportional to the magnitude of the applied voltage. Now let us examine Fig. 2 closely. At point 1 the value is changing rapidly, and also at point 3; as a matter of fact, the value of a sine wave changes most rapidly when it goes through the zero points. Near the extreme excursions of the wave form its value changes least rapidly; at points 2 and 4, the instantaneous rate of change is zero. Thus, point 1 on the current wave form — one of the points at which its rate of change is maximum — must correspond with either point 2 (Fig. 3a) or point 4 (Fig. 3b) on the applied voltage wave form, since these points are those of its maximum magnitude. Similarly, point 2 on the current wave form, which is a point of zero rate of

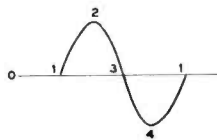

Fig. 2. Significant points on sine wave.

change, must coincide in time with one of the zero-magnitude points on the voltage wave form: point 3 (Fig. 3a) or point 1 (Fig. 3b).

We have noted that the coil's voltage of self-induction is always opposite in polarity to the applied voltage and, in this circuit, of equal magnitude. Consideration of this, and the fact that the voltage induced by changing current is always in a direction such as to prevent the current changes, makes it obvious

that the diagram in Fig. 3a is the correct one. The current is out of phase with the voltage, lagging it by 90° . This can be stated as a formal rule: *In a purely inductive circuit, or in any pure inductance, current lags an applied AC voltage by 90° .* A mathematical proof is given in the appendix.

Chapter VI brought out also that current in an inductive circuit never quite reaches its limiting magnitude after an applied DC voltage is changed; it approaches it more and more closely as time goes on, but theoretically never reaches it. If we do not allow the current time enough to build up appreciably before we remove the source voltage, nor permit it to decay very much before we apply the source voltage again, then the variations in current will be smaller than they would be if we were to allow longer periods of time for the buildup and decay to occur. By flipping the switch still more rapidly, the variations in current will be made smaller yet. A similar situation exists when alternating voltage is applied to an inductive circuit. The faster the voltage polarity reverses — that

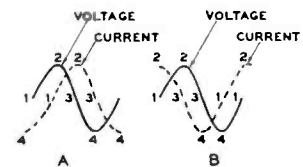

Fig. 3. Possible reactive I-E wave forms.

is, the higher the frequency of the applied voltage — the less time there is for the current to build up in either direction, and the smaller will be the AC current that flows. Not only does an inductor delay an AC current through it by 90° , then, but it limits its value as effectively as a resistance would. An inductor "chokes" an AC current; hence the origin of the synonym *choke* for inductor.

With a larger choke in the circuit, current builds up more slowly; therefore, in any given interval, it changes value less. In a purely inductive circuit, AC current is inversely proportional to frequency and inductance and, of course, directly proportional to the applied voltage. Its exact value is given by

$$I = \frac{E}{2\pi fL}$$

where I is the current in amperes; E is

* AUDIOCRAFT, Apr. 1956.

voltage across the inductor; π is the numerical quantity pi, approximately equal to 3.14; f is frequency in cps; and L is inductance in henries. If E is the RMS or effective value, I will also be the

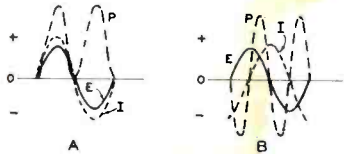

Fig. 4. Instantaneous values of power developed in resistance and reactance.

effective value and, if E is the peak value of the applied AC voltage, I will be the peak value of the AC current.

Upon examination of this equation it will be seen that the term $2\pi fL$ has replaced R in the familiar Ohm's-law equation $I = E/R$. This is only logical, since $2\pi fL$ determines current magnitude for a given voltage, just as R does. It is even expressed in ohms, but it is called *inductive reactance* (X_L). The formula is, then, $X_L = 2\pi fL$, and will be in ohms if f is in cps and L is in henries. As an example: refer again to Fig. 1. Assume that the applied voltage, E , is 10 volts (effective value), and that its frequency is 60 cps. If L is 5 h, then

$$I = \frac{E}{X_L} = \frac{E}{2\pi fL}$$

$$I = \frac{10}{2 \times 3.14 \times 60 \times 5} = 5.3 \text{ ma.}$$

It should not be thought that reactive ohms are the same as resistive ohms, however. For one thing, a reactance does not dissipate energy in heat, as a resistance does. The energy stored in the inductive field twice each cycle during the times of current buildup is returned to the source when the field collapses. This is illustrated clearly in Fig. 4. Current, voltage, and power (the product of current times voltage) are plotted for one cycle of an applied AC voltage for a pure resistive load, Fig. 4a, and for a pure inductive load, Fig. 4b. With a resistive load the current is perfectly in phase with the voltage throughout the cycle; when one is positive so is the other, and when one is negative the other is also. Thus the product of the two, which represents power, is either zero (when E and I are both zero) or some positive value, because the product of two positive quantities or two negative quantities is positive. The average power throughout the cycle is equal to the effective value of I times the effective value of E . With an inductive load, however, E is not in phase with I ; during some parts of the cycle both quantities are of the same sign — both being positive or negative — and their product is accordingly positive. But in other parts of the cycle E and I are of opposite sign, so their product (representing power) is then negative. While the power curve is positive, the source is delivering energy

to the inductor, which is stored in its field; while it is negative, this stored energy is being returned to the source. The average power over the entire cycle is zero.

Another very important difference between the two kinds of ohms is that the phase of inductive reactance must be taken into account when reactance and resistance are combined. Suppose that an inductor is connected in series with a resistor and an AC voltage source, as shown in Fig. 5. Whatever current flows through R must also flow through L , and through the source; moreover, it must flow through them all simultaneously, since they are in series. There-

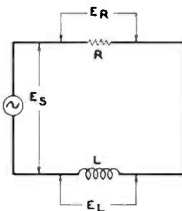

Fig. 5. An RL circuit: a resistor and an inductor in series with AC generator.

fore the current in R is in phase with that through L and through the source. We know also that the voltage across R must of necessity be in phase with the current through R , and accordingly E_R is in phase with I . But the voltage across L must lead the current I by 90° (this is merely another way of saying that I lags E_L by 90°). It follows that the voltage across L leads the voltage across R by 90° . E_S is obviously the sum of E_R and E_L ; but, with one component of E_S 90° out of

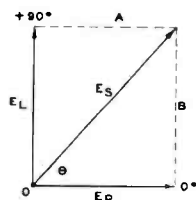

Fig. 6. Vector diagram for RL circuit.

phase with the other, how do we add them?

For this solution we turn to the vector diagram, as shown in Fig. 6. If we consider the current as reference or zero phase (which is plotted on a vector diagram as an arrow facing right from the origin O), then E_R , which is in phase with I , should logically be plotted facing right also. The length of the arrow is made proportional to the magnitude of E_R . Then E_L , which is 90° ahead of E_R in phase, is plotted in the $+90^\circ$ direction: straight upward. Its length is proportional to its magnitude, using the same units as before. This construction so far follows the same scheme as was used in developing the sine wave in the preceding chapter.

To find the resultant value of these voltages, a process known as "complet-

ing the parallelogram" is employed. A construction line is drawn from the end of the E_L vector parallel to the E_R vector, in the same direction, and of the same length. This is construction line A in Fig. 6. The same thing is done from the end of vector E_R ; construction line B is drawn parallel to, in the same direction, and of the same length as E_L . A line then drawn from the origin to the intersection of construction lines A and B represents the resultant of voltage vectors E_R and E_L . That being true, it represents the source voltage E_S also; its length is proportional to its magnitude, measured in the same units as the other vectors. If we had made sine-wave drawings of E_R and E_L in proper magnitude and phase relationship, and had added the two curves point by point, we would have obtained another sine wave representing E_S . Its magnitude would have been in the same relationship to the two original curves as the vector E_S is to E_R and E_L ; its phase would also correspond to that of the E_S vector. Our vector diagram is merely a simpler way of doing the same thing.

This construction can be used to find the sum resultant of any quantities with any phase angles or directions. Fig. 7 shows several sets of vectors and their resultants. We shall use such constructions again in this series.

Now, however, let's go back to Fig. 6. Several points should be made here. First, we know that the same current exists in both L and R . The voltage across each, then, is proportional to their ohmic values; since E_L is slightly larger than E_R , X_L must be slightly larger than R in the same proportion. The same current also flows in the source, and when divided into the source voltage gives the total ohms in the circuit. Because the vector E_S , representing the source voltage, is proportional in length to E_R and E_L — and accordingly to R and X_L — the resultant voltage vector must also represent the resultant ohms vector. The resultant ohmic value of a reactance and a resistance is called the *impedance*. Its symbol is Z . The impedance of R and L in combination can, then, be

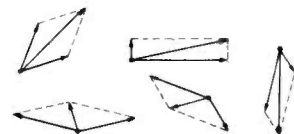
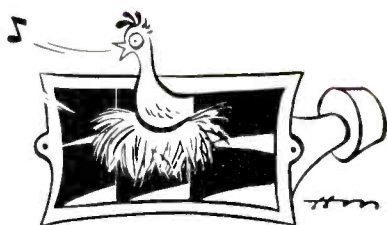

Fig. 7. Some vector pairs and resultants.

found with the same type of vector diagram as in Fig. 6, replacing E_L by X_L and E_R by R . Z would then be the vector now labeled E_S . The same proportions and the same angles would exist.

Second, examination of the diagram reveals that the resultant voltage (and impedance) is greater than either of the two constituents but less than their nu-

Continued on page 48



Sound-Fanciers' Guide

by R. D. DARRELL

TRUE test tapes, otherwise closely akin to the test discs discussed in this column last month, differ not only in the nature of the medium itself, but also in relative newness and scarceness. The latter difference is particularly surprising when one considers their literally essential usefulness in ensuring accurate head alignment and their convenience in helping to achieve proper equalization in playing recorded (musical) tapes on a wide variety of playback equipment. The limiting factor seems to be the extreme difficulty of duplicating a master test tape with rigorous faithfulness. Even when great pains are taken (as described in Refs. 1, 5, 7, and 9), the copy you buy sooner or later may undergo enough stretch or shrinkage to throw the timing indications (if any) off, or be sufficiently perturbed by magnetized heads or stray magnetic fields to depart markedly from its original frequency-response specifications. I have heard many engineers express doubt that any manufacturer's test tapes are absolutely uniform and, although I have had no personal opportunity of checking several copies of any one release against each other, I must repeat the warning that all results obtained from test-tape measurements (perhaps even more than those involving test discs) should be evaluated with great caution; wherever possible, they should be cross-checked against those obtained by other methods.

Yet even if they must be used with care (and more than a grain of salt), test tapes are a wondrously convenient and indeed the only practical means of making a complete *dynamic* check of a tape reproducer's over-all response. I have found them indispensable for setting exact playback-head azimuth alignment; then for making a quick check of playback equalization; and, finally, for rechecking this equalization after the circuits involved have been revised, or originally set up, on the basis of conventional measurements utilizing a signal generator.

Test-Tape Repertory

Best known in professional circles are the Audio Devices *Head-Alignment Tape* No. 200 and two Ampex standard alignment tapes. The former is a 15-ips, 300-foot tape which includes 25 ft. of leader; 30 secs. each of 2-Kc and 10-Kc tones, followed by 60 secs. of

15-Kc tone; then a repetition of the 10-Kc and 2-Kc tones; and a final 25 ft. of leader. Note the symmetrical arrangement of materials, which permits them to be used equally effectively whether run forward or backward. Indeed, it is strongly recommended with all test tapes that after one run-through in the normal manner the reels be switched around and the tape run back on its original reel at regular speed (whether or not the second run is made for actual test purposes), since the use of high-speed rewinding is more likely to stretch the plastic base or adversely affect the calibration of the recorded materials. It might also be noted that this, like most test tapes, is a full-track recording, which can be used equally well with half-track playback equipment; and that, while this particular example is a 15-ips recording, it can also be used at 7.5 ips, doubling the duration of each tone but of course halving its frequency. (See esp. Ref. 7; also Refs. 9 and 10b.)

I have not made personal use of this tape (although many of my professional engineer friends have) since, when it appeared, I had invested already in the 15-ips Ampex *Standard Alignment Tape*. More recently I have depended most heavily on the companion 7.5-ips Ampex No. 5563-A5, which is similar except in the specific spot frequencies included. Since this latter is the most practicable for checking playback systems intended primarily for reproducing recorded (musical) tapes, I shall list only its contents: voice announcement; about 60 secs. of 10-Kc tone for head alignment; about 30 secs. of 250 cps at "standard" (arbitrary 0-db) level; about 15 secs. each of 11 (vocally announced) spot frequencies, from 30 cps to 10 Kc, at the same level; and about 30 secs. of 250 cps again, but this time at "operating" (+10-db) level. The recording characteristics here are, of course, those known variously as "Ampex" or "NARTB" Standard, and any playback installation which can reproduce this frequency run with uniform response (at least within, say, ± 2 db) is correctly equalized for all current commercially released recorded tapes. Here again the whole tape may be played in reverse (although this time the frequency sequence should be jotted down or memorized, since the voice an-

nouncements now sound as if they were spoken in Chinese!), and should always be rewound at normal rather than at high speed. (See esp. Refs. 1 and 5; also Refs. 4a and 4b.)

It is a divergence from this now-standard tape-recording characteristic which demands the only serious criticism of the otherwise extremely useful and even more versatile Dubbings *Test Tape* D 110, full track, 7.5 ips. (There is also a similar Dubbings *Test Tape* D 111 for 15 ips, which *does* have the NARTB characteristics and so can be used, if somewhat awkwardly, for 7.5-ips performance checks.) D 110 is longer than the tapes mentioned above (running for about 15 min.) and includes three valuable timing signals, spaced 5 min. apart. Also, with voice announcements, a 400-cps tone at maximum (arbitrary 0-db) level; another 400-cps tone at normal recording (-10-db) level; and a 5-Kc tone at -15-db level for head alignment. Then a series of brief unannounced spot frequencies, 30 to 7,500 cps, for a quick over-all response check; followed by longer, individually announced runs of the same 13 spot frequencies for more accurate measurements. All of these are at the -15-db level, as is the following 3-Kc steady tone for checking wow and flutter. And a final section is a series of eight 400-cps tones ranging from -15-db to -50-db levels in 5-db steps, which are uniquely valuable for checking signal-to-noise ratios. Accompanying the tape itself is a 68-page *Test Tape Manual* by Harold D. Weiler, which in itself is one of the best guides I've found to tape-recorder-and-reproducer test and maintenance procedures. (See esp. Refs. 6 and 10c; also Refs. 3a, 3b, 4a, and 10a.)

If only the recording characteristics had been standard, this would be an almost ideal test tape at least as far as most of its contents (I should have preferred a much higher head-alignment frequency) and all of its annotations are concerned. But at the time it was issued (early in 1954), the choice of a 7.5-ips standard characteristic had not been definitely established and the Dubbings engineers were trying to promote a compromise characteristic which they believed would best serve the needs of the popular 7.5-ips tape equipment on the general market. Since then, of course, most of even the lower-priced

recorders are designed to equalize the virtually standard "Amplex" or "NARTB" 7.5-ips characteristics—and so play properly all current recorded (musical) tapes. Nevertheless, D 110 still retains considerable value, especially for other-than-equalization checks, and even for that purpose it still can be used (provided a careful record is kept of its deviations from the standard, which may be as much as 7 db or more at certain frequencies) as a means of checking performance deteriorations over any extended period of time.

Combination Tests and Samplings

There may be other exclusively test tapes available or planned (Ref. 10b speaks of a Sonafax test tape not yet on the market), but so far I have no detailed information on them. However, several tape samplers include some test materials which may be helpful, although here the usual warnings of caution must be redoubled, since obviously it is impossible that these popularly priced, mass-produced releases can be engineered and duplicated with the same care as the far more expensive test tapes above. The following, then, are recommended only for rough checks—and only for those who cannot afford something better.

Two of these I have not yet "heard" (i.e., used) myself are: the *Treasure Tape Excerpts* from Dubbings *Test Tape* No. D 110, issued by the Technical Tape Corporation of Morris Heights, New York 53, N. Y., primarily as a sales-promotion sampler of Encore tape; and a *Timing and Test Tape* No. 301 issued by Tape Toons, Box 397, Smithtown, N. Y. The former is a highly abbreviated version of the Dubbings tape already discussed and has the same disadvantages of an arbitrary recording characteristic. All I know about the latter is that it contains 3-minute timing signals, plus a 5-Kc and a 3-Kc tone. However, I have used the Dubbings *Plus-50 Music and Test Tape Sampler* D 210, which contains two timing signals 7 min. apart and a 15-second 5-Kc tone for head alignment (drawn from the D 110 test tape), plus two short—and now hardly impressive—musical selections (Prelude to *Carmen*, and *Song of India*) transferred from Audio-Master Corporation's Mastertape Library. And I also know at first hand that Omegatape D 1, which in addition to some seven samplings from the earliest Omegatape and Jazz-tape musical releases includes, on the second track, a test section comprising a 10-Kc tone for head alignment; 250 cps at standard operating (arbitrary 0-db) and -10-db levels; six spot frequencies from 50 cps to 10 Kc with standard NARTB characteristics; and

an ingenious 60-second speed check which has 1-second timing signals heard against a 440-cps WWV standard A tone. The music recording on this sampler is not nearly as good as that of later Omegatape releases, but this release still retains considerable appeal for the test section itself.

Although they aren't properly part of our recorded test-tape category, or samplers either, perhaps this is the best place to make at least passing mention of two varieties (possibly there are others) of leader tape which, while blank as far as recorded materials go, are printed in definite-length alternating-color strips for timing: Audiotape *Self-Timing Leader* No. 3-L and Scotch *Leader and Timing Tape* No. 43 (see Ref. 2). Unfortunately, "timing" in this case is primarily for editing purposes; as useful as these leaders are, they are not easily adapted for checking tape-transport speed.

So far, indeed, no manufacturer seems to have come up with what we need most—a practicable *stroboscopic* tape. Is one impossible to make? It certainly is possible to make stroboscopically marked movie film (see Chap. 13 of Ref. 10b). At any rate, the serious need for means of making instantaneous, accurate tape-transport-speed checks is dramatically shown in the first of

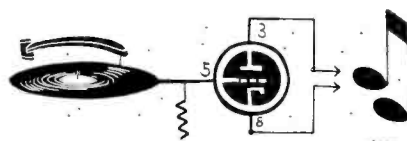

Dr. Fritz A. Kuttner's series of articles on recording and tape-duplicating speed variations, in *HIGH FIDELITY*, June 1956.

Samplers and Demonstrators Only

While we're still on the subject of tapes and checking tape-playback operation, I should also survey, at least briefly, the various sampler releases issued by many manufacturers, usually at attractively low prices, since these reels serve effectively to advertise the tape catalogues from which they are drawn by the direct evidence of what the manufacturer's leading recordings actually sound like—at least in part. With few exceptions these ordinarily are too short for any real musical enjoyment, but they do provide an excellent index to the qualities of the complete tapes they represent *in petto*, and also provide a quick sequence of usually well-varied programs for making aural checks of complete system performance.

Among those I haven't yet heard are Bel Canto DT 27, with excerpts from the first four releases of this

company, and the Livingston *Recital* and *Popular* samplers, LS 5-2 and LS 5-1 respectively, so I can't say whether or not these include voice announcements and/or sales pitches. Nor have I heard the recently announced A-V Tape Libraries' *Invitation Tape*, which differs from other samplers in that it is a specially priced release of complete popular selections, three each by the Doug Duke Trio and Smith-Glamann Quintet.

Of those I do know personally, the first I got was the Berkshire *Highlights*, H 1, which includes a large batch of excerpts (vocally announced, but without sales talk) from the first batch of Berkshire tape releases, largely drawn from the Haydn Society's LP catalogue, all recorded at unusually high level, sometimes with dubiously "standard" characteristics, and for the most part less impressive for their technical than for their musical qualities.

In addition to the D 1 combination sampler-and-test reel mentioned above, Omegatape has four straight samplers, of which D 2 combines classical, light, and jazz selections from fairly early releases; D 3 is a similar combination of classics and jazz from somewhat later releases; D 4 represents the Alphatape catalogue exclusively, mostly with light music; and D 5 exemplifies some of the latest Omegatape and Jazztape releases in various musical categories. All of these have vocal announcements and some sales pitch for tape in general, while D 3 includes a special blurb for recorded tapes by Jim Ameche, Fidelity Unlimited. I'm not much impressed by the talk, but this reel and the current D 5 are by far the best from the point of view of general recording excellence.

Also excellently recorded and even more interesting musically is the Phonotapes-Sonore *Demonstrator* PM 1, which contains nine fairly substantial samples, drawn with one exception from "serious" works in the Vox and Philharmonia LP catalogues. There are no sales talks, nor indeed any voice announcements at all, either here or in the same company's *Pop Music Sampler*, PM 109; this features—among other light materials—an excerpt from the first taping of George Feyer's *Echoes* series for Vox, the *Latin-American Rhythms* section from *Spotlight on Percussion*, and an early Louis Armstrong masterpiece from the Folkways Jazz Series.

Much less interesting to me is the tiny (3-in.) *Tape Toons Sampler*, confined to four excerpts from schmaltzy theater-organ performances by Bobbie Kay. But at least this is effectively enough recorded, while the equally tiny *House of Stone Sampler* seems extremely amateurish, both technically and programmatically—here purportedly comic monologues and skits with very little music. Like Queen Victoria on a sim-

ilar occasion, I can only report: "We are not amused!"

There are other samplers, I'm sure, but this pretty well covers the single-channel examples I know of so far (I'll announce newcomers as they appear), while I'm saving the stereo examples for inclusion in the general discussion of stereo recordings and their psychological effects, which I hope to run here before too long, when I succeed in working out some explanation (that will convince me if nobody else) for some of the widely divergent reactions and opinions on this fascinating—and no less controversial—subject.

Problem Children. . .

Unfortunately, when one moves from constant frequencies and musical snippets back to complete recorded performances, it is no longer comparatively simple to discover whether or not a reproduced tape or disc meets definite technical standards or exhibits a perfectly clear-cut appeal. And although the primary purpose of this department is to draw audiophiles' attention to recordings of unusual sonic interest, it must be evident that "interest" in this connection doesn't necessarily imply unqualifiedly high—or unanimously acknowledged—merit. Most of the recordings singled out for discussion here are exceptionally good from the engineering (if not always from the musical) point of view, and of course there are others which I listen to but decide not to write about, simply because they do not seem to me to represent the highest current technical standards, however satisfactory they may be in other respects. Yet, between these reasonably definite categories, there is a kind of no man's land occupied by the kind of recordings I think of as "problem children"—which I simply can't rank as unqualifiedly good, or average, or bad. Usually they are unmistakably good in some respects, but have some odd characteristic which may or may not be an actual flaw, but is certainly disconcerting; sometimes, they represent what strikes me as a mismatch between the particular engineering techniques employed and the character of the music or performance at hand; but always, they raise unresolved questions and hence, like human problem children, offer a challenge that well may be more profoundly interesting than either unalloyed merit or unredeemed demerit.

But let me give some examples of what I mean. Taking some comparatively easy ones first, I cite Wanda Landowska's *Bach Concerto No. 1 for Harpsichord and Two-Part Inventions* (RCA Victor LM 1974) and the Janos Starker *Spanish Album* cello program (Connoisseur tape D 5 108, via Livingston; also Period LP 584). Now, the *Concerto* is admittedly an old (1938)

recording, whose tubby harpsichord and shrill string tonal qualities have drawn legitimate critical castigation. The obvious question is why, for all its historical value, was this coupled with the brilliantly up-to-date recording of the *Inventions*? But there is also another question in my mind, for despite the critical and public acclaim for the *Inventions*, I am far from convinced that such glittering, high-level, close-to-recording qualities, even if they do match Landowska's blazingly dramatic performances, are aesthetically suitable for the comparative simplicity of the music itself.

The *Spanish Album* also presents curious variances, for it begins with very hollow, oversized cello tone and a confused, distant piano accompaniment; the rest of the recital is more cleanly captured in competent if by no means wide-range recording. I am sure the fault here is in the original engineering rather than in the transfer to tape, although I haven't heard the LP version to check. In any case, to hear Starker's magnificent playing in more authentic sonic crispness and warmth, you must turn to his more recently recorded *French Album* (Connoisseur tape D 5 109, via Livingston; also Period LP 708).

Then there is the Istomin-Ormandy Rachmaninoff *Second Piano Concerto* (Columbia ML 5103), a current best-

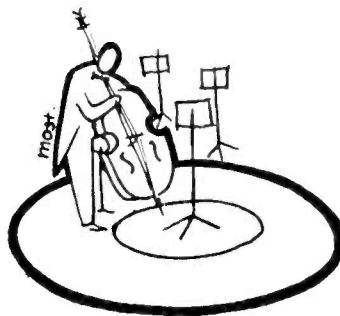

seller, and deservedly so, not merely for excitingly dramatic performance (topped only by the composer's own, in a much older and inferior recording), but also for some of the most tremendously big and steely-hard piano tone ever captured on discs. Here what bothers me is the exaggerated, constant prominence given the piano over the orchestra (surely no solo piano ever so hogged the spotlight in a concert hall!) and the peculiar tendency of the orchestra itself to *move* forward and back in louder and softer passages respectively. I don't think this is the result of monitoring, but, whatever the cause, it makes for a series of enlargements and contractions of the acoustical horizon—not necessarily objectionable, but certainly puzzling, for I don't remember ever having come across anything like it before.

Less inexplicable is the Copland program, *Billy the Kid*, *El Salón México*, and *Fanfare*, conducted by Howard Mitchell (Sonotape SW 1024; also, with *Appalachian Spring*, Westminster WL 5286). This recording is unquestionably and consistently impressive, and the tonal coarseness, low-end ponderousness, and high-end shrillness are partly the composer's responsibility and still more that of the National Symphony Orchestra. Here for once I would gladly tolerate a narrower response spectrum and even some high-end rolloff to obtain over-all sound qualities less hard on one's ears and nerves. Or perhaps everything to which I take aural objection would be eliminated in the greater acoustical spaciousness and warmth of a stereo version.

Stereo probably also would be the cure for somewhat similar tonal coldness and tenseness in Rossi's performance (without recitations) of Stravinsky's *L'Histoire du Soldat* (A-V Tape Libraries A-V 1523; also Vanguard LP 452). The recording here is so sharply focused that it cruelly exposes something less than ideal playing (except for the truly virtuoso florid cornet part), so the question again is the old one of aesthetic or philosophic, rather than technical, *suitability*. Perhaps many devotees will feel that Copland and Stravinsky neither need nor want any softening of their bold musical outlines and acerbities, but I doubt whether they really intended the over-all effect of these works to be as tonally ungratifying as they are—to my ears—in the present versions. Yet, of course, every listener must be his own judge—of what I consider problem-children releases, as well as of all others.

. . . And Gold-Star Winners

Happily, no awkward problems are raised by many other technically outstanding current releases. The only question involved by some of them is how the reviewer can say anything more than "Wonderful!" Unless one talks about the music itself, there isn't much else I can say about the three exotically rich Balakirev tone poems conducted by Von Maticic (Angel 35291); Busoni's trenchantly ironic comic opera *Arlecchino* (RCA Victor LM 1944); the Grieg program by Van Remoortel (Vox PL 9840); and a batch of recent Rodzinski performances with the Philharmonic-Symphony of London: Kodály *Háry Janos* and Mussorgsky *Night on Bald Mountain* (Westminster W-LAB 7034); Mussorgsky-Ravel *Pictures at an Exhibition* (Sonotape SW 1022, or W-LAB 7019); J. Strauss *Waltzes* (SW 1016 or W-LAB 7026); R. Strauss *Don Juan* and *Till Eulenspiegel* (SW 1017 or W-LAB 7016); and Wagner *Ring* excerpts (SW 1021 or W-LAB 7013).

I may have some reservations about

Rodzinski's lack of humor in the *Pictures* and *Till*, and his obvious disdain for the *Ride of the Valkyries* (in the *Ring* program) . . . also for Van Remoortel's somewhat oversophisticated if ultraskillful treatment of Grieg's more naïvely rustic pieces . . . but elsewhere there can be no serious interpretative criticisms, while the reproduced sonority throughout is seldom short of magnificent, and at its best—in the tonal purity and blazing climaxes of the Balakirev and Kodály-Mussorgsky discs and the Wagner tape, in particular—it demands more and stronger superlatives than any I have on hand!

Equally matchless for very different kinds of music and less familiar sonic delights are the first Decca-Deutsche Grammophon *Archive* treasures I have heard: Machaur's great *Notre Dame* Mass and 10 secular works, and the complete set of Purcell's *Fantasies for Viols* (ARC 3032 and 3007 respectively, via Decca). All these works are special favorites of mine, and the present versions are not only the first completely satisfactory readings I have heard (on discs or off), but equally ideal for their executant and technical perfection. In particular I commend these discs to everyone susceptible to truly artistic ensemble singing and the piquant, quaint, infinitely fascinating timbres of ancient instruments—captured here with extraordinary transparency and tonal authenticity.

Tested in the Community

In the lighter realms of popular entertainment music, I am relieved of the necessity of reviewing three tapes by simply reporting that they proved to be the "hits of the show" when I was called upon to provide some background music for a local volunteer fire company carnival. I had been quite impressed at home by "Third Man" Anton Karas's *Mister Zither* (Omega-tape 2001; also in part on Alphatape 16), especially by the appropriate shift from poetic recording qualities in Track 1 (orchestral accompaniment) to brighter, sharp-focus characteristics in Track 2 (zither and accordion only), but I hadn't paid much attention to the lusty dances, *In Old Bavaria*, by Franz Schermann's Alpiners (Bel Canto tape 301; also on a Bowery disc), or the even less inhibited Gay Nineties tunes in *Your Father's Moustache in Hi-Fi* by Albert White's Gaslight Orchestra (which I received both on Bel Canto Tape 107 and the San Francisco LP M 33002). Which just goes to show how ignorant a long-hair reviewer can be! The crowds at the carnival, many of them well along in years and/or of European birth or descent, lapped all this up with unrestrained delight. And perhaps infected by their devotees' en-

thusiasm, as well as by the contagious spirit of the recorded performances themselves, I must admit that all of these sounded mighty good to me too.

Caribbean Cruise — At Home

So many friends have been spellbinding me with the delights of travel in the Caribbean, Mexico, and South America that I was developing a stay-at-home inferiority complex until a batch of Audio Fidelity discs came in to transport me magically to the sunny isles and lands south of the border. Most interesting from the folklorist point of view is *The Singing Gods* (AFLP 1803), in which Katherine Dunham presents the drum rhythms and ritual chants of Haiti, Cuba, and Brazil—fascinating exotic and authentic stuff (although the chief Haitian singer sounds rather too sophisticated for his more primitive materials), especially commendable for its elaborate annotations, describing in detail both the music itself and the strange instruments (set of irons, Mama and Kata drums, calabasse, etc.) used in it.

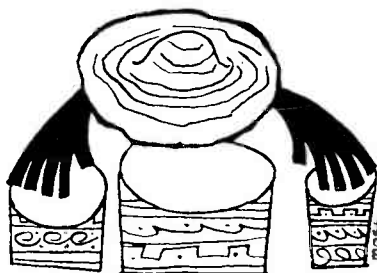

But for more stimulating, strictly sonic attractions, I relished even more Choco and Chimi's superbly intricate rhythms and varied percussive timbres in *Drums of the Caribbean* (AFLP 902), and the scintillating recording of the Orquesta Chiapas's spirited playing in *Marimba Mambo y Cha-Cha-Cha* (AFLP 1802)—although the latter goes on and on until I'd think even the most tireless dancer would faint from exhaustion. And probably the most satisfactory (for combined musical and sonic appeal), certainly the most thrilling, of all is *The Brave Bulls* (AFLP 1801), in which the Plaza Mexico's Banda Taurina, conducted by Genaro Nuñez and starring Rosalio Juarez's trumpet (cornet?) solos, presents the whole sequence of bullfight music in its proper order. I am no aficionado of taumachy myself, so the elaborate notes and inserted portfolio of colored poster reproductions haven't the attraction for me that they undoubtedly have for *corrida* devotees. But even I can't resist the stirring, open-air, festive music itself, above all the dramatic *Toques* (or entry fanfares), captured here to perfection in a spaciouly open recording.

REFERENCES

Note: The following list also may serve as a fairly complete *Test Tape Bibliography* (not otherwise available, as far as I know), except that it does not include references to articles on tape-recording characteristics and playback equalization, and also omits merely passing mentions of test tapes in book chapters and articles primarily concerned with audio-test procedures, equalization-circuit design, etc. As with the similar *Test Disc Bibliography* appended to this column last month, I shall greatly appreciate having my attention called to any significant entries I may have overlooked in compiling the present list.

1. "Specialized Lab Produces Ampex Alignment Tapes." *Ampex Playback*, II (Mar. 1956), 1, 3-4.
2. Barleben, Karl A. "Leader and Timing Tapes" (in Chap. 8). *Ribbons of Sound*, U. S. Camera Pub. Corp., 1956.
- 3a. Burstein, Herman. "Checking Your Tape Recorder." *AUDIO-CRAFT*, I (May 1956), 34-35, 38-39, 40.
- 3b. Burstein, Herman. "Tape Recording Equalization" (No. 6 in *Tape Recording* series). *Radio and Television News*, LV (Feb. 1956), 48-50, 103.
- 4a. Holt, J. Gordon. "Preventive Maintenance" (in *Tape News and Views* series). *AUDIO-CRAFT*, I (July 1956), 12-13, 39-40.
- 4b. Holt, J. Gordon. "More on Incompatibility" (in *Tape News and Views* series). *AUDIO-CRAFT*, I (Dec. 1955), 12-14, 48.
5. Hull, J. B. "Performance Measurements of Magnetic Tape Recorders." *IRE Convention Record 1956* (Part 7: Audio and Broadcasting), 75-79.
6. Konins, Julius A. "Checking Your Audio System." *Radio and Television News*, LI (May 1954), 59-61, 142-145.
7. LeBel, C. J. "A New Alignment Tape." *Audio Record*, IX (Apr. 1953), 7.
8. Mark, David. "Checking Your Tape Recorder by Means of Test Tapes" (in Chap. 7). *How to Select and Use Your Tape Recorder*. Rider, 1956.
9. Radocy, Frank. "Some Notes on Problems Encountered in the Use of the Standard Reference Tape." *Journal of the AES*, II (Jan. 1954), 36-39.
- 10a. Weiler, Harold D. "How to Check Your Recorder." *Tape Recording*, I (Mar., Apr. 1954), 38, 40-41.

Continued on page 44



Balancing Push-Pull Amplifiers

The balance of a push-pull amplifier may be checked without test instruments in the following manner.

Fig. 1 shows the basic circuit of a push-pull output stage. The coupling condensers (C) which usually are con-

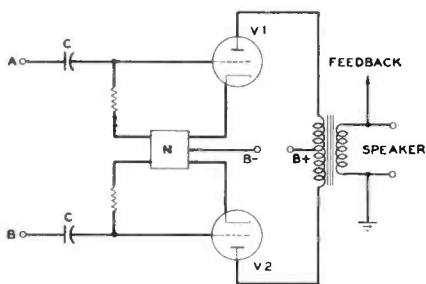

Fig. 1. Generalized output stage circuit.

nected to the plates of the driver tubes are unsoldered at points A and B, and connected as shown in Fig. 2. D is connected to a low-voltage AC source of 1 to 6 volts (the ungrounded terminal of the heater circuit). Now both output tubes are driven in parallel and, therefore, the amplifier should deliver no power to the speaker if it is properly balanced. If it does, the balance control, which is usually incorporated in the biasing network (N), should be adjusted for minimum output. The residual output is a measure of total balance: the lower the output, the better the balance. If an audio signal generator

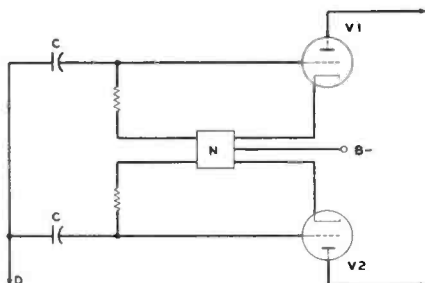

Fig. 2. Temporary change for balancing.

is at hand, D may be connected to it and the balance checked at different frequencies. After balancing the output stage, the driver can be balanced in the same way by feeding the inputs in parallel. If the grids of the output tubes

are directly coupled to the driver stage, this method may still be used if the test voltage is applied as shown in Fig.

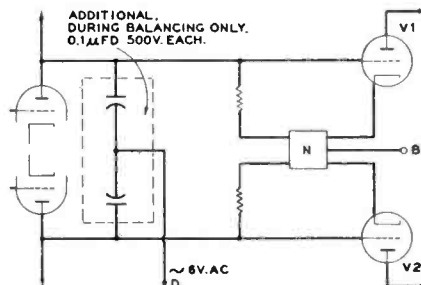

Fig. 3. Checking direct-coupled stages.

3 and the feedback circuit from the secondary of the output transformer is disconnected.

Peter E. Beckmann
Muenster, Germany

Turntable Mounting

Back in 1951, when mounting my then-new Webster-Chicago record changer, I was confronted by the same problem as Mr. Soherr of Dover, Delaware (AUDIACRAFT, March 1956). I had to drill two concentric holes to agree with this drawing.

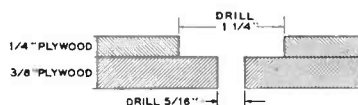

I solved the problem in a different and, what was to me, an original way. I had a piece of 1/4-inch plywood and I purchased a piece of 3/8-inch plywood. I drilled the 1 1/4-inch hole all the way through the 1/4-inch stock, and then nailed the 3/8-inch wood to it with brads. The 5/16-inch hole was then drilled in the center of the larger hole through the 3/8-inch wood.

AUDIO AIDS WANTED

That's right—we'll pay \$5.00 or more for any short cut, suggestion, or new idea that may make life easier for other AUDIACRAFT readers, and which gets published in our Audio Aids department. Entries should be at least 75 words in length, and addressed to Audio Aids editor. No limit on the number of entries.

With the two pieces of wood nailed together, the center cutout was made.

William J. Hurley
New Britain, Conn.

Modified Loudness Control

Those who "roll their own" in assembling hi-fi components might be in-

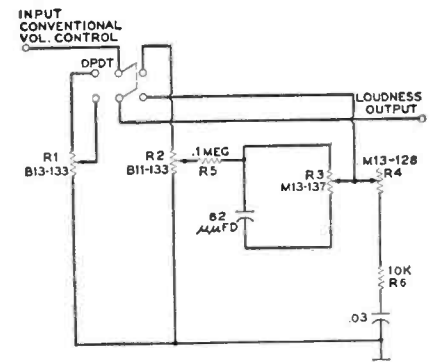

Fig. 1. The IRC Demonstrator control.

terested in a modification of the IRC Demonstrator Loudness Control, Fig. 1. This control, with its switch, can be used either as a conventional volume control or as a loudness control.

The modified control, Fig. 2, does the

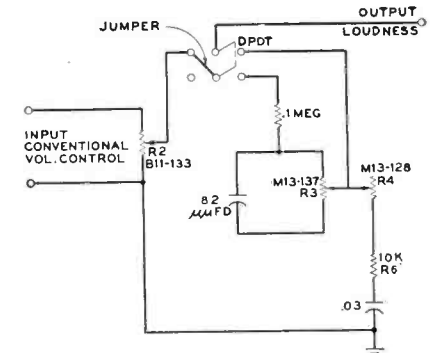

Fig. 2. Simplified version of Fig. 1.

same thing and has the additional advantage of using one less potentiometer, resulting in a saving of chassis space as well as money.

George T. Mitchell, W7ZQX
Seattle, Wash.

Working With Aluminum

Some types of aluminum chassis are not sufficiently rigid for mounting heavy

Continued on page 56

Save yourself time and trouble
by ordering your books directly from us.
Just fill in the coupon below.



audiophile's bookshelf

Now available in this country **AUDIO HANDBOOKS** By Norman H. Crowhurst

- | | | | |
|-----|--|---|-----|
| 213 | <p>AMPLIFIERS</p> <p>Will help solve the problems that often arise when equipment has been built, but won't work. The "Trouble Tracing Guide" gives a table of symptoms, possible causes, and references to appropriate chapters which offer aid in spotting the trouble. 38 diagrams. Index. \$1.00</p> | <p>THE USE OF A.F. TRANSFORMERS</p> <p>Shows in clear detail how circuit values affect a.f. transformer performance. With the aid of a detachable special ruler, the charts included make it effortless to find a circuit suitable for any a.f. transformer. 44 diagrams. Index. \$1.00</p> | 215 |
| 214 | <p>FEEDBACK</p> <p>Explains clearly what feedback can do, where and how to use it, and what its limitations are. The theory of closed loops is presented in easy-to-understand mathematics; design charts use a simplified approach; and the numerous examples illustrate practical applications to circuits. 40 diagrams. Index. \$1.00</p> | <p>THE QUEST FOR QUALITY</p> <p>Discusses the basic requirements for fidelity and the various methods of achieving it. Shows how to design equalizers, how to build circuits for expanding dynamic range, how to check equipment. Also takes up various kinds of stereophony, and the arrangement of a listening room for the greatest pleasure. Diagrams and half tones. Index. \$1.50</p> | 217 |

Each of these handbooks is concise in treatment, clearly written, and without involved mathematics. They are imported from England.

224 RECORD RATINGS **The Music Library Association's Index of Record Reviews**

Compiled by Kurtz Myers, Chief, Music and Drama Department, Detroit Public Library
 Edited by Richard S. Hill, Head, Reference Section, Music Division, Library of Congress

This new book is, without question, an essential reference for the serious buyer of records. Unique both in content and organization, it indexes practically all serious music ever recorded on LPs, listing the date and issue of the most important American and European periodicals in which reviews appeared. Symbols indicate what the reviewer thought of that particular release — i.e. excellent, adequate, or inadequate. The prospective buyer is thus provided with the considered opinion of several critics and thereby given a nearer approximation to objective judgment. Full bibliographical information is given for each record (manufacturer, serial and opus numbers, thematic catalogue listings) and a list of performers follows. The *Index of Performers* provides a complete key to musicians, conductors, artists, and orchestras. **RECORD RATINGS** is the most complete and informative discography available. 440 pages. **\$5.95**

- | | | | |
|-----|---|--|-----|
| 225 | <p>TAPE RECORDERS AND TAPE RECORDING</p> <p>By Harold D. Weiler. Written by the author of the best-selling <i>High Fidelity Simplified</i>, this recently-published book supplies the amateur and semiprofessional tape recordist with sound, practical, and factual information about all aspects of tape recording — microphones and their placement for both indoor and outdoor recording, room acoustics, sound effects, recording from disks and off-the-air, maintenance, etc. Provides all the vital principles necessary for the realization of optimum results with tape recorders. Paper-back edition, \$2.95
 Cloth-bound edition, \$3.95</p> | <p>TRANSISTORS HANDBOOK</p> <p>By William D. Bevirt. The author (Transistor Applications Engineer at CBS-Hytron) here presents for practical use the latest information about transistor circuits and their applications. Diagrams of tested circuits, with typical values of the circuit elements are included where possible. Subject and author indexes. Appendix. \$9.00</p> | 226 |
| | | <p>BINDERS FOR AUDIOCRAFT</p> <p>Now available — attractive, protective blue leatherette binders which will hold 14 issues of AUDIOCRAFT. \$3.50 each.</p> | 223 |

Book Department
 AUDIOCRAFT Magazine
 Great Barrington, Mass.

I enclose \$ for which please send me, postpaid, the books indicated by the circled numbers. (No C.O.D.'s or charge orders, please.)
 Foreign orders sent at buyer's risk. Add 55¢ for postage on foreign orders.

Name
 Street
 City State

213	224	225
214	217	226
215	223	

TRANSISTORS

Continued from page 21

safely, but one recombines with an electron in the base region. In that case, the ratio of collector current to emitter current is 49/50, or 0.98. This ratio is known as the transistor's alpha (α); one of the most useful pieces of information about a transistor is a knowledge of its α .

Further, notice that the collector current is relatively independent of the collector-to-base voltage. That is, it makes little difference whether we apply 6 volts or 15 volts to the collector—the collector current is still determined primarily by the emitter current. And, since the emitter-to-base circuit is merely a forward-biased junction, the emitter voltage is rather small.

These two facts enable the transistor to act as an amplifier. The signal power into the emitter circuit will be the product of the emitter current and the emitter voltage; the power output is the collector current squared times the load resistance. Since the collector current is nearly independent of the collector voltage, a high resistance may be put on the collector side of the transistor without affecting the collector current. Thus the power output can be made several hundred times the power input, which means that transistor action can be used for amplification. It is this fact that makes transistors useful. We will see more of the use of transistors as amplifiers later in this series; in fact, most of the series is devoted to this application. Now we will close this installment by noticing one more way to describe transistor action—this time by considering the base as the "input" terminal. This will lead to hook multiplication, which is merely one more way to describe transistor action.

In Fig. 14, notice the two currents drawn from the collector terminal. One is merely the cutoff current, caused by thermal generation of carriers near the collector junction. This is called I_{co} . The other is the component which is proportional to the emitter current. If the emitter current is I_e , the part of the collector current proportional to it is αI_e . The base current is similarly composed of two opposite components: I_{co} and $(1-\alpha) I_e$. An interesting state of affairs occurs if these two are equal: the base current is zero. This of course is the condition when a battery is connected between the emitter and the collector, with the base left open-circuited. Equating these two currents, we see that

$$I_b = \frac{I_{co}}{(1-\alpha)}$$

Since α is a number quite close to one,

I_b in this condition is many times the normal cutoff current.

Note that an interesting thing has occurred. When we bias the collector junction backwards, the current that flows is much greater if we leave the base open-circuited than if we leave the emitter open-circuited. In fact, it is multiplied by a number $1/(1-\alpha)$ which is characteristic of the transistor. This is known as *hook multiplication*, and applies to whatever current would normally flow through the collector junction—whether thermally caused (I_{co}), light-caused (as in a photocell), or even caused by some known current into the base.

This last result, which is the basis for operating the transistor with the

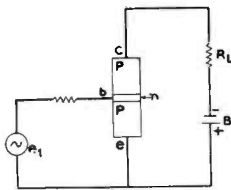

Fig. 15. The common-emitter connection.

emitter common, can be seen another way. Consider the transistor as pictured in Fig. 15, neglecting for the moment the cutoff current. We have shown that for every 50 holes injected from the emitter into the base, 49 go through to the collector, and one flows out the base. This is true regardless of whether we think of the emitter current as "causing" the collector current, or the base current as "causing" the collector current. In short, if we put a signal source at the base, and thus, for practical purposes, control the base current, the collector and emitter currents have no choice but to follow along, both much larger than the base current. For every microampere of base current, the collector current will be 49 microamperes, and the emitter current will be 50 microamperes. Thus the base current is multiplied by 49, or $\alpha/(1-\alpha)$, to get the collector current.

This number 49, or $\alpha/(1-\alpha)$, is so important in transistor work that it is given a special symbol— β . The number 49 is of course merely a number picked for convenience; β runs normally anywhere from 5 or 10 on up into the hundreds, depending on the transistor.

Again, the collector current is pretty much independent of collector voltage; so, if the output from the amplifier is taken from the collector, with the emitter common to both the input and the output, we see that there is a possibility for both current gain and voltage gain—and correspondingly high power gain.

So if we consider the base terminal as the input, the collector as the output, and the emitter common to both, the transistor gives current multiplication

as well as voltage multiplication. If the base is left floating, the only current that flows is the combination of cutoff current and light-caused current multiplied by $1/(1-\alpha)$, or $(1+\beta)$, the hook multiplication factor. If the base current is fixed at some particular value, then current multiplication occurs to give us a collector current many times the base current, plus $(1+\beta)$ times the cutoff current I_{co} .

The reader should recognize that transistor action can be thought of either in terms of hook-multiplication, or in terms of our earlier explanation, which involved considering the fate of the holes injected into the base by the emitter.

Just one point further: Fig. 16a shows the transistor we have been considering. Because it has two p-regions enclosing an n-region, it is called a p-n-p junction transistor. Fig. 16b is the symbol for it. It is equally possible to build a transistor with two n-regions on either side of a thin p-type base. This n-p-n transistor, Fig. 16c, acts in exactly an "equal but opposite" fashion—when reference was made to hole

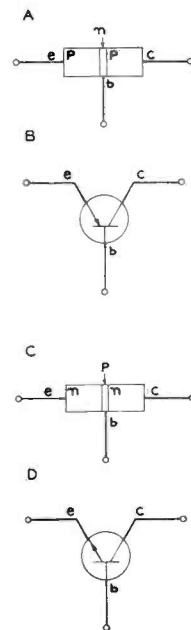

Fig. 16. P-n-p, n-p-n transistor symbols.

injection by the emitter, for an n-p-n transistor that should be "electron injection". Similarly, all currents and battery bias voltages must be reversed. Fig. 16d shows the n-p-n transistor circuit symbol. Note in both cases that the arrow is on the emitter, and that it points in the direction of easy emitter current flow, which is the normal bias direction.

In this first installment we have discussed certain fundamental properties of semiconductors such as germanium, and we have discussed holes and electrons and their behavior in single crystals of germanium. We then examined

how these properties accounted logically for transistor action. We saw that transistor action can be explained either in terms of current passing through from the emitter to the collector, or in the so-called grounded-base circuit, or in terms of hook multiplication and multiplication of base current which occurs in the grounded-emitter circuit.

Further Reading on Transistor Action

References are listed in approximate order of difficulty, with the most advanced ones at the bottom.

Elementary

Garner, L. E. *Transistors and Their Applications*. Chicago: Coyne Publications, 1953, Chapter 2.

28 *Uses for Junction Transistors*. New York: Sylvania Electric Products, Inc., 1955, Sect. 1;3.

Moderately Elementary

Coblentz, A., and Owens, H. L. *Transistors: Theory and Applications*. New York: McGraw-Hill, 1955, Chapters 5 and 7.

Krugman, L. M. *Fundamentals of Transistors*. New York: Rider, 1954, pp. 1-7, 12-18.

Turner, R. P. *Transistors, Theory and Practice*. New York: Gernsback Publications, 1954, Chapters 1 and 2.

Moderately Advanced

Lo, A. W., Endres, R. O., Zawels, J., Waldhauer, F. D., and Cheng, C. C. *Transistor Electronics*. Englewood Cliffs, N. J.: Prentice Hall, 1955, Chapter 1 through p. 27.

Moll, J. L. "Junction Transistor Electronics." *Proc. I.R.E.*, XLIII (Dec. 1955) p. 1807.

Penfield, P., Jr. "Transistor Action." *Audio*, (to be published later this year).

Shea, R. P. *Principles of Transistor Circuits*. New York: Wiley, 1953, Chapter 1.

Advanced

Scott, T. R. *Transistors and Other Crystal Valves*. London: Macdonald and Evans (Distr. in U.S. by Essential Books, Inc.), 1955, Chapters 2 and 3.

Shockley, W. *Electrons and Holes in Semiconductors*. New York: Van Nostrand, 1950.

Shockley, W. "Transistor Electronics: Imperfections, Unipolar and Analog Transistors." *Proc. I. R. E.*, XL (Nov. 1952), p. 1289.

In the author's eyes, the best of those listed are Turner, Lo et al., Moll, and Shockley 1952.

Next issue: other transistor types, including photodiodes and photo-transistors, point-contact and field-effect units.

MAGIC

BELT-DRIVE FOR

RUMBLE → **FREE HI-FI**

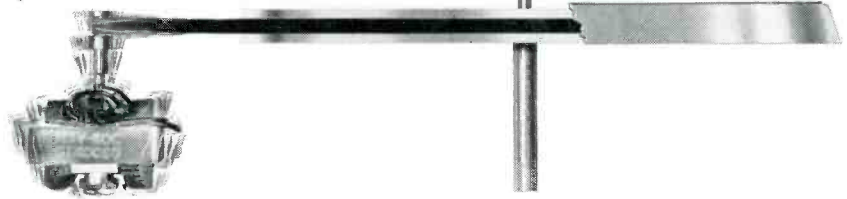

FACT 1: all motors vibrate more than the groove amplitude, necessitating isolation.

FACT 2: motor vibration never reaches the turntable in Components Professional Junior because its belt-drive is engineered to isolate the motor from the turntable.

FACT 3: only a belt-driven turntable can achieve rumble-free performance.

Compare the Professional Junior with five other makes for rumble-free performance at a budget price.

Features	Professional Junior	Brand A	Brand B	Brand C	Brand D	Brand E
Belt Driven	Yes	Yes	No	No	No	No
4-Speed	Yes*	No	No	No	No	Yes
Noise Level 60 DB/7 cm	Yes	No	No	Yes	Yes	No
Wow & Flutter 0.1% r.m.s.	Yes	Yes	Yes	?	Yes	No
Eliminates noisy idlers	Yes	No	No	No	No	Yes
Price Under \$40	Yes	No	No	No	No	No

THE "PROFESSIONAL"

"Junior"

Your Best Turntable Buy

For Only **\$39.50**



* Accessory for Extra Speed \$2.50 each

Hi-Fi Do-It-Yourself Records 89c at your dealer, or \$1.00 postpaid from Components Corp.

Components Corporation

DENVILLE, NEW JERSEY

WOODCRAFTER

Continued from page 11

is fed with the grain into the cutter-head without forcing it so much that it reduces the speed of the blades. Use just enough side pressure to hold it firmly against the fence. As the work passes over the cutterhead hold it flush

Courtesy Rockwell Mfg. Co., Delta Power Tool Div.

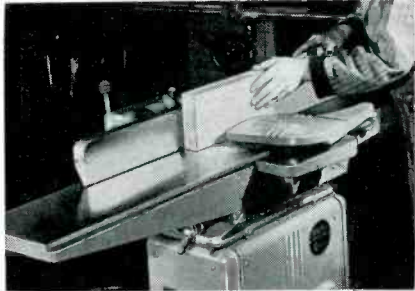

Fig. 5. Hand position for jointing edge.

against the rear table while guiding it against the fence for the remainder of the cut. Keep the hands as far from the knives as possible and make certain that the cutter guard is in place. Avoid planing stock that is less than 1 in. thick and 2 in. wide and less than 12 in. long.

Jointing an End

Planing the end of a board involves the same operations as edge jointing, but it presents the problem of the wood splitting at the end of the cut, much as it does when a hand plane is used on end grain. The solution is the same in both cases — start the cut at one edge for about an inch, then reverse the work and cut from the other edge until the two cuts meet (Fig. 6). Keeping the first cut short leaves sufficient length for the second cut to ride the rear table

Courtesy Atlas Press Co.

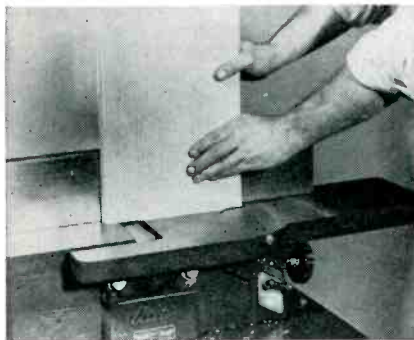

Fig. 6. How to plane the end of a board.

far enough to steady the piece for accurate planing. Try to avoid planing an end grain less than 10 in. wide and always set the machine for light cuts for this operation.

Planing a Surface

Surface planing straight stock presents no great problem except, perhaps, that of safety. Less grip is provided for the

hands than with edge and end planing; the thickness of the stock is all that separates the knives from the fingers unless a safety device is used. If the stock is less than 2 in. thick, use a hold-down of some sort — a pusher hook or stick (Fig. 7) — to give the necessary pressure and guidance. Don't use your fingers! Avoid surfacing boards less than 12 in. long because they do not provide enough holding leverage to prevent kickback of the cutterhead.

Before surface planing, check the stock for warp and wind (twist). If these conditions exist, it is advisable to replace the stock or dress it on a regular planer since it is difficult to handle it squarely on the jointer.

Cutting a Rabbet

The jointer is particularly adept at cutting rabbets (a recessed cut in the end or edge of stock, Fig. 8). For this operation the cutter guard is removed and the fence is moved over the table until enough blade is left exposed to make the desired width of cut. The front table

Courtesy Atlas Press Co.

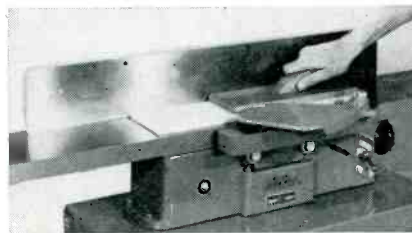

Fig. 7. Using pusher hook for surfacing.

is lowered to the required depth of the rabbet and the cutting operation is done in the same way as for surfacing a piece of stock. Depending upon the depth of the cut, narrow rabbets may be cut in one pass while wide rabbets may require several passes, the front table being lowered with each pass. Using this same type of cut, the jointer is excellent in making lap joints for gluing up stock (Fig. 9).

Some Basic Tips on Jointer Operation

- 1) Check the fence for squareness and check the depth before turning on the machine.
- 2) Always let the machine come to full speed before starting a cut.
- 3) When face planing or end planing, a light cut should be used; for edge planing, use a slightly heavier cut.
- 4) On softwoods you can use a heavier cut than on hardwoods.
- 5) Make a heavy cut when removing excess stock but always finish with a light cut.
- 6) If the stock has a "belly", place the concave surface down.
- 7) Check the direction of the grain and cut with the grain whenever possible.

Courtesy Rockwell Mfg. Co., Delta Power Tool Div.



Fig. 8. Setup for making edge rabbets.

8) Vary the position of the fence periodically so that wear of the knives is more evenly distributed.

9) Pressure should always be on the rear table so that the stock rides flat on it. Never put strong downward pressure on the front table.

Earlier I mentioned that the jointer can be the most dangerous tool in the workshop. However, the operator can make it a safe machine to serve him well if he will abide by certain common-sense safety rules.

- 1) Keep knives sharp; dull knives cause poor planing and have a tendency to cause kickback.
- 2) Keep the fence tight and do not adjust it while the jointer is running.
- 3) Keep the guard in place and operating easily all the time.
- 4) Stand on the side of the jointer, never directly behind it, to avoid injury in case of kickback.

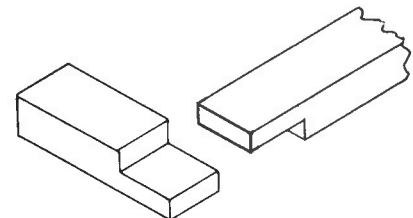

Fig. 9. Jointer can make lap-joint cuts.

- 5) When surface planing thin stock, always use a pusher stick or a pusher hook.
- 6) Don't surface plane any stock less than 12 in. in length.
- 7) Stock should always be more than 1/2 in. thick and 3/4 in. wide. Most jointer accidents are caused by failure to observe this important rule.

SOUND FANCIER

Continued from page 39

- 10b. Weiler, Harold D. "Tape Recorder Maintenance" (Chap. 12). *Tape Recorders and Tape Recording*. Radio Magazines, 1956.
- 10c. Weiler, Harold D. *Test Tape Manual*. The Dubbings Company, 1954 (supplied with test tapes D 110 and D 111).

AMPLIFIER DESIGN

Continued from page 30

the rolloff frequency will be pushed out to around 32 Kc.

We now have an amplifier with a response sensibly flat from 20 cps to beyond 20 Kc, and with a total of 34 db feedback in the two loops, which is fully effective from 200 cps to 3,200 cps. Beyond these frequencies the amount of feedback available rolls off slightly, but there is still not less than 14 db feedback over the output stage to the extreme limits of the band. As we have taken careful steps to see that the distortion in the absence of feedback is at a minimum, the amplifier should give very good performance.

Power Supply Components

The only components we now have left to specify are those in the power supply. R6 and C3 must reduce a supply voltage of 270 (the same as that for the output tube screen grids) and provide some decoupling. The B+ voltage we need for the 12AX7 tube is 180 volts, so we can allow a 90-volt drop in R6 at a total current drain of 1.2 ma (0.6 ma for each tube section). R6 is accordingly set at 75 K. In practice 68 K will serve, because the voltage here is not critical. C3 can be 8 μ fd, 350 volts working; this will give a reactance of less than 20 K down to 1 cps, and hence cannot interfere with the rolloff frequencies we have just calculated.

The cathode bypass capacitor C1, which is across 2.2 K, should be not less than 100 μ fd, 25 volts working. This will give a reactance of less than 1,600 ohms down to a frequency of 1 cps.

For the B+ supply we need a maximum of 360 volts at a total current drain of about 125 ma. This can be



provided by a power transformer with a 350-0-350 secondary winding, a 5U4 rectifier, and a capacitor-choke-capacitor filter, the design of which has been dealt with elsewhere in this magazine.¹

This article has discussed the complete design of a feedback amplifier, and has introduced all the factors to be considered, as painlessly as possible. From this it will be seen that, taken step by step, there is nothing very difficult about the design of such an amplifier. In the next article of this series, we shall take a step further and consider special kinds of output arrangements and the design factors involved in getting the best out of these circuits.

¹Marshall, Joseph. "Practical Audio Design", AUDIOCRAFT, Jan., Feb., Mar., 1956.

Mercury Living Presence

New HIGH FIDELITY Releases

WORLD PREMIERE RECORDING

VAUGHAN WILLIAMS *Symphony No. 8 in D Minor* BUTTERWORTH *A Shropshire Lad*; BAX *Garden of Fand*. Halle Orchestra, Sir John Barbiroli, conducting. MG 50115

DEBUSSY *La Mer*; *Iberia*; *Prelude to "The Afternoon of a Faun"*. Detroit Symphony, Paul Paray conducting. MG 50101

BEETHOVEN *Symphony No. 4 in B-flat*; *Symphony No. 5 in F Major*. Minneapolis Symphony, Antal Dorati conducting. MG 50100

SESSIONS *The Black Maskers*; HOVHANESS *PRELUCE AND QUADRUPLE FUGUE*; LO PRESTI *The Masks*. Eastman-Rochester Orchestra, Edward Hanson conducting. MG 50106

MARCHES FOR TWIRLING—music for baton twirlers. Eastman Wind Ensemble, Frederick Fennell conducting. MG 50113

AMERICA'S BEST SELLER

TCHAIKOVSKY
1812 *Festival Overture* (original scoring with cannon and bells); *Capriccio Italien*. MG 50084

SPARKLING HI-FI SOUNDS

THE SPIRIT OF '76
Music for **FIELD TRUMPETS and DRUMS** Based upon the Field Music of the U.S. ARMY from the Revolutionary War to the present day. MG 50111

RUFFLES AND FLOURISHES
Music for **FIELD TRUMPETS and DRUMS** Based upon the Field Music of the Armed Forces from the Revolutionary War to the present day. MG 50112

HIGH FIDELITY CLASSICS
LIVING PRESENCE

Completely New! DYNAKIT MARK II



Designed by DAVID HAFLER,

Inventor of Famous Ultra-Linear Circuit!
The DYNAKIT Mark II is a complete 50 watt power amplifier kit in ultra-compact form, utilizing a new circuit to increase quality and efficiency. The DYNAKIT uses the DYNACO A-430 output transformer to achieve superior performance. The physical and electronic arrangement of the Mark II is such that it can be easily and simply assembled by the novice, without bugs. Specified performance is assured.

Specifications:

Power Output: 50 watts continuous rating; Distortion: 1% at max power, less than 1% harmonic distortion at any frequency 20 cps to 20 kc within 1 db of maximum; Response: Plus or minus .1 db 20 cps to 20 kc; Square Wave Response: Essentially undistorted 20 cps to 20 kc; Sensitivity: 1.5 volts in for 50 watts out; Damping Factor: 15; Output Impedances: 8 and 16 ohms; Tubes: 6CA7/EL-34 (2) (.6650's can also be used) 6AN8, 5U4GB; Size: 9" x 9" x 6 5/8" high.

69.75
Net

Dynaco Output Transformers

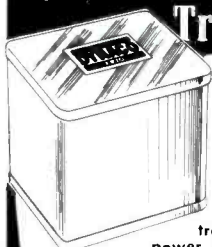

Featuring para-coupled windings, a new design principle (patents pending). These transformers use advanced pulse techniques to insure superior square wave performance and undistorted reproduction of transients. Dynaco transformers handle full rated power over the entire audio spectrum from 20 cps to 20 kc, without sharp rise in distortion at the ends of the band which characterizes most transformers. Conservatively rated and guaranteed to handle double nominal power from 30 cps to 15 kc without loss of performance capabilities.

Specifications:
Response: Plus or minus 1 db 6 cps to 60 kc; Power Curve: Within 1 db 20 cps to 20 kc; Square Wave Response: No ringing or distortion from 20 cps to 20 kc; Permissible Feedback: 30 db.

MODELS

A-410 10 wt-6V6, 6AQ5, EL-84* \$14.95
A-420 25 wt-KT-66, 5881, 807* 19.95
A-430 50 wt-6550, 6CA7/EL-34* 29.95
A-440 100 wt-6550, 6CA7/EL-34** 39.95

* tapped primary
** tertiary winding screen or cathode

Radio Electric

SERVICE CO. OF PENNA., INC.

709 Arch Street, Phil. 6. Pa.

Please ship me the following:

- Dynakit Mark II @ \$69.75
 A-410 @ \$14.95 A-420 @ \$19.95
 A-430 @ \$29.95 A-440 @ \$39.95

Check or Money Order Enclosed
Shipping charges, express collect

Name
Address
City Zone State

The RUMBLE Seat

Gentlemen:

I noted with interest some rather emphatically critical comments* by Joseph Marshall anent overcutting of disc records, and would like to add some observations in a less critical vein.

There are, as far as I can determine, three things that can account for a record behaving as if it were overcut. Two of these, inadequate cutting equipment and misshapen record grooves, are definitely the fault of the recording companies, and are as good a reason as any for blasting away at their sloppiness and lack of conscientiousness. But the third, which manifests itself as various forms of tearing, raucous distortion on loudly recorded passages, is the fault of the playback equipment rather than the records themselves.

There are many records which give every indication of being overcut when played on pickups of sometimes dubious quality, but which somehow seem to clean up when played with a pickup whose compliance and smoothness are considerably above average. As the user of a pickup which claims (and seems to have) higher compliance than any competing type, I must say that I have not noticed any tendency for records to exhibit evidence of overcutting, and must add that I prefer as much dynamic range on a disc as the recording companies dare to put on it. One reason live tapes can sound so impressive is that it isn't necessary to incorporate the volume compression that is used on discs, and because they are so outstandingly clean on loud passages. Comparable dynamic range can be cut on a disc by reducing the over-all recording level, but this often results in dropping quiet sections below the rumble or surface-noise level.

Another way is to raise the entire level of the program so that the quiet sections are above the soup and the loud sections hit high levels of groove excursion. The risks that a record company runs by doing this include such things as being labeled as an overcutter of discs, because the majority of pickup cartridges won't ride such high-level passages.

It doesn't seem right, though, that record manufacturers should be maligned for something that is the fault of much of the available playback equipment, as long as their recorded dynamics stay within the capabilities of the best pickups. To go whole-hog into the thing and cut discs that no pickup could possibly ride would be another matter

altogether. But the fact remains that there are cartridges that will ride even the most loudly recorded discs being produced today, so why not take advantage of them and have records with dynamic range approaching the original program?

Recorded tapes are at present being hailed as the answer (but an expensive answer) to all the problems that discs have created, but if discs lose favor as a home music medium simply because the playback equipment never equaled the discs, it will be a pretty sad commentary on the industry as a whole.

So let's take a thoughtful look at our playback equipment before we start throwing stones at record manufacturers for efforts to better their own products.

J. Gordon Holt

Reply:

You will recall that, in my criticism of overcut records, I took into account the fact that much distortion could be due to the playback equipment. I own nearly a score of pickup cartridges and some six or seven different arms, and I have used many others. Among these are examples of almost every cartridge of any reputation. I acknowledge that some are decidedly better than others, but I know of no pickup that will guarantee distortion-free reproduction of all records. Even with the best pickups there is still too much distortion on too many records. On the other hand, there are also records, not noticeably inferior in dynamic range, which provide highly acceptable and relatively distortion-free reproduction with many of the better pickups. It seems to me that too many records are being produced to perform at a loud level on poor reproducing systems; it does not follow that these loud records have a wider dynamic range. Many of them, in fact, have been compressed in the peaks and boosted in the quiet sections to bring up the average loudness with no improvement in dynamic range; this is especially true of pop records, but it applies also to many classical discs.

I grant that distortion is the product of both the recording and the reproducing systems. Mr. Holt and I are in general agreement that recording companies should record for a higher standard of equipment than that represented by the cheapest, even if it were true that people using the cheapest are in the majority; but I think it is quite impractical to require that they record for the best possible equipment. I believe they have an obligation to reach a happy medium between the best and the poorest, and I don't think it's asking

* "The Grounded Ear." AUDIOCRAFT August 1956, p. 5.

too much to require them to produce records that give good results with any of the dozen or so top-quality pickups now available. Mr. Holt may prefer a wide dynamic range even if it results in distortion; I think that with today's techniques it is possible to produce records with a wide dynamic range relatively free of distortion. I am quite sure that, if a choice had to be made, most listeners would prefer a small sacrifice in dynamic range if it resulted in cleaner reproduction with good (but not necessarily the best available) equipment.

Joseph Marshall

LOUDSPEAKERS

Continued from page 33

lengths are four times the length of the duct and higher. A 6-inch duct will act as a quarter-wave air column at 560 cps, and higher multiples of this frequency. To prevent interference from this source the interior of the cabinet should be lined with Ozite, Fibreglas batting, or some other acoustic material to damp out vibrations above 200 cps.

Similar difficulties are apt to show up in the ductless design. If the vent is close to the speaker some frequencies are apt to find their way out through the opening and introduce cancellation effects above the system resonance point. Also, the cabinet may introduce standing waves in the middle-frequency range. Some designs utilize partial partitions and absorptive filters to smooth out the response and damp unwanted resonances.

Still another source of distortion in reflex cabinets can be traced to the absence of any damping at all one octave below the basic resonance frequency. While the vented cabinet gives clean bass response down to about half an octave below its resonance point, frequencies lower than this are attenuated very rapidly because of cancellation between radiation from the two sides of the speaker cone. An enclosed cabinet restricts the motion of the speaker below system resonance, but the reflex cabinet offers no such limiting action and the speaker cone works against only the compliance of its own suspension. Since cone suspensions are usually none too linear when pushed very far, the cone of a low-resonance speaker is easily overdriven by rumble and other sub-audible effects which muddy up the sounds we're listening to. Some sort of rumble filter in the amplifier is recommended to give a sharp cutoff just below the resonance frequency of the bass-reflex system.

Another rather interesting consideration is the tendency of certain speakers

Continued on next page

This is the book . . .

"During the past several years I have written literally thousands of letters to individuals all over the world, trying to answer their questions about high-fidelity sound reproduction. A good many of my letters have started out along these lines: 'I'm afraid I'll have to give you just a very brief answer to your question; if I were to cover it completely, I'd have to write a book.' This, at last, is the book."

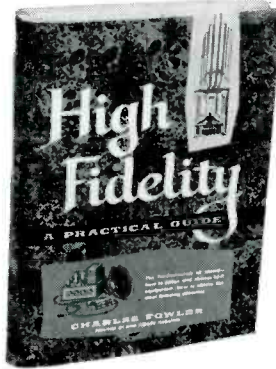

from The Preface to

HIGH FIDELITY

A Practical Guide

By

CHARLES FOWLER

Publisher of HIGH FIDELITY
and AUDIOCRAFT Magazines

There is little need to introduce the author of *High Fidelity: A Practical Guide* to readers of this magazine, nor to assure them of his ability to tell in clear, nontechnical language, just how to evaluate, buy, and operate hi-fi equipment for the optimum in lifelike reproduction.

Whether you plan to build, buy, or add to your high-fidelity system, this new book gives you practical advice and expert guidance each step of the way. It makes plain every aspect of hi-fi . . . shows how you can best re-create the dynamic range and full tonal quality of live music in your own home.

Gives clear and complete information on:

- loudspeakers
- speaker enclosures
- room acoustics
- amplifiers
- control units and preamplifiers
- tuners
- record changers and turntables
- pickups

Starting with a fascinating introduction to sound itself, the author then describes the various links in the hi-fi system. He explains their features and specifications so that you can easily understand and use them as criteria in evaluating different makes of equipment.

With these standards you are shown exactly what to look for when buying each unit in your hi-fi chain, and how to select and match

components for best sound reproduction. You are also shown how to plan ahead for adding to or improving your equipment in the future.

Whether your budget is small or large, whether you are a beginner baffled by the intricacies of hi-fi, or whether you are a high-fidelity fan from way back, this complete and definitive guide can help you get the most enjoyment out of your high-fidelity system.

310 pages, 100 illustrations, \$4.95

Publication Date — September 24 — Order Your Copy Today

About the author:

As publisher of HIGH FIDELITY and AUDIOCRAFT magazines, and author of many articles on high fidelity, Mr. Fowler knows exactly the kind of information you need and want to understand hi-fi fully. In this book you gain the benefit of his many years of experience.

Book Department
AUDIOCRAFT Magazine
Great Barrington, Mass.

I enclose \$..... for which please send me, postpaid, copies of *High Fidelity: A Practical Guide*.

Name

Street

City Zone

State

(No C.O.D.'s or charge orders, please. Foreign orders sent at buyer's risk. Add 55c for postage on foreign orders.)

HI-FI
Fen-tone
IMPORTS

The **FIRST** really
STATIC-FREE, DUST-FREE
NOISE-FREE CARTRIDGE

NOW AVAILABLE
 IN TWO SERIES:

1.

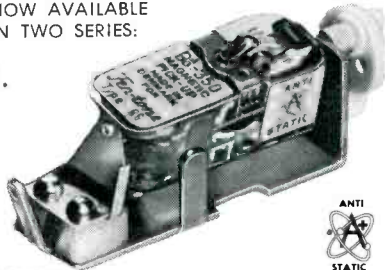

Fen-tone **DS** **A+ STANDARD**

Professional 8-pole magnetic cartridges, reversible and single play cartridges for all modern plug-in shell record players and changers; and

2.

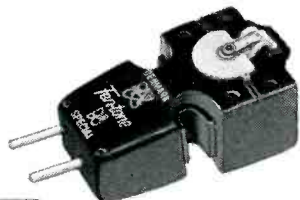

Fen-tone **DS** **A+ SPECIAL**

Professional 8-pole magnetic cartridges, single play only for all professional transcription arms.

Standard and Special series available in two impedances: 350 ohms & 72 ohms to suit high-level (350 ohms = 30mV) or medium level (72 ohms = 10-15 mV) magnetic phono inputs.

Leading audio critics comment:

MONITOR—RADIO-ELECTRONICS: "An extremely fine value . . . Remarkably good on old 78 rpm shellac records . . . with a unique and exclusive feature—a strip of radioactive foil built into the cartridge to neutralize static charge on records."

J. B., BENTON HARBOR, MICH.: "They are absolutely magnificent. I will recommend it to everyone I know as being THE CARTRIDGE!"

ONE DEMONSTRATION WILL CONVINC
 YOU TOO!

Audiophile Net Prices:

	Standard	Special
Single (LP or ST) Sapphire	\$ 9.30	\$11.60
Single (LP or ST) Diamond	\$21.30	\$24.20
RS Dual Sapphire	\$ 9.78	None
RG LP Diamond/ST. Sapphire	\$21.78	None



FREE! 1956 *Fen-tone* Catalog. The above are only samples of the many terrific values in the new 1956 Fen-Tone Hi-Fi catalog including mikes, tape decks, cartridges, record changers, silent listening devices, etc.

FENTON COMPANY
 15 Moore Street, New York 4, N.Y.

Sold through better
 Audio Distributors.
 See yours today!

West of Rockies,
 prices slightly higher.

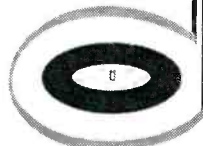

LOUDSPEAKERS

Continued from preceding page

to change cone resonance with weather conditions. The designer of Pro-Plane speaker systems, Antony Doschek, reports that with one speaker tested, the amplitude of the two impedance peaks changed as much as 4 db with daily changes in humidity. Since Mr. Doschek tunes his better systems to maximum impedance tolerances of 1 db, the speaker in question proved unacceptable for this particular enclosure.

The smallest Pro-Plane enclosure is shown in Fig. 8. This little system, the Prismatic I, has received considerable critical praise and seems to be accepted as one of the better bookshelf systems. The design is basically a ducted enclosure using a wide-range 8-inch speaker. The main difference between this \$85.00 system and other small reflex designs selling for about \$50.00, besides the high-quality speaker, is that each unit is individually checked for impedance characteristics and given an A-B listening test against a standard assembly before leaving the factory.

A much larger ducted enclosure, Fig. 9, is the Jensen Bass Ultraflex system, designed for a three-way Jensen speaker system. Jensen pioneered bass-reflex de-

with an occasional middle-frequency horn added to increase efficiency, but has no patience with rear-loaded bass-horn enclosures. Design of horn-type enclosures will be saved for a future article—the remaining paragraphs here will touch upon a few interesting modifications of bass-reflex design in current commercial speaker systems.

The Karlson enclosure is claimed to be an untuned pipe, but I doubt that anybody really believes this, since the dimensions of the cabinet are such that, if it can be called a pipe, its maximum length is about 6 ft. A tube this long, whether tuned or not, won't resonate below 50 cps. The Karlson enclosure, however, is claimed to have flat response to some incredibly low frequency and, in fact, does put out quite thunderous bass response. Actually, the Karlson appears to work along the same lines as the R-J in that both the front and the back of the speaker are loaded by various ducts and resonant cavities. When these are all suitably balanced out by trial and error, acceptably smooth response can be achieved.

GE speaker cabinets feature what is known as a "distributed port", Fig. 12. Instead of one or two large vents, GE drills a great many small holes in the front of the cabinet and the total effect is much the same. But the multiple small openings do increase the viscous resistance of the enclosure, and add acoustic damping to the system. The idea of viscous loading has been carefully studied by Goodmans Industries and a "friction-loading" kit is now available to audiophiles. The gadget is a grille which fits over the reflex vent, and is designed to provide just the right amount of viscous damping for most reflex enclosures.

Needless to say, a bass-reflex enclosure must be made of heavy material and thoroughly braced to prevent any tendency toward panel resonance. Some of the bargain enclosures made of 1/4-inch fiberboard are by no stretch of the imagination bass-reflex cabinets. They might be termed wave-deforming networks, since their main characteristic is the ability to make any signal below 200 cps unrecognizable.

Complete designs for various reflex enclosures are available from Jensen, Altec Lansing, James B. Lansing, and other speaker manufacturers. A list of such material as well as information on other phases of speaker and enclosure design will be given in a bibliography at the end of this series.

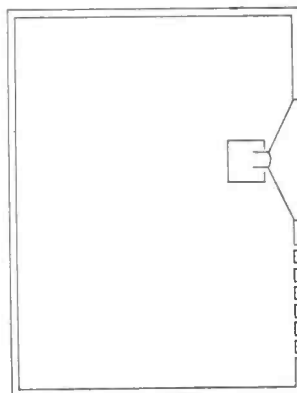

Fig. 12. A distributed-port bass reflex.

sign in America; indeed, the term was for many years a Jensen copyright, and Jensen is one of the manufacturers who have helped kill the "bass-reflex boom" bogey in quality speaker systems. Jensen and Altec Lansing both state that, while an improperly designed enclosure certainly may boom, a properly tuned system is characterized by cleaner bass response rather than by increased coloration. An Altec Lansing corner cabinet utilizing a bass-reflex port is shown in Fig. 10.

Another corner enclosure of striking modern design is the new James B. Lansing reflex cabinet, Fig. 11. James B. Lansing and Jensen utilize both reflex and horn-type enclosures for their speakers. Altec Lansing, on the other hand, sticks to vented design exclusively

BASIC ELECTRONICS

Continued from page 35

merical sum. This is always true in a circuit containing a resistance and inductance in series. The phase of the

source voltage is leading the voltage across the resistor, and lagging that across the inductor. It always falls somewhere between 0 and +90° referred to the current. A more generally useful way to express this is that the current, and the voltage across the resistor, lags the source voltage by some value between 0 and 90°, while the voltage across the choke leads the source voltage by the remaining amount of the 90°.

Third, it isn't necessary to draw a vector diagram for a simple circuit such as this. The vectors E_R and E_S , together with construction line B, form a right triangle. Also, the line B corresponds to the vector E_L . In a right triangle the square of the hypotenuse is equal to the sum of the squares of the two sides; therefore, $E_S^2 = E_R^2 + E_L^2$. Stated in more convenient form, $E_S = \sqrt{E_R^2 + E_L^2}$. Also, and even more useful, $Z = \sqrt{R^2 + X_L^2}$. An example: what is the impedance of a resistance of 1,000 ohms in series with a choke of 0.15 h, at a frequency of 500 cps? First find X_L at 500 cps: $X_L = 2\pi fL = 2 \times 3.14 \times 500 \times 0.15 = 471$ ohms. Then substitute this in the equation above:

$$Z = \sqrt{R^2 + X_L^2}$$

$$Z = \sqrt{(1,000 \times 1,000) + (471 \times 471)}$$

$$Z = \sqrt{1,221,841} = 1,105 \text{ ohms.}$$

If it is necessary to know the phase angle between the source voltage and the current, it can be found by any of the following formulas:

$$\sin \theta = \frac{E_L}{E_S} \quad \sin \theta = \frac{X_L}{Z}$$

$$\tan \theta = \frac{E_L}{E_R} \quad \tan \theta = \frac{X_L}{R}$$

In the example above, for instance, X_L/Z is equal to approximately 0.426. This is (according to a trigonometric table) the sine of an angle slightly larger than 25°.

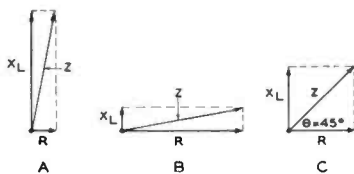

Fig. 8. Important impedance conditions.

Therefore, the voltage across the resistance lags the applied voltage by 25°, and the voltage across the inductor leads the applied voltage by $(90 - 25)^\circ$, or 65°.

The values chosen for Fig. 6 are such that reactance and resistance values are fairly close. If the frequency of the voltage source (or the inductance value) were increased substantially, the reactance would be appreciably higher than the resistance. The vector diagram for impedance would then appear as shown in Fig. 8a. This circuit would be primarily inductive; the voltage across L would be almost equal to the source

voltage, and there would be little voltage across R . Impedance would be determined primarily by X_L . The current, and the voltage across R , would lag the source voltage by almost 90°, while the voltage across L would be almost in phase with the source.

On the other hand, if the frequency or the inductance were decreased markedly, the impedance diagram would appear as in Fig. 8b. This would be a primarily resistive circuit. The magnitude of Z would be fixed mostly by R ; voltage across L would be small. Current, and voltage across R , would be almost in phase with the source. The voltage across L would lead the source voltage by almost 90°.

Finally, if the frequency or inductance were reduced slightly, then the reactance

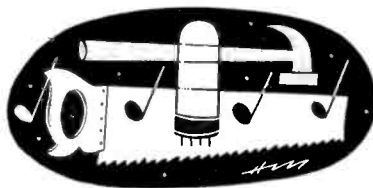

would equal the resistance in the circuit. This situation is diagrammed in Fig. 8c. Now the impedance is determined equally by X_L and R , and is 1.414 times each. Voltage across R is 0.707 times the source voltage, and lags it by 45°; voltage across L is also 0.707 times the source voltage, and leads it by 45°. These are good values to keep in mind, because they are often used in filter design and in rough calculations of cutoff frequency.

Appendix

The instantaneous value of current in a sine wave can be expressed as $i = I_m \sin \omega t$, where i is instantaneous current value, I_m is the peak current value, ω is 2π times the frequency in cps, and t is time in seconds since the beginning of the wave at zero degrees.

It has been shown that the voltage of self-induction is

$$e = -L \frac{di}{dt}$$

where e is the instantaneous voltage in opposition to current change, L is inductance in henries, and di/dt is the instantaneous rate of change of current. Now if the first equation is differentiated with respect to time, the following equivalency is obtained:

$$\frac{di}{dt} = I_m \omega \cos \omega t.$$

Substituting this in the second equation, the expression for e becomes $e = -\omega L I_m \cos \omega t$, which is a cosine curve identical in form to the sine wave, and shifted in phase from it, 90° lagging. Since this voltage is always directly opposite in phase to the source voltage, then the current lags the source voltage by 90° and has the same wave form.

Acousti-Magic

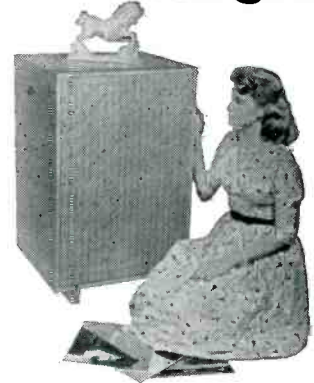

New standards of excellence
in kit cabinetry

NO RISK HOME TRIAL

It's true—a speaker enclosure you may test in your own home with your own equipment—and in money saving KIT form!

SUPERIOR PERFORMANCE

Acousti-Magic incorporates a highly refined, TUNABLE labyrinth design which allows installation of any speaker with space for future expansion to a multiple system. Using only an average \$50. speaker, Acousti-Magic will faithfully reproduce the tremendous pedal tones of the mighty organ. Correct acoustical loading enables you to FEEL fundamental bass to 30 cycles and below.

SUPERIOR KIT DESIGN

Acousti-Magic is prefabricated entirely of 3/4" plywood. Professional lock-mitre joints join the furniture plywood exterior panels—but you use NO CLAMPS or NAILS in the assembly. EXCLUSIVE Acousti-Magic construction with MACHINE SCREWS allows effortless assembly with only a screwdriver in 2-4 hours. Over one hundred pounds of the very finest materials.

SUPERIOR STYLING

Acousti-Magic gives you styling and quality to complement the finest home. The EXCLUSIVE CONVERTI-BASE gives you highboy or lowboy styling in an instant—and either way you will see nothing but furniture. There are no gimmicks—you don't paint it, you don't cover it—it's all genuine furniture plywood—more of it than any other kit speaker enclosure.

ACT NOW—MAIL THIS COUPON!

Order Acousti-Magic in either hardwood Mahogany or Oak. When you receive your kit, assemble it without glue and test it for two weeks. It must give complete satisfaction—sound and sight! If not, disassemble it and return it for a full refund.

For 12" or 15" Speakers & Multiple Systems

Acoustical Development Corporation
Box 572, Hempstead, N. Y.

I Prefer Acousti-Magic

in OAK \$64.75 in MAHOGANY \$59.75

My speaker

Speaker

system is

Size

Send Illustrated Brochure

Name

Address

City

AR-1

Report from the LABORATORY The Audio League Report*

Fig. 5
Acoustic Output at 30 CPS

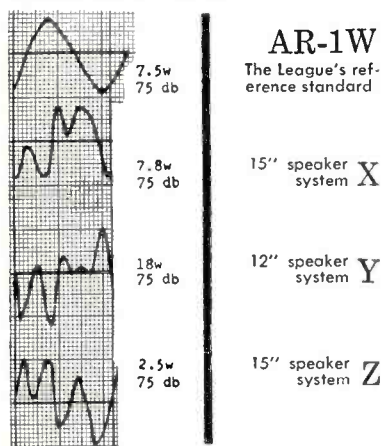

*Vol. 1 No. 9, Oct., '55. Authorized quotation #28. For the complete technical and subjective report on the AR-1 consult Vol. 1 No. 11, The Audio League Report, Pleasantville, N. Y.

Report from the WORLD OF MUSIC

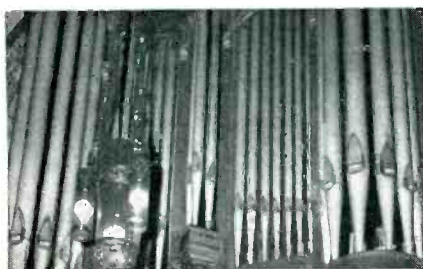

The Aeolian-Skinner Organ Co. uses an AR woofer (with a Janszen electrostatic tweeter) in their sound studio. Joseph S. Whiteford, vice-pres., writes us:

"Your AR-1W speaker has been of inestimable value in the production of our recording series 'The King of Instruments'. No other system I have ever heard does justice to the intent of our recordings. Your speaker, with its even bass line and lack of distortion, has so closely approached 'the truth' that it validates itself immediately to those who are concerned with musical values."

AR speaker systems (2-way, or woofer-only) are priced from \$132 to \$185. Cabinet size 14" x 11 3/8" x 25"; suggested driving power 30 watts or more. Illustrated brochure on request.

ACOUSTIC RESEARCH, INC.
25 Thorndike St., Cambridge 41, Mass
Room 544 N. Y. High Fidelity Show

ACOUSTI-MAGIC

Continued from page 23

a simple two-part finish: two coats of a special primer-sealer-stain with steel-wool rubdowns after each coat; then two applications of a tinted paste wax supplied with the kit, with hand buffing after each coat. The wood was sanded lightly but not filled before this finish was applied. We are highly pleased with the resulting finish, which is a nonglossy sheen that doesn't hide the grain at all—the way oak should look. This finish is much more vulnerable to water, alcohol, and cigarette stains than varnish or lacquer, but is far more easily applied and repaired too.

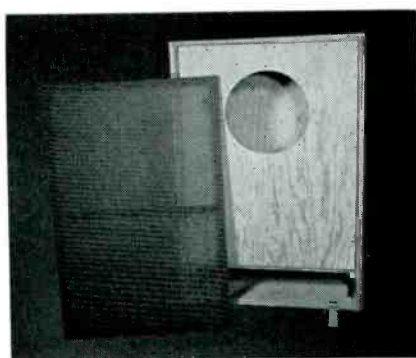

Speaker panel is in place; note grille.

Dimensions of the enclosure: as a high-boy, 38 1/2 in. high by 23 3/4 in. wide by 22 in. deep; as a low-boy, 26 1/2 in. high by 35 3/4 in. wide by 22 in. deep.

AUDIOCRAFT Test Results

Testing an enclosure—even by ear—is a more complex affair than testing a complete speaker system because the results will, of course, depend so much on the speakers used. We have a large (9 1/2 cu. ft.) enclosure that we use for testing speakers. This is exceptionally well braced and rigid, so that we can discount sound coloration from panel resonances, and it can be used as an infinite baffle, a tuned bass-reflex enclosure, or a vented baffle. In comparing the Acousti-Magic enclosure with this we used three speakers: a 12-inch coaxial with a cone resonance frequency of 71 cps; a 15-inch wide-range speaker with cone resonance at 53 cps; and a 12-inch woofer with a cone resonance at 38 cps.

We couldn't make the first speaker sound really good in our test enclosure no matter how it was adjusted. As an infinite baffle (port totally closed) the bass was thin and overwhelmed by the treble range. Opening the port to about 6 by 10 in. produced a large peak at around 40 cps, and a hole in response from 45 to 75 cps; the result was a soggy, booming bass. With the port

open enough to tune the cabinet as a bass-reflex enclosure, too much of the middle range escaped through the port, producing peaky and unsatisfactory middles. The cabinet was simply too large for this speaker. When it was installed in the Acousti-Magic enclosure, however, the results were quite acceptable—unquestionably better than in the standard enclosure. The bass range filled in quite well to about 50 cps and was listenably smooth. There was no audible interference in the middle range.

The wide-range 15-inch speaker sounded noticeably better also in the Acousti-Magic enclosure than in our test cabinet *except* when the latter was critically tuned as a bass reflex. Then it was a toss-up; some listeners would prefer one, some the other. Note, again, that our standard enclosure had to be tuned with test instruments to produce this result, while no adjustment was required to the Acousti-Magic enclosure. It follows that a speaker with a resonance frequency of, say, 49 or 58 cps rather than 53 cps would sound better in the Acousti-Magic unit than in a bass-reflex enclosure adjusted to 53 cps.

With the very low-resonance woofer, it was generally conceded that the large infinite baffle gave best results. Between this, the tuned bass reflex, and the Acousti-Magic the differences were slight, however, and consisted primarily of somewhat better transient response with the infinite baffle. Direct comparison was necessary to notice the difference.

Generally, we should say that Acoustical Development's claim of universal utility for their product is well founded.

Again and again we have been impressed with the great importance of rigid construction in any speaker enclosure. The largest horn or infinite baffle, with the finest drivers, has a very good chance of sounding worse than a modest speaker in a small box unless it is solidly and rigidly built, with heavy braces on any panel larger

Grille-cloth frame is snapped in place.

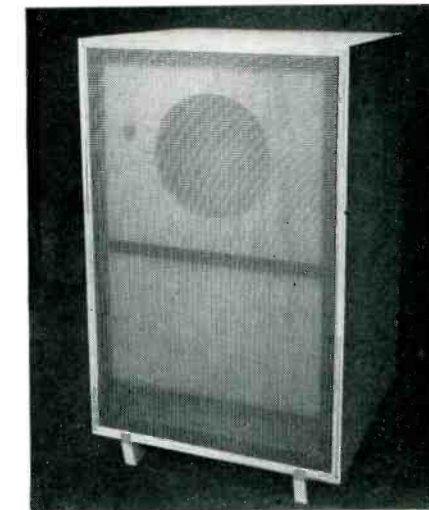

than one or two square feet in area. In this respect the Acousti-Magic enclosure is excellent. It is made of 3/4-inch plywood and, aside from their acoustic function, the internal baffles are almost ideally disposed to stiffen the outer panels. The only member that might benefit materially from additional bracing is the back panel; it would be simple to add a cross brace either on the inside or outside.

With effective acoustical design, sturdy construction, adaptability, fine finish and appearance, and easy assembly, the Acousti-Magic kit is a very good buy.

TAPE NEWS

Continued from page 15

Two impedances are available from the Celeste; lo-Z balanced or hi-Z unbalanced. Either is selected simply by inserting the appropriate cable plug into the mike, so changes can be made from hi-Z to lo-Z with a minimum of time and effort. This impedance selection idea isn't unique, but it is certainly convenient.

Used "raw" (without any additional baffle pads), the Celeste sounds a trifle bottom-heavy when placed close-to, and does not seem to have the phenomenally extended high-frequency range that made the B&O-50 such a remarkable performer. But unless my ears are deceiving me, the Celeste is ever so slightly smoother over its entire range.

The Celeste does not seem to exhibit a tendency to break up on very loud, close-to program material. This roughness from highly transient signals seems to be a very common failing among small ribbon microphones, but the Celeste has yet to do it. Given the right sound it may yet, but time will tell.

The Celeste, in direct comparison with its closest price and quality competitor, the B&O-50, does very much better on pickup of large groups. The B&O-50 performs at its best on speech or solo voice and instrumental recording; the Celeste works best at distances of 6 ft. and more. The low end on the Celeste is fuller and also, I suspect, more extended than that of the B&O-50, which makes it ideal for use when a rather lush sound is required. It also makes it quite unsatisfactory for close talking, and this is where the baffle pads come in handy. Three pads are provided; two thin felt ones and a phenolic-impregnated fiber one. Without the pads, the mike tends to be decreasingly sensitive from the rear as the frequency goes up, so at the extreme high end it is almost perfectly unidirectional. Inserting one felt pad inside the case gives moderate bass reduction, for fairly close talking. One felt pad plus the phenolic one provides

bass reduction with rear discrimination, while all three pads at once give extreme bass reduction (for very close talking) plus full rear discrimination.

None of these pad-induced conditions is likely to be of much use for quality music recording, but they certainly increase the versatility.

If this mike were to be compared with any other well-known mike, I would say that it most closely matched the RCA 44-BX in sound. Its high range is smoother than that of the 44-BX and is, I would guess, also more extended. The price, though, is another matter altogether — \$49.50. This puts it in a class where its only real competitor among the velocity mikes is the B&O-50, and makes it another one of the best buys in the field, if it happens that a velocity mike will suit your needs.

At about the other end of the price range is the other mike I have been using for some time under varied conditions; the Capps CM-2030A condenser system.

This is not by any means what could be called a budget microphone — its cost is \$225, including interconnecting cable and power supply, but its performance is about as close to ideal as I have heard from any microphone.

This is possibly the only microphone

in existence with a reverse presence peak. The "presence range", which when boosted gives the exaggerated brightness that characterizes many "hi-fi" speaker systems, is slightly depressed in the Capps condenser system. Instead of a broad peak between 3,000 and 8,000 cps, the Capps has a slight broad dip, and its response returns to normal at around 8,000 cps. From there it goes on out to a little above 15,000 cps, and collapses above that.

The result is a remarkably sweet sound from all kinds of program material, and the ability to reproduce all musical instruments and voice with a naturalness that I have yet to hear from any other microphone. Reproduction of speech sibilants is completely natural; there is no tendency toward a spitting or pitched quality in them, and this evidence of high-frequency smoothness shows up particularly on reproduced string tone. I had no idea that it was possible to reproduce stringed instruments as well as this microphone does, and its performance in this respect is the more remarkable in view of its response to transient sounds. Many very smooth-sounding microphones give that impression because of poor transient response, but the way the Capps reproduces transients over the entire musical frequency range indicates

Continued on page 53

colbert

LABORATORY, INC.

NEW YORK HIGH FIDELITY SHOW · Sept. 26-30, Room 505

subject:

A Significant Departure in the Direction of Highest Fidelity

featuring:

The COLBERT ELECTRONIC 3-CHANNEL FREQUENCY DIVIDER

specification summary:

- Complete Range Controls for three frequency bands
- Eliminates impedance mismatching
- Complete electronic compensation for unequal speaker efficiencies
- Affords optimum damping of individual loudspeakers
- Provision for use on two or three-way loudspeaker systems
- Includes 10 watt ultra-linear amplifier for use on middle or high range
- For use with regular or electrostatic loudspeakers, or combinations
- Three-channel operation results in lowest over-all distortion

MODEL 3-CFD \$154.50

Decorator style case in blonde or mahogany formica finish... \$15

Slightly higher in west and deep south

For full specifications see your dealer or write to Dept. AC10

colbert

LABORATORY, INC.
160-09 Hillside Avenue
Jamaica 32, New York

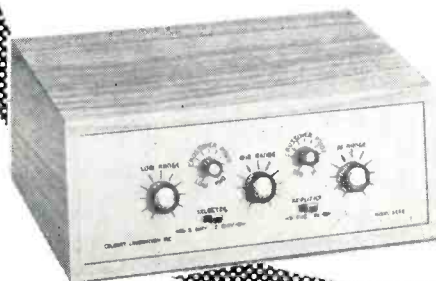

AUDIOCRAFT Sound Sales Directory

Following is a list of dealers who state that they carry the products specified.

KEY TO PRODUCTS HANDLED

- 1 Audio system components
- 2 Speakers and enclosures
- 3 Records and record accessories
- 4 Tape recorders
- 5 Pre-recorded tape
- 6 Radio hardware
- 7 Tools, wood
- 8 Audio parts
- 9 Microphones
- 10 Books
- 11 Test equipment

A series of items numbered consecutively is identified by a hyphen between the first and last numbers. Thus, 1-6 indicates 1 through 6; 8-11 indicates 8, 9, 10, and 11.

CALIFORNIA

Beverly Hills

Minthorne Music of Beverly Hills
230 N. Beverly Dr.
BR. 2-7676; CR. 6-4793 1-5, 9

Culver City

Bar-Shel's Hi-Fi Supply
5512 S. Sepulveda Blvd.
EX. 8-6747 1, 2, 4-6, 8-11

Hollywood

Hollywood Electronics
7460 Melrose Ave.
Webster 3-8208 1, 2, 4, 5

Los Angeles

Crenshaw Hi-Fi Center
107 Santa Barbara Plaza
Axminster 3-8201 1-5, 9

Menlo Park

Science in Sound
777 Santa Cruz Ave.
DA. 2-1611 1-11

Santa Barbara

Pacific Audio Supply
2919 De La Vina St.
Woodland 5-6422 1-5, 9

CONNECTICUT

West Hartford

Audio Workshop, Inc.
1 South Main St.
Adams 3-5041 1-5, 9, 10

DELAWARE

Newark

Delaware Music House
20 Academy St.
Endicott 8-3258 1-5, 8, 9

FLORIDA

Miami

High Fidelity Assoc.
3888 Biscayne Blvd.
82-8401 1-5, 8-10

GEORGIA

Atlanta

Baker Fidelity Corp.
1140 Peachtree St., N. E.
TRinity 5-2156 1-6, 8, 9
High Fidelity Sight & Sound Sys.
606 Peachtree St., N. E.
Vernon 6534 1-10

ILLINOIS

Champaign

The New Sound
35 E. Springfield Ave.
6-9119 1-5, 8-11

Chicago

Allied Radio Corp.
100 N. Western Ave.
HAYmarket 1-6800 1-11

ILLINOIS — Chicago (continued)

Evergreen Allied High Fidelity, Inc.
2025 W. 95th St.
BEverly 8-1067 1-11

Musicraft
48 East Oak St. 1-11

Voice and Vision, Inc.
Rush and Walton Place
Whitehall 3-1166 1-6, 8-10

Evanston

Allied High Fidelity Stores, Inc.
602 Davis St.
DAvis 8-8822 1-11

Oak Park

West Suburban Allied High Fidelity, Inc.
7055 W. North Ave.
ESTebrook 9-4281 1-11

LOUISIANA

New Orleans

The Music Shop, Inc.
4215 South Claiborne Ave.
TW. 1-5871 1-5

MASSACHUSETTS

Boston

The Listening Post, Inc.
161 Newbury St.
COpley 7-7530 1, 2, 4, 5, 8-10

MICHIGAN

Detroit

Hi-Fi Studios
8300 Fenkell
Diamond 1-0894 1-6, 8-10

MISSISSIPPI

Pass Christian

The Music Box
121 Davis Ave.
185 or 301W 1-5, 8, 9

MISSOURI

Kansas City

David Beatty Hi Fi Sound & TV
1616 West 43rd (Westport Rd.)
Jefferson 1-3110 1-10

St. Louis

The High Fidelity Showroom
6383 Clayton Rd.
Parkview 1-6500 1-5, 9

NEW YORK

Albany

Audio-Video Corporation
324 Central Ave.
3-1167 1-5, 8-10

Amsterdam

Adirondack Radio Supply
185-191 West Main St.
VI. 2-8350 1, 2, 4, 8

Buffalo

Frontier Electronics, Inc.
1507 Main St.
GA. 5727 1-5, 8-10

New York City

Arrow Audio Center
65 Cortlandt St.
DIgby 9-4730 1, 2, 4-6, 8-11
Grand Central Radio, Inc.
124 East 44th St. at Lexington Ave.
MUrray Hill 2-3869-70 1-6, 8-11

Yonkers

Westlab Electronics, Inc.
2475 Central Ave.
SP. 9-6400 1-6, 8-10

OHIO

Dayton

Custom Electronics, Inc.
1000 S. Main St.
AD. 3158 1-11

PENNSYLVANIA

Allentown

Baker Communications
9 South 12th St.
Hemloch 3-3326 1-11

Bethlehem

Audio Laboratories, Inc.
808 Mohican St.
UNiversity 7-3909 1-5, 9

Philadelphia

Almo Radio Co.
509 Arch St.
WAlnut 2-5153 1-4, 6-11

Danby Radio Corp.
19 South 21st St.
Rittenhouse 6-5686 1-5, 8-10

Radio Electric Ser. Co. of Pa., Inc.
7th & Arch Sts.
LO. 3-5840 1-11

Ten Cate Associates
6128 Morton St.
Germantown 8-5448 1-5, 8-10

SOUTH CAROLINA

Columbia

Hi-Fi Sound & Records Co.
621-23 Harden St.
6-3538 1-6, 8-10

TENNESSEE

Kingsport

Radio Electric Supply Co.
245 East Market St.
CI. 5-1471; 5-2651 1, 2, 4, 6, 8-11

TEXAS

San Antonio

Bill Case — Records & Sound
4206 Broadway
TAYlor 2-1341 1-5, 8-11

VERMONT

Rutland

Fleetwood Sound Studio
285 S. Main St. (Rt. 7)
Prospect 3-2312 1-5, 8, 9

VIRGINIA

Arlington

Audio Services
3131 N. 10th St.
JACKson 7-2552 1, 2, 4, 5, 8, 9

WASHINGTON

Seattle

High Fidelity Headquarters
603 Broadway North
CApitol 2266 1-4, 8, 10

WEST VIRGINIA

Huntington

Singer Electronics
1555 Third Ave.
3-7439 1-5, 8-9

WISCONSIN

Milwaukee

The Hi-Fi Center, Inc.
4236 W. Capitol Drive
Uptown 1-2113 1-5, 9, 10

CANADA

Montreal

Payette Radio Limited
730 St. James West
UNiversity 6-6681 1-11

Toronto

Electro-Voice Sound Systems
141 Dundas St., W.
EM. 8-7750-8301-8302 1-11

TAPE NEWS

Continued from page 51

that its smooth sound is not the result of an inherent deficiency. It is just the audible characteristic of extreme smoothness and low distortion.

The low end on the Capps condenser system is not as ambitious as that from several other top-quality microphones. But the fact that it starts to fall off below 40 cps rather than below 30 cps isn't likely to make much difference in music recording. As far as my ear (and my speaker system) is concerned, it reproduces about as deep as anything I've heard, so I won't quibble over the loss of ten cps when its present cutoff is as low as it is. As far as I have been able to determine, the Altec 21-B microphone (the M-11 condenser system) still responds deeper than any other mike, but the difference between the low ends of the Capps and the Altec condensers is, for all intents and purposes, inaudible. The Altec will kick a db meter higher when a 16-cps organ pedal note comes along, but I still can't hear the difference through my multiple-woofer speaker system.

The Capps is, however, more tricky to use than are many omnidirectional mikes. Like most of these, its directivity pattern tends to become unidirectional with rising frequency even though the effect is significant only above about 10,000 cps. The mike is smooth enough that a very slight loss at the extreme top is easily detectable. For peak performance, then, it should be located so that sounds reach it at an angle of less than 90° from perpendicular to the plane of the diaphragm. For speech recording or for pickup of most solo instruments the mike can safely be used on a stand, tilted forward slightly, but when recording musical ensembles, large groups, or instruments that propagate overtones from the top surface (violins, for instance), the Capps does best hanging upside down, with its diaphragm above the heads of the performers.

Because of the lack of exaggerated brightness from the Capps, it can (indeed, should) be used somewhat closer to the performers than is usual with an omnidirectional microphone. There's no need to worry about its blasting or overloading—it seems to be able to handle anything without going to pieces.

I should add at this point that the microphone I was using employed a stretched diaphragm, which may help to account for its extreme smoothness. I don't know whether all models of the Capps condenser microphone are produced with stretched diaphragms, or whether they are stretched only on request; but I suspect from the per-

formance of this one that it is well worth while to order it stretched if the choice is offered.

LISTENING

Continued from page 26

the sudden explosion or rapid roll of bass or kettle drums, which are, in fact, accompanied by momentary transients. Percussion recordings are therefore highly popular for measuring transient stability. The better the transient response, and the less the tendency of the reproducing system to hang over or ring, the cleaner, sharper, and more distinct the most rapid and violent drum beats will sound. Single drumbeats present little challenge to today's really good system, no matter how great their amplitude. More significant are rapid series of high-amplitude drum bursts. *Scheherazade* in the final movement, about half-way through, has a wonderful test passage of this sort when a highly damped drum in a low register is beaten at a rather high level. A severe test is also provided by a number of drums being beaten at the same time. In systems with poor transient response and stability the rapid drumbeats in the *Scheherazade* will turn into a roll, rather than a series of distinct beats, and a battery of drums will become an indistinct roar of sound.

Freedom from hangover is evidenced by sharpness of attack and lack of echo. Hangover is a continuing echo which takes away the distinctness of low-frequency transients, and increases the apparent room resonance. This can be verified by listening to the reproduction of a single high-level transient pulse. In many systems such a pulse can be produced by rapidly switching the phono equalizer or input selector, or twitching the phono needle with a finger. The ideal sound should be a single, sharp thump. If an output meter is connected across the speakers, the needle will swing up and come down to rest with a minimum of bounce. When there is hangover, the thump will be rounder and more resonant, as if it were produced in an echo box, and the needle on the meter will make two or three swings instead of one.

Realism; Naturalness

Realism and naturalness seem obvious terms. In general, the whole purpose of high fidelity is to provide realistic or natural reproduction. But, specifically, naturalness refers to the ability of a system to reproduce the tone and color of various sounds and instruments with sufficient accuracy to make them immediately recognizable. That is to say, a violin should sound like a real violin, a flute like a flute, a drum like a real

Continued on page 55

Now! New RCA Victor acetate tape with full High Fidelity response!



Now you can get the full High Fidelity response you hear on professional recordings at no extra cost! Costs only \$3.50 per 7-inch reel. Also available: new RCA Victor acetate tape with full frequency performance — at a special introductory low price! For extra-long performance: new RCA Victor superstrength, extra-long play "Mylar"™ tape. Superstrong, plays 50% longer — costs \$7.50 per 7-inch reel.

*"Mylar" is a registered Dupont trademark for its polyester film. Nationally advertised list prices shown, subject to change.

RCA VICTOR
RADIO CORPORATION OF AMERICA
CAMDEN 8, NEW JERSEY

STYLI INSPECTION MICROSCOPES

GSS MS1 STYLI INSPECTION MICROSCOPE

2 objectives, 75X and 125X, "Society Threads", all brass tubes and cells, cast aluminum base, 8 watt, 2,000 Hr. rated GE lamp, UL approved cord set. Reagent resistant, baked dark blue plastic enamel finish. 2 yr. free service guarantee. Natural Cedar Wood Case. Each \$25.00, postpaid.

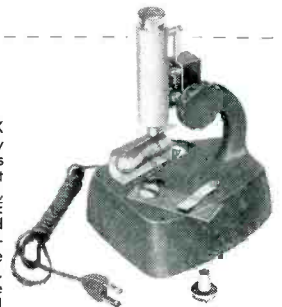

GSS MS2 STYLI INSPECTION MICROSCOPE

Smaller frame than MS1, single objective, 75X, all brass tube and cells, gray baked plastic enamel finish. Identical electrical equipment. Paper Case. Each \$12.50, postpaid.

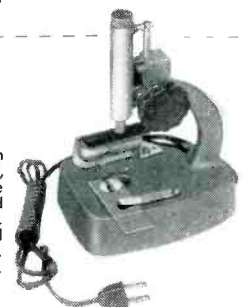

All GSS microscopes, 2 yr. free service guarantee. \$1.00 charge only for packing and postage on return trip.

Over 77,000 GSS Microscopes in U. S. Schools.

THE GENERAL SCIENCE SERVICE CO.
P.O. BOX 8423 — St. Louis Park Station
MINNEAPOLIS 16, MINNESOTA

High Fidelity Magic...



NEW! 20-WATT HIGH FIDELITY AMPLIFIER #HF20

Due to its Ultra-Linear output stage with its conservatively-rated Ultra-Linear output transformer, the #20 features negligible distortion & increased power-handling capacity at both extremes of the audio spectrum. Costliest, complete equalization facilities—plus low-distortion, wide-range tone controls & Centralab Compentrol loudness control—create a preamplifier and control section unsurpassed even in units ticketed at much higher prices.

- Power Response (20W): ±0.5 db 20-20,000 cps; ±1.5 db 10-40,000 cps.
- Frequency Response (1/4W): ±0.5 db 13-35,000 cps; ±1.5 db 7-50,000 cps.
- Rated Power Output: 20 w (34 w peak).
- IM Distortion: (60 cps: 6 kc/4:1) at rated power: 1.3%.
- Mid-Band Harmonic Distortion at rated power: 0.3%.
- Maximum Harmonic Distortion (between 20 & 20,000 cps at 1 db under rated power): approx 1%.
- Speaker Connection Taps: 4, 8 & 16 ohms.
- High quality preamp-equalizer & control section plus complete 20-watt Ultra-Linear Williamson-type power amplifier. Output transformer in compound-filled seamless steel case.

See and HEAR it at your neighborhood distributor. Write for FREE Catalog A-10

EICO 84 Withers St., Brooklyn 11, N. Y. Prices 5% higher on West coast © 56

for the life of your records

BUY A GRAY

viscous-damped

HI-FI TONE ARM



Add a Gray to your hi-fi system. Engineered to get the most out of old and new records.

GRAY RESEARCH & DEVELOPMENT CO., INC.
MANCHESTER, CONNECTICUT
Subsidiary of the GRAY Manufacturing Company

Abbreviations

Following is a list of terms commonly used in this magazine, and their abbreviations. The list is arranged in alphabetical order.

alternating current	AC
ampere, amperes	amp, amps
amplitude modulation	AM
audio frequency	AF
automatic frequency control	AFC
automatic gain control	AGC
automatic volume control	AVC
capacitance	C
cathode ray tube	CRT
characteristic impedance	Z ₀
current	I
cycles per second	cps
decibel	db
decibels referred to 1 milliwatt	dbm
decibels referred to 1 volt	dbv
decibels referred to 1 watt	dbw
direct current	DC
foot, feet	ft.
frequency	f
frequency modulation	FM
henry	h
high frequency	HF
impedance	Z
inch, inches	in.
inches per second	ips
inductance	L
inductance-capacitance	LC
intermediate frequency	IF
intermodulation	IM
kilocycles (thousands of cycles) per second	Kc
kilohms (thousands of ohms)	K
kilovolts (thousands of volts)	KV
kilowatts (thousands of watts)	KW
low frequency	LF
medium frequency	MF
megacycles (millions of cycles) per second	Mc
megohms (millions of ohms)	MΩ
microampere (millionth of an ampere)	μa
microfarad (millionth of a farad)	μfd
microhenry (millionth of a henry)	μh
micromicrofarad	μμfd
microvolt (millionth of a volt)	μv
microwatt (millionth of a watt)	μw
milliampere (thousandth of an ampere)	ma
millihenry (thousandth of a henry)	mh
millivolt (thousandth of a volt)	mv
milliwatt (thousandth of a watt)	mw
ohm	Ω

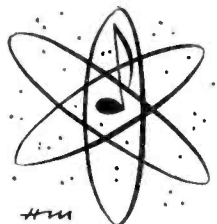

PROFESSIONAL DIRECTORY

TRIAL OFFER

12 for \$1.00
Twelve-Inch Record
COVERS
shipped prepaid
Money Back GUARANTEE



Made of Polyethylene Plastic.
Slips Inside Original Jacket
Keep your valuable records free from dust, scratches, finger marks, spilled liquids, etc.

Introductory SAMPLER DOZEN and
SURPRISE BONUS \$1.00 Prepaid

Dealer Inquiries Invited

BRADLEY MFG. INC.

11 W. Magnolia Blvd. Burbank, Calif.

Artisan Build-It-Yourself ELECTRONIC ORGANS

Send \$1.00 for "Organ Builders Manual"

ELECTRONIC ORGAN ARTS
4878 Eagle Rock Blvd.
Los Angeles 41, Calif.



FM/Q

antenna systems

High gain broadband FM Antennae for max. tuner sensitivity to 72 or 300 ohm inputs. Provides optimum signal level for best recording of high fidelity broadcasts.

APPARATUS DEVELOPMENT CO.

FM/Q Dept. Wethersfield 9, Conn.

permanent magnet	PM
potentiometer	pot
radio frequency	RF
resistance	R
resistance-capacitance	RC
resistance-inductance	RL
revolutions per minute	rpm
root-mean-square; effective value	RMS
synchronous, synchronizing	sync
television	TV
ultra high frequency (radio)	UHF
vacuum-tube voltmeter (multipurpose)	VTVM
vacuum-tube voltmeter for AC measurements only	AC VTVM
variable reluctance	VR
very high frequency (radio)	VHF
volt	v
volt-ampere	va
voltage, or potential difference	E
volts, center-tapped	vct
watt	w

AUDIO AIDS

We'll pay \$5.00 or more for usable Audio Aids. See page 40 for details.

LISTENING

Continued on page 53

drum, and voices should sound exactly as they would sound when heard face to face.

The character of musical instruments, as well as voices, is determined principally by their harmonic structures. All musical tones consist of a fundamental and a number of partials in a relationship which is largely determined by the nature of the instrument. Some of these are very unexpected. Fig. 1 shows three examples indicating three extremes. The harmonic structure of the violin in *A* follows expectations, in that the fundamental is dominant and the amplitudes of the harmonics decrease with their order. But *B*, the pattern of a baritone voice, departs from this order rather severely. Here the middle harmonics are all much

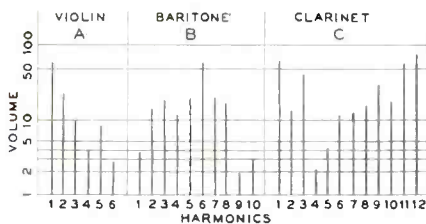

Fig. 1. Distribution of partials, 3 tones. stronger than the fundamental. In *C*, the pattern of a clarinet, we have an even more remarkable departure; the harmonics from the 4th to the 12th rise in amplitude with order until the 11th and 12th equal the fundamental.

To reproduce these sounds, the system must preserve the patterns accurately and intact, but it is easy to see how simply the patterns can be modified. Thus, it is clear that a sloping high-frequency response will seriously affect the structure of the clarinet but will not make so much difference in the case of the violin. On the other hand, it is also obvious that a boost in low frequencies which increases the amplitude of the fundamental of a baritone voice would change the character of the voice—make it more like a basso. Furthermore, it will be noted that in the violin the odd-order harmonics are dominant; so a system with high even-order distortion would raise the even-order harmonics to dominance and once more seriously change the pattern. The clarinet, because of the extraordinary dominance of the high-order harmonics, is obviously an instrument with a rather strident tone; one can easily imagine that the addition of more high-order harmonics by distortion would increase the stridency to the point of annoyance. In fact, we might say that the clarinet has so much built-in distortion that any significant addition can make the sound intolerable.

It is evident that two system qualities are necessary to preserve the harmonic structure of the original sound. First, the system must be perfectly flat, since any peak or valley will change the relationship of fundamental to harmonics. Second, the system must be free of distortion, for any distortion will add harmonics to those in the original and also change the structure.

Judging naturalness demands familiarity with the "natural" sounds of the various instruments, and those who possess such familiarity will find this portion of listening tests very simple. Unfortunately, not everybody is familiar with the natural or live sound of the instruments. A more foolproof test is therefore offered by listening for the differences in tone quality and color of the various instruments. Since each instrument has its own tone, the fine system should reproduce the tone of all faithfully and without eliminating the differences between them. A good test here is a recording of Ravel's *Boléro*. Some 18 choruses of the same melody are played by as many different instruments and, if you know your instruments, you should be able to list the choruses and the instruments involved in each. In three of the choruses two instruments play in unison; if you can recognize them it is a good testimonial not only to the quality of your ear but to the quality of the playback system.

Instruments differ not only from species to species, but between individuals of any species. No two violins or clarinets or pianos sound exactly alike. On a good system, therefore, the individuality of each instrument will be more evident. The more different the tone quality of one recording (even of the same music) is from all other recordings, the better the naturalness of the system.

Since most people are more familiar with noises than with musical instruments, recorded noises provide excellent test materials. There are records today which, between them, offer samples of just about any noise you can think of, from thunder to the catcalls of a burlesque audience.

SOUND SERVICING

Continued from page 12

the very old tuner that the cost of proper repair will be more than the set is worth.

This is not to say, of course, that you shouldn't try a new tube in your own tuner when it has been playing well, and when a tube is clearly defective. Tubes are, in the first several weeks of tuner life and after preliminary adjustments have been properly made, responsible for about 75% of

Continued on next page



SHORTHORN
LOUDSPEAKER SYSTEM



Designed and manufactured by the originator of the KLIPSCHORN* speaker system, the SHORTHORN* is second only to the KLIPSCHORN* system in performance. Using coordinated acoustic elements, including filters, it offers exceptionally smooth response, free from distortion. Back loading horn extends bass range without resonance.

Available in handsomely finished enclosures, in stripped down utility models (as illustrated) or separate components for assembly. Write for literature.

*TRADEMARKS

KLIPSCH & ASSOCIATES
HOPE, ARKANSAS

**CAPPS MICROPHONES
HIGHEST QUALITY AT
THE LOWEST PRICES**



Model CM 2001

Low priced condenser and crystal microphones are available to all who desire the utmost in recording quality. Whether you have an inexpensive or the most costly recorder, you should own a Capps Microphone. These low priced, ultra-high quality microphones are manufactured to rigid quality controls, thereby eliminating all possibility of inferiority. Exceptional performance, beauty, ruggedness, true acoustics, and minimum distortion, are standard with the Capps Condenser and Crystal Microphones.

A most unique feature incorporated in the Capps Crystal Microphone Model CRBB, is that it can be used as a desk model without a stand. It also has a built-in provision for standard stand mounting used in studios.

Why be satisfied with less than a CAPPS MICROPHONE?

Studio Models available in 250 ohm, 30 ohm, and high impedance Professional Model, (as shown), available in high impedance only CRBB Crystal Model (adjustable bass boost feature).

Write for free brochures and technical information to:

Capps & Co., Inc.
20 Addison Place
Valley Stream, New York

audio exchange

is privileged to be the first
to introduce the new

colbert

ELECTRONIC FREQUENCY DIVIDER MODEL 3-CFD

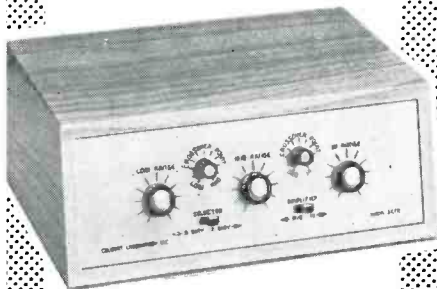

colbert

LABORATORY INC

- Complete Range Controls for three frequency bands
- Eliminates impedance mismatching
- Complete electronic compensation for unequal speaker efficiencies
- Affords optimum damping of individual loudspeakers
- Provision for use on two or three-way loudspeaker systems
- Includes 10 watt ultra-linear amplifier for use on middle or high range
- For use with regular or electrostatic loudspeakers, or combinations
- Three-channel operation results in lowest over-all distortion

MODEL 3-CFD \$154.50

Decorator style case in blonde or mahogany formica finish... **\$15**

*Slightly higher in west
and deep south*

Write Dept. AC10 for
trading information and catalog

audio exchange

THE TRADING ORGANIZATION
OF THE HI-FI FIELD

159-19 Hillside Ave. | 367 Mamaroneck Ave.
Jamaica 32, N. Y. | White Plains, N. Y.
AXtel 7-7577 | White Plains 8-3380
near subway | next to Pix theatre

METER
PARKING



AT BOTH
STORES

audio exchange exchanges audio

SOUND SERVICING

Continued from preceding page

all troubles that I have encountered. Some tuners, even after several years of use, will come back to life with one or two tubes judiciously chosen. You may be one of the lucky owners. On the other hand, chances are that your older tuner needs more than "just a tube" or a little cleaning up when it stops operating. And chances are that you will be happier sooner, and waste less money, if you get it in the hands of experts.

READERS' FORUM

Continued from page 17

a hole are quite common if no lubricant is used, but I have never had any difficulty with a properly lubricated drill or tap.

Rex Pinson, Jr.
Jackson Heights, N. Y.

AUDIO AIDS

Continued from page 40

transformers and chokes. A simple and effective remedy is to cut four triangles of 16-gauge aluminum, approximately 1 by 1 by 1½ in., and fasten them securely inside the four corners of the folded bottom-plate lip, using two small bolts or self-tapping screws in each corner. If use of a bottom plate is necessary, the corners of the plate can be cut off to clear the bolt or screw heads.

Aluminum can be cut and drilled more easily and more accurately if alcohol is applied liberally to the work. When drilling large holes, dip the drill bit in the alcohol. A pleasing, professional job can be turned out with a minimum of effort and tools.

J. A. Bannister
Point Edward, Ont.

TRADERS' MARKETPLACE

Here's the place to buy, swap, or sell audio equipment. Rates are only 20¢ a word (including address) and your advertisement will reach 20,000 to 35,000 readers. Remittance must accompany copy and insertion instructions.

FOR SALE: Alterc 604C (new), Seeburg HFMA1-L6 amplifier (new), Scott 210B, Cabinart K-15 Klipsch kit. Bargains! Allen King, 889 Woodland, Memphis, Tenn.

RECORDERS, Hi-Fi, Tape; Wholesale Prices, Catalogue, Clarstone, 215 E. 88 St., New York 28, N. Y.

PRE-RECORDED TAPES, Low price recording tape accessories, catalog. Efsco Sales, 270-5 Concord Avenue, West Hempstead, N. Y.

ADVERTISING INDEX

Acoustical Development Corp.	49
Acoustic Research, Inc.	50
Allied Radio Corp.	5
Apparatus Development Corp.	54
Audio Exchange	56
Audiophile's Bookshelf	41
Bell Sound Systems, Inc.	15
Bradley Mfg., Inc.	54
Capps & Co.	55
Colbert Associates	51
Components Corp.	43
Conrac, Inc.	13
Dauntless International	1
Eico	54
Electronic Organ Arts	54
Fenton Co.	48
General Science Service Co. ...	53
Gray Research and Development Co.	54
Heath Co.	8-9
Jensen Mfg. Co.	2
Klipsch and Associates	55
Lansing, James B., Sound, Inc.	Inside Back Cover
McGraw-Hill Book Co.	47
Mercury Record Corp.	45
Musicraft	11
North American Philips	Inside Front Cover
Professional Directory	54
RCA Victor	53
Radio Electric Service Co.	46
Rigo Enterprises, Inc.	16
Sound Sales Directory	52
Stephens Mfg. Corp. ...	Back Cover
Traders' Marketplace	56

A SPECIAL SERVICE FOR AUDIOCRAFT READERS

To secure prompt information about products advertised in this issue, just fill in the coupons at the right and drop in your nearest mail box.

PLEASE BE SURE TO:

1. Send *complete* postcard even if all four coupons are not used.
2. Fill out each coupon *completely* and clearly.

The coupons are cut apart mechanically and forwarded to the advertisers you list. Your name and full address must appear on each coupon or the advertiser will not know to whom to send information.

Please use ink or typewriter if at all possible.

USE THIS SERVICE — EVERYTHING, EVEN THE POSTAGE, IS FREE. A SPECIAL SERVICE TO AUDIOCRAFT READERS.

**FOR ADVERTISEMENTS
IN THIS ISSUE ONLY**

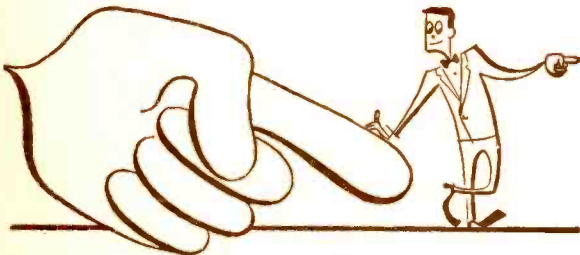

**USE THIS
SERVICE**



BUSINESS REPLY CARD
FIRST CLASS PERMIT NO. 62, SEC. 24.9, P. L. & R., GREAT BARRINGTON, MASS.

audiocraft

POST OFFICE BOX 600

GREAT BARRINGTON, MASS.

PLEASE SEND INFORMATION ABOUT:

Product

Advertiser Page

TO:

K AUDIOCRAFT

PLEASE SEND INFORMATION ABOUT:

Product

Advertiser Page

TO:

K AUDIOCRAFT

PLEASE SEND INFORMATION ABOUT:

Product

Advertiser Page

TO:

K AUDIOCRAFT

PLEASE SEND INFORMATION ABOUT:

Product

Advertiser Page

TO:

K AUDIOCRAFT

PLEASE SEND INFORMATION ABOUT:

Product

Advertiser Page

TO:

K AUDIOCRAFT

PLEASE SEND INFORMATION ABOUT:

Product

Advertiser Page

TO:

K AUDIOCRAFT

PLEASE SEND INFORMATION ABOUT:

Product

Advertiser Page

TO:

K AUDIOCRAFT

PLEASE SEND INFORMATION ABOUT:

Product

Advertiser Page

TO:

K AUDIOCRAFT



SUBSCRIPTION SERVICE PAGE

audiocraft

Great Barrington, Mass.

Please enter my subscription, starting with the next issue, at the **SPECIAL RATE of 3 years for only \$9.00.**

FOREIGN POSTAGE: \$1.00 per year outside the U. S. A., its possessions, and Canada.

- My remittance is enclosed.
- I prefer two years for \$7.00.
- Please send me your bill.
- I prefer one year for \$4.00.

10-6

NAME _____

ADDRESS _____

CITY _____ ZONE _____ STATE _____

- Group subscriptions attached.
- Send me the following back issues:
1 3 6 8
payment for which is enclosed.
- Gift subscriptions attached.



BUSINESS REPLY CARD
FIRST CLASS PERMIT NO. 62, SEC. 34.9, P. L. & R., GREAT BARRINGTON, MASS.

audiocraft

POST OFFICE BOX 600

GREAT BARRINGTON, MASS.

10-6



BUSINESS REPLY CARD
FIRST CLASS PERMIT NO. 62, SEC. 34.9, P. L. & R., GREAT BARRINGTON, MASS.

audiocraft

POST OFFICE BOX 600

GREAT BARRINGTON, MASS.

10-6

On this page you will find complete subscription information about **AUDIOCRAFT**. The full subscription story is here — in one place — for your convenience.

REGULAR SUBSCRIPTION RATES

Three years — Nine Dollars. *Save \$3.60 over the single copy cost.*
Two years — Seven Dollars.
One year — Four Dollars.
(Add \$1.00 per year for postage on all subscriptions sent to addresses outside of the United States, its possessions, and Canada.)

BARGAIN GROUP SUBSCRIPTION RATES

(One-Year Subscriptions Only)
Here's a real saving! Just get together a group of subscriptions and submit them all at one time.
First Subscription — \$4.00.
Each additional subscription — \$3.00.
Send the list to our Circulation Department (and mark it **SPECIAL GROUP SUBSCRIPTION RATE**) with a check or money order in the appropriate amount.

GIFT SUBSCRIPTIONS

You will find that a subscription to **AUDIOCRAFT** makes the perfect gift for any occasion. If you submit more than one subscription (at the same time), the special group rates shown above will apply. We will acknowledge your gift, to the person receiving it, with a special gift announcement card signed with your name, if you request us to do so.

BACK COPIES

At present we have on hand a supply of the November 1955 (No. 1), January (No. 3), April (No. 6), and June (No. 8) 1956 issues of **AUDIOCRAFT**. Copies are available at 35¢ each. To order yours, use the card at upper left, checking the appropriate box at the bottom of the card and circling the number of the issue or issues you want. Please be sure to enclose payment with your order as we cannot bill for single copies.

IMPORTANT

We cannot be responsible for currency sent through the mail. When remitting, please be sure to send only check or money order.

GROW WITH

signature sound



Now you can enjoy your very first year of audio! With a complete line to choose from, you can begin with a Signature precision transducer and grow with J.B.L. all the way. You start with a Signature Extended Range Speaker, install it in a fine enclosure designed, engineered and constructed by James B. Lansing Sound, Inc. Later, you add a Signature Dividing Network and High Frequency Unit to attain the ultimate excellence of a Signature Two-way System. Your nearest Authorized Signature Sound Specialist will help you lay out a plan for progressive purchase that will fit your needs exactly. Write for his name to: James B. Lansing Sound, Inc., 2439 Fletcher Drive, Los Angeles 39, California.



BEGIN WITH A J.B.L. SIGNATURE EXTENDED RANGE SPEAKER...



A 15" MODEL D130 \$76.00



A 15" MODEL D130 \$76.00



OR A 12" MODEL D123 \$54.50



INSTALL THE SPEAKER IN A FINE J.B.L. SIGNATURE ENCLOSURE...



back-loaded folded horn

A MODEL C34M \$135.00



A MODEL C37M \$104.00



minimum volume reflex

A MODEL C38M \$54.00



LATER ADD A J.B.L. SIGNATURE DIVIDING NETWORK...



1200 c.p.s. crossover

A MODEL N1200 \$35.25



2500 c.p.s. crossover

A MODEL N2500 \$15.00



2500 c.p.s. crossover

A MODEL N2500 \$15.00



AND A SIGNATURE PRECISION HIGH FREQUENCY UNIT...



driver-horn-Koustical lens assembly

A MODEL 175DLH \$118.50



made with ring radiator

A MODEL 075 \$54.50



made with ring radiator

A MODEL 075 \$54.50

Model K616



Model K621

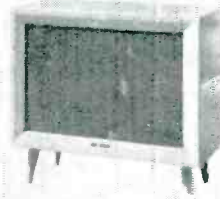

Model K620



Model K622

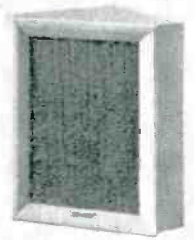

Now you can build your own authentic Stephens Tru-Sonic speaker enclosure with a new Stephens kit. To everyone else it will sound exactly the same as our factory assembled enclosures. To you, it will sound even better because you had the thrill of assembly. Naturally, there is a saving. Provision too for additional speakers. Kits come in

four models. Each with step-by-step illustrated instructions on woodwork, speaker installation and connections.

Start now in high fidelity by building your own speaker enclosure.

Model K620 . . . 14" deep x 21" wide x 29½" high. Folded horn. Price: 49.00

Model K621 . . . 20" deep x 36" wide x 30" high. Horn loaded. Price: 55.00

Model K622 . . . 18" deep x 27½" wide x 29½" high. Folded horn. Price: 59.00

Model K616 . . . 20" deep x 36" wide x 30" high. Bass reflex. Price: 99.00

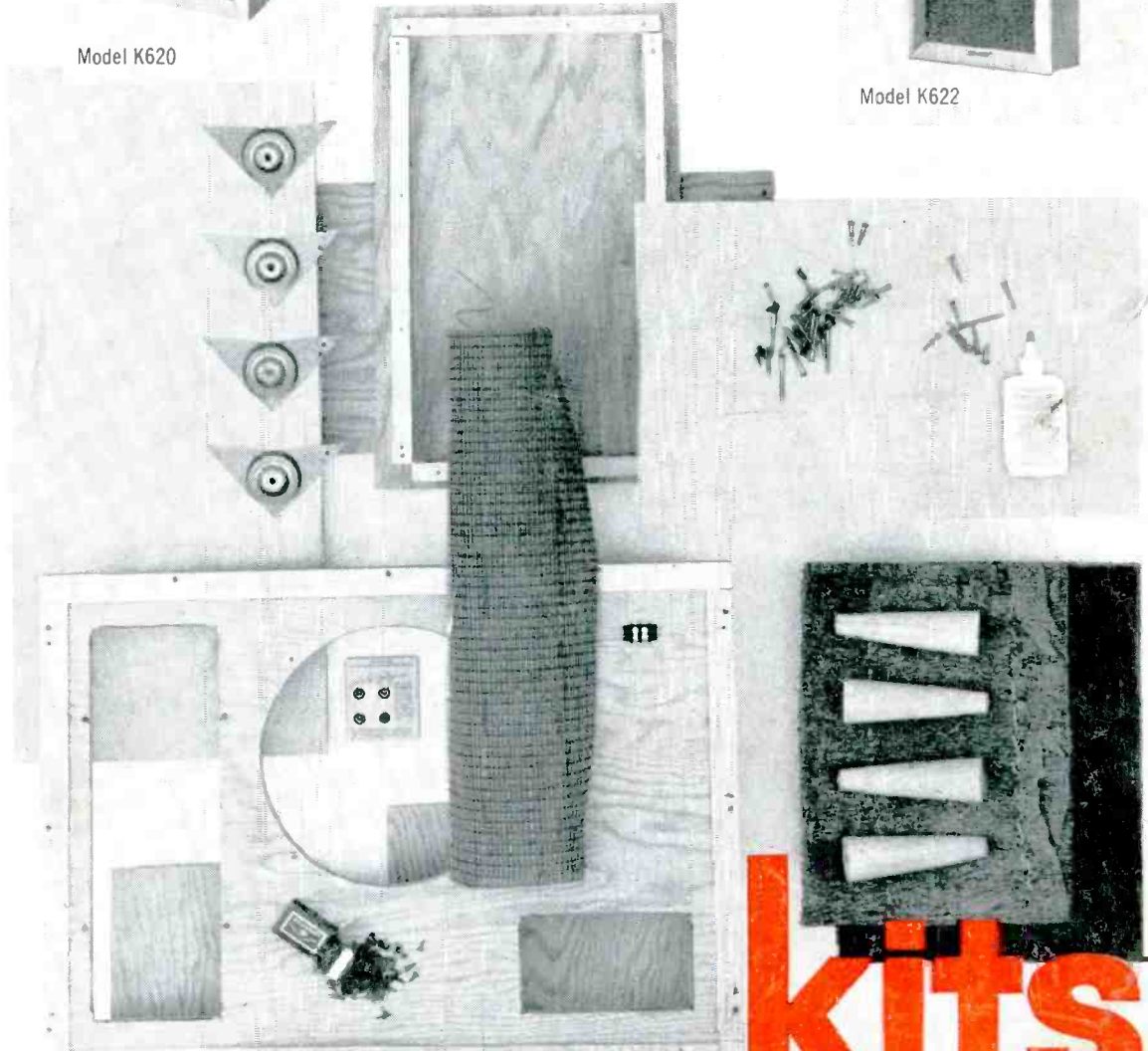

kits

STEPHENS TRU-SONIC

for more information, or the address of your nearest Stephens dealer, write to:
Stephens Tru-Sonic Inc.
8538 Warner Drive
Culver City, California

Cable address: "Morhanex"
Export address: 458 Broadway
New York 13, N.Y.

