

# Your "Round Trip" Ticket

TO HIGH FIDELITY LISTENING PLEASURE

VIA **AUDIO FIDELITY**

Take a Trip in Sound — and right from your favorite easy chair! AUDIO FIDELITY brings all the excitement and color of many countries right into your living room on their super-brilliant, guaranteed total frequency range recordings. Not just hi-fi records . . . but each a new listening thrill!

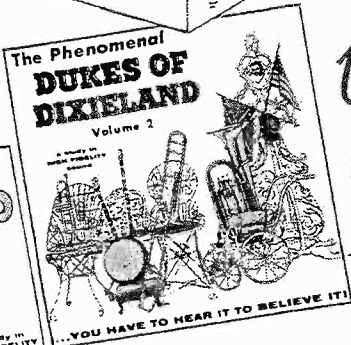

1. THE phenomenal DUKES OF DIXIELAND — Vol. 2. Hot trumpets . . . sweet trumpets . . . crazy clarinets . . . a real-gone tuba and a wild banjo make this the swiftest, low-down Dixie ever recorded! Spontaneity Supreme! **AFLP 1840**
2. HONKY TONK PIANO. The roaring 20's in brilliant Hi-Fi! It's Eddie "Pianola" Barnes at the 88's. Sharps and flats go flying as he plays old-time favorites: My Sister Kate, I Ain't Got Nobody, etc. **AFLP 1827**
3. ROME WITH LOVE. Come wander down Piazza de Spagna and Via Margutta to Trevi Fountain accompanied by enchanting melodies of Rome . . . of Italy . . . played by Jo Basile and his accordion. **AFLP 1822**
4. FIESTA EN ESPANA. Rafael Molero, Guitarist; Alberto Salicru, Dancer. Exciting hand-clapping, heel-tapping music full of fire, passion and desire. Authentic Flamenco, never before recorded, that expresses the heart and soul of the gypsy. **AFLP 1819**
5. TORERO! La Fiesta Brava! Vol. 3. Once again music by the Banda Taurina transports you to the bullfight arena to watch the duel with death! All new selections. Complete with 50-page book, El Toreo, in English. **AFLP 1818**
6. RENDEZVOUS A PARIS. A dimly lit bistro . . . a long, soft sigh — and the singing accordion of Jo Basile create the mysterious enchantment of a Rendezvous in Paris. **AFLP 1821**
7. CHA CHA CHA. Torrid rhythms, vibrantly alive with the mystery of exotic Latin nights . . . the lure of the exciting tropics. Pulsating Latin magic played by Pedro Garcia and his Del Prado Orchestra. **AFLP 1810**
8. BAWDY SONGS and BACKROOM BALLADS Vol. 3. Gather 'round you lovers of lusty lore . . . Oscar Brand has done it again! A complete new album of spicy musical folklore. **AFLP 1824**

each 12-inch LP (33 1/3 rpm)—\$5.95

WRITE FOR FREE CATALOG



NATIONALLY DISTRIBUTED BY **DAUNTLESS INTERNATIONAL**

750 TENTH AVENUE  
NEW YORK 19, N. Y.

# AR-2

The AR-2 speaker system uses the same *acoustic suspension* principle as the AR-1. Because of this fact it is able to achieve a performance quality which, by *pre-acoustic suspension* standards, is associated with a price range several times higher than its 96.00.\*

\*in birch or mahogany; other finishes \$89.00 and 102.00

## SUGGESTED PRICE RANGE FOR INSTALLATIONS USING THE AR-2

COMPONENT	PRICE
AMPLIFIER (10-30 clean watts, complete with controls)	\$75 - - \$125
RECORD PLAYER (changer or manual)	\$40 - - \$60
CARTRIDGE(S) (diamond needle for LP)	\$20 - - \$45
TUNER	\$70 - - \$100
AR-2 SPEAKER SYSTEM (Complete with enclosure; size 13½" x 11¾" x 24")	\$89 - - \$102



*Install on shelves, or in cabinet*

\$294 - - \$432

(phonograph only,  
\$224 - - \$332)

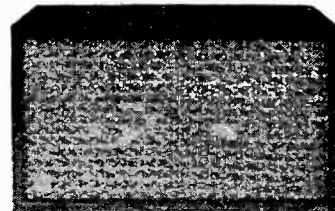

*Literature on request from:*

**ACOUSTIC RESEARCH, INC. 24 Thorndike Street Cambridge 41, Mass.**



February 1957

Volume 2 Number 2

# audiocraft

## THE HOW-TO-DO-IT MAGAZINE OF HOME SOUND REPRODUCTION

Oliver Berliner's name appears on our contents page for the first time this issue. You will agree that it is a most welcome one indeed.

Mr. Berliner, grandson of Emile Berliner, can (and does) speak with authority on virtually any aspect of sound. He is a member of both the Institute of Radio Engineers and the Society of Motion Picture and Television Engineers, and a member and cofounder of the Audio Engineering Society. His radio program series *Sound Thinking* is one of the very few concerned with high fidelity that has received network support. He has written some 100 articles on music and sound, which have appeared in most of the leading publications devoted to these subjects.

Doing business as Oberline, Inc., Mr. Berliner designs and manufactures audio products for the commercial field; two of his better-known items are the Oberline Customixer and Audiometer. He is also a consulting sound engineer on such projects as Disneyland, the Beverly Hilton Hotel, and Hollywood Bowl. He lives in Beverly Hills, California, and has offices in Hollywood.

To discover what Mr. Berliner has to say about maintaining tape recorders, turn to page 20.

CHARLES FOWLER, *Publisher*

ROY F. ALLISON, *Editor*

FRANK R. WRIGHT, *Managing Editor*

ELEANORE B. WRIGHT,  
*Editorial Assistant*

ROY LINDSTROM, *Art Director*

ELEANOR GILCHRIST, *Art Assistant*

FRANCES A. NEWBURY, *Manager,*  
*Book Division*

*Contributing Editors*

R. D. DARRELL

J. GORDON HOLT

JOSEPH MARSHALL

CLAIRE EDDINGS

*Advertising Sales Manager*

WARREN B. SYER, *Business Manager*

ARTHUR J. GRIFFIN, *Circulation*  
*Manager*

### Advertising

Main Office—Claire Eddings, The Publishing House, Great Barrington, Mass. Telephone: Great Barrington 1300.

Midwestern—John R. Rutherford & Associates, Inc., 230 East Ohio St., Chicago, Ill. Telephone: Whitehall 4-6715.

Western—Brand & Brand, Inc., 6314 San Vicente Blvd., Los Angeles, Calif. Telephone: Webster 8-5971.

The Grounded Ear, by Joseph Marshall .....	4
<i>What's new and significant in sound reproduction.</i>	
Audionews .....	6
Tips for the Woodcrafter, by George Bowe .....	8
<i>This issue: How to select and install cabinet hardware.</i>	
Tape News and Views, by J. Gordon Holt .....	12
<i>This issue: Microphone technique II.</i>	
Book Reviews, by Richard D. Keller .....	14
Readers' Forum .....	17
Editorial .....	17
The Knight 10-Watt Hi-Fi Amplifier .....	18
<i>An AUDIOCRAFT kit report.</i>	
Maintaining Your Tape Recorder, by Oliver Berliner .....	20
<i>Routine preventive maintenance can prolong the life of your recorder and assure peak performance consistently.</i>	
Designing Your Own Amplifier, by Norman H. Crowhurst .....	23
<i>Part VIa: Special output circuits.</i>	
Expandable Custom Chassis System .....	26
<i>New breadboard chassis components permit easy assembly of custom-made chassis bases for experimenters.</i>	
Transistors in Audio Circuits, by Paul Penfield, Jr. ....	28
<i>Part 4a: Biasing the transistor.</i>	
Audio Aids .....	30
Basic Electronics, by Roy F. Allison .....	32
<i>Chapter XIV: Parallel RL and RC circuits.</i>	
Sound-Fanciers' Guide, by R. D. Darrell .....	34
<i>Reviews of exceptional disc and tape records.</i>	
Sound Sales Directory .....	44
Traders' Marketplace .....	46
Advertising Index .....	48

Audiocraft Magazine is published monthly by Audiocom, Inc., in Great Barrington, Mass. Telephone: Great Barrington 1300. Editorial, publication, and circulation offices at: The Publishing House, Great Barrington, Mass. Subscriptions: \$4.00 per year in the United States and Canada. Single copies: 35 cents each. Editorial contributions will be welcomed by the editor. Payment for articles accepted will be arranged prior to publication. Unsolicited manuscripts should be accompanied by return postage. Entered as second-class matter October 1, 1955, at the post office, Great Barrington, Mass., under the act of March 3, 1879. Additional entry at the post office, Pittsfield, Mass. Printed in the U. S. A. by the Ben Franklin Press, Pittsfield, Mass. Copyright 1957 by Audiocom, Inc. The cover design and contents of Audiocraft Magazine are fully protected by copyrights and must not be reproduced in any manner.



fits between one of the output tubes and the socket on the amplifier) to supply the DC voltage. Almost anyone should be able to install the Pampa in a few minutes. I didn't have an opportunity to measure the transient response of my own amplifier with the Pampa connected to one of the output tubes, but, so far as I could discern by ear, the addition of the unbalanced capacitance appeared to have no deleterious effects.

I suppose there is no aspect of high fidelity which affords as much room for differences of taste as the tweeter range, and my comments should be taken with due allowance. At any rate, the Pampa suited me nicely. The response seemed very flat to 14,000 cps (where my ears begin to cut off) and to 18,000, as judged by my daughter.

Extreme highs are sharp but clean, and about neutral in coloration between those of a really first-class paper tweeter and a metal one. The Pampa is at its best on triangles, which come through with beautifully bell-like sharpness and clarity, but it also does very well on other percussion, harpsichord overtones, and voice sibilants. I consider it a lot of value in good sound for the money, likely to please a majority of the most critical listeners who want to hear everything on a record with a minimum of coloration.

### Bargain Amplifier

I have just had an opportunity to look over and listen to the LA-59 high-fidelity amplifier, distributed by Lafayette Radio Corp. and made in Japan. Before the war, the *Made in Japan* label was regarded with suspicion. In recent years, however, the Japanese have made remarkable progress in high-quality manufacturing techniques, particularly in the photographic field; their optical products now compete seriously with those of Germany, and in some instances are accepted as superior. Only time will tell how good the individual components of the Lafayette amplifier are, but to the eye both the components and the overall construction look very good indeed. Although the pancake form is used, the size of the transformers indicates no skimping of iron or overloading of small windings. A printed-circuit panel is used for the wiring in the amplifier stages, and the quality of wiring looks good. Capacitors and resistors are of a size which will permit easy replacement with American equivalents in the event of failure. The resistors appear to be oversize and the capacitors seem husky enough; failure should not be anticipated any sooner than with American components in similarly priced equipment.

This is a complete preamplifier-amplifier combination. Facilities include a rumble filter which can be cut out, a

*Continued on page 41*

# Save Money BUILD YOUR OWN Hi-Fi

## It's easy to build knight-kit Hi-Fi

KNIGHT-KITS give you the last word in professional Hi-Fi design, performance, styling and value...and they're easy to build from crystal-clear manuals featuring "Step-and-Chek" assembly. Save money—get true Hi-Fi quality—have fun building custom-designed KNIGHT-KITS!

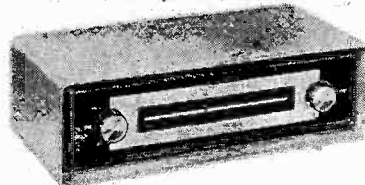

### NEW knight-kit HI-FI BASIC FM TUNER KIT

- Deluxe Custom Hi-Fi Styling
- Automatic Frequency Control
- Flywheel Tuning Control
- Latest Printed Circuit—no critical wiring

Model Y-751  
**\$37<sup>75</sup>**

Here's the best-looking, best-performing tuner kit your money can buy. Covers 88 to 108 mc; features Automatic Frequency Control (with disabling feature for bringing in weak stations); pre-adjusted RF coils; pre-aligned IF's; cascade broadband amplifier; drift-compensated oscillator; illuminated lucite pointer. Sensitivity

is 10 microvolts for 20 db of quieting across entire band. Ideal for use with the Y-750 Knight-Kit 20-Watt Amplifier (see below), or any amplifier with phono-tuner switch. You'll enjoy building and be proud to own this custom Hi-Fi Tuner! Shpg. wt., 12 lbs. Model Y-751. FM Tuner Kit. Net **\$37.75**

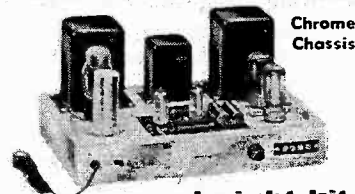

Chrome Chassis

### knight-kit

#### 25-WATT BASIC HI-FI AMPLIFIER KIT

Model Y-755 Here's luxury quality at an extremely low price. This brilliant hi-fi performer rates a position of esteem alongside the most costly components. Use it with any tuner or preamp having a full set of controls. Response is amazingly wide—from 10-120,000 cps,  $\pm 0.5$  db at 20 watts—distortion is only 0.15% at 30 watts. Has beautiful chrome chassis; potted transformers; balance and damping adjustments—plus time-saving printed circuit. Outputs: 4, 8 and 16 ohms.  $6\frac{1}{2} \times 14 \times 9$ ". You get tubes, all parts and instructions. Shpg. wt., 27 lbs. Model Y-755. 25-Watt Kit. Net... **\$44.50** Y-759. Metal enclosure for above... **\$4.25**

ALL PRICES NET  
F.O.B. CHICAGO



Chrome Chassis

### knight-kit 10-WATT HI-FI AMPLIFIER KIT

Model Y-753 The price is incredibly low—tonal reproduction is genuine hi-fi. Response, 30 to 20,000 cps. Input for crystal phono or tuner—chrome-plated chassis is punched for preamp kit below, to permit using magnetic phono. Matches 8-ohm speaker.  $7 \times 13 \times 6$ ". With tubes, all parts, instructions. Shpg. wt., 14 lbs. Model Y-753. 10-Watt Kit. Net... **\$23.50** Y-235. Preamp kit for magnetic cartridges... **\$3.10** Y-757. Metal enclosure with black finish... **\$3.95**

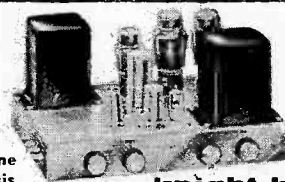

Chrome Chassis

### knight-kit

#### 20-WATT HI-FI AMPLIFIER KIT

Model Y-750 The ideal hi-fi teammate for our FM tuner—and an equally fine unit for use with any other hi-fi components. Its wide, clean response and ample power are your assurance of authentic reproduction. Response is  $\pm 1$  db, 20-20,000 cps at 20 watts—distortion is an insignificant 1%. Inputs: Magnetic phono; mike; recorder; and tuner. Controls: Bass; Treble; Volume; Selector with compensation positions for microgroove and standard discs. Outputs: 4, 8, 16, 500 ohms. Styled in gleaming chrome.  $7 \times 13 \times 8\frac{3}{4}$ ". You get everything—tubes, all parts and instructions. Shpg. wt., 23 lbs. Model Y-750. 20-Watt Kit. Net... **\$35.75** Y-752. Chrome control panel. Net... **\$1.40** Y-758. Metal enclosure for amplifier. **\$4.15**

## order from ALLIED RADIO

America's Hi-Fi Center

Our 36th Year



FREE

ALLIED'S  
1957  
CATALOG

Send for this 356-page value-packed catalog covering everything in Electronics. Complete sections featuring world's largest selection of Hi-Fi components and music systems, many more famous KNIGHT-KITS, recorders, P.A. systems, Amateur gear, parts, tubes, tools and books. Send for your FREE copy today.

ALLIED RADIO CORP., Dept. 89-B-7  
100 N. Western Ave., Chicago 80, Ill.

Ship the following: \_\_\_\_\_

\_\_\_\_\_ \$ \_\_\_\_\_ enclosed

Send me your FREE 1957 ALLIED 356-Page Catalog

Name \_\_\_\_\_

Address \_\_\_\_\_

City \_\_\_\_\_ Zone \_\_\_\_\_ State \_\_\_\_\_



# AudioNews

## RONETTE MICROPHONE

A new semidirectional microphone is now being delivered by Ronette Acoustical Corp. of New York City, makers of phonograph cartridges and microphones.

Called the *Ronomike*, the new microphone is cased in a slim, sturdy, die-cast

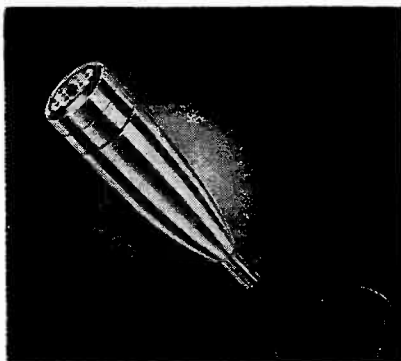

*High-quality high-impedance Ronomike.*

housing that is chrome-plated. Its performance features are said to make it ideal for use with tape recorders, public-address systems, and in ham shacks.

A high-impedance instrument, the Ronomike requires a high value of load resistance, and has a sensitivity of -55 db, according to the manufacturer. It is claimed that the microphone's flat response from 30 to 10,000 cps is peak-free when the instrument is matched to a 1/2- to 1-megohm input of a triode stage. Intermodulation distortion is stated to be negligible. The microphone cable, of special design, is reported to have a minimum of 90% shielding and is included with a fully shielded telephone-type plug.

## MILLER GENERAL CATALOGUE

The J. W. Miller Company of Los Angeles, California, has announced the release of a new general catalogue, No. 57-A.

The catalogue lists nearly 1,000 different replacement coils for television sets, radios, etc. Particularly noteworthy is a new series of transistor antenna rods, oscillator coils, and I. F. transformers. Miller also has a very complete line of adjustable RF coils and chokes.

All items listed in this catalogue are either stocked by, or are available through, leading radio parts distributors throughout the country.

In addition to the items listed in the

catalogue, J. W. Miller Company also makes coils and chokes to meet individual specifications for many leading manufacturers in the electronics industry.

Copies of the J. W. Miller catalogue No. 57-A are available on request.

## SHERWOOD LOW-BOY CABINETS

A decorator line of matching Low-Boy cabinets for the Forester three-way speaker system and associated high-fidelity equipment has been introduced by Sherwood Electronic Laboratories.

Available in natural hand-rubbed walnut or dark mahogany, the two cabinets are designed for use either as a single, long, low unit or for use separately along opposite walls in a remote-control setup.

Each cabinet is 42 by 15 by 27 in. high. The speaker grille is of natural cane. Sliding doors on the speaker cabinet are finished in cane-type grille to match the speaker grille. For a slight additional cost, this may be obtained in

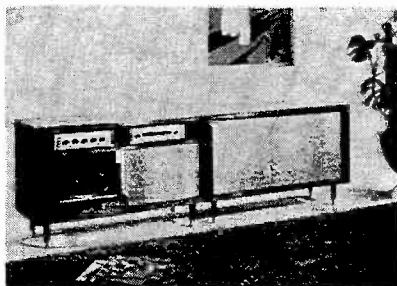

*Matched cabinets in new Sherwood line.*

either plain or ribbed wood to match the cabinet itself.

The equipment cabinet includes a 5-inch shelf for amplifier and tuner,

*For more information about any of the products mentioned in AudioNews, we suggest that you make use of the Product Information Cards bound in at the back of the magazine. Simply fill out the card, giving the name of the product in which you're interested, the manufacturer's name, and the page reference. Be sure to put down your name and address too. Send the cards to us and we'll send them along to the manufacturers. Use this service; save postage and the trouble of making individual inquiries to a number of different addresses.*

a slide-out record-player base, and a roomy record-storage compartment. The compartment dividers are removable, making the space available for other hi-fi gear, such as a tape recorder.

The Low-Boy Forester three-way speaker system's net price is \$239.00; matching equipment cabinet with cane doors, net \$149.50; plain walnut doors, \$5.00 additional; ribbed doors, \$10.00.

Complete technical specifications and performance curves on the Forester three-way speaker system are available on request from the manufacturer.

## PRINTED-CIRCUIT REPAIRS

Walsco's newest servicing kit, *Printed Circuit Kit No. 13-K*, is reported to contain all the aids needed to speed economical repair and replacement work on any printed circuit. In one compact box are packaged special tools and full instructions, with sufficient supplies to complete numerous jobs. Included is Walsco's "Solder-ease" tool with probe on one end for tightening contacts and a fork on the opposite end to handle wires while soldering. Featured also is a silicone resin lacquer that protects the repaired area with a tough film.

Walsco's Printed Circuit Kit holds copper foil with thermo-plastic backing, solder wire and washers with a flux layer, tweezers, a Fibreglas brush, and solder solvent. This kit is priced at \$4.95 dealer net. A master kit (No. 12-K), \$7.95 dealer net, includes an Ungar soldering iron, a special tip, a spray can of lacquer, and a practice wiring board, in addition to the items found in the No. 13-K kit.

Additional information on this and other Walsco products is available in

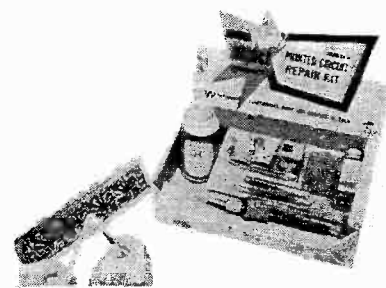

*Complete kit for repairing PC boards.*

a new 62-page catalogue. Free copies of this catalogue will be furnished on request.

## FERROGRAPH SERIES 66 TAPE RECORDER

The Ferrograph *Series 66* is a dual-speed, dual-track tape recorder for use either as part of a complete hi-fi system or by itself, hooked up to any high-quality 15-ohm speaker system.

The amplifier and power pack are unit-assembled in a sturdy metal enclosure and are interconnected for ease

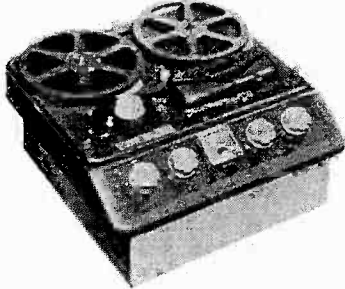

*Hi-fi recorder has a monitor amplifier.*

in servicing. The conservatively rated 2½-watt amplifier can also be used for disc reproduction or in conjunction with FM and other tuners. A synchronous hysteresis motor powers the tape capstan and two shaded-pole motors are provided for takeup and rewind. Separate bass and treble controls and a combination gain-volume control for recording and playback are featured. The entire superstructure is finished in attractive Venetian bronze, with cream-colored control knobs and accessories.

These Series 66 magnetic tape recorders are manufactured by British Ferrograph Recorder Co., Ltd., of London and are available direct or through franchised dealers of the Ercona Corporation, New York City.

### "SOUND TALK" BULLETIN NO. 32

Mechanical considerations in the use of thin-base magnetic recording tapes are discussed in "Sound Talk" Bulletin No. 32, now available upon request from Minnesota Mining and Manufacturing Co., Dept. A6-141, Saint Paul, Minn.

The four-page technical bulletin is illustrated with graphs and compares the physical properties of thin-base and standard-base recording tapes.

Among the considerations covered are conformability to the recording head, acetate *versus* polyester films, inertia effect, and guiding and winding. In addition, four major points in the use of thin-base tapes are summarized.

### JENSEN LOUDSPEAKER CATALOGUE

Jensen Manufacturing Company has released a new catalogue, No. 1070, on its new line of Professional Series loudspeakers designed for commercial, industrial, institutional, and public-address applications.

Jensen Catalogue 1070 contains 24

pages of definitive information on all equipment in the Professional Series line, including the Hypex projector's Lifetime drivers, rectangular horns, transformers, and the Speech Master, high-fidelity, Weather Master, and Viking lines.

Copies of Catalogue 1070 may be obtained on request.

### AUDIO OSCILLATOR

Waveforms, Inc., has announced the addition of a new, general-purpose sine-wave oscillator to its instrument line.

The *Model 401* oscillator (sine wave) features wide tuning range (9 cps to 100 Kc), high accuracy (2% with ½% stability), flat response ( $\pm 1/2$  db), and low distortion (½%).

The instrument's output system is said to afford unusual versatility of use. At

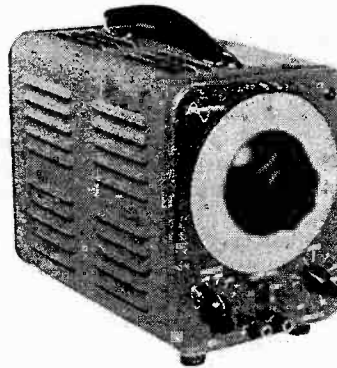

*Oscillator's range is 9 cps to 100 Kc.*

full output the instrument delivers 20 volts open circuit or ½ watt into 600 ohms. Output level is controlled by a logarithmic calibrated potentiometer in tandem with a 100:1 attenuator.

The price of the 401 oscillator is \$125.00.

### INTERSEARCH LINE

Intersearch Associates of Cincinnati, Ohio, have announced the availability of several items of high-fidelity equipment imported from Japan.

The I/S *Velvet Touch* tone arm is viscous damped. The "Velvet Touch" action floats in silicone oil which absorbs mechanical vibration and cushions

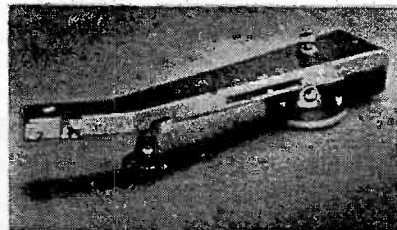

*Imported viscous-damped pickup arm.*

the arm against shock and jarring. Tracking error is said to be lower than that with some 16-inch arms.

The Velvet Touch tone arm is equipped with three slide-in shells to

adapt the arm to most makes of cartridges.

Another offering from Japan is the I/S turntable *Model TP-50* featuring a magnetic eddy-current speed adjust-

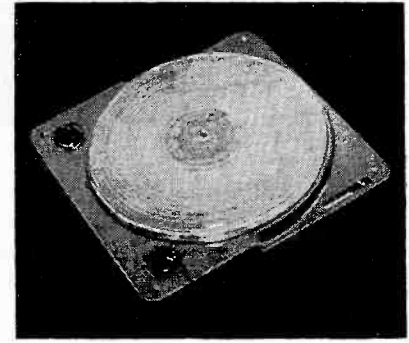

*Turntable with fine speed adjustment.*

ment that permits adjustments of speed up to 23%. A neon-illuminated stroboscope is viewed through an observation window in the motor plate. One speed adjustment corrects all three turntable speeds, with a separate "flip switch" that permits instant selection of 33⅓, 45, or 78 rpm.

The 12-inch cast-aluminum turntable is rim-driven by a new two-phase capacitor-type motor. According to the importer, the motor can be operated for long periods with very little rise in temperature; it is also said to run more smoothly than the shaded-pole motors used in many turntables. The I/S Model TP-50 turntable is sold in the United States for \$57.00.

A turntable cabinet, the *Model CT-1*, is offered in a variety of prefinished woods, knocked down and grooved for simple assembly by the user. The motor board is shock-mounted and equipped with leveling screws. The motor board is cut to fit the I/S Model TP-50 turn-

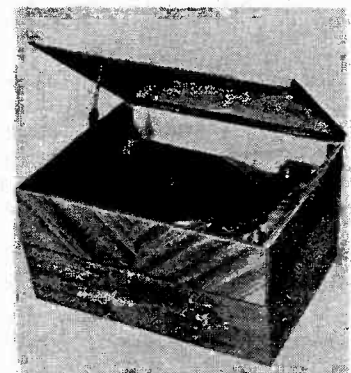

*Cabinet for the tone arm and turntable.*

table and the I/S Velvet Touch tone arm. A preamplifier or small amplifier can be mounted inside the cabinet. Price of the Model CT-1 is \$24.95.

All components are fully guaranteed by the importer, Intersearch. Complete service facilities are available in the United States.

# TIPS FOR THE WOODCRAFTER

by George Bowe

## Cabinet Hardware

In hi-fi cabinet construction, as in building a house, both rough and finish hardware play important roles. The rough hardware includes items such as nails, screws, and bolts; the finish hardware consists principally of hinges, door slides, handles, pulls, latches, and catches. By design, much finish hard-

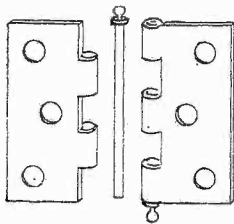

Fig. 1. A butt hinge, exploded view.

ware is equipped to serve in both utilitarian and decorative capacities. Where it will be visible, cabinet hardware can make or break the finest piece of woodcraft, and so requires careful selection for style, finish, and size.

The cabinet and décor of the room influence the choice of hardware, whether it be of traditional or contemporary style. For a rustic or primitive Colonial effect there are reproductions of early American handwrought pieces. If the motif is Sheraton, Hepplewhite, Chippendale, Queen Anne, or Victorian, it might take a bit more searching to locate appropriate knobs and pulls. There should be no problem, however, in finding well-designed cabinet hardware with clean, modern lines. While traditional-style hardware is usually made of metal in such finishes as polished brass, antique brass and copper, and wrought iron black, hardware of modern design is produced not only in the conventional metal finishes but also

in plastics, wood, and glass, with color adding a decorative note.

Of all finish hardware, none is more important than the hinge, so it behooves the craftsman to select the proper hinge and install it carefully. For our purposes, hinges fall into five classifications: *butt*, *continuous*, *surface*, *semiconcealed*, and *invisible*.

The butt hinge, shown in Fig. 1, is the type most commonly used and is usually the most difficult to apply properly. It consists of three parts: the leaves—the plates by which the hinge is fastened to the wood; the knuckles—the cylindrical portion where the two leaves join; and the pin—the rod that goes through the knuckles and holds the leaves together. If the pin is removable, it is known as a *loose pin*; a fixed pin is *fast*.

Now let's go through the details of installing loose-pin butt hinges on a cabinet door. Fit the door so there is 1/16 in. clearance on all sides. In other words, the door should be 1/2 in. less in width and length than the opening into which it is to fit. This allows for the thickness of whatever finish is to be applied as well as for future expansion from atmospheric conditions. Put the door in place and wedge it so there is equal clearance all around. Thin pieces of wood or cardboard will do as wedges, as will a couple of 2d nails wedged along each edge. With the door wedged in position, mark the door and the facing where the hinges will be located. Then remove the door and, using either a combination square, a marking gauge, a knife, or a sharp pencil, outline the position of the hinges on the edge of the door. Repeat the same operation on the corresponding edge of the facing. Be sure to check your measurements so that the door

markings and the facing markings correspond.

Since the leaves of the hinges are to be set flush in the edges of the door and the facing, the next step is to chisel out recesses or *gains* to house the leaves. Set the marking gauge or combination square to the thickness of one leaf of the hinge and mark a line on the door and the facing to indicate the depth to which the stock should be removed. Then, with a sharp chisel, outline the gain on the door and facing, using the beveled part of the chisel facing in toward the gain. Make several shallow

Courtesy Stanley Hardware, division of The Stanley Works

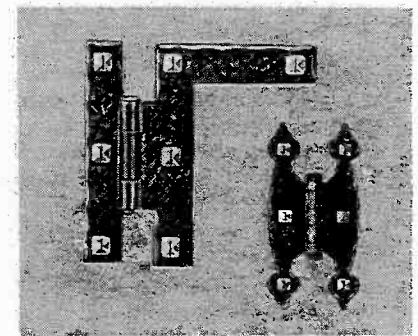

Fig. 3. Two styles of surface hinge.

V cuts in the stock to be removed. This will facilitate removal of the rest of the gain with the flat side of the chisel.

Check to see that the hinge leaf fits correctly in the gains. Remove the pins from the hinges, place the leaves in the gains, and mark the screw holes. With a drill or awl, start the screw holes, being certain that they are on center. Drive in the top and bottom screws only in each leaf, put the door in position and slip the pins into place. If the door hangs properly, drive in the remaining screws. If the door hits against the facing, insert a piece of cardboard behind the hinge leaf to make it flush with the surrounding wood surface. If the door hangs away from the facing, chisel the gains a bit deeper.

The screen or double-acting hinge (Fig. 2A) is a rather complex hinge that makes it possible for a folding screen or a door to swing both ways. It might be used in a cabinet housing a record player and TV receiver side by side. It would swing to cover which-

Fig. 2A. Left, double-acting hinge. Fig. 2B. Right, continuous or piano hinge.

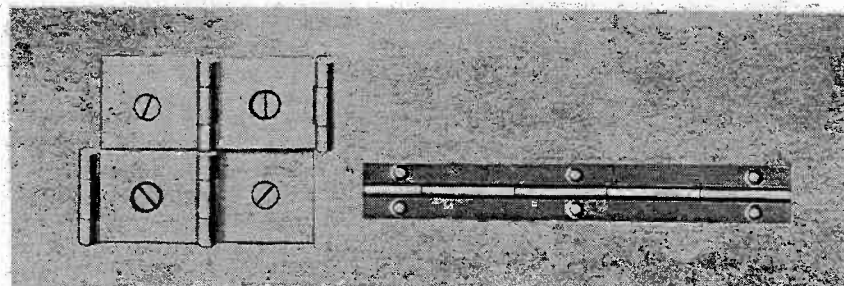

Courtesy Stanley Hardware, division of The Stanley Works

Continued on page 46



# "We're building a HEATHKIT<sup>®</sup>..."

BECAUSE IT'S SUCH GREAT FUN... AND BECAUSE WE GET SO MUCH MORE FOR OUR MONEY!"

Every day more and more people (just like you) are finding out why it's smart to "do-it-yourself" and save by building HEATHKIT high fidelity components. These people have discovered that they get high-quality electronic equipment at approximately one-half the usual cost by dealing directly with the manufacturer, and by doing their own assembly work. It's real fun—and it's real easy too! You don't need a fancy work shop, special tools or special knowledge to put a Heathkit together. You just assemble the individual parts according to complete step-by-step instructions and large picture-diagrams. Anyone can do it!

## Heathkit Model SS-1 Speaker System Kit

This high fidelity speaker system is designed to operate by itself, or with the range extending unit listed below. It covers the frequency range of 50 to 12,000 CPS within  $\pm 5$  db. Two high-quality Jensen speakers are employed. Impedance is 16 ohms, and power rating is 25 watts. Can be built in just one evening. **\$39<sup>95</sup>**  
Shpg. Wt. 30 lbs.

## Heathkit Model SS-1B Speaker System Kit

This high fidelity speaker system kit extends the range of the model SS-1 described above. It employs a 15" woofer and a super-tweeter to provide additional bass and treble response. Combined frequency response of both speaker systems is  $\pm 5$  db from 35 to 16,000 CPS. Impedance is 16 ohms, and power is 35 watts. Attractive styling matches SS-1. Shpg. Wt. **\$99<sup>95</sup>**  
80 lbs.

## HEATHKIT

### "LEGATO" SPEAKER SYSTEM KIT

Months of painstaking engineering by Heath and Altec-Lansing engineers has culminated in the design of the Legato, featuring "CP" (critical phasing) and "LB" (level balance). The result is a *new kind* of high fidelity sound, to satisfy even the most critical audio requirements. Two high-quality 15" theater-type speakers and a high-frequency driver with sectoral horn combine to cover 25 to 20,000 cycles without peaks or valleys. "CP" and "LB" assure you of the smooth, flat audio response so essential to faithful reproduction. Choice of two beautiful cabinet styles below.

### "Legato" Traditional Model HH-1-T

Styled in classic lines to blend with period furniture of all types. Doors attractively paneled. African mahogany for dark finishes unless you specify imported white birch for light finishes. Shpg. Wt. **\$345<sup>00</sup>**  
246 lbs.

### "Legato" Contemporary Model HH-1-C

This fine cabinet features straightforward design to blend with your modern furnishings. Slim, tapered struts run vertically across the grille cloth to produce a strikingly attractive shadowline. Wood parts are precut and predrilled for simple assembly. Supplied in African mahogany for dark finishes unless you specify imported white birch for light finishes. Shpg. Wt. **\$325<sup>00</sup>**  
231 lbs.

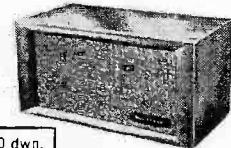

\$4.00 dwn.  
\$3.36 mo.

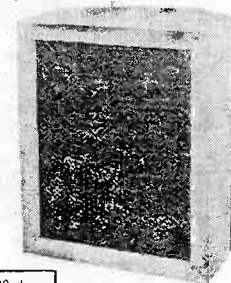

\$10.00 dwn.  
\$8.40 mo.

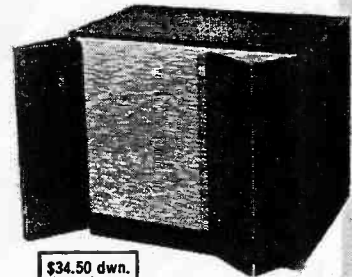

\$34.50 dwn.  
\$28.98 mo.

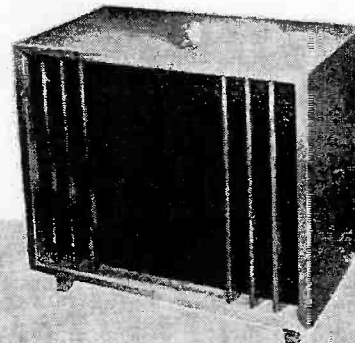

\$32.50 dwn.  
\$27.30 mo.



## HEATH COMPANY

A Subsidiary of Daystrom, Inc.

BENTON HARBOR 18, MICHIGAN

# Make yours a **HEATHKIT**®

**It's Easy (and fun) to Plan Your Own Hi-Fi Installation  
By Choosing the Heathkit Components  
That Best Suit Your Particular Needs.**

As the world's largest manufacturer of electronic equipment in kit form, Heath Company can provide you with a maximum variety of units from which to choose. You can select just the amplifier you need from five different models, ranging in power from 7 watts to 25 watts, some with preamplifiers, and some requiring a separate preamplifier. You can pick your speaker system from four outstanding high fidelity units ranging in price from only \$39.95 to \$345.00. You can even select a fine Heathkit FM or AM Tuner! Should there be a question in your mind about the requirements of an audio system, or about planning your particular hi-fi installation, don't hesitate to contact us. We will be pleased to assist you.



### MATCHING CABINETS . . .

The Heath AM Tuner, FM Tuner and Preamplifier are housed in matching satin-gold finished cabinets to blend with any room decorating scheme. Can be stacked one over the other to create a central control unit for the complete high fidelity system.



MODEL FM-3A



MODEL BC-1

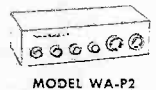

MODEL WA-P2



### PRE-ALIGNED TUNERS . . .

A unique feature of the Heathkit AM and FM Tuners is the fact that both units are pre-aligned. A signal generator is not necessary! IF and ratio transformers are pretuned at the factory, and some front-end components are preassembled and pretuned. Another "extra" to assure you of easy kit assembly.



## HEATH COMPANY

A Subsidiary of Daystrom, Inc.  
BENTON HARBOR 18, MICHIGAN

**EASY TIME PAYMENTS . . .** We invite you to take advantage of the Heath Time Payment Plan on any order amounting to \$90.00 or more. Just 10% down and the balance in twelve monthly payments. **WRITE FOR COMPLETE DETAILS.**



# HIGH FIDELITY SYSTEM

**1 HEATHKIT HIGH FIDELITY FM TUNER KIT** Features AGC and stabilized, temperature-compensated oscillator. Sensitivity is 10 microvolts for 20 db of quieting. Modern circuit covers standard FM band from 88 to 108 mc. Employs ratio detector for efficient hi-fi performance. Power supply is built in. Illuminated slide rule dial for easy tuning. Housed in compact satin-gold enamel cabinet. Features prealigned transformers and front end tuning unit. Shpg. Wt. 7 lbs.

**MODEL FM-3A** Incl. Excise Tax (with cab.) **\$25<sup>95</sup>**  
\$2.60 dwn., \$2.18 mo.

**2 HEATHKIT BROADBAND AM TUNER KIT** This fine AM Tuner was designed especially for use in high fidelity applications, and features broad bandwidth, high sensitivity and good selectivity. Employs special detector circuit using crystal diodes for minimum signal distortion, even at high levels. Covers 550 to 1600 kc. RF and IF coils are prealigned. Power supply is built in. Housed in attractive satin-gold enamel cabinet. Shpg. Wt. 8 lbs.

**MODEL BC-1** Incl. Excise Tax (with cab.) **\$25<sup>95</sup>**  
\$2.60 dwn., \$2.18 mo.

**3 HEATHKIT HIGH FIDELITY PREAMPLIFIER KIT** This pre-amplifier meets or exceeds specifications for even the most rigorous high fidelity applications. It provides a total of 5 inputs, each with individual level controls. Hum and noise are extremely low, with special balance control for absolute minimum hum level. Tone controls provide 18 db boost and 12 db cut at 50 cps, and 15 db boost and 20 db cut at 15,000 cps. Four-position turn-over and four-position rolloff controls for "LP", "RIAA", "AES", and "early 78" equalization. Derives power from main amplifier, requiring only 6.3 VAC at 1A and 300 VDC at 10MA. Beautiful satin-gold enamel finish. Shpg. Wt. 7 lbs.

**MODEL WA-P2** (with cab.) **\$19<sup>75</sup>**  
\$1.98 dwn., \$1.66 mo.

**4 HEATHKIT ADVANCED-DESIGN HI-FI AMPLIFIER KIT** This fine 25-watt high fidelity amplifier employs KT66 output tubes by Genalex and a Peerless output transformer for top performance. Frequency response  $\pm 1$  db from 5 to 160,000 cps at 1 watt. Harmonic distortion less than 1% at 25 watts, an IM distortion less than 1% at 20 watts. Hum and noise are 99 db below 25 watts. Output impedance is 4, 8 or 16 ohms. Extremely stable circuit with "extra" features.

**MODEL W-5:** Consists of W-5M plus WA-P2 Preamplifier **\$59<sup>75</sup>** \$5.98 dwn., \$5.02 mo.  
Shpg. Wt. 38 lbs. **\$79.50** \$7.95 dwn., \$6.68 mo.  
Express only

**5 HEATHKIT DUAL-CHASSIS HI-FI AMPLIFIER KIT** This 20-watt Williamson-type amplifier employs the famous Acrosound model TO-300 output transformer, and uses 5881 tubes. Frequency response is  $\pm 1$  db from 6 cps to 150 kc at 1 watt. Harmonic distortion less than 1% at 21 watts, and IM distortion less than 1.3% at 20 watts. Output impedance is 4, 8 or 16 ohms. Hum and noise are 88 db below 20 watts.

**MODEL W-3M** **\$49<sup>75</sup>** \$4.98 dwn., \$4.18 mo.  
**MODEL W-3:** Consists of W-3M plus WA-P2 Preamplifier  
Shpg. Wt. 37 lbs. **\$69.50** \$6.95 dwn., \$5.84 mo.  
Express only

**6 HEATHKIT SINGLE-CHASSIS HI-FI AMPLIFIER KIT** This 20-watt Williamson-type amplifier combines high performance with economy. Employs Chicago-Standard output transformer and 5881 tubes. Frequency response  $\pm 1$  db from 10 cps to 100 kc at 1 watt. Harmonic distortion less than 1.5% and IM distortion less than 2.7% at full output. Output 4, 8 or 16 ohms. Hum and noise—95 db below 20 watts.

**MODEL W-4AM** **\$39<sup>75</sup>** \$3.98 dwn., \$3.34 mo.  
**MODEL W-4A:** Consists of W-4AM plus WA-P2 Preamplifier  
Shpg. Wt. 35 lbs. **\$59.50** \$5.95 dwn., \$5.00 mo.  
Express only

**7 HEATHKIT 20-WATT HIGH FIDELITY AMPLIFIER KIT** Features full 20 watt output using push-pull 6L6 tubes. Built-in preamplifier provides four separate inputs. Separate bass and treble controls. Output transformer tapped at 4, 8, 16 and 500 ohms. Designed for home use, but also fine for public address work. Response is  $\pm 1$  db from 20 to 20,000 cps. Harmonic distortion less than 1% at 3 db below rated output. Shpg. Wt. 23 lbs.

**MODEL A-9B** **\$35<sup>50</sup>**  
\$3.55 dwn., \$2.98 mo.

**8 HEATHKIT ELECTRONIC CROSS-OVER KIT** This device separates high and low frequencies electronically, so they may be fed through two separate amplifiers driving separate speakers. Eliminates the need for conventional cross-over. Selectable cross-over frequencies are 100, 200, 400, 700, 1200, 2000 and 3500 cps. Separate level controls for high and low frequency channels. Attenuation 12 db per octave. Shpg. Wt. 6 lbs.

**MODEL XO-1** **\$18<sup>95</sup>** \$1.90 dwn., \$1.59 mo.

**9 HEATHKIT 7-WATT ECONOMY AMPLIFIER KIT** Qualifies for high fidelity even though more limited in power than other Heathkit models. Frequency response is  $\pm 1\frac{1}{2}$  db from 20 to 20,000 cps. Push-pull output and separate bass and treble tone controls. Good high fidelity at minimum cost. Uses special tapped-screen output transformer.

**MODEL A-7E:** Same as A-7D except one more tube added for extra preamplification. Two inputs, RIAA compensation and extra gain. **MODEL A-7D** **\$17<sup>95</sup>** \$1.80 dwn., \$1.51 mo.  
Shpg. Wt. 10 lbs. **\$19.95** \$2.00 dwn., \$1.68 mo.  
Incl. Excise Tax

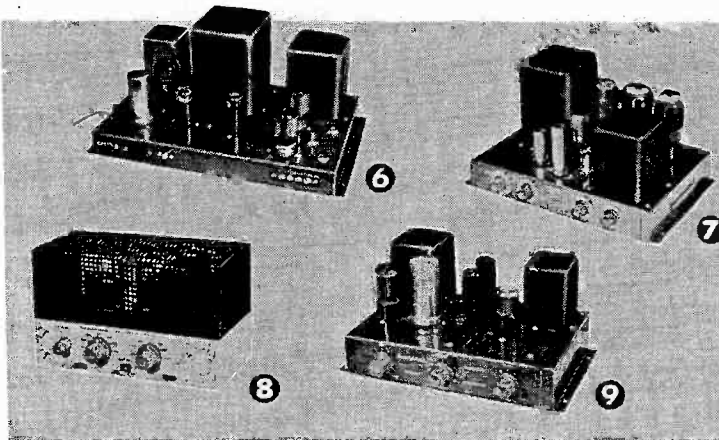

Write for Free Catalog

## HOW TO ORDER

Just identify kit by model number and send order to address below. Write for further details if you wish to budget your purchase on the HEATH TIME PAYMENT PLAN.

## HEATH COMPANY

A Subsidiary of Daystrom, Inc.  
BENTON HARBOR 18, MICHIGAN  
Please send Free HEATHKIT catalog.

Name \_\_\_\_\_  
Address \_\_\_\_\_  
City & Zone \_\_\_\_\_ State \_\_\_\_\_

by J. Gordon Holt

## Microphone Technique II

Last month's column was devoted to a discussion of practical acoustics, and that characteristic of a microphone which most affects the way it is used: its directivity. Before going further into that subject, however, let us pause for a moment and meditate on the relationship between directivity and microphone type.

Engineers and some recordists recognize two distinct types of microphone: the pressure-sensitive mike and the velocity microphone. This distinction is made between microphones which respond to variations in air pressure and those which respond to the speed of moving air particles.

In a velocity microphone, the pole pieces are separated by a large gap which permits free passage of air. The diaphragm is suspended within the gap where draughts can move it back and forth. Since both sides of the diaphragm are exposed to the air, it responds equally well to sounds originating from its front or rear. A sound originating from the side will appear with equal intensity on *both* sides of the air gap; no air moves through it, and the diaphragm fails to respond. Thus the velocity microphone has an essentially bidirectional (figure-8) pickup pattern, with maximum sensitivity at the front and rear and minimum sensitivity at the sides.

A pressure microphone has only one side of its diaphragm exposed to the air. Its diaphragm is baffled like that of a loudspeaker, and its rear surface faces into a very small air space (small, to prevent standing waves within the audible range) or into a cavity or folded tube which helps to support its bass response. Its diaphragm is actuated by variations in air pressure, which, over most of the audible range, will affect it regardless of the direction in which it is facing. It is, then, essentially omnidirectional. But at higher frequencies, air vibrations lose their tendency to flow around intervening objects, so the usual pressure microphone tends to become increasingly unidirectional with rising frequency.

Most ribbon microphones are velocity types; crystal, condenser, dynamic, and (pardon the expression) carbon microphones are pressure-sensitive, although

special design techniques can produce wide variations in the pickup patterns of each type.

For instance, the RCA Starmaker microphone is a ribbon mike, but its ribbon is located at the bottom of a closed cylindrical barrel, producing what is in effect an omnidirectional characteristic. The Shure 333 is also a ribbon type, but has a system of baffles to give a highly unidirectional pattern. Then again, the Altec 21-B and the Electro-Voice 666 are both pressure-sensitive microphones, yet the 21-B has an almost perfectly omnidirectional characteristic, with negligible high-frequency directivity, while the 666 is highly unidirectional, having what is close to an ideal cardioid pattern (also with minimal frequency selectivity).

The important difference between velocity and pressure microphones (apart from their pickup patterns) is the way they behave when moved close to the sound source. Velocity microphones exhibit bass response which rises

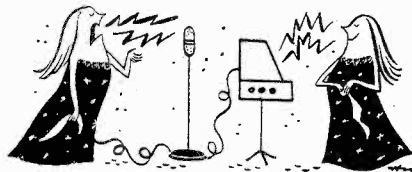

increasingly as they are moved closer to the source of the sound. It is for this reason that many high-quality velocity microphones have a Music-Speech switch, to reduce their bass output when used for close-talking speech pickup. This rising bass response can sometimes be put to good use when close-miking a musical instrument, either as the sole instrument pickup or as a spot pickup to be mixed with other microphones in large-group recordings.

Typical of the kind of thing that we record from time to time (in lieu of the Philadelphia orchestra, which is out of bounds to amateur recordists) is a church choir, with pipe organ. Here one of two situations will present itself: the performers in some churches will be located at the sides of the altar, while in others they will be relegated to a loft at the rear of the church.

A group near the altar is easiest to

pick up, because to get the mike a reasonable distance above the performer's heads it need be hoisted only 8 to 10 ft. from the floor. An extended floor stand will suffice.

Organ and choral music derive much of their effectiveness from the blending and reverberation that a church's acoustic properties impart to the sound. It should be recorded with plenty of echo and should be miked just close enough to maintain adequate definition. Remembering that the congregation will swallow up a great deal of echo, and will soften the sound to some extent, the church acoustics will suggest what sort of microphone should be used: unidirectional if the reverberation time is fairly long, and the sound somewhat harsh (because of bare plaster walls or a low ceiling); or omnidirectional if there is not too much reverberation, and if it is on the soft side. Again, these are only suggestions, and individual conditions may call for other microphone types.

Assuming for a moment that there is appreciable echo and that this is hard in character, the unidirectional microphone can be backed far enough away from the choir to give good blending and to pick up the necessary reverberation from the front of the church, while the mike's dead sides and rear will minimize pickup from the stridently reflective walls, helping to soften the sound. The mike, preferably a cardioid type, might best be located about 15 to 20 ft. from the front of the choir and 8 to 15 ft. above the floor, aimed at the middle of the group or at the feeblest section of the choir if this is not normally well balanced.

An ideal but rarely encountered situation is that in which there is plenty of echo, of a subdued nature rather than hard and "plastery". Then the recordist should take full advantage of his good fortune, because his mike placement need not be compromised by the necessity to soften the echo. He can concern himself instead with matters of balance, blending, definition, and reverberation. Hence, an omnidirectional mike may be used in place of a unidirectional one, if it happens to provide the best all-around results. The reverberation may be treated simply as an ingredient, to be

*Continued on page 43*

# You can have the finest sound reproduction throughout all frequency ranges without distortion

You will hear a remarkable difference in the clarity of Norelco \*Full Response Speakers. In a single speaker, twin-cones reproduce low frequencies, middle range, as well as the higher frequencies extending beyond the audible range—without distortion.

## WHY ARE NORELCO FRS SPEAKERS SO EXCEPTIONAL?

They have incorporated a number of technical refinements which are evident the moment you listen. The air gap has been made long so that the coil is completely enclosed in an even magnetic field at all times. A copper ring has been fitted into the deep air gap to keep the voice coil impedance constant over the whole frequency range; this avoids incorrect matching. High flux densities are obtained through the use of "Ticonal" magnet steel.

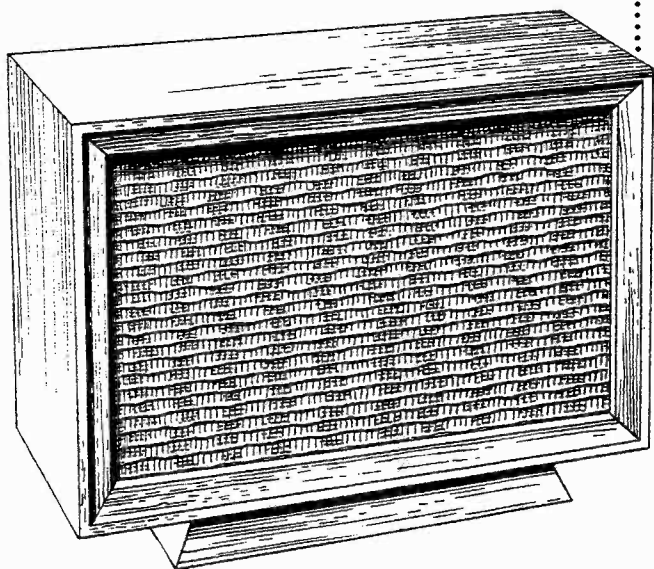
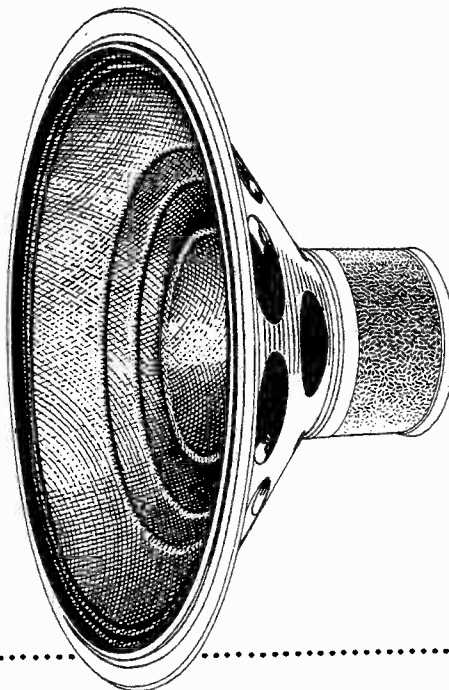

*Norelco FRS Improved Bass Reflex Enclosures are available in three sizes; FRS Enclosures I, II and III. Priced from \$33.75 to \$119.95.*

## *Norelco \*F.R.S.*

*speakers are available  
5", 8" or 12" sizes in standard impedances.  
Priced from \$6.75 to \$59.98  
Blue prints are available for the  
do-it-yourself enclosure builder.*

Norelco speaker-matched enclosures are scientifically designed acoustical boxes which enhance the exceptional tone qualities of FRS speakers; bringing out their true performance values.

Norelco FRS Speaker Enclosures are available in three sizes to match the characteristics of the speaker in use. Supplied in either mahogany or blond, these enclosures incorporate a removable base permitting the enclosures to be placed horizontally or vertically to suit any room arrangement or decor.



ADD TO...and improve any sound system with **Norelco®**  
\*FULL RESPONSE SPEAKERS

Write today to Dept. M2 for brochures and prices of these unique speakers.  
NORTH AMERICAN PHILIPS CO., INC., 100 E. 42nd Street, New York 17, N.Y.

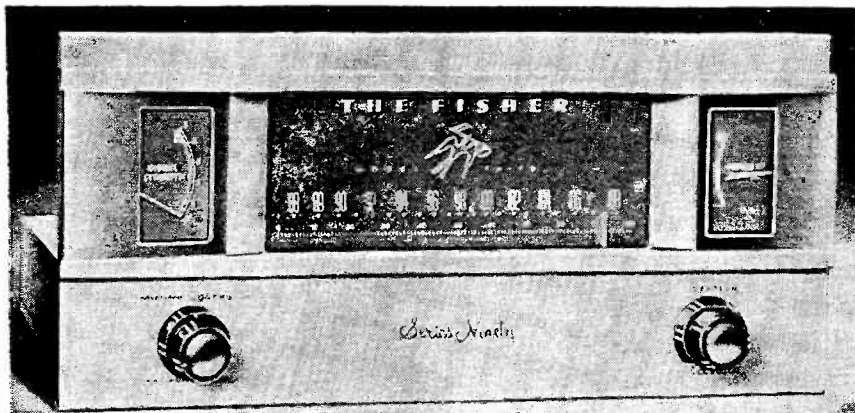

AMERICA'S LEADING FM TUNER • IN SENSITIVITY, APPEARANCE AND WORKMANSHIP

**New!**

THE 

**FISHER**

**FM TUNER**

MODEL FM-90

WHEN WE INTRODUCED our Model FM-80 FM tuner, it immediately established itself as the leader in the field. Today, the FM-80 is standard equipment in many broadcast stations, where its fabulous sensitivity and absolute reliability make it ideal for pickup of distant FM chain programs, for rebroadcast to the local communities. It took FISHER to improve on FISHER and the result is the new Model FM-90. It is some sixteen years since we produced our first FM tuner. The engineering skill and experience that only time, plenty of it, can bestow, are evident in every aspect of THE FISHER FM-90. We can truly say for it that it is the most advanced FM tuner now available.

**Remarkable Features of THE FISHER FM-90**

- TWO meters, for micro-accurate tuning. ▪ Revolutionary, dual dynamic limiters, assure noise-free reception where all others fail. ▪ Full wide-band detector for maximum capture ratio. ▪ Exclusive, variable inter-station noise eliminator. ▪ Full limiting on signals as low as 1 microvolt. ▪ Dual triode, cascode-tuned RF stage, four IF stages. ▪ Uniform response, 20 to 20,000 cycles. ▪ Three outputs (Main, Recorder and Multiplex). ▪ Dual antenna inputs (72 ohms or 300 ohms balanced). ▪ Four controls. ▪ 10 tubes plus four matched germanium crystal diodes. ▪ Special circuits for meter operation. ▪ Chassis completely shielded and shock-mounted. ▪ Beautiful, die-cast, brushed brass escutcheon and control panel. ▪ Dipole antenna supplied. ▪ SIZE: 13 7/16" w. x 6 1/4" high x 8 3/4" deep (plus 1" for knobs). ▪ WGT: 15 lbs.

**Professional FM Tuner • \$149.50**  
**MAHOGANY OR BLONDE CABINET: \$17.95**

Prices Slightly Higher in the Far West

WRITE TODAY FOR COMPLETE SPECIFICATIONS

**FISHER RADIO CORP., 21-31 44th DRIVE • L. I. CITY 1 • N. Y.**



**book reviews**

by RICHARD D. KELLER

**Transistor Circuit Handbook**

Louis E. Garner, Jr; pub. by Coyne Electrical School, Chicago; 410 pages; \$4.95.

Here, at last, is a really useful, up-to-date handbook for transistor experimenters.

It is not an engineering treatise, but rather a constructional handbook jammed full of comparatively simple, practical, workable circuits and projects. It is tailored directly for the home experimenter, since complete assembly directions are given, as well as detailed parts lists and adjustment suggestions for each project.

This is just what the transistor market has needed for a long time—a complete assortment of audio, radio, test-instrument and control, and gadget circuits which have been built, tried, and proven. Most circuits use the more inexpensive types of transistors since these are more widely available from distributors throughout the country. They are perfectly acceptable in these types of projects, even with their acknowledged wide parameter variations, since biases in each circuit may be individually adjusted if necessary for optimum operation. And their dollar-or-so price makes them especially attractive for experimentation.

Finally, too, here is an author who has relegated the point-contact transistor to a mere passing mention in the introduction since, as he says, almost all the major transistor manufacturers have indicated that they have discontinued or are planning to discontinue the production of such units. So he launches right into descriptions and uses of modern grown- and diffused-junction units, surface-barrier transistors, and miniature components designed especially for them. These are used throughout the book.

The last part of the book—Reference Data—is another outstanding feature. This part includes a transistor-characteristics chart of the more popular types, and names and addresses of manufacturers of transistors, transistor test equipment, and components. Other sections deal with definitions, design formulas, special techniques (such as printed

circuits), new developments (meltback and diffusion techniques, etc.), and a very useful bibliography of books and booklets, trade publications, and magazine articles and technical papers (up to about mid-1955).

One only wishes that a more artistic job on the jacket and layout of the volume had been undertaken, for this is one time when the true worth of the book cannot be judged by its cover.

### High Fidelity

*Charles Fowler; pub. by McGraw-Hill, New York; 310 pages; price \$4.95.*

One of the men most often identified with the subject of high fidelity (and publisher of two magazines on the subject) has written this book for the enlightenment of the nontechnical reader who is interested in more than a mere listing of suggested components to buy for a home hi-fi system.

His objective has been to explain, as he says, "... as many of the facts and aspects of sound and sound reproduction as can be considered pertinent to the ultimate and practical achievement of your listening pleasure. . . ."

This he does quite pleasantly, writing in a friendly conversational style as though talking directly with you. A remarkable amount of good, usable, up-to-date high-fidelity knowledge is imparted in the process.

The subject of loudspeakers and enclosures, probably one of the most mysterious and unexplored areas in the field of sound, is surveyed with exceptional clarity from speaker designs right on up to the various types of enclosures with their various features pro and con, as well as room resonances, reverberation, and the effects of room furnishings on over-all sound reproduction.

Amplifiers and preamplifiers are thoroughly explained, along with all the major factors that should be considered when making purchases. Tuners, record turntables, changers, arms, and pickups are presented in the same thorough manner.

To wrap up the whole package, the final chapter is loaded with suggestions and ideas on how to correlate a given budget with the features that you specifically desire in your own home sound system. Even the advanced audiophile will find this volume of real value.

### Electronics

*A. W. Keen; pub. by Philosophical Library, Inc., New York; 254 pages; price \$4.75.*

The title of this volume encompasses a considerable range of knowledge, and the book does make a good attempt to cover it all.

In covering such a broad subject,

*Continued on page 45*



ON ONE COMPACT CHASSIS! FISHER FM-AM TUNER, AUDIO CONTROL AND 30-WATT AMPLIFIER!

**New!**

EVERYTHING YOU NEED!  
ON ONE SUPERB CHASSIS!

# THE FISHER "500"

THOUSANDS have asked us for it—and here it is! An extreme-sensitivity FM-AM tuner, a powerful 30-watt amplifier, and a Master Audio Control—all built on one compact chassis. Simply add a record changer and loudspeaker to the FISHER "500" and, as easily as that, you have a complete high fidelity system. Its quality—in the finest FISHER tradition. Its appearance—the timeless beauty of classic simplicity. Here is the most economical form in which you can own FISHER equipment.

Chassis Only, **\$239.50**

Mahogany or Blonde Cabinet, **\$19.95**

### Outstanding Features of THE FISHER "500"

- Extreme sensitivity on FM and AM. Meter for micro-accurate tuning.
- Full wide-band FM detector for maximum capture ratio.
- Powerful, 30-watt amplifier; handles 60-watt peaks.
- Uniform response, 16 to 32,000 cycles.
- 4 inputs, including separate tape playback preamp-equalizer.
- 4, 8 and 16-ohm outputs match all existing speakers.
- Recorder output ahead of volume and tone controls.
- 7 Controls, including 9-position Channel Selector (AM, FM, AES, RIAA, LP, NAB, TAPE, AUX 1 and AUX 2), Loudness Contour (4-position), Volume, Bass, Treble, AC-Power, Station Selector.
- Beautiful, die-cast, brushed brass escutcheon and control panel.
- Pin-point channel indicator lights.
- Smooth, flywheel tuning.
- Largest, easy-to-read, slide-rule dial, with loading scale.
- High efficiency FM and AM antennas supplied.
- 14 tubes plus 2 matched germanium diodes.
- size: 13 7/16" w. x 12 3/8" d. (excluding knobs) x 6 1/2" high.

*Prices Slightly Higher In The Far West*

WRITE TODAY FOR COMPLETE SPECIFICATIONS

FISHER RADIO CORP., 21-31 44th DRIVE • L. I. CITY 1 • N. Y.

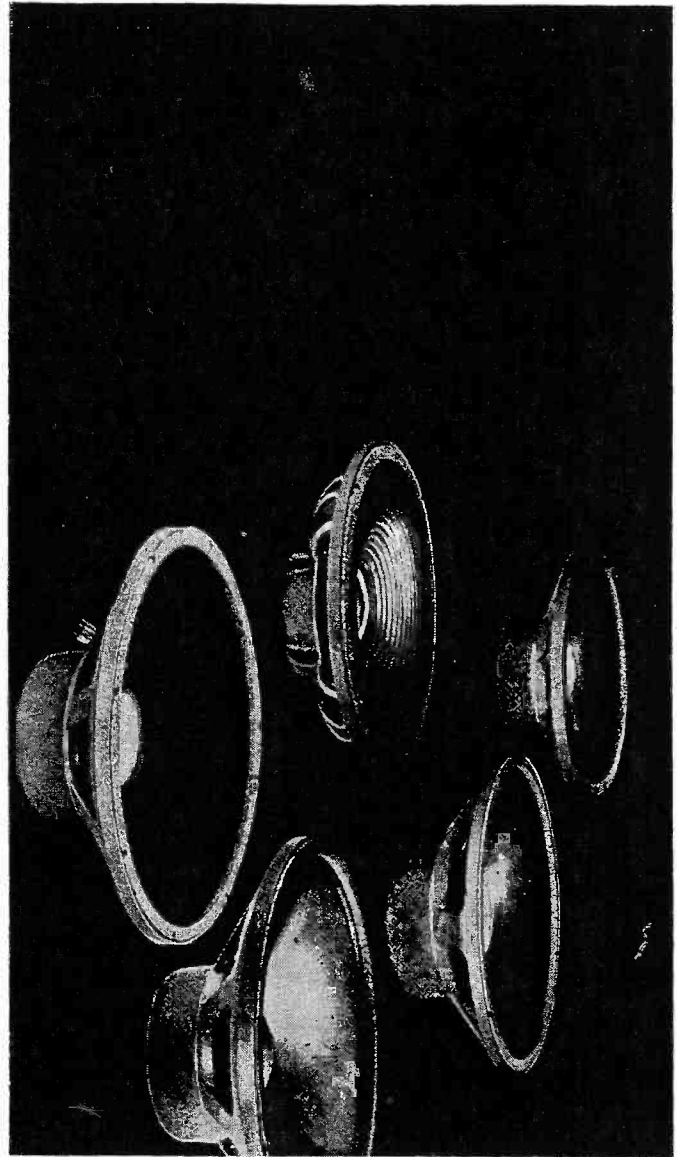

## ALL THAT IT TAKES TO MAKE A SPEAKER GREAT

A great loudspeaker preserves the essence of high fidelity. This essence is the accurate reproduction of complex sound waves of varying magnitudes without distortion. What you hear is lifelike reproduction. It is achieved by thorough acoustical research and engineering, excellent basic design, precision manufacture and assembly, meticulous attention to detail.

JBL Signature Loudspeakers are built around the four-inch voice coil. The coil is made of wire ribbon wound on its narrower edge. Frames are rigid castings. Magnetic circuitry is designed to make maximum use of magnet materials, to eschew superfluous metal, and to avoid stray magnetic fields.

Added to these more obvious differences in JBL Signature Speaker construction are the constant refining of each minute detail, the unflagging, meticulous care with which the precision parts are assembled. These are details you cannot see, but they are most important to what you hear.

These are the reasons why JBL Signature Loudspeakers are the most efficient to be found anywhere. These are the reasons why JBL Signature Speakers cover the audio spectrum with such outstanding smoothness...why they make of "every note a perfect quote." Excellent design, painstaking care—these are what it takes to make a speaker great. There is no short cut.

For free catalog and technical bulletins describing JBL Signature Loudspeakers, write to James B. Lansing Sound, Inc. 2439 Fletcher Drive, Los Angeles 39, California.

*"JBL" means James B. Lansing Sound, Inc.*





# EDITORIAL

Gentlemen:

The November 1956 issue of AUDIOCRAFT, on page 45, contains an item written by Lt. Edward D. Rogers, Jr., which I read with considerable trepidation because it recommends careless handling of radioactive materials by persons who have no knowledge of the precautions that should be exercised to prevent radioactive poisoning. The methods suggested by Lt. Rogers would not be considered safe by responsible manufacturers of luminous paint unless extensive equipment was available — and, even then, only if the personnel were thoroughly instructed and trained to avoid actions which could lead to the radium salts being handled becoming lodged in the body of workers through ingestion or inhalation.

It cannot be argued that the quantities of material to be dealt with by Lt. Rogers's followers are too small to be dangerous, because serious poisoning can occur, according to the National Bureau of Standards, if more than one-tenth of one-millionth of a gram of radium salt becomes lodged in the human body. In order to accumulate enough radium even to begin to accomplish the results promised by Lt. Rogers, several times this maximum permissible dose must be handled by the audio-crafter.

I believe your readers should be warned of the risk involved in collecting, processing, and handling luminous paints containing radium salts in the manner advocated by Lt. Rogers.

E. B. Evleth, President  
Nuclear Products Co.  
El Monte, Calif.

Gentlemen:

The making of the Radioactive Static Eliminator, as outlined in the November 1956 issue of AUDIOCRAFT on page 45, is a source of potential danger to your readers. The author of that article gives explicit directions on how to go about making sure you have the most powerful radioactive substance; then he tells you to crush this material into fine powder! If one inhales any of this hot dust through his nose or mouth, it may cause serious injury. Maybe nothing will happen — but who is going to guarantee that? The risk is too great to take merely to get rid of a little dust on your records. It is better to be safe than sorry.

H. Skalamera  
New York, N. Y.

ACCORDING to a news bulletin from Minnesota Mining and Manufacturing Company, there were 360,000 tape recorders sold in 1955; the 1956 total was expected to be 50% greater.

Not all of them are used with high-fidelity installations. But these figures, together with others of similar nature, reveal the almost incredible rate at which interest in sound is growing in America, and the corresponding rapid increase in the market for high-fidelity equipment.

Such an accelerated growth pattern is bound to be accompanied by growing pains, and this is no exception. One of the more pressing problems that is with us now is a scarcity of competent service organizations and of qualified service personnel to staff them. The problem is not confined to the high-fidelity field, by any means: for instance, have you tried recently to have a new washing machine repaired, when one of its dozen or so push buttons fell out of the control panel? Or to have a color TV adjusted by a serviceman who had never encountered one before? That a shortage of good service is common to other fields does not alleviate its severity in ours, however.

Unless you know the qualifications of your local radio and TV service shop very well, it probably won't be satisfactory to take your hi-fi problems there, as many have discovered the hard way. There isn't any reason why a man who can do a good job of fixing a television set should not be potentially capable of handling hi-fi service. Unfortunately, his training and test equipment are for TV servicing; high-fidelity service requires other training and different test equipment. Until he acquires them he won't be much good at hi-fi work.

Whenever there is sufficient demand for any type of service it will eventually become available, so that we may expect the situation to improve before too much longer. What does the owner of a defective high-fidelity system do in the meantime, unless he is one of the fortunate few who have a competent local hi-fi service agency? To our way of thinking, he is in basically the same sort of situation as the owner of an esoteric sports car, which gives phenomenal performance when properly tuned up—but whose performance suffers more noticeably from slight maladjustment than would, say, a Plymouth. Before he buys the imported bomb, this man knows that he won't be able to depend on the corner garage for much more than gas and oil. He accepts the fact that he will have to

bring the car periodically to the nearest agency (which may be halfway across the state) for routine maintenance; he may even decide to learn something about the simpler types of service himself. The buyer of high-fidelity equipment must realize also that he is acquiring an assembly of precision instruments that require special care; if that care cannot yet be obtained locally, he must be prepared to take or send his equipment to the nearest place it is available, even if that means the factory or the dealer. Also, he may be surprised at how little effort it takes, and how much satisfaction it will give him, to learn enough about what makes his equipment work that he can repair it himself except for major breakdowns.

WE received from a reader, recently, a letter that required a considerable amount of time to answer. When our answer was transcribed it was discovered that he had given no return address other than New York City. Evidently he obtained his copies from a newsstand, for his name was not in our subscriber files. As a result, he is going to consider himself insulted because he will get no reply to a reasonable letter. We are slightly annoyed because the time we spent on his answer has been wasted. This is not the first time such an impasse has happened, and it will undoubtedly happen again.

It needn't happen to you if you make a practice of writing your name and full address on both envelope and letter when you write to us. (If it appears on the letter we can throw away the envelope, which makes handling easier.) We try to answer or acknowledge every letter sent to us, but we can't do it if we don't know where to send the answer. — R.A.

## ERRATA

In "Hi Fi Pure and Simple", by Lee Beeder, AUDIOCRAFT, August 1956, page 23, column 3, line 4, which reads "1- $\mu$ fd oil-filled capacitor . . .", should be changed to "2- $\mu$ fd oil-filled capacitor. . ."

In Fig. 7 on page 35 of the same issue, the value of the 1- $\mu$ fd capacitor in the diagram of the crossover network should be changed to 2  $\mu$ fd.

In "Minimizing Pickup Tracking Error", by Dr. John D. Seagrave, AUDIOCRAFT, December 1956, page 19, column 3; in the last fraction in Eqn. (8), for  $(a/R)$  read  $(\alpha/R)$ .

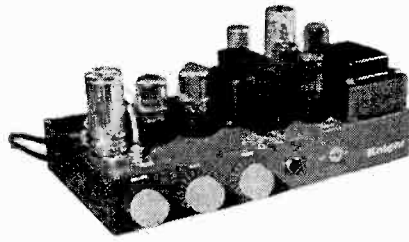

# Knight 10-Watt Amplifier

An AUDIOCRAFT kit report

**E**VEN though most contemporary articles on high fidelity are concerned with super amplifiers, 14-knob control units, and 7-foot-high speaker systems, there is still a great amount of interest in—and many applications for—less impressive and expensive components. For that reason, our kit report this issue is devoted to one of the lowest-priced amplifier-preamp kits that might be expected to provide reasonably good fidelity: the Knight-Kit

10-watt Hi-Fi Amplifier, sold by Allied Radio Corporation.

This kit is a single-chassis unit with one high-level input circuit, suitable for drive from a crystal or ceramic pickup cartridge, a tuner, a control unit, or a preamp-equalizer. Controls are a volume control, individual bass and treble tone controls, and an AC power on-off switch. There is no tape output; the power-amplifier output circuit is for 6- to 8-ohm speakers. Its price is \$23.50.

Two accessories are available. A metal cage cover, to make the amplifier more presentable when not custom installed, costs \$3.95. For \$3.10 you can get an Equalized Preamp Kit, consisting of all the parts necessary to add a dual-triode preamp-equalizer for magnetic cartridges. The latter is meant for use only with this particular amplifier; holes are punched on the amplifier chassis for the preamplifier tube socket and input and output jacks. Equalization is fixed,

Fig. 1. Circuit diagram of the Knight 10-Watt Amplifier. The preamp-equalizer section (optional) is set off by dashed lines.

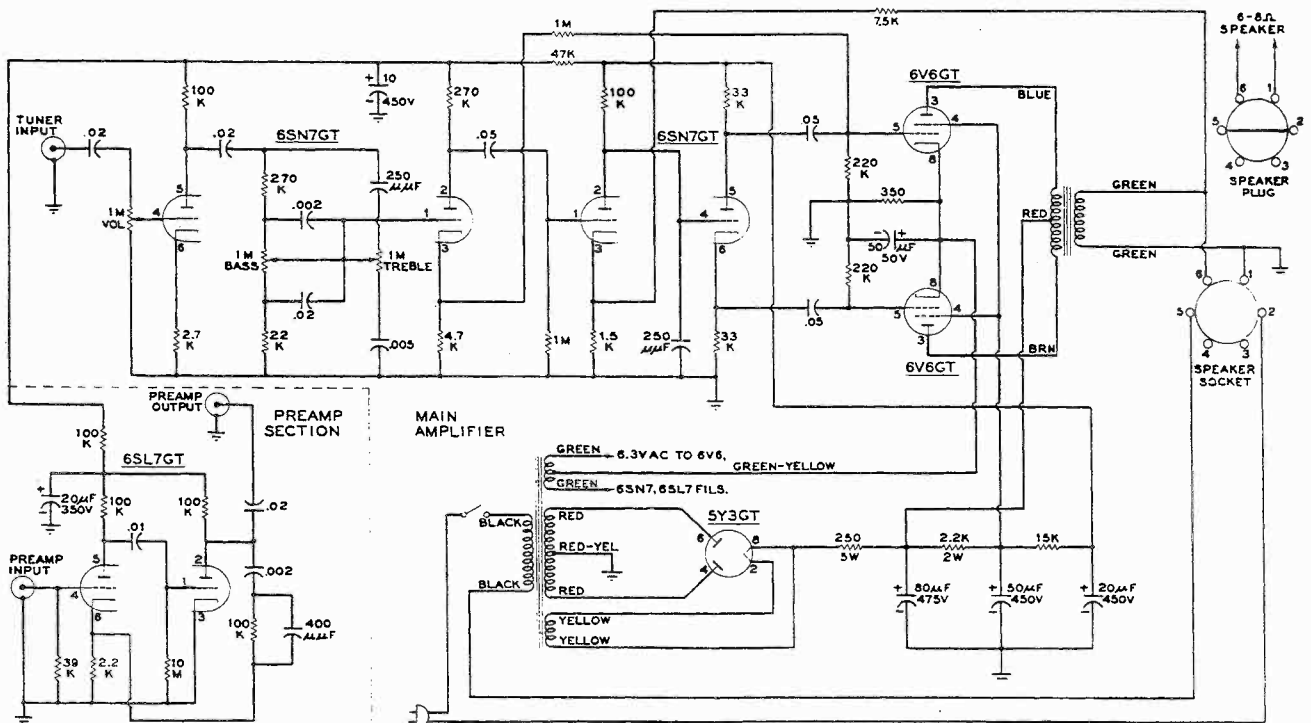

not variable. We obtained the preamp and main amplifier kits, but not the metal cage, as the photographs show.

A complete schematic diagram is given in Fig. 1. The optional preamplifier section is a dual triode with fixed-feedback equalization from second plate to first cathode. Output of the section is fed to a jack on the chassis, because there is no selector switch on the amplifier. If it is to be used only for phonograph reproduction, a short shielded lead must be connected from the preamp output jack to the main amplifier input jack (marked TUNER). If the amplifier is to be used with both a tuner and a phono pickup, however, switching must be done between them externally. Many tuners have switching facilities but no preamplifier. If one such is used with this amplifier, the magnetic pickup would be connected to the preamp input jack, and the preamp output jack would be connected to a switched input on the tuner. Then the output jack of the tuner would be connected to the amplifier's TUNER input.

The TUNER input jack is followed by the volume control and by a stage of straight amplification. This stage feeds tone controls of the lossy type, whose output is connected to another voltage-amplifier stage. Following this is an amplifier stage direct-coupled to a split-load phase inverter which drives the 6V6 push-pull output stage. There are two feedback loops in the power-amplifier section: a positive loop from the upper 6V6 grid to the cathode of the stage following the tone controls, and a standard negative loop from the output-transformer secondary to the cathode of the stage driving the phase inverter. Note that there is one less stage within the negative feedback loop than in the

All photos by Warren Syer

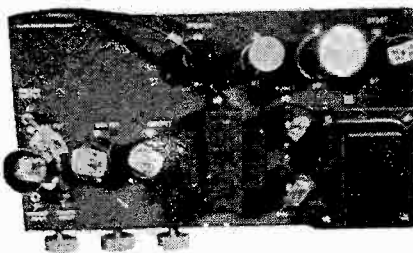

Top and bottom views of the finished amplifier. Preamp stage has been included.

Williamson circuit, which is of great importance to the stability of this amplifier. High-frequency ringing is minimized also by a capacitor bypassing the plate circuit of the stage preceding the phase inverter.

Resistance filtering is employed in the power supply. AC is used on all filaments, but hum is minimized through biasing the filament circuit with a positive voltage obtained from the output-stage cathode circuit. Instead of screw terminals, a speaker plug and socket arrangement is employed. A wire from pins 2 to 5 in the speaker plug completes the circuit of the power-transformer primary winding, thereby making it unlikely that the amplifier will ever be operated without a speaker load; apparently, the output transformer could be damaged by operation into an open circuit, and this is a clever safety device.

### Construction Notes

As we have remarked before, Knight-Kits are supplied with every component necessary to their assembly, even solder; the builder needs only simple hand tools, a soldering iron, a place to work, and the ability to follow extremely simple instructions. Sections of the instruction manual show you how to

solder wires and components to terminals, give you tips on identifying parts and determining their values, tell you what to do in case of trouble, and supply voltage and resistance charts for trouble shooting. The main body of the manual gives step-by-step assembly and wiring instructions that you check off as you go along. As a final evidence of thoughtfulness, all resistors are mounted on cards with identifying numbers printed beside them! It is almost impossible for a conscientious constructor to make a serious error. There are a few matters in which he might be helped, however, by the following notes we made as we put together the amplifier:

On pages 6 and 7, while making transformer lead connections, you may want to cut a bit off some of the leads to make them dress as shown in the diagrams. You don't have to worry about stranded leads, but the solid copper wires are covered with brown enamel. Be sure you scrape off this enamel black to about 1/4 in. from where you cut the leads; if you don't, it will be impossible to solder them.

Lengths of wires are reversed in the seventh and eighth instructions on page 8. A 2 1/2-inch length works better in

*Continued on page 36*

Fig. 2, left: Tone control and maximum power curves. Fig. 3, right: Preamp equalization, and rolloff from volume control.

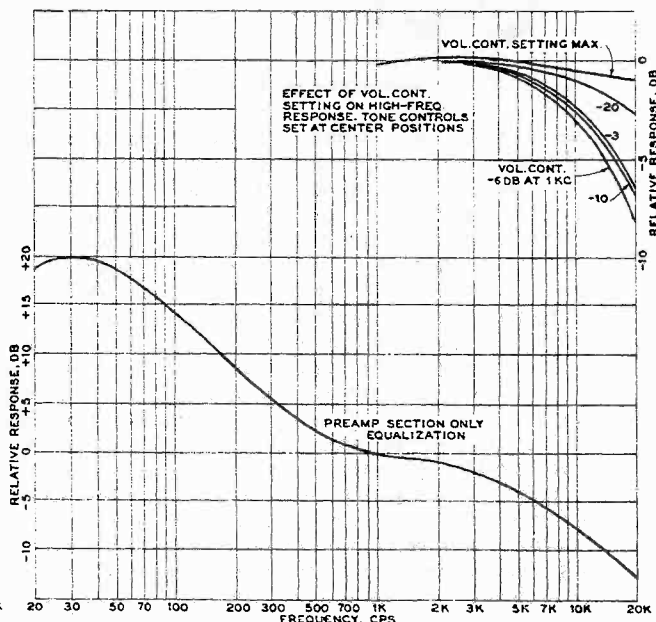
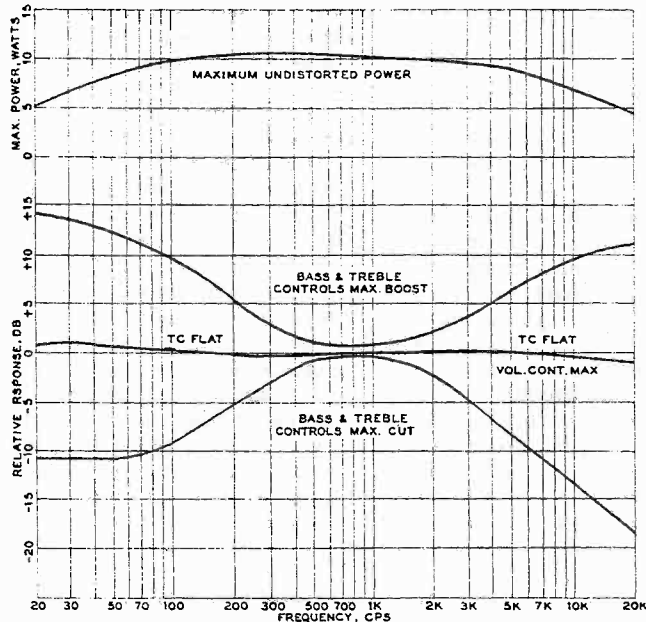

by OLIVER BERLINER

# MAINTAINING

*your tape recorder*

**B**EFORE the advent of magnetic tape, the home recorder (disc, of course) was a rare item, and a simple one. Even a low-priced tape recorder, though, is rather complicated mechanically; the user should be prepared to make routine adjustments on his equipment.

Because of the surprisingly large number of professional tape recorders

complex; but because higher-grade components are used, it is not necessarily more susceptible to failure.

Unfortunately, the average home recordist falls into one of two categories: either he overmaintains the equipment, or he undermaintains it. The latter group is more numerous but no more dangerous. Very few people follow the

of voltage applied to them. Except for the fact that they normally tend to turn in opposite directions when powered, there is no reason why these units should not be exactly the same.

The drive motor of a fully professional tape recorder is usually a hysteresis-synchronous unit, which has proved best when the tape is driven directly from the rotating shaft of the motor. A flywheel with cooling fins can be attached directly to the rotor, which is not true of the salient-pole synchronous motor. This flywheel has three important functions: it cools the motor, particularly the shaft which contacts the tape; it provides the necessary inertia to keep the tape moving evenly; and it filters out the inherent flutter of the motor.

It should be emphasized here that a synchronous motor does not eliminate flutter—it creates it! This flutter, a momentary and nonperiodic change in speed, which alters the pitch of the tones being recorded or played back, is caused by the motor's constant hunting for the proper speed. The motor's *average* speed is determined by the 60-cps power-line frequency—not by the line voltage. Consequently, a fluctuation in voltage that would tend to reduce the speed of the motor brings a subsequent reaction of increased momentary speed. This hunting effect shows up as flutter, and can be controlled only by careful motor design and installation.

It will be realized that should the hunting be reduced too much by flywheel action, the synchronous advantages of the motor will be lost. The real advantage of a synchronous drive motor is that it holds its true average speed over any given period of time, with the result that precise tape timing is made possible. This, of course, is extremely important in broadcasting and recording.

The supply and takeup motors obviously cannot be synchronous, because they must operate over very wide ranges of speed. When the recorder is in the

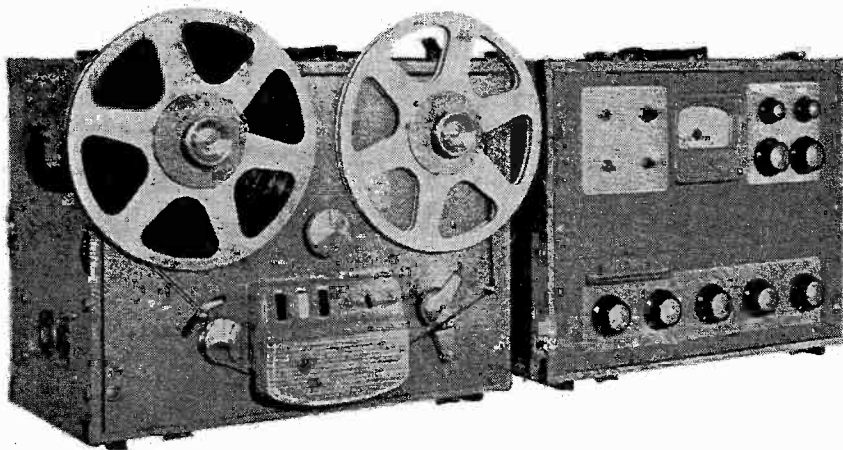

Fig. 1. The Stancil-Hoffman model R-5, typical of professional tape recorders.

used in home sound systems, I will discuss maintenance of the Stancil-Hoffman R-5 (Fig. 1) as an example of a professional machine, and the V-M model 700 (Fig. 2) as one of the better "package" recorders. Since recorders have similar maintenance procedures but divergent repair methods (for which one may have to consult the manufacturer), the scope of this article is limited to preventive maintenance and adjustment.

The professional tape recorder is mechanically far simpler (and consequently more rugged) than its low-priced counterpart. This is primarily a result of the great amount of interlocking linkage necessary to the operation of a home recorder having only one motor. Electrically, of course, the professional machine is considerably more

manufacturer's recommendations. Usually they forget that they have an instruction manual, or they lose it. The owner of a professional machine, in particular, should refer to the instruction manual and follow the recommended maintenance procedures strictly. Less detailed maintenance instructions—or none at all—are usually given with package recorders; yet they require as much or more maintenance.

Many professional tape machines, such as the R-5, contain three motors, each with virtually a single function. They can be seen in Fig. 3. The supply motor, which serves also to rewind the tape, feeds it out as the drive motor pulls the tape through at the required speed. The takeup motors are identical induction motors; their speed is, to a great extent, governed by the amount

drive position, voltage is applied to both these motors. This is often done by way of a simple voltage-dividing resistor, which takes a portion of the power-line voltage and applies it to the takeup motor while applying the remaining voltage to the supply motor. The former gets the bulk of the voltage, usually in the ratio of 3 or 4 to 1.

You will remember that the supply motor tries to turn in the opposite direction to that of the tape motion when voltage is sent to it. This pullback of the tape in drive position serves to feed the tape out very evenly and smoothly. The pull of the drive motor is stronger than that of the supply motor working against it, so the tape feeds out nicely. Since the pullback voltage applied to the supply motor is one-third its rated operating voltage or less, no damage is caused even though it is actually being pulled against its own torque.

Most motors have two oiling points: the bearings at each end of the motor. Under normal service, a small amount of SAE 20 oil of good grade should be applied once every 90 days. The capstan bearing (the capstan is what drives the tape) should probably be lubricated about every 50 hours of operation with a good grade of light machine oil. Tape rubbing over the capstan acts as an abrasive which wears it down. Check the shaft for wear from time to time.

The pinch wheel, which presses the tape against the capstan, and the filter wheel, which acts to reduce further any uneven feeding of tape by the supply motor, should normally not be lubricated. It is possible for the pinch-wheel shaft to stick in its well if the lubricant becomes gummy. Under these circumstances it will be necessary to remove the entire pinch-wheel assembly, disconnecting the shaft at the rear from the solenoid that operates it. Wipe the



Fig. 2. V-M model 700 tape recorder.

shaft and its well completely clean, put some fine oil on the shaft, and replace it. Do not overoil, or the excess may ooze out on the capstan. The pinch wheel should be reset so that it presses just tightly enough to prevent the tape

from slipping (so that the rubber is slightly indented).

Associated with the filter flywheel is a moving tape-guide arm. Its spring tension should be adjusted so that the tape wraps only slightly around the flywheel when the machine is rewinding. With too much tension the tape motion will not be normally damped; with too little tension there will not be sufficient wrap-around to gain the maximum action from the filter flywheel.

Clean the rubber pinch wheel and the capstan very often with pure alcohol. This is to reduce the possibility of tape slippage and flutter. The erase, record, and playback heads should also be cleaned frequently, always before recording sessions. This may be accomplished by gently rubbing them with a pipe cleaner or soft cloth saturated with alcohol or a good commercial head-cleaning compound.

Professional recorders operated by push buttons make use of solenoids to perform certain mechanical functions. When functioning properly, a solenoid can do a job far more quickly and more reliably than it can be done by hand. A solenoid is merely a tubular magnetic plunger surrounded by a coil. When voltage is applied to the coil, the plunger moves in a direction that would center the magnetic material in the coil; the motion is used to perform mechanical operations.

The Stancil-Hoffman R-5 recorder requires three solenoids, one being associated with each motor. Two release the brakes on the supply and takeup motors. The third pulls the pinch wheel against the tape and capstan. In the R-5 the drive motor runs continually to give an instant start to the tape. In addition, since a voltage must be applied to actuate the solenoids, the tape will come to an immediate and easy stop should power fail; that would be essential if power failure should occur during fast-forward or rewind tape motion. A fourth solenoid, unique to the R-5, pulls the tape away from the heads in fast-tape-motion positions.

About the only thing that can happen to a good solenoid, properly rated and installed, is that the plunger may eventually stick against the sides of its well. If that happens, remove the solenoid by unscrewing the necessary attached parts, take out the slug, clean it, sand it lightly with emery paper if necessary, clean the plunger and the well, and reassemble. Do not lubricate the plunger.

Some of the advanced home recorders and semiprofessional units utilize dynamic braking to stop the reels. In this method a 120-volt direct current, injected into a motor designed for alternating current operation, serves to stall the motor. The fully professional ma-

chine, however, usually incorporates a brake and lining similar to that of an automobile wheel.

To increase brake-shoe tension on the R-5, it is necessary merely to stretch the tension spring attached to the brake-actuating arm. As mentioned earlier, the brake on the motor is released by

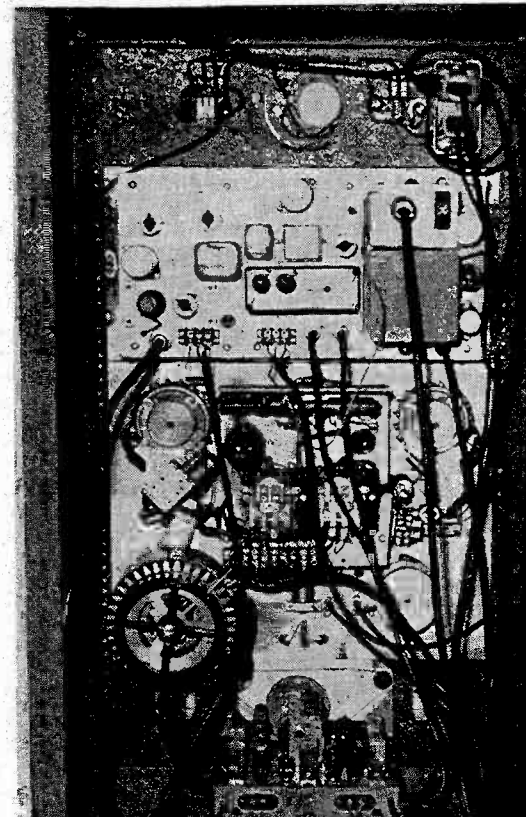
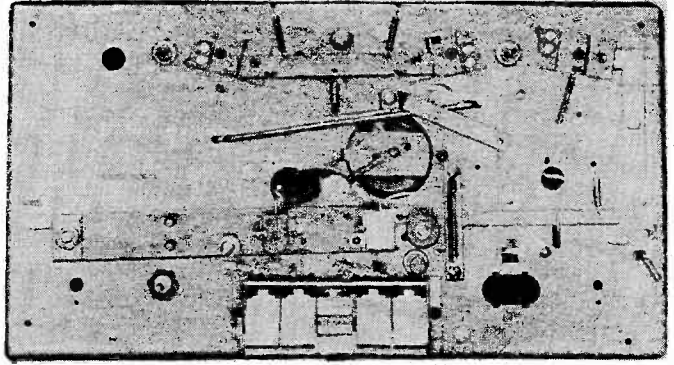
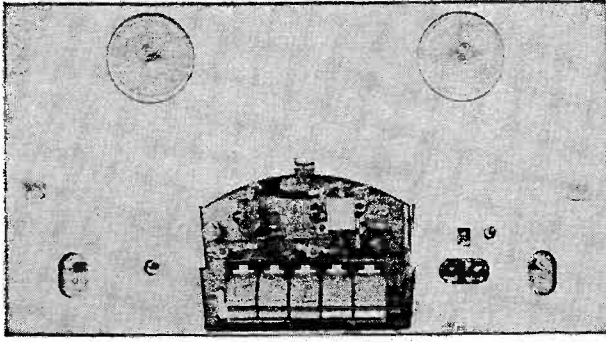

Fig. 3. Back view of rack-mounted R-5.

the action of its associated solenoid. Its position must be such that, when energized (releasing the brake), the lining of the brake will not contact the brake drum. But the solenoid must be situated close enough that its slug will not fail to pull in. A change in solenoid position will also affect brake-shoe tension. When it is no longer possible to secure correct brake action and alignment, it will be time for new brake shoes.

All mechanical fastenings should be checked from time to time, especially in portable equipment. Tighten all parts that might work loose from vibration. Relay contacts may be cleaned with a commercial cleaner or alcohol. If they are exceptionally dirty, it will be necessary to burnish them with fine emery paper. Be careful not to bend the relay springs, and remember that a relay is a switch that operates when voltage is applied to its coil by the action of another switch which you, as the operator, control. Consequently, the power to the recorder should be off when working near or with the relays.

As time passes, the heads on your recorder may slip out of alignment. This



Figs. 4 and 5. Top views of the model 700 with head cover and knobs removed, left; with entire upper panel removed, right.

is caused by the pressure of the tape as it is pulled across them, and also by vibration and jarring. Misalignment results in loss of high frequencies. Unfortunately, external equipment is required to align the heads. The subject of head alignment has been covered thoroughly in other AUDIOCRAFT articles\*.

After the heads have been properly aligned, you can make your own standard-frequency tape. Do this by recording a 400-cps signal of a few minutes' duration at 0-VU (100%) level on the meter. This will be used for setting reference level when checking playback-head alignment later on. Then record a 15,000-cps signal of a few minutes' duration at 0 VU (with the meter checking the record input level). This tape may then be played at any time, while rocking the playback head to the point of maximum signal-output level as indicated on the meter. At the same time that you are rocking the heads for alignment, you should rotate them to the points where they are making optimum contact with the tape.

A few words must be said about bias, for it is what makes high-grade magnetic recording possible. It is a low-current, high-frequency pure tone generated by an oscillator within the recorder. This is the same oscillator that supplies the erase current. The bias voltage is fed to the record head, and the tones to be

recorded are superimposed upon it. The bias signal is inaudible; it is at least five times as high a frequency as the maximum frequency to be recorded ( $5 \times 15,000 = 75,000$  cps); but without it, distortion of the audible sound would be intolerable.

A bias-level adjustment is provided on all professional tape recorders, and may be properly set with ease. Turn the master record gain control of the recorder to maximum. Then, feed a 400-cps tone from your always useful audio oscillator into the machine until the meter reads 100% (0 VU) and start recording. Switch the VU meter to monitor the tape, and bring the output level indicated on it to a reading point at approximately mid-scale. Adjust the bias potentiometer for maximum output level of the 400-cps tone, and continue turning the potentiometer in the same direction until the signal level on the meter drops back one decibel (1 db). The bias is then properly adjusted for that brand of recording tape; should you change brands, it may become necessary to reset the bias.

Certain of the maintenance procedures for professional recorders may be applied to home recorders such as the V-M 700. It will be remembered, though, that recorders of this type contain only one motor (a relatively inexpensive and lightweight unit), usually no solenoids or relays, and no electric push buttons. As a result, a relatively complex mechanical linkage system is required in order to perform the necessary functions easily and simultaneously,

and to make the operation of the machine as foolproof as possible. From time to time, certain assemblies may require adjustment.

Since in a home recorder (Fig. 4), the record and playback heads are one and the same (the second head is for erase purposes), the two will always be in relative alignment. Indeed, the only need for head alignment is for playing tapes made on another machine, or commercial recorded tapes. To align the record/playback head, it will be necessary to use a standard-frequency tape that was made on a perfectly operating professional machine. These alignment tapes are commercially available. With the home recorder set for  $7\frac{1}{2}$ -ips operation, the 15,000-cps tone on the standard tape will drop to 7,500 cps, which is suitable for checking such a unit.

To set the head properly, put the recorder in playback position and run the standard-frequency tape through it. Loosen slightly the two hex nuts that hold the head to the mounting plate on its left side. Gently rock the head until a point of maximum loudness is reached. Carefully tighten the head at this position. As the neon-lamp volume-level indicator is not suitable for critical level adjustments, a voltmeter attached to the output of the recorder may be required for precise settings.

The 700's entire head and pressure-roller (pinch wheel) assemblies are mounted on a moving head bar, Fig. 5. In the drive position the heads are moved against the tape while simulta-

*Continued on page 40*

\*J. Gordon Holt, "Tape News and Views," AUDIOCRAFT, I (Mar. 1956), p. 12; Herman Burstein, "Checking Your Tape Recorder," AUDIOCRAFT, I (May, 1956), p. 34.

Figs. 6 and 7. Lower views of 700, showing complex pulley-and-belt drive system. Single motor is removed in Fig. 7 (right).

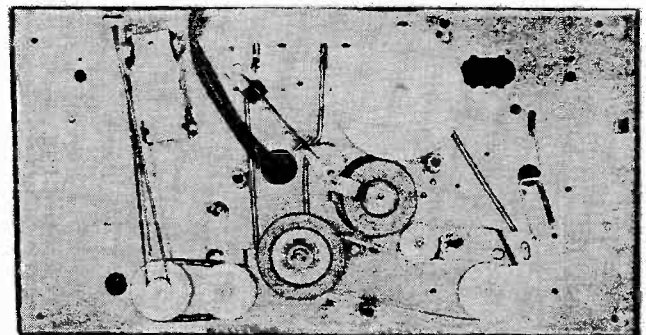
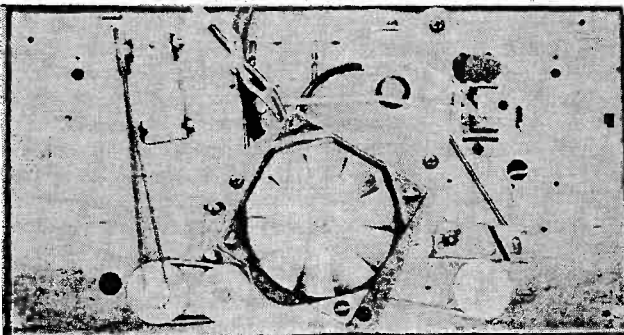

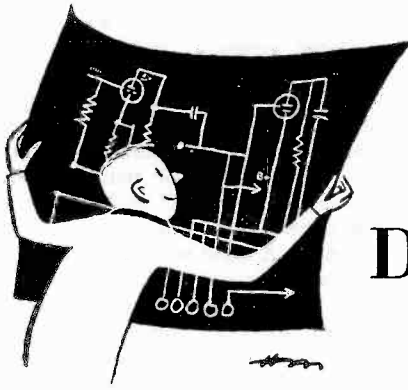

# Designing Your Own Amplifier

by Norman H. Crowhurst

## Part VIa: Special Output Circuits

THE part of amplifier design that has always posed the biggest problem is the output circuit—how to get enough power with low distortion and a satisfactory value of source resistance, or damping factor. To illustrate this problem in more detail, we will try various methods of connection for the 5881 tube as a basis for comparison.

### Triode Connection

Consider first the straight triode connection shown in Fig. 1, with a plate voltage of 400, a fixed bias of 45 volts, and a plate-to-plate load of 4,000 ohms. This is the condition known as class AB<sub>1</sub>, or "low-loading". The reason for the second name is that the load resistance is much lower than the original value intended for class A operation; its advantage is that a greater maximum output can be obtained.

Fig. 2 shows the load line applied to the characteristic curves of a single tube. The solid straight line represents a resistance of 1,000 ohms, which is how 4,000 ohms plate-to-plate appears to one tube; the dashed curved line repre-

sents the load line for this tube, the other tube being complementary so as to produce the straight line as a composite.

From the composite line we can obtain plate-voltage swings (for positive grid excursions from the 45-volt bias point) of 48 volts, 104 volts,

$$\frac{(162)^2}{2 \times 1,000} = 13.1 \text{ watts.}$$

The tube manual quotes a value of 13.3 watts for the same operating conditions, which is near enough to the same answer.

A mathematical analysis of this amplification, based on the three points obtained, gives the distortion figures as 3.3% third and 1.25% fifth harmonic. The method of deriving these figures involves trigonometry and is too involved to go into in detail here. Taking the RMS combination of these two components the total harmonic distortion will be  $\sqrt{(3.3)^2 + (1.25)^2} =$  about 3.5%. The tube manual quotes 4.4% for 13.3 watts. Later in this article we will show a simple graphic method of estimating the amount of distortion.

The source resistance we can calculate from the slope of the -45-volt curve where it intersects the dashed load line. If we draw a tangent through this point of the curve it will pass through 340 volts at zero ma, and 620 volts at 100 ma. This represents a resistance of 2.8 K. As the slope of the composite curve will be twice as steep at this point, this will become 1.4 K at the center point on the load line. This is referred to one half of the output winding and, referred to the 4,000 ohms plate-to-plate, would be 4 times this value, or 5.6 K. So the source resistance, in this case, is about 1.4 times the load resistance.

To produce an output stage that is acceptable by modern standards we must reduce the amount of distortion (quoted as 4.4%), and also the source resistance. This output stage requires a peak-to-peak swing on each grid of 90 volts, for which purpose the previous stage should also be of a push-pull variety, using a low- $\mu$  twin triode. Therefore the grid drive to this

previous stage, without feedback, must be of peak-to-peak amplitude somewhere between 5 and 10 volts.

To obtain adequate feedback over the two stages (which is recognized to be an ideal arrangement from a stability standpoint) we will have to inject some 10 to 50 volts peak-to-peak in the cathode circuit of this drive tube, according to the amount of feedback considered desirable. The cathode resistor of this stage, across which the feedback

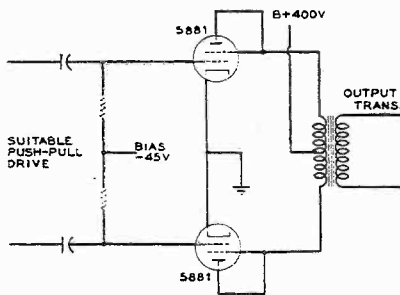

Fig. 1. Schematic of output circuit, using two 5881 tubes as triodes. Note that screens are connected to plates.

previous stage, without feedback, must be of peak-to-peak amplitude somewhere between 5 and 10 volts.

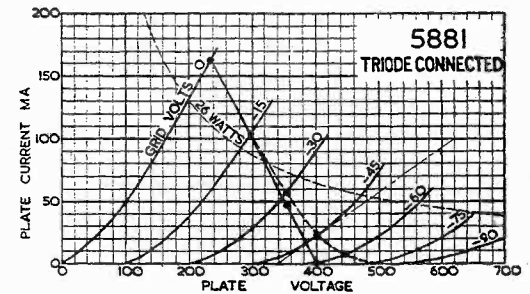

Fig. 2. Characteristics of 5881 tube triode-connected, with load line to illustrate this method of operation. The solid straight line is one half of the composite line for a plate-to-plate resistance of 4,000 ohms. The dotted curved line represents the load component of this composite on the single characteristics shown. Dots on the composite line are projected downward from the intersection with the curved line. The curved line is plotted in the manner described in the article on push-pull operation. Also shown is the maximum dissipation curve, at 26 watts.

voltage must be produced, is probably on the order of 2 K.

If we take the feedback from the plate circuit of the output tubes, the resistors necessary to produce such a large voltage on the cathode of the drive stage will have to be physically large enough to dissipate one or two watts. More important, the output tubes will no longer have 13 watts available for the external circuit, because one or two of them are expended in the feedback.

If we consider taking the feedback

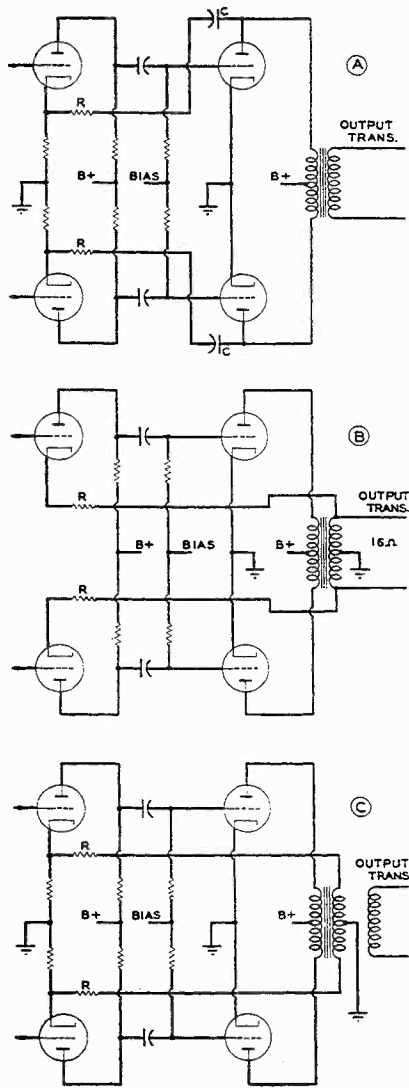

Fig. 3. Different methods of applying feedback over two stages: at A the feedback is taken from the plates of the output tubes, requiring a relatively large value of blocking capacitor, C. Resistor R has to dissipate a considerable proportion of the output power to achieve the desired amount of feedback. At B the feedback is taken from the 16-ohm winding of the output transformer, which is here center-tapped. Resistors R may be necessary to provide the correct bias for the drive stage, but will not contribute to the feedback performance appreciably. At C is a better arrangement than either A or B, but this requires a special output transformer.

from the transformer secondary, using the 16-ohm winding which is usually the highest impedance available, the peak-to-peak voltage developed by 13 watts across 16 ohms is just over 40 volts. This may be sufficient for the purpose, but it is evident that no series resistor can be used, so the 16-ohm winding must be directly coupled to the cathode of the drive stage. This too can involve undesirable complications.

The problem appears to arise with

triodes because the plate-circuit impedance is too high and the secondary-circuit impedance is too low. A compromise that has been adopted by some manufacturers utilizes a special feedback winding with an intermediate number of turns. This obviates the necessity for the large-value blocking capacitor, and reduces power dissipation involved in feeding back from the plate circuit, yet permits use of some isolating resistance.

The foregoing comparison is illustrated in Fig. 3. An obvious snag is that a special transformer must be procured. Consequently, this method is readily available only to manufacturers having facilities for producing transformers with custom specifications. For

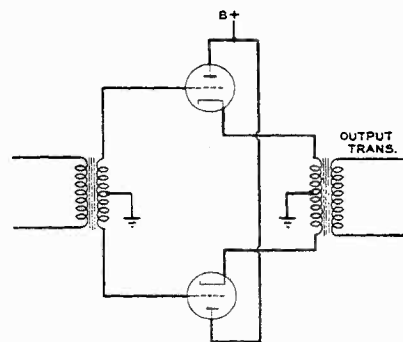

Fig. 4. Use of triode tubes in push-pull cathode-follower connection. As shown, the tubes are assumed to be biased by the DC resistance of the output-transformer primary halves. This may need additional resistance, or fixed bias can be applied to the center tap of the drive transformer, instead of returning it to ground. A drive transformer is the only simple way of getting sufficient swing for a cathode-follower stage, without using a higher B+ for the drive stage.

that reason we will not pursue the discussion of this arrangement further.

Before leaving it, however, we may add that the method is equally applicable to pentode or other methods of connection as output stages. As might be expected, because the pentode has a higher gain than a triode, the previous stage needs to give much less swing to obtain maximum output and this in turn means that a smaller voltage, tapped off from the output, will give a corresponding amount of feedback. What offsets this fact is the high plate resistance of the pentode, which means that a much larger amount of feedback must be used to obtain a satisfactory damping factor.

### Cathode-Follower Output

The next circuit we shall consider here is the cathode follower, because this has several variants that we can discuss later in the article. Fig. 4 shows the arrangement of the cathode follower for a triode output.

Since the plate-voltage swing is now developed across a load connected in the cathode circuit, the grid has to be driven by a voltage made up of the former plate-voltage swing added to the normal grid swing given by the load line. This is a total swing in each direction of  $162 + 45 = 207$  volts: a peak-to-peak drive of 414 volts for each tube. A drive stage using the 400-volt plate supply we have assumed would obviously need a transformer to produce this much voltage.

The stage now requires a grid-voltage swing of 207 volts to produce a grid-to-cathode swing of 45 volts, which represents a feedback ratio of 4.6. Thus the original distortion figure of 4.4% will be reduced to less than 1%.

Now, how about the source resistance? Consider the operating point for 15 volts positive swing; that is, the -30-volt point on the composite load line. This gives 354 plate volts at 48 ma. A negative grid swing of 15 volts from this point brings us to the operating point where the resultant plate current is zero. Assuming that the actual volts on the grid are maintained the same (that this change of condition is brought about by a change of cathode voltage) the plate-to-cathode voltage will now have dropped 15 volts, from 354 volts to 339 volts. Referred to the 1,000-ohm load impedance presented by one half of the output winding, the source resistance gives a change of 15 volts for 48 ma, representing about 312 ohms. This is 1,250 ohms cathode-to-cathode; the source resistance is a little less than  $\frac{1}{3}$  the load.

### Pentode Connection

Fig. 5 shows a pentode connection of this same tube. The composite load condition for one tube is shown in Fig.

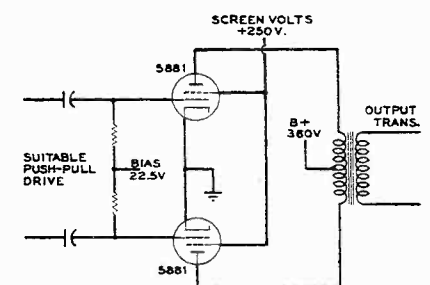

Fig. 5. Schematic of output circuit, using 5881 tubes as tetrodes (commonly called pentodes, because of the similarity of the operating characteristics).

6, assuming a screen voltage of 250 with a plate voltage of 360. The nearest values to this given in the tube manual listing are a plate voltage of 360 and a screen voltage of 270, with the same bias voltage of -22.5. Tube characteristic curves for a screen voltage of 270 are not available, so we compute the



results from the tube curves for the screen voltage of 250, using the plate-to-plate resistance of 6.6 K quoted in the tube manual.

The load-line slope is drawn at 1.65 K. Peak plate-voltage swing is 280, which represents an average output of 23.7 watts, compared to the 26.5 watts quoted in the manual. This seems to be consistent with the difference in screen voltage from 250 to 270.

A mathematical computation from the points on the load line given yields harmonic distortion figures of 2.5% third and 1.5% seventh, a total of 2.9%. The tube manual gives 2% for the screen voltage of 270.

To quote a source resistance for this form of output is somewhat meaningless, because the slope of the tube characteristics varies all the way up the load line. We can apply the cathode-follower connection to the pentode circuit by the arrangement shown in Fig. 7, however, in which case the feedback tends to hold the source resistance more constant. Consider a 2.5-volt change near the operating point. From the characteristics it may be seen that this gives a current change of 22 ma for a voltage change of 2.5 volts, representing an impedance of about 114 ohms, or 450 ohms cathode-to-cathode.

In this case the input swing required is 280 volts cathode swing, plus 22.5 volts grid-to-cathode swing, giving a total of 305, or 610 peak-to-peak for each tube. This is an even larger requirement than for triode operation. But since we are using 305 volts peak to obtain a 22.5-volt effective swing, the feedback ratio is 13.5. This means that the distortion figure of 2.9% will be reduced to about 0.22%.

To operate a pentode as a cathode follower, the screen voltage has to swing exactly with the cathode voltage to keep the cathode-to-screen potential constant. In a voltage-amplifying stage this could probably be accomplished by decoupling the screen to cathode rather than ground, but in a power stage the only feasible way to achieve this end is by use of a transformer with an extra winding, as shown in Fig. 7.

The cathode and screen windings

Fig. 6. Characteristics for 5881 tube for operation in circuit of Fig. 5. Method of derivation is similar to that in Fig. 2.

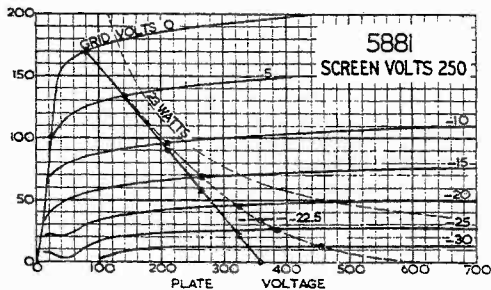

should be extremely tightly coupled so as to avoid any difference in voltage between cathode and screen at any point

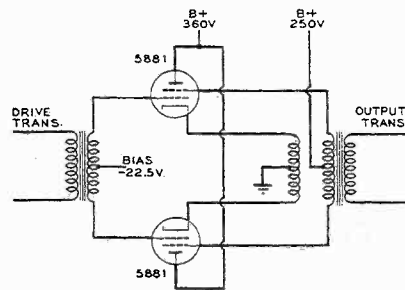

Fig. 7. This circuit arrangement can be used to operate the output tubes as pentode (strictly, tetrode) cathode followers, with the same operating conditions as shown in the load line of Fig. 6.

in the frequency spectrum. A difference in voltage at this point would result in serious distortion because of the extreme nonlinearity of screen current

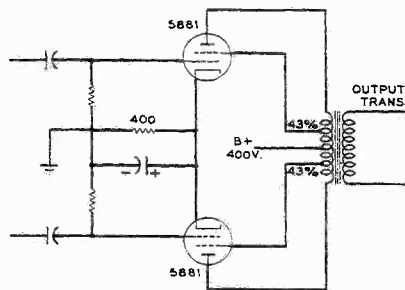
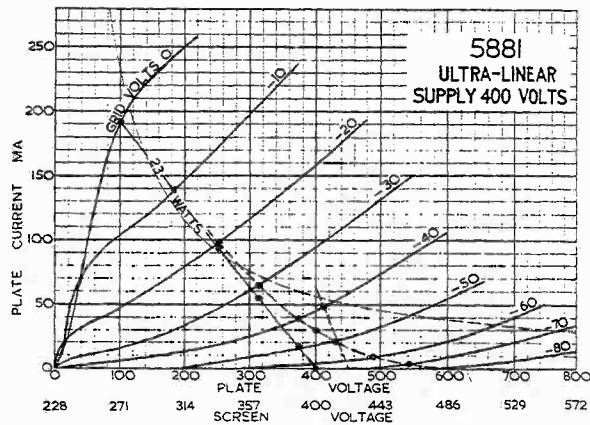

Fig. 8. Schematic of circuit for operating 5881 tubes in the ultra-linear circuit. This particular arrangement uses cathode bias, but fixed bias can also be used. As explained in the text, the ultra-linear operation is not so critical.

with screen voltage. To the best of my knowledge, the cathode follower pentode output is not used. But we will consider later a circuit that is used, and which may be considered to be derived from it.

Fig. 9. Tube characteristics for ultra-linear operation with a supply of 400 volts (plate or screen to cathode). The curves were plotted by reducing the screen voltage from 400 by 43% of the reduction used for the plate (increase same way). Composite and individual load lines are also shown, as for triode and pentode operation.



### Ultra-Linear Circuit

The third operating condition for output tubes is becoming popular for good

reason. From discussions of triode and pentode operation it seems that neither is exactly ideal. It is obvious that a method of operation lying somewhere between these two extremes might be optimal. This is precisely what the ultra-linear or tapped-screen method of operation achieves.

The circuit is shown in Fig. 8. Static tube characteristics for this connection, as published by Tung-Sol, are illustrated in Fig. 9. Ultra-linear operation is fairly simple to understand by comparison with triode and pentode operation. In a pentode circuit, the screen voltage is held constant while the plate voltage is allowed to swing according to the grid-voltage drive. In a triode-connected pentode, the screen is strapped to the plate; hence, its voltage swings by precisely the same amount as the plate voltage. Ultra-linear operation splits the difference and, in the case of the curves shown in Fig. 9, the screen voltage swings by 43% of the plate voltage.

This is achieved in practice by using 43% taps on the plate winding for connecting the screens. The value of the optimal tapping for different tube types will vary somewhat, but 43% has been found ideal for quite a variety of tubes. The ultra-linear circuit (Fig. 8) uses automatic bias, so the bias will change somewhat from zero to full output.

The sloping dashed line in Fig. 9 shows the condition for zero signal. The slope of this line represents a resistance of 800 ohms. Bias-resistor value is actually 400 ohms, but since the current from both tubes passes through it, this can be regarded as representing 800 ohms per tube. The quiescent operating position is thus found to be about -40 volts bias with almost 50 ma plate current in each tube.

Bias at the maximum drive condition rises to about -45 volts. The plate cur-

rent swings from 30 ma per tube, or 60 ma total (where the cycle passes through the operating point), to a peak

Continued on page 40

# Expandable Custom Chassis System

One of the most useful ideas we've seen for the audiocrafter is the SeeZak line of custom parts for chassis, made by U.M.&F. Manufacturing Corp. With these components, as shown in the photos, any chassis can be made up without hole punching; parts can be disassembled and re-used.

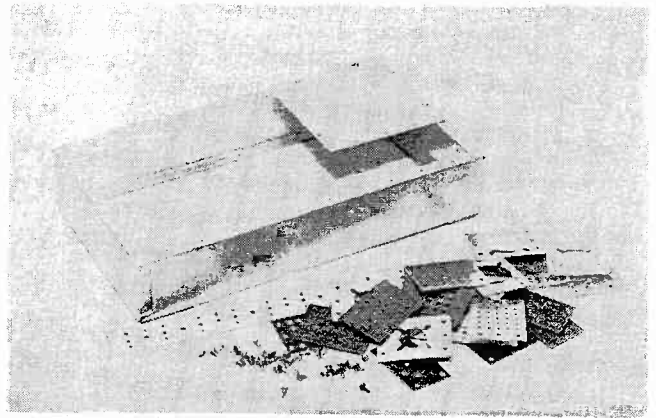

*How a customized chassis is assembled. Side rails of*

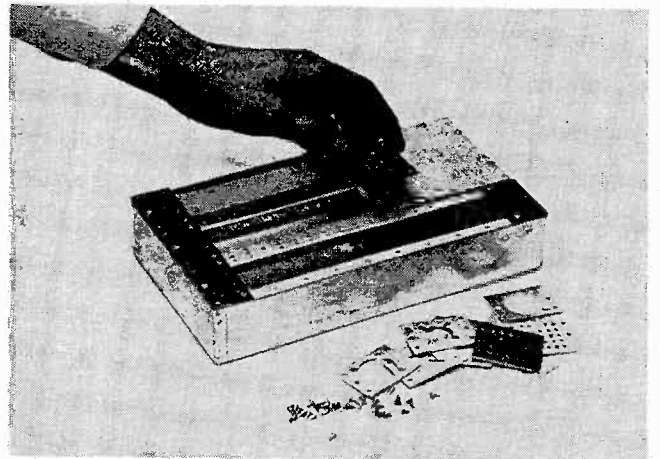

*proper size are snapped together, body angle supports*

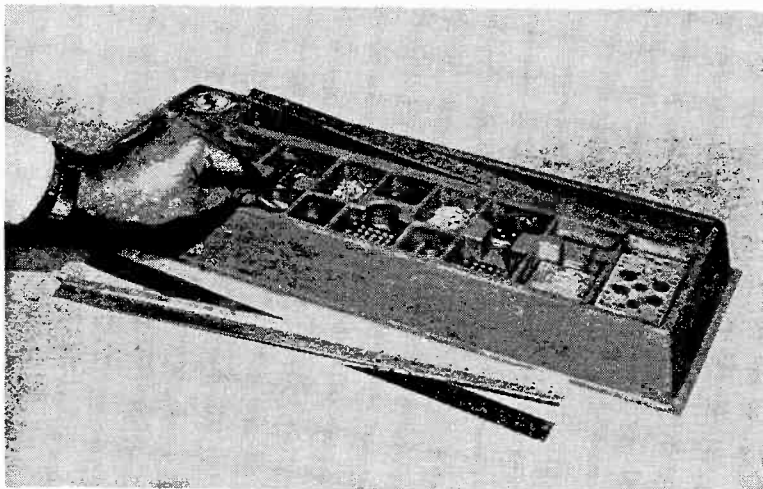

*Starter Kit contains assortment of parts in plastic dispenser.*

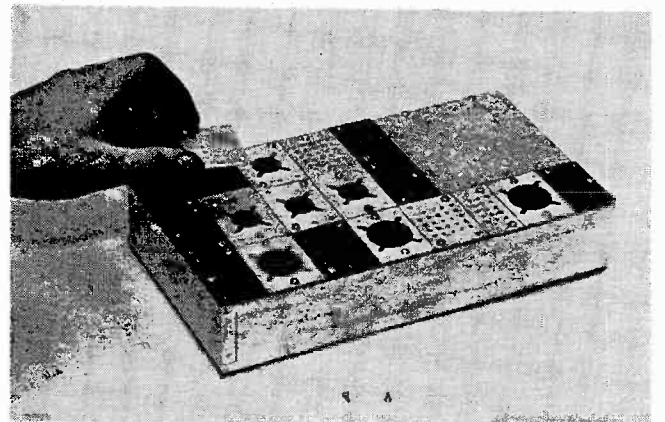

*are added, and appropriate plate modules are attached.*

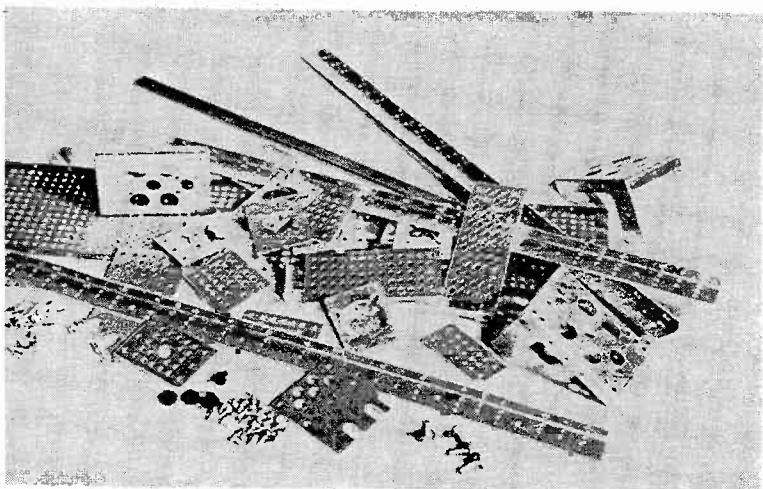

*Standard SeeZak circuit assembly parts are available for just about any conceivable purpose—even end brackets for rack panel mounting.*

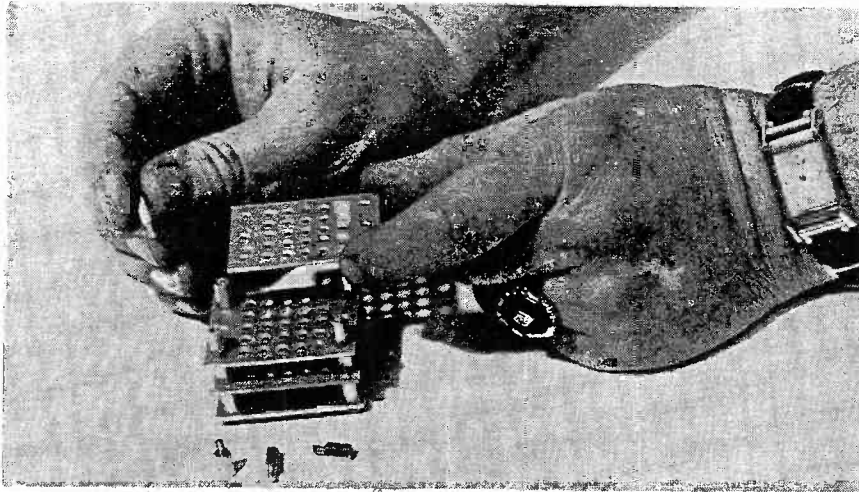

*Double-threaded standoffs can be used for multideck assemblies.*

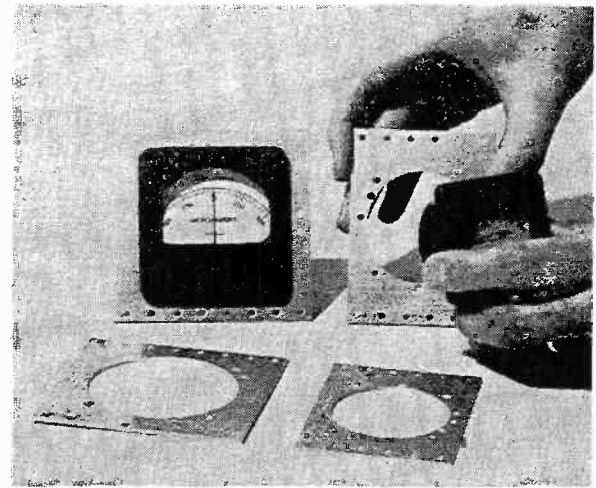

*Mounting plates for 2½ and 3½-inch meters.*

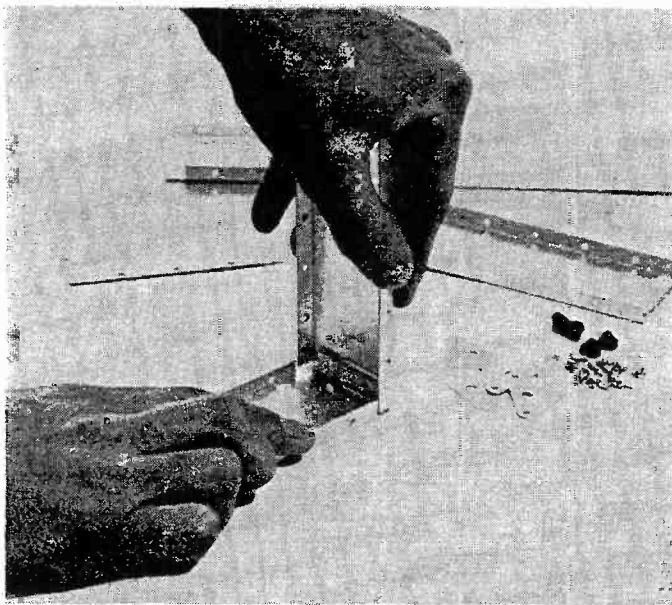

*Chassis side rails simply snap together, can be taken apart easily.*

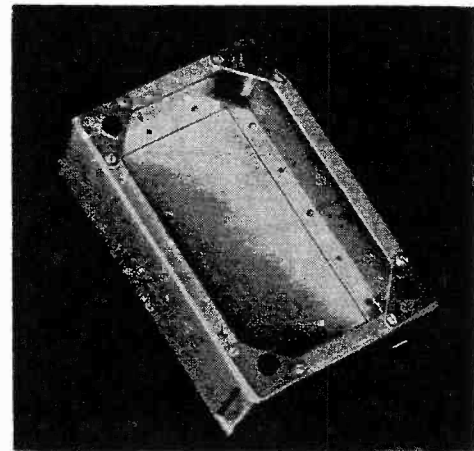

*Rubber-tipped feet add a final custom touch.*



*Solder tie points can be inserted with a screw driver.*

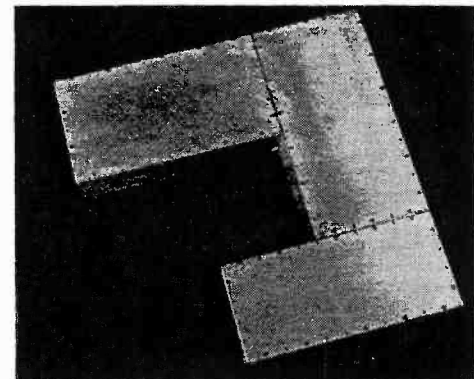

*Practically any chassis shape can be achieved.*

# TRANSISTORS *in Audio Circuits*

by PAUL PENFIELD, JR.

*IVa: Biasing the Transistor*

**T**RANSISTORS, like vacuum tubes, must be biased. That is, they must have certain DC voltages and currents supplied to them. The audio signals of interest, which are AC, are superimposed upon the DC.

AC amplification is very much dependent on the particular point chosen for the DC bias level, or the quiescent point. Determining the best quiescent point is often difficult, as is finding the best circuit to give that bias. In this installment we'll show how to bias the transistor for Class A grounded-emitter operation, which is in almost exclusive use in audio circuits.

The easiest way to specify a quiescent or no-signal condition is to point to it on a graph. Fig. 1, which was discussed at length last month, is the grounded-emitter collector family. A quiescent point such as that labeled *Q* on the graph is determined by its co-ordinates—that is, so much collector current, and so much voltage between collector and emitter. Once these two have been determined, the base-to-emitter voltage and the base current are automatically

set, for only one value of each can satisfy the chart curves for a given combination of  $I_c$  and  $V_{ce}$ .

Quite often the variables that are specified at will to determine the quiescent point are collector-to-emitter voltage and base current. Then the base voltage and collector current are automatically determined.

## Graphical Analysis

Unfortunately, the volt-ampere curves for the transistor cannot be written down easily in mathematical form—

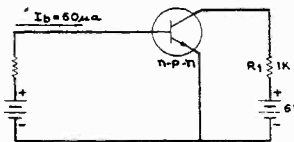

Fig. 2. Very basic transistor amplifier.

that is, no mathematical formula can be found that expresses the collector current in terms of the collector voltage and the base current. Such information can be specified only in graphical form, as in Fig. 1. This means that

ordinary circuits cannot be solved mathematically, but rather must be worked out by using a graph.

The same difficulty exists with vacuum tubes, and many of the same methods apply to transistors. We will work out a few examples here of this graphical procedure. Readers who are familiar with graphical analysis of this sort may want to skip these four examples. Examples are used because they illustrate the principles best.

*Example 1.* Consider the circuit in Fig. 2. Here the base current  $I_b$  is specified as  $60 \mu a$ , the supply voltage  $E$  is 6 v, and the load resistance  $R_1$  is 1,000 ohms. Let's solve this circuit graphically.

What do we mean by solving it? We mean determining all the voltages and currents of interest. Specifically, that means finding the quiescent point—the collector current  $I_c$  and the collector-to-emitter voltage  $V_{ce}$ .

The circuit can be expressed as a sum of voltages:

$$V_{ce} + I_c R_1 = E \quad \dots(1)$$

This gives us one relationship. We get

Fig. 1. Quiescent operating point (*Q*) discussed in the text.

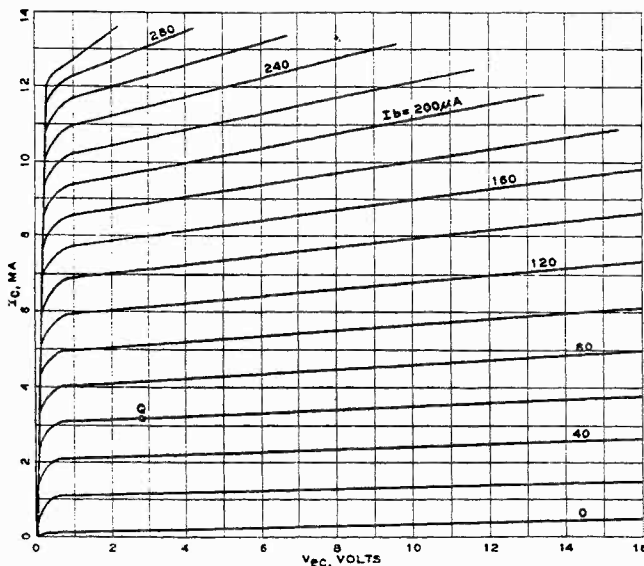
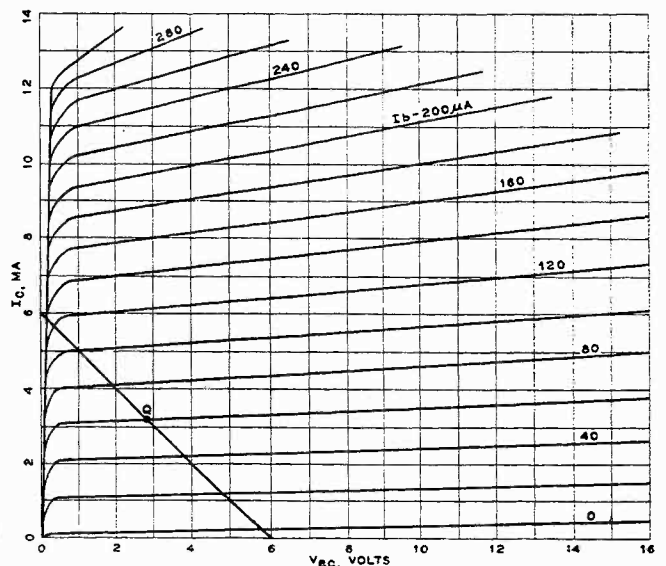

Fig. 4. Combining Figs. 1 and 3 solves circuit in Fig. 2.



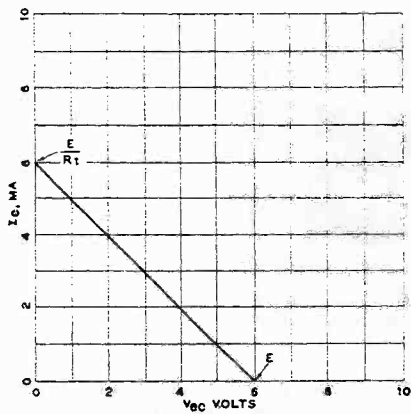

Fig. 3. Charting load line for Fig. 2.

another from the curves in Fig. 1. The point that satisfies both relationships is the quiescent point.

Now, the value of  $I_c R_1$ , the voltage drop across the resistor, is directly proportional to  $I_c$ . That means the graph of this function will be a straight line. Let's rearrange Eqn. (1) into

$$I_c = \frac{E - V_{ec}}{R_1} \quad \dots(2)$$

and plot this function of  $I_c$ . The graph looks like that in Fig. 3. The line

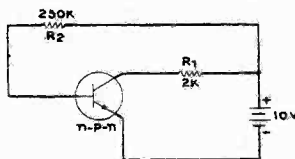

Fig. 5. Circuit for the second example.

slopes to the left because of the minus sign in Eqn. (2), and starts off at E, because  $I_c = 0$  when  $E = V_{ec}$ . Further, it is clear that  $V_{ec} = 0$  when  $I_c = E/R_1$ , or 6 ma, so this is a known point. Between these two points the straight line is drawn.

What we have done is put Eqn. (1), essentially an algebraic equation, into

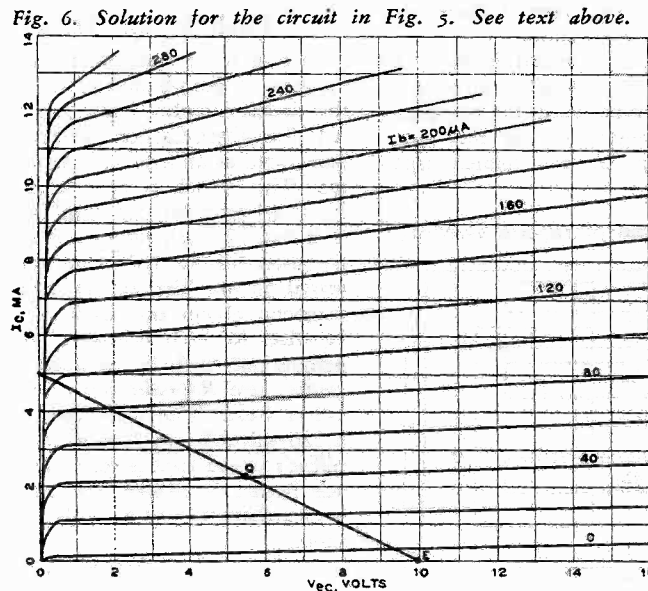

Fig. 6. Solution for the circuit in Fig. 5. See text above.

graphical form. This is necessary because the rest of the information about the circuit is in graphical form.

The way to solve these two graphs (Figs. 1 and 3) is simply to see if there are any points which lie on both of them, and therefore satisfy both relationships. Superimposing Fig. 3 on Fig. 1 yields Fig. 4.

Now the base current is determined by the circuit as being  $60 \mu a$ ; therefore, only points which lie on the line of  $60 \mu a$  base current will satisfy the circuit. And only points which lie on the line of Fig. 3 satisfy the circuit. The one point which lies on both lines is of course their intersection, labeled Q in Fig. 4.

The straight line in Fig. 3 is called a load line because its slope is determined by the value of the load resistor.

If we change the base current from the value given, we still remain on the same load line, but slide up and down it depending on what the base current happens to be. For a base current of  $120 \mu a$ , we'd travel on the load line almost up to saturation. And a base current of zero would take us down almost to cutoff.

Example 2. Fig. 5 is almost the same, except that we have to determine the base current from the circuit.

Again, we construct the load line as in the previous case, but the slope is different and the starting point of 10 v is different. Now the base current is determined very easily by making an approximation. Remember that, since the emitter junction is biased in the forward direction, the base-to-emitter voltage is generally very low. For low-power transistors it is less than half a volt. This voltage will be much smaller than the voltage drop across the 250-K resistor. For practical purposes the current that flows in the base is determined solely by the battery and the

series resistor, and is  $10/250,000$ , or  $40 \mu a$ .

Once the base current is determined, the quiescent point Q is known also, since we already have the load line drawn on the collector family (Fig. 6).

Example 3. We have solved two problems in analysis of circuits that already exist. Now let's build up a circuit to fit the quiescent point shown

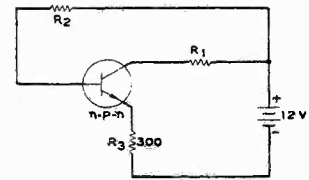

Fig. 8. Built-up circuit for example 3.

in Fig. 7, making it of the configuration shown in Fig. 8. In other words, let's find values for  $R_1$  and  $R_2$  in the circuit.

Here we have a resistor in the emitter circuit, as well as in that of the collector. How do we draw the load line? We can make a helpful approximation. Because the base current is only about 1/50 the collector current, we say that the emitter current is roughly equal to the collector current. For high-gain transistors this is a very good approximation.

Since this is so, the voltage across the transistor will be just the supply voltage minus the two resistor voltage drops, and each voltage drop will be that resistance times the collector current. In short, the two, because of the assumption we made, act together like one resistor whose value is the sum of the two shown. And the load line this time has a slope determined by the sum of  $R_1$  and  $R_2$ .

Drawing in the actual load line (determined by points Q and E), we see

Continued on page 42

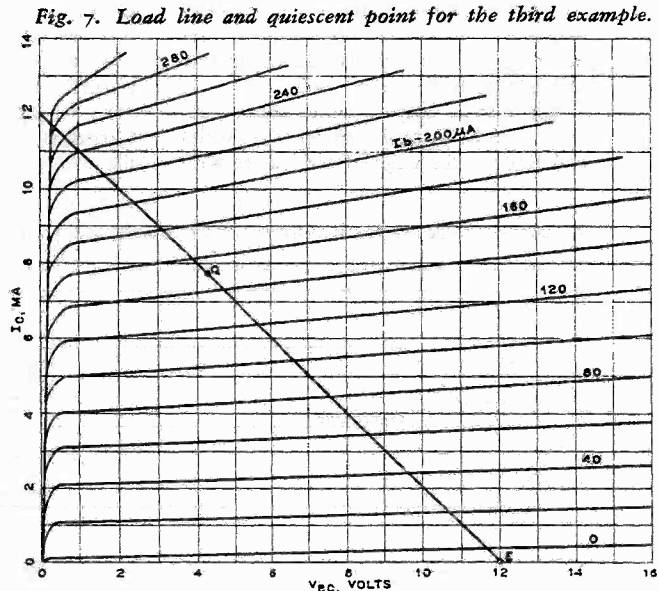

Fig. 7. Load line and quiescent point for the third example.



### Soldering-Iron Dip

The tips of soldering irons and guns invariably become oxidized after being maintained at normal operating temperatures for extended periods of time. The usual remedy is to re-tin the copper tip periodically. A simple expedient which will significantly reduce the frequency of reconditioning is to plunge the tip of the iron or gun in water immediately after the completion of each soldering operation. In tin shops where corrosive agents are not a particular problem, the tinsmith usually dissolves a small quantity of sal ammoniac in the dip to keep the tip of his iron bright. In electronic work the use of this salt is not advisable and, furthermore, plain water is nearly as effective for this purpose.

John E. Turner  
Twin Falls, Idaho

### Overhang Gauge for Pickup Arms

Pickup arms should be mounted with a specific overhang (within 1/32 in.) to avoid distortion and record wear. An overhang gauge, as shown in the detail drawing, is extremely helpful in mounting a pickup arm properly. The gauge is easy to make, consisting of a plastic or wood strip with a hole to fit the center post of the turntable. Two scales graduated in 64th's of an inch are mounted so that the one-inch marks coincide with the center hole.

Slip a small strip of white paper (cut from a 3-by-5 card) under the scales and line up the edge of the paper with

the desired overhang dimension. Place the gauge on the turntable with the pointer directed to the pivot of the tone arm. Locate the pickup arm so that the diamond is in line with the edge of the paper, using a magnifying glass.

This gauge is also handy for testing various overhang settings for best performance. The information supplied by many manufacturers of tone arms is sometimes very vague and yet it is most important to operate pickup arms with the ideal overhang.

Frank J. Lyden  
Manitowoc, Wis.

### Phono-Plug Handle

A practical way to improve the lowly phono plug is to put a handle on it. Cut a thin strip of sheet copper or tin about 3 in. long and from 1/8 to 3/16 in. wide, and bend it in an almost closed circle. The last 1/4 in. of each end should be parallel to the other, with about 3/8 in. space between. Tin both ends of the strip and each side of the phono plug; then solder the phono plug between the ends of the strip.

John R. Bautts  
Fresno, Calif.

### Cuing Magnetic Tape

Cuing magnetic tape properly is a problem faced by all tape recorder owners. Usually a series of passes is made before the selection is found.

A simple cuing method is to stick a small strip of colored Scotch tape (the 1/4-inch type used in wrapping Christmas packages) on the reel web, the outer edge of the colored tape

being placed at the desired cuing point. When the reel is spinning on fast speed, a colored circle is seen and the recorder can be stopped when the tape reaches this circle. The selections thus cued can be noted on the reel box with their corresponding colors. The color tape can easily be moved and, in addition, acts as a reminder that the reel has recorded material on it.

Jewett E. Richardson  
Atlanta 18, Ga.

### Heavy-Walled Enclosure

The big corner speaker cabinet designed by Briggs does a magnificent job of bringing out the best in a speaker. It is a simple bass-reflex design and is easy to build except for providing the heavy walls. Briggs advocates double walls filled with sand to supply the weight necessary to avoid resonance.

A much easier way is to use plasterboard. Build the cabinet of 3/8-inch plywood panels and then cut the plasterboard to fit on the inside of the panels and cement it to the plywood with linoleum cement. This bonds the plywood to the plasterboard to form as rigid a wall as you could want, and it supplies the weight to prevent vibration.

Alfred Larson  
Temple City, Calif.

### Push-Button Hi Fi

I am sure many audiophiles have often dreamed of push-button hi fi. To make this dream a reality I salvaged from an old Stromberg-Carlson a push-button panel used as an automatic station selector. This panel is now used as the input selector for my amplifier.

It has 12 push buttons, 3 of which are used for an FM tuner, tape, and crystal phono. The rest are used for the magnetic phono equalizers, a different equalizer for each switch, following the designs put forth in the book *The Recording and Reproduction of Sound*, by Oliver Read. The remaining switch is a 120-volt AC switch to which the amplifier's power cord is connected. When any button is pushed, the amplifier is automatically turned on with the desired input.

George H. Covey III  
Katonah, N. Y.

*A home-made gauge for measuring and adjusting accurately your pickup-arm overhang.*

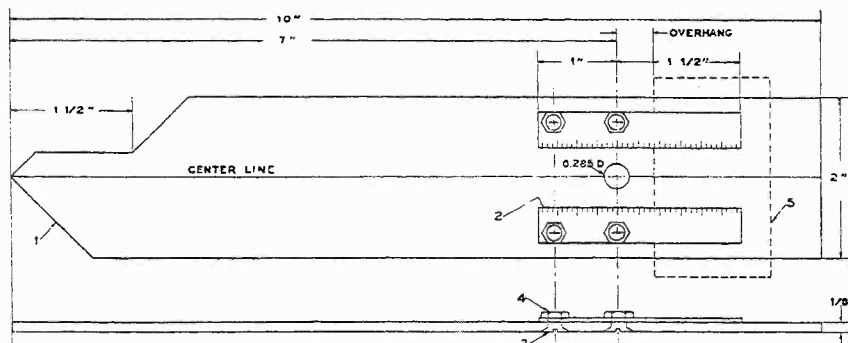

## Salvaged Transformers

Next time you want to use a transformer salvaged from equipment no longer in use and find that the leads have been cut too short for the new application, try this stunt. Mount 2 or 3 multiple-contact tie-point strips on the transformer mounting screws underneath the chassis. Run the short transformer leads to these tie points, and then make the appropriate connections to the other components.

L. E. Johnston  
Madison, Wis.

## Turntable Speed Check

Most turntables and record changers now come with either built-in strobe discs or have one that can be slipped over the spindle to check the speed. The bar or dot pattern isn't too clear under normal incandescent lighting, however.

I solved the problem by mounting an ordinary Drake neon indicating light, Type 110, called the *Flashlite*, in a discarded pocket flashlight of the type women often carry in their purses. To this flashlight I added a cord and plug. The flashlight case was plastic and with well taped leads presented no insulation problems. Just plug the unit into a convenient outlet and you have a handy speed-check light.

Alex Thien  
Milwaukee, Wis.

## Cleaning Audio Equipment

One of the characteristics of equipment in the early days of hi fi was the open chassis. Today's slick packaging is getting away from the open equipment that sat around on our shelves in the late Forties, but this caution still applies to audio equipment, enclosed or not, shelved or in a cabinet. An annual cleaning of all equipment is a good idea, particularly where tuners are concerned. The best procedure is to get the equipment out on an open bench and use a soft cloth and a small, soft-bristled (camel's hair preferably) artist's brush and clean away the accumulated dust on the chassis, around the tubes, and so on. Clean the chassis on top with the tubes in place as much as possible, removing the tubes after the bulk of the dust is removed. Cleaning variable capacitors in the tuning gang of tuners is especially important. I have cleaned some with a 25% improvement in sensitivity as a result.

Don't neglect the underside of the equipment either. Sometimes you will discover all sorts of things underneath—including spiders, millers, etc. I know of a case of a tuner that was disabled by a fly's wing across two terminals. Clean equipment may very well result in "cleaner" sound.

Edward T. Dell, Jr.  
Roxbury, Mass.

## Wiring Mistakes

One of the experimenter's most likely sources of difficulty in building a piece of apparatus from a description appearing in a publication is miswiring. Particularly in complex gadgets it is easy to forget one or two connections.

This possibility can be minimized by marking in colored pencil right on the circuit schematic or pictorial diagram the wires and components as they are installed. Perhaps two colors should be used, one to indicate the wire and the other to denote "soldering done".

Paul Penfield, Jr.  
Brookline, Mass.

## Preventing Heat Damage While Soldering

When soldering  $\frac{1}{2}$ -watt carbon resistors, precision resistors, and practically all types of capacitors into circuits, it's a good idea to prevent damage to the components being handled by taking care not to apply excessive heat to the leads. Various techniques have been used, but the best I have come across is one I stumbled upon accidentally while rumaging through my tool box. Way at the bottom was an old hemostat left over from my days as a Pharmacist's Mate in the Merchant Marine. Being in the middle of an amplifier-construction job in which I was using expensive 1% Carbofilm resistors throughout, I was being slowed down by the task of holding my soldering gun in one hand, and, in the other hand, a strip of solder wound in a coil around the forefinger and a pair of pliers with which I was conducting the heat away from the resistors by gripping the lead between the soldering point and the body of the resistor. The hemostat solved my problem perfectly.

For those who do not know what a hemostat is, here is a brief description. A hemostat is a tool which looks like a pair of scissors on the bottom, but which has teathed grips like needle-nose pliers on the top. As the thumb and forefinger tighten, serrated portions of the hemostat slide across each other toward the inside of the fingers and lock. So the fingers may be removed while the hemostat locks around the artery or vein and clamps off the blood supply. The locking feature makes this tool ideal in audio construction. By clamping the lead between the body of

### AUDIO AIDS WANTED

*That's right—we'll pay \$5.00 or more for any short cut, suggestion, or new idea that may make life easier for other AUDIOCRAFT readers, and which gets published in our Audio Aids department. Entries should be at least 75 words in length, and addressed to Audio Aids editor. No limit on the number of entries.*

the resistor and the soldering point with the hemostat and then locking it, I was able to free my hand and go about the business of soldering with both hands. The hemostat, being made of metal, was allowed to rest against the side of the chassis. It served as a perfect conductor of heat, and let me complete the job in record time with every resistor as perfect in value as it was before soldering.

Hemostats are readily available in medical supply houses, and they may also be found in many war-surplus stores.

Ben Zale  
Bronx, N. Y.

## Foolproof Speaker Connector

Errors in the connection of a loudspeaker to the output of an amplifier will cause the equipment to operate at less than full efficiency. Such errors are particularly likely when one of several speakers is to be connected to one of a number of amplifiers.

It is possible to simplify the connecting procedure so as to eliminate the possibility of error. Four-pin receptacles

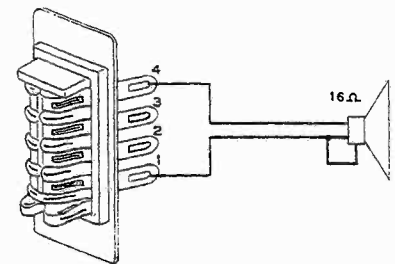
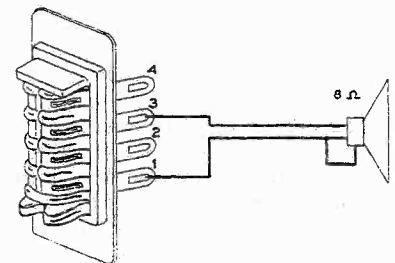
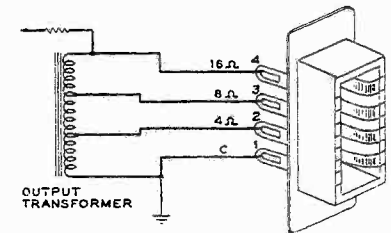

*When more than one speaker system is to be used with an amplifier, arrangement shown gives automatic impedance match.*

are mounted on each amplifier, with connections to the output transformer as pictured above. Each speaker is equipped with a four-pin plug at the end of its cord, and the cord is connected to the two pins of the plug that correspond to the impedance of the speaker.

Ronald L. Ives  
Palo Alto, Calif.

# BASIC ELECTRONICS

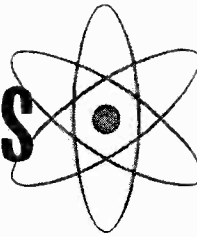

by Roy F. Allison

## XIV: Parallel $RL$ and $RC$ circuits.

WE have been working in the preceding three chapters with series combinations of  $R$  and  $C$ ;  $R$  and  $L$ ; and  $R$ ,  $C$ , and  $L$ . Series resonance was discussed for the latter case. In this chapter we shall go on to parallel combinations of these elements, which are

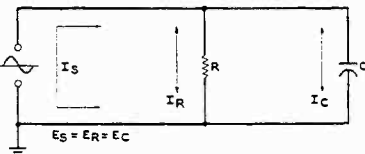

Fig. 1. Parallel  $R$  and  $C$  in AC circuit.

similar in many ways but have important differences.

For example, consider the circuit shown in Fig. 1. This is a simple parallel combination of a resistor and a capacitor across an AC source. In this arrangement the quantity that is common to all elements (the resistor, the capacitor, and the total impedance as seen by the source) is *voltage*;  $E_R$ ,  $E_C$ , and  $E_S$  are identical. They are equal in value and in phase. Current in  $R$  differs from the current in  $C$ , their exact relationships depending on their individual resistance and reactance magnitudes. Current in the source is equal to neither, depending on the total impedance of the external circuit. In a series circuit, it will be re-

voltage across it, is shown at zero phase also. But current through the capacitor,  $I_C$ , leads the voltage by  $90^\circ$ ; therefore it must be plotted  $\frac{1}{4}$  cycle to the left of the voltage wave form. In our example its magnitude is slightly smaller than that of current through the resistor, which indicates that the capacitive reactance ( $X_C$ ) must be slightly *greater* than the resistance of  $R$ . Adding the curves for  $I_R$  and  $I_C$  point by point gives the wave form for  $I_S$ , the total current through the impedance represented by  $R$  and  $C$  in combination, and through the source. It is apparent that the magnitude of  $I_S$  is less than the simple sum of  $I_R$  and  $I_C$ , and the reason for this is also evident: the peak values do not occur at the same time, so that during some parts of their wave forms they are subtractive. Since the total current is less than it would be for two parallel, like (in-phase) reactances of equivalent magnitudes, evidently the resultant impedance is greater than it would be for like reactances or resistances in parallel.

Fig. 3 shows the vector diagram corresponding to the wave forms in Fig. 2. Voltage, the reference quantity, is plotted at zero phase, directly to the right from the origin.  $I_R$ , in phase with  $E$ , is plotted to scale in the same direction. Because current in the capacitor leads the

Examination of Fig. 3 will show its similarity to the *voltage* vector diagrams for series  $RC$  and  $RL$  circuits. One difference is that  $I_C$  is plotted upward from the origin, while  $E_C$  was plotted downward for a series circuit. There is really no inconsistency, however; in each case  $E_C$  lags  $I_C$  by  $90^\circ$ . The difference arises because, in the series case,  $I$  is plotted at zero phase, and, in the parallel case,  $E$  is so plotted. In both cases the vertical vector is equal in length to construction line A (Fig. 3), so that a right triangle

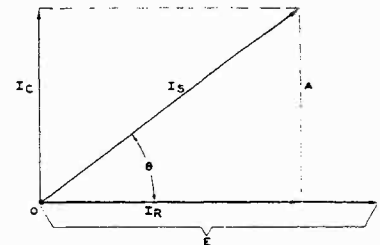

Fig. 3. Vector representation of Fig. 2.

is formed by the three vectors, of which the resultant vector is the hypotenuse. From this we can derive a formula for the resultant current in a parallel circuit that is similar to that for resultant voltage in a series circuit:

$$I_S = \sqrt{I_R^2 + I_C^2}$$

Formulas for the phase angle  $\theta$  are also like those encountered before:

$$\sin \theta = I_C / I_S,$$

$$\tan \theta = I_C / I_R, \text{ etc.}$$

Another difference is that the currents are *inversely* proportional to resistance and reactance magnitudes in parallel  $RC$  circuit, since each element has the same voltage across it. The formula for finding total impedance from the individual elements is, then, different from the series case:

$$Z = \frac{RX_C}{\sqrt{R^2 + X_C^2}}$$

This is derived in the Appendix. Logically, the graphical solution for resultant impedance is different as well; it is shown in Fig. 4.  $R$  is drawn to scale from the origin to the right, and  $X_C$  from the origin upward. A construction line is then drawn from the end of  $R$  to the end of  $X_C$ , and  $Z$  is drawn from the origin perpendicular to the construction line. Its magnitude is in the same proportion to its scalar length as that of  $R$

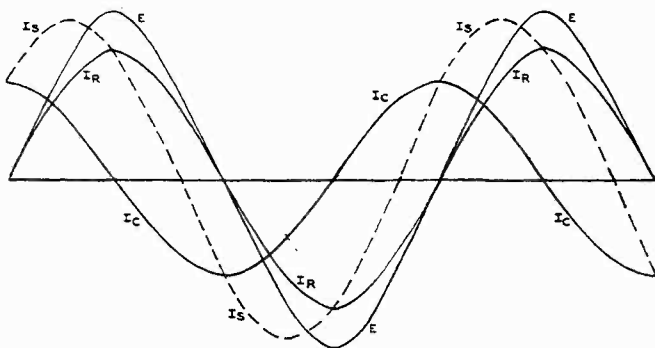

Fig. 2. Wave forms for a parallel  $R$  and  $C$  circuit, shown in proper phase and relative amplitudes.

called, *current* is the value common to all elements, and different voltages appear across each. Plotting wave forms of current in a parallel circuit, therefore, leads to the same sort of information as plotting voltages in a series circuit. This is done for a parallel  $RC$  circuit in Fig. 2.

We choose  $E$  as zero or reference phase, since it is common to all elements.  $I_R$ , since it is always in phase with the

voltage,  $I_C$  is plotted at  $+90^\circ$ , directly upward, also to scale. Completing the parallelogram, and drawing a line from the origin to the opposite corner, gives the scale value of  $I_S$ ; its angle with respect to the voltage vector indicates the phase relationship between source current and voltage. Because  $I_R$  is a little larger than  $I_C$ , this angle is less than  $45^\circ$  leading.



and  $X_C$ . The angle  $\theta$  is the phase angle between current and voltage through the impedance as a unit and, in this case, through the source.

Let us assign specific values to the circuit. Assume that the source voltage is 104 v at a frequency of 92 cps.  $R$  is

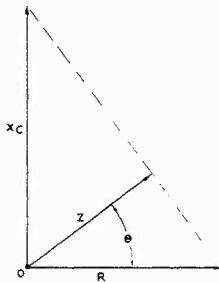

Fig. 4. Parallel impedance construction.

1,300 ohms, and  $C$  is 1  $\mu$ fd. What will be the currents in  $R$ ,  $C$ , and the source; what is the total load impedance; and what will be the phase angle between source current and voltage?

$$I_R = E/R = 104/1,300 = .80 \text{ a} = 80 \text{ ma.}$$

$$X_C = \frac{1}{2\pi fC} = \frac{1}{2 \times 3.14 \times 92 \times 1 \times 10^{-6}} = \frac{1,000,000}{578} = 1,730 \text{ ohms.}$$

$$I_C = E/X_C = 104/1,730 = .06 \text{ a} = 60 \text{ ma.}$$

$$I_S = \sqrt{I_R^2 + I_C^2} = \sqrt{(80)^2 + (60)^2} = \sqrt{10,000} = 100 \text{ ma.}$$

$$\sin \theta = I_C/I_S = 60/100 = 0.6.$$

From a math table,  $\theta = 37^\circ$ , approx.

$$Z = \frac{RX_C}{\sqrt{R^2 + X_C^2}} = \frac{1,300 \times 1,730}{\sqrt{(1,300)^2 + (1,730)^2}} = \frac{2,249,000}{\sqrt{4,682,900}} = \frac{2,249,000}{2,164} = 1,040 \text{ ohms.}$$

As a check,  $Z = E/I_S = 104/0.1 = 1,040$  ohms.

These are the conditions portrayed graphically in Figs. 2, 3, and 4.

In an  $RL$  parallel circuit the procedure is very much the same, with the following obvious exceptions:

1) Current in the  $L$  branch lags the voltage by  $90^\circ$ . Therefore the  $I_L$  wave form would be plotted  $\frac{1}{4}$  cycle to the

right of the  $E$  and  $I_R$  wave forms, Fig. 2, and the  $I_S$  wave form would accordingly lag  $E$  and  $I_R$  by an angle between  $0^\circ$  and  $90^\circ$ , rather than leading them by a similar angle.

2)  $I_L$  would be plotted in a downward direction in Fig. 3, and  $X_L$  would be plotted downward in Fig. 4; in each case  $\theta$  would be a negative angle indicating the current lag.

3) The formulas for resultant current and resultant impedance are:

$$I_S = \sqrt{I_R^2 + I_L^2} \text{ and } Z = \frac{RX_L}{\sqrt{R^2 + X_L^2}}.$$

There should be no need to discuss the parallel  $RL$  situation at length, since it is so closely allied to the parallel  $RC$  case and the reasons for their differences are obvious. Probably it would be more profitable to the reader to use the space for another specific example. Fig. 5 shows a parallel  $RL$  circuit:  $R$  is 1,000 ohms,  $L$  is 0.13 h,  $E$  is 20 v, and  $f$  is 490 cps. What are the currents in each element and the source; the total load impedance; and the phase angle between  $I_S$  and  $E$ ?

$$I_R = E/R = 20/1,000 = .02 = 20 \text{ ma.}$$

$$X_L = 2\pi fL = 2 \times 3.14 \times 490 \times 0.13 = 400 \text{ ohms.}$$

$$I_L = E/X_L = 20/400 = .05 = 50 \text{ ma.}$$

$$I_S = \sqrt{I_R^2 + I_L^2} = \sqrt{(20)^2 + (50)^2} = \sqrt{2,900} = 53.9 \text{ ma.}$$

$$\sin \theta = -I_L/I_S = -50/53.9 = -0.929.$$

Then  $\theta = -68^\circ$ , approximately, and  $I_S$  lags  $E$  by  $68^\circ$ .

$$Z = \frac{RX_L}{\sqrt{R^2 + X_L^2}} = \frac{1,000 \times 400}{\sqrt{(1,000)^2 + (400)^2}} = \frac{400,000}{\sqrt{1,160,000}} = \frac{400,000}{1,077} = 371 \text{ ohms.}$$

To check the problem,  $Z = E/I_S = 20/0.0539 = 371$  ohms.

The wave forms in this circuit are shown in Fig. 6, together with the vector diagram of the currents and the graphical impedance solution.

Basic differences between series and parallel  $RC$  (and  $RL$ ) connections should be summarized at this point. First, there is only one possible path for current

through the load in a series circuit. Therefore, the reactance or resistance having the larger value has most effect on the phase between source voltage and current. In a parallel circuit, with more than one alternative path for the load current, most of it will flow in the smaller reactance or resistance; accordingly, the smaller reactance or resistance has most effect in determining whether the circuit is primarily resistive or reactive. If a large reactance is put in series with a small resistance, the total load impedance is increased radically and becomes mostly reactive; if it is put in parallel with the small resistance, the total impedance is decreased only slightly, and the load remains primarily resistive.

Second, because current in each element of a series load is a common quantity, the individual magnitudes of reactance and resistance are directly proportional to the voltage drops across them. Accordingly, the vector constructions and the formulas used for relating individual voltages to the resultant voltage can be used also for

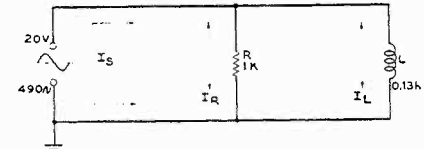

Fig. 5. Parallel  $RL$  circuit with values.

relating individual reactances and resistances to the total impedance. This is not true in parallel circuits, where individual currents are inversely proportional to the branch reactance and resistance magnitudes. A different type of graphical construction, and a different formula, are thus required to find total impedance from the individual elements.

Third, parallel resonance is slightly more complicated than series resonance to deal with; still another formula is necessary to determine total impedance from the individual elements, and graphical construction for this quantity is too unwieldy to be practical. Parallel combinations of  $L$ ,  $C$ , and  $R$  will be discussed in the following chapter.

The subject matter of chapters 11

Continued on page 43

Fig. 6. Instantaneous wave-form relationships for the circuit in Fig. 5, with current vector diagram and impedance graph.

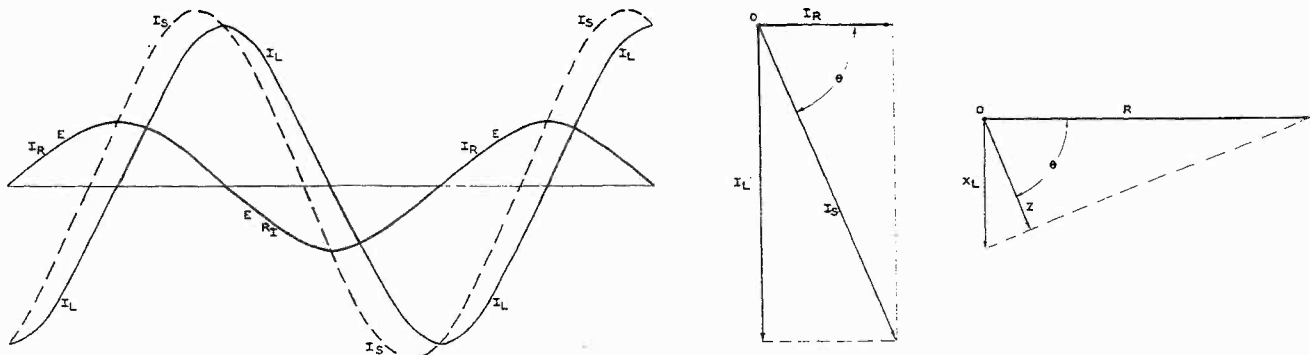

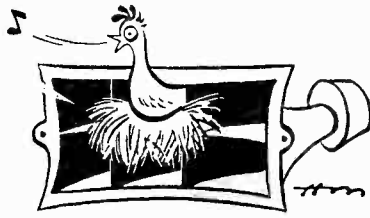

# Sound-Fanciers' Guide

by R. D. DARRELL

## Midwinter Housecleaning

Every so often there comes a time when any reasonably conscientious record reviewer gets panic-stricken about the backlog of releases demanding his attention. Try as he will to keep up with the steady flow of incoming works for review, each month some copy is left over and several more works haven't been listened to. Even for a column primarily centered, as this one is, around recordings of unusual sonic or technical quality, more pertinent materials are appearing nowadays than possibly can be covered in the type space available. And of course the problem is further aggravated by my own personal itch both to write at considerable length about everything I'm particularly interested in and, insofar as possible, to organize these releases in groups, each of which illustrates some special aspect of audiology.

This month, however, I'm forced to ignore such usually irrepressible itches and to get busy sweeping up the shop! But before I begin cleaning off my overloaded backlog shelves, I should make it clear that my devoting no more than a capsule review to any record doesn't necessarily imply any lack of appeal or merit. In most cases, the reason I haven't treated it earlier in more detail is merely that I couldn't fit it conveniently into any previous column. In other instances, there just didn't seem then (and doesn't seem now) much that can be said about them.

For example, Milstein's recital of violin miniatures (Capitol P 8339) obviously doesn't lend itself to extended discussions of its performances (done with typical Milsteinian skill and fine-spun tone to Leon Pommers's over-modest piano accompaniments), its musical contents (some 13 mostly familiar "encore" pieces), or its technical qualities (which meet contemporary standards without being in any way outstanding).

Or take the Honegger-Barber-Debussy program by Willis Page's New Orchestral Society (Cook 10683), a 12-inch Microfusion repressing of works originally issued a couple of years ago on the 10-inchers 1068 and 1063. The playing here is attractively imaginative and the recording admirably transparent; but all these pieces exist in more author-

itative readings, and Cook himself has since demonstrated much more impressive sonic techniques.

With Dr. Fritz A. Kuttner's *Theory of Classical Greek Music* (Musurgia Series A, No. 1), the problem is somewhat different in that this highly specialized documentary would demand a great deal of space to discuss adequately—space which, in view of its restricted interest, I simply don't feel can be spared for it here. So I regretfully have to pass it over with a bare mention, and special praise for one of the most erudite and illuminating accompanying booklets I've ever come across, and hope that this note will be enough for every listener likely to be genuinely attracted by such novel (and, in its own field, invaluable) fare.

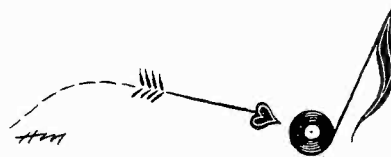

## Showcase Samplers

The Montilla Sampler (FM 79, \$1.98\*) is a natural for anyone with a yen for authentic Spanish light orchestral and guitar music. The rather heavy and sometimes harsh tonal qualities won't please any real sound-fancier's ears, but even he is likely to find the catchy tunes and rhythms here enough delight in themselves. On the other hand, the RCA Victor *Red Seal Showcase in Sound* (SRL 12-28, \$1.49) includes many examples of some of the finest current orchestral, opera, and pops recordings, but these are disconcertingly heterogeneous. The interpolated talks by the artists themselves are nothing anyone except a vocal-autograph collector will care to hear more than once.

Vanguard's two "demonstration" discs (SRV 102 and SRV 103, \$1.98 each) are something else again. They present complete works (Mozart's *Eine kleine Nachtmusik* and G minor Symphony, K. 550, by Prohaska; and Rimsky's *Scheherazade* by Rossi), without sales pitches and at an attractively low price. In each case the performances rank somewhat below the very best ones

\*While list prices are not ordinarily noted in this column, an exception is made whenever they are extraordinarily high or, as in this case, low.

available, but not very far from the top; the recording, if not sensational, is crystal-clear and open. The discophile who has to count his pennies carefully should find these releases real bargains, and for any beginning library builder they can serve as an appetizing introduction to the whole Vanguard catalogue.

## Pianos—Old and New

If you haven't yet heard for yourself the decidedly odd-sounding "strummed" tones of the fabulous Siena Piano, Kathryn Déguire's Mozart Sonatas, K. 282 and K. 331 (with the *Rondo alla Turca*), and *Gluck Variations* (Esoteric ESP 3004) will be a piquant revelation of hitherto unencountered sonorities—here, I think, much better suited to the musical materials than in some of the other Siena releases.

Several modern-piano recordings are tonally richer, if more conventional: extremely clean, cool, and solid in the case of Agi Jambor's six Bach Clavier Partitas (Capitol PBR 8344, two 12-inch); remarkably romantic coloring and singing quality in Nadia Reisenberg's six Chopin Nocturnes (Westminster W-LAB 7029) and Geza Anda's Schumann *Carnaval* and *Kreisleriana* (Angel 35247). Yet enchanting as all these are aurally, I found Jambor's Bach too remote, impersonal, and lacking in variety; while Reisenberg and Anda are almost oppressively Chopinesque and Schumannesque respectively. It was with considerable relief that I turned from such lush romanticism to one of my personal Mozartian favorites, the Quintet for Piano and Wood Winds, K. 452, for once played as it should be in a superbly restrained, precise, and yet glowing performance by Gieseking, Sutcliffe, Walton, James, and Brain (Angel 35303). I even relished their overside Beethoven Quintet, Op. 16, a work I always found unbearably dull in the past, but not here.

## Pops and Christmas Taste Extremes

One of the few musical instruments which disinterests me at best (and actively antagonizes me more often) is the accordion. Since Joe Basile is given so much "presence" that he jumps out of the speakers to play his squeeze box practically in my lap, his *Accordion de*

*Paris* (Audio Fidelity AFLP 1815) is not for me. But for anyone who actually likes the instrument, I must note that I've never heard it recorded more authentically—or more thoroughly drained of its schmaltz potentialities. I'm also usually driven stir-crazy by more than a half side or so of the maniacally repetitive cha-cha-cha beat, but I have to concede that both Pedro Garcia's and Memo Salamanca's Orchestras (Audio Fidelity AFLP 1810 and 1813) are not only as danceable as any, but notably more interesting to listen to: the former largely thanks to his strong secure rhythm (and the crispest recording yet of Latin American percussion instruments); the latter thanks to his more suave songfulness. But, as usual, there's much too much singing for me. (The jacket dance instructions and step diagrams are wasted on me, too, I'm afraid, but they should be welcomed by more energetic cha-cha novices.)

For sophisticated and sophomoric Germanic tastes respectively there are Liane's *Glowing Embers* (Vanguard VRS 7034, 10-inch), attractive café-type vocalizing, closely miked but otherwise sonically undistinguished; and the Guckenheimer Sour Kraut Band's *Oompah-Pah in Hi Fi* (San Francisco M 33005), which is just what it claims to be, and—in small doses of its travesties on old-style street bands—extremely funny. It's genuine hi fi, too, with the most raspberryish instrumental razzing sound captured on discs to date!

Two late holiday specials vary even more widely. *The Sounds of Christmas* (Concertapes stereo 505, 5-inch), by the Halloran Choir and Sorkin Orchestra, may be postmarked Chicago, but it's strictly Hollywood in its disarrangements of familiar tunes, mannered performances, and overblown sound. But *A Christmas Candlelight Service* at the National Presbyterian Church in Washington, D.C., (McIntosh MM 107) is both straightforwardly sung and beautifully recorded. The program is admirably far-ranging too, with some refreshingly novel carol materials, and my only complaints are that the soloists aren't on an artistic par with the fine chorus and that some of the processions, contrasting distant and nearby voices, lose much of the dimensional impressiveness they would have had if stereo recording had been practicable.

### Orchestral Pros and Cons

Employing this same sort of arbitrary division into barely qualified likes and dislikes, I can speed up the task of coping with a whole batch of miscellaneous orchestral releases, illustrating a wide range of sonic and other qualities. Actually, the one I disliked most intensely, the Pennario-Slatkin Gershwin *Rhapsody in Blue* and *American in Paris*

(Capitol P 8343), is recorded with sensational impressiveness—but this only throws a crueler spotlight on the dry studio acoustics, coarseness of orchestral playing, and the tastelessness of the readings themselves, which vary from maudlin sentimentality to cornily melodramatic climaxes. Slatkin appears to far better effect in Debussy's *Children's Corner* and *Petite Suite* (Capitol P 8328), where his mannerisms are less pronounced and the string sonorities in particular are much more aurally ingratiating.

In their different ways, I also resent the tumultuous thunders of Van Otterloo's *Saint-Saëns Organ Symphony* (Epic LC 3077), which tends to be overly tubby at the low end and creamy at the other spectrum extreme; also the eerie sonic fascinations of Boult's *Bartók Music for Strings, Percussion, and Celesta* (Westminster W-LAB 7021), for, while this is much more cleanly recorded, the performance is just too intense and zestless to give this strange work its proper, if singular, magic. More satisfactory in many respects is the broad, highly reverberant, Weber, Mendelssohn, and Schubert Overture program by Jonel Perlea (Vox PL 9590, also announced by Phonotapes-Sonore as PM 138, 7-inch), but for all its rich, dusky atmosphere it lacks the final touch of lyrical delicacy and tenderness. And most sensational of all is Dorati's Tchaikovsky *Sleeping Beauty* Ballet, originally issued in a 3-disc album form as

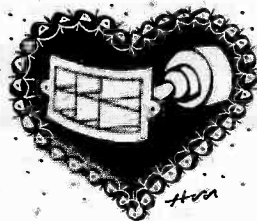

Mercury OL-3-103, but now made available also on four individual discs (Mercury MG 50064/7), of which I have heard only the first (Prologue) and last (Act III, "Aurora's Wedding"). Yet its ultrabrilliance now seems to date back to the Audio-Fair ideals of a year or two ago, when excessively scintillating highs and window-smashing lows were esteemed for their own sake. Today, this still sounds like a terrific recording, all right, but neither its muscularity nor Dorati's reading (which varies between brutal vigor and overripe lushness) gives Tchaikovsky's finest music much of a chance to exert its most characteristic graceful appeal.

But happily, I still *can* be wholeheartedly pleased. I certainly am by Beecham's musically and aurally enchanting Schubert Sixth Symphony, and even, momentarily at least, by the musically less captivating Grieg *In Autumn*

and *Old Norwegian Romance* (Angel 35339). I enjoyed too Keilberth's broader and more overtly expressive reading of the same symphony alone (Telefunken LGM 65026, 10-inch), but its full-blooded sound is not so immaculately pure. More surprisingly, I thoroughly relished Karl Ancerl's Czech Philharmonic version of Shostakovich's Tenth Symphony (Decca DL 9822), much less strenuous than Mitropolous's more celebrated Columbia version (ML 4959), but expressively more convincing to my ears, and aurally extremely interesting as an example of the distant microphoning and beautifully blended orchestral sonorities I'll talk about in more detail a little later in connection with the Decca Glière Symphony by Fricsay. And, not surprisingly at all, what I got my most substantial and lasting pleasure from is Mogens Wöldike's Mozart *Haffner* March and Serenade, K. 249-50 (Vanguard VRS 483). At first hearing, both the delicate musical textures here and the small-orchestra tonal qualities may seem far from exciting—but keep listening! Before long the buoyant verve of the music itself and the light yet brightly alive recorded tone will begin to work their unique sorceries; and no truly discriminating person ever will be able to resist them, or will want to.

### Gateways to Nirvana

Well, that gets me caught up pretty well on my disc backlog, and attention to the tape backlog can wait a little longer while I "steal" the remaining space available this month for a more leisurely discussion of a problem which has been worrying me for a long time. It revolves on the appropriateness of common contemporary technical approaches to certain types of music. In most of the works reviewed here it's obvious that whatever the instruments or compositional styles may be, their innate interest is either largely dependent on or capable of being markedly enhanced by boldly wide-range recording and reproduction. But with quite different types of material, is it equally certain that hi fi is either an absolutely essential or a wholly desirable boon? Devout believer in it that I am, I'm just heretic enough to suggest that in one isolated musical area, and for a highly specialized type of listener, the transcendental qualities of high fidelity (those of its "quieter" virtues as well as its more flamboyant powers) are something less than the correct and unanimously welcomed answer. Hi fi has helped mightily to bring about a true renaissance of baroque and older repertoires . . . it stimulates and strengthens our revitalized insights into the classic composers . . . and it has become absolutely essential for all dramatic romantic and modern music. Yet

its enhanced clarity and sharpened focus have been dubious advantages to intentionally blurred musical impressionism and to a certain variety of quasi-mystical or serenely contemplative musical experience. For music which is primarily an escape from realism—in Santayana's famous phrase, ". . . a drowsy reverie enlivened by nervous thrills . . ."—hi fi too often opens the dreamer's shuttered windows to unwanted harsh sunlight and fresh air.

This seems especially true of the music of Delius, once a potent cult, if not a drug, for many old-time discophiles, but which never has commanded comparable attractions for present-day LP listeners. Perhaps tastes have changed, but I think it's more likely that modern technology as yet has not mastered the knack of properly recording and reproducing such music. In my present mood for nonsensational sonic fare, I seized with avid anticipation a new version (Columbia ML 5079) of the Delian masterpiece for chorus and orchestra, *Sea Drift*, which never had been captured adequately on discs before. But although it is magnificently recorded here, with innumerable score details caught clearly for the first time, and although the performance is by the supreme Delius interpreter, Sir Thomas Beecham, the peculiar sorcery of this most nostalgic of all music is lost. And that this loss is no fault of the recording itself is demonstrated impressively in the overside tone poem *Paris*, a lesser, but far more extroverted work (for orchestra alone) which both demands wide-range techniques and shows off their virtues with marked éclat.

But the introspection and the atmospheric choral writing of *Sea Drift* demand something more, and that something more can only be provided by modern technology working in a new medium: that of stereo sound. I know that most awed listeners at public stereo demonstrations are excited mainly by its widened aural perspectives and "you-are-there" naturalness. What they hardly can realize until they've done considerable stereo listening in their own homes is that this medium is characterized also by its abilities to preserve, and even enhance, the indefinable atmospheric quality of highly impressionistic music, and to space out and open up the normally cramped textures of choral singing. I don't have any really outstanding commercial examples of the latter yet, but the former is convincingly displayed in Monteux's stereo tape of the Debussy Nocturnes (RCA Victor GCS 12) and Neumark's stereo version of the Richard Strauss *Tod und Verklärung* (Concert Hall CHT/BN 12—a curious coincidence of numbering).

Hearing these, you'll realize for the first time how much even the best of

the single-channel recordings of these works have missed. And that isn't a consequence of performance alone, for if Monteux's here is well nigh matchless, it certainly doesn't sound remotely as effective in the LP version (LM 1939), and Neumark's (not yet available on LP) is far from bearing comparison with, say, Toscanini's, on interpretative and executant grounds alone. Yet in each case, works which always have left me entirely cold on discs, and even in most concert-hall performances, suddenly become airborne, soaring, and truly meaningful. I'm sure that *Sea Drift* and other examples of Delius's singularly introspective art—different as they are from Debussy and Strauss in so many other respects—never can be satisfactorily recorded and reproduced in any medium except that of stereo sound.

Happily, not all romantic works are so demanding. The listener who wishes to surrender himself to almost narcotic aural pleasures still has a wide range of choice in single-channel recordings for which engineers choose and adapt their techniques to produce the most fitting, not always the most obviously clean-cut or brilliant, setting. Two pertinent current examples are Bruckner's Ninth Symphony by Horenstein (Phonotapes-Sonore PM 125, or Vox PL 8040) and Glière's *Ilya Mourametz* Symphony by Fricsay (Decca DL 9819).

The former is perhaps the most approachable, or at least the most immediately and powerfully intoxicating of all Bruckner's major works, and on



tape in particular his seemingly endless flow of rich sonorities exerts an overwhelming spell. Yet, unlike some of his other works (for ears and minds like mine anyway), there is real point and poignance of meaning to this never-finished work, whose Adagio movement is at once an agonizing and serene Farewell to Life—one of the most profoundly moving farewells left by any composer.

The latter is a very different kind of release which many collectors are likely to overlook or fail to evaluate adequately, for the music itself is abridged (something I normally disapprove of violently) and the recording has little of the superbrilliance of the famous Scherchen uncut version (Westminster WAL 210). Yet here, for once, both policies are justified by the results: the long, rambling work actually gains by the elimination of some of its hardly essential episodes, while the distant (probably single) microphone placement blends the lush scoring details into a more closely integrated sonic

texture. For romantic-minded, rather than analytic, listeners this version should prove a rare delight. It also proves once more that in the world of art and technology combined there are no hard and fast rules.

The only final criterion for sound reproduction was pronounced long ago by C. J. LeBel, founder of the Audio Engineering Society, in the simple dictum which is so obvious that its full force tends to be ignored: "If it doesn't sound good, it isn't good!" Here, what I've usually considered the overly ripe *Ilya Mourametz* Symphony not only sounds good, but right, at least for listeners who favor the rear seats of concert halls; its engineers are to be congratulated for daring to break with present-day conventions of super-clarity and extreme sonic differentiations in providing an acoustical setting which is perfectly appropriate for its particular materials and purposes.

## KNIGHT AMPLIFIER

*Continued from page 19*

instruction 7, and a 4-inch length in instruction 8.

In the next-to-last instruction on page 8, the lead of C2 with spaghetti on it should be soldered to terminal 3 of R2.

In the next-to-last instruction on page 9, C1 should be positioned against the left apron if you are assembling the preamplifier kit also; refer to the pre-amp pictorial diagram.

Neither lead of C16 should be soldered in step 6, preamplifier wiring instructions.

Both leads of R26 should be soldered in the first step on page 3, pre-amplifier wiring instructions.

It took us 7½ hours, start to finish, for the complete job including the pre-amp section. We were unhurried and careful; because of this, possibly, the amplifier worked perfectly the first time we tried it.

## AUDIOCRAFT Test Results

The weakest part of an inexpensive amplifier is almost invariably the output transformer. Very good transformers are quite costly, while very poor ones are correspondingly cheap. It is tempting to achieve a fine competitive position by selling an amplifier or an amplifier kit with an output transformer weighing ounces instead of pounds. For a few entrepreneurs the temptation is too great, and the prospective purchaser must accordingly be wary of any low-cost amplifier.

Fortunately, the output transformer in this amplifier, while having certain limitations, is nevertheless capable of quite respectable performance. It has only one secondary winding (for 6 to 8

*Continued on page 38*

only **LAFAYETTE** can do it!  
**OUR DIRECT IMPORTATIONS**

**YOU SAVE IMPORTERS PROFIT!**

**SAVE 33 1/3-50%**

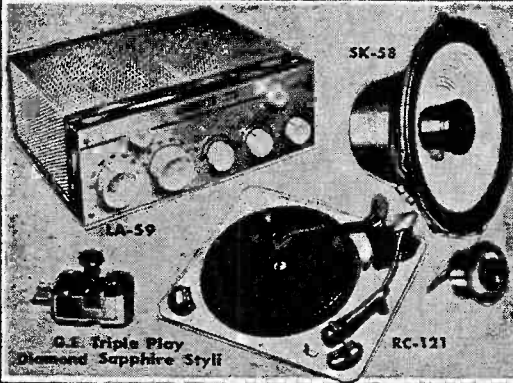

**NOTHING FINER AT THIS PRICE!**

Reg. Value  
~~158.55~~  
**SALE!**  
**119.50**

**LAFAYETTE MATCHED HIGH FIDELITY PHONO SYSTEM**

NEVER—in the annals of HIGH-FIDELITY has a phono system of this quality—at this price—been offered. A Lafayette "best buy" system designed around the new Lafayette LA-59 amplifier. The performance of this Phono system surpasses the most critical requirements of music lovers. Twenty-four combinations of record equalization provide an almost endless variety of tone compensation to match varying recording characteristics. This system includes the famous Garrard RC-121 "Renown" 3 speed automatic and manual record changer, LAFAYETTE LA-59 18 watt amplifier with features found only in the most expensive amplifiers. G.E. triple-play—turnover cartridges with genuine G.E. DIAMOND SAPPHIRE STYLI, AND LAFAYETTE SK-58 12" coaxial HI-FI speaker. All units are supplied with plugs, jacks and prepared color-coded interconnecting cables for quick easy installation. For 110-120 volt, 60 cycle AC. Shpg. wt. 50 lbs

HF-154—Complete Phono System.....Net 119.50

**PROFESSIONAL TRANSCRIPTION TURNTABLE AND VISCOUS-DAMPED TONE ARM**  
 THE FINEST TRANSCRIPTION TURNTABLE AND TONE ARM FOR THE PROFESSIONAL USER AND THE AUDIOPHILE



**PK-100A TRANSCRIPTION TURNTABLE**

New 3-speed instrument with built-in stroboscope and viewer for exact speed determination, and magnetic brake for instantaneous speed variation. Precision engineered to meet professional standards for wow, rumble and flutter content. Heavy 12" cast aluminum rim-driven turntable. Variable speed control permits adjustment of each speed within  $\pm 7\%$  using efficient frictionless magnetic brake. Heavy-duty constant speed 4-pole induction motor freely suspended and isolated by shock-mountings to eliminate vibration transfer. R-C filter network suppresses "pop" in speaker. Truly a delight for the connoisseur. Size: 13 1/2" x 14" and requires 2 3/4" clearance above and 3 3/4" below motorboard. For 110-130V and 60/50 cycle AC. Power consumption 12 watts. Handsome hammertone gray finish. Shpg. wt., 20 lbs.

PK-100-A .....Net 49.50

**PK-90 VISCOUS-DAMPED TONE ARM**

This transcription arm assures dependable and stable operation, utilizing the "floating action" principle of "viscous-damping." The arm is supported at a single point by a pivot and jewel bearing having negligible friction. Damping is accomplished by a silicone fluid occupying the gap between a ball and socket. This damping control permits high compliance and negligible tracking error, and prevents damage to either record or stylus should the tone arm be accidentally dropped. Low frequency resonance, skidding and groove-jumping are likewise minimized. The tone arm accepts all records up to 16" and accommodates virtually all hi-fi cartridges by means of precisely engineered adapters which simplify installation and provide proper stylus pressure.

This tone arm is a quality companion to the PK-100 with matching finish. Shpg. wt., 2 1/2 lbs.

PK-90 .....Net 15.50

PK-100 TURNTABLE, PK-90 TONE ARM AND G.E. CARTRIDGES WITH GENUINE DIAMOND AND SAPPHIRE STYLI.  
**72.50**  
**COMBINATION DEAL**

**New!**

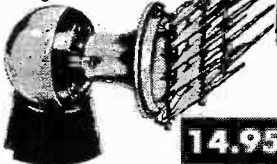

**HIGH FREQUENCY TWEETER WITH ACOUSTIC LENS**  
 DIRECT IMPORTATION MAKES THIS PRICE POSSIBLE!

- FREQUENCY RESPONSE FROM 2000 CPS TO BEYOND AUDIBILITY
- LOUVERED ACOUSTIC LENS FOR UNIFORM SOUND DISPERSION
- HANDLES 25 WATTS OF POWER
- PRICED EXCEPTIONALLY LOW

**14.95**

New high frequency tweeter featuring a louvered acoustic lens for uniform sound dispersion and capable of handling up to 25 watts of distortion-free power. The directional tendency of high frequency notes is overcome by the natural wide dispersion angle of the short horn and the acoustic lens which disperses and radiates the high notes smoothly throughout the entire listening area. The lens is detachable for panel mounting, with a separate base for the tweeter furnished for external mounting where desired. Aluminum voice coil has 16 ohms impedance. Size: 4 1/4" long x 3" diameter. lens extends 2 1/2". Requires a crossover network, preferably one with a level control, such as the LN-2. With full instructions. Shpg. wt., 5 lbs.

HW-7 .....Net 14.95

**METAL-CASED CONE TYPE HI-FI TWEETER**  
 FREQUENCY RESPONSE 2000-16,000 CPS  
 HANDLES 20 WATTS OF POWER

Highest quality cone type high frequency tweeter having a range from 2000 to 16,000 cycles. Especially efficient at higher end of audio spectrum where other cone type tweeters tend to lose clarity and volume. Entirely closed in a metal case with a base so that it can stand by itself or be mounted on a flat surface with mounting bracket supplied. Rated to handle 20 watts of power. A crossover network is required; the Lafayette LN-2 is ideal. Voice coil impedance 8-16 ohms. Size: 3 1/8" x 2 3/8" x 3" Diam. Shpg. wt., 3 lbs.



HK-3 .....Net 5.95

**5.95 Net**

**CROSSOVER NETWORK**  
 CAPACITIVE-INDUCTIVE NETWORK WITH CROSSOVER AT 2000 CPS  
 BUILT-IN LEVEL BRILLIANCE CONTROL



The frequencies above 2000 cycles are channeled to the high frequency tweeter by means of the high-Q inductance and capacitance comprising this efficient crossover network. The highs and lows are brought into acoustic balance by means of a continuously variable level-brilliance control. Control has a 2 1/2 ft. long cable for remote mounting. Network matches 8-16 ohm speakers with insertion loss reduced to a minimum. Enclosed in metal case 6" L x 2 3/8" H x 2 3/8" D. With full instructions. Shpg. wt., 5 lbs.

**8.75**

LN-2 .....Net 8.75

**3 WAY CROSSOVER NETWORK**

Carefully designed and engineered to Lafayette's own specifications. Insertion loss is well below the acceptable minimum. Crossover is at 350 and 5000 cycles. Permits full enjoyment of any 3 way system. Properly balances woofer-mid range speaker and tweeter inputs. Complete with 2 continuously variable "presence" and "brilliance" controls for tonal adjustment and full instructions. 8" L x 3 3/4" H x 2 3/8" W. Shpg. wt., 7 lbs.



LN-3 .....Net 14.95

**3 WAY HI-FI SPEAKER SYSTEM**



**55.50**

- 15" Woofer with 31.5 oz Magnet
- 8" Mid-range speaker
- Acoustical Lens Tweeter
- 3-Way Crossover Network

A complete 3-way system capable of performance heretofore found only in systems at many times this price. The components were specially selected by Lafayette sound engineers to offer the maximum in audio fidelity at the lowest price possible. Includes continuously variable presence and brilliance controls. Offers superb reproduction across the entire audio spectrum. Shpg. wt., 25 lbs.

SY93 .....Net 55.50

**LAFAYETTE RADIO**

DEPT. ACB

100 SIXTH AVE., NEW YORK, N. Y.  
 BOSTON, MASS., 110 Federal St.  
 PLAINFIELD, N. J., 139 West 2nd St.  
 NEWARK, N. J., 24 Central Ave.  
 BRONX, N. Y., 542 E. Fordham Rd.

# Hi-Fi on Low Budgets

## Electro-Voice®

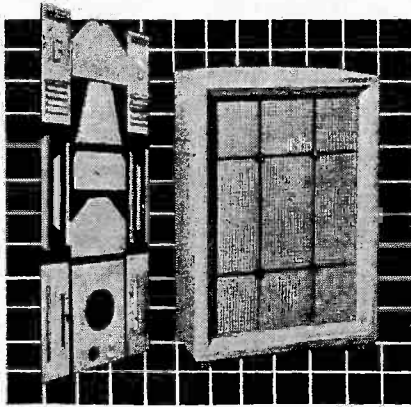

### DO-IT-YOURSELF SPEAKER CABINET KITS

Assemble the Electro-Voice Aristocrat KD 6 corner folded horn cabinet. Factory assembled and finished, it retails for \$69.00. It's yours in kit form for just \$39.00!

Your Aristocrat enclosure comes pre-cut, partially-assembled. You get glue, illustrated step-by-step instructions, *everything you need.*

Finish your Aristocrat cabinet in cherry, cordovan mahogany, walnut, golden oak, fruitwood or ebony. Finishing kits, \$5.

### Build Your Speaker System One Economical Step at a Time

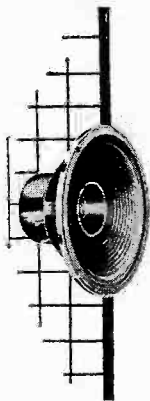

Start with the Electro-Voice Model SP12B coaxial loudspeaker — just \$33.00:

*Step up* your enjoyment by adding E-V Model T35B VHF driver, AT37 level control, X36 crossover for those silky highs.

*Or step up* with T10A HF driver, 8HD horn, AT37 level control and X825 crossover for more mid-range response.

*Complete* your integrated Electro-Voice system by adding *all* the above to your basic speaker. You'll have a custom 3-way hi-fi system.

#### Hear the Difference

See your Electro-Voice dealer TODAY! Use the Electro-Voice Speaker Systems Selector to hear the difference as you dial from a single speaker to a multi-way system.

Write for Bulletin 211--B72

## Electro-Voice®

ELECTRO-VOICE, INC. • BUCHANAN, MICHIGAN  
Export: 13 East 40th Street, New York 16, U.S.A.  
Cables: ARLAB

## KNIGHT AMPLIFIER

Continued from page 36

ohms), so that it is restricted in application for optimum results—but it will work with 4- or 16-ohm speakers at a slight reduction in maximum undistorted power output. It cannot be operated without a load, but that merely makes the usual precaution more important, for no amplifier really should be operated that way. These are minor points in view of the amplifier's power response when used properly; this is shown in the top curve, Fig. 2. The curve was obtained by measuring at various frequencies the power output just below that at which distortion became visible on an oscilloscope. It is an imprecise measurement, to be sure, but it gives a fairly good idea of the steady-state power capability of an amplifier at very low and very high frequencies. According to this test, maximum power is down 3 db from rated power at 21 and 17,000 cps. Among amplifier-preamps under \$75 that stands up very well.

On the same chart are shown curves of frequency response at maximum setting of the volume control: with tone controls flat, at maximum boost, and at maximum cut. In the flat setting the response specification is exceeded easily. Note the low turnover frequency of the bass control, which is desirable in this type of control to minimize boom.

Fig. 3 shows, in the lower curve, the equalization characteristic of the pre-amplifier section. It is a compromise, as any fixed equalization curve must be, but the rolloff is substantially less than the RIAA curve or any of the formerly popular curves (with the exception of some European records). There are three ways in which the requisite additional rolloff might be obtained: first, by means of cartridge loading; the 39-K input resistor is a low enough termination to produce rolloff in some variable-reluctance pickups. Second, the treble control has an operating range that is appropriate for fine adjustments of equalization. Third, some extra loss

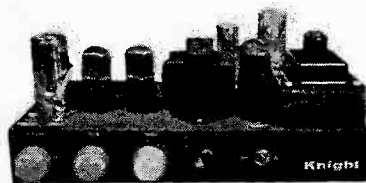

Appearance of the front control panel.

of extreme high frequencies is obtained, whether desired or not, whenever the volume is set at other than maximum or minimum position. This is caused by capacitive loading of the control; the effect is illustrated in the upper curves, Fig. 3.

At maximum setting there is no ap-

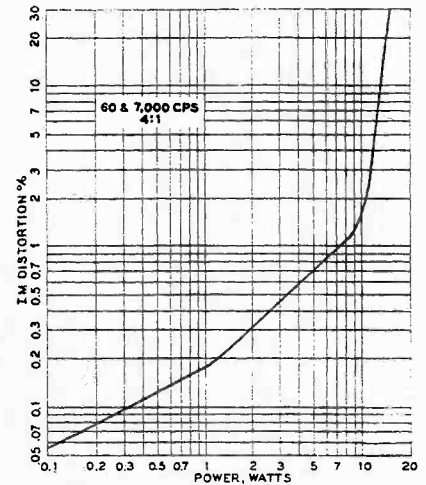

Fig. 4. IM distortion, high-level input.

preciable loss, because there is no resistance in series with the shunt capacitance to form a low-pass filter. When the volume control is turned down to give 3 db attenuation at 1 Kc, there is a little more than 6 db extra attenuation at 20 Kc. For a —6-db setting of the control, the relative rolloff is at its maximum, about 8 db at 20 Kc. At lower settings this rolloff decreases, being about 7 db and 2.5 db at 20 Kc for volume attenuations of 10 db and 20 db, respectively. Since the amount of rolloff is variable with the volume setting and would be effective on any source, not only records, it must be compensated for in each listening circumstance by adjustment of the treble control as required. Alternatively, permanent partial compensation probably could be obtained by using a tapped volume control, with a small capacitor connected from the top of the control to the tap.

To our way of thinking, that is the only serious disadvantage of the amplifier. The intermodulation distortion curve in Fig. 4 is something to boast of. At 10 watts we measured 1.53% —almost exactly the 1.5% specified— and it was measured after 20 hours of use. It is less than 1% at 7 watts, and 0.17% at 1 watt. That is good performance for any 10-watt amplifier. Stability is excellent at both ends of the frequency range. Hum level is very low; at normal volume-control settings noise cannot be heard. Gain is higher than that specified, 0.5 volt for full output. On records it requires some adjustment of tone controls to achieve proper balance. Once this is done, the sound is excellent up to fairly high sound levels.

In sum, the amplifier has some important limitations and many surprisingly fine features. It can't compete with ultraquality amplifiers. But you don't expect to get Rolls-Royce quality when you pay for a Crosley; you are delighted if the Crosley gives Ford comfort and performance. This Crosley does.

Save yourself time and trouble  
by ordering your books directly from us.  
Just fill in the coupon below.

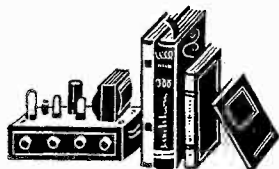

# audiophile's bookshelf

## HIGH FIDELITY RECORD ANNUAL: 1956

Edited by **ROLAND GELATT**. The second volume in the planned series of *High Fidelity Record Annuals*. Included in this new collection are reviews of classical music and the spoken word which appeared in *HIGH FIDELITY Magazine* from July 1955 through June 1956. Comparisons with recordings of previous years emphasized. A performer index is included. \$4.50 **237**

## MAINTAINING HI-FI EQUIPMENT

By **JOSEPH MARSHALL**. A much needed book on the specialized approach necessary to service high-fidelity equipment. The author discusses not only electronic faults, but the mechanical and acoustical defects which cause a hi-fi system to function less than perfectly. Hard cover, \$5.00 **232** Soft cover, \$2.90 **233**

## HIGH FIDELITY CIRCUIT DESIGN

By **CROWHURST & COOPER**. Two of England's top high-fidelity writers give complete information on high-quality audio circuit design procedures. The authors discuss circuit components, derive design formulas, describe testing methods and test equipment, and give examples of how to design data for the improvement of existing audio systems. Numerous diagrams and charts. \$5.95 **218**

## AMPLIFIERS

By **NORMAN H. CROWHURST**. Will help solve the problems that often arise when equipment has been built, but won't work. The "Trouble Tracing Guide" gives a table of symptoms, possible causes, and references to chapters which offer aid. \$1.00 **213**

## THE QUEST FOR QUALITY

By **NORMAN H. CROWHURST**. Discusses the basic requirements for fidelity and the various methods of achieving it. Shows how to design equalizers, how to build circuits for expanding dynamic range, how to check equipment. Also takes up various kinds of stereophony, and the arrangement of a listening room for the greatest pleasure. \$1.50 **217**

**BINDERS FOR AUDIOCRAFT** — attractive blue leatherette — each holds 14 issues. \$3.50 each. **223**

## HI-FI YEAR BOOK

Edited by **MILES HENSLOW** of *Record News*

The first complete, authoritative handbook about hi-fi in England. Not only the basic concepts of high-fidelity sound reproduction but complete descriptions of all major British hi-fi components.

Percy Wilson in *The Gramophone* says: "I know of no other book like it, or one that is so full of up-to-date and highly informative technical matter." \$2.25 **238**

FEBRUARY 1957

## HIGH FIDELITY A Practical Guide

By **CHARLES FOWLER**, Publisher of *AUDIOCRAFT Magazine*

Whether your budget is small or large, whether you are a beginner or a devotee from way back, this complete and definitive guide can help you get the most enjoyment out of your high-fidelity system.

Here is the practical, expert advice needed by everyone who has, or expects to have, a high-fidelity system. Starting with an introduction to sound, the author then describes the various links in the hi-fi system, explaining their features and specifications so as to provide the most helpful criteria for evaluating, and for selecting and matching components. \$4.95 **234**

## TAPE RECORDERS AND TAPE RECORDING

By **HAROLD D. WEILER**. This book, by the author of the best-selling *High Fidelity Simplified*, supplies the amateur and semi-professional tape recordist with sound, practical, and factual information about all aspects of tape recording — microphones and their placement for both indoor and outdoor recording, room acoustics, sound effects, recording from discs and off-the-air, maintenance, etc. All the vital principles necessary for the realization of optimum results with tape recorders. Paper, \$2.95 **225** Cloth, \$3.95 **243**

## THE FORMS OF MUSIC

By **SIR DONALD FRANCIS TOVEY**. Written by one of the most literate and profound of modern interpreters of music — its theory and history, these essays are all drawn from those articles on music which Tovey prepared for the *Encyclopaedia Britannica*. There are in all twenty-eight articles on different kinds and elements of music — aria, chamber music, concerto, harmony, mass, melody, opera, programme music, sonata, symphony, and others. Paper, \$1.35 **239**

1 Book Department  
1 AUDIOCRAFT Magazine  
1 Great Barrington, Mass.

1 I enclose \$..... for which please send me, postpaid, the  
1 books indicated by the circled numbers below. (No C.O.D.'s  
1 or charge orders, please.) Foreign orders sent at buyer's risk.  
1 Add 55¢ per book for postage on all foreign orders except  
1 Canadian.

1	NAME .....	213	233
1	.....	217	234
1	.....	218	237
1	ADDRESS .....	223	238
1	.....	225	239
1	.....	232	243

HAVE LESS  
RUMBLE  
FLUTTER  
WOW  
FOR  
HALF  
THE  
PRICE\*



GET A  
BELT  
DRIVEN

*Professional*  
JUNIOR  
TURNTABLE

Write for complete details and name of dealer nearest you.

COMPONENTS  
CORPORATION

DENVILLE, NEW JERSEY  
Department J.

\$39.50\*

## RECORDER MAINTENANCE

*Continued from page 22*

neously the pressure roller pushes the tape against the drive capstan. In most home recorders the tape is not driven directly by the motor's shaft, but by a capstan flywheel connected to the motor by a rubber idler puck. These parts are located beneath the base plate and within the carrying case, Fig. 6. Occasionally the surfaces of the motor shaft, puck, capstan flywheel, and pressure roller should be cleaned with a solvent preparation or alcohol. The pressure roller and drive puck should be removed, the bearings and shafts cleaned, a small amount of SAE 5 motor oil added, and then everything carefully replaced.

Most of this needs to be done but once a year or at the time parts are replaced; however, the heads, pressure

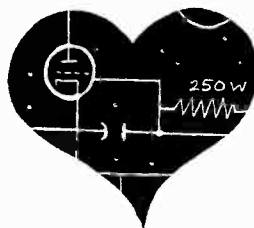

rollers, and capstan should be cleaned frequently, as in the case of a professional machine. The pressure-roller stud (shaft) must be parallel to the capstan or the tape will creep up or down on the capstan. Straighten the stud as needed to return it to the parallel position.

Through continual use the stop-button lever, to which is attached the brake activating hook, may become so bent as to be intermittent or ineffective in operation. This must be bent back to the point where the brakes will release the reel discs completely when any other of the buttons is depressed. When the stop button is depressed, the bell crank attached to the lever's actuating hook must disengage the capstan idler puck from the motor shaft and capstan flywheel assembly. When the recorder is not in use, the stop button must usually be depressed to disengage the linkage, so that flat spots will not develop in the pucks. Certain motors used in recorders of this type may develop a slight bind that will cause them to run slow or to flutter. This difficulty may be corrected by removing the motor's fan and end bell (Fig. 7), bending the shaft-centering spring so that the shaft rotates freely, and then replacing the parts. Be sure to replace washers and gaskets in exactly the positions from which they were removed.

The statements made in reference to the adjustment of the Stancil-Hoffman

R-5 and the V-M 700 Tape-O-Matic machines may be applied to other tape recorders in similar classes, although the actual parts used and adjustment methods may differ. No attempt has been made to discuss repair methods, for they depend upon the particular part or function that has failed. It may be necessary to consult the manufacturer, or the instruction manual, or to send the machine out for service. The purpose of this article has been to give information that will prevent mechanical failures.

I should like to express thanks to William V. Stancil of the Stancil-Hoffman Corp., Roy Parr of the V-M Corp., and W. D. Renner of the Howard W. Sams Co. for technical assistance and photographs.

## AMPLIFIER DESIGN

*Continued from page 25*

of about 190 ma, giving an average of about 115 ma. This produces 46 watts across 400 ohms.

The solid load line in Fig. 9 represents a plate-to-plate resistance of 6.5 K (or a resistance for the single plate of 1.625 K). The peak plate voltage swing, 300 volts, produces an output power of 28 watts, which is higher than either the pentode or triode method of operation.

Distortion is found to be about 3.3%, almost pure third harmonic. It may be wondered at this point why such a method of operation is called "ultra-linear" since the distortion is not appreciably better than either of the other methods of operation. What the simple figure of distortion does not indicate is how tolerant the circuit is of different impedances.

Compared with triode operation this arrangement gives more than twice the power. Compared with pentode operation the increase in power is not so great, but the performance is almost as independent of load as with triode operation. The composite characteristics, if drawn in full, would prove to be much nearer to a set of parallel straight lines than any of the other methods of operation, with the result that this circuit is not critical of inductance components in the load. That is very important in the practical working of the circuit, although it may not be so important when the amplifier is tested with a resistance load.

It would of course be possible to operate the ultra-linear circuit as a cathode follower, by so coupling the screen that its voltage swings by 57% of the cathode swing while the plate voltage is connected to B+, as shown in Fig. 10. This would require an input drive of  $300 + 45 = 345$  volts



peak, or 690 volts peak-to-peak, which is even more than the drive required for pentode operation. The feedback ratio is 345/45 or 7.67, which would reduce the distortion to less than 0.5%.

The source resistance as a cathode follower can be obtained by considering 5 volts excursion from the operating point at full output. This is 18 ma

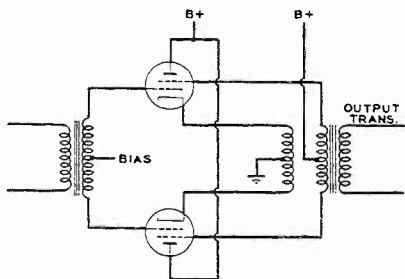

Fig. 10. Schematic of circuit for operating tubes as ultra-linear cathode followers. For 43% equivalent tapping, the screen winding must have 57% of the turns in the cathode winding. Extremely good coupling between the cathode and screen windings is essential.

for 5 volts, or about 280 ohms. There would be about 1,100 ohms cathode-to-cathode, or about 1/6th of the load resistance. The ultra-linear circuit operating normally will have over 7½ times this value, or about 1.25 times the load resistance. As described in the previous article, this would be a good starting point for applying over-all feedback and it would be quite permissible to use, say, 20 db of over-all feedback to achieve a damping factor of about 8.

*This article, and the current series, will be concluded next issue.*

## GROUNDING EAR

*Continued from page 5*

loudness control from which compensation can be removed, good bass and treble controls, and independent 5-position phono rolloff and turnover controls. Input circuits will accommodate both amplitude and magnetic pickups, as well as radio, TV, and tape sources. There is a jack to feed a tape recorder, although it follows the tone controls.

Two 6BQ5's are used as pentodes in the output stage for a claimed 18 watts output. These are driven by half of a 12AX7 direct-coupled to another half as a split-load inverter. A high feedback factor is obtained by a loop from the voice-coil winding to the cathode of the driver stage. The high sensitivity of pentode operation, permitting the use of such a simple driver arrangement, makes possible an unusually great amount of feedback because there is only one RC coupling network within the loop. In spite of the fact that the preamplifier is fed by the same power

*Continued on next page*

# Jones Apparatus supplies

## The ONE Biamplifier Filter with ALL filter Advantages

PLUS a new accuracy, unheard of before in filters

PLUS a modernization service for older units.

AND the PRICES are RIGHT — Kits, Assembled-to-Order Units,

Modernization, Special Units — all on a direct to you basis.

TOPS in MULTIAMPLIFIER DRIVES, where two (or more) amplifiers are desired to work by range, each direct to a speaker unit. JONES ACo. Powered Variable Cross-over Controls have what it takes to combine with the highest quality audio units. It receives the usual high impedance preamplifier output. Outputs are independent and separately level controlled. By the turn of the pointer the crossover may be set for anywhere from 90 to 1,100 cps., or on the high range units, from 900 to 11,000 cps. Kits include a "how to make and operate" Manual, a prepared chassis and all parts needed for operation.

Prices: Stock Kit, state range, either "HIGH" or "LOW" ..... \$39.90  
Packing and Mailing ..... 1.10  
These Kits are made up in lots. Allow for delivery time.

Illustrated Manual only ..... \$1.00, refundable as credit on next purchase  
Units Assembled to order, as above ..... \$64.00. Sent by Express, shipping collect.  
Custom variations of above are extra.

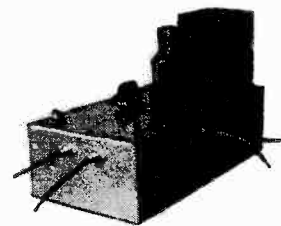

Recognizing the need for a completely versatile Biamplifier System, as shown by Allison's article in HIGH FIDELITY, we list our answers from the widest field of experience.

1. Why only 1/20 of the former low level of distortion? So that the full benefits of reduced distortion from biamplifier operation may be retained.
2. Why no gain? (This feature may be cut out). To prevent increasing the pre-amp hum and noise.
3. Why a single unit, safe to use in pairs or combined threes? To maintain full unit control; to allow flexibility in sequence arrangement for producing desired effects.
4. Why a Modernization Service? All JONES APPARATUS units can and should be the best of their kind. \$15 does it. Write.

## PARTS FOR FIXED NETWORKS

It is simply a matter of highest known Network efficiency, flexibility and completeness, all there at once. Easy to follow, illustrated instructions are always supplied.

TOPS in ALLOCATING TRUE OUTPUT to Woofer Mid-Range and Tweeter, JONES APPARATUS Cross-over Networks in heavy duty, half section, air core design are available, with 2 inductors, 2 caps, 2 speaker controls and accessories:

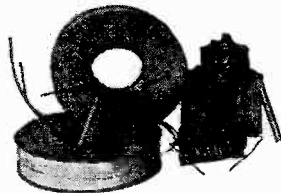

### For 8 ohm impedance to match 8 ohm speakers:

Crossover freq. & Order No.	Inductors In mh.	Capacitors in mfd.	Price complete
85-S 8	10.2	320	\$26.50
175-P 8	10.2	80	24.00
350-P 8	5.1	40	16.50
1,100-P 8	1.6	12	11.50
2,200-P 8	0.8	6	11.60
4,400-P 8	0.4	3	10.50

### For 8-12 ohm mid-range speakers with 10-16 ohm tweeters

2,800-P 10	0.8	4	\$ 9.00
------------	-----	---	---------

### For 16 ohm impedance to match 15-16 ohm speakers:

175-S 16	10.2	80	\$24.00
350-S 16	5.1	40	16.50
1,100-S 16	1.6	12	11.50
2,200-P 16	1.6	3	12.50
4,400-P 16	0.8	1.5	10.80

(Match Network to speaker on low output wherever speakers do not match each other. Limit of mismatch is a ratio of 1 to 2, with preference for lower impedance on speaker of lower tone.)

WALTER M. JONES

*Apparatus Co.*  
INCORPORATED

P. O. BOX 277

SHEFFIELD, MASS.

**BEST BUY  
IN HI-FI  
Grommes  
KITS**

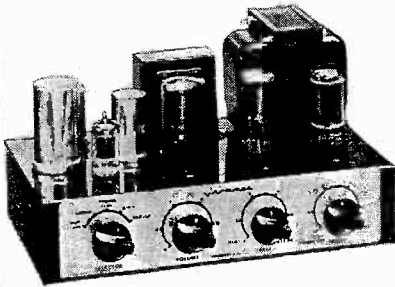

**THE Little Jewel  
MUSIC LOVERS AMPLIFIER**

Featured by Life Magazine as the best buy in the field . . . now available in Kit Form. It's easy and fun to assemble. Power Output: 10 Watts. Freq. Response:  $\pm 1$  DB, 20 to 20,000 CPS. With 3 inputs: Radio, Magnetic and Crystal Phono and Microphone. Charcoal and Gold Finish. Including 5 tubes and complete instructions. Shipping Weight: 9 lbs. LJK Kit ..... Net **\$24.95**

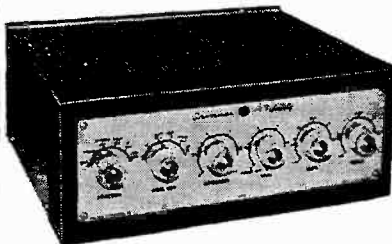

**61-PGK 20 Watt AMPLIFIER**

Single unit Hi-Fi amplifier with built-in pre-amplifier and all the controls. This exceptional Kit provides separate turnover and roll off record compensators and loudness, volume, feedback bass and treble tone controls. Freq. Response:  $\pm 0.5$  DB, 15 to 30,000 CPS. Charcoal and Gold Finish. Shipping Wt. 20 lbs. Complete with easy-to-follow instructions. 61-PGK ..... Net **\$59.50**

See your Hi-Fi Dealer.  
If he cannot help you, write . . .

**Grommes**

A Div. of Precision Electronics, Inc.

Dept. C-2, 9101 King St., Franklin Park, Illinois

- Send complete Kit details.
- Send ..... Kit.
- COD (\$5 enclosed).  Postpaid. Full payment enclosed. Enclose name of Dealer.

Name .....

Address .....

City ..... Zone ..... State .....

10-day money back guarantee on all Kits

**GROUNDING EAR**

*Continued from preceding page*

supply, the stability is excellent even with maximum bass boost.

In the preamplifier, two halves of another 12AX7 are cascaded with the tone controls between. Both stages, however, have large amounts of feedback which results in a commendably low order of distortion.

The performance of the unit was very good, indeed; at the price (\$65) it represents an excellent buy—and a challenge to our own industry.

**TRANSISTORS**

*Continued from page 29*

that it represents 1,000 ohms, so  $R_1 = 1,000 - 300 = 700$  ohms. Also,  $R_1$  can be found because its current is

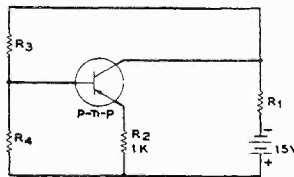

Fig. 9. Widely used practical circuit.

(reading from the graph)  $150 \mu a$ , and its voltage (reading from the circuit) is  $(12 - I_c R_2)$  volts or 9.7 v. Thus

$$R_1 = \frac{9.7 \text{ v}}{150 \mu a} = 65 \text{ K.}$$

*Example 4.* Now we're ready for the last problem—one of considerable complexity. Fig. 9 is a bias network that is quite common, because of its good stability. Assume that the desired quiescent point is as shown in Fig. 10, and that the current through  $R_1$  must be

ten times the base current for good regulation in the  $R_3$ - $R_4$  voltage divider. Further, the emitter resistor is fixed by design at 1,000 ohms. Values for  $R_1$ ,  $R_3$ , and  $R_4$  are desired.

The voltage drop across the emitter resistor is known, since we know the emitter current is approximately equal to the collector current of 4 ma (determined by the quiescent point). It is just 4 v. Since the voltage across the transistor is 7 v (read from the quiescent point also), and the supply is 15 v, the drop across  $R_1$  must be  $15 - 7 - 4$ , or 4 v.

Current flowing through  $R_1$  is the sum of the collector current and ten times the base current of  $70 \mu a$ , or just 4.7 ma. Therefore, the resistance  $R_1$  must be  $4 \text{ v} / 4.7 \text{ ma}$ , or 850 ohms.

$R_3$  has a current 10 times the base current flowing through it, or 0.7 ma. The voltage across it, under the assumption that the base-to-emitter voltage is negligible, is 7 v, the emitter-to-collector quiescent value. Therefore its resistance is  $7 \text{ v} / 0.7 \text{ ma}$ , or 10 K. Similarly, the voltage across  $R_4$  is the same as that across  $R_3$ , or 4 v. With a current of 0.63 ma the correct resistance turns out to be 6,400 ohms.

We have solved Fig. 9 completely now—and have designed, on paper, a bias network that will produce the desired quiescent point.

The purpose of these examples was to show the reader the two approximations usually made in designing bias networks, and to show that this part of the work, determining resistance values, is straightforward. However, determining which of several bias networks is the *best* in each case, and finding the best quiescent point, are not so easy.

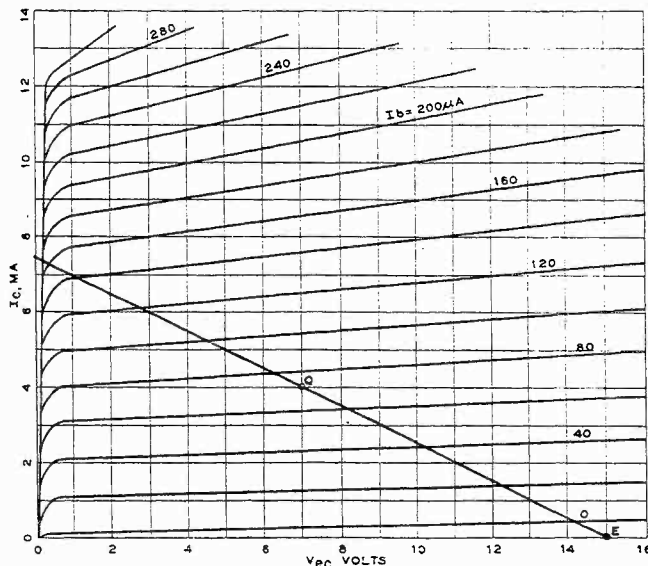

Fig. 10. Chart that shows operating conditions for which resistance values in Fig. 9 are calculated.

Part b, the concluding half of this article, will appear next issue.

We'll pay \$5.00 or more for usable Audio Aids. See page 31 for details.

## BASIC ELECTRONICS

*Continued from page 33*

through 15 is undoubtedly the most difficult of any covered in this series — not because it is especially complex or hard to comprehend, but because the actions of elements in various combinations are so alike in some ways, yet so different in others. The fact that the calculations involved are tedious merely adds to the fog. Yet a clear understanding of reactive effects and resonance is necessary if frequency discrimination, coupling networks, tone controls, filters, and a great many other important matters are to be understood. The reader is urged, therefore, to go over these chapters two, three, or more times until the material is absorbed thoroughly.

### Appendix

It is required to derive a formula for the resultant impedance of resistance and capacitance in parallel. Refer to Figs. 1 and 3.

$$R = E/I_R, \text{ or } I_R = E/R;$$

$$X_C = E/I_C, \text{ or } I_C = E/X_C.$$

$$I_S = \sqrt{I_R^2 + I_C^2} = \sqrt{\left(\frac{E}{R}\right)^2 + \left(\frac{E}{X_C}\right)^2}$$

$$= \sqrt{\frac{E^2}{R^2} + \frac{E^2}{X_C^2}}$$

$$Z = \frac{E}{I_S} = \frac{E}{\sqrt{\frac{E^2}{R^2} + \frac{E^2}{X_C^2}}}$$

$$Z^2 = \frac{E^2}{\frac{E^2}{R^2} + \frac{E^2}{X_C^2}} = \frac{E^2(R^2 X_C^2)}{E^2(R^2 + X_C^2)}$$

$$Z^2 = \frac{R^2 X_C^2}{R^2 + X_C^2}$$

$$Z = \frac{R X_C}{\sqrt{R^2 + X_C^2}}$$

### TAPE NEWS

*Continued from page 12*

added to taste by adjustment of microphone distance. A cardioid mike will have to be situated several times as far away as an omnidirectional one, of course, for the same amount of blending and reverberation. Except for this generalized observation, an ideal recording environment like this is best left up to the ingenuity of the recordist. The usual rules of mike placement (outlined in the preceding issue) should be followed, but the possibilities of recording in such acoustic conditions are so unlimited that a suggested mike placement could be more misleading than helpful.

Lack of reverberation is much more difficult to cope with than excessive reverberation, since it is always easier to suppress sounds than to conjure them up from nowhere. An omnidirectional or bidirectional mike is almost a must

*Continued on next page*

# COMING to your city HIGH FIDELITY MUSIC SHOWS

*See and hear the latest in HIGH FIDELITY from leading high fidelity manufacturers . . .*

Don't miss these public showings of Hi-Fi Equipment . . . from the most economical units for the budget-minded to spectacular home music theatres . . . compare and enjoy them all. Components and complete systems will be displayed.

## THREE DAYS OF CONTINUOUS DEMONSTRATIONS

1 P.M. to 10 P.M.

Detroit	February 1, 2, 3	Statler Hotel
Cleveland	February 22, 23, 24	Hollenden Hotel
Pittsburgh	March 8, 9, 10	Penn-Sheraton Hotel
Baltimore	March 22, 23, 24	To be announced
Seattle	August 23, 24, 25	To be announced
Portland, Ore.	Sept. 6, 7, 8	To be announced
Cincinnati	September 20, 21, 22	Sheraton-Gibson Hotel
Miami	October 18, 19, 20	McAllister Hotel
St. Louis	November 22, 23, 24	Statler Hotel

Rigo Enterprises, Inc. 500 North Dearborn Street, Chicago 10, Illinois

## COLBERT ELECTRONIC 3-CHANNEL FREQUENCY DIVIDER

As appears in  
**TESTED IN THE HOME**  
November 1956 issue

**MODEL 3-CFD \$154.50**

Decorator style case in blonde or mahogany formica finish... **\$15**

*Slightly higher in west and deep south*

Over-all output is excellently clean; cut-off rates are 6 to 9 db per octave; levels change somewhat with adjustment of crossover controls; hum and noise are not audible — which is quite an accomplishment for an electronic crossover. Just proves it can be done if enough attention is paid to design and manufacture. All in all, highly commendable. If anyone doubts the value of an electronic frequency divider, this should convince them. — C.F.

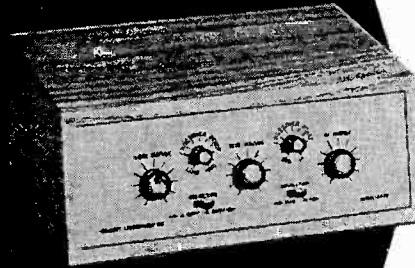

For full specifications see your dealer or write to Dept. AC27

**colbert**

LABORATORY, INC.  
160-09 Hillside Avenue  
Jamaica 32, New York



**colbert**  
LABORATORY, INC.

### SPECIFICATION SUMMARY

- Eliminates speaker impedance and efficiency mismatches
- Eliminates resonant filters (fixed crossover networks)
- Three-channel operation results in lowest over-all distortion
- Affords optimum damping of individual loudspeakers
- Features variable cross-over controls for low, mid and high ranges
- Provides individual level controls for each sound channel
- Designed for use on two or three way systems
- Eliminates distortion due to higher frequency harmonics
- For use with regular or electrostatic loudspeakers, or combinations
- Includes high quality 10 watt ultralinear amplifier of great stability

# AUDIOCRAFT

## Sound Sales Directory

Following is a list of dealers who state that they carry the products specified.

KEY TO PRODUCTS HANDLED	
1	Audio system components
2	Speakers and enclosures
3	Records and record accessories
4	Tape recorders
5	Pre-recorded tape
6	Radio hardware
7	Tools, wood
8	Audio parts
9	Microphones
10	Books
11	Test equipment

*A series of items numbered consecutively is identified by a hyphen between the first and last numbers. Thus, 1-6 indicates 1 through 6; 8-11 indicates 8, 9, 10, and 11.*

### CALIFORNIA

#### Hollywood

Hollywood Electronics  
7460 Melrose Ave.  
Webster 3-8208 1, 2, 4, 5

#### Los Angeles

Beverly Hi-Fi  
468 S. Robertson Blvd.  
CRestview 4-8045 1, 2, 4, 5, 9

### CONNECTICUT

#### Hartford

Belmont Record Shop  
163 Washington St.  
CHapel 9-0414 1-5, 8-10

#### West Hartford

Audio Workshop, Inc.  
1 South Main St.  
Adams 3-5041 1-5, 9, 10

### DELAWARE

#### Newark

Delaware Music House  
20 Academy St.  
Endicott 8-3258 1-5, 8, 9

### GEORGIA

#### Atlanta

Baker Fidelity Corp.  
1140 Peachtree St., N. E.  
TRinity 5-2156 1-6, 8, 9

### ILLINOIS

#### Chicago

Allied Radio Corp.  
100 N. Western Ave.  
HAYmarket 1-6800 1-11

Evergreen Allied High Fidelity, Inc.  
2025 W. 95th St.  
BEverly 8-1067 1-11

Voice and Vision, Inc.  
921 N. Rush St. 1-11

#### Evanston

Allied High Fidelity Stores, Inc.  
602 Davis St.  
DAvis 8-8822 1-11

#### Oak Park

West Suburban Allied High Fidelity, Inc.  
7055 W. North Ave.  
EStebrook 9-4281 1-11

### LOUISIANA

#### New Orleans

The Music Shop, Inc.  
4215 South Claiborne Ave.  
TW. 1-5871 1-5

### MASSACHUSETTS

#### Boston

The Listening Post, Inc.  
161 Newbury St.  
COpley 7-7530 1, 2, 4, 8-10

### MISSOURI

#### St. Louis

The High Fidelity Showroom  
6383 Clayton Rd.  
Parkview 1-6500 15, 9

### NEW JERSEY

#### New Brunswick

Monmouth Music House  
215 Bevier Road  
CHarter 9-5130 1, 2, 4, 5, 9

### NEW YORK

#### Albany

Audio-Video Corporation  
324 Central Ave.  
3-1167 1-5, 8-10

#### Buffalo

Frontier Electronics, Inc.  
1507 Main St.  
GA. 5727 1-5, 8-10

#### New York City

Arrow Audio Center  
65 Cortlandt St.  
Dlgy 9-4730 1, 2, 4-6, 8-11

### PENNSYLVANIA

#### Philadelphia

Danby Radio Corp.  
19 South 21st St.  
Rittenhouse 6-5686 1-5, 8-10

Ten Cate Associates  
6128 Morton St.  
Germantown 8-8500 1-5, 8-10

### WASHINGTON

#### Seattle

High Fidelity Headquarters  
603 Broadway North  
CApitol 2266 1-4, 8, 10

### WEST VIRGINIA

#### Charleston

Electronic Specialty Co.  
Virginia Street W., At Park Avenue  
3-5656 1-11

### CANADA

#### Montreal

Payette Radio Limited  
730 St. James West  
UNiversity 6-6681 1-11

### TAPE NEWS

Continued from preceding page

where echo is inadequate; every available bit of rear pickup will be needed. If the acoustic environment is hard, a bidirectional mike will minimize reflections from the side walls and ceiling (where most of the hardness is likely to originate). Soft reverberation will produce about the same results with either an omnidirectional or a bidirectional mike. The mike will have to be an appreciable distance from the group, to bring up the reverberation as much as possible, but it should not be backed off far enough to lose definition of the sound. A distance of 8 to 15 ft. will often prove to be ideal, although, again, it is a good idea to experiment with several different placements at an earlier rehearsal of the group.

Now let's shift the choir and the organ to the back of the church and stow them in a loft, just to complicate matters. Here the same acoustical considerations will apply, although the acoustics of any building usually become more live as the mike is raised toward the ceiling. The required mike placements at the rear of the church will be similar to those at the front; the problem arises when we try to get the microphone far enough away from, or high enough above, the group. A choir loft is by convention occupied entirely by the choir, with a small railing at the front (to prevent acrophobic choristers from falling into the congregation) and then a sheer drop of 20 to 30 ft. This means that a microphone stand of sufficient height to put the mike above the choir would have to be 30 or 40 ft. high, which is as unlikely as it would be dangerous.

Fortunately for the recordist, churches often have a few wooden or steel beams stretching at intervals across the ceiling, from side wall to side wall. These can be used to hang a microphone above the heads of the choir at any one of several predetermined distances. While a ladder could conceivably be used by a courageous individual to climb up and attach the mike, it is much simpler, safer, and more considerate of the church sexton to use a long length of rope (laundry cord, dyed black for low visibility, is ideal), which can be tossed over a beam and used to hoist the microphone and its cable to the desired height. Then the ends of the rope and cable may be brought back to the front of the choir loft and fastened to some out-of-the-way projection.

Two matters should be mentioned at this point, with regard to recording public performances and particularly when hanging microphones in the air. First, no recording like this should ever be attempted without first getting per-

mission from the performing group and those responsible for operating the church, auditorium, dance hall, or what have you. Failure to get prior permission can create unpleasant incidents, make you liable to law suits, and create ill feeling that will be disadvantageous if you ever need future favors from those involved. It is also conducive to good will and future co-operation if you inquire as to whether your proposed mike placement will be aesthetically offensive. Some clergymen, for instance, are remarkably tolerant of long ropes and cables festooned from the walls and ceiling; others will object if even the microphone is visible. If you find that the limitations so imposed will materially interfere with the quality of the recording, point this out to those who are most interested in the recording venture (besides yourself and your cohort). If nothing can be done about it, accept defeat with head unbowed and either do the best you can with the restrictions or fold your cables, like the Arabs, and as silently steal away.

Second, audiences are, in general, clumsy and unobserving. Keep all mike stands, ropes, and trailing cables where they cannot conceivably be tripped over; or ask if you can rope off a small section of seats for the mike stand, and then run the cables underneath carpets or small throw rugs (where the latter



**CABINET STYLES  
UTILITY STYLES  
(ILLUSTRATED)  
ASSEMBLY KITS**



DESIGNED AND MANUFACTURED by PAUL W. KLIPSCH, originator of the KLIPSCHORN\* speaker system, the SHORTHORN\* is second only to the KLIPSCHORN\* system in performance. Using coordinated acoustic elements, including filters, it offers exceptionally smooth response, free from distortion. Back loading horn extends bass range without resonance.

Available in handsomely finished enclosures, in stripped down utility styles (as illustrated) or separate components for assembly.

\*REGISTERED TRADEMARKS

**KLIPSCH**  
AND ASSOCIATES  
HOPE, ARKANSAS

will not prove too unsightly), or close to the wall baseboards. It is for this reason that I prefer to hang *all* microphones that must be located within the area normally occupied by an audience, running the ropes and cables across to one wall and thence to the recorder, keeping them above a height of 6 ft. until they leave the seating area (or area of maximum jeopardy).

Whenever a mike stand is used at a public performance, it is a useful safety measure to tie a half hitch in the cable around the bottom of the stand pipe. Then if someone becomes enmeshed in the cable there will not be enough leverage to knock the stand over onto the floor. Another precaution which is popular with recordists who frequently record public performances is an insurance policy covering your liability for injuries sustained by the man who breaks his leg tripping over your mike cable, or by the innocent bystander who gets clubbed by the falling mike stand. It isn't likely that your insurance company would ever have to pay up on this, but if they did, it would certainly make the small cost of the policy worthwhile.

Just what all this has to do with microphone technique may seem rather obscure, but it will have a direct bearing on cable placement, if not on mike placement, at public-performance recordings.

**BOOK REVIEWS**

*Continued from page 15*

however, the English author has had to spread himself rather thin, brushing lightly over the surface of a good many matters which go to make up the total electronics picture today. The work gives the reader the semblance of an air view of a great city, with the broad avenues and over-all outline and contours clearly discernible, but not the individual bricks or windows or even buildings which go to make up the total.

Being an engineer, he probably found it difficult at times to abstain from mathematics and engineering terminology to explain the subject, but in general he has succeeded rather well in describing some fairly involved phenomena in terms the layman can grasp.

The book starts with a roundup of the major fields of electronics, and recounts the history of modern electronics and physics research, then gives the basic details of electronic conductors and control devices, such as diodes, grid tubes, beam tubes, semiconductors, and so on. It goes on to cover signals and circuits, control of power, communications and broadcasting systems, navigational aids and radar, television, com-

*Continued on next page*

*entirely* **NEW type**  
**test record**



**the ONLY ONE**  
using actual  
**musical pitches**

The usual mathematical frequencies (ie 1000 cycles) are not musical pitches. The Series 60 uses actual scale tones to test your playback over entire chromatic range of 8 octaves—1 beyond the piano.

**the ONLY ONE**  
based on the  
established facts of  
human hearing

(FLETCHER-MUNSON CURVE)

Normal human hearing is not "even." Fletcher-Munson research has defined the exact variations at each pitch level. Side A of the Series 60 is adjusted so each tone will sound with equal loudness *to the ear* over the entire range. (Side B recorded flat.)

**the new COOK Series 60  
Chromatic Scale Test Record**

**the only one which tests  
BY EAR ALONE for:**

- frequency response
- transients (new tone burst device)
- room acoustics
- speaker hangover tones
- false resonances (spkr. enclosure)
- comparative loudness levels
- Absolute Pitch reference (stroboscopic label)

**12"—33-1/3 rpm—\$4.98**  
**With Informative Booklet**

At Your Dealer Now or send direct

**COOK Labs**

101 Second Street, Stamford, Conn.

Please send:

- Chromatic Scale Test Record
- New 1957 catalog
- (other).....

NAME .....

ADDRESS .....

\$4.98 enclosed

Bill me.

...the ultimate goal  
of the  
critical listener

**marantz**

*Audio Console*  
preamplifier, complete \$168\*

*Power Amplifier*  
\$198\*

\*slightly higher  
west of  
the Mississippi

write for literature

**marantz company**  
44-15 Vernon Blvd., Long Island City 1, N. Y.

If you're  
interested  
in true  
high fidelity

**YOU NEED THIS!**

... The authoritative, easy-to-understand story of how a hi-fi loudspeaker works. Tells you how to judge a good loudspeaker . . . what to look for, listen for. 32 fascinating pages, including dozens of diagrams and delightful cartoons. *Only book like it!* A wonderful guide for everyone who has a hi-fi system. A *must* for everyone who plans to purchase one!

Yours FREE—just send a dime to cover cost of mailing.

University Loudspeakers, Inc., White Plains, N. Y.



UNIVERSITY LOUDSPEAKERS, INC. Desk V-11.  
80 South Kensico Ave., White Plains, N. Y.

Gentlemen: Please send me my copy of "Speaking about Loudspeakers." Enclosed is Dime to cover the cost of mailing.

NAME \_\_\_\_\_

ADDRESS \_\_\_\_\_

CITY \_\_\_\_\_ STATE \_\_\_\_\_

## BOOK REVIEWS

Continued from preceding page

puters, instruments, and industrial electronics applications; a very comprehensive range of subjects indeed.

As explained in the introduction, the treatment is entirely descriptive and inevitably superficial, but should inspire the curious reader to progress to less elementary and more specialized literature.

## WOODCRAFTER

Continued from page 8

ever instrument was not in use. Installation is much the same as for a regular butt hinge.

The continuous or piano hinge (Fig. 2B) is actually a long butt hinge, ideal for hi fi, radio, television, desks, chests, tables and, of course, piano lids. Continuous hinges are available in various widths and can be cut to the length desired. They provide excellent support and prevent warping of the wood along the hinge side.

In the main, surface hinges (Fig. 3) are decorative in design, since, as the name implies, they are exposed to view. This category encompasses an almost endless variety of shapes and finishes. They are easy to install once the door is fitted correctly. Wedge the door in position allowing 1/16 in. clearance on each side. Holding each hinge in place, mark for screws and use a drill or awl to make a pilot hole. Then drive home the screws.

Several other types of hinge are shown in Fig. 4. The offset cabinet hinge is a type of surface hinge used for overlapping, lipped doors. The offset is generally 3/8 in., and the overlapping lip also is 3/8 in. To provide for this overlap, the door should be made 3/4 in. longer and wider than the opening it is to cover. When the door is pushed through the shaper, slightly more than 3/8 in. should be rabbeted off each inner edge to allow for an easy fit. The amount of offset, however, must be exactly 3/8 in., or whatever is the offset dimension of the hinge.

The semiconcealed hinge is another style of the offset hinge in which one leaf is fastened to the face of the cabinet and the other to the back of the door. It is made for both flush and lipped doors. In rabbeting the edge of a lipped door to take this hinge, an additional 1/16 in. must be removed from the inner

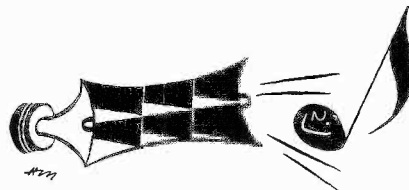

## PROFESSIONAL DIRECTORY

**TRIAL OFFER**

12 for \$1.00  
Twelve-Inch Record  
**COVERS**  
shipped prepaid  
Money Back GUARANTEE

Made of Polyethylene Plastic.  
Slips Inside Original Jacket

Keep your valuable records free from dust, scratches, finger marks, spilled liquids, etc.

Introductory SAMPLER DOZEN and SURPRISE BONUS \$1.00 Prepaid

Dealer Inquiries Invited

**BRADLEY MFG. INC.**  
11 W. Magnolia Blvd. Burbank, Calif.

**Artisan**  
**Build-It-Yourself**  
**ELECTRONIC ORGANS**

Send \$1.00 for "Organ Builders Manual"

**ELECTRONIC ORGAN ARTS**  
4878 Eagle Rock Blvd.  
Los Angeles 41, Calif.

**GIBSON GIRL TAPE SPLICERS**

splices in a wink!  
NO SCISSORS!  
NO RAZOR BLADES!  
Disposable cut tape ends  
and trim splice edges  
At Your Dealers

**ROBINS INDUSTRIES CORP.** Bayside 61, N. Y.

**AUTOMATIC CHANGER NEEDLE BRUSH**

**KLeeNeedLE**

KLeeNeedLE automatically keeps record changer needles clean. It is designed to remove the familiar "dust-blob" from under the needle point. At Your Dealer

**ROBINS INDUSTRIES CORP.** Bayside 61, N. Y.

**AUD-O-FILE**  
An entirely new method for filing Inc. records

NO INDEXES!  
NO JACKETS!  
NO SLEEVES!  
NO ALBUMS!

**ROBINS INDUSTRIES CORP.** Bayside 61, N. Y.

## TRADERS' MARKETPLACE

Here's the place to buy, swap, or sell audio equipment. Rates are only 20¢ a word (excluding address) and your advertisement will reach 20,000 to 35,000 readers. Remittance must accompany copy and insertion instructions.

TEST YOUR RECORDER'S PERFORMANCE. Excerpt Dubbings D-110 test tape \$98\*. Blank recording tape 3" reel: 3 reels \$1.00\*. Free catalog! \*Add postage. AMERTEST PRODUCTS CORP., 1280-B Sheridan Ave., Dept. AC2, New York 56, N. Y.

\$200 MONTHLY POSSIBLE, sewing babywear! No house selling! Send stamped, addressed envelope. Babygay, Warsaw 105, Indiana.

TAPE RECORDERS, tape. Unusual values. Free catalog. Dressner, 69-02D, 174 St., Flushing 65, N. Y.

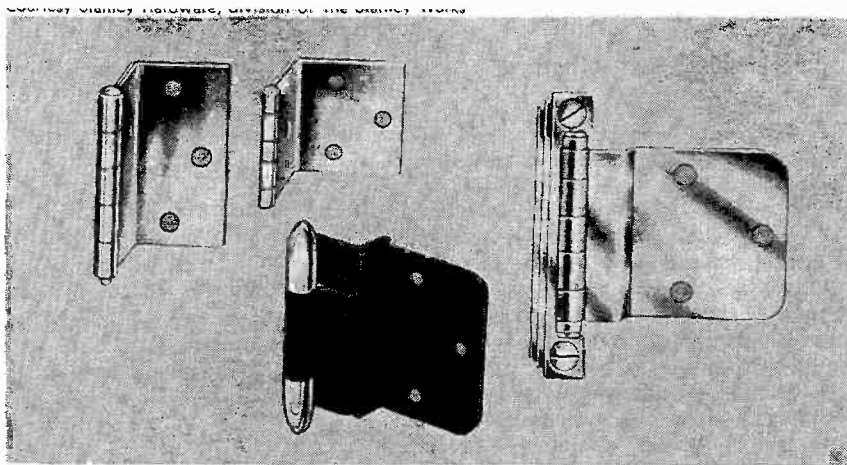

Fig. 4. Other types of hinge. Two at upper left are for use on plywood doors; hinge at lower center is for use on lipped door. Only barrel shows when mounted. Hinge at right is semiconcealed type; left leaf and barrel show when mounted.

width to accommodate the thickness of that portion of the hinge leaf that fits between the frame and the door.

The invisible hinge is employed principally on fine cabinet work. Holes bored into the corresponding edges of the door and the facing are the mortises into which these hinges are set. When the door is closed, no hinge is visible.

If you don't have a shaper or other power equipment for cutting lips on doors, cut your plywood to the required outside dimensions and take the doors to a cabinet shop. There the operation

can be performed quickly and reasonably.

A note of economic caution when working with the more expensive plywoods such as oak, walnut, mahogany, etc.: make maximum use of standard-size panels to avoid waste. For instance, for flush doors make the cabinet openings not more than 12 in., 24 in., or 36 in. in width. With an opening of not more than 12 in., it would be possible to cut two doors from a 24-inch width of plywood. An opening of over 12 in. would mean that only one door could be made from that same panel. For lipped doors, make the openings even smaller by at least  $\frac{3}{4}$  in.

Today's cabinet design frequently calls for sliding doors, and several excellent devices are available to provide for their smooth operation. You'll find them in nylon, metal, fiber, and wood — each with its own method of installation, some simple and some more involved. Whichever you select, follow the manufacturer's directions carefully during installation.

The choice of knobs and pulls can prove bewildering, but keep in mind that these pieces should be in harmony with the other hardware. Wood, metal, plastics, and glass have been shaped into a large assortment of designs with finishes ranging from natural to colored, in high sheen or flat tone. This is usually the simplest of all cabinet hardware to apply; some pieces are attached with screws, while others require a hole drilled through the wood to permit fastening from the inside with a washer-head machine screw. For sliding doors there are flush pulls that are mounted in recesses in the wood.

When a cabinet door is closed, it is the function of the catch or latch (Fig. 5) to hold it securely and yet release its grip easily when the door is opened again. One of the most widely used catches is the friction catch, which is

*Continued on next page*

## STEREOPHONIC BROADCASTING

EACH SUNDAY 2:05 P.M.

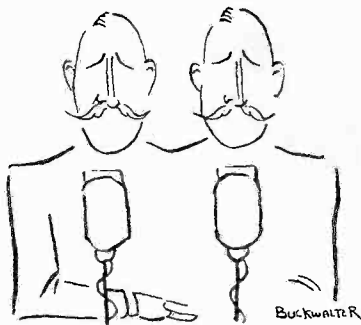

# WCRB

1330 AM

102.5 FM

**Boston's  
Concert Music Station**

A Good Music Broadcasters Affiliate

The specs prove it... IN HI-FI

### BEST BUYS are EICO

**NEW! HF20** **20-WATT Ultra-Linear AMPLIFIER**

**KIT \$49<sup>95</sup>**  
**WIRED \$79<sup>95</sup>**

COMPLETE with  
Preamplifier, Equalizer & Control Section

Highest quality Williamson-type complete-facility amplifier that sets a new standard of performance at the price, kit or wired. Rated Power Output: 20 w (34 w peak). IM Distortion: 1.3%. Max Harmonic Distortion: approx 1%. Power Resp (20 w):  $\pm 0.5$  db 20-20,000 cps;  $\pm 1.5$  db 10-40,000 cps. Freq Resp ( $\frac{3}{4}$  w):  $\pm 0.5$  db 13-35,000 cps;  $\pm 1.5$  db 7-50,000 cps. 5 feedback equalizations. Low-distortion feedback tone controls. 4 hi-level & 2 lo-level inputs. Conservatively rated, fully potted output transformer; grain-oriented steel, interleaved windings.  $8\frac{1}{2}$ " x 15" x 10". 24 lbs.

**HF60** **NEW! 60-WATT Ultra-Linear POWER AMPLIFIER**

**KIT \$72<sup>95</sup>**  
**WIRED \$99<sup>95</sup>**

with ACRO TO-330 Output XFMR

Superlative performance through world's finest components & circuitry — at incredibly low price. EF86 volt ampl direct-coupled to 6SN7GTB K-coupled phase inverter driving two U/L-connected p-p EL34 output tubes. GZ34 extra-rugged rectifier. Rated output: 60 w. (130 w. pk). IM Distortion: less than 1% at 60 w; 0.5% at 50 w. Harmonic Distortion: less than 0.5% from 20-20,000 cps within 1 db of rated power. Sine Freq Resp: at 1 w:  $\pm 0.1$  db 5-90,000 cps ( $\pm 1$  db 2-160,000 cps); at 60 w:  $\pm 0.1$  db 16-90,000 cps. Square Wave Resp: excellent 20-25,000 cps; 3 usec rise-time. Sens: 0.55 v for 60 w. Inverse Feedback: 21 db. Damping Factor: 17. Input level control. Both bias & DC-bal adj.  $7$ " x  $14$ " x  $8$ ". 25 lbs.

**NEW! HF61 PREAMPLIFIER**

**KIT \$24.95**  
**WIRED \$37.95**

with Power Supply: **KIT \$29.95** **WIRED \$44.95**

Does not add distortion or detract from wide-band or transient response of finest power amplifiers at any control settings. High-quality feedback circuitry throughout & most complete control & switching facilities. Feedback scratch & rumble filters, equalizations, tone controls. Centralab Senior "Compentrol" loudness control, concentric level control. 4 hi-level, 2 lo-level switched inputs. Extremely flat wideband freq resp:  $\pm 1$  db 8-100,000 cps;  $\pm 0.3$  db 12-50,000 cps. Extremely sensitive. Negligible hum, noise, harmonic or IM distortion.  $4\frac{7}{8}$ " x  $12\frac{5}{16}$ " x  $4\frac{7}{8}$ ". 8 lbs.

**COMPLETE with FACTORY-BUILT Cabinet**

**NEW!**

**2-WAY SPEAKER SYSTEM HF51** **\$39.95**

Jensen heavy-duty 8" woofer (6.8 oz. magnet) & matching Jensen compression-driver exponential horn tweeter with level control. Smooth clean bass & crisp, extended natural highs. Factory-built tuned bass reflex imported white birch hardwood cabinet (not a kit). Neutral acoustical grille cloth framed by smooth-sanded solid birch molding. Freq Resp — woofer:  $\pm 4$  db max. variation 80-2000 cps; tweeter:  $\pm 2$  db max. variation 2000-10,000 cps; overall response:  $\pm 6$  db 70-12,000 cps. Power-handling capacity: 25 w. Bookshelf size:  $23$ " x  $11$ " x  $9$ ". 19 lbs. Wiring Time 15 min.

See these "BEST BUYS" IN STOCK at your distributor. Write for FREE Catalog AC-2

**EICO** Prices 5% higher on West Coast.  
Brooklyn 11, N. Y.

# AR-1

PRESS COMMENT

*"Atlantic*

"The AR-1W woofer gives the cleanest bass response I ever have heard."

**AUDIO** (Edward Tatnall Canby)

"...the highs impressed me immediately as very lovely, smooth, unprepossessing, musical (for music) and unusually natural. No super-hi-fi screech and scratch... As to the lows... I was no end impressed, from the first time I ran my finger over a pickup stylus and got that hearty, wall-shaking thump that betokens real bottom bass to the time when I had played records and tapes on the speaker for some months on end."

## The Audio League Report\*

"Speaker systems that will develop much less than 30% distortion at 30 cycles are few and far between. Our standard reference speaker system,† the best we've ever seen, has about 5% distortion at 30 cycles."

\*Vol. 1 No. 9, Oct., '55. Authorized quotation #30. For the complete technical and subjective report on the AR-1 consult Vol. 1 No. 11, The Audio League Report, Pleasantville, N. Y.

†The AR-1W

## The Saturday Review (R. S. Lanier)

"... goes down into the low, low bass with exemplary smoothness and low distortion. It is startling to hear the fundamentals of low organ notes come out, pure and undefiled, from a box that is two feet long and about a foot high."

## High Fidelity (Roy Allison)

"...a woofer that works exceptionally well because of its small size, not in spite of it... I have heard clean extended bass like this only from enclosures that were at least six or seven times its size."

## THE Nation (B. H. Haggin)

"... achieves the seemingly impossible; a real and clearly defined bass in a cabinet only 14 by 11 $\frac{3}{8}$  by 25 inches in size."

## audiocraft

"The reproduced sound\* so perfectly duplicated that of the organ that no one could be sure which was playing."

\*At a demonstration of live vs. recorded pipe organ, in which the reproducing system included four AR-1's.

**ACOUSTIC RESEARCH, INC.**  
25 Thorndike St., Cambridge 41, Mass.

## WOODCRAFTER

Continued from preceding page

manufactured in many types including the bullet catch. The smallness of the bullet catch allows it to be used inconspicuously on the edge of the door which is bored to receive the bullet-like portion of the catch. Its strike plate is held to the cabinet by a brad. Another design of the bullet catch is mounted on the back of the door with a strike plate either inside the cabinet or on the edge of the facing.

One of the least expensive and most effective friction catches consists of small springy metal fingers fastened to

Courtesy Stanley Hardware, division of The Stanley Works

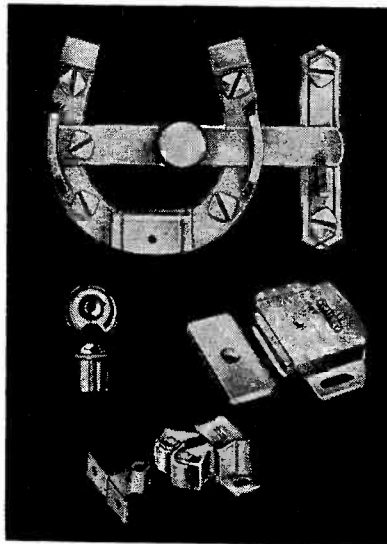

Fig. 5. Latch and catches. At left is bullet catch, magnetic catch at right, spring catch with rubber rollers below.

the inside of the door so that when it closes, a clip or a knob is grasped and held by the tension of the fingers.

Where double doors are installed, an elbow catch installed on the back of one door holds it stationary, while the other door can be locked or held to it by means of a surface latch.

Where latches are used, there is no necessity for other pulls, since latches are pulls and catches combined.

Generally, it is wise to locate door catches as near as possible to the door pull to avoid an uneven strain on the hinges. It also spares the hinges to confine the width of single cabinet doors to 24 in. or less. If the opening to be covered is greater than that, make double doors.

Take time in selecting your cabinet hardware, and ask the advice of your hardware dealer. Try to purchase all the hardware needed for a single job at one time—this way you can see if you are getting a harmonizing ensemble. And always remember that only the best hardware is good enough.

## ADVERTISING INDEX

Acoustic Research, Inc.	2, 48
Allied Radio Corp.	5
Audio Fidelity Records	1
Audiophile's Bookshelf	39
Bradley Mfg. Co.	46
Colbert Associates	43
Components Corp.	40
Conrac, Inc.	Inside Back Cover
Cook Laboratories	45
Dauntless International	1
Eico	47
Electro-Voice, Inc.	38
Electronic Organ Arts	46
Fisher Radio Corp.	14-15
Fleerwood	Inside Back Cover
Grommes	42
Heath Co.	9-11
Jones, Walter M., Apparatus Co.	41
Klipsch & Associates	45
Lafayette Radio	37
Lansing, James B., Sound, Inc.	16
Marantz Co.	46
North American Phillips Co.	13
ORRadio Industries, Inc.	Inside Front Cover
Precision Electronics, Inc.	42
Professional Directory	46
Rigo Enterprises, Inc.	43
Rinehart and Co.	48
Robins Industries Corp.	46
Sound Sales Directory	44
Stephens Tru-Sonic	Back Cover
Traders' Marketplace	46
University Loudspeakers, Inc.	46
WCRB	47

## GET BETTER HIGH FIDELITY RESULTS

at less cost!

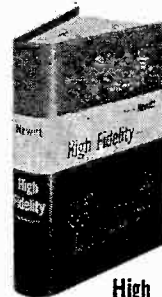

### High Fidelity Techniques

by John H. Newitt

The book that says goodbye to guesswork in choosing, building and servicing modern hi-fi equipment.

512 pages  
203 pictures

Whether you specialize in high fidelity service, custom building or simply want to build a top-notch outfit for yourself, this big 512-page book will guide you every step of the way.

Helps you get better results at less cost. Shows what to do... what mistakes to avoid. Gives you a full understanding of the many different methods, circuits, designs, equipment, components and other subjects that are debated whenever hi-fi fans get together.

**CASH IN ON HI-FI SERVICE AND CUSTOM BUILDING PROFITS!**

High Fidelity Techniques is complete, authentic and easy to understand. From beginning to end, it is chock full of how-to-do-it tips, service data, charts and diagrams of the most helpful sort. The ideal book either for the hi-fi hobbyist or professional.

## 10-DAY FREE EXAMINATION!

Dept. AC-27, RINEHART & CO., INC.  
232 Madison Ave., New York 16, N. Y.

Send HIGH FIDELITY TECHNIQUES for 10-day FREE EXAMINATION. If I like the book, I will then promptly send \$7.50 (plus a few cents postage) in full payment. Otherwise, I will return book postpaid and owe you nothing!

Name .....

Address .....

City, Zone, State .....

OUTSIDE U.S.A. — Price \$8.00 cash with order only. Money back if book is returned in 10 days.