

Broadcast Engineering

www.broadcastengineering.com

July 2009
Celebrating 50 years of excellence

AUTOMATION Key to survival

ALSO INSIDE:

LONG-GOP EDITING

Embrace faster workflows

2GHz BAS RELOCATION

Are we there ye:?

PRODUCTION SWITCHERS

Expect next generation to be 1080p60

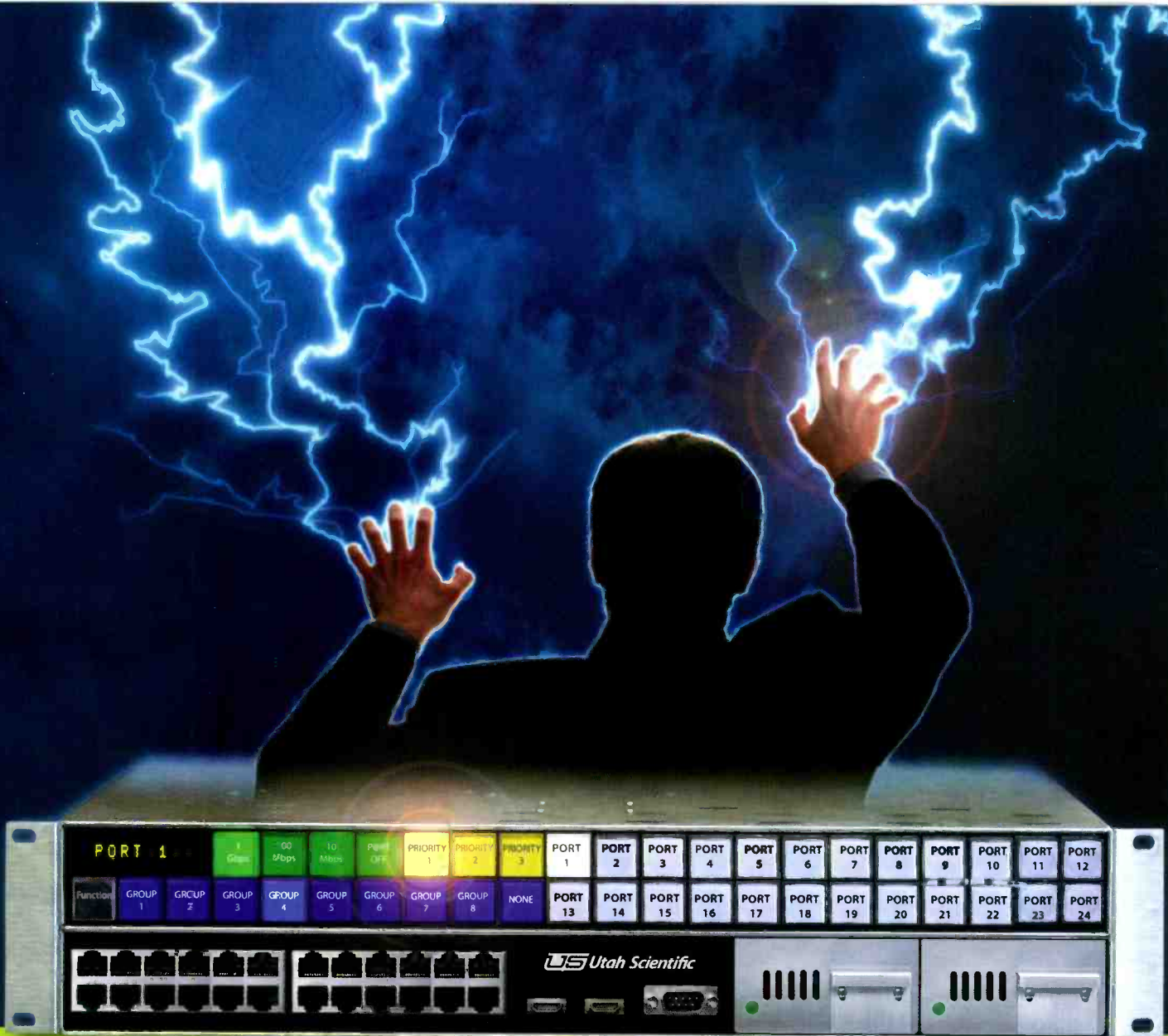

The UTAH-400 iP Router Gives You the Power.

What you do with it is up to you.

Real-time, on-the-fly control of your Ethernet network. Impossible? Not with the UTAH-400 iP Workgroup Router.

The breakthrough UTAH-400 iP is the Gigabit Ethernet Router for broadcasters. It gives you the power to control your IT infrastructure the same way you've always controlled your broadcast routing — with the push of a button. This patent-pending control method allows you to change port priorities, security groups, and port speed at will. Instantaneously re-allocate bandwidth so that when you need video delivered now, you know it gets there.

The impossible is exactly what you'd expect from Utah Scientific. After all, we've been delivering the most advanced, dynamically controlled switching infrastructures for three decades.

The Best In The Business

www.utahscientific.com



US Utah Scientific



© 2008 Avid Technology, Inc. All rights reserved. Avid and the Avid logo are trademarks or registered trademarks of Avid Technology, Inc. in the United States and/or other countries. All other trademarks are the property of their respective owners.

Big news. Bigger savings.

Avid HD news will save you money.

Explore 10 ways to boost your bottom-line at avid.com/HDvalue



BroadcastEngineering®

FEATURES

42 Broadcast automation is critical in today's economy

The keys to survival are automating processes, lowering staff count, smartening efficiencies and doing more with less.

BEYOND THE HEADLINES

DOWNLOAD

12 Tapeless acquisitions

File-based acquisition can produce faster, more versatile content.

FCC UPDATE

16 Ownership reporting requirements change

The new rules take effect Nov. 1.

DIGITAL HANDBOOK

TRANSITION TO DIGITAL

18 MPEG tools

For a good encoder, the challenge is to maintain constant picture quality with a fixed channel rate.

COMPUTERS & NETWORKS

24 High-availability networks

As more equipment moves to Ethernet, reassess the reliability of your infrastructure.

PRODUCTION CLIPS

28 Long-GOP editing

Today's enhanced NLEs support various types of MPEG-2, resulting in a faster workflow.

continued on page 6

SEE IT ONLINE!



Check out Brad On Broadcast for the latest industry news. A generator may be required to back up your facility. The current series discusses designing and installing a backup power system.

Learn more at <http://blog.broadcastengineering.com/brad>

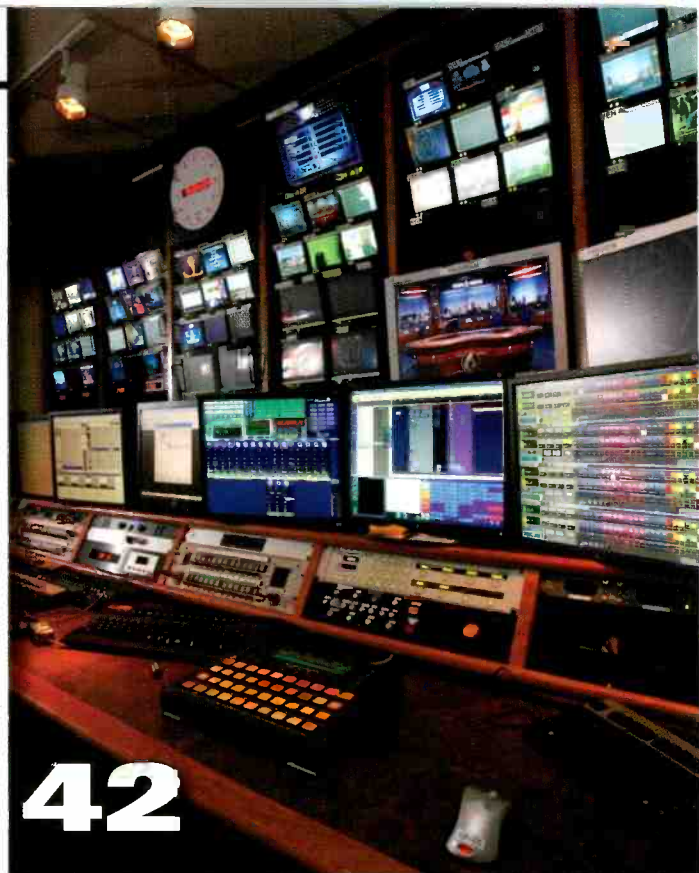

ON THE COVER:

KOIN-TV, the CBS affiliate in Portland, OR, installed a Grass Valley Ignite integrated production system that enables operational efficiency, allowing the station to add more news programming and real-time cut-ins.



28

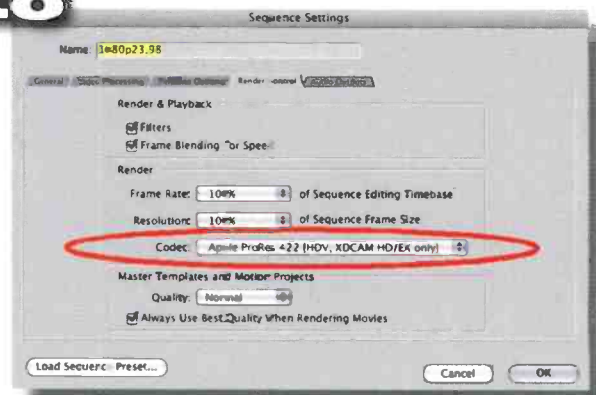

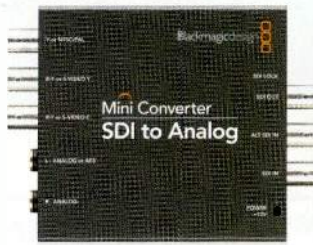

SDI to Analog
\$495

New Down Converter!

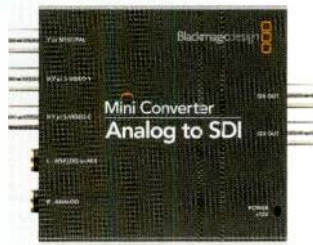

Analog to SDI
\$495



SDI to Audio
\$495

New for 2009!

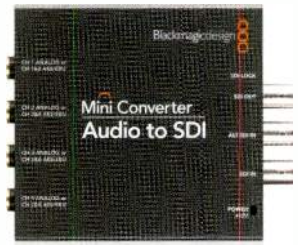

Audio to SDI
\$495

New for 2009!

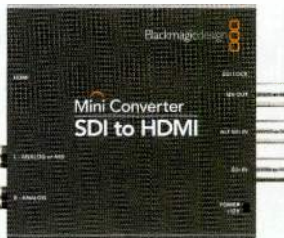

SDI to HDMI
\$495

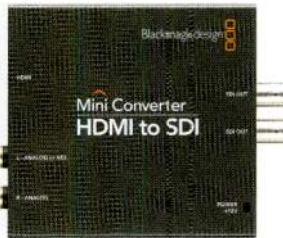

HDMI to SDI
\$495



Optical Fiber
\$495

New for 2009!



Sync Generator
\$295

The most advanced 3 Gb/s converters for SD and HD that include AES/EBU and analog audio!

Build your studio with the world's most advanced converters. Only Mini Converters include auto SD/HD switching, redundant input, AES/EBU and analog audio on 1/4 inch jack connections, plus advanced 3 Gb/s SDI! There are 8 great models to choose from depending on the conversion you need!



Auto Switching SD and HD

Mini Converters instantly switch between all SD and HD formats, including NTSC, PAL, 1080i/59.94, 1080i/50, 1080PsF/23.98, 1080PsF/24, 720p/59.94,

720p/50. Updates can be loaded via USB.

Redundant SDI Input

Most Mini Converters feature a redundant input and loop through SDI output. Connect a redundant SDI cable to the second input, and if the main SDI input is lost, Mini Converters will automatically switch over in an instant. That's great for mission critical tasks such as live events.

Pro Analog and AES/EBU Audio

Standard 1/4 inch jacks are built in to most Mini Converters for professional balanced audio that switches between AES/EBU or analog. Unlike other converters you don't need expensive custom audio cables.



3 Gb/s SDI Technology

Mini Converters include the latest 3 Gb/s SDI technology, so you're always future proofed! 3 Gb/s SDI is also fully compatible with all your existing standard definition and high definition SDI equipment.

Broadcast Quality

Mini Converters are built to the highest quality standards with low SDI jitter, so you get the longest SDI cable lengths combined with ultra low noise broadcast quality analog video and audio. Mini Converters are the world's first converters to include 3 Gb/s SDI on all models!

Eight Exciting Models

Mini Converters include more new technologies than other converters, while every model is an affordable \$495. The Sync Generator model is only \$295!



Mini Converters

\$495

Sync Generator

\$295

Learn more today at www.blackmagic-design.com

SYSTEMS INTEGRATION

INFRASTRUCTURE SOLUTIONS

- 34 2GHz BAS relocation**
The BAS relocation project took two important steps in June, but a possible hiccup remains.

DIGITAL TUTORIAL

- 38 Implementing IPv6**
The transition to IPv6 will be necessary sooner rather than later.

NEW PRODUCTS & REVIEWS

FIELD REPORT

- 52 Avid Interplay**

TECHNOLOGY IN TRANSITION

- 54 A switcher's life cycle**
Expect next-gen production switchers to be 1080p60.

NEW PRODUCTS

- 58 RTW's 10800X and more ...**

DEPARTMENTS

- 8 EDITORIAL**
- 10 FEEDBACK**
- 64 CLASSIFIEDS**
- 65 ADVERTISERS INDEX**
- 66 EOM**

GET CONNECTED!

Have a burning question? Go to *Broadcast Engineering's* Forum and ask questions of fellow experts. Or join our online community on Facebook.

Learn more at <http://community.broadcastengineering.com/forums>

LATEST NEWS!

Apple's new iPhone 3G S could have a huge impact on newsgathering. The mass market smart phone features a built-in three-megapixel camera that shoots both still and 30fps video.

Learn more at www.broadcastengineering.com

52



54



58



8



Beauty on the outside. Beast on the inside.

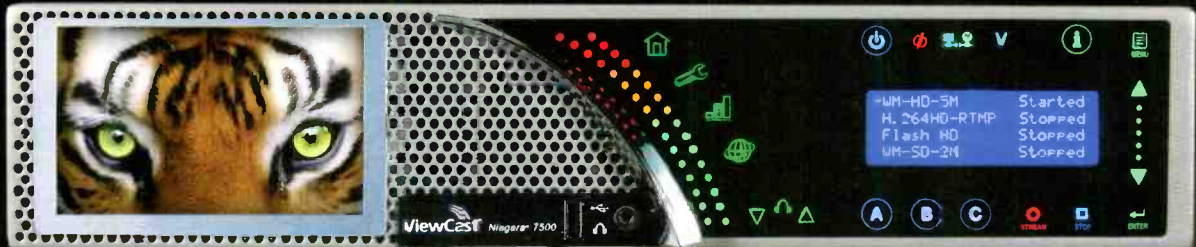

It's easy to be enticed by the alluring good looks of the Niagara[®] 7500 – the newest HD streaming solution from ViewCast. On the outside, its sleek, innovative design and responsive touch-control interface will excite you. Its brilliant high-resolution HD display will dazzle you. But on the inside, it's a beast.

The Niagara 7500 devours your HD video and easily transforms it into high-quality streams for delivery to IP and mobile networks. Its powerful video pre-processing features streamline and simplify your workflow. Inverse telecine, closed caption extraction and rendering, de-interlacing, scaling, cropping and bitmap overlay are just a few of its standard features.

You can switch on-the-fly between HD or SD video, and with ViewCast's SimulStream[®] technology, you've got the power to stream simultaneously in multiple formats, bit rates and resolutions from a single SDI video source.

The Niagara 7500 from ViewCast. Beauty on the outside... a beast on the inside.

Speak with one of our streaming experts today at **800-540-4119**, or visit us on the Web at viewcast.com/be to learn more.

The ViewCast logo, featuring a stylized blue wave icon above the word "ViewCast" in a bold, white, sans-serif font.

USA 800.540.4119 | Europe, Middle East, Africa +44 1256 345610

Digital payoff

Breezing through the garbage, euphemistically called “press releases,” that crosses my desk daily, I came across one from PricewaterhouseCoopers (PWC). The release was designed to look like news, but it was really a sales brochure for the company’s latest economic forecast, “Global Entertainment & Media Outlook 2009-2013.” You can get yourself a copy for a mere \$995, or \$3000 if you want to share it across your organization. Let me save you some money and summarize the release.



The firm says that throughout the next five years, the media industry will see *structural* not *cyclical* change, calling these changes “intensified ... digital migration.” Maybe I’ve missed something, but I think digital is already here. In fact, I don’t see much in the media today that isn’t already digital.

For the front office folks, the report’s key numbers focused on advertiser spending. PWC says the global entertainment and media market as a whole, including both consumer and advertising spending, will grow by 2.7 percent over the next five years, reaching \$1.6 trillion in 2013. Unfortunately, if you were hoping for good news for the remainder of 2009, forget it. PWC says advertising will see a 3.9 percent drop this year, but recover with a 0.4 percent advance in 2010.

The report refers to consumer activities using the term “digital behaviors,” i.e. consumers seeking more control over where, when and how they consume content, while simultaneously cutting back and looking for bargains. Let’s see, consumers want more for less. That’s not news.

Consumer spending through digital/mobile platforms accounted for about one-quarter of the overall market in 2008, but PWC says that segment will account for three times that amount (78 percent) of total growth over the next five years. Hey broadcasters, now are you thinking about mobile TV?

One unsurprising aspect of the report verifies that viewers are increasingly focused on “time-shifting” using DVRs and VOD to free themselves from scheduled TV viewing. In addition, the Web is enabling them to access a larger variety of content from divergent sources through better downloading and streaming technologies.

Because we depend on advertising, the report’s predictions of ad spending are worth consideration. PWC predicts that as consumers receive an increasing proportion of their content through digital and mobile platforms, advertisers will shift their resources to reflect this increasingly fragmented ad market. In the mobile arena, opportunities across the advertising continuum will enable the growth between brands and consumers, ranging from click-through banner ads and preroll ads on video clips to coupons and online subscriptions. This migration to mobile, games and on-demand services will reinforce the need for greater transparency and accuracy in audience metrics, which the company calls a “must have” in this new media world.

The press release concluded by saying, “The winners will be those players who focus on driving and leading change that delivers real value for consumers. Segments will have to consolidate, the least loyal customers will have already left, higher-quality products will be valued by both consumers and advertisers, and digital distribution will have become mainstream, commanding fees more in line with its value. But for each of the industry’s diverse segments to participate fully in this growth, they will first need to embrace the digital future.”

Correct me if I’m wrong, but hasn’t the broadcast industry already embraced the digital future?

So where’s our payoff?

BE

Broad Dick

EDITORIAL DIRECTOR

Send comments to: editor@broadcastengineering.com

VERTIGO

XMEDIA SUITE



Rethink graphics operating costs

There's a lot of talk about operating cost reduction. However, our Vertigo Xmedia Suite graphics automation has a proven track record of delivering big savings. So, whether you're considering a centralized news graphics system, or more streamlined branding and promo generation, you'll find that we're happy to talk real numbers. It's time to rethink what's possible.



Rethink what's possible

www.miranda.com/xmedia

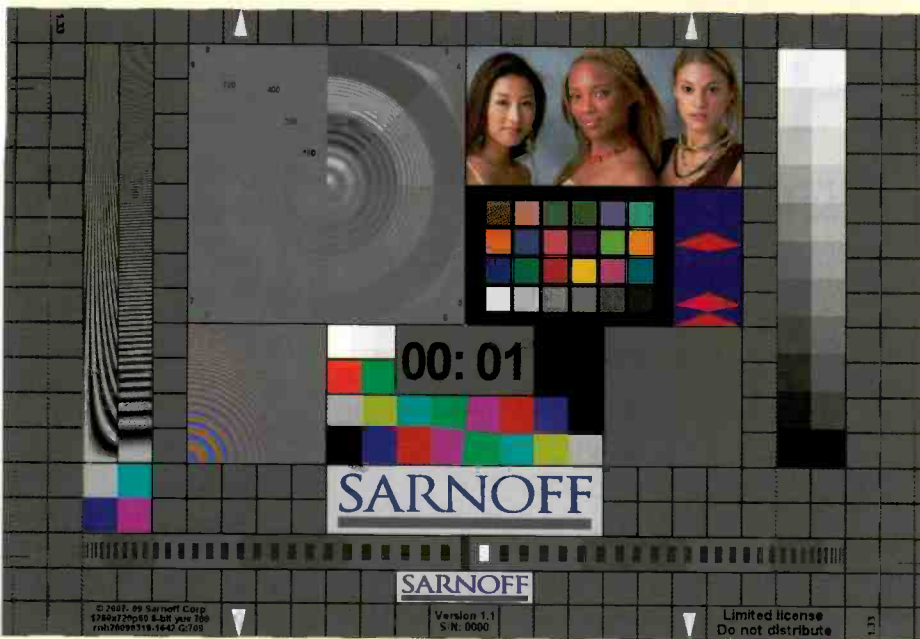

Sarnoff Visualizer DTV test pattern

DTV test pattern

Dear Anthony Gargano:

Regarding your article "A test pattern for DTV" in the May issue, is the Visualizer HDTV test signal available, and how does the lip sync test signal work? Is there a file that can be downloaded to, for example, the Ensemble Designs 7400 TSG?

Steve Paugh

Project engineer, WISC-TV
Madison, WI

Anthony Gargano responds:

For lip sync testing, there is a moving block that appears on the set of what looks like film sprocket holes that appear between the two Sarnoff logos. The test generator provides a stereo audio track that contains a mono tick every two seconds. When the moving block flashes at the center sprocket hole and coincides with the audio tick, audio and video are in sync. The tick marks are one frame or one field apart, depending on the package being used. Using this method, you can actually measure lip sync offset to +/- 1 frame or field.

I've oversimplified a bit, but you really have to see this new test pattern in action. The developer at Sarnoff, Norm Hurst, has done a masterful job providing simple tools that produce highly accurate signal performance measurements. I first saw it demonstrated by Norm at the Hollywood Post Alliance Technology Retreat in February, and I was highly impressed with what he had done.

Sarnoff is currently selling the Visualizer directly. You can contact Jerry Berger at jberger@Sarnoff.com, who can provide you with pricing and further details.

Ergonomic workstations?

Dear editor:

I happened to leaf through the May issue of your magazine. I was eager to look at the Field Report article on the new "ergonomic" workstations at Winsted. I was dismayed to see the photo from KENW-TV. How could a setup that includes those large flat panels mounted that high and close to where a worker is seated ever be considered ergonomic? Let me state the obvious: Screens of that size are designed to be viewed from much farther back. I can tell you from my own unfortunate experience working with a similar setup that the result is a very sore neck. Ergonomic? No way!

Maureen Crowe

Video servers

Dear John Luff:

I read your article on video servers in the May issue, as well as the response you received. Maybe it's my memory, but I don't recall a 10-second limitation on the Betacart. While at KGUN in Tucson, we went from a TCR-100 to a Betacart and never seemed to have limitations. The only problems we might have had were when the elevator went down or one of the four decks was down. Maybe our traffic department was trained to schedule around the TCR limits. As much as I hated the TCR, which we had slaved to a TR-60, I loved the Betacart. After spending years in front of a TR-70, TR-60, TR-600, and TCR-100, 1in and Betacart was a welcome change.

Richard Erickson

Manager, master control
Saint Paul Neighborhood Network
St. Paul, MN

NEWSONESTOP
at www.broadcastengineering.com

For more news, visit our Web site
and click on the News
link at the top of the page

K2™ DYNO INSTANT REPLAY SYSTEM

RETURN OF THE KING.



For years, our LVS Live Controller reigned as the ultimate in replay control. Today we're proud to announce the next-generation of replay controllers, the Grass Valley™ K2 Dyno. This replay controller, coupled with the new K2 Summit production client, allows producers to capture live events in crystal-clear HD and instantly replay them at variable speeds for critical analysis during fast-paced events.



*It's Gotta Be A **Grass!***

For more information, visit us on the web at
www.grassvalley.com/K2



grass valley
50 Years of On-Air Innovation

Tapeless acquisitions

File-based acquisition can produce faster, more versatile content.

BY KEN YAS

The newsgathering business is all about speed and productivity. Getting stories to air faster means improved ratings — thus the industry's continuing migration to camera technologies capturing video footage as digital files.

Recording onto videotape has been a hallmark of the electronic newsgathering community for more than 40 years. The reliability and predictability of that workflow was beneficial and usually worked. However, the advent of digital has brought new features and benefits to workflow that could never occur in the tape world.

Adding digital acquisition to a digital production workflow further increases the benefits digital technology brings to the creative process. A camera that records video in a variety of digitally compressed file formats, onto removable media (or a hard drive) can both speed and improve a newsroom's creativity. However, the process can also, at least initially, become a bit more challenging.

Are the images really saved? What

do they look like? Do I have enough storage? Is my editor going to be able to work with this file? Can that file be easily located and retrieved? The digital process requires staff retraining on the handling of video and audio. This includes the use of metadata that's electronic and not written on a tape label.

Doing more without tape

Once you embrace an IT-centric model, the benefits of ENG activities are easy to see. Some ENG cameras provide multiple recording formats; this benefits the news crew, allowing it to shoot in a DV-compressed SD mode in the field. Later, that same camera



The process for creating a news story benefits from the ability to ingest footage into an edit system faster than real time, allowing the editorial staff to easily share files and work collaboratively.

FRAME GRAB *A look at the issues driving today's technology*

Plasma and LCD shipments are up 17.3 percent

7.8 million TVs were purchased in Q1 2009.

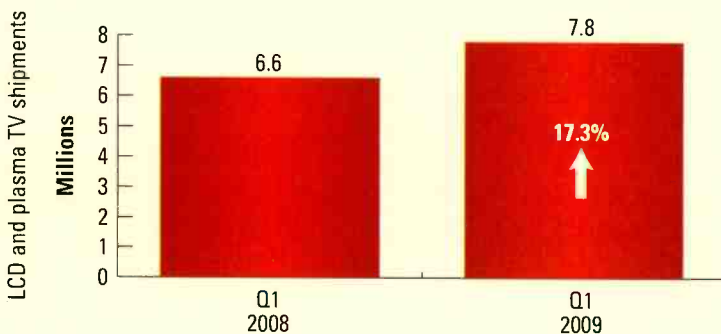

Source: iSuppli

www.isuppli.com

can be used in the studio outputting MPEG-2 for a program package delivered to an outside client.

When it comes to sports, that same crew can produce local HD at different bit rates and formats (720p or 1080i). Such technology frees a shooter from worrying about signal bandwidth and storage capacity requirements. The shooter can focus on creating good content, knowing the technology has the flexibility needed to provide good entertainment and news.

Fast file-based workflow

The process for creating a news story first and foremost benefits from the ability to ingest footage into an

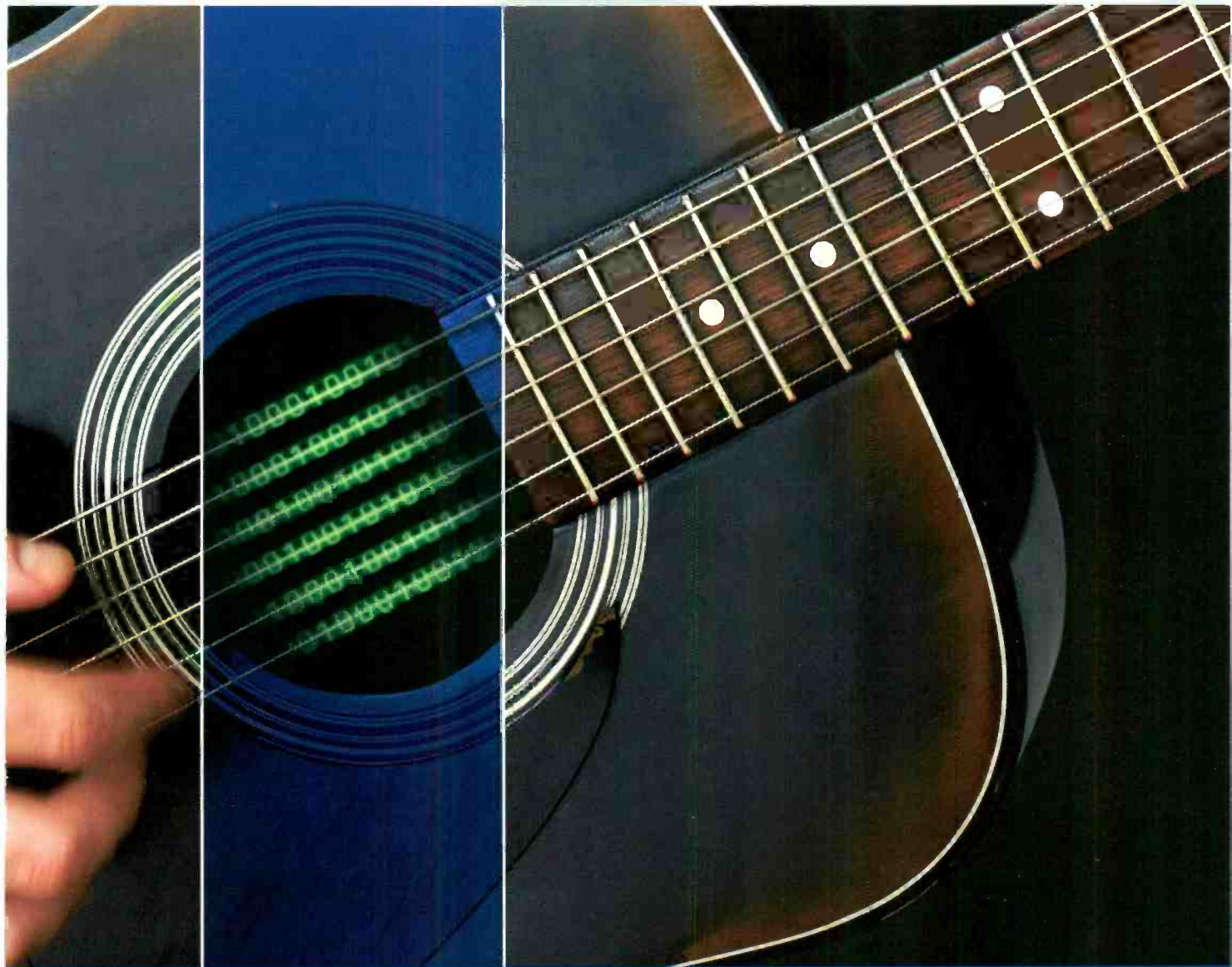

Consistent, vibrant audio from the source to the sofa.

Introducing Dolby Pulse. It's HE AAC optimized by Dolby.

Now you can deliver amazing broadcast audio virtually anywhere. Dolby® Pulse combines the advanced low-bit-rate efficiencies of HE AAC with the proven performance of Dolby—making it ideal for any bandwidth-critical application: HDTV, IPTV, mobile, or online. Like Dolby Digital Plus, Dolby Pulse supports industry-standardized metadata to ensure consistent audio delivery from content creation all the way to the home or portable device. Add our unrivaled support and worldwide home-entertainment system compatibility to the mix, and you've got high-efficiency broadcast audio at your fingertips.

Now available.
Find out more at www.dolby.com/pulse.

 **DOLBY**[®]
PULSE

Dolby and the double-D symbol are registered trademarks of Dolby Laboratories.
© 2009 Dolby Laboratories, Inc. All rights reserved. 509/20740/21465



Tapeless acquisition allows someone other than an editor to create an offline EDL in the field using low-res or proxy files on a laptop (right), and then send that EDL on to an editor at the station for an online conform using the original footage.

editing system faster than real time. A file-based workflow enables the editorial staff to easily share files and work collaboratively. It also allows footage to be repurposed across a variety of delivery platforms. In today's mobile and Internet environments, a station's local content may be as valuable when viewed on those platforms as when seen on the 6 p.m. newscast. Simultaneously creating multiple formats for such platforms is easy with digital.

Tapeless acquisition also allows someone other than an editor to create an offline edit decision list (EDL) using low-resolution or proxy files. That person can then send the EDL to an editor for an online conform using the original footage.

Because the infield reporters and shooters know what the best shots are, they may be better qualified to make fast creative decisions related to that particular story. Also, if there's a bad take, the shooter can delete the file, saving storage space and editing time.

By completing this preliminary work in the field, the studio editor can focus on other tasks while the story is being acquired. With budgets and staff stretched to their limits, today's news teams need to cooperate and help each other whenever possible. The days of highly compartmentalized job descriptions are long gone. File-based

workflows facilitate this collaboration across production environments.

New IT advantages

Using next-generation compression formats makes storing large HD video files on a shoulder-mounted camera — and in the edit suite — practical. While the industry has grown up on MPEG-2 and later DV compression, AVC H.264 and JPEG2000 are providing new benefits for this file-based environment.

JPEG2000, in particular, provides certain benefits as an acquisition format. Fast-moving or busy scenes compressed with JPEG2000 do not degrade like they sometimes can in MPEG and DV. JPEG2000 images simply get softer.

File-based cameras can also take advantage of wireless technologies like Bluetooth and Wi-Fi, working in tandem with ancillary devices like a PDA or cell phone. Shooters now have the ability to make annotations



Many new camcorders offer a choice of recording media in the same camera. This innate flexibility means a station using a camcorder could be recording to a REV PRO disk one day and solid-state CompactFlash memory the next, depending on the needs of the workflow.

to a specific file and send instructions to the editor, making their jobs more interactive and cohesive.

Coming together

For the station's news department staff, the integration of a file-based workflow into an existing tape-based environment can, at first, be difficult to grasp. The transition will require discussion, organization and training to get it right. You can't just thrust a new file-based camera on a videographer without first consulting with the rest of the editorial staff and explaining how the handling and logging of footage will change.

There are also important infrastructure issues to consider. Don't plan on file-based productions running on the same network as a company's e-mail or general-purpose Ethernet. Start with a fully secured production and GigE network.

It's not uncommon for stations first implementing a file-based workflow to have a few growing pains. However, once the equipment and

bringing benefits staffs have never before imagined. While there are still many stations using videotape, it's only a matter of time before the use

The file-sharing features provided by a digital workflow increase the collaborative process, bringing benefits staffs have never before imagined.

human bugs are overcome, the benefits far outweigh any early hiccups. News crews quickly learn how to create better news content faster with fewer people. And the content can more easily include images, sophisticated transitions and better audio. The bottom line is that the quality of the images and content delivered are simply better.

In addition, the file-sharing features provided by a digital workflow increase the collaborative process,

of tape for news acquisition becomes another relic in the museum of television history. **BE**

Ken Yas is the market development manager for Americas Camera Products, Grass Valley.

ATTENTION READERS!
Sign up now for
Broadcast Engineering's
ENG Technology Update
e-newsletter
at www.broadcastengineering.com

is your broadcast operation costing the earth?

iTX - saving you money, saving energy

When did you last think about the environmental impact of your broadcast facility ... or what it costs you in power consumption alone?

Making the move to IT-based technologies delivers lower CAPEX, lower energy consumption, lower OPEX.

It's time to join the iTX revolution.

the future starts here...

OMNIBUS
Innovate | Integrate | Deliver
www.omnibus.tv

itx
INTELLIGENT TRANSMISSION

Ownership reporting requirements change

The new rules take effect Nov. 1.

BY HARRY C. MARTIN

A new FCC ownership reporting system goes into effect Nov. 1. The current plan is for all commercial licensees — along with a variety of broadcast owners and investors previously exempt from any such filing — to file new reports on that date. The filing of biennial ownership reports for commercial stations on June 1, Aug. 1 and Oct. 1 has been suspended. Noncommercial TV licensees must still file the usual biennial reports on those dates.

The shift in reporting requirements, and a change to new reporting forms, arises from concern about the relatively low percentages of minority individuals and females among the ranks of broadcast owners.

List of changes

The following changes have been made:

- All commercial licensees must

Dateline

- Nov. 1 is the deadline for submission of biennial ownership reports for commercial TV stations in all states and territories.
- For noncommercial TV stations in Iowa and Missouri only, the biennial ownership report deadline is Oct. 1.
- Oct. 1 is the deadline for TV stations in Iowa and Missouri to electronically file their broadcast EEO midterm reports (Form 397) with the FCC.
- Oct. 1 is the deadline for TV stations licensed in the following states to place their annual EEO reports in their public files: Alaska, Florida, Hawaii, Iowa, Missouri, Oregon, the Pacific Islands, Puerto Rico, the Virgin Islands and Washington.

file, even previously-exempt stations owned by one person or a partnership of natural persons.

- LPTV stations and Class A TV stations are no longer exempt from reporting.
- All affected entities will file on the same date, every two years, beginning Nov. 1.

- The data reported must be accurate as of Oct. 1 of the same year in which the report is filed.

- Equity owners whose reporting exemption was based on the single majority owner rule must now report their interests.

- Equity owners whose interests would be attributable but for the higher EDP threshold for investors in minority-controlled companies (generally 50 percent vs. 33 percent) will not be exempt from reporting.

- Investors and affected lenders must not only report the names of the licensees and the stations owned by those licensees at present, they must also provide the FCC-issued Federal Registration Number (FRN) for each licensee in which they have a reportable interest.

- The FCC will begin random audits to verify what is reported.

- Information will no longer be accepted in uploaded attachments to the ownership report form. Everything must be submitted on the ownership reporting form itself.

Implementation of this new regulatory scheme is dependent on speedy adoption of a new Form 323 and its approval by the Office of Management and Budget. It is likely that the Nov. 1 start date will have to be postponed if the form is not ready in time.

The commission also has separately proposed revisions to the ownership report form (Form 323-E) for non-

commercial educational (NCE) radio and TV stations to include information about the ethnic, racial and gender makeup of their governing bodies. In the meantime, as noted above, NCE licensees must continue to file their ownership reports biennially on the anniversaries of their renewal filing dates.

Implementation of this new regulatory scheme is dependent on speedy adoption of a new Form 323.

2009 annual regulatory fees

In May, the FCC proposed the 2009 annual regulatory fees for commercial TV stations. The fees for analog VHF stations as of Oct. 1, 2008, are:

- Markets 1-10: \$77,575
- Markets 11-25: \$60,550
- Markets 26-50: \$37,575
- Markets 51-100: \$22,950
- Remaining markets: \$5950
- Construction permits: \$5950

The fees for analog UHF stations as of Oct. 1, 2008, are:

- Markets 1-10: \$24,250
- Markets 11-25: \$21,525
- Markets 26-50: \$13,350
- Markets 51-100: \$7600
- Remaining markets: \$1950
- Construction permits: \$1950

Annual regulatory fees are due this August or September. **BE**

Harry C. Martin is a member of Fletcher, Heald and Hildreth, PLC.

? Send questions and comments to: harry.martin@penton.com

Imagination to Creation

www.for-a.com

- Head Office (Japan)
Tel: +81 (0)3-3446-3936
- USA Western (CA)
Tel: +1 714-894-3311
- USA Eastern & Midwest (NJ)
Tel: +1 201-944-1120
- USA Southern (FL)
Tel: +1 352-371-1505
- Latin America & Caribbean (FL)
Tel: +1 305-931-1700
- Canada (Toronto)
Tel: +1 416-977-0343
- UK (London)
Tel: +44 (0)20-8391-7979
- Italy (Milan)
Tel: +39 02-254-3635/6
- Korea (Seoul)
Tel: +82 (0)2-2637-0761
- China (Beijing)
Tel: +86 (0)10-5170-9870

FOR.A[®]
INNOVATIONS IN VIDEO
and AUDIO TECHNOLOGY



HVS-300HS: The New Standard in Small HD/SD Switchers!

Unrivalled Features, Unequaled Cost Performance

- Very compact main unit (1RU high)
- 4 types of control panels: standard panel, front panel, remote panel, and control GUI
- HD/SD-SDI 4 input/4 output standard Max. 12 input/8 output
- Frame sync, re-sizing engine, and Proc Amp on each input
- Variety of I/O options: HD/SD-SDI, DVI-D, VGA, HD/SD analog component, and analog composite
- Built-in 16-split multiviewer, supporting 4, 10 or 16-split view with tally and title display
- Up-stream Keyer (with Chroma Key) and DSK both with 2D DVE
- Dual Picture-in-Picture function
- Various 2D and 3D DVE transitions
- Over 100 wipe patterns
- Two channels of still stores
- ANC data pass through
- Aux remote control (option)



Main Unit with HVS-300RU Remote Panel



Main Unit with HVS-300FP Front Panel



Main Unit with HVS-300U Operation Unit

Now FOR-A offers a complete line of switchers from our affordable 1M/E up to our new 3Gbps ready 4M/E model

MPEG tools

For a good encoder, the challenge is to maintain constant picture quality with a fixed channel rate.

BY ALDO CUGNINI

While MPEG has existed for more than a decade and continues to evolve, there are many options within the standards that seem new to many observers. In this and future articles, we will look at some of these interesting features.

By now, we all know that video quality is affected by bit rate, but what are the factors that affect quality when we are dealing with practical (for example, fixed-bandwidth) systems? As MPEG compression is based on a Group of Pictures (GOP) construct, we can change both the number of pictures in a GOP as well as the sequence of I, P, and B-pictures (Intra, Predictive and Bi-directionally predicted).

In general, longer GOPs mean less bits needed for the same quality because the I-frame repetition rate is lower, but that comes at a cost. Because all pictures within a GOP are ultimately referenced back to the I-frame, both transmission errors and channel changes can mean corrupted (or no) pictures until the next

I-frame is decoded. For a GOP length of 15 pictures at 30fps, this means a possible delay of up to half a second for clean pictures to reappear.

But a longer GOP can also mean that coding errors due to aggressive compression will tend to persist longer too. One way to get around

a fade-to-black sequence and a motion sequence, more bits can be allocated to static content change rather than spuriously generating unneeded motion vectors. Dual-pass encoding is another feature of many encoders, whereby the bit allocation for a frame (or group of frames) is established

Because all pictures within a GOP are ultimately referenced back to the I-frame, both transmission errors and channel changes can mean corrupted (or no) pictures until the next I-frame is decoded.

the visibility of these artifacts is for the encoder to automatically insert I-frames on significant scene changes. The challenge here is to control the sensitivity of the scene-change detection algorithm, lest the encoder force too many I-frames on busily changing content.

Scene fade detection is another way to improve encoding quality; if the encoder can differentiate between

by encoding the video twice — once with a rough estimate of quantization levels, and then a second time by using picture statistics to refine the quantization process. This usually means an extra frame of delay for live encoders. An offline software encoder, on the other hand, can perform this dual-pass encoding over large spans of time, even over an entire program.

Normally, real-time transmission of MPEG-encoded pictures uses what is called an open GOP structure. This means that B-frames within one GOP can reference future I-frames from another GOP. However, in certain applications, a closed GOP can be used, where all B-frames from one GOP reference only the (previous) I- and P-frames from within the same GOP. In other words, B-pictures will have been encoded using only backward prediction (or intra coding in MPEG-4). This is usually the case when offline editing must be facilitated, as well as real-time splicing of bit streams, because all frames of the GOP can be decoded without the need of another GOP.

FRAME GRAB

A look at tomorrow's technology

One-third of homes own an HDTV

The percent of homes with an HDTV is up 13.2 percent from 2008.

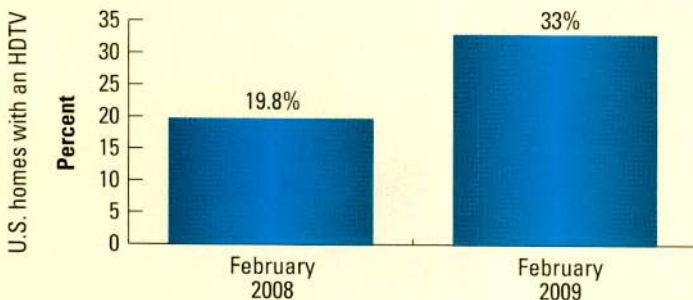

Source: Nielsen

www.nielsen.com



When you need **scalable capacity,**
bandwidth and **processing power**

MediaGrid™ **Performs.**



Grow your way to an optimized file-based workflow, with a storage system that lets you add both capacity and bandwidth. MediaGrid combines the bandwidth you need for collaborative editing with the resiliency you need for transmission operations. It even lets you transcode between production and delivery formats within the storage system. Whatever your workflow, isn't it time for your storage to play an active role?
Omneon MediaGrid – active storage for digital content.

www.omneon.com

For details, go to www.omneon.com/MediaGridPerforms
or call us at 1-866-861-5690

 **OMNEON**®
Active Storage for Digital Content™

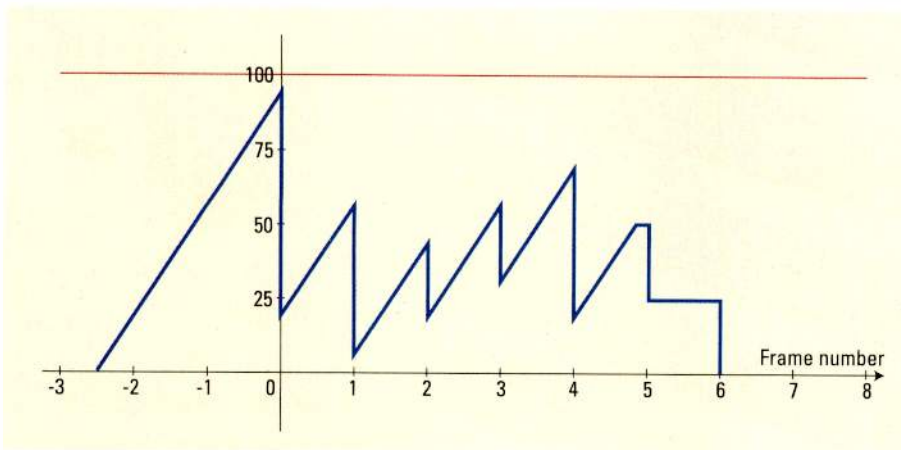

Figure 1. With constant bit rate (CBR) encoding, individual pictures will have variable sizes, but they are then buffered into a constant bit rate channel.

However, B-pictures will often be larger when using closed GOPs, as there are fewer reference pictures from which to generate a prediction. In practice, when picture size is limited by a constrained bit rate, this means that continuous coding with closed GOPs can yield a lower picture quality. Bottom line: When encoding live video, open GOPs should be used, unless splicing capability is needed, and the encoder can seamlessly switch between open and closed GOPs without artifacts.

Bit rates are not fixed

While the choice of a bit rate may seem limited from an allocation standpoint, the actual transmitted bit rate of course varies from frame to frame. With constant bit rate (CBR) encoding, individual pictures will have variable sizes, but they are then buffered into a constant bit rate channel. One can think of this buffer like a reservoir with different filling and emptying characteristics.

Figure 1 shows the behavior of such a buffer, as realized in an MPEG decoder; the diagram illustrates the instantaneous number of bits in the decoding buffer, for a hypothetical seven-picture sequence. The diagonal slope of the curve shows the buffer filling with bits, and the vertical lines show the bits being removed from the buffer (and displayed for each picture or frame). The slope of the

diagonals thus represents the coding bit rate and, ignoring the discontinuities of the picture removals, can be seen to be constant. This model, called the video buffering verifier (VBV) is present in the encoder so that it can anticipate the behavior of the decoder and avoid overflow of underflow of the buffer.

The startup time to the left of frame #0 is called the VBV delay of the system and often can be adjusted in the encoder. In practice, this startup delay can be several frames in length, and

Bottom line: When encoding live video, open GOPs should be used, unless splicing capability is needed, and the encoder can seamlessly switch between open and closed GOPs without artifacts.

the buffer can be large enough to hold a half-second's worth of data or more. This length of time is needed to allow the encoder to average the bit rate over enough pictures and to provide enough headroom so that the encoder can maintain quality while picture content fluctuates.

Coding delays can be adjusted

The long VBV delay, however, has other consequences, such as picture decoding delay, which adds to the GOP considerations we saw earlier.

When tuning to a new channel, the video buffer starts filling with about half a second of delay, and picture decoding starts at an arbitrary picture, creating a total of between half a second to one second of delay before pictures are presented to the display. MPEG offers a low-delay mode to ameliorate this, producing a total encoding and decoding delay of less than 150ms.

This mode, when used, indicates that the sequence does not contain any B-pictures, that the frame reordering delay (due to out-of-display-order B-frames) is not present, and that the VBV buffer is allowed to underflow when encoding pictures. (Underflow will cause the decoder to repeat pictures.) Such a mode, while not practical for high-quality video, is useful for closed-production applications such as IFB, which enables a news studio to communicate live with a field reporter over a back-channel IP connection.

For a good encoder, the challenge is to maintain constant picture quality with a fixed channel rate, without overflowing or underflowing the buffer. Under this constraint, the picture

quality with CBR typically varies inversely according to the complexity of the video. Encoders will attempt to assign different quantization scales to different parts of a picture; because complex pictures require more bits, trying to maintain a constant bit rate will result in complex pictures having more artifacts than simpler pictures.

Bit rates can be varied on the fly

An alternate way of coding, when there is sufficient instantaneous

PLAYBOX TECHNOLOGY

**Fully Automated Playout and Branding Solutions
Reliable, Cost Effective and Easy to Use**

SD, HD and Streaming. It's All in a PlayBox ...



100% of Functionality for 25% of the Cost

PlayBox Technology has radically changed the broadcast and corporate TV markets forever, delivering over 6,500 SD, HD and DVB playout and branding solutions in over 100 countries.

Offering 100% of the functionality at 25% of the cost means PlayBox Technology can provide the solution you want at your price.

With state-of-the-art software loaded onto commercial off-the-shelf IT hardware we can deliver affordable solutions for budget TV channels and the scalability to power the largest multichannel broadcast centres.

TV channel-in-a-box solutions deliver the entire transmission chain including ingest master control, video server, automation, CG, interactive graphics, animated logo, subtitling, scheduling, etc. They also provide the resilience to operate as the transmission engine in remote playout locations, managed and monitored via internet.

PlayBox Technology's worldwide operation is based in London, with R&D in Sofia, and country offices in Bulgaria, Germany, India (Mumbai and New Delhi), Latin America, Malaysia (Asia Pacific), Romania, Serbia, Turkey, UK, USA (Atlanta and Los Angeles). It's all in a PlayBox.

Talk to one of our systems experts or visit www.playbox.tv :

PlayBox UK + 44 1707 66 44 44 • PlayBox Bulgaria + 359 2 9703050 • PlayBox Romania +4 031 106 5115

PlayBox Turkey +90 216 3379402 • PlayBox Germany +49 2233 969 7562 • PlayBox Adria + 381 11 3117286

PlayBox USA +1 404 424 9283 • PlayBox Asia Pacific +6012 288 0760 • PlayBox India +91 9811913333

PlayBox Latin America Sales +598 99 192929

 IBC 2009

Join PlayBox on Booth
8.B31

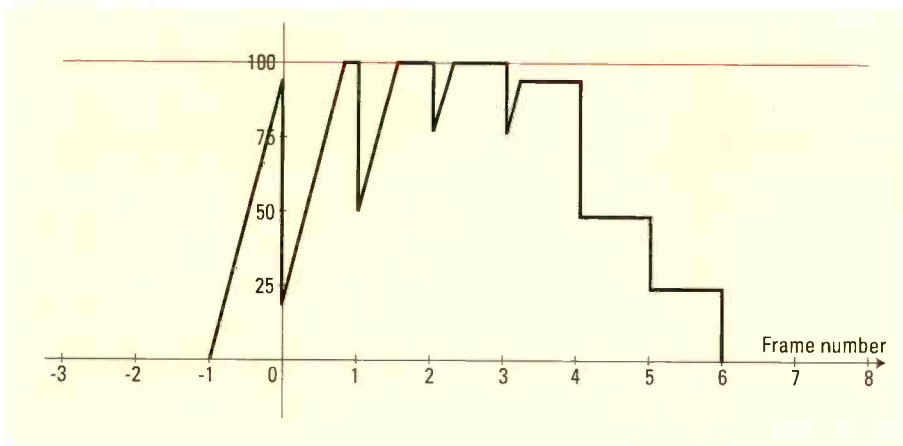

Figure 2. An alternate way of coding, when there is sufficient instantaneous bandwidth, is to use variable bit rate coding. In this mode, the encoder assigns bits according to a peak target bit rate and simply stops sending bits when a defined buffer level is reached.

bandwidth, is to use variable bit rate coding (VBR). In Figure 2, we see the behavior of a decoder buffer when VBR coding is used. In this mode, the encoder assigns bits according to a peak target bit rate and simply stops sending bits when a defined buffer

level is reached.

The simplest VBR stream is one where the picture quality is held constant (for example, by applying the same quantization scale over an entire picture), with no other constraints. In this case, the bit rate gen-

The simplest VBR stream is one where the picture quality is held constant (for example, by applying the same quantization scale over an entire picture), with no other constraints.

erally varies directly according to the complexity of the video. A sophisticated VBR encoder — especially an offline one — can take into account capacity over a large period of time or the available bandwidth in a channel. (In practice, encoder designers will always use a larger buffer than shown here, both for practical hardware reasons, as well as to account for operational anomalies.) DVD encoding suites, for instance, typically use a two-pass VBR encoding. In this application, the bit rate need not be constant, just the total number of bits on the disc.

In future articles, we'll look at how bit allocation works across a multiplex of services, and how MPEG supports some rather appealing opportunities for controlling multicast program delivery.

BE

Aldo Cugnini is a consultant in the digital television industry.

? Send questions and comments to: aldo.cugnini@penton.com

ATTENTION READERS!
Sign up now for
BroadcastEngineering's
Transition to Digital
e-newsletter
at www.broadcastengineering.com

Curious? Please visit our website www.riedel.net

RIEDEL
The Communications People

ARTIST DIGITAL MATRIX INTERCOM
The Solution for World Class Events.

Riedel Communications Inc. • 1721 Victory Blvd • Glendale, CA 91201 • USA • www.riedel.net

planting the seed...

Outfitted with dual DM2000's, Record Plant Remote's "The Lounge" digital truck has been busy making waves at numerous live recording events across the country.

We caught up with Kooster McAllister, Owner and Chief Engineer of Record Plant Remote, to gather his thoughts on his Yamaha gear. Here's what he had to say...

"Coming from an analog background, having a lot of faders in front of me is comforting. All 95 tracks can be viewed and accessed on just two layers. Having the two consoles tied together make the DM2000's perform as one large format digital desk. It also gives me the added functionality of being able to call up effects, routing, auxes, etc. from either center section making it easy to get around quickly.

In my line of work where you only have one chance to capture a live moment on stage, you must be able to count on your equipment not to fail. These consoles have withstood being bounced down the road from gig to gig and have always come through for me.

Most importantly, they sound great. Orchestral recordings I have done with them sound simply amazing."

— Kooster McAllister



www.yamahacsa.com



When you need help, time zones shouldn't matter. Yamaha provides coast-to-coast 24/7 technical support across the United States. With dedicated staff and regional service centers, assistance is around the corner. If we can't fix it over the phone, we'll put a part or a person on the next plane out. It's that simple.

Yamaha Commercial Audio Systems, Inc. • P. O. Box 6600, Buena Park, CA 90620-6600
©2009 Yamaha Commercial Audio Systems, Inc.



High-availability networks

As more equipment moves to Ethernet, reassess the reliability of your infrastructure.

BY BRAD GILMER

For some time now, on-air facilities have relied on Ethernet networks. In many cases, these networks have grown organically over time. As more equipment moves to Ethernet for critical functionality, it may be time to reassess the availability of your Ethernet infrastructure.

High availability vs. high reliability

We may throw around the terms high availability and high reliability interchangeably, but they actually have different meanings when applied to systems. A system is highly available when the services it provides are available the majority of the time. High availability does not mean that components will never fail. It means that the overall system is there when you need it, even if components fail. High reliability, on the other hand, means that the components in the system are highly reliable. While the

difference between these two approaches may seem identical, they have a big impact on the design philosophy and cost of your network.

The critical point is that highly reliable network equipment is expensive because it is designed not to break.

fail more often than the more expensive equipment. However, if the overall network design takes into account the fact that equipment may fail, then end users will still be able to access the network even if something goes wrong. Let's take a

The critical point is that highly reliable network equipment is expensive because it is designed not to break.

Highly reliable equipment typically includes things like dual power supplies, watchdog processors and redundant disk systems. Building a network from these sorts of components can be an expensive proposition.

A highly available system may be built out of less expensive network products. These components may lack the redundant power supplies or other features of high-reliability equipment, and therefore, they may

look at how this might be applied in a broadcast facility.

You may recognize Figure 1 from the August 2008 *Broadcast Engineering* article titled "Computer architectures." It illustrates a typical station facility. Because the focus of the 2008 article was on security, the broadcast core was not shown in detail.

Figure 2 on page 26 shows more detail in the broadcast core. While there is nothing inherently wrong with this

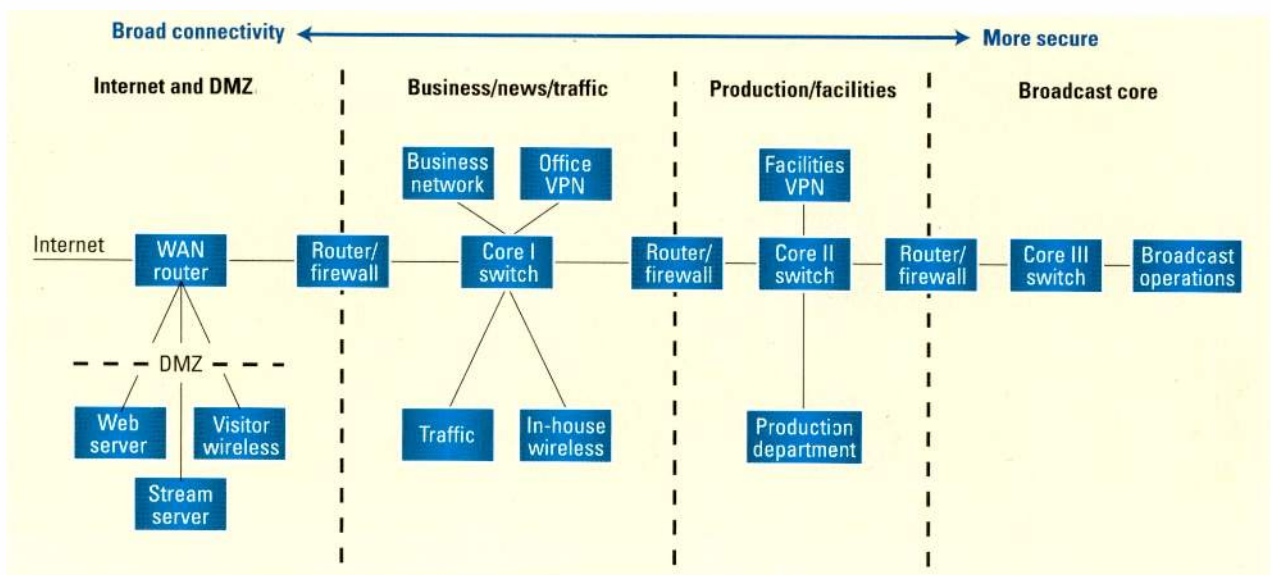
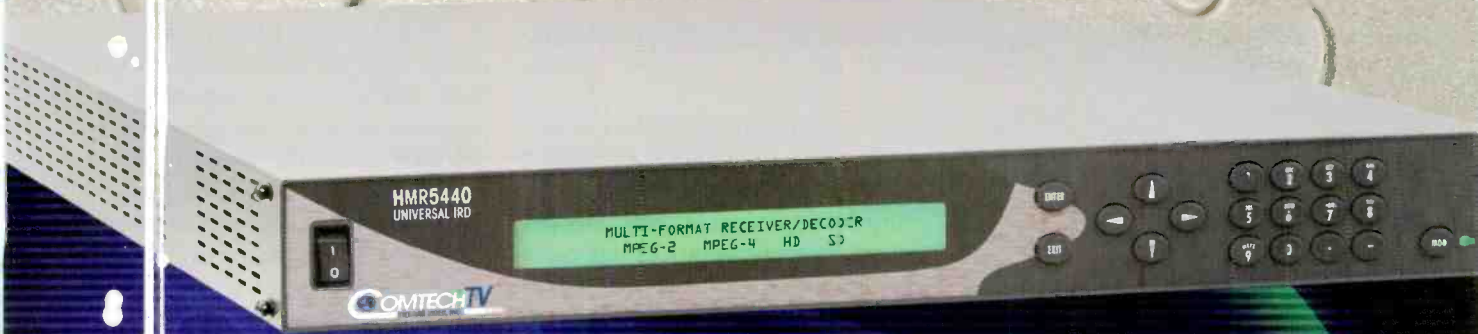
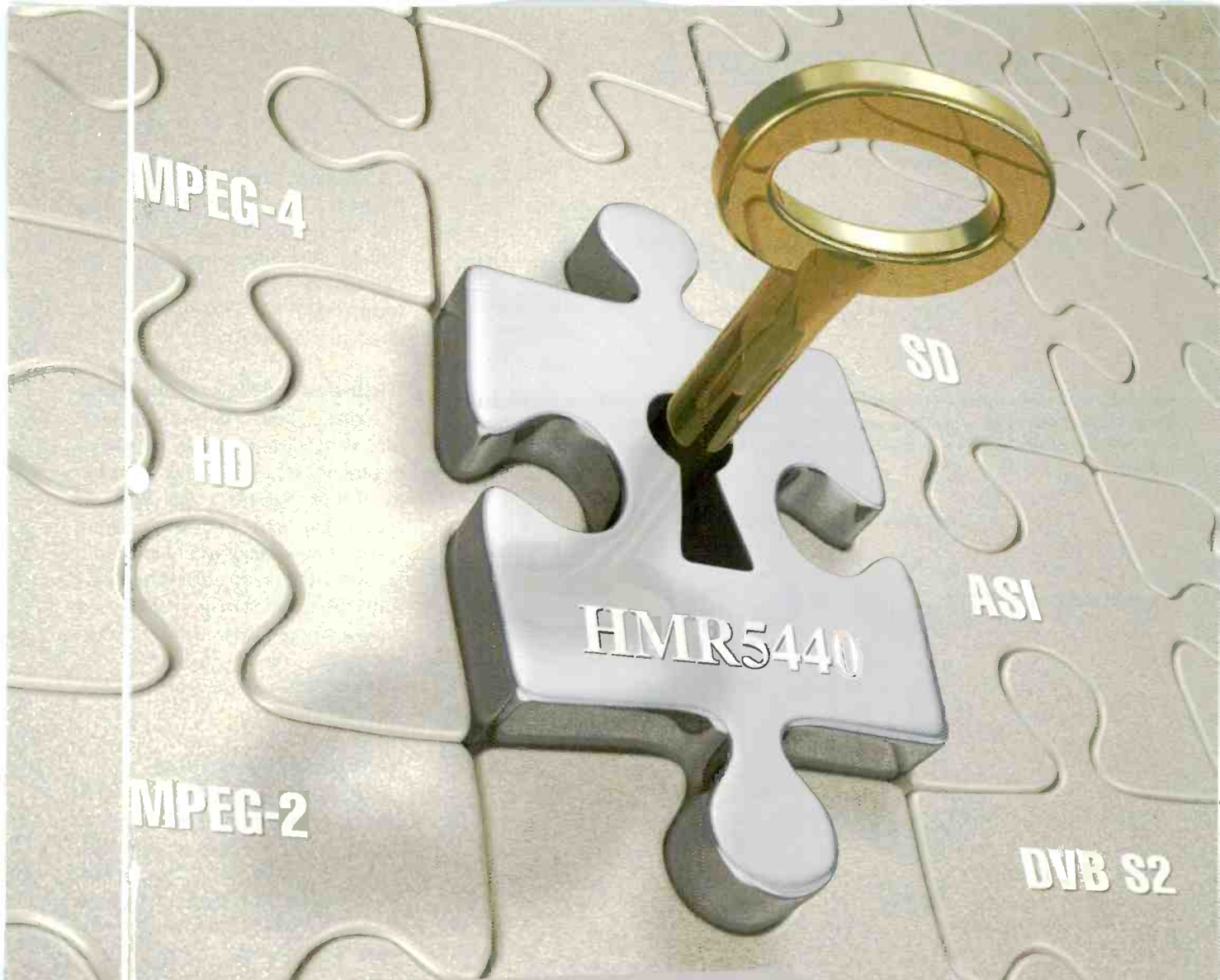

Figure 1. This diagram shows the high-level architectural design of a typical broadcast facility. Note that this architecture takes advantage of several different layers of security, while providing a high degree of connectivity within related departments.



ComtechTV unlocks multi-format decoding.

HMR5440 Multi-format Receiver/Decoder

- MPEG-2 & MPEG-4, HD & SD
- Integrated Frame Sync (Genlock)
- Perfect (<1ms) Lip sync
- All formats (1080i, 720p, PAL, NTSC)
- IP with FEC, DVB-S/S2, ASI, DS3, E3

www.comtechtv.com • (858) 805-7000

COMTECHTV
TIERNAN VIDEO, INC.

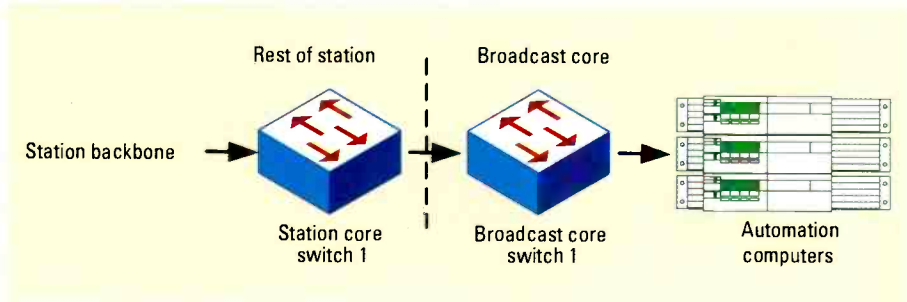

Figure 2. This diagram illustrates a bare-bones network architecture for a broadcast core. Note that the failure of any single network component results in either a loss of connectivity with the rest of the facility or a loss of connectivity between equipment within the on-air operation.

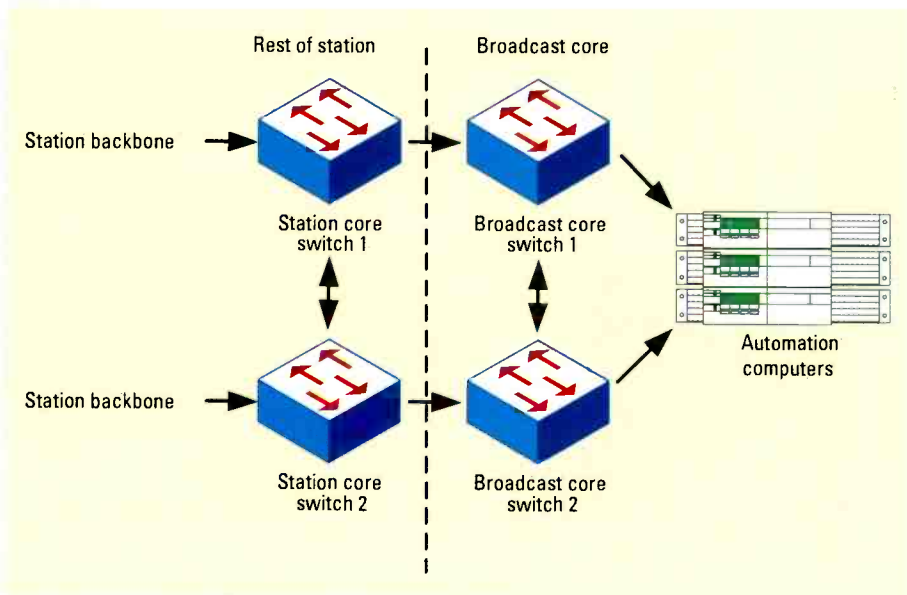

Figure 3. This diagram illustrates one way to create a simple high-availability network for your broadcast core.

Resources

- Visit www.cisco.com. Search for "Catalyst 3550 Multilayer Switch Software Configuration Guide." Look for "configuring HSRP" in the table of contents.
- Visit www.rfcs.org. Search for "RFC 2338, Virtual Router Redundancy Protocol (VRRP)."
- Visit www.ciscopress.com. Search for article 375501, "CCDP Self-Study: Designing High-Availability Services" from the book *CCDP Self Study: Designing Cisco Network Architectures* by Amir Ranjbar and Keith Hutton, Cisco Press, ISBN 1-58705-185-0, 2005.

simple configuration, the loss of any single piece of network equipment will cause the automation system to either lose connectivity with other departments in the facility, or will cause the automation system components to be unable to communicate with each other. One approach to resolving this problem is to purchase highly reliable network components. With this approach, the network architecture remains simple, but the cost of components is high. Figure 3 illustrates another approach.

In this figure, critical network components are duplicated. The architecture looks simple to implement, but there are a few key points. First, note that this is not simply two networks in parallel. There are connections between the two networks at criti-

cal points. Second, the automation computers have two Ethernet ports, one connected to each broadcast core switch. Third, these switches are configured using Hot Swap Router Protocol (HSRP) or Virtual Router Redundancy Protocol.

High-availability techniques

Figure 3 shows a network architecture that takes advantage of several techniques to achieve high availability. In this example, I will cite some specific hardware and software from Cisco because that is what I am familiar with. Other manufacturers have similar technologies available. Also, the descriptions below are just a starting point. Creating high-availability networks will require some research. (See "Resources.")

Redundant switching

The Cisco 3550 switch is a very capable device and, at around \$700 on the used market, it is affordable as well. Besides providing typical switching functionality, it supports the Cisco HSRP. Using HSRP, a network engineer can configure two routers so that they appear to a client as a single virtual gateway interface with a single IP address and a single MAC address. Client computers are programmed to use the virtual gateway address, not the physical address of the gateway routers themselves. One of the core switches is automatically selected as the active router. Should that switch fail, the second switch automatically responds to requests from clients for the virtual gateway address.

Note that the two routers in the broadcast core provide redundancy for connectivity between automation computers. The two routers in the station core provide redundancy for connectivity between the broadcast core and other parts of the station.

Multiple Ethernet ports

While the detail is not shown in Figure 3, it is assumed that each automation computer has two Ethernet

interfaces. In this example, one interface is connected to broadcast core router 1, and the other interface is connected to broadcast core router 2. If one interface fails, the computer is still connected to the network.

Don't assume that just because you have connected two 100BASE-T ports on the client to two separate switches that 200Mbps/s is automatically available. The interaction between the client and the switches is not straightforward. Just because there are two cables connected to two different Ethernet cards and they both have LEDs that light up green, it does not mean both of them are working. As with any backup system, test it to confirm that your client and switch are configured properly to make use of both connections.

Monitoring

Anytime one puts a high availabil-

ity system in place, it is important to consider how to monitor the system. Because the system is designed to continue to function even if a component fails, there may not be any outward signs that there is a problem. For this reason, it is important to monitor the health of the components in any mission-critical network. There are many network monitoring tools available. Most of these tools not only allow you to remotely monitor the health of network components, but they also provide levels of alarms and notification methods, whether by e-mail, SMS or some other technology.

How much protection?

As you consider these systems, think about how much protection you need, and whether the cost and time required to configure them really makes sense. Remember that you can always have an extra switch sit-

ting on the shelf. Also keep in mind that while it may make sense to deploy these sorts of systems in your broadcast core, other areas of the network may not require the same level of availability.

Results

The architecture in Figure 3 is quite resilient. In this configuration, automation computers continue to function even if one of the broadcast core switches fails, one of the station core switches fails, and one of the network interfaces in the automation computer fails, all simultaneously. That is a lot of protection for relatively little expense. **BE**

Brad Gilmer is executive director of the Advanced Media Workflow Association, executive director of the Video Services Forum and president of Gilmer & Associates.

? Send questions and comments to:
brad.gilmer@penton.com

TEMPEST® 2400. TAKING WIRELESS PRODUCTION BY STORM.

Like nothing seen or heard before from a digital wireless intercom system, Tempest2400 makes intercommunication a breeze in any indoor and outdoor broadcast production environment, anywhere in the world.

- Operates in unlicensed 2.4GHz band
- All digital, 4-audio channels
- 5 full-duplex beltpacks per basestation; Up to 50 beltpacks on 10 basestations
- 2xTX-Transmission/Frequency Hopping Spread Spectrum
- Accu-Sync™ Basestation Coordination
- Easy setup—No frequency coordination required
- Stage Announce; Unique GPIO Contact Closures; Vibration Call Function
- Easy-to-operate T-Desk software for monitoring and configuration



Clear-Com

www.clearcom.com

◆ **NOW SHIPPING!** ◆

DIGITAL WIRELESS

© 2009, Vitec Group Communications, LLC. All rights reserved. ® Clear-Com is a registered trademark of The Vitec Group plc.

Long-GOP editing

Today's enhanced NLEs support various types of MPEG-2, resulting in a faster workflow.

BY STEVE MULLEN

Product presentations at NAB are a great way to rest your burning feet while looking like you are absorbing significant information. At the 2009 NAB Show, in a state somewhere before sleep, I heard a presenter tie long-GOP formats to generational loss caused by adding titles to a production. Say what?

While the industry may have moved past a pronouncement made in 2004 that "...MPEG-2 ain't supposed to be edited," the NAB 2009 statement sadly matched comments made over the last five years — often by Hollywood influencers — that reveal a profound misunderstanding about how modern editing tools work.

A few years ago, negative statements about long GOP were simply veiled attacks on MPEG-2. But, now with AVCHD and AVCCAM — both long-GOP versions of MPEG-4 — claims about GOP length and editing cover a wide range of formats and products. By addressing the myths surrounding MPEG-2, we can hopefully prevent the same myths resurfacing with long-GOP H.264/AVC.

Performance concerns

Some myths about interframe encoding may result from explaining, in simple terms, how encoding works. A key frame often was described as though it were a photograph, with no mention that an I-frame itself is highly compressed. Using terms that better fit a description of delta-modulation, subsequent frames were described as containing differences from the initial frame.

It's not surprising that those who conceive of computer-based editing as nothing more than the replacement of VTRs with hard disks were sure the need to keep "rewinding" the disk

files to find I-frames would make jog and shuttle sluggish and, therefore, a serious hindrance to editing.

In reality, NLEs access a disk only to replenish large buffers held in RAM. Moreover, B and P frames are stored within a GOP in a series that facilitates decoding. (For a brief review of interframe and intraframe MPEG-2 and MPEG-4 encoding, see

editing or compositing work.

Converting MPEG-2 (or H.264/AVC) to an intermediate codec — other than uncompressed — results in at least some quality loss because it involves a decode followed by a recompression using an intermediate codec. Moreover, conversion always increases the size of all your source files because interframe source files

The question is at what point in the editing process 4:2:0 video is upsampled to either 4:2:2 or 4:4:4.

the "MPEG-2 and H.264/AVC" article in the July 2008 issue.)

A more realistic concern was that the enormous number of calculations required to obtain each image would prevent multistream real-time editing. However, as reported in my review of a RAID system ("CalDigit's HDPro" in the September 2008 issue), I measured nine streams of 1920 x 1080 XDCAM EX from a Mac Book Pro. These kinds of numbers effectively refute this concern.

Unfortunately, this concern remains true for AVCHD and AVCCAM, as well as AVC-Intra. Nevertheless, there will be a day when H.264/AVC performance concerns will vanish.

Native vs. intermediate editing

There have always been warnings about long-GOP MPEG-2, such as the one I heard at NAB. Although they sound reasonable, they involve invalid assumptions. At heart is the belief that because long-GOP MPEG-2 is highly compressed, you'll probably want to convert that MPEG-2 stream to something else before you do any

require the least possible storage space. But, more importantly, conversion during import in no way can improve or preserve image quality. Even with a conversion to uncompressed video, image quality only remains constant.

Additional warnings and recommendations involve reference to the evils of 4:2:0 chroma sampling and generation loss caused by multiple re-encodes of long-GOP files to long-GOP files. First, it is important to note that although most long-GOP formats have employed 4:2:0 sampling, this is not an inherent characteristic of interframe encoding. For example, 50Mb/s Sony HDCAM 422HD is a long-GOP format.

Second, the quality of 4:2:0 sampling is not the subject of this debate. Rather, the question is at what point in the editing process 4:2:0 video is upsampled to either 4:2:2 or 4:4:4. A 4:2:2 conversion is made so various video formats can be mixed together. To mix RGB graphics with video, a conversion to 4:4:4 is performed.

A conversion can be made within a VTR when MPEG-2 is decoded prior



High Performance Contribution & Distribution Solutions



Ellipse™ contribution encoders

- Fixed contribution with the Ellipse 1000
- Low latency DSNG and event coverage with the Ellipse 2000
- SD or HD, MPEG-2 or AVC



Electra® 8000 universal broadcast encoder

- Improves MPEG-2 performance by 20%
- Integrated statmux supports multiple HD and SD channels
- 4 channels in 1RU, SD or HD, MPEG-2 or AVC, CBR or VBR
- Integrated broadcast quality up/down conversion
- 1080p 24/50/60 native support



ProView™ IRDs

- ProView 7000: integrated receiver and processor with descrambling and decoding – ideal for DTA
- ProView 2900: broadcast quality decoder, decryptor and interface converter
- Leveraging the industry-leading Scopus technology

harmonic
REDEFINING VIDEO DELIVERY

www.harmonicinc.com

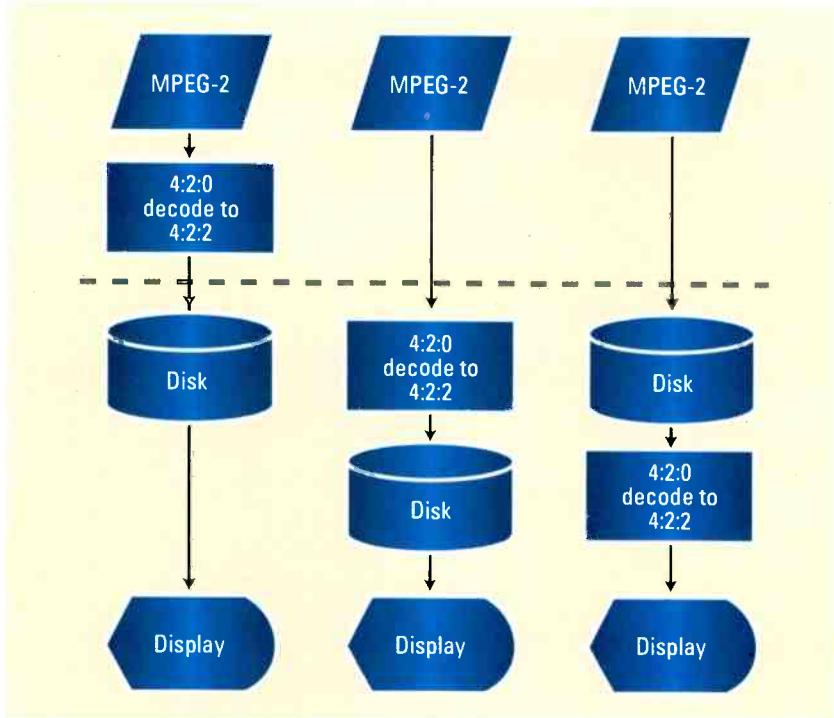

Figure 1. Time of decoding (VTR above line)

to being sent as uncompressed 4:2:2 video over an HD-SDI connection. Another option is to perform the conversion during import when MPEG-2 or AVCHD/AVCCAM is transcoded to an intermediate codec. And, of course, the conversion can be made on the fly as MPEG-2 or AVCHD is decoded to an uncompressed YCrCb signal. In all cases, the key to upconversion quality is the equations themselves and the degree to which rounding errors are prevented. The point at which the conversion occurs is irrelevant. (See Figure 1.)

Early NLE operation

Early NLEs generated effects following this process: One or more sources were decompressed to 4:2:2 YCrCb. The digital data stream(s) was mathematically (dissolves) or logically (wipes) combined. The resulting 4:2:2 YCrCb data were then recompressed using the same codec used by the source files. The recompressed files were called preview, render or precompute files.

Using this procedure, long-GOP video was subjected to generation loss during recompression. Moreover, graphics and titles would also be sub-

jected to long-GOP compression that would indeed cause significant graphics degradation.

In order to save rendering time, many NLEs would reuse the render files when an editor, for example, added another layer to the layers already rendered. Likewise, to save compute time, renders were used when a project was exported to another format.

If modern professional NLEs such as Avid Media Composer and Apple Final Cut Pro worked in the manner described, generation loss would indeed be a valid concern. Thankfully, they do not.

Current NLE operation

When MPEG-2 sources are used by a project, some of the processes previously described are the same. One, or more, MPEG-2 sources are decoded on the fly to 4:2:2 or 4:4:4 YCrCb data. One data stream, one data stream combined with one or more graphics, or the computed result of combining several data streams (plus one or more graphics) become a real-time video stream that is sent to a monitor window on the computer's display and/or to an external monitor. The computed result is used only as a real-time preview. (See Figure 2.)

In this cycle, long-GOP sources are decoded only once. And, it makes no difference when there are decoded — during ingest or at the time of playback. Moreover, if, as recommended by some, our 4:2:0 video had been decoded and recompressed, this 4:2:2 intermediate format would also have had to be decompressed on the fly to 4:4:4 YCrCb data. Upsampling 4:2:0 to 4:2:2 and then later upsampling

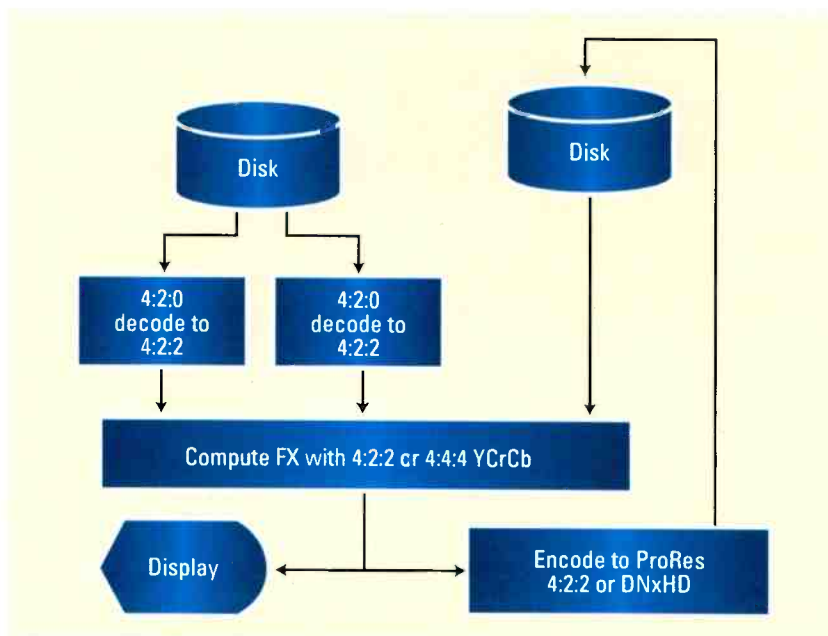

Figure 2. Native MPEG-2 editing

Ready for Primetime



Lowest Cost Per Channel

Outstanding Video Quality

Highest Reliability

Smart Economics

We've done it again — in High Definition!

Five years ago, 360 Systems' Image Servers set a new standard for price and performance, and became the all-time best-seller. Now, we've done it again with our new family of *MAXX High Definition* servers.

MAXX-1200 HD provides three simultaneous video channels, 24 audio channels, and over 70 hours of storage—plus slow-motion, 3-channel key-and-fill, and even remote workstation software.

MAXX-2400 HD provides the power of *four* video outputs, *two* inputs, more than 200 hours of storage, and all the features you expect in a broadcast quality server. Better image quality, multiple audio formats, and smart economics clearly position the MAXX-HD servers as Best of Class. Priced from just \$16,000, they also make very good business sense.

Visit our web site to learn more about MAXX high-definition servers. Or e-mail us at HDservers@360systems.com and request color brochures on the new MAXX-HD family.

+1 (818) 991-0360 HDservers@360Systems.com www.360Systems.com

360 Systems
BROADCAST

from 4:2:2 to 4:4:4 opens the window to more conversion rounding errors.

The same logic applies to recommendations to convert 8-bit sources to an intermediate format that uses 10-bit data. Placing 8-bit samples within 10-bit words, of course, does not increase the precision of the digital data. It simply needlessly increases the size of all source files.

To increase the accuracy of preview or render calculations, the NLE itself need only be set to use a high-precision mode. Final Cut Pro, for example, can compute effects at 8 bits, 10 bits or 32-bit floating-point. Media Composer works at either 8 bits or 16 bits. In all cases, 8-bit data are on the fly fed into higher precision calculations.

As the number of layers increases and effects become computationally more complex, real-time previews are no longer practical. In this case, the

editor can choose to render all, or portions, of a project. While making this choice might seem to open the door to generation loss, it does not.

Final Cut Pro offers an editor the option of selecting Apple's "uncompressed quality" ProRes 422 HQ as the render codec. (See Figure 3.) Generation loss caused by re-encoding to a long-GOP codec is prevented. A render file can be played back for a smooth preview, or combined with new video and/or effects.

Transfer from and to NLEs

While video transfer to Apple's Color application can be long-GOP MPEG-2, during color correction, data are decoded to 4:2:2 video. Color correction is

never performed with MPEG-2. Color corrected results are returned to Final Cut Pro using ProRes 422 HQ.

This same procedure can be used to transfer segments from Final Cut Pro (or Media Composer) to another application. Working this way saves the needless conversion of hundreds of hours of source material to an intermediate codec. Transfer back is via ProRes 422 HQ to Final Cut Pro or Avid's mastering quality DNxHD codec to Media Composer.

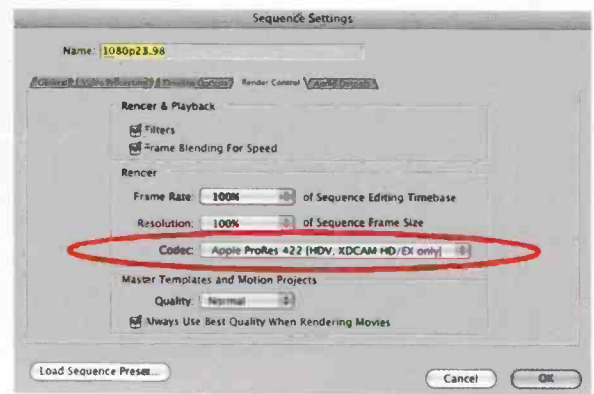

Figure 3. Apple's Final Cut Pro enables editors to select the 4:2:2 render codec.

VISLINK

News & Entertainment

New applications and solutions for the demanding and changing Broadcast world – fixed and mobile microwave links, wireless camera systems, cellular receive city centre networks, satellite uplinks and IP data transfer.

Professional broadcast equipment and support services for news, sports and Outside Broadcast. Quick set up, effective operations and superb performance for 24 hour live news, sensational sports and creative camera work.

Secure Communications from Vislink.

ADVENT

LINK

MRC

UK: +44 1923 474060 Middle East: +971 4886 5226 Singapore: +65 6248 4676 USA: +1 978 671 5700 www.vislink.com

32 broadcastengineering.com | July 2009

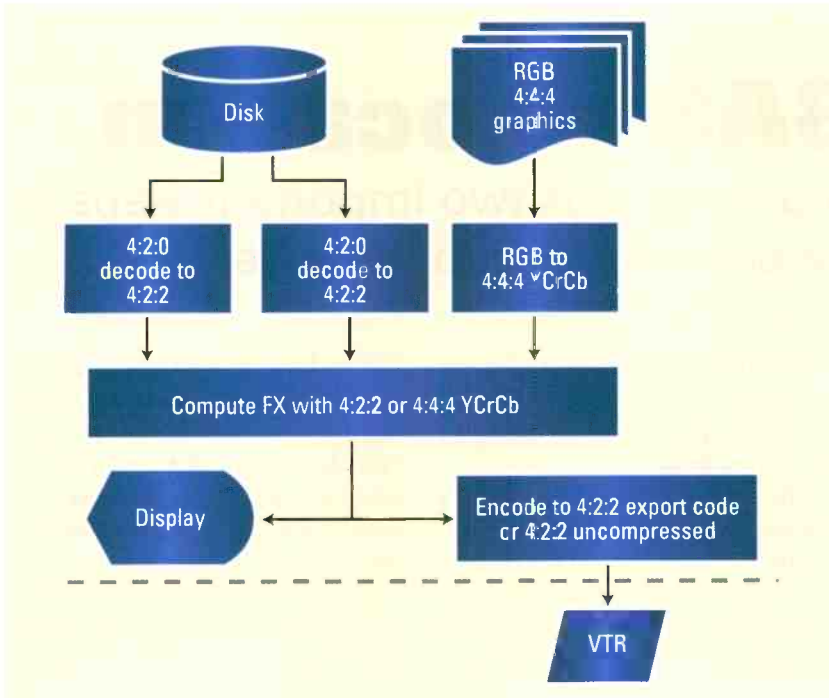

Figure 4. Export is done without the use of renders.

Export

Long-GOP generation loss during export is prevented because Final Cut

Pro always generates each export frame from source files. Render files are not used. (See Figure 4.) With an Avid Me-

dia Composer, deleting precomputes before export prevents render files from being used during export — even though they use DNxHD or DVCPRO HD codecs.

Given the fear, uncertainty and doubt that has too long existed around long-GOP MPEG-2, is there a scenario in which generation loss can occur from natively editing long-GOP MPEG-2? Yes. Were an editor to not export an HD master to HDCAM SR, HDCAM, XDCAM 422HD, D5 or tape-based DVCPRO HD and instead export to a tape format that employs long-GOP MPEG-2, then the master would indeed be second-generation long-GOP MPEG-2. However, formats such as HDV are rarely accepted as master tapes.

BE

Steve Mullen is owner of Digital Video Consulting, which provides consulting and conducts seminars on digital video technology.

GOOD THINGS COME IN ALL SIZES

Marshall Electronics offers the widest selection of professional rack-mount and standalone LCD monitors in the industry. Marshall's video offerings range from 10-screen rack monitors and Quad Viewers to Super Transflective Outdoor monitors and a full series of displays with integrated In-Mon for Display (IMD) capability. We also offer a variety of Digital Audio Monitors, professional microphones, and pro audio cable.

- Quality · Innovation · Experience
- Customer Service
- Designed, Engineered, and Assembled in the USA

Marshall Electronics / LCDracks.com Tel.: 310-333-0606 / Toll Free: 800-800-6608

2GHz BAS relocation

The BAS relocation project took two important steps in June, but a possible hiccup remains.

BY PHIL KURZ

The Los Angeles market, which includes TV stations in Los Angeles, San Diego, Santa Barbara and Palm Beach, CA, achieved an important milestone in June when the Broadcast Auxiliary Service licensees completed their 2GHz BAS relocation.

Finishing the project in the Los Angeles cluster is significant because of the magnitude of the task and

tion of the market cluster represents as a sign that the overall project nationwide is proceeding expeditiously that's most important.

The transition of the Los Angeles market cluster takes the total number of markets relocated to 108 as of June 8. This tally and other benchmarks, such as the percentage of BAS licensees that have completed frequency relocation agreements and

In its June 10 report and order and further notice of proposed rulemaking, the commission said as much: "We also believe that Sprint Nextel, working with the broadcasters, has made a good faith effort to increase the pace of the BAS transition."

That good faith effort was enough for the commission to grant Sprint Nextel and broadcasters until Feb. 8, 2010, to wind up the nationwide

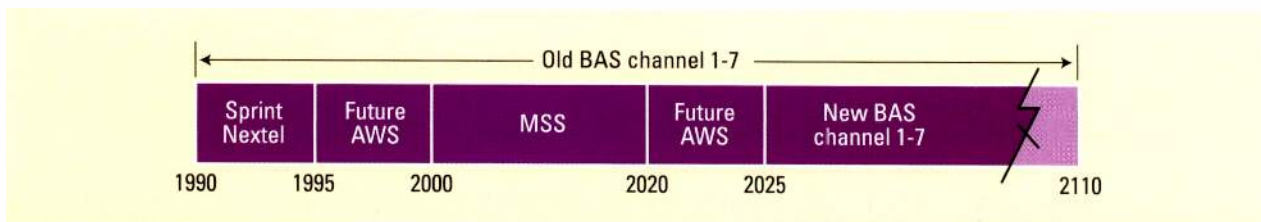

Figure 1. An illustration from a recent FCC report and order makes clear how the spectrum currently used for analog Broadcast Auxiliary Service at 2GHz will be used following the relocation.

the progress it represents in the nationwide effort to complete the relocation. The size of the job, which required replacing ENG equipment in some 200 vehicles, 14 helicopters and at 175 receive sites, is impressive. However, it may be what the comple-

the percentage that possess all of the equipment needed to finish the job, are important signs to the FCC that despite various unanticipated delays, Sprint Nextel and broadcasters are serious about completing the project and deserve more time to finish.

project. Originally, the commission had set a deadline of Sept. 7, 2007, to complete relocation of seven analog BAS channels between 1990MHz and 2110MHz to seven digital channels between 2025MHz and 2110MHz. (See Figure 1.) However, a variety of unforeseen circumstances have delayed the relocation, making it necessary for the FCC to grant a series of extensions until this month when it reset the deadline to February 2010.

Once cleared, 5MHz of the freed-up spectrum will be allocated to Sprint Nextel for cell phone use, and 30MHz of reclaimed spectrum will be allocated to new mobile satellite service companies and future ancillary terrestrial component network providers.

The delay in completing the BAS relocation has put the commission in the position of trying to balance competing priorities in serving the public interest — specifically, maintaining live news shots from the field and

FRAME GRAB

A look at the consumer side of DTV

Statistics show men watch more mobile TV than women

Fifty-nine percent of mobile video consumers are men.

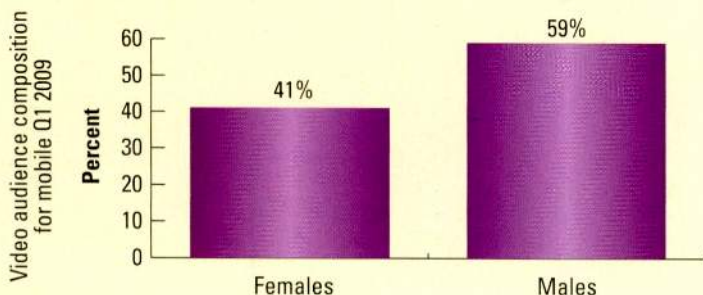

Source: Nielsen

www.nielsen.com

Ki Pro Worldwide Roadshow

From Lens to Post.

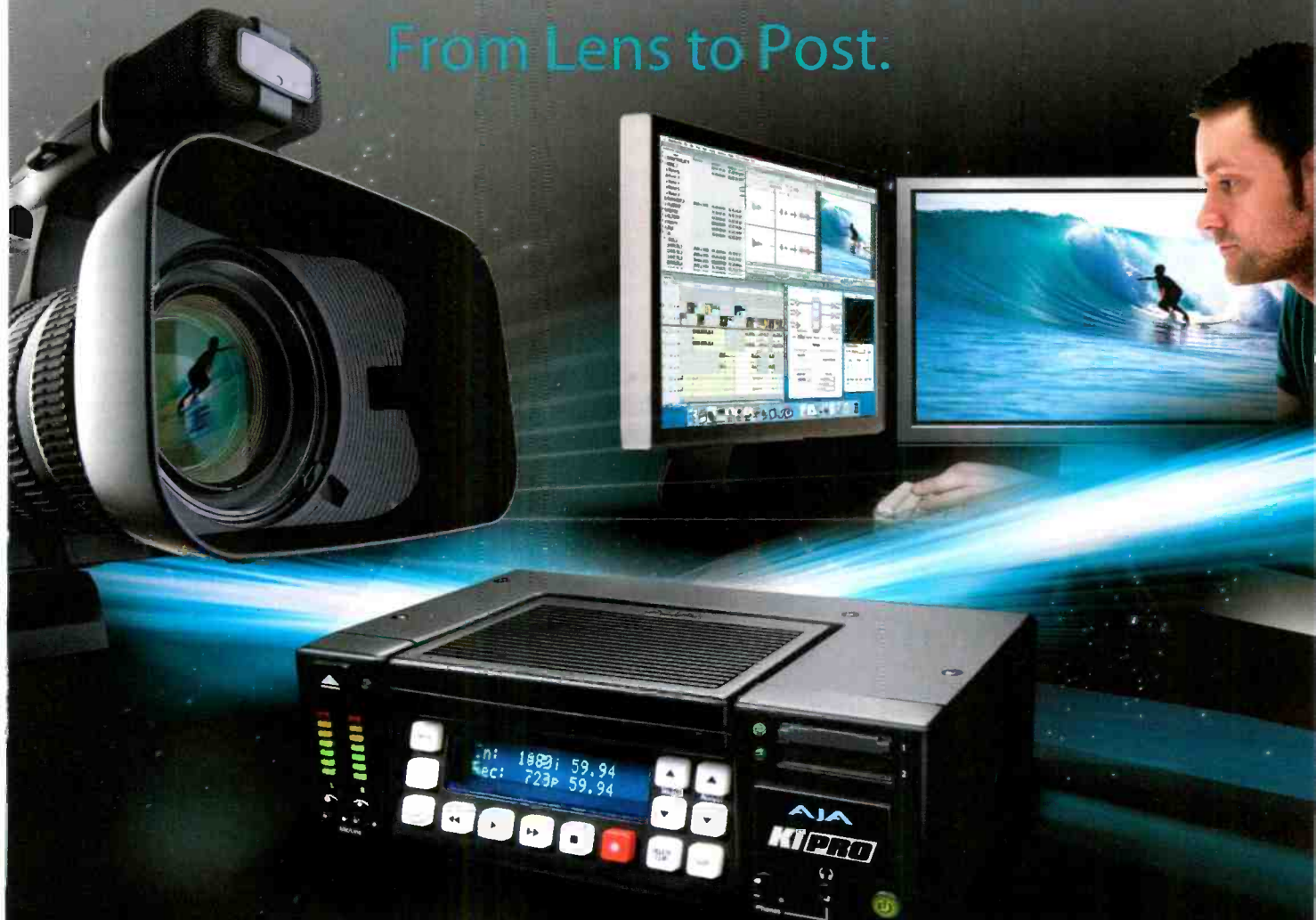

Ki Pro

ProRes

AJA Video just announced the revolutionary Ki Pro at NAB 2009, and now we're taking it on the road so you can see it for yourself!

Finally, shoot on the same codec as you edit with, full raster 10-bit Apple ProRes 422, built natively into Ki Pro's stand-alone, portable hardware.

Experience Ki Pro for yourself at one of our US roadshows

Chicago - June 10th

Miami - June 25th

Toronto - June 16th

Vancouver - July 14th

Los Angeles - June 17th

Dallas - July 16th

New York - June 18th

Mexico City - July 21st

Atlanta - June 23rd

Sao Paulo - July 23rd



Find a city near you,
and register today!

Register at:
www.aja.com/kiprotour

Ki Pro. Because it matters.

AJA

VIDEO SYSTEMS

allowing new communications services to come online. Still, the accelerated pace of progress has helped the FCC decide to maintain the primary status of BAS operations in the band at least until Feb. 8, 2010.

The lesson from Los Angeles

If there's one thing that can be learned from the success of the BAS relocation project in the Los Angeles market cluster, it is the importance of cooperation and testing.

"We really wanted to force people to do due diligence in testing the equipment to see what was going to happen," said Chris Neuman, an independent consultant and owner of CNC Consulting in Los Angeles.

Neuman, the former director of broadcast operations and engineering at KTLA-TV in Los Angeles and the person selected by Sprint Nextel

to coordinate the relocation in the market cluster, conducted two separate tests of the newly retrofitted ENG resources with all of the BAS licensees in the area. During the first digital BAS shakedown held April 25 at Sweetwater Video Productions in Van Nuys, CA, Neuman and the broadcasters followed a test script, checking different operating parameters every five minutes. The tests revealed that some of the new radios had firmware problems, which were corrected by time the second test was conducted in late May.

As a result, when the cluster transitioned June 6, "we had ironed out 98 percent of the issues, which made the actual day of the transition — one that we had not relished for years — very uneventful and smooth."

John Krueger, manager of technical operations at KNBC/KVEA in Los Angeles, also attributed the success of the transition in the market cluster to

cooperation among BAS licensees. "Especially in LA, all of the broadcasters worked together," he said. "We were extremely cooperative and called each other. Everybody covered each other's back."

Cooperation alone, however, is no guarantee of success. Planning proved invaluable in making the relocation a success on the ground as well as in the air. According to Carston Bell, director of aerial photography for Angel City Air flying out of Whiteman Airport in the San Fernando Valley, planning was particularly crucial to converting the market cluster's news helicopters.

"Here in LA, we have a very intense newsgathering cycle from the air due to geography, topology and news environment," he said. "Aircraft can't be out of service for an extended length of time, and there are not many helicopters to move in to backup those taken out of service to be retrofitted."

**GET THE
STORY.
OR WATCH
SOMEONE
ELSE
REPORT IT.**

NOTE TO SELF: LOWER YOUR COST.

Competition fuels the news business. It's get or get out. So give your team an unfair advantage: Streambox. Instead of rolling ENG/SNG trucks, broadcasters can deploy a scalable IP-based solution that helps you move more content faster and at a lower cost. Go live-to-air, edit the story for later broadcast, or feed video to websites and affiliates. Call us to schedule a demo.

 **Streambox**
Innovation is in the box™

Learn more at www.streambox.com
or call +1.206.956.0544 ext 3.



The Los Angeles market cluster held a test of the new digital 2GHz Broadcast Auxiliary Service in the parking lot of Sweetwater Video Productions on April 25.

Angel City Air, which is contracted to fly news copters for KCBS, KTLA and KCAL in Los Angeles, had to plan carefully to draw from a limited pool on backup aircraft to meet ongoing newsgathering demands while shuffling its helicopters through difficult, regulated retrofits, he said.

A possible bump

While the success of the relocation in the Los Angeles market cluster should give the industry a reason to cheer, there remains the fact that much work needs to be done industry wide to complete the project. The FCC has given Sprint Nextel and broadcasters almost an additional six months to finish the project, but the commission also wants to advance roll out of MSS service in the band.

For the time being, the FCC has reaffirmed that BAS licensees in uncleared markets maintain their right to protection from harmful interference from MSS service, said David Donovan, president of the Association for Maximum Service Television. "BAS licensees in uncleared markets have remained primary, and MSS can't interfere with ENG operations," he said.

However, the recent FCC report and order and further notice of proposed rulemaking seeks comment on whether or not BAS licensees that haven't relocated by February 2010 should maintain their primary status. The commission even asked for comment on whether they should lose their right to transmit on the old BAS frequencies after the new deadline.

According to Donovan, finishing the project by Feb. 8, 2010, prevents the possibility entirely. "We are working mightily to achieve that," he said. "But if for some unforeseen reason we don't, we believe we should still be primary in the band. News shouldn't be interfered with." **BE**

Phil Kurz writes Broadcast Engineering's "ENG Update" e-newsletter.



Adder II™
Audio Excellence



TeleThon™
CWDM/HD Transport



Rattler™
HD/SDI Solutions



CopperHead™
Camera-back Interfaces

In the field, you never get a second chance to get it right.

That is where you need the dependability of Telecast Fiber Systems. We pioneered the fiber optic industry, and we have been by your side for over fifteen years providing the products you need every day.

We owe our success to you, your feedback and your ideas. The result is excellent products that help you "get the shot", no matter what.

And that is why we are outstanding in our field, and yours.



508.754.4858 • www.telecast-fiber.com

© 2008 Telecast Fiber Systems. All rights reserved.
All trademarks are the property of Telecast Fiber Systems.

Implementing IPv6

The transition to IPv6 will be necessary sooner rather than later.

BY CIPRIAN POPOCIVIU

One by one all communications services and applications have migrated or are in the process of migrating to Internet Protocol (IP)-based transport. IP enables the convergence of all data, voice and video services onto a common infrastructure that delivers both increased returns on investment and reduced operational costs.

The open-standards nature of IP eases integration of new capabilities and features, increases the agility and scalability of the infrastructure and facilitates the creation of new or enhanced services through mash-ups of existing ones. Broadcast services infrastructures are on track to inevitably converge to IP. While the production and contribution components of the infrastructure

opportunities offered by the converged infrastructure, but also on the capabilities of today's IP and multiprotocol label switching (MPLS) networks. According to the *Broadcast Engineering* article "Video over IP" from February 2008, high-bandwidth, Ethernet-based transport media features enable network convergence within 0.5 and 0.05 seconds, low jitter and error correction capabilities, along with protocols such as multicast and quality of service (QoS), which enable optimal use of the infrastructure and make IP networks fully capable of supporting video services.

The next generation of IP

With the case for a migration to IP infrastructures made, there is only one step left to justify the very existence of this article: explain its

ing number and types of devices connected via IP and to enable services that rely on peer-to-peer and mobility-focused communication. While IPv6 is not dramatically different from IPv4, the version of IP currently in use, it provides the resources needed to scale up IP-based infrastructures and services. The adoption of IPv6 is picking up steam, so it makes sense to keep it in mind when planning the deployment of broadcast services over IP.

The adoption of IPv6 in certain areas of broadcast services infrastructure is easily justified. With end systems such as mobile handsets and home networking devices adopting IPv6, it makes practical and strategic sense to consider IPv6 for distribution. There are already broadband access providers that deliver video content over IPv6.

For other areas, however, the case for IPv6 adoption might be less evident, which could lead to a mix of IPv4 and IPv6 infrastructures, each supporting specific aspects of the broadcast service. It is important to remember that the two protocols are incompatible, and the insertion of protocol translation gateways that lead to loss of functionality and performance should be avoided. Instead, the boundaries between the IPv4 and IPv6 domains should be aligned with the boundaries for the various components of the broadcast service. For example, content sources and production centers could be connected over an existing IPv4 network, while distribution is done over IPv6.

Although the coverage of today's IPv6 networks might not be sufficient to support the entire broadcast services chain, planning should be done for end-to-end IPv6 transport.

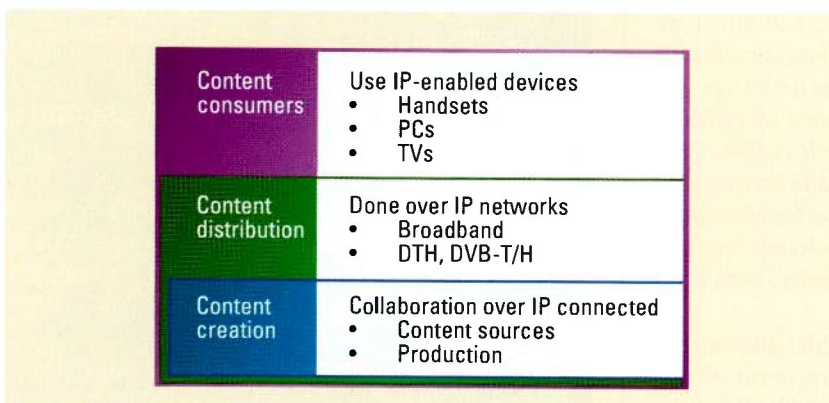

Figure 1. Convergence of broadcasting services over IP infrastructures

might lag behind distribution in adopting IP, the characteristics of current and future content sources and content consumers demand a converged, end-to-end IP network. (See Figure 1.)

The business and technical case for IP-based broadcast networks is not based only on the envisioned op-

focus on IPv6, the next generation of IP. The main characteristics of IPv6 and the case for its adoption were covered in a December 2008 article in *Broadcast Engineering* titled "IPv6 is coming." It emphasized the need for a large IP address space to sustain the rapid and continued adoption of the Internet to support the increas-

"I need a faster, more accurate audio analyzer."

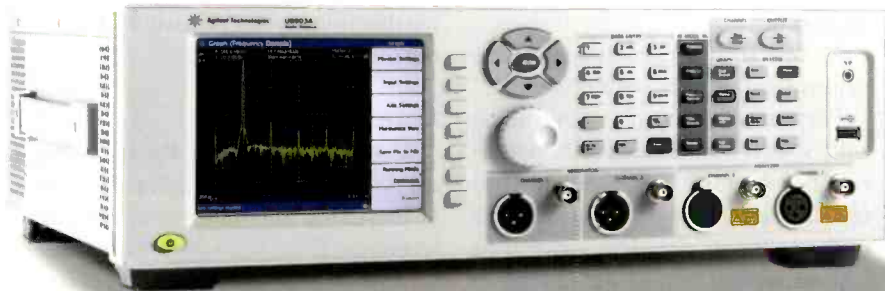

We knew you'd say that.

The new Agilent U8903A audio analyzer is four times more accurate and over seven times faster than its popular HP 8903B ancestor. In fact, it is among the fastest and most accurate currently in its class. It's also a more fully capable audio analyzer, letting you make crosstalk measurements and phase measurements, FFT analysis, and graph sweep. And it will soon be upgradable to eight channels. You can't find that anywhere else. Go online to learn more about this remarkable new audio analyzer.

Save \$2,400

when you trade in your old HP 8903B
for a new Agilent U8903A audio analyzer*
www.agilent.com/find/U8903APromo

©Copyright Agilent Technologies 2009
Trade in offer good for a limited time.

u.s. 1-800-829-4444 canada: 1-877-894-4414



Agilent Technologies

IPv6 infrastructures

The architecture, design and products needed to deploy broadcasting services over IPv4 are well understood and are already being used. Because, for the most part, IPv4 and IPv6 are similar, the same architecture and design principles apply to both protocols:

- The forwarding features and performance for IPv4 and IPv6 are similar.
- Routing concepts are the same, so design is IP version agnostic but topology and environment dependent.
- Similar network convergence times can be achieved with either protocol.

the protocol as needed to support new services.

- IPv6 offers a new rendezvous point (RP) discovery with the introduction of embedded RP, while the overall deployment of multicast is made easier in IPv6 through the new address architecture.
- Mobile IP provides more scalable deployment options with IPv6.

For infrastructures leveraging MPLS, there is no real differentiation between the way IPv4 and IPv6 is being tunneled. The control plane of the MPLS infrastructure might be supported and implemented only in

mind. Major manufacturers have been supporting IPv6 for some time, and feature or performance gaps (in comparison with IPv4) are fewer and less constraining. Nevertheless, as part of the planning process, it is important to identify gaps and future needs while working closely with vendors to mitigate the gaps.

Summary

The convergence of broadcasting services onto an IP infrastructure is inevitable. If your service already leverages IPv4 transport, you need to start planning for the integration of IPv6 and a migration and expansion of existing services to IPv6. Most technical and operational aspects of operating an IP network for broadcasting services will apply to the new infrastructure, which at first will operate in parallel over the same hardware as the IPv4 one.

If you are looking to implement IP transport, then you should plan it in a version-agnostic (IPv4/IPv6) way and focus on IPv6 wherever possible; plan to leapfrog. (See Figure 2.) IPv6 transport or capabilities might not be available in all infrastructures you need; however, with expected exhaustion of the IPv4 address space by 2011, the transition to IPv6 will become necessary sooner rather than later. The important thing is to be prepared, to understand where IPv6 will become critical first (distribution, for example) and to address the needs of existing customers and those of new ones. (At the consumer level, IPv6 adoption is faster in Asia and Europe.)

It is never too early to start inventorying IPv6 capabilities and the needs of the IP infrastructure supporting your current or future broadcast services. Early planning ensures timely readiness and lower implementation and operating costs.

BE

Ciprian Popoviciu, PhD, CCIE, leads the Systems and Infrastructure Data Center architecture team at Cisco Systems. He is co-author of two IPv6 books, "Deploying IPv6 Networks" and "Global IPv6 Strategies," and is a senior member of the IEEE.

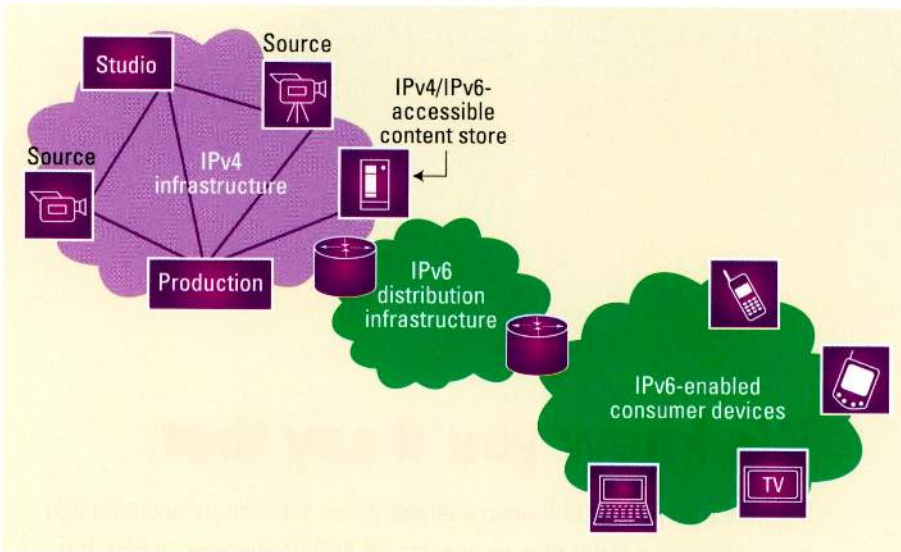

Figure 2. IPv4/IPv6 mixed infrastructures supporting broadcasting services

- IPv4 multicast capabilities and architectures are available with IPv6.
- The same features and capabilities available for implementing QoS for IPv4 are available with IPv6.
- For the most part, the same security policies apply to both IPv4 and IPv6. While some threats are eliminated by IPv6, new ones are introduced, which require explicit mitigation.

There are finer differences, however, between the two protocols, which provide alternative design options and service implementation or enhancement:

- The new IP header structure provides the resources to enhance content delivery services and to extend

IPv4; however, this has limited impact on transporting video content over IPv6.

In reality, the main concern of the broadcaster who is implementing broadcast services over an IPv6 infrastructure most likely is the full support of the protocol by all the elements involved in supporting the service. Everything from encoder/decoders and headends to video gateways and networking equipment needs to be evaluated for IPv6 readiness.

The adoption of the protocol is ongoing, and so is its maturity in terms of product support. Any equipment that leverages hardware assistance needs to be designed with IPv6 in

TRAINING DOESN'T COST, IT PAYS.

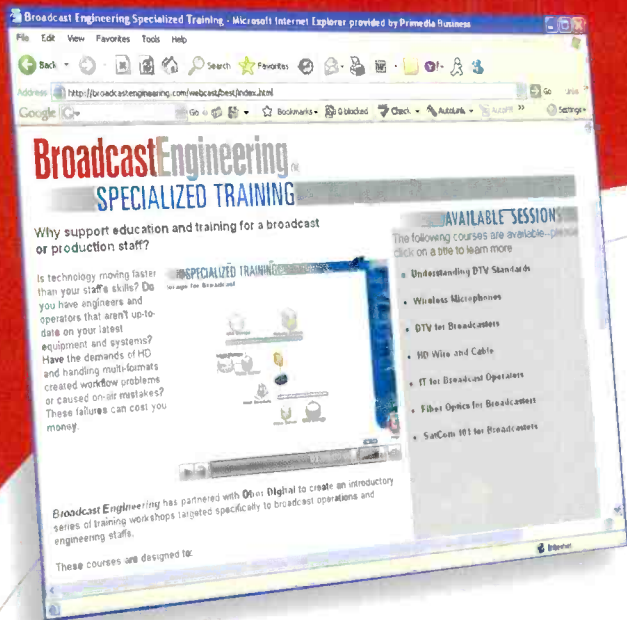

Is technology moving faster than your staff's skills? Do you have engineers and operators that aren't up-to-date on your latest equipment and systems? Have the demands of HD and handling multi-formats created workflow problems or caused on-air mistakes? These failures can cost you money.

Broadcast Engineering is excited to offer you an introductory series of training workshops targeted specifically to broadcast operations and engineering staffs.

These courses are designed to:

- introduce new technology, solutions and operations to younger staff members, and
- provide a structured and thorough review for your more experienced staff.

All this is contained in a self-paced, complete program accessible from any computer.

Log on to www.broadcastengineering.com/webcast/best to learn more, or to enroll.

Leave the teaching to the experts,
the consultants at *Broadcast Engineering*.



POWERED BY

ZEUS[™]
BROADCAST
An Obor Digital Company

TRAINING DOESN'T COST, IT PAYS.
Visit broadcastengineering.com/webcast/best

Broadcast automation is critical in today's economy

BY SID GUEL

The elephant in the room is clearly the ailing economy and how the inevitable chain reaction has now affected the broadcast industry. It's no secret that the economy has indirectly affected a broadcaster's capital purchase plans. Every day we hear of more and more layoffs in the broadcast industry. The low attendance at the 2009 NAB Show is yet another indicator of the economy's effect on our industry.

The broadcaster's focus has shifted to outright survival tactics and tried and proven ROI projects. As we march through one of the darkest times in our history, let's look at how critical automation is to broadcasting during these tough times. Several industry analysts and leaders have said automating processes, lowering staff count, smartening efficiencies and doing more with less are all critical for survival. This article examines the automation changes broadcasters can make

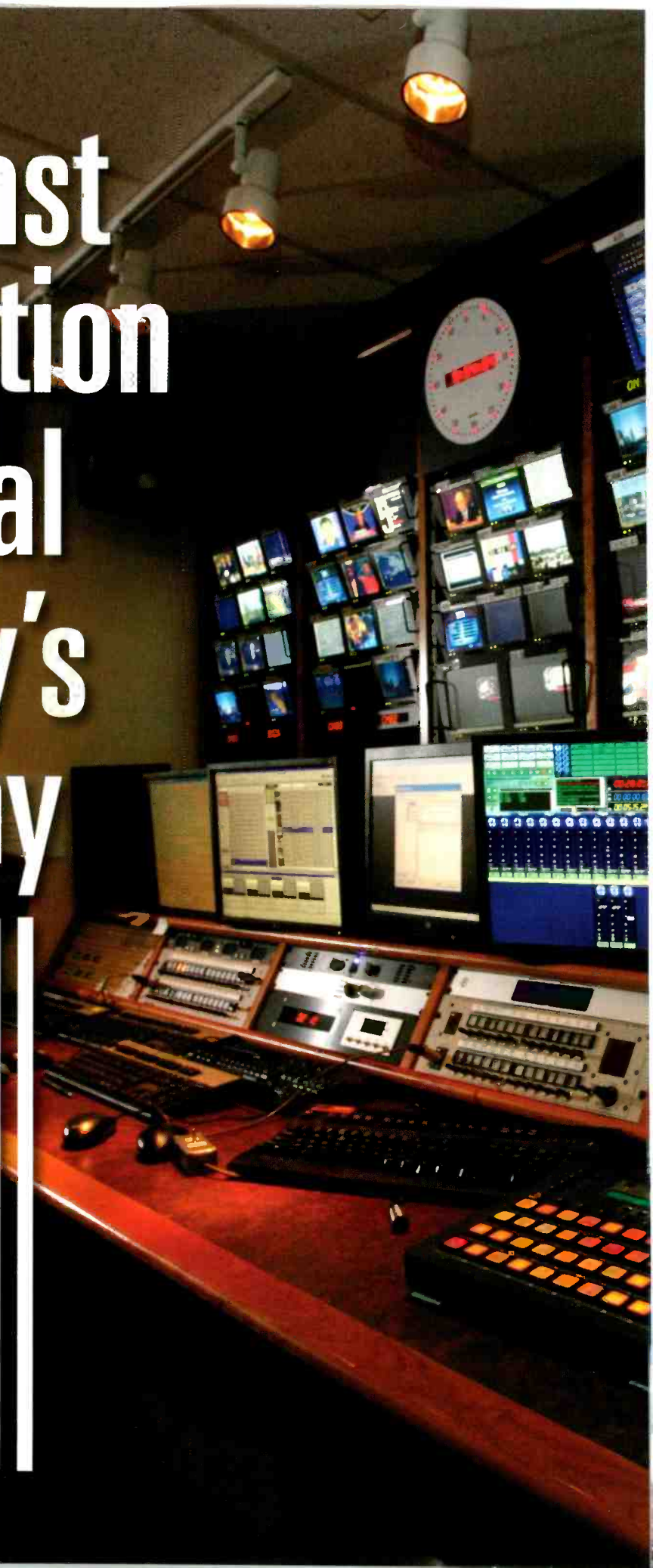



KOIN-TV, the CBS affiliate in Portland, OR, installed a Grass Valley Ignite integrated production system that enables operational efficiency, allowing the station to add more news programming and real-time cut-ins.

to survive and succeed during these hard times.

Master control automation

Master control automation is critical in today's broadcasting world. Automation systems are now advanced and proven to the point of normal everyday usage, regardless of the level of broadcaster. Whether you're a network broadcaster, a KXYZ or WXYZ, a public, educational and governmental (PEG) market broadcaster, or an audio/video corporate broadcaster, there are proven solid-state automation solutions available today.

There are three different types of automation systems. In standard systems, a PC- and software-based unit controls primarily third-party devices. A combo system consists of an internal video server and automation system combined in one box. The hybrid system is a channel-in-a-box solution in which the video server, automation applications, routers, switchers, graphics, character generators, etc., are included within one box or system. The combo and hybrid systems are growing in popularity. One of the principal reasons is because of costs, savings, simplicity of integration and low maintenance costs.

News automation

News automation is increasing in popularity, and it's a good way to cut

News automation is increasing in popularity, and it's a good way to cut costs in struggling news departments.

costs in struggling news departments. There are two types of news automation systems: hardware and software. The hardware news automation system is usually a news production switcher with advanced software for the automation of various processes.

The upside of these systems is that they do well in late-breaking live news or live production events. The downside is that they primarily only control proprietary devices and only limited external devices.

The software news automation systems are PC-based and are external to switchers, routers and video servers.

The more a production can be predefined, the better a production automation system will function.

Syndicated programming and commercial interstitial

Syndicated programming and commercial interstitial delivery systems are another way to automate



Systems integration firm Advanced Broadcast Solutions did an extensive upgrade of the newsroom production environment at KBCI, the CBS affiliate in Boise, ID. The automated newsroom production workflow reduced control room personnel.

Software-based systems control a variety of third-party devices via IP/API or Serial Control. The upside of these systems is that they can control a variety of third-party devices, regardless of the manufacturer. The downside is that they are not as flexible in late-breaking live news events.

Production automation

Production automation can also be effective in reducing headcount and increasing efficiencies. Regardless of the task, such as studio production or sports, there is most likely a production automation solution to fit the need. Like news automation, there are upsides and downsides to production automation systems, and they're usually based on on-the-fly live productions or late-breaking live events versus a predefined and scripted pro-

and advance your workflow. Several companies have applications in which rich media, along with metadata, is automatically pulled or pushed to play out video servers and automation databases. Several master control automation manufacturers have partnered with these companies to streamline the workflow and automate the delivery process. Features and options include real-time messaging, hot folders, auto distribution and transcoding, QA notifications, and auto database importing. These are all common functions with automated media content delivery systems.

The new trend with station groups is HD content distribution using their own networks. Because of the high cost of distributing HD programming commercially, station groups are

Innovation from
Pro-Bel and Snell & Wilcox
snellgroup.com



snell



Pro-Bel and Snell & Wilcox have joined forces and created a new company to better serve the needs of the digital media market. The combination of Pro-Bel and Snell & Wilcox brings together hundreds of talented staff, and promises to deliver a new level of innovation, integrated solutions and service to customers worldwide.

- Routing
- Modular Infrastructure

- Conversion & Restoration
- Production & Master Control Switching

- Automation & Media Management
- Control & Monitoring

installing distribution solutions that will work using their own networks or the public Internet. At the 2009 NAB Show, several new distribution companies moved into the broadcast industry from the IT, IPTV and Internet world. With more competition in place, the price of HD distribution should normalize and be more cost-effective for uplink facilities, stations and station groups.

Automated rich media distribution

Automated rich media distribution systems are now critical to an operation in which all the rich media assets are centralized. Several companies specialize in automated rich media distribution, nearline storage and archive management, and transcoding.

Most master control automation systems have limited to advanced forms of automated distribution applications. Some are more sophisticated than others. With master control automation systems, their primary purpose is to get rich media from any storage point to the playout server with minimal human intervention.

Monitoring and control systems are now a must as multiple channels are a norm in any given broadcast facility.

Master control automation systems are increasingly becoming more sophisticated in the area of rich media ingest, transcoding and distribution. Several master control automation companies can ingest rich media into the playout servers, nearline servers and archive servers, and in various formats for outlets such as IPTV, the Internet and mobile.

They can also simultaneously



The control room at KNTV in San Jose, CA, features a Ross Video OverDrive automated production control system.

transcode rich media for use in other areas such as proxy low-resolution copies for desktop viewing and EDL editing. Master control automation's ingest process can also auto transcode in a variety of formats such as Windows Media Player for Web VOD or Web streaming. In addition, master control can distribute content to where it's needed and wanted such as a local or remote playout video server, nearline system, archive system, or even a directory on a Web site.

Nearline and archive

Automated nearline and archive systems are available for smaller operations. Some master control automation companies have bypassed third-party traditional nearline and archive management systems. Several master control manufacturers can control and manage the storage and archiving within their systems using low-level API control. Master control automation companies now provide direct control automated solutions for nearline and archive storage.

Automated ingest

Automated ingest systems have been around for many years. Master control automation systems include these as a standard application

with their systems. The difference is how new formats are prepared and transcoded for new business model audience delivery systems such as mobile, Internet, IPTV, etc. Master control and asset management companies now offer built-in transcoding options for the automated transcoding of rich media. Several master control automation companies include built-in transcoders as a built-in or external option with their systems.

Some third-party ingest systems are becoming more and more visible since the explosion in new media outlets. These systems were designed as ingest systems with an advanced level of transcoding, databasing, distribution and management.

Monitoring and control

Monitoring and control systems are now a must as multiple channels are a norm in any given broadcast facility. When stations combine channel facilities, they use less broadcast engineers and operators to manage more channels and facilities. Monitoring and control systems help an engineer do more with less. An engineer can be more efficient if he or she has tools to help monitor broadcast equipment and report on specific problems and/or errors. A good

BROADCAST ENGINEERING: B.E. IN THE KNOW!



Broadcast Engineering's not just in your mailbox. It's online. It's in your inbox. It's on your mp-3 player. It's delivering all of the industry's latest news, technology, and updates in the format you choose, and providing the solutions, training, and answers you need to help you get the job done right.

Visit us online at <http://broadcastengineering.com> to sign up for the FREE coverage you need to keep on top of the latest developments.

US/Canada Edition
World Edition
Podcasts
Essential Guides
broadcastengineering.com
Broadcast Engineering E-zine

E-newsletter Suite
Webcasts
NAB Special Report
IBC Product Source
Digital Reference Guide

BroadcastEngineering®

It's Your 360-degree Connection to the World of Broadcasting.

FEATURE

BROADCAST AUTOMATION

monitoring and control system can automate emergency backup signal scenarios and pin-point problem areas without having to spend wasteful time searching for the problem.

Workflow automation

Workflow automation systems are growing in popularity. Several new companies have exploded into the broadcast world with an array of workflow automation systems that control a multitude of subsystems via Serial, API and other forms of communication. Some are SNMP-compatible and can also report systems errors. These companies are IT-based and manage and monitor file distribution regardless if it is high-resolution or low-resolution. The companies

SMPTE standard MXF is the best proven audio/video standard for the interconnectivity and transporting of rich media.



Lexington, KY, NBC affiliate WLEX-TV recently converted its automated master control system to HD, which included the installation of a Harris IconMaster switcher and IconStation advanced channel branding station.

are especially strong in new business models such as mobile, IPTV and iTV because they manage transcoding, distribution, storage and archiving.

All the while, they report continual status of operations. These are usually enterprise- or facility-wide systems that manage and monitor other systems from a high level. They are important in the sense that they will help identify workflow holes across the broadcast facility and work to resolve gaps and brick walls.

Standards

SMPTE standard MXF is the best proven audio/video standard for the interconnectivity and transporting of rich media. Since manufacturing companies are slow to build systems with more interoperability, the SMPTE standard MXF can act as the common ground between production, news, master control and other external groups.

The new SMPTE BXF standard is one of the biggest advances in

HD DIGITAL

CANARE
digital interconnect technology

COU-***
Connector Unit

COU-BP*
Blank Panel

COP-***
Connector Panel

COF-FM3
1 Unit Terminal Panel

COF-**
Frame

Support 5-Directional Wiring

Cabling Direction

Connection Unit Vertical

Connection Unit Horizontal

Connecting Direction of Connection Unit & Cabling Direction

- Vertical/Horizontal
- Horizontal
- Vertical

Hybrid Fiber-Optic Camera Connector Panels

Features

- SMPT 311 Standard
- Integrated splice enclosure
- Easy maintenance & Installation
- Patent Design modular system
- Available in 2RU, 3RU and a variety of Configurations

canare.com | lcano@canare.com | 973.837.0070 | hybrid fiber-optics & EO/OE | snake systems | connectors | cable reels | patchbays | cables



BroadcastEngineering®

SPECIALIZED TRAINING

GIVE YOUR EMPLOYEES THE TRAINING THEY NEED TO CLIMB THE LADDER OF SUCCESS!

Does your staff need training on the latest technology? Can't afford to send them to expensive seminars? *Broadcast Engineering's* Specialized Training Corporate Subscriptions provide the solution.

Broadcast Engineering has assembled key and knowledgeable instructors to prepare a catalog of video, broadcast, satellite, engineering and operational courses for station and production staff. These courses are designed to provide tutorial, non-product, training on the basics and intricacies of video, audio, and basic electronics.

Best of all—courses are self-paced and accessible from any computer at any time! Students can start and stop the courses at their leisure. All that's required is a standard internet connection and computer audio.

Our catalog has something for everyone. Some courses are designed for newly-hired and less-trained employees. Other courses provide an engineer-level tutorial. There will be courses appropriate for any level of training you may need! Enjoy courses such as IT for Engineers, Satcom, Intro to Video Compression and many more.

BENEFITS OF A CORPORATE SUBSCRIPTION:

- Provides low cost training. No travel housing or overtime pay required.
- Ensures a standard basic level of training for all employees.
- Provides a refresher course to current staff.
- Helps employees keep pace with the times and technology.
- Use the courses to prepare key staff for promotions to new duties.
- Material is industry targeted and thus useful in preparing for SBE certification (though not designed for any specific SBE certification test).
- Authors are broadcast engineers, consultants and industry-specific experts with more than 100 years of combined experience.
- New courses are continually being developed. Let us know if there are specific course topics you'd like us to develop and cover!

For a complete catalog of current courses, or more information on purchasing your corporate subscription, please contact:
Steven Bell at 913-967-7221 or steven.bell@penton.com.

Powered by
ZEUS[™]
BROADCAST
An Ober Digital Company

**TRAINING DOESN'T
COST, IT PAYS!**

master control automation in this decade. Creating a standard simplifies and automates metadata between traffic systems and master control systems. The holy grail of automation has always been to provide a system that uses a central database for metadata between traffic and master control. Of all the systems in a broadcast facility, there is more interaction between traffic and master control. Because a central database system is easier said than done, the next best thing is to standardize on a format. SMPTE took the standard one step further by establishing an HTML messaging protocol for the delivery of messages in real time or near real time. Traffic and master control can make or react to programming and interstitial changes or missing material throughout the broadcast day.

This year SMPTE is working on expanding BXF by creating a standard for extracting metadata from MXF files and using them in a normal metadata fashion. For example, if a station or network receives a file from a distributor, SMPTE is working on allowing BXF applications to extract the metadata from the BXF file without having to wait for a separate timing sheet. Combining metadata with

rich media is a common operation in Europe. In fact, Europe extracts metadata that is automatically entered into the master control automation system for playout. Databases in master control and traffic for spot or programming metadata are not very common like it is in the United States.

Branding and graphics

Branding and graphics automation systems have been around for a

Because a central database system is easier said than done, the next best thing is to standardize on a format.

while and are now advanced to the point in which they can literally fully automate a broadcast channel like a combo or hybrid automation system can. Although graphic systems companies don't advertise themselves as master control automation, they essentially are branding versions of

master control automation systems. The major difference between graphic systems and master control combo or hybrid systems is usually the quality and sophistication of the graphics themselves. Some companies output stunningly good-looking graphics that are hard to match with a typical combo or hybrid automation system. If channel branding is important to your channel's success, consider a graphic automation system. There has been an increase in branding automation systems in secondary DTV channels from coast to coast.

Centralization

Centralization or centralcasting is once again a focus for station groups. Many have already installed solutions to control multiple remote broadcast stations. Centralized and centralcasting systems are quickly advancing as Internet and internal networks are increasing bandwidth, transcoders are lowering bit rates, and Internet applications are becoming more sophisticated. At this year's NAB Show, one company's executives noted centralization and centralcasting installations as one of its biggest revenue generators. BEC (Broadcast Engineering Conference) hosted a session

WBS

1967 SINCE

AMS16 WITH DolbyE/AC3 DECODING

- + A sound solution for embedded audio.
- + Extracts and displays 16 channels of audio from HD or SD SDI signal streams.
- + Solo listening to each channel DSP based, makes it readily configurable to suit your application.

Visit Us at Booth **B.E31**

Ward-Beck Systems Ltd. // 10-455 Milner Avenue / Toronto, Ontario / M1B 2K4 // North America / 800.771.2556 // International / 416.335.5999 // www.ward-beck.com

openGear **DashBoard** **Dolby E PARTNER**

during NAB featuring centralization systems installed at one of the major U.S. broadcast groups.

There are a multitude of master control automation companies that have advanced systems to control a hub and spoke operation. A few of the standard automation manufacturers have centralized systems that use internal peer-to-peer networks for master control operations, ingest and databasing operations in which programming is ingested and timed once, and the metadata and rich media is distributed to all stations that need it on the network.

Conclusion

At the end of the day, review the areas of your broadcast facility and determine how they interconnect with each other. Identify the workflow holes. Ask yourself, "What are the workflow processes, and how many people do we have doing these tasks?" Also, de-

termine what applications are running in these areas and how they really provide an automated workflow.

Upgrading or changing applications may prove to be a quick

At the end of the day, review the areas of your broadcast facility and determine how they interconnect with each other.

return on your investment. There are automation solutions for each area of a broadcast facility. Solutions are available for large and small station groups. Look for smarter systems that can interconnect and interact better than others. If you're not pleased

with the interconnectivity of varying systems, the industry has many glue companies with sophisticated applications designed to tie varying systems together. There are several long-standing companies that specialize in gluing systems together. Look for companies that have OEM partnerships. These companies tend to be more responsive with less finger-pointing when a situation arises. Find the right applications to streamline your operation.

Broadcasters are demanding more interconnectivity with variable systems, but it seems the broadcast manufacturing industry is moving slowly in bringing interconnectivity solutions forward. Beware: Many manufacturing companies talk a good story, but open interconnectivity appears to be slow in developing. **BE**

Sid Guel is the president and founder of Broadcast Automation Consulting.

Getting ahead means changing the dynamics



Immediately eliminate costs to positively impact your bottom line ROI. **Verity™** is an advanced real-time SINGLE management system that automates your back office, from Sales to Traffic to Operations to Billing

Visit www.vcsolutions.com/verity to learn more



vcsolutions

Avid's Interplay

Interplay helps Versus kick off its HD tapeless workflow.

BY PAUL KOOPMANN

Achieving an HD tapeless workflow was a daunting task for Versus, a national cable sports network. In 2007, the company launched an aggressive project to archive its growing videotape library. Budgeting was as difficult as obtaining the goal.

Budgeting for tapeless

The key budget objective was to find out what the annual costs were to keep one videotape on a shelf at the facility in Stamford, CT. The secondary budget objective was to calculate the annual cost and time it takes to move the content off of that single tape, into an edit room and eventually to air. Factors for determining these costs were broken down into facility, operational and production categories.

Facility costs included:

- base rent (price per square foot);
- environmental (AC, electric);
- shelving; and
- insurance.

Operational costs included:

- librarians' salary;

- library database support and maintenance;
- courier; and
- VTR maintenance.

Production costs included:

- tape stock;
- digitizing time (loss of edit time due to digitizing);
- logging time; and
- third shift staffing for digitizing to meet production timeline.

Once all of these factors were tallied, the annual cost to use one 60-minute videotape once a year was outrageously expensive. This gave the archive project momentum.

Saving real estate

Another major need for the network was to reclaim the valuable production real estate being swallowed by this ever growing library of videotapes. More than 20 percent of the facility was used to store media and tape stock.

Versus' large library of sports properties included SD and HD content for the National Hockey League (NHL), Professional Bull Riders (PBR), Tour

de France and other professional cycling races, World Extreme Cage-fighting (WEC), college football, field sports programming and, most recently, the IndyCar Series. With multiple locations requiring these tapes, the costs exponentially grew each time a tape was needed.

Choosing a solution

The budget to build, encode and support a tapeless post and production workflow amortized itself quickly. A team evaluated technologies and companies that could meet the goals within the tight timeline and budget. Selecting the right technologies and resources were paramount to the success of the project.

Versus chose Avid's Interplay in part because of the network's existing ISIS storage array, multiple edit systems and AirSpeed. The team tested Interplay in length and found it to have advanced toolsets that would aid post and production teams, as well as creative services and new media departments.

With Interplay selected, the network wanted to make sure the next pieces of the puzzle worked seamlessly with Interplay. SGL's FlashNet was openly supported within Avid's workflow and brought in for another round of testing. It proved to be extremely compatible.

The next step was selecting a robot that could store all of the media assets onto LTO4 tapes. The network researched all of the major manufacturers and found Spectra Logic to have the most expandability, reliability and overall best customer service based on the feedback it received from users in both the financial and broadcasting sectors.

Getting up and running

With the three key components



Versus chose Avid's Interplay in part because of the network's existing ISIS storage array, multiple edit systems and AirSpeed.

selected, we created a timeline for rolling out these intricate solutions.

The first phase, upgrading from Avid's Media Manger to Interplay, was scheduled to happen over a weekend in August 2007. This was a daunting task due to tight production schedules. The upgrade was successfully completed within 72 hours. During this same period, the network was building out a new HD studio in Stamford and was working around the clock to meet the Oct. 3 launch date of the NHL.

Phase two happened in September 2007 and included the addition of eight SD/HD AirSpeeds and three additional Adrenaline edit suites.

Phase three occurred in February 2008 and included the installation and configuration of FlashNet and a Spectra Logic T950 robot. This install was flawless and happened right in the middle of the NHL season.

The encoding workflow

After the technologies were in place, the next step was getting the encoded content into Interplay. Versus' production staff was already taxed with creation of content to keep up with programming and could not encode thousands of tapes. Installing a dozen encoding stations and hiring freelancers to digitize was sheer insanity

and would never make even a small dent into the library. Creating digital content with rich metadata that was useable, searchable and conformed to our tape logs was something freelance digitizers could not do.

The most critical piece became metadata. How does the network extract the rich metadata that already lived in its Nesbit library database?

After a long search, the network was introduced to Mediakive, a New Hampshire-based company specializing in encoding vast tape libraries. Mediakive's team worked closely to extract the metadata from Nesbit and thousands of tape logs. Once the metadata structure was created, the network new it was almost there.

Mediakive took on the task of encoding the tape library with the ideology of creating a media conveyor belt. Thousands of tapes were packed up and shipped to New Hampshire for encoding and eventual long-term storage in their environmental controlled warehouse. Content began to arrive in March 2008 on 1TB ESATA drives for consolidation and checking into Interplay. The entire process is ridiculously simple.

In less than a year, Mediakive has encoded thousands of hours of SD and HD content for Versus. High-

resolution content is encoded at DV50 and DNX145, then transcoded to a 2MB proxy while the high-res media is offloaded to the T950 through FlashNet.

Versus' workflow enables all editors, producers and other departments to browse, search and edit with the proxies. This keeps its ISIS storage lean and mean. With more than 120TB of ISIS storage, the network would fill it quickly due to all the HD feeds happening along with the content that Mediakive is delivering. The proxy workflow enables the creative teams to only restore the needed high-res content.

Selecting the right technologies for a digital asset management and archive is 30 percent of the equation. Another 30 percent is refining workflow and educating the production team. The last 40 percent is amassing enough digital content in a short period of time to make the technology and workflow viable. Without the content, the technology and workflow is useless.

This workflow has reduced operational and production costs, increased productivity and creative collaboration, and protected Versus' valuable media assets indefinitely. **BE**

Paul Koopmann is the director of broadcast engineering for Versus.

MEDIORNET

Re-Defining Fiber-Optic Networks

- Fiber Signal Transport for Multi-Channel HD/SD Video Audio, Intercom & Data
- Supports any Combination of Network Topologies
- Integrated CWDM Multiplexing
- Uncompressed Real-Time Signal Distribution and Routing
- Supports 3rd Party Router Control
- Software-based Signal Processing and Conversion
- Future-proof Hardware Platform

www.mediornet.com



RIEDEL
The Communications People

A switcher's life cycle

Expect next-gen production switchers to be 1080p60.

BY JOHN LUFF

This month, let's look at production switchers from the standpoint of product life cycles. Every manufacturer looks at the four stages of product life cycle (introduction, growth, mature, saturation/decline) as both opportunity and risk to be managed. As an industry, we might look at the overall product category and decide where opportunities remain for innovation, whereas as users, we should be aware of the likely decisions manufacturers must inevitably make.

The early days

The first production switchers, developed for monochrome television in the late 1930s, provided little more than cuts, fades and mixes. In the 1960s, the second stage of switchers emerged. They evolved to successfully accommodate color, with completely different processing needed for the three principal color standards worldwide (PAL, SECAM and NTSC). Bandwidths had to be higher and signal electronics more linear in performance. In that same generation came significant new effects, with complex wipe generators and the introduction of chroma key. These products developed into mature offerings, and new generations replaced them with more effects rows and new capabilities to accommodate the increasingly complex production styles in vogue.

In this period, the first digital techniques were introduced as both stand-alone and integrated tools. The key capability was to break the fixed nature of the plane of the image, allowing digital video effects to zoom and pan the picture. Eventually, full 3-D manipulations became possible as software evolved, but the basic tools from the 1960s until the late 1980s were essentially unchanged.

In the late 1980s came the third



Sandor Bondorowsky, an owner of Remote Digital Media in Montclair, NJ, uses a FOR-A HVS-300 switcher during the production of a concert at the Nokia Theater Times Square in New York City. The HD unit supports 1080i, 720p and SD sources.

cycle of products. They were radically different in that processing was not analog, but rather entirely digital. Functionally, little was new, but in terms of picture quality and the ability to create complex layering, this cycle produced a major divergence from the past, every bit as fundamental as the move from monochrome to color-capable versions. Over time, digital effects moved into newer switchers. System stability improved, and electronics units reduced in size.

Today's and next-gen units

Now we have entered an era when HD content predominates. Ten years ago, an HD-capable switcher cost \$750,000, making HD more of a science project than a business tool. I question how fundamentally different the early HD switchers were from SD digital, but now several manufacturers deliver units with clear differentiation. These are what I interpret as the third generation of products — those that allow mixing of different resolutions (i.e., 525-, 1080- and 720-line systems) in one product. Though not

quite resolution-independent, they free users from technical restraints regarding the way content is manipulated during a production, and they simplify system designs.

It might be useful to think about the life cycle of a switcher in a station, which is determined by three essentially independent timelines. The depreciation cycle is of interest mostly to senior management and the CFO, for it affects long-term capital investment needs. The production cycle is determined by the desires of the production staff and the competitive landscape in which productions are developed. And the technology timeline is determined by both the reliability of the product and the way it fits into a slowly evolving system architecture. When a new switcher is installed, all three clocks reset, but all except the depreciation clock run at only slightly predictable speeds. The goal is to maximize the product's long-term viability in both producers' and engineers' perspectives and approximate the depreciation cycle, or ideally — from the CFO's view —

**If your production is this critical,
chances are, you're already using Ross.**

Martha can't hear as well as she used to. But, after all these years, the one thing that hasn't changed is JJ's sparkle. 4 robotic cameras, a Vision switcher panel, a loaded 4 ME QMD/X chassis, and built-in UltraChrome™ advanced chroma keying
From headlines to lotto numbers. Ross - Give 'em what they came for.

Vision QMD/X

The Vision QMD/X is the most powerful production switcher we make. It combines our modular control panel with the powerful QMD or QMD/X live production engine, providing up to 4 full MLEs with up to 6 downstream keyers. The Vision QMD/X is a great choice for the most demanding newscasts, sports and special events with either HD or SD requirements or a mix of both. With a Vision QMD/X you'll know that whatever the production challenge, you've got it covered.

OverDrive Production Control System



openGear Terminal Equipment



SoftMetal Video Server



XPression 3D HD Character Generator and Graphics System



CrossOver Compact Video Production Switchers



Vision QMD/X HL/SD Production Switchers

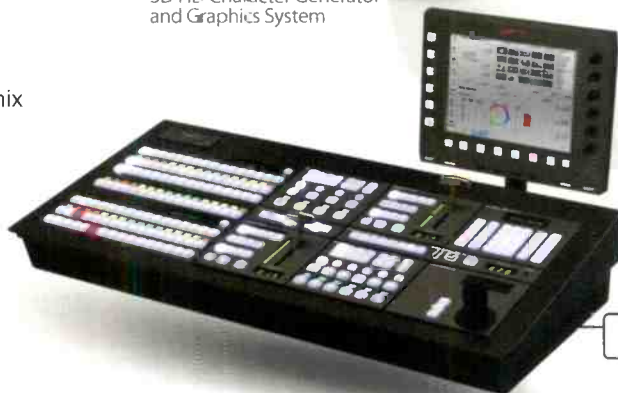

Ross Video designs, markets, manufactures, and supports a wide range of innovative products for use in broadcast, distribution, live event and production applications. Ross products are found in over 100 countries and are used 24 hours a day, 365 days a year to produce and distribute video and audio signals. www.rossvideo.com



Live Production Technology™

exceed it. This might be possible in stable markets, but this is not a stable time. As I write this article, the June analog cutoff has just occurred, and no one expects stability in our industry given the dynamic and the generally foul business climate.

Times of change breed more change, and in this case it seems likely that the momentum behind HD production will only continue to accelerate. Very few 4:3 receivers are purchased today, and consumers seem to want everything in HD on their big flat panels. That demand will undoubtedly drive more production switcher development in HD.

Going back to product life cycle planning, the generation of products we are in now best fits the growth stage, where costs come down due to economies of scale, and sales volumes increase significantly. In combination, that creates profits, public awareness

and competition, which keeps prices in check as new players and products pop into view. It would not be unreasonable to see HD switcher prices generally, though slightly, decline to essential parity with where SD switcher prices were a couple of years ago. Stable prices will move capital dollars when the first signs of economic recovery appear. Those dollars will further accelerate the pace of technology innovation as manufacturers move to participate in the maturing market.

When digital switchers first came out, it seemed that a simple translation of analog production techniques had been embedded in the digital products. At NAB this year, the new production switchers seemed to have moved past that to new features not possible with old thinking or analog devices. Control panels have become modular work surfaces that are simply user interfaces for sophisticated digital processing.

That got me thinking how long it might be before conventional video hardware exists only in the I/O for switchers. When pressed, one manufacturer admitted that the next generation of switchers will be capable of 1080p60, with 3-D content switching a production requirement for many live productions. They will likely include a work surface tied to a rack of blade servers processing content. When that happens, we will certainly have achieved a fourth generation and perhaps the last where hardware is differentiated between generations. Once a switcher is mostly software on common IT platforms, the evolution of the production process will take a giant leap forward. **BE**

John Luff is a broadcast technology consultant.

? Send questions and comments to: john.luff@penton.com

subscriptions subscriptions

Let *Broadcast Engineering* keep you up-to-date on the latest industry news, technology developments, new products and services...and more.

Apply for your free subscription today. Log on to broadcastengineering.com and click on "subscribe."

And...you can also sign up for any of the industry's leading e-newsletters from *Broadcast Engineering*.

broadcastengineering.com

BroadcastEngineering®



Tune into Brad on **Broadcast**



for an inside take on the industry's hottest topics

Broadcast Engineering has launched an exciting new weekly dialog called *Brad on Broadcast*. Editorial Director, Brad Dick, hosts the blog and offers his viewpoints on key industry issues and those most affecting the magazine's readers. From technology to budgets, from competition to industry cutbacks, Brad tackles them all—and invites your feedback.

Armed with 18 years as a broadcast engineer and more than 20 years as a *Broadcast Engineering* editor, Brad Dick understands the challenges and needs that technical managers and engineers face. He's been on the front line, solved problems and learned from the experiences. Now he's sharing those thoughts in a weekly blog.

Tune in to become a part of this critical industry conversation.

<http://blog.broadcastengineering.com/brad>



**Transmitting
straight from
the desk of
*Broadcast
Engineering*
editorial director,
Brad Dick.**

**Read his
latest rants,
raves and
reviews.**

NEW PRODUCTS

NEW PRODUCTS & REVIEWS

AXON Digital Design **GDK100**

HD/SD/3Gb/s downstream keyer module for Synapse includes four triple-rate inputs (two background inputs, one fill input and one key input) and outputs (two program, one preview and a user-definable output); features adjustable slice level and transparency, as well as transparency for 16 channels of embedded audio and all ANC data.

301-854-6557; www.axon.tv

Adtec Digital **signEdge**

TV converter distributes HD and SD audio and video content over the digital television tier; allows audio and video signals from digital signage products, DVD players and TV receivers from direct-to-home satellite TV providers to be distributed over a digital cable system in a cost-effective manner.

615-256-6619; www.adtecinc.com

ComNet **F32V8DT/R(M)(S)1**



Digital fiber-optic video and data multiplexer transmitters and receivers support 32 channels of high-quality video with eight channels of bidirectional serial data; available for use over multimode or single-mode optical fiber; offer 10-bit RS-250C short-haul quality video performance; can transport video up to 20km between locations.

203-796-5300; www.comnet.net

Vector 3 **VECTORBOX DSX**

Playout system includes automation, multiformat support and graphics features for full channel branding; supports a single SDI or analog input and simultaneous output; uses new multimedia technology, SATA storage and software-based processes such as VGA trimming and browsing to create a system for users needing numerous playout channels.

**+34 934 151 285
www.vectorbox.com**

Technomad **PowerChiton**

Power amplifier module unites a high-performance, passively cooled amplifier with an IP66-rated, low-profile encoder; networking options include widespread wireless networking using FM audio distribution technology, Ethernet networking capabilities for wide-area distribution or facility LAN and twisted-pair networking for long-distance distribution; features a broadcast-quality balanced line input, second input and internal mixer.

800-464-7757; www.technomad.com

Optical Zonu **SFC Transceivers**

Dual-rate, single-fiber, full-duplex CWDM transceivers allow for a single-SKU optical link with identical transceivers at both the hub and customer premises; feature SFP-MSA digital diagnostics monitoring; work in conjunction with multiplexers/demultiplexers to support up to 10 business-class SONET/SDH or GigE customers on a single fiber with full-duplex operation over long-range distances up to 75km; provide data input required to support the operations, administration and maintenance features of IEEE 802.3ag and ITU Y.1731 standards.

818-780-9701; www.opticalzonu.com

K-Tek **Kwiksock**



Windscreen provides additional layer of wind protection underneath an existing zeppelin; features short-hair faux fur and fleece lining; rolls up tightly and packs easily into small bag or provided carrying pouch; available in short, medium and long sizes; comes in 21mm or 19mm diameters to fit most shotgun microphones.

760-727-0593; www.ktekbooms.com

Compix **CompactCG**

Portable CG offers specs and feature set of a full-size system in 1RU chassis; provides automated template-based graphics generation and real-time graphics overlay of live video; supports 16:9 and 4:3 aspect ratios, Windows IME multiple language settings and True Type fonts; meets SD-SDI and analog composite NTSC and PAL specs including SMPTE 170M, SMPTE 259M with embedded audio pass-through and EIA-608b closed-captioning compatibility; available in SD-SDI and analog configurations.

949-585-0055; www.compix.tv

TV One **EDID Manager**

Designed for C2-2000A series of video switcher/scalers; allows user to copy EDID data from a display attached to the unit's output and simulate its presence to a PC that is attached to its input, giving the scaler transparent EDID operation; holds multiple copies of EDID data in non-volatile memory and allows user to select which one is shown to a PC on the DVI input; up to six custom EDID settings can be stored in the CORIO2 unit.

800-721-4044; www.tvone.com

Petrol **PRP-2**



Rain poncho is sized to cover a user carrying a mixer and fully loaded sound bag; features front section made of transparent polyurethane, slotted hand openings on either side, long sleeves, two-sided bungee cords and anchor clips to adjust the hood, fabric-covered front zipper and sealed and reinforced seams.

845-268-0100; www.petrolbags.com

AV Toolbox

VS-226



HDMI downconverter converts HDMI input, or DVI-D with optional adapter, to an interlaced NTSC or PAL SD video signal; provides analog stereo audio and coax S/PDIF outputs as well as reclocked HDMI signal; automatically detects the HDTV signal's resolution and is fully compliant with HDMI v1.2, DVI v1.0 and HDCP v1.1 specs; ships with an AC to DC power adapter.

800-721-4044; www.tvone.com

Litepanels

1x1 Low Profile



LED lighting fixture mounts flat against a ceiling or wall and sticks down 3in from the surface where it is mounted; draws little power and can be operated from a 12V DC connection; cool to the touch and dimmable via DMX or control on the fixture; available in flood, spot and super spot configurations.

818-752-7009; www.litepanels.com

Facilis Technology TerraBlock 4.0

Shared file system enables write access for multiple clients on the TerraBlock Virtual Volume 8Gb Fibre Channel SAN; allows file-level and volume-level sharing on the same network; enables users to designate their virtual volumes as multiuser write or single-user write; supports up to 220Mb HD and uncompressed SD capture on a file-level Windows volume.

800-620-7022; www.facilis.com

Snell

Family of routing switchers features a wide range of signal cards that can mix and match signal types in a 1RU or 3RU frame; high packing density allows 17 x 17 SDI (SD, HD or 3G) in 1RU and up to 72 x 72 in 3RU, up to 144 x 144 stereo AES and analog audio in 3RU, or 36 x 36 in 1RU; includes an integral system controller; can be slaved from external control systems with control via Ethernet or RS-422.

818-556-2616; www.snellgroup.com

NTP Technology

RCCoreV3

Router control system handles configuration, control and supervision of all router modules in an NTP audio signal distribution system; forms a communication interface to third-party communication protocols; operates through a network-based infrastructure with all communication based on TCP/IP link protocol and a 10Mb/s or 100Mb/s LAN/WAN interface; features an integral solid-state server providing fast control access and resources for additional control applications.

+45 4453 1188; www.ntp.dk

RTW

10800X

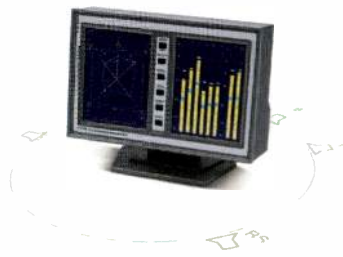

Eight-channel desktop audio vectorscope features peak program meters, a surround-sound analyzer with graphic display, and analog and digital inputs; supports 2/0, 3/0, 3/1 and 3/2 (5.1) formats; modes include 31-band RTA, real-time vectorscopes (two and four channels), multiphase meters and an AES/EBU status monitor.

+49 221 709130; www.rtw.de

Wohler

RMT-150-SD

Single-screen 15in SD monitor handles composite/S-video/component (HD/SD) and VGA/DVI-D/HDMI video; features two SD-SDI inputs and an SD-SDI active loop-through; can display eight channels of PPM over VU audio level meters, IMD, safe areas, frame marks, cropping, switchable aspect ratios and built-in color bars; available as a rack- or table-mount system, or can be used with a standard VESA mount.

510-870-0810; www.wohler.com

QuStream

QFX DL-DVI



Compact media extender enables long-distance transport of DVI, VGA, RGB and RGBHV signals up to 1920 x 1200 at 60Hz over a single copper or fiber interface cable; can be used as part of a switch matrix or as stand-alone distribution module; supports 1080p and is based on SMPTE 425 Level A format specs; rack mount holds up to two units in 1RU and stand-alone includes screw holes for rack-rail mounting; includes a USB configuration port for setup and diagnosis.

800-328-1008; www.qustream.com

Sachtler

Cine 7+7 HD



Cine-style 100mm fluid head system features a front pan bar, sideload clamp, 6in wide displacement area, 16-step counterbalance and multicontact switching; offers payload range of 4.4lbs to 48.5lbs and seven horizontal and seven vertical adjustable levels of drag; available in five complete systems when matched with different types of tripods.

845-268-0100; www.sachtler.us

NEW PRODUCTS

NEW PRODUCTS & REVIEWS

Wireworks

Network cables provide tactical Cat 5e Ethernet interconnection in a heavy-duty construction; available with Neutrik's etherCON data connectors or traditional RJ45 Ethernet connectors, both with colored boots for fast recognition, and in lengths ranging from 25ft to 250ft, with custom lengths to order.

800-642-9473; www.wireworks.com

Bridge Technologies



VideoBRIDGE module for monitoring and analysis of satellite signals with both DVB-S and DVB-S2 demodulation complements capabilities of VB250 for DVB-T networks and VB260 for cable networks; features QPSK capabilities including DiS-EqC 2.x compliance, SNR and BER monitoring, analog RF carrier signal level measurements, built-in GPI and configurable round-robin transponder testing.

+47 22 38 51 00; www.bridgetech.tv

Element Technica



Mounting system replaces Velcro or gaffer tape to attach camera accessories; features a female V-LOCK interface and spring-loaded split clamp as well as a separate male V-LOCK that attaches to accessories to allow fast, easy mounting; anchors anywhere on a single 15mm or 19mm iris rod.

323-641-7327
www.elementtechnica.com

Vaddio

ClearVIEW HD-18

Robotic HD, single CCD PTZ camera offers high-quality HD/SD integration with Cat 5 cabling technology, a multielement wide dynamic lens with 18X zoom, "right light" compensation and freedom to choose any resolution.

800-572-2011; www.vaddio.com

TacCat

ComNet



Digital fiber-optic video transmitter and receiver line consists of FVT/FVR1010-SHR single channel with data series, FVT/FVR4014SHR series with four video and four data channels and FVT/FVR8018-SHR series with eight video and eight data channels; incorporate self-healing features that seamlessly reroutes the video and data transmission in the event of a broken fiber connection; bidirectional data transmission allows for the camera PTZ function to be controlled from any monitoring location.

203-796-5300; www.comnet.net

Sennheiser

MZF 8000

Filter module for the MKH 8000 microphone series; allows microphone series to provide excellent sound and climate resistance in tough broadcasting and film applications, effectively suppressing both handling and wind noise; signal level can be lowered via a high-quality pad that allows it to be optimally adapted to the recording equipment; is small and lightweight; ideal for boom applications.

860-434-9190
www.sennheiserusa.com

Gepco

VHD13F

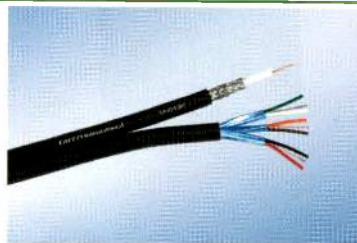

Extra-flexible HD coax cable with three audio twisted pairs houses the audio and video components side by side; each audio pair is individually shielded and isolated with a mylar/foil shield and drain wire; features a precision, stranded, center conductor and double-braided shield; rated to a 4.5GHz bandwidth.

800-966-0069; www.gepco.com

SHR line

Aviom

Pro64 Network Manager



Software control application provides global and device-specific information to the user, as well as remote control of every Pro64 device in a network using a PC connected to the I/O module set as the control master; connects to an audio network via RS-232; uses built-in managed mode to simplify tasks related to supporting and configuring Pro64 networks.

610-738-9005; www.aviom.com

MultiDyne

HDMI-ONE



HDMI/DVI fiber link with HDCP copyright protection support provides bidirectional communication over one fiber, pixel-for-pixel image transport and a 100 percent 24-bit scan rate with no contouring or bit reduction; supports WUXGA up to 1920 x 1200 and is transparent with no frame dropping; allows transmissions of up to 1000m over multimode fiber.

877-MULTIDYNE
www.multidyne.com

Noise Industries

FxFactory v2.0.7

Visual effects software for Adobe After Effects CS 3/CS 4, Apple Final Cut Studio and Apple Final Cut Express applications offers more than 300 plug-ins; features improvements to all filters in the blur and glow categories; includes new PDF Animator, Alpha Merger and Perlin Noise generator modules.

415-401-7382
www.noiseindustries.com

WASP3D

WASPi Mimosa

Touch-screen-based broadcast presentation tool includes user-friendly features such as touch-screen controls, menu groups for creating custom menus and built-in telestration tools.

+91 120 430 8888; www.wasp3d.com

OConnor Engineering

120Exe



Encoded heavy-duty fluid head provides high-precision pan-and-tilt position information for cinema-quality visual effects production via an external 19-pin Fischer connector; features built-in encoders and doesn't require bolt-on assembly; can support up to a 120lb camera package through the entire tilt range of 90 degrees and can counterbalance up to 240lbs through a tilt range of 60 degrees.

818-847-8666; www.ocon.com

Panavision

Louma 2

Camera movement system built on an open-architecture platform features a newly developed arm for more than 24ft of telescopic travel and two- or three-axis remote head and leveling gear that can be switched easily from overslung to underslung and back; ShotAssist software handles pan compensation; includes custom trolleys and an operator's cart.

818-316-1080; www.panavision.com

Custom Consoles

System 2

Multielement furniture system accommodates free-standing or pod-mounted equipment such as graphics workstations and editing terminals; features a front-facing cable-access slot; includes the S2-01B desk and S2-02B monitor shelf, both electronically adjustable in height from 660mm to 1200mm.

+44 1525 379909

www.customconsoles.co.uk

Harris

QVM6800+ Quad

Small-footprint, quad-split multiviewer in a card is designed to bring high-quality, multi-image processing functionality to the Harris 6800+ modular core processing platform; features minimum processing delays of less than one frame and integration with Harris CCS Navigator remote monitoring and control software; designed for AV studio and production applications and OB/mobile production vehicles.

800-442-7747

www.broadcast.harris.com

OmniBus

iTX GFX

Graphics platform combines iTX with rtSoftwareOG rendering engine to deliver 2D/3D graphics and real-time DVE effects; runs on an enhanced hardware platform; can handle CG compatibility as well as live video and DVE moves that can be previewed on the iTX desktop; creates resolution-independent graphics for SD, HD or Web streaming.

303-237-4868; www.omnibus.tv



Wish you could predict the future?

You can with Zeus.

Don't be caught off guard with unnecessary equipment issues. Get Zeus...the most trusted web-based equipment management and trouble-ticket system.





Anytime, anywhere. That's the beauty of our 100% web-based equipment and service management system. Made by broadcasters for broadcasters, Zeus allows an infinite number of users to access the site from any Internet connection at anytime. Isn't that simple?

A PENTON MEDIA PUBLICATION

BroadcastEngineering®

www.broadcastengineering.com

Editorial Director: Brad Dick, brad.dick@penton.com

Editor/World Edition: David Austerberry, editor@broadcastengineeringworld.com

Managing Editor: Susan Anderson, susan.anderson@penton.com

Assoc. Editor: Collin LaJoie, collin.lajoie@penton.com

Assoc. Editor: Angela Snell, angela.snell@penton.com

Sr. Art Director: Michael J. Krust, mike.krust@penton.com

Art Director: Robin Metheny, robin.metheny@penton.com

Technical Consultants: Computers & Networking – Brad Gilmer

Antennas/Radiation – Don Markley

Digital Video – Aldo Cugini

Transmission Facilities – Donald L. Markley

Legal – Harry C. Martin

New Technology – John Luff

Industry Watcher – Anthony Gargano

New Media – Craig Birkmaier

Group Publisher: Wayne Madden, wayne.madden@penton.com

Marketing Dir.: Kirby Asplund, kirby.asplund@penton.com

Dir., Online Product Development: Dean Muscio, dean.muscio@penton.com

Vice President of Production: Lisa Parks, lisa.parks@penton.com

Production Manager: Kathy Daniels, kathy.daniels@penton.com

Classified Ad Coord.: Sarah Maxey, sarah.maxey@penton.com

Dir., Audience Marketing: Barbara Kummer, barbara.kummer@penton.com

Group Show Director/LDI: Sharon Morabito, sharon.morabito@penton.com

Penton Media

Penton Media, Inc.

249 West 17th Street

New York, NY 10011

Chief Executive Officer: Sharon Rowlands, sharon.rowlands@penton.com



MEMBER ORGANIZATIONS

Sustaining Member of:

• Society of Broadcast Engineers

Member, American Business Media; Member, BPA International,

The Missouri Association of Publications

BE US/Canada SUBSCRIPTION RATES: Free and controlled circulation to qualified subscribers. Non-qualified persons may subscribe at the following rates (Prices subject to change): USA and Canada, 1 year, \$99.00, 2 years, \$171.00, 3 years, \$242.00; Outside USA and Canada, 1 year, \$116, 2 years, \$204.00, 3 years, \$292.00 surface mail (1 year, \$193.00, 2 years, \$347.00, 3 years, \$506.00 airmail delivery).

BE World SUBSCRIPTION RATES: Free and controlled circulation to qualified subscribers. Non-qualified persons may subscribe at the following rates (Prices subject to change): USA, 1 year, \$94.00, 2 years, \$160.00, 3 years, \$226.00; Outside USA, 1 year, \$110, 2 years, \$193.00, 3 years, \$275.00 surface mail (1 year, \$182.00, 2 years, \$336.00, 3 years, \$490.00 airmail delivery).

ARCHIVES AND MICROFORM: This magazine is available for research and retrieval of selected archived articles from leading electronic databases and online search services, including Factiva, LexisNexis and Proquest. For microform availability, contact National Archive Publishing Company at 800-521-0600 or 734-761-4700, or search the Serials in Microform listings at napubco.com.

REPRINTS: Contact Penton Reprints to purchase quality custom reprints or e-reprints of articles appearing in this publication at 888-858-8851. Website: www.pentonreprints.com. Email: reprints@pentonreprints.com

PHOTOCOPIES: Authorization to photocopy articles for internal corporate, personal, or instructional use may be obtained from the Copyright Clearance Center (CCC) at 978-750-8400. Obtain further information at copyright.com.

PRIVACY POLICY: Your privacy is a priority to us. For a detailed policy statement about privacy and information dissemination practices related to Penton Media products, please visit our Web site at www.penton.com.

EDITORIAL and BUSINESS OFFICE: Penton Media, 9800 Metcalf, Overland Park, Kansas 66212 • 913-341-1300 • penton.com

Copyright 2009, Penton Media, Inc. All rights reserved.

NEW PRODUCTS

NEW PRODUCTS & REVIEWS

HaiVision Network Video

MAKITO



HD video encoder combines efficiencies of H.264 video compression and the image quality of full HD video within a compact form factor; supports SD and HD up to 1080p60; can produce multiple stream resolutions from a single source, send high bit rate video to required endpoints and provide lower-bandwidth video for mass consumption.

877-224-5445; www.haivision.com

Neutrik

USB/FireWire Chassis Connectors

Connectors meet the demand for lockable and watertight digital interface connections; feature a sealing ring and D-style housing; offers optional screen-to-chassis grounding for improved shielding effectiveness.

732-901-9488; www.neutrik.com



Schneider Optics

Hollywood Black Magic

Diffusion filters for HD digital cameras remove blemishes and wrinkles while providing a smooth transition in the highlights; provide a wide range of diffusion choices and softening of bright highlights to control the exposure while maintaining rich blacks and colors; available in five strengths from 1/8 to two and in popular professional rectangular sizes for HD, DV and video, as well as screw-on sizes for professional DSLR photography.

800-228-1254; www.schneideroptics.com

Anton/Bauer

USB Battery Management

Application includes battery management software and USB to Anton/Bauer battery mount adapter; downloads battery information via management software, which automatically opens a file based on the serial number and manufacture date and stores all data for usage tracking; displays essential information as well as remaining battery capacity; offers a user-definable capacity trip point selection.

800-422-3473; www.antonbauer.com



Auralex Acoustics

Room Analysis Kit

Package for acoustical analysis includes an omnidirectional measurement mic, a USB drive featuring swept sine signals and a complete instructional guide; users can send files via e-mail for examination and receive a written report within five to seven business days detailing frequency response, impulse response, waterfall plots and reverberation time values.

800-959-3343; www.auralex.com

Dielectric Communications

UHF CP

Low-power, circularly polarized antenna fills coverage gaps in networks; features lightweight aluminum construction with ABS Radome, single Type N or 7/16 DIN input and 65-degree beam width; can be configured in standard narrow and wide cardioids, peanut and omni azimuthal patterns with various elevation gains; custom patterns are available upon request.

800-341-9678; www.dielectric.com



STOP EXPERIMENTING WITH H.D.!



GET THE COM1000 FOR YOUR PROJECT TODAY!



- H.D.MPEG4/QAM 256 over COAX!
- I.P.T.V. over L.A.N. to P.C. or I.P. Set Top
- Perfect for Corporate Offices, Campus, Hotel and Stadiums

SKY WEB, INC.

*Certified Installer for COM1000 System



Authorized Dealer

**INTEGRATORS/RESELLERS WELCOME
RF SIGNAL DISTRIBUTION • HD UPGRADES**

Sales, Design, and Engineering Services Nationwide

1(888)759-9321 www.skywebtv.com



TRILITHIC

Emergency Alert Messages for DTV

Trilithic's EASyCAST EAS System integrates with RGB Networks' Broadcast Network Processor (BNP) to deliver digital Emergency Alert Messages and graphics overlays for DTV and LPDTV stations.



With the integration, all services in a broadcaster's ASI stream can have graphical EAS overlays including audio substitution for all or selected program streams. EAS messages and graphics are inserted as MPEG-into-MPEG in real-time without the need to demux or decode the ASI stream. This also enables digital multicast broadcasters for the first time to selectively target the delivery of EAS overlays to a single market or multiple targeted markets. Targeting specific transmitters or covering the entire is now possible with this new system.

For more information on the system integration, contact Trilithic at (800) 344-2412 or visit www.trilithicEAS.com

Usedtowers.com



**FREE Tower Removal
Site Decommission
All Sizes
NO CHARGE**

**List your
Towers and Broadcast
Stations For Sale
NO CHARGE**

**Guaranteed Results
Since 1998**

**Over 700K hits
per month.**

**sales@usedtowers.com
360.474.8991**

AirPaint Wireless Camera Paint System



Introducing the AirPaint Wireless Camera Paint System consisting of a transmitter attached to the standard manufacturers RCP and a receiver on-board the camera (feeding to the Remote input). This system allows the user to utilize the standard Remote Control Panel (RCP-750, RMB-150, etc.) to wirelessly control all of the CCU functionality of the camera. The AirPaint system utilizes an advanced data modem enabling the operator great range of operation. This new system accommodates all popular camera manufacturers with their standard remote panels. The unit can either be powered by a standard battery for remote production or AC power where available. In addition, the unit can be integrated into a production truck type environment for sports venue type applications for wireless operation into stadiums.

Contact:

Keith Stephenson - SkyDreams Technologies
(323) 819-1001
www.skydreams.tv Keith@SkyDreams.tv

Big Budget Technology

Small Budget Pricing!

TITANIUM SERIES

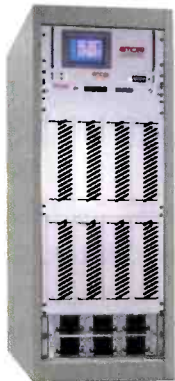

**UHF DTV
TRANSMITTERS
& TRANSLATORS
250 Watts to 5 KW**

- *Designed Right!*
- *Built Right!*
- *Priced Right!*



SEE THE COMPLETE SPECIFICATIONS ON-LINE, THEN CALL FOR YOUR QUOTE

EMCEE

CALL 480-315-9283 www.EMCEE.com
SERVING BROADCAST SINCE 1960

Check Out the NEW

Broadcast Engineering

**PRODUCTS & SERVICES
SPOTLIGHT SECTION**

Starting with the July Issue, check out the new Product & Services Spotlight section that launched in this issue of Broadcast Engineering. Don't miss out on this cost effective way to highlight your products and services.

**To advertise in the
Products & Services
Spotlight Section,
contact:**

JULIE DAHLSTROM

P 312.840.8436 F 913.514.3684

JULIE.DAHLSTROM@PENTON.COM

For Sale

We've changed our name, and expanded our product line. Supplying the newest CITYTECH and ANSSO Technology products.



Your source for Lithium-Ion Batteries, Camera mounted LED Lights and the new DLM 1080 TFT-LCD 8-inch HD-SDI Monitor

For the support you need, find us at:
videotechsupply.com

EQUIPMENT FOR SALE

**Channel 24 DTV PSI
Digital Antenna**

1yr old

Contact: Kevin Grice/Omni Media Group
(580) 256-4101 for details.

Help Wanted

CHIEF ENGINEER

WFFT-TV FOX Ft Wayne is seeking an experienced broadcast Chief Engineer, responsibilities include. Manage planning, installation and repair of all television systems and equipment. Manage maintenance engineers and master control operators. Communicate professionally with individuals and groups within and outside of station. Communicate on a frequent basis with all other departments. Keep station compliant with the FCC Rules and Regulations, as well as related local, state and federal regulations. Work with Corporate personnel in particular areas of common interest. Strong IT background preferred. To apply send resume to:

WFFT FOX Fort Wayne
Attn: Chief Engineer
3707 Hillegas Road
Fort Wayne, IN 46808
or email to Fox55@wfft.com

Acoustics First[®]
Toll-Free Number: **888-765-2900**
Materials to Control Sound and Eliminate Noise™
<http://www.acousticsfirst.com>

KSBI-DT, home of the OKC Thunder, is looking to fill the **Assistant Chief Engineer** position. Requires extensive experience in maintaining & troubleshooting a wide variety of broadcast equipment, Thomson transmitters, remote translators, microwave and studio equipment, Wolfcoach SNG truck, video servers and IT infrastructure. 40 ft. video production truck. Must exhibit an advanced knowledge of electronics, digital technology, networking, computer and network security, station automation. RF systems as well as studio and remote production. Must have at least 8 years experience in the maintenance and operation of broadcast RF equipment. Trade school, military training or college degree preferred. SBE certification or equivalent credentials desired. Send resume to info@ksbitv.com or fax: (405) 631-7367.

	Page #	Advertiser Hotline	Website Address
Agilent Technologies.....	39	800-829-4444	agilent.com/ find/u8903apromo
AJA Video	35	800-251-4224	aja.com/kiprotour
Avid Technology	3	800-949-AVID	avid.com/hdvalue
Blackmagic Design.....	5	408-954-0500	blackmagic-design.com
Canare Cable Inc.	48	973-837-0070	canare.com
Clear-Com Communication Systems.....	27	510-496-6600	clearcom.com
Comtech Tiernan Video Inc.	25	858-805-7000	comtechtv.com
Dolby Laboratories Inc.	13		dolby.com/pulse
Evertz Microsystems Ltd.	IBC	877-995-3700	evertz.com
For. A Corporation of America.....	17	714-894-3311	for-a.com
Grass Valley	11		grassvalley.com/k2
Harmonic Inc.	29		harmonicinc.com
Harris.....	BC	800-231-9673	broadcast. harris.com/x85
Marshall Electronics Inc.....	33	800-800-6608	lcdracks.com
Miranda Technologies Inc.....	9	514-333-1772	miranda.com/xmedia
Omneon	19	866-861-5690	omneon.com/ mediagridperforms
Omnibus Systems Inc.....	15		omnibus.tv
PlayBox.....	21	404-424-9283	playbox.tv
Riedel Communications	22	914-592-0220	riedel.net
Riedel Communications	53		mediornet.com
Ross Video Ltd.....	55	613-652-4886	rossvideo.com
Snell Group.....	45		snellgroup.com
Streambox	36	206-956-0544	streambox.com
Telecast Fiber Systems Inc.....	37	508-754-4858	telecast-fiber.com
Utah Scientific.....	IFC	800-453-8782	utahscientific.com
VCI	51	512-837-3737	vcisolutions.com/verity
ViewCast	7	800-540-4119	viewcast.com/be
Vislink News & Entertainment.....	32	978-671-5700	vislink.com
Ward-Beck Systems Ltd.....	50	800-771-2556	ward-beck.com
Yamaha Commercial Audio.....	23		yamahaca.com
Zeus Broadcast.....	61	407-352-6501	zeusbroadcast.com
360 Systems.....	31	818-991-0360	360systems.com

SALES OFFICES

US/CANADA WEST

George Watts III
(360) 546-0379; Fax: (360) 546-0388
georgeww3@aol.com

EAST

Josh Gordon
(718) 802-0488; Fax: (718) 522-4751
jgordon5@verizon.net

MIDWEST

Emily Kalmus
(312) 840-8473; Fax: (913) 514-6301
emily.kalmus@penton.com

INTERNATIONAL EUROPE

Richard Woolley
+44-1295-278-407
Fax: +44-1295-278-408
richardwoolley@btclick.com

Israel

Asa Talbar
Talbar Media
+972-3-5629565; Fax: +972-3-5629567
talbar@talbar.co.il

JAPAN

Mashy Yoshikawa
Orient Echo, Inc.
+81-3-3235-5961; Fax: +81-3-3235-5852
mashy@fa2.so-net.ne.jp

CLASSIFIED ADVERTISING

Julie Dahlstrom
(312) 840-8436
Fax: (913) 514-3684
julie.dahlstrom@penton.com

REPRINTS

Penton Reprints
888-858-8851
www.pentonreprints.com

LIST RENTAL SERVICES

Marie Briganti, Walter Karl
(845) 620-0700
(845) 620-1885
marie.briganti@walterkarl.infousa.com

Customer Service: 913-967-1707 or 800-441-0294

Broadcast Engineering, July 2009, Vol. 51, No. 7 (ISSN 0007-1994) is published monthly and mailed free to qualified persons by Penton Media, Inc. 9800 Metcalf Ave., Overland Park, KS 66212-2216. Periodicals postage paid at Shawnee Mission, KS, and additional mailing offices. Canadian Post Publications Mail Agreement No. 40612608. Canada return address: Bleuchip International, P.O. Box 25542, London, ON N6C 6B2. PDSTMASTER: Send address changes to Broadcast Engineering, P.O. Box 2100, Skokie, IL 60075-7800 USA. CORRESPONDENCE: Editorial and Advertising: 9800 Metcalf, Overland Park, KS 66212-2216 Phone: 913-341-1300, Edit. fax: 913-967-1905, Advert. fax: 913-967-1904. © 2009 by Penton Media, Inc. All rights reserved.

Princess Leia visits NAB

Here's a look at the nascent state of holographic video.

BY ANTHONY GARGANO

It's hard to believe it has been 32 years since George Lucas introduced millions of filmgoers to the concept of holographic video. In the original "Star Wars" movie, Lucas created a memorable scene where Princess Leia appeared to Obi-Wan Kenobi as a live video hologram pleading: "Help me, Obi-Wan Kenobi; you're my only hope." That famous special effect has stayed with us through the years, and it seems we are now approaching the time when science fiction is coming closer to being science fact.

Not just a science project

At this year's NAB, the Japanese National Institute of Information and Communications Technology (NICT), with relatively little fanfare, demonstrated its latest development in video holography. The demonstration, a small, noisy hologram that

his lab saying, "Mr. Watson, come here. I want to see you." Or perhaps more on point, it was like a view of Stooky Bill being transmitted from pioneering television developer John Logie Baird's laboratory in 1925 as a 30-line mechanically scanned image at five pictures per second. Some had the presence of mind to realize that they were viewing a moment in history — the infancy of a technology that will have far-reaching effects on our society in the decades to come. For far-flung applications from broadcast to medical, from advertising to entertainment, the utilization of electronic holography will absolutely revolutionize everything it touches.

NICT, with a long development history in specialized imaging and communications technologies, continues to move its electronic holography project forward. The current iteration, which it calls gCubik,

urge to put your hands out there to "touch" the image. gCubik will be on display next month at the SIGGRAPH 2009 event in New Orleans from Aug. 3-7. If you are there, you owe it to yourself to drop by and view history in the making.

Holographic video to the home

Last year, SMPTE gathered together one of its largest task forces ever. The group's charge was to define those standards that would be needed for a 3-D television system from content generation through delivery to the home. The result of the effort, "Report of SMPTE Task Force on 3D to the Home," was announced at the 2009 NAB Show and is now available as a 75-page download at <http://store.smppte.org/product-p/tf3d.htm>.

Clearly, we are in the Bell and Baird era of live holographic video, so perhaps it is a tad premature for the convening of yet another new technology task force. Given the rapidity of 21st century technological advancements, however, this broadcast industry veteran hopes to still be around for the release of the "Report of SMPTE Task Force on Holographic Video to the Home." After all, just look at how far we have come since that fateful SMPTE Winter Television Conference in San Francisco in February 1981. It was there that Japan's NHK provided a demonstration of its developmental 1125/60 MUSE (multiple subnyquist sampling encoding) HDTV system. From experimental MUSE to ATSC HDTV, from analog 4:3 to digital 16:9 — a virtually complete transition occurred in just 29 years. **BE**

Anthony R. Gargano is a consultant and former industry executive.

It also produces that innately human "Wet paint: Do not touch" curiosity reaction that we all have. How many times have you left a sticky fingerprint?

floated in the air, was far from the level of a sophisticated Industrial Light & Magic (ILM) special effect. (ILM, located at George Lucas' Skywalker Ranch, is one of Hollywood's go-to special effects houses.)

As a result, most attendees just walked right by it or took a passing peek, thought it was gimmicky and kept walking. Even many of those who did stop to look dismissed it as a science fair project. But for a few, just viewing that magical apparition was enough to give them pause. It was like watching a scene of Alexander Graham Bell's noisy, crackly voice being heard in 1876 in the other room from

generates 3-D images inside a cube that is approximately 10cm on a side and is readily viewable with no need for special glasses. It is three times brighter, exhibits less noise and has twice the resolution of the previous generation implementation. The floating-in-air ethereal image that is generated can be viewed from any of the six facets of that ephemeral cubic display. Thus, you can view what's "inside" from all directions. It also produces that innately human "Wet paint: Do not touch" curiosity reaction that we all have. How many times have you left a sticky fingerprint? You just cannot help that uncontrollable

? Send questions and comments to: anthony.gargano@penton.com

IntelliTrak™ Program Video & Audio Lip Sync Analyzer

IntelliTrak™ measures the lip sync error between the audio and video with precise accuracy. It is unique as it does not introduce any type of watermarking or flag insertion into the stream, operating in a completely non-intrusive manner.

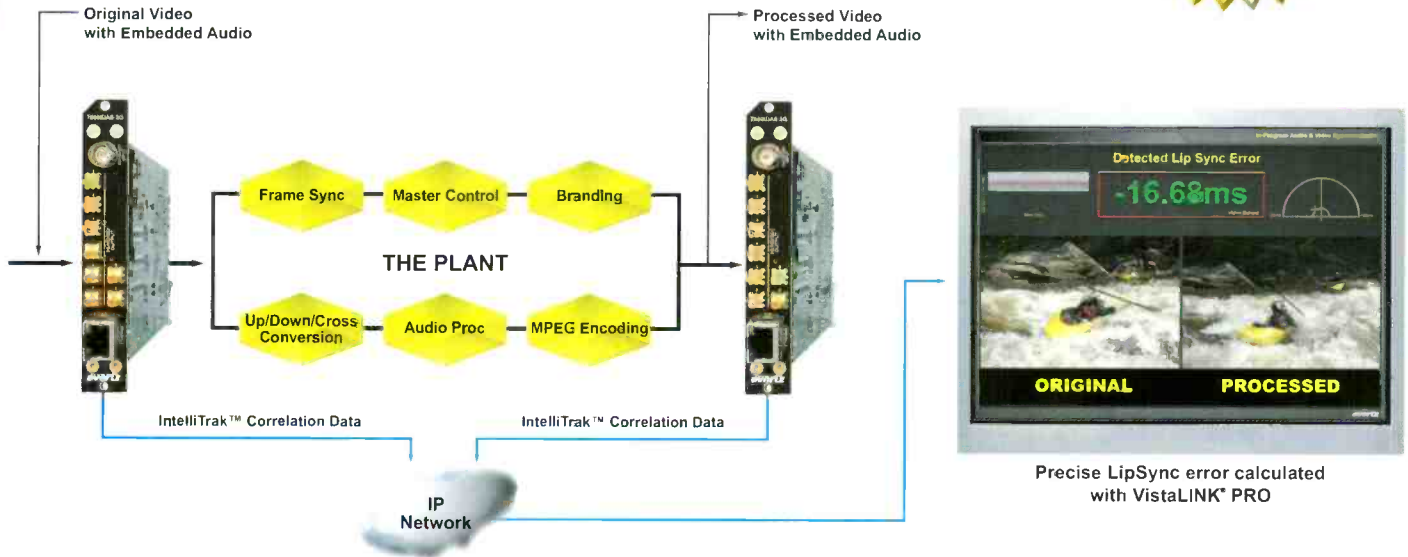

IntelliTrak™ • Features and Applications

Features:

- Non-intrusive, in-service lip sync error measurement (no watermarking)
- Precise sub-millisecond accuracy
- Works with all types of audio and video signals
- For use within the plant or external with outdoor broadcasting units
- An advanced ordering option for many Evertz® products
- Designed to provide precise measurements through all sorts of facility signal processing such as up/down/cross conversion, mpeg encoding/decoding, dolby processing and more

Applications:

- Inter-Facility Lip Synchronization
- LipSync Validation through MPEG Encoding/Decoding
- Mobile Applications

See Us At IPTV - New York - Booth #20



1-877-995-3700 • sales@evertz.com • www.evertz.com

US West Coast Sales
818.558.3910
LASales@evertz.com

New York Sales
newyorksales@evertz.com

Washington DC Sales
703.330.8600
dcsales@evertz.com

UK Sales
+44 118 935 0200
uksales@evertz.com

South-East Europe Sales
+385-1-2059-325
SEEuropeSales@evertz.com

Dubai Sales Office
011-971-50693-0204
middleeastSales@evertz.com

Asia Pacific Sales
+852 2850-7989
asiapacificSales@evertz.com

The Xceptional X85™

See what 1RU can do for you!

Hybrid Signal Processing Color Corrector 3 Gb/s

Multiple Application Video and Audio Platform

Fiber I/O HD and SD 1080p Level A and Level

Program Delay Adaptive Comb Filter Dolby/DTS Neural

IP-Enabled



X explore unlimited configuration options
experience unprecedented processing power
exceed all your expectations

The all-new X85 — the most functionality in a space-saving package.

For more information, please visit www.broadcast.harris.com/X85.

North America +1 800 231 9673 • Caribbean and Latin America +1 786 437 1960

ONE Company. ONE Direction. The Future.

HARRIS

assuredcommunications®
Broadcast Communications • RF Communications • Government Communications Systems

www.harris.com