

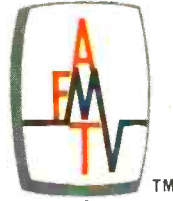

A HOWARD W. SAMS PUBLICATION



FEBRUARY 1968/75 cents

# Broadcast Engineering

*the technical journal  
of the broadcast-  
communications industry*

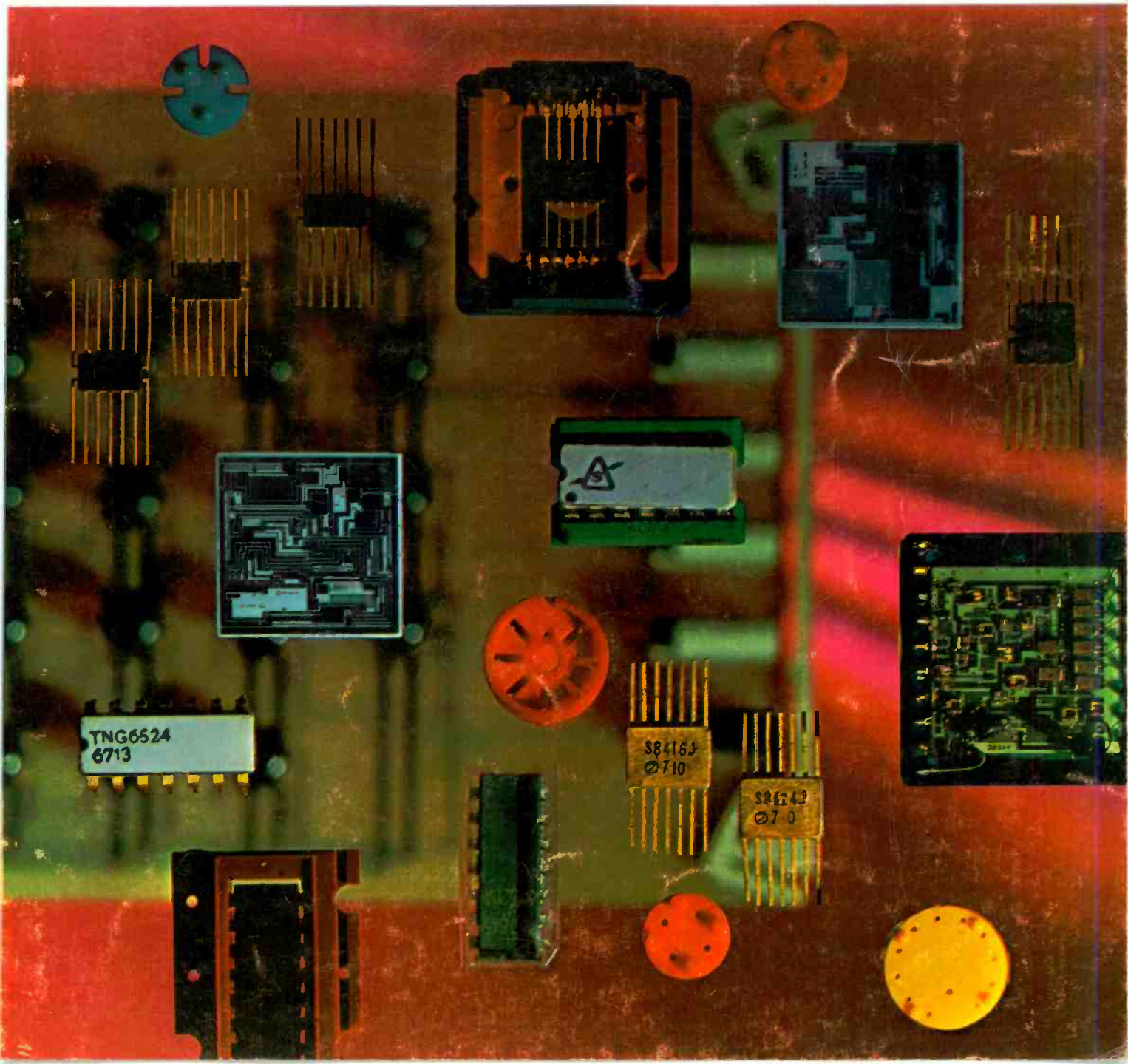

TNG6524  
6713

S8416J  
Q710

S8416J  
Q70

## model 1551 video test set



**here's a new, lightweight  
portable video test set  
that's as reliable  
in death valley as it is  
on pike's peak**



Removable front cover and accessories are self-storing.

### available test signals

10 Step Linearity  
Window  
Sin<sup>2</sup> Window  
Multiburst  
Bar & Dot

### features

Temperature stable  
Reliable solid state design  
Modular test signal generators  
Dual isolated outputs  
Self-storing accessories  
Easily serviced in the field

Riker's new 1551 Video Test Set has been developed specifically for the telephone industry to insure accurate analysis of video transmission quality and is presently in use in a number of Bell System installations. The 1551 is lightweight, shock resistant and especially suited to field use, providing continuous and reliable operation over the widest possible range of climatic conditions.

All test signals generated by the 1551 are composite with standard EIA Sync. Dual outputs are provided at 124 ohms balanced and 75 ohms unbalanced allowing measurements to be made into balanced terminal equipment and unbalanced lines or facilities.

The plug-in design of the individual test signal modules makes it easy to service and maintain the test set in field locations. Failure or removal of any single module will not affect the performance of the remaining test signal generators. All accessories, including a removable cover, are self-storing to prevent loss during long term use.

# RIKER

PRODUCTS FOR VIDEO ANALYSIS, SIMULATION & CONTROL.

RIKER VIDEO INDUSTRIES • 100 PARKWAY DRIVE SOUTH • HAUPPAUGE, L.I., NEW YORK 11787 • (516) 543-5200

# Introducing the most versatile vidicon camera ever built – Cohu's new 3200 series!

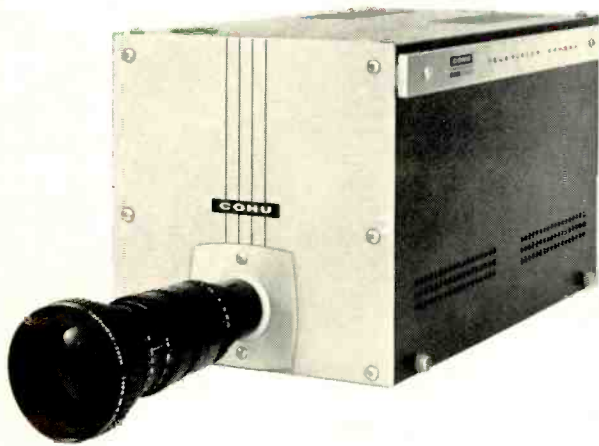

**IT'S A CCTV CAMERA** – completely self-contained. Just add a single coaxial cable to any video monitor and it's ready to operate. Want high resolution? Plug in one of four optional integrated-circuit sync generator boards for 525-, 729-, 873-, or 945-line scan patterns.



**IT'S A BROADCAST CAMERA, TOO!** Add a "mounts-in-minutes" 5-inch viewfinder and the Cohu 3200 is ideal for studio, education, or remote applications. An optional film chain adapter further enhances its versatility and provides all necessary remote controls.

For prices, delivery and full details, contact Cohu engineering representatives in major cities throughout the United States and Canada.

**COHU**  
ELECTRONICS, INC.  
SAN DIEGO DIVISION

Box 623  
San Diego, California 92112  
Phone: 714-277-6700

**publisher**  
Howard W. Sams

**publications director**  
J. J. Lieland

**editor**  
William E. Burke

**managing editor**  
James M. Moore

**regional editors**  
George M. Frese, Northwest  
Howard T. Head, Wash., D.C.  
Robert A. Jones, Midwest

**research librarian**  
Bonny Howland

**production manager**  
Susan M. Hayes

**photography**  
Paul A. Cornelius, Jr.

**circulation manager**  
Pat Osborne

**advertising sales manager**

Roy Henry  
Howard W. Sams & Co., Inc.  
4300 West 62nd St.  
Indianapolis, Ind. 46206  
(317) 291-3100

**regional sales managers**

**eastern**  
Alfred A. Menegus  
Howard W. Sams & Co., Inc.  
3 West 57th St.  
New York, N.Y. 10019  
(212) 688-6350

**southwestern**  
Martin Taylor  
P.O. Box 22025  
Houston, Tex. 77027,  
(713) 621-0000

**advertising sales representatives**

**western**  
LOS ANGELES OFFICE  
G. R. Holtz  
The Maurice A. Kimball Co., Inc.  
2008 West Carson St., Suites 203-204  
Torrance, California 90501  
(213) 320-2204

**SAN FRANCISCO OFFICE**  
The Maurice A. Kimball Co., Inc.  
580 Market St., Room 400  
San Francisco, California 94104  
(415) 392-3365

**foreign**  
LONDON W.C. 2, ENGLAND  
John Ashcraft, Leicester Square  
Whitehall 0525

**AMSTERDAM**  
John Ashcraft, Herengracht 365  
Telefoon 24 09 08

**PARIS 5, FRANCE**  
John Ashcraft, 9 Rue Lagrange  
ODeon 20-87

**TOKYO, JAPAN**  
International Media Representatives,  
Ltd., 2-4, 6—Chrome,  
Akasaka, Minatoku,  
Tokyo, Japan



Copyright © 1968

by Howard W. Sams & Co., Inc.

BROADCAST ENGINEERING is published monthly by Howard W. Sams & Co., Inc., 4300 West 62nd Street, Indianapolis, Indiana 46206. SUBSCRIPTION PRICES: U.S.A. \$6.00, one year; \$10.00, two years; \$13.00, three years. Outside the U.S.A., add \$1.00 per year for postage. Single copies are 75 cents, back issues are \$1.00.

the technical journal of the broadcast-communications industry



# Broadcast Engineering

Volume 10, No. 2

February, 1968

## CONTENTS

### Features

**Digital Circuits for Broadcasters** J. L. Smith 12

The broadcast engineer can expect to encounter digital circuits more and more in his daily work. This series presents basic information necessary to understand them. Part 1 of four parts.

**Dropout Compensation for High-Band Color** Fred J. Hodge 19

This article shows how a troublesome problem in video-tape reproduction can be solved electronically.

**A Push-Button Master Control** Len Spencer 26

Operating speed and convenience are achieved when patch cords are replaced with push-button switching.

**Maintenance of the Directional Antenna** Barry Atwood 30

A careful maintenance program based on common-sense principles can minimize problems with the directional antenna system.

**The Two-Tower Test** Robert A. Jones 38

A complex array is easier to understand when it is considered to be made up of simpler parts.

### Departments

**Letters to the Editor** 6 **Engineers' Tech Data** 58

**Washington Bulletin** 43 **Advertisers' Index** 60

**News of the Industry** 48 **Classified Ads** 61

**New Products** 54

Integrated circuits such as these are typical of the trend toward new concepts in electronic design. In broadcasting, digital circuits soon will be as commonplace as tuned circuits. The series of articles beginning on page 12 of this issue is designed to help the broadcast engineer prepare himself to work with tomorrow's equipment.

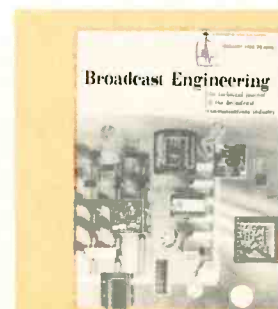



**Mobile TV Systems:** TV coverage capability in a class by itself. Goes anywhere, sees everything. Whether it's two cameras or twelve, CBS Laboratories will design and produce vans for your particular needs.



**Cameras for special television needs.** The sophisticated Minicam III multi-purpose wireless camera may be used at waist-level, eye-level, or periscope viewing positions.

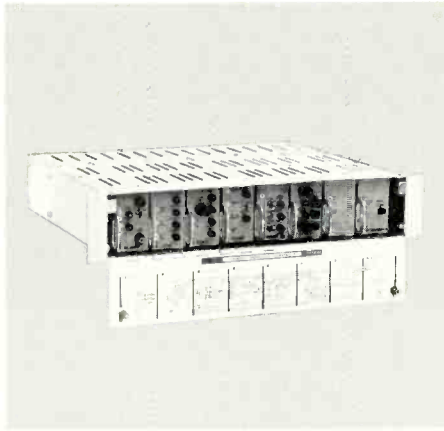

**Image Enhancers for color or monochrome TV cameras.** Provides both vertical and horizontal aperture equalization — plus "crispening" Made only by CBS Laboratories.



**Audimax/Volumax:** Provides automatic, hands-off audio level and modulation control — **without distortion.** Available in AM, FM, and FM stereo.

## Tomorrow's electronics today from CBS Laboratories

The greatest television program in the world is no better than the equipment that produces it. And there's no better equipment made than the equipment that bears the label, "CBS Laboratories".

Whether it's precise automatic audio controls, television display systems, video distribution and control equipment, or highly versatile mobile TV systems, these Professional Products will give your programming the sound and picture quality it deserves.

And with greater profit. Reason? Not because the equipment is the least expensive. It's not. But because it's the best. That means a one-time investment in quality — and that's the kind that pays off.

It's good business to buy the best answers to equipment problems. So if you are looking for a solution to a problem — or even if you don't think there is a solution — write or call us collect (203) 327-2000. We're on your side.

PROFESSIONAL  
PRODUCTS



**CBS LABORATORIES**  
Stamford, Connecticut. A Division of  
Columbia Broadcasting System, Inc.

# REVERBERATION UNLIMITED!

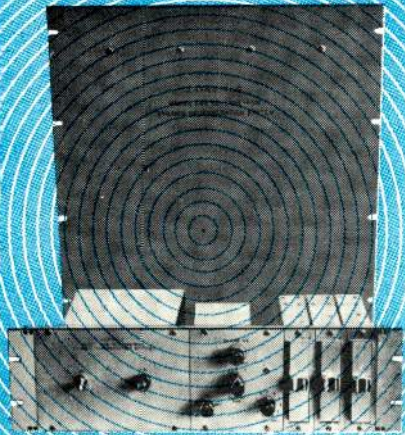

only with

## FAIRCHILD REVERBERTRONS

Now with the FAIRCHILD REVERBERTRON you can reproduce the thrilling reverberated sounds of the Grand Canyon or the colorful reverberation qualities inherent only in good acoustical chambers. In addition, because reverberated sound is apparently louder than the same non-reverberated signal, by utilizing the FAIRCHILD REVERBERTRON in motion picture, radio and television studios you can create realistic sound effects and attention holding commercials.

No longer do you need expensive reverberation chambers or special "on location" recordings. The FAIRCHILD REVERBERTRON costs less than you imagine and is available in economy model too.

The advantages of a FAIRCHILD REVERBERTRON in your studio are virtually unlimited for creating wide audience appeal and impact and literally hundreds of "ear appealing" sounds.

The next time you want to "glue" your audience's ears to the sound you're making be sure to use a FAIRCHILD REVERBERTRON!

### SPECIFICATIONS OF MODEL 658A (Pictured above)

The 658A is a complete solid state reverberation system with electronically controlled reverb time adjustments up to 5 seconds; mixing control for adjustment of reverberated to non-reverberated signal ratios; reverb equalization at 2, 3, and 5 KHZ. Size: 24 1/2 x 19".

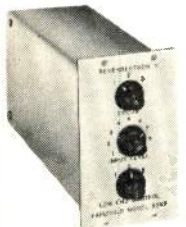

### ECONOMY MODEL 658B ALSO AVAILABLE

Compact, reverberation system for the "big" sound in a small space. Contains reverb equalization in mid and low frequency range; level control; sold state design. Size: Only 5 1/4 x 3 x 10" deep.

Write to FAIRCHILD — the pacemaker in professional audio products — for complete details

**FAIRCHILD**  
RECORDING EQUIPMENT CORPORATION  
10-40 45th Ave., Long Island City 1, N. Y.

Circle Item 4 on Tech Data Card

## LETTERS TO THE EDITOR

DEAR EDITOR:

I look forward to receiving every issue of BROADCAST ENGINEERING. Keeping a file of back issues is like having a textbook of engineering practice.

Referring to the June 1966 issue, in which Thomas R. Haskett discussed the small-budget audio-proof package, I have put together the exact package that he described. I have one question about the RF detection box: What type of antenna should be used? I connected the unit to the modulation-monitor RF connection and found it worked; however, I'm afraid of burning out the IN34 diode. I'd also like to know what to do if too much distortion is found within this unit.

One modification that could be made in the input matching box is a more complex switching arrangement. I added positions for 333 ohms, 500/600 ohms grounded center tap, 250 ohms grounded center tap, and load (no audio) for each resistor. Although these positions may not be used as much as others, they add convenience for the engineer as he searches for the most desirable adjustments.

I have run into a couple of problems while running proofs when considerable RF was present; this makes distortion readings difficult to obtain. Good grounding cannot be overemphasized. I made some ground cable compatible with the five-way connectors on the equipment. Also it is good to have various cables with banana plugs, alligator clips, microphone plugs, and whatever else might be encountered. One can spend useless hours making up "compromise connectors."

PAUL SCHUETT  
Station Engineer  
KWG, Stockton, Cal.

*Author Haskett answers Mr. Schuett's questions regarding the RF box as follows.—Ed.*

Present HD meters require 0.1 to 0.8 volt of audio input, so the detector box must furnish that much output. The amount of RF input needed for the detector box may be from 5 to 10 volts rms. You can easily determine whether you have sufficient RF by the following method: Connect the detector output to

the HD-meter input. Set the HD meter to "Set Level" and turn the SET LEVEL control wide open. (This applies to the Heath IM-12; perform the equivalent for other HD meters.) Couple tone-modulated RF into the detector box until you see deflection on the HD meter. Back off the SET LEVEL control, and increase the RF input to the box until you have a comfortable margin of input to the HD meter.

You can couple RF into the box from the modulation-monitor output on your transmitter, as you found. The usual 1-kw transmitter has a modulation-monitor output of about 10-15 volts of rms RF, which should do.

Another way to get RF to the box is as follows: Make up 4 or 5 turns of hookup wire (insulated) into a coil about the size of one turn on the final plate tank coil on your transmitter. Tape this coil next to the tank, and connect the wire ends to the box input through shielded line—as shown in Fig. 4, page 18 of the June 1966 issue. For less RF, turn or move the pickup coil away from the plate tank. For more RF, increase the number of turns in the coil. Continue adjusting until you have enough audio at the HD meter.

If you intend using the box at a point remote from the transmitter, you'll have to use an RF preamp delivering about 10 volts across 75 ohms, which is more or less standard. The box requires so much RF that I prefer speaking of a "pickup loop" rather than an "antenna."

The IN34 and IN34A diodes have PIV's of 60 and 75 volts, respectively. This means they will break down if you put more than 42 or 53 volts, respectively, of rms RF across them. Thus, when 10-15 volts of rms RF is used, the diode should be safe.

I don't think you'll find much distortion in the box, as it's a passive circuit. Check it by comparison with your modulation monitor. Run a distortion curve on each using 1000-Hz, 50% modulation. Rated residual harmonic distortion of monitors is typically 0.1 to 0.5%. If you do find distortion in the box, try a new diode (use a IN34A) and a new electrolytic.

THOMAS R. HASKETT

# coast-to-coast\* the switch is to.WARD switchers



... the choice of the skeptics, whose proof is performance!

Ward Electronic's all solid-state vertical interval switchers are years ahead. Hard to believe? Once you've checked the features and compared the performance of our switchers, you'll understand why so many major TV stations are switching to, and with Ward.

Here are only a few of the many features you will find of special interest in our Studio, Master Control and Routing Switchers.

- Automatic Composite / Non Composite Input Handling Capability
- Sync sensing, automatic sync adding and clamping on each input

- Spare 75 ohm clamped output from each input
- Two Independently Equalized Outputs per buss
- Additive / Non Additive solid state mixing amplifier
- Automatic Direct take when attempting to mix non synchronous sources
- Each buss self-contained with individual power supply, trigger pulse generator, latch and tally circuits
- Transient-less vertical interval switching
- Low Impedance, transmission line type input buss

\* Write for a list of the TV stations that have switched to Ward, . . . and complete switcher specifications.



## WARD ELECTRONIC INDUSTRIES

142 CENTRAL AVE., CLARK, NEW JERSEY 07066 • (201) 382-3700

Circle Item 5 on Tech Data Card

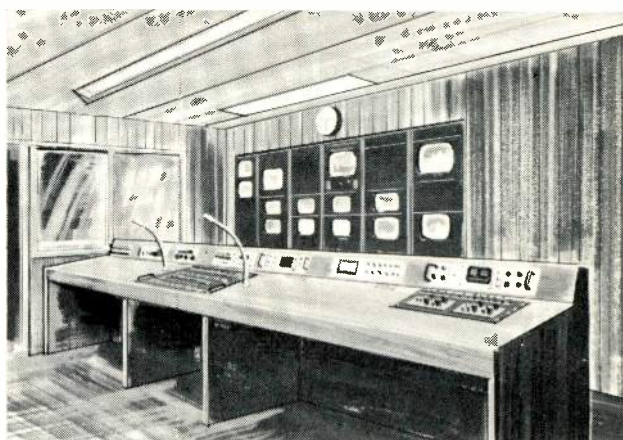
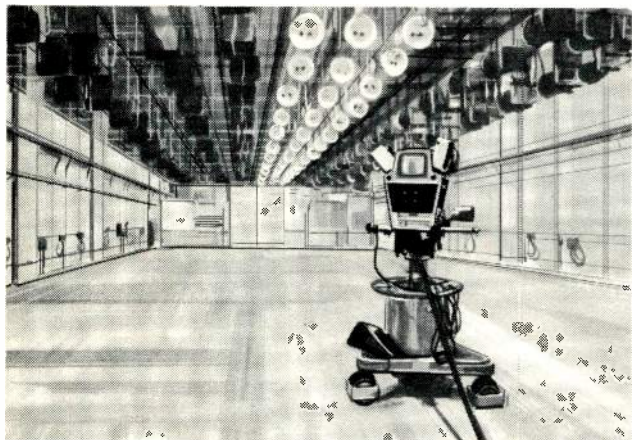
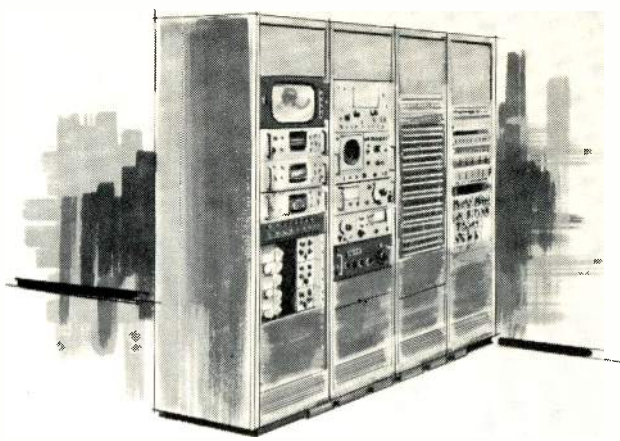
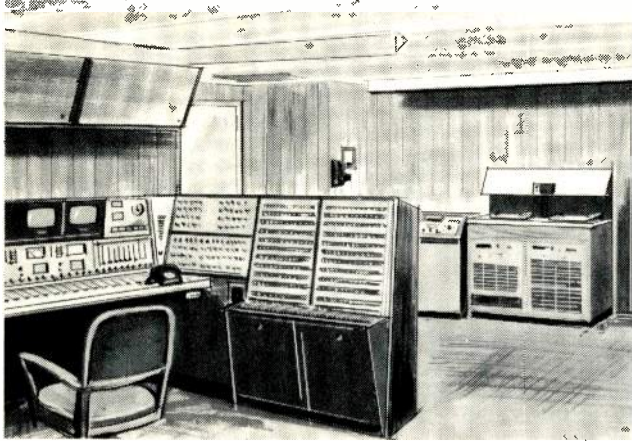

## Now, from a single source, a full range of TV studio engineering services.

Studio engineers seeking the best in TV broadcasting technology rely on Federal Electric Corporation's full range of studio services, backed by the experience, skill and resources of ITT, world leader in communications research and engineering.

Federal Electric offers studio design, installation, and backup maintenance, custom-tailored to improve your studio's effi-

ciency and flexibility. Result: your station equipment is current, competitive and profit-making.

We design systems, select, install, tuneup and checkout equipment, and deliver as-installed records and technical manuals. Whether you are building a station from the ground up . . . adding remote pickup . . . converting from monochrome to color . . . or

merely adding updated or expanded recording facilities, you'll find that service from Federal Electric brings you top professional people, fully matured in TV studio engineering.

ITT's Service Associate,  
Federal Electric Corporation,  
621 Industrial Avenue,  
Paramus, N. J. 07652.  
(201) 967-2554

# ITT





# Vital News in Switching!

## VIX-108

*First new concept  
in Switching in a  
decade is here*

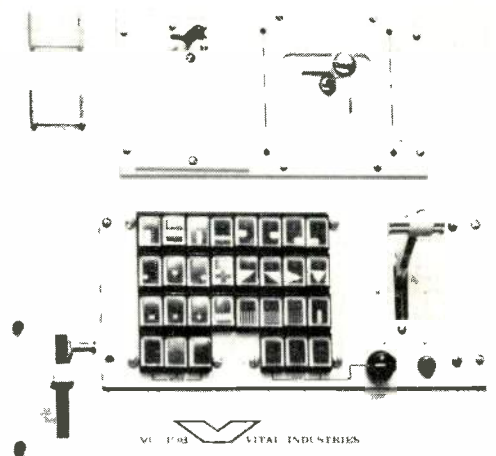
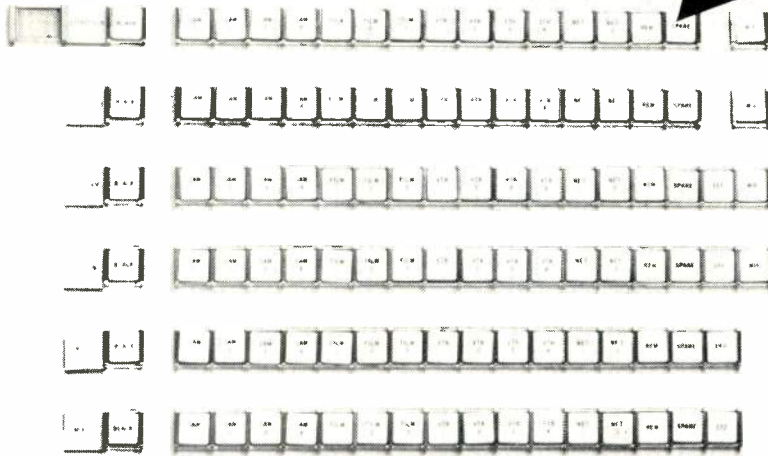

Vital Industries, Inc. has taken the custom cost and complications out of custom switching. A unique combination of mechanical and electrical packaging has yielded exceptionally high performance and specifications in the VIX-108 vertical interval switching system.

### FEATURES:

- All solid state with integrated circuits including crosspoints and control circuits.
- Complete basic package 18 in by 6 out system complete with power supply control circuitry, in 5 1/4" rack space. UHF Connectors.
- Production or routing switcher. Any size.
- Vertical interval or random switch in less than 0.1 micro-second.
- Auto sync add for comp/non comp operation. Auto inhibit non synchronous mix.
- Custom built with any kind of control buttons or panels. All state of the art accessories also furnished by Vital Industries, Inc.

### SPECIFICATIONS for one typical 18 in 6 out system:

- Exceptional isolation between crosspoints . . . 65 DB down at 4 Mhz.
- Differential phase through the system . . . Less than 0.1 degree at 1 volt output.
- Differential gain . . . less than 0.1 percent at 1 volt output.
- Frequency response . . . Flat within 0.1 db from 10 Hz to 10 Mhz under all conditions.
- Tilt . . . Less than 0.5% over 1 field.
- K factor less than 1%.

*Selecting the right switcher is Vital*

GOOD ENGINEERING IS VITAL



*Write for complete information and specifications.*

## VITAL INDUSTRIES, INC.

3614 SOUTHWEST ARCHER ROAD  
GAINESVILLE, FLORIDA 32601 - PHONE (904) 378-1581

Circle Item 7 on Tech Data Card

When engineers get together,  
the conversation turns to pickups.



PHOTOGRAPHED BY FRANZ EDSON AT THE CAPITOL TOWER, HOLLYWOOD.

It's an irresistible topic.

Especially since Stanton came out with the Model 500 stereo cartridge.

That's an engineer's pickup, if there ever was one.

Beautiful curve—within 1 db from 20 to 10,000 Hz, 2 db from 10,000 to 20,000 Hz.

Fantastically small moving system to trace the wildest twists in the groove.

Light weight (only 5 grams!) to take advantage of low-mass tone arms.

And, of course, Stanton's legendary quality control.

No wonder engineers use the Stanton 500 for critical broadcasting  
and auditioning applications.

And to impress other engineers with their pickupmanship.

(Available with 0.7 or 0.5-mil diamond, \$30; with elliptical diamond, \$35.

For free literature, write to Stanton Magnetics, Inc., Plainview, L.I., N.Y.)



# NOW GATES MONITORS GATES

Three new solid-state FM monitors from Gates . . . supplier of the most complete line of FM broadcast equipment from a single-source manufacturer. From microphone to antenna, and everything in-between.

Advanced modular design of our monaural monitor permits conversion for stereo, a bonus feature for monaural users. Space program integrated circuits add to Gates reliability. And, of course, they can be used to monitor whatever brand of FM transmitting equipment you have.

Available from stock, our new solid-state FM monitors are fully FCC approved and thoroughly field tested. So check with Gates first - your single source for all FM broadcast equipment.

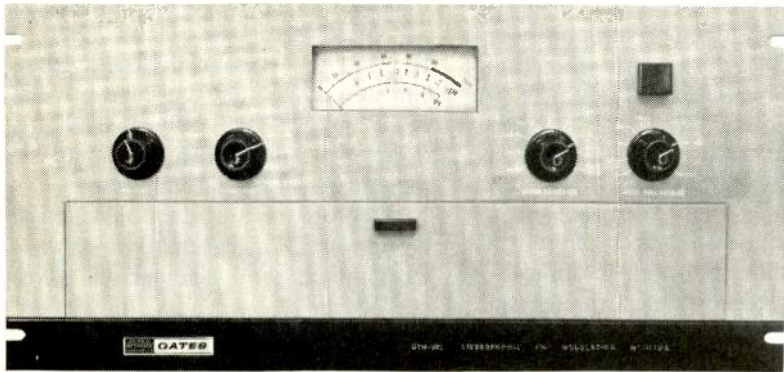

**GTM-88S FM Stereo Modulation Monitor**  
Integrated circuits for greater dependability. Full provision for adding SCA adapter. All controls accessible from front panel. Silicon solid-state circuitry.



**GTM-88M FM Monaural Modulation Monitor**  
Convertible to stereo operation. Provision for adapting to SCA operation. Integrated circuits for highest reliability. All controls accessible from front panel. Silicon solid-state circuitry.

**GTM-88F FM Frequency Monitor**  
Wide-band pulse counting detector. No tuned circuits in pulse detector. All controls on front panel. Fully temperature compensated. Silicon solid-state circuitry.



**HARRIS  
INTERTYPE  
CORPORATION**

**GATES**  
GATES RADIO COMPANY  
QUINCY, ILLINOIS 62301, U.S.A.  
A subsidiary of Harris-Intertype Corporation

Circle Item 8 on Tech Data Card



by a 0 or 1, that a certain power of 2 is included or is not included. The powers of 2 start with  $2^0$  at the left of the binary point<sup>1</sup> and increase by 1 for each position to the left. They decrease by 1 for each position to the right. Fig. 2 illustrates the binary construction of the same number used in Fig. 1.

The decimal number 107.25 is written in binary form as 1101011.01. At first glance it may appear that the large number of digits necessary for the binary representation is a disadvantage in terms of the electronic circuitry necessary to store and handle these digits. In fact, however, the required circuitry is actually less than for the decimal counterpart. This is because it is only necessary to register either 0 or 1 for each digital position in the binary system, whereas the decimal system requires that each digital position register 0 through 9. Thus the nine binary digits require nine *two-state* devices, or a total of 18 states for the sample number in Fig. 2. The five decimal digits of the corresponding sample number in Fig. 1 require five *ten-state* devices, or a total of 50 states. This, plus the fact that two-state devices occur so naturally, forms the foundation for the use of the binary system in digital circuits.

### Decimal/Binary Conversions

Binary numbers are converted to decimal numbers simply by adding the weighted digits as in Fig. 2.

<sup>1</sup> The decimal system uses a decimal point, but the binary system uses a binary point.

Decimal numbers are converted to binary numbers in two steps. The decimal number is separated at the decimal point. That portion to the left of the decimal is converted by a process of division and that to the right of the decimal is converted by a process of multiplication. The final result is the combination of the two.

Consider the conversion to binary notation of the decimal number 26.625. The portion to the left of the decimal (26) is successively divided by two, with the remainders noted in a column to the right. The remainders are then weighted starting with  $2^0$  at the top and increasing downward by a power of 2 for each remainder. The process is carried out as follows:

	Remainders	Weighting Factor
2) 26		
2) 13	0	$2^0$
2) 6	1	$2^1$
2) 3	0	$2^2$
2) 1	1	$2^3$
0	1	$2^4$

The binary equivalent of the number 26 is then 1 1 0 1 0. This binary number is made up of the remainders placed in sequence with the bottom digit being placed on the left.

The fractional number (.625) is converted by successively multiplying the fraction by 2 and noting the "spill-over," *i.e.*, that which results to the left of the decimal. The spill-over is not multiplied in succeeding steps.

Weighting Factor	Spill-Over
	.625
	<u>×2</u>
$2^{-1}$	1 .250
	<u>×2</u>
$2^{-2}$	0 .500
	<u>×2</u>
$2^{-3}$	1 .000

Thus the binary equivalent of 0.625 is 0.101, which is written by collecting the spill-overs in sequence with the top spill-over on the left.

Then the total number 26.625 is written in binary form as the sum of the whole and fractional parts:

$$26.625 \rightarrow 11010.101$$

### Binary Arithmetic

The four basic arithmetical operations can be performed with binary numbers just as they can be performed with decimal numbers. Table 1 gives the rules for each operation. These rules are identical with those of decimal arithmetic, even though this fact may not be readily apparent because the radix 2 is not familiar to most of us.

*Example 1.* Add the binary equivalents of the decimal numbers 7, 6, and 3.

	11	} Carries
	111	
7 →	111	
6 →	110	
3 →	011	
Sum	16 → 10000	

As shown in Table 1,  $1 + 1 = 0$  with 1 to carry. Each time a carry is generated, it is placed above the next column to the left and includ-

Fig. 2. A binary number is the sum of its digits weighted by powers of 2.

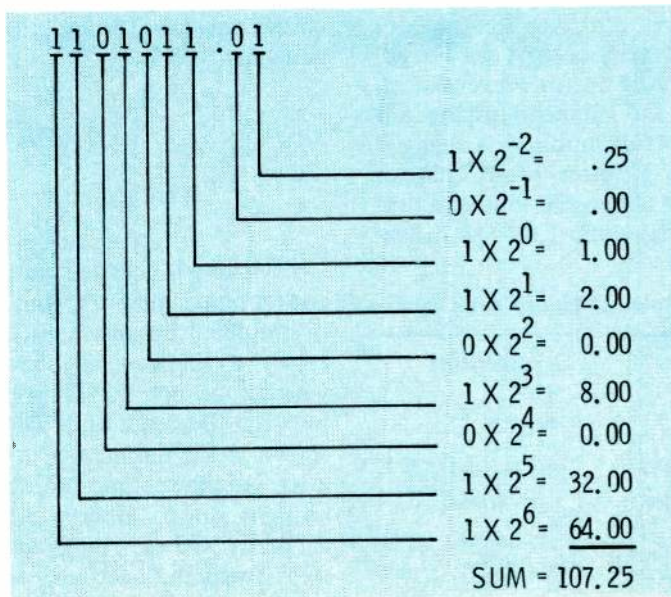

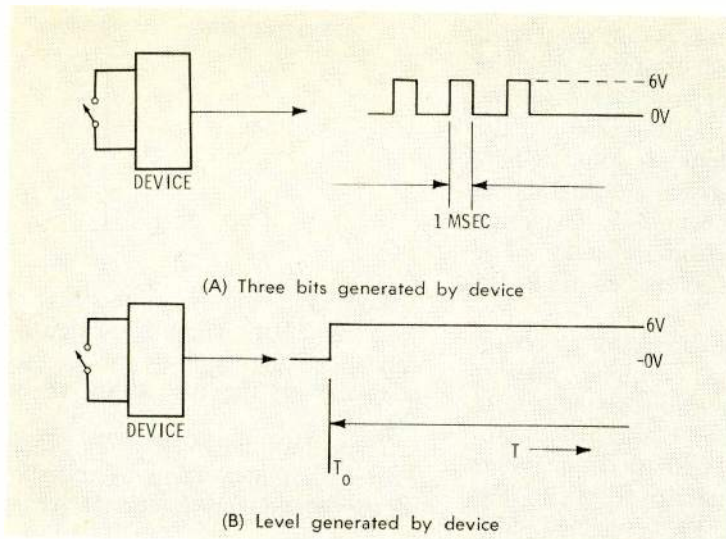

Fig. 3. Bits and levels are distinguished by duration.

ed in the sum of that column. If two or more carries are generated, then each is included above the column to the left. In the example shown, the right column generated one carry. The next column to the left generated two carries, which in turn generated two additional carries. The binary sum resulted as 10000, or 16.

*Example 2.* Subtract the binary equivalent of 6 from the binary equivalent of 9.

$$\begin{array}{r}
 \phantom{9} \rightarrow \phantom{0}1 \text{ Borrows} \\
 9 \rightarrow \phantom{0}1001 \\
 -6 \rightarrow \phantom{0}110 \\
 \hline
 3 \rightarrow \phantom{0}0011
 \end{array}$$

Although subtraction is not extremely difficult, it is the most complicated of the four binary operations. The steps are identical with those of decimal subtraction, except that the unfamiliar radix makes the borrow process somewhat vexing. Borrowing is easy by the following rule:

$0 - 1 = 1$  and borrow 1. To accomplish the borrow, reverse each digit in the minuend to the left of the borrow, until a 1 is changed to a 0. Register these changes in a row above the minuend and use the uppermost row as a new minuend.

Table 1. Rules of Binary Arithmetic

Addition	Subtraction
$0+0=0$	$1-1=0$
$0+1=1$	$1-0=1$
$1+0=1$	$0-0=0$
$1+1=0$ & Carry 1	$0-1=1$ & Borrow 1
Multiplication	Division
$1 \times 1 = 1$	$1 \div 1 = 1$
$1 \times 0 = 0$	$0 \div 1 = 0$
$0 \times 1 = 0$	$0 \div 0 = 0$
$0 \times 0 = 0$	

In the example shown, the second column from the right required a borrow from its left neighbor. This borrow in turn resulted in a borrow from the extreme left column. These borrows were registered above the minuend and became the new minuend.

*Example 3.* Multiply the binary equivalents of 3 and 4.

$$\begin{array}{r}
 4 \rightarrow \phantom{0}100 \\
 \times 3 \rightarrow \phantom{0}011 \\
 \hline
 12 \rightarrow \phantom{0}100 \\
 \phantom{0}000 \\
 \hline
 01100
 \end{array}$$

Multiplication is the most simple of the operations. It is carried out in a manner identical with decimal multiplication, but is simplified by the fact that it is only necessary to multiply by either 0 or 1. The partial products are added in accordance with the rules of binary addition.

*Example 4.* Divide the binary equivalent of 18 by the binary equivalent of 3.

$$\begin{array}{r}
 6 \\
 3 \overline{) 18} \\
 \underline{18} \\
 0
 \end{array}
 \qquad
 \begin{array}{r}
 110 \\
 011 \overline{) 10010} \\
 \underline{011} \\
 011 \\
 \underline{011} \\
 00
 \end{array}$$

Division is carried out in the conventional manner, but it, too, is simplified because it is only necessary to indicate in the quotient whether or not the divisor will go into the dividend. If it will, a 1 is shown in the quotient. If it will not, a 0 is shown and another digit brought down. Binary subtraction is performed in the intermediate steps (with the borrows carried out mentally in the example).

### Digital Data

The binary 1 and 0 are represented in digital circuits by voltage levels. It is common to let zero volts represent logic 0 and a voltage value, e.g., +6 volts, represent logic 1. The logic levels are a matter of definition, however, and any consistent scheme may be used. The manipulation of these voltage levels constitutes the digital logic operations. In practice, the logic levels are not precisely 0 or 6 volts, but may vary slightly about these points. For example, logic 0 may not be precisely 0 volts because it may be formed by a shunting transistor which has a finite saturation voltage amounting to a few tenths of a volt. By the same token, there can be variations in the logic-1 level. The circuits are designed to accommodate these variations, however.

Both logic-1 and logic-0 levels may also be subjected to variations due to transient spikes or stray AC pickup. All of the variations in the logic levels, regardless of the nature or origin, are considered logic noise and must be considered in the design and maintenance of digital equipment. A noise spike riding on logic 0 can be confused for a logic 1 if the spike is large enough. Fortunately, the logic levels are separated widely enough that the noise levels encountered are not significant in most cases. One must be familiar with the fact that logic noise exists, however, so that noise will be recognized should it be encountered.

A binary digit is called a bit (Binary digIT). The binary number 11011 is made up of five bits. Likewise, voltage levels making up

## New E-V Model 668 Dynamic Cardioid Boom Microphone

with built-in  
programming panel!

**E-V** It's just like having 36 microphones in one, at the end of your boom. Simply match the computer-style programming pins to the color-coded jack field inside the new E-V668. You'll get any combination of flat response (40 to 12,000 cps), bass and/or treble rolloff, treble rise, and 80 or 8,000 cps cutoff. The 668 built-in passive equalizer matches response to need precisely without loss in output level—mixes perfectly with any other microphone.

The 668 cardioid pattern is symmetrical in every plane with excellent rear cancellation at every program setting. Two independent Continuously Variable-D\* systems provide this uniformity, yet permit high output (-51 dbm) for distant pickup without added equipment or special cables.

Light in weight and small in size, the 668 with integral Acoustifoam™ wind-screen and shock mount minimizes shadow problems while allowing noise-free fast panning, indoors and out. Its 1 lb., 11 oz. weight eliminates "fishpole fatigue" and counterbalancing problems.

The 668 is guaranteed **UNCONDITIONALLY** against malfunction of any kind—even if caused by accident or abuse—for two years. And, like all E-V Professional microphones, it's guaranteed for life against failure of materials or workmanship.

The E-V 668 is the result of a three year intensive field testing program in movie and TV studios from coast to coast. It has proved itself superior to every other boom microphone available. Find out why with a no cost, no obligation trial in your studio. Call your E-V Professional microphone distributor today, or write us direct for complete specifications.

NEW! MC DEL 667A identical to Model 668 except sharp cutoff filters and HF-rolloff eliminated. List price: Model 667A, \$345.00; Model 668, \$495.00 (less normal trade discounts).

\* Patent No. 3115207 covers the exclusive E-V Continuously Variable-D design.

**ELECTRO-VOICE, INC.**, Dept. 281V  
338 Cecil Street, Buchanan, Michigan 49107

**Electro-Voice**<sup>®</sup>  
SETTING NEW STANDARDS IN SOUND

Circle Item 38 on Tech Date Card

# **BRAIN ON A BOOM!**





# The Norelco "Little Shaver" does everything its big brother, the PC-70, can do ...and gets around a lot more.

This is the new Norelco PCP-70 Portable Color Television Camera. We call it the "Little Shaver" for short.

Like its big brother, the PC-70, which is used on the majority of top network live



and taped shows, it employs the exclusive Norelco 3-Plumbicon\* tube system that provides the truest color, highest resolution and maximum sensitivity available today.

The "Little Shaver" goes where the action is.

Sports. News and documentaries. Political events... just about anywhere a man can go.

The "Little Shaver" is fully compatible with the camera control unit of the PC-70 studio camera. Thus, present PC-70 owners have an even greater advantage in that they can have the versatility of the PCP-70 with



no further expense for control equipment.

Instantly accepted by all the major networks, the Norelco PCP-70 is the portable that gives you the

world's best color television picture.

If you want faithful color reproduction in a port-



able camera, you want the "Little Shaver." For a live demonstration and technical data, call or write our representative, Visual Electronics.

\*Registered trade mark for television camera tubes.

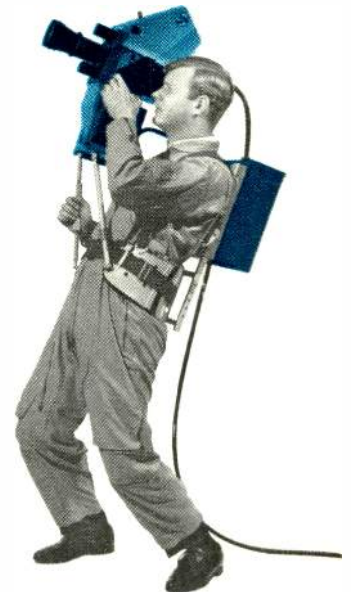

*Norelco*

PHILIPS BROADCAST  
EQUIPMENT CORP.

299 Raute 17, Paramus, N.J. 07652 • 201/262-7300

Circle Item 9 on Tech Data Card



(A) Serial data 11011

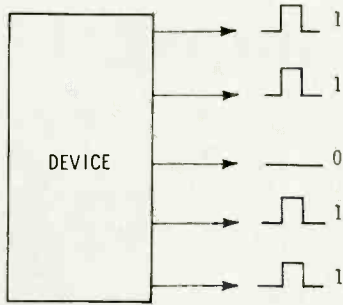

(B) Parallel data 11011

Fig. 4. Data may be transmitted serially or in parallel.

the binary 1 and 0 are called bits if they have a time duration that is relatively short and controlled by the equipment. For example, if a switch is thrown in a circuit and from the circuit emerges a +6-volt pulse of, say, 1-msec duration, then 1 bit has been generated. If, however, when the switch is thrown +6 volts appears and remains until the switch is opened, then a level, not a bit, has been generated. See Fig. 3 for a pictorial display of this concept.

A collection of bits which have assigned meanings is called digital data. The number of bits generated or handled per second is called the bit rate. This is a measure of how rapidly equipment can process digital data.

Digital data exist in two forms, serial and parallel (Fig. 4). Serial data consist of bits which occur in a time sequence on a single conductor. The first bit is present for a given length of time; then it goes away and the second bit appears.

The second goes away and the third appears. This continues with the complete data appearing at a single point serially in time. For parallel data, a separate conductor exists for each bit, and all bits appear simultaneously. It is evident that greater speed is possible with parallel data than with serial data, because all the parallel data are presented in the amount of time required to present a single bit in the serial form. The price that must be paid for this speed is the fact that more complex equipment is required to handle all bits at once, whereas the equipment can be shared when data are in the serial form.

The data bits frequently are associated in groups of special meaning. These groups are called words. Suppose a device were used to send the five-bit equivalent of a series of decimal numbers. Then perhaps the five bits comprising a single number are designated a word. As a result, the processing of the data can be handled by words, *i.e.*, groups of five bits. It is also possible to handle a word as parallel data and handle a group of words in serial fashion. Such a scheme is called serial/parallel data handling because both serial and parallel data are present (Fig. 5). These data may represent the input to a computer where the words represent binary numbers to be added.

Next month, the second part of this series will examine the logic elements which form the basis of digital circuits. ▲

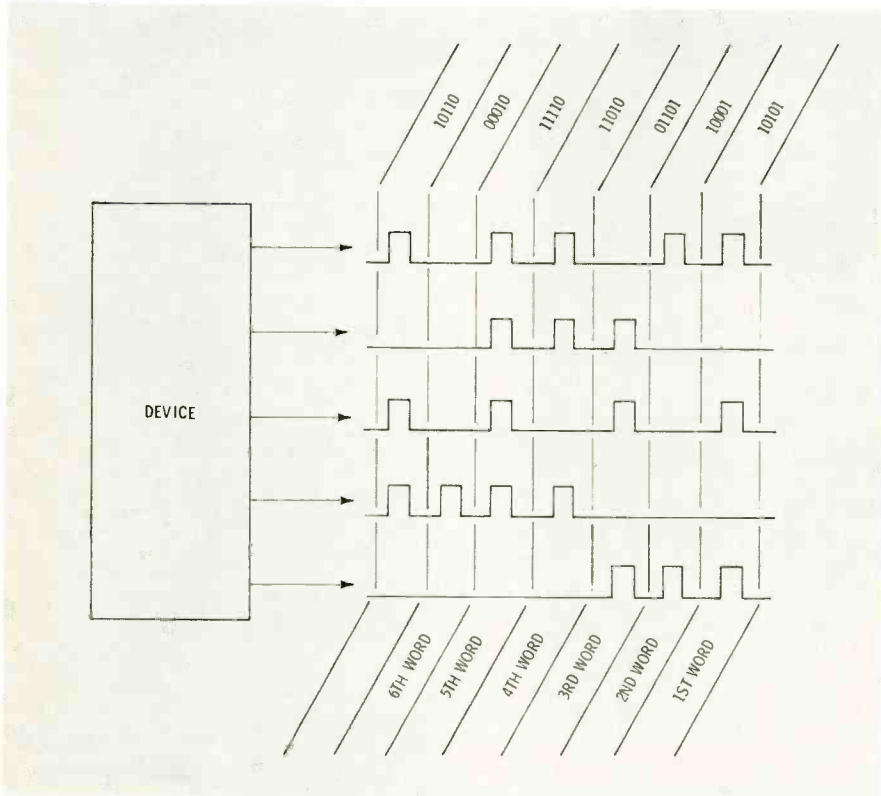

Fig. 5. Words consisting of parallel bits may be presented serially in time.

---

---

# DROPOUT COMPENSATION FOR HIGH-BAND COLOR

—Some of the problems, and their solutions, in compensating dropouts in color video tape are explained.

by *Fred J. Hodge\**

The 1965-66 television season was a turning point for color. Technological advances, plus a large increase in the number of viewers, caused a shift in program emphasis from compatible monochrome to high-quality color transmission. Prior to 1965, nearly all scenes telecast in color or black-and-white featured picture composition in which the primary brightness stimulus was caused by the luminance portion of the picture. Consequently, redundant luminance dropout compensation had been a satisfactory solution to the video-tape dropout problem. This situation changed when attention shifted to the color audience. Higher-saturation color systems became popular, and it was apparent that full-color replacement would be required for adequate dropout protection.

## Physical Nature of Dropouts

The discussion of full-color substitution starts properly with an analysis of what a dropout actually is. When a particle in the video-tape coating interferes with head-to-tape contact (1), or a void exists in the oxide due to a scratch, a reduction in the recorded or reproduced signal can be caused. (2). As a result, the normally constant FM signal used for video recording becomes amplitude modulated to a degree which depends on the signal loss produced by the particle or scratch. When this degree of amplitude modulation cannot be accommodated by the playback limiter circuits of a recorder, a momentary streak appears in the reproduced picture.

Most dropouts caused by scratches result from handling at the user level and produce diagonally organized groups on the television screen. Multiple-generation tape copies contain defects origi-

---

\*Video Project Supervisor, Mincom Div., 3M Co., Camarillo, Calif.

nated in previous recordings and thus multiply the incidence of visible dropouts.

High-band recording, by its very nature, increases the incidence of dropouts over that for low-band operation. Over half of the recorded energy is in the first 1/10 wavelength of penetration into the recording medium. Since the wavelength is shorter in high-band recording, the energy is closer to the surface of the tape, and therefore the recording is more susceptible to the surface contamination effects which produce dropout (3).

Dropout streaks in a reproduced picture may be either light or dark, or any color, depending on the exact transient nature of the video signal as well as other instantaneous machine factors. Furthermore, should defects occur during the period of video clamping or color burst, polarity of the resulting effect becomes unpredictable.

In general, dropouts are most annoying when they appear as bright streaks on a predominantly dark or low-key background. It should be kept in mind that more defects may be apparent to the viewer's eye as picture composition varies, even though tape quality and machine constants remain unchanged.

### Effect of Head Penetration

Manufacturer's tests indicate that video tapes exhibit fewer dropouts at the higher head-to-tape contact pressures secured by deeper penetration. Also, and within limits, these higher penetrations have a greater tendency to remove certain offending particles in or on the surface of the tape.

With some brands of tape, definite improvement from a dropout standpoint usually results after a tape has been preconditioned through several passes with deeper head penetrations. Most defects which remain despite initial head passes still produce visible dropouts in a degree related to head penetration.

As a matter of operating practice, tapes must be recorded so that "skew" and "scallop" patterns in the individual head bands remain complementary even when tape is spliced onto stock recorded with heads having different head projections. This requires that the degree of ac-

tual penetration of the heads into the tape surface be different for different head projections; the penetration should be reduced approximately 1 mil for each change of 1 mil in average head projection. Therefore, as heads gradually wear from, for example a 3-mil to a 1-mil projection, the penetration into the center of the tape would undergo a reduction of about 2 mils when the female guide is adjusted for minimum "skew" and "scallop."

Inasmuch as shallower head penetration results in less intimate contact in a potential tape-defect area, it is to be expected that higher dropout counts will occur with worn heads during both record and playback modes. Even if a disturbing particle is removed by the heads during the recording pass, the disturbed magnetic pattern remains and affects reproduction during ensuing playbacks. Future recordings, however, may show few or no defects in the particular area.

### Electrical Nature of Dropouts

A signal dropout in a video recording system consists of an abrupt negative amplitude-modulated notch in the carrier. The effectiveness of limiter circuitry in the demodulator can have marked effects on how clearly this AM component is reproduced through the FM system.

An examination of the playback carrier prior to its introduction into the limiter stages discloses that, with most samples of tape, the signal contains an entire family of dropouts of different amplitudes and durations (2). The change in amplitude of the carrier during these momentary events may range from a reduction of only a few percent to a complete failure. A majority of these dropouts are never seen, as their effects are absorbed by the action of the limiters in the demodulator chassis.

Head wear or circuit changes can cause partial loss of total limiting gain. If this occurs, an increasing number of the carrier depressions reach the discriminator and become visible on the television screen. Furthermore, improper transient response in the RF amplifying system can exaggerate the durations and amplitudes of the carrier dropouts, making their effects more pronounced.

Excessive noise also can reduce dropout immunity, since the carrier cannot be recovered by the limiter when momentarily reduced to a value less than the noise level.

### Psychophysical Factors

Several psychophysical attributes of human perception enter into what viewers *think* they see on the television screen. It is well to review these to gain better insight into what can be done to understand and implement compensator action.

In the normal process of visual perception, the viewer is engaged in a whole-perceiving attitude, as opposed to a part-isolating attitude; that is, he is concerned primarily with the total image (4). The phenomenon of figural persistence—the tendency of the observer to carry over the same figure and background organization of an image—was discovered early in twentieth-century psychophysical studies (5). Perceptions of figures are organized along certain principles (6). These include:

1. Nearness — Dots close together will be seen as a group.
2. Sameness — Dots of the same color or shape will be seen as a group.
3. Common Fate — Dots which move simultaneously in the same direction will be seen as a group.
4. Good Continuation and Good Figure — A nearly complete circle will be seen as a circle. A sweeping smooth line with a bump on it gives the viewer an almost irrepressible desire to smooth the bump.

### Use of Redundant Signal

Early in 1960, the principle of redundancy was applied to a standard video recorder system to compensate for the visual effects of signal dropouts. In this system, an artificial and essentially redundant signal was obtained through a delay line of requisite signal characteristics and a time delay corresponding to one television line (approximately 63.5 microseconds). This selection was based on the following factors:

1. The inherently high redundancy existing between signal profiles in most time-adjacent line periods (two successive lines as displayed on a kinescope screen) comprising a television signal.

2. General inability to detect minor geometric distortions of pictorial detail which exist for short time durations.
3. The increasing availability of economically feasible delay devices of requisite bandwidths and duration.

Ideally, the one-line delay system for compensator use should retard the television signal 63.5 microseconds (63.55 microseconds for color) and display a conventional video frequency response and rise time. A full-bandwidth system was developed and evaluated, but until the new generation of high-band color video tape recorders became popular, a 63.5-microsecond delay line with a frequency response of 500 kHz was used to store the highly redundant components of the video and sync signals.

Although the bandwidth of the replacement signal was less than that required to pass burst and color information, the system was compatible with color operation. The viewer could not perceive the lack of color in the dropout area if the brightness information provided was similar to the surrounding scene (7), so long as the color saturation was relatively low. Low-band color recorders were not capable of highly saturated color operation.

Another factor which helped was that these early color television recorders employed the heterodyne color-recovery system. In this system, the phase jitter in the chrominance and color-burst signals was eliminated by separating the chrominance and burst information from the video, and then developing a correction signal from the tape burst for use in cancelling the chrominance phase jitter. The heterodyne color system was tolerant of missing burst pulse and other dropout effects. It had the disadvantages of limiting the luminance bandwidth and of not removing the positional jitter from the synchronizing signal. The direct color-recovery system was developed to solve these problems.

In direct color recovery, line-by-line sampling of tape sync and color-burst phase is used to control electrically variable delay lines through which the entire signal is passed. In this way, time-base jitter is removed from the video and chrominance information.

## The complete story on our broadcast communications components and capability...no charge!



### Why not write for your copy today?

**Coaxial Cable** Air dielectric and foam dielectric types offer reliability and lower loss characteristics.

**Connectors** Type N, HN, UHF, TNC, LC, EIA, splices and end seals. From stock delivery.

**Coaxial Cable Accessories** Off-the-shelf delivery of cable grips, grounding kits, tubing cutters, two-stage regulators, automatic dehydrators.

**Rigid Line** Available in four diameters. Meets or exceeds EIA RS225 specifications.

**Rigid Line Accessories** Miter elbows, gas barriers, reducers, tee assemblies, adapters, flanges are available.

**Supporting Hardware** Anchor fittings, hangers, braces, supports, clamps, bulkhead fittings.

**PHELPS DODGE** ELECTRONIC PRODUCTS  
NORTH HAVEN, CONNECTICUT



Circle Item 10 on Tech Data Card

Direct color recovery is not tolerant of dropout; even one missing color burst or sync pulse produces an annoying flash in the picture display. Furthermore, there is now great popularity of high-band color recording and of receivers capable of producing more vivid colors. Although before the 1965-66 season replacement of only the redundant luminance considerably improved all television tape recordings, at present there are problems with less-than-correct color-dropout compensation, particularly in cases of high saturation (9).

The constant-luminance principle is the basis for redundant-luminance dropout compensation. Unfortunately, constant luminance is not valid at high saturation, and because of this, the subcarrier information affects the picture brightness. Thus, dropout-substitution material which replaces only redundant luminance or incorrect color information can substitute wrong color and intensity values in the high-saturation areas.

A second problem occurs when a saturated color appears with reduced luminance level. In these scenes, redundant-luminance dropout compensation appears black.

Trouble is also present when monitor or receiver convergence is considerably less than perfect (not unusual near the edges of the raster.) A dropout replacement of only luminance poses the same problem as edge information in the picture, since it represents a color discontinuity. The result is wrong color or intensity replacement.

Full color replacement does not have these problems. The solution to the dropout problem, therefore, is to provide full-color dropout substitution.

### Full-Color Compensation

Before discussing full-color repair, it is necessary to consider the required accuracy of the information. Visual tests have shown that even a slight color-hue error in substitute information is actually more objectionable than no color at all. These tests indicate that correct luminance compensation is still superior to *wrong-color* compensation, especially in the primary colors.

To obtain accurate color replacement information, it is necessary to overcome three basic problems:

(1.) Time-base stability of  $4^\circ$  phase, or about three nanoseconds. (2.) Differential phase and gain of  $3^\circ$  and 3%. (3.) Allowance must be made for dot interlace of the 3.58-MHz chroma subcarrier information.

There are several ways to produce delayed substitution material for dropout compensation, and a number of circuit variations have been tested. All involve detection of the signal defect in the radio-frequency portion of a magnetic video recorder; they differ as to the location in the playback circuit where information is stored and re-inserted, and as to the sequence and duration of these insertion periods.

### FM Compensation

One possible method employs an FM dropout compensator in which detection and substitution are accomplished in the RF signal portion of the reproduce electronics. In such a system, the FM signal is delayed and used directly for substitution. This is the simplest method for wideband monochrome information, since the FM carrier can be transmitted directly through a high-frequency glass or quartz ultrasonic delay line. However, FM substitution in the RF signal produces the same sort of discontinuity as an FM head-switch transient at the beginning and end of the dropout pulse, due to the introduction of a considerable phase discontinuity. This method cannot properly compensate the first and last portion of the dropout.

There are other problems: Ringing and spurious signals in glass delay lines distort the stored information. Also, the dispersive character of these delay lines tends to shift the FM axis and cause a level error in substitution. These problems are difficult to overcome.

### Video Compensation

In a second basic system, the principal delay and switching operations are accomplished in the video-signal portion of the recorder/playback system, after demodulation of the RF carrier. This usually is called a video-substitution compensator (8). It has the advantage that the inherent delay of the filter and demodulator can be used to insure that the dropout substitution starts before the actual disturbance. Video switch-

ing can also be done with no transients, and the fill-in match in luminance and chrominance can be made nearly perfect.

A video delay system for NTSC color presents special problems because of the nature of the signals. The color subcarrier (3.579545 MHz) is 227.5 times the horizontal line rate. Thus, the subcarrier is automatically phase-inverted  $180^\circ$  on each successive scan line. A delay system timed exactly for one horizontal line stores the signal for one line but will not phase-invert the subcarrier. If this type of delay signal is switched into the direct video signal as a substitution, the noninverted chroma signal will produce the wrong color.

There are several possible solutions to this problem, such as: (1.) Store the delay signal for two lines instead of one. (2.) Set the delay timing either long or short of exactly one line by one-half cycle of color subcarrier. The first approach is unsatisfactory because time-base errors in the recorder or fill-in material errors become twice as objectionable as in the one-line system. It also requires twice the delay bandwidth product. The second method cannot be used with direct color-recovery systems, since the time-correcting elements will restore this introduced delay timing error whenever there is a dropout in sync. This will cause the entire line to flash a wrong color. A lockout during sync has similar problems, since the absence of sync pulses or burst also puts a false error signal in the direct color-recovery equipment.

A third method is to separate the color signals from the monochrome video signal, invert the color signal  $180^\circ$ , and recombine it with the monochrome signal. This system requires additional circuitry and can be used only with a video compensator. It introduces phase discontinuities in the monochrome signal above 2.5 MHz. Despite these difficulties, this method produces the best overall results.

Another problem associated with processing an NTSC color signal is the effect of differential phase and gain on the color information. The third method of color correction, described in the preceding paragraph, is insensitive to this effect, as the color signal can be delayed and processed independently of the

FOR BEST ALL AROUND FM SOUND...



...GO TRUE **CIRCULARIZED!**

**JAMPRO CP-IX FM ANTENNAS** The only true circularly polarized FM antenna with variable power ratio

VARIABLE HORIZONTAL TO VERTICAL RATIOS are available only in JAMPRO circularized antennas. These ratios may be adjusted from 50-50 or varied to other percentages up to 90% horizontal and 10% vertical.

EXCLUSIVE DIGITAL TUNING END STUBS allow extremely low VSWR. JAMPRO guarantees a VSWR of under 1.1 to 1 when mounted on your tower, then field trimmed to 1.0± to 1, carrier, ± 200 KC.

AVAILABLE IN TWO DIFFERENT FEED SYSTEMS  
**PARALLEL SYSTEM** using individual interbay cables from one power divider, resulting in the best possible FM antenna performance.  
**SHUNT SYSTEM** with elements across a single 3 1/8" rigid coaxial line.

**TAKE A CIRCULAR STEP!**

Write for full specifications, or make a circular motion on your phone dial (915) 383-1177.

**J A M P R O**

A Division of Computer Equipment Corp.

**ANTENNA COMPANY**

6939 POWER INN ROAD

SACRAMENTO, CALIFORNIA 95828

luminance level. A 2.5-MHz bandwidth is required of the luminance (monochrome) signal to provide proper sync rise time. Otherwise, dropouts in sync, compensated or not, would destroy the color-signal phase relation in direct color-recovery systems.

### Color Video Compensator Design

A block diagram of a complete compensator is shown in Fig. 1. The detector actually is a double-acting device. First, a constant-current source applies the RF signal to the level-detector stage, tunnel diode D1. The RF drive causes D1 to change state on the peaks of the RF pulses, resulting in a square wave. The threshold-level control adjusts the gain of the amplifier stages to determine the lowest RF level which will cause D1 to fire. The square wave from the dropout detector is used to reset repeatedly a ramp generator. If the generator is not reset (as is the case if loss of RF interrupts the square-wave output from D1), the ramp continues to rise and eventually triggers the dropout pulse generator. This double process correlates the depth and duration of the RF amplitude disturbance for faster

and more accurate dropout detection.

The delay caused by the ramp generator is just long enough to permit the activation of dropout substitution before the beginning of the dropout, which occurs in the video at a time delayed from the FM by the demodulator and filter in the recorder.

A detector timing adjustment controls the time lapse between loss of RF and dropout pulse generation. This adjustment is set to delay triggering just long enough so that the detector ignores spikes in the RF caused by such defects as noise and pre-emphasis in the video-recorder system for black-to-white transition.

The pulse circuitry extends the dropout signal for a short duration in case any limiter disturbance follows the dropout interval. The negative-going dropout pulse is routed to the video switch. The video switch is placed in the output of the recorder demodulator after filtering but before any sync separation or signal division. If this cannot be done, separate dropout protection must be devised for tape signal paths not routed through the switch.

The heart of the storage system is a pair of special glass memories. The

• Please turn to page 42.

### References

1. *Video Talk, Bulletin No. 2*. St. Paul, Minn.: Minnesota Mining and Mfg. Co., March 1, 1960.
2. Carson, R. H. *Dropouts in Magnetic Tape Recording Systems*, Washington, D. C.: U.S. Naval Research Labs. From an IRE paper originally presented at the 1962 IRE Convention, New York.
3. Wallace, R. L., Jr. "The Reproduction of Magnetically Recorded Signals," 1924 *BSTJ*, 30, Pt. 2, (October, 1951), 1145-1173.
4. Benussi, V. "Zur Psychologie der Gestalterfassens," A. Meinong, "Untersuchung Gegenstandstheorie," 1904, 303-448.
5. Rubin, E. "Visuell wahrgenommene Figuren," *COPEN*, Gyldendalska, 1921.
6. Wertheneisner, M. "Untersuchungen zur Gestalttheories." Erlangen, Philosophischen Akademie, 1923.
7. Heider, G. M. "New Studies in Transparency, Form, and Color," *Ps Forsch* 17, 1932, 13-55.
8. Moskowitz, I. "Compensator," U.S. Patent No. 3,328,521, June 27, 1967.
9. Fink, D. G. *Television Engineering Handbook*. New York: McGraw-Hill Book Co., 1957.

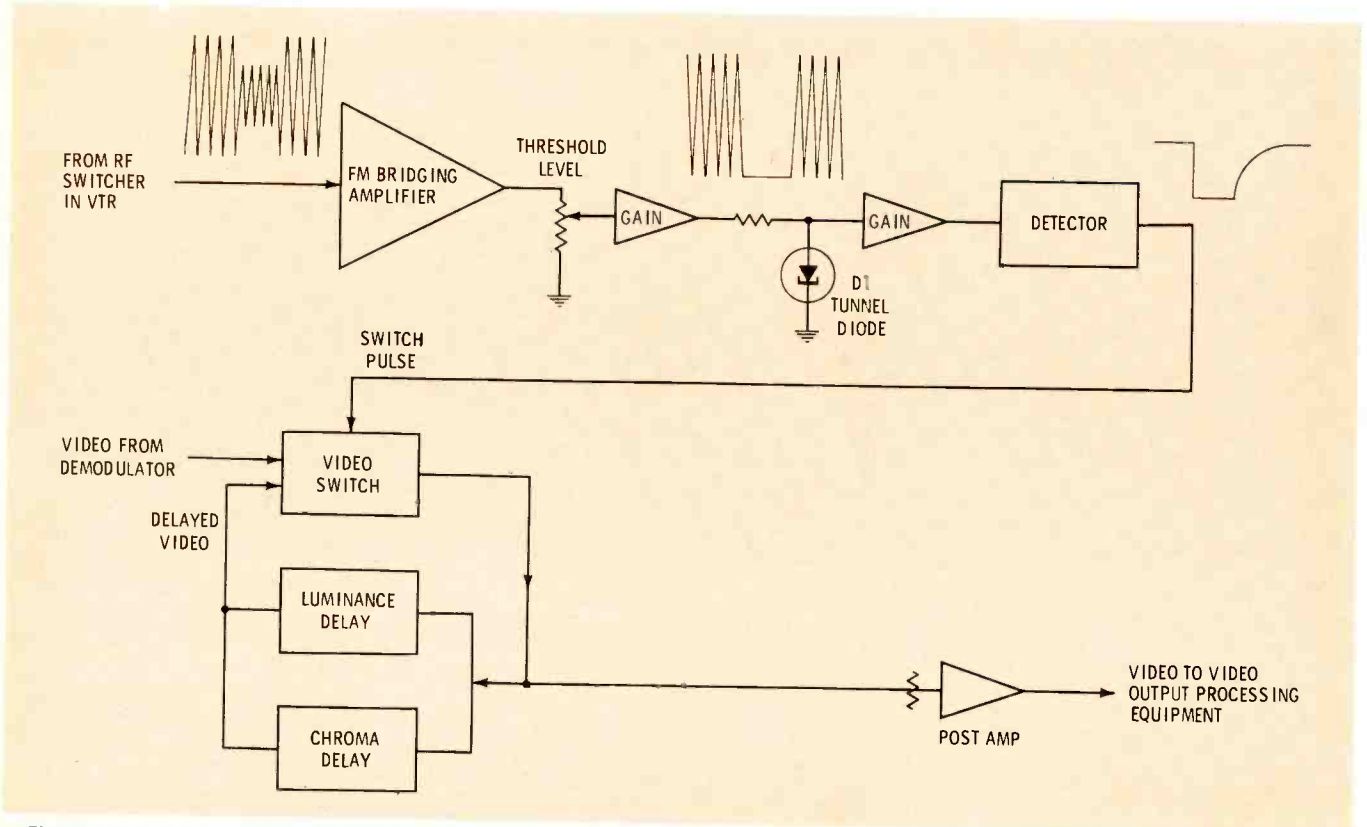

Fig. 1. Dropout compensator routes luminance, chrominance through separate delay lines, also uses demodulator delay.



# Instant Audio:

You create your own customized professional equipment with our Finished Solid-State Circuit Modules.

Make intercoms, line amplifiers, mixers, monitors, turntable pre-amplifiers, stereo amps, language labs, etc. They'll be better, cost you less.

Just create your own electronics with our Finished Solid-State Circuit Modules. Make audio/RF/communications/radio-controlled systems. Quality will be high, cost you less.

## AUDIO AMPLIFIERS

AA-100  
UTILITY AMPLIFIER

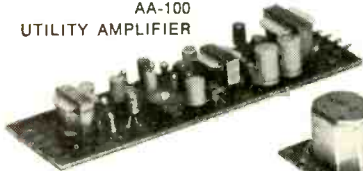

For general purpose uses; and to modulate TR-100 Transmitter (below). Includes volume control and input (low Z) and output transformers.

AA-300  
PROFESSIONAL  
AMPLIFIER

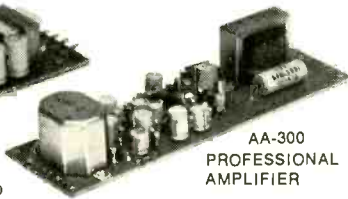

Designed for broadcast/recording/TV uses. Includes input and output transformers.

AA-400  
PROFESSIONAL  
POWER AMPLIFIER



When driven by AA-100 or AA-300, a hi-gain 1-watt audio system results.

AA-500  
PROFESSIONAL  
PRE-AMPLIFIER



Specially designed for broadcast/TV/recording/hi-fi/commercial usage. With any low-level hi-Z input device, they deliver undistorted 5VRMS to drive a hi-Z input power amp. Usable with low-level low-Z mikes if fed by quality input transformer (150 to 50K  $\Omega$  balanced). To feed 600  $\Omega$  lines, use a transformer (2.5 to 600  $\Omega$  balanced) in the output stage.

	Model AA-100 UTILITY AMPLIFIER	Model AA-300 PROFESSIONAL AMPLIFIER	Model AA-400 PROFESSIONAL POWER AMPLIFIER	Model AA-500 PROFESSIONAL PRE-AMPLIFIER	Model AA-500R PROFESSIONAL PRE-AMPLIFIER	Model AA-500N PROFESSIONAL PRE-AMPLIFIER
Freq. Resp.	$\pm 3$ db, 100-12K cps	$\pm 1$ db, 20-20K cps, 200MW $\pm 2$ db, 20-35K cps, 100MW	$\pm 1$ db, 20-20K cps, 1W	$\pm 1/2$ db, 20-20K cps	RIAA-Equalized	NAB-Equalized
Harmonic Dist.	<3%, 100-12K cps	<1%, 20-20K cps, 100MW <2%, 20-20K cps, 200MW	<1/2%, 20-20K cps, 1W	<0.5% 20-20K cps	<0.5% 20-20K cps	<0.5% 20-20K cps
Input Z	50-150 $\Omega$ (shielded transformer) & 100K $\Omega$	50-150 $\Omega$ , or 600 $\Omega$ , balanced (mu-metal shielded permalloy core transformer) 2K or 100K $\Omega$ unbalanced	500 $\Omega$ & 2K $\Omega$	48K $\Omega$ (May be used with input transformers)	48K $\Omega$ (May be used with input transformers)	48K $\Omega$ (May be used with input transformers)
Output Z	500 $\Omega$ & 8 $\Omega$ (grain oriented transformer) 200MW	500 $\Omega$ & 8 $\Omega$ (grain oriented transformer) 200MW	4-16 $\Omega$ (OTL)	5K $\Omega$ (May be used with output transformers)	5K $\Omega$ (May be used with output transformers)	5K $\Omega$ (May be used with output transformers)
Gain	70db	80db	1/2V for 1W output	70db	70db	70db
Circuit	5 transistors, 1 thermistor	7 transistors, 1 thermistor	5 transistors	4 transistors	4 transistors	4 transistors
Power	9VDC, 50MA	9VDC, 100MA	14VDC, 200MA	40VDC, 5MA	40VDC, 5MA	40VDC, 5MA
Size	5 1/2" L x 1 3/4" W x 1" H	8" L x 2 1/4" W x 1 1/2" H	5" L x 2 1/2" W x 2" H	4 1/2" L x 3" W x 1 1/4" H	4 1/2" L x 3" W x 1 1/4" H	4 1/2" L x 3" W x 1 1/4" H
Weight	3 1/2 oz.	12 oz.	4 oz.	2 oz.	2 oz.	2 oz.
Price	\$7.95	\$14.95	\$10.95	\$23.95	\$23.95	\$23.95

## REGULATED POWER SUPPLY

Zener-referenced, delivers highly stable, extremely low ripple DC output of 9VDC with loads up to 200MA; and unregulated 14VDC at 1 Amp. For wherever well-filtered regulated DC is needed. Input: 105-120VAC, 60cps, 5W. Regulation: Line + load 5MV. Ripple: Under full load 10MV, p-to-p. Max. Load Current: 200MA, 4 1/2" L x 2" W x 1 1/2" H. Wt.: 23 oz. (with transformer)

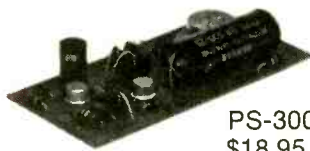

PS-300  
\$18.95

## TRANSMITTER

Complete crystal controlled 3-transistor transmitter for Citizens' Band. Factory pre-tuned for any CB channel; supplied with channel 10 crystal. Modulation: CW or AM with external modulator such as AA-100. RF output: 100MW, 50  $\Omega$  load. Power: 9VDC, 50MA. 5 1/2" L x 1 3/4" W x 2" H, 3 1/2 oz. Add. CB Crystals: \$3.00 ea.

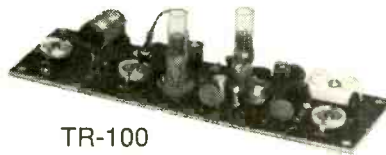

TR-100  
\$10.95

## POWER OSCILLATOR

All-transistor push-pull sine wave oscillator, 20KC-150KC, 1% harmonic distortion. Power needed: 18-22V, 100MA. Input terminals permit AM modulation (by amplifiers AA-100, 200, 300). Uses: biasing recorder heads, powering tape erasers, signal generator/transmitter. 5" L x 3" W x 2" H.

OS-100  
\$21.95

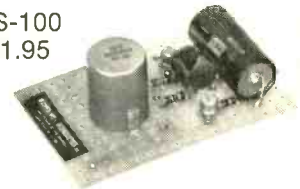

Please send me the following circuit boards:

Model	Qty.	Price ea.	AMOUNT
AA-100 Utility Amplifier		\$ 7.95	\$
AA-300 Professional Amplifier		14.95	
AA-400 Professional Power Amplifier		10.95	
AA-500 Professional Pre-Amp		23.95	
AA-500N Professional Pre-Amp		23.95	
AA-500R Professional Pre-Amp		23.95	
PS-300 Power Supply		18.95	
TR-100 Transmitter		10.95	
OS-100 Power Oscillator		21.95	
		TOTAL	



## ROUND HILL ASSOCIATES, INC.

434 Avenue of the Americas, New York, N. Y. 10011

Send postpaid: enclosed is full payment.  Send C.O.D. BE-2

NAME \_\_\_\_\_

ADDRESS \_\_\_\_\_

CITY \_\_\_\_\_

STATE \_\_\_\_\_ ZIP \_\_\_\_\_

DEALERS INVITED.

# A PUSH-BUTTON MASTER CONTROL

by **Len Spencer\*** — Push-button control takes the panic out of the "panic period" at this busy station.

This master control unit was designed to meet a twofold objective. It was to tie in with an announce studio that was of itself as near breakdown-proof as possible<sup>1</sup>, and it was to fit into an operation that could be adapted eventually for a nontechnical staff.

In a normally busy 50-kw metropolitan station, the line patching panel is a confusing array of patch cords connecting the various parts of the station system. To aggravate this condition, reel-to-reel tape machines and monitor systems have to be connected or disconnected many times during the busiest times of the day. When an operator goes off shift, it takes even an experienced replacement some time to trace out the various interconnections that confront him, and sometimes this leads to serious error.

At first thought, it seems a very complicated project to "push-button" 100 remote lines and their

ancillary equipment. And, the economic factor had to be considered, also. After a study in depth was made, however, it became apparent that many of these interconnections were in use almost continually so that it was possible to establish priorities of importance.

At CKAC, program commitments are made in 13-, 26-, and 52-week segments. It was decided, therefore, that the respective incoming jacks for the longer-term programs would be paralleled with numbers 1, 2, 3, etc., on the push-button matrix. In no case did we destroy the availability of the jack bays or deprive ourselves of complete flexibility of patch cords if and when required.

It was also thought prudent to assign different colors to the illuminated buttons of each master-control bay so that all interconnections could be seen at a glance. To this end, the control desk is divided into three sections, remote programs (with their telephone circuits)

switching panel, and level-control panel. In this article, these sections will be referred to as Bay No. 1, Bay No. 2, and Bay No. 3, respectively (Fig. 1). Fig. 2 shows the basic circuits as they relate to the various bays.

## Remote-Line Switcher (Bay 1)

At the top of each bay are the volume indicators associated with the function of the bay. In Bay No. 1 (remote-line switcher), volume indicator No. 1 indicates the output of a line amplifier which is fed from a line transformer common to the top row of remote selector buttons; the level is controlled by the potentiometer at the right of this row. The second volume indicator is associated with the second row of buttons and has its own line transformer and amplifier. Both outputs are normal to the bay but can be patched out at a jack strip if required.

\*BROADCAST ENGINEERING Consulting Author, Montreal, Quebec.

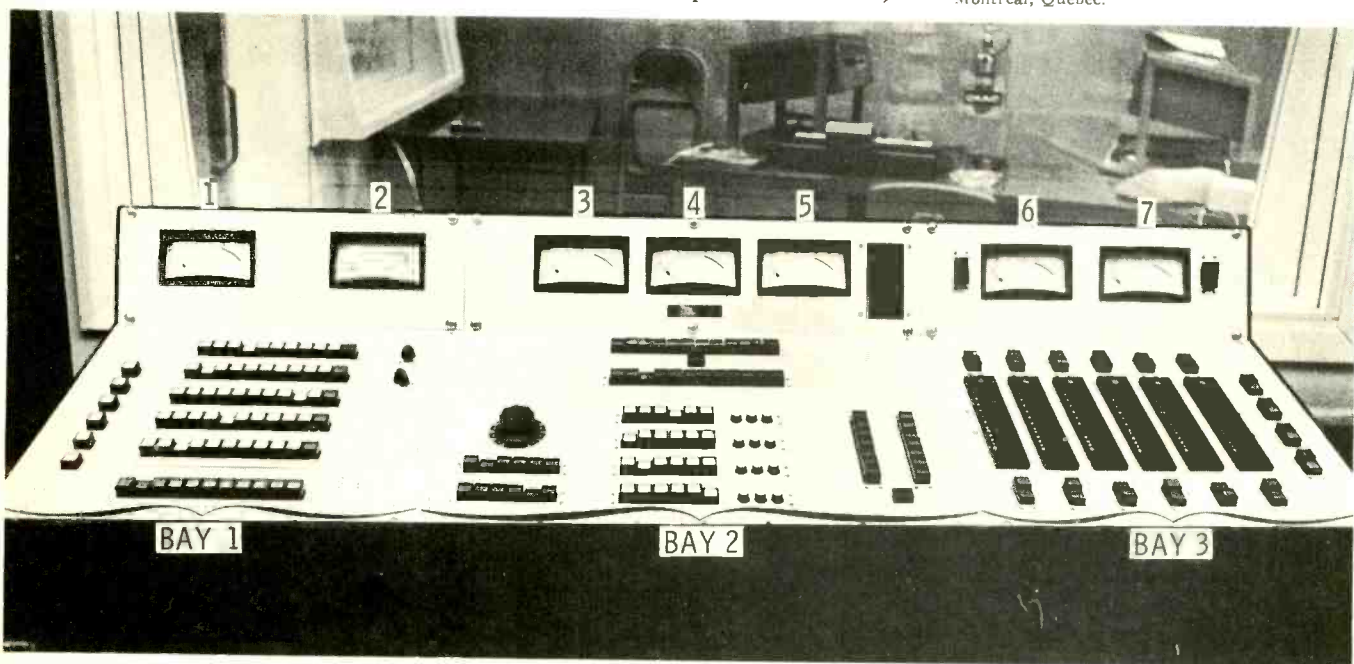

Fig. 1. The push-button master control. The functions of the numbered bays and VU meters are described in the text.



The incoming lines are in parallel with 10 monitor-selector buttons in the fifth row down. This allows monitoring and level adjustment of any of the 10 remote lines before it is punched up on the program bay (Bay No. 2).

The bottom row contains the telephone signalling and calling control buttons, which are illuminated by any incoming calls from a remote program point.

The monitor speaker is connected to the remote matrix by means of the six monitor-speaker buttons along the left-hand side of the bay.

### Master Switcher (Bay 2)

On the center panel are found outputs from four studios and four reel-to-reel tape machines, and the individual start-stop and rewind controls for the tape decks. It is possible to record on one or two of these tape machines and play back on the air one or both of the others, or to record on the four machines simultaneously, from any of the remote lines or studios. Every studio output also appears in the recording department, as do four remote lines.

By means of the No. 3 volume indicator, any feed associated with the two rows of buttons at the lower left may be checked. The top row carries four studios plus remote lines, and the bottom row includes the feeds from any prepunched remote, two transmitter inputs, and the radio receiver. The controlling potentiometer is situated directly above these rows of buttons.

The second control strip from the top is the preselector; this allows the operator to set up as many as ten supplies, from tapes, remotes, four studios, and any prepatched program. When they are to be put on the air, the single push button at the center is operated, and a corresponding indicator in the top row of illuminated status lights goes on. The levels of these programs are controlled from Bay No. 3.

At the bottom center of Bay No. 2 are four rows of six buttons, which are the switchers for the four tape recorders. These allow recording from any remote point or studio. The start, stop, and rewind buttons are to the right of each row.

Instant intercom is, of course, very necessary, and this function is supplied by the final two rows of buttons at the right of this bay. The loudspeaker for all operations is adjacent to meter No. 5

### Level-Control Panel (Bay 3)

The choice of program destination, either to the transmitter or to some other point, is made by the push buttons at the tops of the six slider potentiometers.

The No. 7 volume indicator is across the line after the level-control amplifier. The No. 5 indicator (on the switching panel, Bay 2) is connected across the detector circuit of a radio receiver; it is adjusted so that the fluctuations of both level indicators (5 and 7) coincide. This double check shows if there is a sudden drop of level on the transmitter feed line, a reduction in radio output power, or low modulation caused by tube failure anywhere between studio and antenna.

Volume indicator No. 4 is used to pre-adjust the levels from the different sources. When all is in order, operating the single button between the two upper rows of Bay 2 transfers the preselected program to the air via the indicated potentiometer on the level-control bay. To accomplish this, a high-speed magnetic latching crossbar switch is used. This device has a switching time of 2-5 milliseconds and draws about 200 milliwatts momentarily during operation; no holding current is required. It is basically a multicontact relay with twelve coupling systems and a restoring assembly that is common to all twelve systems. In the switching panel, this multicontact relay is used for switching on the status lights and feeding twelve functions to program-output and mixer-input switches.

Below the potentiometers are buttons that permit overriding the preselect so that, if necessary, all six program sources can be mixed and/or faded into the output circuits. Since these switches are double throw, 12 feeds are thus available.

The final row of buttons at the extreme right of Bay 3 contains emergency-operation controls. The N button for normal operation is

colored green, and the U for urgency is, of course, red. Should any complication arise, it is possible to bypass the three bays and put any of the four studios on the air directly by connecting it to the transmitter program line. The switches also connect the transmitter order wire or phone line directly to whatever studio is selected. They can also be paralleled if required.

### Using the System

On reading the detailed operation of this complex, one would be right in questioning the basic policy that led to its construction, since it appears that a great deal of effort and ingenuity has gone into replacing a dozen or so patch cords. This, however, is not the case.

A stopwatch has been used to time elementary set-up. With the old method there was much wasted effort and time loss, and if the ease of determining the exact operation after each operator shift change is considered, the project was and is worthwhile.

Consider a typical operation, which consists of patching a remote program and a prerecorded program from a tape recorder into the master mixer using patchcords and a jack field. In most cases, the mixer section in the control room is operated from a sitting position. Therefore, the operator would have to leave his control board, go to the jack bay and answer the remote phone, select a patchcord, find the correct jack, manipulate a volume control and patch another circuit into his mixer, and then look for another patchcord, patch the output of the tape recorder to his mixer, and start the tape machine before returning to his control position.

All this can be accomplished on the push-button control in 7.5 seconds without moving from the mixer control position! And, as each button lights, the exact status of the circuitry is clearly indicated. It is during "panic periods" that this modern approach is appreciated most.

The overall concept of the system described in this article was developed by the author. Construction and assembly were in the hands of N. J. Pappas & Associates, whose assistance is gratefully acknowledged. ▲

# simultaneous record & playback

## ... plus dubbing

### with Collins' new compact Twintape System

Collins' new Twintape System, completely solid-state and available in monaural or stereo models, is the most convenient, flexible, and easy to operate cartridge machine on the market. The Twintape System consists of two units: the 642E Twintape Playback Unit, and the companion 216D Record Amplifier. Combined, these units permit:

- Playback on both cartridges simultaneously.
- Recording on one cartridge while playing the other.
- Dubbing from one cartridge to the other.

Tape transport assemblies in the Playback Unit are easily removed. Rugged, direct-drive capstan motors eliminate flywheels, rubber belts, etc., and produce extremely low wow and flutter. With extra heavy Mu-metal magnetic shields, the unit has very low susceptibility to magnetic pickup of noise. Rear terminal strips provide for optional remote control, automatic sequencing of multiple machines, cue detector contact outputs, etc. Routine maintenance of the Playback Unit may be performed in seconds.

Cue tone oscillators, record level metering, operation controls, and an amplifier are contained in the 216D Record Amplifier. One cue tone is standard, with option for three cue tones. The amplifier may be stacked compactly with the Playback Unit, or rack mounted with an optional adaptor.

All Twintape System electronic circuits are mounted on plug-in, etched epoxy boards.

For a descriptive brochure on this new Twintape System, write or call Broadcast Communication Division, Collins Radio Company, Dallas, Texas 75207. Phone (214) AD 5-9511.

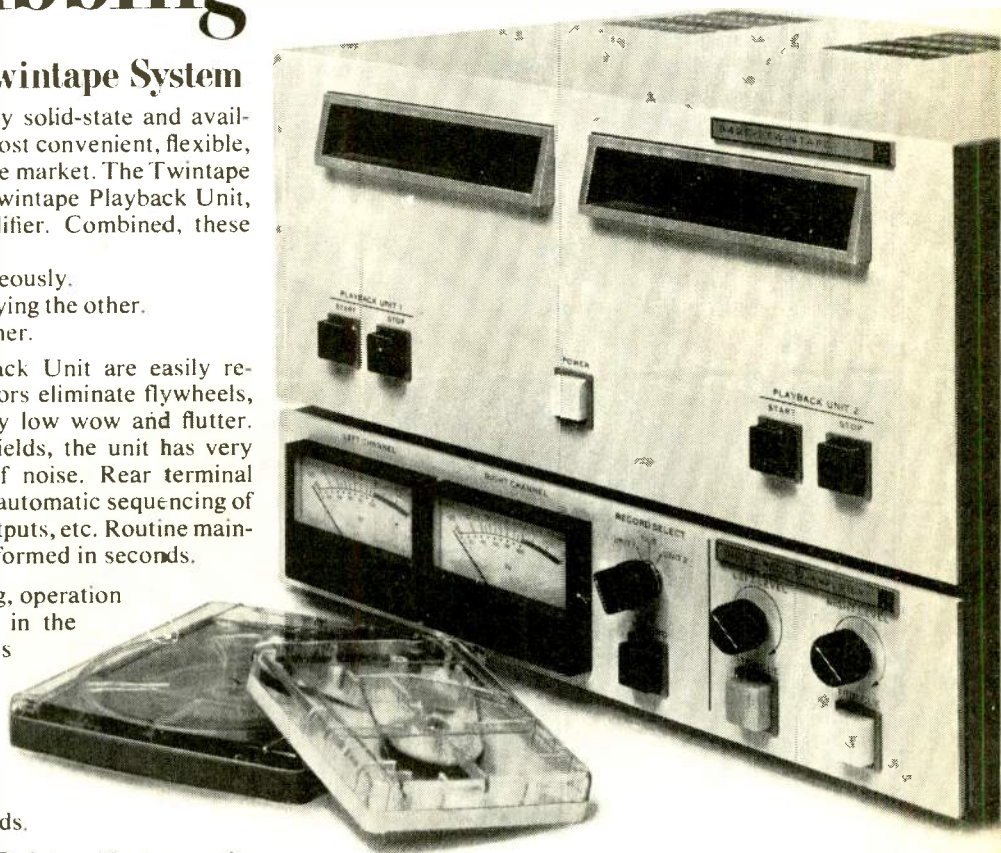

COMMUNICATION / COMPUTATION / CONTROL



Circle Item 12 on Tech Data Card

# MAINTENANCE OF THE DIRECTIONAL ANTENNA

by Barry Atwood\*—Care and common sense are the chief ingredients in keeping this portion of the station in good order.

As the final "output" of the entire station, the antenna system is one of the most important items in the plant; yet, it is probably the most frequently neglected with respect to maintenance. It is of particular importance that a directional antenna be maintained properly, since it must confine the radiated signal to certain areas specified by the station license or construction permit. It must present the proper load impedance to the transmitter, and it must be stable. If the antenna system fails to perform these functions properly, interference may be caused to other stations; null points may shift azimuth position, causing listeners to complain of weak reception; or the common-point impedance could change, preventing proper transmitter loading.

It is helpful if the antenna system is considered in terms of several subsystems (Fig. 1); each of these subsystems will be discussed in terms of its functions and maintenance requirements. It is realized that no detailed maintenance program can be devised which will apply universally to all directional antennas. Each system is designed for a particular application, and each has its own peculiarities. However, a number of basic principles may be applied to any directional antenna, so long as the engineer has an understanding of the operation, tolerances, and specifications of his installation.

## Phasing System

In many respects, the phasor is the "heart" of the antenna system.

It is here that the power output from the transmitter is divided in the proper proportions and with the proper phase relationships to feed the line to each tower. The phasor also must present the proper load impedance to the transmitter. To accomplish these ends, a combination of inductors and capacitors, fixed and variable, is employed in the phasor.

The inductors and their connections place resistance as well as reactance in the circuit. This resistance must be kept as low as possible, to minimize power dissipation. Since dirty or corroded connections present a high resistance, one of the most basic rules of any maintenance program must be observed: Keep connections as well as components clean. For the same reason, all connections must be kept tight. In the case of variable inductors, these rules apply to the movable contacts as well. Do not forget the drive mechanisms for variable coils; these must work freely without binding. The drive system should be checked for sufficient lubrication, and if there are any loose parts, appropriate repairs should be made. All insulators must be kept clean, to prevent leakage and possible arcing.

Capacitors require much the same maintenance as inductors. They must be kept clean, and connections must be tight. Mica capacitors should be checked for cracks in the ceramic center portion, and vacuum capacitors should have the glass inspected, especially at the end seals. Drive mechanisms for variable capacitors should be checked in the same way as those for variable coils. Gas-filled capacitors should be checked to insure proper pressure.

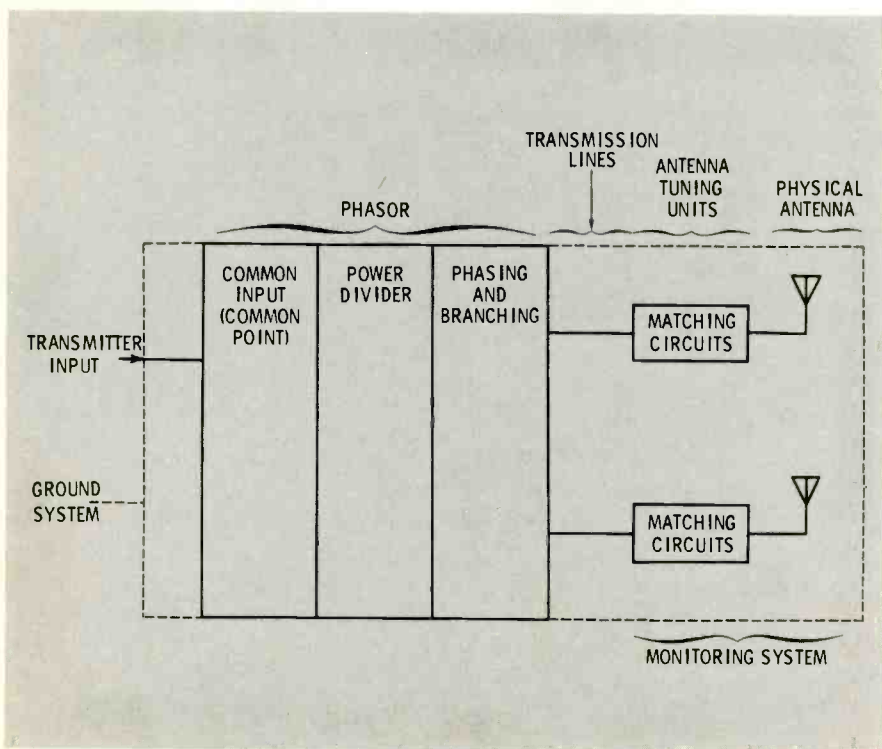

Fig. 1. A directional antenna may be considered to be made up of subsystems.

\*Chief Engineer, WBKY, Lexington, Ky.

Do not overlook connections to the station ground, meter-shortening switches, RF contactors, or any other component in the RF path. All these should be kept clean and tight. RF relays should be checked for pitted contacts, improper contact alignment, and overheating of the coil.

Since the entire power output of the transmitter is applied to the phasor, heat will develop anywhere there is a defective component or poor connection. All of the phasor components should be checked for signs of overheating after sign-off. One important point should be considered, however: If the station operates with reduced power at night, the system should be operated at full power for about one-half hour during the experimental period before this check is made. A component which is approaching failure may feel quite cool after a run on low power, but become hot on rated power. (Of course, components should not be subjected to power levels in excess of their ratings, or damage may result.)

A few other points deserve consideration: Most phasor cabinets are interlocked, and these interlocks should receive the same attention given those on the transmitter; be sure they are operating properly! Lightning can do severe damage to antenna equipment; if an electrical storm is experienced, the entire phasor should be inspected after sign-off for indications of damage and component overheating. A final point to be considered in phasor maintenance is common-point impedance; if this impedance is incorrect, the radiated power may also be incorrect.

Fig. 2 shows a portion of the inside of a typical phasor. Notice the gas-filled capacitor at the left. The metal box at the bottom right of the photograph is an in-line type of common-point impedance bridge; this type of bridge permits measuring the common-point impedance while the station is on the air. The large coil in the center, in conjunction with the gas-filled capacitor, constitutes the input tank circuit. It is here that the power tap-offs are made; this is an important spot to check for overheating.

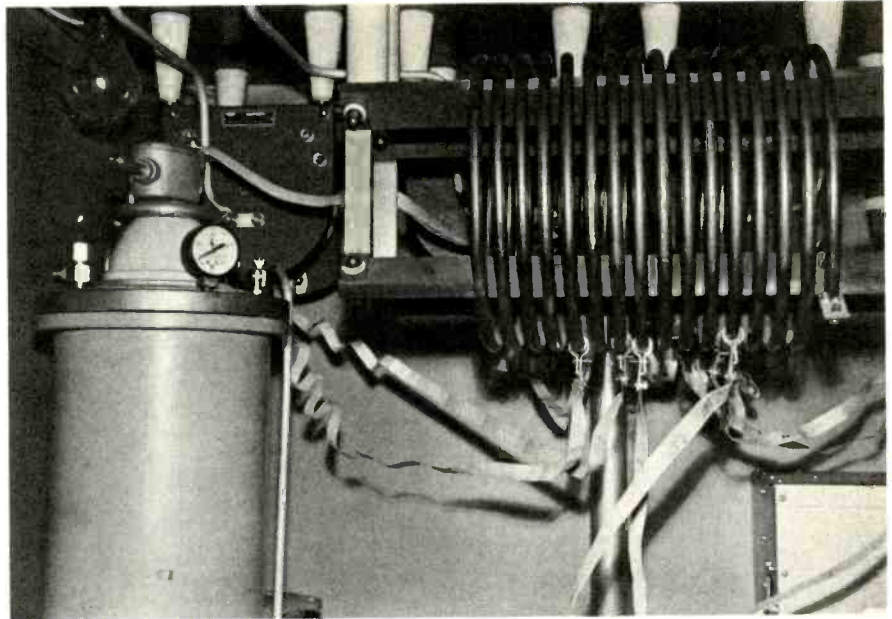

Fig. 2. Gas-filled capacitor (left), coil with taps, in-circuit bridge (lower right).

### Transmission-Line System

Transmission lines may be buried or above ground. They may have a solid dielectric, or they may be filled with an inert gas or dry air. Maintenance of buried lines is limited to the accessible end terminations or seals, to the maintenance of proper gas pressure, and to checking for obvious faults, such as lines which have worked out of the ground, plow cuts, etc. Regardless of the type of line, all end seals must be kept scrupulously clean. Pressurized lines should be checked for leaks; gas or air pressure should be maintained at the level recommended by the manufacturer. Each end of the transmission line is bonded to the ground system, and these bonds should be checked for security and corrosion.

Rigid copper lines installed above the ground require special consideration. Expansion and contraction with temperature variations may

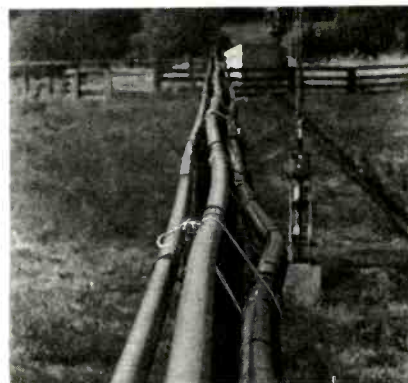

Fig. 3. Rigid coax line buckled when subjected to variation of temperature.

cause the lines to buckle, or to separate at the joints. Fig. 3 shows transmission lines which have buckled from this cause. A right-angle joint can be a particular trouble spot because the stresses are applied from different directions. The upper line in Fig. 4 separated at a double right-angle joint such as in the line just below. The rigid angle joints were removed, and a section of flexible line was spliced in place.

### Matching System

The antenna tuning unit must match the impedance of the tower to the impedance of the transmission line. Depending on the design of the system, part of the current



Fig. 4. Right-angle joint separated, was replaced with a curved section.

Maybe our microwave STL system can put you in clover. Its color performance exceeds FCC, EIA, and CCIR. Its reliability can't be beat, and maintenance is negligible. The reason . . . our all-solid-state design. No tubes, no mechanical relays, no klystron.

Whether you're upgrading an existing STL capability, moving to new quarters, or changing transmitter sites, it'll pay to check out our STL systems . . . single or dual. Units are typewriter size and available for 2, 7 or 13 GHz bands, with optional manual or automatic switch-over. Single or multiple audio multiplex too.

Join 200 other green thumbs. Ask for Catalog SF-9501.

## Is the grass always greener on the other channel?

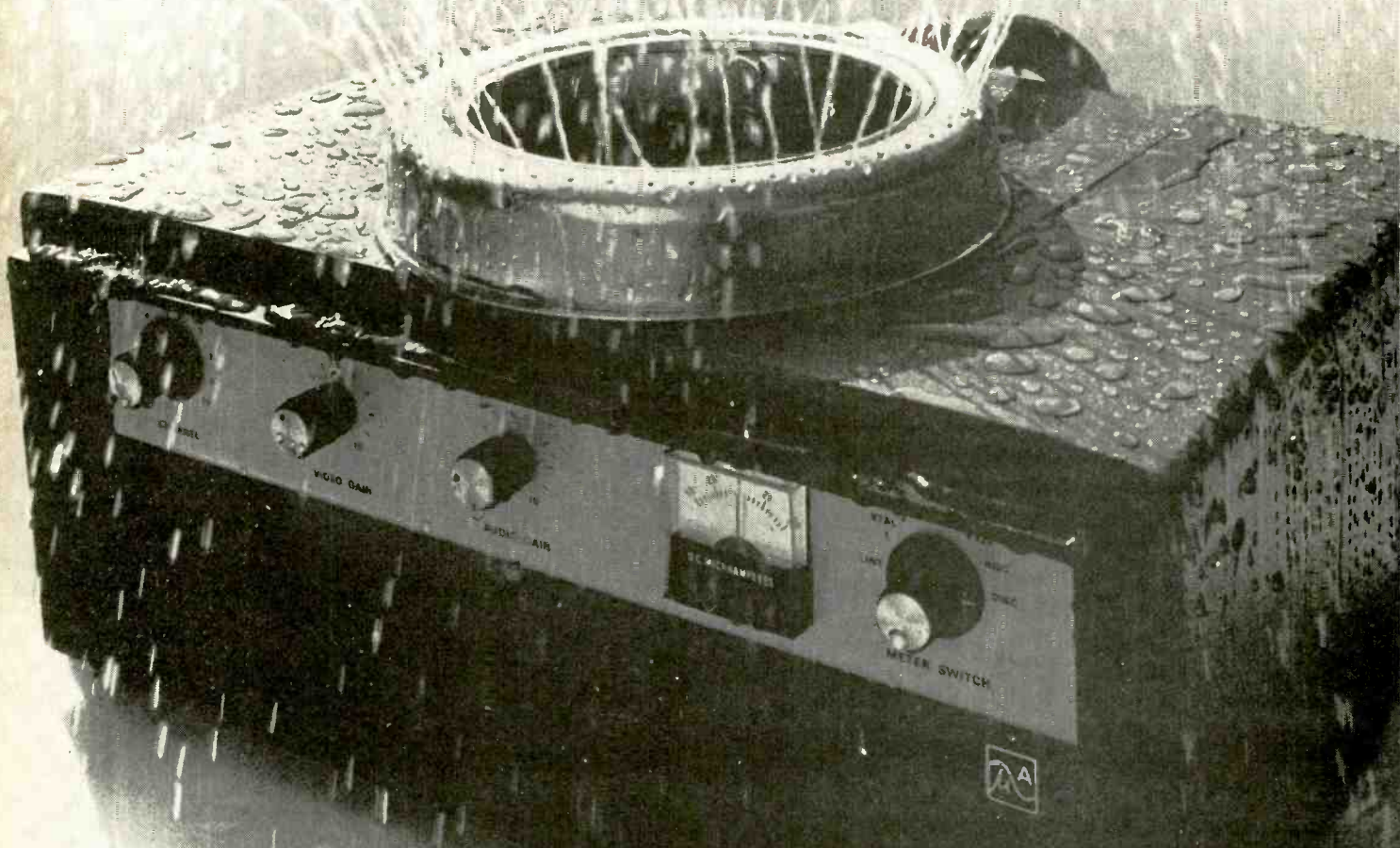

### **MICROWAVE ASSOCIATES**

Burlington, Massachusetts

Offices: Northwest Industrial Park, Burlington, Mass. 01803;

3605 Long Beach Blvd., Long Beach, Calif. 90807

International Sales: Microwave Associates International

Northwest Industrial Park, Burlington, Mass. 01803



phasing may be accomplished here also. The matching system may include remote sampling units for measuring antenna base-current magnitude and phase; these will be discussed in a later section. In the series-excited array (the most common type), some means must be provided for isolation of the tower-light wiring, and of the phase-sampling line if a tower-mounted sampling loop is employed.

The antenna matching unit contains many of the same kinds of components as the phasor. Therefore, everything that has been said concerning phasor maintenance applies to the antenna tuning units (with the exception of impedance checks). The frame on which the matching-system components are mounted, if it is metal, is also bonded to the ground system, along with the end of the transmission line and phase-sampling line. This is an especially important place to check for loose or corroded connections.

Mice, rats, snakes, and other vermin have a habit of seeking refuge from the elements inside the matching-system enclosure. This must be discouraged as much as possible. Mice have been known to nest inside coils and thus upset the operating constants. Also, they may be "fried" when they come in contact with conductors carrying RF current. The enclosure should be kept clean, and all openings should be sealed to prevent entry. Poison baits may also be employed.

### Towers

At first glance, it may appear that there is little to be maintained about a tower. Nothing, however, could be further from the truth. The tower must be plumb and without any evidence of torque damage. The tower paint must be in good condition, as required by the FCC and FAA rules. The guy wires must have the proper tension, and fasteners and anchors must be secure. The base insulator must be kept clean, and there must be no sign of cracks or other damage. The lightning gap must be spaced properly, and the ends must be clean and free from obstruction.

The tower lighting system must be maintained in good order. This includes the obstruction lamps and any alarm or indicator devices, photocell systems, and rotating or flashing beacons. FCC rules require that an inspection be made every three months of alarm or indicating devices and automatic or mechanical control systems. At some stations, a tower rigger is employed to replace all the tower-light bulbs at three-month intervals. The other checks should be made at this time also. But regardless of who does this work, be sure that everything is checked. In systems which employ a photoelectric control, the cell must turn on the lights at the proper light level (northern skylight intensity of 3 foot candles). If the lighting-control uses tubes, they should be tested at monthly intervals. Relays should receive standard maintenance. The opening in front of the enclosure which permits the light to strike the photocell must be clean and free from obstructions.

Do not forget the actual RF connections to the tower. This is a likely place for temperature changes to cause a separation of the bond.

It is a good idea to observe the tower base insulators at least once during a rain storm. Poor-quality paint, or dirt on the tower, may be washed across the base in-

## "Want a Good Job in Broadcasting?"



## You'll Need a First Class FCC License."

Matt Stuczynski knows. He's the Senior Transmitter Operator of Radio Station WBOE. His story is typical of hundreds of men who have used Cleveland Institute Training as a springboard to success in Broadcasting. Here's what Matt says about Cleveland Institute:

"I give Cleveland Institute credit for my First Class FCC License. Even though I had only 6 weeks of high school algebra, CIE's AUTO-PROGRAMMED™ lessons really made electronics theory and fundamentals easy. After completing the CIE course, I took and passed the First Class Exam. I now have a good job in studio operation, transmitting, proof of performance, equipment servicing. Believe me, a Commercial FCC License is a 'must' for a career in Broadcasting."

If you want rapid advancement in broadcasting, the first step is a First Class FCC ticket with *your* name on it. And Cleveland Institute Home Study is a fast, economical way to get one. What's more, CIE backs their licensing programs with this money-back warranty:

"A CIE License Course will quickly prepare you for a First Class FCC License. If you complete the course but fail to pass the exam on *your first attempt*, CIE will refund all tuition."

With Cleveland Institute you get your First Class FCC License or your money back! Send coupon today for FREE book or write to Cleveland Institute of Electronics, 1776 E. 17th St., Dept. BE-44, Cleveland, Ohio 44114.

### ENROLL UNDER NEW G.I. BILL

All CIE courses are available under the new G.I. Bill. If you served on active duty since January 31, 1955, or are in service now, check box in coupon for G.I. Bill information.

### MAIL COUPON TODAY FOR FREE BOOK



**CIE** Cleveland Institute of Electronics

1776 East 17th Street, Cleveland, Ohio 44114

Please send me your FREE book, "How To Get A Commercial FCC License."

Name \_\_\_\_\_ (please print)

Address \_\_\_\_\_

City \_\_\_\_\_ State \_\_\_\_\_ Zip \_\_\_\_\_

Occupation \_\_\_\_\_ Age \_\_\_\_\_

Veterans check here for GI Bill information

Accredited Member National Home Study Council  
A Leader in Electronics Training . . . Since 1934

BE-44

Circle Item 13 on Tech Data Card

ulator. This mixture may ignite with the RF energy present and burn a path across the insulator. The bottom of the antenna base insulator is bonded to the ground system, along with one side of the lightning gap. Be sure to check these connections. Fig. 5 illustrates a typical base insulator and the RF feed line, lightning gap, and ground connections.

Guy-wire anchors which employ exposed turnbuckles are subject to "cattle itch." In areas where cattle roam the antenna site, they may

scratch themselves by rubbing along the turnbuckle or the guy wire. This can cause the turnbuckle to unwind. Fig. 6 shows a more protected installation in which the turnbuckles are enclosed. Be sure to check all guy bolts and wire clamps, and do not overlook the foundation.

### Ground System

The FCC Rules establish minimum effective field intensities for the various classes of AM broadcast stations. To meet these requirements, a rather extensive ground

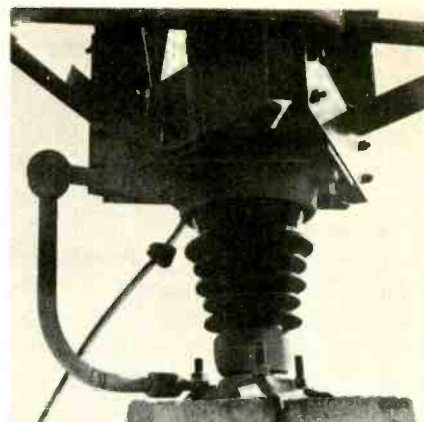

Fig. 5. Base assembly of a series-fed tower should have regular inspections.

system is necessary so that good radiation efficiency can be achieved. This ground system normally consists of about 120 buried radial wires, each about 1/4 wavelength long, spaced evenly around each tower. In cases where electrically tall towers (approaching 1/2 wavelength) are employed, a ground screen may be used to reduce the dielectric losses caused by the high base voltages which are developed.

The ground system around the towers is the ground reference for the entire system. The individual radial wires are brought up to the tower base and bonded to a ring which encircles the tower. The rings for all towers are then bonded together and to the source, which includes the phasor and transmitter, with heavy copper strap. All other RF and audio ground connections must somehow be made to this system, either inside or outside the transmitter building.

All ground connections must be inspected for looseness and corro-

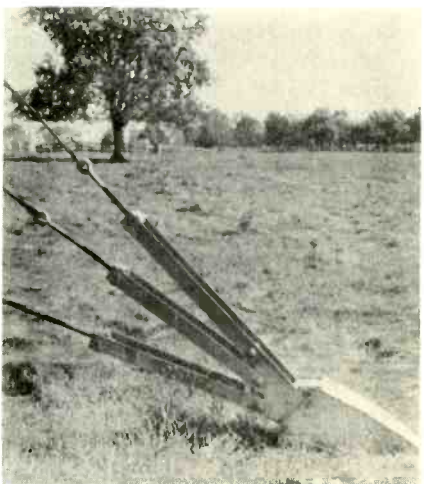
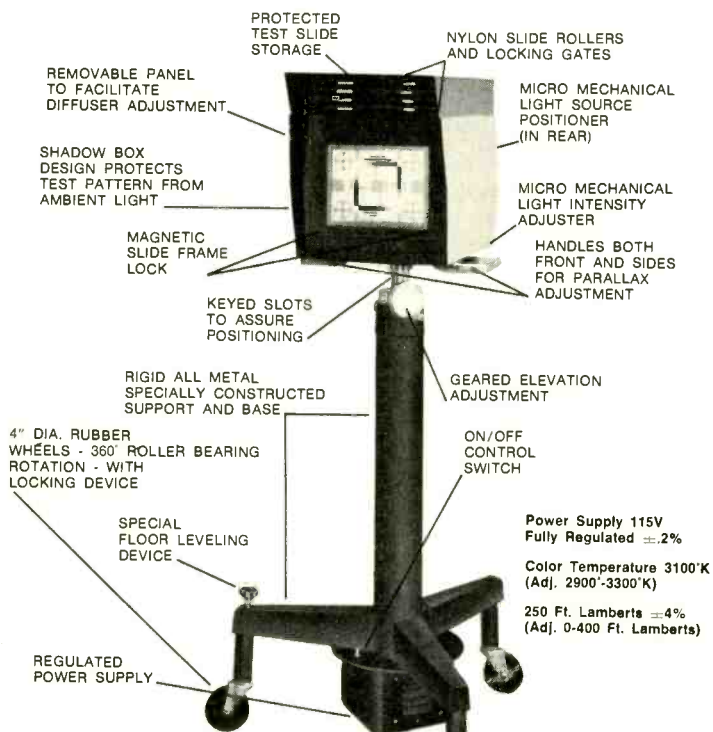

Fig. 6. Protected guy turnbuckles can not be turned by rubbing of animals.

# NOW TELE-PAT IV

is the ONLY TEST PATTERN ILLUMINATOR for 100% TV COLOR or MONO-CHROME CAMERA SET-UP/PERFORMANCE CONTROL



# NETWORK APPROVED

## TELE-MEASUREMENTS, INC.

145 MAIN AVENUE, CLIFTON, NEW JERSEY 07014  
PHONE: (201) 473-8822; (212) 581-9020

Providing the only complete line of precision test slides and illuminators for color and mono-chrome cameras. Send for catalog listing 8" x 10" and 2" x 2" test pattern slides available.



Circle Item 14 on Tech Data Card

sion. The areas immediately surrounding the towers should be inspected to insure that none of the radials have worked out of the ground or become cut. Any path over which there is evidence of repeated travel by a vehicle or livestock should receive a thorough check for broken radials. The area adjacent to the towers, usually enclosed by a fence, must be kept free from vegetation. This growth will increase the dielectric losses of the system and may cause the array to become unstable with varying weather conditions. And, finally, the tower fence itself should not be overlooked.

### Monitoring System

The monitoring system enables the operator to observe the operating constants of the directional antenna. Remote indications may be provided for antenna base current, phasing, and common-point current. Any component mounted in the enclosure of the antenna tuning unit should be given the standard checks. Look for loose and corroded connections. Be sure that any pickup devices are in proper adjustment. Test any tubes or crystal diodes, and check the calibration at the proper intervals.

Inside the transmitter building or remote-control point, the same checks apply. All meters should be kept clean, and their connections should be tight. Cables from local to remote points should be checked for loose or corroded connections, and for any sign of damage to the cable body. Switches and calibration potentiometers in the phase monitor and remote-metering units should be cleaned periodically with the proper cleaner. Vacuum tubes or crystal diodes should be tested.

Remote indicating units are subject to lightning damage, and they should be checked after an electrical storm. Coaxial cables connected to the phase monitor may be protected with lightning arrestors. Cables should be spliced properly when damaged sections are replaced, because moisture which enters a phase-sample line may upset the phase indication. Fig. 7 shows an example of a poor splice through which moisture is almost sure to enter.

### Preventive Maintenance Schedule

**Daily**

1. Check calibration of remote antenna and common-point meters.
2. Check pressure in transmission lines.
3. Check tower lights at dusk, and again at dawn.
4. In the event of lightning, check transmission-line end seals, phasor and "dog-house" components, and tower lightning gaps for signs of damage.

**Weekly**

1. Check all meters for incorrect mechanical zero and bent pointers.
2. Check pressure in gas-filled capacitors.
3. Check operation of all interlocks and grounding switches.
4. After sign-off, check all phasor and "dog-house" components for signs of overheating.
5. Clean enclosures of phasor and "dog houses."
6. Inspect, and if necessary service, relays and RF contactors.
7. Make general detailed visual inspection of phasor and "dog houses."

**Monthly**

1. Clean all monitoring unit switches and calibration potentiometers.
2. Check all tubes and crystal diodes in monitoring units and tower-light control units.
3. Inspect, and if necessary service, all tower-lighting control, indicating, and alarm relays.
4. Inspect all variable-coil wipers.
5. Clean phasor and "dog-house" components.

**Quarterly**

1. Clean and tighten all connections in phasor and "dog-houses."
2. Make complete inspection of towers, guy wires, base insulators, lighting systems, and automatic control or alarm systems.
3. Check all exterior cables and transmission lines for signs of damage.

Fig. 8 illustrates checking for the obvious. A wooden support beam for the phase-sampling lines has rotted away at one end, and the cables are now supporting the brace.

One final point: Do not overlook the monitor-point field-intensity readings. Improper readings are a sure indication something is wrong (although the pattern shift may not necessarily be the result of poor maintenance).

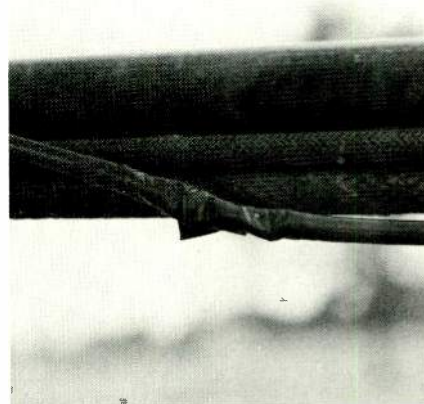

Fig. 7. Poorly made splice lets moisture enter; coaxial cable then deteriorates.

### Conclusion

Shown here is a preventive-maintenance schedule which may be applied with but perhaps minor change to most directional-antenna systems. The proper maintenance of your array is just as important as the maintenance you perform on the transmitter or limiter amplifier. Regular preventive maintenance will pay dividends in the form of fewer violations and fewer listener complaints, and it will enable the station engineer to become more proficient in the operation of his antenna system. ▲



Fig. 8. Poor maintenance has allowed a wooden cable support to collapse.

*Only the finest play the*



# PALACE... where the new RE15 was born!

 The biggest names in show business play the Hollywood Palace on ABC-TV. They demand the finest sound possible. And they get it from the new Electro-Voice RE15. It's no accident, and here's why: ABC-TV sound engineers worked with us for almost two years perfecting the RE15. Their demands reflected the problems that make TV variety programs one of the toughest assignments for any sound engineer.

## Small in Size

They asked for a small, light microphone. The RE15 is shorter than a pencil, with a body no thicker than a Cannon XL connector. And it weighs just 8 ounces. Perfect for a fast-moving boom or for hand-held applications.

## Flat Off-Axis Response

ABC engineers requested the same response curve off axis as on axis. With a big band in the same studio, some band pickup from the back of the solo microphone would be inevitable. It wasn't easy to make this "off mike" pickup as smooth, flat and wide range as the on-axis response, but that's exactly what the RE15 has to offer at every angle.

## Super-Cardioid Pattern

But the next request almost stumped us. They asked for wide front pickup, so that a boom operator could easily "work" two or more performers, yet they wanted the RE15 dead at the rear for longer "reach". In short, a polar pattern similar to a ball sliced neatly in half! And that's almost what they got.

The RE15 is down only 3 db at 80° off axis (in any plane) and just 8 db at 90°. But at 120° and 180° the level drops over 19 db, and at 150° the RE15 response is almost 26 db below the on-axis level. This super-cardioid pattern (with a small lobe at the back, 15 db down) proved much more useful than a classic cardioid. With the microphone tipped 30° (a



L. to R.: Robert Crawford, Chief Utility; Eric Reid, Chief Boom Operator; Eugene Lukowski, Technical Director; John Neal, Audio Engineer, for ABC's Hollywood Palace.

typical boom or stand operating position) the area of greatest cancellation is oriented directly at the sources of unwanted sound—the audience and the sound reinforcement speakers.

## E-V Reliability

ABC-TV also demanded plenty of output. They got it. A crisp -55db. And they got the reliability and ruggedness typical of all E-V professional dynamic microphones, as well. Famous E-V Acoustalloy® diaphragm plus multiple dust and magnetic filters assured unchanging response and sensitivity. Plus a "bass tilt" switch to cure boomy acoustical problems.

The slotted "backbone" of the RE15 identifies it as the latest in the Electro-Voice series of Variable-D® and Continuously Variable-D® microphones.

It's very possibly the most significant achievement of them all. Write for your copy of

Microphone Facts that gives all the details. And, for an impressive demonstration of RE15 capability, find a TV set with really good audio, and tune to the Hollywood Palace on ABC-TV, any Saturday night. Or match the RE15 with your own list of demands. We think you'll agree that a star was born on the Hollywood Palace!

FREE! Any E-V professional microphone will be repaired without cost if it fails in the first two years—regardless of cause. That's right, repairs are free for the first two years... no questions asked!

ELECTRO-VOICE, INC.  
Cecil Street, Eucharan, Michigan 49107

# Electro-Voice®

A SUBSIDIARY OF GULTON INDUSTRIES, INC.

high fidelity speakers and systems • tuners, amplifiers, receivers • public address loudspeakers  
• microphones • phonograph needles and cartridges • organs • space and defense electronics

# THE TWO-TOWER TEST

by Robert A. Jones\*

Directional antennas are not quite as complicated as they seem; the method of analysis makes a difference.

Although some operators at one-tower stations may question use of the word "simple," the simplest directional antenna is the two-tower array. And, while it may not be obvious, any combination of towers, even or odd in number, can be bro-

ken down into combinations of two-tower arrays. The method is analogous to algebraic factoring, the breaking down of a complex expression into a combination of simpler parts.

## Theory

Fig. 1 shows how a pattern from three towers in line can be considered

to be produced by two two-tower arrays. Adjacent to the final pattern can be seen the two component patterns which form it. The patterns must be expressed in what is known as the "multiplication" form.<sup>1</sup> As can be seen, two-tower pattern B is multiplied by two-tower pattern C to produce three-tower pattern A. Further, it can be seen that wherever one of the two-tower patterns has a null, the three-tower pattern also has a null. The same is true for lobes.

The foregoing method may be carried one step further. Fig. 2 shows an approach to a four-tower final pattern. Three two-tower basic building blocks are used. In general, the number of two-tower basic patterns will be one less than the total number of towers; this is reasonable, since the reference tower is common to all. The same facts hold true for the four-tower array as for the three-tower case: At each azimuth where one of the basic patterns has a null or a lobe, the final pattern will also have a null or lobe. The same principles may be applied to systems of five, six, or even more towers.

It should be noted that in each of the above cases the towers have been assumed to be in a straight line. This is commonly referred to as the "in-line" array.

\*Consulting Engineer, LaGrange, Ill., and BE Midwest Regional Editor.

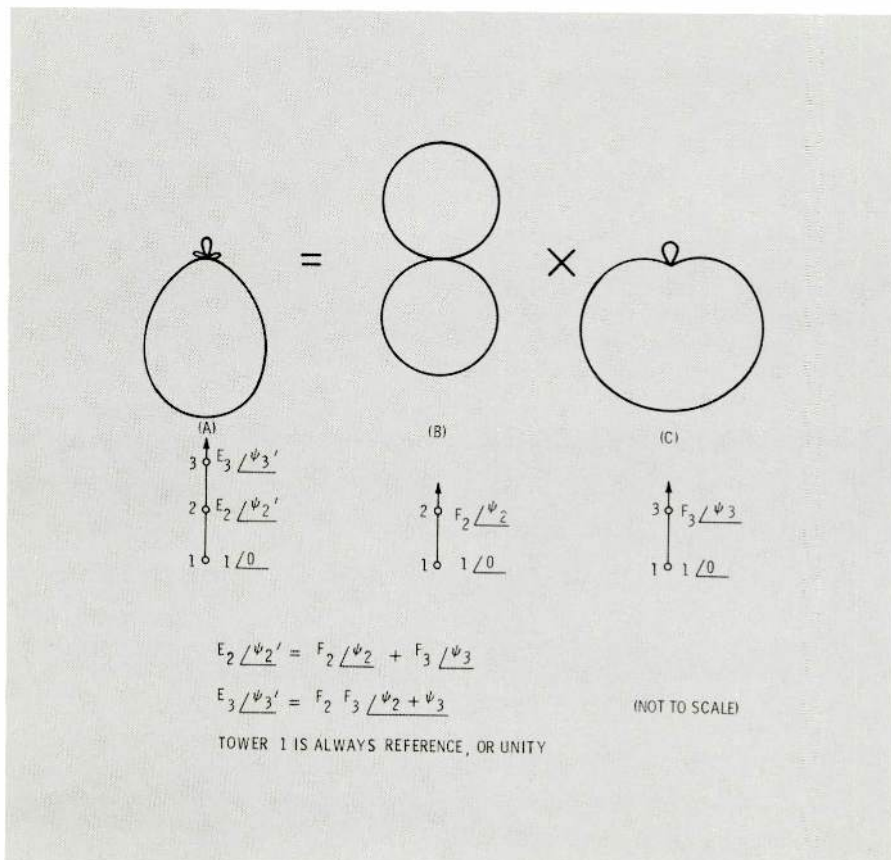

Fig. 1. Multiplying two two-tower patterns gives three-tower result (left).

<sup>1</sup> See Carl E. Smith, *Theory and Design of Directional Antennas*, Cleveland Institute of Electronics, 1951, p2-1-36.

A special case of pattern multiplication is shown in Fig. 3. Again, two two-tower patterns are involved, but this time a different result is obtained when they are multiplied. As the reader can see, the end result has four towers, not three, and the final pattern is not symmetrical about the line of towers as was the case in Fig. 1.

Careful inspection reveals that in Fig. 1 both two-tower patterns had their tower lines oriented the same way. This is not so in Fig. 3. When the two basic pairs do not have the same orientation and/or spacing, the resulting array has four towers instead of three. In fact, the three-tower array may be considered a four-tower array, with the two middle towers identically located (or one considered to be on top of the other). For example, if the tower lines in Fig. 3 are rotated toward the same bearing, the two middle towers will move closer and closer together until they merge.

Certain facts about the two-tower basic pattern should be reviewed before proceeding. A two-tower pattern from close-spaced (less than half-wave spacing) towers can have no more than two nulls. These are spaced equally with respect to the tower line, and they are of equal

depth. For example, if there is a null  $20^\circ$  to the right of the tower line, there will be a similar null  $20^\circ$  to the left. And, if one of these nulls is "pulled" down to zero signal, the other will be brought to zero also. Keep in mind, of course, these are the theoretical conditions, and when they do not work out in practice, it can mean something is wrong with the array.

### Practical Applications

The "factoring" of an array into two-tower elements may be used as a tool in adjusting and maintaining the typical directional antenna. One of the most common uses of the two-tower pattern as a testing device is in the calibration of meters and phase monitors. If there are two towers—or any number—and it is desired to compare the proportional radiation from each, this testing technique may be used. Logically, one assumes that if the base currents are equal and the towers are the same height, the radiations are equal. This is not always the case, as was discovered while tuning the antenna of WRHL, Rochelle, Illinois. In fact, at WRHL it was necessary to introduce some 15% more base current into the center

tower to achieve equal radiations.

Our method of checking for equal radiation is to place a co-worker, in a car with two-way radio, about one or two miles from the transmitter site directly in line with the towers. Normally he is close enough to verify his position on the tower line visually. (In some cases this is easier to do at night by lining up the tower lights.) This operator watches his field-intensity meter as we tune for a lower and lower signal. When we have achieved the lowest possible signal, usually around 0.1 mv/m, we know the radiations from the two towers are equal and in phase opposition along the tower line. By reading the base currents under these conditions, we can uncover any slight differences in radiation. And, as we found at WRHL, differences sometimes are found. This is true even when all the tower base-current meters previously have been connected in series at one point. As a general rule, however, equal base currents mean equal radiated fields.

In cases of multiple-element arrays, each pair of towers can be checked, one at a time, if for any reason it is thought the radiations are not directly proportional to the base-current ratios. As the height of the towers approaches one-half

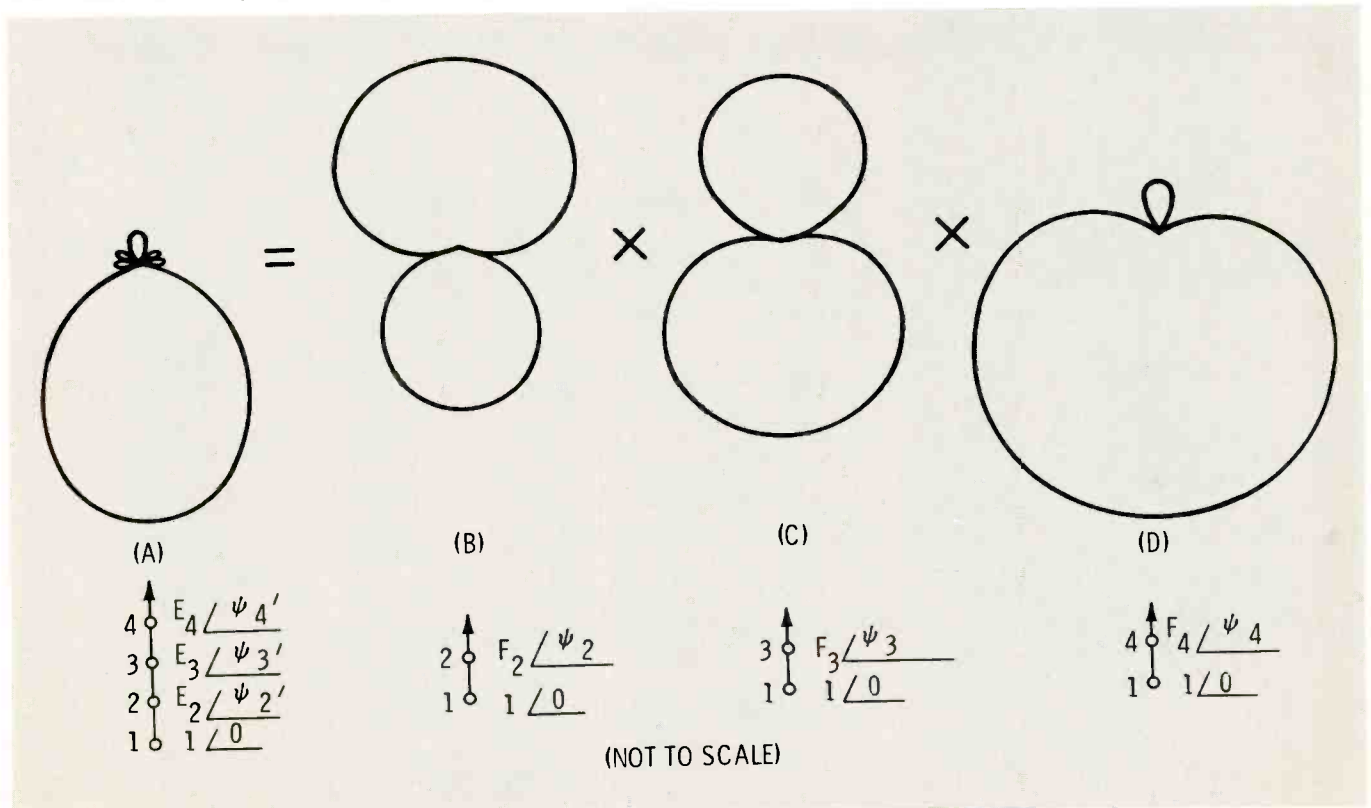

Fig. 2. Pattern of four-tower in-line array at left is result of three two-tower arrays with the same orientation.

wavelength, the likelihood of difference in base current increases. If towers of unequal height are used, it is absolutely necessary to conduct the above test.

The same test is used to check for instrumentation errors in the station phase monitor. If two towers  $90^\circ$  apart are assumed, a theoretical phase difference between the two of  $90^\circ$  is required to produce a null on the tower-line bearing. If the null is reduced to a minimum and the phase monitor reads, say,  $93^\circ$ , an error of  $+3^\circ$  exists between this particular pair of towers. With other than  $90^\circ$  spacing, the theoretical phase must equal the difference between the actual spacing and  $180^\circ$ .

In a like manner, each pair of towers can be checked, one at a time, to discover any individual errors in phase angles. This can also show up errors in the remotely indicated tower-base currents. These phase-angle and current-ratio errors can then be introduced into the theoretical pattern parameters as a starting point in tuning the antenna.

Certain precautions must be taken in order not to be misled while mak-

ing these tests for errors. First, in most cases it is wise to use more than one location along the line of towers for "talking down" the null; then average the base currents, remote currents, and phase-angle errors found. The reason for this is that any one field location can be affected by some local phenomenon. If, however, there are wide variations in, say, two or three points, other troubles may be present. One possibility, of course, is instability in the metering, but a more likely cause is severe reflections.

Another use of the basic two-tower pattern is in identifying reflecting objects. This is done as follows. Determine the bearing from the station to the suspected object or source of reflections. Then, using the two-way-radio car, adjust the two-tower pattern for a null at this azimuth; if there is no signal in the direction of the reflector, there can be no reflections. Then drive around to the other side of the pattern and check for a symmetrical null. Two equally deep nulls indicate no serious reflections, or that under these conditions the reflecting object lies in the null. (See "The

'Hot' Water Tank at WJIL," by Robert A. Jones, January 1963 BROADCAST ENGINEERING, page 19.)

In some instances, it may not be known whether any reflecting objects are in the vicinity of an array. To check for this, one can set up a null, say  $40^\circ$  off the tower line, and tune for minimum. Then the depths of this and the companion null are compared. If they are similar, there are no reflections. Additional checks can be made at, say,  $60^\circ$  and  $80^\circ$  to give a spread angle. This approach also will reveal deformities in the ground system, or noncircular tower radiations. All of these conditions can result in a measured pattern that is not in accord with the predicted one.

### Conclusion

It is easy to become confused by the complexity of many of the multi-element directional antennas in use today, and by the high-powered mathematics involved in their computations. However, the total array can be understood, if it is realized that each is composed of basic two-tower building blocks which can be taken one at a time. ▲

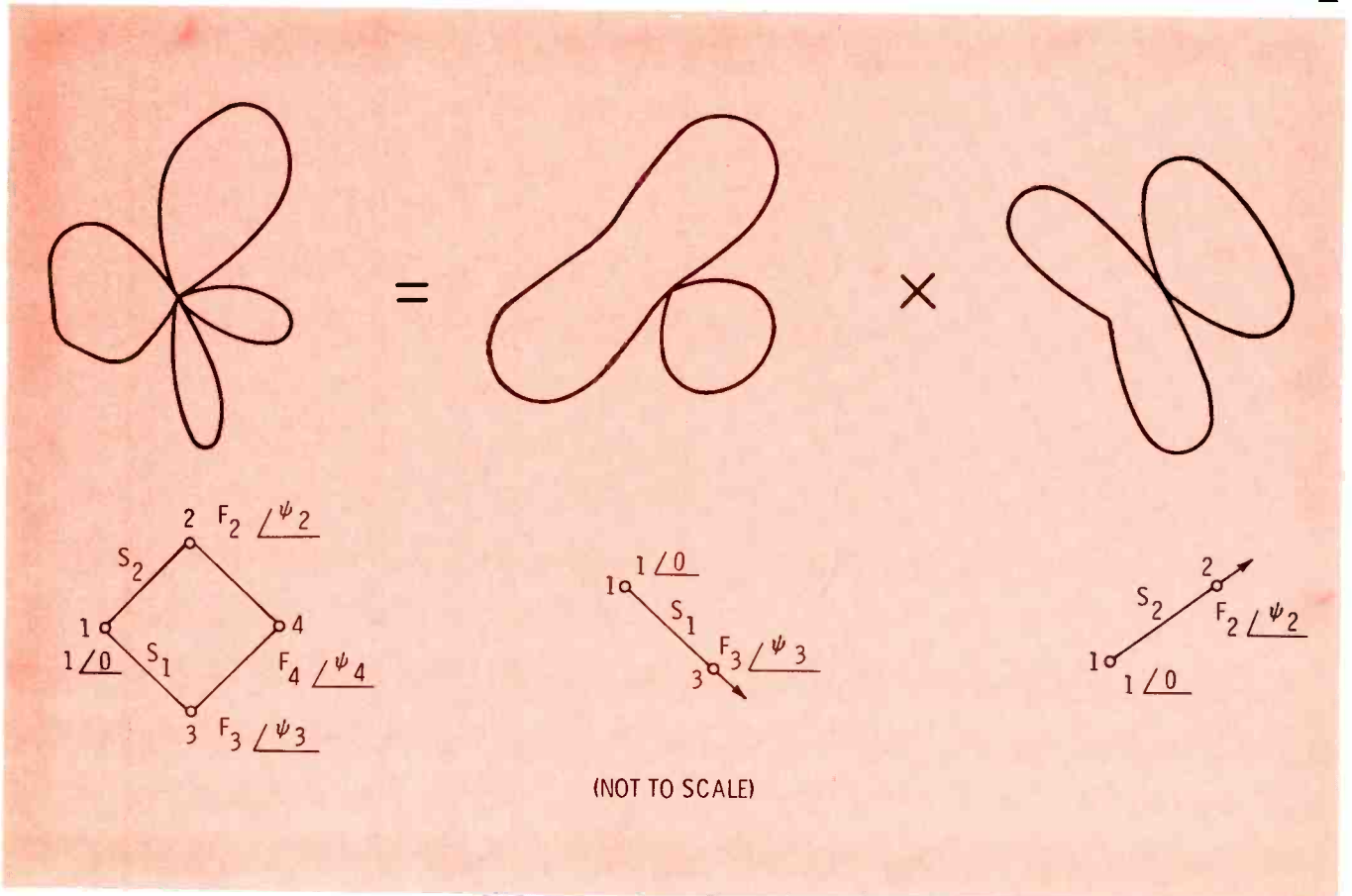
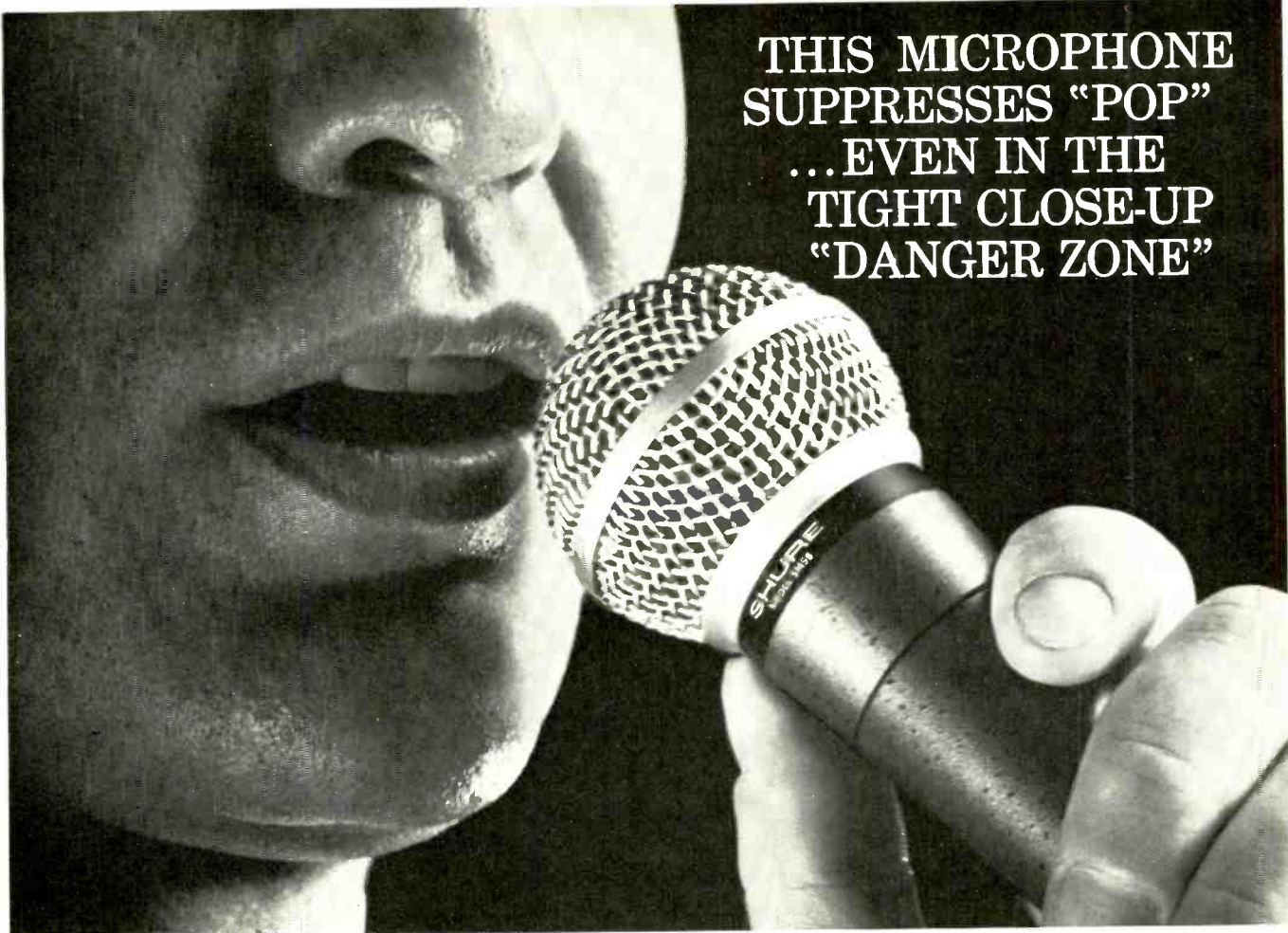

Fig. 3. Nonsymmetrical four-tower pattern from multiplying patterns of two-tower arrays with different orientations.



**THIS MICROPHONE  
SUPPRESSES "POP"  
...EVEN IN THE  
TIGHT CLOSE-UP  
"DANGER ZONE"**



The Shure SM58 *self-windscreened* unidirectional microphone is ideal for broadcast uses such as remote news, sports, interview and vocal recordings because it eliminates or minimizes the irritating "pop" caused by explosive breath sounds. With the SM58 you will have the peace-of-mind assurance that you're delivering the quality audio that goes with pop-free pickup. It's great for studio announcing, too—or wherever the announcer or vocalist has the audio-degrading habit of "mouthing" the microphone. Of course, the same filters that eliminate pop also do away with the necessity for an add-on windscreen in outdoor uses.

On the other hand, the unusually effective unidirectional cardioid pickup pattern (uniform at *all* frequencies, in *all* planes) means that it is a real problem-solver where background noise is high or where the microphone must be operated at some distance from the performer. Incidentally,

but very important, the SM58 tends to control the low frequency "boominess" that is usually accented by close-up microphones.

All in all, close up or at a distance, the Shure SM58 solves the kind of ever-present perplexing problems the audio engineer may have felt were necessary evils. The SM58 might well be the finest all-purpose hand-held microphone in manufacture today. And, all things considered, it is moderate in cost.

Other features: the complete pop-proof filter assembly is instantly replaceable in the field, without tools. Filters can be easily cleaned, too. Stand or hand operation. Detachable cable. Rubber-mounted cartridge minimizes handling noise. Special TV-tested non-glare finish.

For additional information, write directly to Mr. Robert Carr, Manager of Professional Products Division, Shure Brothers, Inc., 222 Hartrey Ave., Evanston, Illinois 60204.

**SHURE**

**SM58**

SELF-WINDSCREENED UNIDIRECTIONAL DYNAMIC MICROPHONE

OTHER SHURE PROFESSIONAL MICROPHONES... FOR SUPERIOR AUDIO

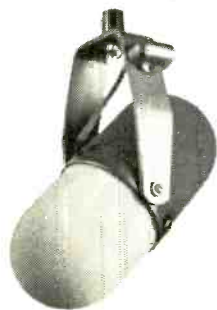

**MODEL SM5  
CARDIOID BOOM DYNAMIC**

Because its cardioid directional pattern is uniquely uniform with frequency and symmetrical about its axis, the SM5 is singularly independent of the effects of environment. Even in extreme shooting situations (such as with tight sets, low ceilings, hard walls, low microphone angles, traffic or air-conditioner noise and rumble and changing distance) the SM5 minimizes sound coloration and ambient noise pickup.



**MODEL SM76  
3/4" OMNIDIRECTIONAL  
DYNAMIC**

Ideal for interviews and audience participation, yet unusually smooth wide range response (40-20 KC) for critical music reproduction. Instantly detachable from stand. Steel case with Cannon connector.



**MODEL SM50  
OMNIDIRECTIONAL  
DYNAMIC**

Self-windscreened and pop-free for news, sports, remotes, and interviews. Also ideal for many studio and control room applications. Comfortably balanced for hand or stand use. Natural response.

Circle Item 15 on Tech Data Card

a

# sound investment

for the Broadcast Industry...

## REMOTE CONTROL MIKE REELS

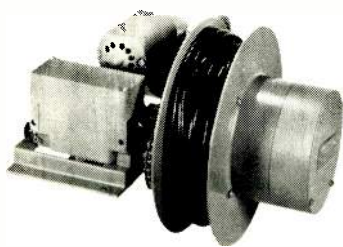

Specially designed reels. Remote control by drum, push button or station relay. 115 volt reversible chain driven motor. 2 to 8 conductor slip rings available. 150' cable capacity.

## POWER CABLE REELS

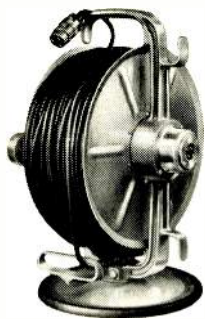

I.E.R.'s level wind Port-O-Reels protect and prevent mike or extension cord break-downs. Up to 400' cable capacity.

Write for Specification Data on the most complete line of Remote Control Reels and Port-O-Reels.



**INDUSTRIAL  
ELECTRIC  
REELS  
INCORPORATED**  
1503 CHICAGO ST.  
OMAHA, NEBRASKA 68102

Circle Item 16 on Tech Data Card

## Dropout

(Continued from page 24)

operation of these devices is demonstrated in Fig. 2. A shear-mode ceramic transducer, A, is bonded to glass blank B and driven with electrical energy at or near its resonant frequency. This generates a sonic vibration which travels through the glass to surface C, where it is reflected to D, then back to ceramic transducer E. At E, the sonic energy excites piezoelectric current, which is amplified to recover the original and now delayed signal.

The glass blank is made with special modifiers which give it a zero temperature coefficient at approximately 30°C. The blank is several wavelengths thick.

Special design features optimize the performance of these devices for handling a television signal. One of the two glass memories is designed to handle the 3.58-MHz chrominance information directly. It provides necessary response plus freedom from spurious reflections over the chroma bandwidth of 2 MHz to 4.2 MHz, as required for NTSC color. The other memory de-

lays the luminance information at a carrier frequency of 10 MHz. (Acoustic delay lines cannot be designed to operate below 1 MHz. Thus, a carrier system is necessary for the luminance information.)

Adequate sync and blanking response to preserve timing relationships is the criterion for the luminance-channel response. Above 2.5 MHz, all energy must be removed from the luminance signal processed by the color channel. Otherwise, edge interference between the phase-corrected color and the luminance is apparent in the delay material.

The chroma signals (2.3 to 4.2 MHz) can be delayed directly, since glass delay lines can be designed to operate in this frequency range. The total delay time for the chroma signal is trimmed by a variable delay line. Incorrect total delay time of the chroma signal shows as a change in the hue of the fill-in material. The chroma signal, inverted 180° in phase, is added to the delayed luminance signal and applied to the delayed-video input of the video switch.

## System Performance

A properly designed and operated dropout compensator detects and compensates not only the gross dropouts producing the high-contrast flashes, but also the dropouts of lesser amplitude that appear in high-saturation color signals due to changes in recorder equalization. The speed of switching action is such that the switching transients are past the response limits of standard television systems. These factors, together with the relatively wide-bandwidth luminance and full-bandwidth color fill-in material, produce a system that makes it virtually impossible to see compensated dropouts on a random basis. In addition, full compensation during the sync interval eliminates time-correction errors and servo instability caused by dropouts. When such compensation is achieved, useful tape life is extended and program quality is improved.

The contributions of B. A. Holmberg, I. Moskowitz, R. R. Barclay, and K. E. Williams to the information on which this article is based are gratefully acknowledged. ▲

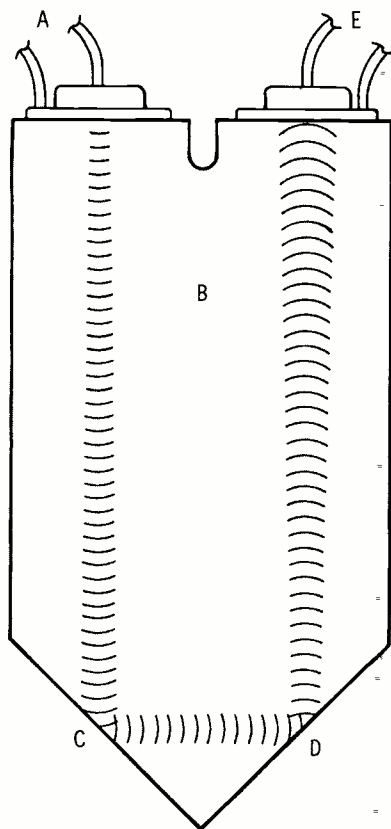

Fig. 2. Blank of special glass forms heart of the acoustical delay lines.

(References are listed on page 24.)

February 1968

We interrupt this magazine to bring you. . .

## Late Bulletin from Washington

by Howard T. Head

### Latin American Interference Below Expectations

AM radio in Central and South America has experienced rapid growth in recent years. Not only have many new stations gone on the air, but there have been an increasing number of reports of stations operating with powers ranging as high as 1000 kw. This operation, which is often undertaken on the same frequencies assigned to United States Class I-A clear-channel stations, has become a source of concern to American broadcasters and the FCC.

Surprisingly, in many instances interference levels received in the U. S. from these high-power stations have been considerably less than those predicted from established curves of skywave field strength vs distance. This has proved true even in cases of high-power operation in countries as close to the U. S. as Costa Rica, Surinam, and even Cuba (see April 1967 Bulletin). Additionally, reports indicate that mutual interference between stations in the United States and Mexico is often less than expected.

All of these situations involve skywave propagation over predominantly north-south paths. Authorities point out that north-south propagation should be different from east-west propagation, although there is little agreement as to the nature and extent of the difference. Existing skywave curves are based on recordings made over predominantly east-west paths, and few, if any, recordings applicable to north-south propagation are available.

The Commission is considering the possibility of establishing a research program to obtain skywave recordings over north-south paths, and to analyze the data with the view toward preparing new skywave curves. The 1967-1968 FCC budget includes \$600,000 for research studies, essentially none of which has yet been committed.

### Satellite-to-Home Broadcasting Shows Little Progress

Plans for a domestic satellite system for radio and television relaying await the report of a special Presidential Study Committee (see October 1967 Bulletin); meanwhile, there continues to be much talk and little progress in the development of space satellites for radio and television broadcasting directly to homes. NASA has awarded some study contracts for investigation of the feasibility of direct shortwave and FM radio broadcasting to homes, but satellite-to-home television broadcasting remains in the early study stages.

Numerous technical problems are involved. One of the more important is the fact that a television broadcasting satellite will require substantial amounts of primary power -- variously estimated as ranging up from 1 Mw to 5 Mw -- in order to provide good-quality television pictures to large areas. Of equal importance is the difficulty of finding available television channels, even in the UHF band. Sharing of channels between space and ground broadcasting stations would cause intolerable interference, and the demands for spectrum space make it unlikely for exclusive space-broadcasting channels to be made available through reallocation.

In addition to the technical problems, there are obvious political problems requiring a high degree of international cooperation. Until a way is pointed to a solution of technical and other problems, direct satellite-to-home broadcasting will remain little more than a concept.

#### Commission Gropes for Solution to Land-Mobile Problems

In the face of mounting pressures from the land mobile services, the Commission is intensifying its search for ways to make additional channels available for land mobile use (see January 1968 Bulletin). Special study committees are considering several possibilities, including sharing of the VHF television channels with land-mobile users, similar sharing of UHF television channels, and the outright diversion of a group of UHF television channels. If UHF channels are to be diverted, the land-mobile groups would prefer the frequencies immediately above the lower end of the UHF television band (470 MHz), but these channels have the highest occupancy by television stations. At the upper end of the UHF television band, immediately below 890 MHz, Channels 70-83 are occupied by literally thousands of UHF television translators.

No entirely satisfactory solution to the problem is evident. It appears unlikely that any compromise can be worked out which will be fully acceptable to both the broadcast and land-mobile interests.

#### Short Circuits

The Supreme Court has agreed to hear the case which upheld the liability of CATV operators for the carriage of copyrighted program material (see July 1966 Bulletin). . . The only pay-TV station in operation, an experimental grant at Hartford, Connecticut (see September 1967 Bulletin), is discontinuing operation. . . The Commission continues to levy frequent and heavy fines on licensees for rule violations -- common infractions include failures to make equipment-performance measurements and daily inspections, and the late filing of license-renewal applications. . . The Commission has extended the testing period for FM broadcast stations (see June 1967 Bulletin). . . The First Circuit Court of Appeals has vacated a Commission order forbidding a Maine CATV system from carrying Canadian programs prior to their showing in the U.S. (see June 1967 Bulletin).



## these connectors aren't just accessories!

Andrew is one of the world's largest manufacturers of RF connectors. Our engineers develop connectors not just as accessories but as part of complete antenna, cable and transmission line systems. Be sure of proved performance and reliability. Contact your regional Andrew sales engineer or write Andrew Corporation, P. O. Box 807, Chicago, Illinois, U.S.A. 60642.

10-66

*Andrew*  
CORPORATION  
29 YEARS OF ENGINEERING INTEGRITY

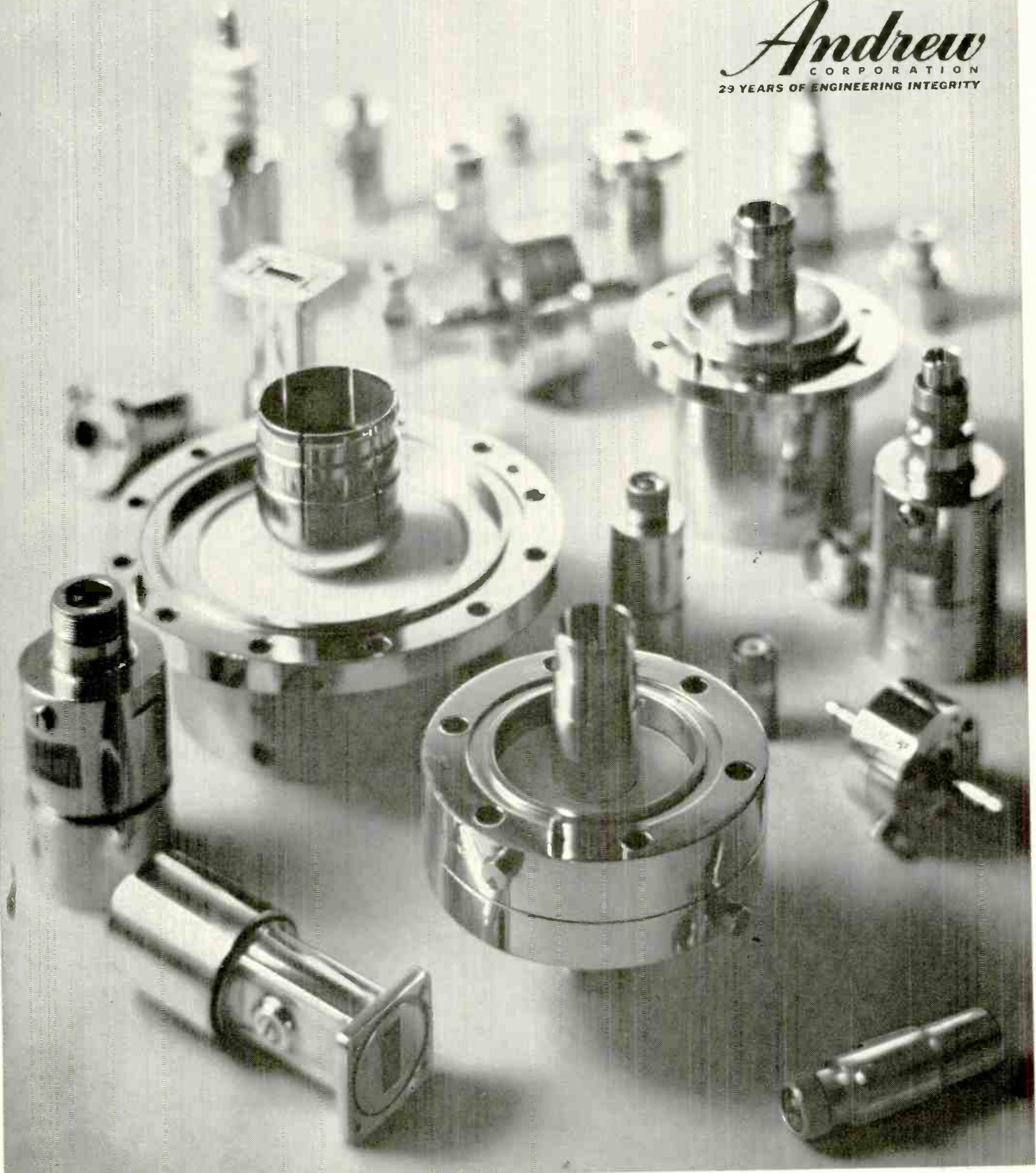

# The International Set.

Conrac watches television in about a hundred languages. Japanese, Thai, Swedish, Norwegian, Hebrew, French, German, you name it. In fact, just about every major TV broadcaster in the world uses Conrac monitors. Except the Russians. (But, you know how that is.)

**conrac**

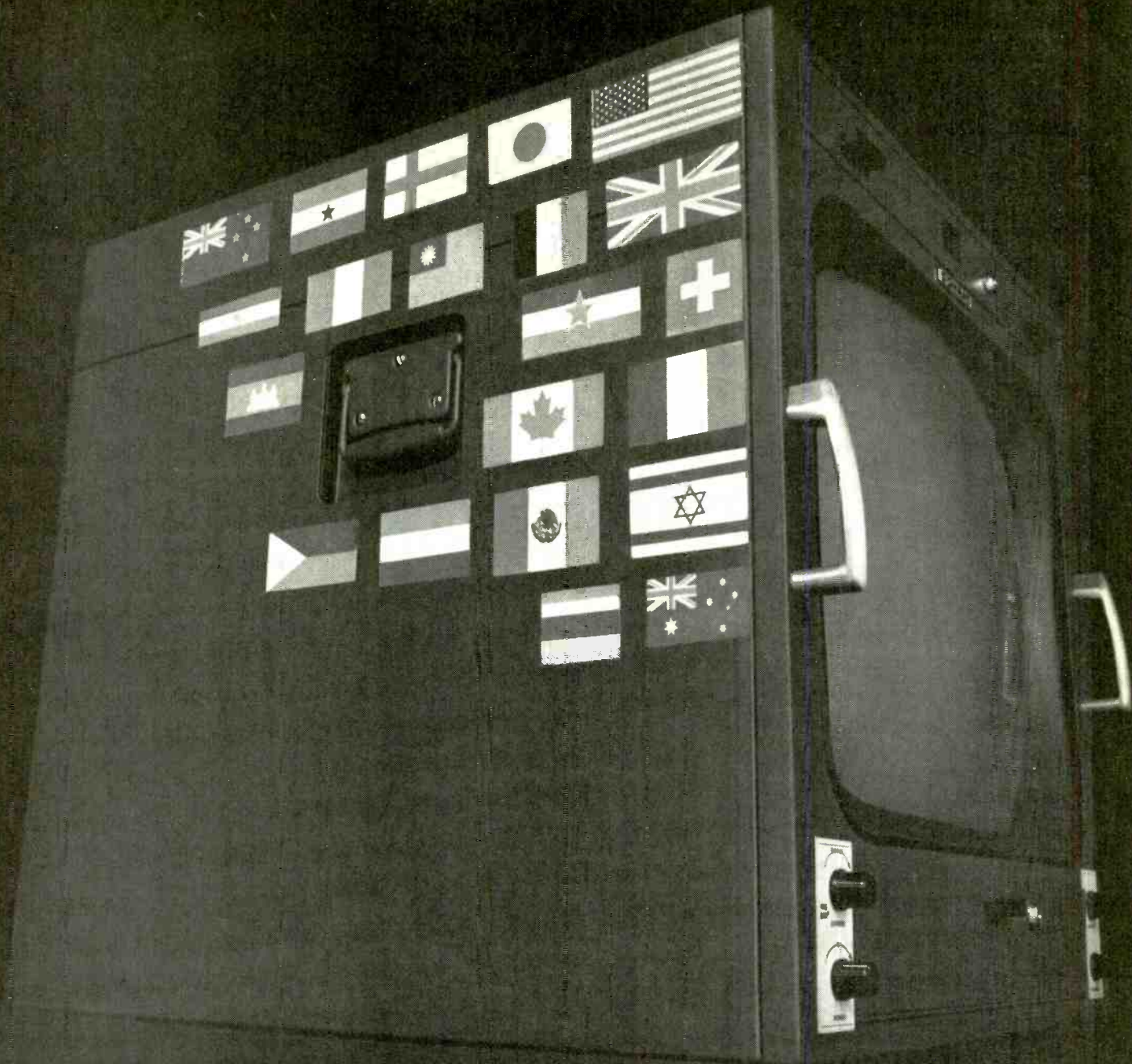

Circle Item 18 on Tech Data Card

# NEWS OF THE INDUSTRY

## INTERNATIONAL

### TV for the Bahamas

The forthcoming inauguration of television service in the Bahamas has been announced. Intended to serve eventually more than 90% of the Islands' population of about 100,000, three phases of the Government's seven-phase plan will be implemented immediately, concurrent with plans to revamp and extend present radio services.

Award of the three-phase project implementation, plus the revamping of radio facilities, operations, programming, etc., has been made to **N. J. Pappas & Associates**, Montreal. Completion of the main network production center at Nassau is expected by early 1969.

The system will include AM and FM radio, a television network center, television distribution, rebroadcast fa-

cilities, ETV, and all related requirements. Initially, the television system will be monochrome, with provision for the later addition of color. All Bahamian broadcasting facilities will be commercial, under the jurisdiction of the **Bahamas Broadcasting and Television Commission**. The Commission presently operates two commercial AM-FM facilities designated ZNS-1 and 2, operating at 1540 kHz, 1240 kHz, 107.2 MHz, and 107.9 MHz.

## NATIONAL

### New Cable Plant

Completion of a new coaxial-cable plant at Sherrill's Ford, N.C. was scheduled for January by **Superior Cable Div. of Superior Continental Corp.** The 50,000 square-foot production facility, a one-story, steel-frame brick building, will incorporate 3000 square feet of air-conditioned office space as well as 2000 square feet of storage and shipping space in addition to the manufacturing area. The plant site includes approximately 44 acres. A dam 1100-feet long was constructed to create an 11-acre lake for plant fire protection; the lake and surrounding watershed area will be further developed following plant completion.

### Distributorship Ended

**Philips Broadcast Equipment Corp.** has agreed to the termination of the **Visual Electronics Corp.** exclusive distributorship of Norelco color cameras, due to a projected overlap of the manufactured product lines and market activities of the two companies.

According to the announcement made by Visual, both companies plan the early introduction of new TV transmitters, audio product lines, closed-circuit television equipment, and color-television equipment. Visual has undertaken a program for developing its own color camera line, which is expected to be ready for the fall 1968 program season.

### Opens Sales Office

A Minneapolis office serving Minnesota, North and South Dakota, and portions of Iowa and Wisconsin has been opened by **Memorex Corp.** Lary L. Lindsey, formerly working out of the Memorex regional office in Chicago, has been named to the new of-

## Spotmaster Multiple Cartridge Playback Units

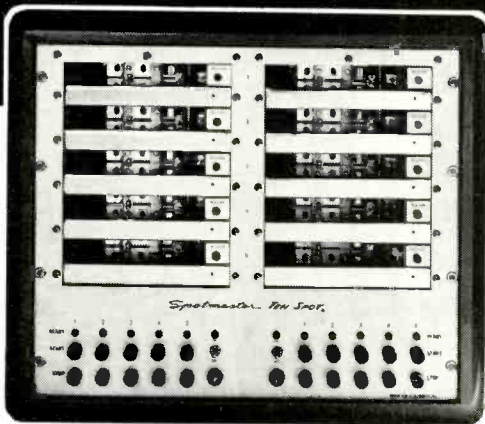

Ten • Spot Model 610B

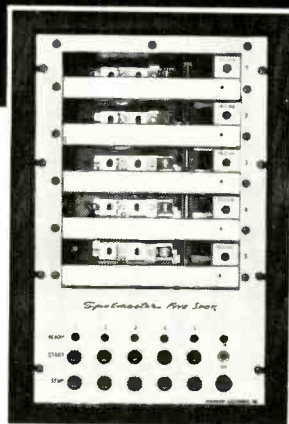

Five • Spot Model 605B

## ... bringing a new dimension to pushbutton broadcasting

Spotmaster Ten • Spot (holding 10 cartridges) and Five • Spot (holding five) will reproduce any NAB Type A or B cartridge instantly at the push of a button . . . at random or in sequence. They may be operated manually or incorporated into programmed automation systems, using one, two or three NAB standard electronic cueing tones.

The Ten • Spot is designed for 19" rack mounting while the Five • Spot is available either in an attractive walnut-finished case or with a 19" front panel containing a cartridge storage cubicle. Both are backed by Spotmaster's iron-clad full-year guarantee.

For further information about these and other Spotmaster cartridge tape units, call or write today. Remember, Broadcast Electronics is the No. 1 designer/producer of broadcast quality cartridge tape equipment . . . worldwide!

**BROADCAST ELECTRONICS, INC.**

8810 Brookville Road, Silver Spring, Maryland 20910; Area Code 301, 588-4983







**FULLY  
EQUALIZED**

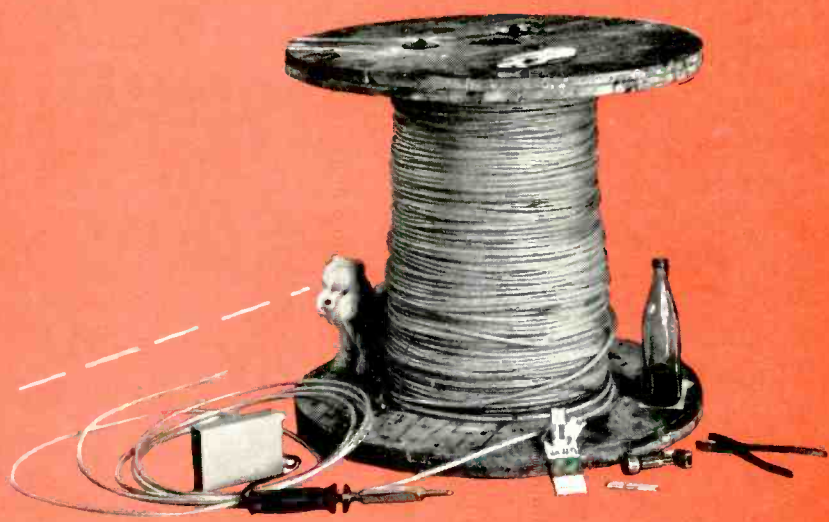

## HOW *KAPPA* GETS VIDEO CABLE PERFORMANCE...*WITHOUT CABLE!*

We replace it! . . . with Kappa Super-η Delay Lines. As a result we can help you avoid large coils of video cable, storage compartments, and separate equalizers. Kappa Super-η Delay Lines outperform conventional (m-derived) lines because they are more efficient . . . they yield inherently greater delay-bandwidth from fewer components. The performance of Kappa Super-η more nearly approaches constant delay at all transmitted frequencies . . . an essential characteristic of the ideal low pass, dispersionless delay line.

Unit-to-unit uniformity and excellent temperature stability are also marked features of Kappa Super-η Video Delay Lines.

Where you need equalized cable performance without physical length in your video systems, do the job efficiently and economically . . . use Kappa Super-η Delay Lines!

### KAPPA SUPER-η VIDEO CABLE SIMULATOR GUIDE

Model No.	Length of Cable Simulated* (in feet)	Package Length (x 7/8" square)	Approx. Delay Range (nsec.)	Max. Insertion Loss (db)	Price**
10A50	50	5"	78	0.5	\$52.75
10A100	100	8"	157	1.0	\$69.50
10A150	150	11"	235	1.5	\$86.25
10A200	200	14"	314	2.0	\$103.00
10A250	250	16"	392	2.5	\$119.75

**ACTUAL  
SIZE**

\*±2 ft. or 2%, whichever is greater. \*\*Additional discounts available for quantity orders.

#### SPECIFICATIONS OF KAPPA SERIES 10A SUPER-η DELAY LINES

Impedance: 75 ohms ± 2%	Size: 7/8" square x length required
K factor: less than 0.25% for sin <sup>2</sup> T Pulse	Case material: Electro-tinned brass
Cross talk: less than 46 db	Finish: Mil-spec gray lacquer

For prompt engineering assistance call us collect at (201) 541-4226

## KAPPA NETWORKS, INC.

Delay Line Specialists Manufacturing Engineers  
165 ROOSEVELT AVENUE · CARTERET, NEW JERSEY 07008 · TEL (201) 541-4226

*World's largest manufacturer of broadcast quality delay lines.*

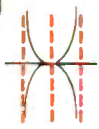



# TELECTERN™

## 3-in-1 Versatility!

- Self-Contained Production Center
- Compact Lecture Console
- Overhead Camera System

TELECTERN® . . . for instructors who want the advantages of TV teaching without the extra work and time usually involved. Rehearsals and special preparation are reduced to a minimum, because the instructor handles all the controls. He can switch up to five video sources, adjust illumination, control the 10:1 zoom lens, show slides, superimpose the TELECTERN® video over any other input source — all the while giving a relaxed, smooth, professional presentation at a pace he sets himself.

Any type of instruction — in industry, the military, and medicine, as well as in schools, colleges and universities — can be made more effective with less distress, using TELECTERN®.



® Trademark, TeleMation, Inc.

Write for complete details — request Form TPB-110

## Television Equipment for Education, Industry and Military . . .



MULTICASTER™



PORTA-SYNC™



TELECTERN™



VR 660 Video Processor

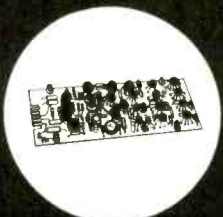

2:1 Interlace Sync Generator

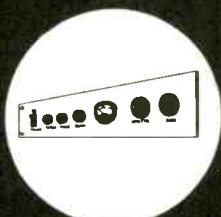

EIA Camera Control

. . . from TeleMation — where experience powers pacesetting products!



## TELEMATION, INC.

2275 So. West Temple / Salt Lake City, Utah 84115  
Telephone (801) 486-7564

office. The office is located at 7710 Computer Avenue.

## Industry Outlook Good

The broadcasting industry should see a resumption in 1968 of vigorous growth in sales and earnings, according to an industry survey by **Goodbody & Co.** Commercial broadcasting gains, along with the general economy, slowed in 1967, but are expected to accelerate in coming months. This expectation stems from the fact that all signs point to improvement in general economic activity this year and that this improvement should lead to higher expenditures for advertising, the broadcasting industry's principal source of revenue. Advertising outlays, Goodbody believes, can rise about 7% in 1968, as compared with a gain of about 3% in 1967 over 1966.

The industry's revenues now total over \$3 billion annually, and the end of their rise is not in sight, according to the study. Color broadcasting is expanding rapidly, regular international exchange of programs via satellite transmission is in the offing, while the growth of community antenna television, educational television, and even pay TV should stimulate, rather than hinder, the industry's progress.

## ORGANIZATIONS

### IEEE

Dr. S. W. Herwald, vice-president, electronic components and specialty products group, Westinghouse Electric Corp., has been elected president of the Institute of Electrical and Electronics Engineers. He succeeds Walter K. MacAdam, vice-president, government communications, American Telephone and Telegraph Co.

The board of directors also announced the election of Lynn C. Holmes, assistant to the vice-president, research and engineering, General Dynamics Electronics Div., as a vice-president.

A Fellow of the IEEE since 1960, Dr. Herwald will become the organization's fifth president since it was formed in 1963 by the merger of the American Institute of Electrical Engineers (AIEE) and the Institute of Radio Engineers (IRE). AIEE was founded in 1884 and IRE in 1912.

Born in Cleveland, Dr. Herwald received his BSME from Case Institute of Technology in 1938, and his MSME in 1940 from the University of Pittsburgh. In 1944, he completed advanced studies at the University of Pittsburgh and received a doctor's degree in mathematics. He joined Westinghouse in 1939, and early in his

career he specialized on technical problems in the ordnance field, particularly in servomechanism development.

In 1952, Dr. Herwald was named engineering manager of the air arm division at Baltimore, and four years later he was appointed manager of the division. In 1959, he was elected a vice-president of Westinghouse in charge of research and development.

He has been active in the American Society of Mechanical Engineers and the American Institute of Aeronautics. He is a member of the National Academy of Engineering and also a member of the Executive Committee of the Air Force Scientific Advisory Board.

### NAB

The Broadcast Engineering Conference Committee of the National Association of Broadcasters has approved preliminary plans for next year's Broadcast Engineering Conference to be held as part of the 46th annual convention in Chicago.

The committee approved the appointment of two subcommittees to select conference luncheon speakers and the recipient of the annual Engineering Achievement Award. It also sifted through proposed topics of engineering papers to be submitted during the conference.

Albert H. Chismark, director of engineering for the Meredith Broadcasting Co., Syracuse, N.Y., and chairman of the Conference Committee, will head up the five-member Awards Subcommittee. Other members are William S. Duttera, director of allocations engineering, National Broadcasting Co., New York; George Jacobs, engineering director, Corinthian Broadcasting Co., New York; James D. Parker, staff consultant on telecommunications, Columbia Broadcasting System Television Network, New York; and Robert J. Sinnett, vice-president for engineering, WHBF AM-FM-TV, Rock Island, Ill.

Leslie S. Learned, vice-president for engineering of the Mutual Broadcasting System, New York, was named chairman of the Luncheon Speaker Subcommittee. Named to serve with him were LeRoy Bellwood, chief engineer of KOGO-TV, San Diego, Calif.; Clure H. Owen, manager of allocations, American Broadcasting Co., New York; John T. Wilner, vice-president for broadcast engineering, The Hearst Corp., Baltimore, Md.; and Benjamin Wolfe, vice-president for engineering, Westinghouse Broadcasting Co. (Group W), New York, N.Y.

Members of the two subcommittees comprise the membership of the full Conference Committee.



## All Digital Color Sync Generator



Pat. Pending

#### Exclusive Features —

- All pulses and transitions clock derived
- No monostables — no delay lines
- Integrated circuit reliability
- Dual outputs — permit pulse assignment with full standby
- Subcarrier vs. horizontal jitter better than 0.25 nsec.
- Pulse jitter better than 4 nsec throughout frame
- 1 3/4" rack space — including all "Add-In" modules

#### Add-In Modules —

- Monochrome Genlock
- Bar Dot Generator
- Color Genlock
- Sync Changeover Switch

#### Monochrome

Model TSG-2000M

**\$1,000**

#### Color

Model TSG-2000C

**\$1,500**

Prices and specifications subject to change without notice.

## NEW PORTA-SYNC™

Identical  
Performance  
at a Great  
Savings!



Pat. Pending

Ideal for . . . REMOTE FIELD APPLICATIONS . . .  
PORTABLE TEST GENERATOR . . . SYSTEM SPARE  
. . . FULL TIME DUTY. Economical, yet absolutely  
no sacrifice of waveform performance.  
Specifications are the same as Models  
TSG-2000M/C, but Add-In modules are not  
available because of ultra-compact dimensions of  
3 1/4" h x 5 1/4" w x 10" d.

#### Monochrome

Model TSG-1000M

**\$695**

#### Color

Model TSG-1000C

**\$1000**

For complete details, request Form TPB-30

Prices and specifications subject to change without notice.

. . . from Telemation — where experience powers pacesetting products!



## TELEMATION, INC.

2275 So. West Temple / Salt Lake City, Utah 84115

Telephone (801) 486-7564

**SMPT E**

The following officers have been elected for two-year terms, 1968 and 1969. Engineering Vice-President — William T. Wintringham, Bell Telephone Laboratories, Holmdel, N.J.; Financial Vice-President — Joseph T. Dougherty, E. I. du Pont de Nemours and Co., Inc., Clifton, N.J.; Sections Vice-President—Wilton R. Holm, E. I. du Pont de Nemours and Co., Inc., Burbank, Calif.; Vice-President for Educational Affairs — D. Max Beard, Naval Ordnance Laboratory, Washington, D.C.; Vice-President for Instrumentation and High-Speed Photography Affairs — William G. Hyzer, Consultant, Janesville, Wis.; Vice-President for Motion Picture Affairs — Richard J. Goldberg, Houston Fearless Corp., Los Angeles, Calif.; Vice-President for Photo-Science Affairs—J. S. Courtney-Pratt, Bell Telephone Laboratories, Holmdel, N.J.; Vice-President for Television Affairs—Richard S. O'Brien, CBS Television, New York, N.Y.; Treasurer—Saul Jeffee, Movie-lab, Inc., New York, N.Y.

Elected to the Board of Governors were: (Representing the Eastern Region) K. Blair Benson, CBS Television, New York, N.Y.; John J. Kowalak, Movie-lab, Inc., New York, N.Y.; Henry M. Kozanowski, Radio Corp. of America, Camden, N.J.; Allan L. Williams, Eastman Kodak Co., Rochester, N.Y.; (Representing the Central Region) Jack Behrend, Behrend's, Inc., Chicago, Ill.; (Representing the Western Region) Jack P. Hall, DeLuxe Laboratories, Inc., Hollywood, Calif.; Edward H. Reichard, Consolidated Film Industries, Hollywood, Calif.

Other Society officers and board members continue in office through 1968.

**PERSONALITIES**

Two new appointments have been made at **Broadcast Electronics, Inc.** **Donald R. Smith**, the company's business manager since 1962, has been elected vice-president, administration by the Board of Directors. Prior to joining Broadcast Electronics, Mr. Smith, a graduate of the University of Florida, was station manager of WMBR, Jacksonville, Fla. and had previously served in various capacities in radio and television stations in Florida, New York, and Arizona.

The new production-engineering manager is **Clifford D. Ratliff**, who was formerly chief engineer of Magnetic Heads, Inc. Mr. Ratliff has a 15-year background in electronic engineering, with emphasis on the design of equipment employing magnetic tape heads.

**ALLEN AVIONICS "HF" SERIES** is an extremely high quality group of Delay Lines. Superior temperature stability, excellent phase linearity & low pulse distortion characterize this group, making them more than adequate electrical replacements for coaxial cable. The inconvenience of handling & storing cable is eliminated. Standard impedances are 50 & 75 ohms. Units are normally furnished with BNC connectors for your input & output connections & can be supplied with taps to your specs. Other time delays available. For longer delays with fast rise time, ask about our "HR" & "VHR" Delay Lines.

**WRITE FOR CATALOG**

100/1 RATIO ATTENUATION 15 db MAXIMUM SIZE: 4 1/2" x 5 1/2" x 15"		
Time Delay Micro-seconds	Rise Time Nanoseconds Maximum	Bandwidth (3db) Megacycles
3.0	30	12
3.25	32.5	11.1
3.5	35	10.3
3.75	37.5	9.6
4.0	40	9
4.25	42.5	8.48
4.5	45	8
4.75	47.5	7.58

75/1 RATIO ATTENUATION 12 db MAXIMUM SIZE: 3 1/2" x 4 1/2" x 12"		
Time Delay Micro-seconds	Rise Time Nanoseconds Maximum	Bandwidth (3db) Megacycles
2.0	26.7	13.5
2.25	30	12.0
2.50	33.4	10.8
2.75	36.7	9.8
3.0	40	9.0
3.25	43.3	8.3
3.50	46.7	7.7
3.75	50	7.2
4.0	53.4	6.75
4.25	56.7	6.35
4.50	60	6.0
4.75	63.4	5.7

50/1 RATIO ATTENUATION 9 db MAXIMUM SIZE: 2 1/2" x 4 1/4" x 12"		
Time Delay Micro-seconds	Rise Time Nanoseconds Maximum	Bandwidth (3db) Megacycles
.5	10	36.0
.6	12	30.0
.7	14	25.7
.8	16	22.5
.9	18	20.0
1.0	20	18.0
1.25	25	14.4
1.5	30	12.0
1.75	35	10.3
2.0	40	9.0
2.5	50	7.2
3.0	60	6
3.5	70	5.15
4.0	80	4.5
4.5	90	4.0

**ALLEN AVIONICS, INC.** Division of A. K. ALLEN CO., Inc. 255 E. 2nd ST., MINEOLA, N.Y. 11501

Circle Item 22 on Tech Data Card

# CF2 ULTRASONIC CLEANER for MOTION PICTURE FILM

*Presented The Academy of Motion Picture Arts and Sciences Award of Merit for Outstanding Technical Achievement.*



Ultrasonic energy is the most effective and economical way to thoroughly and rapidly clean motion picture film without mechanical scrubbing and wiping. The cold boiling effect (cavitation) of ultrasonic energy performs the entire operation. Only the solvent touches the film and a forced air, flash dry-off removes all solvent and residue.

- Restores clarity and sound to maximum quality.
- Enhances the entertainment value of motion picture film and improves commercials.
- Assures static free film with color balance undisturbed.
- Cuts projector maintenance costs . . . no dirt or dust carried into gates and orifices . . . less breakdowns.
- Completely automatic . . . requires only loading and unloading.
- Costs only 1/20 of a penny per running foot to operate.
- Used by every major motion picture lab in the world.

DESCRIPTIVE BROCHURE WILL BE SENT ON REQUEST.

Patents

USA—2,967,119 Luxembourg—37,634  
Belgium—582,469 Great Britain—909,421  
France—1,238,523 Other World Pats.Pend.

**LIPSNER-SMITH CORPORATION**

7334 No. Clark St., Chicago, Ill. 60626  
Telephone: 312—338-3040

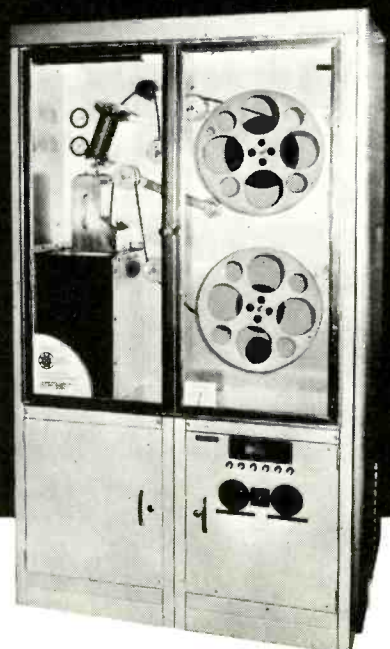

Three appointments have been announced by **Philips Broadcast Equipment Corp.** **Thomas G. Kenney** has been promoted to manager of purchasing. Prior to his association with Philips, Mr. Kenney was with Ceramics International Corp.

**Charles E. Irvin** has been appointed applications engineer. Before joining Philips, Mr. Irvin held positions with Equitable Life Assurance Society of the United States, CBS, RCA, and Dynasciences Corp.

**Herbert M. Holzberg** has been named northeast regional sales manager. Prior to joining Philips, he was with Ampex Corp.

**Memorex Corp.** has made five appointments. **Robert L. Herhusky** has been named product manager, instrumentation tape. Until recently he was with Dalmo Victor, Inc. **John B. Mandle** has been appointed director of quality control. Mr. Mandle has been associated with Memorex for two years as manager of product test laboratory; he was previously with Ampex Corp. **William Patsuris** has been appointed northwest regional sales manager. He has been associated with Memorex for four years as a sales engineer; previously, he was associated with Standard Supply Co. **John C. Wieggers** has been made southwest regional sales manager. He has been associated with Memorex for over five years, and previously was associated with Civil Air Transport Co. **John R. Studer** has been named sales engineer, serving accounts from a newly opened branch office in Cleveland. Prior to joining Memorex, he was with Burroughs Corp.

## TRANSACTIONS

Cable systems in McGehee, Dermott, and Lake Village, Ark. have been purchased by **Jim Davidson** from **Philip Farr, Jr.**

The assets of radio station **WGLB**, licensed to Port Washington, Wis. and operating on the frequency of 1560 kHz with 250 watts, have been sold, subject to FCC approval, to **Ray Friedman** and **Tom Davis**. The purchasers also own **KLEE**, Ottumwa, Iowa. The price was \$90,000. The sellers are **Mrs. Lucy Jeffers** and **Harvey Kitz**.

Subject to the approval of the FCC, the assets of radio station **KCHY**, 1590 kHz, 1000 watts, owned by **Charles Stone**, have been sold to **George McCarthy**, **Robert Chevalier**, and **Ron Overlander** for \$50,000. **KCHY** is located in Cheyenne, Wyo.▲

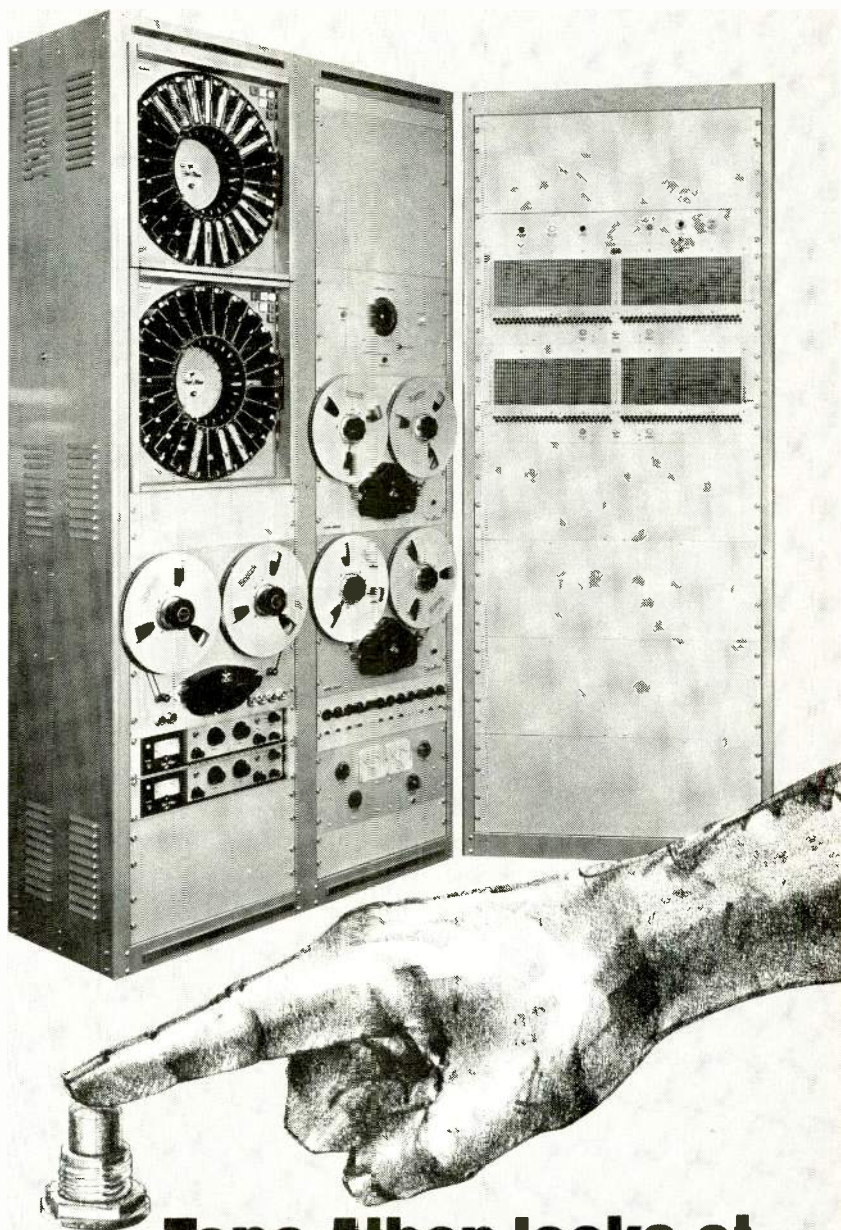

## Tape-Athon looks at the human factor in station automation

In the final analysis, all that's required to start a Tape-Athon Model 5000 Automatic Broadcasting System operating is a finger — to push the "ON" button. But, we realize the user must also get involved prior to start-up and have, therefore, designed the 5000 with his (or her) comfort in mind.

**Programming** usually a complex endeavor, has been reduced to a menial task of simply setting a switch bank to correspond with the program format. **Reel changing** has been made foolproof by Tape-Athon's exclusive one-hand reel lock and quick threading system. **Timing** for daily or weekly operation is set by merely punching a timer clock, which will start and stop the system automatically — so now you don't even need the finger any more.

A NEW BROCHURE PROVIDING DETAILS AND SPECIFICATIONS ON THE 5000 IS AVAILABLE ON REQUEST.

**Tape-Athon** 523 S. Hindry, Inglewood, Calif. 90307 • 213-678-5445

Circle Item 24 on Tech Data Card

# SPOTMASTER

## Solid-State Portable

# REMOTE AMPLIFIER

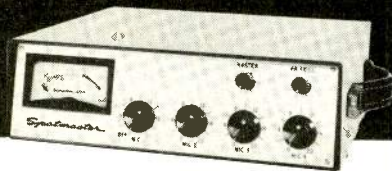

The RA-4CA is a lightweight, four-channel portable mixer amplifier specifically designed for remote broadcast or auxiliary studio use. It is completely self-contained and operates from either AC or batteries (switching automatically to battery operation if AC power fails); runs as long as 200 hours on low-cost "D" cells. It offers four microphone channels with master gain and P.A. feed, all controlled from the front panel. Lightweight construction (just 11 pounds with batteries), a convenient carrying handle and a snap-on front cover mean the RA-4CA can be easily set up to operate anywhere. For further information, please write or call today:

*Spotmaster*

**BROADCAST ELECTRONICS, INC.**

8810 Brookville Road  
Silver Spring, Maryland 20910  
Area Code 301 • 588-4983

# SUPERIOR!



## WILKINSON 4N1

### Portable Solid-State

1. FIELD INTENSITY METER
2. NULL DETECTOR
3. STANDARD SIGNAL GENERATOR
4. AM MONITOR RECEIVER

SUPERIOR BECAUSE THE 4N1:

Measures field intensity with superior accuracy and reduces measurement time.  
• Requires only a bridge for easy RF impedance measurements. • Powered by rechargeable batteries and self-lighted for nighttime measurements. • Easier to carry and operate.

FOR COMPLETE DETAILS WRITE:

# WILKINSON

## ELECTRONICS, INC.

1937 MacDADE BLVD. • WOODLYN, PA. 19094  
• TELEPHONE (215) 874-5236 874-5237 •

# NEW PRODUCTS

For further information about any item, circle the associated number on the Tech Data Card.



**Zoom Lens**  
(43)

This new 11:1 zoom lens for color and black-and-white vidicon systems features 14-mm to 145-mm depth and an  $f/2.2$  aperture. The 3M Co. Wollensak TV Raptar 11:1 zoom lens is designed for maximum flexibility in outdoor and studio operations, and to offer extended zoom range, close-up focusing (down to three feet with close-up adapting accessories), wide-angle field for close-range shooting, and wide aperture for improved picture brightness under limited lighting conditions. The seven-inch lens is available in both motorized and manual configurations.

transmits monochrome or color TV with program audio at a minimum output power of 1 watt over a frequency range of 5.9 to 8.5 GHz or 10.7 to 13.25 GHz. The system is all solid state except for the transmitter klystron, and is intended to operate over a temperature range of  $-22$  to  $+131$  degrees Fahrenheit. The equipment is designed to provide up to four high-fidelity audio program channels; to exceed all applicable NTSC color standards, FCC Rules and Regulations, Bell System practices, and EIA standards; to have no crosstalk between main and standby channels; and to allow replacement of equipment without service interruption.



**Loudness Controller**  
(46)

The availability of the new Model 710 loudness controller as part of its standard audio product line has been announced by **CBS Laboratories**. The loudness controller analyzes audio material for such factors as frequency content, combinations of complex signals, peak signal factor, and other related phenomena. The results are compared against human hearing-response standards to determine if the signal will sound louder than the surrounding program material to the listener. If the signal is louder, the instrument acts automatically to reduce the overall gain to maintain the signal within acceptable levels.

The Model 710 automatic loudness controller is priced at \$825.

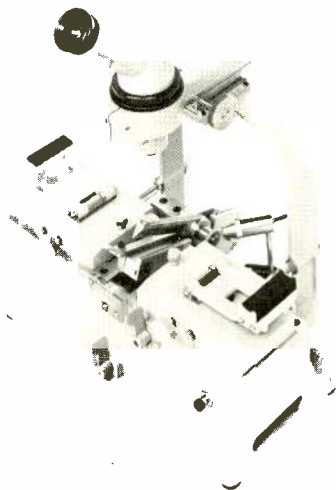

**Tape Splicer**  
(44)

The VTR tape splicer is designed to splice mechanically 2-inch video tape. The selling price is \$1250, and the splicer can be purchased directly from **Birns & Sawyer Cine Equipment Co., Inc.** or through Ampex or RCA.

**Microwave System**  
(45)

A hot-standby television microwave radio system with automatic transmitter switching is available from the **Raytheon Co.** The equipment, designated the Dual Link 2A, is a second-generation addition to the company's existing KTR microwave systems. It



**Tape Threader**  
(47)

A device to facilitate threading reel-to-reel recorders is a product of the **Turnex Co.** Called *Tape-It-Easy*, the

nonmetallic threader is constructed to prevent tape from slipping out of the take-up reel, once it has been inserted in the slot found in standard reels. It does this by pressing the tape against the side of the hole into which the tape end is threaded.

The device consists of four flexible vanes in a configuration which, combined with the elasticity of the soft rubber material, is intended to permit constant pressure against the sides of the hole. The purpose of this design is to provide these characteristics: While the threader is strong enough to hold the tape firmly for instant start of the transport, the pressure of the flexible vane will not damage the tape. Should the threader be left in a reel which is being unwound, the tape slips out when the end is reached. The threader may be withdrawn after one to two turns, or it may be left in the reel, since its weight does not upset the balance.

*Tape-It-Easy* is sold in a two-reel package which contains two of the tape threaders and two plastic holders which may be mounted on or near the recorder. The price is \$2.00.

#### **Stereo Converter for Microwave**

(48)

A solid-state FM stereo subcarrier converter has been developed by the **Catel Co.** for use in microwave relay service. The Model FMR-2500 offers a choice of subcarrier frequencies from 5.8 MHz to 8.0 MHz for the transmitter link, and converts back to 88-108 MHz at the receiving end. Specifications include an output level of +35 dBmV and 50-dB rejection of spurious signals. Price of the converter is \$450.



#### **New Transmitter**

(49)

The Model FM-1KA broadcast transmitter is powered by a 4CX1000K power tetrode which requires less than 10 watts of RF drive. The tube incorporates a solid screen ring which is connected directly to ground; this arrangement is to provide isolation between input and output circuits and eliminate the need for neutralization. Because of the high gain of the 4CX-1000K, the transmitter has no inter-

# 4-TUBE PERFORMANCE 3-TUBE SIMPLICITY

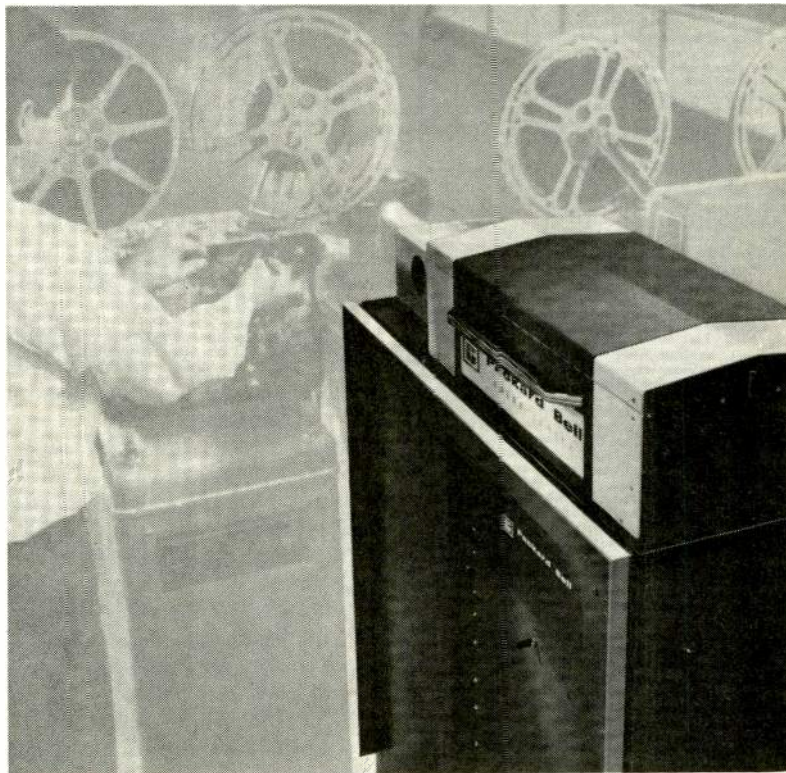

### **Only new Packard Bell Color Camera for film chains combines all these high-performance features in one economical package**

*Complete matched system*—camera plus optical multiplexer permits wide projector flexibility.

*Full EIA/NTSC compatibility* obtained with optional plug-in EIA sync modules and encoder.

*Unmatrixed monochromatic signal* for maximum definition and contrast.

*Combination of precision fixed optics* and 3-vidicon simplicity provides 4-channel standards of resolution, contrast and ease of registration.

*Superior sensitivity*—150 foot-lamberts high light-reflectance.

Write today for full information and prices. CS6

**Packard Bell**



Lawrence & Arnold Drive, Newbury Park, Calif. 91320 • Tel: (805) 498-6601



**Ideal instant playbacks at low cost with the cae Model 221 Mechanical Instant Playback Adapter**

**SATISFIES THE MOST DEMANDING VIDEO ENGINEER**

**Easily installed**

Integrates with normal VTR operation. Levelling feet for precise tracking.

**Fast, simple loading**

Takes only 5 minutes, including splicing.

**Efficient tape storage**

Accommodates 18 to 39-second playbacks.

**Adjustable**

Sliding pulley adjusts tension for odd lengths of tape.

**Strong and lightweight**

Heavy gauge aluminum construction for easy portability.

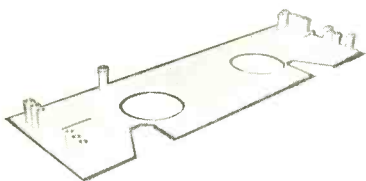

**Let us solve your instant playback problems. Contact ONEIDA ELECTRONICS INC.**

805 Court Street,  
UTICA, New York.

**cae INDUSTRIES LTD.**  
Electronics Division (Western),  
387 Sutherland Avenue,  
WINNIPEG 4, Manitoba.



Circle Item 27 on Tech Data Card

mediate power amplifier. The power-amplifier filament supply is regulated for improved tube life.

Specified line-power requirement is 2.3 kw. The transmitter is designed for remote control (including plate tuning), and it measures 76" x 28" x 28".

Available from stock, the **American Electronics Laboratories, Inc.** Model FM-1KA is priced at \$5990.

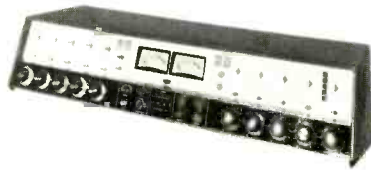

**Dual-Channel Audio Console (50)**

A self-contained dual-channel audio console designed for use in broadcast and recording applications is available from **McCurdy Radio Industries, Inc.** The all-solid-state console (Model SS-4360) is comprised of ten mixing channels; two program channels; control-room and studio monitors with muting and warning-light relays; a cue and talkback system; and a built-in power supply with individual regulated outputs for program amplifiers, cue amplifiers, and monitor amplifiers.

The mixing channels can accommodate up to 34 program sources, and any input mixing channel may be used for high- or low-level operation by using the proper plug-in module. Mixer positions 1 through 9 have 3-position input selector switches. Mixer position 10 has a 5-position selector in addition to the 3-position key for remote and network inputs.

The console accommodates two plug-in 10-watt program-monitor amplifiers in addition to the cue amplifier. The control-room monitor is supplied as an integral part of the console. The studio monitor amplifier is available as an option.

Program levels are continuously monitored by two VU meters. The B-channel meter may be selected to read four external program levels. In addition, jacks are provided for cue and monitor headsets.

The cue-intercom system provides for use of an internal, separate talkback microphone and cue speaker for optimum intelligibility and simplified switching.

**1-kw UHF Translator (51)**

A new UHF television translator, developed by **Emcee Broadcast Products**, a division of **Electronics, Missiles & Communications, Inc.**, retransmits signals at 1000 watts peak visual power, 100 watts average aural power. The translator is self-contained

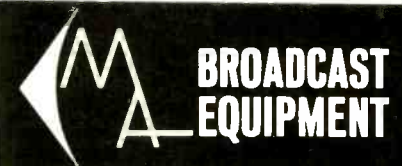

**ALL SOLID STATE AURAL STL**

Model PCL-303

- + 8 watts at 950 MHz
- + True direct FM
- + Silicon semiconductors
- + Sensitive receiver with ratio detector
- + For all STL bands

**MOSELEY ASSOCIATES, INC.**  
135 NOGAL DRIVE  
SANTA BARBARA, CALIFORNIA  
(805) 967-0424

Circle Item 28 on Tech Data Card

**You can't buy a better tape at any price!**



**And—you make more, much more, with Irish!**

Complete line of cassettes, 4 and 8 track cartridge tape, reel-to-reel tape and 1/2 and 1 inch video tapes. Write for complete details.

**IRISH TAPE**  
458 Broadway, N.Y. 10013

Circle Item 40 on Tech Data Card

**MOVING?**

Don't lose touch . . .

RECEIVE BE AS USUAL

(INCLUDE OLD AND NEW ADDRESS)

**BROADCAST ENGINEERING CIRCULATION DEPT.**  
4300 W. 62nd St.,  
Indianapolis, Ind. 46206



and includes control circuitry for automatic, unattended operation. When used with an antenna providing a gain of 10, it can be used to provide 10 kw ERP.

The new translator design incorporates transistorized circuitry throughout, with the exception of the mixer and final amplifier. The manufacturer is currently marketing two 1-kw translator models and a 1-kw add-on amplifier to increase the power output of existing translator stations.

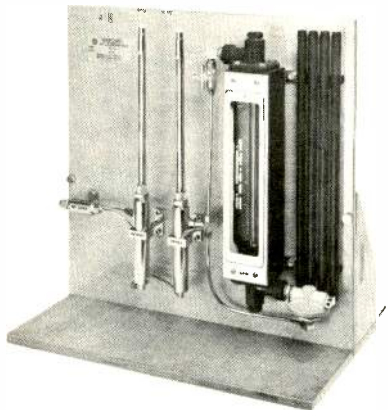

**Kilowatt RF Calorimeter**  
(52)

A new RF calorimeter designed to measure power in 50-ohm coaxial systems up to 1000 watts with 3% typical accuracy is available in five versions with "N," "C," or 1 1/4-inch EIA flanged connectors. Power is determined from input-to-output temperature differential at a constant flow rate.

These **Bird Electronic Corp.** *Termaline* RF calorimeters are self-checking at DC or 60 Hz AC, resulting in 1 1/2% stated accuracy. The instruments are portable to the point of measurement and are built to be unaffected by ambient conditions. Because of low thermal inertia of the RF loads, response time to stability is short. Specifications include: VSWR, 1.1 max DC-1000 MHz, 1.25 max to 3500 MHz; price, Model 6020, \$895.

The Model 398 flutter is an all-solid-state instrument intended to make pre-



**Flutter Meter**  
(53)

cision rms flutter measurements on any magnetic tape recorder. The internal oscillator develops a 3-kHz reference tone which is recorded on tape. Speed variations (flutter) in the recorder drive mechanism are then sensed during playback by a pulse-averaging discriminator and displayed on a dual-range panel meter. A precalibrated scope output permits viewing the flutter waveform directly.

Specifications of this **Video Research Corp.** instrument include: reference frequency, 3 kHz; reference output level, 2 volts rms; reference output impedance, 75 ohms; discriminator input-level range, .15 to 15 volts rms; discriminator input impedance, 5000 ohms; meter ranges, 0.3% and 1.0% rms full scale; scope output, 2 volts p-p equal full scale. Price of the Model 398 is \$485.

A color broadcast camera designed for one-man coverage of news and sports events has been developed by **Ampex Corp.** at the request of the **American Broadcasting Co.** The Model BC-100 may be operated over a miniature cable up to 2000 feet long, or it may also be operated by a battery-powered unit via a built-in microwave link.

The *Plumbicon* camera head weighs less than 20 pounds and is mounted on a shoulder harness to permit hand-held operation. Associated camera electronics are contained in an attache-type carrying case on the cameraman's back. Equipped for microwave opera-



**Portable Color Camera**  
(54)

tion, the pack weighs 30 pounds; when equipped for cable use, it weighs 15 pounds.

The color picture from the camera is relayed to a base station, which consists of the processing electronics, an encoder, picture and waveform monitors, and sync generator. From the base station the picture is fed to the television station for broadcasting.

The camera is 18-3/8 inches long with its 6:1 zoom lens, 13-inches high and 7 1/2-inches wide with electronic viewfinder. The back panel is 23" x 13 3/4" x 6". At a light level of 150 foot candles, a signal-to-noise ratio of 42 dB and a bandwidth of 4 MHz are specified for the camera. ▲

## Operating Remote Control? Be safe and sure!



with **ALL SOLID-STATE AM RF AMPLIFIER FROM WILKINSON!**

### Features of the Model TRF 1A:

- VERY LOW DISTORTION AND CARRIER SHIFT
- BROAD GAIN CHARACTERISTICS
- EXTREME STABILITY
- EXCELLENT SELECTIVITY
- ULTRA LINEARITY

PRICE: **\$395**

For complete details write:

**WILKINSON ELECTRONICS, INC.**

1937 MacDADE BLVD. • WOODLYN, PA. 19094  
• TELEPHONE (215) 874-5236 874-5237 •

Circle Item 30 on Tech Data Card



(Model DM-200)

**SPARTA ELECTRONIC CORPORATION**

5851 Florin Perkins Road  
Sacramento, Calif. 95828 (916) 383-5353

## NOW A DEMAGNETIZER WITH AN EXTRA-LONG WAND

### MAGNETISM CAN RUIN TAPES!

The original sound quality of all tapes can only be maintained by using a demagnetizer. The EXTRA-LONG wand of the DM-200 lets you reach the most inaccessible tape head areas of any machine. Takes just a few minutes and will eliminate distortion and background noise caused by magnetism.

PRICE: **\$6.95**  
FOB Sacramento, Calif.

Circle Item 29 on Tech Data Card

# Primo

## NEW!!



**UD-865**

**Uni-Directional  
Dynamic  
Microphone**

Designed for use at broadcasting stations, music stages and suitable for hi-fi recording.

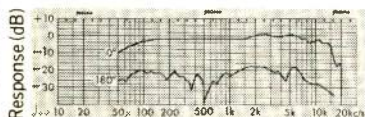

#### SPECIFICATIONS:

- Cartridge: DM-33
- Frequency Response: 50~15,000 cps  $\pm$  5dB
- Impedance: 600 $\Omega$ , 50k $\Omega$
- Sensitivity: -72dB/-53dB  $\pm$  3dB
- Dimensions: 341 x 160m/m

\* For further information please write to

### PRIMO COMPANY LTD.

Head Office: 25-1, 6-chome, Mure, Mitakashi, Tokyo, Japan. Tel. 0422-43-3121-6  
Cable: "Primo Musashino Mitaka" Telex: 2822-326 PRIMO MUS  
Chicago Illinois Office: A.P.T. No.204, 530 W. Surf. St., Chicago Illinois 60657,  
U.S.A. Tel. 312-472-61421 Telex: 25-4225 PRIMO MUS CGOILLUSA

Circle Item 31 on Tech Data Card



**COOPERATE  
WITH THE  
ZIP CODE PROGRAM  
OF THE  
POST OFFICE DEPARTMENT  
USE ZIP CODE NUMBERS  
IN ALL ADDRESSES**

## ENGINEERS' TECH DATA

### ANTENNAS, TOWERS & TRANSMISSION LINES

55. DELHI—Twelve-page catalog concerns towers and masts for Citizens-band and similar applications.
56. JAMPRO—Catalog contains specifications on new CP series circularly polarized antennas for FM broadcasting.

### AUDIO EQUIPMENT

57. ATLAS SOUND—Form PP-1840 is catalog sheet for microphone stands, booms, and accessories.
58. CROWN—SA30-30 two-channel, solid-state audio power amplifier is subject of information sheet.
59. FAIRCHILD RECORDING EQUIPT.—One-page Technical Bulletin presents FICM integrated-module strip for console development.
60. GATES—Brochures have as their subjects professional turntables and accessories, and Model M-6600 all-purpose and remote amplifier.
61. RYDER MAGNETIC SALES — Information about Sela 2880 audio mixer for use with Nagra recorders is offered.
62. SHURE—Eight-page Professional Products catalog lists microphones, circuitry, cartridges, tone arms, and microphone accessories.
63. SWITCHCRAFT—New Product Bulletin No. 170 gives descriptions and prices of seven new audio accessories, including jack, adapter, and cables.
64. UNIVERSITY — 28-page Commercial Sound Product Catalog lists speakers, horns, drivers, microphones, and sound columns; includes sound-system design chart, formulas, and technical data.

### COMPONENTS & MATERIALS

65. ELCO—Catalogs offered are: Printed-Circuit Connector Guide (64 pages), MIL-C-26482 Connector Catalog (20 pages), Variplate Connector Catalog (24 pages), Tube and Transistor Socket Catalog (14 pages), and Varicon Rack and Panel Connector Catalog (24 pages).
66. IERC — Eight-page, illustrated Short-Form Catalog includes specifications and prices for line of semiconductor heat dissipators and tube shields.
67. TROMPETER—Catalogs M-4 and T-6, listing coax, twinax, and triax patching and switching products, are offered.

### LIGHTING EQUIPMENT

68. BERKEY COLORTRAN—Issue No. 4 of **ColorTran News** features application stories of interest in the motion-picture and television industries.
69. MOLE-RICHARDSON—Supplement No. 1 to Catalog K illustrates seven new quartz lighting fixtures and several other products. Twenty-page price list for the company's products also is available.

### MICROWAVE & STL EQUIPMENT

70. MICRO-LINK/VARIAN — Descriptive specification sheet is about TVL Series TV-relay equipment.

### MISCELLANEOUS

71. DENSON—Sheets include descriptions of numerous items of new and used equipment.
72. TEXWIPE — Folder has as its subject the Texwipe Precision Cleaning Kit for magnetic tape equipment.

### POWER DEVICES

73. CLARE-ELECTROSEAL—Bulletin 1352 is about **Electro-Pac "A"** standby power supply; Bulletin 1351 is about **Electro-Pac "B"** sine-wave inverter; and Bulletin 1371 is about **Electro-Pac "C"** all-solid-state AC voltage regulator.
74. ONAN — Two-page specification sheet has illustrations and

data for line of electric generating plants designed for mobile applications.

### RECORDING & PLAYBACK EQUIPMENT

75. AMPEX—Literature available includes Bulletin V138 about VR-1200B high-band color video tape recorder, Bulletin V131 about VR-2000B high-band color recorder, and Bulletin T160 about 142 Series video tape for helical-scan machines.
76. ELECTRONIC ENG'G—Eight-page booklet contains information about **On Time** editing and control equipment for TV tape recorders.
77. JOA—Prices and data are given for new tape cartridges and for cartridge-reconditioning service.
78. METROTECH—500A Series recorders, reproducers, and slow-speed loggers are presented in two-page circular.
79. TELEX — Descriptions of Viking Studio 96 and Magnecord Models 1021 and 1022 tape recording and reproducing equipment are given in literature.

### REFERENCE MATERIAL & SCHOOLS

80. CLEVELAND INSTITUTE OF ELECTRONICS—Pocket-size plastic "Electronics Data Guide" includes formulas and tables for: frequency vs. wavelength, dB, length of antennas, and color code.

### TELEVISION EQUIPMENT

81. ALBION—Model 520 servo-controlled pan and tilt system is shown in four-page, two-color brochure.
82. ALMA—Publication gives information about AS 6500 Custom Series video switching systems.
83. CANOGA ELECTRONICS — Series VT-500 long-haul video transmission and terminal equipment, and Series 1270 miniature TV camera control are subjects of literature offer.
84. CANON USA—Literature having to do with 16-mm lenses for movie and TV use is available.
85. CLEVELAND ELECTRONICS—A 52-page quick-reference step-down die-cut catalog gives information on vidicon, **Plumbicon**, and image-orthicon deflection components.
86. COHU—Eight-page booklet, No. 8-91, is titled "The ABC's of ETV."
87. COLORADO VIDEO—Short Form 100 lists bar graph generators, video analyzers, slow-scan TV, scan converters, laboratory cameras, sync generators, and video-to-digital converters.
88. DYNAIR—Eight-page, illustrated short-form catalog lists line of professional television equipment.
89. KALART—Literature is offered for Model STV-TB 16-mm TV projector, "Moviematic" and "Duolite" 16-mm projectors, and **Tele-Beam** large-screen TV projector.
90. TELEMATION — **Porta-Sync**, all-digital miniature broadcast synchronizing generator, is described in catalog brochure.
91. TELEMET—Information sheets are for Model 3252-A1 differential phase and gain corrector, and Model 3701-A1 differential phase and gain test receiver.
92. VITAL—Model VIX-108, new integrated-circuit vertical interval switching system, is subject of literature.

### TEST & MEASURING EQUIPMENT

93. BALL BROS. RESEARCH—Specifications and information about Mark 21-RM video waveform monitor are given in catalog sheet.
94. B & K—Bulletins are available for the following instruments: Model 2409 AC voltmeter/amplifier; Model 4240 simulated voice mechanism, for testing telephone transmitters and handsets; Model 2410 AF voltmeter/amplifier; Model 2417 rms voltmeter; Model 2006 heterodyne voltmeter; and Model 3350/51 electroacoustic transmission measuring system, for tests on telephone handsets.
95. DELTA—Information sheet has as its subject the Model RG-1 receiver/generator for use with impedance bridges in antenna-system measurements.
96. EICO—1968 short-form catalog, including test equipment in kit or wired form, is offered.
97. METRON—Information about Model 506B-1 amplitude modulation monitor is contained in specification sheet.
98. TEKTRONIX—Description and specifications are available for Type 520/R520 NTSC vectorscope, designed to measure luminance, hue, and saturation of NTSC color TV signal.

# New...

## FADER ARM

*Now available  
for use  
with AEM  
Lap-dissolve  
Amplifiers*

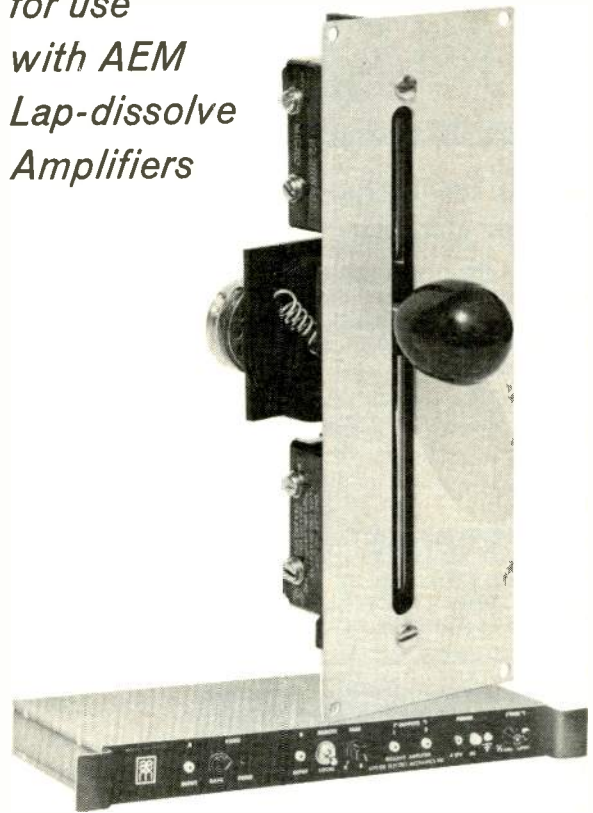

**Now...** the smooth, velvety transition function associated with AEM's Lap-Dissolve amplifiers can be remotely obtained by means of AEM's new, compact fader arm assembly.

Easily paralleled into existing LDA-1 or LDA-2 amplifiers, the assembly can be readily mounted into a control console with minimum interconnections. Teflon slides assure ease of movement while built-in limit switches, at each end of travel, can control external functions. Although designed for operation with AEM's LDA-series amplifiers, the fader arm control can also be adapted for use with other similar equipment. Panel mounting dimensions are  $2\frac{5}{8}$ " x  $7\frac{5}{8}$ ", and weight is  $1\frac{1}{2}$  pounds. Prices: \$65 if purchased for use with LDA-series amplifier; \$95 if purchased alone. For further information, please contact:

### APPLIED ELECTRO MECHANICS, INC.

2350 Duke Street, Alexandria, Virginia 22314  
PHONE: (703) 548-2166



The soundest sound in audio  
is the new sound of Gates

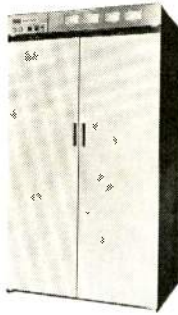

### What FM transmitter power do you need?

Gates has the most complete line of FM transmitters in the industry. From 10 watts to 40,000 watts. All with the solid state "DCFM" 10-watt FM exciter. Tell us the power you need and ask for data on our FM antennas. Write or phone (217) 222-8202 today.



**GATES**

GATES RADIO COMPANY  
QUINCY, ILLINOIS 62301, U.S.A.  
A subsidiary of Harris-Intertype Corporation

Circle Item 33 on Tech Data Card

## SPOTMASTER

The all solid state AD1A

## AUDIO DISTRIBUTION AMPLIFIER



Meet the AD1A, a solid state audio distribution amplifier specifically designed for AM, FM and TV broadcast stations and recording studios. The AD1A distributes audio signals via five separate output channels (up to 25 with the addition of AD1A-X extenders), and incorporates a front-panel VU meter and monitor jack to permit visual and aural monitoring of the incoming signal at the output of the line amplifier. Response is essentially flat from 40 to 20,000 Hz, with low distortion and noise, 60 db channel isolation and 12 db peak factor. For further information, write or call today:

*Spotmaster*  
**BROADCAST ELECTRONICS, INC.**

8810 Brookville Road  
Silver Spring, Maryland 20910  
Area Code 301 • 588-4983

## Advertisers' Index

Allen Avionics, Inc. ....	52
Andrew Corp. ....	45
Applied Electro Mechanics, Inc. ....	59
CAE Industries, Ltd. ....	56
CBS Laboratories, Div. of CBS, Inc. ....	5
Cleveland Institute of Electronics ....	33
Cohu Electronics, Inc. ....	3
Collins Radio Co. ....	29
Conrac Div., Conrac Corp. ....	46, 47
Electro-Voice, Inc. ....	15, 36, 37
Fairchild Recording Equipment Co. ....	6
Gates Radio Co. ....	11, 60
Industrial Electric Reels, Inc. ....	42
International Nuclear Corp. ....	Cover 3
ITT Federal Electric Corp. ....	8
Jampro Antenna Co. ....	23
Kappa Networks, Inc. ....	49
Lipsner-Smith Corp. ....	52
Microwave Associates ....	32
Morhan National Sales ....	56
Moseley Associates, Inc. ....	56
Packard Bell, Space & Systems Div. ....	55
Phelps Dodge Electronic Products Corp. ....	21
Philips Broadcast Equipment Corp. ....	16, 17
Primo Co., Ltd. ....	58
Riker Video Industries, Inc. ....	Cover 2
Round Hill Associates, Inc. ....	25
Shure Brothers, Inc. ....	41
Sparta Electronic Corp. ....	57
Spotmaster (Broadcast Electronics, Inc.) ....	48, 54, 60
Stanton Magnetics ....	10
Tape-Athon ....	53
TeleMation, Inc. ....	50, 51
Tele-Measurements, Inc. ....	34
Telemet Co. ....	Cover 4
Vital Industries ....	9
Ward Electronic Industries, Inc. ....	7
Wilkinson Electronics, Inc. ....	54, 57, 60

Replace  
Mercury  
Vapor  
Tubes  
Directly  
with

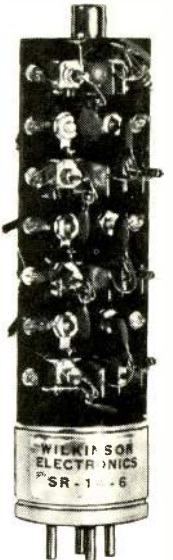

**WILKINSON**  
**Silicon Rectifier**  
**Stacks!**

Because...

- Only non-encapsulated WILKINSON Silicon Rectifiers can be repaired in seconds with low-cost replacement diodes!
- Exclusive "GO, NO GO" indicator automatically warns when the reverse leakage of any diode is in excess of 50 microamps.
- Only WILKINSON Silicon Rectifiers are available in a complete tube replacement range of from 866 to 857B.
- WILKINSON Silicon Rectifiers function in ambient temperatures of from - 85 F to +158 F.
- No more filament heat and consequent filament burnout... lower power cost and reduced hum, too.
- No warm up time is necessary... instantaneous operation!
- Just plug in WILKINSON Silicon Rectifiers... no re-wiring is necessary.
- Only WILKINSON Silicon Rectifiers are fully guaranteed and have a safety margin well in excess of tube rating.

For complete details write today to:

**WILKINSON**  
**ELECTRONICS, INC.**

1937 MACDADE BLVD. WOODLYN, PA. 19094  
TELEPHONE (215) 874-5236 874-5237

Circle Item 34 on Tech Data Card

BROADCAST ENGINEERING

## Professional Services

### VIR JAMES

CONSULTING RADIO ENGINEERS  
Applications and Field Engineering  
345 Colorado Blvd.  
Phone: (Area Code 303) 333-5562  
**DENVER, COLORADO 80206**  
Member AFCCE  
TWX 910-931-0514

### JAMES C. McNARY

Consulting Engineer  
National Press Bldg.

Washington 4, D. C.  
Telephone District 7-1205  
Member AFCCE

### CAMBRIDGE CRYSTALS PRECISION FREQUENCY MEASURING SERVICE

SPECIALISTS FOR AM-FM-TV  
445 Concord Ave. Phone 876-2810  
Cambridge, Mass. 02138

**AMPEX HEAD ASSEMBLY RECONDI-  
TIONING SERVICE** for all Ampex pro-  
fessional model recorders. This pro-  
fessional service features precision relap-  
ping of all heads for maximum head life.  
Your assembly is thoroughly cleaned and  
guides are replaced as required. Price in-  
cludes optical and electrical inspection  
and complete testing on Ampex equip-  
ment in our plant. Full track or half  
track assemblies . . . \$35.00. One to two  
day service. "Loaner" assemblies avail-  
able if necessary. LIPPS, INC., 1630  
Euclid Street, Santa Monica, California  
90404. (213) EX 3-0449. tf

**CRYSTAL AND MONITOR SERVICE** — Fre-  
quency change and repair service for AM  
monitors including G.R., RCA, Gates, W.E.,  
and Doolittle; also H-P 335B FM. AM moni-  
tors bought and sold. What have you, what  
do you need? New or regrinding of AM  
crystals for RCA, Gates, Billey, W.E., and  
J-K oven holders, repairs, etc. Fastest ser-  
vice, reasonable prices. Over 25 years in  
this business. Eidson Electronic Co., Box  
96, Temple, Texas 76501, Phone 817 773-3901.  
2-67-tf

### ROSNER TELEVISION SYSTEMS

ENGINEERS  
120 E. 56 St.  
New York  
N. Y. 10022

CONTRACTORS  
230 Newtown Rd.  
Plainview  
N. Y. 11803

### VIDEO TAPE RECORDER

#### AUDIO HEAD ASSEMBLY SERVICE

Precision relapping of all heads and sup-  
porting posts, including cleaning and  
testing. Ampex head assembly with "cue"  
tracks, \$75.00 complete. RCA units also  
relapped. One to two day service. LIPPS,  
INC., 1630 Euclid St., Santa Monica, Calif.  
90404. (213) EX 3-0449. tf

### JOHN H. MULLANEY and ASSOCIATES

Suite 71,  
1150 Connecticut Ave., N.W.  
Washington, D. C. 20036  
Phone 202-223-1180  
Member AFCCE

### CANADA

LEONARD H. MAILE  
B.Sc., M.E.I.C., P.ENG

CONSULTING STRUCTURAL ENGINEER  
COMMUNICATIONS TOWERS

TELEPHONE BOX 512, STATION Q  
489-6587 TORONTO 7, ONTARIO

### FRANK A. ZOELLER

Television Systems Consultant  
20 yrs. experience in TV and ETV  
— All phases. Box 366, San Carlos,  
Calif. 94070. Pr. (415) 593-1751

## Classified

Advertising rates in the Classified  
Section are fifteen cents per word.  
Minimum charge is \$2.00. Blind box  
number is 50 cents extra.

## Equipment for Sale

**SPOTMASTER** cartridge equipment and  
accessories, Crow tape recorders, QRK,  
versal Audio Products, Pultec, Norelco  
Rek-O-Kut, Russco (turntables and  
preamplifiers) Gray and Euphonics tone-  
arms, Metron modulation monitors,  
Universal Audio Products, Pultec, Norel-  
co-AKG microphones, Fidelipac and  
Audiopak cartridges. Writes for special  
money saving offers. Audiovox, Box  
7067-55, Miami, Florida 33155. 11-67-tf

**CO-AXIAL CABLE** Helix, Styroflex, Spiro-  
line, etc. Also rigid and RG types in stock.  
New material. Write for list. Sierra-Western  
Electric Co., Willow and 24th Streets, Oak-  
land, Calif. Phone 415 832-3527 5-66-tf

**Television / Radio / communications gear of  
any type available. From a tower to a  
tube. Microwave, transmitters, cameras,  
studio equipment, mikes, etc. Advise your  
needs—offers. Electrofind Co., 440 Columbus  
Ave., NYC. 212-EN-25680. 8-64 tf**

**"AUDIO EQUIPMENT** — Whatever your  
needs, check us first. New and used. Amp-  
ex, Altec, AKG, EV, Fairchild, Neumann,  
Langevin, Rek-O-Kut, Uher, Viking. Send  
for equipment list." Audio Distributors,  
Inc., 2342 S. Division Ave., Grand Rapids,  
Michigan 49507. 6-66-tf

## CARTRIDGE TAPE EQUIPMENT

Completely reconditioned and guaranteed.  
Spotmaster Model 500 Record/Playbacks,  
\$350.00. Model 505 Playbacks \$250.00. 30-  
day money-back guarantee on all equip-  
ment.

### BROADCAST PRODUCTS COMPANY

18804 Woodway Drive, Derwood, Maryland,  
20855  
(301) 926-4600 3-67-12t

Everything in used broadcast equipment.  
Write for complete listings. Broadcast  
Equipment and Supply Co., Box 3141, Bris-  
tol, Tennessee. 11-64-tf

**Audio Equipment** bought, sold, traded.  
Ampex, Fairchild, Crown, McIntosh, Viking  
F. T. C. Brewer Company, Town & Country  
Plaza, Pensacola, Florida. 3-64-tf

**BROADCAST EQUIPMENT REBUILDERS . . .**  
your headquarters for tape cartridge recon-  
ditioning, all work fully guaranteed! Write  
Quin Morrison about your used equipment  
needs. New Address: Box 276, Hickory, N.C.  
28601. 11-67-tf

**Coils, Contactors, Switches, Complete ATU**  
systems. Top Quality, Lowest Prices, Fast  
Delivery, No Duty. Write for catalogue:  
Geleco Electronics Ltd., 2 Thorncliffe Pk.  
Dr., Toronto 17, Ont. 416-421-5631. 11-67-12t

**TOWERS, lights and accessories AM FM com-  
munication, CATV, sales, erection and complete  
service, world wide. Write Dixie Steeplejack  
Company, 2832 Riverview Blvd. West, Braden-  
ton, Florida. tf**

**RCA TT-5A, CHANNEL 5 Transmitter** with  
side-band filter, WM-12, WM-13, Visual Mod-  
ulation Converters and Power Supply. No con-  
trol console. R. E. Oldfield, Southern Colorado  
State College, Pueblo, Colorado 81005. 1-68-2t

**FOR SALE: Two Gates CB-11 16" turntables**  
in cases, complete with Rek-o-cut 160 arms,  
GE VR-11 pickup, Gates pre-amp & Daven  
Pot w/cue. 600 ohms out, connect and go!  
\$200.00. Fairchild disc recorder with head,  
no amplifier. \$125.00. Gates dynonote remote  
amplifier, 4 channel, \$200. Cleaning house.  
WFOX Radio, Milwaukee, Wis. 53202 (Chief  
Engineer). 2-68-1t

## Equipment Wanted

**We need used 250, 500, 5K & 10K Watts  
AM Transmitters. No Junk. Guarantee**  
Radio Supply Corp., 1314 Iturbide St.,  
Laredo, Texas 78040. 3-66-tf

**SPOTMASTERS WANTED**—Model 500 Re-  
cord/Playbacks and Model 505 Playbacks.  
Send full details to: BROADCAST PROD-  
UCTS COMPANY, 18804 Woodway Drive,  
Derwood, Maryland 20855 (301) 926-4600.  
10-67-6t

**WANTED**—Used 3 to 10 Kilowatt FM Trans-  
mitter with exciter (stereo if available),  
modulation monitors, and FM antenna. In-  
terested in complete station as above or  
individual items. Write giving full details  
to Box No. 195. BROADCAST ENGINEERING.  
2-68-1t

## Employment

**IMMEDIATE OPENINGS**—Qualify for any of the following positions: Technicians for RCA Closed Circuit Television equipment, Cameramen, Maintenance men, Video Tape men, Video Engineers, Sales Engineers. RCA Rep. 143-08 94th Ave., Jamaica, New York, or (212) 297-7344. 7-67-tf

**Electrical Engineers** needed immediately for TV/Radio stations, manufacturers, and CATV for all positions. Send well prepared resume to Nationwide Broadcast Personnel Consultants, 645 North Michigan Avenue, Chicago, Illinois, 60611. We have openings for all qualified applicants and the employer pays our fee. 10-67-tf

**Immediate opening for Broadcast Engineer.** All color station, second class license or better required. Send resume to WNYS-TV Channel 9, Syracuse, Inc. P.O. Box 9, Syracuse, N.Y. 13214. 10-67-tf

**Job Headquarters** for all Radio and Television Engineers. Immediate openings exist in 9 western states and elsewhere for qualified engineer and technical personnel. All categories from trainees to experienced transmitter maintenance, chief, assistant chief, live color video maintenance and technical operations. Send us your complete resume now. The AMPS Agency, 3924 Wilshire Blvd., Los Angeles, California 90005. Telephone DU 8-3116.

By Broadcasters—For Broadcasters 11-66-tf

**Opportunity for engineer** with black-and-white TV experience to learn color in a medium sized market using new Plumbicon cameras and highband VTR's Call Chief Engineer collect today — 313-239-6611. 12-67-3t

**Wanted: Chief Engineer** for medium market AM/FM station. Northeast U.S. No announcing. Market leader. \$130/wk. Send resume to Box 190. 12-67-4t

**Opportunity to work** in all phases of TV technical operation with live color-VHF in beautiful Texas resort city. Box 194. 1-68-2t

**WANTED**—First Phone licensed engineer to work in South. Must have four to five years experience in TV broadcasting as studio maintenance engineer. Send resume with salary requirements to Box 191. 1-68-3t

**WANTED**—Experienced CATV technician to work in South. Send resume with salary requirements to Box 192. 1-68-3t

Established western manufacturer & distributor needs **SERVICE MANAGER**. Must be experienced in:  
Broadcast Studio Equipment,  
Including VTR  
Color TV Equipment,  
Supervision of Technical Personnel  
Limited travel. Excellent benefits.  
Salary dependent on qualifications. Send resume to Box 197. 2-68-2t

## BROADCAST SALES ENGINEER

Exclusive territory for sale of rapidly expanding line of broadcast equipment requires highly motivated, sales-minded individual with strong technical knowledge of equipment primarily to AM, FM, and TV stations. Leading company with history of high profit and rapid growth. Salary plus commission—with full fringe benefits and travel expenses paid. An equal opportunity employer. Send resume to Box 196. 2-68-2t

## Training

To advance in electronics, knowledge and ability are required. Grantham offers correspondence and resident instruction, in depth, leading to the degree of Associate in Science in Electronics Engineering. G.I. Bill approved. Credit for previous training and experience allowed. Free Catalog. Write: Dept. E-2, Grantham School of Electronics, 1505 N. Western Ave., Hollywood, California 90027. 6-67-tf



## GOING TO THE NAB CONVENTION?

We are.

We'll tell you  
about it in

Broadcast Engineering

## Is Your Blood Pressure HIGH?

Only your doctor can tell. Now he can control most cases with pressure-lowering drugs and new methods of treatment.

But more research is needed to find ways of preventing this leading cause of heart attack and stroke.

Your Heart Fund dollars help make this research possible.

GIVE...  
so more will live  
**HEART FUND**



Contributed by the Publisher

BROADCAST ENGINEERING

Name \_\_\_\_\_

Address \_\_\_\_\_

Title \_\_\_\_\_ Company \_\_\_\_\_

City \_\_\_\_\_ State \_\_\_\_\_ Zip \_\_\_\_\_

Mail your entry to International Nuclear Corporation, 608 Norris Avenue, Nashville, Tennessee. Decision of the Judges is final, and duplicate prizes cannot (understandably) be awarded. The winner, if any, will receive the secretarial services of Miss International Nuclear for a five day work week.

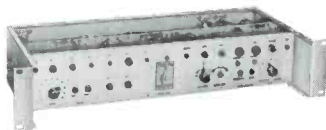

1



2



3



4



5

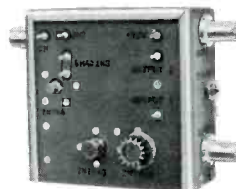

6



7



9



8



10

# Win Miss International Nuclear for seven fun-filled days.

Here's a nifty contest. Simple rules. If you can name all the International Nuclear products pictured above, we'll send you a neat 8 x 10 glossy picture of Miss International Nuclear (in a plain brown wrapper). We'll even send you one for a good try. If you own one or more of each of the International Nuclear products pictured above, we'll send you Miss International Nuclear . . . to keep as your personal secretary for one glorious week. Offer good until March 15, 1968. Order at least one of everything NOW!



# MAKE YOUR LF NOISE FEEL "REJECTED" with these Clamping Champs by Telemet

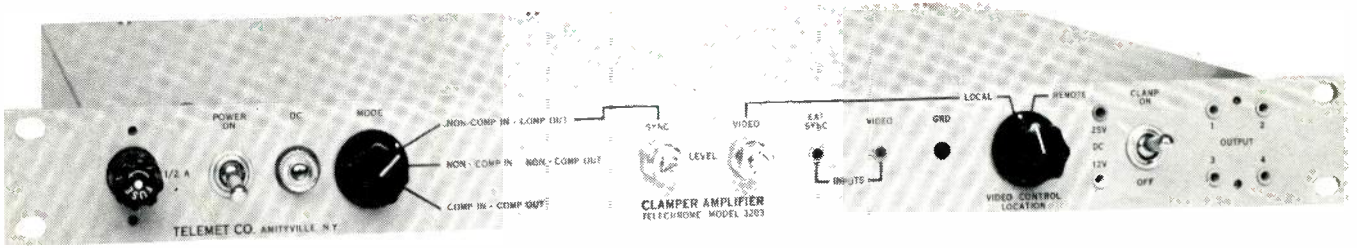

## CLAMPER AMPLIFIER MODEL 3203

- For general use in 75 ohm systems
- Feedback type clamp with four outputs
  - Hum rejection 34 dB nominal
  - Sync addition capabilities for non-composite signals

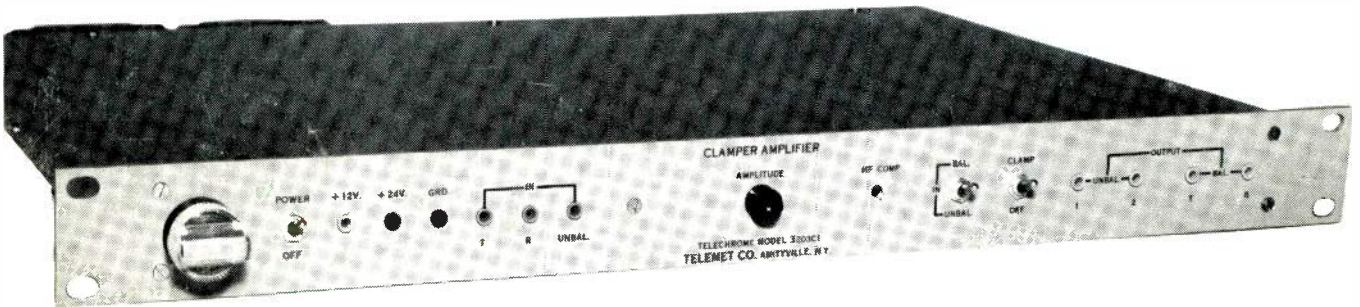

## CLAMPER AMPLIFIER MODEL 3203-C1

- Multi-purpose clamper
  - Switchable inputs 75 ohm unbalanced and 124 ohm balanced
  - 18 dB gain for microwave applications
    - Ideal for clamping 124 ohm balanced video pairs
    - High frequency compensation on front panel

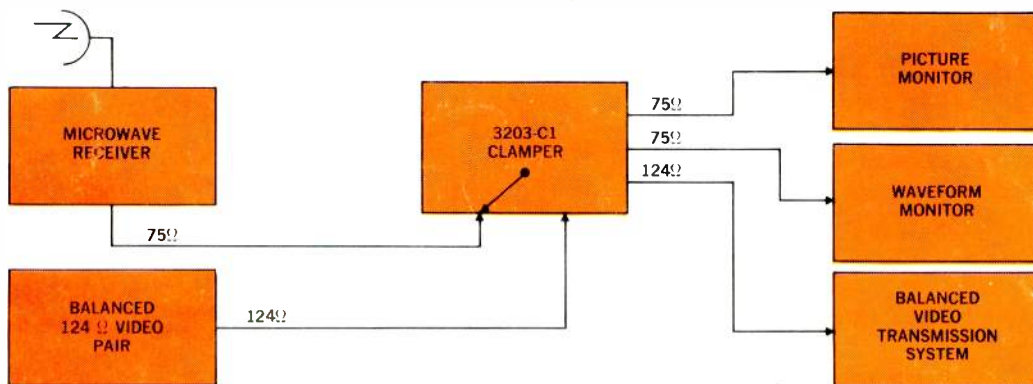

**TELEMET COMPANY**

185 DIXON AVENUE / AMITYVILLE, NEW YORK 11701 / PHONE: (516) 541-3600

Circle Item 36 on Tech Data Card