



A HOWARD W. SAMS PUBLICATION



AUGUST, 1968/75 cents

Broadcast Engineering

*the technical journal
of the broadcast-
communications industry*

ETV In Las Vegas, Page 12



model 1551 video test set

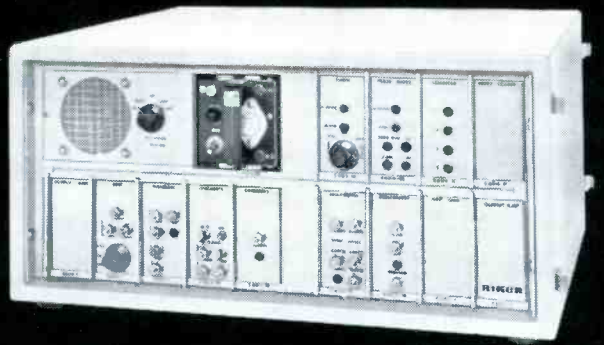

**here's a new, lightweight
portable video test set
that's as reliable
in death valley as it is
on pike's peak**



Removable front cover and accessories are self-storing.

available test signals

10 Step Linearity
Window
Sin² Window
Multiburst
Bar & Dot

features

Temperature stable
Reliable solid state design
Modular test signal generators
Dual isolated outputs
Self-storing accessories
Easily serviced in the field

Riker's new 1551 Video Test Set has been developed specifically for the telephone industry to insure accurate analysis of video transmission quality and is presently in use in a number of Bell System installations. The 1551 is lightweight, shock resistant and especially suited to field use, providing continuous and reliable operation over the widest possible range of climatic conditions.

All test signals generated by the 1551 are composite with standard EIA Sync. Dual outputs are provided at 124 ohms balanced and 75 ohms unbalanced allowing measurements to be made into balanced terminal equipment and unbalanced lines or facilities.

The plug-in design of the individual test signal modules makes it easy to service and maintain the test set in field locations. Failure or removal of any single module will not affect the performance of the remaining test signal generators. All accessories, including a removable cover, are self-storing to prevent loss during long term use.

RIKER

PRODUCTS FOR VIDEO ANALYSIS, SIMULATION & CONTROL.

RIKER VIDEO INDUSTRIES • 100 PARKWAY DRIVE SOUTH • HAUPPAUGE, L.I., NEW YORK 11787 • (516) 543-5200

GROOVY!

Cohu's new TV accessory modules fit in anywhere.

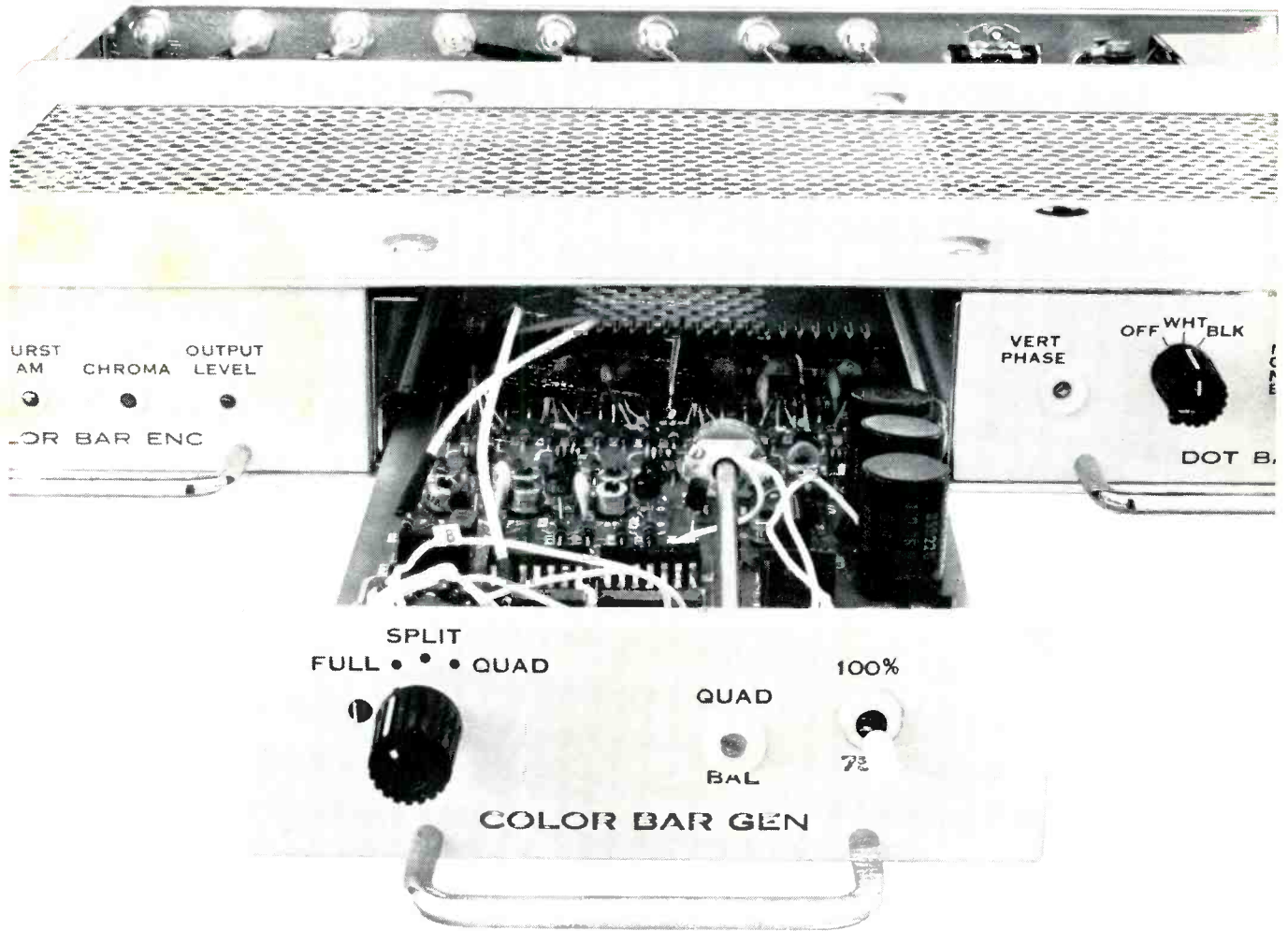

Modular construction and solid-state design provide excellent compatibility between Cohu's new 2610/2620 Accessory Series and existing broadcast equipment. Each frame occupies only 1 $\frac{3}{4}$ " of rack space, has a plug-in power supply, and is prewired for a combination of three modules. Accessories include a drive generator, colorlock, black burst generator, dot • bar • crosshatch generator, color bar generator and color bar encoder.

Also available in the 2610/2620 Series is the chroma detector, which improves the quality of monochrome transmission by automatically removing all chrominance from the encoder output during transition.

See us at Wescon Sports Arena booths
1601-1602. August 20-23.

For specific data on each accessory, contact your local Cohu engineering representative, or call Bob Boulio direct at 714-277-6700. Box 623 • San Diego, California 92112 • TWX 910-335-1244.

ELECTRONICS, INC.
SAN DIEGO DIVISION

Circle Item 2 on Tech Data Card



Broadcast Engineering

The technical journal of the broadcast-communications industry

in this issue...

12 KLVX complex: ETV for school and the Community. Station KLVX is part of a complex educational television system planned to overcome the problem of scheduling. **Thomes E. Wilson.**

16 Understanding Klystron Amplifiers. A review of klystron fundamentals including operation and tuning procedures. **Perry Dudley.**

22 Reworking the Link 2210 for Remote Pickup Duty. Converting the Link model 2210 to a lightweight remote pickup unit. **Phil Whitney.**

27 NTCA Convention Features Progress and Promise. Coverage of the annual convention held in July.

ABOUT THE COVER

Shown on the cover is part of the transmitting complex of KLVX, an ETV complex designed to overcome one of the problems facing educational television: scheduling.

DEPARTMENTS

News of the Industry ... 4
Washington Bulletin ... 33
Personalities in the
Industry ... 42
New Products ... 38
Engineers' Tech Data ... 36
Advertisers' Index ... 46
Classified Ads ... 47, 48

EDITORIAL

GEO. H. SEFEROVICH, Director
RONALD N. MERRELL, Editor
ANN L. GURLEY, Editorial Assistant
DUDLEY ROSE, Art Director
LEE JOHNSON, Assistant Artist

REGIONAL EDITORS

GEORGE M. FRESE, Northwest
HOWARD T. HEAD, Washington, D.C.
ROBERT A. JONES, Midwest

EDITORIAL ADVISORY BOARD

LES NELSON, Chairman
Howard W. Sams & Co., Indianapolis

CIRCULATION

R. VINCENT WARD, Director
PAT OSBORNE, Manager

ADVERTISING

E. P. LANGAN, Director
R. JACK HANCOCK, Manager
S. F. WILSON, Production
LEE MILLER, Promotion

REGIONAL ADVERTISING SALES OFFICES

Indianapolis, Indiana 46206
ROY HENRY
HOWARD W. SAMS & CO., INC.
4300 West 62nd St.
Tele: 317/291-3100

New York, New York 10019
ALFRED A. MENGUS
3 W. 57th St.
Tele: 212/Murray Hill 8-6350

Los Angeles, California
G.R. HOLTZ
THE MAURICE A. KIMBALL CO., INC.
2008 Carson St., Suites 203-204
Torrance, California 90501
Tele: 415/392-3365

San Francisco, California 94104
THE MAURICE A. KIMBALL CO., INC.
580 Market Street, Room 400
Tele: 415/392-3365

London W. C. 2, England
JOHN ASHCRAFT & CO.
12 Bear Street
Leicester Square
Tele: Whitehall 0525

Amsterdam C, Holland
JOHN ASHCRAFT & CO.
W.J.M. Sanders, Mgr.
Herengracht 365
for Benelux & Germany
Tele: 24.09.08

Paris 5, France
9 Rue Lagrange
ODEon 20.87

Tokyo, Japan
INTERNATIONAL MEDIA
REPRESENTATIVES, LTD.
3, Nakanochō, Akasaka, Minato-ku
Tele: 582-5881



BROADCAST ENGINEERING is published monthly by Intertec Publishing Corp., 1014 Wyandotte Street, Kansas City, Missouri 64105.

Subscription Prices: U.S.A. \$6.00, one year; \$10.00 two years; \$13.00 three years. Outside the U.S.A., add \$1.00 per year for postage. Single copies are 75 cents, back issues are \$1.00.

Controlled Circulation Postage Paid at Indianapolis, Ind. Published monthly by INTERTEC PUBLISHING CORP., 1014 Wyandotte St., Kansas City, Mo. 64105.

Copyright, 1968, Howard W. Sams Co., Inc. All Rights Reserved. Material may not be reproduced or photocopied in any form without written permission of publisher.



Robert E. Hertel, Publisher

Intertec Publishing Corp.
Subsidiary of Howard W. Sams & Co., Inc.

For years we've been offering a 30-day free trial, a full year's warranty on parts and labor, an increase in effective coverage, a guarantee of protection against overmodulation without distortion—but there are still a few of you who haven't tried AUDIMAX and VOLUMAX.

You sure are a tough audience!

Audimax reacts to any given program situation in exactly the same way as your best audio man would — only a lot faster and more efficiently. It eliminates distortion, thumping, pumping, audio "holes", and bridges through program pauses to eliminate the "swish-up" of background noise. It even returns the gain to normal during standby conditions. Big claims? You bet. But we're willing to back them up with a 30-day free trial in your own studio. After that, send us \$665 if you like it. If not, send it back — freight charges collect. What can you lose? By keeping average modulation up, everybody wins. Volumax for AM broadcasters costs the same as Aud-

imax and limits peaks without side effects. Its action may be gentle or microsecond fast. That depends on the program waveform but the end result of the Audimax-Volumax team is **always a more even and pleasant sounding program that may be transmitted safely at much higher effective power levels.** That's another big claim we'll back up with a free trial.

We've even got a claim for FM and TV broadcasters. FM Volumax is absolutely guaranteed to prevent FM overmodulation and SCA crosstalk without distortion. This one costs \$695.

Write and let us back these claims with a 30-day free trial. Or better yet—call us collect at (203) 327-2000.

PROFESSIONAL
PRODUCTS
 **CBS LABORATORIES**
Stamford, Connecticut. A Division of
Columbia Broadcasting System, Inc.

NEWS OF THE INDUSTRY

NATIONAL

Improved FM Radio For Trenton, N.J.

WTOA, Trenton, N.J. turned on its full 50,000 watts of stereo power on Monday, June 24th making it New Jersey's most powerful station.

Dedication ceremonies of the improved facilities took place on May 17th during a live broadcast which included Governor Hughes and Trenton Government officials.

The 19 year old FM station, which was acquired by Nassau Broadcasting Company three years ago, will have 50,000 watts of horizontal power and 50,000 watts of verticle power. With full primary service over Trenton, Philadelphia, and New Brunswick, WTOA, will be one of the country's top 100 markets.

CATV Comes To Titusville, Fla.

Gulf + Western Industries, Inc. and North Brevard Cable Television Company announced a short time ago a venture to build and operate a cable television facility in Titusville, Florida. Benjamin E. Lewis, general manager and founder of North Brevard, said construction would begin in early September and at least one hundred miles of co-axial cable would be completed within a year.

WBLG-TV Begins Broadcasting In Lexington, Kentucky

WLGB-TV, a new commercial TV station on channel 62 in Lexington, Ky., went on the air with regular programming at 9:30 A.M. June 2.

The 998 foot WBLG-TV tower is the highest above sea level in Kentucky and the station's power of 1¼ million watts is the greatest in the state. A construction permit for the station was issued to the company by the Federal Communications Commission last September. The application was first filed with the FCC in the fall of 1965.

Continental CATV Announces New System For N.J.

John F. Gault, president of Continental CATV, recently announced

the opening of a new CATV system. General CATV covers the towns of Willingboro, Burlington and Delran, N.J. and is a total complex covering 450 miles. The system has a potential of 30,000 subscribers. The first phase of 90 miles has been opened. Many celebrities of the CATV industry were present for the two days of festivities.

INTERNATIONAL

Indonesian Govt. Orders Satellite Equipment

Construction of satellite communication equipment for the terminal ordered by the Indonesian government has begun at ITT Defense Communications Division in Nutley, N.J.

The terminal, to be located 80 miles southeast of Djakarta, will consist of a 90-foot-diameter antenna, operations control building and a power station. It will be Indonesia's commercial telephone, telegraph and television link to the world via Intelsat III series of satellites.

RCA Will Supply TV-FM Station In Brazil

RCA has announced that it will supply studio and transmitting equipment for a new combination TV-FM broadcast station in Sao Paulo, Brazil.

The station's TV and radio transmitters will be located at an altitude of 3,500 feet on Jaragua Mountain on the outskirts of Sao Paulo.

Carlos A. Schmidt Sarmento, vice-president of the Father Anchieta Foundation, said the two stations and the existing AM facilities would be operated by the Radio and TV Educational Center for Sao Paulo. Programming will concentrate on cultural and educational activities and plans call for remote pickups at theaters, opera houses and similar locations.

Construction In Chile

A permanent satellite communications earth station in Chile was expected to be completed in July. Located at Longovillo, the facility

will serve as a ground terminal for voice, television, and data communications to and from an Intelsat II satellite in synchronous orbit 22,300 miles over the Atlantic Ocean. GT&E International is constructing the station under a contract awarded by Empresa Nacional de Telecomunicaciones S.A., a company established in 1964 with responsibility for Chile's long-distance telecommunications.

ORGANIZATIONS

Communications Assn. Elects New Officers

The Niagra Frontier Communications Association, a group interested in radio and television broadcasting, meeting monthly, have elected the following officers for the year 1968-1969: Frank Maser, chief engineer for WBEN-TV, was elected chairman. Leroy Fielder, chief engineer of WKBW-AM, vice-chairman. Duane W. Fischer, associated with Hamburg Central Schools, secretary-treasurer.

A Recent Meeting of The Board of Directors NAB

In a June meeting of the Board of Directors of the National Association of Broadcasters, Oklahoma broadcasters and their state associations were commended for "firm handling" of a recent attempt by two Federal Communication Commission members to obtain operational details from the stations without approval of a majority of the Commission.

The action relates to a request of Oklahoma broadcasters by FCC Commissioners Nicholas Johnson and Kenneth Cox. The request was made independent of regular Commission procedure for studying license renewals.

GAB Gives TV And Radio Awards At Convention

The Georgia Association of Broadcasters this year named WJBF-TV, Augusta, the state's "TV Station of the Year." The presentation was made at the annual GAB

5 QUESTIONS

engineers ask before they buy our solid-state transmitter COLOR Phase Equalizer & Low Pass Video Filter

**NOW IN USE IN
OVER 200 STATIONS**

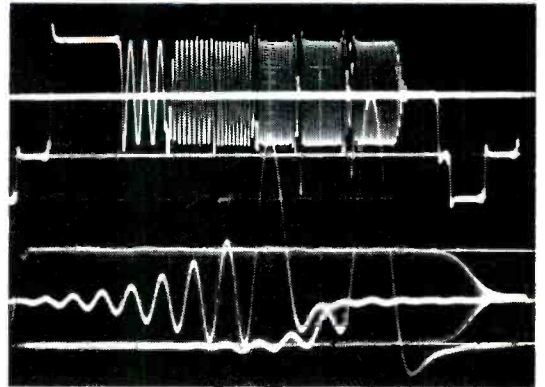

TYPICAL SYSTEM OUTPUT — SWEEP,
MULTI-BURST, 2 T AND T PULSE

1. What is the overall Frequency Response of the Equalizer System including the Video Low Pass Filter?

Ans. ± 0.5 db 10 cps to 4.0 Mc/s; -1.0 db max. at 4.2 Mc/s; -20.0 db min. at 4.75 Mc/s; more than 20.0 db down above 4.75 Mc/s.

2. Will it work with my transmitter? What type of variable delay does it have?

Ans. This system has 50 delay positions in each of the LF, HF and Notch Equalizers, approaching continuously variable delay — adequate to meet any phase correction requirement of your transmitter.

3. How much rack space does it take?

Ans. A Complete system for a transmitter occupies only half of a $5\frac{1}{4}$ " rack frame.

4. Does it have by-pass facilities?

Ans. Yes, automatic by-pass for the entire system, and selectable by-pass for video low pass filter, receiver equalizer, and variable delay modules.

5. How much does it cost, and how long is delivery?

Ans. The system is only \$3,200 (or \$3,875 with notch equalizer) F.O.B. Clark, and we are currently making delivery from stock.

NOTE: If Phase Equalizer does not meet with your satisfaction, it may be returned within 30 days for full credit.

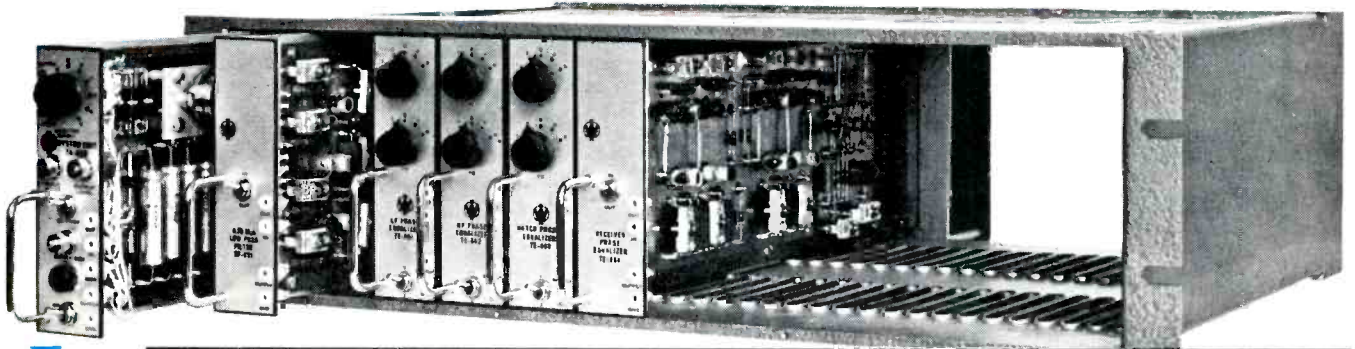

WARD ELECTRONIC INDUSTRIES

142 CENTRAL AVE., CLARK, N. J. 07066 • (201) 382-3700

Circle Item 4 on Tech Data Card

convention at Callaway Gardens, Georgia, June 15th.

The award is presented to the GAB member station best exemplifying the finest standards and practices in broadcasting. Judging is based on all aspects of station operations: physical plant, programming, reputation in the community, public service and co-operation with the Georgia Association of Broadcasters.

WJBF-TV is part of Fuqua Industries owned by J. B. Fuqua and

is affiliated with the American Broadcasting Company.

Also during the convention, WNEG, Toccoa, Georgia was awarded the 1968 Radio Station of the Year. The 1968 Promotion of the Year for its Farm Day Promotion went to WLOR, Thomisville.

Lubbock, Texas, Site of Electronics Clinic

The Southwestern Electronics Clinic and Fair will be held in Lub-

bock, Texas. The fair will be in the Lubbock Municipal Coliseum August 1-4, 1968.

Sept. 18-20 Are Dates For Symposium

A symposium on Thermal Expansion of Solids, sponsored by the Westinghouse Astronuclear Laboratory and the National Bureau of Standards, will be held at the NBS Gaithersburg, Md. facilities September 18-20. The theme of the symposium is the measurement and analysis of this thermophysical property.

IEEE Convention Scheduled For September

The Advance Program for the IEEE-GB Symposium has been announced. The following programs have been planned:

Thursday, September 21

Welcome to Registrants by:
Howard T. Head Chairman,
Washington Chapter

Gamma Correction in Live Color TV Cameras.

A Simplified Approach to Measurements of Line Pulse Distribution.

The Use of Special Effects in Television Programming.

Corrections of Hue and Saturation Errors in TV Tape Recording.

Color TV in the U.K. and Europe.

Improvement of Pattern Circuitry of Pan Antennas Mounted on Large Towers.

Design Considerations for High-Gain UHF-TV Antennas.

A Solid State Demodulator for TV Transmitters.

Correlation Between TV Transmitter Performance Measurements and Picture Quality.

Friday, September 22

Summation of Sweep Testing of CATV Systems.

Planning 13 GHz TV Relay Systems.

Panel Discussion: CATV and its Relation to Broadcasting.

Saturday September 23

A New Look At Phase Sampling.

Reduction of Adjacent Channel Splatter in the Standard (AM) Broadcast Band.

Radio Automation Today.

A Loudness Level Monitor for Broadcasting.

Special Bonus Paper: A Simple Method to Achieve Power Reduction for Pre-Sunrise Operation. ▲

The Spotlight Is on

Spotmaster

Superior Tape Cartridge Recording and Playback Equipment

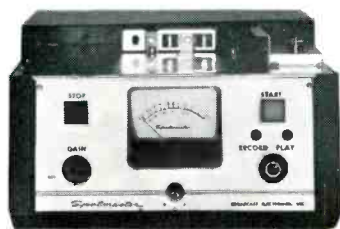

Model 500 C



Model 400 A

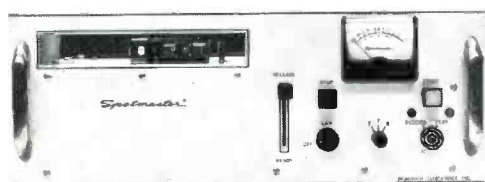

Model 500 CR

COMPACT 500 C SERIES—Completely solid state, handsome 500 C equipment features functional styling and ease of operation, modular design, choice of 1, 2, or 3 automatic electronic cueing tones, automatic record pre-set, separate record and play heads, A-B monitoring, biased cue recording, triple zener controlled power supply, transformer output . . . adding up to pushbutton broadcasting at its finest. Specs and performance equal or exceed NAB standards. Record-play and playback-only models are available.

RACK-MOUNTED 500 C MODELS—The 500 CR rack models offer the same Model C design and performance features and are equipped with chassis slides ready to mount in your rack. Each unit slides out for easy head and capstan cleaning and other routine maintenance.

All 500 C models carry iron-clad full-year guarantees.

ECONOMICAL 400 A SERIES—Now even the smallest stations can enjoy Spotmaster dependability with the low-cost, all solid state 400 A series, available in compact record-play and playback-only models. Performance and specifications are second only to the 500 C series.

For complete details about these and other Spotmaster cartridge units (stereo, delayed-programming and multiple-cartridge models, too), write, wire or call today. Remember, Broadcast Electronics is the No. 1 designer/producer of broadcast quality cartridge tape equipment. . . worldwide!

BROADCAST ELECTRONICS, INC.



8810 Brookville Road, Silver Spring, Maryland 20910; Area Code 301, 588-4983



Vital News in Switching!

VIX-108

*First new concept
in Switching in a
decade is here*

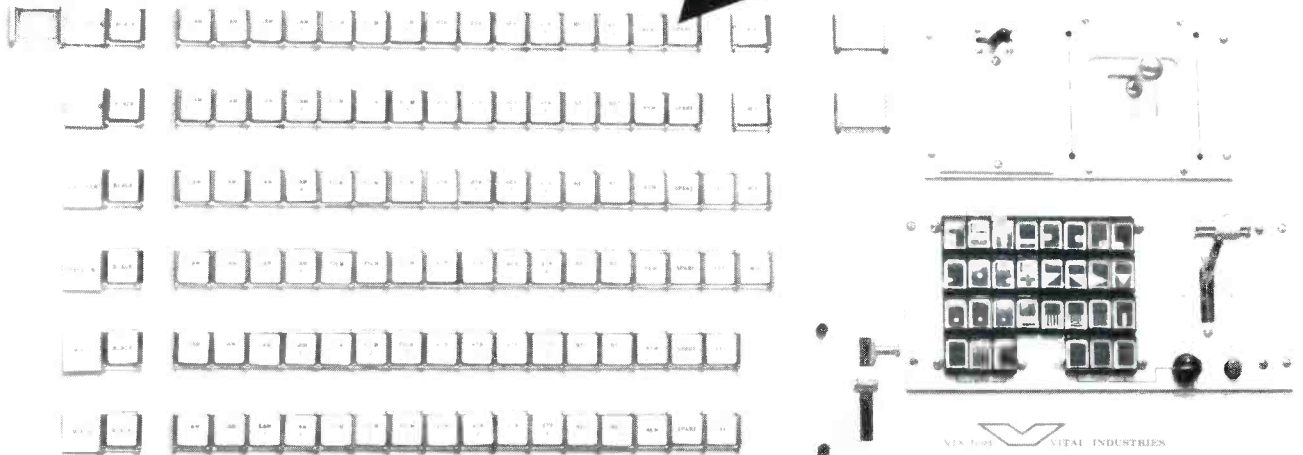

Vital Industries, Inc. has taken the custom cost and complications out of custom switching. A unique combination of mechanical and electrical packaging has yielded exceptionally high performance and specifications in the VIX-108 vertical interval switching system.

FEATURES:

- All solid state with integrated circuits including crosspoints and control circuits.
- Complete basic package 18 in by 6 out system complete with power supply control circuitry, in 5¼" rack space. UHF Connectors.
- Production or routing switcher. Any size.
- Vertical interval or random switch in less than 0.1 micro-second.
- Auto sync add for comp/non comp operation. Auto inhibit non synchronous mix.
- Custom built with any kind of control buttons or panels. All state of the art accessories also furnished by Vital Industries, Inc.

SPECIFICATIONS for one typical 18 in 6 out system:

- Exceptional isolation between crosspoints . . . 65 DB down at 4 Mhz.
- Differential phase through the system . . . Less than 0.1 degree at 1 volt output.
- Differential gain . . . less than 0.1 percent at 1 volt output.
- Frequency response . . . Flat within 0.1 db from 10 Hz to 10 Mhz under all conditions.
- Tilt . . . Less than 0.5% over 1 field.
- K factor less than 1%.

Selecting the right switcher is Vital

GOOD ENGINEERING IS VITAL



Write for complete information and specifications.

VITAL INDUSTRIES, INC.

3614 SOUTHWEST ARCHER ROAD
GAINESVILLE, FLORIDA 32601 - PHONE (904) 378-1581

Circle Item 5 on Tech Data Card

THE 900

is a 33 $\frac{1}{3}$ %⁰ver!

And that's no arbitrary figure. Here's a recorder/reproducer that out performs its competition by a third more, costs 33 $\frac{1}{3}$ % less, and has a reliability factor $\frac{1}{3}$ better than most.

Using dual capstans for smooth and precise tape control, the Tape-Athon 900 performs with a new low in wow, flutter, and scrape. Recorded sound is pure and sure every time.

That other big plus factor, reliability, is a function of component selection and craftsmanship, and Tape-Athon has staked its reputation on excellence in both areas throughout production of over 15,000 tape transport units.

But price is something we can prove right away. Let us quote your next system, and get you started out 33 $\frac{1}{3}$ % better off.

If you'd like more details on the Tape-Athon 900 Recorder/Reproducer, write for catalog TA250, Tape-Athon Corp., 523 S. Hindry, Inglewood, Calif. 90307

Tape-Athon

Tape-Athon Corp. 523 S. Hindry, Inglewood, Calif. 90307

Yes, send me catalog TA250 today.

Name _____

Firm _____

Address _____

City _____ State _____ Zip _____



Circle Item 6 on Tech Data Card

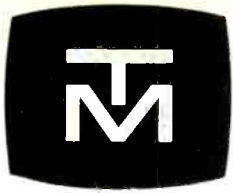

New from TeleMation ..TMC-2100 Vidicon Camera

Designed to be the most versatile camera
ever offered to the television industry

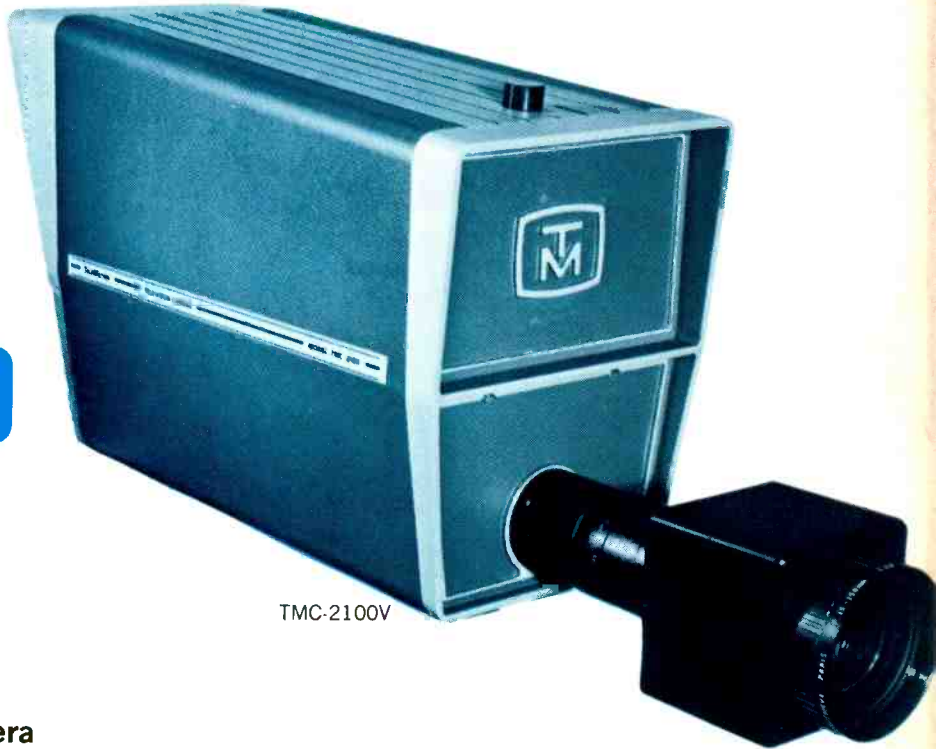

TMC-2100V



TMC-2100



REAR VIEW
TMC-2100

FEATURES:

- Camera may be operated self-contained or driven — All modes of operation are "switch selectable." Internal sync options are Crystal/Drive, 2:1 Interlace, and EIA.
- TMC-2100 non-viewfinder cameras feature all diecast or extruded framework — rugged but good looking!
- Extruded side panels hinge upward for easy access to camera circuitry and vidicon assembly.
- All circuit boards are made of high-quality glass epoxy materials and "plug-in" for easy field replacement.
- Addition of 7" transistorized viewfinder is simple but permanent. "Piggyback" look is avoided by use of full-length side panels and front casting.
- 800-volt power supply and 60-gauss focus field assure maximum performance from all vidicon tubes, including new separate-mesh types — 800 lines resolution guaranteed.



TELEMATION, INC.

2275 South West Temple/Salt Lake City, Utah 84115
Telephone (801) 486-7564



GOES WHERE THE ACTION IS!...

The SM60 cannot be stereotyped—is equally at home in the studio or in the field—stand-mounted or handheld—in uses as diverse as outdoor sporting events and elaborate variety shows. Small wonder that audio engineers have called it one of the most versatile omnidirectional dynamics they've ever encountered, for the SM60 is a unique combination of good-looks, strength, performance and economy.

The smooth, wide-range response provides cleanest, natural reproduction of both speech and music. A very effective built-in wind and "pop" filter protects against undesirable effects of close-talking.

Lustrous, non-glare metallic finish and tailored-to-the-

hand dimensions provide striking on-camera appearance and superior handability. Specially reinforced machined-steel case front is designed to take abuse that would ruin other microphones—you can drop it on its nose without damage to the internal structure! Efficient windscreen and front end are *quickly* and *easily* removable for cleaning.

Best of all, it is priced competitively with conventional "workhorse" microphones. Why not check out an SM60 now? See your Shure Professional Products Distributor, or contact Mr. Robert Carr, Manager of Professional Products Division, Shure Brothers, Inc., 222 Hartrey Ave., Evanston, Ill. 60204—Phone 312 - 328-9000.

SHURE SM60

VERSATILE OMNIDIRECTIONAL DYNAMIC MICROPHONE

THE LAST WORD IN WEARABLE LAVALIER MICROPHONES... BY SHURE



Specifically designed for radio, TV, motion pictures... matches well in sound with stand or desk mounted units. Smoothly-contoured, machined-steel case and recessed grille for minimum clothing noise. Exclusive snap-in mounting of microphone for greater convenience, security. "Positive Lock" lavalier goes on in an instant—provides simple, noiseless position adjustment. Extra-flexible, kink-free rubber cable is easily replaceable.

MODEL SM51 DYNAMIC LAVALIER

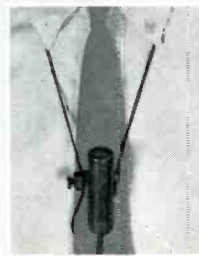

© 1967 Shure Brothers, Inc.

Circle Item 8 on Tech Data Card

WDXL's top talent is getting bunions.



Ben Enochs says we're to blame.

Says Ben, "Automation worked so well for our FM operation, we decided to automate our AM. Some people say it doesn't pay to automate an AM station with small-town programming. But the Gates people built an Automatic Tape Control System to fit our format, worked with us until we had exactly what we wanted. Now even our log is automated. We've got the boys out on the street selling spots while they're on the air."

WDXL is another station that has found a new source of profit in Gates Automatic Tape Control.

What about you? We have a wide and flexible choice of automatic systems. We might be able to get you automated for as little as \$65 a week. And how much would that save you? We're all experienced broadcasters here and we'll be glad to help you figure. Just dial (309) 829-7006.

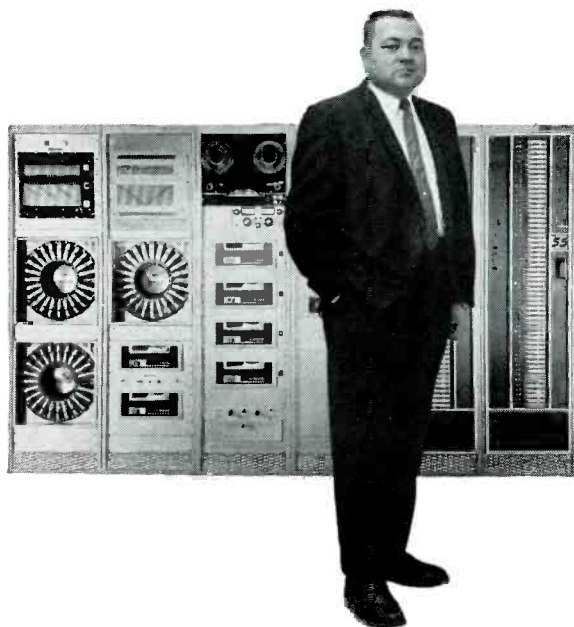

*Ben Enochs, Chief Engineer,
WDXL, Lexington, Tennessee*

GATES

HARRIS
INTERTYPE
CORPORATION

AUTOMATIC TAPE CONTROL DIVISION

1107 East Croxton Avenue
Bloomington, Illinois 61702, U.S.A.

Circle Item 9 on Tech Data Card

ETV for school and the community

by Thomas E. Wilson

At 5:58 p.m. on March 25, station KLVX in Las Vegas commenced broadcasting as Nevada's first educational television station. Licensed to the trustees of the Clark County School District, the station is part of a complex educational television system planned to overcome one of the most serious problems facing educational television: scheduling.

System Requirements

Although the Clark County School District is among the smallest in the nation to operate an educational television outlet, its innovative approach to education will complicate its scheduling. Some of the district's elementary schools are ungraded with moderately unstructured instructional programs. An experimental program for exceptional students is now underway. Two of the high schools in the district employ modular class scheduling, which may make it impossible to employ district-wide broadcasts in many classes. A laboratory school designed to develop better teaching methods on a 12-grade basis may present added problems.

Among other problems facing system designers were those of distance and terrain. Clark County embraces more than 8000 square miles and includes mountains which are about 12,000 feet high, while other areas dip down to less than 1000 feet. Most of the 65,000 students in the district are concentrated in the Las Vegas Valley. Thus, the system had to satisfy demands of both a sprawling desert with scattered rural communities and those of a fast-growing metropolitan area. In addition, the system had to fulfill the need for a public educational television channel while at the same time meeting the complex needs of a diversified school district.

The result was a system design calling for an open, public educational television channel; four closed Instructional Television Fixed (ITFS) channels; and a sixth, internal channel to serve each school in the district. With this approach, school district officials believe they can solve most of their basic scheduling problems. The internal channels will permit each school to transmit material to any classroom in the school whenever the tape or film is not available

through conveniently scheduled district-wide broadcasts.

KLVX Facilities

Station KLVX is the first part of the system to become operational. The studio facilities were installed in a wing of the District's new Southern Nevada Vocational Technical Center. Initially, the space was intended for classrooms and a hallway, but it was re-allocated for the television station when funds and grants became available.

A hallway was revamped into a studio. The standard acoustical ceiling was removed to make space available for lighting and wiring. This modification was expected to create heat and sound problems, since the studio lies beneath a flight pattern to McCarran Airport and is subject to fierce desert temperatures. However, standard asbestos insulation proved adequate to eliminate outside sound, serve as an acoustical surface, and minimize heat transfer.

Three black-and-white transistor image-orthicon cameras serve the studio. Station officials plan to add color cameras later. The studio has some lights equipped with hoods, others on banks, and some spots. Light intensity is sufficient for color broadcasts. A dimmer board controls the lighting.

The adjoining studio control utilizes a standard switcher. Its special-effects unit can handle 92 different patterns. The switcher has the capacity to control three live cameras, four tape units, and two film islands. A dual-channel audio board controls audio sources.

Three tape machines and two film chains are located in the telecine room. Two of the video tape recorders are equipped for high-band color operation and have an automatic timing corrector and a dropout compensator. One of the two film islands has color capability.

The master control unit is designed to handle both the KLVX public-education broadcast channel and the four ITFS channels. It is divided into three general control areas.

The channel 10 switcher has an audio system that was designed to handle basic inputs from tape-cartridge equipment, the audio channel of video sources, and studio microphones. Another segment of the control console contains inputs for the ITFS channels.

A simple audio-video system is used. This control segment also has a preview section and provision for video-tape dubbing. The final segment of the console contains controls for the studio cameras. (Cover picture for this issue shows KLVX master control console.)

Careful planning resulted in a highly workable plan to obtain maximum utilization of a fourth VTR. The station purchased a second-hand mobile unit and rebuilt it. The new design included ample space for the tape machine and adequate room to load and unload it easily. In this way, the VTR can be utilized fully in the telecine room for dubbing and double as a key tool in the mobile unit whenever needed.

Signals leave the station from a four-foot microwave dish and are beamed to the transmitter atop Black Mountain, a mesa in the city of Henderson, some 14 miles south of Las Vegas. The station has an

authorized effective radiated power of 296,000 watt, at a height above average terrain of 1220 feet. The 25,000 watt transmitter was designed for color.

A transmitter atop a high-rise resort hotel will serve the ITFS channels. The transmitter will have the capacity to broadcast simultaneously over all four channels.

In-School Facilities

Although details of the engineering design for the in-school systems have not been finalized, the broad outline has been spelled out. Two high schools have already begun experimenting with the system on a limited basis.

Each of the primary and secondary schools in the district will be equipped to receive the KLVX (channel 10) broadcasts. Some schools are located about 100 miles from the KLVX transmitter. The district is studying the possibility of installing solar-powered translators to relay broadcasts into remote areas where mountains would block reception.

The equipment schedule calls for providing most secondary schools with two cameras and a switcher to permit internal school-wide broadcast of important events and broad-interest instructional material.

On the elementary school level, the schedule includes installing permanently mounted television receivers in classrooms in grades four, five, and six. Three portable black-and-white receivers will be allocated elementary schools for use in kindergarten and grades one through three. Also, a portable color receiver will be given each elementary school for place-

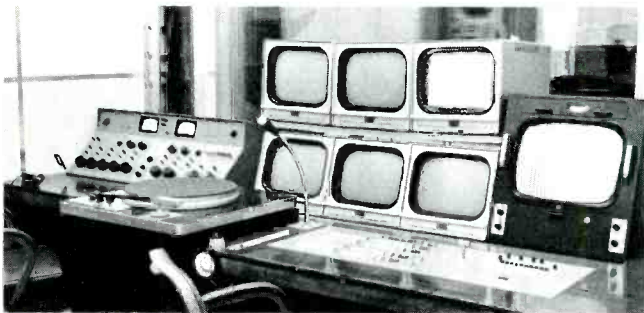

Fig. 1 The studio control layout of KLVX

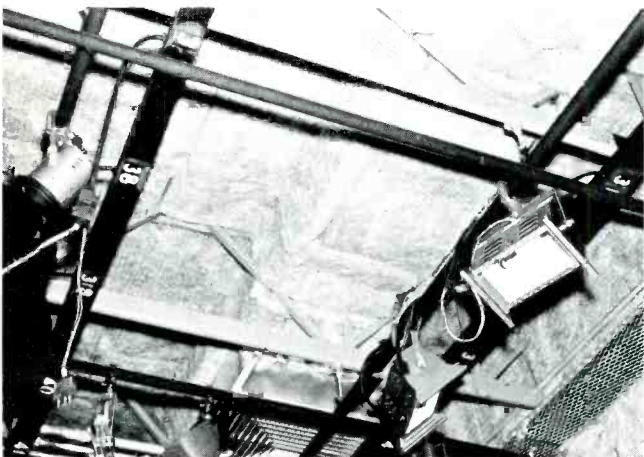

Fig. 2 The standard asbestos insulation used on the studio eliminates outside sound, serves as an acoustical surface, and minimizes heat transfer.

ment wherever the school staff decides it would best serve their individual needs.

Receivers for the fixed-service channels will be installed only in schools within the Las Vegas Valley. Remote schools will depend on portable origination units and channel 10 broadcasts.

Educational Center

Perhaps the use of educational television will reach a zenith in the Research Experimental Center scheduled to be constructed within a year. The heart of this 1500-student facility will be a center of control, to be staffed by a specially trained team of research directors. From this center, programs will be initiated, controlled, and evaluated through the use of closed-circuit monitoring television.

In effect, the nerve center will be a theater-conference room where new instructional methods can be observed. Plans include staffing the laboratory research center with a volunteer instructional staff with prime teaching credentials.

Thus, one may find a classroom where a teacher employs audio-visual materials and portable origination units as teaching aids. The classroom activity itself will be observed, gauged, and controlled through the television staff.

Conclusion

The channel 10 format calls for general public-oriented broadcasts during evening hours and instructional broadcasts during school hours. Thus far KLVX has been broadcasting only five hours a day, during the evening hours, essentially because its operation began late in the school year. No student instructional programs have been planned prior to the 1968-69 school year. The district has begun production of in-service teacher-training programs in "new math" in its studio facilities.

This \$1.6 million project has removed Nevada from the list of states which have no educational television facilities. Funds for the station came from three sources. The district received a \$340,000 grant from the U.S. Department of Health, Education and Welfare under the Federal Communications and Educational Television Act of 1963. A National Defense Education Act grant added another \$60,000. The district provided the balance of funds by earmarking \$1.2 million from a school-bond issue for purchasing station equipment.

Progress toward a statewide network has been slow but steady. Last year, an educational television commission was created and funded and it has begun studying problems involved in creating such a network. The studies include probing the possibility of tying the television net into relay facilities needed by the Nevada Highway Patrol, State Highway Department, and other agencies which must communicate across Nevada's sparsely populated 110,000 square miles.

The school district already has provided other school districts in Nevada with portable units on a lease basis. The state Department of Education provides films and tapes for districts outside Clark County. The Washoe County (Reno) School District and Ormsby County (Carson City) District have begun modest programs experimenting with educational television. ▲

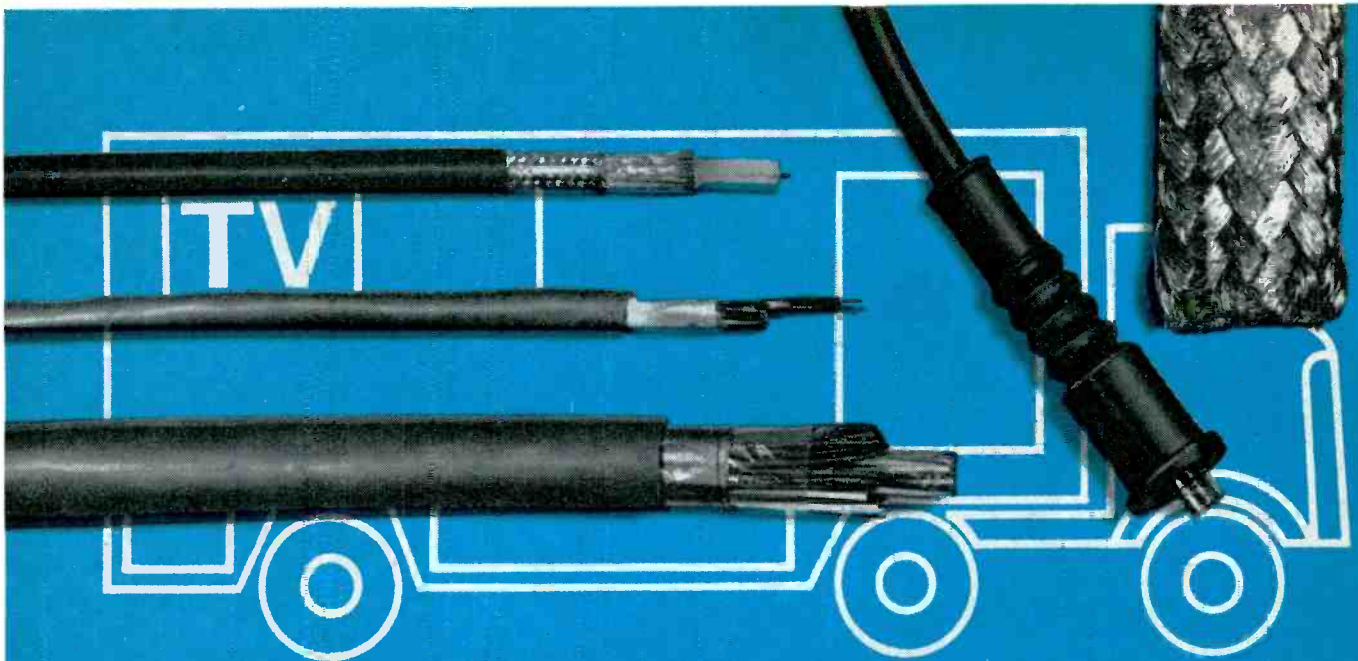

talk about systems...

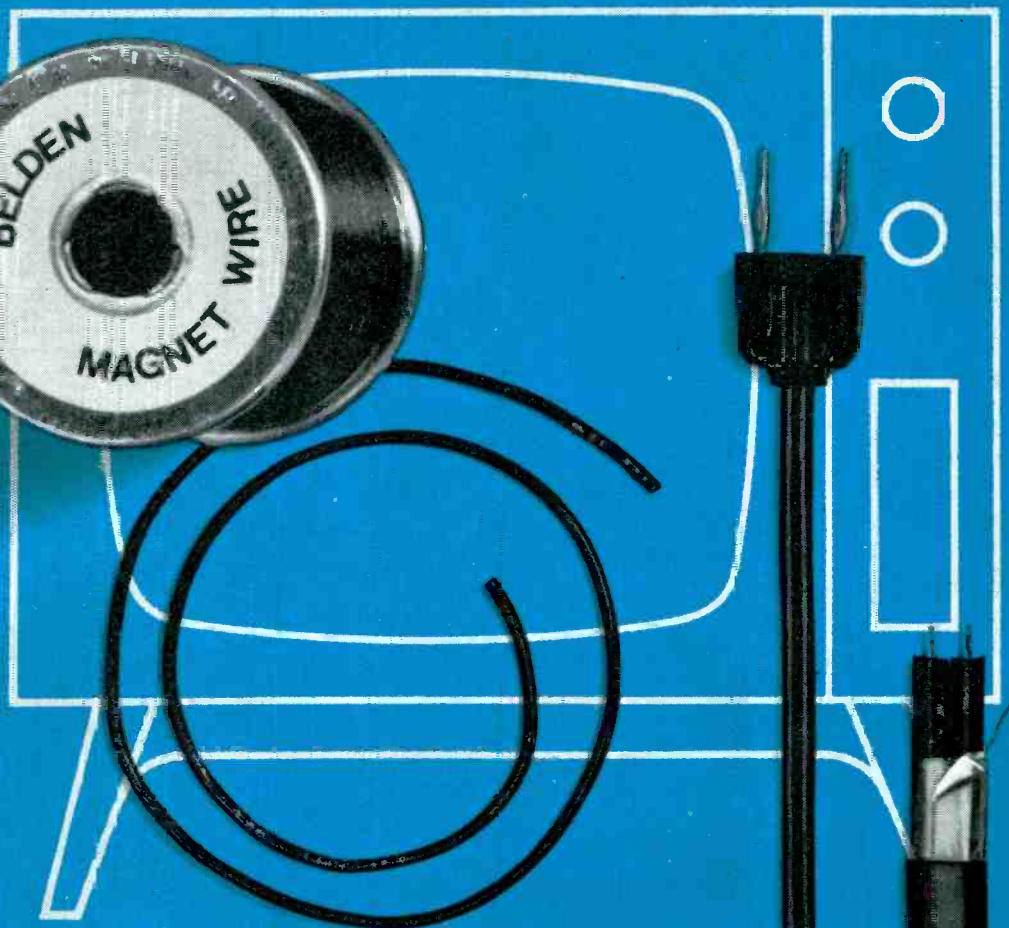

new ideas for moving electrical energy

G-2-7A

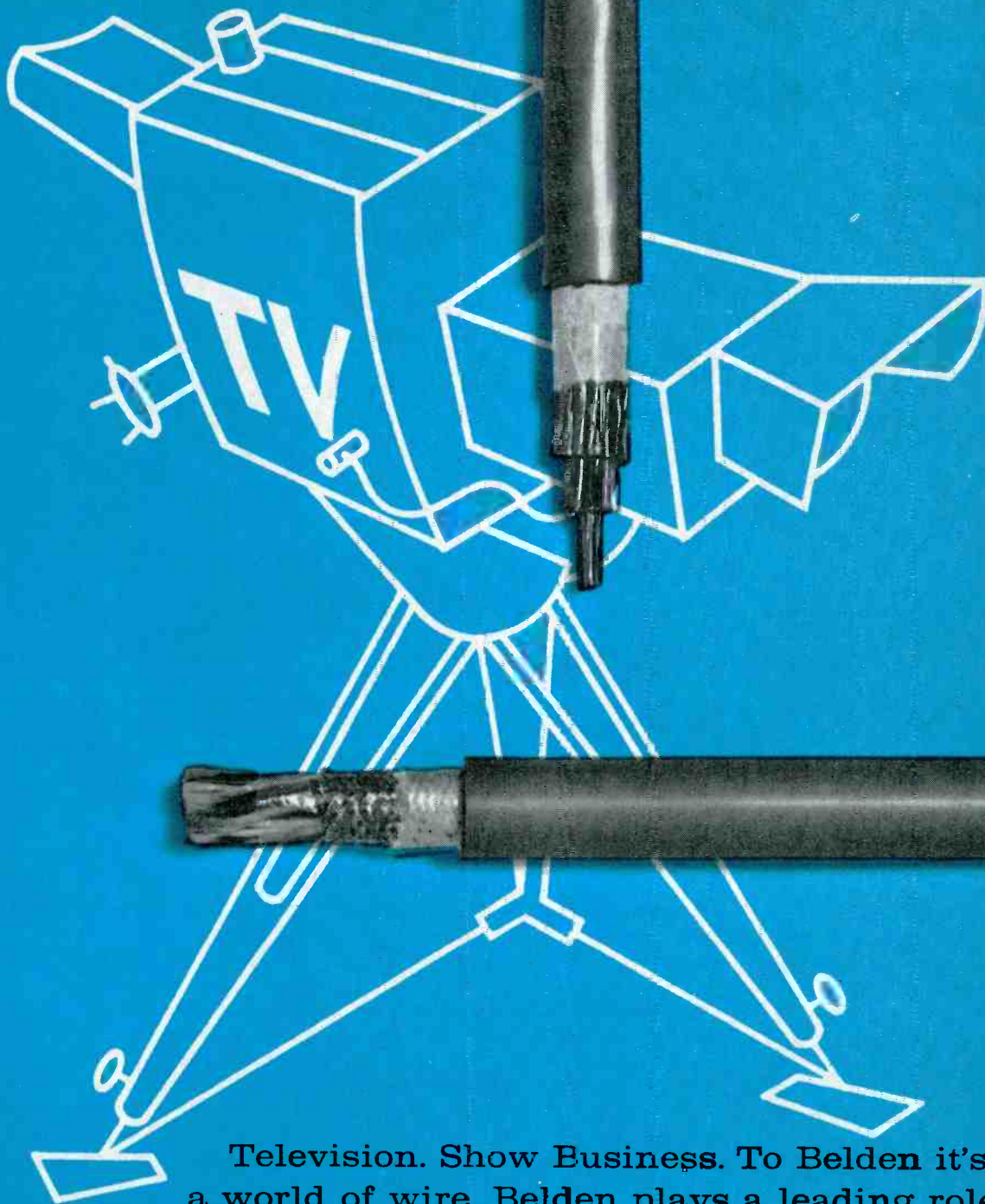

Television. Show Business. To Belden it's all a world of wire. Belden plays a leading role in many complex systems of sight and sound communication. By delving into design, processing, packaging and a host of factors, Belden's team of wire specialists have helped many people wring out hidden costs. Success takes a supplier that is really perceptive – one who makes all kinds of wire for all kinds of systems. Want to join us in wringing out values and costs? Just call us in...Belden Corporation
P.O. Box 5070-A, Chicago, Illinois 60680.

BELDEN 

Introduction to KLYSTRONS

Part two of two parts

by Perry Dudley*

Part 1 of this series covered the operating principles of the klystron. This, the concluding portion of the series, reviews the fundamentals of operation and places emphasis on those characteristics of interest to broadcast applications.

In most broadcast transmitters, the final RF power amplifier is comprised of lumped electrical components and a conventional power grid tube amplifier. At very high frequencies, however, the normal modulation of an electron stream in a conventional vacuum tube is very difficult to achieve. This phenomenon occurs because the signal impressed upon the grid may go through several oscillations during the period of time required for one electron to traverse the field. The result is chaos among the electrons and little or no amplification.

By increasing the electron accelerating voltages and reducing the spacing within the tube, high-frequency amplification can be enhanced, but at microwave frequencies it is difficult to achieve adequate power amplification for most UHF-TV usage. At these frequencies klystron power amplifiers are employed. Klystrons use a conventional electron gun and distributed electrical components to amplify at microwave frequencies. Figs. 1 and 2 show two of the klystron constructions most commonly used in UHF-TV broadcasting. Although each

tube is individually unique—one is mounted collector up, the other collector down—they both are composed of the same basic components and perform identically in the broadcast transmitter.

Emission

The electron gun of the klystron consists of a heater, an emitter, a beam-forming electrode, and a modulating anode. Fig. 3 shows a simple diagram of the gun assembly. The emitter, or cathode, is raised to its operating temperature by the heater. Electrons are then emitted from its surface.

The modulating anode, which is positive with respect to the cathode, draws the emitted electrons toward itself. The focusing electrode, placed between the emitter and the modulating anode, forms an electronic lens, similar to the lens in the gun end of a kinescope tube. This lens forms the electrons into a beam.

The part of the klystron including the emitting cathode and the modulating anode has the characteristics of a conventional diode. The current in the beam follows the "square law," and as it passes through this section of the tube it is proportional to the value of the voltage raised to the 3/2 power. The number of electrons that leave the cathode as well as their acceleration through the modulating anode are dependent upon the modulating-anode voltage.

The accelerating anode is con-

nected to the body, or RF circuit, of the tube, and the potential between it and the modulating anode accelerates the beam electrons after they are past the modulating anode. The modulating anode, then, determines not only how many electrons leave the cathode, but also their velocity as they approach the modulating anode. The accelerating-anode voltage has no influence upon the number of electrons in the beam, but it does accelerate electrons after they are beyond the modulating anode.

The total DC input beam power is the product of the beam current times the sum of the voltages between the cathode and modulating anode and the cathode and accelerating anode.

Magnetic Field

When operating in a transmitter, a klystron is mounted in an electromagnet so that a magnetic field runs parallel to the beam axis of the tube. This field keeps the beam that was formed in the gun section confined as the electrons pass through the body of the klystron. If the field were not present, the beam would expand rapidly after it passed the accelerating anode, and never traverse the klystron.

The magnetic field enters and leaves the tube through two pole pieces, one at each end of the RF section. Sometimes additional stray field is desirable in the gun section of the tube to help form the beam.

Usually, the electromagnet is excited by a filtered direct current. The strength of the magnetic field between the two pole pieces is a critical factor in the performance of the tube. If the field is not strong enough, the beam will expand and be intercepted by parts of the RF structure in the body of the tube; if the field is too strong, the beam will not disperse properly after leaving the RF section. The most important aspects of the magnetic field are that it must be strong enough to maintain the beam size, and that it must run parallel to the beam axis to minimize beam interception by the RF circuits.

The focusing electromagnets can be considered a permanent part of

*Senior Application Engineer, Varian Associates.

the broadcast transmitter, whereas the klystrons are changed from time to time, much the same as other final-amplifier tubes are changed. Some general precautions should be followed when moving klystrons in and out of the magnet:

1. The klystron must be placed in the magnet assembly carefully so that damage does not occur from striking bending, etc.
2. If two klystrons are operated side by side, the fields developed by the two magnet assemblies must be in the same direction, or partial cancellation of the fields will take place.
3. There must always be adequate current through the coils so that the klystron is not damaged by heavy beam interception in the body of the tube.
4. Magnetic materials such as wrenches, bolts, or nuts must not be left inside the electromagnet after the klystron has been assembled into the magnet.
5. All magnetic material in the areas surrounding the cathode and the collector must be removed so that they will not become attracted after the field is activated.

RF Structure

The RF structure of the klystron is comprised of tunable resonant cavities positioned along the axis of the tube. Fig. 2 clearly shows four external cavities placed along the klystron. These cavities are external to the vacuum; they are placed on the tube by the transmitter engineers prior to installing the tube in the magnet.

The cavities in Fig. 1 are not quite as obvious, but four distinct sections of the klystron body can be seen, each with a tuner in the center. Imagine each cavity as being doughnut shaped with a continuous gap where the inner wall of the cavity should be. The gaps then are concentric with the center of the klystron, and the electron beam passes through the center of the cavities. Although the electrical

components of a cavity are distributed, the gap next to the beam is a greater concentration of capacitance than any other part of the cavity. Likewise, the cavity volume is a concentration of inductance.

Although this presumption is an oversimplification of the actual circuit, the concept aids in understanding what is happening within the klystron.

As it goes through the RF section, the beam passes through the space bounded by the inner walls of the cavities (which are tubular in shape and called drift tubes) and past the gaps. When RF power is

introduced into the input cavity (the cavity closest to the gun assembly), the voltage on the tip of one drift tube in the cavity is positive at the same time the tip on the other is negative. These voltages, although small in magnitude, accelerate some electrons and decelerate others.

As the electrons pass through the drift tubes, they form into bunches; some move ahead slightly faster than the average speed of the beam, and others drop behind, slightly slower than the average speed of the beam. As the bunches pass the second cavity, RF power is induced into it that is approximately 10-db

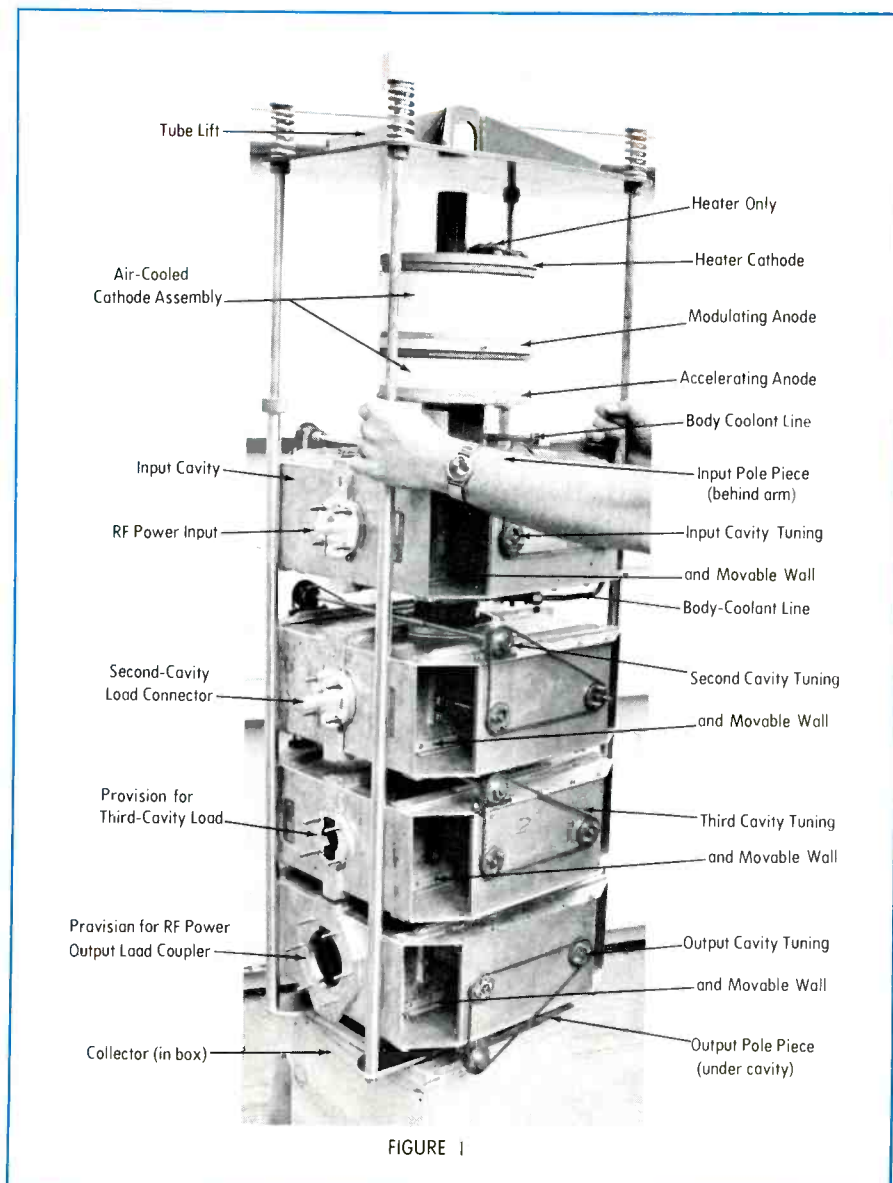

FIGURE 1

greater than that introduced into the first cavity. Even greater RF voltages appear across the gaps of this cavity, exerting even greater influence on the speed of the individual electrons passing through.

As the electrons pass through the drift tubes, they are grouped more and more tightly until they pass the gap of the final cavity and induce RF power into it. Here a coupling loop placed in the cavity intercepts the energy and transfers it to a properly matched transmission line which feeds the antenna. This process of electron-beam modulation is known as "velocity modulation." Conventional amplifier tubes employ density modulation, in which the output power is a function of the plate voltage of the tube. In the klystron amplifier, the power dissipated in the collector is lost energy and must be removed by some collector-cooling process.

The success of velocity modulation is dependent upon the proper tuning of the cavities. They should be tuned at or near resonance to the frequency of the input signal. This is accomplished by changing either the inductance or capacitance of the

cavity. Both methods are employed in UHF-TV klystrons.

The chain-and-sprocket linkages in Fig. 2 show the method by which the external-cavity klystrons are tuned. Here the walls of the cavity are moved in and out, changing the cavity volume. This is the equivalent of inductive tuning. The method of changing the capacitance in the integral-cavity tubes can be seen in Fig. 4. Here a paddle moves in and out near the cavity gap. By changing the distance from the paddle to the drift tubes, the capacitance of the gap can be changed. The paddle is coupled to the cavity tuners pictured in Fig. 1 through vacuum-tight bellows.

The resonant frequency of a cavity is changed in much the same way as the resonant frequency a conventional tuned circuit is changed. The resonant frequency can be increased by decreasing the value of either the capacitance or inductance, or it may be decreased by increasing them. Tuning a klystron from aural to visual frequency, then, would be accomplished either by turning each of the integral-cavity paddle tuners a little closer to

the drift tubes, or by moving the cavity walls of each of the external cavities out a small amount to increase the cavity volume.

Collector

The electron beam leaves the RF section and enters the collector, where all remaining energy is dissipated. The collector is operated at the same voltage as the body of the tube, but it is separated from it by a short ceramic insulator. The sole objective of providing DC isolation between the body and the collector is to allow for the body current to be monitored.

This arrangement provides for tube protection in the event the beam current is either diverted or "blown up" and intercepted by a drift tube or some other part of the body. A concentration of a portion of the beam current could damage the tube permanently by melting copper. A small amount of body current distributed along the drift tubes is desirable however, because it indicates that the beam is filling the drift tubes and allowing for maximum coupling to the cavities.

The collector is a hollowed-out block of copper with extensive channels for water or other coolant. Sometimes a thermocouple is buried in the collector to sense temperature increases and trigger protective circuits in the transmitter. Klystron collectors must be capable of dissipating all of the beam power that the tube is capable of handling.

Whenever RF drive is removed and there is no RF output, all of the beam energy enters the collector. Also, the visual amplifier does not operate at maximum available power continuously; the maximum average power is 59.5% of peak power for black level. The rest of the energy is dissipated in the collector. It is extremely important that the collector cooling system be maintained properly to assure long life from the tube.

Two methods currently employed to cool UHF-TV klystrons are high-pressure water cooling and vapor-phase cooling. A typical high-pressure collector requires about 45 gallons of water per minute that flows through small veins in the collector, picking up heat in the critical areas and carrying it out of the tube. A vapor-phase-cooled collector boils away between 2 and 3 gallons per

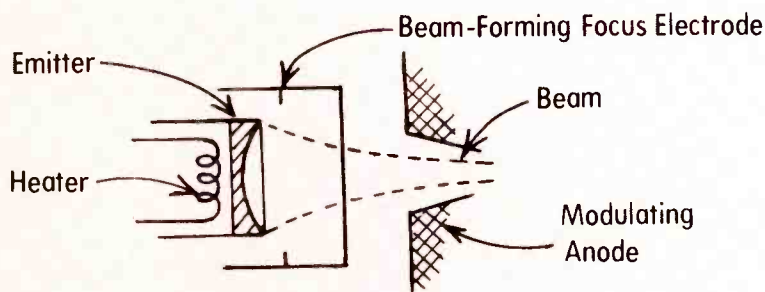

FIGURE 2

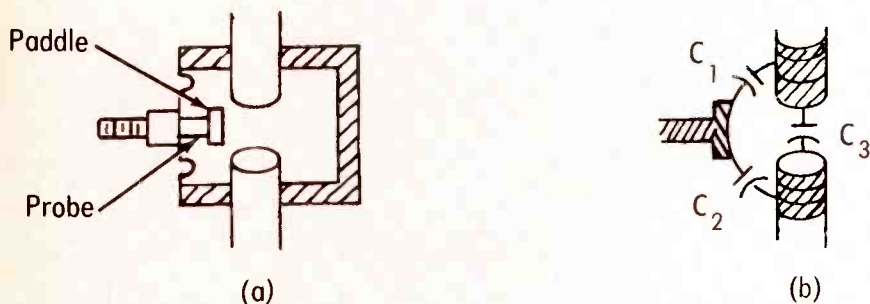

FIGURE 3

When engineers get together,
the conversation turns to pickups.



PHOTOGRAPHED BY FRANZ EDSON AT THE CAPITOL TOWER, HOLLYWOOD.

It's an irresistible topic.

Especially since Stanton came out with the Model 500 stereo cartridge.

That's an engineer's pickup, if there ever was one.

Beautiful curve—within 1 db from 20 to 10,000 Hz, 2 db from 10,000 to 20,000 Hz.

Fantastically small moving system to trace the wildest twists in the groove.

Light weight (only 5 grams!) to take advantage of low-mass tone arms.

And, of course, Stanton's legendary quality control.

No wonder engineers use the Stanton 500 for critical broadcasting and auditioning applications.

And to impress other engineers with their pickupmanship.

(Available with 0.7 or 0.5-mil diamond, \$30; with elliptical diamond, \$35.)

For free literature, write to Stanton Magnetics, Inc., Plainview, L.I., N.Y.)



minute of water in a shell that surrounds the collector block. In addition to the collector coolant, a few gallons per minute of water are required to cool the body, and a few cubic feet per minute of air should be circulated around the gun assembly.

From the point of view of successful operation of the klystron, either method of cooling a collector is satisfactory, and both are used extensively by UHF-TV broadcasters. The selection of which system to use usually depends on the transmitter system.

Operation

The power output of a klystron is sensitive to changes in the beam voltage, the input or drive power and frequency, and to the cavity tuning. Variations in any of these can change if the RF response.

As previously discussed, the beam power is dependent upon the voltage between the cathode and the accelerating anode as well as the voltage between the cathode and the modulating anode. When two tubes are operated in parallel (one to amplify the visual signal, the other to amplify the aural signal), they can be identical tubes, and both can be operated from the same beam power supply. The aural tube can be reduced in power output by changing the voltage on its modulating anode.

The power output of a klystron also changes when the amplitude of the drive signal is changed. This is the method employed to modulate the visual amplifier.

The gain linearity of the video portion of the signal is excellent. Gain does fall off with an increase in drive power as the tube approaches saturation, and there is some sync-pulse compression in klystron visual amplifiers. As the drive power is increased after saturation, power output decreases. Fig. 5 shows the variation in RF power output with RF drive power. Visual amplifiers are operated in the under-driven portion of the curve; aural amplifiers are operated at saturation.

The frequency of the RF drive source also affects the performance of a klystron. There is a point at which the RF output power is the greatest for any given RF drive frequency. The cavities can be con-

sidered parallel tank circuits, and their frequency response carries the same analogy.

Generally, there are three ways a klystron can be tuned. When all of the cavities are tuned to the same frequency, the gain is maximum. Under this condition, the tube is said to be "synchronously tuned". When the next-to-last, or penultimate, cavity is tuned on the high side of the synchronous frequency so that there is an additional increase in RF power output with an increase in drive power, the tube is "efficiency tuned."

When all of the cavities except the input and output cavities are stagger tuned above and below the synchronous frequency so that the frequency response curve of the klystron is flat across the top, the tube is "broadband tuned." In UHF-TV broadcasting, the visual amplifier is operated broadband tuned, and the aural amplifier is operated efficiency tuned.

Tuning Procedures

The exact procedure for tuning a klystron for TV broadcasting varies from one transmitter to the next, and from one tube type to the next. There are many refinements to a

general discussion on tuning that must be followed in order to assure optimum performance from the transmitter.

A broadcaster rarely is required to tune a klystron out of the 6-MHz channel for which it was initially intended. Usually he is required to shift the frequency from the visual frequency to the aural frequency, or to make final band-pass adjustments for visual operation.

Whenever the frequency of a klystron is changed, it is advisable to tune the tube synchronously first, and then to change the cavity tuning carefully for the desired type of operation. It is extremely important to set the drive power before each phase of the tuning procedure. The tube should be operating at the under-driven side of the power saturation curve when the cavities are synchronously tuned. If the drive level is too high, there is a chance that there will be confusion during the final stages of tuning.

A simple procedure for synchronously tuning a klystron is as follows:

1. Set the drive frequency so that there is RF power output on the monitor.

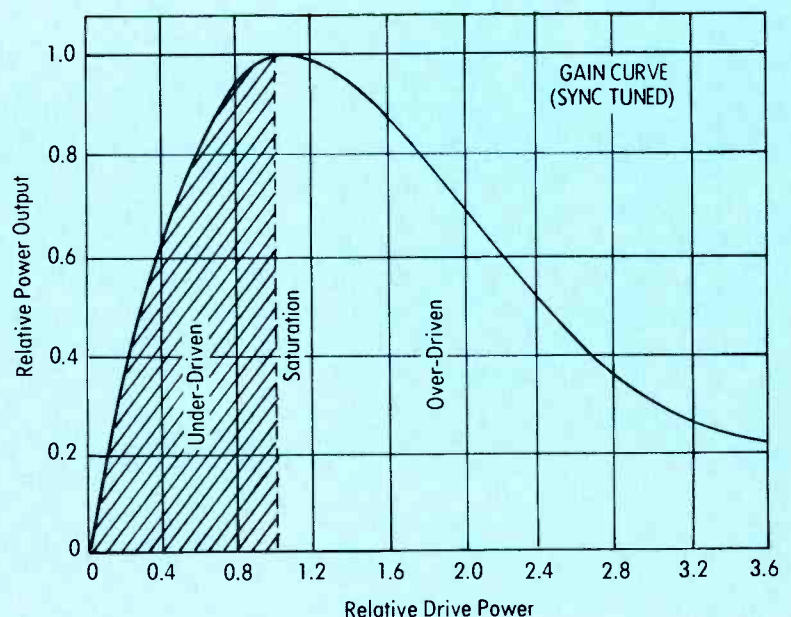

FIGURE 4

2. Adjust the drive frequency until the RF output is at a peak; then increase the drive power until the output power is at the saturation point. Then the drive should be reduced until the output power is about half the saturated power output.
3. Adjust the drive frequency toward the desired frequency just far enough to maintain a power-output reading.
4. Starting with the first, or input, cavity, individually tune each cavity for maximum power output. Reduce the RF drive as each cavity is tuned to keep the output power at half the original saturated power.
5. Again, move the driver frequency toward the desired frequency, and repeat the above steps as required until the desired frequency is reached. Peak the frequency on all cavities, and then increase the drive power to optimize the RF power output.

There are two important factors to remember when tuning by this procedure: The RF drive must be kept at a level such that the RF power output is not at saturation; and, do not lose the response of any cavities when changing frequencies.

All other methods of tuning a klystron start with the tube being synchronously tuned. An aural tube, for instance, can be efficiency tuned once it is synchronously tuned, providing there is 8 to 10 dB of additional drive power available. After a tube has been synchronously tuned on the proper frequency, it can be efficiency tuned by the following procedure:

1. With the RF drive level set for maximum RF power output, tune the penultimate cavity in a direction to make its resonant frequency higher. Tuning it to a lower frequency can result in damage to the tube during step 2 when the drive is increased.
2. Re-adjust the RF drive power until maximum RF output power is reached. Measure the RF output power and, if possible, the RF drive power. Refer to the tube data for rel-

ative power settings. If the output power is too low, continue to tune the penultimate cavity to a higher frequency, and increase the drive power.

3. The indication that the penultimate cavity is tuned too high will be that an increase in RF drive power will not produce the specified saturated RF power output.
4. Should there be limited RF driver power, set the driver to the proper level and tune the cavity until maximum RF power output is obtained.

Detuning a klystron lowers the gain of the RF structure, and care must be taken not to go too far or to go in the wrong direction when tuning the penultimate cavity. With a given RF drive level, detuning the cavity in either a high or a low direction will cause a drop in the RF power output. Should you feel that you have tuned the penultimate cavity too high, or otherwise lost your place in the tuning procedure, return the tube to the synchronously tuned position and start again.

Broadband tuning of a tube for operation in visual service starts from a synchronously tuned position. The exact procedure is explained by the broadcast-transmitter manufacturers, and their directions should be followed.

Generally, the first and final cavities are tuned to the visual-transmitter frequency, although they sometimes are "rocked" to shape the frequency-response curve. Where only four cavities are employed on a klystron, the second cavity is tuned low to improve the response at the lower frequencies; the third cavity is tuned high. Tubes with other numbers of cavities are tuned differently, all with the objective of giving a flat frequency response over the visual-transmitter bandwidth.

Often, tubes must be provided with external cavity loads or adjustable cavity-load coupling loops to achieve the proper frequency response. Explicit instructions usually are given for adjusting and connecting them, and the instructions must be followed to receive satisfactory performance from the tube. In other cases, a minor adjustment in the electromagnetic-field focusing current will optimize the performance of a klystron. Whatever the

procedures may be, however, they are carefully explained and easy to learn so that broadcast engineers can become competent klystron operators in a short time.

Conclusion

The klystrons discussed herein are the most widely used types of CW klystron amplifier. Tubes very similar to those used for television have been used in point-to-point troposcatter communications links operating since 1955. Shortly thereafter, smaller, higher-frequency klystrons came into use in satellite-communications ground stations. Typically, a CW klystron is about 30 to 40% efficient and has a gain of nearly 10 dB for each of the 4 or 5 cavities when broadband tuned.

Almost all power klystrons are focused with electromagnets; some high-frequency tubes with short RF structures are focused with permanent magnets to conserve weight and power consumption. Typical uses are in airborne applications. Recently, some tubes using electrostatic focusing have been developed for both UHF-TV translators and troposcatter transmitters. These tubes have not yet realized their full potential.

Klystrons have been used to amplify pulsed signals since the late 1940's and early 1950's. Defense from enemy aircraft and missiles has caused a need for early-warning radar systems ever since. Typically, these systems employ tubes with peak power ratings of from 3 to 5 megawatts. The tubes have from 5 to 7 cavities, but are stagger tuned so that the overall gain is from 40 to 50 dB. Similar pulse-amplifier tubes are used in equipment for experiments in high-energy physics. A typical application is the Linear Accelerator at Stanford University; RF energy from klystrons placed along the two-mile-long machine accelerates the electron beam.

Of all the signals that are amplified by klystrons, there is none more complex than the video signal of a TV transmitter. The tube must amplify a pulse, low-level video information, and the color burst, and at the same time have good gain linearity and minimum phase shift for color fidelity. Thus the visual signal is one of the toughest there is for a klystron to amplify. ▲

Reworking the Link 2210 for remote pickup duty

By Philip Whitney

The Link Model 2210 and its later editions have been around since the late 1940's. Recently many of them have been taken out of service in taxicabs, fire and police equipment, and other applications; some of these units are now available through surplus stores, communications suppliers, and shops at prices ranging from \$25.00 to \$60.00.

The 2210 is a battery-operated (originally 6 volts, with many conversions to 12) combination transmitter and receiver. The power supply was a vibrator with selenium rectifier. The transmitter output power, from a single 2E24 or 2E26 final, was about ten watts.

Some broadcast stations are now using the units in their original form in their news vehicles; others have removed the vibrator and added transistor power supplies. Most stations do not need the receiver portion, but need a lightweight unit any announcer can carry easily to a remote. The solution is to remove the transmitter components from the old chassis and reassemble them on a new one.

The finished unit measures 6½ x 7 x 9 inches, and even anemic announcers have no difficulty carrying it. The ten-watts output provides a clean signal out to about ten miles, depending upon terrain, and covers most needs. The unit described operates on 117 volts AC, but there is no reason it could not be built with a transistor supply. Its low power drain enables its use with a transistor inverter (117 volts AC output) in the mobile units.

Illustrated in Fig. 1 is the transmitter schematic and the power sup-

ply. Fig. 2 diagrams the parts placement to scale. Compare this to Fig. 3 which is the inside view showing the parts placement and the ventilating fan. A local tinsmith fabricated the aluminum cover, but a combination chassis and cover could be purchased.

The only basic change in the reworking operation is the replacement of the original 7F7 with a 12AT7 in the oscillator-modulator circuit. Type 6AQ5 tubes were substituted for the original 2E30's and a 2E26 for the original 2E24 final.

Type approval is not required for equipment operating in this service, so these tube changes created no problems.

The B+ for the low-power multiplier stages and the screens was obtained through a dropping resistor instead of the original high-voltage relay. The resistor was mounted on top of the chassis for better ventilation.

There is no trick circuitry in the transmitter. It is a straightforward oscillator-modulator-quadrupler-tripler-doubler-doubler-final lineup.

Power Supply

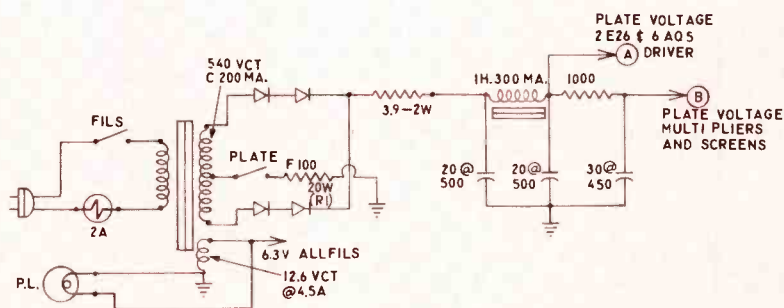

T₁, T₂, and T₃ are shielded coils mounted on top of the chassis. L₃, L₆, and L₇ are small coils mounted on the miniature variable capacitors under the chassis; L₁ is a small, slug-tuned coil also underneath the chassis.

The new power supply is a full-wave silicon system using a Thor-darson 26R49 (or equivalent) power transformer and four 500-ma, 800-PIV diodes. A single 1000-PIV rectifier in each leg would also do the job.

Begin construction by unsoldering all wires in the old transmitter, being SURE to label all transformer plates, grid, ground-return, and B+ terminals as the wires are removed. Carefully remove the underchassis coils and capacitors, noting the location of each coil and its resonant frequency. (A grid dip meter is very helpful when reassembling.)

Arrange all the parts on the new 7 x 9 inch aluminum chassis as

they are removed from the old unit. Follow Fig. 3 as closely as possible. Use new tube sockets, preferably mica-filled or ceramic. The small tubes should be provided with shields. The 6AQ5's can be provided with heat-radiating shields or left unshielded if no stability problems develop. The base of the final must be only 1/4 inch away from the T₃ coil can.

Cut the new chassis and mount the power transformer and choke as shown (choke above chassis). On the end of the chassis mount the fuse holder, filament switch, pilot light, and plate switch in that order from left to right, then insert a grommet in the last hole of the right for the power cord.

On the opposite end of the chassis, mount the output coax connector just below the L₃ coil can, but be sure to leave enough room for the top cover to fit down over the chassis for fastening. The choice of coax socket depends upon the type

of cabling commonly used.

Discard all the transmit-receive relays. The plate voltage is now controlled by grounding the center tap of the plate winding through the plate switch.

Afer mounting all parts, wire them in, using the shortest leads possible. At this frequency an extra 1/4" of wire can change the resonant frequency of a coil up to ten MHz.

In the final alignment, the transmitter operating frequency should be brought into zero beat by adjustment of the crystal padder, using a good frequency meter. (Frequency tolerance in this band is .005%, or ± 8 kHz at 160MHz.) The crystal frequency is 1/48th of the final frequency.

The unit we modified contained a transistor microphone preamplifier atop the chassis. RF problems caused rectified DC to change the bias on the transistors and thus their gain, until elaborate shielding and filtering were applied. It was felt

FIGURE 1 TRANSMITTER SCHEMATIC

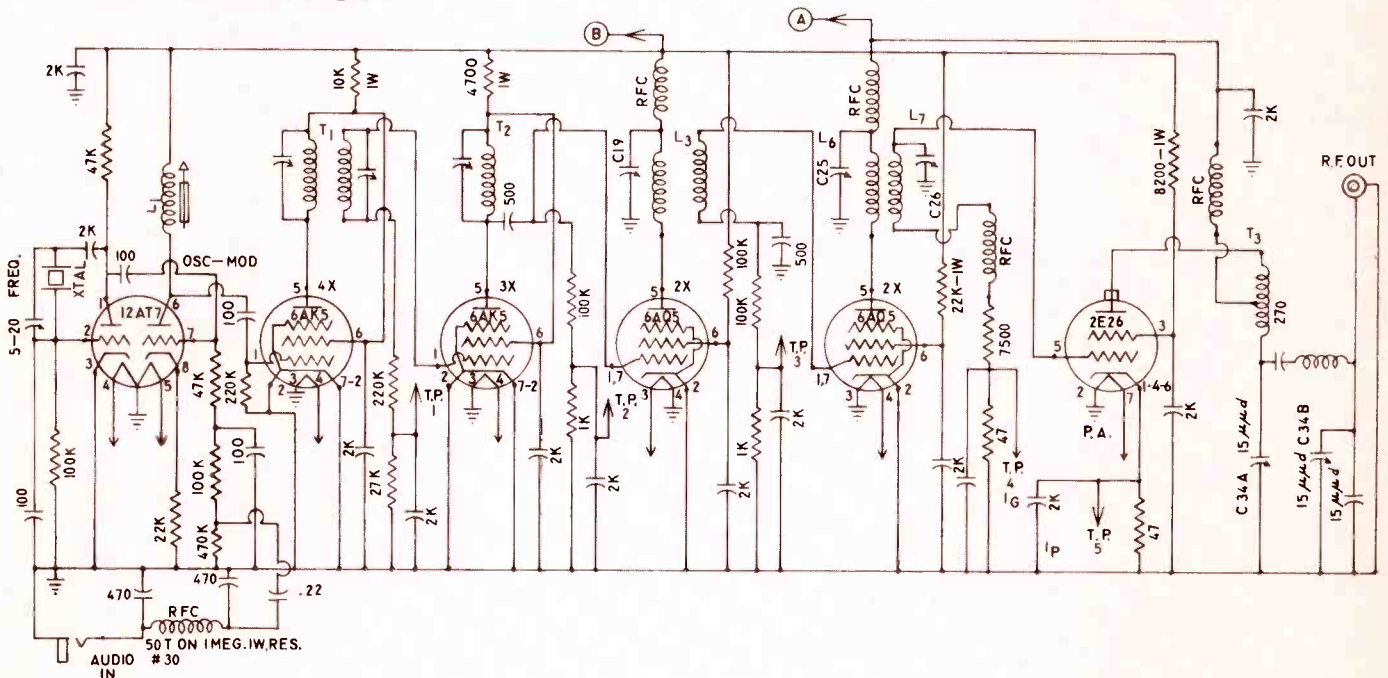

**New high band
TR-50
tape recorder
saves you \$19,000.***

The TR-50 was designed for high band taping at low cost. It is built to give you high band performance where it counts—in greatly improved signal-to-noise and moire. Other high band features have been made possible by borrowing from some of the advanced techniques of the deluxe recorders. It can save you \$19,000 over the nearest economy model. Yet the TR-50's high band performance is as good as or better than the other, as you can see for yourself when you look at the picture. How's this for cost effectiveness?



**Look what
you can buy
for the
\$19,000.***

You get a great value in the TR-50. It's so good that you not only make money with it—you save money on it! With the \$19,000 savings you can buy a lot of things for your station. You can get enough tape to keep the machine in business for years. Or you can get TV monitors, new studio lights, microphones and other broadcast equipment. Stations where tapes for network delays, local commercials and program production are required will welcome the TR-50. Your RCA Field Man has the complete story. Call him about it. Or write RCA Broadcast and TV Equipment, Building 15-5, Camden, N.J. 08102.

*Saving over cost of nearest economy model high band recorder.



FIGURE 2 DIAGRAM OF PARTS LAYOUT

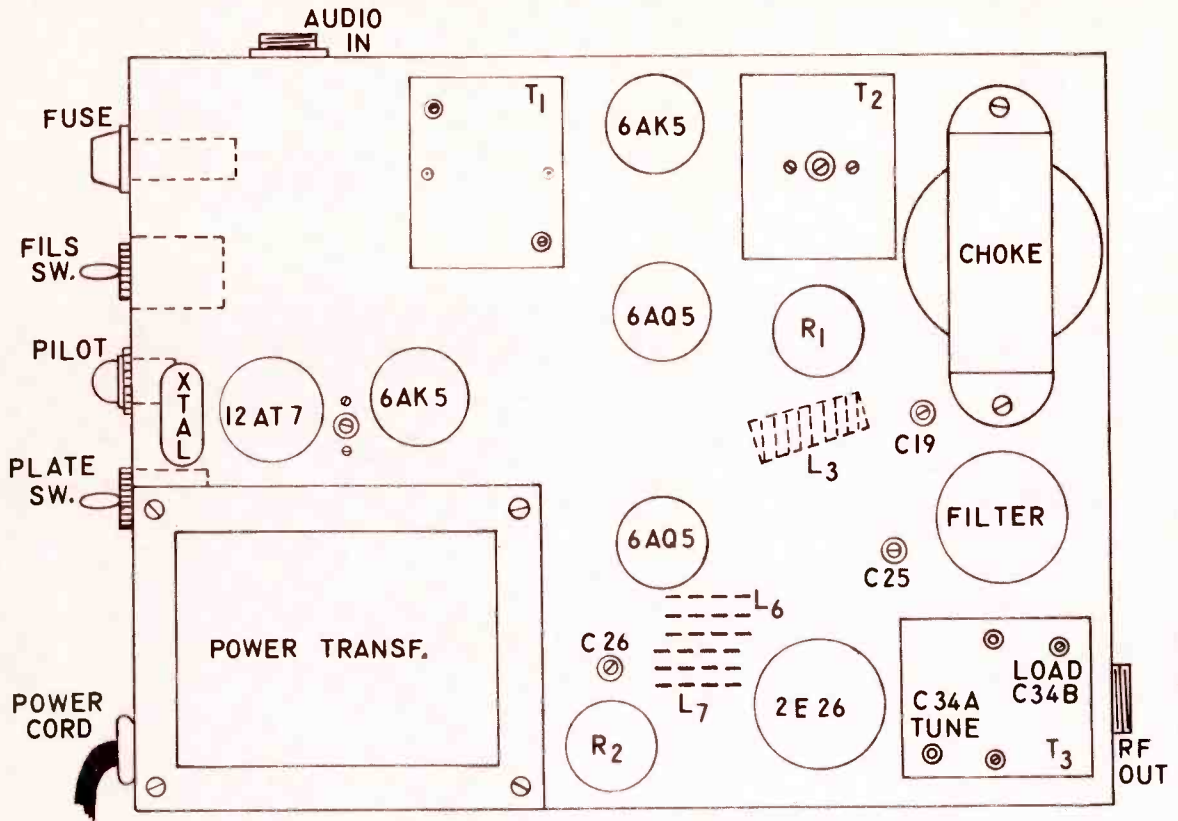

that for utmost stability under all conditions, it was better to use an external preamp, feeding about 0-db audio into the bottom of the modulator grid circuit. A microphone with built-in preamp did the job nicely, so a phone jack was installed in the side of the chassis to receive the audio from any preamp.

To avoid hum pickup, no audio

matching transformer was used in the final design. The mismatch helped to flatten the original audio response curve, which was designed for communications bandwidth only. Further equalization can be introduced into the grid circuit of the modulator to give quite acceptable broadcast quality, but this requires more gain in the preamp to compensate for the equalization losses. Since the unit was built for sports and news use, its fairly flat response from 100 to 5000 Hz was acceptable, and speech is sharp and clean.

Transmitter modulation swing should be measured after completion. The proper audio level to give the required modulation should be measured and maintained thereafter. Allowable modulation swing varies according to the frequency used. Communications channels in the five frequencies centering on 161.70-HMz are only 30 kHz wide. The allowable frequency drift should be subtracted from this figure, (30 — 8 = 22), and the remainder divided

by two, (less a guard band), so that allowable frequency swing is about ± 8 KHz. Other frequencies assigned for this service allow a 60-kHz bandwidth, thus a ± 15 kHz swing is possible.

As compact as the transmitter is, there is a great concentration of heat atop the chassis, mainly from the 6AQ5's, and the 2E26, and the plate dropping resistors. Therefore a small fan was installed in the top of the cover, and vent holes were cut in the cover to allow for cool air to enter. These holes were then covered with screen wire. When the fan is mounted, it should not be close to the 2E26 plate cap.

Excluding labor, the unit illustrated cost about \$100. This price includes the old transmitter, chassis and cover, new power supply, sockets, tubes, and other parts. It is quite possible that the job could have been done for appreciably less. As much as the unit has been used, it has been worth many times that amount!

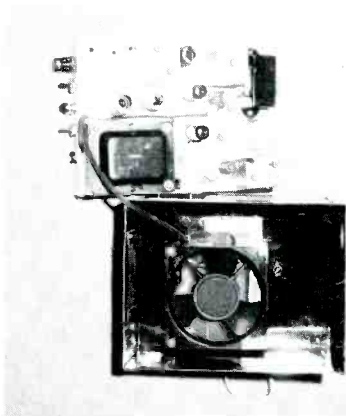

Fig. 3 Parts placement, vent fan.

NCTA Convention Features

PROGRESS and PROMISE

Nineteen years ago the first commercial CATV system in the United States began serving a community of subscribers in Lansford, Pa. It was the beginning of an industry. And its roller coaster growth chart reflects the scaling of many obstacles.

Doubtless, there will be other obstacles; yet in the light of continually expanding systems and recent U.S. Supreme Courts decisions, there is little doubt that CATV has gained a place in the nation's communications community.

And so it was that as the 17th Annual Convention of the National Cable Television Association got underway in Boston on June 29 there was a sense of accomplishment, a renewed solidarity and a dedication to progress among the 3,000 delegates and exhibitors.

Frederick W. Ford, NCTA President, in his address entitled "The Polar Star Of CATV," said, "Last year, at our Convention, the title of my address was 'Year of Decision for CATV.' And it certainly has been—just that—a year of decision. We resolved to fight harder in the firm belief that our service to the public was demonstratively and indispensably in the public interest. Now, after two important decisions by the U.S. Supreme Court we are a stable industry. Our property is secure. Our dreams a reality. Our business a full-fledged member of the mass media complex. Our faith justified. Our reputations vindicated. We have arrived."

Beisswenger On Cable Gains

Shortly after his election, NCTA national chairman Robert H. Beisswenger told a S.R.O. news conference that he expects sharp gains in the expansion rate of cable TV. The Jerrold Corp. president predicted

that even with present FCC restriction, cable TV's growth this year will exceed the 700,000 homes hooked up last year. Without major FCC restraints, Biesswenger declared, 90 per cent of the country will be wired in 10 years, assuming continued advances in cable technology, enabling the industry to expand service to rural areas.

Hyde Sees New Era

FCC chairman Rosel H. Hyde raised the prospect of a new era in FCC cable industry relations. "We ask you," he told an audience of cable operators, "to give us your best thinking in a spirit of enlightened self-interest. We need to know what you want to do, what service you hope to bring to the public, how you see the future for yourselves and for related technologies and related industries."

"The FCC," Hyde said, "fully intends to do a great deal of new thinking, and it will seek your help." He continued: "It is a time for reflection; it is a time for new ideas and a new look. We must now begin to reexamine policy. . . There is obviously a challenge and opportunity for regulatory leadership and for industry statesmanship."

Panel Discusses CATV Future

One of the highlights of the convention was a "Future of Cable TV" panel featuring industry representatives Irving Kahn, TelePrompTer Corp.; Alfred Stern, Television Communications Corp.; J. Leonard Reinsch, Cox Broadcasting; and Bill Daniels, Daniels and Associates.

Kahn said the cable industry—through such innovations as TelePrompTer's FCC-approved proposal to use shorthaul microwave in New York City and rural areas—has "seized an initiative." According to

Kahn, cable operators should welcome broadcasters, publishers, and "even telephone companies" as partners in the development of cable television.

Stern Proposes Research

Stern, called for the launching of a three-year, \$750,000-program, to research and develop new uses for cable TV—such services as facsimile reproduction of newspapers, the selling of merchandise by cable, and instant playback of earlier TV broadcasts.

The former NCTA national chairman suggested that this work be carried out by an independent company, "Cable Communication Development, Inc.," working closely with NCTA. He said the company might be composed of an engineer, a market analyst, an administrator



Channel 9 was the official Convention Cablecasting Channel at the NCTA Convention.

and a board of directors made up of firms contributing \$50,000 or more each.

FCC Forecast

Reinsch forecast a relaxation of the FCC's present curbs on cable television. "Eventually," he predicted, "the Commission and others will realize that without cable communications the goals of a complete television service will never be fully achieved."

Referring to the Supreme Court decision upholding FCC jurisdiction over cable television, the Cox official declared: "I believe the fact our industry has gained equal standing with other electronic media is more important than the fact the FCC regulates us."

Daniels said the future of cable television is in the big cities. He urged underground construction whenever possible and the purchase of all-color equipment by systems interested in cablecasting.

The cable industry pioneer indicated his agreement with a recent Merrill Lynch prediction that in the next 10 years cable TV subscribers will soar from the present three million to about 20 million and industry revenues will jump from today's \$110 million to some \$1 billion annually.

Color Camera Reviewed

"A Low-cost Television Camera for CATV Live Color Originations" was the topic of a paper by Frederick J. Hines, Applications Engineering, International Video Corporation.

For the first time since the advent of color television, the CATV

operator, educator and industrial user finds live color television within his means, said Hines.

"During a recent experiment, the IVC-100 camera was used to broadcast a public service color television program via a 10,000 subscriber community antenna system. The results on both black-and-white and color sets were excellent, and it is believed to be the first time a local color origination was broadcast on a CATV system," Hines told his audience.

Awards Presented

Pioneer cable operator Fred Stevenson was named recipient of the 1968 Larry Boggs Award, highest industry honor presented "in recognition of outstanding contributions to the advancement of the community antenna television industry."

Stevenson was cited by industry leader George Barco for "long and sincere devotion" to a wide range of industry causes, including exceptional service as a former NCTA chairman, executive president, member of the "Committee of Three" responsible for the association's Code of Ethics, and member of the By-Laws Committee.

Other convention awards were made for public relations, advertising and promotion. First place winners—in various categories were **Coachella Valley Television**, Palm Desert, Calif., for developing good relations with community and civic groups through cablecasting and related activities; **Better TV of Zanesville, Inc.**, Zanesville, Ohio, for a comprehensive public relations program leading to defeat of an effort by the local community monopoly to gain sanction for a second CATV franchise.

Florida TV Cable, Inc., Melbourne, Fla., earned an award for extraordinary involvement in community affairs and for a comprehensive information program designed to keep subscribers abreast of company activities; **Imperial Valley Cable Co.**, El Centro, Calif., for improving relations with subscribers, civic groups and the community-at-large.

Quincy Cablevision, Quincy, Ill., received an award for use of all available media to advertise and promote the system's opening; **West-terly Cable Television, Inc.**, for an

imaginative flower giveaway program typifying low-budget promotion avenues open to smaller systems; **Perfect TV, Inc.**, Harrisburg, Pa., for a "Cable Wagon" promotion building effective system-subscriber relations.

Elmira Video, Elmira, N. Y., won an award for a diversified program of continuing system promotion demonstrating highly effective advance planning and coordination; **Beckley Telecable**, Beckley, W. Va., for continuous use of newspaper aids and comedy radio spots to promote goodwill and sales.

Officers Elected

Jerrold president Bob Beisswenger was elected national chairman for the coming year. Convention delegates chose these officers and directors:

National vice chairman—Richard A. Moore, president of Southwestern Cable Co.

Secretary—Marcus Bartlett, Cox Broadcasting vice president for cable operations;

Treasurer—Monroe M. Rifkin, president of Daniels Management Co.;

Directors—Ralph L. (Bud) Weir, Jr., Kansas broadcaster and cable operator; William J. Bresnan, Jack Kent Cooke, Inc.; Giles Hubert Dodson, Dorate, Inc.; F. Gordon Fuqua Co.; William F. Hemminger, Gulf Coast Teleception; Amos B. (Bud) Hostetter, Jr., Continental Cablevision, Inc.; Fred Liberman, TeleSystems Corp.; Robert H. Symons, TelePromPTer Corp.; W. Randolph Tucker, Cypress Communications Corp.; John Walson, Service Electric Cable TV, Inc., and Benjamin H. Hughes (associate member representative), Superior Continental Corp.

Albert J. Ricci of Keene, N.H., outgoing NCTA secretary, and Sam Street, NCTA's convention and field services director were responsible for planning and coordination of the convention. A record three and one-half acres of exhibit space was sold for the convention. This volume, about 20 per cent above last year's figure, covered the entire width and breadth of Boston's War Memorial Auditorium, immediately adjacent to the Sheraton-Boston Hotel, scene of the convention business sessions. ▲

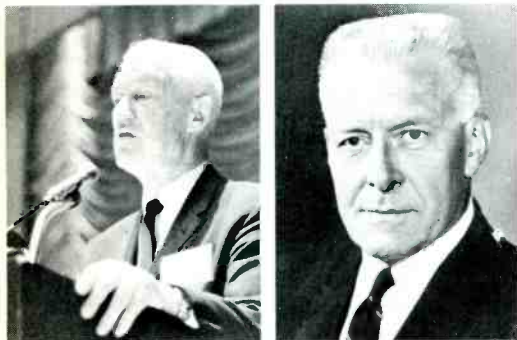

Left. Rosel H. Hyde, FCC Chairman; Right, Robert H. Beisswenger, newly elected National Chairman of the National Cable Television Assoc.

for local origination— look to the Pros' equipment

VISUAL...

**New
Dimensions
in Cable-
Casting**



WITH "PAGE" INFORMATION CHANNELS

Visual's equipment to convert digital information into "Pages" of readable information on television screens, coupled with Visual Data Files for storing, retrieving and communicating the digital information, can now provide one or many channels of "Page" information to a cable system by low-cost remote wire services or through *local origination no more complex than the operation of a typewriter keyboard.*

"Page" Format information channels can provide:

Wire ServicesNews, Stock Market Information, Sports.

Local OriginationNews, Weather, Public Service,
Advertising, TV Program Schedule
Directory, School Bulletins,
Classified Ads.

Syndicated Materialfor any of these services from
other sources.

Automatic pre-programmed information can include titles or "Pages" of information changing periodically, or "rolling" or "crawling" constantly. These can be combined in automatic operation with slides and sound.



VISUAL ELECTRONICS CORPORATION

356 west 40th street • new york, n.y. 10018 • (212) 736-5840

YOUR MAJOR SOURCE FOR ADVANCED EQUIPMENT

FLEXIBILITY

- 4 switch-selectable inputs: hi-level/mike/equal phone cannon XL connector/barrier strip input.
- External studio and local speaker.
- P. A. output (public address).
- Muting relay contacts on barrier strip.

ELECTRONICS

- Etched-epoxy circuit board.
- Plug-in silicon transistors.
- 4 preamplifiers (each normal on equal RIAA phono).
- 1 program amplifier.
- 1 monitor amplifier.
- Speaker muting relays for local and studio speakers.
- May be strapped to operate from any mixer.
- Two-speaker muting.

PORTABILITY

Weight: 28 pounds
Height: 5"
Width: 14"
Length: 17"

PARALLEL OPERATION

Optional plug-in cable allows parallel operation of two 212J-1's. Arrangement provides 8 input channels (hi-level/mike/phone), two metered program output channels, and two switchable input monitor channels.

ACCESSIBILITY

Top and bottom covers removed individually to expose all components. Circuit board hinged for easy access to reverse side and cables.

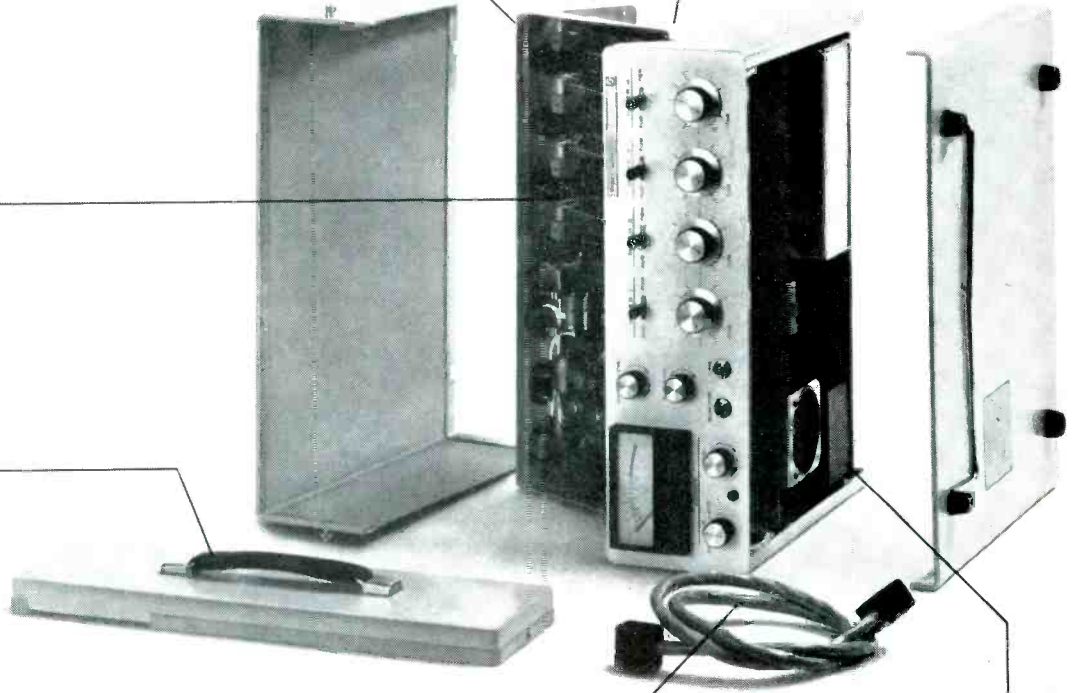

OPTIONAL POWER SOURCE

Self-contained power supply that operates the unit on AC also serves as charger for optional internal nickel-cadmium 12-volt battery. Unit switches automatically to battery in the event of an AC power loss. Unit also operates on external 12-volt battery.

a studio production console and remote pickup amplifier in one unit

That's the combination you get in Collins' new 212J-1 Console. Produce spots, conduct remote pickups, or operate the control room in emergency situations.

Completely solid-state, the 212J-1 offers:

- *Four input channels, each with selectable switches for hi-level, microphone, or phone (RIAA equalization).*
- *One program output channel.*
 - *Switch-selectable monitor amplifier with internal speaker.*
 - *Cue on all mixers overriding into monitor channel.*
- *Local and studio speaker muting.*
- *Public address system feed with level control.*

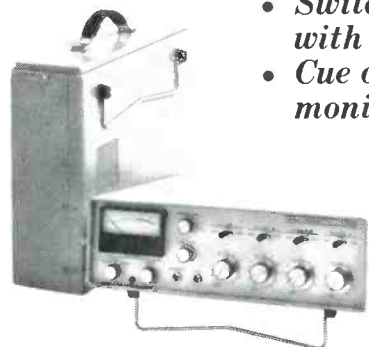

COMMUNICATION / COMPUTATION / CONTROL



Attention TV Stations:

We've got news for you!

FILMLINE'S professional color film processors now available for TV NEWS

The FILMLINE Models FE-30 and FE-50 are exciting new color film processors designed specifically for use in television station news departments. The design is backed by Filmline's reputation as the world's leading manufacturer of professional film processors for the commercial motion picture laboratory industry.

Now for the first time the television industry can enjoy the benefits of professional caliber equipment incorporating exclusive FILMLINE features that have paced the state-of-the-art in commercial laboratories, at a cost lower than processors offering less.

After you check these exclusive Filmline features you'll want to install a Filmline processor in your news department **NOW!**

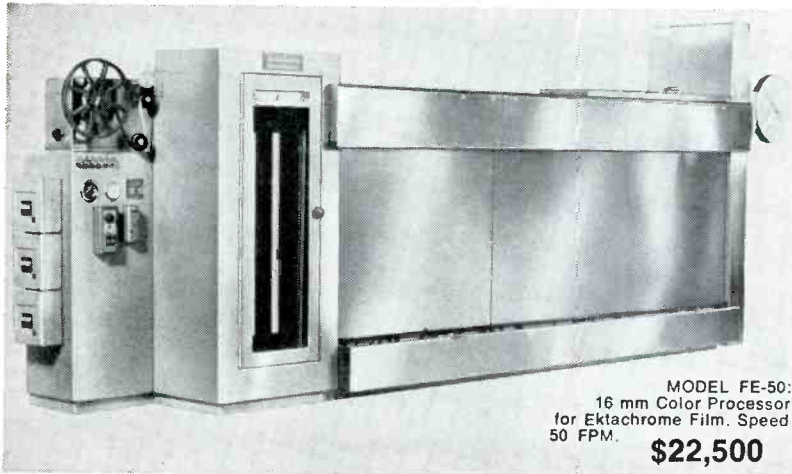

● "FILMLINE OVERDRIVE FILM TRANSPORT SYSTEM"

This marvel of engineering completely eliminates film breakage, pulled perforations, scratches and operator error. The film can be deliberately stalled in the machine without film breakage or significant change of film footage in solutions. The heart of any film processor is the drive system. No other film drive system such as sprocket drive, bottom drive or simple clutch drives with floating lower assemblies can give you the performance capability of the unique Filmline Overdrive Film Transport System.

● "TORQUE MOTOR TAKE-UP" gives you constant film take-up and does not impose any stress or strain on the film itself. Completely independent of the film transport system. This FILMLINE feature is usually found in professional commercial processors but is incorporated on the FE-30 and

FE-50 models as standard equipment. Don't settle for less!

● "TEMP-GUARD" positive temperature control system. Completely transistorized circuitry insures temperature control to well within processing tolerances. Temp-Guard controls temperatures accurately and without the problems of other systems of lesser sophistication.

● "TURBO-FLOW" impingement dryer. Shortens dry-to-dry time, improves film results, and carefully controls humidity content of your valuable (and sometimes rare) originals. Immediate projection capability is assured because the film dries flat without the usual curl associated with other film processors.

● "ZERO DOWN TIME" The reputation of any film processor is only as good as its reliability. The

combination of the exclusive and special added Filmline features guarantees trouble-free operation with absolute minimum down-time and without continual operator adjustments. Recapture your original investment in 2 years on maintenance savings alone. Filmline's "Push the button and walk-away processing" allows inexperienced operators to turn out highest quality film.

● "MATERIALS, CONSTRUCTION AND DESIGN" All Filmline machines are constructed entirely of metal and tanks are type 316 stainless steel, heliarc welded to government specifications. The finest components available are used and rigid quality control standards are maintained.

Compare Filmline features to other processors costing more money. Feature-by-feature, a careful evaluation will convince you that Filmline offers you more for your investment.

Additional Features included in price of machine (Not as extras).

Magazine load, daylight operation ■ Feed-in time delay elevator (completely accessible) ■ Take-up time delay elevator (completely accessible) ■ Red brass bleach tank, shafts, etc. Prehardener solution filter ■ Precision Filmline Venturi air squeegee prior to drybox entry ■ Air vent on prehardener ■ Solid state variable speed D.C. drive main motor ■ Bottom drains and valves on all tanks ■ Extended development time up to two additional camera stops at 50 FPM ■ Pump recirculation of all eight solutions thru spray bars ■ Temperature is sensed in the recirculation line ■ All solutions temperature controlled, no chilled water required ■ Built-in air compressor ■ Captive bottom assemblies assure you constant footage in each solution ■ Change over from standard developing to extended developing can be accomplished in a matter of seconds ■ Impingement dryer allows shorter put through time.

Partial listing of Filmline Color Installations: — NBC- New York, NBC- Washington, NBC- Cleveland, NBC- Chicago, CBS & ABC Networks, Eastman Kodak, Rochester.

Laboratories: De Luxe Labs, General Film Labs (Hollywood), Pathe-Labs, Precision Labs, Mecca Labs, Color Service Co., Capital Film Labs, Byron Film Labs, MGM, Movie Lab, Lab-TV, Technical Film Labs, Telecolor Film Labs, Guffanti Film Labs, A-One Labs, All-service Labs, NASA Cape Kennedy, Ford Motion Picture Labs.

TV Stations: WAPI-TV, KTVI-TV, WXYZ-TV, WTPA-TV, WBTU-TV, WEAT-TV, WMAL-TV, WSYR-TV, WDSU-TV, WVUE-TV, WJXT-TV, WTOP-TV, WAVY-TV, KTAR-TV, WTVR-TV, WFBC-TV, WMAR-TV, WCKT-TV, WAVE-TV, WCPO-TV, WAPA-TV, WCIV-TV, WJIM-TV, WWL-TV, KYW-TV, KETV-TV, WNBQ-TV, KSLA-TV, WSZA-TV, WHP-TV, WHCT-TV, WTWO-TV.



Dept. BEA-68

Send for Literature.

Time & Lease Plans Available.

All prices F.O.B. MILFORD, CONN.

"When you buy quality Filmline Costs Less"

Circle Item 13 on Tech Data Card



As Goes Maine, So Goes the Nation?

Soon many residents of Maine, New Hampshire, Vermont and eastern Canada will be enjoying better-than-ever TV color quality, picture resolution and audio fidelity.

Why? Because northern New England affiliates of ABC are installing over 300 miles of intercity, STL and TSL microwave relay links . . . B-Line fixed links from Microwave Associates.

How come better performance? Because wideband linear phase and amplitude designs provide minimal differential phase, gain and group delay. Because both transmitter and receiver are totally solid-state. And because there are no klystron tubes. That means higher reliability, lower power consumption, less heat, no harmful voltages . . . and reduced operating costs.

All good reasons for electing B-Line fixed microwave links. And systems are available for 2 to 13 GHz frequency bands, along with complete RF system engineering assistance. They're dossierled in Bulletin 9025, yours for the asking.

As goes Maine, so goes the nation.



MICROWAVE ASSOCIATES
Burlington, Massachusetts

Offices: Northwest Industrial Park, Burlington, Mass. 01803
International Sales: Microwave Associates International
Northwest Industrial Park, Burlington, Mass. 01803

Circle Item 14 on Tech Data Card

August 1968

Late Bulletin from Washington

by Howard T. Head

Decisions May Change Face of CATV

The U.S. Supreme Court has handed down its decisions in the cases involving the Commission's authority to regulate CATV, and the liability of CATV operators under the copyright laws (see April, 1968 Bulletin). In the first case involving a CATV system in San Diego, the 9th Circuit Court of Appeals had held that the Commission was without authority under law to regulate CATV systems. The Supreme Court overturned this ruling, holding that the Communications Act of 1934 empowers the Commission to adopt reasonable regulations of any character relating to radio and wire communications in the United States. Intrastate transmissions are specifically included.

In the copyright case, the 2d Circuit Court of Appeals had held that CATV systems were fully liable for copyright payments for any copyrighted material carried. Again, the Supreme Court reversed the Court of Appeals, holding that CATV distribution does not constitute a "performance" within the meaning of the Copyright Act of 1909, and that consequently, CATV systems are not liable for payments for any copyrighted material, with the possible exception of shows originated by a CATV system.

The Supreme Court invited Congress to clarify the entire copyright picture with suitable legislation if Congress should so desire. In the meantime, however, the Supreme Court stated its intention of interpreting the 1909 Copyright Act "as we find it".

Shortly after the Supreme Court decision in these two cases, the Commission ruled, in the so-called "Section 214 case", that telephone companies providing CATV channel service must obtain "certificates of convenience and necessity" from the Commission in order to do so. Certificates must now be obtained by telephone companies already providing CATV channel service; any telephone company CATV construction in progress must halt until such certificates are obtained; and telephone companies may undertake no new CATV construction without certificates. Intrastate as well as interstate service is affected by the Commission's ruling, which applies to circuits of any length. The ruling has no effect on CATV systems which operate their own plants on the basis of pole attachment rights from a telephone company.

Proposals for New Land Mobile Spectrum Space

The White Office of Telecommunications Management (OTM) has notified the Commission that 26 MHz of frequency spectrum immediately above 890 MHz,

presently reserved for Government operations, can be made available for re-assignment by the Commission to non-Government users. Suggestions have been made that the newly available spectrum space be assigned to the land mobile services, which are continuing to clamor insistently for additional spectrum space. The common carriers have also expressed interest in using all or part of these frequencies.

Land mobile manufacturers and users are cool to suggestions for operation in this frequency region, largely because of the UHF television band immediately above 470 MHz, where equipment has been developed and is currently available for use. The commission is expected to propose shortly the possibility of sharing the lower portion of the UHF band between television broadcasting and the land mobile users. At present, however, there have been no tests of the feasibility of land mobile/UHF television sharing.

New Television Translator Rules Adopted

The Commission has adopted considerably liberalized rules governing the operation of both VHF and UHF television translators (see August, 1967 Bulletin). The permissible antenna input power for VHF translators west of the Mississippi River and Alaska and Hawaii has been increased from one watt to ten watts, and television licensees are now permitted to own and operate VHF translators outside of their predicted Grade B contours. UHF translators may originate announcements to solicit financial support; a maximum of twenty-second spot per hour is permitted.

Fulltime AM Stations to Lose Some PSA Privileges

As a result of a favorable Court ruling (July, 1968 Bulletin), the Commission is making plans to terminate "extra-power" Presunrise Service Authority (PSA) privileges for fulltime stations. The ordinary PSA permits presunrise operation beginning at 6:00 A.M. for both fulltime and daytime-only stations, but in no case may a power in excess of 500 watts be employed between 6:00 A.M. and local sunrise. During the pendency of Court cases in opposition to the PSA rules, however, the Commission had authorized a number of fulltime stations to employ power in excess of 500 watts during this period, whenever no interference was caused to foreign stations.

With the resolution of these cases before the Court, these extra-power privileges for the fulltime stations will be terminated. It appears likely that individual stations will be notified of the withdrawal of these privileges prior to the end of Daylight Saving Time in October. Daytime-only stations are not affected by the ruling.

Howard T. Head...in Washington

Primo

New!! UD-900

UNI-DIRECTIONAL MICROPHONE
(with tone control)

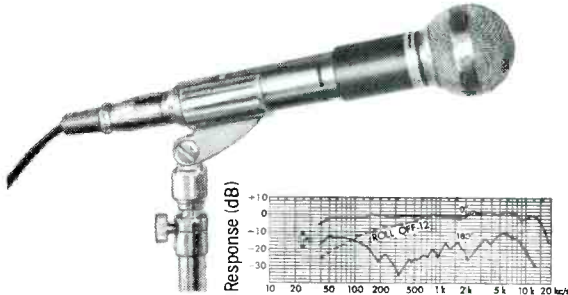

SPECIFICATIONS:

- Cartridge DM-49
- Impedance 600 ohms
- Sensitivity -73db \pm 2db/ μ bar
- Frequency Response 50 to 15000Hz \pm 5db
- Dimensions 50mm dia, 250 Length

* For further information please write to

PRIMO COMPANY LTD.

Head Office: 25-1, 6-chome, Mure, Mitakashi, Tokyo, Japan Tel. 0422-43-3121~7
 Cable: "Primo-Musashino Mitaka" Telex: 2822-326 PRIMO MUS
 Chicago Illinois Office: A.P.T. No 204, 530 W. Surf. St. Chicago Illinois 60657.
 U.S.A. Tel. 312-472-61421 Telex: 25-4225 PRIMO MUS CGOILLUSA

Circle Item 15 on Tech Data Card

Lawrence Radiation Laboratory with over 5700 employees is located in the San Francisco Bay Area and is engaged in virtually all phases of nuclear energy research.

TV ENGINEER

To engage in engineering and design of experimental and special application closed-circuit systems and modification of existing systems. Requires a minimum of two years' engineering and operating experience in all phases of TV transmission and reception, including closed circuit TV. BS or MS.

For further information please send resume to Mr. Ken Englund, Personnel Department.



P.O. Box 808, 82-88
 Livermore, California 94550

An Equal Opportunity Employer U.S. Citizenship Required

Circle Item 16 on Tech Data Card

FOURMOST IN CARTRIDGE SYSTEMS

MC-104 MULTI-CARTRIDGE PLAYBACK

Four independent transport modules, each with its own direct motor/capstan drive transport & individual transistorized program and cue amplifiers. Vertical cabinet or horizontal rack mountings \$1650. Stereo Model \$2095.

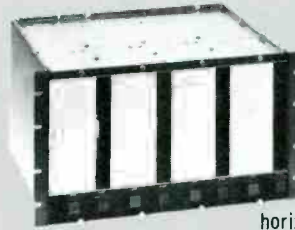

300C PLAYBACK

Solid state amplifiers, relays and bias stages. 1000 HZ stop cue tone standard. 2nd & 3rd cue tones available. For rack or custom cabinet installation \$550. Record/Playback Model \$795.



800C RECORD/PLAYBACK

Ultra modern, compact design. Easy access to plug-in heads and transistorized modular circuitry. 3 way tape guide head mount. Direct motor/capstan drive transport. \$675. Playback Model \$495.



BP-22 SALESMAN'S PORTABLE PLAYBACK

Make your sales presentations more impressive. Demonstrate your programming and production skills on AC or battery power, instantly. Housed in slim style attache case. Makes selling easy. \$189.50



SEE ALL OF SPARTA'S NEW LOOK!
 Write or call for complete product brochure.



A DIVISION OF COMPUTER EQUIPMENT CORPORATION
 5851 FLORIN-PERKINS ROAD
 SACRAMENTO, CALIFORNIA 95828
 (916) 383-5353

Circle Item 17 on Tech Data Card

For a top job in broadcasting . . . get a FIRST CLASS FCC LICENSE ...or your money back!

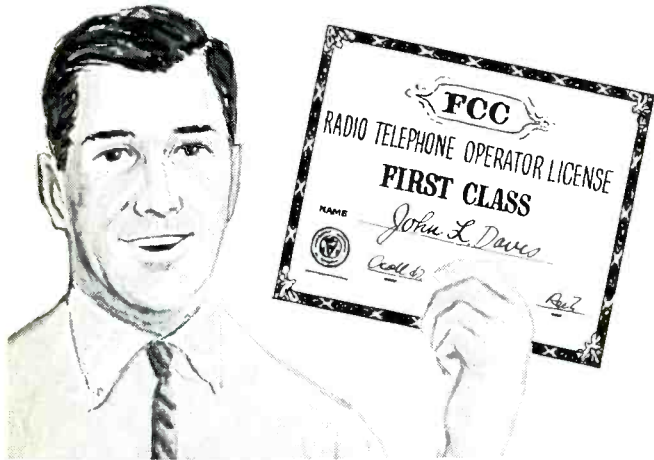

YOUR key to future success in electronics is a First-Class FCC License. It will permit you to operate and maintain transmitting equipment used in aviation, broadcasting, marine, microwave, mobile communications, or Citizens-Band. Cleveland Institute home study is the ideal way to get your FCC License. Here's why:

Our electronics course will *quickly* prepare you for a First-Class FCC License. Should you fail to pass the FCC examination after completing your course, you will get a *full refund* of all tuition payments. You get an FCC License . . . or your money back!

And only CIE offers you new, up-to-the-minute lessons in all these subjects: Logical Troubleshooting, Microminiaturization, Single Sideband Technique, Pulse Theory and Application, Boolean Algebra, and many more.

You owe it to yourself, your family, your future to get the complete details on our "proven effective" Cleveland Institute home study. Just send the coupon below for FREE book or write to Cleveland Institute of Electronics, 1776 E. 17th St., Dept. BE 50, Cleveland, Ohio 44114.

ENROLL UNDER NEW G. I. BILL

All CIE courses are available under the new G. I. Bill. If you served on active duty since January 31, 1955, OR are in service now, check box in coupon for G. I. Bill information.

MAIL COUPON TODAY FOR FREE BOOK



CIE Cleveland Institute of Electronics

1776 East 17th Street, Cleveland, Ohio 44114

Please send me your FREE book, "How To Get A Commercial FCC License."

Name _____ (please print)

Address _____

City _____ State _____ Zip _____

Occupation _____ Age _____

Check here for G. I. Bill information.

Accredited Member National Home Study Council
A Leader in Electronics Training . . . since 1934

BE-50

Circle Item 18 on Tech Data Card

ENGINEERS' TECH DATA

65. **ACME FILM & VIDEOTAPE LABORATORIES**—A new 28-page film and videotape processing catalog and price list contains some useful information including a glossary of the latest laboratory terms, a detachable footage conversion chart, and comprehensible diagrams and information on preparing "A" & "B" 16mm originals for printing.
66. **AMPEX**—A brochure on reporter test tapes is available, including a specification sheet for standard reproducer alignment test tapes and two related articles reprinted from the JOURNAL OF THE APES.
67. **ASTRODYNE**—Four natural convection heat sinks, designed for use with printed circuit boards, are described in a new bulletin from Astrodyne. The 2300 Series, low-profile units are of square configuration with a common base of 1.81" square and heights ranging from 1/4 to 1/2 inch. The bulletin illustrates the new units and provides both performance and mechanical data and is available from Astrodyne, Inc., 207 Cambridge Street, Burlington, Mass., 01803.
68. **ATLAS SOUND**—Form PP-1840 describes microphone stands, microphone booms, components, and studio accessories.
69. **B & K**—A product-data sheet gives applications and specifications for Model 123 1/3-octave spectrum shaper and Model 1612/S2L 1/3-octave shaper and analyzer.
70. **BENCO**—Specification sheets describing the Benco Benfeed transistorized distribution and feeder line amplifier, and the Benco solid state automatic video/audio headend control unit, are offered.
71. **BENRUS TECHNICAL PRODUCTS**—Catalog No. 802 gives descriptions and specifications for CRT-display units and interchangeable deflection amplifiers.
72. **BIRD ELECTRONIC**—Bulletin TLR-50kw-7, describes a 1kw to 50kw air and water-cooled RF coax. A new 5000 watt miniature RF coaxial load resistor is described in Bulletin TLR8720-8.
73. **CLEVELAND ELECTRONICS**—A 52-page quick reference catalog gives information on vidicon, Plumbicon, and image-orthicon reflection components.
74. **CHOU**—Data Sheet No. 6-394 describes an Airborne TV System, and No. 6-302 discusses Systems Interconnections. A new brochure "The ABC's of ETV" includes photographs, applications and systems layouts for educational television and discussions on video tape recording, video and audio switching, synchronization and camera accessories.
75. **COLLINS RADIO CO.**—A brochure on Collins' new 212J-1 Production/Remote Console is offered.
76. **COLORADO VIDEO-SMPTE**—reprint "A New Method of Television Waveform Display" is available.
77. **DELHI**—Twelve-page catalog concerns towers and masts for Citizens-band and similar applications.
78. **DELTA ELECTRONICS**—Specification sheets and application bulletins give information about the OIB-1 operating impedance bridge and CPB-1 and 1-A common-point impedance bridges.
79. **DYNAIR ELECTRONICS**—A technical paper describes DYNAIR TS-100B Solid-State Sideband Analyzer and its application for use in testing and alignment of broadcast TV Transmitters and CATV Modulators.
80. **ELCO CORPORATION**—Catalogs offered are: Printed Circuit Connector Guide (64 pages), MIL-C-26482 Connector Catalog (20 pages), Variplate Connector Catalog (24 pages), Tube and Transistor Socket Catalog (14 pages), and Varicon Rack and Panel Connector Catalog (24 pages).
81. **FILMLINE CORPORATION**—Full Product Line literature and price lists concerning Continuous Film Processors are available.
82. **FORT WORTH TOWER**—Literature dealing with towers, passive reflectors, and equipment buildings is offered.
83. **GATES RADIO COMPANY**—A Remote Amplifier Guide describing Gates "70" series of transistorized remote amplifiers (the Dynamote "70", the Attache "70", the Courier "70" and the Unimote "70") is available.
84. **GRANGER ASSOCIATES, BAUER BROADCAST PRODUCTS DIV.**—A complete line of audio equipment including mono, stereo and dual consoles and other studio equipment is described in a catalog. A data sheet describes a new solid state FM exciter with 20-watt output. Also new 3 and 5kw FM transmitters are the subject of another data sheet.
85. **INDUSTRIAL ELECTRONIC RESEARCH CORP.**—Bulletin 151 gives information about IERC heat-dissipating devices for microcircuit packages.
86. **JOA**—Prices and data are given for new cartridges and cartridge-reconditioning service.
87. **JONARD INDUSTRIES**—Catalog No. 150 of JIC Tools includes all new additions and changes since 1964. Tools include spring adjusters gauges, burnishers, and other precision hand tools. This catalog also describes the custom-made tool departments available for items made to manufacturers' own specifications.
88. **JSH ELECTRONICS CO.**—The Heinz and Kaufman Tube OEM Price List is available.
89. **KALART/VICTOR**—Victor Models STV-18 and STV-TB 16-mm projectors and Tele-Beam Model A912 large screen television projection systems are covered in three brochures.
90. **MICROWAVE ASSOCIATES**—An illustrated 29-page microwave semiconductor short form catalog is offered, containing the most recent electrical and mechanical specifications for the company's complete line of microwave semiconductors.
91. **D. B. MILLIKEN**—Model DBM-RI video-film recording system is described in data sheets.
92. **MOTOROLA SEMICONDUCTOR PRODUCTS**—An Application Note Catalog lists the number, title, and gives a brief summary of more than 130 papers describing circuit and system application designs.
93. **MUELLER**—An eight page catalog illustrates and describes materials, sizes, characteristics, and capacities of all clips and insulators made by Mueller.
94. **NAGRA**—Synchronous 1/4-inch tape recorders and accessories are subject of leaflet.
95. **ROUND HILL ASSOCIATES**—Data sheets and technical bulletins provide information on five models of audio amplifiers, a regulated power supply, a power oscillator, and a wireless cueing amplifier.
96. **RUSSCO ELECTRONIC MFG.**—Turntables and phone preamplifiers, stereo and mono, are the subjects of two new brochures.
97. **SIMPSON ELECTRIC**—A new test equipment catalog is available.
98. **SORENSEN**—Short form catalog No. 68A lists power supplies, AC-line regulators, and frequency changes.
99. **SWITCHCRAFT**—Bulletin 174 describes a new low-cost multiple station push-button switch, the DW "Multi-Switch", series 65000. This series is available with choice of three standard functions, 2-C circuitry per station and up to 18 stations in a row depending on function.
100. **TAPECASTER TCM**—A two page brochure has specifications, prices and detailed schematics of the Tapecaster TCM series 700 Tape Cartridge Machines.
101. **TECH LABORATORIES**—A brochure describing a programming switch, is offered.
102. **TELEX**—Descriptions of Viking Studio 96 and Magnecord Models 1021 and 1022 tape recording and reproducing equipment are given in literature.
103. **TEWPIPE**—Information and prices for tape-head cleaning kit and its individual components are offered.

Don't be satisfied with half the answer!

Check the FULL bandwidth of your studio facilities with the NEW Videometrics Polyburst.

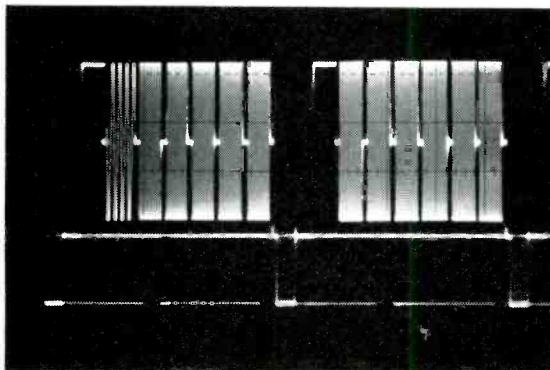

Alternate Line

0.5 to 10 MHz

This new test signal provides a total of 12 different frequency bursts from 0.5 to 10 MHz over two sequential television lines. The first line contains the standard multiburst signal with white flag followed by 6 bursts from 0.5 to 4.2 MHz. The second line contains a white flag followed by another 6 bursts from 5 to 10 MHz. This alternate line signal is repeated over the entire active field.

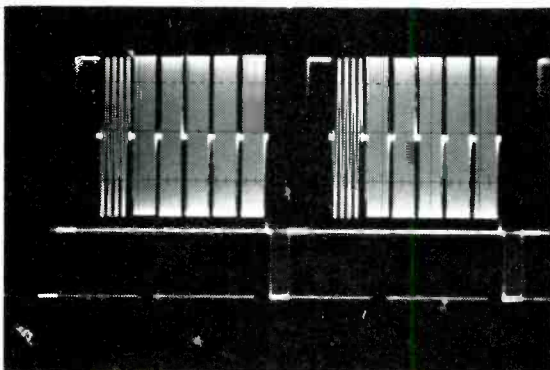

Low Band Only

0.5 to 4.2 MHz

Or by front panel switching, you can select the low band only (standard multiburst) or high band only, as pictured in the accompanying waveform photographs.

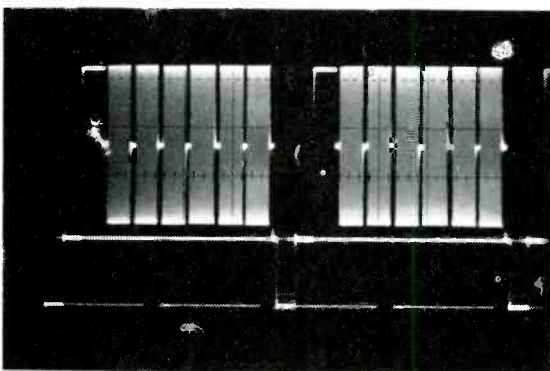

High Band Only

5 to 10 MHz

The polyburst is available individually in the Model 511A or as part of a complete modular test signal package, Model 503A.

Let Videometrics show you the difference truly professional test equipment can make to the performance of your television facilities. We manufacture a complete line of test signal generators including the Polyburst, Stairstep and Ramp, Sine Squared Pulse & Window and 20T Pulse for Full Field and VIT use.



VIDEOMETRICS, INC.

subsidiary of **CENTRAL DYNAMICS CORP**

33 Cain Dr., Plainview, N.Y. 11803

Tel. (516) 249-5662

Circle Item 19 on Tech Data Card

COLOR THE NEWS



ON THE
AIR IN
30
MINUTES

SMALLEST! LOWEST PRICED! EKTACHROME PROCESSOR

Add the impact of vivid color to local news coverage. Shoot in economical Super-8mm or 16mm Ektachrome. Develop 20 feet per minute in the fully-automatic Houston E-16-8-30 processor. All processing cycles are precisely timed and temperatures rigidly controlled to assure perfect results. Simple, goof-proof operation. Solutions never touch hands. Standard Kodak chemicals. About 8 ft. long. Fits anywhere. Use in lighted room. Finest Houston quality. Priced far lower than any comparable machine. Send for brochure.

HOUSTON
PHOTO PRODUCTS, INC.
THE WORLD KNOWS OUR PRODUCT

HOUSTON PHOTO PRODUCTS, INC.
655 E. 20th St.
Yuma, Arizona 85364
Phone: (602) 782-3677

*A Tradition of
Excellence since 1932*

Circle Item 20 on Tech Data Card

NEW PRODUCTS

For further information about any item, circle the associated number on the Tech Data Card.



Tape Recorder

(50)

The Model 11, a new tape recorder has been introduced by **Tandberg of America, Inc.** This solid state recorder has three separate heads and is available in two versions.

According to Robert Bowman, Sales Manager, the Model 11-2 is a half-track unit and is suited for musical, technical, educational, and professional broadcasting. A full-track unit, the Model 11-1 is also offered for audio-visual, journalism and business uses. Each model is easily portable and operates on ten "D" cells or Nicad rechargeable batteries.

Frequency response of Models 11-2 and 2 @ 7½ ips is 40-16,000 cps plus or minus; signal-to-noise ratio @ 7 ips is better than 56dB; and distortion is less than 0.5%. In addition, a Pilotone model is available for synchronization of sound with 16 or 35 mm. film in professional motion picture work.

Both models include a servo-type speed control (1 per mil accuracy), built-in mixer and limiter, Cannon microphone input, and a three-speed DC motor.

The retail price in both full and half-track versions is \$449.50.



Contel "101"

(51)

The Contel "101" broadcast equipment line is now available in the United States from the **Conti-**

mental Electrical Wholesale Corp. or from authorized Contel distributors, as announced at this year's NAB convention.

This line includes the CT-101-P cartridge tape recorder and the CT-101-R, cartridge tape recorder/reproducer. Both models feature solid state circuitry in color-coded, plug-in modules, a flutter-filter capstan drive system, and built-in remote control facilities.

The Contel cartridge tape equipment is complemented by the new TC-101 tape cartridges. There are three models available, all conforming to NAB standards.

Another new product is the TT-101-A High-performance turntable, available with a variety of tonearm, phono cartridge, and preamp combinations.

Video Cable Equalizer

(52)

Dynair Electronics has added six new products to its Mini-Series equipment line. One unit, a Mini-Cha Amplifier, amplifies the pass-



band of a standard low or highband VHFTV signal while suppressing the spurious in the adjacent channels. The Mini-Fade Video Fader provides a means of fading between two composite video inputs. The Mini-Seq Sequential Switcher provides automatic sequential switching of multiple camera inputs to a single monitor.

Another product is the Mini-Pre Audio Preamplifier with a low-impedance mic and a high-impedance phono input and a 600-ohm program level output. The Mini-Aud Audio Power Amplifier drives a speaker for general monitoring applications, and the Mini-Spk Speaker is used with the audio power amplifier.



WILKINSON 4N1 Portable Solid-State

1. FIELD INTENSITY METER
2. NULL DETECTOR
3. STANDARD SIGNAL GENERATOR
4. AM MONITOR RECEIVER

SUPERIOR BECAUSE THE 4N1:

Measures field intensity with superior accuracy and reduces measurement time • Requires only a bridge for easy RF impedance measurements • Powered by rechargeable batteries and self-lighted for nighttime measurements • Easier to carry and operate

FOR COMPLETE DETAILS WRITE:

WILKINSON

ELECTRONICS, INC.

1937 MacDADE BLVD. • WOODLYN, PA. 19094
• TELEPHONE (215) 874-5236 874-5237 •

Circle Item 21 on Tech Data Card



THE GRASS VALLEY GROUP, INC.

P.O. BOX 1114, GRASS VALLEY, CALIFORNIA 95945 • TELEPHONE (916) 273-8421

VIDEO DA's

- 800 SERIES 1 IN 2 OUT
- 900 SERIES 1 IN 4 OUT
- SPECIAL DA's WITH DIFFERENTIAL INPUT, CLAMPS AND EQUALIZATION

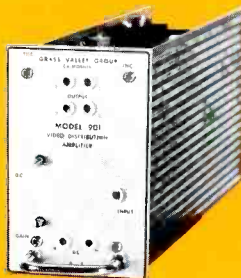

MODEL 901 VDA \$185.00

PULSE DA's

- STANDARD 1 IN 4 OUT
- PULSE FAN OUT
- PULSE DELAY AMP FOR DELAYS UP TO 5 MICROSECONDS

DISTRIBUTION AMPLIFIERS



MODEL 900TPS FRAME & POWER SUPPLY • HOLDS 7 MODULES • \$250.00

SOLD EXCLUSIVELY BY: **GRAVCO SALES, INC.**

6515 SUNSET BLVD., LOS ANGELES, CALIF. 90028/PHONE: (213) 462-6618 ■ STATION PLAZA EAST, GREAT NECK L.I., N.Y. 11021/PHONE: (516) 487-1311

Circle Item 22 on Tech Data Card

SPOTMASTER

The all solid state AD1A

AUDIO DISTRIBUTION AMPLIFIER



Meet the AD1A, a solid state audio distribution amplifier specifically designed for AM, FM and TV broadcast stations and recording studios. The AD1A distributes audio signals via five separate output channels (up to 25 with the addition of AD1A-X extenders), and incorporates a front-panel VU meter and monitor jack to permit visual and aural monitoring of the incoming signal at the output of the line amplifier. Response is essentially flat from 40 to 20,000 Hz, with low distortion and noise, 60 db channel isolation and 12 db peak factor. For further information, write or call today:

Spotmaster

BROADCAST ELECTRONICS, INC.

8810 Brookville Road
Silver Spring, Maryland 20910
Area Code 301 • 588-4983



Field Effect Meter

(53)

A new field effect meter is being marketed by Sencore, Inc. The manufacturer claims that the FE16 High Accuracy Field Effect Meter combines the features and advantages of the VTM and the VOM. It is said to have a 1.5% accuracy on seven DC ranges from 0 to 1 volt to 1000 volts and 3% on seven AC ranges from 0 to 1 volt to 1000 volts.

It measures peak to peak on its AC ranges, and has a zero center DC range of plus or minus .5 volt. It also measures DC current from 0 to 100 microamps to 1 amp and resistance to 1000 megohms.

Other features include the banana input jacks that offer flexibility and versatility in measurements, and a mirrored scale for antiparallax readings. Also the FE16 is protected so that the application of the wrong voltage will not damage the circuit or meter.

The FE16 is battery operated from a standard 9-volt transistor radio battery (not supplied) with a battery check position. The optional high voltage probe, 39A19, extends the range of the FE16 to 30V for high voltage measurements. The FE16 is priced at \$84.50.



Audio Mixing System

(54)

A 12-channel audio mixing system has been designed for the Sound Director by Norelco. The manufacturer says that the mixing unit is of compact design and that the controls have been presented with ease of operation as a prime consideration.

The twelve identical channel modules in the system contain: a channel amplifier, a channel fader, switching to group outputs, prefade switch, a switch for the introduction of frequency equalization, etc. by external amplifiers, high-low level input selection, input impedance selection, gain balancing, echo gain control, and P.A. gain control.

The six identical output amplifiers contain: three group output amplifiers, public address feed amplifier, echo feed amplifier, and prefade amplifier. Other amplifiers and facilities are: talkback microphone and amplifier, talkback se-

This is the old
EMT-140st
Reverberation Unit.

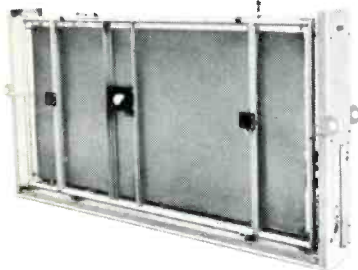

This is the
new one.

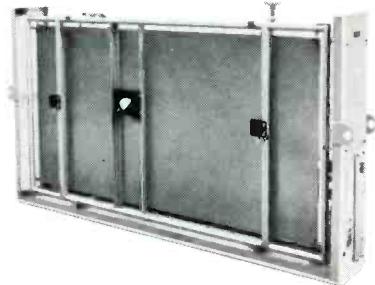

What's the difference?

We've made the amplifier unit solid state. And you can now obtain an inexpensive decay period remote controller.

Nothing else has changed. Not even the price. The EMT-140st is still the world standard in the recording and broadcasting industries. Its renowned steel plate device gives you the same unmatched stereo/mono performance. And increased fringe area reception for AM broadcasts. And unusual flexibility—its decay period can be varied from 0.5 to 5.0 seconds. (Try that with an echo chamber!)

These are just a few of the reasons why every major record company and independent recording studio owns at least one EMT-140st Reverberation Unit. Right now, more than 1000 are in use from coast-to-coast; more than 2000 throughout the world.

For the complete story, write today for our free 8-page brochure. It can make quite a difference for you.

GOTHAM
AUDIO CORPORATION
2 WEST 46 STREET, NEW YORK, N. Y. 10036 • 212-CO-5-4111
In Canada: J-Mar Electronics Ltd.

Circle Item 24 on Tech Data Card

lection buttons, a return talkback loudspeaker and amplifier (also used for prefade), and a tone generator with five switched frequencies.



Epitaxial Silicon Tuning Varactors

(55)

A new MA-45000 series of 75 and 110 volt epitaxial silicon tuning varactors introduced by **Microwave Associates** consists of twenty-two varactors designed for large capacitance variation with bias.

The manufacturer claims that the performance of the new series is represented by the MA-45011 which has a typical RF input power of 5.0w; minimum breakdown voltage of 75v and has a power dissipation of 350 watts.

This series has been designed for solid state electronic tuning, harmonic generation, frequency modulation and automatic frequency control with wide applications to the VHF-UHF range, and is also available in ceramic channels or chip form for use in microwave circuit design applications.



Relay Tool Kit

(56)

A new, 15-piece relay tool kit is offered by **Jonard Industries**. It

contains a selected group of tools for use by the electronic and telecommunications industries such as, tools for adjusting, servicing, and calibrating all types of relays.

All tools are made of carbon steel, with heavy chrome plating. The manufacturer says that dielectric tools permit adjusting and repair on "live" equipment without stopping operation.

The kit includes the following: two spring adjusters, one armature bender, one spring tension gauge, one four-way tool, one stop bender, one thickness gauge, one cleaning spray, one duck bill plier, one inspection mirror, one pen-type contact burnisher, twelve burnisher blades, one screw driver, one tweezers and one selector switch brush. The kit is priced at \$34.00. ▲

Notice to Manufacturers: Broadcast Engineering has discontinued sending New Product and Technical data forms to advertising agencies and manufacturers. All information concerning new products and free literature should be directed to Broadcast Engineering, attn: Editor.

ROHN® THE DEPENDABLES

Stand as tall in the tower field as ROHN. Only then are you high enough to see far into the future. That's the only direction the men at ROHN are looking — ahead.

What's it mean? Simply that in 10, 15, 20 years from now, ROHN will still be here to provide service for the ROHN towers you erect today. Still have the engineering files, drawings, and specifications to update, upgrade, or make whatever changes the future brings.

You see, ROHN has tremendous investments in plant and equipment. In other words, financial and personal integrity. ROHN supports this industry, believes in it, and plans to be here for a long, long time to come. There's only one way to do that. And that's to be absolutely dependable.

Think how important this is when you make an investment in a tower!

Home Office — Factory
P.O. Box 2000, Peoria, Illinois, U.S.A. 61601
Phone 309-637-8416 TWX 309-697-1488

Systems Office —
Box 877, Richardson, Texas 75080
Phone 214-AD1-3481

ROHN®

Western Office —
310 Quincy Street, Reno, Nevada 89502
Phone 702-322-9300

Eastern Office —
P.O. Box 2101
Hanover, Mass. 02339
Phone 617-826-2511

Southern Office —
P.O. Box 6537, Birmingham, Ala., 35217
Phone 205-841-1789

Circle Item 25 on Tech Data Card

PERSONALITIES IN THE INDUSTRY

Canada's Department of Transport has announced the retirement of **W.A. (Bill) Canton** as Chief of Radio Regulations after 44 years of service to Canadian radio communications with the Department's Telecommunications Bureau.

Among the highlights of his career was the part he played in

the technical operation of the first trans-Canada radio broadcast in 1927. When he first came to Ottawa he was immediately involved in helping design the Radio Act of 1938.

Canton headed the Canadian delegation to the first worldwide Extraordinary Administrative Radio

Conference on frequencies for space satellite radio communications in Geneva in 1963.



James W. Bentley, television management consultant, has been appointed assistant professor of television at the University of Mississippi. Prior to the Middle East crisis, last June, Bentley was the U.S. television advisor and project director to the Hashemite Kingdom of Jordan. During the past 20 years, he held management and staff positions with KRON-TV, KCRL-TV and was a television instructor at Stanford University.

William C. Lewis, Technical Services Director of the Delaware Educational Network, was moved to the position of Managing Director of the Delaware Network. Mr. Lewis has been with the Network since 1965.

Before joining the Delaware ETV staff, Mr. Lewis was Chief Engineer for Television at the University of Colorado. He holds a First Class Radiotelephone License. He has written articles for **Broadcast Engineering** and other technical magazines and has made a number of presentations before various professional groups.

Robert R. Pauley has been elected president of the Mutual Broadcasting System, Inc.

Immediately prior to accepting the MBS position, Mr. Pauley resigned as chairman and president of the Independent Broadcasting Company, Inc. He served as president of the American Broadcasting

Replace Your Present AM Monitor with a *Metron**

all
solid
state



* AM MODULATION MONITOR

The Metron Model 506B-1 Amplitude Modulation Monitor is a high quality instrument, field-proven for several years.

- FCC Type Approval 3-127
- Compact — Only 5¼" high on a standard 19" rack
- All solid state circuits — silicon transistors for greater reliability.
- Low Cost — only \$550.00.



METRON INSTRUMENTS, INC.

1051 South Platte River Drive Denver, Colo. 80223
(303) 744-1791 • TELEX 04-5729

Circle Item 26 on Tech Data Card

ANNOUNCING . . .

POTOMAC INSTRUMENTS, inc.

- Complete Field Intensity Meter Recalibration Service
- Design and Manufacture of Antenna and Signal Measurement Equipment
- Specialists in Remote Measurement/Monitoring Instrumentation



POTOMAC INSTRUMENTS, Inc.

932 Philadelphia Ave. • Silver Spring, Md. 20910
Phone: (301) 589-3125

Circle Item 27 on Tech Data Card

SPOTMASTER

Solid-State Portable

REMOTE AMPLIFIER

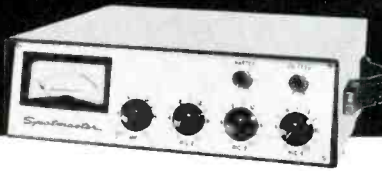

The RA-4CA is a lightweight, four-channel portable mixer amplifier specifically designed for remote broadcast or auxiliary studio use. It is completely self-contained and operates from either AC or batteries (switching automatically to battery operation if AC power fails); runs as long as 200 hours on low-cost "D" cells. It offers four microphone channels with master gain and P.A. feed, all controlled from the front panel. Lightweight construction (just 11 pounds with batteries), a convenient carrying handle and a snap-on front cover mean the RA-4CA can be easily set up to operate anywhere. For further information, please write or call today:

Spotmaster
BROADCAST ELECTRONICS, INC.
 8810 Brookville Road
 Silver Spring, Maryland 20910
 Area Code 301 • 588-4983

TAPECASTER

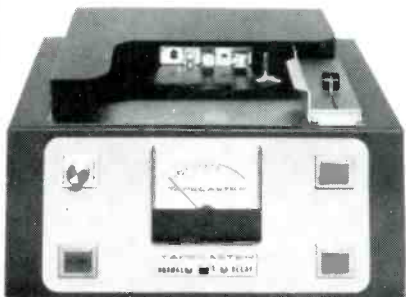

Model 700-RPD

Solid state combination
 record-playback unit
 for delayed programming
 Broadcaster net price \$500.

For information write
 Box 662 • Rockville, Maryland 20851
 or call 301-942-6666

TAPECASTER



Circle Item 28 on Tech Data Card

Company's radio network from 1960 to 1967.

The Georgia Association of Broadcasters, Inc. (GAB) has selected **J. W. (Jim) Woodruff, Jr.** for their Broadcaster Citizen of the Year Award.

Woodruff is the president and general manager of the Columbus Broadcasting Company, Inc.—WRBL-AM, FM and TV. A past-president of the GAB, he first entered radio in 1934. He installed and operated the first commercial FM station in Georgia.

J. Lawrence Pozzi, maintenance supervisor at KBHK-TV, has been promoted to engineering manager at the Kaiser Broadcasting station in San Francisco.

Previously, Pozzi was a technician with KRON-TV San Francisco and KOVR (TV) Sacramento-Stockton. He was a microwave/carrier specialist with Pacific Telephone & Telegraph Oakland for seven years and is a member of the American Radio Relay League. He is a graduate of Oakland City College in electronics.

The Radio Board of Directors of the National Association of Broadcasters unanimously re-elected **Richard D. Dudley**, president and general manager of radio station WSAU, Wausau, Wis., as its chairman.

Donald A. Thurston, president of the Northern Berkshire Broadcasting Co., owners of WMNB Radio, North Adams, Mass., was elected vice chairman.

Kenneth M. Mason has been named financial vice-president of the Society of Motion Picture and Television Engineers, it was announced by SMPTE President G. Carleton Hunt. Mason succeeds Joseph T. Dougherty, who resigned.

Mason has been an SMPTE member since 1946. He has served as SMPTE governor, national membership chairman and as conference vice-president. He is an SMPTE fellow.

Jack Pegler, TV Zoomar director, announced his retirement effective June 1, 1968, and indicated future plans to be announced later. Known by broadcast management and engineers around the world as "Mr. Zoomar," Pegler concludes 21 years association with Zoomar and

COMPARE...

YOU'LL BUY

a CCA

FM Transmitter

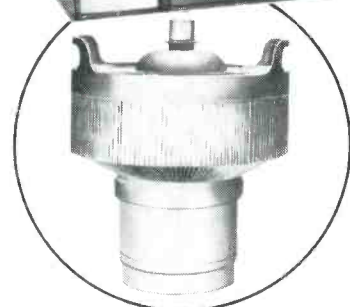

CCA is the only major FM equipment supplier who uses modern zero bias triodes in a grounded grid configuration. We've only lost three tubes in over 100 installations and some of these tubes are in operation after 20,000 hours. CCA tube cost is almost negligible. CCA FM Transmitters don't require neutralization. They're superstable and extremely reliable. They are very efficient and draw less power from the line than any competitive transmitter.

Compare — you'll agree with your fellow broadcasters. CCA FM transmitters cost less to buy, less to operate, are unsurpassed for reliability.



CCA Electronics Corp.
 716 Jersey Avenue
 Gloucester City, N. J. 08030
 Telephone: (609) 456-1716

Circle Item 29 on Tech Data Card

the TV industry. Assisted by his younger brother Bill who joined the organization in 1957, the Pleger's personality visited most TV stations around the world.

Kenneth R. Clark has been named Project Director of "Program for the Disadvantaged" at the National Association of Educational Broadcasters.

In making the announcement, NAEB President William G. Harley said Clark will spend the next three months coordinating efforts of ETV and educational radio stations as

they relate to programming for the disadvantaged.

Clark comes to NAEB from a two year tour as Program-Production Advisor to Radio Ethiopia (RTV International). Prior to that, he was station manager of KFJC-FM, Los Altos Hills, Calif.

At a recent meeting of the Board of Directors of KPRO, Inc., Riverside, Calif., it was announced that **Steve Gibson**, who joined the station as chief engineer in February 1965, has been named director of engineering, Dick Clark Stations.

Clark who acquired the station in June, 1965, has since purchased KGUD, Santa Barbara and is negotiating for the purchase of an additional station in North California.

Deciphering the weather pictures transmitted to earth from satellites far out in space is usually a costly, sophisticated and full-time business. But **Rex L. Smith**, a senior technician at the Westinghouse electronic tube division, Elmira, N.Y., has a different approach.

He gets the whole job done in his spare time with a handful of used and borrowed electronic equipment located in a corner of his basement. Putting it together was a six-month, do-it-yourself project.

Key elements of his apparatus are an \$18 surplus military FM radio receiver, a homemade transistorized amplifier to make the receiver more sensitive to the satellite's weak signals, an ordinary home tape recorder, and a electronic storage tube that resembles a television picture tube but holds its glowing pictures for a half-hour at a time.

Rex tunes in the satellite's beeping picture signals, decodes them, records them on tape and watches them build up, line by line, on the storage tube. Then, with a simple Polaroid snapshot, he records the pictures permanently.

His photographs, coming from a Nimbus weather satellite passing overhead some 625 miles in space, show areas of the United States about 1200 miles square.

It takes about three minutes to record a complete weather picture, which comes from the satellite at intervals of about three and one-half minutes.

The photographs show in clear detail the cloud patterns over nearly a million and a half square miles of the earth's surface, with enough faint background of the earth to roughly identify the geographical location, provided the cloud cover is not too heavy.

One unusual feature of Rex's experiments is that he receives his weather signals on a home-built high-frequency antenna which leans against a wall of his workshop. "I'd probably do better," he observes, "if I'd get that antenna out of the basement and up on a pole in the backyard."

NEW . . . Type 19 Precision Antenna Monitoring System

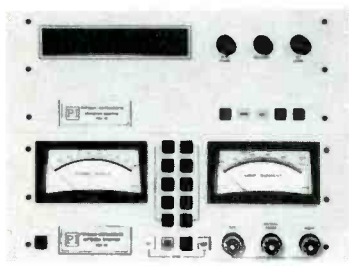

- ±0.1 Degree Resolution
- Up to 12 Towers
- For DA-1, DA-2 or DA-3
- Mercury-Wetted Relays

For further information, contact:

PI

POTOMAC INSTRUMENTS, inc.

932 Philadelphia Ave. • Silver Spring, Md. 20910
Phone: (301) 589-3125

Circle Item 30 on Tech Data Card

cut holes fast!



"Key"



Square



"D"



Double "D"

Round—Inches and mm



with Greenlee punches

Here's the simple speedy way to cut smooth, accurate holes in metal, hard rubber, plastics, epoxy, etc.

Save hours of hard work . . . punch clean, true holes in seconds for sockets, controls, meters, and other components. Easy to operate. Simply insert punch in a small drilled hole and turn with a wrench. For use in up to 16-gauge metal. Available at leading radio and electronic parts dealers.

GREENLEE TOOL CO
DIVISION OF GREENLEE BROS. & CO.

1866 Columbia Avenue, Rockford, Ill. 61101
Circle Item 31 on Tech Data Card

NOTICE TO READERS:

Be sure to take advantage of the Tech Data Card. Numbers correspond to ads, new products, and Tech Data. Also fill in the information on the right hand corner concerning occupation and type of articles preferred. Notice the data card deadline.

**MODERNIZE
and
ECONOMIZE**

with

WILKINSON
LIFETIME DIRECT REPLACEMENT
SILICON RECTIFIERS

EXCLUSIVE FEATURES:

- Self-testing and Repairable
- 200% Safety Built in
- Plug in Direct—No Rewiring
- Operates -85° to $+185^{\circ}$ F
- All Types in Stock from 866 to 857B
- Can Last Forever

FOR COMPLETE DETAILS WRITE:

WILKINSON
ELECTRONICS, INC.

1937 MacDADE BLVD. • WOODLYN, PA. 19094
• TELEPHONE (215) 874-5236 874-5237 •

Circle Item 32 on Tech Data Card

TAPECASTER

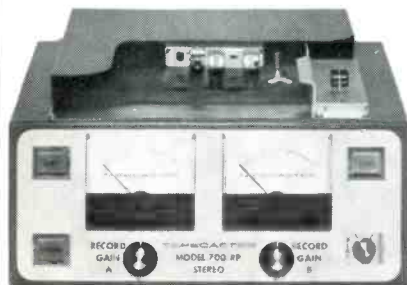

Model 700-RPS

Solid state stereo
combination
record-playback unit

Broadcaster net price \$700.

For information write
Box 662 • Rockville, Maryland 20851
or call 301-942-6666

TAPECASTER



Circle Item 28 on Tech Data Card

August, 1968

Orrin W. Towner, retired from WHAS, Louisville, on July 13, 1968, completing an association which began in 1938 when he was named technical director of the station's AM, FM and Facsimile operations.

As director of engineering for WHAS since 1945, Towner designed and supervised construction of broadcast facilities and installation of technical equipment for TV, AM and FM.

His career started in 1926 at WREN, Lawrence, Kansas. He then joined Bell Telephone Laboratories as a member of the Broadcast Transmitter Development Department. He later became broadcast equipment field supervisor.

During World War II, Towner was associate director of the Airborne Instruments Laboratory, and director of the Alhambra Branch, Airborne Instruments Laboratory, both at the Columbia University of War Research. In 1948, he was awarded a Presidential Citation of Merit.

He has been a member of every major national broadcast engineering association and committee, and has chaired many of them.

Within a few weeks Towner is expected to announce his entrance into the consultation field.



Kenneth W. Heady, station manager of Meredith-owned KCMO-TV, Kansas City, Missouri, has been appointed general manager of the Meredith stations in Phoenix, KPHO TV and KPHO Radio, effective Friday, June 28. He succeeds R. B. ("Dick") Rawls, resigned. ▲

JAMPRO

**RUNS CIRCLES AROUND
FM ANTENNAS
FOR BETTER RECEPTION**

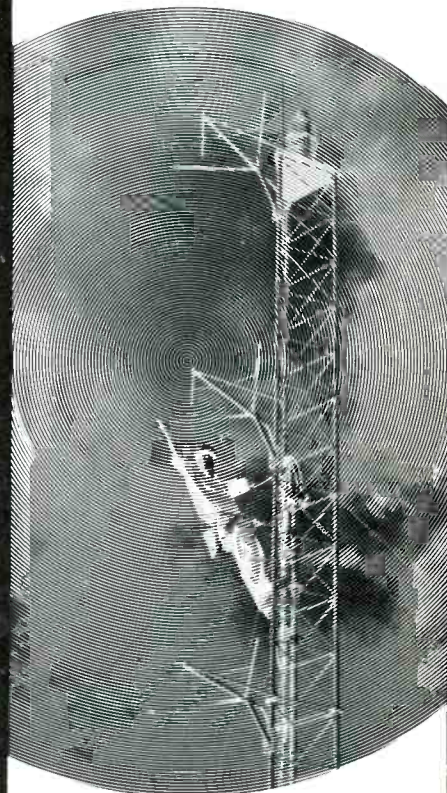

JAMPRO advanced technology has developed another industry "first"! A circularly polarized FM Antenna with variable horizontal to vertical gain ratios! Jampro will adjust the ratio to your exacting specifications for the best possible reception performance available—Reception to the outer fringes, and to more auto FM receivers, too.

EXCLUSIVE DIGITAL TUNING END STUBS allow lower VSWR on your tower (GUARANTEED under 1.1 to 1), and field trimming to 1.08 to 1, \pm 200 KC.

AVAILABLE IN EITHER PARALLEL OR SHUNT FEED SYSTEMS.

Write for full specifications or make a circular motion on your phone dial—Call Jampro today. (916) 383-1177.

JAMPRO

ANTENNA COMPANY
A DIVISION OF COMPUTER EQUIPMENT CORP.
6939 Power Inn Road
Sacramento, California 95828

Circle Item 33 on Tech Data Card

SAF-T-CLIMB™



means what it says



... Absolute protection against falling with a positive locking pawl limiting any fall to a maximum of 6 inches. Ease of use insures workers acceptance of the life saving device.

Durable, maintenance free Saf-T-Climb is proven effective for all climbing up, around and over... on any surface, concave or convex, above or below ground.

Galvanized, aluminum or stainless Saf-T-Notch Rail attaches rigidly to any structure. Saf-T-Climb's high quality tested construction has been saving lives for over 18 years on structures of all kinds... such as broadcast and transmission towers, stadium lights, smoke stacks, water tanks, etc.

To do the job the best and safest way... do it with Saf-T-Climb.

asd

Write for free brochure.



AIR SPACE DEVICES, INC.

DEPT. S1, P.O. BOX 338
PARAMOUNT, CALIF. 90723
PHONE (213) 774-4905

Circle Item 34 on Tech Data Card

Advertisers' Index

Air Space Devices	46
Allen Avionics, Inc.	46
Beldon Corp.	14-15
Broadcast Electronics, Inc.	6, 40, 43
CBS Laboratories, Div. of CBS, Inc.	3
CCA Electronics Corp.	43
Central Dynamics Corp.	37
Cleveland Institute of Electronics	36
Cohu Electronics, Inc.	1
Collins Radio Co.	30
Electro-Voice, Inc.	48
Fairchild Recording Equipment Corp.	47
Filmline Corp.	31
Gates Radio Co.	11
Gotham Audio Corp.	40
Grass Valley Group, Inc.	39
Greenlee Tool Co.	44
Houston Photo Products, Inc.	38
International Nuclear Corp.	Cover 3
Jampro Antenna Co.	45
Lawrence Radiation	35
Metron Instruments, Inc.	42
Microwave Associates	32
Potomac Instruments, Inc.	42, 44
Primo Co., Ltd.	35
RCA Broadcast and Telephone Equipment	24-25
Riker Video Industries, Inc.	Cover 2
Rohn Mfg. Co.	41
Shure Brothers, Inc.	10
Sparta Electronic Corp.	35
Spotmaster	6, 40, 43
Stanton Magnetics, Inc.	19
Taber Mfg. & Engineering Co.	46
Tape-Athon Corp.	8
Tapecaster TCM	43, 45
Telemation	9
Telemet Co.	Cover 4
Visual Electronics Corp.	29
Vital Industries, Inc.	7
Ward Electronic Industries	5
Wilkinson Electronics, Inc.	39, 45

COMING IN SEPTEMBER

Services
and facilities of
WWV,
National Bureau
of Standards

NOW!

ALLEN AVIONICS

TIME DELAY = 250
RISE TIME = 1

**PRODUCES THE
HIGHEST RATIO EVER!**



**SERIES "VHR"
LUMPED CONSTANT
DELAY LINES**

These Delay Lines have the highest ratio of time delay to rise time that has ever been built in a Lumped Constant Line. Unlike other types of high ratio lines, the Lumped Constant Delay Line has a passband from D.C. to its cutoff frequency and maintains a constant delay over these frequencies. These lines are also unique in that they offer relatively low insertion loss.

This group of lines is characterized by tight time delay tolerances, low pulse distortion, excellent phase linearity and good temperature stability. The "VHR" Series have a characteristic impedance of 50 ohms. We can manufacture the "VHR" Lines to your exact delay specifications. Variable Decade Delay Units can be manufactured for laboratory use from the "VHR" Lines.

150/1 RATIO

Max. Attenuation 16 db. Time Delay 10µs-70µs.

200/1 RATIO

Max. Attenuation 18db. Time Delay 15µs-75µs.

250/1 RATIO

Max. Attenuation 20 db. Time Delay 15µs-100µs.

WRITE FOR CATALOG

ALLEN AVIONICS, INC.

Division of A. K. ALLEN CO., Inc.

255 E. 2nd ST., MINEOLA, N.Y. 11501

Circle Item 35 on Tech Data Card

PROTECT YOUR SOUND REPUTATION

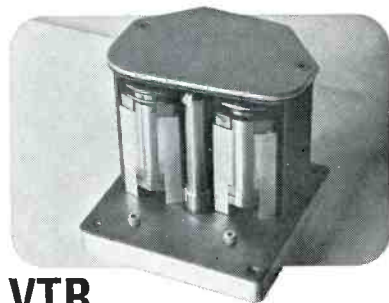

VTR

RECONDITIONED BY TABER

Nationally recognized recorder head manufacturing and reconditioning experts.

- Heads reconditioned under controlled laboratory conditions.
- Reconditioned heads guaranteed to meet, or exceed, equipment manufacturer's specifications.
- Modern precision machine shop, and sophisticated laboratory installations insure highest quality reconditioning.
- Free loaner assemblies available on request.
- 24 hour service.
- Cost—\$100.00 for four (4) heads.

TABER'S sophisticated quality control, and test procedures, insure total frequency response and uninterrupted sound playback. Maintain the high quality audio that your equipment was engineered to produce.

Call or **TABER** MANUFACTURING AND
write: **ENGINEERING COMPANY**

OAKLAND INTERNATIONAL AIRPORT, BLDG., L-821
P. O. BOX 2365 • OAKLAND, CALIFORNIA 94614
Telephone (415) 635-3832

Circle Item 36 on Tech Data Card

BROADCAST ENGINEERING

Professional Services

VIR JAMES

CONSULTING RADIO ENGINEERS
Applications and Field Engineering

345 Colorado Blvd.
Phone: (Area Code 303) 333-5562

DENVER, COLORADO 80206

Member AFCCE
TWX 910-931-0514

JAMES C. McNARY

Consulting Engineer

National Press Bldg.

Washington 4, D.C.

Telephone District 7-1205

Member AFCCE

CAMBRIDGE CRYSTALS PRECISION FREQUENCY MEASURING SERVICE

SPECIALISTS FOR AM-FM-TV

445 Concord Ave. Phone 876-2810
Cambridge, Mass. 02138

JOHN H. MULLANEY and ASSOCIATES

Suite 71,
1150 Connecticut Ave., N.W.
Washington, D. C. 20036
Phone 202-223-1180

Member AFCCE

CRYSTAL AND MONITOR SERVICE—
Frequency change and repair service for
AM monitors including G.R., RCA, Gates,
W. E., and Doolittle; also H-P 335B FM.
AM monitors bought and sold. What have
you, what do you need? New or regrinding
of AM crystals for RCA, Gates, Bli-
ley, W.E., and J-K oven holders, repairs,
etc. Fastest service, reasonable prices.
Over 25 years in this business. Eidson
Electronic Co., Box 96, Temple, Texas
76501. Phone 817 773-3901. 2-67-tf

ROSNER TELEVISION SYSTEMS

ENGINEERS
120 E. 56 St.
New York
N. Y. 10022

CONTRACTORS
29 South Mall
Plainview
N. Y. 11803

TAPE CARTRIDGE SERVICE

Completely recondition your old tape
cartridges, all sizes of new tape car-
tridges in stock available for immediate
shipment. Will supply complete price
list on request.

M.S.I. CARTRIDGE SERVICE

279 W. Main Street
Amsterdam, N. Y. 12010
Phone (Area Code 518) 843-2242

AMPEX HEAD ASSEMBLY

Relapping and replacement head ser-
vice for all AMPEX professional stu-
dio model recorders. Our precision
relapping extends head life for maxi-
mum use. Brand new shelf stock re-
placement heads of our manufacturer
available when relapping not advis-
able. Prices include thorough assem-
bly cleaning, optical and electrical in-
spection and complete testing on Am-
pex equipment. Monaural assembly re-
lapping . . . \$35.00 complete. Monaural
assembly replacements . . . \$119.50
complete. "Loaner" assemblies avail-
able. For more data, contact LIPPS,
INC., 1630 Euclid St., Santa Monica,
Calif. 90404 (213) EX 3-0449.

FRANK A. ZOELLER

TELEVISION SYSTEMS
CONSULTANT

20 Years Experience

Box 366 • San Carlos, Cal. 94070
(415) 593-1751

GUARANTEED FIRST PHONE, 4-6
weeks. Broadcast Engineering Academy,
3700 Lemay Ferry, St. Louis, Mo. 63125.
314/892-1155. 5-68-tf

Classified

Advertising rates in the Classified
Section are fifteen cents per word.
Minimum charge is \$2.00. Blind
box number is 50 cents extra.

Equipment for Sale

EQUIPMENT FOR SALE

Scully tape recorders as low as \$13.55
weekly. Three Spotmasters, one record
/playback, and two playbacks, all
three, \$38.25 monthly. Multiple units,
Spot Five, \$47.25 monthly. Two QRK
or Russco deluxe turntables, \$10.80
monthly. Lower payments with trade.
Write for list. Purchase your car-
tridges from us, we ship freight pre-
paid. Audiovox, Box 7067-55, Miami,
Florida 33155. 4-68-tf

Coils, Contactors, Switches, Complete
ATU systems. Top Quality, Lowest Prices,
Fast Delivery, No Duty. Write for cata-
logue: Geleco Electronics Ltd., 2 Thorn-
cliffe Pk. Dr., Toronto 17, Ont. 416-421-
5631. 11-67-12t

CARTRIDGE TAPE EQUIPMENT

Completely reconditioned and guaran-
teed. Spotmaster Model 500 Record/Play-
backs, \$350.00. Model 505 Playbacks
\$250.00. 30-day moneyback guarantee on
all equipment.

BROADCAST PRODUCTS COMPANY

18804 Woodway Dr., Derwood, Maryland,
20855
(301) 926-4600 3-67-tf

**REVERBERATION
UNLIMITED!**

only with
**FAIRCHILD
REVERBERTRONS**

Now with the FAIRCHILD REVERBERTRON
you can reproduce the thrilling reverberated
sounds of the Grand Canyon or the colorful
reverberation qualities inherent only in good
acoustical chambers. In addition, because
reverberated sound is apparently louder than
the same non-reverberated signal, by utilizing
the FAIRCHILD REVERBERTRON in motion pic-
ture, radio and television studios you can
create realistic sound effects and attention
holding commercials.

No longer do you need expensive reverbera-
tion chambers or special "on location"
recordings. The FAIRCHILD REVERBERTRON
costs less than you imagine and is available
in economy model too.

The advantages of a FAIRCHILD REVERBER-
TRON in your studio are virtually unlimited for
creating wide audience appeal and impact and
literally hundreds of "ear appealing" sounds.

The next time you want to "glue" your
audience's ears to the sound you're making be
sure to use a FAIRCHILD REVERBERTRON!

SPECIFICATIONS OF MODEL 658A (Pictured above)

The 658A is a complete solid state reverbera-
tion system with electronically controlled reverb
time adjustments up to 5 seconds; mixing
control for adjustment of reverberated to non-
reverberated signal ratios; verb equalization
at 2, 3, and 5 KHZ. Size: 2 1/2" x 19".



ECONOMY MODEL 658B ALSO AVAILABLE

Compact, reverberation
system for the "big" sound
in a small space. Con-
tains reverb equalization
in mid and low frequen-
cy range; level control;
solid state design. Size:
Only 5 1/4" x 3" x 10" deep.

Write to FAIRCHILD — the pacemaker in pro-
fessional audio products — for complete details

FAIRCHILD
RECORDING EQUIPMENT CORPORATION
10-40 45th Ave., Long Island City 1, N. Y.

Circle Item 37 on Tech Data Card

One of a series of brief discussions
by Electro-Voice engineers

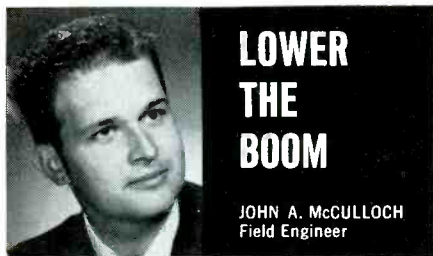

LOWER THE BOOM

JOHN A. McCULLOCH
Field Engineer

High pass filters have long been an important tool for sound engineers faced with noise problems in broadcasting, recording, and sound reinforcement. The elimination of low frequencies can reduce the effects of unwanted hum, noise, and other disturbances.

In field testing microphones in a variety of studio and stage environments, we have noted increasing application of filters to correct faults that may have no other practical solution.

For instance, it is well known that most directional microphones become increasingly omnidirectional as frequency decreases. Addition of a filter, such as the Electro-Voice Model 513 100 Hz filter can reduce the consequences of this unwanted sound pickup. It is often desirable to filter only the microphone(s) where extended "reaching" for distant performers is anticipated. Other microphones can be left unfiltered if they are to be used close to the desired sound, thus minimizing the apparent reduction in overall response range.

Fear is sometimes expressed that addition of a high pass filter will create an effect of weak, thin sound. Experience usually proves otherwise. In many instances, cutting off the extreme low bass also cleans up muddy response. The subjective result is often an increase in clarity and strength of the bass instruments.

In other experiments, addition of a high pass filter in the microphone circuit eliminated sub-audible overloading of the microphone input circuit. The result was improved clarity over the entire range. The filter has also been helpful in reducing wind noise, and can prove as effective as a windscreen in some instances.

In several critical sound reinforcement installations, insertion of the Model 513 Filter has provided an increase of from 3 to 6 dB more level before feedback. Although few rooms will sustain feedback at the low frequencies affected by the filter, very low frequency noise apparently acts as a "trigger" for oscillation at higher frequencies. By substantially lowering the amplification of this room noise, the system achieves notably improved stability. In addition the hollow sound usually heard just before a sound reinforcement system starts "ringing" is also sharply reduced. The improvement is greatest where input gain must be high to reach long distances for the desired sound.

Creative use of the high pass filter can often result in a net improvement in sound character. Improved definition of bass signals usually more than offsets the slight loss of range. While unfiltered sound is always a desirable goal, ambient conditions must be considered in determining the usefulness of an unfiltered system.

For reprints of other discussions in this series,
or technical data on any E-V product, write:
ELECTRO-VOICE, INC., Dept. 883V
638 Cecil St., Buchanan, Michigan 49107



Circle Item 38 on Tech Data Card

Everything in used broadcast equipment. Write for complete listings. Broadcast Equipment and Supply Co., Box 3141, Bristol, Tennessee. 11-64-tf

"AUDIO EQUIPMENT"—Whatever your needs, check us first. New and used. Ampex, Aitec, AKG, EV, Fairchild, Neumann, Langevin, Rek-O-Kut, Uher, Viking. Send for equipment. Audio Distributors, Inc., 2342 S. Division Ave., Grand Rapids, Michigan 49507. 6-66-tf

Audio Equipment bought, sold, traded. Ampex, Fairchild, Crown, McIntosh, Viking, F. T. C. Brewer Company, Town & Country Plaza, Pensacola, Florida. 3-64-tf

BROADCAST EQUIPMENT REBUILDERS. The best in tape cartridge re-winding and reconditioning. List your used equipment with us for fast sale. Send for cartridge price list. Route 8, Box 718, Fayetteville, N. C. 28304. Telephone 425-7332. 5-68-tf

CO-AXIAL CABLE Heliac, Styroflex, Spiroline, etc. Also rigid and RG types in stock. New material. Write for list. Sierra-Western Electric Co., Willow and 24th Streets, Oakland, Calif. Phone 415 832-3537. 5-66-tf

TOWERS, lights and accessories. AM, FM communication, CATV, sales, erection and complete service, world wide. Write Dixie Steeplejack Company, 2832 Riverview Blvd. West, Bradenton, Florida. tf

Color movie labs for less than \$5000! Use new Fulton Automatic Processors. Fast, low cost, reliable. Design proven ten years in TV, commercial labs, missile bases. Fulton Productions, Inc. Manufacturing Div., Box 980, Tulare, Calif. 93274. 7-68-3t

Attention General Electric Transmitter owners. Used Machlett 5681. Run 7,460 hours. 30,000 hours is general life of tube. New tube cost \$2,000.00. Make reasonable offer. Call Willard Matten, KFSA-TV, 501-783-3131. 8-68-1t

SMALL STATION OR STUDIO STAND-BY: Hol-Gar 10 KW 120/240V, 60Hz 1 or 3 phase, weatherized gasoline plant, used with manuals. \$650. F.O.B. Contact R. R. Hogg, 1304 Chestnut, #1, Garden City, Kansas 67846 8-68-1t

Equipment Wanted

We need used 250, 500, 5K & 10K Watts AM Transmitters. No junk. Guarantee Radio Supply Corp., 1314 Iturbide St., Laredo, Texas 78040. 3-66-tf

WANTED: Equipment donations for Christian broadcast station in Congo. Need audio, tape, and SK transmitter (9 Meg. 31 meter band) contact Mr. C. Sebastian, WTAQ LaGrange, Illinois. 8-68-1t

Employment

Job Headquarters for all Radio and Television Engineers. Immediate openings exist in 9 western states and elsewhere for qualified engineer and technical personnel. All categories from trainees to experienced transmitter maintenance, chief, assistant chief, live color video maintenance and technical operations. Send us your complete resume now. The AMPS Agency, 3924 Wilshire Blvd., Los Angeles, California 90005. Telephone DU 8-3116. By Broadcasters—For Broadcasters 11-66-tf

IMMEDIATE OPENINGS—Qualify for any of the following positions: Technicians for RCA Closed Circuit Television equipment, Camera Technicians—Video Tape Technicians—Video Technicians—TV Maintenance men—Maintenance Supervisors—TV Systems Supervisors—Video Engineers—TV Operations Managers—Sales Engineers. RCA Rep., 143-08 94th Ave., Jamaica, New York, or (212) 297-7344. 5-68-tf

THE GRASS VALLEY GROUP

is forming a SALES organization.

Broadcast Television Engineers

are needed for all areas.

Sales experience helpful but not essential.



GRAVCO SALES, INC.
6311 Yucca St.,
Los Angeles, California
Call or Write:
(213) 462-6618

Chief Engineer position open. Educational FM broadcast station with audio and language lab maintenance, plus some studio recording experience required. Salary open depending on experience. Ideal working conditions. Contact Business Manager, Lawrence University, Appleton, Wisconsin 54911. 7-68-2t

CATV Technicians are urgently needed in all parts of the country. Send resume to Nationwide CATV Consultants, 645 N. Michigan Avenue, Chicago, Illinois 60611. No fee and confidential. 8-68-tf

WANTED—Assistant Chief Engineer for established Midwest VHF full color station. Must be knowledgeable in all operational phases. Broadcast Engineering Dept. 217, 1014 Wyandotte St., Kansas City, Mo. 64105. 8-68-2t

Chief Engineer or Supervisor retiring to warm, dry climate for physical reasons: Looking for minimal employment preferably with Educational FM plant. Twenty years experience: stereo, SCA, all transmitters, audio. Reply to Broadcast Engineering, Dept. 216, 1014 Wyandotte St., Kansas City, Mo. 64105. 8-68-2t

First Class Phone. Married. 23, 11 months VHF TV transmitter maint. DJ ability. Experienced in radio, TV, and two-way radio repair. Will work any field of electronics in the nine western states. Would like remote area. Minimum \$650. Collect (206) 376-2911. 8-68-1t

Training

To advance in electronics, knowledge and ability are required. Grantham offers correspondence and resident instruction, in depth, leading to the degree of Associate in Science in Electronics Engineering. G. I. Bill approved. Credit for previous training and experience allowed. Free Catalog Write: Dept. E-2, Grantham School of Electronics, 1505 N. Western Ave., Hollywood, California. 90027. 6-67-tf

First phone through tape recorded lessons at home then one week personal instruction in Minneapolis, Atlanta, Washington, Detroit, Denver, Seattle, or Los Angeles. Sixteen years FCC license teaching experience. Proven results. 95% passing. Bob Johnson Radio License Preparation, 1060D Duncan, Manhattan Beach, Calif. 90266. Telephone 379-4461. 4-68-tf

TDA2D VIDEO/PULSE DISTRIBUTION AMPLIFIER



The now-famous TDA2 Distribution Amplifier, in use at most television stations and networks, has a recently added feature. The "D" stands for Differential Input, which we added to the TDA2. And not only did we add a differential input, we subtracted \$30.00 from the price. Instead of \$325.00, we're selling the new improved TDA2D for \$295.00 F.O.B. Nashville, Tennessee. The compact TDA2D fits neatly into 1 3/4 inches of panel space and produces virtually no heat. For complete information, write to:



INTERNATIONAL NUCLEAR CORPORATION

608 Norris Ave • Nashville, Tenn. 37204 • Ph.: (615) 254-3365

TDA5 BALANCED/UNBALANCED VIDEO/PULSE DISTRIBUTION AMPLIFIER

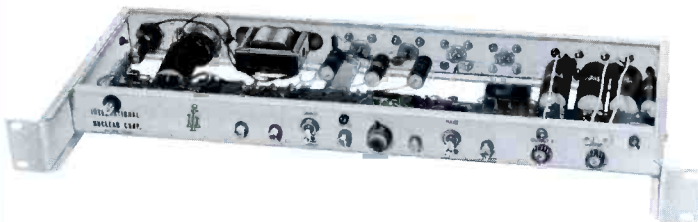

For the many occasions when signals must be transmitted balanced, yet must be fed to other equipment unbalanced, International Nuclear offers the TDA5. Two inputs are provided, selection of which is accomplished by a front panel switch. The balanced input is the bridging type and may be terminated in 124 ohms. The unbalanced input is high impedance and may be terminated in 75 ohms. The TDA5 serves both video and pulse functions at the flip of a switch. The TDA5 sells for \$400.00 F.O.B. Nashville. For additional benefits of this system and complete information, write to:



INTERNATIONAL NUCLEAR CORPORATION

608 Norris Ave • Nashville, Tenn. 37204 • Ph.: (615) 254-3365

TDA7 VIDEO/PULSE DISTRIBUTION AMPLIFIER



The TDA7 is a completely transistorized distribution amplifier constructed as a plug-in module. The rack will hold 10 TDA7's and occupies only 5 1/4 inches of panel space. Each plug-in unit provides the video and pulse functions with the flip of a switch. Provision is made to add a sync-adding circuit directly to the TDA7. This is specified as TDA9. The individual TDA7 plug-in units are \$295.00 each F.O.B. Nashville, Tennessee . . . with sync-add feature \$320.00. The mounting frame accommodates up to 10 units and sells for \$270.00. For complete specifications and information on other accessories, write to:



INTERNATIONAL NUCLEAR CORPORATION

608 Norris Ave • Nashville, Tenn. 37204 • Ph.: (615) 254-3365

TDA26 HIGH GAIN VIDEO AMPLIFIER



The TDA26 is a compact, completely transistorized Pulse Distribution Amplifier designed to be used at the output of camera branching pads or in any application where 28 DB gain is required. The TDA26 mounts in a standard 19-inch rack, using type 83 connectors throughout. It has 3 signal outputs, weighs less than 4 pounds, mounts in 1 3/4 inches of panel space. The TDA26 sells for \$400.00 F.O.B. Nashville, Tennessee. For complete information, write to:



INTERNATIONAL NUCLEAR CORPORATION

608 Norris Ave • Nashville, Tenn. 37204 • Ph.: (615) 254-3365

Do you suffer from:

- Anemic washed out color feeds?
- Soft pictures?
- Streaking?
- Under- and overshoots?

Then you need Doctor Telemet's Equalizer-Amplifier – the best prescription for acute mid-frequency phase shift and color anemia.

R_x TELEMET
a division of **GEOTEL, INC.**
185 DIXON AVENUE, AMITYVILLE, NEW YORK 11701 • (516) 541-3600

EXPONENTIAL UNDERSHOOT

TILT (STREAKING)

**EQUALIZER-AMPLIFIER
MODEL 3205-B2
OUTPUT**

PILOT IN OUT GRD
VIDEO GAIN H FREQ BOOST TIME CONSTANT CORRECTION LEVEL
BY-PASS OPERATE SHORT T.C. LONG

MODEL 3205

CORRECTED OUTPUT SIGNAL

Show your true colors. Get Dr. Telemet's Equalizer-Amplifier soon...and be the picture of health.

Circle Item 40 on Tech Data Card