

# Spotmaster

## AUDIO CONSOLE

- FET SWITCHING
- SOLID-STATE PLUG-IN CIRCUITRY
- LO/HI LEVEL PREAMP IN EACH CHANNEL
- INTERNAL POWER SUPPLY
- THREE MUTING RELAYS

### MODEL 5M11 MONO



### 5 Channel Audio Console

*Spotmaster* is introducing a quality audio console for the budget conscious operator. The Model 5M11 has provisions for eleven low or high level inputs into five mixers with preamplifiers in each channel. Daven (or equiv.) ladder attenuators are provided. Identical program and audition output channels provide dual console capability in a 5-channel console. Electronic switching (FET) of input channels to program and audition buses is a design standard. All active circuitry is on plug-in boards, terminating on a master board to which all input and output connections are made.

#### SPECIFICATIONS

##### Input:

- Low level (mic)  
-60 dBm into 150 ohm (nom.) balanced.
- High level  
-20 dBm into 600 ohm (nom.) balanced.
- Switching  
11 inputs into 5 fades - Ch. 1 - 4 each have 2 inputs.  
Ch. 5 has 1 direct input and 2 remote.

##### Output:

- Program  
+8 dBm into 600 ohm (nom.) balanced. Clipping level in excess of +18 dBm.
- Audition  
+8 dBm, etc.
- Monitor  
10 watts into 8 ohms, unbalanced.
- Cue  
0.5 watts into 30 ohms, unbalanced, internal speaker provided.
- Headphone  
8 ohms (nom.).

##### Frequency Response:

- Program & Audition  
±1.5 db, 20 Hz to 20 kHz.
- Monitor  
±2 db, 50 Hz to 20 kHz.

##### Distortion:

- Program & Audition  
0.5% or less @ +8 dBm output. Clipping level over +18 dBm.
- Monitor  
1% or less at rated output.

##### Signal-to-Noise:

- 65 db below +8 dBm output, referenced to -50 dBm input.

##### Muting:

- Monitor  
Channels 1, 2 and 3; separate outputs.
- Cue  
Channel 1, both internal and external speakers.

##### Finish:

- Spotmaster* blue, matte black, and wood grain side panels.

##### Power:

- 115/230 VAC, 50/60 Hz. 60 watts.

##### Dimensions:

- 25½" long x 14" high x 14" wide.



**BROADCAST ELECTRONICS, INC.**  
— A FILMWAYS COMPANY —

8810 BROOKVILLE ROAD • SILVER SPRING, MD. 20910  
PHONE 301-588-4983 • CABLE "SPOTMASTER"

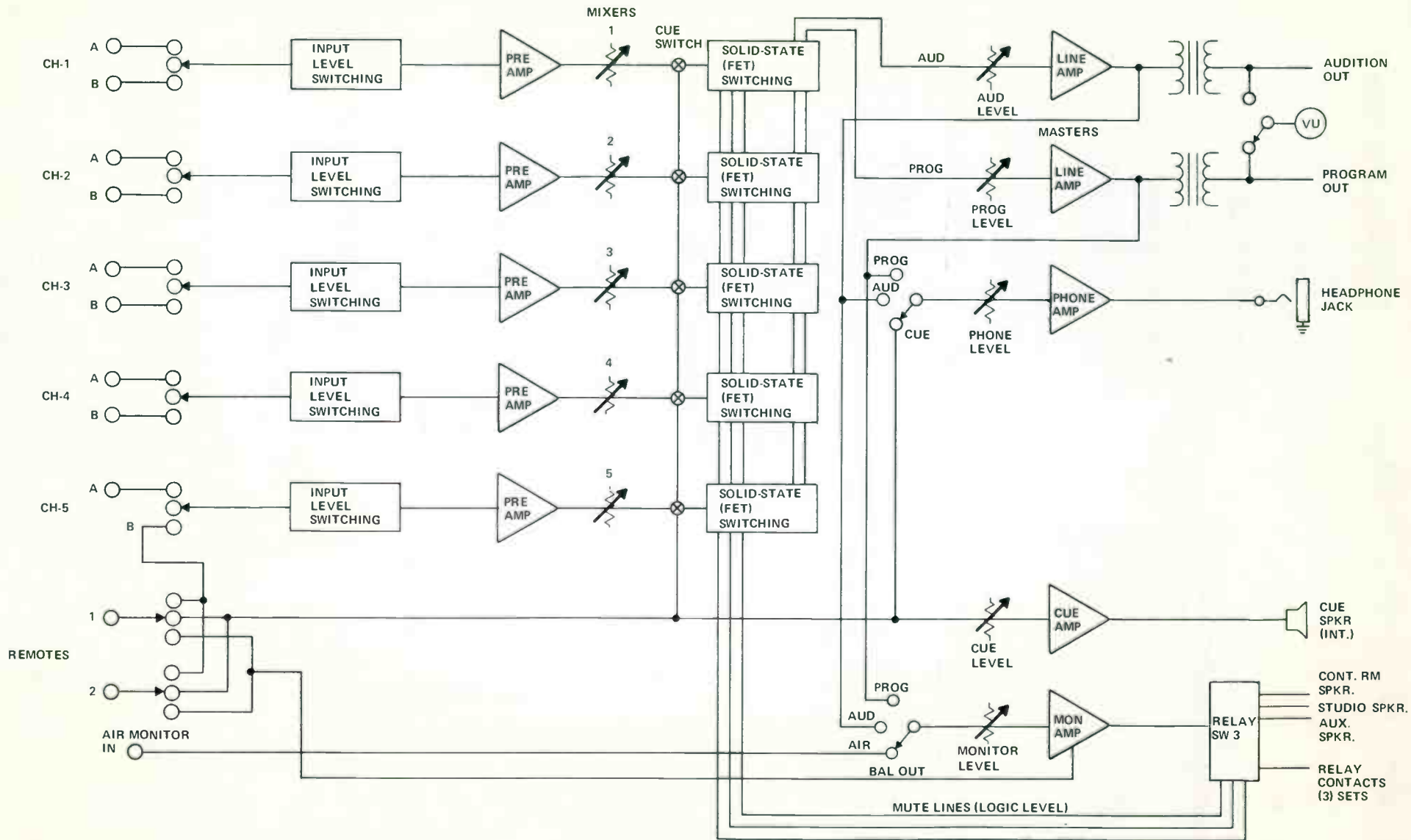

5-CHANNEL MONO AUDIO CONSOLE Model 5M11

### MODEL 5S11 STEREO

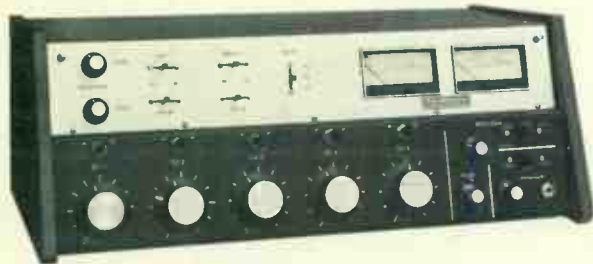

- FET SWITCHING
- MONO MIXDOWN OUTPUT
- ACCEPTS 11 STEREO INPUTS
- INDIVIDUAL PROGRAM, AUDITION, MONITOR, MIXDOWN, CUE AND HEADPHONE AMPLIFIERS PROVIDED
- SELF-CONTAINED POWER SUPPLY

### 5 Channel Audio Console

The *Spotmaster* Model 5S11 Stereo Audio Console is a full-stereo 5-mixer control console. All input channels are provided with preamplifiers adaptable to either low or high level inputs. Solid-state (FET) electronic switching is utilized in switching of input channels to program and audition buses. High quality ladder attenuators (Daven or equiv.) are provided on all input channels. Special stereo amplifier is included for headphone monitoring.

#### SPECIFICATIONS

##### Input:

Low level (mic.)

-60 dBm into 150 ohm (nom.) balanced.

High level

-20 dBm into 600 ohm (nom.) balanced.

Switching

11 inputs into 5 mixers. Ch. 1 - 4 have (2) stereo inputs, Ch. 5 has 3.

##### Output:

Program

+8 dBm into 600 ohms, balanced. Clipping level in excess of +18 dBm.

Audition

+8 dBm into 600 ohms, balanced. Clipping level in excess of +18 dBm.

Monitor

10 watts into 8 ohms, unbalanced.

Cue

0.5 watts into 30 ohms, unbalanced; internal speaker provided.

Headphone

8 ohms, switchable to Program, Audition or Cue.

##### Frequency Response:

Program & Audition

±1.5 db, 20 Hz to 20 kHz.

Monitor

±2 db, 50 Hz to 20 kHz.

##### Distortion:

Program & Audition

0.5% or less @ +8 dBm output.

Monitor

1% or less @ rated output.

##### Signal-to-Noise:

65 db below +8 dBm output referenced to -50 dBm input.

##### Muting:

Monitor

Channels 1, 2 and 3; separate outputs.

Cue

Channel 1, both internal and external speakers.

##### Finish:

*Spotmaster* blue, matte black and wood grain side panels.

##### Power:

115/230 VAC, 50/60 Hz, 90 watts.

##### Dimensions:

25½" long x 14" high x 14" wide.



**BROADCAST ELECTRONICS, INC.**  
— A FILMWAYS COMPANY —

8810 BROOKVILLE ROAD • SILVER SPRING, MD. 20910  
PHONE 301-588-4983 • CABLE "SPOTMASTER"

ALL INPUTS ARE STEREO  
EX. CH-1 A-LEFT & RIGHT  
B-LEFT & RIGHT

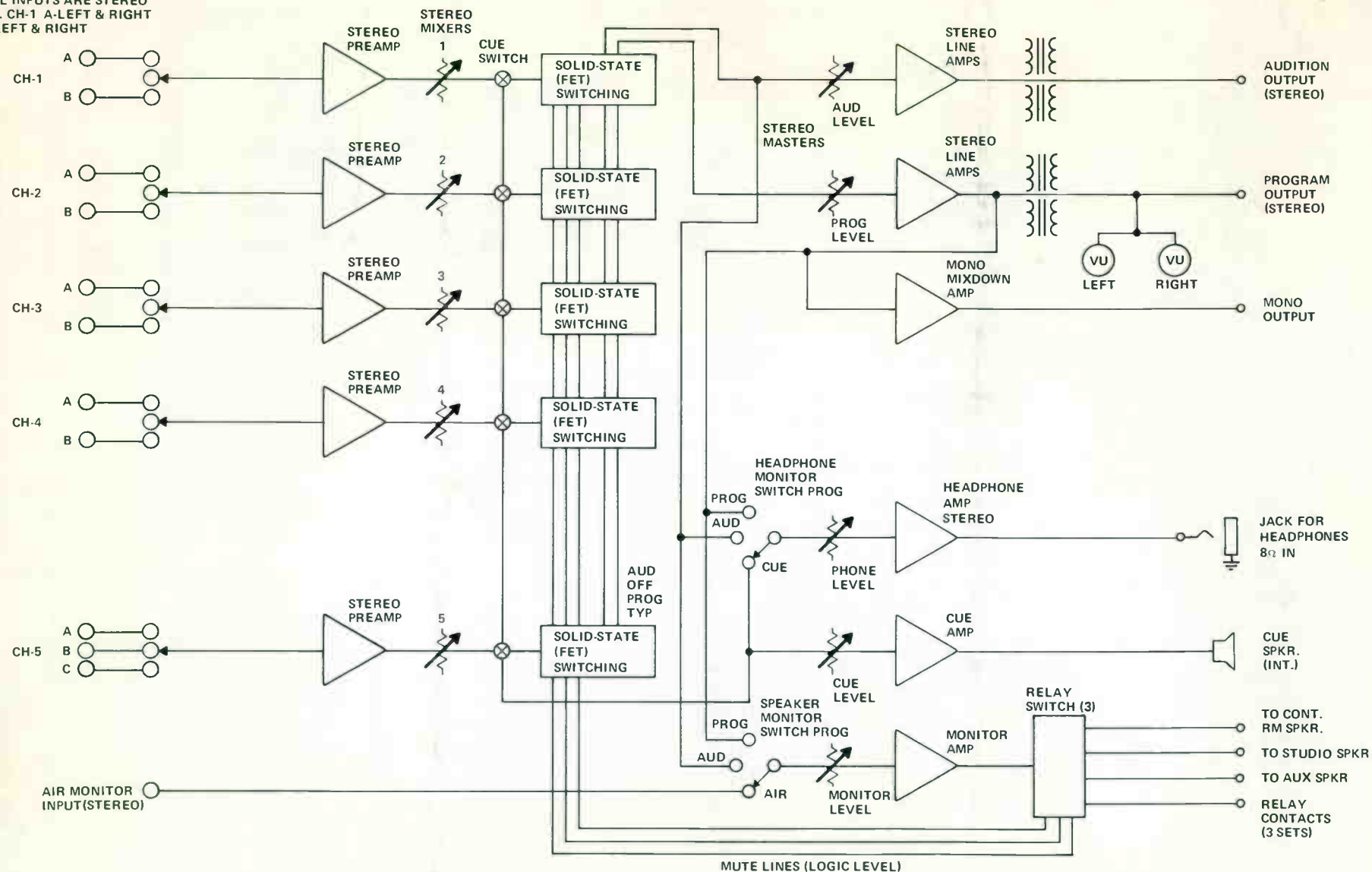

5-CHANNEL STEREO AUDIO CONSOLE Model 5S11