

TECHNICAL MANUAL OPERATION AND MAINTENANCE INSTRUCTIONS

TYPE 802B EXCITER

(P/N 180200-2)

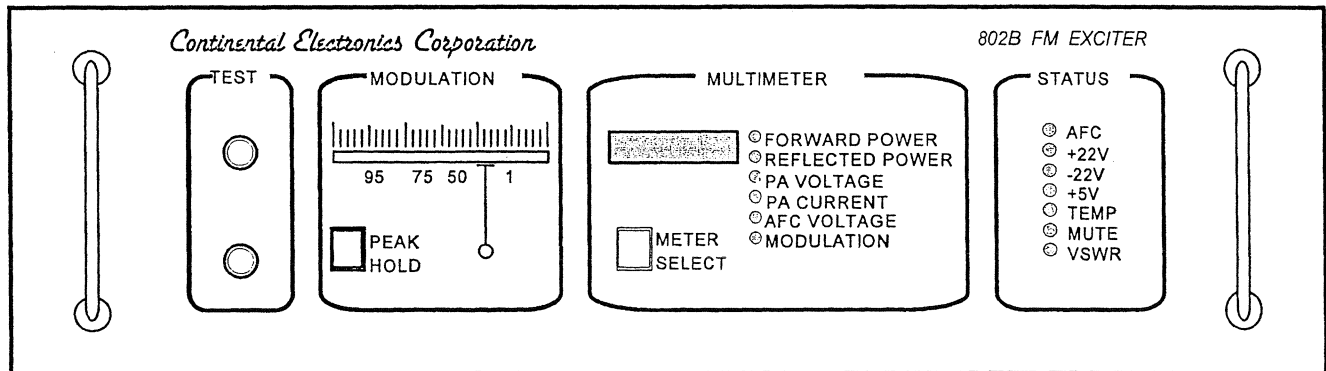

00G0030

COPYRIGHTED © 1999 by
CONTINENTAL ELECTRONICS CORP.
4212 S. BUCKNER BLVD.
DALLAS, TEXAS 75227-4299

(214) 381-7161

www@contelec.com

FAX (214) 381-4949

ISSUED - 19 NOVEMBER 1992
Change 8 - 14 DECEMBER 2001

PREFACE

This Operation and Maintenance manual gives the physical and functional description, installation, operation, theory of operation, maintenance, parts lists, and diagrams for the identified equipment. Operator and service personnel should become familiar with the manual contents before attempting to install, operate, or maintain the equipment. In addition to the Safety Summary which follows the Table of Contents, specific **WARNINGS**, **CAUTIONS** and **NOTES** are located throughout this manual where they apply. Continental Electronics Corporation (CEC) manufactured this equipment to conform with current electrical, radiation, and safety codes of the United States to the extent that they apply. **It is the user's responsibility to comply with all local and national codes during installation and operation of the equipment.**

CEC reserves the right to make any changes, without notice, to this or any of CEC's products to improve reliability, performance, function, or design.

CEC does not assume any liability resulting from the application or use of any product or circuit described herein; nor does CEC convey any license under its patent rights or the rights of others.

The information in this document has been carefully checked and is believed to be entirely reliable. While all reasonable efforts to ensure accuracy have been taken in the preparation of this manual, CEC assumes no responsibility resulting from omissions or errors in this manual, or from the use of information contained herein.

These instructions do not purport to cover all details or variations in equipment nor to provide for every possible contingency that might be met during installation, operation, or maintenance. Should further information be desired or should particular problems arise which are not covered sufficiently for the user's purpose, the matter should be referred to CEC.

All Rights Reserved
This document contains proprietary information of Continental Electronics Corporation and shall not be duplicated, nor its contents used for any purpose, unless express written permission is obtained from Continental Electronics Corporation.

CUSTOMER SERVICE

Continental Electronics Corporation customer service is available for assistance at any time, 24 hours a day, weekends and holidays included. Call anytime day or night:

Parts Services	(214) 388-3737
Engineering Services	(214) 388-5800
Main Offices	(214) 381-7161 (8:00 am - 5:00 pm CT)
FAX	(214) 381-4949
Web Address	www@worf.contelec.com

You may write to any of these services at 4212 S. Buckner Blvd., Dallas, Texas 75227-4299.

LIST OF EFFECTIVE PAGES

NOTE: The portion of text affected by the changes is indicated by a vertical line in the outer margin of the page.

Dates of issue for original pages are:

Original 0 19 November 1992
 Change 1 19 September 1993
 Change 2 9 September 1994
 Change 3 9 February 1995
 Change 4 9 February 1996
 Change 5 19 September 1996
 Change 6 21 January 1999
 Change 7 27 October 2000
 Change 8 14 December 2001

TOTAL NUMBER OF PAGES IN THIS PUBLICATION IS 167 CONSISTING OF THE FOLLOWING:

Page No.	*Change No.	Page No.	*Change No.	Page No.	*Change No.
Title	8	4-7	0	6-36 - 6-38	5
Preface	5	4-8	1	6-39 - 6-51	6
A	8	4-9 - 4-14	6	6-52	5
i	1	4-15	1	6-53	5
ii	0	4-16 Blank	1	6-54 - 6-57	5
iii - iv	1	4-17	1	6-58	6
v	0	4-18 Blank	1	6-59	6
vi - viii	1	4-19	1	6-60 Blank	5
ix - xiv	3	4-20 Blank	1	7-1	6
1-1	1	4-21	3	7-2 Blank	1
1-2 - 1-3	0	4-22 Blank	3	7-3	6
1-4	7	4-23	1	7-4 Blank	6
1-5	7	4-24 Blank	1	7-5	1
1-6	0	4-25	1	7-6 Blank	1
2-1	1	4-26 Blank	1	7-7	0
2-2 - 2-9	0	5-1	1	7-8 Blank	0
2-10	1	5-2 - 5-3	0	7-9	1
3-1 - 3-2	1	5-4 - 5-6	1	7-10 Blank	1
3-3 - 3-4	0	6-1	5	7-11	2
3-5	1	6-2	5	7-12 Blank	2
3-6 - 3-7	0	6-3	6	7-13	1
3-8	1	6-4 - 6-12	5	7-14 Blank	1
3-9	0	6-13 - 6-15	6	7-15	1
3-10	1	6-16	8	7-16 Blank	1
3-11	0	6-17 Blank	5	7-17	1
3-12	1	6-18	5	7-18 Blank	1
3-13	0	6-19 - 6-24	6	7-19	1
3-14	4	6-25 Blank	5	7-20 Blank	1
3-15 - 3-17	1	6-26 - 6-28	5	7-21	2
3-18 Blank	0	6-29 Blank	5	7-22 Blank	2
4-1 - 4-3	1	6-30	5	7-23	6
4-4	0	6-31 - 6-34	5	7-24 Blank	6
4-5 - 4-6	1	6-35 Blank	5		

TABLE OF CONTENTS

Para.	Description	Page No.
SECTION 1 - GENERAL INFORMATION		
1-1	Introduction	1-1
1-2	Physical Description	1-1
1-3	Functional Description	1-1
1-4	Technical Characteristics	1-1
SECTION 2 - INSTALLATION		
2-1	Introduction	2-1
2-2	Unpacking and Inspection	2-1
2-2.1	Domestic Shipments	2-1
2-2.2	International Shipments	2-1
2-3	Internal Options	2-1
2-3.1	AC Power	2-1
2-3.2	Operating Frequency	2-1
2-3.3	Pre-Emphasis	2-4
2-3.4	Muting Polarity	2-4
2-3.5	Input Balance/Unbalance Switch	2-4
2-4	Installation	2-4
2-4.1	Rack Mounting	2-4
2-4.2	Input Connections	2-6
2-4.2.1	AC Power	2-6
2-4.2.2	Composite Signal Input	2-6
2-4.2.3	SCA Signal Inputs	2-6
2-4.2.4	Monaural Input	2-6
2-4.2.5	Muting Connection	2-8
2-4.2.6	Power Output Control Connection	2-8
2-4.2.7	Metering Select Input	2-8

TABLE OF CONTENTS - Continued

Para.	Description	Page No.
2-4.3	Output Connections	2-9
2-4.3.1	AFC Fault	2-9
2-4.3.2	VSWR Fault	2-9
2-4.3.3	Cooling Fault	2-9
2-4.3.4	Metering Sample Output	2-9
2-4.3.5	Meter Index Output	2-9
2-4.3.6	RF Output	2-9
2-4.3.7	RF Sample Output	2-10
2-5	Initial Operation	2-10
2-5.1	Turn Exciter On	2-10
2-5.2	Turn Exciter Off	2-10

SECTION 3 - OPERATION

3-1	Introduction	3-1
3-2	Controls and Indicators	3-1
3-3	Operating Procedures	3-1
3-3.1	Local Operation	3-1
3-3.2	Remote Operation	3-1
3-3.3	Change Operating Frequency	3-16
3-4	Operational Parameters	3-16
3-4.1	RF Amplifier	3-16
3-4.2	AFC Voltage	3-17

SECTION 4 - THEORY OF OPERATION

4-1	Introduction	4-1
4-2	AFC Circuits	4-1
4-2.1	Modulated Oscillator (A1)	4-1
4-2.2	Frequency Divider (A2)	4-1
4-2.3	Audio/AFC (A3)	4-1

TABLE OF CONTENTS - Continued

Para.	Description	Page No.
4-3	Audio Circuits	4-1
4-3.1	Rear Panel	4-1
4-3.2	Audio/AFC	4-3
4-4	Power Amplifier	4-3
4-4.1	RF Amplifier	4-3
4-4.2	Amplifier Control	4-3
4-5	Metering and Status	4-3
4-5.1	Metering Circuits	4-4
4-5.2	Monitoring Circuits	4-4
4-6	Power Supplies	4-4
4-6.1	+32 Volt Supply	4-4
4-6.2	+22 Volt Supply	4-4
4-6.3	-22 Volt Supply	4-4
4-6.4	+15 Volt Supply	4-4
4-6.5	\pm 15 Volt Supplies	4-4
4-6.6	+5 Volt Supply	4-5
4-7	Detailed Circuit Descriptions	4-5
4-7.1	Modulated Oscillator Assembly (A1)	4-5
4-7.2	Frequency Divider Assembly (A2)	4-5
4-7.3	Audio / AFC Assembly (A3)	4-7
4-7.3.1	Audio Circuits	4-7
4-7.3.2	AFC Circuits	4-9
4-7.4	RF Amplifier Assembly (A8)	4-9
4-7.5	Amplifier Control Assembly (A5)	4-10
4-7.6	Front Panel Assembly (A6)	4-11
4-7.6.1	Multimeter Group	4-11
4-7.6.2	Status Group	4-12
4-7.6.3	Modulation Group	4-13
4-7.7	Power Supply Assembly (A4)	4-14

TABLE OF CONTENTS - Continued

Para.	Description	Page No.
SECTION 5 - MAINTENANCE		
5-1	Introduction	5-1
5-2	Remove and Replace	5-1
5-2.1	PC Board Assemblies	5-1
5-2.2	RF Amplifier Assembly	5-1
5-2.3	Power Transformer	5-1
5-2.4	Frequency Divider Assembly	5-1
5-2.5	Audio/AFC Assembly	5-2
5-2.6	Front Panel Circuit Card	5-2
5-2.7	Rear Panel Circuit Card	5-2
5-2.8	Blower Assembly	5-2
5-3	Adjustments	5-2
5-3.1	Frequency Divider Adjustments	5-2
5-3.2	Audio/AFC Adjustments	5-2
5-3.2.1	Monaural Input Common-Mode Null Adjustment	5-3
5-3.2.2	Composite Input Common-Mode Null Adjustment	5-3
5-3.2.3	Predistortion Input Level Adjustment	5-3
5-3.2.4	Predistortion Adjustment	5-3
5-3.2.5	Deviation Adjustment	5-4
5-3.3	Front Panel Circuit Card Adjustments	5-4
5-3.3.1	RF Power Level Adjustment	5-4
5-3.3.2	RF Low Power Level Adjustment	5-4
5-3.3.3	DVM Reference Adjustment	5-4
5-3.3.4	Bargraph Calibration	5-4
5-3.3.5	DVM Input Control	5-4
5-3.3.6	Modulation Calibrate Control	5-5
5-3.4	Rear Panel Circuit Card Adjustments	5-5
5-3.5	Amplifier Control Circuit Card Adjustments	5-5
5-3.5.1	Forward Power Meter Adjustment	5-5
5-3.5.2	Reflected Power Meter Adjustment	5-5
5-3.5.3	PA Current Adjustment	5-5

TABLE OF CONTENTS - Continued

Para.	Description	Page No.
SECTION 6 - PARTS LIST		
6-1	Introduction	6-1
6-2	Reference Designator	6-1
6-3	Description	6-1
6-4	Part Number	6-1
6-5	Illustrations	6-1
6-6	List of Equipment	6-1
SECTION 7 - SCHEMATIC DIAGRAMS		
7-1	Introduction	7-1

LIST OF ILLUSTRATIONS

Figure	Description	Page No.
SECTION 1 - GENERAL DESCRIPTION		
1-1	Type 802B FM Exciter	1-2
1-2	Simplified Block Diagram	1-3
SECTION 2 - INSTALLATION		
2-1	FM Exciter Outline and Installation Drawing	2-2
2-2	AC Power Voltage Selection	2-3
2-3	Muting Polarity Jumper Installation	2-5
2-4	Rear Panel Connections, Type 802B FM Exciter	2-7
SECTION 3 - OPERATION		
3-1	Front Panel, A6	3-2
3-2	Front Panel Circuit Card Assembly, A6A1	3-5
3-3	Rear Panel, A7	3-8
3-4	Rear Panel Circuit Card Assembly, A7A1	3-8
3-5	Frequency Divider, A2	3-10
3-6	Audio/AFC, A3	3-12
3-7	Amplifier Control Circuit Card Assembly, A5	3-14
SECTION 4 - THEORY OF OPERATION		
4-1	Type 802B FM Exciter Assembly Locator	4-2
4-2	Frequency Selection	4-6
4-3	Pre-Emphasis Selection	4-8
4-4	AFC Circuits Simplified Diagram	4-15
4-5	Audio Circuits Simplified Diagram	4-17
4-6	Digital Voltmeter and Selection Circuitry Simplified Diagram ..	4-19
4-7	Power Supply Circuits Simplified Diagram	4-21
4-8	Muting, Overtemp, and Power Control Simplified Diagram	4-23
4-9	Modulation Measurement Simplified Diagram	4-25

LIST OF ILLUSTRATIONS - Continued

Figure	Description	Page No.
SECTION 6 - PARTS LIST		
6-1	802B FM Exciter	6-2
6-2	Cable Assembly	6-4
6-3	Modulated Oscillator Assembly, A1	6-6
6-4	Modulated Oscillator Circuit Card, A1A1	6-8
6-5	Frequency Divider, A2	6-12
6-6	Audio/AFC, A3	6-18
6-7	Rear Panel Circuit Card, A7A1	6-26
6-8	Power Supply Assembly, A4	6-30
6-9	Amplifier Control, A5	6-36
6-10	Front Panel Assembly, A6	6-38
6-11	Front Panel Circuit Card, A6A1	6-52
6-12	Rear Panel Assembly, A7	6-54
6-13	Output Amplifier Assembly, A8	6-58

SECTION 7 - SCHEMATIC DIAGRAMS

7-1	Type 802B FM Exciter Schematic	7-3
7-2	Modulated Oscillator PCB	7-5
7-3	Frequency Divider PCB	7-7
7-4	Audio/AFC PCB	7-9
7-5	Power Supply PCB	7-11
7-6	Amplifier Control PCB	7-13
7-7	Front Panel PCB (Sheet 1 of 3)	7-15
7-7	Front Panel PCB (Sheet 2 of 3)	7-17
7-7	Front Panel PCB (Sheet 3 of 3)	7-19
7-8	Rear Panel PCB	7-21
7-9	50 Watt Amplifier Card	7-23

LIST OF TABLES

Table	Description	Page No.
SECTION 1 - GENERAL DESCRIPTION		
1-1	List of Major Assemblies	1-1
1-2	Technical Characteristics	1-4
SECTION 3 - OPERATION		
3-1	Front Panel, A6	3-3
3-2	Front Panel Circuit Card Assembly, A6A1	3-6
3-3	Rear Panel, A7	3-9
3-4	Rear Panel Circuit Card Assembly, A7A1	3-9
3-5	Frequency Divider, A2	3-11
3-6	Audio/AFC, A3	3-13
3-7	Amplifier Control Circuit Card Assembly, A5	3-15
3-8	Divider Switch Example	3-16
3-9	RF Amplifier Current and Voltage	3-16
3-10	AFC Voltage at Frequencies	3-17
SECTION 6 - PARTS LIST		
6-1	List of Equipment	6-1
SECTION 7 - SCHEMATIC DIAGRAMS		
7-1	Index of Schematic Diagrams	7-1

SAFETY INFORMATION

I GENERAL

This safety summary is intended for trained and qualified personnel who are aware of the dangers inherent in handling potentially hazardous electrical circuits. It is not intended as a complete or authoritative medical treatment course, but should serve as a reminder of accepted emergency techniques. The equipment documentation must be reviewed for familiarization with safety markings and instructions before operation or maintenance activities are attempted. Know where and how to turn off main electrical power to the equipment. User personnel should have training in first aid and cardiopulmonary resuscitation (CPR) techniques. Emergency medical, fire, and ambulance telephone numbers should be posted in clear view adjacent to each telephone. Make a note if 911 service is available.

II ELECTRICAL SHOCK TREATMENT

In case of an electrical shock the A-B-Cs of basic life support treatment may be used while medical assistance is being summoned.

WARNING

HIGH VOLTAGE/RF HAZARD

WHEN A VICTIM IS IN CONTACT WITH HIGH VOLTAGE OR RF, ENSURE SOURCE POTENTIAL IS REMOVED AND CIRCUIT GROUNDED BEFORE ATTEMPTING ARTIFICIAL RESPIRATION. FAILURE TO COMPLY MAY RESULT IN PERSONAL INJURY OR DEATH.

1. If the victim is not responsive follow the A-B-Cs of basic life support. Place victim face-up on a flat hard surface. Three critical areas (Airway, Breathing, and Circulation) need immediate attention:

WARNING
BITE HAZARD

USE CAUTION WHEN PLACING FINGERS IN VICTIM'S MOUTH, MUSCLE SPASMS CAN CAUSE THE MOUTH TO CLOSE WITH FORCE SUFFICIENT TO SEVER YOUR FINGERS. FAILURE TO COMPLY MAY RESULT IN LOSS OF FINGERS.

- a. Airway - If victim is unconscious, open airway by lifting up the neck while pushing back on the victim's forehead. Refer to Figure 1A. Clear mouth of obstructions and observe for breathing.

WARNING
RESCUER KEEP CALM

EXCESSIVELY DEEP AND RAPID BREATHING BY THE RESCUER MAY RESULT IN RESCUER BECOMING FAINT, TO TINGLE, AND EVEN LOSE CONSCIOUSNESS. BREATHING SHOULD BE NORMAL IN RATE WITH ONLY MODERATE INCREASE IN VOLUME. FAILURE TO COMPLY MAY RESULT IN RESCUE BEING PREMATURELY STOPPED DUE TO FATIGUE.

- b. Breathing - If victim is not breathing begin artificial breathing. Tilt head, pinch nostrils, make airtight seal with your mouth, and blow 4 quick full breaths into the victim's lungs. Refer to Figure 1B.
- c. Circulation - If victim does not have a pulse, see Figure 1C, begin artificial circulation. Depress sternum 1½ to 2 inches then release. Refer to Figures 1D and 1E. WITH ONE rescuer: Perform 15 compressions and 2 quick breaths at the rate of 80 per minute. WITH TWO rescuers: Perform 5 compressions and 1 breath at the rate of 60 per minute.

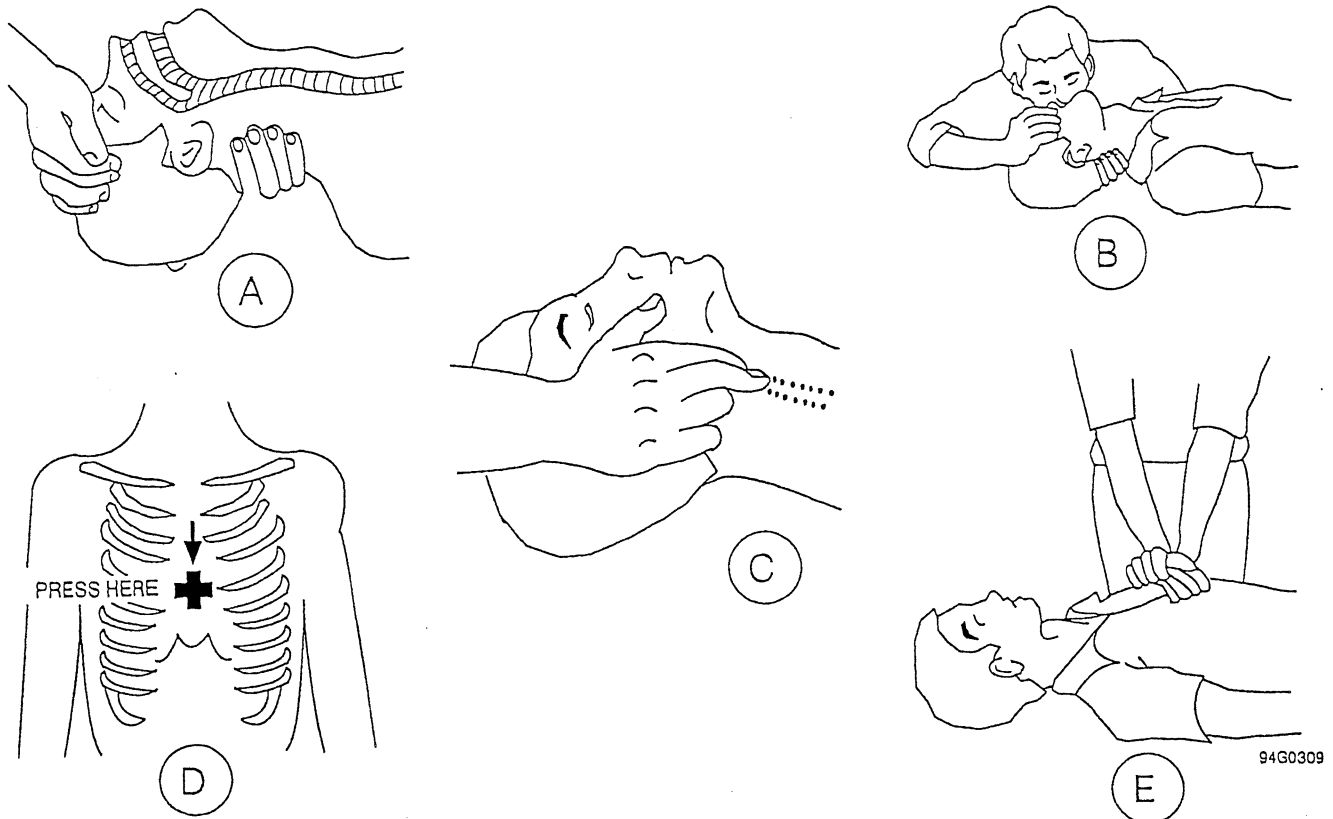

Figure 1. Artificial Breathing and Circulation.

2. If the victim is responsive treat for shock in the following way:
 - a. Keep victim warm.
 - b. Keep victim as quiet as possible.
 - c. Loosen victim's clothing.
 - d. Place victim in a reclining position if possible.
1. In case of extensive electrical burns and broken skin:
 - a. Cover area with clean sheet or cloth. (Cleanest available cloth article.)
 - b. Do Not break blisters, remove tissue, remove adhered particles of clothing, or apply any salve or ointment.
 - c. Treat victim for shock as follows: Keep victim warm, quiet, reclined, and loosen clothing.
 - d. Arrange transportation to a hospital as quickly as possible.

III FIRST-AID

Users of this equipment are urged to become familiar with first-aid theory and practices. The following information is intended for reference only. It is important that all personnel using this equipment be prepared to give adequate Emergency First-Aid to fellow users.

- e. If arms or legs are affected keep them elevated.

NOTE

If medical help will not be available within an hour and the victim is conscious and not vomiting, give him a weak solution of salt and soda: 1 level teaspoon of salt and 1/2 level teaspoon of baking soda to each quart of water (neither hot nor cold). Allow victim to sip slowly about 4 ounces (a half glass) over a period of 15 minutes. Discontinue fluid if vomiting occurs. (Do Not give alcohol.)

2. In case of less severe electrical burns (1st. or 2nd. degree) with no broken skin:
 - a. Apply cool (not ice cold) compresses using the cleanest available cloth article.
 - b. Do Not break blisters, remove tissue, remove adhered particles of clothing, or apply any salve or ointment.
 - c. Apply clean dry dressing if necessary.
 - d. Treat victim for shock as follows: Keep victim warm, quiet, reclined, and loosen clothing.
 - e. Arrange transportation to a hospital as quickly as possible.
 - f. If arms or legs are affected keep them elevated.

IV SAFETY SYMBOLS

Safety symbols shown below are typical of those used in the operation and maintenance manual:

WARNING

The WARNING sign as shown above, denotes a personal hazard. It calls attention to a procedure, practice, or the like, which, if not correctly performed or adhered to, may result in personal injury. Do not proceed beyond a WARNING sign until the indicated conditions are fully understood and met.

CAUTION

The CAUTION sign as shown above, denotes an equipment hazard. It calls attention to an operating procedure, practice, or the like, which, if not correctly performed or adhered to, may result in damage to or destruction of part or all of the equipment. Do not proceed beyond a CAUTION sign until the indicated conditions are fully understood and met.

V SAFETY PRECAUTIONS

Follow the safety precautions listed below in addition to any site safety precautions when servicing this equipment. Failure to observe these safety precautions may result in serious injury or death.

WARNING

DEATH OR SERIOUS INJURY MAY RESULT IF PERSONNEL FAIL TO OBSERVE THE FOLLOWING SAFETY PRECAUTIONS.

1. Never work on electronic equipment unless there is another person present who is familiar with the operation and hazards of the equipment and who is competent in administering first aid. When the engineer or technician is aided by operators, he must warn them about dangerous areas.
2. Do not contact high voltage or current connections when power is applied to this equipment.
3. Whenever the nature of the procedure permits, keep one hand away from the equipment to reduce the hazard of current flowing through vital organs of the body.

V SAFETY PRECAUTIONS - Continued

4. Make sure that all rings, watches, necklaces, metallic ear-rings, and other similar items are removed before working with this equipment.
5. Whenever possible, the power supply to the equipment must be turned-off and tagged or locked before beginning work on the equipment.
6. Extremely high current, low voltage, dc is used in portions of the equipment. Do not be misled by the low voltage rating (5 to 30 V dc) of the current sources. Severe injury to personnel and damage to the equipment can occur if the voltage sources are shorted (directly connected) to ground or ground returns by tools or test equipment.

VI VOLTAGE, CURRENT, and LIGHTNING HAZARDS

The voltage, current, and lightning hazards listed in 1 through 3 below exist for the equipment. For hazards associated with vendor equipment, refer to appropriate manuals furnished with the item.

1. The dc voltage hazards consist of potentials of 5 V dc to 10 kV dc between power supply lines within the equipment.
2. High voltage, high current, 50/60 Hz ac power is supplied to the equipment.
3. Antenna systems acting as an attracting device presents a lightning hazard to personnel performing maintenance on the equipment. No maintenance should be performed on the unit when thunderstorms are imminent or in progress, while the antenna is connected.

VII RF RADIATION HAZARDS

The rf radiation hazards listed in 1 and 2 below exist for the equipment. For hazards associated with vendor equipment, refer to appropriate manuals furnished with the item.

1. RF radiation from the equipment could present a potential hazard to personnel wearing cardiac pacemakers.
2. The following rf radiation hazard precautions shall be observed when operating or performing maintenance on the equipment:

- a. Proper precautions shall be taken to protect cardiac pacemaker users.
- b. Ensure that radiation restrictions for nearby equipment or other high power rf radiation sources are observed before performing maintenance on this equipment.
- c. Prior to and during operation and maintenance, observe all radiation restrictions in effect at the site.
- d. If personnel are suspected or known to have been exposed to rf radiation in excess of rf radiation protection guidelines, consult medical personnel immediately.

VIII TOXIC MATERIAL/ENVIRONMENTAL HAZARDS

The hazards listed in 1 and 2 below may exist when performing maintenance of the equipment. For hazards associated with vendor equipment, refer to appropriate manuals furnished with the item.

1. Toxic or flammable solvents and corrosive chemicals used in cleaning operations may involve the use of caustic or acid solutions, skin irritants, and organic solvents that are flammable and/or toxic. The following precautions, as a minimum, must be observed by personnel using such materials.
 - a. Work only in well ventilated areas.
 - b. Wear organic vapor respirators when using organic solvents or corrosive chemicals.
 - c. Wear chemical safety goggles, gloves and aprons when using corrosive chemicals.
 - d. Do not use flammable chemicals near or inside the equipment while power is applied to the system.
 - e. Maintain a fully stocked first aid cabinet nearby for emergency treatment of scalds, burns, etc.
 - f. Flush away coolant or cleaning solvent contamination from any part of the body.
2. Benzene, Carbon Tetrachloride, Freon, and Trichloroethane based Solvents should only be used in well ventilated areas. The fumes are toxic and may be hazardous to your health or can cause death by suffocation.

IX MAJOR EMPLACEMENT AND MAINTENANCE HAZARDS

The precautions given in 1 and 2 below must be observed to prevent injury or death to personnel:

1. Installation and assembly hazards associated with the equipment are as follows:
 - a. After performing maintenance ensure the doors and covers are installed prior to attempting to return the equipment to service.
 - b. On all electrolytic capacitors, make sure terminal polarity markings [positive (+) and negative (-)] are observed when connecting capacitors to \pm dc buses.
2. While performing maintenance on the equipment, observe the following precautions:
 - a. Maintenance of equipment shall not be performed when thunderstorms and lightning are imminent or in progress.
 - b. When performing maintenance on the equipment make sure all ac power to the unit is removed.

X STATIC SENSITIVE DEVICES

There are some circuits throughout the equipment using metal-oxide-semiconductor (MOS) and complementary MOS (CMOS) integrated circuits. This requires stringent attention to handling techniques due to the sensitivity to static electricity. The following paragraphs outline the procedures to use when handling MOS or CMOS devices.

1. Electrostatic discharge hazards in MOS/CMOS devices are prevalent. Such damage can be produced by Electrostatic Discharge (ESD) due to improper handling or installation. All MOS/CMOS devices are susceptible to damage by the discharge of electrostatic energy between any two pins. This sensitivity to static charge is due to the fact that gate input capacitance (5 picofarads typical) in parallel with an extremely high input resistance (10^{12} ohms typical) lends itself to a high input impedance and hence readily builds up the electrostatic charges.

2. Electrostatic handling of MOS devices is of prime importance. Static electricity is always present in any work environment. It is generated when ever two different materials are rubbed together. A person walking across the floor can generate a charge of thousands of volts. A person working at a bench, sliding around on a stool, or rubbing his arms on the work bench can develop a high static potential. For preventing damage to devices due to ESD, use the following precautions:
 - a. Table tops or work areas should be covered with grounded conductive tops. Test areas should have conductive floor mats.
 - b. Tools and test equipment used in protected work areas shall be properly grounded. Ensure that soldering-iron tips are grounded. If plastic handled tools must be used, they shall be treated with a topical antistat.
 - c. Devices, or circuit cards with devices, should not be inserted into or removed from circuits with the power on because transient voltages may cause permanent damage.
 - d. Use a conductive wrist strap when removing a circuit card containing MOS/CMOS devices from a card cage or when removing a device from a circuit card.
 - e. The devices are to be stored or transported in static shielding bags, anti-static rails, or conductive foam.
3. ESD grounding is critical to safe handling of ESD sensitive devices. Earth ground rods for ESD protection shall be solid copper or copper jacketed steel and shall be driven six to eight feet into the earth beyond the work area floor slab with approximately six inches exposed for making connection. Dry soil conditions may require a copper sulfate drip. Electrical grounds shall be isolated from static grounds.

Water pipes offer convenient grounds; however, they may not be connected to earth ground. These techniques are for minimizing the difference of potential between separate grounds, and not for reducing the ohmic resistance to earth.

(This Page Intentionally Left Blank)

SECTION 1 - GENERAL INFORMATION

1-1 INTRODUCTION.

The 802B FM Exciter is a solid state unit which generates an FM signal at a power level adjustable from 5 to 50 watts. Its center frequency is controlled by means of a programmable phase-locked-loop, allowing frequency selection in 10 kHz steps from 87 to 109 MHz. The 802B is designed to provide years of service with little or no maintenance or adjustment. Modulation characteristics are excellent. A list of major assemblies is provided in Table 1-1.

1-2. PHYSICAL DESCRIPTION

The exciter is housed in an enclosed chassis with a standard 19 by 5-1/4 inch front panel (Refer to Figure 1-1). The chassis depth is 22 inches and is equipped with slide-rails for ease of servicing the unit. The front panel contains indicators and controls for normal operation of the Exciter. The rear panel provides interface

connectors and terminal strips to accommodate a composite input, a monaural input, and three subsidiary communication authorization (SCA) subcarrier inputs. AC power, 200 watts maximum, 120/240 volts at 50/60 Hz, is input through an international power connector.

1-3. FUNCTIONAL DESCRIPTION

The 802B is designed primarily as an exciter for higher-powered transmitters. However, it can be used as a low power transmitter (FCC BQQ82H802B) (DOC 243 532 108); this is made possible in part by the built-in harmonic filter. A block diagram of the exciter is provided in Figure 1-2.

1-4. TECHNICAL CHARACTERISTICS

Table 1-2 contains the electrical, mechanical, and environmental specifications for the 802B Exciter.

TABLE 1-1. List of Major Assemblies

Assy.	Description	Part No.	Schematic No.
-	802B FM Exciter	180200-2	180201
A1	Mod. Osc. Assy	180207-1	
A1A1	Mod. Osc. PCB	180239-1	180240
A2	Frequency Divider PCB	643-0003-002	643-0004-001
A3	Audio/AFC PCB	180197-2	180199
A4	Power Supply PCB	643-0009-002	643-0010-001
A5	Amplifier Control PCB	180247-2	180246
A6	Front Panel	180214-1	180201
A6A1	Front Panel PCB	180202-2	180203
A7	Rear Panel	180215-1	180201
A7A1	Rear Panel PCB	180210-2	180211
A8	RF Amplifier	180428-1	180497

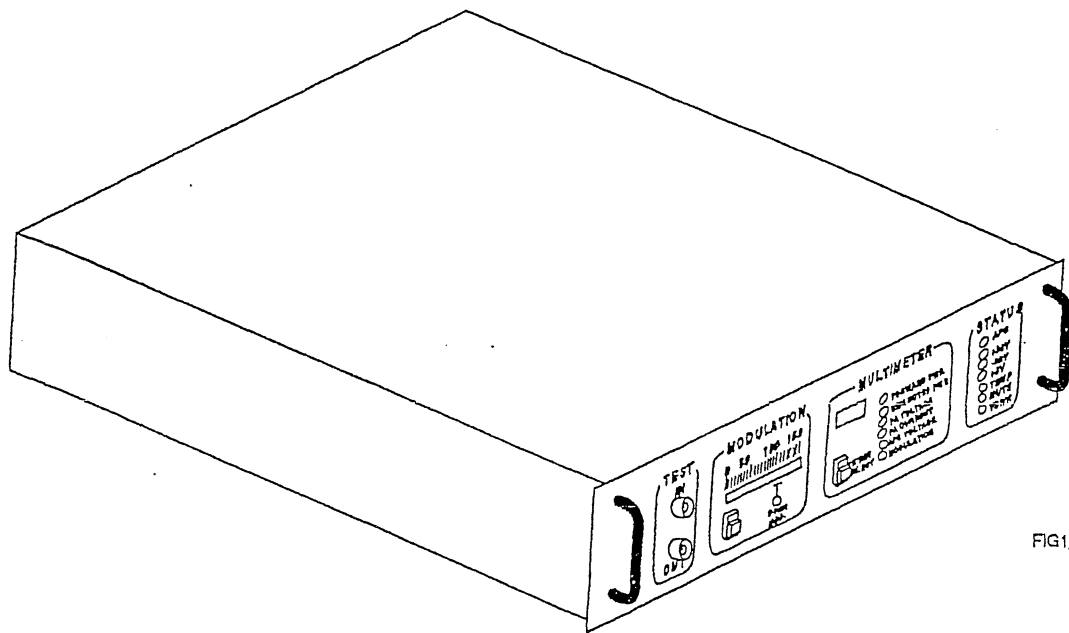

FIG1.1.DRW

Figure 1-1 Type 802B FM Exciter.

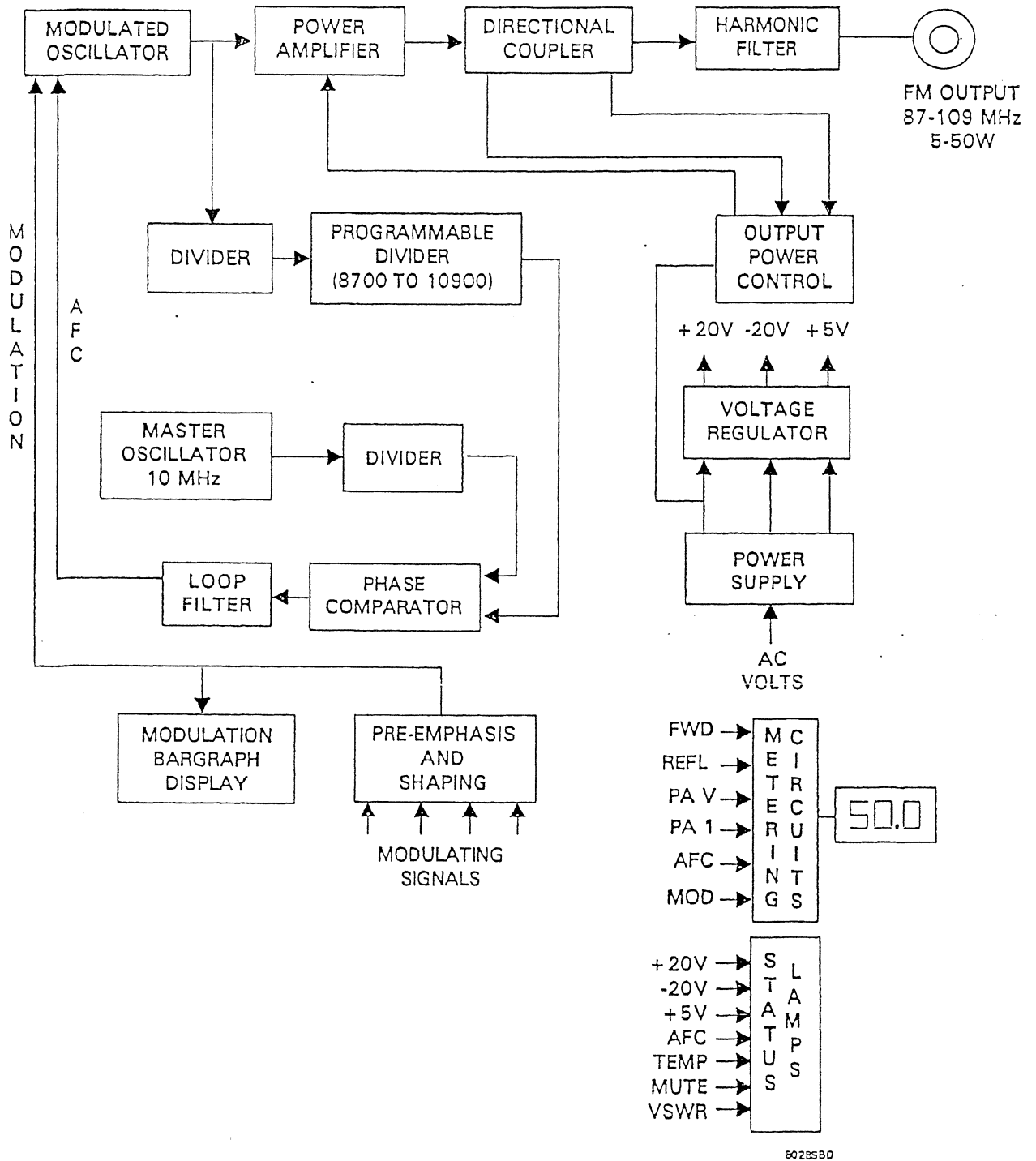

Figure 1-2 Simplified Block Diagram.

TABLE 1-2. Technical Characteristics

Electrical

Input Power:	120 V, 220 V, or 240 V +10%; 50/60 Hz; single phase, 200 W maximum.
Power Output:	5 to 50 W, continuously adjustable.
Harmonic & Spurious Output:	60 dB or more below rated output.
Frequency Range:	87 to 109 MHz in 10 kHz steps.
Frequency Control:	Phase-locked loop controlled by high-stability master oscillator.
Frequency Stability:	±250 Hz, over 0 °C to 55 °C temperature range. (Within FCC frequency stability limits from -30 °C to +60 °C)
Modulation Type:	Direct carrier frequency modulation.
Modulation Capability:	±200 kHz Deviation.
Modulation Indication:	Peak reading LED display with over-modulation indicator.
Asynchronous AM S/N:	70 dB minimum.
Synchronous AM S/N:	60 dB minimum.

MONAURAL OPERATION

Audio Input Impedance:	600 ohms ±5%, Balanced
Audio Input Level:	+10 dBm ±2 dB
Audio Frequency Response:	±0.5 dB, 20 Hz to 15 kHz, referenced to 0 dB at 100 Hz. Flat, 25, 50, or 75 μs pre-emphasis provided.
Total Harmonic Distortion:	0.005% maximum, using "A" weighted filter.
FM S/N Ratio:	80 dB, 75 μs de-emphasis.

TABLE 1-2. Technical Characteristics - Cont'd

COMPOSITE OPERATION

Composite Inputs:	Balanced and unbalanced (rear panel); Test (unbalanced, front panel).
Composite Input Impedance:	5 k ohms, nominal
Composite Input Level:	3.50 volts peak-to-peak for ± 75 kHz deviation.
Composite Amplitude Response:	± 0.2 dB, 20 Hz to 60 kHz referenced to 0 dB at 100 Hz.
Composite Phase Response:	$\pm 0.5^\circ$, 20 Hz to 75 kHz.
Composite Total Harmonic Distortion:	0.009% maximum using "A" weighted filter.
Composite Intermodulation Distortion:	0.009% maximum, 60 Hz/7 kHz, 4:1 using CCIR-2K filter.
Composite FM S/N ratio:	80 dB minimum, 75 μ s de-emphasis.
SCA Inputs:	Three, unbalanced.
SCA Input Impedance:	15 k ohms, nominal.
SCA Input Level:	1.25 V _{rms} for 10% injection.
SCA Amplitude Response:	± 0.3 dB, 40 kHz to 100 kHz.

STEREO OPERATION

NOTE

Most stereo performance parameters are determined primarily by the stereo generator used.

Stereo separation:	50 dB minimum, 50 Hz to 15 kHz. (60 dB typical, 400 Hz to 7,500 Hz)
--------------------	------------------------------------------------------------------------

TABLE 1-2. Technical Characteristics - Cont'd

SCA OPERATION

NOTE

Most SCA performance parameters are determined primarily by the SCA Generator used.

Mechanical

Size:	17-1/2" wide (444.5 mm) centered in a 19 inch wide (482.6 mm) rack-mounting panel; 5-1/4" (133.35 mm) high; 22" (558.8 mm) deep.
Weight:	Approximately 38 lbs. (17.3 kg).
Shipping weight:	Approximately 50 lbs. (22.7 kg).

Environmental (Operating)

Temperature Range:	-4 °F to +131 °F (-20 °C to +55 °C).
Altitude Range:	0 to 15,100 ft. (0 to 4,600 Meters).
Relative Humidity Range:	0 to 95%.

SECTION 2 - INSTALLATION

2-1. INTRODUCTION

This section will guide the user in the unpacking, inspection, selection of internal options, and installation of the 802B exciter.

Refer to Figure 2-1 for chassis dimensions and location of the interface connections and internal fan intake port.

2-2. UNPACKING AND INSPECTION

2-2.1 Domestic Shipments.

Remove the exciter from its shipping crate and packing material. Remove top cover from the exciter by turning six fasteners ccw. Inspect the equipment for loose screws and fasteners. Ensure front panel switches operate freely and cable and wiring connections are tight. Replace top cover and tighten fasteners when inspection is complete. If any item is damaged in transit, note the damage on the shipping documents and immediately file a freight claim. All boxes and packing material should be retained for the freight inspector.

When the 802B is shipped as a stand-alone item, perform the items outlined in the following paragraphs.

When the 802B is shipped as an integral part of a transmitter, the line voltage, fuse rating, rack mounting, and appropriate internal options are selected at the factory. The user should skip ahead to Input Connections, paragraph 2-4.2.

2-2.2 International Shipments.

The Exciter international shipping installation instructions are identical to those for domestic shipment. Refer to instructions in Paragraph 2-2.1 for unpacking and inspection.

2-3. INTERNAL OPTIONS

Prior to installing the 802B Exciter, examine the following paragraphs to ensure the internal options are set for the desired configuration.

2-3.1 AC Power.

The 802B is shipped from the factory set for operation on 120 V ac unless directed otherwise by the customer. When operation at another line voltage is desired (refer to Figure 2-2) pull the line voltage selector card from the AC line connector on the rear of the 802B. Reinsert the selector card so that the desired voltage is visible on the card.

CAUTION **EQUIPMENT DAMAGE**

**OPERATOR MUST CONFIRM THAT
THE PROPER OPERATING
VOLTAGE HAS BEEN SELECTED
(SEE FIGURE 2.2) AND
CORRESPONDS TO THE VOLTAGE
BEING APPLIED PRIOR TO
MAKING CONNECTION.**

For line voltage of 120 V ac, the fuse shall be rated at 3 amperes. For line voltage of 220 or 240 V ac, the fuse shall be rated at 1.5 amperes.

2-3.2 Operating Frequency.

The 802B is shipped from the factory set to the customer's operating frequency. If the operating frequency was not specified, the 802B will be shipped set to 98.1 MHz; refer to Paragraph 3-3.3 for instructions on changing the operating frequency.

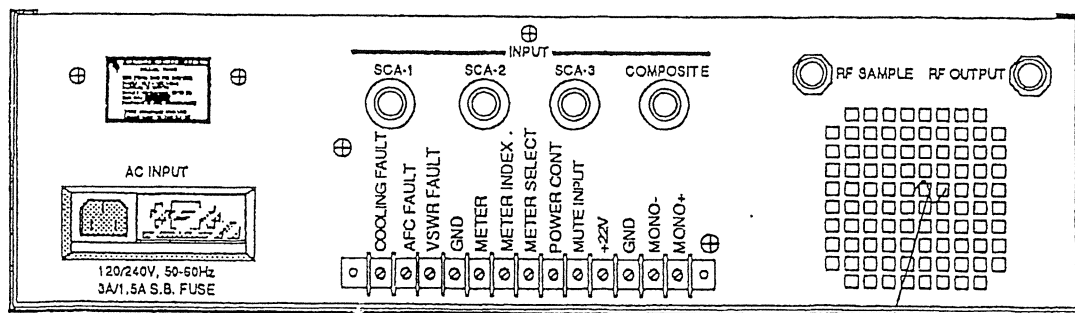
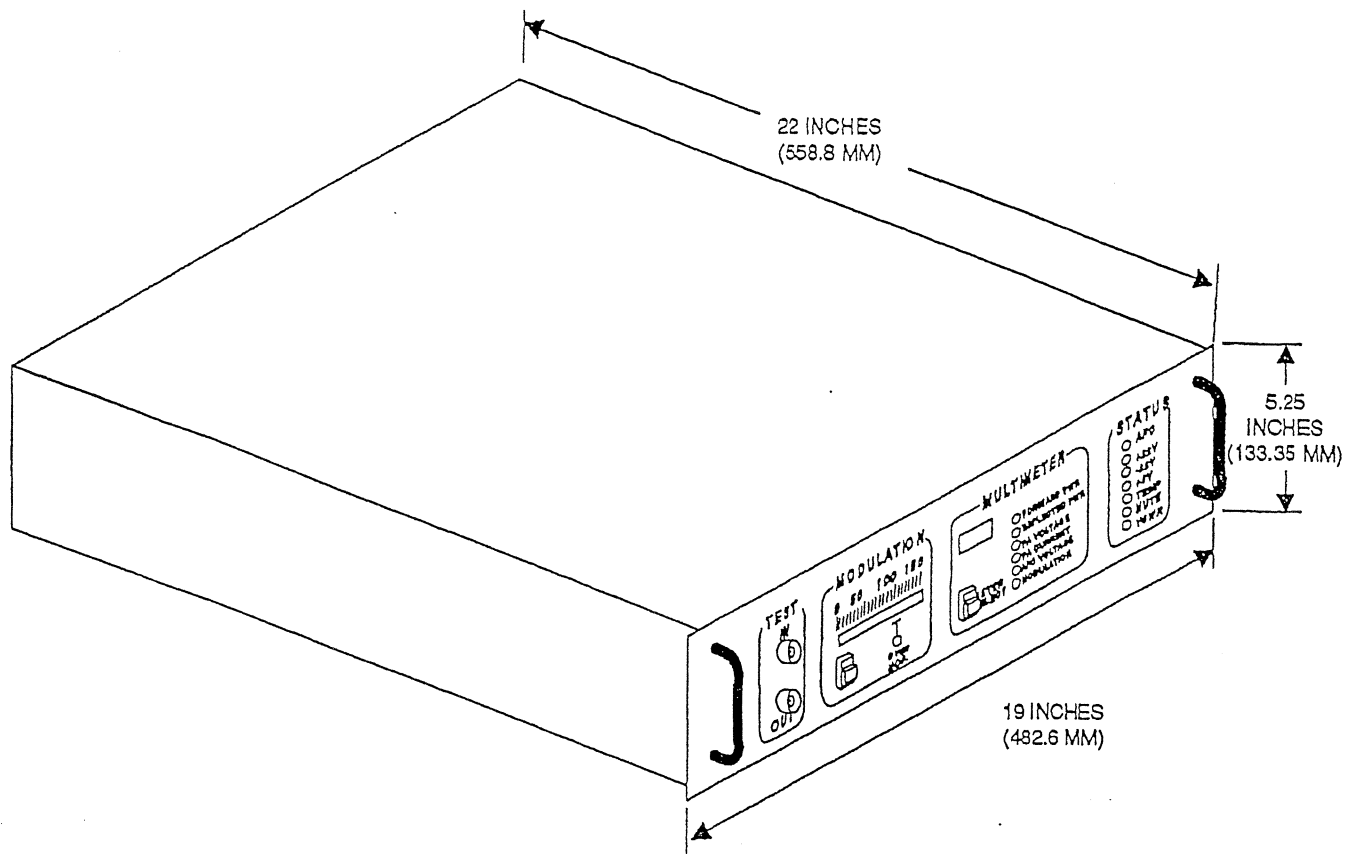

REAR VIEW (ROTATED)

9069LR2

INTAKE AIR PORT

Figure 2-1. FM Exciter Outline and Installation Drawing

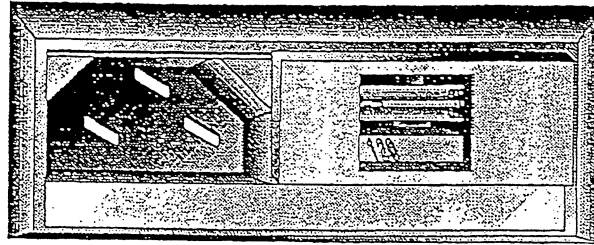

- a. Slide fuse cover door to the left for access to fuse and voltage selecting card.

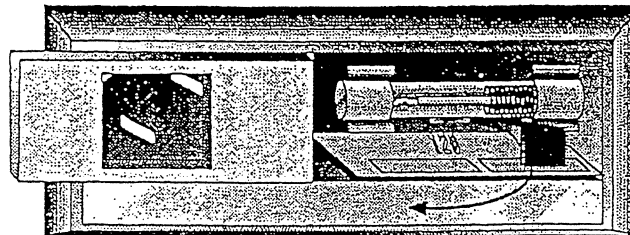

- b. To remove fuse and gain access to voltage selecting card, pull black lever out and to the left.

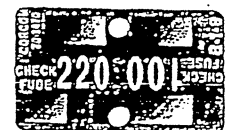
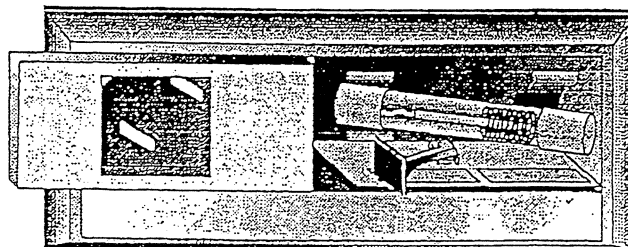

- c. Fuse may be changed or examined; voltage selecting card may be removed with pliers and reinserted to select appropriate voltage.

Figure 2-2. AC Power Voltage Selection

2-3.3 Pre-emphasis.

The 802B is shipped from the factory with the internal monophonic pre-emphasis set to 75 microsecond time constant unless otherwise specified. If the pre-emphasis is to be changed, refer to Paragraph 4-7.3.1.

2-3.4 Muting Polarity.

The exciter is shipped from the factory with the internal muting polarity option jumper set so that applying a voltage to the external muting terminal on the rear of the exciter will cause muting. This is the method of muting used with Continental Electronics transmitters. Another option is to set the polarity such that a pulldown of the muting input terminal to ground will enable exciter output. This is another commonly used method of controlling the exciter. If the muting polarity is to be changed, refer to Figure 2-3.

2-3.5 Input Balanced/Unbalanced Switch.

The exciter has a switch on the inside of the rear panel which allows the user to switch the composite input from a balanced to an unbalanced input. Normally this switch should be left in the balanced position. Under some conditions the unbalanced position may yield a better signal-to-noise ratio.

2-4. INSTALLATION

Perform the instructions in the following paragraphs to install the exciter in the equipment rack and make the necessary interface connections.

NOTE

The Exciter shall be positioned to allow access to the top cover (for service and maintenance) when the unit is extended from the rack on its mounting rails.

WARNING HIGH VOLTAGE HAZARD

ENSURE AC POWER IS REMOVED FROM THE EXCITER BEFORE SERVICING. FAILURE TO COMPLY MAY RESULT IN DEATH OR INJURY TO PERSONNEL.

CAUTION THERMAL DAMAGE

ENSURE COOLING AIR INLET PORT IS NOT OBSTRUCTED WHEN THE EXCITER IS IN OPERATION. FAILURE TO COMPLY MAY RESULT IN THERMAL DAMAGE TO THE EQUIPMENT.

2-4.1 Rack Mounting.

Remove detachable halves of the rack mounting slides from the 802B Exciter chassis. Install the rack slides in the equipment rack where the exciter is to be located.

WARNING WEIGHT HAZARD

ENSURE SAFETY CATCHES ON THE RACK SLIDES ENGAGE WHEN THE CHASSIS IS PULLED FROM THE EQUIPMENT RACK. FAILURE TO COMPLY MAY RESULT IN INJURY TO PERSONNEL.

Insert the exciter into the slides and push the unit into the equipment rack.

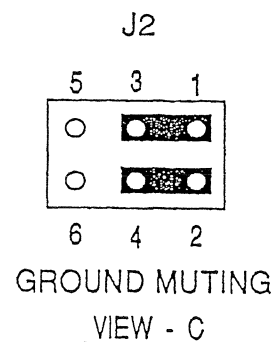
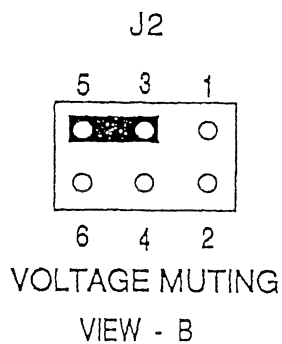
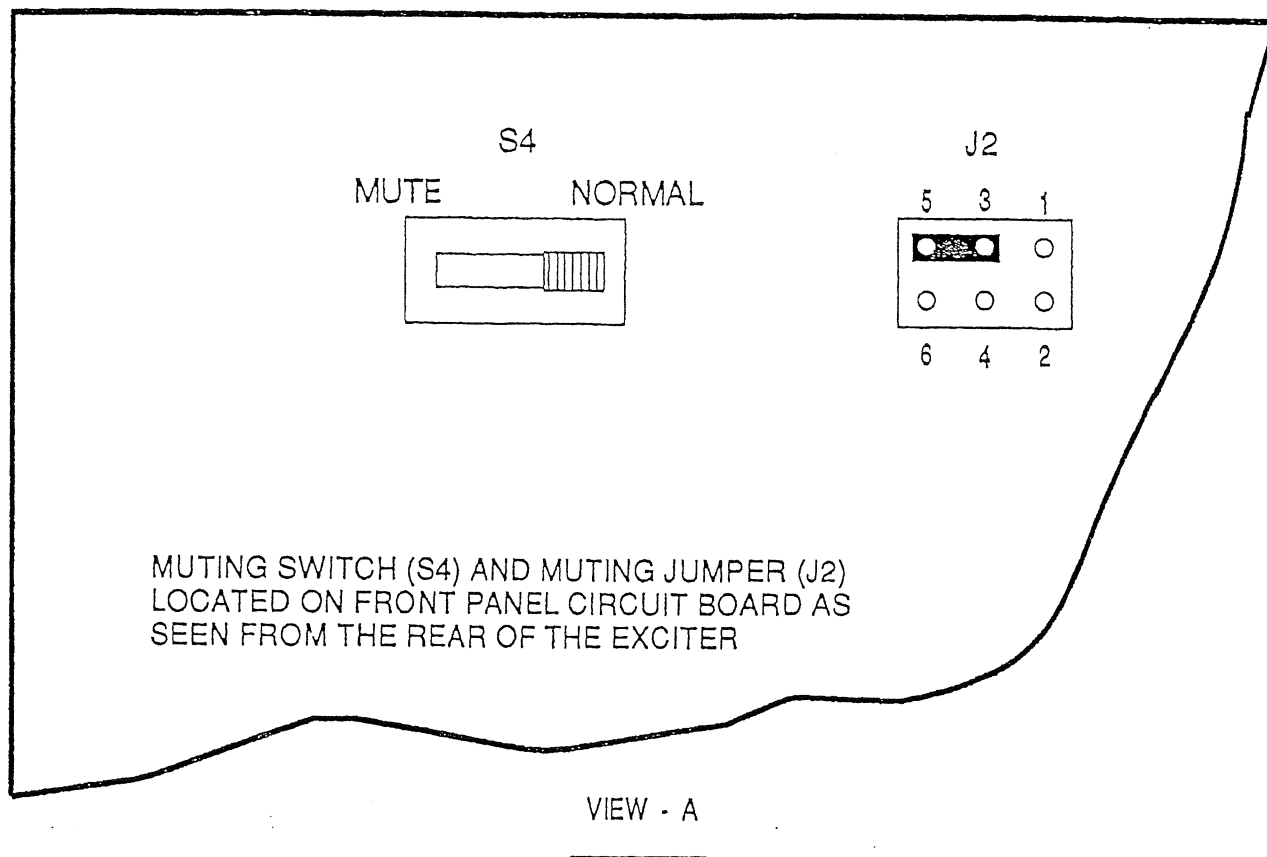

- a. Operate switch (S4) to MUTE the exciter. Operate it to the right for NORMAL operation (Refer to View A).
- b. To mute the exciter by applying a voltage to the rear panel muting terminal, jumper J2 pin 3 to 5 as shown in View B.
- c. To mute the exciter by applying a closure to ground, jumper J2 pins 2 to 4 and pin 1 to 3 as shown in View C. A closure to ground enables the exciter and an open will mute the exciter.

Figure 2-3. Muting Polarity Jumper Installation

NOTE

When very tight signal-to-noise ratio specifications are sought, it is advisable to mount the exciter external to the transmitter. This will reduce the exposure the exciter receives from acoustic and electrical noise sources. In addition, it facilitates connecting composite signal sources to the exciter.

2-4.2 Input Connections.

The following paragraphs outline connections to be made to the 802B Exciter from external power and signal sources.

2-4.2.1 AC Power. Connect the power cord female end to the AC line connector on the rear of the exciter. Plug the male connector end into a compatible power source (refer to Figure 2-4).

2-4.2.2 Composite Signal Input. When the exciter is used in a monophonic operation, no connection will be made to the composite connector (refer to Figure 2-4).

Connect the program source to the composite input connector when the exciter is used in a stereophonic operation. Normally the program source will be the output of a stereo generator or a composite STL. The composite inputs are through BNC type connectors. The normal signal amplitude is 3.50 volts peak-to-peak for 100% modulation.

Because this signal input port has a remarkably flat frequency response up to about 100 kHz, SCA subcarriers may be summed with the composite signal prior to connection to the 802B Exciter. When the signal source allows summing, it is preferred to minimize the possibility of ground loops causing signal-to-noise ratio degradation.

2-4.2.3 SCA Signal Inputs. When the exciter is used without subcarrier operation, no

connections will be made to any of the SCA subcarrier input connectors.

When subcarriers are used, they shall be applied to the subcarrier input connectors (refer to Figure 2-4). These connectors are not intended to accept audio or data modulation; the signals applied to these connectors should be subcarriers in the 40 to 100 kHz region.

An alternate method of applying the subcarrier(s) to the exciter is to use any loop-thru or daisy chaining capability of the composite signal source, as mentioned in the Composite Signal Input Paragraph 2-4.2.2.

Use of a subcarrier which has sidebands of significance at 53 kHz and below will be precluded during simultaneous stereo transmission. Use of a subcarrier which has sidebands of significance at 20 kHz and below will be precluded. The responsibility for complying with any regulations regarding SCA transmission lies with the user.

2-4.2.4 Monaural Input. When the exciter will be used primarily in a stereophonic operation, no connection will be made to the monaural input terminals. If any connections are made to the monaural input, for example to a patch panel, those connections can be a source of noise input. There is no switch to disable them; they are active at all times.

For monaural operation, the program source shall be connected to the MONO input terminals on the rear of the exciter (refer to Figure 2-4). Normally the program source will be the output of a limiter or STL receiver.

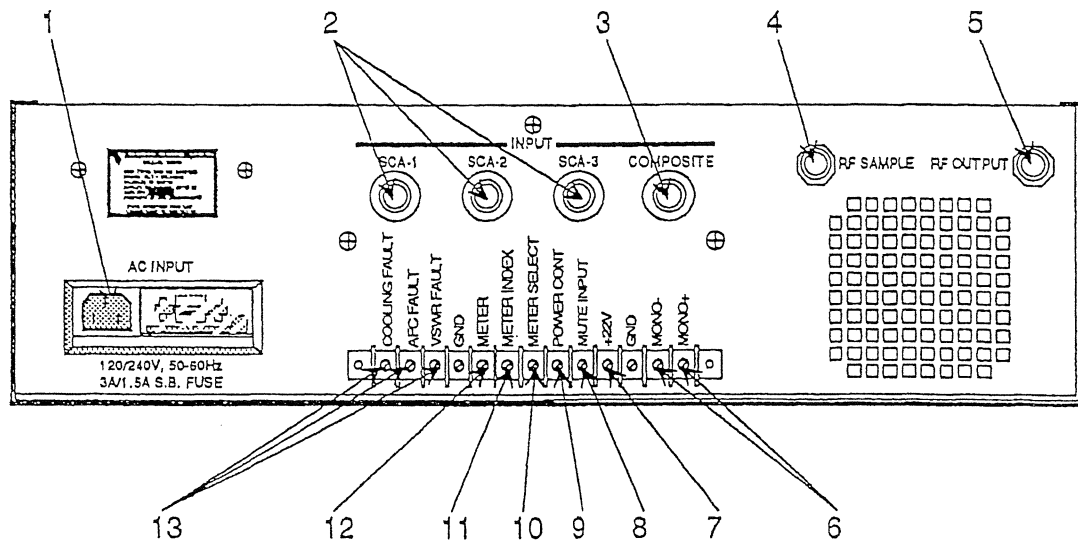

9069LR2

1. Power input from AC power source.
2. Subcarrier signal input from SCA Generator (three inputs).
3. Composite signal input from composite STL or stereo generator.
4. RF sample connector to monitor.
5. RF output connector to transmitter or antenna.
6. Monaural audio input may be applied to the MONO terminals, connect the shield to the GND terminal.
7. A voltage source of +22 V dc for use in conjunction with an external contact closure going to the MUTE input terminal to mute the exciter.
8. The MUTE INPUT signal will mute the exciter when a voltage is applied or when a closure to ground is removed.
9. The POWER CONT terminal is an input which reduces the exciter output RF power level when a positive voltage is applied.
10. The METER SELECT terminal is an input signal which advances the metering system in the 802B one step each time it is pulled to ground. It may be connected to a control output of a remote control system.
11. The METER INDEX terminal is an open-collector output which is pulled to ground when "forward power" is selected. It may be connected to a status input of a remote control system.
12. The METER output terminal may be connected to a metering channel input of a remote control system. The analog signal is referenced to ground.
13. The fault outputs may be connected to the status inputs of a remote control system. All fault signals are open-collector outputs pulled to ground.

Figure 2-4. Rear Panel Connections, Type 802B FM Exciter

2-4.2.4 Monaural Input. - Cont'd

The monaural input connection shall be made using ordinary shielded twisted pair cable and spade lugs. The normal signal amplitude at low audio frequencies is about +10 dBm for 100% modulation.

The MONO input port may be pre-emphasized when the exciter's internal pre-emphasis has been selected (refer to Paragraph 2-3.3). For this reason a frequency sensitive limiter should be used for modulation control. If the exciter is driven directly by a good limiter, it is best to operate the exciter in a flat mode (no pre-emphasis) and obtain the pre-emphasis in the limiter.

If any SCA subcarriers are used, a 15 kHz lowpass filter should be used in the *audio* chain to spectrally sterilize the baseband spectrum. (Such lowpass filtering would be integral to a good limiter.)

2-4.2.5 Muting Connection. The 802B has the capability to locally or remotely mute the RF output. This allows setting the bias on a following power amplifier, or at any time essentially remove all RF output power from the exciter.

Local muting may be executed by operating the RF MUTE switch located on the inside of the exciter front panel.

Remote muting may be executed by applying a voltage to the MUTE terminal located on the exciter rear panel (refer to Figure 2-4). This voltage should be greater than 5 V dc and less than 24 V dc. The assumption is made that the internal muting option jumper is set for voltage mode (refer to Paragraph 2-3.4). The exciter will be configured for voltage muting, if it is

internal to a Continental Electronics transmitter.

When remote muting is to be executed by pulling the MUTE terminal to ground (operate by releasing the connection from ground), the correct muting option jumper must be selected (refer to Paragraph 2-3.4).

In either case, shielded wire shall be used to make this connection to prevent RF from entering into the exciter. Connect the center conductor to the MUTE INPUT terminal and the shield to the GND (ground terminal), refer to Figure 2-4.

2-4.2.6 Power Output Control Connection. The RF output power from the 802B Exciter may be controlled remotely by applying a positive voltage to the POWER CONT terminal on the exciter rear panel (refer to Figure 2-4).

The voltage applied to this point shall be positive-going and ground-referenced. RF power will start to be reduced when the control voltage is about 3 V dc, and power will reduce smoothly to near zero watts output when the control voltage has been increased to about 11 V dc. The control circuit has a time delay (about 1.1 seconds) which should be taken into account if the system is to be servo-controlled.

2-4.2.7 Metering Select Input. The METER SELECT terminal provides a way to remotely select the signal to be metered. Each closure to ground, provided by a remote control system, will cause the metering system to advance one reading. Grounding the METER SELECT line advances both the front panel digital multimeter and the rear panel METER output signal terminal.

2-4.3 Output Connections.

The following paragraphs describe connections to be made from the 802B Exciter to the transmitting and monitoring equipment.

2-4.3.1 AFC Fault. The exciter's AFC loop status can be monitored remotely by connecting to the AFC FAULT terminal (refer to Figure 2-4). This terminal is pulled to ground when AFC lock is lost. For example, the signal may be used to operate a lamp or relay. The exciter circuitry consists of an open-collector output logic gate. The external voltage applied to this open-collector output should not exceed 50 V dc. The circuit can sink a maximum of 500 mA current.

2-4.3.2 VSWR Fault. The VSWR presented to the output of the exciter can be monitored remotely by connecting to the VSWR FAULT terminal (refer to Figure 2-4). This terminal is pulled to ground when VSWR is excessive. For example, the signal may be used to operate a lamp or relay. The exciter circuitry consists of an open-collector output logic gate. The external voltage applied to this open-collector output should not exceed 50 V dc. The circuit can sink a maximum of 500 mA current.

2-4.3.3 Cooling Fault. The status of the over-temperature switch on the RF amplifier heatsink can be monitored remotely by connecting to the COOLING FAULT terminal (refer to Figure 2-4). This terminal is pulled to ground when the heatsink temperature is excessive. The exciter circuitry consists of an open-collector output logic gate. The external voltage applied to this open-collector output should not exceed 50 V dc. The circuit can sink a maximum of 500 mA current.

2-4.3.4 Metering Sample Output. The signal

which is being displayed by the front panel digital multimeter is also routed to the rear-panel METER output terminal (refer to Figure 2-4). This signal is the analog DC signal which is read by the voltmeter. It can be connected to a remote control system metering input. This will allow that channel of the remote control system to read the same signal that the digital multimeter on the exciter is reading.

2-4.3.5 Meter Index Output. The signal at this point, a voltage of about +3 V dc, is present when the exciter's digital multimeter is reading forward power. When the multimeter is stepped to read any other signal this voltage drops to essentially 0 V dc. The METER INDEX terminal can be connected to a remote control system status input. This will allow that channel of the remote control system to flag that the digital multimeter on the exciter is reading forward power, the first signal on the list of metered signals.

2-4.3.6 RF Output. The RF output from the exciter appears at the RF OUTPUT connector on the rear of the exciter (refer to Figure 2-4). The load should be 50 ohms.

When the 802B Exciter is used as a stand-alone transmitter, the antenna will be connected to the exciter's RF OUTPUT connector.

When the 802B FM Exciter is used to drive a transmitter then the exciter's RF OUTPUT connector will be connected to the transmitter's RF power input port.

The connection made to the RF OUTPUT connector shall be made with a nominal 50 ohm coaxial cable. RF power available at the RF OUTPUT connector is adjustable from about 5 to 50 watts, into a 50 ohm load.

2-4.3.7 RF Sample Output. A sample of the exciter RF output, at a power level of about 2.5 milliwatts, appears at the RF SAMPLE connector located on the rear panel (refer to Figure 2-4). When connecting to this point use a nominal 50 ohm coaxial cable. The RF SAMPLE output is intended to drive a modulation monitor.

2-5 INITIAL OPERATION.

The following information will guide the user in operation of the 802B Exciter.

2-5.1 Turn Exciter On.

Place the 802B Exciter in operation and turn it on using the following steps.

1. Confirm that all connections and options have been selected correctly as outlined in the previous paragraphs.
2. With the exciter power cable connected to its source and the source circuit breaker closed, the status indicators (except AFC) will illuminate immediately.
3. After about 8 seconds the AFC indicator LED will illuminate.
4. The digital meter should be in the FORWARD PWR position, the WATTS indicator should illuminate, and the power should ramp up to the chosen value.
5. To adjust the output power, use the POWER control adjustment accessible through the hole in the top cover near the right front (refer to Figure 3-2).
6. Step through the various meter readings by pressing the METER SELECT button.

The appropriate unit of measure indicator should illuminate. Readings should be approximately as listed below:

- a. FORWARD PWR should be as chosen, probably in the 20 to 40 watt region.
- b. REFLECTED PWR will be a function of the VSWR of the load, probably in the 0.1 to 1 watt region.
- c. PA VOLTAGE should be in the 15 to 28 volt region, depending on the selected output power. Typical values of voltage for various power levels are shown in Table 3-10.
- d. PA CURRENT should be in the 0.5 to 4 ampere region, depending on the output power. As with the voltage, typical values of current are shown in Table 3-10.
- e. AFC VOLTAGE should be in the 3 to 12 volt region, depending on the carrier frequency only. Typical values for various frequencies are given in Table 3-11.
- f. MODULATION will be dependent on the modulating signal(s) applied to the exciter; shown as %. With program material this will be a less than useful reading but with steady signals such as a pilot or SCA sub-carrier the resolution is to 0.1%.

2-5.2 Turn Exciter Off.

To turn the 802B Exciter off, simply place the source power circuit breaker to OFF or remove the power cord from its connector. There are no items internal to the exciter, such as crystal ovens, that require standby power. The exciter can be left on at all times if there is no reason to remove AC power.

SECTION 3 - OPERATION

3-1 INTRODUCTION.

This section of the Operation and Maintenance Manual describes the 802B Exciter controls and indicators and initial operation of the unit.

3-2 CONTROLS AND INDICATORS

Refer to the following figures and tables for a general description of the operating controls and indicators found on the major assemblies of the exciter. Figure 1-1 shows the location of the exciter major assemblies. Figures 3-1 through 3-8 show details of each assembly. Tables 3-1 through 3-8 supplement Figures 3-1 through 3-8 and identify the function of each control and indicator.

3-3 OPERATING PROCEDURES

The following information will guide the user in operation of the 802B Exciter in either the local or remote modes.

3-3.1 Local Operation.

Place the exciter in local operation following the procedures of Paragraph 2-5. Once normal operation has been established, continue operation according to local program requirements. Use the controls and indicators as described in Figures 3-1 through 3-8 and Tables 3-1 through 3-8 to achieve the desired operating conditions.

The following procedure will allow the user to verify proper operation of the exciter unit.

1. When the exciter is operational the top four indicators in the STATUS block will be illuminated.
2. Verify programming by observing the modulation bar/dot graph.
3. Verify RF Output power by selecting and observing the FORWARD and

REFLECTED POWER on the front panel multimeter.

4. Additional exciter conditional information can be examined by selecting and observing multimeter readings on the front panel. Tables 3-10 and 3-11 provide a list of PA Current, PA Voltage, and AFC Voltage values for the exciter's normal operating range.

3-3.2 Remote Operation.

Place the exciter in remote operation following the procedures of Paragraph 2-5. Once normal operation has been established, continue operation according to site program requirements.

Use the controls and indicators of your remote control system to operate the exciter and achieve the desired operating conditions. Instructions for making desired remote connections are provided in Paragraphs 2-4.2 through 2-4.3.5.

The following procedure will allow the user to verify proper operation of the exciter unit.

1. Verify programming by observing the modulation indicator in the remote control system status panel.
2. Verify RF Output power by selecting and observing the FORWARD and REFLECTED POWER on the remote control system status panel.
3. Additional exciter conditional information can be examined by selecting and observing the PA Current, PA Voltage, and AFC Voltage values as monitored on the remote control system metering device. Tables 3-10 and 3-11 provide a list of typical readings over the exciter's normal operating range.

(Continued on page 3-16)

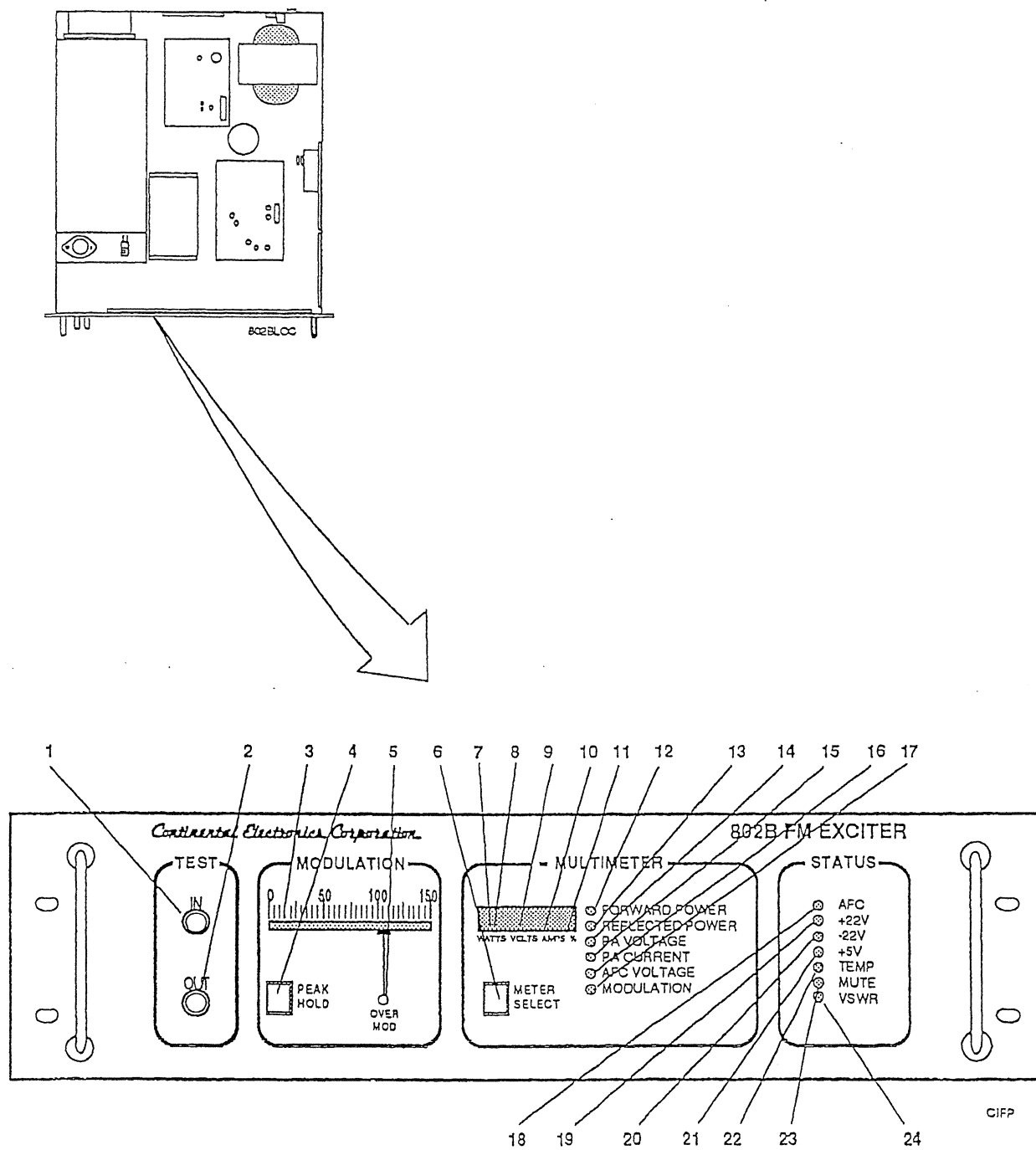

Figure 3-1 Front Panel, A6.

TABLE 3-1. Front Panel, A6

Index No.	Control or Indicator	Function
<u>TEST GROUP</u>		
1	IN connector (BNC) A6J1	Composite test input signal.
2	OUT connector (BNC) A6J2	Composite test signal output from Audio/AFC assembly.
<u>MODULATION GROUP</u>		
3	Bar Indicator A6A1DS3, DS4, and DS5	Continuously indicates percent modulation as either a dot or bar, depending on the position of internal select. Switch A6A1S1.
4	PEAK HOLD indicator switch A6A1S3	An alternate action switch which enables the bar display to vary continuously or hold the peak modulation level. The peak-hold mode is selected when the red indicator is illuminated.
5	OVER MOD indicator A6A1CR44	Indicator illuminates to signal the selected threshold for modulation has been exceeded. Available thresholds are 100%, 105%, or 110% as selected by A6A1J4.
<u>MULTIMETER GROUP</u>		
6	METER SELECT switch A6A1S2	Pressing the switch sequentially steps through the DMM functions. The selected meter function is also present on the rear panel METER SELECT terminal.
7	WATTS Legend Indicator A6A1CR16	Indicates the DMM is reading Watt units when illuminated.
8	VOLTS Legend Indicator A6A1CR15	Indicates the DMM is reading volt units when illuminated.
9	AMPS Legend Indicator A6A1CR14	Indicates the DMM is reading ampere units when illuminated.
10	% Legend Indicator A6A1CR13	Indicates the DMM is reading percent units when illuminated.

TABLE 3-1. Front Panel, A6 - Cont'd

Index No.	Control or Indicator	Function
11	Digital Multimeter A6A1DS1 and DS2	A 3-1/2 digit multimeter display of the function selected by the Meter Select switch (A6A1S2). The unit of measure legend is located beneath the display.
12	FORWARD POWER indicator A6A1CR4	Indicator will illuminate when forward power is selected as the DMM display function.
13	REFLECTED POWER indicator A6A1CR11	Indicator will illuminate when reflected power is selected as the DMM display function.
14	PA VOLTAGE indicator A6A1CR12	Indicator will illuminate when PA voltage is selected as the DMM display function.
15	PA CURRENT indicator A6A1CR36	Indicator will illuminate when PA current is selected as the DMM display function.
16	AFC VOLTAGE indicator A6A1CR37	Indicator will illuminate when AFC voltage is selected as the DMM display function.
17	MODULATION indicator A6A1CR38	Indicator will illuminate when modulation percentage is selected as the DMM display function.
<u>STATUS GROUP</u>		
18	AFC indicator A6A1CR2	Indicator will illuminate when AFC is normal.
19	+22V indicator A6A1CR6	Indicator will illuminate when +22 V dc is normal.
20	-22V indicator A6A1CR7	Indicator will illuminate when -22 V dc is normal.
21	+5V indicator A6A1CR25	Indicator will illuminate when +5 V dc is normal.
22	TEMP indicator A6A1CR26	Indicator will illuminate when an RF amplifier heat sink over-temperature fault condition exist.
23	MUTE indicator A6A1CR27	Indicator will illuminate when the exciter is in a MUTE condition.
24	VSWR indicator A6A1CR28	Indicator will illuminate when the exciter VSWR is in a fault condition.

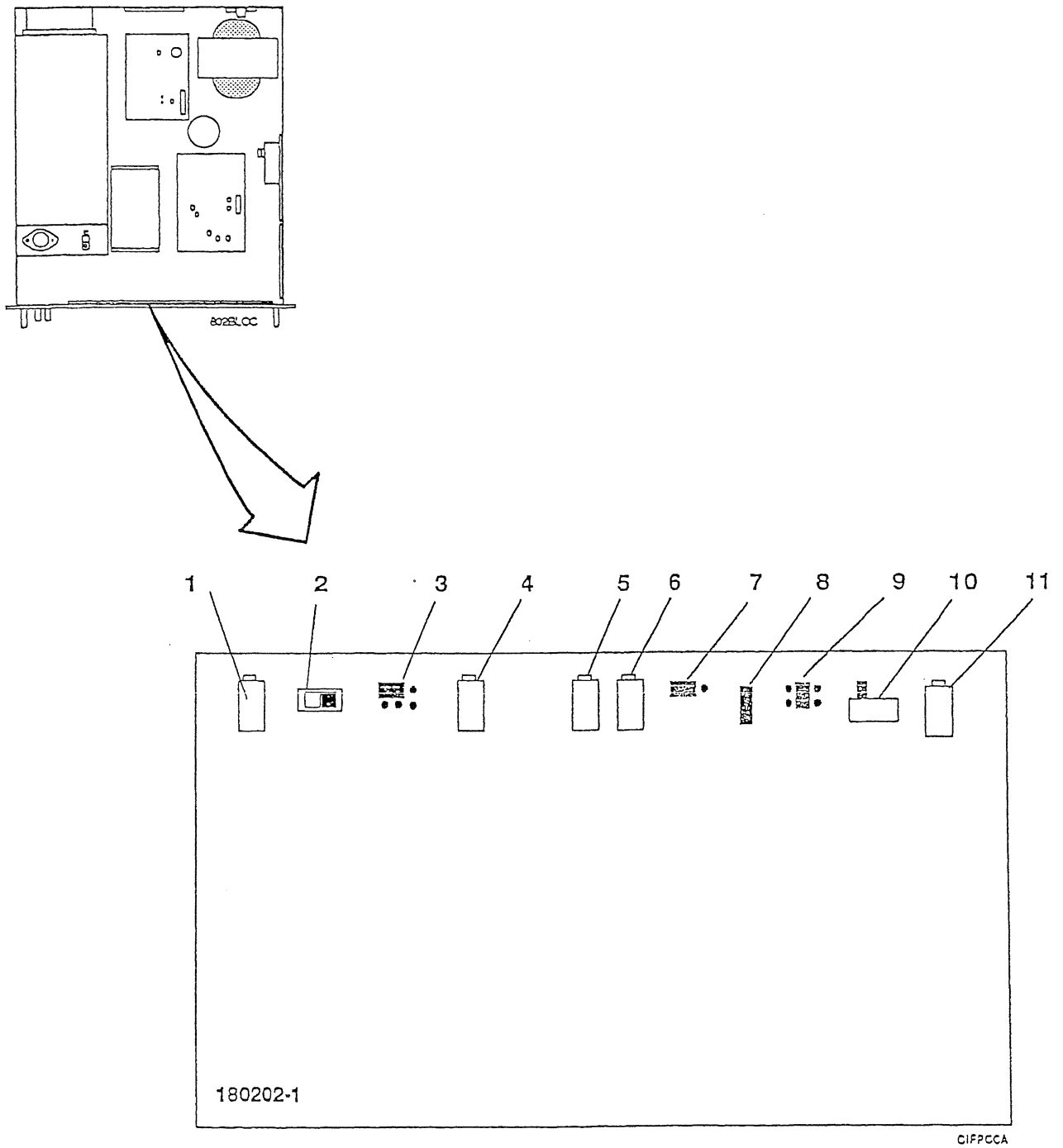

Figure 3-2 Front Panel Circuit Card Assembly, A6A1.

TABLE 3-2. Front Panel Circuit Card Assembly, A6A1

Index No.	Control or Indicator	Function
1	PWR control A6A1R1	Adjusts exciter RF output level as viewed on the DMM display. The potentiometer is accessible through a cutout in the exciter top cover.
2	RF MUTE switch A6A1S4	A two position switch used to place the exciter in MUTE or NORMAL mode of operation. The switch is accessible through a cutout in the exciter top cover.
3	EXT MUTE jumper A6A1J2	Enables the exciter to respond to the appropriate mute signal polarity.
4	LOW PWR control A6A1R9	Sets the reduced RF power output level to provided by the exciter when an over temperature condition exist in the RF power amplifier circuit. Typically the low power will be set to half of the normal RF power output level.
5	DVM CAL control A6A1R14	Adjusts the DMM reference voltage to 1.000 V dc, as measured between voltage (A6A1TP2) and ground (A6A1TP3). Use the most accurate digital voltmeter available to make this adjustment.
6	BAR CAL control A6A1R16	Adjusts the bar graph calibration to ensure accurate level tracking with the modulation percentage displayed on the DMM. NOTE: This calibration shall always follow the adjustment of the modulation calibration control (A6A1R25).
7	DVM jumper A6A1J6	Selects input to the DMM circuit. When the jumper is between pins 2 and 3 the DVM input is from the standard METER SELECT functions. When the jumper is between pins 1 and 2 the input is from the DVM PROBE jack A6A1J1.
8	MOD PEAK LAMP jumper A6A1J4	Selects 100%, 105%, or 110% over modulation threshold level. The triggering signal is derived from the bar graph circuit ensuring a precise relationship to the bar graph indicator.

TABLE 3-2. Front Panel Circuit Card Assembly, A6A1, - Cont'd

Index No.	Control or Indicator	Function
9	DVM PROBE jack A6A1J1	Provides an auxiliary input to the DVM by inserting a probe tipped lead into the jack. Probe jack is enabled by strapping of A6A1J6.
10	DISPLAY SELECT switch A6A1S1	Selects a dot display function for the modulation graphic indicator when set to the DOT position. Selects a successive LED illumination when set to the BAR position.
11	MOD CAL control A6A1R25	Adjust modulation digital display to be in agreement with the station modulation monitor or other standard. Adjustment is required following adjustment of predistortion or deviation controls.

TABLE 3-3. Rear Panel, A7

Index No.	Control or Indicator	Function
1	AC INPUT selector	Selects configuration of exciter to match input AC power (120, or 240 V ac) source. Remove and rotate printed circuit card until the appropriate voltage is visible through the protective window.
2	FUSE AC power	Select 3 ampere or 1.5 ampere slow-blow fuse to be compatible with 120 or 240 V ac power source respectively.

TABLE 3-4. Rear Panel Circuit Card Assembly, A7A1

Index No.	Control or Indicator	Function
1	COMPOSITE switch A7A1S1	Selects balanced (BAL) or unbalanced (UNBAL) input circuit for the composite input signal. Normal switch setting is BAL.
2	SCA 3 LEVEL control A7A1R5	Adjusts the target subcarrier injection level, typically 10%. After initial adjustment of the SCA 3 level, further trimming of the subcarrier level can be done at the subcarrier source.
3	SCA 2 LEVEL control A7A1R3	Adjusts the target subcarrier injection level, typically 10%. After initial adjustment of the SCA 2 level, further trimming of the subcarrier level can be done at the subcarrier source.
4	SCA 1 LEVEL control A7A1R1	Adjusts the target subcarrier injection level, typically 10%. After initial adjustment of the SCA 1 level, further trimming of the subcarrier level can be done at the subcarrier source.

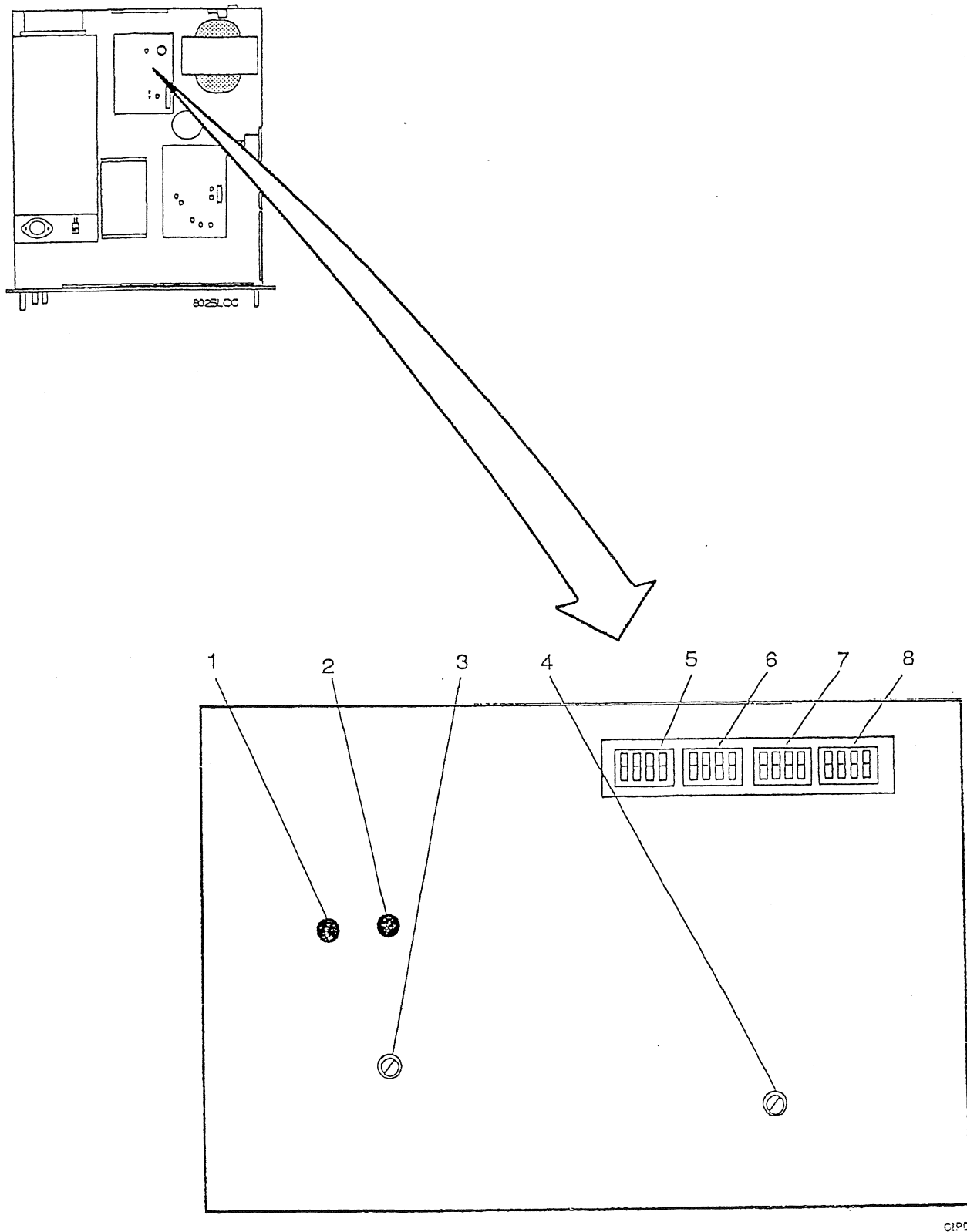

Figure 3-5 Frequency Divider, A2.

TABLE 3-5. Frequency Divider, A2

Index No.	Control or Indicator	Function
1	REF OSC indicator A2DS2	Indicator will illuminate green when the reference oscillator and its divider circuits are functioning normal. It will go out if the circuits fail.
2	MOD OSC indicator A2DS1	Indicator will illuminate green when the modulated oscillator and its divider circuits are functioning normal. It will go out if the circuits fail.
3	REF FREQ ADJ control A2Y1	Adjust the control while monitoring the REF FREQ CAL test point A2TP1 for the desired output frequency. Refer to Paragraph 4-7.2 for reference oscillator samples.
4	REF FREQ CAL test point	Provides test point for monitoring oscillator frequency while adjusting the reference frequency.

FREQUENCY SELECTION SWITCHES

5	10 MHZ switch A2S4	Four pole DIP switch for selection of hundreds digit of the exciter frequency. Refer to Table 3-9 for the binary weight of each pole of the switch and example of frequency selection.
6	1 MHZ switch A2S3	Four pole DIP switch for selection of units and tens digit of the exciter frequency. Refer to Table 3-9 for the binary weight of each pole of the switch and example of frequency selection.
7	100 KHZ switch A2S2	Four pole DIP switch for selection of tenths digit of the exciter frequency. Refer to Table 3-9 for the binary weight of each pole of the switch and example of frequency selection.
8	10 KHZ switch A2S1	Four pole DIP switch for selection of hundredths digit of the exciter frequency. Refer to Table 3-9 for the binary weight of each pole of the switch and example of frequency selection.

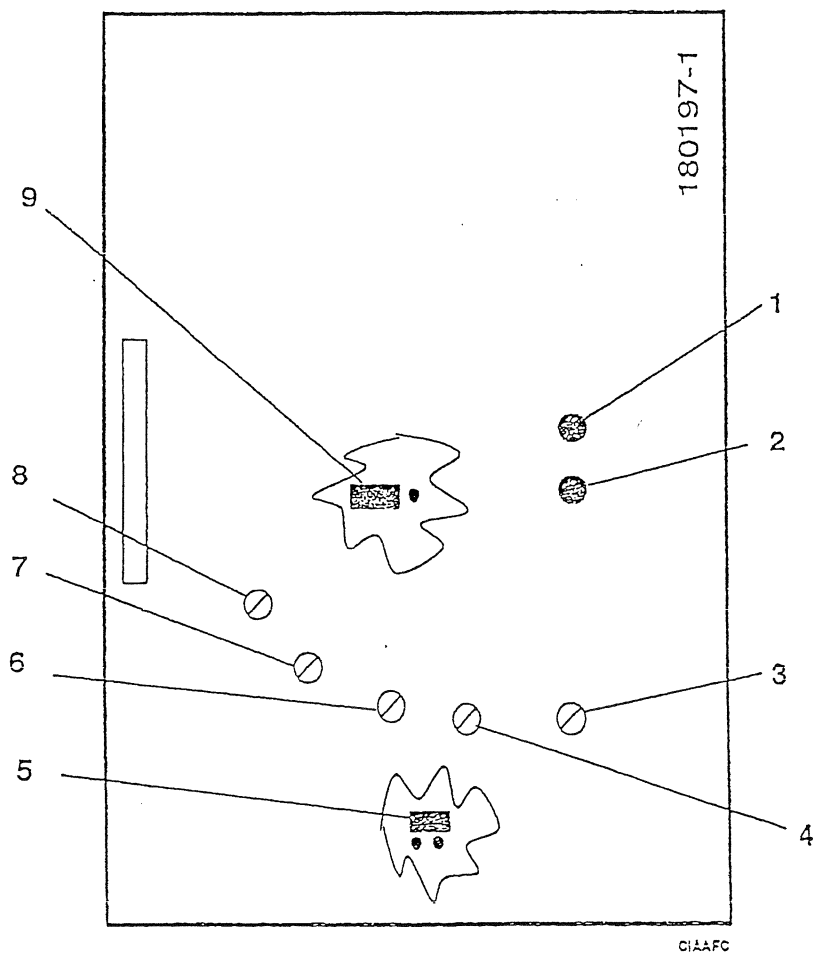
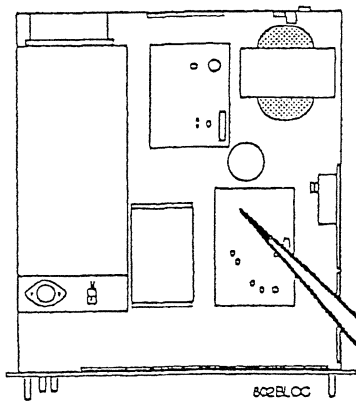

Figure 3-6 Audio/AFC, A3.

TABLE 3-6. Audio/AFC, A3

Index No.	Control or Indicator	Function
1	+15V indicator A3DS1	Indicates the +15 V dc is normal, the indicator will extinguish when the voltage drops below approximately +12 volts.
2	-15V indicator A3DS2	Indicates the -15 V dc is normal, the indicator will extinguish when the voltage drops below approximately -12 volts.
3	MOD CMR control A3R10	Adjusts the monaural input common-mode rejection. Refer to Paragraph 5-3.2.1 for alignment procedures.
4	STEREO CMR control A3R35	Adjusts the composite (stereo) input common-mode rejection. Refer to Paragraph 5-3.2.2 for alignment procedures.
5	Pre-emphasis jumper A3E1	Selects the pre-emphasis time constant of the monaural input to the exciter. Refer to Paragraph 4-7.3.1 for selection options.
6	PREDISTORT INPUT control A3R38	Compensates for component tolerances between modulating signal input and the SUM signal test point A3E7. Refer to Paragraph 5-3.2.3 for alignment procedure.
7	PREDISTORTION control A3R52	Cancels the small distortion generated by the inherent nonlinearity of the modulating diodes. Refer to Paragraph 5-3.2.4 for alignment procedure.
8	DEVIATION control A3R51	Adjusts the exciter deviation when the various signal levels are correct in the exciter. Refer to Paragraph 5-3.2.5 for calibration instructions.
9	Predistortion Polarity jumper A3E2	Internal pins used to select NORMAL or INVERTED polarity of the distortion component used to cancel the modulating diode nonlinearity. Refer to Paragraph 4-7.3.1 for selection instruction.

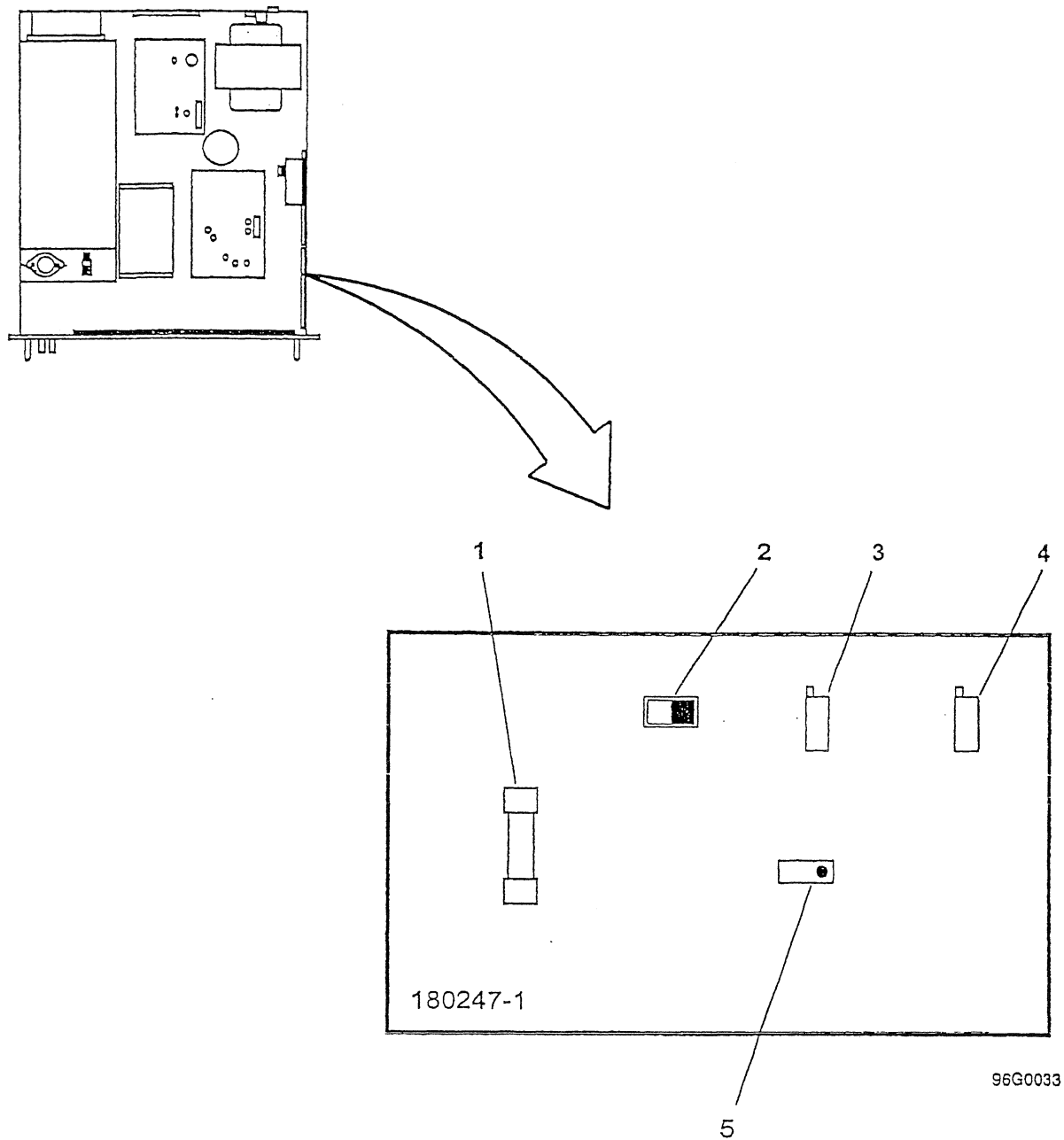

Figure 3-7 Amplifier Control Circuit Card Assembly, A5.

TABLE 3-7. Amplifier Control Circuit Card Assembly, A5

Index No.	Control or Indicator	Function
1	Fuse protection A5F1	Provides 5 ampere protection in the unregulated input line.
2	AGC switch A5S1	Selects automatic gain control to ON or OFF mode. Normally the AGC switch will remain in the OFF mode.
3	Forward Power control A5R5	Adjusts the FORWARD PWR reading on the front panel DMM to agree with an external power meter reading. Refer to Paragraph 5-3.6.1 for calibration procedure.
4	Reverse Power control A5R13	Adjusts the REVERSE PWR reading on the front panel DMM to agree with an external power meter reading. Refer to Paragraph 5-3.6.2 for calibration procedure.
5	PA Current control A5R40	Adjusts the PA CURRENT reading on the front panel DMM to agree with an external DVM reading. Refer to Paragraph 5-3.6.3 for calibration procedure.

(Continued From Page 3-1)

3-3.3 Change Operating Frequency.

Channel frequency selection is accomplished by setting a series of switches on the frequency divider. Refer to, Figure 3-5, Frequency Divider for location of divider switches and Paragraph 4-7.2 Frequency Divider Assembly. These switches are arranged to form a BCD code. Each of the four digits used is selected by the setting of the individual switches in that switch bank.

As an example, Figure 3-8 shows the relationship between the switch labels and binary values to achieve the switch settings for 103.7 MHz are:

TABLE 3-8. DIVIDER SWITCH EXAMPLE

Switch:	(S4)	(S3)	(S2)	(S1)
	10 MHz	1 MHz	100kHz	10kHz
Label:	4 3 2 1	4 3 2 1	4 3 2 1	4 3 2 1
Values:	8 4 2 1	8 4 2 1	8 4 2 1	8 4 2 1
Settings:	1 0 1 0	0 0 1 1	0 1 1 1	0 0 0 0
Sum:	10	3	7	0
Frequency:	100 MHz	3 MHz	700 kHz	00 kHz

"Label" is how the switch is numbered.
 "Values" is the binary value that a given switch element will set. "Settings" is how a switch will be set for our example; a switch to "1" selects that binary digit.

To select a binary digit, set that rocker so that its outside end is down. Use a pencil or ballpoint pen or similar item.

In our example, the 8 and the 2 digits in the 10 MHz switches are set to "1"; this gives a total value of 10. Multiplying this by 10 MHz gives us a frequency of 100 MHz.

The 2 and the 1 digits in the 1 MHz switch are set to "1"; this gives us a total of 3. Multiplying this by 1 MHz gives us a frequency of 3 MHz.

The 4, 2, and 1 digits in the 100 kHz switch are set to "1"; this gives us a total of 7. Multiplying this by 100 kHz gives us a frequency of 700 kHz.

Finally, no digits in the 10 kHz switch are set to "1"; this gives us a total of 0. Multiplying this by 10 kHz gives us a frequency of 00 kHz.

The 802B carrier frequency in this example will be the sum of the frequencies shown: 100 MHz + 3 MHz + 700 kHz + 00 kHz = 103.7 MHz.

NOTE

Exciters operating at or above 100 MHz will require varactor diodes CR3 and CR5 be removed from their normal sockets and stored in the adjacent STORAGE sockets.

When the exciter is operated below 100 MHz, install CR3 and CR5 in the sockets as shown on Figure 7-2, Modulated Oscillator Schematic. After installation of the diodes, proceed to Paragraph 5-3 and perform the exciter alignments.

3-4 OPERATIONAL PARAMETERS.

The following paragraphs contain tables of data identifying common voltage and current reading associated with the 802B Exciter. The readings may be observed on the front panel DMM. Refer to Figure 3-1 and Table 3-1 for control and indicator function and location.

3-4.1 RF Amplifier.

Table 3-9 shows typical RF Amplifier voltage and current values for common power levels.

TABLE 3-9. RF Amplifier Current and Voltage

Freq.	Pwr Out	PA Voltage	PA Current
98.1 MHz	5	8.0	.85
	10	10.9	1.32
	15	13.2	1.67
	20	15.3	1.95
	25	17.2	2.18
	30	19.0	2.38
	35	20.8	2.58
	40	22.6	2.75
	45	24.5	2.91
	50	26.6	3.06

3-4.2 AFC Voltage.

Table 3-10 shows the typical AFC voltage versus frequency as applied to the AFC port on the modulated oscillator.

TABLE 3-10. AFC Voltage vs. Frequencies

Fo MHz	AFC VOLTAGE
88	4.7
90	5.05
92	5.4
94	5.9
96	6.3
98	6.75
100	7.2
102	7.75
104	8.3
106	8.9
108	9.6

(This Page Intentionally Left Blank)

SECTION 4 - THEORY OF OPERATION

4-1 INTRODUCTION.

This section contains a description of the 802B FM Exciter by functional area. Also contained in this section is the detailed theory of operation for each major assembly of the exciter. Refer to Figure 4-1 for the location of major assemblies.

4-2 AFC CIRCUITS.

The Automatic Frequency Control circuits are comprised of the Modulated Oscillator Assembly (A1), Frequency Divider Assembly (A2) and the AFC loop filter portion of the Audio/AFC Assembly (A3). Refer to Figure 4-4 AFC Circuits Simplified Schematic.

4-2.1 Modulated Oscillator (A1).

The Modulated Oscillator assembly (A1) is designed around a field effect transistor oscillator. Varactor diodes are used for frequency control and for modulation. The modulated oscillator board has two outputs. One is used to drive the RF Power Amplifier and the other drives the Frequency Divider.

4-2.2 Frequency Divider.

The Frequency Divider assembly (A2) contains the high-stability 10 Mhz reference oscillator and two frequency divider chains. One chain divides the reference oscillator frequency down to 62.5 KHz. The second chain divides the modulated oscillator sample down to 625 Hz. The second chain is programmable. It can be set to the appropriate division ratio to accommodate a given carrier frequency. Programming is done with DIP switches.

4-2.3 Audio/AFC.

The 62.5 KHz signal is routed to the Audio/AFC module (A3) for further division down to 625 Hz. In the phase comparator of the Audio/AFC module the 625 Hz signal from the Modulated Oscillator is phase- compared with the 625 Hz signal from the Reference Oscillator. The output from the phase comparison IC is routed to an integrator and loop filter. The resulting DC signal is used to drive the AFC port on the Modulated Oscillator assembly.

If the phase comparison process fails then lock is lost. This will cause the front panel AFC light to go out, the rear panel AFC status line is pulled low, RF output from the exciter is muted, and the AFC system goes into a wideband re-capture mode.

4-3 AUDIO CIRCUITS.

Audio Circuits includes the modulation-input circuits on the rear panel card and the audio portion of the Audio/AFC assembly. Refer to Figure 4-5 Audio Circuits Simplified Schematic.

4-3.1 Rear Panel.

All modulating input signals first pass through RFI filters on the exciter rear panel Circuit Board (A7A1) and are then routed to the Audio/AFC Assembly (A3).

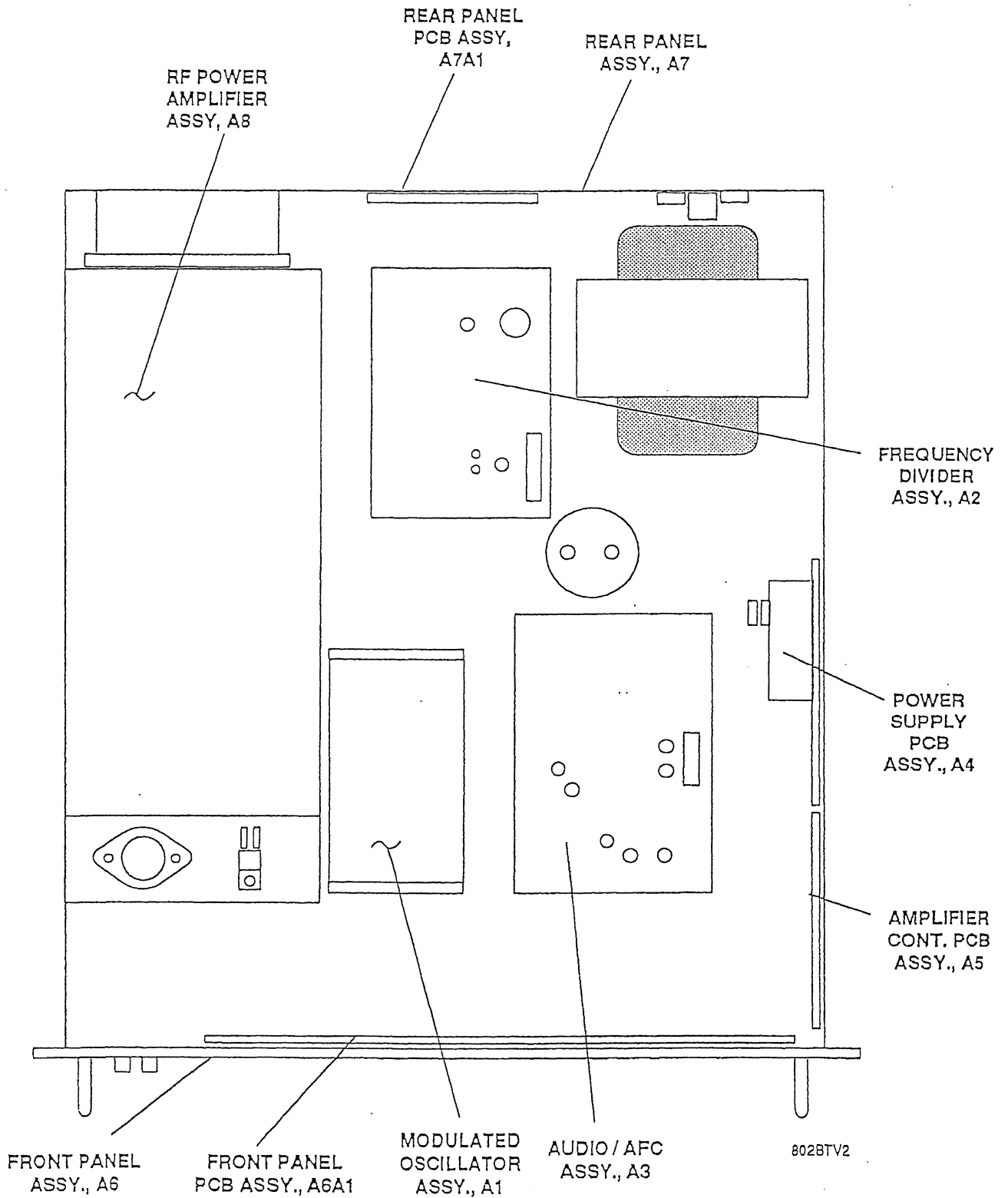

Figure 4-1 Type 802B FM Exciter Assembly Locator.

4-3.2 Audio/AFC.

On the Audio/AFC assembly (A3) the monaural input signal is applied to a differential amplifier for common-mode rejection. This amplifier is followed by a pre-emphasis network. The composite (stereo) input signal is applied to another differential amplifier, also for common-mode rejection. The SCA subcarriers are summed using yet another op-amp. The monaural signal, the composite signal and the SCA signal(s) are all summed in a final op-amp.

This sum is routed via a buffer to the modulation monitoring circuitry and to the front panel. It is also routed to another summer and to a predistortion circuit. A summer sums the intended modulation and the predistortion component and provides drive to the modulated oscillator. The predistortion component is added to the normal modulation signal to cancel out the small modulation nonlinearities of the varactor diodes in the modulated oscillator.

4-4 POWER AMPLIFIER.

The Power Amplifier (A8) amplifies the signal from the Modulated Oscillator to the 50 watt output level. A harmonic filter follows the Power Amplifier. The Amplifier Control Assembly (A5) provides output power adjustment and protective features controlling the amplifier collector voltage. Refer to Amplifier Schematic diagram 180497 in Section 7.

4-4.1 RF Amplifier.

The Power Amplifier (A8) is a solid state amplifier which operates broadband over the 87 to 109 Mhz frequency range with

no tuning. The amplifier PC board is mounted on a large heat sink.

4-4.2 Amplifier Control.

The Amplifier Control Assembly (A5) contains the regulator circuitry which controls the amplifier collector voltage. A sample of the collector supply voltage is applied to an input on the regulator. The regulator compares this voltage with the reference voltage derived from the front-panel POWER SET control. The regulator adjusts the output voltage so that the feedback signal (the amplifier collector voltage) agrees with the reference voltage.

The directional coupler reflected power signal is amplified and used to protect the amplifier from damage when operating into a high VSWR. The reflected signal is coupled into the regulator and acts to reduce power output to a safe level. At approximately a 2:1 VSWR the front panel VSWR indicator will come on. Under open or short circuit conditions, power output is limited to approximately 8 watts.

Over-voltage protection for the RF Amplifier is provided by a crowbar circuit. If the collector voltage to the amplifier exceeds a threshold voltage the crowbar will fire, shorting the collector voltage feed to ground and blowing fuse A5F1. Over-current protection for the amplifier is provided by foldback current limiting in the regulator.

4-5 METERING AND STATUS.

The digital multimeter on the front panel of the 802B may be switched to read various essential items. Refer to Figure 4-6 Digital Voltmeter and Selection Circuit Simplified Schematic.

4-5.1 Metering Circuits.

The exciter defaults at power-on to read forward power. By pressing the METER SELECT button the digital meter will display reflected power, the supply voltage to the RF Amplifier, the current to the RF Amplifier, the AFC voltage or modulation.

A full-wave peak-responding rectifier is used by the digital multimeter to measure modulation and drive the bar graph modulation display. The bar graph display may be switched to display in a dot or a bar mode. In addition, a peak-hold function may be selected.

4-5.2 Monitoring Circuits.

In addition to the measuring circuits described in Paragraph 4-5.1, the 802B Exciter uses an extensive series of GO/NO-GO type status indicators. Front-panel LED indicators are used to monitor the AFC system status, the ± 22 volt and +5 volt supplies, over-temperature (sensed by a thermostat [A8S1] on the RF Amplifier heat sink), muting (regardless of the command source) and excessive VSWR.

Internal LED indicators are on the Audio/AFC module to indicate the condition of the ± 15 volt supplies. Also two indicators are used on the Frequency Divider module to indicate activity of the divider chains.

Status LED indicators are also used to indicate the function being displayed by the digital multimeter.

4-6 POWER SUPPLIES.

The AC input power is applied through the input connector to the power transformer (T1). The input AC power assembly contains a printed circuit card which allows selection of various mains voltages. The AC power assembly also houses the fuseblock and a power line filter. Refer to Figure 4-7 Power Supply Circuits Simplified Schematic.

The cooling fan (A7B1) is operated directly

from a 120 volt winding on the primary of the power transformer. When the exciter is operated at 240 V ac, the fan receives 120 V ac because of the autotransformer action of the power transformer (T1).

4-6.1 +32 Volt Supply.

The grey leads on T1 (approximately 30 V ac) are applied to rectifier CR1 to obtain a nominal +35 volts. The +35 V dc is routed directly to the Amplifier Control Assembly (A5). The +35 V dc is dropped by resistors and then applied as a +32 volt source to the Power Supply assembly (A4).

4-6.2 +22 Volt Supply.

The +32 V dc from Paragraph 4-6.1 is passed through regulator U2 to obtain a +22 V dc output. The +22 V dc is used to supply the first stage of the amplifier and other applications in the exciter where a very low noise voltage is not essential.

4-6.3 -22 Volt Supply.

The red leads on T1 (approximately 24 V ac) are applied to rectifier CR2 to obtain a nominal -35 volts. The -35 V dc is routed to the Power Supply Assembly (A4). The -35 V dc is regulated by U1 to -22 volts.

4-6.4 +15 Volt Supply.

The pre-regulated +22 V dc from Paragraph 4-6.2 is further regulated to +15 V dc in the modulated oscillator.

4-6.5 ± 15 Volt Supplies.

The pre-regulated ± 22 V dc is also regulated to ± 15 volts on the Audio/AFC Assembly (A3) by regulators U10 and U11.

4-6.6 +5 Volt Supply.

The orange leads on T1 (approximately 8 V ac) are routed directly to the Power Supply assembly (A4). The 8 V ac is rectified by A4CR5 to produce a nominal +10.5 V dc, which is regulated down to +5 V dc.

4-7 DETAILED CIRCUIT DESCRIPTIONS.

This section provides detailed circuit description on a module-by-module basis. Simplified schematics are provided where appropriate. A complete set of schematic diagrams may be found in Section 7.

4-7.1 Modulated Oscillator Assembly (A1).

The Modulated Oscillator assembly is comprised of the Modulated Oscillator Board (A1A1) and associated RFI filtering components and connectors. Refer to schematic 180240.

Supply voltage for the modulated oscillator is derived from the +22V supply by voltage regulator VR1. Resistors R1 and R11 determine the output voltage of VR1 (+15V). CR1 and CR2 protect the regulator from transients caused by shorting the power supply input voltage. Resistors R2 and R3, with C2, drive buffer U1 to supply an extremely low noise voltage source for the oscillator itself.

The oscillator uses FETs Q4 and Q5. The frequency is determined primarily by inductor L6 operating in conjunction with the varactor diodes CR3, CR4, CR5, and CR6.

The voltage applied to the AFC port is a steady DC voltage ranging from approximately 3 to 12 V dc, depending on the center frequency. The voltage applied to the modulation port is a signal working against ground (0 V dc with no modulation).

The output of the oscillator is coupled through C12 to source follower Q1. Source follower Q1 in turn drives emitter follower Q2 through C13. Emitter follower Q2 drives amplifier Q3 through C14. Amplifier Q3 is a conventional common emitter, Class A amplifier. Capacitor

C21, inductor L8 and capacitor C22 provide harmonic rejection and impedance matching. The modulated oscillator has two outputs, which drive the power amplifier (A8) and the frequency divider (A2) AFC circuits.

The oscillator board is housed in a damped, rigid box, weighted and shock mounted to minimize susceptibility to vibration.

4-7.2 Frequency Divider Assembly (A2).

Refer to schematic 643-0004-001. The carrier frequency from the modulated oscillator (A1) is applied to ECL prescaler U1. Circuit U1 divides the carrier frequency by eight. Circuit U1 contains an ECL to TTL translator and the translator output is used to drive a D-Type flip-flop U2, half of which is used to further divide the carrier frequency by two. Resistor R1 provides a termination for the carrier signal input, R2 and C2 are required for U1 operation, and R3 ensures U1 stability. Circuits U3-U7 comprise the BCD program-mable counter (divide by 8700 to 10900) as previously described. Frequency is programmed by the DIP switches S1 through S4. Integrated circuit resistor networks R11 and R12 act as pull-up resistors. Refer to Figure 4-2 Frequency Selection.

One shot U8 stretches the pulse from the programmable counter. Resistor R4 and capacitor C6 determine the output pulse width of U8.

A 10 MHz crystal oscillator (Y1) is the reference oscillator for the AFC circuits. The AFC circuits phase lock the carrier frequency to the reference oscillator. The 10 MHz TTL output of Y1 is divided by 16 at circuit U9 and further divided by 10 at circuit U10. The divide by 2 and the divide by 4 frequency outputs of U9 are applied to J3 along with the 10 MHz signal. Jumper P1 may be used to select 2.5 MHz, 5 MHz or 10 MHz for

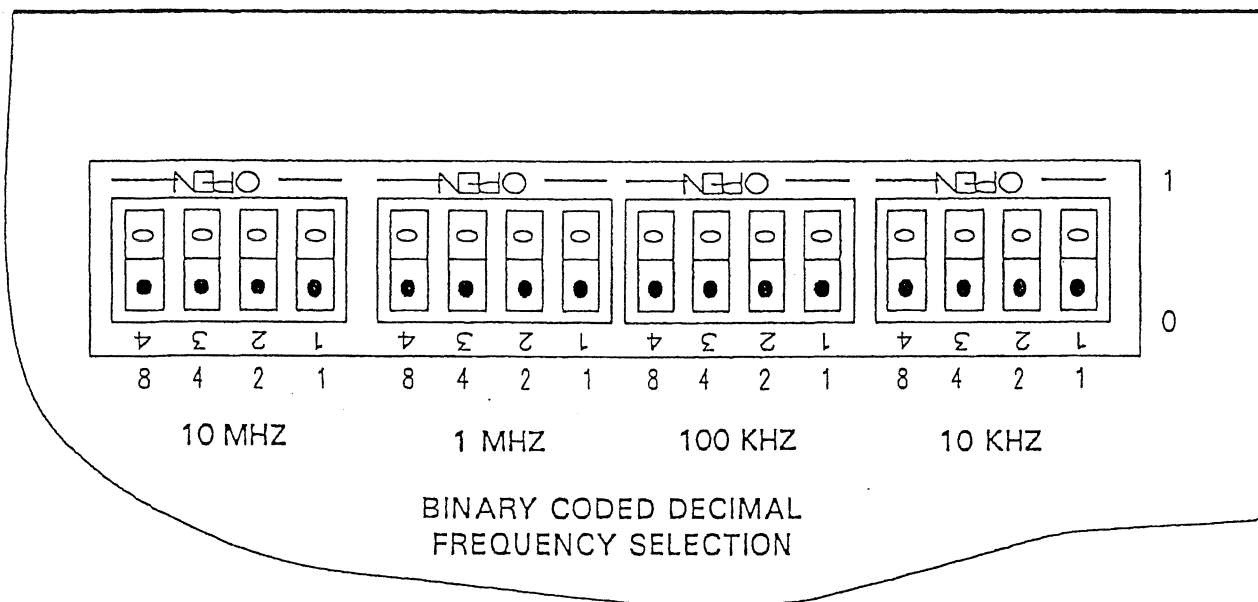
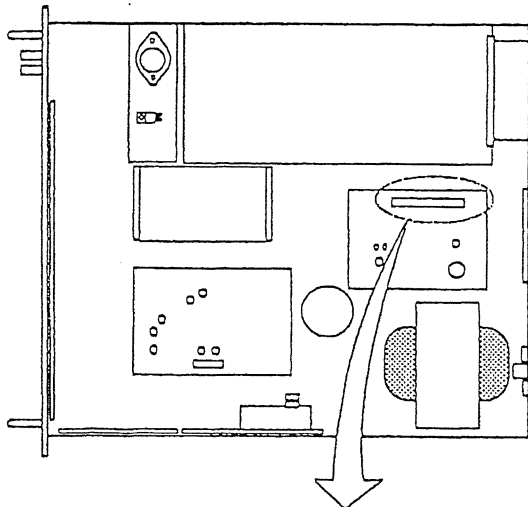

10 MHz	1 MHz	100 KHz	10 KHz
8 = 1000	0 = 0000	0 = 0000	0 = 0000
9 = 1001	1 = 0001	1 = 0001	1 = 0001
10 = 1010	2 = 0010	2 = 0010	2 = 0010
	3 = 0011	3 = 0011	3 = 0011
	4 = 0100	4 = 0100	4 = 0100
	5 = 0101	5 = 0101	5 = 0101
	6 = 0110	6 = 0110	6 = 0110
	7 = 0111	7 = 0111	7 = 0111
	8 = 1000	8 = 1000	8 = 1000
	9 = 1001	9 = 1001	9 = 1001

THE SWITCH SETTINGS FOR 103.7 MHz WOULD BE:

802B FREQ

1010 0011 0111 0000

Figure 4-2. Frequency Selection

4-7.2 Frequency Divider Assembly (A2). - Cont'd

application to TP1 for use during frequency calibration. Refer to Schematic 643-0004-001.

The Frequency Divider (A2) operates from the +5 V dc supply which is RFI filtered by C13, C14, C15 and L1. Further decoupling of the digital circuits from the power supply is provided by 0.1 μ F capacitors placed close to the chip V_{cc} pins (C4, C5, C9, C10, etc.).

The modulated oscillator and reference oscillator and their respective divider chains are monitored for activity by identical circuits which drive LED indicators. The indicators are illuminated when activity is detected. Each activity monitor is coupled by a series resistor/capacitor network (R5, C7) to a diode detector (CR1) which drives an emitter follower stage (Q1). The emitter follower stage then drives the LED driver (Q2). Should either oscillator or counter chain fail, the activity monitor LED will extinguish and the AFC, front panel, LED will also extinguish.

4-7.3 Audio/AFC Assembly (A3).

The Audio/AFC assembly consists of the audio circuits, AFC phase comparator, loop filter, and lock detector. Refer to schematic 180199.

4-7.3.1 Audio Circuits.

The monaural audio input is applied to differential amplifier U4 pins 9 and 10. Common-mode balance is adjusted by R10. The output of this stage is applied to the pre-emphasis network using R11, R12, C17 and C18. The output of the pre-emphasis network, as selected by E1, is applied to the summer circuit (U4). Refer to Figure 4-3 Pre-Emphasis Selection.

The composite signal input is applied to differential amplifier U4 pins 2 and 3. Common-mode balance is adjusted by R35. The output of this stage is applied to the summer circuit (U4).

The SCA subcarrier signals are applied to differential amplifier U4 pins 13 and 12. The output of this stage is applied to the summer circuit (U4).

Summer U4 (pins 6, 5 and 7) has a small amount of gain adjusted by R38 to accommodate manufacturing tolerances. The output of this stage is a target 6.4 volts peak-to-peak for 100% modulation.

The summer (U4) drives the modulation measuring circuitry through buffer U9 and resistor R56. The front panel composite signal, TEST OUT, sample is taken through resistor R57.

The summer circuit U4 also drives the pre-distortion generator using Q3 and the signal/pre-distortion summer U9. The modulating signal is applied to divider R54 and R52. A pre-distortion adjusted portion of the signal is applied to transistor Q3. The pre-distortion circuit generates a signal whose shape approximates that of the modulated oscillator modulation nonlinearity. Since the required polarity of nonlinearity correction signal can change, an option using jumpers at E2 is provided to select the correct polarity for a given carrier frequency. The distortion component selected by E2 is then applied to the pre-distortion summer U9. The modulating signal and the distortion-correction signal are summed in U9 and applied to the modulated oscillator. Since the amount of signal required for full modulation can change depending on several factors, the deviation can be set correctly by adjusting R51.

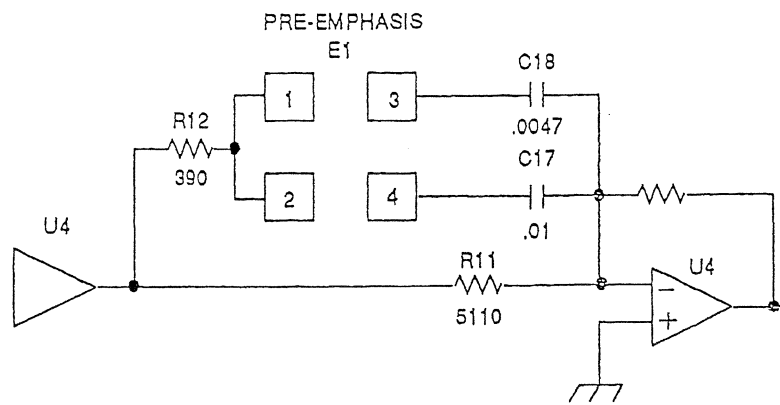

PARTIAL SCHEMATIC, AUDIO AFC

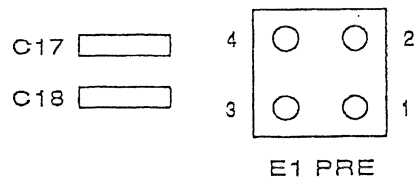

Partial Component Layout, Audio AFC

- REMOVE JUMPERS FOR FLAT (NO PRE-EMPHASIS) OPERATION
- JUMPER 1 TO 3 FOR 25 MICROSECOND OPERATION
- JUMPER 2 TO 4 FOR 50 MICROSECOND OPERATION
- JUMPER 1 TO 3 AND 2 TO 4 FOR 75 MICROSECOND OPERATION

SC690016.AL

Figure 4-3. Pre-Emphasis Selection

4-7.3.2 AFC Circuits.

The 62.5 KHz reference signal from the Frequency Divider (A2) is applied to U7 where it is divided by 100 down to 625 Hz. The phase comparator portion of U7 then compares this standard signal against the 625 Hz signal from the modulated oscillator divider chain. The output of U7 (pin 13) will be HIGH if the carrier frequency is higher than the reference frequency and LOW if the carrier frequency is lower than the reference. If the carrier and reference frequency are the same, but different in phase, the output of U7 will be HIGH for the time equal to the phase difference if the carrier leads the reference and LOW for the time equal to the phase difference if the carrier lags the reference frequency phase. When the carrier and reference frequency are the same frequency and in phase, the output of U7 will be approximately 2.5 V dc. The output of the phase comparator is applied to the AFC loop active filter comprised of integrator U5A and lowpass filter U5B. A high degree of filtering is necessary to remove the 625 Hz comparison frequency from the filter output. The loop filter output is then a DC voltage which will vary between about 3 and 12 volts depending on the center frequency.

The AFC lock detection function is accomplished by flip-flop U8. An output from phase comparator U7 (pin 12) and the 625 Hz signal are compared in U8. The output from U8 pin 6 is HIGH if the carrier and reference frequency are in phase. If the carrier and reference frequency are not in phase, the output from U8 will go LOW for a length of time equal to the phase difference. Since the inverted 625 Hz is applied to the lock detector U8, when the time that the U1 output is low exceeds 90 degrees the output of U8 at pin 6 will go HIGH. The HIGH signal is applied through the fast charge/slow discharge circuit formed by CR6, R47, R46 and C23 to lock driver U6 output LOW. The output of U6 is used to mute the Power Amplifier (A8) output through diode

CR7. The output of U6 drives the front panel AFC LED through Q1 and Q2. The output of U6 is also used to drive optically coupled variable resistors U1, U2 and U3. The variable resistors decrease in value when loss of lock is detected to speed up the loop filter response and decrease the amount of time required to achieve lock.

To ensure low noise power supplies for the operational amplifiers used in the audio and AFC circuits, the preregulated ± 22 V dc voltages are conditioned by regulators VR1 and VR2 to obtain ± 15 V dc. The ± 15 V dc supplies are also routed to the modulation display assembly. The ± 15 V dc supplies are monitored by LEDs DS1 and DS2, operating with R1 and VR3 and R2 and VR4 respectively. Indicator DS1 will extinguish should the +15V fail, and DS2 will extinguish should the -15V fail.

4-7.4 RF Amplifier Assembly (A8).

The RF Amplifier consists of the amplifier PC board, and integrated heat-sink. The amplifier is comprised of three solid state stages which provide approximately 37 dB of gain. Regulated DC voltage for the final stage is provided by a dedicated voltage regulator, Q1, mounted on the integral heat sink but external to the RF amplifier enclosure. Overtemperature protection (over dissipation) for the regulator is provided by a temperature switch, S1, mounted to the integral heat sink and adjacent to the regulator. The amplifier also contains an RFI filter which attenuates the spurious and harmonic components to meet the FCC requirement of -60 dB allowing it to be connected directly to a stations antenna if desired.

4-7.5 Amplifier Control Assembly (A5).

The amplifier control assembly primary function is to regulate and control the collector voltage (V_{cc}) applied to the final two stages of the power amplifier (A8). Refer to Schematic 180246. Unregulated supply voltage is routed through fuse F1 and then applied to the collector of the series pass regulator transistor Q1 (mounted on the RF Amplifier heat sink).

A sample of the collector supply voltage is applied to regulator U2's inverting input pin 4. The regulator compares this voltage with the reference voltage derived from the front panel POWER SET control which appears at the non-inverting input, pin 5. Regulator U2 conditions the output voltage so that the feedback signal (the amplifier collector voltage) agrees with the reference voltage.

The output of U2, pin 10, is applied to the base of the series pass transistor Q1. The output of the series pass transistor Q1 is routed through current limiting and monitoring resistors R30 and R31 and applied to the amplifier. The voltage developed across R30 and R31 is sensed and applied to the current sense (pin 3) and limit (pin 2) inputs of U2 regulator by resistors R26, R27, and R28. Resistor R23 provides a bias voltage to ensure fast foldback current limiting in the event of a short circuit. Operational amplifier U3B is connected to differentially amplify the voltage drop across R30 and R31. The output of U3B is a voltage representing the PA current.

Potentiometer R40 is used to adjust the output voltage of U3B to twice the voltage across the precision resistors R30 and R31. If the current to the amplifier is 4 amperes, the voltage across R30 and R31 will be 0.4 V dc and the output of U3B will be 0.8 V dc. The output voltage of U3B is routed to the front panel PA CURRENT metering system.

VSWR protection is provided by U1B which amplifies the reflected power sample from the amplifier (A8). The U1B output (pin 7) is routed through CR1 and summed with the forward power sample by R6, R7 and R8 and acts to reduce power output as VSWR increases. Amplifier (A8) is protected from excessive VSWR conditions by controlling the collector voltage.

The output of U1A (pin 1) forward power analog is routed through R14 to the front panel FORWARD PWR metering system. The reflected power signal is routed in a similar manner through U1B and is also applied to VSWR detector U3A (pin 3). When the reflected power signal at the non-inverting input to U3A exceeds the bias voltage at the inverting input (pin 2) established by R16 and R17, the output of U3A will go HIGH and cause the front panel VSWR indicator to illuminate and actuate the remote fault indication relay.

Silicon controlled rectifier (SCR) Q1 provides overvoltage crowbar protection. Zener diode VR2 monitors the regulated voltage from the series pass transistor Q1 and will trigger SCR Q1 should the collector voltage exceed 36 V dc. Resistor R34 provides current limiting for the crowbar circuit. Fuse F1 will open in the event the crowbar triggers.

The output of U2 (pin 10) is applied to the base of the series pass transistor Q1 via current limiting resistor R24. Zener diode VR1 clamps the output of the regulator to prohibit application of excessive voltage to the RF Amplifier.

4-7.6 Front Panel Assembly (A6).

The Front Panel assembly contains three groups of controls and indicators. Refer to Schematic diagram 180203 and simplified diagrams as identified. The groups are multimeter, status, and modulation.

4-7.6.1 Multimeter Group.

The multimeter group of the Front Panel CCA (A6A1) circuitry is devoted to the digital multimeter. The multimeter circuit centers around U2. Refer to Schematic 180203 sheet 3 and Figure 4-6 Digital Voltmeter and Selection Circuitry Simplified Schematic.

The voltmeter actually compares the voltage to be measured against a reference voltage. It is in fact a ratio meter. By setting the reference voltage to one volt, the meter becomes a voltmeter with its display indicating volts. The standard voltage is derived from high-stability source VR6. The adjustment R14 (DVM CAL) is set for a precise voltage of 1.000 volts at TP2. The remaining circuits around the digital multimeter (U2) are for input selection and display. In addition a Watts-to-volts conversion is made by the circuitry associated with U18.

The meter input selection is made by a series of IC switches, which are driven by a binary counter and decoder. The counter is triggered by pressing the button labelled METER SELECT. When this button is pressed, a pulse is generated by monostable U16. This pulse is used to toggle the binary count of U12. Three of the four bits from U12 are decoded by U13. One output of U13 at a time is LOW; the remaining outputs are HIGH. The outputs of U13 are buffered and inverted by the six sections of U14. One output of U14 at a time is HIGH.

When FORWARD PWR is selected, the output of U14 pin 2 is HIGH, and the forward power voltage sample is applied by switch U9 pins 6 and 7 to the conversion circuit using U18. The output of the conversion circuit is routed to the digital multimeter by U19 pins 3 and 2. Driver U15 pin 1 is HIGH, pulling down U15 pin 16. The WATTS indicator CR16 is illuminated through CR30. The FORWARD PWR lamp CR4 is illuminated and the correct decimal point is selected by CR3.

When REFLECTED PWR is selected, the output of U14 pin 4 is HIGH, and the reflected power voltage sample is applied through switch U9 pins 11 and 10 to the conversion circuit. The output of the conversion circuit is routed to the digital multimeter by U19 pins 3 and 2. Driver U15 pin 2 is HIGH, pulling down U15 pin 15. The WATTS indicator CR16 is illuminated through CR31. The REFLECTED PWR lamp CR4 is illuminated and the correct decimal point is selected by CR8.

When PA VOLTAGE is selected, the output of U14 pin 6 is HIGH, and the RF Amplifier collector voltage sample is applied via switch U19 pins 14 and 15 directly to the digital multimeter. Driver U15 pin 3 is HIGH, pulling down U15 pin 14. The VOLTS indicator CR15 is illuminated through CR32. The PA VOLTAGE lamp CR12 is illuminated and the correct decimal point is selected by CR9.

When PA CURRENT is selected, the output of U14 pin 8 is HIGH, and the RF Amplifier collector current sample is applied through switch U19 pins 11 and 10 directly to the digital multimeter. Driver U15 pin 4 is HIGH, pulling down U15 pin 13. This allows the AMPS indicator to be illuminated. The PA CURRENT lamp CR36 is illuminated and the correct decimal point is selected by CR10.

4-7.6.1 Multimeter Group - Continued

When AFC VOLTAGE is selected, the output of U14 pin 10 is HIGH, and the AFC voltage sample is applied through switch U19 pins 6 and 7 directly to the digital multimeter. Driver U15 pin 5 is HIGH, pulling down U15 pin 12. The VOLTS indicator CR15 is illuminated through CR34. The AFC VOLTAGE lamp CR37 is illuminated and the correct decimal point is selected by CR33.

When MODULATION is selected, the output of U14 pin 12 is HIGH, and the modulation voltage sample is applied through switch U9 pins 14 and 15 directly to the digital multimeter. Driver U15 pin 6 is HIGH, pulling down U15 pin 11. The MODULATION indicator CR38 is illuminated. The % lamp CR13 is illuminated and the correct decimal point is selected by CR35.

4-7.6.2 Status Group

The status group of circuits on the front panel circuit board (A6A1) deal with the exciter normal status and fault indications. Refer to Schematic 180203 sheet 1 and Figure 4-8 Muting, Overtemperature and Power Control Simplified Schematic.

As discussed in Paragraph 4-7.5, RF power from the exciter is controlled by adjusting the collector voltage (V_c) to the final two stages in the RF Amplifier. The collector voltage is controlled by the Amplifier Control assembly (A5). The amplifier control assembly uses a reference voltage derived from the POWER ADJ control A6A1R1.

The +15 volt power supply voltage is divided down to a lower voltage by R28 and R27 and applied to amplifier U1 at pin 3. The output of U3 pin 1 is approximately +7.5 volts. The voltage is routed through R5 and R6 to buffer U1 pin 5. The output of the buffer is applied to

the POWER ADJ control R1. The wiper of R1 can be set to any voltage from zero up to +7.5 V dc. The reference voltage signal is routed to the Amplifier Control (A5) to be used to set the power output of the exciter.

To mute the exciter output, this reference voltage is dropped to zero by shorting the junction of R5 and R6 to ground with Q1. Transistor Q1 can be switched ON by an input from the MUTE switch S4 through R58 and CR24. Transistor Q1 may also be switched ON by an input (loss of AFC lock) from the Audio/AFC assembly through CR23.

If either of these signals go positive, Q1 conducts and removes the excitation to buffer U1. The reference voltage to R1 is then removed and the exciter output is muted. The exciter may be muted by applying a positive voltage to the rear panel (A7A1) muting input. This control method requires that a jumper be placed on J2 between pins 5 and 3. The positive voltage is then routed through CR1, R58 and CR24 to the base of Q1, removing the reference voltage out of U1 pin 7.

The exciter may also be muted by applying a closure to ground on the rear panel muting input. The ground signal muting requires that jumpers be placed on J2 between pins 2 and 4 and pins 1 and 3. When ground is applied, the anode of CR1 will be at ground when the rear panel muting input is grounded. The grounding will result in loss of excitation to Q1 and operation will be normal. When the rear panel muting input is ungrounded current will flow through CR1, R58, and CR24 into the base of Q1, causing muting.

For remote control of the exciter RF power output, apply a voltage signal to the rear panel power control input. Control is accomplished by routing that control voltage signal through R50 and CR22 to the inverting input of the amplifier U1. When the control voltage goes positive, it

causes the output of U1 to be less positive, causing a reduction in the reference voltage originating at U1 pin 1.

The status lamps are operated by U11 lamp drivers, one for each lamp. When VSWR is sensed as being excessive, the signal at J3 pin 9 is positive. This operates a pair of lamp drivers on U11 pins 6 and 7, one for the VSWR lamp and one to pull down the VSWR status terminal on the rear panel.

When over-temperature is sensed the signal at J3 pin 7 is positive. This operates a pair of lamp drivers on U11 pins 4 and 5, one for the TEMP lamp and one to pull down the TEMP status terminal on the rear panel. In addition, the LOW POWER SET pot is reduced to near zero at the low end.

The ground signal allows the LOW POWER SET pot R9 to become active. When overtemperature occurs, or simulated by shorting the thermal switch leads, the LOW POWER SET pot R9 can be set to reduce the RF power level by shunting the reference voltage drive to U1. The output of the LOW POWER SET pot is routed to buffer Q2 and disconnect diode CR5 to the line shunting the drive to U1 pin 5.

When AFC lock is lost, the AFC mute line from the Audio/AFC line (J3 pin 4) goes HIGH. The HIGH biases Q1 through CR23. The HIGH is also routed to U11 pin 3, which drives the rear-panel AFC status terminal through R55.

Power supply status indicators on the front panel are similar in design to those used elsewhere in the exciter. Ballast resistor R31,

Zener diode VR9 and indicator CR6 are all in series to indicate a satisfactory +22 volt line. Similarly, ballast resistor R32, Zener diode VR7 and indicator CR6 are all in series to indicate a satisfactory -22 volt line. The +5 volt line is simply monitored by ballast R61 and indicator CR25.

4-7.6.3 Modulation Group.

The next paragraphs cover the modulation measurement circuits in the 802B. Refer to Schematic 180203 sheet 2. Also refer to Figure 4-9 Modulation Measurement Simplified Schematic.

A sample of the modulating signal is applied to the Front Panel Assembly (A6A1) at J5 pin 6 and routed to the MOD CAL control R25. Amplifier U20 provides a small amount of gain and buffering for driving the full-wave (absolute-value) circuit using two more sections of U20. The output of U20 pin 7 is the modulating signal converted to absolute value. The modulating signal is applied to comparator U4, which drives Q3 to charge capacitor C27 through diode CR19. The signal at capacitor C27 is applied to the fourth section of U20. The output of this buffer U20 pin 1 is applied back to the input of the comparator U4 pin 3. The entire circuit just described forms a slideback type peak-detecting voltmeter.

Capacitor C27 charges to the peak value of the modulation. Capacitor C27 can discharge only through R45 to ground; therefore R45 sets the fall time of the modulation display. Electronic switch U9 pins 3 and 2 can interrupt the discharge path of C27. The switch U9 is controlled by the PEAK HOLD circuit. The peak hold circuit is toggled (ON/OFF) by pressing PEAK HOLD switch S3. The peak

4-7.6.3 Modulation Group, - Continued

hold switch triggers debouncing pulse generator U16, which drives a binary counter U17. One output of U17 pin 15 is used to drive Q5 to key ON or OFF the PEAK HOLD lamp in the middle of the PEAK HOLD switch button. The other output of U17 pin 14 is used to operate switch U9 pin 1.

The output of the buffer U20 pin 1 drives the digital multimeter input selector circuitry U9 pin 14 and the modulation bar graph displays U6, U7, and U8. The modulation bar graph is active at all times.

The bar graph circuit uses three ICs (U6, U7, and U8). Each IC has ten comparators and ten lamp drivers. A signal to be displayed (modulation) is applied in parallel to all three ICs. As the signal starts up from zero voltage it will cross the threshold of one comparator at a time until it has crossed thirty thresholds.

When the DOT/BAR selector switch S1 is set to BAR, as each threshold is crossed a corresponding bar graph element is illuminated. When the DOT/BAR selector switch S1 is set to DOT, only one lamp driver at a time is operated.

4-7.7 Power Supply Assembly (A4).

The orange leads (approximately 8 V ac) from the power transformer T1 are applied to full wave bridge rectifier CR5. Refer to Schematic 643-0010-001 and Figure 4-7 Power Supply Circuits Simplified Schematic. Capacitor C8 provides ripple filtering. Regulator U3 regulates the output of CR5 to +5 V dc.

Diodes CR6 and CR7 provide transient protection while capacitor C9 provides additional filtering.

The full wave rectified +32 volts from the chassis ripple filter C1 through a pair of resistors in parallel is applied to voltage regulator U2 to provide +22 V dc output. Resistors R3 and R4 set the output of U3 to +22V. Diodes CR3 and CR5 provide transient protection while capacitors C5, C6, and C7 provide additional filtering.

The full wave rectified -35 volts from chassis rectifier CR2 is filtered by C1 and C2 and applied to voltage regulator U1. Resistors R1 and R2 set the output of U1 to -22 V dc. Diodes CR1 and CR2 provide transient protection while capacitors C3 and C4 provide additional ripple filtering.

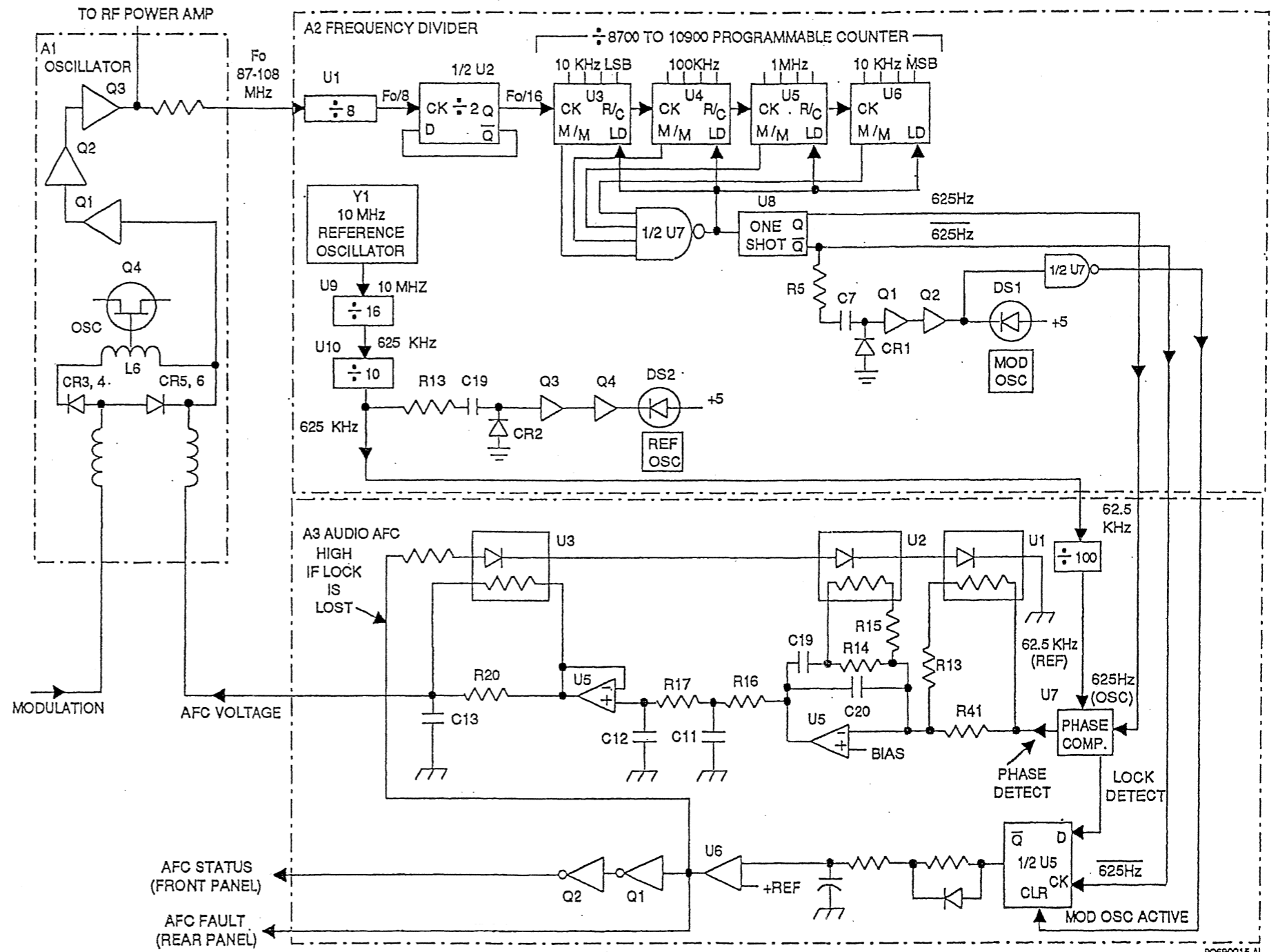
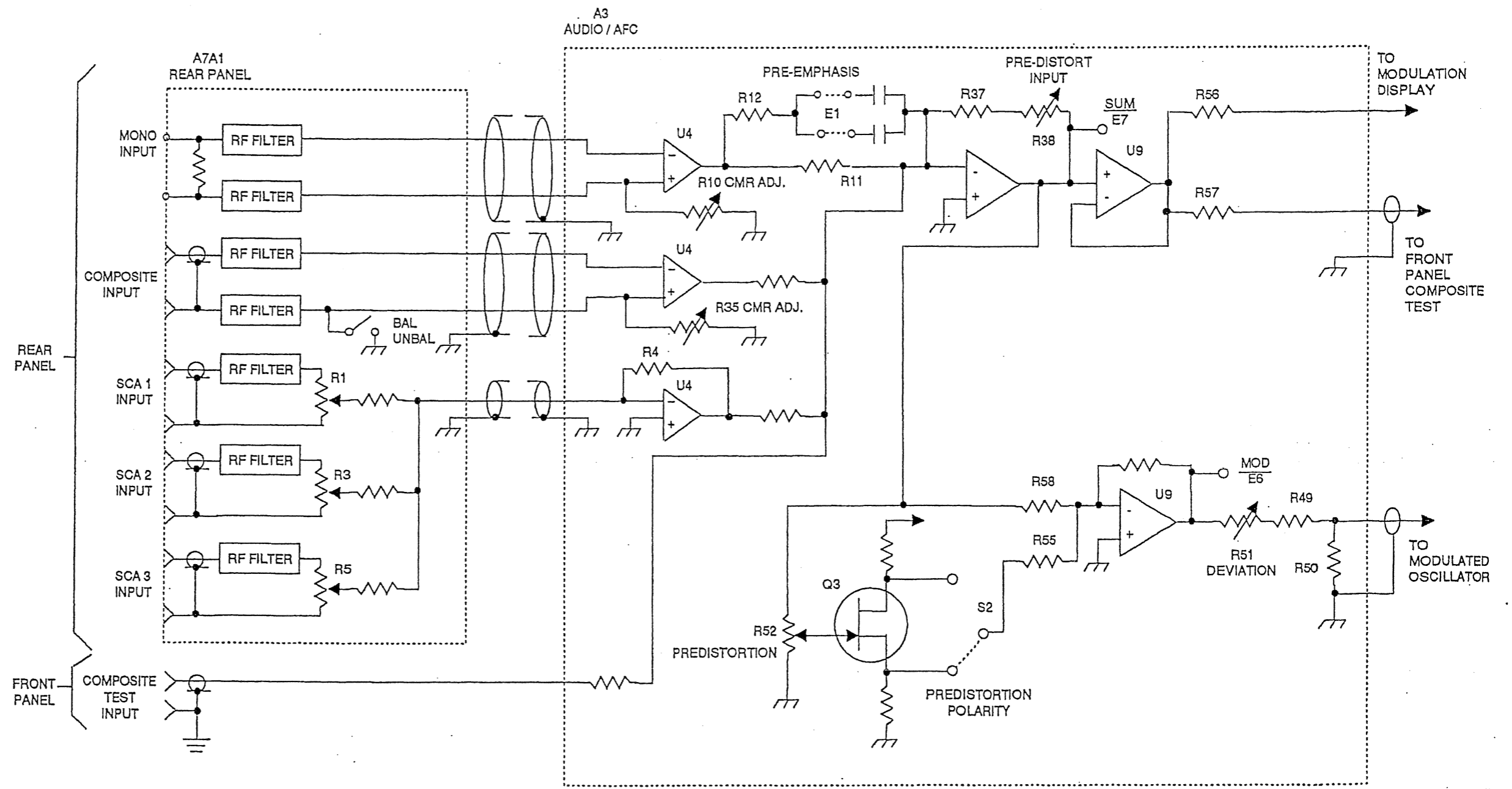

Figure 4-4 AFC Circuits Simplified Diagram.



90890012AL

Figure 4.5 Audio Circuits Simplified Diagram.

Change 1

4-17/(4-18 Blank)

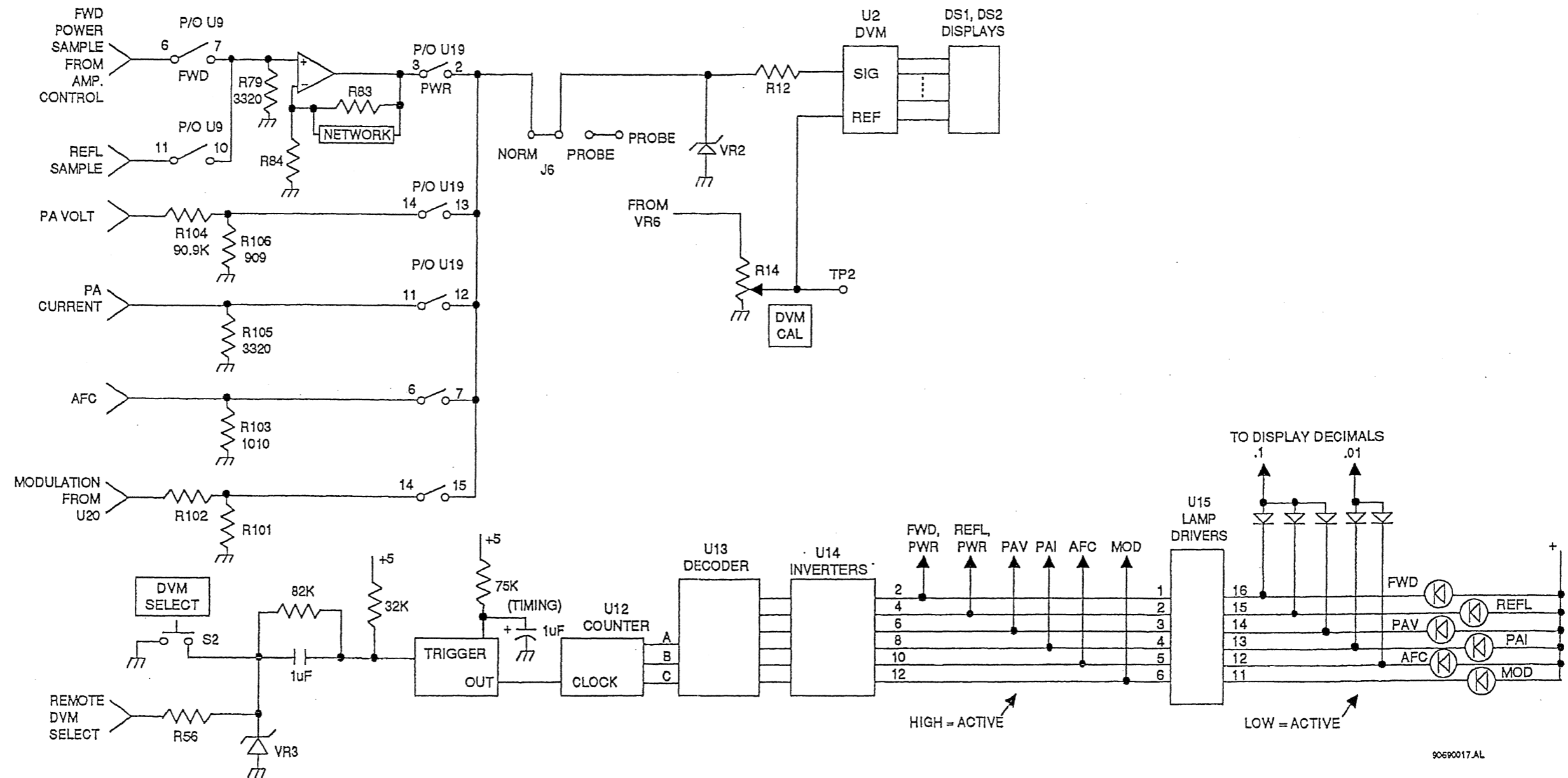

Figure 4-6 Digital Voltmeter and Selection Circuitry Simplified Diagram.

Change 1

4-19/(4-20 Blank)

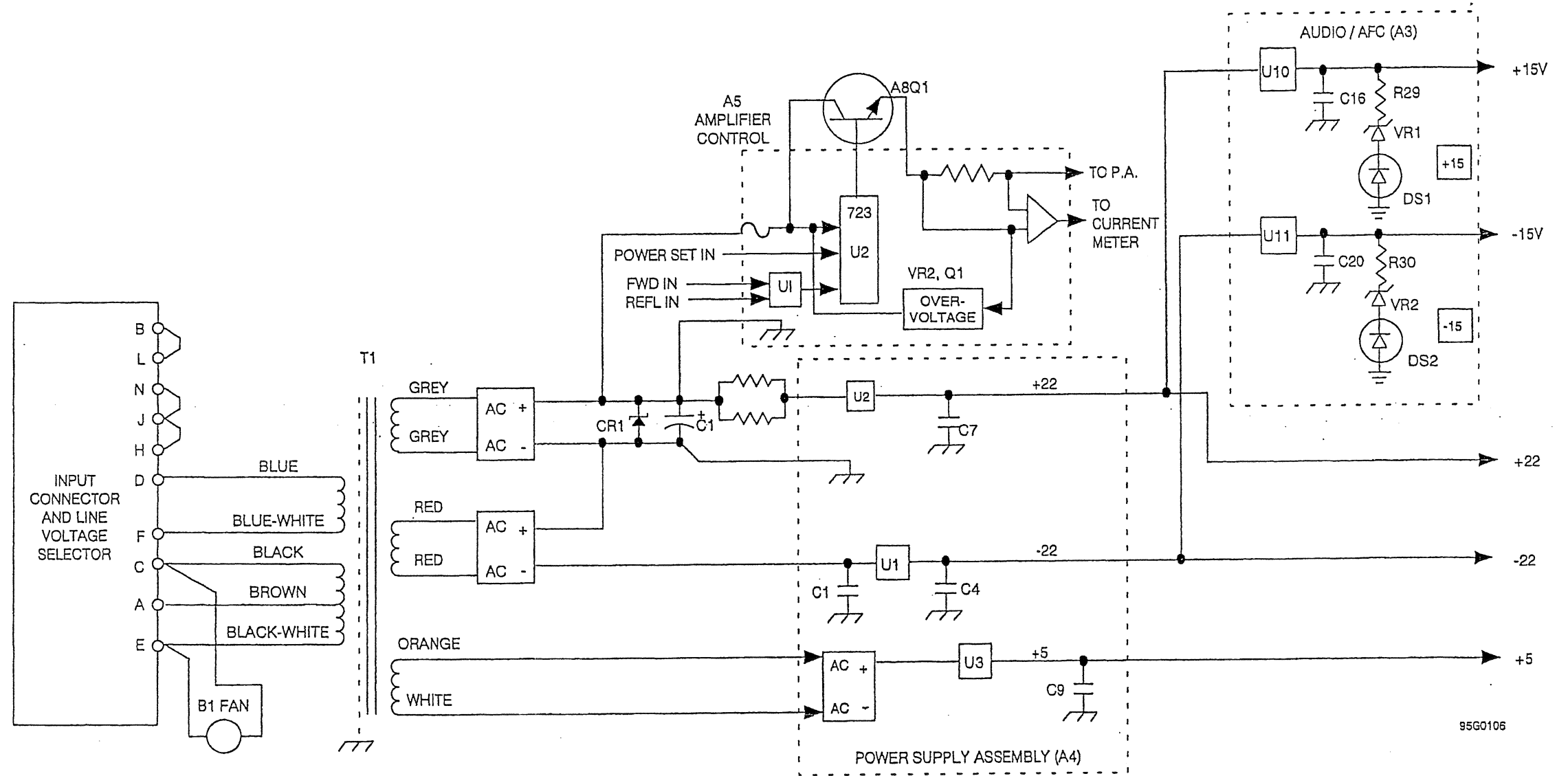
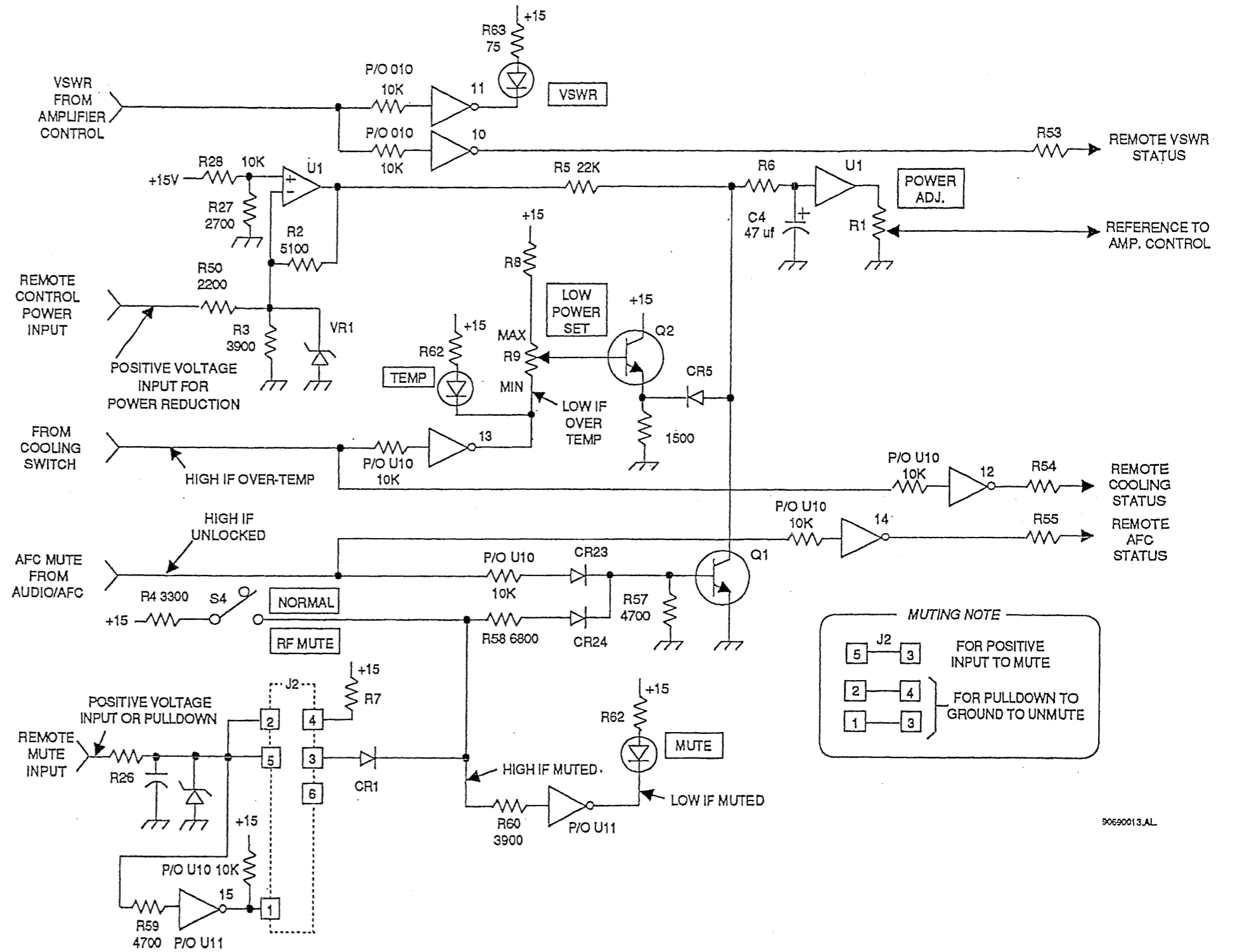
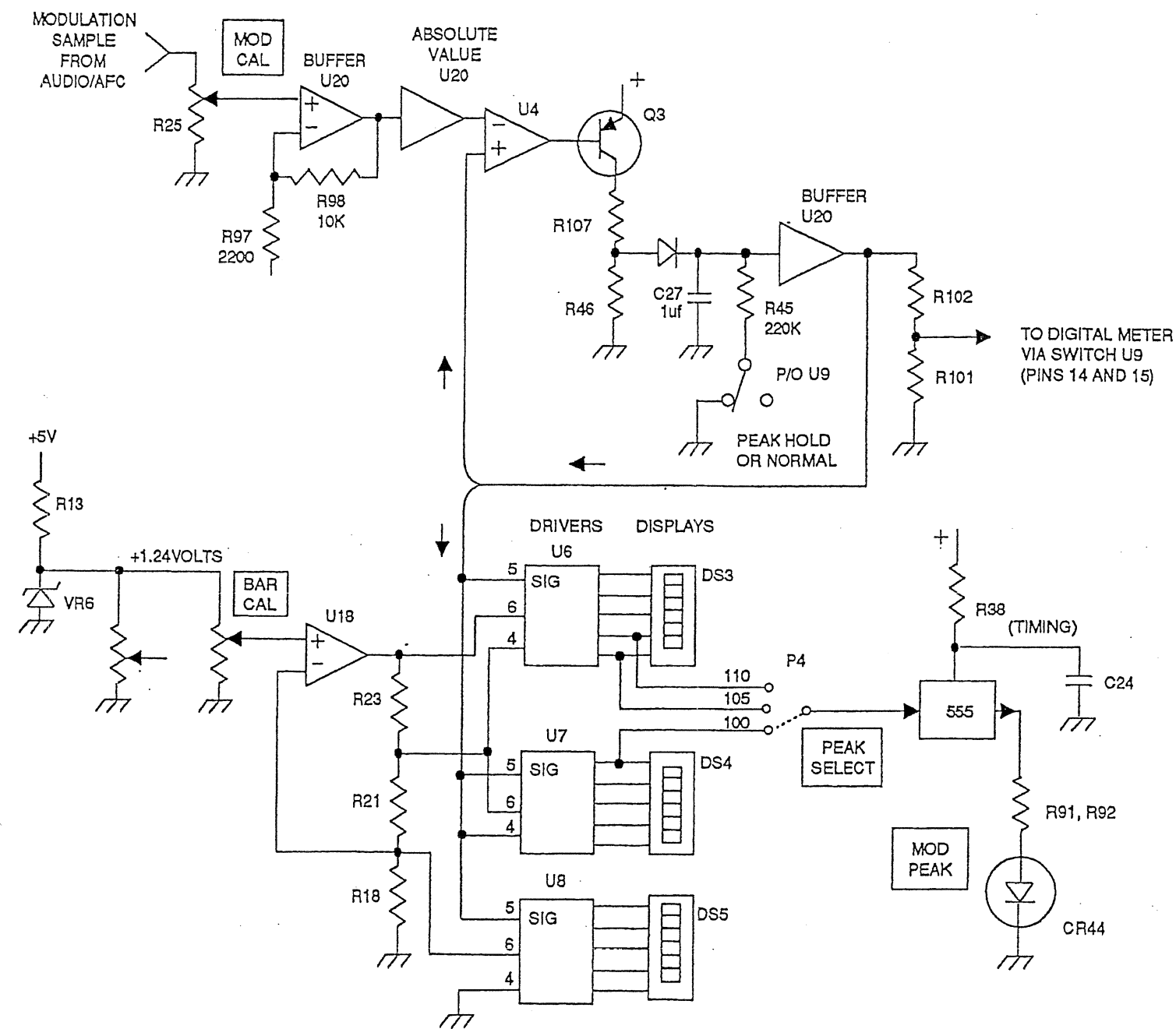

Figure 4-7 Power Supply Circuits Simplified Diagram.



90690013.AL

Figure 4-8 Muting, Overtemp, and Power Control Simplified Diagram.



90590014.AL

Figure 4-9 Modulation Measurement Simplified Diagram.

SECTION 5 - MAINTENANCE

5-1 INTRODUCTION.

The following information describes maintenance and alignment for the 802B FM Exciter. Logical and methodical trouble-shooting procedures should be used, proceeding from front panel indicators and meter readings to circuit checks and measurements. Refer to Section 3 for the location of adjustable or selectable components of the exciter.

WARNING
HIGH VOLTAGE HAZARD

**ENSURE AC POWER IS
REMOVED FROM THE EXCITER
BEFORE SERVICING. FAILURE
TO COMPLY MAY RESULT IN
DEATH OR INJURY TO
PERSONNEL.**

5-2 REMOVE AND REPLACE.

The following information may be used when assemblies are removed and replaced from the exciter chassis for maintenance.

5-2.1 PC Board Assemblies.

The PC board assemblies in the exciter may be removed by unplugging the connectors from the board and removing the assembly mounting hardware.

5-2.2 RF Amplifier Assembly.

The top cover of the RF amplifier (A8) may be removed for in-place troubleshooting. Remove the RF amplifier by removing the six screws mounting the amplifier to the chassis bottom, which are accessible from the bottom of the exciter. Once the six bottom amplifier screws are removed, and the amplifier plugs are disconnected, the amplifier may be lifted out.

5-2.3 Power Transformer.

WARNING
HIGH VOLTAGE HAZARD

**ENSURE AC POWER IS
REMOVED FROM THE EXCITER
BEFORE SERVICING. FAILURE
TO COMPLY MAY RESULT IN
DEATH OR INJURY TO
PERSONNEL.**

Remove AC power from the exciter by disconnecting the AC line cord prior to removing the transformer. Remove the power transformer (T1) by removing the four mounting screws. Disconnect transformer leads and lift the unit from the chassis.

5-2.4 Frequency Divider Assembly.

The frequency divider assembly (A2) cover may be removed by removing four screws from the bottom of the exciter. The circuit card may then be removed by removing four screws from the chassis.

5-2.5 Audio/AFC Assembly.

The audio/AFC (A3) assembly cover may be removed by removing the four screws accessible from the bottom of the exciter. The circuit card may then be removed by removing four screws from the chassis.

5-2.6 Front Panel Circuit Card.

Remove the front panel circuit card by removing the four flat head screws which hold the front panel mounting angles to the exciter chassis. Fold the front panel forward and remove the six nuts and washers which hold the circuit card to the front panel. Disconnect P1 and P2 then lift the circuit card from the front panel.

5-2.7 Rear Panel Circuit Card.

Remove the rear panel circuit card by removing the four screws which hold the rear panel circuit card to the exciter chassis. Disconnect P8 and wiring from TB1 then lift the circuit card from the rear panel.

5-2.8 Blower Assembly.

Remove the blower assembly by removing the six screws which hold the rear panel to the exciter chassis. Fold the rear panel outward and remove the four screws, washers, and nuts which hold the blower to the rear panel. Disconnect the power leads and lift the blower from the rear panel.

5-3 ADJUSTMENTS.

All exciters are factory adjusted and pretuned to specific user requirements. No adjustments are required by the user unless a broken part is replaced, meter readings are not within allowable tolerances, or the exciter is to be operated at a different frequency or power level. The following information will assist the user in performing field calibration.

5-3.1 Frequency Divider Adjustments.

The adjustment on A2Y1 controls the frequency of the reference oscillator. The oscillator should be adjusted for a frequency of 10 Mhz or for a station carrier frequency which is correct when the divider switches are properly set. Use the most precise test equipment available for this particular adjustment.

Monitor the reference oscillator sample directly from the oscillator at A2TP1, in which case it will be 10 MHz. The sample may also be taken from one or two binary counters downstream, in which case the sample will be at 5 or 2.5 MHz. The frequency is selected by using a jumper on J3. Connect pin 1 to pin 2 for a 10 MHz sample. Connect pin 4 to pin 3 for a 5 MHz sample. Connect pin 6 to pin 5 for a 2.5 MHz sample. Set the reference oscillator frequency while measuring it, using a precision counter.

A quicker method of setting the station's frequency is to use a frequency counter. Remove modulation momentarily and measure the carrier frequency. Adjust the frequency of the reference oscillator to set the station on- frequency using a counter measuring the signal at the exciter output connector. The sample output from the transmitter's final amplifier may be used for this procedure.

5-3.2 Audio / AFC Adjustments.

The following adjustments are found on the Audio/AFC card mounted on the floor of the exciter. If necessary, the cover to the Audio/AFC assembly may be removed by removing the four screws which hold the cover on the exciter floor.

5-3.2.1 Monaural Input Common-Mode Null Adjustment.

The monaural input null adjustment (A3R10) allows the common-mode signal on the monaural input to be nulled out. Nulling is done to eliminate hum on the monaural input.

To adjust the null control, apply a 400 Hz tone to the monaural input terminals and adjust the level for 100% modulation. Next, reconnect the source so that one side is at chassis ground and the other side connects to both monaural input terminals. The modulation should disappear. Adjust the monaural input common mode null control for minimum modulation. A null of about 70 to 80 dB should be obtained.

5-3.2.2 Composite Input Common-Mode Null Adjustment.

The composite input null adjustment (A3R35) allows the common-mode signal on the composite (stereo) input to be nulled out. Nulling is done to eliminate hum on the composite input.

To adjust the null control, apply a 400 Hz tone to the composite input connector and adjust the level for 100% modulation. Next, reconnect the source so that one side is at chassis ground and the other side connects to both the shield and the center terminal of the composite input connector. The modulation should disappear. Adjust the composite input common mode null control for minimum modulation. A null of about 70 to 80 dB should be obtained.

5-3.2.3 Predistort Input Level Adjustment.

The predistort input control (A3R38) is used to accommodate manufacturing tolerances on

components from the modulating signal input connectors up to the SUM signal test point E7. To adjust the predistort control, first confirm that the composite input common mode null control has been set correctly as was described in Paragraph 5-3.2.2. Then apply a 400 Hz tone to the composite input connector and set its level to 3.500 volts peak to peak. Next adjust the Predistort Input control for a reading of 6.4 volts peak to peak at the SUM test point E7.

5-3.2.4 Predistortion Adjustment.

The predistortion control (A3R52) is used to cancel the small distortion generated by the inherent nonlinearity of the modulating diodes.

To adjust this control modulate the exciter to the 100% level using a 400 Hz audio tone. Then adjust the control for minimum harmonic distortion as read on a good modulation monitor.

If a particular method of distortion measurement has found favor in a given radio station, use that method to set this control. For example one of the standard inter-modulation distortion tests may be used to set this control.

Another method of setting this control is to modulate the exciter fully with a clean 12 kHz tone. Switch the stereo modulation monitor to read the stereo subchannel; this will extract the second, third and fourth harmonics of the 12 kHz tone. Next, adjust the predistortion control for a minimum reading in the stereo subchannel.

5-3.2.5 Deviation Adjustment.

The deviation control (A3R51) allows setting the exciter deviation when the various exciter signal levels are correct. Set it to 100% modulation when 6.4 volts peak-to-peak are present at the SUM test point E7.

5-3.3 Front Panel Circuit Card Adjustments.

Front panel circuit card assembly (CCA) adjustments and selections are internal to the chassis and will require removal of the exciter top cover to gain access to the controls. A cutout exists for two of the controls, A6A1R1 (Power Adjust) and A6A1S4 (Exciter Mute).

5-3.3.1 RF Power Level Adjustment.

The RF power level control (A6A1R1), accessible through a cutout in the top cover, is used to set the exciter's output power level. The control may be used to set the power to a particular wattage level or to provide a certain indication of excitation on a subsequent transmitter meter.

5-3.3.2 RF Low Power Level Adjustment.

The RF low level power control (A6A1R9) is used to set the exciter's low RF output power level. Low level RF activates when the thermostat on the amplifier heat sink is tripped by excessive operating temperature. To adjust the low RF power control, short the thermostat (A8S1) using a jumper and then set the LOW PWR level adjustment (A6A1R9) to the desired level. The level can be any level from zero up to the maximum level as set by the primary power level adjustment control (Paragraph 5-3.3.1). Typically the RF low power level will be set for about half normal power level.

5-3.3.3 DVM Reference Adjustment.

The DVM reference control (A6A1R14) adjusts the digital multimeter standard voltage against which all readings are made. It is set to produce a reading of 1.000 volt DC as measured at A6A1TP2 (DVM REF VOLTAGE) on the front panel circuit card assembly.

5-3.3.4 Bar Graph Calibration.

The bar graph calibration control (A6A1R16) adjusts the bar graph to indicate the modulation percentage of the exciter in an analog manner. After the modulation calibrate control (Paragraph 5-3.3.6) has been adjusted, this control may be adjusted so that the bar graph agrees with the digital multimeter when it is reading modulation.

5-3.3.5 DVM Input Control.

The DVM input control (A6A1J6) controls the input circuit to the digital voltmeter.

CAUTION EQUIPMENT VOLTAGE HAZARD

**NO VOLTAGE GREATER THAN
50 V DC SHALL BE INPUT
THROUGH DVM PROBE JACK
(A6A1J1). FAILURE TO
OBSERVE THIS CAUTION MAY
RESULT IN DVM METER
CIRCUIT DAMAGE.**

Place the jumper to DVM for normal metering operations. Move the jumper to IN for use of the DVM for testing purposes.

5-3.3.6 Modulation Calibrate Control.

The modulation calibrate control (A6A1R25) adjusts the digital multimeter to correctly read the modulation percentage of the exciter. After the predistortion (Paragraphs 5-3.2.3 and 5-3.2.4) and deviation (Paragraph 5-3.2.5) adjustments have been made, this control may be adjusted so that the digital multimeter agrees with the station modulation monitor.

5-3.4 Rear Panel Circuit Card Adjustments.

Rear panel CCA adjustments and controls are internal to the chassis and will require removal of the top cover to gain access.

There are three individual SCA level adjustment controls (A7A1R1, R3, and R5). They are mounted on the circuit card located on the rear panel of the exciter.

The SCA controls are adjusted for the target subcarrier injection (probably 10%) when the subcarrier source is operating at its nominal output level. After the initial adjustment, they can be ignored and further trimming of the subcarrier level can be done at the subcarrier source.

5-3.5 Amplifier Control Circuit Card Adjustment.

The following adjustments are found on the amplifier control circuit card mounted on the right wall of the exciter.

5-3.5.1 Forward Power Meter Adjustment.

Adjust the forward power meter by connecting the exciter output through a calibrated 50 ohm, in line wattmeter to a 50 ohm termination. Place the AGC switch in the OFF position. Use the METER SELECT button to select FORWARD PWR. Adjust the power output control (A6A1R1) for 30 Watts on the external power meter. Adjust the forward power calibration potentiometer (A5R5) for 30 Watts indication on the exciter front panel meter.

5-3.5.2 Reflected Power Meter Adjustment.

After calibration of the forward power meter, Paragraph 5-3.5.1, adjust the power level control (A6A1R1) for minimum output. Disconnect the 50 ohm termination from the exciter output. Using the METER SELECT button select REFLECTED PWR and adjust A6A1R1 until VSWR LED lights (approximately 2.1 Watts). Select forward power on the front panel switch and adjust A5R13 for 6.3 Watts forward. Repeat the process if necessary and adjust the power level control (A6A1R1) and reflected power calibration (A5R13) until 6.3 Watts forward and 2.1 Watts reflected is obtained. Do not adjust the forward calibration (A5R5) during this process. The reiteration of the reflected power calibration is necessary due to the fact that the VSWR protection is active at all times. Therefore, changing the gain of the reflected power amplifier will cause some change in power output.

Reconnect the 50 ohm load and adjust the output power control (A6A1R1) for the desired output level.

5-3.5.3 PA Current Adjustment.

To calibrate the PA current reading use a digital voltmeter, 3-1/2 digit hand held DMM, and record the voltage drop across R30 and R31 on the Amplifier Control Assembly. Be very careful not to short R30 and R31 to ground with the meter leads. Connect the digital voltmeter from J2-14 or R6 to ground. Adjust R40 until a voltage exactly twice that recorded across R30 and R31 is obtained. Select Amplifier current on the front panel switch.

(This Page Intentionally Left Blank)

SECTION 6 - PARTS LIST

6-1 INTRODUCTION.

This section contains a list of all repairable/replaceable electrical, and critical mechanical parts for the 802B FM Exciter.

6-2 REFERENCE DESIGNATOR.

The first column contains the electrical reference designators (REF DES) of parts appearing on schematics or wiring diagrams. When a reference designator, within a series of reference designators, has not been assigned a part number, the unassigned reference designator will be reflected as "NOT USED" in the PART NUMBER column.

6-3 DESCRIPTION.

The second column contains the identifying noun or item name followed by a brief description. The descriptions for electrical and electronic parts includes the application ratings and tolerances.

6-4 PART NUMBER.

The third column contains the Continental Electronics Corporation (CEC) specification or drawing number for each item listed.

6-5 ILLUSTRATIONS.

Parts listed in the REF DES column are located on corresponding illustrations which precede each parts list. When a replaceable electrical item is hidden from view by structural parts of wiring, a dotted leader line is used to show the locations of the item on the illustration.

6-6 LIST OF EQUIPMENT.

Table 6-1 lists exciter assemblies and page numbers of corresponding illustrations preceding each parts list. The first parts list covers items not included in a specific subassembly.

TABLE 6-1. List of Equipment

REF DES	DESCRIPTION	CEC PARTS LIST	PAGE
-	802B FM Exciter	180200-2	
6-2			
-	Cable Assembly	180206-2	6-4
A1	Modulated Oscillator Assembly	180207-1	6-6
A1A1	Modulated Oscillator	180239-1	6-8
A2	Frequency Divider Assembly	643-0003-002	6-12
A3	Audio/AFC Assembly	180197-2	6-18
A4	Power Supply	643-0009-002	6-26
A5	Amplifier Control Circuit Card	180247-2	6-30
A6	Front Panel Assembly	180214-1	6-36
A6A1	Front Panel Circuit Card	180202-2	6-38
A7	Rear Panel Assembly	180215-1	6-52
A7A1	Rear Panel Circuit Card	180210-2	6-54
A8	Output Amplifier Assembly	180428-1	6-58

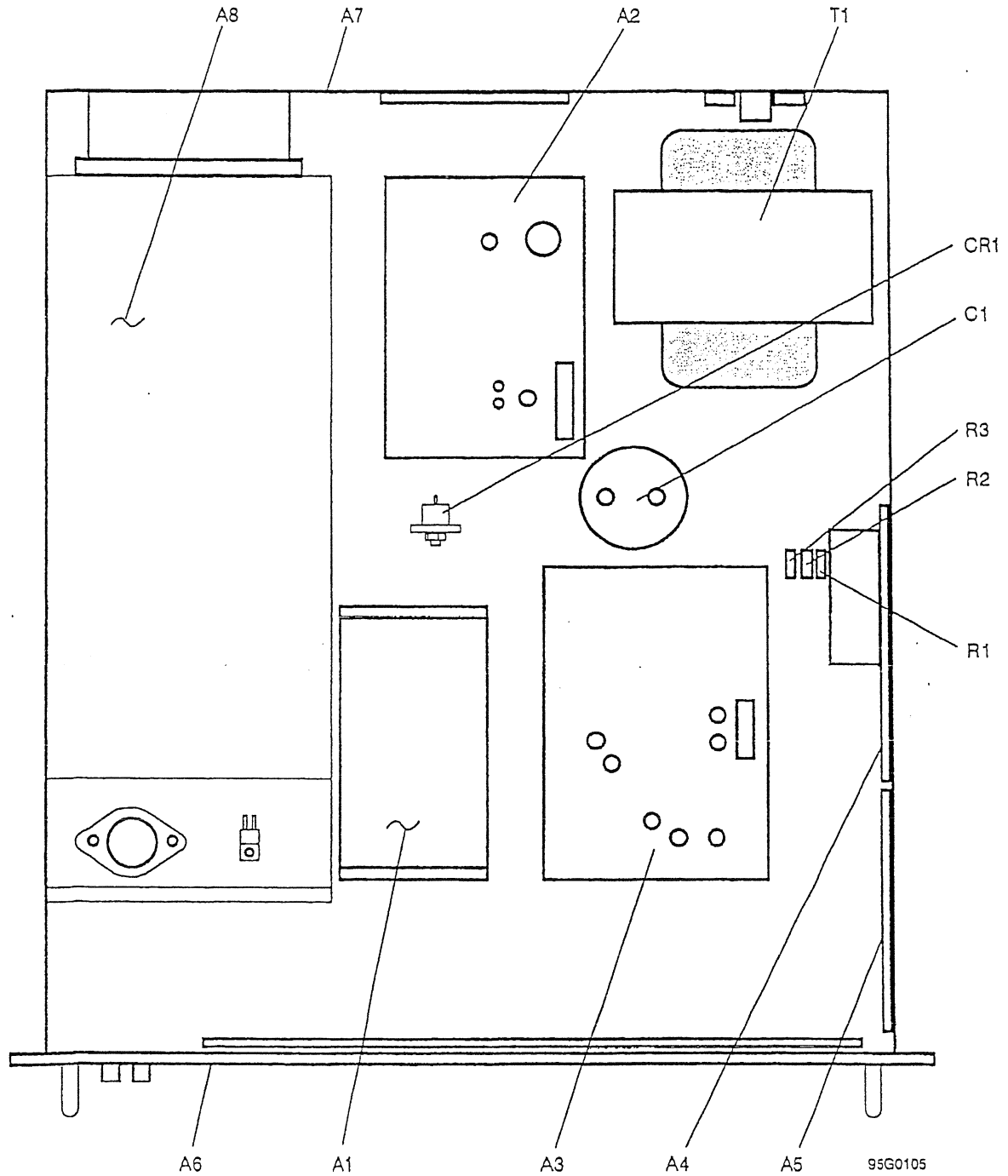

Figure 6-1 802B FM Exciter.

PL180200-2

802B FM EXCITER

Rev G

Ref. Des.	Description	Part No.
A1	MODULATED OSCILLATOR ASSY	180207-1
A2	CIRCUIT CARD ASSEMBLY, FREQUENCY DIVIDER	643-0003-002
A3	CIRCUIT CARD ASSY, AUDIO/AFC	180197-2
A4	CCA, POWER SUPPLY	643-0009-002
A5	CIRCUIT CARD ASSEMBLY, AMPLIFIER CONTROL	180247-2
A6	FRONT PANEL ASSEMBLY	180214-1
A7	REAR PANEL ASSEMBLY	180215-1
A8	ASSEMBLY, OUTPUT AMPLIFIER	180428-1
C1	CAPACITOR, FIXED, ELECTROLYTIC, 16,000 μ f, +75-10%, 50 WVDC	183-5008-010
CR1	SEMICONDUCTOR DEVICE, DIODE:ZENER, 47 V \pm 5%, 50 WATT, STUD MTG.	353-5197-020
E1	TERMINAL, STUD, 6K VOLT, 5/8 X 4-40 UNC-2B THD	306-0976-000
E2	TERMINAL, STUD, 6K VOLT, 5/8 X 4-40 UNC-2B THD	306-0976-000
R1	RESISTOR, FIXED, COMPOSITION, 47 Ω , \pm 5%, 2W @ 70C	724-5055-210
R2	RESISTOR, FIXED, COMPOSITION, 68 Ω , \pm 5%, 2W	724-5055-230
R3	RESISTOR, FIXED, COMPOSITION, 68 Ω , \pm 5%, 2W	724-5055-230
T1	TRANSFORMER, POWER, STEP-DOWN, 120/220-240V DUAL PRI 50/60HZ, 3 SECS, 8V, 24V, and 30V, ENCLOSED, SHIELDED	662-6239-010

(This Page Intentionally Left Blank)

Figure 6-2 Cable Assembly.

PL180206-2 CABLE ASSEMBLY		Rev A
Ref. Des.	Description	Part No.
P1	CONNECTOR BODY, PLUG, ELECTRICAL, 16 POSITIONS SINGLE ROW CONTACT HOUSING	372-9766-010
P2	CONNECTOR BODY, PLUG, ELECTRICAL, 16 POSITIONS SINGLE ROW CONTACT HOUSING	372-9766-010
P3	CONNECTOR BODY, PLUG, ELECTRICAL, 16 POSITIONS SINGLE ROW CONTACT HOUSING	372-9766-010
P4	CONNECTOR BODY, PLUG, ELECTRICAL, 16 POSITIONS SINGLE ROW CONTACT HOUSING	372-9766-010
P5	CONNECTOR BODY, PLUG, ELECTRICAL, 16 POSITIONS SINGLE ROW CONTACT HOUSING	372-9766-010
P6	CONNECTOR BODY, PLUG, ELECTRICAL, 16 POSITIONS SINGLE ROW CONTACT HOUSING	372-9766-010
P7	CONNECTOR BODY, RECEPTACLE, ELECTRICAL, HOUSING, 6 CAVITY, RECEPTACLE, W/LOCK ONLY, NO MOUNTING EARS	372-9604-110
P8	CONNECTOR BODY, PLUG, ELECTRICAL, 20 POSITIONS SINGLE ROW CONTACT HOUSING	372-9766-020
P9	CONNECTOR BODY, PLUG, ELECTRICAL, 12 CAVITY PLUG, W/LOCK ONLY, NO MOUNTING EARS	372-5909-790
P10	CONNECTOR BODY, PLUG, ELECTRICAL, 16 POSITIONS SINGLE ROW CONTACT HOUSING	372-9766-010
P11	CONNECTOR, RECEPTACLE, ELECTRICAL, HOUSING, 6 PIN	372-9604-090
P12	CONNECTOR, RECEPTACLE, ELECTRICAL, HOUSING, 6 PIN	372-9604-090

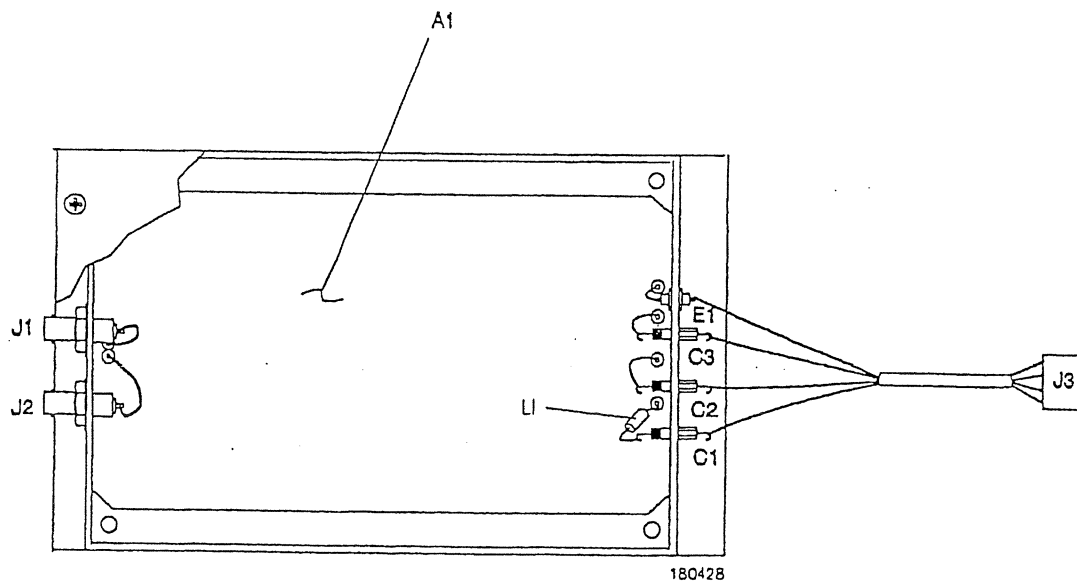

Figure 6-3 Modulated Oscillator Assembly.

PL180207-1 MODULATED OSCILLATOR ASSEMBLY

Rev C

Ref. Des.	Description	Part No.
A1	MODULATED OSCILLATOR	180239-1
C1	CAPACITOR, FIXED, CERAMIC, 1,000 pf, ±20%, 500 WVDC	CK70AW102M
C2	CAPACITOR, FIXED, CERAMIC, 1,000 pf, ±20%, 500 WVDC	CK70AW102M
C3	CAPACITOR, FIXED, CERAMIC, 1,000 pf, ±20%, 500 WVDC	CK70AW102M
E1	TERMINAL, FEEDTHRU, TURRET TYPE, BRASS, SILVER PLATED 8-32 THD MOUNT, TEFLON INSUL, WHITE, W/MTG HARDWARE	306-3002-010
J1	CONNECTOR, RECEPTACLE, ELECTRICAL, BNC, FEMALE JAM NUT MOUNTED (OD UG-625B/U)	M39012/21 -0001
J2	CONNECTOR, RECEPTACLE, ELECTRICAL, BNC, FEMALE JAM NUT MOUNTED (OD UG-625B/U)	M39012/21 -0001
J3	CONNECTOR, PLUG, ELECTRICAL, HOUSING, 6 PIN	372-9604-100
L1	COIL, RADIO FREQUENCY, 850Ω @ 180 MHz, 80-220 MHz	240-2679-040

PL180239-1 MODULATED OSCILLATOR		Rev F
Ref. Des.	Description	Part No.
C1	CAPACITOR, FIXED, CERAMIC, 470 pf, $\pm 20\%$, 1,000 WVDC DISC TYPE	913-1189-000
C2	CAPACITOR, FIXED, ELECTROLYTIC, 10 μf , $\pm 10\%$, 20 WVDC DIPPED TANTALUM	183-5016-040
C3	CAPACITOR, FIXED, CERAMIC, 0.01 μf , $\pm 10\%$, 100 WVDC	CK05BX103K
C4	CAPACITOR, FIXED, CERAMIC, 470 pf, $\pm 20\%$, 1,000 WVDC DISC TYPE	913-1189-000
C5	CAPACITOR, FIXED, CERAMIC, 470 pf, $\pm 20\%$, 1,000 WVDC DISC TYPE	913-1189-000
C6	CAPACITOR, FIXED, ELECTROLYTIC, 10 μf , $\pm 20\%$, 50 WVDC DIPPED TANTALUM	183-5049-130
C7	CAPACITOR, FIXED, ELECTROLYTIC, 10 μf , $\pm 10\%$, 20 WVDC DIPPED TANTALUM	183-5016-040
C8	CAPACITOR, FIXED, ELECTROLYTIC, 10 μf , $\pm 10\%$, 20 WVDC DIPPED TANTALUM	183-5016-040
C9	CAPACITOR, FIXED, MICA, 390 pf, $\pm 1\%$, 100 WVDC	912-3921-000
C10	CAPACITOR, FIXED, CERAMIC, 0.1 μf , $\pm 10\%$, 50 WVDC	CK05BX104K
C11	CAPACITOR, FIXED, CERAMIC, 0.1 μf , $\pm 10\%$, 50 WVDC	CK05BX104K
C12	CAPACITOR, FIXED, MICA, 5 pf, $\pm 0.5\%$, 500 WVDC	CM04CD050DO3
C13	CAPACITOR, FIXED, CERAMIC, 470 pf, $\pm 20\%$, 1,000 WVDC DISC TYPE	913-1189-000
C14	CAPACITOR, FIXED, CERAMIC, 470 pf, $\pm 20\%$, 1,000 WVDC DISC TYPE	913-1189-000
C15	CAPACITOR, FIXED, CERAMIC, 470 pf, $\pm 20\%$, 1,000 WVDC DISC TYPE	913-1189-000
C16	CAPACITOR, FIXED, MICA, 390 pf, $\pm 1\%$, 100 WVDC	912-3921-000
C17	CAPACITOR, FIXED, MICA, 390 pf, $\pm 1\%$, 100 WVDC	912-3921-000
C18	CAPACITOR, FIXED, MICA, 390 pf, $\pm 1\%$, 100 WVDC	912-3921-000
C19	CAPACITOR, FIXED, MICA, 390 pf, $\pm 1\%$, 100 WVDC	912-3921-000
C20	CAPACITOR, FIXED, CERAMIC, 470 pf, $\pm 20\%$, 1,000 WVDC DISC TYPE	913-1189-000
C21	CAPACITOR, FIXED, MICA, 27 pf, $\pm 5\%$, 500 WVDC	CM04ED270JO3
C22	CAPACITOR, FIXED, MICA, 22 pf, $\pm 5\%$, 500 WVDC	CM04ED220JO3
CR1	SEMICONDUCTOR DEVICE, DIODE, 1 AMP, 600Vdc, 420 Vrms	353-6442-050

PL180239-1 MODULATED OSCILLATOR		Rev F
Ref. Des.	Description	Part No.
CR2	SEMICONDUCTOR DEVICE, DIODE, 1 AMP, 600Vdc, 420 Vrms	353-6442-050
CR3	SEMICONDUCTOR DEVICE, DIODE, SILICON, CATHODE BAND	922-8004-020
CR4	SEMICONDUCTOR DEVICE, DIODE, SILICON, CATHODE BAND	922-8004-020
CR5	SEMICONDUCTOR DEVICE, DIODE, SILICON, CATHODE BAND	922-8004-020
CR6	SEMICONDUCTOR DEVICE, DIODE, SILICON, CATHODE BAND	922-8004-020
E1	TERMINAL, STUD, MINIATURE TURRET TYPE STANDOFF	306-1126-000
E2	TERMINAL, STUD, MINIATURE TURRET TYPE STANDOFF	306-1126-000
E3	TERMINAL, STUD, MINIATURE TURRET TYPE STANDOFF	306-1126-000
E4	TERMINAL, STUD, MINIATURE TURRET TYPE STANDOFF	306-1126-000
E5	TERMINAL, STUD, MINIATURE TURRET TYPE STANDOFF	306-1126-000
E6	TERMINAL, STUD, MINIATURE TURRET TYPE STANDOFF	306-1126-000
L1	COIL, RADIO FREQUENCY, 1.80 μ H, \pm 10%, 0.525 AMPS	MS18130-11
L2	COIL, RADIO FREQUENCY, 1 μ H, \pm 10%, 930 DCMA	MS75008-28
L3	COIL, RADIO FREQUENCY, 1 μ H, \pm 10%, 930 DCMA	MS75008-28
L4	COIL, RADIO FREQUENCY, 1.80 μ H, \pm 10%, 0.525 AMPS	MS18130-11
L5	COIL, RADIO FREQUENCY, FIXED, UNSHIELDED, 720 nH \pm 5%, 66 Q MIN, 20-1/2 TURNS, BLACK	278-5071-010
L6	COIL, RADIO FREQUENCY, TUNEABLE, UNSHIELDED, 0.154 μ H W/O CORE, 5-1/2 TURNS, TAP @ 2-7/8 TURN FROM START	278-5070-010
L7	COIL, RADIO FREQUENCY, 1 μ H, \pm 10%, 930 DCMA	MS75008-28
L8	COIL, RF, .110 μ H, 1 AMP	278-5042-010
Q1	TRANSISTOR, JFET, N-CHANNEL, 25 VDC, 10 MADC GATE, 350 MW DISS, TO-226AA PKG.	352-5178-010
Q2	TRANSISTOR, SILICON, NPN, 2N5109	352-0863-020
Q3	TRANSISTOR, SILICON, NPN, 2N5109	352-0863-020
Q4	TRANSISTOR, JFET, N-CHANNEL, 25 VDC, 10 MADC GATE, 350 MW DISS, TO-226AA PKG.	352-5178-010
Q5	TRANSISTOR, JFET, N-CHANNEL, 25 VDC, 10 MADC GATE, 350 MW DISS, TO-226AA PKG.	352-5178-010

PL180239-1 MODULATED OSCILLATOR		Rev F
Ref. Des.	Description	Part No.
R1	RESISTOR, FIXED, FILM: 243 Ω , $\pm 1\%$, 1/4 WATT @ 70C	724-5052-250
R2	RESISTOR, FIXED, FILM: 12.1K Ω , $\pm 1\%$, 1/4 WATT @ 70C	724-5052-625
R3	RESISTOR, FIXED, FILM: 33.2K Ω , $\pm 1\%$, 1/4 WATT @ 70C	724-5052-700
R4	RESISTOR, FIXED, FILM: 1000 Ω , $\pm 1\%$, 1/4 WATT @ 70C	724-5052-400
R5	RESISTOR, FIXED, FILM: 3320 Ω , $\pm 1\%$, 1/4 WATT @ 70C	724-5052-490
R6	RESISTOR, FIXED, FILM: 150 Ω , $\pm 1\%$, 1/4 WATT @ 70C	724-5052-225
R7	RESISTOR, FIXED, FILM: 3320 Ω , $\pm 1\%$, 1/4 WATT @ 70C	724-5052-490
R8	RESISTOR, FIXED, FILM: 100 Ω , $\pm 1\%$, 1/4 WATT @ 70C	724-5052-200
R9	RESISTOR, FIXED, FILM: 1000 Ω , $\pm 1\%$, 1/4 WATT @ 70C	724-5052-400
R10	RESISTOR, FIXED, FILM: 150 Ω , $\pm 1\%$, 1/4 WATT @ 70C	724-5052-225
R11	RESISTOR, FIXED, FILM: 2670 Ω , $\pm 1\%$, 1/4 WATT @ 70C	724-5052-475
R12	RESISTOR, FIXED, FILM: 2210 Ω , $\pm 1\%$, 1/4 WATT @ 70C	724-5052-460
R13	RESISTOR, FIXED, FILM: 1500 Ω , $\pm 1\%$, 1/4 WATT @ 70C	724-5052-425
R14	RESISTOR, FIXED, FILM: 182 Ω , $\pm 1\%$, 1/4 WATT @ 70C	724-5052-235
R15	RESISTOR, FIXED, FILM: 1500 Ω , $\pm 1\%$, 1/4 WATT @ 70C	724-5052-425
R16	NOT-USED	
R17	RESISTOR, FIXED, FILM: 47.5 Ω , $\pm 1\%$, 1/4 WATT @ 70C	724-5052-090
R18	NOT-USED	
R19	RESISTOR, FIXED, FILM: 2210 Ω , $\pm 1\%$, 1/4 WATT @ 70C	724-5052-460
R20	RESISTOR, FIXED, FILM: 10K Ω , $\pm 1\%$, 1/4 WATT @ 70C	724-5052-600
R21	RESISTOR, FIXED, FILM: 47.5K Ω , $\pm 1\%$, 1/4 WATT @ 70C	724-5052-740
U1	MICROCIRCUIT, LINEAR, DUAL OPERATIONAL AMPLIFIER, 8 LEAD PLASTIC DUAL IN-LINE PACKAGE	351-1370-040
VR1	MICROCIRCUIT, LINEAR, 5 VOLT REGULATOR, TO-220 PKG	351-1271-010
XU1	SOCKET, INTEGRATED CIRCUIT, DUAL IN-LINE, 8 PINS	220-0049-100

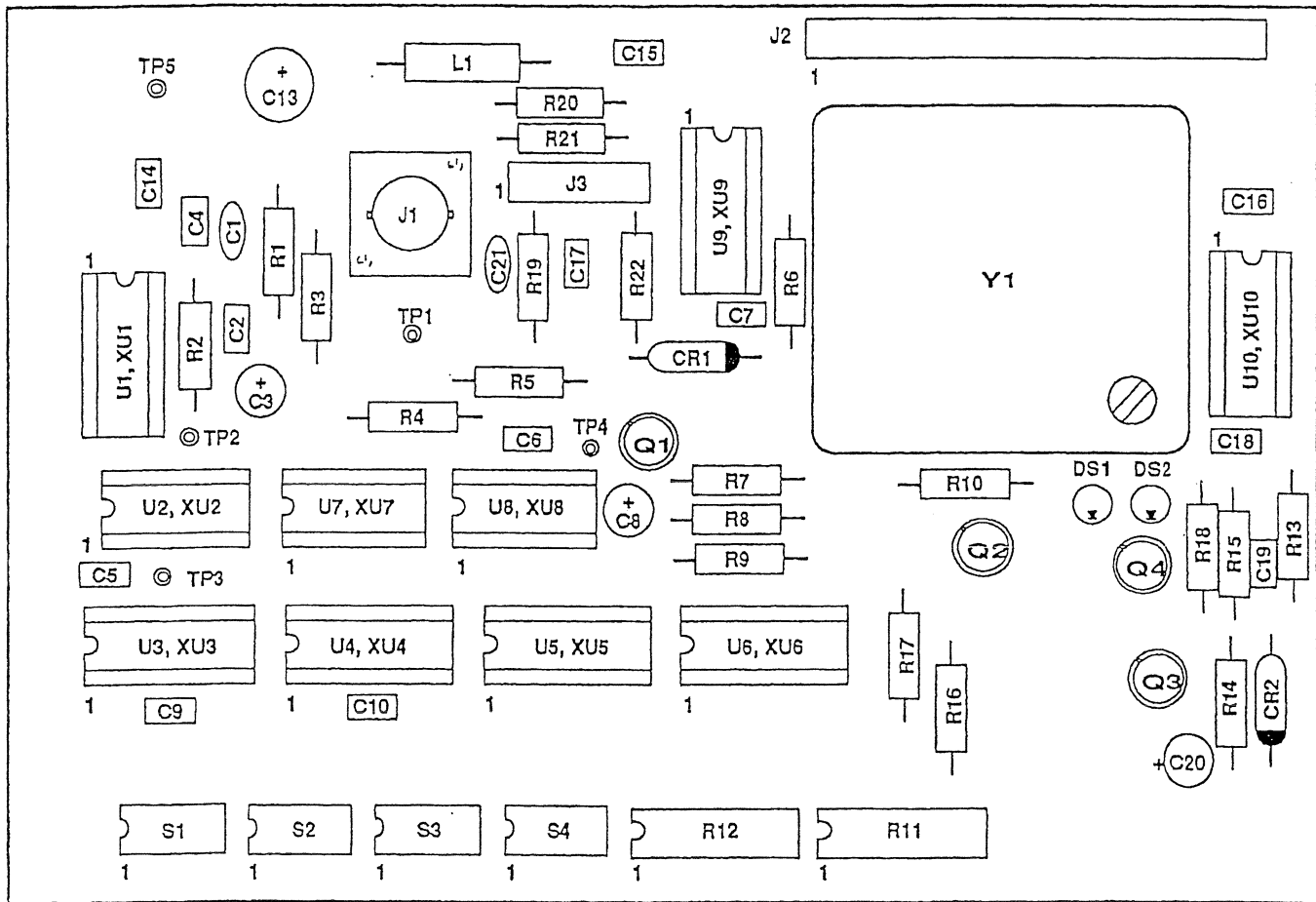

543-0003-002

Figure 6-5 Frequency Divider Circuit Card Assembly.

PL643-0003-002 CIRCUIT CARD ASSEMBLY, FREQUENCY DIVIDER

Rev E

Ref. Des.	Description	Part No.
C1	CAPACITOR, FIXED, CERAMIC, 1,000 pf, ±20%, 1,000 WVDC	913-1186-000
C2	CAPACITOR, FIXED, CERAMIC, 0.1 pf, ±10%, 50 WVDC	CK05BX104K
C3	CAPACITOR, FIXED, ELECTROLYTIC, 10 pf, ±20%, 50 WVDC	183-5007-060
C4	CAPACITOR, FIXED, CERAMIC, 0.1 pf, ±10%, 50 WVDC	CK05BX104K
C5	CAPACITOR, FIXED, CERAMIC, 0.1 pf, ±10%, 50 WVDC	CK05BX104K
C6	CAPACITOR, FIXED, CERAMIC, 0.1 pf, ±10%, 50 WVDC	CK05BX104K
C7	CAPACITOR, FIXED, CERAMIC, 0.1 pf, ±10%, 50 WVDC	CK05BX104K
C8	CAPACITOR, FIXED, ELECTROLYTIC, 10 pf, ±20%, 50 WVDC	183-5007-060
C9	CAPACITOR, FIXED, CERAMIC, 0.1 pf, ±10%, 50 WVDC	CK05BX104K
C10	CAPACITOR, FIXED, CERAMIC, 0.1 pf, ±10%, 50 WVDC	CK05BX104K
C11	CAPACITOR, FIXED, CERAMIC, 0.1 pf, ±10%, 50 WVDC	CK05BX104K
C12	CAPACITOR, FIXED, CERAMIC, 0.1 pf, ±10%, 50 WVDC	CK05BX104K
C13	CAPACITOR, FIXED, ELECTROLYTIC, 47 pf, ±20%, 50 WVDC	183-5007-020
C14	CAPACITOR, FIXED, CERAMIC, 0.1 pf, ±10%, 50 WVDC	CK05BX104K
C15	CAPACITOR, FIXED, CERAMIC, 0.1 pf, ±10%, 50 WVDC	CK05BX104K
C16	CAPACITOR, FIXED, CERAMIC, 0.1 pf, ±10%, 50 WVDC	CK05BX104K
C17	CAPACITOR, FIXED, CERAMIC, 0.1 pf, ±10%, 50 WVDC	CK05BX104K
C18	CAPACITOR, FIXED, CERAMIC, 0.1 pf, ±10%, 50 WVDC	CK05BX104K
C19	CAPACITOR, FIXED, CERAMIC, 0.1 pf, ±10%, 50 WVDC	CK05BX104K
C20	CAPACITOR, FIXED, ELECTROLYTIC, 10 pf, ±20%, 50 WVDC	183-5007-060
C21	CAPACITOR, FIXED, CERAMIC, 1,000 pf, ±20%, 1,000 WVDC	913-1186-000
CR1	SEMICONDUCTOR DEVICE, DIODE, SILICON, 100V PIV, 300MA FAST RECOVERY, DO-35 PKG (TYPE 1N4148)	353-3763-010
CR2	SEMICONDUCTOR DEVICE, DIODE, SILICON, 100V PIV, 300MA FAST RECOVERY, DO-35 PKG (TYPE 1N4148)	353-3763-010
DS1	SEMICONDUCTOR DEVICE, PHOTO, GREEN	353-0293-010

PL643-0003-002 CIRCUIT CARD ASSEMBLY, FREQUENCY DIVIDER

Rev E

Ref. Des.	Description	Part No.
DS2	SEMICONDUCTOR DEVICE, PHOTO, GREEN	353-0293-010
J1	CONNECTOR, RECEPTACLE, ELECTRICAL, BNC PANEL MOUNT	259-5205-010
J2	CONNECTOR, RECEPTACLE, ELECTRICAL, 16 POSITIONS SINGLE ROW, SHROUDED HEADER, SQ STRAIGHT POST	372-9765-010
J3	CONNECTOR, PIN HEADER, 6 PIN, ELECTRICAL, PC MOUNT SNGL ROW, 0.100" CENTERS, 0.025" SQ PIN, GOLD FINISH	372-9604-180
L1	COIL, RADIO FREQUENCY, 1.80 μ H, \pm 10%, 0.525 AMPS	MS18130-11
P1	CONNECTOR, JUMPER, 2-CIRCUIT	372-9604-150
Q1	TRANSISTOR, SILICON, NPN	352-0661-020
Q2	TRANSISTOR, SILICON, NPN	352-0661-020
Q3	TRANSISTOR, SILICON, NPN	352-0661-020
Q4	TRANSISTOR, SILICON, NPN	352-0661-020
R1	RESISTOR, FIXED, FILM: 47.5 Ω , \pm 1%, 1/4 WATT @ 70C	724-5052-090
R2	RESISTOR, FIXED, FILM: 1000 Ω , \pm 1%, 1/4 WATT @ 70C	724-5052-400
R3	RESISTOR, FIXED, FILM: 10K Ω , \pm 1%, 1/4 WATT @ 70C	724-5052-600
R4	RESISTOR, FIXED, FILM: 5620 Ω , \pm 1%, 1/4 WATT @ 70C	724-5052-535
R5	RESISTOR, FIXED, FILM: 6810 Ω , \pm 1%, 1/4 WATT @ 70C	724-5052-545
R6	RESISTOR, FIXED, FILM: 221K Ω , \pm 1%, 1/4 WATT @ 70C	724-5052-855
R7	RESISTOR, FIXED, FILM: 100 Ω , \pm 1%, 1/4 WATT @ 70C	724-5052-200
R8	RESISTOR, FIXED, FILM: 681 Ω , \pm 1%, 1/4 WATT @ 70C	724-5052-310
R9	RESISTOR, FIXED, FILM: 221K Ω , \pm 1%, 1/4 WATT @ 70C	724-5052-855
R10	RESISTOR, FIXED, FILM: 182 Ω , \pm 1%, 1/4 WATT @ 70C	724-5052-235
R11	RESISTOR NETWORK: 8 RESISTORS, 10K Ω , \pm 2%, 1/4 WATT	736-7026-360
R12	RESISTOR NETWORK: 8 RESISTORS, 10K Ω , \pm 2%, 1/4 WATT	736-7026-360
R13	RESISTOR, FIXED, FILM: 6810 Ω , \pm 1%, 1/4 WATT @ 70C	724-5052-545
R14	RESISTOR, FIXED, FILM: 221K Ω , \pm 1%, 1/4 WATT @ 70C	724-5052-855

PL643-0003-002 CIRCUIT CARD ASSEMBLY, FREQUENCY DIVIDER

Rev E

Ref. Des.	Description	Part No.
R15	RESISTOR, FIXED, FILM: 100 Ω , $\pm 1\%$, 1/4 WATT @ 70C	724-5052-200
R16	RESISTOR, FIXED, FILM: 681 Ω , $\pm 1\%$, 1/4 WATT @ 70C	724-5052-310
R17	RESISTOR, FIXED, FILM: 221K Ω , $\pm 1\%$, 1/4 WATT @ 70C	724-5052-855
R18	RESISTOR, FIXED, FILM: 182 Ω , $\pm 1\%$, 1/4 WATT @ 70C	724-5052-235
R19	RESISTOR, FIXED, FILM: 475 Ω , $\pm 1\%$, 1/4 WATT @ 70C	724-5052-285
R20	RESISTOR, FIXED, FILM: 2740 Ω $\pm 1\%$, 1/4 WATT @ 70C	724-5052-480
R21	RESISTOR, FIXED, FILM: 2740 Ω $\pm 1\%$, 1/4 WATT @ 70C	724-5052-480
R22	RESISTOR, FIXED, FILM: 2740 Ω $\pm 1\%$, 1/4 WATT @ 70C	724-5052-480
S1	SWITCH, DUAL-IN-LINE PACKAGE, 4 POSITIONS, SPST	266-0243-010
S2	SWITCH, DUAL-IN-LINE PACKAGE, 4 POSITIONS, SPST	266-0243-010
S3	SWITCH, DUAL-IN-LINE PACKAGE, 4 POSITIONS, SPST	266-0243-010
S4	SWITCH, DUAL-IN-LINE PACKAGE, 4 POSITIONS, SPST	266-0243-010
TP1	JACK, TIP, 1/16 BOARD THICKNESS, 0.040 PIN DIA	360-5003-010
TP2	TERMINAL, STUD, MINIATURE TURRET TYPE STANDOFF	306-1126-000
TP3	TERMINAL, STUD, MINIATURE TURRET TYPE STANDOFF	306-1126-000
TP4	TERMINAL, STUD, MINIATURE TURRET TYPE STANDOFF	306-1126-000
TP5	TERMINAL, STUD, MINIATURE TURRET TYPE STANDOFF	306-1126-000
U1	MICROCIRCUIT, DIGITAL, 2 MODULUS PRESCALER 16 PIN DIP	351-4708-010
U2	MICROCIRCUIT, DIGITAL, D-TYPE FLIP-FLOP, TTL, PLASTIC	351-1710-020
U3	MICROCIRCUIT, DIGITAL, BCD COUNTER, 16 PIN DIP	351-1711-010
U4	MICROCIRCUIT, DIGITAL, BCD COUNTER, 16 PIN DIP	351-1711-010
U5	MICROCIRCUIT, DIGITAL, BCD COUNTER, 16 PIN DIP	351-1711-010
U6	MICROCIRCUIT, DIGITAL, BCD COUNTER, 16 PIN DIP	351-1711-010
U7	MICROCIRCUIT, DIGITAL: DUAL 4-INPUT LOGIC GATE	351-1548-090
U8	MICROCIRCUIT, DIGITAL, MONOSTABLE MULTIVIBRATOR, TTL	351-7645-010

PL643-0003-002 CIRCUIT CARD ASSEMBLY, FREQUENCY DIVIDER

Rev E

Ref. Des.	Description	Part No.
U9	MICROCIRCUIT, DIGITAL, 4 BIT BINARY COUNTER, 14 PIN	351-1711-060
U10	MICROCIRCUIT, DIGITAL, DECADE COUNTER, 14 PIN DIP	351-1711-050
XU1	SOCKET, INTEGRATED CIRCUIT, DUAL IN-LINE, 16 PINS	220-0049-020
XU2	SOCKET, INTEGRATED CIRCUIT, DUAL IN-LINE, 14 PINS	220-0049-010
XU3	SOCKET, INTEGRATED CIRCUIT, DUAL IN-LINE, 16 PINS	220-0049-020
XU4	SOCKET, INTEGRATED CIRCUIT, DUAL IN-LINE, 16 PINS	220-0049-020
XU5	SOCKET, INTEGRATED CIRCUIT, DUAL IN-LINE, 16 PINS	220-0049-020
XU6	SOCKET, INTEGRATED CIRCUIT, DUAL IN-LINE, 16 PINS	220-0049-020
XU7	SOCKET, INTEGRATED CIRCUIT, DUAL IN-LINE, 14 PINS	220-0049-010
XU8	SOCKET, INTEGRATED CIRCUIT, DUAL IN-LINE, 14 PINS	220-0049-010
XU9	SOCKET, INTEGRATED CIRCUIT, DUAL IN-LINE, 14 PINS	220-0049-010
XU10	SOCKET, INTEGRATED CIRCUIT, DUAL IN-LINE, 14 PINS	220-0049-010
Y1	CCA, DAUGHTER BOARD, FREQUENCY DIVIDER	196990-1

(This Page Intentionally Left Blank)

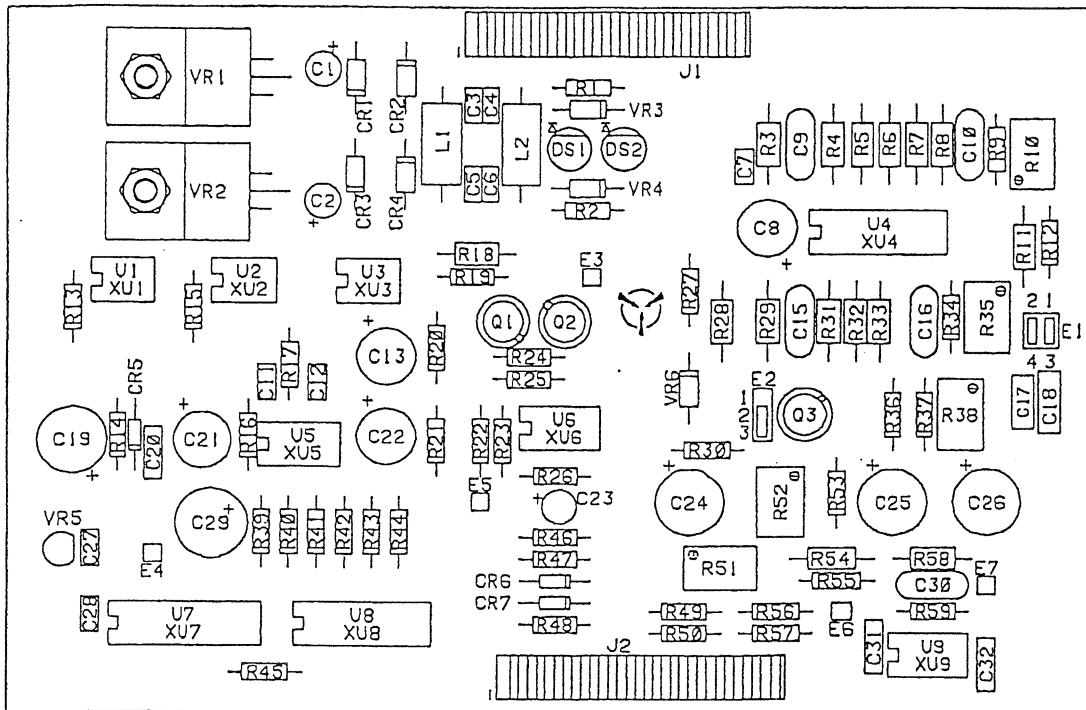

180197

Figure 6-6 Audio/AFC Assembly.

PL180197-2 AUDIO/AFC ASSEMBLY

Rev J

Ref. Des.	Description	Part No.
C1	CAPACITOR, FIXED, ELECTROLYTIC, 10 pf, $\pm 20\%$, 50 WVDC	183-5007-060
C2	CAPACITOR, FIXED, ELECTROLYTIC, 10 pf, $\pm 20\%$, 50 WVDC	183-5007-060
C3	CAPACITOR, FIXED, CERAMIC, 0.1 pf, $\pm 10\%$, 50 WVDC	CK05BX104K
C4	CAPACITOR, FIXED, CERAMIC, 0.1 pf, $\pm 10\%$, 50 WVDC	CK05BX104K
C5	CAPACITOR, FIXED, CERAMIC, 0.1 pf, $\pm 10\%$, 50 WVDC	CK05BX104K
C6	CAPACITOR, FIXED, CERAMIC, 0.1 pf, $\pm 10\%$, 50 WVDC	CK05BX104K
C7	CAPACITOR, FIXED, CERAMIC, 0.1 pf, $\pm 10\%$, 50 WVDC	CK05BX104K
C8	CAPACITOR, FIXED, ELECTROLYTIC, 47 pf, $\pm 10\%$, 20 WVDC	183-5016-080
C9	CAPACITOR, FIXED, CERAMIC, 6.8 pf, $\pm 10\%$, 1,000 WVDC	913-7006-030
C10	CAPACITOR, FIXED, CERAMIC, 6.8 pf, $\pm 10\%$, 1,000 WVDC	913-7006-030
C11	CAPACITOR, FIXED, CERAMIC, 0.01 pf, $\pm 10\%$, 100 WVDC	CK05BX103K
C12	CAPACITOR, FIXED, CERAMIC, 0.01 pf, $\pm 10\%$, 100 WVDC	CK05BX103K
C13	CAPACITOR, FIXED, ELECTROLYTIC, 47 pf, $\pm 10\%$, 20 WVDC	183-5016-080
C15	CAPACITOR, FIXED, CERAMIC, 6.8 pf, $\pm 10\%$, 1,000 WVDC	913-7006-030
C16	CAPACITOR, FIXED, CERAMIC, 6.8 pf, $\pm 10\%$, 1,000 WVDC	913-7006-030
C17	CAPACITOR, FIXED, CERAMIC, 10,000 pf, $\pm 5\%$, 50 WVDC	913-7016-510
C18	CAPACITOR, FIXED, CERAMIC, 4,700 pf, $\pm 5\%$, 50 WVDC	913-7085-020
C19	CAPACITOR, FIXED, ELECTROLYTIC, 100 pf, $\pm 10\%$, 20 WVDC	183-5016-100
C20	CAPACITOR, FIXED, CERAMIC, 1 pf, $\pm 10\%$, 50 WVDC	CK06BX105K
C21	CAPACITOR, FIXED, ELECTROLYTIC, 47 pf, $\pm 10\%$, 20 WVDC	183-5016-080
C22	CAPACITOR, FIXED, ELECTROLYTIC, 47 pf, $\pm 10\%$, 20 WVDC	183-5016-080
C23	CAPACITOR, FIXED, ELECTROLYTIC, 10 pf, $\pm 20\%$, 50 WVDC	183-5007-060
C24	CAPACITOR, FIXED, ELECTROLYTIC, 100 pf, $\pm 10\%$, 20 WVDC	183-5016-100
C25	CAPACITOR, FIXED, ELECTROLYTIC, 100 pf, $\pm 10\%$, 20 WVDC	183-5016-100

PL180197-2 AUDIO/AFC ASSEMBLY

Rev J

Ref. Des.	Description	Part No.
C26	CAPACITOR, FIXED, ELECTROLYTIC, 100 pf, $\pm 10\%$, 20 WVDC	183-5016-100
C27	CAPACITOR, FIXED, CERAMIC, 0.1 pf, $\pm 10\%$, 50 WVDC	CK05BX104K
C28	CAPACITOR, FIXED, CERAMIC, 0.1 pf, $\pm 10\%$, 50 WVDC	CK05BX104K
C29	CAPACITOR, FIXED, ELECTROLYTIC, 470 pf, $\pm 20\%$, 16 WVDC	183-5007-010
C30	CAPACITOR, FIXED, CERAMIC, 6.8 pf, $\pm 10\%$, 1,000 WVDC	913-7006-030
C31	CAPACITOR, FIXED, CERAMIC, 0.27 pf, $\pm 10\%$, 50 WVDC	CK06BX274K
C32	CAPACITOR, FIXED, CERAMIC, 0.27 pf, $\pm 10\%$, 50 WVDC	CK06BX274K
CR1	SEMICONDUCTOR DEVICE, DIODE, 1 AMP, 600Vdc, 420 Vrms	353-6442-050
CR2	SEMICONDUCTOR DEVICE, DIODE, 1 AMP, 600Vdc, 420 Vrms	353-6442-050
CR3	SEMICONDUCTOR DEVICE, DIODE, 1 AMP, 600Vdc, 420 Vrms	353-6442-050
CR4	SEMICONDUCTOR DEVICE, DIODE, 1 AMP, 600Vdc, 420 Vrms	353-6442-050
CR5	SEMICONDUCTOR DEVICE, DIODE, SILICON SWITCHING	353-3763-010
CR6	SEMICONDUCTOR DEVICE, DIODE, SILICON SWITCHING	353-3763-010
CR7	SEMICONDUCTOR DEVICE, DIODE, SILICON SWITCHING	353-3763-010
DS1	SEMICONDUCTOR DEVICE, PHOTO, GREEN	353-0293-010
DS2	SEMICONDUCTOR DEVICE, PHOTO, GREEN	353-0293-010
E1	CONNECTOR, RECEPTACLE, ELECTRICAL, PWB MOUNT, 4 PIN STRAIGHT, 0.100 CENTER, GOLD PLATED	372-9643-060
E2	CONNECTOR, RECEPTACLE, ELECTRICAL, PWB MOUNT, 3 PIN STRAIGHT, 0.100 CENTER, GOLD PLATED	372-9643-040
J1	CONNECTOR, RECEPTACLE, ELECTRICAL, 16 POSITIONS SINGLE ROW, SHROUDED HEADER, SQ STRAIGHT POST	372-9765-010
J2	CONNECTOR, RECEPTACLE, ELECTRICAL, 16 POSITIONS SINGLE ROW, SHROUDED HEADER, SQ STRAIGHT POST	372-9765-010
L1	COIL, RADIO FREQUENCY, 1.80 pH, $\pm 10\%$, 0.525 AMPS	MS18130-11
L2	COIL, RADIO FREQUENCY, 1.80 pH, $\pm 10\%$, 0.525 AMPS	MS18130-11

PL180197-2 AUDIO/AFC ASSEMBLY

Rev J

Ref. Des.	Description	Part No.
Q1	TRANSISTOR, SILICON, NPN	352-0661-020
Q2	TRANSISTOR, SILICON, NPN	352-0661-020
Q3	TRANSISTOR, N-CHANNEL JFET, 3 LEAD TO-52	352-5178-010
R1	RESISTOR, FIXED, FILM: 182 Ω , $\pm 1\%$, 1/4 WATT @ 70C	724-5052-235
R2	RESISTOR, FIXED, FILM: 182 Ω , $\pm 1\%$, 1/4 WATT @ 70C	724-5052-235
R3	RESISTOR, FIXED, FILM: 25.5K Ω , $\pm 1\%$, 1/4 WATT @ 70C	724-5052-680
R4	RESISTOR, FIXED, FILM: 24.9K Ω , $\pm 1\%$, 1/4 WATT @ 70C	724-5052-675
R5	RESISTOR, FIXED, FILM: 24.9K Ω , $\pm 1\%$, 1/4 WATT @ 70C	724-5052-675
R6	RESISTOR, FIXED, FILM: 24.9K Ω , $\pm 1\%$, 1/4 WATT @ 70C	724-5052-675
R7	RESISTOR, FIXED, FILM: 24.9K Ω , $\pm 1\%$, 1/4 WATT @ 70C	724-5052-675
R8	RESISTOR, FIXED, FILM: 24.9K Ω , $\pm 1\%$, 1/4 WATT @ 70C	724-5052-675
R9	RESISTOR, FIXED, FILM: 22.1K Ω , $\pm 1\%$, 1/4 WATT @ 70C	724-5052-665
R10	RESISTOR, VARIABLE, NONWIRE WOUND: 5000 Ω S, $\pm 10\%$, 1/2 WATT	382-1405-060
R11	RESISTOR, FIXED, FILM: 5110 Ω , $\pm 1\%$, 1/4 WATT @ 70C	724-5052-530
R12	RESISTOR, FIXED, FILM: 182 Ω , $\pm 1\%$, 1/4 WATT @ 70C	724-5052-235
R13	RESISTOR, FIXED, FILM: 10K Ω , $\pm 1\%$, 1/4 WATT @ 70C	724-5052-600
R14	RESISTOR, FIXED, FILM: 5620 Ω , $\pm 1\%$, 1/4 WATT @ 70C	724-5052-535
R15	RESISTOR, FIXED, FILM: 3320 Ω , $\pm 1\%$, 1/4 WATT @ 70C	724-5052-490
R16	RESISTOR, FIXED, FILM: 150K Ω , $\pm 1\%$, 1/4 WATT @ 70C	724-5052-835
R17	RESISTOR, FIXED, FILM: 150K Ω , $\pm 1\%$, 1/4 WATT @ 70C	724-5052-835
R18	RESISTOR, FIXED, FILM: 9090 Ω , $\pm 1\%$, 1/4 WATT @ 70C	724-5052-570
R19	RESISTOR, FIXED, FILM: 10 Ω , $\pm 1\%$, 1/4 WATT @ 70C	724-5052-010
R20	RESISTOR, FIXED, FILM: 2210 Ω , $\pm 1\%$, 1/4 WATT @ 70C	724-5052-460
R21	RESISTOR, FIXED, FILM: 825 Ω , $\pm 1\%$, 1/4 WATT @ 70C	724-5052-325
R22	RESISTOR, FIXED, FILM: 12.1K Ω , $\pm 1\%$, 1/4 WATT @ 70C	724-5052-625

PL180197-2 AUDIO/AFC ASSEMBLY

Rev J

Ref. Des.	Description	Part No.
R23	RESISTOR, FIXED, FILM: 6810 Ω , $\pm 1\%$, 1/4 WATT @ 70C	724-5052-545
R24	RESISTOR, FIXED, FILM: 6810 Ω , $\pm 1\%$, 1/4 WATT @ 70C	724-5052-545
R25	RESISTOR, FIXED, FILM: 6810 Ω , $\pm 1\%$, 1/4 WATT @ 70C	724-5052-545
R26	RESISTOR, FIXED, FILM: 1000 Ω , $\pm 1\%$, 1/4 WATT @ 70C	724-5052-400
R27	RESISTOR, FIXED, FILM: 332 Ω , $\pm 1\%$, 1/4 WATT @ 70C	724-5052-265
R28	RESISTOR, FIXED, FILM: 2050 Ω , $\pm 1\%$, 1/4 WATT @ 70C	724-5052-455
R29	RESISTOR, FIXED, FILM: 2550 Ω , $\pm 1\%$, 1/4 WATT @ 70C	724-5052-470
R30	RESISTOR, FIXED, FILM: 332 Ω , $\pm 1\%$, 1/4 WATT @ 70C	724-5052-265
R31	RESISTOR, FIXED, FILM: 24.9K Ω , $\pm 1\%$, 1/4 WATT @ 70C	724-5052-675
R32	RESISTOR, FIXED, FILM: 24.9K Ω , $\pm 1\%$, 1/4 WATT @ 70C	724-5052-675
R33	RESISTOR, FIXED, FILM: 24.9K Ω , $\pm 1\%$, 1/4 WATT @ 70C	724-5052-675
R34	RESISTOR, FIXED, FILM: 22.1K Ω , $\pm 1\%$, 1/4 WATT @ 70C	724-5052-665
R35	RESISTOR, VARIABLE, NONWIRE WOUND: 5000 Ω S, $\pm 10\%$, 1/2 WATT	382-1405-060
R36	RESISTOR, FIXED, FILM: 100K Ω , $\pm 1\%$, 1/4 WATT @ 70C	724-5052-800
R37	RESISTOR, FIXED, FILM: 3320 Ω , $\pm 1\%$, 1/4 WATT @ 70C	724-5052-490
R38	RESISTOR, VARIABLE, NONWIRE WOUND: 2000 Ω S, $\pm 10\%$, 1/2 WATT	382-1405-050
R39	RESISTOR, FIXED, FILM: 10K Ω , $\pm 1\%$, 1/4 WATT @ 70C	724-5052-600
R40	RESISTOR, FIXED, FILM: 100K Ω , $\pm 1\%$, 1/4 WATT @ 70C	724-5052-800
R41	RESISTOR, FIXED, FILM: 100K Ω , $\pm 1\%$, 1/4 WATT @ 70C	724-5052-800
R42	RESISTOR, FIXED, FILM: 100K Ω , $\pm 1\%$, 1/4 WATT @ 70C	724-5052-800
R43	RESISTOR, FIXED, FILM: 10K Ω , $\pm 1\%$, 1/4 WATT @ 70C	724-5052-600
R44	RESISTOR, FIXED, FILM: 475 Ω , $\pm 1\%$, 1/4 WATT @ 70C	724-5052-285
R45	RESISTOR, FIXED, FILM: 10K Ω , $\pm 1\%$, 1/4 WATT @ 70C	724-5052-600
R46	RESISTOR, FIXED, FILM: 1000 Ω , $\pm 1\%$, 1/4 WATT @ 70C	724-5052-400
R47	RESISTOR, FIXED, FILM: 475K Ω , $\pm 1\%$, 1/4 WATT @ 70C	724-5052-905

PL180197-2 AUDIO/AFC ASSEMBLY

Rev J

Ref. Des.	Description	Part No.
R48	RESISTOR, FIXED, FILM: 10K Ω , $\pm 1\%$, 1/4 WATT @ 70C	724-5052-600
R49	RESISTOR, FIXED, FILM: 681 Ω , $\pm 1\%$, 1/4 WATT @ 70C	724-5052-310
R50	RESISTOR, FIXED, FILM: 10 Ω , $\pm 1\%$, 1/4 WATT @ 70C	724-5052-010
R51	RESISTOR, VARIABLE, NONWIRE WOUND: 2000 Ω S, $\pm 10\%$, 1/2 WATT	382-1405-050
R52	RESISTOR, VARIABLE, NONWIRE WOUND: 5000 Ω S, $\pm 10\%$, 1/2 WATT	382-1405-060
R53	RESISTOR, FIXED, FILM: 332 Ω , $\pm 1\%$, 1/4 WATT @ 70C	724-5052-265
R54	RESISTOR, FIXED, FILM: 8250 Ω , $\pm 1\%$, 1/4 WATT @ 70C	724-5052-560
R55	RESISTOR, FIXED, FILM: 3320 Ω , $\pm 1\%$, 1/4 WATT @ 70C	724-5052-490
R56	RESISTOR, FIXED, FILM: 1000 Ω , $\pm 1\%$, 1/4 WATT @ 70C	724-5052-400
R57	RESISTOR, FIXED, FILM: 1000 Ω , $\pm 1\%$, 1/4 WATT @ 70C	724-5052-400
R58	RESISTOR, FIXED, FILM: 9090 Ω , $\pm 1\%$, 1/4 WATT @ 70C	724-5052-570
R59	RESISTOR, FIXED, FILM: 10K Ω , $\pm 1\%$, 1/4 WATT @ 70C	724-5052-600
U1	COUPLER, OPTOELECTRONIC, FET OUTPUT, 6 PIN PLASTIC DIP PKG	419-0094-010
U2	COUPLER, OPTOELECTRONIC, FET OUTPUT, 6 PIN PLASTIC DIP PKG	419-0094-010
U3	COUPLER, OPTOELECTRONIC, FET OUTPUT, 6 PIN PLASTIC DIP PKG	419-0094-010
U4	MICROCIRCUIT, LINEAR, QUAD OPERATIONAL AMPLIFIER, 14 LEAD PLASTIC DUAL IN-LINE PACKAGE	351-1370-020
U5	MICROCIRCUIT, LINEAR, DUAL OPERATIONAL AMPLIFIER, 8 LEAD PLASTIC DUAL IN-LINE PACKAGE	351-1370-040
U6	MICROCIRCUIT, LINEAR, DUAL OP-AMP, 8 PIN DIP, PLASTIC	351-1211-040
U7	MICROCIRCUIT, DIGITAL, PHASE COMPARATOR, PROG COUNTER	351-8883-010
U8	MICROCIRCUIT, DIGITAL, D-TYPE FLIP-FLOP, TTL, PLASTIC	351-1710-020
U9	MICROCIRCUIT, LINEAR, DUAL OPERATIONAL AMPLIFIER DUAL IN-LINE PACKAGE	351-1370-040
VR1	MICROCIRCUIT, LINEAR, VOLTAGE REGULATOR, -15 VOLT, 0.5 AMP, PLASTIC PACKAGE, TO-221A-03	351-4909-010

PL180197-2 AUDIO/AFC ASSEMBLY

Rev J

Ref. Des.	Description	Part No.
VR2	MICROCIRCUIT, LINEAR, +15 V @ 1 A VOLTAGE REGULATOR TO-220 PLASTIC PACKAGE	351-1120-050
VR3	SEMICONDUCTOR DEVICE, DIODE, ZENER, 9.1 VOLT, ±5%	353-6481-230
VR4	SEMICONDUCTOR DEVICE, DIODE, ZENER, 9.1 VOLT, ±5%	353-6481-230
VR5	MICROCIRCUIT, LINEAR, VOLTAGE REGULATOR, 5 VOLTS, ±5%, 100mA	351-5306-010
VR6	SEMICONDUCTOR DEVICE, DIODE, SILICON, 12 VOLT, 1W	353-6481-300
XU1	SOCKET, MICROCIRCUIT, 6 PINS, DUAL IN-LINE, 0.3 PIN SPACING	220-6015-010
XU2	SOCKET, MICROCIRCUIT, 6 PINS, DUAL IN-LINE, 0.3 PIN SPACING	220-6015-010
XU3	SOCKET, MICROCIRCUIT, 6 PINS, DUAL IN-LINE, 0.3 PIN SPACING	220-6015-010
XU4	SOCKET, INTEGRATED CIRCUIT, DUAL IN-LINE, 14 PINS	220-0049-010
XU5	SOCKET, INTEGRATED CIRCUIT, DUAL IN-LINE, 8 PINS	220-0049-100
XU6	SOCKET, INTEGRATED CIRCUIT, DUAL IN-LINE, 8 PINS	220-0049-100
XU7	SOCKET, INTEGRATED CIRCUIT, DUAL IN-LINE, 16 PINS	220-0049-020
XU8	SOCKET, INTEGRATED CIRCUIT, DUAL IN-LINE, 14 PINS	220-0049-010
XU9	SOCKET, INTEGRATED CIRCUIT, DUAL IN-LINE, 8 PINS	220-0049-100

(This Page Intentionally Left Blank)

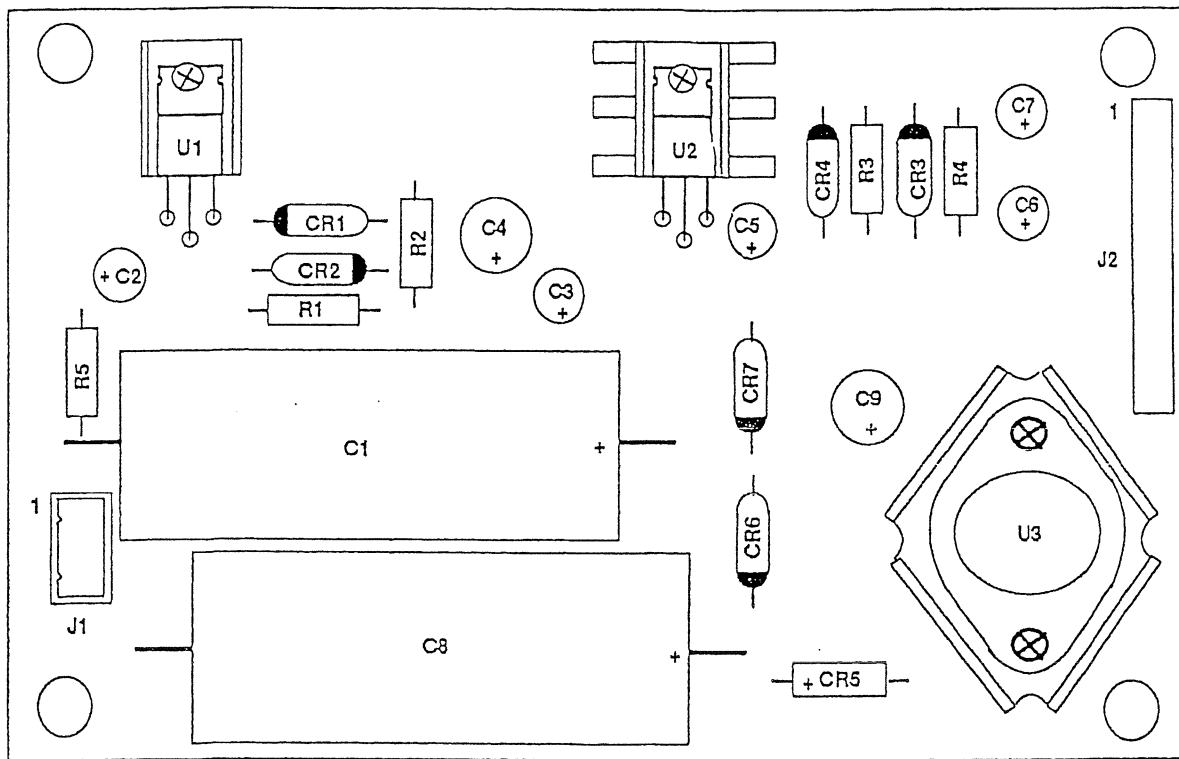

643-0008-002

Figure 6-7 Power Supply Circuit Card Assembly.

PL643-0009-002 CCA, POWER SUPPLY

Rev B

Ref. Des.	Description	Part No.
C1	CAPACITOR, FIXED, ELECTROLYTIC, 1100 μ f, +75-10%, 50 WVDC	183-5006-010
C2	CAPACITOR, FIXED, ELECTROLYTIC, 10 μ f, \pm 20%, 50 WVDC	183-5007-060
C3	CAPACITOR, FIXED, ELECTROLYTIC, 10 μ f, \pm 20%, 50 WVDC	183-5007-060
C4	CAPACITOR, FIXED, ELECTROLYTIC, 100 μ f, \pm 20%, 50 WVDC	183-5007-040
C5	CAPACITOR, FIXED, ELECTROLYTIC, 10 μ f, \pm 20%, 50 WVDC	183-5007-060
C6	CAPACITOR, FIXED, ELECTROLYTIC, 10 μ f, \pm 20%, 50 WVDC	183-5007-060
C7	CAPACITOR, FIXED, ELECTROLYTIC, 100 μ f, \pm 20%, 50 WVDC	183-5007-040
C8	CAPACITOR, FIXED, ELECTROLYTIC, 5300 μ f, +75-10%, 15 WVDC	183-5006-020
C9	CAPACITOR, FIXED, ELECTROLYTIC, 100 μ f, \pm 20%, 50 WVDC	183-5007-040
CR1	SEMICONDUCTOR DEVICE, DIODE, 1 AMP, 600Vdc, 420 Vrms	353-6442-050
CR2	SEMICONDUCTOR DEVICE, DIODE, 1 AMP, 600Vdc, 420 Vrms	353-6442-050
CR3	SEMICONDUCTOR DEVICE, DIODE, 1 AMP, 600Vdc, 420 Vrms	353-6442-050
CR4	SEMICONDUCTOR DEVICE, DIODE, 1 AMP, 600Vdc, 420 Vrms	353-6442-050
CR5	RECTIFIER, SEMICONDUCTOR DEVICE, 1 PH, 2 AMP, 400 VOLT	353-5015-010
CR6	SEMICONDUCTOR DEVICE, DIODE, 1 AMP, 600Vdc, 420 Vrms	353-6442-050
CR7	SEMICONDUCTOR DEVICE, DIODE, 1 AMP, 600Vdc, 420 Vrms	353-6442-050
J1	CONNECTOR, PLUG, ELECTRICAL, HOUSING, 6 PIN	372-9604-100
J2	CONNECTOR, RECEPTACLE, ELECTRICAL, 16 POSITIONS SINGLE ROW, SHROUDED HEADER, SQ STRAIGHT POST	372-9765-010
R1	RESISTOR, FIXED, FILM: 121 Ω , \pm 1%, 1/4 WATT @ 70C	724-5052-210
R2	RESISTOR, FIXED, FILM: 2000 Ω , \pm 1%, 1/4 WATT @ 70C	724-5052-450
R3	RESISTOR, FIXED, FILM: 221 Ω , \pm 1%, 1/4 WTT @ 70C	724-5052-245
R4	RESISTOR, FIXED, FILM: 3650 Ω , \pm 1%, 1/4 WATT @ 70C	724-5052-500
R5	RESSITOR, FIXED, FILM: 22.1 Ω , \pm 1%, 1/2 WATT @ 70C	724-5053-050

PL643-0009-002 CCA, POWER SUPPLY

Rev B

Ref. Des.	Description	Part No.
U1	MICROCIRCUIT, LINEAR, VOLTAGE REGULATOR, NEG, ADJ OUT TO-220	351-1345-030
U2	MICROCIRCUIT, LINEAR, 5 VOLT REGULATOR, TO-220 PKG	351-1271-010
U3	MICROCIRCUIT, LINEAR, +5 VOLT @ 1 AMP, V REGULATOR	351-1120-080

(This Page Intentionally Left Blank)

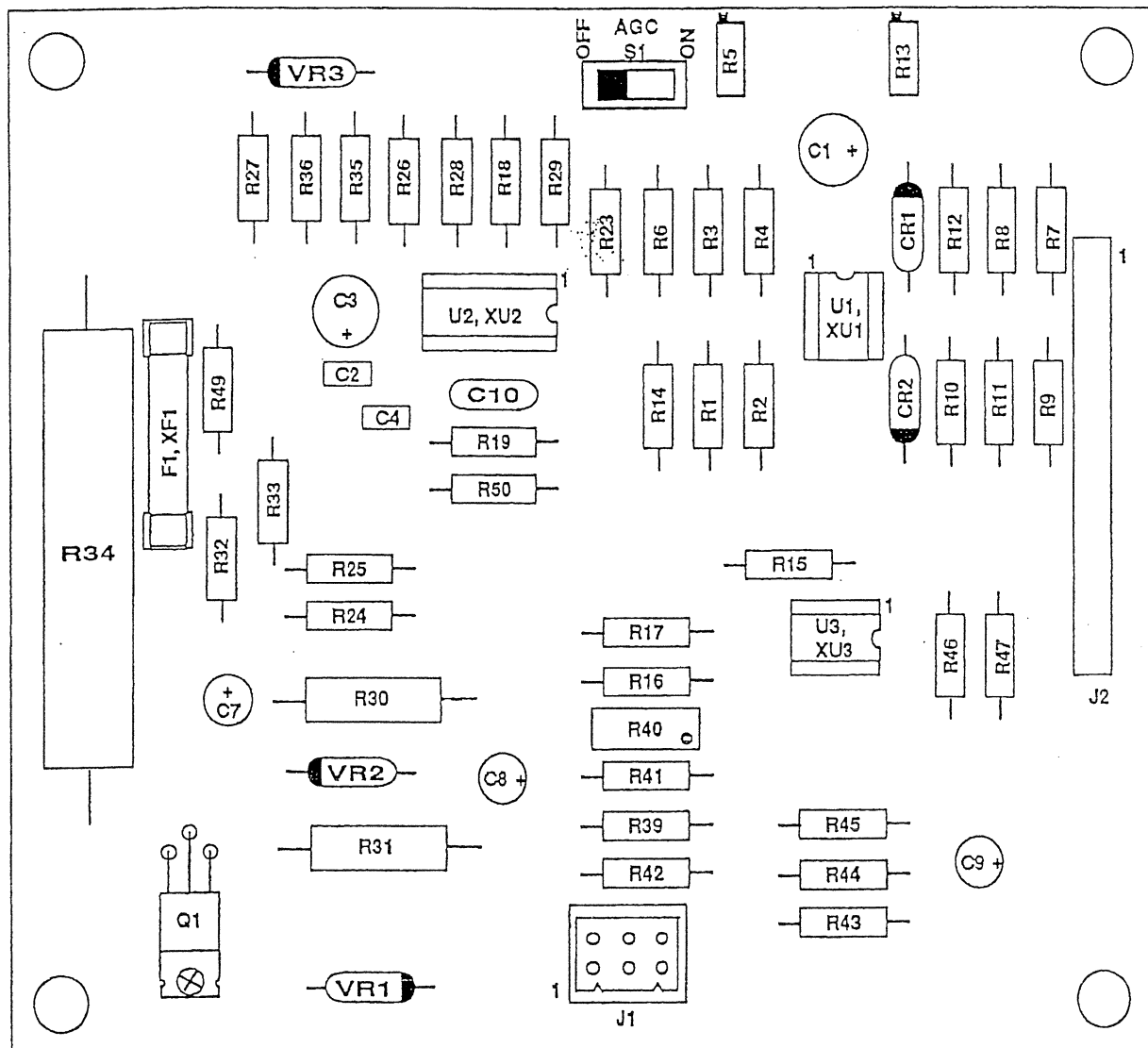

180247-2

Figure 6-8 Amplifier Control Circuit Card Assembly.

PL180247-2 CIRCUIT CARD ASSEMBLY, AMPLIFIER CONTROL

Rev J

Ref. Des.	Description	Part No.
C1	CAPACITOR, FIXED, ELECTROLYTIC, 33 uf, ±20%, 50 WVDC	183-5007-030
C2	CAPACITOR, FIXED, CERAMIC, 0.1 uf, ±10%, 50 WVDC	CK05BX104K
C3	CAPACITOR, FIXED, ELECTROLYTIC, 33 uf, ±20%, 50 WVDC	183-5007-030
C4	CAPACITOR, FIXED, CERAMIC, 0.1 uf, ±10%, 50 WVDC	CK05BX104K
C5	NOT-USED	
C6	NOT-USED	
C7	CAPACITOR, FIXED, ELECTROLYTIC, 33 uf, ±10%, 20 WVDC	183-5016-070
C8	CAPACITOR, FIXED, ELECTROLYTIC, 33 uf, ±10%, 20 WVDC	183-5016-070
C9	CAPACITOR, FIXED, ELECTROLYTIC, 33 uf, ±10%, 20 WVDC	183-5016-070
C10	CAPACITOR, FIXED, CERAMIC, 0.33 uf, ±10%, 50 WVDC	CK06BX334K
CR1	SEMICONDUCTOR DEVICE, DIODE, SILICON SWITCHING	353-3763-010
CR2	SEMICONDUCTOR DEVICE, DIODE, SILICON SWITCHING	353-3763-010
F1	FUSE, CARTRIDGE, 5 AMPS, 250V, NORMAL BLOW, 1/4 X 1-1/4	264-0726-000
J1	CONNECTOR BODY, PLUG, ELECTRICAL, 6 CAVITY PLUG, W/LOCK ONLY, NO MOUNTING EARS	372-5909-770
J2	CONNECTOR, RECEPTACLE, ELECTRICAL, 16 POSITIONS SINGLE ROW, SHROUDED HEADER, SQ STRAIGHT POST	372-9765-010
Q1	SEMICONDUCTOR DEVICE, THYRISTOR, 100 VOLT, 10 AMP	352-4008-010
R1	RESISTOR, FIXED, FILM: 10Kohm, ±1%, 1/4 WATT @ 70C	724-5052-600
R2	RESISTOR, FIXED, FILM: 10Kohm, ±1%, 1/4 WATT @ 70C	724-5052-600
R3	RESISTOR, FIXED, FILM: 1820 ohm, ±1%, 1/4 WATT @ 70C	724-5052-445
R4	RESISTOR, FIXED, FILM: 1820 ohm, ±1%, 1/4 WATT @ 70C	724-5052-445
R5	RESISTOR, VARIABLE, NONWIRE WOUND: 10Kohm, ±10%, 1/2 WATT	382-1405-220
R6	RESISTOR, FIXED, FILM: 15Kohm, ±ohm, 1%, 1/4 WATT @ 70C	724-5052-645

PL180247-2 CIRCUIT CARD ASSEMBLY, AMPLIFIER CONTROL

Rev J

Ref. Des.	Description	Part No.
R7	RESISTOR, FIXED, FILM: 3920 ohm, ±1%, 1/4 WATT @ 70C	724-5052-510
R8	RESISTOR, FIXED, FILM: 3920 ohm, ±1%, 1/4 WATT @ 70C	724-5052-510
R9	RESISTOR, FIXED, FILM: 10K ohm, ±1%, 1/4 WATT @ 70C	724-5052-600
R10	RESISTOR, FIXED, FILM: 1820 ohm, ±1%, 1/4 WATT @ 70C	724-5052-445
R11	RESISTOR, FIXED, FILM: 10K ohm, ±1%, 1/4 WATT @ 70C	724-5052-600
R12	RESISTOR, FIXED, FILM: 1000 ohm, ±1%, 1/4 WATT @ 70C	724-5052-400
R13	RESISTOR, VARIABLE, NONWIRE WOUND: 10K ohm, ±10%, 1/2 WATT	382-1405-220
R14	RESISTOR, FIXED, FILM: 10K ohm, ±1%, 1/4 WATT @ 70C	724-5052-600
R15	RESISTOR, FIXED, FILM: 15K ohm, ±1%, 1/4 WATT @ 70C	724-5052-645
R16	RESISTOR, FIXED, FILM: 10K ohm, ±1%, 1/4 WATT @ 70C	724-5052-600
R17	RESISTOR, FIXED, FILM: 1000 ohm, ±1%, 1/4 WATT @ 70C	724-5052-400
R18	RESISTOR, FIXED, FILM: 82.5K ohm, ±1%, 1/4 WATT @ 70C	724-5052-780
R19	RESISTOR, FIXED, FILM: 1000 ohm, ±1%, 1/4 WATT @ 70C	724-5052-400
R20	NOT-USED	
R21	RESISTOR, FIXED, FILM: 10K ohm, ±1%, 1/4 WATT @ 70C	724-5052-600
R22	NOT-USED	
R23	RESISTOR, FIXED, FILM: 8250 ohm, ±1%, 1/4 WATT @ 70C	724-5052-560
R24	RESISTOR, FIXED, FILM: 182 ohm, ±1%, 1/4 WATT @ 70C	724-5052-235
R25	RESISTOR, FIXED, FILM: 8250 ohm, ±1%, 1/4 WATT @ 70C	724-5052-560
R26	RESISTOR, FIXED, FILM: 182 ohm ±1%, 1/4 WATT @ 70C	724-5052-235
R27	RESISTOR, FIXED, FILM: 22.1 ohm, ±1%, 1/4 WATT @ 70C	724-5052-050
R28	RESISTOR, FIXED, FILM: 1000 ohm, ±1%, 1/4 WATT @ 70C	724-5052-400
R29	RESISTOR, FIXED, FILM: 27.4K ohm, ±1%, 1/4 WATT @ 70C	724-5052-685
R30	RESISTOR, FIXED, WIRE WOUND: 0.2 ohm, ±1%, 3 WATT	725-3002-020
R31	RESISTOR, FIXED, WIRE WOUND: 0.2 ohm, ±1%, 3 WATT	725-3002-020

PL180247-2 CIRCUIT CARD ASSEMBLY, AMPLIFIER CONTROL

Rev J

Ref. Des.	Description	Part No.
R32	RESISTOR, FIXED, FILM: 121 ohm, ±1%, 1/4 WATT @ 70C	724-5052-210
R33	RESISTOR, FIXED, FILM: 1000 ohm, ±1%, 1/4 WATT @ 70C	724-5052-400
R34	RESISTOR, FIXED, WIRE WOUND: 2.2 ohm, ±5%, 10 WATT	725-3002-010
R35	RESISTOR, FIXED, FILM: 3920 ohm, ±1%, 1/4 WATT @ 70C	724-5052-510
R36	RESISTOR, FIXED, FILM: 3920 ohm, ±1%, 1/4 WATT @ 70C	724-5052-510
R37	NOT-USED	
R38	NOT-USED	
R39	RESISTOR, FIXED, FILM: 10K ohm, ±1%, 1/4 WATT @ 70C	724-5052-600
R40	RESISTOR, VARIABLE, NONWIRE WOUND: 10K ohm, ±10%, 1/2 WATT	382-1405-070
R41	RESISTOR, FIXED, FILM: 4990 ohm, ±1%, 1/4 WATT @ 70C	724-5052-525
R42	RESISTOR, FIXED, FILM: 10K ohm, ±1%, 1/4 WATT @ 70C	724-5052-600
R43	RESISTOR, FIXED, FILM: 10K ohm, ±1%, 1/4 WATT @ 70C	724-5052-600
R44	RESISTOR, FIXED, FILM: 249K ohm, ±1%, 1/4 WATT @ 70C	724-5052-865
R45	RESISTOR, FIXED, FILM: 1MEG ohm, ±1%, 1/4 WATT @ 70C	724-5052-995
R46	RESISTOR, FIXED, FILM: 3320 ohm, ±1%, 1/4 WATT @ 70C	724-5052-490
R47	RESISTOR, FIXED, FILM: 681 ohm, ±1%, 1/4 WATT @ 70C	724-5052-310
R48	NOT-USED	
R49	RESISTOR, FIXED, WIRE WOUND: 270 ohm, ±5%, 3 WATT	747-5349-000
R50	RESISTOR, FIXED, FILM: 10K ohm, ±1%, 1/4 WATT @ 70C	724-5052-600
S1	SWITCH, SLIDE, SPDT, 4 A @ 115 VAC, 2 A @ 230 VAC	266-9714-010
U1	MICROCIRCUIT, LINEAR, DUAL OP-AMP, 8 PIN DIP, PLASTIC	351-1211-040
U2	MICROCIRCUIT, LINEAR, VOLTAGE REGULATOR, 40 VOLTS INPUT-OUTPUT DIFFERENTIAL, 150mA MAX OUT	351-1035-060
U3	MICROCIRCUIT, LINEAR, DUAL OP-AMP, 8 PIN DIP, PLASTIC	351-1211-040
VR1	SEMICONDUCTOR DEVICE, DIODE, ZENER, 33 VOLT, ±5%	353-6481-490

PL180247-2 CIRCUIT CARD ASSEMBLY, AMPLIFIER CONTROL

Rev J

Ref. Des.	Description	Part No.
VR2	SEMICONDUCTOR DEVICE, DIODE, ZENER, 36 VOLT, $\pm 5\%$,	353-6481-510
VR3	SEMICONDUCTOR DEVICE, DIODE, ZENER, 36 VOLT, $\pm 5\%$,	353-6481-510
XU1	SOCKET, INTEGRATED CIRCUIT, DUAL IN-LINE, 8 PINS	220-0049-100
XU2	SOCKET, INTEGRATED CIRCUIT, DUAL IN-LINE, 14 PINS	220-0049-010
XU3	SOCKET, INTEGRATED CIRCUIT, DUAL IN-LINE, 8 PINS	220-0049-100

(This Page Intentionally Left Blank)

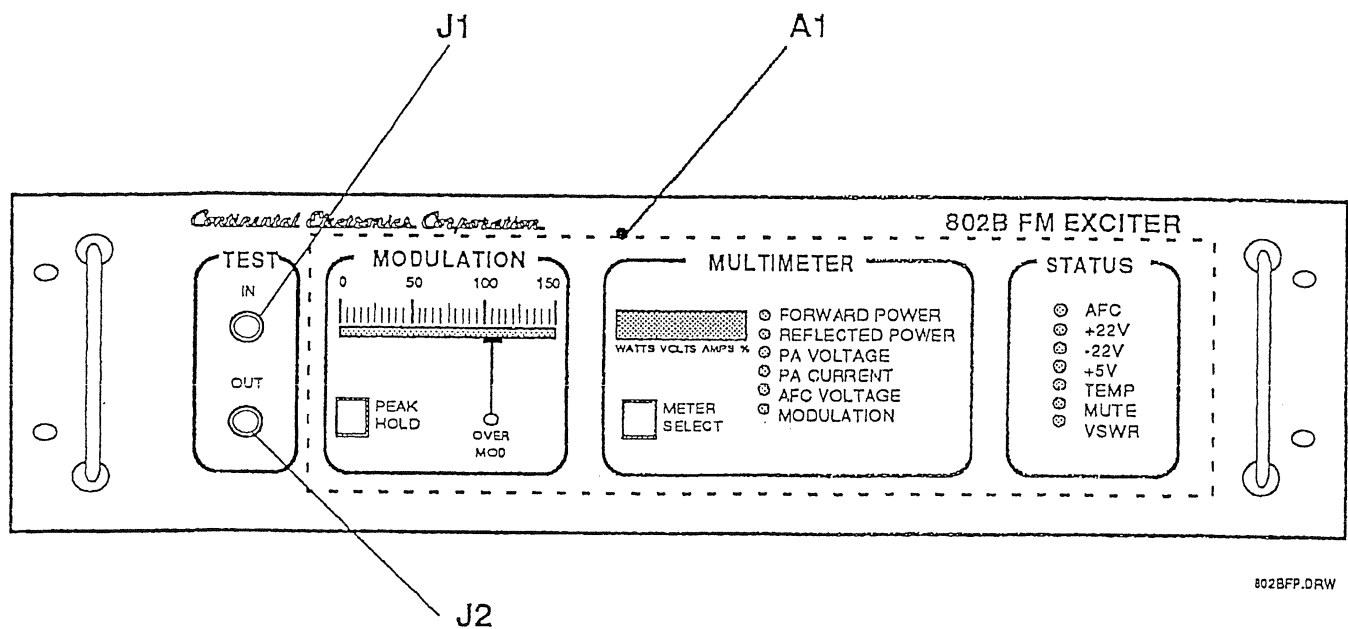

Figure 6-9 Front Panel Assembly.

PL180214-1 FRONT PANEL ASSEMBLY

Rev B

Ref. Des.	Description	Part No.
A1	CIRCUIT CARD ASSY, FRONT PANEL	180202-2
J1	CONNECTOR, RECEPTACLE, ELECTRICAL, BNC, (OD UG-625B/U)	M39012/21-0001
J2	CONNECTOR, RECEPTACLE, ELECTRICAL, BNC, (OD UG-625B/U)	M39012/21-0001

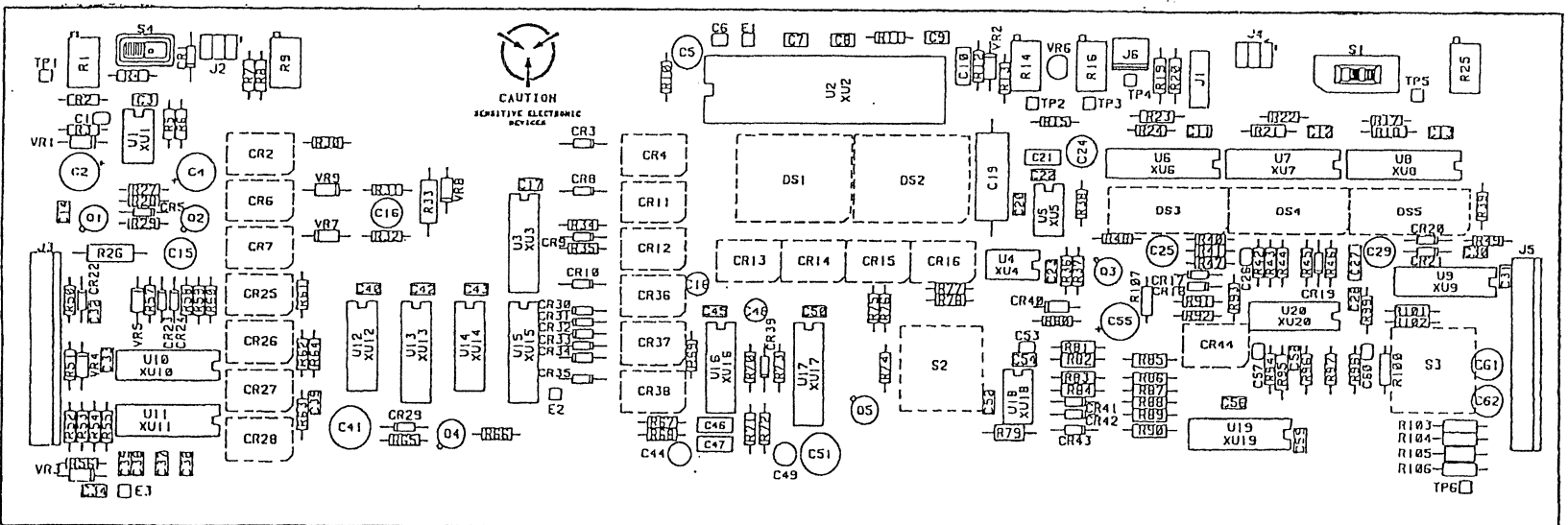

Figure 6-10 Front Panel Circuit Card Assembly.

PL180202-2 CIRCUIT CARD ASSEMBLY, FRONT PANEL

Rev. H

Ref. Des.	Description	Part No.
C1	CAPACITOR, FIXED, CERAMIC, 100 pf, $\pm 5\%$, 50 WVDC	913-7016-150
C2	CAPACITOR, FIXED, ELECTROLYTIC, 47 uf, $\pm 20\%$, 20 WVDC	183-5016-080
C3	CAPACITOR, FIXED, CERAMIC, 0.1 uf, $\pm 10\%$, 50 WVDC	CK05BX104K
C4	CAPACITOR, FIXED, ELECTROLYTIC, 47 uf, $\pm 20\%$, 20 WVDC	183-5016-080
C5	CAPACITOR, FIXED, ELECTROLYTIC, 10 uf, $\pm 10\%$, 25 WVDC	183-5017-070
C6	CAPACITOR, FIXED, CERAMIC, 100 pf, $\pm 5\%$, 50 WVDC	913-7016-150
C7	CAPACITOR, FIXED, CERAMIC, 0.1 uf, $\pm 10\%$, 50 WVDC	CK05BX104K
C8	CAPACITOR, FIXED, CERAMIC, 0.1 uf, $\pm 10\%$, 50 WVDC	CK05BX104K
C9	CAPACITOR, FIXED, CERAMIC, 0.1 uf, $\pm 10\%$, 50 WVDC	CK05BX104K
C10	CAPACITOR, FIXED, CERAMIC, 10,000 pf, $\pm 5\%$, 50 WVDC	913-7016-510
C11	CAPACITOR, FIXED, CERAMIC, 0.1 uf, $\pm 10\%$, 50 WVDC	CK05BX104K
C12	CAPACITOR, FIXED, CERAMIC, 0.1 uf, $\pm 10\%$, 50 WVDC	CK05BX104K
C13	CAPACITOR, FIXED, CERAMIC, 0.1 uf, $\pm 10\%$, 50 WVDC	CK05BX104K
C14	CAPACITOR, FIXED, CERAMIC, 0.1 uf, $\pm 10\%$, 50 WVDC	CK05BX104K
C15	CAPACITOR, FIXED, ELECTROLYTIC, 10 uf, $\pm 10\%$, 25 WVDC	183-5017-070
C16	CAPACITOR, FIXED, ELECTROLYTIC, 10 uf, $\pm 10\%$, 25 WVDC	183-5017-070
C17	CAPACITOR, FIXED, CERAMIC, 0.1 uf, $\pm 10\%$, 50 WVDC	CK05BX104K
C18	CAPACITOR, FIXED, ELECTROLYTIC, 1 uf, $\pm 10\%$, 35 WVDC	183-5018-070
C19	CAPACITOR, FIXED, FILM, .22 uf, $\pm 5\%$, 50WVDC, AXIAL LEADS	933-5049-010
C20	CAPACITOR, FIXED, CERAMIC, 0.1 uf, $\pm 10\%$, 50 WVDC	CK05BX104K
C21	CAPACITOR, FIXED, CERAMIC, 10,000 pf, $\pm 5\%$, 50 WVDC	913-7016-510
C22	CAPACITOR, FIXED, CERAMIC, 0.1 uf, $\pm 10\%$, 50 WVDC	CK05BX104K
C23	CAPACITOR, FIXED, CERAMIC, 0.1 uf, $\pm 10\%$, 50 WVDC	CK05BX104K
C24	CAPACITOR, FIXED, ELECTROLYTIC, 10 uf, $\pm 10\%$, 25 WVDC	183-5017-070

PL180202-2 CIRCUIT CARD ASSEMBLY, FRONT PANEL		Rev. H
Ref. Des.	Description	Part No.
C25	CAPACITOR, FIXED, ELECTROLYTIC, 10 uf, ±10%, 25 WVDC	183-5017-070
C26	CAPACITOR, FIXED, CERAMIC, 6.8 pf, ±10%, 1,000 WVDC	913-7006-030
C27	CAPACITOR, FIXED, CERAMIC, 1 uf, ±10%, 50 WVDC	CK06BX105K
C28	CAPACITOR, FIXED, CERAMIC, 0.1 uf, ±10%, 50 WVDC	CK05BX104K
C29	CAPACITOR, FIXED, ELECTROLYTIC, 10 uf, ±10%, 25 WVDC	183-5017-070
C30	CAPACITOR, FIXED, CERAMIC, 0.1 uf, ±10%, 50 WVDC	CK05BX104K
C31	CAPACITOR, FIXED, CERAMIC, 0.1 uf, ±10%, 50 WVDC	CK05BX104K
C32	CAPACITOR, FIXED, CERAMIC, 0.1 uf, ±10%, 50 WVDC	CK05BX104K
C33	CAPACITOR, FIXED, CERAMIC, 0.1 uf, ±10%, 50 WVDC	CK05BX104K
C34	CAPACITOR, FIXED, CERAMIC, 0.1 uf, ±10%, 50 WVDC	CK05BX104K
C35	CAPACITOR, FIXED, CERAMIC, 0.1 uf, ±10%, 50 WVDC	CK05BX104K
C36	CAPACITOR, FIXED, CERAMIC, 0.1 uf, ±10%, 50 WVDC	CK05BX104K
C37	CAPACITOR, FIXED, CERAMIC, 0.1 uf, ±10%, 50 WVDC	CK05BX104K
C38	CAPACITOR, FIXED, CERAMIC, 0.1 uf, ±10%, 50 WVDC	CK05BX104K
C39	CAPACITOR, FIXED, CERAMIC, 0.1 uf, ±10%, 50 WVDC	CK05BX104K
C40	CAPACITOR, FIXED, CERAMIC, 0.1 uf, ±10%, 50 WVDC	CK05BX104K
C41	CAPACITOR, FIXED, ELECTROLYTIC, 100 uf, ±10%, 6.3 WVDC	184-9612-010
C42	CAPACITOR, FIXED, CERAMIC, 0.1 uf, ±10%, 50 WVDC	CK05BX104K
C43	CAPACITOR, FIXED, CERAMIC, 0.1 uf, ±10%, 50 WVDC	CK05BX104K
C44	CAPACITOR, FIXED, ELECTROLYTIC, 1 uf, ±10%, 35 WVDC	183-5018-070
C45	CAPACITOR, FIXED, CERAMIC, 0.1 uf, ±10%, 50 WVDC	CK05BX104K
C46	CAPACITOR, FIXED, CERAMIC, 10,000 pf, ±5%, 50 WVDC	913-7016-510
C47	CAPACITOR, FIXED, CERAMIC, 10,000 pf, ±5%, 50 WVDC	913-7016-510
C48	CAPACITOR, FIXED, ELECTROLYTIC, 1 uf, ±10%, 35 WVDC	183-5018-070
C49	CAPACITOR, FIXED, ELECTROLYTIC, 1 uf, ±10%, 35 WVDC	183-5018-070

PL180202-2 CIRCUIT CARD ASSEMBLY, FRONT PANEL		Rev. H
Ref. Des.	Description	Part No.
C50	CAPACITOR, FIXED, CERAMIC, 0.1 uf, ±10%, 50 WVDC	CK05BX104K
C51	CAPACITOR, FIXED, ELECTROLYTIC, 100 uf, ±10%, 6.3 WVDC	184-9612-010
C52	CAPACITOR, FIXED, CERAMIC, 0.1 uf, ±10%, 50 WVDC	CK05BX104K
C53	CAPACITOR, FIXED, CERAMIC, 100 pf, ±5%, 50 WVDC	913-7016-150
C54	CAPACITOR, FIXED, CERAMIC, 0.1 uf, ±10%, 50 WVDC	CK05BX104K
C55	CAPACITOR, FIXED, ELECTROLYTIC, 47 uf, ±20%, 20 WVDC	183-5016-080
C56	CAPACITOR, FIXED, CERAMIC, 0.1 uf, ±10%, 50 WVDC	CK05BX104K
C57	CAPACITOR, FIXED, CERAMIC, 6.8 pf, ±10%, 1,000 WVDC	913-7006-030
C58	CAPACITOR, FIXED, CERAMIC, 0.1 uf, ±10%, 50 WVDC	CK05BX104K
C59	CAPACITOR, FIXED, CERAMIC, 0.1 uf, ±10%, 50 WVDC	CK05BX104K
C60	CAPACITOR, FIXED, CERAMIC, 6.8 pf, ±10%, 1,000 WVDC	913-7006-030
C61	CAPACITOR, FIXED, ELECTROLYTIC, 10 uf, ±10%, 25 WVDC	183-5017-070
C62	CAPACITOR, FIXED, ELECTROLYTIC, 10 pf, ±10%, 25 WVDC	183-5017-070
CR1	SEMICONDUCTOR DEVICE, DIODE, SILICON, 100V PIV, 300MA, DO-35 PKG (TYPE 1N4148)	353-3763-010
CR2	DISPLAY, OPTOELECTRONIC, 0.5" RECTANGULAR GREEN LED	419-0089-010
CR3	SEMICONDUCTOR DEVICE, DIODE, SILICON, 100V PIV, 300MA, DO-35 PKG (TYPE 1N4148)	353-3763-010
CR4	DISPLAY, OPTOELECTRONIC, 0.5" RECTANGULAR GREEN LED	419-0089-010
CR5	SEMICONDUCTOR DEVICE, DIODE, SILICON, 100V PIV, 300MA, DO-35 PKG (TYPE 1N4148)	353-3763-010
CR6	DISPLAY, OPTOELECTRONIC, 0.5" RECTANGULAR GREEN LED	419-0089-010
CR7	DISPLAY, OPTOELECTRONIC, 0.5" RECTANGULAR GREEN LED	419-0089-010
CR8	SEMICONDUCTOR DEVICE, DIODE, SILICON, 100V PIV, 300MA FAST RECOVERY, DO-35 PKG (TYPE 1N4148)	353-3763-010
CR9	SEMICONDUCTOR DEVICE, DIODE, SILICON, 100V PIV, 300MA FAST RECOVERY, DO-35 PKG (TYPE 1N4148)	353-3763-010

PL180202-2 CIRCUIT CARD ASSEMBLY, FRONT PANEL		Rev. H
Ref. Des.	Description	Part No.
CR10	SEMICONDUCTOR DEVICE, DIODE, SILICON, 100V PIV, 300MA FAST RECOVERY, DO-35 PKG (TYPE 1N4148)	353-3763-010
CR11	DISPLAY, OPTOELECTRONIC, 0.5" RECTANGULAR GREEN LED	419-0089-010
CR12	DISPLAY, OPTOELECTRONIC, 0.5" RECTANGULAR GREEN LED	419-0089-010
CR13	DISPLAY, OPTOELECTRONIC, 0.5" RECTANGULAR GREEN LED	419-0089-010
CR14	DISPLAY, OPTOELECTRONIC, 0.5" RECTANGULAR GREEN LED	419-0089-010
CR15	DISPLAY, OPTOELECTRONIC, 0.5" RECTANGULAR GREEN LED	419-0089-010
CR16	DISPLAY, OPTOELECTRONIC, 0.5" RECTANGULAR GREEN LED	419-0089-010
CR17	SEMICONDUCTOR DEVICE, DIODE, HOT CARRIER	353-3691-010
CR18	SEMICONDUCTOR DEVICE, DIODE, HOT CARRIER	353-3691-010
CR19	SEMICONDUCTOR DEVICE, DIODE, HOT CARRIER	353-3691-010
CR20	SEMICONDUCTOR DEVICE, DIODE, SILICON, 100V PIV, 300MA FAST RECOVERY, DO-35 PKG (TYPE 1N4148)	353-3763-010
CR21	SEMICONDUCTOR DEVICE, DIODE, SILICON, 100V PIV, 300MA FAST RECOVERY, DO-35 PKG (TYPE 1N4148)	353-3763-010
CR22	SEMICONDUCTOR DEVICE, DIODE, SILICON, 100V PIV, 300MA FAST RECOVERY, DO-35 PKG (TYPE 1N4148)	353-3763-010
CR23	SEMICONDUCTOR DEVICE, DIODE, SILICON, 100V PIV, 300MA FAST RECOVERY, DO-35 PKG (TYPE 1N4148)	353-3763-010
CR24	SEMICONDUCTOR DEVICE, DIODE, SILICON, 100V PIV, 300MA FAST RECOVERY, DO-35 PKG (TYPE 1N4148)	353-3763-010
CR25	DISPLAY, OPTOELECTRONIC, 0.5" RECTANGULAR GREEN LED	419-0089-010
CR26	DISPLAY, OPTOELECTRONIC, 0.5" RECTANGULAR RED LED	419-0089-020
CR27	DISPLAY, OPTOELECTRONIC, 0.5" RECTANGULAR RED LED	419-0089-020
CR28	DISPLAY, OPTOELECTRONIC, 0.5" RECTANGULAR RED LED	419-0089-020
CR29	SEMICONDUCTOR DEVICE, DIODE, SILICON, 100V PIV, 300MA FAST RECOVERY, DO-35 PKG (TYPE 1N4148)	353-3763-010
CR30	SEMICONDUCTOR DEVICE, DIODE, SILICON, 100V PIV, 300MA FAST RECOVERY, DO-35 PKG (TYPE 1N4148)	353-3763-010

PL180202-2 CIRCUIT CARD ASSEMBLY, FRONT PANEL		Rev. H
Ref. Des.	Description	Part No.
CR31	SEMICONDUCTOR DEVICE, DIODE, SILICON, 100V PIV, 300MA FAST RECOVERY, DO-35 PKG (TYPE 1N4148)	353-3763-010
CR32	SEMICONDUCTOR DEVICE, DIODE, SILICON, 100V PIV, 300MA FAST RECOVERY, DO-35 PKG (TYPE 1N4148)	353-3763-010
CR33	SEMICONDUCTOR DEVICE, DIODE, SILICON, 100V PIV, 300MA FAST RECOVERY, DO-35 PKG (TYPE 1N4148)	353-3763-010
CR34	SEMICONDUCTOR DEVICE, DIODE, SILICON, 100V PIV, 300MA FAST RECOVERY, DO-35 PKG (TYPE 1N4148)	353-3763-010
CR35	SEMICONDUCTOR DEVICE, DIODE, SILICON, 100V PIV, 300MA FAST RECOVERY, DO-35 PKG (TYPE 1N4148)	353-3763-010
CR36	DISPLAY, OPTOELECTRONIC, 0.5" RECTANGULAR GREEN LED	419-0089-010
CR37	DISPLAY, OPTOELECTRONIC, 0.5" RECTANGULAR GREEN LED	419-0089-010
CR38	DISPLAY, OPTOELECTRONIC, 0.5" RECTANGULAR GREEN LED	419-0089-010
CR39	SEMICONDUCTOR DEVICE, DIODE, SILICON, 100V PIV, 300MA FAST RECOVERY, DO-35 PKG (TYPE 1N4148)	353-3763-010
CR40	SEMICONDUCTOR DEVICE, DIODE, 1 AMP, 1,000Vdc, 700 Vrms	353-6442-070
CR41	SEMICONDUCTOR DEVICE, DIODE, SILICON, 100V PIV, 300MA FAST RECOVERY, DO-35 PKG (TYPE 1N4148)	353-3763-010
CR42	SEMICONDUCTOR DEVICE, DIODE, SILICON, 100V PIV, 300MA FAST RECOVERY, DO-35 PKG (TYPE 1N4148)	353-3763-010
CR43	SEMICONDUCTOR DEVICE, DIODE, SILICON, 100V PIV, 300MA FAST RECOVERY, DO-35 PKG (TYPE 1N4148)	353-3763-010
CR44	DISPLAY, OPTOELECTRONIC, 0.5" RECTANGULAR RED LED	419-0089-020
DS1	DISPLAY, OPTOELECTRONIC, 2 DIGIT, 0.56" HIGH RED LED, COMMON ANODE, 1,600 UCD @ 10mA, HIGH EFFICIENCY	419-0091-030
DS2	DISPLAY, OPTOELECTRONIC, 1-1/2 DIGIT, 0.56" HIGH RED LED, COMMON ANODE, 1,600 UCD @ 10mA, HIGH EFFICIENCY	419-0091-040
DS3	DISPLAY, OPTOELECTRONIC, 10 ELEMENT BAR GRAPH RED LED	419-0090-020
DS4	DISPLAY, OPTOELECTRONIC, 10 ELEMENT BAR GRAPH GREEN LED	419-0090-010
DS5	DISPLAY, OPTOELECTRONIC, 10 ELEMENT BAR GRAPH GREEN LED	419-0090-010

PL180202-2 CIRCUIT CARD ASSEMBLY, FRONT PANEL

Rev. H

Ref. Des.	Description	Part No.
J1	JACK, TIP, RED, NYLON INSULATED, PWB MOUNTING HIGH PROFILE	360-0495-030
J2	CONNECTOR, PIN HEADER, 6 PIN, ELECTRICAL, PC MOUNT DUAL ROW, 0.100" CENTERS, 0.025" SQ PIN, GOLD FINISH	372-9604-260
J3	CONNECTOR, RECEPTACLE, ELECTRICAL, 16 POSITIONS SINGLE ROW, SQ STRAIGHT POST	372-9765-010
J4	CONNECTOR, PIN HEADER, 6 PIN, ELECTRICAL, PC MOUNT DUAL ROW, 0.100" CENTERS, 0.025" SQ PIN, GOLD FINISH	372-9604-260
J5	CONNECTOR, RECEPTACLE, ELECTRICAL, 16 POSITIONS SINGLE ROW, SQ STRAIGHT POST	372-9765-010
J6	CONNECTOR, RECEPTACLE, ELECTRICAL, PWB MOUNT, 3 PIN, 0.100 CENTER, GOLD PLATED	372-9643-040
P1	NOT-USED	
P2	CONNECTOR, JUMPER, 2-CIRCUIT	372-9604-150
P3	CONNECTOR, JUMPER, 2-CIRCUIT	372-9604-150
P4	CONNECTOR, JUMPER, 2-CIRCUIT	372-9604-150
P5	NOT-USED	
P6	CONNECTOR, JUMPER, 2-CIRCUIT	372-9604-150
Q1	TRANSISTOR, SILICON, NPN	352-0661-020
Q2	TRANSISTOR, SILICON, NPN	352-0661-020
Q3	TRANSISTOR, PNP, HIGH SPEED EPTAXIAL, 60V C-E 600MA COLLECTOR CURRENT, 400mW, TO-18 CASE	352-0551-010
Q4	TRANSISTOR, SILICON, NPN	352-0661-020
Q5	TRANSISTOR, SILICON, NPN	352-0661-020
R1	RESISTOR, VARIABLE, NONWIRE WOUND, 2,000 Ω , \pm 10%, 1/2W, CERMET	382-1405-200
R2	RESISTOR, FIXED, FILM: 5110 Ohm, \pm 1%, 1/4 WATT @ 70C	724-5052-530
R3	RESISTOR, FIXED, FILM: 3650 Ohm, \pm 1%, 1/4 WATT @ 70C	724-5052-500
R4	RESISTOR, FIXED, FILM: 3320 Ohm, \pm 1%, 1/4 WATT @ 70C	724-5052-490
R5	RESISTOR, FIXED, FILM: 22.1K Ohm, \pm 1%, 1/4 WATT @ 70C	724-5052-665

PL180202-2 CIRCUIT CARD ASSEMBLY, FRONT PANEL

Rev. H

Ref. Des.	Description	Part No.
R6	RESISTOR, FIXED, FILM: 2210 Ohm, ±1%, 1/4 WATT @ 70C	724-5052-460
R7	RESISTOR, FIXED, FILM: 6810 Ohm, ±1%, 1/4 WATT @ 70C	724-5052-545
R8	RESISTOR, FIXED, FILM: 2210 Ohm, ±1%, 1/4 WATT @ 70C	724-5052-460
R9	RESISTOR, VARIABLE, NONWIRE WOUND: 5000 Ohm, ±10%, 1/2 WATT	382-1405-210
R10	RESISTOR, FIXED, FILM: 100K Ohm, ±1%, 1/4 WATT @ 70C	724-5052-800
R11	RESISTOR, FIXED, FILM: 475K Ohm, ±1%, 1/4 WATT @ 70C	724-5052-905
R12	RESISTOR, FIXED, FILM: 1MEG Ohm, ±1%, 1/4 WATT @ 70C	724-5052-995
R13	RESISTOR, FIXED, FILM: 4750 Ohm, ±1%, 1/4 WATT @ 70C	724-5052-520
R14	RESISTOR, VARIABLE, NONWIRE WOUND: 5000 Ohm, ±10%, 1/2 WATT	382-1405-210
R15	RESISTOR, FIXED, FILM: 1MEG Ohm, ±1%, 1/4 WATT @ 70C	724-5052-995
R16	RESISTOR, VARIABLE, NONWIRE WOUND: 5000 Ohm, ±10%, 1/2 WATT	382-1405-210
R17	RESISTOR, FIXED, FILM: 2210 Ohm, ±1%, 1/4 WATT @ 70C	724-5052-460
R18	RESISTOR, FIXED, FILM: 100 Ohm, ±1%, 1/4 WATT @ 70C	724-5052-200
R19	RESISTOR, FIXED, FILM: 90.9K Ohm, ±1%, 1/4 WATT @ 70C	724-5052-785
R20	RESISTOR, FIXED, FILM: 909 Ohm, ±1%, 1/4 WATT @ 70C	724-5052-330
R21	RESISTOR, FIXED, FILM: 100 Ohm, ±1%, 1/4 WATT @ 70C	724-5052-200
R22	RESISTOR, FIXED, FILM: 2210 Ohm, ±1%, 1/4 WATT @ 70C	724-5052-460
R23	RESISTOR, FIXED, FILM: 100 Ohm, ±1%, 1/4 WATT @ 70C	724-5052-200
R24	RESISTOR, FIXED, FILM: 1820 Ohm, ±1%, 1/4 WATT @ 70C	724-5052-445
R25	RESISTOR, VARIABLE, NONWIRE WOUND: 2000 Ohm, ±10%, 1/2 WATT	382-1405-200
R26	RESISTOR, FIXED, FILM: 332 Ohm, ±1%, 1/2 WATT @ 70C	724-5053-260
R27	RESISTOR, FIXED, FILM: 2740 Ohm ±1%, 1/4 WATT @ 70C	724-5052-480
R28	RESISTOR, FIXED, FILM: 10K Ohm, ±1%, 1/4 WATT @ 70C	724-5052-600
R29	RESISTOR, FIXED, FILM: 1500 Ohm, ±1%, 1/4 WATT @ 70C	724-5052-425
R30	RESISTOR, FIXED, FILM: 82.5 Ohm, ±1%, 1/4 WATT @ 70C	724-5052-120

PL180202-2 CIRCUIT CARD ASSEMBLY, FRONT PANEL

Rev. H

Ref. Des.	Description	Part No.
R31	RESISTOR, FIXED, FILM: 274 Ohm, ±1%, 1/4 WATT @ 70C	724-5052-255
R32	RESISTOR, FIXED, FILM: 274 Ohm, ±1%, 1/4 WATT @ 70C	724-5052-255
R33	RESISTOR, FIXED, FILM: 1210 Ohm, ±1%, 1/2 WATT @ 70C	724-5053-410
R34	RESISTOR, FIXED, FILM: 221 Ohm, ±1%, 1/4 WTT @ 70C	724-5052-245
R35	RESISTOR, FIXED, FILM: 221 Ohm, ±1%, 1/4 WTT @ 70C	724-5052-245
R36	RESISTOR, FIXED, FILM: 1000 Ohm, ±1%, 1/4 WATT @ 70C	724-5052-400
R37	RESISTOR, FIXED, FILM: 1000 Ohm, ±1%, 1/4 WATT @ 70C	724-5052-400
R38	RESISTOR, FIXED, FILM: 221K Ohm, ±1%, 1/4 WATT @ 70C	724-5052-855
R39	RESISTOR, FIXED, FILM: 22.1K Ohm, +1%, 1/4 WATT @ 70C	724-5052-665
R40	RESISTOR, FIXED, FILM: 392 Ohm, ±1%, 1/4 WATT @ 70C	724-5052-275
R41	RESISTOR, FIXED, FILM: 22.1K Ohm, +1%, 1/4 WATT @ 70C	724-5052-665
R42	RESISTOR, FIXED, FILM: 10K Ohm, ±1%, 1/4 WATT @ 70C	724-5052-600
R43	RESISTOR, FIXED, FILM: 10K Ohm, ±1%, 1/4 WATT @ 70C	724-5052-600
R44	RESISTOR, FIXED, FILM: 10K Ohm, ±1%, 1/4 WATT @ 70C	724-5052-600
R45	RESISTOR, FIXED, FILM: 221K Ohm, ±1%, 1/4 WATT @ 70C	724-5052-855
R46	RESISTOR, FIXED, FILM: 2210 Ohm, ±1%, 1/4 WATT @ 70C	724-5052-460
R47	RESISTOR, FIXED, FILM: 365 Ohm, ±1%, 1/4 WATT @ 70C	724-5052-270
R48	RESISTOR, FIXED, FILM: 365 Ohm, ±1%, 1/4 WATT @ 70C	724-5052-270
R49	RESISTOR, FIXED, FILM: 10K Ohm, ±1%, 1/4 WATT @ 70C	724-5052-600
R50	RESISTOR, FIXED, FILM: 2210 Ohm, ±1%, 1/4 WATT @ 70C	724-5052-460
R51	RESISTOR, FIXED, FILM: 475 Ohm, ±1%, 1/4 WATT @ 70C	724-5052-285
R52	RESISTOR, FIXED, FILM: 22.1 Ohm, ±1%, 1/4 WATT @ 70C	724-5052-050
R53	RESISTOR, FIXED, FILM: 22.1 Ohm, ±1%, 1/4 WATT @ 70C	724-5052-050
R54	RESISTOR, FIXED, FILM: 22.1 Ohm, ±1%, 1/4 WATT @ 70C	724-5052-050
R55	RESISTOR, FIXED, FILM: 22.1 Ohm, ±1%, 1/4 WATT @ 70C	724-5052-050

PL180202-2 CIRCUIT CARD ASSEMBLY, FRONT PANEL

Rev. H

Ref. Des.	Description	Part No.
R56	RESISTOR, FIXED, FILM: 475 Ohm, ±1%, 1/4 WATT @ 70C	724-5052-285
R57	RESISTOR, FIXED, FILM: 4750 Ohm, ±1%, 1/4 WATT @ 70C	724-5052-520
R58	RESISTOR, FIXED, FILM: 6810 Ohm, ±1%, 1/4 WATT @ 70C	724-5052-545
R59	RESISTOR, FIXED, FILM: 4750 Ohm, ±1%, 1/4 WATT @ 70C	724-5052-520
R60	RESISTOR, FIXED, FILM: 3920 Ohm, ±1%, 1/4 WATT @ 70C	724-5052-510
R61	RESISTOR, FIXED, FILM: 100 Ohm, ±1%, 1/4 WATT @ 70C	724-5052-200
R62	RESISTOR, FIXED, FILM: 75 Ohm, ±1%, 1/4 WATT @ 70C	724-5052-115
R63	RESISTOR, FIXED, FILM: 75 Ohm, ±1%, 1/4 WATT @ 70C	724-5052-115
R64	RESISTOR, FIXED, FILM: 1210 Ohm, ±1%, 1/4 WATT @ 70C	724-5052-410
R65	RESISTOR, FIXED, FILM: 1000 Ohm, ±1%, 1/4 WATT @ 70C	724-5052-400
R66	RESISTOR, FIXED, FILM: 4750 Ohm, ±1%, 1/4 WATT @ 70C	724-5052-520
R67	RESISTOR, FIXED, FILM: 82.5K Ohm, ±1%, 1/4 WATT @ 70C	724-5052-780
R68	RESISTOR, FIXED, FILM: 2210 Ohm, ±1%, 1/4 WATT @ 70C	724-5052-460
R69	RESISTOR, FIXED, FILM: 75K Ohm, ±1%, 1/4 WATT @ 70C	724-5052-775
R70	RESISTOR, FIXED, FILM: 75K Ohm, ±1%, 1/4 WATT @ 70C	724-5052-775
R71	RESISTOR, FIXED, FILM: 82.5K Ohm, ±1%, 1/4 WATT @ 70C	724-5052-780
R72	RESISTOR, FIXED, FILM: 82.5K Ohm, ±1%, 1/4 WATT @ 70C	724-5052-780
R73	RESISTOR, FIXED, FILM: 1000 Ohm, ±1%, 1/4 WATT @ 70C	724-5052-400
R74	RESISTOR, FIXED, FILM: 2210 Ohm, ±1%, 1/4 WATT @ 70C	724-5052-460
R75	RESISTOR, FIXED, FILM: 150 Ohm, ±1%, 1/4 WATT @ 70C	724-5052-225
R76	RESISTOR, FIXED, FILM: 150 Ohm, ±1%, 1/4 WATT @ 70C	724-5052-225
R77	RESISTOR, FIXED, FILM: 150 Ohm, ±1%, 1/4 WATT @ 70C	724-5052-225
R78	RESISTOR, FIXED, FILM: 150 Ohm, ±1%, 1/4 WATT @ 70C	724-5052-225
R79	RESISTOR, FIXED, FILM: 3320 Ohm, ±1%, 1/4 WATT @ 70C	724-5052-490
R80	RESISTOR, FIXED, FILM: 1000 Ohm, ±1%, 1/4 WATT @ 70C	724-5052-400

PL180202-2 CIRCUIT CARD ASSEMBLY, FRONT PANEL

Rev. H

Ref. Des.	Description	Part No.
R81	RESISTOR, FIXED, FILM: 28K Ohm, ±1%, 1/4 WATT @ 70C	724-5052-690
R82	RESISTOR, FIXED, FILM: 1470 Ohm, ±1%, 1/4 WATT @ 70C	724-5052-420
R83	RESISTOR, FIXED, FILM: 4990 Ohm, ±1%, 1/4 WATT @ 70C	724-5052-525
R84	RESISTOR, FIXED, FILM: 45.3K Ohm, ±1%, 1/4 WATT @ 70C	724-5052-730
R85	RESISTOR, FIXED, FILM: 3830 Ohm, ±1%, 1/4 WATT @ 70C	724-5052-505
R86	RESISTOR, FIXED, FILM: 3480 Ohm, ±1%, 1/4 WATT @ 70C	724-5052-495
R87	RESISTOR, FIXED, FILM: 8450 Ohm, ±1%, 1/4 WATT @ 70C	724-5052-565
R88	RESISTOR, FIXED, FILM: 412K Ohm, ±1%, 1/4 WATT @ 70C	724-5052-895
R89	RESISTOR, FIXED, FILM: 52.3K Ohm, ±1%, 1/4 WATT @ 70C	724-5052-755
R90	RESISTOR, FIXED, FILM: 28K Ohm, ±1%, 1/4 WATT @ 70C	724-5052-690
R91	RESISTOR, FIXED, FILM: 182 Ohm, ±1%, 1/4 WATT @ 70C	724-5052-235
R92	RESISTOR, FIXED, FILM: 182 Ohm, ±1%, 1/4 WATT @ 70C	724-5052-235
R93	RESISTOR, FIXED, FILM: 10K Ohm, ±1%, 1/4 WATT @ 70C	724-5052-600
R94	RESISTOR, FIXED, FILM: 100K Ohm, ±1%, 1/4 WATT @ 70C	724-5052-800
R95	RESISTOR, FIXED, FILM: 4990 Ohm, ±1%, 1/4 WATT @ 70C	724-5052-525
R96	RESISTOR, FIXED, FILM: 1000 Ohm, ±1%, 1/4 WATT @ 70C	724-5052-400
R97	RESISTOR, FIXED, FILM: 2210 Ohm, ±1%, 1/4 WATT @ 70C	724-5052-460
R98	RESISTOR, FIXED, FILM: 10K Ohm, ±1%, 1/4 WATT @ 70C	724-5052-600
R99	RESISTOR, FIXED, FILM: 10K Ohm, ±1%, 1/4 WATT @ 70C	724-5052-600
R100	RESISTOR, FIXED, FILM: 392 Ohm, ±1%, 1/4 WATT @ 70C	724-5052-275
R101	RESISTOR, FIXED, FILM: 13.3K Ohm, ±1%, 1/4 WATT @ 70C	724-5052-640
R102	RESISTOR, FIXED, FILM: 9090 Ohm, ±1%, 1/4 WATT @ 70C	724-5052-570
R103	RESISTOR, FIXED, FILM: 1000 Ohm, ±1%, 1/4 WATT @ 70C	724-5052-400
R104	RESISTOR, FIXED, FILM: 90.9K Ohm, ±1%, 1/4 WATT @ 70C	724-5052-785
R105	RESISTOR, FIXED, FILM: 3320 Ohm, ±1%, 1/4 WATT @ 70C	724-5052-490

PL180202-2 CIRCUIT CARD ASSEMBLY, FRONT PANEL

Rev. H

Ref. Des.	Description	Part No.
R106	RESISTOR, FIXED, FILM: 909 Ohm, ±1%, 1/4 WATT @ 70C	724-5052-330
R107	RESISTOR, FIXED, FILM: 1820 Ohm, ±1%, 1/4 WATT @ 70C	724-5052-445
S1	SWITCH, SLIDE, 4PDT, 0.4 VA, 20Vdc, GOLD CONTACTS EXTENDED SIDE ACTUATOR, OPEN ENDED CASE	266-9955-010
S2	SWITCH, PUSH, SPDT, MOMENTARY, BLACK KEYCAP, 60Vdc MAX	266-9952-020
S3	SWITCH, PUSH, SPDT, MOMENTARY, BLACK KEYCAP, W/RED LED, 60Vdc MAX	266-9952-010
S4	SWITCH, SLIDE, SPDT, 4 A @ 115 VAC, 2 A @ 230 VAC	266-9714-010
U1	MICROCIRCUIT, LINEAR, DUAL OP-AMP, 8 PIN DIP, PLASTIC	351-1211-040
U2	MICROCIRCUIT, LINEAR, A/D CONVERTER, CMOS 40 PIN PLATIC DIP	351-5300-010
U3	RESISTOR NETWORK, 15 RESISTORS, 33 Ohm ±1Ohm, 1/8 W, 16 PIN DIP	736-7001-040
U4	MICROCIRCUIT, LINEAR	351-4719-030
U5	MICROCIRCUIT, LINEAR, TIMER, +18V, 600mW	351-1137-020
U6	MICROCIRCUIT, LINEAR, DISPLAY DRIVER, 18 PIN DIP PLASTIC	351-4709-010
U7	MICROCIRCUIT, LINEAR, DISPLAY DRIVER, 18 PIN DIP PLASTIC	351-4709-010
U8	MICROCIRCUIT, LINEAR, DISPLAY DRIVER, 18 PIN DIP PLASTIC	351-4709-010
U9	MICROCIRCUIT, LINEAR, QUAD SPDT JFET ANALOG SWITCH NO	351-5298-010
U10	RESISTOR NETWORK, 8 RESISTORS, 10KOhm, ±2% 1/4W/RESISTOR, 16 PIN DIP PACKAGE, 2.4 W/PKG	736-7026-360
U11	MICROCIRCUIT, LINEAR, TRANSISTOR ARRAY, HV, HIGH CUR, DARL. PAIRS, 7 CKT, 16 PIN PLASTIC DIP	351-4864-010
U12	MICROCIRCUIT, DIGITAL, LOW PWR SCHOTTKY, DIV BY 12 COUNTER, 14 PIN DIP, PLASTIC PACKAGE	351-5305-010
U13	MICROCIRCUIT, DIGITAL, DECODER, 3 LINE TO 8 LINE, TTL, 15 PIN DIP, LOW POWER SCHOTTKY	351-4750-010
U14	MICROCIRCUIT, DIGITAL, LOGIC GATE	351-7630-010
U15	MICROCIRCUIT, LINEAR, TRANSISTOR ARRAY, HV, HIGH CUR, DARL. PAIRS, 7 CKT, 16 PIN PLASTIC DIP	351-4864-010

PL180202-2 CIRCUIT CARD ASSEMBLY, FRONT PANEL

Rev. H

Ref. Des.	Description	Part No.
U16	MICROCIRCUIT, LINEAR, DUAL TIMER, +16 V, 600mW	351-4706-010
U17	MICROCIRCUIT, DIGITAL, FLIP-FLOP, 7Vdc, 5.5Vdc INPUT 16 PIN DIP,	351-7702-010
U18	MICROCIRCUIT, LINEAR, DUAL OP-AMP, 8 PIN DIP, PLASTIC	351-1211-040
U19	MICROCIRCUIT, LINEAR, QUAD SPDT JFET SWITCH NO, 16 PIN DIP	351-5298-010
U20	MICROCIRCUIT, LINEAR, QUAD OP AMP, 14 LEAD PLASTIC DUAL IN-LINE PACKAGE	351-1370-020
VR1	SEMICONDUCTOR DEVICE, DIODE, SILICON, 1W, 12 VOLT	353-6481-290
VR2	SEMICONDUCTOR DEVICE, DIODE, ZENER, 3.3 VOLT, ±5%	353-6481-010
VR3	SEMICONDUCTOR DEVICE, DIODE, ZENER, 5.1 V, 1W DISS	353-6481-110
VR4	SEMICONDUCTOR DEVICE, DIODE, SILICON, 1W, 12 VOLT	353-6481-290
VR5	SEMICONDUCTOR DEVICE, DIODE, SILICON, 1W, 12 VOLT	353-6481-290
VR6	MICROCIRCUIT, LINEAR, LV REF., 1.2 VOLT TEMPERATURE COMPENSATED, TO-92 CASE	351-5299-010
VR7	SEMICONDUCTOR DEVICE, DIODE, ZENER, 15Vdc, 1W, COMMERCIAL	353-6481-330
VR8	SEMICONDUCTOR DEVICE, DIODE, ZENER, 5.1 V, 1W DISS	353-6481-110
VR9	SEMICONDUCTOR DEVICE, DIODE, ZENER, 15Vdc, 1W, COMMERCIAL	353-6481-330
XU1	SOCKET, PLUG-IN, 8 CONTACTS OPEN FRAME, 0.3" WIDE PIN SPACING	220-6017-020
XU2	SOCKET, PLUG-IN, 40 CONTACTS OPEN FRAME, 0.6" WIDE PIN SPACING	220-6017-110
XU3	SOCKET, PLUG-IN, 16 CONTACTS OPEN FRAME, 0.3" WIDE PIN SPACING	220-6017-040
XU4	SOCKET, PLUG-IN, 8 CONTACTS OPEN FRAME, 0.3" WIDE PIN SPACING	220-6017-020
XU5	SOCKET, PLUG-IN, 8 CONTACTS OPEN FRAME, 0.3" WIDE PIN SPACING	220-6017-020
XU6	SOCKET, PLUG-IN, 18 CONTACTS OPEN FRAME, 0.3" WIDE PIN SPACING	220-6017-050
XU7	SOCKET, PLUG-IN, 18 CONTACTS OPEN FRAME, 0.3" WIDE PIN SPACING	220-6017-050
XU8	SOCKET, PLUG-IN, 18 CONTACTS OPEN FRAME, 0.3" WIDE PIN SPACING	220-6017-050
XU9	SOCKET, PLUG-IN, 16 CONTACTS OPEN FRAME, 0.3" WIDE PIN SPACING	220-6017-040
XU10	SOCKET, PLUG-IN, 16 CONTACTS OPEN FRAME, 0.3" WIDE PIN SPACING	220-6017-040

PL180202-2 CIRCUIT CARD ASSEMBLY, FRONT PANEL

Rev. H

Ref. Des.	Description	Part No.
XU11	SOCKET, PLUG-IN, 16 CONTACTS OPEN FRAME, 0.3" WIDE PIN SPACING	220-6017-040
XU12	SOCKET, PLUG-IN, 14 CONTACTS OPEN FRAME, 0.3" WIDE PIN SPACING	220-6017-030
XU13	SOCKET, PLUG-IN, 16 CONTACTS OPEN FRAME, 0.3" WIDE PIN SPACING	220-6017-040
XU14	SOCKET, PLUG-IN, 14 CONTACTS OPEN FRAME, 0.3" WIDE PIN SPACING	220-6017-030
XU15	SOCKET, PLUG-IN, 16 CONTACTS OPEN FRAME, 0.3" WIDE PIN SPACING	220-6017-040
XU16	SOCKET, PLUG-IN, 14 CONTACTS OPEN FRAME, 0.3" WIDE PIN SPACING	220-6017-030
XU17	SOCKET, PLUG-IN, 16 CONTACTS OPEN FRAME, 0.3" WIDE PIN SPACING	220-6017-040
XU18	SOCKET, PLUG-IN, 8 CONTACTS OPEN FRAME, 0.3" WIDE PIN SPACING	220-6017-020
XU19	SOCKET, PLUG-IN, 16 CONTACTS OPEN FRAME, 0.3" WIDE PIN SPACING	220-6017-040
XU20	SOCKET, PLUG-IN, 14 CONTACTS OPEN FRAME, 0.3" WIDE PIN SPACING	220-6017-030

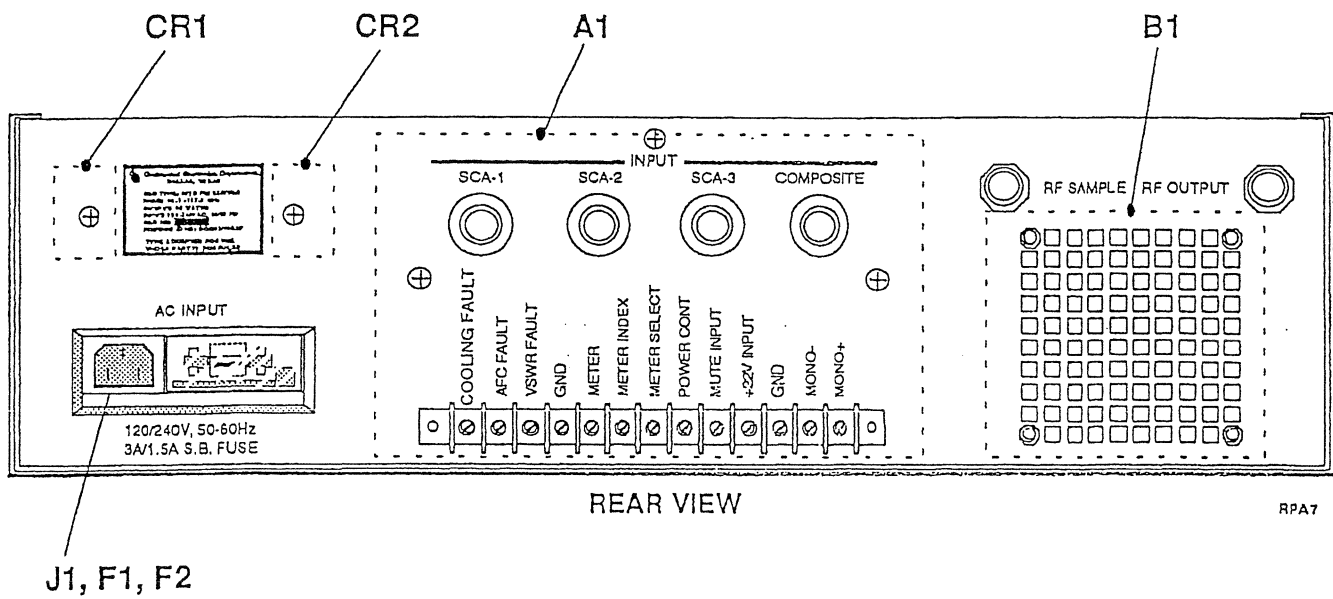
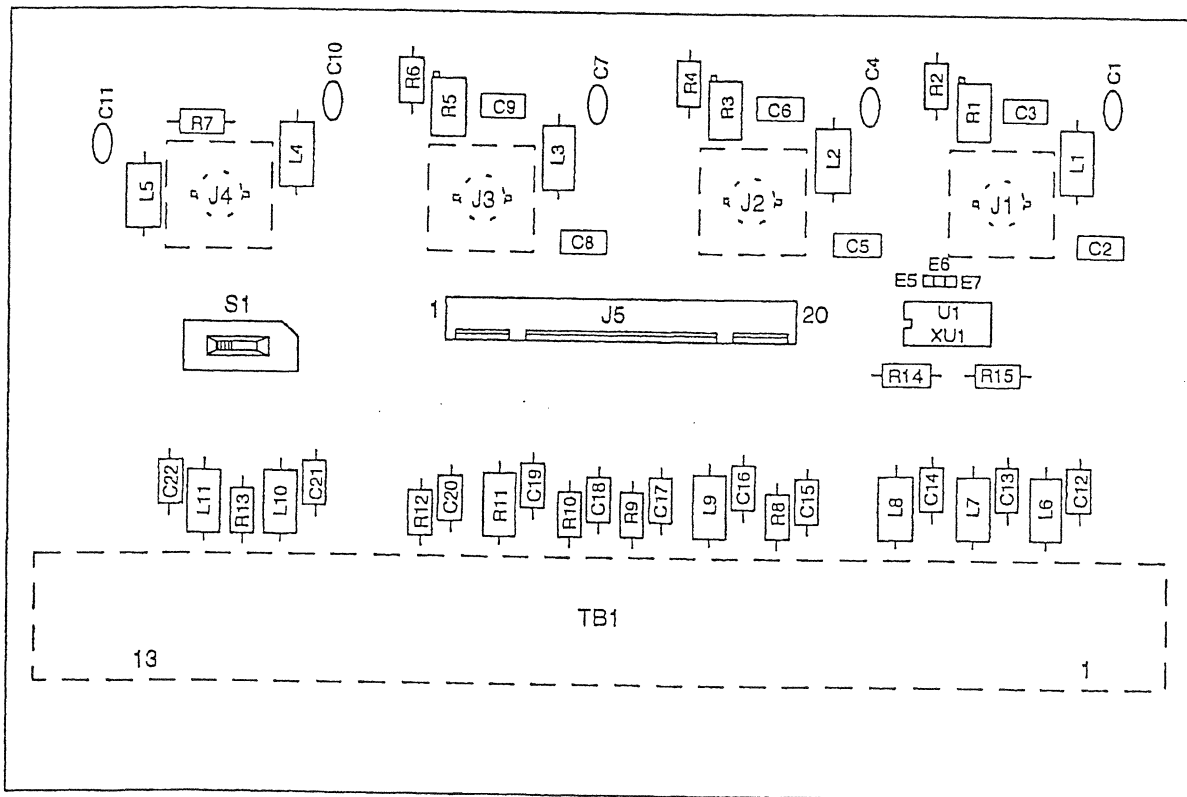

Figure 6-11 Rear Panel Assembly.

PL180215-1 REAR PANEL ASSEMBLY

Rev D

Ref. Des.	Description	Part No.
A1	CIRCUIT CARD ASSY, REAR PANEL	180210-2
B1	FAN, TUBEAXIAL, 40 CFM AT 0 SP, 115 VAC/60 HZ	009-5007-000
CR1	RECTIFIER, SEMICONDUCTOR DEVICE, 1 PHASE, 35 AMP, 400 VRRM	353-5234-010
CR2	RECTIFIER, SEMICONDUCTOR DEVICE, 1 PHASE, 35 AMP, 400 VRRM	353-5234-010
F1	FUSE, CARTRIDGE, 1-1/2 AMPERES, 250 VOLTS, HIGH TIME LAG	264-0303-000
F2	FUSE, CARTRIDGE, 3 AMP, 125 VOLT, HIGH TIME LAG	264-0306-000
J1	CONNECTOR, FUSED, VOLTAGE SELECTING, 64 AC, 50-400 HZ	357-6601-010



94G0190

Figure 6-12 Rear Panel Circuit Card Assembly.

PL180210-2 CIRCUIT CARD ASSEMBLY, REAR PANEL

Rev B

Ref. Des.	Description	Part No.
C1	CAPACITOR, FIXED, CERAMIC, 100 pf, ±5%, 50 WVDC	913-7016-150
C2	CAPACITOR, FIXED, CERAMIC, 0.1 μf, ±10%, 50 WVDC	CK05BX104K
C3	CAPACITOR, FIXED, CERAMIC, 0.1 μf, ±10%, 50 WVDC	CK05BX104K
C4	CAPACITOR, FIXED, CERAMIC, 100 pf, ±5%, 50 WVDC	913-7016-150
C5	CAPACITOR, FIXED, CERAMIC, 0.1 μf, ±10%, 50 WVDC	CK05BX104K
C6	CAPACITOR, FIXED, CERAMIC, 0.1 μf, ±10%, 50 WVDC	CK05BX104K
C7	CAPACITOR, FIXED, CERAMIC, 100 pf, ±5%, 50 WVDC	913-7016-150
C8	CAPACITOR, FIXED, CERAMIC, 0.1 μf, ±10%, 50 WVDC	CK05BX104K
C9	CAPACITOR, FIXED, CERAMIC, 0.1 μf, ±10%, 50 WVDC	CK05BX104K
C10	CAPACITOR, FIXED, CERAMIC, 100 pf, ±5%, 50 WVDC	913-7016-150
C11	CAPACITOR, FIXED, CERAMIC, 100 pf, ±5%, 50 WVDC	913-7016-150
C12	CAPACITOR, FIXED, CERAMIC, 0.1 μf, ±10%, 50 WVDC	CK05BX104K
C13	CAPACITOR, FIXED, CERAMIC, 0.1 μf, ±10%, 50 WVDC	CK05BX104K
C14	CAPACITOR, FIXED, CERAMIC, 0.1 μf, ±10%, 50 WVDC	CK05BX104K
C15	CAPACITOR, FIXED, CERAMIC, 0.1 μf, ±10%, 50 WVDC	CK05BX104K
C16	CAPACITOR, FIXED, CERAMIC, 0.1 μf, ±10%, 50 WVDC	CK05BX104K
C17	CAPACITOR, FIXED, CERAMIC, 0.1 μf, ±10%, 50 WVDC	CK05BX104K
C18	CAPACITOR, FIXED, CERAMIC, 0.1 μf, ±10%, 50 WVDC	CK05BX104K
C19	CAPACITOR, FIXED, CERAMIC, 0.1 μf, ±10%, 50 WVDC	CK05BX104K
C20	CAPACITOR, FIXED, CERAMIC, 0.1 μf, ±10%, 50 WVDC	CK05BX104K
C21	CAPACITOR, FIXED, CERAMIC, 1,000 pf, ±5%, 50 WVDC	913-7016-300
C22	CAPACITOR, FIXED, CERAMIC, 1,000 pf, ±5%, 50 WVDC	913-7016-300
J1	CONNECTOR, RECEPTACLE, ELECTRICAL, BNC, PCB MOUNT	357-9991-010
J2	CONNECTOR, RECEPTACLE, ELECTRICAL, BNC, PCB MOUNT	357-9991-010

PL180210-2 CIRCUIT CARD ASSEMBLY, REAR PANEL

Rev B

Ref. Des.	Description	Part No.
J3	CONNECTOR, RECEPTACLE, ELECTRICAL, BNC, PCB MOUNT	357-9991-010
J4	CONNECTOR, RECEPTACLE, ELECTRICAL, BNC, PCB MOUNT	357-9991-010
J5	CONNECTOR, RECEPTACLE, ELECTRICAL, 20 POSITIONS, SHROUDED HEADER, SQ STRAIGHT POST	372-9765-020
L1	COIL, RADIO FREQUENCY, 850g @ 180 MHz, 80-220 MHz	240-2679-040
L2	COIL, RADIO FREQUENCY, 850Ω @ 180 MHz, 80-220 MHz	240-2679-040
L3	COIL, RADIO FREQUENCY, 850Ω @ 180 MHz, 80-220 MHz	240-2679-040
L4	COIL, RADIO FREQUENCY, 850Ω @ 180 MHz, 80-220 MHz	240-2679-040
L5	COIL, RADIO FREQUENCY, 850Ω @ 180 MHz, 80-220 MHz	240-2679-040
L6	COIL, RADIO FREQUENCY, 850Ω @ 180 MHz, 80-220 MHz	240-2679-040
L7	COIL, RADIO FREQUENCY, 850Ω @ 180 MHz, 80-220 MHz	240-2679-040
L8	COIL, RADIO FREQUENCY, 850Ω @ 180 MHz, 80-220 MHz	240-2679-040
L9	COIL, RADIO FREQUENCY, 850Ω @ 180 MHz, 80-220 MHz	240-2679-040
L10	COIL, RADIO FREQUENCY, 1 μH, ±10%, 930 DCMA	MS75008-28
L11	COIL, RADIO FREQUENCY, 1 μH, ±10%, 930 DCMA	MS75008-28
R1	RESISTOR, VARIABLE, NONWIRE WOUND, 20KΩ ±10%, 1/2W, 25 TURN	382-1405-230
R2	RESISTOR, FIXED, FILM: 24.9K Ω, ±1%, 1/4 WATT @ 70C	724-5052-675
R3	RESISTOR, VARIABLE, NONWIRE WOUND: 20K Ω, ±10%, 1/2 WATT	382-1405-230
R4	RESISTOR, FIXED, FILM: 24.9K Ω, ±1%, 1/4 WATT @ 70C	724-5052-675
R5	RESISTOR, VARIABLE, NONWIRE WOUND: 20K Ω, ±10%, 1/2 WATT	382-1405-230
R6	RESISTOR, FIXED, FILM: 24.9K Ω, ±1%, 1/4 WATT @ 70C	724-5052-675
R7	RESISTOR, FIXED, FILM: 5620 Ω, ±1%, 1/4 WATT @ 70C	724-5052-535
R8	RESISTOR, FIXED, FILM: 475 Ω, ±1%, 1/4 WATT @ 70C	724-5052-285
R9	RESISTOR, FIXED, FILM: 475 Ω, ±1%, 1/4 WATT @ 70C	724-5052-285
R10	RESISTOR, FIXED, FILM: 3320 Ω, ±1%, 1/4 WATT @ 70C	724-5052-490

PL180210-2 CIRCUIT CARD ASSEMBLY, REAR PANEL

Rev B

Ref. Des.	Description	Part No.
R11	RESISTOR, FIXED, FILM: 365 Ω , $\pm 1\%$, 1/2 WATT @ 70C	724-5053-265
R12	RESISTOR, FIXED, FILM: 3320 Ω , $\pm 1\%$, 1/4 WATT @ 70C	724-5052-490
R13	RESISTOR, FIXED, FILM: 634 Ω , $\pm 1\%$, 1/4 WATT @ 70C	724-5052-305
R14	RESISTOR, FIXED, FILM: 4750 Ω , $\pm 1\%$, 1/4 WATT @ 70C	724-5052-520
R15	RESISTOR, FIXED, FILM: 1000 Ω , $\pm 1\%$, 1/4 WATT @ 70C	724-5052-400
S1	SWITCH, SLIDE, 4PDT, 0.4 VA, 20Vdc, GOLD CONTACTS EXTENDED SIDE ACTUATOR, OPEN ENDED CASE	266-9955-010
TB1	TERMINAL BOARD, 13 TERMINALS, 20 AMP, 250 VOLT, 1 ROW, PC FLUSH MT, SCREW TYPE, THERMOPLASTIC, 10,500V	367-1888-240
U1	MICROCIRCUIT, LINEAR: DUAL OP-AMP, 8 PIN DIP, PLASTIC	351-1211-040
XU1	SOCKET, PLUG-IN ELECTRONIC COMPONENT: 8 CONTACTS OPEN FRAME, 0.3" WIDE PINSPACING	220-6017-020

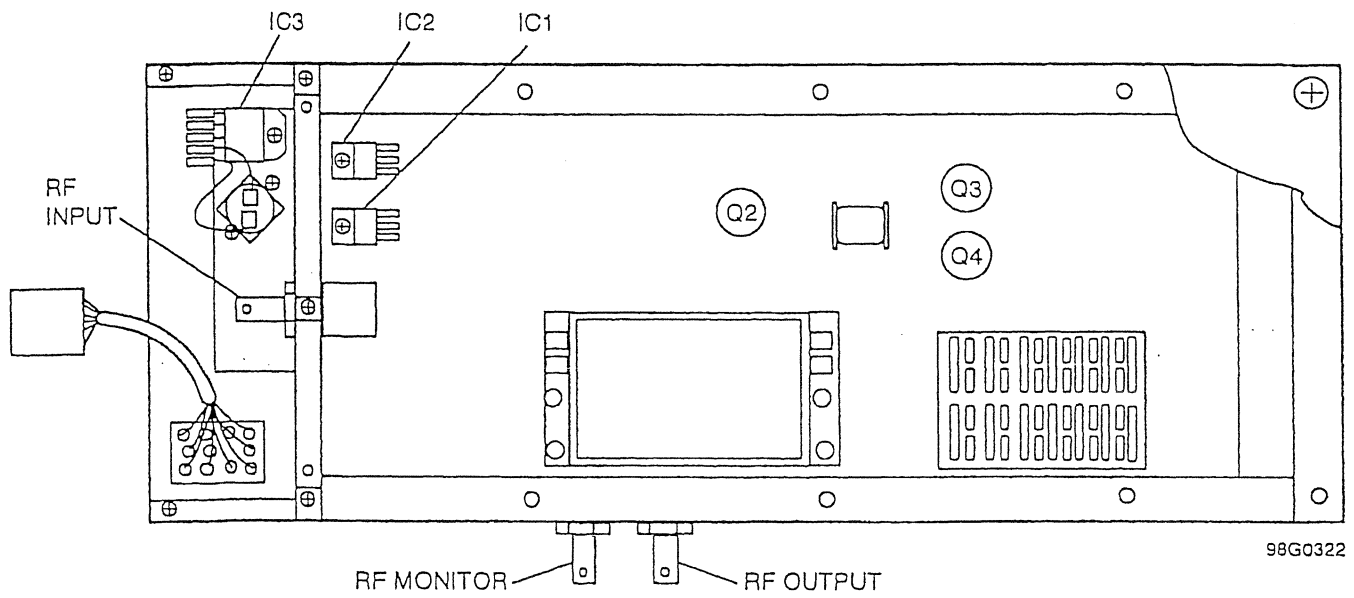

Figure 6-13 Output Amplifier Assembly.

PL180428-1 ASSEMBLY, OUTPUT AMPLIFIER

Rev D

Ref. Des.	Description	Part No.
IC1	MICROCIRCUIT, LINEAR: REGULATOR, +12V, 1 AMP, TO-220	351-1120-040
IC2	MICROCIRCUIT, LINEAR: REGULATOR, ADJ 1.2-37V, 1.5 AMP, POS OUTPUT, TO-220	351-1271-010
IC3	TRANSISTOR: NPN, DARLINGTON, 100V, 10A, 125W, TO-218	352-5193-010
Q2	TRANSISTOR: MOSFET, N-CHANNEL, 65VDC, 2.5A, 53 W, SOT121 FLANGE MTG, 4-PIN CONN	352-5160-040
Q3	TRANSISTOR: POWER MOSFET, N-CHANNEL, VDS=65VDC, ID=13A, PD=130 WATTS, SOT121 FLANGE MTG, 4-PIN CONN.	352-5160-030
Q4	TRANSISTOR: POWER MOSFET, N-CHANNEL, VDS=65VDC, ID=13A, PD=130 WATTS, SOT121 FLANGE MTG, 4-PIN CONN.	352-5160-030

(This Page Intentionally Left Blank)

SECTION 7 - SCHEMATIC DIAGRAMS

7-1 INTRODUCTION.

This section of the Operation and Maintenance manual contains schematic diagrams for the 802B FM Exciter. Symbology used in the preparation of these schematics is in accordance with ANSI Y32.2-1975.

Descriptions of circuits are provided in Section 4, Theory of Operation. An index of schematic diagrams is provided in Table 7-1.

TABLE 7-1. Index of Schematic Diagrams

Unit No.	Unit Description	Figure No.	Schematic No.	Rev.
-	802B FM Exciter	7-1	180201	E
A1A1	Modulated Oscillator PCB	7-2	180240	C
A2	Frequency Divider PCB	7-3	643-0004-001	-
A3	Audio/AFC PCB	7-4	180199	D
A4	Power Supply PCB	7-5	643-0010-001	B
A5	Amplifier Control PCB	7-6	180246	B
A6A1	Front Panel PCB	7-7	180203 (3 Shts)	-
A7A1	Rear Panel PCB	7-8	180211	A
A8	50 Watt Amplifier Card	7-9	195162	-

(This Page Intentionally Left Blank)

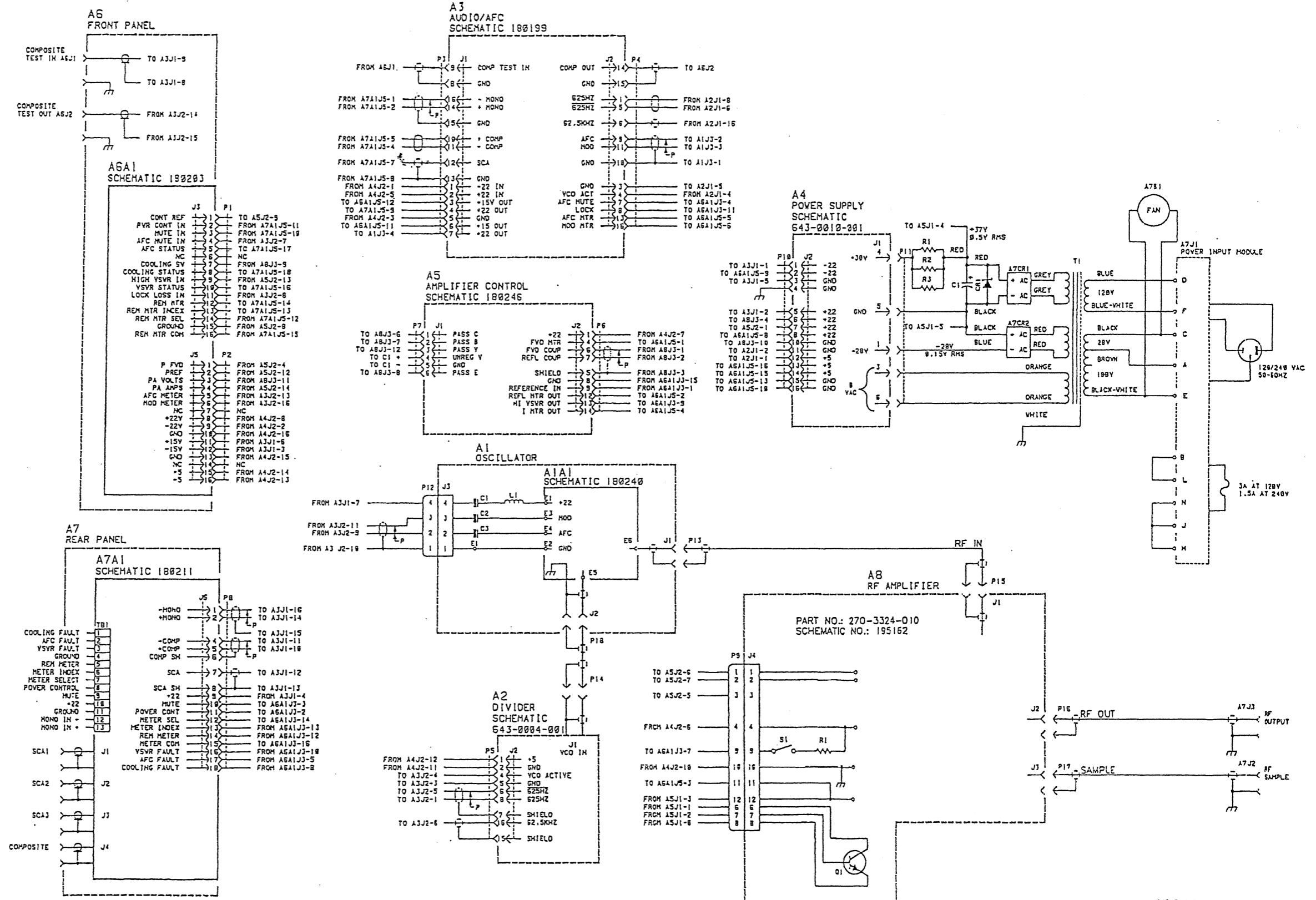

180201 Rev.E
Figure 7-1 Type 802B FM Exciter Schematic.

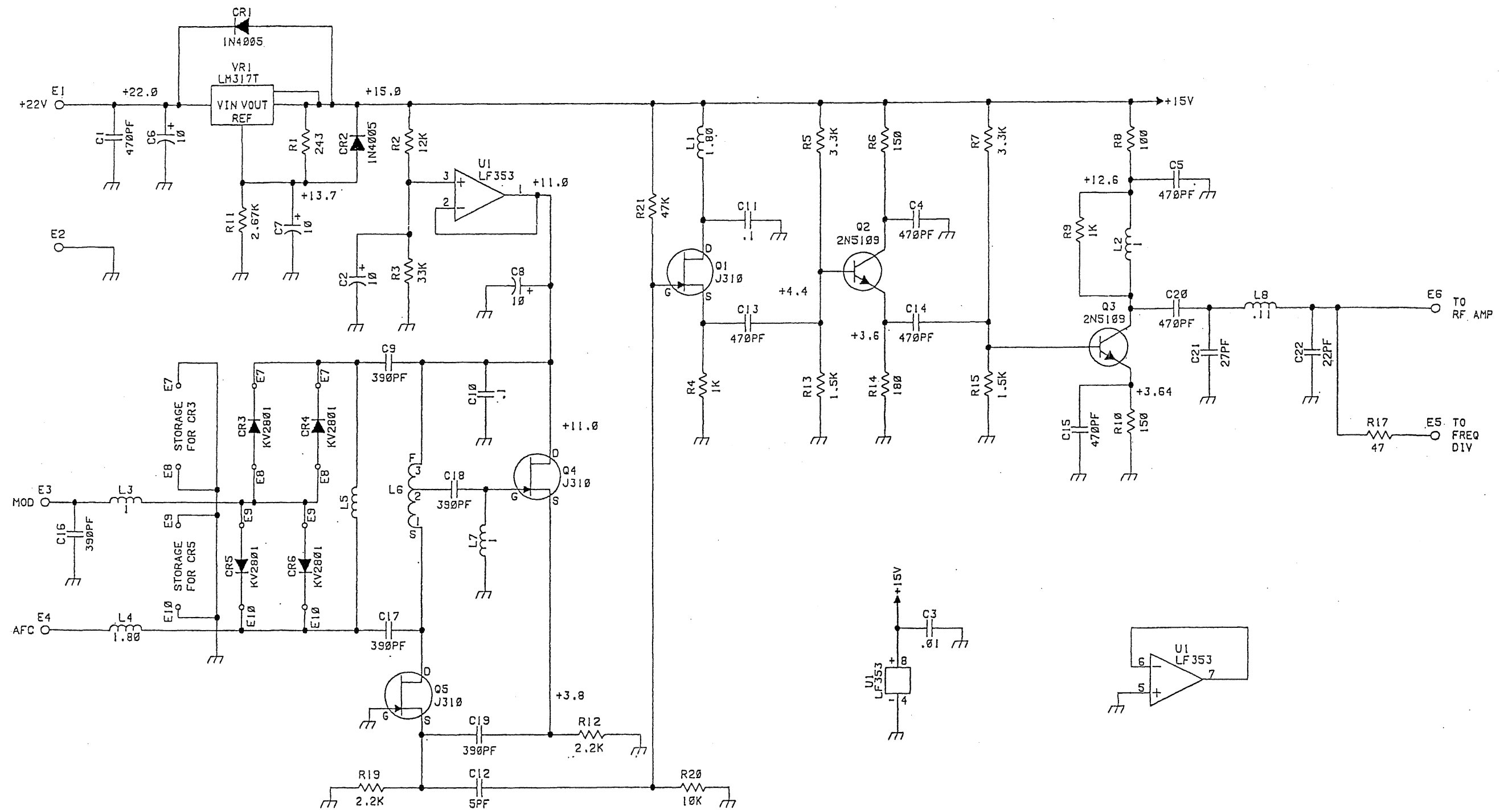

NOTE: DC VOLTAGE MEASUREMENTS ARE MADE VIA,
A 10K ISOLATION RESISTOR.

180240 Rev C

Figure 7-2 Modulated Oscillator PCB.

Change 1

7-5/(7-6 Blank)

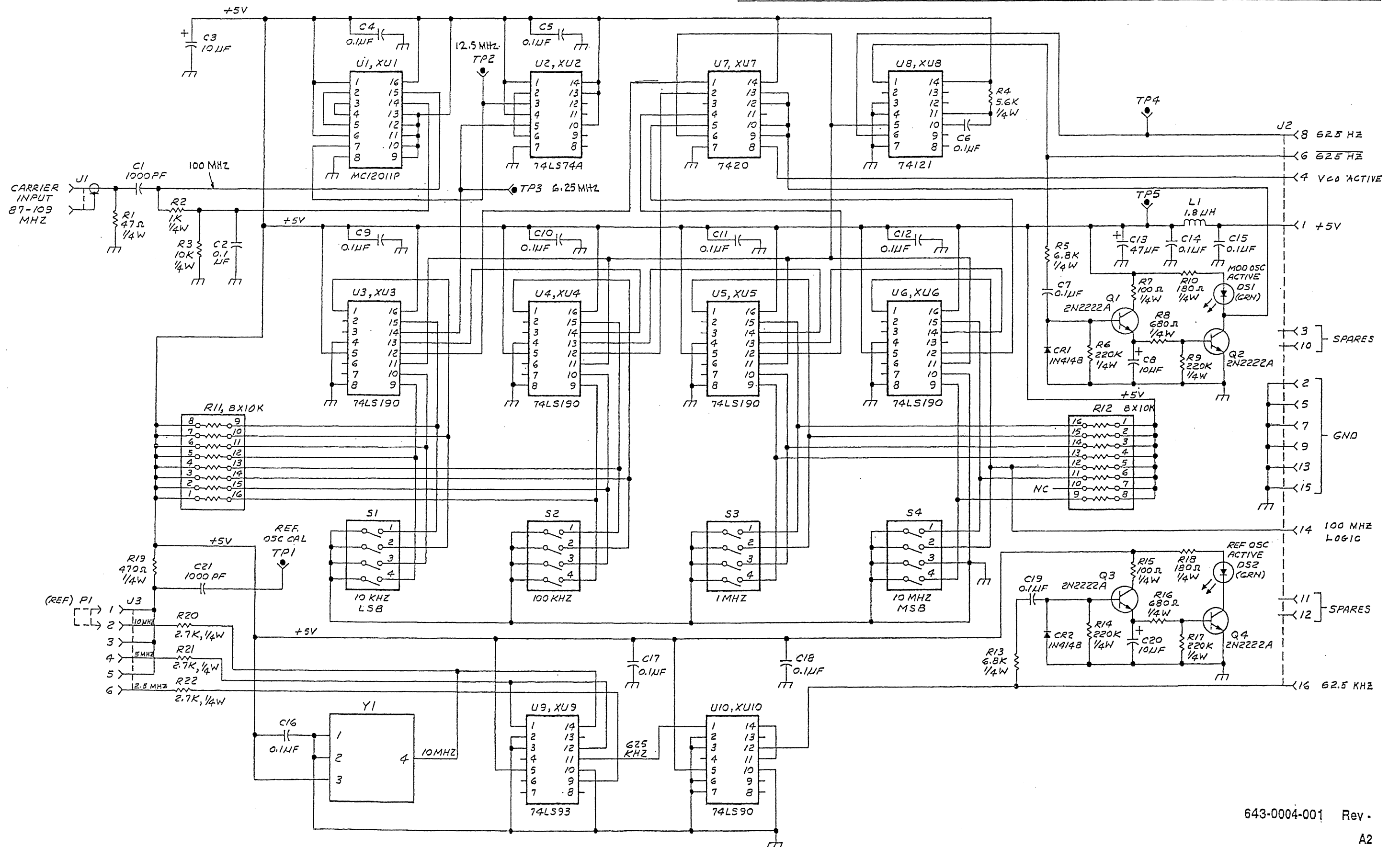

643-0004-001 Rev.

A2

Figure 7-3 Frequency Divider PCB.

7-7/(7-8 Blank)

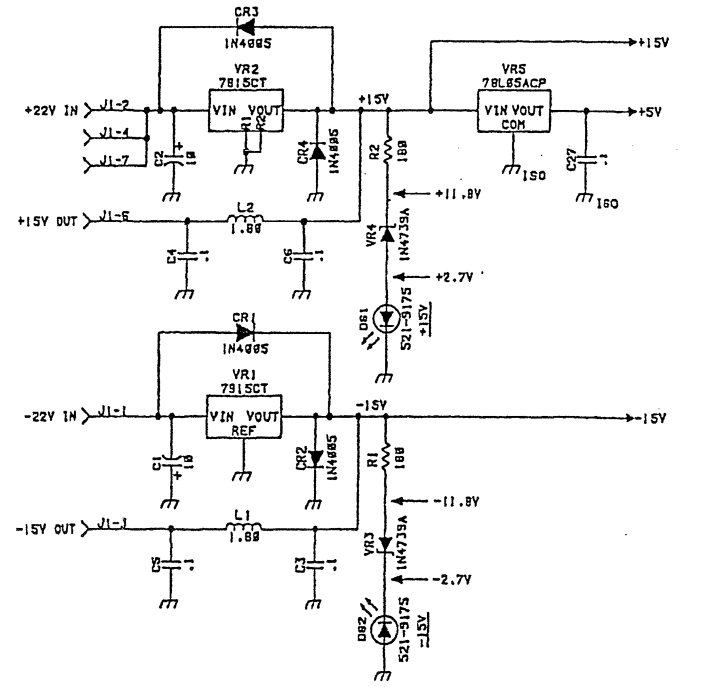
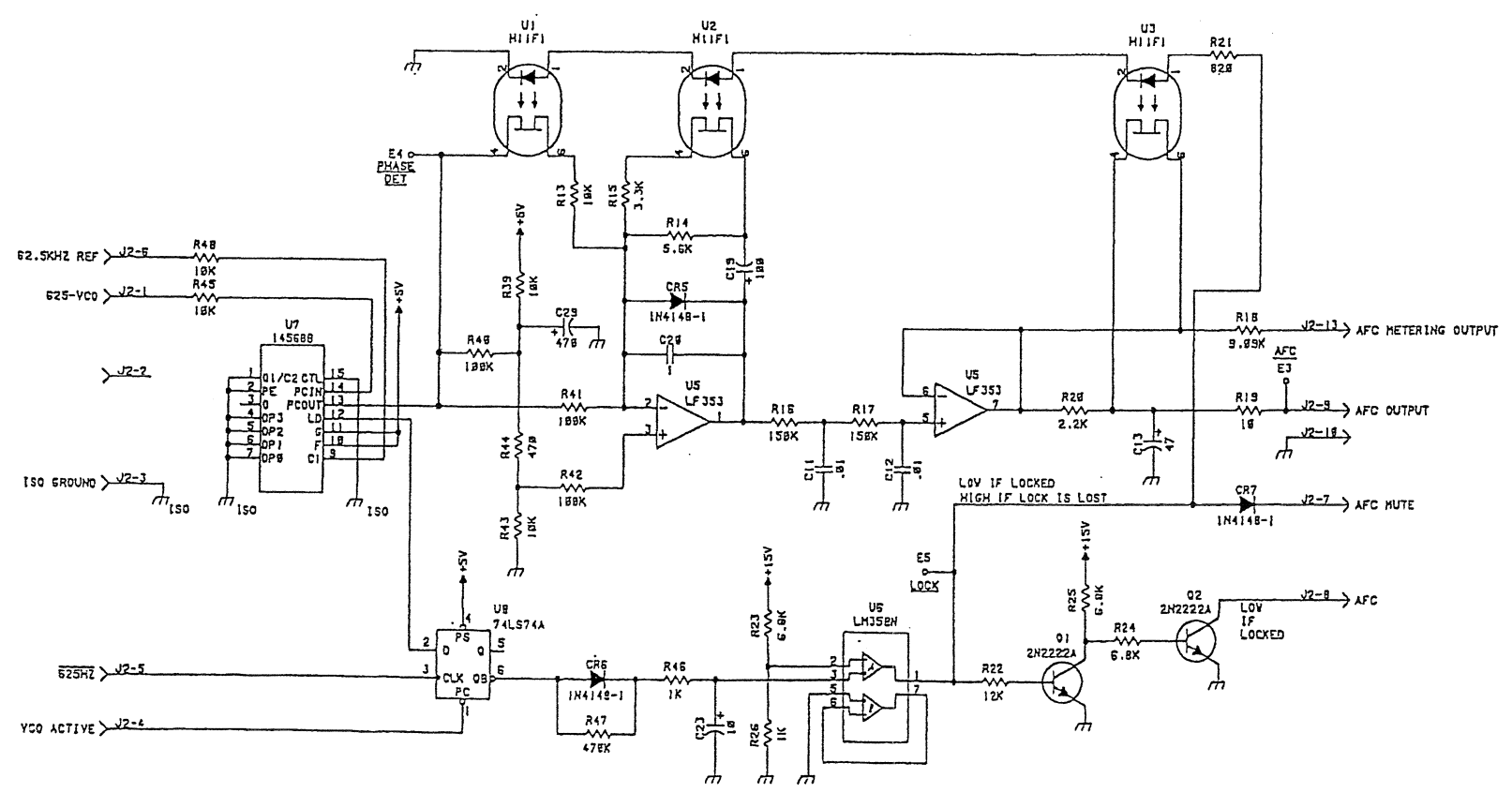
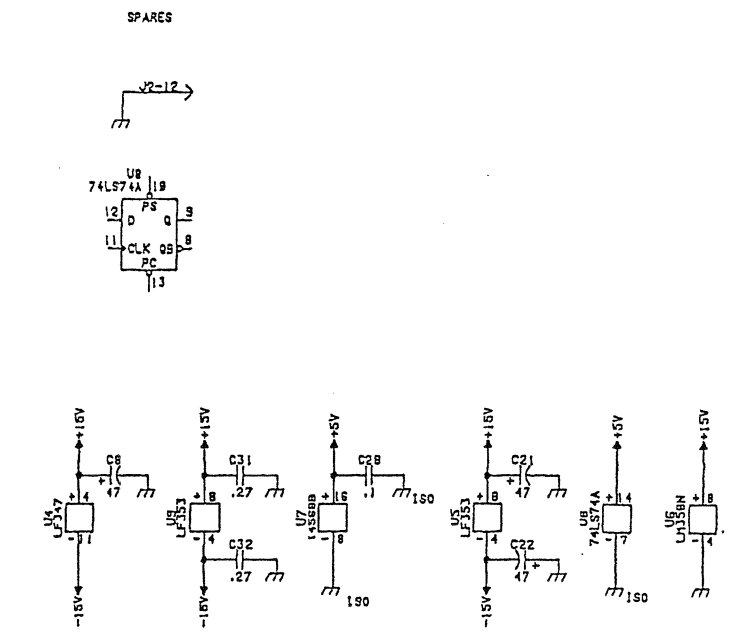
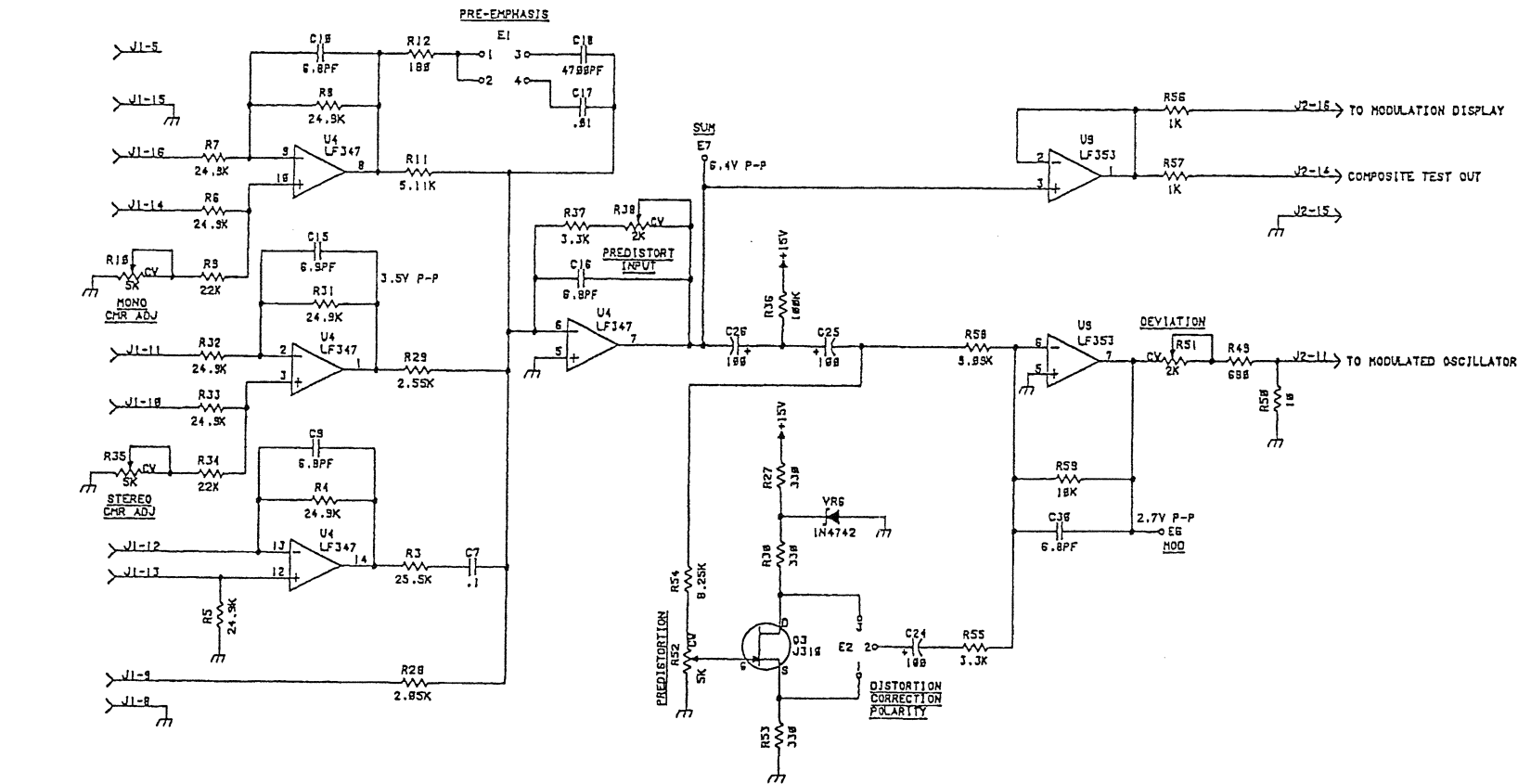

180199 Rev D

A3

Figure 7-4 Audio/AFC PCB

Change 1

7-9/(7-10 Blank)

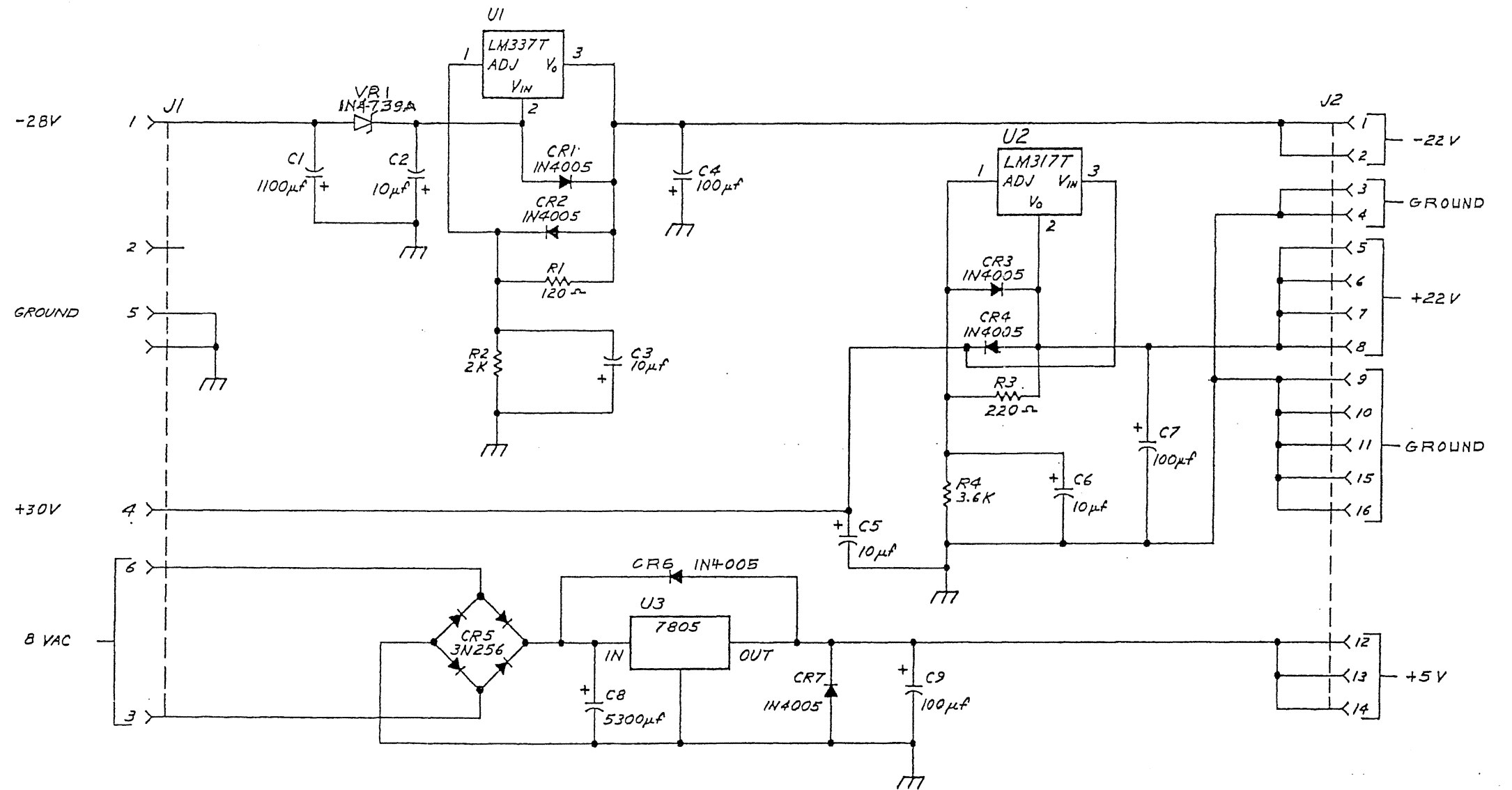

643-0010-001 Rev B

A4

Figure 7-5 Power Supply PCB.

Change 2

7-11/(7-12 Blank)

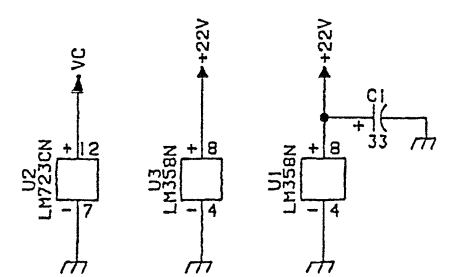
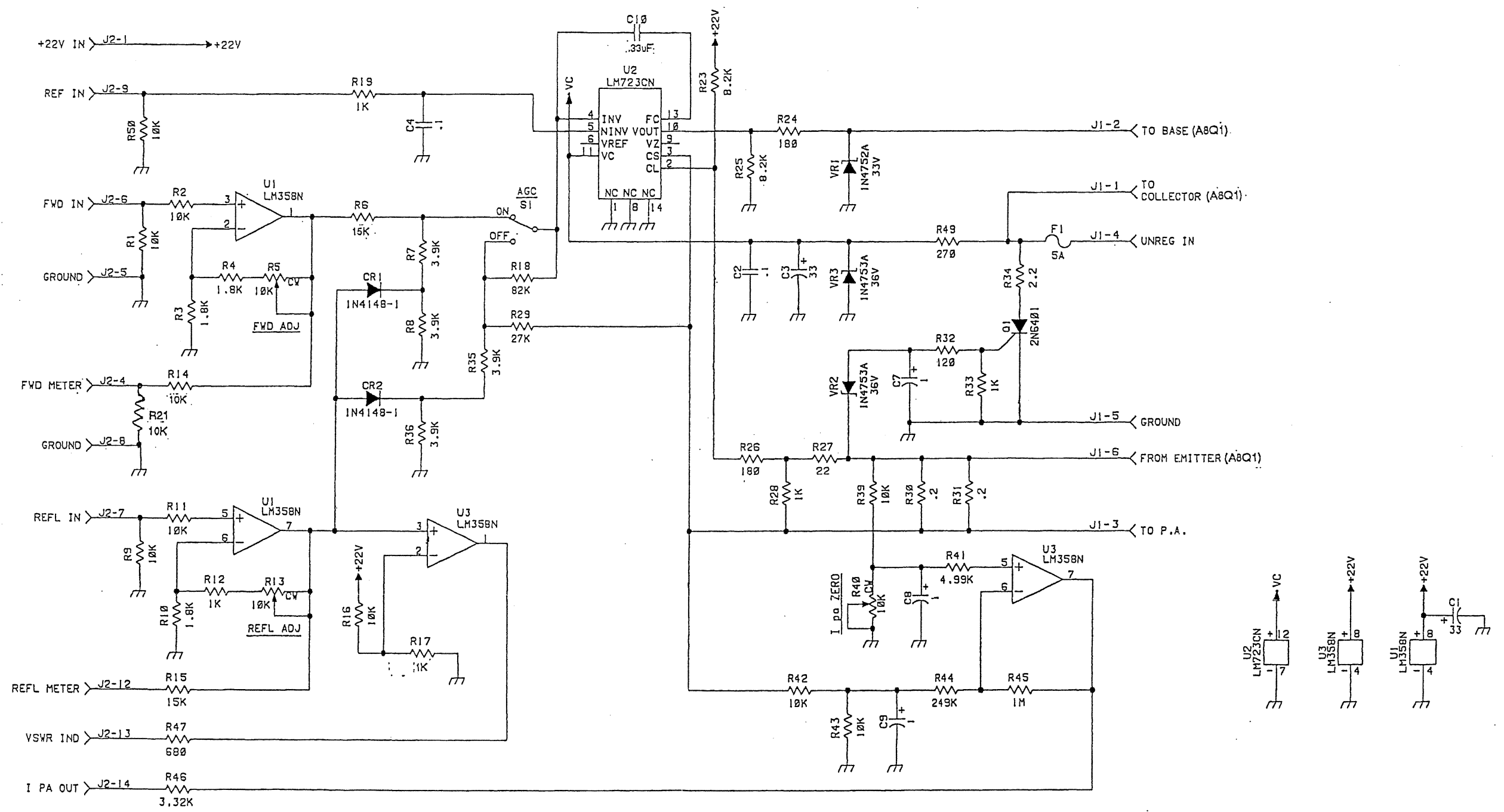

180246 Rev B

A5

Figure 7-6 Amplifier Control PCB.

Change 1

7-13/(7-14 Blank)

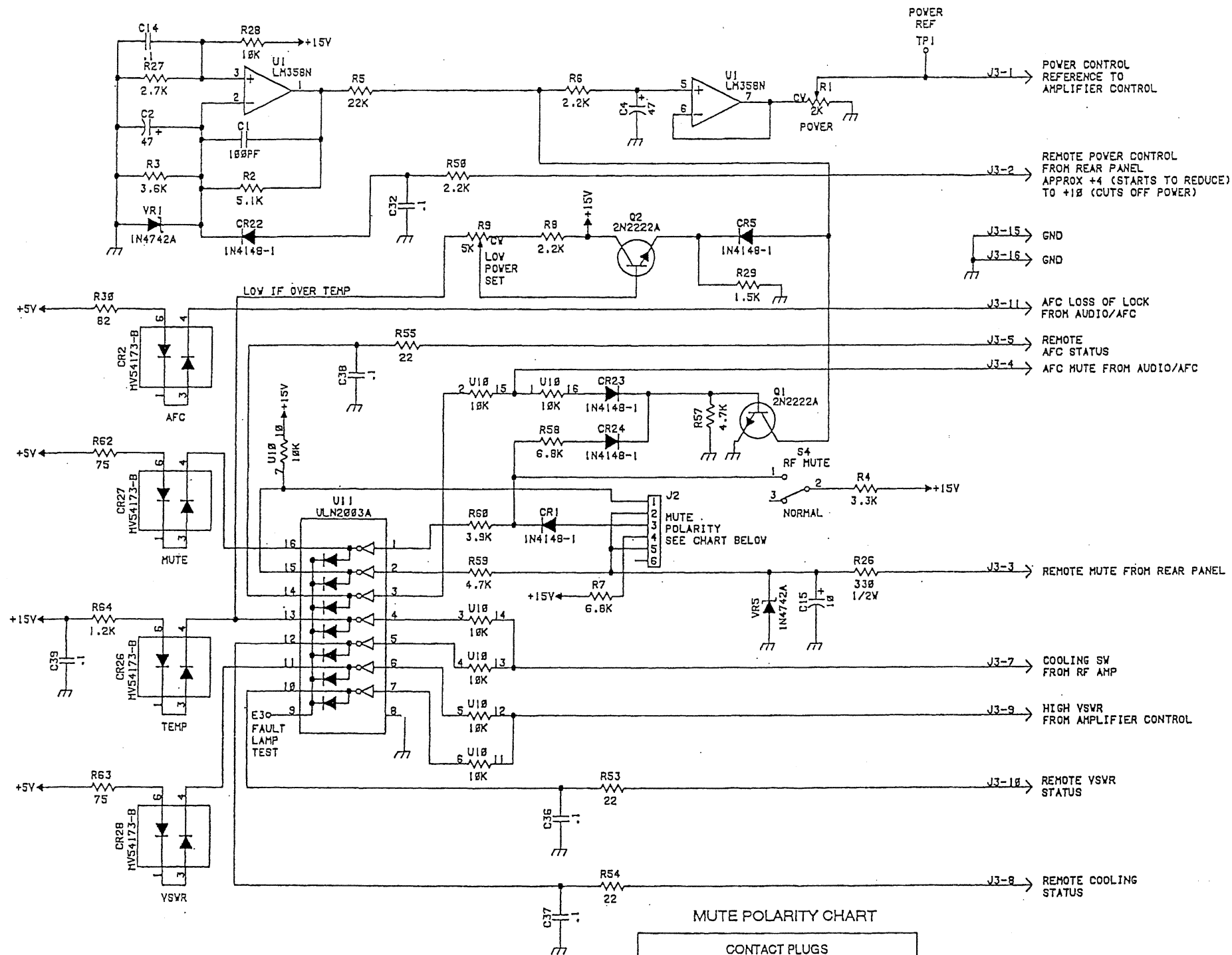

MUTE POLARITY CHART

CONTACT PLUGS P2 AND P3		
LOW	1-3, 2-4	PULL DOWN TO MUTE
HIGH	3-5, 4-6	APPLY VOLTAGE TO MUTE

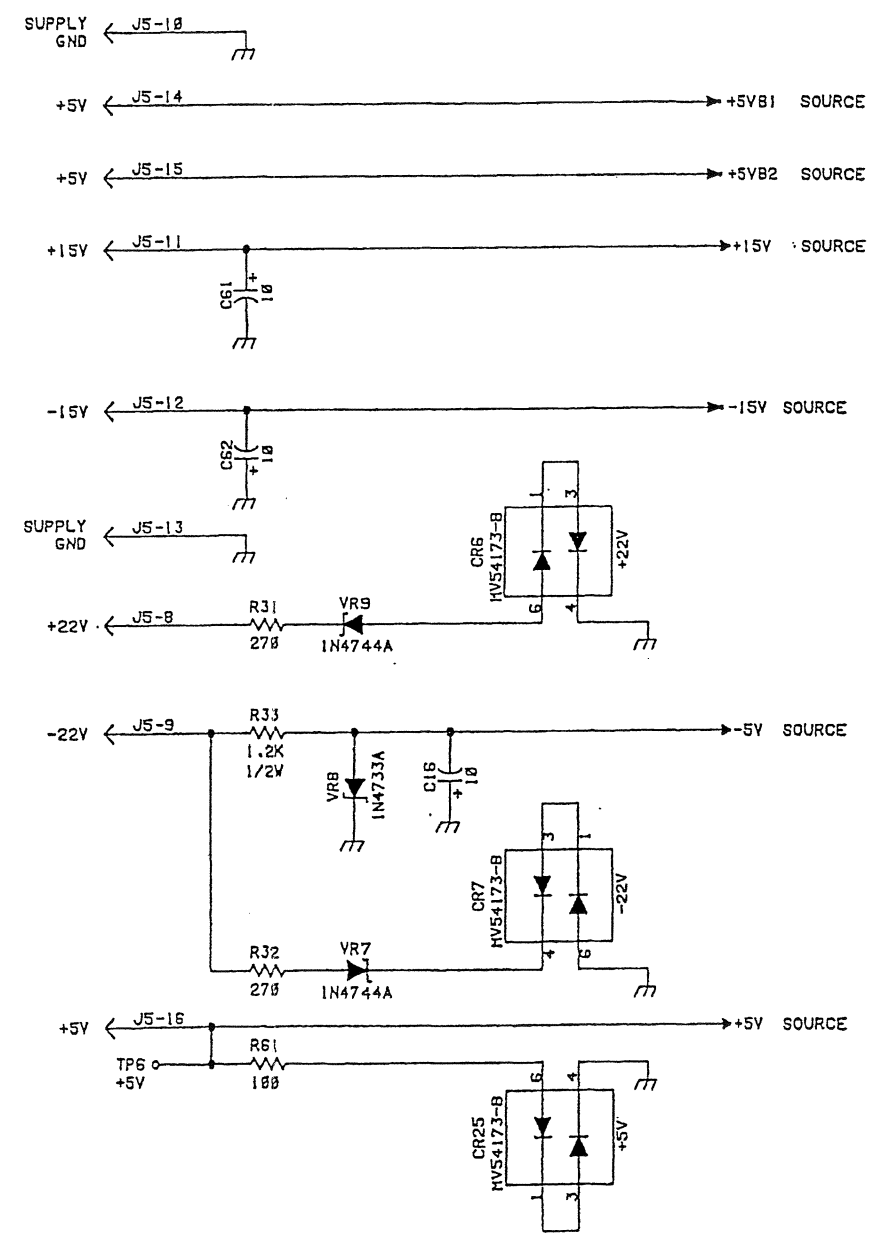

180203 (Sht 1) REV -

A6A1

Figure 7-7 Front Panel PCB (Sheet 1).

Change 1

7-15/(7-16 Blank)

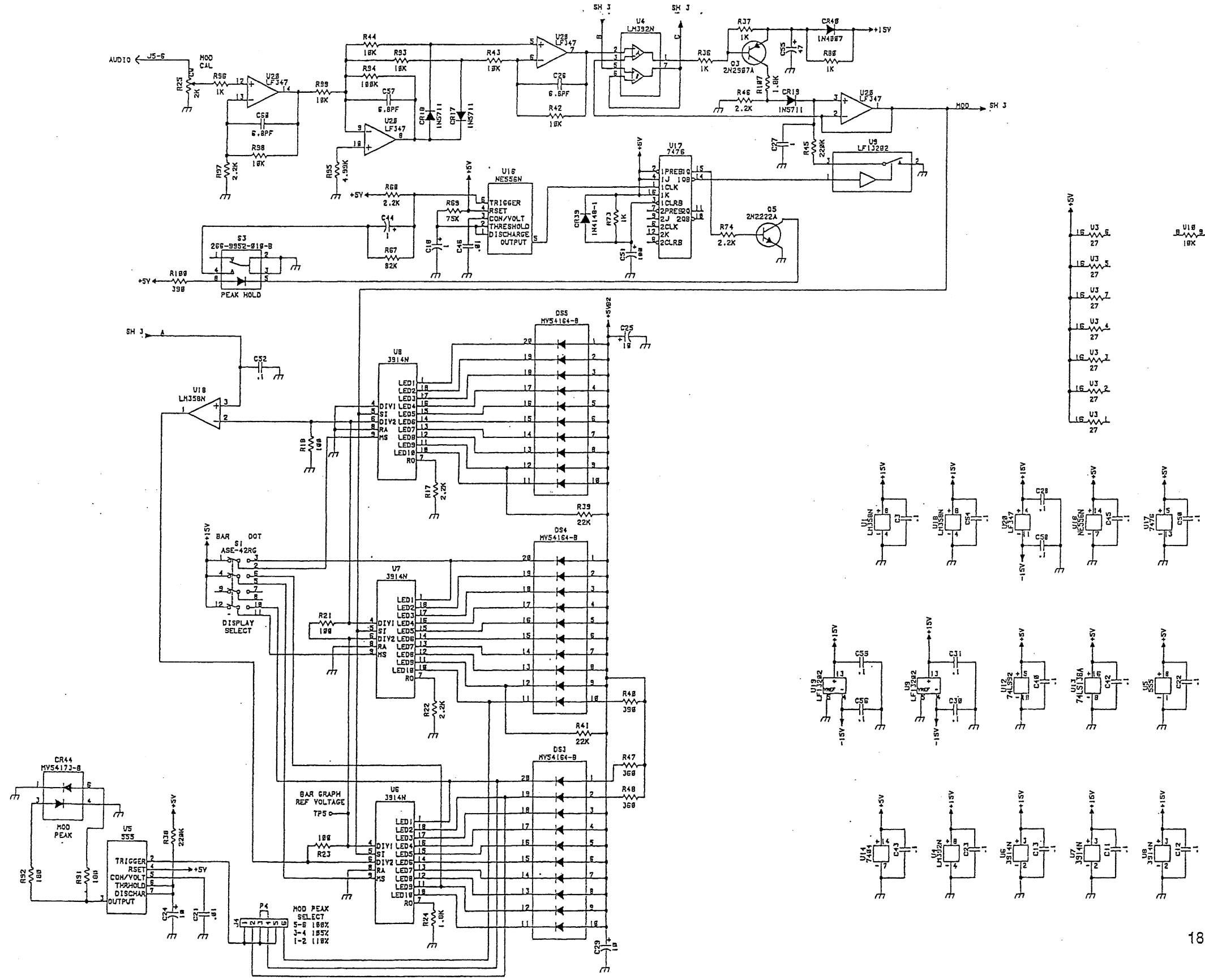

180203 (Sht 2) REV -

Figure 7-7 Front Panel PCB (Sheet 2).

Change 1

7-17/(7-18 Blank)

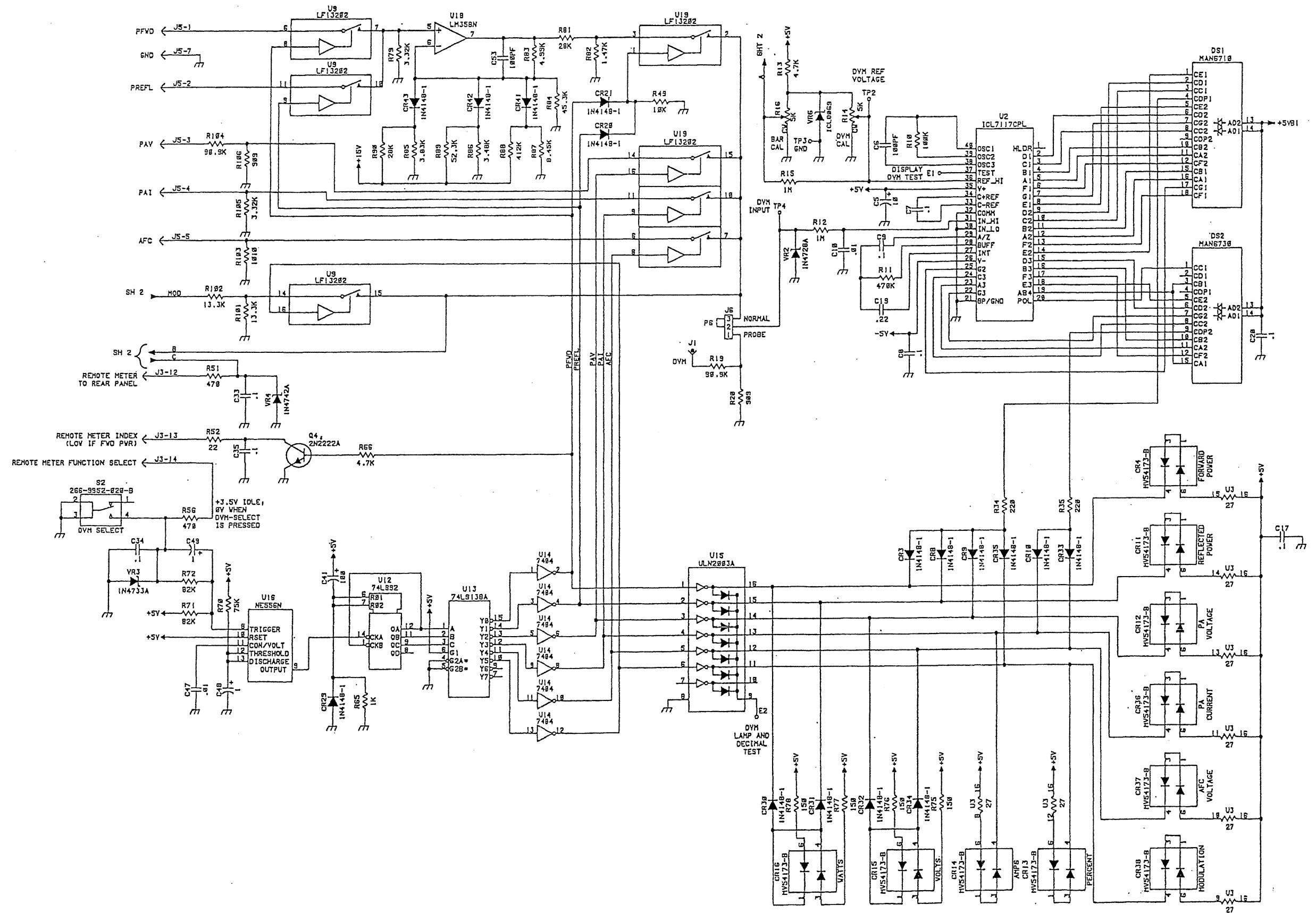

180203 (Sht 3) REV -

Figure 7-7 Front Panel PCB (Sheet 3).

Change 1

7-19/(7-20 Blank)

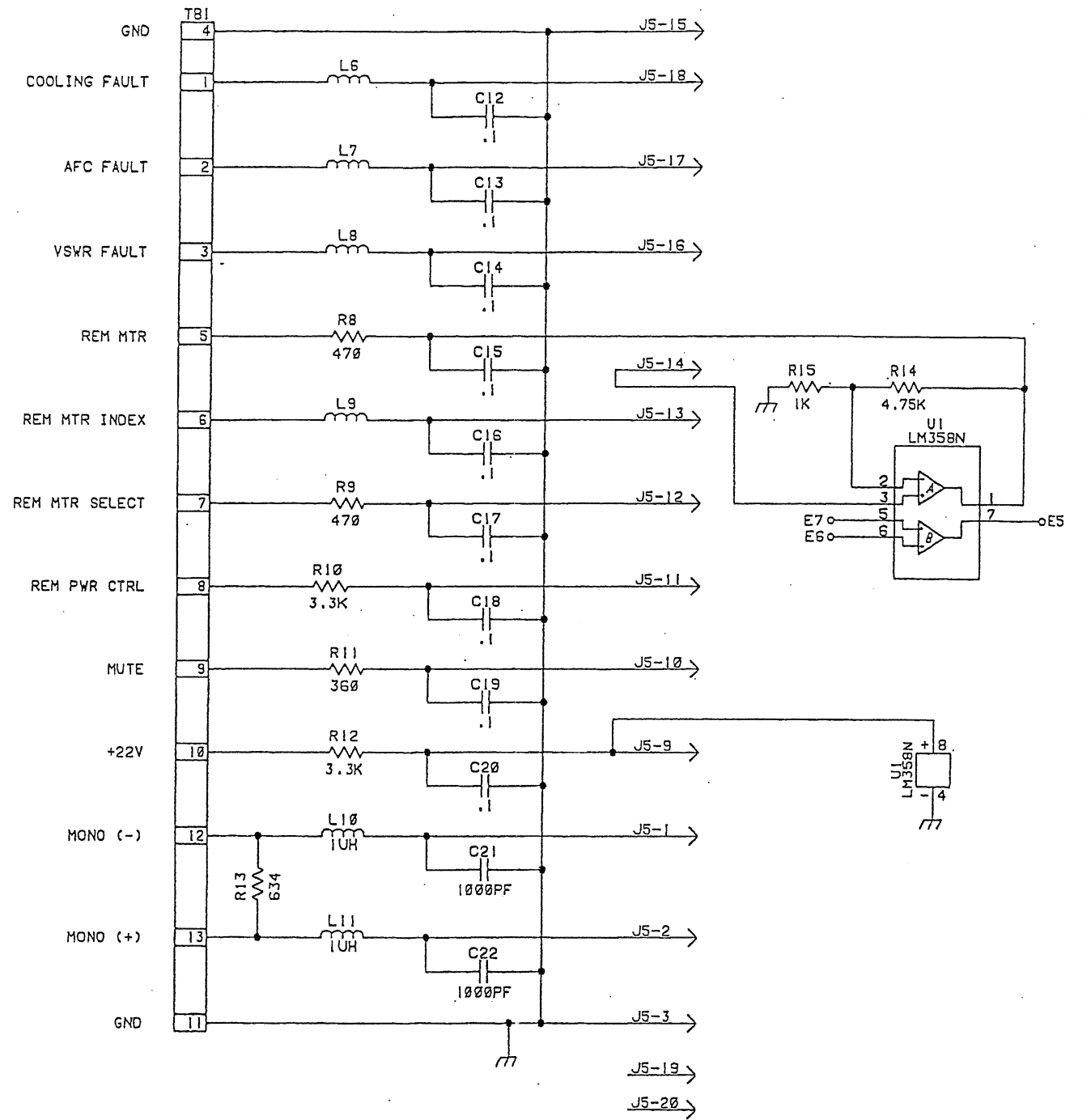
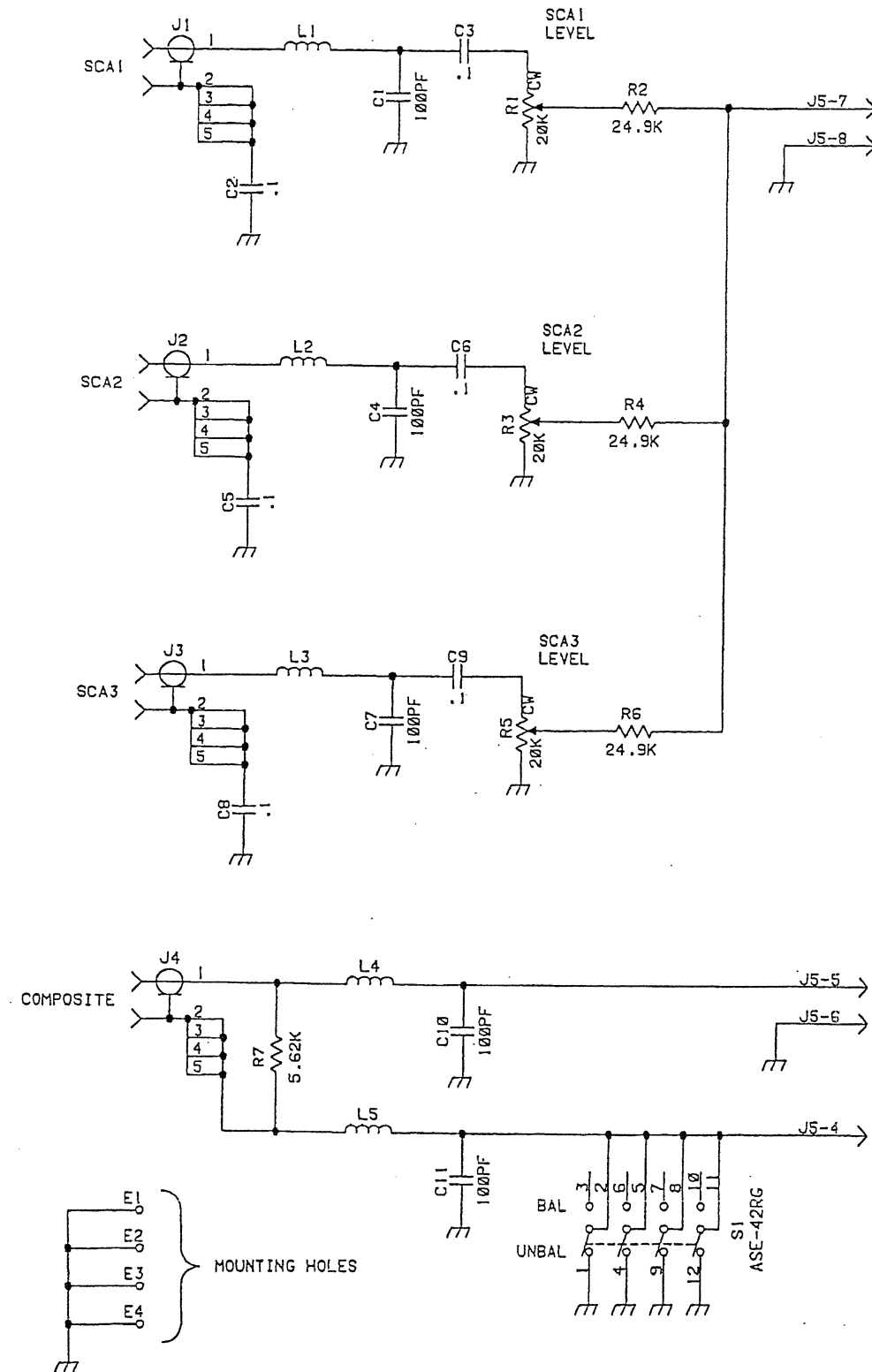

180211 Rev A

Ä7A1

Figure 7-8 Rear Panel PCB.

Change 2

7-21/(7-22 Blank)

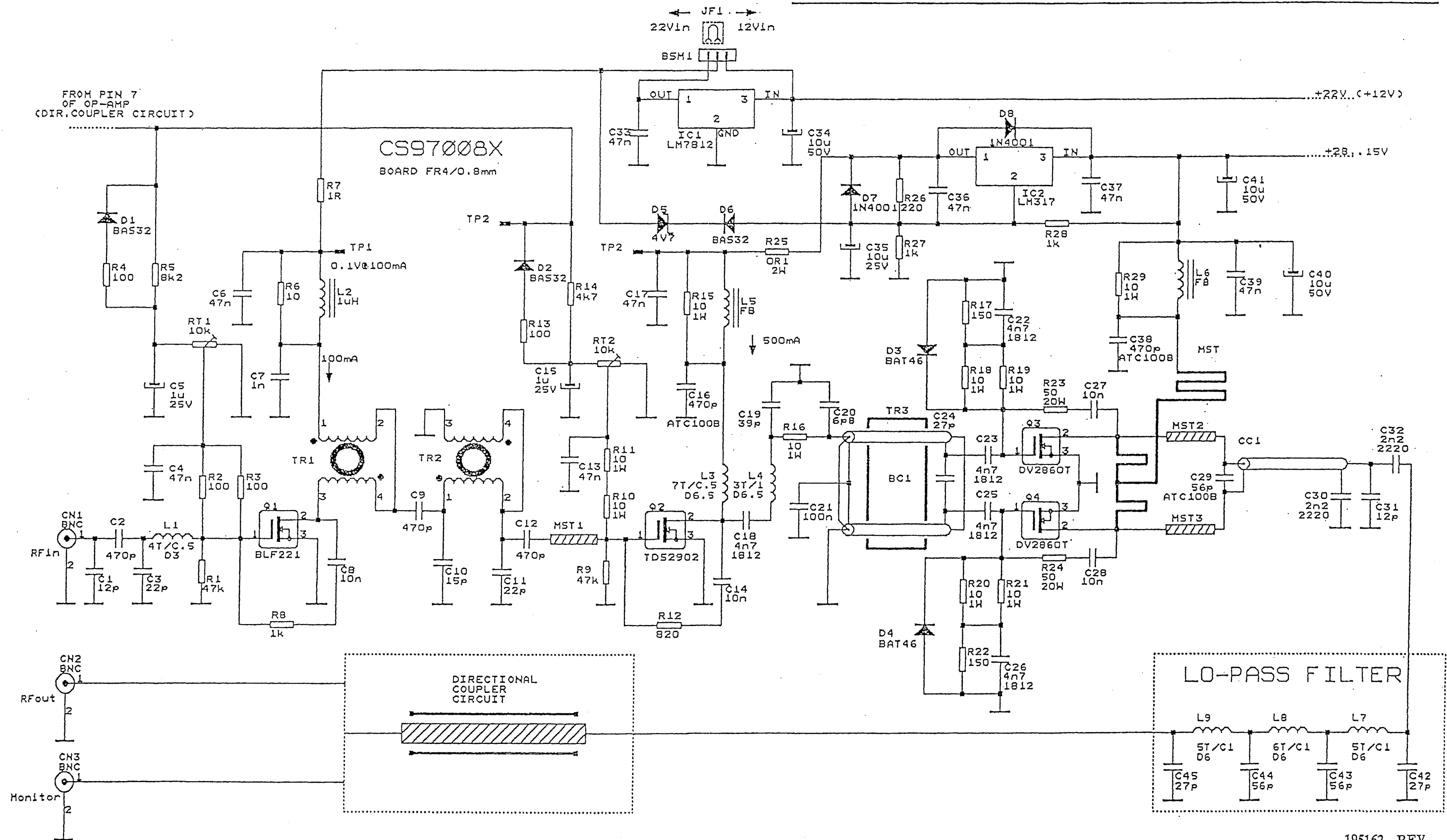

195162 REV-A8

Figure 7-9 50 Watt Amplifier Card.