

Model 610

The Discriminate Audio Processor

Instruction Manual

DORROUGH ELECTRONICS

5221 Collier Place
Woodland Hills, CA 91364
Telephone: (213) 999-1132

818 998 4886

CAUTION

Do not short the line output to ground. This will damage the output stage. If the system is to be used unbalanced, use one side of the output and ground only: leave the second disconnected.

IMPORTANT

The input control to the peak limiter labeled LIMITER DRIVE determines the amount of clipping desired. This is adjusted subjectively. Turn the control clockwise until you arrive at audible distortion and then back out of the distortion. The LED above the control indicates only that the limiter circuit is active, not that the maximum level set has been reached.

TABLE OF CONTENTS

- I INTRODUCTION

- II SPECIFICATIONS

- III BLOCK DIAGRAM OF SIGNAL FLOW

- IV THEORY OF OPERATION

- V INSTALLATION AND SETUP PROCEDURE

- VI AM STEREO - SUM AND DIFFERENCE SETUP

- VII SYSTEM SCHEMATICS
 - A. Control Display
 - B. Compressor Channel
 - C. Peak Limiter
 - D. Line Amplifier
 - E. Motherboard
 - F. Relative Loudness to Peak Modulation Meter

SPECIFICATIONS

DISCRIMINATE AUDIO PROCESSOR - DIGITAL CONTROLLED MODEL 610

A tri-band AGC (Automatic Gain Control) with Peak Limiter.

TRI-BAND CROSSOVERS AT 3 dB POINTS

Low	20 Hz to 173 Hz
Mid	173 Hz to 6.5 kHz
High	6.5 kHz to 20 kHz

Chosen for best accoustical masking of compression effects. This section is not used for frequency response.

FOUR POSITION EQUALIZER FOR SIGNAL RESPONSE POSITIONED AFTER TRI-BAND

Low	19 Hz to 71 Hz
Low/Mid	71 Hz to 710 Hz
High/Mid	710 Hz to 4.2 kHz
High	4.2 kHz to 15 kHz

PEAK LIMITER - ACTIVE ADJUSTABLE HARD/SOFT CLIP

COMPRESSION LED METERING - 16 LFDs IN 1 dB INCREMENTS

Relative Loudness to Peak Meter on Output
Meter readings for both Internal and External ranges
-10 dB for 0 indication

<u>INPUT</u>	Differential 600 ohm bal. -30 dBm to +20 dBm
<u>MAXIMUM OUTPUT</u>	Balanced to ground +24 dBm
<u>COMPRESSION RANGE</u>	24 dBm in each channel
<u>ATTACK TIME</u>	EPROM factory set
<u>RELEASE TIME</u>	EPROM factory set
<u>THRESHOLDS</u>	EPROM controlled
<u>DISTORTION</u>	.3% below clipping threshold
<u>SIGNAL TO NOISE</u>	72 dBm at compression threshold; 79 dBm in test mode
<u>POWER REQUIREMENTS</u>	110/220 V, 50/60 Hz, 75 watts



INTRODUCTION

Technical alignment procedures are not required for the installation of the Discriminate Audio Processor Model 610 as there are no linearity or DC balance controls due to the use of digital technology. There are input setup adjustments and the lid should be removed.

In order to prevent overload of input buffer amplifiers which cause clipping before the signal reaches the Master Input control, determine if the input pads should be switched in or out. A reference indication of proper ranges for these switches can be determined by setting Master Input control to one-half open, Low and Mid to one-half open, and High Frequency Input, full open. The internal switches and pads should be adjusted so that program will compress no more than 8 to 10 dB. This will be more pronounced on the Mid Meter because of the broadness of this band.

The Input Sensitivity procedure assures that adequate head room is available for program dynamics and transients. These switchable and variable pads are S1 & S2, VR1 & VR2, respectively, and are located on a pc board at the rear terminal internally on units Serial 299 and down, and in front of the Low Compressor channel on all others.

The FM units should operate directly into the Stereo Generator ports. The de-emphasis capacitor should be removed from the peak limiters. The pre-emphasis should not be removed as this forms the 75 microsecond curve.

The processing, pre-emphasis and bandwidth limiting circuits incorporated in the Optimod can be bypassed by placing the Test Switch of the Optimod in the "TEST" position. This will allow program material to be fed directly into the Stereo Generator section of this device via the RCA type connectors located immediately adjacent to the Test Switch on the rear panel. The Optimod has a bridging input at this point and requires that the DAP be terminated with a 560 ohm resistor.

Simplified Block Diagram

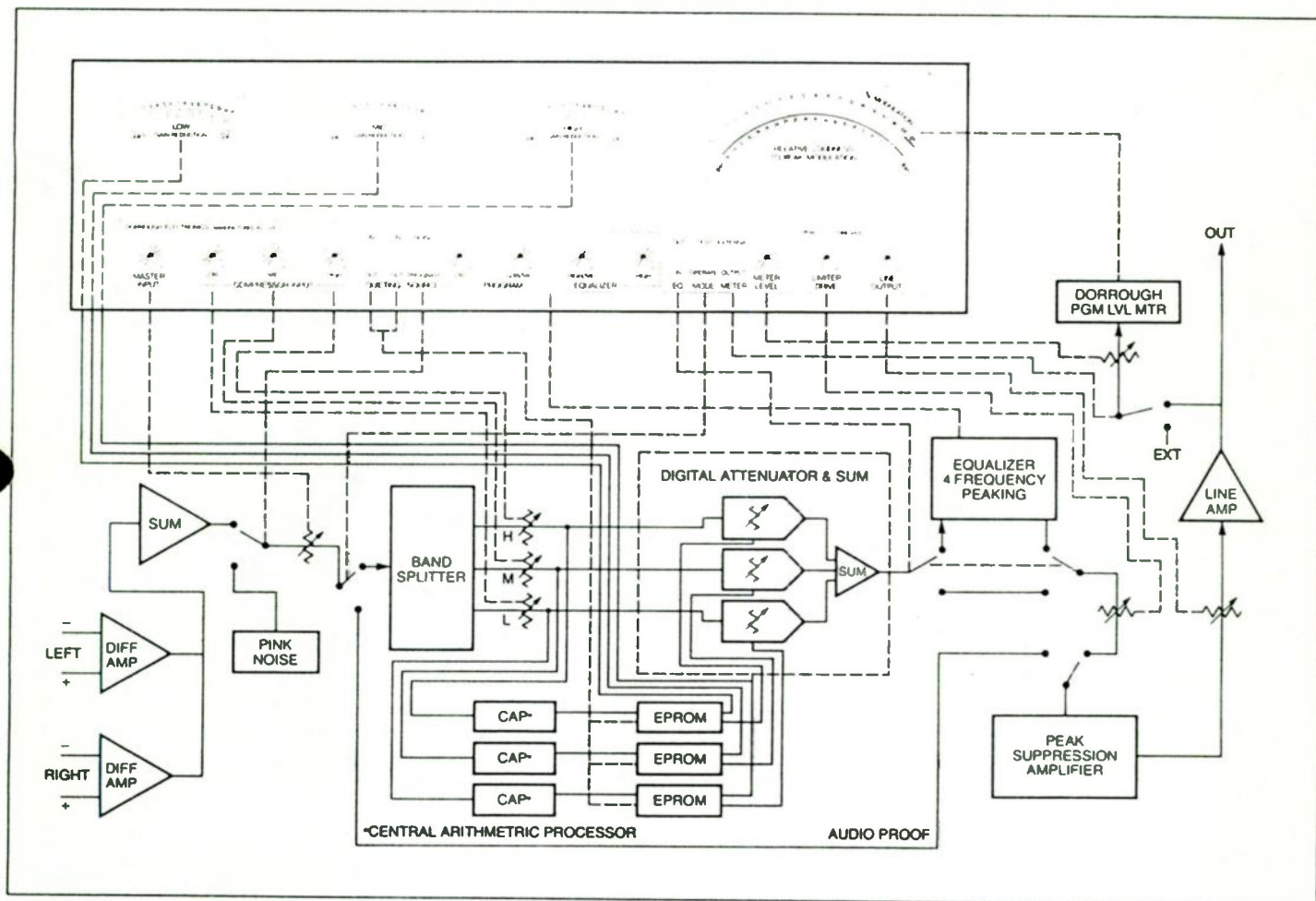

THEORY OF OPERATION

The Discriminate Audio Processor Model 610 makes use of the most up-to-date technology available. The unit has been computer designed to deliver the most colorless and clean audio available.

TRI-BAND SYSTEM

The unit splits the audio into three discriminate bands. One only needs to reflect on loudspeaker technology theory to note that 3-way loudspeaker systems offer low levels of IM distortion. Further investigation into spectral density shows that the maximum amplitudes occur at mid frequencies, with gentle slopes toward the low and high frequencies. Low frequencies exhibit lower amplitudes because, for equal power distribution of amplitude vs time, the longer the period the lower will be the amplitude. The high frequency content in music and speech is also lower in amplitude. This part of the audible spectrum carries the harmonic or overtone content of the program, which by its nature is reduced in amplitude.

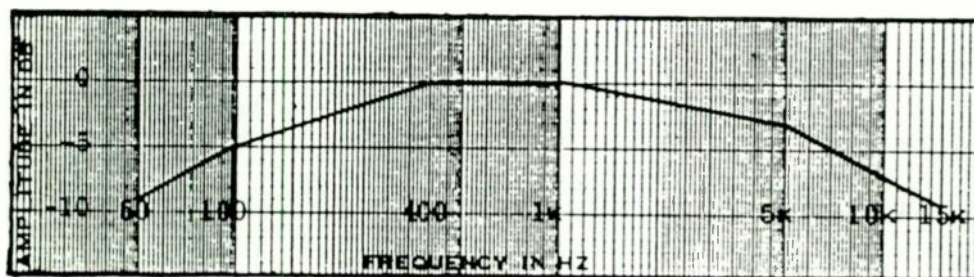

Spectral Analysis Showing Amplitude Rolloffs

Even if program material were very bright, electrically, the higher the frequency, the less amplitude necessary to satisfy the ear acoustically.

EQUALIZATION SLOPES

Six dB per octave equalization slopes were chosen as crossover points to the compressors. These slopes make for the best possible acoustic masking of the effects of compression. Intentionally, the three channels do not sum flat electrically, though they sum flat acoustically.

To prove that this system and its crossovers are not modifying the integrity of the program source, listen to the processor summed out-of-phase with the source feeding it. Even with heavy compression, the summation should null smoothly at better than 20 dB.

Thus, the physics of the concept argue with the analysis of tone, but confirm what the ear is able to hear.

DIGITAL CONTROLLED ATTENUATORS

ATTACK TIMES

The band splitter feeds the three digital controlled/analog attenuators through individual input controls on the front panel. These controls determine the amount of AGC action of the compressor channels. The gain changes in the three channels are extremely fast, even at 15 kHz, the attenuation will act on the first one-half cycle. The attenuators will automatically adjust to the dynamic parameters of program. This fast action, rather than the conventional smooth RMS, preserves the differential of the fundamentals, and its harmonic content. In addition, this fast action retards peaks as the channels are summed and prevents intermodulation distortion buildup in the peak clipper.

RECOVERY TIMES

The discriminate channels are identical. The recovery times for each are located on the large motherboard directly under each card. The recoveries, like the crossovers, play an important part in the quality of the system.

Slower times were chosen to allow for better dynamics at even deep compression ranges.

If more sensationalism, that crowded up-beat sound, is desired, these recovery times can be spedup by lowering the value of the time constant resistors.

EQUALIZATION

From the summation of the three channels, a four position equalizer can be switched in for subjective or technical response changes. Q's will move about the spectrum in accordance with the boost and attenuation of the four positions.

SOFT PEAK CLIPPING

The Equalizer feeds the active soft peak clipper. This system does not demand the necessity of a wide band peak limiter. The very nature of the wide band limiter would destroy the quality of the discriminate system feeding it. Rather, a soft clipper is used.

Soft clipping does not mean the lack of good peak protection, but rather the ratio of the clip is spongy. The peak is "slamming" into a padded brick wall. As a result, the waveform then becomes rounded at the top, rather than squared. The current limiting device used limits the rate of acceleration of the leading edge of the input waveform, reducing odd order harmonic content. This is more appealing accoustically.

Soft clipping does not show a high average on an analog modulation monitor, A reading of 75 to 90% is normal and only on sustaining notes will the readings be higher. The true effectiveness of this type of clipping can be seen on an oscilloscope or on the Relative Loudness to Peak Modulation Meter on the output of the DAP. This Meter should be calibrated to the Modulation Monitor which will then enable you to set your clipping level for maximum loudness.

INSTANTANEOUS LED METERING

The Relative Loudness to Peak Modulation Meter serves an important function. First, by nature of the LEDs, it gives an instantaneous reading of the crest factor, in addition to displaying duty time. These two visual functions allow you to consider Peak information and RMS content at the same time.

When applying the Pink Noise source heavily into the Peak Limiter, the Loudness Meter will show a Peak and an Average of a given amount. When the Meter is switched to an external source, such as the Modulation Monitor audio output, it can easily be noted if the reading is identical to that of the output of the processor. If there is modification of the audio peak and the modulated duty time from the transmitter, such as the modulated duty time registering higher, this would show that the transmitter tends to saturate; if the modulation duty time remains constant, but the peak fluctuates, this would indicate probably "ringing" in the transmitter, thus proving that modification of the audio is taking place external to the processor.

Once you calibrate this Meter you will discover how erroneous analog meter readings can be as indicators of complex waveforms.

INSTALLATION AND SETUP PROCEDURES

INSTALLATION

The Am unit and the TV unit should be installed at the transmitter and the FM units should be installed as close to the stereo generator as possible. This system can be installed at the studio when using the Transmitter Drive/Soft Clipper Dorrrough Model 610XU. In this case, the clipper on the studio unit should be used with caution to prevent ringing, overshoot, and unpredictable gain changes between the studio and transmitter interface.

INPUT BUFFERS

To protect input buffer amplifier from overloading, adjust Master Input pot on the front panel one-half open, High Compressor Input full open, and Mid and Low Compressor Inputs one-half open. While feeding program material, adjust internal variable attenuators located in front of the Low Compressor, until one or all compression meters read up to the red LEDs, approximately 8 to 10 dB. These internal controls should be set somewhere between one-half and full open; if not, check Sensitivity Switches located next to the variable attenuators.

INPUTS

When using the unit for mono or for conventional stereo, one unit for left and a second for right, Input 1 or Input 2 can be used. Two inputs have been provided for Sum and Difference processing.

FRONT PANEL ADJUSTMENTS

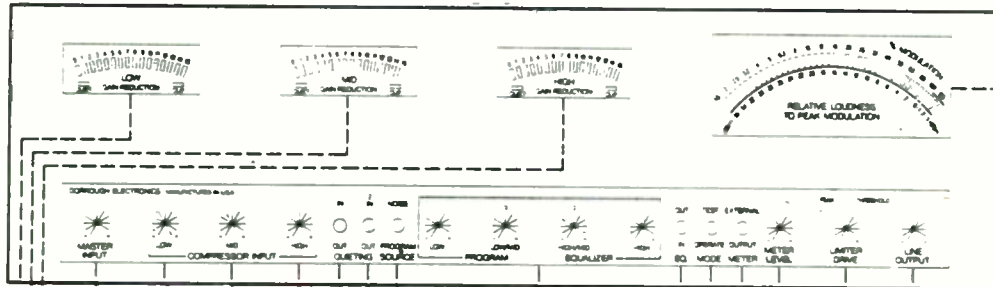

MASTER INPUT

The two internal variable input attenuators are buffered, mixed, and fed to the Master Input Control on the front panel which then feeds the crossovers. The crossover outputs appear on the panel as Low, Mid, and High Compression Inputs. The crossover points for the compressors are:

Low	20 Hz to 173 Hz
Mid	173 Hz to 6.5 kHz
High	6.5 kHz to 20 kHz

This section is for establishing AGC ranges and is not used for frequency response.

QUIETING SOURCE

There are two switches for noise gating. They are labeled Quieting 1 & 2. In the "up" position, these switches will gate 3 dB each, for a total of 6 dB in the absence of audio. The noise reduction is programmed in the EPROM. This prevents a "click-in" effect when the unit responds to program or returns to a quiescent state. The Quieting Mode is not needed when using small amounts

of compression, approximately 7 dB or less. When the quieting circuits are activated, a quieting LED will illuminate. The systems operate independently for each channel but will track when tied to a second unit. A clip LED in each display window indicates channel overload.

PINK NOISE/PROGRAM SOURCE

The next switch will select either Pink Noise or Program Source. This switch should be in the "down" position when running normal program.

PROGRAM EQUALIZER

The three compressor channels are summed and buffered internally, and electrically feed the Program Equalizer. The Equalizer has four positions.

Low	19 Hz to 71 Hz
Low/Mid	71 Hz to 710 Hz
High/Mid	710 Hz to 4.2 kHz
High	4.2 kHz to 15 kHz

The Equalizer can be switched In or Out. Subjective timbre and quality is provided by the Equalizer. It should be noted that as you increase any range of frequencies, they will be boosted into the limiter circuit, therefore, slight attenuation of the Limiter Drive may be necessary.

MODE

A Mode switch to bypass the entire Discriminate System is provided. In Operate the Limiter Drive is connected to the output of the Equalizer. In Test position the switch is looking at the internal submix ahead of the Master Input Control.

METER AND METER LEVEL

When the Meter Switch is in the Output position, the Meter is fed by the Meter Level control which can be adjusted to a specific reading for the output of the system. When in the External position, the control is not active. In this position the large Meter is looking at two buffer amplifiers summed and fed by two mixing controls located internally on the Motherboard at the rear of the chassis. This Meter should be calibrated with the Modulation Monitor or any external monitoring source. Calibration should be done with tone.

LIMITER DRIVE

The input control to the Peak Limiter designated Limiter Drive determines the extent of modification of the Peak amplitude in reference to the duty time. The LED indicator located above the control will illuminate when the limiter circuits are active indicating clip threshold. The clip should be adjusted subjectively. The clip ratio can be observed on the Loudness Meter under program conditions. Heavy peak limiting will reduce the differential between Peak and Persistence. Maximum modulation setting should generally be done with dynamic solo material, such as voice. In this way the ear can more readily discern the distortion factor.

LINE OUTPUT

The Line Amplifier is driven by the Line Output control which will vary the output from infinity to +24 dB. This circuit does not use a transformer output, rather it operates as a differential high and low to ground designated as + or - and ground. If the output is to be used unbalanced, it is important not to short high or low to ground. Use one side or the other, and ground.

The performance of the Discriminate Audio Processor should not be judged along side of other multibands at the transmitter site while listening to a wide band monitor. Systems begin "chasing", fatigue sets in, and judgements are mistakenly made on extremes of response characteristics that will "in the real world" have no validity. Your evaluation at your transmitter does not take into consideration your total system. Your station is relative to your competition. Your adjustments and judgements should be made by comparison to your competitors. If your station is tuned well, it should sound good on most any radio. The equalization and clipping should be tuned for rich, full, open, yet clean apparent loudness. Brightness alone is not the answer, but overall good fidelity.

AM STEREO - SUM & DIFFERENCE SETUP

Entry portals for AM stereo operation in Sum & Difference have been provided. In this setup, Input 1 is Left and Input 2 is Right on both units which when paralleled out-of-phase to a second 610, forms the Sum for the first unit and the difference for the second unit.

Internal input attenuators serve as mixers for these two inputs. In order to obtain a proper match in level for these two inputs, feed from a stereo source, a Mono signal. Connect the Left to Input 1 and follow the Input Buffer Setup procedure in order to protect input buffers. Once this is accomplished, feed the Right channel out-of-phase to Input 2 and adjust its internal trim pot until signal nulls. The channels are now balanced. Return Input 2 lead to proper phase. This now forms the Sum of Left plus Right. The input of the second 610 should be paralleled to the first and the same procedure should be followed with the exception that this unit should be left out-of-phase. The second unit then forms the difference. Disconnect the mono source, and return to stereo.

Follow interface instructions from specific Am Stereo Exciter manufacturer to complete the setup.

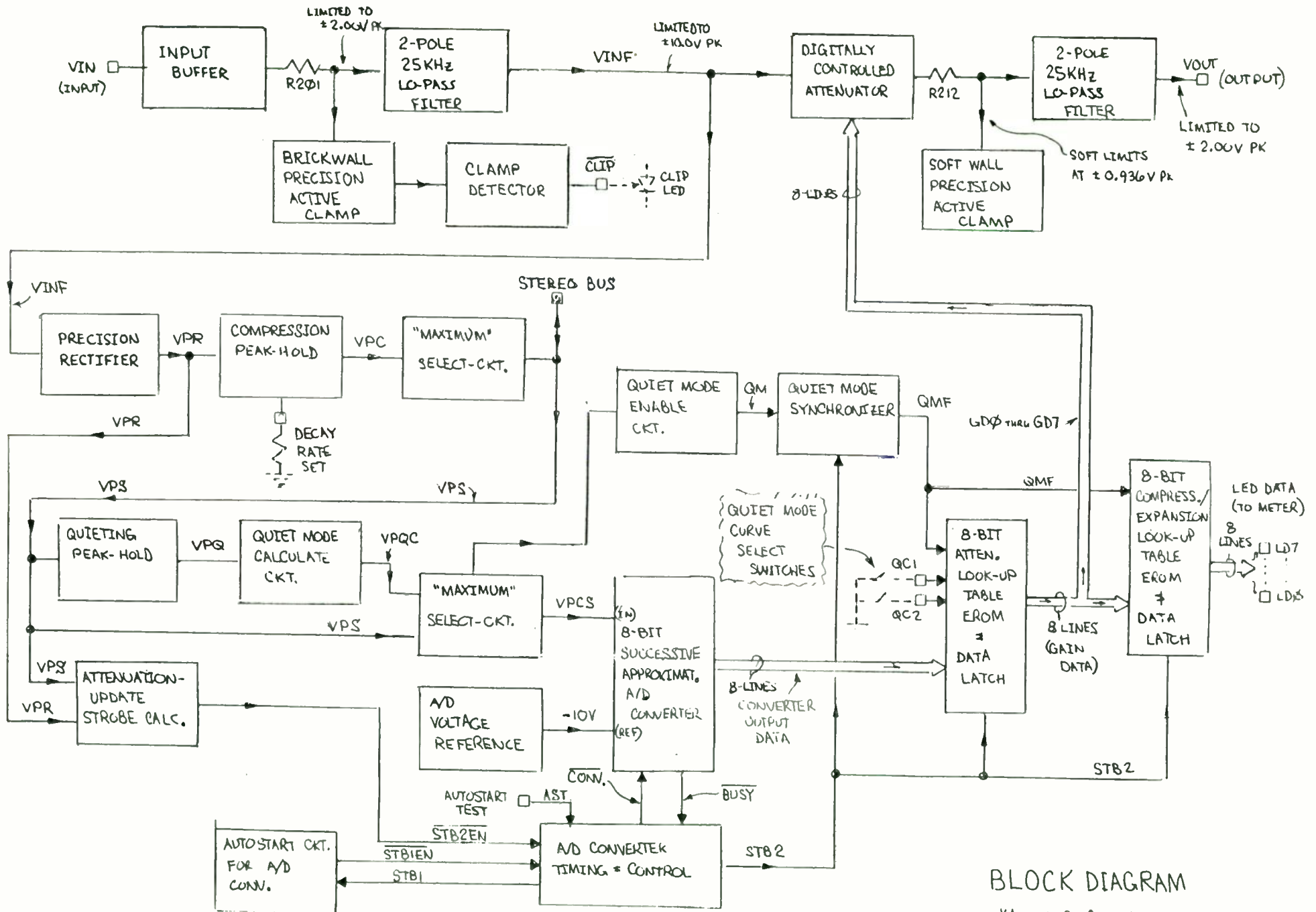

BLOCK DIAGRAM

VA 1-26-83 01 11

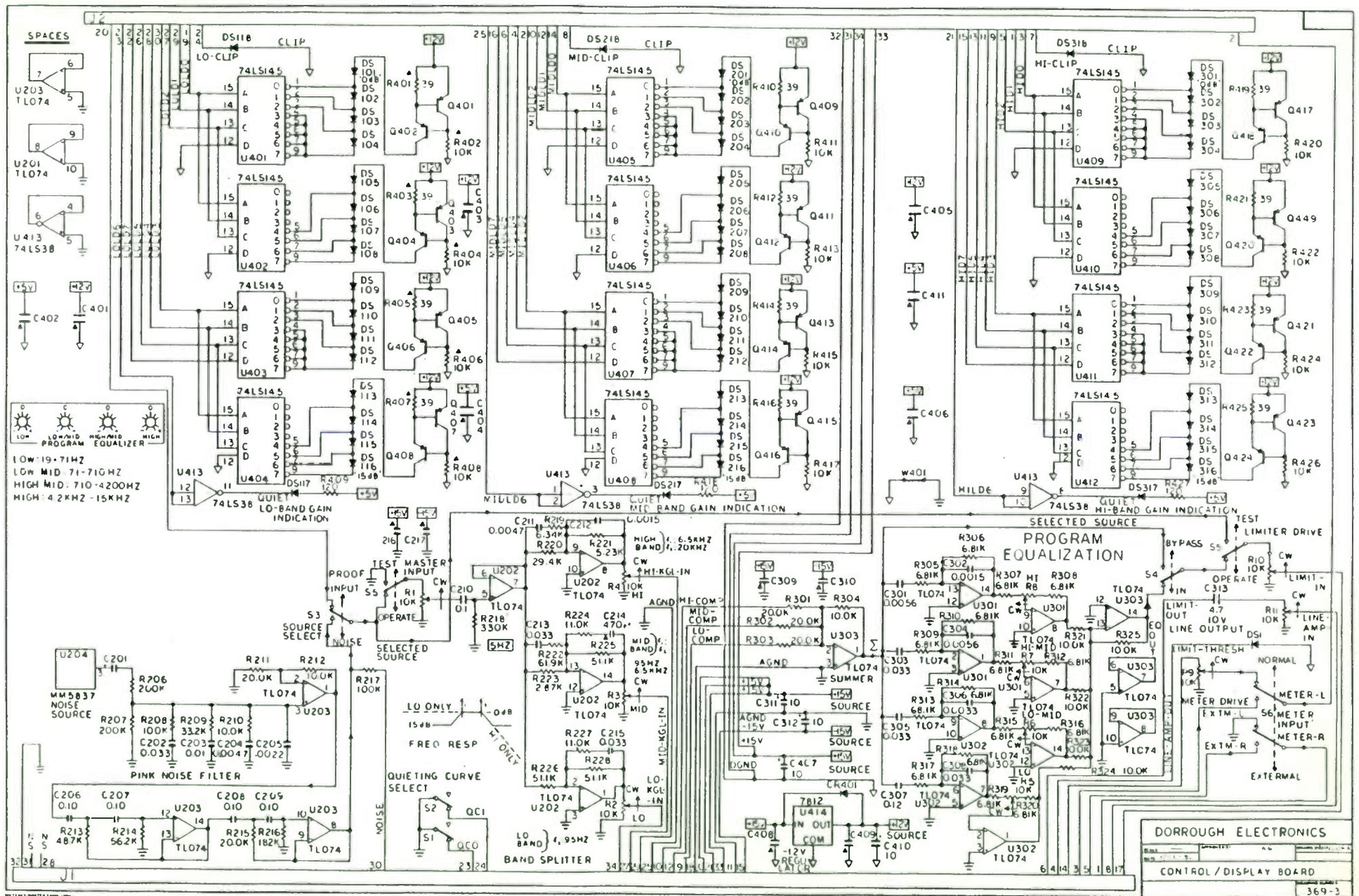

Single Digital Channel

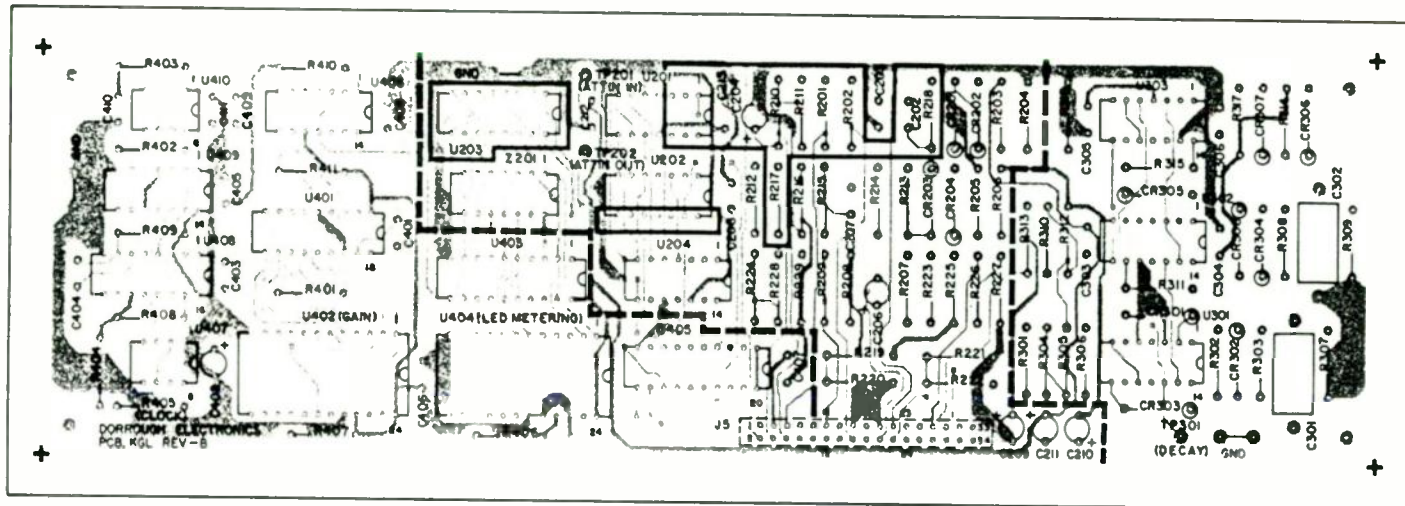

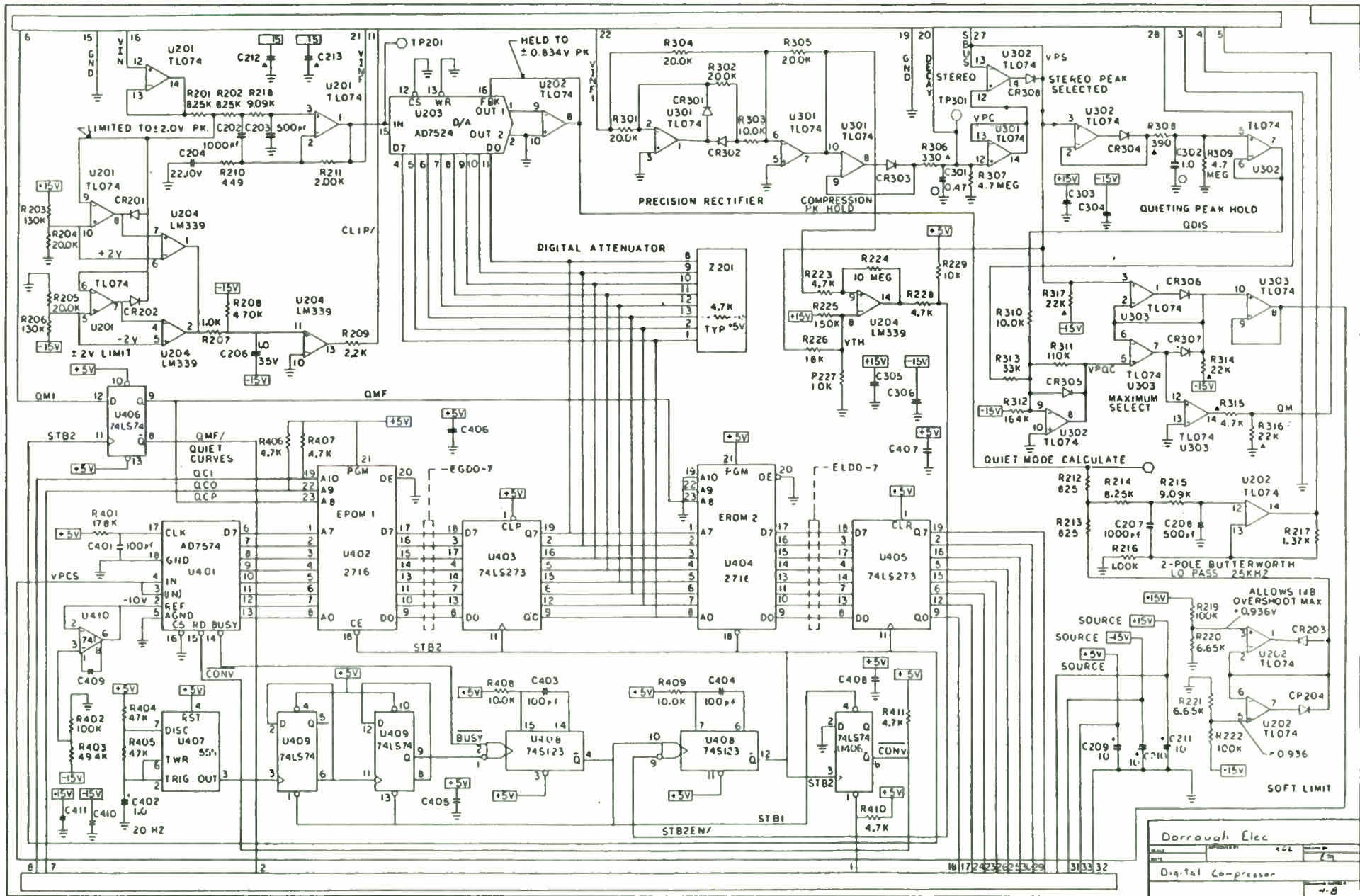

Darraugh Elec
 1611724232623329 313332
 Digital Compressor
 4-B

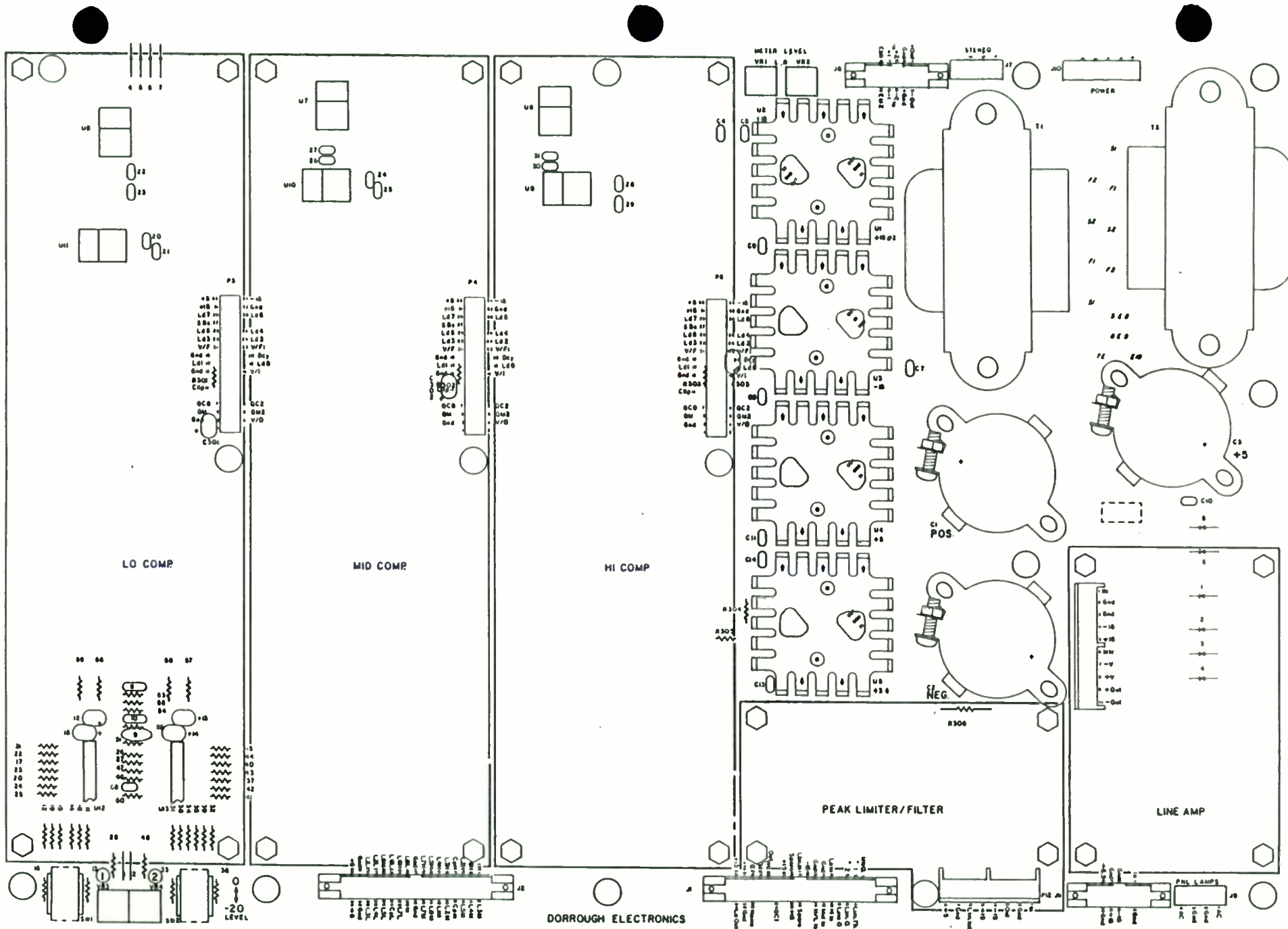

DORROUGH ELECTRONICS

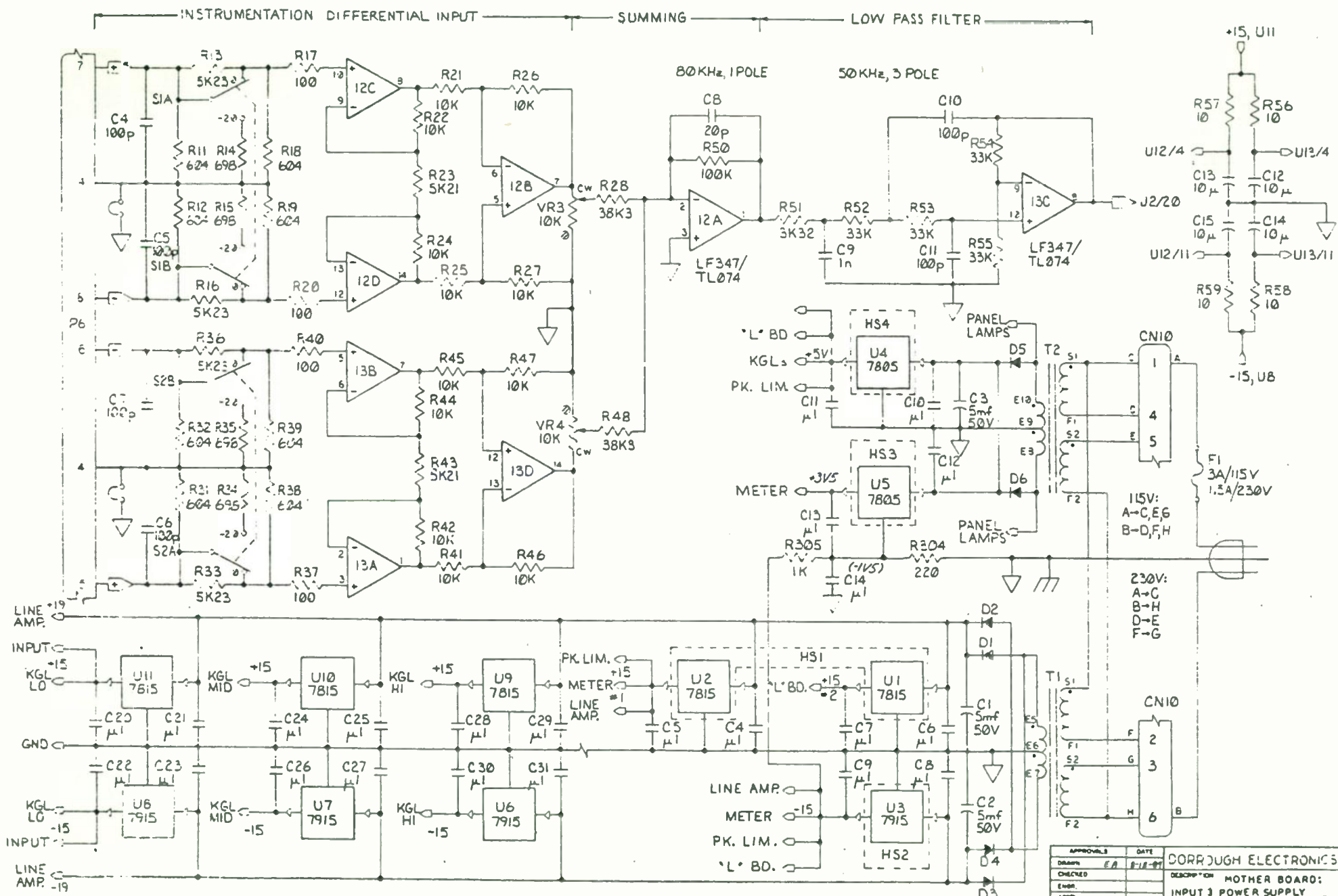

2. MULTIPLIER: P=10⁻¹², n=10⁻⁹, μ=10⁻⁶, m=10⁻³, K=10³, M=10⁶
 1. TO SCALE INPUTS TO HI Z: CHANGE R11, 12, 10, P, 31, 32, 38, 39 TO 12K, R14, 15, 34, 35 TO 14K, R13, 33 TO 100K.
 NOTES: UNLESS OTHERWISE SPECIFIED.

APPROVALS	DATE	DESCRIPTION
DESIGN	EA	8-18-71
CHECKED		
ENGR.		
APP'D		
MAT'L		
FRONT		

CORRUGH ELECTRONICS	
MODEL NO	DAP610
REV	E
SCALE	STATE OF OHIO
	SHEET OF

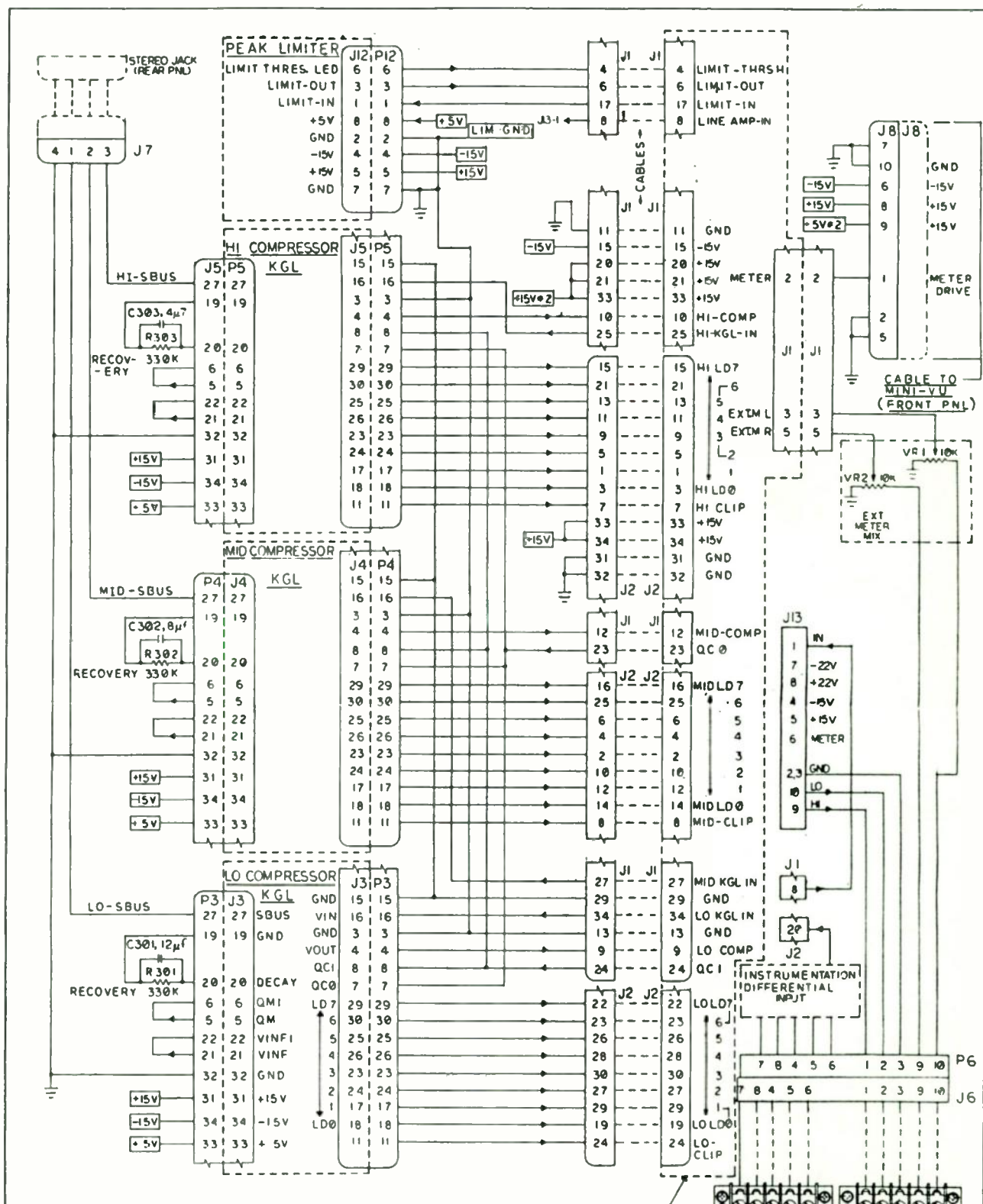

LAST USED DESIGNATORS
 R 311, P/J13, E306, W303

SIGNAL DISPLAY BOARD

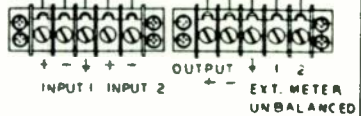

TB2 TB1

DORROUGH ELECTRONICS

MOTHER BOARD/CIRCUIT INTERCONNECTS

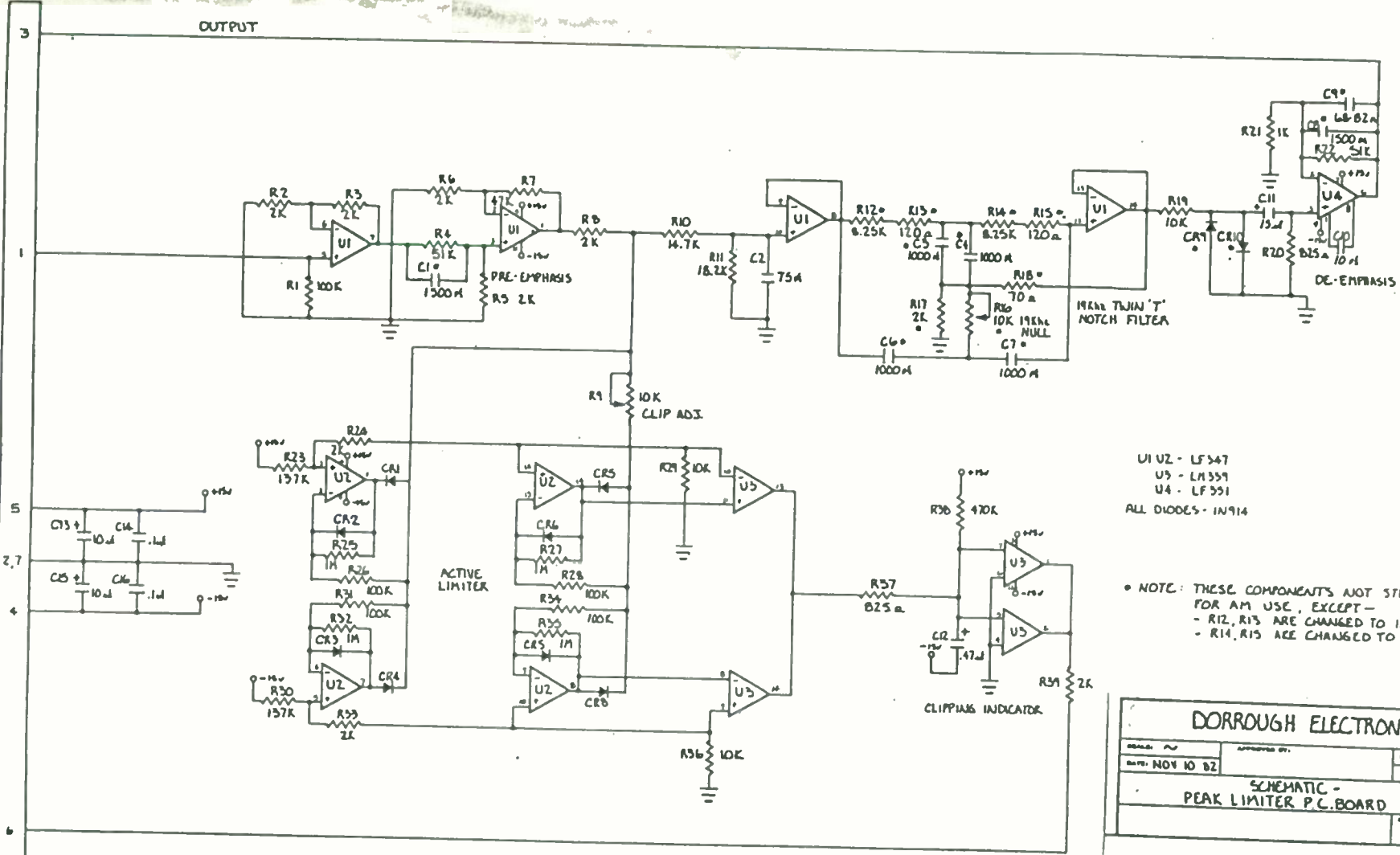

U1 U2 - LF347
 U3 - LM359
 U4 - LF351
 ALL DIODES - 1N914

• NOTE: THESE COMPONENTS NOT STUFFED FOR AM USE, EXCEPT -
 - R12, R13 ARE CHANGED TO 1.0K
 - R14, R15 ARE CHANGED TO JUMPERS

DORROUGH ELECTRONICS		
DESIGNED BY	APPROVED BY	DATE OF DB
NOV 10 82		
SCHEMATIC -		
PEAK LIMITER P.C. BOARD REV. F.		

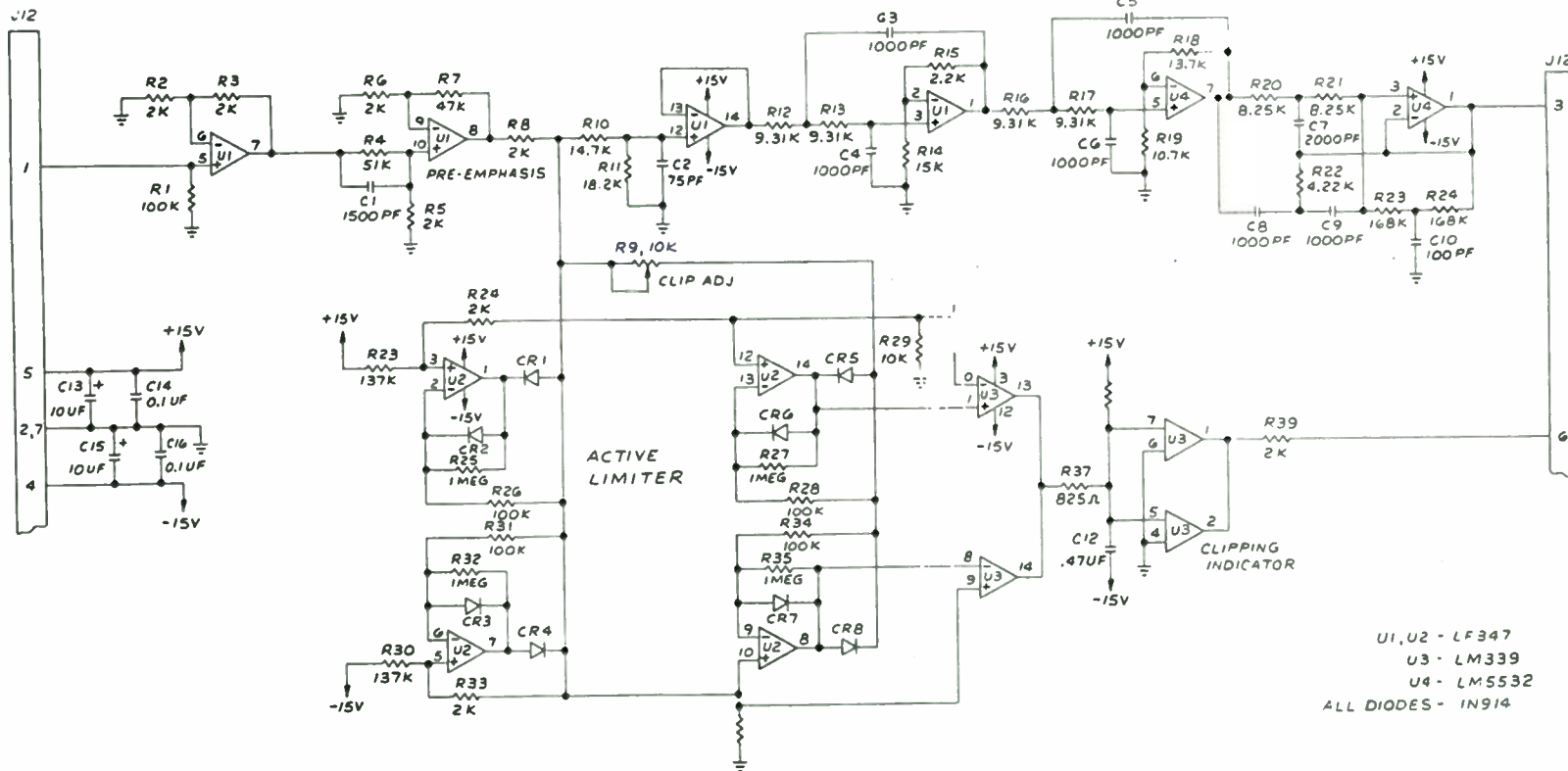

U1, U2 - LF347
 U3 - LM339
 U4 - LM5532
 ALL DIODES - 1N914

DORROUGH ELECTRONICS			
Rev. 1	Proj. LMR101	Sheet 1 of 1	10-1988
Rev. 2	Rev. B 12/15/88		

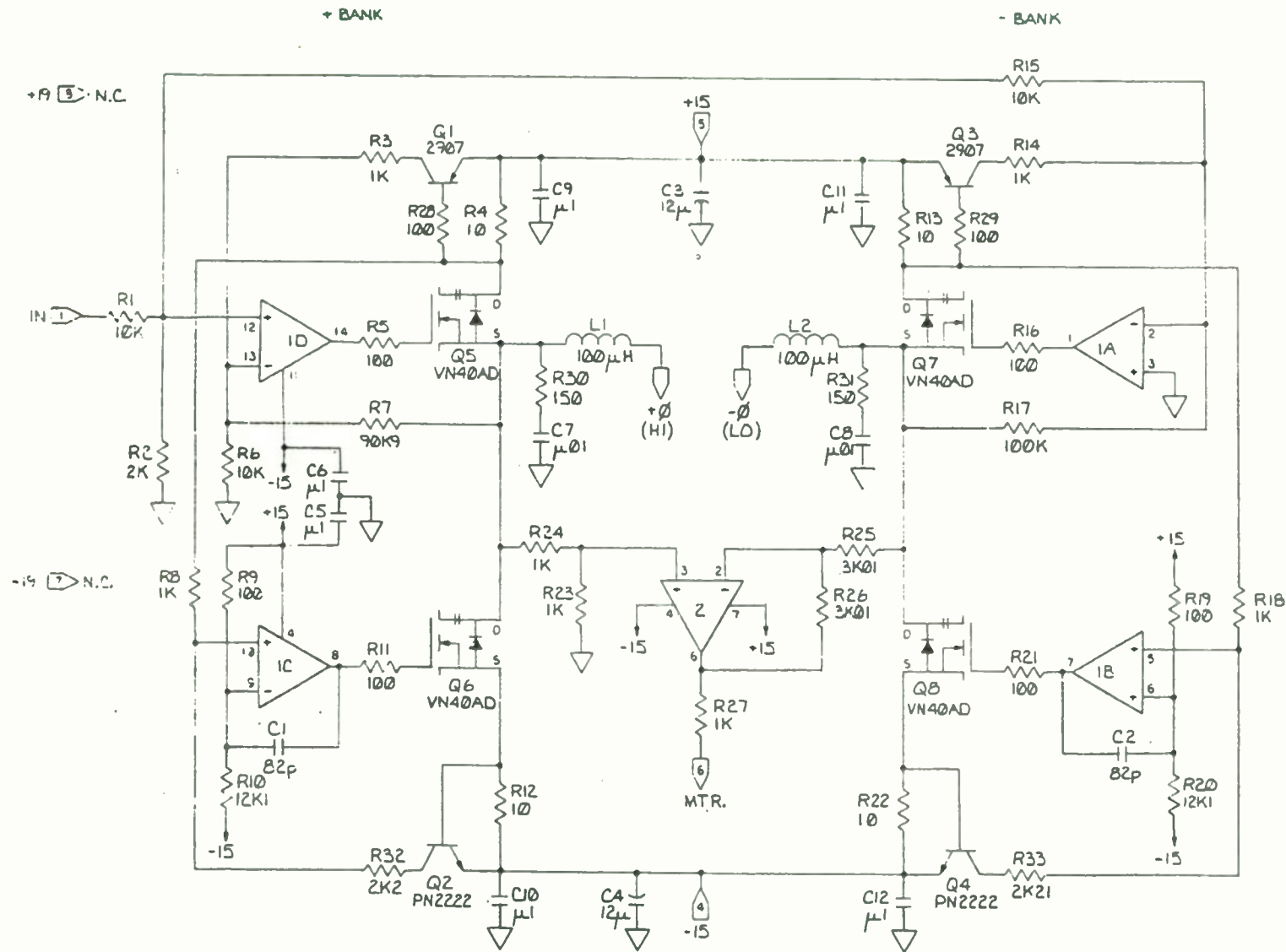

2. ALL RESISTORS PNSEC.

1. a. ALL RESISTANCE VALUES IN OHMS
- b. ALL CAPACITANCE VALUES IN FARADS
- c. ALL VALUES:

1. MULTIPLIER AT DECIMAL LOCATION,
i.e. 5.6K = 5K6, .02μ = μ02
2. p = 10⁻¹², n = 10⁻⁹, μ = 10⁻⁶, m = 10⁻³, K = 10³, M = 10⁶

NOTES: UNLESS OTHERWISE SPECIFIED.

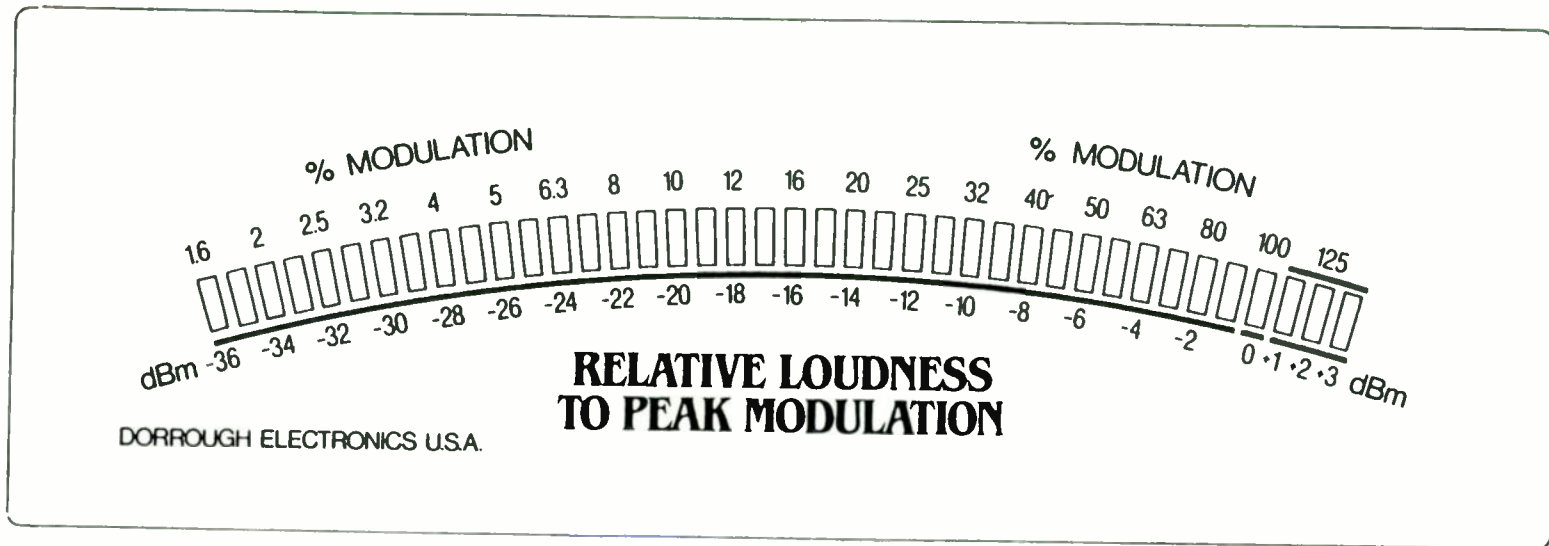

Block Diagram

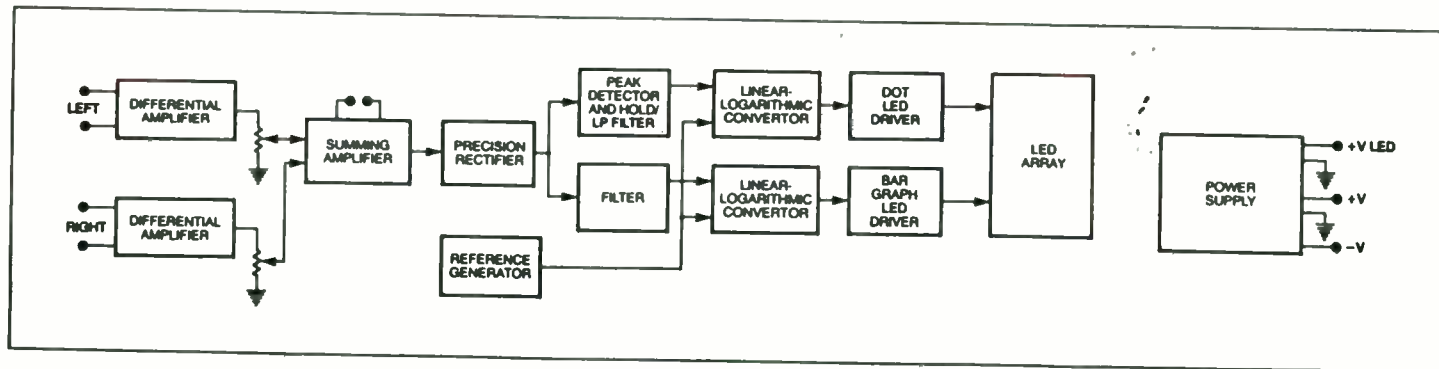

REV	NO	REV	DESCRIPTION	DATE	APPROVED
A	1		ENIG RELEASE		

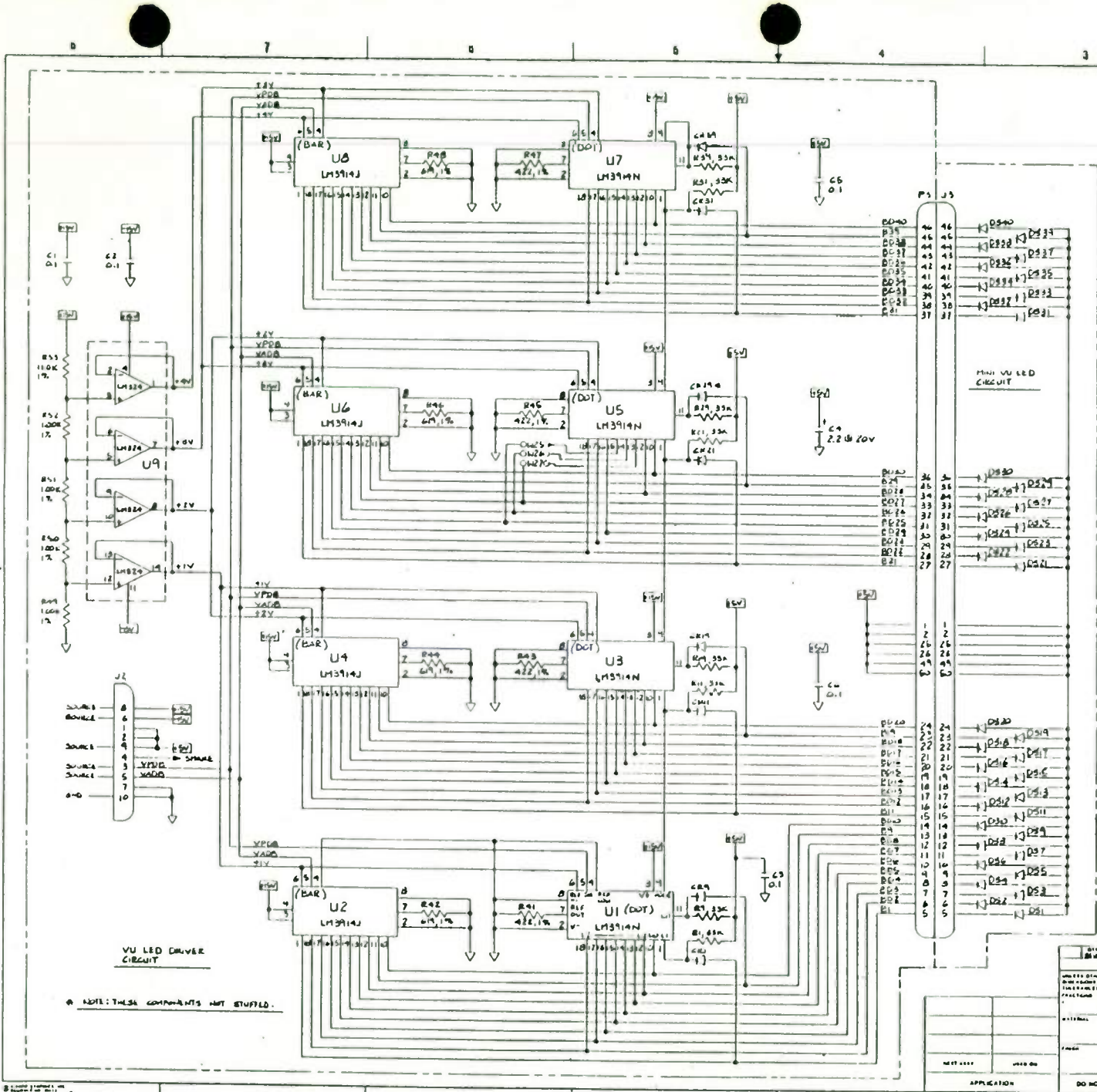

COMPONENT REF INFORMATION

DESIGN	TYPE	DESCRIPTION	PKS	QTY	REF	QTY
U1	LM3914	QUAD (1/4) AMP	14-DIP	4	11	11
U2, U3, U4	LM3914	UNIT / BAR DISPLAY DRIVER	16-DIP	2	3	3
U5, U6, U7	LM3914	DOT / BAR DISPLAY DRIVER	16-DIP	2	3	3
U8, U9, U10	LM324	DIODE	14-DIP	2	3	3

LAST DESIGNATOR USED: C1, R3, U3, U4

NOTE: THESE COMPONENTS NOT STUFFED.

DESIGNED BY: [] CHECKED BY: [] DATE: []	PART NO: [] REV: []	DRAWN BY: [] DATE: []	CHECKED BY: [] DATE: []	APPROVED BY: [] DATE: []	PART NO: [] REV: []
DORROUGH ELECTRONICS SCHEMATIC VU LED & DRIVER CIRCUITS			PART NO: [] REV: []		
DO NOT SCALE DRAWING			SHEET 1 OF 1		

REV	DATE	APPROVED
A	EMS RELEASE	

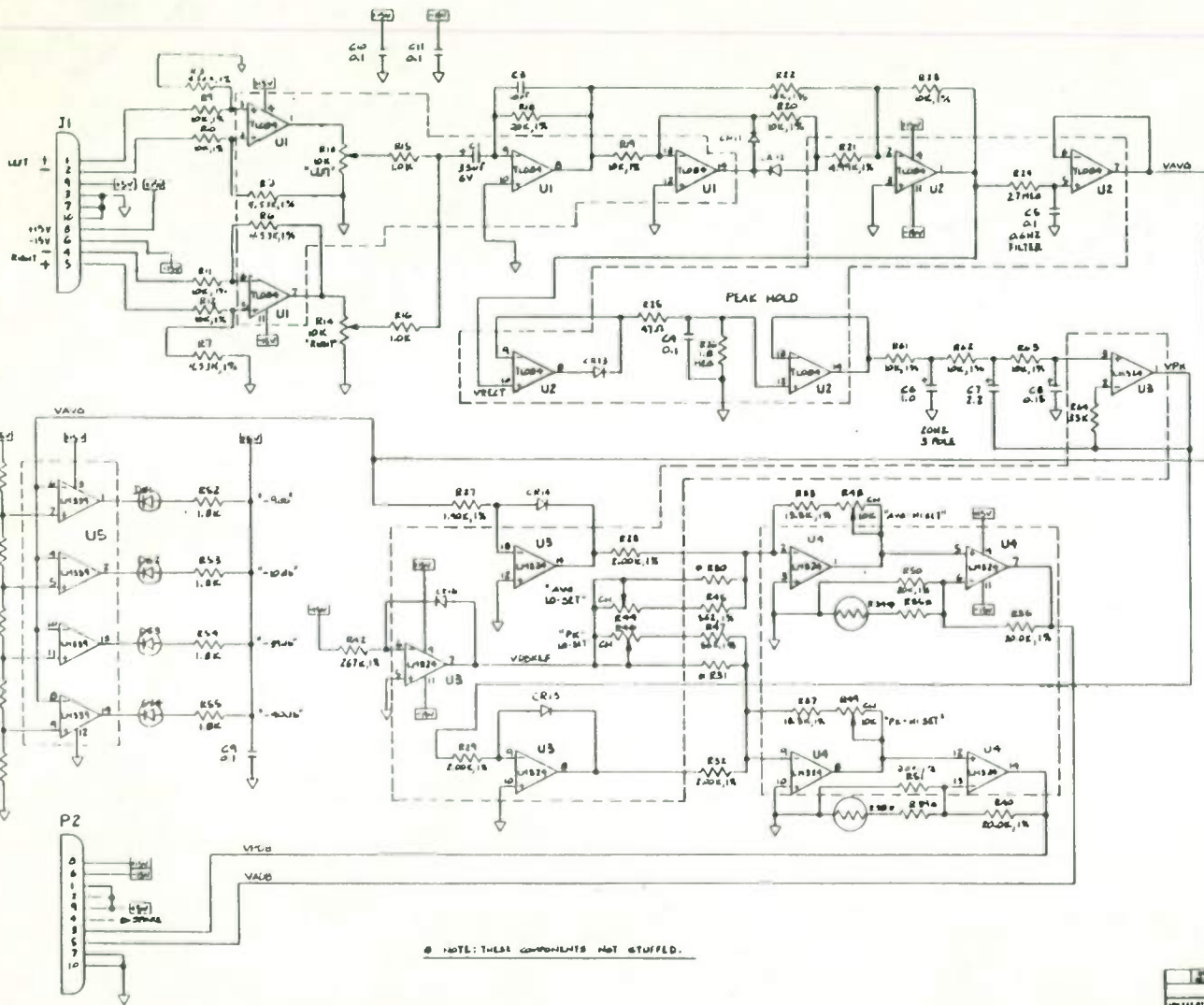

NOTE: THESE COMPONENTS NOT STUFFED.

DESIGN REF	TYPE	DESCRIPTION	PKS	REV	DATE
U1, U2	TL084CN	QUAD O-SET OP-AMP	4-DIP	4	11
U3, U4	LM324	QUAD OP-AMP	14-DIP	4	11
U5	LM324	QUAD COMPARATOR	14-DIP	12	3
ES-ES2		NOT USED			
ES3-ES4	10MΩ	DIODE, 100V			
ES5-ES6	10MΩ	DIODE, 100V			

LAST USED: U5, C8, R24, R41
NOT USED: R21, R23

REV	DATE	PART OF	DESCRIPTION	REVISION

CONTRACT NO		PARTS LIST	
APPROVALS	DATE	DORROUGH ELECTRONICS	
DESIGN	1-25-82	SCHEMATIC, INPUT SIGNAL AUDIO TO LOG CONVERSION	
CHECKED	QK	REV 1-82	
DATE		REV	
1-25-82		D	5K060182
APPROVED		REV	
			1 OF 1

