

M-5735  
SPOT TAPE

# INSTRUCTION BOOK

**GATES**

**GATES RADIO COMPANY**

*A Subsidiary of Harris-Intertype Corporation*

**QUINCY, ILLINOIS**

ADDENDUM

842 2494 001 (D-22494) Control Schematic

842 2495 001 (D-22495) Audio Schematic

S3 was changed from a SPST switch to DPST switch.

The added pole breaks the other side of the AC line.

ECN 8690  
June 8, 1961

Spot Tape

THE ST101 SPOT TAPE  
PATENT APPLIED FOR

The enclosed drawings and specifications are tentative and are subject to change for either mechanical or electrical improvements without notice either prior or subsequent to purchase.

7/17/59

Gates Radio Company  
Quincy, Illinois

IMPORTANT - PLEASE READ CAREFULLY

SPOT TAPE IMPROVEMENTS

The Gates Radio Company has always pursued a very aggressive policy of product improvement. Advances in technology and the availability of improved materials are reflected in Gates products through a continuous product improvement program. This same philosophy of product improvement is evident in the Gates Spot Tape Recorder.

Your new Spot Tape Recorder has received the benefit of various improvements in circuit design, materials and manufacturing techniques. The most apparent change will be found in the reduction of maintenance required for cleaning the brake band and idler wheel.

Your new Spot Tape Recorder is equipped with a different type of brake band and brake band material, which will give you many more hours of operation between routine maintenance. An adjusting screw has been added to the brake band to facilitate the adjustment of the brake tension. It is important to realize, however, that a routine maintenance program should be set up in order to obtain the optimum performance from this machine. The idler wheel, brake band and associated drive surfaces should be cleaned once a month with normal use and twice a month for heavy use of the machine. The maintenance guide section of this instruction book will give you complete cleaning instructions and optimum tension figures.

Please read the instruction book and the maintenance guide section of the instruction book before placing this machine into operation.

11/3/60

Gates Radio Company  
Quincy, Illinois

INDEX

	Page
Electrical Specifications.....	1
Programming With Spot Tape.....	1
Introduction.....	1
Installation.....	1
Pre-operation.....	4
Operation.....	6
Theory of Operation.....	10
Control Circuit Sequence.....	13
Electrical Maintenance.....	17
Mechanical Maintenance.....	18
Guarantee.....	1-2
Parts List.....	1-3
 Photos	
 Drawings	

## ELECTRICAL SPECIFICATIONS

Frequency Response:  $\pm 2$  db. 50-8000 cps.  
Distortion: 2% or less @ normal recording level.  
Noise: -45 db or lower from peak recording level.  
Wow or Flutter: .35% or less  
Tape Speed: 5¼ ips  
Playing Time: 90 seconds.  
Full Rewind Time: 24 seconds (automatic P.E. Cell controlled)  
Cueing Accuracy:  $\pm 0.25$  inches or  $\pm 0.05$  seconds.  
Number of tracks: 101. (Recorded on tape 13" wide and 45 feet long).  
Record Amplifier Input: 150 ohm @ -60 dbm matching (Factory connection). May be strapped for 50 ohm or 10,000 ohm @ -35 dbm to +3 dbm bridging.  
Play Amplifier Output: -20 dbm @ 600 ohm. (Factory connection) May be strapped for 150 ohm (shorted in record mode).  
VU Meter Indications: Recording level (audio)  
Bias Current  
Erase Current  
Shorted in play mode.  
Power Requirements: 100 watts.

## MECHANICAL SPECIFICATIONS

Height: 8-3/4" rack mounting  
Depth Behind Panel: 16½"  
Width: 19" with Shelf Assembly  
Mounting: Rack  
Desk Cabinet  
Desk Cover  
Weight: 47 pounds  
Remote Control Box: 3 pounds - 3½" high x 4" deep x 5½" wide.

7/17/59

-1-

Spot Tape

## PROGRAMMING WITH SPOT TAPE

Standard tape machines of the reel-to-reel type have been perfected to the point that wow or flutter is no longer a serious problem. One of the reasons is the direct drive used in most machines. With the motor running continuously, and a heavy fly-wheel attached to smooth out motor speed variations, the main requirement is that the motor shaft (drive capstan) be essentially free of run-out. Other parts of the machine such as the pressure roller, take-up motor, supply reel brake, etc. have quite a bit of latitude in adjustment and concentricity before they affect tape speed with resultant wow and flutter.

If the drive capstan is running true (a minimum of run-out) the standard tape machine will generally sound excellent on most types of music and voice. The better grade of standard machines will sound good on piano music and fair on sine wave tones. It is true that many of these machines are rated from .2% to .25% on wow or flutter. Many of them will measure substantially better, however.

Due to the unique feature of having 101 tracks side by side, the Spot Tape machine must use an entirely different drive mechanism than standard tape machines. There are at least five shafts and wheels to hold to minimum run-out instead of just the motor shaft (drive capstan) as mentioned previously. The total run-out on all five must not be more than that encountered on the motor shaft of a standard machine or the wow and flutter will be increased. Thus, each part must be five times as accurate to accumulate the same degree of run-out. Such precision is economically impractical. Therefore, the wow and flutter on the Spot Tape machine will run from .1% to .35%.

Fortunately, the content of most spots is not the type of music that wow and flutter can be detected on. Lively piano music, of the type generally used in spots, sounds most acceptable with up to .35% wow or flutter. This makes the Spot Tape machine ideal for all of the spots it was designed to handle so conveniently.

## INTRODUCTION

The Spot Tape Recorder is designed to play spots, themes, station identifications, times, temperatures, program introductions and many other short recordings associated with radio and television broadcasting stations. One hundred and one tracks may be recorded side by side the full length of the tape. Other uses include paging or repeated message operation.

Although Spot Tape removes the necessity of having each spot on a separate tape, it is advisable to keep a record of these spots on a master tape recorded end to end.

The machine plays for 90 seconds and rewinds in about 24 seconds. If the full 90 seconds is not used, the rewind time is proportionally shorter by using manual rewind switch. When two or more spots are run consecutively, they may be recorded on the same track, if the total time is 90 seconds or less. For longer spots back to back, two machines may be used for continuous playing as with standard tape recorders.

The machine consists of a tape pulling mechanism, a movable indexing head, play and record amplifiers and the power supplies for the amplifiers and control section. All the necessary control functions are located on the front panel. A remote control box is supplied for use if the recorder is rack mounted so that the machine may be started, stopped and rewound from the operating position at the console or other desired location.

Spots may be selected by moving the head laterally to any of the 101 indexed positions.

## INSTALLATION

UNPACKING - The Spot Tape Recorder will be received in three boxes. The basic recorder is packed with the instruction book in one box. The second box holds the remote control box, tape supply roller, idler wheel assembly, and spare parts and tools for installation of idler-flywheel. The third box contains either a panel adaptor for rack mounting, or a cabinet with the panel adaptor mounted in it. Before putting the machine into operation, it will be necessary to remove the cord which holds the head arm during shipment and install the idler assembly.

In order to be certain that the idler-flywheel assembly will not be damaged during shipment of the Spot Tape Recorder, this assembly has been packaged separately. Installation is simple, and is described in the following steps.



1. Carefully place the idler assembly into position on the machine, being careful not to damage the surfaces of the idler wheels. DO NOT FORCE MECHANISM. Install and tighten the idler arm pivot. Be sure the arm is free on the pivot.
2. Place the flywheel on the idler assembly with the countersunk side of the mounting holes out.

NOTE: A locating key has been punched in both the flywheel and the idler insert.

It is important that these keys line up when the flywheel is installed. The flywheel has been turned and balanced in this position.

3. Install the four flathead screws that secure the flywheel to the idler assembly. Be sure the flywheel is free on its bearing.
4. If a noticeable amount of wobble of the flywheel is observed while the machine is running, loosen the four screws holding the flywheel to the idler and re-seat them.

Drawing A-33907 locates the various parts.

If the machine is repacked for reshipment, the parts should be secured in the same manner as it is received.

Mounting the Rack Model - The rack mounted unit requires 8-3/4" of panel and a total depth of 16" behind the panel. Mount the rack panel adapter in the rack at the desired place with 4 rack screws. The recorder slides into the panel adapter similar to the way a drawer slides into a desk. Do not push recorder all the way in with the front panel closed! Open the front panel to allow the locking brackets to raise. Then push the unit all the way into the adapter and close and lock the front panel. To pull the machine out for servicing or inspection, the front panel must be opened to release the locking brackets from the panel adapter.

The remote control box will probably be used with the rack mounted model. Locate the remote box near the console where the operator may easily reach it. Route the cable through the existing wiring channels to the recorder unit and insert the plug in J2 at the rear of the main chassis. If the remote box is not used, insert the shorting plug P2 in J2. If neither the remote box nor the shorting plug are in J2, the machine will run forward to reverse until (1) a plug is inserted in J2, (2) the STOP-REVERSE switch is thrown to stop (down) or (3) the machine is turned off (S3).

The audio output of the Spot Tape appears at terminals 1 and 2 of J1. An audio plug (P1) is furnished but not wired. Connect a shielded pair to terminals 1 and 2 of J1 and terminate at the desired console input, or terminate in the jack field. This output is 600 ohm balanced at about -20 dbm.

This may be reconnected for 150 ohms output by restrapping T2 (shown on drawing D-22495):

- A. Jumper from Green to Black/White.
- B. Jumper from Black to Yellow.
- C. Remove jumper Black to Black/White.
- D. Connect output to Green and Yellow.

The audio input appears at two places. A high level bridging input is available on pins 5 and 6 of J1. This is approximately correct for bridging a +8 dbm or +14 dbm line. If it is desired to bridge a lower level line of about -20 dbm, modify the bridging pad (AT1) located under the main chassis near J1 (see drawing A-31921) as follows:

1. Remove both R1 resistors and replace with shorting straps.
2. Remove R3.

If one of these high level inputs is to be used, connect a shielded pair to terminals 5 and 6 of J1 and terminate in the jack field or connect to other appropriate source. To use this input be sure that the input selector switch (S1) is thrown towards J1. Pins 3 and 4 of J1 are chassis ground and the shields should be connected here.

If a level of -40 dbm to -60 dbm is contemplated, J4 should be used. Wire a shielded pair to pins 2 and 3 of P4, and connect the shield to pin 1. This pair could be connected to the jack field or other low level source. Input impedance is 150 ohms balanced. A microphone may be plugged directly into J4. Be sure that the input selector switch (S1) is thrown towards J4.

Plug the a.c. cord furnished with the recorder into J3 and to the 115 V. a.c. line source.

Mounting the Cabinet Model - If it is not possible to mount the cabinet at least a foot behind the front of the table or desk, it is recommended that the cabinet be secured with suitable hardware to the desk top. This is because the recorder is quite "Front Heavy" when pulled out for cleaning and maintenance. To secure the cabinet to the table top, or other surface, remove the rack panel adapter from the cabinet, and fasten the cabinet with screws or bolts through the bottom of the cabinet to the table top. After the cabinet has been mounted, replace the adapter.

The remote control box probably will not be used if the recorder is placed within reach of the operator. If so, insert shorted plug (P2) in J2 so that the control circuit will operate properly.

The recorder is now ready for testing. The remainder of the installation is the same as for the rack model.

## PREOPERATION

Mechanical Testing - Before applying power to the unit:

1. Switch S3 (power switch) to the OFF position. (On the right hand side plate behind flywheel.)
2. Plug the a.c. line cord into the rear of the Spot Tape Unit and to the 115 volt line.
3. Switch S4 down to the OFF position.
4. Push in the flywheel release button. This button is located in the lower right hand corner of the front panel. (On serial numbers 66,457 and higher, this button must be pushed in a given a quarter turn clockwise to lock it in. To release: push in and give button a quarter turn counterclockwise and release.)
5. Switch S2 to PLAY position.
6. Switch S3 to the ON position. The green lamp A3 should come on at this point indicating power is being supplied to the unit, and that the unit is in the PLAY position. A1 and A2, the exciter lamps for PT1 and PT2, the reverse and stop photocells, should be lighted. Drawing A-31920 shows these lamps with the recording tape on and off the machine.
7. Switch S2 to the ERASE (E) position. A5, the red record lamp, should come on. The VU meter should indicate zero. The VU meter, M1, will kick when S2 is switched, indicating that the coupling condenser to the meter is charging. This kick is normal.
8. Switch S2 to the BIAS position (B). The VU meter should indicate zero.
9. Switch S2 to RECORD position. These adjustments have already been made at the factory, so it will probably not be necessary to reset. If necessary, refer to the "Maintenance Section".
10. Return S2 to PLAY position. The stop window (or clear portion of the tape) should be located under the stop exciter lamp, A2. This is the top lamp, located closest to the right side plate.
11. Pull out the flywheel RELEASE button.
12. Move S4 from the OFF position (down) to center position, normal.

13. Push S6, the PLAY button. The machine will now run in the forward position. Let the tape play through to the end to check the automatic reverse. When the second clear portion of the tape passes between the reverse lamp (A1) and the reverse photocell (PT1), the machine will automatically reverse and the white light (indicating the rewind cycle) will go on. At the end of the rewind cycle, the first clear portion of the tape should pass between the STOP lamp (A2) and the STOP photocell (PT2).

The machine will stop and automatically cue itself. Push the START button as before and allow the tape to run for several seconds. Throw S4 up to the REWIND position. The recorder will rewind and cue.

Start the recorder again by pushing the start button (S6). Let the tape run in a few feet and move the REWIND-STOP switch to the OFF (down) position. The tape should stop. Return the REWIND-STOP switch to the center position and the tape should start again in the forward direction. The mute relay will remain energized, however. Push the PLAY button (S6) and listen for the mute relay (K4) to release. In the play mode, only the PLAY button (S6) will start the recorder; and in the record mode, only the RECORD button (S5) will start the machine.

If trouble is experienced in any of the preceding steps consult the "Maintenance Section" of the book. If no trouble is experienced the unit may now be connected for electrical testing.

Electrical Testing - If the audio, control and power connections have been made as described under "Installation", the electrical testing of the recorder may now be performed. With an audio signal applied through J1 or J4 (with S1 in the correct position, either mic. or bridge, and S2 in the record position, slowly turn AT2 clockwise until the correct level is indicated on the VU meter. The red RECORD lamp indicates the machine is in the RECORD mode. Select one of the tracks by pulling the head indexing arm out and the head laterally to the desired track. Be sure that the indexing pin falls into the correct detent in the positioning rack rather than on a tooth between two tracks. The tape may now be started by depressing S5, the RECORD ON switch. NOTE - When making a recording, if the function switch (S2) is left in the record position during the rewind and cue functions; a pop will be recorded on the tape at the start of the track. It is recommended that the function switch be switched from RECORD to PLAY during the rewind cycle to prevent this.

When a recording of sufficient length for test purposes has been made, rewind the machine. Switch S2 to the PLAY position (during the rewind cycle) and monitor the recording just made. If no trouble has been experienced in the preceding steps, the machine may now be put into operation.

## OPERATION

All the necessary controls for the operation of Spot Tape Recorder are located on the front panel.

1. Record Volume Control. This is an interstage volume control (AT2) located after the first stage in the recording amplifier. It controls only the recording level and has no function in the playback mode.
2. Function Switch. In the counterclockwise position the switch is in the PLAY mode. The switch connects the record-play head to the input of the playback amplifier, disconnects the erase head, shorts the VU meter, removes the plate voltage from the bias oscillator, feeds voltage to the green indicator lamp and connects the play START button (S6) into the control circuit. When the switch is in this position it is only necessary to select the spot to be played and push the START button.

The second position clockwise is the ERASE position. This function is the same as for the recording mode except that the VU meters reads erase current to the erase head. A reading of zero in this position is correct.

The third position clockwise is the BIAS position. All functions are the same as for the recording position except that the VU meter is connected to read bias to the recording head. An indication of zero in this position is correct.

The full clockwise position of this switch is the RECORD position. In this position the switch connects the record play head to the output of the recording amplifier, the erase head to the output of the bias oscillator, the VU meter to the output of the cathode follower in the recording amplifier, feeds high voltage to the bias oscillator, lights the red indicator lamp and connects the RECORD START button into the control circuit. When the switch is in this position, recordings may be made by feeding audio signal into recording amplifier, adjusting the level on the VU meter, and pressing the RECORD START button.

It should be noted that in the Schematic D-22495 that as the function switch is moved from PLAY to ERASE, two resistors R63 and R64 are inserted in series with the recording head. Switching to BIAS bypasses one of these resistors (R64), and switching to RECORD bypasses the other one (R63). This is to prevent a pop being recorded on the tape. When switching directly from PLAY to RECORD, the switching transient is recorded on the tape. This problem is peculiar to Spot Tape Recorder - most other professional recorders apply bias after the tape is moving.

As can be seen on the schematic drawing D-22495, the record volume control is located between the first and second stages in the recording amplifier. This was done, of course, to achieve the highest possible signal to noise ratio in this amplifier. However, using this method, it is possible to overload the first stage of the recording amplifier if too high a signal level is fed to the input. It has been found that the optimum setting for the best compromise between noise and distortion is a setting of about "12" on the record gain control. Settings below about "8" tend to increase the distortion in the amplifier, while settings above about "14" will degrade the signal to noise ratio. If the low level input jack (J4) is used, a setting of about "12" is correct for most broadcast microphones operating at a level of -60 or -65 dbm.

If the high level bridging input jack (J1) is used, it is recommended that either the input level or the bridging pad (AT1) be adjusted so that the record gain control may be operated at approximately "12" on the scale. Instructions for modifying AT1 may be found elsewhere in the instruction book.

3. Indicator Lamps. The green lamp indicates that the machine is in the PLAY mode, and the red lamp indicates that the machine is in the RECORD mode. The white lamp indicates that the machine is in the REWIND cycle from either PLAY or RECORD. It will be noticed that either the green or red lamp is at half brilliance when the recorder is in the cued position. When the recorder runs in the forward direction, either PLAY or RECORD, the lamp (red or green) comes up to full brilliance to indicate tape motion. This is accomplished by contacts on the mute relay (K4) which short out a dropping resistor when the recorder is playing or recording.



4. VU Meter. As described under the heading "Function Switch": The VU meter is shorted in the PLAY position. It reads the audio recording level in the RECORD position. It reads the bias current to the play record head in the BIAS position, and reads erase current to the erase head in the ERASE position. In the recording position the VU meter is fed from a cathode follower, which is connected after the second stage in the recording amplifier.
5. The START pushbutton starts the tape and de-energizes the mute relay. This pushbutton operates only when the machine is in the play mode.  
  
The red RECORD start pushbutton in the red switch guard performs the same function in the record mode.
6. The STOP-REVERSE Switch. The up (spring return) position will reverse the tape and bring it to the automatic cue position. It is not necessary to hold this switch up as the reverse relay locks in. The down (positive) position of this switch will stop the tape in its forward motion at any point during its run. When the switch is returned to the center position the tape will start, but the output of the tape machine will be muted. If it is desired to remove this mute, simply push the START button.
7. Remote Box. The PLAY START pushbutton, the STOP-REVERSE switch, the RECORD START pushbutton and the three INDICATOR lamps, are duplicated in the Remote Box. This Box may be plugged into J2 on the amplifier deck and these functions controlled from the operating console. If the remote box is not used, a dummy plug must be inserted in J2, with terminals 5, 7 and 8 shorted, or the machine will run continuously as described under "Installation".

To Make a Recording:

1. Pull the tape arm indexing lever out and move the pointer laterally to the desired track and release the lever.
2. Operate the FUNCTION switch to the RECORD position.
3. Turn the record volume control off. The red indicator lamp should be lighted. The tape should be in the CUE position at the start.
4. Set the recording level by feeding an audio signal to the tape recorder and turning the record volume control clockwise until the correct recording level is indicated on the



VU meter. 0 VU is the correct recording level.

Recordings will normally be made from the standard tape recorder. If this is the case:

5. Cue the regular tape recorder to about one second start time. If a tight cue is desired, push the START buttons for both the Spot Tape Recorder and the regular Tape Recorder at the same time. If a slower cue time is desired operate the record START button on the Spot Tape machine first, and the standard tape machine about 1 second or 1/2 second later. Proceed with the recording to the end.
6. At the end of the "Spot", turn the record volume control down.
7. Then either let the tape run to the end (it will automatically reverse and cue) or operate the REVERSE switch, and the tape will reverse and cue automatically.

NOTE - When making a recording: if the function switch (S2) is left in the record position during the rewind and cue functions, a pop will be recorded on the tape at the start of the track. It is recommended that the function switch be switched from record to play during the rewind cycle to prevent this.

8. This spot may now be monitored by throwing the FUNCTION switch to play mode and starting the machine with the PLAY START pushbutton.

Turning the Unit On and Off - When the unit is turned off, after the days operation, it is necessary to push and turn the FLYWHEEL RELEASE button. This raises the flywheel and idler wheel off of the drive wheels, and prevents putting flat spots in the idler wheel. These would, of course, show up as "wow" when the machine is operated. Throw the STOP REVERSE switch to the stop position. If it is desired to remove power at the Spot Tape Recorder, release the front panel and pull the machine part way out of the cabinet. The power OFF-ON switch and the line fuse are located on the right side plate, just behind the flywheel.

When turning the unit on at the start of the days operation, be sure that the STOP-REVERSE switch is in the STOP position. (If this switch is in the CENTER position the tape may move forward before the lamps can actuate the STOP photocell. However, this will not hurt the machine. It will simply run

7/22/60

-8-

Spot Tape

to the end of the tape, automatically reverse, and return to the cue position). Pull out the flywheel release lever.

In case of difficulty with any of the foregoing steps consult the "Maintenance Section".

TO CHANGE TAPE ROLLS - Spare rolls of tape may be ordered under the part number M5840. This consists of 90 seconds of 13" wide tape rolled on a cardboard tube. To remove a worn or otherwise damaged tape, the following steps should be followed:

1. Pull the recorder out of the cabinet or rack. Turn the unit on and run the tape through to the reverse window. When the tape reaches this point, operate the STOP-REVERSE switch to the STOP position and turn off the a.c. power.
2. Place the cardboard tube with its end caps in the machine as shown in the pictures in the back of the instruction book, and attach drive pulley belt.
3. Continue rolling the tape by hand until the tape just pulls off the top roller. Close the front panel and release the flywheel. Pull the end of the tape up far enough to attach it to the cardboard supply tube, being careful to keep the tape between the pressure web and the exciter lamps. Roll the tape by hand until the reverse window in the tape is several inches above the exciter lamps.
4. Switch S3 to stop. Apply a.c. power. Release flywheel idler button. Now switch S4 to the center position and let recorder rewind and cue.
5. Remove a.c. power. Switch S4 to STOP. Push flywheel release button in. Wind the remaining 16" of tape onto the supply roll by hand. Remove rewind belt and supply rolls with its end caps.
6. Place the end caps on the new roll of tape and insert in machine. Be sure that the oxide is up and that the windows in the tape are on the right hand side next to the exciter lamps and photocells. Place the rubber belt in the grooves in the pulleys on the left hand or the top roller and supply roll.
7. Pull the recording tape over the top roll and attach the end of it to the lower roll (use one piece of Scotch 171 tape, 1" long). Be sure that the recording tape is

centered laterally on the lower roll and that the recording tape is under the exciter lamps. A single piece of tape (171) is used on each end of the recording tape so that the tape may straighten itself without wrinkling or climbing the sides of the rolls.

8. Wind the tape onto the bottom roll a few turns by hand. Switch S4 to STOP. Apply a.c. power. Pull out flywheel release button. Switch S4 to the center position. Tape may be re-started by pressing S6. The machine will run until the STOP window moves under the STOP exciter lamp.

CAUTION! Roll tape onto the lower roll very slowly. If tape begins to wrinkle against one end of the tap roll, stop machine and shift tape on supply roll slightly. This tape may shift slightly during packing and shipping. If necessary, remove the pulley belt to slacken the tension on the tape during this operation.

9. Continue spooling tape onto the lower roll until the reverse window passes under the exciter lamp. Operate S4 to stop. Remove a.c. power. Release flywheel. Wind rest of tape onto lower roll. Remove supply roll with end caps and belt from machine.

10. Pull tape up and fasten to top roll with a 1" length of scotch 171 tape. Be sure that recording tape is centered laterally on top roll and under the exciter lamps. Wind tape onto top roll by hand until reverse window is a few inches above the exciter lamps. Switch S4 to STOP. Apply a.c. power. Release flywheel. Switch S4 to center position and let tape reverse, rewind, and cue. Run tape through its cycle several times before putting in service.

#### THEORY OF OPERATION

1. The Play Amplifier is a three stage fixed gain amplifier, with a gain of approximately 55 DB at 1000 cycles. A modified NARTB Playback Curve is used for equalization. This curve has been universally adopted as the best compromise between distortion and noise. The playback head is connected directly to the input grid of the EF86 pre-amplifier tube. The filament of this tube is heated by DC. In order to achieve a flat response to 8000 cycles, headpeaking is used. This is accomplished by placing C3 across the play head. The resultant peak is just over 8000 cycles.

A lossy type equalizing circuit follows the first stage. R7 is part of this equalizing network and may be varied slightly to compensate for variations in the recording curve from machine to machine. This adjustment has been made at the factory so it should not be necessary to re-adjust this control. Because of variations in tube characteristics it may be necessary to adjust this control slightly when tubes are replaced. The second and third stage of the Play Amplifier are conventional. About 18 DB of feedback has been used to reduce distortion to a very low level.

The normal output level of this amplifier, when playing back a tape that has been recorded at a normal level, is about -20 VU. However, the distortion of the amplifier at 0 VU out is less than 1/2% maximum. The output transformer T2 is connected for 600 ohms out. This is a correct value for most consoles. If it is desired to connect this output for 150 ohms refer to the schematic diagram and installation section.

The output of the playback amplifier is shorted in the record mode. In the play mode a 620 ohm resistor is substituted for the amplifier during rewind and cue functions. If the amplifier is strapped for 150 ohms out, R60 must be changed from 620 ohms to 150 ohms. No volume control is used in the playback amplifier, since a normally recorded tape will produce a correct level for feeding a console.

2. The Recording Amplifier is also a three stage amplifier. A gain control follows the first stage. The gain of this amplifier is high enough to record standard level on the tape from a microphone input. Two inputs are provided. J4 is a microphone plug in which a microphone may be plugged. Any other low level source 150 ohms at approximately -50 to -60 DB level may be connected to this input.

When S1 is thrown toward J1, a six prong audio plug, the input will bridge a plus 8 line. Bridging pad AT1 is connected between J1 and the input transformer T3. It should be noted that this is a double bridging pad. If it is desired to bridge a -20 to -30 signal line this pad may be altered by strapping out the two 4700 ohm resistors and removing the 620 ohm resistor.

The first stage of the recording amplifier is a low noise EF86 tube. The filament of this tube is also heated by DC. Both the record preamplifier and the play preamplifier filaments are supplied through a Silicon Bridge Rectifier. The second stage is conventional, with the exception

of a .005 condenser from cathode to ground. This gives this a slight amount of high peaking at 15,000 cycles, so that the overall frequency response is flat. The third stage is also an EF86 tube. Recording equalization is applied to this stage. L3 and C17 in the grid circuit are resonated to approximately 9,000 cycles. The un-bypassed cathode resistor, R26, plus R30 in series with the recording head provide the necessary constant current characteristic to the recording head. L3 and C17 compensate for the gap losses in the recording head.

A cathode follower is connected after the second stage before equalization to operate the VU meter. The cathode loading on this stage is adjusted to provide the correct source to drive the VU meter. C40 shunted across R44, the grid resistor of the cathode follower, effectively traps the bias voltage and keeps it from indicating on the VU meter. The measured distortion of this amplifier at the normal recording level is less than 1/2%.

3. Bias Oscillator. The Bias Oscillator will be recognized as being similar to the oscillators used in most high quality tape recorders marketed today. It is located on the Play Amplifier printed board. The secondary of T4 furnishes both the bias current to the recording head and the erase current to the erase head. C39 adjusts the erase current and R29 controls the bias current.
4. Power Supply. Transformer T1 is a special low flux density preamplifier power transformer. All the rectifiers used in the amplifier power supply and in the control circuit power supplies, as well as the blocking diodes in the control circuit, are silicon rectifiers. These are chosen because of their long life and cool operation, as well as their small size. Chokes L1, L2 and C1a/b/c provide DC to the amplifier plates with a very low ripple content. The preamplifier stages of both the recording and play-back amplifiers are further de-coupled by R1 and C27. High voltage is removed from V6, the bias oscillator, during the play mode. The high voltage to all the amplifier circuits is removed during the rewind cycle, both play and record. A hum balance potentiometer, R8, is used to balance the a.c. filaments to ground for the lowest noise level in the play mode. Noise is approximately 65 DB down in the record amplifier and presents no problem.

Extensive heat runs and field testing indicated that no trouble should be experienced in any of these circuits. All tubes and parts are operated below their maximum rating for safety. Printed wiring boards are used for

the play and record amplifiers and the bias oscillator for ease in trouble shooting and uniformity in production. A section is included in this book explaining techniques in replacing parts on printed boards. The two boards are mounted on a bracket on the main chassis for easy access, such as changing tubes, etc.

### CONTROL CIRCUIT SEQUENCE

The semi-automatic operation of the machine requires a rather complex relay control circuit. The overall Control Schematic, D-22494, shows all of the parts, including the power supplies. The circuit can be traced on this schematic but the sequence is difficult to follow. The Simplified Control Circuit Schematic, B-65856, shows only the switches, relays, photocells, diodes and components necessary to control the motor. It is drawn with a minimum of circuit cross-overs to avoid confusion.

The switching sequence is progressive from left to right on the schematic, B-65856. The remote control box contains the remote RECORD, PLAY and STOP-REVERSE switches. The remote RECORD and PLAY switches are in series with the local RECORD and PLAY switches. The remote STOP-REVERSE switch is in parallel with the local STOP-REVERSE switch. The remote box and its associated switches can be replaced with the shorting plug, P2, which shorts pins 5, 7 and 8.

The photocells, PT1 and PT2, change in resistance with the application of light. This change in resistance is from several megohms, in the dark condition, to about 1000 ohms with the application of light. Essentially they are a switch and may be treated as such in this circuit. CR11, CR12 and CR14 are polarizing diodes, used to pass current in one direction but not the other in this circuit. Electron current flows against the arrow in the standard symbol used. CR13 is used to short out the collapsing flux field of the coil of the relay, K4, when it is de-energized, this gives this relay a slow release characteristic.

Three control relays (K1, K2 and K4) and a slave relay (K3) are used to control the machine sequence. K1 is the STOP relay, it is energized by the STOP photocell (PT2) or the local (S4) or the remote STOP switch. When it is energized, contacts K1-7 and K1-6 open, breaking the 115 V. a.c. to the motor; directly on the blue-green winding, through K3 to the orange-black winding.

K2 is the REVERSE relay, it is energized by the REVERSE photocell (PT1) or the local (S4) or the remote REVERSE switch. When it is energized, contacts K2-8 and K2-7 close to apply 110 V. d.c. to the head lifting solenoid (L4) and to the coil of the slave REVERSE relay (K3). Contacts K3-3 through K3-8 on the slave

relay reverse the orange-black motor winding in relation to the blue-green winding, thus reversing the direction of the motor (B1).

K4 is the MUTE relay, used to disconnect the output of the playback amplifier from the input to the console and to back-load the input of the console with the correct terminating resistance (R60). This action is achieved when the relay (K4) is energized. Contacts K4-3 through K4-5 are used in the machine control sequence. Their function will be explained as the various sequences are traced out.

Relay K1 is rendered a "slow make" relay by having the 1000 ohms in series with the coil, R56 in one circuit and the 1000 ohms residual resistance in the photocell (PT2). This changes its operating time from the normal 15 milliseconds to around 30 milliseconds. K1 has only an R-C arc suppressor across the coil to delay the release time, which makes a total of about 15 milliseconds release time. K2 is also a "slow make", "fast release" relay because of R50 in series on the "make" and similar R-C arc suppression on "release".

K4 is a "fast make" relay because it has no series resistance with the coil to delay it. However, it is "slow-release" because of the diode (CR13) across the coil to delay the collapse of the flux field when de-energized. This release time is about 30 milliseconds, while the make time is the normal 15 milliseconds.

#### INITIAL TURN-ON

S4 must be placed in the STOP position when power is applied to the machine to energize the MUTE relay (K4). Otherwise, the motor will start to run because no power is applied to the STOP relay (K1). Power is obtained from the 90 V. d.c. supply, through contacts S4-4 and S4-1, through R56 to K1 and through CR11 to K4. Relay timing is not important on this operation. Now the STOP switch (S4) may be returned to the center position. The holding power for relays K1 and K4 comes from the 90V. d.c. supply, through remote plug contact 8 to the remote PLAY switch. It goes through this switch to contact 5, to the local PLAY switch (S6); through S2-F, through K4 holding contacts (K4-4 and K4-5) to the coil of K4 to hold the MUTE relay. Power is also obtained from this coil, through the photocell (PT2, which is energized by light through the STOP window on the tape) to the coil of the STOP relay (K1).  
AT THIS POINT THE MACHINE IS READY TO PLAY.

#### TO PLAY

Push either the local or remote PLAY switch. This opens the holding circuit set up in the paragraph above. The STOP relay (K1) releases in 15 milliseconds, thus starting the motor in the forward direction. The MUTE relay (K4) releases in 30 milliseconds (remember the slow release) to remove the mute after all switching noises have occurred.

## TO STOP

Push either the local or remote STOP switch. This applies the 90V. supply directly to the MUTE relay (K4), which operates in 15 milliseconds, and through R56 to the STOP relay (K1) which operates in 30 milliseconds. Thus, the output of the machine is muted before switching noises occur and (if stopped during program on the tape) before the tape comes to a stop with the resulting wow. The machine may be started again by returning the STOP switch to the center position, and pressing the PLAY switch.

## REWIND AUTOMATICALLY

After the tape has played through its entire usable length, the REWIND window will appear over the REWIND photocell (PT1). This applies the 90 V. supply through PT1, through CR12, directly to the coil of the MUTE relay (K4) which operates in 15 milliseconds. It also applies 90 V. through R50 to the coil of the REVERSE relay (K2) which operates in 30 milliseconds. Thus, the output of the machine is muted before switching noises occur.

K2 energizes the coils of the head lifting solenoid (L4) and the slave relay (K3) from the 110 V. d.c. supply, through contacts K2-8 and K2-7. K3 reverses the orange-black motor winding, which reverses the rotation of the motor and puts the machine in the rewind mode of operation. Holding power for the REVERSE relay (K2) is obtained through the remote PLAY switch, S6, S2-F, K1-4 & 3 and the holding contacts on K2 (K2-5 & 4).

After the tape has rewound to the STOP window, power is applied from the 90 V. supply through the remote PLAY switch, through S6, through S2-F, through K4-4 & 5, through the STOP photocell (PT2) to the STOP relay (K1). Contacts K1-4 & 3 open, breaking the holding circuit of the REVERSE relay (K2), which drops out the head lifting solenoid (L4) and slave relay (K3), which restores the motor to the forward direction.

However, the momentum of the mechanism carries the STOP window on past the STOP photocell (PT2) and the STOP relay (K1) drops out again, letting the motor run forward again. This is known as the CUE CYCLE portion of the operation.

## CUE CYCLE

In the CUE CYCLE, the tape is driven forward the inch or two that the tape was carried past the STOP window until the STOP window is again over the STOP photocell (PT2). At this point the STOP relay (K1) is energized again from the 90 V. supply, through the remote PLAY switch, S6, S2-F, K4-4 & 5 and the STOP photocell (PT2). THE MUTE RELAY HAS BEEN ENERGIZED THROUGH THE ENTIRE REWIND AND CUE CYCLE. It remains energized (and keeps the output muted) until after the machine is started again.



## REWIND MANUALLY

After the tape has played through the desired length, the machine may be rewound by pushing either the remote or local REVERSE switch (S4). At this time the REVERSE relay (K2) is energized by the 90 V. charge stored in the 3.0 mfd. capacitor (C42). C42 is charged through the remote PLAY switch, S6, S2-F, K4-4 & 3 (while the MUTE relay (K4) is de-energized and the muting is removed).

C42 is required to hold a charge long enough to energize the "slow make" relay (K2) even though the 90 V. power circuit is broken first by the contacts (K4-4 & 3) on the "fast-make" MUTE relay. C42 must be small enough to discharge almost fully during the energizing of K2. This allows K2 to drop out when the STOP window appears over the STOP photocell and energizes the STOP relay (which removes the 90 V. power to the holding contacts of K2) EVEN THOUGH THE REVERSE SWITCH IS HELD ON DURING THIS ENTIRE PART OF THE CYCLE. Tests indicate that this capacitor may range from 1.5 to 4.5 mfd., 3.0 mfd. is chosen as the optimum value. The 47 ohm resistor is used to limit the charging and discharge currents to less than two amperes to protect the relay contacts and switch contacts.

When the REVERSE switch is pushed, power from the 90 V. supply is fed through the remote PLAY switch, S6, S2-F, K4-4 & 3, S4-8 & 5, and CR14 to the junction of R50 and CR12. From this junction it is fed through CR12 to the coil of K4 to mute in 15 milliseconds. From this junction it is also fed through R50 to operate K2 (the reverse relay) in 30 milliseconds. From this point on, the operation is similar to that listed under "REWIND AUTOMATICALLY".

## POLARIZING DIODES

When the STOP switch (S4) is pushed, the STOP relay (K1) is energized and the MUTE relay (K4) is energized through CR11. However, when the MUTE relay is energized from the REVERSE photocell or the REVERSE switches, the STOP relay is not energized because current would have to pass the opposite way through CR11 (at this time the resistance is very high in CR11).

When the REVERSE photocell is energized, the MUTE relay (K4) and the REVERSE relay (K2) are energized. K4 is energized through CR12. However, when the MUTE relay is energized from the STOP switch (S4), the REVERSE relay is not energized because current would have to pass the opposite way through CR12.

When the REVERSE switch is pushed, the MUTE relay and REVERSE relay are energized. Current is passed through CR14 during this time. Under the chapter "REWIND MANUALLY", it is explained that C42 should discharge during the energizing of the REVERSE relay. This relay has holding contacts which apply holding power to its coil and would recharge C42 if CR14 would allow current to pass in the opposite direction.

## ELECTRICAL MAINTENANCE

1. Alignment. If it becomes necessary, because of tube changes or component aging, to realign for correction of frequency response the following procedure should be followed: Record tones of 100, 500, 1000, 3000, 5000, 7000 and 8000 cycles per second. Record a 1000 cycle tone as the reference level. These tones may be recorded all on the same track, or each tone on a separate track. Play these tones back and record the response of each frequency as referred to a 1000 cycles. Using these same tracks, adjust R7 slightly to see if the curve can be brought within specifications. This control moves the turnover frequency of the equalizing curve in the playback amplifier.

If the curve is still out of specifications it will be necessary to re-equalize the recording amplifier, reset the bias voltage, or find a source of trouble that may have occurred. Adjust R7 for a flat response at 100, 500 and 1000 cycles reference and leave this control in this position while checking the next steps. If the higher frequencies are too high (as referred to a 1000 cycles) the recording bias may be too low. Place the FUNCTION switch, S2, in the bias position and read the bias on the VU meter. The correct setting for this is at the 0 VU point. This is adjusted by R29. If this setting was off, set the level to 0 on the VU meter and re-record the previous tones. Check the playback curve again, this will probably be the most common source of trouble and should be checked first. If the higher frequencies are too low in amplitude, as referred to 1000 cycles, the recording bias current may be too high. In this case, reset the bias current (as instructed above) and re-record the tone, then check the playback curve. If the recording bias is found to be set properly, or a readjustment of the bias does not correct the condition, check the tubes in the recording amplifier, V3, V4 and V5. Check the DC voltages in the recording amplifier with the values given on the schematic. If bad tubes are found, replace them. If the voltages are off more than 10 or 15%, determine which component is out of tolerance and replace the component. Repeat the recording and playback procedure as above. If no trouble is found in the preceding steps it may be necessary to change the values of the equalizing components in the recording amplifier. To determine this, proceed as follows: Feed a 1000 cycle tone into the recording amplifier at a level approximately 20 DB under standard recording level. Remove the bias oscillator tube, V6. Connect a vacuum tube voltmeter to the junction of R30 and C19. The cold side of the voltmeter is, of course, connected to ground. The vacuum tube voltmeter should be calibrated in DB. This is to prevent overloading the equalizing circuits and the tape so that a true response curve may be obtained. Feed

a sufficient number of tones (high and low) into the amplifier to record a response curve. This curve should be similar to the one shown in drawing A-32233. A peak in the response should occur at about 9000 cycles. Readjust C17 to get this peak. The response curve taken in this manner, when compared to the standard curve, will probably show what the difficulty is. Replace C38 or C41, or both, with slightly different values to compensate the response so it will correspond with the standard. A larger value capacitor, in either place, will raise the high frequency response. A lower value will decrease the high frequency response. Disconnect the vacuum tube voltmeter and replace the bias oscillator tube V6. Repeat the recording and playback procedure as above and readjust R7, if necessary.

7/20/60

-18-

Spot Tape

## SPOT TAPE MAINTENANCE GUIDE

ENGINEERING ISSUE #1

MAY 16, 1960

Your Gates Spot Tape, ST-101, has been designed and constructed for long useful service. It is, however, a precision machine and, therefore, requires a degree of preventative maintenance for continued optimum performance.

It is the intent of this Maintenance Guide to point out areas of preventative maintenance and to provide a means of rapid analysis, should any malfunction develop.

IB-3062

Gates Radio Company  
Quincy, Illinois

## INDEX

	<u>Page</u>
1. FLUTTER (over 10 cps)	1
2. WOW (under 10 cps)	1
3. CROSSTALK (between tracks)	2
4. NON-ERASURE	2
5. LOW LEVEL OR DISTORTED RECORDING	3
6. NOISY SOLENOID DURING REWIND	4
7. PROGRAM FEED THROUGH	4
8. TAPE PASSES REVERSE WINDOW	4
9. TAPE PASSES STOP WINDOW	5
10. HEAD NOT TOUCHING TAPE	5
11. TAPE REVERSES AT WINDOW AND SWITCHES FROM REVERSE TO FOWARD CONTINUOUSLY	6
12. RECORDER RUNS SLOW IN FORWARD MODE	6
13. RECORDER REWINDS SLOW	7
14. RECORDER STARTS TO REWIND; THEN FALLS OUT	7
15. HEAD ARM JUMPS OUT OF END TRACKS DURING REWIND	8
16. MAINTENANCE CLEANING	8
17. HEAD CURRENTS & VOLTAGES	9
18. TENSION MEASUREMENTS	10
19. DRAWINGS -	
A-34277	
A-34291	
A-33907	

1. FLUTTER (over 10 cps)

- A. Idler-flywheel assembly bearing not free. Remove assembly and clean. Lubricate with a fine grade of machine oil. Gulf household lubricant is recommended. (Available from Gates.)

NOTE: DO NOT OVERLUBRICATE

- B. Bumping or slippage. Foreign matter which causes bumping, or glazing which causes slippage may cause flutter or wow. Clean idler surfaces, brake band and upper drive wheel as described in Section #16.
- C. Tape wrinkle may be a factor in flutter. Some machines exhibit low flutter with considerable tape wrinkle. Flutter on other machines is lowered by reducing tape wrinkle. Wrinkle may be reduced by adjusting the top roller laterally by means of the adjusting nuts (threaded bushings) at each end of the roller. Be sure roller is perfectly free but with little or no end play after adjustment.
- D. A phenomenon similar to flutter, and sometimes indistinguishable from it, is caused by fingerprints and particles of dirt on the tape surface. Although visual inspection may not reveal fingerprints or dirt on the tape, it is advisable to clean the tape as described in Section #16 whenever this symptom is noticed. Even new tapes may exhibit this peculiarity. Clean the glass rods on the tape pressure bar occasionally with denatured alcohol.

2. WOW (under 10 cps)

- A. Idler-flywheel assembly bearing not free. Remove assembly and clean. Lubricate with a fine grade of machine oil. Gulf household lubricant is recommended. (Available from Gates.)

NOTE: DO NOT OVERLUBRICATE.

- B. Bumping or slippage. Foreign matter which causes bumping, or glazing which causes slippage may cause flutter or wow. Clean idler surfaces, brake band felt, and upper drive wheel as described in Section #16.
- C. Too much spring tension on idler assembly may cause indentations on large idler surface if it is left engaged for some time. If it is possible

to decrease this tension and still maintain proper mechanical operation, this should be done. The proper spring tension is measured by pushing the idler shaft rod behind the counterweight. About 3 pounds tension should just lift the idler off the motor pulley. Too little tension will cause slippage between the motor shaft capstan and the large idler surface. Too much tension will cause indentations to appear on the large idler surface. These indentations should disappear when the machine is run through its cycle several times. If they do not run out with use, replace the assembly.

- D. Top and/or lower rollers not free. Re-adjust roller end bearings so that rollers are free with very little or no end play. Lower roller bearing is fixed on left side and should be adjusted on right side only. Both top roller bearings are adjustable and the roller should be positioned laterally for least tape wrinkle while the machine is running.

3. CROSSTALK (between tracks)

- A. End play in front panel. Install front panel spring kit. This kit will be sent upon request, no charge. Machines of serial #66656 and higher have this modification. It may be necessary to re-record some spots which were recorded previously.

- B. Mal-adjustment of or damage to tape head indexing arm.

Adjust the arm, by set screw in side of head arm, so that head indents tape about 1/16 inch when the indexing pin rests in the bottom of the groove in the index bar. It may be necessary to re-record tracks which were recorded during the mal-adjustment.

- C. Too little tension on head arm spring. Increase spring tension slightly by removing a turn or two, or by replacing with a slightly heavier spring. This tension, measured at index arm handle, should be 12 oz. to 16 oz. Light spring tension will not, in itself, cause crosstalk; but may cause incorrect head to tape pressure.

Too much spring tension here will prevent the head lift solenoid from operating, resulting in increased head wear and solenoid "buzzing". Also refer to Section #6.

4. NON-ERASURE (or incomplete erasure)

- A. Bias oscillator not operating. Replace V6 - 12AU7 tube. Defective circuit component - replace. Low

bias or no bias will cause low level and distorted recordings.

- B. Erase voltage not applied to erase head. Broken wire. Defective component.
- C. May be caused by end play in front panel. See Section #3 above.
- D. Shorted or open erase head. Proper D.C. resistance 68 ohms,  $\pm 20\%$ .
- E. Erase head not contacting tape properly. Adjust indexing arm so that head depresses tape about 1/16" while tape is running. If head touches tape at one point laterally but not at another, the slotted index bar may have to be shimmed at the point where the head does not contact tape. If this is the result of a bent head arm bearing rod, the part should be replaced.
- F. Dirty head or tape. Clean head and tape with de-natured alcohol as described in Section #16.
- G. Low erase voltage at erase head. Set (S2) function switch to "E" position and adjust C39 for a reading of 100 on V. I. meter.

5. LOW LEVEL OR DISTORTED RECORDING.

- A. Bias oscillator not operating. See Section 4-A above.
- B. Bias voltage not applied to record head. Broken wire. Defective component in bias oscillator or recording amplifier output circuits.
- C. Recording head not contacting tape properly. See Section 4-E above.
- D. Recording amplifier not operating properly. Check and measure amplifier as described in instruction book and schematic. Check tubes.
- E. Play amplifier not operating properly. Check and measure amplifier as described in instruction book and schematic. Check tubes.
- F. Head winding may be grounded. Examine the soldered junction of the two series connected windings. Insulating spaghetti may have slipped loose.
- G. Low bias at recording head. Set (S2) function switch to "B" position and adjust R29 for a reading of 100 on V. I. meter.



- H. Dirt on recording head or tape. Clean tape and recording head with de-natured alcohol. Even apparently clean tapes may be dirty or finger-printed.
- I. Shorted or open recording head. Proper DC resistance 100 ohms,  $\pm 20\%$ .

NOTE: RECORDING HEAD SHOULD BE DE-MAGNETIZED AFTER MEASUREMENT WITH AN OHMMETER.

6. NOISY SOLENOID DURING REWIND.

- A. Grommet in solenoid cavity missing. Replace with grommet of correct size, Gates A-4405-12. This rubber grommet is placed in cavity to reduce noise when the plunger seats. It may become hard with age or be mis-seated.
- B. Solenoid plunger not completely seating to grommet. Pull link (wire) may be too short allowing plunger to vibrate against side of cavity. Re-form hooks on ends of link to lengthen it. With the correct length, the head should be raised about 1/16 inch off the tape when the plunger is fully seated during rewind.

7. PROGRAM FEED-THROUGH

- A. In the first models of SPOT TAPE, the high voltage was left on the recording amplifier continuously to prevent magnetization of the recording head. If a program signal was fed into the recording amplifier input all the time, feed-through would occur into the play amplifier. Later models apply the high voltage to the recording amplifier only in the RECORD mode. This will cause some head magnetization, but this appears to be the lesser evil. Heads should be de-magnetized as routine maintenance every month or two anyway. Necessary instructions are shown on dwg. A-33580 which is included in this guide. This removes the high voltage from the recording amplifier during the PLAY mode.

8. TAPE PASSES REVERSE WINDOW.

- A. Photocell (PT1) defective. With the tape window over the photocell, and S4 in the stop position, disconnect wire #104 from TS3-11. Connect ohmmeter between wire #104 and TS6-7. Resistance should be no greater than 3000 ohms. Power must be applied to machine during this test. (115 V. line condition). If cell resistance is greater than 3000 ohms, replace cell.

To replace cell, remove exciter lamp bracket (on right side plate), photocell cable clamp (on left side plate), and the four screws holding the tape pressure bar through both side plates. Carefully move the tape bar forward so that it can be turned over. Replace bad photocell and re-install bar.

NOTE: BE SURE TO MOVE THE BAR PARALLEL TO THE ROLLERS AT ALL TIMES, SO THAT THE GLASS RODS WILL NOT BE BROKEN.

- B. Voltage from CR10-R55-C33 power supply too low. Measure voltage at R55 as indicated on dwg. D-22494; if less than 90 volts, re-adjust slider on R55 to 90 volts. If this cannot be done, replace CR10 and/or C33. If machine can only be made to operate with a higher voltage here, it is permissible to raise this voltage to 105 maximum.
- C. Exciter lamp (A-1) burned out. Replace lamp.

9. TAPE PASSES STOP WINDOW

- A. Photocell (PT2) defective. With the tape window over the photocell, and S4 in the STOP position, disconnect wire #102 from TS3-10. Connect ohm-meter between wire #102 and TS6-2. With power applied to machine the resistance should be no greater than 3000 ohms (115 V. line condition). If cell resistance is more than 3000 ohms, replace cell as in Section 8-A above.
- B. Voltage from CR10-R55-C33 power supply too low. Measure voltage at R55 as indicated on dwg. D-22494; if less than 90 volts, re-adjust slider on R55 to 90 volts. If this cannot be done, replace CR10 and/or C33. If machine can only be made to operate with a higher voltage here, it is permissible to raise this voltage to 105 maximum.
- C. Exciter lamp (A2) burned out. Replace lamp.

10. HEAD NOT TOUCHING TAPE.

- A. Index arm not adjust properly. Loosen set screw in head arm and re-adjust index arm. This adjustment should allow the tape head to indent the tape about 1/16 inch when the pin in the index arm seats fully in the index bar.
- B. Too little tension on head arm spring. Increase spring tension slightly by removing a turn or two, or by replacing with a slightly heavier spring. This tension, measured at index arm handle, should be 12 oz. to 16 oz. Light spring tension will not,

in itself, cause crosstalk; but may cause incorrect head to tape pressure.

To much spring tension here will prevent the head lift solenoid from operating, resulting in increased head wear and solenoid "buzzing". Also refer to Section #6.

11. TAPE REVERSES AT WINDOW AND SWITCHES FROM REVERSE TO FORWARD CONTINUOUSLY.

- A. Shorting plug (P2) or remote box not plugged into socket (J2). Either the shorting plug or remote box must be plugged into J2 whenever the machine is in operation, or the recorder will run continuously and switch from reverse to forward at end of tape.
- B. Broken connection in the series circuit of play switch or record start switch. Refer to dwg. B-65856 and the control circuit sequence in the instruction book for trouble shooting information.

12. RECORDER RUNS SLOW IN FORWARD MODE.

- A. Band brake felt dirty. Clean felt as described in Section #16.
- B. Rewind roller drive pulley dirty. Clean pulley as described in Section #16.
- C. Band brake spring tension too great. Reduce spring tension slightly by re-forming the end loops to make the overall spring longer.

NOTE: IF THIS TENSION IS REDUCED TOO MUCH, WOW AND FLUTTER WILL INCREASE.

A value of 24 oz. tension, when spring is extended to 1-7/8 inches (including hooks), is the nominal value.

- D. Upper or lower tape roller binds or is tight. If roller cannot be made free by the bearing end adjustment, replace entire roller assembly.
- E. Flywheel-idler wheel bearing binding or sluggish. Remove idler wheel assembly. Remove idler & flywheel from rest of assembly and clean bearing and idler shaft. Re-assemble and lubricate with a fine grade of machine oil. Gulf household lubricant is recommended. (Available from Gates.)

NOTE: DO NOT OVERLUBRICATE.

- F. Defective motor. Replace motor.
- G. Defective motor starting capacitor. Replace capacitor.
- H. Low line voltage. The recorder is designed to operate at 115 V. AC line voltage. Recorder will operate normally at voltage up to 125. If line voltage is constantly low, a transformer or auto-former should be used to raise voltage to 115 V. nominal.

13. RECORDER REWINDS SLOW.

- A. Any of the troubles under Section #12.
- B. Rewind brake tension too great. Reduce spring tension slightly by loosening the lock nut and turning the adjusting nut counter clockwise a turn or two. Relock with lock nut.

14. RECORDER STARTS TO REWIND, THEN FALLS OUT.

- A. Idler wheels dirty or glazed. Clean idler wheels with de-natured alcohol. If glaze still persists, sand the large idler wheel lightly with very fine sandpaper while recorder is running in forward direction.

Clean idler wheel and drive wheels.

Clean band brake felt several times until all deposit has been removed. Use de-natured alcohol for all cleaning. Refer to Section #16 for cleaning methods.

- B. Not enough rewind brake tension. Increase brake spring tension slightly by loosening the lock nut and turning the adjusting nut clockwise a turn or two.
- C. Not enough idler-flywheel counterweight spring tension. Remove counterweight and springs, and stretch springs slightly. Replace springs and counterweight. In later models move spring retaining bar forward to increase spring tension. This revised assembly is available on order, part M-5908.

In stop position, when flywheel is lifted, it should just fall back to lower drive wheel by its own weight. Adjust counterweight to achieve this. Refer to Section #18.

15. HEAD ARM JUMPS OUT OF END TRACKS DURING REWIND.

- A. This is due to the head cable stiffness and may be expected. It is recommended that seldom used announcements, such as sign-on and sign-off, be recorded on these end tracks. A new head cable is available that will alleviate this difficulty, part B-65822.

16. MAINTENANCE CLEANING

The following parts should be cleaned once a month as a regular preventative maintenance measure. The cleaning in general should be done with a clean cloth moistened with de-natured alcohol.

NOTE: USE ONLY DE-NATURED ALCOHOL.

- A. IDLER WHEELS. The large and small idler wheels may be cleaned on the machine if desired. Cleaning will be much easier if the flywheel is removed. Clean idlers using a clean cloth moistened with de-natured alcohol. If glazing of the large idler wheel still persists, apply very fine sandpaper to idler while machine is running in the forward mode - then clean idler wheel thoroughly, as well as the rewind drive wheel and the band brake felt.
- B. BAND BRAKE FELT. Unhook spring and clean brake felt lightly with a clean cloth moistened with de-natured alcohol. Clean until all foreign deposit on felt has been removed. Do not rub hard enough to damage or remove felt.
- C. REWIND DRIVE WHEEL. While the band brake is disconnected for cleaning, clean the drive wheel that the brake acts on using a clean cloth moistened with de-natured alcohol. Inspect the surface of the wheel for nicks and scratches that might tear the felt brake. If any scratches are found, sand them lightly with a fine grade of sandpaper and clean again with the damp rag.
- D. FORWARD DRIVE WHEEL. Clean this wheel using a clean cloth moistened with de-natured alcohol.
- E. REWIND BRAKE FELT & NYLON BALL.

Remove the rewind brake assembly from the left end of the lower tape roll by loosening the locking nut, then removing both nuts and the spring from the shaft. Remove the brake clutch plate and clutch felt assembly by pulling them straight off the shaft. DO NOT LOSE NYLON BALL. Clean the brake felt and the clutch plate using a clean

cloth moistened with de-natured alcohol. Clean the nylon ball in the same manner. DO NOT rub felt hard enough to remove or damage felt. Re-assemble the brake assembly and nylon ball.

Consult Section #18 for proper adjustment of re-wind brake spring.

- F. TAPE HEADS. Clean the face of the tape heads using a clean cloth moistened in de-natured alcohol. Rub with enough pressure to remove all tape deposit and dirt.
- G. TAPE. Clean the recording tape using a clean cloth moistened with de-natured alcohol by running the recorder in the forward mode while holding the cloth lightly on a portion of the tape at the top tape roller. This step should be repeated several times until the entire width of tape has been cleaned. To clean the tape at the start of the roll, throw the STOP-REWIND switch down to the stop position and wind the tape backwards a few inches at a time while wiping across the upper roll. Continue rewinding and cleaning until about 8 or 10 inches of tape has been cleaned past the cue position.

## 17. HEAD CURRENTS & VOLTAGES.

### A. ERASE HEAD.

Current	=	7.5 ma. to 8.0 ma.
Frequency	=	50 Kc approximately
Impedance	=	22K ohm @ 50 Kc
Voltage	=	150 V. to 170 V. across head
D.C. Resistance	=	58 ohm, $\pm 20\%$ .

NOTE: Voltage may be measured using a H.P. 330-C noise and distortion meter using the voltmeter input. Ground both the voltmeter and the recorder, and measure head voltage using an unshielded lead no longer than 20 to 24 inches.

The V.U. meter is used to measure the drop across a resistor in the ground return lead of the erase head when S2 is in the "E" position; however, the V.U. meter is not accurate at 50 Kc. so the resistor must be chosen for each recorder after the erase voltage at the erase head has been adjusted.

### B. RECORD HEAD.

Current	=	0.8 ma.
Frequency	=	50 Kc approximately
Impedance	=	112K ohm @ 50 Kc
Voltage	=	90 V. across head
D.C. Resistance	=	100 ohm, $\pm 20\%$ .

NOTE: Voltage may be measured using a H.P. 330-C noise and distortion meter using the voltmeter input. Ground both the voltmeter and the recorder, and measure head voltage using an unshielded lead no longer than 20 to 24 inches.

The V.U. meter on the recorder is used to measure the voltage drop across a resistor in the ground return lead of the recording head when S2 is in the "B" position; however, the V.U. meter is not accurate at 50 Kc so the resistor must be chosen for each recorder after the bias voltage at the recording head has been adjusted.

The voltage at the recording head is adjusted on the basis of the lowest intermodulation figure (3% to 4% average), and frequency equalization adjusted for this bias value.

## 18. TENSION MEASUREMENTS

The following tension measurements were made using push-pull gauges manufactured by - John Chatillon & Sons  
85 Cliff Street  
New York 38, N.Y.

Model 766 - 0 to 64 oz.  
Model 767 - 0 to 12 lb.

These scales may be ordered from the manufacturer or from the Gates Radio Company.

- A. REWIND BRAKE. Wind tape on top roller. Secure a cord to the center of the lower roller with scotch tape, and wind the cord around the roller several times so that when the cord is pulled, the roller will turn counterclockwise when viewed from left side of machine. Attach pull scales to the cord and measure pressure necessary to turn the roller against the brake slowly. To increase the brake tension, loosen the locking nut and turn the adjusting nut clockwise. To decrease tension turn adjusting nut counterclockwise. Tighten locking nut.

RECOMMENDED OPTIMUM TENSION      16 to 40 oz.

NOTE: If all brake tension is lost, replace nylon ball, Item 11 in parts list.

- B. DRAG BRAKE (band brake). Wind tape on lower roller; secure a cord to the center of the upper roller with scotch tape and wind the cord around the roller several times so that when the cord is pulled, the roller will turn clockwise when viewed from the left side of the machine. Attach pull scales to the cord and measure the pressure necessary to turn the roller

ADDENDUM

PAGE 11 after "against the brake slowly."

To increase or decrease the tension, adjust the nut on the spade bolt. Tightening the nut increases the tension, and loosening the nut decreases the tension.



against the brake slowly. To increase or decrease the tension, form the end loops of the spring to lengthen or shorten it. A longer spring gives less tension - a shorter spring gives more tension.

RECOMMENDED OPTIMUM TENSION 20 to 30 oz.

- C. IDLER-FLYWHEEL & COUNTERWEIGHT. Remove idler-flywheel assembly from machine and lay flat on table. Hold pivot block steady and apply scales to back side of the counterweight. Measure tension necessary to compress the two springs slowly. Replace mechanism.

RECOMMENDED OPTIMUM TENSION 2½ to 4 lb. push.

Adjust tension by moving spring tension bar forwards or backwards. If tensions must be changed on older machines, order two W. B. Jones spring #7 and one spring tension bar A-33902 so that tension may be adjust independently of counterweight position.

Counterweight should be adjusted so that idler-flywheel just falls back when lifted by hand when mechanism is mounted on machine.

- D. HEAD ARM SPRING. Attach pull scales to head indexing arm which protrudes through front panel. Measure tension necessary to lift head from tape.

RECOMMENDED OPTIMUM TENSION 12 to 16 oz.

- E. HEAD LIFT CAM SPRING. Open front panel to move head arm away from lift cam. Attach pull scales to the cam arm and pull in the same plane as the spring. Measure tension necessary to operate cam half-way through its movement.

RECOMMENDED OPTIMUM TENSION 2 to 6 oz.

- F. FRONT PANEL SIDE THRUST. This measurement is for reference only. Measured by holding the recorder firm in a clamp, and using a lever to move front panel against spring. Tension is the pressure necessary to move the front panel against the spring multiplied by the lever length.

OPTIMUM TENSION 16 to 40 lbs./in.

MECHANICAL PARTS - SPOT TAPE

<u>ITEM</u>	<u>DESCRIPTION</u>	<u>PART NO.</u>
1.	Head Cable Assembly .....	B-65822-101
2.	Rollers/with tape .....	M-5840
3.	Gray Viscose Fluid (tube) .....	VF-1
4.	Pushbutton Guard .....	A-31844-1
5.	Lever Switch Guard .....	A-32472-1
6.	Dummy Plug, Elco .....	M-11224
7.	Audio Plug, Elco .....	M-10624
8.	Plug, Hold Down .....	A-32970-1
9.	Motor .....	B-65836-1
10.	Motor Starting Capacitor .....	A-32456-1
11.	Nylon Ball (Grade #1) .....	5/32" dia.
12.	Panel Pivot Shaft .....	A-33128-1
13.	"O" Ring, Std. Comp. (Reed Rubber) .....	#902-41
14.	Allen Head Wrench .....	#6
15.	Allen Head Wrench .....	#8
16.	Nylon Roller (W. L. Moulding) .....	WL314N
17.	Flywheel & Idler Wheel Assembly .....	M-5908
18.	Clutch Plate Assembly .....	A-32564-101
19.	Brake Band Assembly .....	A-32523-102
20.	Index Arm Assembly .....	A-32526-101
21.	Drive Roller Assembly .....	B-66191-101
22.	Rewind Roller Assembly .....	B-66190-101
23.	Bearing Cap Assembly .....	A-32557-101
24.	Left Bearing Assembly .....	A-32565-101
25.	Index Bar .....	B-65857-1
26.	Clutch Spring .....	A-32561-1
27.	Balance Spring .....	A-32516-1
28.	Lift Cam .....	A-31892-1
29.	Drag Brake Spring .....	A-32521-1
30.	Tape Bar Assembly .....	A-32530-101
31.	Arm Spring .....	A-32520-1
32.	Slide Pad for Head Arm .....	A-31924-1
33.	Balance Weight Collar .....	A-33044-1
34.	Supply Roll Tube .....	B-65841-1
35.	Idler Arm Pivot .....	A-32846-1
36.	Motor Mounting Screw, FHMS Steel .....	10-24X3/4
37.	Right Supply Roll Cap .....	A-32580-101
38.	Left Supply Roll Cap .....	A-32565-101
39.	Right Panel Catch .....	A-32514-2
40.	Solenoid Pull Link .....	A-32519
41.	Idler Release Cam .....	A-31892-1
42.	Brake Pulley Assembly .....	A-32560-101

ELECTRICAL PARTS - SPOT TAPE

<u>ITEM</u>	<u>DESCRIPTION</u>	<u>ITEM NO.</u>
1.	Lamps .....	A-34599-101
2.	Solenoid .....	A-32513-101
3.	VU Meter, Simpson, Non-mag .....	#1347
4.	Photo Cell ..... <i>913-5786-001</i>	<del>008-10</del>
5.	Erase Head, Brush .....	BK-1110
6.	Record-play Head, Brush .....	BK-1090
7.	Rotary Selector Switch .....	B-66192-101
8.	Lever Switch .....	A-10900-1
9.	Texas Instruments Rectifier .....	IN2071
10.	Texas Instruments Rectifier .....	IN2069
11.	A.C. Line Cord, Belden .....	17176-S
12.	Relay (stop-reverse) .....	AK-12643
13.	Relay (slave-reverse) .....	AK-12644
14.	Relay (mute) .....	AK-12650
15.	Power Transformer .....	AP-32729-T
16.	Choke (equalizer) .5 hy. ....	AC-31789-T
17.	Bias Transformer, Nortronics .....	T-60-C
18.	Rectifier Board (small) .....	A-33655-1
19.	Rectifier Board (large) .....	A-33689-1

SPARE PARTS FOR SPOT TAPE  
 RECOMMENDED FIELD SPARES  
 SHOULD BE MAINTAINED BY THE STATION

		<u>Qty.</u>
1.	Set Tubes EF86	2
	12AX7	2
	12AU7	1
2.	Rectifier, Texas Instruments IN2069	2
	IN2071	4
3.	Fuse, 2 amp., 250 V., 3 AG	5
4.	Lamp #12 (A-34599-101)	4
	#47	4
5.	Nylon Ball, 5/32" Dia. (Grade #1)	2
6.	A-32523-101 Brake Band Assembly	1
7.	A-32564-101 Clutch Plate Assembly	1
8.	A-32560-101 Brake Pulley	1

7/20/60

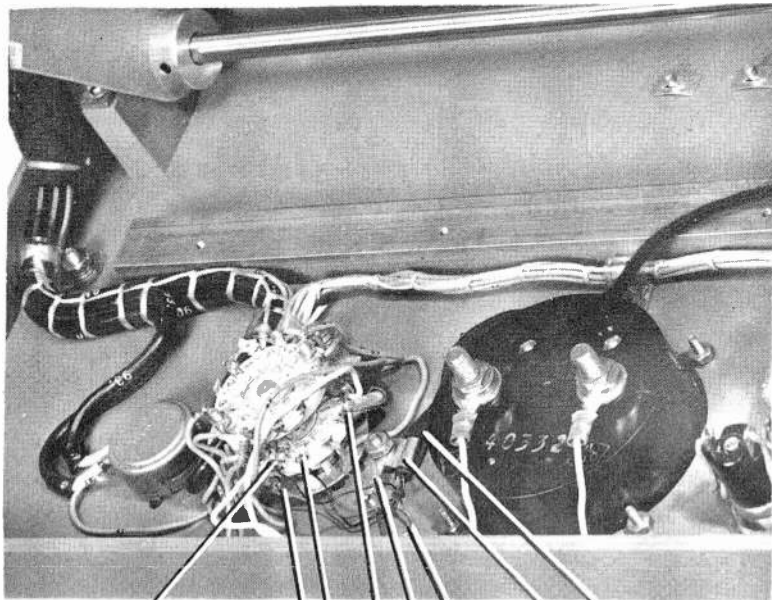

ERASE HEAD (GND. RETURN)  
RECORD HEAD (HOT)  
RECORD HEAD (GND. RETURN)  
SHIELD  
GND. LUG  
CABLE CLAMP  
ERASE HEAD (HOT)

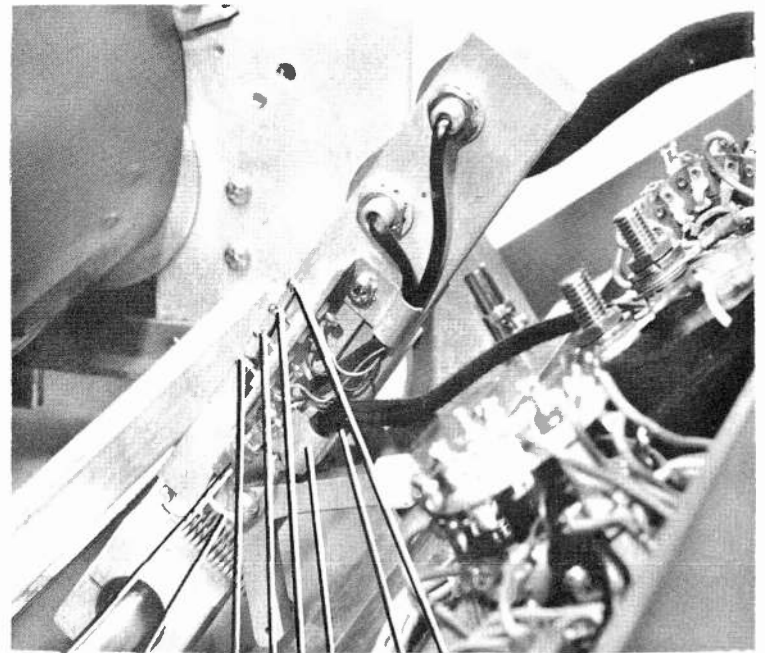

GND. LUG  
SHIELD  
RECORD HEAD (HOT)  
CABLE  
CABLE CLAMP  
RECORD HEAD (GND. RETURN)  
ERASE HEAD (HOT)  
ERASE HEAD (GND. RETURN)

PARTS LOCATION  
SPOT TAPE M5735

A-34291

LEFT SIDE

RIGHT SIDE

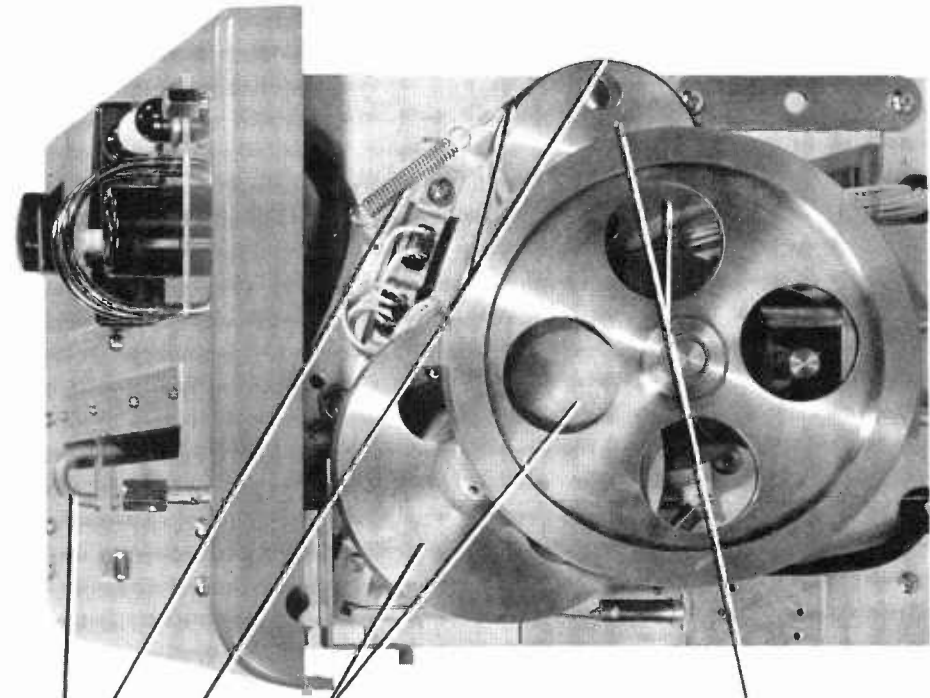
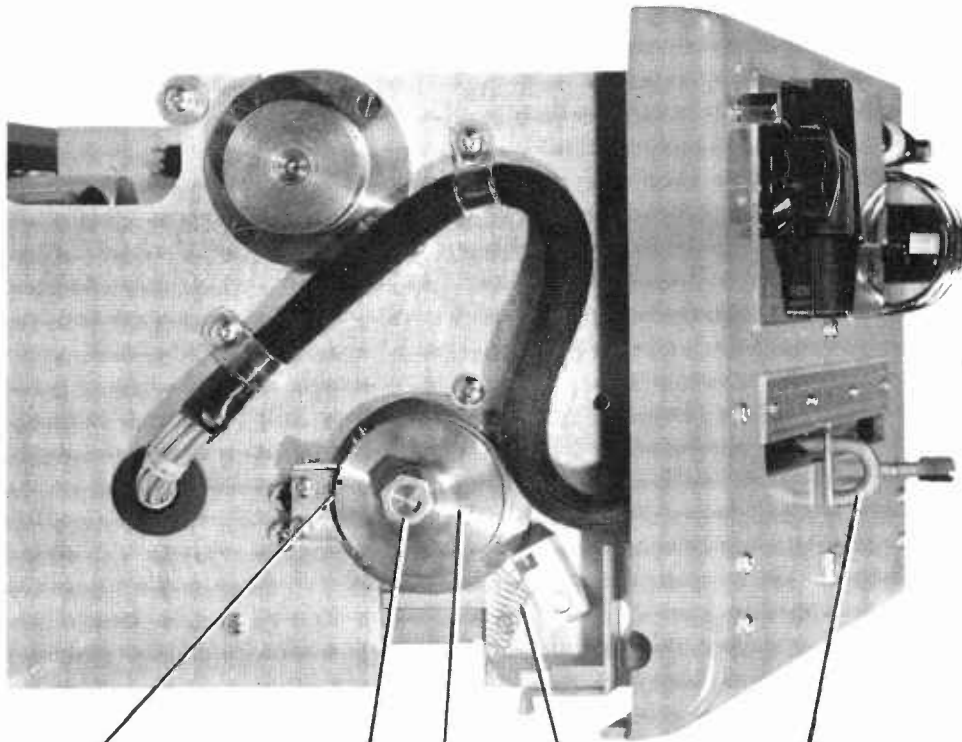

HEAD INDEX ARM

NYLON BALL

LOCK NUT  
ADJUSTING NUT

HEAD LIFT CAM  
SPRING

REWIND BRAKE  
AND CLUTCH

DRAG BRAKE

FORWARD DRIVE  
WHEEL

DRAG BRAKE  
SPRING

REWIND DRIVE  
WHEEL

SPOT TAPE PARTS  
M-5735

## PARTS LIST

<u>Symbol No.</u>	<u>Drawing No.</u>	<u>Description</u>
A1, A2 A3, A4, A5	A-34599-101	Lamp, GE 12 Lamp, #47
AT1 AT2	A-31863-101	Bridging Pad Potentiometer, 500K ohm, 2W.
B1	B-65836-1	Motor
C1		Cap., 40-40-10 uf., 450V.
C2, C29, C30, C31, C32		Cap., .5 uf., 200 V.
C3		Cap., .00075 uf., 500 V.
C4		Cap., 100 uf., 6(W) V.
C5, C9, C11		Cap., .47 uf., 400 V.
C6		Cap., .047 uf., 400 V.
C7, C8		Cap., .1 uf., 400 V.
C10		Cap., 25 uf., 25 V.
C12		Cap., 100 uf., 6(W)V.
C13, C18, C19		Cap., .47 uf., 400 V.
C14, C15, C16		Cap., .1 uf., 400 V.
C17		Variable Cap., 170-780 uuf.
C20, C24		Cap., .001 uf., 1 KV
C21		Cap., 10 uf., 150(W)V.
C22, C23		Cap., .0006 uf., 500 V.
C25		Cap., .01 uf., 1 KV
C26		Cap., 3000 uf., 15 V.
C27		Cap., 16 uf., 450 V.
C28		Cap., 1 uf., 200 V.
C33		Cap., 40 uf., 150 V.
C34		Cap., 40 uf., 250 V.
C35		Motor Starting Cap., 2 uf., 220 V. a.c., $\pm 5\%$
C36		Cap., .005 uf., 1 KV
C37		Cap., .005 uf., 1 KV
C38		Cap., 24 uuf., 500 V. (Det. by Freq.)
C39		Variable Cap., 9-180 uuf.
C40, C43		Cap., 120 uuf., 500 V.
C41		Cap., 200 uuf. (Det. by Freq.)
C42		Cap., 3 uf., 150 V.
CR1, CR2, CR3, CR4, CR5, CR6, CR7, CR8, CR9, CR10, CR11, CR12, CR13, CR14	IN 207	Rectifier
F1		Fuse, 2 amp., 250V., 3AG
J1		Receptacle, 6 terminal
J2		Receptacle, 12 terminal
J3		Chassis Receptacle & A.C. Line Cord
J4		Receptacle
K1, K2	AK-12643	Stop & Reverse Relay
K3	AK-12644	Reverse Slave Relay
K4	AK-12650	Mute Relay

7/7/59

-1-

Spot Tape

<u>Symbol No.</u>	<u>Drawing No.</u>	<u>Description</u>
L1,L2	AC-31789T	Choke
L3		Choke, .5 hy.
L4		Solenoid
M1		630 0093 000
PT1,PT2		Photocells
PU1		Erase Head
PU2		Record-Play Head
R1		Res., 100K ohm; 1W., 10%
R2,R52,R53		Res., 200 ohms, 1/2W., 5%
R3,R9,R12		Res., 510K ohm, 1/2W., 5%
R4		Res., 3300 ohm, 1/2W., 1%
R5		Res., 330K ohm, 1/2W., 1%
R6		Res., 1.5 megohm, 1/2W., 1%
R7		Potentiometer, 5000 ohms, 1/2W.
R8		Control, 100 ohm, .5W., wirewound
R10		Res., 2200 ohm, 1/2W., 5%
R11		Res., 220K ohm, 1/2W., 10%
R13		Res., 47K ohm, 1/2W., 5%
R14		Res., 180K ohm, 1/2W., 5%
R15,R48		Res., 1000 ohm, 1/2W., 10%
R16		Res., 82 ohm, 1/2W., 5%
R17		Res., 910 ohm, 1/2W., 5%
R18		Res., 2200 ohm, 1/2W., 5%
R19		Res., 180K ohm, 1/2W., 1%
R20		Res., 820K ohm, 1/2W., 5%
R21		Res., 3300 ohm, 1/2W., 5%
R22		Res., 220K ohm, 1/2W., 10%
R23		Res., 330K ohm, 1/2W., 5%
R24,R30		Res., 150K ohm, 1/2W., 5%
R25,R31		Res., 1 megohm, 1/2W., 10%
R26		Res., 1500 ohm, 1/2W., 10%
R27		Res., 100K ohm, 1/2W., 5%
R28		Res., 560K ohm, 1/2W., 5%
R29		Potentiometer, 50K ohm, 1/2W.
R32		Res., 33K ohm, 1/2W., 10%
R33		Res., 1600 ohm, 1/2W., 5%
R44		Res., 510K ohm, 1/2W., 5%
R45		Res., 5600 Ohm, 1/2W., 5%
R46		Res., 10K ohm, 1/2W., 5%
R47,R49		Res., 33K ohm, 1/2W., 10%
R50,R56		Res., 1000 ohm, 1/2W., 10%
R51,R57,R58		Res., 200 ohms, 1W., 5%
R54,R66		Res., 25 ohm, 10W.
R55		Res., Adj. 2500 ohm, 25W.
R59		Res., 100 ohm, 1/2W., 10%
R60		Res., 620 ohm, 1/2W., 5%
R61		Res., 47 ohm, 1/2W., 10%
R62		Res., 150K ohm, 1/2W., 10%
R63		Res., 24K ohm, 1/2W., 5%
R64		Res., 47K ohm, 1/2W., 10%
R65		Res., 15K ohm, 1/2W., 10%

<u>Symbol No.</u>	<u>Drawing No.</u>	<u>Description</u>
S1		Switch
S2		Rotary Selector Switch
S3		Toggle Switch
S4	A-10900-1	Lever Switch
S5		Black Pushbutton Switch
S6		Red Pushbutton Switch
T1	AP-32729T	Power Transformer
T2	AO-10427T	Output Transformer
T3	AI-10426T	Input Transformer
T4		Transformer
TS1, TS2	A-2751-18	Terminal Strip, 6 terminal
TS3, TS4	A-2751-24	Terminal Strip, 13 terminal
V1, V3, V5		Tube, EF-86
V2, V4		Tube, 12AX7
V6		Tube, 12AU7
XA1, XA2		Receptacle
XA3		Pilot Light, Green
XA4		Pilot Light, White
XA5		Pilot Light, Red
XF1		Fuseholder
XV1, XV2, XV6, XV3, XV4, XV5		Socket, 9 pin

#### REMOTE CONTROL BOX

A101, A102, A103		Lamp, #47
S101		Black Pushbutton Switch
S102		Red Pushbutton Switch
S103	A-10900-1	Lever Switch
TB101		Terminal Board
XA101		Pilot Light, Green
XA102		Pilot Light, White
XA103		Pilot Light, Red



### IDLER-FLYWHEEL ASSEMBLY

In order to be certain that the idler-flywheel assembly will not be damaged during shipment of the SPOT TAPE RECORDER, this assembly has been packaged separately. Installation is simple, and is described in the following steps.

1. Carefully place the idler assembly into position on the machine, being careful not to damage the surfaces of the idler wheels. DO NOT FORCE MECHANISM. Install and tighten the idler arm pivot. Be sure the arm is free on the pivot.
2. Place the flywheel on the idler assembly with the countersunk side of the mounting holes out.

NOTE: A locating key has been punched in both the flywheel and the idler insert.

It is important that these keys line up when the flywheel is installed. The flywheel has been turned and balanced in this position.

3. Install the four flathead screws that secure the flywheel to the idler assembly. Be sure the flywheel is free on its bearing.
4. If a noticeable amount of wobble of the flywheel is observed while the machine is running, loosen the four screws holding the flywheel to the idler and re-seat them.

The enclosed drawing A-33907 locates the various parts.

3/15/60

IB3061

Spot Tape

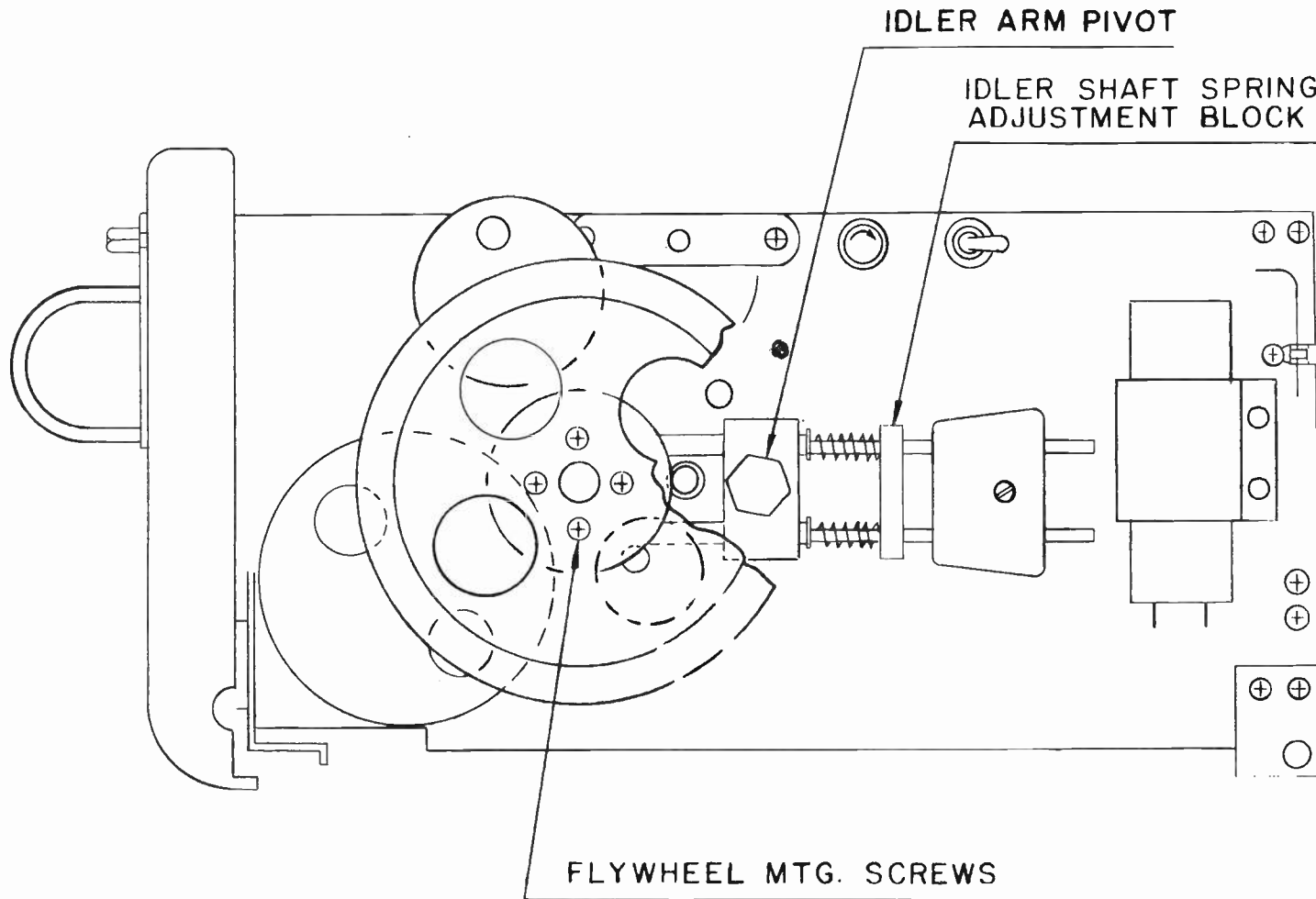

IDLER FLYWHEEL ASSEMBLY  
INSTRUCTIONS FOR SPOT TAPE

A-33907

## WARRANTY

This equipment is warranted by Gates Radio Company of Quincy, Illinois to be free from defects in workmanship and material and will be repaired or replaced in accordance with the terms and conditions set forth below:

1. Gates Radio Company believes that the purchaser has every right to expect first-class quality, materials and workmanship and has created rigid inspection and test procedures to that end, and excellent packing methods to assure arrival of equipment in good condition at destination.
2. Gates Radio Company will endeavor to make emergency shipments at the earliest possible time giving consideration to all conditions.
3. Gates Radio Company warrants new equipment of its manufacture for one (1) year and (six (6) months on moving parts), against breakage or failure of parts due to imperfection of workmanship or material, its obligation being limited to repair or replacement of defective parts upon return thereof f.o.b. Gates Radio Company's factory, within the applicable period of time stated. Electron tubes shall bear only the warranty of the manufacturer thereof in effect at the time of the shipment to the purchaser. Other manufacturers' equipment covered by a purchaser's order will carry only such manufacturers' standard warranty. These warranty periods commence from the date of invoice and continue in effect as to all notices, alleging a defect covered by this warranty, received by Gates Radio Company prior to the expiration of the applicable warranty period.

The following will illustrate features of the Gates Radio Company warranty:

Transmitter Parts: The main power or plate transformer, modulation transformer, modulation reactor, main tank variable condensers all bear the one (1) year warranty mentioned above.

Moving Parts: As stated above, these are warranted for a period of six (6) months.

Electron Tubes: As stated, electron tubes will bear such warranty, if any, as provided by the manufacturer at the time of their shipment. Gates Radio Company will make such adjustments with purchasers as given to Gates Radio Company by the tube manufacturer.

All other component parts (except as otherwise stated): Warranted for one (1) year.

Abuse: Damage resulting from abuse, an Act of God, or by fire, wind, rain, hail, in transportation, or by reason of any other cause or condition, except normal usage, is not covered by this warranty.

4. Operational warranty - Gates Radio Company warrants that any new transmitter of its manufacture, when properly installed by purchaser and connected with a suitable electrical load, will deliver the specified radio frequency power output at the output terminal(s) of the transmitter, but Gates Radio Company makes no warranty or representation as to the

coverage or range of such apparatus. If a transmitter does not so perform, or in the event that any equipment sold by Gates Radio Company does not conform to any written statement in a contract of sale relative to its operating characteristics or capabilities, the sale liability of Gates Radio Company shall be, at the option of Gates Radio Company, either to demonstrate the operation of the equipment in conformance with its warranty, or to replace it with equipment conforming to its warranty, or to accept its return, f.o.b. purchaser's point of installation and refund to purchaser all payments made on the equipment, without interest. Gates Radio Company shall have no responsibility to the purchaser under a warranty with respect to operation of equipment unless purchaser shall give Gates Radio Company a written notice, within one (1) month after arrival of equipment at purchaser's shipping point, that the equipment does not conform to such warranty.

5. Any item alleged by a purchaser to be defective, and not in conformance with a warranty of Gates Radio Company shall not be returned to Gates Radio Company until after written permission has been first obtained from the Gates Radio Company home office for such return. Where a replacement part must be supplied under a warranty before the defective part can be returned for inspection, as might be required to determine the cause of a defect, purchaser will be invoiced in full for such part, and if it is determined that an adjustment in favor of the purchaser is required, a credit for an adjustment will be given by Gates Radio Company upon its receipt and inspection of a part so returned.

6. All shipments by Gates Radio Company under a warranty will be f.o.b. Quincy, Illinois or f.o.b. the applicable Gates Radio Company shipping point.

7. Gates Radio Company is not responsible for the loss of, or damage to, equipment during transportation or for injuries to persons or damage to property arising out of the use or operation of Gates equipment. If damage or loss during transportation occurs, or if the equipment supplied by Gates Radio Company is otherwise damaged, Gates will endeavor to make shipment of replacement parts at the earliest possible time giving consideration to all conditions. It is the responsibility of a purchaser to file any claim for loss or damage in transit with the transportation company and Gates will cooperate in the preparation of such claims to the extent feasible when so requested.

8. Gates Radio Company, in fulfilling its obligations under its warranties, shall not be responsible for delays in deliveries due to depleted stock, floods, wars, strikes, power failures, transportation delays, or failure of suppliers to deliver, acts of God, or for any condition beyond the control of Gates that may cause a delayed delivery.

9. This warranty may not be transferred by the original purchaser and no party, except the original purchaser, whether by operation of law or otherwise, shall have or acquire any rights against Gates Radio Company by virtue of this warranty.

10. Gates Radio Company reserves the right to modify or rescind, without notice, any warranty herein except that such modification or rescission shall not affect a warranty in effect on equipment at the time of its shipment. In the event of a conflict between a warranty in a proposal and acceptance and a warranty herein, the warranty in the proposal and acceptance shall prevail.

11. This warranty shall be applicable to all standard Gates catalog items sold on or after March 1, 1960.

Gates Radio Company  
Quincy, Illinois

1/6/60

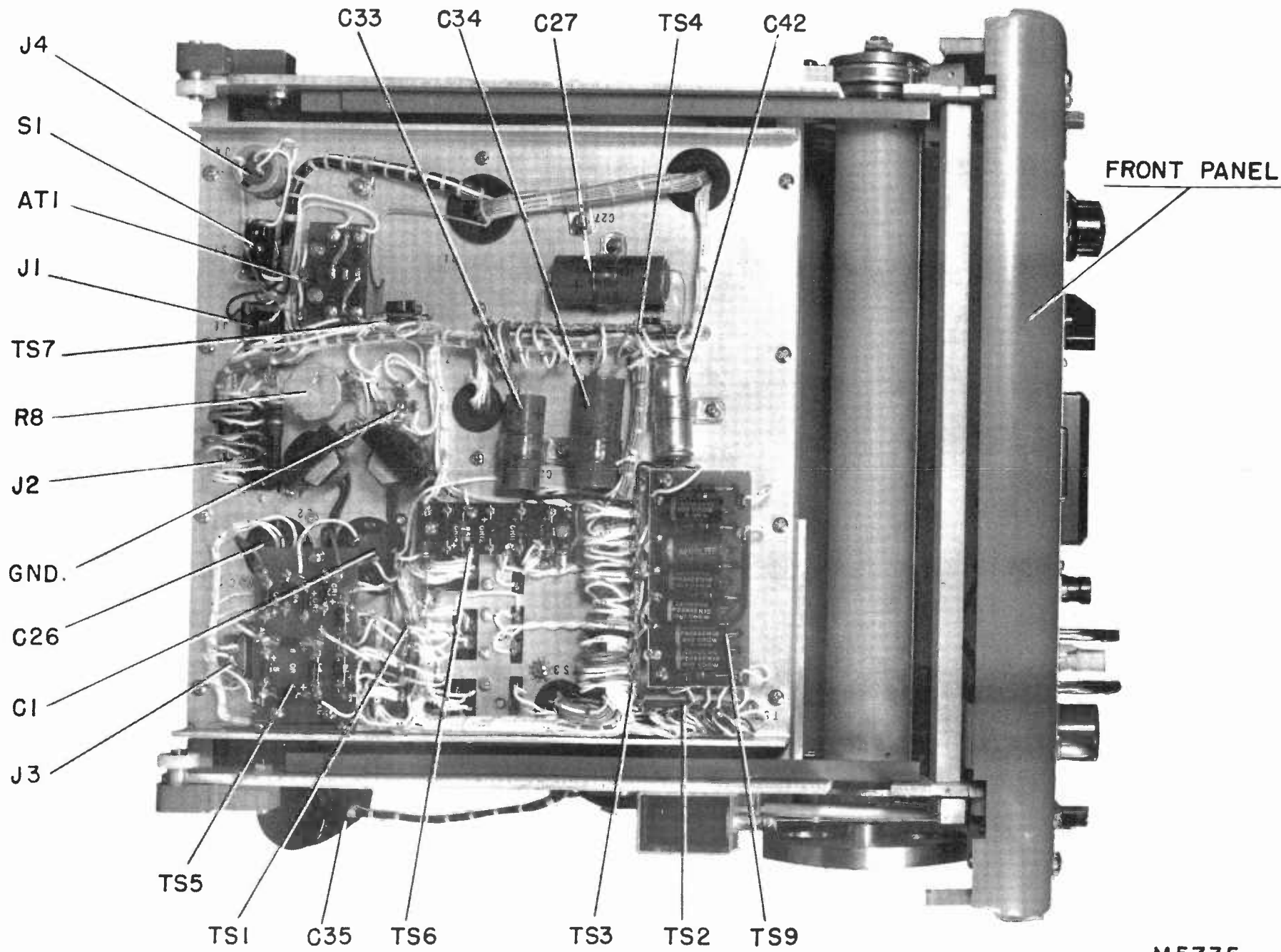

**MAIN CHASSIS - BOTTOM VIEW**

M5735

A-31921 B

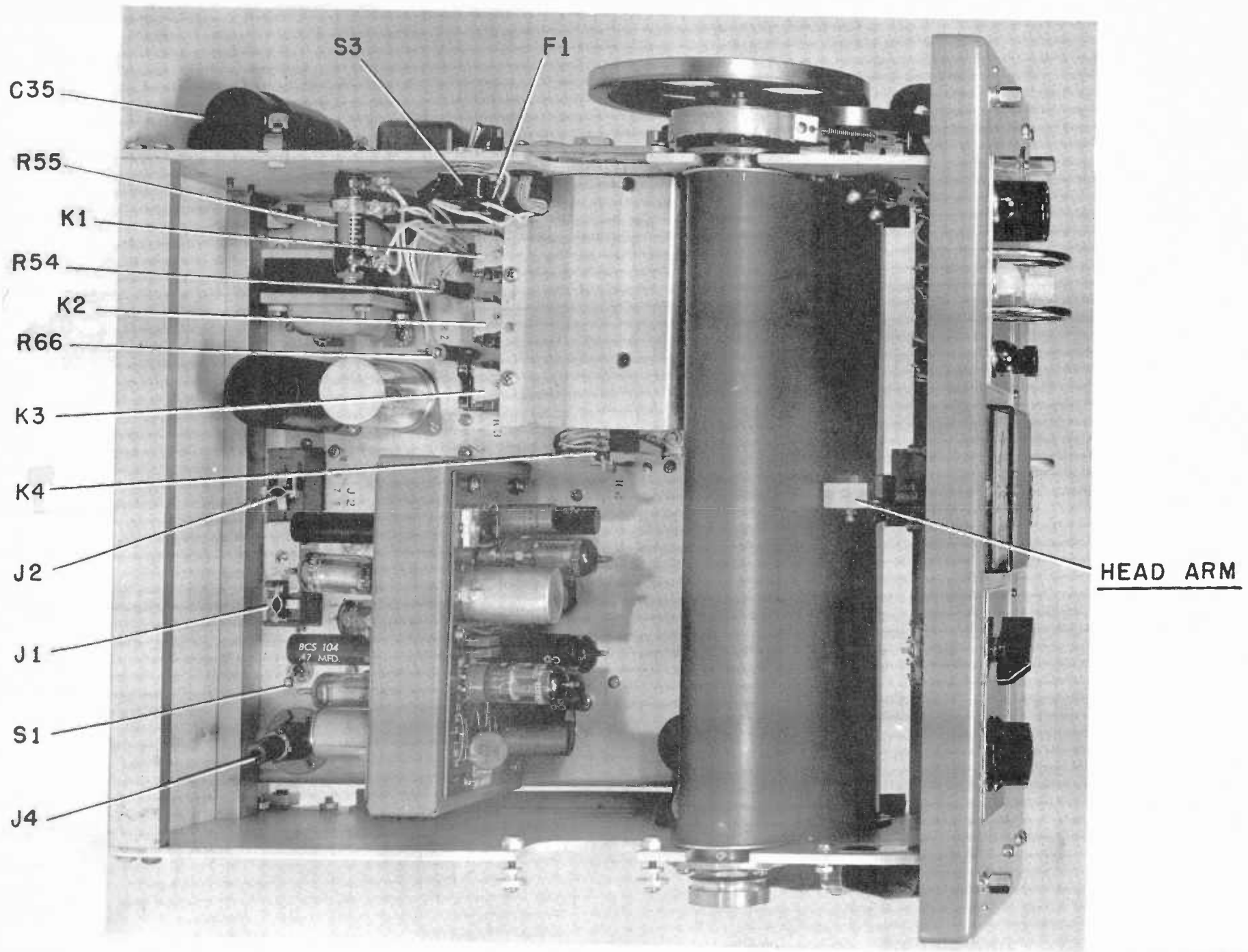

MAIN CHASSIS - TOP VIEW

M-5735

A-31922A

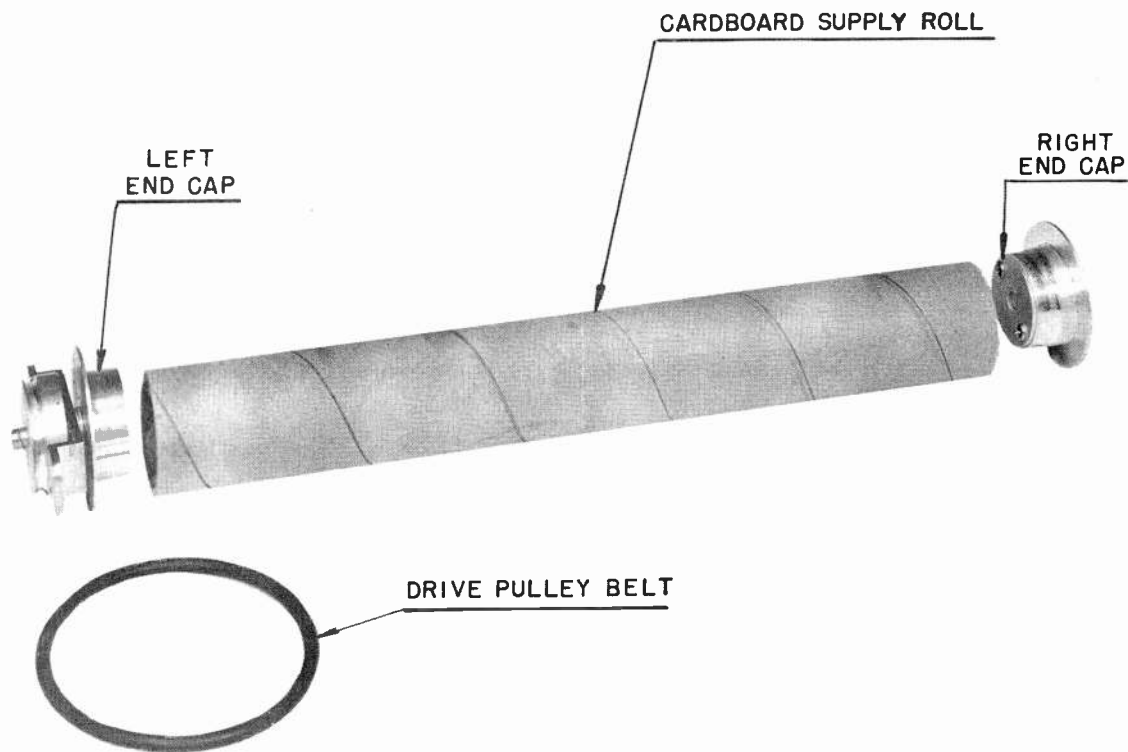

SUPPLY ROLLER ASSEMBLY  
M5735 SPOT TAPE

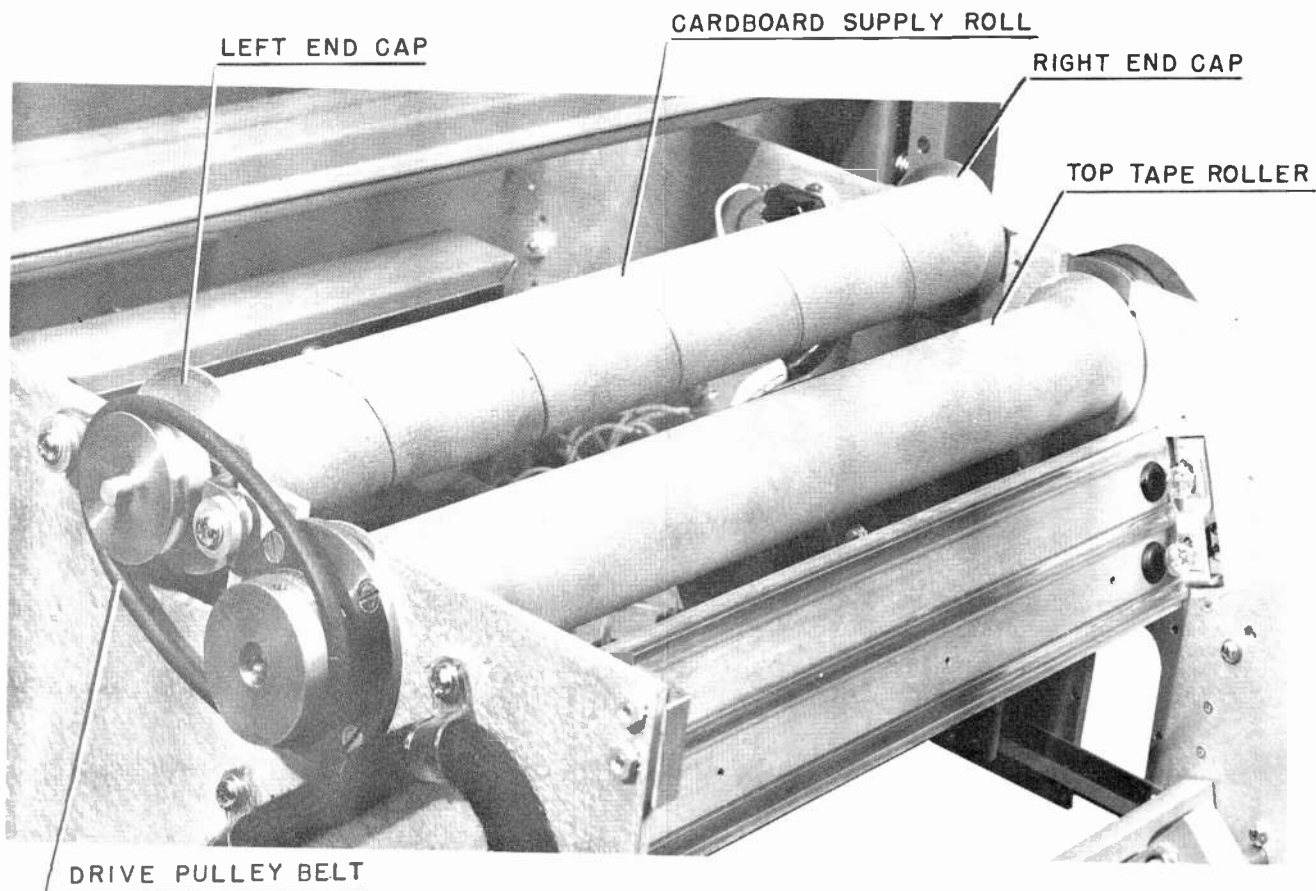

SUPPLY ROLLER ASSEMBLY  
M5735 SPOT TAPE

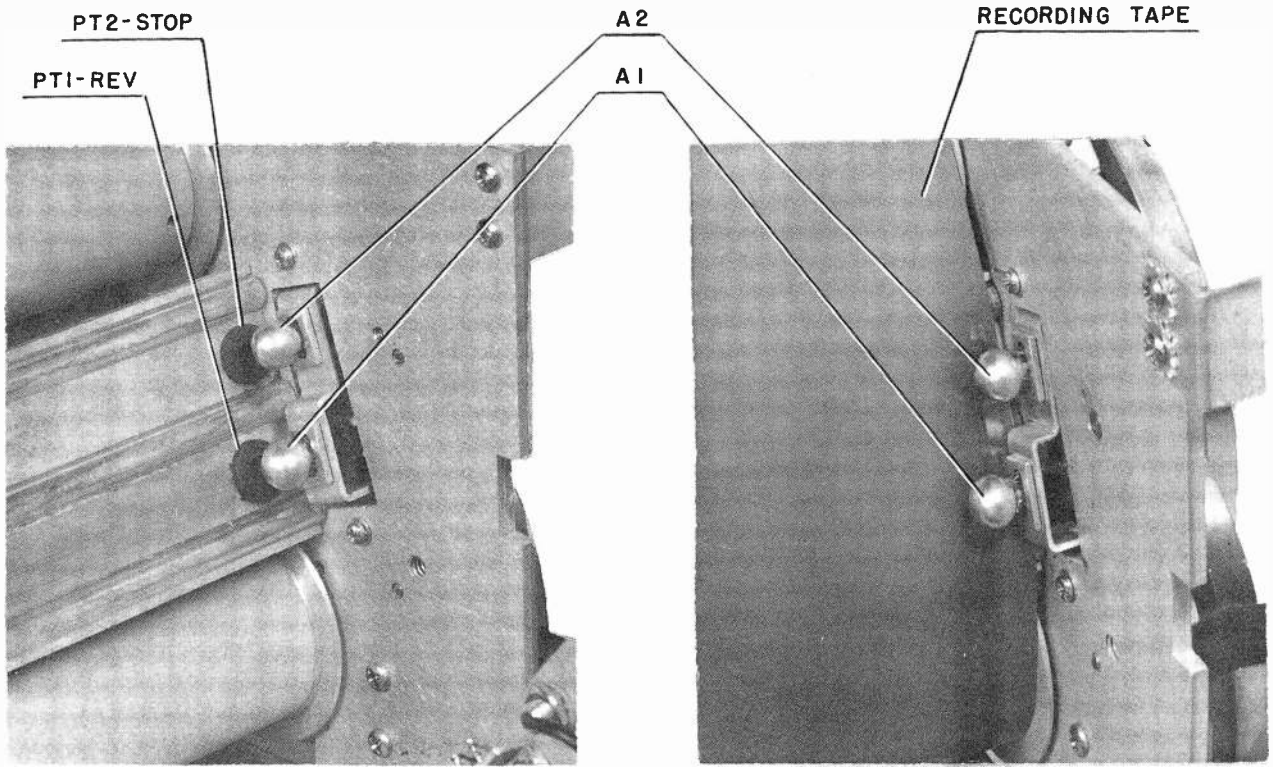

PHOTOCELL AND EXCITER LAMPS  
M5735

A - 31920A

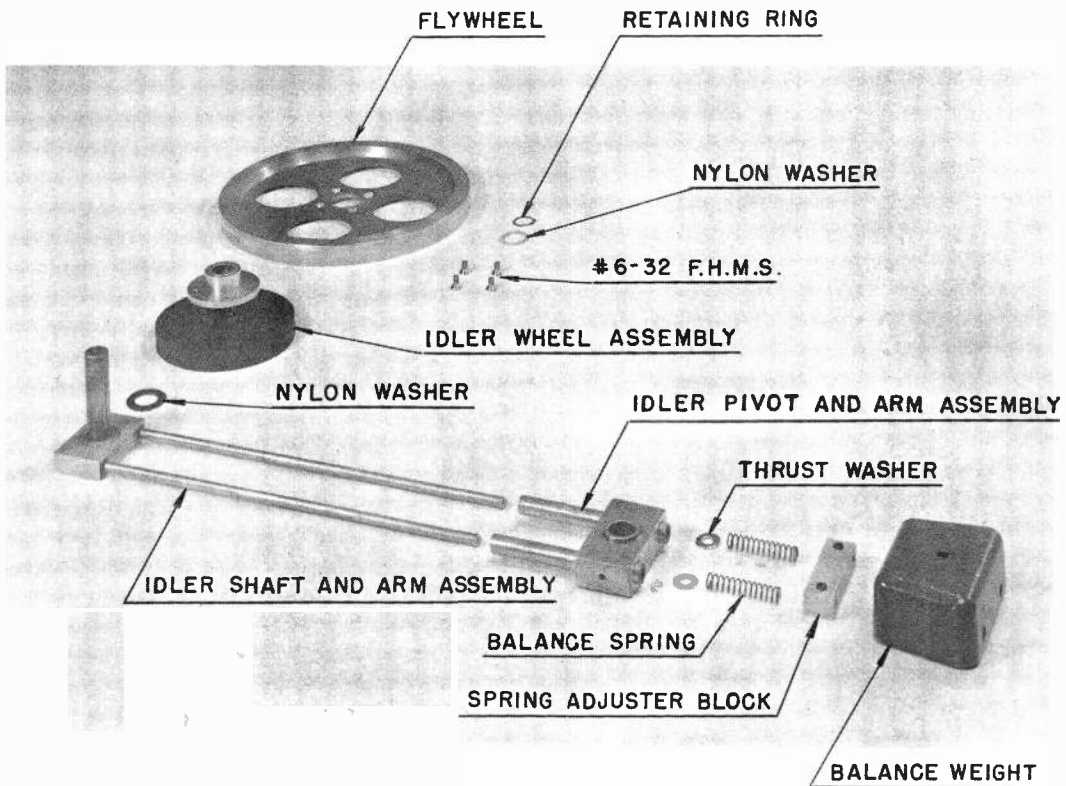

DRIVE ASSEMBLY  
SPOT TAPE M-5735

A-32601A



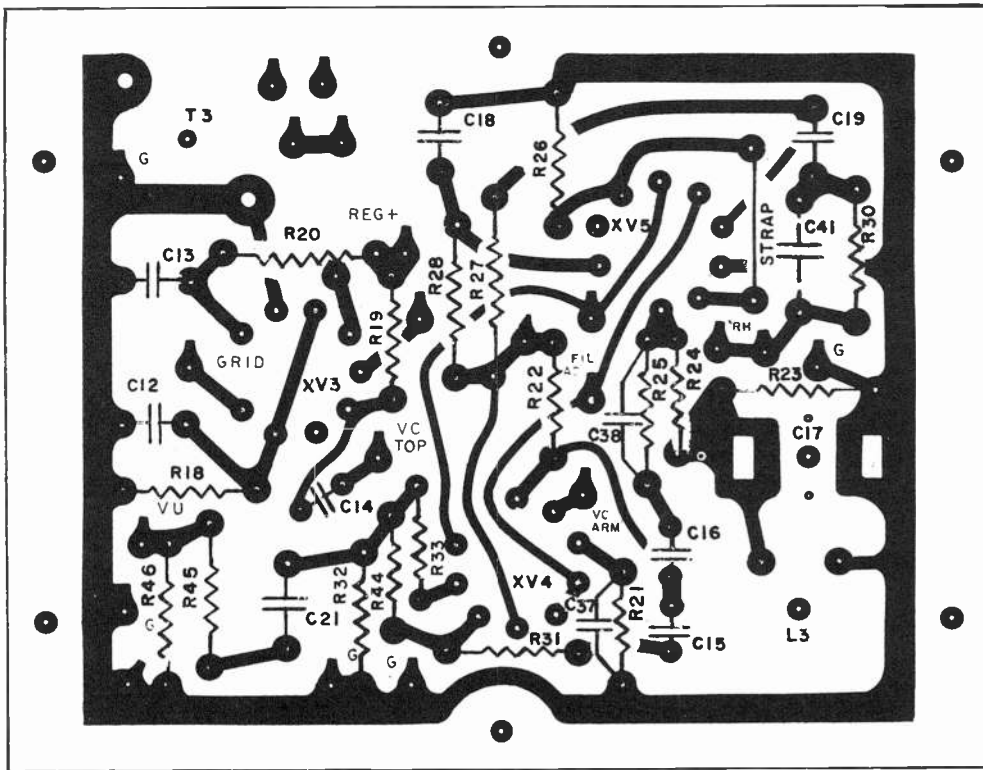

PRINTED CHASSIS LAYOUT SHOWING COMPONENTS AND WIRE CONNECTIONS RECORDING AMPLIFIER

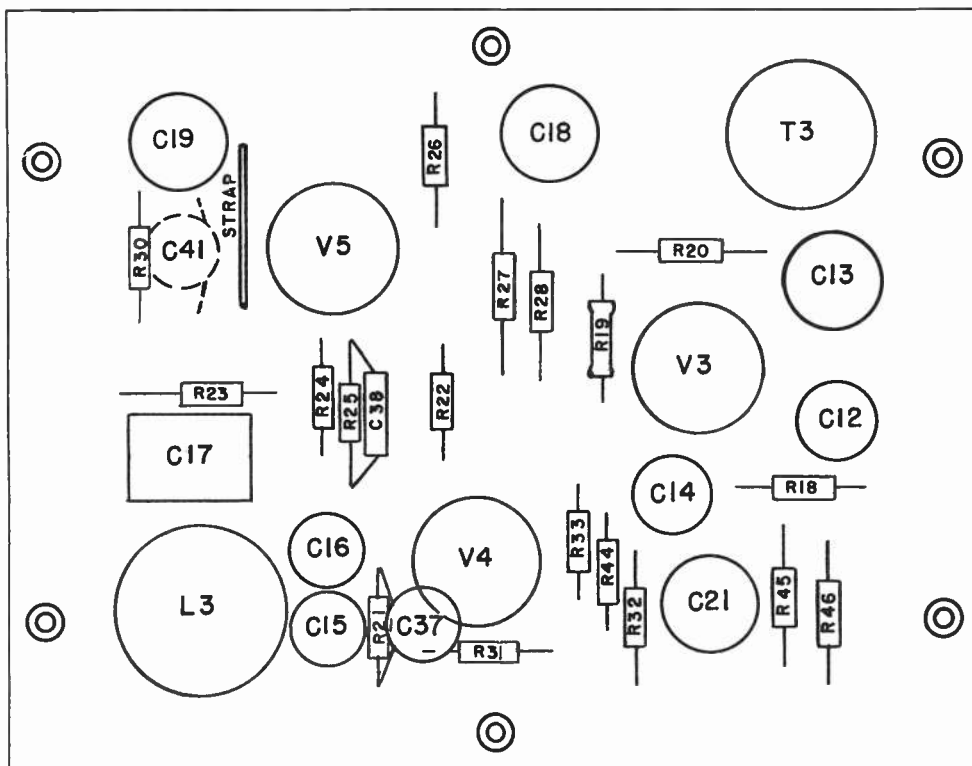

PRINTED CHASSIS COMPONENT LAYOUT RECORDING AMPLIFIER

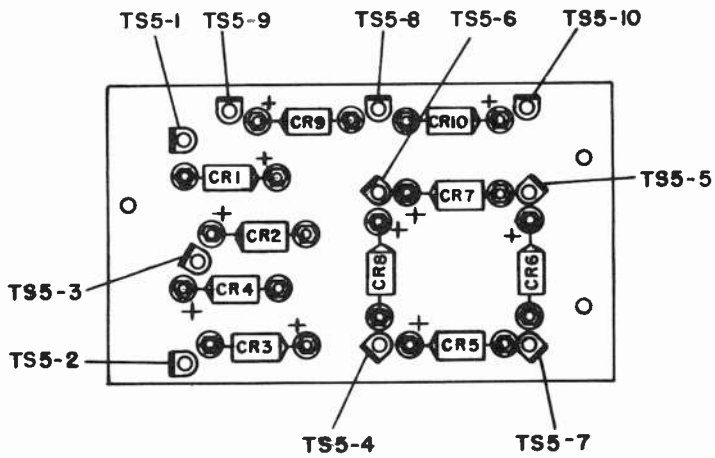

RECTIFIER BOARD TS-5  
SPOT TAPE M5735

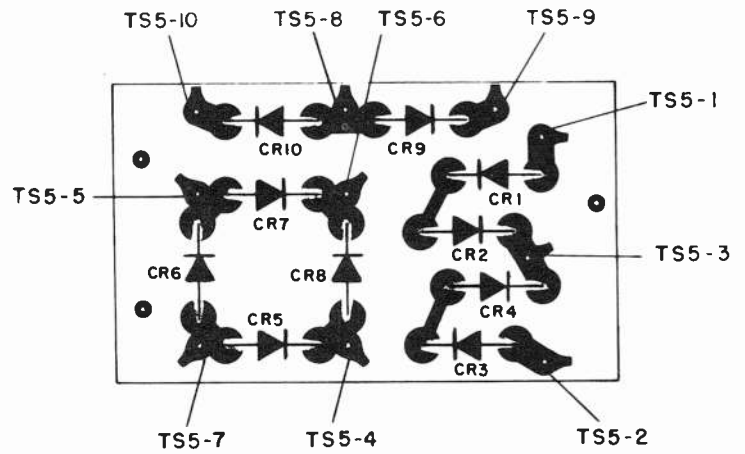

WIRING CONNECTIONS  
RECTIFIER BOARD TS-5  
SPOT TAPE M5735

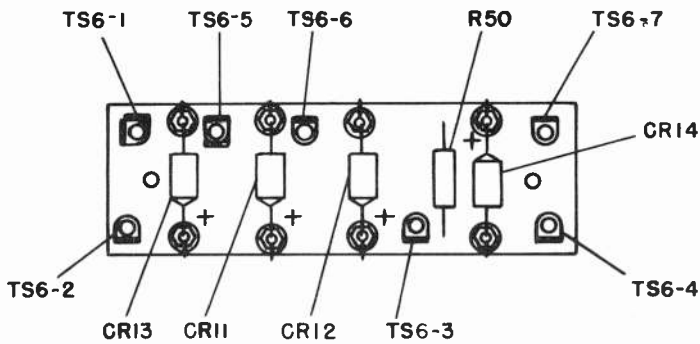

RECTIFIER BOARD TS6  
SPOT TAPE M5735

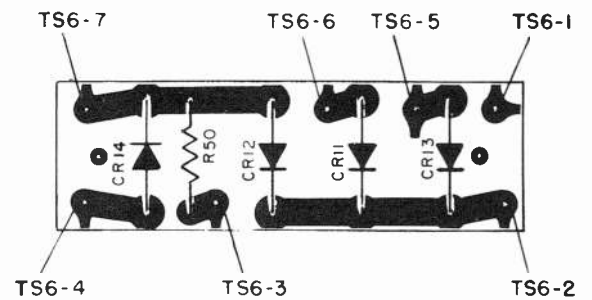

WIRING CONNECTIONS  
RECTIFIER BOARD TS6  
SPOT TAPE M5735

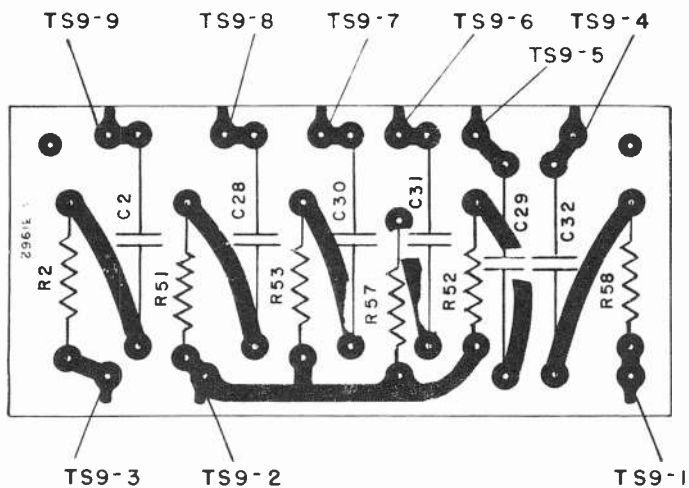

PRINTED CHASSIS LAYOUT SHOWING  
COMPONENT AND WIRE CONNECTIONS  
SPOT TAPE ARC SUPPRESSOR M5735

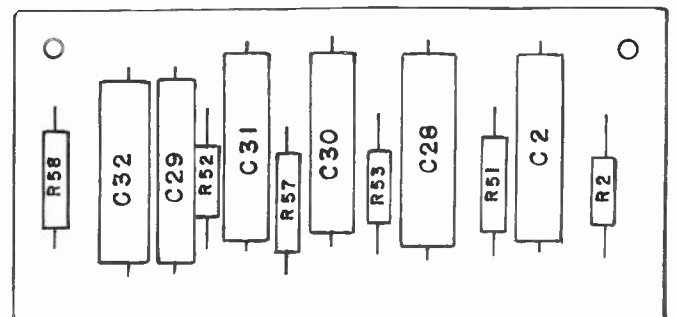

PRINTED CHASSIS COMPONENT LAYOUT  
SPOT TAPE ARC SUPPRESSOR M5735

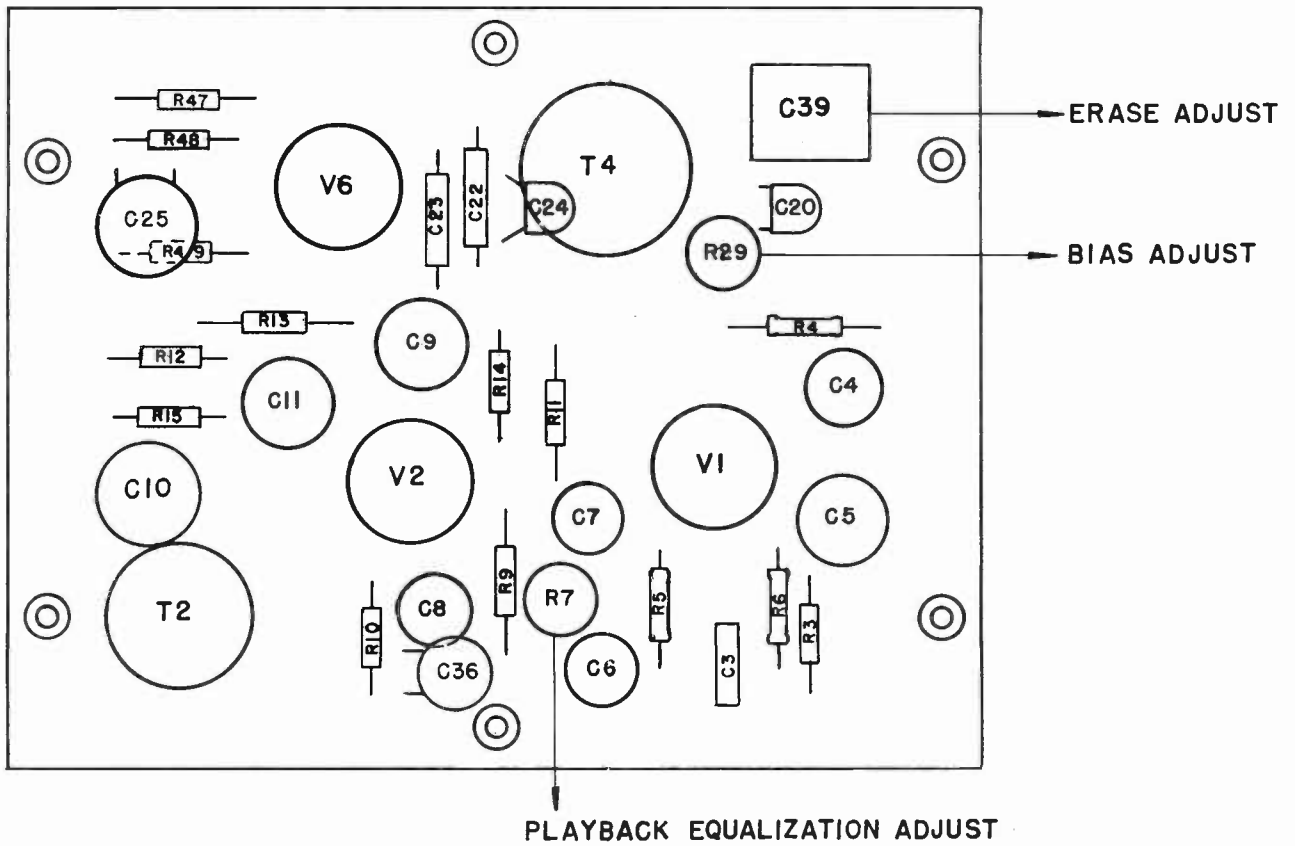

PRINTED CHASSIS COMPONENT LAYOUT  
PLAY AMPLIFIER

A-31912

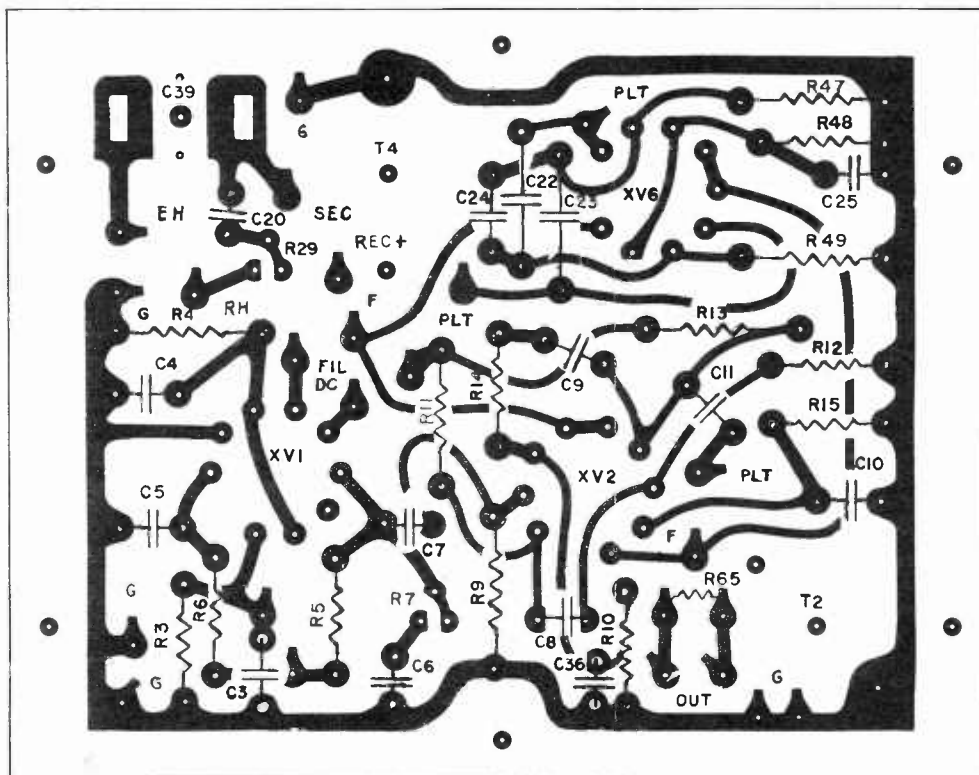

PRINTED CHASSIS LAYOUT SHOWING  
COMPONENT AND WIRE CONNECTIONS  
PLAY AMPLIFIER

A-31913

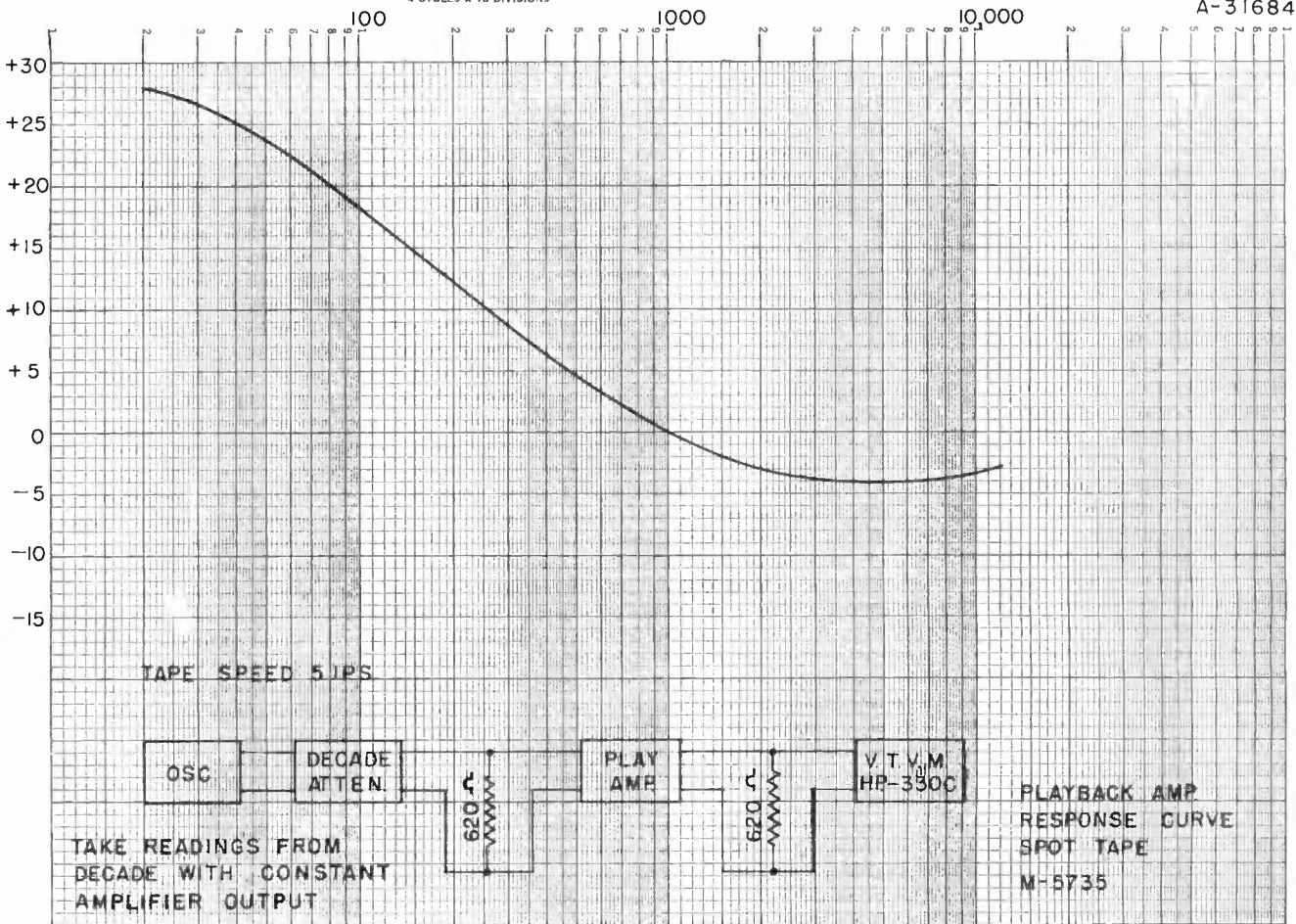

A-31684

A-32233

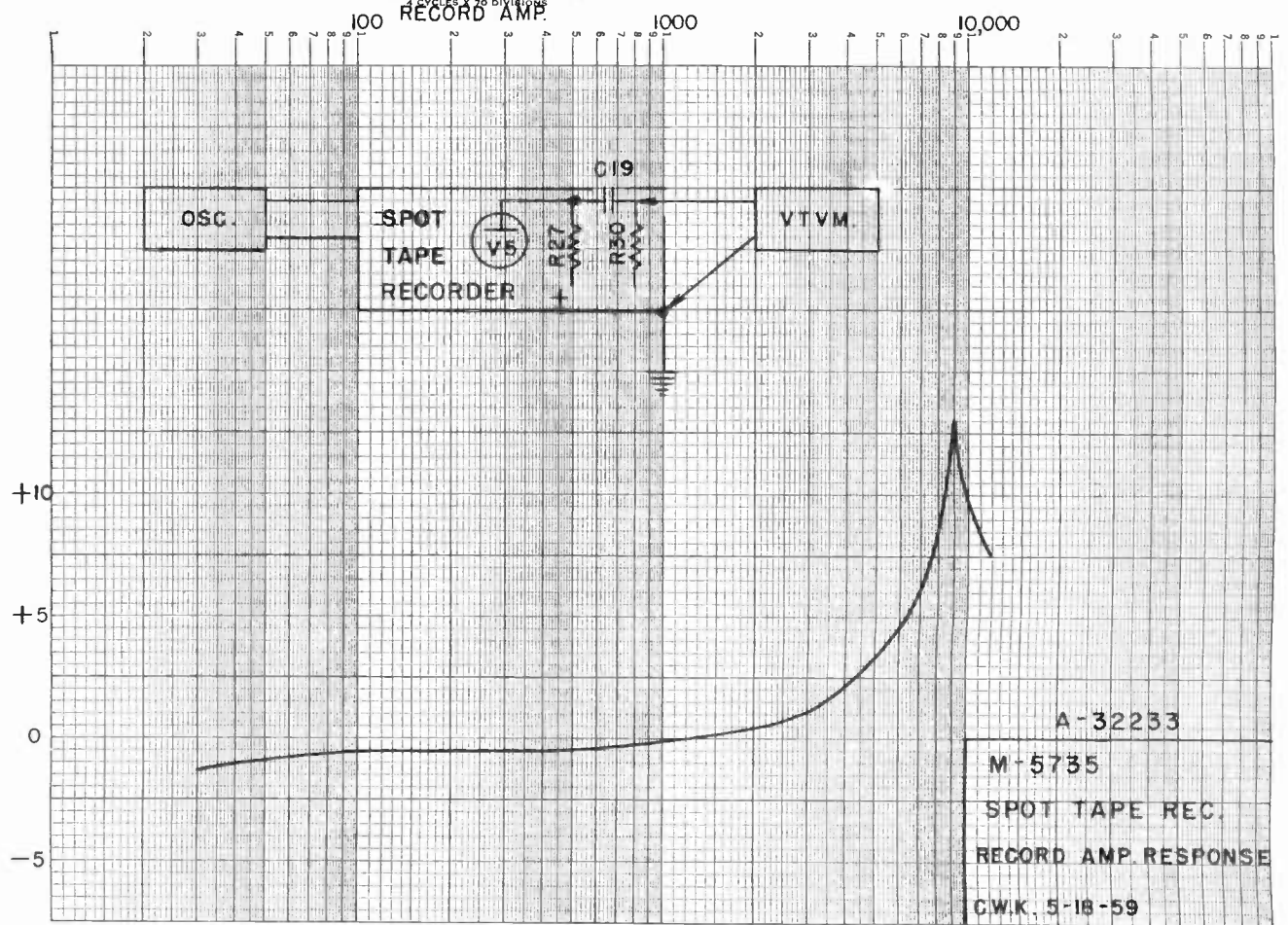

A-32233

M-5735  
 SPOT TAPE REC.  
 RECORD AMP RESPONSE  
 C.W.K. 5-18-59

							GATES RADIO COMPANY QUINCY, ILLINOIS			B-65851	
										SCALE	
106	105	104	103	102	101	GR. NO.	LIST OF PARTS				
QTY.	QTY.	QTY.	QTY.	QTY.	QTY.	ITEM	REFERENCE	PT. OR G.N.	FIN.	DESCRIPTION	MATERIAL

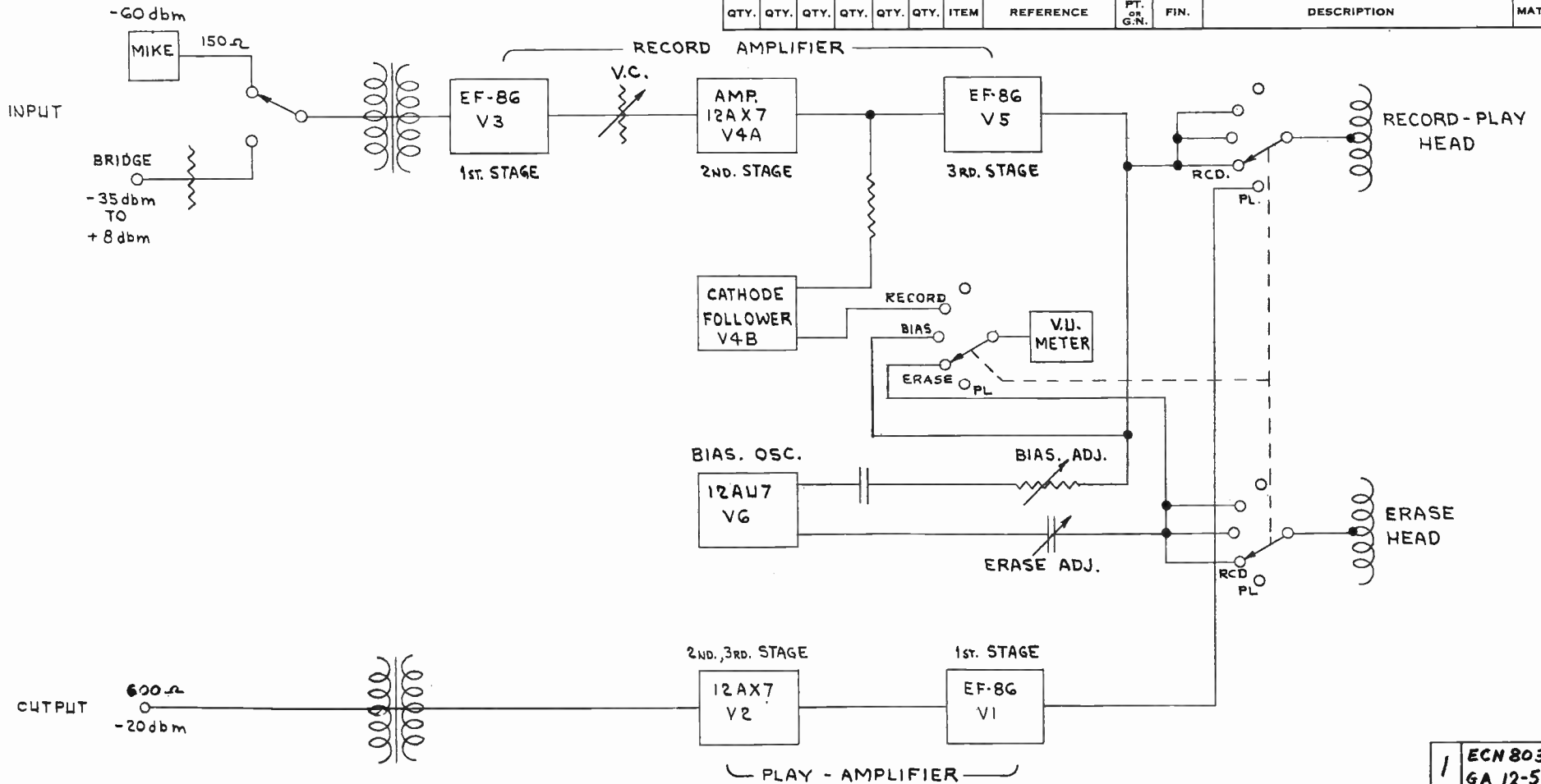

1 ECN 8030  
GA 12-5-59

TITLE BLOCK DIAGRAM, ST-101, SPOT TAPE, M5735

REVISED 7-27-59	STATUS	
	DEVELOPMENT	PRODUCTION
	MECH. CHK.	
	PROJ. ENG.	CWR
	APPROV. PRODUCTION BY	

MTL	FIN.	UNLESS OTHERWISE SPECIFIED, ALL TOLERANCES PER GATES SPEC DEMOS.	
DR. BY <i>[Signature]</i>	CH. BY	ENG.	SHEET OF B-65851
DATE 3-2-59			

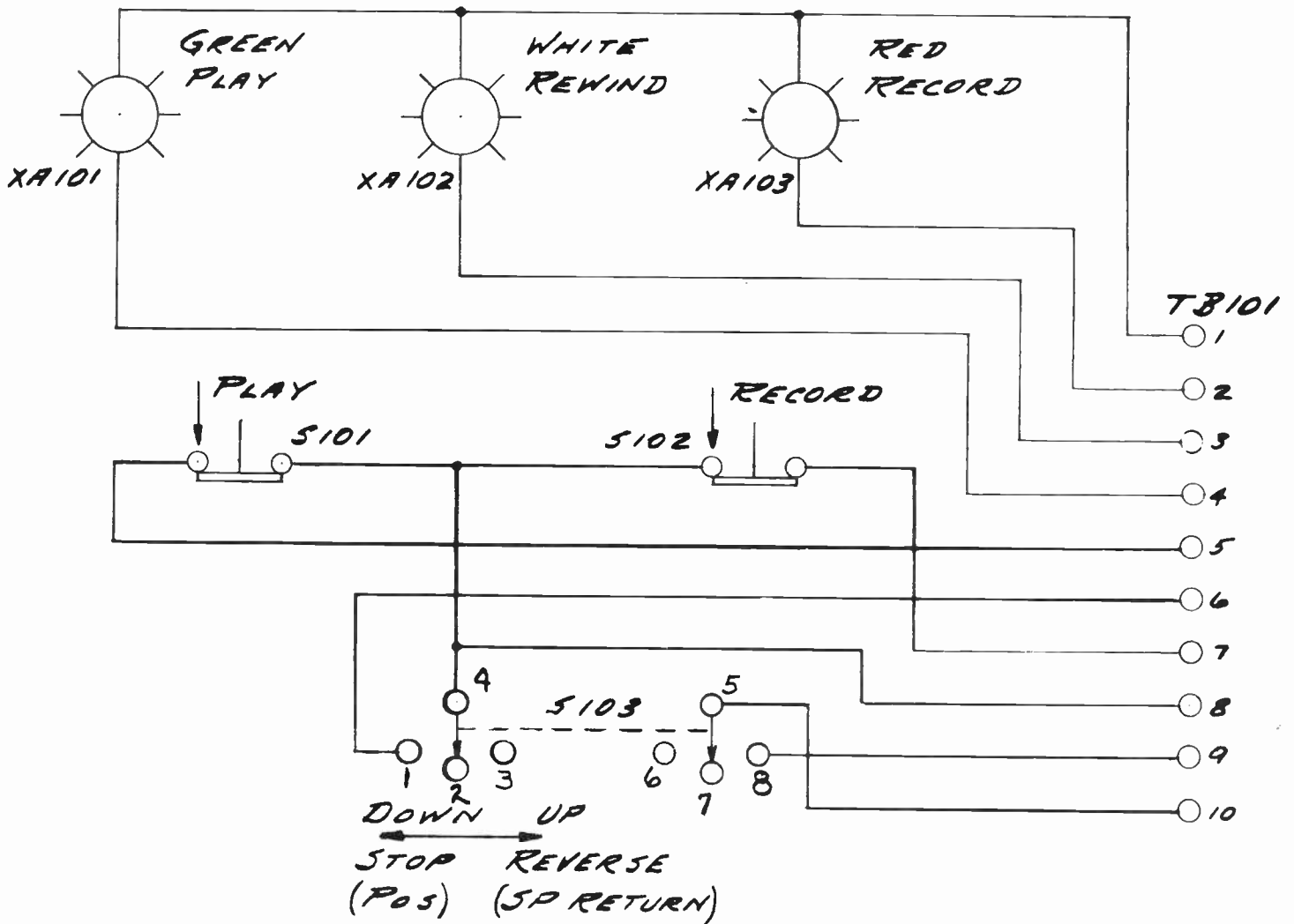

WIRING DIAGRAM - REMOTE CONTROL PANEL  
SPOT TAPE M5735

NOTE: PINS 11 & 12 ON  
PLUG ARE JUMPED

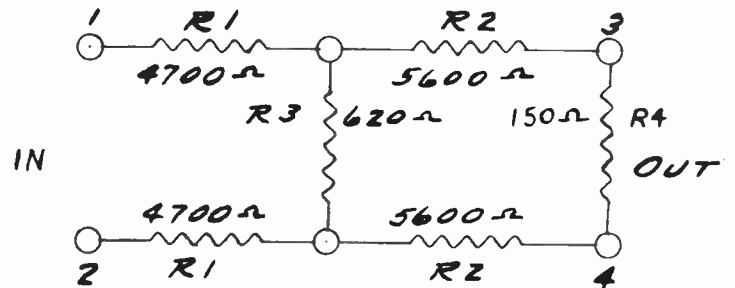
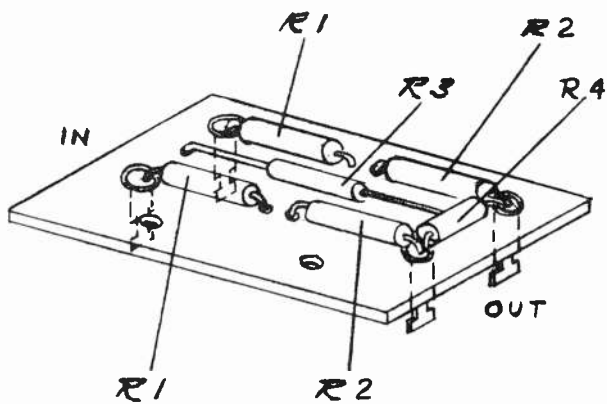

BRIDGING INPUT PAD ASSEMBLY  
SPOT TAPE M5735

ECN 8252  
HMC 8-31-60

ECN 8102  
GA 1-20-60

A-32723

TERMINAL VIEW  
J10- E 54

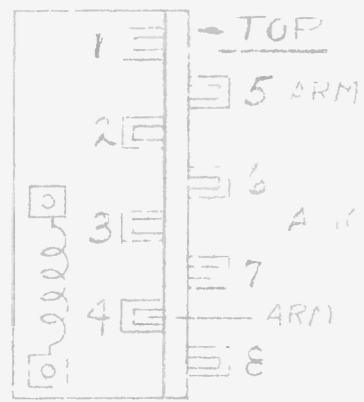

A 190C-1 (CL PA 220-153)

TERMINAL VIEW  
K1-K4

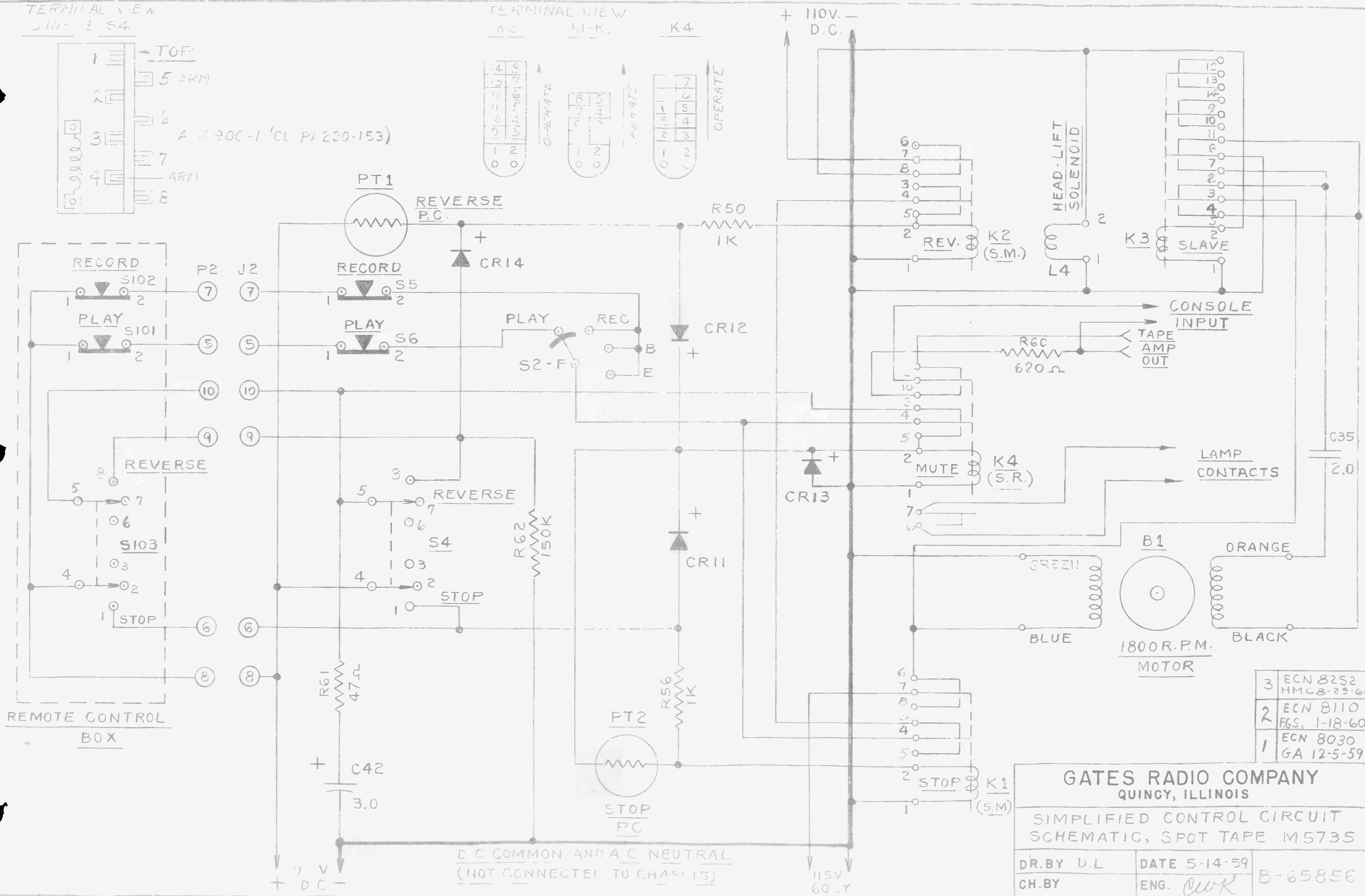
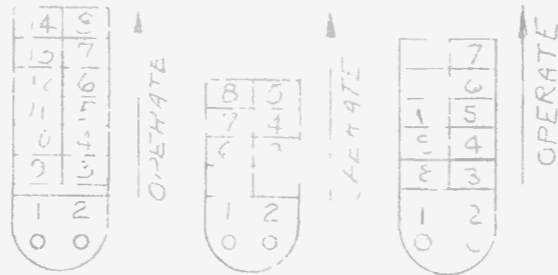

3	ECN 8252 HMCB-29-60
2	ECN 8110 FGS, 1-18-60
1	ECN 8030 GA 12-5-59

**GATES RADIO COMPANY**  
QUINCY, ILLINOIS

SIMPLIFIED CONTROL CIRCUIT  
SCHEMATIC, SPOT TAPE M5735

DR. BY D.L.	DATE 5-14-59
CH. BY	ENG. <i>CKR</i>

B-65856

D.C. COMMON AND A.C. NEUTRAL  
(NOT CONNECTED TO CHASSIS)

NOTE: PLAY AMPLIFIER SIGNAL VOLTAGES ( ) MEASURED ON H.P. 330C @ 1000 CPS WITH -20 DBM OUT @ 150Ω. D.C. VOLTAGES MEASURED ON SIMPSON 240. ALL VOLTAGES MEASURED TO GND.

NOTE: RECORD AMPLIFIER SIGNAL VOLTAGES ( ) MEASURED ON H.P. 330C -1000 CPS @ NORMAL RECORDING LEVEL (0 ON VU METER). D.C. VOLTAGES MEASURED ON SIMPSON 260. ALL VOLTAGES MEASURED TO GND.

GATES RADIO COMPANY QUINCY, ILLINOIS										D-22495
LIST OF PARTS										SCALE
108	109	104	103	102	101	100	99	98	97	96
QTY.	QTY.	QTY.	QTY.	QTY.	QTY.	QTY.	QTY.	QTY.	QTY.	QTY.
REFERENCE	FIN.	DESCRIPTION	MATERIAL							

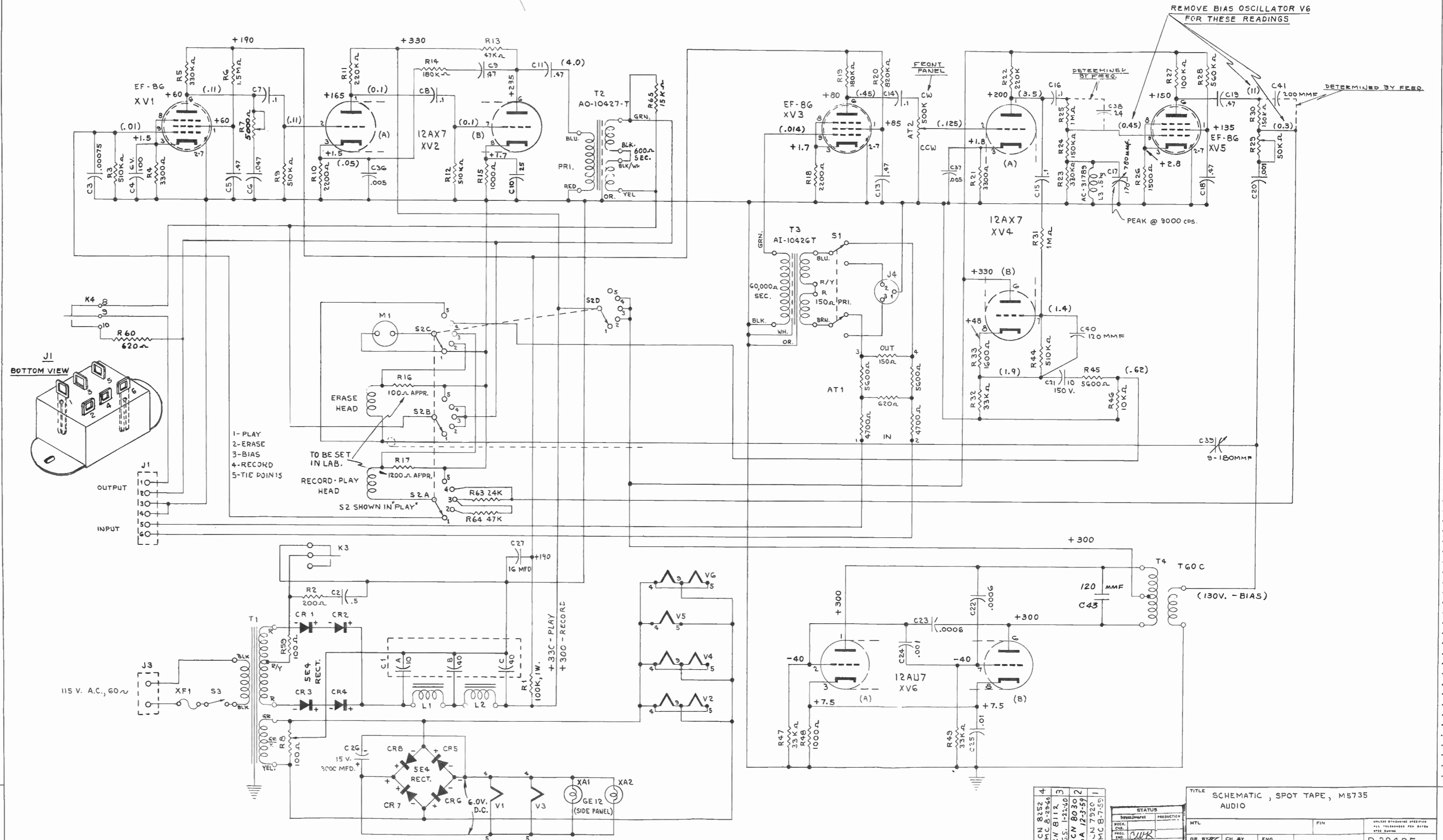

ENCL 8282	4	STATUS	PRODUCTION
ENCL 8283	3	REVISION	
ENCL 8284	3	DATE	
ENCL 8285	2	DATE	
ENCL 8286	1	DATE	
ENCL 8287	1	DATE	

TITLE SCHEMATIC, SPOT TAPE, M5735  
AUDIO

DATE: 1957  
CH. DATE: 1957  
ENG. DATE: 1957

D-22495



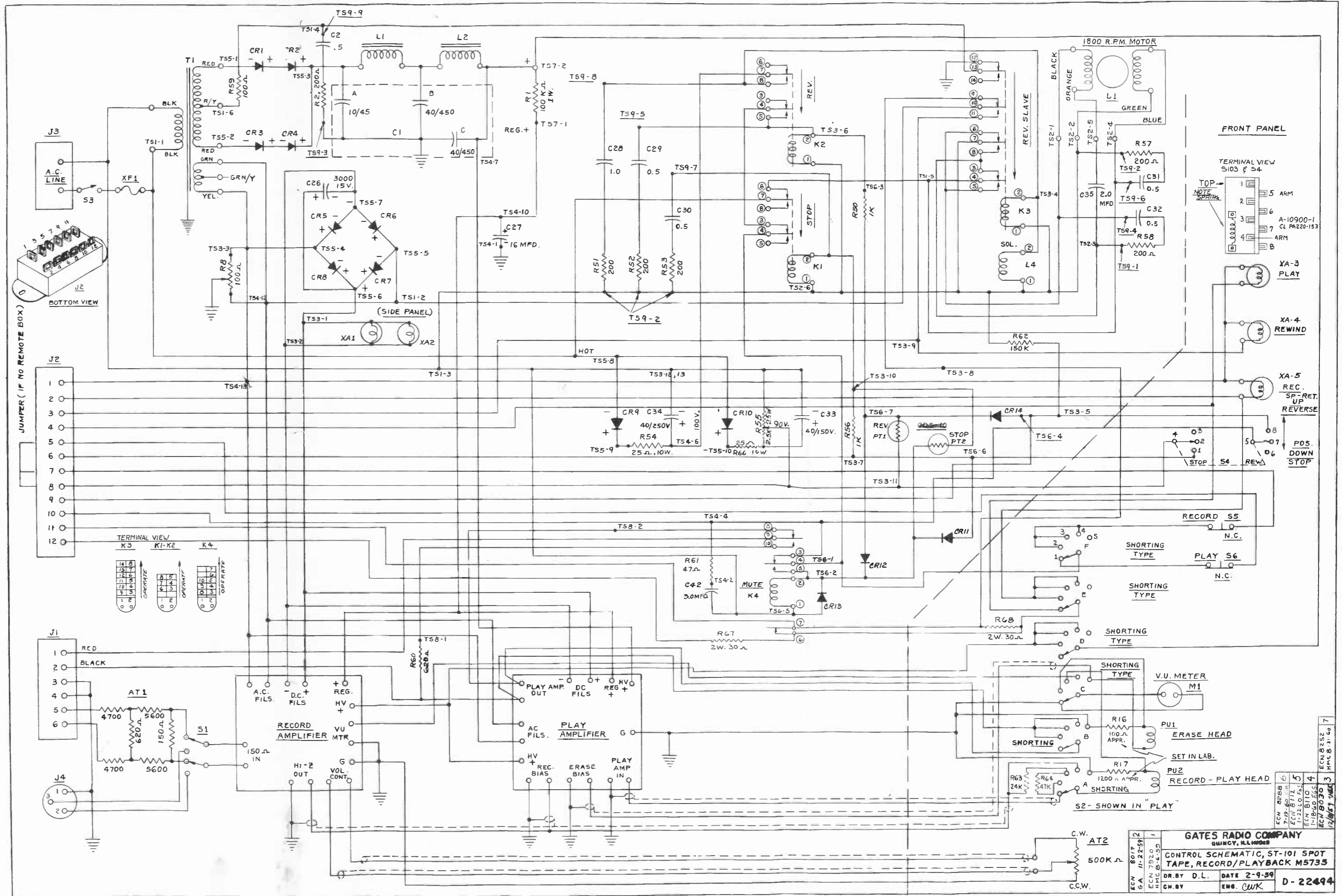

**GATES RADIO COMPANY**  
 QUINCY, ILLINOIS  
**CONTROL SCHEMATIC, ST-101 SPOT TAPE, RECORD/PLAYBACK M5735**  
 DR. BY D.L. DATE 2-9-59  
 ENG. C.W.K. **D-22494**

## REPLACING COMPONENTS ON THE PRINTED CHASSIS

Since this is a destructive operation, the engineer must be reasonably sure that the part is defective before removing it. He may determine this from the D.C. and signal voltage measurements or by visual observation.

**WARNING:** The copper conductors are only .0027" thick on the printed chassis. They are easily damaged! Do not attempt to pull one component lead loose to check the component. Use only the approved procedure as outlined in the sketches and the sub-paragraphs listed below.

Use a small electric soldering iron (60 watts or less) and allow it to come up to full heat before starting the repair job. The tip must be clean and well tinned.

**CAUTION:** Do not use a soldering gun. The extremely high temperature of the tip will damage the phenolic board.

Put the iron tip on the fillet under the chassis, right beside the component lead being removed. Put a gentle, but firm pressure on all leads and components being moved while the heat is applied. Do not hold the iron to the printed chassis for long periods of time. If the lead or component is difficult to remove, make repeated short passes at it rather than one long period that may overheat the board.

### 1. REMOVING PARALLEL MOUNTED COMPONENTS WITH AXIAL LEADS:

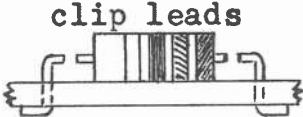
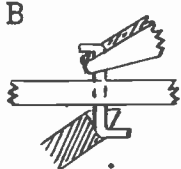
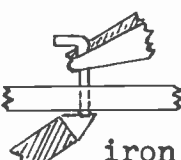
- A clip leads
- 
- B pliers push wire through hole until hook can be clipped off.
- 
- clip off hook that was soldered to chassis.
- C pliers
- 
- iron tip place iron on fillet again and pull the wire out of the hole on the top side of the chassis.
- iron tip

### 2. REMOVING VERTICALLY MOUNTED RESISTORS AND COMPONENTS WITH AXIAL LEADS:

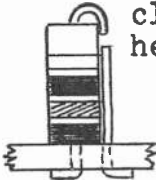
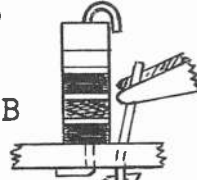
- A clip here
- 
- B pliers
- 
- place iron on fillet and push wire through the hole until the hook can be clipped off.
- clip off hook that was soldered to chassis.
- iron tip
- remove wire as illustrated in paragraph 1. (c).

2. (continued)

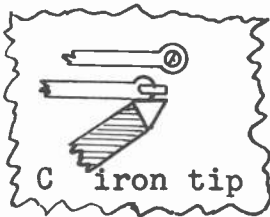

place the iron against the folded wire and rotate it away from the conductor leading into the fillet (2-c).

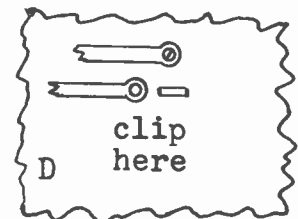

cut the wire as near the chassis as possible after

removing as much excess solder as possible. Remove solder by carrying it away with the iron tip and wiping the tip on a clean cloth. Repeat until the hook can be clipped with small sharp diagonal cutters, illustrated in (2-D).

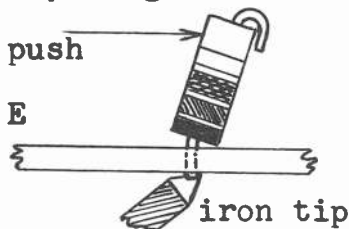

place iron on fillet again and push the resistor body over until the lead comes out of the hole.

3. REMOVING PRINTED WIRING TYPE CAPACITORS:

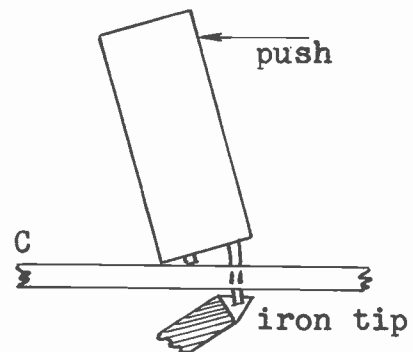
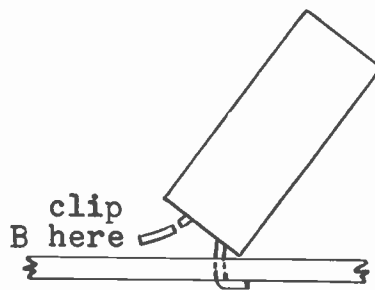
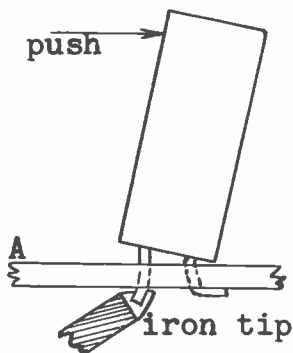

(A) hold iron tip on one of the folded leads, as soon as the solder melts - push gently but firmly on the side that will lift this lead. The capacitor should be pushed over just far enough to clear the lead from the hole.

(B) cut the lead off to prevent it from going back into the hole when removing the other lead.

(C) hold the iron tip to the other lead and push the capacitor over until it comes free.

4. REMOVING SADDLE TYPE ELECTROLYTIC CAPACITORS:

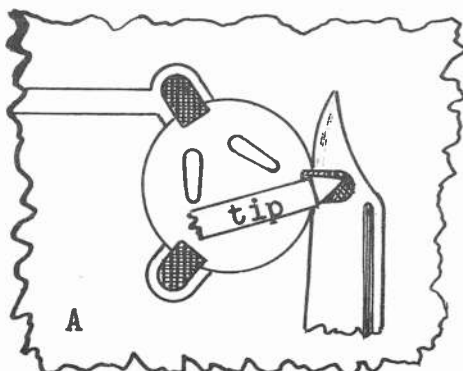

Place the iron tip on top of the folded over mounting ear. As the solder melts, slip a thin knife between the mounting ear and the copper conductor pad. DO NOT PRY THE TAB UP WITH THE KNIFE! See (4-B) for bending ears away from chassis. When the knife is completely under the ear, remove iron and let the solder cool.

Repeat on other two mounting ears.

4. (continued)

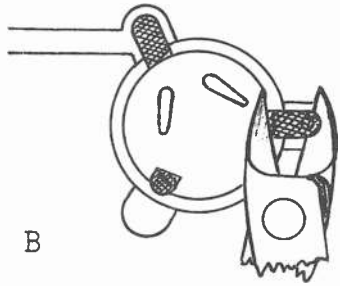

Using a pair of small sharp diagonal cutters, bend the mounting ears up and away from the copper conductor pads. DO NOT PRY THE MOUNTING EARS UP WITH A KNIFE OR SCREWDRIVER!

Repeat the process on the other two mounting ears and drop the capacitor off the board.

5. PREPARING THE HOLES FOR THE REPLACEMENT COMPONENT:

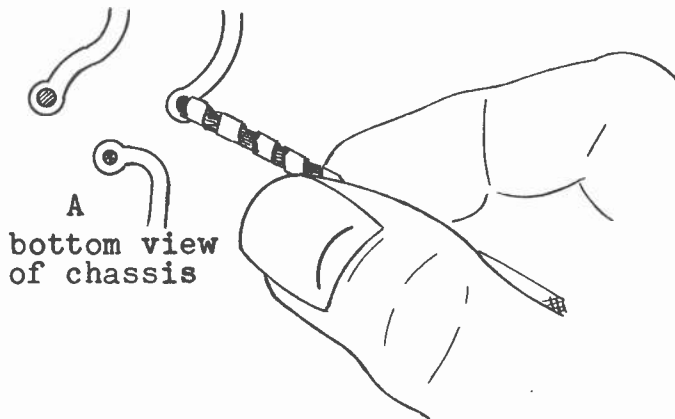

Use a small metal twist drill (1/8" dia. or less) to clear the hole only in the fillet of solder. Twirl the drill by hand. Do not attempt to remove all of the solder in one turn, do it slowly and carefully.

Do not attempt to increase the hole size, just remove the solder. It is soft and easily removed in this way.

6. REPLACING THE COMPONENTS:

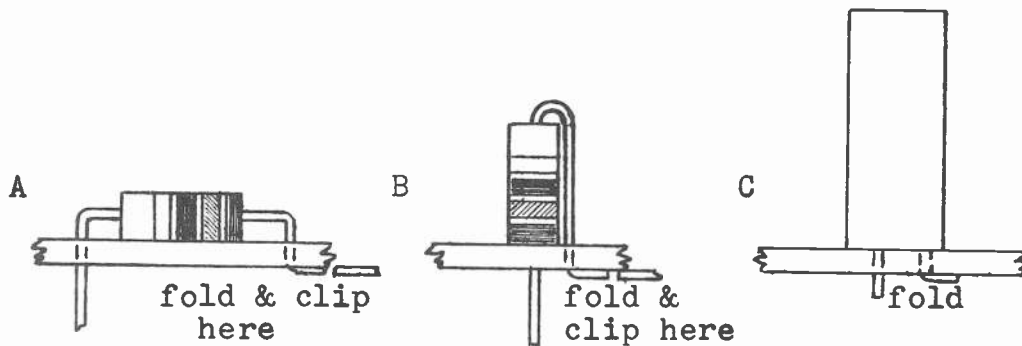

(A) & (B) Fold the leads on the new part to the same spacing as the mounting holes. Insert the part and fold the leads under the chassis to hold the part tightly against the top of the chassis. Clip off the excess wire.

Put the iron tip on the fillet and lead. Solder swiftly and securely. If the printed chassis is damaged by accident it is seldom necessary to scrap it. If one of the conductors is broken, lay a piece of small wire (#18 to #24 AWG) across the break and solder each end to the conductor. If a fillet is pulled loose, break it off to get rid of the loose end. Fold the new component lead toward the end of the conductor and solder the lead to the conductor. If the component lead is cut too short, lay a small piece of wire across the gap solder it in.

## 7. REPLACING TUBE SOCKETS:

Tube sockets are very difficult to replace and should not be replaced until you are positive that the one in question is actually defective. Resolder all of the socket pin fillets to assure that this is not the trouble. Inspect the top side to see if the tube pin sleeve is bent and can be straightened. Use a socket alignment tool to re-size. Check continuity from the top to the bottom side of the chassis. If there is a connection and the socket sleeve is not out of alignment or spread open, the socket is O.K. and should not be removed.

(A) If the socket has been damaged or is excessively corroded it must be replaced. Stand the unit so that the chassis is vertical. Hold a small iron to the hex nut in the center of the socket (if the socket is retained in this manner). After the solder has melted, unscrew the retaining screw.

(B) Remove the excess solder from all pin fillets by carrying it away with the tip of the iron. Repeat until all solder that will come loose is removed. Do not hold the iron to the chassis for long periods of time.

(C) Starting at pin 1 or pin 7 (8 or 9 on other sockets), apply the iron and push against the socket to raise it at this point. Use the thumb and fingers only to raise socket to prevent damage to the board. The socket will not move very much but any movement at all is helping. Place the iron on each pin in rotation around the socket while pushing up on the side of the socket adjacent to the pin being heated. After several passes around the socket it will no longer be held in by solder. Gently rock the socket and pull it free of the holes.

(D) Use a small metal twist drill as illustrated in paragraph 5 of these instructions to clear the fillet holes of solder.

(E) Install the new socket and put in a new retaining screw similar to the one removed (if retaining screws are used). Do not tighten the nut excessively and put a great strain on the phenolic board.

(F) Solder the screw, nut and each socket pin fillet swiftly and securely. Be sure that there is no solder bridging between adjacent fillets or conductors.

(G) If one of the fillets was damaged in the replacement operation, form a small loop on the end of a small piece of wire. Drop the loop over the socket pin and lay the wire to join the proper conductor. Flow solder on the connections and clip off the excess wire.

From the Engineering Department of  
The Gates Radio Company  
A Subsidiary of the Harris-Intertype Corp.