

HARRIS

Broadcast Equipment Catalog

For HARRIS Equipment
Call Marvin Bredemeier
505 - 293-4707

FOREWORD

Harris Corporation, Broadcast Group, presents a Short Form Catalog. Our latest all-products catalog features television and radio transmitting equipment, audio and video studio products, program and broadcast microwave equipment. The comprehensive product line represented on these pages meets virtually every requirement of the television and radio broadcaster.

The Harris sales network and service facilities are extensive. International market activities are coordinated by the International Sales Department in Quincy, Illinois with representatives located throughout the world.

Among the nation's 500 largest corporations, Harris is a world leader in the communications industry. Two separate operating arms of the Broadcast Group produce specialized products for the broadcaster. Harris Video Systems, located in Sunnyvale, California, manufactures an extensive line of digital video products. Harris Broadcast Microwave Operation, Mountain View, California, manufactures ENG receivers, miniature portable microwave receivers and transmitters.

Drawing on the considerable resources of research centers within Harris, the Broadcast Group has ready access to a large staff of professional scientists and engineers, in addition to maintaining an impressive engineering and service organization in Quincy.

Harris' reputation stands on the products in this catalog. Harris values your patronage, and will strive for continued excellence in product design and execution, in an innovative posture that fosters the advancement of the broadcast industry.



HARRIS

MEDIUM WAVE BROADCAST TRANSMITTER



HARRIS

P.O. Box 4290
Quincy, IL 62305-4290
(217) 222-8200

VP-100A 100,000 Watt Medium Wave Broadcast Transmitter

- Overall efficiency better than 65%
- Exclusive Pulse Duration Modulator (PDM)* for high level plate modulation
- Redundancy in solid state circuits
- Vapor phase cooling for quiet operation and extended tube life
- Only five tubes, with three tube types
- Designed for a wide climate range

Featuring Harris' exclusive high level Pulse Duration Modulator*, the VP-100A provides the finest performance of any medium wave broadcast transmitter in the same power range on the market today ...at significantly lower operating costs.

EFFICIENCY EXCEEDS 65%. The VP-100A has an unusually high overall efficiency of more than 65%. This is made possible by the almost 90% efficiency of the Pulse Duration Modulator—and means about one-third less power consumption than other high level plate modulated 100 kilowatt transmitters.

HIGH AVERAGE MODULATION CAPABILITY. The transmitter is capable of sustained high average modulation such as that experienced with trapezoidal audio processing—which means greater loudness at the receiver without increased transmitter carrier power. This is a feature of the high efficiency, DC coupled PDM modulator that avoids the use of large, inefficient transformers in the modulation process. Another feature of this high efficiency series type modulator is convenient front panel carrier power adjustment over a wide range.

ONLY FIVE TUBES. The entire transmitter employs just five tubes—with a modern ceramic 4CV100,000C power tetrode in the modulator and final RF power amplifier sockets. All power supplies utilize long-life solid state silicon rectifiers. High quality components, conservatively rated, are used throughout the VP-100A to assure greatest reliability.

VAPOR PHASE COOLING. Cooling by the Vapor Phase method produces quiet operation by eliminating the need for large blowers—the heat exchanger is cooled by a two horsepower blower. This method of cooling also extends tube life by helping to eliminate "hot spots" and by maintaining tube anode temperatures far below those attained by other methods.

DESIGNED FOR WIDE RANGE OF CLIMATES. The transmitter will give top performance in a wide range of climates—from hot and humid, to dry and dusty. With Vapor Phase cooling, ducting outside air into the transmitter is not necessary. All transformers and similar components are hermetically sealed, encased, or vacuum impregnated. All high power radio frequency networks contain silver-plated inductors and vacuum capacitors.

GREATLY REDUCED FLOOR SPACE. Due to the high efficiency of the transmitter and the elimination of large iron core components (no modulation transformer and reactor), the VP-100A requires only 7.0 square meters (76 square feet) of floor space. Careful cabinet design provides easy accessibility to all components.

*U.S. Patent

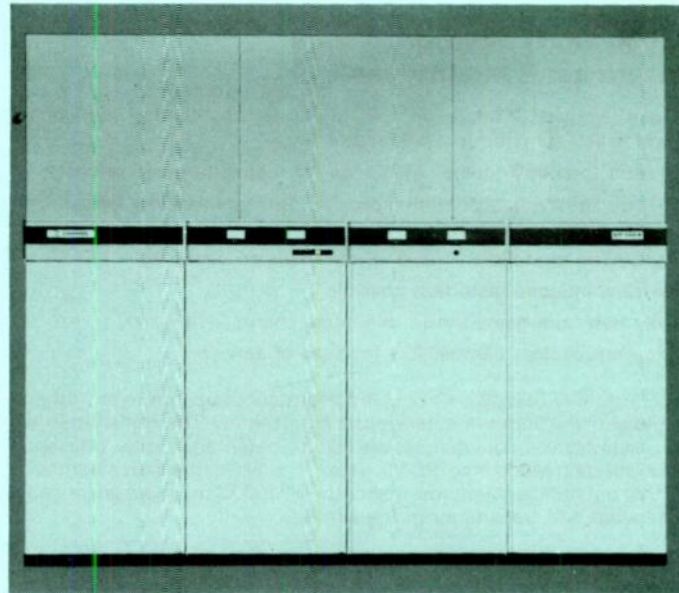

VP-100A Specifications

POWER OUTPUT: 100,000 watts nominal unmodulated, capable 110,000 watts.

RF FREQUENCY RANGE: 535 kHz to 1620 kHz.

RF OUTPUT IMPEDANCE: 230 ohms, unbalanced.

RF FREQUENCY STABILITY: ± 5 Hz.

SPURIOUS AND HARMONIC EMISSION: Less than 50 mW.

CARRIER SHIFT: Less than 5% at 100% modulation at 1,000 Hz.

AUDIO FREQUENCY RESPONSE: ± 1.5 dB from 40 to 10,000 Hz referenced to 1,000 Hz at 95% modulation.

AUDIO FREQUENCY DISTORTION: Less than 3% from 40 to 10,000 Hz at 95% modulation.

NOISE: 55 dB below 100% modulation at 1,000 Hz.

AUDIO INPUT LEVEL: 10 dBm ± 2 dB for 100% modulation.

AUDIO INPUT IMPEDANCE: 600/150 ohms, balanced or unbalanced.

MODULATION LEVEL: 100% sinusoidal, 10 minutes, 50 to 5,000 Hz.

TRAPEZOIDAL MODULATION: Less than 5% tilt or overshoot, 100 Hz to 2,000 Hz.

POWER INPUT: Any specified voltage 380V to 480V, 3 phase, 50 or 60 Hz.

POWER CONSUMPTION: 155 kW—No modulation

160 kW—30% modulation

215 kW—100% modulation

POWER FACTOR: 95%.

VOLTAGE REGULATOR: Electronic voltage regulation for all power supplies other than high voltage.

OVERALL EFFICIENCY: 65% at average modulation.

TUBES: Two 4CV100,000C; two 4CX1500A; one 2CX10,000F.

TEMPERATURE RANGE: 0-50°C ambient air temperature.

HUMIDITY: 95% relative humidity, maximum.

STORAGE TEMPERATURE: -35°C to +60°C (with no water in system)

ALTITUDE: Up to 1,829 meters (6,000 feet) above sea level.

CABINET DATA: Each of two cabinets measures 1.83 meters (6 feet) wide, 1.37 meters (4.5 feet) deep, and 1.98 meters (6.5 feet) high. The heat exchanger adds another 1.06 meters (3.5 feet) in height.

Ordering Information

VP-100A, 100,000 watt medium wave transmitter with one set of tubes, crystals and silicon rectifiers, for operation from 380 to 480 volts, 3 phase, 50 or 60 Hz 994-7651-001

Prices and Specifications Subject to Change Without Notice.



HARRIS

P.O. Box 4290
Quincy, IL 62305-4290
(217) 222-8200

MEDIUM WAVE BROADCAST TRANSMITTER

MW-50C

50,000 Watt Medium Wave Broadcast Transmitter

- Pulse Duration Modulation* (PDM) eliminates costly, inefficient modulation transformer and reactor
- Greater than 60% overall efficiency for reduced operating costs
- DC coupled modulator section provides unsurpassed low frequency square wave performance
- Automatic modulation tracking minimizes adjustments
- No slew induced distortion possible
- Only two tube types used...minimizes spares inventory
- Excellent cabinet accessibility for ease of service

The Harris MW-50C delivers overall performance superior to any other 50 kilowatt medium wave broadcast transmitter. The transmitter is high level plate modulated, using Harris' patented, highly efficient Pulse Duration Modulator (PDM). This, in combination with a number of other outstanding features, makes the MW-50C the most advanced 50 kilowatt AM transmitter in the world.

Specifications

Power Output:	50,000 watts (rated), 60,000 watts (capable). Convenient power reduction through 10,000 watts.
RF Frequency Range:	535 kHz to 1620 kHz, supplied to frequency as ordered.
RF Output Impedance:	50 ohms unbalanced (higher on special order).
RF Output Terminal:	3-1/8" EIA 50 ohm flange.
RF Frequency Stability:	± 10 Hz.
RF Harmonics And Spurious Emissions:	Exceeds FCC and CCIR specifications.
Carrier Amplitude Regulation:	Less than 2% at 100% modulation (measured at 1000 Hz).
Audio Intermodulation Distortion:	3.0% or less, 60/7000 Hz 4:1, SMPTE standard at 55 kW operation at 50% modulation.
Audio Frequency Response:	± 1.0 dB, from 20 to 12,500 Hz referenced to 1,000 Hz at 95% modulation at 55 kW with Besel filter out.
Squarewave Overshoot:	Less than 3.0% using 1000 Hz 6 dB clipped sinewave at 90% modulation.
Total Harmonic Distortion (Unenhanced)¹:	Less than 2.5%, 20 to 10,000 Hz at 95% modulation at 55 kW. 3% at 25 to 10 kW.
Squarewave Tilt:	Less than 8% at 20 Hz at 60% modulation.
Compression Ratio:	4/1 dB at 3 dB of enhancement; -95%, +125% modulation.
Positive Peak Capability:	+125% with program modulation at 55 kW.
Noise (Unweighted)²:	-60dB or better below 100% modulation. Typical -62 dB.
AM Stereo Operation:	Incidental Quadrature Modulation (IQM) is down 25 dB or better at 95% modulation.
Audio Input:	600 ohms at 0 to +10 dBm for 100% modulation, unenhanced; +16 dBm with enhancement activated.
Power Input:	480V ± 5%, 3 phase, 60 Hz. Available for 380V ± 5%, 3 phase, 50 Hz.
Power Consumption³:	80 kW at 0% modulation; 87 kW at 30% modulation; 110 kW at 100% modulation.

*Patented

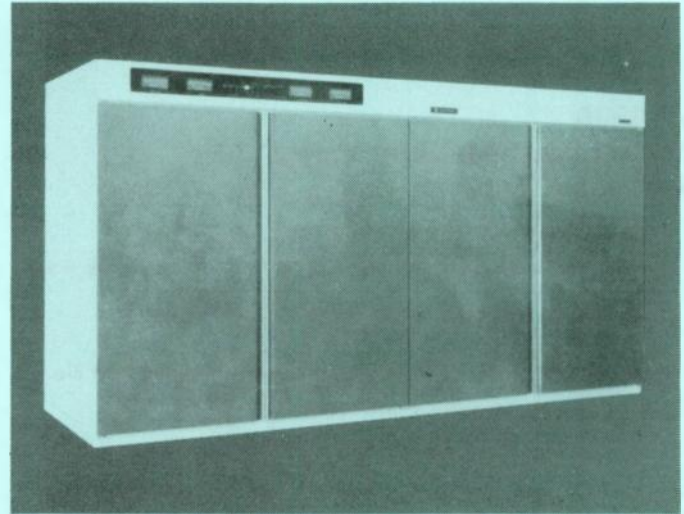

Overall Efficiency:	Better than 60% at average modulation.
Power Factor:	95%.
Tubes Used:	(2) 4CX35,000C; (2) 4CX1500A.
Monitor Provision:	An unmodulated sample is provided for freq monitor and a modulated sample for modulation monitoring.
Remote Control:	Self-contained interface for extended or remote control.
Air Flow:	5200 CFM total by internal blowers.
Operating Acoustical Noise:	Better than 70 dBA acoustic rating 3 ft. from front of transmitter.
Temperature Range⁴:	-20°C to +50°C.
Humidity:	95%.
Altitude:	Up to 3,048 meters (10,000 feet) above sea level. Higher on special order.
Size⁵:	78"H x 144"W x 48"D (2.0 x 3.7 x 1.2m) (transmitter cabinet). External components include high voltage power supply and wall mounted circuit breaker assembly.
Floor Space:	Main transmitter assembly 48 square feet (4.5 square meters). Power supply 15 square feet (1.4 square meters).
Weight (Approx.):	
Main Transmitter Assembly:	Net unpacked 5,000 lbs. (2268 kg). Domestic packed 6,000 lbs. (2722 kg). Export packed 7,200 lbs. (3266 kg).
Power Supply:	Net unpacked 1,370 lbs. (622 kg). Domestic packed 1,500 lbs. (681 kg). Export packed 1,800 lbs. (817 kg).

1. If transmitter is operated into a bandwidth limited antenna system, distortion at the higher modulation frequencies may degrade.
2. Noise measured over the band 20 Hz to 20 kHz, with line to line voltages of the supply line balanced. Noise may degrade with line voltage unbalance.
3. Typical power consumption figures are for 50 kilowatts output and for optimum transmitter adjustment. For higher output powers and/or transmitter misadjustments, power consumption may be higher.
4. Maximum operating temperature derates linearly to +29°C (84.2°F) at 10,000 feet AMSL (3048 meters).
5. Does not include height of output connector, which may be removed for transport.

Ordering Information

MW-50C, with one set of tubes and 2 crystals, 60 Hz . . . 994-8832-001
 MW-50C, with one set of tubes and 2 crystals, 50 Hz . . . 994-8832-002
 Recommended spare parts kit for MW-50C transmitter . . . 994-8909-001

Prices and Specifications Subject to Change Without Notice.

MEDIUM WAVE BROADCAST TRANSMITTER

HARRIS
P.O. Box 4290
Quincy, IL 62305-4290
(217) 222-8200

MW-10B 10,000 Watt Medium Wave Broadcast Transmitter

- Pulse Duration Modulation* (PDM) eliminates costly, inefficient modulation transformer and reactor
- Unsurpassed low frequency square wave performance
- Automatic modulation tracking minimizes adjustments
- No significant overshoot...yielding maximum modulation capability
- No Slew Induced Distortion possible
- High modulator and PA efficiency yields low power consumption
- Only two tube types
- Produces faithful transmission of today's demanding formats in a cost effective manner

The Harris MW-10B delivers overall performance superior to any other 10 kilowatt medium wave broadcast transmitter. The transmitter is high level plate modulated, using Harris' patented, highly efficient Pulse Duration Modulator (PDM). This, in combination with a number of other outstanding features, makes the MW-10B the most advanced 10 kilowatt AM transmitter in the world.

Specifications

Power Output:	(Rated) 10,000 watts. (Capable) 11,000 watts. FCC type accepted at 10,000, 5000, 2500 and 1000 watts.
Modulation Method:	Pulse Duration Modulation.
Carrier Shift:	(At 95% modulation with 400 Hz tone) 2% or less.
Audio Input:	(For 95% modulation) +10 dBm, ± 2 dB.
Audio Input Impedance:	600 ohms balanced.
Audio Frequency Response:	± 1 dB, 20 to 10,000 Hz. (Response referred to 1 kHz, 95% modulation, with modulations at other frequencies held to same percentage. Response may degrade at higher modulating frequencies if transmitter is operated into a bandwidth limited antenna system.)
THD Distortion¹:	2% or less at 95% modulation, 20 to 10,000 Hz unenhanced.
RF Harmonics:	Meets or exceeds FCC and CCIR requirements.
Spurious Output:	-80 dB or better.
RF Frequency Range:	535 to 1605 kHz. Supplied to one frequency as ordered.
RF Output Impedance:	50 ohms, unbalanced. Other output impedances available on special order.
RF Output Connector:	1-5/8" male EIA flange. Other types of output connectors available on special order.
Maximum VSWR:	1.3 to 1.
Noise²:	Unweighted, 60 dB below 100% modulation. Weighted (CCIR Rec. 468-1), 70 dB below 100% modulation.
Positive Peak Capability:	125% at 11 kW output, when modulated with processed program type material.
Negative Peak Capability:	95%.
Frequency Stability:	± 20 Hz or less over operating temperature range.
Supply Voltage:	200/500 volts, 3 phase, 60 Hz, closed delta/wye or 350/430 volts, 3 phase, 50 Hz, 4 wire wye.
Line Voltage Regulation And Variation:	5% maximum.
Line Voltage Unbalance²:	4% maximum.

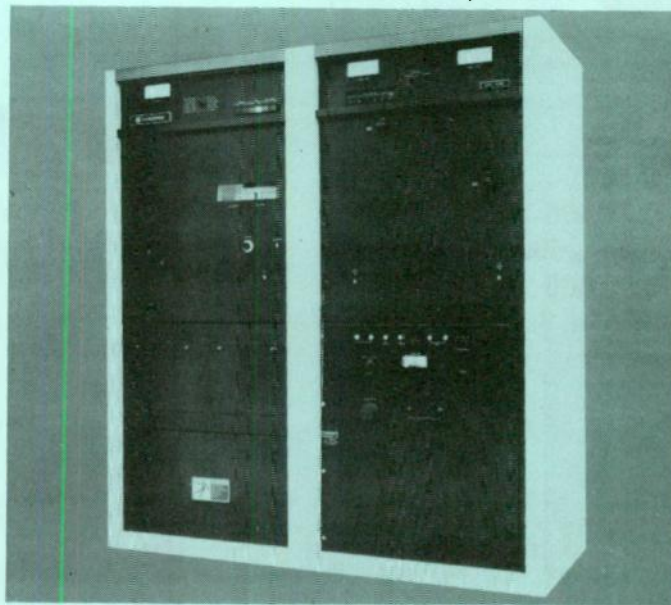

Power Consumption (10 kW Carrier)³:	(Typical) 20.5 kW, 0% modulation; 22.1 kW, 50% tone modulation; 28.0 kW, 100% tone modulation. (Maximum) 22.1 kW, 0% modulation; 24.3 kW, 50% tone modulation; 30.8 kW, 100% tone modulation.
Power Factor:	95% or better.
Ambient Temperature Range⁴:	-20° to +50°C (-4° to +122°F) at sea level. Decreases 3.5° per 1,000 feet of altitude (84°F at 10,000 feet).
Maximum Relative Humidity:	95%.
Maximum Altitude For Full Power Rating:	10,000 feet AMSL (3048 meters). Transmitters for operation above 10,000 feet AMSL require special order.
Size⁵:	78" H x 72" W x 32" D (198 x 183 x 81.3cm)
Weight:	Unpacked, 1500 lbs. (680.4 kg) approx. Domestic packed, 1900 lbs. (861.8 kg) approx. Export packed, 2150 lbs. (975.2 kg) approx.
Cubage:	120 cu. ft. (3.4 cu. meters) packed, approx.
Finish:	Blue, white and black.
Tubes Used:	(1) 3CX15,000H3 and (1) 4CX15,000A.
Remote Control:	Normal terminal board interface.

1. Distortion measured at 95% modulation, or less, down to 25%. If transmitter is operated into a bandwidth limited antenna system, distortion at the higher modulating frequencies may degrade.
2. Noise measured over the band 20 Hz to 20 kHz, with line to line voltages of the supply line balanced. Noise may degrade to 56 dB below 100% modulation with line voltage unbalance not exceeding 4%.
3. Typical power consumption figures are for 10 kilowatts output and for optimum transmitter adjustment. For higher output powers and/or transmitter misadjustments, power consumption may be higher.
4. Maximum operating temperature derates linearly to +29°C (84.2°F) at 10,000 feet AMSL (3048 meters).
5. Does not include height of output connector, which may be removed for transport.

Ordering Information

MW-10B Transmitter with one set of operating tubes and two crystals, for 200-250 Volts or 350-430 Volts, 3 phase, 60 Hz operation 994-8624-004
MW-10B Transmitter with one set of operating tubes and two crystals, for 200-250 Volts or 350-430 Volts, 3 phase, 50 Hz operation 994-8624-006
Recommended spare semiconductor kit 990-1018-001
 Low voltage and filament voltage regulator, and line voltage regulator for MW-10B available. *Patented

Prices and Specifications Subject to Change Without Notice.

MEDIUM WAVE BROADCAST TRANSMITTER

SX-1 1000 Watt
SX-2.5 2500 Watt
SX-5 5000 Watt
All Solid-State Medium Wave
Broadcast Transmitters

FEATURES

- 100% solid-state for highest reliability
- Exceptionally high operating efficiency offers direct power cost savings over other designs
- New concept dual microprocessor control and status monitoring simplifies operation and service
- Flat-Pass output network for exceptional phase and amplitude linearity
- Designed for stereo operation (optional)
- Unique air handling system lowers maintenance time

The entire SX Series of solid-state AM transmitters are based on a rigid design philosophy. Central to this concept are the commitments to achieve:

- The highest possible audio performance
- The highest possible overall efficiency
- Maximum reliability
- Optimum stereo performance

The SX Series broadcast transmitters are in a class by themselves. They are computer designed and computer tested, with their own self-contained dual status and control computers. The SX Series are 100% solid-state and not affected by loss of emission, shorted elements or other problems found in tube type transmitters.

EASE OF INSTALLATION AND SERVICE

The SX Series arrive ready for installation. Included is a wall mounted AC disconnect panel designed to interface with the station's electrical distribution system. Installation is essentially positioning the SX Series transmitter and making final AC, RF and audio connections. No special air handling systems are required.

TODAY'S TRANSMITTER FOR TODAY'S BROADCASTER

Exceptionally high overall efficiency; maximum reliability; improved audio performance; full service microprocessor control and status monitoring; readiness for AM Stereo, these are just a few of the features in the SX broadcast transmitter. Never before has Harris incorporated as many benefits in today's transmitter for today's broadcaster, with an advanced design to ensure years of reliable operation.

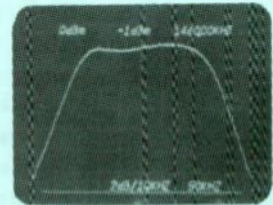
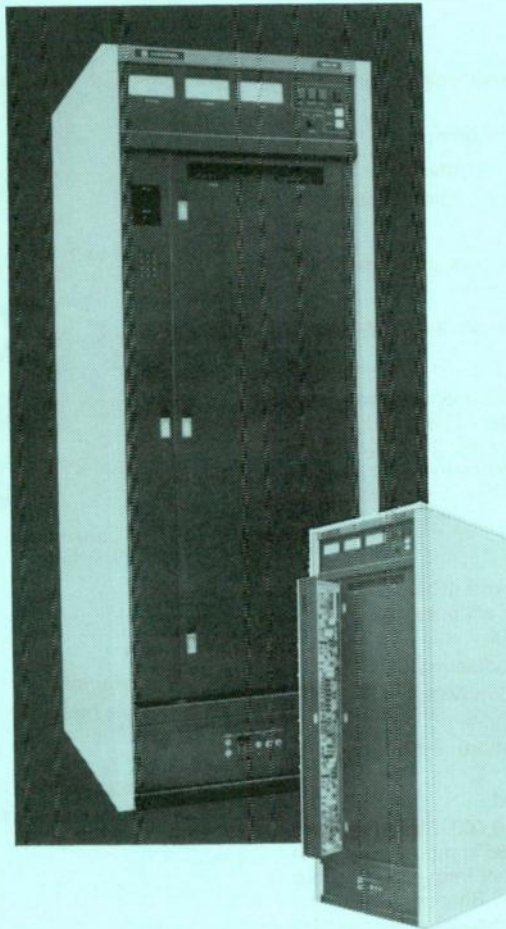

Spectrum analyzer response of Flat-Pass output network maximizes mono and stereo performance.

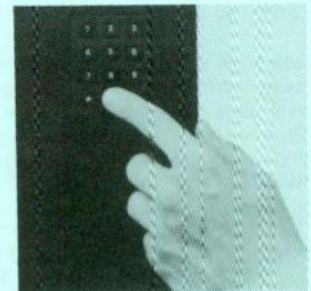

The SX Series transmitters brings a wealth of diagnostic information to your fingertips through the microprocessor keypad located on the front panel.

Low level plug-in circuit boards are conveniently housed on a vertical slide-out drawer for easy maintenance.

ORDERING INFORMATION

SX-1 TRANSMITTER, complete with all solid-state devices, crystal oscillator, technical manual.	
Specify frequency	994-8581-001
SX-1 Transmitter, complete with all solid-state devices, frequency synthesizer, technical manual.	
Specify frequency	994-8581-003
Recommended spare semiconductor kit	990-1012-001
Spare crystal	444-XXXX-000
Ancillary Equipment	
AM-90 modulation monitor	994-8424-001
Potomac AT-51 test set	700-0499-000
SX-2.5 TRANSMITTER, complete with all solid-state devices, crystal oscillator, technical manual.	
Specify frequency	994-8582-001
SX-2.5 Transmitter, complete with all solid-state devices, frequency synthesizer, technical manual.	
Specify frequency	994-8582-003
Recommended spare semiconductor kit	990-1013-001
Spare crystal	444-XXXX-000
Ancillary Equipment	
AM-90 modulation monitor	994-8424-001
Potomac AT-51 test set	700-0499-000
SX-5 TRANSMITTER, complete with all solid-state devices, crystal oscillator, technical manual.	
Specify frequency	994-8583-001
SX-5 Transmitter, complete with all solid-state devices, frequency synthesizer, technical manual.	
Specify frequency	994-8583-003
Recommended spare semiconductor kit	990-1014-001
Spare crystal	444-XXXX-000
Ancillary Equipment	
AM-90 modulation monitor	994-8424-001
Potomac AT-51 test set	700-0499-000



HARRIS

P.O. Box 4290
Quincy, IL 62305-4290
(217) 222-8200

SX-1 SPECIFICATIONS

Power Output: (Rated 1000 watts. (Capable) 1100 watts. Power reduction through 100 watts.

RF Frequency Range: 535 kHz through 1620 kHz. Supplied to one frequency as ordered.

Carrier Frequency Stability: A) Crystal Oscillator — ± 20 Hz over temperature range. B) Frequency Synthesizer (optional) — ± 10 Hz over temperature range.

RF Output Impedance: 50 ohms unbalanced. Will match into a VSWR of 1.5:1 at carrier.

RF Output Terminal: Female N connector.

Carrier Amplitude Variation: (Carrier Shift): Less than 2% at 100% modulation at 1000 Hz.

RF Harmonics: Exceeds FCC and CCIR specifications.

Type Of Modulator: Patented Polyphase PDM.

Audio Frequency Response: +0.5 dB, -1.5 dB from 20 to 12,500 Hz at 95% modulation with Bessel filter out, ref. 1000 Hz.

Audio Harmonic Distortion: 95% modulation, 20 Hz to 12.5 kHz: 1% or less at 1 kW; 1.5% or less at 500W; 2.0% or less at 250W; 3.0% or less at 100W.

Audio Intermodulation Distortion: 95% modulation, 60/7000 Hz, 1:1 or 4:1 ratio: 1.5% or less at 1 kW; 1.5% or less at 500W; 2% or less at 250W; 3% or less at 100W.

Squarewave Overshoot: 5% or less at 400 Hz and 90% modulation with Bessel filter.

Squarewave Tilt: 5% or less at 20 Hz at 90% modulation.

Noise (Unweighted): Better than 60 dB below 100% modulation.

Positive Peak Capability: 125% positive peak program modulation capability at 1.1 kW.

AM Stereo Specifications: Incidental phase: 0.2 radian average IPM at 95% envelope modulation at 1 kHz; 0.5 peak radians.

Audio Input: -10 to +10 dBm (adjustable) transformerless, 600 ohms balanced.

AC Voltage Input: 197-251 VAC, 48 to 63 Hz, single phase. $\pm 5\%$ from nominal line voltage to maintain full performance.

PA Efficiency: 85% or better.

Overall Efficiency: 535-1200 kHz, 66% $\pm 2\%$; 1200-1620 kHz, 70% $\pm 2\%$.

Power Consumption ¹: 1.5 kW at 0% modulation at 1000 watts. 2.2 kW at 100% tone modulation at 1000 watts carrier. 1.9 kW under average programming conditions.

Spurious Output: Exceeds FCC and CCIR requirements.

Monitor Provisions: 10 volts RF (RMS) modulated output sample at 50 ohms (High/Medium/Low) power.

Remote Control: Self-contained interface for most remote control or facility control systems.

Ambient Temperature Range: -20°C to +50°C (derate upper limit 2°C per 1000 feet altitude).

Ambient Humidity Range: To 95% non condensing.

Air Flow: Free convection.

Altitude: Sea Level to 13,000 feet (4000 meters).

Operating Acoustical Noise: Better than 45 dBA.

Size: 72"H x 28"W x 30"D (1830 x 712 x 762 mm).

Weight: (Unpacked), 400 lbs. (181 kg) — approximate. Domestic packed, 600 lbs. (275 kg) — approximate. Export packed, 700 lbs. (320 kg) — approximate.

Cubage: 68.7 cubic feet (2 cubic meters) packed.

Colors: Black and white.

Type Of Active Components: 100% solid state.

Power Supply: Self-contained, dry.

¹A/C Mains requirements of 3.5 kVA with a minimum of 5% voltage regulation.

Note: The above audio performance may be degraded should the transmitter be operated into a bandwidth restricted antenna system.

SX-2.5 SPECIFICATIONS

Power Output: (Rated) 2500 watts. (Capable) 2750 watts. Power reduction through 250 watts.

RF Frequency Range: 531 kHz through 1620 kHz. Supplied to one frequency as ordered.

Carrier Frequency Stability: A) Crystal Oscillator: ± 20 Hz over temperature range. B) Frequency Synthesizer (optional): ± 10 Hz over temperature range.

RF Output Impedance: 50 ohms unbalanced. Will match into a VSWR of 1.5:1 at carrier.

RF Output Terminal: 7/8" EIA male flange connector.

Carrier Amplitude Variation: (Carrier Shift): Less than 2% at 100% modulation at 1000 Hz.

RF Harmonics And Spurious Emissions: Exceeds FCC and CCIR specifications.

Type Of Modulator: Patented Polyphase PDM.

Audio Frequency Response: +0.5 dB, -1.5 dB from 20 to 12,500 Hz at 95% modulation with Bessel filter out, ref. 1000 Hz.

Audio Harmonic Distortion: At 95% modulation: 1.0% or less at 2.5 kW, 20 to 12,500 Hz; 1.5% or less at 1000 watt operation, 20 to 12,500 Hz; 3% or less at 250 W, 20 to 12,500 Hz.

Audio Intermodulation Distortion: 2.0% or less at 2.5 kW, 60/7000 Hz 4:1, SMPTE standards at 80% modulation.

Squarewave Overshoot: Less than 5% at 400 Hz at 90% modulation with Bessel filter.

Squarewave Tilt: Less than 5% at 20 Hz at 90% modulation.

Noise (Unweighted): Better than 60 dB below 100% modulation.

Positive Peak Capability: 125% positive peak program modulation capability at 2750 watts.

AM Stereo Specifications: Incidental Quadrature Modulation (IQM): Better than 24 dB below 95% modulation of L + R channel at 1 kHz.

Audio Input: -10 to +10 dBm, transformerless 600 ohms balanced, continuously adjustable.

AC Voltage Input: 197-251 VAC, 48 to 63 Hz, single phase.

Overall Efficiency: 65% or better at 2500 W.

Power Consumption ¹: 3.85 kW at 0% modulation at 2500 watts. 5.8 kW at 100% tone modulation at 2500 watts carrier. 5.4 kW under average programming conditions.

Monitor Provisions: 10 volts RF (RMS) modulated output sample at 50 ohms (High/Medium/Low) power.

Remote Control: Self-contained interface for most remote control or facility control systems.

Ambient Temperature Range: -20°C to +50°C AMSL (derate upper limit 2°C per 1000 feet altitude).

Ambient Humidity Range: To 95% non condensing.

Air Flow: 250 CFM fan.

Altitude: Sea Level to 13,000 feet (4000 meters).

Operating Acoustical Noise: Better than 64 dBA acoustic rating, 3 feet from transmitter.

Size: 72"H x 28"W x 30"D (1830 x 712 x 762 mm).

Weight: (Unpacked), 450 lbs. (204 kg) — approximate. Domestic packed, 650 lbs. (298 kg) — approximate. Export packed, 750 lbs. (343 kg) — approximate.

Cubage: 68.7 cubic feet (2 cubic meters) packed.

Colors: Black and white.

Type Of Active Components: 100% solid-state.

Power Supply: Self-contained, dry.

¹For AC service connection, please provide 8.2 KVA with a minimum of 5% voltage demand regulation.

Note: The above audio performance may be degraded should the transmitter be operated into a bandwidth restricted antenna system. Also, all specifications are referenced to operation at 2500 watts except when noted.

SX-5 SPECIFICATIONS

Power Output: (Rated) 5000 watts. (Capable) 5600 watts. Power reduction through 500 watts.

RF Frequency Range: 531 kHz through 1620 kHz. Supplied to one frequency as ordered.

Carrier Frequency Stability: A) Crystal Oscillator — ± 20 Hz over temperature range. B) Frequency Synthesizer (optional) — ± 10 Hz over temperature range.

RF Output Impedance: 50 ohms unbalanced. Will match into a VSWR of 1.5:1 at carrier.

RF Output Terminal: 7/8" EIA male flange connector.

Carrier Amplitude Variation: (Carrier Shift): Less than 2% at 100% modulation at 1000 Hz.

RF Harmonics And Spurious Emissions: Exceeds FCC and CCIR specifications.

Type Of Modulator: Patented Polyphase PDM.

Audio Frequency Response: +0.5 dB, -1.5 dB from 20 to 12,500 Hz. Reference 1000 Hz with Bessel filter out.

Audio Harmonic Distortion: 1.5% or less at 5 kW, 20 to 12,500 Hz at 95% modulation. 2% or less at 1000 watts operation, 20 to 12,500 Hz at 95% modulation. 3% or less at 500 watts, 20 to 12,500 Hz at 95% modulation.

Audio Intermodulation Distortion: 1.0% or less, 60/7000 Hz 1:1, 2% or less, 60/7000 Hz 4:1, SMPTE standards at 5 kW operation at 95% modulation.

Squarewave Overshoot: Less than 5% at 400 Hz.

Squarewave Tilt: Less than 5% at 20 Hz at 90% modulation.

Noise (Unweighted): Better than 60 dB below 100% modulation, 1000 Hz at 5 kW.

Positive Peak Capability: 125% positive peak program modulation capability at 5600 watts.

AM Stereo Specifications: Incidental Phase: 0.2 Average (Radians) at 95% Envelope Modulation at 1 kHz; 0.5 Peak (Radians).

Audio Input: -10 to +10 dBm, transformerless 600 ohms balanced, continuously adjustable.

AC Voltage Input: 197-251 VAC, 48 to 63 Hz, three phase, 3 wire or 341 to 434 VAC, three phase, 4 wire, 48 to 63 Hz, +5% from nominal line voltage to maintain full performance.

Overall Efficiency: Better than 65%.

Power Consumption ¹: 7.7 kW at 0% modulation at 5000 watts. 11.6 kW at 100% tone modulation at 5000 watts carrier. 10.4 kW under average programming conditions.

Monitor Provisions: 10 volts RF (RMS) modulated output sample at 50 ohms (High/Medium/Low) power.

Remote Control: Self-contained interface for most remote control or facility control systems.

Ambient Temperature Range: -20°C to +50°C AMSL (derate upper limit 2°C per 1000 feet altitude).

Ambient Humidity Range: To 95% non condensing.

Air Flow: 500 CFM fan.

Altitude: Sea Level to 13,000 feet (4000 meters).

Operating Acoustical Noise: Better than 64 dBA acoustic rating, 3 feet from transmitter.

Size: 72"H x 28"W x 30"D (1830 x 712 x 762 mm).

Weight: (Unpacked), 500 lbs. (230 kg) — approximate. Domestic packed, 700 lbs. (320 kg) — approximate. Export packed, 800 lbs. (370 kg) — approximate.

Cubage: 68.7 cubic feet (2 cubic meters) packed.

Colors: Black and white.

Type Of Active Components: 100% solid-state.

Power Supply: Self-contained, dry.

¹For AC service connection, please provide 14 KVA with a minimum of 5% voltage demand regulation.

Note: The above specifications apply to operation at 5 kW except where noted. Furthermore, the above audio performance may be degraded should the transmitter be operated into a bandwidth restricted antenna system.

Harris Maintains A Policy Of Continuous Improvement On Its Equipment And Therefore Reserves The Right To Change Specifications Without Notice.

Prices and Specifications Subject to Change Without Notice.

MEDIUM WAVE MODULATION/ FREQUENCY MONITORS

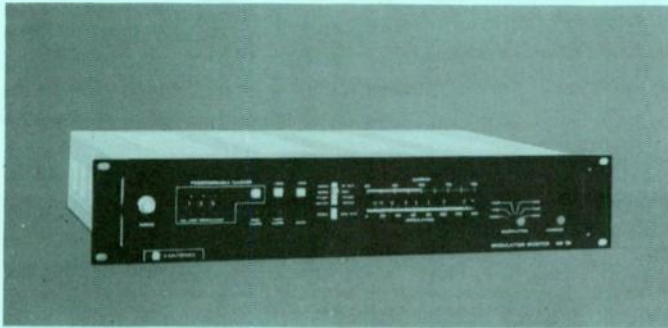

AM-90 Medium Wave Modulation Monitor

The new Harris AM-90 Modulation Monitor is designed for continuous monitoring of the amplitude modulation envelope in the 450 kHz to 30 MHz frequency range. This sensitive instrument assures strict compliance with FCC rules and regulations. The AM-90 Modulation Monitor is an all solid-state self-contained rack mounted unit consisting of compact mainframe and two printed circuit cards. All controls are front panel mounted. Connections to a remote unit, primary power and RF inputs are mounted on the rear of the chassis.

Specifications

Frequency Range: 450 kHz to 30 MHz
 RF Input: 1.0 V RMS to 10.0 V RMS
 Power Input: 115 VAC \pm 15%, 50-60 Hz (230 VAC \pm 15% available)

MODULATION INDICATION

Display Meter: 0% to 100% on negative peaks.
 0% to 140% on positive peaks.

Flasher Frequency Response: +0%, -5%; 20 Hz to 20 kHz
 Flasher Accuracy: \pm 1% at 1 kHz

AUDIO TEST OUTPUTS

Frequency Response: +0 dB, -0.5 dB; 20 Hz to 20 kHz
 Distortion: 0.15% maximum at 99% modulation, 1 kHz audio, 450 kHz to 1.8 MHz carrier; 0.50% maximum, 1.8 MHz to 30 MHz carrier
 Signal-To-Noise: 75 dB minimum referenced to 100% sine wave modulation

ELECTRONICALLY BALANCED OUTPUT

Output Impedance: 75 ohms balanced
 Output Level: +10 dBm into 600 ohms at 100% sine wave modulation

INSTRUMENT OUTPUT

Output Impedance: 100 ohms (unbalanced)
 Output Level: 5 volts RMS into 10K ohms at 100% sine wave modulation
 Modulation Calibration: Built-in calibration, digitally synthesized RF source, +125% and -100% modulation, RMS value 111% \pm 0.1%
 Remote Output: For meter and flasher indications at another location, use Harris' remote meter panel 994-8487-001

GENERAL

Size: 19" long x 3.5" high x 13.5" deep (48cm x 9cm x 34cm). Mounts in standard relay rack
 Weight: 15 lbs. (6.82 kg). Export Packed: approx. 20 lbs. (9 kg)
 Ambient Temperature Range: -20°C to +55°C (-4°F to 131°F)
 Humidity: 95% maximum (non-condensing)
 Altitude: 10,000 feet maximum (3048 meters)

Ordering Information

AM-90 Solid-State AM Modulation Monitor 994-8424-001
 AM-90 Remote Meter Panel 994-8487-001

It's Harris who has it all!

- Most advanced and complete line of radio and television broadcast equipment.
- 24-hour-per-day, 365-days-per-year emergency service and parts.
- 24-hour-per-day technical and engineering consulting assistance.
- More than 30,000 different items in inventory, from 2,000 manufacturers.
- One responsible point of contact.
- Proven reputation for product quality and service responsiveness.

FOR A COMPLETE LINE OF RADIO AND TELEVISION BROADCAST
 EQUIPMENT NEEDS AND SERVICE
 CALL HARRIS

MEDIUM WAVE ANTENNA ACCESSORIES

HARRIS
 P. O. Box 4290
 Quincy, IL 62305-4290
 (217) 222-8200

Tower Light Isolation Chokes

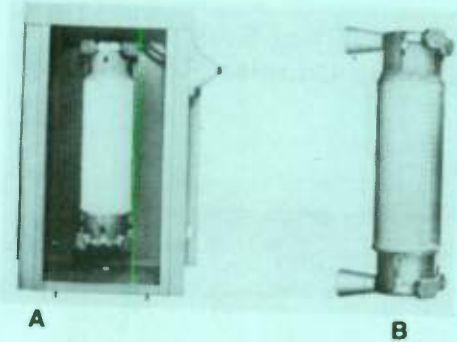

(20 AMP AC RATING)

Most popular of all tower light isolation chokes. Available in 2 or 3 wire models and in open type, or weatherproof as illustrated. Wound on heavy triple X tubing with mica-by-pass condensers on each circuit end. Inductance approximately 350 uH. 3" stand-off insulators are part of coil. (Weatherproof type), 24" high, 17 3/4" wide, 10 1/4" deep. Illustration on left shows weatherproof unit with front cover removed.

ORDERING INFORMATION

- Tower Choke, 2 wire, weatherproof, Fig. A994-3937-001
- Tower Choke, 3 wire, weatherproof, Fig. A994-3938-001
- Tower Choke, 2 wire, open type, Fig. B994-3935-001
- Tower Choke, 3 wire, open type, Fig. B994-3936-001

FEED-THRU BOWLS

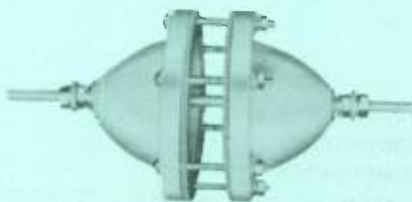

FEED-THRU BOWL ASSEMBLY

A large feed-thru bowl with 50 kW modulated rating. Available in single and double units and with solid or hollow studs as listed below. Bowls are Alsimag. Hardware, heavy brass. Velutex seals are provided for weathertight installation.

ORDERING INFORMATION

- Solid stud, 2 bowls, for walls to 10 1/2" thick994-2870-001
- Same as above but hollow stud ..994-3254-001
- Solid stud, single bowl, for walls 1" thick994-5280-001
- Same as above but hollow stud ..994-5281-001

RF Contactors

Harris offers a complete line of RF contactors of both the mechanical and vacuum variety.

The popular mechanical contactors, that handle a wide range of medium wave antenna applications, are available from stock.

DIODE TYPE REMOTE METER EQUIPMENT



For remote indication of RF current. Consists of a carefully constructed pickup loop attached through a short coaxial cable to a solid-state rectifier assembly. RF current is measured without breaking the main lead. No AC power is required. May be used with any good 1 MA DC meter. Power range: 250 watts to 50,000 watts. Frequency range: 540 kHz to 1600 kHz.

ORDERING INFORMATION

- Diode remote meter unit, less meter994-6112-001
- 0-1 MA METERS**
- Meter 3" sq. case, scale 0-3 R.F. amperes632-0418-000
- Meter 3" sq. case, scale 0-6 R.F. amperes632-0405-000
- Meter 3" sq. case, scale 0-8 R.F. amperes632-0420-000
- Meter 3" sq. case, scale 0-10 R.F. amperes632-0421-000
- Meter 4" sq. case, scale 0-3 R.F. amperes632-0424-000
- Meter 4" sq. case, scale 0-8 R.F. amperes632-0426-000
- Meter 4" sq. case, scale 0-10 R.F. amperes632-0361-000
- Meter 4" sq. case, scale 0-15 R.F. amperes632-0428-000
- NOTE: Other meter scale ranges available at extra cost. Above for use with diode remote unit, not thermocouple.

Heavy Duty Sampling Loop

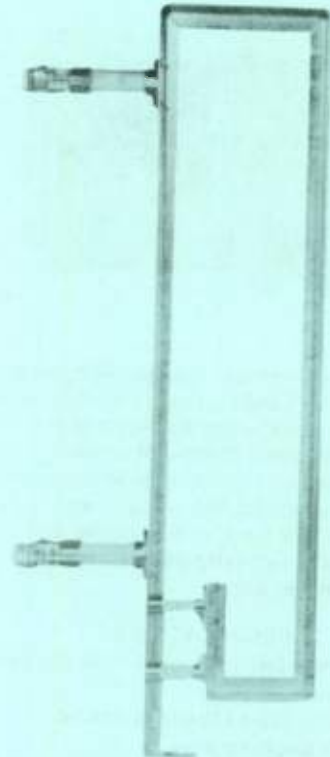

This is a very rugged fixed non-shielded RF sampling loop. It is heavily galvanized after welding, and is fitted with large steatite insulators and heavy duty tower leg clamps for easy and positive mounting. Complete with type female "N" jack. For 50 to 70 ohm sampling line.

ORDERING INFORMATION

- Heavy duty sampling loop994-6126-001

ISOLATION COILS

Harris manufactures several types of sampling loop isolation coils to meet the needs of the directional array and associated monitoring system.

Standard units available use either 1/2 inch or 3/8 inch phase stabilized foam transmission line. The isolation coils are available with an optional resonating capacitor. The unit can be mounted on a flat aluminum wall panel or housed in a weatherproof enclosure.

Prices and Specifications Subject to Change Without Notice.

**Weatherproof 5-10 KW
Antenna Coupling Units**

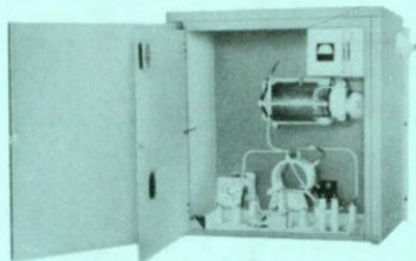

Housed in aluminum cabinet with double front doors. Large coils combined with capacitors of generous voltage and current ratings to assure a lifetime of service under extreme heat or cold. A large antenna lead in bowl is provided. Mounting is with metal flanges on the back of the tuning unit for attachment to wooden poles set in ground or for mounting on wall.

SPECIFICATIONS

CARRIER POWER: 5,000 watts or 10,000 watts AM, as ordered.
FREQUENCY: 525-1,700 kHz as ordered.
LINE IMPEDANCE: 50 ohms
TO MATCH: Series fed tower of from 70° to 100° electrical length.
CIRCUIT: Full Tee Network.
WEIGHT: Approximately 200 lbs.
SIZE: 38" high, 37" wide, 21½" deep.

ORDERING INFORMATION

Antenna Coupling Unit, 5 kW994-5309-001
Antenna Coupling Unit, 10 kW ...994-5309-002
NOTE: When ordering, state carrier frequency, transmission line impedance, power, tower height and tower measurements, if known. Couplers to match unusual loads such as short or tall towers, shunt feed, etc., are available on special order, at extra cost.

RF ANTENNA METERS

Internal thermocouple standard scale. Weston Model 308, three-inch square case. Other ranges not listed below are available with many carried in stock. Also expanded scale meters in inventory.

ORDERING INFORMATION

Meter, 0-3 R.F. amperes634-0206-000
Meter, 0-6 R.F. amperes634-0238-000
Meter, 0-8 R.F. amperes634-0209-000
Meter, 0-10 R.F. amperes634-0210-000

Test Jacks



Harris manufactures both a medium power and high power RF test jack for use in several medium wave antenna network applications. The medium power test jack (shown at left) is rated for 35 amperes while the high power version (shown at right) is rated for 100 amperes. These units are constructed to assure maintenance free operation.

ORDERING INFORMATION

Medium Power Test Jack994-3280-002
High Power Test Jack994-3280-003

METER SHORTING SWITCH

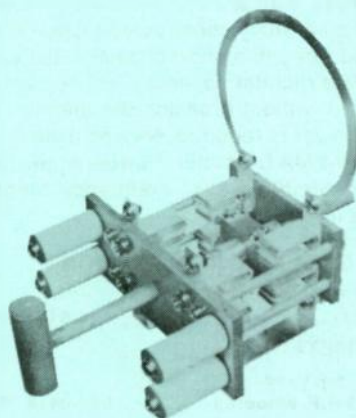

A heavy duty, make-before-break meter shorting switch of the plunger or push type. Heavy bronze tempered spring grips on both sides assure accuracy and durability.

ORDERING INFORMATION

Meter Shorting Switch, rating 15 amperes994-3493-001
Meter Shorting Switch, rating 40 amperes (shown above)994-6527-001

**Weatherproof Series — FED
Antenna Coupler, 1250 Watts**

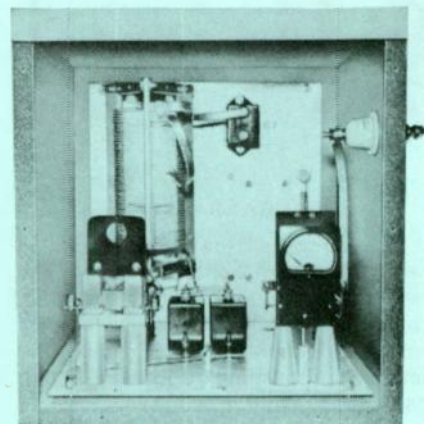

Recommended for broadcast transmitter powers of 1,000, 500 and 250 watts, 100% modulated. Heavy edgewound coil has generous inductance for a Tee network along with fixed mica capacitors supplied. Extra room is provided to install either diode or thermocouple remote metering equipment. Heavy duty meter shorting switch eliminates antenna meter from the circuit when not in use for lightning protection. Meter is observed through plexiglass porthole. Front door of cabinet has been removed for illustrative purposes.

SPECIFICATIONS

CARRIER POWER: Up to 1250 watts AM.
FREQUENCY: 525-1700 kHz as ordered.
LINE IMPEDANCE: 50 ohms.
TO MATCH: Series-fed tower of from 70° to 100° electrical length.
CIRCUIT: Full Tee Network.
WEIGHT: 98 lbs.
SIZE: 20" high, 20¼" wide, 18¾" deep.

ORDERING INFORMATION

Antenna Coupler with antenna meter994-3494-001
NOTE: When ordering, state transmission line impedance, frequency, tower height, and tower measurements, if known. Couplers to match unusual loads such as short or tall towers, shunt feed, etc., are available on special order at extra cost.

SHORT WAVE BROADCAST TRANSMITTER



SW-50A 50,000 Watt Short Wave Broadcast Transmitter

- High level Pulse Duration Modulation
- Exceeds 57% overall efficiency
- 10-Channel pre-set tuning, crystals included
- Low power consumption
- Only five tubes for 50 kW
- Vapor phase cooling
- Designed for trapezoidal programming
- Minimum floor space
- Full front and rear accessibility

Harris' SW-50A is a high-level, plate modulated short wave broadcast transmitter, featuring automatic 10-channel pre-set tuning. Utilizing the exclusive Pulse Duration Modulator, the SW-50A provides higher efficiency, lower operating costs and overall performance superior to that of any other short wave transmitter in the 50 kilowatt power range. The transmitter is capable of operating at any frequency between 3.2 and 22 MHz.

Specifications

POWER OUTPUT: 50,000 watts nominal unmodulated.

RF FREQUENCY RANGE: 3.2 to 22.0 MHz.

METHOD OF TUNING: Manual, or selection of 10 pre-set channels.

RF OUTPUT IMPEDANCE: 300 ohms balanced, 2.0 to 1 maximum VSWR.

RF FREQUENCY STABILITY: $\pm 1 \times 10^{-6}$ (± 22 Hz at 22 MHz).

SPURIOUS AND HARMONIC EMISSION: Less than 50 mW.

CARRIER SHIFT: Less than 2% at 95% modulation at 1000 Hz.

AUDIO FREQUENCY RESPONSE: ± 1.5 dB from 50 to 10,000 Hz referenced to 1000 Hz at 95% modulation.

AUDIO FREQUENCY DISTORTION: Less than 3% from 50 to 10,000 Hz at 95% modulation.

NOISE: 55 dB below 1000 Hz, 100% modulated level.

AUDIO INPUT LEVEL: 0 dBm ± 2 dB for 100% modulation.

AUDIO INPUT IMPEDANCE: 600/150 ohms, balanced or unbalanced.

MODULATION LEVEL: 100% sinusoidal, 60 minutes, 500-5000 Hz.

TRAPEZOIDAL MODULATION: Less than 5% tilt or overshoot, 100 Hz to 2000 Hz measured using 12 dB clipped sine wave.

POWER INPUT: Any specified voltage 380V to 480V, 3 phase, 50 or 60 Hz. Phase unbalance 5%, Regulation 5%.

POWER CONSUMPTION:

No modulation	89 kW
30% modulation	92 kW
100% modulation	130 kW

POWER FACTOR: Greater than 95%.

VOLTAGE REGULATOR: Electronic voltage regulation for all power supplies other than high voltage.

OVERALL EFFICIENCY: 57% or greater @ average modulation.

TUBES: Two 4CV50,000E, two 4CX1500A, one F-1099.

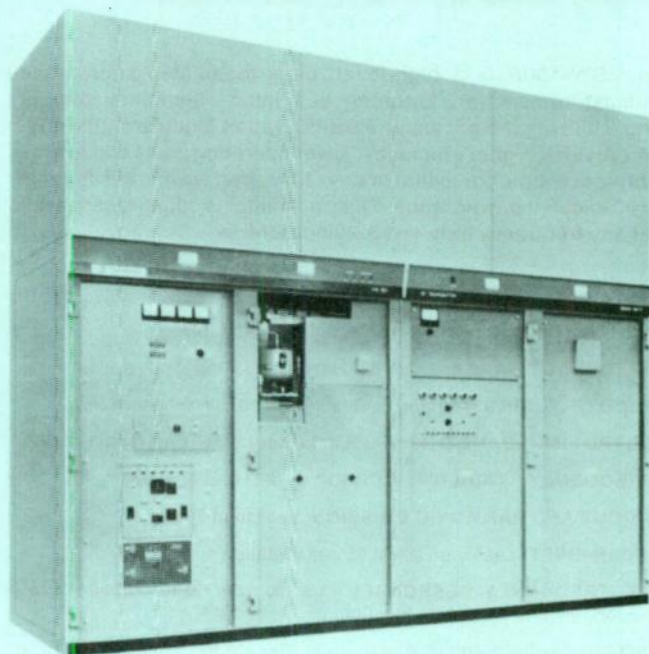
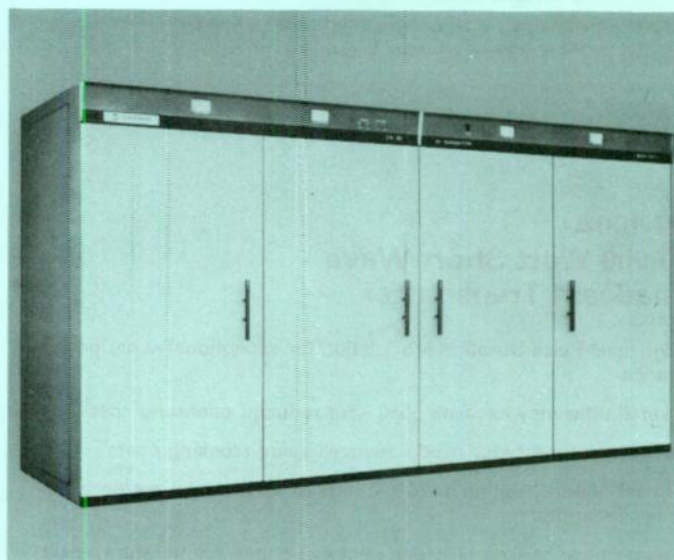

SW-50A with front doors removed.

TEMPERATURE RANGE: 0 to +50°C ambient air temperature. Sea level decrease 2°C/1000 ft. altitude (38°C @ 6000 ft.)

HUMIDITY: 95% relative humidity, maximum.

STORAGE TEMPERATURE: -35°C to +60°C.

ALTITUDE: Up to 1829 meters (6000 feet) above sea level.

CABINET DATA: The two cabinets measure 366 cm (12 feet) wide, 137 cm (4.5 feet) deep, and 304 cm (10 feet) high.

Ordering Information

SW-50A, 50,000 watt short wave broadcast transmitter, with remote heat exchanger994-8630-001

SHORT WAVE BROADCAST TRANSMITTER

SW-100A 100,000 Watt Short Wave Broadcast Transmitter

- High level Pulse Duration Modulation for exceptional audio performance
- Overall efficiency exceeds 55% - for reduced operating costs
- Only three tube types used - reduces spare stocking costs
- Pre-set channel tuning in 20 seconds or less, minimizes programming disruption
- Vapor phase cooling provides constant anode temperature resulting in extended tube life
- Front and rear cabinet accessibility eases maintenance

Harris' SW-100A is a high-level, plate modulated short wave broadcast transmitter, featuring automatic 10-channel pre-set tuning. Utilizing the exclusive Pulse Duration Modulator, the SW-100A provides higher efficiency, lower operating costs and overall performance superior to that of any other short wave transmitter in the 100 kilowatt power range. The transmitter is capable of operating at any frequency between 3.2 and 22 MHz.

SW-100A Specifications

- POWER OUTPUT:** 100,000 watts nominal unmodulated.
- RF FREQUENCY RANGE:** 3.2 to 22.0 MHz.
- METHOD OF TUNING:** Manual, or selection of 10 pre-set channels.
- RF OUTPUT IMPEDANCE:** 300 ohms balanced, 2.0 to 1 maximum VSWR.
- RF FREQUENCY STABILITY:** $\pm 1 \times 10^{-6}$ (± 22 Hz at 22 MHz).
- SPURIOUS AND HARMONIC EMISSION:** Less than 50 mW.
- CARRIER SHIFT:** Less than 2% at 95% modulation at 1000 Hz.
- AUDIO FREQUENCY RESPONSE:** ± 1.5 dB from 50 to 10,000 Hz referenced to 1,000 Hz at 95% modulation.
- AUDIO FREQUENCY DISTORTION:** Less than 3% from 50 to 10,000 Hz at 95% modulation.
- NOISE:** 55 dB below 1,000 Hz, 100% modulated level.
- AUDIO INPUT LEVEL:** 0 dBm ± 2 dB for 100% modulation.
- AUDIO INPUT IMPEDANCE:** 600/150 ohms, balanced or unbalanced.
- MODULATION LEVEL:** 100% sinusoidal, 10 minutes, 500-5000 Hz.
- TRAPEZOIDAL MODULATION:** Less than 5% tilt or overshoot, 100 Hz to 2000 Hz measured using 12 dB clipped sine wave.
- POWER INPUT:** Any specified voltage 380V to 480V, 3 phase, 50 or 60 Hz. Phase unbalance 5%, Regulation 5%.
- POWER CONSUMPTION:**
- | | |
|-----------------|--------|
| No modulation | 180 kW |
| 30% modulation | 190 kW |
| 100% modulation | 250 kW |

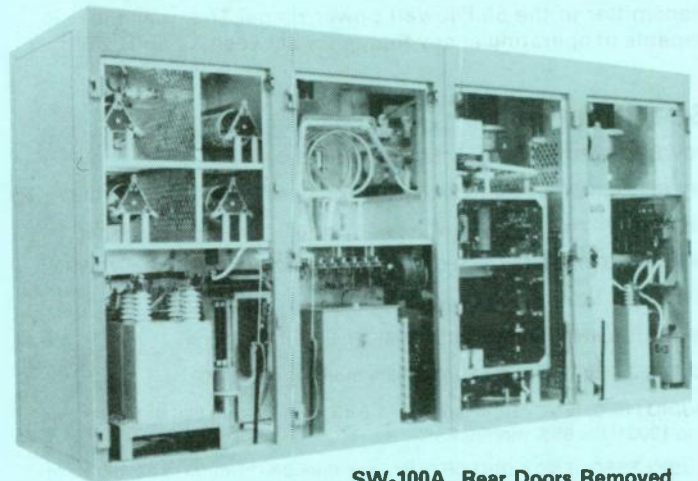

**SW-100A, Rear Doors Removed
 (Air Plenum Not Shown)**

- POWER FACTOR:** Greater than 95%.
- VOLTAGE REGULATOR:** Electronic voltage regulation for all power supplies.
- OVERALL EFFICIENCY:** 55% @ average modulation.
- TUBES:** Two 4CV100,000E, two-4CX1500A; one F-1099.
- TEMPERATURE RANGE:** 0 to +50°C ambient air temperature.
- HUMIDITY:** 95% relative humidity, maximum.
- STORAGE TEMPERATURE:** -35°C to +60°C.
- ALTITUDE:** Up to 1829 meters (6000 feet) above sea level.
- CABINET DATA:** The two cabinets measure 366 cm (12 feet) wide, 137 cm (4.5 feet) deep, and 304 cm (10 feet) high.

ORDERING INFORMATION

SW-100A, 100,000 watt short wave broadcast transmitter, with remote heat exchanger994-8629-001

FM EXCITER



MX-15 Maximum Signal FM Exciter

- Improved ultra linear VCO yields -80 dB FM S/N, and .02% Intermodulation Distortion for maximum signal clarity
- DSM (Digitally Synthesized Modulation) Stereo Generator provides 50 dB separation minimum, typically 60 dB midband, for increased stereo realism
- DTR* (Dynamic Transient Response) stereo generator filter maximizes modulation level without overmodulating
- Automatic stereo pilot phase control* and digital circuitry provide long term adjustment-free performance
- Balanced floating composite input minimizes system interface problems
- Available as an FCC type accepted 15 watt transmitter

*Patented

Continuing in its trend-setting tradition, Harris has incorporated state-of-the-art refinements in exciter technology to introduce the MX-15 FM Exciter. Using various advanced techniques, such as DRT (Dynamic Transient Response) and DSM (Digitally Synthesized Modulation), the MX-15 Exciter provides the broadcaster with new levels of excellence in audio performance.

Specifications

GENERAL

POWER OUTPUT: 3 watts to 15 watts continuously variable.
FREQUENCY RANGE: 87.5 MHz to 108 MHz tested to one specified frequency. (exciter programmable to 50 kHz channel spacing).
RF OUTPUT IMPEDANCE: 50 ohms, open and short circuit proof.
OUTPUT CONNECTION: Female BNC.
FREQUENCY STABILITY: ± 300 Hz 0° to 50°C temperature compensated reference oscillator.
TYPE OF MODULATION: Direct carrier frequency modulation (DCFM).
MODULATION CAPABILITY: ± 100 kHz.
AC INPUT POWER: 100 to 130 VAC or 200 to 250 VAC, 60 Hz or 50 Hz, 150 watts.
RF HARMONICS: Suppression meets all FCC requirements for 10 watt and 15 watt educational transmitter requirements.
ALTITUDE RANGE: 15,000 feet.
AMBIENT TEMPERATURE RANGE: 0° to 50°C (operational to -20°C).
OVERALL CABINET SIZE: 17.7" Wide (44 cm) x 14" High (35 cm) x 12" Deep (30 cm). 19" EIA rack mounting standard.
FINISH: Black.
CONSTRUCTION: Main printed circuit boards individually enclosed, plug-in modules. Module service extender board included.
AUDIO/CONTROL CONNECTIONS: Two 18 terminal barrier strips paralleled by 36 pin and socket connectors. RFI bypassing on input/output lines.
MODULATION METER: 10 position, fast rise time AC metering (adjustable to meet FCC ballistics).
MULTIMETER: 10 position, DC metering.
TOTAL METERING FUNCTIONS: 20
REMOTE METERING PROVISIONS: PA voltage, PA current, forward power, reflected power.

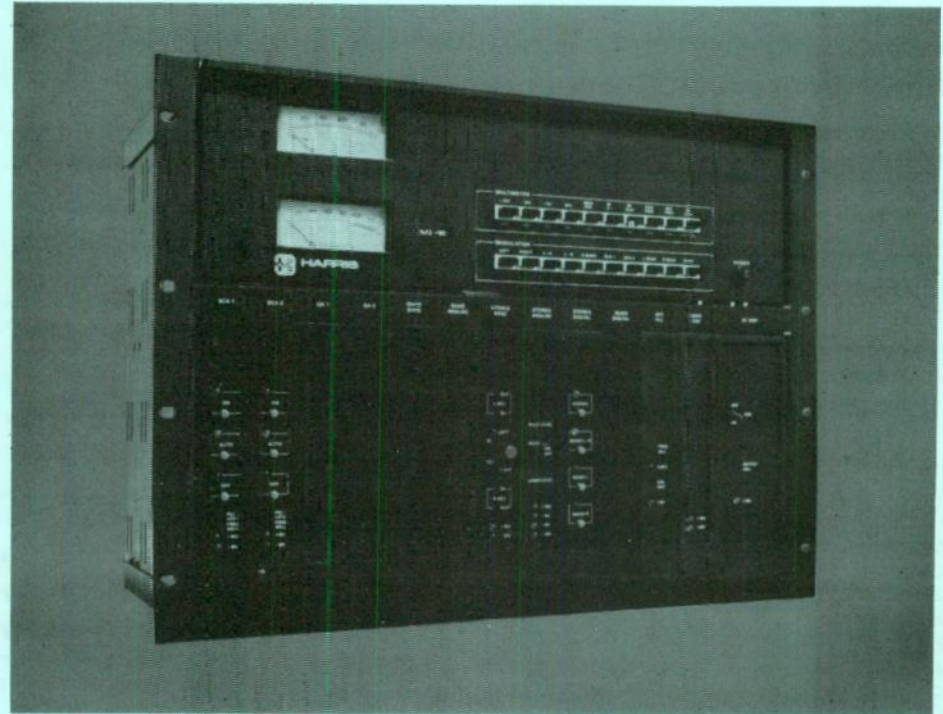

STATUS INDICATION: 27 independent LED indicators (when equipped with all options).

WIDEBAND COMPOSITE OPERATION

COMPOSITE INPUT: One balanced floating input
COMPOSITE INPUT IMPEDANCE: 2000 ohms resistive
COMPOSITE INPUT CONNECTOR: Female BNC.
COMPOSITE INPUT LEVEL: 1.0 volt RMS nominal for ± 75 kHz deviation
EXTERNAL SCA GENERATOR INPUTS: Up to two unbalanced inputs (optional).
COMPOSITE FM SIGNAL TO NOISE: 80 dB below 100% modulation (reference 400 Hz @ ± 75 kHz deviation with 75 microsecond de-emphasis, 20 Hz to 200 kHz bandwidth)
COMPOSITE HARMONIC DISTORTION: 0%
COMPOSITE INTERMODULATION DISTORTION: 0.2% @ 80 Hz/7 kHz 1:1 tone pairs.
COMPOSITE CCIF INTERMODULATION DISTORTION: All distortion products below 80 dB (reference 14 kHz/15 kHz test tone pair).
COMPOSITE AMPLITUDE RESPONSE: ± 0.1 dB 30 Hz-53 kHz.
ASYNCHRONOUS AM SIGNAL TO NOISE: 73 dB below referenced carrier AM modulation: 100% output power, 15 watts.
SYNCHRONOUS AM SIGNAL TO NOISE: 51 dB below referenced carrier with 100% AM modulation @ 400 Hz, 75 microsecond de-emphasis (FM modulation ± 75 kHz @ 400 Hz).

MONAURAL OPERATION

AUDIO INPUT IMPEDANCE: 600 ohms, balanced, resistive, transformerless, adaptable to other impedances.
INPUT FILTER: Controlled response low pass filter, defeatable.
AUDIO INPUT LEVEL: -10 dBm, ± 1 dB for 100% modulation at 400 Hz.
AUDIO FREQUENCY RESPONSE: Standard 75 microsecond FCC pre-emphasis curve ± 0.5 dB, 30 Hz-15 kHz. Selectable: flat, 25 or 50 microsecond pre-emphasis.
HARMONIC DISTORTION: 0.15%, 30 Hz to 15 kHz de-emphasized.
INTERMODULATION DISTORTION: 0.45%, 60 Hz/7 kHz test tone pair, 4:1 ratio.
CCIF INTERMODULATION DISTORTION: All distortion products down 70 dB (reference 14 kHz/15 kHz test tone pair).
FM SIGNAL TO NOISE RATIO: 80 dB below 100% modulation (reference 400 Hz @ ± 75 kHz deviation, measured 20 Hz to 200 kHz bandwidth, 75 microsecond de-emphasis).

STEREO OPERATION

TYPE OF MODULATION: Digitally Synthesized Modulation (DSM).
AUDIO INPUT IMPEDANCE: Left and right channels: 600 ohms, balanced, resistive, transformerless, adaptable to other impedances.
AUDIO INPUT LEVEL: -10 dBm, ± 1 dB for 100% modulation.
AUDIO FREQUENCY RESPONSE: Left and right standard 75 microsecond FCC pre-emphasis curve ± 0.5 dB, 30 Hz-15 kHz. Selectable: flat, 25 or 50 microsecond pre-emphasis.
INPUT FILTERING: 15 kHz low pass filter, 45 dB rejection at 19 kHz.
OVERSHOOT PROTECTION: Harris patented Dynamic Transient Response (DTR) filter. Defeatable for test purposes.
AUDIO TRANSIENT RESPONSE: 2% maximum overshoot beyond steady state.

HARMONIC DISTORTION: (Left or right) 0.2% or less, 30-15,000 Hz.
INTERMODULATION DISTORTION: (Left or right) 0.1% 60 Hz/7 kHz test tone pair, 4:1 ratio.
CCIF INTERMODULATION DISTORTION: (Left or right) all distortion products down 80 dB (reference 14 kHz/15 kHz test tone pair).
STEREO SEPARATION: 50 dB, 30 Hz-15 kHz; typically 60 dB at midband frequencies.
DYNAMIC STEREO SEPARATION: 48 dB under normal programming conditions.
LINEAR CROSSTALK: -52 dB
NON-LINEAR CROSSTALK: -60 dB
76 KHZ SUPPRESSION: -68 dB
38 KHZ SUPPRESSION: -73 dB
FM NOISE: (Left or right) -74 dB minimum below 100% modulation. Reference: 400 Hz, 75 microsecond de-emphasis, ± 75 kHz deviation, measured 30 Hz to 15 kHz bandwidth.
PILOT OSCILLATOR: Crystal controlled.
PILOT PHASE: Harris patented automatic pilot phasing circuit.
PILOT STABILITY: 19 kHz ± 1 Hz 0° to 90°.
OPERATIONAL MODES: Stereo, mono (left and right), mono (left), mono (right) — remotable.

SCA OPERATION

MODULATION: Direct FM.
FREQUENCY OF OPERATION: 41 or 67 kHz programmable, any frequency between 25 and 75 kHz on special order.
FREQUENCY STABILITY: ± 500 Hz.
MODULATION CAPABILITY: ± 7.5 kHz.
AUDIO FREQUENCY RESPONSE: 41 kHz and 67 kHz AC coupled input, 150 microsecond pre-emphasis ± 1 dB, standard. Selectable flat, 50 or 75 microsecond pre-emphasis DC coupled input. No pre-emphasis DC to 4 kHz ± 0.5 dB.
AUDIO INPUT IMPEDANCE: 600 ohms balanced (AC coupled). Also 2000 ohms DC coupled unbalanced input through rear BNC connector.
AC INPUT LEVEL: +10 dBm ± 1 dB for 100% modulation at 400 Hz @ 600 ohms.
DC INPUT LEVEL: 1.0 volt peak for 5 kHz deviation.
INPUT FILTERING: Programmable LPF, 4.5 kHz standard, 3 kHz, 5 kHz, 7.5 kHz selectable. Low pass filter defeatable.
HARMONIC DISTORTION: 0.5%, 30-4,500 Hz ± 5 kHz deviation.
INTERMODULATION DISTORTION: 1%, 60 Hz/7 kHz, 1:1 ratio (audio low pass filter and pre-emphasis bypassed).
FM NOISE: (Main channel not modulated) -63 dB (reference 100% modulation) ± 5 kHz deviation at 400 Hz.
CROSSTALK: (SCA to main or stereo sub-channel) -60 dB or better.
CROSSTALK: (Main or stereo sub-channel to SCA) 57 dB below ± 5 kHz deviation of SCA with mono or stereo channels modulated by frequencies 30 Hz-15 kHz, SCA demodulated with 150 microsecond de-emphasis.
CROSSTALK: SCA to SCA (47 kHz/67 kHz) 50 dB demodulated with 150 microsecond de-emphasis.
AUTOMATIC MUTE LEVEL: Variable from 0 to -30 dBm.
MUTE DELAY: Adjustable 0.5 to 23 seconds.
INJECTION LEVEL: 1% to 30% of composite level (adjustable).

Ordering Information

MX-15 Exciter for wideband composite operation, 19-inch rack mounted 994-7950-003
Mono option (add for mono operation) 994-8019-001
DSM Stereo Generator with DTR Filter (add one for stereo operation) 994-8020-001
SCA Generator (add one for each SCA service, specify 67 or 92 kHz) 994-7992-002
External SCA Generator Jumper Card
(for use with externally mounted SCA Generator) 994-8377-001

Prices and Specifications Subject to Change Without Notice.



HARRIS

P.O. Box 4290
Quincy, IL 62305-4290
(217) 222-8200

SCA GENERATOR

MX-15 Multi-Purpose SCA Generator

- Designed for operation on 67 kHz or 92 kHz (with other frequencies available) to meet the new applications of SCA service
- Improved carrier mute decay circuit considerably reduces annoying SCA receiver squelch pops
- Transformerless audio input stage improves SCA aural performance
- DC coupled data input port provides accurate transmission of digital information
- Automatic MX-15 SCA/composite level control maintains maximum main channel modulation

The MX-15 multipurpose SCA generator is designed to meet the expanded needs of today's SCA service requirements, and is ideal for high quality aural service or for accurate transmission of digital data.

Expanded Range Of Operation

The MX-15 multipurpose SCA generator can be user programmed to operate on 67 kHz or 92 kHz by simply positioning a jumper plug. Other operating frequencies can be easily accommodated upon request. Two SCA generators, one on 67 kHz and the other on 92 kHz, can simultaneously operate with stereo. The MX-15 exciter accommodates additional SCA channels through the composite input.

Improved Aural Performance

The transformerless audio input stage improves aural performance in comparison with other designs. Stations will note lower harmonic distortion for improved SCA fidelity.

The transformerless input stage is low pass filtered to meet the technical needs of the SCA information transmitted. A 4.5 kHz low pass response is provided as standard. This can be easily changed for 3 kHz, 5 kHz or 7.5 kHz response, or may be defeated if desired.

The MX-15 multipurpose SCA generator meets the precise transmission requirements of stations transmitting digital information. A rear mounted BNC input connector DC couples the digital data to the SCA generator's FM modulator for precise transmission quality.

Improved Mute Decay Circuit

SCA operators recognize that abrupt muting of the SCA carrier may cause an annoying "pop" in the SCA receivers. Harris has incorporated a carrier mute decay circuit to eliminate this objectionable noise.

In addition to the mute decay circuit, stations may select the mute delay time constant they desire—anywhere between 0.5 seconds and 20 seconds. Automatic mute threshold level can also be adjusted between 0 and -30 dBm in order to meet varying input levels.

Automatic Composite Level Adjustment

The MX-15 exciter and multipurpose SCA generator work as an effective system to automatically maintain maximum main channel modulation at all times. Here's how: When the SCA generator is activated, the composite level is automatically lowered to allow for insertion of the SCA channel. The converse is also true. Stations need not compromise 10% to 30% of modulation when SCA is not used continuously.

Expanded Applications

Whether you are planning to use your SCA channel for conventional aural services (such as background music), or are looking at some of the new expanded applications possible today, the Harris MX-15 multipurpose SCA generator meets your needs.

Specifications

MODULATION: Direct FM

FREQUENCY OF OPERATION: Selectable 67 kHz or 92 kHz. Any frequency between 25 kHz and 92 kHz available on special order.

FREQUENCY STABILITY: ± 500 Hz.

MODULATION CAPABILITY: ± 7.5 kHz.

AUDIO FREQUENCY RESPONSE: 67 kHz and 92 kHz AC coupled input, 150 microsecond pre-emphasis, ± 1 dB, standard. Selectable flat, 50 or 75 microsecond pre-emphasis. DC coupled input: No pre-emphasis: DC to 4 kHz ± 0.5 dB.

AUDIO INPUT IMPEDANCE: 600 ohms balanced transformerless (AC coupled). Also 2000 ohms DC coupled unbalanced input through rear BNC connector.

AC INPUT LEVEL: +10 dBm, ± 1 dB for 100% modulation at 400 Hz @ 600 ohms.

DC INPUT LEVEL: 1.0 volt peak for 5 kHz deviation.

INPUT FILTERING: Programmable LPF, 4.5 kHz standard. 3 kHz, 5 kHz, 7.5 kHz selectable. Low pass filter defeatable.

HARMONIC DISTORTION: 0.5%, 30-4500 Hz, ± 5 kHz deviation.

INTERMODULATION DISTORTION: 1%, 60 Hz/7 kHz, 1:1 ratio (audio low pass filter and pre-emphasis bypassed).

FM NOISE: (Main channel not modulated) -63 dB (reference: 100% modulation = ± 5 kHz deviation at 400 Hz).

CROSSTALK: (SCA to main or stereo sub-channel) -60 dB or better.

CROSSTALK: (Main or stereo sub-channel to SCA) 57 dB below ± 5 kHz deviation of SCA with mono or stereo channels modulated by frequencies 30 Hz-15 kHz, SCA demodulated with 150 microsecond de-emphasis).

CROSSTALK: SCA to SCA (41 kHz/67 kHz) 50 dB demodulated with 150 microsecond de-emphasis.

AUTOMATIC MUTE LEVEL: Variable from 0 to -30 dBm.

MUTE DELAY: Adjustable 0.5 to 20 seconds.

CARRIER MUTE DECAY: Greater than 30 milliseconds.

INJECTION LEVEL: 1% to 30% of composite level (adjustable).

Ordering Information

Multi-Purpose SCA Generator (specify 67 or 92 kHz) 994-7992-002

FM BROADCAST TRANSMITTERS



- FM-300K 300 Watt
- FM-1K 1 Kilowatt
- FM-3.5K 3.5 Kilowatt
- FM-5K 5 Kilowatt
- FM-10K 10 Kilowatt
- FM-20K 20 Kilowatt
- FM-25K 25 Kilowatt
- FM-40K 40 Kilowatt
- FMD-50K 50 Kilowatt (Dual)

FM BROADCAST TRANSMITTERS

STANDARD FEATURES

- MX-15 Exciter with ultra linear modulated oscillator for minimum distortion, maximum signal clarity
- Digitally Synthesized Modulation stereo generator provides excellent midband separation for increased stereo realism
- Dynamic Transient Response (DTR*) stereo generator filter maximizes modulation level without overshoot

*Patented

FM-300K

Solid-State 300 Watt FM Transmitter

FM-300KD

Solid-State Main/Alternate 300 Watt FM Transmitter

Harris' 300 watt FM transmitter is available in two configurations; the standard model (FM-300K) or the dual FM-300KD which can be equipped for one of three configurations.

1. Separate 300 watt transmitters operating on different frequencies for two program channels.
2. Main/alternate main configuration where one transmitter acts as a full backup to the other transmitter permitting uninterrupted program service should one unit fail.
3. Combined operation yielding 600 watts of power for program services requiring increased coverage area.

Both the FM-300K and the FM-300KD are housed in a single 24 inch wide cabinet. Since the FM-300K only contains one transmitter, the extra cabinet space may be used for monitoring and test equipment.

Both transmitters are 100% solid-state for top reliability and represent one of the first all-solid state 300 watt broadband transmitters ever developed. Harris was the first equipment manufacturer to introduce an all solid-state radio broadcast transmitter; the MW-1, one kilowatt AM transmitter. The same solid-state transmitter engineering experience that has given the MW-1 an excellent reliability and performance track record brings you the Harris FM-300K/KD.

FM-1K

1 Kilowatt FM Broadcast Transmitter

The FM-1K employs Harris' advanced-design MX-15 solid-state exciter to provide the cleanest and the loudest FM signal of any one-kilowatt FM transmitter available today. The DSM (Digitally Synthesized Modulation) stereo generator allows the transmitter to provide stereo separation of 50 dB minimum, 30-15,000 Hz, while the DTR (Dynamic Transient Response) filter permits a 2 to 6 dB increase in loudness, with no degradation of audio quality, by limiting overshoot to 2% or less.

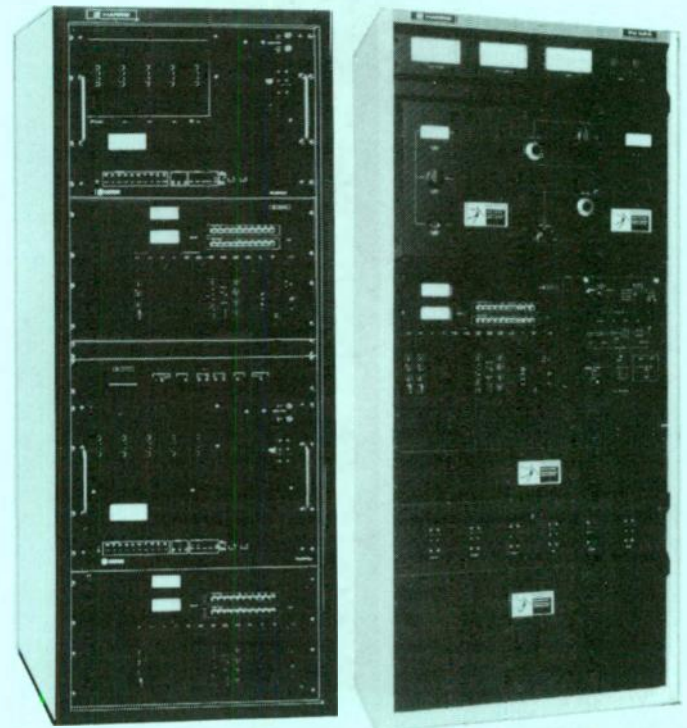

FM-300KD

FM-3.5K

FM-3.5K

3.5 Kilowatt FM Broadcast Transmitter

When considering 3.5 kW FM transmitters, local service FM broadcasters in general have two major requirements; long term reliability and audio performance. Without question the Harris FM-3.5K meets these crucial requirements and more.

POWER TO MEET YOUR TRANSMISSION SYSTEM'S REQUIREMENT

The Harris FM-3.5K can provide any output power from 800 to 3800 watts. This full range allows you to select the most effective antenna size, tower height and transmission line combination to meet your coverage requirements.

The FM-3.5K consumes only 7 kW of power at 3.5 kW output. Based on an 18 hour broadcast day and a typical power charge of \$0.08 per kilowatt hour, this represents an operating cost of only \$10.08 per day.

Even at full 3.5 kW output, the FM-3.5K requires only single phase AC power. Unlike other transmitters in this power range, there is no need to bring in costly 3-phase AC service to your facility.

FM-5K/10K/20K

5/10/20 Kilowatt FM Broadcast Transmitters

The Series features the advanced-design MX-15 exciter. The Harris 5 kW, 10 kW or the 20 kW. FM series provides the cleanest and the loudest stereo signal of any FM transmitter in their power range. The DSM (Digitally Synthesized Modulation) stereo generator allows the transmitter to provide stereo separation of 48 dB minimum, 30-15,000 Hz, while the DTR (Dynamic Transient Response) filter permits a 2 to 6 dB increase in loudness, with no degradation of audio quality, by limiting overshoot of 2% or less. Add to this high efficiency plus conservatively rated components and you have truly exceptional FM transmitters.



HARRIS

P.O. Box 4290
Quincy, IL 62305-4290
(217) 222-8200

FM BROADCAST TRANSMITTERS

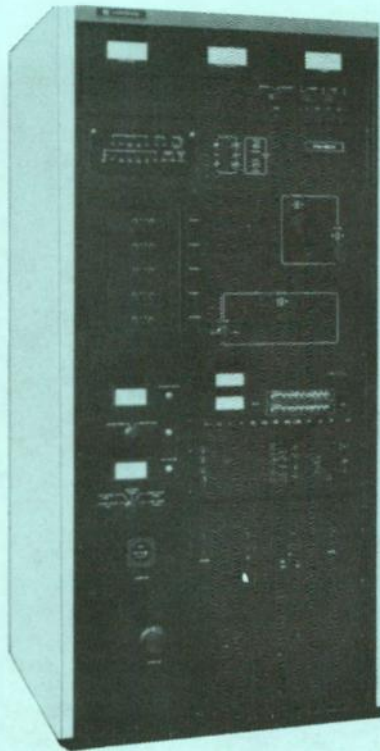

FM-25K

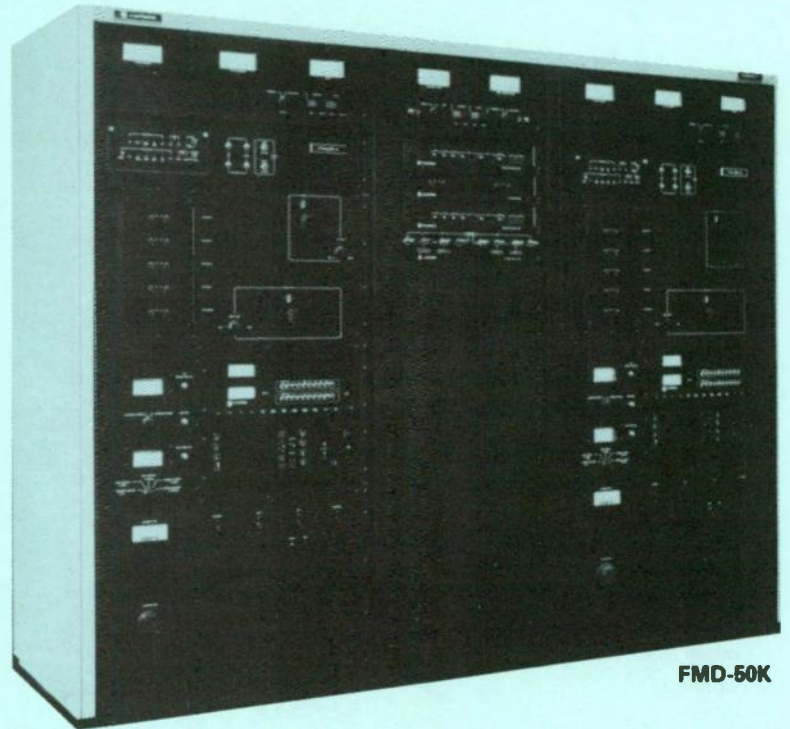

FMD-50K

FM-25K 25-Kilowatt FM Broadcast Transmitter

Harris' technology has combined advances in both tube and transistor designs, to bring you a major step forward in high-power FM transmitters. Transistors are now available which provide 50 watts of RF power at reasonable gain and low junction temperatures. By combining several of these transistors in wideband RF circuits, enough power can be generated to drive an advanced high-gain Eimac tetrode tube, the 8990. This tube, when grid driven in a grounded cathode, quarter-wave cavity, can produce 25 kilowatts with 350 watts of drive at nearly 80% plate efficiency.

The FM-25K, 25 kilowatt FM transmitter reflects Harris' design philosophy that FM transmitters should deliver RF power efficiently, should not limit exciter performance, and should integrate dependable solid-state control logic. In the FM-25K, these features are teamed with efficient, single-tube design, and with the high performance MX-15 exciter.

The FM-25K was designed for applications with tower limitations or specific coverage requirements. The higher RF power output reduces the number of antenna bays required for a given ERP; and fewer bays mean a reduction in windloading and mounting area, so that tower size and/or height may be reduced. Also, fewer antenna bays, with less gain, can mean improved close-in coverage and the elimination of null fills.

FM-40K 40-Kilowatt FM Broadcast Transmitter

Reliability through redundancy, that's the story on Harris' FM-40K, 40 kilowatt transmitter.

The basic FM-40K transmitter system consists of two 20 kilowatt amplifiers, and a center control cabinet containing the MX-15 exciter, and provides redundancy in all areas except the exciter and isolation amplifier. In case emergency operation is required, you stay on the air at one-quarter normal power output.

The complete 40 kilowatt FM transmitter system includes an optional Automatic Exciter Switching Kit and RF Output Switching Kit, and provides total redundancy. Should a malfunction occur anywhere in the system, you are still on the air at one-half normal power.

In the basic system, outputs of each amplifier are coupled through harmonic filters to the output combining network. This hybrid network sums the two 20 kilowatt signals to produce a 40 kilowatt output to the transmission line. However, the two amplifiers remain isolated from each other.

With the addition of the Automatic Exciter Switching Kit, automatic backup exciter protection is provided. And with the further addition of the RF Output Switching System, power output becomes one-half the normal output during emergency operation. Either or both of these options may be included in the FM-40K at the time you order, or added later in the field.

FMD-50K 50-Kilowatt Dual FM Broadcast Transmitter

The FMD-50K dual 50 kilowatt transmitter offers real protection against off-air time through redundancy, and through extensive use of solid-state circuitry. Only two tubes are employed in the entire FMD-50K high-gain, highly efficient 8990 tetrodes used as the final power amplifiers. The 8990 uses a wavy fin radiator which provides exceptional cooling at reduced air requirements, for quiet operation. The quarter-wave PA cavity design eliminates troublesome sliding contacts for tuning, and assures wide RF bandwidth. This results in a signal path that is transparent to the MX-15 exciter.

The basic FMD-50K transmitter consists of two 25 kilowatt amplifiers, and a center control cabinet. It provides redundancy in all areas except the exciters. In case emergency operation is required, you stay on the air at one-quarter normal power output. An even higher level of redundancy is achieved in the complete FMD-50K through an optional arrangement of switches, sensors and circuits that make the FMD-50K totally redundant from audio input to RF output.

The FMD-50K with the RF output switching option provides the capability of automatically switching either transmitter directly to the antenna, thus providing one-half normal operating power in the event of a transmitter malfunction.

With the addition of the automatic exciter switching option, automatic backup exciter protection is provided. Also, an optional RF input patch panel is available to connect either exciter directly to either transmitter by bypassing all of the automatic exciter switching equipment.

FM BROADCASTING TRANSMITTERS

SPECIFICATIONS

	FM-300K FM-300KD	FM-1K	FM-3.5K	FM-5K	FM-10K	FM-20K	FM-25K	FM-40K	FM-50K		
GENERAL POWER OUTPUT:	300 watts	1 kw	800 to 3800 watts	1.0 to 5.1 kw	10 kw	10 kw to 20 kw	10 kw to 25 kw	20 kw to 40 kw	20 kw to 50 kw		
FREQUENCY RANGE:	87.5 to 108 MHz, tuned to specified operating frequency.										
RF OUTPUT IMPEDANCE:	50 ohms.										
OUTPUT TERMINATION:	TypeN fem.	1-5/8" EIA flange.		3-1/8" EIA flange.				6-1/8" EIA flange.			
FREQUENCY STABILITY:	± 300 Hz 0° to 45°C TCXO.										
TYPE OF MODULATION:	Direct Carrier Frequency Modulation (DCFM).										
MODULATION CAPABILITY:	± 100 kHz.		133%		± 100 kHz.						
AC INPUT POWER:	208 to 245 VAC, 50 to 60 Hz. Single phase, ± 5% variation.										
		AC INPUT POWER: 208/240 V, 60 or 50 Hz, single phase, three-wire. Power consumption: 2100 watts (approx.). 115/230 V, 60 or 50 Hz, 150 watts for MX-15.			AC INPUT POWER: 197/250 V, 60 or 50 Hz, single phase, two-wire. Power consumption: 7000 watts (approx.). 60 or 50 Hz, 150 watts for MX-15.		AC INPUT POWER: 208/240 V, 3-phase, 60 Hz (50 Hz available.) Power consumption (approx.): 10 kW consumption at 5 kW output. 115/230 V, 60 or 50 Hz, 150 watts for MX-15.		AC INPUT POWER: 208/240 V, 3-phase, 60 Hz (50 Hz available.) Power consumption 17,000 watts (approx.): 115/230 V, 60 or 50 Hz, 150 watts for MX-15.		
			AC INPUT POWER: 208/240 V, 3-phase, 60 Hz. (50 Hz available on special order.) Power consumption: 30,000 watts (approx.). 115/230 V, 60 or 50 Hz, 150 watts for MX-15.			AC INPUT POWER: 208/240 V, 3-phase, 50/60 Hz and 360/415 V, 3-phase, 50/60 Hz, 4-wire. Power consumption: 40 kW typical.		AC INPUT POWER: 208/240 V, 3-phase, 60 Hz. (50 Hz available on special order.) Power consumption: 60,000 watts (approx.). 115/230 V, 60 or 50 Hz, 150 watts for MX-15, for an overall efficiency of approx. 66%.		AC INPUT POWER: 208/240 V, 3-phase, 50/60 Hz, 360/415 V, 3-phase, 50/60 Hz. Power consumption: 80,000 watts (approx.). 115 V as available.	
RF HARMONICS:	Suppression meets all FCC requirements.										
ALTITUDE:	12,000 ft.	10,000 ft.	10,000 ft. / 60 Hz 7500 ft. 50 Hz	7500 ft.	10,000 ft.	7500 ft.	10,000 ft.	7500 ft.	10,000 ft.		
AMBIENT TEMPERATURE RANGE:	0°C to +50°C.	-20°C to +45°C.									
MAXIMUM VSWR:	1.2:1	1.7:1	2.0:1	1.7:1							
OVERALL CABINET SIZE:	Approx. 27-3/4"W x 71-3/4"H x 29-3/4"D (70.5cm x 182.3cm x 75.6cm).										
		OVERALL CABINET SIZE: 29"W x 78"H x 33"D (74cm x 198cm x 84cm).			OVERALL CABINET SIZE: 33"W x 72"H x 34"D (84cm x 182cm x 99cm).		SIZE: Transmitter cabinet, 42"W x 78"H x 33"D (107cm x 198cm x 84cm).		SIZE: Transmitter cabinet, 42"W x 78"H x 33"D (107cm x 198cm x 84cm). HV power supply cabinet: 30"W x 49"H x 30"D (76cm x 125cm x 76cm).		
			SIZE: Transmitter cabinet, 42"W x 78"H x 33"D (107cm x 198cm x 84cm). HV power supply cabinet: 30"W x 49"H x 30"D (76cm x 125cm x 76cm).			SIZE: Transmitter cabinet, 34.6"W x 71.7"H x 31.0"D (87.8cm x 182.1cm x 78.7cm). HV power supply cabinet: 48.0"W x 60.2"H x 24.2"D (121.9cm x 152.9cm x 61.5cm).		SIZE: Transmitter: 113"W x 78"H x 33"D (287cm x 198cm x 84cm). HV power supply cabinets (2): each 30"W x 49"H x 30"D (76cm x 125cm x 76cm).		SIZE: Transmitter: 90.2"W x 72"H x 30.5"D (229cm x 183cm x 77.5cm). HV power supply cabinets: (each) 48"W x 60.2"H x 24.2"D (122cm x 153cm x 61.5cm).	
FINISH:	White, blue and black.										

Prices and Specifications Subject to Change Without Notice.



HARRIS

P. O. Box 4290
Quincy, IL 62305-4290
(217) 222-8200

**FM BROADCASTING
TRANSMITTERS**

SPECIFICATIONS (Cont'd)

	FM-300K FM-300KD	FM-1K	FM-3.5K	FM-5K	FM-10K	FM-20K	FM-25K	FM-40K	FM-50K
PILOT OSCILLATOR:	Crystal controlled.								
PILOT PHASE:	Harris patented automatic pilot phasing circuit.								
PILOT STABILITY:	19 kHz + 1 Hz 0° to 50°C.								
OPERATIONAL MODES:	Stereo, mono (left and right), mono (left), mono (right)—remoteable.								
SCA OPERATION									
MODULATION:	Direct FM.								
FREQUENCY OF OPERATION:	67 or 92 kHz programmable, any frequency between 25 and 92 kHz on special order.								
FREQUENCY STABILITY:	± 500 Hz.								
MODULATION CAPABILITY:	± 7.5 kHz.								
AUDIO FREQUENCY RESPONSE:	67 kHz and 92 kHz AC coupled input, 150 microsecond pre-emphasis ± 1 dB, standard. Selectable flat, 50 or 75 microsecond pre-emphasis. DC coupled input: No pre-emphasis: DC to 4 kHz ± 0.5 dB.								
AUDIO INPUT IMPEDANCE:	600 ohms balanced (AC coupled). Also 2000 ohms DC coupled unbalanced input through rear BNC connector.								
AC INPUT LEVEL:	+ 10 dBm, ± 1 dB for 100% modulation at 400 Hz @ 600 ohms.								
DC INPUT LEVEL:	1.0 volt peak for 5 kHz deviation.								
INPUT FILTERING:	Programmable LPF, 4.5 kHz standard. 3 kHz, 5 kHz, 7.5 kHz selectable. Low pass filter defeatable.								
HARMONIC DISTORTION:	0.5%, 30-4,500 Hz ± 5 kHz deviation.								
INTERMODULATION DISTORTION:	1%, 60 Hz/7 kHz, 1:1 ratio (audio low pass filter and pre-emphasis bypassed).								
FM NOISE:	(Main channel not modulated) -63 dB (reference: 100% modulation = ± 5 kHz deviation at 400 Hz).								
CROSSTALK:	(SCA to main or stereo sub-channel) -60 dB or better.								
CROSSTALK:	*57 dB	*57 dB	*55 dB	*55 dB	*55 dB	*55 dB	*57 dB	*52 dB	*57 dB
	(Main or stereo sub-channel to SCA) * below ± 5 kHz deviation of SCA with mono or stereo channels modulated by frequencies 30 Hz-15 kHz, SCA demodulated with 150 microsecond de-emphasis.								
CROSSTALK:	SCA to SCA (67 kHz/92 kHz) -50 dB demodulated with 150 microsecond de-emphasis.								
AUTOMATIC MUTE LEVEL:	Variable from 0 to -30 dBm.								
MUTE DELAY:	Adjustable 0.5 to 20 seconds.								
INJECTION LEVEL:	1% to 30% of composite level (adjustable).								

FM BROADCASTING TRANSMITTERS

SPECIFICATIONS (Cont'd)

	FM-300K FM-300KD	FM-1K	FM-3.5K	FM-5K	FM-10K	FM-20K	FM-25K	FM-40K	FM-50K	
MONAURAL OPERATION										
AUDIO INPUT IMPEDANCE:	600 ohms, balanced, resistive, transformerless, adaptable to other impedances.									
INPUT FILTER:	Controlled response low pass filter, defeatable.									
AUDIO INPUT LEVEL:	+ 10 dBm \pm 1 dB for 100% modulation at 400 Hz.									
AUDIO FREQUENCY RESPONSE:	Standard 75 microsecond FCC pre-emphasis curve \pm 0.5 dB, 30 Hz-15 kHz. microsecond pre-emphasis. Selectable: flat, 25 or 50									
HARMONIC DISTORTION:	0.15%, 30 Hz to 15 kHz de-emphasized.									
INTERMODULATION DISTORTION:	0.1%	0.1%	.045%	.15%	.1%	0.1%	0.1%	.15%	.045%	
CCIF INTERMODULATION DISTORTION:	All distortion products down 70 dB (reference 14 kHz/15 kHz test tone pair).									
FM SIGNAL TO NOISE RATIO:	80 dB below 100% modulation (reference 400 Hz @ \pm 75 kHz deviation, measured 20 Hz to 200 kHz bandwidth, 75 microsecond de-emphasis).									
STEREO OPERATION										
TYPE OF MODULATION:	Digitally Synthesized Modulation (DSM).									
AUDIO INPUT IMPEDANCE:	Left and right channels: 600 ohms, balanced, resistive, transformerless, adaptable to other impedances.									
AUDIO INPUT LEVEL:	+ 10 dBm, \pm 1 dB for 100% modulation.									
AUDIO FREQUENCY RESPONSE:	(Left and right) standard 75 microsecond FCC pre-emphasis curve \pm 0.5 dB, 30 Hz-15 kHz. Selectable: flat, 25 or 50 microsecond pre-emphasis.									
INPUT FILTERING:	15 kHz low pass filter, 45 dB rejection at 19 kHz.									
OVERSHOOT PROTECTION:	Harris patented Dynamic Transient Response (DTR) filter. Defeatable for test purposes.									
AUDIO TRANSIENT RESPONSE:	2% maximum overshoot beyond steady state.									
HARMONIC DISTORTION:	(Left or right) 0.2% or less, 30-15,000 Hz.									
CCIF INTERMODULATION DISTORTION:	(Left or right) 0.1% 60 Hz/7 kHz test tone pair, 4:1 ratio.									
CCIF INTERMODULATION DISTORTION:	*80 dB	*80 dB	*75 dB	*80 dB	*80 dB	*75 dB	*75 dB	*70 dB	*80 dB	
	(Left or right) all distortion products down * (reference 14 kHz/15 kHz test tone pair).									
STEREO SEPARATION:	*50 dB	*50 dB	*50 dB	*48 dB	*50 dB	*48 dB	*50 dB	*48 dB	*48 dB	
	* 30 Hz-15 kHz; typically 60 dB at midband frequencies.									
DYNAMIC STEREO SEPARATION:	48 dB under normal programming conditions.									
LINEAR CROSSTALK:	-52 dB	-50 dB	-50 dB	-50 dB	-50 dB	-48 dB	-50 dB	-50 dB	-52 dB	
NON-LINEAR CROSSTALK:	-60 dB	-60 dB	-60 dB	-60 dB	-60 dB	-60 dB	-60 dB	-60 dB	-60 dB	
76 kHz SUPPRESSION:	-68 dB	-68 dB	-68 dB	-68 dB	-68 dB	-68 dB	-68 dB	-68 dB	-68 dB	
38 kHz SUPPRESSION:	-73 dB	-73 dB	-73 dB	-73 dB	-73 dB	-73 dB	-73 dB	-73 dB	-73 dB	
FM NOISE:	*-74 dB	*-70 dB	*-72 dB	*-74 dB	*-70 dB	*-72 dB	*-72 dB	*-74 dB	*-74 dB	
	(Left or right) * dB minimum below 100% modulation. Reference: 400 Hz, 75 microsecond de-emphasis, \pm 75 kHz deviation, measured 30 Hz to 15 kHz bandwidth.									

Prices and Specifications Subject to Change Without Notice.



HARRIS
P. O. Box 4290
Quincy, IL 62305-4290
(217) 222-8200

	FM-300K FM-300KD	FM-1K	FM-3.5K	FM-5K	FM-10K	FM-20K	FM-25K	FM-40K	FM-50K
WEIGHT & CUBAGE:		WEIGHT & CUBAGE: Export: 1300 lbs. (590kg), Domestic: 1050 lbs. (476kg). 104 cu. ft. (2.9 cu. m).	WEIGHT & CUBAGE: Export: 980 lbs. (445kg), Domestic: 880 lbs. (400kg). Cubage—Export: 46.7cu. ft. (1.322 cu. m).	WEIGHT AND CUBAGE: Export: 2100 lbs. (953kg), Domestic: 1700 lbs. (771kg). 120 cubic feet.	WEIGHT & CUBAGE: Export: 2200 lbs. (998kg), Domestic: 1800 lbs. (817kg). 120 cu. ft.	WEIGHT & CUBAGE: Export: 2800 lbs. (1270kg), Domestic: 2300 lbs. (1043kg). 141 cu. ft.	WEIGHT & CUBAGE: (Estimated) Export: 3000 lbs. (1361kg), Domestic: 2700 lbs. (1225kg). Cubage: 150 cu. ft.	WEIGHT & CUBAGE: Export: 6800 lbs. (3087kg), Domestic: 6000 lbs. (2724kg). 270 cu. ft. (7.5 cu. m).	WEIGHT & CUBAGE (Approximate): Export: 7000 lbs. (3178kg), Domestic: 6800 lbs. (3087kg). Cubage: 400 cu. ft. (11.3 cu. m).
WIDEBAND COMPOSITE OPERATION									
COMPOSITE INPUT:	One balanced floating input.								
COMPOSITE INPUT IMPEDANCE:	2000 ohms resistive.								
COMPOSITE INPUT CONNECTOR:	Female BNC.								
COMPOSITE INPUT LEVEL:	1.0 volt RMS nominal for ± 75 kHz deviation.								
EXTERNAL SCA GENERATOR INPUTS:	Up to two unbalanced inputs (optional).								
COMPOSITE FM SIGNAL TO NOISE:	80 dB below 100% modulation (reference 400 Hz @ ± 75 kHz deviation with 75 microsecond de-emphasis, 20 Hz to 200 kHz bandwidth).								
COMPOSITE HARMONIC DISTORTION:	.08%		.15%		.08%				
COMPOSITE INTERMODULATION DISTORTION:	.02%	.1%	.02%		.1%	.02%	.1%	.02%	
COMPOSITE CCIF INTERMODULATION DISTORTION, All distortion products below:	80 dB	77 dB	80 dB		75 dB	80 dB	75 dB	80 dB	
COMPOSITE AMPLITUDE RESPONSE:	± 0.1 dB, 30 Hz-53 kHz.								
ASYNCHRONOUS AM SIGNAL TO NOISE:	65 dB below reference carrier AM modulation 100% output power: (300 watts).								
		ASYNCHRONOUS AM SIGNAL TO NOISE: 50 dB below reference carrier AM modulation 100% output power: 15 watts.							
			ASYNCHRONOUS AM SIGNAL TO NOISE: 55 dB below reference carrier AM modulation 100% output power.						
				ASYNCHRONOUS AM SIGNAL TO NOISE: 50 dB below reference carrier AM modulation 100% output power: 15 watts.					
					ASYNCHRONOUS AM SIGNAL TO NOISE: 50 dB below reference carrier AM modulation 100% output power.				
						ASYNCHRONOUS AM SIGNAL TO NOISE: 52 dB below reference carrier AM modulation 100% output power: 15 watts.			
							ASYNCHRONOUS AM SIGNAL TO NOISE: 55 dB below reference carrier AM modulation 100% output power.		
								ASYNCHRONOUS AM SIGNAL TO NOISE: 50 dB below referenced carrier AM modulation 100% output power: 15 watts.	

SPECIFICATIONS (Cont'd)

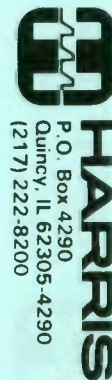

FM BROADCASTING TRANSMITTERS



ORDERING INFORMATION

FM-300K , 300 Watt All Solid-State Transmitter, mounted in a 24" cabinet, for 50/60 Hz operation. 50 ohm type N female connector, equipped for wide band operation	994-8296-001
FM-300KD , Basic, Two Identical 300 Watt All Solid-State Transmitters, mounted in a single 24" cabinet, for 50/60 Hz operation, 50 ohm type N female output connectors. Equipped for wide band operation with STL	994-8297-001
FM-1K , 1 kW FM transmitter with MX-15 exciter, for wideband operation, 50/60 Hz	994-8046-001
Mono generator (add for mono operation)	994-8019-001
DSM stereo generator with DTR (add for stereo operation)	994-8020-001
SCA generator (add for SCA operation, specify 41 or 67 kHz)	994-7992-001
FM-3.5K , 3500 Watt FM Broadcast Transmitter with MX-15 Exciter for wideband operation, 197 to 250 VAC, Single Phase 50 or 60 Hz (specify)	994-8766-001
Options	
Constant Voltage Filament Regulator Transformer	472-0586-000 for 60 Hz 472-1244-000 for 50 Hz
Spare 4CX3500A PA Tube	374-0169-000
Mono Generator (Add For Mono Operation)	994-8019-001
Harris DSM Stereo Generator (For Stereo Operation)	994-8020-001
Harris SCA Generator (67 or 92 kHz Operation)	994-7992-002
FM-5K , 5 kW FM transmitter with MX-15 exciter, for wideband operation, 60 Hz	994-8049-003
As above, except for 50 Hz operation	994-8049-006
Mono generator (add for mono operation)	994-8019-001
DSM stereo generator with DTR (add for stereo operation)	994-8020-001
SCA generator (add for SCA operation, specify 67 or 92 kHz)	994-7992-002
FM-10K , 10,000 watt FM transmitter with MX-15 exciter, for wideband operation, 60 Hz	994-8051-005
As above, except for 50 Hz operation	994-8051-006
Mono generator (add for mono operation)	994-8019-001
DSM stereo generator with DTR (add for stereo operation)	994-8020-001
SCA generator (add for SCA operation, specify 67 or 92 kHz)	994-7992-002
FM-20K , 20,000 watt FM broadcast transmitter with MX-15 exciter, for wideband operation, 60 Hz	994-8052-002
Mono generator (add for mono operation)	994-8019-001
DSM stereo generator with DTR (add for stereo operation)	994-8020-001
SCA generator (add for SCA operation, specify 67 or 92 kHz)	994-7992-002
FM-25K , 25,000 watt FM broadcast transmitter with MX-15 exciter, for wideband operation, 50/60 Hz (specify 50 or 60 Hz)	994-8258-001
Spare tube	374-0151-000
Mono generator (add for mono operation)	994-8019-001
DSM stereo generator with DTR (add for stereo operation)	994-8020-001
SCA generator (add for SCA operation, specify 67 or 92 kHz)	994-7992-002
Extended Control Panel for FM-25K	994-8475-001
FM-40K , 40 kilowatt FM transmitter, basic system, for wideband operation, 60 Hz	994-8053-002
Automatic exciter/isolation amplifier switching kit	994-6876-001
RF output switching package	994-6877-001
Monaural generator (add for mono operation)	994-8019-001
DSM stereo generator with DTR (add for stereo operation)	994-8020-001
SCA generator (add for SCA operation, specify 67 or 92 kHz)	994-7992-002
50 kilowatt air-cooled test load	700-0317-000
50 kilowatt water-cooled test load	700-0239-000
FMD-50K , dual 50 kilowatt FM transmitter, with automatic RF output switching, for wideband operation	994-8455-001
FMD-50K , dual 50 kilowatt FM transmitter, basic system, for wideband operation	994-8455-002
Automatic exciter switching option (does not include second exciter)	994-8456-001
MX-15 exciter (does not include generator modules)	994-7950-004
Monaural generator (add for mono operation)	994-8019-001
DSM stereo generator with DTR (add for stereo operation)	994-8020-001
SCA generator (add for SCA operation, specify 67 or 92 kHz)	994-7992-002
RF input patch panel	994-8473-001

**HARRIS**P.O. Box 4290
Quincy, IL 62305-4290
(217) 222-8200**FM ANTENNAS****FMXH High Power, High Performance
Circularly Polarized FM Antenna**

- Horizontal circularity is typically ± 2 dB when pole mounted or face mounted on a 24" tower for uniform signal coverage
- Excellent bandwidth minimizes degradation to stereo and SCA channels
- High power handling capability provides flexibility in transmission system design
- Rugged brass construction and silver-plated inner-conductor connectors insure long, trouble-free service
- Standard corrosion-resistant steel support brackets and hardware
- Antenna pattern optimization available to meet exact requirements

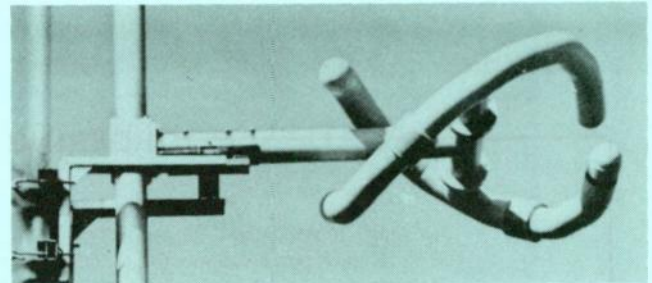
**Specifications And Ordering Information**

"A" MODEL, 3/8" INTERBAY LINE, 3/8" ELEMENT STEM										
Harris Part No.	No. of Bays	Power Gain	DB Gain	Type Feed	Female 50 OHM Input	Power Input Capability	Calculated Weight	Calculated Wind Load	Calculated Weight with Radome and Brackets	Calculated Wind Load with Radome and Brackets
710-0473-000	FMXH-1AE	0.4611	3.3623	End	3/8"	32kW	119	147	190	364
710-0474-000	FMXH-2AE	0.9971	0.0128	End	3/8"	32kW	230	314	381	752
710-0475-000	FMXH-2AC	0.9971	0.0128	Center	3/8"	39kW	255	329	390	759
710-0476-000	FMXH-2AC6	0.9971	0.0128	Center	6/8"	64kW	306	431	441	995
710-0477-000	FMXH-3AE	1.5588	1.9278	End	3/8"	32kW	341	480	573	1,140
710-0478-000	FMXH-4AE	2.1332	3.2903	End	3/8"	32kW	452	647	764	1,528
710-0479-000	FMXH-4AC	2.1332	3.2903	Center	3/8"	39kW	477	662	773	1,535
710-0480-000	FMXH-4AC6	2.1332	3.2903	Center	6/8"	64kW	528	768	824	1,780
710-0481-000	FMXH-5AE	2.7154	4.3384	End	3/8"	32kW	563	814	956	1,915
710-0482-000	FMXH-6AE	3.3028	5.1888	End	3/8"	32kW	574	981	1,147	2,304
710-0483-000	FMXH-6AC	3.3028	5.1888	Center	3/8"	39kW	699	996	1,156	2,310
710-0484-000	FMXH-6AC6	3.3028	5.1888	Center	6/8"	64kW	750	1,106	1,207	2,565
710-0485-000	FMXH-7AE	3.8935	5.9034	End	3/8"	32kW	785	1,148	1,339	2,692
710-0486-000	FMXH-8AE	4.4872	6.5197	End	3/8"	32kW	896	1,315	1,530	3,080
710-0487-000	FMXH-8AC	4.4872	6.5197	Center	3/8"	39kW	921	1,330	1,439	3,086
710-0488-000	FMXH-8AC6	4.4872	6.5197	Center	6/8"	64kW	972	1,443	1,490	3,348
710-0489-000	FMXH-10AC	5.6800	7.5435	Center	3/8"	39kW	1,143	1,663	1,923	3,862
710-0490-000	FMXH-10AC6	5.6800	7.5435	Center	6/8"	64kW	1,194	1,780	1,974	4,134
710-0491-000	FMXH-12AC	6.8781	8.3747	Center	3/8"	39kW	1,365	1,997	2,305	4,638
710-0492-000	FMXH-12AC6	6.8781	8.3747	Center	6/8"	64kW	1,416	2,118	2,356	4,919
"B" MODEL, 4/8" INTERBAY LINE, 4/8" ELEMENT STEM										
710-0493-000	FMXH-1BE	0.4611	3.3623	End	6/8"	40kW	165	214	229	434
710-0494-000	FMXH-2BE	0.9971	0.0128	End	6/8"	56kW	303	420	431	860
710-0495-000	FMXH-2BC	0.9971	0.0128	Center	6/8"	80kW	342	481	470	921
710-0496-000	FMXH-3BE	1.5888	1.9278	End	6/8"	56kW	441	626	633	1,286
710-0497-000	FMXH-4BE	2.1332	3.2903	End	6/8"	56kW	579	831	835	1,712
710-0498-000	FMXH-4BC	2.1332	3.2903	Center	6/8"	112kW	618	892	874	1,775
710-0499-000	FMXH-5BE	2.7154	4.3384	End	6/8"	56kW	717	1,037	1,037	2,138
710-0500-000	FMXH-6BE	3.3028	5.1888	End	6/8"	56kW	855	1,242	1,239	2,564
710-0501-000	FMXH-6BC	3.3028	5.1888	Center	6/8"	112kW	894	1,303	1,278	2,625
710-0502-000	FMXH-7BE	3.8935	5.9034	End	6/8"	56kW	993	1,448	1,441	2,990
710-0503-000	FMXH-8BE	4.4872	6.5197	End	6/8"	56kW	1,131	1,654	1,643	3,416
710-0504-000	FMXH-8BC	4.4872	6.5197	Center	6/8"	112kW	1,170	1,715	1,682	3,475
710-0505-000	FMXH-10BC	5.6800	7.5435	Center	6/8"	112kW	1,446	2,126	2,086	4,325
710-0506-000	FMXH-12BC	6.8781	8.3747	Center	6/8"	112kW	1,722	2,537	2,490	5,175
"C" MODEL, 6/8" INTERBAY LINE, 4/8" ELEMENT STEM										
710-0507-000	FMXH-1CE	0.4611	3.3623	End	6/8"	40kW	211	273	274	493
710-0508-000	FMXH-2CE	0.9971	0.0128	End	6/8"	80kW	416	533	544	973
710-0509-000	FMXH-3CE	1.5888	1.9278	End	6/8"	120kW	621	793	813	1,453
710-0510-000	FMXH-4CE	2.1332	3.2903	End	6/8"	120kW	826	1,053	1,082	1,933
710-0511-000	FMXH-5CE	2.7154	4.3384	End	6/8"	120kW	1,031	1,313	1,351	2,413
710-0512-000	FMXH-6CE	3.3023	5.1888	End	6/8"	120kW	1,236	1,573	1,620	2,893

FOOTNOTES—(Apply to all models) 1. Horizontal and vertical power gain and dB gain are the same. 2. Power input capability up to 2,000 ft above mean sea level. Derating required above 2,000 ft. 3. Windload based on 50.33 PSF, 112 m.p.h. actual wind velocity. NOTE: Brackets included in weight and windload calculations. 4. Heaters add 4 lbs. to each half loop for a single bay. Heater box, hardware, interbay connecting A.C. cable, and copper conduit add a total of 7 lbs. to each bay. The total effect of adding heaters is 15 lbs. per bay level.

FMXH Options

- FMXH Radomes 710-0530-000
 FMXH Electrical Deicers (less control sensor) 710-0532-000
 Mounting Brackets for Special Tower Configurations
 FMXH Pattern Optimization for a 24 inch uniform cross sectional tower
 FMXH Custom Pattern Measurement and Optimization for other structures

FM ANTENNAS

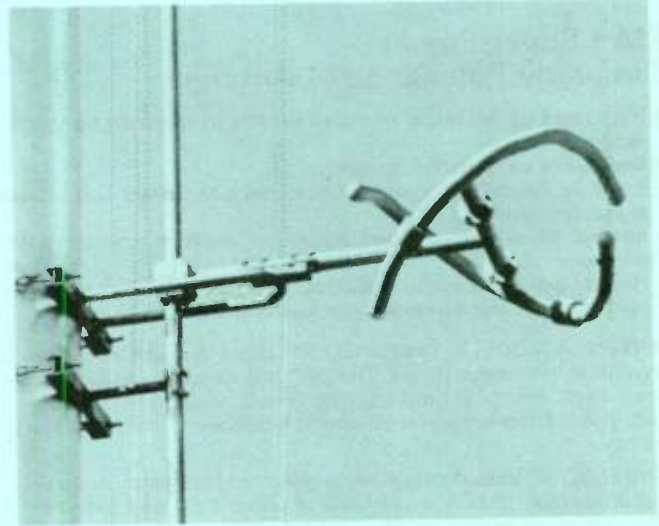

FMXL Low Power, High Performance Circularly Polarized FM Antenna

- Horizontal circularity is typically ± 2 dB when pole mounted or face mounted on a 24" tower for uniform signal coverage
- Excellent bandwidth provides excellent performance for stereo and SCA channels
- Power handling capability provides flexibility in transmission system design
- Rugged brass construction and silver-plated inner-conductor connectors insure long, trouble-free service
- Standard corrosion-resistant steel support brackets and hardware
- Antenna pattern optimization available to meet exact requirements

Specifications And Ordering Information

Harris Part No.	No. of Bays	Power Gain	DB Gain	Type Feed	50 OHM Input	Input Rating	Lbs. Weight	Lbs. Wind Load	Calculated Weight with Radome and Brackets	Calculated Wind Load with Radome and Brackets
710-0513-000	FMXL-1E	0.4611	3.3632	END	1 $\frac{5}{8}$ "	9kW	57	102	88	228
710-0514-000	FMXL-2E	0.9971	0.0128	END	1 $\frac{5}{8}$ "	9kW	114	212	171	461
710-0515-000	FMXL-3E	1.5588	1.9278	END	1 $\frac{5}{8}$ "	9kW	170	323	253	693
710-0516-000	FMXL-4E	2.1332	3.2903	END	1 $\frac{5}{8}$ "	9kW	227	433	336	926
710-0517-000	FMXL-5E	2.7154	4.3384	END	1 $\frac{5}{8}$ "	9kW	283	543	418	1,158
710-0518-000	FMXL-6E	3.3028	5.1888	END	1 $\frac{5}{8}$ "	9kW	340	654	501	1,391
CENTER FED										
710-0519-000	FMXL-2C	0.9971	0.0128	CENTER	3 $\frac{1}{8}$ "	12kW	152	302	204	538
710-0520-000	FMXL-3C	1.9278	1.5588	OFF CENTER	3 $\frac{1}{8}$ "	12kW	207	412	287	770
710-0521-000	FMXL-4C	2.1332	3.2903	CENTER	3 $\frac{1}{8}$ "	12kW	260	509	371	1,002
710-0522-000	FMXL-5C	2.7154	4.3384	OFF CENTER	3 $\frac{1}{8}$ "	12kW	317	620	452	1,235
710-0523-000	FMXL-6C	3.3028	5.1888	CENTER	3 $\frac{1}{8}$ "	12kW	373	730	534	1,467
710-0524-000	FMXL-7C	3.8935	5.9034	OFF CENTER	3 $\frac{1}{8}$ "	12kW	430	840	617	1,700
710-0525-000	FMXL-8C	4.4872	6.5197	CENTER	3 $\frac{1}{8}$ "	12kW	486	950	699	1,932
710-0526-000	FMXL-9C	5.0826	7.0608	OFF CENTER	3 $\frac{1}{8}$ "	12kW	543	1,060	782	2,164
710-0527-000	FMXL-10C	5.6800	7.5435	CENTER	3 $\frac{1}{8}$ "	12kW	599	1,171	864	2,397
710-0528-000	FMXL-11C	6.2783	7.9785	OFF CENTER	3 $\frac{1}{8}$ "	12kW	656	1,281	947	2,630
710-0529-000	FMXL-12C	6.8781	8.3847	CENTER	3 $\frac{1}{8}$ "	12kW	713	1,391	1,029	2,862

FOOTNOTES. 1. Horizontal and vertical power gain and dB gain are the same. 2. Power input capability up to 2,000 ft. above mean sea level. Derating required above 2,000 ft. 3. Wind load based on 112 mph wind velocity (50.33 psf) and the wind blowing normal to the side of the antenna. Weight and wind load calculations include brackets, interbay line and the transformer section. Calculations based on the frequency of 95 MHz. 4. Heaters add 4 lbs. to each half loop for a single bay. Heater box, hardware, interbay connecting A.C. cable, and copper conduit add a total of 7 lbs. to each bay. The total effect of adding heaters is 15 lbs. per bay level.

FMXL Options

The following options are available for the FMXL antenna in order to meet special requirements. Your Harris representative can provide you with additional information.

- FMXL Radomes 710-0531-000
- FMXL Electrical Deicers (less control sensor) 710-0533-000
- Mounting Brackets for Special Tower Configurations
- FMXL Pattern Optimization for a 24 inch uniform cross sectional tower
- FMXL Custom Pattern Measurement and Optimization for other structures



HARRIS

P.O. Box 4290
Quincy, IL 62305-4290
(217) 222-8200

FM ANTENNAS

FMH Super-Power Circularly Polarized FM Antenna

- High input power rating permits flexibility in transmitting system design
- Capable of multi-station operation
- Excellent bandwidth characteristics minimize VSWR and related signal degradation
- Internal element feed point minimizes weather related VSWR problems
- Rugged brass element construction, along with stainless steel support brackets and hardware, impedes corrosion

ANTENNA MODELS. The Harris FMH super-power FM antenna is available in three versions. The "A" version uses a 3-1/8" element feed stem, and 3-1/8" rigid interbay line. It is available in 3-1/8" end fed, 3-1/8" center fed and 6-1/8" center fed models, in arrays of up to 16 bays.

The FMH "B" version uses a 4-1/8" element feed stem, and a 4-1/8" rigid interbay line. It is available in either 6-1/8" end fed or 6-1/8" center fed models in arrays of up to 12 bays.

The FMH "C" version uses a 4-1/8" element feed stem, and a 6-1/8" rigid interbay line, with 6-1/8" end feed. It is available in arrays of up to 6 bays.

Each antenna is supplied with a 6-foot input transformer. The input is 50 ohm EIA with either a 3-1/8" flange or a 6-1/8" flange, depending on the model type. All antennas are completely assembled and tuned to the customer's frequency at the factory. Also, pressure testing is done at that time to assure the customer of a leak-free antenna, provided the antenna is properly installed by a qualified erector and is free of damage.

MOUNTING. Stainless steel mounting brackets and hardware are supplied for standard constant cross section towers having less than 4 ft. face or steel poles at no additional cost. Brackets for mounting on tapered towers are available at additional cost.

DIMENSIONS. Each FMH element is approximately 47-1/2 inches long, and 30 inches high. Weight is approximately 57 pounds per element with line block.

"A" Model, 3-1/8" Interbay Line, 3-1/8" Element Stem

TYPE NO.	POWER GAIN ¹		FEMALE 50 OHM INPUT	POWER ² INPUT CAPABILITY	CALCULATED WT. [LBS]	CALCU. ³ LATED WIND-LOAD [LBS]
	POWER	dB				
FMH-1AE	0.4611	-3.3623	3 1/8"	32kW	114	137
FMH-2AE	0.9971	-0.0128	3 1/8"	32kW	225	304
FMH-2AC	0.9971	-0.0128	3 1/8"	39kW	250	319
FMH-2AC6	0.9971	-0.0128	6 1/8"	64kW	301	421
FMH-3AE	1.5588	1.9278	3 1/8"	32kW	336	470
FMH-4AE	2.1332	3.2903	3 1/8"	32kW	447	637
FMH-4AC	2.1332	3.2903	3 1/8"	39kW	472	652
FMH-4AC6	2.1332	3.2903	6 1/8"	64kW	523	758
FMH-5AE	2.7154	4.3384	3 1/8"	32kW	558	804
FMH-6AE	3.3028	5.1888	3 1/8"	32kW	669	971
FMH-6AC	3.3028	5.1888	3 1/8"	39kW	694	986
FMH-6AC6	3.3028	5.1888	6 1/8"	64kW	745	1096
FMH-7AE	3.8935	5.9034	3 1/8"	32kW	780	1138
FMH-8AE	4.4872	6.5197	3 1/8"	32kW	891	1305
FMH-8AC	4.4872	6.5197	3 1/8"	39kW	916	1320
FMH-8AC6	4.4872	6.5197	6 1/8"	64kW	967	1433
FMH-10AC	5.6800	7.5435	3 1/8"	39kW	1138	1653
FMH-10AC6	5.6800	7.5435	6 1/8"	64kW	1189	1770
FMH-12AC	6.8781	8.3747	3 1/8"	39kW	1360	1987
FMH-12AC6	6.8781	8.3747	6 1/8"	64kW	1411	2108

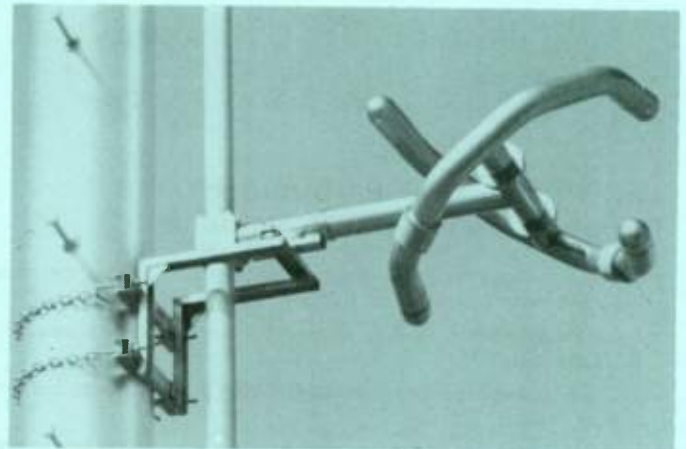

FMH OPTIONS. The following options are available for the FMH antenna in order to meet special requirements. Your Harris representative can provide you with additional option information for your consideration.

- DC shorting stub for lightning protection.
- FMH radomes or electrical deicers.
- Mounting brackets for special tower configurations.
- FMH custom pattern measurements and optimization.

"B" Model, 4-1/8" Interbay Line, 4-1/8" Element Stem

TYPE NO.	POWER GAIN ¹		FEMALE 50 OHM INPUT	POWER ² INPUT CAPABILITY	CALCULATED WT. [LBS]	CALCU. ³ LATED WIND-LOAD [LBS]
	POWER	dB				
FMH-1BE	0.4611	-3.3623	6 1/8"	40kW	159	201
FMH-2BE	0.9971	-0.0128	6 1/8"	56kW	297	407
FMH-2BC	0.9971	-0.0128	6 1/8"	80kW	336	468
FMH-3BE	1.5888	1.9278	6 1/8"	56kW	435	613
FMH-4BE	2.1332	3.2903	6 1/8"	56kW	573	818
FMH-4BC	2.1332	3.2903	6 1/8"	112kW	612	879
FMH-5BE	2.7154	4.3384	6 1/8"	56kW	711	1024
FMH-6BE	3.3028	5.1888	6 1/8"	56kW	849	1229
FMH-6BC	3.3028	5.1888	6 1/8"	112kW	888	1290
FMH-7BE	3.8935	5.9034	6 1/8"	56kW	987	1435
FMH-8BE	4.4872	6.5197	6 1/8"	56kW	1125	1641
FMH-8BC	4.4872	6.5197	6 1/8"	112kW	1164	1702
FMH-10BC	5.6800	7.5435	6 1/8"	112kW	1440	2113
FMH-12BC	6.8781	8.3747	6 1/8"	112kW	1716	2524

"C" Model, 6-1/8" Interbay Line, 4-1/8" Element Stem

TYPE NO.	POWER GAIN ¹		FEMALE 50 OHM INPUT	POWER ² INPUT CAPABILITY	CALCULATED WT. [LBS]	CALCU. ³ LATED WIND-LOAD [LBS]
	POWER	dB				
FMH-1CE	0.4611	-3.3623	6 1/8"	40kW	205	260
FMH-2CE	0.9971	-0.0128	6 1/8"	80kW	410	520
FMH-3CE	1.5888	1.9278	6 1/8"	120kW	615	780
FMH-4CE	2.1332	3.2903	6 1/8"	120kW	820	1040
FMH-5CE	2.7154	4.3384	6 1/8"	120kW	1025	1300
FMH-6CE	3.3028	5.1888	6 1/8"	120kW	1230	1560

FOOTNOTES-(Apply to all models)

1. Horizontal and vertical power gain and dB gain are the same. 2. Power input capability up to 2,000 ft. above mean sea level. Derating required above 2,000 ft. 3. Windload based on 50/33 PSF, 112 m.p.h. actual wind velocity. NOTE: Brackets included in weight and windload calculations.

FM ANTENNAS

FML LOW POWER CIRCULARLY POLARIZED FM ANTENNA

- High input power rating permits flexibility in transmitting system design
- Rugged brass element construction with stainless steel support brackets impedes corrosion to insure long, trouble-free life
- Excellent bandwidth minimizes VSWR and related signal degradation
- Custom pattern optimization service available to meet special requirements

The Harris low power FML circularly polarized FM antenna features excellent bandwidth characteristics and the same rugged construction as Harris' higher-power FM antennas to insure top service and long life.

ANTENNA MODELS. Two versions of the FML are available. The "E" version is an end fed model mounted on 1-5/8", 50 ohm rigid line. The "C" version is center fed, and uses 3-1/8", 50 ohm rigid line.

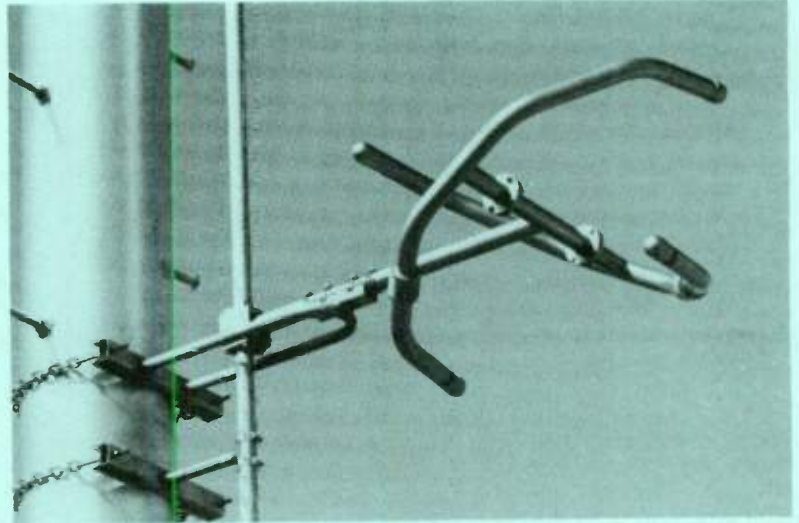

FML LOW POWER CIRCULARLY POLARIZED FM ANTENNAS

TYPE NO.	POWER GAIN ¹		TYPE FEED	FEMALE 50 OHM INPUT	POWER ² INPUT CAPABILITY	CALCULATED WEIGHT [LBS.]	CALCULATED WIND LOAD [LBS.]
	POWER	dB					
FML-1E	0.4611	-3.3623	END	1-5/8"	9 kW	57	102
FML-2E	0.9971	-0.0128	END	1-5/8"	9 kW	114	212
FML-3E	1.5588	1.9278	END	1-5/8"	9 kW	170	323
FML-4E	2.1322	3.2903	END	1-5/8"	9 kW	227	433
FML-4C	2.1322	3.2903	CENTER	3-1/8"	12 kW	260	509
FML-5E	2.7154	4.3384	END	1-5/8"	9 kW	283	543
FML-5C	2.7154	4.3384	OFF CENTER	3-1/8"	12 kW	317	620
FML-6E	3.3028	5.1888	END	1-5/8"	9 kW	340	654
FML-6C	3.3028	5.1888	CENTER	3-1/8"	12 kW	373	730
FML-7E	3.8935	5.9034	END	1-5/8"	9 kW	396	764
FML-7C	3.8935	5.9034	OFF CENTER	3-1/8"	12 kW	430	840
FML-8E	4.4872	6.5197	END	1-5/8"	9 kW	453	874
FML-8C	4.4872	6.5197	CENTER	3-1/8"	12 kW	486	950
FML-9C	5.0826	7.0608	OFF CENTER	3-1/8"	12 kW	543	1060
FML-10C	5.6800	7.5435	CENTER	3-1/8"	12 kW	599	1171
FML-11C	6.2783	7.9785	OFF CENTER	3-1/8"	12 kW	656	1281
FML-12C	6.8781	8.3747	CENTER	3-1/8"	12 kW	712	1391
FML-13C	7.4785	8.7381	OFF CENTER	3-1/8"	12 kW	769	1501
FML-14C	8.0800	9.0741	CENTER	3-1/8"	12 kW	825	1612

FOOTNOTES. 1. Horizontal and vertical power gain and dB gain are the same. 2. Power input capability up to 2,000 ft. above mean sea level. Derating required above 2,000 ft. 3. Wind load based on 112 mph wind velocity (50/30 psf) and the wind blowing normal to the side of the antenna. Weight and wind load calculations include brackets, interbay line and the transformer section. Calculations based on the frequency of 95 MHz.

FML OPTIONS. The following options are available for the FML antenna in order to meet special requirements. Your Harris representative can provide you with additional information for your consideration.

- DC shorting stub for lightning protection.
- FML radomes or electrical deicers.
- Mounting brackets for special tower configurations.
- FML custom pattern measurements and optimization.

DIRECTIONAL DUAL POLARIZED FM ANTENNA

- Pattern factory tested for proven results
- Deicers not needed in most environments, eliminating associated maintenance and operating costs
- Excellent bandwidth characteristics minimize VSWR problems
- Rugged brass element construction, with stainless steel support brackets, impedes corrosion

Harris' FMD-(X) is a directional dual polarized FM antenna designed for pole mounting. It is available with up to eight bays and with either 1- 5/8 inch or 3- 1/8 inch EIA 50 ohm female input. The "X" in the type number indicates the number of bays. The suffix "A" following the complete type number signifies 1- 5/8" input and the suffix "B" indicates 3- 1/8" input. (Example—FMD-4A is a 4-bay antenna with 1- 5/8" input).

UP TO 40 KW INPUT POWER. The maximum power input capability for the "A" series is 12 kilowatts. The maximum power input capability for the "B" series is 20 kilowatts for a single bay, and 40 kilowatts for two (2) through eight (8) bays.

The interbay lines use 3- 1/8 inch rigid, with three such lines used between bays, two for the horizontal element feeds and one for the vertical element feeds. A combiner, for combining the three transmission line feeds, is used below the bottom bay. A six foot transformer section is used immediately below this combiner.

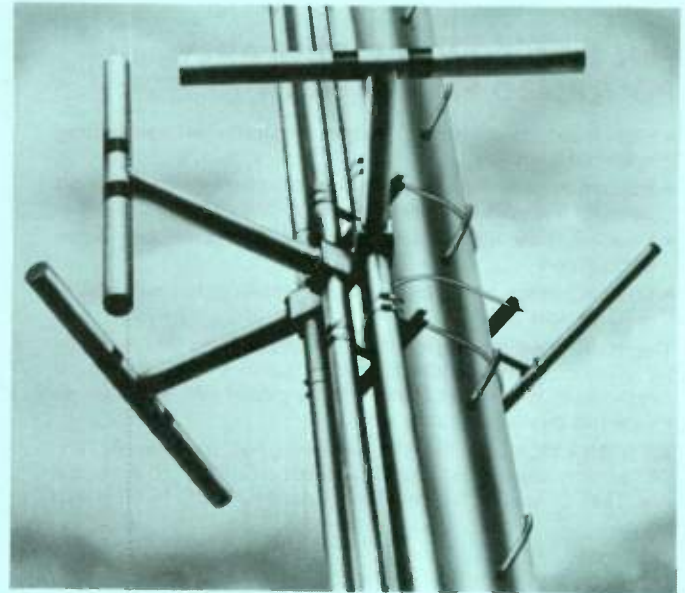

ORDERING INFORMATION. Orders for the Harris Dual Polarized Directional FM Antenna should specify the desired true azimuth orientation, maximum ERP permitted, radiated power limitations and their true orientation, transmission line efficiency (or specify the type of transmission line and its length), and the transmitter power output capability. Such antenna pattern requirements are normally specified by the stations's consultant. Ideally, a copy of the FCC construction permit should be supplied so that the manufacturer can assure full compliance with the requirements of such authorization relative to the antenna.

Electrical And Mechanical Data

HARRIS TYPE NO.	INPUT POWER RATING KW	FEMALE INPUT FLANGE	POLE LENGTH FT	WEIGHT POLE AND ANTENNA LBS	TOTAL WIND LOAD [BASED ON 50/33 PSF] LBS	OVER-TURNING MOMENT FT LBS	HEIGHT ELEC-TRICAL CENTER ABOVE TOWER TOP FT	BOLT CIRCLE DIAMETER INCHES
FMD-1A	12	1 5/8 "	20	606	796	9595	16	9
FMD-1B	20	3 1/8 "	20	626	832	10000	16	9
FMD-2A	12	1 5/8 "	30	2240	1821	30024	21	17
FMD-2B	40	3 1/8 "	30	2260	1856	30593	21	17
FMD-3A	12	1 5/8 "	40	2994	2557	54917	26	17
FMD-3B	40	3 1/8 "	40	3014	2593	55682	26	17
FMD-4A	12	1 5/8 "	50	4245	3490	89308	31	17
FMD-4B	40	3 1/8 "	50	4265	3526	90254	31	17
FMD-5A	12	1 5/8 "	62	5901	4680	153210	38	17
FMD-5B	40	3 1/8 "	62	5921	4716	154407	38	17
FMD-6A	12	1 5/8 "	72	7956	5523	208204	43	17
FMD-6B	40	3 1/8 "	72	7976	5559	209581	43	17
FMD-7A	12	1 5/8 "	82	9250	6350	271315	48	17
FMD-7B	40	3 1/8 "	82	9270	6386	272872	48	17
FMD-8A	12	1 5/8 "	92	11305	7192	343159	53	17
FMD-8B	40	3 1/8 "	92	11325	7227	344847	53	17

FM ANTENNAS

CBR

Cavity Backed Radiator Circularly Polarized FM Antenna

- The ideal antenna for multistation FM operations
- Wide bandwidth provides low VSWR across the FM band
- Superb horizontal circularity and excellent vertical pattern control insure uniform coverage
- High power handling capabilities provide wide latitude in transmission system design
- Wire-grid cavity design minimizes windloading and the associated cost impact on the support structure
- Available in one, two, three or four around configuration to meet the required coverage contour
- Fully assembled and tested at Harris' full capability antenna test range to insure top performance

The Harris Cavity Backed Radiator (CBR) antenna offers ideal characteristics to FM stations desiring the advantages of combined station operation or to stations requiring special directional coverage. Extensive field experience has proven the CBR to be the best approach to circularly polarized FM transmission.

The Harris Cavity Backed Radiator consists of a crossed dipole radiator fed in phase quadrature and mounted within a circular cavity. Rotating RF energy is produced when the cavity is excited by the dipole elements. The signal emanating from the cavity is right-hand circular. The field rotates clockwise as viewed in the direction of propagation. Cavity size is principally determined by beamwidth requirements. A beamwidth of 90 degrees is required for a 4-around array and 120 degrees is required for a 3-around array, (measured at the half-voltage coordinates).

GRID CAVITY

The cavity used in the Harris circularly polarized FM antenna is a welded steel galvanized grid. The cavity grid is supported from a center mounting plate, which also serves as a mounting for the dipole assembly and for attachment of the unit to the supporting structure.

The use of grid cavities and aerodynamic design significantly reduce weight and windload requirements on the supporting structure. This often represents substantial savings in support structure cost compared with other panel style antenna designs.

MULTISTATION OPERATION

Multistation FM operation where two or more stations share the same antenna has increased in popularity due to the inherent cost savings which can be realized. Multistation operation can be achieved only with the wide bandwidth characteristics the Harris CBR antenna offers.

These characteristics are achieved through the use of a broadband radiating element in conjunction with high power hybrid junctions. A VSWR plot of a Harris CBR antenna is shown on the facing page.

Harris also offers the associated combining equipment necessary for multistation operation. Harris' experience with multiplexer installations insures proper combiner operation to optimize the operation of stereo and SCA services.

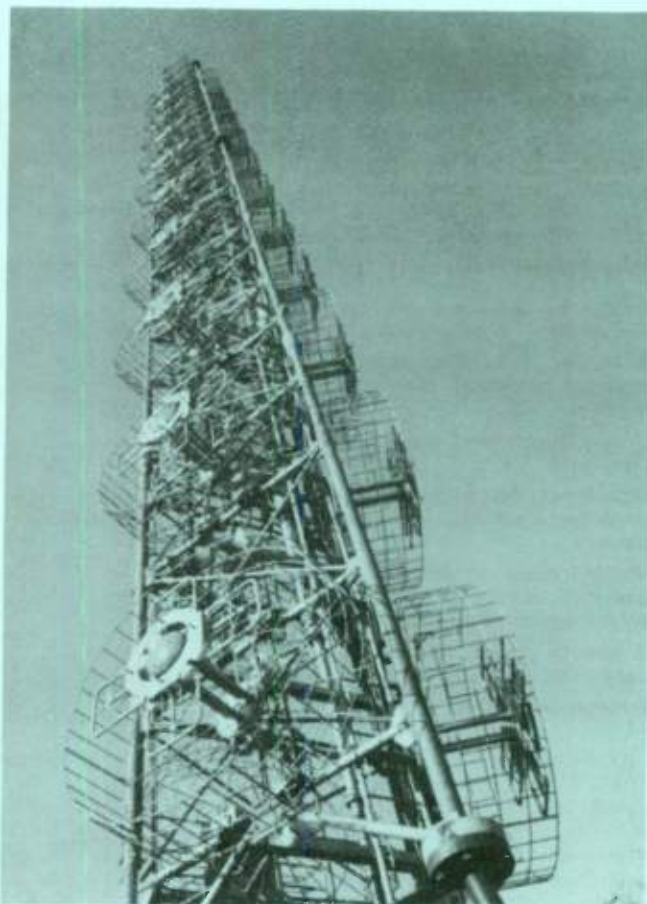

AZIMUTH CIRCULARITY

For omnidirectional operation, the shape of the standard azimuth pattern will vary from omni by less than ± 2.0 dB for three-sided tower configurations. With a four-around antenna array, the typical circularity will be comparable.

Stations employing directional arrays will find one of the several patterns available to be ideally suited to their specific needs.

ELEVATION PATTERN

The unique design of the CBR antenna offers precision control of the elevation pattern which is critical in auto receiver reception. Vertical pattern contouring to introduce beam tilt and null fill may be provided by means of standard phase and power distribution techniques.

HIGH POWER CAPABILITIES

The Harris CBR antenna is designed for high power operation enabling station flexibility in transmission system design. Harris' conservative power rating insures adequate design headroom for long term reliability.

The Harris CBR antenna can be configured with one or two input ports. This feature allows the top and bottom six bays of a typical twelve bay antenna to be fed by two independent transmission lines. Should standby operation be necessary, one half of the system may be used at reduced power.



HARRIS

P. O. Box 4290
Quincy, IL 62305-4290
(217) 222-8200

VHF LOW BAND COLOR TELEVISION TRANSMITTERS

TV-20L 22.5 Kilowatt TV-30L 30 Kilowatt VHF Low Band Color Television Transmitter

- Straightforward design for high reliability and stability
- Advanced SAW filter, built-in receiver equalizer eliminates separate correction modules
- Unique Quadrature Corrector cancels tube distortions
- Ultra-linear driver with solid-state IPAs for maximum reliability and signal transparency
- Highly linear IF Modulation of the visual and aural carriers for superior color and sound reproduction
- Automatic power control insures essentially constant power output
- Emergency multiplex option

Harris' TV-20L, 22.5 kilowatt and TV-30L, 30 kilowatt low band VHF television transmitters are the most cost-effective TV transmitters available in their power range. Their straightforward design requires less complicated circuitry to meet the high performance standards demanded by today's discriminating broadcaster. And less complicated circuitry means greater reliability, the type of year-in, year-out dependability broadcasters need for impressive bottom line results.

The ultra-linear driver employs a broadband Class A solid-state IPA and a single conservatively-operated tetrode to drive the final visual amplifier. This linear design insures the maximum signal transparency required for premium quality broadcasting.

The solid-state visual and aural IPAs not only enhance reliability, but also reduce tuning requirements, as they contain broadband amplifiers so that periodic bandpass adjustment is not required. They are fully protected against damage caused by overloads or load variations. For added transmitter protection, RF drive is applied over a one to two second interval, which permits DC voltage stabilization before full RF drive application to power amplifiers. The IPAs are fully metered for monitoring and maintenance, while excellent cooling helps maintain long transistor life.

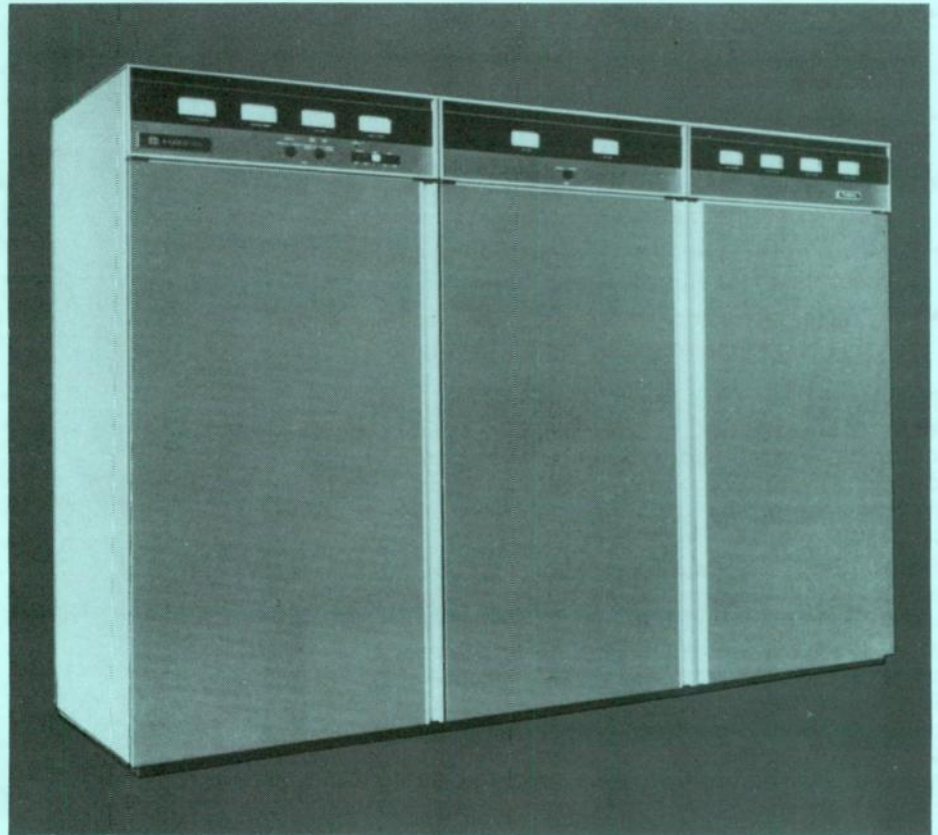

In the visual exciter, Harris employs its advanced VIDEO* SAW vestigial sideband filter (CCIR M only) and a unique Quadrature Corrector to insure the highest level of picture quality.

These compact transmitters require only three tubes, visual PA, visual driver and aural PA, to provide a 22.5 kilowatt visual and a 4.5 kilowatt aural output and 30 kilowatt visual and a 6 kilowatt aural output. Under normal operating conditions the quick heat tubes permit transmitter turn-on within 120 seconds; faster turn-on times are possible in an emergency. A circulator between the visual stages minimizes retuning requirements after a tube change.

In addition to the ultra-linear driver, solid-state IPAs and VIDEO SAW filter, Harris'

TV-20L and TV-30L incorporate such features as IF Modulation, true linear operation of power amplifiers, and a solid-state visual exciter/modulator to provide the finest color performance available today.

As no envelope delay correction or adjustments are required for the sideband filter and receiver equalizer, stability, reliability and color quality are greatly enhanced. Frequency adjustment, power output control and amplifier tuning are straightforward and uncomplicated, while conservatively-rated components assure long-term "hands-off" operation and minimum maintenance.

The transmitter employs a single-ended visual PA (9007 tetrode) and DC filaments in every visual stage for an excellent signal-to-noise ratio.

VHF LOW BAND COLOR TELEVISION TRANSMITTERS



SPECIFICATIONS

VISUAL PERFORMANCE

POWER OUTPUT:
LOAD IMPEDANCE:
FREQUENCY RANGE:
CARRIER FREQUENCY STABILITY:¹

REG. OF RF OUTPUT POWER (All black to all white pic.):
VARIATION OF OUTPUT (over one frame):
VISUAL SIDEBAND RESPONSE:²

FREQUENCY RESPONSE VS. BRIGHTNESS:³
VISUAL MODULATION CAPABILITY:
DIFFERENTIAL GAIN:⁴
INCIDENTAL PHASE MODULATION:
SYNC OVERSHOOT:

LINEARITY (LOW FREQUENCY):⁵
DIFFERENTIAL PHASE:⁴
SIGNAL-TO-NOISE:
 Hum and low frequency:⁶
 Periodic noise 10 kHz to 5.2 MHz:⁶
 Total random and periodic noise unweighted:
K-FACTORS:
EQUIVALENT ENVELOPE DELAY:

VIDEO INPUT LEVEL:
HARMONIC RADIATION:
AURAL PERFORMANCE
POWER OUTPUT:⁷
LOAD IMPEDANCE:

AUDIO INPUT LEVEL:
FREQUENCY DEVIATION:
INPUT IMPEDANCE:
PRE-EMPHASIS:
FREQUENCY RESPONSE:
DISTORTION:⁸

FM NOISE:⁹
INTERCARRIER PHASE MODULATION (noise):⁸
AM NOISE:

SYNCHRONOUS AM NOISE:⁹
FREQUENCY STABILITY:¹⁰
EMERGENCY AURAL/VISUAL MULTIPLEX (Optional):

Spurious radiation at visual carrier
 + and -920 kHz:
Output power:

SERVICE CONDITIONS
AMBIENT TEMPERATURE:¹¹
AMBIENT HUMIDITY RANGE:
ALTITUDE:
PHYSICAL AND MECHANICAL DIMENSIONS:

ELECTRICAL REQUIREMENTS:

TV-20L

SYSTEM M/NTSC

22.5 kW peak.
 50 ohms. Output connectors: 3/4" EIA standard.
 54-88 MHz (Channels 2-6).
 ±250 Hz (maximum variation over 30 days).
 ±2 Hz with optional precise frequency control.

3% or less relative to sync peak.
 Less than 2%.
 -3.58 MHz -42 dB or better
 -1.25 MHz and lower -26 dB or better
 -0.75 MHz to +4.10 MHz ±0.4 dB
 +4.18 MHz +0.4, -1 dB
 +4.5 MHz -15 dB or better
 +4.75 MHz to +5.0 MHz -30 dB or better
 +5.0 MHz and higher -40 dB or better
 ±0.75 dB.

0%
 3% or better.
 ±1.5" or better relative to blanking.
 2% or less of sync peak within 200 nsec of leading/
 trailing edge.
 1.0 db or better.
 ±1" or better.

-55 dB or better peak to peak.
 -40 dB peak to peak.
 -55 dB RMS or better relative to sync peak.
 2T 2%, 20T less than 5% baseline disturbance.
 0.2 to 2.1 MHz ±40 ns
 at 3.58 MHz ±25 ns
 at 4.18 MHz ±60 ns
 (referenced to FCC standard curve)
 75 ohm, -30 dB or better return loss up to 5.5 MHz.
 -80 dB relative to peak of sync.

4.5 kW.
 50 ohms. Output connector: 1 1/2" EIA standard,
 unflanged.
 +10 dBm, ±2 dB.
 ±25 kHz.
 600 ohms, balanced.
 75 microseconds.
 ±0.5 dB rel. to pre-emphasis curve, (30-15,000 Hz).
 0.5% THD or less with ±25 kHz deviation from
 30-15,000 Hz.
 -60 dB RMS or better rel. to ±25 kHz dev.
 -46 dB RMS or better rel. to ±25 kHz dev.
 -55 dB RMS rel. to 100% amplitude modulation of
 aural carrier.
 -40 dB RMS or better.
 ±20 Hz (maximum variation over 30 days).

-52 dB or better below visual carrier (typical).
 13 kW visual @ 10% aural.
 -10° to +50°C (14° to 122°F).
 0 to 95% relative humidity.
 Sea level to 10,000 feet.
 Trans.: 98.3" W x 32" D x 72" H. Weight: 2,200 lbs.
 Power supply: 57" W x 34" D x 54.25" H. Weight 1,500 lbs.

Power input: 208/240 volts, ±11 volts, 3 phase, 50/60 Hz.
 Power consumption: 48 kW, black picture, 10% aural;
 40 kW, average picture (50% APL), 10% aural; 51 kW,
 black picture at 20% aural; 45 kW, average picture at
 20% aural.

TV-30L SYSTEM M/NTSC

Power input: 208/240 volts, ±11 volts, 3 phase,
 50/60 Hz.
 Power consumption: 60 kW, black picture, 10% aural;
 50 kW, average picture (50% APL), 10% aural; 67 kW,
 black picture at 20% aural; 58 kW, average picture at
 20% aural.

TV-30L

30 kW peak.

3% or less relative to sync peak.
 Less than 2%.
 -4.43 MHz -30 dB or better
 -1.25 MHz -22 dB or better
 -0.75 MHz to 5.0 MHz ±0.5 dB
 +5.5 MHz -22 dB or better

±0.75 dB.
 0%
 3% or better.
 ±1.5" or better relative to blanking.
 2% or less of sync peak within 200 nsec of leading/
 trailing edge.
 10% or better.
 ±1" or better.

-55 dB or better peak to peak.
 -40 dB peak to peak.
 -55 dB RMS or better relative to sync peak.
 2T 2%, 20T less than 5% baseline disturbance.
 Transmitter supplied with receiver equalizer compliant
 with CCIR Report 624, Figure 3, Curve A or B.
 75 ohm, -30 dB or better return loss up to 5.5 MHz.
 -80 dB relative to peak of sync.

6 kW.

Up to 4 kW.
 50 ohms. Output connector: 1 1/2" EIA standard,
 unflanged.
 0 to +12 dBm.
 ±50 kHz.
 600 ohms, balanced.
 50 microseconds.
 ±0.5 dB rel. to pre-emphasis curve, (30-15,000 Hz).
 1% THD from 30 to 15,000 Hz with ±50 kHz deviation.
 Less than 2% at ±70 kHz deviation.
 -60 dB RMS or better rel. to ±50 kHz dev.
 -46 dB RMS or better rel. to ±50 kHz dev.
 -55 dB RMS rel. to 100% amplitude modulation of
 aural carrier.
 -40 dB RMS or better.
 ±20 Hz (maximum variation over 30 days).

50 dB
 17 kW
 11 kW visual @ 10% aural.

-10° to +50°C.
 0 to 95% relative humidity.
 Sea level to 3048 meters.
 Trans.: 249.7 cm W x 81.3 cm D x 182.9 cm H. Weight:
 998 kg. Power supply: 144.8 cm W x 86.4 cm D x
 137.8 cm H. Weight: 680 kg.
 Power input: 380/415 volts, ±17 volts, 3 phase, 50/60 Hz.
 Power consumption: 48 kW, black picture, 10% aural;
 40 kW, average picture (50% APL), 10% aural; 51 kW,
 black picture at 20% aural; 45 kW, average picture at
 20% aural.

TV-30L SYSTEMS B/PAL AND B/SECAM

Power input: 380/415 volts, ±17 volts, 3 phase,
 50/60 Hz.
 Power consumption: 60 kW, black picture, 10% aural;
 50 kW, average picture (50% APL), 10% aural; 67 kW,
 black picture at 20% aural; 58 kW, average picture at
 20% aural.

TV-30L

25 kW peak.

3% or less relative to sync peak.
 Less than 2%.
 -4.43 MHz -30 dB or better
 -1.25 MHz -22 dB or better
 -0.75 MHz to 5.0 MHz ±0.5 dB
 +5.5 MHz -22 dB or better

±0.75 dB.
 0%
 3% or better.
 ±1.5" or better relative to blanking.
 2% or less of sync peak within 200 nsec of leading/
 trailing edge.
 10% or better.
 ±1" or better.

-55 dB or better peak to peak.
 -40 dB peak to peak.
 -55 dB RMS or better relative to sync peak.
 2T 2%, 20T less than 5% baseline disturbance.
 Transmitter supplied with receiver equalizer compliant
 with CCIR Report 624, Figure 3, Curve A or B.
 75 ohm, -30 dB or better return loss up to 5.5 MHz.
 -80 dB relative to peak of sync.

Up to 6 kW.

50 ohms. Output connector: 1 1/2" EIA standard,
 unflanged.
 0 to +12 dBm.
 ±50 kHz.
 600 ohms, balanced.
 50 microseconds.
 ±0.5 dB rel. to pre-emphasis curve, (30-15,000 Hz).
 1% THD from 30 to 15,000 Hz with ±50 kHz deviation.
 Less than 2% at ±70 kHz deviation.
 -60 dB RMS or better rel. to ±50 kHz dev.
 -46 dB RMS or better rel. to ±50 kHz dev.
 -55 dB RMS rel. to 100% amplitude modulation of
 aural carrier.
 -40 dB RMS or better.
 ±20 Hz (maximum variation over 30 days).

50 dB
 14 kW

- After initial aging of 60 days.
- Response specified for transmitter operating into a resistive load of 1.05 VSWR or better.
- Measured using 20% p.p. amplitude swept video modulation with pedestal set at black 10%, white 90% with reference to gray level 50%. All percentages relative to blanking to white excursion.
- Measured with 5-step riser signal from 75% to 12.5% of sync peak. Sub-carrier mod. percentage 12.5% peak to peak.
- Measured with a 5-step riser signal. Test signal No. 3 CCIR REC 421-3.

- Noise measured with respect to a blanking to white transition.
- Capable of additional 0.5 dB power output above rated output to compensate for diplexer loss.
- After de-emphasis.
- Rel. to 100% amplitude modulation at rated deviation.
- Relative to frequency offset of 4.5 MHz (System M), 5.5 MHz (System B), from the visual carrier, after initial aging of 60 days.
- Derate 2°C per 1000 feet (305 meters) altitude above sea level.

Ordering Information

TV-20L, 22.5 kW VHF-TV transmitter for System M service, Channels 2-6, complete with operating tubes, semiconductors, crystals, required pre-correction circuitry, low-level vestigial sideband filter, harmonic and color notch filters, 208/240 volts, 50/60 Hz
 994-8608-001

TV-20L, 20 kW VHF-TV transmitter for System B service, 65-68 MHz (Channels E3 and E4, Band I), complete with operating tubes, semiconductors, crystals, required pre-correction circuitry, low-level vestigial sideband filter, harmonic filter, 308/415 volts, 50/60 Hz
 994-8608-002

TV-30L, 30 kW VHF-TV transmitter for System M service, Channels 2-6, complete with operating tubes, semiconductors, crystals, required pre-correction circuitry, low-level vestigial sideband filter, harmonic and color notch filters, 208/240 volts, 50/60 Hz
 994-8532-001

TV-30L, 30 kW VHF-TV transmitter for System B service, 65-68 MHz (Channels E3 and E4, Band I), complete with operating tubes, semiconductors, crystals, required pre-correction circuitry, low-level vestigial sideband filter, harmonic filter, 308/415 volts, 50/60 Hz
 994-8532-002

Prices and Specifications Subject to Change Without Notice.

TVD-40L 45 Kilowatt TVD-60L 60 Kilowatt Dual VHF Low Band Color Television Transmitters

- Ultra-linear drivers with solid-state IPAs for maximum reliability and signal transparency
- Two independent, complete transmitters for total redundancy and on-the-air reliability
- "Hot" standby exciters, modulators and sideband filter for maximum redundancy
- Harris Dualtran output switching system allows parallel, single transmitter or alternate/main operation
- Advanced Transversal SideBand (TSB) filters, no group delay, no tuning adjustments required
- IF Modulation of the visual and aural carriers
- Superior color performance, with minimal correction circuitry
- Ideal for circularly polarized applications
- Easily interfaced with ATS and remote control systems

The Harris TVD-40L, 45 kilowatt and the TVD-60L, 60 kilowatt dual low band VHF TV transmitters are designed for television broadcasters who want the utmost in reliability and performance, with the flexibility for remote control or automatic operation. Ideal for circularly polarized applications, this powerful dual transmitter incorporates such state-of-the-art features as ultra-linear drivers with solid-state IPAs and Harris Transversal SideBand (TSB) filters.

The TVD-40L consists of two completely independent 22.5 kilowatt transmitters operating in parallel, and the TVD-60L consists of two completely independent 30 kilowatt transmitters operating in parallel, both combined through the Harris Dualtran RF switching system.

Each of the two ultra-linear drivers employs a broadband Class A solid-state IPA and a single conservatively-operated tetrode to drive the final visual amplifier. This means maximum linearity and signal transparency without the need for complicated correction circuitry...for unmatched reliability and maintainability.

Surface acoustic wave technology is applied to vestigial sideband filtering in the visual exciters. The Harris Transversal SideBand filter displays a near-ideal bandpass function for Systems M (FCC) and B bandwidths. This, combined with the filter's true linear phase characteristic, offers excellent reproduction of pulse waveforms and encoded information.

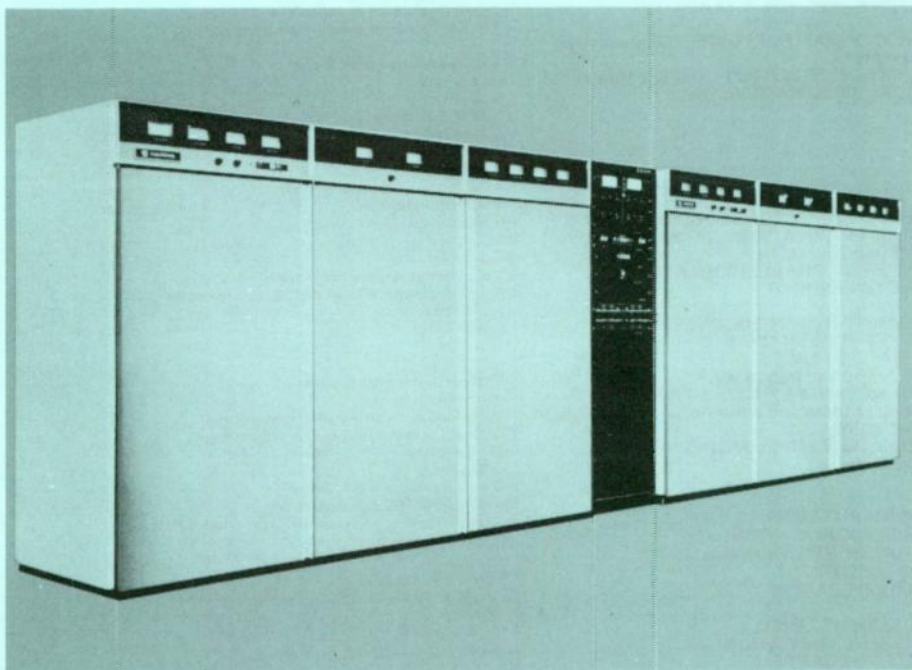

With the TVD-40L and TVD-60L you get two visual exciter/modulators, two aural exciter/modulators, two TSB filters, two solid-state visual and aural IPAs, two visual and aural PAs, and two HV power supplies, in short, total redundancy. Complete reliability.

The Dualtran switching system is factory assembled in one cabinet, and can be supplied to interface with either a hybrid or a notch diplexer.

IF (intermediate frequency) Modulation, low-level sideband filtering, true linear operation of power amplifiers and solid-state visual and aural exciter/modulators combine to provide outstanding color and sound fidelity. As no envelope delay correction or adjustments are required for the solid-state Transversal SideBand filter(s), stability, reliability and color quality are greatly enhanced.

Frequency adjustment, power output control and amplifier tuning are straightforward and uncomplicated, while conservatively rated components assure long-term "hands-off" operation.

In the event of a malfunction of one-half of the parallel combination, the Harris TVD-40L and TVD-60L offer automatic and instantaneous reduction to one-fourth authorized power. This function will occur without interruption of the carrier. With the touch of a button, half-power operation is achieved in less than two seconds.

Visual and aural exciters are connected in a hot standby condition, and will automatically switch in less than 10 milliseconds in case of failure in either unit. In all modes, aural follows visual for simplified logic control and reliable operation.

Four modes of operation may be obtained electrically by means of control pushbuttons on the output switcher; by control buttons on the transmitter control panel; or by remote control.

These are:

- Transmitters A and B combined On-Air.
- Transmitter A On-Air and transmitter B into the station loads.
- Transmitter B On-Air and transmitter A into the station loads.
- Transmitters A and B combined to the station loads (test mode).

The switching operation from one mode to any other mode requires less than two seconds.

When using a notch diplexer, three other operating modes may be selected manually by changing links on the Dualtran output switching cabinet: transmitters A and B combined and diplexed to the station load; transmitter A diplexed into the station load; and transmitter B diplexed into the station load.

DUAL VHF LOW BAND COLOR TELEVISION TRANSMITTERS



SPECIFICATIONS

VISUAL PERFORMANCE

POWER OUTPUT:
LOAD IMPEDANCE:
FREQUENCY RANGE:
CARRIER FREQUENCY STABILITY:¹

REG. OF RF OUTPUT POWER (All black to all white pic.):
VARIATION OF OUTPUT (over one frame):
VISUAL SIDEBAND RESPONSE:²

FREQUENCY RESPONSE VS. BRIGHTNESS:³
VISUAL MODULATION CAPABILITY:
DIFFERENTIAL GAIN:⁴
INCIDENTAL PHASE MODULATION:
LINEARITY (LOW FREQUENCY):⁵
DIFFERENTIAL PHASE:⁴

SIGNAL-TO-NOISE:
Hum and low frequency:⁶
Periodic noise 10 kHz to 5.2 MHz:⁶
Total random and periodic noise unweighted:

K-FACTORS:
EQUIVALENT ENVELOPE DELAY:

VIDEO INPUT LEVEL:
HARMONIC RADIATION:

AURAL PERFORMANCE

POWER OUTPUT:⁷
LOAD IMPEDANCE:
AUDIO INPUT LEVEL:
FREQUENCY DEVIATION:
INPUT IMPEDANCE:
PRE-EMPHASIS:
FREQUENCY RESPONSE:
DISTORTION:⁸
FM NOISE:⁹
INTERCARRIER PHASE MODULATION (noise):⁹
AM NOISE:
SYNCHRONOUS AM NOISE:⁹
FREQUENCY STABILITY:¹⁰

SERVICE CONDITIONS

AMBIENT TEMPERATURE:¹¹
AMBIENT HUMIDITY RANGE:
ALTITUDE:
PHYSICAL AND MECHANICAL DIMENSIONS:

ELECTRICAL REQUIREMENTS:

TVD-40L

System M/NTSC

45 kW peak.
50 ohms. Output connectors: 3/16" EIA standard.
54-88 MHz (Channels 2-6).
±250 Hz (maximum variation over 30 days).
±2 Hz with optional precise frequency control.

3% or less relative to sync peak.
Less than 2%.
-3.58 MHz -42 dB or better
-1.25 MHz and lower -26 dB or better
-0.75 MHz to +4.10 MHz ±0.5 dB
+4.18 MHz +0.5, -1 dB
+4.75 MHz and higher -30 dB or better
±0.75 dB.
0%.
3% or better.
±3° or better relative to blanking.
1.0 dB or better.
±1° or better.
-55 dB or better peak to peak.
-40 dB peak to peak.
-55 dB RMS or better relative to sync peak.
2T 2%, 20T less than 5% baseline disturbance. ±40 ns
0.2 to 2.1 MHz ±25 ns
at 3.58 MHz ±60 ns
at 4.18 MHz ±60 ns
(referenced to FCC standard curve)
75 ohm, -30 dB or better return loss up to 5.5 MHz.
-80 dB relative to peak of sync.

9 kW.
50 ohms. Output connector: 1/2" EIA standard, unflanged.
+10 dBm, ±2 dB.
±25 kHz.
600 ohms, balanced.
75 microseconds.
±0.5 dB rel. to pre-emphasis curve, (30-15,000 Hz).
0.5% THD or less with ±25 kHz deviation from 30-15,000 Hz.
-60 dB RMS or better rel. to ±25 kHz dev.
-46 dB RMS or better rel. to ±25 kHz dev.
-55 dB RMS rel. to 100% amplitude modulation of aural carrier.
-40 dB RMS or better.
±20 Hz (maximum variation over 30 days).

-10° to +50° C (14° to 122° F).
0 to 95% relative humidity.
Sea level to 10,000 feet.
Transmitters (2): each 98.3" W x 32" D x 72" H. Weight each: 2,200 lbs. Switcher cabinet (without side panels): 22 1/2" W x 24 1/2" D (with front and rear doors) x 72" H. Weight: 300 lbs. RF Output Switcher: 48" W x 34" D x 72" H. Weight: 1,350 lbs. Power Supplies (2): each 57" W x 34" D x 54.25" H. Weight each: 1,500 lbs.
Power input: 208/240 volts, ±11 volts, 3 phase, 50/60 Hz. Power consumption: 112 kW, black picture; 96 kW, average picture.

TVD-60L

60 kW peak.

12 kW.

7500 feet.

Power input: 208/240 volts, ±11 volts, 3 phase, 50/60 Hz. Power consumption: 132 kW, black picture; 108 kW, average picture.

¹ After initial aging of 60 days.

² Response specified for transmitter operating into a resistive load of 1.05 VSWR or better.

³ Measured using 20% p.p. amplitude swept video modulation with pedestal set at black 10%, white 90% with reference to grey level 50%. All percentages relative to blanking to white excursion.

⁴ Measured with 5-step riser signal from 75% to 12.5% of sync peak. Sub-carrier mod. percentage 12.5% peak to peak.

⁵ Measured with a 5-step riser signal. Test signal No. 3 CCIR REC 421-3.

⁶ Noise measured with respect to a blanking to white transition.

⁷ Capable of additional 0.5 dB power output above rated output to compensate for diplexer loss.

⁸ After de-emphasis.

⁹ Rel. to 100% amplitude modulation at rated deviation.

¹⁰ Relative to frequency offset of 4.5 MHz (System M), from the visual carrier, after initial aging of 60 days.

¹¹ Derate 2° C per 1000 feet (305 meters) altitude above sea level.

Ordering Information

TVD-40L, 45 kW dual VHF-TV transmitter for System M standards service, Channels 2-6, with operating tubes, semiconductors, crystals, VSB filter, harmonic and color notch filters, output combiner, input and output switchers 994-8609-001

TVD-60L, 60 kW dual VHF-TV transmitter for System M standards service, Channels 2-6, with operating tubes, semiconductors, crystals, VSB filter, harmonic and color notch filters, output combiner, input and output switchers 994-8616-001

**TV-35H 35 Kilowatt
 TV-50H 50 Kilowatt
 VHF High Band Color
 Television Transmitter**

- Straightforward design for high reliability and stability
- Advanced new SAW filter, built-in receiver equalizer eliminates separate correction modules
- New Quadrature Corrector cancels tube distortions
- Ultra-linear driver with solid-state IPAs for maximum reliability and signal transparency
- Highly linear IF Modulation of the visual and aural carriers for superior color and sound reproduction
- Automatic power control insures essentially constant power output
- Emergency multiplex option

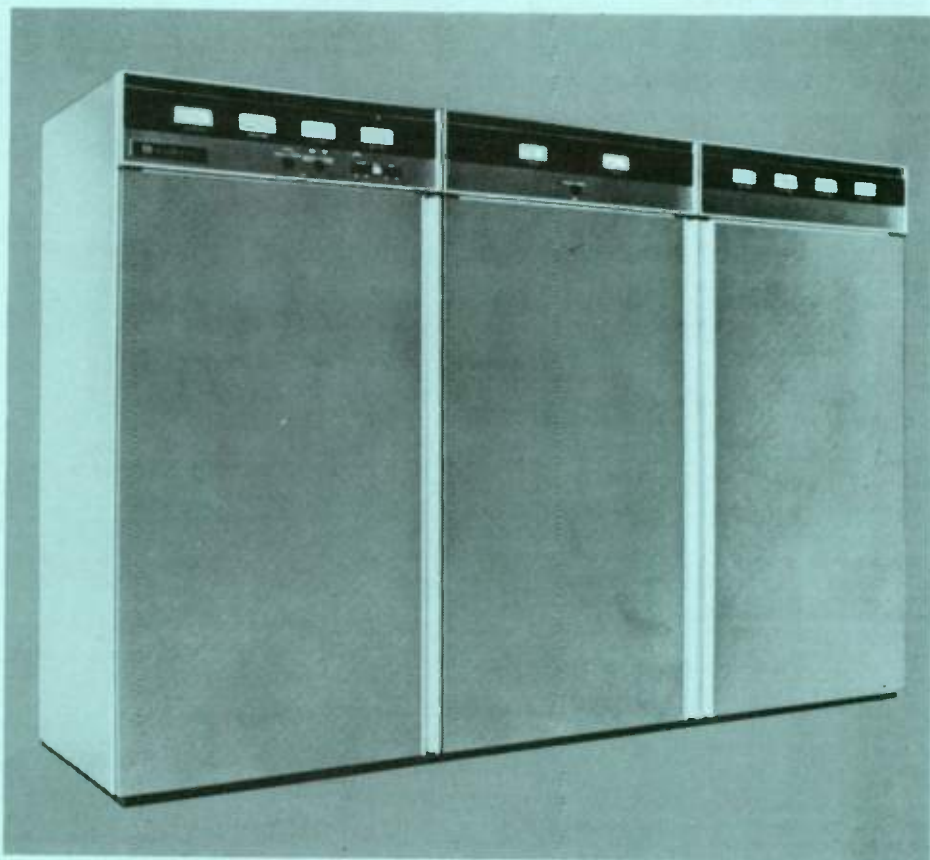

Harris' TV-35H, 35 kilowatt and the TV-50H, 50 kilowatt high band VHF television transmitters, are the most cost-effective TV transmitters available in their power range. Their straightforward design requires less complicated circuitry to meet the high performance standards demanded by today's discriminating broadcaster. And less complicated circuitry means greater reliability...the type of year-in, year-out dependability broadcasters need for impressive bottom line results.

The ultra-linear driver employs a broadband Class A solid-state IPA and a single conservatively-operated tetrode to drive the final visual amplifier. This linear design insures the maximum signal transparency required for premium quality broadcasting.

The solid-state visual and aural PIAs not only enhance reliability, but also reduce tuning requirements, as they contain broadband amplifiers so that periodic bandpass adjustment is not required. They are fully protected against damage caused by overloads or load variations. For added transmitter protection,

RF drive is applied over a one to two second interval, which permits DC voltage stabilization before full RF drive application to power amplifiers. The PIAs are fully metered for monitoring and maintenance, while excellent cooling helps maintain long transistor life.

In the visual exciter, Harris employs its advanced VIDEO* SAW vestigial sideband filter (CCIR M only) and a new Quadrature Corrector to insure the highest level of picture quality.

These compact transmitters require only three tubes: visual PA, visual driver and aural PA, to provide a 35 kilowatt visual and a 4.5 kilowatt aural output or a 50 kilowatt visual and a 5 kilowatt aural output. Under normal operating conditions, the quick heat tubes permit transmitter turn-on within 120 seconds; faster turn-on times are possible in emergency conditions. A circulator between the visual stages minimizes returning requirements after a tube change.

In addition to the ultra-linear driver, solid-state IPAs and VIDEO SAW filter, the transmitters incorporate such features as IF Modulation, true linear operation of power amplifiers, and a solid-state visual exciter/modulator, to provide the finest color performance available today.

As no envelope delay correction or adjustments are required for the sideband filter and receiver equalizer, stability, reliability and color quality are greatly enhanced. Frequency adjustment, power output control and amplifier tuning are straightforward and uncomplicated, while conservatively-rated components assure long-term "hands-off" operation and minimum maintenance.

The transmitter employs a single-ended visual PA (8984 tetrode), and DC filaments in every visual stage for an excellent signal-to-noise ratio.

*Visual IF Delay Equalized Output

VHF HIGH BAND COLOR TELEVISION TRANSMITTERS



HARRIS

P.O. Box 4290
Quincy, IL 62305-4290
(217) 222-8200

SPECIFICATIONS

TV-35H

TV-50H

VISUAL PERFORMANCE

System M/NTSC

(Systems B/PAL and B/SECAM specifications available on request.)

POWER OUTPUT: 35 kW peak.
LOAD IMPEDANCE: 50 ohms. Output connectors: 3/16" EIA standard.
FREQUENCY RANGE: 174-216 MHz (Channels 7-13).
CARRIER FREQUENCY STABILITY: ±250 Hz (maximum variation over 30 days).
±2 Hz with optional precise frequency control.

50 kW peak.

REG. OF RF OUTPUT POWER (All black to all white pic.): 3% or less relative to sync peak.
VARIATION OF OUTPUT (over one frame): Less than 2%.

2%

VISUAL SIDEBAND RESPONSE:²

-3.58 MHz -42 dB or better
-1.25 MHz and lower -26 dB or better
-0.75 MHz to +4.10 MHz ±0.5 dB
+4.18 MHz +0.5, -1 dB
+4.75 MHz and higher -30 dB or better
±0.75 dB.

±0.4 dB

-40 dB

FREQUENCY RESPONSE VS. BRIGHTNESS:³

VISUAL MODULATION CAPABILITY:

DIFFERENTIAL GAIN:⁴

INCIDENTAL PHASE MODULATION:

LINEARITY (LOW FREQUENCY):⁵

DIFFERENTIAL PHASE:⁴

SIGNAL-TO-NOISE:

Total random and periodic noise unweighted:

K-FACTORS:

EQUIVALENT ENVELOPE DELAY:

0%.
3% or better.
±3° or better relative to blanking.
1.0 dB or better.
±1° or better.

±1.5°

-60 dB

-55 dB RMS or better relative to sync peak.
2T 2%, 20T less than 5% baseline disturbance.

0.2 to 2.1 MHz ±40 ns

at 3.58 MHz ±25 ns

at 4.18 MHz ±60 ns

(referenced to FCC standard curve)

75 ohm, -30 dB or better return loss up to 5.5 MHz.
-80 dB relative to peak of sync.

VIDEO INPUT LEVEL:

HARMONIC RADIATION:

AURAL PERFORMANCE

POWER OUTPUT:⁶

LOAD IMPEDANCE:

AUDIO INPUT LEVEL:

FREQUENCY DEVIATION CAPABILITY:

INPUT IMPEDANCE:

PRE-EMPHASIS:

FREQUENCY RESPONSE:

DISTORTION:⁷

FM NOISE:

INTERCARRIER PHASE MODULATION (noise):⁷

AM NOISE:

SYNCHRONOUS AM NOISE:⁸

FREQUENCY STABILITY:⁹

4.5 kW.
50 ohms. Output connector: 3/16" EIA standard, enflanged.
+10 dBm, ±2 dB.
±50 kHz.
600 ohms, balanced.
75 microseconds.
±0.5 dB rel. to pre-emphasis curve, (30-15,000 Hz).
0.5% THD or less with ±25 kHz deviation from 30-15,000 Hz.
-60 dB RMS or better rel. to ±25 kHz dev.
-46 dB RMS or better rel. to ±25 kHz dev.
-55 dB RMS rel. to 100% amplitude modulation of aural carrier.
-40 dB RMS or better.
±20 Hz (maximum variation over 30 days).

5 kW.

SERVICE CONDITIONS

AMBIENT TEMPERATURE:¹⁰

AMBIENT HUMIDITY RANGE:

ALTITUDE:

PHYSICAL AND MECHANICAL DIMENSIONS:

0° to +50° C (32° to 122° F).

0 to 95% relative humidity.

Sea level to 7,500 feet.

Trans.: 106" W x 32.2" D x 72" H. Weight:

2,385 lbs. Power supply:

69.9" W x 33.9" D x 54" H. Weight: 3,000 lbs.

Power input: 208/240 volts, ±11 vclts,

3 phase, 60 Hz. Power consumption (typical): 78 kW, black picture,

10% aural; 66 kW, average picture (50% APL), 10% aural; power

factor better than 0.97.

-10° to +50°C (14° to 122°F)

ELECTRICAL REQUIREMENTS:

Power input: 455/480/505 volts, ±11 volts, 3 phase, 60 Hz.
Power consumption: Average picture (50% APL): 85 kW. Black picture: 107 kW.

¹ After initial aging of 60 days.

² Response specified for transmitter operating into a resistive load of 1.05 VSWR or better.

³ Measured using 20% p.p. amplitude swept video modulation with pedestal set at black 10%, white 90% with reference to grey level 50%. All percentages relative to blanking to white excursion.

⁴ Measured with 5-step riser signal from 75% to 12.5% of sync peak. Sub-carrier mod. percentage 12.5% peak to peak

⁵ Measured with a 5-step riser signal. Test signal No. 3 CCR REC 421-3.

⁶ Capable of additional 0.5 dB power output above rated output to compensate for diplexer loss.

⁷ After de-emphasis.

⁸ Rel. to 100% amplitude modulation at rated deviation.

⁹ Relative to frequency offset of 4.5 MHz from the visual carrier, after initial aging of 60 days.

¹⁰ Derate 2° C per 1000 feet (305 meters) altitude above sea level.

Ordering Information

TV-35H, 35 kW VHF-TV transmitter for System M service, Channels 7-13, complete with operating tubes, semiconductors, crystals, required pre-correction circuitry, low-level vestigial sideband filter, harmonic and color notch filters, 208/240 volts, 60 Hz 994-8498-001

TVD-70H, 70 kW dual VHF-TV transmitter for System M service, Channels 7-13, complete with operating tubes, semiconductors, crystals, required pre-correction circuitry, low-level vestigial sideband filter, harmonic and color notch filter, output combiner, input and output switchers, 208/240 volts, 60 Hz 994-8667-001

TV-50H, 50 kW VHF-TV transmitter for System M service, Channels 7-13, complete with operating tubes, semiconductors, crystals, required pre-correction circuitry, low-level vestigial sideband filter, harmonic and color notch filters, 480 volts, 60 Hz 994-8745-001

TV-50H, 42 kW VHF-TV transmitter for System B service, 174-230 MHz (Channels E5-E12, Band III), complete with operating tubes, semiconductors, crystals, required pre-correction circuitry, low-level vestigial sideband filter, harmonic filter, 308/415 volts, 50 Hz 994-8745-002



HARRIS

P.O. Box 4290
Quincy, IL 62305-4290
(217) 222-8200

DUAL VHF HIGH BAND COLOR TELEVISION TRANSMITTERS

TVD-70H (70kW) TVD-100H (100kW) Dual VHF High Band Color Television Transmitters

- Ultra-linear drivers with solid-state IPAs for maximum reliability and signal transparency
- Two independent, complete transmitter for total redundancy and on-the-air reliability
- "Hot" standby exciters, modulators and sideband filters for maximum redundancy
- Harris' Dualtran output switching system allows parallel or single transmitter operation
- Ideal for circularly polarized applications
- Advanced new SAW filter — built-in receiver equalizer eliminates separate correction modules
- New Quadrature Corrector cancels tube distortions
- Notch diplexer included

The TVD-100H and TVD-70H television transmitters are designed for Channels 7-13 and Channels E5-E12. These transmitters are made up of two separate and independent 50kW or 35kW transmitters whose visual and aural outputs are combined to provide the high power required for maximum ERP with circularly polarized antennas. The TVD-70H and TVD-100H transmitters are identical except for the high voltage power supplies.

In addition to the two complete transmitters, these high power dual transmitters are equipped with a control cabinet located between the transmitters and a Dualtran RF System that is normally located behind the transmitters.

"A + B Air": This is the normal operating mode in which the two visual and aural transmitters are combined and fed to the antenna line through the diplexer.

"A + B Test": In this mode the combined aural and combined visual signals are connected to dummy loads for testing.

"A Air": In this mode the "A" transmitter is connected to the antenna line through the diplexer while the "B" transmitter is connected to the test loads.

"B Air": This mode is identical to the "A Air"

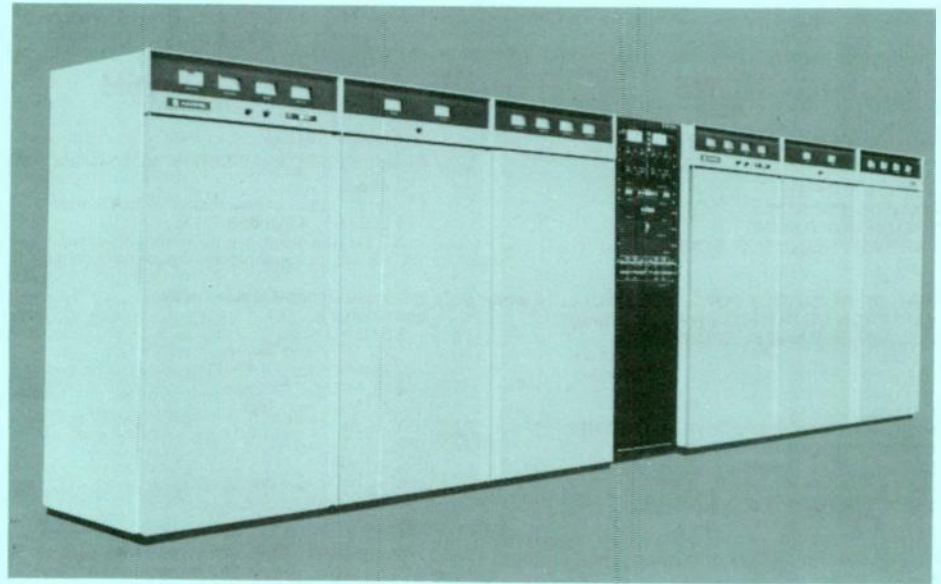

mode except that the "B" transmitter is connected to the antenna line while the "A" transmitter is connected to the test loads.

The "A Air" and "B Air" modes may also be used to operate the two transmitters in a main/alternate main configuration. In this configuration the full output power capability of each transmitter is available to feed the antenna line while the second transmitter is kept in a hot or cold reserve status.

The Dualtran concept that Harris has used for many years in lower power transmitters is now applied to high power transmitters. The 100kW Dualtran RF System is a factory assembled, tested and optimized coaxial system that contains all of the components necessary for operating the dual transmitters in the modes described above. A 100kW notch diplexer is also supplied as part of this system for combining the aural and visual signals together for feeding the antenna line.

All of these components are mounted in an open frame cabinet for ease of handling and simple installation.

Parallel operation of the two identical transmitters provides the redundancy needed to prevent any loss of air time. If one of the two transmitters should malfunction, the transmitter output power automatically decreases 6dB with no interruption in service. If desired, the Dualtran RF System may be switched to a single transmitter mode that will provide the full power output capability of that single transmitter.

The dual transmitters may be completely controlled and monitored from a remote

location by a Harris Facilities Control System or by any standard remote control hardware. The Dualtran RF System mode switching may also be accomplished by remote control.

The Dualtran RF System is equipped with three water cooled test loads. Each test load is equipped with a calibrated in-line wattmeter. In addition, the water lines for each load are equipped with thermometer wells for precise calorimetric power measurements.

The Dualtran RF System also contains all directional couplers and voltage probes necessary for internal metering and monitoring of the transmitter operation. Extra couplers and probes are included for connection to monitoring and test equipment. A 4 port 6-1/8" manual patch panel (optional) permits use of the visual load for diplexer output testing.

Every Harris dual transmitter contains two MCP-2 visual and aural exciters. The RF output of one set of exciters is split into two signal paths and fed to both transmitters through the splitting and phasing networks. An exciter switcher automatically switches to the reserve exciters in the event of a malfunction. The exciter outputs are on-carrier, providing maximum redundancy of the important exciter circuitry. All low level circuits are 100% redundant, including video processors, modulators, VSB filters, IF correctors, oscillators and up-converters.

The RF Input Patch Panel provides the capability of driving any transmitter from any exciter for test purposes or in the event of malfunction in the exciter switcher or phasing and control panel.

DUAL VHF HIGH BAND COLOR TELEVISION TRANSMITTERS



HARRIS
P.O. Box 4290
Quincy, IL 62305-4290
(217) 222-8200

TVD-100H And TVD-70H SPECIFICATIONS

	TVD-100H	TVD-70H
VISUAL POWER OUTPUT:	100 kW peak (System M). 84 kW peak (System B).	70 kW peak (System M). 60 kW peak (System B).
AURAL POWER OUTPUT:	Up to 14 kW (20 kW optional).	Up to 12 kW.
ELECTRICAL REQUIREMENTS:	480 volts, +5%, 3 phase, 60 Hz or 380/415 volts, +5%, 3 phase, 50 Hz.	208/240 volts, +5%, 3 phase, 60 Hz or 380/415 volts, +5%, 3 phase, 50 Hz.
POWER CONSUMPTION (Typical at 10% aural):		
Average Picture (50% APL):	172 kW.	134 kW.
Black Picture:	216 kW.	158 kW.
Specifications below apply to both the TVD-70H and TVD-100H.		
PHYSICAL AND MECHANICAL DIMENSIONS:	Transmitter cabinets (2): each 106" W x 32" D x 72" H. (269 cm x 82 cm x 183 cm). Weight (each): 2385 lbs. (1082 kg). Power supplies (2): each 70" W x 35" H x 52" D. (178 cm x 89 cm x 132 cm). Weight (each): 2600 lbs. (1179 kg). Central control cabinet: 22" W x 25" D x 72" H. (56 cm x 62 cm x 183 cm). Weight: 300 lbs. (136 kg). RF output switcher system: 122" W x 48" D x 80" H. (310 cm x 122 cm x 203 cm). Weight: 1800 lbs. (816 kg).	
VISUAL PERFORMANCE	System M/NTSC	Systems B/PAL and B/SECAM
TYPE EMISSION:	A5C Negative.	A5C Negative.
FREQUENCY RANGE:	174-216 MHz, Channels 7-13.	174-230 MHz, Channels E5-E12.
VIDEO INPUT IMPEDANCE:	75 Ohms.	75 Ohms.
VIDEO INPUT LEVEL:	0.7 to 2.0 volts, peak to peak, sync negative.	0.7 to 2.0 volts, peak to peak, sync negative.
RF LOAD IMPEDANCE:	50 Ohms, diplexer output connector: 6% EIA, flanged.	50 Ohms, diplexer output connector: 6% EIA, flanged.
AM NOISE:		
Total random and periodic noise unweighted:	-55 dB RMS or better relative to sync peak.	-55 dB RMS or better relative to sync peak.
Hum and low frequency:	-52 dB or better peak to peak.	-52 dB or better peak to peak.
Periodic noise 10 kHz to 5.2 MHz:	-40 dB peak to peak.	-40 dB peak to peak.
MODULATION CAPABILITY:	0%, sync equal to 100%.	0%, sync equal to 100%.
REGULATION OF OUTPUT POWER:	Less than 2% (black to white picture).	Less than 2% (black to white picture).
VARIATION OF OUTPUT OVER ONE FIELD:	Less than 2% at sync peak (measured with a field square wave signal with reference to sync peak voltage.)	Less than 2% at sync peak (measured with a field square wave signal with reference to sync peak voltage.)
FREQUENCY RESPONSE VARIATION:	Less than ± 0.75 dB.	Less than ± 0.75 dB.
LUMINANCE NONLINEARITY:	10% or better.	10% or better.
VISUAL SIDEBAND RESPONSE:	-3.58 MHz -42 dB. -1.25 MHz -26 dB. -0.75 to 4.10 MHz ± 0.4 dB. 4.18 MHz +0.4, -1 dB. 4.5 MHz -35 dB or better. 4.5 MHz and higher -40 dB.	-4.43 MHz -30 dB. -1.25 MHz -22 dB. -0.75 to 5.0 MHz ± 0.5 dB. +5.5 MHz -22 dB.
DIFFERENTIAL GAIN:	3% or better.	3% or better.
DIFFERENTIAL PHASE:	$\pm 1^\circ$ or better.	$\pm 1^\circ$ or better.
2t K FACTOR:	2% maximum.	2% maximum.
20t GAIN AND DELAY RESPONSE:	5% or less total baseline disturbance.	5% or less total baseline disturbance.
CHROMINANCE INTERMODULATION:	Less than 2% total distortion.	Less than 2% total distortion.
FIELD FREQUENCY SQUARE WAVE TILT:	Less than 2% total variation.	Less than 2% total variation.
INCIDENTAL PHASE MODULATION:	$\pm 1.5^\circ$ or less relative to blanking.	$\pm 1.5^\circ$ or less relative to blanking.
ENVELOPE DELAY:	0.5 to 2.1 MHz ± 40 ns at 3.58 MHz ± 25 ns at 4.18 MHz ± 60 ns ± 250 Hz (maximum variation over 30 days). -80 dB or better below peak of sync.	± 250 Hz (maximum variation over 30 days). -80 dB or better below peak of sync.
CARRIER STABILITY:	F3.	F3.
HARMONIC RADIATION:	± 20 Hz (for 30 days relative to frequency offset of 4.5 MHz from visual carrier).	± 20 Hz (for 30 days relative to frequency offset of 5.5 MHz from visual carrier).
AURAL PERFORMANCE	50 Ohms.	50 Ohms.
TYPE EMISSION:	600 Ohms, balanced.	600 Ohms, balanced.
FREQUENCY STABILITY:	+10 dBm, ± 2 dB. ± 25 kHz. ± 5 dB relative to 75 microsecond pre-emphasis.	0 to +20 dBm. ± 50 kHz. ± 5 dB relative to 50 microsecond pre-emphasis.
RF LOAD IMPEDANCE:	Less than 0.5% from 30 to 15,000 Hz with ± 25 kHz deviation.	Less than 1% from 30 to 15,000 Hz with ± 50 kHz deviation; less than 2% for ± 70 kHz deviation.
AUDIO INPUT IMPEDANCE:	-55 dB or better relative to 100% AM modulation.	-55 dB or better relative to 100% AM modulation.
AUDIO INPUT LEVEL:	-60 dB or better relative to ± 25 kHz deviation.	-60 dB or better relative to ± 50 kHz deviation.
FREQUENCY DEVIATION:	Less than 1% relative to 100% AM modulation from 30 to 15,000 Hz, with ± 25 kHz deviation.	Less than 1% relative to 100% AM modulation from 30 to 15,000 Hz, with ± 50 kHz deviation.
FREQUENCY RESPONSE:	-46 dB or better relative to ± 25 kHz deviation.	-46 dB or better relative to ± 50 kHz deviation.
AUDIO DISTORTION:		
AM NOISE:		
FM NOISE:	-10° to +50° C (14° to 122° F).	-10° to +50° C (14° to 122° F).
SYNCHRONOUS AM NOISE:	0 to 95% relative humidity.	0 to 95% relative humidity.
INTERCARRIER NOISE:	Sea level to 7500 feet (2286 meters).	Sea level to 2286 meters (7500 feet).
SERVICE CONDITIONS	(Derate 2° C per 1000 feet above sea level).	(Derate 2° C per 300 meters above sea level).
AMBIENT TEMPERATURE:		
AMBIENT HUMIDITY RANGE:		
ALTITUDE:		

Ordering Information

TVD-100H, 100 kW VHF-TV transmitter for CCIR System M service, 174-216 MHz, Channels 7-13, 480 volts, $\pm 5\%$, 60 Hz, with operating tubes, transistors, IC's, solid-state rectifiers, crystals, required precorrection circuitry, low level sideband filter, harmonic filters, input and output switchers, power combiners, dual exciter sets, high power notch diplexer, and stepdown transformers	.994-8457-001
TVD-100H, 84 kW VHF-TV transmitter for CCIR System B service, 174-230 MHz (Band III), 380/415 volts, $\pm 5\%$, 50 Hz. Includes same as above, with line frequency inverters added	.994-8457-002
TVD-70H, 70 kW VHF-TV transmitter for CCIR System M service, 174-216 MHz, Channels 7-13, 208/240 volts, $\pm 5\%$, 60 Hz, with operating tubes, transistors, IC's, solid state rectifiers, crystals, required precorrection circuitry, low level sideband filter, harmonic filters, input and output switchers, power combiners, dual exciter sets, high power notch diplexer	.994-8667-001
TVD-70H, 60 kW VHF-TV transmitter for CCIR System B service, 174-230 MHz (Band III), 380/415 volts, $\pm 5\%$, 50 Hz. Includes same as above, with stepdown transformers and line frequency inverters added	.994-8667-002

Prices and Specifications Subject to Change Without Notice.

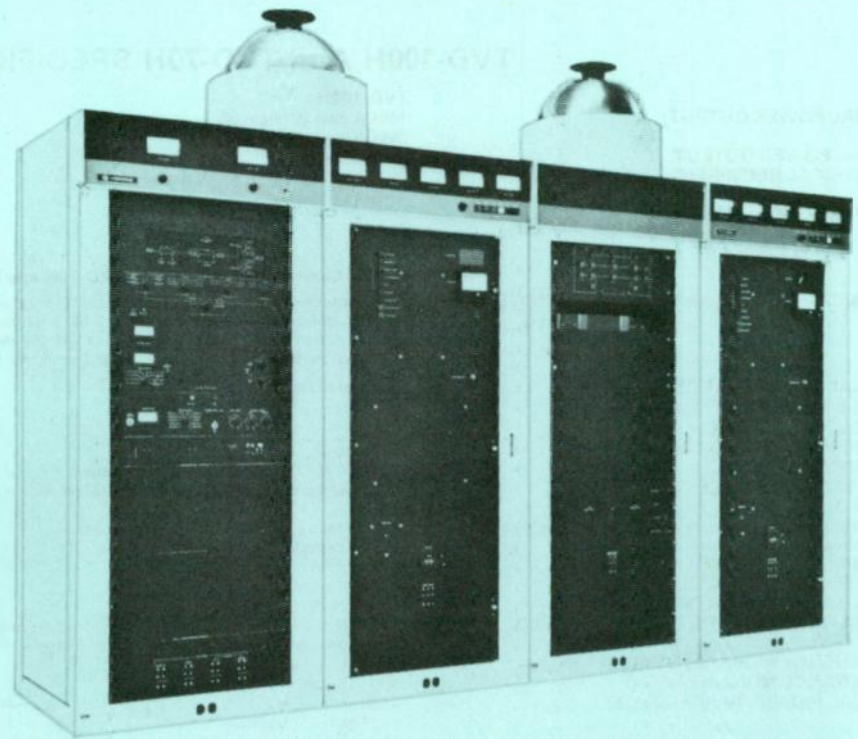

UHF Color Television Transmitters

- Variable Visual Coupler for higher klystron efficiency
- Advanced new SAW filter, built-in receiver equalizer eliminates separate correction modules
- New Quadrature Corrector cancels klystron distortions
- High efficiency 5-cavity klystrons
- Highly linear IF Modulation of the visual and aural carriers for superior color and sound reproduction
- Mod Anode Pulser for increased transmitter efficiency
- Straightforward design for high stability, reliability
- Low-loss waveguide diplexer
- Emergency multiplex operation minimizes off-air time

TVE-30 30 Kilowatt UHF Color Television Transmitter

The Harris TVE-30 is designed to meet the critical performance standards demanded by today's discriminating broadcaster. State-of-the-art technology, such as Harris' VIDEO* SAW receiver equalized filter and the Quadrature Corrector, is used to provide the highest levels of performance, reliability and stability. This performance level assures standard and subscription television broadcasters the best quality picture and sound, now and in the future.

The TVE-30 transmitter includes a newly developed device that significantly reduces power consumption. This is the Variable Visual Coupler (VVC), which greatly increases the visual klystron's operating efficiency over previously used fixed couplers.

Several other energy-saving devices are also standard in the TVE-30, including "H" type high-efficiency klystrons, the Mod Anode Pulser, and a high-efficiency aural klystron coupler.

For maximum efficiency, high power RF losses are kept to a minimum by using a 100% waveguide diplexer and color notch filter.

The Harris TVE-60S, 60 kilowatt UHF-TV transmitter, incorporates all of the latest efficiency-improving technologies to help keep power costs down. At 60 kilowatts peak visual power with 10% aural, total power consumption is only 130 kilowatts.

The TVE-60S visual amplifier uses a single Varian 5-cavity VKP-7550 "S" Series klystron for a full 60 kilowatt visual power output. This super-high-efficiency, high-power integral cavity klystron utilizes a new modified-cavity Q tuning technique for maximum beam efficiency.

TVE-60S 60 Kilowatt UHF Color Television Transmitter

The VKP-7550 "S" Series klystron is an improved version of the popular Varian VA-950 "H" Series klystron currently in use in hundreds of UHF transmitters worldwide. For redundancy, the aural amplifier uses an identical klystron.

To further increase beam efficiency of the VKP-7550S, the TVE-60S includes as standard a variable visual coupler (VVC). This device, installed on the output of the klystron, is tuned to optimize coupling to the output transmission line for 60 kilowatt power output at reduced klystron beam current. For maximum aural efficiency, a high-efficiency aural klystron coupler is also

included as standard. Another energy saving device included as standard with the TVE-60S is a mod anode pulser.

TVE-120S 120 Kilowatt UHF Color Television Transmitter

The Harris TVE-120S is designed to meet the critical performance standards demanded by today's discriminating broadcaster; State-of-the-art technology, VIDEO* SAW receiver equalized filter and the Quadrature Corrector.

The TVE-120 transmitter includes the Variable Visual Coupler (VVC), which greatly increases the visual klystron's operating efficiency.

Standard in the TVE-120, are "S" type high-efficiency klystrons, the Mod Anode Pulser, and a high-efficiency aural klystron coupler.

High power RF losses are kept to a minimum by using a waveguide visual combiner, a 100% waveguide diplexer and color notch filter.

*Visual IF Delay Equalized Output

TVE-60S



HARRIS

P.O. Box 4290
Quincy, IL 62305-4290
(217) 222-8200

UHF-TV EXCITER RETROFIT

UHF-TV EXCITER RETROFIT PACKAGE

- MCP-2U visual exciter for highly superior color performance
- Wideband, linear aural exciter for high fidelity audio transmission
- Stable, drift-free operation reduces tuning and maintenance
- Fully assembled and tested for easy installation at transmitter site
- Excellent performance for subscription television stations (STV)

The Harris UHF-TV Exciter Retrofit Package (E.R.P.) is designed specifically for use as an exciter/driver for non-Harris klystron transmitters...permitting users of older non-Harris transmitters to enjoy state-of-the-art performance.

STANDARD EXCITER RETROFIT PACKAGE

The standard Exciter Retrofit Package consists of a Harris MCP visual exciter, a Harris MCP aural exciter, and a solid-state visual/aural amplifier. A notch diplexer phase equalizer is also included. All equipment is mounted in a 24-inch rack cabinet and is interconnected. Special configurations, such as dual exciters, can also be supplied. Drawer slides are used so that exciters may be easily pulled out for adjustment purposes.

VISUAL EXCITER

The Harris MCP-2U visual exciter incorporates Harris' new VIDEO* SAW filter (CCIR M only), which provides vestigial sideband shaping, plus the required FCC group delay pre-correction. This new filter eliminates conventional receiver equalizers that require periodic maintenance with special test equipment. The visual exciter also uses a unique Quadrature Corrector that compensates for several types of klystron non-linearities, such as differential gain, incidental phase and intermodulation distortions.

POWER RATING

The Exciter Retrofit Package output power is 10 watts visual and 5 watts aural, which is adequate power for most klystrons currently being used in television transmitters.

ASSEMBLY AND TESTING

The Exciter Retrofit Package is fully assembled and tested at the Harris factory before shipment. Factory test data sheets and complete technical manuals are shipped with each Package.

INSTALLATION SERVICES

The services of a Harris field engineer are included with each E.R.P. (48 contiguous states only) to assist the station engineers in the installation and check-out of the Package with the transmitter. The Harris proof of performance (included) will be in a form sufficient to aid the customer in obtaining FCC type acceptance of the hybrid exciter/transmitter.

*Visual IF Delay Equalized Output

Ordering Information

UHF Exciter Retrofit Package for use as klystron driver in non-Harris transmitters. 10 watts visual, 5 watts aural. Please specify transmitter type, channel and offset 790-XXXX-XXX
Options available include: (1) dual exciters with automatic exciter switcher, and (2) emergency multiplex.

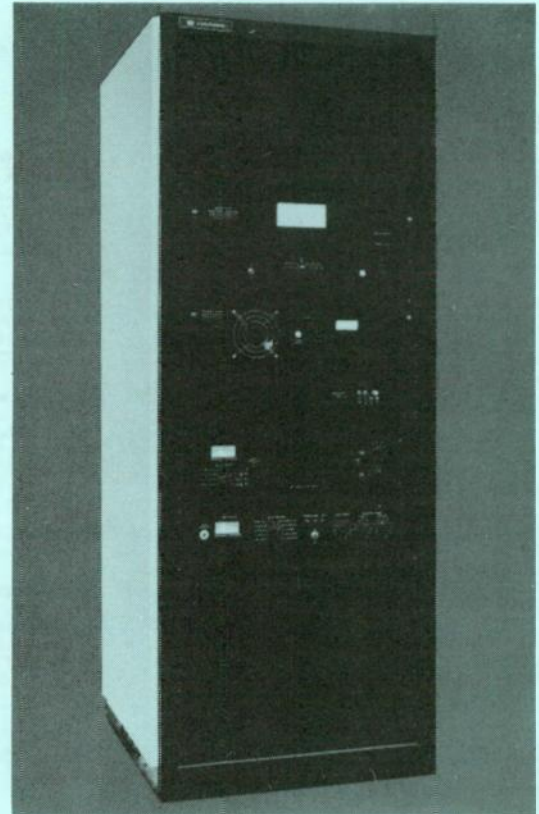

Specifications

VISUAL EXCITER

POWER OUTPUT:

FREQUENCY RANGE:

VIDEO INPUT:

Level:

Impedance:

SYSTEM M/NTSC

0.75 watt peak.

470-806 MHz (Channels 14 through 69).

1 volt peak-to-peak, ± 3 dB.

75 ohms, unbalanced.

Complete visual exciter specifications available on MCP-2U page.

VISUAL AMPLIFIER

POWER OUTPUT:

FREQUENCY RANGE:

CLASS OF OPERATION:

OUTPUT VSWR:

10 watts peak.

470-806 MHz (Channels 14 through 69).

Class A, solid state.

1.2:1 maximum.

AURAL EXCITER

POWER OUTPUT:

FREQUENCY RANGE:

AUDIO INPUT:

Level:

Impedance:

SUB-CARRIER INPUT:

Range:

Deviation:

Level:

Impedance:

FREQUENCY RESPONSE:

DISTORTION:

FM NOISE:

0.5 watt average.

470-806 MHz (Channels 14 through 69).

+10 dBm, ± 2 dB.

600 ohms, balanced.

30 kHz to 100 kHz.

± 5 kHz.

1 volt RMS.

10K ohms, unbalanced.

± 0.5 dB maximum.

0.5% maximum.

-60 dB maximum.

AURAL AMPLIFIER

POWER OUTPUT:

FREQUENCY RANGE:

OUTPUT VSWR:

5 watts average.

470-806 MHz (Channels 14 through 69).

1.5:1 maximum.

CORRECTION CAPABILITY

INCIDENTAL PHASE:

DIFFERENTIAL PHASE:

DIFFERENTIAL GAIN:

$\pm 10^\circ$

10°

3 dB.

NOTE: Overall transmitter performance is dependent on klystron tuning and operation, diplexers and external harmonic filters. Consequently, overall performance is not guaranteed, but performance similar to current Harris UHF transmitters can be anticipated.

UHF TELEVISION ANTENNAS



QUADRAPOWER UHF Television Antenna

- Unlimited range of patterns
- Omnidirectional gains up to 45
- High power handling capability
- Radomes for reduced windloading
- High reliability, low maintenance
- Factory assembled and tested, no field tuning required

Harris' Quadrapower antennas are panel type antennas specifically designed for high power UHF transmission with omnidirectional patterns.

The antenna consists of four panels per bay mounted on a square mast section. The antenna may be top mounted on a tower or the panels may be supplied without the mast for side mounting on a tower or other structure.

Starting with the original Harris Zig-Zag antenna design, Harris re-engineered the antenna to provide the Quadrapower's improved performance and mechanical specifications. Smooth vertical patterns are the result of computer-aided optimization of the feed system and panel pattern shape. Lower windloading is achieved by the addition of radome covers that give the antenna a nearly cylindrical profile.

The mast is constructed of structural quality steel, the panels are of structural grade aluminum to minimize weight, and the radiating elements are sturdy "Copperweld" steel supported by low-loss insulators. The RF transparent radomes are of fiberglass construction, and are color impregnated so that they never require painting. All materials used in the antenna are corrosion resistant to insure long life, low maintenance and optimum performance.

CUSTOM PATTERNS

Because of its multiple panel construction, the Quadrapower antenna can easily provide an unlimited number of directional patterns in the horizontal plane. This high degree of pattern flexibility enables the Harris antenna engineers to custom design a pattern to meet the specific requirements of each station. This pattern shaping permits the most efficient use of available transmitter power to cover a geographic area.

Computer-aided design is used extensively to rapidly and accurately calculate nearly any desired pattern.

RADOMES

Quadrapower antennas may be equipped with radome covers that significantly reduce windloading and eliminate the need for electrical deicing. The radome covers effectively protect the antenna elements from

precipitation, and are constructed so that they can be easily removed for inspection or maintenance of one antenna panel at a time.

Electrical deicing is available on non-radomed Quadrapower antennas.

INPUT CONNECTIONS AND POWER RATINGS

The standard input connector is 6-1/8", 75 ohm coax line to permit power levels up to 75 kilowatts. Since the antenna feed system is conservatively designed for safe high power operation, 8-3/16" coax, 9-3/16" coax, waveguide or dual 6-1/8" coax input connectors can be supplied for input power levels of 110 kilowatts or greater.

ASSEMBLY AND TESTING

To insure the best possible performance, every Quadrapower antenna is completely assembled and tested at the Harris antenna facility in Palmyra, Missouri. In addition to the testing of each panel and bay, the entire antenna is tested for correct azimuth pattern, elevation pattern and VSWR.

Length permitting, Quadrapower antennas are shipped fully assembled. The factory assembly and testing, along with one-piece shipping, minimize installation time required after delivery to the antenna site.

FILING INFORMATION AVAILABLE

Complete specifications and filing information are available on request. Harris antenna engineers are also available by telephone to discuss your specific antenna requirements.

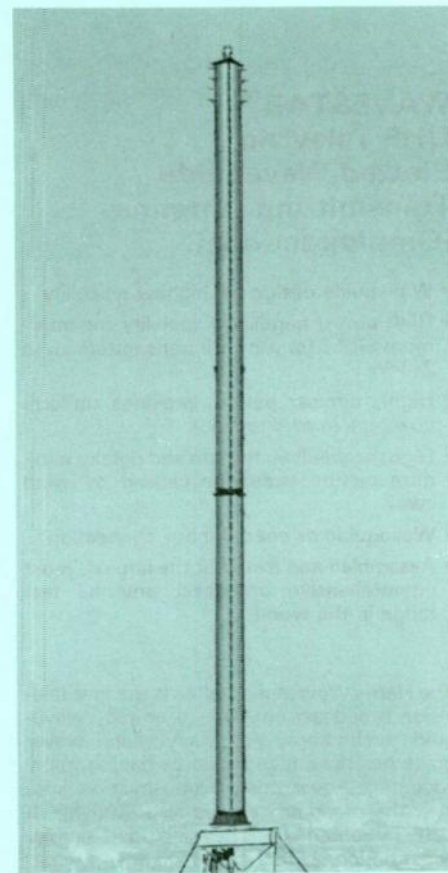

Ordering Information

When ordering UHF Quadrapower antennas, please specify channel number, pattern, beam tilt and null fill. Antennas supplied with lightning protector, beacon cable and prime coating on mast. Assistance with antenna assembly and ground test also supplied. Beacon, painting and ground support structures are not included.

TAZ-24U three bay Quadrapower antenna	994-7623-001
TAZ-24U three bay Quadrapower antenna with deicing	994-7623-002
TAZ-24UR three bay Quadrapower antenna with radomes	994-7623-003
TAZ-31U four bay Quadrapower antenna	994-7624-001
TAZ-31U four bay Quadrapower antenna with deicing	994-7624-002
TAZ-31UR four bay Quadrapower antenna with radomes	994-7624-003
TAZ-38U five bay Quadrapower antenna	994-7625-001
TAZ-38U five bay Quadrapower antenna with deicing	994-7625-002
TAZ-38UR five bay Quadrapower antenna with radomes	994-7625-003
TAZ-45U six bay Quadrapower antenna	994-7626-001
TAZ-45U six bay Quadrapower antenna with deicing	994-7626-002
TAZ-45UR six bay Quadrapower antenna with radomes	994-7626-003

Note: One bay and two bay UHF Quadrapower antennas and VHF Quadrapower antennas are available on request. All antennas are F.O.B. Harris' antenna facility, Palmyra, Missouri.

Options And Accessories

Input Connectors:	Dual 6-1/8", 8-3/16", 9-3/16" or waveguide.
Input Power:	Up to 150 kilowatts.
Rosemount Ice Warning System:	Consists of Model 871CB1 Ice Detector and Model 524B1 Controller.



HARRIS

P.O. Box 4290
Quincy, IL 62305-4290
(217) 222-8200

UHF TELEVISION TRANSMITTING ANTENNAS

WAVESTAR™ UHF Television Slotted Waveguide Transmitting Antenna (Omnidirectional)

- Waveguide design for highest reliability
- High power handling capability for maximum ERP...for use with transmitters up to 240kW
- Highly circular pattern provides uniform coverage in all directions
- High mechanical strength and rigidity minimize picture variations caused by wind sway
- Waveguide or coaxial input connection
- Assembled and tested at the largest, most comprehensive broadcast antenna test range in the world

The Harris Wavestar antenna is the first television broadcast antenna to employ waveguide technology. For many years, waveguide has been recognized as having many advantages over coaxial transmission line, now these advantages are also available in UHF-TV antennas. They include: simpler construction; higher power handling capability; and higher reliability. Although the Wavestar is of a unique waveguide construction, it performs in the same manner as coaxial antenna designs.

This new slotted waveguide antenna is the ultimate in design simplicity. Unlike coaxial antennas, it has no center conductor, bullets or insulators, fewer components mean higher reliability and longer life.

POWER RATING

Because of its waveguide design, the Wavestar antenna is inherently capable of handling in excess of 240 kilowatts. The overall power handling capability is limited only by the size of the input feed system coaxial line.

Power is transferred from the tower transmission line by an input feed adaptor at the base of the antenna, just below the tower top. The Wavestar can be supplied with an input connection to match nearly any coaxial or waveguide transmission line. The operating channel and the desired power rating of the antenna input will determine the optimum input connection.

For power ratings up to 80kW, the Wavestar is supplied with a 6-1/8" 75 ohm coaxial

input. For higher power ratings, the Wavestar can also be supplied with 8-3/16" or 9-3/16" coaxial input connections. The Wavestar can also be fed directly from rectangular or circular waveguide, thus eliminating the power handling and high frequency limitations of coaxial line.

PATTERNS

The TWS-30 is designed for a highly circular azimuth pattern for uniform radiation in all directions. The power gain of 30 can provide over 1500kW of radiated power from 55-60kW transmitters, 3000kW from 110-120 kW transmitters, and the maximum 5000kW of radiated power from 220-240kW transmitters.

Elevation pattern shapes approximate the ideal cosecant-squared shape required for uniform field strength versus distance from the transmitting location.

The Wavestar design minimizes variations in beam tilt, or "beam rocking", over the channel width, thereby preventing large variations in radiated power at different frequencies within the channel.

CONSTRUCTION

The Wavestar is a hollow galvanized steel cylinder with six rows of slots around the circumference of the antenna. Depending on the channel, two or three sections are stacked vertically to achieve the required gain. Fiberglass climbing steps are used to prevent pattern distortions that might be caused by metal steps.

The TWS-30 is designed for top mounting. It is constructed of structural steel that provides the high strength needed to prevent wind swaying (which causes reception problems such as color flutter in receivers). The standard Wavestar is engineered for wind up to 125 miles per hour (65/43 PSF) to provide excellent mechanical safety margins. The antenna is designed in accordance with the American Institute of Steel Construction Code and EIA Standard RS-222C.

The Wavestar slots are covered by Teflon radomes to protect the slots from ice build-up and subsequent performance degradation. Electrical de-icing is normally not required, which means substantial savings in installation and operating costs. For extremely severe icing environments, radome heaters can be provided.

The antenna is galvanized after fabrication, insuring that all surfaces inside and outside are protected from corrosion. In addition, the Wavestar is primed and finish painted before shipment.

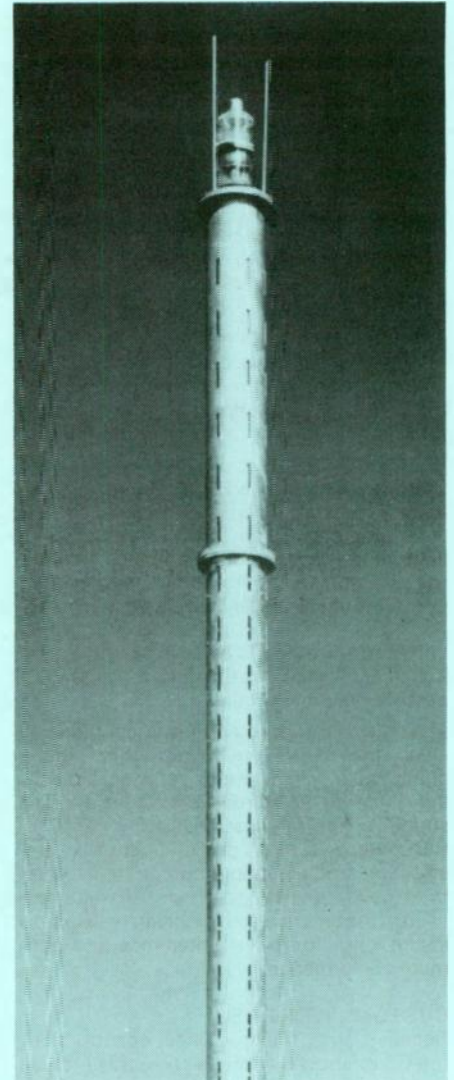

HARRIS ANTENNA FACILITY

The Wavestar is assembled and tested at the Harris antenna test range...the largest, most comprehensive facility of its kind. Situated atop a 230-foot bluff, with test transmitters located up to 3 miles away on flat, unobstructed Mississippi River bottom lands, the uncluttered range offers ideal conditions for testing, approaching the "free space" situation of an installed antenna. The test range, with its sophisticated test equipment, is ideal for testing broadcast antennas, and provides accurate comparisons between theoretical predictions and actual antenna performance.

UHF TELEVISION TRANSMITTING ANTENNAS

HARRIS
 P.O. Box 4290
 Quincy, IL 62305-4290
 (217) 222-8200

WAVESTAR™ UHF Television Slotted Waveguide Transmitting Antenna (Cardioid Pattern)

- Waveguide design for highest reliability
- High power handling capability
- Cardioid pattern provides for maximum ERP with 110kW transmitter
- Teflon® radomes eliminate requirements for electrical deicing
- High mechanical strength and rigidity minimize picture variations caused by wind sway
- Assembled and tested at the largest, most comprehensive broadcast antenna test range in the world

The Harris Wavestar antenna is the first television broadcast antenna to employ waveguide technology. For many years, waveguide has been recognized as having many advantages over coaxial transmission line, now these advantages are also available in UHF-TV antennas. They include: simpler construction; higher power handling capability; and higher reliability. Although the Wavestar is of a unique waveguide construction, its performance is similar to coaxial antenna designs.

This new slotted waveguide antenna is the ultimate in design simplicity. Unlike coaxial antennas, it has no center conductor, slot couplers, bullets or insulators, and fewer components mean higher reliability and longer life.

POWER RATING

Because of its waveguide design, the Wavestar antenna is inherently capable of handling in excess of 110 kilowatts. The overall power handling capability is limited only by the size of the input feed system coaxial line.

Power is transferred from the tower transmission line by an input feed adaptor at the base of the antenna, just below the tower top. The standard design is a coax to waveguide transition with 8-3/16", 75 ohm input for Channels 14-56 or 6-1/8", 75 ohm for Channels 57-69. Waveguide input can be provided for Channels 57-69 when higher power input is desired.

PATTERNS

The TWS-30C azimuth pattern is cardioid, or skull shaped, for maximum radiation in one direction. A peak power gain of 60 permits the maximum permissible five megawatts ERP from 110-kilowatt transmitters.

Elevation pattern shapes approximate the ideal cosecant-squared shape required for uniform field strength versus distance from the transmitting location.

The Wavestar design minimizes variations in beam tilt, or "beam rocking", over the channel width, thereby preventing large variations in radiated power at different frequencies within the channel.

CONSTRUCTION

The Wavestar is a hollow galvanized steel cylinder with a single row of slots on one side of the antenna. Depending on the channel, two or three sections are stacked vertically to achieve the required gain. Fiberglass climbing steps are used to prevent pattern distortions that might be caused by metal steps.

The antenna is designed for low tip deflection to minimize wind swaying that causes reception problems such as color flutter in receivers. The standard Wavestar is engineered for wind up to 125 miles per hour (65/43 PSF), which results in excellent mechanical safety margins.

The Wavestar slots are covered by Teflon® radomes to protect the slots from ice buildup and subsequent performance degradation. Electrical deicing is not required, which means substantial savings in installation and operating costs. The antenna is galvanized after fabrication, insuring that all surfaces inside and outside are protected from corrosion. In addition, the Wavestar is primed and finish painted before shipment.

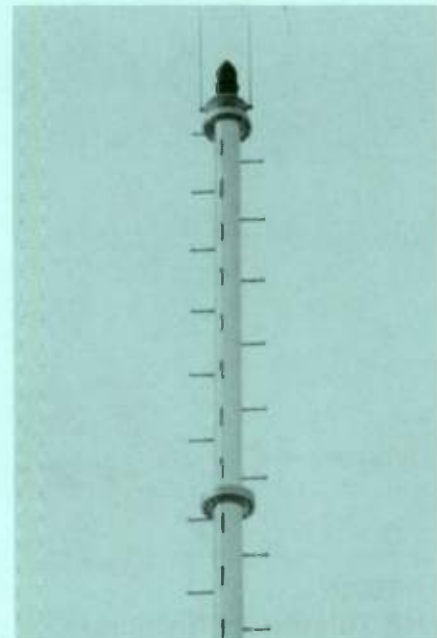

Wavestar antenna with Teflon radomes removed to show size and spacing of the slots.

Electrical Specifications

Channel Range: 14-69 (470-806 MHz).

Peak Power Gain: 60 (17.8 dB).

Input Connector: 8-3/16", 75 ohm (Channels 14-56); 6 1/8", 75 ohm (Channels 57-69). Waveguide input available.

Input Power Rating (with 20% aural): 136 kW to 104 kW (Channels 14-56). 80 kW to 56 kW (Channels 57-69).

Input VSWR:

Visual Carrier: 1.05 to 1.

Color Sub-carrier: 1.08 to 1.

Rest of Channel: 1.10 to 1.

Mechanical Specifications

Channel	Antenna Height (ft.)	Radiation Center (ft.)	Moment (a) (ft.-lbs.)	Shear (a) (lbs.)	Weight (lbs.)
14	76.7	36.0	115,500	3,080	10,300
20	71.6	33.5	94,100	2,690	8,900
25	67.9	31.6	84,400	2,550	8,500
30	64.6	29.9	71,100	2,250	7,500
35	61.6	28.4	60,000	1,990	6,500
40	58.9	27.1	54,800	1,900	6,300
45	56.4	25.9	46,500	1,670	5,500
50	54.2	24.7	40,300	1,500	4,900
55	52.1	23.9	37,200	1,450	4,700
60	50.2	22.7	32,800	1,310	4,200
65	48.4	21.9	30,500	1,270	4,000
69	47.1	21.2	28,900	1,230	3,900

Specifications for other UHF channels available on request. Specifications subject to change without notice.
 (a) Windload data for 50,33 PSF including effect of beacon.

Ordering Information

TWS-30C Wavestar antenna, cardioid pattern. Includes: assistance with antenna reassembly and ground check at customer's site; beacon cable; and finish painting. Beacon and ground support structure not included. Please specify channel number, beam tilt and null fill.

.....994-8807-001

Prices and Specifications Subject to Change Without Notice.



HARRIS

P.O. Box 4290
Quincy, IL 62305-4290
(217) 222-8200

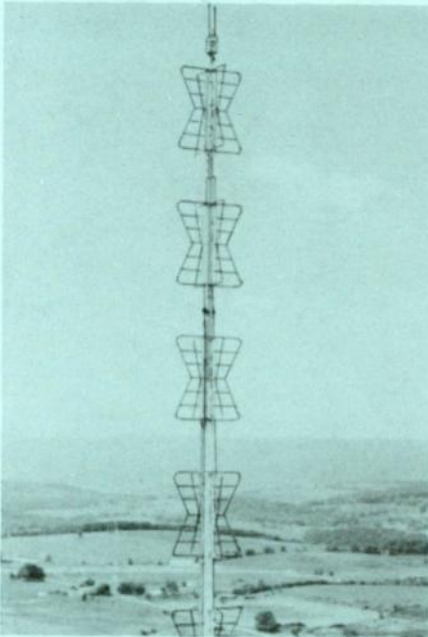

BATWING VHF Television Antenna

- Field tested and proven designs
- Multi-channel operation available
- Factory assembly
- Copper feed lines
- Galvanized mast and radiators
- Rugged mechanical design
- Conservative electrical design

The Harris VHF Batwing antenna has been widely used in television broadcasting service for many years. This well-proven design provides broadcasters with fine performance and long, reliable service.

The antenna consists of four "Batwing" radiators per bay, which are bolted to a cylindrical mast section. The antenna is engineered for top mounting on a tower, but smaller antennas are frequently side mounted for standby antenna service.

The radiators and the mast are hot-dipped galvanized steel, and corrosion-resistant components are used throughout to prevent electrical and mechanical degradation. The radiators are solidly bolted to the mast, which is ground potential for maximum lightning protection.

PATTERNS

The Batwing antenna normally provides a circular, or omnidirectional, radiation pattern in the horizontal plane. For special locations, the antenna design can be customized to provide a peanut, or figure-eight, pattern. A notch diplexer and phasing equipment are required for these special patterns.

Vertical plane patterns can be provided with beam tilt and null fill to satisfy nearly all special requirements.

MULTI-CHANNEL OPERATION

The inherently wide bandwidth and high power handling capability of the Batwing

antenna make it suitable for transmitting two multiplexed television signals within the same channel group.

INPUT CONNECTIONS

The Harris Batwing antenna is normally fed by two 3-1/8", 50-ohm transmission lines. The 90° phasing between lines is normally provided by a hybrid diplexer that is available as an accessory.

As an option, the antenna can be equipped to accept a signal from a single transmission line. In this case, a notch diplexer is required for combining the aural and visual transmitter signals.

DEICERS

Batwing antennas are not severely affected by moderate amounts of icing because of the

inherently low feed point impedance. Deicers are recommended, however, in areas where severe icing may be expected.

ASSEMBLY AND TESTING

Each Batwing antenna is completely assembled and tested at the Harris antenna facility in Palmyra, Missouri. After assembly and test, the antenna may be partially disassembled to facilitate shipping; however, shorter antennas may be shipped in one piece. The factory assembly and testing minimize installation time required after delivery to the antenna site.

FILING INFORMATION

Complete specifications and filing information are available on request. Harris antenna engineers are also available by telephone to discuss your specific antenna requirements.

Electrical Specifications

Channel Range:	54-88 MHz (FCC Ch. 2-6); 174-216 MHz (FCC Ch. 7-13).
Power Gain:	1 to 6, Ch. 2-6; 1 to 12, Ch. 7-13.
Input Connector:	Dual 3-1/8", 50 ohm.
Input Power Rating:	102 to 120 kW, TAB-6L. 70 to 77 kW, TAB-12H.
Input VSWR:	
Visual Carrier:	1.05 to 1.
Color Subcarrier:	1.08 to 1.
Rest of Channel:	1.10 to 1.
Circularity:	± 2dB.
Deicer Power:	3 kW per bay, Ch. 2, 3; 2 kW per bay, Ch. 4-6; 1 kW per bay, Ch. 7-13; 208/240 VAC, 60 Hz.

Ordering Information

When ordering Harris Batwing antennas, please specify channel number, pattern, beam tilt and null fill. Antennas supplied with lightning protector, beacon cable and finish painting in international orange. Assistance with antenna assembly and ground test also supplied. Beacon and ground support structures are not included.

TAB-1L single bay Batwing antenna, Ch. 2-6	994-7602-001
TAB-3L three bay Batwing antenna, Ch. 2-6	994-7604-001
TAB-4L four bay Batwing antenna, Ch. 2-6	994-7605-001
TAB-5L five bay Batwing antenna, Ch. 2-6	994-7606-001
TAB-6L six bay Batwing antenna, Ch. 2-6	994-7607-001
TAB-2H two bay Batwing antenna, Ch. 7-13	994-7603-001
TAB-6H six bay Batwing antenna, Ch. 7-13	994-7608-001
TAB-12H twelve bay Batwing antenna, Ch. 7-13	994-7609-001

Note: Two bay antennas for Ch. 2-6 available on request. One, four, eight and ten bay antennas for Ch. 7-13 available on request. All antennas are F.O.B. Harris' antenna facility, Palmyra, Missouri.

Options And Accessories

Rosemount Ice Warning System:	Consists of Model 871CB1 Ice Detector and Model 425B1 Controller.
Input Connector:	Single line input.
Pattern:	Peanut, or figure-eight
Hybrid Diplexer:	26 kW, Ch. 2-6. 66 kW, Ch. 2-6. 15 kW, Ch. 7-13. 55 kW, Ch. 7-13.

Test Range Pattern Measurements

Single Bay Rental Antennas Available on Request

Prices and Specifications Subject to Change Without Notice.

LOW BAND VHF-TV TRANSMITTING ANTENNAS

HARRIS
 P.O. Box 4290
 Quincy, IL 62305-4290
 (217) 222-8200

TAV-5L AND TAV-5LE Circularly Polarized Low Band VHF-TV Transmitting Antennas

- Low windload design for lower tower and installation cost
- TAV-5LE directly replaces Batwing antenna
- Excellent axial ratio — reduces ghosting effects
- Upper-lower feed system for maximum redundancy
- Radomed feed points and baluns-maximum protection from ice and corrosives
- Requires no electrical deicing

TAV-5L

The TAV-5L is a five-bay CPV antenna designed for excellent circularly polarized performance and for low windload. Each bay of the antenna consists of three crossed vee dipoles mounted at 120° intervals around a vertical mast. As a direct result of the precise tailoring of the radiated pattern of the vee dipoles, the TAV-5L has superb axial ratio characteristics.

The antenna is designed for maximum ERP (Effective Radiated Power) using today's 60-kilowatt low band television transmitters.

TAV-5LE

The TAV-5LE antenna is designed specifically as a replacement for the commonly used six-bay Batwing horizontally polarized antenna. The 5LE's radiation center, mechanical characteristics and tower bury section are engineered so that a Batwing antenna may be easily replaced on an existing tower. The 5LE's "extended radiation center" is slightly higher than the 5L to place it within two meters of existing Batwing antennas.

PATTERNS

Elevation pattern contouring to introduce beam tilt and null fill may be provided by means of standard phase distribution techniques. Control of the elevation pattern is accomplished with no degradation of the axial ratio. For omnidirectional stations, the shape of the azimuth pattern will vary from circular less than ±2 dB.

RADOMES

Fiberglass radome covers are standard, and protect the feed point and balun from exposure to moisture, ice and atmosphere corrosives. Consequently, the antennas are not subject to performance degradations caused by the environment.

INPUT CONNECTIONS

The standard 5L antennas are supplied with dual 3/8", 50 ohm input connections. The upper two bays and lower three bays of the antenna are each fed by a separate, independent transmission line. This feature permits using one-half of the antenna in an emergency situation (with appropriate patching) with only a minor reduction in signal strength. The TAV-5L may also be supplied with a single input connection.

All 5L antenna masts are hot dip galvanized and all hardware is stainless steel for excellent corrosion protection. In addition, all antennas are primed and finish painted before assembly.

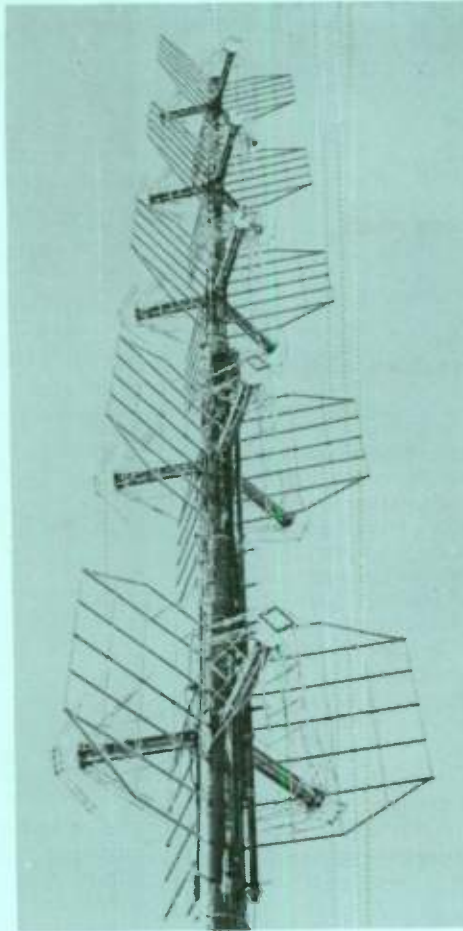

TAV-5L/5LE Electrical Specifications

FREQUENCY RANGE: 54-88 MHz
CHANNELS: 2-6, E2-E4
INPUT POWER RATING: 70 KW VISUAL
 WITH 20% AURAL
INPUT CONNECTOR: DUAL 3/8", 50 OHM
INPUT VSWR:
 VISUAL CARRIER: 1.05 to 1
 COLOR SUB-CARRIER: 1.08 to 1
 REMAINDER OF CHANNEL: 1.10 to 1
CIRCULARITY: ±2.0 dB
AXIAL RATIO: 2 dB

	POWER GAIN (PER POLARIZATION)	NULL FILL (PERCENT)	
	2.40	3.80 dB	7%
	2.39	3.78 dB	10%
	2.35	3.71 dB	15%
	2.29	3.60 dB	20%
	2.19	3.40 dB	25%
	2.08	3.18 dB	30%

NOTE: Gain may vary slightly with channel.

TAV-5L Mechanical Specifications

CHANNEL	ANTENNA (a) HEIGHT-(FT)	RAD. CENTER (FEET)	MOMENT (FT-LBS)	SHEAR (LBS)	WEIGHT (LBS)
2	81.5	41.4	230,000	7,500	13,300
3	75.5	38.0	197,000	7,050	11,500
4	69.0	34.7	161,000	6,050	9,500
5	62.25	30.9	126,000	5,350	8,200
6	59.0	29.1	111,000	5,050	7,700

NOTE: a) Height includes 4 foot lightning protector.
 b) Windloads for 50/33 PSF EIA wind.

TAV-5LE Mechanical Specifications

CHANNEL	ANTENNA (a) HEIGHT-(FT)	RAD. CENTER (FEET) (b)	MOMENT (FT-LBS)	SHEAR (LBS)	WEIGHT (LBS)
2	85.0	44.9	252,000	7,850	14,500
3	82.5	45.0	241,000	7,750	13,000
4	69.75	35.4	163,000	6,250	11,000
5	67.0	35.6	147,000	5,850	9,500
6	65.5	35.6	139,000	5,700	9,200

NOTE: a) Height includes 4 foot lightning protector.
 b) Radiation center within 2 meters of corresponding 6 bay Batwings.
 c) Bury section same as 6 bay Batwing.
 d) Windloads for 50/33 PSF EIA wind.

Ordering Information

When ordering, please specify channel number, pattern, beam tilt, and null fill. Antennas supplied with lightning protector, beacon cable and finish painting in international orange. Assistance with antenna assembly and ground test also supplied. Beacon and ground support structures not included. Standard antenna is bury mounted.

TAV-5L five-bay CPV antenna 994-8798-001
 TAV-5LE five-bay CPV antenna 994-8799-001

NOTE: Four and six bay CPV antennas for Channels 2-6 are available. All antennas are F.O.B. Harris' antenna facility, Palmyra, Missouri.

Options And Accessories

Input Connector: Dual 4/8" or single line.
 Pattern: Directional.
 Notch Diplexer: TD-60L, 66 kW rating, Channels 2-6.
 Antenna Mounting: Flange mounted.

Prices and Specifications Subject to Change Without Notice.

CPV Circularly Polarized Television Antenna

- Top mount design
- Excellent axial ratio — reduces ghosting effects
- High power handling capabilities
- Requires no electrical deicing
- Superb horizontal circularity
- Excellent control of vertical pattern
- Directional pattern capability
- Antenna elements are at DC ground potential for lightning protection
- Dual or single line input

In addition to its outstanding mechanical specifications, the Harris CPV antenna also features excellent circularity (standard omnidirectional pattern varies less than ± 2 dB); low axial ratio (less than 2 dB); VSWR less than 1.05:1 at visual carrier and below 1.1:1 over each channel; directional horizontal pattern capability; and a variety of vertical patterns that may be tailored to specific coverage requirements. Harris has spent years in research and development of the CP concept for TV broadcasting, so that the current design now combines optimum circularly polarized performance with all of the regular features of the Harris line of television antennas.

With the Harris CPV, picture quality may be improved through ghost reduction. Also, increased signal-to-noise ratios may be achieved whether the viewer uses a CP receiving antenna, conventional rabbit ears or an ordinary outside receiving antenna.

DESIGN

Each bay of the CPV consists of three crossed vee dipoles mounted at 120° intervals around a vertical mast. These dipoles are separated by three vertical grids which isolate the vee dipoles and provide horizontal beam shaping. Each set of crossed dipoles is fed in phase quadrature to produce rotating RF energy. The signal emanating from each set of dipoles is considered right hand circular since the field rotation is clockwise as viewed in the direction of propagation.

The Harris CPV is available with power ratings up to 100 kilowatts, and a special wideband flat dipole is used to safely handle the required power levels. Each dipole is mechanically supported and fed from special baluns for both vertical and horizontal polarization.

RADOMES

Fibergalss radome covers are standard, and protect the radiating elements from exposure to moisture, ice and atmospheric corrosives. Consequently, the CPV antenna is very insensitive to performance degradations caused by the environment. As the need for electrical deicing is eliminated, substantial annual savings in power costs can result—in addition to the initial savings in not having to purchase deicer elements, transformers and wiring.

AXIAL RATIO

The CPV has superb axial ratio characteristics as a direct result of the precise tailoring of the radiated pattern of the vee dipoles. Axial ratio, the ratio of the major and minor axes of the polarization ellipse, critically defines the quality of a radiating element. When circularly polarized receiving antennas are used by the viewer, reflected signals may be attenuated, thereby reducing ghosting effects.

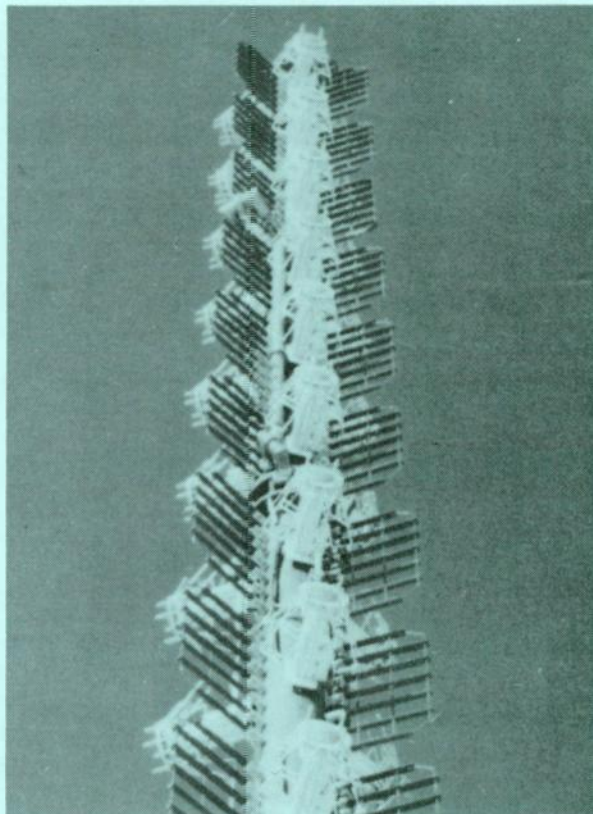

VERTICAL PATTERN

Vertical pattern contouring to introduce beam tilt and null fill may be provided by means of standard phase distribution techniques—such as those used in many successful Batwing installations. Control of the vertical pattern is accomplished with no degradation of the axial ratio. Therefore, contoured vertical patterns are available much the same as in conventional horizontally polarized TV antennas.

HORIZONTAL CIRCULARITY

For omnidirectional stations, the shape of the horizontal pattern will vary from circular by less ± 1.5 dB for Ch. 7-13; 2.0 dB for Ch. 2-6. Stations employing directional arrays will find one of the several patterns available to be ideally suited to their specific need.

INPUT CONNECTIONS

The CPV antennas are uniquely designed in a manner that permits the use of either single or dual transmission lines. This feature permits maximum flexibility for the broadcaster who is replacing an existing antenna or planning a completely new installation.

The standard TAV-6L low band CPV antenna is supplied with dual $3\frac{1}{8}$ " 50 ohm input connections. The upper and lower halves of the antenna are each fed by a separate, independent transmission line, a feature that permits using one-half of the antenna in an emergency situation (with appropriate patching) with only a minor reduction in signal strength. The TAV-6L may also be supplied with a single input connection.

The standard TAV-12H high band CPV antenna is supplied with a single $6\frac{1}{8}$ " 50 ohm input connection. The TAV-12H may also be supplied with a dual line input, which will permit feeding power to one-half of the antenna in an emergency.

All CPV antenna masts are hot dip galvanized and finish painted before assembly. All hardware is stainless steel for excellent corrosion protection.

Prices and Specifications Subject to Change Without Notice.

VHF TELEVISION ANTENNAS



TAV-6L Electrical Specifications

Channel Range: FCC Channels 2-6 (54-88 MHz).
Power Gain (10% Null Fill): 2.92 (4.65 dB) per polarization.
Input Connector: Dual 3-1/8", 50 ohm.
Input Power Rating: 70 kW visual with 20% aural.
Input VSWR:
 Visual Carrier: 1.05 to 1.
 Color Sub-carrier: 1.08 to 1.
 Rest of Channel: 1.10 to 1.
Axial Ratio: 2 dB.
Circularity: ± 2 dB.

TAV-12H Electrical Specifications

Channel Range: FCC Channels 7-13 (174-216 MHz).
Power Gain (15% Null Fill): 5.81 (7.64 dB) per polarization.
Input Connector: Single 6-1/8", 50 ohm.
Input Power Rating: 75 kW visual with 20% aural.
Input VSWR:
 Visual Carrier: 1.05 to 1.
 Color Sub-carrier: 1.08 to 1.
 Rest of Channel: 1.10 to 1.
Axial Ratio: 2 dB.
Circularity: ± 1.5 dB.

TAV-6L Mechanical Specifications

Channel	Antenna Height (ft.)	Rad. Center (feet)	Moment (ft.-lbs.)	Shear (lbs.)	Weight (lbs.)
2	95.5	46.25	337,000	9,450	16,000
3	88.0	42.33	291,000	8,900	15,000
4	80.5	38.75	232,000	7,650	13,000
5	74.0	35.25	174,000	6,700	11,000
6	70.0	32.60	164,000	6,450	10,100

Note: Antennas are designed in accordance with the American Institute of Steel Construction Code. The loading data shown in the table is based on a wind pressure of 50 lbs. per sq. ft. acting normal to flat surfaces. Loading data includes windload effects for beacon (not provided by Harris), and also bury sections if not flange mounted.

TAV-12H Mechanical Specifications

Channel	Antenna Height (ft.)	Rad. Center (feet)	Moment (ft.-lbs.)	Shear (lbs.)	Weight (lbs.)
7	69.0	32.7	172,750	5,275	9,150
8	68.2	32.3	169,400	5,250	9,050
9	65.0	30.7	155,550	5,050	8,800
10	64.2	30.3	152,250	5,000	8,750
11	60.7	28.6	136,550	4,725	8,000
12	60.7	28.6	136,550	4,725	8,000
13	59.0	27.7	130,700	4,650	7,600

Note: Antennas are designed in accordance with the American Institute of Steel Construction Code. The loading data shown in the table is based on a wind pressure of 50 lbs. per sq. ft. acting normal to flat surfaces. Loading data includes windload effects for beacon (not provided by Harris), and also bury sections if not flange mounted.

Low Band CPV Ordering Information

When ordering Harris low band CPV antennas, please specify channel number, pattern, beam tilt and null fill. Antennas supplied with lightning protector, beacon cable and primer coating. Assistance with antenna assembly and ground test also supplied. Beacon, painting and ground support structures not included. Standard antenna is bury mounted.

TAV-6L six bay CPV antenna, Channels 2, 3 994-8602-00X
TAV-6L six bay CPV antenna, Channels 4, 5 and 6 994-8602-0XX

Note: Four and five bay CPV antennas for Channels 2-6 are available on request. All antennas are F.O.B. Harris' antenna facility, Palmyra, Missouri.

Options And Accessories

Input Connector: Dual 4-1/16" or single line.
Pattern: Directional.
Test Range Pattern Measurements
Notch Diplexer: TD-60L, 66 kW rating, Ch. 2-6.
Antenna Mounting: Flange mounted.

High Band CPV Ordering Information

When ordering Harris high band CPV antennas, please specify channel number, pattern, beam tilt and null fill. Antennas supplied with lightning protector, beacon cable and finish painting in international orange. Assistance with antenna assembly and ground test also supplied. Beacon and ground support structures not included. Standard antenna is flange mounted.

TAV-12H twelve bay CPV antenna, Channels 7-13 994-8707-001
TAV-12H twelve bay CPV antenna, Channels 7-13, as above, except with dual 3-1/8", 50 ohm input 994-8707-002

Note: 8, 10, 14, 16 and 18 bay CPV antennas for Channels 7-13 are available on request. All antennas are F.O.B. Harris' antenna facility, Palmyra, Missouri.

Options And Accessories

Input Connector: Dual 3-1/8" or dual 4-1/16", 50 ohm.
Pattern: Directional.
Test Range Pattern Measurements
Notch Diplexer: TD-100H, 100 kW rating, Ch. 7-13
Impedance Transformer: 6-1/8" 50 ohm to 6-1/8" 75 ohm.
Power Splitter for Dual Line Feed
Antenna Mounting: Bury mounted.

Prices and Specifications Subject to Change Without Notice.



HARRIS

P.O. Box 4290
Quincy, IL 62305-4290
(217) 222-8200

AUDIO CONSOLE

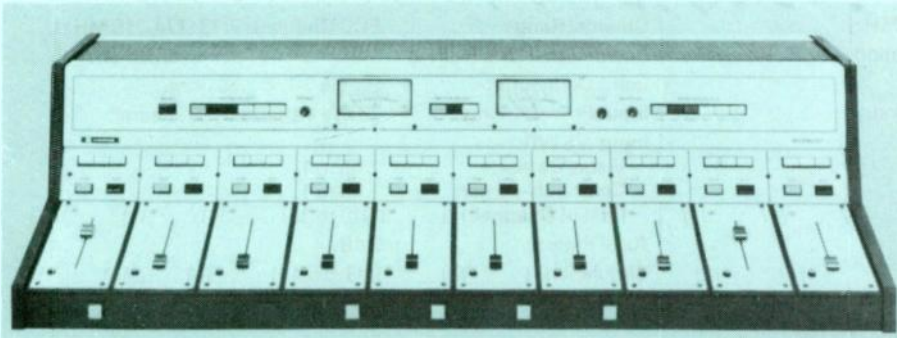

MEDALIST-10, 10 Channel



MEDALIST-8, 8 Channel

MEDALIST 8, 10 or 12 Channel Dual Stereo Audio Consoles

- Plug-in, interchangeable attenuator modules provide quick replacement, even with unskilled personnel
- Choice of rotary or linear attenuators for the best performance by your operating staff
- Mic input available on any channel to provide individual station configuration of console channel assignments
- Up to 3 sources into each input channel to eliminate patch panels and external switching panels
- Virtually transparent performance assures the best possible signal quality and listener satisfaction
- 25 dB minimum headroom in all circuits provides excellent station sound, even with the VU meters pinned
- Excellent RFI/EMI immunity assures noise-free signal of your programming, without interference from nearby stations
- Ideal for stereo on-air and production applications where you want the cleanest signal in the area

The Harris Medalist Series of dual stereo audio consoles is ideal for AM and FM on-air and production applications. The Harris Medalist-12 offers facilities for up to 36 sources into 12 input channels. It provides full visibility of all output signal levels via five dedicated meters for Program, Audition, and Mono/Sum. It also has mounting provisions for one or two up/down counters, synchronous clock or master clock readouts. The Medalist-10 allows facilities for up to 30 sources into 10 input channels. The

Medalist-8 has the capability for 24 sources into 8 input channels. Microphone capability on all input channels makes the Medalist audio console an attractive choice for small TV operations. Other applications include Cable TV, post-production facilities and sound distribution systems. Features typically found only in more expensive modular audio consoles are standard in the Harris Medalist. Multiple input selectors are provided for headphone and monitor circuits. And the best in human engineering is evident in the choice and location of front panel components.

RELIABILITY

A heavy duty power supply with plenty of reserve capacity is included in the Medalist console. The components in the supply have power and voltage ratings well above nominal requirements to assure optimum reliability and long life. Burned-in ICs, selected and screened for important operating parameters, are used for high reliability and stability in the various signal paths.

Top line components such as the DBX[™] VCAs, Penny and Giles attenuators and Schadow switches provide unquestioned reliability and performance in their respective areas of the console. Even the quick connect AMP Barrel Terminals for the input and output connections are gas tight and were selected for reliability as well as for convenience.

YOU SPECIFY THE STYLE OF PLUG-IN ATTENUATORS

You may select either rotary or linear Penny and Giles or alternate, lower cost attenuators with 100 millimeter (four inch) throw in your Harris Medalist audio console. In either con-

figuration, the plug-in, interchangeable attenuator modules offer operating ease and new dimensions of service convenience.

TRANSPARENT PERFORMANCE

Active transformerless balanced input and output circuits give the Medalist virtually transparent performance rarely matched in competitive consoles of any size. The frequency response is very flat, with no transformers to cause rolloff or sharp rise in distortion within the audio passband.

AMPLIFIER COMPLEMENT

Two microphone preamps with plug-in connections are provided as standard equipment. A pan pot on the output of the preamps sets the desired left/right stereo mix. Additionally, two stereo program amplifiers are included for the Program and Audition line outputs. Other amplifiers provided are: A stereo headphone amplifier capable of driving either low or high impedance phones; a line level stereo amplifier to drive the optional external monitor speaker amplifier; and a powerful cue amplifier with built-in speaker.

SWITCHING PHILOSOPHY

All front panel switching on the Harris Medalist audio console is effected through high quality pushbutton switches. Large, rectangular buttons aid comfortable, positive operation.

MEETING IMPORTANT CRITERIA

In the tradition of all Harris audio consoles, the Medalist is a skillful blend of engineering advances, no-compromise performance, and user-friendly design—all wrapped in a functional, cost competitive package. This innovative audio console merits serious consideration in present or future plans to update your facility.

AUDIO CONSOLE



SPECIFICATIONS

OUTPUT CHANNELS:

Stereo PROGRAM and AUDITION, plus optional mono SUM channel with +8 VU output level (+4 VU and 0 VU field adjustable).

INPUT CHANNELS:

12 total on the Medalist-12, 10 on the Medalist-10 and 8 on the Medalist-8. Stereo line level, or mono mic level with pan-pot for left/right imaging.

INPUT CIRCUITS:

Medalist-12, 36 total; Medalist-10, 30 total; Medalist-8, 24 total. Has three-position source selector in each input channel with the first position of each group capable of mic input for up to 8 mics in the Medalist-8, 10 in the Medalist-10 and 12 in the Medalist-12. The second and third positions on the last two input channels of each console are capable of remote line operation, with program cue feed down the line before being switched into the console. All others are for line level sources such as cart machines, reel-reel and turntables.

STANDARD AMPLIFIER COMPLEMENT:

2 microphone preamps, 2 stereo program line amplifiers, stereo headphone amplifier, stereo monitor driver (to optional external speaker power amplifier), and mono/sum cue amplifier with built in speaker.

OUTPUT CIRCUITS:

2 stereo plus optional mono/sum program line level outputs, stereo driver @ .25 volt nominal output (10V maximum, external power amplifier required), stereo headphone feed for external power amplifier (if more than 2 watts/channel internal headphone amplifier is desired).

INPUT IMPEDANCES:

MICROPHONE: 5K ohms or better, balanced
CART MACHINES, ETC.: 8K ohms or better, balanced
EXT 1, EXT 2: 8K ohms or better, balanced
NETWORK: 620 ohms terminated, balanced

SOURCE IMPEDANCES:

MICROPHONE: 150/250 ohms
CART MACHINES, ETC.: 150/600 ohms
EXT 1, EXT 2: 150/600 ohms
NETWORK: 600 ohms

OUTPUT IMPEDANCES:

PGM, AUD, MONO: 20 ohms, resistive
MONITOR FEED: 50 ohms maximum, resistive
PROGRAM CUE TO REMOTE LINES: Approx. 2K ohms, resistive
EXTERNAL PHONE FEED: 50 ohms maximum, resistive

LOAD IMPEDANCES:

PGM, AUD, MONO: 150/600 ohms
MONITOR FEED: 1K ohms or greater
PROGRAM CUE TO REMOTE LINES: Approx. 2K ohms, resistive
EXTERNAL PHONE FEED: 1K ohms or greater

GAIN:

MIC TO LINE: 94 dB \pm 2 dB* with controls @ minimum attenuation
TAPE TO LINE: 30 dB \pm 2 dB* with controls @ minimum attenuation
*May be changed with circuit value changes

FREQUENCY RESPONSE:

MIC TO LINE: +0, -0.5 dB, 20 Hz to 20 kHz
TAPE TO LINE: +0, -0.25 dB, 20 Hz to 20 kHz
BANDPASS: -3 dB @ 3 Hz and 100 kHz

TOTAL HARMONIC & IM DISTORTION:

PGM, AUD, MONO: 0.05% maximum, 20 Hz to 20 kHz @ 8 dBm output
0.1% maximum, 20 Hz to 20 kHz @ +18 dBm output
Clipping Level: +26 dBm/600 ohms, or higher

SIGNAL TO NOISE:

MIC TO LINE: 77 dB (or better) below +18 dBm output with -50 dBv input level, for typical proof measurements; -127 dBv (or better) equivalent input noise with 20 Hz to 20 kHz bandpass and normal control settings
TAPE TO LINE: 95 dB (or better) below +18 dBm output with +14 dBv input level and normal control settings
MONITOR & PHONE FEED: Approx. same as TAPE TO LINE

CUE AMPLIFIER OUTPUT:

6 watts with complex wave into 8 ohm speaker

HEADPHONE AMPLIFIER:

2 watts per channel with complex wave into 8 ohm phones, 7 volts RMS into phones of 600 ohms or greater.

POWER REQUIREMENTS:

125 watts max. for Medalist-12; 100 watts max. for Medalist-10; 80 watts max. for Medalist-8.

SIZE:

MAINFRAME: 513 mm (20 in.) deep \times 278 mm (11 in.) high.
Width: Medalist-12 — 1241 mm (49 in.)
Medalist-10 — 1038 mm (41 in.)
Medalist-8 — 835 mm (33 in.)
POWER TRANSFORMER/FUSE ASSEMBLY: 152 mm (6 in.) deep \times 133 mm (5 1/4 in.) high (with 25 ft. interconnecting cable, plugs on each end).

WEIGHT:

Medalist-12 — 36 kg (80 lbs.)
Medalist-10 — 31 kg (69 lbs.)
Medalist-8 — 27 kg (60 lbs.)

ORDERING INFORMATION

Medalist-12 console, with two stereo program amplifiers, two mic preamplifiers, less input channel attenuators	994-8835-001
Medalist-12 4-digit, 100-minute up/down timer with .3" LED display and 3 controls	436-0248-000
Medalist-12 6-digit, 12 hour line synch. clock with .3" LED display and 3 controls	436-0249-000
Medalist-12 6-digit, remote display for ESE master clocks with serial time code	436-0250-000
Medalist-10 console, with two stereo program amplifiers, two mic preamplifiers, less input channel attenuators	994-8758-000
Medalist-8 console, with two stereo program amplifiers, two mic preamplifiers, less input channel attenuators	994-8759-001
Stereo program amplifier for Mono/Sum and remote program cue	994-8776-001
Additional microphone preamps	994-8775-001
Penny & Giles linear attenuators*	994-8762-001
Penny & Giles rotary attenuators*	994-8763-001
Alternate linear attenuator*	994-8812-001
Alternate rotary attenuator*	994-8811-001
Blank attenuator module (use when less than full complement of attenuator modules specified)	994-8826-001
Remote start switch, momentary action	992-6281-001
Remote start switch, alternate action	992-6282-001
BGW-75 dual monitor power amplifier	740-0606-000

*May be intermixed; order up to 10 total

**Harris Medalist Functional Block Diagram
 For 10-Channel Medalist
 (Typical Of All Medalist Series)**

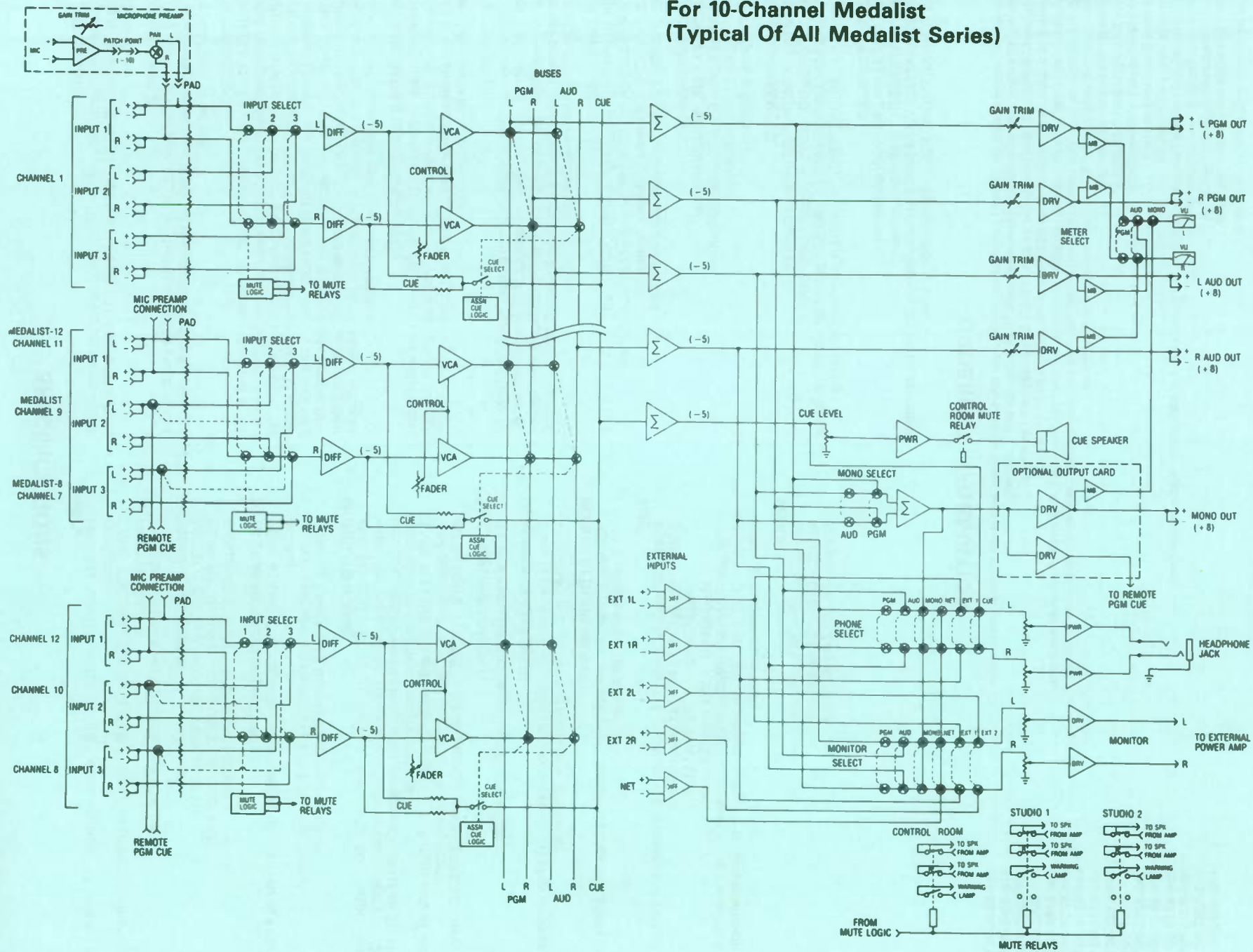

Prices and Specifications Subject to Change Without Notice.

PHONO PREAMPLIFIER



PX-91 Mastering Quality Phono Preamp

- Dual mono or stereo operation
- Extremely low transient intermod and dynamic distortion, assures faithful reproduction of even the most demanding disc cuts
- High accuracy equalization and excellent response, +0.25 dB maximum from ideal RIAA curve
- Polypropylene equalization components insure excellent transient response
- All integrated circuits burned in and factory tested for high reliability
- Low noise design for dead quiet mastering operation
- High input overload immunity, 630 mV at 1 kHz insures adequate headroom and extraordinary quality

Excellent audio fidelity in the broadcast chain is of vital concern to broadcasters. The phono preamplifier is a critical component in this chain. The advent of inexpensive integrated circuit technology has produced an array of low cost phono preamplifiers which advertise excellent steady-state performance. However, static measurements do not adequately describe dynamic listening criteria.

The new Harris PX-91 Mastering Quality Phono Preamp is the result of a careful evaluation of the performance requirements of broadcast phono preamplifiers.

SPLIT EQUALIZATION

Broadcast phono preamps generally employ only a single stage for equalization and amplification. These designs suffer from inadequate feedback loop gain due to the stringent requirements imposed by RIAA equalization and the gain required for a usable output level.

The Harris PX-91 Mastering Quality Phono Preamp splits the equalization and amplification requirements into two separate stages. This allows considerably more conservative operation of each amplifier stage to insure excellent transient performance. The first stage buffers the phono cartridge, provides equalization time constants of 3180 and 318 microseconds, and supplies a small amount of overall gain. Unlike composite amplifier preamps, this first stage is DC coupled to the cartridge, eliminating a coupling capacitor that can easily degrade the small signal level present.

The 7950 μ sec and the 75 μ sec time constants are provided by a passive interstage network. This output is directly coupled to the second stage which provides the additional gain necessary to bring the cartridge level up to line level. It is electronically balanced, provides 20 dB of variable gain range and an output capability in excess of +20 dBv into a 600 ohm load.



NOISE

The Harris PX-91 Phono Preamp design effort has been supplemented by an equally extensive measurement program. The unit is subjected to a battery of tests which completely and unambiguously define its actual performance. Typical noise is 85 dB below 10 mV input level, 600 ohm termination, which approaches the theoretical limit of performance. In addition, 1/3 octave analysis reveals a smooth noise vs. frequency curve, indicating hum- and pop-free performance.

FREQUENCY RESPONSE

The 2 stage design of the Harris PX-91 allows for theoretically perfect equalization. Use of the finest 1% film and foil polypropylene capacitors and 1% metal film resistors insures compliance with the ideal IEC-RIAA curve within 0.25 dB.

DISTORTION

The static and transient distortions of the Harris PX-91 Phono Preamp are so low that they are difficult or impossible to measure. Over one year of solid research into low noise amplifier design and transient distortion culminated in the production of this preamp.

Distortion in the Harris Phono Preamp was measured with classical and modern techniques that more closely approximate auditory perception. Swept two-tone Intermodulation Distortion and Transient Intermodulation Distortion test results were limited by modern state-of-the-art test equipment performance, not by the performance of the preamp.

OTHER FEATURES

Amplifier slew rates are better than 15V/ μ sec, more than adequate for the small signal levels involved. Adjustable gain and capacitive cartridge loading assure optimum performance with any moving magnetic cartridge. The power supply is regulated and doubly filtered to eliminate power line transients from the preamp output. Conservative operation of all components provides trouble-free operation, even in brownout or surge conditions. Professional XLR output connec-

to s eliminate RFI prone barrier strips. RCA type phono input connectors assure RF immunity and compatibility with quality tone arms.

Specifications

Input Impedance: 47K ohms in parallel with 100pf to 300pf, adjustable in 50pf steps.

Input Stage Overload: 630 mV RMS (1.78 vPP) at 1 kHz.

Maximum Input Sensitivity: 3.2mV RMS for +4 dBv output.

Output Impedance: 100 ohm, electronically balanced, resistive.

Maximum Output Level: +20 dBv.

Frequency Response: Within ± 0.25 dB of standard IEC-RIAA curve, 20 Hz to 20 kHz.

Harmonic Distortion: Less than 0.02%, 20 Hz to 20 kHz, +10 dBv output. Typically less than 0.005%.

Intermodulation Distortion: Less than 0.02%, 60 Hz/7 kHz, 4:1 ratio, +10 dBv output. Typically less than 0.008%.

Transient Intermodulation Distortion: Less than 0.01%, CCIF two tone method, 20 Hz difference frequency. Typically less than 0.002%, DIM-100 sine/square (Otal) method below 0.05% measurement limit.

Signal To Noise: Greater than 80 dB below 10 mV RMS input reference, 20 Hz to 20 kHz, 600 ohm input termination. Typically: 85 dB below 10 mV input, 600 ohm terminated, non-weighted, 90 dB below 10 mV input, 600 ohm terminated, A weighted.

Equivalent Input Noise: -122 dBv, 20 Hz to 20 kHz, 600 ohm terminated.

Audio Slew Rate: ± 15 V/ μ sec.

Gain: 32-52 dB, continuously variable.

Channel Separation: Greater than 70 dB.

AC Power: 117 VAC/234 VAC, 50/60 Hz, 4 watts.

Audio Input Connectors: RCA phono jacks.

Audio Output Connectors: Male XLR type.

Size: 10.5" L x 2.25" H x 4" W (267mm x 57mm x 102mm).

Weight: Domestic packed, 3.25 lbs. (1.5 kg).

Cubage: 2 cubic feet.

Ordering Information

Harris PX-91 Mastering Quality Phonograph Preamp for dual mono or stereo operation 994-8915-001

**HARRIS 9000
 PROGRAM CONTROL SERIES**

- Video editing and display
- MULTI-FILE™ Program Memory
- Jock-assist countdown clock with 10-second warning
- Automatic power failure restart
- Built-in time announce control
- Interfaces to all popular random access machines
- Ready sensing to prevent dead air
- Crystal-controlled 7-day clock
- Simple one-time bulletin insertion
- Operator "error sensing"
- Automatic voice track control
- Programmable fade-under for talk-over
- Software logic — your safeguard against future obsolescence
- Front panel access to test points and adjustments
- Full function monitoring and audition
- Optional logging, which provides discrepancy diagnostics
- 25 Hz detection included for all reel-to-reel sources
- Ready for most syndicated programming services
- Four "coffee pot" function relays included
- Micro-computer versatility
- Complete system remote control
- Dual silence sensors
- Stereo and sum-channel mono outputs
- Emergency back-up operation panel

The purpose of radio program control equipment is to maximize station profits through greater operating efficiency and through the presentation of a more saleable program product. That's pretty basic, but that's what it's all about...saving time...improving your product...increasing your profits.

That's what the Harris 9000 Program Control is all about, too. It has been designed to give you the best tool available to increase the efficiency and effectiveness of your staff, while providing the opportunity to improve your sound—whatever your format may be.

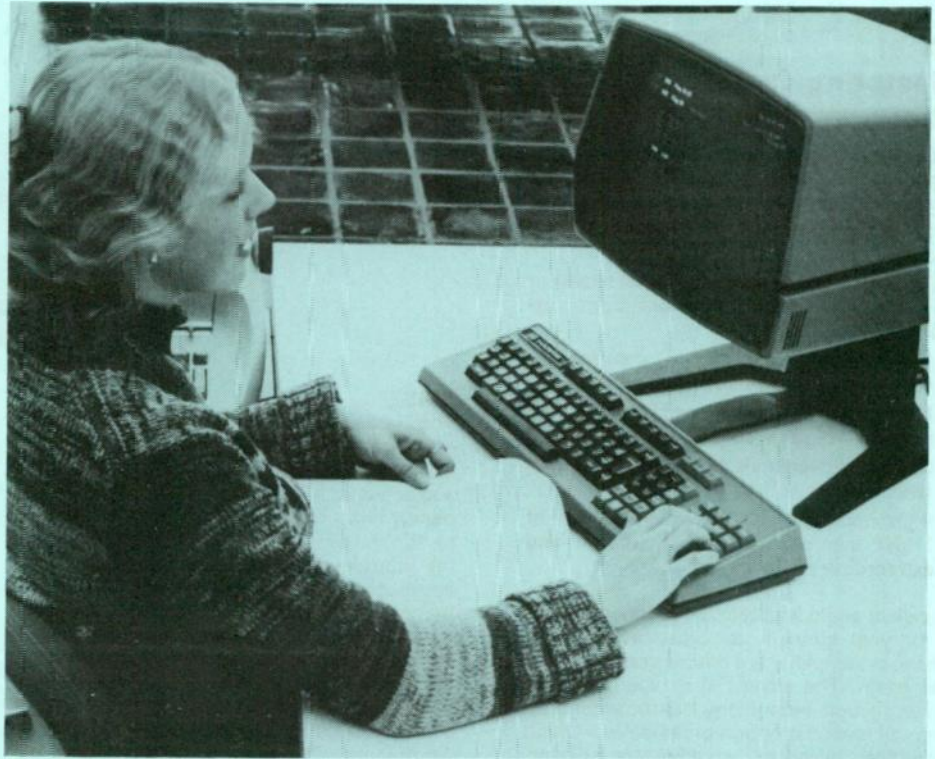

• Three distinct systems available, offering the broadcaster a complete selection to meet his particular requirements • MULTI-FILE™ Program Memory saves you time...and money • Easy-to-understand video display of current system status • Conversational messages • No special skills required to operate system • Live-assist features and ease of operation meet the needs of today's fast-paced combo operator • Advanced micro-computer design • Operationally and environmentally proven... hundreds of Harris' systems in field use.

As the originator of micro-computer program automation, Harris has drawn on its years of experience, and taken the next step forward to give you more flexible, more convenient, more reliable, and easier to operate systems than any available before. Harris 9000 systems will handle any format flawlessly, yet are so easy to understand, and so easy to program that even the most non-technical person in your station will readily see how they work and appreciate their help.

With many exclusives, from live-assist features to the truly advanced MULTI-FILE™ Program Memory, the Harris 9000 Series is definitely the most advanced concept in program automation, and the best there is at its job—helping you improve your results, on the air and on the bottom line.

**UNLIMITED FLEXIBILITY
 TO HANDLE ANY FORMAT...**

With the wide variety of program formats that are on the air today, a system must have great versatility if it is to be able to handle any one of them. Harris' 9000 systems have that versatility.

No programming is too complicated—or too simple. They will faultlessly handle everything from fast-paced "lots-of-music, lots-of-talk" programming to a more simple sequence of reel-to-reel events integrated with commercials at the proper times. In addition, the Harris 9000 enables management to achieve its goal of minimizing the time and errors associated with entering commercials and other schedule changes.

**EFFICIENCY AT
 EVERY STAGE...**

The Harris 9000 aggressively pursues maximum efficiency at every stage of station operation. The video terminal provides necessary information—very complete yet very simple—for schedule entry and review. Even during editing, a status display informs the operator of the on-air situation, alerting him to possible problems. Conversational messages provide easy-to-understand prompting regarding the nature of errors. The keyboard layout, developed from Harris' experience in hundreds of installations, is aimed at fast and reliable scheduling.

PROGRAM CONTROL



9000 Series Control Terminal

Programming and operating instructions are communicated to the system from a terminal that may be located up to 150 feet from the system electronics. The terminal provides continuous video display of various operational functions, and is also used for editing purposes.

SIMPLIFIED SCHEDULE ENTRY WITH MULTI-FILE PROGRAM MEMORY...

The need to separate commercials from repetitive format elements was partially satisfied with the use of sub-routines, a concept developed by Harris and now widely copied throughout the industry. With the MULTI-FILE Program Memory, Harris' 9000 has vastly improved on a good idea, providing a real solution to an error-prone, time-consuming problem.

Commercial schedules, music rotations, repetitive format elements and special programs are all independent schedules which must be integrated to create the broadcast day. MULTI-FILE Program Memory provides independent files for these schedules, eliminating the need to refer to unrelated material. Traffic, for instance, no longer needs to know where to go after a commercial cluster. Traffic keeps the commercial file, the music director keeps the playlist file, etc. This is a real time-saver.

The Harris 9000 with MULTI-FILE Program Memory keeps things simple by integrating these various schedule files, according to plan and always on time. The operator can highlight on the video screen the look-ahead display of entries from any particular file; in addition, a bar graph can be displayed, distinctly illustrating the integration of upcoming schedule files. The innovative use of graphics in the Harris 9000 is not only of great assistance to the operator, but minimizes effort in the area of operator training.

IMPECCABLE EXECUTION...

Today's competitive operation can't afford to waste time deciding whether or not a format change is possible. The Harris 9000 Program Control knows that any format is possible, and concentrates on impeccable execution. "Tighter playlist control...more consistent air sound...increased ratings" are broadcaster comments that are frequently made about Harris' program control equipment.

Live or automated operation is no longer the issue when the end result is a significant advantage in ratings and revenues. The Harris 9000 provides multiple overlaps, dependable voice-track synchronization, plus solid support or the fast-paced live announcer.

Live-assist means never having to keep a program log, stack carts or cue records. A countdown timer, complete with a ten-second warning, helps maintain a tight sound. Insertion of unscheduled material is easy. This is live-assist that really aids your on-air talent and encourages more creative performance.

Upper area shows on-air status, real time, and the next scheduled event.

Lower area shows, in the various operational displays, a list of upcoming schedule entries. In the editing modes, this serves as a "work area".

A full typewriter keyboard is provided for entering log messages for encoding. In the 9003, the keyboard is also used for titles and for live copy insertions.

In the 9003, up to 3 lines may be used for bulletins or other copy for live insertions. For instance, this copy may be typed on the news room terminal and will appear on the studio terminal video display.

The Mode Control Keys are used to determine what data is to be entered (scheduling, set clock, log encoding, etc.). Manual operation keys are used for remote control (START, STOP, FADE, etc.).

The Data Entry Keyboard is used for entering instructions. It includes dedicated function keys to eliminate typing frequently used instructions (PLAY, INTRO, LINK, etc.).

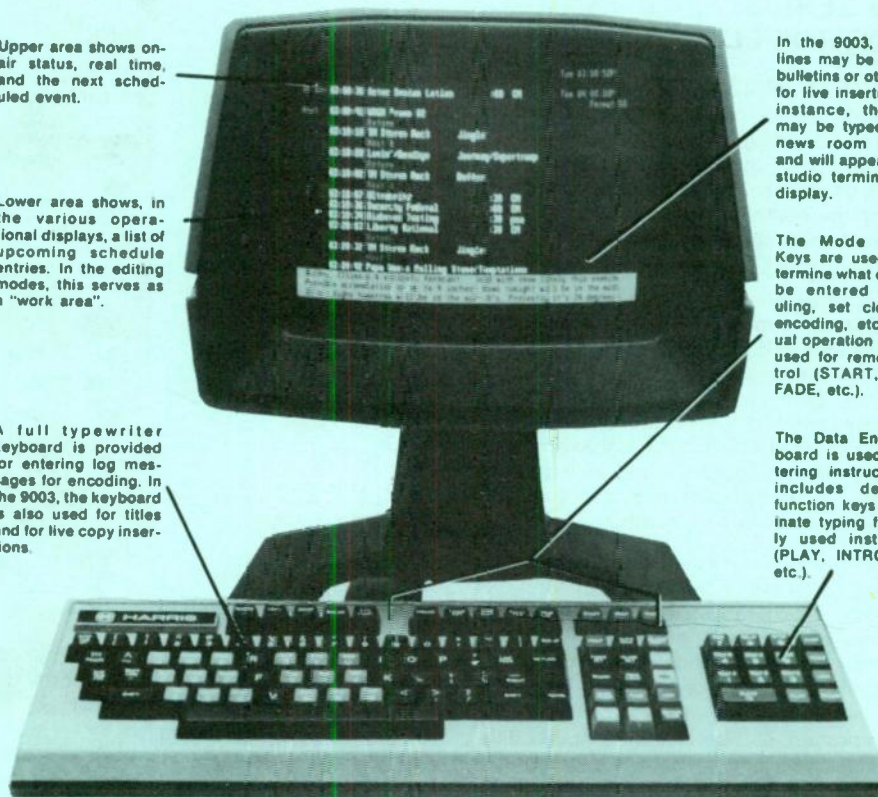

YOUR CHOICE OF SYSTEMS TO MEET YOUR PARTICULAR REQUIREMENTS. The Harris 9000 Series is composed of three distinct systems, each showing a progressive increase in programming capability. The 9001 is a basic program control system which can be used for any automation requirement. It uses a single video terminal, and has a 1,999-event memory, which is expandable up to 9,999 events. The 9002 fills all program control requirements, plus has the ability to interface with an external business system, and can be programmed from totally independent terminals. It has a 1,999-event memory, expandable up to 9,999 events. The 9003 handles even the most sophisticated format faultlessly.

The Harris 9000 Series has been designed to expand as your needs expand. All 9000 Series models can easily be upgraded in the field to a higher numbered model.

THE HARRIS 9001. The 9001 has the full mainframe, audio switcher and heavy-duty power supply already in use in hundreds of installations worldwide. The 1,999-event memory (expandable to 9,999 events) and the 7-day clock allow you to program for a weekend or an entire week ahead. The simple keyboard and plain-text programming assure

mastery of system operation by most station personnel in less than a day. Dual-intensity video allows highlighting of the schedule items chosen by the operator. The types of highlighted entries could be commercial clusters, music sets, contest/promos—any file from the MULTI-FILE™ Program Memory.

Among the many other important 9001 features are: automatic power failure restart, time announce control, network join, ready sensing to prevent dead air, remote control and countdown clock for live-assist, bulletin insertion, "coffee pot" function relays, and MULTI-FILE Program Memory.

THE HARRIS 9002. In addition to the many features of the 9001, the 9002 includes dual flexible-disk drives to increase the memory capability and to provide a permanent memory storage medium.

Another key innovation is the ability of the 9002 to support totally independent terminals. Using MULTI-FILE Program Memory, the traffic director and program director can have their own files in the program memory. Now they can both edit their respective areas of event memory simultaneously! And, while this is happening, data can be received or transmitted to an external business system using the port provided for this purpose.

Prices and Specifications Subject to Change Without Notice.

World Radio History

**9000 SERIES
CONTROL ELECTRONICS**

THE HARRIS 9003. The Harris 9003 has revolutionized the role of program control in radio broadcasting by integrating the program system into the planning process—extending the benefits of program control beyond the operations level to everyone concerned with the on-air product.

The Traffic Director can enter on the CRT display a new commercial order. He selects an account number, enters time, anticipated running time and the desired description, which will also appear on the display (and optionally on the log). The Traffic Director may also specify one of several live copy tags to be associated with the announcement, and that tag will also appear on the control room terminal. All further references can then be made using the account number.

With the plain-text title display feature, the music director no longer has to wonder if the system will air the recurrent record he wants following a commercial break. With Harris 9003 in charge of a random access music library, it is now possible to specify the names of the music selections. Instead of a "Play 05-27" indication, an operator will see that the scheduled selection is "Sara by Fleetwood Mac", along with other information, on the same line, such as intro/running time and chart position.

As more stations seek to better localize their syndicated programming, there is a need for periods of live programming; this may be for drive time or news blocks. In any case, the Harris 9003 is ideal for the live operator. The display shows the name of a song or commercial that is on the air, plus the names

At right is a typical system for use with a program service. Music is on reel-to-reel. Commercials (and other cartridge material) are in the instant access Instacart (5) and the random access Go-Carts (6 & 7). When time-announce is used, deck 14 has even numbered minutes and deck 15 has odd numbered minutes. The system electronics require only half of a standard rack for mounting.

- A. The computer mainframe includes the monitor panel and control electronics.
- B. The solid-state Audio Switcher houses source modules, dual silence sensors, program amplifiers, faders and 25 Hz-filters.
- C. Computer-grade power supply.
- D. Dual flexible-disk drives for increased memory storage capabilities (9002 and 9003).

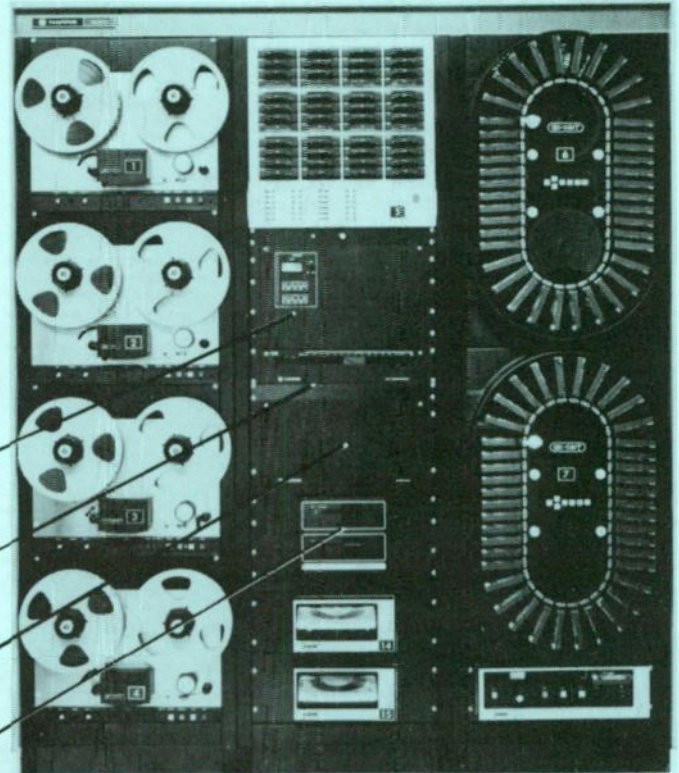

and starting times of upcoming scheduled events.

The system software is contained on the disk. In the unlikely event of disk failure, the system defaults to programmed Read-Only Memory (EPROM) chips located on the single 8080 CPU board; it would then operate similarly to the Harris 9002.

Going beyond the traditional role of the program system, the Harris 9003 brings significant benefits to the broadcaster—cost reduction due to reduced workload at the planning stage; improved on-air performance from scheduling flexibility; reduction in lost revenue due to scheduling errors; and improved operator performance due to easier system operation.

Major System Capabilities

Harris 9000 Series Model	Standard No. of Days Operation (Walk-away)	Stand. No. of Days with Optional Memory Expansion	Interfaces with Business Automation	Countdown Clock	Independent Editing/Prog. Terminals	Logging	Plain-Text Programming	Plain-Text Title Display	Live Copy Display
9001	3*	15*	Optional	Programmable	Yes (Optional)	Optional	Yes	No	No
9002	3-15*	15-31*	Yes	Programmable	Yes (Optional)	Included	Yes	No	No
9003	31**	Not Applicable	Yes	Automatic	Yes (Optional)	Included	Yes	Yes	Yes

*Based on average of 50 events per hour

**Based on average of 110 events per hour.

FACILITIES CONTROL

HARRIS
P.O. Box 4290
Quincy, IL 62305-4290
(217) 222-8200

HARRIS 9100 FACILITIES CONTROL For TV Or Radio

- Building block concept allows a wide variety of applications, from complete automatic facilities control (including ATS), to simple remote or local control
- Reduces operating expenses
- Improves transmission quality
- Improves transmission system reliability
- Offers automatic security measures to protect your capital investment
- Allows automatic control of building environment
- Handles time-related functions automatically, tower lights on/off, etc.

The Harris 9100 is a facilities control system designed to improve your performance, protect your investment and cut your operating costs. The Harris 9100 in its various configurations can provide intelligent remote control; automatic transmitter control; automatic logging; plant protection through intrusion and fire alarms; automatic control of such items as tower lights and building temperature; and automatic exercising of standby equipment.

In short, the Harris 9100 Facilities Control provides surveillance over your transmission system and your physical plant, and offers protection from costly failures wherever they may occur.

The system is composed of a family of micro-computer controlled "building blocks" which determine the configuration, based on a specific application. Whether your need is to monitor and control a single co-located site or to operate up to three remote sites from a single location, the Harris 9100 Facilities Control has the flexibility to meet your requirements. No matter what the size of your operation—whether you're AM, FM or TV—you will find many beneficial applications for the Harris 9100 Facilities Control to help improve your profitability.

WHAT HARRIS 9100 CAN DO FOR YOU

There are three major areas where Harris 9100 Facilities Control can provide significant savings and/or improvements in a station's operation—1) manpower allocation, 2) protection, and 3) equipment performance. Let's take a closer look at each of these for specific examples.

Improved Manpower Allocation. The FCC requires monitoring and adjusting the broadcast transmission to assure compliance with technical standards. In addition, it is imperative that optimum use be made of the equipment while simultaneously protecting it from catastrophic failure. These requirements have been complicated by the increasing use of remote transmitter sites which, while ideal for transmission, are not conducive to manned operation.



The trend in both radio and television has been toward delegation of the transmission system to operations personnel. Remote control equipment has been used increasingly as the only acceptable alternative to a full-time staff at the remote site. This has been a cost-effective approach for management, consistent with the increased stability and reliability of transmitting equipment. However, this approach does not provide the continuous monitoring which can spot trouble about to happen, which can provide trend analysis through careful parameter logging and which can allow operation at peak performance without rule violation.

The first responsibility of operations personnel is usually to the program chain. Even in those stations with a full-time transmitter engineering staff, monitoring the transmitter system may give way to higher priorities of equipment maintenance and repair.

The Harris 9100 Facilities Control meets all existing and currently proposed FCC regulations governing the monitoring, adjustment and remote control of radio and television transmitters. It can offer very valuable assistance to your operators for flawless transmission monitoring, adjustment and logging—freeing them for more effective work elsewhere.

Operation, Equipment and Plant Protection. The broadcaster is faced with potentially costly mishaps on a daily basis. One such area is violation of FCC rules and the resulting fines, particularly since Congress has dramatically

raised the amount of maximum fines. This potential for higher fines has also increased as more stations operate their equipment at the legal maximum power and modulation levels, and operate with lower skilled, often untrained operators.

The transmission system also must meet its own rules in terms of what constitutes safe operation. Careful monitoring together with the proper action and associated alarms, as provided by the Harris 9100 Facilities Control, can help prevent operation outside the legal limits, or costly equipment failures with resulting lost air time.

Additional protection can be provided for the entire physical plant with monitoring and alarms for intrusion or fire which may lead to reduced insurance premiums for these sites.

Improved Performance. Maximizing equipment life and minimizing FCC violations are not the only advantages of Harris 9100 Facilities Control. In an increasing number of markets, large and small, operating equipment at the maximum levels is a key to the successful competition for higher ratings and increased revenues. Even the most stable transmission system needs the attention of the Harris 9100 to operate at peak performance over extended periods of time with minimum equipment problems, and without FCC rule violations.

Another area for improved performance with the Harris 9100 is in trend analysis. Long-range tracking of very accurate readings helps locate problem areas in the transmission system and pinpoint areas for improvement.

How Harris 9100 Facilities Control Is Used

Remote Control. The Harris 9100 Facilities Control opens a new dimension in remote control, providing intelligent surveillance and decision-making. Channels are automatically scanned and compared with pre-programmed limits; and alarms are initiated or corrective action taken, as appropriate. Power can be computed using the indirect method of power determination and the Harris 9100 can serve either as an efficiency monitor or as the primary means of power control.

Automatic logging of all parameters can be performed on a regular basis, eliminating periodic interruptions of station personnel. Also, the logger fully records out-of-limits conditions when they occur.

Time-initiated switching may be employed for power levels, changing control limits, checking tower lights, and other time-oriented functions.

Automated Transmission System (ATS). The Harris 9160 and 9161 Automatic Control Unit (ACU) provides for ATS operation with its power and modulation control, yielding additional benefits to management. Relaxed operator restrictions will give greater flexibility in the selection of staff and duties; the FCC requirement for a person to be present for monitoring can now easily be met by utilizing a receptionist, switchboard operator or guard. Under existing and currently proposed ATS rules, there will be a reduction in requirements for routine inspections, meter readings and logging requirements. And there will be much less anxiety concerning the reliability of switching power modes in AM stations, very often a problem where "combo" operators are employed.

To sum it up, the Harris 9100, operating under ATS rules, will provide cost savings considerably beyond those provided by remote control, through more efficient use of manpower.

Facilities Control. The Harris 9100 Facilities Control is a true systems approach to the transmission system and related physical plant. Up to three remote sites can be controlled from a single common control unit at the studio. In addition to control of the transmission system, related functions can be surveyed and controlled. Heating, air conditioning and ventilation equipment can be monitored. Backup equipment can be exercised and performance logged, all on an automatic basis. And temperature sensors and intrusion alarms can be constantly on guard for plant protection. By combining the

monitoring and control of all functions, the Harris 9100 Facilities Control will profitably produce greater consistency, precision and reliability of operation than is obtainable with existing manually operated equipment. In addition, the Harris 9100 will allow maximum operation of the transmission system to provide the most competitive broadcast signal in your market.

The Harris 9100 Facilities Control design is based on over half-a-century of experience by Harris in the broadcast equipment field—and the quality is backed by the most experienced service organization in the industry.

Harris 9100 Facilities Control Components

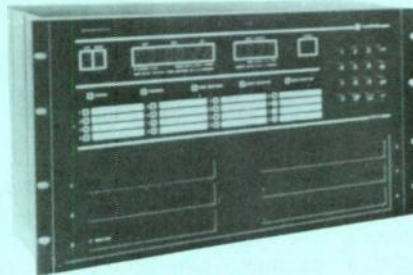

Studio Unit (9120). Location: studio facility. Function: communicates with the Transmitter Unit (9130) or the Automatic Control Unit (9160) to provide monitoring and control of the transmitter facility.

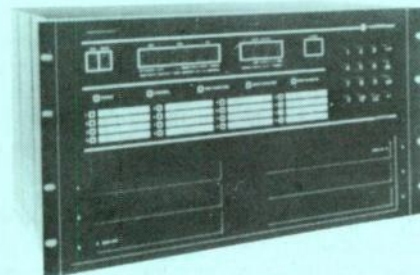

Transmitter Unit (9130). Location: transmitter site. Function: provides remote control of the transmission facility when used with a Studio Unit (9120) or an Automatic Control Unit (9160). Allows remote control from a studio facility or from another transmitter facility. Alternate function: provides local control of the transmission facility.

FACILITIES CONTROL

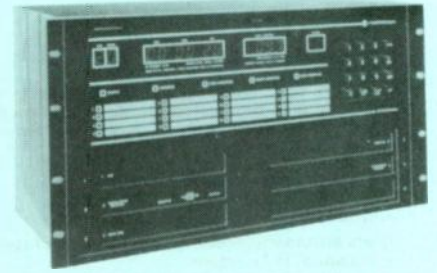

Automatic Control Unit (9160). Location: transmitter or studio site. Function: provides automatic facility control—i.e., intelligent remote or automatic control of transmitter (ATS), building environment, security measures, etc.

CRT Terminal Models

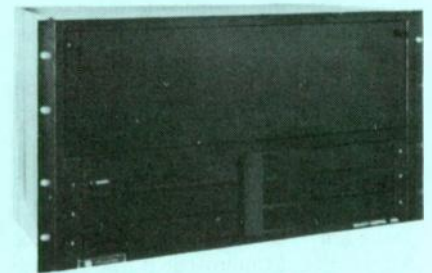

Studio Unit (9121). Location: studio facility. Function: communicates with the Automatic Control Unit (9161) to provide monitoring and control of the transmitter facility.

Automatic Control Unit (9161). Location: transmitter or studio site. Function: provides automatic facility control—i.e., intelligent remote or automatic control of transmitter (ATS), building environment, security measures, etc.

FACILITIES CONTROL

HARRIS
P.O. Box 4290
Quincy, IL 62305-4290
(217) 222-8200

Options



Monitor and Alarm Panel. Used in conjunction with the Automatic Control Unit (9160), provides minimal monitoring and control in compliance with FCC ATS rules for monitor and alarm points.

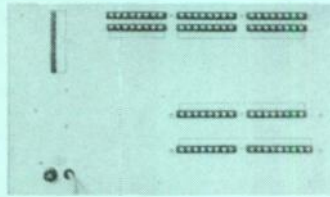

Channel Expansion Panel. Offers additional channels for the Transmitter Unit (9130) and Automatic Control Units (9160 and 9161). Each panel adds 8 telemetry, 16 status and 16 command functions. Up to 7 Channel Expansion Panels may be added to each 9130, 9160 and 9161 unit.

Multi-Site Module (not shown). Allows a Studio, Transmitter or Automatic Control Unit to communicate with up to three remote sites.

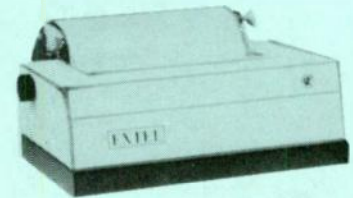

Extel



TI-820

Loggers. Extel (300 baud), for 9120, 9130 or 9160; Texas Instruments TI-820 (9600 baud), required on 9121 and 9161. Optional on other models.

9100 FACILITIES CONTROL INFORMATION

	9120	9130	9160	9121	9161		9120	9130	9160	9121	9161
Keyboard or CRT Terminal I/O	KBD	KBD	KBD	CRT	CRT	Maximum status input display per display group	16	16	16	128	128
Communicates with remote sites, display and control identical to unit at remote site	XX	XX	XX	XX	XX	User-defined CRT displays, messages, logs and log headings	—	—	—	—	XX
User-assignable time functions	—	5	64	—	64	DCA type channel squaring	—	XX	XX	—	XX
Limits monitoring and executive action, number of analog channels	—	5	all	—	all	Calculation channels	—	—	3*	—	6
Status monitoring and alarm	—	all	all	—	all	Can interface with MONITOR and ALARM PANEL (used for ATS only)	no	no	opt.	no	no
Status monitoring/alarm and executive action channels	—	—	all	—	all	Multi-site module	opt.	opt.	opt.	opt.	opt.
15-step series functions	—	—	4	—	4	Log printer (opt.) minimum CPS	30	30	30	150	150
5-step mini-series functions	—	—	—	—	6	CHANNEL EXPANSION PANELS, units included + maximum (opt.) add-on	—	1+7	1+7	—	1+7
Modulation level control	—	—	XX	—	XX	Analog input channels per CHANNEL EXPANSION PANEL (CEP)	—	8	8	—	8
Separate data bases	—	—	3	—	3	Number of control relays with 5A-120VAC contacts per CEP	—	16	16	—	16
Separate partitions	—	—	4	—	6	Number of (opto-isolated) status input channels per CEP	—	16	16	—	16
Logging capability	opt.	XX	XX	XX	XX	Automatic system restoration after power failure and return	—	—	XX	—	XX
Real-time clock—hrs/min/sec	1 day	1 day	1 day	7 day	7 day	Auto link switching capability	—	XX	XX	—	XX
CRT entry of scaling factors	—	—	—	—	XX	Battery backup for user program	opt.	opt.	opt.	opt.	opt.
Momentary or latching relay action at mode entry	—	XX	XX	—	—	*1 calculation channel per data base					
Assignable momentary or latching relay action via CRT terminal	—	—	—	—	XX						

TYPICAL 9100 FACILITIES CONTROL SYSTEMS

For ATS OPERATION

- A. 9160 Automatic Control Unit + (N) Channel Expansion Panels
9100 Monitor and Alarm Panel
9100 Battery Backup for 9160
- B. 9161 Automatic Control Unit/CRT + (N) Channel Expansion Panels
9121 Studio Control Unit/CRT I/O Terminal
9100 Battery Backup for 9161 and 9121 (2)

For INTELLIGENT REMOTE CONTROL

- A. 9130 Transmitter Control Unit + (N) Channel Expansion Panels
9120 Studio Control Unit (Keyboard I/O)
9100 Logging Electronics Package

- Extel 30 CPS Log Printer
9100 Battery Backup for 9130 and 9120 (2)
- B. 9160 Automatic Control Unit + (N) Channel Expansion Panels
9120 Studio Control Unit (Keyboard I/O)
9100 Logging Electronics Package
Extel 30 CPS Log Printer
Battery Backup for 9160 and 9120 (2)
- C. 9161 Automatic Control Unit/CRT + (N) Channel Expansion Panels
9121 Studio Control Unit/CRT I/O Terminal
TI-820 150 CPS Log Printer
9100 Battery Backup for 9161 and 9121 (2)

Ordering Information

9161 Automatic Control Unit	994-8494-001
9121 Studio Control Unit	994-8493-001
9160 Automatic Control Unit	994-8232-001
9120 Studio Control Unit	994-8233-001
9130 Remote Control Unit	994-8234-001

Channel Expansion panel for 9130, 9160 and 9161 Control Units	994-8240-001
9100 Monitor and Alarm Panel for 9160 Automatic Control Unit	994-8244-001
Extel Log Printer (9120, 9130, 9160)	749-0051-000
Texas Instruments TI-820 Log Printer	749-0072-000
9100 Multi-Site Module	994-8241-001

Prices and Specifications Subject to Change Without Notice.

DISK DRIVE/EARTH STATION CONTROLLER

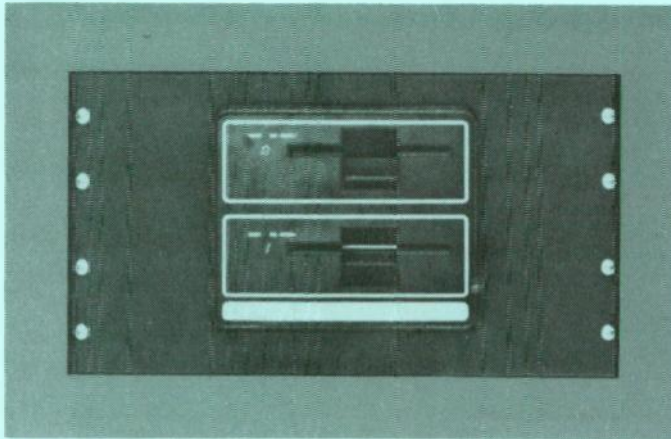

9100 Facilities Controller Disk Memory Option

- Reduces operational display time
- Changeable diskettes provide non-volatile memory for user flexibility and file security
- Dual disk drives increase system reliability and provide user with file copy capability

The addition of the Floppy Disk Drive Memory Option provides some unique system enhancements. Greater software security results from having a non-volatile memory in the form of diskettes which can be reproduced for storage. The time required to receive operational displays is significant for large information displays.

TIMELY CONTROL AND MONITORING

The Harris 9100 CRT based Facilities Control System engages in a continual data exchange between sites to provide up-to-the-minute monitoring and control. This surveillance may include control of the transmitter facility, building environment, security measurers, etc.

The 9100 Disk Memory Option is available to enhance the standard CRT based facilities controller with large-scale non-volatile memory. This protects all user entered programming, including multiple site information. In addition, the operation speed of the 9100 System is improved via accelerated display time of user entered programming.

The 9100 Disk memory operates as an option to all Harris CRT based Facilities Control systems.

Specifications

DUAL FLOPPY DISK DRIVE SYSTEM

Height: 10 inches (25.4 cm)

Width: 19 inches (48.5 cm) rack mount

Depth: 13.5 inches (34.3 cm)

Weight: 18.5 lbs. (8 kg)

Spindle Speed: 300 RPM ($\pm 3\%$)

Sectoring, GCR Encoding: 5¼ inch soft sectored

Density (inner track): 6,380 bits/inch

ENVIRONMENTAL*

Temperature Range: 32°F to 131°F—0°C to 55°C (operating)

Relative Humidity: 5% to 95% non-condensing (operating)

Altitude: To 10,000 feet (3048 meters)

* Typically located in a controlled studio environment, which is dust and contaminant free.

Ordering Information

9100 Disk Memory Option 994-8675-001



One of 24 CRT displays available on command, which gives detailed status information on earth satellite parameters.

9165 Advanced Earth Station Facilities Controller

- Can be used for on-site, remote site, and multi-site applications
- Programmable switching from transponder to transponder and satellite to satellite for up to 525 signal paths
- Controls 6.1, 9, or 11 meter Harris antennas
- Signal switching can be pre-programmed for up to one week
- System will handle up to 8 frequency agile Harris video receivers, up to 4 frequency agile Harris video exciters, and up to 4 tunable HPAs (High Power Amplifiers)

For the satellite broadcaster who desires maximum control, flexibility and documentation in his operation, the Harris 9165 Advanced Earth Station Facilities Controller is an ideal choice.

BUILT-IN VERSATILITY

While the standard 9100 Automatic Control Units contain up to eight CEPs (Channel Expansion Panels), the 9165 Advanced Earth Station Facilities Controller replaces one CEP with an ACP (Antenna Control Panel). The remaining CEPs may be assigned any of various "housekeeping" and monitoring duties. Additionally, the 9125 Studio Control Unit accesses all parameters remotely via microwave or telco data circuits.

COMMANDING DEGREE OF CONTROL

The Antenna Control Panel in the Harris 9165 is designed to interface with Harris 6.1, 9, or 11 meter satellite antennas, providing remote control of azimuth, elevation and polarization. Most remarkable is the software approach which allows a 24-entry file format accessing antenna position, frequency tuning for up to eight receivers, four exciters and four HPAs (High Power Amplifiers). This data can be retrieved on manual command or by time clock function. For a further degree of operating latitude, all individual units may be addressed separately and independently. All automatic functions found in the Harris 9100 Facilities Control (limits monitoring, series functions, partitioning, etc.) apply here as well.

Specifications

FOR MAIN FRAME AND CEP, SPECIFICATIONS ARE THE SAME AS FOR THE 9100 FACILITIES CONTROL.

Antenna Control Panel: Accommodates Harris SSL (Studio to Satellite Link) antenna system utilizing the 7022 Control Electronics Package.

Also accommodates 8 Harris 6521 or 6522 frequency agile receivers, 4 Harris frequency agile exciters and 4 Varian VZJ-2700 klystron HPAs (High Power Amplifiers).

Power: 117 VAC $\pm 10\%$, 50 watts

Dimensions

Height: 14 inches (35.5 cm)

Width: 19 inches (48.5 cm) rear rack mounted

Depth: 4 inches (10.2 cm)

Ordering Information

9165 Advanced Earth Station
Facilities Controller 994-8681-001

9125 Earth Station Studio Controller Unit 994-8688-001

ANTENNA CONTROL SYSTEM



9135 ANTENNA CONTROL SYSTEM

- Pre-stored antenna positions
- Position/Receiver changes on a time-corrected basis
- Full-computer control of antenna position
- Control of up to 16 output relays (Manual or time)
- Monitoring of 8 analog channels and 16 status inputs

The 9135 computer-based antenna control system gives the Harris receive-only satellite earth station operator complete control through pre-programmed time corrections or manual operation.

A CRT terminal provides monitoring capability of the antenna. The CRT displays the current antenna position (azimuth, elevation and polarization), the transponder and format for each of the four receivers in use, plus additional status fields. As many as 50 user-programmed antenna positions may be defined in the computer for immediate reference. A 365-day program-ahead feature allows memory storage of changes in antenna position or receiver channels.

Status Checks

The CRT will display the values of eight analog channels, and the decimal position may be individually set for each channel. The system will also monitor 16 status inputs, and display the status of each on the CRT. If desired, each input can be programmed for alarms. One of these inputs can be programmed to cause a site-specific message to appear on the CRT screen. The next time correction is displayed at the bottom of the CRT display. An optional color CRT will highlight alarms and other important messages in red. Other values and messages will be shown in appropriate colors.

Manual Control

The CRT can be used to manually control any aspect of the antenna, or changes can be programmed to make time-based antenna adjustments. Up to four receivers can be controlled by the computer. Both the antenna position and the transponder setting of any receiver can be changed automatically by the computer. Changes to receivers and antenna position can be made independently.

ANTENNA CONTROL SYSTEM SPECIFICATIONS

OPERATING ENVIRONMENT

RELATIVE HUMIDITY: 5% to 95% non-conducting

ALTITUDE: 0 to 10,000 feet

TEMPERATURE: 0 to 50 degrees C

SIZE: 19" wide x 18.5" deep x 12.12" high

WEIGHT: 36 lbs.

REAL TIME CLOCK

Day: Seconds, minutes, hours

Calendar: Days, months, years

Accuracy: ± 10 seconds per month



ELECTRICAL SPECIFICATIONS

STANDARD: Three RS232C, async, 300 to 19.2K baud

DISPLAY: 12" video monitor

KEYBOARD: Standard ASCII, with keypad

POWER: 115/230 volts AC, 50/60 Hz, $\pm 10\%$, 260W max.

ANALOG INPUT: 8

INPUT RANGE: $\pm 2.000V$

COMMON MODE: + Signal $\pm 4V$

ACCURACY: ± 10 mV over input range

DIFFERENTIAL INPUT CONNECTOR: 37 Pin D

STATUS GENERAL PURPOSE: 16, optional signal fan-out barrier strip

SYSTEM CONTROL: Direct drive 30V hold-off sync mA

CONNECTOR: 37 Pin D

SYSTEM STATUS: Direct TTL inputs with pull up resistors to +5V, or opto isolation couplers

ANTENNA CONTROL I/O

Accommodates Harris 91350U Outside Electronics Box located on antenna pad. Includes command outputs, position and status inputs for AZIMUTH, ELEVATION, and POLARIZATION control of antenna. Requires one each 25 conductor cable, two each 3 conductor shielded, and one each 5 conductor shielded. Connectors are one each 25 PIN female, and one each 15 PIN male.

RECEIVER INTERFACE: TTL compatible current sink control

CAPACITY: Up to 4 receivers (Harris 6521 or 6522). Two receiver interfaces included as standard. Eight signals; 6 BCD frequency select; 1 polarity select; 1 frequency spacing select

RATING: TTL levels

CONNECTOR: 20 pin ribbon cable at board end, 9 pin D male connector when appropriate interface cable is used.

ORDERING INFORMATION

Harris 9135 computer based antenna control system
(with 12-inch green-on-black CRT control terminal) 994-8833-001
Optional 12-inch color CRT control terminal 749-0178-000

Prices and Specifications Subject to Change Without Notice.

FACILITY CONTROLLER COMMUNICATIONS OPTION

9100 HIGH SPEED COMMUNICATIONS OPTION

- 400% improvement in communications speed for the Harris 9100 Facility Controllers
- Easy to install
- Reliable transmission of control information
- Choice of conditioned or unconditioned telephone lines, 2- or 4-wire circuits
- RS-232C Industry standard communication interface

With the installation of the High Speed Communications Option, your Harris 9100 Facility Control Units can communicate four times faster between the studio and remote sites. This 9100 option replaces the clock modem, which runs at 30 characters per second (300 BAUD), with a new clock board and RS-232 board which connects to industry standard modems.

MODEMS: The appropriate 9100 High Speed Communications Option should be ordered for each end of the communications link. The option contains a clock board and a board with three RS-232 ports and appropriate cables. These cables connect an RS-232 port from the 9100 at the remote site to a 202T or 212A (or equivalent) modem. The modem at the remote site is connected via telephone line to a similar modem at the studio control site. This is connected to one of the ports on the High Speed Option in the 9100 studio control system.

Telephone lines may be C2 conditioned or unconditioned, depending on the transmission rate desired. Over unconditioned lines, a transmission rate of 300, 600 or 1200 BAUD (approximately 120 cps) can be supported. C2 conditioned lines can support transmission rates of 300, 600, 1200 or 1800 BAUD (180 cps). The 202T modem requires a 4-wire circuit. The 212A modem requires a 2-wire circuit.

With these connections, information on monitored alarms and inputs is communicated almost instantaneously to the studio control site for display. Commands are returned with equal speed and accuracy.

The High Speed Communications Option can be ordered with the 9100 Facility Control, or may be added at any time in the future when system configuration requirements change.

SPECIFICATIONS

(212A MODEM)

HIGH SPEED MODE: 1200 bps + 1.0% to 2.5%, character-asynchronous format; 1200 bps, synchronous format.

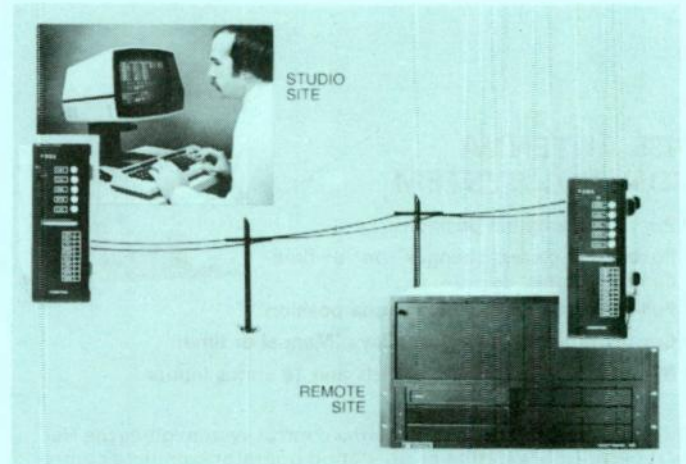

OPERATING MODE: Full duplex at all speeds.

LINE INTERFACE: 2-wire switched network.

INTERFACE VOLTAGES: Per EIA RS-232C.

AC POWER: 117 volts \pm 10%, 60 Hz \pm 5%, 9.5 VA maximum.

AMBIENT TEMPERATURE: 40 degrees F (4 degrees C) to 120 degrees F (50 degrees C).

RELATIVE HUMIDITY: 20% to 90% at 75 degrees F (25 degrees C); 20% to 40% at 120 degrees F (50 degrees C).

WEIGHT: (Stand-alone unit) 5 lbs. (2.3 kg)
 (Rack mount unit) 1 lb. 6 oz. (0.6 kg)
 (Wall mount transformer) 14 oz. (0.4 kg)

DIMENSIONS:

(Stand-alone unit): 2.3"H x 6.37"W x 11.65"D
 (Rack mount unit): 7.0"H x 19.0"W x 11.65"D

(202T MODEM)

FCC REGISTRATION NUMBER: A0794S-67622-DM-N

OPERATION: Asynchronous, serial binary

MODES: Simplex, half-duplex, full-duplex

DIGITAL INTERFACE: EIA standard RS-232C

LINE INTERFACE: Two- or four-wire private line

LINE IMPEDANCE: 600 ohms nominal

DATA RATE: 300, 600, 1200 bps with unconditioned line;
 300, 600, 1200 or 1800 bps with C2 conditioned line.

ENVIRONMENT: Storage: -30 degrees to +70 degrees C
 Operating: 0 degrees C to 45 degrees C
 Altitude: 10,000 ft. maximum
 Humidity: 20-95% non-condensing

DIMENSIONS: 2"W x 4"H x 7.5"D

AC POWER: 117 volts \pm 10%, 60 Hz \pm 5%, 9.5 VA maximum

ORDERING INFORMATION

In order to utilize the new Harris 9100 High-Speed Communications option you will need:

One High-Speed Package located at the studio.

Order No. 994-8828-02—Studio Package includes (1) RS-232 board; (1) clock/interface board; (3) RS-232 Cables; (1) ribbon cable.

One High-Speed Package of each remote site.

Order No. 994-8828-001—Remote Site Package includes (1) RS-232 board; (1) clock/interface board; (1) RS-232 cable; (1) ribbon cable

Two 202T modems for each remote site.

Order No. 746-0057-000—202T modem (order two)

or

Two 212A modems for each remote site.

Order No. 746-0043-000—212A modem (order two)

Prices and Specifications Subject to Change Without Notice.

BROADCAST MICROWAVE

HARRIS
 P.O. Box 4290
 Quincy, IL 62305-4290
 (217) 222-8200

ENG/EJ/EFP (Portable) System Equipment

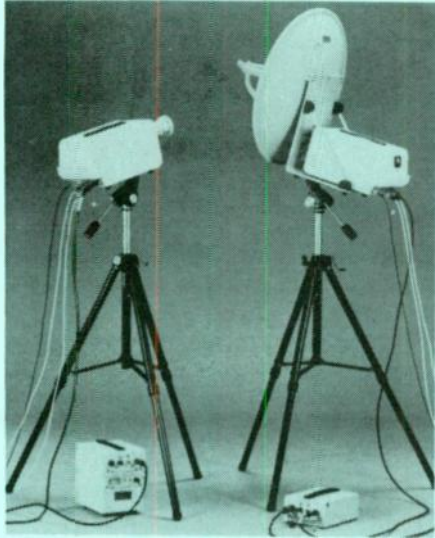

An FV13MP miniature-portable, frequency-agile video and sound transmission system replacing existing cable or bulky equipment.

FV-MP "Mini-Link" Series: Lightweight, Compact, Fully Self-contained One-way microwave-radio system that offers both terminal and repeater-station service. Capacity is a single color-video channel (either 525-Line NTSC or 625-Line PAL, PAL-M or SECAM) and one or two full-quality program-audio subcarrier channels. AC, -24 VDC or portable-battery powered; with a multi-purpose charger.

May be tripod or, optionally, rack mounted. Accessories include antennas, transport cases, narrow-band pre-select filters, power cables, Duplexers, etc.

Available for following RF bands (GHz) (up to 12 channels in the selected band):

FV2MP	1.700-1.915 and 1.990-2.110
FV2.5MP	2.300-2.690
FV6MP	6.425-6.525
FV7MP	6.875-7.125
FV8MP	7.125-8.500
FV11MP	10.550-11.700
FV12MP	11.700-12.200 and 12.200-12.700
FV13MP	12.700-13.250

Transmitter RF Power Output:	
FV2/2.5MP	1 watt, min (+30 dBm)
FV6/7MP	1 watt (+30 dBm)
FV8MP	0.8 watt (+29 dBm)
FV11/12/13MP	63 mW (+18 dBm)

Receiver Noise Figure:	
FV2/2.5MP	6.0 dB (w/o pre-select filter)
FV7/8MP	6.0 dB
FV11/12/13MP	10.5 dB (with pre-select filter) 8.5 dB (w/o pre-select filter)

FCC type accepted for Parts 21, 74, 78 and 94.

Reference

Form 7604 (FV2/2.5MP)
 Form 7610 (FV7 thru 13MP)



Type 60732: Transmitting RF Power Amplifier for 1.990 to 2.110 GHz. Provides 12 watts of RF output power with an input drive range of 0.1 to 2.0 watts. The unit is designed for installation directly at the transmitter antenna. The amplifier is contained in a weather-resistant, pressurizable housing. Coordinates with the transmitter of the FV2MP Miniature Portable Microwave-Radio system.

RF Input/Output connectors are Type N (female).

Operates from an external source of -24 VDC.

Reference

Form 7905 (Type 60732 RF Power Amplifier)



FV2G "Challenger": A portable microwave-radio transmitter that is similar to the FV2/2.5G Global IX™ Transmitter. The major difference concerns the reduced RF bandwidth 1.990 to 2.110 GHz and the higher, 3-watt (+34.8 dBm) RF output power of the Challenger. The RF band, generally, limits service to 525-Line NTSC operation. Accessories, limited to the requirements of the restricted RF bandwidth, are essentially the same as those offered for the Global IX™ Transmitter.

FCC type accepted for Part 74.



GLOBAL IX™ Transmitter shown with Optional Parabolic Quick-Disconnect Antenna.

FV2/2.5G "Global IX™": Portable Microwave-Radio Transmitter for the frequency band 1.990 to 2.700 GHz (uses up to 16 separate frequency plans, with each plan having up to 60 RF channels). The transmitter is lightweight, compact, self-sufficient, weather resistant, and adaptable to both indoor and outdoor use. RF power output is +34.5 dBm (2.8W) typical and +33.5 dBm (2.2 W) minimum.

Applications include ENG/EJ/EFP services and other services requiring a mobile ground or airborne link. Capacity is one 525- or 625-Line color-video signal and two high-quality program audio subcarriers. Baseband interface with camera and audio-initiating equipment is standard. Accessories include a selection of antennas, tripod, battery pack, etc.

Programmable FM-subcarrier line frequencies. AC or Battery powered. Transmitter Frequency Stability $\pm 0.005\%$. Standard Video or 70 MHz IF Input; can be used in repeater applications. Remote or Local Control — Local or remote monitor and control features available. In addition to remote monitoring of transmitter status, the following functions can be controlled: On/Standby and Frequency Selection. Construction — Mechanically constructed for operation in extreme environmental conditions and helicopter applications. Multi-level shielding is provided for RFI environments.

Input operating voltage to the transmitter can be either +10.5 to +16 VDC (car battery or camera-belt power pack) or 115/230 VAC, 50/60 Hz (selectable by a switch in the power supply.)

FCC type accepted for Part 74.

Reference

Form 8175 (FV2/2.5G Transmitter)



HARRIS

P.O. Box 4290
Quincy, IL 62305-4290
(217) 222-8200

BROADCAST MICROWAVE

FV-MF Series: Miniaturized baseband, self-contained microwave transmitter terminals that require only three vertical spaces on a 19" equipment rack. RF Power Output is typically 1 watt (+30 dBm). May be optionally configured for up to two FM audio/program subcarrier channels. The 2/2.5GHz transmitter may be factory-arranged for 525-Line NTSC or 625-Line PAL, PAL-M or SECAM service. The 8GHz version is limited, on a standard basis, to NTSC-type operation.

Applications include ENG/EJ/EFP service in mobile vans, aircraft or helicopters, fixed-plant utilization for surveillance and security systems, and repeater-station functions. Readily adaptable to Government and specialized military observation and training functions.

For operation from a power source of:

FV2/2.5MF: +28, -24, -48 VDC or 117/220 VAC, 50/60 Hz.

FV8MF: -22 to -28 VDC or 117/220 VAC, 50/60 Hz.

Type 60828: Transmitting RF power Amplifier for the 2 and 2.5 GHz bands. A built-in AGC circuit assures a constant output power level with input drive variations. Typically, 12 or 15 watts RF output power depending on frequency band. Drive level requirement as low as 0.1 watt.

For frequency bands 1.990-2.110 GHz or 2.301-2.690 GHz.

Requires two vertical mounting spaces on a 19" equipment rack. RF Input/Output connectors are Type N (Jack).

Operates from a source of 115/230 VAC, 50/60 Hz, or from positive or negative 21 to 30 VDC.

Coordinates with the FV2/2.5 Miniature Fixed Transmitter and the Transmitters of the FV2MP and FV2.5MP Miniature Portable systems.

Reference

Form 8181 (Type 60828 Power Amplifier)

FV8FA: Miniature Fixed, Frequency-Agile Baseband Microwave Receiver for low-noise receiving applications. Coordinates with the FV8MF Transmitter. Instantaneously phase locks to any manually-selected frequency (0.1 MHz steps) in the receiver's RF band of operation.

For operation in the microwave bands: 7.125-7.800 or 7.800-8.500 GHz.

Capacity is one NTSC color video signal and up to two optional program-audio sub-carriers.

Requires only three vertical mounting spaces in a 19" equipment rack. Operates from a power source of either 115/230 VAC, 50/60 Hz or from positive or negative 22 to 29 VDC. Noise figure is a 9 dB, maximum.

Reference

Form 8076 (FV8FA Receiver)

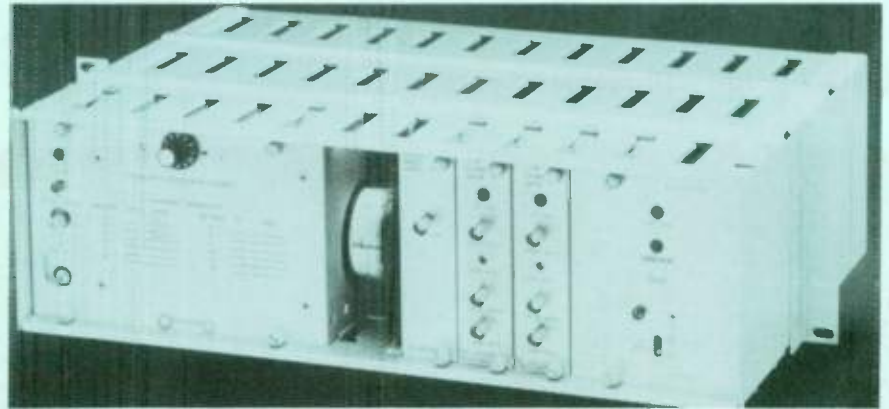

Shown is the compact, lightweight, frequency-agile 2/2.5 GHz video and sound transmitter for ENG/EJ applications including helicopters, mobile broadcast vans and repeater stations.

Available Frequency Bands:

FV2/2.5MF: 1.990-2.110 GHz, 2.450-2.690 GHz (up to 12 discrete frequencies, any one of which is selected by a switched-crystal oscillator). Coordinates with FV-MP Miniature-Portable Receivers, FV-F Fixed Receivers or FV2/2.5CR Central Receivers.

FV8MF: 7.125-8.500 GHz (one predesigna-

ted and pretuned frequency). Usually coordinates with a companion FV8FA Frequency-Agile Receiver.

Reference

Form 7728 (FV2/2.5MF Transmitter)

Form 8180 (FV8MF Transmitter)

Form 8076 (FV8FA Receiver)



60828 Amplifier

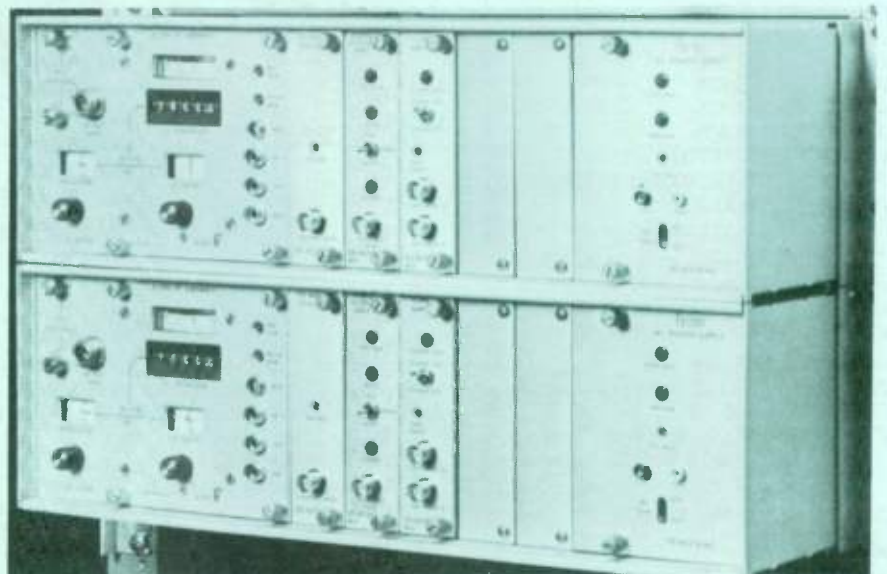

A Pair of Rack Mounted FV8FA Receivers

Prices and Specifications Subject to Change Without Notice.

BROADCAST MICROWAVE

HARRIS
 P.O. Box 4290
 Quincy, IL 62305-4290
 (217) 222-8200

Fixed Wideband Microwave-Radio Transmission Systems

FV-CR Series: Microwave-radio Central Receivers for Electronic Newsgathering (ENG) applications. Miniaturized, frequency-agile, low-noise, narrow-band, and designed specifically for video and program-audio pick up from "at-the-scene" news crews. Coordinates with FV-MP, FV-MF and FV-G portable ENG transmitter equipment within the total "live" news collection network.

Frequency Bands:

- FV2CR** 1.990-2.110 GHz (for 525-Line NTSC service)
FV2.5CR 2.300-2.690 GHz (for either 525-Line NTSC or 625-Line PAL, PAL-M or SECAM service)
FV7CR 6.425-6.525 or 6.875-7.125 GHz (for either 525-Line NTSC or 625-Line PAL, PAL-M or SECAM service)
FV8CR 7.125-7.425 GHz (for either 525-Line NTSC or 625-Line PAL, PAL-M or SECAM service)

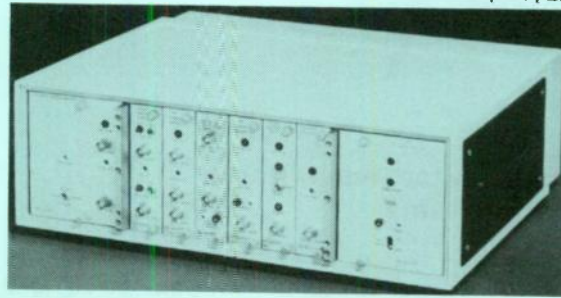

Operates from 115/220 VAC, 50/60 Hz, or from -24 or +28 VDC. Capacity is one color video signal and up to two FM program-audio subcarrier channels.

21 Synthesized RF Channels for FV2CR (up to 60 channels in the other bands), Instantaneous Phase Lock — locally or remotely selected. Noise Figure 3 dB at 2 GHz, 4 dB at 2.5 GHz and only 6 dB at 7 or 8 GHz. Narrow-band IF SAW Filter — for "state-of-the-art" split-channel operation. 78 to 81 dB (depending on band) Dynamic Input Signal Level

Range — crews operate from maximum range to within the shadow of the receiver's antenna. Auxiliary IF Output — for heterodyne interconnection where desired. RFI Shielding — for operation in an interfering environment. Fully Alarmed — with dry contacts for remote indication.

Reference

- Form 7903 (FV2CR Central Receiver)
 Form 8006 (FV2.5CR Central Receiver)
 Form 8007 (FV7CR and FV8CR Central Receivers)

Low-Noise Receiving Preamp

Type 60576: Low-Noise Receiving Preamp — General-purpose device used with 2/2.5 GHz receiving antenna systems requiring long transmission lines. Suitable for numerous ENG/EJ/EFP applications. Is "out-of-band" protected by a combine input filter. Amplifier is isolator coupled.

Equipped for remotely-controlled amplifier bypassing when a strong input signal is present or should an amplifier failure occur. Mounted in a weather-resistant box; RF Input/Output connectors are Type N (Jack).

Amplifier operates from an external source of -21 VDC, regulated. The optional bypass relay operation requires a source of -21 to -24 VDC or a ground indication.

Frequency Range Options (GHz)	Noise Figure (dB, max.)	Gain (dB, min.)
1.990-2.110	3.0	20
2.300-2.500	3.5	19
2.450-2.690	3.5	19

Reference

- Form 7729 (Type 60576 Low-Noise Preamp)



Program Audio Subsystem

FV43-02: FM Transmission Channel System is a high-quality baseband subcarrier facility designed to allow up to five broadcast-quality program audio channels to be transmitted over a microwave-radio or video-cable system simultaneously with a composite NTSC or CCIR television signal. The FV43 equipment provides transmit-only and receive-only terminals for coordinated subcarrier transmission in the range 5.8 through 8.59 MHz. The equipment is Bell-System compatible and operates, end-to-end, with the FV43-01 Diplexer.

Operates from 115/220 VAC, 50/60 Hz, or from -24 or -48 VDC. Has no front-panel controls; requires no operating adjustments after initial performance check. Requires 2 (with up to 2 channels) or 4 (up to a total of 5 channels) vertical mounting spaces on a 19" equipment rack.

Interfaces with standard video and audio line levels and impedances. Normally arranged for 75-ohm video or diplexed video and subcarrier input and output impedances. Option-

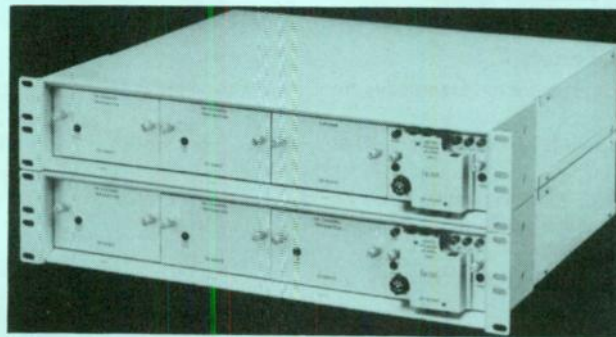

ally, is available with user-selectable 75 and 124-ohm impedances.

Available Channel Subcarrier Frequencies (MHz):

- Bell System Network: 5.8, 6.4
 Std US FM Subcxrs: 6.2, 6.7, 7.5, 8.2
 Std. Canadian wide-band FM Subcxrs: 5.6, 6.17, 6.8, 7.67, 8.3
 Std. Canadian narrow-band FM Subcxrs: 5.35, 5.8, 6.17, 6.7, 7.7
 CCIR FM Subcarriers: 7.02, 7.5, 8.065, 8.59

EIA-quality NTSC 525-line or CCIR 625-line television service over microwave-radio, video cable, CATV/CARS head-end, or satellite transmission media. 5 MHz pass-

band for NTSC or 6 MHz passband for PAL, PAL-M or SECAM.

Optionally equipped for low-noise, low-distortion, flat response 15 kHz audio subcarrier channels in the 5.8 through 8.59 MHz range. Utilizing two specific frequency plans, here referred to as the Standard Canadian plans, frequencies in a wideband or narrowband spectrum can be optionally equipped. Audio Pre-emphasis/De-emphasis — 75 μ s for North American Standard or 5 μ s for CCIR.

Reference

- Form 7725 (FV43-02 FM Trans. Chan. System)



HARRIS

P.O. Box 4290
Quincy, IL 62305-4290
(217) 222-8200

BROADCAST MICROWAVE

Fixed Wideband Microwave-Radio Transmission Systems

Features

- Non-protected or Monitored Hot-Standby Protected service. May be configured for frequency diversity operation or space/hybrid diversity receiving.
- TV version for 525-Line NTSC or 625-Line PAL, PAL-M or SECAM color systems.
- Radio-System noise and continuity-pilot monitors.
- 70-MHz Modulation and Demodulation (IF) interface.

- May be equipped for engineering order wire and for radio and station-keeping alarm and supervisory facilities, or multiplexed voice and data VF channels on baseband subcarriers.
 - Up to five FM or AM Subcarrier Channels.
 - Optional video clamper/amplifier.
- FCC type accepted for Parts 21, 74, 78 and 94.

Reference

Form 7411 (FV-F Radio)
Form 7430 (FV40 Vid. Transm. Equip)
Form 7621 (FV44 Radar-Remoting Equip)

FV-F series: One-way microwave terminals and heterodyne repeaters. Combined with FV40 Video Transmission Equipment for STL, Inter-city and Satellite Backhaul video/audio program transmission—and used with FV44 Video Transmission Equipment for Vessel Traffic Management System (VTMS) or Air Traffic Control (ATC) Radar-Remoting services.

Available mounted on 19-inch Equipment Rack or Rack Cabinet, or on shipping bars for field installation on existing rack facilities. For operation from a power source of 117 or 220 Vac, 50/60 Hz, or from -24 or -48 Vdc.

For operation in any one of the following frequency bands (GHz):

FV2F	1.990-2.110, 1.700-1.850, 1.850-1.990, 1.700-2.100, 1.900-2.300
FV2.5F	2.300-2.500, 2.500-2.700
FV6/7F	5.925-6.425, 6.425-7.125, 6.875-7.125
FV8F	7.100-7.800, 7.700-8.500
FV11/12/13F	10.7-11.7, 11.7-12.2, 12.2-12.7, 12.7-13.25

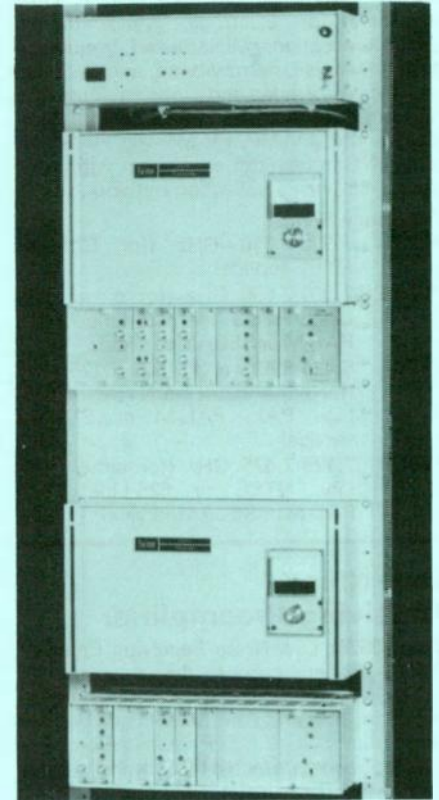

Features

- Standard video and audio equipment levels and impedances.
- Video clamper is standard.
- Non-protected and protected assemblies are available.
- 7-dB noise figure at 7 GHz and only 9 dB at 13 GHz.
- A number of 7 or 13-GHz systems can be placed on the same equipment rack, or cross-band configurations.
- All modules plug in. Radio is easy to maintain.
- Radio-System noise and continuity-pilot monitors.
- May be equipped for engineering order wire and for radio and station-keeping alarm and supervisory facilities.

FCC type accepted for Parts 21, 74, 78 and 94.

FV-FB series: One-way Baseband microwave terminals and drop/insert remodulating repeaters—for TV Broadcast STL and many economical multi-hop services. The FV13FB radio also offers superior performance as the CARS head-end system in the Cable Television Relay Service. May also be used with FV-F Heterodyne Repeaters for medium-haul inter-city service.

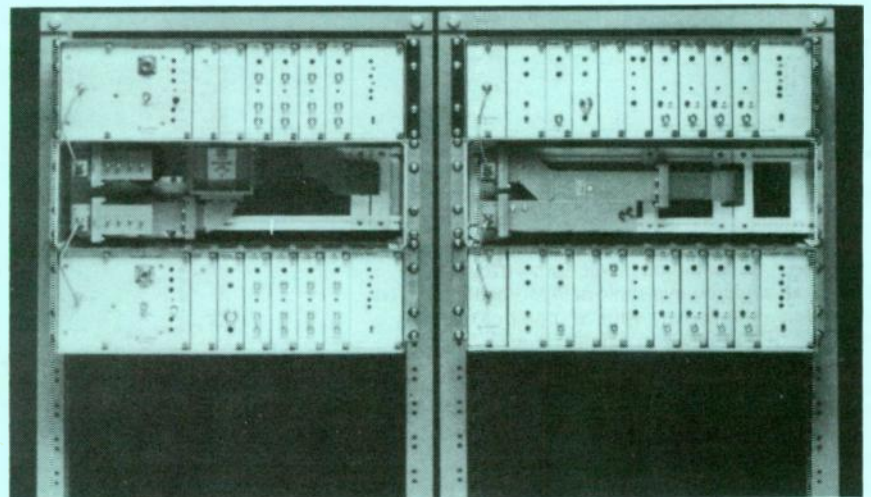

Available mounted on 19-inch Equipment Rack or Rack Cabinet, or on shipping bars for field installation on existing rack facilities. For operation from a power source of 117 or 220 Vac, 50/60 Hz, or from -24 or -48 Vdc.

Operating Frequency Bands:
FV7FB 6.875-7.125 GHz
FV13FB 12.700-13.250 GHz

Capacity: One 525-Line NTSC color TV channel plus a maximum of four FM audio (program) subcarriers.

Reference

Form 8375 (FV7FB)
Form 8377 (FV13FB)

Satellite Microwave-Radio Up-Link Equipment

TYPE 60950 Ku Band Video Exciter: Consists of two interrelated shelf assemblies; the 60946 Video Exciter Modulator and the 60945 Video Exciter Upconverter. The Modulator assembly accepts an NTSC composite color signal and up to three multiplexed 15-kHz audio program channels. Two standard subcarrier line frequencies are used; 6.2 MHz (Chan. 1) and 6.8 MHz (Chan. 2). When required, Channel 3 line frequency is selected from a compatible plan. The resulting frequency-modulated video/audio line signal is centered at 70 MHz and drives the Upconverter assembly. The triple-conversion upconverter RF output signal is channelized within the band 14 to 14.5 GHz. Nine hundred and ninety nine-channel selection is available by front-panel thumb-wheel manipulation or from a remote location. Video/audio baseband inputs and RF output levels and impedances are designed to current industry standards for this form of equipment.



60950

A spreading waveform generator is incorporated in the video path, ahead of the modulator, for producing a 1-MHz p-p spectral energy spreading, at a 30-Hz rate, of the FM modulator's unmodulated and modulated, combined carrier output signal. Total installation space for the Exciter is six vertical mounting spaces on a 19-inch equipment

rack. (A four-space version is planned for early 1984.) The exciter operates from a source of 117/220 Vac, 50/60 Hz.

Reference

Please contact your local Harris Sales Engineer.

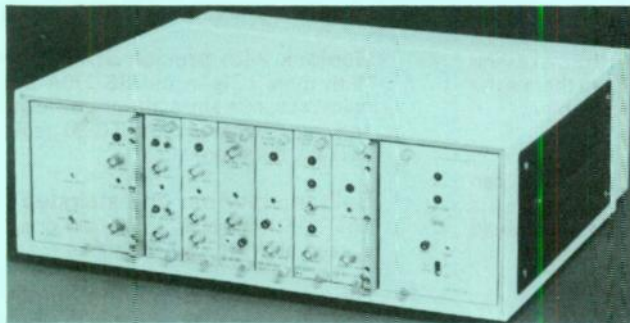

60367

System Accessories

TYPE 60367: PORTABLE TEST UNIT, while suitable for numerous high-quality fixed and portable microwave-radio test application, is primarily intended as a temporary modem for drop and/or insert transmission service, or testing, at an IF repeater of a fixed, heterodyne microwave system. Composite video and program audio appear as separate line interfaces, at standard input and output levels and impedances. Radio interconnection is at the conventional 70-MHz IF point.

FM Subcarrier Frequency-Plan Options (MHz):

6.2, 6.7, 7.5, 8.2	Std. U.S. FM Subcxrs.
6.17, 6.8, 7.67, 8.3	Std. Canadian Subcxrs.
7.02, 7.5, 8.065, 8.59	CCIR FM Subcxrs.
	Earth Station Applications.
5.14, 5.36, 5.79, 6.2, 6.8	Narrow-band Operation (ENG).
4.83	Bell System Network Transmission.
5.8, 6.4	

Optional Pilot Frequencies (MHz): 6.199, 8.500, 9.023, 11.88, or 13.627.

Video Service: 525-line or 625-line composite monochrome or color, with or without sound subcarrier, sync negative transmission mode, emphasis is standard CCIR/Bell System weighting.

Features

- For 5 or 6-MHz video (525-line NTSC No. American or 625-line PAL/PAL-M/SECAM International Service.)
- For all standard FM program subcarrier frequencies. Special frequencies are available on order.
- Light-weight, weatherproof mechanics. Covered metal case.
- Operates for -24 or -48 Vdc, or from 115 or 220 Vac, 50/60 Hz.

- Self-contained Deviation Test Unit for setting modulation deviation of the FM radio carrier.
- Plug-in circuit modules of the portable tester are interchangeable with those of the FV40 video transmission/modem equipment that usually is used with FV-series microwave—provides spares backup for emergencies.

Reference

Form 7801 (60367 Port. Test Unit)

TYPE 60888-series Portable Microwave-Radio Parabolic (reflector/feed) and Rod Type Antennas: For Harris Broadcast Microwave's family of portable radio systems.

Features

- 1.99 to 13.25-GHz range, with Reflector Diameters of 14, 25, 50, and 72 inches. Also 2 and 4-foot Rods and for the low-frequency bands.
- Quick Mounting and Disconnect fittings.
- Interchangeable Feeds: Circular polarization; some feeds can also be operated in a linear-polarization mode.
- Rugged Design, Reliable Operation in most outdoor Environments.

Reference

Form 8275 (Portable Microwave Antennas)

TYPE GTS-04C Ultra-lightweight, Low-cost Tracking Antenna System for ENG Central Receiving. Manufactured for Harris Broadcast Microwave by EMP, inc. (Electro-Magnetic Processes, Inc.). A single-axis tracking system using a multi-mode (dual-beam) antenna may be directed (steered) locally (manual) or on a programmed unattended basis, as a master, slave or stand-alone unit; uses the associated ACU-6 Series Microprocessor-Based Antenna Control Unit.

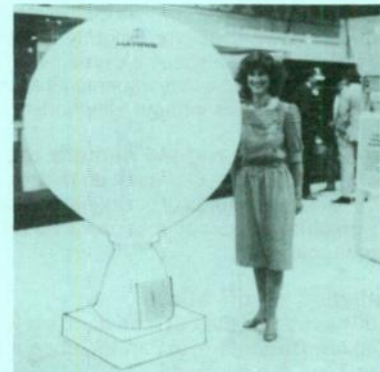

GTS-04C

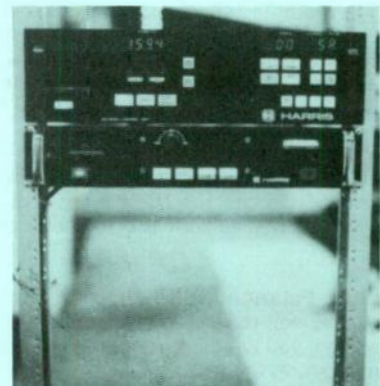

60888

May be ordered for either the 1.435 to 2.300-GHz band or the 2.200 to 2.400-GHz band. Offers various remote interface options, for either serial or parallel low-bit-rate control line operation.

Antenna Performance:

	High Gain	Low Gain
Gain:	22 dBi at 1485 MHz 26 dBi at 2250 MHz	10 dBi, nominal
Bandwidth:	12° at 1485 MHz 8° at 2250 MHz	65°, nominal
Rotation:	Continuous (no limits)	
Feed	Polarization: RHCP (LHCP optional)	

Reference

Please see your local Harris Sales Engineer.



HARRIS

P.O. Box 4290
Quincy, IL 62305-4290
(217) 222-8200

ENG/EFP CAMERA

TC-90 ENG/EFP CAMERA

The Harris TC-90 brings out the best in your cameraperson...and your pictures. The just-right camera balance makes sure-footed shooting from even the most difficult angles a snap. And the super lightweight adds to the ease of handling and eliminates fatigue as a factor on long days in the field.

Better yet, the TC-90 provides excellent pictures, like a studio camera. It uses three LOC, mixed field 1/2" (13mm) diode gun Plumbicon® tubes, an extremely stable f/1.4 prism and exclusive FET preamps for outstanding picture performance. The TC-90 reproduces colors the way you actually see colors, and the pictures have a sharpness and clarity you rarely get from a portable camera. Even the reds are clearly defined. With most cameras, anything red tends to become a little fuzzy; with the TC-90, an exclusive contours-from-red* circuit maintains sharp detail on all red objects.

A terrific balancing act

The TC-90 could be smaller, but we deliberately designed it just a little longer than it had to be, making it slightly tail-heavy to counterbalance the weight of the lens. It also has a low center of gravity that makes the TC-90 practically cling to a cameraperson's shoulder. Then there's the weight, only 8.2 pounds without viewfinder, lens and battery.

It may be the most rugged camera there is.

Lightweight as it is, the TC-90 may be the toughest camera you can buy. Every part was selected or designed to take a beating. The case is built of a graphite composite that needs no maintenance and should never need repair.

FCC radiation certification.

The TC-90 has passed the FCC radiation test with flying colors, and is suitably labelled to conform to Part 15 Subpart J FCC Rules and Regulations for Type A equipment.

Tubes — smaller is better.

The LOC (low output capacitance), mixed field 1/2" diode gun Plumbicon tubes used in the TC-90 provide registration performance so much better than 2/3" magnetic tubes that the additional complication of computer-controlled geometry correction is not required.

Pictures with "snap".

From its exclusive f/1.4 prism to its sophisticated use of Large Scale Integrated (LSI) circuits, the TC-90 is designed to deliver outstanding picture clarity as well as perfect colorimetry under all lighting conditions.

Auto white balance in 0.3 second.

When the auto white balance switch is activated, with the TC-90's test signal inserted, you will get a perfect white balance for 3200°K scene color temperature. Or, when the auto white switch is activated with scene content, a perfect white balance is achieved for that scene content in 0.3 second. This is stored in memory until reset.

Auto black balance assures perfect colorimetry.

When the TC-90's black balance switch is momentarily activated, the lens iris closes automatically, the blacks are balanced in 0.3 second, and the lens opens to its previous iris setting. This ensures perfectly balanced individual black levels for red, green and blue channels, which are stored in memory until reset.

Comet tail suppression.

The TC-90 employs comet tail suppression circuits to minimize the effects of bright scene highlights.

The TC-90 delivers a S/N of at least — 60dB.

An outstanding S/N ratio of -60dB is achieved at light levels as low as 56 foot-candles at f/1.4.

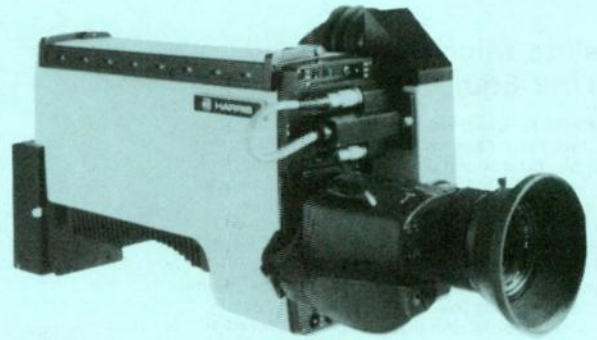

TC-90

Simultaneous contours from red and green.

Other cameras offer contouring on only one color at a time. The TC-90 provides contours out of green and red simultaneously to enhance image sharpness over a wide color spectrum.

Genlock with precise SC/H phasing.

With three LSIs in the RS-170A sync generator system, timing is quick, accurate and at the proper relationship between horizontal sync and color subcarrier. The TC-90 genlocks to either a composite color or black-burst signal.

Built-in color bar and staircase test signals.

The TC-90 has built-in full field or split field color bars that meet or exceed all NTSC specifications.

High-fidelity microphone amplifier.

The TC-90 includes a built-in microphone preamplifier to supply line level audio to all VTRs.

Built-in RTS-compatible intercom amplifier.

The TC-90 camera head has a built-in RTS-compatible intercom amplifier.

Runs on very little power from a big array of sources.

You can power the TC-90 on DC voltage from +10.5 to +15 volts, from any of six sources: 1) two-ampere/hour on-board battery pack; 2) four-ampere/hour on-board battery pack; 3) VTR/VCR battery; 4) an AC-to-DC converter power pack which attaches like a battery pack; 5) a battery belt; 6) any automotive 12-volt DC power supply with negative ground.

You get more than a good view on the 1-1/2" diagonal CRT in the TC-90 viewfinder.

An oscilloscope-type display provides an actual video waveform, which, with a 100% exposure cursor line, lets you make precise manual iris adjustments. You can turn it off when you don't want it. Four LEDs in the viewfinder give you four different warnings: 1) the VTR/VCR is in record mode; 2) end-of-tape of VTR/VCR not connected to camera; 3) VTR/VCR battery low; 4) on-board camera battery low.

A filter for any type of shot.

The TC-90 has a built-in 5-position filter wheel to allow the camera operator great flexibility for color temperature compensation and scene illumination correction.

With the "Smart Package"™ option, the TC-90 may just be the smartest ENG/EFP camera available anywhere.

Add the exclusive Smart Package™ option to the TC-90, and you get microprocessor time code generation that lets you record SMPTE and VITC time codes as you shoot. The Smart Package also adds diagnostics, auto centering and encoder balance. No diascopes lenses or special test charts are needed for the automatic adjustment of these parameters, only normal scene content is required.

COLOR STUDIO TELEVISION CAMERAS

HARRIS
 P.O. Box 4290
 Quincy, IL 62305-4290
 (217) 222-8200

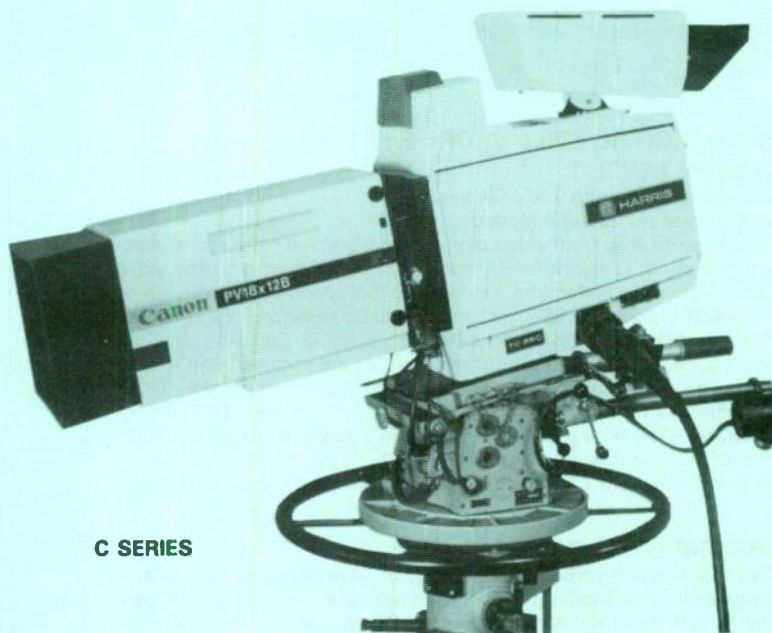

C SERIES

C SERIES COLOR STUDIO TELEVISION CAMERAS

The Harris C Series offers a wide range of choices to give you the exact camera configuration that best fits your production needs. Now you can have a camera that is essentially custom designed for your operation. You make the choices...and you get exactly what you want.

The basic C Series model is a manual setup camera with automatics. The C Series also offers a full computer-controlled automatic setup version that features a separate computer in each camera for simultaneous setup and greater flexibility. The basic model may be upgraded in the field to full computer setup capability as your requirements change.

The C Series operates with TV-81 multicore cable, Triax cable or TV-81 mini multicore cable. This gives you the flexibility of utilizing camera cable that may already be in place in your facility or at remote sites. All types of pickup tubes designed for the 25mm format can be accommodated. These include standard Plumbicons[®], Diode Gun Plumbicons, ACT Plumbicons and Saticons. Choose the tube that best fits your operating environment. From your local newscast to a remote sports event, the C Series offers a lens to "bring it home". 10:1 to more than 42:1 zoom ranges are available from all major lens manufacturers.

- Color fidelity and picture integrity of the Harris C Series cameras are unsurpassed. High resolution with low lag, high sensitivity, low noise, unique contouring from red and green simultaneously, highlight handling that virtually eliminates comet-tailing, and variable contrast give you color as you really see it, and clean sharp video even under the most severe lighting conditions.
- Harris C Series cameras are designed for easy operation from the control panel on through to the camera head.
- The Harris C Series cameras are reliable, rugged and ready to operate over long periods of time with minimal engineering attention.
- In the C Series computer setup model, 48 operator functions are controlled by the computer and adjusted according to preset parameters. Each camera has a built-in independent computer to eliminate camera interdependence in multi-camera installations.

TC-80C Manual Studio Camera without Tubes and Lens

TC-85C Computer Studio Camera without Tubes and Lens



Camera-head modules are readily accessible for servicing, and controls are front-edge mounted.



Utility panel provides connections for test equipment and external intercoms, tallies, monitors.

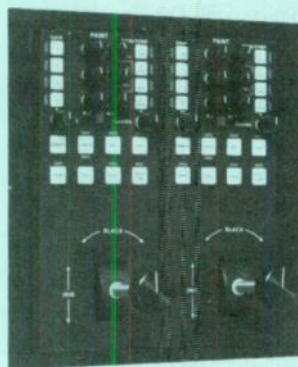

Joystick remote control panels.



Operator's view of Harris C Series tiltable, rotatable viewfinder showing electronic-generated safe-title area and variable grease pencil window.

IRIS II DIGITAL STILL STORE SYSTEM

SYSTEM LEVEL 1

One user station with 260 stills available.
 Digital noise reduction included.

You can store stills from video tape recorders, video cameras, character generators, network feeds, and reflective art, virtually any video input, from a free-standing keyboard. The space-saving 80 Mbyte removable disk drive (RSD) will store up to 260 images on a small, removable disk pack. This allows you to remove the disk pack for security, or use at another location. You, or a computer, can access images as quickly as they are stored. The System Controller (SCU) coordinates the system via an Intel Multibus™ based Z8000 micro-computer. The Floppy Disk Drive allows easily updated software control, while the Disk Controller (DCU) gives you the freedom to add up to 8 disk drives as your image storage requirements increase.

SYSTEM LEVEL 2

Two user stations with 780 stills available, plus digital keying, picture compression/positioning, digital noise reduction and remote keypad. IRIS II, in this configuration, allows two users to store stills and build/retrieve lists simultaneously. A Remote Keypad has also been added which can be slaved to the master keyboard, or used independently for limited space applications. This level 2 system is completed with the addition of: 1) a 160 Mbyte fixed disk drive (FSD) to give you 520 more stills. 2) Another 632 Frame Synchronizer to provide preview and line capability, plus montage effects.

SYSTEM LEVEL 3

Four user stations with 1776 stills available. Also equipped with production graphics/effects, high resolution titling, digital keying, DNRs, picture compression/positioning, and a remote keypad.

This level system has Harris' new four-frame synchronizer, the 650, and the Iris Composition Station (ICS) for exciting production graphics. ICS gives you:

- Variable compression and 2X expansion
- Joystick positioning and cropping
- Variable aspect ratio
- Infinite border and background color
- Soft border capability
- H & V inversion
- Cut and paste
- Digital keyer with 17ns resolution
- Removable memory modules
- Frame-to-field interpolation

Digifont, a 35ns resolution character generator, has also been added. With Digifont, you can preformat any titling sequence, and then key the titles over Iris II stills. Digifont, in combination with Digikey, lets you retitle background slides hundreds of times with no perceptible degradation.

SYSTEM LEVEL 4

Six user stations and 3 remote keypads, with over 17,000 stills. A full complement of production graphics/effects, high resolution titling, digital keying, DNRs, picture compression/positioning, and a library management system.

Here it is. The ultimate Iris. The Library Management System we've added has the most powerful routines of any in existence. Over 80,000 stills can be cataloged, either on or off-line. Retrieval is simple, because you can catalog stills under five categories, and search each category with an unlimited number of keywords. Library entry information is stored on a Winchester-type drive which can be instantly accessed via any of the six user stations.

SYSTEM LEVEL 1

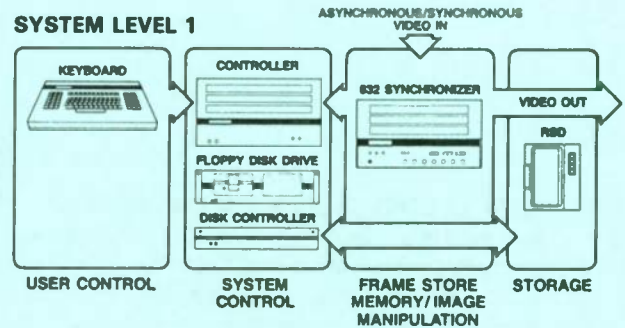

SYSTEM LEVEL 2

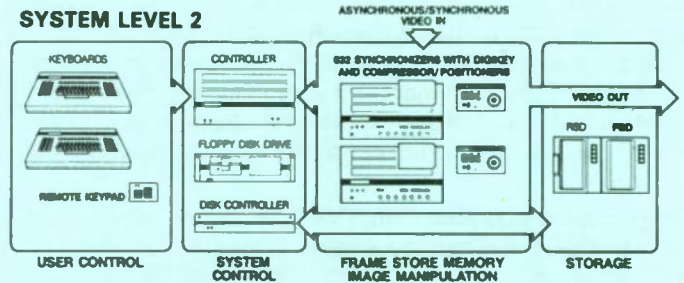

SYSTEM LEVEL 3

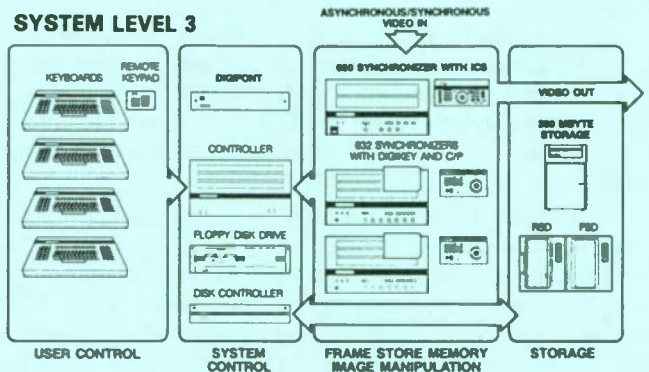

SYSTEM LEVEL 4

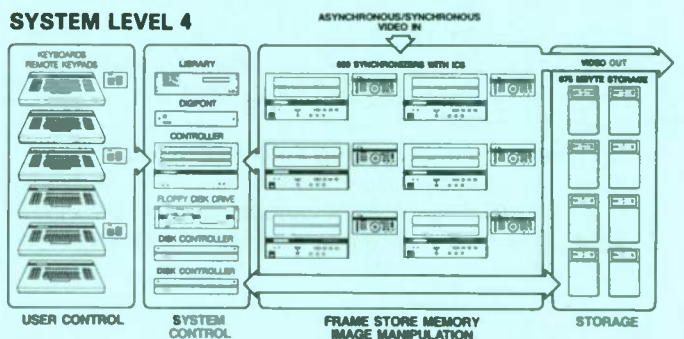



The crop box indicates the image area to be used in the composition.



The cropped image area is first expanded, then traced and keyed (cut and pasted) over another background still.



The new image is compressed, given a border, then overlaid upon another existing still that includes a digitally keyed-in title w/drop shadow.



It's easy to create complex effects with first generation resolution on the ICS. Any number of stills, with effects, can be generated and keyed over each — here into an area (black box) that is also used to define a transparent drop shadow.

NOTE: All effects illustrated were made on an IRIS Composition System and photographed directly off a monitor. No simulations were used.

Who now offers exciting effects for graphics production on your IRIS Still Store?

Harris' IRIS Composition System — ICS — is the newest component in the IRIS family of still store systems. The ICS gives you a wide range of effects.

- Compression
- Expansion
- Variable aspect ratio
- Hard and soft borders
- Continuously variable border width/color
- Internal matte generator
- Opaque and transparent overlay
- Cut and paste
- Joystick positioning and cropping
- Luminance keyer with adjustable polarity and key level

The ICS can store up to 9 sets of effects in removable, erasable Archive Modules. So you can recall your best effects — at the touch of a button.

Who gives you the freedom to build graphics with unlimited layers?

With the ICS, an unlimited number of images can be manipulated and overlaid. And because it's all done digitally, there is no generation loss in image quality, from the first layer to the last.

Who gives you the ability to digitally key characters and irregular shapes without tying up your switcher?

With the ICS keyer, any video source (character generator, camera, internal color generator, or another IRIS still) can be keyed into a background still under control of an external key signal. In the ICS dynamic keying mode, key signals corresponding to irregular shapes can be created to allow cutting and pasting of one piece of a still into another — all while maintaining first generation quality. For more information, or to arrange for a demonstration, contact:

Harris Studio Division, Video Systems Operation,
1255 Ease Arques Ave., Sunnyvale, CA 94086
(408) 737-2100 Telex: 4992172

For your information, our name is Harris.

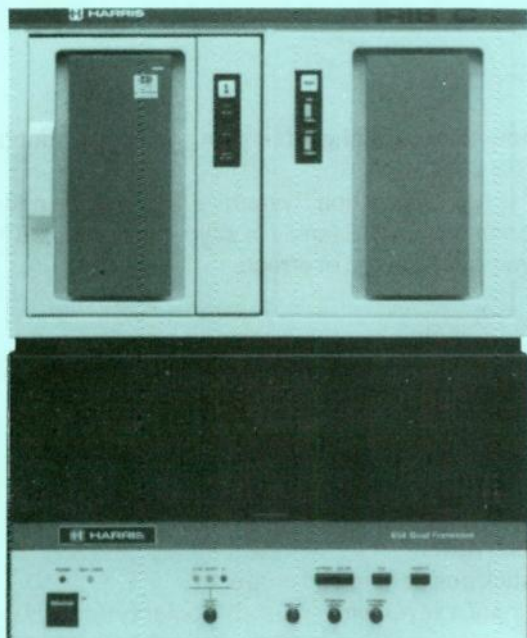

The IRIS C, including one RSD/FSD drive and framestore, take up less than 24 inches of rack space.



The 5-1/4" x 6" Mini-Controller interfaces with an interactive monitor screen and allows recall, store, browse, erase, build, edit, and print operations.

IRIS C, DIGITAL STILL STORE SYSTEM

Several years ago an ambitious engineering program began that resulted in the world's most flexible and powerful digital still store system, Harris' IRIS II. Built with component-coded framestores and designed to evolve as the needs of the industry changed, it offered six simultaneous users, each with preview/program output, library management, production graphics and effects, field-to-frame interpolation, titling, digital keying, picture compression/positioning, digital noise reduction and on-line storage for over 17,000 stills. It also interfaced to many types of fixed and removable media disk drives.

Now, the evolution continues with IRIS C, a new version that maintains the broadcast quality signal performance and rigorous system design standards of IRIS II, yet offers a compact still store at significantly lower cost to the facility that does not need large storage capacity or six-user flexibility.

Two simultaneous users and a compact package

IRIS C will support two simultaneous users with dual channel capability for both. This

means that each user has both preview and program capability. And, installation in cramped spaces like mobile vans is easy because IRIS C occupies less than 24 inches of rack space.

A new quad framestore synchronizer with optional transition effects for increased flexibility

IRIS C incorporates the Model 654 framestore which contains four frames of component-coded memory and up to four NTSC encoders to produce four separate outputs. (The 654 is available as either a 2 or 4 output unit, and the 654-2, two output unit can be expanded to the 654-4, four output unit by field retrofit). The 654 transitions option provides dissolves and left/right, up/down wipes with programmable transition frame rates between pairs of outputs. When two users are operating IRIS C, transitions can be utilized by each user independently, and transitions can also be programmed into sequence lists. This advanced framestore synchronizer also provides time base correction and optional RGB input/output.

Control Flexibility

IRIS C can be operated by the new Mini-Controller or the IRIS II keyboard. The interactive menu screen of the Mini-Controller allows a first time user to be instantly effective with the system. IRIS C also provides an RS232 control port for full remote control from a host computer or editing system. A parallel printer port is also provided, allowing all the on-line library information as well as sequence lists, IDs and descriptions, to be printed.

Built-in, on-line Library Management

No index cards or hand written lists. The on-line library system catalogs stills using a six character numeric or alpha numeric ID, in addition to a description of up to 20 characters. Alpha numeric ID provides much more flexibility than other systems. For example, "News" stills may have ID's that start with "N", or "Basketball" stills with "B". Users may store their stills by their initials or other mnemonic identification.

PRODUCTION SWITCHER

HARRIS
P.O. Box 4290
Quincy, IL 62305-4290
(217) 222-8200

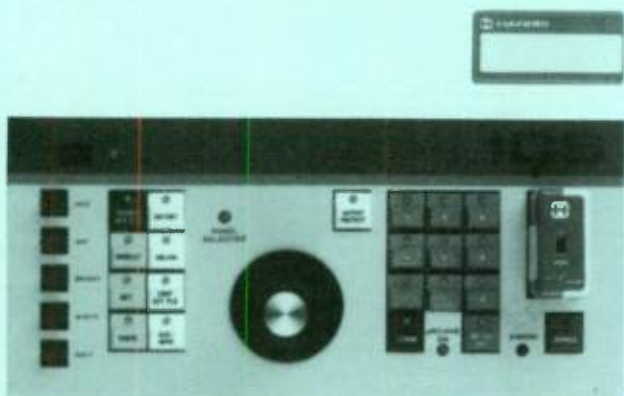

The IRIS Composition System (ICS) provides a full range of production graphics and effects for both IRIS C and IRIS II. Two ICSs may be used simultaneously on the IRIS C. The removable, erasable Archive Module (right) can store up to nine sets of effects.



IRIS C's optional full-function keyboard provides color-codings and familiar ASCII key layout. Stills may be cataloged numerically, alpha numerically, or by description in the library.

IRIS COMPOSITION SYSTEM (ICS)

Compatible with IRIS II

IRIS C stored picture data is compatible with IRIS II, so the pictures stored by the IRIS C in your van are perfectly interchangeable with the pictures stored by the IRIS II in your studio.

Exciting effects available

The IRIS Composition System (ICS) option, available on both IRIS II and IRIS C, provides a wide range of effects:

- Compression
- Expansion
- Variable aspect ratio
- Hard and soft borders
- Continuously variable border width/color
- Internal matte generator
- Opaque and transparent overlay
- Cut and paste
- Joystick positioning and cropping
- Luminance keyer with adjustable polarity and key level (keyed signals may be colorized)
- Dynamic key mode — continuous keying for creative camera copy-stand techniques
- Field-to-frame interpolation

The ICS can store up to 9 sets of effects in removable, erasable Archive Modules. You can recall your best effects at the touch of a button or have them automatically recalled

by a sequence list. The Archive Module is also compatible with IRIS II.

With the ICS, an unlimited number of images can be manipulated and overlaid. And because it's all done digitally, there is no generation loss in image quality, from the first layer to the last.

With the ICS keyer, any video source (character generator, camera, internal color generator, or another IRIS still) can be keyed into a background still under control of an external key signal. In the ICS dynamic keying mode, key signals corresponding to irregular shapes can be created to allow cutting and pasting of one piece of still into another — without tying up your switcher.

Media Flexibility

The constantly changing demands of the video industry's customers make storage media flexibility a necessity. IRIS C is compatible with many media storage drives from CDC.* Any two drives (below) may be used.

80 MB	RSD (cartridge)
160 MB	FSD
300 MB	SMD
340 MB	FSD
675 MB	FMD

The IRIS Series Still Stores; evolving to keep you in the lead as your needs change.

HVS manufactures digital electronic equipment for television broadcast and post-production. Our products range from hardworking Time Base Correctors used throughout the video industry, to the sophisticated digital still store and image manipulation systems described here. So if you're looking for the newest in special effects to enhance your programming, or for a cost-effective solution to almost any signal processing problem, look to a company that is famous for its innovative products and high-level product support.

For more information or a demonstration, contact:

Harris Studio Division,
Video Systems Operation,
1255 East Arques Avenue,
Sunnyvale, CA 94086
(408) 737-2100
Telex: 4992172.

*Control Data Corporation

Physical and Electrical

Unit	Power	Size	Weight
Disk drive (RSD & FSD)	250 watts	10.2" h x 8.5" w x 23" d* (25.9 cm x 21.6 cm x 76.2 cm)	60 lb 27.27 kg
Disk drive (SMD & FMD)	1000 watts	36" h x 23" w x 36" d (91.44 cm x 58.42 cm x 91.44 cm)	550 lb 249.47 kg
Systems controller	180 watts	12.25" h x 19" w x 25" d (31.11 cm x 48.26 cm x 63.5 cm) Includes space for one RSD/FSD drive	51 lb 23.18 kg
Quad Framestore (654)	550 watts	10.5" h x 19" w x 22" d (26.67 cm x 48.26 cm x 55.88 cm)	50 lb 22.68 kg
Keyboard	5 watts	4" h x 19" w x 10" d (10.16 cm x 48.26 cm x 25.40 cm)	10 lb 4.54 kg
Mini-controller	5 watts	5.25" h x 6" w x 4" d (13.33 cm x 15.24 cm x 10.16 cm)	2.3 lb 1.04 kg
ICS Panel	50 watts	5.25" h x 11.5" w x 13" d (13.34 cm x 29.21 cm x 33.02 cm)	5 lb 2.27 kg

* One drive fits inside system controller

Model 654-2 Two Output Framestore Synchronizer Model 654-4 Four Output Framestore Synchronizer

GENERAL		
Signal Inputs		1 V p-p stable direct or unstable heterodyne, composite
Video		0.7 V p-p into 75 ohms
RGB (Optional)		0.7 V p-p into 75 ohms
Genlock		1 V p-p composite video or composite sync and subcarrier. High impedance looping.
SIGNAL OUTPUTS		
	654-2	654-4
Video Outputs	2	4
Key Outputs	2	4
RGB	2	4
Sync and Blanking Outputs		4 V p-p
STABILITY		
Residual Luma TBE		± 10 ns with 50 dB S/N input ± 20 ns with 40 dB S/N input
Residual Chroma TBE		± 2° with 50 dB S/N input ± 4° with 40 dB S/N input
PERFORMANCE		
Video Bandwidth		Luma ± 0.2 dB to 4.2 MHz Chroma 1.25 MHz
S/N ratio (p-p signal to RMS noise) (R/S noise meter with bandpass filter, SC Trap and 10 kHz LPF)		57 dB (avg)
Differential phase		1.0°
Differential gain		1%
2T K factor		1%
C/L delay		17 ns max
ELECTRICAL AND ENVIRONMENTAL		
Ambient temperature		10°-40°C
Humidity		10%-90% non-condensing
A C voltage		115 V ± 10%, 50/60 Hz
A C power		550 W

All specifications subject to change without notice

System

On-line storage capacity
4264 Max NTSC

Number of users: up to two maximum; additional user stations may be allocated to an RS232 computer interface. Up to 2 disk drives in any combination.

Storage/recall format: field or frame storage with field 1, field 2, or frame recall

Number of fields per drive	
80 MB RSD	260
160 MB FSD	520
300 MB SMD/FSD	996
340 MB FSD	1100
675 MB FMD	2132

Library (Provided as standard)

On-board library system capable of cataloging and recalling stills by identification number (six characters numeric or alpha numeric), or by description (up to 20 characters)

Parallel Printer Port Centronix and TI compatible

**For your information
our name is Harris.**

EFFECTS SYSTEM

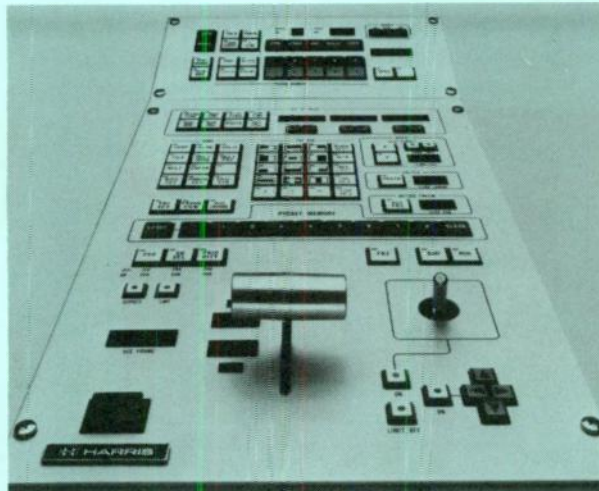

HDE 100/150/200

DIGITAL VIDEO EFFECTS SYSTEM

Harris introduces the HDE 200. This easy-to-use production tool features a 150 event bubble memory and easily upgradeable multi-channel capability. It is also available in two expandable versions, the HDE 100 and HDE 150. So now your effects capability can expand with your needs, and you can stay within your budget.

HDE 100 Features

- Variable Squeeze and Compression
- Slide/Push
- Split and Compression Split
- H & V Invert
- Freeze/Stop Action
- Programmable Multi-Pix Freeze
- Posterization
- Mirror/Reflect
- Montage
- Separate Border/Background
- Variable Aspect Ratio
- Fader Limiter
- Preset Effect Registers

HDE 150

All the effects of the HDE 100, plus:

- Variable Expansion/Zoom
- Programmable Trajectory
- Multi Move
- Mosaic (Tile)
- Flip/Tumble
- Wipe Follow
- Chroma Key Tracking
- Auto Operation of up to 150 Programmed Events
- On-Board Event Memory with Battery Back-up
- Removable Event Bubble Memory
- Editor Interface

HDE 200

All the effects of the HDE 150, plus:

- Automatic Input Switching
- Strobe Caption
- Decay
- Prewired for Dual Channel Option

Specifications

GENERAL

Signal processing system	PCM binary-coded signal processing
No. of bits per word	8 bits
Sampling frequency	14.3 MHz
Input signals	NTSC composite sync or monochrome signal: 1 V p-p, 75 ohms
Input key signal	0.7 V p-p or TTL
Output signals	NTSC composite sync, 1 V p-p, 75 ohms, 4 outputs
Output key signal	0.7 V p-p, 75 ohms, 3 outputs
External Reference	Black Burst: 0.3 V p-p Composite Video: 0.3 V p-p, high impedance SYNC: 4 V p-p SC: 2 V p-p

SIGNAL PERFORMANCE

Video input return loss	>30 dB at 3.58 Hz
Reference input return loss	>30 dB at 3.58 MHz
Video output return loss	>28 dB at 3.58 MHz
Frequency response	1 kHz to 5.0 MHz: ± 0.2 dB >7.5 MHz: < -40 dB
(A/D, D/A only)	
K factor	$< 1\%$
Diff gain	2%
Diff phase	2°
Signal-to-noise ratio	50 dB/rms (quantizing noise included)
Periodic noise	< 30 mV p-p
Hum	< -50 dB
Adjustable ranges	
Video level	Adjustable to 0.7 V p-p with input of 0.56 to 0.84 V p-p
Chroma level	$\pm 10\%$
Set-up	0 to 17.5 IRE
Burst phase	360°
HUE	$\pm 20^\circ$
SYNC level	0.3 V ± 0.1 V
Burst level	0.3 V ± 0.1 V

MECHANICAL & ENVIRONMENTAL

Dimensions	Video Processor: 11.7" (30 cm) H x 19" (48 cm) W x 17.6" (45 cm) D System Controller: 5.9" (15 cm) H x 19" (48 cm) W x 17.6" (45 cm) D Control Panel: 17.2" (44 cm) H x 7.8" (20 cm) W x 5.9" (15 cm) D
EMI: Conducted & Radiated	Meets FCC Class A specifications
Operating temperature	0°C to 40°C
Spec temperature	10°C to 30°C
Power requirements	110 V $\pm 10\%$ 220 V $\pm 10\%$, 50/60 Hz

HDE 100	\$47,000.00
HDE 150	\$55,250.00
HDE 200 Single Channel	\$79,000.00
HDE 200 Dual Channel	\$135,000.00



HARRIS

P.O. Box 4290
Quincy, IL 62305-4290
(217) 222-8200

FRAME SYNCHRONIZERS/ TIME BASE CORRECTORS



HVS 632

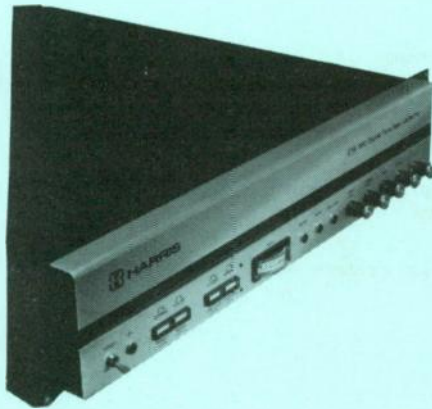

HVS 516WB

HVS 632/DNR NTSC

Frame Synchronizer and Time Base Corrector

Frame Synchronizer and Time Base Corrector which offers superb performance with outstanding flexibility. It operates with time base stable direct color, and monochrome signals and also time base unstable heterodyne or monochrome signals. The unit is shipped as a stand-alone unit with manuals and rack slides.

- Stable or unstable inputs
- "Dual Mode" hot switching
- Smooth handling of odd field edits
- Compensation for lost video
- Picture freeze
- High noise immunity
- Exceptional write clock range
- RGB mode
- Digital interface
- Convenient front panel operation
- Easy maintenance

Part #	Product	Price
7-18482-01	HVS 632/DNR	\$21,800.00
7-13106-03	Compress/Positioner	4500.00
TBA	Spare Parts Kit	2500.00
5-16356-01	Maintenance Manual	125.00
5-16357-01	Operators Manual	50.00
7-16212-01	Remote Control	2000.00
7-16391-01	Digikey	4500.00
1-14745-01	Rackmount for C/P and/or Remote Control Panel	75.00
	HVS 632C (RGB)	24,800.00
	HVS 632/DNR Package (includes C/P, Digikey and Remote Control)	27,990.00



HVS 690

HVS 690 Frame Synchronizer and Time Base Corrector STANDARD FEATURES:

- Freeze frame or freeze field for production versatility
- Dropout compensation to clean up bad tapes
- Line-by-line velocity compensation with look-ahead for high accuracy correction with direct signals
- Preset proc amp level controls for complete control over input video
- Hysteresis circuitry for smooth signal handling
- Transparent signal performance for perfect originals and clean, crisp dubs
- Industry standard components to speed maintenance
- 3.5 inch height to conserve rack space, or to make tabletop use more convenient
- Auto-freeze when incoming signal is lost to reduce output video disturbance
- Automatic mode switching between stable and unstable inputs to reduce operator set-up time
- Built-in TBC for heterodyne and direct signals for complete versatility with all formats

Part #	Product	Price
7-16154-01	HVS 690	\$14,850.00
1-10440-01	Quad Head Switch Amplifier	295.00
1-11203-00	FM Sampler for D.O.C.	95.00
1-18244-01	C-MOD (option)	350.00
1-18253-01	C-MOD (retrofit)*	500.00
7-11245-01	Fiberglass Shipping Case	275.00
5-14113-01	Operators Manual	50.00
5-14114-01	Maintenance Manual	75.00
1-18140-01	Spare Parts Kit	975.00

HVS 516WB Digital Time Base Corrector (Wide Band)

The HVS 516WB is a broadcast quality, NTSC digital time base corrector. This wide-band TBC gives the user of any non-segmented, heterodyne VTR all the proven advantages of modern digital video processing, plus the bandwidth to handle the extended frequency response of the new generation VTRs.

ENG/EFP, CATV, Production and Post-production applications benefit from the 516WB's component-coded processing techniques and 4 x Fsc sampling in terms of excellent time base error handling characteristics and reduced video noise levels. The 516WB, based on HVS's experience with over 8000 digital TBCs, is our most advanced and reliable 516 yet.

The HVS 516WB accepts an input video signal, separates it into component form, digitizes and stores it. The signal is then encoded, clocked out at a corrected rate and referenced to either an external or an internal sync generator. The result is a time base corrected video signal.

Part #	Product	Price
7-11852-03	HVS 516WB	\$9800.00
1-13093-01	H & V Blanking (option)	295.00
7-13591-01	H & V Blanking (kit)	468.00
7-11245-01	Fiberglass Shipping Case	275.00
5-11853-02	Operators Manual	50.00
5-11854-02	Maintenance Manual	75.00
TBA*	Spare Parts Kit	1345.00
1-11203-00	FM Sampler for D.O.C. (kit)	95.00

*To Be Announced

TIME BASE CORRECTOR



Model 550

HVS 550 Digital Time Base Corrector

The Harris 550 operates with all capstan servo heterodyne video recorders, from the older, non-subcarrier feedback machines to the new highband VCRs. 3.58 feedback and process modes are both available to offer superb performance over a wide range of VTRs.

For easy editing, the 550 will handle 10X shuttle speeds. And its full remote panel is small enough so that two can fit side-by-side in a 1 1/4" rack space.

The 550's 8-bit, 4xfsc architecture provides virtually-transparent signal performance, while its 16-line memory and Automatic Vertical Advance handles large gyro errors with ease. A built-in proc amp, plus RS-170A sync output circuitry, allow complete operator control of video signals and gen-lock of external equipment.

This new TBC is also FCC certified for radiated and conducted EMI.

To keep down-time to a minimum the 550 is designed with features that make it ultra reliable and, at the same time, quick and easy to repair.

- Printed circuit signal paths, versus wire harnesses
- Redundant circuit board contacts
- Front-removable, three-board architecture
- Shields integral with the chassis, not the PCBs
- Sturdy, two-piece package

HVS 540 Time Base Corrector

The 540 is a low cost TBC similar to the HVS 550 except it operates in the 3.58 MHz (subcarrier) feedback mode only.

SPECIFICATIONS

Signal Inputs

- Video: 0.5 to 1.5 V p-p into 75 ohms, 525 lines, 60 fields/sec
- Video input return loss: greater than 43 dB at 3.58 MHz
- DOC: 1 V p-p RF, 75 ohm terminating

Signal Outputs

- Video out 1: 1 V p-p into 75 ohm comp. video by-passable
- Video out 2: 1 V p-p into 75 ohm comp. video not by-passable
- ADV VTR Sync Out: 0.3 V or 4 V p-p into 75 ohm
- VTR 3.58 feedback: 1 V p-p into 75 ohm

Memory Architecture

- Sampling rate: 4 X subcarrier
- Quantizing: 8 bit
- Memory capacity: 98K bits
- Time base correction window: 16 H lines

Signal Performance

- Frequency response
- 3.58 feedback mode: + / - 0.5 dB from 10 Hz to 4.2 MHz less than 3 dB down at 5 MHz
- Process mode: luminance 2.5 MHz (550 only)

- Differential gain: 2%
- Differential phase: 2°
- Low frequency linearity: 0.2 dB
- Tilt
 - Field rate: 1%
 - Line rate: 1%
- K factor
 - 3.58 feedback mode: 2T 1%/20T 1% baseline error
 - Process mode: 2T 5%/20T 3% baseline error (550 only)
- Signal-to-noise ratio (p-p signal to RMS noise): 59 dB (ave.)
- Residual time base error
 - 3.58 feedback mode: Luma + / - 20 ns, Chroma + / - 2 ns
 - Process mode: + / - 3 ns relative to burst (550 only)

Mechanical, Environmental and Power

- Dimensions: 19" x 3.5" x 16.75" (48.3 x 8.8 x 42.55 cm)
- Weight: 27 lbs. (62.3 kg)
- Operating temperature: 32°F to 104°F (0°C to 40°C)
- Spec temperature: 50°F to 104°F (10°C to 40°C)
- Storage temperature: 14°F to 140°F (-10°C to 60°C)
- Altitude: sea level to 12,000 feet (3,700 M)
- Max humidity: 95% relative non-condensing
- Power requirements: 100, 120, 220 or 240 V + / - 5%, -10% 50-60 Hz 175 watts

VARIABLE TRACKING OPTION FOR 540/550 TBCs

The new Variable Tracking (VT) option allows either TBC to be used with slow-motion heterodyne VTRs such as the Sony BVU 820 with its Dynamic Tracking mode. The 540VT and 550VT will dynamically track from 1x reverse play speed to 3x forward play speed and will hold color lock to + / - 5x shuttle speed. In addition, the 540VT and 550VT will enable the VTR to present a stable picture in "pause" as well as present a viewable picture in fast forward and rewind modes (+ / - 40x normal speed). Included with the option, an interconnect harness compatible with the Sony BVU 820.

Part #	Product	Price
7-18000-02	HVS 540 (16L)	\$6450.00
	HVS 540VT (16-L)	6950.00
7-18000-01	HVS 550 (16L)	7950.00
	HVS 550VT (16-L)	8450.00
7-18478-01	Remote Control (540/550)	975.00
5-18043-01	Operators/Maintenance Manual (540/550)	75.00

INDEX

MEDIUM WAVE BROADCAST TRANSMITTERS AND ACCESSORIES

100,000 watt, VP-100A	1
50,000 watt, MW-50C	2
10,000 watt, MW-10B	3
5000 watt solid state, SX-5	4, 5
2500 watt solid state, SX-2.5	4, 5
1000 watt solid state, SX-1	4, 5
Antenna phasing equipment	8
Medium wave modulation monitor, AM-90	6

SHORT WAVE BROADCAST TRANSMITTERS

50,000 watt, SW-50A	9
100,000 watt, SW-100A	10

FM BROADCAST TRANSMITTERS

50 kilowatt, FMD-50K	14-19
40 kilowatt, FM-40K	14-19
25 kilowatt, FM-25K	14-19
20 kilowatt, FM-20K	13, 15-19
10 kilowatt, FM-10K	13, 15-19
5 kilowatt, FM-5K	13, 15-19
3.5 kilowatt, FM-3.5K	13, 15-19
1 kilowatt, FM-1K	13, 15-19
300 watt, FM-300KD/FM-300K	13, 15-19
FM exciter, MX-15	11, 12

CIRCULARLY POLARIZED FM ANTENNAS

High power, high performance, FMXH	20
Low power, high performance, FMXL	21
Super power, FMH	22
Low power, FML	23
Directional dual polarized	24
Cavity backed radiator, CBR	25

VHF COLOR TV TRANSMITTERS AND ACCESSORIES

70 kilowatt/100 kilowatt dual high band, TVD-70H/TVD-100H	32, 33
50 kilowatt high band, TV-50H	30, 31
35 kilowatt high band, TV-35H	30, 31
60 kilowatt dual low band, TVD-60L	28, 29
45 kilowatt dual low band, TVD-40L	28, 29
30 kilowatt low band, TV-30L	26, 27
22.5 kilowatt low band, TV-20L	26, 27

UHF COLOR TV TRANSMITTERS AND ACCESSORIES

120 kilowatt, TVE-120S	34, 35
60 kilowatt, TVE-60S	34, 35
30 kilowatt, TVE-30	34, 35
UHF-TV exciter retrofit package	36

TV ANTENNAS

Circularly polarized, CPV	42, 43
Circularly polarized TAV-5L and TAV-5LE	41
UHF, quadrapower	37
UHF, Wavestar™ slotted waveguide	38, 39
VHF, Batwing	40

LIVE COLOR TV CAMERAS	
Computer setup camera, TC-85C	63
Portable ENG/EFP camera, TC-90	62
DIGITAL VIDEO EQUIPMENT	
IRIS digital still store	64-68
Digital video effects system HDE100/150/200	69
Digital time base corrector (wide band) HVS516WB	70
Digital time base corrector HVS550	71
Frame synchronizer and TBC HVS632/DNR NTSC	70
Frame synchronizer and TBC HVS690	70
BROADCAST MICROWAVE EQUIPMENT	
ENG microwave transmitter, Global IX	57
Video transmission equipment, FV-40	60
Miniature portable microwave link, FV-MP	57
Fixed wideband microwave radio transmission systems	60
Miniature portable transmitter for ENG, FV2/2.5MF	58
ENG microwave receiver, FV2CR	59
Microwave radio receiver for ENG, FV2.5CR	59
ENG microwave radio receiver, FV7CR	59
ENG microwave radio receiver, FV8CR	59
Low noise preamplifier, 60576	59
Program audio subsystem	59
Satellite microwave radio up-link equipment	59
	61
AUTOMATION	
Facilities control for radio or TV, Harris 9100	51-53
Satellite controller, 9165	54
Floppy disk unit for Harris 9100	54
Antenna control system 9135	55
High speed option for Harris 9100	56
Harris 9000 program control series	48-50
AUDIO	
8, 10 or 12 channel dual stereo audio consoles, medalist series	44-46
Phono preamplifier PX-91	47

The mechanical and electrical design of the equipment described herein is subject to change without notice as deemed necessary by the Broadcast Group of Harris Corporation or its suppliers, in the interest of advancing industry requirements or the state of the art.





HARRIS

**HARRIS CORPORATION
BROADCAST GROUP**

**217 - 222 - 8200 TELEX 40 - 4347
P.O. Box 4290 QUINCY, ILLINOIS 62305-4290 U.S.A.**
