

PRICE \$1.00

HEATHKIT® ASSEMBLY MANUAL

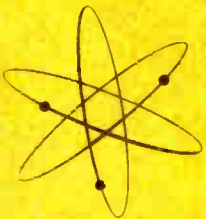











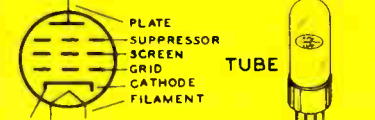
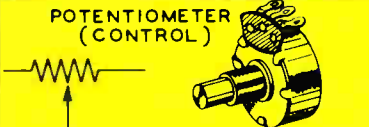
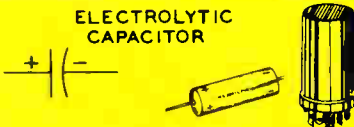
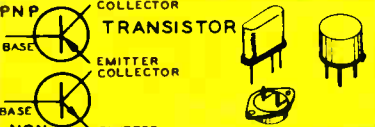

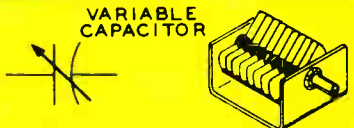
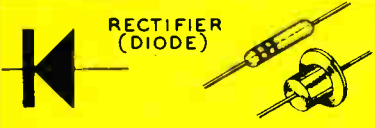
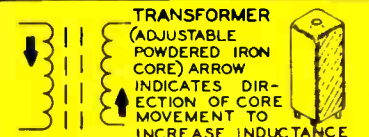
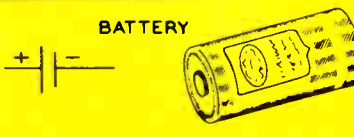
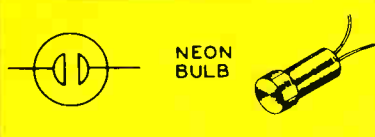
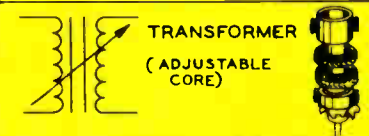

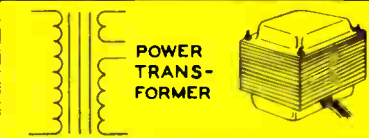

DEPTH SOUNDER
MODEL MI-11A

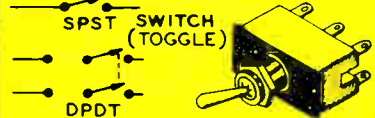
TYPICAL COMPONENT TYPES

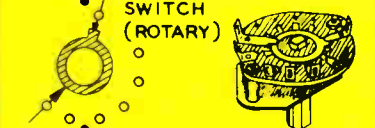
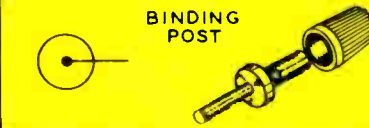
This chart is a guide to commonly used types of electronic components. The symbols and related illustrations

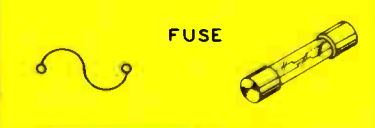
should prove helpful in identifying most parts and reading the schematic diagrams.

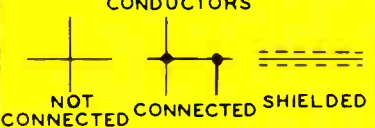
<p style="text-align: center;">RESISTOR</p> 	<p style="text-align: center;">CAPACITOR</p> 	<p style="text-align: center;">TUBE</p> 
<p style="text-align: center;">POTENTIOMETER (CONTROL)</p> 	<p style="text-align: center;">ELECTROLYTIC CAPACITOR</p> 	<p style="text-align: center;">TRANSISTOR</p> 
<p style="text-align: center;">TRANSFORMER (IRON CORE)</p> 	<p style="text-align: center;">VARIABLE CAPACITOR</p> 	<p style="text-align: center;">RECTIFIER (DIODE)</p> 
<p style="text-align: center;">TRANSFORMER (ADJUSTABLE POWDERED IRON CORE) ARROW INDICATES DIRECTION OF CORE MOVEMENT TO INCREASE INDUCTANCE</p> 	<p style="text-align: center;">BATTERY</p> 	<p style="text-align: center;">NEON BULB</p> 
<p style="text-align: center;">TRANSFORMER (ADJUSTABLE CORE)</p> 	<p style="text-align: center;">PHONO JACK</p> 	<p style="text-align: center;">ILLUMINATING BULB</p> 
<p style="text-align: center;">POWER TRANSFORMER</p> 	<p style="text-align: center;">PHONE JACK</p> 	<p style="text-align: center;">METER</p> 
<p style="text-align: center;">INDUCTOR (COIL)</p> 	<p style="text-align: center;">RECEPTACLE</p> 	<p style="text-align: center;">SWITCH (TOGGLE)</p> 
<p style="text-align: center;">PIEZOELECTRIC CRYSTAL</p> 	<p style="text-align: center;">SPEAKER</p> 	<p style="text-align: center;">SWITCH (ROTARY)</p> 
<p style="text-align: center;">BINDING POST</p> 	<p style="text-align: center;">MICROPHONE</p> 	<p style="text-align: center;">FUSE</p> 
<p style="text-align: center;">ANTENNA</p> 	<p style="text-align: center;">EARTH GROUND</p> 	<p style="text-align: center;">CONDUCTORS</p> 

Assembly
and
Operation
of the



DEPTH
SOUNDER
MODEL MI-11A



HEATH COMPANY
BENTON HARBOR,
MICHIGAN

TABLE OF CONTENTS

Introduction.	
Construction Notes.	3
Parts List.	4
Proper Soldering Techniques.	5
Circuit Board Wiring And Soldering.	7
Step-By-Step Procedure.	8
Step-By-Step Assembly -	
Circuit Board Wiring.	9
Circuit Board Parts Mounting.	10
Cabinet Rear Plate Assembly and Wiring.	15
Preliminary Cabinet Assembly.	18
Final Wiring.	22
Initial Test.	24
Final Assembly.	25
Alignment.	25
Ignition Interference Suppression.	26
Installation.	31
Operation.	33
Bibliography.	36
Maintenance.	36
In Case Of Difficulty.	38
Troubleshooting Chart.	39
Service Information.	40
Specifications.	42
Theory Of Operation.	43
Circuit Description.	44
Circuit Board X-Ray View.	46
Warranty.	47
Schematic. . . . (fold-out from page).	47

INTRODUCTION

Your Heathkit Depth Sounder Model MI-11A is a precision electronic device which accurately measures the depth of water up to 200 feet. The Depth Sounder will help you to locate dangerous underwater obstacles and provide additional safety for your passengers and boat when you navigate in unknown waters. Also, the Depth Sounder helps to determine the depth and location of schools of fish for your sporting pleasure or for commercial fishing.

Portable use is provided by using the self-contained batteries or the Depth Sounder may be connected to your boat's battery to reduce the cost of operation. Since transistors do not require any warmup time, the Depth Sounder is ready to operate when it is turned on except for the few seconds needed by the motor to reach proper operating speed.

An electro-acoustical method of operation is used to project an ultrasonic beam from the transducer to the bottom. The relatively intense beam is reflected or "bounced back" to the transducer from the bottom, from schools of fish, or from obstacles beneath the boat. The depth of water to the obstacles and to the bottom are registered on the indicator dial as flashes of bright light on the calibrated scale.

The calibrated scale is always easy to read since it is recessed and shielded from sunlight or other interfering bright lights. The parts of the Depth Sounder are nonferrous materials or have been especially treated to minimize the possibility of damage by damp or salt air. The transducer is of waterproof construction and is supplied with a brass fitting and brass mounting hardware. The special attached cable, when properly connected to the Depth Sounder, provides a watertight installation.

PARTS PICTORIAL

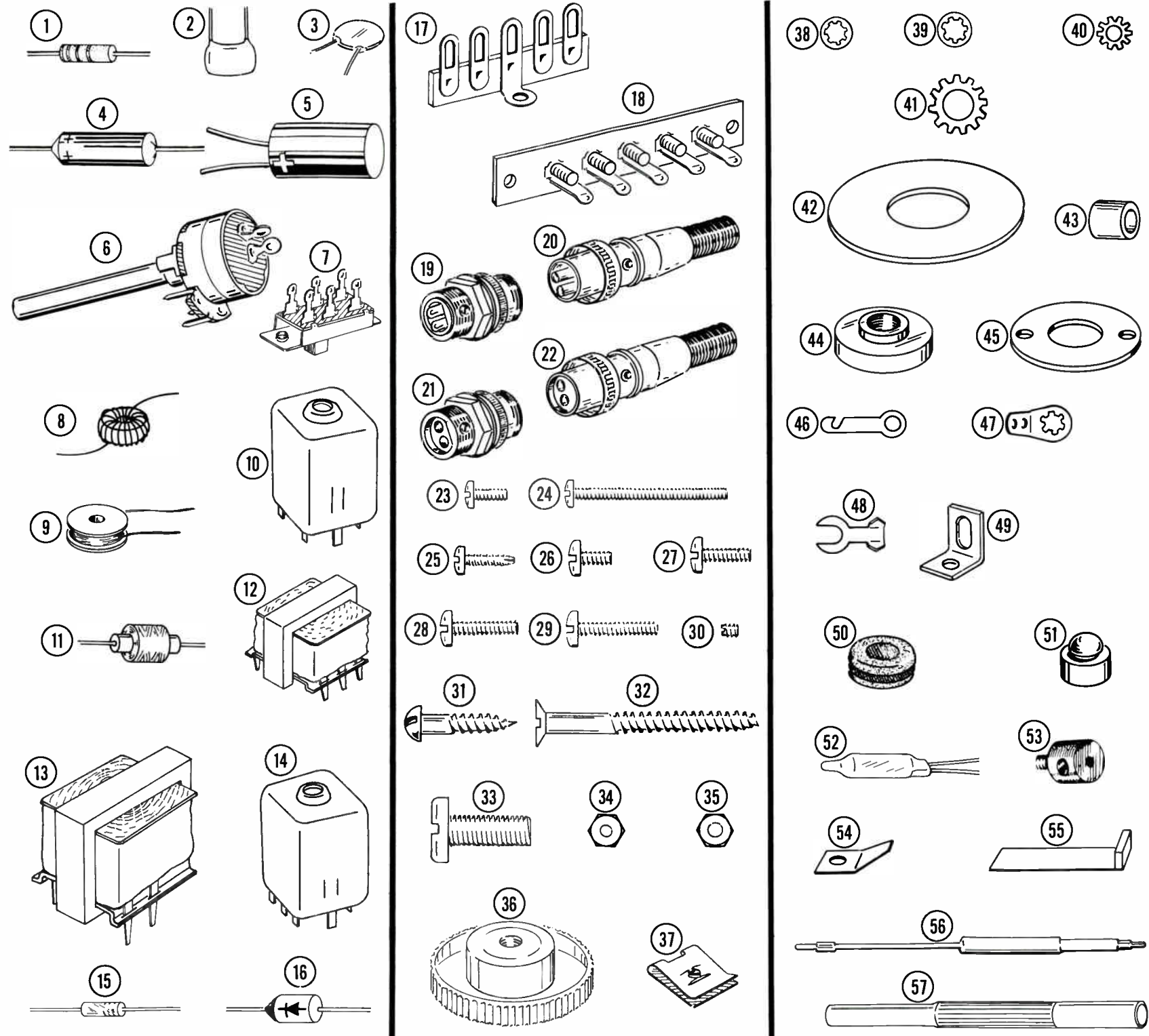

PARTS LIST

The numbers in parentheses in the Parts List are keyed to the numbers on the Parts Pictorial to aid in parts identification.

PART No.	PARTS Per Kit	DESCRIPTION	PART No.	PARTS Per Kit	DESCRIPTION
RESISTORS - 1/2 Watt					
(1)1-45	2	220 Ω (red-red-brown)	(17) 431-11	1	5-lug terminal strip
1-9	3	1000 Ω (brown-black-red)	(18) 431-17	1	5-screw terminal strip
1-10	2	1200 Ω (brown-red-red)	(19) 432-39	1	Female chassis connector
1-73	1	8200 Ω (gray-red-red)	(20) 432-38	1	Male cable connector
1-20	1	10 KΩ (brown-black-orange)	(21) 432-61	1	Male chassis connector
1-109	2	12 KΩ (brown-red-orange)	(22) 432-62	1	Female cable connector
1-102	2	82 KΩ (gray-red-orange)	TERMINAL STRIPS-CONNECTORS		
CAPACITORS					
(2)20-115	3	300 μmf mica	(23) 250-52	2	4-40 x 1/4" screw
20-127	1	1300 μmf mica	(24) 250-226	3	4-40 x 1-1/4" screw
(3)21-46	2	.005 μfd disc	(25) 250-295	6	5-40 x 3/8" screw
21-48	5	.05 μfd disc	(26) 250-235	7	6-32 x 1/4" screw
(4)25-129	1	3.5 μfd electrolytic	(27) 250-233	16	6-32 x 3/8" screw
(5)25-117	4	100 μfd electrolytic	(28) 250-234	6	6-32 x 1/2" screw
CONTROL-SWITCH					
(6)19-77	1	1000 Ω control with SPST switch	(29) 250-26	1	6-32 x 5/8" screw
(7)60-2	1	DPDT slide switch	(30) 250-33	1	6-32 x 1/8" setscrew
COILS-CHOKE-TRANSFORMERS					
(8)40-319	1	Toroid coil	(31) 250-41	4	#8 x 3/4" wood screw
(9)40-443	1	Pickup coil	(32) 250-165	1	#8 x 1-3/4" brass wood screw
(10)40-444	1	Oscillator coil	(33) 250-247	2	1/4-28 x 5/8" screw
(11)45-47	1	RF choke	(34) 252-2	3	4-40 nut
(12)51-72	1	Driver transformer	(35) 252-3	15	6-32 nut
(13)51-91	1	Output transformer	(36) 252-88	2	Thumbnut
(14)52-53	2	Interstage transformer	(37) 252-22	14	Speednut
DIODES-TRANSISTORS-FUSE					
(15)56-26	1	Crystal diode (brown-white-brown) 1N191	(38) 254-9	5	#4 lockwasher
(16)57-29	2	Silicon diode	(39) 254-1	19	#6 lockwasher
417-20	1	R265A (2N1039) transistor	(40) 254-6	1	#6 external tooth lockwasher
417-24	2	2N1274 transistor	(41) 254-12	2	1/4" external tooth lockwasher
417-53	1	TI 364 transistor	(42) 253-65	1	Thin brass washer
417-78	1	2N1524 transistor	(43) 255-13	2	1/4" spacer
421-13	1	1/2 ampere fuse	(44) 255-48	2	1/4-28 threaded spacer
HARDWARE					
DIODES-TRANSISTORS-FUSE					
(45) 255-64	1	Phenolic spacer	(46) 259-6	1	Small #6 solder lug
(46) 259-6	1	Small #6 solder lug	(47) 259-1	2	Large #6 solder lug
(47) 259-1	2	Large #6 solder lug	(48) 259-11	6	Spade lug
(48) 259-11	6	Spade lug	CABLE-WIRE-SLEEVING		
CABLE-WIRE-SLEEVING					
343-7	1	Shielded cable	343-7	1	Shielded cable
344-16	1	Stranded hookup wire	344-16	1	Stranded hookup wire
344-58	1	Hookup wire	344-58	1	Hookup wire
346-1	1	Sleeving	346-1	1	Sleeving

CONSTRUCTION NOTES

This manual is supplied to assist you in every way to complete your kit with the least possible chance for error. The arrangement shown is the result of extensive experimentation and trial. If followed carefully, the result will be highly stable and dependable performance. We suggest that you retain the manual in your files for future reference, both in the use of the equipment and for its maintenance.

UNPACK THE KIT CAREFULLY AND CHECK EACH PART AGAINST THE PARTS LIST. In so doing, you will become acquainted with the parts. Refer to the information on the inside covers of the manual to help you identify the components. If some shortage or parts damage is found in checking the Parts List, please read the Replacements section and supply the information called for therein.

Resistors generally have a tolerance rating of 10% unless otherwise stated in the Parts List. Tolerances on capacitors are generally even greater. Limits of +100% and -20% are common for electrolytic capacitors.

We suggest that you do the following before work is started:

1. Lay out all parts so that they are readily available.
2. Provide yourself with good quality tools. Basic tool requirements consist of a screwdriver with a 1/4" blade; a small screwdriver with a 1/8" blade; long-nose pliers; wire cutters, preferably separate diagonal cutters; a penknife or a tool for stripping insulation from wires; a soldering iron or gun. A set of nut drivers, while not necessary, will aid extensively in construction of the kit.

Most kit builders find it helpful to separate the various parts into convenient categories. Muffin tins or molded egg cartons make convenient trays for small parts. Resistors and capacitors may be placed with their lead ends inserted in the edge of a piece of corrugated cardboard until they are needed. Values can be written on the cardboard next to each component. The illustration shows one method that may be used.

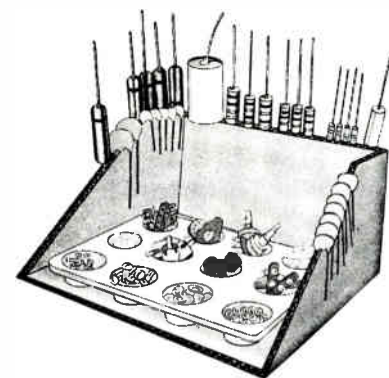

PART No.	PARTS Per Kit	DESCRIPTION	PART No.	PARTS Per Kit	DESCRIPTION
METAL PARTS			MISCELLANEOUS (Cont'd.)		
90-225F730	1	Cabinet top shell	100-377	1	Transducer assembly
90-M226F731P172	1	Cabinet bottom	210-19	1	Dial bezel
205-M477P173	1	Cabinet rear plate	214-19	3	Battery holder
(49)204-135	4	Angle bracket	(51)261-4	4	Rubber foot
204-M488F	1	Right end bracket	391-8	1	Adhesive label
204-M489F	1	Left end bracket	(52)412-23F	1	NE-86A neon lamp
204-M490F	1	Gimbal bracket	420-23	1	Motor
MISCELLANEOUS			422-1	1	Fuseholder
(50)73-1	1	Rubber grommet	(53)456-13	1	Shaft coupling
85-113P171	1	Circuit board	462-151	1	Knob
100-M376	1	Rotor assembly	464-25	1	Plastic dial
			(54)469-2	1	Ground brush
			(55)469-8	1	Carbon brush
			(56)490-1	1	Alignment tool
			(57)490-5	1	Nut starter
			331-6		Solder
			391-34	1	Blue and white label
			597-367	1	Registration card
			595-737	1	Manual

Nine standard size C flashlight batteries should be purchased at this time for use in the completed Depth Sounder. If you intend to use only the boat battery or an external battery, the flashlight batteries are not needed.

PROPER SOLDERING TECHNIQUES

Only a small percentage of customers find it necessary to return equipment for factory service. By far the largest portion of malfunctions in this equipment is due to poor or improper soldering.

If terminals are bright and clean and free of wax, frayed insulation and other foreign substances, no difficulty will be experienced in soldering. Correctly soldered connections are essential if the performance engineered into a kit is to be fully realized. If you are a beginner with no experience in soldering, a half hour's practice with some odd lengths of wire may be a worthwhile investment.

For most wiring, a 25 to 100 watt iron or its equivalent in a soldering gun is very satisfactory. A lower wattage iron than this may not heat the connection enough to flow the solder smoothly. Keep the iron tip clean by wiping it from time to time with a cloth.

WIRING AND SOLDERING

1. Unless otherwise indicated, all wire used is the type with colored insulation (hookup wire). In preparing a length of hookup wire, 1/4" of insulation should be removed from each end unless directed otherwise in the assembly step.

2. Wherever there is a possibility of bare leads shorting to other parts or to the chassis, the leads should be covered with insulating sleeving. Where the use of sleeving is specifically intended, the phrase "use sleeving" is included in the associated assembly step. In any case where there is the possibility of an unintentional short circuit, sleeving should be used. Extra sleeving is provided for this purpose.

3. Crimp or bend the lead (or leads) around the terminal without relying on solder for physical strength. If the lead is too large to allow bending or if the step states that it is not to be crimped, position it so that a good solder connection can still be made.

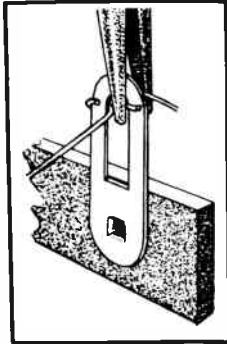

4. Position the work if possible, so that gravity will help to keep the solder where you want it.
5. Place a flat side of the soldering iron tip against the joint to be soldered until it is heated sufficiently to melt the solder.

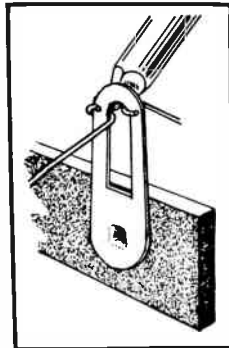

6. Then place the solder against the connection and it will immediately flow over the joint; use only enough solder to thoroughly wet the junction. It is usually not necessary to fill the entire hole in the terminal with solder.

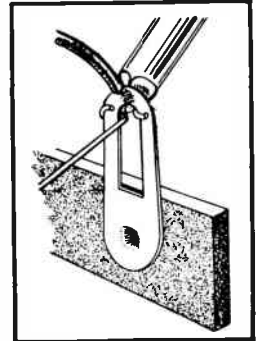

7. Remove the solder and then the iron from the completed joint. Use care not to move the leads until the solder is solidified.

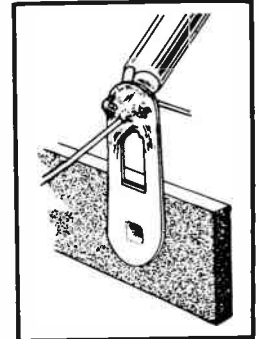

A poor or cold solder joint will usually look crystalline and have a grainy texture, or the solder will stand up in a blob and will not have adhered to the joint. Such joints should be reheated until the solder flows smoothly. In some cases, it may be necessary to add a little more solder to achieve a smooth, bright appearance.

ROSIN CORE SOLDER HAS BEEN SUPPLIED WITH THIS KIT. THIS TYPE OF SOLDER MUST BE USED FOR ALL SOLDERING IN THIS KIT. ALL GUARANTEES ARE VOIDED AND WE WILL NOT REPAIR OR SERVICE EQUIPMENT IN WHICH ACID CORE SOLDER OR PASTE FLUXES HAVE BEEN USED. IF ADDITIONAL SOLDER IS NEEDED, BE SURE TO PURCHASE ROSIN CORE (60:40 or 50:50 TIN-LEAD CONTENT) RADIO TYPE SOLDER.

CIRCUIT BOARD WIRING AND SOLDERING

Before attempting any work on the circuit board, read the following instructions carefully and study the Figures. It is only necessary to observe the following basic precautions to insure proper operation of the unit the first time it is turned on.

Proper mounting of components on the board is essential for good performance. A good general rule to follow is that all components on the board should be mounted tightly to the board, unless instructions state otherwise. All leads should be kept as short as possible to minimize the effects of stray capacity in the wiring. Proper and improper methods of mounting are illustrated in the accompanying Figures.

NOTE: Exercise care not to damage resistors or capacitors when bending the leads as shown.

Tubular capacitors and resistors will fit properly if the leads are bent as shown. Disc capacitors will generally fit in place with no lead preparation other than determining that the leads are straight. Components with lugs normally require no preparation unless the lugs appear to be bent, in which case they can be straightened with pliers.

Parts should be inserted as instructed, and the leads bent outward, as illustrated, to lock them in place. When a group of parts have been installed on a circuit board, solder each lead to the foil pattern and clip off the excess wire.

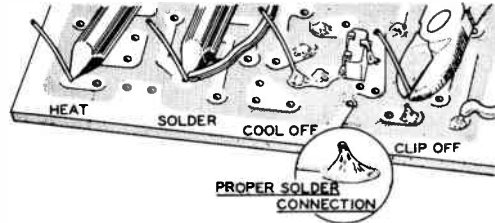
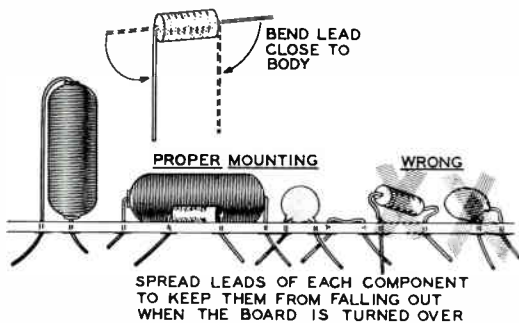

The actual technique of soldering leads to a circuit board is quite simple. Position the tip of the soldering iron so that it firmly contacts both the circuit board foil and the wire or lug to be soldered, as shown. The iron should be held so that solder is not likely to flow to adjacent foil conductors or connections. The solder should immediately be placed between the iron and the joint to be soldered. Remove the length of solder as soon as its end begins to melt and flow onto the lead and foil. Hold the tip of the iron in place only until the solder begins to flow outward over the foil; then remove the iron quickly.

Avoid overheating the connection. A soldering pencil or small iron (approximately 25 watts) is ideal for use in circuit board work. If only a high wattage iron or soldering gun is available, precautions must be taken to avoid circuit board damage due to overheating and excess solder.

The use of excessive amount of solder will increase the possibility of bridging between foil conductors or plugging holes which are to be left open for wires which may be added later on. If solder is accidentally bridged across insulating areas between conductors, it can be cleaned off by heating the connection carefully and quickly wiping or brushing the solder away with a soft cloth or clean brush. Holes which

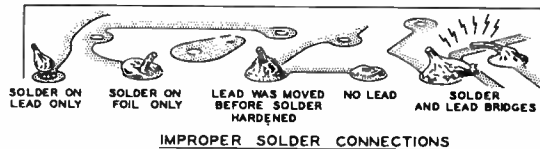



become plugged can be cleared by heating the area immediately over the hole while gently pushing the lead of a resistor through the hole from the opposite side, and withdrawing the lead before the solder rehardens. Do not force the lead through; too much pressure before the solder has time to soften may separate the foil from the board.

In cases where foil does become damaged, repairs can usually be made with little difficulty. A break in the foil can be rejoined with a small piece of bare wire soldered across the gap; or between the foil and the lead of a component. "Hairline" breaks can usually be repaired by bridging them with a small amount of solder.

STEP-BY-STEP PROCEDURE

The following instructions are presented in a logical step-by-step sequence to enable you to complete your kit with the least possible confusion. Be sure to read each step all the way through before beginning the specified operation. Also read several steps ahead of the actual step being performed. This will familiarize you with the relationship of the subsequent operations. When the step is completed, check it off in the space provided. This is particularly important as it may prevent errors or omissions, especially if your work is interrupted. Some kit builders have also found it helpful to mark each wire and part in colored pencil on the Pictorial as it is added.

ILLUSTRATIONS

The fold-out diagrams in this manual may be removed and attached to the wall above your working area; but because they are an integral part of the instructions, they should be returned to the manual after the kit is completed.

In general, the illustrations in this manual correspond to the actual configuration of the kit; however, in some instances the illustrations may be slightly distorted to facilitate clearly showing all of the parts.

SOLDERING

The abbreviation "NS" indicates that a connection should not be soldered yet as other wires will be added. When the last wire is installed, the terminal should be soldered and the abbreviation "S" is used to indicate this. Note that a number will appear after each solder instruction. This number indicates the number of leads that are supposed to be connected to the terminal in point before it is soldered. For example, if the instruction reads, "Connect a wire to lug 1 (S-2)," it will be understood that there will be two wires connected to the terminal at the time it is soldered. (In cases where a wire passes through a terminal or lug and then connects to another point, it will count as two wires, one entering and one leaving the terminal.)

STEP-BY-STEP ASSEMBLY

CIRCUIT BOARD WIRING

Parts will be installed to the left-hand section of the circuit board on Pictorial 1. On Pictorial 2, the parts will be installed to the right-hand section of the circuit board.

() Locate the circuit board and position it as shown in Pictorial 1, with the lettered side up.

Complete each of the indicated steps as shown on Pictorials 1 and 2.

START ↓

NOTE: Solder and clip off excess leads after every six or eight components are installed. Resistors will be called out by their resistance value and color code only in the steps.

(X) 300 μ fd mica capacitor.

(X) .05 μ fd disc capacitor.

(X) 1200 Ω (brown-red-red).

(X) 82 K Ω (gray-red-orange).

(X) 12 K Ω (brown-red-orange).

(X) 300 μ fd mica capacitor.

(X) 1300 μ fd mica capacitor.

(X) .005 μ fd disc capacitor.

NOTE: Position the electrolytic capacitors so the positive (+) leads go in the positive (+) holes of the circuit board.

(X) 3.5 μ fd electrolytic capacitor.

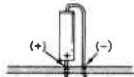

VERTICAL MOUNTING

(X) 1000 Ω (brown-black-red).

(X) RF choke (#45-47).

(X) Be sure to solder all connections and cut off excess leads.

CONTINUE ↓

(X) 12 K Ω (brown-red-orange).

(X) .005 μ fd disc capacitor.

(X) .05 μ fd disc capacitor.

(X) 1200 Ω (brown-red-red).

(X) 82 K Ω (gray-red-orange).

NOTE: When a step calls for bare wire, use hookup wire and strip all the insulation from the wire. Do not use the stranded hookup wire until it is specifically called for.

(X) 1" bare wire.

(X) 220 Ω (red-red-brown).

(X) 100 μ fd electrolytic capacitor.

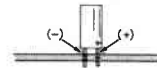

VERTICAL MOUNTING

(X) 220 Ω (red-red-brown).

(X) 8200 Ω (gray-red-red).

(X) 100 μ fd electrolytic capacitor.

(X) 100 μ fd electrolytic capacitor.

(X) Be sure to solder all connections and cut off excess leads.

FINISH

• PROCEED TO PICTORIAL 2

PICTORIAL 1



START ↓

- (✓) Crystal diode (brown-white-brown). Position the color-band end as shown.
- (✓) .05 μ f disc capacitor.
- (✓) 10 K Ω (brown-black-orange).
- (✓) 300 μ f mica capacitor.
- (✓) 100 μ f electrolytic capacitor.
- (✓) 2" bare wire.
- (✓) 1000 Ω (brown-black-red).
- (✓) Be sure to solder all connections and cut off excess leads.

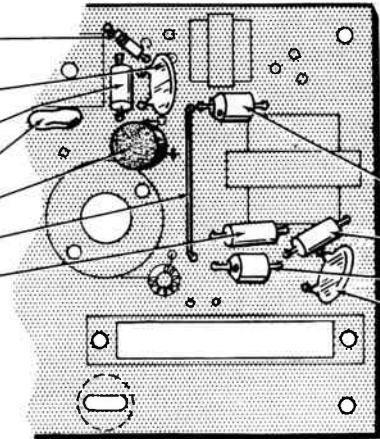

CONTINUE ↓

- NOTE:** When installing silicon diodes, the cathode end must be placed as directed. The cathode end is marked with either a color end, color dot, or color band.
-
- (✓) Silicon diode (#57-29). Position the cathode end as shown.
 - (✓) 1000 Ω (brown-black-red).
 - (✓) Silicon diode (#57-29).
 - (✓) .05 μ f disc capacitor.
 - (✓) Be sure to solder all connections and cut off excess leads.

FINISH

PROCEED TO CIRCUIT BOARD PARTS MOUNTING.

PICTORIAL 2

CIRCUIT BOARD PARTS MOUNTING

Refer to Pictorial 3 (fold-out from Page 13) for the following steps.

- (✓) Prepare the 5-screw terminal strip as shown in the inset drawing on Detail 3A. Bend all five lugs and allow a 5/16" space between the insulator and the point where the lug is bent.
- (✓) Locate the small metal tab near the head of each screw on the 5-screw terminal strip. Refer to the inset drawing on Detail 3A and bend each metal tab so it is flat against the insulator.
- (✓) Mount this prepared 5-screw terminal strip on the lettered side of the circuit board at N. Use 6-32 x 1/2" screws, 1/4" spacers, #6 lockwashers, and 6-32 nuts. Mount a large #6 solder lug under the mounting screw at H. Position the solder lug as shown in Pictorial 3.
- (✓) Now solder lugs 2, 3, 4, and 5 of terminal strip N to the foils on the circuit board.

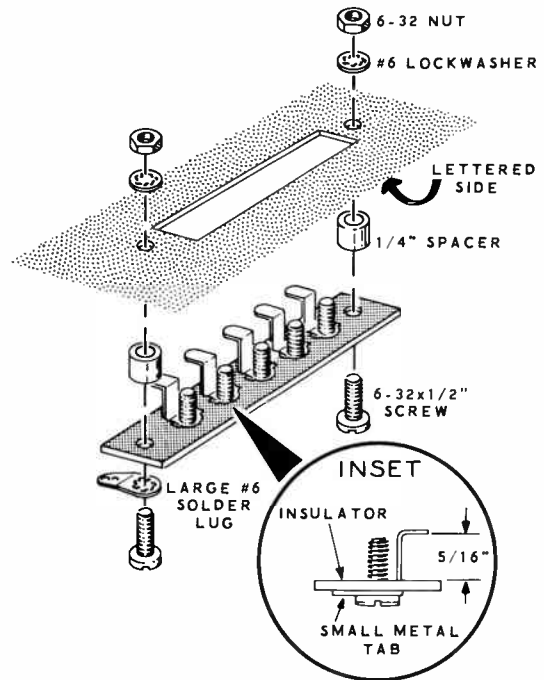

Detail 3A

Detail 3B

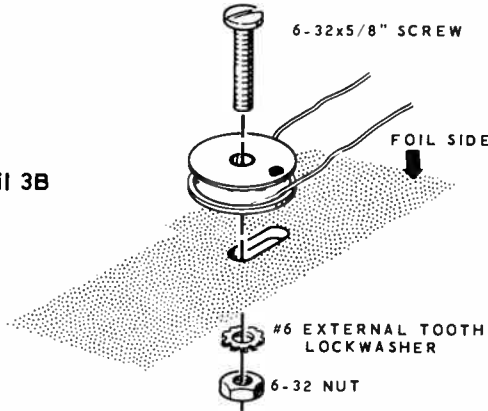

- (X) Refer to Detail 3B and mount the pickup coil (#40-443) to the foil side of the circuit board at P. Position the coil with the color dot as shown. Also, position the coil as far away as possible from the foils marked B and C. Use a 6-32 x 5/8" screw, #6 external tooth lockwasher, and 6-32 nut for mounting the coil. Be sure to use the correct screw.

The leads of pickup coil P will be connected to the foil side of the circuit board in the following two steps. Do not shorten these leads as the extra length may be needed for coil adjustment later. Insert the leads into the holes only until the tip of the lead is flush with the lettered side of the circuit board.

- (X) Connect the lead near the color dot to hole B (S-1).
- (X) Connect the other lead to hole C (S-1).

- (X) Refer to Detail 3C and mount the phenolic spacer, motor, and ground brush on the circuit board. Position the motor so the red dot is near hole F. This hole is identified on the lettered side of the board. Use 4-40 x 1/4" screws and #4 lockwashers. Place the #4 lockwasher between the ground brush and circuit board at hole R. Position the side of the ground brush 1/16" from the motor shaft as shown in the inset drawing on Pictorial 3.

- (X) Locate the carbon brush and bend it as shown in Detail 3D.

- (X) Insert the metal end of the carbon brush in hole S on the foil side of the circuit board. Position the carbon brush 5/16" from the motor shaft as shown in the inset drawing on Pictorial 3 and solder the brush to the foil.

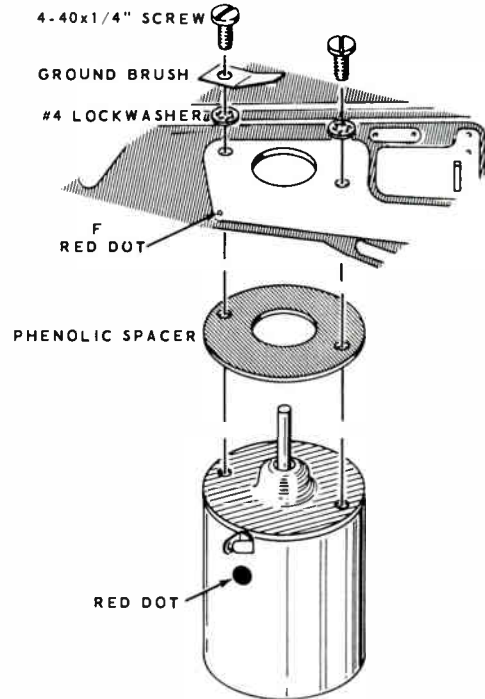

Detail 3C

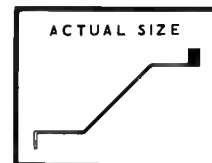
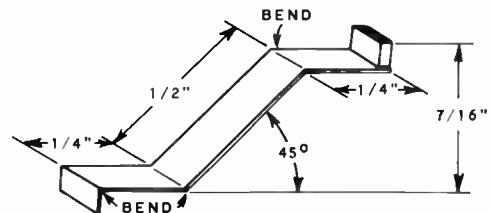

Detail 3D

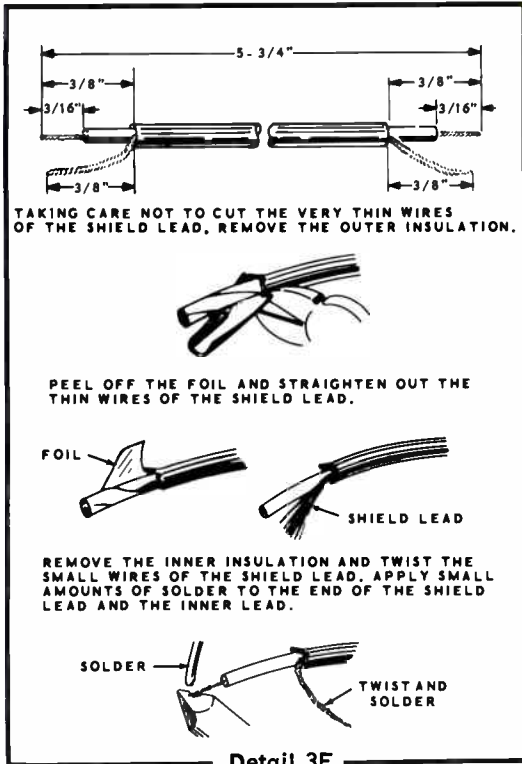

Detail 3E

- (X) Prepare a 5-3/4" length of shielded cable as shown in Detail 3E.
- (X) At one end of the shielded cable, place the inner lead in hole A near terminal strip N (S-1) and connect the shield to the adjacent ground foil (S-1) on the circuit board as shown. Do not use the hole in the circuit board for the shield connection.
- (X) At the other end of the shielded cable, place the inner lead in hole A near the right end of the circuit board (S-1) and connect the shield to the adjacent ground foil as shown (S-1). Do not use the hole in the circuit board for the shield connection.
- (X) Remove all the insulation from a 1-5/8" wire. This bare wire will be used in the following step.
- (X) Insert one end of the 1-5/8" bare wire in hole F so that 5/8" of this wire is on the foil side of the circuit board. Bend this wire over the shielded cable and solder it to the ground foil as shown in the Pictorial. Now solder the wire at hole F (S-1).
- (X) Proceed to Pictorial 4 and perform the steps around it. Position the circuit board as shown in the Pictorial before performing the steps.

START

NOTE: Solder all connections as each coil or transformer is installed. It is not necessary to cut off the lugs after soldering.

1. Oscillator coil (#40-444).

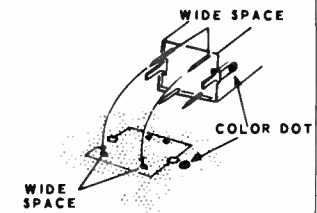

2. Interstage transformer (#52-53).

3. Interstage transformer (#52-53).

4. Driver transformer (#51-72).

5. Output transformer (#51-91). Cut off the four small plastic tips between the lugs of the transformer before mounting.

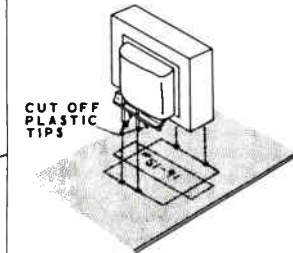

6. Check to see that all connections are soldered.

7. Set the circuit board assembly aside temporarily to be installed later.

FINISH

PROCEED TO THE CABINET REAR PLATE ASSEMBLY AND WIRING.

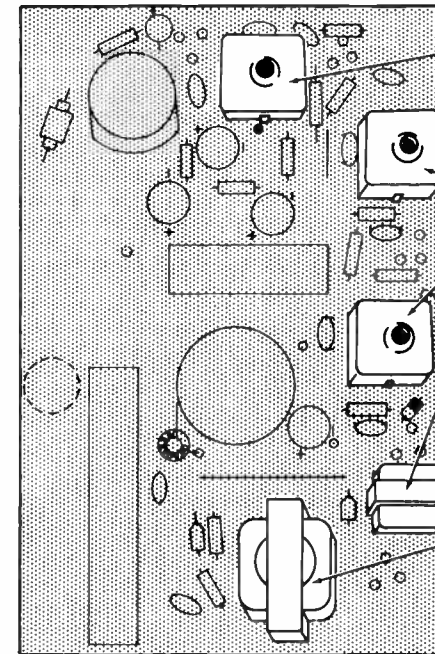

PICTORIAL 5

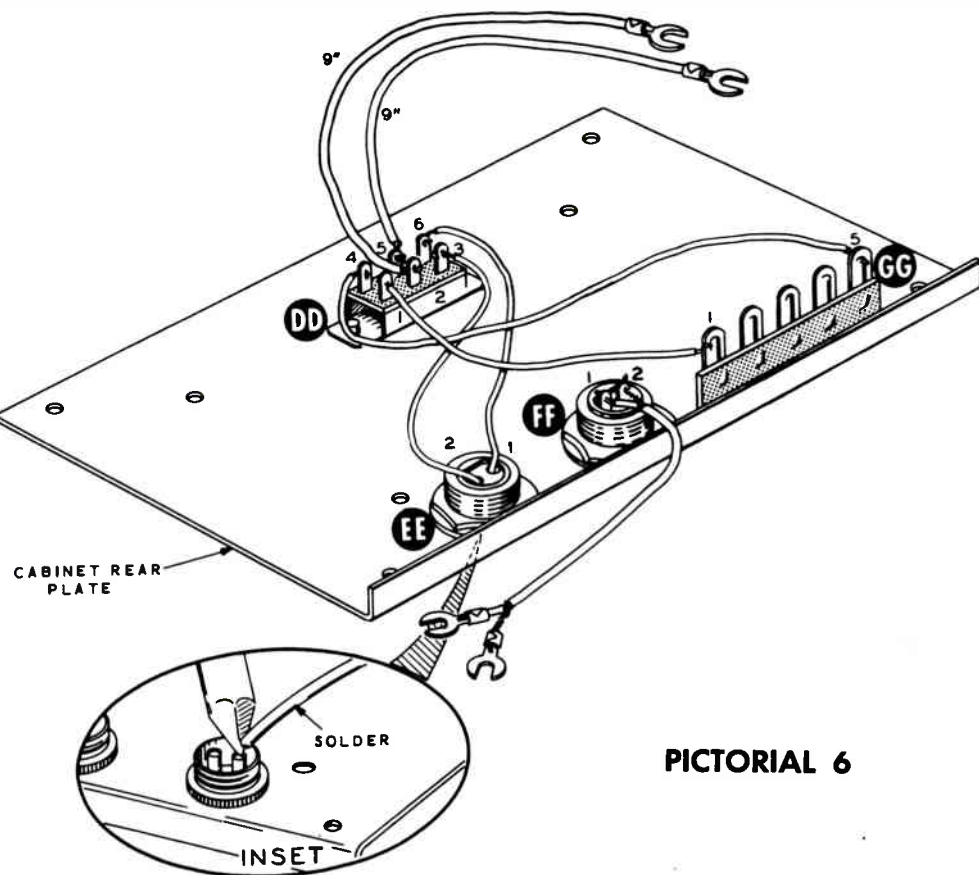

PICTORIAL 6

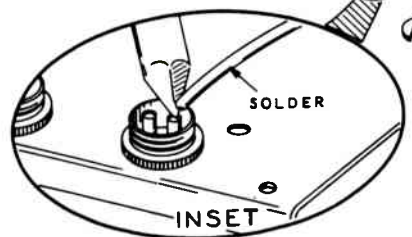

START

NOTE: Solder all connections as each part or wire is installed and cut off excess leads. Do not cut off the lugs of the control after soldering.

2N1274 transistor with a yellow color dot. Use a 1/4" length of sleeving on each lead. Position the metal tab as shown in Detail 4A.

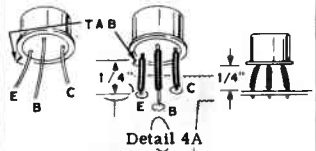

1000 Ω control with SPST switch (#19-77). Solder all five lugs.

2-1/2" wire from lug 1 of control to hole D.

Mount the fuseholder using a 6-32 x 3/8" screw, #6 lockwasher, and 6-32 nut.

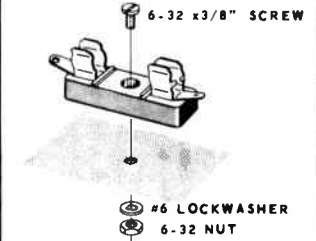

Locate the bare wire coming through hole F and solder the wire to the motor lug and to the motor housing. Scrape the motor housing before you solder the wire to it.

Locate the toroid coil (#40-319) and add one more turn to each end of the coil with each lead. Connect one lead to the motor lug and the other lead to hole E.

.05 μfd disc capacitor.

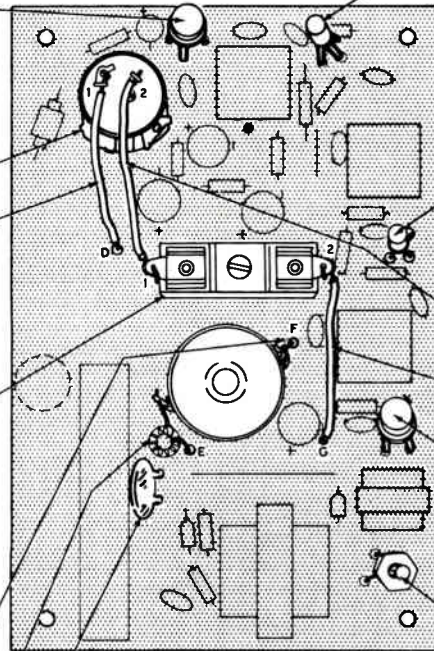

PICTORIAL 4

CONTINUE

2N1524 transistor. Use a 1/4" length of sleeving on each lead. Observe the red dot at the collector (C) lead on the transistor.

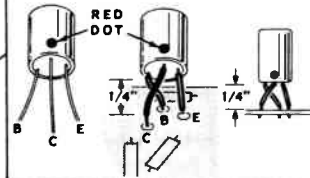

TI 364 transistor. Remove the plastic base from the transistor before mounting.

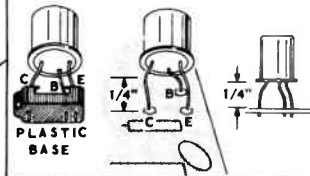

2-1/2" wire from lug 2 of control to lug 1 of fuseholder.

2-1/2" wire from lug 2 of fuseholder to hole G.

2N1274 transistor with red or orange color dot. Refer to Detail 4A in the first step for mounting.

R265A transistor. Position the metal tab as shown and mount the transistor 1/8" above the circuit board.

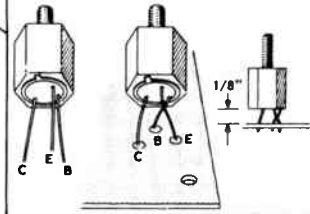

Check to see that all connections are soldered and cut off excess leads.

FINISH

PROCEED TO PICTORIAL 5 ON PAGE 14.

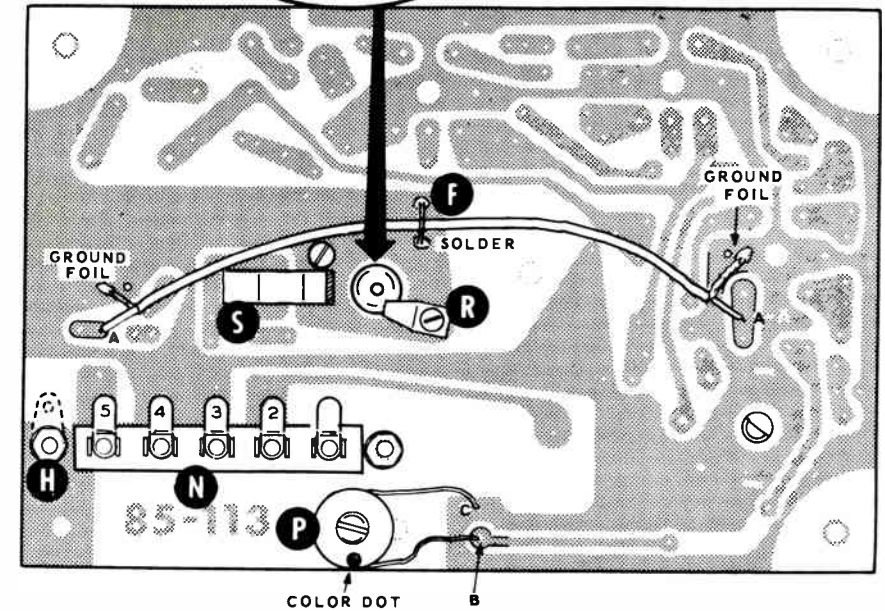
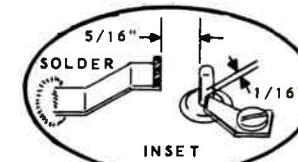

PICTORIAL 3

CABINET REAR PLATE ASSEMBLY AND WIRING

Refer to Pictorial 6 for the following steps.

- ✗ Position the cabinet rear plate as shown.
- ✗ Refer to Detail 6A and mount the DPDT slide switch at DD. Use a 6-32 x 1/4" screw in each mounting hole.

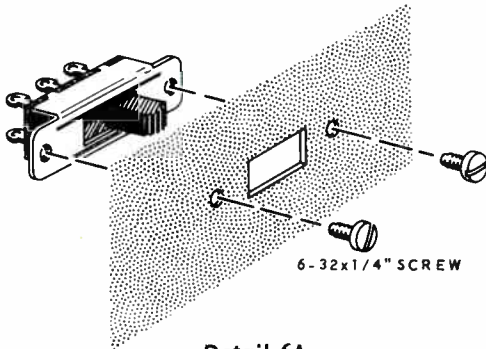

Detail 6A

- ✗ Refer to Detail 6B and mount a male chassis connector (#432-61) at EE. Identify holes 1 and 2 as marked on the connector and position the connector as shown. Use the lockwasher and nut supplied with the connector.
- ✗ Similarly, mount a female chassis connector (#432-39) at FF. Position the connector with the lugs as shown.
- ✗ Refer to Detail 6B and mount the 5-lug terminal strip at GG. Use a 6-32 x 3/8" screw, two #6 lockwashers, and a 6-32 nut.

NOTE: Do not use the stranded hookup wire until it is specifically called for.

- () Precut the following lengths of hookup wire. Strip 1/4" of insulation from both ends of each wire. These wires are listed in the sequence that they will be used in the following steps.

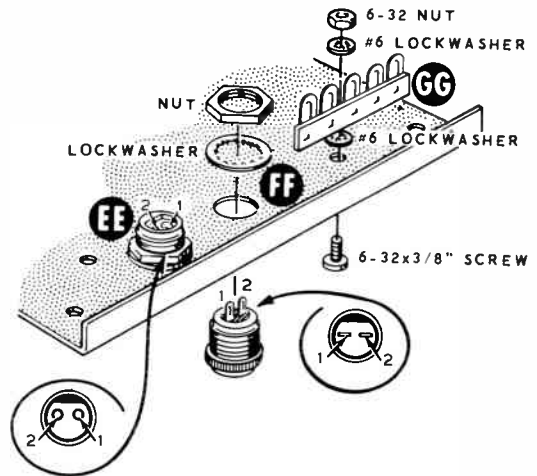

Detail 6B



- ✗ Refer to the inset drawing in Pictorial 6 and connect a 5" wire from pin 1 of chassis connector EE (S-1) to lug 6 of slide switch DD (S-1).
- ✗ Connect a 5" wire from pin 2 of chassis connector EE (S-1) to lug 3 of slide switch DD (S-1).
- ✗ Connect a 4" wire from lug 1 of terminal strip GG (NS) to lug 1 of slide switch DD (S-1).
- ✗ Connect a 6" wire from lug 5 of terminal strip GG (NS) to lug 4 of slide switch DD (S-1).

(X) Use stranded hookup wire and prepare the following lengths of wire. Strip 1/4" of insulation from both ends of each wire.

9"

9"

(X) Refer to Detail 6C and solder a spade lug to one end of each prepared length of stranded wire. At the other end of each wire, melt a small amount of solder on the bared wire.

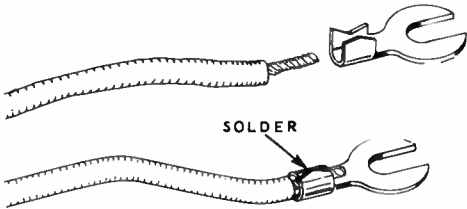

Detail 6C

(X) Connect the end (without the spade lug) of the 9" prepared wire to lug 5 of switch DD (S-1). The spade lug on this wire will be connected in a later step.

(X) Similarly, connect a 9" wire to lug 2 of slide switch DD (S-1).

() Refer to Detail 6D and prepare a 6" length of shielded cable. Solder spade lugs to the inner lead and shield at one end of the cable.

() At the other end of the shielded cable, connect the inner lead to lug 1 (S-1) and the shield to lug 2 (S-1) of chassis connector FF.

Refer to Detail 7A for the following steps.

() Locate the lead that is on the end opposite the cap of one battery holder. Place a 3/8" length of sleeving over this lead and slide the sleeving over the exposed lug on the end of the battery holder.

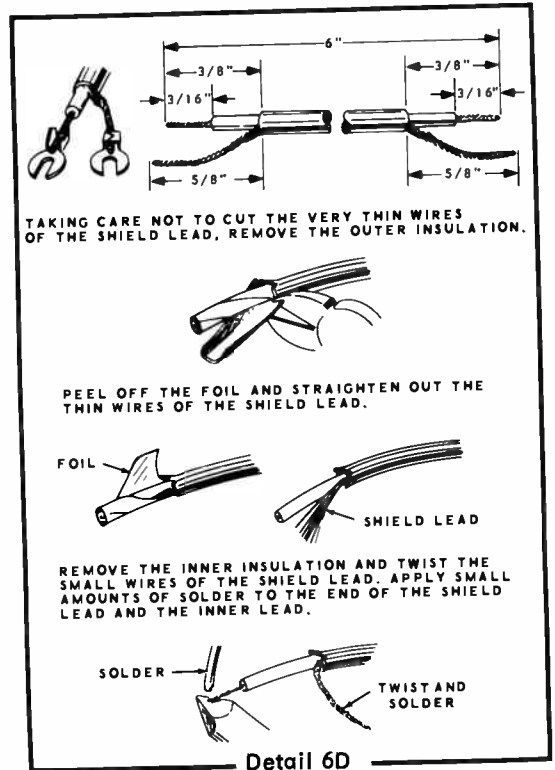

Detail 6D

() Similarly, place a 3/8" length of sleeving on the indicated lead of each of the two remaining battery holders.

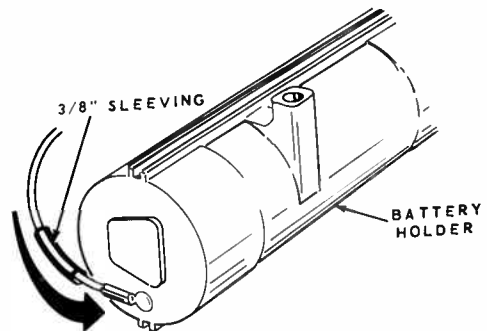

Detail 7A

Refer to Pictorial 7 for the following steps.

- () Mount a battery holder at CC. Position the battery holder with the cap at the left end of the cabinet rear plate. Use a 5-40 x 3/8" screw in each mounting hole. Tighten the screws just enough so the battery holder is tight against the cabinet rear plate. Over-tightening will strip the threads.
- () Connect lead #1 of battery holder CC to lug 4 of terminal strip GG (NS). Cut lead #2 to a length of 6-1/2" and connect it to lug 5 of terminal strip GG (S-2).
- () Mount a battery holder at BB. Be sure to position the battery holder with the cap at the right end of the cabinet rear plate. Use two 5-40 x 3/8" screws. Position the wire coming from lug 5 of switch DD as shown in the Pictorial before mounting the battery holder.
- () Cut lead #2 of battery holder BB to a length of 6-1/2" and connect it to lug 4 of terminal strip GG (S-2). Cut lead #1 to a length of 4" and connect it to lug 2 of terminal strip GG (NS).
- () Mount the remaining battery holder at AA. Position the battery holder with the cap at the left end of the cabinet rear plate. Use two 5-40 x 3/8" screws.
- () On battery holder AA, cut lead #1 and lead #2 to a length of 4-1/2". Connect lead #1 to lug 1 of terminal strip GG (S-2). Connect lead #2 to lug 2 of terminal strip GG (S-2).
- () Set the cabinet rear plate aside temporarily to be installed later.

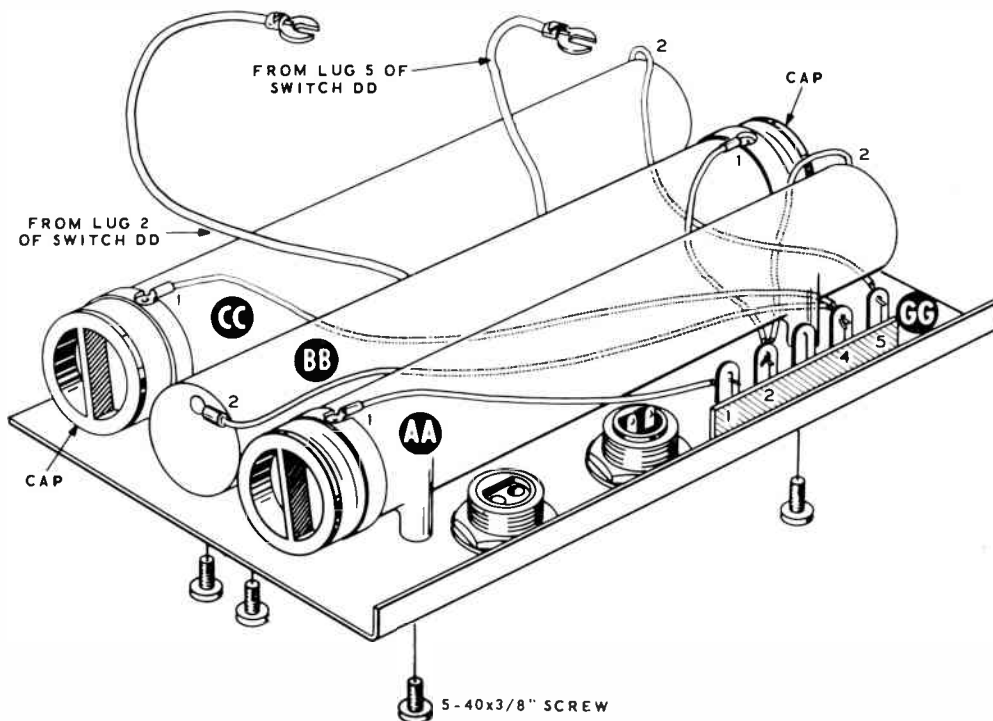

PICTORIAL 7

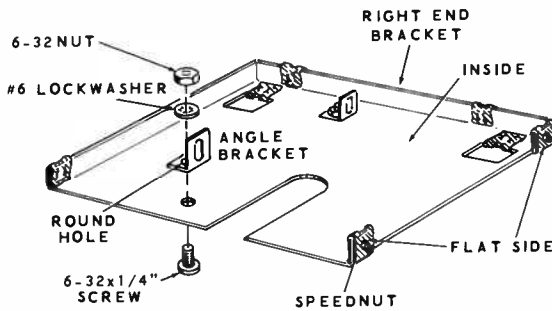

Detail 8A

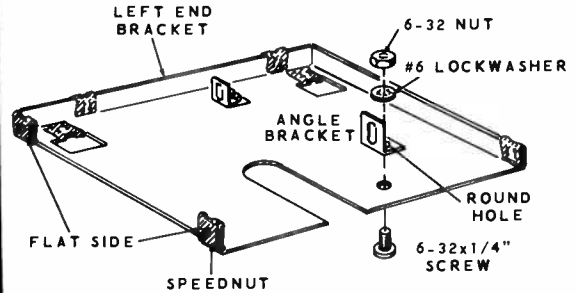

Detail 8B

PRELIMINARY CABINET ASSEMBLY

Refer to Pictorial 8 (fold-out from Page 19) for the following steps.

- (→) Locate the right end bracket and install seven speednuts as shown in Detail 8A. Be sure the flat side of each speednut is on the outside of the end bracket.
- (→) Mount two angle brackets on the right end bracket using the round hole in each bracket. Use 6-32 x 1/4" screws, #6 lockwashers, and 6-32 nuts. Position each angle bracket as shown.
- (→) Refer to Detail 8B and install seven speednuts on the left end bracket. Be sure the flat side of each speednut is on the outside of the end bracket.

(→) Mount two angle brackets on the left end bracket, using the round hole in each bracket. Use 6-32 x 1/4" screws, #6 lockwashers, and 6-32 nuts. Position each angle bracket as shown.

(→) Mount the left and right end brackets on the circuit board assembly at T, U, X and Y, as shown in Pictorial 8. Use a 6-32 x 3/8" screw, two #6 lockwashers, and a 6-32 nut. Position the ends of the circuit board 1/16" away from the end brackets. Be sure to place one lockwasher between the circuit board and the angle bracket and place the other lockwasher under the nut. Refer to inset drawing #1 on Pictorial 8.

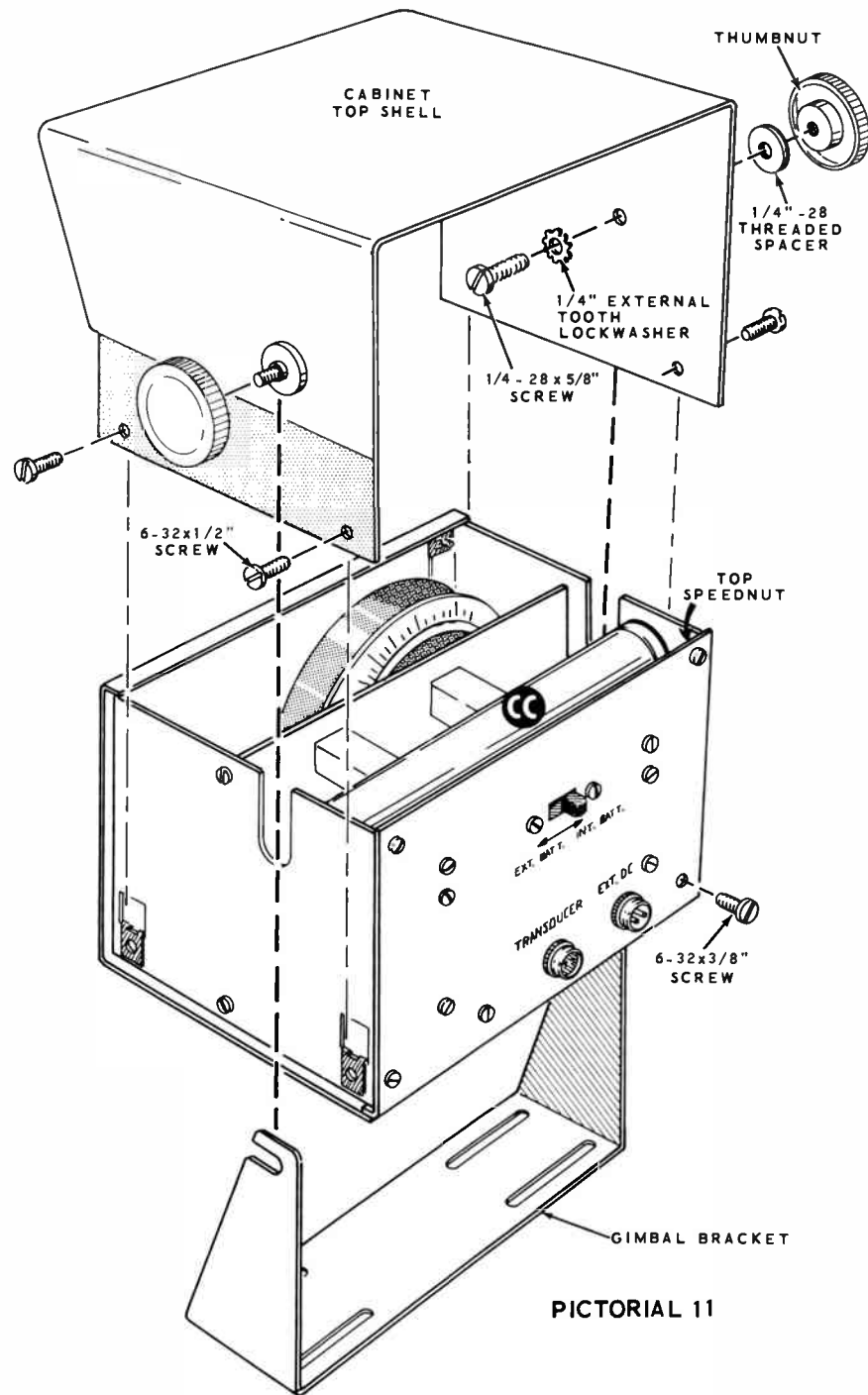

PICTORIAL 11

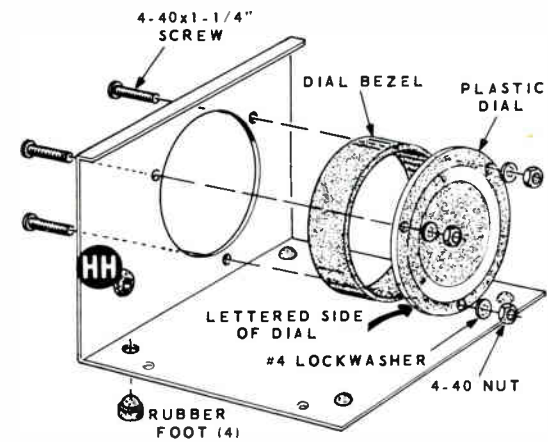

Detail 9A

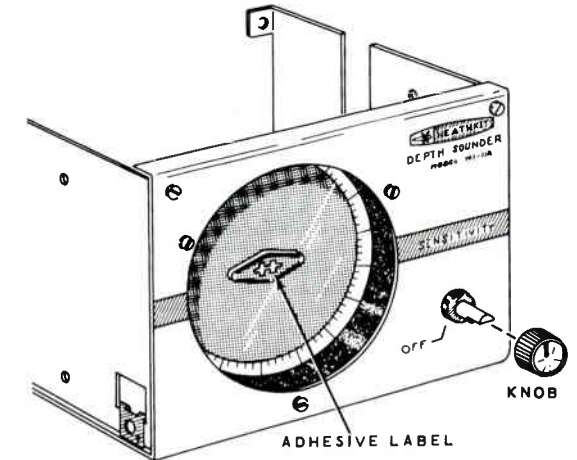

Detail 9B

Refer to Pictorial 9 for the following steps.

- () Locate the cabinet bottom and position it as shown in Detail 9A.
- () Install the rubber grommet in hole HH of the cabinet bottom.
- () Install the four rubber feet as shown in the Detail.
- () Mount the dial bezel and plastic dial to the cabinet bottom with the lettered side of the plastic dial as shown. Use a 4-40 x 1-1/4" screw, #4 lockwasher, and 4-40 nut in each of three mounting holes. Do not overtighten the screws as the plastic dial may be damaged.

- () Install a 6-32 x 1/4" screw, large #6 solder lug, and a 6-32 nut at Z on the cabinet bottom.
- () Position the end brackets and circuit board assembly on top of the cabinet bottom and push the shaft of the control through grommet HH on the cabinet bottom. Mount the end brackets to the cabinet bottom, using six 6-32 x 3/8" screws into the speednuts.
- () Remove the protective backing from the adhesive label. Refer to Detail 9B and press the label in place in the center of the plastic dial.
- () Install the knob on the control shaft and turn the SENSITIVITY control fully counterclockwise to the OFF position.

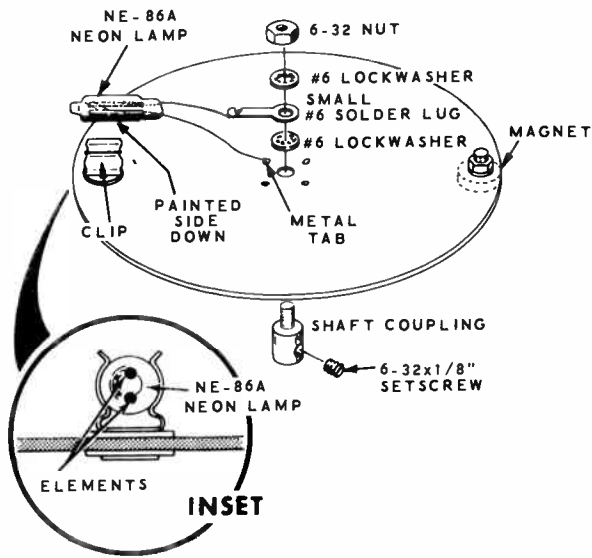

Detail 8C

- () Refer to Detail 8C and start the 6-32 x 1/8" setscrew into the shaft coupling.
- () Mount the shaft coupling on the rotor assembly. Use a #6 lockwasher, small #6 solder lug, and 6-32 nut. Position the solder lug so it is pointing toward the clip. Also, be sure the solder lug does not touch the metal tabs on the rotor assembly.
- () Place the NE-86A neon lamp into the clip on the rotor assembly with the painted side down. Refer to the inset drawing on Detail 8C and be sure the elements of the neon lamp are in a vertical plane. The tip of the neon lamp should not extend beyond the outside edge of the rotor assembly.

NOTE: If necessary, connect and solder a 1" bare wire to the end of each lead on the neon lamp before connecting the leads in the next two steps.

- () Connect the bottom lead near the painted side of the neon lamp to a metal tab on the rotor assembly (S-1).
- () Connect the top lead of the neon lamp to the small #6 solder lug (S-1). Be sure the neon lamp leads do not touch each other.
- () Refer to inset drawing #2 on Pictorial 8 and mount the rotor assembly on the shaft of the motor as follows:

1. Place the rotor assembly on the motor shaft.
2. The ground brush and the carbon brush should depress approximately 1/32". If they depress more than 1/32" there will be too much drag on the motor.
3. Tighten the setscrew on the rotor assembly.
4. Turn the rotor slowly to be sure the magnet mounted on the rotor assembly does not touch the screw holding the pickup coil.
5. As the rotor is turned the carbon brush should contact the slip ring and the ground brush should contact the end of the shaft coupling.
6. Check to see that the rotor assembly does not touch any lugs or the shielded cable on the circuit board.

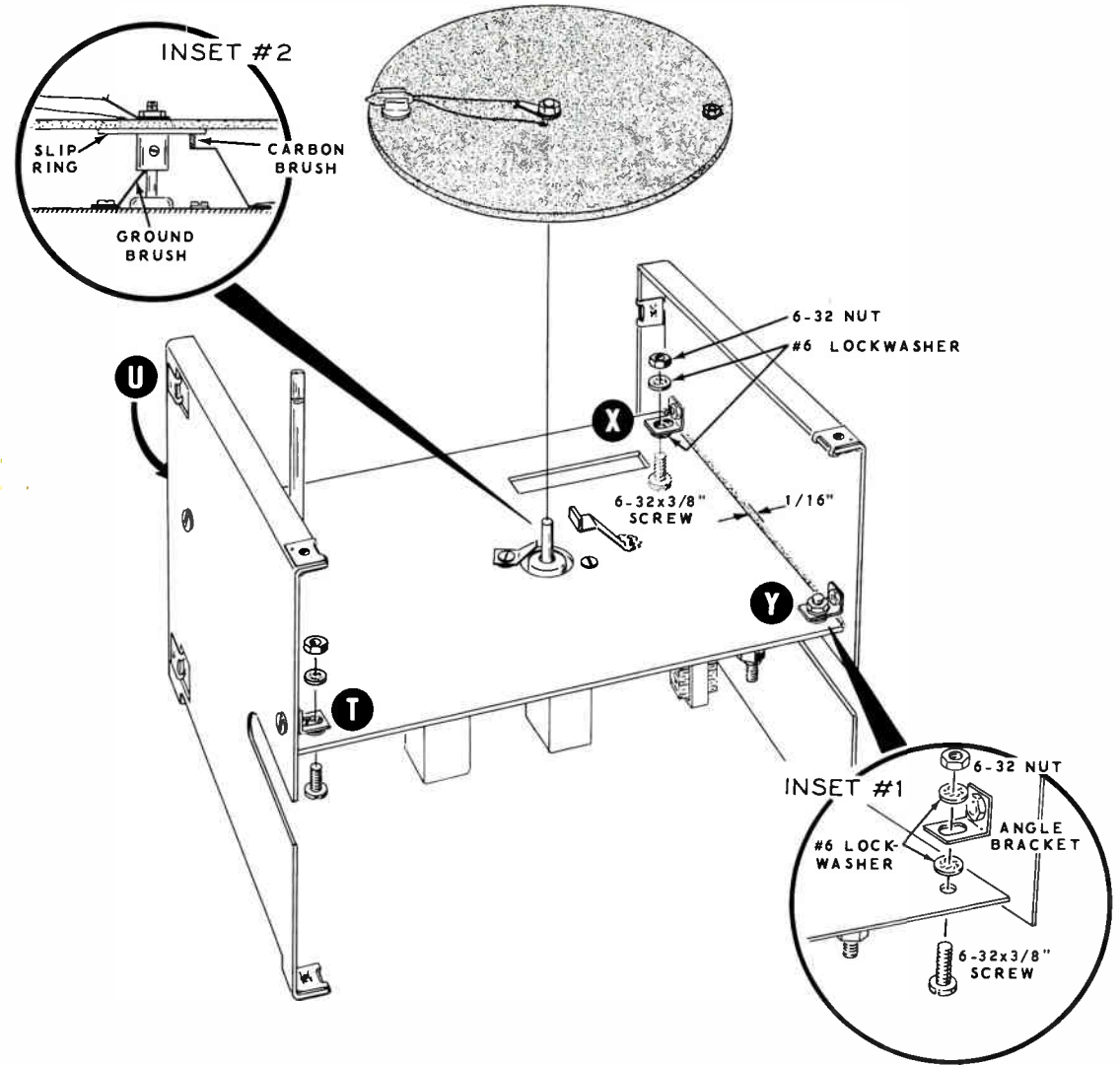

PICTORIAL 8

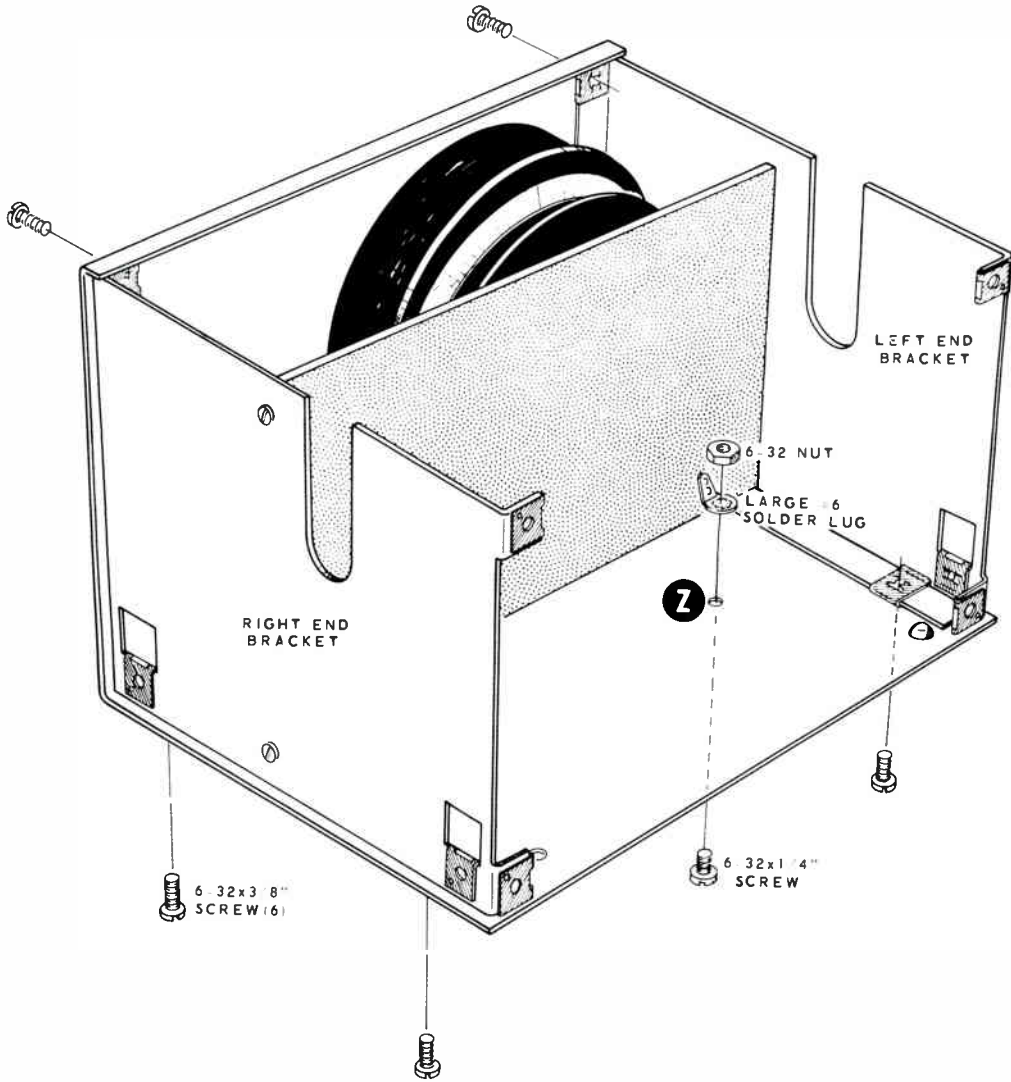

PICTORIAL 9

FINAL WIRING

Refer to Pictorial 10 for the following steps.

- (✓) Connect a 2-1/2" wire from solder lug Z (S-1) to solder lug H (NS).
- (✓) Strip 1/4" of insulation from each end of a 3" stranded wire; then solder a spade lug to one end.
- (✓) Connect the other end of this wire to solder lug H (S-2).
- (✓) Place the cabinet rear plate assembly near the cabinet bottom.

NOTE: The wires with spade lugs will be connected to 5-screw terminal strip N in the following steps. Tighten each screw on terminal strip N after the wire has been connected. Also, be sure that the spade lugs do not touch each other.

- (✓) Locate the free end of the shielded cable coming from chassis connector FF. Connect the inner lead to lug 5 and the shield to lug 4 of terminal strip N.
- (✓) Connect the free end of the wire coming from lug 2 of slide switch DD to lug 3 of terminal strip N.
- (✓) Locate the free end of the wire coming from lug 5 of slide switch DD and connect it to lug 2 of terminal strip N.

NOTE: The Depth Sounder can be used with either a negative battery or a positive battery ground, or an ungrounded battery system. However, the jumper wire from solder lug H must be connected to the proper screw on terminal strip N. If the Depth Sounder will be used only on its internal batteries, it is suggested that you connect the jumper wire as for ungrounded battery systems.

Choose one of the following three steps:

1. For ungrounded battery systems, connect the jumper wire to lug 1 of terminal strip N.
2. For negative ground systems, connect the jumper wire to lug 2 of terminal strip N.
3. For positive ground systems, connect the jumper wire to lug 3 of terminal strip N.

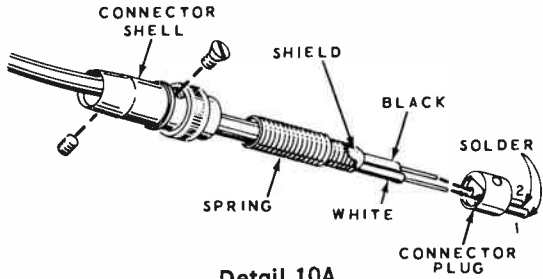

Detail 10A

CAUTION: A cable connector will be installed on the free end of the transducer cable in the following steps. Do not shorten the transducer cable. This is a special, low capacitance cable. The cable capacitance is used as part of the Depth Sounder circuit.

- (✓) Refer to Detail 10A and install a male cable connector (#432-38) on the free end of the transducer cable.
- (✓) Remove the two screws that hold the cable connector together.
- (✓) Place the connector shell and the spring over the end of the cable as shown.
- (✓) Identify pin 1 as marked on the connector plug. Connect the white center wire of the cable to pin 1 of the connector plug (S-1).
- (✓) Connect the black center wire of the cable to pin 2 of the connector plug (S-1).
- (✓) Push the spring under the shield and bend the shield back over the spring. Flatten the shield and solder it to the spring (S-1).
- (✓) Reassemble the cable connector and replace the two screws.
- (✓) Install the 1/2 ampere fuse in the fuse-holder.

NOTE: If you intend to use only an external battery, omit the next step and proceed to Initial Test on Page 24.

- (✓) Install three size C batteries in each battery holder as shown in Pictorial 10. Install each battery in the holder with the negative (flat) end inserted first. The cap on battery holder BB is on the opposite end from battery holders AA and CC.

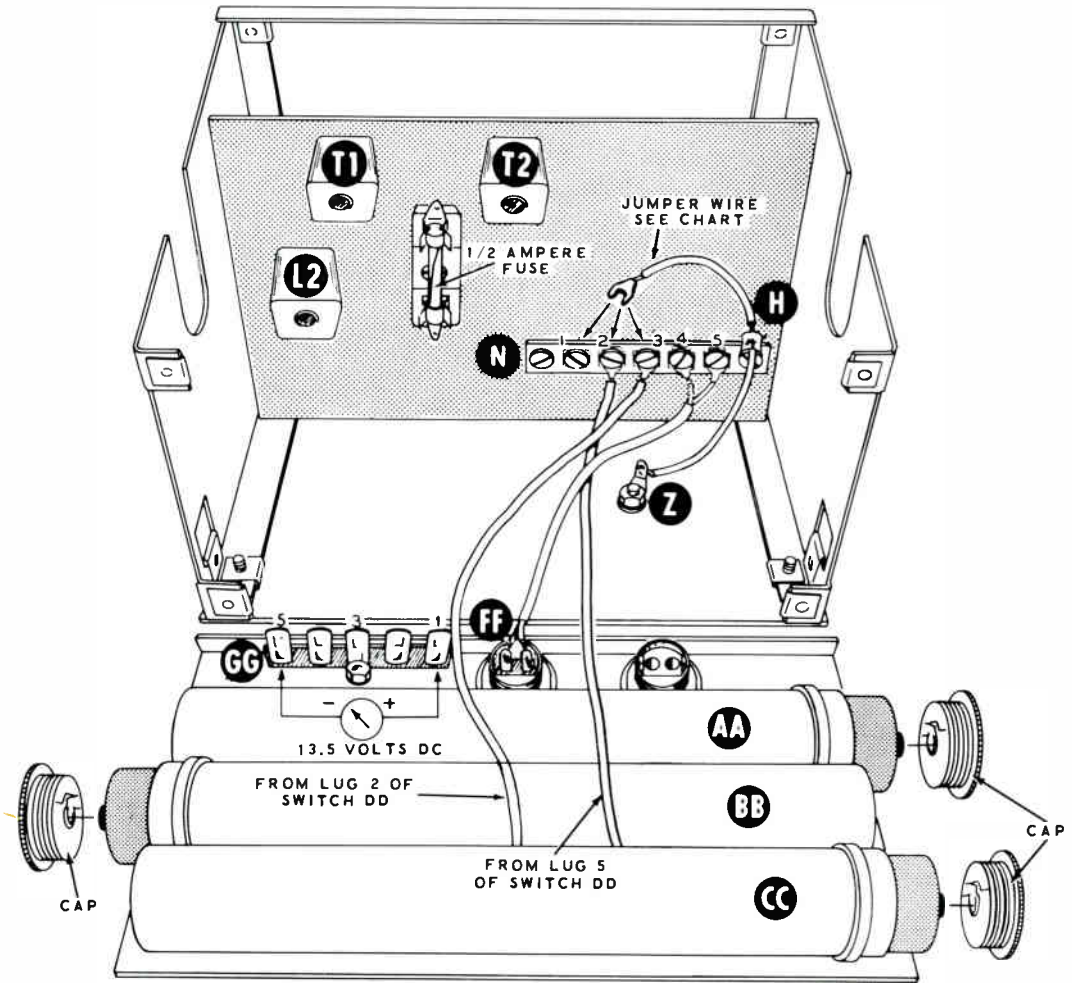

PICTORIAL 10

JUMPER WIRE CONNECTION TO TERMINAL STRIP N	
EXTERNAL BATTERY GROUND	CONNECT JUMPER TO
1. UNGROUNDED OR INTERNAL	LUG 1
2. NEGATIVE	LUG 2
3. POSITIVE	LUG 3

INITIAL TEST

If an external battery is used when testing the Depth Sounder, complete the steps under External Battery Wiring on Page 31. Then proceed with the following steps.

- (✓) Set the slide switch (on the back of the cabinet rear plate) to the proper position. The switch position will depend on whether you use internal batteries (C cells) or an external battery for power.
- (✓) Connect the transducer cable connector to the connector labeled TRANSDUCER on the cabinet rear plate.

NOTE: If any difficulty is encountered in the following steps, turn the Depth Sounder OFF and refer to the In Case Of Difficulty section on Page 38 of this manual.

- () Turn the Depth Sounder on with the SENSITIVITY control. Do not advance the SENSITIVITY control beyond the point at which the switch is just actuated. The Depth Sounder will be operating properly if the rotor assembly spins and the neon lamp flashes at approximately the zero location on the dial.

NOTE: If the motor does not start, either check the connections to the external battery or check the internal battery supply in the following manner. Be sure the caps on the battery holders are making good contact. Remove the cap from each battery holder and scrape away any excess plastic that may be around the small contacts inside each holder. If a voltmeter is available, check the DC voltage between lugs 1 and 5 of terminal strip GG. The voltage should be about 13.5 volts DC as shown in Pictorial 10 on Page 23.

If a flash does not occur at zero but does occur at about 5 feet or 95 feet or at both locations, turn the Depth Sounder off and complete the following steps.

- () Turn the rotor assembly so that the magnet is to the top of the unit.
- () Note the position of the color dot on the magnet located on the rotor assembly.
- () Loosen the nut used to secure the magnet and rotate the magnet 180 degrees or until the color dot is in a position directly opposite its original position.
- () Retighten the nut, making sure the magnet does not turn.
- () Turn the Depth Sounder on. There should be a flash at about the zero location. Exact zero adjustment will be completed later.
- () If no flash occurs, try different positions of the magnet by moving the color dot with respect to the rotor assembly.
- () Now slowly advance the SENSITIVITY control toward the full clockwise position. Random flashes should now occur at or near the full clockwise position. If there are flashes covering the complete dial, immediately turn the Depth Sounder OFF and refer to the In Case Of Difficulty section. If the operation appears normal, continue with the zero adjustment.

ZERO ADJUSTMENT

- (✓) Turn the SENSITIVITY control clockwise just far enough to turn on the Depth Sounder. If the neon lamp does not flash directly under zero on the dial, turn the unit OFF.
- (✓) Loosen the nut holding the pickup coil and slide the coil to one side or the other in the slot of the circuit board and retighten. Be careful not to rotate the coil. Turn the unit on and check the zero indication.
- (✓) Repeat the above procedure until a proper zero indication is obtained.

FINAL ASSEMBLY

Refer to Pictorial 11 (fold-out from Page 20) for the following steps.

- () Locate the cabinet top shell and mount the two 1/4-28 threaded spacers. Use 1/4-28 x 5/8" screws and 1/4" external tooth lock-washers. Be sure to tighten the screws securely.
- () Slide the cabinet top shell down on the cabinet bottom. Fasten the cabinet with four 6-32 x 1/2" screws.

The cabinet rear plate and gimbal bracket will be installed later.

ALIGNMENT

The transducer must be in 3 to 10 feet of water during alignment of the Depth Sounder.

NOTE: Use Pictorial 10 on Page 23 to identify the alignment points called out in the following steps.

- () Place the transducer in water of known depth (3 to 10 feet deep). The transducer housing should be just under the surface of the water.

OSCILLATOR COIL

- () Turn the Depth Sounder on and advance the SENSITIVITY control just enough to see an echo at 3 to 10 feet on the dial.
- () Use the alignment tool supplied and turn the slug in oscillator coil L2 for maximum brightness of the dial light at the echo position.
- () Now decrease the SENSITIVITY control setting until the dial light is very dim at the echo position. Adjust L2 again for maximum brightness of the dial light. The slug should be about 1/4" in from the top of the coil.

TRANSFORMERS T1 AND T2

- () With the transducer in about 10 feet of water, turn the SENSITIVITY control until an echo or flash is seen on the dial.
- () Adjust transformer T2 for maximum brightness of the neon lamp at the echo position. Turn the slug clockwise (inward) several turns. If there is no improvement, turn the slug counterclockwise to the point of maximum lamp brightness.

- () Reduce the setting of the SENSITIVITY control until the echo becomes dim.

- () Adjust transformer T1 for maximum brightness of the neon lamp at the echo position. Turn the slug clockwise (inward) several turns. If there is no improvement, turn the slug counterclockwise to the point of maximum lamp brightness.

- () Repeat the adjustment of transformers T2 and T1 until the echo cannot be made any brighter.

- () If possible, repeat the adjustments of transformers T2 and T1 in water over 50 feet deep.

This completes the alignment of the Depth Sounder.

Refer to Pictorial 11 (fold-out from Page 20) for the following steps.

- () Remove the four 6-32 x 1/2" screws which fasten the cabinet top shell to the Depth Sounder. Now remove the cabinet top shell.
- () Mount the cabinet rear plate to the rear of the end brackets. The top of the cabinet rear plate must be installed first so that battery holder CC is positioned behind the two top speednuts. Use four 6-32 x 3/8" screws.
- () Reinstall the cabinet top shell using the four screws removed previously.



NOTE: The blue and white identification label shows the Model Number and Production Series Number of your kit. Refer to these numbers in any communications with the Heath Company; this assures you that you will receive the most complete and up-to-date information in return.

() Install the identification label in the following manner:

1. Select a location for the label where it can easily be seen when needed, but will not show when the unit is in operation. This location might be on the rear panel or the top of the chassis, or on the rear or bottom of the cabinet.
2. Carefully peel away the backing paper. Then press the label into position.

IGNITION INTERFERENCE SUPPRESSION

The following information on Ignition Interference Suppression should be referred to when you install and operate the Depth Sounder in your boat. Due to the many different types of boat engines and installations, it is impossible for us to guarantee the results of any specific ignition interference suppression instructions. However, these tips should in many cases prove helpful in obtaining optimum performance from your Heathkit Depth Sounder.

Higher ignition voltage levels in present day engines, plus the highly sensitive receiver in the Depth Sounder, which is necessary for a deep sounding capability, makes ignition interference a growing problem.

Random flashes which may show up on the Depth Sounder dial when the engine is running are usually caused by the engine ignition system. Figure 1 illustrates the result of ignition interference on the dial. These indications will increase in number as the speed of the engine is increased. At high speeds, the indications may be so numerous that it will be virtually impossible to determine which one is the echo. Normally, the Depth Sounder would not be operated at very high boat speeds, as the water turbulence created around the transducer will cause the Depth Sounder indications to be inaccurate.

Random noise is also caused by the water turbulence created by the turning propeller. This is especially true when the transducer is mounted on the transom of the boat near the turning propeller. (For that reason a transom

mount should be used only as a temporary expedient.) It is usually best to mount the transducer away from the propeller to prevent this water turbulence "noise."

Ignition interference is caused by energy radiated from the spark plugs and the associated wiring of the ignition system. High voltage, from the ignition coil, is applied through the distributor and spark plug wires to the spark plugs. At the spark plug, this voltage jumps from one electrode to the other, creating a high tension arc. See Figure 2. As the arc is made, high radio frequency energy is developed. This energy is radiated by the spark plugs and associated spark plug wiring as well as by the high voltage wire from the coil to the distributor. The radiated energy is picked up by the transducer cable shield and is carried into the Depth Sounder as interference. If the 12 volt wiring to the Depth Sounder is connected to the boat battery, it will also pick up this energy and carry it into the Depth Sounder as interference.

Ignition systems operating at higher voltage levels will generally radiate stronger interference signals. Worn, ragged spark plug gaps require higher ignition voltage and, therefore, can cause more interference as well as decreased engine performance. Flat, parallel spark plug gaps, and factory recommended gap settings require less voltage and decrease the interference.

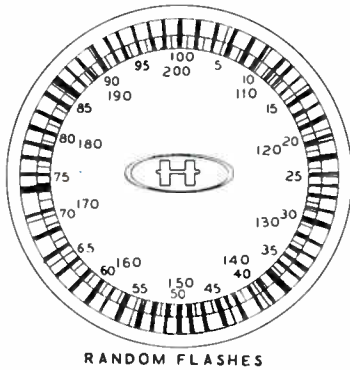

Figure 1

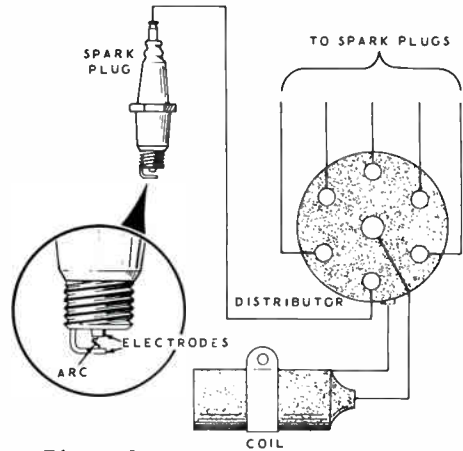

Figure 2

OUTBOARD ENGINES

To reduce ignition interference in an outboard engine, we strongly urge you to purchase an ignition interference suppression kit from the engine manufacturer. Details on some ignition interference suppression kits are listed in Figure 6 on Page 30. The chart shows some engine manufacturers suppression measures that are used to quiet the various types of outboard ignition systems. The installation of one of these kits on your outboard engine should sig-

nificantly reduce the ignition interference. If your engine is not listed in this chart, consult your engine manufacturer before taking any suppression measures.

Suppression kits should not affect engine performance, providing the ignition system is in top operating condition. Outboards that tend to foul spark plugs may have greater difficulty after the suppression kit is installed. Before suppressing, correct the cause or causes of spark plug fouling.

Spark plug fouling can be caused by excessive combustion chamber deposits, poor breaker point synchronization, clogged passages in the manifold bleed-off system, cracks in the distributor cap, improper carburetion, and poor coordination of spark advance controls in conjunction with carburetor butterfly movement.

Some outboards operated at low speeds (slow trolling) may misfire from a carbon build-up between the spark plug electrodes even though the spark plug insulator remains fairly clean. Outboards not usually prone to this type of fouling, may become susceptible to spark plug "gap bridging" once suppression is installed. It is good practice to inspect the spark plug electrodes more often after suppression has been installed. It appears that an outboard with coil-battery ignition is less troublesome in this respect.

To minimize spark fouling, use the proper type of gasoline and the recommended type and amount of oil at all times.

Also, to help reduce ignition interference, shield the entire length of the tachometer wire from the control panel to the engine. See Figure 3. As the tachometer picks up its impulses from the ignition primary, these signals can radiate interference along the entire length of the wire. Be sure to ground the shield part of the wire to the engine. Some ignition tachometers may require adjustment or may not operate at all after the shielding has been added. This is because the shielding may change the characteristics of the impulses to the tachometer.

Other troublesome causes of ignition interference are magneto grounding wires or battery ignition wires running from the engine to the control panel switch. These wires should also be shielded and the shield part of each wire grounded to the engine.

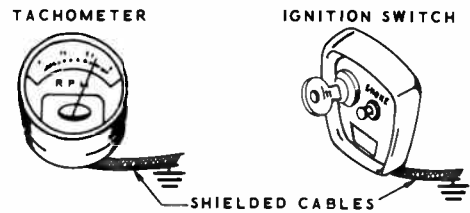

Figure 3

Large diameter metal braid can be slipped over electrical cables to shield them. The metal braid should be grounded at the control panel and to the engine.

On outboards using battery ignition, a feed-through coaxial type 0.1 μfd capacitor can be installed in the lead between the ignition switch and coil. This capacitor should be connected as close to the coil as possible. See Figure 4.

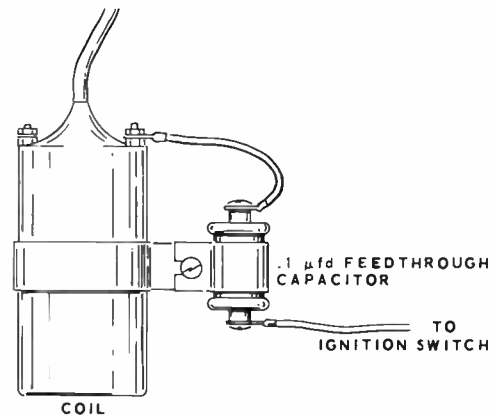

Figure 4



Again, we strongly urge you to contact your engine manufacturer for specific guidance on solving ignition interference problems in your particular engine.

Resistor type spark plugs may also be used to reduce the ignition interference in an inboard engine. If resistor type spark plugs are used, be sure to keep your ignition system in top operating condition. Normally, suppression will not affect the performance on an ignition system that is in good condition.

INBOARD ENGINES

To minimize ignition interference in inboard engines, it is recommended that the spark plug wires, including the high voltage wire from the coil to the distributor, be replaced with resistance type ignition wire. Except at very high boat speeds, this will reduce the interference to an extremely low level. When replacing this wire, new wire connectors should be installed at the ends of the wires to insure a good contact. The wire and connectors should be of good quality and can be purchased from an automotive parts supply store.

To replace the ignition wires, cut the new wires to the same lengths as the original wires. Install the new connectors by placing them over the wire ends and bending the two sides against the insulation. See Figure 5. Be sure the wire is in the connector all the way before bending connector sides.

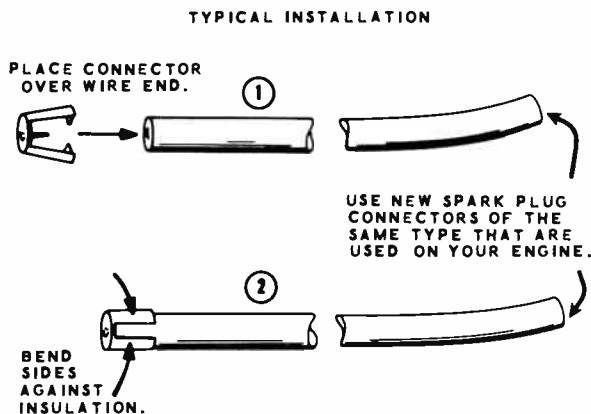
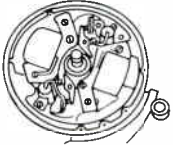

Figure 5

OUTBOARD MARINE CORPORATION – Johnson, Evinrude, Gale

35-40 HP



FLYWHEEL MAGNETO

50-60-75 HP

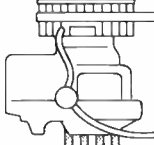

DISTRIBUTOR MAGNETO

75 HP WITH ALTERNATOR

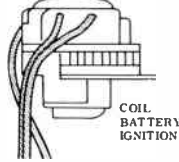

COIL BATTERY IGNITION

MODIFICATIONS TO PRIMARY AND SECONDARY

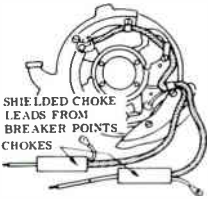

SHIELDED CHOKE LEADS FROM BREAKER POINTS CHOKES

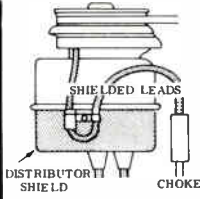

SHIELDED LEADS DISTRIBUTOR SHIELD CHOKE

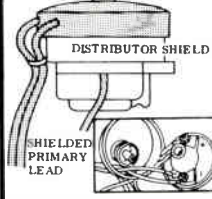

DISTRIBUTOR SHIELD SHIELDED PRIMARY LEAD

SPARK PLUG CABLES



REGULAR

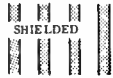

SHIELDED



SHIELDED

SPARK PLUG TYPES

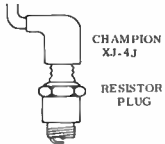

CHAMPION XJ-4J RESISTOR PLUG

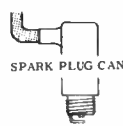

SPARK PLUG CAN

CHAMPION J-4J OR XJ-4J *

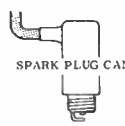

SPARK PLUG CAN

CHAMPION J-4J OR XJ-4J *

GENERATOR CHARGING SYSTEM

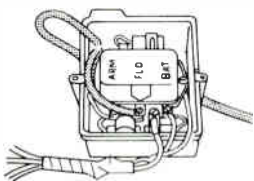

SHIELDED LEADS SUPPRESSOR CONDENSERS

ALTERNATOR

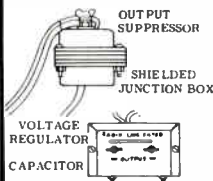

OUTPUT SUPPRESSOR SHIELDED JUNCTION BOX VOLTAGE REGULATOR CAPACITOR

KIEKHAEFER CORPORATION – Mercury

25-50 HP

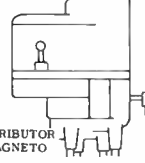

DISTRIBUTOR MAGNETO

60-70-80 HP

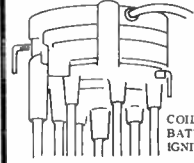

COIL BATTERY IGNITION

NOTE: MERCURY'S COMPLETE SUPPRESSION HARNESS CONSISTS OF A NEW DISTRIBUTOR CAP, DISTRIBUTOR-COIL CABLES, AND SPARK PLUG SUPPRESSION CABLES. THE KIT IS COMPLETE. MAKE NO ATTEMPT AT "DO-IT-YOURSELF" INSTALLATIONS WITH AUTOMOTIVE TYPE SUPPRESSION COILS.

SPARK PLUG CABLES



SUPPRESSOR TYPE



SUPPRESSOR TYPE

SPARK PLUG TYPES



CHAMPION J-6J

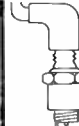

CHAMPION J-6J OR XJ-6J * 80 HP MODEL J-4J OR XJ-4J *

NOTE: * RESISTOR (X PREFIX LETTER) SPARK PLUGS IN SERIES WITH SUPPRESSOR TYPE CABLES ARE NOT RECOMMENDED ON MERCURY 4-CYLINDER MAGNETOS. RESISTOR SPARK PLUGS MAY BE USED WITH MERCURY'S COIL-BATTERY 6-CYLINDER IGNITION IF OWNER DESIRES. USE ONLY J-4J OR XJ-4J HEAT RANGE IN 80 H.P. MODEL.

OUTBOARD SPARK PLUG CHART

REACH	TEMPERATURE	RESISTOR	REGULAR
		XJ-12J	J-14J
14 MM 3/8"	HOT	XJ-12J	J-12J
		XJ-8J	J-8J
	COLD	XJ-6J	J-6J
		XJ-4J	J-4J
14 MM 7/16"	HOT		H-12J
			H-11J
	COLD	XH-10J	H-10J
		XH-8J	H-8J

IMPORTANT:

THIS CHART ILLUSTRATES SOME GENERAL METHODS OF REDUCING IGNITION INTERFERENCE. BE SURE TO CONTACT THE OUTBOARD ENGINE MANUFACTURER FOR SPECIFIC GUIDANCE ON THE MAKE OR MODEL NUMBER OF YOUR ENGINE.

The plating on Champion outboard plugs provides an excellent ground. The shielding "can" completely covers the plug and has three internal grounding "nibs" which contact the shell of the spark plug.

*Champion XJ-4J's are included in the suppression kit for flywheel magnetos. However, with a shielded system, the outboard operator has a choice of regular or resistor plugs. The J-4J's will generally give better performance in prolonged trolling operations. Unless you have a thorough knowledge of outboard ignition and charging systems, Outboard Marine recommends these kits be installed by their dealers.

Figure 6

INSTALLATION

EXTERNAL BATTERY WIRING

NOTE: If an external battery will be used to power your Depth Sounder, refer to Figures 7 and 8 and check the jumper wire connection to either lug 2 or lug 3 of terminal strip N. If the negative terminal of the external battery is connected to the ground system of the boat, the jumper wire should be on lug 2. If the positive terminal of the external battery is connected to ground, the jumper wire should be on lug 3. CAUTION: Be sure the jumper wire is on the correct terminal for your installation before you perform the following step. For an ungrounded external battery, or for operation from the internal batteries, connect the jumper wire to lug 1 of terminal strip N.

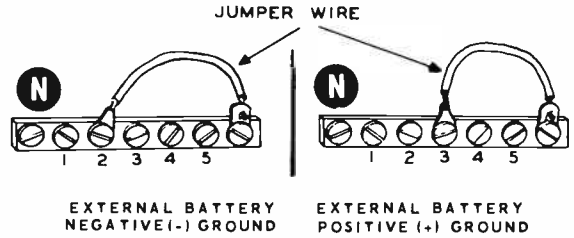

Figure 7

Figure 8

- () Connect two wires between the external battery terminals and a female cable connector (#432-62) as shown in Figure 9. Connect the negative (-) battery terminal to lug 1 and the positive (+) battery terminal to lug 2 of the connector socket.

MAIN UNIT INSTALLATION

- () Install the gimbal bracket in the boat where the Depth Sounder is to be located. The four #8 x 3/4" wood screws may be used. Other mounting hardware may be needed depending on the material of the mounting surface.
- () Fit the threaded spacers on the cabinet top shell of the Depth Sounder into the slots of the gimbal bracket. Secure with two thumb-nuts.

When only the internal batteries are used, it may be necessary to establish a good ground between the cabinet of the Depth Sounder and the boat's electrical ground system. A ground wire should then be connected from the boat's ground system to one of the mounting screws for the EXT. BATT.-INT. BATT. switch.

If the boat battery is used, the ground wire is not connected as a good ground is established when the battery is connected to the connector labeled EXT, DC.

TEMPORARY OR OUTBOARD TRANSDUCER INSTALLATIONS

If you desire to use the Depth Sounder only for checking the depth at certain places and when the boat is not moving, the transducer may be hung over the side of the boat into the water. If it is inconvenient to mount the transducer through the boat hull or if you plan to use the Depth Sounder on rented boats, a transom transducer mounting bracket may be used.

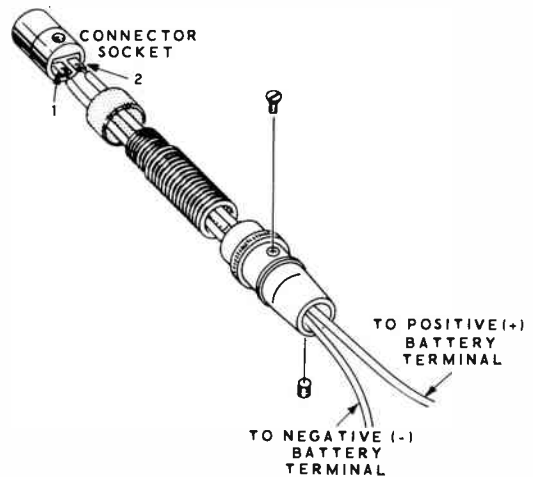

Figure 9

TRANSDUCER INSTALLATION

A fairing block should be shaped to the outline of the transducer housing. See Figure 10. Locate the position on the hull where the transducer is to be mounted, See Figure 11. This should be approximately amidships, but not near any underwater fittings which protrude from the hull, and not so far aft that propellor noise will be picked up. It is important that the transducer be mounted where water flow across the face will be smooth, with no turbulence or air bubbles in the stream. Pick a position as near the keel and as near the point of maximum draft as practical. It is not recommended that the transducer be mounted on the bottom of the keel, since a grounding may tear it loose and the keel may be weakened. The point chosen for mounting should be as nearly flat as possible to make fairing out easier.

At the point of mounting, drill a $3/4"$ hole through the hull. Measure the dead rise angle (angle of bottom with respect to horizontal) formed by the surface of the hull at this point to the horizontal. Transfer this angular measurement to the fairing block and make a saw cut at this angle. See Figure 10. Thoroughly paint both pieces of fairing with a good grade of marine paint, and allow to dry. Smear both flat surfaces of the outside fairing block with bedding compound.

NOTE: To eliminate the need of removing the cable connector from the cable in order to get the nut off the transducer, remove the snapping from the cable connector which allows the knurled nut to be removed.

Remove the $3/4"$ nut and thick brass washer from the brass fitting on the transducer. Place the thin brass washer on the brass fitting of the transducer. Now place the transducer, the thin brass washer, and the outside fairing block together. Then feed the cable and the brass fitting through the hull as shown in Figure 10. Smear the angled (cut) face of the

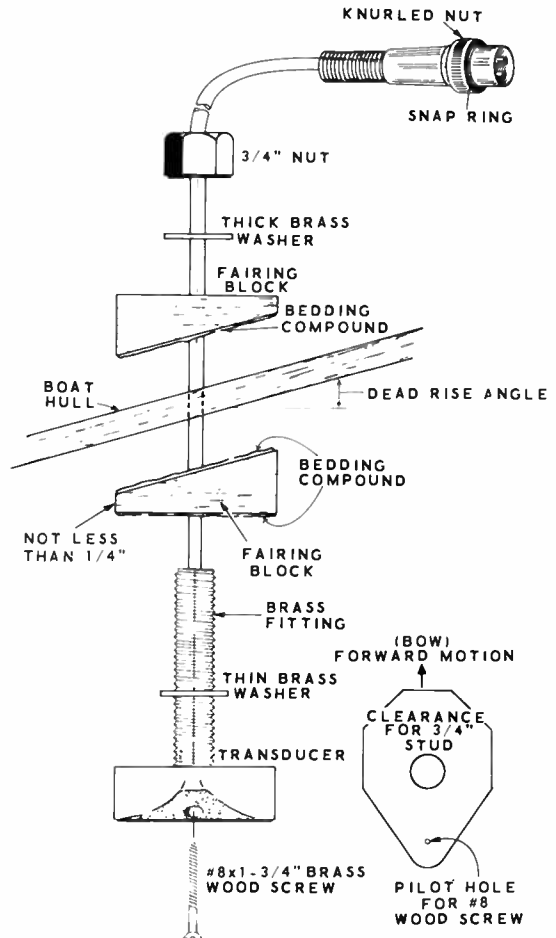

Figure 10

inner fairing block with bedding compound and fit it over the cable and brass fitting until it abuts against the hull. Place the thick brass washer and $3/4"$ nut on the brass fitting of the transducer. Tighten the nut finger tight. Do not use a wrench at this time.

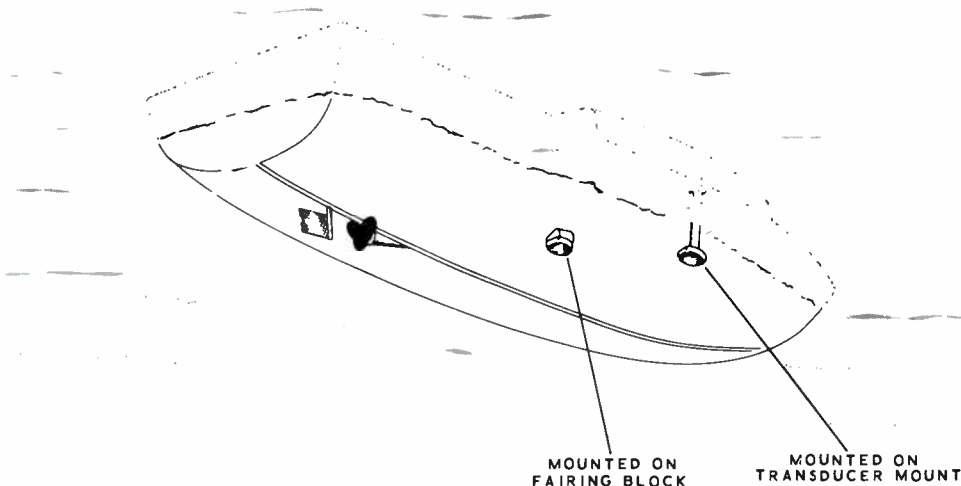

Figure 11

Outside of the hull, align the transducer and fairing block together so that the sharpest end points toward the stern. Hold the assembly against the hull and drill a clearance hole through the fairing block for the brass wood screw. Start the #8 x 1-3/4" brass wood screw through the transducer.

NOTE: DO NOT OVERTIGHTEN THE 3/4" NUT OR THE TRANSDUCER HOUSING MAY BE BROKEN. TRANSDUCERS BROKEN IN THIS

MANNER BY THE CUSTOMER WILL NOT BE REPLACED FREE OF CHARGE. Inside of the hull, tighten the 3/4" nut on the brass fitting snugly against the brass washer. Now tighten the #8 x 1-3/4" brass wood screw. Position the running end of the cable above deck to your Depth Sounder. Route the cable away from the boat's ignition system. Now replace the knurled nut and snap-ring on the cable connector.

This completes the installation of your Depth Sounder.

OPERATION

Your Depth Sounder will serve you in many ways. However, its two primary functions are: (1) to determine the depth of water between the transducer and the bottom; and (2) to assist in the location of schools of fish for both sport and commercial fisherman. Every flash of the

indicator has a definite meaning to the boat owner, and this section will deal with the interpretation of these displays, since the mechanical operation of the instrument requires only that it be turned on and the SENSITIVITY control be adjusted occasionally.

INDICATION OF HARD, SOLID BOTTOM
AND SCHOOL OF FISH

Figure 12

INDICATION OF SOFT MUDDY BOTTOM

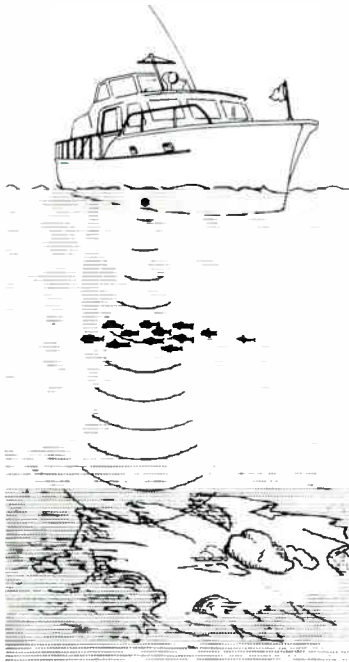
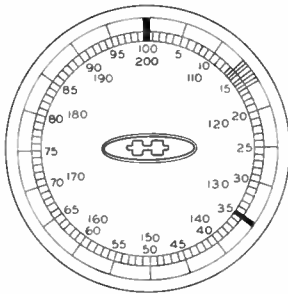
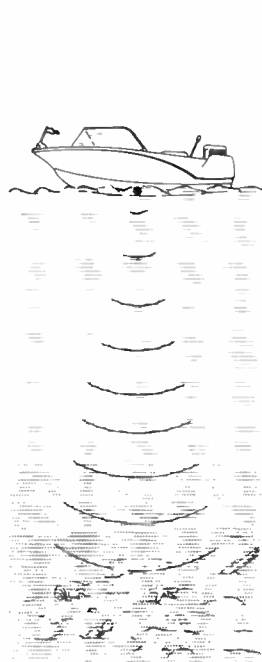
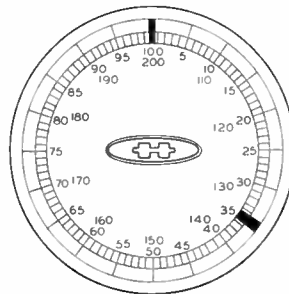

Figure 13

INDICATION OF SOFT BOTTOM WITH
BRUSH OR VEGETATION

Figure 14

Refer to Figure 12. This is a more or less normal display which will occur on a boat cruising in about 35 feet of water over a hard sand or rock bottom, with a school of fish at about 15 feet. Notice the definite echo return at 35 feet. Now compare this with Figure 13, with another boat cruising at the same depth, but over a soft mud bottom. Notice here that the echo, while clear, is wider (and may consist of

several flashes close together), denoting the softer bottom underlaid with a relatively solid layer.

See Figure 14. In this display the boat is in 40 feet of water, the bottom is relatively solid, and there appears bright erratic flashes of the indicator up to 27 feet. This is the case when the bottom is covered with vegetation or brush,

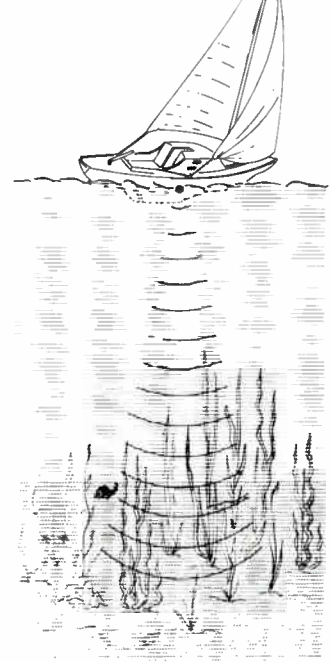
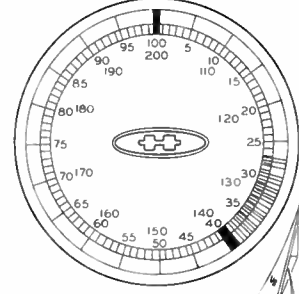
It is simple to determine the existence of a quantity of fish and determine the depth to them, as well as to see the depth to the bottom. To a fisherman, the ability to not only determine the kind of bottom and depth of water, but to also "see" the school of fish, is of great value. Single fish, too, will register on the Depth Sounder, if they are sufficiently large. The high frequency used, 200 kc, allows detection of single fish smaller than that possible to detect with other lower frequency depth sounders. Actually the body of the fish is essentially transparent to ultrasonic energy; it is the air bladder which actually reflects the echo from a fish. The larger the air bladder, the stronger return available from an individual fish. Small fish, when schooling, will return a strong echo due to the numerous small air bladders available for energy reflection, whereas the small fish alone would swim undetected.

Refer to Figure 15. In this case, it is difficult to determine the actual bottom echo, due to the many strong returns on the indicator. This indication may be seen in relatively shallow water when the SENSITIVITY control is advanced too far. Reducing the SENSITIVITY setting should make the indication appear as in Figure 16, where the boat is cruising in 4 feet of water.

The Depth Sounder will also record depths in water more than 100 feet deep. For example, a boat in 130 feet of water will display an echo at 30 feet and 130 feet on the dial. The rotor has simply gone one complete revolution plus 30 feet. Just use the 100-200 scale in water that you know to be over 100 feet deep but less than 200 feet deep.

Occasionally, random flashes may occur with the boat under way that do not appear to be caused by anything thus far discussed. Some of these flashes might be traced to a loose electrical

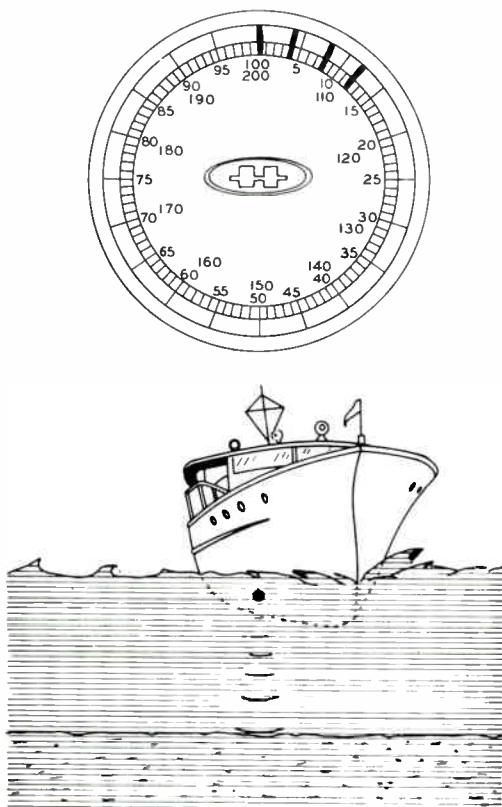

Figure 15

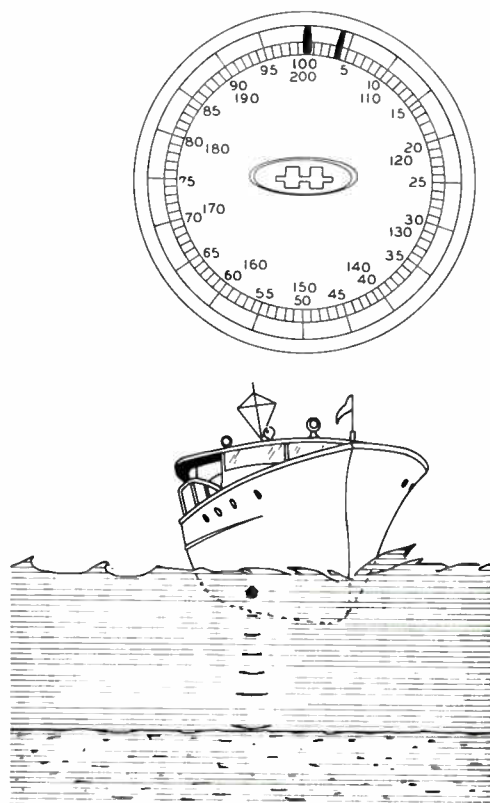

Figure 16



connection somewhere in the boat, to propeller slap or cavitation, or to actual fish noise. Some fish, particularly in the oceans, are known to actually make sounds. Even though not at the proper frequency, any sound in the water causing actual wave motion beneath the surface may reach the transducer and be amplified much as a normal echo. This random pulsing may be seen occasionally, but it is of minor consequence if it does occur, since the bottom and/or fish echo will be much more prominent. As in

any other instrument, even one as simple as a radio receiver, the operator must learn not only to properly adjust the controls, but also to correctly interpret what he sees or hears.

NOTE: Remember that the transducer will probably not be mounted at the point of maximum draft of your vessel. Allowance should be made when cruising in shallow water for any portions of your craft extending below the face of the transducer.

BIBLIOGRAPHY

CHART OF VARIOUS WATERWAYS

Charts, U.S. Coastal Waters - available from United States Coast and Geodetic Survey, Washington 25, D.C.

Charts, Great Lakes - available from U.S. Lake Survey, 630 Federal Building, Detroit 26, Michigan.

Charts, New York State Canals - available from U.S. Lake Survey, 630 Federal Building, Detroit 26, Michigan.

Charts, Mississippi River and Tributaries: Illinois Waterway, Lake Michigan to Mississippi River (U.S. Engineer Office, 520 Merchandise Mart, Chicago 54, Illinois); Mississippi River, Cairo, Illinois to Minneapolis, Minnesota (U.S. Division Engineer Office, 831 Customs House, Upper Mississippi Valley Division, St. Louis, Missouri); Mississippi River, Cairo, Illinois to Gulf of Mexico (Mississippi River Commission, Corps of Engineers, P.O. Box 80, Vicksburg, Mississippi); Ohio River, Pittsburgh,

Pennsylvania to Mississippi River (Pittsburgh District, Corps of Engineers, 925 New Federal Building, Pittsburgh 19, Pennsylvania); Tennessee River (Tennessee Valley Central Map Division, Knoxville, Tennessee); Missouri River (U.S. Engineer Office, Omaha, Nebraska); Big Sunflower, St. Francis, White, Atchafalaya, and other Mississippi River Tributaries (Mississippi River Commission, Corps of Engineers, P.O. Box 80, Vicksburg, Mississippi).

Charts, Canadian Waters (Dominion Hydrographer, Canadian Hydrographic Service, Surveys and Mapping Branch, No. 8 Temporary Building, Ottawa, Ontario, Canada); Trent Waterway (Superintending Engineer, Trent Canal Office, Department of Transport, Peterborough, Ontario, Canada); Rideau Waterway (Canal Services, Department of Transport, Ottawa, Ontario, Canada).

Charts, Foreign Waters - available from Hydrographic Office of the U.S. Navy, Washington 25, D.C.

MAINTENANCE

BATTERY LIFE

Conservative operation should be practiced to obtain maximum life from the batteries. Unless there is a definite need for it, the Depth Sounder

should not be turned on all the time you are cruising. Since the Depth Sounder is ready to operate and take soundings seconds after it is turned on, it should only be necessary to turn it on long enough to ascertain the depth of the water below the transducer.

If the Depth Sounder is used intermittently, so that it is on an average of one hour a day, five days a week, the battery life should be about 50 hours. If it is used more, the battery life will be shortened proportionately. If the Depth Sounder is left on continuously, the maximum battery life that can be expected is approximately 25 hours.

BATTERY REPLACEMENT

When it is noticed that the motor is slowing down, or that the flashes are not as bright, the old batteries should be immediately removed. If the old batteries are not removed in time and they leak battery fluid into the holders, the following should be done. Remove the battery holders and wash them with soap and water, being sure they are completely dry before replacing them in the unit and installing new batteries.

Manganese alkaline batteries are excellent for replacement purposes. While the cost of these batteries is higher, they will last four to five times longer than standard batteries, or about two to three boating seasons if the Depth Sounder is operated as recommended.

To replace the batteries, refer to Pictorial 11 (fold-out from Page 20) and remove the four 6-32 x 3/8" screws which secure the cabinet rear plate to the Depth Sounder. Remove the three caps from the ends of the battery holders and remove the batteries. Insert nine new size C flashlight batteries with the negative (flat) ends first. Then reinstall the three caps into the battery holders.

GENERAL MAINTENANCE

The neon indicator lamp, like any other light bulb, gradually wears out. This will be preceded by a gradual darkening of the glass and a decrease in the brightness of the zero and echo flashes.

The carbon and ground brushes are delicate and should be so treated. They will eventually wear down, but will last for many seasons of use.

The slip ring may occasionally require cleaning. Lighter fluid or any other suitable solvent may be used. Be careful not to bend or break the brushes.

If, after long periods of use, the motor no longer governs the motor speed correctly, it may be necessary to clean the motor's governor contacts. To do this, remove the small piece of vinyl tape covering the access hole located on the motor housing. A few drops of any good radio contact cleaner or solvent applied to the contacts should restore the motor to the correct speed.

MOTOR SPEED ADJUSTMENT

The accuracy of the Depth Sounder depends only on the motor speed of the unit. If it becomes obvious that the indicated depth is in error, the motor speed can be adjusted as follows: Remove the vinyl tape covering the access hole located on the motor housing. Rotate the motor by hand and find the adjustment screw in this hole. Place the transducer in water of known depth (measured from transducer to bottom); turn the unit on and note the depth indication. Turn the unit off and turn the adjustment screw very slightly with a screwdriver. Turn the Depth Sounder on again and note the indicated depth. Continue motor speed adjustment until the indicated depth agrees with the actual depth. This should be done in at least ten feet of water. After completing adjustment, be sure to replace the vinyl tape.

Under no circumstance should the motor be disassembled or tampered with, other than the instruction given above.

A desirable safety factor is the fact that as the motor slows down with low battery voltage, below 10 volts, the depth indication will be less than the actual depth. Therefore, the possibility of running aground because of an error in the Depth Sounder's indication will not be possible. When you notice that the motor has slowed down, the batteries should be changed.

IN CASE OF DIFFICULTY

NOTE: In checking for proper location of components with respect to the foil side of the circuit board, refer to the Circuit Board X-Ray view on Page 46.

1. Recheck the wiring. Trace each lead in colored pencil on the Pictorial as it is checked. It is frequently helpful to have a friend check your work. Someone who is not familiar with the unit may notice something consistently overlooked by the constructor.
2. It is interesting to note that about 90% of the kits that are returned for repair, do not function properly due to poor connections and soldering. Therefore, many troubles can be eliminated by reheating all connections to make sure that they are soldered as described in the Proper Soldering Techniques section of this manual.
3. Check to be sure that all transistors are in their proper locations.
4. Check the values of the parts. Be sure that the proper part has been wired into the circuit, as shown in the pictorial diagrams and as called out in the wiring instructions.
5. Check for bits of solder, wire ends or other foreign matter which may be lodged in the wiring.
6. If, after careful checks, the trouble is still not located and a voltmeter is available, check voltage readings against those shown on the Schematic Diagram. **NOTE:** All voltage readings were taken with an 11 megohm input vacuum tube voltmeter. Voltages may vary as much as 10%.
7. A review of the Circuit Description will prove helpful in indicating where to look for trouble.

TROUBLESHOOTING CHART

SYMPTOM	POSSIBLE CAUSE
Motor fails to operate correctly.	<ol style="list-style-type: none"> 1. Dead battery. 2. Batteries not connected properly. 3. Rotor blade obstructed. 4. EXT. BATT.-INT. BATT. switch in wrong position. 5. Brush tension too great. 6. Fuse not in place, or blown. 7. Shorted transistor, Q4 or Q5. 8. Battery holder cap not making contact. 9. Defective motor.
Motor runs backwards (counterclockwise as viewed from the front).	<ol style="list-style-type: none"> 1. Batteries connected wrong. 2. Motor installed wrong.
Motor operates but no zero indication.	<ol style="list-style-type: none"> 1. Shorted or open transistor. 2. Diodes D1, D2, or D3 installed wrong. 3. Brushes not making contact. 4. Defective neon lamp. 5. Pickup coil open or connected in reverse. 6. Red dot on permanent magnet not in proper position.
Indication at zero but a weak or no depth indication.	<ol style="list-style-type: none"> 1. Misaligned transformers, T1 and T2. 2. Damaged transducer. 3. Low battery voltage. 4. Transistor leads may be interchanged. 5. Faulty transistor Q2, Q3, Q4, or Q5.
Bright flashes over entire range of dial.	<ol style="list-style-type: none"> 1. Shorted or leaky transistor. 2. Ignition interference. 3. Faulty transistor Q1. 4. Poor ground connection. 5. Poor ground connection to motor case. 6. Sensitivity control set too high. 7. Poor alignment of L2, T1 and T2.
Neon indicator lamp glows blue rather than bright orange.	<ol style="list-style-type: none"> 1. Ground brush not making good contact. 2. Carbon brush not making good contact.

SERVICE INFORMATION

SERVICE

If, after applying the information in this manual and your best efforts, you are still unable to obtain proper performance, it is suggested that you take advantage of the technical facilities which the Heath Company makes available to its customers.

The Technical Consultation Department is maintained for your benefit. This service is available to you at no charge. Its primary purpose is to provide assistance for those who encounter difficulty in the construction, operation or maintenance of HEATHKIT equipment. It is not intended, and is not equipped to function as a general source of technical information involving kit modifications nor anything other than the normal and specified performance of HEATHKIT equipment.

Although the Technical Consultants are familiar with all details of this kit, the effectiveness of their advice will depend entirely upon the amount and the accuracy of the information furnished by you. In a sense, YOU MUST QUALIFY for GOOD technical advice by helping the consultants to help you. Please use this outline:

1. Before writing, fully investigate each of the hints and suggestions listed in this manual under In Case Of Difficulty. Possibly it will not be necessary to write.
2. When writing, clearly describe the nature of the trouble and mention all associated equipment. Specifically report operating procedures, switch positions, connections to other units, and anything else that might help to isolate the cause of trouble.
3. Report fully on the results obtained when testing the unit initially and when following the suggestions under In Case Of Difficulty. Be as specific as possible and include voltage readings if test equipment is available.

4. Identify the kit Model Number and Series Number, and date of purchase, if available. Also mention the date of the kit assembly manual. (Date at bottom of Page 1.)
5. Print or type your name and address, preferably in two places on the letter.

With the preceding information, the consultant will know exactly what kit you have, what you would like it to do for you and the difficulty you wish to correct. The date of purchase tells him whether or not engineering changes have been made since it was shipped to you. He will know what you have done in an effort to locate the cause of trouble and, thereby, avoid repetitious suggestions. In short, he will devote full time to the problem at hand, and through his familiarity with the kit, plus your accurate report, he will be able to give you a complete and helpful answer. If replacement parts are required, they will be shipped to you, subject to the terms of the Warranty.

The Factory Service facilities are also available to you, in case you are not familiar enough with electronics to provide our consultants with sufficient information on which to base a diagnosis of your difficulty, or in the event that you prefer to have the difficulty corrected in this manner. You may return the completed equipment to the Heath Company for inspection and necessary repairs and adjustments. You will be charged a minimal service fee, plus the price of any additional parts or material required. However, if the completed kit is returned within the Warranty period, parts charges will be governed by the terms of the Warranty. State the date of purchase, if possible.

Local Service by Authorized HEATHKIT Service Centers is also available in some areas and often will be your fastest, most efficient method of obtaining service for your HEATHKIT equipment. HEATHKIT Service Centers will honor the regular 90 day HEATHKIT Parts Warranty on all kits, whether purchased through a dealer or directly from Heath Company; however, it will be necessary that you verify the purchase date of your kit.

Under the conditions specified in the Warranty, replacement parts are supplied without charge; however, if the Service Center assists you in locating a defective part (or parts) in your kit, or installs a replacement part for you, you may be charged for this service.

HEATHKIT equipment purchased locally and returned to Heath Company for service must be accompanied by your copy of the dated sales receipt from your authorized HEATHKIT dealer in order to be eligible for parts replacement under the terms of the Warranty.

THIS SERVICE POLICY APPLIES ONLY TO COMPLETED EQUIPMENT CONSTRUCTED IN ACCORDANCE WITH THE INSTRUCTIONS AS STATED IN THE MANUAL. Equipment that has been modified in design will not be accepted for repair. If there is evidence of acid core solder or paste fluxes, the equipment will be returned NOT repaired.

For information regarding modification of HEATHKIT equipment for special applications, it is suggested that you refer to any one or more of the many publications that are available on all phases of electronics. They can be obtained at or through your local library, as well as at most electronic equipment stores. Although the Heath Company sincerely welcomes all comments and suggestions, it would be impossible to design, test, evaluate and assume responsibility for proposed circuit changes for special purposes. Therefore, such modifications must be made at the discretion of the kit builder, using information available from sources other than the Heath Company.

REPLACEMENTS

Material supplied with HEATHKIT products has been carefully selected to meet design requirements and ordinarily will fulfill its function without difficulty. Occasionally, improper operation can be traced to a faulty component. Should inspection reveal the necessity for replacement, write to the Heath Company and supply all of the following information.

- A. Thoroughly identify the part in question by using the part number and description found in the manual Parts List.
- B. Identify the kit Model Number and Series Number.

C. Mention date of purchase.

D. Describe the nature of defect or reason for requesting replacement.

The Heath Company will promptly supply the necessary replacement, PLEASE DO NOT RETURN THE ORIGINAL COMPONENT UNTIL SPECIFICALLY REQUESTED TO DO SO. Do not dismantle the component in question as this will void the guarantee. This replacement policy does not cover the free replacement of parts that may have been broken or damaged through carelessness on the part of the kit builder.

SHIPPING INSTRUCTIONS

In the event that your instrument must be returned for service, these instructions should be carefully followed. Return the complete Depth Sounder, less batteries. Also return the transducer if it is not permanently mounted to the boat.

Wrap the equipment in heavy paper, exercising care to prevent damage. Place the wrapped equipment in a stout carton of such size that at least three inches of shredded paper, excelsior, or other resilient packing material can be placed between all sides of the wrapped equipment and the carton. Close and seal the carton with gummed paper tape, or alternately, tie securely with stout cord. Clearly print the address on the carton as follows:

To: HEATH COMPANY
Benton Harbor, Michigan 49022

ATTACH A LETTER TO THE OUTSIDE OF THE CARTON BEARING YOUR NAME, COMPLETE ADDRESS, DATE OF PURCHASE, AND A BRIEF DESCRIPTION OF THE DIFFICULTY ENCOUNTERED. Also, include your name and return address on the outside of the carton. Preferably affix one or more "Fragile" or "Handle With Care" labels to the carton, or otherwise so mark with a crayon of bright color. Ship by insured parcel post or prepaid express; note that a carrier cannot be held responsible for damage in transit if, in HIS OPINION, the article is inadequately packed for shipment.



SPECIFICATIONS

Dial,	0 to 200 feet in one foot divisions.
Range,	0 to 200 feet on hard bottoms, 0 to 100 feet on soft bottoms.
Sounding -	
Rate,	1440 per minute or 24 per second.
Frequency,	200 kc.
Accuracy,	Within 5% of actual depth.
Depth Indication,	Neon lamp flashing at zero feet and again at indicated depth.
Transducer,	Barium titanate ceramic element encased in a watertight housing with solid brass fittings; attached 15 foot length of shielded cable.
Controls -	
Front Panel,	Sensitivity, with Depth Sounder On-Off switch.
Rear Panel,	External Battery-Internal Battery switch.
Transistor Complement,	2N1274 Pulsed Hartley Oscillator, 2N1524 First Amplifier, TI 364 Second Amplifier, 2N1274 Detector and Pulse Amplifier, R265A (2N1039) Power Amplifier.
Power Supply,	13.5 volts from nine self-contained size C flashlight cells, or external 12 volt battery.
Battery Drain,	80 to 100 milliamperes.
Average Battery Life (C Cells),	Up to 50 hours intermittent operation, Up to 25 hours continuous operation.
Cabinet,	Heavy gauge aluminum with one-piece top cover to provide protection from spray and splash. The recessed dial is shielded from sunlight and other interfering bright lights.
Dimensions,	7-1/4" wide x 5-1/4" high x 7-1/2" deep.
Net Weight,	7 lbs.

The Heath Company reserves the right to discontinue instruments and to change specifications at any time without incurring any obligation to

incorporate new features in instruments previously sold.

THEORY OF OPERATION

To help you clearly understand the operation of the Depth Sounder, the following is an explanation of how the ultrasonic beam is transmitted and received by the transducer in water. Figure 17 shows what happens when electrical pulses from the Depth Sounder are applied to the transducer. Inside the transducer a piezoelectric ceramic element immediately starts to oscillate, in its thickness mode, at a frequency of approximately 200 kc (kilocycles). In other words, it alternately becomes thinner and thicker, vibrating in much the same way as the cone of a loudspeaker. This introduces a motion or signal into the water which is directed toward the bottom in a relatively narrow beam. This motion takes place at approximately 200 kc, or at an ultrasonic rate. Because this frequency is not audible, it may be considered as a "silent sound" traveling at an average rate of approximately 4800 feet per second in water, or, conversely, .000208 seconds per foot.

Assume that the depth of water under your boat is 50 feet. The time it will take the signal to reach the bottom will be the product of distance and the speed of sound in water,

$$50 \text{ feet} \times .000208 \text{ seconds/foot} = .0104 \text{ seconds.}$$

The signal is bounced, or reflected, from the bottom back up to the transducer at the same speed. Since the bottom rarely is a smooth flat surface, this reflection scatters the signal widely; therefore, only a very small amount of the reflected signal actually reaches the transducer. The time for the return is another .0104 seconds. The total elapsed time is .0208 seconds. When the echo strikes the transducer, it vibrates the transducer at the same frequency that was originally generated, which due to its piezoelectric nature generates a small electrical pulse across an oscillator coil. This pulse is amplified in the Depth Sounder and is then applied to the neon indicator lamp, causing a bright flash of light.

Between the time the signal was first transmitted and then received, the indicator assembly, spinning at 1440 rpm, has rotated a given amount. Because the 1440 rpm represents a time of .0416 seconds for each revolution, the indicator lamp has traveled one-half of one revolution during the time lapse, causing the lamp to "fire" at the bottom of its arc, or at 50 feet, since 100 feet is a complete revolution. Remember that the lamp also flashed at zero when the lamp was at the top of its arc at zero feet.

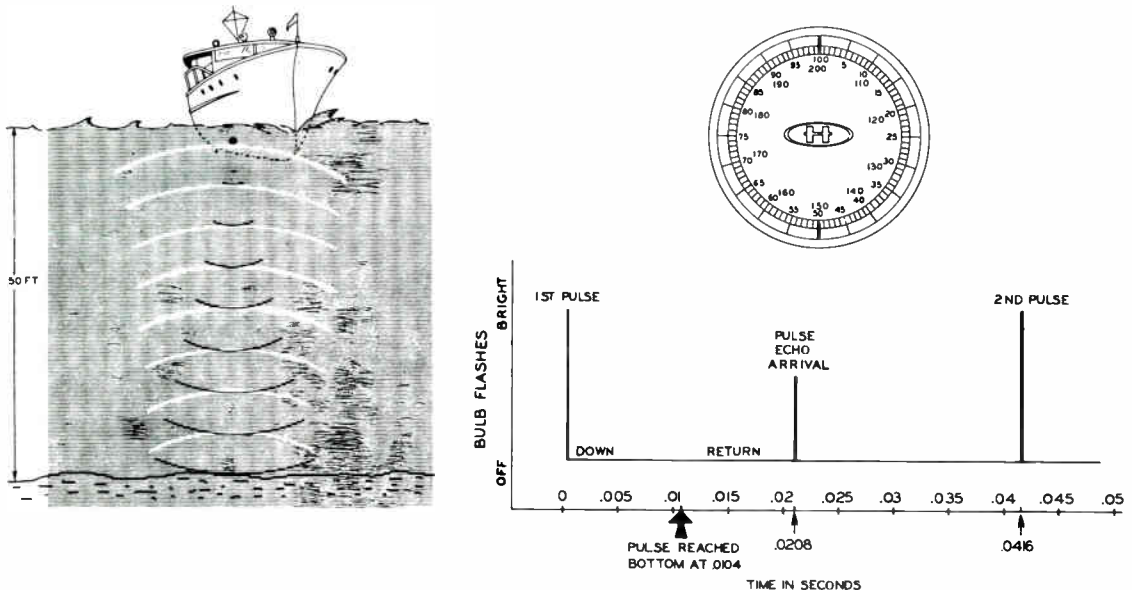

Figure 17

The motor speed of the Depth Sounder is determined by a knowledge of the velocity of sound waves in water. Since the velocity varies from fresh water to sea water, the average velocity of 4800 feet per second was chosen. The effect of temperature on velocity over the range of temperature extremes normally encountered is so slight it may be disregarded. If the Depth Sounder is used in either fresh or sea water, the change in indicated depth is still well within the accuracy stated in the Specifications.

The accuracy is dependent upon the speed of the motor, which is governor-controlled over a range of 10 to 15 volts DC.

Since the transmit-receive cycle is repeated approximately 1440 times a minute, or 24 times a second, the effect is actually a continuous sounding. Therefore, relatively small variations of the bottom contour may readily be observed when the boat is in motion.

CIRCUIT DESCRIPTION

Refer to the Block Diagram and Schematic (fold-out from Page 47) to follow the circuit and identify the circuit components while reading this description. The Depth Sounder Circuit Description is separated into three sections; Transmitting, Receiving, and Power Supply.

TRANSMITTING

A permanent magnet is mounted on the rotor assembly which in turn is rotated by the motor. A sounding pulse is developed each time the magnet rotates past pickup coil L1. For each revolution of the rotor, a current is induced in pickup coil L1 as the magnet passes it; much the same as a generator produces current. This current through coil L1 produces a voltage in the form of a pulse, which is applied to the base of transistor Q1. Since coil L1 also picks up noise from the DC motor, RF choke L4 prevents this noise from being amplified and causing meaningless flashes on the dial.

This almost instantaneous pulse from the pickup coil causes Q1 to turn on, like a light switch. This permits current to flow through Q1 and a few turns of oscillator coil L2.

Due to the transformer action of coil L2, the voltage developed across these few turns is stepped up to about 50 volts (peak-to-peak).

Some of this voltage is fed back to the base of transistor Q1 through capacitor C3. This feedback causes Q1 to oscillate for a few cycles at a frequency of 200 kc, which is much higher than the pulse rate of 24 cps (1440 rpm). Transistor Q1 will oscillate as long as it is triggered by the pulse from pickup coil L1. This oscillator supplies the necessary pulse power to the transducer. From L2 a signal voltage is coupled through capacitor C6 to the base of transistor Q2 which is the first 200 kc amplifier stage. The amplified signal voltage at the collector of Q2 is coupled through interstage transformer T1 to the second amplifier transistor Q3. Sensitivity control R9 determines how much Q2 and Q3 will amplify the signal voltage. The amplified signal voltage at the collector of Q3 is coupled through transformer T2 to diode D1.

Diode D1 functions as a detector and allows the negative pulses from the signal voltage to pass. Capacitor C13 at the base of transistor Q4 bypasses the unwanted part of the signal voltage to ground so that only the negative pulses are amplified by transistor Q4. These amplified pulses are coupled from Q4 to transistor Q5 by transformer T3.

The output of transistor Q5 is developed across the primary of transformer T4. Due to the voltage step-up action of T4, the pulse developed

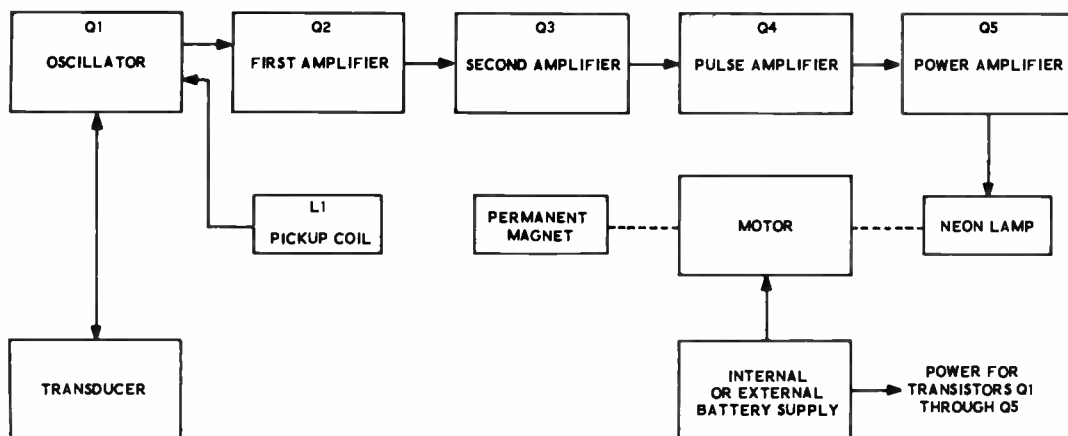

BLOCK DIAGRAM

across its secondary is large enough to fire the neon indicator lamp NE-86A.

The pulse from the secondary of T4 is transferred to the neon lamp through the carbon brush and slip ring on the rotor assembly. Since the action takes place rapidly, the lamp is fired at essentially the same time the magnet on the rotor assembly passes by coil L1. Thus, the neon lamp flashes with each revolution and this flash appears at zero feet on the dial. Also, at the same time that a flash appears at zero feet on the dial, an electrical pulse is applied to the transducer. The transducer changes the electrical pulse to a motion or signal which is transmitted toward the bottom. The signal hits the bottom and bounces back to be picked up by the transducer.

RECEIVING

The transducer receives the reflected signal and changes it into an electrical pulse. This pulse from the transducer is coupled back to oscillator coil L2 and amplified in the same manner as the original transmitted pulse. The amplified pulse is applied to the neon lamp causing another bright flash on the dial. This flash will indicate the distance in feet between the transducer and the bottom or the water depth.

POWER SUPPLY

Nine standard size C flashlight batteries supply the power to operate the motor and amplifier section of the Depth Sounder. An external 12 volt battery may be used for a permanent installation.

WARRANTY

The Heath Company warrants that the parts supplied in its kits (except batteries) shall be free of defects in materials and workmanship under normal conditions of use and service. The obligation of Heath under this warranty is limited to replacing or repairing any such part upon verification that it is defective in this manner. This obligation is further limited to such defective parts for which Heath is notified of the defect within a period of ninety (90) days from the original date of shipment of the kit.

The obligation of Heath under this warranty does not include either the furnishing or the expense of any labor in connection with the installation of such repaired or replacement parts. The obligation of Heath with respect to transportation expenses is limited to the cost of shipping the repaired or replacement parts to the buyer, provided such repair or replacement comes within the terms of this warranty.

The foregoing warranty extends only to the original buyer and is expressly in lieu of all other warranties, expressed or implied. The foregoing warranty is further in lieu of all other obligations or liabilities on the part of Heath and in no event shall the Heath Company be liable for any anticipated profits, consequential damages, loss of time or other losses incurred by the buyer in connection with the purchase, assembly or use of the kit product or components thereof.

The foregoing warranty shall be deemed completely void if acid core solder or paste flux or other corrosive solders or fluxes have been used in assembling or repairing the kit product. Heath will not replace or repair any parts of any kit products in which such corrosive solders or fluxes have been used.

This warranty applies only to Heath products sold and shipped to points within the continental United States and to APO and FPO shipments. Warranty replacement for Heath products sold or shipped outside the United States is on an f.o.b. factory basis. Contact the Heath authorized distributor in your country or write: Heath Company, International Division, Benton Harbor, Michigan, U.S.A.

HEATH COMPANY

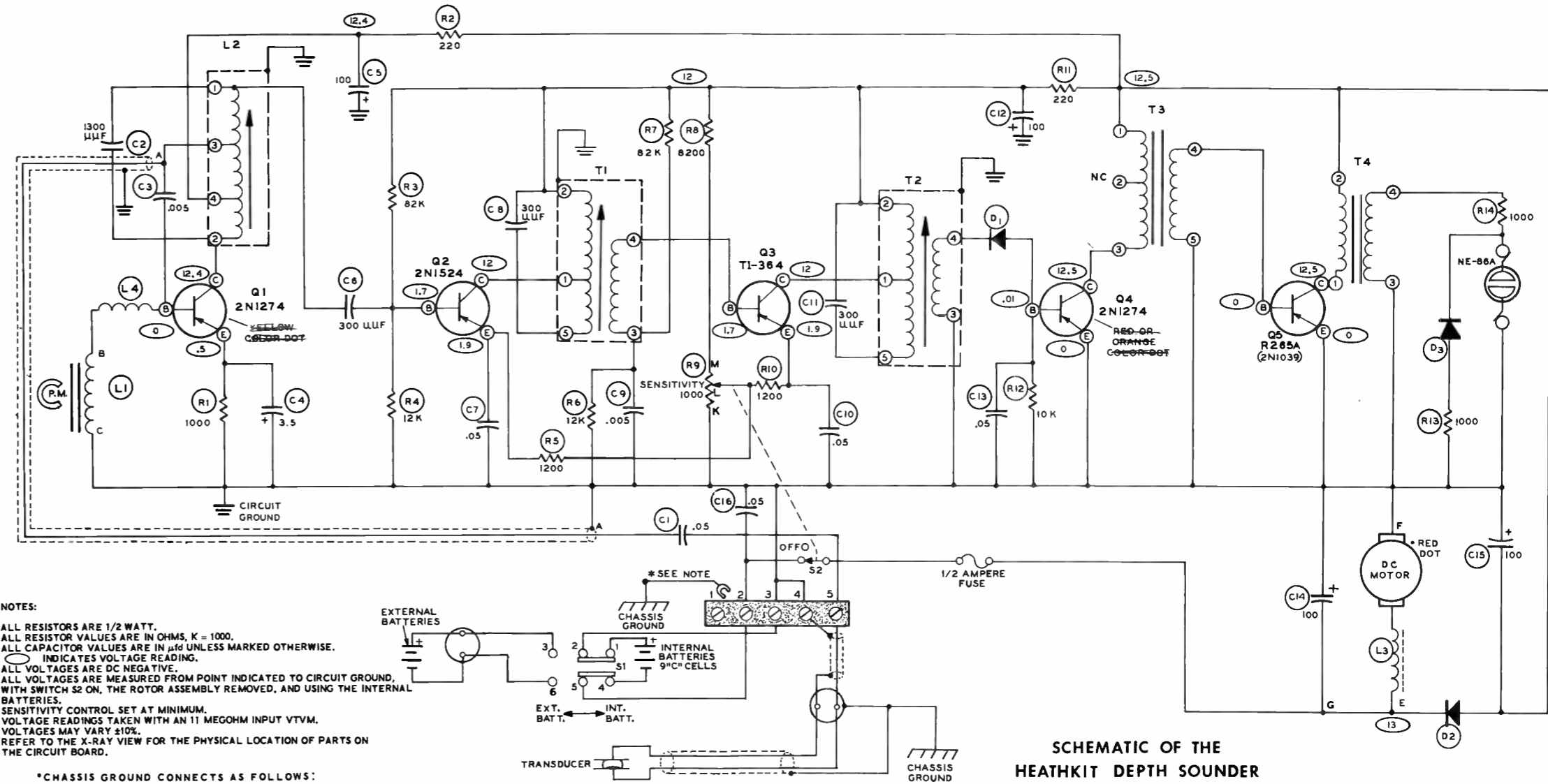

**SCHEMATIC OF THE
HEATHKIT DEPTH SOUNDER
MODEL MI-11A**

NOTES:

- ALL RESISTORS ARE 1/2 WATT.
- ALL RESISTOR VALUES ARE IN OHMS, K = 1000.
- ALL CAPACITOR VALUES ARE IN μfd UNLESS MARKED OTHERWISE.
- INDICATES VOLTAGE READING.
- ALL VOLTAGES ARE DC NEGATIVE.
- ALL VOLTAGES ARE MEASURED FROM POINT INDICATED TO CIRCUIT GROUND, WITH SWITCH S2 ON, THE ROTOR ASSEMBLY REMOVED, AND USING THE INTERNAL BATTERIES.
- SENSITIVITY CONTROL SET AT MINIMUM.
- VOLTAGE READINGS TAKEN WITH AN 11 MEGOHM INPUT VTVM.
- VOLTAGES MAY VARY $\pm 10\%$.
- REFER TO THE X-RAY VIEW FOR THE PHYSICAL LOCATION OF PARTS ON THE CIRCUIT BOARD.

***CHASSIS GROUND CONNECTS AS FOLLOWS:**

1. TO LUG 1 FOR UNGROUNDED OR INTERNAL BATTERY.
2. TO LUG 2 FOR NEGATIVE GROUND EXTERNAL BATTERY.
3. TO LUG 3 FOR POSITIVE GROUND EXTERNAL BATTERY.

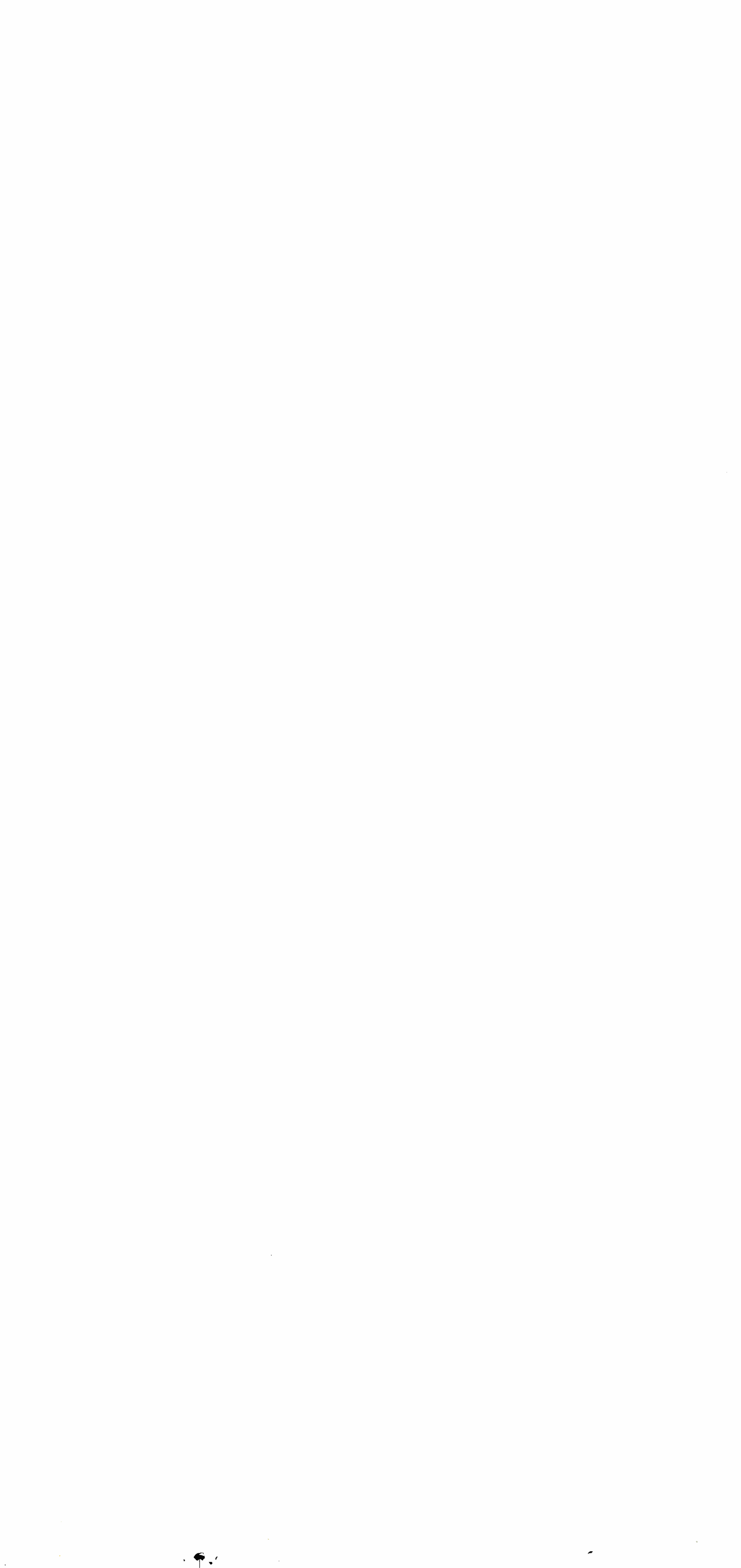



HEATH COMPANY

BENTON HARBOR, MICHIGAN

THE WORLD'S FINEST ELECTRONIC EQUIPMENT IN KIT FORM