

PRICE \$2.00

HEATHKIT® ASSEMBLY MANUAL

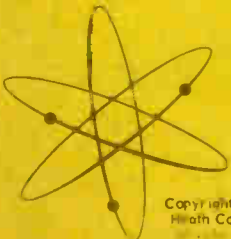

Copyright © 1968
Heath Company













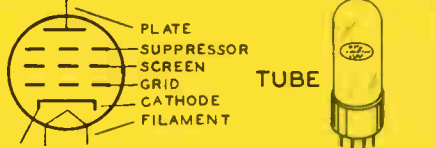
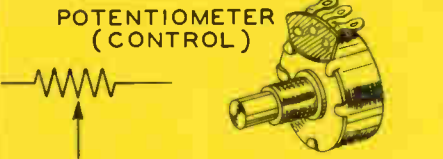

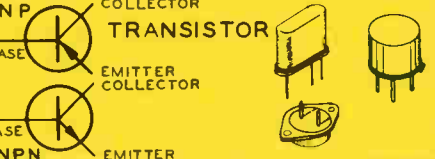
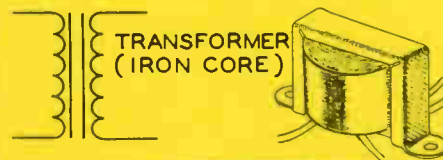

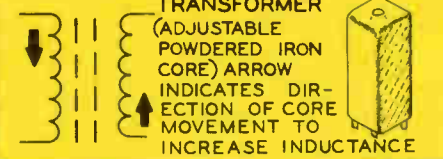
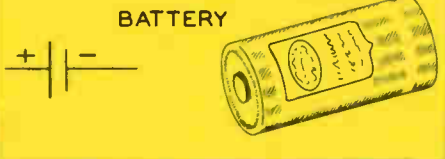

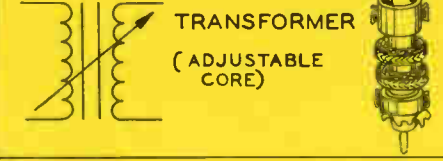

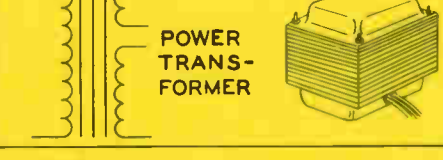

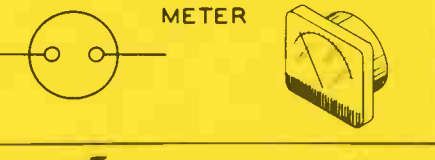
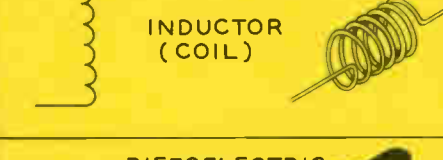
REMOTE CONTROL

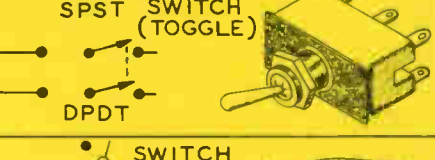
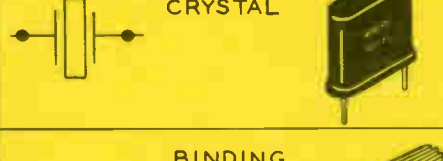
MODEL GRA-227-6, MODEL GRA-295-6
and MODEL GRA-681-6

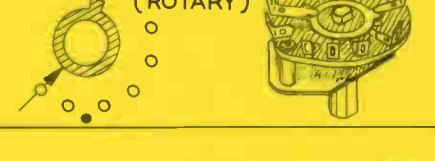
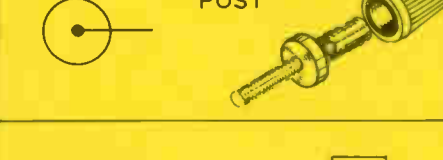
TYPICAL COMPONENT TYPES

This chart is a guide to commonly used types of electronic components. The symbols and related illustrations

should prove helpful in identifying most parts and reading the schematic diagrams.

<p style="text-align: center;">RESISTOR</p> 	<p style="text-align: center;">CAPACITOR</p> 	<p style="text-align: center;">TUBE</p> 
<p style="text-align: center;">POTENTIOMETER (CONTROL)</p> 	<p style="text-align: center;">ELECTROLYTIC CAPACITOR</p> 	<p style="text-align: center;">TRANSISTOR</p> 
<p style="text-align: center;">TRANSFORMER (IRON CORE)</p> 	<p style="text-align: center;">VARIABLE CAPACITOR</p> 	<p style="text-align: center;">RECTIFIER (DIODE)</p> 
<p style="text-align: center;">TRANSFORMER (ADJUSTABLE POWDERED IRON CORE) ARROW INDICATES DIRECTION OF CORE MOVEMENT TO INCREASE INDUCTANCE</p> 	<p style="text-align: center;">BATTERY</p> 	<p style="text-align: center;">NEON BULB</p> 
<p style="text-align: center;">TRANSFORMER (ADJUSTABLE CORE)</p> 	<p style="text-align: center;">PHONO JACK</p> 	<p style="text-align: center;">ILLUMINATING BULB</p> 
<p style="text-align: center;">POWER TRANSFORMER</p> 	<p style="text-align: center;">PHONE JACK</p> 	<p style="text-align: center;">METER</p> 
<p style="text-align: center;">INDUCTOR (COIL)</p> 	<p style="text-align: center;">RECEPTACLE</p> 	<p style="text-align: center;">SWITCH (TOGGLE)</p> 
<p style="text-align: center;">PIEZOELECTRIC CRYSTAL</p> 	<p style="text-align: center;">SPEAKER</p> 	<p style="text-align: center;">SWITCH (ROTARY)</p> 
<p style="text-align: center;">BINDING POST</p> 	<p style="text-align: center;">MICROPHONE</p> 	<p style="text-align: center;">FUSE</p> 
<p style="text-align: center;">ANTENNA</p> <p style="text-align: center;">GENERAL LOOP</p> 	<p style="text-align: center;">EARTH GROUND</p> <p style="text-align: center;">CHASSIS GROUND</p> 	<p style="text-align: center;">CONDUCTORS</p> <p style="text-align: center;">NOT CONNECTED CONNECTED SHIELDED</p> 

Assembly
and
Operation
of the



REMOTE CONTROL

Model GRA-227-6, Model GRA-295-6 And
Model GRA-681-6

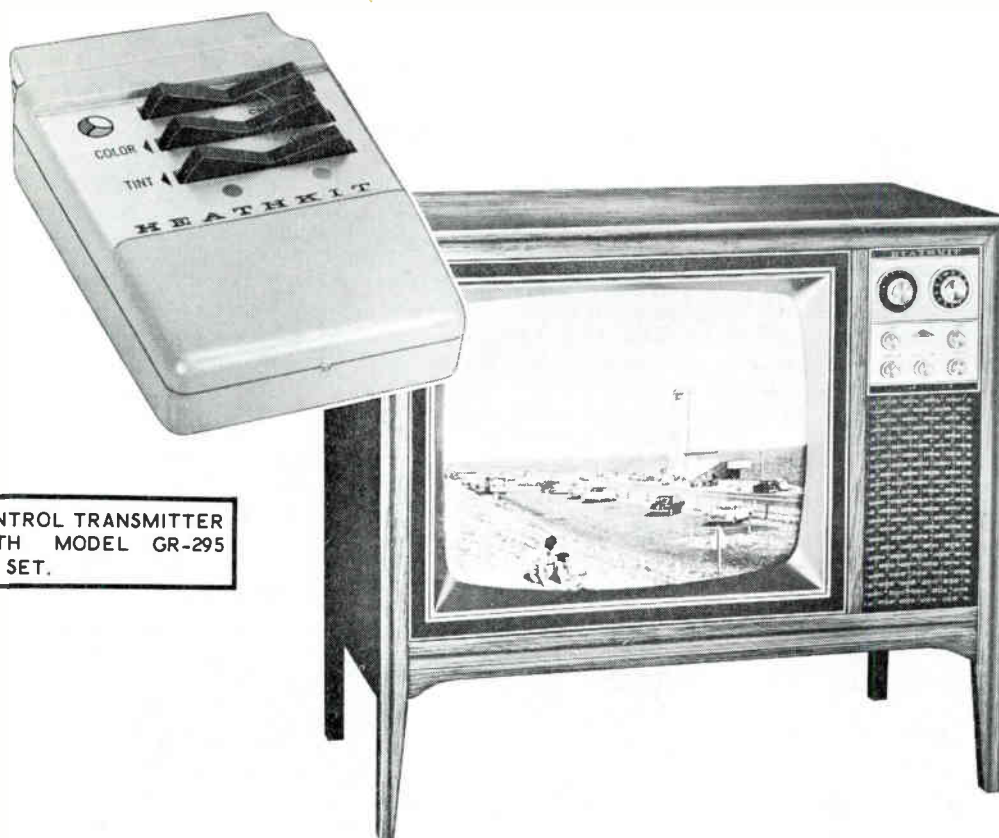

REMOTE CONTROL TRANSMITTER
SHOWN WITH MODEL GR-295
TELEVISION SET.

HEATH COMPANY
BENTON HARBOR, MICHIGAN 49022

7-19-68

TABLE OF CONTENTS

INTRODUCTION.	3
PARTS LIST.	4
STEP-BY-STEP ASSEMBLY	
Transmitter Circuit Board Assembly.	8
Receiver Circuit Board.	12
Chassis Parts Mounting And Wiring.	18
Instructions For Installing Remote Control	
In Models GR-180 or GR-227 Television Sets	
Removing Television Set From Cabinet.	28
Removing Chassis From Shield Assembly.	28
Disconnecting Wires To Main Control Bracket.	32
Installing Motors.	34
Rewiring Main Control Bracket.	38
Final Assembly.	45
Receiver Adjustments.	50
Final Checkout.	54
Installing Television Set In Cabinet.	57
Microphone Installation For Model GR-180 Television.	56
Instructions For Installing Remote Control	
In Models GR-295, GR-681, And GR-25 Television Sets	
Removing Television Set From Cabinet.	58
Disconnecting Wires To Tuner Bracket.	59
Installing Motors.	61
Rewiring Main Control Bracket.	64
Receiver Adjustments.	70
Final Checkout.	72
Installing Television Set In Cabinet.	72
Final Assembly.	75
NORMAL OPERATING CONDITIONS.	76
OPERATION.	76
IN CASE OF DIFFICULTY.	78
TROUBLESHOOTING CHARTS.	79
ALIGNMENT WITH INSTRUMENTS.	81
SPECIFICATIONS.	82
CIRCUIT DESCRIPTION.	83
CIRCUIT BOARD X-RAY VIEWS.	87
VOLTAGE CHARTS.	88
CHASSIS PHOTOGRAPH.	89
REPLACEMENT PARTS PRICE LIST.	90
SCHEMATIC. . . . (fold-out from page).	91

INTRODUCTION

This Manual contains instructions to install the Heathkit Remote Control in the Heathkit Color Television Sets. It is actually three Manuals in one, since it includes instructions for the Model GRA-227-6, Model GRA-295-6, and GRA-681-6. The GRA-227-6 instructions are used for installing the Remote Control in Models GR-180 and GR-227 Television Sets. The GRA-295-6 and GRA-681-6 instructions are used for Models GR-295, GR-681, and GR-25. Also included are instructions for converting these same Television Sets from the Remote Control Switch (the first Heathkit Remote Control) to this Remote Control.

The Remote Control consists basically of a transmitter that sends out an ultrasonic signal, a microphone which picks up this signal, and a receiver that produces the correct function in your TV set. To use the Remote Control, you merely point the transmitter toward the TV set and push the switch for the desired function.

There are actually nine TV functions that can be controlled with the transmitter; they are as follows: TV on, reduced volume, volume minimum, TV off, VHF channel selector, tint clockwise and counterclockwise, color clockwise and counterclockwise. For Model GR-227, a pushbutton switch has also been provided to mount on the TV set for changing VHF channels.

The transmitter requires no wires between it and the TV set. It can operate the TV controls from a distance of at least 20 feet as long as there are no obstructions between the transmitter and TV set. The transmitter circuitry is transistorized and contained on a printed circuit board. A 9-volt battery supplies power to this circuit board. The circuit board and battery are both enclosed inside an attractive beige plastic case.

The solid-state receiver is mounted inside the TV set. It consists of six transistors, one integrated circuit (equivalent to 10 transistors, one diode, and 15 resistors); all of which are mounted on a circuit board. An excellent feature of the receiver is its self-contained meter for adjustment purposes.

This Remote Control is a luxury item that should supply you with many years of service and easy TV watching.

Refer to the "Kit Builders Guide" for complete information on unpacking, parts identification, tools, wiring, soldering, and step-by-step assembly procedures.



PARTS LIST

This section of the Manual is divided into Parts List #1, Parts List #2, and Parts List #3. If you have the Heathkit Model GR-180 or GR-227 Color Television Set, use Parts Lists #1 and #2. If you have the Heathkit Model GR-295, GR-681 or GR-25 Color Television Set, use Parts Lists #1 and #3 (Page 6).

Parts List #1

The numbers in parentheses are keyed to the numbers on the Parts Pictorial (fold-out from Page 5).

PART No.	PARTS Per Kit	DESCRIPTION	PART No.	PARTS Per Kit	DESCRIPTION
RESISTORS			CAPACITORS		
1/2 Watt			Silver Mica		
(1)1-103	1 ✓	33 Ω (orange-orange-black)	(3)20-160	1 ✓	33 pF
1-83	2 ✓	56 Ω 5% (green-blue-black-gold)	20-161	1 ✓	68 pF
1-151	6 ✓	330 Ω 5% (orange-orange-brown-gold)	20-162	1 ✓	105 pF
1-9	1 ✓	1000 Ω (brown-black-red)	20-163	1 ✓	115 pF
1-44	1 ✓	2200 Ω (red-red-red)	20-149	1 ✓	150 pF
1-16	2 ✓	4700 Ω (yellow-violet-red)	20-164	1 ✓	180 pF
1-73	1 ✓	8200 Ω (gray-red-red)	20-165	1 ✓	200 pF
1-105	7 ✓	10 kΩ 5% (brown-black-orange-gold)	20-107	6 ✓	680 pF
1-24	1 ✓	33 kΩ (orange-orange-orange)	Disc		
1-26	1 ✓	100 kΩ (brown-black-yellow)	(4)21-7	1 ✓	33 pF
1-27	1 ✓	150 kΩ (brown-green-yellow)	21-36	1 ✓	.002 μF
1-35	1 ✓	1 MΩ (brown-black-green)	21-27	1 ✓	.005 μF
1-37	1 ✓	2.2 MΩ (red-red-green)	21-16	2 ✓	.01 μF
1-86	1 ✓	5.6 MΩ (green-blue-green)	(5)21-70	4 ✓	.01 μF, 1.4 kV
2 Watt			Mylar*		
NOTE: The following 2 watt wire-wound resistor is physically smaller than the 2 watt composition resistor.			(6)27-63	2 ✓	.022 μF
(2)3-5-2	1 ✓	2.2 Ω (red-red-gold) wire-wound	27-46	1 ✓	.047 μF
1-20-2	1 ✓	100 Ω (brown-black-brown)	27-47	1 ✓	.1 μF, 50 V or 100 V
			(7)27-28	1 ✓	.1 μF, 400 V
			27-80	2 ✓	.33 μF
			Electrolytic		
			(8)25-54	1 ✓	10 μF
			25-145	6 ✓	25 μF
			(9)25-116	1 ✓	50 μF
			25-146	1 ✓	100 μF

*DuPont Registered Trademark

PARTS PICTORIAL #1
(For GR-180,GR-227,GR-295,GR-681,and GR-25)

PART No. PARTS Per Kit DESCRIPTION

PART No. PARTS Per Kit DESCRIPTION

DIODES-TRANSISTORS

General (cont'd.)

- (10)56-45 1 ✓ Zener diode
- (11)57-27 2 ✓ Silicon diode
- (12)417-118 7 ✓ 2N3393 transistors
- (13)442-4 1 ✓ Integrated circuit

- (30)266-110 3 ✓ Plastic rocker arm
- (31)263-7 1 ✓ Round felt pad
- (32)73-64 1 ✓ Foam tape
- (33)453-164 1 ✓ Rocker arm shaft
- (34)209-52 1 ✓ Transmitter case grille
- (35)432-33 1 ✓ Battery connector
- 407-116 1 ✓ Meter
- (36)473-4 1 ✓ Microphone with shielded cable
- (37)473-5 1 ✓ Transducer
- (38)10-251 1 ✓ 500 Ω control

COILS-TRANSFORMERS

- (14)40-848 1 ✓ Oscillator coil
- (15)40-844 2 ✓ 40 kHz coil
- 40-843 2 ✓ 42 kHz coil
- 40-842 2 ✓ 44 kHz coil
- (16)40-849 1 ✓ Driver transformer
- (17)54-213 1 ✓ Power transformer

WIRE-SLEEVING-CABLE ASSEMBLY

- 344-81 1 ✓ Violet stranded wire
- 344-51 1 ✓ Brown hookup wire
- 344-50 1 ✓ Black hookup wire
- 344-52 1 ✓ Red hookup wire
- 344-53 1 ✓ Orange hookup wire
- 344-54 1 ✓ Yellow hookup wire
- 344-55 1 ✓ Green hookup wire
- 344-56 1 ✓ Blue hookup wire
- 344-58 1 ✓ Gray hookup wire
- 344-59 1 ✓ White hookup wire
- 344-76 1 ✓ White-blue hookup wire
- 346-2 1 ✓ Large clear sleeving
- 346-7 1 ✓ Small clear sleeving
- 134-180 1 ✓ Remote control cable assembly

RELAYS-MOTORS

- (18)69-50 6 ✓ Relay
- (19)69-49 1 ✓ Stepping relay
- (20)420-57 2 ✓ Control motor
- (21)420-54 1 ✓ Tuner drive motor NOTE:
This motor is not supplied with the GRA-681-6, since it is already a part of the GR-681 Television Set.

GENERAL

- (22)204-866 1 ✓ Rocker arm bracket
- (23)205-599 2 ✓ Control mounting plate
- (24)431-14 1 ✓ 2-lug terminal strip (one lug ground)
- (25)431-45 1 ✓ 6-lug terminal strip
- (26)73-1 1 ✓ 3/8" grommet
- 73-3 1 ✓ 1/2" grommet
- (27)434-42 1 ✓ Phono socket
- (28)432-70 1 ✓ 9-terminal cable connector
- (29)432-71 1 ✓ 9-terminal chassis connector

HARDWARE

- #3 Hardware**
- (39)250-49 7 ✓ 3-48 x 1/4" screw
 - (40)252-1 7 ✓ 3-48 nut
 - (41)254-7 14 ✓ #3 lockwasher

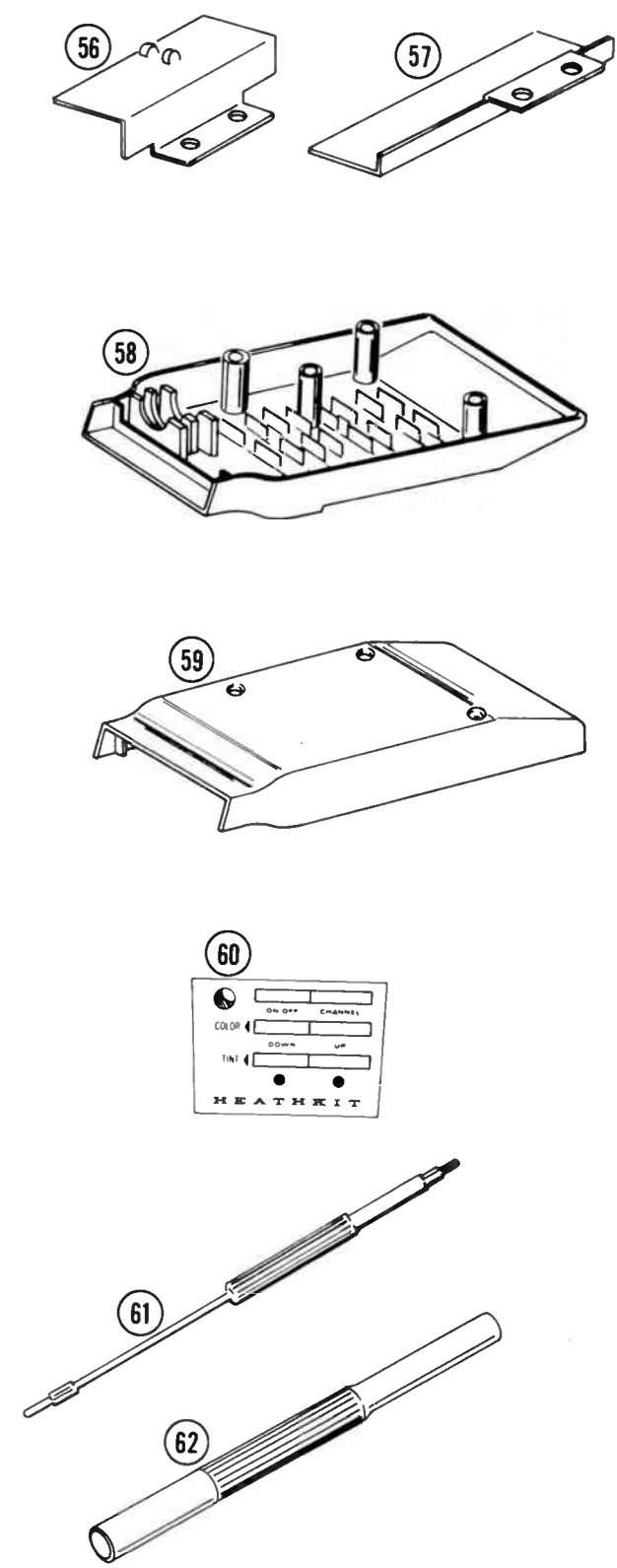
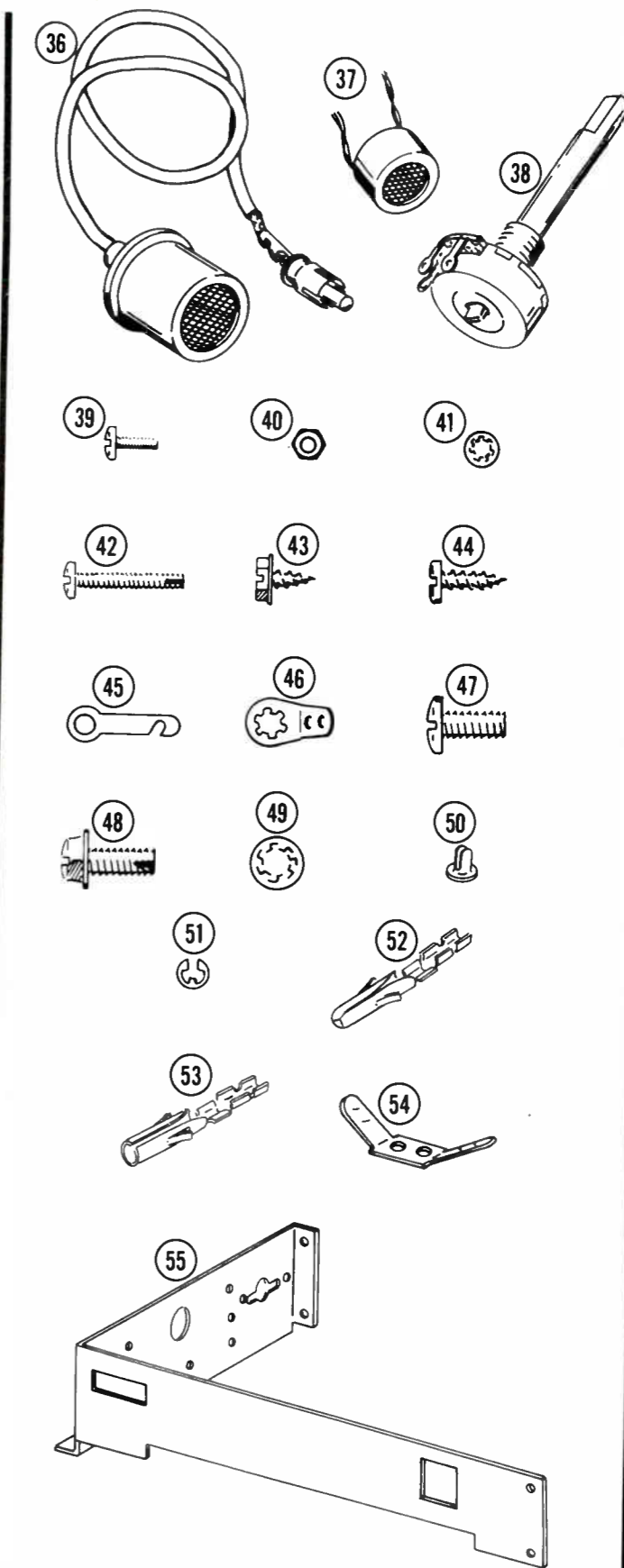
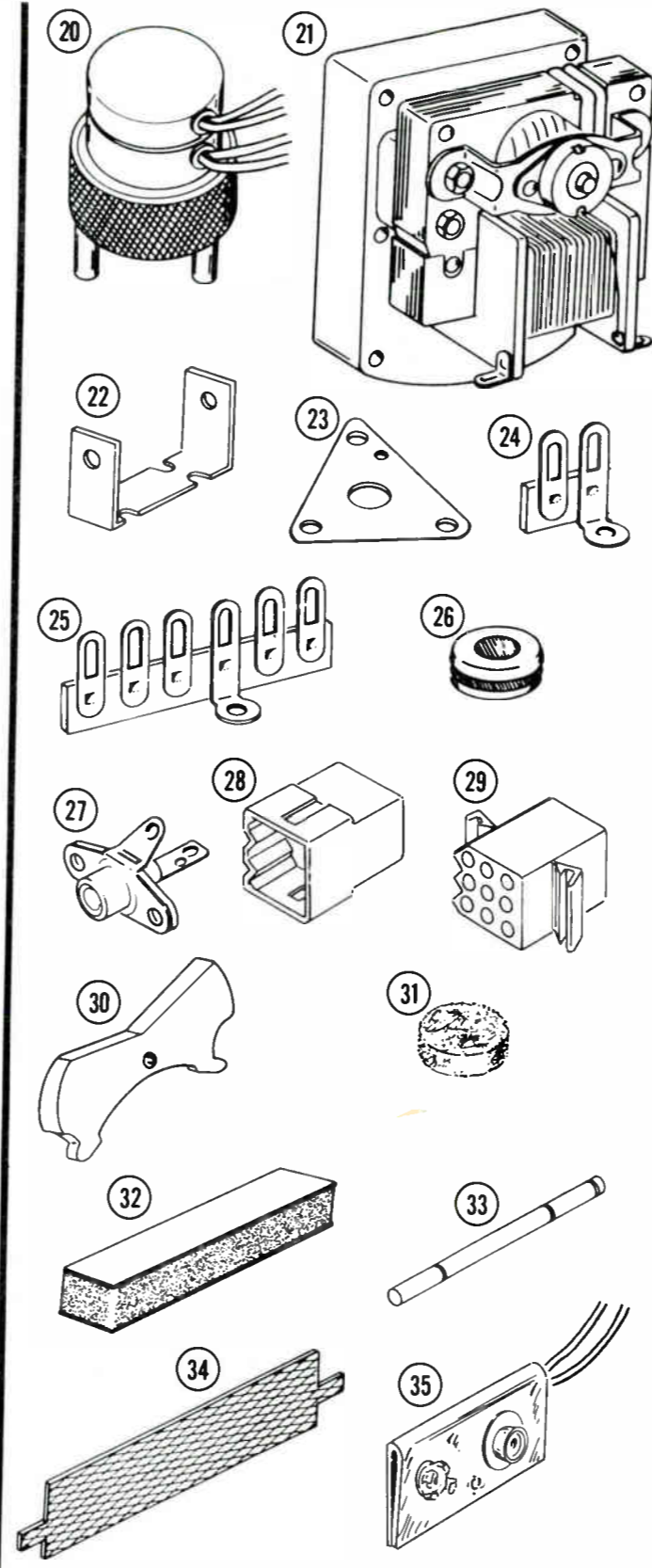
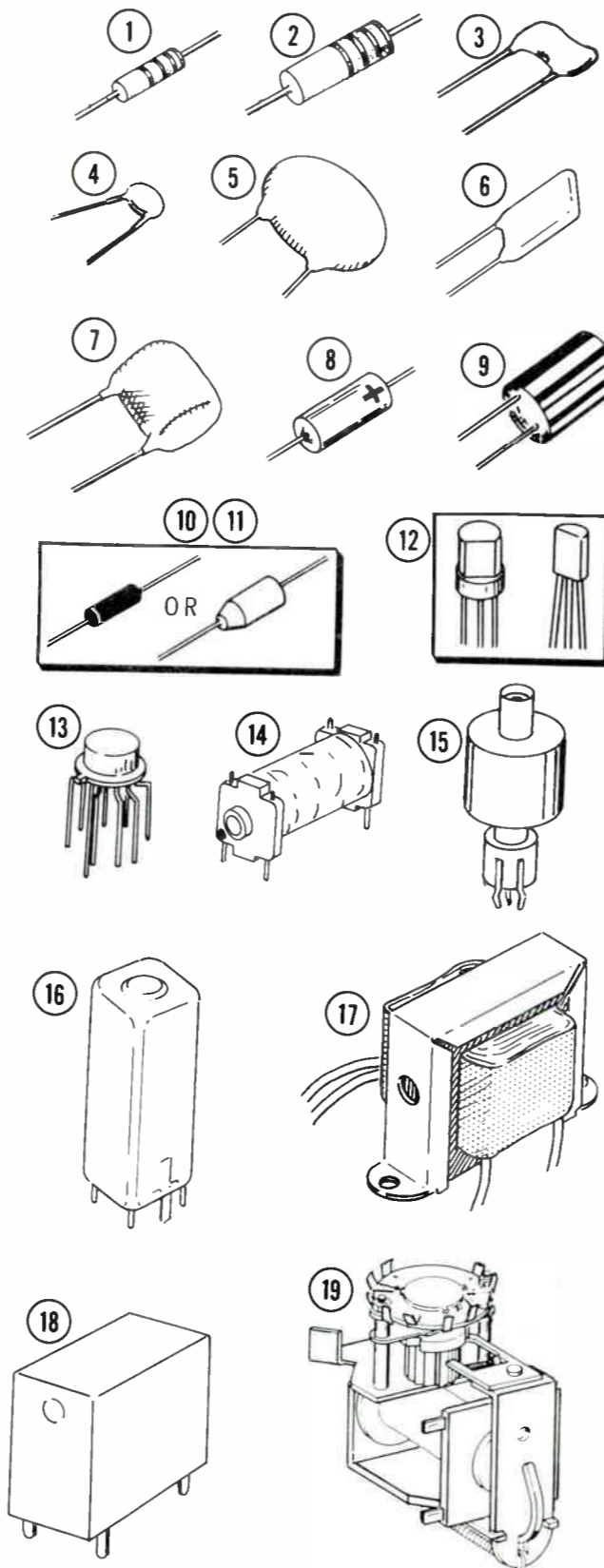

PARTS PICTORIAL #2
(For GR-180 and GR-227 only)

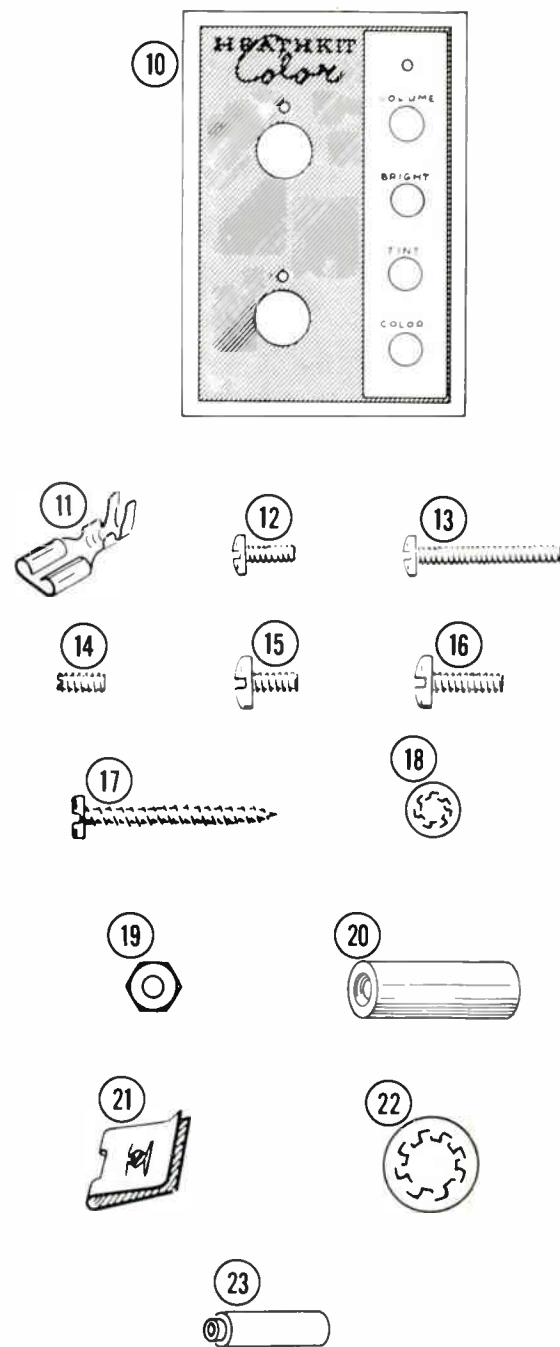
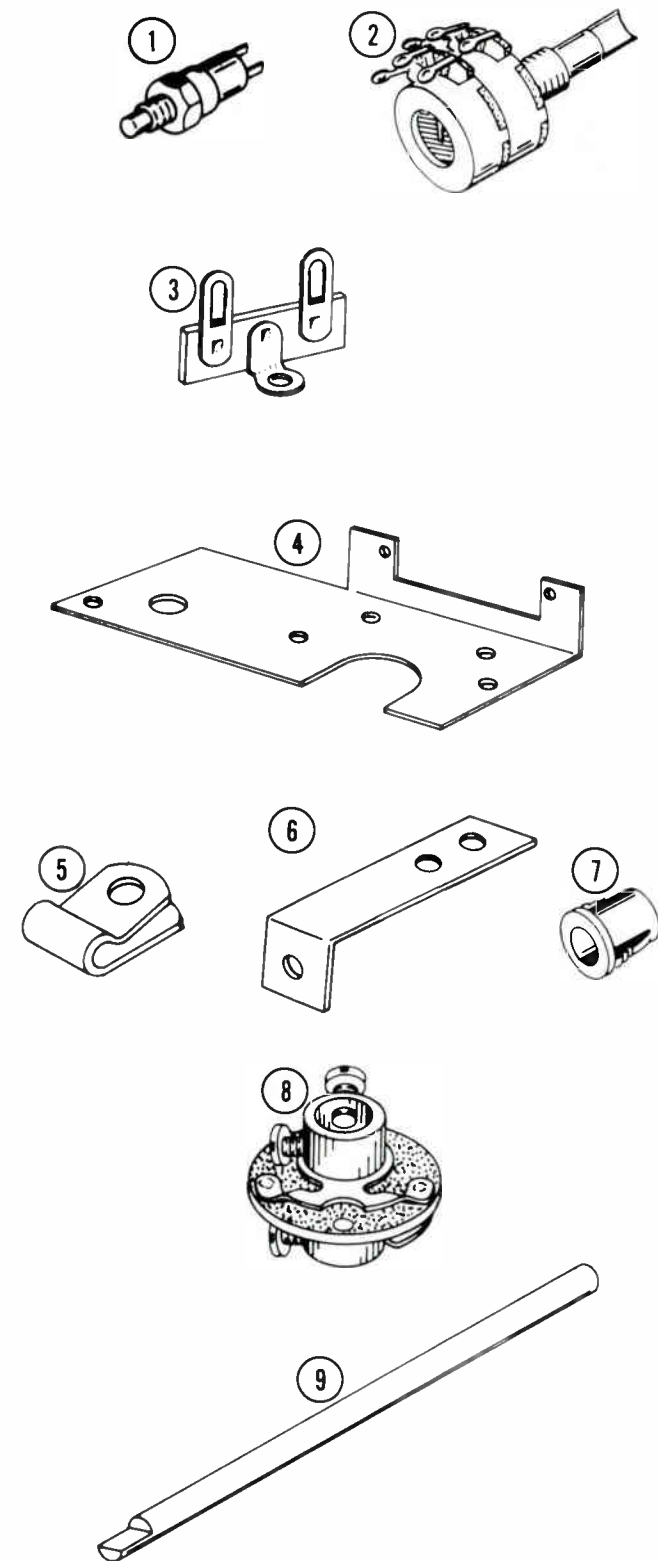

PARTS PICTORIAL #3
(For GR-295, GR-681, and GR-25 only)

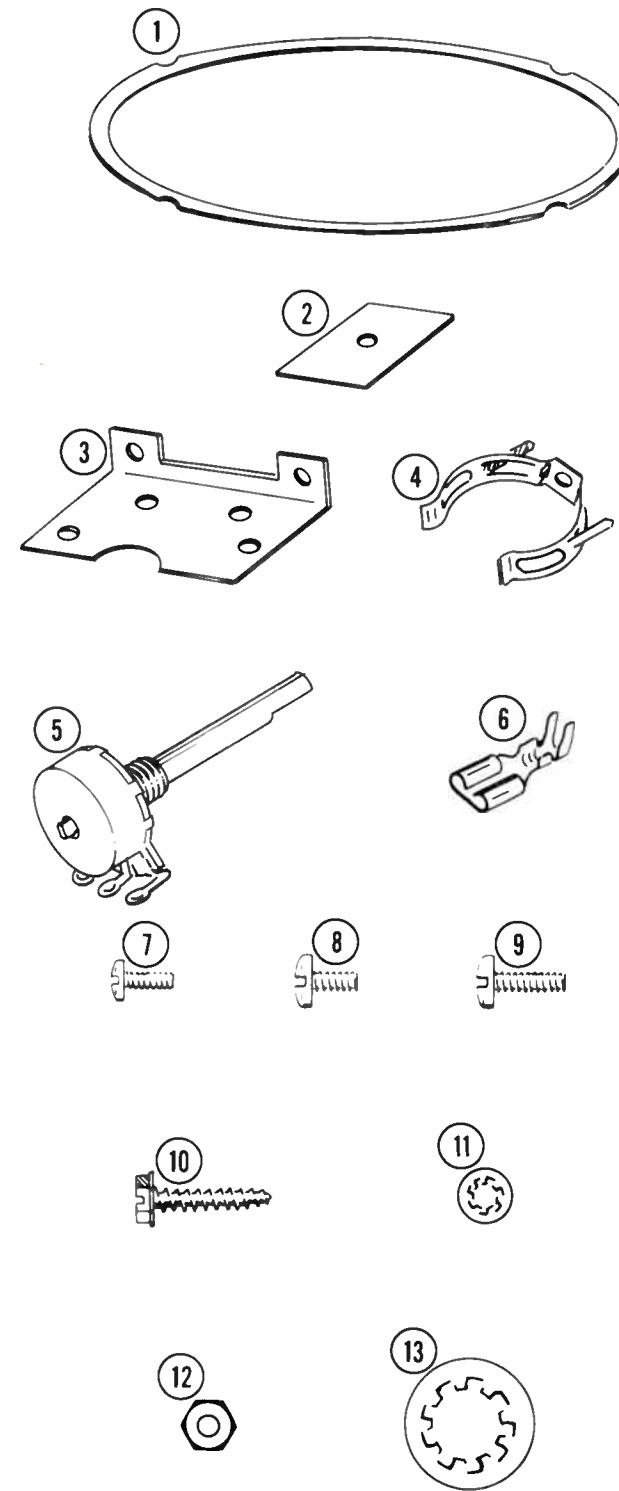

PART No. **PARTS Per Kit** **DESCRIPTION**

#4 Hardware
(42)250-419 4 ✓ 4-24 x 5/8" screw

#6 Hardware
(43)250-365 6 ✓ #6 x 1/4" sheet metal screw
(44)250-8 4 ✓ #6 x 3/8" sheet metal screw
(45)259-6 1 ✓ #6 small solder lug
(46)259-1 1 ✓ #6 large solder lug

#8 Hardware
(47)250-137 1 ✓ 8-32 x 3/8" binder head screw
(48)250-348 2 ✓ 8-32 x 3/8" hex washer head screw (not supplied with Model GRA-681-6)
(49)254-2 3 ✓ #8 lockwasher

Other Hardware
(50)256-49 12 Split rivet
(51)253-107 2 E-washer
(52)432-72 9 Male terminal
(53)432-73 11 Female terminal
(54)258-95 3 Spring contact

PART No. **PARTS Per Kit** **DESCRIPTION**

MISCELLANEOUS

85-266-1 1 ✓ Transmitter circuit board
85-267-1 1 ✓ Receiver circuit board
(55)200-522 2 ✓ Chassis-half
(56)206-390 1 ✓ Top shield
(57)206-391 1 ✓ Bottom shield
(58)92-45 1 ✓ Transmitter case (top)
(59)92-46 1 ✓ Transmitter case (bottom)
(60)390-227 1 ✓ Transmitter trim panel
391-34 1 ✓ Blue and white identification label
597-260 1 ✓ Parts Order Form
597-308 1 ✓ Kit Builders Guide
(61)490-1 1 ✓ Plastic alignment tool
(62)490-5 1 ✓ Nut starter
Solder
595-985 1 ✓ Manual

NOTE: It will be necessary to purchase a 9-volt dry cell battery (NEDA type #1604) before the Remote Control can be put into operation. *NEDA #1604 batteries include the following types: Burgess #2U6, Eveready #216, Mallory #MN1604, RCA #V5323, and Ray-O-Vac #1604.



HEATH COMPANY

Phone 616-983-3961 • TWX-616-983-3897 • Benton Harbor, Michigan 49022

October 4, 1968

Dear Customer:

If you have purchased the GRA-295-6 or GRA-681-6 Remote Control, please mark the following changes in your Manual. If you have purchased the GRA-227-6 Remote Control you may disregard these changes.

Page 60 - Change the note to read as follows:

NOTE: The following boxed-in steps should be completed only if you are installing the GRA-681-6 Remote Control in your GR-681 TV Set.

Page 62 - Replace the second step in the left-hand column with the following step.

- () Mount the completed motor assembly on the tuner bracket at FD as shown in Detail 4-3B. Use a control lockwasher and nut. Be sure to use the larger lockwasher which was supplied with the kit and not the small lockwasher that was removed from the other control. Do not overtighten the nut; this could cause the control to bind. Rotate the shaft to make sure it turns freely.

Page 64 - Replace this page with the new Page 64 supplied with this letter.

Page 65 - Replace this page with the new Page 65 supplied with this letter.

Page 65 fold-out - Cross out GR-681 under Pictorial 4-5. Place the Detail 4-5A supplied with this letter on the right-hand side of this fold-out page.

Page 67 - Replace this page with the new Page 67 supplied with this letter.

Parts List #2

The following Parts are for the Heathkit Models
GR-180 and GR-227 Color Television Sets.

<u>PART No.</u>	<u>PARTS Per Kit</u>	<u>DESCRIPTION</u>	<u>PART No.</u>	<u>PARTS Per Kit</u>	<u>DESCRIPTION</u>
SWITCHES-CONTROLS			HARDWARE		
(1)64-31	1	Pushbutton switch	(12)250-52	3	4-40 x 1/4" screw
(2)12-93	1	250 k Ω - 1 M Ω dual control	(13)250-312	3	4-40 x 3/4" screw
12-94	1	1200 Ω - 1 M Ω dual control	(14)250-28	1	6-32 x 1/4" setscrew
GENERAL			(15)250-56	11	6-32 x 1/4" screw
(3)431-2	1	2-lug terminal strip	(16)250-89	7	6-32 x 3/8" screw
(4)204-867	1	Motor mounting plate	(17)250-347	1	#6 x 1" sheet metal screw
(5)207-3	1	1/8" cable clamp	(18)254-1	16	#6 lockwasher
207-5	1	3/16" cable clamp	(19)252-3	13	6-32 nut
(6)204-182	1	Microphone bracket	(20)255-5	1	#6 x 3/4" spacer
(7)455-70	1	Nylon bushing	(21)252-22	5	6-32 speednut
(8)456-1	1	Shaft coupler	(22)254-14	1	1/4" lockwasher
(9)453-168	1	Control shaft	(23)255-92	3	#4 x 9/16" spacer
(10)390-228	1	Television trim panel			
(11)432-66	4	Terminal strip connector			
344-79	1	Brown stranded wire			

Parts List #3

The following Parts are for the Heathkit Models
GR-295, GR-681, and GR-25 Color Television
Sets.

<u>PART No.</u>	<u>PARTS Per Kit</u>	<u>DESCRIPTION</u>	<u>PART No.</u>	<u>PARTS Per Kit</u>	<u>DESCRIPTION</u>
(1)73-62	1 ✓	Speaker gasket	344-79	1 ✓	Brown stranded wire
(2)205-141	1 ✓	Microphone mounting plate	(7)250-52	6 ✓	4-40 x 1/4" screw
(3)204-813	1 ✓	Motor mounting plate (not supplied with Model GRA-681-6)	(8)250-56	10 ✓	6-32 x 1/4" screw
(4)208-6	1 ✓	Microphone mounting clip	(9)250-89	3 ✓	6-32 x 3/8" screw
(5)10-252	1 ✓	1200 Ω control	(10)250-252	4 ✓	#6 x 5/8" bronze screw
(6)432-66	2 ✓	Terminal strip connector	(11)254-1	14 ✓	#6 lockwasher
			(12)252-3	12 ✓	6-32 nut
			(13)254-4	2 ✓	Control lockwasher

STEP-BY-STEP ASSEMBLY

Before starting to assemble this kit, read the Kit Builders Guide for complete information on wiring, soldering, and step-by-step assembly procedures.

TRANSMITTER CIRCUIT BOARD ASSEMBLY

Refer to the Circuit Board Parts Mounting and Soldering sections (Pages 11, 12, and 13) of the Kit Builders Guide before starting the circuit board assembly.

Resistors will be called out by the resistance value (in Ω , $k\Omega$, or $M\Omega$) and color code. Use 1/2

watt resistors unless directed otherwise in a step.

Capacitors will be called out by the capacitance value (in pF or μF) and type (disc, silver mica, Mylar, or electrolytic).

A plastic nut starter has been provided with this kit. Use this nut starter to hold and start 3-48 and 6-32 nuts on screws.

Position the transmitter circuit board (#85-266-1) as shown in Pictorial 1-1. Complete each step on the Pictorial.

START



() Locate six split rivets and insert them in the indicated holes.

() Place a piece of paper on the rivets and, while holding the paper in place, turn the circuit board over so the foil is toward you as shown. The paper will prevent the rivets from dropping out.

(✓) Bend the rivets out slightly as shown. Then turn the rivets as shown in the Pictorial and solder them to the foil. Make sure they do not touch adjacent foils.

BEND RIVETS APART WITH SCREWDRIVER

(✓) Repeat the same procedure with the remaining six holes which are next to the rivets that were just installed. However, use #3 lockwashers under the heads of the rivets as shown.

RIVET
#3 LOCKWASHER

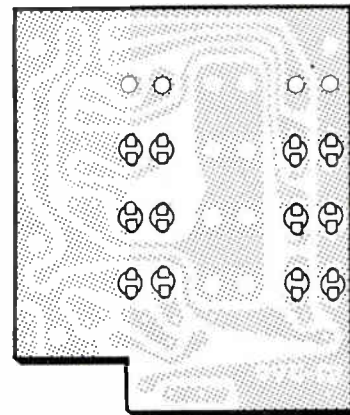
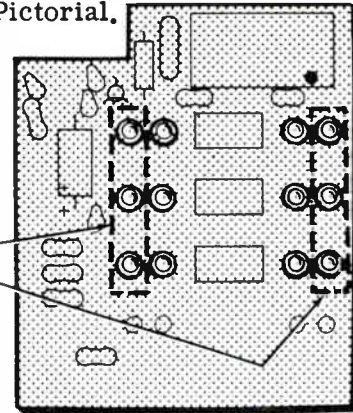

PROCEED TO PICTORIAL 1-2

PICTORIAL 1-1

START



(✓) Install a 2N3393 (#417-118) transistor in the following manner, as shown: First line up the flat on the transistor with the outline of the flat on the circuit board. Then insert the leads into their correct holes, which are indicated by E, C, and B. Position the transistor 1/4" above the circuit board. Then solder each lead to the foil and cut off the excess lead lengths.

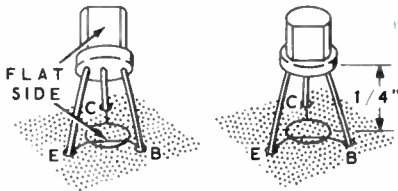

- (✓) 115 pF silver mica.
- (✓) 150 pF silver mica.
- (✓) 180 pF silver mica.
- (✓) 33 pF silver mica.
- (✓) 200 pF silver mica.
- (✓) Solder all leads to the foil and cut off the excess lead lengths.

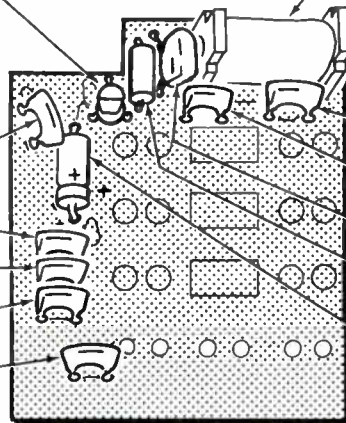

CONTINUE



(✓) Oscillator coil (#40-848). Position the end with the color dot as shown. Solder the four leads to the foil.

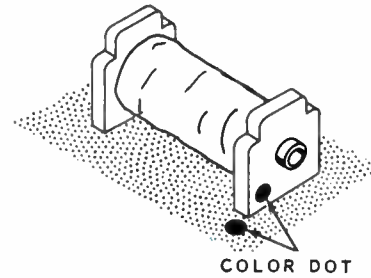

- (✓) 105 pF silver mica.
- (✓) 68 pF silver mica.
- (✓) .1 μF Mylar, 50 V or 100 V.
- (✓) 8200 Ω (gray-red-red).

(✓) 10 μF electrolytic. Position the positive (+) end as shown.



(✓) Solder all leads to the foil and cut off the excess lead lengths.

PROCEED TO PICTORIAL 1-3.

PICTORIAL 1-2

START

Position the circuit board as shown.

Locate the following parts:

- (✓) Three spring contacts.
- (✓) Rocker arm bracket.
- (✓) Six 3-48 x 1/4" screws.
- (✓) Six #3 lockwashers.
- (✓) Six 3-48 nuts.

- (✓) Mount a spring contact with two 3-48 x 1/4" screws, #3 lockwashers, and 3-48 nuts as shown. Before tightening the screws, center the spring contact in the rectangular outline on the circuit board.

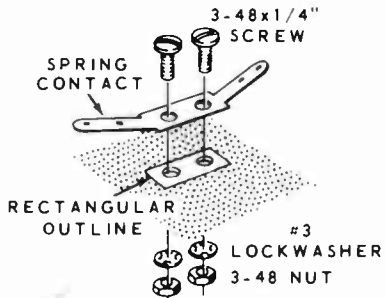

- (✓) Mount two spring contacts and the rocker arm bracket with four 3-48 x 1/4" screws, #3 lockwashers and 3-48 nuts. Center the spring contacts in the rectangular outline on the circuit board. Also make sure the rocker arm bracket is centered over both rectangular outlines.

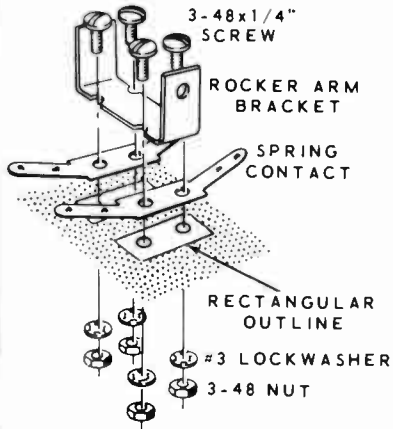

BATTERY CONNECTOR

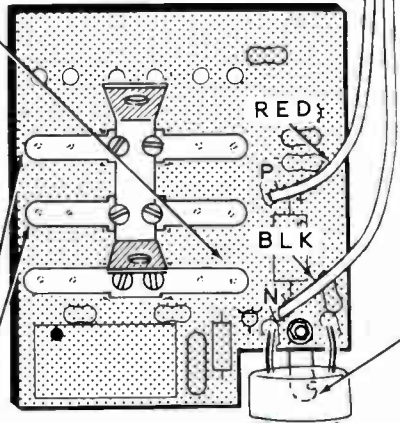

CONTINUE

- (✓) Prepare the leads of the battery connector as shown.

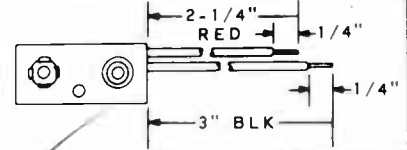

- (✓) Connect the black lead of the battery connector to hole N (S-1).

- (✓) Connect the red lead to hole P (S-1).

- (✓) Mount a small #6 solder lug on the foil side of the circuit board. Use a 3-48 x 1/4" screw, two #3 lockwashers, and a 3-48 nut.

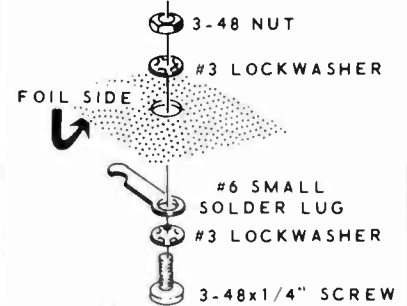

- (✓) Locate the transducer. Note that one lead is connected to the metal case. Install the transducer by inserting this ground lead in hole L and the other lead in hole K. Position the transducer against the solder lug. Then solder both leads to the foil and cut off the excess lead lengths. Do not solder the transducer to the solder lug.

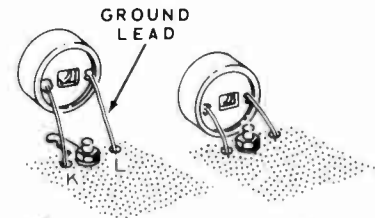

- (✓) Carefully inspect the foil side of the circuit board and solder any connections that might have been missed. Also inspect the circuit board for any solder bridges between foils.

PICTORIAL 1-3

Refer to Pictorial 1-4 for the following steps.

Locate the following parts:

- (✓) Three plastic rocker arms.
- (✓) Rocker arm shaft.
- (✓) Two E-washers.
- (✓) Install an E-washer on the indicated groove of the rocker arm shaft. Push the washer in place around the groove. Refer to Part A of Pictorial 1-4.
- (✓) Start the shaft in the mounting hole of the rocker arm bracket. Then place two rocker arms inside the bracket and slide the shaft through them and the other hole in the bracket.
- (✓) Place the remaining rocker arm on the outside of the bracket and push the shaft through the hole. Then install the other E-washer around the groove between the rocker arm and bracket. Refer to Part B of Pictorial 1-4.
- (✓) Position each rocker arm over its respective spring contact.
- (✓) Depress each side of the rocker arms while observing the spring contacts. Make sure the protrusions on the spring contacts make contact with the rivets.

NOTE: There are several holes in the circuit board that are not used.

Refer to Detail 1-5A for the following steps.

- (✓) Position the transmitter case (top half) as shown.
- (✓) Position the transmitter case grille with the wide space side as shown. Then insert the grille in the slot in front of the transducer support. Bend the grille tabs against the support and touch the case and tab slightly with a hot soldering iron as shown in the inset drawing. This will fasten the grille to the case.

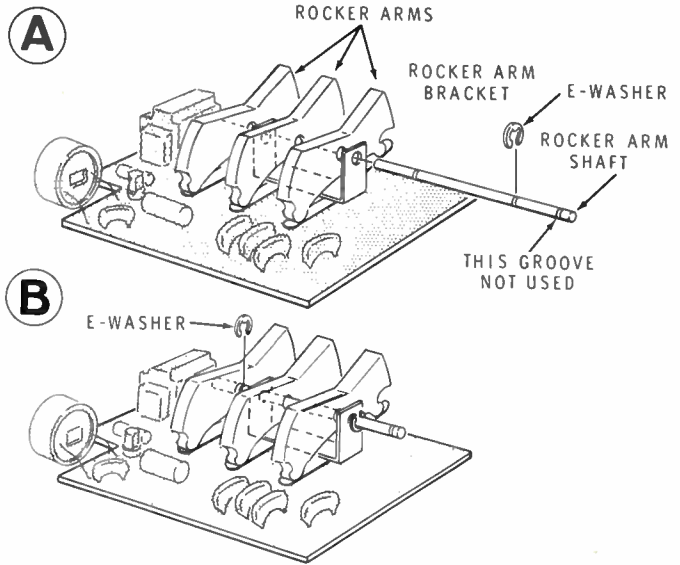

PICTORIAL 1-4

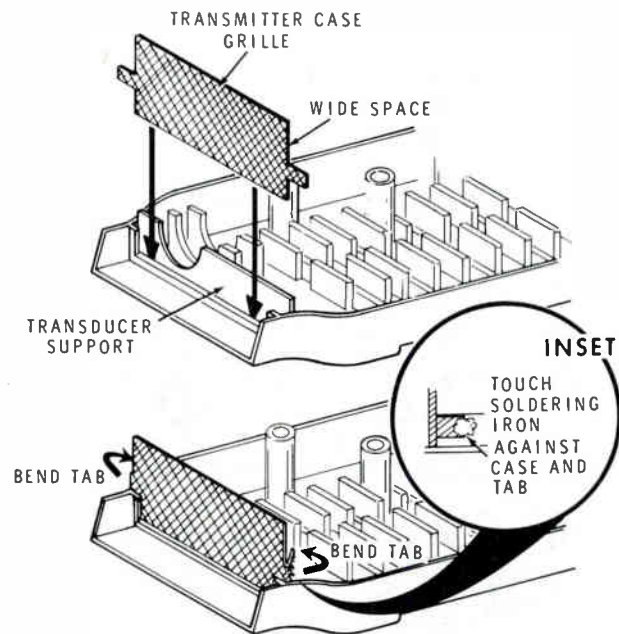

Detail 1-5A



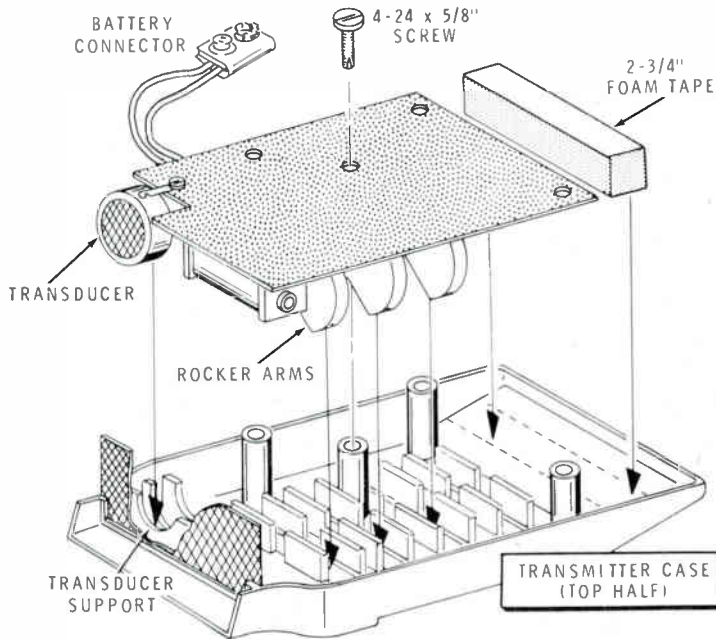

PICTORIAL 1-5

Refer to Pictorial 1-5 for the following steps.

- (✓) Peel away the backing paper from one side of the foam tape and press the tape inside the case at the location shown.
- (✓) Place the transmitter circuit board in the case with the transducer resting on the support and the rocker arms protruding through their respective slots.
- (✓) Fasten the circuit board to the case with a 4-24 x 5/8" screw. Make sure the battery connector is positioned as shown.

Refer to Pictorial 1-6 for the following steps.

- (✓) Clip the battery connector on the 9 volt battery (not supplied). Then place the battery on the foam tape.
- (✓) Place the bottom half of the transmitter case on the top half. Make sure the grille fits into the case groove. Then fasten the bottom half to the top half with three 4-24 x 5/8" screws.
- (✓) Peel away the backing paper from the transmitter trim panel. Center the trim panel carefully over the rocker arms and press it in place on the case as shown in Pictorial 1-7.

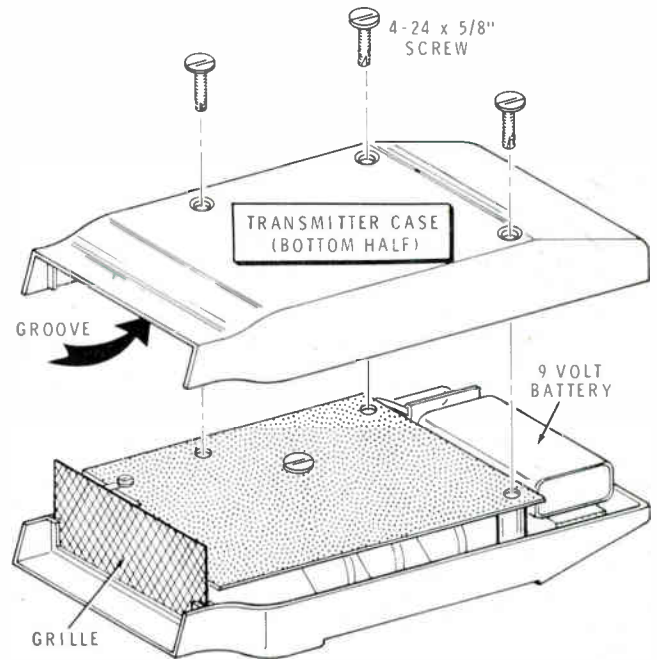

PICTORIAL 1-6

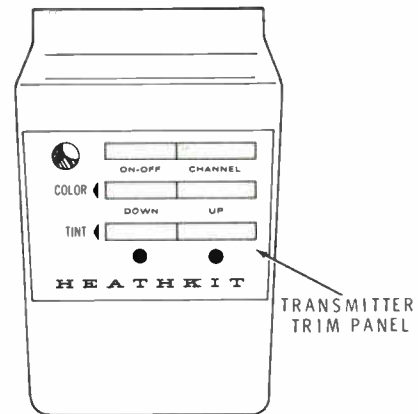

PICTORIAL 1-7

This completes the assembly of the transmitter. It can be set aside until used in the Initial Check-out section.

RECEIVER CIRCUIT BOARD

Position the receiver circuit board #85-267-1 as shown in Pictorial 2-1. Complete each step on the Pictorial.

START



- (✓) Position the receiver circuit board as shown.
- (✓) 33 Ω (orange-orange-black).
- (✓) 100 Ω 2 watt (brown-black-brown).
- (✓) 330 Ω (orange-orange-brown).
- (✓) 10 kΩ (brown-black-orange).
- (✓) 330 Ω (orange-orange-brown).
- (✓) 10 kΩ (brown-black-orange).
- (✓) 56 Ω (green-blue-black).
- (✓) 330 Ω (orange-orange-brown).
- (✓) 10 kΩ (brown-black-orange).
- (✓) 330 Ω (orange-orange-brown).
- (✓) 10 kΩ (brown-black-orange).
- (✓) 330 Ω (orange-orange-brown).
- (✓) 10 kΩ (brown-black-orange).
- (✓) Solder all leads to the foil and cut off the excess lead lengths.
- (✓) 330 Ω (orange-orange-brown).
- (✓) 10 kΩ (brown-black-orange).
- (✓) 56 Ω (green-blue-black).
- (✓) 4700 Ω (yellow-violet-red).
- (✓) 2200 Ω (red-red-red).
- (✓) 2.2 MΩ (red-red-green).
- (✓) 100 kΩ (brown-black-yellow).
- (✓) 33 kΩ (orange-orange-orange).
- (✓) 1000 Ω (brown-black-red).
- (✓) 150 kΩ (brown-green-yellow).
- (✓) 10 kΩ (brown-black-orange).
- (✓) Mount this resistor as shown in the inset drawing at the right.
- (✓) 4700 Ω (yellow-violet-red).
- (✓) Solder all leads to the foil and cut off the excess lead lengths.

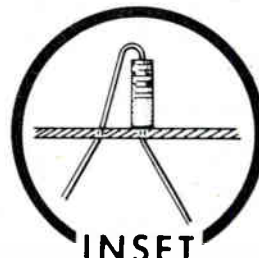
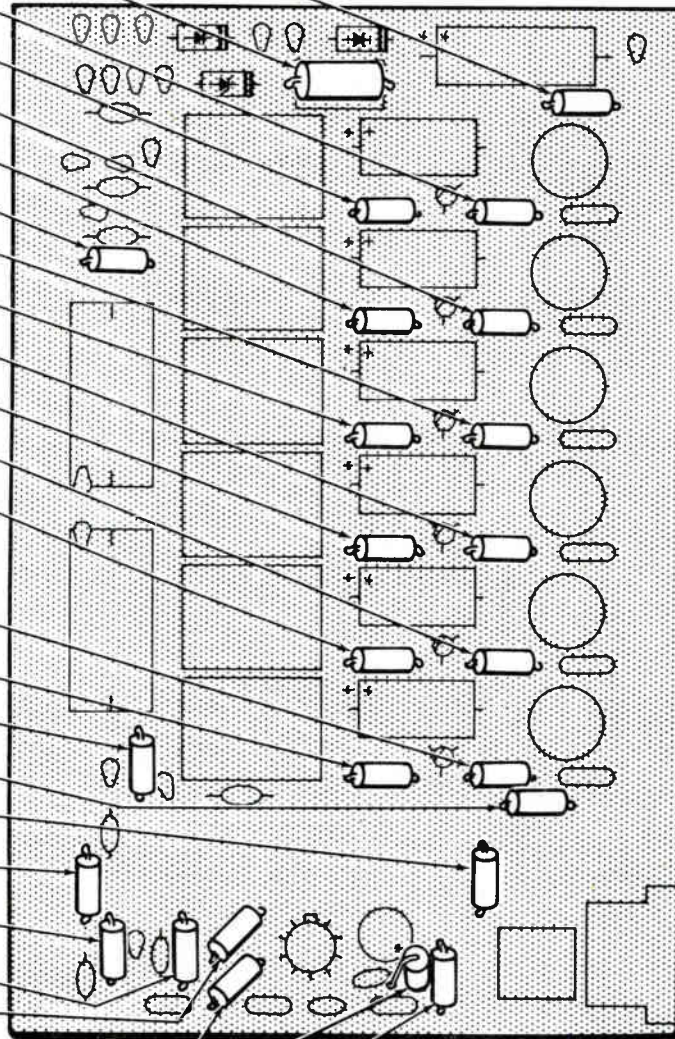

PROCEED TO PICTORIAL 2-2.

PICTORIAL 2-1

START

NOTE: Install the transistors in the following manner: First line up the flat of the transistor with the outline of the flat on the circuit board. Then insert the transistor leads into their correct holes, which are indicated by E, C, and B. Position the transistor 1/4" away from the circuit board. Then solder each lead to the foil and clip off the excess lead lengths.

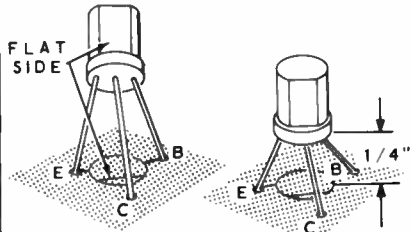

Install 2N3393 transistors (#417-118) at the following locations:

- (✓) 2N3393 transistor at Q102.
- (✓) 2N3393 transistor at Q103.
- (✓) 2N3393 transistor at Q104.
- (✓) 2N3393 transistor at Q105.
- (✓) 2N3393 transistor at Q106.
- (✓) 2N3393 transistor at Q107.

Locate the integrated circuit. Do not straighten the leads; they are preformed to match the mounting holes in the circuit board.

- (✓) Install the integrated circuit in the following manner: First line up the locating tab of the integrated circuit with the outline of the locating tab on the circuit board. Then insert the leads of the integrated circuit into their respective holes 1 through 10. Turn the circuit board over and solder the ten leads to the foil. Cut off the excess length from lead 10.

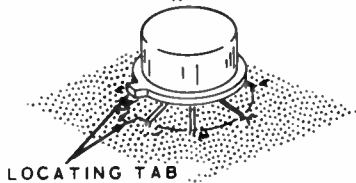

LOCATING TAB

CONTINUE

NOTE: When installing the following silicon diodes, be sure to position the cathode end as shown. The cathode end is marked with either a color end or band.

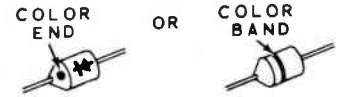

- (✓) Silicon diode (#57-27) at D101.
- (✓) Silicon diode (#57-27) at D102.
- (✓) Zener diode (#56-45) at D103. Be sure to position the cathode end of the diode as shown. The cathode end is marked with a band or bands.

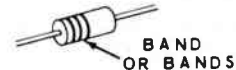

- (✓) Solder all leads to the foil and cut off the excess lead length.

PROCEED TO PICTORIAL 2-3.

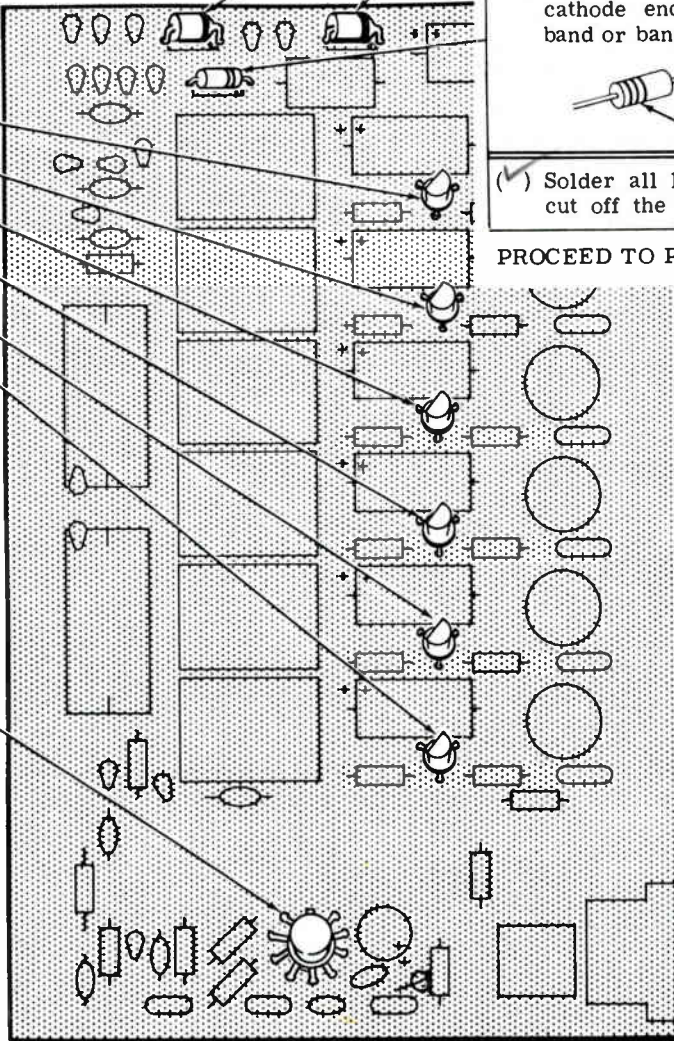

PICTORIAL 2-2

START



- (✓) .01 μ F disc 1.4 kV.
- (✓) .01 μ F disc 1.4 kV.
- (✓) .01 μ F disc 1.4 kV.
- (✓) 680 pF silver mica.
- (✓) 680 pF silver mica.
- (✓) 680 pF silver mica.
- (✓) 680 pF silver mica.
- (✓) 680 pF silver mica.
- (✓) 680 pF silver mica.
- (✓) Solder all leads to the foil and cut off the excess lead lengths.
- (✓) .01 μ F disc 1.4 kV.
- (✓) .01 μ F disc.
- (✓) .005 μ F disc.
- (✓) .01 μ F disc.

- (✓) 33 pF disc.
- (✓) .022 μ F Mylar.
- (✓) .022 μ F Mylar.
- (✓) .002 μ F disc.
- (✓) .047 μ F Mylar.
- (✓) Solder all leads to the foil and cut off the excess lead lengths.

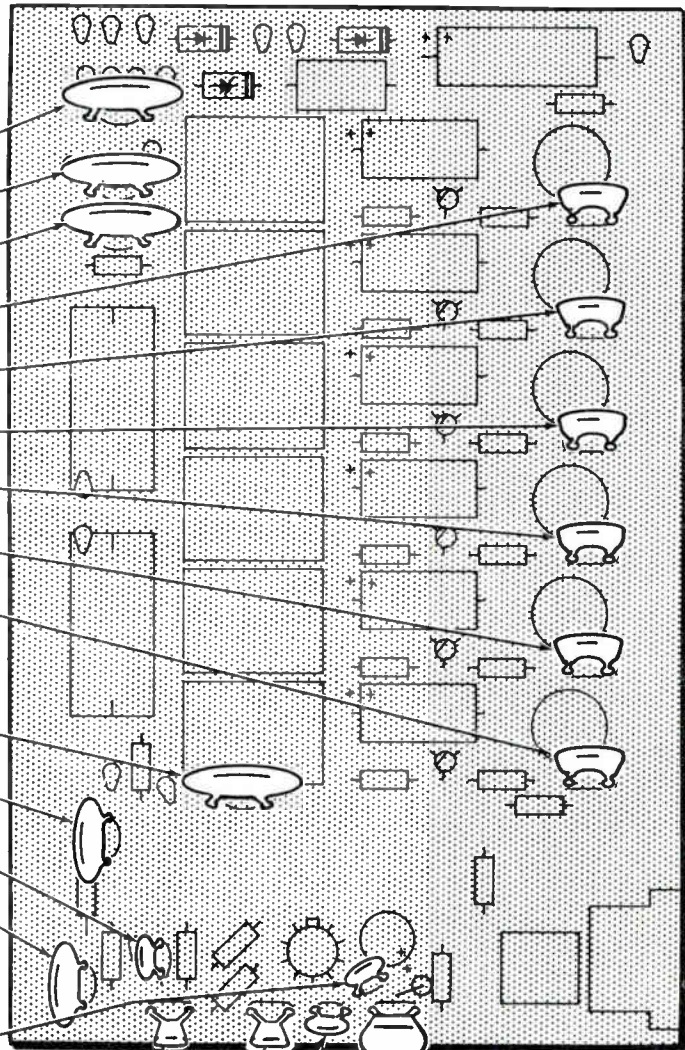

PROCEED TO PICTORIAL 2-4.

PICTORIAL 2-3

START

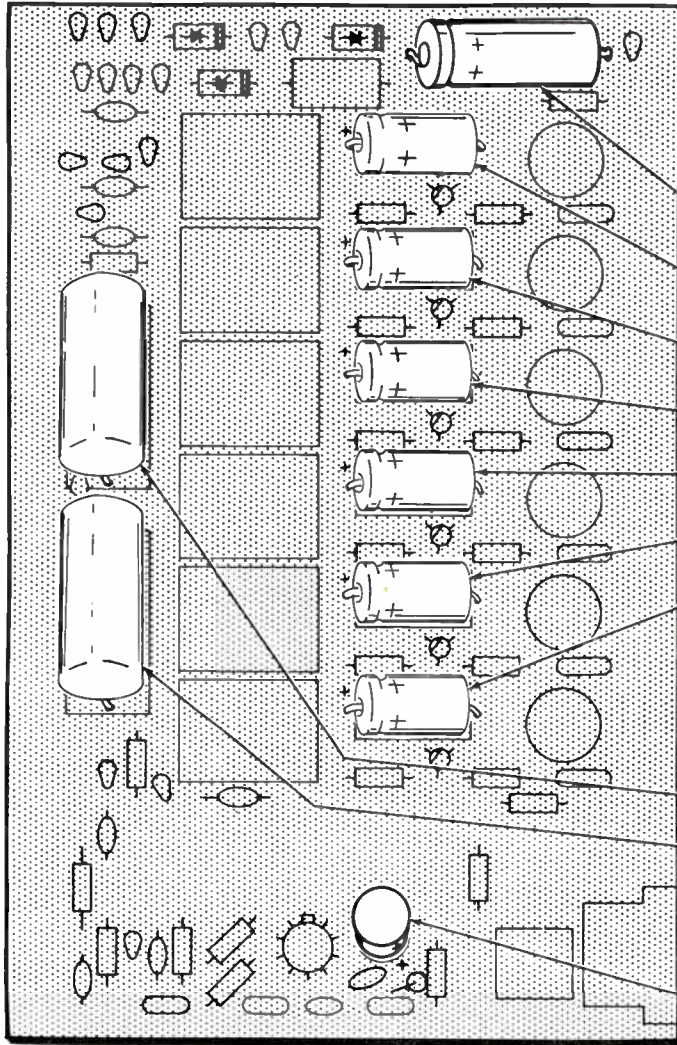

NOTE: When mounting electrolytic capacitors, always match the positive (+) end on the capacitor with the positive (+) mark on the circuit board.



(✓) 100 μ F electrolytic.

(✓) 25 μ F electrolytic.

(✓) 25 μ F electrolytic.

(✓) 25 μ F electrolytic.

(✓) 25 μ F electrolytic.

(✓) 25 μ F electrolytic.

(✓) 25 μ F electrolytic.

(✓) Solder all leads to the foil and cut off the excess lead lengths.

NOTE: Disregard the marked end of the next two capacitors; they can be installed either way.

(✓) .33 μ F Mylar.

(✓) .33 μ F Mylar.

(✓) 50 μ F vertical mounting electrolytic. Mount this type of capacitor as shown.

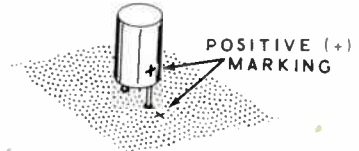

(✓) Solder all leads to the foil and cut off the excess lead lengths.

PROCEED TO PICTORIAL 2-5.

PICTORIAL 2-4

START

NOTE: To install the following relays, line up the lugs of the relay with the correct holes in the circuit board. Then push the relay in place and solder each lug to the foil.

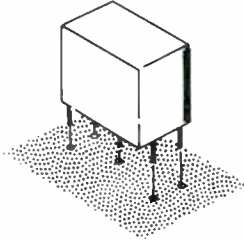

- (✓) Relay (#69-50).
- (✓) Relay (#69-50).
- (✓) Relay (#69-50).
- (✓) Relay (#69-50).
- (✓) Relay (#69-50).
- (✓) Relay (#69-50).

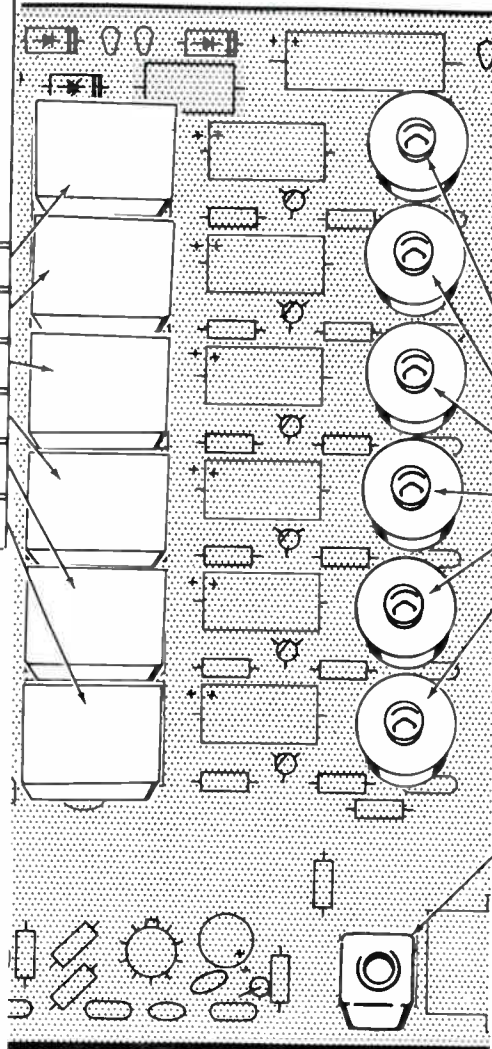

CONTINUE

NOTE: To install the following coils, line up the coil lugs with the correct holes in the circuit board. Then push the coil in place and solder each lug to the foil. Handle the coils carefully to avoid breaking the fine wires that are connected to the lugs.

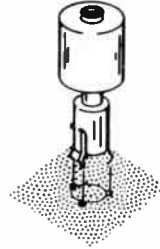

- (✓) 42 kHz coil (#40-843) at L101.
- (✓) 42 kHz coil (#40-843) at L102.
- (✓) 44 kHz coil (#40-842) at L103.
- (✓) 44 kHz coil (#40-842) at L104.
- (✓) 40 kHz coil (#40-844) at L105.
- (✓) 40 kHz coil (#40-844) at L106.
- (✓) Driver Transformer (#40-849) at T101. Line up the coil lugs with the correct holes in the circuit board. Then push the coil in place and solder each lug to the foil.

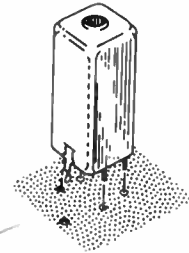

Carefully inspect the foil side of the circuit board and solder any connections that might have been missed. Then set the circuit board aside temporarily.

PROCEED TO PAGE 18

CHASSIS PARTS MOUNTING AND WIRING

Refer to Pictorial 3-1 (fold-out from Page 23) for the following steps.

- (✓) Locate one of the chassis-halves; both are identical. Parts will be mounted on the half that makes up the left side and bottom part of Pictorial 3-1.
- (✓) Install a 3/8" rubber grommet in hole DB.
- () Install a 1/2" rubber grommet in hole DD.
- (✓) Mount a 2-lug terminal strip (one lug ground) at DA with a 6-32 x 1/4" screw, two #6 lockwashers, and a 6-32 nut. Refer to Detail 3-1A.

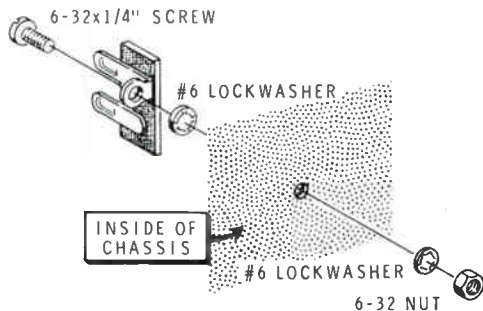

Detail 3-1A

- (✓) Mount the power transformer at DE with 6-32 x 1/4" screws, #6 lockwashers, and 6-32 nuts. Insert all of the leads except the indicated black one through grommet DD. Refer to Detail 3-1B.

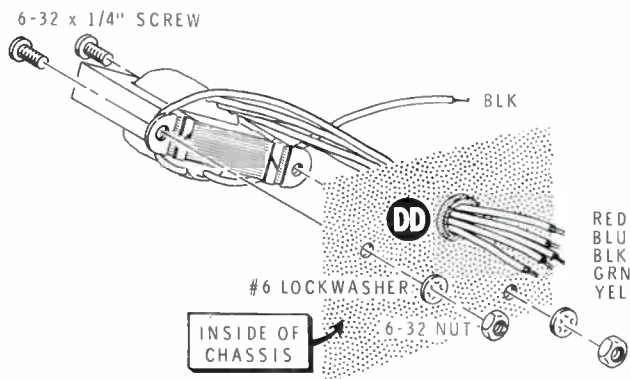

Detail 3-1B

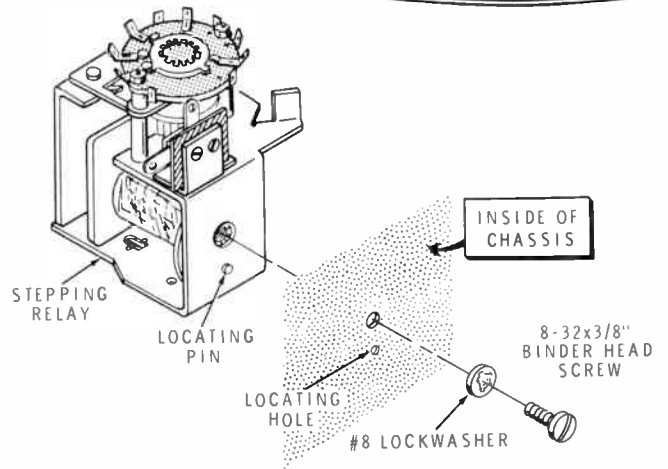

Detail 3-1C

- (✓) Mount the stepping relay at DC with an 8-32 x 3/8" binder head screw and a #8 lockwasher. Make sure the locating pin of the relay is inserted in the locating hole in the chassis. Refer to Detail 3-1C.

Set the chassis aside temporarily.

NOTE: Prepare the lengths of wire ahead of time as in the following step. To prepare a wire, cut it to the indicated length and strip 1/4" of insulation from each end. For stranded wires, twist the strands and melt a small amount of solder on each end to hold the strands together.

- (✓) Prepare the following lengths of hookup and stranded wire. Use the ruler printed on Page 19.

- 6-1/2" brown stranded ✓
- 5-1/2" violet stranded ✓
- 13" white hookup ✓
- 13" white-blue hookup ✓
- 3" orange hookup ✓
- 3-1/2" green hookup ✓
- 2" yellow hookup ✓
- 5-1/2" gray hookup ✓
- 6-1/4" blue hookup ✓

- (✓) Locate nine female terminals. Then refer to Detail 3-1D and install one terminal on each of the previously prepared wires.

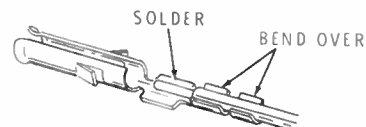

Detail 3-1D

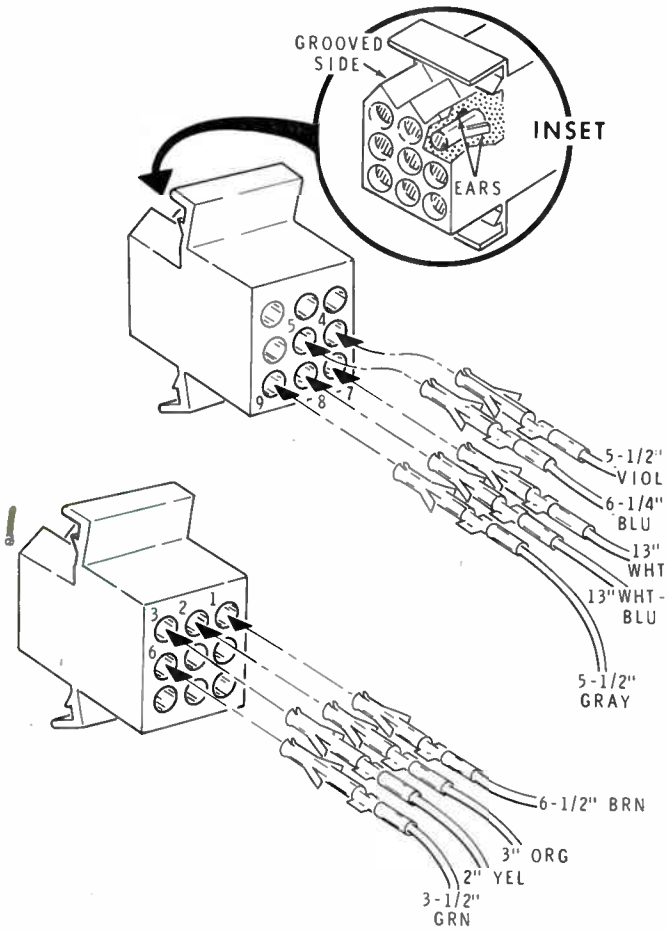

Detail 3-1E

- (✓) Gray wire in hole 9.
- (✗) White-blue wire in hole 8.
- (✓) White wire in hole 7.
- (✗) Green wire in hole 6.
- (✓) Blue wire in hole 5.
- (✗) Violet wire in hole 4.
- (✗) Yellow wire in hole 3.
- (✓) Orange wire in hole 2.
- (✗) Brown wire in hole 1.

Locate the remote control cable assembly. The 9-terminal cable connector will be installed on the wires that break out from the center of the assembly.

- (✓) Locate nine male terminals. Then refer to Detail 3-1F and install the terminals on the end of all the wires except the black one.

- (✓) Position the 9-terminal chassis connector with the grooved side up as shown in Detail 3-1E.

Insert the terminal end of the wires in the connector holes in the following steps. The inset drawing on Detail 3-1E shows how the metal ears lock each terminal in place. NOTE: Be very careful to insert the correct wire in each hole, since the terminals were not designed to be pulled out again. However, if an error was made, cut the wire approximately 1/4" from the connector and resolder the correct color wire on the 1/4" wire stub. A small piece of insulating tape should be wrapped around the bare wire.

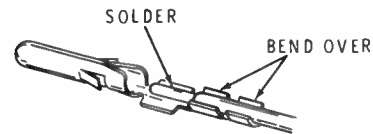

Detail 3-1F

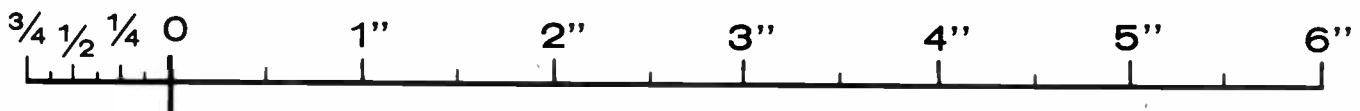

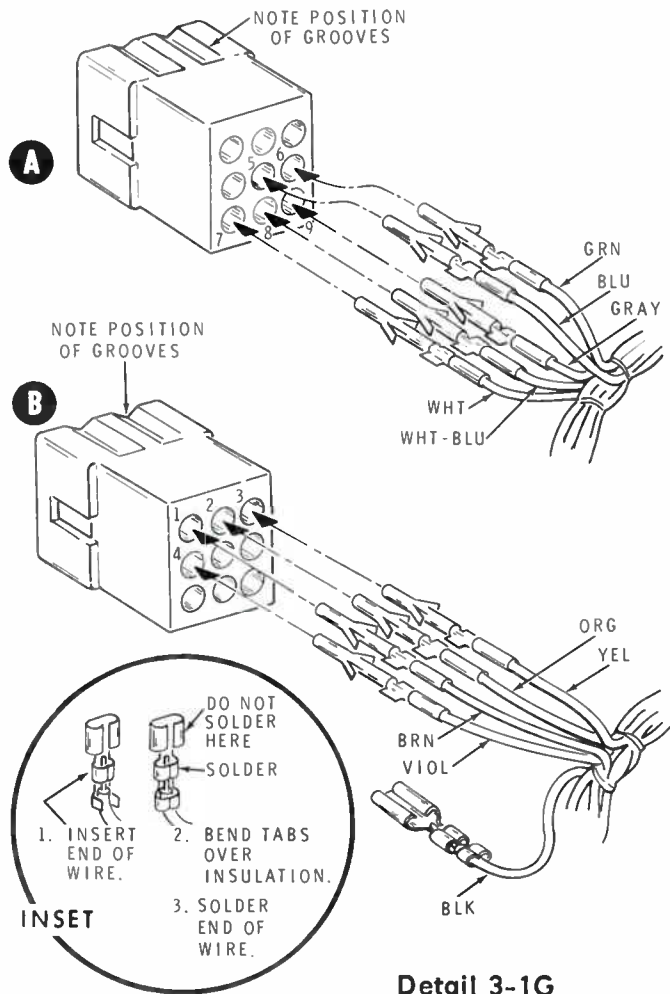

(✓) Install a terminal strip connector on the end of the black wire as shown in the inset drawing on Detail 3-1G.

Set the cable assembly aside; it will be used later.

(✓) Refer to Detail 3-1H and install the 9-terminal chassis connector from the inside of the chassis at DF. To install the connector, position the grooved side up, bend back both tabs, and push it into place.

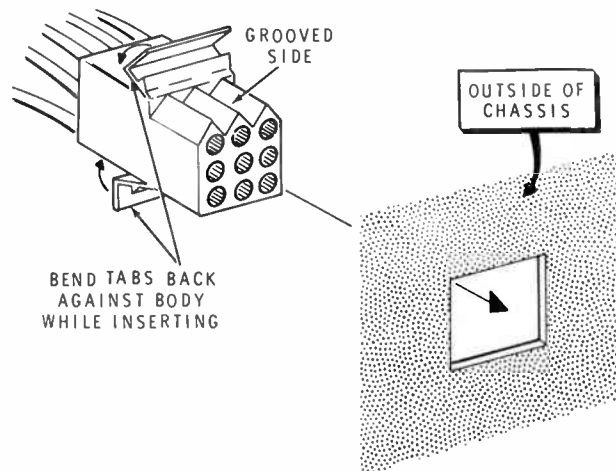

() Position the 9-terminal cable connector with the grooved side up as shown in Detail 3-1G.

Insert the terminal ends of the wires in the connector holes in the following steps. Use the same method you used with the other connector.

- (✓) Gray wire in hole 9.
- (✓) White-blue wire in hole 8.
- (✓) White wire in hole 7.
- (✓) Green wire in hole 6.
- (✓) Blue wire in hole 5.
- (✓) Violet wire in hole 4.
- (✓) Yellow wire in hole 3.
- (✓) Orange wire in hole 2.
- (✓) Brown wire in hole 1.

(✓) Remove all of the insulation from a 1" black hookup wire. Refer to Detail 3-1J and install a female terminal on each end of the wire. Then slip a 2-3/8" length of small clear sleeving over the connectors.

(✓) Tape this jumper wire on the receiver chassis near the 9-pin connector. The purpose for this wire will be explained in another section of the Manual.

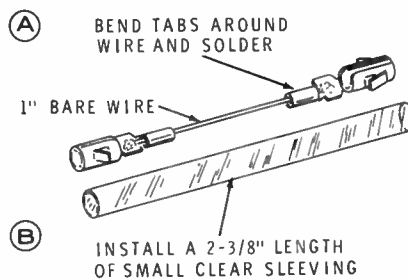

Refer to Detail 3-1K for the following steps.

- (✓) Bend the wires coming from the connector and transformer over the chassis to keep them out of the way for the next step.
- (✓) Position the receiver circuit board as shown and mount it inside the chassis-half with three #6 x 1/4" sheet metal screws.

Refer to Detail 3-1L for the following steps.

- (✓) Mount the phono socket on the remaining chassis-half at DG with 6-32 x 1/4" screws, #6 lockwashers, and 6-32 nuts. Position the socket with the lugs as shown. NOTE: Some of the holes in this chassis-half will not be used.
- (✓) Slide this chassis-half in place on the other chassis-half as shown by the two large arrows.

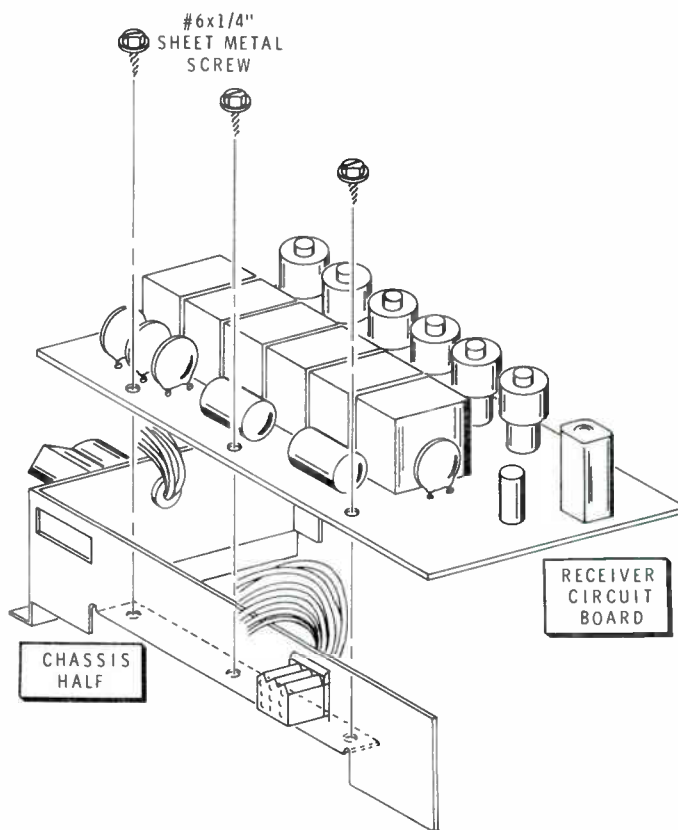

Detail 3-1K

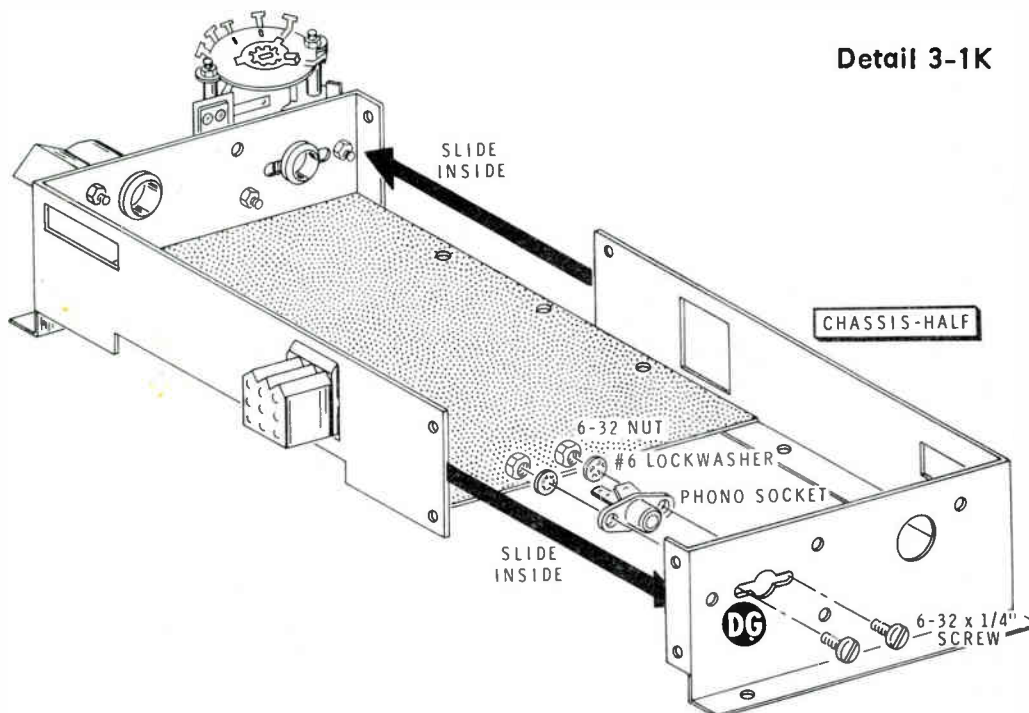

Detail 3-1L



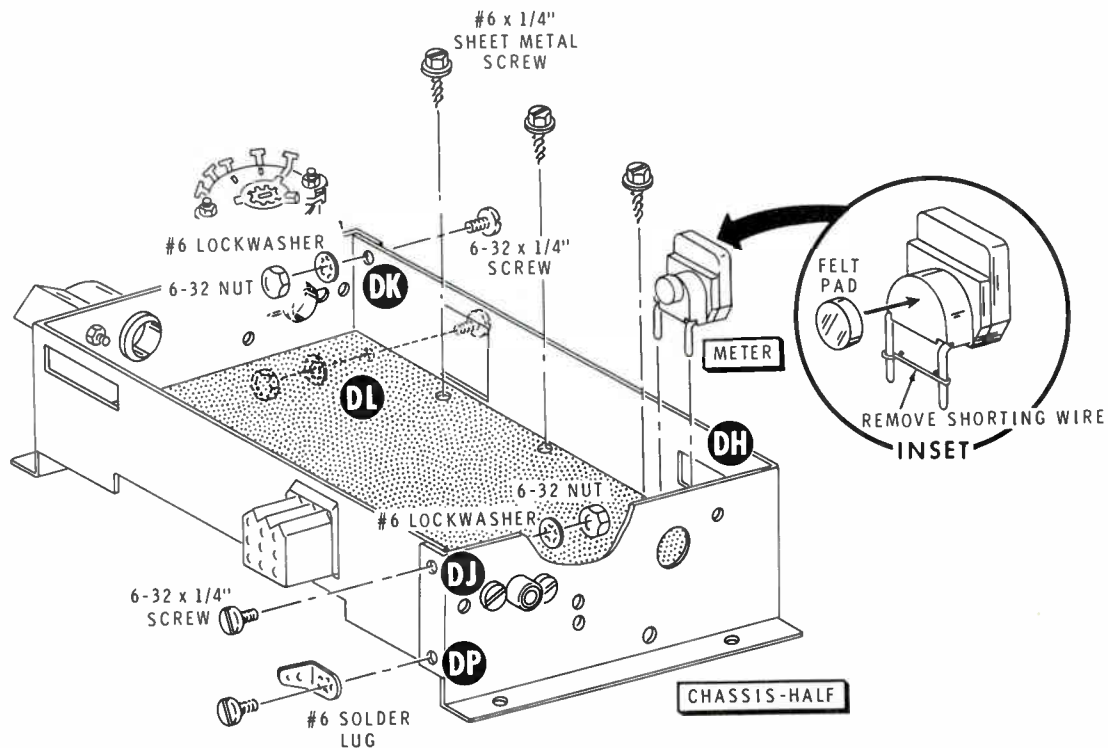

Detail 3-1M

NOTE: Be careful not to damage the switch wafer on the stepping relay when the chassis is turned over.

Refer to Detail 3-1M for the following steps.

- ✓) Fasten the two chassis halves together with 6-32 x 1/4" screws, #6 lockwashers, and 6-32 nuts at DJ, DK, DL, and DP. Also use a #6 solder lug at DP.
- ✓) Fasten the circuit board to the chassis-half with three #6 x 1/4" sheet metal screws.
- ✓) Remove and discard the shorting wire from between the meter leads. Refer to the inset drawing on Detail 3-1M.

✓) Remove the backing paper from the round felt pad. Then press the pad in place on the back of the meter. Refer to the inset drawing on Detail 3-1M.

✓) Install the meter on the circuit board by inserting the respective leads into the positive (+) and negative (-) holes and the meter face into cutout DH. NOTE: The felt pad will press firmly against transformer T101.

✓) Turn the receiver over, being careful not to damage the switch wafer on the stepping relay, and solder both meter lugs to the foil.



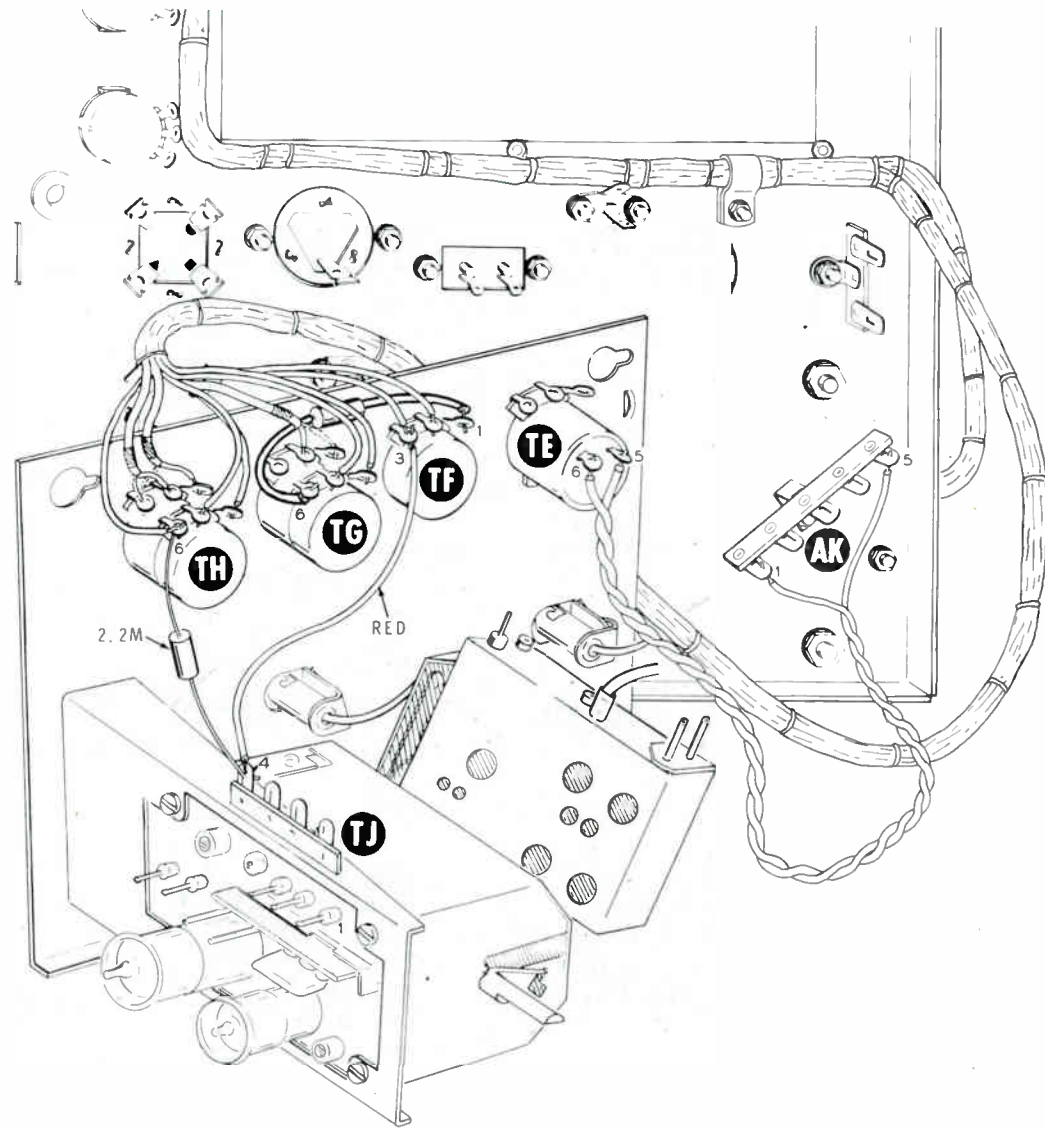

PICTORIAL 4-6

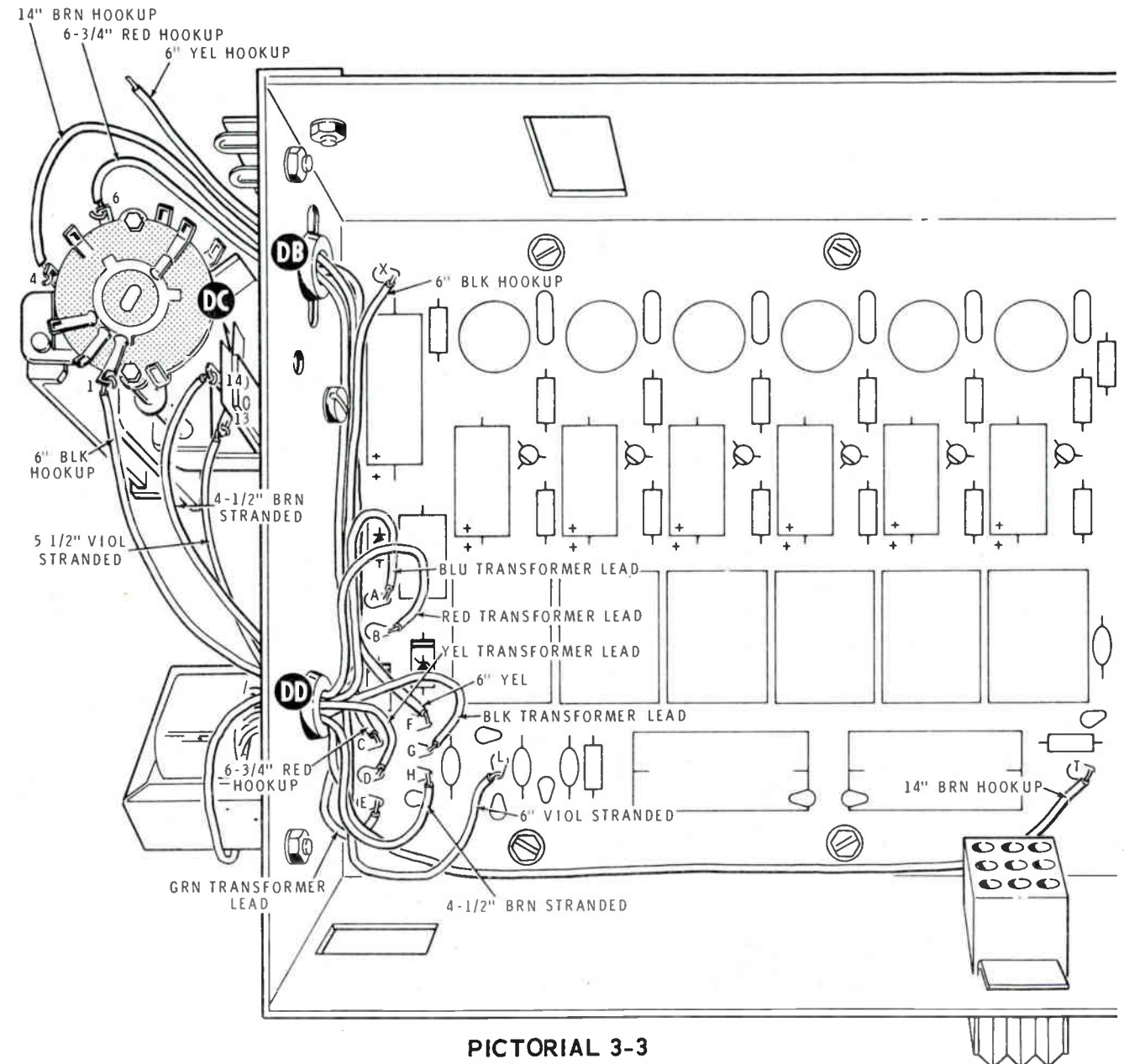

PICTORIAL 3-3

Refer to Pictorial 3-3 for the following steps.

- (*) Prepare the following lengths of hookup and stranded wire. The wires are listed in the order in which they will be used.

- 6-3/4" red hookup ✓
- 14" brown hookup ✓
- 6" yellow hookup ✓
- 6" black hookup ✓
- 4-1/2" brown stranded ✓
- 6" violet stranded ✓

Connect the following wires from the receiver circuit board to stepping relay DC. Route these wires under the power transformer leads.

- (*) 6-3/4" red hookup wire from hole C (S-1), through grommet DB, to lug 6 of relay DC (S-1).
- (*) 14" brown hookup wire from hole T (S-1), through grommet DB, to lug 4 of relay DC (S-1).

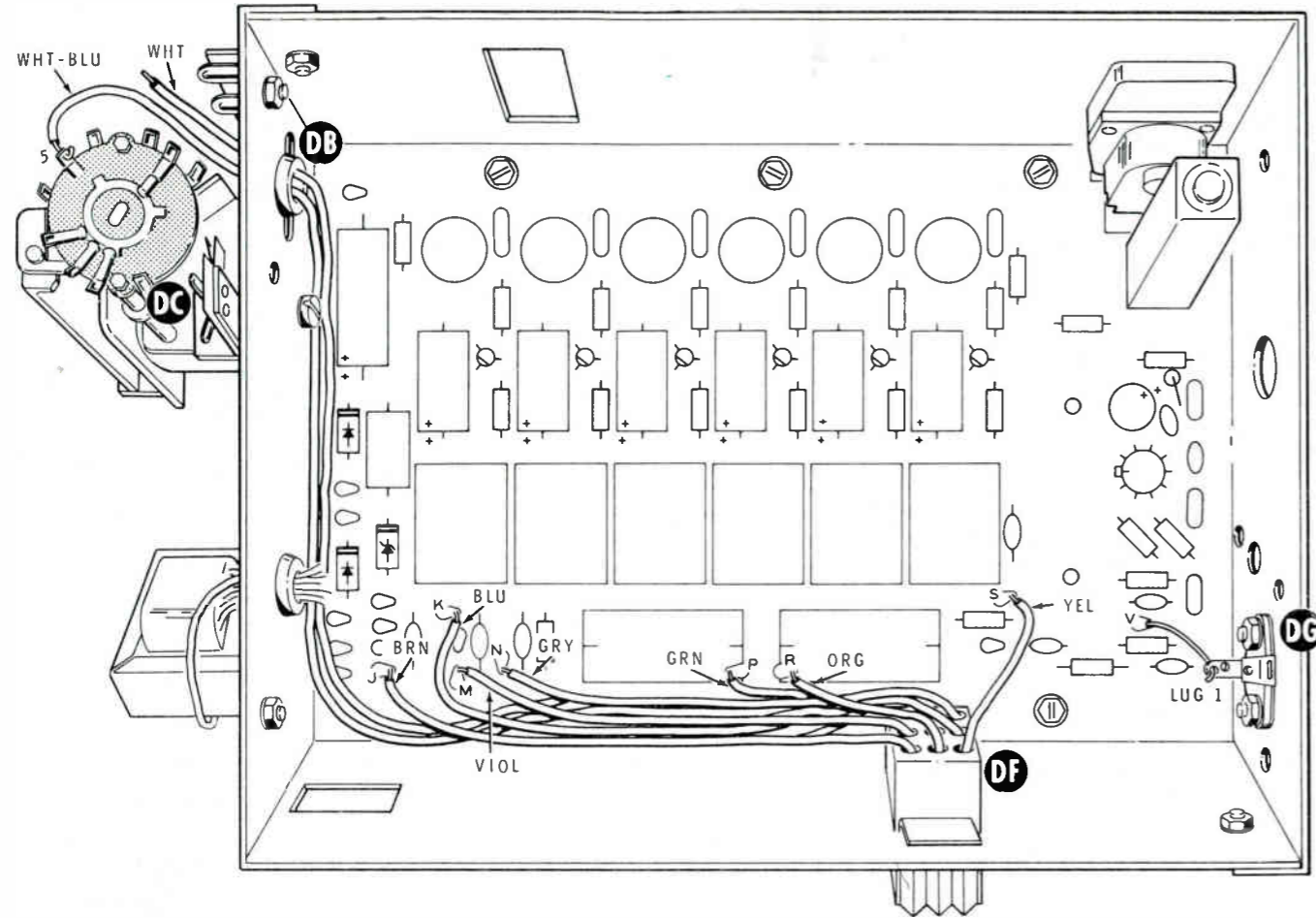

PICTORIAL 3-2

Refer to Pictorial 3-2 for the following steps.

✓ Route the white-blue wire from connector DF through grommet DB and connect it to lug 5 of the switch wafer (NS).

✓ Route the white wire from connector DF through grommet DB; it will be connected later.

Connect the remaining wires from connector DF to the circuit board in the following steps. Route the wires as shown and solder each one as it is installed.

✓ Gray wire to hole N.

✓ Violet wire to hole M.

✓ Blue wire to hole K.

✓ Green wire to hole P.

✓ Brown wire to hole J.

✓ Orange wire to hole R.

✓ Yellow wire to hole S.

✓ Remove all of the insulation from a 1-1/4" black wire. Connect the wire from lug 1 of phono socket DG (S-1) to hole V (S-1).

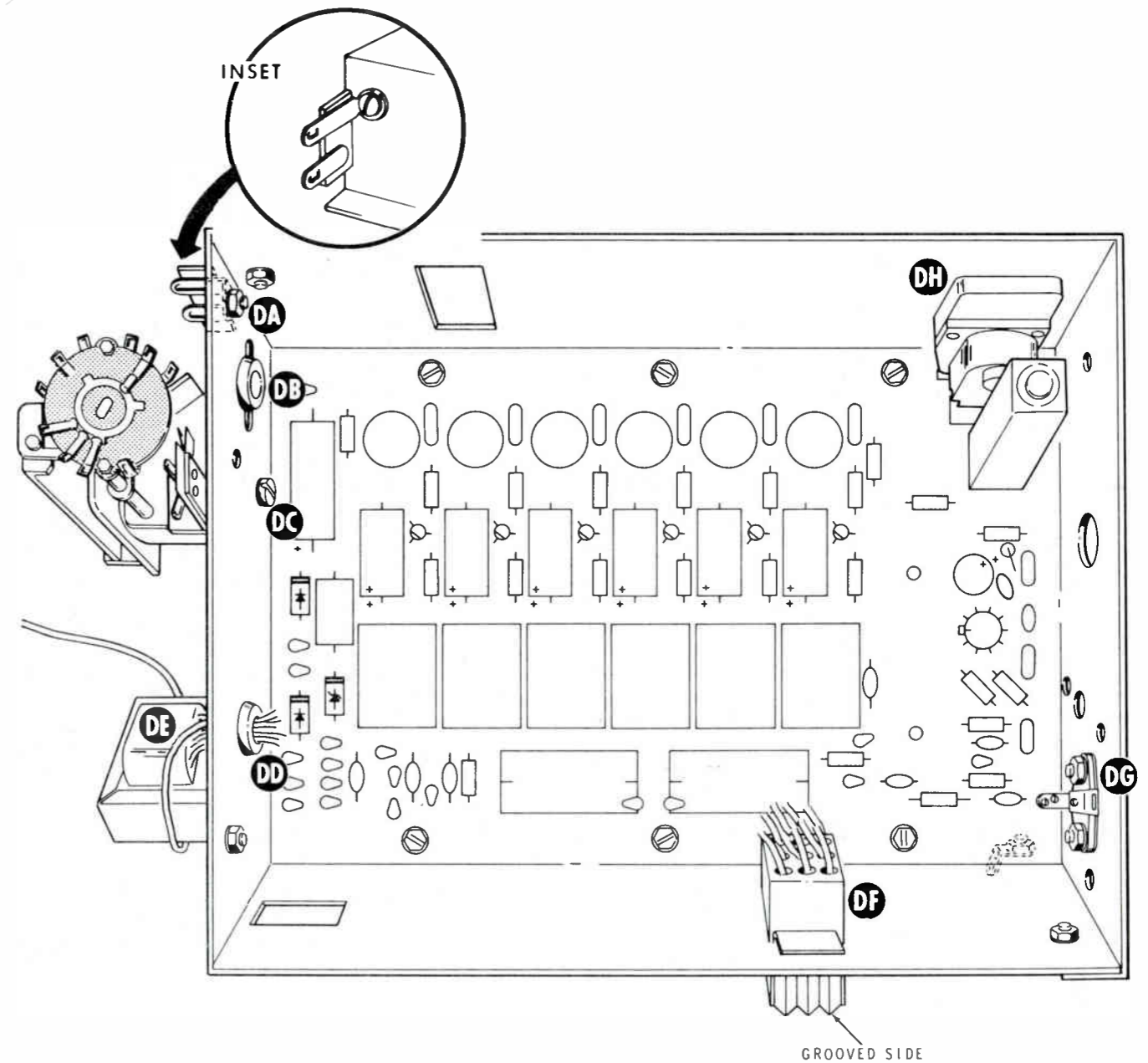

PICTORIAL 3-1

- (✓) 6" yellow hookup wire from hole F (S-1) through grommet DB; this end will be connected later.
- (✓) 6" black hookup wire from hole X (S-1), through grommet DD, to lug 1 of relay DC (NS).
- (✓) 4-1/2" brown stranded wire from hole H (S-1), through grommet DD, to lug 14 of relay DC (S-1).
- (✓) 6" violet stranded wire from hole L (S-1), through grommet DD, to lug 13 of relay DC (S-1).

Connect the power transformer leads coming through grommet DD to the circuit board in the following steps.

- (✓) Blue lead to hole A (S-1).
- (✓) Green lead to hole B (S-1).
- (✓) Yellow lead to hold D (S-1).
- (✓) Red lead to hole E (S-1).
- (✓) Black lead to hole G (S-1).
- (✓) Cut off the excess lead lengths from the power transformer leads, hookup wires, and stranded wires that protrude from the foil side of the board.

Refer to Pictorial 3-4 for the following steps.

- (✓) Position the receiver as shown.
- (✓) Place a 3/4" length of large clear sleeving over the yellow wire coming through grommet DB. Connect the wire to lug 15 of relay DC (S-1), and then slide the sleeving over the lug.
- (✓) Place a 3/4" length of large clear sleeving over the white wire coming from grommet DB and the black transformer lead. Connect the lead and wire to lug 16 of relay DC (S-2). Then slide the sleeving over the lug. Route the black lead against the chassis and under the relay as shown.

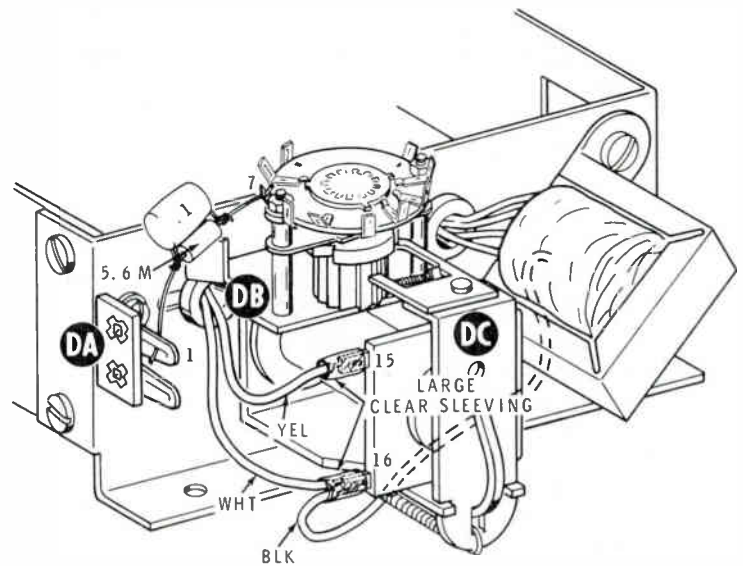

PICTORIAL 3-4

- (✓) Prepare a resistor-capacitor combination as shown in Detail 3-4A. Use a .1 μ F capacitor and 5.6 M Ω (green-blue-green) resistor.
- (✓) Connect this combination from lug 1 of terminal strip DA (S-1) to lug 7 of relay DC (NS).

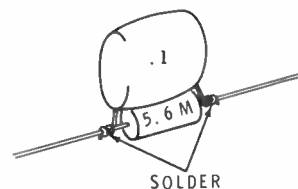

Detail 3-4A

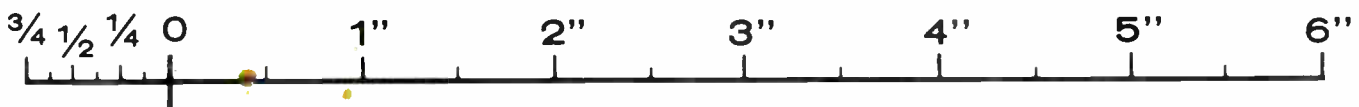

Refer to Pictorial 3-5 for the following steps.

() Prepare the following lengths of hookup wire:

- 1-1/2" yellow ✓
- 1-3/4" yellow ✓
- 3" green ✓

- (✓) Connect a 1-1/2" yellow wire between lugs 7 (NS) and 9 (NS) of relay DC.
- (✓) Connect a 1-3/4" yellow wire between lugs 9 (S-2) and 12 (S-1) of relay DC.
- (✓) Connect a 3" green wire from the eyelet of lug 2 of terminal strip DA (S-1) to lug 8 of relay DC (S-1).
- (✓) Connect a 1 M Ω (brown-black-green) resistor between lugs 5 (S-2) and 7 (S-3) of relay DC.

NOTE: Where a wire passes through a connection and then goes to another point, as in the next step, it will count as two wires in the solder instructions (S-2), one entering and one leaving the connection.

- (✓) Connect one lead of the 2.2 Ω (red-red-gold) 2 watt wire-wound resistor through lug 1 (S-3) to lug 2 (S-1) of relay DC. Connect the other lead to lug 3 (S-1).

Refer to Pictorial 3-6 for the following steps.

- (✓) Locate the top and bottom shields. Mount the shields to the circuit board with 6-32 x 3/8" screws, #6 lockwashers, and 6-32 nuts. Do not tighten the screws at this time.
- (✓) Fasten the top shield to the chassis with a #6 x 3/8" sheet metal screw. Then tighten the other two screws.

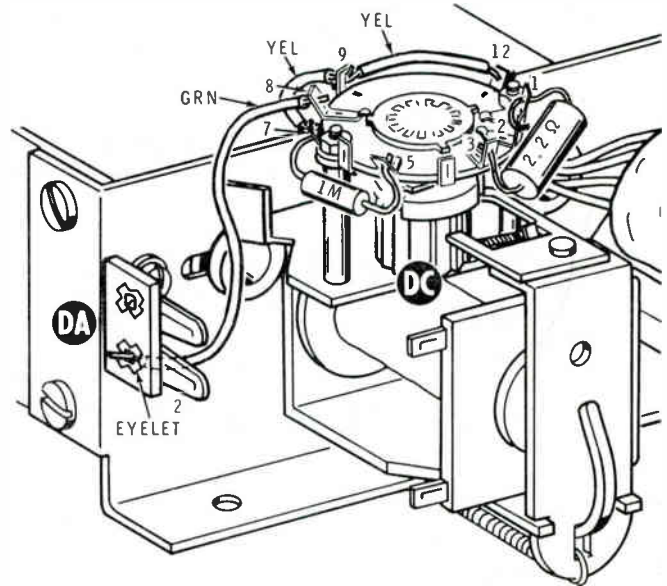

PICTORIAL 3-5

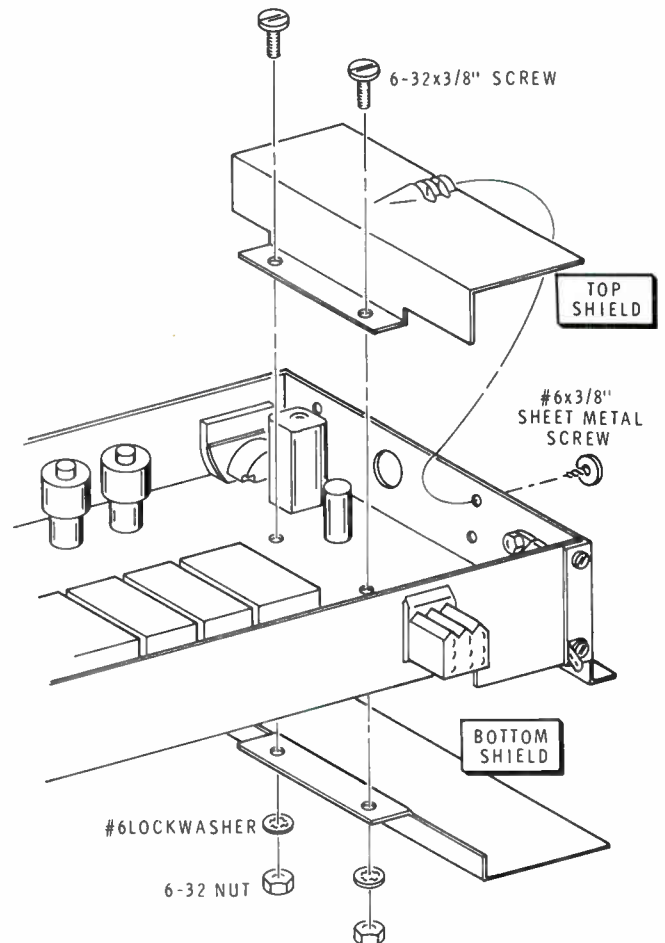

PICTORIAL 3-6

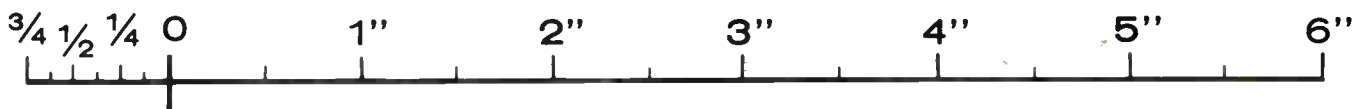

- () Carefully peel away the backing paper from the blue and white identification label. Then press the label onto the receiver alongside the meter. Be sure to refer to the numbers on this label in any communications you have with the Heath Company about this kit.
- (✓) Refer to Pictorial 3-7 and position the receiver so the foil side is toward you. Then solder the foil to the chassis at the three indicated locations.

This completes the assembly of the receiver. Turn the unit over and shake out any loose bits of solder or wire that may have lodged in the wiring. Also inspect the circuit board foil for any solder bridges between foils. Solder any connections that might have been missed. Then set the receiver aside temporarily.

NOTE: The following instructions are for Models GR-180 and GR-227 Color Television Sets. For Models GR-295, GR-681 and GR-25 Color Television Sets, proceed to Page 58.

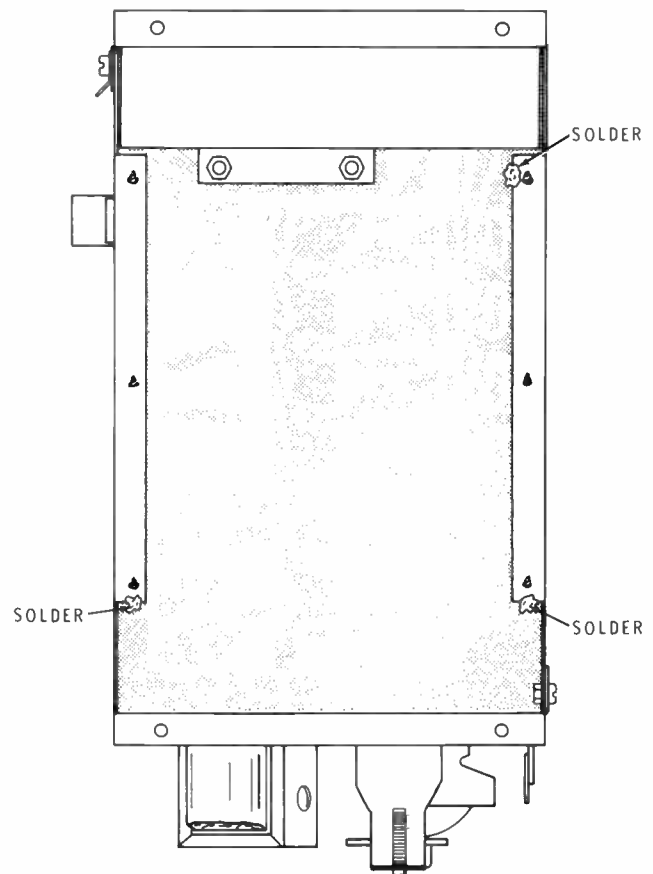

PICTORIAL 3-7

Instructions For Installing Remote Control In Models GR-180 Or GR-227 Television Sets

REMOVING TELEVISION SET FROM CABINET

In the following steps, the television set will be removed from the cabinet and placed on a work bench in order to make the necessary revisions to incorporate the Remote Control. If your set is custom installed, some of these instructions will not pertain to you. However, read the instructions and use the ones that do apply.

- () Unplug the line cord and fold it to keep it out of the way.
- () Disconnect the antenna.
- () Remove the cabinet back panel by loosening the bottom row of screws and removing all of the other screws that fasten it to the cabinet.
- () Remove the four screws that fasten the television to the bottom of the cabinet.
- () Loosen the two screws that fasten the convergence bracket to the cabinet. Place the bracket on the floor behind the set, being careful not to disturb any of the control settings.
- () Remove the screw that fastens the antenna terminals strip to the cabinet.
- () Remove all of the front panel knobs. Set all of the hardware and knobs aside; they will be used again when the set is reinstalled in the cabinet.

NOTE: The following boxed-in step should be completed for the Model GR-227 TV set only.

- () Remove the trim panel from the picture tube mask and discard it.

- () Carefully pull the set out of the cabinet; put the convergence bracket on top of the set, and place the set on your work bench. The back of the set should be toward you.

NOTE: The following boxed-in step should be completed only if you are converting your TV set from the Remote Control Switch Model GRA-27 to the Remote Control Model GRA-227-6.

- () Refer to Detail 4-1A and remove the screw and plastic clamp that fastens the remote control switch cable to the picture tube shield. The clamp may be discarded, but re-install the screw.

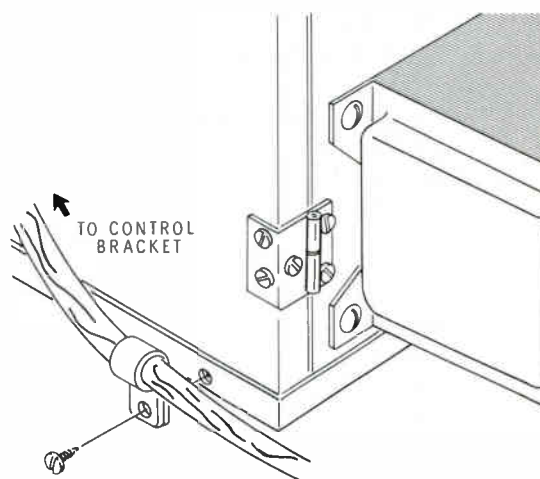

Detail 4-1A

REMOVING CHASSIS FROM SHIELD ASSEMBLY

Refer to Pictorial 4-1 for the following steps.

- () Unplug the picture tube socket, convergence cable, and yoke cable.
- () Remove the three screws that fasten the chassis to the shield assembly.

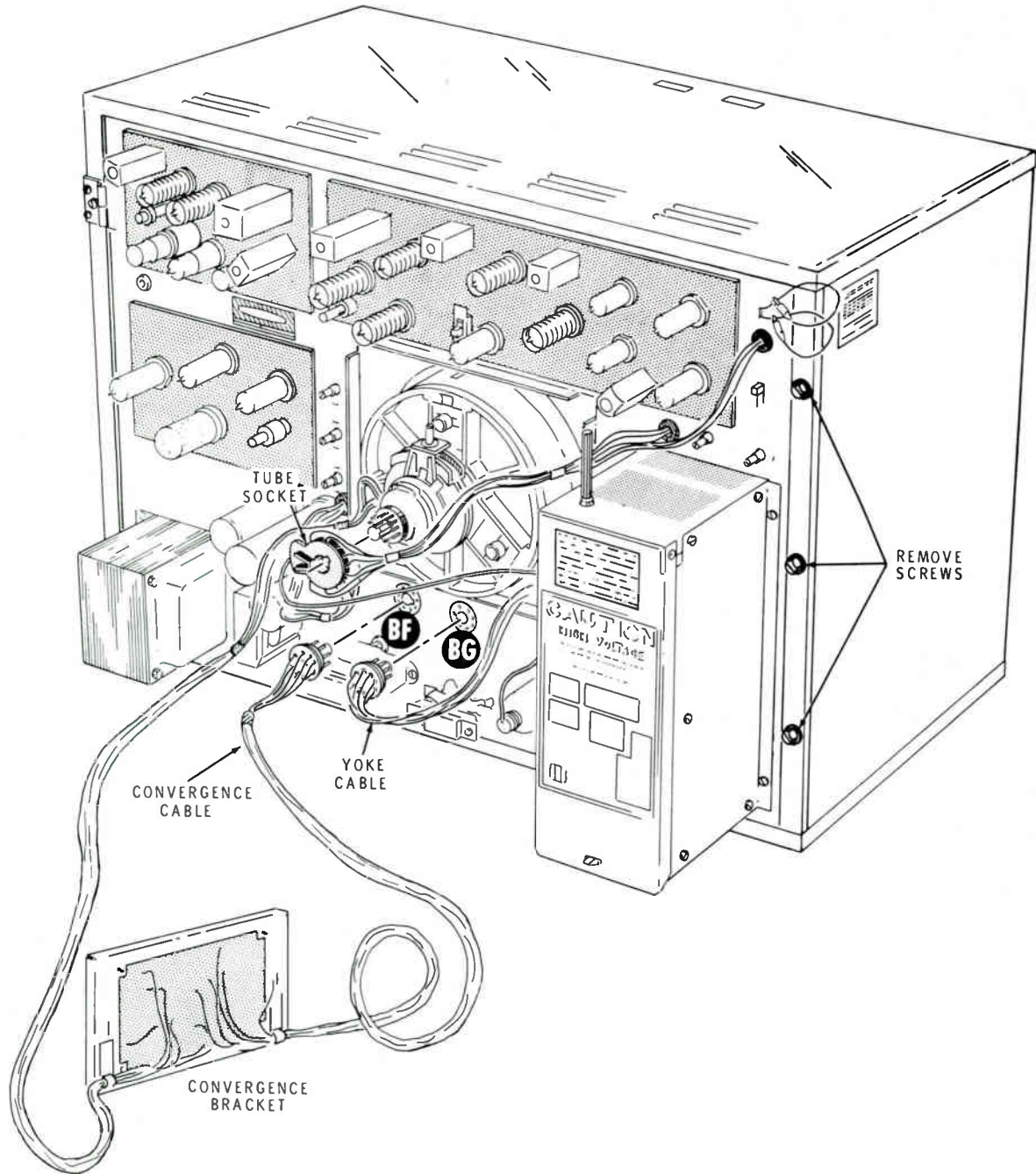

PICTORIAL 4-1

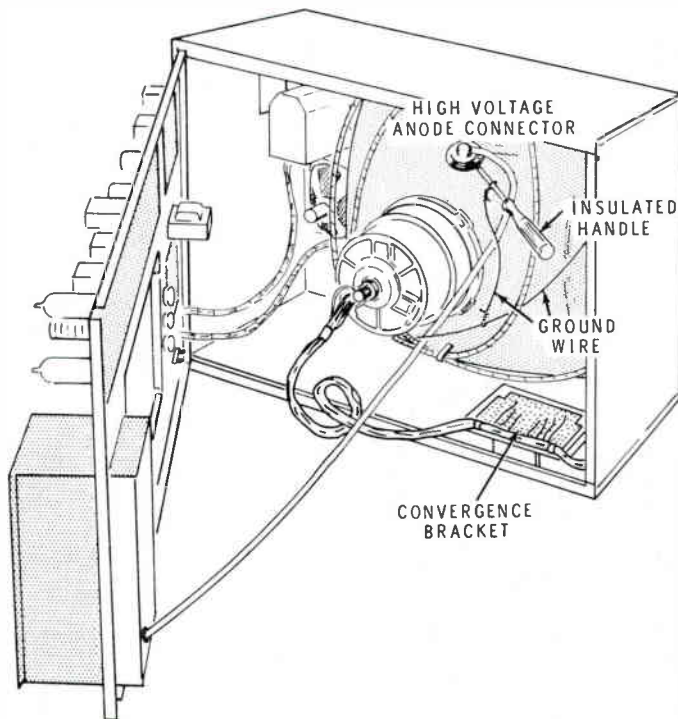

PICTORIAL 4-2

Refer to Pictorial 4-2 for the following steps.

- () Swing the chassis open and position the convergence bracket through the large opening in the chassis; place it inside of the shield assembly.
- () Discharge the high voltage anode by wrapping one end of a bare wire around the ground wire. Then wrap the other end of the bare wire around the metal part of a screwdriver. Hold the screwdriver by the insulated handle and touch the blade to the wire under the rubber cap of the high voltage anode connector.

Refer to Pictorial 4-3 for the following steps.

- () Remove the high voltage anode lead as shown in the inset drawing on Pictorial 4-3. Lift the rubber cap and compress one wire with the blade of a screwdriver.
- () Unplug the two degaussing leads from terminal strip AR.

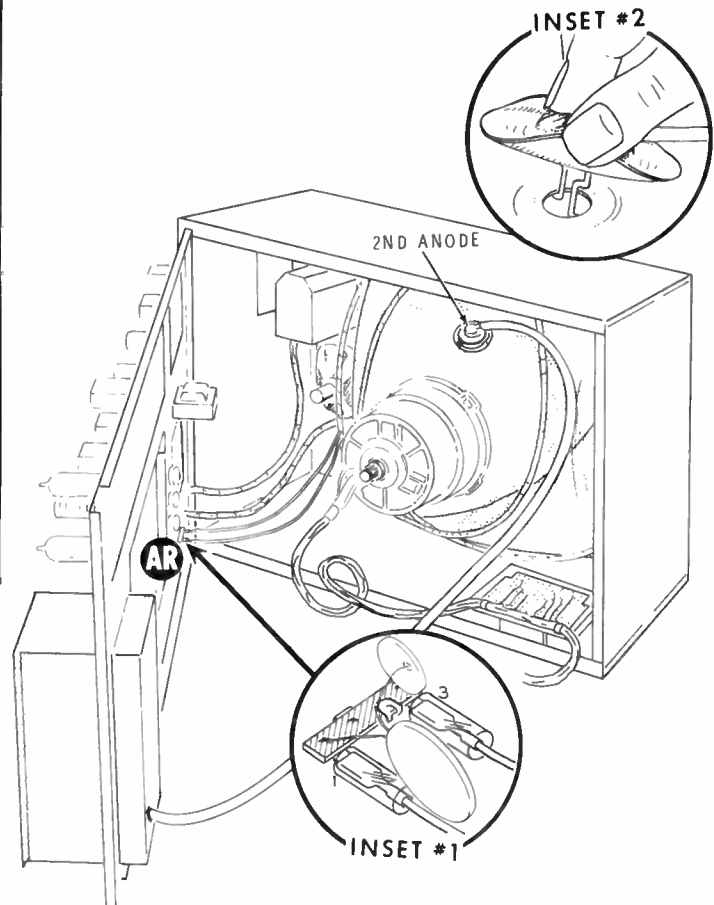

PICTORIAL 4-3

Refer to Pictorial 4-4 for the following steps.

- () Unplug the coaxial cable from socket TX of the VHF tuner as shown in the inset drawing.
- () Unplug both speaker leads from the speaker terminals.
- () Loosen screws HE and HF and remove the auxiliary control bracket.
- () Loosen screws HA, HB, HC, and HD and remove the main control bracket. As you remove the bracket, pull the VHF-UHF antenna terminal strip through opening in the left picture tube shield.

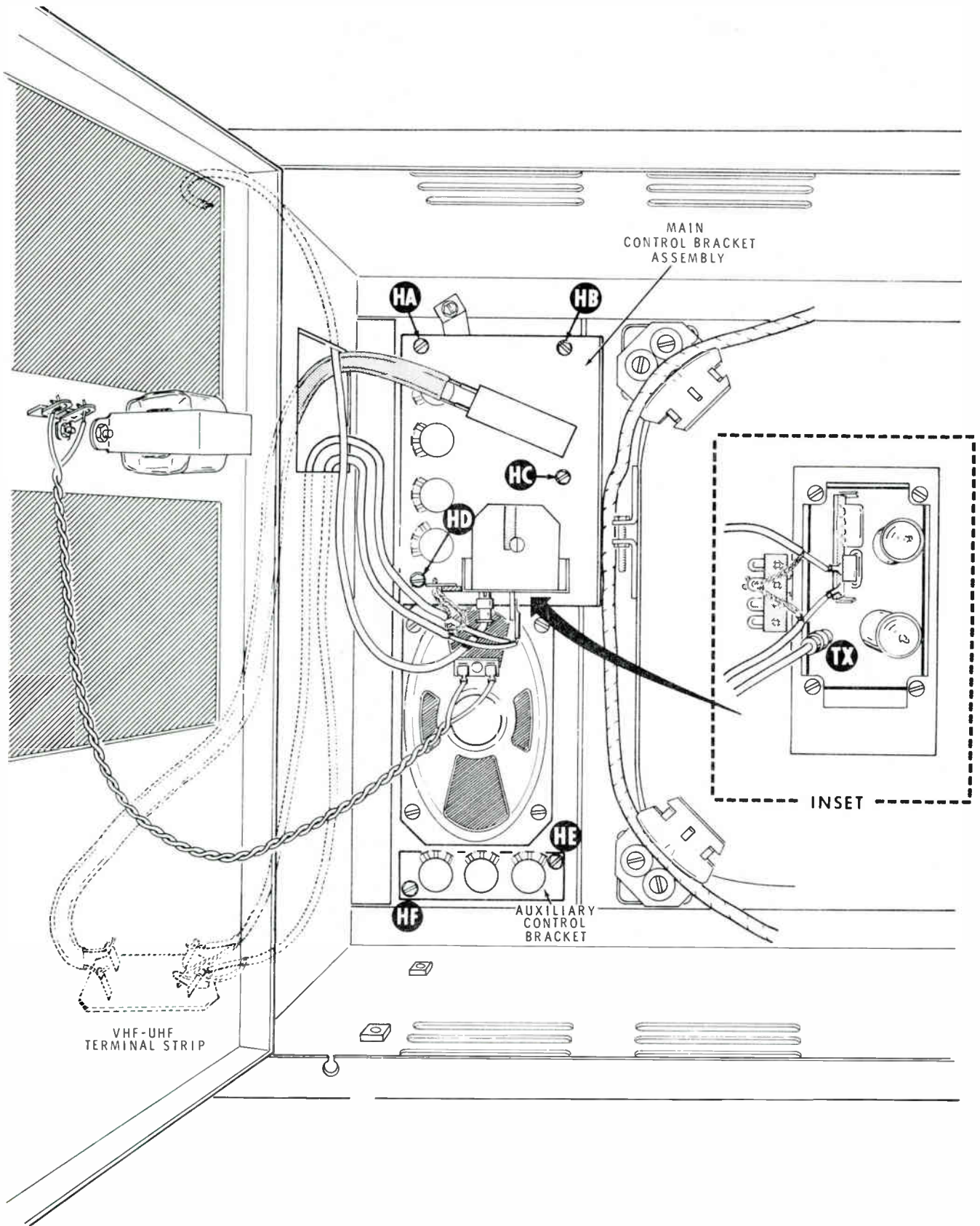

PICTORIAL 4-4

- () Refer to Pictorial 4-5 and lift the chassis from the hinges. The shield assembly can be set aside temporarily.

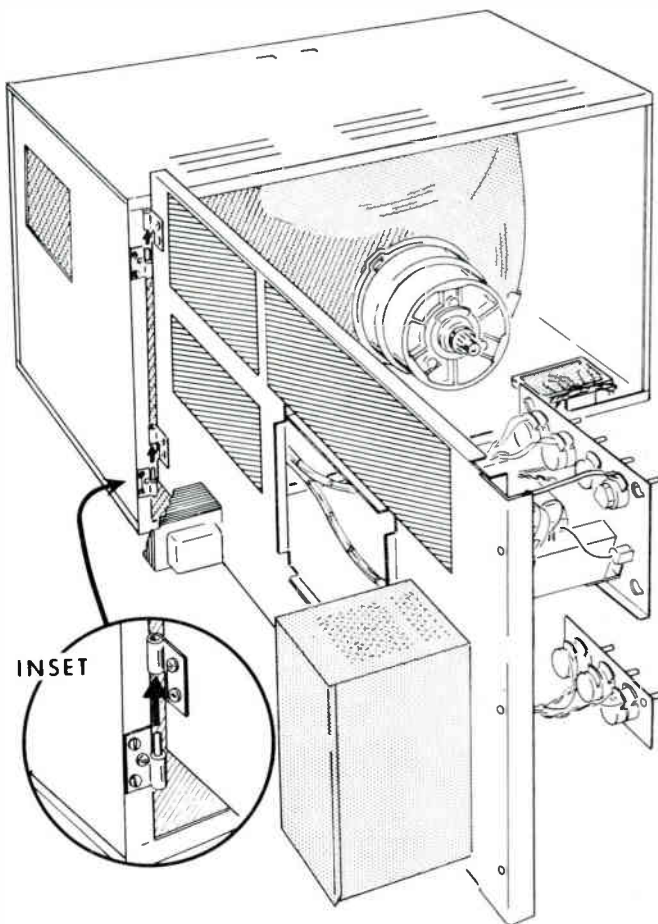

PICTORIAL 4-5

DISCONNECTING WIRES TO MAIN CONTROL BRACKET

NOTE: The following boxed-in steps should be completed only if you are converting your TV set from the Remote Control Switch Model GRA-27 to the Remote Control Model GRA-227-6.

Refer to Detail 4-6A for the following steps.

- () Position the chassis and main control bracket as shown.
- () Disconnect the three wires of the remote control switch that are connected to the motor and to control TE on the main control bracket.
- () Disconnect and discard the red and black twisted pair of wires connected between the motor and terminal strip AK.
- () Disconnect and discard the jumper wires connected between the motor lugs.
- () Disconnect and discard the black wire connected between control TE and lug 5 of terminal strip AK.
- () Remove and discard the two screws that fasten the tuner drive motor assembly to the VHF tuner bracket.
- () Refer to Detail 4-6B and remove the two screws and lockwashers that fasten the motor mounting bracket to the motor. Discard the bracket, screws, and lockwashers and set the motor aside temporarily.
- () Remove the screw, lockwasher, and clamp that fastens the remote control switch cable to the motor. The clamp may be discarded, but reinstall the lockwasher and screw. Set aside the remote control switch.

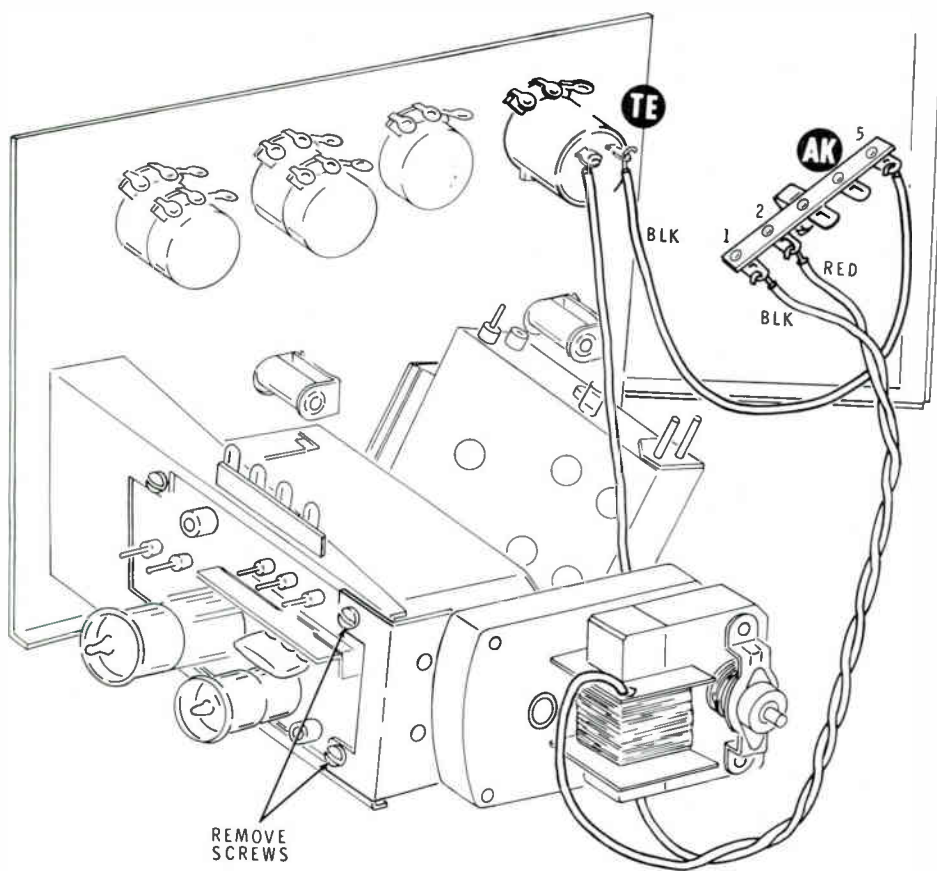

Detail 4-6A

Refer to Pictorial 4-6 (fold-out from Page 24) for the following steps.

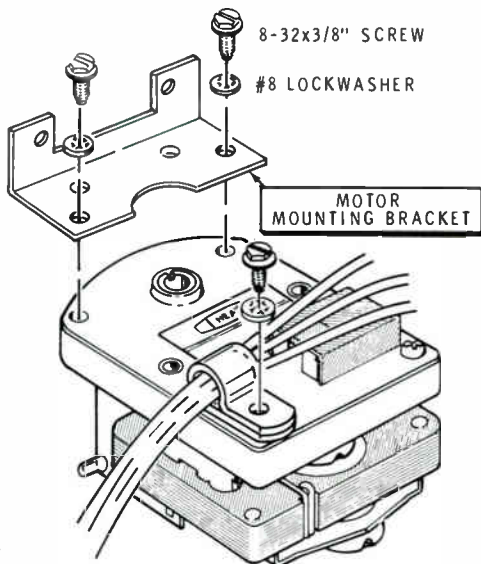

Detail 4-6B

- () Unsolder and discard the black twisted pair of wires connected between control TE and terminal strip AK, NOTE: If this is a conversion from the GRA-27 to the GRA-227-6, disregard this step.
- () Unsolder all of the connections to control TF.
- () Unsolder all of the connections to control TG. Save the resistor and sleeving that are on the leads.
- () Unsolder all of the connections to control TH.
- () Unsolder the connections to lug 4 of terminal strip TJ. Discard the red wire, but save the resistor.
- () Remove controls TF, TG, and TH. The controls may be discarded, but save the lock-washers and nuts.

INSTALLING MOTORS

Refer to Detail 5-1A for the following steps.

Locate the following parts:

- () One control motor.
- () 500 Ω control (#10-251).
- () Control mounting plate.
- () Three 4-40 x 1/4" screws.
- () Cut the leads of the control motor to 6-1/2" and remove 1/4" of insulation from the ends. Then apply a small amount of solder to the end of each lead.
- () Position the control motor with the leads as shown.
- () Place the 500 Ω control on the motor with the control lugs positioned between the indicated motor spacers. Make sure the end of the control shaft is inserted in the control motor slot.
- () Install the control mounting plate on the motor spacers with 4-40 x 1/4" screws. Make sure the locating tab on the control lines up with the locating hole in the plate. Also make sure the three spacers seat properly in the mounting plate holes.

Set the motor assembly aside temporarily.

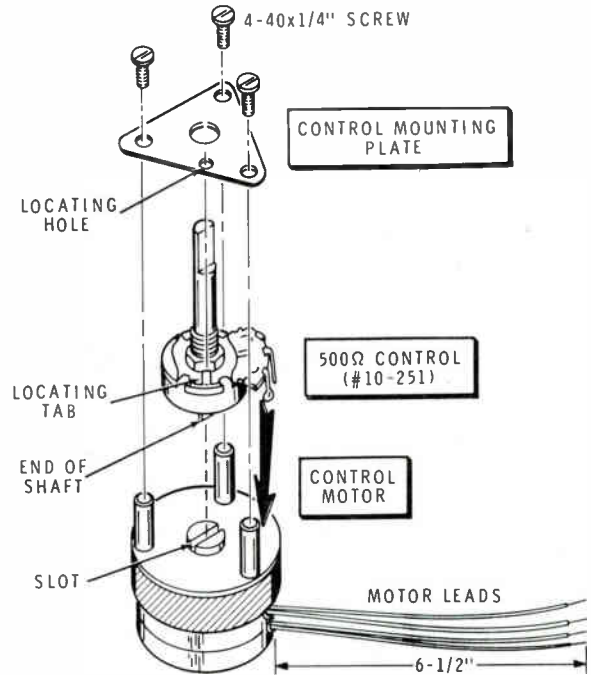

Detail 5-1A

Refer to Pictorial 5-1 for the following steps.

Locate the following parts:

- () Motor mounting plate.
- () Tuner drive motor. NOTE: If this is a conversion from the GRA-27 to the GRA-227-6, either motor can be used.
- () 6-lug terminal strip.

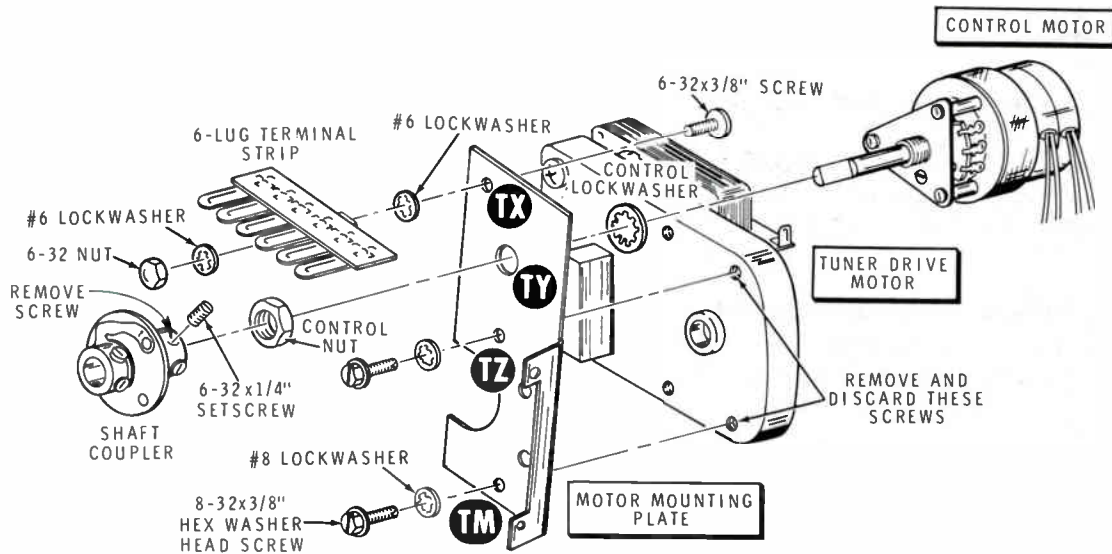

PICTORIAL 5-1

- () Shaft coupler.
- () 6-32 x 3/8" screw.
- () 6-32 x 1/4" setscrew.
- () Two 8-32 x 3/8" hex washer head screws.
- () Two #8 lockwashers.
- () Two #6 lockwashers.
- () 6-32 nut.
- () Control lockwasher (previously removed from control).
- () Control nut (previously removed from control).
- () Position the motor mounting plate as shown. Then mount the 6-lug terminal strip at TX with a 6-32 x 3/8" screw, two #6 lockwashers, and a 6-32 nut.
- () Remove and discard the two indicated screws from the tuner drive motor. NOTE: If this is a conversion from the GRA-27 to the GRA-227-6, disregard this step.
- () Mount the motor to the plate with 8-32 x 3/8" hex washer head screws and #8 lockwashers at TM and TZ. Do not tighten these screws at this time.
- () Position the control motor assembly as shown and mount it on the plate with a control lockwasher and control nut. Do not over-tighten the nut; this could cause the control to bind. After tightening the nut the correct amount, rotate the control shaft to make sure it turns freely.
- () Replace one screw in the shaft coupler with a 6-32 x 1/4" setscrew. Then install the coupler on the control shaft (with the end of the shaft flush with the inside of the coupler); tighten the setscrew against the flat side of the shaft. Tighten the other screw also. Set this assembly aside temporarily.

Refer to Pictorial 5-2 (fold-out from Page 37) for the following steps.

- () Position the main control bracket as shown.
- () Locate one of the control lockwashers and control nuts previously removed from the discarded controls.
- () Refer to Detail 5-2A and install the 250 k Ω - 1 M Ω dual control (#12-93) at TF with a control lockwasher and control nut.

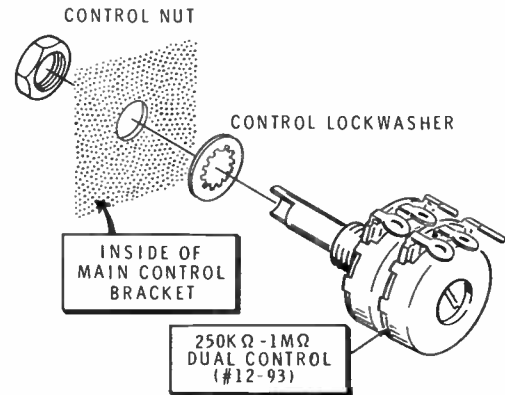

Detail 5-2A

Refer to Detail 5-2B for the following steps. Locate the following parts.

- () Control motor.
- () 1200 Ω - 1 M Ω dual control.
- () Control mounting plate.
- () Three #4 x 9/16" spacers.
- () Three 4-40 x 3/4" screws.
- () Control lockwasher (previously removed from control).
- () Cut the leads of the control motor to 4-1/2" and remove 1/4" of insulation from the ends. Then apply a small amount of solder to the end of each lead.
- () Position the control motor with the leads as shown.
- () Place the 1200 Ω - 1 M Ω dual control on the motor with the control lugs positioned between the indicated motor spacers. Make sure the end of the control shaft is inserted in the control motor slot.

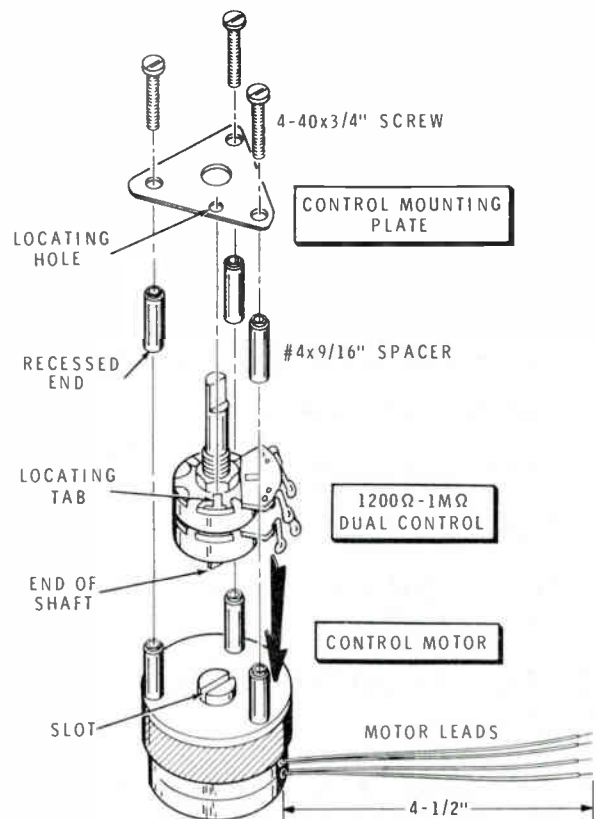

Detail 5-2B



- () Place the recessed end of the #4 x 9/16" spacers on the control motor spacers.
- () Install the control mounting plate on the spacers with 4-40 x 3/4" screws. Make sure the locating tab on the control lines up with the locating hole in the plate. Also make sure the three spacers seat properly in the mounting plate holes.
- () Place a control lockwasher on the control bushing and mount the assembly on the main control bracket at TG with a control nut. Position the assembly with the lugs as shown. Do not overtighten the nut; this could cause the control to bind. After tightening the nut the correct amount, rotate the control shaft to make sure it turns freely.
- () Refer to Detail 5-2C and push the nylon bushing into hole TH.

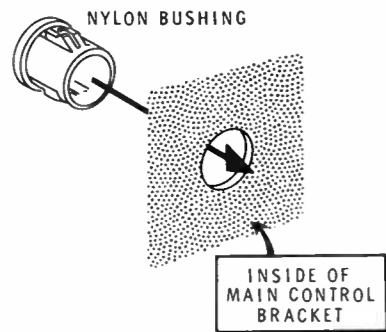

Detail 5-2C

NOTE: If this is a conversion from the GRA-27 to the GRA-227-6, disregard the following boxed-in step.

- () Remove and discard the two indicated tuner screws.
- () Remove and discard the cardboard sleeve that is located between the rotor and bearing assembly of the tuner drive motor.

- () Position the motor directly behind the VHF tuner and, if necessary, rotate the shaft of the tuner so its "flat" lines up with the "flat" of the motor.
- () Fit the motor onto the rear shaft of the VHF tuner and temporarily install two #6 x 3/8" sheet metal screws as shown in the inset drawing on Pictorial 5-2.
- () Now rotate the shaft of the VHF tuner one complete revolution with the Channel Selector knob to be sure the motor is not binding.
- () Make a pencil line on the motor mounting bracket along the edge of the motor as shown.
- () Remove the motor mounting bracket from the VHF tuner by removing the #6 x 3/8" sheet metal screws just installed.
- () Line up the motor with the pencil line on the motor mounting bracket and tighten the motor mounting screws.
- () Replace the motor on the VHF tuner and install the #6 x 3/8" sheet metal screws.
- () Rotate the shaft of the VHF tuner through at least one complete revolution to be sure it does not bind.
- () Insert the control shaft (not the end with the flat) through bushing TH and into the shaft coupler. Adjust the shaft to protrude out from the main control bracket the same amount as the other three control shafts do. Then tighten both coupler screws.

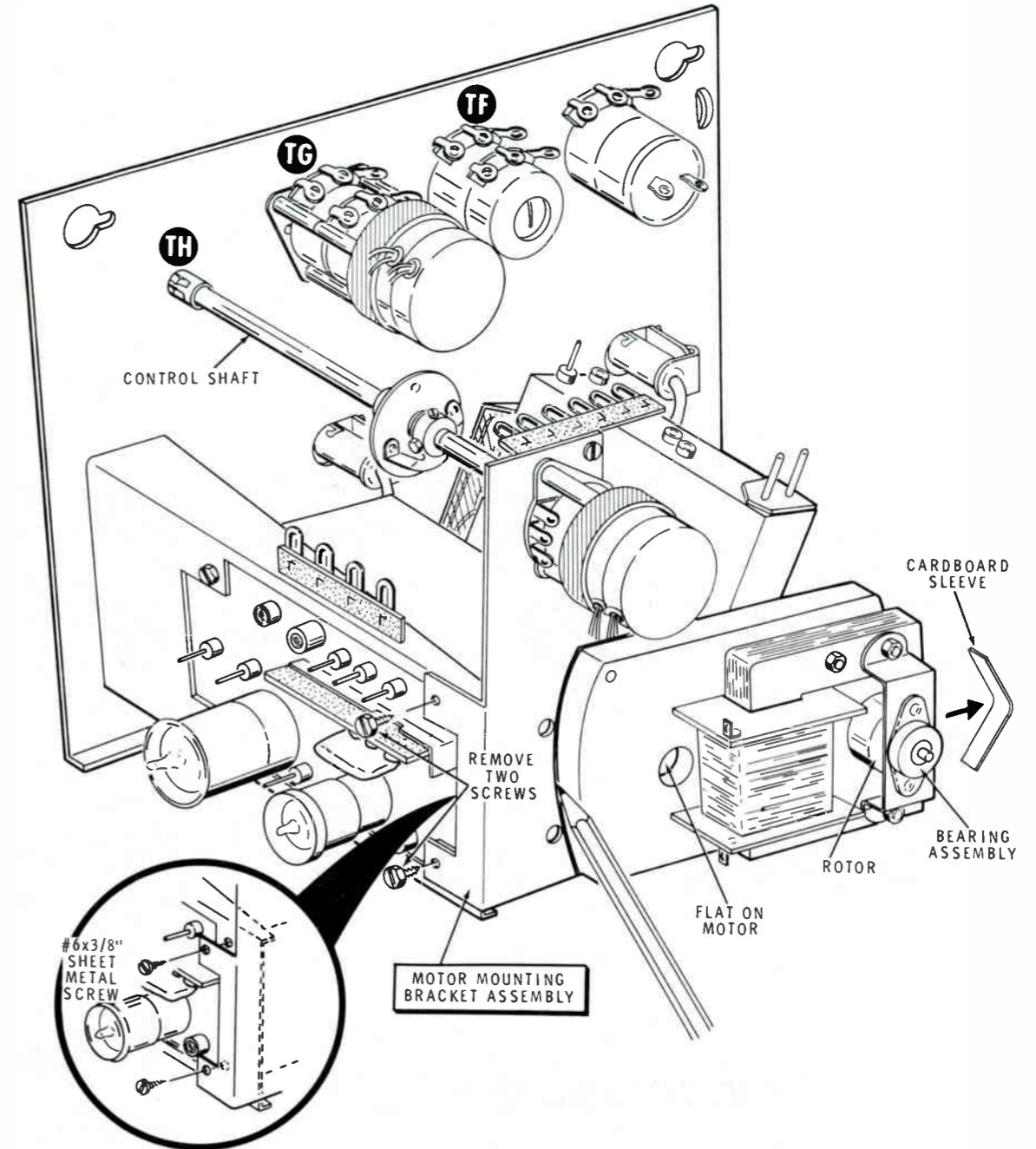

PICTORIAL 5-2

(For GR-180 and GR-227 only)

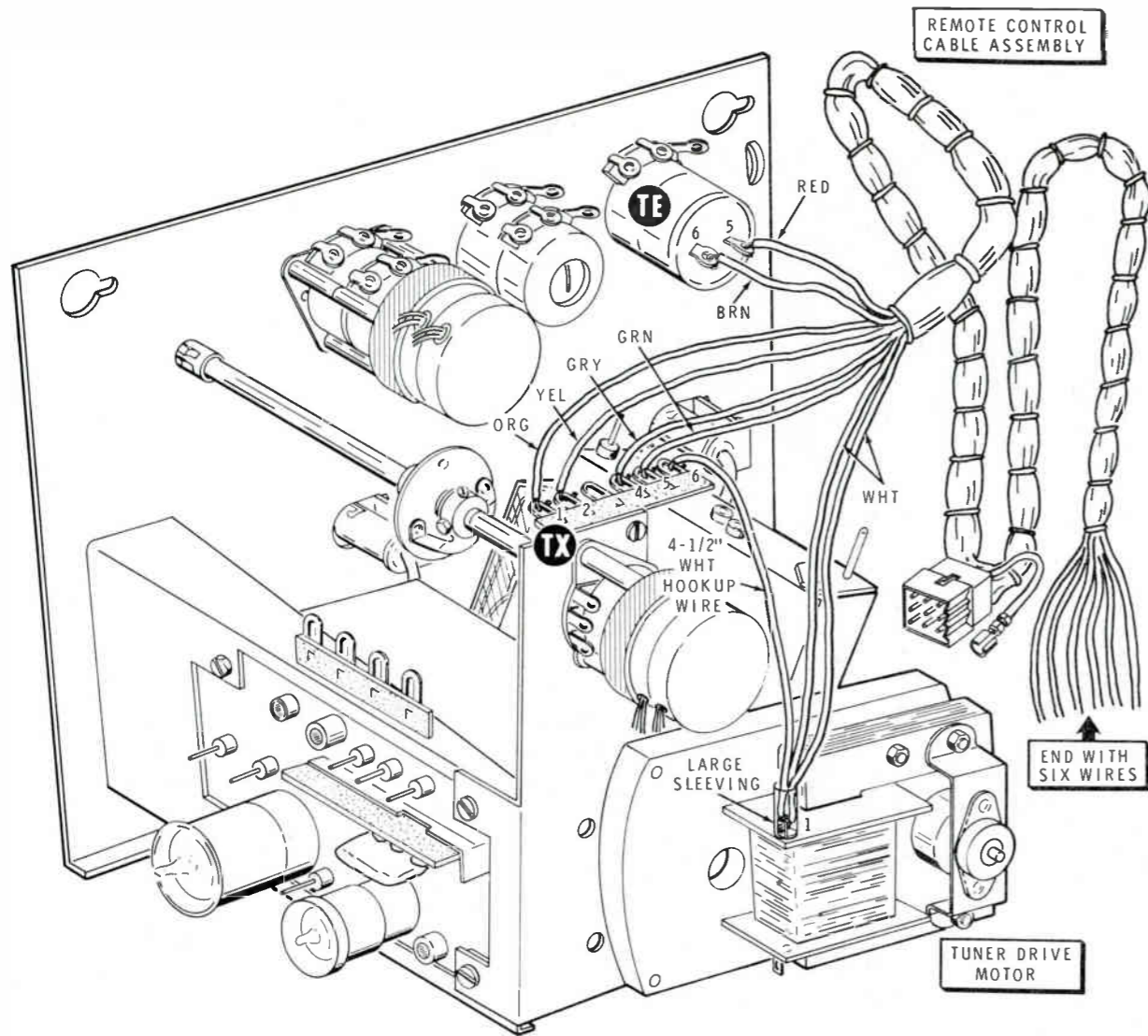

PICTORIAL 5-5

(For GR-180 and GR-227 only)

REWIRING MAIN CONTROL BRACKET

Refer to Pictorial 5-3 for the following steps.

In the following steps, the wiring harness and components that were previously disconnected will be reconnected to the main control bracket.

- () Connect the free end of the white wire coming from TP to lug 1 of control TF (NS).

NOTE: Make sure the sleeving is still on the leads of the resistor before connecting it in the following step.

- () Connect the 470 kΩ (yellow-violet-yellow) resistor from lug 1 of control TF (S-2) to lug 6 of control TG (S-1).

- () Connect the 2.2 MΩ (red-red-green) resistor between lugs 3 (NS) and 6 (NS) of control TF.

Connect the wiring harness wires to the controls in the following steps. NOTE: If some of the wires are not long enough to reach the controls, remove one or two of the wiring harness lacing ties as shown.

- () White-yellow-brown wire to lug 2 of TF (S-1).
- () White-black wire to lug 3 of TF (S-2).
- () White-green wire to lug 4 of TF (S-1).
- () White-yellow wire to lug 5 of TF (S-1).
- () White-orange wire to lug 6 of TF (S-2).

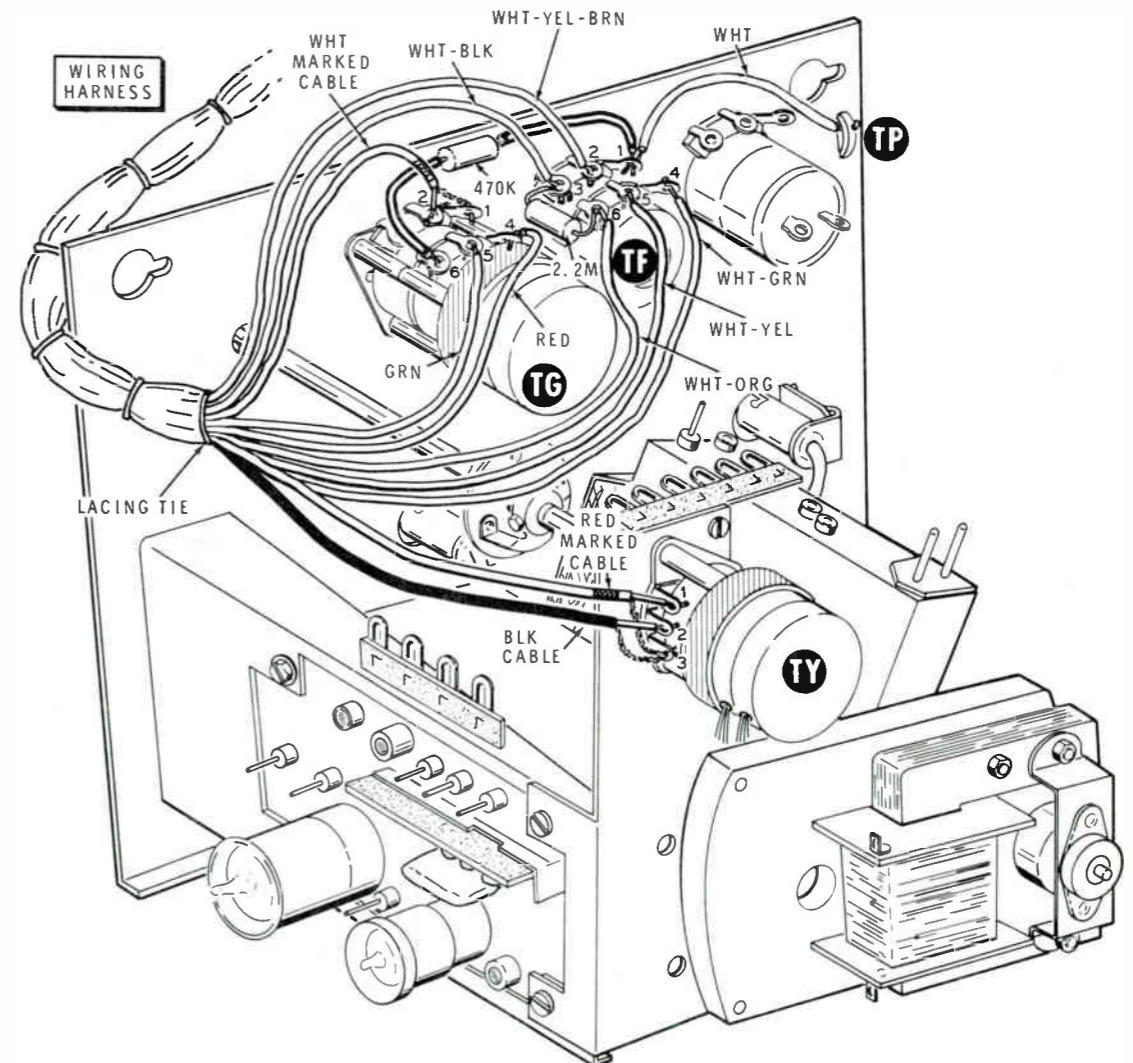

PICTORIAL 5-3

- () Red wire to lug 4 of TG (S-1).
- () Green wire to lug 5 of TG (S-1).
- () Inner lead of the white marked cable to lug 2 of TG (S-1) and shield lead to lug 1 (S-1).
- () Inner lead of the red marked cable to lug 1 of TY (S-1) and shield lead to lug 3 (NS).
- () Inner lead of the black marked cable to lug 2 of TY (S-1) and shield lead to lug 3 (S-2).
- () Both white leads of motor TG to lug 6 of TX (NS).
- () Red lead of motor TG to lug 2 of TX (NS).
- () Brown lead of motor TG to lug 1 of TX (NS).
- () Both white leads of motor TY to lug 6 of TX (NS).
- () Brown lead of motor TY to lug 4 of TX (NS).
- () Red lead of motor TY to lug 5 of TX (NS).

Refer to Pictorial 5-4 for the following steps.

Connect the motor leads to terminal strip TX in the following steps. Twist together the indicated color leads as shown in the Pictorial before connecting them.

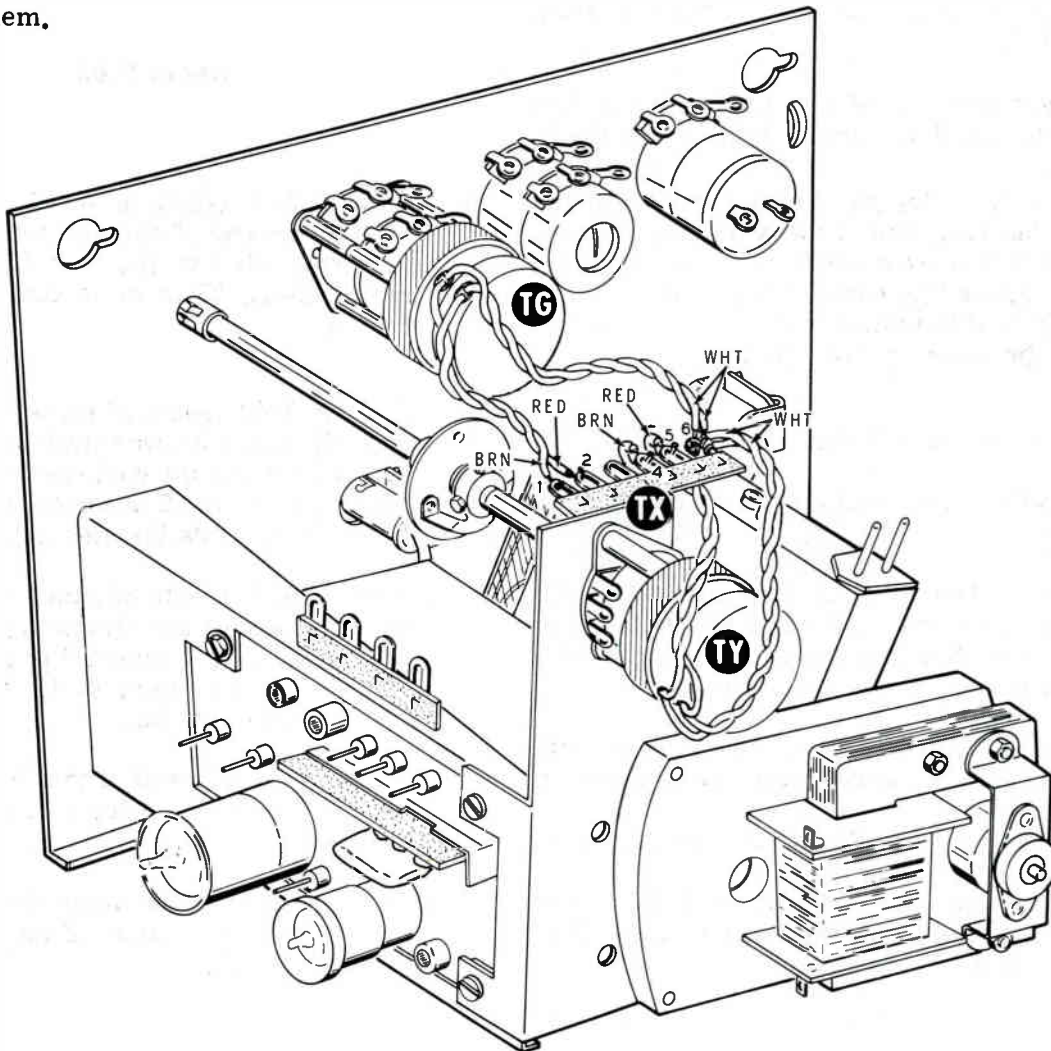

PICTORIAL 5-4

Refer to Pictorial 5-5 (fold-out from Page 38) for the following steps.

Locate the remote control cable assembly and connect the end with the ten wires to the main control bracket in the following steps.

- () Red wire to lug 5 of control TE (S-1).
- () Brown wire to lug 6 of control TE (S-1).
- () Green wire to lug 5 of terminal strip TX (S-2).
- () Gray wire to lug 4 of terminal strip TX (S-2).
- () Yellow wire to lug 2 of terminal strip TX (S-2).
- () Orange wire to lug 1 of terminal strip TX (S-2).
- () Connect one end of a 4-1/2" white hookup wire to lug 6 of terminal strip TX (S-5).

- () Slide a 3/4" length of large clear sleeving over the free end of the white hookup wire and both white wires from the remote control cable assembly. Connect these three wires to lug 1 of the tuner drive motor (S-3) and slide the sleeving over the lug.

Refer to Pictorial 5-6 for the following steps.

- () Reposition the main control bracket as shown.
- () Refer to Detail 5-6A and install a 6-32 speednut on the VHF tuner bracket at hole TW. Note that there are two holes in the bracket; use the one indicated.
- () Install a 2-lug terminal strip at TW with a 6-32 x 1/4" screw and #6 lockwasher.
- () Prepare three 4-1/2" brown stranded wires.
- () Connect one end of two 4-1/2" brown stranded wires to the eyelet of lug 2 of terminal strip TW (S-2).

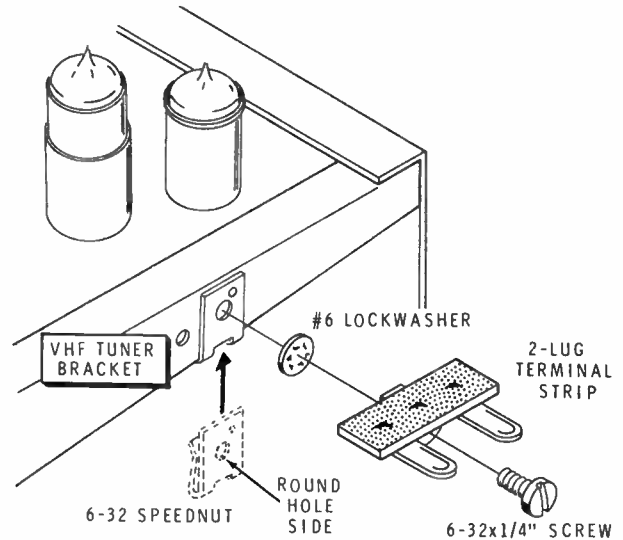

Detail 5-6A

- () Slide a 5/8" length of small clear sleeving on the free end of one wire from lug 2. Connect this wire to lug 3 of the tuner drive motor (S-1). Then slide the sleeving over the lug.
- () Slide a 3/4" length of large clear sleeving over the other brown wire from lug 2 and the blue wire from the cable assembly. Connect both wires to lug 2 of the tuner drive motor (S-2). Then slide the sleeving over the lug.
- () Slide a 5/8" length of small clear sleeving over one end of the remaining 4-1/2" brown stranded wire. Connect this end to lug 4 of the tuner drive motor (S-1). Then slide the sleeving over the lug.
- () Connect the free end of this brown stranded wire to the eyelet of lug 1 of terminal strip TW (NS).
- () Connect the violet wire from the cable assembly to the eyelet of lug 1 of terminal strip TW (S-2).

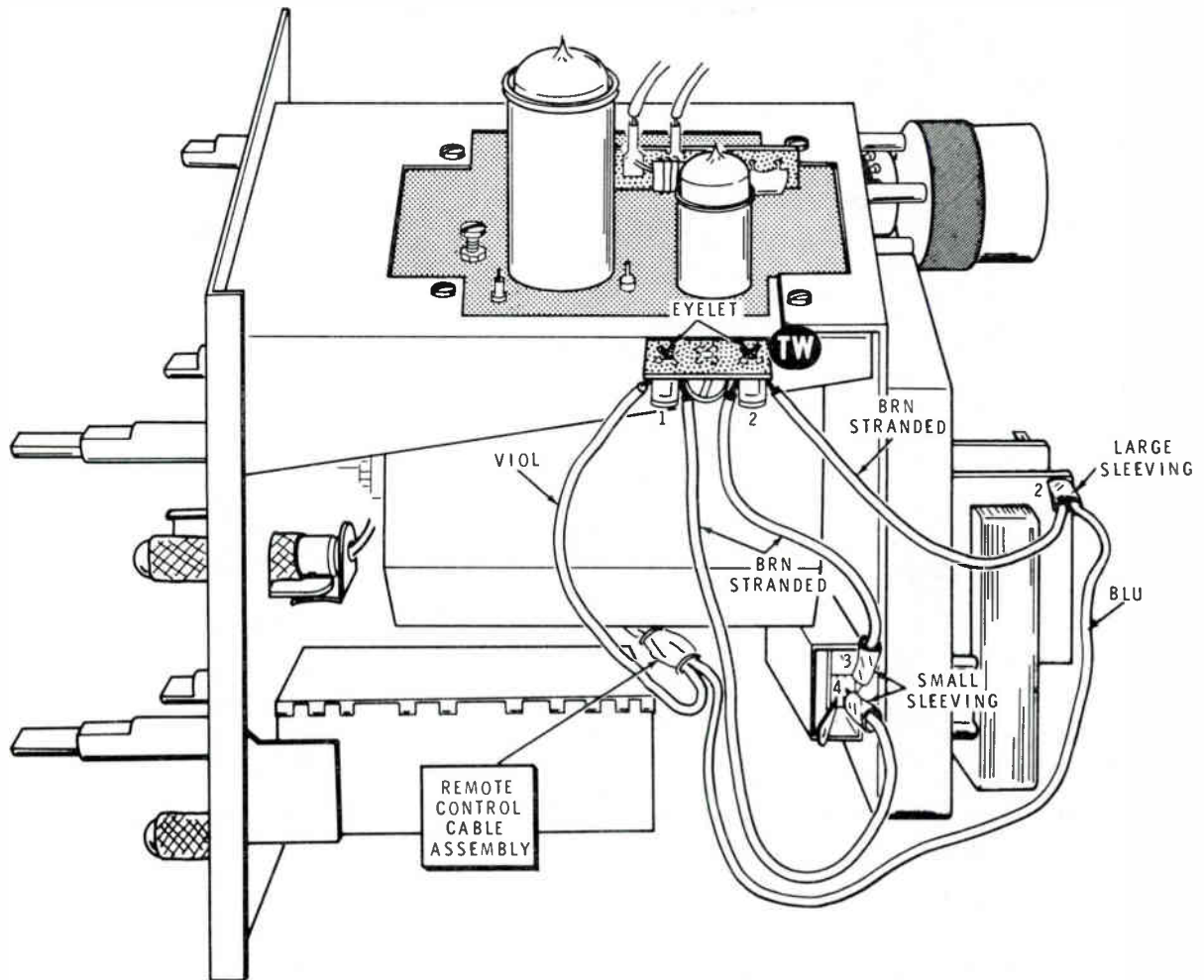

PICTORIAL 5-6

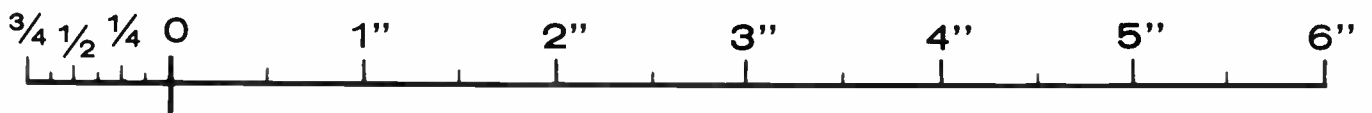

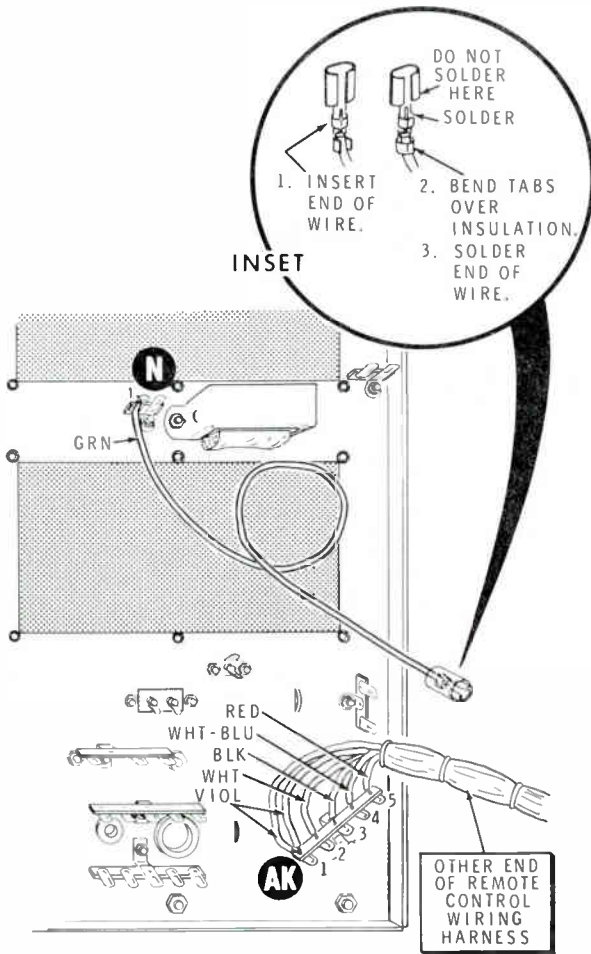

PICTORIAL 5-7

Refer to Pictorial 5-7 for the following steps.

In the following steps, you will connect the remaining wires from the remote control cable assembly to the eyelets of the lugs of terminal strip AK on the inside of the television chassis. After connecting the wires, route them away from the 750 Ω resistor which is connected to this terminal strip.

- () Both violet wires to lug 1 of AK (S-2).
- () White wire to lug 2 of AK (S-1).
- () Black wire to lug 3 of AK (S-1).
- () White-blue wire to lug 4 of AK (S-1).
- () Red wire to lug 5 of AK (S-1).

- () Install a terminal strip connector on one end of a 24" length of green hookup wire as shown in the inset drawing on Pictorial 5-7. Then slide a 3/4" length of large clear sleeving over the connector.
- () Connect the free end of the green wire to lug 1 of terminal strip N (S-5).

Refer to Pictorial 5-8 for the following steps.

In the following steps, we will be working with the television shield assembly.

NOTE: For the following steps, you will need a center punch and a 5/32" drill. Be very careful when drilling holes in the shield assembly to avoid touching the picture tube.

- () Cut out the full size template printed on fold-out from Page 57 of the Manual.
- () Place the template on the left rear corner of the top shield as viewed from the back of the TV Set. Line up the template with the edges of the shield. Then follow instructions A, B, and C on the template.

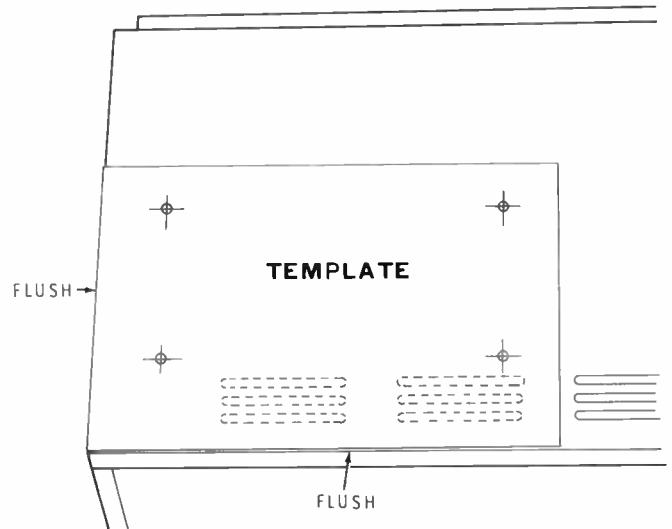

PICTORIAL 5-8

NOTE: In the Model GR-227 TV set, the picture tube mask and trim panel have mounting holes to install a pushbutton switch. This switch is used to turn the VHF Channel Selector automatically.

If this switch is to be installed in the Model GR-180 TV set, a 1/4" hole has to be drilled in the mask. Use the following method to find a good location for the switch. First, remove the trim panel from the picture tube mask and install the one supplied for the GR-227 TV set. Then drill a 1/4" hole through the trim panel (at the existing 5/32" hole) and through the mask. Then mount the switch as instructed in the following steps. If you do not prefer to install this switch in your GR-180 TV set, disregard the following seven steps.

Refer to Detail 5-9A for the following steps.

- () Prepare two 18" brown stranded wires.
- () Slide a 3/4" length of large clear sleeving over one end of each wire. Install a terminal strip connector on this end of each wire as shown in inset drawing #1 on Detail 5-9A. Then slide the sleeving over the connections.

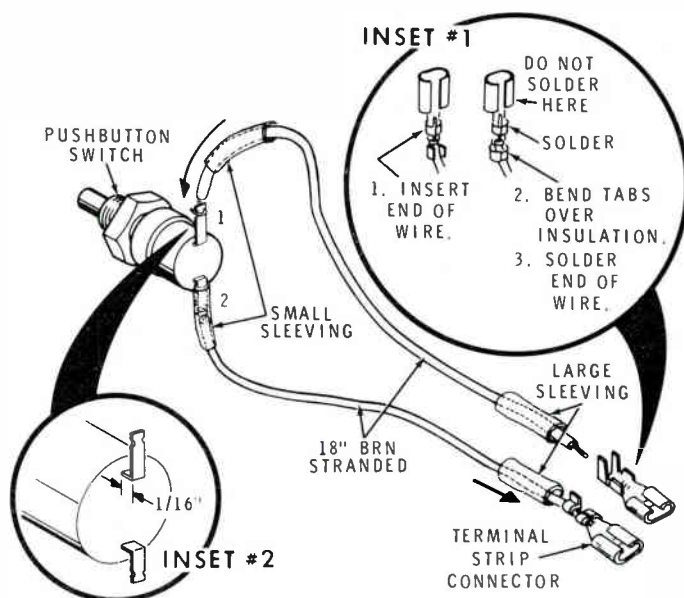

Detail 5-9A

- () Slide a 5/8" length of small clear sleeving over the other end of each of these wires. Then form a small hook at the bare end of each wire.
- () Locate the pushbutton switch and carefully bend the lugs away from the switch body as shown in inset drawing #2.
- () Solder the brown wires to the lugs and slide the sleeving over them.

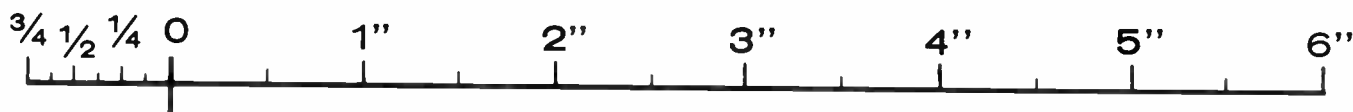

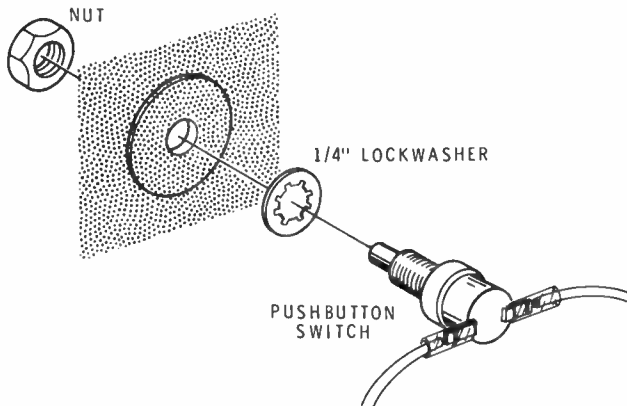

Detail 5-9B

Refer to Pictorial 5-9 and Detail 5-9B for the following steps.

- () Remove the nut from the pushbutton switch. Mount the switch on the picture tube mask at HJ with a 1/4" lockwasher and the nut. Position the switch as shown. NOTE: Do not use a lockwasher with the GR-180 TV set.
- () Install the 1/8" cable clamp around the switch wires. Then remove the indicated screw from the picture tube mask and re-mount the clamp with the screw.

NOTE: The following boxed-in step should be completed for the Model GR-227 TV set only. The microphone installation for the GR-180 TV set will be completed later.

- () Refer to Detail 5-9C and push the microphone in the large recess at HK.

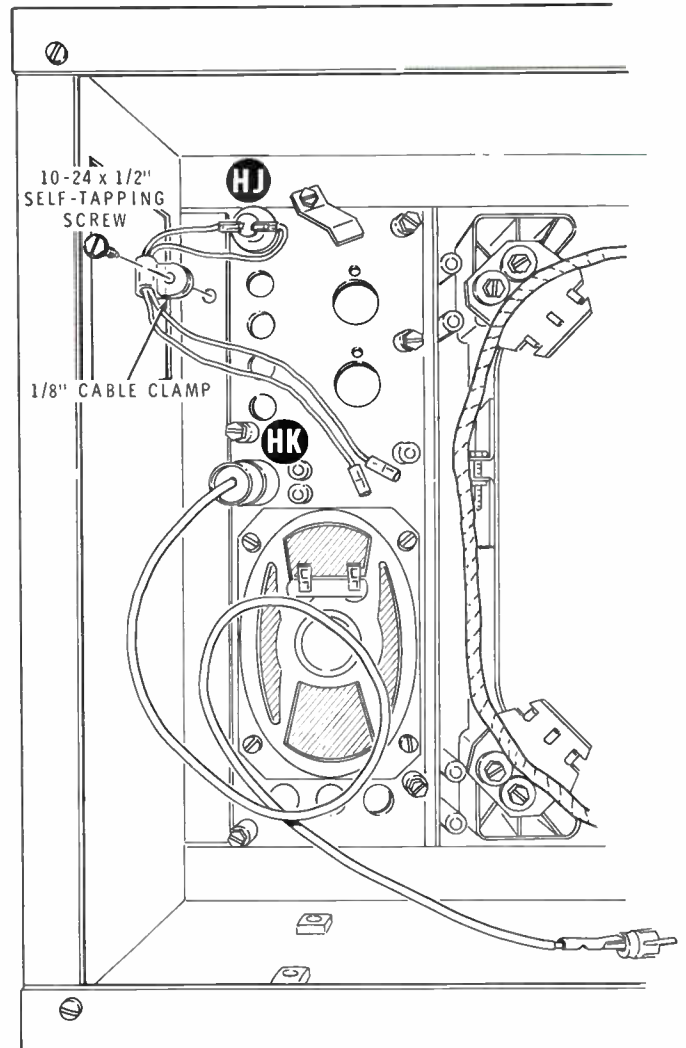

PICTORIAL 5-9

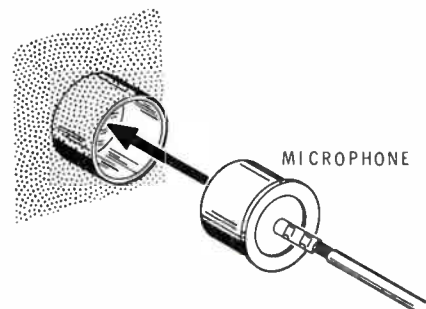

Detail 5-9C

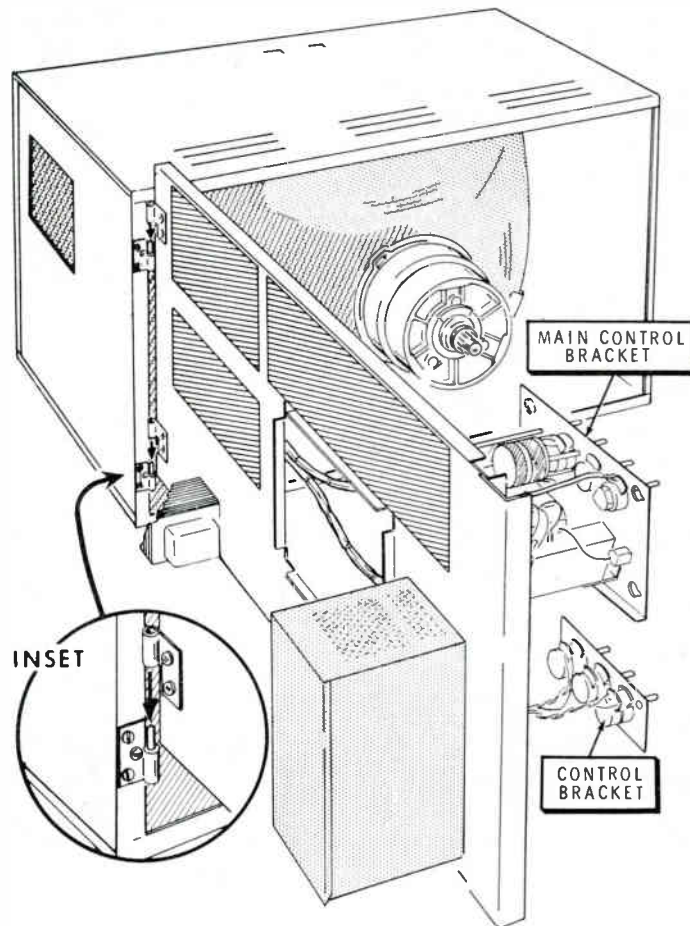

PICTORIAL 5-10

FINAL ASSEMBLY

Refer to Pictorial 5-10 for the following steps.

NOTE: Be careful not to bump the neck of the picture tube while handling the chassis in the following step.

- () Position the chassis and control bracket assemblies as shown. Line up the hinges on the chassis with the hinges on the picture tube shield as shown in the inset drawing on Pictorial 5-10. Then hang the chassis on the tube shield as shown. **NOTE:** As a precautionary measure, brace the edge of the chassis near the high voltage power supply when it is opened all the way.

Refer to Pictorial 5-11 for the following steps.

NOTE: The following boxed-in step should be completed for the Model GR-180 TV set only.

() Refer to Detail 5-11A and remove the indicated screw that fastens the VHF tuner bracket to the main control bracket. Then mount the 3/4" spacer with a #6 x 1" sheet metal screw.

() Position the auxiliary control bracket with the control lugs as shown. Then hang the control bracket on the screws at HE and HF and tighten the screws.

() Connect the green wire of the twisted pair coming from terminal strip N to lug 1 and the black wire to lug 2 of the speaker. Push the connectors onto the terminal strip lugs.

() Route the coaxial cable coming from the lettered side of the IF circuit board through the square hole in the left picture-tube shield. Plug the end of this cable into socket TX of the VHF tuner. See the inset drawing on Pictorial 5-11.

() Hang the main control bracket on the screws at HA, HB, HC, and HD and then tighten them. Make sure the spring contact at HG is under the control bracket and the wires from the pushbutton switch are routed as shown. NOTE: This spring contact may not be used in your GR-180 TV set.

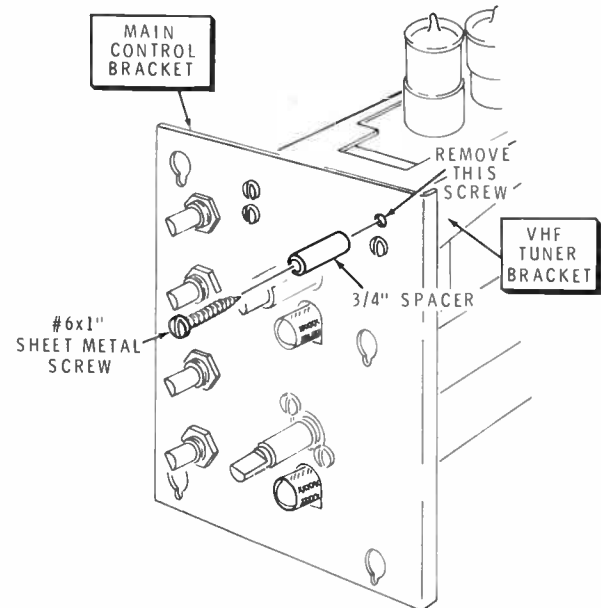

Detail 5-11A

() Insert the 4-lug VHF-UHF terminal strip through the hole in the left picture-tube shield. Then carefully route the twin lead and coaxial cables through the hole as shown.

() Loosely twist together the brown wires coming from the pushbutton switch. Insert the connector of one wire on lug 1 and the connector of the other wire on lug 2 of terminal strip TW. Refer to the inset drawing on Pictorial 5-11.

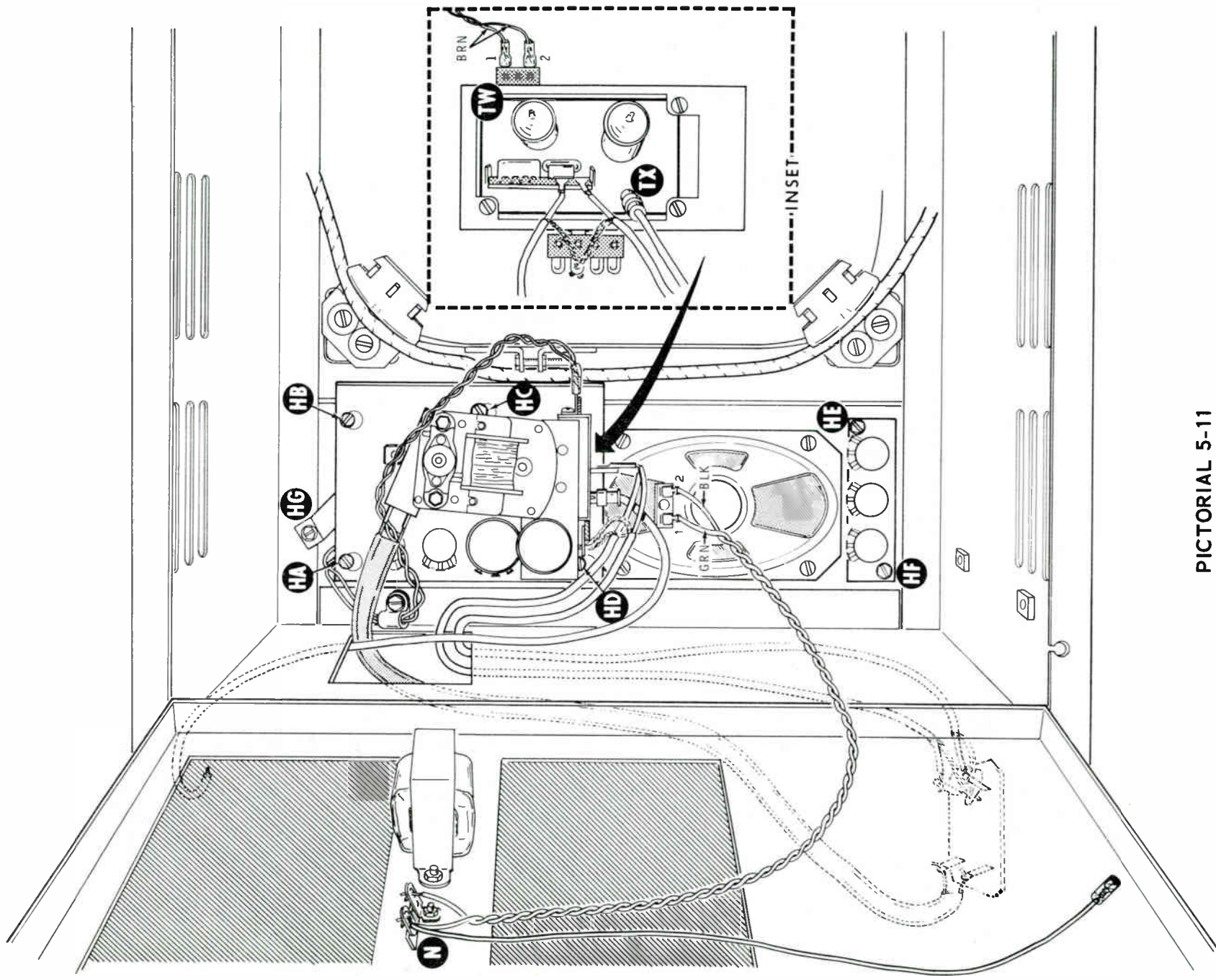

PICTORIAL 5-11

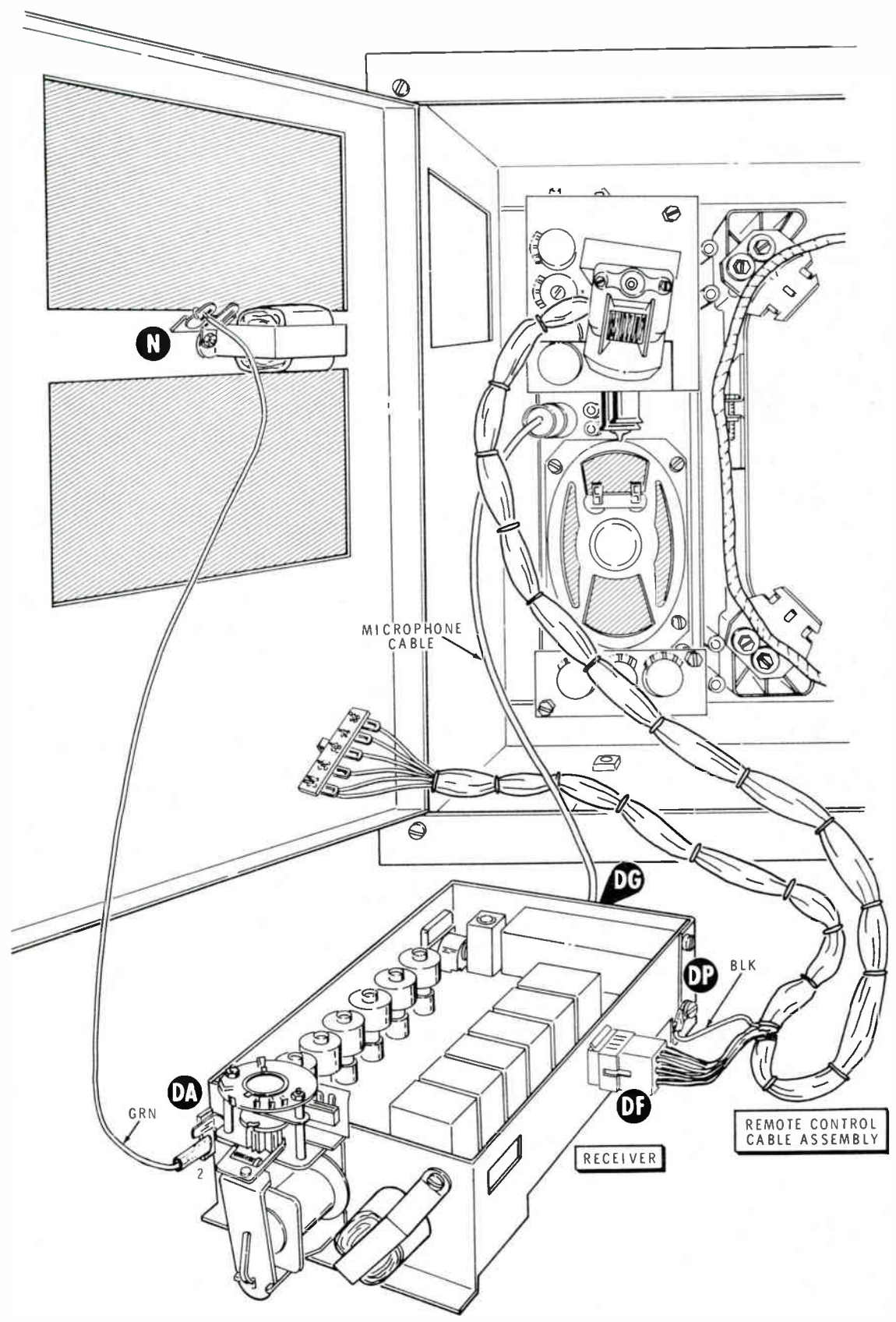

PICTORIAL 5-12

Refer to Pictorial 5-12 for the following steps.

- () Position the receiver behind the shield assembly as shown.
- () Plug the microphone cable in socket DG. NOTE: For the GR-180 TV set, let the microphone end of the cable hang free temporarily.
- () Insert the connector of the green wire coming from terminal strip N onto lug 2 of terminal strip DA.
- () Plug the connector of the remote control cable assembly in connector DF.
- () Insert the connector of the black wire coming from the remote control cable assembly onto solder lug DP.

Refer to Pictorial 5-13 for the following steps.

NOTE: Complete the following boxed-in step for the Model GRA-227-6 only.

- () Peel away the backing paper from the trim panel. Then press the panel in place on the picture tube mask. NOTE: Be sure the holes are lined up before pressing the panel in place.

Install the knobs on the tuner bracket in the following steps:

- () VHF Fine Tuning and VHF Channel Selector knobs on the VHF tuner shaft.
- () UHF Channel Indicator and UHF Tuning knobs on the UHF tuner shaft.
- () Seven front panel knobs on the shafts of the remaining controls.

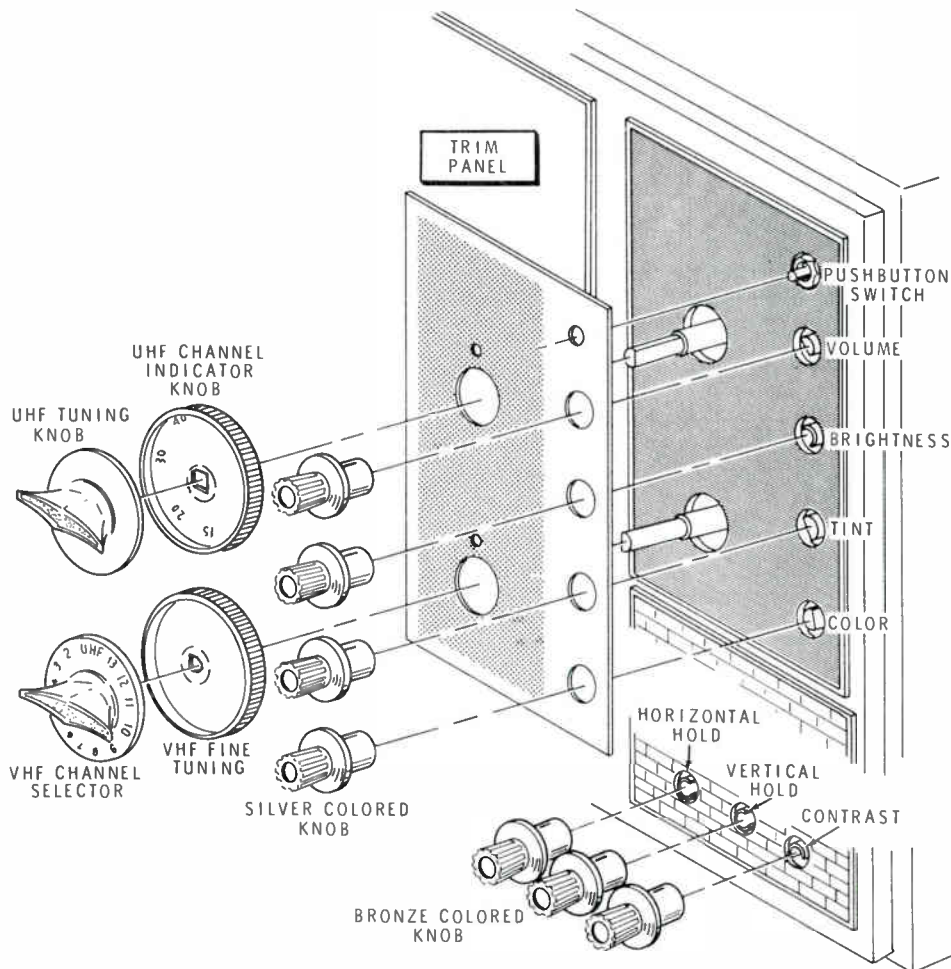

PICTORIAL 5-13

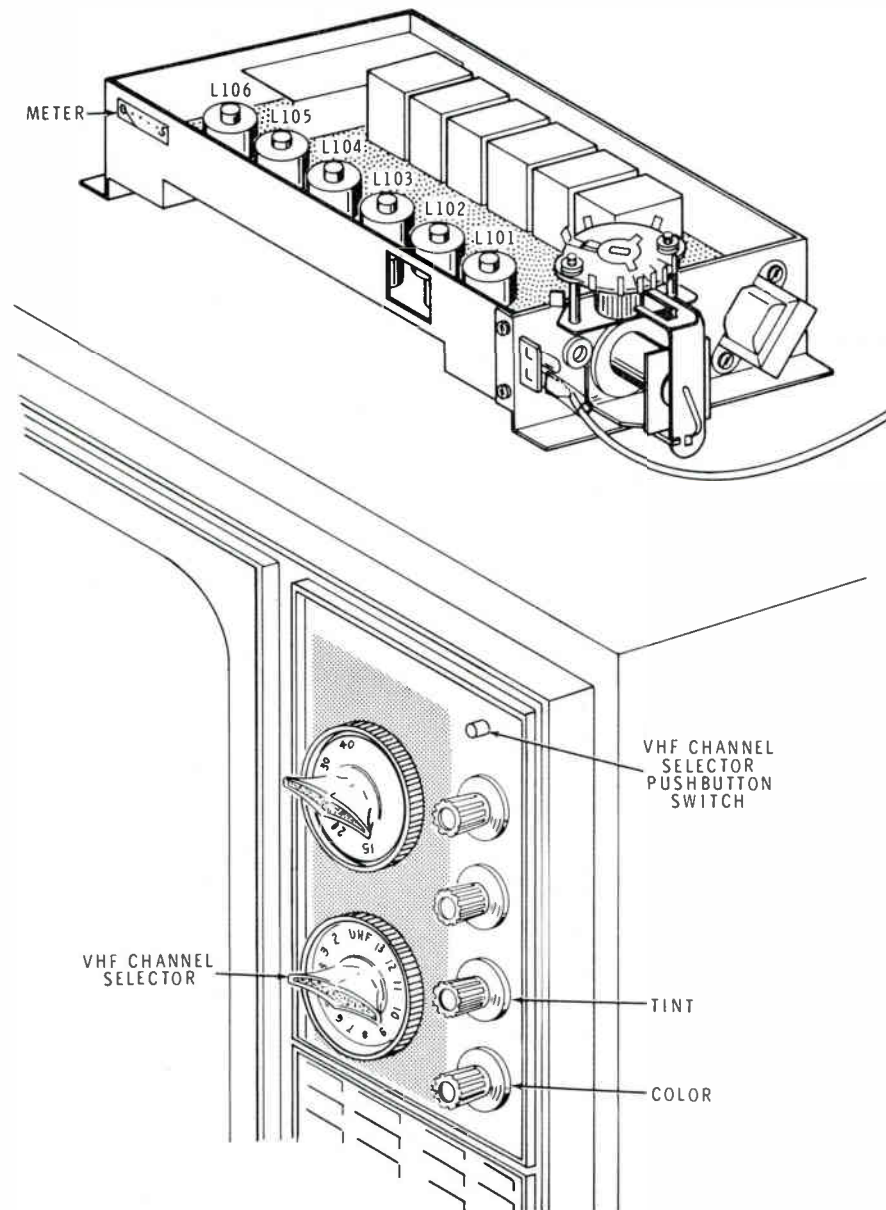

PICTORIAL 5-14

RECEIVER ADJUSTMENTS

Refer to Pictorial 5-14 for the following steps.

() Position the receiver on top of the television as shown.

NOTE: Complete the following boxed-in step for the model GR-180 TV set only.

() Place the microphone next to the remote control receiver. Make sure the front of the microphone is pointing toward you as you view the TV set from the front.

() Refer to Detail 5-14A and remove the fuse wire from the lugs of terminal strip AC. This wire will be reinstalled after the adjustments have been completed.

To make the following adjustments, hold the transmitter approximately two feet from the front of the television. Press and hold down each rocker switch as you are instructed in the steps. Then adjust the core inside the coils with the plastic alignment tool while observing the meter reading. If the correct results are not obtained in this Adjustment procedure, refer to the In Case of Difficulty section on Page 77. After locating and correcting the problem, continue with the Adjustments.

CAUTION: When the TV set is plugged in and turned On in the following steps, voltage will be present at various points on the inside of the chassis and Remote Control receiver. Also notice that some connections still have to be made between the picture tube assembly and chassis. This will be done after the Receiver Adjustments. **NOTE:** There is no high voltage present at the anode lead coming from the high voltage cage.

NOTE: The remote control functions will not operate until the following adjustments are completed.

- () Plug the TV set line cord into an AC outlet.
- () Turn the TV set on by pulling out on the VOLUME control knob.

Complete the adjustments listed in the chart.

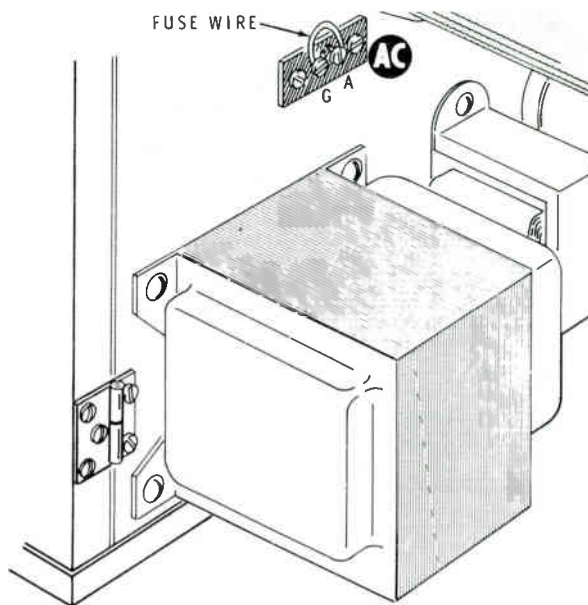

Detail 5-14A

This completes the adjustments.

- () Turn the TV set off and unplug the line cord.
- () Reinstall the fuse wire between the lugs of terminal strip AC.

TRANSMITTER SWITCH	RECEIVER COIL (adjust clockwise)	METER READING
() TINT (UP)	L106	Maximum
() TINT (DOWN)	L105	Maximum
() COLOR (UP)	L104	Maximum
() COLOR (DOWN)	L103	Maximum
() CHANNEL	L102	Maximum
() ON-OFF	L101	Maximum

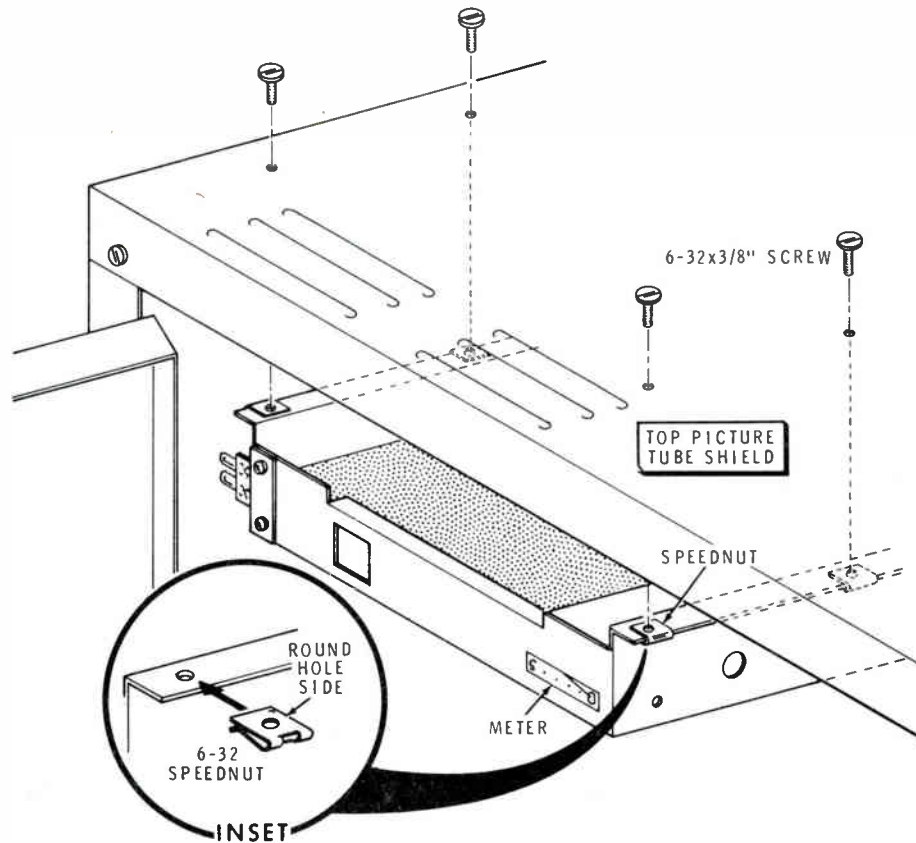

PICTORIAL 5-15

Refer to Pictorial 5-15 for the following steps.

- () Install 6-32 speednuts over the four holes in the bottom flanges of the receiver. Position the speednut with the round hole side as shown in the inset drawing on Pictorial 5-15.

- () Mount the receiver on the inside of the shield assembly with 6-32 x 3/8" screws.

Refer to Pictorial 5-16 for the following steps.

- () Route the convergence bracket through the large cutout in the chassis.

NOTE: Complete the following boxed-in step for the Model GR-180 TV set only.

- () Route the microphone through the large cutout in the chassis.

- () Clip one of the automatic degaussing coil leads on lug 1 and the other lead on lug 3 of terminal strip AR. Refer to inset drawing #1.

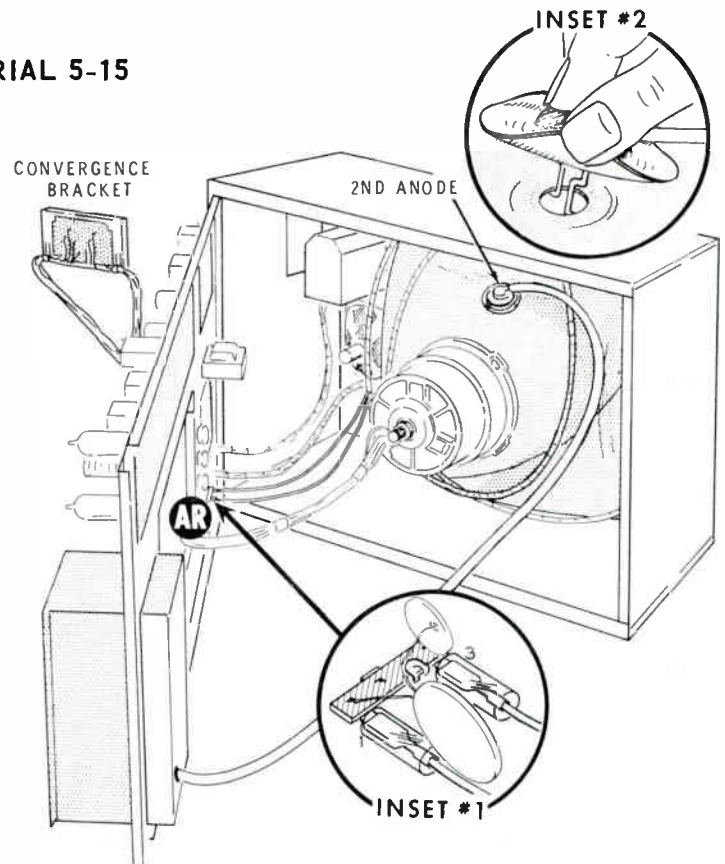

PICTORIAL 5-16

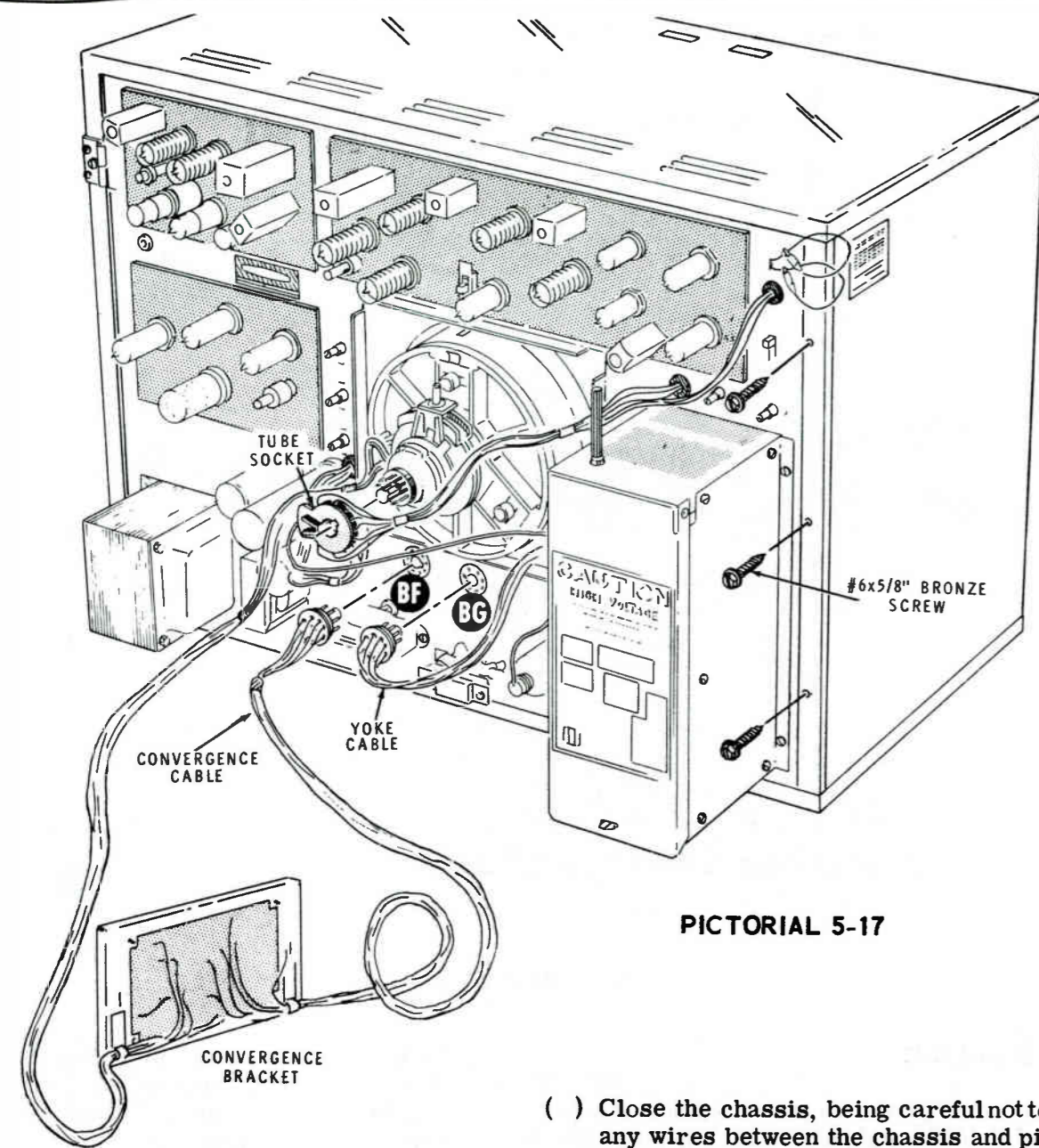

PICTORIAL 5-17

- () Connect the high voltage lead from the horizontal output assembly to the 2nd anode socket of the picture tube as shown in inset drawing #2. Be sure both clips are inside of the hole as shown in the inset drawing on the Pictorial, and be sure the anode connector is turned as shown.

Refer to Pictorial 5-17 for the following steps.

- () Insert the free end of the yoke cable through the large chassis cutout and insert the octal plug in socket BG.

- () Close the chassis, being careful not to pinch any wires between the chassis and picture-tube shield. Then fasten the right side of the chassis to the shield with three #6 x 5/8" bronze screws.
- () Insert the convergence cable plug in socket BF.
- () Route the yoke wires away from the tubes near the high voltage cage.
- () Mount the convergence assembly on the left side of the top shield by loosening one of the sheet metal screws along the top edge of the shield. Fasten the convergence bracket at this location.

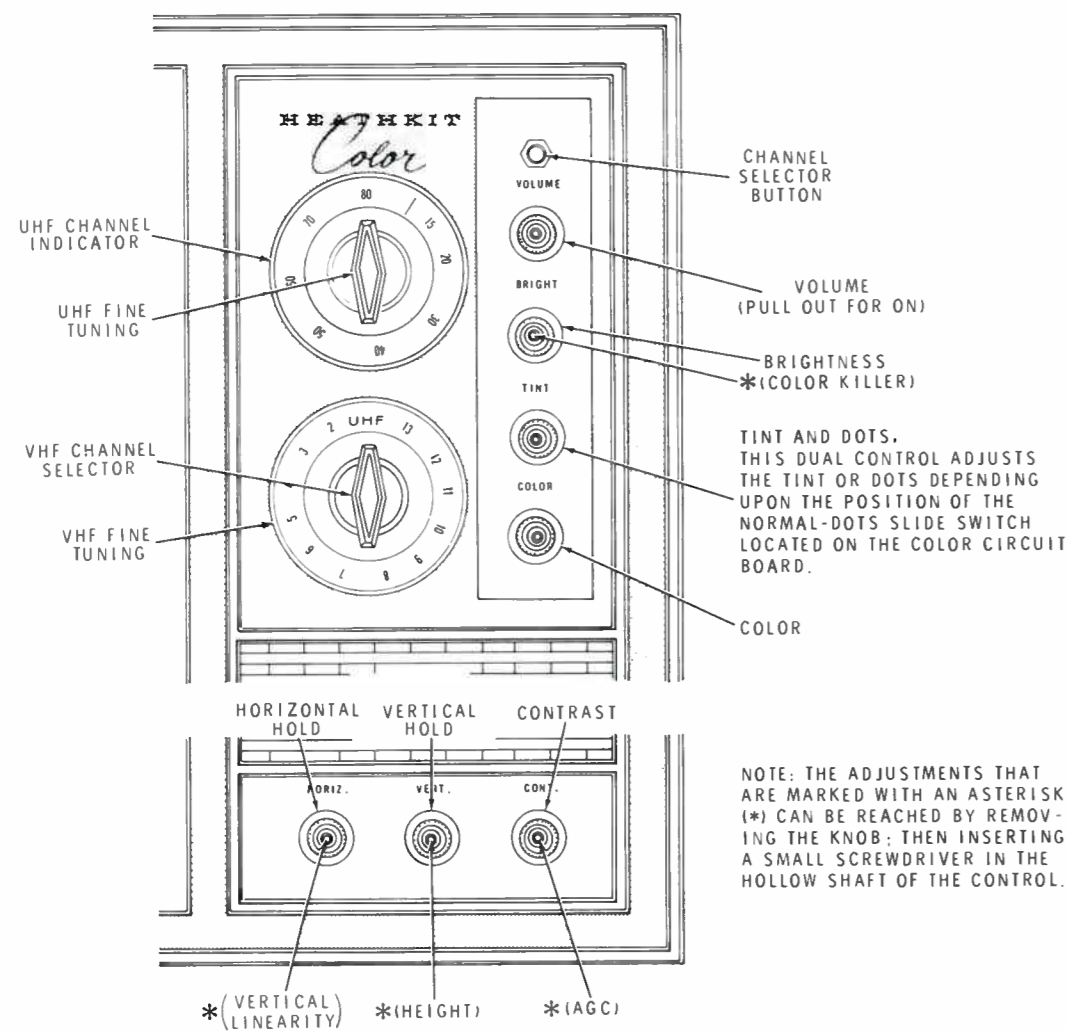

GR-180 FRONT PANEL

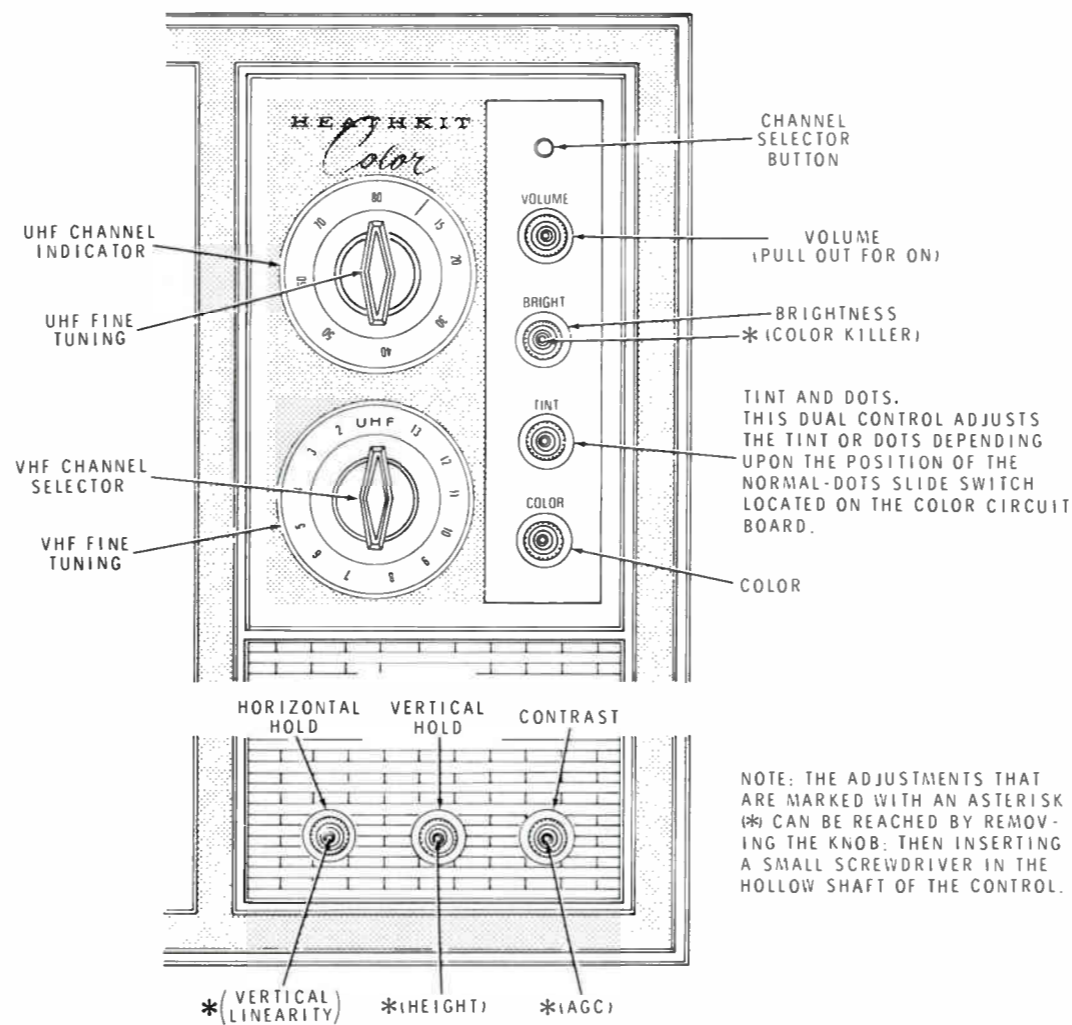

GR-227 FRONT PANEL

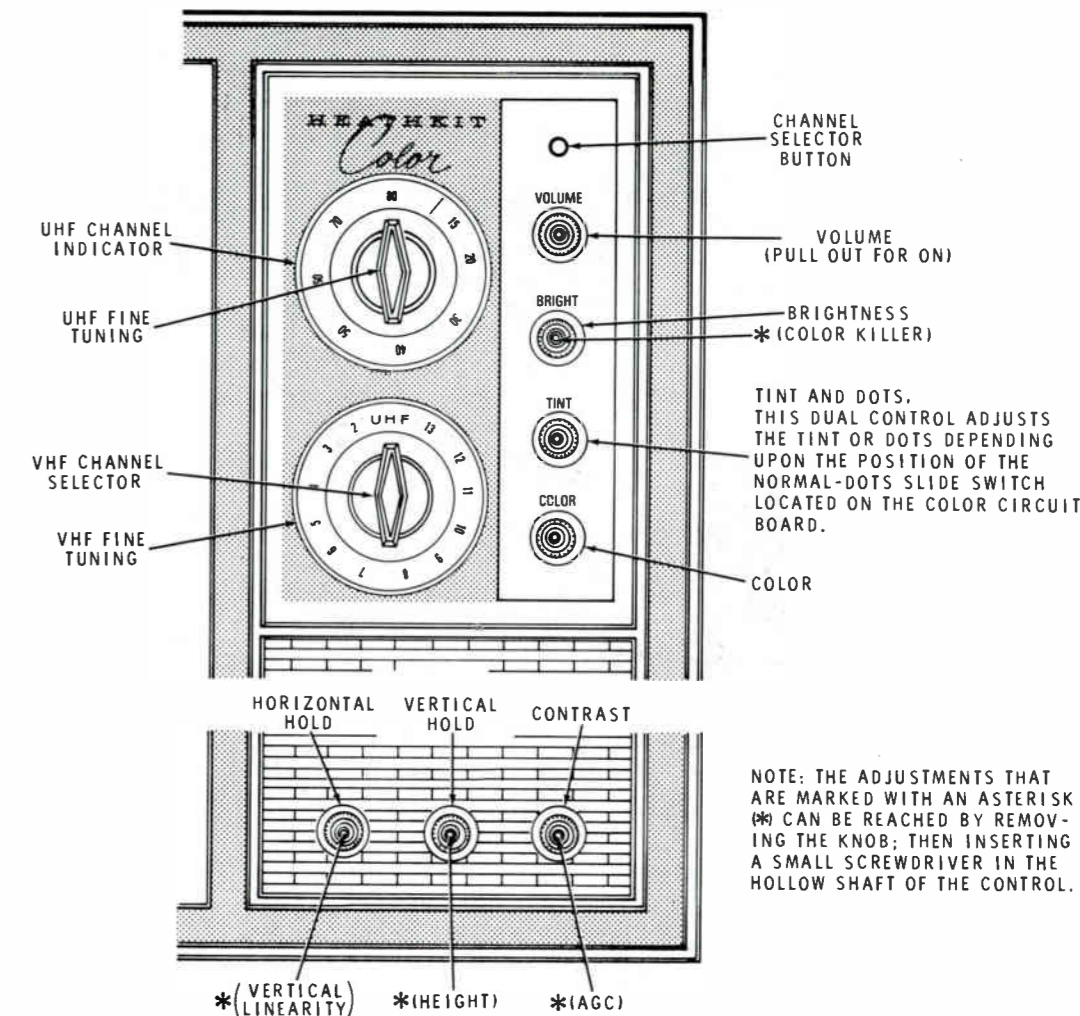

PICTORIAL 5-18

FINAL CHECKOUT

Pictorial 5-18 shows the new location of the COLOR KILLER control. It also explains the operation of the new TINT and DOTS control. A duplication of this drawing is printed on fold-out from Page 54. Cut the drawing out and tape it over the same portion of Figure 1-1A in your Television Manual.

Refer to Pictorial 5-18 for the following steps.

- () Plug the TV set line cord into an AC outlet.
- () Turn the TV set on.
- () Adjust the COLOR KILLER control fully counterclockwise.

() Tune in a weak black and white picture and check to see if colored confetti (small flashing colored spots caused by noise) shows in the picture.

() If colored confetti appears on black and white programs, adjust the COLOR KILLER control clockwise slightly until the color is removed.

() Recheck on a color program to make sure the color signal is still received normally. The COLOR KILLER control is set properly when color programs are reproduced in color, and black and white programs are free from colored confetti.

Each position of the transmitter switches will be checked in the following steps. Stand approximately 5 feet in front of the TV set with the transmitter pointing toward the set when performing these checks.

NOTE: Complete the following boxed-in step for the Model GR-180 TV set only.

- () Reposition the microphone on top of the TV set as you did in the Adjustment section.

On-Off

- () Turn the TV set off with the transmitter by pressing the ON-OFF switch. NOTE: This switch performs four steps due to the stepping relay. The steps follow this order: TV off, TV on, reduced volume, and minimum volume. At the present time the stepping relay could be in any one of these four positions. Therefore alternately press and release the switch until the TV set is turned off.

Now check each position of the ON-OFF switch. The results should be as described in the following list.

- () First position - TV set off.
- () Second position - TV set on.
- () Third position - Approximately 1/2 volume.
- () Fourth position - Volume off.

Channel

- () Push and release this switch several times. The channel selector knob should stop at each channel.

- () Press the pushbutton switch on the TV set. The channel selector should rotate.

Tint

- () Push the UP position of this switch until the TINT control turns fully clockwise and stops.
- () Push the DOWN position of this switch until the TINT control turns fully counterclockwise and stops.
- () Now push the switch to adjust the TINT control for a normal color picture.

Color

- () Push the UP position of this switch until the COLOR control turns fully clockwise and stops.
- () Push the DOWN position of this switch until the COLOR control turns fully counterclockwise and stops.
- () Now push the switch to adjust the COLOR control for a normal color picture.

This completes the Final Checkout procedure.

If your TV Set was a custom installation, disregard the following cabinet installation instructions and reinstall the TV Set back in its original location. Then mount the microphone to the microphone bracket with a 3/16" cable clamp, 6-32 x 3/8" screw, #6 lockwasher, and 6-32 nut. Mount the bracket in a convenient location so the front of the microphone is facing the TV viewer. Then proceed to the "Normal Operating Conditions" and "Operation" sections of the Manual.

NOTE: Perform the following boxed-in steps for mounting the microphone bracket in the Model GR-180 TV Set only.

MICROPHONE INSTALLATION FOR MODEL GR-180 TELEVISION

The following instructions are divided into three groups; Installation In Contemporary Cabinet, Installation In Early American Cabinet, and Installation In Table Model Cabinet. Complete the set of instructions for the cabinet you have purchased. Then proceed to the instructions "Installing Television Set In Cabinet."

Installation In Contemporary Cabinet

Refer to Pictorial 5-19 for the following steps.

- () Lay the TV cabinet on a rug face downward.
- () Mount the microphone bracket near the left rear leg with a #6 x 3/8" sheet metal screw. The edge of the bracket should be flush with the leg mount, as shown, to prevent the bracket from turning.

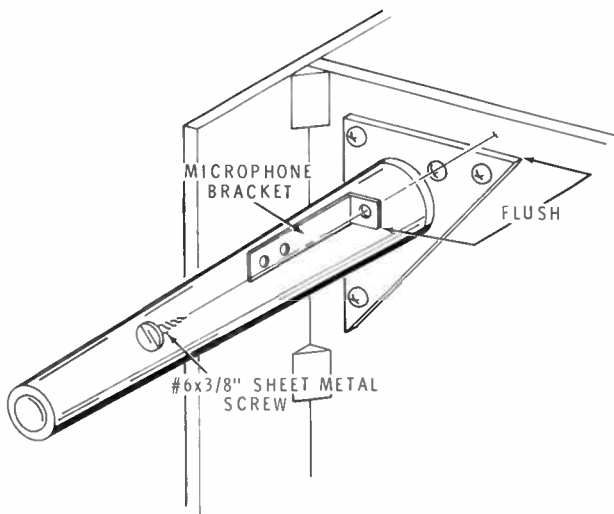

PICTORIAL 5-19

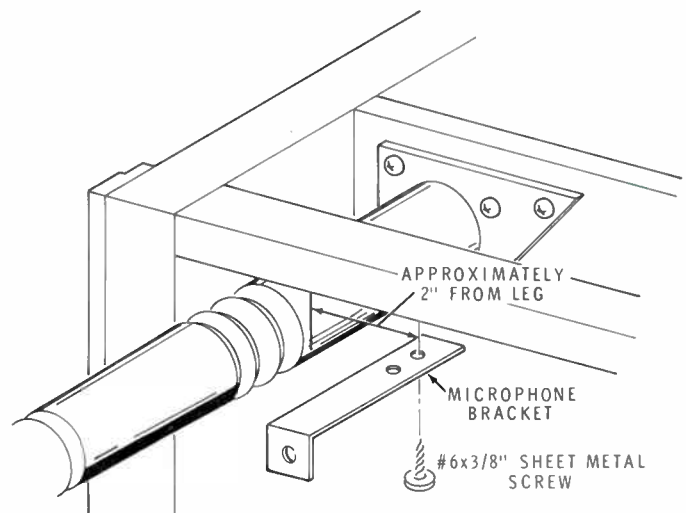

PICTORIAL 5-20

Installation In Early American Cabinet

Refer to Pictorial 5-20 for the following steps.

- () Lay the cabinet on a rug face downward.
- () Mount the microphone bracket approximately 2" from the left rear leg with a #6 x 3/8" sheet metal screw.

Installation In Table Model Cabinet

Find a suitable location to mount the microphone bracket behind this cabinet or its stand. Make sure no obstructions are placed directly in front of it.

- () Mount the microphone bracket behind the cabinet or stand.

INSTALLING TELEVISION SET IN CABINET

- () Position the TV Set on the floor directly behind the Cabinet.
- () Remove the convergence bracket from the shield. Lay the bracket (and the microphone for the GR-180 TV Set) on the floor behind the TV Set temporarily.
- () Move the antenna terminal strip around to the rear of the TV Set so the terminal strip and its leads do not catch or squeeze between the TV Set and the Cabinet during the next step.
- () Carefully lift the TV Set into the Cabinet. Slide it forward as far as possible so the picture tube mask fits into the opening in the front of the Cabinet.
- () Secure the TV Set to the Cabinet with the four 1/4-20 x 7/8" screws and four 3/4" flat washers.
- () Mount the antenna terminal strip on the rear of the Cabinet. Use a #6 x 5/8" bronze screw. Be sure the UHF antenna twin lead is not twisted among the VHF antenna coaxial cables.
- () Install the convergence bracket in the Service position on the back of the cabinet on the two #6 x 5/8" screws.
- () Set the cabinet back panel on the three bronze screws started in the bottom edge of the cabinet. Then fasten the back panel to the cabinet with #6 x 5/8" bronze screws in the other seven cabinet starting holes. Be sure to position the line cord in the back panel cutout as shown. For the GR-180 TV Set, the microphone also has to be routed through this cutout.

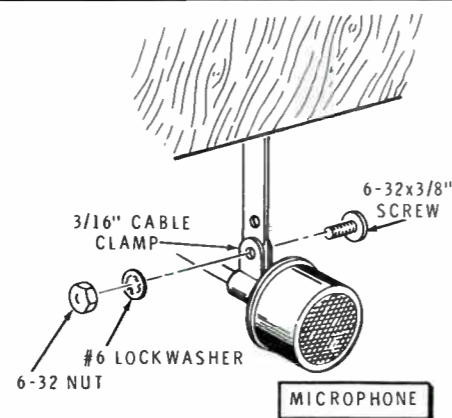

Detail 5-20A

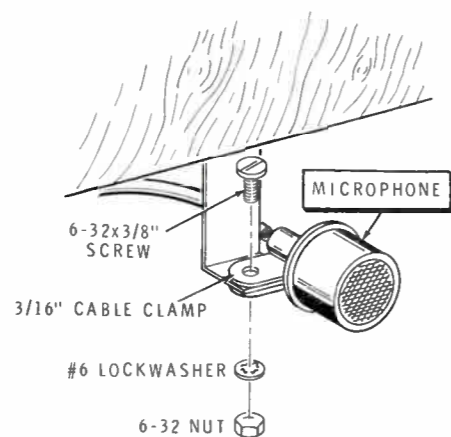

Detail 5-20B

Complete the following boxed-in step for the Model GR-180 TV Set only.

- () Place the 3/16" cable clamp around the microphone cable near the microphone. Then mount the clamp to the bracket with a 6-32 x 3/8" screw, #6 lockwasher, and 6-32 nut. Make sure the microphone is pointing toward the front of the TV Set. Refer to Detail 2-20A or 2-20B.

Proceed to the "Normal Operating Conditions" and "Operation" sections of the Manual.

CUT ALONG DOTTED LINE

TEMPLATE

- A** HOLD TEMPLATE IN PLACE.
- B** CENTERPUNCH FOUR HOLES.
- C** DRILL HOLES WITH 5/32" DRILL.

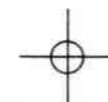

CUT ALONG DOTTED LINE

Instructions For Installing Remote Control In Models GR-295, GR-681, And GR-25 Television Sets

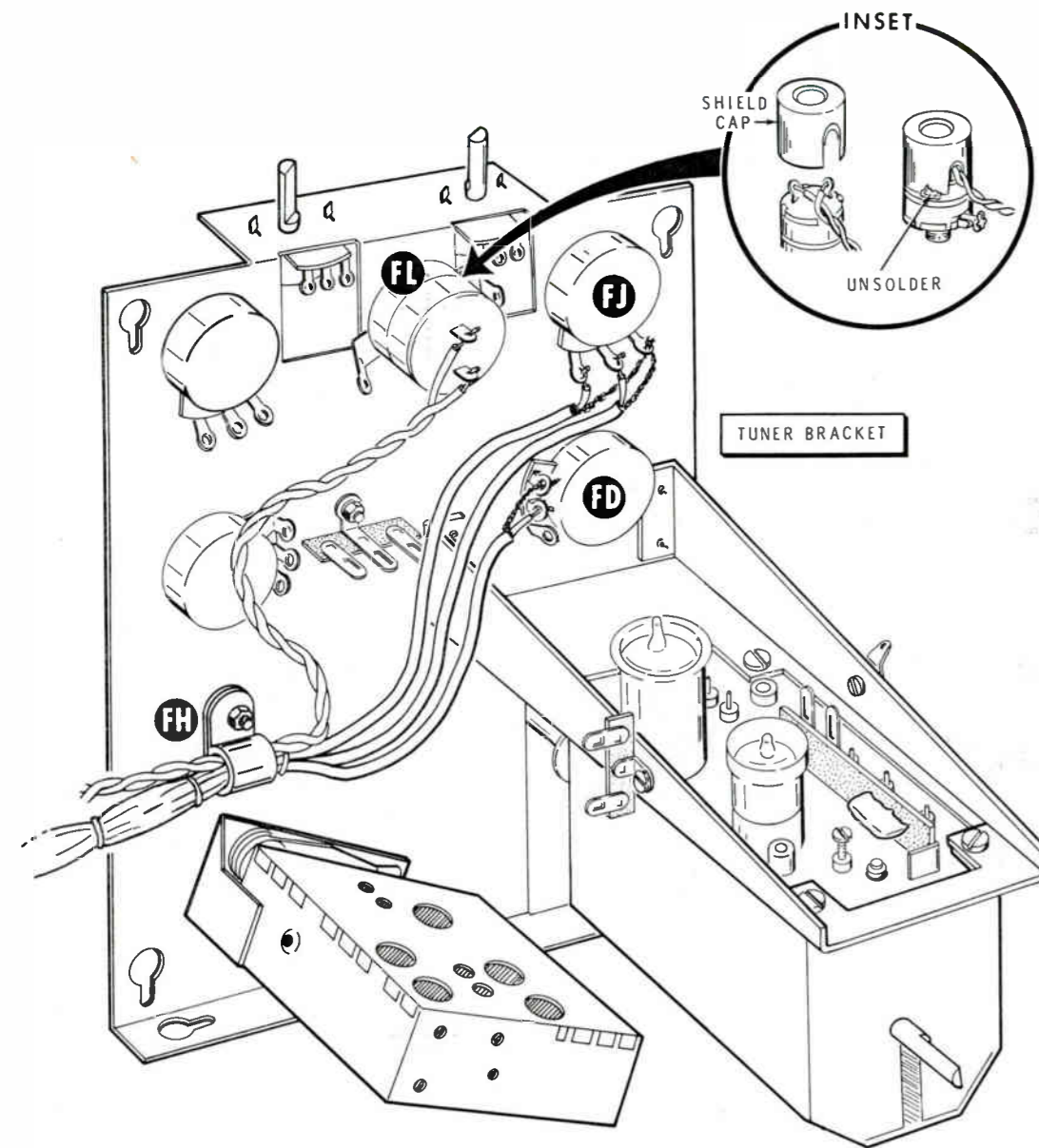

PICTORIAL 4-2

(For GR-295, GR-681, and GR-25 only)

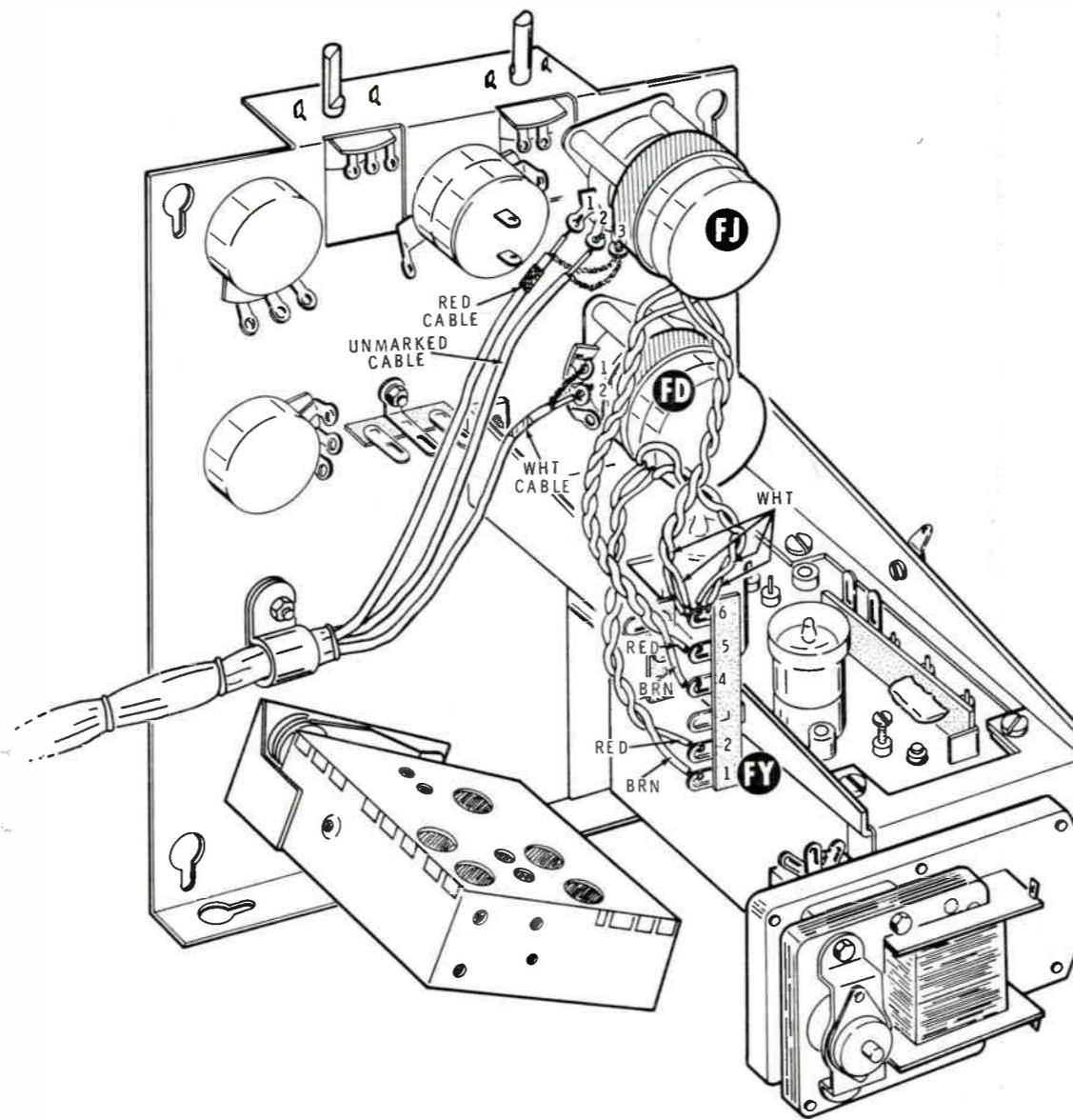

PICTORIAL 4-4

(For GR-295, GR-681, and GR-25 only)

REMOVING TELEVISION SET FROM CABINET

In the following steps, the television set will be removed from the cabinet and placed on a work bench in order to make the necessary revisions to incorporate the Remote Control. If your set is custom installed, some of these instructions will not pertain to you. However, read the instructions and use the ones that do apply.

- () Remove the knobs from the TV set.
- () Unplug the line cord and fold it to keep it out of the way.
- () Disconnect the antenna.
- () Remove the cabinet back panel by loosening the bottom row of screws and removing all of the other screws that fasten it to the cabinet.
- () Remove the four screws that fasten the television to the bottom of the cabinet.
- () Remove the screw that fastens the antenna terminal strip to the cabinet.

Refer to Pictorial 4-1 for the following steps.

- () Loosen screws HA, HB, HC, and HD and remove the tuner bracket. Set it on the floor behind the TV set.
- () Unplug the speaker cable from the TV set.
- () Remove the four nuts that fasten the convergence bracket to the speaker door. Set the bracket on the floor behind the TV set, being careful not to disturb any of the control or coil settings.
- () Set aside the knobs and hardware; they will be used again when the set is reinstalled in the cabinet.
- () Carefully pull the set out of the cabinet, temporarily mount the convergence bracket and tuner bracket on the left side of the set, and place the set on your work bench. The back of the set should be toward you,

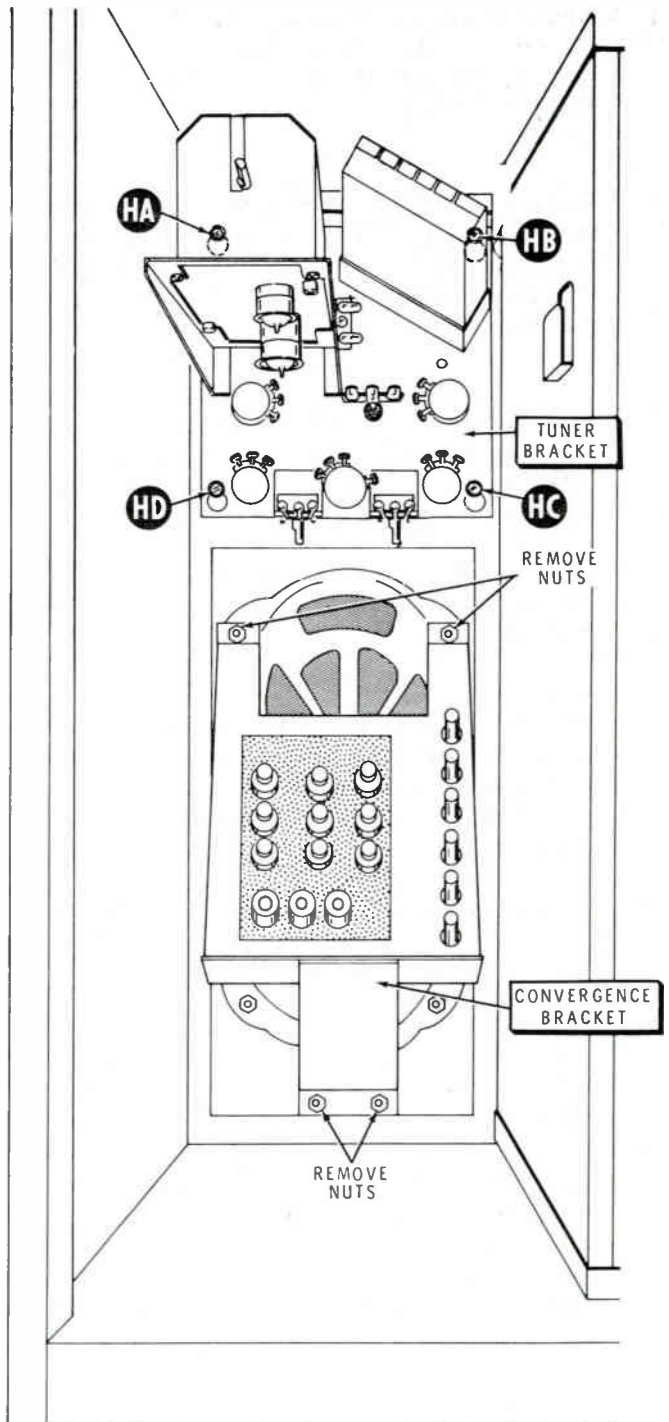

PICTORIAL 4-1

DISCONNECTING WIRES TO TUNER BRACKET

NOTE: The following boxed-in steps should be completed only if you are converting your TV set from the Remote Control Switch Model GRA-27 to the Remote Control Model GRA-295-6.

Refer to Detail 4-2A for the following steps.

- () Position the tuner bracket on your work bench behind the TV set as shown.
- () Remove the screw and plastic clamp that fastens the remote control switch cable to the picture tube shield. The clamp may be discarded, but reinstall the screw.
- () Remove the shield cap from control FL as shown in the inset drawing on Detail 4-2A.
- () Disconnect the three wires of the remote control switch that are connected to the motor and to control FL on the tuner bracket.

- () Disconnect the twisted pair of wires connected to the motor. Pull the wires out of clamp FH. The other end of these wires will be disconnected later.
- () Unsolder the black wire that is connected to lug 5 of control FL.
- () Disconnect and discard the wires connected between the motor lugs.
- () Remove the screw, lockwasher, and clamp that fastens the remote control switch cable to the motor. The clamp may be discarded, but reinstall the lockwasher and screw. Then set aside the remote control switch.

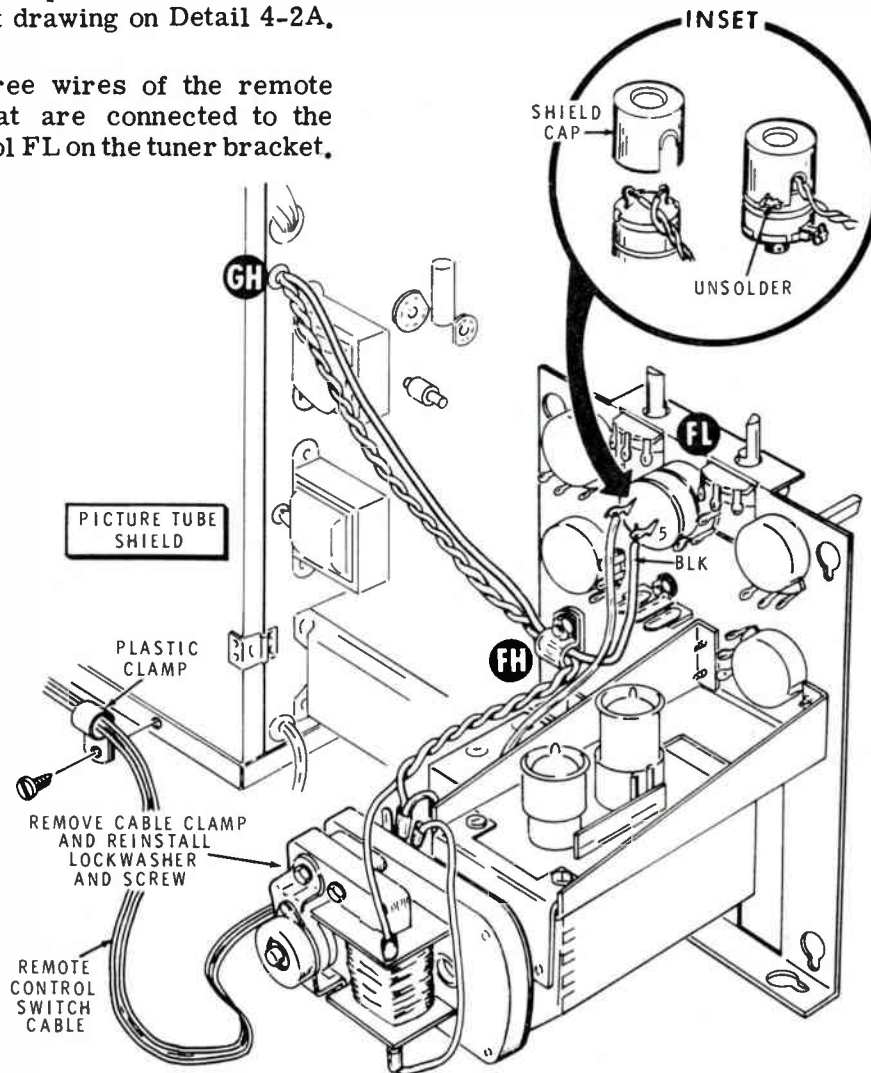

Detail 4-2A

DISCONNECTING WIRES TO TUNER BRACKET

NOTE: The following boxed-in steps should be completed only if you are converting your TV set from the Remote Control Switch Model GRA-27 to the Remote Control Model GRA-681-6.

Refer to Detail 4-2B for the following steps.

- () Position the tuner bracket on your work bench behind the TV set as shown.
- () Remove the screw and plastic clamp that fastens the remote control switch cable to the picture tube shield. The clamp may be discarded, but reinstall the screw.
- () Remove the shield cap from control FL as shown in the inset drawing on Detail 4-2B.
- () Disconnect the wires of the remote control switch that are connected to control FL and terminal strip FS.
- () Push the sleeving back from lug 2 of the tuner drive motor. Then cut off the remaining remote control switch wire and slide the sleeving back on the lug. Do not cut off the red wire that is connected between this lug and lug 2 of terminal strip FS.

- () Disconnect the three twisted wires (coming through clamp FH) and connected to the motor, terminal strip FS, and control FL. Pull the wires out of clamp FH. The other end of each of these wires will be disconnected later.
- () Remove the screw, lockwasher, and clamp that fastens the remote control switch cable to the motor. The clamp may be discarded, but reinstall the lockwasher and screw. Then set aside the remote control switch.

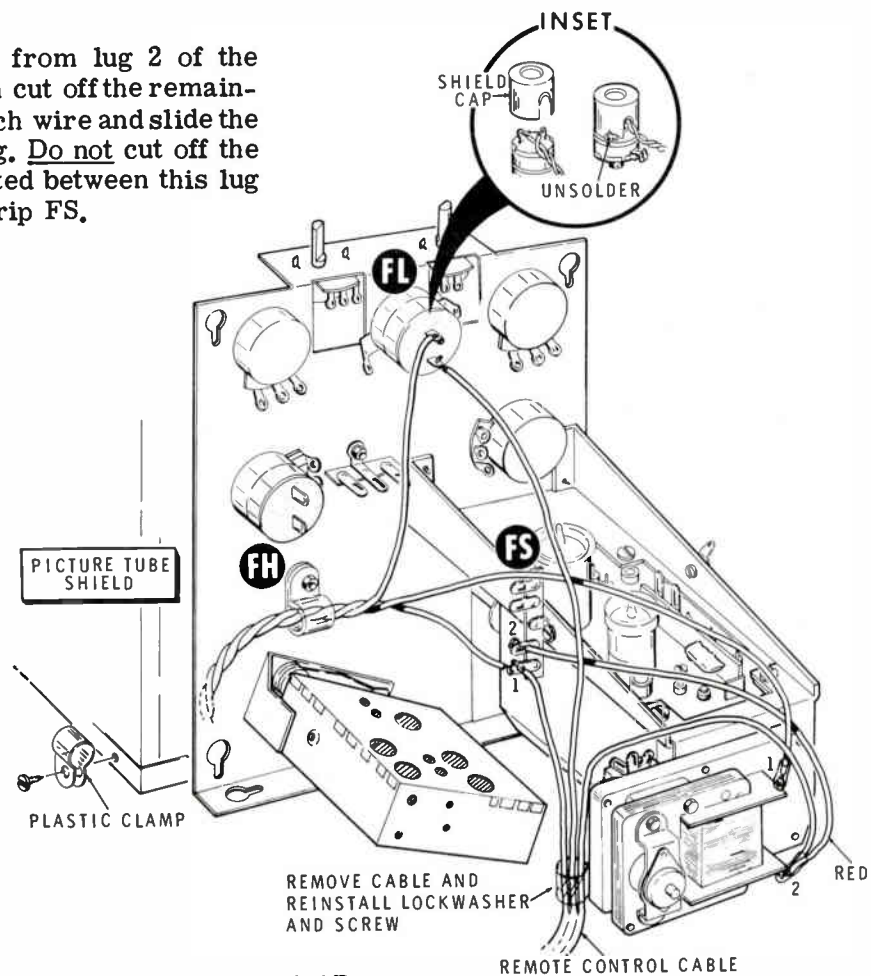

Detail 4-2B

Refer to Pictorial 4-2 (fold-out from Page 58) for the following steps.

- (✓) Position the tuner bracket on your work bench behind the TV set as shown.

NOTE: The following boxed-in steps should be completed only for the Models GR-295 and GR-25 TV Sets that are not equipped with the Remote Control Switch Model GRA-27.

- (✓) Remove the shield cap from control FL as shown in the inset drawing on Pictorial 4-2.

- (✓) Unsolder the black twisted pair of wires from control FL. Then pull these wires out of clamp FH; the other ends will be disconnected later.

- (✓) Unsolder all of the connections to control FJ.

- (✓) Unsolder all of the connections to control FD.

- (✓) Remove controls FD and FJ. The controls and lockwashers may be discarded, but save the control nuts.

INSTALLING MOTORS

Refer to Detail 4-3A for the following steps.

Locate the following parts:

- (✓) Two control motors.
- (✓) 1200 Ω control (#10-252).
- (✓) 500 Ω control (#10-251).
- (✓) Two control mounting plates.
- (✓) Six 4-40 x 1/4" screws.

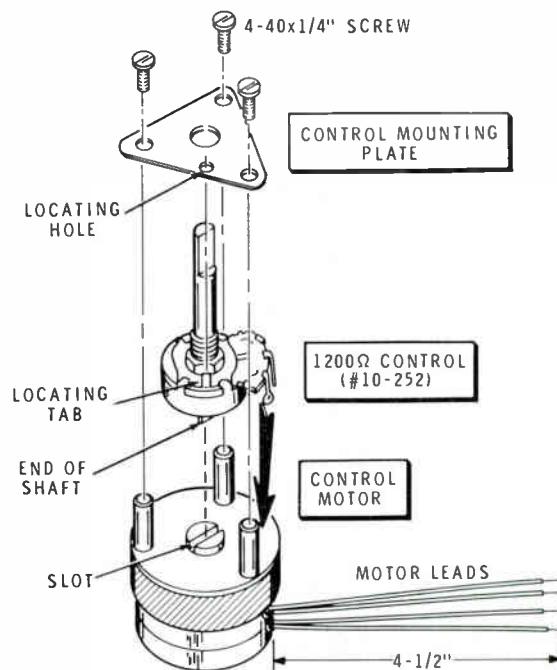

Detail 4-3A

- (✓) Cut the leads of one control motor to 4-1/2" and remove 1/4" of insulation from the ends. Then apply a small amount of solder to the end of each lead.

- (✓) Position the control motor with the leads as shown.

- (✓) Place the 1200 Ω control (#10-252) on the motor with the control lugs positioned between the indicated motor spacers. Make sure the end of the control shaft is inserted in the control motor slot.

- (✓) Install the control mounting plate on the motor spacers with 4-40 x 1/4" screws. Make sure the locating tab on the control lines up with the locating hole in the plate. Also make sure the three spacers seat properly in the mounting plate holes.



Refer to Pictorial 4-3 for the following steps.

- (✓) Cut off the indicated lug of control FK.

NOTE: When mounting the following control, make sure the mounting spacer screws do not touch the VHF tuner bracket.

- (✓) Mount the completed motor assembly on the tuner bracket at FD as shown in Detail 4-3B. Use a control lockwasher and the nut ~~that~~ was removed from the other control. Do not overtighten the nut; this could cause the control to bind. Rotate the shaft to make sure it turns freely.

- (✓) Cut the leads of the remaining motor to 4-1/2".

- (✓) Assemble the motor and 500 Ω control (#10-251) in a similar manner and mount it on the tuner bracket at FJ. Turn the motor assembly so it does not obstruct the hole at FJ.

NOTE: Disregard the following boxed-in steps if you are converting your TV set from the Remote Control Switch GRA-27 to the Remote Control Model GRA-295-6 or GRA-681-6.

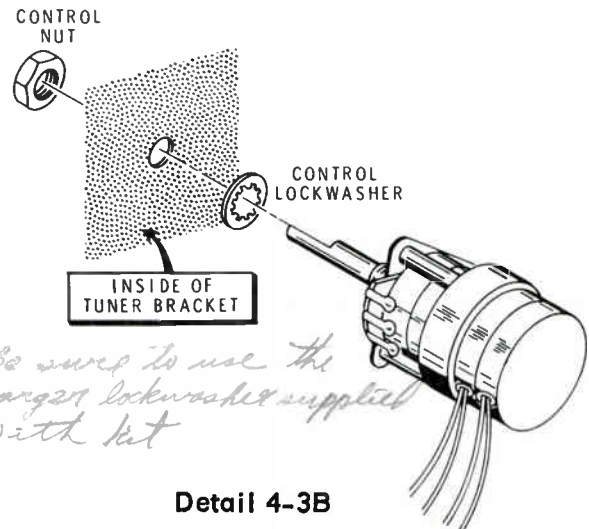

Detail 4-3B

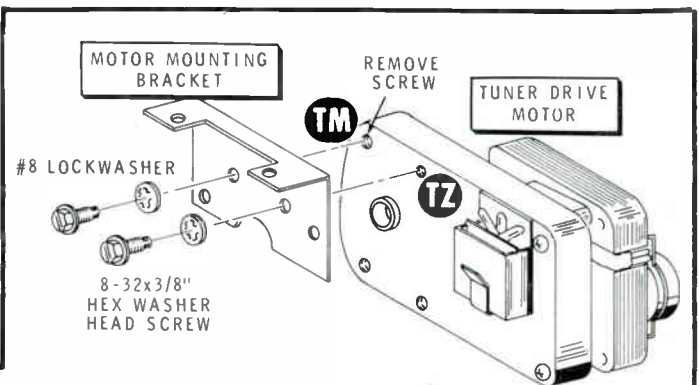

Detail 4-3C

- (✓) Refer to Detail 4-3C and remove and discard the indicated screw from the tuner drive motor. Then mount the plate to the motor with 8-32 x 3/8" hex washer head screws and #8 lockwashers at TM and TZ. Do not tighten these screws at this time.
- (✓) Remove and discard the two indicated tuner screws shown in Pictorial 4-3.
- (✓) Remove and discard the cardboard sleeve that is located between the rotor and bearing assembly of the motor.
- (✓) Position the motor directly behind the VHF tuner and, if necessary, rotate the shaft of the tuner so its "flat" lines up with the "flat" of the motor.
- () Fit the motor onto the rear shaft of the VHF tuner and temporarily install two #6 x 3/8" screws as shown in the inset drawing on Pictorial 4-3.

- (✓) Now rotate the shaft of the VHF tuner one complete revolution to be sure the motor is not binding.
- (✓) Make a pencil line on the motor mounting bracket along the edge of the motor as shown.
- (✓) Remove the motor mounting bracket from the VHF tuner by removing the #6 x 3/8" screws just installed.
- (✓) Line up the motor with the pencil line on the motor mounting bracket and tighten the motor mounting screws.
- (✓) Replace the motor on the VHF tuner and install the #6 x 3/8" screws.
- (✓) Rotate the shaft of the VHF tuner through at least one complete revolution to be sure it does not bind.

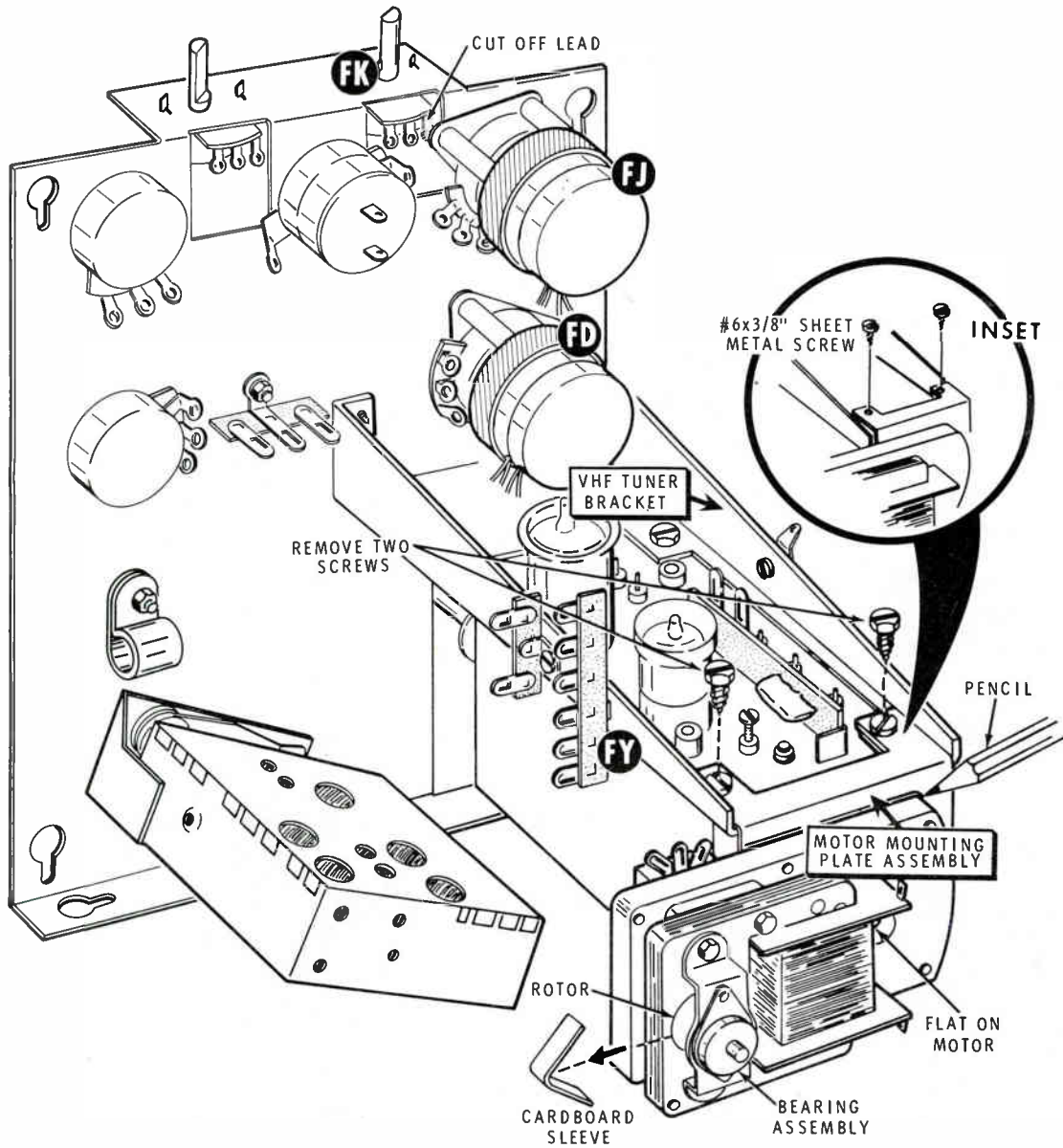

PICTORIAL 4-3

✓) Refer to Detail 4-3D and mount the 6-lug terminal strip on the tuner bracket at FY. Use a 6-32 x 3/8" screw, two #6 lockwashers, and a 6-32 nut.

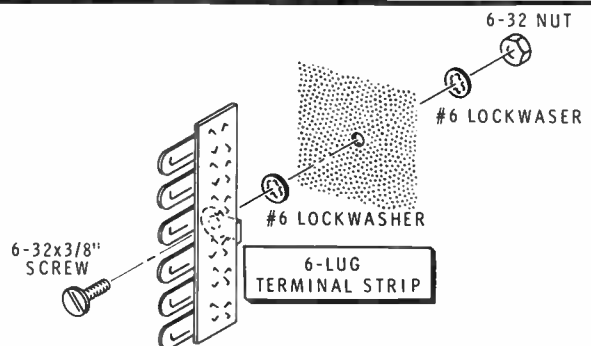

Detail 4-3D

REWIRING MAIN CONTROL BRACKET

Refer to Pictorial 4-4 (fold-out from Page 58) for the following steps.

In the following steps, the wiring harness and components that were previously disconnected will be reconnected to the main control bracket.

Connect the wiring harness wires to the controls in the following steps.

(✓) Inner lead of the white marked cable to lug 2 of FD (S-1) and shield lead to lug 1 (S-1).

(✓) Inner lead of the unmarked cable to lug 2 of FJ (S-1) and shield lead to lug 3 (NS).

(✓) Inner lead of the red marked cable to lug 1 of FJ (S-1) and shield lead to lug 3 (S-2).

Connect the motor leads to terminal strip FY in the following steps. Twist together the red and brown motor leads and the white motor leads as shown.

(✓) Both white leads of motor FD to lug 6 of FY (NS).

(✓) Red lead of motor FD to lug 2 (NS) and brown lead to lug 1 (NS) of FY.

(✓) Both white leads of motor FJ to lug 6 of FY (NS).

(✓) Brown lead of motor FJ to lug 4 (NS) and red lead to lug 5 (NS) of FY.

Refer to Pictorial 4-5 (fold-out from Page 65) for the following steps.

Locate the remote control cable assembly. Connect the end of the cable assembly with the ten wires to the main control bracket in the following steps.

() Red wire to lug 5 of control FL (S-1).

() Brown wire to lug 6 of control FL (S-1).

() Refer to the inset drawing on Pictorial 4-5 and reinstall the shield cap on control FL. Route the wires through the cutout on the side of the shield cap. Then solder the cap to the control.

() Green wire to lug 5 of terminal strip FY (S-2).

() Gray wire to lug 4 of terminal strip FY (S-2).

() Yellow wire to lug 2 of terminal strip FY (S-2).

() Orange wire to lug 1 of terminal strip FY (S-2).

() Connect one end of a 5-1/2" white hookup wire to lug 6 of terminal strip FY (S-5).

NOTE: Complete the following boxed-in steps for the Model GRA-295-6 only.

() Slide a 3/4" length of large clear sleeving over the free end of the white hookup wire and both white wires from the remote control cable assembly. Connect these three wires to lug 1 of the tuner drive motor (S-3) and slide the sleeving over the lug.

() Prepare both ends of a 6-1/2" brown stranded wire. Slide a 3/4" length of small clear sleeving over one end of the wire. Connect this end to lug 3 of the tuner drive motor (S-1) and slide the sleeving over the lug.

() Slide a 3/4" length of large clear sleeving over the other end of the brown wire and the blue wire of the remote control cable assembly. Then connect both wires to lug 2 of the tuner drive motor (S-2). Slide the sleeving over the lug.

() Slide a 3/4" length of small clear sleeving over the violet wire of the remote cable assembly. Connect this wire to lug 4 of the tuner drive motor (S-1). Then slide the sleeving over the lug.

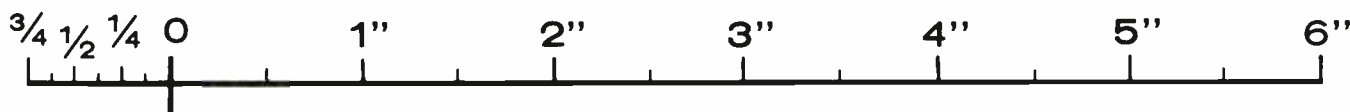



NOTE: Complete the following boxed-in steps for the Model GRA-681-6 only.

Refer to Detail 4-5A (fold-out from this Page) for the following steps.

Locate the remote control cable assembly. Connect the end of the cable assembly with the ten wires to the main control bracket in the following steps.

- () Red wire to lug 5 of control FL (S-1).
- () Brown wire to lug 6 of control FL (S-1).
- () Refer to the inset drawing on Pictorial 4-5 and reinstall the shield cap on control FL. Route the wires through the cutout on the side of the shield cap. Then solder the cap to the control.
- () Green wire to lug 5 of terminal strip FY (S-2).
- () Gray wire to lug 4 of terminal strip FY (S-2).
- () Yellow wire to lug 2 of terminal strip FY (S-2).
- () Orange wire to lug 1 of terminal strip FY (S-2).
- () Violet wire to lug 1 of terminal strip FS (S-3).
- () Blue wire to lug 2 of terminal strip FS (S-4).
- () Connect one end of a 5-1/2" white hookup wire to lug 6 of terminal strip FY (S-5).
- () Slide a 3/4" length of large clear sleeving over the free end of the white hookup wire and both white wires from the remote control cable assembly. Connect these three wires to lug 1 of the tuner drive motor (S-3) and slide the sleeving over the lug.

REWIRING MAIN CONTROL BRACKET

Refer to Pictorial 4-4 (fold-out from Page 58) for the following steps.

In the following steps, the wiring harness and components that were previously disconnected will be reconnected to the main control bracket.

Connect the wiring harness wires to the controls in the following steps.

- (✓) Inner lead of the white marked cable to lug 2 of FD (S-1) and shield lead to lug 1 (S-1).
- (✓) Inner lead of the unmarked cable to lug 2 of FJ (S-1) and shield lead to lug 3 (NS).
- (✓) Inner lead of the red marked cable to lug 1 of FJ (S-1) and shield lead to lug 3 (S-2).

Connect the motor leads to terminal strip FY in the following steps. Twist together the red and brown motor leads and the white motor leads as shown.

- (✓) Both white leads of motor FD to lug 6 of FY (NS).
- (✓) Red lead of motor FD to lug 2 (NS) and brown lead to lug 1 (NS) of FY.
- (✓) Both white leads of motor FJ to lug 6 of FY (NS).
- (✓) Brown lead of motor FJ to lug 4 (NS) and red lead to lug 5 (NS) of FY.

NOTE: Complete the following boxed-in steps for the Model GRA-295-6 only.

Refer to Pictorial 4-5 (fold-out from Page 65) for the following steps.

Locate the remote control cable assembly. Connect the end of the cable assembly with the ten wires to the main control bracket in the following steps.

- (✓) Red wire to lug 5 of control FL (S-1).
- (✓) Brown wire to lug 6 of control FL (S-1).
- (✓) Refer to the inset drawing on Pictorial 4-5 and reinstall the shield cap on control FL. Route the wires through the cutout on the side of the shield cap. Then solder the cap to the control.
- (✓) Green wire to lug 5 of terminal strip FY (S-2).
- (✓) Gray wire to lug 4 of terminal strip FY (S-2).
- (✓) Yellow wire to lug 2 of terminal strip FY (S-2).
- (✓) Orange wire to lug 1 of terminal strip FY (S-2).
- (✓) Connect one end of a 5-1/2" white hookup wire to lug 6 of terminal strip FY (S-5).
- (✓) Slide a 3/4" length of large clear sleeving over the free end of the white hookup wire and both white wires from the remote control cable assembly. Connect these three wires to lug 1 of the tuner drive motor (S-3) and slide the sleeving over the lug.
- (✓) Prepare both ends of a 6-1/2" brown stranded wire. Slide a 3/4" length of small clear sleeving over one end of the wire. Connect this end to lug 3 of the tuner drive motor (S-1) and slide the sleeving over the lug.
- (✓) Slide a 3/4" length of large clear sleeving over the other end of the brown wire and the blue wire of the remote control cable assembly. Then connect both wires to lug 2 of the tuner drive motor (S-2). Slide the sleeving over the lug.
- (✓) Slide a 3/4" length of small clear sleeving over the violet wire of the remote cable assembly. Connect this wire to lug 4 of the tuner drive motor (S-1). Then slide the sleeving over the lug.

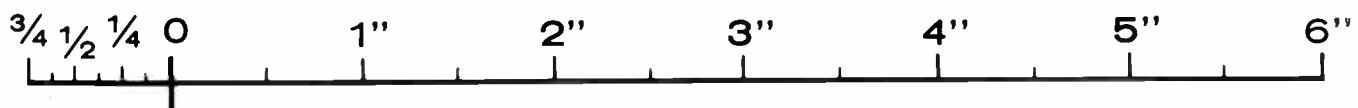

NOTE: Complete the following boxed-in steps for the Model GRA-681-6 only.

Refer to Detail 4-4A for the following steps.

- () Connect the violet wire from the remote control cable assembly to lug 1 of terminal strip FS (S-3).
- () Connect the blue wire from the cable assembly to lug 2 of terminal strip FS (S-4).

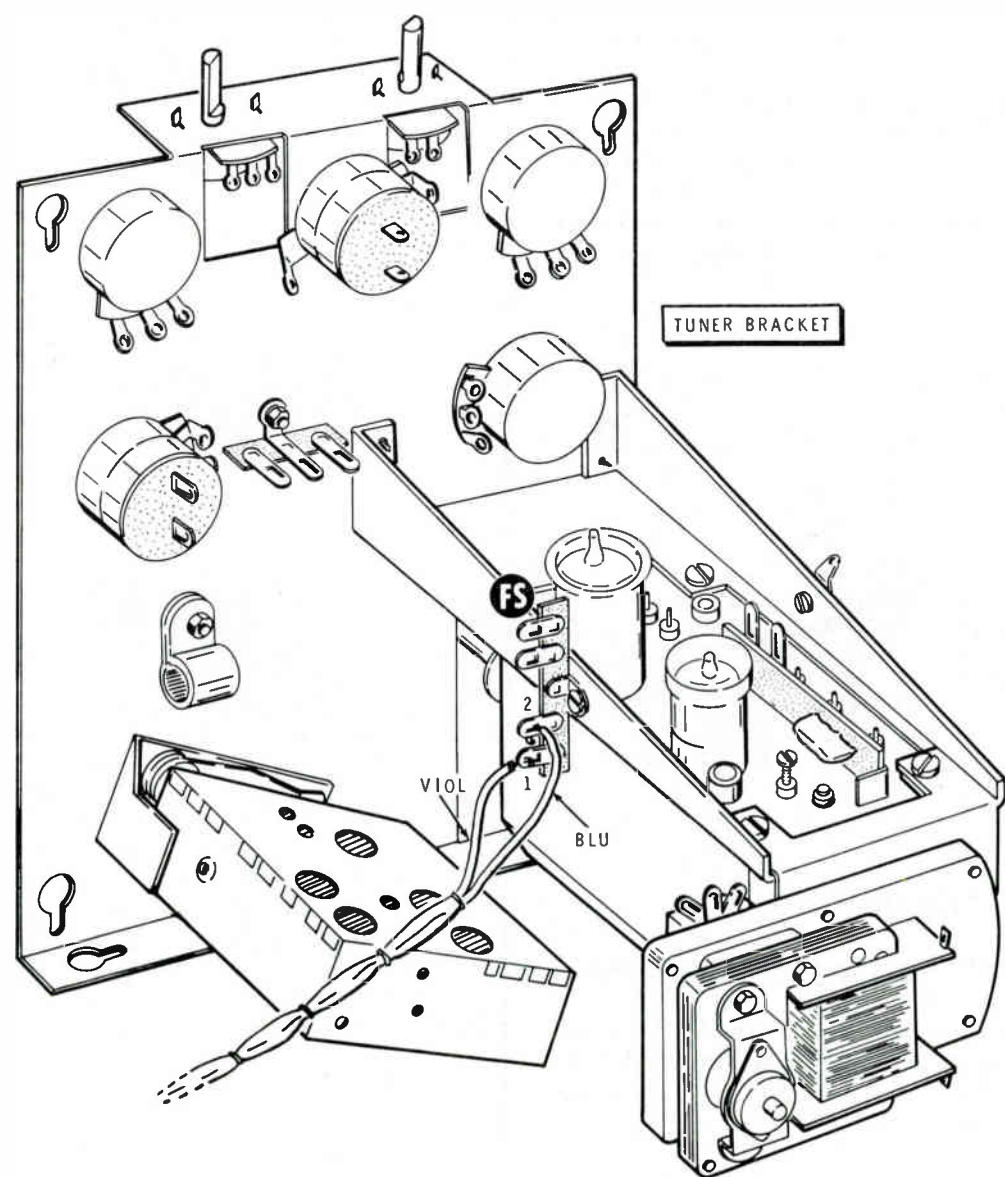

Detail 4-4A

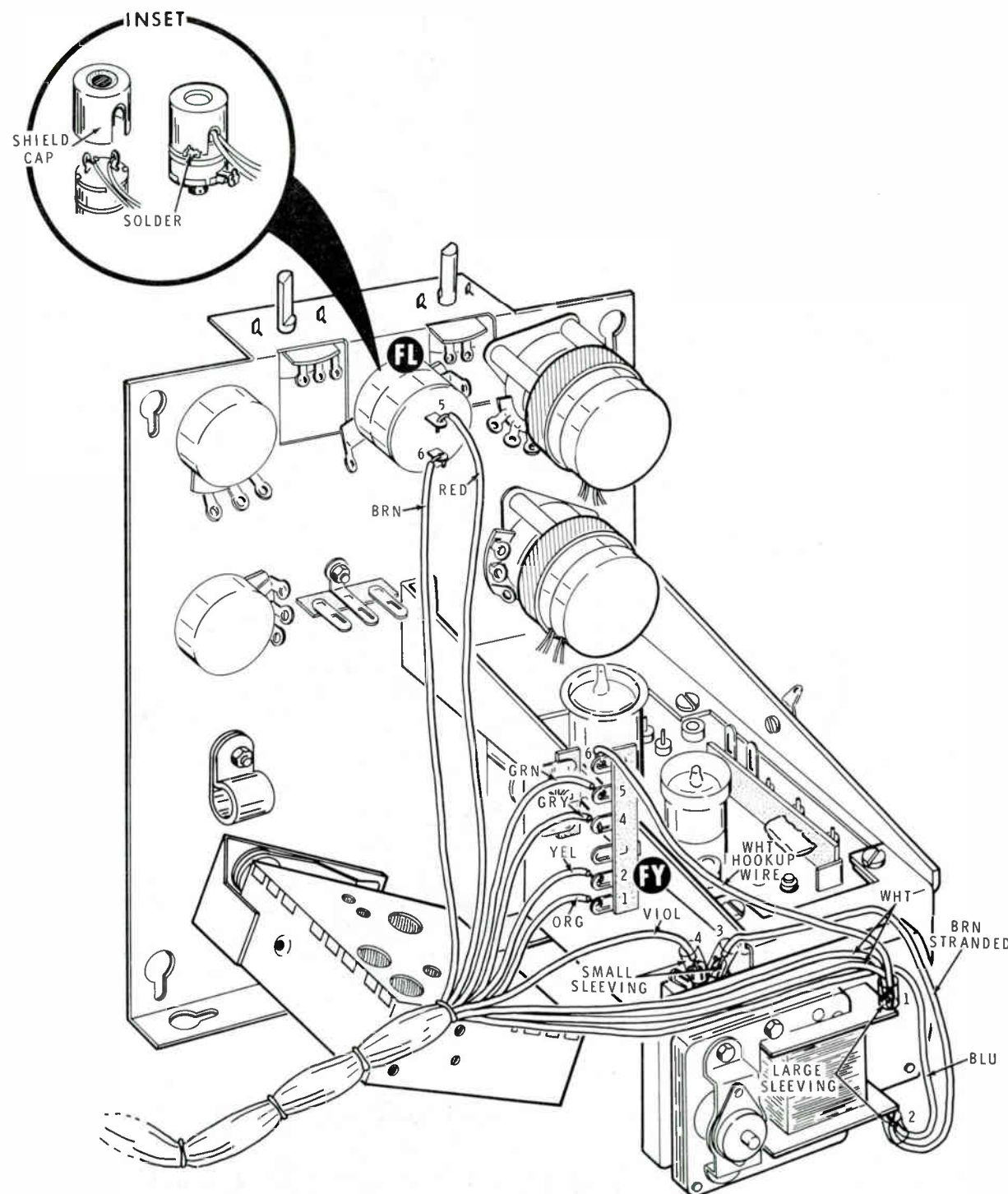

PICTORIAL 4-5

(For GR-295, GR-681, and GR-25 only)

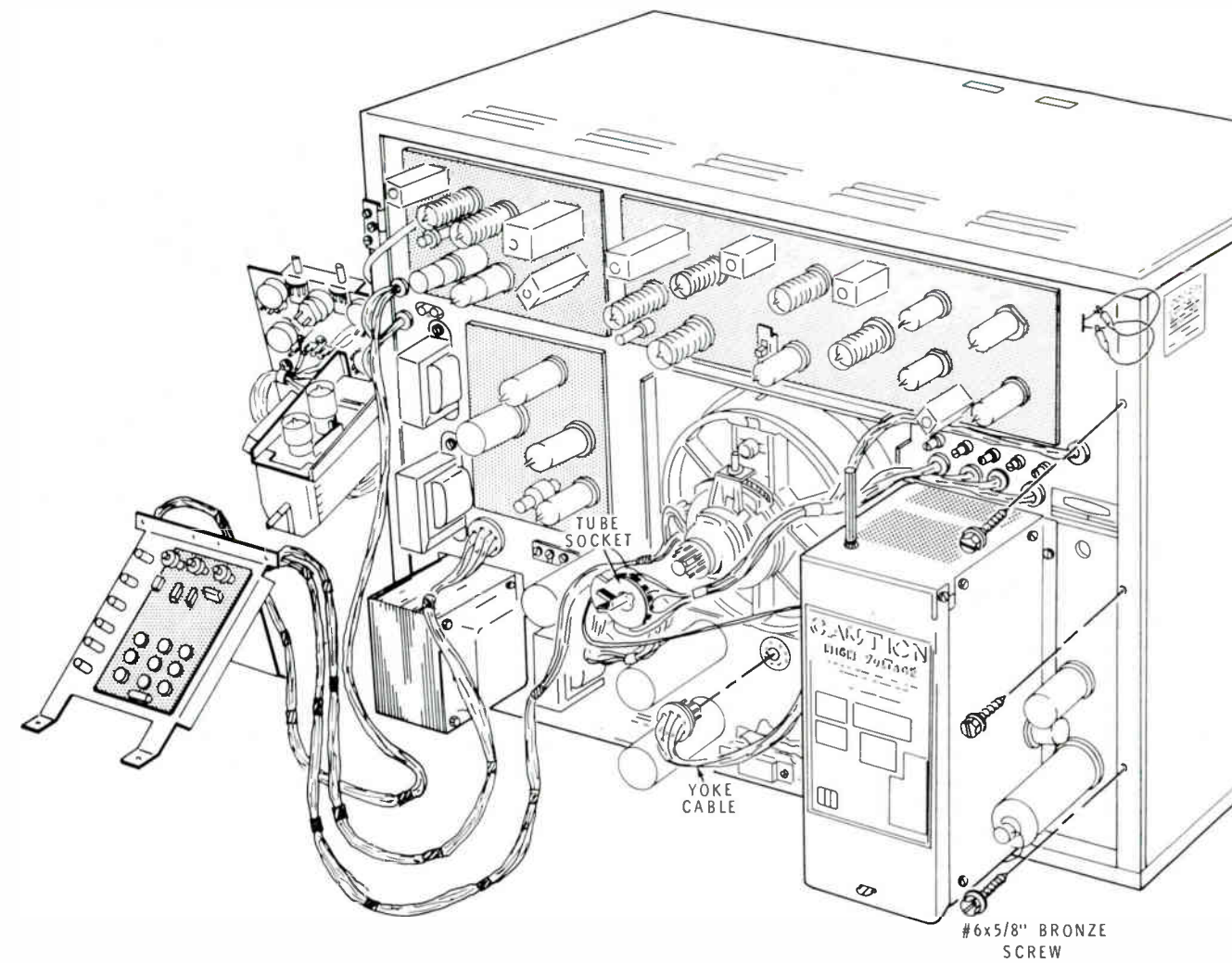

PICTORIAL 4-6

(For GR-295, GR-681, and GR-25 only)

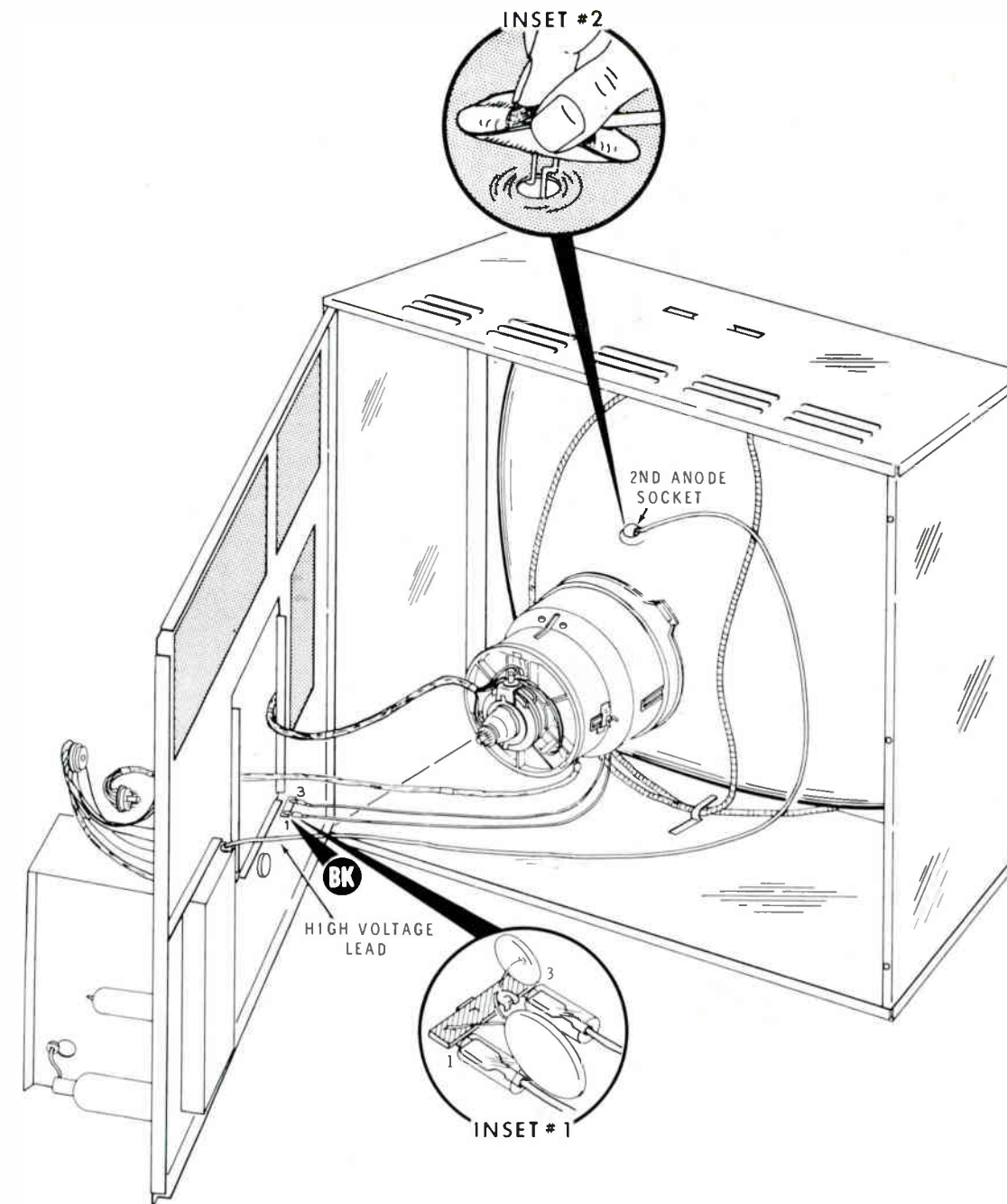

PICTORIAL 4-8

(For GR-295, GR-681, and GR-25 only)

Refer to Pictorial 4-6 (fold-out from this Page) for the following steps.

- () Unplug the picture tube socket and yoke cable.
- () Remove the three screws that fasten the chassis to the shield assembly.
- () Place the convergence bracket and tuner bracket on the left side of the TV set on your work bench. This will keep them out of the way for the following steps.

Refer to Pictorial 4-7 for the following steps.

- () Swing the chassis open and discharge the high voltage anode by wrapping one end of a bare wire around the ground wire. Then wrap the other end of the bare wire around the metal part of a screwdriver. Hold the screwdriver by the insulated handle and touch the blade to the wires under the rubber cap of the high voltage anode connector.

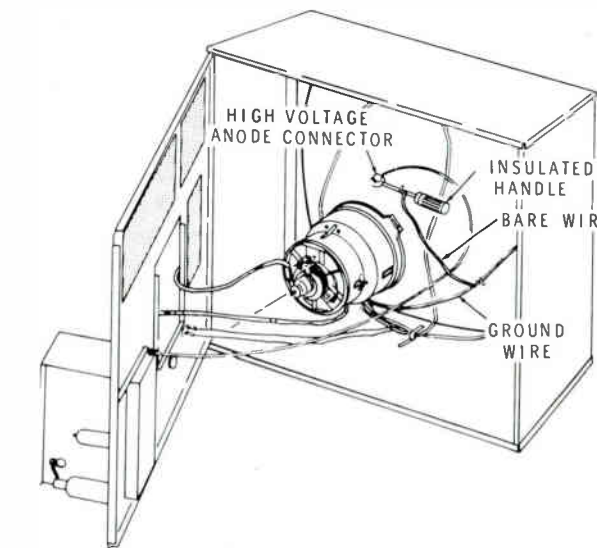

PICTORIAL 4-7

Refer to Pictorial 4-8 for the following steps.

- () Remove the high voltage anode lead as shown in inset drawing #2 on Pictorial 4-8. Lift the rubber cap and compress one wire with the blade of a screwdriver.
- () Unplug the two degaussing coil leads from terminal strip BK as shown in inset drawing #1.

NOTE: The following boxed-in step should be completed only for the Models GR-295 and GR-25 TV Sets that are not equipped with Remote Control Switch Model GRA-27.

Refer to Detail 4-9A and unsolder the black twisted pair of wires connected to lugs 1 and 5 of terminal strip BH. Then pull these wires through grommet GH and discard them.

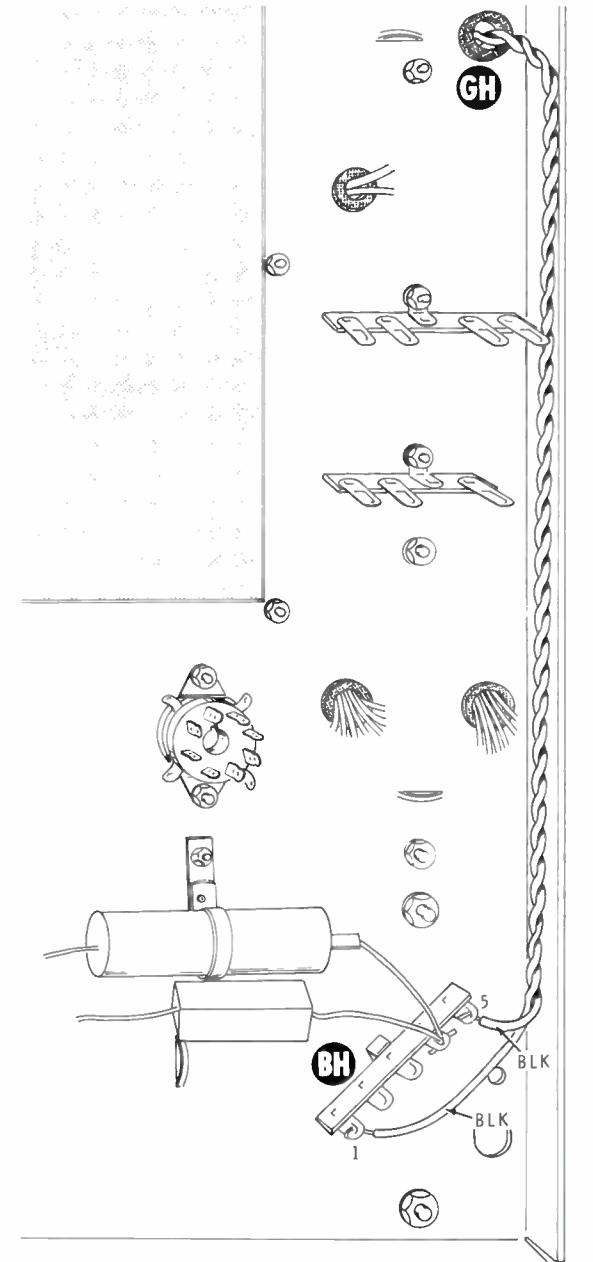

Detail 4-9A

The following boxed-in step should be completed for the Model GR-681 TV Set and also for the Model GR-295 and GR-25 TV Sets that are equipped with the Remote Control switch Model GRA-27.

Refer to Detail 4-9B for the following step.

- () Unsolder the red and black twisted wires connected to lugs 1 and 2 and the black wire (brown in GR-681) connected to lug 5 of terminal strip BH. Pull these wires through the grommet and discard them.

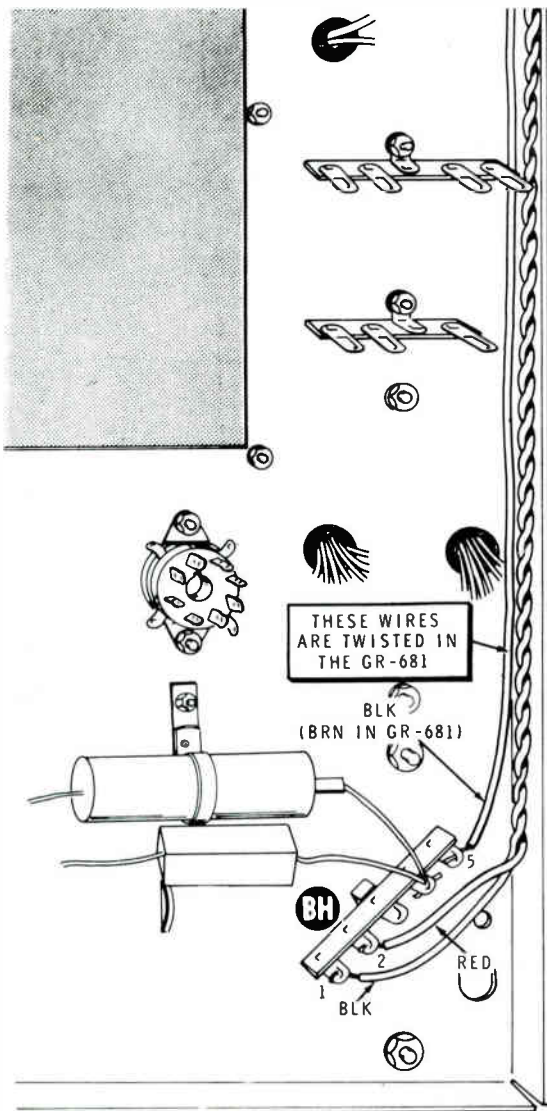

Detail 4-9B

Refer to Pictorial 4-9 for the following steps.

- (✓) Route the wires coming from the remote cable assembly through grommet GF in the chassis.

Connect the cable assembly wires coming through grommet GF to the bottom eyelet of the lugs of terminal strip BH in the following steps. After connecting the wires, route them away from the 750 Ω resistor which is connected to this terminal strip.

- (✓) Both violet wires to lug 1 of BH (S-2).
- (✓) White wire to lug 2 of BH (S-1).
- (✓) Black wire to lug 3 of BH (S-1).
- (✓) White-blue wire to lug 4 of BH (S-1).
- (✓) Red wire to lug 5 of BH (S-1).

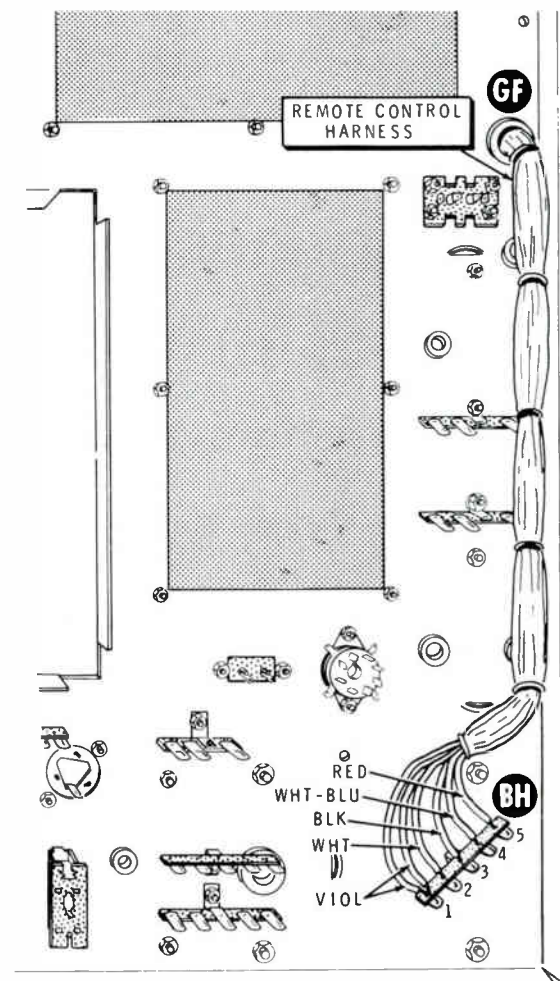

PICTORIAL 4-9

NOTE: The following boxed-in step should be completed only if you are converting your GR-681 TV set or the Remote Control Switch Model GRA-27 to the Remote Control Model GRA-295-6 or GRA-681-6.

Refer to Detail 4-9B for the following step.

- () Unsolder the red and black twisted pair of wires connected to lugs 1 and 2 and the black wire connected to lug 5 of terminal strip BH. Pull these wires through grommet GH and discard them.

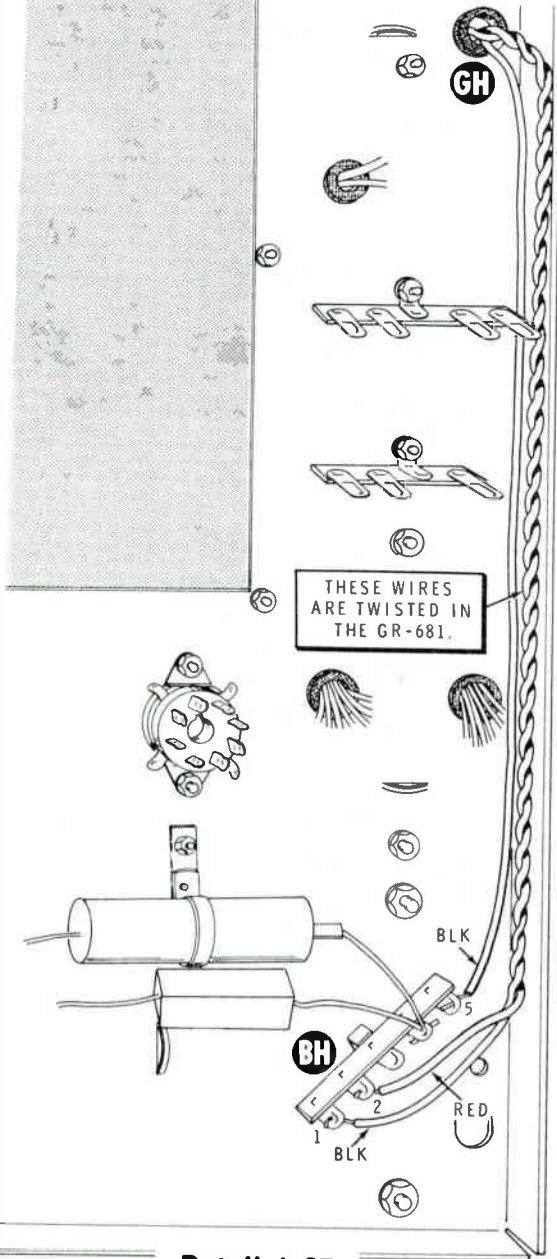

Detail 4-9B

Refer to Pictorial 4-9 for the following steps.

- () Route the wires coming from the remote cable assembly through grommet GF in the chassis.

Connect the cable assembly wires coming through grommet GF to the bottom eyelet of the lugs of terminal strip BH in the following steps. After connecting the wires, route them away from the 750 Ω resistor which is connected to this terminal strip.

- () Both violet wires to lug 1 of BH (S-2).
- () White wire to lug 2 of BH (S-1).
- () Black wire to lug 3 of BH (S-1).
- () White-blue wire to lug 4 of BH (S-1).
- () Red wire to lug 5 of BH (S-1).

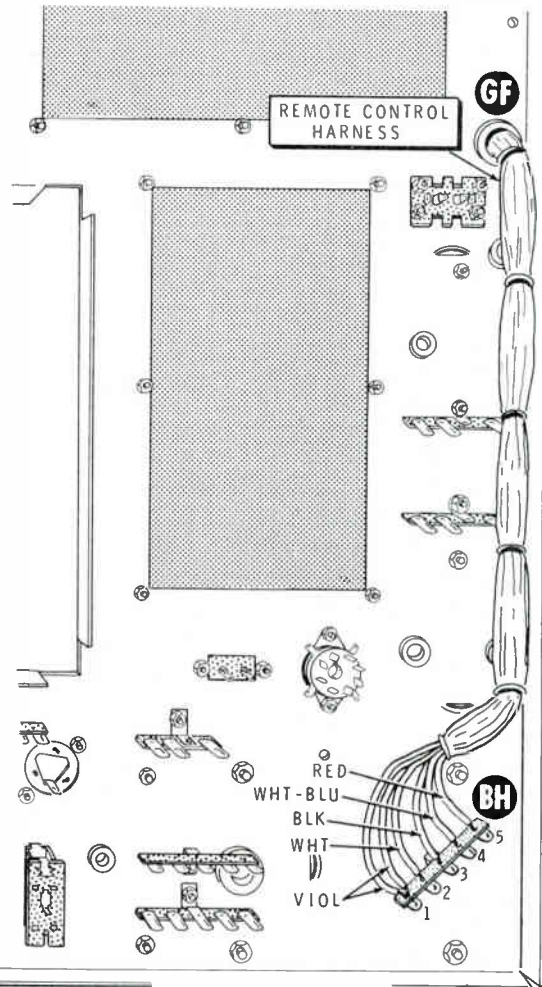

PICTORIAL 4-9

Refer back to Pictorial 4-8 for the following steps.

- () Clip one of the automatic degaussing coil leads on lug 1 and the other lead on lug 3 of terminal strip BK. Refer to inset drawing #1.
- () Discharge the 2nd anode socket of the picture tube by repeating the method previously used.
- () Connect the high voltage lead from the horizontal output assembly to the 2nd anode socket of the picture tube as shown in inset drawing #2. Be sure both clips are inside of the hole as shown in the inset drawing on the Pictorial, and be sure the anode connector is turned as shown.

Refer back to Pictorial 4-6 for the following steps.

- () Install the picture tube socket.
- () Insert the free end of the yoke cable through the large chassis cutout and insert the octal plug in socket BG.
- () Close the chassis, being careful not to pinch any wires between the chassis and picture tube shield. Then fasten the right side of the chassis to the shield with the three #6 x 5/8" bronze screws.

In the following steps, you will be instructed to mount the microphone on the speaker door.

NOTE: If your TV Set was custom mounted, find a suitable location to install the microphone. The front of the microphone should be pointing toward the TV viewer. Make sure no obstructions are directly in front of it, with the exception of grille cloth or screening.

- () Open the speaker door by turning the wing lock inside the cabinet.
- () Refer to Detail 4-10A and remove the door by pushing the two pins inward with a screwdriver.

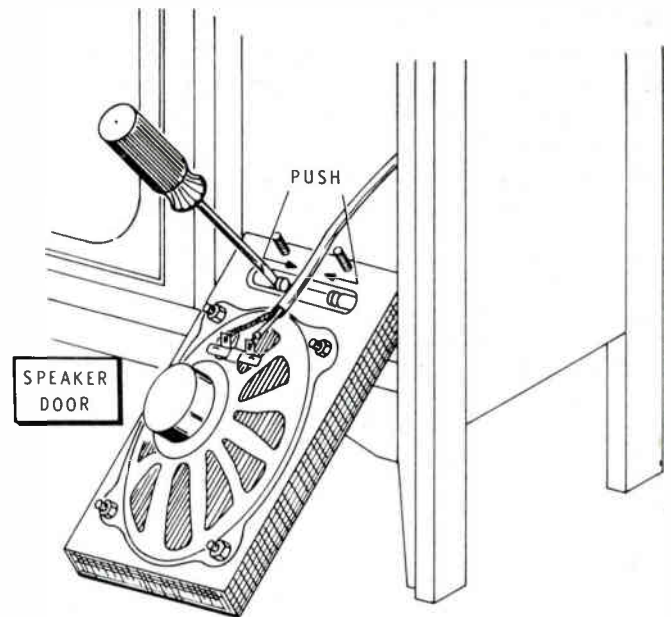

Detail 4-10A

Refer to Pictorial 4-10 for the following steps.

- () Remove the speaker from the door by removing the four nuts and washers. Then set the speaker aside temporarily.
- () Refer to Detail 4-10B and mount the microphone mounting plate and clip at FZ with a #6 x 3/8" sheet metal screw. It may be necessary to make a starter hole in the door with a nail. Also, make sure the edge of the plate does not push against the speaker grille cloth.

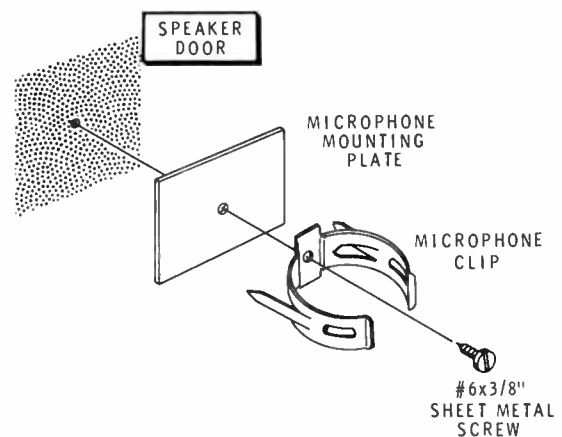

Detail 4-10B

Page 68 - Add the following Note in the right-hand column after "Refer to Pictorial 4-10 for the following steps".

NOTE: If the speaker door on your TV Set has a hole at location FX, disregard steps 1 through 6 and merely insert the microphone all the way into the hole. Then complete steps 7 and 8.

Page 68 - Number the steps 1 and 2 in the right-hand column.

Page 69 - Number the steps 3, 4, 5, 6, 7, and 8 on this Page.

Replace Pictorial 4-10 on this Page with the new Pictorial 4-10 supplied with this letter.

Thank you,

HEATH COMPANY

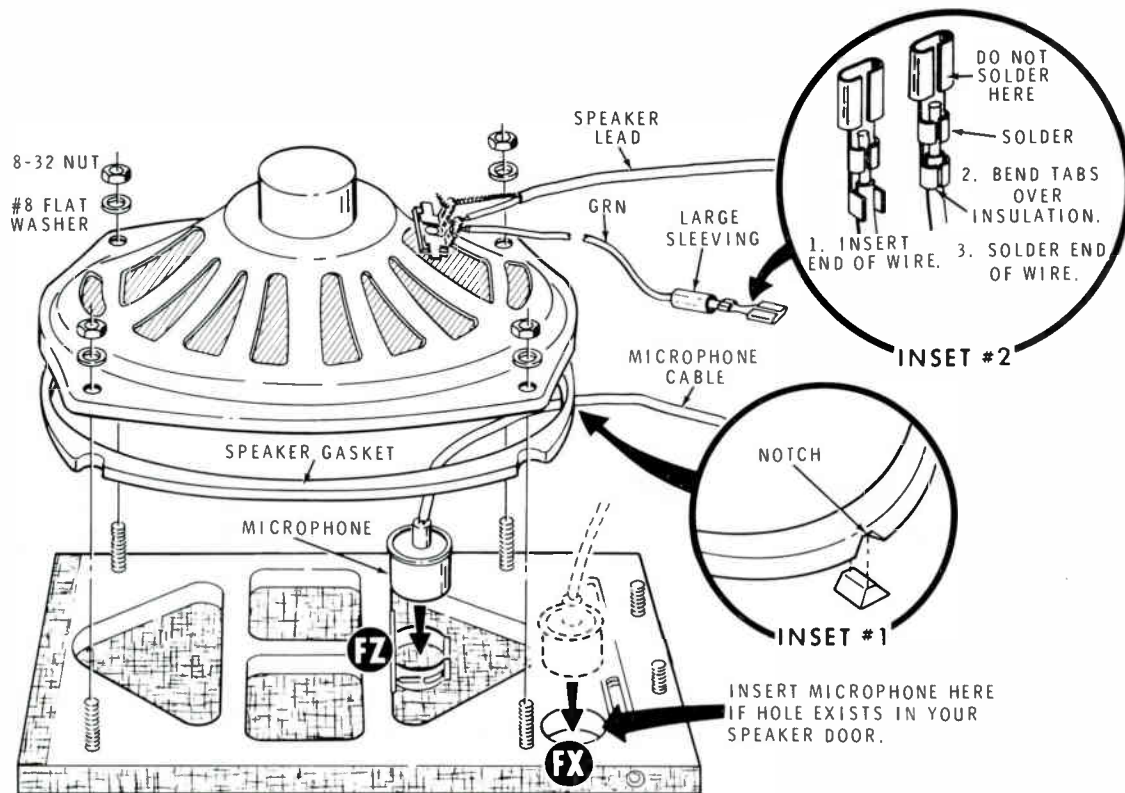

PICTORIAL 4-10

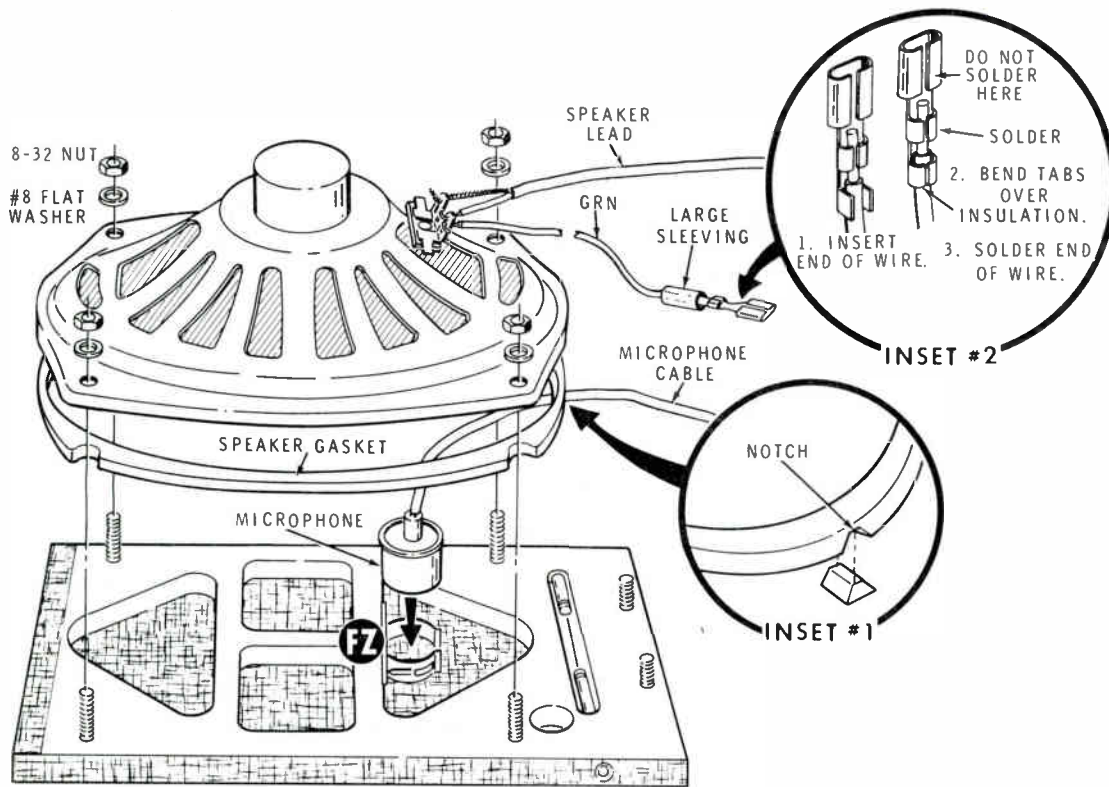

PICTORIAL 4-10

- () ³ Insert the microphone into clip FZ.
- () ⁴ Cut a small V-shaped notch in the gasket at the approximate location shown in the Pictorial. The notch should be small enough to act as a strain relief for the cable so the microphone can not be pulled out of the bracket accidentally. Refer to inset drawing #1.
- () ⁵ Place the gasket on the speaker door between the four studs. The notch in the gasket should be positioned over the microphone cable. Make sure there is no loop in the cable that could touch the speaker cone.
- () ⁶ Install the speaker on the studs and fasten it with the 8-32 nuts and #8 lockwashers.
- () ⁷ Slip a 3/4" length of large sleeving over one end of a 24" green hookup wire. Then install a terminal strip connector on this end of the wire as shown in inset drawing #2 on Pictorial 4-10, and slide the sleeving over the connector.
- () ⁸ Connect the other end of the green wire to the speaker terminal strip lug that has the inner lead of the speaker cable connected to it (S-2).

Set the speaker aside temporarily.

() Refer to Detail 4-11A and place the receiver inside of the cabinet. Then position the receiver according to the dimension shown in the Detail. Mark the four mounting holes with a pencil and remove the receiver. Set the receiver aside temporarily.

() Make a starter hole at each of the four locations with a nail. Then prethread each hole with a #6 x 5/8" bronze screw.

RECEIVER ADJUSTMENTS

Refer to Pictorial 4-11 for the following steps.

() Loosen four of the picture tube shield screws and hang the tuner bracket and convergence bracket on them as shown.

() Position the Remote Control receiver and speaker door on top of the TV Set. Position them as shown.

() Plug the speaker cable in the speaker socket. This cable is thinner than the microphone cable.

() Insert the connector of the green wire coming from the speaker onto lug 2 of terminal strip DA.

() Plug the microphone cable in socket DG.

() Plug the connector of the remote control cable in connector DF.

() Insert the connector of the black wire from the remote control cable on solder lug DP. Refer to inset drawing.

To make the following adjustments, hold the transmitter a convenient distance from the front of the television. Press and hold down each

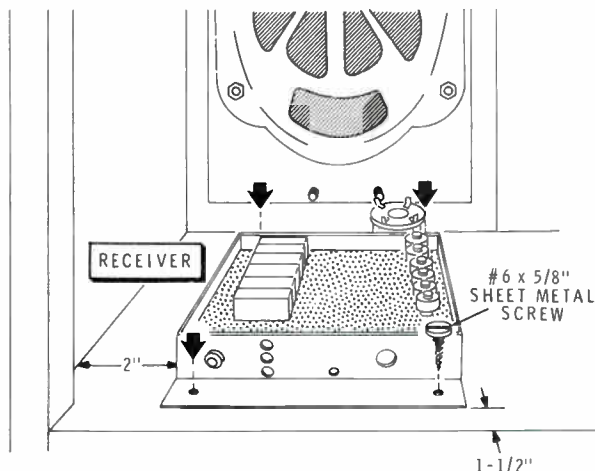

Detail 4-11A

rocker switch as you are instructed to in the steps. Then adjust the core inside the coils with the plastic alignment tool while observing the meter reading. If the correct results are not obtained in this Adjustment procedure, refer to the In Case Of Difficulty section on Page 78. After locating and correcting the problem, continue with the Adjustments.

NOTE: The Remote control functions will not operate until the following adjustments are completed.

() Plug the TV set line cord into an AC outlet.

() Turn the TV set on by pulling out on the VOLUME control knob. **NOTE:** If the TV set does not come on with this switch, push and release the relay stepper until it does. Refer to Detail 4-11B.

To complete the adjustments perform the steps listed in the following chart.

TRANSMITTER SWITCH	RECEIVER COIL (adjust clockwise)	METER READING
() TINT (UP)	L106	Maximum
() TINT (DOWN)	L105	Maximum
() COLOR (UP)	L104	Maximum
() COLOR (DOWN)	L103	Maximum
() CHANNEL	L102	Maximum
() ON-OFF	L101	Maximum

CAUTION: Be careful when making these adjustments, as the AC power line voltage is present at several places on the Remote Control receiver.

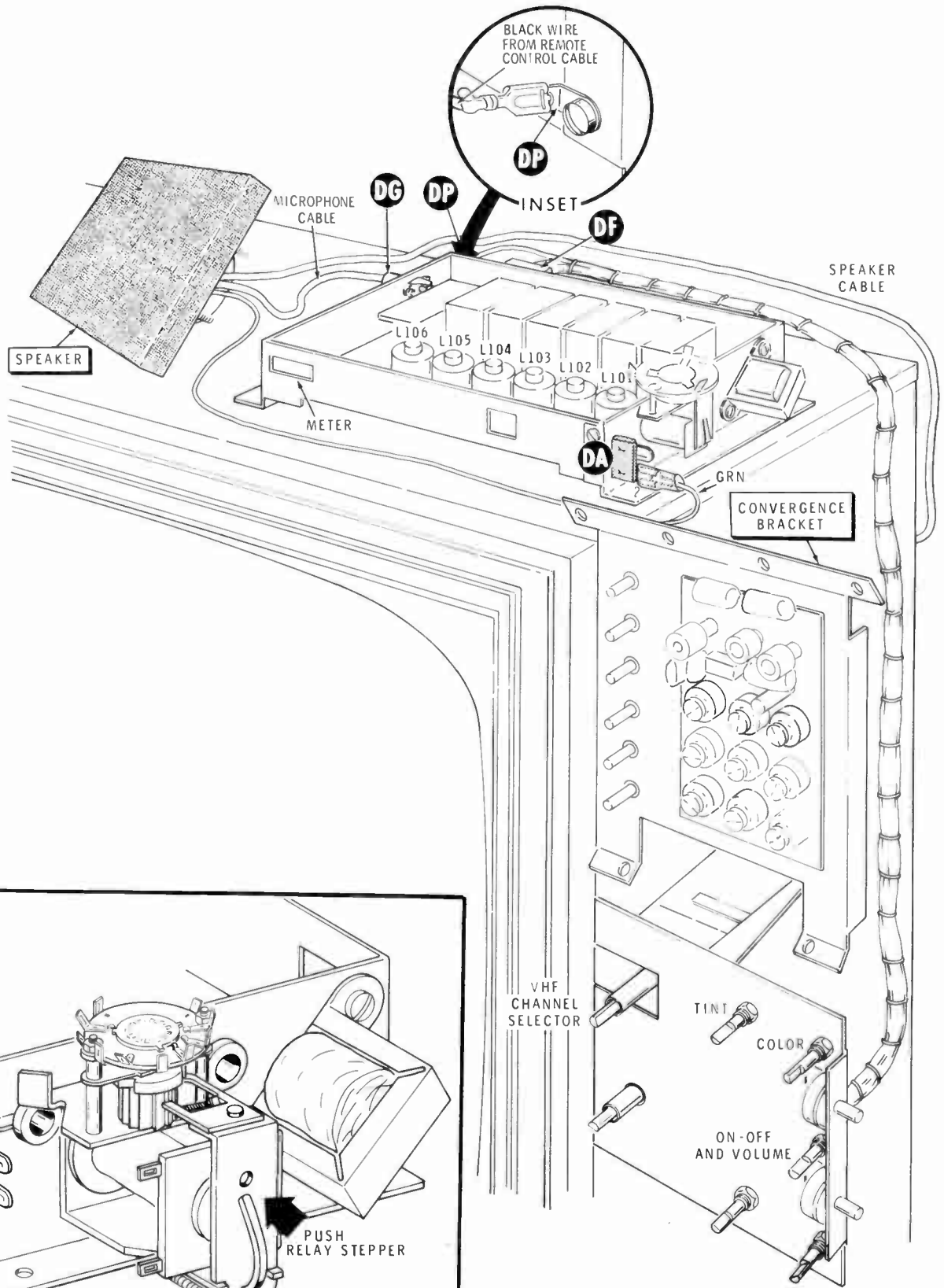

Detail 4-11B

PICTORIAL 4-11

FINAL CHECKOUT

Each position of the transmitter switches will be checked in the following steps. Stand approximately 5 feet in front of the TV set with the transmitter pointing toward the set when performing these checks.

On-Off

- () Turn the TV set off with the transmitter by pressing the ON-OFF switch. NOTE: This switch performs four steps due to the stepping relay. The steps follow this order: TV off, TV on, half volume, and volume off. At the present time the stepping relay could be in any one of these four positions. Therefore alternately press and release the switch until the TV set is turned off.

Now check each position of the ON-OFF switch. The results should be as described in the following list.

- () First position - TV set off.
- () Second position - TV set on, normal volume.
- () Third position - Reduced volume.
- () Fourth position - Minimum volume.

Channel

- () Push this switch and release it several times. The channel selector knob should stop at each channel.

Tint

- () Push the UP position of this switch until the TINT control turns fully clockwise and stops.
- () Push the DOWN position of this switch until the TINT control turns fully counterclockwise and stops.

- () Now push the switch to adjust the TINT control for a normal picture.

Color

- () Push the UP position of this switch until the COLOR control turns fully clockwise and stops.
- () Push the DOWN position of this switch until the COLOR control turns fully counterclockwise and stops.
- () Now push the switch to adjust the COLOR control for a normal color picture.

This completes the Final Checkout procedure.

- () Unplug the speaker cable from the TV set and the green speaker wire from the Remote Control receiver.
- () Unplug the microphone cable from the receiver.
- () Unplug the TV set.

INSTALLING TELEVISION SET IN CABINET

Refer to Pictorial 4-12 for the following steps.

- () Install the speaker door in the cabinet, slide the two pins in place, and lock the door in place with the wing lock.
- () Position the tuner bracket, antenna terminal strip, convergence bracket and receiver behind the TV set.
- () Carefully lift the TV set into the cabinet. Slide it forward as far as possible so the picture tube mask fits into the opening in the front of the cabinet.
- () Fasten the TV set to the cabinet with the four 1/4-20 x 7/8" screws and 1/4" flat washers.

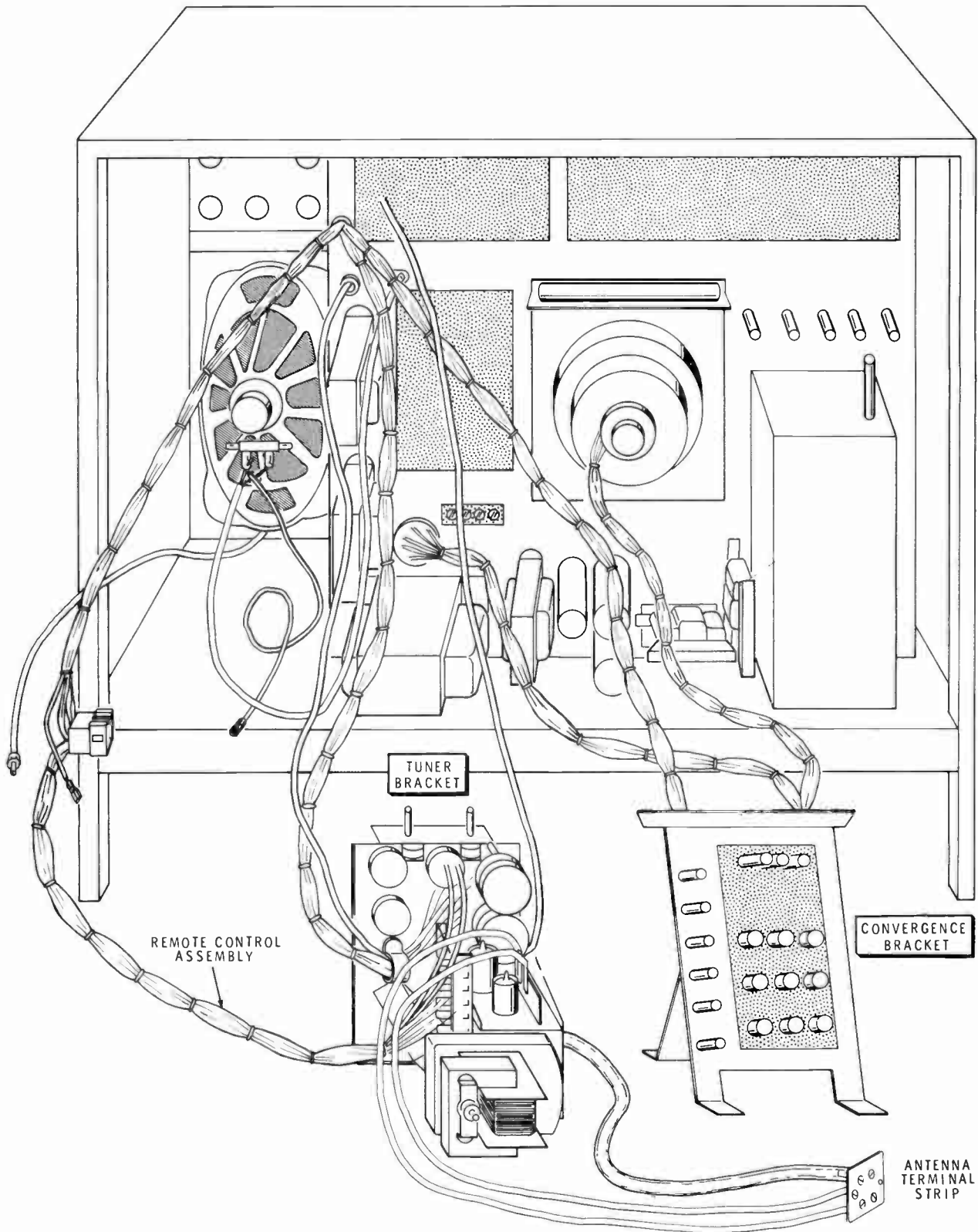

PICTORIAL 4-12

Refer to Pictorial 4-13 for the following steps.

- () Hang the tuner bracket on the four screws inside the cabinet. Make sure the two thumb-wheel knobs are not binding. Also, check the two pilot lamps to make sure they are directly behind the two holes in the panel. Then tighten the screws.

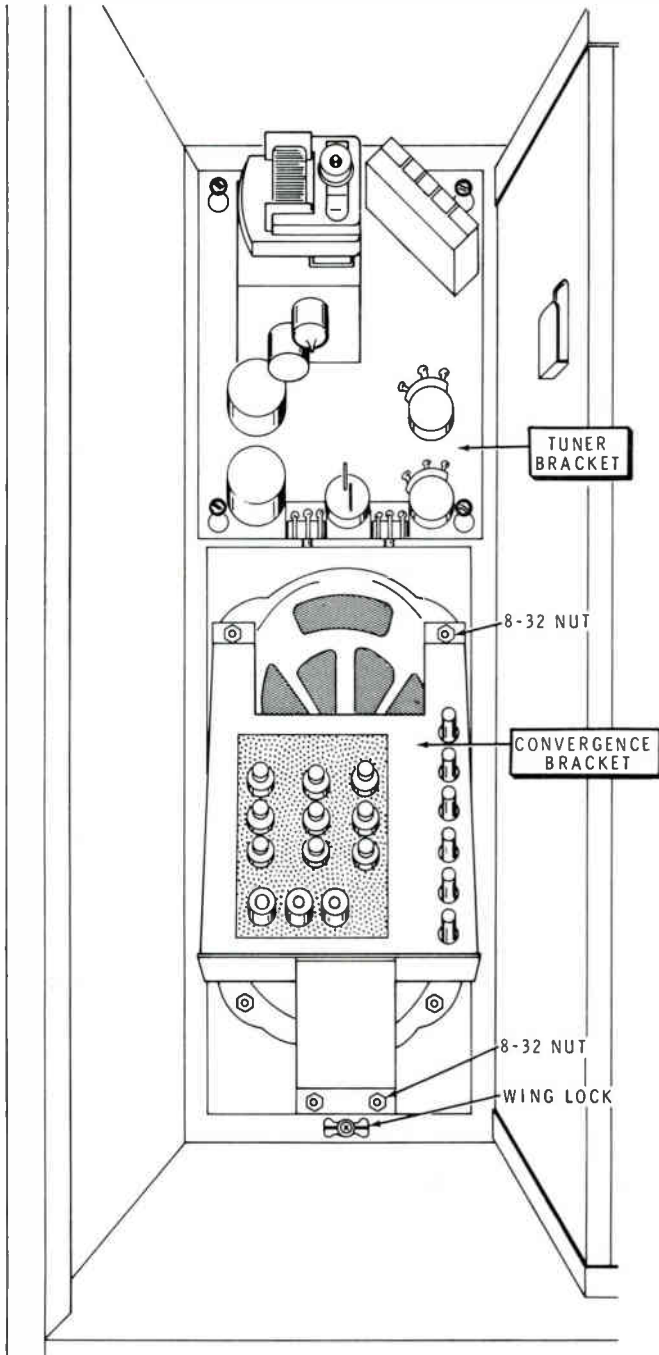

PICTORIAL 4-13

- () Mount the convergence bracket on the speaker door with 8-32 nuts. It will be necessary to turn the wing lock holding the door to position the bracket over the two studs. Then turn the wing lock back to the position to lock the door.

Refer to Detail 4-13A for the following steps.

- () Mount the antenna terminal strip on the cabinet with a #6 x 5/8" bronze screw. Form the excess antenna cables in a loop and secure them with a length of hookup wire.

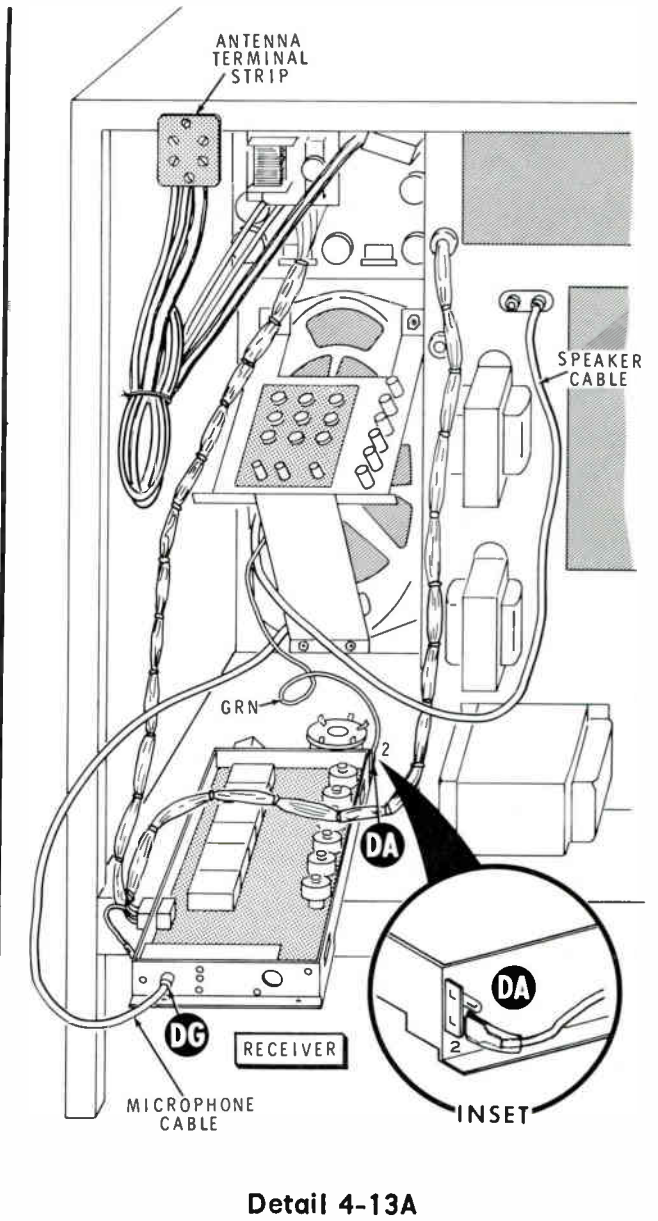

Detail 4-13A

- () Set the receiver inside the TV cabinet temporarily as shown. Then plug the speaker cable in the speaker socket of the TV set. Insert the green speaker lead on lug 2 of terminal strip DA of the receiver as shown in the inset drawing.
- () Plug the microphone cable in socket DG of the receiver.

FINAL ASSEMBLY

Refer to Pictorial 4-14 for the following steps.

- () Mount the Remote Control receiver inside the cabinet with four #6 x 5/8" bronze screws. NOTE: In order to install the front two screws, it will be necessary to turn the wing lock and tip the speaker door forward.
- () Wrap a length of hookup wire around the wires and cables. Then hook the wire over the tab on the picture tube shield. Make sure none of the wires are touching the stepping relay on the receiver.
- () Set the cabinet back panel on the three bronze screws started in the bottom edge of the cabinet. Then fasten the back panel to the cabinet with #6 x 5/8" bronze screws in the other seven cabinet starting holes. Be sure to position the line cord in the back panel cutout as shown.

Refer to Pictorial 4-15 for the following steps.

Install the knobs on the tuner bracket in the following steps.

- () VHF Fine Tuning and VHF Channel Selector knobs on the VHF tuner shaft.

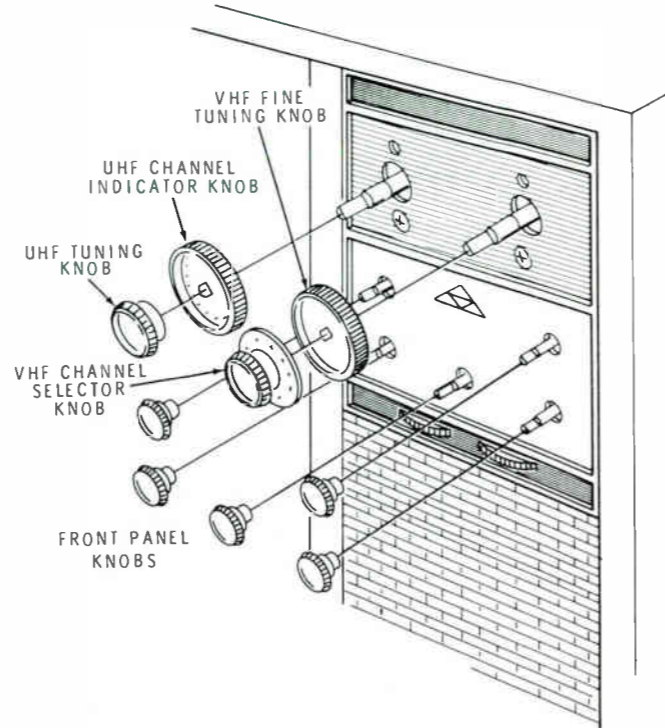

PICTORIAL 4-15

- () UHF Channel Indicator and UHF Tuning knobs on the UHF tuner shaft.
- () Five front panel knobs on the remaining controls. Make sure these knobs do not bind against the trim panel.

This completes the installation of the Remote Control. Proceed to the "Normal Operating Conditions" and "Operation" sections of the Manual.

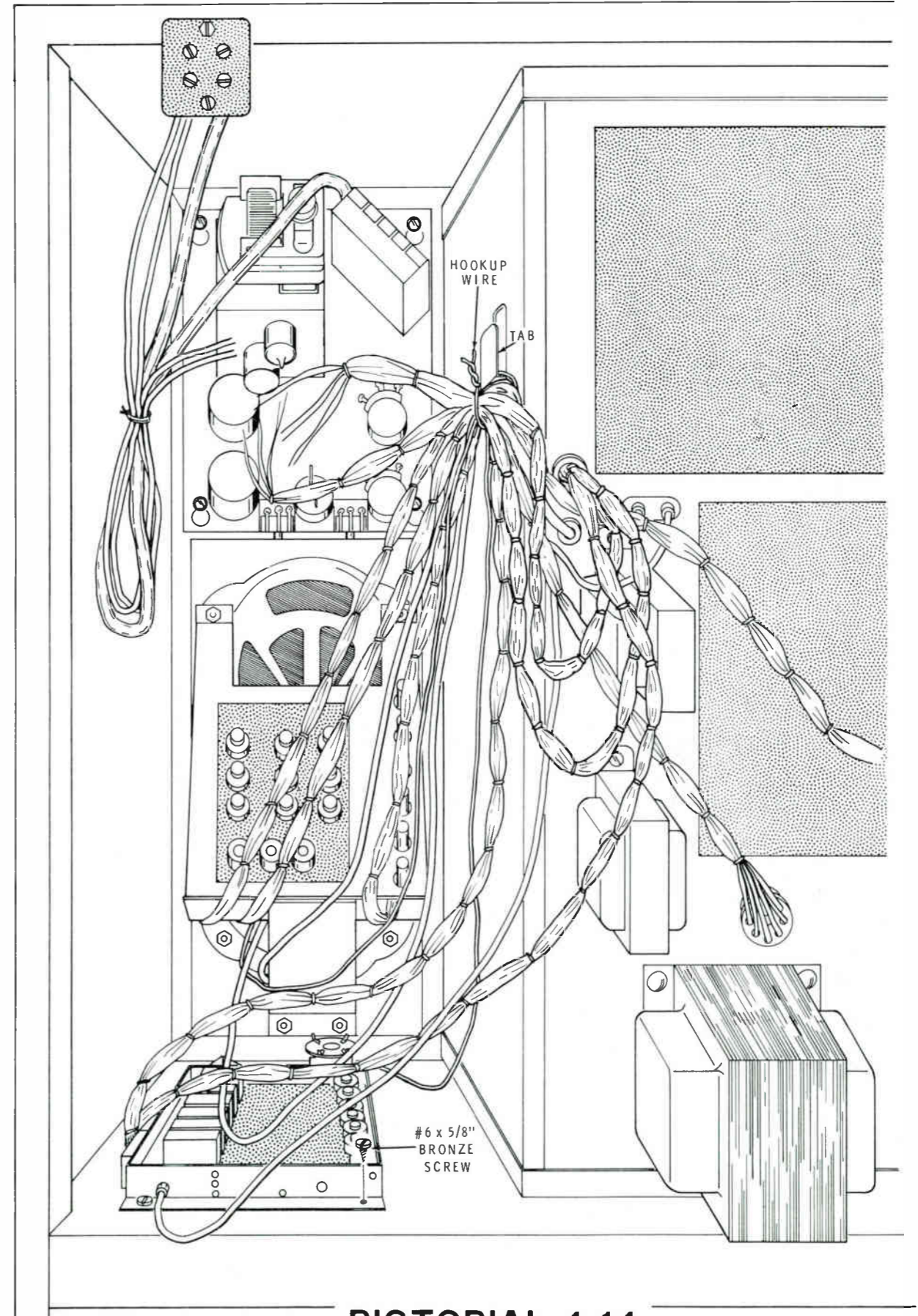

PICTORIAL 4-14

(For GR-295, GR-681, and GR-25 only)

NORMAL OPERATING CONDITIONS

This section of the Manual will cover certain operating characteristics of the Remote Control which are normal, but may appear as problems to the operator.

could cancel out the main signal temporarily and cause it to be, in effect, turned on and off. This would actuate the relay another step without your having pressed and released the ON-OFF switch a second time.

REFLECTIONS

The Remote Control transmitter is capable of sending one main signal for each function. When the transmitter is pointing directly at the microphone in the TV set, it will perform the function properly. However, if the transmitter is not pointed correctly, the main signal can be reflected from the floor, walls, ceiling, or other objects in the room. These reflected signals could temporarily cancel out the main signal causing intermittent operation of that function. However, rugs and draperies will reduce these reflected signals considerably. The operating distance of the Remote Control is also affected by the reflected signals.

On-Off Function Switch

The proper way to operate this switch to obtain the OFF, ON, reduced volume, and minimum volume positions is to press and release the switch quickly. It only takes a short pulse to actuate the switch to the next position. If the switch is held down too long, a reflected signal

HORIZONTAL FREQUENCY HARMONICS

The frequencies used in this Remote Control (34 kHz to 44 kHz) are between the second and third harmonics of the TV sets horizontal oscillator frequency. If the horizontal hold control is turned too far clockwise or counterclockwise, one or more of the Remote Control functions could be actuated. However, if this happened, the picture would be out of horizontal synchronization and could not be viewed until the horizontal hold control was adjusted properly.

It is also possible for the horizontal oscillator circuit (when this part of the TV set is not properly aligned) to trigger one or more Remote Control functions while the TV set is warming up. To correct a problem of this type, perform the Horizontal Stabilizing Coil (L301) Adjustments in the Alignment section of your TV manual. These adjustments can be made without instruments and without previous TV alignment experience.

OPERATION

Position the Transmitter as shown in Figure 1. You can push down on either the right or the left side of each of the three rocker switches. Releasing the pressure permits a switch to return to its "center off" position. Note that the left side of the switch at the top is called "ON-OFF", and that the right side is called "CHANNEL".

Turn the TV set ON. If the dial lamp does not light up, push and release once the ON-OFF switch on the Transmitter. Let the set warm up thoroughly, and turn the Channel Selector to one of the stronger VHF stations in your area. Then adjust the remaining controls for best reception.

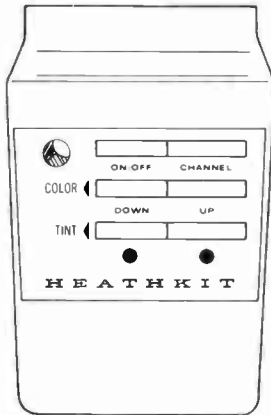

Figure 1

SWITCH FUNCTIONS

On-Off Switch

This switch performs a set of four actions in sequence, which comprise a "cycle". Each time this switch is pushed and released, one action in the cycle is performed. When all four actions have been completed, the cycle repeats as you continue to push and release the switch. The tabulation following shows how each position of the switch cycle affects the TV set:

<u>POSITION</u>	<u>POWER</u>	<u>SOUND (VOLUME)</u>	<u>PICTURE</u>
1	Off	Off	Off
2	On	As set	On
3	On	Reduced	On
4	On	Minimum	On

In the "Sound" column above, the volume in Position #2 is at the level which you set with the Volume control. In Position #3, the volume of sound is reduced, and in Position #4 the sound is minimum (if you put your ear near the speaker the sound may still be faintly heard).

Channel

Pushing down on the CHANNEL switch causes the VHF Channel Selector on the TV set to rotate in a clockwise direction. It will continue rotating as long as the switch is depressed. One quick push and release of the switch will move the selector one channel only.

Color

Depressing the left side of this switch rotates the COLOR control in a counterclockwise direction to decrease the amount of color in the picture. Depressing the right side of the switch rotates the control clockwise to increase the amount of color.

Tint

Select the color flesh tone you desire by depressing the left side of this switch to rotate the TINT control in a counterclockwise direction. The red dot directly below the switch indicates that this direction will result in more of a red color. Depress the right side of the switch to rotate the control in a clockwise direction. The green dot below this switch indicates that this direction will result in more of a green color.

OPERATING DISTANCE

The Transmitter should be used in the same room with the TV set. However, in exceptionally large enclosures, such as an auditorium, the Transmitter should normally be positioned not farther than twenty feet from the TV set.

PUSHBUTTON CHANNEL SELECTOR (Model GRA-227-6 only).

The pushbutton which you installed on the control panel of the TV set changes channels automatically in the same manner as the CHANNEL switch on the Transmitter unit.

OPERATING WITHOUT REMOTE CONTROL

Anyone wishing to turn on and operate your color TV set must use the Transmitter to do so. However, if you intentionally desire to use the TV set without the Remote Control, first make sure the set is operating with full sound (position #2 of the ON-OFF switch). Then turn the set OFF with the manual On-Off switch on the TV set, and put the Transmitter aside where no one can push the switches. The TV set will now operate as it did before the Remote Control unit was installed.

If a problem should develop in the receiver section of the Remote Control, you can operate the TV set while the receiver is being repaired by using the jumper wire that was prepared earlier and taped to the receiver chassis. First, the 9-terminal cable connector should be unplugged

from the receiver. Then the jumper wire should be installed on pins 1 and 4 of the connector (brown and violet wires) as shown in Figure 2. This bypasses the Remote Control receiver and supplies line voltage directly to the TV set. After the Remote Control is put back into operation be sure to retape the jumper wire on the receiver for future use.

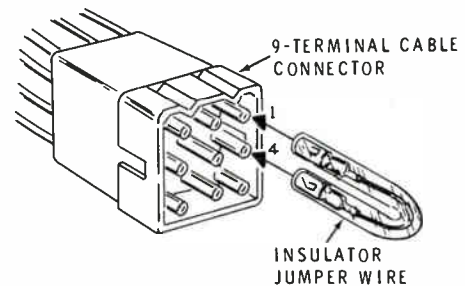

Figure 2

IN CASE OF DIFFICULTY

If your Remote Control (Transmitter or Receiver) does not operate properly after assembly, the following information will help you locate and correct the difficulty.

This part of the Manual is divided into three sections: Finding The Area Of Trouble, General Tests, and a Troubleshooting Chart. Refer to "Finding The Area Of Trouble" first. After you determine the area of the trouble, refer to the General Tests and the Troubleshooting Chart to pinpoint and correct the difficulty.

When necessary, refer to other parts of the Manual. For example, you may wish to refer to the Block Diagram, Identification Photos, Circuit Board X-Ray Views, and parts of the Step-By-Step Assembly section for help in locating parts and wires. If you have a knowledge of electronics, you will also find additional valuable information in the Circuit Description and Schematic Diagram. All voltages listed on the Schematic Diagram were taken with an 11 megohm input voltmeter.

FINDING THE AREA OF TROUBLE

The first step in locating your difficulty is to determine whether it is in the transmitter or receiver. Begin, as directed below, by making sure the problem is not with the 9-volt battery. Then refer to the checks that follow for the

transmitter and receiver. Once the problem is narrowed down to one of these two areas, refer to the General Tests and Troubleshooting Chart to locate and repair the difficulty.

Battery

Before you suspect a faulty piece of equipment, you must first be sure that the battery is properly connected and has a sufficient charge to provide proper operation. Make sure that the battery connector is wired with the red wire to hole P and the black wire to hole N.

If the transmitter will activate the receiver when held near the receiver but not at a normal distance (15 to 20 feet), the battery charge is probably low and the battery should be replaced. The battery can also be checked with a voltmeter. To get an accurate check, however, the battery must be checked under load. That is, with the battery connected and with one of the transmitter buttons pressed down.

Transmitter

With the battery connected, hold the transmitter transducer near your ear and press down on one of the buttons intermittently. A slight click should be heard in the transducer each time the button is pressed. If the click is heard, this would

indicate that the transmitter is operating. If you do not hear the click, the transmitter is not operating properly; refer to the General Tests and Troubleshooting Charts.

Receiver

1. If the receiver does not operate at all when the transmitter On-Off switch is pressed, push on the relay stepper and advance the stepping relay one position by hand. This should turn the television set on. If it does not, check the wiring to the stepping relay.
2. Repeat the Receiver Adjustments, as described on Pages 50 (GR-180, GR-227) and 70 (GR-295, GR-681). This should help you narrow down the difficulty to a smaller area of the receiver. Then refer to the General Tests and Troubleshooting Chart to locate and repair the difficulty.

GENERAL TESTS

The following paragraphs deal with the types of difficulties that may show up right after a kit is assembled. These difficulties are most likely to be caused by assembly errors or faulty soldering. These checks will help you locate any error of this type that might be made. NOTE: Refer to the Kit Builders Guide for Service and Warranty information.

1. Recheck the wiring. Trace each lead in colored pencil on the Pictorial as it is checked. It is frequently helpful to have a friend check your work. Someone who is not familiar with the unit may notice something consistently overlooked by the builder.

2. About 90% of the kits that are returned for repair do not function properly due to poor connections and soldering. Therefore, many troubles can be eliminated by reheating all connections to make sure they are soldered as described in the Soldering section of the Kit Builders Guide.
3. Check the values of the parts. Be sure the proper parts have been wired into each circuit as shown in the Pictorial Diagrams. It would be easy, for example, to install a 10 k Ω (brown-black-orange) resistor where a 100 k Ω (brown-black-yellow) resistor should have been installed.
4. Check for bits of solder, wire ends, or other foreign matter which may be lodged in the wiring.
5. Check for solder bridges between circuit board foils.
6. If, after careful checks, the trouble is still not located and a voltmeter is available, check voltage readings in the circuits of the unit you are having trouble with against those shown on the Schematic Diagram. All voltage readings were taken with an 11 megohm input voltmeter. Voltages may vary as much as $\pm 20\%$.
7. A review of the Circuit Description (Page 83) and Schematic Diagram (fold-out from Page 91) may also help you locate any difficulties in the Kit. NOTE: Refer to the Circuit Board X-Ray Views on Page 87 to help locate parts.

Troubleshooting Charts

TRANSMITTER

DIFFICULTY	POSSIBLE CAUSE
<p>A click cannot be heard in the transducer when a switch is pressed.</p>	<ol style="list-style-type: none"> 1. Battery weak or not connected. 2. Loose connections on transmitter circuit board. 3. Transducer leads installed backward. 4. Contact springs not aligned properly with the contact rivets in the circuit board. 5. Rocker arm shaft bracket is not positioned properly and the rocker arm is not hitting the spring contacts properly. 6. Coil L1 installed backward. 7. Capacitor C1, shorted. 8. Transistor Q8 defective. 9. Transducer defective.

DIFFICULTY	POSSIBLE CAUSE
Television set does not turn on and stepping relay RL107 does not operate when the transmitter On/Off button is pressed. No meter indication.	<ol style="list-style-type: none"> 1. On-Off switch on television set not turned on. 2. Coil L101 not adjusted properly. 3. Capacitor C102, C104, or C105, or coil 101 may be defective or poorly soldered. 4. Transformer T101 shorted or open. 5. Microphone not plugged in. 6. Integrated circuit Q101 or transistor Q102 defective or installed incorrectly. 7. Diode D102 or C128 defective or installed backward.
A switch for one function is pressed and a different function is performed by the receiver.	<ol style="list-style-type: none"> 1. Coils L101 through L106 are adjusted to the wrong frequency. 2. The switch contacts on the transmitter circuit board are not making proper contact. 3. Wires to the individual motors are improperly connected.
A function is performed by the receiver without being triggered by the transmitter.	<ol style="list-style-type: none"> 1. C103 and C105 interchanged, causing oscillation. 2. Shorted detector transistor for that function. 3. Bias resistors R110 and R111 (for On-Off function) or respective bias resistors for other functions are wrong value or poorly soldered.
A given function does not operate and the meter does not give an indication. Transmitter operating properly.	<ol style="list-style-type: none"> 1. Receiver coil for that function not adjusted properly. 2. The capacitor across the relay for that function (C110 for On-Off function) open or poorly soldered. 3. Collector or emitter lead of the transistor for that function may be open or poorly soldered. (Q102 for On-Off function.) 4. Open relay coil for that function.
Transmitter will turn the set on at a distance but other functions will not operate unless the transmitter is close to the receiver.	<ol style="list-style-type: none"> 1. Receiver coil for that function not adjusted for maximum meter reading. 2. Wires at lugs 7, 8, 9, and 12 of the wafer switch on stepping relay RL107 are interchanged or poorly soldered. 3. Loose connection at lug 4 of terminal strip AR on the television chassis.
Signal meter indicates a signal from the transmitter, the relay closes, but the operation is not performed.	<ol style="list-style-type: none"> 1. Individual motor wired incorrectly. 2. R120 or C120 for color motor and R128 or C125 for tint motor may be defective or poorly soldered. 3. Relay contacts dirty or do not close properly.
Meter needle goes off scale to the right. None of the functions operate.	<ol style="list-style-type: none"> 1. Resistor R112 open or wrong value.
All functions operate properly when the transmitter is near the receiver, but difficult to operate at any distance from the receiver.	<ol style="list-style-type: none"> 1. Receiver coils not adjusted for maximum meter reading. 2. Wiring of wafer switch on stepping relay RL107 incorrect or poorly soldered. 3. Resistor R101 or R102 open. 4. Capacitor C107 or C108 open. 5. Diode D101 defective. 6. Microphone defective. 7. Transducer in transmitter defective. 8. Transmitter battery weak.

ALIGNMENT WITH INSTRUMENTS

The transmitter comes preset from the factory. However, this Alignment With Instruments section is furnished in case the transmitter should have to be aligned at some future time.

Refer to Figure 3 for the following steps.

To align the transmitter you will need an oscilloscope and a signal generator capable of producing a 34 to 44 kHz signal.

- () Open the transmitter case so that coil L1 can be reached.
- () Set the signal generator to 44 kHz.
- () Connect the output cable from the generator to the horizontal input of the oscilloscope.
- () Connect the oscilloscope cable to the vertical input jack. Then place the probe 1" from the front of the transmitter as shown.
- () Adjust the output of the generator for a 2" horizontal trace on the oscilloscope screen.
- () Press the COLOR DOWN switch and set the oscilloscope for a 2" vertical trace.

NOTE: When making the following adjustment, do not turn the coil slug more than 1/2 turn clockwise or counterclockwise from its present position.

- () Press the COLOR DOWN switch and adjust oscillator coil L1 for the Lissajous figure shown in Figure 3. **NOTE:** Make sure the circuit board is not touching any metal object or your hand.

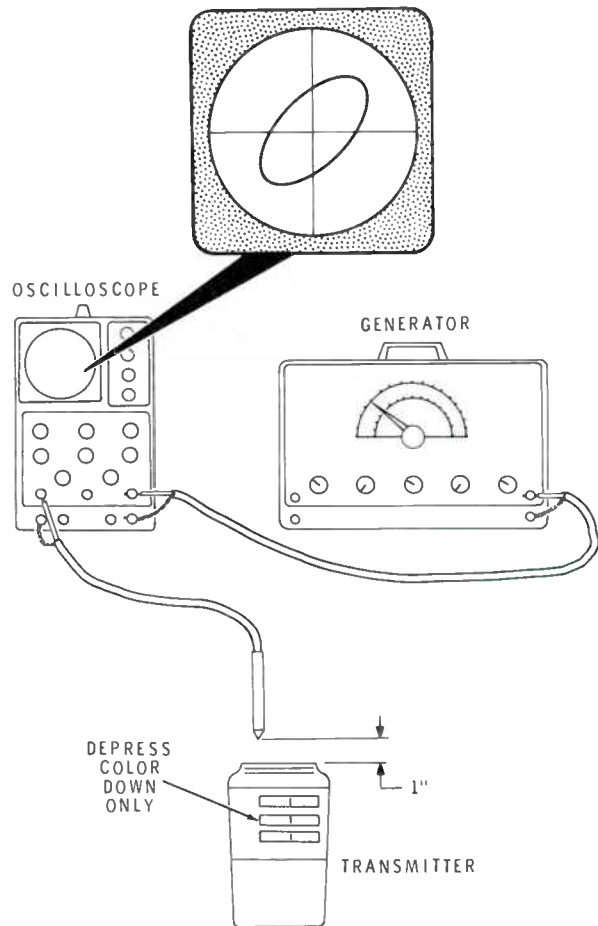

Figure 3

This completes the transmitter alignment. Now readjust the receiver coils as instructed in the Receiver Adjustments (Page 50 for Models GR-180, and GR-227; Page 70 for Models GR-295, GR-25 and GR-681).



SPECIFICATIONS

Switch Functions.	On-Off, Channel Selector, Color-Down, Color-Up, Tint-Red, Tint-Green.
Channel Frequencies.	On-Off: 40 kHz, Channel Selector: 38 kHz, Color-Down: 44 kHz, Color-Up: 42 kHz, Tint-Red: 36 kHz, Tint-Green: 34 kHz.
Semiconductor Complement.	7 - 2N3393 transistors. 2 - Silicon power diodes. 1 - 20 volt zener diode. 1 - Integrated circuit
Power Requirements	
Transmitter.	100 milliwatts at 9 volts; supplied by a NEDA #1604* battery.
Receiver.	1.5 watts (idling) at 120 VAC.
Color.	Beige (transmitter case).
Meter.	Tuning.
Transmitter Dimensions.	4-3/4" x 3-1/4" x 1-3/8".
Net Weight.	6-1/2 lbs.

*NEDA #1604 batteries include the following types: Burgess #2U6, Eveready #216, Mallory #MN1604, RCA #V5323, and Ray-O-Vac #1604.

The Heath Company reserves the right to discontinue instruments and to change specifications at any time without incurring any obligation to incorporate new features in instruments previously sold.

CIRCUIT DESCRIPTION

Refer to the Schematic Diagram (fold-out from Page 91) and to the Block Diagram while reading this Circuit Description. The part numbers on the Schematic Diagram are arranged in the following groups to help you locate specific parts on the Schematic, chassis, and circuit board:

- 1- 99 Parts in the transmitter
- 100-199 Parts in the receiver

The transmitter and receiver schematics are both included on the overall Schematic Diagram along with a schematic representation of integrated circuit Q101.

TRANSMITTER

The transmitter is completely self-contained and operates from an internal 9-volt battery. Four control functions provide Channel select, On-Off, Color adjust, and Tint adjust. The transmitter is basically a Hartley oscillator circuit and a capacitor switching arrangement which selects a desired control frequency to drive a capacity-type of transducer.

When a rocker switch is pressed, it performs two functions. The battery is connected through the switch contacts to ground, turning the transmitter On. At the same time, a certain capacitance is connected in parallel with the secondary winding of oscillator coil L1. This capacitance, plus the inductance of coil L1, determines the frequency for that particular function.

Each rocker switch has its own capacitor, and C8 and C9 are common for all switches. (Color Down function, however, uses C8 and C9 only.) The capacitors C8 and C9 also form a voltage divider for the transducer. The capacitance for the channel function for example, includes capacitors C3, C8, and C9.

Resistor R1 sets up the proper bias and capacitor C2 couples the proper feedback voltage to the base of Q8. Capacitor C1 reduces the effects of the battery internal resistance, increasing the useful battery life.

RECEIVER

The receiver for your Remote Control unit is composed of the following sections: The Integrated Circuit Amplifier, the Detector And Relay Circuits, and the Control Circuits. Each of these sections will be described separately in the following pages. Briefly, these circuits work together in the following manner: The receiver microphone senses the transmitted signal and couples it to the integrated circuit for amplification. The signal is then amplified, clipped, and shaped to produce pulses at the output of the integrated circuit. The output pulses are then coupled to six detector circuits, and each detector circuit controls a relay. Each relay, when it is activated and its contacts close, in turn activates a control function (Channel, Tint, etc.) in the TV set.

Integrated Circuit Amplifier

The transmitter signal is received by the capacity-type microphone and coupled through capacitor C102 and resistor R103 to pin 1 of integrated circuit Q101. Capacitors C100 and C101 and resistors R101 and R102 act as a filter and isolation for the microphone polarization voltage. The microphone polarization voltage will be described separately in a later paragraph.

Because of its high gain and to avoid unwanted feedback, the integrated circuit amplifier is carefully divided into three sections which are coupled together with external capacitors. The sections are arranged as follows:

<u>Section</u>	<u>Is Composed of</u>	<u>Output Terminal</u>
one	Q101-1, Q101-2, Q101-3	3
two	Q101-4, -5, -6, -7	5
three	Q101-8, -9, -10	7

The input signal from pin 1 is first applied to transistors Q101-1 and Q101-2, which are connected in a Darlington amplifier circuit to provide a high input impedance for the

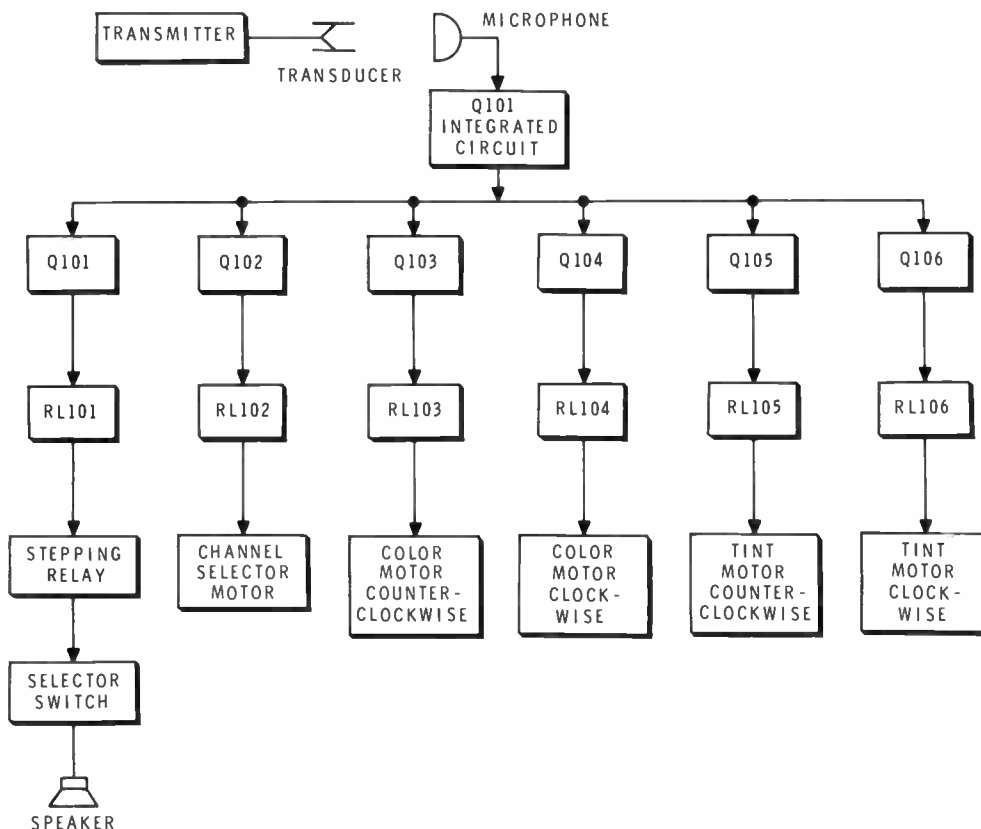

BLOCK DIAGRAM

microphone. From Q101-2, the signal is coupled through emitter follower stage Q101-3 and coupling capacitor C104 to the second section. R104, R106, and C103 provide negative feedback at the lower frequencies so section one will have a high pass frequency characteristic. (The selectivity curve of this section is centered around 45 kHz.)

NOTE: All larger signals are limited in amplifier section one and again in amplifier section two. This results in a clipped sine wave at the input to section three. This limiting is necessary so the detector circuits are not overdriven.

In the second section, the signal is coupled through grounded emitter amplifier Q101-4 and emitter follower Q101-5. Q101-6 and Q101-7 are connected in an amplifier configuration to supply negative feedback to Q101-4 to maintain bias stability.

From Q101-5, the signal is coupled through C105 to grounded emitter output stage Q101-8. Q101-9 and Q101-10 are connected as a bias supply that is identical to the circuit of Q101-6 and Q101-7.

The collector of Q101-8 is connected to the primary winding of T101, which is tuned by stray capacitance (and the output capacitance of this transistor) to a resonant frequency of approximately 180 kHz. Each negative-going input waveform to Q101-8 cuts off this stage, allowing the primary of T101 to ring at its resonant frequency. The output signal that results is clipped by the transistor, and a series of sharp positive pulses are coupled to the detector circuits. These pulses have a repetition rate equal to the frequency of the input signal.

Because of the limiting and nonlinearity of the amplifiers, the receiver is quite immune to random noises such as ringing bells, rattling keys, or jingling coins which otherwise could trigger the receiver relays.

When a weak signal is received (for example if you were using the transmitter some distance from the TV set), the first two sections of Q101 amplify the signal without any clipping or limiting. However, this weak signal is contaminated with noise generated by the circuitry. The weak signal modulates this noise in the third section, resulting in noise bursts which are at the same frequency as the input signal, and these modulated noise bursts drive Q101-8 into clipping. The noise bursts are fed to the proper detector circuit.

Detector And Relay Circuit

The output signal from transformer T101 is fed to six detector circuits. Each circuit is tuned to one of the control signal frequencies as follows: On-Off, 40 kHz; Channel selector; 38 kHz; Color (Down), 44 kHz; Color (Up), 42 kHz; Tint (Red), 36 kHz; Tint (Green), 34 kHz.

The six detector transistors have a common emitter resistor, R112. When one transistor is conducting, the voltage drop across R112 increases. This increases the emitter voltage of the remaining transistors so they cannot conduct. A meter and current limiting resistor R127 is also connected to the emitters of these transistors for the alignment of each detector circuit.

In the following description, the operation of the detector circuits will be described starting with the On-Off circuit.

When a 40 kHz signal (positive pulses at a 40 kHz repetition rate) is present at transformer T101, the signal is coupled through capacitor C109 to coil L101. These pulses cause L101, which is tuned to this frequency, to resonate at 40 kHz, and

the resulting sine wave is then coupled through resistor R110 to the base of transistor Q102, causing it to conduct. Q102 draws collector current through the coil of relay RL101, closing the contacts and energizing the coil of stepping relay RL107.

The stepping relay performs three functions: it turns the TV set on and off, controls the volume, and controls the polarization voltage for the microphone. The stepping relay contacts, which are operated by a cam, turn the TV set on, keep it on for three more steps, and then turn it off again.

The same cam also turns the contacts on both sides of wafer switch S1, which controls the volume from the speaker and the microphone polarization voltage. The polarity of this voltage is switched to prevent the microphone from losing its sensitivity over long periods of operation.

The following operating sequence of stepping relay RL107 will begin with the relay in the Off, or #1 position. In this #1 position, the TV set is off and a negative polarization voltage, which is supplied by diode D101, is coupled through lugs 6 and 4 of the switch and resistors R101 and R102 to the microphone. When the On-Off transmitter switch is pressed and released, the stepping relay will move one position.

In step #2 of the relay, the TV set is turned On. A positive polarization voltage is also applied from the TV set to a voltage divider consisting of resistors R113 and R114, and from the voltage divider through lugs 9 and 4 of the switch to the microphone. In this #2 position, the volume is at the level that was set with the TV set Volume control.

In step #3, the set remains On and the positive polarization voltage is still in the circuit, but the speaker sound is reduced by resistor R115 which is connected in parallel with the speaker by the wafer switch.

In step #4, the positive polarization is still in the circuit and the TV set stays On, but the sound is at minimum because the speaker is shorted to ground through the wafer switch contacts.

In step #5, the stepping relay contacts open, the TV is turned Off, and the negative polarization voltage is switched back into the circuit. This completes the stepping relay cycle.

When the transmitter CHANNEL selector switch is pressed, a 38 kHz signal is coupled to the base of Q103, causing the contacts of relay RL102 to close and turn on the channel selector motor. A set of cam-operated contacts on the motor are connected in parallel with the contacts of RL102. This allows the motor to receive power through the motor contacts as well as through the relay contacts. When the transmitter CHANNEL selector switch is released, the relay contacts open, allowing the motor to receive power through the motor contacts only. The motor stops automatically on a channel when these contacts are opened by the cam in the motor.

The remaining four control circuits operate the same as the one previously described except for different operating frequencies. The only differ-

ence is that the relays control the clockwise and counterclockwise rotation of the color and tint motors. Capacitor C120 provides the phase shift necessary for starting the color motor and resistor R120 protects C120 from excessive voltage spikes. Capacitor C125 and resistor R128 perform the same function for the tint motor.

POWER SUPPLY

When the On-Off switch of the TV set is turned On, line voltage is supplied only to the remote power supply of the receiver and to one side of the stepping relay coil. As the stepping relay is activated by the transmitter to the On position, the TV set is turned On and line voltage is then available for the Channel, Color, and Tint motors.

The power supply for the detector stages is contained in the receiver and consists of transformer T102 and a half-wave rectifier D102. The voltage from D102 is filtered by capacitor C128 and resistor R129. This resistor also provides the proper current for zener diode D103, which regulates the 20 volt output. Diode D101 supplies a negative DC voltage to the microphone when the TV set is turned Off.

CIRCUIT BOARD X-RAY VIEWS (VIEWED FROM FOIL SIDE)

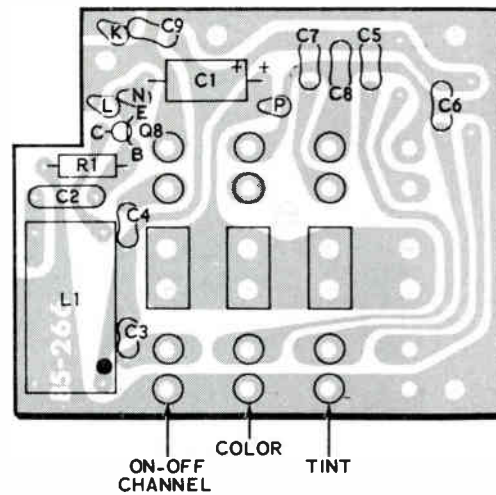

TRANSMITTER

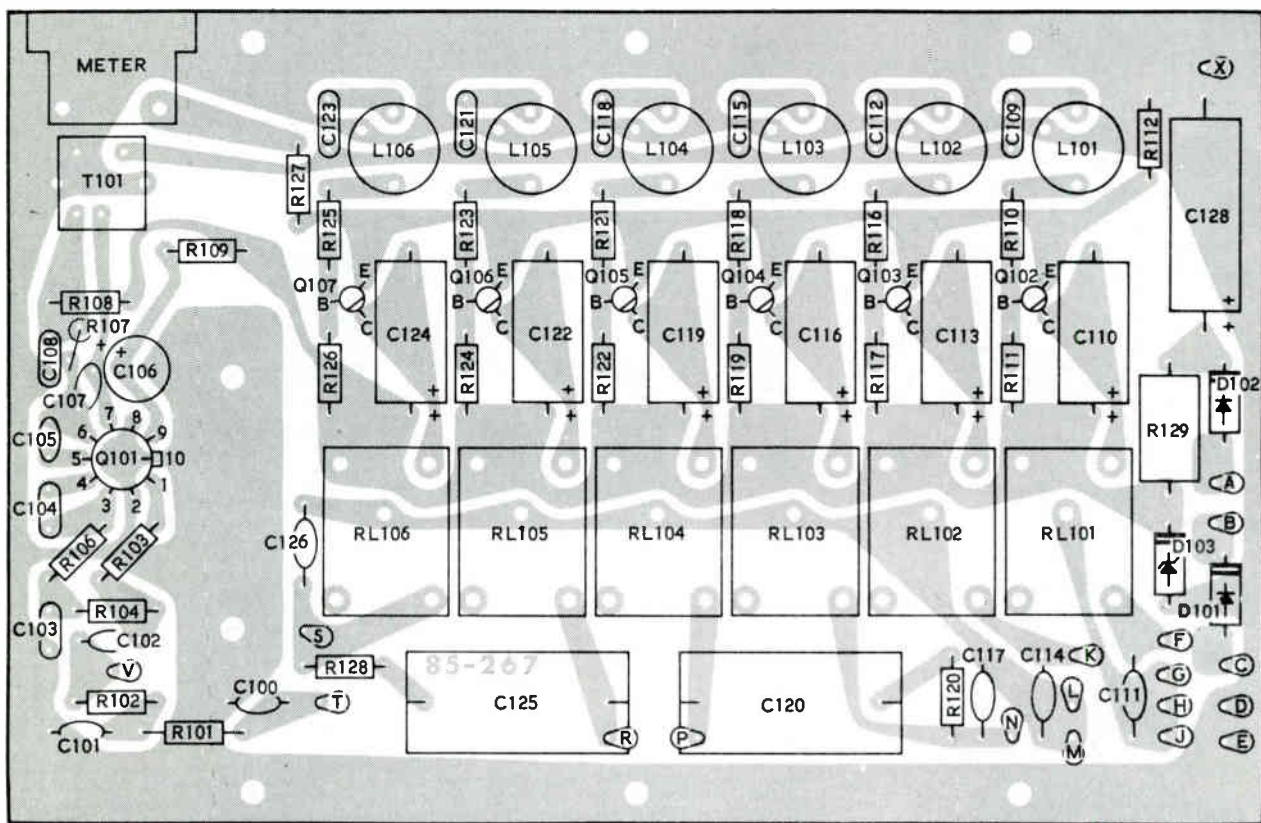

RECEIVER

CHASSIS PHOTOGRAPH

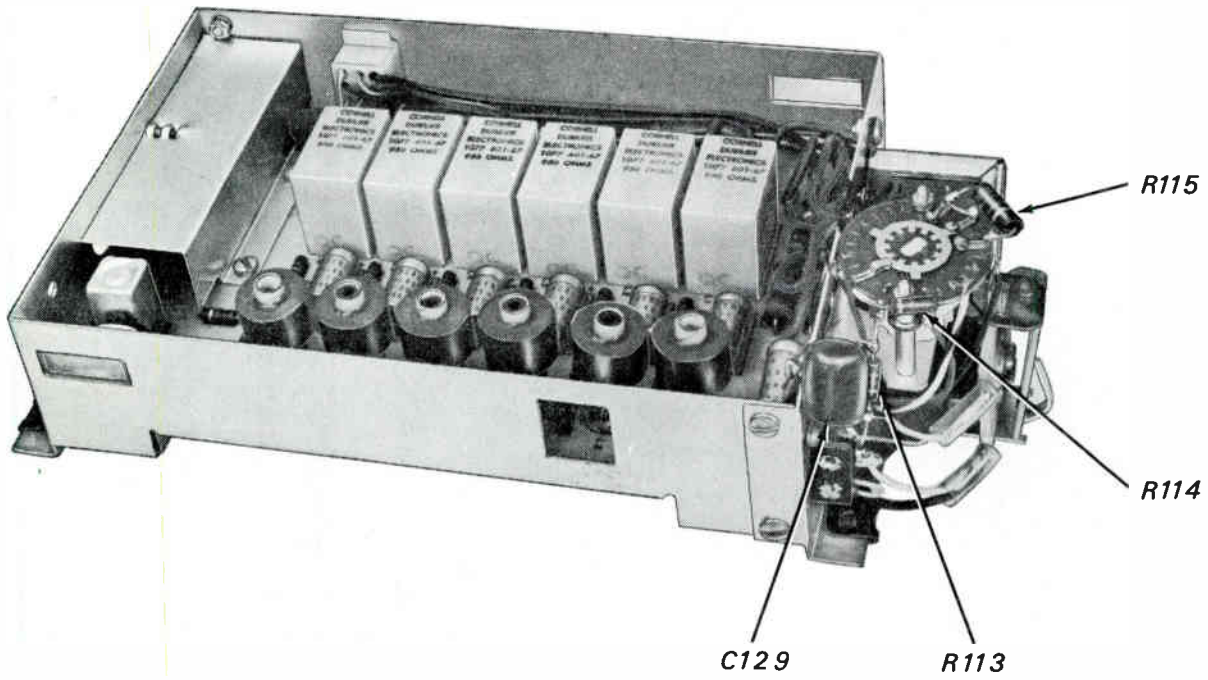

REPLACEMENT PARTS PRICE LISTS

PARTS LIST #1

The following prices apply only on purchases from the Heath Company where shipment is to a U.S.A. destination. Add 10% (minimum 25 cents) to the price when ordering from an authorized Service Center or Heathkit Electronic Center to cover local sales tax, postage and handling. Outside the U.S.A. parts and service are available from your local Heathkit source and will reflect additional transportation, taxes, duties and rates of exchange.

PART No.	PRICE Each	DESCRIPTION
----------	------------	-------------

RESISTORS

1/2 Watt

1-103	.10	33 Ω
1-83	.10	56 Ω 5%
1-151	.10	330 Ω 5%
1-9	.10	1000 Ω
1-44	.10	2200 Ω
1-16	.10	4700 Ω
1-73	.10	8200 Ω
1-105	.10	10 k Ω 5%
1-24	.10	33 k Ω
1-26	.10	100 k Ω
1-27	.10	150 k Ω
1-35	.10	1 M Ω
1-37	.10	2.2 M Ω
1-86	.10	5.6 M Ω

2 Watt

3-5-2	.10	2.2 Ω
1-20-2	.15	100 Ω

CAPACITORS

Silver Mica

20-160	.15	33 pF
20-161	.30	68 pF
20-162	.25	105 pF
20-163	.25	115 pF
20-149	.25	150 pF
20-164	.30	180 pF
20-165	.30	200 pF
20-107	.40	680 pF

PART No.	PRICE Each	DESCRIPTION
Disc		
21-7	.10	33 pF
21-36	.10	.002 μ F
21-27	.10	.005 μ F
21-16	.10	.01 μ F
21-70	.15	.01 μ F, 1.4 kV
Mylar		
27-63	.10	.022 μ F
27-46	.15	.047 μ F
27-47	.20	.1 μ F, 50 V or 100 V
27-28	.20	.1 μ F, 400 V
27-80	.40	.33 μ F

Electrolytic

25-54	.20	10 μ F
25-145	.50	25 μ F
25-116	.50	50 μ F
25-146	.45	100 μ F

DIODES-TRANSISTORS

56-45	1.00	Zener diode
57-27	.50	Silicon diode
417-118	.40	2N3393 transistor
442-4	3.90	Integrated circuit

COILS-TRANSFORMERS

40-848	1.35	Oscillator coil
40-844	.80	40 kHz coil
40-843	.80	42 kHz coil
40-842	.75	44 kHz coil
40-849	.90	Driver transformer
54-213	2.05	Power transformer

RELAYS-MOTORS

69-50	2.70	Relay
69-49	6.25	Stepping relay
420-57	5.70	Control motor
420-54	7.90	Tuner drive motor

PARTS LIST #2

The following Parts are for the Heathkit Models
GR-180 and GR-227 Color Television Sets.

<u>PART</u> <u>No.</u>	<u>PRICE</u> <u>Each</u>	<u>DESCRIPTION</u>	<u>PART</u> <u>No.</u>	<u>PRICE</u> <u>Each</u>	<u>DESCRIPTION</u>
SWITCHES-CONTROLS			HARDWARE		
64-31	1.45	Pushbutton switch	250-52	.05	4-40 x 1/4" screw
12-93	1.00	250 k Ω - 1 M Ω dual control	250-312	.05	4-40 x 3/4" screw
12-94	1.35	1200 Ω - 1 M Ω dual control	250-28	.05	6-32 x 1/4" setscrew
GENERAL			250-56	.05	6-32 x 1/4" screw
431-2	.10	2-lug terminal strip	250-89	.05	6-32 x 3/8" screw
204-867	.20	Motor mounting plate	250-347	.05	#6 x 1" sheet metal screw
207-3	.10	1/8" cable clamp	254-1	.05	#6 lockwasher
207-5	.10	3/16" cable clamp	252-3	.05	6-32 nut
204-182	.10	Microphone bracket	255-5	.05	#6 x 3/4" spacer
455-70	.10	Nylon bushing	252-22	.05	6-32 speednut
456-1	.70	Shaft coupler	254-14	.05	1/4" lockwasher
453-168	.25	Control shaft	255-92	.10	#4 x 9/16" spacer
390-228	.60	Television trim panel			
432-66	.10	Terminal strip connector			
344-79	.05	Brown stranded wire			

PARTS LIST #3

The following Parts are for the Heathkit Models
GR-295, GR-681, and GR-25 Color Television
Sets.

<u>PART</u> <u>No.</u>	<u>PRICE</u> <u>Each</u>	<u>DESCRIPTION</u>	<u>PART</u> <u>No.</u>	<u>PRICE</u> <u>Each</u>	<u>DESCRIPTION</u>
73-62	.15	Speaker gasket	250-52	.05	4-40 x 1/4" screw
205-141	.10	Microphone mounting plate	250-56	.05	6-32 x 1/4" screw
204-813	.15	Motor mounting plate	250-89	.05	6-32 x 3/8" screw
208-6	.15	Microphone mounting clip	250-252	.05	#6 x 5/8" bronze screw
10-252	.70	1200 Ω control	254-1	.05	#6 lockwasher
432-66	.10	Terminal strip connector	252-3	.05	6-32 nut
344-79	.05	Brown stranded wire	254-4	.05	Control lockwasher

PART No.	PRICE Each	DESCRIPTION
GENERAL		
204-866	.10	Rocker arm bracket
205-599	.10	Control mounting plate
431-14	.10	2-lug terminal strip (one lug ground)
431-45	.10	6-lug terminal strip
73-1	.10	3/8" grommet
73-3	.10	1/2" grommet
434-42	.10	Phono socket
432-70	.15	9-terminal cable connector
432-71	.55	9-terminal chassis connector
266-10	.10	Plastic rocker arm
263-7	.05	Round felt pad
73-64	.25	Foam tape
453-164	.10	Rocker arm shaft
209-52	.20	Transmitter case grille
432-33	.25	Battery connector
407-116	3.00	Meter
473-4	3.60	Microphone with shielded cable
473-5	2.20	Transducer
10-251	.70	500 Ω control

WIRE-SLEEVING-CABLE ASSEMBLY

344-81	.05	Violet stranded wire
344-51	.05	Brown hookup wire
344-50	.05	Black hookup wire
344-52	.05	Red hookup wire
344-53	.05	Orange hookup wire
344-54	.05	Yellow hookup wire
344-55	.05	Green hookup wire
344-56	.05	Blue hookup wire
344-58	.05	Gray hookup wire
344-59	.05	White hookup wire
344-76	.05	White-blue hookup wire
46-2	.05	Large clear sleeving
46-7	.05	Small clear sleeving
4-180	1.90	Remote control cable assembly

PART No.	PRICE Each	DESCRIPTION
HARDWARE		
#3 Hardware		
250-49	.05	3-48 x 1/4" screw
252-1	.05	3-48 nut
254-7	.05	#3 lockwasher
#4 Hardware		
250-419	.05	4-24 x 5/8" screw
#6 Hardware		
250-365	.05	#6 x 1/4" sheet metal screw
250-8	.05	#6 x 3/8" sheet metal screw
259-6	.05	#6 small solder lug
259-1	.05	#6 large solder lug
#8 Hardware		
250-137	.05	8-32 x 3/8" binder head screw
250-348	.05	8-32 x 3/8" hex washer head screw (not supplied with Model GRA-681-6)
254-2	.05	#8 lockwasher
Other Hardware		
256-49	.05	Split rivet
253-107	.05	E-washer
432-72	.10	Male terminal
432-73	.10	Female terminal
258-95	.05	Spring contact

MISCELLANEOUS

85-266-1	.60	Transmitter circuit board
85-267-1	1.80	Receiver circuit board
200-522	.70	Chassis-half
206-390	.30	Top shield
206-391	.30	Bottom shield
92-45	.65	Transmitter case (top)
92-46	.65	Transmitter case (bottom)
390-227	.25	Transmitter trim panel
490-1	.10	Plastic alignment tool
490-5	.10	Nut starter
331-6	.15	Solder
595-985	2.00	Manual

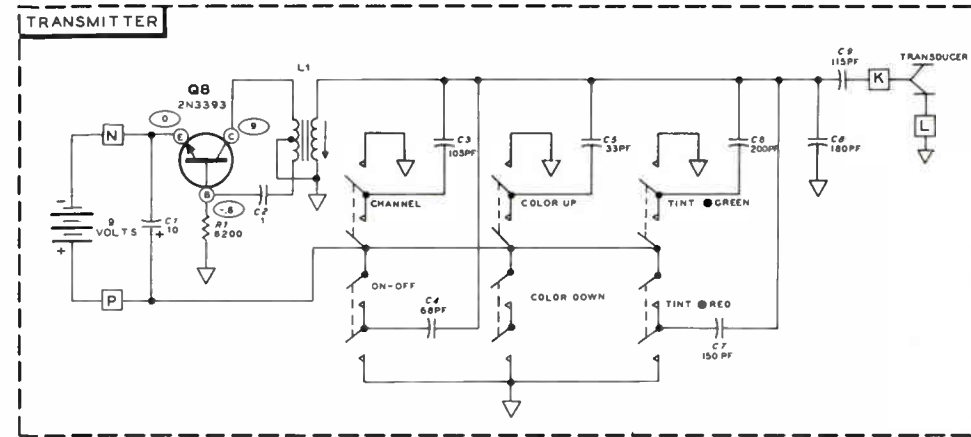

NOTES:

1. THE CIRCUIT PART NUMBERS FOR THE COMPONENTS ARE IN THE FOLLOWING GROUPS:
0-99 PARTS IN TRANSMITTER
100-199 PARTS IN RECEIVER
200-299 PARTS IN INTEGRATED CIRCUIT
2. ALL RESISTORS ARE 1/2 WATT UNLESS MARKED OTHERWISE. RESISTOR VALUES ARE IN OHMS (K=1,000, M=1,000,000).
3. ALL CAPACITOR VALUES ARE IN μFD UNLESS MARKED OTHERWISE.
4. pF=μμF (MICROMICROFARAD).
5. THIS SYMBOL INDICATES A DC VOLTAGE MEASUREMENT, TAKEN WITH AN 11 MEGOHM VTVM, FROM THE POINT INDICATED TO CHASSIS GROUND. VOLTAGES ARE POSITIVE UNLESS INDICATED OTHERWISE.
6. VOLTAGES IN TRANSMITTER TAKEN IN COLOR DOWN POSITION.
7. VOLTAGES MAY VARY ±20%.
8. VOLTAGE MEASUREMENTS WERE MADE WITH NO SIGNAL INPUT AND AT 120 VAC LINE VOLTAGE.
9. REFER TO THE CHASSIS PHOTOGRAPHS AND CIRCUIT BOARD X-RAY VIEW FOR THE PHYSICAL LOCATION OF PARTS.
10. ⊥ INDICATES CHASSIS GROUND CONNECTION.
11. ▽ INDICATES CIRCUIT BOARD GROUND CONNECTION.
12. □ LETTERS IN BOX INDICATE LOCATIONS ON RECEIVER CIRCUIT BOARD.
13. WAFER SWITCH VIEWED FROM REAR. SWITCH ROTATES COUNTERCLOCKWISE WITH NO STOP POSITION. SWITCH CONTACTS SHOWN IN POWER OFF POSITION.

PARTS ON TV SET

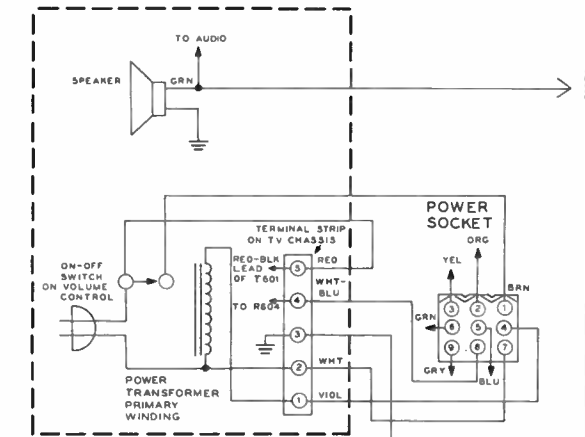

SCHEMATIC OF THE HEATHKIT® REMOTE CONTROL MODEL GRA-227-6, GRA-295-6 AND GRA-681-6

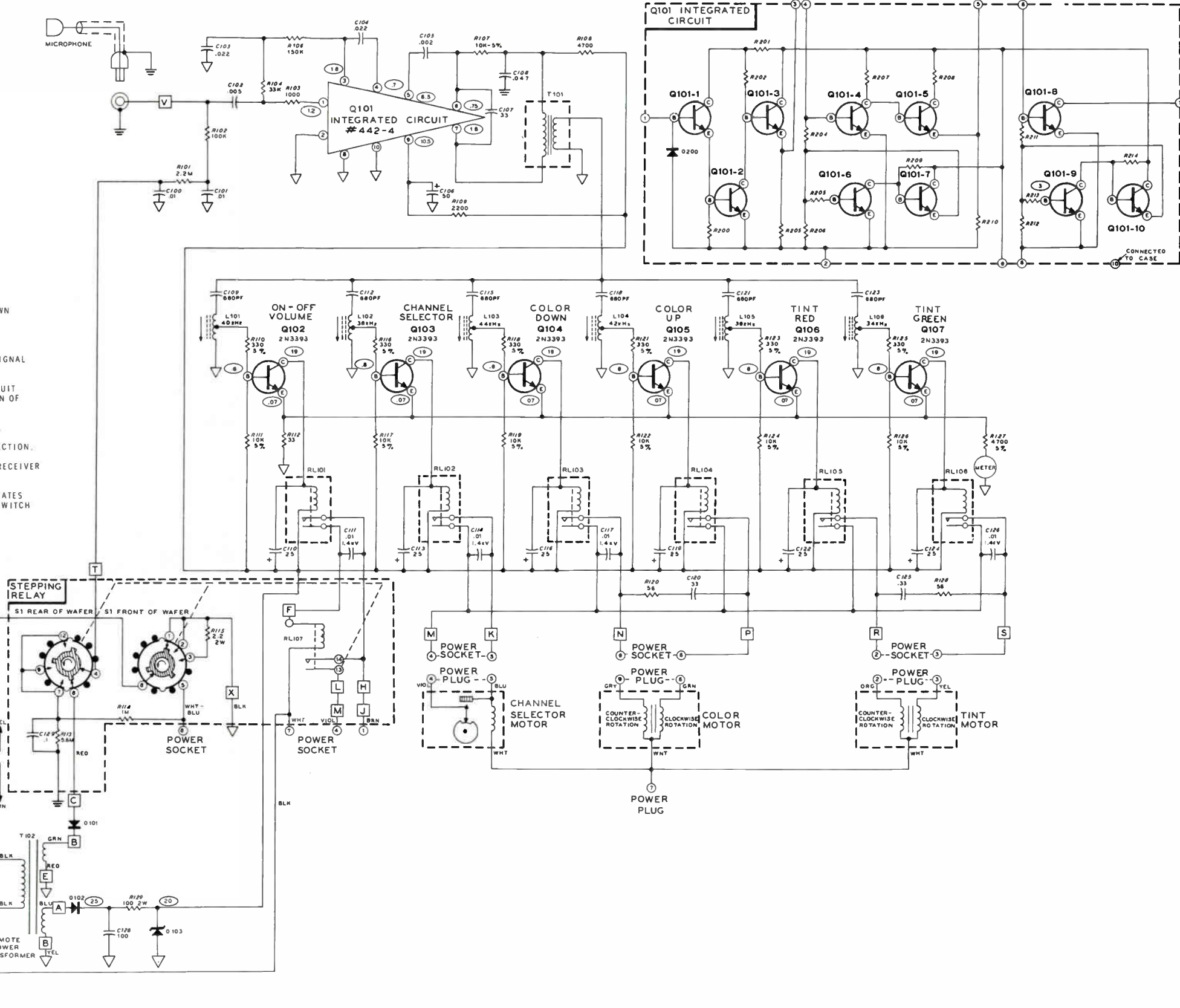

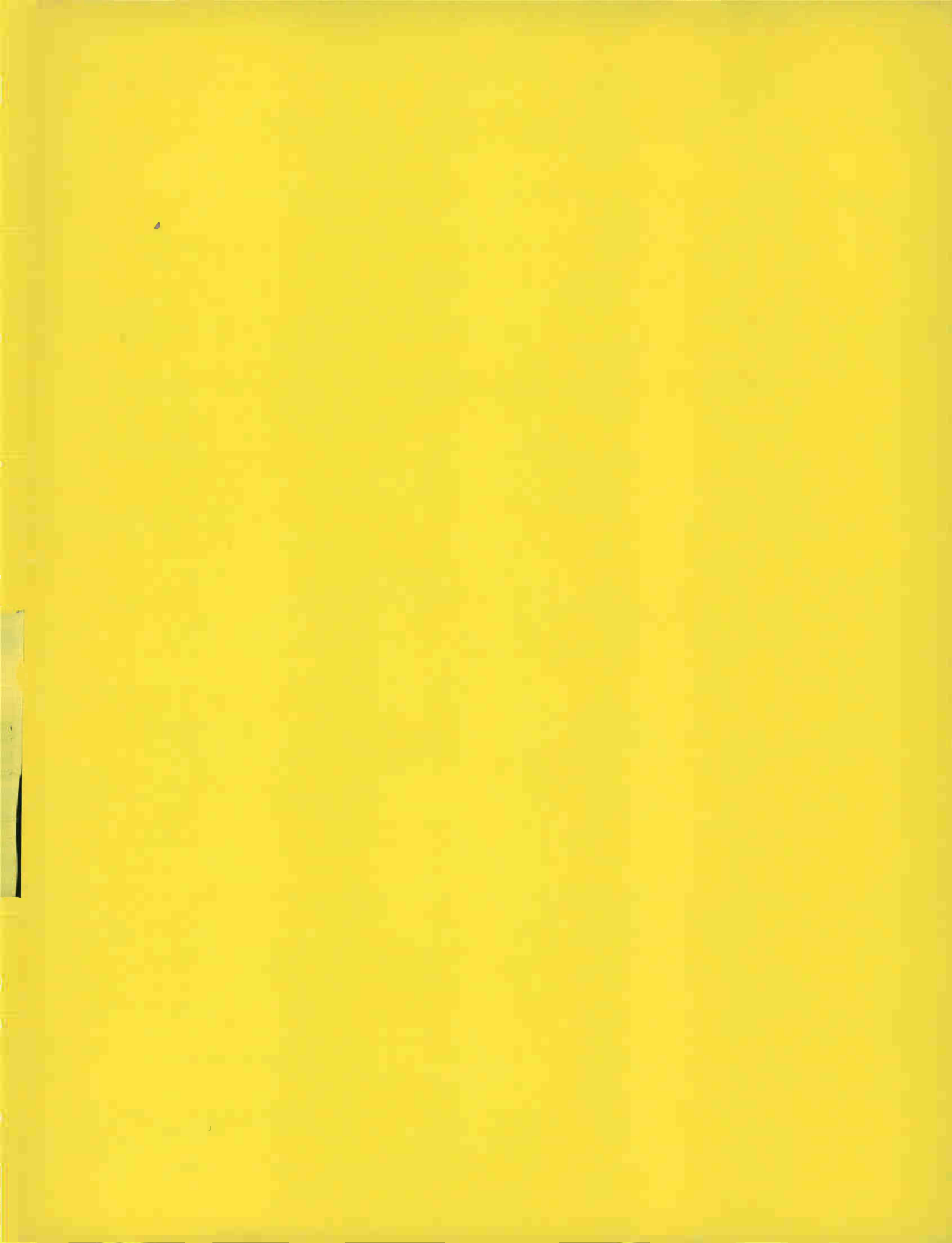

HEATH COMPANY

BENTON HARBOR MICHIGAN

THE WORLD'S FINEST ELECTRONIC EQUIPMENT IN KIT FORM