

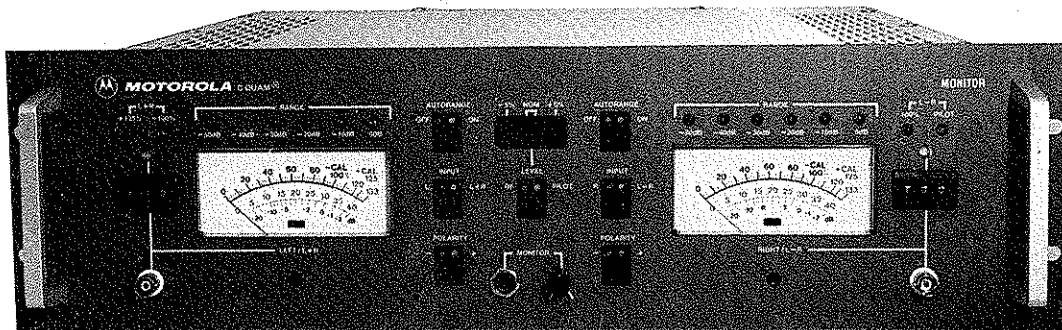

MOTOROLA INC.

C-QUAM® AM STEREO OWNERS MANUAL



MONITOR MODEL 1410

C-QUAM® IS A REGISTERED TRADEMARK OF MOTOROLA, INC.

www.americanradiohistory.com

EQUIPMENT LOST OR DAMAGED IN TRANSIT

When delivering the equipment to you, the truck driver or carrier's agent will present a receipt for your signature. Do not sign it until you have (a) inspected the containers for visible signs of damage and (b) counted the containers and compared with the amount shown on the shipping papers. If a shortage or evidence of damage is noted, insist that notation to that effect be made on the shipping papers before you sign them.

Further, after receiving the equipment, unpack it and inspect thoroughly for concealed damage. If concealed damage is discovered, immediately notify the carrier, confirming the notification in writing, and secure an inspection report. This item should be unpacked and inspected for damage WITHIN 15 DAYS after receipt. Claims for loss or damage will not be honored without proper notification of inspection by the carrier.

TECHNICAL ASSISTANCE AND REPAIR SERVICE

Technical assistance is available by letter or prepaid telephone or telegram. Equipment requiring repair or overhaul should be sent by common carrier, prepaid, insured and well protected. Do not mail equipment. We can assume no liability for inbound damage, and necessary repairs become the obligation of the shipper. Prior arrangement is necessary. Contact Customer Service Department for a Return Authorization.

FOR TECHNICAL ASSISTANCE
Phone (312) 576-3591

WARRANTY ADJUSTMENT

Warranty information is included on the last page of this manual. In the event of a warranty claim, replacement or repair parts will be supplied F.O.B. factory at the discretion of the manufacturer. The customer may be required to return the defective part or equipment. Warranty replacements of defective merchandise will be billed to your account. This billing will be cleared by a credit issued upon return of the defective item.

RETURN, REPAIR AND EXCHANGES

Do not return any merchandise without our approval and Return Authorization. We will provide special shipping instructions and a code number that will assure proper handling and prompt issuance of credit. Please furnish complete details as to circumstances and reasons when requesting return of merchandise. All returned merchandise must be sent freight prepaid and properly insured by the customer.

REPLACEMENT PARTS

Replacement and Warranty Parts may be ordered from the address below. Be sure to include equipment model and serial number and part description and part number.

MOTOROLA AM STEREO
1216 Remington Road
Schaumburg, Illinois 60173
312-576-2879

TELEX NUMBERS
TTY 28-2562
TWX 910-693-4078
-or-
910-693-4079

PROPRIETARY NOTICE

This document contains proprietary data. No disclosure, reproduction, or use of any part thereof may be made except by prior written permission from the manufacturer.

MODIFICATIONS

The manufacturer reserves the right to modify the design and specifications of the equipment in this manual without notice. Any modifications shall not adversely affect performance of the equipment so modified.

NOTE: The model 1410 modulation monitor is manufactured to Motorola Inc. specifications and quality by Broadcast Electronics, Inc. Any inquires about this product should be directed to Motorola AM Stereo at the address shown above.

TABLE OF CONTENTS

<u>PARAGRAPH</u>		<u>PAGE NO.</u>
SECTION I	GENERAL INFORMATION	
1-1	Introduction	1-1
1-3	Equipment Description	1-1
1-5	Electrical Description	1-2
1-7	Decoding Circuitry	1-2
1-8	Metering Circuitry	1-2
1-10	Physical Description	1-2
1-12	Equipment Specifications	1-3
SECTION II	INSTALLATION	
2-1	Introduction	2-1
2-3	Unpacking	2-1
2-6	Installation Requirements	2-1
2-8	Installation	2-1
2-10	Preliminary Installation	2-1
2-12	Circuit Board Programming Check	2-2
2-13	Input Voltage Check	2-2
2-16	Placement	2-2
2-19	Wiring	2-2
2-20	RF Wiring	2-2
2-21	Ground	2-2
2-22	Remote Indications	2-2
2-23	Audio Outputs	2-5
2-24	Installation Adjustments	2-5
2-25	RF Attenuator	2-5
SECTION III	OPERATION	
3-1	Introduction	3-1
3-3	Controls and Indicators	3-1
3-5	Operation	3-6
3-7	Preliminary Operation	3-6
3-9	RF/Pilot Level Monitoring	3-6
3-11	Input Selection	3-6
3-13	Adjustable Peak Modulation Indicator Operation	3-8
3-15	Modulation Meter Operation	3-8
3-16	Autorange Operation	3-8
3-17	Manual Operation	3-8
3-18	Polarity Selection	3-8
3-20	Audio Monitoring	3-8

COPYRIGHT © MOTOROLA INC. MARCH 1988

MANUAL NUMBER 597-0105-900

PARAGRAPHPAGE NO.

SECTION IV

THEORY OF OPERATION

4-1	Introduction	4-1
4-4	Functional Description	4-1
4-5	RF Demodulator Circuit Board	4-1
4-6	RF Input Circuit	4-1
4-9	Frequency Synthesizer Circuit	4-1
4-15	Automatic-Gain-Control (AGC) Circuit	4-2
4-19	RF Level Circuit	4-9
4-20	Decoding Circuit	4-9
4-34	L-R Audio Circuit	4-11
4-35	L+R Audio Circuit	4-11
4-36	Power Supply Circuit	4-11
4-39	Audio Circuit Board	4-12
4-40	Audio Input Circuit	4-12
4-41	Audio Dematrix Circuit	4-12
4-42	Pilot Detection Circuit	4-12
4-46	L-R/L+R Indicator Circuitry	4-12
4-49	Left/L+R Channel Meter Input Circuit	4-13
4-54	Left/L+R Channel Meter Amplifier Circuit	4-13
4-61	Left/L+R Channel Meter Mode Control Circuit	4-14
4-67	Preset Power Circuit	4-15
4-68	Headphone Circuit	4-15
4-69	Regulator Circuit	4-15
4-70	Meter Circuit Board	4-15
4-73	Audio Control Circuit Board	4-16
4-75	L+R Indicator Circuitry	4-16
4-76	Left/L+R Channel Meter Control and Indicator Circuitry	4-16
4-77	Left/L+R Channel Adjustable Peak Indicator Circuit	4-17
4-78	RF/Pilot Level Indicator Circuit	4-17
4-82	Interface Circuit Board	4-17

SECTION V

MAINTENANCE

5-1	Introduction	5-1
5-3	Safety Considerations	5-1
5-5	First Level Maintenance	5-1
5-8	Second Level Maintenance	5-1
5-11	Electrical Adjustments	5-2
5-13	Test Equipment Preparation	5-2
5-15	Signal Source - AM Stereo Exciter	5-2
5-17	Signal Source - C-Quam Signal Generator	5-2
5-18	RF Demodulator Circuit Board Adjustments	5-3
5-19	450 kHz Band-Pass Filter Alignment	5-3
5-34	900 kHz Notch Filter Adjustments	5-6
5-51	1.8 MHz Notch Filter Adjustment	5-8
5-64	Decoding Circuit Alignment	5-9
5-88	AGC Circuit Adjustments	5-11
5-107	Pilot Tone Null	5-13
5-121	Frequency Synthesizer Calibration	5-14
5-138	RF Level Calibration	5-15

<u>PARAGRAPH</u>		<u>PAGE NO.</u>
5-152	Separation	5-16
5-174	Meter Circuit Board Adjustments	5-18
5-175	Right Channel/Left Channel Meter Circuit Board Adjustments	5-18
5-201	Audio Circuit Board Adjustments	5-20
5-202	Pilot Level Calibration	5-20
5-214	+125% L+R, -100% L+R, and 100% L-R Peak Indicator Adjustments	5-21
5-228	Pilot Notch Adjustment	5-23
5-243	Audio Control Circuit Board Adjustments	5-24
5-244	Adjustable Peak Indicator Calibration	5-24
5-258	Operating Frequency Reprogramming	5-25
5-265	Troubleshooting	5-26
5-267	Component Replacement	5-29
5-273	Integrated Circuits	5-29
SECTION VI	PARTS LISTS	
6-1	Introduction	6-1
SECTION VII	DRAWINGS	
7-1	Introduction	7-1
APPENDIX A	MANUFACTURERS DATA	
A-1	Introduction	A-1

LIST OF ILLUSTRATIONS

<u>FIGURE NO.</u>	<u>DESCRIPTION</u>	<u>PAGE NO.</u>
1-1	MODEL 1410 AM STEREO MODULATION MONITOR	1-1
2-1	CIRCUIT BOARD JUMPER AND SWITCH PROGRAMMING	2-3
2-2	REMOTE INDICATOR AND AUDIO WIRING	2-4
2-3	RF ATTENUATOR AND INDICATORS	2-6
3-1	MONITOR CONTROLS AND INDICATORS	3-7
4-1	MONITOR SIMPLIFIED SCHEMATIC	4-3
5-1	RF DEMODULATOR CIRCUIT BOARD ACCESS	5-3
5-2	RF DEMODULATOR CIRCUIT BOARD ADJUSTMENT CONTROLS	5-5
5-3	450 kHz BAND-PASS FILTER ALIGNMENT	5-6
5-4	MODULATION METER CIRCUIT BOARD ADJUSTMENT CONTROLS	5-19
5-5	AUDIO CIRCUIT BOARD ADJUSTMENT CONTROLS	5-22
5-6	AUDIO CONTROL CIRCUIT BOARD ADJUSTMENT CONTROLS	5-25
5-7	FREQUENCY SYNTHESIZER PROGRAMMING	5-27
5-8	TROUBLESHOOTING TREE, L+R CIRCUIT	5-32

<u>FIGURE NO.</u>	<u>DESCRIPTION</u>	<u>PAGE NO.</u>
5-9	TROUBLESHOOTING TREE, INTERMEDIATE FREQUENCY CIRCUIT	5-33
5-10	TROUBLESHOOTING TREE, L-R CIRCUIT	5-34
5-11	AUDIO CIRCUIT BOARD TROUBLESHOOTING	5-35
5-12	TROUBLESHOOTING TREE, DEFECTIVE FREQUENCY SYNTHESIZER	5-36

LIST OF TABLES

<u>TABLE NO.</u>	<u>DESCRIPTION</u>	<u>PAGE NO.</u>
1-1	ELECTRICAL, PHYSICAL, AND ENVIRONMENTAL SPECIFICATIONS	1-3
3-1	CONTROLS AND INDICATORS	3-1
5-1	MODEL 1410 MONITOR TROUBLESHOOTING	5-30
6-1	REPLACEABLE PARTS LISTS	6-1

SECTION I
GENERAL INFORMATION

1-1. INTRODUCTION.

1-2. Information presented by this section provides a general description of the Motorola Model 1410 AM Stereo Modulation Monitor and lists equipment specifications.

1-3. EQUIPMENT DESCRIPTION.

1-4. The Motorola Model 1410 is a totally solid-state modulation monitor designed to decode C-QUAM AM stereo within the AM broadcast band (refer to Figure 1-1). The unit is programmed for 10 kHz increment operation with 9 kHz increment operation available from an optional feature. The following text presents ordering information, optional features, and recommended spare parts kits.

<u>MODEL</u>	<u>PART NO.</u>	<u>DESCRIPTION</u>
1410	907-0100-900	Model 1410 AM Stereo Modulation Monitor designed for C-QUAM system operation on a single specified frequency in the AM broadcast band. 10 kHz increment programming. 19 inch (48.21 cm) rack mount, 117V ac 50/60 Hz operation.
1410	907-0100-903	Model 1410 AM Stereo Modulation Monitor designed for C-QUAM system operation on a single specified frequency in the AM broadcast band. 10 kHz increment programming. 19 inch (48.21 cm) rack mount, 220V ac 50/60 Hz operation.
----	907-0104	9 kHz increment programming option.

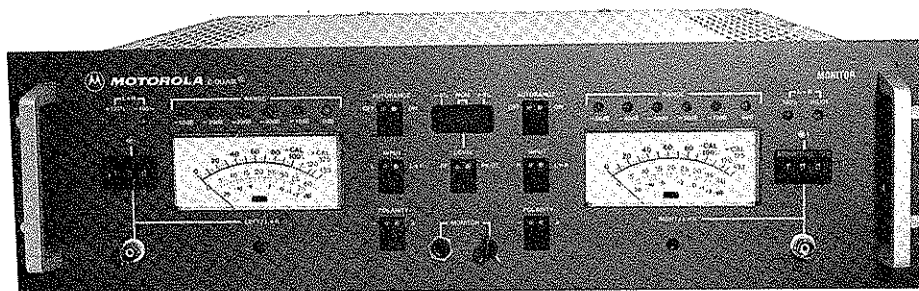

597-0105-1

FIGURE 1-1. MODEL 1410 AM STEREO MODULATION MONITOR

- 977-0004 Recommended spare parts kit for the Model 1410 AM stereo modulation monitor. Includes selected fuses, meters, crystals, and switches.
- 977-0005 Recommended semi-conductor kit for the Model 1410 AM stereo modulation monitor.
- 977-0006 100% semi-conductor kit for the Model 1410 AM stereo modulation monitor.

1-5. ELECTRICAL DESCRIPTION.

1-6. The Model 1410 is a completely solid-state second-generation modulation monitor designed to decode C-QUAM AM stereo. Advanced decoding techniques such as a single RF AGC circuit and digital pilot detection provide accurate and reliable signal monitoring. Metering features include analog modulation meters, a high resolution moving bar LED RF/pilot level display, two adjustable peak modulation indicator displays, and three fixed peak modulation indicators. An exclusive modulation meter autorange feature allows the operator to conveniently observe a wide range of signal levels. Front and rear panel test receptacles provide the operator with convenient access to the decoded audio signals.

1-7. DECODING CIRCUITRY. The monitor decoding circuitry employs a single RF AGC circuit at the signal input. This type of circuit exhibits accurate and stable decoding and eliminates tracking errors inherent in dual AGC decoding circuitry. Precision filters in the decoding circuit eliminate overshoot and enhance modulation monitoring accuracy. The decoding circuitry also features a digital pilot detection circuit which provides increased pilot detection stability and reliability.

1-8. METERING CIRCUITRY. The metering circuitry consists of a combination of analog and LED displays. Two analog meters present the left/L+R channel and right/L-R channel modulation level parameters. Modulation meter range is displayed on a six LED range display. An exclusive autorange feature allows the operator to conveniently observe a wide range of modulation levels without manual meter adjustment. Two adjustable peak modulation indicator displays allow monitoring of left/L+R channel and right/L-R channel modulation parameters from 0% to 133%.

1-9. Carrier/pilot level parameters are presented on a high resolution moving bar LED display. +125% L+R, -100% L+R, 100% L-R, and pilot tone parameters are displayed on individual peak indicators. Metering parameters are selected from front panel microswitches with LED indicators to provide easy recognition of operational parameters.

1-10. PHYSICAL DESCRIPTION.

1-11. The monitor circuitry is designed in modular assemblies to provide ease of maintenance. A hinged upper circuit board allows convenient access to lower circuit board components. Front and rear panel audio receptacles are provided for convenient test equipment connections.

1-12. EQUIPMENT SPECIFICATIONS.

1-13. Refer to Table 1-1 for the electrical, physical, and environmental specifications of the Model 1410 AM stereo modulation monitor.

TABLE 1-1. ELECTRICAL, PHYSICAL, AND ENVIRONMENTAL SPECIFICATIONS
(Sheet 1 of 2)

PARAMETER	SPECIFICATIONS
<p><u>ELECTRICAL</u></p> <p>OPERATING FREQUENCY RANGE Standard</p> <p>Optional</p> <p>RF INPUT IMPEDANCE</p> <p>RF INPUT LEVEL</p> <p>RF ATTENUATOR</p> <p>MODULATION METER CALIBRATION</p> <p>MODULATION METER RANGE</p> <p>MODULATION METER ACCURACY</p> <p>MODULATION METER FUNCTIONS</p> <p>PEAK INDICATOR FUNCTIONS</p> <p>ADJUSTABLE PEAK INDICATOR</p> <p>REAR PANEL OUTPUTS Left Channel Right Channel L+R L-R</p>	<p>530 to 1620 kHz as specified. Programmable in 10 kHz increments.</p> <p>522 to 1620 kHz as specified. Programmable in 9 kHz increments.</p> <p>50 Ohms.</p> <p>500 mV to 15 V RMS.</p> <p>Adjustable from 0 dB to 30 dB in 6 dB increments. Fine adjustment: 0 dB to 6 dB, AGC controlled.</p> <p>0% to 133% (-20 dB to +2 dB).</p> <p>+2 dB to -70 dB, Autorange or manual.</p> <p>±2% at 100% modulation, 400 Hz Reference.</p> <p>Left/L+R, Right/L-R.</p> <p>+125% envelope. -100% envelope. 100% phase.</p> <p>From 0% to 133%. Positive or Negative indication.</p> <p> 0.775V RMS equals 100% modulation.</p>

TABLE 1-1. ELECTRICAL, PHYSICAL, AND ENVIRONMENTAL SPECIFICATIONS
(Sheet 2 of 2)

PARAMETER	SPECIFICATIONS
Pilot	0.775V RMS equals 5% pilot injection.
Left/Right channel Audio Impedance	600 Ohms, Active Balanced.
Left/Right channel Audio Level	2.45V RMS at 100% modulation.
HEADPHONE OUTPUT	2 watts into 8 Ohms.
AC POWER REQUIREMENTS	97V to 133V ac, 50/60 Hz or 194V to 266V ac, 50/60 Hz.
<u>PHYSICAL</u>	
DIMENSIONS	
Width	19 inches (48.3 cm).
Height	5.25 inches (13.3 cm).
Depth	17 inches (43.2 cm).
WEIGHT	25 lbs (11.3 kg).
<u>ENVIRONMENTAL</u>	
AMBIENT TEMPERATURE RANGE	+32°F to +122°F (0°C to +50°C).
MAXIMUM HUMIDITY	95%, Non-condensing.
MAXIMUM ALTITUDE	15,000 feet above sea level (4572 m).
COOLING	Natural convection and conduction.

SECTION II INSTALLATION

2-1. INTRODUCTION.

2-2. This section contains information required for the installation and preliminary checkout of the Motorola Model 1410 AM stereo modulation monitor.

2-3. UNPACKING.

2-4. The equipment becomes the property of the customer when the equipment is delivered to the carrier. Carefully unpack the modulation monitor. Perform a visual inspection to determine that no apparent damage has been incurred during shipment. All shipping materials should be retained until it is determined that the unit has not been damaged. Claims for damaged equipment must be promptly filed with the carrier or the carrier may not accept the claim.

2-5. The contents of the shipment should be as indicated on the packing list. If the contents are incomplete, or if the unit is damaged electrically or mechanically, notify both the carrier and Motorola.

2-6. INSTALLATION REQUIREMENTS.

2-7. Refer to the environmental specifications in Table 1-1 and ensure a proper operational environment exists prior to installation.

2-8. INSTALLATION.

2-9. Each modulation monitor is assembled, operated, tested, and inspected at the factory prior to shipment and is ready for installation when received. Prior to installation, this publication should be studied to obtain a thorough understanding of the operation, circuitry, nomenclature, and installation requirements. Installation is accomplished as follows: 1) Preliminary Installation, 2) Placement, 3) Wiring, and 4) Installation Adjustments.

2-10. PRELIMINARY INSTALLATION.

WARNING

ENSURE NO PRIMARY POWER IS CONNECTED TO THE MONITOR BEFORE PROCEEDING.

2-11. Refer to the following information and perform the preliminary installation procedures. The procedures will require the unit be placed on a work surface with the top-panel removed. After completion of the procedures, replace the unit top-panel.

2-12. CIRCUIT BOARD PROGRAMMING CHECK. The monitor circuit boards are factory programmed during final test. To assure the circuit board jumpers and switches have not become dislodged or changed during shipment, refer to Figure 2-1 and check the position of each circuit board jumper and switch.

WARNING

ENSURE NO PRIMARY POWER IS CONNECTED TO THE MONITOR BEFORE PROCEEDING.

2-13. INPUT VOLTAGE CHECK. The monitor is programmed for the proper power supply voltage when shipped from the factory. Ensure the power supply voltage programming is correct as follows.

2-14. Ensure the power supply voltage to be used (100V, 115/120V, 220V, or 230/240V) is visible from the ac line voltage selector device on the monitor rear-panel. If the ac line voltage must be changed, proceed as follows:

- A. Remove the ac voltage selector circuit board with a small pair of needle-nose pliers. Re-insert the circuit board so that the correct ac line voltage is visible from the ac voltage selector device window.

2-15. Remove the fuse from the ac voltage selector device. Ensure the fuse and the spare fuse are slow-blow types rated at 1.0 amperes for 100V to 120V operation or 0.5 amperes for 220V to 240V operation.

2-16. PLACEMENT.

2-17 The Model 1410 modulation monitor requires 5.25 inches (13.3 cm) of a 19 inch (48.3 cm) cabinet and may be mounted in any convenient location within reach of signal and power cables. An additional 1.75 inches (4.4 cm) of cabinet space above and below the unit is required to provide adequate cooling. The unit should not be mounted directly above or below heat-generating equipment, otherwise no special requirements need be observed.

2-19. WIRING.

2-20. RF WIRING. Connect the RF input to the RF IN receptacle (located on the rear-panel). Ensure the input voltage is less than 15V RMS.

2-21. GROUND. A terminal is provided on the monitor rear-panel for a ground connection. Connect an earth ground to the terminal as required.

2-22. REMOTE INDICATIONS. Remote meter indications are provided on the REMOTE 1 and REMOTE 2 rear-panel connectors. Refer to Figure 2-2 and construct remote interface cables as required. Mating connectors for the cables are provided in the monitor accessory kit.

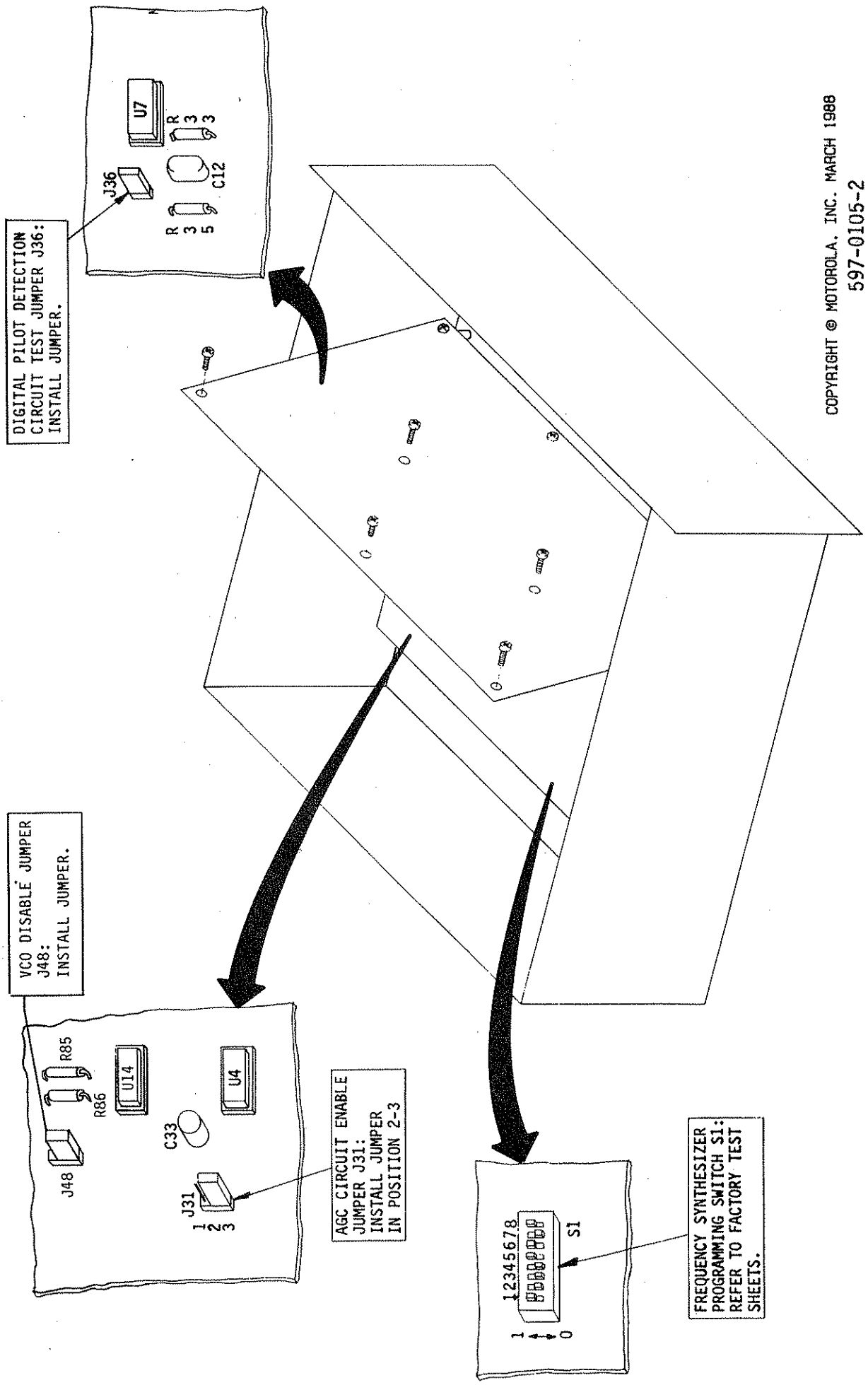

COPYRIGHT © MOTOROLA, INC. MARCH 1988
597-0105-2

FIGURE 2-1. CIRCUIT BOARD JUMPER AND SWITCH PROGRAMMING

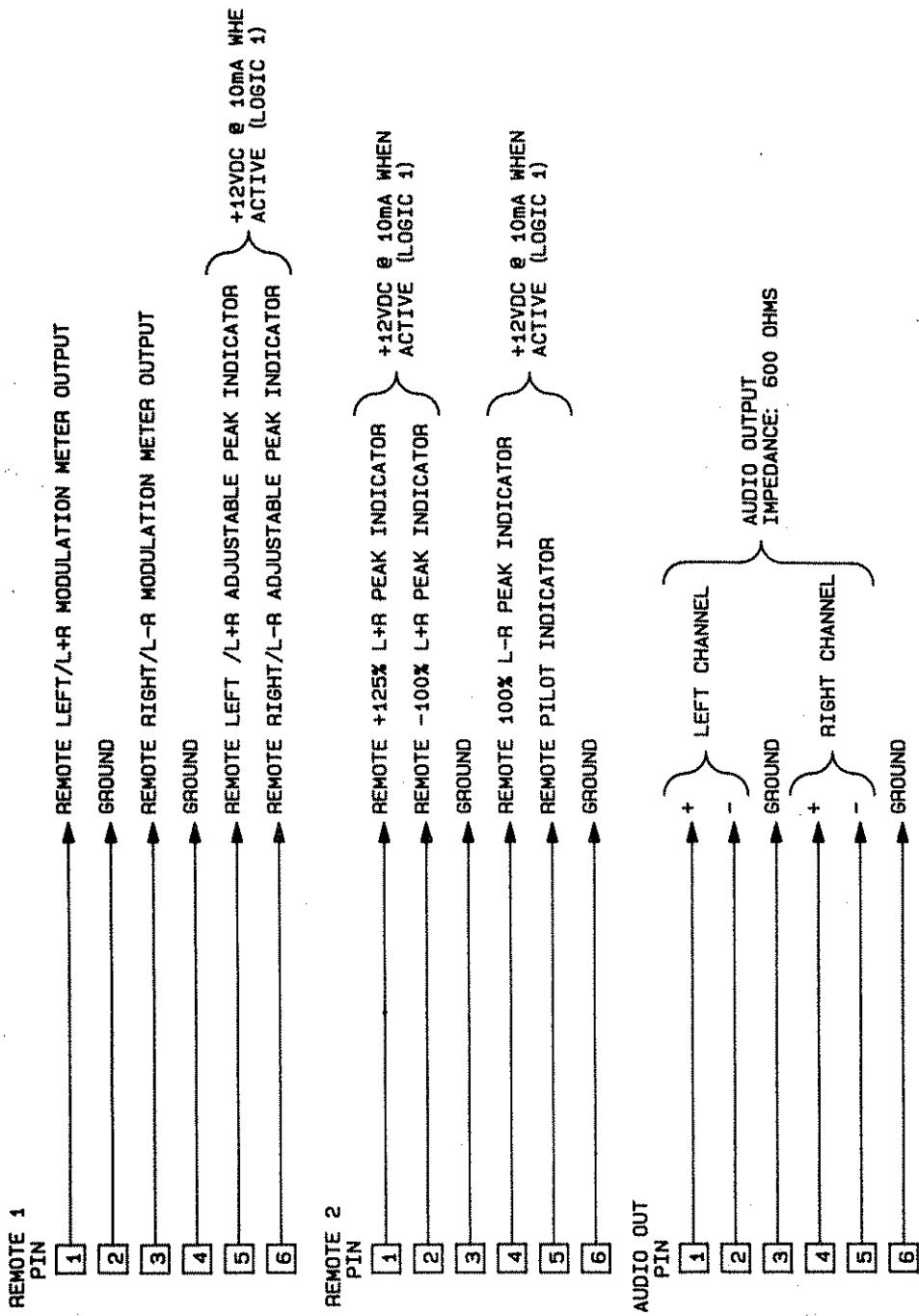
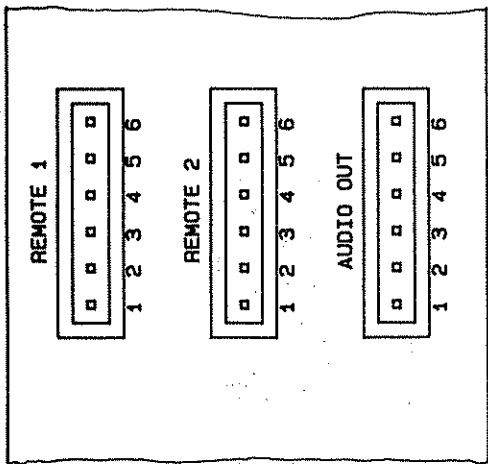

COPYRIGHT © MOTOROLA, INC. MARCH 1988
597-0105-4

FIGURE 2-2. REMOTE INDICATOR AND AUDIO WIRING

2-23. AUDIO OUTPUTS. Balanced, 600 Ohm left and right channel audio outputs are provided on the AUDIO OUT rear-panel connector. Refer to Figure 2-2 and construct an audio interface cable as required. A mating connector for the cable is provided in the monitor accessory kit.

2-24. INSTALLATION ADJUSTMENTS.

2-25. RF ATTENUATOR. Installation adjustments involve the adjustment of the RF attenuator which determines the acceptable carrier input level to the internal AGC circuitry. Once the RF attenuator is correctly positioned, future adjustment will not be required. To adjust the RF attenuator, proceed as follows.

2-26. Apply power to the monitor by connecting the ac cord to an appropriate power source.

2-27. Apply the normal operating RF signal to the monitor.

2-28. Refer to Figure 2-3 and observe the RF ATTENUATOR and the RF HIGH and RF LOW indicators. With the RF ATTENUATOR at the 0 dB position, adjust the control clockwise to the -6 dB position. Wait approximately 30 seconds to allow the internal AGC circuitry to track the new input level and observe the RF HIGH and RF LOW indicators. Continue slowly adjusting the attenuator as directed by the indicators until both the RF HIGH and RF LOW indicators are extinguished.

2-29. After adjusting the RF ATTENUATOR, ensure the front-panel RF indicator on the RF/PILOT switch/indicator is illuminated and observe the RF/PILOT LEVEL display (refer to Figure 2-3). Both indicators in the NOM display must be illuminated. If only one indicator is illuminated, adjust the RF ATTENUATOR one position clockwise or counterclockwise as required until: 1) both RF LEVEL NOM indicators illuminate and 2) both the RF HIGH and RF LOW indicators extinguish.

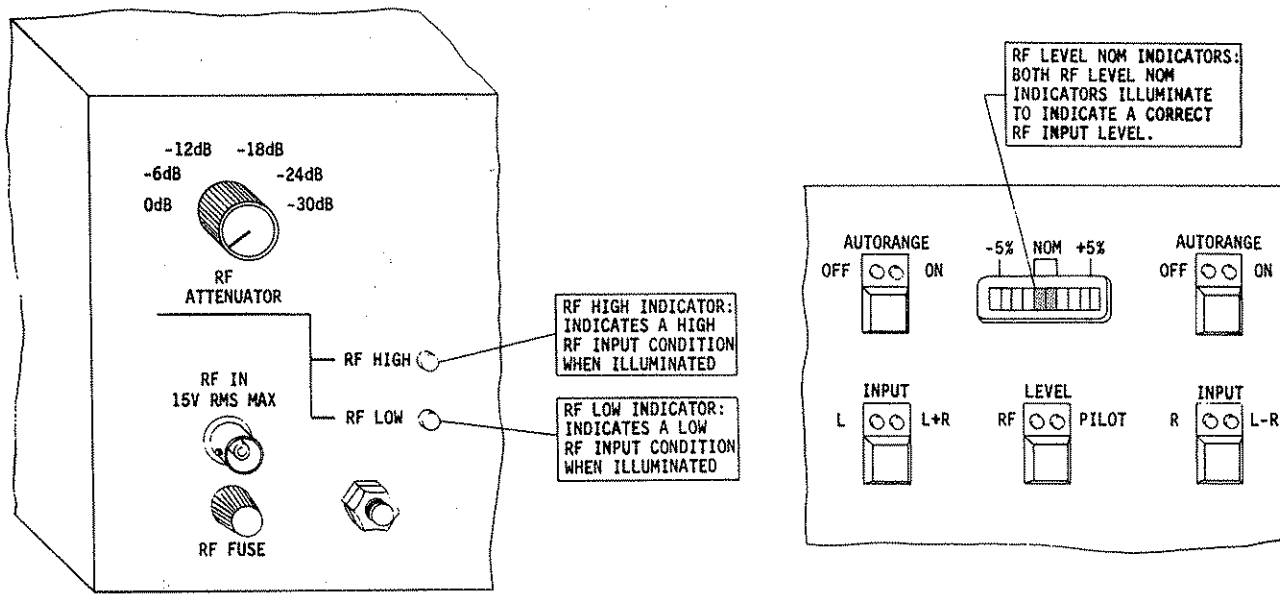

RF ATTENUATOR

RF LEVEL NOM INDICATORS

COPYRIGHT © MOTOROLA, INC. MARCH 1988

597-0105-5

FIGURE 2-3. RF ATTENUATOR AND INDICATORS

SECTION III
OPERATION

3-1. INTRODUCTION.

3-2. This section identifies all controls and indicators associated with the Model 1410 AM stereo modulation monitor and provides standard operating procedures.

3-3. CONTROLS AND INDICATORS.

3-4. Refer to Figure 3-1 for the location of all controls and indicators associated with the Model 1410 AM stereo modulation monitor. The function of each control or indicator is described by Table 3-1.

TABLE 3-1. CONTROLS AND INDICATORS
(Sheet 1 of 6)

INDEX NO.	NOMENCLATURE	FUNCTION
1	LEFT, RIGHT, L+R, L-R, and PILOT Connections	Decoded audio samples for external test equipment.
2	+125% L+R Peak Indicator	Indicates +125% L+R peak modulation when illuminated. The indicator is independent of the INPUT L/L+R switch/indicator and continuously monitors positive peak L+R modulation.
3	-100% L+R Peak Indicator	Indicates -100% L+R peak modulation when illuminated. The indicator is independent of the INPUT L/L+R switch/indicator and continuously monitors negative peak L+R modulation.
4	LEFT/L+R Channel Modulation Meter RANGE Indicators	Indicators which illuminate to indicate the various LEFT/L+R channel modulation meter ranges.
5	LEFT/L+R Channel Modulation Meter AUTORANGE Switch/Indicator	SWITCH: Selects manual or autorange operation of the LEFT/L+R channel modulation meter. Autorange operation is selected only when simultaneously operated with the RIGHT/L-R channel AUTORANGE switch/indicator.

TABLE 3-1. CONTROLS AND INDICATORS
(Sheet 2 of 6)

INDEX NO.	NOMENCLATURE	FUNCTION
6	RF/PILOT LEVEL Switch/Indicator	<p>ON INDICATOR: Indicates autorange operation of the LEFT/L+R channel modulation meter when illuminated.</p> <p>OFF INDICATOR: Indicates manual operation of the LEFT/L+R channel modulation meter when illuminated.</p> <p>SWITCH: Selects RF or pilot level parameters to be presented on the LEVEL display.</p> <p>PILOT LEVEL INDICATOR: Indicates the pilot level parameter is selected for display when illuminated.</p> <p>RF LEVEL INDICATOR: Indicates the RF level parameter is selected for display when illuminated.</p>
7	LEVEL Display	<p>Displays the RF LEVEL or PILOT LEVEL parameters as selected by the RF/PILOT LEVEL switch/indicator.</p> <p>RF LEVEL DISPLAY: Scale: -5% to +5%</p> <p>Operation: Two NOM indicators illuminate to indicate a correct RF input level. Carrier shift is displayed by individual indicators which illuminate at 1% increments between -5% and +5%.</p> <p>PILOT LEVEL DISPLAY: Scale: 0% to 10%</p> <p>Operation: Two NOM indicators illuminate to indicate 5% pilot injection. Additional pilot level parameters are displayed by individual indicators which illuminate at 1% increments between 0% and 10%.</p>
8	RIGHT/L-R Channel Modulation Meter AUTORANGE Switch/Indicator	<p>SWITCH: Selects manual or autorange operation of the RIGHT/L-R channel modulation meter. Autorange operation is selected only when simultaneously operated with the LEFT/L+R channel AUTORANGE switch/indicator.</p>

TABLE 3-1. CONTROLS AND INDICATORS
(Sheet 3 of 6)

INDEX NO.	NOMENCLATURE	FUNCTION																
		<p>ON INDICATOR: Indicates autorange operation of the RIGHT/L-R channel modulation meter when illuminated.</p> <p>OFF INDICATOR: Indicates manual operation of the RIGHT/L-R channel modulation meter when illuminated.</p>																
9	RIGHT/L-R Channel Modulation Meter RANGE Indicators	Indicators which illuminate to indicate the various RIGHT/L-R channel modulation meter ranges.																
10	L-R 100% Peak Indicator	Indicates 100% L-R peak modulation when illuminated. The indicator is independent of the INPUT R/L-R switch/indicator and continuously monitors L-R modulation.																
11	PILOT Indicator	Illuminates to indicate the detection of a 25 Hz pilot tone.																
12	RIGHT/L-R Channel Adjustable Peak Modulation Indicator	Illuminates to indicate the right/L-R channel modulation as selected by the right/L-R channel adjustable peak modulation indicator control.																
13	RIGHT/L-R Channel Adjustable Peak Modulation Indicator Control	Selects the right/L-R channel modulation percentage displayed on the right/L-R channel adjustable peak modulation indicator.																
14	RIGHT/L-R Channel Test Receptacle	Decoded right/L-R channel audio samples for external test equipment.																
15	RIGHT/L-R Channel Modulation Meter	<p>Displays right channel or L-R channel modulation levels. The modulation parameters are displayed by semi-peak and average meter ballistics.</p> <table border="0" data-bbox="792 1583 1393 1866"> <thead> <tr> <th data-bbox="792 1583 974 1617"><u>METER RANGE</u></th> <th data-bbox="1127 1583 1393 1617"><u>METER BALLISTICS</u></th> </tr> </thead> <tbody> <tr> <td data-bbox="831 1646 1029 1717"> <table border="0"> <tr><td>∅ dB</td><td rowspan="2">}</td><td rowspan="2">—</td></tr> <tr><td>-10 dB</td></tr> </table> </td> <td data-bbox="1166 1667 1312 1696">Semi-Peak</td> </tr> <tr> <td data-bbox="831 1747 1029 1866"> <table border="0"> <tr><td>-20 dB</td><td rowspan="4">}</td><td rowspan="4">—</td></tr> <tr><td>-30 dB</td></tr> <tr><td>-40 dB</td></tr> <tr><td>-50 dB</td></tr> </table> </td> <td data-bbox="1166 1793 1279 1822">Average</td> </tr> </tbody> </table>	<u>METER RANGE</u>	<u>METER BALLISTICS</u>	<table border="0"> <tr><td>∅ dB</td><td rowspan="2">}</td><td rowspan="2">—</td></tr> <tr><td>-10 dB</td></tr> </table>	∅ dB	}	—	-10 dB	Semi-Peak	<table border="0"> <tr><td>-20 dB</td><td rowspan="4">}</td><td rowspan="4">—</td></tr> <tr><td>-30 dB</td></tr> <tr><td>-40 dB</td></tr> <tr><td>-50 dB</td></tr> </table>	-20 dB	}	—	-30 dB	-40 dB	-50 dB	Average
<u>METER RANGE</u>	<u>METER BALLISTICS</u>																	
<table border="0"> <tr><td>∅ dB</td><td rowspan="2">}</td><td rowspan="2">—</td></tr> <tr><td>-10 dB</td></tr> </table>	∅ dB	}	—	-10 dB	Semi-Peak													
∅ dB	}			—														
-10 dB																		
<table border="0"> <tr><td>-20 dB</td><td rowspan="4">}</td><td rowspan="4">—</td></tr> <tr><td>-30 dB</td></tr> <tr><td>-40 dB</td></tr> <tr><td>-50 dB</td></tr> </table>	-20 dB	}	—	-30 dB	-40 dB	-50 dB	Average											
-20 dB	}			—														
-30 dB																		
-40 dB																		
-50 dB																		

TABLE 3-1. CONTROLS AND INDICATORS
(Sheet 4 of 6)

INDEX NO.	NOMENCLATURE	FUNCTION
16	R/L-R INPUT Switch/Indicator	<p>SWITCH: Selects right channel or L-R channel information to be presented on the right/L-R channel modulation meter, adjustable peak modulation indicator, and front-panel test receptacle.</p> <p>L-R INDICATOR: Indicates L-R modulation information is presented on the right/L-R channel modulation meter, adjustable peak modulation indicator, and front-panel test receptacle when illuminated.</p> <p>R INDICATOR: Indicates right channel modulation information is presented on the right/L-R channel modulation meter, adjustable peak modulation indicator, and front-panel test receptacle when illuminated.</p>
17	RIGHT/L-R -/+ POLARITY Switch/Indicator	<p>SWITCH: Selects positive or negative peak right/L-R channel information to be displayed by the right/L-R channel modulation meter and adjustable peak modulation indicator.</p> <p>+ INDICATOR: Indicates positive peak information is displayed on the right/L-R channel modulation meter and adjustable peak modulation indicator.</p> <p>- INDICATOR: Indicates negative peak information is displayed on the right/L-R channel modulation meter and peak modulation indicator.</p>
18	MONITOR Level Control	Adjusts the headphone level.
19	MONITOR Receptacle	Headphone receptacle.
20	L/L+R INPUT Switch/Indicator	<p>SWITCH: Selects left channel or L+R channel information to be presented on the left/L+R channel modulation meter, adjustable peak modulation indicator, and front-panel test receptacle.</p>

TABLE 3-1. CONTROLS AND INDICATORS
(Sheet 5 of 6)

INDEX NO.	NOMENCLATURE	FUNCTION						
21	LEFT/L+R -/+ POLARITY Switch/ Indicator	<p>L+R INDICATOR: Indicates L+R modulation information is presented on the left/L+R channel modulation meter, adjustable peak modulation indicator, and front-panel test receptacle when illuminated.</p> <p>L INDICATOR: Indicates left channel modulation information is presented on the left/L+R channel modulation meter, adjustable peak modulation indicator, and front-panel test receptacle when illuminated.</p> <p>SWITCH: Selects positive or negative peak left/L+R channel information to be displayed by the left/L+R channel modulation meter and adjustable peak modulation indicator.</p> <p>+ INDICATOR: Indicates positive peak information is displayed on the left/L+R channel modulation meter and adjustable peak modulation indicator.</p> <p>- INDICATOR: Indicates negative peak information is displayed on the left/L+R channel modulation meter and adjustable peak modulation indicator.</p>						
22	LEFT/L+R Channel Modulation Meter	<p>Displays left channel or L+R channel modulation levels. The modulation parameters are displayed by semi-peak and average meter ballistics.</p> <table border="0" data-bbox="803 1438 1388 1732"> <thead> <tr> <th data-bbox="803 1438 982 1470"><u>METER RANGE</u></th> <th data-bbox="1120 1438 1388 1470"><u>METER BALLISTICS</u></th> </tr> </thead> <tbody> <tr> <td data-bbox="836 1491 1031 1564"> <div style="display: flex; align-items: center;"> <div style="border-left: 1px solid black; border-right: 1px solid black; padding: 0 5px;"> 0 dB -10 dB </div> <div style="margin-left: 5px;">}</div> </div> </td> <td data-bbox="1153 1512 1307 1543">Semi-Peak</td> </tr> <tr> <td data-bbox="836 1585 1031 1722"> <div style="display: flex; align-items: center;"> <div style="border-left: 1px solid black; border-right: 1px solid black; padding: 0 5px;"> -20 dB -30 dB -40 dB -50 dB </div> <div style="margin-left: 5px;">}</div> </div> </td> <td data-bbox="1153 1638 1274 1669">Average</td> </tr> </tbody> </table>	<u>METER RANGE</u>	<u>METER BALLISTICS</u>	<div style="display: flex; align-items: center;"> <div style="border-left: 1px solid black; border-right: 1px solid black; padding: 0 5px;"> 0 dB -10 dB </div> <div style="margin-left: 5px;">}</div> </div>	Semi-Peak	<div style="display: flex; align-items: center;"> <div style="border-left: 1px solid black; border-right: 1px solid black; padding: 0 5px;"> -20 dB -30 dB -40 dB -50 dB </div> <div style="margin-left: 5px;">}</div> </div>	Average
<u>METER RANGE</u>	<u>METER BALLISTICS</u>							
<div style="display: flex; align-items: center;"> <div style="border-left: 1px solid black; border-right: 1px solid black; padding: 0 5px;"> 0 dB -10 dB </div> <div style="margin-left: 5px;">}</div> </div>	Semi-Peak							
<div style="display: flex; align-items: center;"> <div style="border-left: 1px solid black; border-right: 1px solid black; padding: 0 5px;"> -20 dB -30 dB -40 dB -50 dB </div> <div style="margin-left: 5px;">}</div> </div>	Average							

TABLE 3-1. CONTROLS AND INDICATORS
(Sheet 6 of 6)

INDEX NO.	NOMENCLATURE	FUNCTION
23	LEFT/L+R Channel Adjustable Peak Modulation Indicator Control	Illuminates to indicate the left/L+R channel modulation as selected by the left/L+R adjustable peak modulation indicator control.
24	LEFT/L+R Channel Adjustable Peak Modulation Indicator Control	Selects the left/L+R channel modulation percentage displayed on the left/L+R channel adjustable peak modulation indicator.
25	LEFT/L+R Channel Test Receptacle	Decoded left/L+R channel audio samples for external test equipment.

NOTE

THE FOLLOWING PROCEDURE ASSUMES THAT THE MODULATION MONITOR IS COMPLETELY INSTALLED AND IS FREE OF ANY DISCREPANCIES.

NOTE

3-5. OPERATION.

3-6. The following text presents operating procedures for specific monitoring functions. Perform the appropriate procedure for the type of monitoring function desired.

3-7. PRELIMINARY OPERATION.

3-8. Apply primary power to the monitor by connecting the ac power cord to an acceptable power source. Check for an acceptable RF input level by ensuring: 1) the two NOM indicators on the front-panel LEVEL display are illuminated and 2) the rear-panel RF HIGH and RF LOW indicators are extinguished. If RF input level adjustment is required, refer to the INSTALLATION ADJUSTMENT procedures in SECTION II, INSTALLATION.

3-9. RF/PILOT LEVEL MONITORING.

3-10. The RF/PILOT level display normally operates in the RF LEVEL mode. Depress the RF/PILOT LEVEL switch/indicator to illuminate the PILOT indicator and observe the pilot level parameter on the RF/PILOT LEVEL display.

3-11. INPUT SELECTION.

3-12. Depress the L/L+R INPUT or the R/L-R INPUT switch/indicators to illuminate the desired parameter indicator. The parameter will be presented on the associated channel modulation meter, adjustable peak modulation indicator, and front-panel test receptacle.

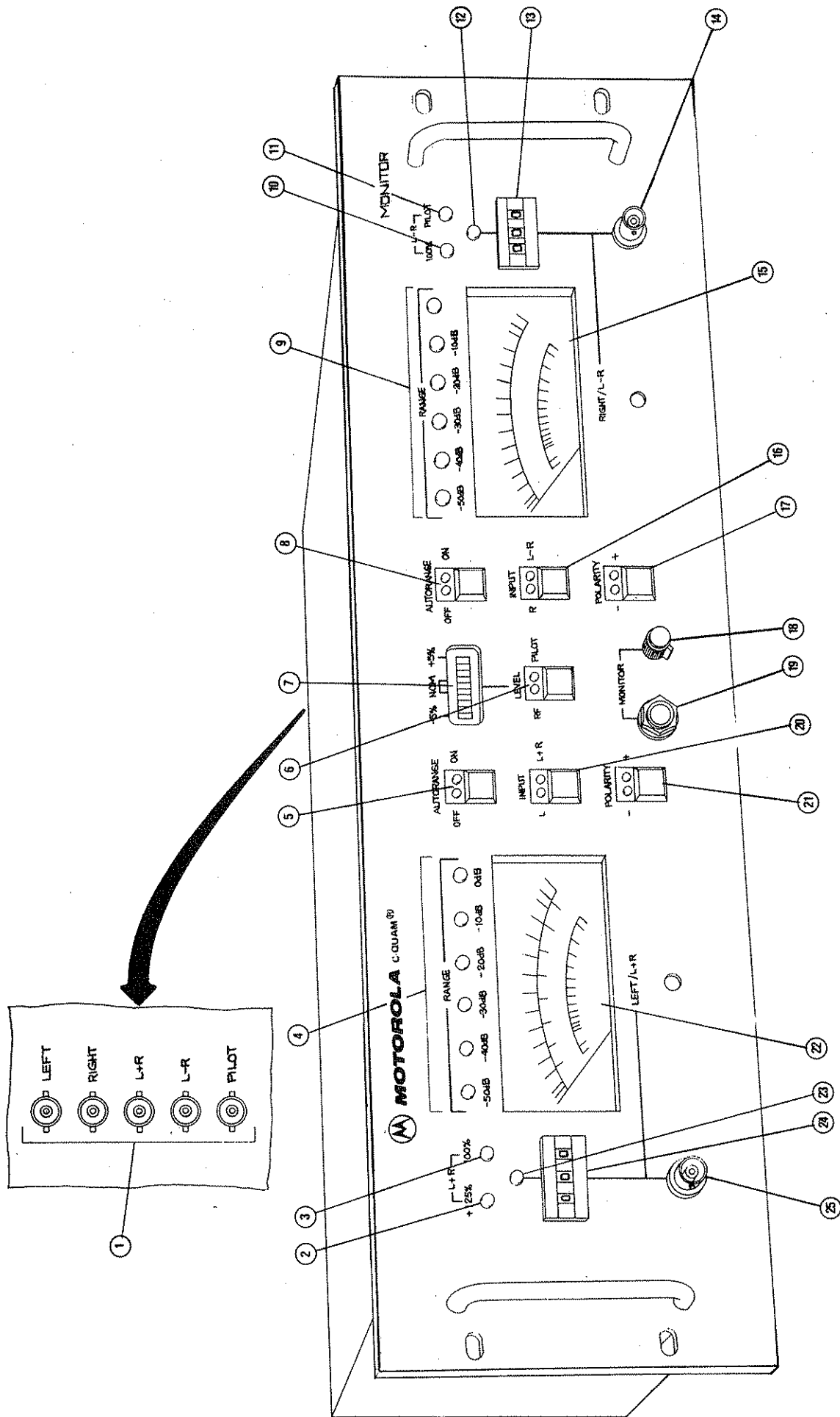

COPYRIGHT © MOTOROLA, INC. MARCH 1968
597-0105-6

FIGURE 3-1. MONITOR CONTROLS AND INDICATORS

3-13. ADJUSTABLE PEAK MODULATION INDICATOR OPERATION.

3-14. Operate the adjustable peak modulation indicator control to the desired modulation percentage. The adjustable peak modulation indicator will illuminate at the selected modulation parameter when applicable.

3-15. MODULATION METER OPERATION.

3-16. AUTORANGE OPERATION. Select autorange operation of the modulation meters by simultaneously depressing BOTH the LEFT/L+R channel and RIGHT/L-R channel AUTORANGE ON/OFF switch/indicators. The AUTORANGE ON indicators will illuminate to indicate autorange operation. The meter circuitry will automatically select the correct operating range and present the value on the RANGE display.

3-17. MANUAL OPERATION. To select the manual mode of operation, proceed as follows:

- A. Depress the desired channel AUTORANGE ON/OFF switch/indicator to illuminate the OFF indicator.
- B. To select the meter operating range, depress the channel AUTORANGE ON/OFF switch/indicator. The meter circuitry will increment -10 dB and present the value on the RANGE display. Continue depressing the AUTORANGE ON/OFF switch/indicator until the desired operating range is presented on the RANGE display.

3-18. POLARITY SELECTION.

3-19. Depress the LEFT/L+R channel POLARITY +/- or the RIGHT/L-R channel POLARITY +/- switch/indicators to illuminate the desired parameter indicator. The selected parameter will be presented on the associated channel adjustable peak modulation indicator and modulation meter.

3-20. AUDIO MONITORING.

CAUTION

DO NOT CONNECT MONOPHONIC HEADPHONES TO THE MONITOR RECEPTACLE.

3-21. The MONITOR headphone receptacle accepts a wide variety of stereophonic headphones. The MONITOR receptacle will not accept monophonic headphones without damage to the monitor circuitry. Ensure that only stereophonic headphones are connected to the headphone receptacle.

3-22. Insert a stereophonic headphone into the MONITOR receptacle to monitor program audio.

3-21. Operate the MONITOR level control to adjust the headphone level as required.

SECTION IV
THEORY OF OPERATION

4-1. INTRODUCTION.

4-2. This section presents the theory of operation for the Motorola Model 1410 AM stereo modulation monitor. A simplified schematic of the unit is presented in Figure 4-1. Refer to the simplified schematic as required for the following functional equipment description.

4-3. When applicable, the text will describe the operation of the left/L+R channel and the right/L-R channel audio circuits. The left/L+R and right/L-R channels contain identical circuitry, therefore only the left/L+R channel will be discussed.

4-4. FUNCTIONAL DESCRIPTION.

4-5. RF DEMODULATOR CIRCUIT BOARD.

4-6. RF INPUT CIRCUIT. C-QUAM AM stereo is applied to the monitor through a \emptyset to -30 dB RF attenuator which provides coarse level control of the input signal. Impedance matching transformer T1 provides unbalanced-to-balanced signal conversion and dc isolation. Integrated circuit U1 functions as the control device of an RF AGC circuit which acts to maintain a constant RF input level for precision decoding operations. Transistors Q1 and Q2 operate as a buffer stage and provide dc bias transformation.

4-7. The C-QUAM signal from the transistor buffer stage is applied to intermediate frequency (IF) down converter U3. Down conversion is accomplished by subtracting the RF input signal from a synthesizer frequency (carrier frequency + 450 kHz) to yield a 450 kHz C-QUAM signal. The output of the down converter is applied directly to a 4th order 450 kHz band-pass filter consisting of inductor-capacitors pairs L1-C27, L3-C47, L2-C28, and L4-C48.

4-8. The band-pass filter output is applied to unbalanced-to-balanced signal converter U2. The output of the signal converter is applied to a buffer stage consisting of transistors Q16, Q17, Q21, and Q22 for distribution to the decoding circuitry.

4-9. FREQUENCY SYNTHESIZER CIRCUIT. The frequency synthesizer is a phase-locked-loop circuit which generates and maintains the phase and frequency of a voltage-controlled-oscillator (VCO) to a high level of precision. The circuit is designed with the ability to synthesize: 1) 111 frequencies within the 530 kHz to 1620 kHz AM broadcast band in 10 kHz increments, or 2) 123 frequencies within the 522 kHz to 1620 kHz AM broadcast band in 9 kHz increments (with 9 kHz increment programming option 907-0104).

4-10. The synthesizer operates from binary coded carrier frequency information entered through programming switch S1. Programming switch S1 and resistor network R133 function together to generate a binary formatted frequency which is routed through tri-state data driver U9 to program frequency synthesizer U7. A secondary frequency programming circuit is included as a provision for a preselector.

4-11. Frequency synthesizer U7 operates from a 10.24 MHz oscillator reference (Y1) and the frequency programming information. Once programmed, U7 will output a series of rectangular-wave pulses to loop filter U13A and low-pass filter U13B. U13A and U13B function together to generate a stable dc control voltage for application to a voltage-controlled-oscillator (VCO) module. The control voltage is used by the VCO module to generate a precision frequency reference (4 [carrier frequency + 450 kHz]).

4-12. The output of the VCO module is applied through a transistor amplifier/buffer stage (Q6 and Q7) to divider U14. U14 is a divide-by-four counter which significantly improves the phase noise of the frequency synthesizer circuit. The output of U14 (carrier frequency + 450 kHz) is applied directly to the RF input circuit down converter (U3).

4-13. Precision alignment of the VCO output is maintained by the phase-locked-loop design. Feedback samples from the VCO are monitored by a phase comparator circuit within U7. If the VCO frequency shifts from the programmed operating state, the output of U7 will change to adjust the control voltage and maintain a stable VCO output.

4-14. AM Band Decoder Circuit. Integrated circuits U12, U8A, and transistor Q5 operate as a AM band decoder. The synthesizer requires maximum gain at the upper end of the AM band. The band decoder operates to determine the programming of the synthesizer and control the gain of the circuit via transistor Q8. At the upper end of the AM band, Q8 is biased off to allow maximum synthesizer loop gain. At the low end of the AM band, Q8 is biased on to divide the synthesizer loop gain and increase the stability.

4-15. AUTOMATIC-GAIN-CONTROL (AGC) CIRCUIT. The monitor is equipped with a single dual-speed automatic-gain-control circuit (AGC). The circuit acts to maintain a constant RF input level for precision decoding circuit operations.

4-16. The AGC circuit operates from an L+R feedback sample generated by the decoding circuit. The L+R audio sample is applied to first stage 10 Hz low-pass filter U4A. U4A is a second order low-pass filter which generates a stable dc voltage for application to AGC circuit integrator U4B. Integrator U4B evaluates the dc voltage from U4A and generates a corresponding dc control voltage. The control voltage is routed through AGC disable jumper J31 and driver Q3 to light-dependent-resistor LDR1. LDR1 is a continuously variable active device which acts to control the gain of AGC circuit amplifier U1. As the control voltage from U4B goes negative, the resistance of LDR1 will increase which decreases the gain of U1. As the control voltage goes positive, the resistance of LDR1 will decrease which increases the gain of the U1.

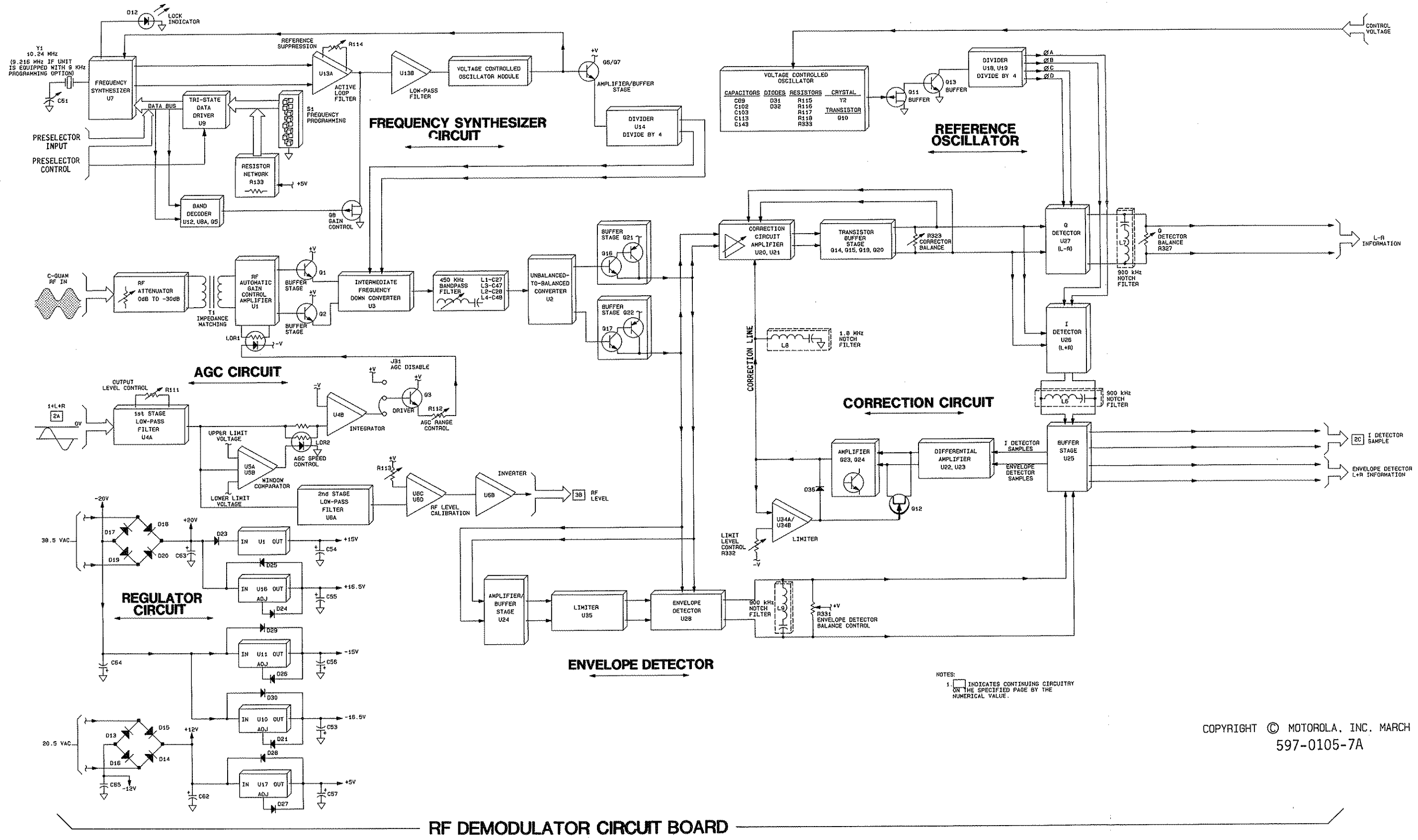

RF DEMODULATOR CIRCUIT BOARD

COPYRIGHT © MOTOROLA, INC. MARCH 1988
 597-0105-7A

FIGURE 4-1. MONITOR SIMPLIFIED SCHEMATIC (Sheet 1 of 3)

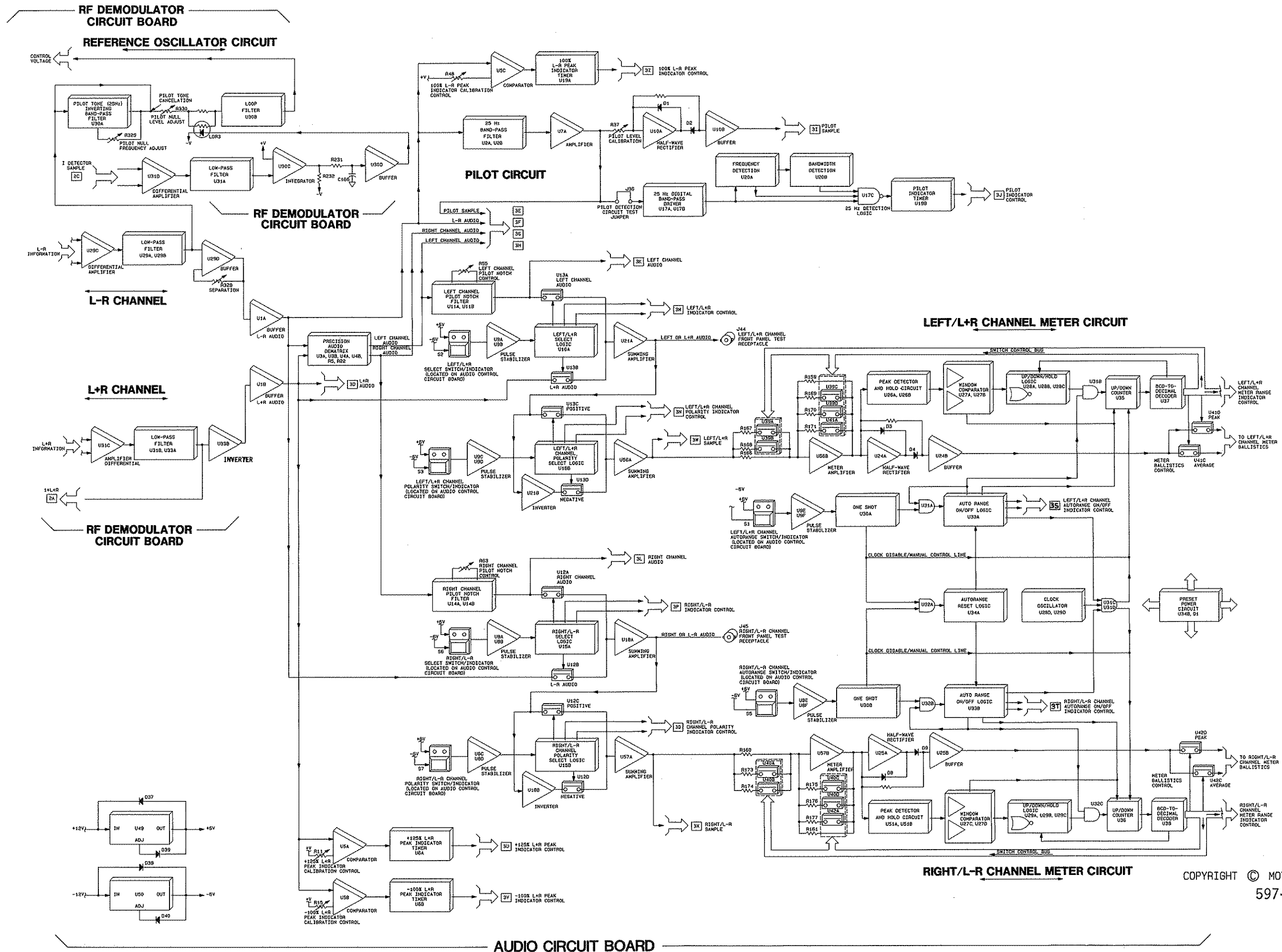

COPYRIGHT © MOTOROLA, INC. MARCH 1988
597-0105-7B

FIGURE 4-1. MONITOR SIMPLIFIED SCHEMATIC (Sheet 2 of 3)

4-5/4-6

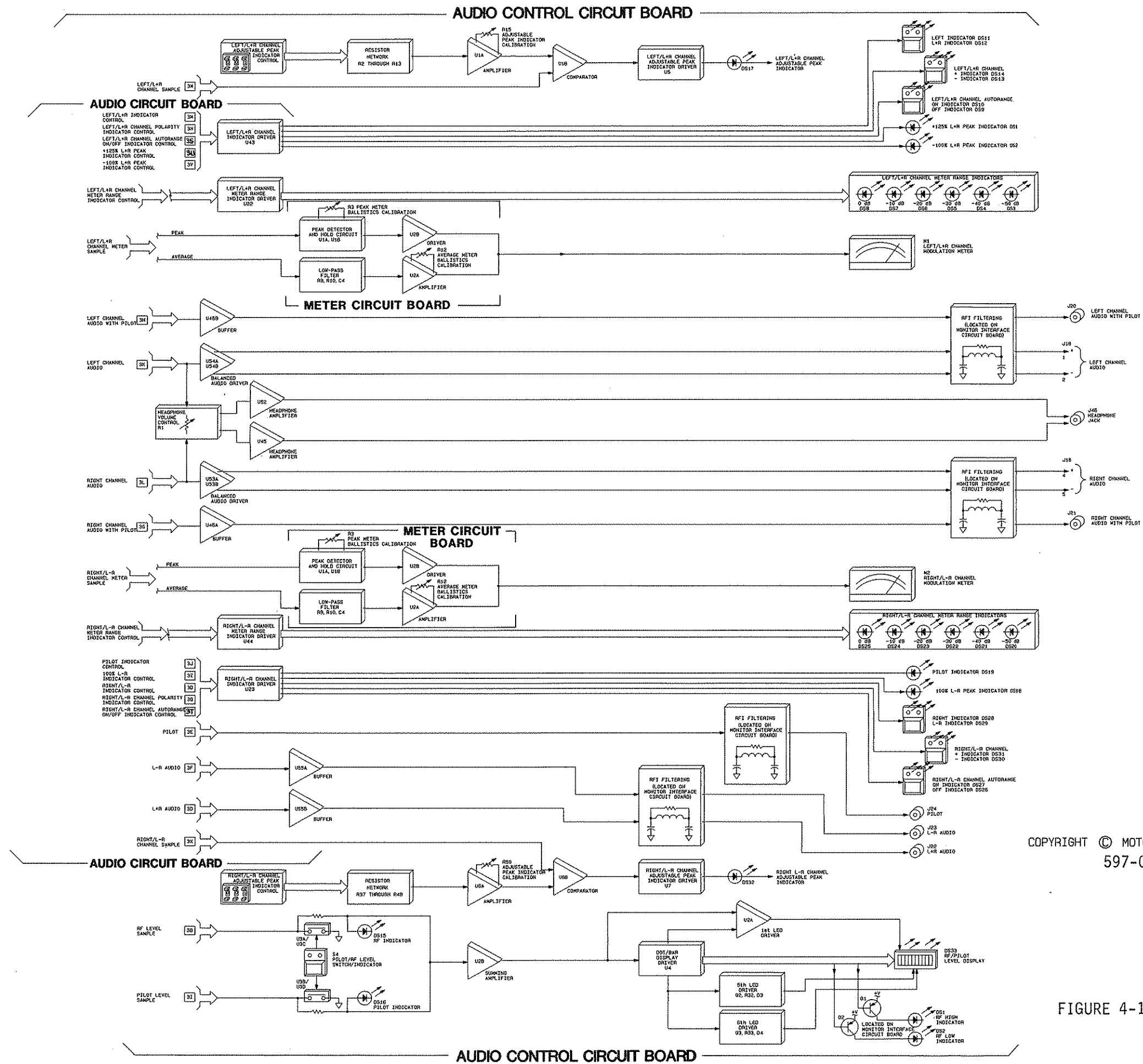

COPYRIGHT © MOTOROLA, INC. MARCH 1988
597-0105-7C

FIGURE 4-1. MONITOR SIMPLIFIED SCHEMATIC
(Sheet 3 of 3)

4-17. The AGC circuit contains two potentiometers. Potentiometer R111 determines the audio output level. Potentiometer R112 adjusts the AGC circuit range.

4-18. AGC Circuit Speed Control. The AGC is designed to operate at two speeds: 1) normal speed and 2) high speed. Operational amplifiers U5A and U5B function as a window comparator circuit which evaluates a voltage sample from low-pass filter U4A. The AGC circuit will operate at a normal rate when the voltage sample from U4A is within the window comparator threshold limits. When the voltage sample is above or below the window comparator limits, the comparator will output a HIGH to bias light-dependent-resistor LDR1 on which increases the AGC speed and the rate of RF level correction. As the RF level nears the optimum point, the output of the window comparator will go LOW to return the AGC circuit speed to normal.

4-19. RF LEVEL CIRCUIT. A voltage sample from U4A is also routed to the RF level circuit. The sample is applied to second stage 10 Hz low-pass filter U6A. U6A is a second order low-pass filter designed to further refine the signal from U4A. The output of U6A is applied to operational amplifiers U6C, U6D and potentiometer R113 which function as a RF level calibration circuit. The output of the calibration circuit is inverted by U6B for application to the RF/pilot level display.

4-20. DECODING CIRCUIT. The decoding circuitry consists of: 1) three individual detector circuits, 2) a correction circuit, and 3) a reference oscillator circuit. The circuits operate as part of a closed loop to accurately decode the C-QUAM signal into L+R and L-R audio.

4-21. Envelope Detector Circuit. 450 kHz C-QUAM from the transistor buffer stage (Q16, Q17, Q21, and Q22) is applied to a second amplifier/buffer stage (U24). The output of buffer stage U24 is applied to U35 which functions as an amplitude limiter. The limiter provides a carrier and phase reference for application to the envelope detector.

4-22. Integrated circuit U28 operates as an envelope detector to decode the L+R portion of the C-QUAM signal. The output of U28 is applied through a 900 kHz notch filter (L9) to buffer stage U25. Calibration of the envelope detector is provided by potentiometer R331.

4-23. Q Detector/I Detector Circuits. 450 kHz C-QUAM from the transistor buffer stage (Q16, Q17, Q21, and Q22) is also applied to integrated circuits U20 and U21 which operate as a correction circuit amplifier. The function of the amplifier is to introduce a correction signal which converts the applied C-QUAM into quadrature modulation (QUAM) for application to a conventional quadrature (Q) detector.

4-24. The output of the correction circuit amplifier is applied through a transistor buffer stage (Q14, Q15, Q19, and Q20) and balance control R323 to the Q and I detector circuits. Phase references for the detector circuitry is provided a phase-locked-loop oscillator circuit.

4-25. Integrated circuit U27 functions as a conventional quadrature (Q) detector. U27 compares a phase reference to the input signal to accurately decode the L-R information from the applied signal. The output of U27 is applied through 900 kHz notch filter L7 to the L-R audio circuit. Calibration of the Q detector is provided by potentiometer R327.

4-26. Integrated circuit U26 operates as the I (in-phase) detector. The function of U26 is to decode in-phase L+R information from the applied signal for application to the correction circuit. 900 kHz notch filter L6 is provided to attenuate the second harmonic in the output signal.

4-27. Correction Circuit. Due to the removal of a modulation component in the C-QUAM encoding system for envelope detector compatibility, the C-QUAM demodulating circuit requires the re-generation of the component for L-R decoding operations. The modulation component is generated by a correction circuit which processes envelope and I detector samples for application to a correction circuit amplifier. The amplifier converts the applied C-QUAM into normal quadrature modulation (QUAM) to allow the use of a conventional quadrature detector for L-R decoding.

4-28. Samples of the envelope and I detectors outputs from buffer stage U25 are applied to integrated circuits U22 and U23 which are configured as a differential amplifier. The circuit differentially amplifies the input signals to generate a correction signal. The differential output of the circuit is amplified by Q23 and Q24 and applied to correction circuit amplifier U20 and U21. U20 and U21 are configured as a variable gain amplifier which adds the correction signal to the applied C-QUAM.

4-29. Comparator U34A/U34B and transistor Q12 function as a correction circuit limiter. U34A/U34B compares the correction signal to a fixed voltage reference established by limit level control R332. If the correction signal increases above the reference, the comparator will bias diode D36 and transistor Q12 on to clamp the signal at a maximum level. This circuit is required to increase the stability of the decoding circuit by preventing the excessive application of correction signal. A 1.8 MHz notch filter (L8) is provided in the circuit to attenuate the correction signal fourth harmonic.

4-30. Reference Oscillator Circuit. An L-R sample is routed to a phase-locked-loop oscillator circuit which generates and maintains a phase reference for the Q and I detector circuits. The sample is applied to integrated circuit U30A which operates as a pilot tone inverting band-pass filter. The inverted output of U30A is summed with a non-inverted L-R sample to provide pilot tone cancellation. Potentiometer R329 provides pilot tone filter frequency adjustment. Potentiometer R330 is provided as a pilot tone null control.

4-31. The output of the pilot tone cancellation circuit is applied to oscillator loop filter U30B. U30B produces a stable dc control voltage for application to a voltage-controlled-oscillator (VCO). The control voltage is used by the VCO to generate a precision reference signal. The output of the VCO is applied through buffer stages Q11 and Q13 to divider U18/U19. U18 and U19 are configured as a divide-by-four counter which generates four phase references for application to the Q and I detector circuitry.

4-32. Reference Oscillator Loop Filter Control Circuit. The speed of the oscillator loop filter is determined by a control circuit. An I detector sample is routed to U31D which functions as a differential amplifier. The differential output of U31D is routed through second order low-pass filter U31A to integrator U30C which operates to control the speed of the loop filter. Resistors R231, R232, and capacitor C166 operate as a control voltage processing circuit. Buffer U30D provides isolation between the processing circuit and active control device LDR3.

4-33. When a sample from low-pass filter U31A increases above the threshold limit of integrator U30C, the integrator will output a voltage to the RC processing circuit. The circuit will respond by generating a control voltage to gradually bias LDR3 on and increase the loop filter speed. As the decoding loop stabilizes, the sample from U31A will decrease below the threshold limit of U30C. The output of integrator U30C will go LOW. Capacitor C166 in the RC processing circuit will discharge to gradually bias LDR3 off and return the loop filter speed to normal.

4-34. L-R AUDIO CIRCUIT. L-R audio from Q detector U27 is applied to differential amplifier U29C. The differential output of U29C is applied to fourth order low-pass filter U29A/U29B. The output of the filter is applied through separation control circuit U29D and R328 to the audio circuit board input circuit.

4-35. L+R AUDIO CIRCUIT. L+R audio from buffer stage U25 is applied to differential amplifier U31C. The differential output of U31C is applied to U31B and U33A which are configured as a fourth order low-pass filter. The output of the filter is inverted by U33B and routed to the audio circuit board input circuit.

4-36. POWER SUPPLY CIRCUIT. The power supply circuit consists of a dual rectifier network which generates a variety of dc voltage potentials. A 38.5V ac potential from power supply transformer T1 is full-wave rectified by diodes D17 through D20 and filtered by capacitors C63 and C64 to produce unregulated $\pm 20V$ dc potentials. The $\pm 20V$ potentials are routed to regulators U1, U10, U11, and U16 to produce $\pm 15V$ and $\pm 16.5V$ dc supplies.

4-37. A 20.5V ac potential is full-wave rectified by diodes D13 through D16 and filtered by capacitors C62 and C65 to produce unregulated $\pm 12V$ potentials. A sample of the +12V potential is regulated by U17 into a +5V dc supply.

4-38. All power supply circuit regulators are operated as fixed voltage devices and contain internal thermal and short-circuit current limiting features. The regulators are further protected from reverse polarity potentials applied to the inputs and outputs by diode networks.

4-39. AUDIO CIRCUIT BOARD.

4-40. AUDIO INPUT CIRCUIT. L-R and L+R audio from the demodulator circuit board is routed to input buffers U1A and U1B. The outputs from U1A and U1B are distributed to: 1) the audio dematrix circuit, 2) the pilot detection circuit, and 3) the L-R/L+R indicator circuit.

4-41. AUDIO DEMATRIX CIRCUIT. L-R and L+R audio is routed to integrated circuits U3A/U3B and U4A/U4B which are configured as a precision audio dematrix circuit. The dematrix circuit decodes the L-R and L+R audio into separate left and right channel information for application to several audio circuits.

4-42. PILOT DETECTION CIRCUIT. L-R audio is routed to U2A/U2B which is configured as a 25 Hz band-pass filter. The output of the band-pass filter is applied through amplifier stage U7A to the pilot indicator and level circuits.

4-43. Pilot Indicator Circuit. A pilot sample from U7A is applied through pilot circuit test jumper J36 to a digital pilot detection circuit. Integrated circuits U17A/U17B are configured as a 25 Hz digital signal converter. U17A/U17B convert the analog pilot information into a digital format. Integrated circuit U20A operates as a digital frequency detector and U20B functions as a digital bandwidth detector.

4-44. The circuit functions by processing the pilot information through the signal converter, frequency detector, and bandwidth detector. As 25 Hz pilot information is detected by U20A and U20B, control logic U17C will go LOW. The LOW from U17C will generate a HIGH from indicator timer U19B to indicate the detection of pilot tone information.

4-45. Pilot Level Circuit. A pilot sample from U7A is also routed to a pilot level circuit. The sample is applied to integrated circuit U10A and diodes D1 and D2 which operate as a half-wave rectifier. The rectified output from U10A is applied through buffer U10B to the RF/pilot level display circuitry. Potentiometer R37 provides pilot level calibration.

4-46. L-R/L+R INDICATOR CIRCUITRY. L-R audio is applied to 100% L-R indicator comparator U5C. When the L-R level increases above the reference established by 100% L-R peak indicator calibration control R48, the output of U5C will go HIGH. The HIGH from U5C will generate a HIGH from 100% L-R peak indicator timer U19A which is applied to the right/L-R channel indicator driver array.

4-47 L+R audio is applied to +125% L+R indicator comparator U5A. When the positive L+R level increases above the reference established by +125% L+R peak indicator calibration control R11, the output of U5A will go HIGH. The HIGH from U5A will generate a HIGH from +125% L+R peak indicator timer U6A which is applied to the left/L+R channel indicator driver array.

4-48 L+R audio is also applied to -100% L+R indicator comparator U5B. When the negative L+R level increases above the reference established by -100% L+R peak indicator calibration control R15, the output of U5B will go HIGH. The HIGH from U5B will generate a HIGH from -100% L+R peak indicator timer U6B which is applied to the left/L+R channel indicator driver array.

4-49. LEFT/L+R CHANNEL METER INPUT CIRCUIT. Left channel information from the audio dematrix circuit is routed to integrated circuits U11A/U11B which are configured as a left channel pilot notch filter. The output of the filter is applied to the left/L+R select circuit.

4-50. Left/L+R Select Circuit. Left or L+R parameter selection is accomplished by a front-panel toggle switch and control logic circuit. Left channel information from the pilot notch filter is applied to switch U13A. L+R audio information from buffer U1B is applied to switch U13B.

4-51. Input commands from left/L+R select switch/indicator S2 are routed through pulse stabilizer U9A/U9B to left/L+R select logic U16A. The commands direct flip-flop U16A to select either left channel or L+R channel audio via switches U13A and U13B. The selected audio from the switch matrix is routed through summing amplifier U21A to the front panel test receptacle and the left/L+R channel polarity select circuit. An indication of the parameter selection is initiated by select logic U16A which routes a control pulse to the left/L+R channel LED driver array for application to the input indicators.

4-52. Left/L+R Polarity Select Circuit. Left or L+R polarity selection is also accomplished by a toggle switch and control logic circuit. Left or L+R information from buffer U21A is applied to switch U13C. A sample of left or L+R information is also routed through inverter U21B to switch U13D.

4-53. Input commands from left/L+R channel polarity switch/indicator S3 are routed through pulse stabilizer U9C/U9D to left/L+R channel polarity select logic U16B. The commands direct flip-flop U16B to select either positive or negative audio via switches U13C and U13D. The selected audio from the switch matrix is routed through summing amplifier U56A for application to the meter amplifier circuit. An indication of the parameter selection is initiated by select logic U16B which routes a control pulse to the left/L+R channel LED driver array for application to the polarity indicators.

4-54. LEFT/L+R CHANNEL METER AMPLIFIER CIRCUIT. Audio from the meter input circuit is applied to meter amplifier U56B. U56B is configured as a multi-range amplifier designed to provide the appropriate gain required for the applied input signal. The gain of the amplifier is determined by a CMOS switch and resistor network. Control of the network is provided by an automatic/manual meter range circuit.

4-55. Once the gain of meter amplifier U56B is established, the output signal is applied to a half-wave rectifier circuit consisting of integrated circuit U24A and diodes D1 and D2. The output of the rectifier is applied through buffer U24B to meter ballistics control switches U41C and U41D.

4-56. Meter Range Circuit. Control of the meter amplifier is provided by the meter range circuit. The circuit utilizes comparators and up/down counter technology to change the range of the meter circuit.

4-57. A sample from the meter amplifier output is applied to U26A and U26B which are configured as a peak detector and hold circuit. The circuit detects and holds peak energy for range circuit evaluation. The output of the peak detector circuit is applied to window comparator U27A/U27B. The window comparator evaluates the applied input signal and determines if the signal is within the normal full-scale range of the modulation meter.

4-58. The output of the window comparator is routed to NOR gates U28A, U28B, and U28C which function as up/down/hold logic. The output of the up/down/hold logic controls the actions of up/down counter U35. U35 is binary up/down counter which determines the range of the meter amplifier. The binary output of U35 is routed directly to BCD-to-decimal decoder U37. U37 decodes the binary output of U35 and routes control signals to: 1) the meter amplifier gain control network and 2) meter ballistics control switches U41C/U41D.

4-59. Meter Gain Control Network. Resistors R159, R166 through R171 and CMOS switches U39A through U39D and U41A are configured as a meter gain control circuit. Control signals from BCD-to-decimal decoder U37 direct the operations of switches U39A through U39D and U41 to establish the appropriate gain of the meter amplifier for the applied input signal.

4-60. Meter Ballistics Control. CMOS switches U41C and U41D control the application of the rectified audio signal to the meter circuitry. Control signals from BCD-to-decimal decoder U37 close switch U41D for application to the peak meter ballistics or U41C for application to the average meter ballistics.

4-61. LEFT/L+R CHANNEL METER MODE CONTROL CIRCUIT. The left/L+R channel modulation meter is designed for two modes of operation: 1) manual and 2) autorange. Autorange/manual meter operation is accomplished by control switch commands and a digital logic circuit. The logic determines if the meter range circuitry is operated in the autorange or manual mode.

4-62. Manual Operation. Manual meter operation is initiated when left/L+R channel autorange switch/indicator S1 is operated to the off position. The command is applied through pulse stabilizer U9E/U9F to one-shot generator U30A. U30A generates control signals for application to AND gate U31A and the autorange reset logic.

4-63. With the control input from U30A, AND gate U31A will generate a pulse to autorange on/off logic U33A. U33A generates a control pulse which produces a LOW from AND gate U31B to enable up/down counter U35. U33A also generates two additional control pulses which: 1) instructs U35 to count in the up direction and 2) disables the clock oscillator. The result of this action operates the control logic and meter range circuitry to the manual mode.

4-64. Manual meter range selection is accomplished by continued operation of autorange switch/indicator S1. Feedback from autorange on/off logic U33A to AND gate U31A prevents the autorange on/off logic from operating to the automatic mode. When a meter range command is initiated, U30A will route a clock pulse through the clock disable/manual control line which instructs up/down counter U35 to count up one increment. U37 decodes the command from U35 and lowers the meter range one increment.

4-65. Autorange Operation. Automatic operation of the meter circuitry is initiated at the application of primary power or by operation of both the left/L+R and right/L-R channel autorange on/off switch/indicators. When autorange on/off switch/indicators S1 and S5 are simultaneously depressed, command signals are processed through pulse stabilizers U9E/U9F (left/L+R channel) and U8E/U8F (right/L-R channel) to one-shot generators U30A (left/L+R channel) and U30B (right/L-R channel). U30A and U30B will simultaneously generate HIGH outputs to AND gate U32A. The output of U32A will go HIGH to activate autorange reset logic U34A. U34A applies reset pulses to autorange on/off logic U33A and U33B to operate the logic to the autorange mode. With the logic in the autorange mode, control pulses from U33A and U33B will be routed to AND gates U31C/D to enable the clock circuit.

4-66. To operate the left/L-R channel meter range circuitry for autorange operation, U33A will apply a control pulse to AND gate U31B which allows the up/down/hold logic to control counter U35. The operation of U33A to the autorange state also allows the window comparator to establish the count direction of U35 which controls the direction of the meter range.

4-67. PRESET POWER CIRCUIT. Integrated circuit U34B and transistor Q1 operate as a preset power circuit. Whenever power is applied to the monitor, the preset power circuit will act to initialize the logic circuitry to a preset format.

4-68. HEADPHONE CIRCUIT. The modulation monitor is equipped with a stereo headphone circuit for audio monitoring. Left and right channel audio is applied to potentiometer R1 which provides headphone level control. Audio from R1 is routed through left channel headphone amplifier U52 and right channel headphone amplifier U45 to the headphone receptacle.

4-69. REGULATOR CIRCUIT. $\pm 12V$ dc potentials from the demodulator circuit board are regulated into $\pm 6V$ dc supplies by U49 and U50. Regulators U49 and U50 contain internal thermal and short-circuit current limiting features. The regulators are further protected from reverse polarity potentials applied to the inputs and outputs by diode networks.

4-70. METER CIRCUIT BOARD.

4-71. The meter circuit board contains two types of meter ballistic circuits: peak and average. The peak meter ballistic circuitry consists of a peak detector and driver stage. Integrated circuits U1A and U1B function as a peak detector and hold circuit. U2B functions as a driver. The circuit generates peak audio information for application to the modulation meter.

4-72. The average meter ballistic circuit consists of a low-pass filter and amplifier stage. Resistors R9, R10, and capacitor C4 function as a passive low-pass filter. Integrated circuit U2A operates as a gain stage. The circuit generates average audio information for application to the modulation meter.

4-73. AUDIO CONTROL CIRCUIT BOARD.

4-74. The audio control circuit board contains all the metering control switches and indicators. The control circuitry consists of the following individual circuits.

- A. L+R indicator circuitry.
- B. Left/L+R channel meter control and indicator circuit.
- C. Left/L+R channel adjustable peak indicator circuit.
- D. RF/Pilot level indicator circuit.

4-75. L+R INDICATOR CIRCUITRY. L+R maximum modulation parameters are displayed on two status indicators. +125% L+R indicator DS1 and -100% L+R indicator DS2 illuminate to indicate the status of the L+R information. The indicators are controlled by L+R indicator circuit signals which are processed through left/L+R channel indicator driver U43 to provide isolation.

4-76. LEFT/L+R CHANNEL METER CONTROL AND INDICATOR CIRCUITRY. Display of left/L+R channel meter operating parameters such as input conditions, autorange status, and range status are presented by a network of indicators. Control of the meter operating parameters is accomplished by toggle switches which utilize $\pm 6V$ switching logic. Indicator control signals are processed through meter range indicator driver U22 and left/L+R channel indicator driver U43 to provide isolation. The following list presents a description and reference designator of each left/L+R channel operational switch and indicator.

<u>REFERENCE DESIGNATOR</u>	<u>DESCRIPTION</u>
DS3 through DS8	Meter RANGE Indicators.
DS9	LEFT/L+R Channel AUTORANGE OFF Indicator
DS10	LEFT/L+R Channel AUTORANGE ON Indicator
DS11	LEFT Input Indicator
DS12	L+R Input Indicator
DS13	LEFT/L+R Channel - Indicator
DS14	LEFT/L+R Channel + Indicator
S1	LEFT/L+R Channel AUTORANGE ON/OFF Switch/Indicator
S2	LEFT/L+R Input Select Switch/Indicator
S3	LEFT/L+R Channel Polarity Switch/Indicator

4-77. LEFT/L+R CHANNEL ADJUSTABLE PEAK INDICATOR CIRCUIT. The left/L+R channel adjustable peak indicator circuit provides peak modulation monitoring of channel information from 0 to 133%. Selection of the modulation percentage is accomplished by an adjustable selector switch and a formatted resistor network (R2 through R13). When a modulation value is selected, the adjustable switch will route a dc voltage through the resistor network to produce a representative control voltage. The control voltage is applied through calibration circuit U1A and potentiometer R15 to comparator U1B. U1B compares the control voltage to a left/L+R channel peak audio sample. When the audio sample is above the reference voltage, U1B will output a HIGH to adjustable peak indicator driver/timer U5. The output of U5 will go HIGH to illuminate adjustable peak indicator DS17.

4-78. RF/PILOT LEVEL INDICATOR CIRCUIT. RF and pilot level parameters are presented on a moving bar LED display. Selection of the desired parameter is determined a control and driver circuit.

4-79. RF and pilot level samples are routed to a control circuit consisting of RF/pilot level select switch/indicator S4 and CMOS switches U3A through U3D. The desired parameter is selected by switch S4 which opens the appropriate CMOS shorting switch. The output of the control circuit is applied to summing amplifier U2B. The output of U2B is routed directly to integrated circuit U4.

4-80. U4 is a bar/dot display driver which controls the operation of RF/pilot level display DS33. DS33 is a ten-segment LED display operated in a moving bar format. Due to the dual-function design of the RF/pilot level circuit, special control of the first, fifth, and sixth segments of the display is required. Control signals from display driver U4 are routed to the following special control circuits: 1) first segment driver circuit consisting of comparator U2A, 2) fifth segment driver circuit consisting of transistor Q2, resistor R32, and diode D3, and 3) sixth segment driver circuit consisting of transistor Q3, resistor R33, and diode D4.

4-81. Display driver U4 also controls the operation of the rear-panel RF high and low indicators DS1 and DS2. Control signals from U4 are applied to driver Q1 and Q2 to illuminate or extinguish the indicators as required in response to the applied RF sample.

4-82. INTERFACE CIRCUIT BOARD.

4-83. The interface circuit board contains all the circuitry required for external communication. All remote control commands and remote indications are processed through optical couplers to provide a high degree of isolation. All test signal outputs are protected from RFI by PI-section LC low-pass filters. The circuit board also contains the RF high/low indicators and the associated driver components.

SECTION V
MAINTENANCE

5-1. INTRODUCTION.

5-2. This section provides general maintenance information, electrical adjustment procedures, and troubleshooting information for the Motorola Model 1410 AM stereo modulation monitor.

5-3. SAFETY CONSIDERATIONS.

5-4. Low voltages are used throughout the monitor circuit boards, however maintenance with power energized is always considered hazardous and caution should be observed. All high voltages have been shielded, however do not touch any component within the monitor chassis with power energized. Good judgement, care, and common sense must be practiced to prevent accidents. The procedures contained in this section should be performed only by experienced and trained maintenance personnel.

5-5. FIRST LEVEL MAINTENANCE.

5-6. First level maintenance consists of precautionary procedures applied to the equipment to prevent future failures. The procedures are performed on a regular basis and the results recorded in a performance log.

WARNING

DISCONNECT ALL MONITOR PRIMARY POWER BEFORE
ATTEMPTING ANY EQUIPMENT MAINTENANCE.

5-7. The monitor should be cleaned of accumulated dust as required using a brush and vacuum cleaner. Check the circuit boards for improperly seated semiconductors and components damaged by overheating. Also, periodically check the circuit boards and chassis for loose hardware.

5-8. SECOND LEVEL MAINTENANCE.

5-9. Second level maintenance consists of procedures required to restore the modulation monitor to operation after a fault has occurred. The following procedures are divided into electrical adjustments and troubleshooting.

5-10. The maintenance philosophy of the monitor consists of isolating a problem to a specific assembly with subsequent troubleshooting as required to isolate the defective components. The defective components may be repaired locally or the entire device may be returned to Motorola for repair or replacement.

5-11. ELECTRICAL ADJUSTMENTS.

5-12. The following text provides adjustment procedures for all controls associated with the Model 1410 modulation monitor. The procedures are presented as follows:

- A. Test Equipment Preparation.
- B. RF Demodulator Circuit Board Adjustments.
- C. Meter Circuit Board Adjustments.
- D. Audio Circuit Board Adjustments.
- E. Monitor Control Circuit Board Adjustments.
- F. Operating Frequency Reprogramming.

5-13. TEST EQUIPMENT PREPARATION.

5-14. The electrical adjustment procedures will require the use of a high quality signal source. It is strongly recommended that the procedures be performed with a C-QUAM signal generator such as the Delta Electronics Model CQS-3. As an alternative, the procedures may be performed using an AM stereo exciter as the signal source. However, performance inaccuracies may be introduced into the monitor due to the operating condition of the exciter.

5-15. SIGNAL SOURCE - AM STEREO EXCITER. If an exciter is used as the signal source, ensure the exciter is in peak operating condition. Do not adjust the exciter to obtain peak monitor performance.

5-16. The exciter sample transmitter circuitry generates the signal required for the monitor alignment procedures. Connect an appropriate test cable to the exciter sample transmitter output receptacle as required for the adjustment procedures.

5-17. SIGNAL SOURCE - C-QUAM SIGNAL GENERATOR. If a C-QUAM signal generator is used as the signal source, the monitor voltage-controlled-oscillator (VCO) module must be disabled. To disable the VCO module, refer to Figure 5-1 and proceed as follows:

- A. Disconnect the monitor primary power.
- B. Disconnect ribbon cable connector J1 on the audio circuit board.
- C. Remove the five Phillips-head screws securing the audio circuit board to the RF demodulator circuit board and place the audio circuit board in the vertical position.
- D. Remove VCO disable jumper J48 on the RF demodulator circuit board.

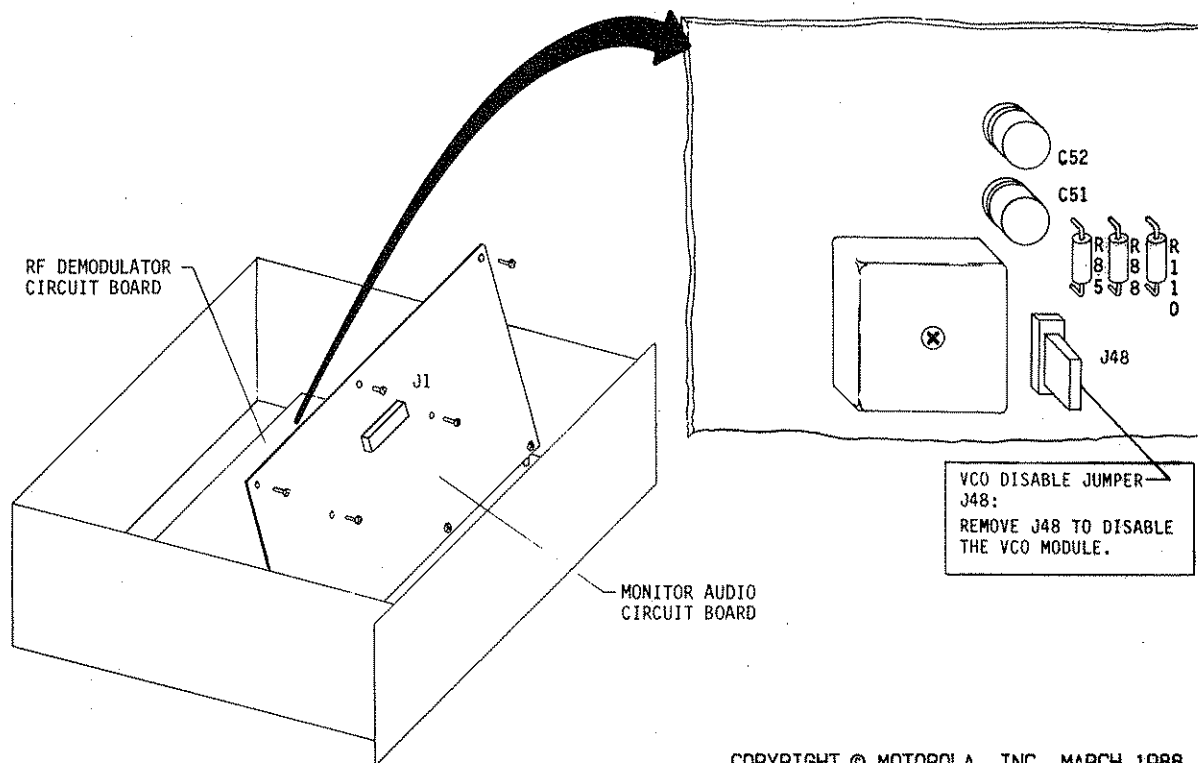

FIGURE 5-1. RF DEMODULATOR CIRCUIT BOARD ACCESS

5-18. RF DEMODULATOR CIRCUIT BOARD ADJUSTMENTS.

5-19. 450 kHz BAND-PASS FILTER ALIGNMENT. 450 kHz band-pass controls L1 through L4 adjust the filter corner frequencies. Alignment of the filter will not be required unless replacement components are installed in the filter circuit. To align the 450 kHz band-pass filter, proceed as follows.

5-20. Required Equipment. The following equipment is required to align the 450 kHz band-pass filter.

- A. Flat-Tip Screwdriver, 4 inch (10.2 cm) blade, 1/4 inch (0.6 cm) tip.
- B. Non-Metallic Adjustment Tool.
- C. Number 2 Phillips Screwdriver, 4 inch (10.2 cm) blade.
- D. Tracking Generator (Tektronics Module 25 for 7613 Oscilloscope Main-Frame or equivalent).

E. Spectrum Analyzer (Tektronics 7613 Oscilloscope Main-Frame and 7L5 Spectrum Analyzer with Module L3 or equivalent).

5-21. Procedure. To align the 450 kHz band-pass filter, proceed as follows:

5-22. Disconnect the monitor primary power and remove the top-panel.

5-23. Refer to Figure 5-1 and place the audio circuit board in the vertical position.

5-24. Record the monitor RF ATTENUATOR level _____ dB. Adjust the attenuator to 0 dB.

5-25. Refer to Figure 5-2 and install AGC circuit enable jumper J31 in position 1-2.

5-26. Connect the tracking generator to the monitor rear-panel RF IN receptacle. Adjust the tracking generator for a -13 dBv output at 50 Ohms.

5-27. Refer to Figure 5-2 and connect the spectrum analyzer test probe to TP-18. Connect the test probe ground to TP-23 (refer to Figure 5-2). Adjust the spectrum analyzer as follows:

- | | |
|----------------------|--------------------------------|
| A. Input: 1 Meg Ohm. | C. Center Frequency: 450 kHz |
| B. Level: -23dB | D. Frequency Span: 200 kHz/div |
| | E. Vertical Scale: 10 dB/div |

5-28. Apply power to the monitor.

5-29. Refer to Figure 5-2 and adjust 450 kHz band-pass filter controls L1 through L4 for a peak and symmetrical pass band as shown in Figure 5-3A.

5-30. Adjust the spectrum analyzer as follows:

- | |
|-------------------------------|
| A. Frequency Span: 10 kHz/div |
| B. Vertical Scale: Linear |

5-31. Adjust filter controls L1 through L4 for a spectrum analyzer presentation as shown in Figure 5-3B.

5-32. Disconnect the monitor primary power.

5-33. Remove all test equipment, re-adjust the RF ATTENUATOR, install AGC enable jumper J31 in position 2-3, replace the audio circuit board, and return the unit to service.

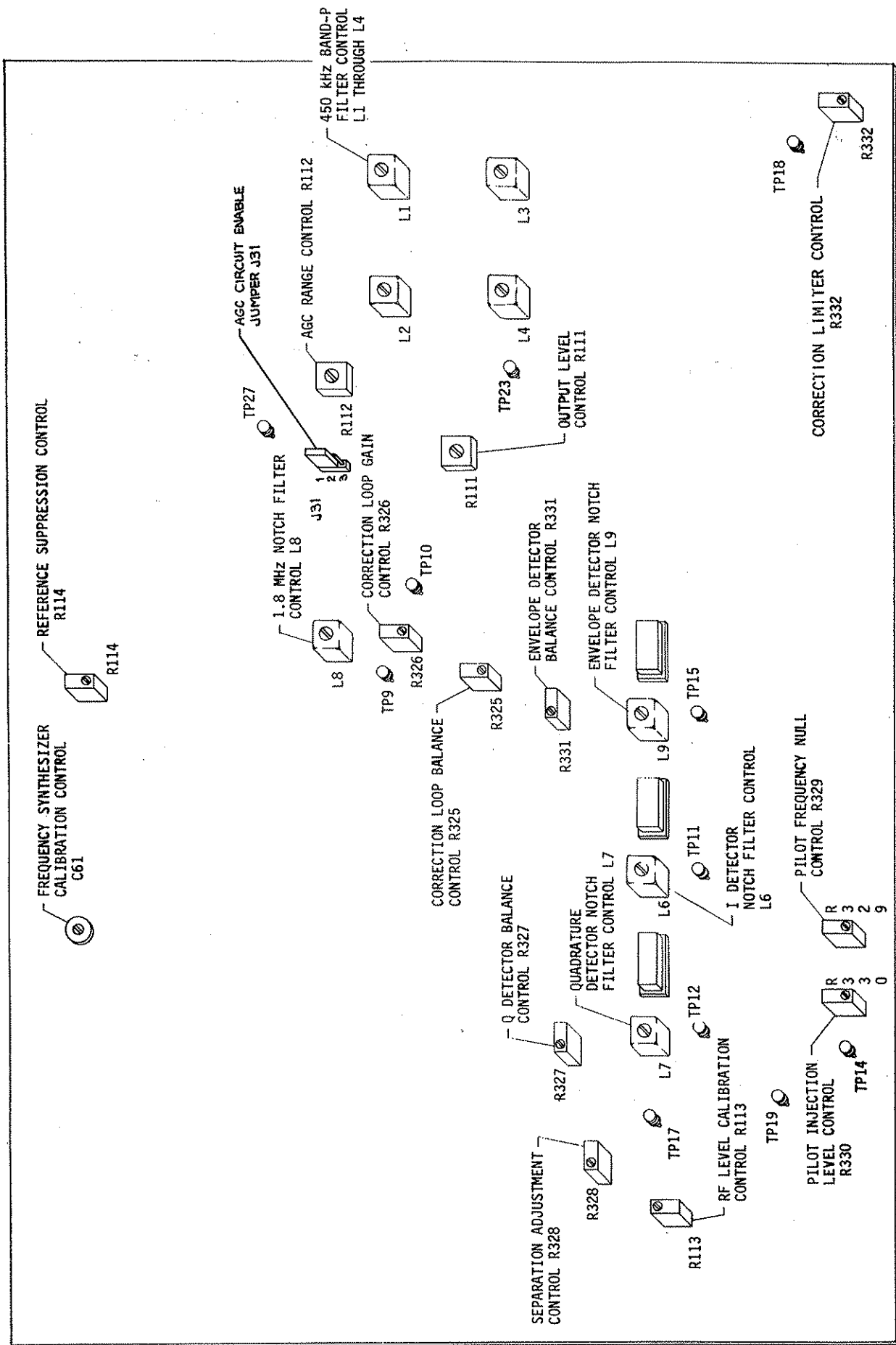

597-0105-21

COPYRIGHT © MOTOROLA, INC. MARCH 1988

FIGURE 5-2. RF DEMODULATOR CIRCUIT BOARD ADJUSTMENT CONTROLS

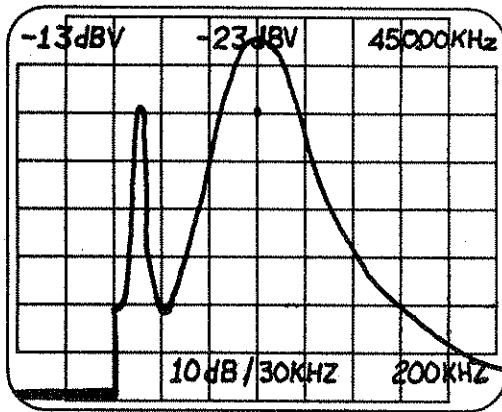

FIGURE 5-3A

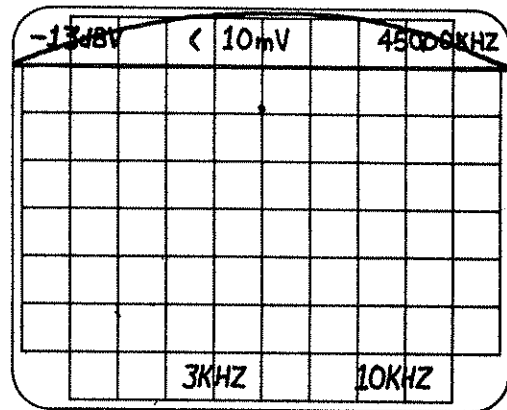

FIGURE 5-3B

COPYRIGHT © MOTOROLA, INC. MARCH 1988
597-0105-22

FIGURE 5-3. 450 kHz BAND-PASS FILTER ALIGNMENT

5-34. 900 kHz NOTCH FILTER ADJUSTMENTS. Individual notch filters attenuate the 900 kHz component of three detection circuit outputs (refer to the information below for control descriptions). Adjustment of the filters will not be required unless replacement components are installed in the notch filter circuits or the complete RF demodulator circuit board is replaced. To align the 900 kHz notch filters, proceed as follows.

<u>NOTCH FILTER CONTROL</u>	<u>FUNCTION</u>
L6	I Detector Notch Filter Control
L7	Quadrature Detector Notch Filter Control
L9	Envelope Detector Notch Filter Control

5-35. Required Equipment. The following equipment is required to adjust the 900 kHz notch filters.

- A. Flat-Tip Screwdriver, 4 inch (10.2 cm) blade, 1/4 inch (0.6 cm) tip.
- B. Non-Metallic Adjustment Tool.
- C. Number 2 Phillips Screwdriver, 4 inch (10.2 cm) blade.

D. Calibrated Signal Source (refer to TEST EQUIPMENT PREPARATION in the preceding text for signal source application information).

Recommended: Delta Electronics Model CQS-3 C-QUAM Synthesizer or equivalent.

Alternate: AM Stereo Exciter.

E. Spectrum Analyzer (Tektronics 7613 Oscilloscope Main-Frame and 7L5 Spectrum Analyzer with Module L3 or equivalent).

5-36. Procedure. To adjust the 900 kHz notch filters, proceed as follows:

5-37. Disconnect the monitor primary power and remove the top-panel.

5-38. Refer to Figure 5-1 and place the audio circuit board in the vertical position.

5-39. Record the monitor RF ATTENUATOR level _____ dB. Adjust the attenuator to 0 dB.

5-40. Connect the signal source to the monitor rear-panel RF IN receptacle.

5-41. Refer to Figure 5-2 and connect the spectrum analyzer to TP-15 on the RF demodulator circuit board. Adjust the spectrum analyzer for a 900 kHz indication.

5-42. Apply power to the monitor.

5-43. Operate the signal source without modulation.

5-44. Refer to Figure 5-2 and adjust envelope detector notch filter control L9 for a minimum 900 kHz indication on the spectrum analyzer.

5-45. Refer to Figure 5-2 and connect the spectrum analyzer to TP-11 on the RF demodulator circuit board.

5-46. Refer to Figure 5-2 and adjust I detector notch filter control L6 for a minimum 900 kHz indication on the spectrum analyzer.

5-47. Refer to Figure 5-2 and connect the spectrum analyzer to TP-12 on the RF demodulator circuit board.

5-48. Refer to Figure 5-2 and adjust quadrature detector notch filter control L7 for a minimum 900 kHz indication on the spectrum analyzer.

5-49. Disconnect the monitor primary power.

- 5-50. Remove all test equipment, re-adjust the RF ATTENUATOR, replace the audio circuit board, and return the unit to service.
- 5-51. 1.8 MHz NOTCH FILTER ADJUSTMENT. Notch filter control L8 attenuates the 1.8 MHz component in the correction loop. Adjustment of the filter will not be required unless replacement components are installed in the filter circuit or the complete RF demodulator circuit board is replaced. To align the 1.8 MHz notch filter, proceed as follows.
- 5-52. Required Equipment. The following equipment is required to adjust the 1.8 MHz notch filter.
- A. Flat-Tip Screwdriver, 4 inch (10.2 cm) blade, 1/4 inch (0.6 cm) tip.
 - B. Non-Metallic Adjustment Tool.
 - C. Number 2 Phillips Screwdriver, 4 inch (10.2 cm) blade.
 - D. Calibrated Signal Source (refer to TEST EQUIPMENT PREPARATION in the preceding text for signal source application information).
 - Recommended: Delta Electronics Model CQS-3 C-QUAM Synthesizer or equivalent.
 - Alternate: AM Stereo Exciter.
 - E. Spectrum Analyzer (Tektronics 7613 Oscilloscope Main-Frame and 7L5 Spectrum Analyzer with Module L3 or equivalent).
- 5-53. Procedure. To adjust the 1.8 MHz notch filter, proceed as follows:
- 5-54. Disconnect the monitor primary power and remove the top-panel.
- 5-55. Refer to Figure 5-1 and place the audio circuit board in the vertical position.
- 5-56. Record the monitor RF ATTENUATOR level _____ dB. Adjust the attenuator to 0 dB.
- 5-57. Connect the signal source to the monitor rear-panel RF IN receptacle.
- 5-58. Refer to Figure 5-2 and connect the spectrum analyzer to TP-9 on the RF demodulator circuit board. Adjust the spectrum analyzer for a 1.8 MHz indication.
- 5-59. Apply power to the monitor.

- 5-60. Operate the signal source without modulation.
- 5-61. Refer to Figure 5-2 and adjust 1.8 MHz notch filter control L8 for a minimum 1.8 MHz indication on the spectrum analyzer.
- 5-62. Disconnect the monitor primary power.
- 5-63. Remove all test equipment, re-adjust the RF ATTENUATOR, replace the audio circuit board, and return the unit to service.
- 5-64. **DECODING CIRCUIT ALIGNMENT.** Adjustment controls R325 through R327, R331, and R332 align the decoding circuit (refer to the information below for control descriptions). Alignment of the decoding circuit will not be required unless replacement components are installed in the circuit. To align the decoding circuit, proceed as follows.

<u>DECODING CIRCUIT CONTROL</u>	<u>FUNCTION</u>
R325	Correction Loop Balance
R326	Correction Loop Gain
R327	Q Detector Balance
R331	Envelope Detector Balance
R332	Correction Limiter Control

5-65. Required Equipment. The following equipment is required to align the decoding circuit.

- A. Flat-Tip Screwdriver, 4 inch (10.2 cm) blade, 1/4 inch (0.6 cm) tip.
- B. Non-Metallic Adjustment Tool.
- C. Number 2 Phillips Screwdriver, 4 inch (10.2 cm) blade.
- D. Calibrated Signal Source (refer to TEST EQUIPMENT PREPARATION in the preceding text for signal source application information).
 - Recommended: Delta Electronics Model CQS-3 C-QUAM Synthesizer or equivalent.
 - Alternate: AM Stereo Exciter.
- E. Oscilloscope (Tektronics 7613 Oscilloscope Main-Frame or equivalent).
- F. Audio Analyzer (Tektronics Model AA-501 or equivalent).

5-66. Procedure. To align the decoding circuit, proceed as follows:

5-67. Disconnect the monitor primary power and remove the top-panel.

- 5-68. Refer to Figure 5-1 and place the audio circuit board in the vertical position.
- 5-69. Record the monitor RF ATTENUATOR level _____ dB. Adjust the attenuator to 0 dB.
- 5-70. Refer to Figure 5-2 and connect the oscilloscope to TP-10.
- 5-71. Connect the signal source to the monitor rear-panel RF IN receptacle.
- 5-72. Apply power to the monitor.
- 5-73. Operate the signal source without modulation.
- 5-74. Adjust correction gain control R326 for a -3.5V dc oscilloscope indication.
- 5-75. Refer to Figure 5-2 and connect the audio analyzer to TP-17 and connect the oscilloscope to a audio analyzer output receptacle.
- 5-76. Operate the audio analyzer to the audio level display mode.
- 5-77. Adjust the signal source for a 95% L+R modulation output at 1 kHz.
- 5-78. Place the audio circuit board in the horizontal position.
- 5-79. Adjust Q detector balance control R327 for a minimum audio analyzer indication.
- 5-80. Operate the audio analyzer to the distortion display mode.
- 5-81. Adjust envelope detector balance control R331 as follows:
- A. Adjust the signal source for a 50% left channel modulation output at 1 kHz.
 - B. Observe the audio analyzer indication.
 - C. Adjust the signal source for a 50% right channel modulation output at 1 kHz.
 - D. Observe the audio analyzer indication.
 - E. Operate the signal source as required to adjust envelope detector balance control R331 to obtain equal distortion performance from both input conditions. Refer to Figure 5-2 as required for the location of envelope detector balance control R331.

- 5-82. Adjust correction loop balance control R325 as follows:
- A. Adjust the signal source for a 75% left channel modulation output at 1 kHz.
 - B. Observe the audio analyzer indication.
 - C. Adjust the signal source for a 75% right channel modulation output at 1 kHz.
 - D. Observe the audio analyzer indication.
 - E. Operate the signal source as required to adjust correction loop balance control R325 to obtain equal distortion performance from both input conditions. Refer to Figure 5-2 as required for the location of correction loop balance control R325.
- 5-83. Place the audio circuit board in the vertical position.
- 5-84. Adjust the signal source for a 75% right channel modulation output at 1 kHz.
- 5-85. Adjust correction limiter control R332 counterclockwise until the oscilloscope signal presentation begins to clip, then adjust the control slightly clockwise for an unclipped signal presentation.
- 5-86. Disconnect the monitor primary power.
- 5-87. Remove all test equipment, re-adjust the RF ATTENUATOR, replace the audio circuit board, and return the unit to service.
- 5-88. AGC CIRCUIT ADJUSTMENTS. Range control R112 and output level control R111 adjust AGC circuit operation. Adjustment of the AGC circuit will not be required unless replacement components are installed in the circuit or the complete RF demodulator circuit board is replaced. To align the AGC circuit, proceed as follows.
- 5-89. Required Equipment. The following equipment is required to align the AGC circuit.
- A. Flat-Tip Screwdriver, 4 inch (10.2 cm) blade, 1/4 inch (0.6 cm) tip.
 - B. Non-Metallic Adjustment Tool.
 - C. Number 2 Phillips Screwdriver, 4 inch (10.2 cm) blade.

D. Calibrated Signal Source (refer to TEST EQUIPMENT PREPARATION in the preceding text for signal source application information).

Recommended: Delta Electronics Model CQS-3 C-QUAM Synthesizer or equivalent.

Alternate: AM Stereo Exciter.

E. Audio Analyzer (Tektronics Model AA-501 or equivalent).

5-90. Procedure. To adjust the AGC circuit, proceed as follows:

5-91. Disconnect the monitor primary power and remove the top-panel.

5-92. Refer to Figure 5-1 and place the audio circuit board in the vertical position.

5-93. Record the monitor RF ATTENUATOR level _____ dB. Adjust the attenuator to 0 dB.

5-94. Refer to Figure 5-2 and connect the audio analyzer to TP-19.

5-95. Connect the signal source to the monitor rear-panel RF IN receptacle.

5-96. Refer to Figure 5-2 and install AGC circuit enable jumper J31 in position 1-2.

5-97. Apply power to the monitor.

5-98. Adjust the signal source for a 100% L+R modulation output at 1 kHz.

5-99. Operate the audio analyzer to the audio level display mode.

5-100. Refer to Figure 5-2 and adjust AGC range control R112 for a 0 dBm audio analyzer indication.

5-101. Disconnect the monitor primary power.

5-102. Refer to Figure 5-2 and install AGC circuit enable jumper J31 in position 2-3.

5-103. Apply power to the monitor.

5-104. Refer to Figure 5-2 and adjust output level control R111 for a 0 dBm audio analyzer indication.

5-105. Disconnect the monitor primary power.

5-106. Remove all test equipment, re-adjust the RF ATTENUATOR, replace the audio circuit board, and return the unit to service.

5-107. PILOT TONE NULL. Frequency null control R329 and injection level null control R330 null the pilot tone in the decoding circuitry. Adjustment of the pilot null circuit will not be required unless replacement components are installed in the circuit. To adjust the pilot null circuit, proceed as follows.

5-108. Required Equipment. The following equipment is required to adjust the pilot null circuitry.

- A. Flat-Tip Screwdriver, 4 inch (10.2 cm) blade, 1/4 inch (0.6 cm) tip.
- B. Non-Metallic Adjustment Tool.
- C. Number 2 Phillips Screwdriver, 4 inch (10.2 cm) blade.
- D. Calibrated Signal Source (refer to TEST EQUIPMENT PREPARATION in the preceding text for signal source application information).

Recommended: Delta Electronics Model CQS-3 C-QUAM Synthesizer.

Alternate: AM Stereo Exciter.

- E. Audio Analyzer (Tektronics Model AA-501 or equivalent).

5-109. Procedure. To adjust the pilot null circuitry, proceed as follows:

5-110. Disconnect the monitor primary power and remove the top-panel.

5-111. Refer to Figure 5-1 and place the audio circuit board in the vertical position.

5-112. Record the monitor RF ATTENUATOR level _____ dB. Adjust the attenuator to 0 dB.

5-113. Refer to Figure 5-2 and connect the audio analyzer to TP-14.

5-114. Connect the signal source to the monitor rear-panel RF IN receptacle.

5-115. Apply power to the monitor.

5-116. Adjust the signal source for a 5% pilot tone output.

5-117. Operate the audio analyzer to the audio level display mode.

5-118. Refer to Figure 5-2 and adjust pilot frequency null control R329 and pilot injection level null control R330 for a minimum audio analyzer indication.

- 5-119. Disconnect the monitor primary power.
- 5-120. Remove all test equipment, re-adjust the RF ATTENUATOR, replace the audio circuit board, and return the unit to service.
- 5-121. FREQUENCY SYNTHESIZER CALIBRATION. Calibration control C61 and reference suppression control R114 align the frequency synthesizer circuitry. Adjustment of circuit will not be required unless replacement components are installed in the oscillator circuit. To calibrate the frequency synthesizer circuit, proceed as follows.
- 5-122. Required Equipment. The following equipment is required to calibrate the frequency synthesizer circuit.
- A. Flat-Tip Screwdriver, 4 inch (10.2 cm) blade, 1/4 inch (0.6 cm) tip.
 - B. Non-Metallic Adjustment Tool.
 - C. Number 2 Phillips Screwdriver, 4 inch (10.2 cm) blade.
 - D. Calibrated Frequency Counter (Hewlett-Packard 5315A or equivalent).
 - E. Spectrum Analyzer (Tektronics 7613 Oscilloscope Main-Frame and 7L5 Spectrum Analyzer with Module L3 or equivalent).
- 5-123. Procedure. To calibrate the frequency synthesizer circuit, proceed as follows:
- 5-124. Disconnect the monitor primary power and remove the top-panel.
- 5-125. Refer to Figure 5-1 and place the audio circuit board in the vertical position.
- 5-126. Refer to Figure 5-2 and connect the frequency counter to TP-27 on the RF demodulator circuit board.
- 5-127. Ensure the VCO assembly is enabled (refer to Figure 5-1).
- 5-128. Refer to Figure 5-7 and program frequency synthesizer switch S1 for 1080 kHz.
- 5-129. Apply power to the monitor.
- 5-130. Refer to Figure 5-2 and adjust frequency synthesizer calibration control C61 for a 1,530,000 Hz frequency counter indication.
- 5-131. Disconnect the monitor primary power.

5-132. Refer to Figure 5-2 and connect the spectrum analyzer to TP-27 on the RF demodulator circuit. Adjust the spectrum analyzer for a center frequency equal to:

$$\text{Center Frequency} = \text{Station carrier frequency} + 450 \text{ kHz.}$$

5-133. Refer to Figure 5-7 and program frequency synthesizer switch S1 for the station operating frequency.

5-134. Apply power to the monitor.

5-135. Refer to Figure 5-2 and adjust reference suppression control R114 to null the 40 kHz side-bands (36 kHz side-bands if unit is programmed for 9 kHz operation).

5-136. Disconnect the monitor primary power.

5-137. Remove all test equipment, replace the audio circuit board, and return the unit to service.

5-138. RF LEVEL CALIBRATION. RF level calibration control R113 adjusts the RF level circuit. Adjustment of the RF level calibration circuit will not be required unless replacement components are installed in the circuit or the complete RF demodulator circuit board is replaced. To adjust the RF level calibration control, proceed as follows.

5-139. Required Equipment. The following equipment is required to adjust the RF level calibration control.

- A. Flat-Tip Screwdriver, 4 inch (10.2 cm) blade, 1/4 inch (0.6 cm) tip.
- B. Non-Metallic Adjustment Tool.
- C. Number 2 Phillips Screwdriver, 4 inch (10.2 cm) blade.
- D. Calibrated Signal Source (refer to TEST EQUIPMENT PREPARATION in the preceding text for signal source application information).

Recommended: Delta Electronics Model CQS-3 C-QUAM Synthesizer or equivalent.

Alternate: AM Stereo Exciter.

5-140. Procedure. To adjust RF level calibration control R113, proceed as follows:

5-141. Disconnect the monitor primary power and remove the top-panel.

5-142. Refer to Figure 5-1 and place the audio circuit board in the vertical position.

- 5-143. Record the monitor RF ATTENUATOR level _____ dB.
Adjust the attenuator to 0 dB.
- 5-144. Connect the signal source to the monitor rear-panel RF IN receptacle.
- 5-145. Apply power to the monitor.
- 5-146. Adjust the signal source for a carrier signal output without pilot tone and modulation information.
- 5-147. Ensure the LEVEL switch RF indicator is illuminated.
- 5-148. Wait approximately 60 seconds to allow the AGC circuitry to track the RF input.
- 5-149. Refer to Figure 5-2 and adjust RF level control R113 until the two NOM indicators on the front-panel LEVEL display illuminate.
- 5-150. Disconnect the monitor primary power.
- 5-151. Remove all test equipment, re-adjust the RF ATTENUATOR, replace the audio circuit board, and return the unit to service.
- 5-152. SEPARATION. Adjustment control R328 determines the decoding circuitry separation. Adjustment of the control will not be required unless separation degrades or the RF demodulator circuit board is replaced. To adjust separation control R328, proceed as follows.
- 5-153. Required Equipment. The following equipment is required to adjust the separation control.
- A. Flat-Tip Screwdriver, 4 inch (10.2 cm) blade, 1/4 inch (0.6 cm) tip.
 - B. Non-Metallic Adjustment Tool.
 - C. Number 2 Phillips Screwdriver, 4 inch (10.2 cm) blade.
 - D. Calibrated Signal Source (refer to TEST EQUIPMENT PREPARATION in the preceding text for signal source application information).
 - Recommended: Delta Electronics Model CQS-3 C-QUAM Synthesizer or equivalent.
 - Alternate: AM Stereo Exciter.
 - E. Audio Analyzer (Tektronics Model AA-501 or equivalent).
- 5-154. Procedure. To adjust separation control R328, proceed as follows:

- 5-155. Disconnect the monitor primary power and remove the top-panel.
- 5-156. Refer to Figure 5-1 and place the audio circuit board in the vertical position.
- 5-157. Record the monitor RF ATTENUATOR level _____ dB. Adjust the attenuator to 0 dB.
- 5-158. Connect the audio analyzer to RIGHT/L-R channel front-panel test receptacle.
- 5-159. Connect the signal source to the monitor rear-panel RF IN receptacle.
- 5-160. Apply power to the monitor.
- 5-161. Adjust the signal source for a 50% right channel modulation output at 1 kHz.
- 5-162. Operate the audio analyzer to the audio level display mode.
- 5-163. Operate the RIGHT/L-R channel INPUT switch/indicator to illuminate the R indicator.
- 5-164. Operate the audio analyzer to obtain a reference display.
- 5-165. Adjust the signal source for a 50% left channel modulation output at 1 kHz.
- 5-166. Refer to Figure 5-2 and adjust separation control R328 for a minimum audio analyzer indication.
- 5-167. Connect the audio analyzer to the LEFT/L+R channel front-panel monitor receptacle.
- 5-168. Operate the LEFT/L+R channel INPUT switch/indicator to illuminate the L indicator.
- 5-169. Adjust the signal source for a 50% right channel modulation output at 1 kHz.
- 5-170. Refer to Figure 5-2 and adjust separation control R328 for a minimum audio analyzer indication.
- 5-171. Repeat the procedure as required for a minimum audio analyzer indication in both channels.
- 5-172. Disconnect the monitor primary power.
- 5-173. Remove all test equipment, re-adjust the RF ATTENUATOR, and return the unit to service.

5-174. METER CIRCUIT BOARD ADJUSTMENTS.

5-175. RIGHT CHANNEL/LEFT CHANNEL METER CIRCUIT BOARD ADJUSTMENTS. Peak calibrate control R3 and average calibrate control R12 adjust the meter circuitry for proper operation. Adjustment of the meter circuit will not be required unless replacement components are installed in the circuit or the complete meter circuit board is replaced. To adjust the meter calibrate circuitry, proceed as follows.

5-176. Required Equipment. The following equipment is required to adjust the meter calibrate circuitry.

- A. Flat-Tip Screwdriver, 4 inch (10.2 cm) blade, 1/4 inch (0.6 cm) tip.
- B. Non-Metallic Adjustment Tool.
- C. Calibrated Signal Source (refer to TEST EQUIPMENT PREPARATION in the preceding text for signal source application information).

Recommended: Delta Electronics Model CQS-3 C-QUAM Synthesizer or equivalent.

Alternate: AM Stereo Exciter.

5-177. Procedure. To adjust the meter calibrate circuitry, proceed as follows:

5-178. Disconnect the monitor primary power and remove the top-panel.

5-179. Record the monitor RF ATTENUATOR level _____ dB. Adjust the attenuator to 0 dB.

5-180. Connect the signal source to the monitor rear-panel RF IN receptacle.

5-181. Apply power to the monitor.

5-182. Adjust the signal source for a 100% L+R modulation output at 1 kHz without a pilot tone.

5-183. Operate the LEFT/L+R channel INPUT switch/indicator to illuminate the L+R indicator.

5-184. Operate the LEFT/L+R channel modulation meter to the manual mode by depressing the LEFT/L+R AUTORANGE switch/indicator to illuminate the OFF indicator.

5-185. Operate the LEFT/L+R channel modulation meter to the 0 dB range.

- 5-186. Refer to Figure 5-4 and adjust peak calibrate control R3 on the LEFT/L+R channel meter circuit board for a 100% LEFT/L+R channel modulation meter indication.
- 5-187. Adjust the signal source for a 25% L+R modulation output at 1 kHz.
- 5-188. Operate the LEFT/L+R channel modulation meter to the -20 dB range.
- 5-189. Refer to Figure 5-4 and adjust average calibrate control R12 on the LEFT/L+R channel meter circuit board for a 125% LEFT/L+R channel modulation meter indication.
- 5-190. Adjust the signal source for a 100% L-R modulation output at 1 kHz without a pilot tone.
- 5-191. Operate the RIGHT/L-R channel INPUT switch/indicator to illuminate the L-R indicator.
- 5-192. Operate the RIGHT/L-R channel modulation meter to the manual mode by depressing the RIGHT/L-R AUTORANGE switch/indicator to illuminate the OFF indicator.
- 5-193. Operate the RIGHT/L-R channel modulation meter to the \emptyset dB range.
- 5-194. Refer to Figure 5-4 and adjust peak calibration control R3 on the RIGHT/L-R channel meter circuit board for a 100% RIGHT/L-R channel modulation meter indication.

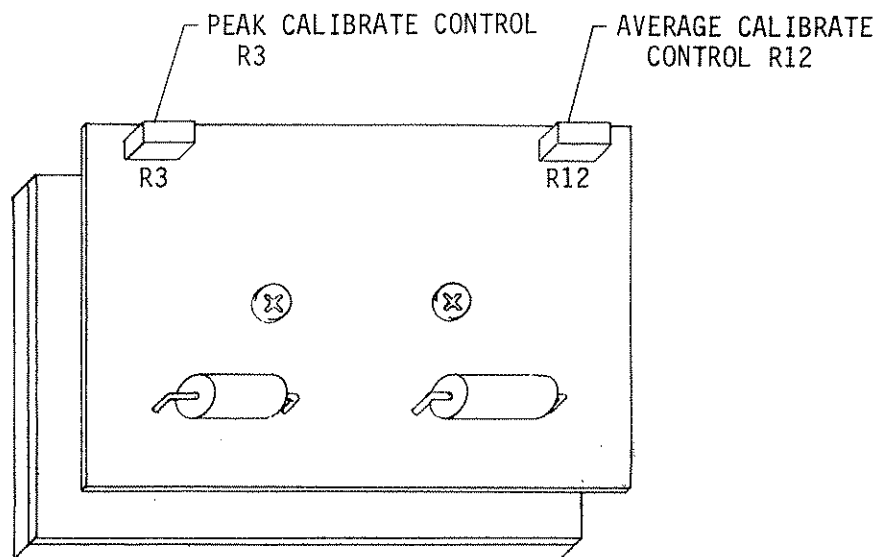

COPYRIGHT © MOTOROLA, INC. MARCH 1988
597-0105-24

FIGURE 5-4. MODULATION METER CIRCUIT BOARD ADJUSTMENT CONTROLS

- 5-195. Adjust the signal source for a 25% L+R modulation output at 1 kHz.
- 5-196. Operate the RIGHT/L-R channel INPUT switch/indicator to illuminate the R indicator.
- 5-197. Operate the RIGHT/L-R channel modulation meter to the -20 dB range.
- 5-198. Refer to Figure 5-4 and adjust average calibrate control R12 on the RIGHT/L-R channel meter circuit board for a 125% RIGHT/L-R channel modulation meter indication.
- 5-199. Disconnect the monitor primary power.
- 5-200. Disconnect all test equipment, re-adjust the RF ATTENUATOR and return the unit to service.
- 5-201. AUDIO CIRCUIT BOARD ADJUSTMENTS.
- 5-202. PILOT LEVEL CALIBRATION. Pilot level calibration control R37 adjusts the pilot level circuit. Adjustment of the pilot level calibration circuit will not be required unless replacement components are installed in the circuit or the complete audio circuit board is replaced. To adjust the pilot level calibration control, proceed as follows.
- 5-203. Required Equipment. The following equipment is required to adjust the pilot level calibration control.
- A. Flat-Tip Screwdriver, 4 inch (10.2 cm) blade, 1/4 inch (0.6 cm) tip.
 - B. Non-Metallic Adjustment Tool.
 - C. Calibrated Signal Source (refer to TEST EQUIPMENT PREPARATION in the preceding text for signal source application information).
 - Recommended: Delta Electronics Model CQS-3 C-QUAM Synthesizer or equivalent.
 - Alternate: AM Stereo Exciter.
- 5-204. Procedure. To adjust pilot level calibration control R37, proceed as follows:
- 5-205. Disconnect the monitor primary power and remove the top-panel.
- 5-206. Record the monitor RF ATTENUATOR level _____ dB. Adjust the attenuator to 0 dB.
- 5-207. Connect the signal source to the monitor rear-panel RF IN receptacle.
- 5-208. Apply power to the monitor.

- 5-209. Adjust the signal source for a 5% pilot tone output without modulation.
- 5-210. Depress and hold the LEVEL switch/indicator to illuminate the PILOT indicator.
- 5-211. While depressing the LEVEL switch/indicator (PILOT indicator illuminated), refer to Figure 5-5 and adjust pilot level control R37 until the two NOM indicators on the front-panel LEVEL display illuminate.
- 5-212. Disconnect the monitor primary power.
- 5-213. Remove all test equipment, re-adjust the RF ATTENUATOR, and return the unit to service.
- 5-214. +125% L+R, -100% L+R, AND 100% L-R PEAK INDICATOR ADJUSTMENTS. Adjustment controls on the audio circuit board allow calibration of the +125% L+R, -100% L+R, and 100% L-R peak indicators (refer to the information below for control descriptions). Adjustment of the controls will not be required unless replacement components are installed in the calibration circuit or the complete audio circuit board is replaced. To adjust the peak indicator calibration controls, proceed as follows.

<u>ADJUSTMENT CONTROL</u>	<u>DESCRIPTION</u>
R11	+125% L+R Peak Indicator Calibration Control
R16	-100% L+R Peak Indicator Calibration Control
R48	100% L-R Peak Indicator Calibration Control

5-215. Required Equipment. The following equipment is required to adjust the +125% L+R, -100% L+R, and 100% L-R peak indicator calibration controls.

- A. Flat-Tip Screwdriver, 4 inch (10.2 cm) blade, 1/4 inch (0.6 cm) tip.
- B. Non-Metallic Adjustment Tool.
- C. Calibrated Signal Source (Delta Electronics Model CQS-3 C-QUAM Synthesizer or equivalent).

5-216. Procedure. To adjust the +125% L+R, -100% L+R, and 100% L-R peak indicators, proceed as follows:

- 5-217. Disconnect the monitor primary power and remove the top-panel.
- 5-218. Record the monitor RF ATTENUATOR level _____ dB. Adjust the attenuator to 0 dB.

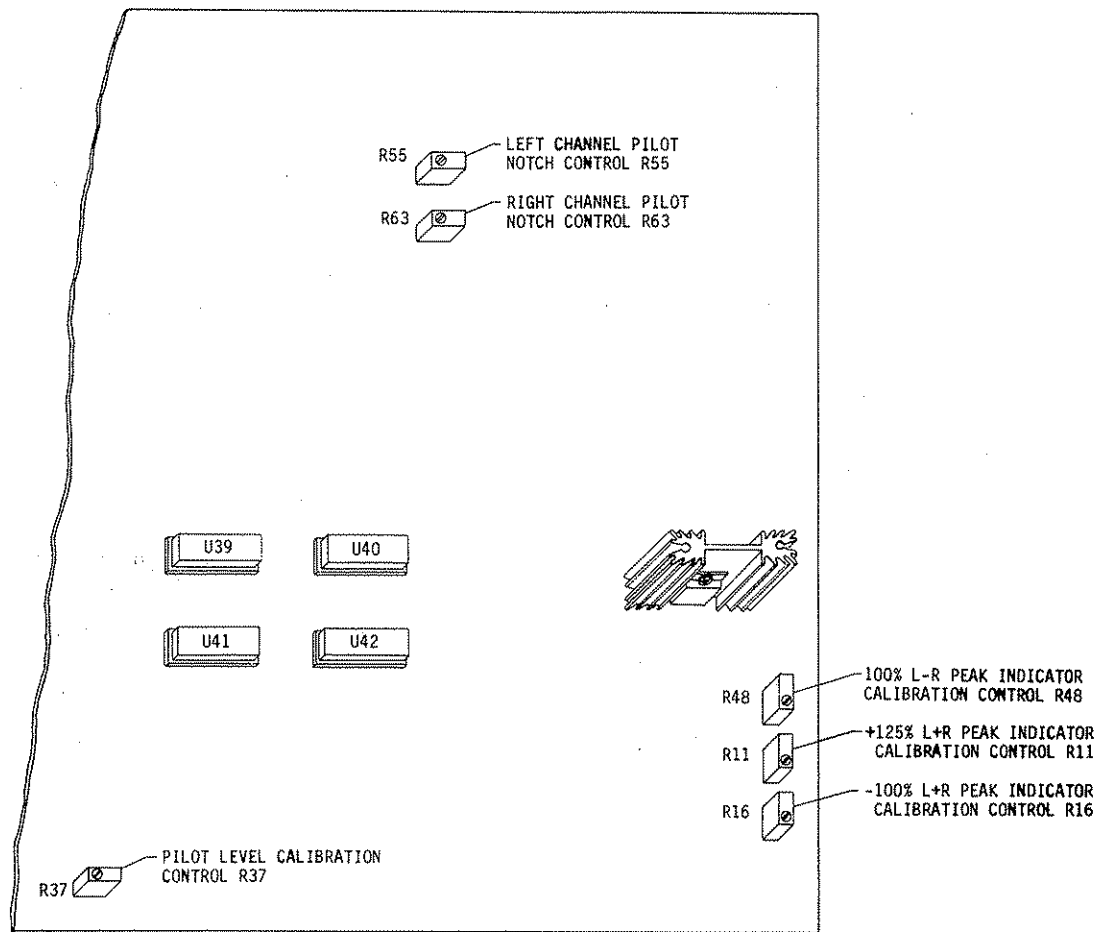

COPYRIGHT © MOTOROLA, INC. MARCH 1988
597-0105-25

FIGURE 5-5. AUDIO CIRCUIT BOARD ADJUSTMENT CONTROLS

- 5-219. Connect the C-QUAM synthesizer to the monitor rear-panel RF IN receptacle.
- 5-220. Apply power to the monitor.
- 5-221. Adjust the C-QUAM synthesizer for a +125%/-100% L+R modulation output at 1 kHz.
- 5-222. Refer to Figure 5-5 and adjust +125% L+R peak indicator calibration control R11 until the +125% L+R peak indicator begins to illuminate.
- 5-223. Refer to Figure 5-5 and adjust -100% L+R peak indicator calibration control R16 until the -100% L+R peak indicator begins to illuminate.
- 5-224. Adjust the C-QUAM synthesizer for a 100% L-R modulation output at 1 kHz.

5-225. Refer to Figure 5-5 and adjust 100% L-R peak indicator calibration control R48 until the 100% L-R peak indicator begins to illuminate.

5-226. Disconnect the monitor primary power.

5-227. Remove all test equipment, re-adjust the RF ATTENUATOR, and return the unit to service.

5-228. PILOT NOTCH ADJUSTMENT. Left channel pilot notch control R55 and right channel pilot notch control R63 adjust the pilot notch filters in the left and right channel audio circuitry. Adjustment of the notch filters will not be required unless replacement components are installed in the filter circuitry. To adjust the pilot notch controls, proceed as follows.

5-229. Required Equipment. The following equipment is required to adjust the left and right channel pilot notch controls.

A. Flat-Tip Screwdriver, 4 inch (10.2 cm) blade, 1/4 inch (0.6 cm) tip.

B. Non-Metallic Adjustment Tool.

C. Calibrated Signal Source (refer to TEST EQUIPMENT PREPARATION in the preceding text for signal source application information).

Recommended: Delta Electronics Model CQS-3 C-QUAM Synthesizer or equivalent.

Alternate: AM Stereo Exciter.

5-230. Procedure. To adjust the left and right channel pilot notch controls, proceed as follows:

5-231. Disconnect the monitor primary power and remove the top-panel.

5-232. Record the monitor RF ATTENUATOR level _____ dB. Adjust the attenuator to 0 dB.

5-233. Connect the signal source to the monitor rear-panel RF IN receptacle.

5-234. Apply power to the monitor.

5-235. Adjust the signal source for a 5% pilot tone output without modulation.

5-236. Operate the LEFT/L+R channel INPUT switch/indicator to illuminate the L indicator.

5-237. Operate the modulation meters to the manual mode by depressing the AUTORANGE switch/indicators to illuminate the OFF indicators.

- 5-238. Operate the LEFT/L+R channel modulation meter to the -50 dB range.
- 5-239. Refer to Figure 5-5 and adjust left channel pilot notch control R55 for a minimum LEFT/L+R channel meter indication.
- 5-240. Repeat the procedure for the right channel. Adjust the circuit with right channel pilot notch control R63 (refer to Figure 5-5).
- 5-241. Disconnect the monitor primary power.
- 5-242. Remove all test equipment, re-adjust the RF ATTENUATOR, and return the unit to service.
- 5-243. **AUDIO CONTROL CIRCUIT BOARD ADJUSTMENTS.**
- 5-244. **ADJUSTABLE PEAK INDICATOR CALIBRATION.** LEFT/L+R channel adjustable peak indicator control R15 and RIGHT/L-R channel adjustable peak indicator control R50 calibrate the adjustable peak indicator circuitry. Calibration of the adjustable peak indication circuitry will not be required unless replacement components are installed in the circuit or the complete audio control circuit board is replaced. To calibrate the adjustable peak indicator circuitry, proceed as follows.
- 5-245. Required Equipment. The following equipment is required to calibrate the adjustable peak indicator circuitry.
- A. Flat-Tip Screwdriver, 4 inch (10.2 cm) blade, 1/4 inch (0.6 cm) tip.
 - B. Non-Metallic Adjustment Tool.
 - C. Calibrated Signal Source (refer to TEST EQUIPMENT PREPARATION in the preceding text for signal source application information).
 - Recommended: Delta Electronics Model CQS-3 C-QUAM Synthesizer or equivalent.
 - Alternate: AM Stereo Exciter.
- 5-246. Procedure. To calibrate the adjustable peak indicator circuitry, proceed as follows:
- 5-247. Disconnect the monitor primary power and remove the top-panel.
- 5-248. Record the monitor RF ATTENUATOR level _____ dB. Adjust the attenuator to 0 dB.
- 5-249. Connect the signal source to the monitor rear-panel RF IN receptacle.
- 5-250. Apply power to the monitor.

- 5-251. Adjust the signal source for a 100% L+R modulation output at 1 kHz without the pilot tone.
- 5-252. Operate the LEFT/L+R channel INPUT switch/indicator to illuminate the L+R indicator.
- 5-253. Operate the LEFT/L+R channel adjustable peak indicator control to 100%.
- 5-254. Refer to Figure 5-6 and adjust LEFT/L-R channel adjustable peak indicator calibration control R15 until the LEFT/L-R channel adjustable peak indicator begins to illuminate.
- 5-255. Repeat the procedure for the RIGHT/L-R channel. Perform the RIGHT/L-R channel adjustment procedure with a 100% L-R modulation input at 1 kHz without the pilot tone. Adjust the circuitry using RIGHT/L-R channel adjustable peak indicator calibration control R50 (refer to Figure 5-6).
- 5-256. Disconnect the monitor primary power.
- 2-257. Remove all test equipment, re-adjust the RF ATTENUATOR, and return the unit to service.
- 5-258. OPERATING FREQUENCY REPROGRAMMING. The monitor operating frequency is determined by a frequency synthesizer on the RF demodulator circuit board. The synthesizer is programmed by one eight-segment DIP switch. To re-program the monitor operating frequency, proceed as follows.

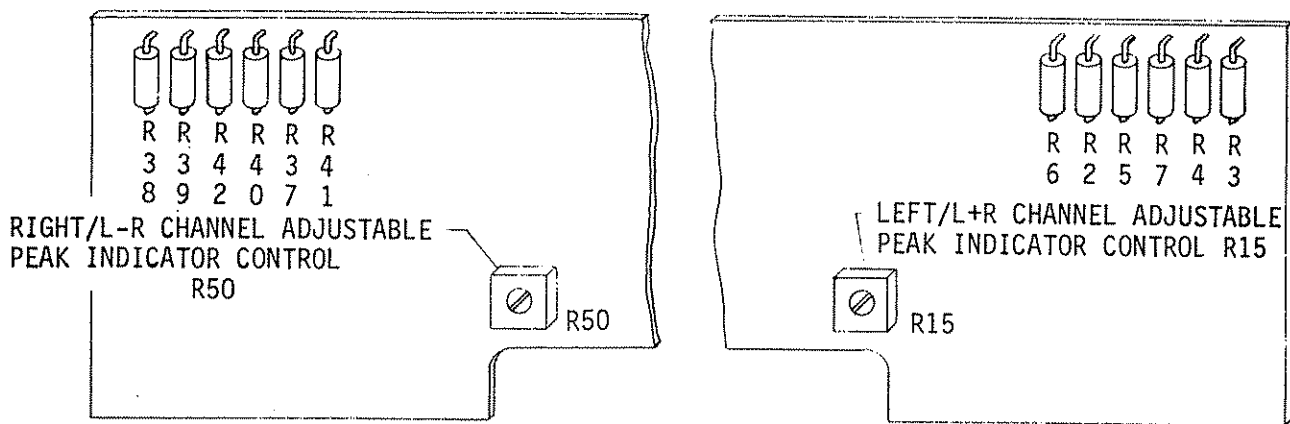

COPYRIGHT © MOTOROLA, INC. MARCH 1988

597-0105-26

FIGURE 5-6. AUDIO CONTROL CIRCUIT BOARD ADJUSTMENT CONTROLS

5-259. Required Equipment. The following equipment is required to re-program the monitor operating frequency.

- A. Flat-Tip Screwdriver, 4 inch (10.2 cm) blade, 1/4 inch (0.6 cm) tip.
- B. Non-Metallic Adjustment Tool.
- C. Number 2 Phillips Screwdriver, 4 inch (10.2 cm) blade.

5-260. Procedure. To re-program the monitor operating frequency, proceed as follows:

5-261. Disconnect the monitor primary power and remove the top-panel.

5-262. Refer to Figure 5-1 and place the audio circuit board in the vertical position.

5-263. Refer to Figure 5-7 and program frequency synthesizer switch S1 for the desired operating frequency. If the frequency synthesizer is configured from 10 kHz programming to 9 kHz programming, 10.24 MHz crystal oscillator Y1 on the RF demodulator circuit board must be replaced with a 9.216 MHz oscillator (refer to 1410 9 kHz SPACING OPTION in SECTION VI, PARTS LIST). Refer to RF demodulator assembly diagram AD917-0063 in SECTION VII, DRAWINGS and replace crystal oscillator Y1.

5-264. Replace the audio circuit board and return the unit to service.

5-265. TROUBLESHOOTING.

5-266. Troubleshooting within the Model 1410 monitor is not considered hazardous due to the low voltages and currents involved. All high voltages used within the monitor have been shielded, however do not touch any component within the monitor when power is energized.

5-267. The troubleshooting philosophy for the monitor consists of isolating a problem to a specific circuit board. The problem may be isolated by referencing Table 5-1 which presents the monitor troubleshooting information.

WARNING

DISCONNECT ALL MONITOR PRIMARY POWER BEFORE REPLACING ANY COMPONENTS.

CAUTION

INADVERTENT CONTACT BETWEEN ADJACENT COMPONENTS WITH TEST EQUIPMENT CAN CAUSE SERIOUS DAMAGE TO THE MONITOR CIRCUITRY.

CAUTION

5-268. Once the trouble is isolated and power is totally deenergized, refer to the schematic diagrams and the theory of operation to assist in problem resolution. The defective component may be repaired locally or the entire device may be returned to Motorola for repair or replacement.

WARNING

DISCONNECT POWER BEFORE REMOVING OR REPLACING
CIRCUIT BOARDS OR COMPONENTS.

5-269. COMPONENT REPLACEMENT. The circuit boards used in the Model 1410 monitor are double-sided with plated-through holes. Due to the plated-through hole design, solder fills the holes by capillary action. This condition requires that defective components be removed carefully to avoid damage to the circuit board.

5-270. On all circuit boards, the adhesion between the copper trace and the circuit board fails at almost the same temperature as solder melts. A circuit board trace can be destroyed by excessive heat or lateral movement during soldering. Use of a small soldering iron with steady pressure is required for circuit board repairs.

5-271. To remove a soldered component from a circuit board, cut the leads from the body of the defective component while the device is still soldered to the board. Grip a component lead with needle-nose pliers. Touch the soldering iron to the lead at the solder connection on the circuit side of the board. When the solder begins to melt, push the lead through the back side of the board and cut off the clinched end of the lead. Each lead may now be heated independently and pulled out of each hole. The holes may be cleared by careful re-heating with a low wattage iron and removing the residual solder with a soldering vacuum tool.

5-272. Install the new component and apply solder from the circuit side of the board. If no damage has been incurred to the plated-through holes, soldering of the component side of the board will not be required.

WARNING

MOST SOLVENTS WHICH REMOVE ROSIN FLUX ARE
VOLATILE AND TOXIC BY NATURE AND SHOULD BE
USED ONLY IN SMALL AMOUNTS IN A WELL VEN-
TILATED AREA AWAY FROM FLAME, CIGARETTES,
AND HOT SOLDERING IRONS.

WARNING

WARNING

WARNING

OBSERVE THE MANUFACTURERS CAUTIONARY
INSTRUCTIONS.

5-273. After soldering, remove residual flux with a suitable solvent. Rubbing alcohol is highly diluted and is not effective.

5-274. The board should be checked to ensure the flux has been completely removed. Rosin flux is not normally corrosive, however in time, the flux will absorb enough moisture to become conductive and create problems.

5-275. INTEGRATED CIRCUITS. Special care should be exercised with integrated circuits. Each integrated circuit must be installed by matching the integrated circuit notch with the notch on the socket. Do not attempt to remove an integrated circuit from a socket with your fingers. Use an integrated circuit puller to lightly pry the component from the socket.

TABLE 5-1. MODEL 1410 MONITOR TROUBLESHOOTING
(Sheet 1 of 2)

SYMPTOM	REMEDY
<p>INCORRECT RF LEVEL INDICATIONS:</p> <p>A. HIGH</p> <p>B. LOW</p> <p>NO LEFT/L+R INDICATIONS</p> <p>NO RIGHT/L-R INDICATIONS</p> <p>NO PILOT STATUS INDICATION</p> <p>NO PILOT LEVEL INDICATION</p> <p>NO +125% L+R INDICATION</p>	<ol style="list-style-type: none"> 1. Check the RF attenuator adjustment. 2. Troubleshoot the AGC circuit on the RF demodulator circuit board. 3. Refer to Figure 5-8 and troubleshoot the L+R decoder circuit. <ol style="list-style-type: none"> 1. Check the RF attenuator adjustment. 2. Refer to Figure 5-9 and troubleshoot the IF circuit on the RF demodulator circuit board. 3. Troubleshoot the AGC circuit on the RF demodulator circuit board. <p>Refer to Figure 5-8 and troubleshoot the L+R circuit.</p> <p>Refer to Figure 5-10 and troubleshoot the L-R circuit.</p> <ol style="list-style-type: none"> 1. Ensure pilot detection circuit test jumper J36 on the audio circuit board is installed. 2. Check pilot indicator DS19 on the audio control circuit board. 3. Check integrated circuits U19B, U17A, U17B, U17C, and U20, on the audio circuit board. <p>Check integrated circuits U10, U7A, and U2 on the audio circuit board.</p> <ol style="list-style-type: none"> 1. Check +125% L+R indicator DS1 on the audio control circuit board. 2. Check integrated circuits U6A and U5A on the audio circuit board.

TABLE 5-1. MODEL 1410 MONITOR TROUBLESHOOTING
(Sheet 2 of 2)

SYMPTOM	REMEDY
NO -100% L+R INDICAITON	<ol style="list-style-type: none"> 1. Check -100% L+R indicator DS2 on the audio control circuit board.
NO 100% L-R INDICATION	<ol style="list-style-type: none"> 2. Check integrated circuits U6B and U5B on the audio circuit board.
NO 100% L-R INDICATION	<ol style="list-style-type: none"> 1. Check 100% L-R indicator DS18 on the audio control circuit board.
NO LEFT/L+R CHANNEL ADJUSTABLE PEAK INDICATOR OPERATION	<ol style="list-style-type: none"> 2. Check integrated circuits U19A and U5C on the audio circuit board.
NO LEFT/L+R CHANNEL ADJUSTABLE PEAK INDICATOR OPERATION	<ol style="list-style-type: none"> 1. Check left/L+R channel adjustable peak indicator DS17 on the audio control circuit board.
NO LEFT/L+R CHANNEL ADJUSTABLE PEAK INDICATOR OPERATION	<ol style="list-style-type: none"> 2. Check the left/L+R channel adjustable peak indicator control.
NO LEFT/L+R CHANNEL ADJUSTABLE PEAK INDICATOR OPERATION	<ol style="list-style-type: none"> 3. Check integrated circuits U5, U1, and resistor network R2 through R13 on the audio control circuit board.
NO RIGHT/L-R CHANNEL ADJUSTABLE PEAK INDICATOR OPERATION	<ol style="list-style-type: none"> 1. Check right/L-R channel adjustable peak indicator DS32 on the audio control circuit board.
NO RIGHT/L-R CHANNEL ADJUSTABLE PEAK INDICATOR OPERATION	<ol style="list-style-type: none"> 2. Check the right/L-R channel adjustable peak indicator control.
NO RIGHT/L-R CHANNEL ADJUSTABLE PEAK INDICATOR OPERATION	<ol style="list-style-type: none"> 3. Check integrated circuits U7, U6, and resistor network R37 through R48 on the audio control circuit board.
NO HEADPHONE OUTPUT	<ol style="list-style-type: none"> 1. Check potentiometer R1.
NO HEADPHONE OUTPUT	<ol style="list-style-type: none"> 2. Check integrated circuits U52 and U45 on the audio circuit board.

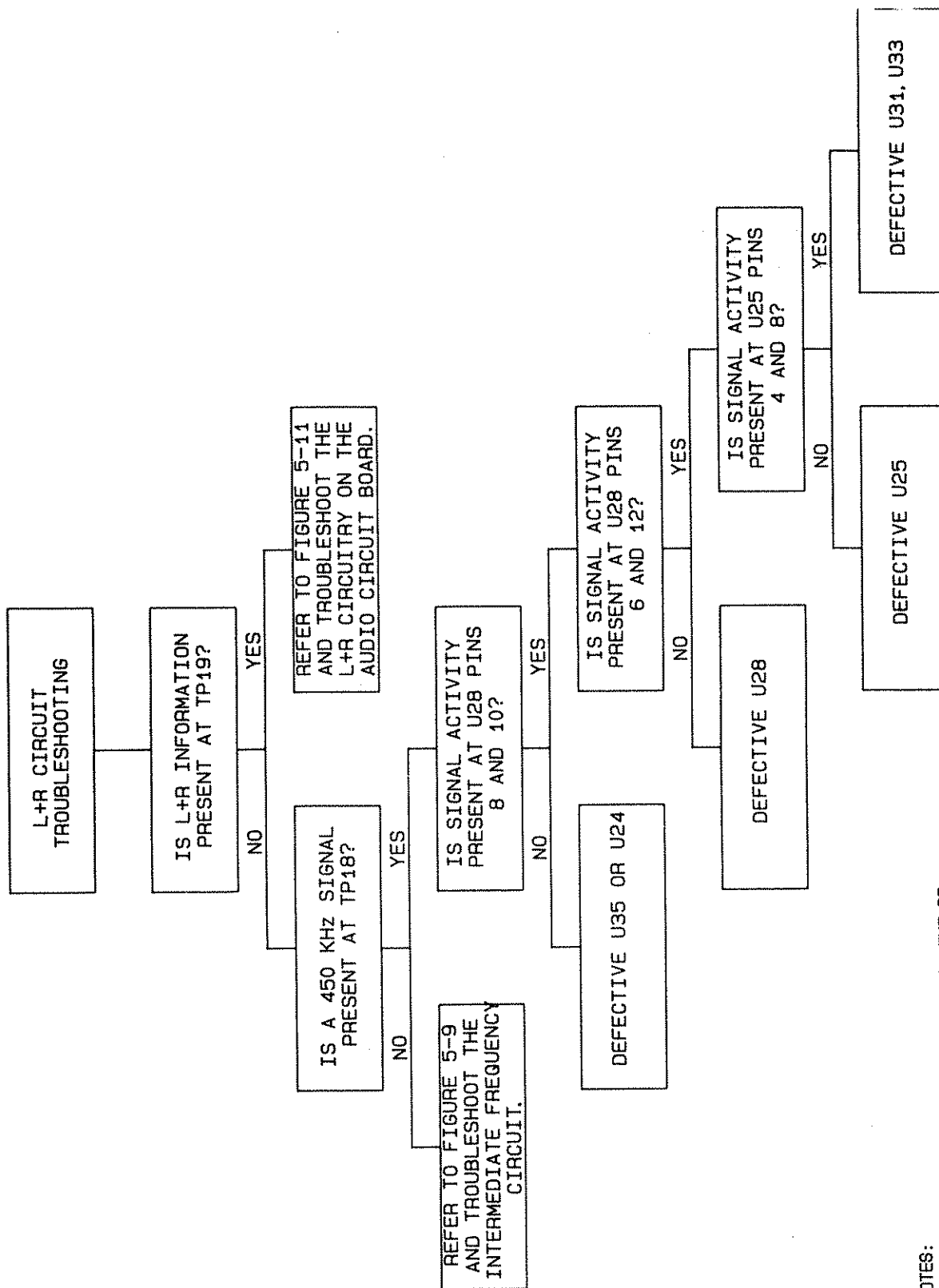

- NOTES:
1. ALL COMPONENTS ARE LOCATED ON THE RF DEMODULATOR CIRCUIT BOARD UNLESS OTHERWISE SPECIFIED.
 2. THE TROUBLESHOOTING INFORMATION PRESENTED IS GENERATED BY THE MONITOR CIRCUITRY WITH AN 80% L+R MODULATION INPUT.

COPYRIGHT © MOTOROLA, INC. MARCH 1988
597-0105-28

FIGURE 5-8. TROUBLESHOOTING TREE, L+R CIRCUIT

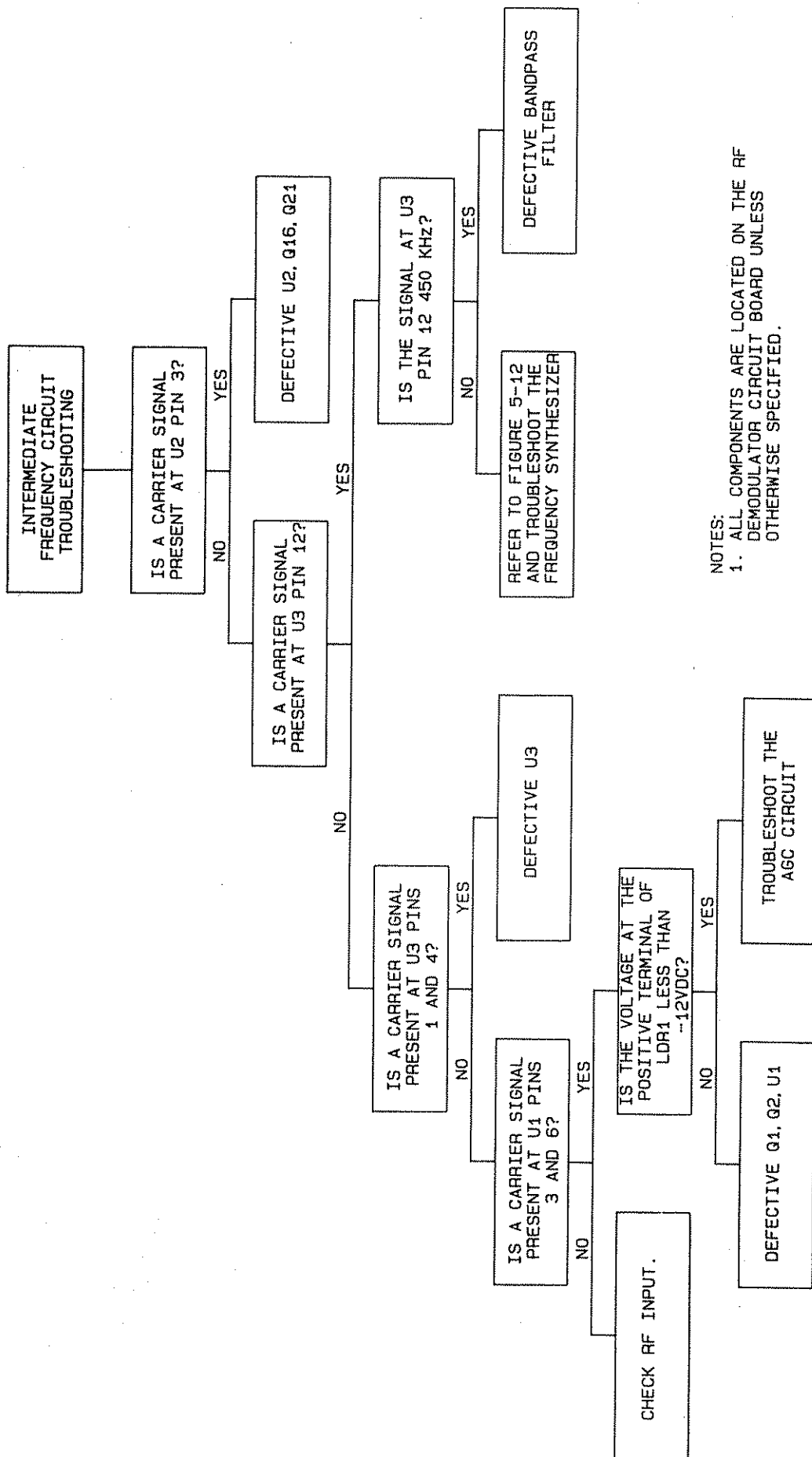

NOTES:
 1. ALL COMPONENTS ARE LOCATED ON THE RF DEMODULATOR CIRCUIT BOARD UNLESS OTHERWISE SPECIFIED.

597-0105-29
 COPYRIGHT © MOTOROLA, INC. MARCH 1988

FIGURE 5-9. TROUBLESHOOTING TREE, INTERMEDIATE FREQUENCY CIRCUIT.

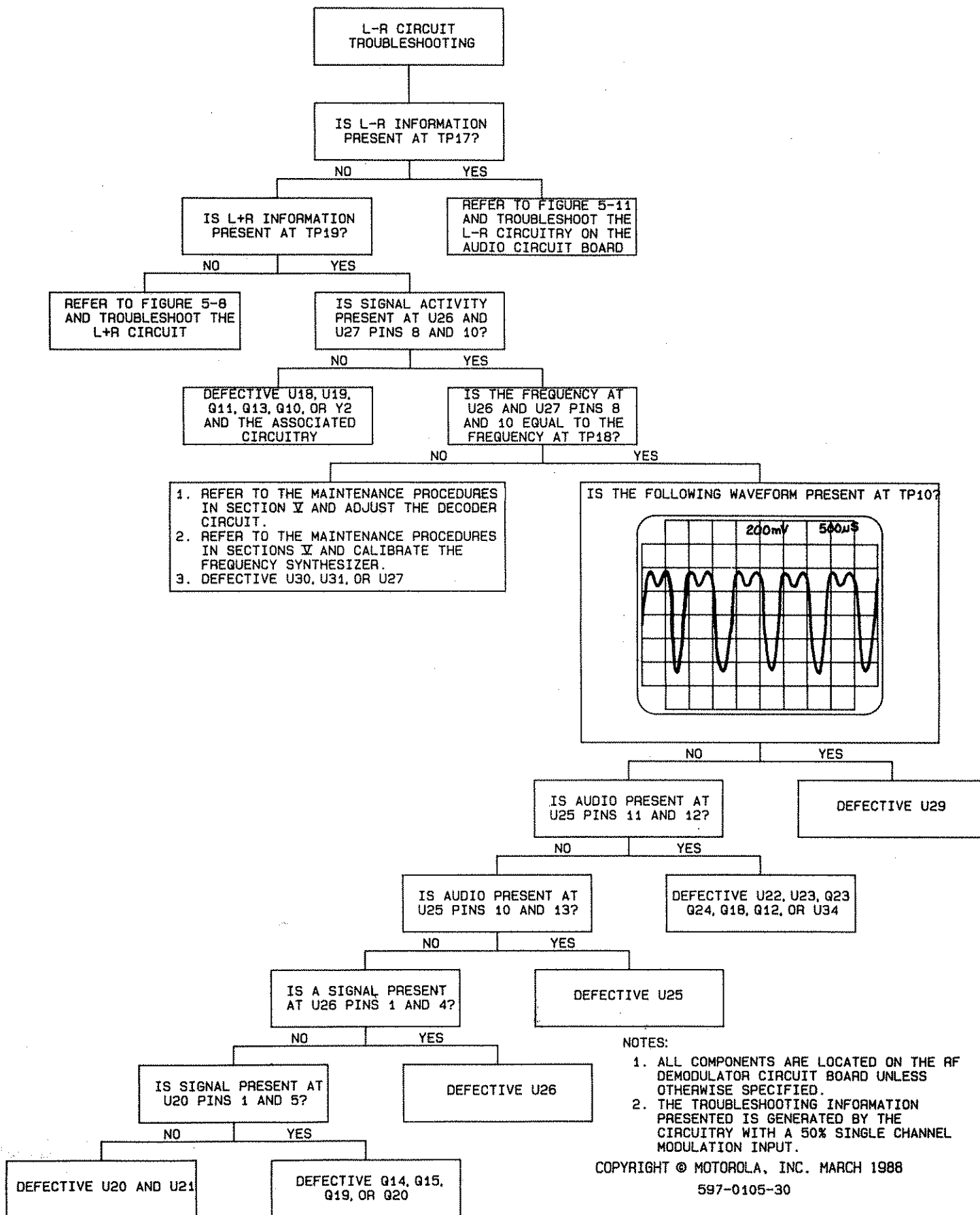
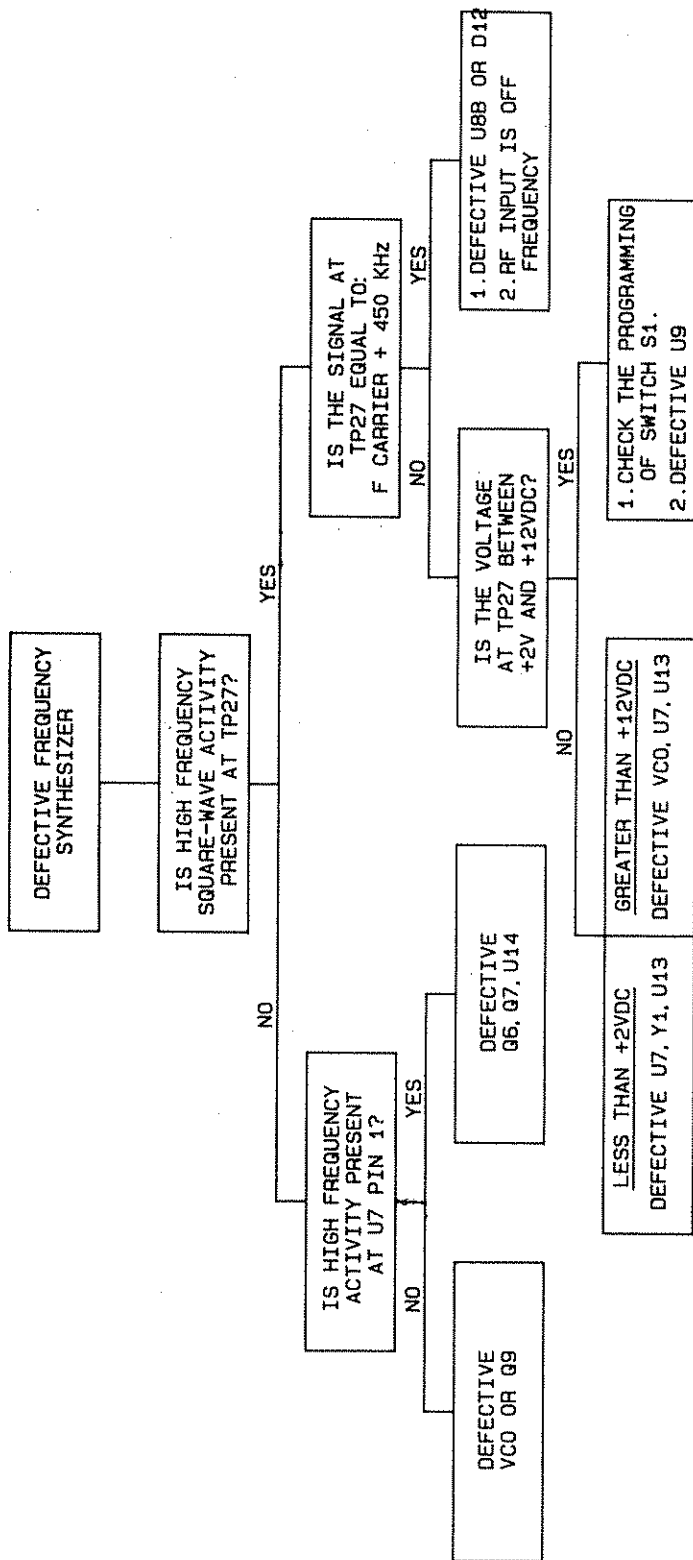

FIGURE 5-10. TROUBLESHOOTING TREE, L-R CIRCUIT

<u>SYMPTOM</u>	<u>REMEDY</u>
NO L+R INFORMATION	Check switch U13B and integrated circuit U1B and U55B.
NO L-R INFORMATION	Check switch U12B and integrated circuit U1A and U55A.
NO LEFT/L+R INFORMATION	1. Check switches U13C, U13D, U41C, and U41D.
NO RIGHT/L-R INFORMATION	2. Check integrated circuits U21, U24, and U56.
NO RIGHT/L-R INFORMATION	1. Check switches U12C, U12D, U42C, and U42D.
NO LEFT CHANNEL INFORMATION	2. Check integrated circuits U18, U25, and U57.
NO LEFT CHANNEL INFORMATION	1. Check switch U13A.
NO RIGHT CHANNEL INFORMATION	2. Check integrated circuits U3, U4, U11, U54, and U46B.
NO RIGHT CHANNEL INFORMATION	1. Check switch U12A.
NO PILOT INFORMATION (STATUS OR LEVEL)	2. Check integrated circuits U3, U4, U14, U53 and U46A.
NO PILOT INFORMATION (STATUS OR LEVEL)	Check integrated circuits U1A, U2, and U7.

597-0105-31

FIGURE 5-11. AUDIO CIRCUIT BOARD TROUBLESHOOTING



NOTES:
1. ALL COMPONENTS AND TEST POINTS ARE LOCATED ON RF DEMODULATOR CIRCUIT BOARD UNLESS OTHERWISE SPECIFIED.

COPYRIGHT © MOTOROLA, INC. MARCH 1988
597-0105-32

FIGURE 5-12. TROUBLESHOOTING TREE, DEFECTIVE FREQUENCY SYNTHESIZER

SECTION VI
PARTS LISTS

6-1. INTRODUCTION.

6-2. This section provides descriptions and part numbers of electrical components, assemblies, and selected mechanical parts required for maintenance of the Motorola Model 1410 AM Stereo Modulation Monitor. Each table entry in this section is indexed by reference designators appearing on the applicable schematic diagram.

TABLE 6-1. REPLACEABLE PARTS LISTS

TABLE NO.	DESCRIPTION	PAGE NO.
6-2	MODEL 1410 MONITOR FINAL ASSEMBLY	6-2
6-3	MODEL 1410 MONITOR HARNESS ASSEMBLY	6-2
6-4	MODEL 1410 MONITOR ACCESSORY KIT	6-3
6-5	MONITOR RF DEMODULATOR CIRCUIT BOARD ASSEMBLY	6-3
6-6	MONITOR AUDIO CIRCUIT BOARD ASSEMBLY	6-10
6-7	AUDIO CONTROL CIRCUIT BOARD ASSEMBLY	6-16
6-8	MONITOR INTERFACE CIRCUIT BOARD ASSEMBLY	6-18
6-9	MONITOR METER CIRCUIT BOARD ASSEMBLY	6-18
6-10	RF ATTENUATOR CIRCUIT BOARD ASSEMBLY	6-19
6-11	VCO MODULE CIRCUIT BOARD ASSEMBLY	6-19
6-12	MODEL 1410 MONITOR 9 kHz SPACING OPTION	6-20

TABLE 6-2. MODEL 1410 MONITOR FINAL ASSEMBLY - 907-0100-900/-903

REF. DES.	DESCRIPTION	PART NO.	QTY.
C1,C2	Capacitor, Mylar, 0.1 uF ±10%, 100V	030-1053	2
F2	Fuse, Micro, 1/4 Ampere, 125V	330-0026	1
FL1	Fused Power Connector/Voltage Selector/EMI Filter, 120/240V	360-6504	1
J27	Connector, 90° Angle, BNC	417-0222	1
J37 THRU J42	Connector, Header, 5-Pin In-line	417-4000-002	6
J44,J45	Receptacle, BNC, Insulated	417-0048	2
J46	Phone Jack, 1/4 inch (0.635 cm), 3 Conductor	417-0311	1
J47	Receptacle, BNC	417-0016	1
M1,M2	Meter, 3.5 Inch (8.89 cm), Taut Band Type	310-0039	2
P30	Connector, Housing, 6-Pin	418-0670	1
R1	Potentiometer, Dual Section, Audio Taper, 10 k Ohm ±10%, 1W	190-0009	1
T1	Transformer, Power, Line Primary: 110/220V ±10% 50/60 Hz, Single Phase Dual Secondary: 40V CT @ +700 mA/-400 mA 20.5V CT @ ±800mA	370-2358	1
U1	Integrated Circuit, MC7815CK, Positive 15V Regulator, T0-3 Case	227-7815-A	1
----	Switch, Pushwheel, 0-9 BCD, EECO 120102J (Part of Adjustable Peak Indicator Control)	340-0076	4
----	Switch, Pushwheel, 0-1 STOP, EECO 120102J01 (Part of Adjustable Peak Indicator Control)	340-0077	2
----	Socket, Transistor, T0-3 (for U1)	417-0298	1
----	Insulator, Transistor, T0-3 (for U1)	409-1815	1
----	Fuse Holder, Subminiature (for F2)	330-0001	1
----	Fuse Clip (for F1)	415-1001	2
----	Pins, Connector (for P30)	417-0053	6
----	Knob, Rogan G-30P-WD (Headphone Volume Control)	481-0021	1
----	Knob, Rogan RB-67-1-DC-M-L (RF Attenuator Assembly)	481-0021	1
----	Fastener, Turn-Lock Stud	420-0019	9
----	Retainer	420-0021	9
----	Receptacle	420-0022	9
----	RF Demodulator Circuit Board Assembly	917-0063	1
----	Monitor Audio Circuit Board Assembly	917-0064	1
----	Monitor Audio Control Circuit Board Assembly	917-0065	1
----	Monitor Interface Circuit Board Assembly	917-0066	1
----	Monitor Meter Circuit Board Assembly	917-0067	2
----	RF Attenuator Circuit Board Assembly	917-0068	1
----	VCO Module Circuit Board Assembly	917-0069	1
----	1410 Harness Assembly	947-0142	1
----	1410 Accessory Kit	957-0002	1
----- For 117V 50/60 Hz - 907-0100-900 -----			
F1	Fuse, AGC, 1A, 250V, Slow-Blow	334-0100	2
----- For 220V 50/60 Hz - 907-0100-903 -----			
F1	Fuse, AGC, 1/2A, 250V, Slow-Blow	334-0050	2
----	AC Line Cord, CEE 7/7 3-Wire European Plug	682-0003	1

TABLE 6-3. MODEL 1410 MONITOR HARNESS ASSEMBLY - 947-0142
(Sheet 1 of 2)

REF. DES.	DESCRIPTION	PART NO.	QTY.
P1 THRU P3	Connector, Ribbon Cable, 13-Pin Dual In-line	418-2600	3
P4	Plug, Housing, 8-Pin	417-0046	1
P5	Connector, Ribbon Cable, 13-Pin Dual In-line	418-2600	1
P6,P7	Plug, Housing, 2-Pin	417-0499	2
P8,P9	Connector, Ribbon Cable, 16-Pin	417-0131	2
P10,P11	Connector, Ribbon Cable, 13-Pin Dual In-line	418-2600	2
P12,P13	Plug, Housing, 14-Pin	417-1401	2

TABLE 6-3. MODEL 1410 MONITOR HARNESS ASSEMBLY - 947-0142
(Sheet 2 of 2)

REF. DES.	DESCRIPTION	PART NO.	QTY.
P14	Connector, Ribbon Cable, 13-Pin Dual In-line	418-2600	1
P25,P26	Connector, 16-Pin	417-0131	2
P28	Connector, Ribbon Cable, 13-Pin Dual In-line	418-2600	1
P37 THRU P42	Connector, Housing, 5-Pin In-line	417-0165	6
P43	Connector, Housing, 3-Pin	417-0003-001	1
----	Pins, Crimp Type (for P4, P12, P13, P37 thru P42)	417-8766	63

TABLE 6-4. MODEL 1410 MONITOR ACCESSORY KIT (Packed With Unit) - 957-0002

REF. DES.	DESCRIPTION	PART NO.	QTY.
----	Fuse, Micro, 125V, 1/4 Ampere	330-0026	1
----	Connector, Male, 6 Terminal	418-0046	3
----	AC Line Cord, N.E.M.A. 3-Wire North American Plug	682-0001	1

TABLE 6-5. MONITOR DEMODULATOR CIRCUIT BOARD ASSEMBLY - 917-0063
(Sheet 1 of 8)

REF. DES.	DESCRIPTION	PART NO.	QTY.
C1 THRU C24	Capacitor, Monolithic Ceramic, 0.1 uF ±20%, 50V	003-1054	24
C25,C26	Capacitor, Mica, 390 pF ±5%, 100V	042-3922	2
C27	Capacitor, Mica, 270pF ±5%, 300V	041-2722	1
C28	Capacitor, Silvered Mica, 100pF ±5%, 500V	040-1022	1
C29,C30	Capacitor, Mica, 270pF ±5%, 300V	041-2722	2
C31,C32	Capacitor, Electrolytic, 10 uF, 35V	023-1076	2
C33	Capacitor, Electrolytic, 10 uF, 25V, Non-Polarized	023-1075	1
C34	Capacitor, Electrolytic, 1 uF, 50V	024-1064	1
C35,C36	Capacitor, Electrolytic, 10 uF, 35V	023-1076	2
C37	Capacitor, Electrolytic, 10 uF, 25V, Non-Polarized	023-1075	1
C38 THRU C40, C42 THRU C45	Capacitor, Electrolytic, 10 uF, 35V	023-1076	7
C46	Capacitor, Electrolytic, 1 uF, 50V	024-1064	1
C47	Capacitor, Mica, 820pF ±5%, 300V	042-8222	1
C48	Capacitor, Polyester, 0.0022 uF ±10%, 100V	031-2033	1
C49	Capacitor, Monolithic Ceramic, 0.0047 uF ±5%, 100V	003-4723	1
C50	Capacitor, Electrolytic, 100 uF, 16V	020-1084	1
C51 THRU C57	Capacitor, Electrolytic, 100 uF, 25V	023-1084	7
C58	Capacitor, Ceramic Disc, 68 pF ±5%, N330, 63 Vdc, EDPT	000-6813	1
C59,C60	Capacitor, Ceramic Disc, 10 pF ±10%, 1kV, Non-Polarized	001-1014	2
C61	Capacitor, Variable, Polycarbonate, 2-27 pF	096-0009	1
C62 THRU C65	Capacitor, Electrolytic, 4700 uF, 35V	014-4795	4
C66 THRU C68	Capacitor, Mylar Film, 0.022 uF ±10%, 100V	031-2243	3
C69	Capacitor, Monolithic Ceramic, 56 pF ±10%, 200V	001-5613	1
C70 THRU C74	Capacitor, Silvered Mica, 100 pF ±5%, 500V	040-1022	5
C75,C76	Capacitor, Mica, 33 pF ±5%, 500V	042-3312	2
C77 THRU C80	Capacitor, Silvered Mica, 100pF ±5%, 500V	040-1022	4
C81,C82	Capacitor, Mica, 270 pF ±5%, 300V	041-2722	2
C83 THRU C86	Capacitor, Silvered Mica, 100 pF ±5%, 500V	040-1022	4
C87	Capacitor, Mica, 330 pF ±5%, 500V	042-3322	1
C88	Capacitor, Silvered Mica, 100 pF ±5%, 500V	040-1022	1
C89,C90	Capacitor, Mica, 270 pF ±5%, 300V	041-2722	2
C91	Capacitor, Mica, 330 pF ±5%, 500V	042-3322	1

TABLE 6-5. MONITOR DEMODULATOR CIRCUIT BOARD ASSEMBLY - 917-0063
(Sheet 2 of 8)

REF. DES.	DESCRIPTION	PART NO.	QTY.
C92	Capacitor, Mica, 470 pF ±1%, 500V	040-4721	1
C93	Capacitor, Silvered Mica, 100 pF ±5%, 500V	040-1022	1
C94	Capacitor, Mica, 150 pF ±5%, 500V	040-1522	1
C95	Capacitor, Mica, 33 pF ±5%, 500V	042-3312	1
C96 THRU C101	Capacitor, Silvered Mica, 100 pF ±5%, 500V	040-1022	6
C102	Capacitor, Ceramic Disc, 100 pF ±5%, N750, 63V, EDPT	000-1023	1
C103	Capacitor, Mylar, 0.01 uF ±10%, 100V	031-1043	1
C104 THRU C108	Capacitor, Mylar Film, 0.022 uF ±10%, 100V	031-2243	5
C109 THRU C142	Capacitor, Monolithic Ceramic, 0.1 uF ±20%, 50V	003-1054	34
C143 THRU C147, C150 THRU C154	Capacitor, Electrolytic, 10 uF, 35V	023-1076	10
C155, C156	Capacitor, Electrolytic, 3.3 uF, 50V, Non-Polarized	024-3364	2
C157, C158	Capacitor, Ceramic Disc, 10 pF ±10%, 1kV, Non-Polarized	001-1014	2
C159	Capacitor, Mica, 470 pF ±1%, 500V	040-4721	1
C160, C161	Capacitor, Mica, 680 pF ±5%, 300V	040-6824	2
C162, C163	Capacitor, Polycarbonate, 0.10 uF ±1%, 100V	030-1051	2
C164	Capacitor, Mylar, 0.22 uF ±10%, 100V	030-2253	1
C165	Capacitor, Polyester, 0.47 uF ±10%, 100V	038-4753	1
C166	Capacitor, Mylar Film, 0.047 uF ±10%, 100V	030-4743	1
C167 THRU C170	Capacitor, Polyester, 0.0022 uF ±10%, 100V	031-2033	4
C171 THRU C176	Capacitor, Mica, 5000 pF ±1%, 500V	042-5031	6
C177	Capacitor, Polyester, 6.8 uF ±10%, 63V	030-6862	1
D1, D2	Diode, Zener, 1N4733A, 5.1V ±5%, 1W	200-4733	2
D3 THRU D11	Diode, 1N4148, Silicon, 75V @ 0.3 Amperes	203-4148	9
D12	Light Emitting Diode, HLMP-1200, Red, 1.6V @ 20 mA Maximum, T1 Size	323-7344	1
D13 THRU D20	Diode, MR502, Silicon, 200V @ 3 Amperes	202-0502	8
D21, D23 THRU D30	Diode, 1N4005, Silicon, 600V @ 1 Ampere	203-4005	9
D31	Diode, MV209, Voltage Variable Capacitance, 26 pF to 32 pF range, 30V dc Maximum Reverse Voltage	205-0109	1
D32 THRU D37	Diode, 1N4148, Silicon, 75V @ 0.3 Amperes	203-4148	6
J28	Receptacle, Header, Dual In-line 13-Pin	417-2600	1
J29	Receptacle, Header, Dual In-line 8-Pin	417-1603	1
J30	Receptacle, 6-Pin	417-0677	1
J31	Receptacle, Header, 3-Pin In-line	417-0003	1
J32 THRU J35	Receptacle, Single Pin	417-0071-001	4
J43	Receptacle, Header, 3-Pin In-line	417-0003	1
J48	Receptacle, 2-Pin In-line	417-0220	1
L1	Shielded Adjustable Coil, 422-1100 uH, 92 mA Maximum, 27.84 Ohms DC Resistance	360-0038	1
L2	Shielded Adjustable Coil, 1050-3740 uH, 76 mA Maximum, 41.06 Ohms DC Resistance	360-0037	1
L3	Shielded Adjustable Coil, 147-430 uH, 121 mA Maximum, 16.32 Ohms DC Resistance	360-0035	1
L4	Shielded Adjustable Coil, 26-71 uH, 185 mA Maximum, 6.97 Ohms DC Resistance	360-0062	1
L6, L7	RF Choke, 900 kHz Tuning Range: 900 kHz ±3% Tuning Capacitance: 33 pF Q (Unloaded): 100 No. of Turns: 152	360-0060	2
L8	RF Choke, 1.8 MHz Tuning Range: 1.8 MHz ±3% Tuning Capacitance: 82 pF Q (Unloaded): 100 No. of Turns: 66	360-0061	1

TABLE 6-5. MONITOR DEMODULATOR CIRCUIT BOARD ASSEMBLY - 917-0063
(Sheet 3 of 8)

REF. DES.	DESCRIPTION	PART NO.	QTY.
L9	RF Choke, 900 kHz Tuning Range: 900 kHz $\pm 3\%$ Tuning Capacitance: 33 pF Q (Unloaded): 100 No. of Turns: 152	360-0060	1
L10 YTHRU L19	Ferrite Bead	360-0007	10
LDR1 YTHRU LDR3	Optical Isolator, VTL5C2, LDR/LED Type On Resistance: 500 Ohms Off Resistance: 1 Meg Ohm Cell Voltage: 200V Maximum Cell Current: 10 to 40 mA	323-7345	3
P27	Plug, BNC, Dual Crimp	418-0034	1
P31,P48	Jumper, Programmable, 2-Pin	340-0004	2
Q1 THRU Q7	Transistor, 2N3904, NPN, Silicon, TO-92 Case	211-3904	7
Q8	Field Effect Transistor, J271, P-Channel JFET, TO-92 Case	210-0271	1
Q9	Transistor, MPS-A14, Silicon, NPN, Darlington, TO-92 Case	211-0014	1
Q10 YTHRU Q12	Field Effect Transistor, J3100, RF, N-Channel, TO-92 Case	212-0310	3
Q13 THRU Q18	Transistor, 2N3904, NPN, Silicon, TO-92 Case	211-3904	6
Q19 YTHRU Q24	Transistor, 2N3906, PNP, Silicon, TO-92 Case	210-3906	6
R1,R2	Resistor, 845 Ohm $\pm 1\%$, 1/4W	103-8453	2
R3	Resistor, 510 Ohm $\pm 5\%$, 1/4W	100-5133	1
R4	Resistor, 2.7 k Ohm $\pm 5\%$, 1/4W	100-2743	1
R5,R6	Resistor, 510 Ohm $\pm 5\%$, 1/4W	100-5133	2
R7,R8	Resistor, 4.99 k Ohm $\pm 1\%$, 1/4W	100-5041	2
R9,R10	Resistor, 1.33 k Ohm $\pm 1\%$, 1/4W	103-1331	2
R11,R12	Resistor, 2.74 k Ohm $\pm 1\%$, 1/4W	103-2744	2
R13,R14	Resistor, 22.1 Ohm $\pm 1\%$, 1/4W	103-2212	2
R15	Resistor, 2.49 k Ohm $\pm 1\%$, 1/4W	103-2494	1
R16,R17	Resistor, 1 k Ohm $\pm 1\%$, 1/4W	103-1041	2
R18	Resistor, 100 Ohm $\pm 5\%$, 1/4W	100-1033	1
R19	Resistor, 3.6 k Ohm $\pm 5\%$, 1/4W	100-3643	1
R20	Resistor, 51 Ohm 5%, 1/4W	100-5123	1
R21	Resistor, 430 Ohm $\pm 5\%$, 1/4W	100-4333	1
R22	Resistor, 510 Ohm $\pm 5\%$, 1/4W	100-5133	1
R23	Resistor, 2.7 k Ohm $\pm 5\%$, 1/4W	100-2743	1
R24,R25	Resistor, 510 Ohm $\pm 5\%$, 1/4W	100-5133	2
R26,R27	Resistor, 1.5 k Ohm $\pm 1\%$, 1/4W	103-1504	2
R28	Resistor, 1 k Ohm $\pm 1\%$, 1/4W	103-1041	1
R29	Resistor, 649 Ohm $\pm 1\%$, 1/4W	103-6493	1
R30	Resistor, 2.7 k Ohm $\pm 5\%$, 1/4W	100-2743	1
R31	Resistor, 2.2 k Ohm $\pm 5\%$, 1/4W	100-2243	1
R32	Resistor, 180 k Ohm $\pm 5\%$, 1/4W	100-1863	1
R33	Resistor, 4.7 k Ohm $\pm 5\%$, 1/4W	100-4743	1
R34	Resistor, 24.9 k Ohm $\pm 1\%$, 1/4W	103-2495	1
R35	Resistor, 11 k Ohm $\pm 1\%$, 1/4W	103-1105	1
R36	Resistor, 10 k Ohm $\pm 5\%$, 1/4W	100-1053	1
R37	Resistor, 4.3 k Ohm $\pm 5\%$, 1/4W	100-4343	1
R38	Resistor, 51 k Ohm $\pm 5\%$, 1/4W	100-5153	1
R39	Resistor, 13.7 k Ohm $\pm 1\%$, 1/4W	103-1375	1
R40	Resistor, 5.76 k Ohm $\pm 1\%$, 1/4W	103-5764	1
R41	Resistor, 1 k Ohm $\pm 1\%$, 1/4W	103-1041	1
R42	Resistor, 4.7 k Ohm $\pm 5\%$, 1/4W	100-4743	1
R43	Resistor, 10 k Ohm $\pm 5\%$, 1/4W	100-1053	1
R44	Resistor, 1 k Ohm $\pm 5\%$, 1/4W	100-1043	1
R45,R46	Resistor, 2.7 k Ohm $\pm 5\%$, 1/4W	100-2743	2
R47	Resistor, 4.53 k Ohm $\pm 1\%$, 1/4W	103-4534	1
R48	Resistor, 11 k Ohm $\pm 1\%$, 1/4W	103-1105	1
R49	Resistor, 1.05 k Ohm $\pm 1\%$, 1/4W	103-1054	1
R50	Resistor, 20 k Ohm $\pm 1\%$, 1/4W	103-2051	1
R51,R52	Resistor, 10 k Ohm $\pm 1\%$, 1/4W	100-1051	2
R53	Resistor, 4.99 k Ohm $\pm 1\%$, 1/4W	100-5041	1
R54,R55	Resistor, 10 Ohm $\pm 5\%$, 1/4W	100-1023	2
R56	Resistor, 11.3 k Ohm $\pm 1\%$, 1/4W	103-1135	1

TABLE 6-5. MONITOR DEMODULATOR CIRCUIT BOARD ASSEMBLY - 917-0063
(Sheet 4 of 8)

REF. DES.	DESCRIPTION	PART NO.	QTY.
R57	Resistor, 1 Meg $\pm 5\%$, 1/4W	100-1073	1
R58	Resistor, 820 Ohm $\pm 5\%$, 1/4W	100-8233	1
R59	Resistor, 100 Ohm $\pm 5\%$, 1/4W	100-1033	1
R60,R61	Resistor, 10 k Ohm $\pm 5\%$, 1/4W	100-1053	2
R62	Resistor, 4.53 k Ohm $\pm 1\%$, 1/4W	103-4534	1
R63	Resistor, 10 k Ohm $\pm 1\%$, 1/4W	100-1051	1
R64	Resistor, 100 k Ohm $\pm 5\%$, 1/4W	100-1063	1
R65	Resistor, 1.82 k Ohm $\pm 1\%$, 1/4W	100-1841	1
R66,R67	Resistor, 10 k Ohm $\pm 5\%$, 1/4W	100-1053	2
R68	Resistor, 100 k Ohm $\pm 5\%$, 1/4W	100-1063	1
R69	Resistor, 10 k Ohm $\pm 5\%$, 1/4W	100-1053	1
R70	Resistor, 1 Meg Ohm $\pm 5\%$, 1/4W	100-1073	1
R71 THRU R74	Resistor, 10 k Ohm $\pm 5\%$, 1/4W	100-1053	4
R75,R76	Resistor, 24.3 k Ohm $\pm 1\%$, 1/4W	103-2435	2
R77,R78	Resistor, 24.9 k Ohm $\pm 1\%$, 1/4W	103-2495	2
R79	Resistor, 10 Ohm $\pm 5\%$, 1/4W	100-1023	1
R80,R81	Resistor, 1.2 k Ohm $\pm 5\%$, 1/4W	100-1243	2
R82	Resistor, 6.8 k Ohm $\pm 5\%$, 1/4W	100-6843	1
R83	Resistor, 10 Meg Ohm $\pm 5\%$, 1/4W	100-1083	1
R84	Resistor, 10 Ohm $\pm 5\%$, 1/4W	100-1023	1
R85	Resistor, 1.5 k Ohm $\pm 5\%$, 1/4W	100-1543	1
R86	Resistor, 1 k Ohm $\pm 5\%$, 1/4W	100-1043	1
R87	Resistor, 47 Ohm $\pm 5\%$, 1/4W	100-4723	1
R88	Resistor, 470 Ohm $\pm 5\%$, 1/4W	100-4733	1
R89	Resistor, 27 k Ohm $\pm 5\%$, 1/4W	100-2753	1
R90	Resistor, 1 k Ohm $\pm 5\%$, 1/4W	100-1043	1
R91	Resistor, 100 Ohm $\pm 5\%$, 1/4W	100-1033	1
R92	Resistor, 5.1 k Ohm $\pm 5\%$, 1/4W	100-5143	1
R93	Resistor, 27 k Ohm $\pm 5\%$, 1/4W	100-2753	1
R94	Resistor, 51 Ohm $\pm 5\%$, 1/4W	100-5123	1
R95	Resistor, 220 Ohm $\pm 5\%$, 1/4W	100-2233	1
R96	Resistor, 68.1 Ohm $\pm 1\%$, 1/4W	103-6812	1
R97	Resistor, 22.1 Ohm $\pm 1\%$, 1/4W	103-2212	1
R98	Resistor, 68.1 Ohm $\pm 1\%$, 1/4W	103-6812	1
R99	Resistor, 22.1 Ohm $\pm 1\%$, 1/4W	103-2212	1
R100	Resistor, 332 Ohm $\pm 1\%$, 1/4W	103-3323	1
R101,R104	Resistor, 150 Ohm $\pm 1\%$, 1/4W	100-1531	2
R105	Resistor, 1.82 k Ohm $\pm 1\%$, 1/4W	100-1841	1
R106	Resistor, 121 Ohm $\pm 1\%$, 1/4W	100-1231	1
R107	Resistor, 1.33 k Ohm $\pm 1\%$, 1/4W	103-1331	1
R108	Resistor, 121 Ohm $\pm 1\%$, 1/4W	100-1231	1
R109	Resistor, 365 Ohm $\pm 1\%$, 1/4W	103-3631	1
R110	Resistor, 470 Ohm $\pm 5\%$, 1/4W	100-4733	1
R111	Potentiometer, 2 k Ohm $\pm 10\%$, 1/2W	177-2044	1
R112	Potentiometer, 10 k Ohm $\pm 10\%$, 1/2W	177-1054	1
R113	Potentiometer, 1 k Ohm $\pm 10\%$, 1/2W	177-1044	1
R114	Potentiometer, 10 k Ohm $\pm 10\%$, 1/2W	177-1055	1
R115	Resistor, 470 k Ohm $\pm 5\%$, 1/4W	100-4763	1
R116	Resistor, 100 Ohm $\pm 5\%$, 1/4W	100-1033	1
R117	Resistor, 470 k Ohm $\pm 5\%$, 1/4W	100-4763	1
R118	Resistor, 2.2 k Ohm $\pm 5\%$, 1/4W	100-2243	1
R119	Resistor, 1 Meg Ohm $\pm 5\%$, 1/4W	100-1073	1
R120	Resistor, 470 k Ohm $\pm 5\%$, 1/4W	100-4763	1
R121	Resistor, 470 Ohm $\pm 5\%$, 1/4W	100-4733	1
R122	Resistor, 1.5 k Ohm $\pm 5\%$, 1/4W	100-1543	1
R123	Resistor, 5.1 k Ohm $\pm 5\%$, 1/4W	100-5143	1
R124	Resistor, 1 k Ohm $\pm 5\%$, 1/4W	100-1043	1
R125	Resistor, 330 Ohm $\pm 5\%$, 1/4W	100-3333	1
R126	Resistor, 100 Ohm $\pm 5\%$, 1/4W	100-1033	1
R127	Resistor, 1 k Ohm $\pm 5\%$, 1/4W	100-1043	1
R128,R129	Resistor, 475 Ohm $\pm 1\%$, 1/4W	103-4753	2
R130	Resistor, 4.75 k Ohm $\pm 1\%$, 1/4W	103-4741	1
R131	Resistor, 2.67 k Ohm $\pm 1\%$, 1/4W	103-2674	1
R132	Resistor, 6.19 k Ohm $\pm 1\%$, 1/4W	103-6194	1
R133	Resistor Network, 9 - 10 k Ohm $\pm 2\%$, 1/4W Resistors, Single In-line 10-Pin Package	226-1050	1

TABLE 6-5. MONITOR DEMODULATOR CIRCUIT BOARD ASSEMBLY - 917-0063
(Sheet 5 of 8)

REF. DES.	DESCRIPTION	PART NO.	QTY.
R135	Resistor, 2.43 k Ohm $\pm 1\%$, 1/4W	103-2434	1
R136	Resistor, 1.21 k Ohm $\pm 1\%$, 1/4W	103-1214	1
R137	Resistor, 2.74 k Ohm $\pm 1\%$, 1/4W	103-2744	1
R138	Resistor, 100 Ohm $\pm 1\%$, 1/4W	100-1031	1
R139	Resistor, 2.43 k Ohm $\pm 1\%$, 1/4W	103-2434	1
R140	Resistor, 5.11 k Ohm $\pm 1\%$, 1/4W	103-5141	1
R141	Resistor, 100 Ohm $\pm 1\%$, 1/4W	100-1031	1
R142	Resistor, 2.74 k Ohm $\pm 1\%$, 1/4W	103-2744	1
R143, R144	Resistor, 825 Ohm $\pm 1\%$, 1/4W	103-8253	2
R145	Resistor, 100 Ohm $\pm 5\%$, 1/4W	100-1033	1
R146	Resistor, 3.32 k Ohm $\pm 1\%$, 1/4W	103-3324	1
R147	Resistor, 2.74 k Ohm $\pm 1\%$, 1/4W	103-2744	1
R148	Resistor, 121 Ohm $\pm 1\%$, 1/4W	100-1231	1
R149	Resistor, 2.67 k Ohm $\pm 1\%$, 1/4W	103-2674	1
R150	Resistor, 100 Ohm $\pm 1\%$, 1/4W	100-1031	1
R151, R152	Resistor, 475 Ohm $\pm 1\%$, 1/4W	103-4753	2
R153	Resistor, 100 Ohm $\pm 1\%$, 1/4W	100-1031	1
R154	Resistor, 2.74 k Ohm $\pm 1\%$, 1/4W	103-2744	1
R155	Resistor, 2.43 k Ohm $\pm 1\%$, 1/4W	103-2434	1
R156	Resistor, 2.74 k Ohm $\pm 1\%$, 1/4W	103-2744	1
R157	Resistor, 2.43 k Ohm $\pm 1\%$, 1/4W	103-2434	1
R158	Resistor, 20 k Ohm $\pm 1\%$, 1/4W	103-2051	1
R159	Resistor, 5.90 k Ohm $\pm 1\%$, 1/4W	103-5904	1
R160	Resistor, 100 Ohm $\pm 1\%$, 1/4W	100-1031	1
R161, R162	Resistor, 249 Ohm $\pm 1\%$, 1/4W	103-2493	2
R163	Resistor, 4.99 k Ohm $\pm 1\%$, 1/4W	100-5041	1
R164	Resistor, 22 Ohm $\pm 5\%$, 1/4W	100-2223	1
R165	Resistor, 1.5 k Ohm $\pm 1\%$, 1/4W	103-1504	1
R166	Resistor, 4.99 k Ohm $\pm 1\%$, 1/4W	100-5041	1
R167	Resistor, 22 Ohm $\pm 5\%$, 1/4W	100-2223	1
R168	Resistor, 1.5 k Ohm $\pm 1\%$, 1/4W	103-1504	1
R169, R170	Resistor, 2.74 k Ohm $\pm 1\%$, 1/4W	103-2744	2
R172, R173	Resistor, 51.1 Ohm $\pm 1\%$, 1/4W	103-5112	2
R174	Resistor, 681 Ohm $\pm 1\%$, 1/4W	103-6813	1
R176, R177	Resistor, 22.1 Ohm $\pm 1\%$, 1/4W	103-2212	2
R178, R179	Resistor, 10 k Ohm $\pm 1\%$, 1/4W	100-1051	2
R180	Resistor, 1.62 k Ohm $\pm 1\%$, 1/4W	103-1624	1
R181	Resistor, 1.82 k Ohm $\pm 1\%$, 1/4W	100-1841	1
R182	Resistor, 1.21 k Ohm $\pm 1\%$, 1/4W	103-1214	1
R183, R184	Resistor, 68.1 Ohm $\pm 1\%$, 1/4W	103-6812	2
R185, R186	Resistor, 22.1 Ohm $\pm 1\%$, 1/4W	103-2212	2
R187	Resistor, 332 Ohm $\pm 1\%$, 1/4W	103-3323	1
R188, R189	Resistor, 475 Ohm $\pm 1\%$, 1/4W	103-4753	2
R190	Resistor, 681 Ohm $\pm 1\%$, 1/4W	103-6813	1
R191, R192	Resistor, 2.74 k Ohm $\pm 1\%$, 1/4W	103-2744	2
R195	Resistor, 1.62 k Ohm $\pm 1\%$, 1/4W	103-1624	1
R196	Resistor, 1.21 k Ohm $\pm 1\%$, 1/4W	103-1214	1
R197	Resistor, 1.82 k Ohm $\pm 1\%$, 1/4W	100-1841	1
R198 THRU R201	Resistor, 22.1 Ohm $\pm 1\%$, 1/4W	103-2212	4
R202	Resistor, 332 Ohm $\pm 1\%$, 1/4W	103-3323	1
R203, R204	Resistor, 68.1 Ohm $\pm 1\%$, 1/4W	103-6812	2
R205	Resistor, 40.2 k Ohm $\pm 1\%$, 1/4W	103-4025	1
R206	Resistor, 6.81 k Ohm $\pm 1\%$, 1/4W	103-6814	1
R207	Resistor, 5.36 k Ohm $\pm 1\%$, 1/4W	103-5364	1
R208	Resistor, 19.1 k Ohm $\pm 1\%$, 1/4W	103-1915	1
R209	Resistor, 86.6 k Ohm $\pm 1\%$, 1/4W	103-8665	1
R210	Resistor, 5.36 k Ohm $\pm 1\%$, 1/4W	103-5364	1
R211 THRU R213	Resistor, 10 Ohm $\pm 5\%$, 1/4W	100-1023	3
R214, R215	Resistor, 4.64 k Ohm $\pm 1\%$, 1/4W	103-4641	2
R216	Resistor, 10 k Ohm $\pm 1\%$, 1/4W	100-1051	1
R217	Resistor, 2.49 k Ohm $\pm 1\%$, 1/4W	103-2494	1
R218	Resistor, 10 Ohm $\pm 5\%$, 1/4W	100-1023	1
R219	Resistor, 61.9 k Ohm $\pm 1\%$, 1/4W	103-6195	1
R220	Resistor, 3.32 k Ohm $\pm 1\%$, 1/4W	103-3324	1
R221	Resistor, 1.2 Meg Ohm $\pm 5\%$, 1/4W	100-1273	1

TABLE 6-5. MONITOR DEMODULATOR CIRCUIT BOARD ASSEMBLY - 917-0063
(Sheet 6 of 8)

REF. DES.	DESCRIPTION	PART NO.	QTY.
R222	Resistor, 3.32 k Ohm \pm 1%, 1/4W	103-3324	1
R223	Resistor, 475 Ohm \pm 1%, 1/4W	103-4753	1
R224	Resistor, 100 k Ohm \pm 5%, 1/4W	100-1063	1
R226	Resistor, 150 k Ohm \pm 5%, 1/4W	100-1563	1
R228	Resistor, 10 k Ohm \pm 5%, 1/4W	100-1053	1
R229	Resistor, 10 Ohm \pm 5%, 1/4W	100-1023	1
R230	Resistor, 1.5 k Ohm \pm 5%, 1/4W	100-1543	1
R231	Resistor, 4.7 k Ohm \pm 5%, 1/4W	100-4743	1
R232	Resistor, 2.2 Meg Ohm \pm 5%, 1/4W	100-2273	1
R233	Resistor, 2.74 k Ohm \pm 1%, 1/4W	103-2744	1
R234	Resistor, 82.5 k Ohm \pm 1%, 1/4W	103-8255	1
R235	Resistor, 10 Ohm \pm 5%, 1/4W	100-1023	1
R236	Resistor, 100 Ohm \pm 5%, 1/4W	100-1033	1
R237	Resistor, 2.74 k Ohm \pm 1%, 1/4W	103-2744	1
R238	Resistor, 4.75 k Ohm \pm 1%, 1/4W	103-4741	1
R239	Resistor, 2.74 k Ohm \pm 1%, 1/4W	103-2744	1
R240	Resistor, 4.75 k Ohm \pm 1%, 1/4W	103-4741	1
R241	Resistor, 2.74 k Ohm \pm 1%, 1/4W	103-2744	1
R242	Resistor, 4.75 k Ohm \pm 1%, 1/4W	103-4741	1
R243	Resistor, 2.74 k Ohm \pm 1%, 1/4W	103-2744	1
R244	Resistor, 4.75 k Ohm \pm 1%, 1/4W	103-4741	1
R245	Resistor, 40.2 k Ohm \pm 1%, 1/4W	103-4025	1
R246,R247	Resistor, 2.74 k Ohm \pm 1%, 1/4W	103-2744	2
R248	Resistor, 8.66 k Ohm \pm 1%, 1/4W	100-8641	1
R249	Resistor, 43.2 k Ohm \pm 1%, 1/4W	103-4325	1
R250	Resistor, 11.5 k Ohm \pm 1%, 1/4W	103-1155	1
R251	Resistor, 2.74 k Ohm \pm 1%, 1/4W	103-2744	1
R252	Resistor, 40.2 k Ohm \pm 1%, 1/4W	103-4025	1
R253	Resistor, 86.6 k Ohm \pm 1%, 1/4W	103-8665	1
R254	Resistor, 19.1 k Ohm \pm 1%, 1/4W	103-1915	1
R255	Resistor, 6.81 k Ohm \pm 1%, 1/4W	103-6814	1
R256	Resistor, 2.74 k Ohm \pm 1%, 1/4W	103-2744	1
R258	Resistor, 1.5 k Ohm \pm 1%, 1/4W	103-1504	1
R259	Resistor, 1.21 k Ohm \pm 1%, 1/4W	103-1214	1
R260	Resistor, 1 k Ohm \pm 1%, 1/4W	103-1041	1
R261,R262	Resistor, 5.36 k Ohm \pm 1%, 1/4W	103-5364	2
R263,R264	Resistor, 4.64 k Ohm \pm 1%, 1/4W	103-4641	2
R265,R266	Resistor, 10 Ohm \pm 5%, 1/4W	100-1023	2
R267	Resistor, 20 k Ohm \pm 5%, 1/4W	100-2053	1
R268	Resistor, 681 Ohm \pm 1%, 1/4W	103-6813	1
R269,R270	Resistor, 2.74 k Ohm \pm 1%, 1/4W	103-2744	2
R273	Resistor, 1.62 k Ohm \pm 1%, 1/4W	103-1624	1
R274	Resistor, 750 Ohm \pm 1%, 1/4W	103-7503	1
R275	Resistor, 1.82 k Ohm \pm 1%, 1/4W	100-1841	1
R276,R277, R280,R281	Resistor, 22.1 Ohm \pm 1%, 1/4W	103-2212	4
R282,R283	Resistor, 1.5 k Ohm \pm 1%, 1/4W	103-1504	2
R284,R285	Resistor, 3.01 k Ohm \pm 1%, 1/4W	103-3014	2
R286,R287	Resistor, 1 k Ohm \pm 1%, 1/4W	103-1041	2
R288,R289	Resistor, 68.1 Ohm \pm 1%, 1/4W	103-6812	2
R290,R291	Resistor, 22.1 Ohm \pm 1%, 1/4W	103-2212	2
R292,R293	Resistor, 1 k Ohm \pm 1%, 1/4W	103-1041	2
R294	Resistor, 267 Ohm \pm 1%, 1/4W	103-2673	1
R295,R296	Resistor, 51.1 Ohm \pm 1%, 1/4W	103-5112	2
R297	Resistor, 6.81 k Ohm \pm 1%, 1/4W	103-6814	1
R298	Resistor, 332 Ohm \pm 1%, 1/4W	103-3323	1
R299,R300	Resistor, 51.1 Ohm \pm 1%, 1/4W	103-5112	2
R301	Resistor, 2.74 k Ohm \pm 1%, 1/4W	103-2744	1
R302	Resistor, 332 Ohm \pm 1%, 1/4W	103-3323	1
R303	Resistor, 2.74 k Ohm \pm 1%, 1/4W	103-2744	1
R304	Resistor, 6.81 k Ohm \pm 1%, 1/4W	103-6814	1
R305	Resistor, 51.1 Ohm \pm 1%, 1/4W	103-5112	1
R306	Resistor, 150 k Ohm \pm 5%, 1/4W	100-1563	1
R307	Resistor, 51.1 Ohm \pm 1%, 1/4W	103-5112	1
R308	Resistor, 475 Ohm \pm 1%, 1/4W	103-4753	1
R309	Resistor, 150 k Ohm \pm 5%, 1/4W	100-1563	1
R310	Resistor, 475 Ohm \pm 1%, 1/4W	103-4753	1

TABLE 6-5. MONITOR DEMODULATOR CIRCUIT BOARD ASSEMBLY - 917-0063
(Sheet 7 of 8)

REF. DES.	DESCRIPTION	PART NO.	QTY.
R311,R312	Resistor, 39.2 Ohm $\pm 1\%$, 1/4W	103-3922	2
R313	Resistor, 1.21 k Ohm $\pm 1\%$, 1/4W	103-1214	1
R314	Resistor, 6.81 k Ohm $\pm 1\%$, 1/4W	103-6814	1
R315	Resistor, 121 k Ohm $\pm 1\%$, 1/4W	103-1261	1
R316	Resistor, 475 Ohm $\pm 1\%$, 1/4W	103-4753	1
R317	Resistor, 3.92 k Ohm $\pm 1\%$, 1/4W	103-3924	1
R318	Resistor, 5.62 k Ohm $\pm 1\%$, 1/4W	103-5624	1
R319	Resistor, 221 k Ohm $\pm 1\%$, 1/4W	103-2216	1
R320	Resistor, 10 k Ohm $\pm 1\%$, 1/4W	100-1051	1
R321	Resistor, 332 k Ohm $\pm 1\%$, 1/4W	103-3326	1
R322	Resistor, 10 k Ohm $\pm 1\%$, 1/4W	100-1051	1
R323	Resistor, 39.2 k Ohm $\pm 1\%$, 1/4W	100-3951	1
R324	Resistor, 1 Meg Ohm $\pm 5\%$, 1/4W	100-1073	1
R325	Potentiometer, 500 Ohm $\pm 10\%$, 1/2W, 25T	177-5033	1
R326	Potentiometer, 10 k Ohm $\pm 10\%$, 1/2W	177-1055	1
R327	Potentiometer, 100 Ohm $\pm 10\%$, 1/2W	177-1035	1
R328	Potentiometer, 1 k Ohm $\pm 10\%$, 1/2W	177-1044	1
R329	Potentiometer, 500 k Ohm $\pm 10\%$, 1/2W	179-5065	1
R330	Potentiometer, 5 k Ohm $\pm 10\%$, 1/2W	178-5045	1
R331	Potentiometer, 100 Ohm $\pm 10\%$, 1/2W	177-1035	1
R332	Potentiometer, 10 k Ohm $\pm 10\%$, 1/2W	177-1055	1
R333	Resistor, 10 Ohm $\pm 5\%$, 1/4W	100-1023	1
R334,R335	Resistor, 1 k Ohm $\pm 5\%$, 1/4W	100-1043	2
R336	Resistor, 3.48 k Ohm $\pm 1\%$, 1/4W	103-3484	1
S1	Switch, SPST, 8-Segment, 16-Pin DIP	340-0003	1
T1	Wideband RF Transformer, 0.01 to 100 MHz, Impedance Ratio 2.5:1 Primary Impedance= 50 Ohms Secondary Impedance= 125 Ohms, Center-Tapped	370-0018	1
YP1 THRU YP24	Terminal, Turret, Double Shoulder	413-1597	24
YP25	Terminal, Turret, Single Shoulder	413-0315	1
YP26,YP27	Terminal, Turret, Double Shoulder	413-1597	2
U1,U2	Integrated Circuit, CA3183E, Five transistor Array, NPN, 16-Pin DIP	220-3183	2
U3	Integrated Circuit, MC1596L, Balanced Modulator/Demodulator, 14-Pin DIP	220-1596	1
U4,U5	Integrated Circuit, TL072CP, Dual JFET-Input Operational Amplifier, 8-Pin DIP	221-0072	2
U6	Integrated Circuit, TL074CN, Quad JFET-Input Operational Amplifier, 14-Pin DIP	221-0074	1
U7	Integrated Circuit, MC145151P, Programmable Divide-by-N 4-Bit Counter, CMOS LSI, 14-Pin DIP	220-5151	1
U8	Integrated Circuit, LM358N, Dual Operational Amplifier, 8-Pin DIP	221-0358	1
U9	Integrated Circuit, SN74HC244N, Octal Tri-State Bus Driver, 20-Pin DIP	220-4244	1
U10,U11	Integrated Circuit, LM337Y, Adjustable Negative Voltage Regulator, 1.2V to 37V, 1.5 Ampere, TO-220 Case	227-0337	2
U12	Integrated Circuit, MC14011BCP, Quad 2-Input NAND Gate, CMOS, 14-Pin DIP	228-4011	1
U13	Integrated Circuit, OP227GY, Dual Operational Amplifier, 14-Pin DIP	220-0227	1
U14	Integrated Circuit, MC10131P, Dual Type D Master-Slave, Flip-Flop, 16-Pin DIP	220-0131	1
U16,U17	Integrated Circuit, LM317Y, Adjustable Positive Voltage Regulator, 1.2V to 37V, 1.5 Ampere, TO-220 Case	227-0317	2
U18,U19	Integrated Circuit, MC10131P, Dual Type D Master-Slave, Flip-Flop, 16-Pin DIP	220-0131	2
U20 THRU U23	Integrated Circuit, CA3045D, Five Transistor Array, NPN, 14-Pin DIP	220-3045	4
U24,U25	Integrated Circuit, CA3183E, Five Transistor Array, NPN, 16-Pin DIP	220-3183	2
U26 THRU U28	Integrated Circuit, MC1596L, Balanced Modulator/Demodulator, 14-Pin DIP	220-1596	3
U29 THRU U31	Integrated Circuit, TL074CN, Quad JFET-Input Operational Amplifier, 14-Pin DIP	221-0074	3

TABLE 6-5. MONITOR DEMODULATOR CIRCUIT BOARD ASSEMBLY - 917-0063
(Sheet 8 of 8)

REF. DES.	DESCRIPTION	PART NO.	QTY.
U33,U34	Integrated Circuit, TL072CP, Dual JFET-Input Operational Amplifier, 8-Pin DIP	221-0072	2
U35	Integrated Circuit, MC10116P, Triple Differential Amplifier, 16-Pin DIP	220-0116	1
XU1,XU2	Socket, 16-Pin DIP	417-1604	2
XU3	Socket, 14-Pin DIP	417-1404	1
XU4,XU5	Socket, 8-Pin DIP	417-0804	2
XU6	Socket, 14-Pin DIP	417-1404	1
XU7	Socket, 28-Pin DIP	417-2804	1
XU8	Socket, 8-Pin DIP	417-0804	1
XU9	Socket, 20-Pin DIP	417-2004	1
XU12,XU13	Socket, 14-Pin DIP	417-1404	2
XU14,XU18, XU19,XU24, XU25	Socket, 16-Pin DIP	417-1604	5
XU29 THRU XU31	Socket, 14-Pin DIP	417-1404	3
XU33,XU34	Socket, 8-Pin DIP	417-0804	2
XU35	Socket, 16-Pin DIP	417-1604	1
Y1	Crystal, 48PD1002, 10.24 MHz, HC-18 Cinox	390-0013	1
Y2	Crystal, 3.6 MHz ± 20 parts per million from -30°C to +80°C, A/T Cut, HC18 Case	390-0014	1
----	Insulator, T0-220 (for U10,U11,U16 & U17)	409-7403	4
----	Blank Circuit Board, Monitor Demodulator	517-0063	1

TABLE 6-6. MONITOR AUDIO CIRCUIT BOARD ASSEMBLY - 917-0064
(Sheet 1 of 7)

REF. DES.	DESCRIPTION	PART NO.	QTY.
C1,C2	Capacitor, Electrolytic, 10 uF, 35V	023-1076	2
C3,C4	Capacitor, Mylar Film, 0.47 uF $\pm 2\%$, 100V	030-4753	2
C5,C6	Capacitor, Electrolytic, 10 uF, 35V	023-1076	2
C7,C8	Capacitor, Mylar Film, 0.47 uF $\pm 2\%$, 100V	030-4753	2
C9,C10	Capacitor, Electrolytic, 10 uF, 35V	023-1076	2
C11	Capacitor, Monolythic Ceramic, 0.1 uF $\pm 20\%$, 50V	003-1054	1
C12	Capacitor, Mica, 1000 pF $\pm 1\%$, 100V	041-1031	1
C13 THRU C15	Capacitor, Monolythic Ceramic, 0.1 uF $\pm 20\%$, 50V	003-1054	3
C16	Capacitor, Electrolytic, 100 uF, 16V	020-1084	1
C17,C18	Capacitor, Electrolytic, 10 uF, 35V	023-1076	2
C19,C20	Capacitor, Monolythic Ceramic, 0.1 uF $\pm 20\%$, 50V	003-1054	2
C21	Capacitor, Electrolytic, 10 uF, 35V	023-1076	1
C22	Capacitor, Polycarbonate, 0.10 uF $\pm 1\%$, 100V	030-1051	1
C23	Capacitor, Monolythic Ceramic, 0.1 uF $\pm 20\%$, 50V	003-1054	1
C24,C25	Capacitor, Silvered Mica, 100 pF $\pm 5\%$, 500V	040-1022	2
C26	Capacitor, Electrolytic, 10 uF, 35V	023-1076	1
C27	Capacitor, Polycarbonate, 0.10 uF $\pm 1\%$, 100V	030-1051	1
C28	Capacitor, Monolythic Ceramic, 0.1 uF $\pm 20\%$, 50V	003-1054	1
C29,C30	Capacitor, Polycarbonate, 0.10 uF $\pm 1\%$, 100V	030-1051	2
C31	Capacitor, Monolythic Ceramic, 0.1 uF $\pm 20\%$, 50V	003-1054	1
C32	Capacitor, Electrolytic, 100 uF, 16V	020-1084	1
C33	Capacitor, Monolythic Ceramic, 0.1 uF $\pm 20\%$, 50V	003-1054	1
C34	Capacitor, Electrolytic, 10 uF, 35V	023-1076	1
C35	Capacitor, Monolythic Ceramic, 0.1 uF $\pm 20\%$, 50V	003-1054	1
C36 THRU C39	Capacitor, Electrolytic, 10uF, 35V	023-1076	4
C40	Capacitor, Polycarbonate, 0.10 uF $\pm 1\%$, 100V	030-1051	1
C41,C42	Capacitor, Monolythic Ceramic, 0.1 uF $\pm 20\%$, 50V	003-1054	2
C43	Capacitor, Electrolytic, 10 uF, 35V	023-1076	1
C44	Capacitor, Electrolytic, 10 uF, 25V, Non-Polarized	023-1075	1
C45,C46	Capacitor, Electrolytic, 10 uF, 35V	023-1076	2
C47	Capacitor, Monolythic Ceramic, 0.1 uF $\pm 20\%$, 50V	003-1054	1
C48	Capacitor, Polycarbonate, 0.10 uF $\pm 1\%$, 100V	030-1051	1
C49	Capacitor, Monolythic Ceramic, 0.1 uF $\pm 20\%$, 50V	003-1054	1
C50	Capacitor, Electrolytic, 10 uF, 25V, Non-Polarized	023-1075	1

TABLE 6-6. MONITOR AUDIO CIRCUIT BOARD ASSEMBLY - 917-0064
(Sheet 2 of 7)

REF. DES.	DESCRIPTION	PART NO.	QTY.
C51	Capacitor, Monolythic Ceramic, 0.1 uF ±20%, 50V	003-1054	1
C52	Capacitor, Electrolytic, 10 uF, 25V, Non-Polarized	023-1075	1
C53	Capacitor, Electrolytic, 10 uF, 35V	023-1076	1
C54	Capacitor, Monolythic Ceramic, 0.1 uF ±20%, 50V	003-1054	1
C55	Capacitor, Electrolytic, 10 uF, 35V	023-1076	1
C56 THRU C61	Capacitor, Monolythic Ceramic, 0.1 uF ±20%, 50V	003-1054	6
C62	Capacitor, Electrolytic, 10 uF, 25V, Non-Polarized	023-1075	1
C63,C64	Capacitor, Monolythic Ceramic, 0.1 uF ±20%, 50V	003-1054	2
C65	Capacitor, Electrolytic, 10 uF, 25V, Non-Polarized	023-1075	1
C66	Capacitor, Ceramic Disc, 20 pF ±10%, 1kV	002-2013	1
C67	Capacitor, Electrolytic, 10 uF, 35V	023-1076	1
C68	Capacitor, Ceramic Disc, 20 pF ±10%, 1kV	002-2013	1
C69	Capacitor, Electrolytic, 10 uF, 35V	023-1076	1
C70	Capacitor, Ceramic Disc, 20 pF ±10%, 1kV	002-2013	1
C71	Capacitor, Electrolytic, 10 uF, 35V	023-1076	1
C72,C73	Capacitor, Electrolytic, 4.7 uF, 35V	024-4753	2
C74	Capacitor, Electrolytic, 10 uF, 35V	023-1076	1
C75	Capacitor, Ceramic Disc, 20 pF ±10%, 1kV	002-2013	1
C76,C77	Capacitor, Monolythic Ceramic, 0.1 uF ±20%, 50V	003-1054	2
C78,C79	Capacitor, Electrolytic, 2.2 uF, 25V dc	013-2064	2
C80	Capacitor, Electrolytic, 4.7 uF, 35V	024-4753	1
C81	Capacitor, Electrolytic, 1 uF, 50V	024-1064	1
C82	Capacitor, Monolythic Ceramic, 0.1 uF ±20%, 50V	003-1054	1
C83	Capacitor, Electrolytic, 10 uF, 35V	023-1076	1
C84	Capacitor, Electrolytic, 4.7 uF, 35V	024-4753	1
C85	Capacitor, Ceramic, 5 pF ±5%, 500V, NPO	001-5004	1
C86 THRU C88	Capacitor, Ceramic Disc, 10 pF ±10%, 1kV, Non-Polarized	001-1014	3
C89,C90	Capacitor, Monolythic Ceramic, 0.1 uF ±20%, 50V	003-1054	2
C91 THRU C93	Capacitor, Ceramic Disc, 10 pF ±10%, 1kV, Non-Polarized	001-1014	3
C94,C95	Capacitor, Monolythic Ceramic, 0.1 uF ±20%, 50V	003-1054	2
C96	Capacitor, Ceramic, 5 pF ±5%, 500V, NPO	001-5004	1
C97 THRU C107	Capacitor, Monolythic Ceramic, 0.1 uF ±20%, 50V	003-1054	11
C108	Capacitor, Electrolytic, 10 uF, 35V	023-1076	1
C109	Capacitor, Electrolytic, 100 uF, 25V	023-1084	1
C110	Capacitor, Electrolytic, 10 uF, 35V	023-1076	1
C111	Capacitor, Electrolytic, 100 uF, 25V	023-1084	1
C112	Capacitor, Electrolytic, 10 uF, 35V	023-1076	1
C113	Capacitor, Mylar, 0.22 uF ±10%, 100V	030-2253	1
C114	Capacitor, Electrolytic, 2.2 uF, 50V, Non-Polarized	020-2264	1
C115	Capacitor, Electrolytic, 1000 uF ±20%, 35V	024-1000	1
C116	Capacitor, Monolythic Ceramic, 0.1 uF ±20%, 50V	003-1054	1
C117	Capacitor, Electrolytic, 22 uF, 50V	024-2274	1
C118	Capacitor, Electrolytic, 1000 uF ±20%, 35V	024-1000	1
C119	Capacitor, Monolythic Ceramic, 0.1 uF ±20%, 50V	003-1054	1
C120	Capacitor, Mylar, 0.22 uF ±10%, 100V	030-2253	1
C121 THRU C127	Capacitor, Electrolytic, 10 uF, 35V	023-1076	7
C128 THRU C131	Capacitor, Electrolytic, 100 uF, 25V	023-1084	4
C134	Capacitor, Electrolytic, 2.2 uF, 50V, Non-Polarized	020-2264	1
C135	Capacitor, Electrolytic, 22 uF, 50V	024-2274	1
C136,C137	Capacitor, Electrolytic, 1000 uF ±20%, 35V	024-1000	2
C138,C139	Capacitor, Monolythic Ceramic, 0.1 uF ±20%, 50V	003-1054	2
C140	Capacitor, Electrolytic, 10 uF, 35V	023-1076	1
C143,C144	Capacitor, Ceramic Disc, 10 pF ±10%, 1 kV, Non-Polarized	001-1014	2
D1 THRU D30	Diode, 1N4148, Silicon, 75V @ 0.3 Amperes	203-4148	30
D31,D32	Diode, 1N4005, Silicon, 600V @ 1 Ampere	203-4005	2
D35,D36	Diode, 1N4148, Silicon, 75V @ 0.3 Amperes	203-4148	2
D37 THRU D42	Diode, 1N4005, Silicon, 600V @ 1 Ampere	203-4005	6
J1 THRU J3	Connector, Header, 13-Pin Dual In-Line	417-2600	3
J4	Connector, Header, 20-Pin In-Line	417-0200	.4
J5	Connector, Header, 13-Pin Dual In-Line	417-2600	1
J6,J7	Connector, Header, 2-Pin In-Line	417-4004	2

TABLE 6-6. MONITOR AUDIO CIRCUIT BOARD ASSEMBLY - 917-0064
(Sheet 3 of 7)

REF. DES.	DESCRIPTION	PART NO.	QTY.
J8,J9	Connector, Header, 8-Pin Dual In-Line	417-1603	2
J36	Connector, Header, 2 Pin In-Line	417-4004	1
P36	Jumper, Programmable, 2-Pin	340-0004	1
Q1	Transistor, 2N3906, PNP, Silicon, TO-92 Case	210-3906	1
R1,R2	Resistor, 10 Ohm $\pm 5\%$, 1/4W	100-1023	2
R3	Resistor, 88.7 k Ohm $\pm 1\%$, 1/4W	103-8875	1
R4	Resistor, 590 Ohm $\pm 1\%$, 1/4W	100-5931	1
R5	Resistor Network, 10-10 k Ohm 0.5% Resistors, 0.7W Total Dissipation, 16-Pin DIP	226-0392	1
R6	Resistor, 357 k Ohm $\pm 1\%$, 1/4W	103-3576	1
R7,R8	Resistor, 10 Ohm $\pm 5\%$, 1/4W	100-1023	2
R9	Resistor, 10 k Ohm $\pm 5\%$, 1/4W	100-1053	1
R10	Resistor, 3.32 k Ohm $\pm 1\%$, 1/4W	103-3324	1
R11	Potentiometer, 500 Ohm $\pm 10\%$, 1/2W	177-5033	1
R12	Resistor, 806 Ohm $\pm 1\%$, 1/4W	100-8031	1
R13	Resistor, 2.4 k Ohm $\pm 5\%$, 1/4W	100-2443	1
R14	Resistor, 10k Ohm $\pm 5\%$, 1/4W	100-1053	1
R15	Resistor, 4.42 k Ohm $\pm 1\%$, 1/4W	103-4441	1
R16	Potentiometer, 500 Ohm $\pm 10\%$, 1/2W	177-5033	1
R17	Resistor, 806 Ohm $\pm 1\%$, 1/4W	100-8031	1
R18,R19	Resistor, 10 Meg Ohm $\pm 5\%$, 1/4W	100-1083	2
R20	Resistor, 78.7 k Ohm $\pm 1\%$, 1/4W	103-7875	1
R21	Resistor, 523 Ohm $\pm 1\%$, 1/4W	103-5233	1
R22	Resistor Network, 10-10 k Ohm 0.5% Resistors, 0.7W Total Dissipation, 16-Pin DIP	226-0392	1
R23	Resistor, 316 k Ohm $\pm 1\%$, 1/4W	100-3161	1
R24,R25	Resistor, 10 Ohm $\pm 5\%$, 1/4W	100-1023	2
R26,R27	Resistor, 1.5 Meg Ohm $\pm 5\%$, 1/4W	100-1573	2
R28	Resistor, 10 Ohm $\pm 5\%$, 1/4W	100-1023	1
R29 THRU R31	Resistor, 20 k Ohm $\pm 5\%$, 1/4W	100-2053	3
R32	Resistor, 100 k Ohm $\pm 5\%$, 1/4W	100-1063	1
R33	Resistor, 1.05 k Ohm $\pm 1\%$, 1/4W	103-1054	1
R34	Resistor, 10 Ohm $\pm 5\%$, 1/4W	100-1023	1
R35	Resistor, 69.8 k Ohm $\pm 1\%$, 1/4W	103-6985	1
R36	Resistor, 6.2 k Ohm $\pm 5\%$, 1/4W	100-6243	1
R37	Potentiometer, 10 k Ohm $\pm 10\%$, 1/2W	177-1055	1
R38,R39	Resistor, 63.4 k Ohm $\pm 1\%$, 1/4W	103-6345	2
R40	Resistor, 100 k Ohm $\pm 5\%$, 1/4W	100-1063	1
R41 THRU R43	Resistor, 63.4 k Ohm $\pm 1\%$, 1/4W	103-6345	3
R44	Resistor, 5.1 k Ohm $\pm 5\%$, 1/4W	100-5143	1
R45	Resistor Network, 10-10 k Ohm 0.5% Resistors, 0.7W Total Dissipation, 16-Pin DIP	226-0392	1
R46	Resistor, 63.4 k Ohm $\pm 1\%$, 1/4W	103-6345	1
R47	Resistor, 4.42 k Ohm $\pm 1\%$, 1/4W	103-4441	1
R48	Potentiometer, 500 Ohm $\pm 10\%$, 1/2W	177-5033	1
R49	Resistor, 806 Ohm $\pm 1\%$, 1/4W	100-8031	1
R50	Resistor, 10 k Ohm $\pm 5\%$, 1/4W	100-1053	1
R51	Resistor, 2.4 k Ohm $\pm 5\%$, 1/4W	100-2443	1
R52	Resistor, 10 Meg Ohm $\pm 5\%$, 1/4W	100-1083	1
R53	Resistor, 4.99 k Ohm $\pm 1\%$, 1/4W	100-5041	1
R54	Resistor, 59.0 k Ohm $\pm 1\%$, 1/4W	103-5905	1
R55	Potentiometer, 10 k Ohm $\pm 10\%$, 1/2W	177-1055	1
R56	Resistor Network, 10-10 k Ohm 0.5% Resistors, 0.7W Total Dissipation, 16-Pin DIP	226-0392	1
R57,R58	Resistor, 453 k Ohm $\pm 1\%$, 1/4W	100-4561	2
R59,R60	Resistor, 10 Ohm $\pm 5\%$, 1/4W	100-1023	2
R61	Resistor, 5.1 k Ohm $\pm 5\%$, 1/4W	100-5143	1
R62	Resistor, 59.0 k Ohm $\pm 1\%$, 1/4W	103-5905	1
R63	Potentiometer, 10 k Ohm $\pm 10\%$, 1/2W	177-1055	1
R64,R65	Resistor, 453 k Ohm $\pm 1\%$, 1/4W	100-4561	2
R66	Resistor, 10 k Ohm $\pm 5\%$, 1/4W	100-1053	1
R67	Resistor, 1.5 Meg Ohm $\pm 5\%$, 1/4W	100-1573	1
R68	Resistor, 1 k Ohm $\pm 5\%$, 1/4W	100-1043	1
R69 THRU R72	Resistor, 10 Ohm $\pm 5\%$, 1/4W	100-1023	4

TABLE 6-6. MONITOR AUDIO CIRCUIT BOARD ASSEMBLY - 917-0064
(Sheet 4 of 7)

REF. DES.	DESCRIPTION	PART NO.	QTY.
R73	Resistor, 1 Meg Ohm $\pm 5\%$, 1/4W	100-1073	1
R74	Resistor, 10 Ohm $\pm 5\%$, 1/4W	100-1023	1
R75	Resistor, 374 k Ohm $\pm 1\%$, 1/4W	103-3746	1
R76	Resistor, 20 k Ohm $\pm 5\%$, 1/4W	100-2053	1
R77	Resistor, 100 k Ohm $\pm 5\%$, 1/4W	100-1063	1
R78 THRU R80	Resistor, 10 Ohm $\pm 5\%$, 1/4W	100-1023	3
R81	Resistor, 100 k Ohm $\pm 5\%$, 1/4W	100-1063	1
R83,R84	Resistor, 10 Ohm $\pm 5\%$, 1/4W	100-1023	2
R85	Resistor, 10.0 k Ohm $\pm 1\%$, 1/4W	100-1051	1
R86	Resistor, 27.4 k Ohm $\pm 1\%$, 1/4W	103-2751	1
R87,R88	Resistor, 2 k Ohm $\pm 5\%$, 1/4W	100-2043	2
R89	Resistor, 1.2 Meg Ohm $\pm 5\%$, 1/4W	100-1273	1
R90 THRU R103	Resistor, 1.5 K Ohm $\pm 5\%$, 1/4W	100-1543	14
R104	Resistor, 10 k Ohm $\pm 5\%$, 1/4W	100-1053	1
R105	Resistor, 10 k Ohm $\pm 1\%$, 1/4W	100-1051	1
R106	Resistor, 5.1 k Ohm $\pm 5\%$, 1/4W	100-5143	1
R107	Resistor, 1 k Ohm $\pm 1\%$, 1/4W	100-1041	1
R108	Resistor, 100 k Ohm $\pm 5\%$, 1/4W	100-1063	1
R109	Resistor, 1 k Ohm $\pm 1\%$, 1/4W	100-1041	1
R110,R111	Resistor, 100 k Ohm $\pm 5\%$, 1/4W	100-1063	2
R112	Resistor, 10 k Ohm $\pm 1\%$, 1/4W	100-1051	1
R113	Resistor, 5.1 k Ohm $\pm 5\%$, 1/4W	100-5143	1
R114	Resistor, 10 k Ohm $\pm 1\%$, 1/4W	100-1051	1
R115	Resistor, 10 Ohm $\pm 5\%$, 1/4W	100-1023	1
R116	Resistor, 15.8 k Ohm $\pm 1\%$, 1/4W	103-1585	1
R117	Resistor, 2.15 k Ohm $\pm 1\%$, 1/4W	103-2154	1
R118	Resistor, 17.4 k Ohm $\pm 1\%$, 1/4W	103-1745	1
R119	Resistor, 10 k Ohm $\pm 1\%$, 1/4W	100-1051	1
R120	Resistor, 10 Ohm $\pm 5\%$, 1/4W	100-1023	1
R121	Resistor, 2.15 k Ohm $\pm 1\%$, 1/4W	103-2154	1
R122	Resistor, 10 k Ohm $\pm 1\%$, 1/4W	100-1051	1
R123	Resistor, 10 Ohm $\pm 5\%$, 1/4W	100-1023	1
R124,R125	Resistor, 750 k Ohm $\pm 5\%$, 1/4W	100-7563	2
R126	Resistor, 10 Ohm $\pm 5\%$, 1/4W	100-1023	1
R127	Resistor, 100 k Ohm $\pm 5\%$, 1/4W	100-1063	1
R128	Resistor, 9.09 k Ohm $\pm 1\%$, 1/4	103-9041	1
R129	Resistor, 2.05 k Ohm $\pm 1\%$, 1/4W	103-2054	1
R130	Resistor, 2.15 k Ohm $\pm 1\%$, 1/4W	103-2154	1
R131	Resistor, 1 k Ohm $\pm 1\%$, 1/4W	100-1041	1
R132	Resistor, 681 Ohm $\pm 1\%$, 1/4W	103-6813	1
R133	Resistor, 2.15 k Ohm $\pm 1\%$, 1/4W	103-2154	1
R134	Resistor, 1 k Ohm $\pm 1\%$, 1/4W	100-1041	1
R135	Resistor, 9.09 k Ohm $\pm 1\%$, 1/4W	103-9041	1
R136	Resistor, 2.05 k Ohm $\pm 1\%$, 1/4W	103-2054	1
R137	Resistor, 681 Ohm $\pm 1\%$, 1/4W	103-6813	1
R138,R139	Resistor, 10 k Ohm $\pm 5\%$, 1/4W	100-1053	2
R140,R141	Resistor, 100 k Ohm $\pm 5\%$, 1/4W	100-1063	2
R142,R143	Resistor, 10 k Ohm $\pm 5\%$, 1/4W	100-1053	2
R144,R145	Resistor, 100 k Ohm $\pm 5\%$, 1/4W	100-1063	2
R146	Resistor, 200 k Ohm $\pm 5\%$, 1/4W	100-2063	1
R147	Resistor, 100 K Ohm $\pm 5\%$, 1/4W	100-1063	1
R148	Resistor, 6.2 k Ohm $\pm 5\%$, 1/4W	100-6243	1
R149	Resistor, 1 Meg Ohm $\pm 5\%$, 1/4W	100-1073	1
R150	Resistor, 20 k Ohm $\pm 5\%$, 1/4W	100-2053	1
R151,R152	Resistor, 100 k Ohm $\pm 5\%$, 1/4W	100-1063	2
R153	Resistor, 47 k Ohm $\pm 5\%$, 1/4W	100-4753	1
R154	Resistor, 10 Ohm $\pm 5\%$, 1/4W	100-1023	1
R155	Resistor, 10 k Ohm $\pm 5\%$, 1/4W	100-1053	1
R156 THRU R158	Resistor, 100 k Ohm $\pm 5\%$, 1/4W	100-1063	3
R159	Resistor, 316 k Ohm $\pm 1\%$, 1/4W	100-3161	1
R160	Resistor, 10 k Ohm $\pm 1\%$, 1/4W	100-1051	1
R161	Resistor, 316 k Ohm $\pm 1\%$, 1/4W	100-3161	1
R162 THRU R165	Resistor, 100 k Ohm $\pm 5\%$, 1/4W	100-1063	4

TABLE 6-6. MONITOR AUDIO CIRCUIT BOARD ASSEMBLY - 917-0064
(Sheet 5 of 7)

REF. DES.	DESCRIPTION	PART NO.	QTY.
R166	Resistor, 10 k Ohm $\pm 1\%$, 1/4W	100-1051	1
R167	Resistor, 1 K Ohm $\pm 1\%$, 1/4W	100-1041	1
R168	Resistor, 4.53 k Ohm $\pm 1\%$, 1/4W	103-4534	1
R169	Resistor, 147 k Ohm $\pm 1\%$, 1/4W	103-1476	1
R170	Resistor, 34.8 k Ohm $\pm 1\%$, 1/4W	103-3485	1
R171	Resistor, 10.2 k Ohm $\pm 1\%$, 1/4W	103-1025	1
R172	Resistor, 100 k Ohm $\pm 5\%$, 1/4W	100-1063	1
R173	Resistor, 1 k Ohm $\pm 1\%$, 1/4W	100-1041	1
R174	Resistor, 4.53 k Ohm $\pm 1\%$, 1/4W	103-4534	1
R175	Resistor, 147 k Ohm $\pm 1\%$, 1/4W	103-1476	1
R176	Resistor, 34.8 k Ohm $\pm 1\%$, 1/4W	103-3485	1
R177	Resistor, 10.2 k Ohm $\pm 1\%$, 1/4W	103-1025	1
R178 THRU R180	Resistor, 100 k Ohm $\pm 5\%$, 1/4W	100-1063	3
R181 THRU R187	Resistor, 1.5 k Ohm $\pm 5\%$, 1/4W	100-1543	7
R188	Resistor, 10 k Ohm $\pm 5\%$, 1/4W	100-1053	1
R189,R190	Resistor, 20 k Ohm $\pm 5\%$, 1/4W	100-2053	2
R191 THRU R197	Resistor, 1.5 k Ohm $\pm 5\%$, 1/4W	100-1543	7
R198	Resistor, 10 k Ohm $\pm 5\%$, 1/4W	100-1053	1
R199,R200	Resistor, 20 k Ohm $\pm 5\%$, 1/4W	100-2053	2
R201	Resistor, 22 k Ohm $\pm 5\%$, 1/4W	100-2253	1
R202	Resistor, 680 Ohm $\pm 5\%$, 1/4W	100-6833	1
R203	Resistor, 22 k Ohm $\pm 5\%$, 1/4W	100-2253	1
R204,R205	Resistor, 10 Ohm $\pm 5\%$, 2W	130-1023	2
R206	Resistor, 2 Ohm $\pm 5\%$, 1/4W	100-1013	1
R207,R208	Resistor, 10 Ohm $\pm 5\%$, 1/4W	100-1023	2
R210	Resistor, 10 k Ohm $\pm 1\%$, 1/4W	100-1051	1
R211	Resistor, 100 Ohm $\pm 1\%$, 1/4W	100-1031	1
R212	Resistor, 383 Ohm $\pm 1\%$, 1/4W	103-3833	1
R213	Resistor, 100 Ohm $\pm 1\%$, 1/4W	100-1031	1
R214	Resistor, 383 Ohm $\pm 1\%$, 1/4W	103-3833	1
R215	Resistor, 10 k Ohm $\pm 1\%$, 1/4W	100-1051	1
R216	Resistor, 17.4 k Ohm $\pm 1\%$, 1/4W	103-1745	1
R217	Resistor, 15.8 k Ohm $\pm 1\%$, 1/4W	103-1585	1
R218	Resistor, 12 k Ohm $\pm 5\%$, 1/4W	100-1253	1
R219	Resistor, 22 k Ohm $\pm 5\%$, 1/4W	100-2253	1
R220	Resistor, 680 Ohm $\pm 5\%$, 1/4W	100-6833	1
R221	Resistor, 22 k Ohm $\pm 5\%$, 1/4W	100-2253	1
R222,R223	Resistor, 10 Ohm $\pm 5\%$, 2W	130-1023	2
R224	Resistor, 2 Ohm $\pm 5\%$, 1/4W	100-1013	1
R225	Resistor, 12 k Ohm $\pm 5\%$, 1/4W	100-1253	1
R226,R227	Resistor, 5.1 k Ohm $\pm 5\%$, 1/4W	100-5143	2
R228 THRU R231	Resistor, 10 Ohm $\pm 5\%$, 1/4W	100-1023	4
R232 THRU R235	Resistor, 150 Ohm $\pm 1\%$, 1/4W	100-1531	4
R236,R237	Resistor, 10 Ohm $\pm 5\%$, 1/4W	100-1023	2
R238	Resistor, 4.87 k Ohm $\pm 1\%$, 1/4W	103-4874	1
R239	Resistor, 1.37 k Ohm $\pm 1\%$, 1/4W	100-1341	1
R240	Resistor, 10 Ohm $\pm 5\%$, 1/4W	100-1023	1
R241,R242	Resistor, 2 k Ohm $\pm 5\%$, 1/4W	100-2043	2
R243,R245	Resistor, 7.50 k Ohm $\pm 1\%$, 1/4W	103-7541	2
R247,R248	Resistor, 10 k Ohm $\pm 5\%$, 1/4W	100-1053	2
TP1 THRU TP10	Terminal, Turret, Double Shoulder	413-1597	10
TP-11	Terminal, Turret, Single Shoulder	413-0315	1
U1,U2	Integrated Circuit, TL072CP, Dual JFET-Input Operational Amplifier, 8-Pin DIP	221-0072	2
U3,U4	Integrated Circuit, RC4559NB, Dual Low Noise Operational Amplifier, 8-Pin DIP	221-4559	2
U5	Integrated Circuit, LM339AN, Quad Comparator, 14-Pin DIP	221-0339	1
U6	Integrated Circuit, MC14538B, Dual Retriggerable, Resettable Monostable Multivibrator, CMOS, 16-Pin DIP	228-4538	1
U7	Integrated Circuit, RC4559NB, Dual Low Noise Operational Amplifier, 8-Pin DIP	221-4559	1
U8,U9	Integrated Circuit, CD4069CN, Hex Inverter, CMOS, 14-Pin DIP	228-4069	2

TABLE 6-6. MONITOR AUDIO CIRCUIT BOARD ASSEMBLY - 917-0064
(Sheet 6 of 7)

REF. DES.	DESCRIPTION	PART NO.	QTY.
U10,U11	Integrated Circuit, TL072CP, Dual JFET-Input Operational Amplifier, 8-Pin DIP	221-0072	2
U12,U13	Integrated Circuit, CD4066BE, Quad Bilateral Switch, 14-Pin DIP	225-0004	2
U14	Integrated Circuit, TL072CP, Dual JFET-Input Operational Amplifier, 8-Pin DIP	221-0072	1
U15,U16	Integrated Circuit, MC14013BCP, Dual Type D Flip-Flop, CMOS, 14-Pin DIP	228-4013	2
U17	Integrated Circuit, MC14023B, CMOS, Triple 3-Input NAND Gate	228-4023	1
U18	Integrated Circuit, TL072CP, Dual JFET-Input Operational Amplifier, 8-Pin DIP	221-0072	1
U19,U20	Integrated Circuit, MC14538B, Dual Retriggerable, Resettable Monostable Multivibrator, CMOS, 16-Pin DIP	228-4538	2
U21	Integrated Circuit, TL072CP, Dual JFET-Input Operational Amplifier, 8-Pin DIP	221-0072	1
U22,U23	Integrated Circuit, ULN2004A, 7 NPN Darlington Driver Pack, 16-Pin DIP	226-2004	2
U24 THRU U26	Integrated Circuit, TL072CP, Dual JFET-Input Operational Amplifier, 8-Pin DIP	221-0072	3
U27	Integrated Circuit, LM339AN, Quad Comparator, 14-Pin DIP	221-0339	1
U28,U29	Integrated Circuit, MC14001, CMOS, Quad 2-Input NOR Gate, 14-Pin DIP	228-4001	2
U30	Integrated Circuit, MC14538B, Dual Retriggerable, Resettable Monostable Multivibrator, CMOS, 16-Pin DIP	228-4538	1
U31,U32	Integrated Circuit, CD4081B, AND Gate, CMOS, 14-Pin DIP	225-0008	2
U33	Integrated Circuit, MC14013BCP, Dual Type D Flip-Flop, CMOS, 14-Pin DIP	228-4013	1
U34	Integrated Circuit, MC14538B, Dual Retriggerable, Resettable Monostable Multivibrator, CMOS, 16-Pin DIP	228-4538	1
U35,U36	Integrated Circuit, MC14516B, Binary Up/Down Counter, CMOS, 16-Pin DIP	228-4516	2
U37,U38	Integrated Circuit, MC14028BCP, BCD-to-Decimal Decoder, 14-Pin DIP	228-4028	2
U39 THRU U42	Integrated Circuit, CD4066BE, CMOS, Quad Bilateral Switch, 14-Pin DIP	225-0004	4
U43,U44	Integrated Circuit, ULN2004A, 7 NPN Darlington Driver Pack, 16-Pin DIP	226-2004	2
U45	Integrated Circuit, TDA2030V, Audio Power Amplifier, 14W Output, Pentawatt Package	220-2030	1
U46	Integrated Circuit, RC4559NB, Dual Low Noise Operational Amplifier, 8-Pin DIP	221-4559	1
U49	Integrated Circuit, LM317T, Adjustable Positive Voltage Regulator, 1.2V to 37V, 1.5 Ampere, TO-220 Case	227-0317	1
U50	Integrated Circuit, LM337T, Adjustable Negative Voltage Regulator, 1.2V to 37V, 1.5 Ampere, TO-220 Case	227-0337	1
U51	Integrated Circuit, TL072CP, Dual JFET-Input Operational Amplifier, 8-Pin DIP	221-0072	1
U52	Integrated Circuit, TDA2030V, Audio Power Amplifier, 14W Output, Pentawatt Package	220-2030	1
U53 THRU U55	Integrated Circuit, RC4559NB, Dual Low Noise Operational Amplifier, 8-Pin DIP	221-4559	3
U56,U57	Integrated Circuit, TL072CP, Dual JFET-Input Operational Amplifier, 8-Pin DIP	221-0072	2
XR5,XR22, XR45,XR56	Socket, 16-Pin DIP	417-1604	4
XU1 THRU XU4	Socket, 8-Pin DIP	417-0804	4
XU5	Socket, 14-Pin DIP	417-1404	1
XU6	Socket, 16-Pin DIP	417-1604	1
XU7	Socket, 8-Pin DIP	417-0804	1
XU8,XU9	Socket, 14-Pin DIP	417-1404	2
XU10,XU11	Socket, 8-Pin DIP	417-0804	2
XU12,XU13	Socket, 14-Pin DIP	417-1404	2
XU14	Socket, 8-Pin DIP	417-0804	1
XU15 THRU XU17	Socket, 14-Pin DIP	417-1404	3
XU18	Socket, 8-Pin DIP	417-0804	1
XU19,XU20	Socket, 16-Pin DIP	417-1604	2

TABLE 6-6. MONITOR AUDIO CIRCUIT BOARD ASSEMBLY - 917-0064
(Sheet 7 of 7)

REF. DES.	DESCRIPTION	PART NO.	QTY.
XU21	Socket, 8-Pin DIP	417-0804	1
XU22,XU23	Socket, 16-Pin DIP	417-1604	2
XU24 THRU XU26	Socket, 8-Pin DIP	417-0804	3
XU27 THRU XU29	Socket, 14-Pin DIP	417-1404	3
XU30	Socket, 16-Pin DIP	417-1604	1
XU31 THRU XU33	Socket, 14-Pin DIP	417-1404	3
XU34 THRU XU38	Socket, 16-Pin DIP	417-1604	5
XU39 THRU XU42	Socket, 14-Pin DIP	417-1404	4
XU43,XU44	Socket, 16-Pin DIP	417-1604	2
XU46,XU51, XU53 THRU XU57	Socket, 8-Pin DIP	417-0804	7
----	Insulator, Y0-220 (for U45,U49,U50, and U52)	409-7403	4
----	Blank Circuit Board Monitor Audio	517-0064	1

TABLE 6-7. AUDIO CONTROL CIRCUIT BOARD ASSEMBLY - 917-0065
(Sheet 1 of 2)

REF. DES.	DESCRIPTION	PART NO.	QTY.
C1,C2	Capacitor, Electrolytic, 100 uF, 25V	023-1084	2
C3,C4	Capacitor, Monolythic Ceramic, 0.1 uF ±20%, 50V	003-1054	2
C5,C7	Capacitor, Electrolytic, 100 uF, 25V	023-1084	2
C8 THRU C10	Capacitor, Monolythic Ceramic, 0.1 uF ±20%, 50V	003-1054	3
D1 THRU D6	Diode, 1N4148, Silicon, 75V @ 0.3 Amperes	203-4148	6
DS1	Indicator, LED, Red, 521-9212, 1.7V @ 50 mA Maximum	323-9217	1
DS2	Indicator, LED, Green, 521-9175, 3V @ 40 mA Maximum	323-9224	1
DS3 THRU DS7	Indicator, LED, Red, 521-9212, 1.7V @ 50 mA Maximum	323-9217	5
DS8	Indicator, LED, Green, 521-9175, 3V @ 40 mA Maximum	323-9224	1
DS17	Indicator, LED, Yellow, 521-9176, 3V @ 40 mA Maximum	323-9225	1
DS18	Indicator, LED, Red, 521-9212, 1.7V @ 50 mA Maximum	323-9217	1
DS19	Indicator, LED, Green, 521-9175, 3V @ 40 mA Maximum	323-9224	1
DS20 THRU DS24	Indicator, LED, Red, 521-9212, 1.7V @ 50 mA Maximum	323-9217	5
DS25	Indicator, LED, Green, 521-9175, 3V @ 40 mA Maximum	323-9224	1
DS32	Indicator, LED, Yellow, 521-9176, 3V @ 40 mA Maximum	323-9225	1
DS33	LED, Multicolor, HDSP-4836, 10-Element Bar Graph Array	320-0013	1
J10,J11	Connector, Header, 13-Pin Dual In-Line	417-2600	2
J12,J13	Connector, Header, 20-Pin In-Line	417-0200	2
Q1	Transistor, 2N3904, NPN, Silicon, Y0-92 Case	211-3904	1
Q2,Q3	Transistor, 2N3906, PNP, Silicon, Y0-92 Case	210-3906	2
R1	Resistor Network, 9 - 10 k Ohm ±2%, 1/4W Resistors, Single In-Line 10-Pin Package	226-1050	1
R2	Resistor, 1 k Ohm ±1%, 1/4W	103-1041	1
R3	Resistor, 1.24 k Ohm ±1%, 1/4W	103-1244	1
R4	Resistor, 10 Ohm ±5%, 1/4W	100-1023	1
R5	Resistor, 2.49 k Ohm ±1%, 1/4W	103-2494	1
R6	Resistor, 4.99 k Ohm ±1%, 1/4W	100-5041	1
R7	Resistor, 10 k Ohm ±1%, 1/4W	100-1051	1
R8	Resistor, 12.4 k Ohm ±1%, 1/4W	103-1245	1
R9	Resistor, 100 Ohm ±5%, 1/4W	100-1033	1
R10	Resistor, 24.9 k Ohm ±1%, 1/4W	103-2495	1
R11	Resistor, 49.9 k Ohm ±1%, 1/4W	103-4951	1
R12	Resistor, 100 k Ohm ±1%, 1/4W	103-1062	1
R13	Resistor, 4.7 Meg Ohm ±5%, 1/4W	100-4773	1
R14	Resistor, 1.24 k Ohm ±1%, 1/4W	103-1244	1
R15	Potentiometer, 500 Ohm ±10%, 1/2W	177-5032	1
R16	Resistor, 2 k Ohm ±5%, 1/4W	100-2043	1
R17	Resistor, 10 k Ohm ±1%, 1/4W	100-1051	1

TABLE 6-7. AUDIO CONTROL CIRCUIT BOARD ASSEMBLY - 917-0065
(Sheet 2 of 2)

REF. DES.	DESCRIPTION	PART NO.	QTY.
R19	Resistor, 1.3 Meg Ohm $\pm 5\%$, 1/4W	100-1373	1
R20	Resistor, 4.7 k Ohm $\pm 5\%$, 1/4W	100-4743	1
R21	Resistor, 1 k Ohm $\pm 5\%$, 1/4W	100-1043	1
R22	Resistor, 100 k Ohm $\pm 5\%$, 1/4W	100-1063	1
R23	Resistor, 60.4 k Ohm $\pm 1\%$, 1/4W	103-6045	1
R24	Resistor, 4.7 k Ohm $\pm 5\%$, 1/4W	100-4743	1
R25,R26	Resistor, 383 k Ohm $\pm 1\%$, 1/4W	103-3836	2
R27	Resistor, 4.7 k Ohm $\pm 5\%$, 1/4W	100-4743	1
R28	Resistor, 1.21 k Ohm $\pm 1\%$, 1/4W	103-1214	1
R29	Resistor, 7.15 k Ohm $\pm 1\%$, 1/4W	103-7154	1
R30	Resistor, 464 Ohm $\pm 1\%$, 1/4W	103-4643	1
R31	Resistor, 60.4 k Ohm $\pm 1\%$, 1/4W	103-6045	1
R32,R33	Resistor, 820 Ohm $\pm 5\%$, 1/4W	100-8233	2
R34	Resistor, 1 k Ohm $\pm 5\%$, 1/4W	100-1043	1
R35,R36	Resistor, 820 Ohm $\pm 5\%$, 1/4W	100-8233	2
R37	Resistor, 1 k Ohm $\pm 1\%$, 1/4W	103-1041	1
R38	Resistor, 1.24 k Ohm $\pm 1\%$, 1/4W	103-1244	1
R39	Resistor, 10 Ohm $\pm 5\%$, 1/4W	100-1023	1
R40	Resistor, 2.49 k Ohm $\pm 1\%$, 1/4W	103-2494	1
R41	Resistor, 4.99 k Ohm $\pm 1\%$, 1/4W	100-5041	1
R42	Resistor, 10 k Ohm $\pm 1\%$, 1/4W	100-1051	1
R43	Resistor, 12.4 k Ohm $\pm 1\%$, 1/4W	103-1245	1
R44	Resistor, 100 Ohm $\pm 5\%$, 1/4W	100-1033	1
R45	Resistor, 24.9 k Ohm $\pm 1\%$, 1/4W	103-2495	1
R46	Resistor, 49.9 K Ohm $\pm 1\%$, 1/4W	103-4951	1
R47	Resistor, 100 k Ohm $\pm 1\%$, 1/4W	103-1062	1
R48	Resistor, 4.7 Meg Ohm $\pm 5\%$, 1/4W	100-4773	1
R49	Resistor, 1.24 k Ohm $\pm 1\%$, 1/4W	103-1244	1
R50	Potentiometer, 500 Ohm $\pm 10\%$, 1/2W	177-5032	1
R51	Resistor, 2 k Ohm $\pm 5\%$, 1/4W	100-2043	1
R52	Resistor, 10 k Ohm $\pm 1\%$, 1/4W	100-1051	1
R54	Resistor, 1.3 Meg Ohm $\pm 5\%$, 1/4W	100-1373	1
R55	Resistor, 4.7 k Ohm $\pm 5\%$, 1/4W	100-4743	1
R56	Resistor, 1 k Ohm $\pm 5\%$, 1/4W	100-1043	1
R57,R58	Resistor, 1.40 k Ohm $\pm 1\%$, 1/4W	103-1404	2
R59,R60	Resistor, 10 k Ohm $\pm 1\%$, 1/4W	100-1051	2
R61,R62	Resistor, 1 k Ohm $\pm 5\%$, 1/4W	100-1043	2
S1 THRU S7	Switch, Micro with Red/Green LED Indicators, SPDT, 0.4W Maximum @ 20V ac/dc	340-0072	7
U1	Integrated Circuit, NE5532AP, Dual Low Noise Operational Amplifier, 8-Pin DIP	221-5532-001	1
U2	Integrated Circuit, TL072CP, Dual JFET-Input Operational Amplifier, 8-Pin DIP	221-0072	1
U3	Integrated Circuit, CD4066BE, Quad Bilateral Switch, 14-Pin DIP	225-0004	1
U4	Integrated Circuit, LM3914N, Dot/Bar Display Driver, 18-Pin DIP	229-3914	1
U5	Integrated Circuit, NE555V, Timer, 8-Pin DIP	229-0555	1
U6	Integrated Circuit, NE5532AP, Dual Low Noise Operational Amplifier, 8-Pin DIP	221-5532-001	1
U7	Integrated Circuit, NE555V, Timer, 8-Pin DIP	229-0555	1
XU1,XU2	Socket, 8-Pin DIP	417-0804	2
XU3	Socket, 14-Pin DIP	417-1404	1
XU4	Socket, 18-Pin DIP	417-1804	1
XU5 THRU XU7	Socket, 8-Pin DIP	417-0804	3
-----	Blank Circuit Board, Audio Control	517-0065	1

TABLE 6-8. MONITOR INTERFACE CIRCUIT BOARD ASSEMBLY - 917-0066

REF. DES.	DESCRIPTION	PART NO.	QTY.
C1 THRU C16	Capacitor, Monolythic Ceramic, 0.1 uF ±20%, 50V	003-1054	16
C17	Capacitor, Electrolytic, 100 uF, 25V	023-1084	1
C18 THRU C21, C26 THRU C29, C39 THRU C41, C47 THRU C53	Capacitor, Polyester, 0.0022 uF ±10%, 100V	031-2033	18
C55	Capacitor, Monolythic Ceramic, 0.1 uF ±20%, 50V	003-1054	1
DS1,DS2	Indicator, LED, Red, 521-9212, 1.7V @ 50 mA Maximum	323-9217	2
J14	Connector, Header, 13-Pin Dual In-Line	417-2600	1
J16 THRU J18	Header, Open End, Vertical, 6-Pin, Printed Circuit Board Mount	417-0128	3
J20 THRU J24	Receptacle, BNC	417-0203	5
L1 THRU L9	RF Choke, 910 uH ±5%, 79 mA Maximum, 15.8 Ohms DC Resistance	360-0047	9
Q1,Q2	Transistor, 2N3906, PNP, Silicon, TO-92 Case	210-3906	2
R1,R2	Resistor, 820 Ohm ±5%, 1/4W	100-8233	2
R3 THRU R14	Resistor, 1 k Ohm ±5%, 1/4W	100-1043	12
R15 THRU R18	Resistor, 4.7 k Ohm ±5%, 1/4W	100-4743	4
R28 THRU R30	Resistor, 150 Ohm ±5%, 1/4W	100-1533	3
R31 THRU R33	Resistor, 4.7 k Ohm ±5%, 1/4W	100-4743	3
R34,R35	Resistor, 150 Ohm ±5%, 1/4W	100-1533	2
R36,R37	Resistor, 4.7 k Ohm ±5%, 1/4W	100-4743	2
R38,R39	Resistor, 1.5 k Ohm ±5%, 1/4W	100-1543	2
R40,R41	Resistor, 820 Ohm ±5%, 1/4W	100-8233	2
U1 THRU U6	Integrated Circuit, 4N33, Optical Isolator, NPN Photo Transistor/Infared Emitting Diode Type, 1500V Isolation, Response: 30 kHz Maximum, Current: 50 mA Maximum, 6-Pin DIP	229-0033	6
XU1 THRU XU6	Socket, 6-Pin DIP	417-0600	6
----	Blank Circuit Board, Monitor Interface	517-0066	1

TABLE 6-9. MONITOR METER CIRCUIT BOARD ASSEMBLY - 917-0067
(Sheet 1 of 2)

REF. DES.	DESCRIPTION	PART NO.	QTY.
C1,C2	Capacitor, Electrolytic, 100 uF, 25V	013-1084	2
C3	Capacitor, Monolythic Ceramic, 0.1 uF ±20%, 50V	003-1054	1
C4	Capacitor, Electrolytic, 10 uF, 35V	023-1076	1
D1	Diode, 1N4148, Silicon, 75V @ 0.3 Amperes	203-4148	1
D2	Diode, HP5082-2800, High Voltage, Schottky Barrier Type, 70V, 15 mA	201-2800	1
R1	Resistor, 100 k Ohm ±5%, 1/4W	100-1063	1
R2	Resistor, 2.2 k Ohm ±5%, 1/4W	100-2243	1
R3	Potentiometer, 5 k Ohm ±10%, 1/2W	178-5043	1
R4,R5	Resistor, 10 Ohm ±5%, 1/4W	100-1023	2
R6	Resistor, 8.2 k Ohm ±5%, 1/4W	100-8243	1
R7	Resistor, 10 k Ohm ±5%, 1/4W	100-1053	1
R8	Resistor, 10 Meg Ohm ±5%, 1/4W	100-1083	1
R9	Resistor, 100 k Ohm ±5%, 1/4W	100-1063	1
R10	Resistor, 10 k Ohm ±5%, 1/4W	100-1053	1
R11	Resistor, 3 k Ohm ±5%, 1/4W	100-3043	1
R12	Potentiometer, 10 k Ohm ±10%, 1/2W	178-1053	1
R13	Resistor, 2.2 k Ohm ±5%, 1/4W	100-2243	1
R14	Resistor, 150 k Ohm ±5%, 1/4W	100-1563	1
R15	Resistor, 2.7 k Ohm ±5%, 1/4W	100-2743	1
R16,R17	Resistor, 470 Ohm ±5%, 1/4W	100-4733	2
R18	Resistor, 3.6 k Ohm ±5%, 1/4W	100-3643	1

TABLE 6-9. MONITOR METER CIRCUIT BOARD ASSEMBLY - 917-0067
(Sheet 2 of 2)

REF. DES.	DESCRIPTION	PART NO.	QTY.
U1,U2	Integrated Circuit, TL072CP, Dual JFET-Input Operational Amplifier, 8-Pin DIP	221-0072	2
XU1,XU2	Socket, 8-Pin DIP	417-0804	2
----	Receptacle, Header, Dual In-Line 8-Pin	417-1603	1
----	Blank Circuit Board, Monitor Meter	517-0067	1

TABLE 6-10. RF ATTENUATOR CIRCUIT BOARD ASSEMBLY - 917-0068

REF. DES.	DESCRIPTION	PART NO.	QTY.
R1	Resistor, 150 Ohm $\pm 5\%$, 2W	130-1533	1
R2	Resistor, 36 Ohm $\pm 5\%$, 2W	130-3623	1
R3	Resistor, 75 Ohm $\pm 5\%$, 1W	120-7523	1
R4	Resistor, 36 Ohm $\pm 5\%$, 1/2W	110-3623	1
R5	Resistor, 75 Ohm $\pm 5\%$, 1/4W	100-7523	1
R6	Resistor, 36 Ohm $\pm 5\%$, 1/4W	100-3623	1
R7	Resistor, 75 Ohm $\pm 5\%$, 1/4W	100-7523	1
R8	Resistor, 36 Ohm $\pm 5\%$, 1/4W	100-3623	1
R9	Resistor, 75 Ohm $\pm 5\%$, 1/4W	100-7523	1
R10,R11	Resistor, 36 Ohm $\pm 5\%$, 1/4W	100-3623	2
S1	Switch, 1/2 inch Rotary, 6 Position, Rear Mount, 1.5A @ 28V dc, 0.50A @ 115V ac	340-0074-001	1
----	Blank Circuit Board, RF Attenuator	517-0068	1

TABLE 6-11. VCO MODULE CIRCUIT BOARD ASSEMBLY - 917-0069

REF. DES	DESCRIPTION	PART NO.	QTY.
C1,C2	Capacitor, Monolythic Ceramic, 0.01 uF $\pm 5\%$, 100V	003-1013	2
C3	Capacitor, Monolythic Ceramic, 0.1 uF $\pm 20\%$, 50V	003-1054	1
C4	Capacitor, Mica, 50 pF $\pm 5\%$, 500V	040-5013	1
C5	Capacitor, Monolythic Ceramic, 0.1 uF $\pm 20\%$, 50V	003-1054	1
D1	Diode, Varactor, MVAM115, 500 pF at 1 V _R , 25 pF at 15 V _R , Motorola Case 182-03	200-0115	1
D2,D3	Diode, 1N4148, Silicon, 75V @ 0.3 Amperes	203-4148	2
P32 THRU P35	Plug, Male, Single Pin	417-0119	4
Q1,Q2	Field Effect Transistor, U311, N-Channel Junction Type, T0-92 Case	210-0311	2
R1	Resistor, 620 Ohm $\pm 5\%$, 1/4W	100-6233	1
R2	Resistor, 100 Ohm $\pm 5\%$, 1/4W	100-1033	1
R3	Resistor, 470 Ohm $\pm 5\%$, 1/4W	100-4733	1
R4	Resistor, 100 k Ohm $\pm 5\%$, 1/4W	100-1063	1
R5	Resistor, 100 Ohm $\pm 5\%$, 1/4W	100-1033	1
R6	Resistor, 470 Ohm $\pm 5\%$, 1/4W	100-4733	1
----	Ferrite Toroid, OD = 0.375 IN, ID = 0.188 IN, W = 0.125 IN	360-0023	1
----	Blank Circuit Board, VCO Module	517-0069	1

TABLE 6-12. MODEL 1410 MONITOR 9 kHz SPACING OPTION - 907-0104

REF. DES.	DESCRIPTION	PART NO.	QTY.
<u>DELETE FROM TABLE 6-5</u>			
----	Crystal, 48PD1002, 10.24 MHz, HC-18 Case	390-0013	1
<u>ADD TO TABLE 6-5</u>			
----	Crystal, 9.216 MHz ± 15 PPM, 18 pF Load Capacitance, 35 Ohms, A/T Cut, HC-18 Case	390-0017	1

SECTION VII
DRAWINGS

7-1. INTRODUCTION.

7-2. This section provides assembly drawings, wiring diagrams, and schematic diagrams as listed below for the Motorola Model 1410 AM stereo modulation monitor.

<u>FIGURE</u>	<u>TITLE</u>	<u>NUMBER</u>
7-1	SCHEMATIC DIAGRAM, MODEL 1410 MONITOR OVERALL	SD907-0100-900
7-2	ASSEMBLY DIAGRAM, MODEL 1410 MONITOR OVERALL	597-0105-100
7-3	SCHEMATIC DIAGRAM, RF DEMODULATOR CIRCUIT BOARD	SD917-0063
7-4	ASSEMBLY DIAGRAM, RF DEMODULATOR CIRCUIT BOARD	AD917-0063
7-5	COMPONENT LOCATOR, RF DEMODULATOR CIRCUIT BOARD	597-0105-101
7-5	SCHEMATIC DIAGRAM, AUDIO CIRCUIT BOARD	SD917-0064
7-6	ASSEMBLY DIAGRAM, AUDIO CIRCUIT BOARD	AD917-0064
7-7	COMPONENT LOCATOR, AUDIO CIRCUIT BOARD	597-0105-102
7-8	SCHEMATIC DIAGRAM, AUDIO CONTROL CIRCUIT BOARD	SD917-0065
7-9	ASSEMBLY DIAGRAM, AUDIO CONTROL CIRCUIT BOARD	AD917-0065
7-10	SCHEMATIC DIAGRAM, INTERFACE CIRCUIT BOARD	SC917-0066
7-11	ASSEMBLY DIAGRAM, INTERFACE CIRCUIT BOARD	AC917-0066
7-12	SCHEMATIC DIAGRAM, METER CIRCUIT BOARD	SC917-0067
7-13	ASSEMBLY DIAGRAM, METER CIRCUIT BOARD	AC917-0067
7-14	SCHEMATIC DIAGRAM, RF ATTENUATOR CIRCUIT BOARD	SB917-0068
7-15	ASSEMBLY DIAGRAM, RF ATTENUATOR CIRCUIT BOARD	AB917-0068
7-16	SCHEMATIC DIAGRAM, VCO MODULE	SB917-0069
7-17	ASSEMBLY DIAGRAM, VCO MODULE	AB917-0069

1
2
3
4
5
6
7
8
9
10
11
12
13
14
15
16
17
18
19
20
21
22
23
24
25
26
27
28
29
30
31
32
33
34
35
36
37
38
39
40
41
42
43
44
45
46
47
48
49
50
51
52
53
54
55
56
57
58
59
60
61
62
63
64
65
66
67
68
69
70
71
72
73
74
75
76
77
78
79
80
81
82
83
84
85
86
87
88
89
90
91
92
93
94
95
96
97
98
99
100

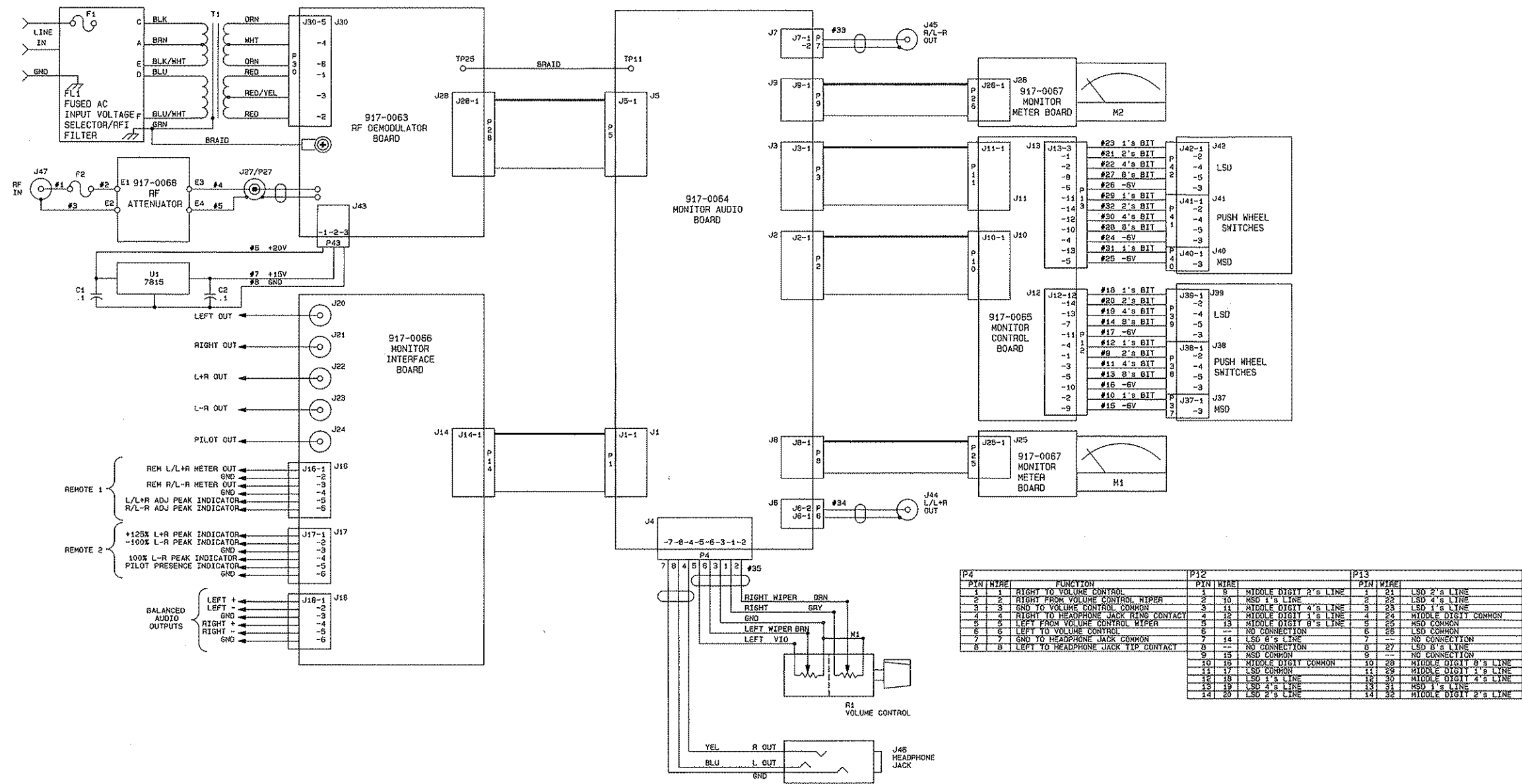

P4	PIN	WIRE	FUNCTION	P12	PIN	WIRE	FUNCTION	P13	PIN	WIRE	FUNCTION
1	1	1	RIGHT TO VOLUME CONTROL	1	9	1	MIDDLE DIGIT 2'S LINE	1	21	1	LSB 2'S LINE
2	2	2	RIGHT FROM VOLUME CONTROL WIPER	2	10	2	MSD 1'S LINE	2	22	2	LSB 4'S LINE
3	3	3	GND TO VOLUME CONTROL COMMON	3	11	3	MIDDLE DIGIT 4'S LINE	3	23	3	LSB 1'S LINE
4	4	4	RIGHT TO HEADPHONE JACK RING CONTACT	4	12	4	MIDDLE DIGIT 1'S LINE	4	24	4	MIDDLE DIGIT COMMON
5	5	5	LEFT FROM VOLUME CONTROL WIPER	5	13	5	MIDDLE DIGIT 8'S LINE	5	25	5	MSD COMMON
6	6	6	LEFT TO VOLUME CONTROL	6	--	--	NO CONNECTION	6	26	6	LSB COMMON
7	7	7	GND TO HEADPHONE JACK COMMON	7	14	7	LSB 6'S LINE	7	--	--	NO CONNECTION
8	8	8	LEFT TO HEADPHONE JACK TIP CONTACT	8	--	--	NO CONNECTION	8	27	8	LSB 8'S LINE
				9	15	9	MSD COMMON	9	--	--	NO CONNECTION
				10	16	10	MIDDLE DIGIT COMMON	10	28	10	MIDDLE DIGIT 8'S LINE
				11	17	11	LSB COMMON	11	29	11	MIDDLE DIGIT 1'S LINE
				12	18	12	LSB 1'S LINE	12	30	12	MIDDLE DIGIT 4'S LINE
				13	19	13	LSB 4'S LINE	13	31	13	MSD 1'S LINE
				14	20	14	LSB 2'S LINE	14	32	14	MIDDLE DIGIT 2'S LINE

RIBBON CABLES:

P1 TO P14	P2 TO P10	P3 TO P11	P5 TO P28	P8 TO P25	P9 TO P26
1. PILOT OUT	1. -6V	1. L-R INPUT	1. -12V	1. GND	1. GND
2. L-R OUT	2. L/L+R -30dB RANGE	2. R/L-R POLARITY SELECT	2. -12V	2. GND	2. GND
3. RIGHT OUT	3. L/L+R TO ADJ PEAK	3. R/L-R AUTO RANGE SELECT	3. -20V	3. -15V	3. -15V
4. R/L-R ADJ. PEAK IND	4. GND	4. R/L-R AUTO RANGE ON	4. -20V	4. -15V	4. -15V
5. L/L+R REM METER SAMPLE	5. GND	5. GND	5. +15V	5. -15V	5. -15V
6. +15V	6. L/L+R ADJ PEAK REM IND	6. R/L-R AUTO RANGE OFF	6. +12V	6. +15V	6. +15V
7. -100X L-R REM IND	7. GND	7. RF HIGH	7. +20V	7. +15V	7. +15V
8. 100X L-R REM IND	8. L/L+R AUTO RANGE SELECT	8. RF LOW	8. +20V	8. +15V	8. +15V
9. LEFT - BAL OUT	9. L/L+R AUTO RANGE ON	9. +15V	9. GND	9. GND	9. GND
10. RIGHT - BAL OUT	10. L/L+R AUTO RANGE OFF	10. R/L-R ADJ PEAK REM IND	10. GND	10. GND	10. GND
11. GND	11. PILOT LEVEL	11. R/L-R TO ADJ PEAK	11. L-R	11. L/L+R REMOTE METER SAMPLE	11. R/L-R REMOTE METER SAMPLE
12. GND	12. RF LEVEL	12. R/L-R -20dB RANGE	12. RF LEVEL	12. L/L+R REMOTE METER SAMPLE	12. R/L-R REMOTE METER SAMPLE
13. GND	13. L/L+R POLARITY SELECT	13. +15V	13. L+R	13. L/L+R TO AVG METER BALLISTICS	13. R/L-R TO AVG METER BALLISTICS
14. RF LOW	14. +125X L+R PEAK IND	14. R/L-R INPUT SELECT	14. -12V	14. L/L+R TO AVG METER BALLISTICS	14. R/L-R TO AVG METER BALLISTICS
15. RF HIGH	15. -100X L+R PEAK IND	15. R INPUT	15. -12V	15. L/L+R TO PEAK METER BALLISTICS	15. R/L-R TO PEAK METER BALLISTICS
16. L+R OUT	16. L/L+R -40dB RANGE	16. R/L-R - POLARITY	16. -20V	16. L/L+R TO PEAK METER BALLISTICS	16. R/L-R TO PEAK METER BALLISTICS
17. LEFT OUT	17. L/L+R -20dB RANGE	17. R/L-R + POLARITY	17. -20V		
18. L/L+R ADJ PEAK IND	18. L/L+R -50dB RANGE	18. GND	18. +12V		
19. R/L-R REM METER SAMPLE	19. L/L+R -10dB RANGE	19. R/L-R -50dB RANGE	19. +12V		
20. +125X L+R REM IND	20. +6V	20. -15V	20. +20V		
21. PILOT PRESENCE REM IND	21. L/L+R 0dB RANGE	21. R/L-R -40dB RANGE	21. +20V		
22. LEFT + BAL OUT	22. L/L+R INPUT SELECT	22. R/L-R 0dB RANGE	22. GND		
23. RIGHT + BAL OUT	23. L INPUT	23. R/L-R -80dB RANGE	23. GND		
24. GND	24. L+R INPUT	24. 100X L-R PEAK IND	24. L-R		
25. GND	25. L/L+R - POLARITY	25. R/L-R -10dB RANGE	25. RF LEVEL		
26. GND	26. L/L+R + POLARITY	26. PILOT PRESENCE IND	26. L+R		

1410 AM STEREO MODULATION MONITOR
OVERALL SCHEMATIC

SD 907-0100-900 REV. A
COPYRIGHT © MOTOROLA, INC. MARCH 1988

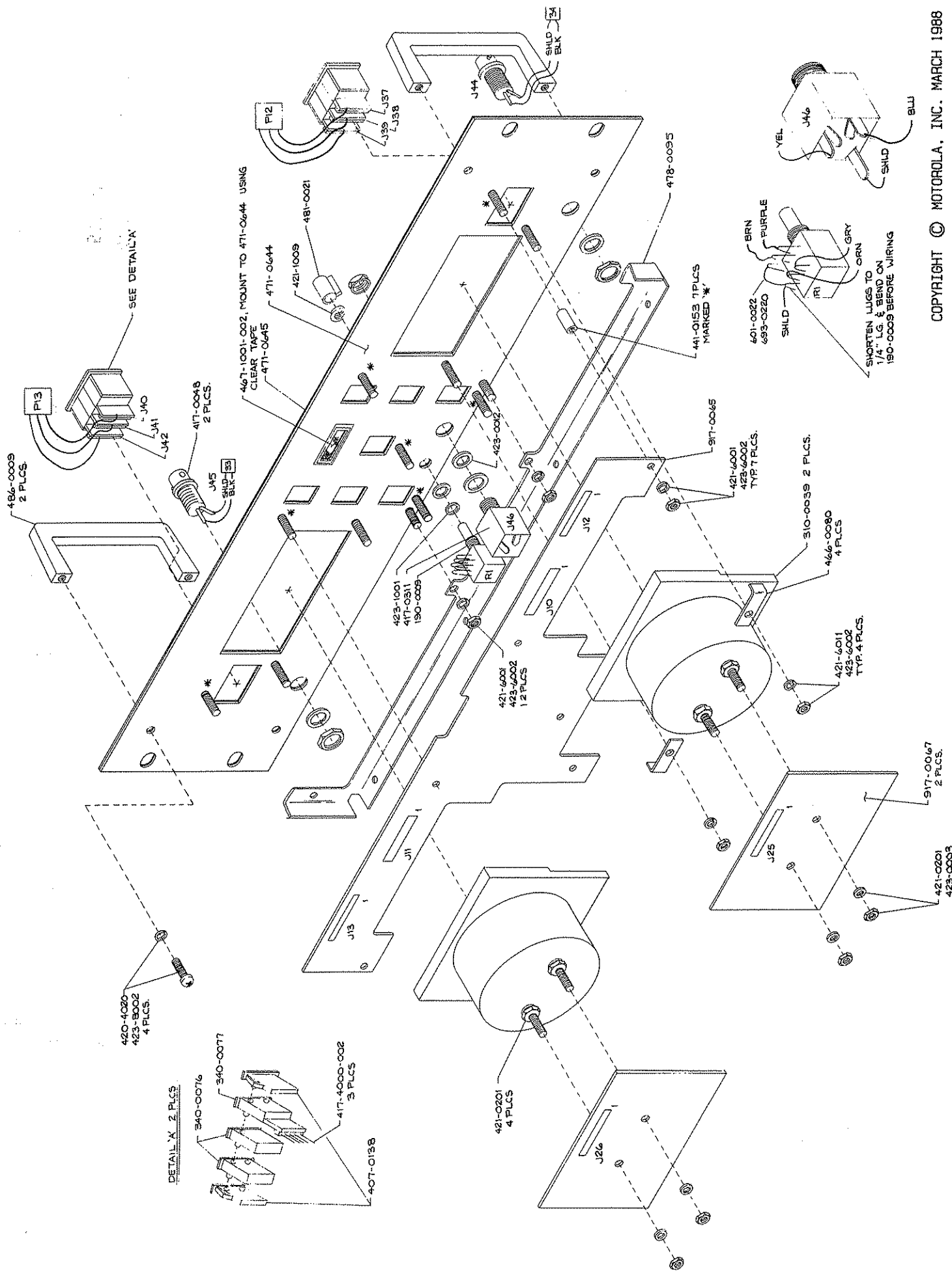

FIGURE 7-2. ASSEMBLY DIAGRAM, MODEL 1410 MONITOR OVERALL
(Sheet 1 of 3)

TRANSFORMER TO LINE VOLT FILTER (240-600) WIREMAP	LINE PINS
BROWN	A
BLACK	C
BLUE	D
BLK/WHIT	E
BLU/WHIT	F
GREEN	GND LUG
B+L	JUMPER WITH
N+J	600-8009

NOTE: USE HEATSHRINK (#11-10716)
ON ALL PINS OF 360-6504.

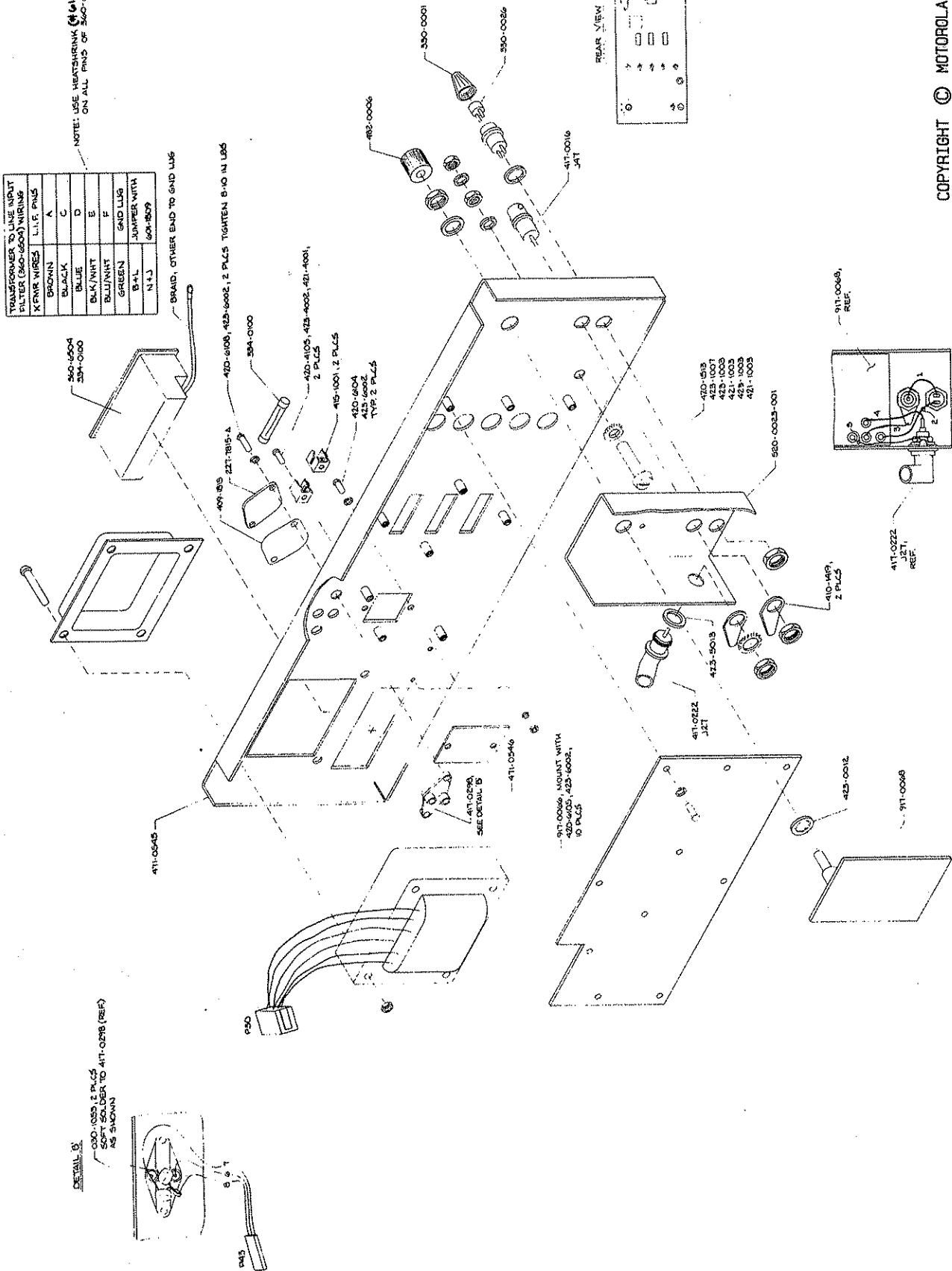
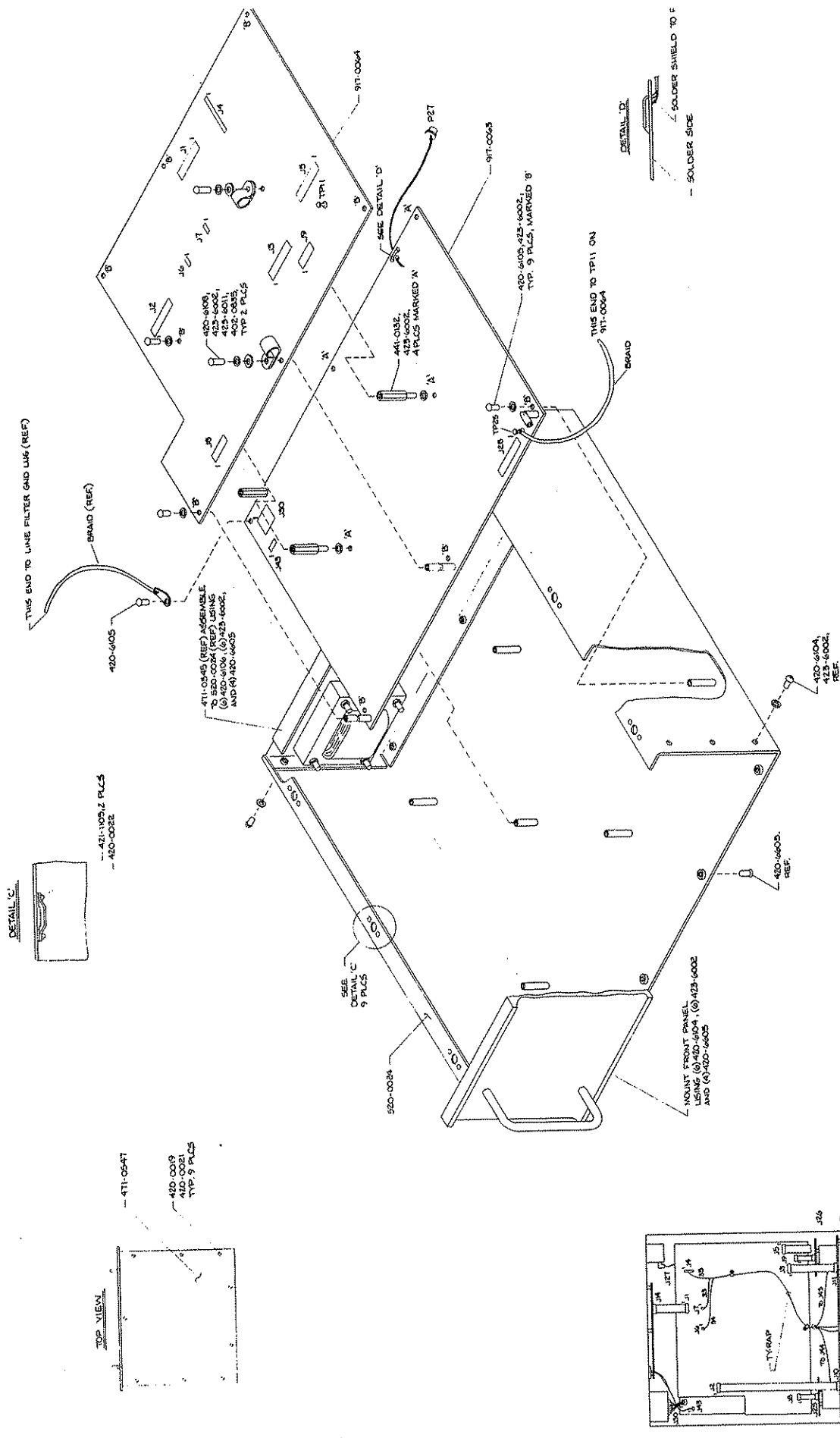
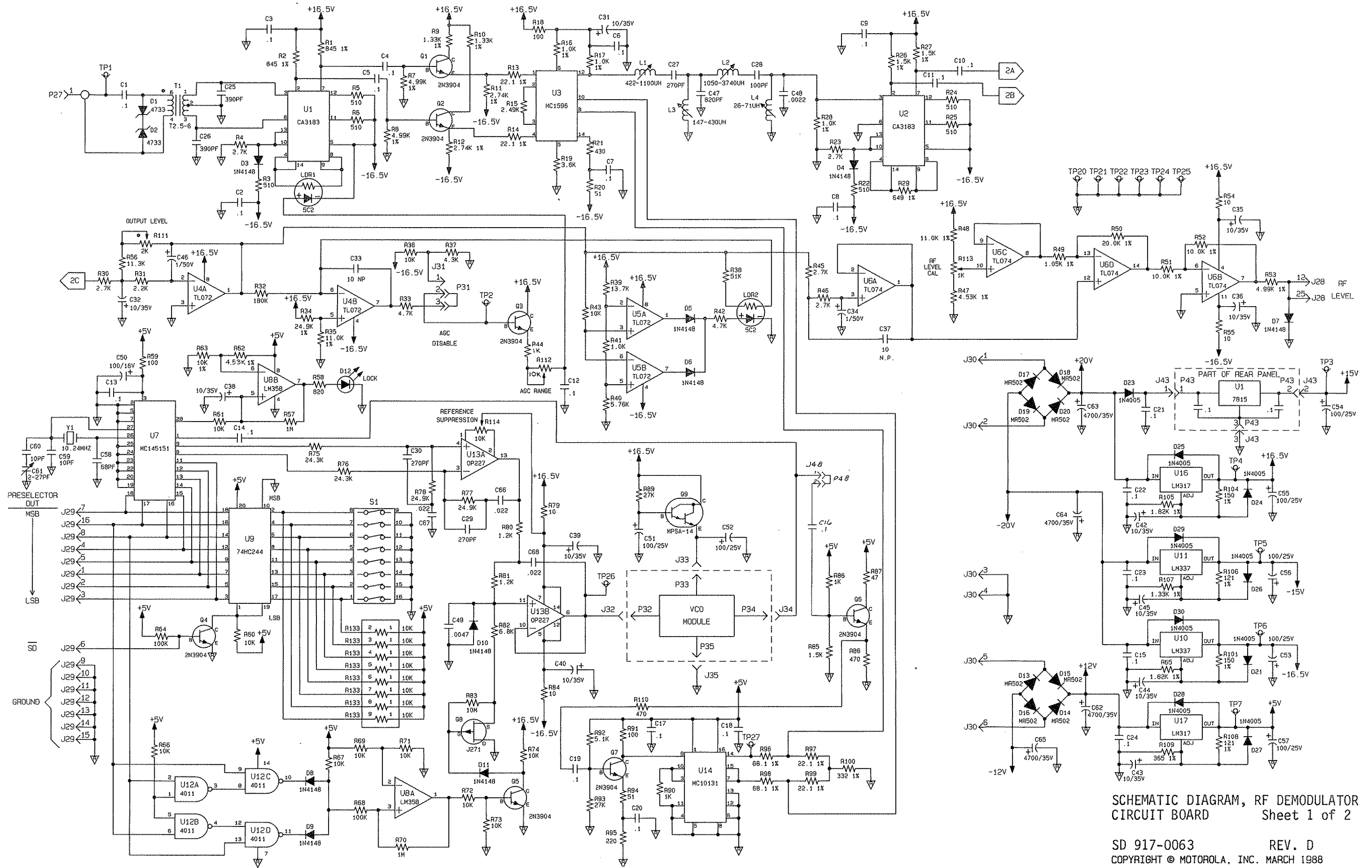

FIGURE 7-2. ASSEMBLY DIAGRAM, MODEL 1410 MONITOR OVERALL
(Sheet 2 of 3)



COPYRIGHT © MOTOROLA, INC. MARCH 1988
 597-0105-100

FIGURE 7-2. ASSEMBLY DIAGRAM, MODEL 1410 MONITOR OVERALL
 (Sheet 3 of 3)



SCHEMATIC DIAGRAM, RF DEMODULATOR
CIRCUIT BOARD Sheet 1 of 2

SD 917-0063 REV. D
COPYRIGHT © MOTOROLA, INC. MARCH 1988

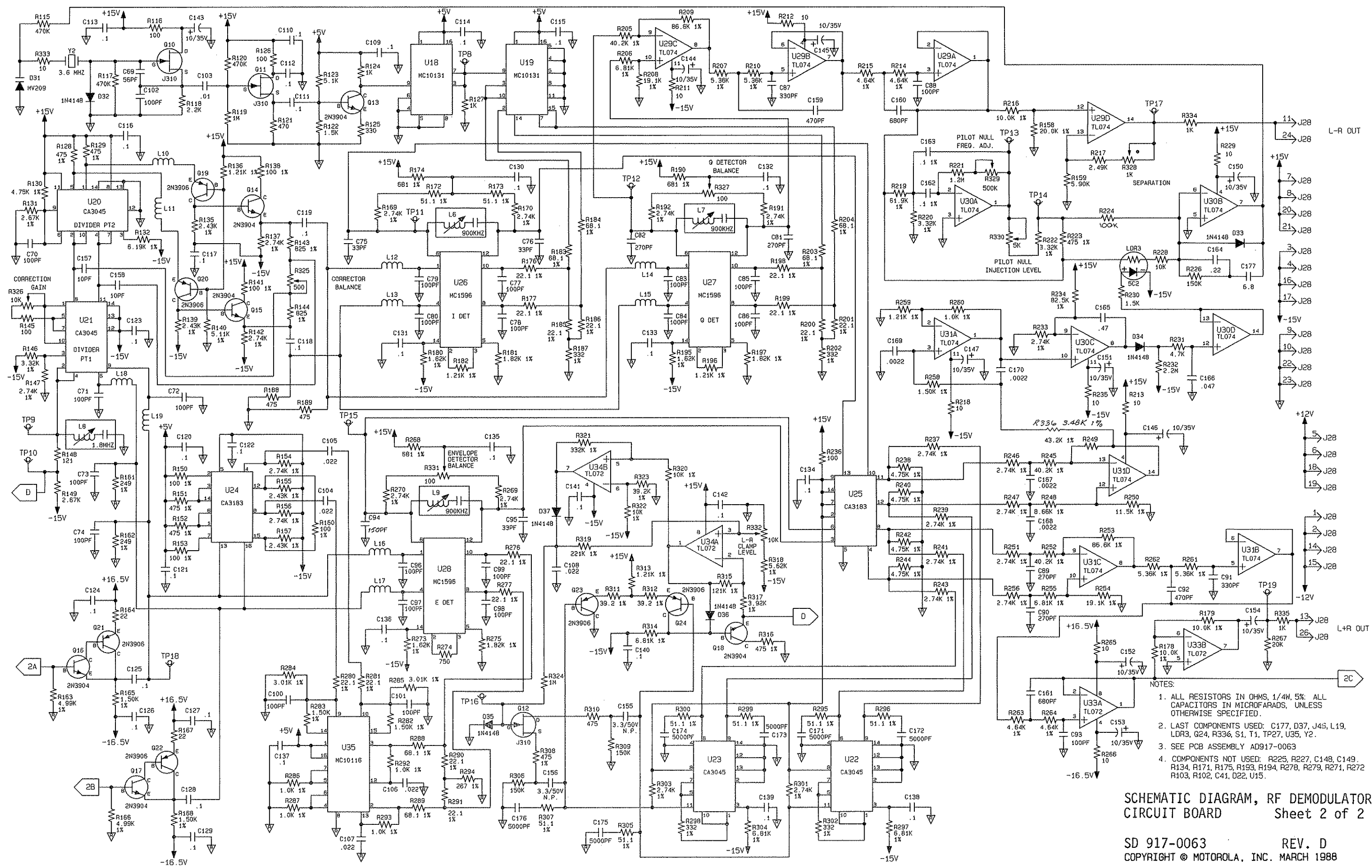

- NOTES:
1. ALL RESISTORS IN OHMS, 1/4W, 5%. ALL CAPACITORS IN MICROFARADS, UNLESS OTHERWISE SPECIFIED.
 2. LAST COMPONENTS USED: C177, D37, J4S, L19, LDR3, Q24, R336, S1, T1, TP27, U35, Y2.
 3. SEE PCB ASSEMBLY AD917-0063
 4. COMPONENTS NOT USED: R225, R227, C148, C149, R134, R171, R175, R193, R194, R278, R279, R271, R272, R103, R102, C41, D22, U15.

**SCHEMATIC DIAGRAM, RF DEMODULATOR
CIRCUIT BOARD**

Sheet 2 of 2

SD 917-0063 REV. D
COPYRIGHT © MOTOROLA, INC. MARCH 1988

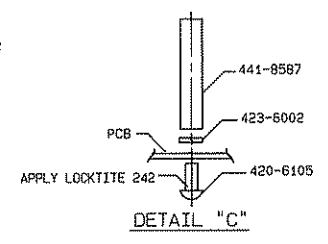
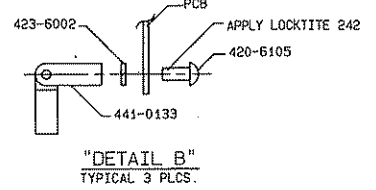
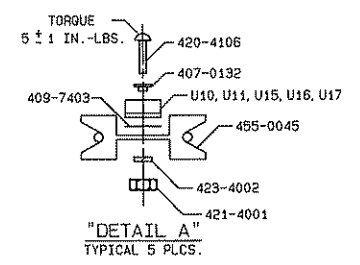
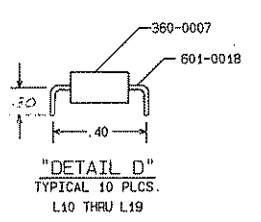
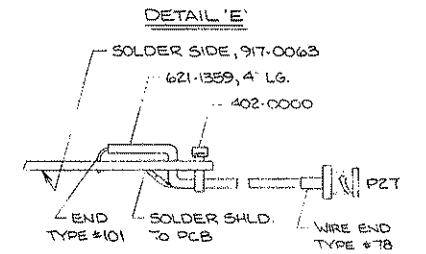
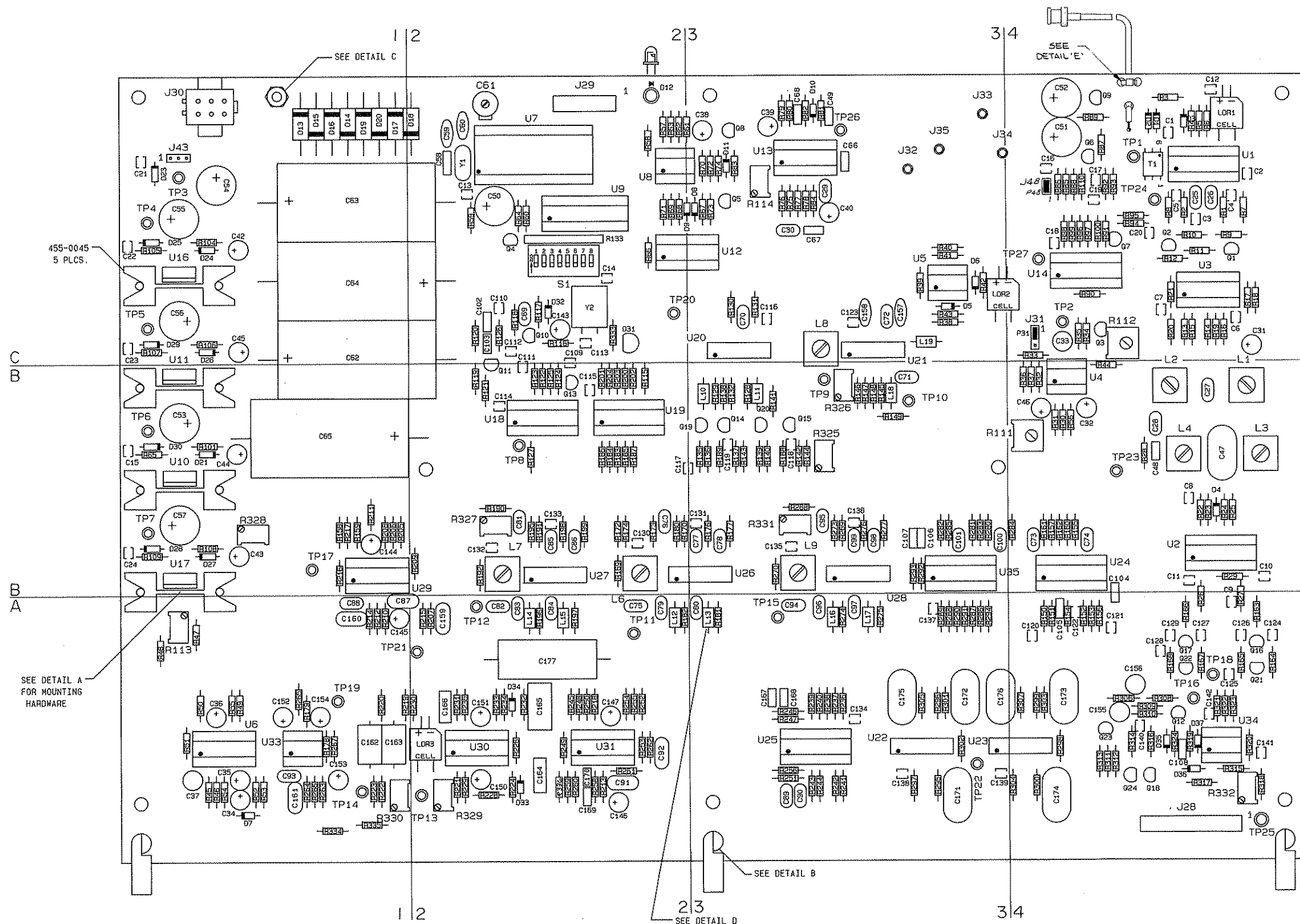

NOTES:
1. SEE SCHEMATICS S0917-0063

ASSEMBLY DIAGRAM, RF DEMODULATOR
CIRCUIT BOARD

AD 917-0063 REV. F
COPYRIGHT © MOTOROLA, INC. MARCH 1988

REF	ZONE	REF	ZONE	REF	ZONE	REF	ZONE	REF	ZONE	REF	ZONE	REF	ZONE	REF	ZONE	REF	ZONE
C1	C4	C51	C4	C100	B3	C151	A2	D24	C1	Q4	C2	R29	B4	R78	C3		
C2	C4	C52	C4	C101	B3	C152	A1	D25	C1	Q5	C3	R30	B4	R79	C3		
C3	C4	C53	B1	C102	C2	C153	A1	D26	C1	Q6	C4	R31	B4	R80	C3		
C4	C4	C54	C1	C103	C2	C154	A1	D27	B1	Q7	C4	R32	B4	R81	C3		
C5	C4	C55	C1	C104	A4-B4	C155	A4	D28	B1	Q8	C3	R33	B4	R82	C3		
C6	C4	C56	C1	C105	A4	C156	A4	D29	C1	Q9	C4	R34	C4	R83	C3		
C7	C4	C57	B1	C106	B3	C157	C3	D30	B1	Q10	C2	R35	C4	R84	C3		
C8	B4	C58	C2	C107	B3	C158	C3	D31	C2	Q11	B2-C2	R36	B4	R85	C4		
C9	B4	C59	C2	C108	A4	C159	A2	D32	C2	Q12	A4	R37	B4	R86	C4		
C10	B4	C60	C2	C109	B2-C2	C160	A1	D33	A2	Q13	B2	R38	C3	R87	C4		
C11	B4	C61	C2	C110	C2	C161	A1	D34	A2	Q14	B3	R39	C3	R88	C4		
C12	C4	C62	B1-C1	C111	B2	C162	A1	D35	A4	Q15	B3	R40	C3	R89	C4		
C13	C2	C63	C1-C2	C112	C2	C163	A1	D36	A4	Q16	A4	R41	C3	R90	C4		
C14	C2	C64	C1-C2	C113	C2	C164	A2	D37	A4	Q17	A4	R42	C3	R91	C4		
C15	B1	C65	B1	C114	B2	C165	A2	J28	A4	Q18	A4	R43	C3	R92	C4		
C16	C4	C66	C3	C115	B2	C166	A2	J29	C2	Q19	B3	R44	B4	R93	C4		
C17	C4	C67	C3	C116	C3	C167	A3	J30	C1	Q20	B3	R45	A1	R94	C4		
C18	C4	C68	C3	C117	B2-B3	C168	A3	J31	C4	Q21	A4	R46	A1	R95	C4		
C19	C4	C69	C2	C118	B3	C169	A2	J32	C3	Q22	A4	R47	A1	R96	C4		
C20	C4	C70	C3	C119	B3	C170	A2	J33	C3	Q23	A4	R48	A1	R97	C4		
C21	C1	C71	B3	C120	A4	C171	A3	J34	C3	Q24	A4	R49	A1	R98	C4		
C22	C1	C72	C3	C121	A4	C172	A3	J35	C3	R1	C4	R50	A1	R99	C4		
C23	C1	C73	B4	C122	A4	C173	A4	J43	C1	R2	C4	R51	A1	R100	C4		
C24	B1	C74	B4	C123	C3	C174	A4	J48	C4	R3	C4	R52	A1	R101	C4		
C25	C4	C75	A2	C124	A4	C175	A3	L1	B4	R4	C4	R53	A1	R104	B1		
C26	C4	C76	B2	C125	A4	C176	A3-A4	L2	B4	R5	C4	R54	A1	R105	C1		
C27	B4	C77	B3	C126	A4	C177	A2	L3	B4	R6	C4	R55	A1	R106	C1		
C28	B4	C78	A2	C127	A4	D1	C4	L4	B4	R7	C4	R56	B4	R107	C1		
C29	C3	C79	A2	C128	A4	D2	C4	L6	B2	R8	C4	R57	C2	R108	B1		
C30	C3	C80	A3	C129	A4	D3	C4	L7	B2	R9	C4	R58	C2	R109	B1		
C31	C4	C81	B2	C130	B2	D4	B4	L8	B3-C3	R10	C4	R59	C2	R110	C4		
C32	B4	C82	A2	C131	B3	D5	C3	L9	B3	R11	C4	R60	C2	R111	B4		
C33	C4	C83	A2	C132	B2	D6	C3	L10	B3	R12	C4	R61	C2-C3	R112	C4		
C34	A1	C84	A2	C133	B2	D7	A1	L11	B3	R13	C4	R62	C2	R113	A1		
C35	A1	C85	B2	C134	A3	D8	C2	L12	A2	R14	C4	R63	C2	R114	C3		
C36	A1	C86	B2	C135	B3	D9	C2-C3	L13	A3	R15	C4	R64	C2	R115	B2		
C37	A1	C87	A1-A2	C136	B3	D10	C3	L14	A2	R16	C4	R65	B1	R116	C2		
C38	C3	C88	A1	C137	A3	D11	C3	L15	A2	R17	C4	R66	C2	R117	C2		
C39	C3	C89	A3	C138	A3	D12	C2	L16	A3	R18	C4	R67	C3	R118	C2		
C40	C3	C90	A3	C139	A4	D13	C1	L17	A3	R19	C4	R68	C2	R119	B2		
C41	C1	C91	A2	C140	A4	D14	C1	L18	B3	R20	C4	R69	C2	R120	B2		
C42	B1	C92	A2	C141	A4	D15	C1	L19	C3	R21	C4	R70	C3	R121	B2		
C43	B1	C93	A1	C142	A4	D16	C1	LDR1	C4	R22	B4	R71	C2	R122	B2		
C44	B1	C94	A1	C143	C2	D17	C1	LDR2	C3-C4	R23	B4	R72	C3	R123	B2		
C45	B4	C95	A3	C144	B1	D18	C1-C2	LDR3	A2	R24	B4	R73	C3	R124	B2		
C46	B4	C96	A3	C145	A1	D19	C1	P31	C4	R25	B4	R74	C3	R125	B2		
C47	B4	C97	A3	C146	A2	D20	C1	Q1	C4	R26	A4-B4	R75	C3	R126	B2		
C48	B4	C98	A3	C147	A2	D21	B1	Q2	C4	R27	A4-B4	R76	C3	R127	B2		
C49	C3	C99	B3	C150	A2	D22	C1	Q3	C4	R28	B4	R77	C3	R128	B3		

FIGURE 7-5. COMPONENT LOCATOR, RF DEMODULATOR CIRCUIT BOARD (Sheet 1 of 2)

REF	ZONE	REF	ZONE	REF	ZONE	REF	ZONE	REF	ZONE	REF	ZONE	REF	ZONE	REF	ZONE	REF	ZONE	REF	ZONE
R129	B3	R180	B2	R232	A2	R285	B3	R333	C2	U17	B1	R334	A1	U18	B2	R335	A1	U19	B2
R130	C3	R181	A3	R233	A2	R286	A3	R334	A1	U18	B2	R335	A1	U19	B2	R336	A2	U20	C3
R131	C3	R182	A2	R234	A2	R287	A3	R335	A2	U21	C3	R336	A2	U21	C3	S1	C2	U22	A3
R132	B3	R183	B2	R235	A2	R288	A3	S1	C4	T1	C4	T1	C4	U23	A3	T1	C4	U24	A3-A4
R133	C2	R184	B2	R236	A3	R289	A3	T1	C4	TP1	C4	TP1	C4	U25	B4	TP2	C4	U26	A3
R135	B3	R185	B2	R237	A3	R290	A3	T1	C4	TP2	C4	TP2	C4	U27	B2	TP3	C1	U28	B2-B3
R136	B3	R186	B2	R238	A3	R291	A3	TP1	C4	TP4	C1	TP4	C1	U29	B1	TP5	C1	U30	B1
R137	B3	R187	B2	R239	A3	R292	B3	TP2	C4	TP6	B1	TP6	B1	U31	A2	TP7	B1	U32	A2
R138	B3	R188	B3	R240	A3	R293	B3	TP3	C1	TP8	B2	TP8	B2	U33	A1	TP9	B3	U34	A1
R139	B3	R189	B3	R241	A3	R294	B3	TP4	C1	TP10	A2	TP10	A2	U35	A4	TP11	A2	Y1	C2
R140	B3	R190	B2	R242	A3	R295	A3	TP5	C1	TP12	A2	TP12	A2	Y2	C2	TP13	A2		
R141	B3	R191	B2	R243	A3	R296	A3	TP6	B1	TP14	A1	TP14	A1			TP15	A3		
R142	B3	R192	B2	R244	A3	R297	A3	TP7	B1	TP15	A4	TP15	A4			TP16	A4		
R143	B3	R195	B2	R245	A2	R298	A4	TP8	B2	TP17	B1	TP17	B1			TP18	A4		
R144	B3	R196	A2	R246	A3	R299	A4	TP9	B3	TP18	A4	TP18	A4			TP19	A1		
R145	B3	R197	A2	R247	A3	R300	A4	TP10	B3	TP20	C2	TP20	C2			TP21	A2		
R146	B3	R198	B2	R248	A2	R301	A3	TP11	A2	TP22	A3	TP22	A3			TP23	B4		
R147	B3	R199	B2	R249	A2	R302	A3	TP12	A2	TP24	B4	TP24	B4			TP25	C4		
R148	B3	R200	B2	R250	A2	R303	A4	TP13	A2	TP25	A4	TP25	A4			TP26	C3		
R149	B3	R201	B2	R251	A3	R304	A4	TP14	A1	TP27	C4	TP27	C4			U1	C4		
R150	A4	R202	B2	R252	A2	R305	A3	TP15	A3	U2	B4	U2	B4			U3	C4		
R151	A4	R203	B2	R253	A2	R306	A4	TP16	A4	U4	B4	U4	B4			U5	C2		
R152	A4	R204	B2	R254	A2	R307	A4	TP17	B1	U5	C3	U5	C3			U6	A1		
R153	A4	R205	B1	R255	A2	R308	A4	TP18	A4	U7	C2	U7	C2			U8	C2-C3		
R154	A4	R206	B1	R256	A2	R309	A4	TP19	A1	U8	B1	U8	B1			U9	C2		
R155	B4	R207	A2	R258	A2	R310	A4	TP20	C2	U10	B1	U10	B1			U11	B1		
R156	A4	R208	B1	R259	A2	R311	A4	TP21	A2	U12	C2-C3	U12	C2-C3			U13	C2		
R157	B4	R209	B2	R260	A2	R312	A4	TP22	A3	U14	C4	U14	C4			U16	C1		
R158	B1	R210	A1	R261	A2	R313	A4	TP23	B4										
R159	B1	R211	B1	R262	A2	R314	A4	TP24	C4										
R160	B4	R212	A1	R263	A1	R315	A4	TP25	A4										
R161	B4	R213	A2	R264	A1	R316	A4	TP26	C3										
R162	B4	R214	A1	R265	A1	R317	A4	TP27	C4										
R163	A4	R215	A2	R266	A1	R318	A4	U1	C4										
R164	A4	R216	B1	R267	A1	R319	A4	U2	B4										
R165	A4	R217	B1	R268	B3	R320	A4	U3	C4										
R166	A4	R218	A2	R269	B3	R321	A4	U4	A2										
R167	A4	R219	A1	R270	B3	R322	A4	U5	C3										
R168	A4	R220	A1	R273	B3	R323	A4	U6	A1										
R169	B2	R221	A2	R274	A3	R324	A4	U7	C2										
R170	B2	R222	A1	R275	A3	R325	B3	U8	B1										
R172	B2	R223	A1	R276	B3	R326	B3	U9	C2										
R173	B2	R224	A2	R277	B3	R327	B2	U10	B1										
R174	B2	R226	A2	R280	B3	R328	B1	U11	B1										
R176	B3	R228	A2	R281	B3	R329	A2	U12	C2-C3										
R177	B3	R229	A2	R282	B3	R330	A1	U13	C3										
R178	A1	R230	A2	R283	B3	R331	B3	U14	C4										
R179	A1	R231	A2	R284	B4	R332	A4	U16	C1										

FIGURE 7-5. COMPONENT LOCATOR, RF DEMODULATOR CIRCUIT BOARD (Sheet 2 of 2)

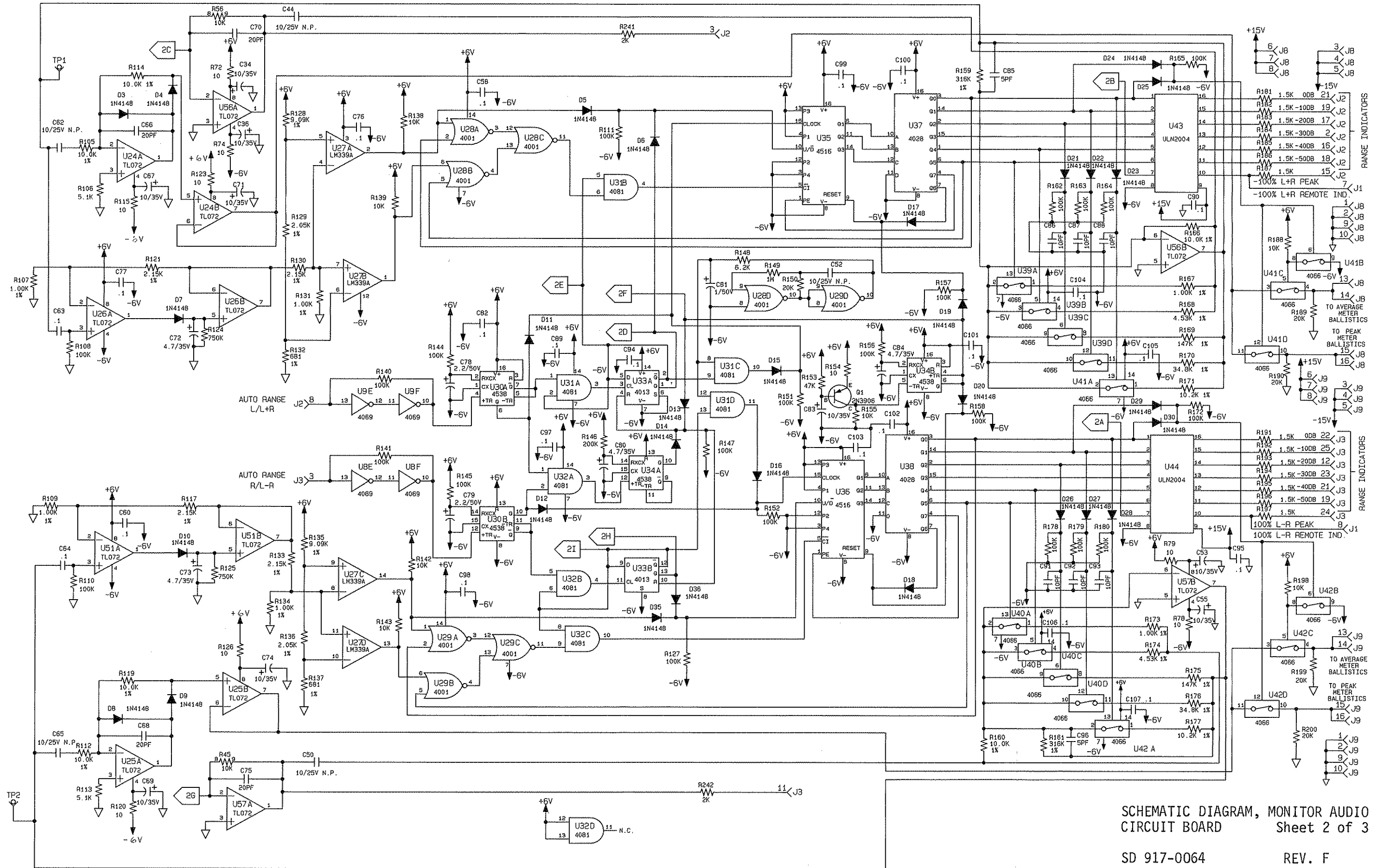

SCHMATIC DIAGRAM, MONITOR AUDIO
CIRCUIT BOARD Sheet 2 of 3

SD 917-0064 REV. F
COPYRIGHT © MOTOROLA, INC. MARCH 1988

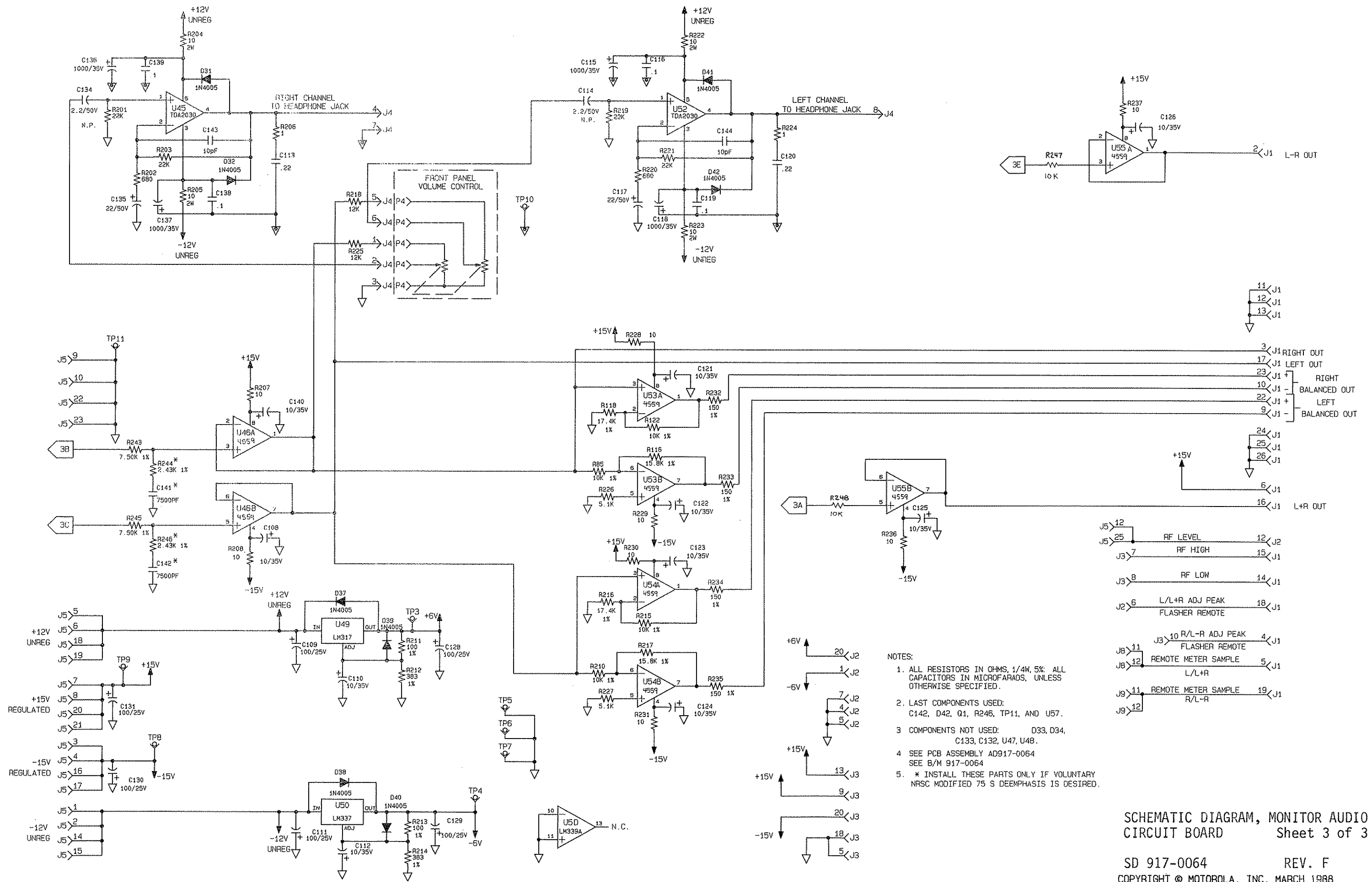

SCHEMATIC DIAGRAM, MONITOR AUDIO CIRCUIT BOARD Sheet 3 of 3

SD 917-0064 REV. F
 COPYRIGHT © MOTOROLA, INC. MARCH 1988

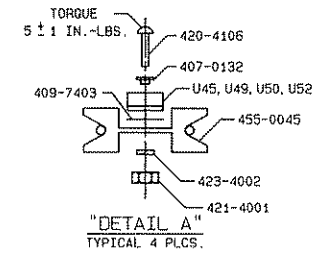
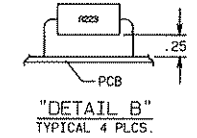
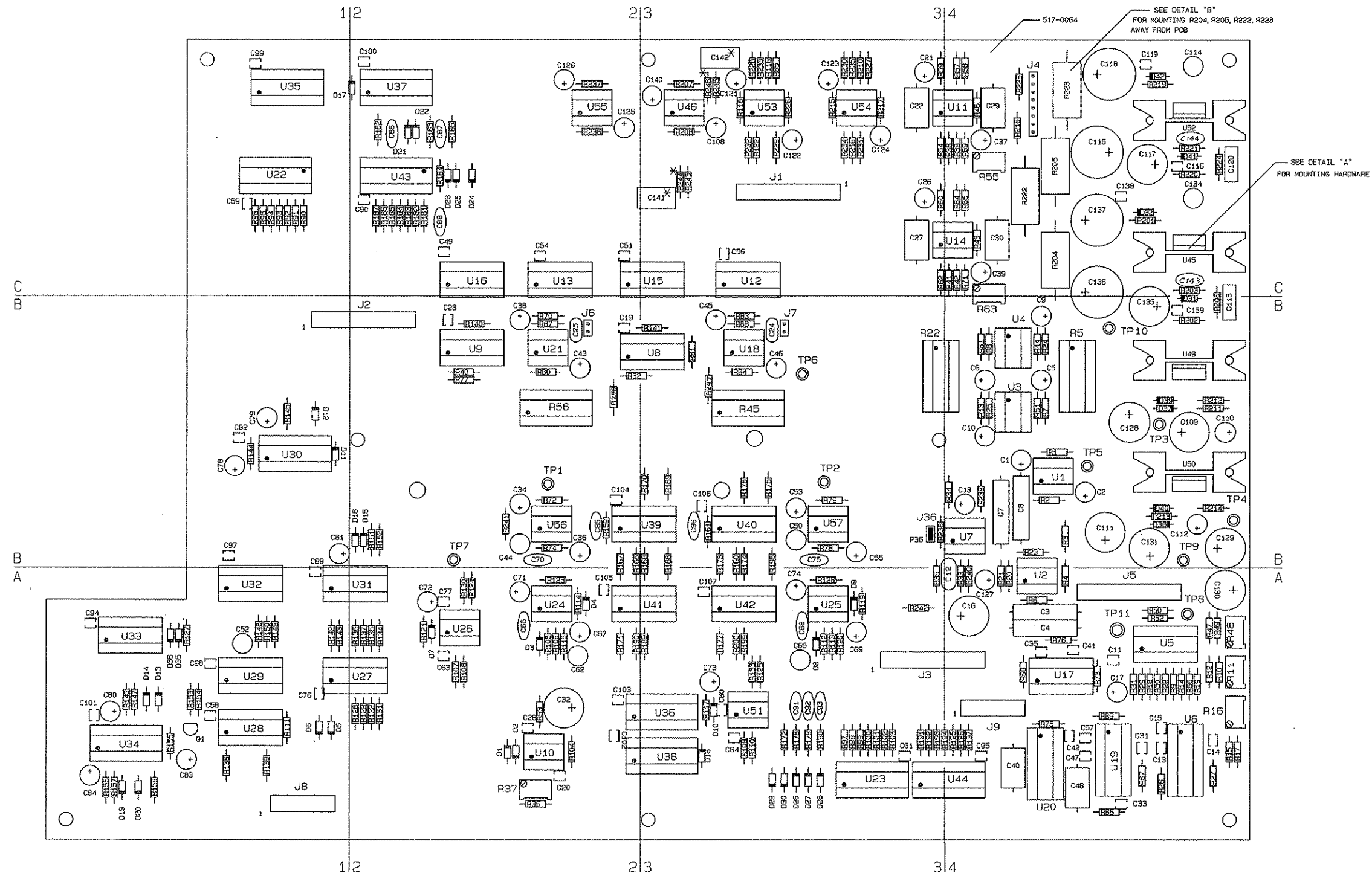

NOTE:
 1. SEE SCHEMATICS SD917-0064
 2. * INSTALL THESE PARTS ONLY IF VOLUNTARY NRSC MODIFIED 75µs DEEMPHASIS IS DESIRED.

ASSEMBLY DIAGRAM, MONITOR AUDIO CIRCUIT BOARD

AD 917-0064 REV. E
 COPYRIGHT © MOTOROLA, INC. MARCH 1988

REF	ZONE	REF	ZONE	REF	ZONE	REF	ZONE	REF	ZONE	REF	ZONE	REF	ZONE	REF	ZONE	REF	ZONE
C1	B4	C51	C2	D11	B1	R9	A4	R59	C3	R110	A3	R160	A3-B3				
C2	B4	C52	A1	D12	B1	R10	A4	R60	C3	R111	A1	R161	B3				
C3	A4	C53	B3	D13	A1	R11	A4	R61	B4	R112	A3	R162	C2				
C4	A4	C54	C2	D14	A1	R12	A4	R62	C3	R113	A3	R163	C2				
C5	B4	C55	B2	D15	B2	R13	A4	R63	B4-C4	R114	A2	R164	C2				
C6	B4	C56	B3	D16	B2	R14	A4	R64	C4	R115	A2	R165	C2				
C7	B4	C57	C3	D17	C2	R15	A4	R65	C4	R116	C3	R166	A2-B2				
C8	B4	C58	A1	D18	A3	R16	A4	R66	A4	R117	A3	R167	A2-B2				
C9	B4	C59	C1	D19	A1	R17	A4	R67	A4	R118	C3	R168	B2-B3				
C10	B4	C60	A3	D20	A1	R18	A4	R68	A4	R119	A3	R169	B3				
C11	A4	C61	B4	D21	C2	R19	A4	R69	C4	R120	A3	R170	B2-B3				
C12	A4-B4	C62	B4	D22	C2	R20	A4-B4	R70	B2	R121	A2	R171	A2				
C13	A4	C63	B4-C4	D23	C2	R21	A4-B4	R71	C4	R122	C3	R172	A2				
C14	A4	C64	C4	D24	C2	R22	B3-B4	R72	B2	R123	A2	R173	A3-B3				
C15	A4	C65	C4	D25	C2	R23	B4	R73	A4	R124	A2	R174	A3-B3				
C16	A4	C66	C4	D26	A3	R24	B4	R74	B2	R125	A3	R175	B3				
C17	A4	C67	C4	D27	A3	R25	B4	R75	A4	R126	A3	R176	B3				
C18	B4	C68	C4	D28	A3	R26	A4	R76	A4	R127	A1	R177	A3				
C19	B2	C69	C4	D29	A3	R27	A4	R77	B2	R128	A2	R178	A3				
C20	A2	C70	C4	D30	A3	R28	A4	R78	B3	R129	A2	R179	A3				
C21	C3	C71	C3	D31	B4	R29	A4	R79	B3	R130	A2	R180	A3				
C22	C3	C72	C2	D32	C4	R30	A4	R80	B2	R131	A2	R181	C2				
C23	B2	C73	C3	D33	A1	R31	A4	R81	B3	R132	A2	R182	C2				
C24	B3	C74	C3	D34	A1	R32	B2	R82	B3	R133	A3	R183	C2				
C25	B2	C75	C2	D35	B4	R33	A4-B4	R83	B3	R134	A2	R184	C2				
C26	C3	C76	C2	D36	B4	R34	B4	R84	C3	R135	A2	R185	C2				
C27	C3	C77	A2	D37	B4	R35	A3-B3	R85	A4	R136	A2	R186	C2				
C28	A2	C78	B1	D38	B4	R36	A2	R86	B2	R137	A2	R187	C2				
C29	C4	C79	B1	D39	C4	R37	A2	R87	B3	R138	A1	R188	A3-B3				
C30	C4	C80	A1	D40	C4	R38	C4	R88	A4	R139	A1	R189	A2-A3				
C31	A4	C81	B1	D41	C4	R39	C4	R89	A4	R140	B2	R190	A2				
C32	A2	C82	B1	D42	C4	R40	B2	R90	C1	R141	B3	R191	A3				
C33	A4	C83	A1	J1	C3	R41	C4	R91	C1	R142	A1	R192	A3				
C34	B2	C84	A1	J2	B1-B2	R42	C4	R92	C1	R143	A1	R193	A3				
C35	A4	C85	B2	J3	A3-A4	R43	C4	R93	C1	R144	B1	R194	A3-A4				
C36	B2	C86	C2	J4	A4	R44	C4	R94	C1	R145	B1	R195	A4				
C37	C4	C87	C2	J5	B2	R45	B4	R95	C1	R146	A1	R196	A4				
C38	B2	C88	C2	J6	B3	R46	C4	R96	C1	R147	A1	R197	A4				
C39	C4	C89	A1-B1	J7	A1	R47	A4	R97	A3	R148	A1	R198	A3-B3				
C40	A4	C90	C2	J8	A4	R48	A4	R98	A3	R149	A1	R199	A3				
C41	A4	C91	A3	J9	B3	R49	A4	R99	A3	R150	A1	R200	A3				
C42	A4	C92	A3	P36	A1	R50	A4	R100	A3	R151	B2	R201	C4				
C43	B2	C93	A3	Q1	A1	R51	A4	R101	A3	R152	B2	R202	B4				
C44	B2	C94	A1	R1	B4	R52	B4	R102	A3	R153	A1	R203	C4				
C45	B3	C95	A4	R2	B4	R53	A2	R103	A3	R154	A1	R204	C4				
C46	B3	C96	A1	R3	B4	R54	C3	R104	A2	R155	A1	R205	C4				
C47	A4	C97	B1	R4	A4-B4	R55	C4	R105	A2	R156	A1	R206	B4				
C48	A4	C98	A1	R5	B4	R56	B2	R106	A2	R157	A1	R207	C3				
C49	C2	C99	C1	R6	B4	R57	C4	R107	A2	R158	A1	R208	C3				
C50	B3	C100	C2	R7	B4	R58	C4	R108	A2	R159	B2	R210	C3				
				R8	B4			R109	A3								

597-0105-102

FIGURE 7-7. COMPONENT LOCATOR, AUDIO CIRCUIT BOARD
(Sheet 1 of 2)

REF	ZONE	REF	ZONE	REF	ZONE	REF	ZONE	REF	ZONE
R211	B4	YP11	A4	U46	C3	U46	C3	U46	C3
R212	B4	U1	B4	U49	B4	U49	B4	U49	B4
R213	B4	U2	A4-B4	U50	B4	U50	B4	U50	B4
R214	B4	U3	B4	U51	A3	U51	A3	U51	A3
R215	C3	U4	B4	U52	C4	U52	C4	U52	C4
R216	C3	U5	A4	U53	C3	U53	C3	U53	C3
R217	C3	U6	A4	U54	C3	U54	C3	U54	C3
R218	C4	U7	B4	U55	C2	U55	C2	U55	C2
R219	C4	U8	B2-B3	U56	B2	U56	B2	U56	B2
R220	C4	U9	B2	U57	B3	U57	B3	U57	B3
R221	C4	U10	A2						
R222	C4	U11	C3-C4						
R223	C4	U12	C3						
R224	C4	U13	C2						
R225	C4	U14	C3-C4						
R226	C3	U15	C2-C3						
R227	C3	U16	C2						
R228	C3	U17	A4						
R229	C3	U18	B3						
R230	C3	U19	A4						
R231	C3	U20	A4						
R232	C3	U21	B2						
R233	C3	U22	C1						
R234	C3	U23	A3						
R235	C3	U24	A2						
R236	C2	U25	A3						
R237	C2	U26	A2						
R238	B3	U27	A1-A2						
R239	B4	U28	A1						
R240	A4-B4	U29	A1						
R241	B2	U30	B1						
R242	A3	U31	A1-A2						
R243	C3	U32	A1-B1						
R245	C3	U33	A1						
R247	B3	U34	A1						
R248	B2	U35	C1						
YP1	B2	U36	A2-A3						
YP2	B3	U37	C2						
YP3	B4	U38	A2-A3						
YP4	B4	U39	B2-B3						
YP5	B4	U40	B3						
YP6	B3	U41	A2-A3						
YP7	B2	U42	A3						
YP8	A4	U43	C2						
YP9	B4	U44	A3-A4						
YP10	B4	U45	C4						

FIGURE 7-7. COMPONENT LOCATOR, AUDIO CIRCUIT BOARD
(Sheet 2 of 2)

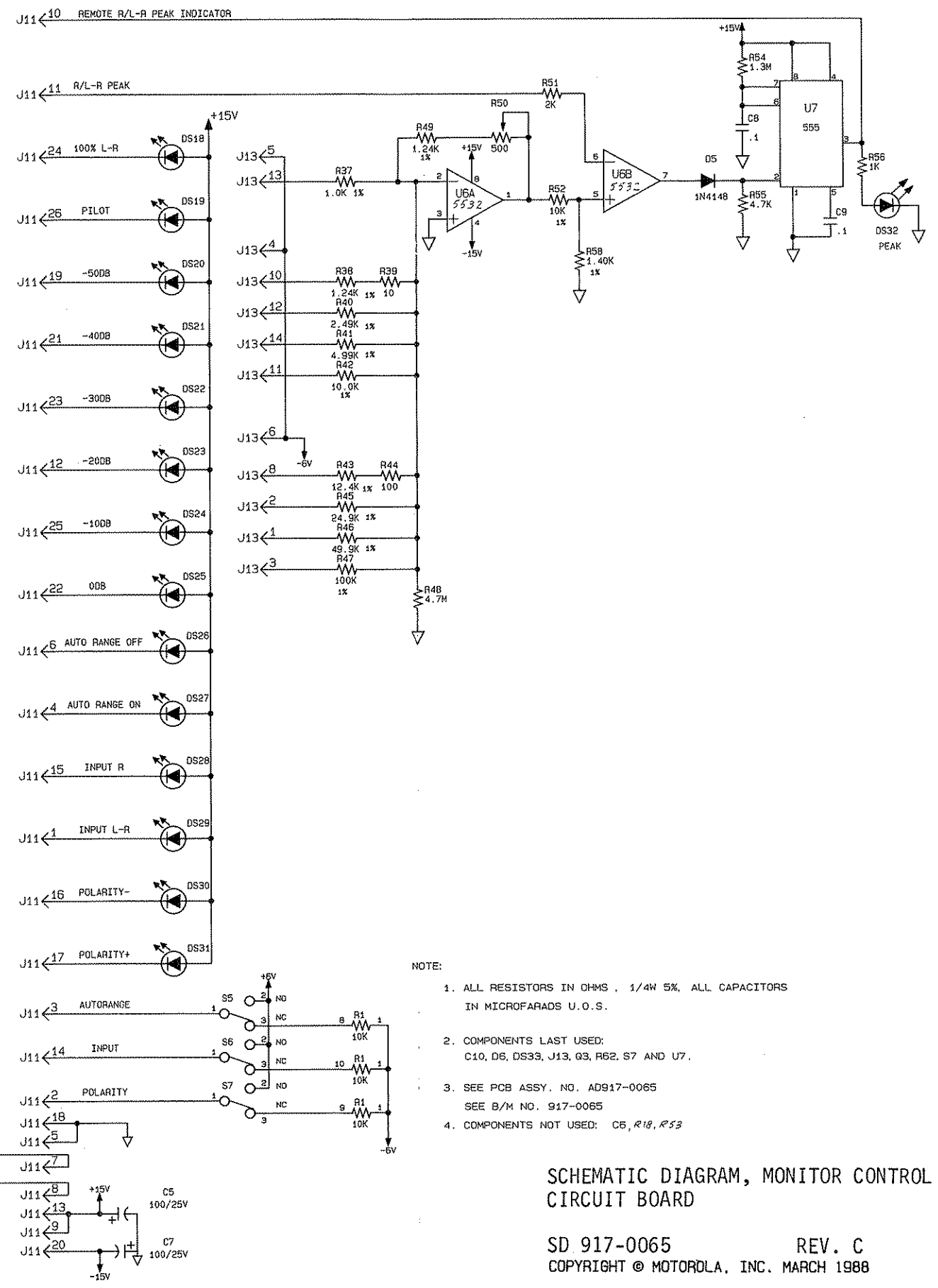
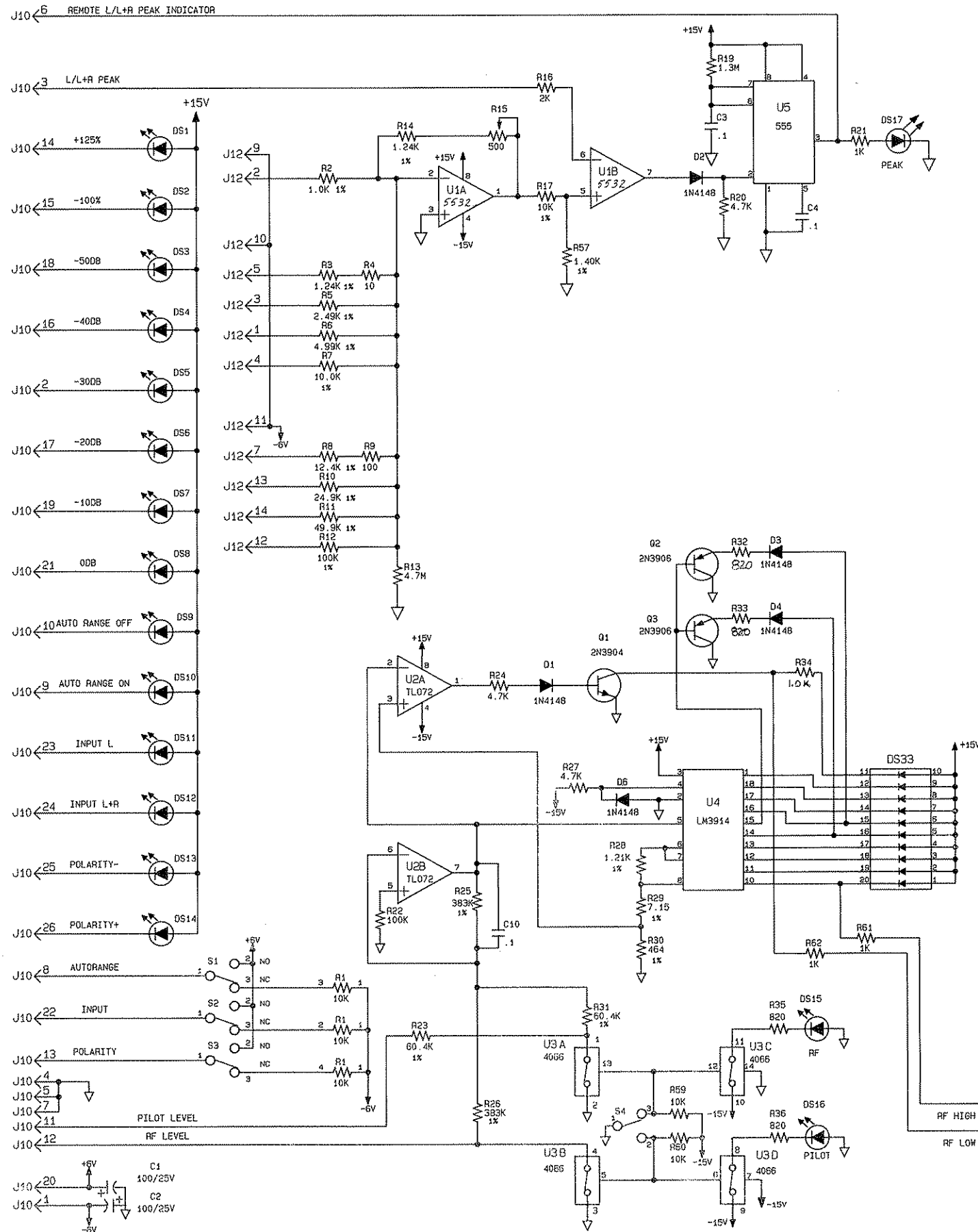

- NOTE:
1. ALL RESISTORS IN OHMS, 1/4W 5%, ALL CAPACITORS IN MICROFARADS U.O.S.
 2. COMPONENTS LAST USED: C10, D6, DS33, J13, Q3, R62, S7 AND U7.
 3. SEE PCB ASSY. NO. AD917-0065 SEE B/M NO. 917-0065
 4. COMPONENTS NOT USED: C6, R18, R53

SCHEMATIC DIAGRAM, MONITOR CONTROL CIRCUIT BOARD

SD 917-0065 REV. C
 COPYRIGHT © MOTOROLA, INC. MARCH 1988

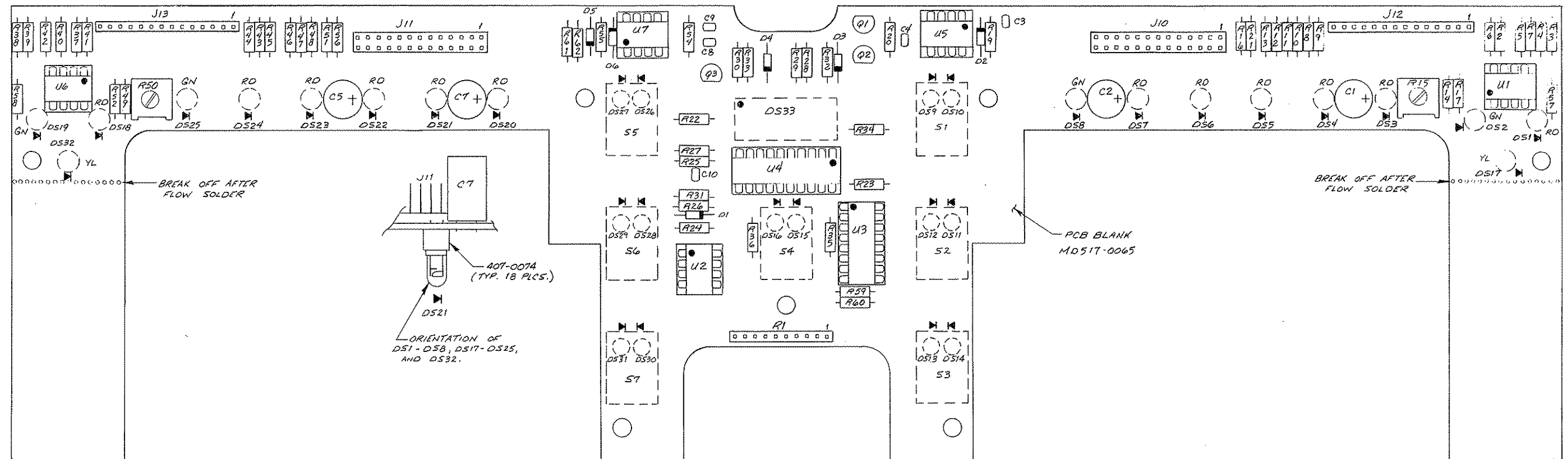

SEE SCHEMATIC SD917-0065
SEE B1M # 917-0065

ASSEMBLY DIAGRAM, MONITOR CONTROL
CIRCUIT BOARD

AD 917-0065 REV. C
COPYRIGHT © MOTOROLA, INC. MARCH 1988

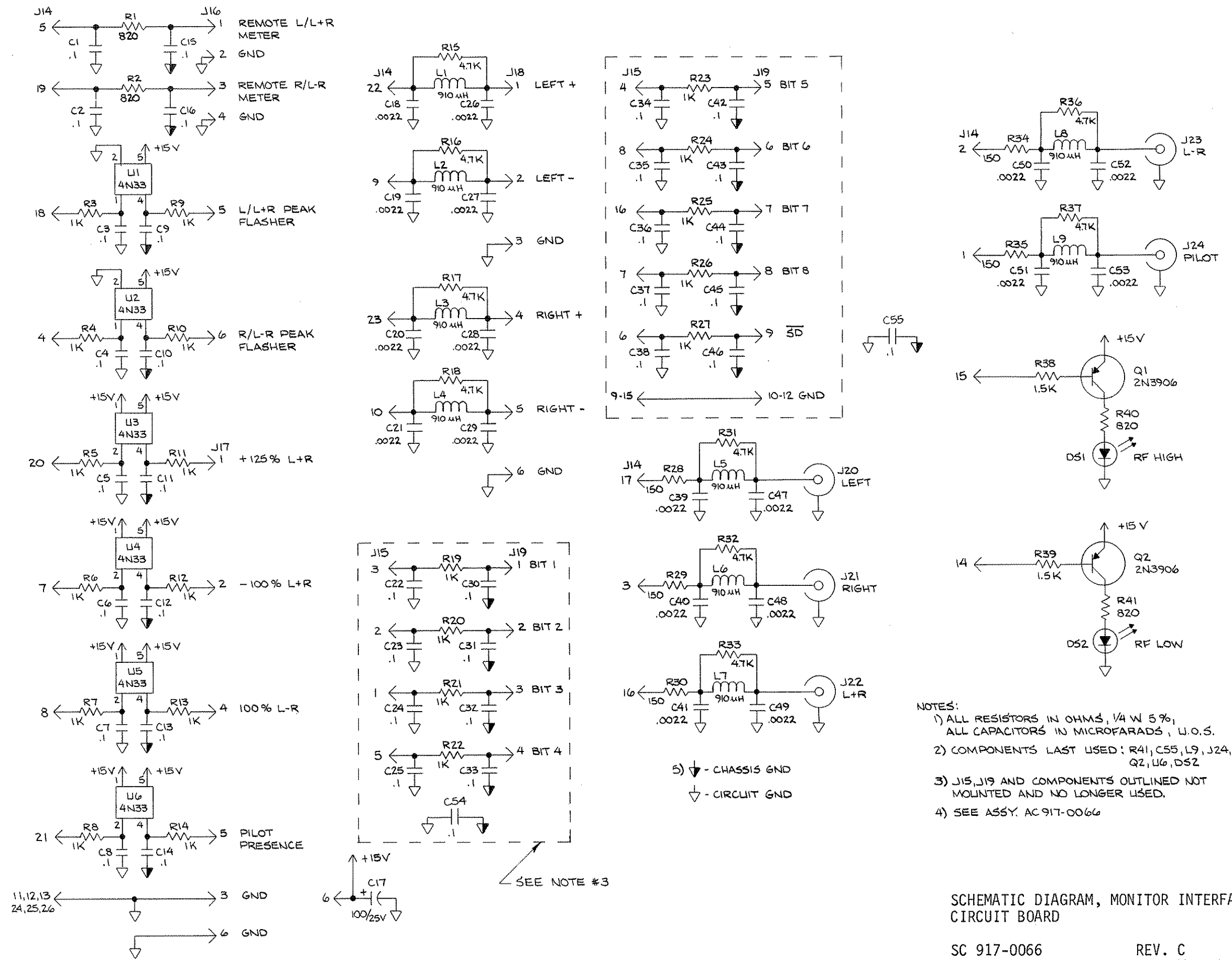

- NOTES:
- 1) ALL RESISTORS IN OHMS, 1/4 W 5%, ALL CAPACITORS IN MICROFARADS, U.O.S.
 - 2) COMPONENTS LAST USED: R41, C55, L9, J24, Q2, U6, DS2
 - 3) J15, J19 AND COMPONENTS OUTLINED NOT MOUNTED AND NO LONGER USED.
 - 4) SEE ASSY. AC 917-0066

SCHEMATIC DIAGRAM, MONITOR INTERFACE CIRCUIT BOARD

SC 917-0066 REV. C
 COPYRIGHT © MOTOROLA, INC. MARCH 1988

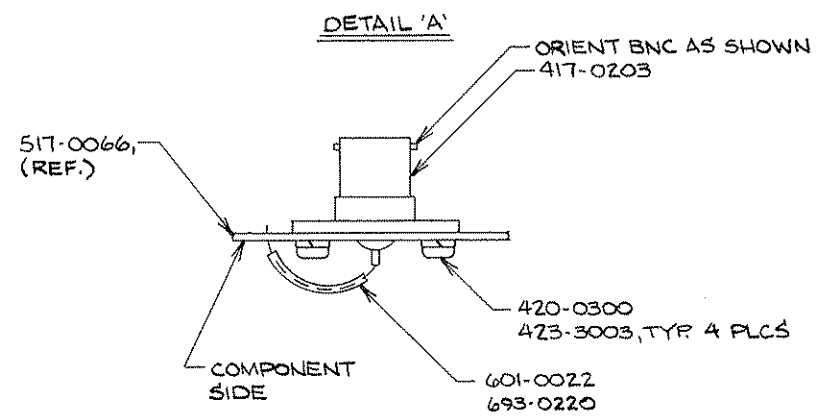
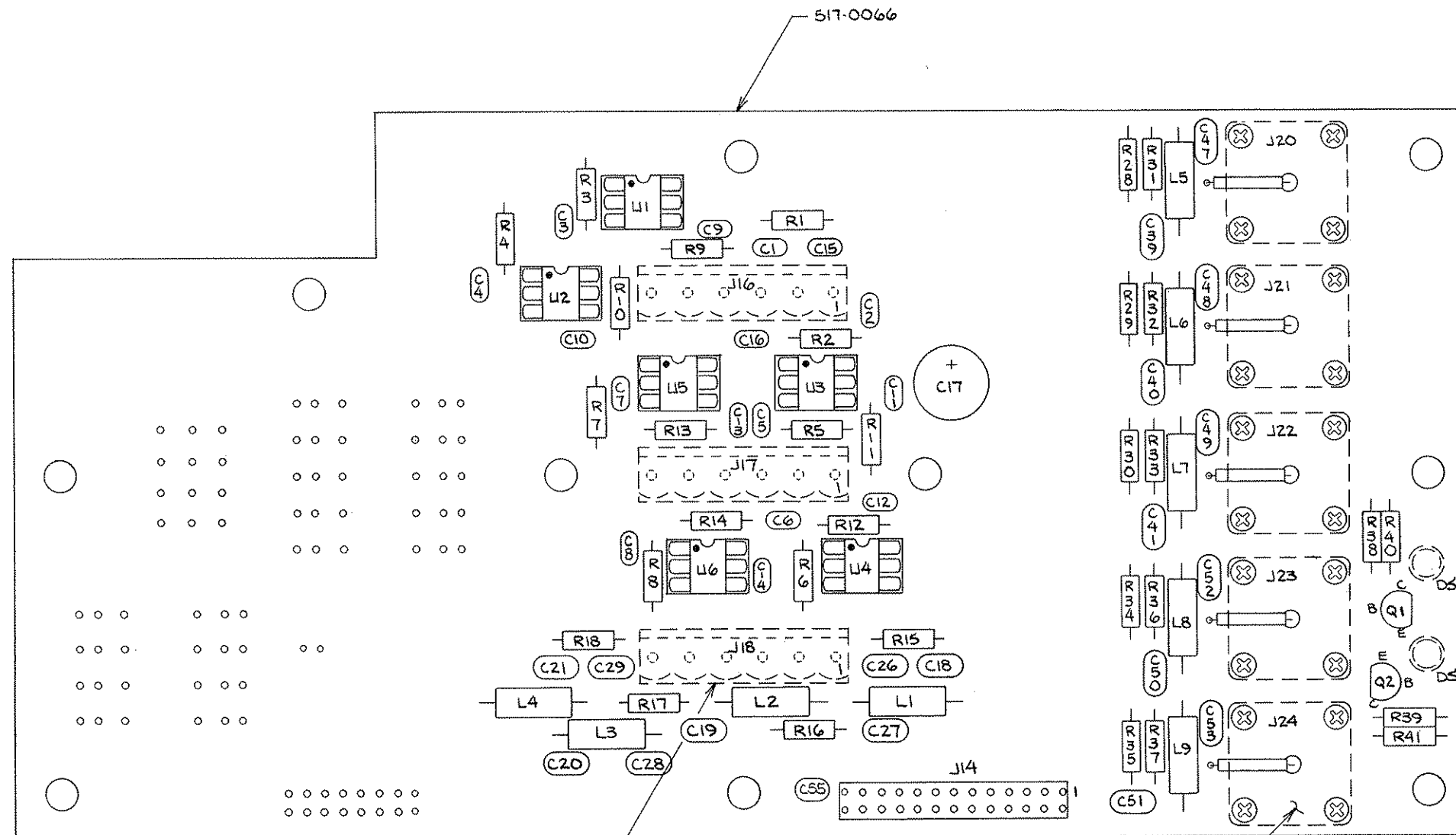

DASHED LINE COMPONENTS MOUNTED ON CIRCUIT SIDE OF BOARD

SEE DETAIL 'A', TYP. 5 PLCS

SEE SCHEMATIC: SC 917-0066

ASSEMBLY DIAGRAM, MONITOR INTERFACE CIRCUIT BOARD

AC 917-0066 REV. C
 COPYRIGHT © MOTOROLA, INC. MARCH 1988

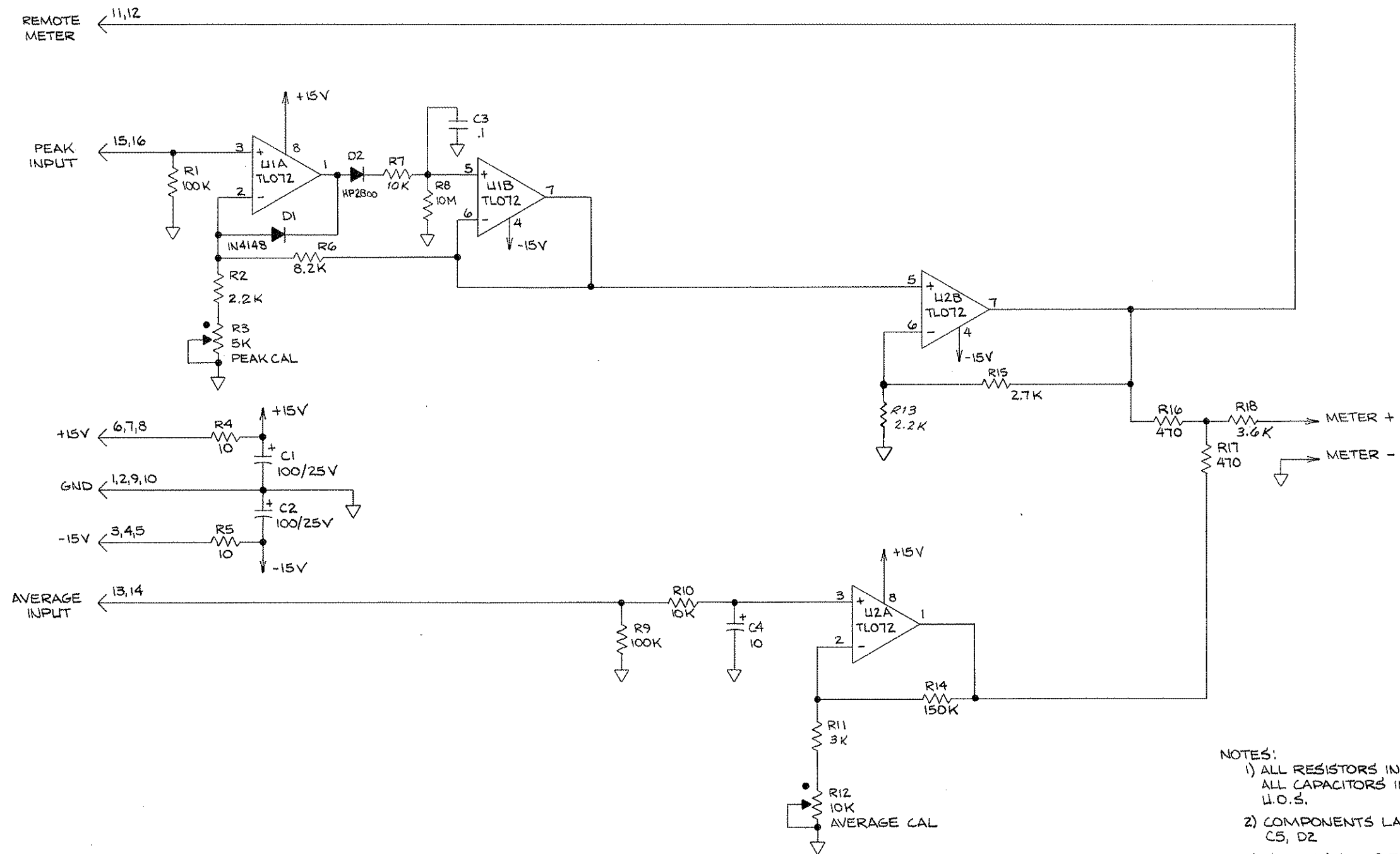

- NOTES:
- 1) ALL RESISTORS IN OHMS, 1/4 W 5%, ALL CAPACITORS IN MICROFARADS, U.O.S.
 - 2) COMPONENTS LAST USED: R18 C5, D2
 - 3) SEE ASSY AC 917-0067

SCHMATIC DIAGRAM, MONITOR METER
CIRCUIT BOARD

SC 917-0067 REV. D
COPYRIGHT © MOTOROLA, INC. MARCH 1988

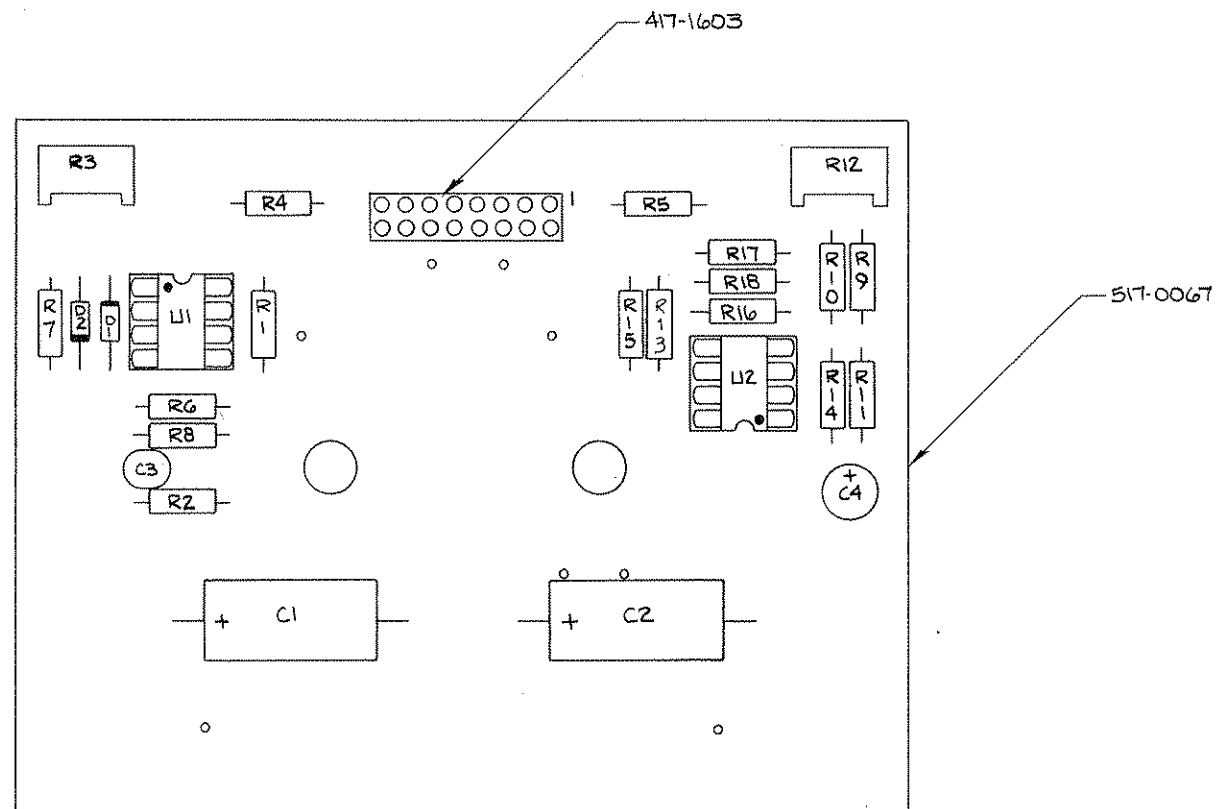

SEE SCHEMATIC: SC 917-0067

ASSEMBLY DIAGRAM, MONITOR METER
CIRCUIT BOARD

AC 917-0067 REV. D
COPYRIGHT © MOTOROLA, INC. MARCH 1988

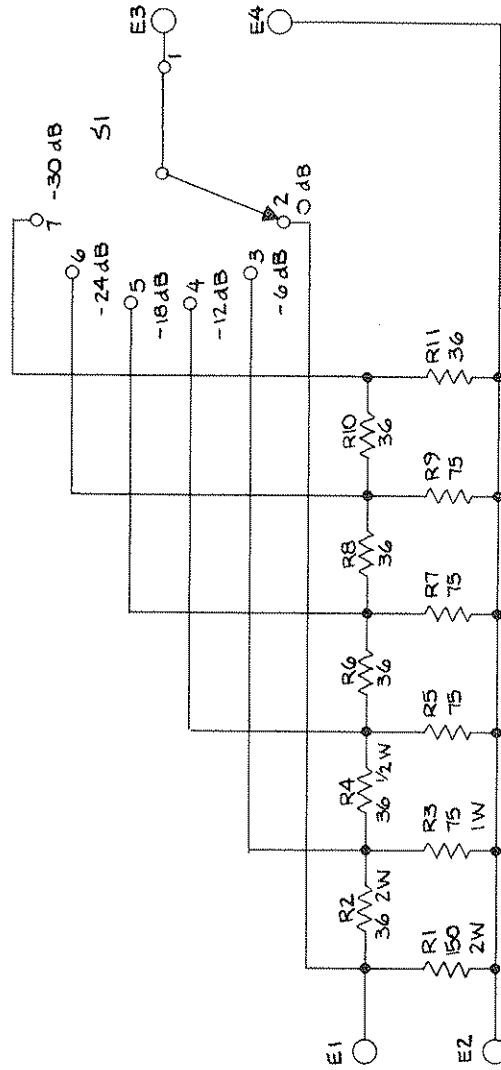

- NOTES:
- 1) ALL RESISTORS IN OHMS, 1/4 W 5%, UNLESS OTHERWISE STATED
 - 2) COMPONENTS LAST USED: R11, E4, S1
 - 3) SEE ASSY: AC 917-0068

SCHEMATIC DIAGRAM, RF ATTENUATOR
CIRCUIT BOARD

SB 917-0068 REV. B
COPYRIGHT © MOTOROLA, INC. MARCH 1988

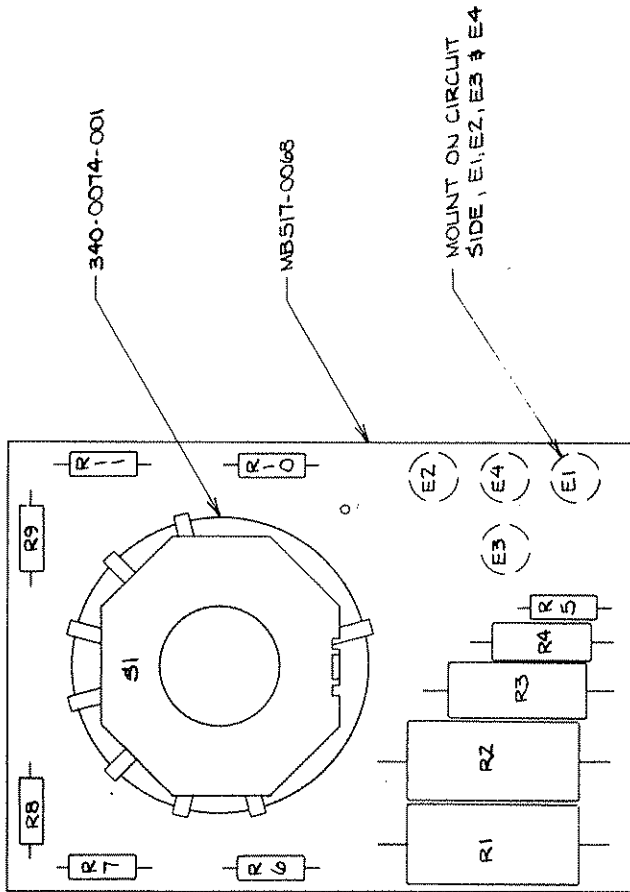

SEE SCHEMATIC SC 917-0068

ASSEMBLY DIAGRAM, RF ATTENUATOR
CIRCUIT BOARD

AB 917-0068 REV. B
COPYRIGHT © MOTOROLA, INC. MARCH 1988

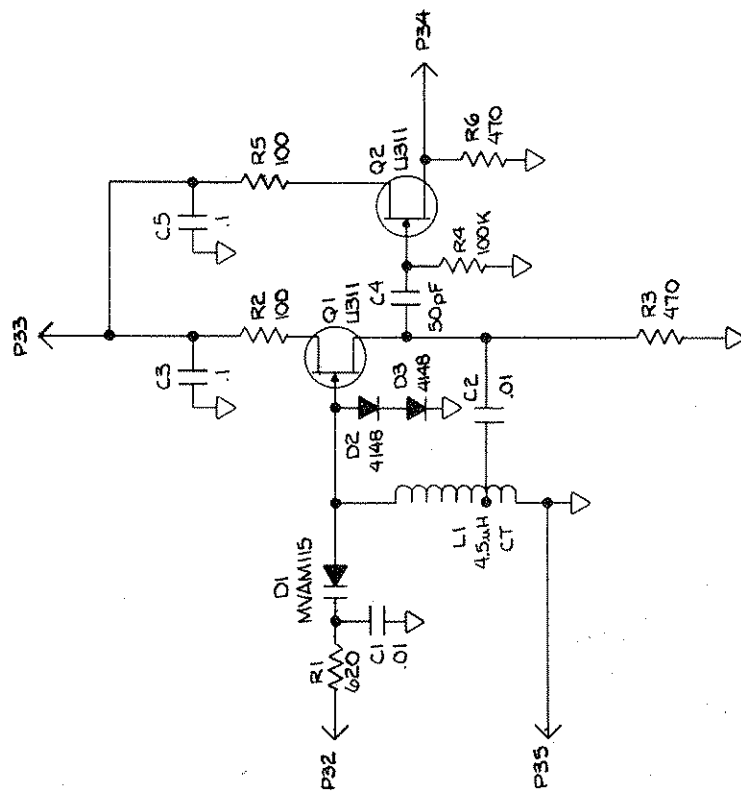

NOTES:

- 1) ALL RESISTORS IN OHMS, 1/4 W 5% ;
CAPACITORS IN MICROFARADS, U.O.S.
- 2) LAST COMPONENTS USED: R6, C5, D3,
L1, Q2,
- 3) SEE ASSY AB 917-0069

SCHEMATIC DIAGRAM, VCO MODULE

SB 917-0069

REV. C

COPYRIGHT © MOTOROLA, INC. MARCH 1988

USE LOCTITE #601 (#700-0074) TO SECURE (420-6103) SCREW AND (441-0013) STANDOFF TO (471-0479-001) COVER. INVERT COVER AND FILL WITH SYLGARD #184 (700-0027) TO WITHIN .01 OF END OF STANDOFF. MOUNT PCB 517-0069 TO STANDOFF USING WASHER (423-6003) AND SCREW (420-6104). HEAT COMPLETE ASSY. AT 150° F FOR 2 HRS. AFTER COOLING SPOT SOLDER (▽) DESIGNATED AREA OF PCB TO COVER

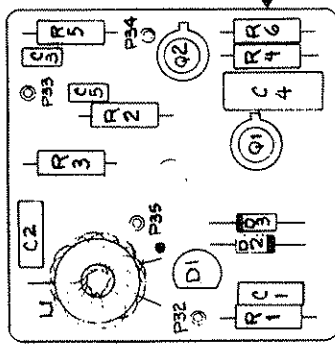

KEYSTONE PINS (# 417-0119) INSERTED AS SHOWN AFTER FLOW SOLDER PROCESS. PINS TO BE SECURED BY SOLDERING SIDE MARKED *.

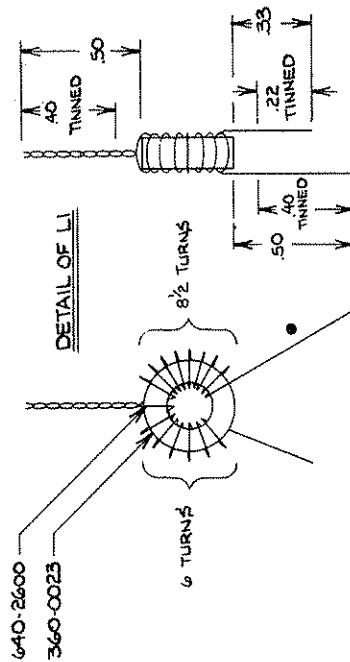
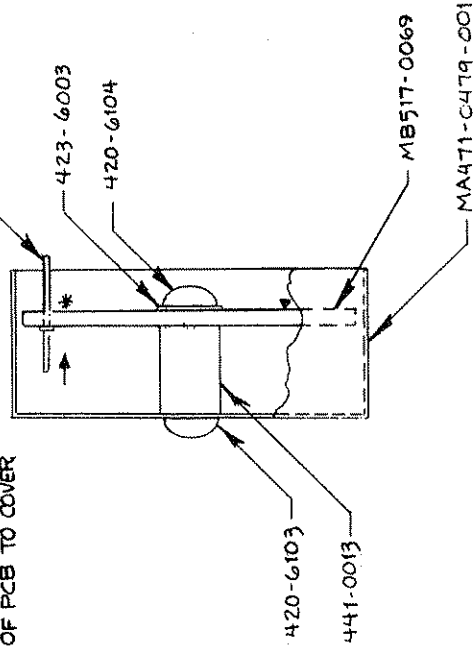

SEE SCHEMATIC # 5B 917-0069
SEE # 917-0069

ASSEMBLY DIAGRAM, VCO MODULE

AB 917-0069 REV. C
COPYRIGHT © MOTOROLA, INC. MARCH 1988

APPENDIX A
MANUFACTURERS DATA

A-1. INTRODUCTION.

A-2. This appendix provides technical data associated with the maintenance of the Model 1410 AM stereo modulation monitor. The information contained in this appendix is presented in the following order.

- A. Technical Information, Motorola Parallel Input PLL Frequency Synthesizer, MC145151.
- B. 1). Technical Information, RCA General Purpose Transistor Array, CA3045.
 2). Technical Information, RCA High-Voltage Transistor Array, CA3183.
- C. 1). Technical Information, Motorola Balanced Modulator/Demodulator, MC1496/MC1596.
 2). Technical Information, Precision Monolythics Inc. Dual Low-Noise Instrumentation Operational Amplifier, OP-227.

PARALLEL INPUT PLL FREQUENCY SYNTHESIZER

The MC145151 is one of a family of LSI PLL frequency synthesizer parts from Motorola CMOS. The family includes devices having serial, parallel and 4-bit data bus programmable inputs. Options include single or dual-modulus capability, transmit/receive offsets, choice of phase detector types and choice of reference divider integer values.

The MC145151 is programmed by 14 parallel input-data lines. The device features consist of a reference oscillator, selectable reference divider, digital-phase detector and 14-bit programmable divide-by-N counter. When combined with a loop filter and VCO, the MC145151 can provide all the remaining functions for a PLL frequency synthesizer operating up to the device's frequency limit. For higher VCO frequency operation, a down mixer or a fixed divide prescaler can be used between the VCO and MC145151.

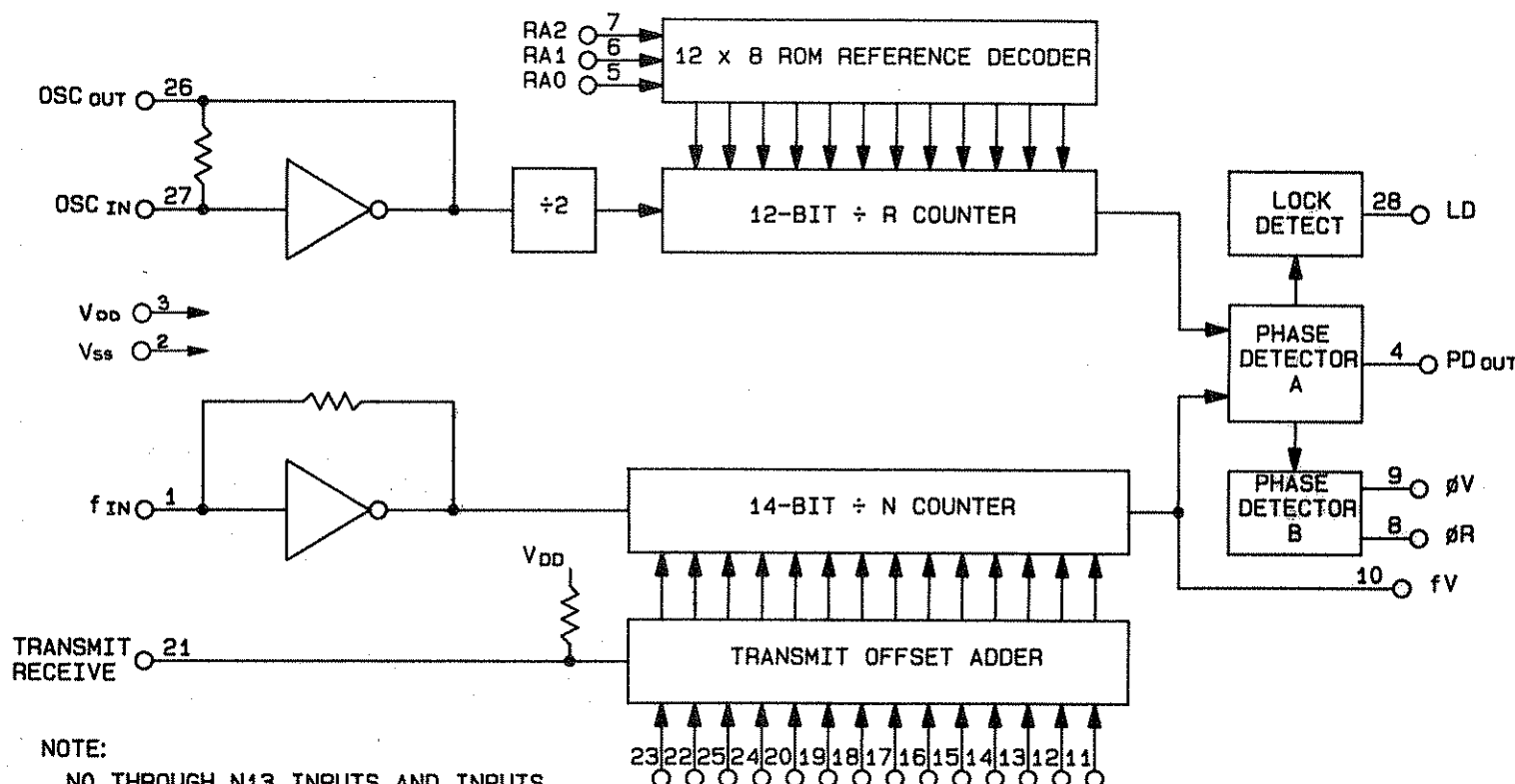
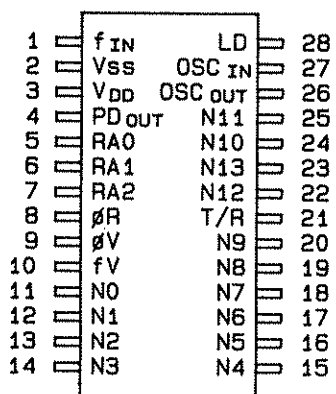

NOTE:

NO THROUGH N13 INPUTS AND INPUTS
 RA0, RA1 AND RA2 HAVE PULLUP RESISTORS N13 N11 N9 N7 N6 N4 N2 N0
 NOT SHOWN.

CA3045

GENERAL-PURPOSE TRANSISTOR ARRAYS

The CA3045 and CA3046 each consist of five general-purpose silicon n-p-n transistors on a common monolithic substrate. Two of the transistors are internally connected to form a differentially-connected pair.

The transistors of the CA3045 and CA3046 are well suited to a wide variety of applications in low power systems in the DC through VHF range. They may be used as discrete transistors in conventional circuits. However, in addition, they provide the very significant inherent integrated circuit advantages of close electrical and thermal matching.

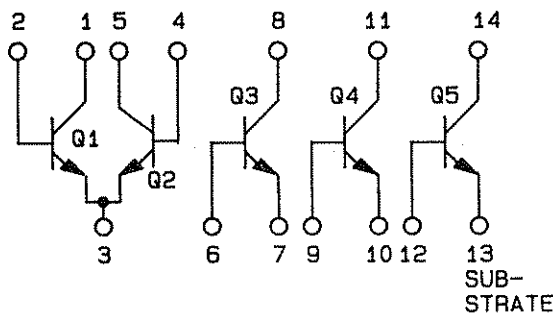
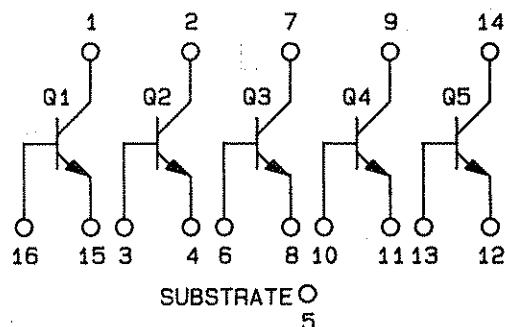

FIG.1 SCHEMATIC DIAGRAM

CA3183

HIGH-VOLTAGE TRANSISTOR ARRAYS

Types CA3183AE and CA3183E consist of five high-current transistors with independent connections for each transistor. In addition two of these transistors (Q1 and Q2) are matched at low-current (i.e. 1mA) for applications where offset parameters are of special importance. A special substrate terminal is also included for greater flexibility in circuit design. Both types are supplied in a 16-lead dual-in-line plastic package and operate over the ambient temperature range of -40°C to $+85^{\circ}\text{C}$. (CA3183AE and CA3183E are high-voltage versions of the popular predecessor type CA3083.)



CA3183AE, CA3183E

MC1496
MC1596

BALANCED MODULATOR/DEMODULATOR

Designed for use where the output voltage is a product of an input voltage (signal) and a switching function (carrier). Typical applications include suppressed carrier and amplitude modulation synchronous detection, FM detection, phase detection, and chopper applications. See Motorola Application Note AN-531 for additional design information.

- Excellent Carrier Suppression - 65 dB typ @ 0.5 MHz
- 50 dB typ @ 10 MHz
- Adjustable Gain and Signal Handling
- Balanced Inputs and Outputs
- High Common-Mode Rejection - 85 dB typ

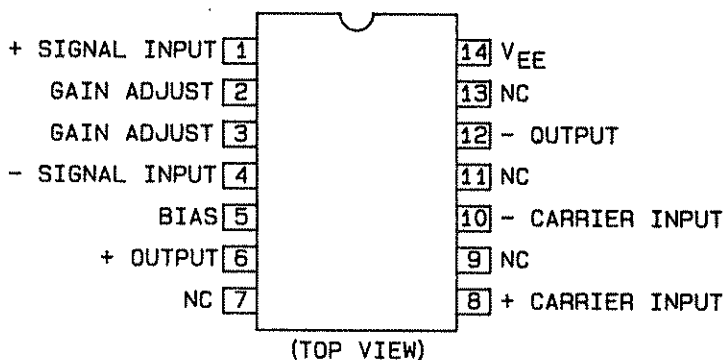

OP-227

DUAL LOW-NOISE INSTRUMENTATION OPERATIONAL AMPLIFIER

The OP-227 is the first dual amplifier to offer a combination of low offset, low noise, high speed and guaranteed amplifier matching characteristics in one device. The OP-227 with a V_{os} match of 25 μV , a TCV_{os} match of 0.3 $\mu\text{V}/^\circ\text{C}$, and a $1/f$ corner of only 2.7 Hz is an excellent choice for precision low noise designs. These D.C. characteristics, coupled with a slew rate of 2.8 $\text{V}/\mu\text{s}$ and a small-signal bandwidth of 8 MHz, allow the designer to achieve AC performance previously unattainable with op-amp-based instrumentation designs.

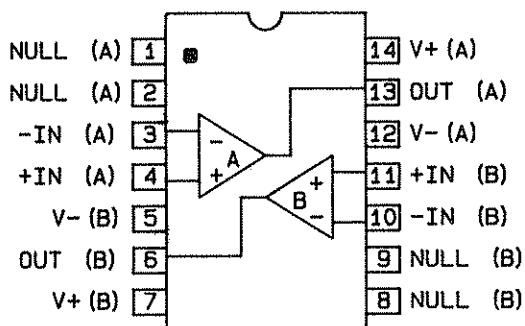

COMMERCIAL WARRANTY (STANDARD)

Motorola AM stereo radio broadcast products are warranted to be free from defects in material and workmanship for a period of one (1) year, (except for crystals and channel elements which are warranted for a period of ten (10) years) from the date of shipment. In the event of a defect during the applicable warranty period, if customer returns the defective part or product to Motorola, transportation prepaid, Motorola, at its option, will either repair or replace such part or product, and such action by Motorola shall be the full extent of Motorola's obligation hereunder. Motorola will pay the transportation charges to return the part or product to customer.

This warranty is void if:

- a. the product is used in other than its normal and customary manner;
- b. the product is subject to misuse, accident, neglect or damage;
- c. unauthorized alterations or repairs are made, or unapproved parts are used in the equipment.

This warranty extends only to individual products. Because each radio broadcast system is unique, Motorola disclaims liability under this warranty or otherwise for range, coverage, performance or operation of the system as a whole. This warranty applies only within the United States and is extended by Motorola Inc., 1216 Remington Road, Schaumburg, Illinois 60173, to the original purchaser, and only to those purchasing the product solely for commercial, industrial, or governmental use. In order to obtain performance of this warranty, customer must contact its Motorola salesperson or Motorola at the address stated herein, attention: Quality Assurance Department.

THIS WARRANTY IS GIVEN IN LIEU OF ALL OTHER WARRANTIES EXPRESS OR IMPLIED, ALL OF WHICH ARE SPECIFICALLY EXCLUDED, INCLUDING, BUT NOT LIMITED TO, THE WARRANTIES OF MERCHANTABILITY OR FITNESS FOR A PARTICULAR PURPOSE. IN NO EVENT SHALL MOTOROLA BE LIABLE FOR INCIDENTAL OR CONSEQUENTIAL DAMAGES.

