

Specifications

RANGES: Resistance: 1 milliohm to 11 megohms. Capacitance: 1 micromicrofarad to 1100 microfarads. Inductance: 1 microhenry to 1100 henrys. Dissipation Factor ($D=R/X=R\omega C$): 0.001 to 1.0. Storage Factor ($Q=X/R=\omega L/R$): 0.02 to 1000.

ACCURACY: Resistance: $\pm (0.15\% + 1$ division on LRC dial). Capacitance: $\pm (0.5\% + 1$ division on LRC dial). Inductance: $\pm (1.0\% + 1$ division on LRC dial). Dissipation Factor or Storage Factor expressed in terms of its reciprocal $\pm (7\% + .0025)$.*

*Note: $\pm 5\%$ of the dissipation factor error is associated with the possible variation in frequency of the internal 1000 cps generator. If the bridge is used with the Model 855-A Amplifier-Oscillator, this error is reduced to approximately $\pm (3\% + .0025)$. The above limits of error are stated for the intermediate ranges of the bridge. When measuring inductors with storage factors below 15 on the Hay bridge, the inductance error rises to $\pm (1.5\% + 1$ division on the LRC dial). On the lowest impedance range, the accuracy falls off because of small residual resistances and inductances associated with the bridge wiring and switches. On the two highest impedance ranges, small stray capacitances associated with the bridge arms and the bridge generator may cause significant errors particularly in the dissipation factor and storage factor readings. Corrections may generally be applied to these readings to approximate the stated accuracies on all ranges.

PRECISION OF BALANCE: The main LRC slidewire has 38,000 effective turns, an effective length of nearly 60 feet and a scale with 11,000 graduations spaced approximately 1 millimeter apart. The internal galvanometer permits d-c resistance balances to be made to approximately 0.1% or better on the intermediate ranges. With an accessory null amplifier such as the BECO Model 850-B or the BECO Model 855-A, the LRC dial may be resolved to better than 1 division on most measurements of inductance and capacitance. The BECO Model 855-A Amplifier-Oscillator is also recommended for supplying the higher d-c voltages necessary for good precision on the high resistance ranges.

FREQUENCY RESPONSE: The readings of the main LRC dial are essentially independent of frequency from a few cycles to 10 kilocycles on the intermediate ranges. The readings of the storage factor dials must be divided by and the dissipation factor dial readings multiplied by the generator frequency in kilocycles to give the correct values.

Provision is made for adding external resistance if necessary to extend the ranges of the D and Q dials. On the lowest and two highest impedance ranges, it may be necessary to apply corrections to the LRC dial readings to compensate for the effects of the small

residual impedances associated with the bridge arms and the errors introduced by stray capacitances to ground associated with the external generator. The errors in the dissipation factor and storage factor dials are proportional to frequency except at very low frequencies where they may still remain as high as 2%. By applying corrections to the LRC dial readings, the frequency range of the bridge may be extended considerably beyond 10 kilocycles on the intermediate ranges.

INTERNAL GENERATOR: A 1000 cps microphone hummer accurate to within $\pm 5\%$ is used as the internal bridge generator. The generator is coupled to the bridge by a carefully isolated and shielded coil to minimize the effects of stray capacitances to ground and eliminate extraneous voltages across the bridge arms. The entire generator is enclosed in a special shield which provides both electromagnetic and electrostatic shielding and reduces errors caused by the effects of stray fields upon the components being measured.

POWER SUPPLY: Four size "D" flashlight cells in a convenient cartridge power the bridge. Provision is made for the use of an external battery or oscillator.

DETECTOR: A suspension type galvanometer of 0.5 microampere per millimeter deflection sensitivity is used for d-c resistance measurements. Terminals on the front panel permit independent use of the bridge galvanometer. Terminals also are provided for the use of an external galvanometer in conjunction with the bridge. High impedance headphones such as Trimm K29-D or Western Electric 1002-C or other suitable null detector may be used for a-c null detection. For increased sensitivity, the battery operated BECO Model 850-B Amplifier or the a-c powered BECO Model 855-A Amplifier-Oscillator is recommended as an accessory for the bridge.

MOUNTING: All controls, terminals and components are mounted on an 8"x10" aluminum panel which may be removed as a unit from the case for easy servicing. Controls and terminals are clearly marked as to their function. The sturdy aluminum cabinet has a removable cover to protect the controls and is provided with a comfortable handle for easy portability. Space is provided inside the cabinet for the storage of headphones, test leads, operating instructions, batteries and the accessory null amplifiers.

DIMENSIONS: Overall size of the bridge is approximately $8\frac{3}{4}'' \times 10\frac{1}{2}'' \times 10\frac{1}{2}''$.

WEIGHT: Net, 17 pounds including batteries. Shipping, 22 pounds.

ACCESSORIES: Test leads, batteries and operating instructions are furnished with the bridge.

PRICE: \$295.00 F.O.B. Portland, Oregon. When full payment accompanies an order for new equipment, we will pay transportation charges to any point in continental United States except Alaska.

FIELD REPRESENTATIVES FOR BECO INSTRUMENTS

Albuquerque, New Mexico
Neely Enterprises
8211 E. Central Ave.
Phone: 5-5978

Chicago 40, Illinois
Alfred Crossley & Associates
4501 N. Ravenswood Ave.
Uptown 8-1141

Cleveland 18, Ohio
J. R. Dannemiller Associates
4334 Graveland Road
EVergreen 5100

Dallas 5, Texas
Earl Lipscomb Associates
4433 Stanford St.
LOgan 6-5097

Dayton 2, Ohio
Alfred Crossley & Associates
410 West First St.
Michigan 8721

Houston 5, Texas
Earl Lipscomb Associates
3919 Riley Street
Linden 9303

Los Angeles 46, California
Neely Enterprises
7422 Melrose Ave.
WHitney 1147

Portland 14, Oregon
Hawthorne Electronics
712 S. E. Hawthorne Blvd.
VERmont 5585

Sacramento, California
Neely Enterprises
309 Ochsner Bldg.
Gilbert 3-7461

San Francisco 3, California
Neely Enterprises
954 Howard Street
DOuglas 2-2609

Canada
Measurement Engineering Ltd.
Amprior, Ontario

BROWN ELECTRO-MEASUREMENT CORP.

4635-37 S. E. Hawthorne Blvd., Portland 15, Oregon, U. S. A.



Presents...

the model 250-C

UNIVERSAL IMPEDANCE BRIDGE

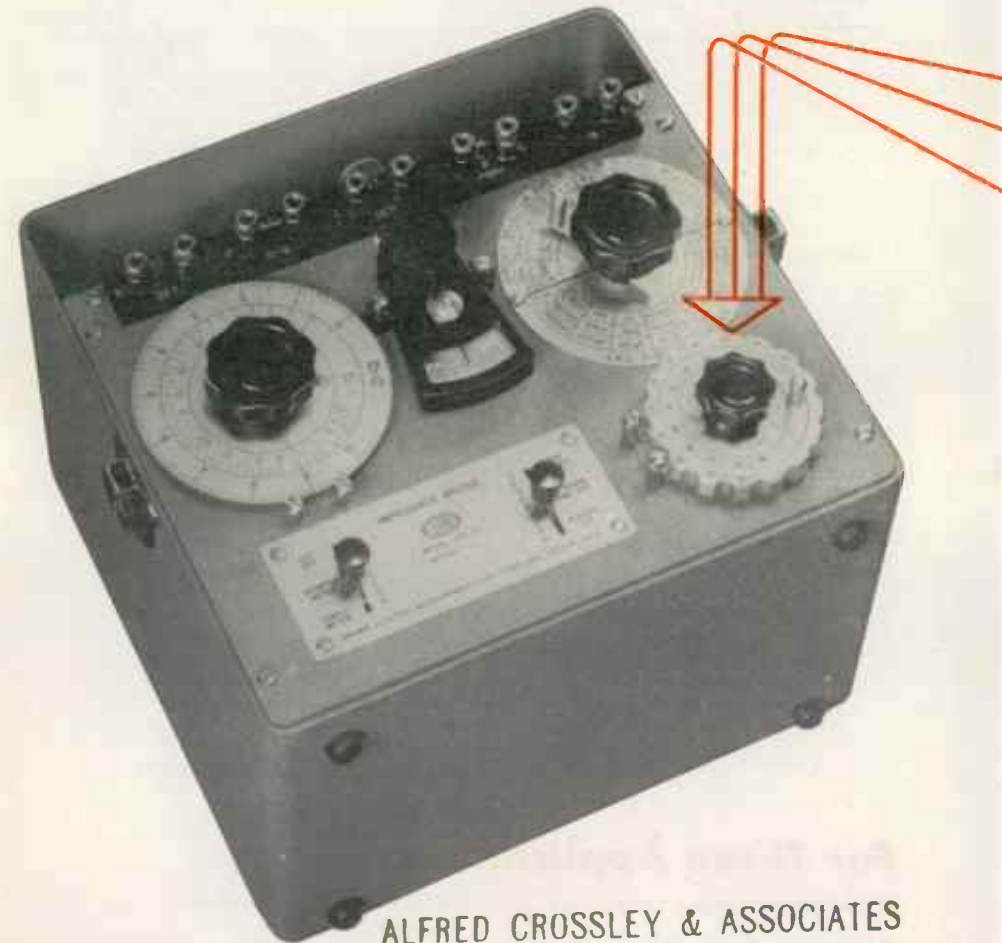

ALFRED CROSSLEY & ASSOCIATES
MIDWEST SALES ENGINEERS
4501 N. Ravenswood Ave., Chicago 40, Ill.
PHONE Uptown 8-1141

for the

Precise measurement of

RESISTANCE • CAPACITANCE • INDUCTANCE

FOUR versatile bridges in ONE instrument

Wheatstone Resistance Bridge

Range: 1 milliohm to 11 megohms

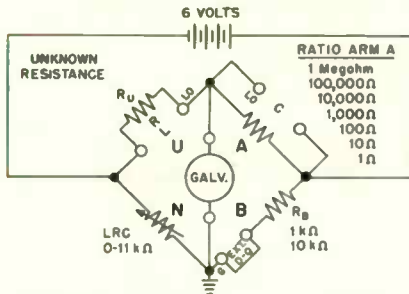

1 milliohm to 1.1 megohms



Circuit Selector Setting

Modified DeSauty Capacitance Bridge

Range: 1 μ f to 1100 μ f; D_1 0.001 to 1.05

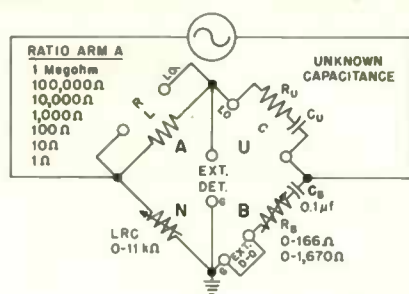

D_1 .001 to .105
 D_2 .001 to 1.05



Circuit Selector Setting

Maxwell Inductance Bridge

Range: 1 μ h to 1100 h; Q_1 .02 to 10.5

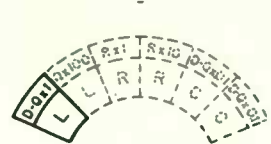
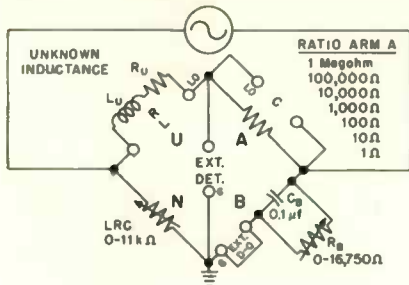

Circuit Selector Setting

Hay Inductance Bridge

Range: 1 μ h to 1100 h; Q_1 9.5 to 1000

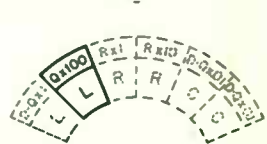
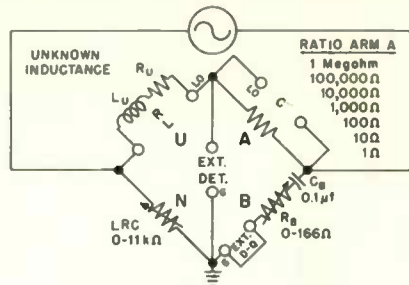

Circuit Selector Setting

Eleven billion to one on resistance measurements. More than one billion to one on capacitance and inductance measurements.

Resistance: 1 milliohm to 11 megohms.

Capacitance: 1 micromicrofarad to 1100 microfarads.

Inductance: 1 microhenry to 1100 henrys.

Bridge resistors adjusted to within $\pm 0.05\%$ of their nominal value. (Except 1 ohm ratio arm $\pm 0.25\%$; 1 megohm arm $\pm 0.1\%$.) Resistors are non-inductively wound on thin mica cards except for the 0.1 and 1.0 megohm ratio arms which are non-inductively wound on ceramic bobbins. The temperature coefficient of all resistors is less than 20 parts per million per degree Centigrade. The mica capacitance standard is adjusted to better than $\pm 0.25\%$ of the nominal value and carefully stabilized. Stray capacitances and inductances associated with the bridge arms have been minimized.

A Unique DEKADIAL LRC Scale, with 11,000 effective graduations, controls a coaxial decade and rheostat combination. This provides nearly 60 feet of slidewire having 38,000 effective turns. On the lowest ranges, one division on this dial represents 0.1 microhenry, 0.1 milliohm or 0.1 micromicrofarad. All resistors in the two precision decades are adjusted to better than $\pm 0.05\%$. The interpolating rheostat is adjusted to better than $\pm 1\%$ and introduces an error of less than $\pm 0.01\%$ in the full scale value of the LRC slidewire. Precious metal contacts on the interpolating rheostat and the D and Q rheostats insure excellent resolution and noise free operation.

D and Q rheostats are ganged on a single control to avoid confusion in the selection of the proper rheostat to adjust for balance. Color indexed dials and switches are provided for rapid scale selection. Range and function switches are clearly marked in simplified units to avoid errors in the placing of the decimal point in dial readings. All bridge arm junctions are clearly marked and available on the terminal strip. Test terminals are marked with both the appropriate letter and proper symbol representing inductance, capacitance or resistance. Inductance and d-c resistance of inductors are measured on the same pair of test terminals.

Compact — 8 3/4" x 10 1/2" x 10 1/2". Light weight — 17 pounds. Detachable cover protects meter and controls. The four flashlight cells used to power the bridge can be replaced in a few seconds without the use of tools. Excellent for field and industrial applications.

BECO Null Amplifiers may be placed in the accessory compartment of the bridge to increase the precision of balance and provide visual null indication on capacitance and inductance measurements.

Featuring

Wide Range

High Accuracy

Simplified Operation

Easy Portability

Accessory Null Amplifiers

For These Applications:

- Precision matching of resistors.
- Selection of capacitors and inductors for resonant circuits.
- Testing of samples.
- "Q" measurement of inductors.
- A-C resistance measurements of electrolytic cells.
- Many other applications in laboratory and field testing.
- Fault location and field maintenance.
- Quality checks on capacitors by dissipation factor measurement.
- Measurement of terminal capacitances of shielded inductors.
- Measurement of circuit components in experimental equipment.

BECO instruments are carefully engineered and made to the most exacting standards of workmanship and accuracy in a modern and well equipped factory.

Sales representatives are maintained in principal cities as a service to our customers. Customers are invited to contact our nearest field representative or to consult our engineering staff for further information regarding BECO instruments and their applications.



WARRANTY

Brown Electro-Measurement Corporation warrants each new instrument of its manufacture to be free from defects in material and workmanship. Our obligation under this Warranty is limited to repairing or replacing any instrument or part thereof except tubes, batteries and fuses which shall, within one year after making delivery to the original purchaser, be returned to us with transportation charges prepaid and which upon our examination shall prove to have been thus defective.

Brown Electro-Measurement Corporation reserves the right to make changes in design at any time without incurring any obligation to make such changes on instruments previously sold.

This Warranty is expressly in lieu of all other obligations and liabilities on the part of Brown Electro-Measurement Corporation and Brown Electro-Measurement Corporation neither assumes nor authorizes any other person to assume any other liability in connection with the sale of BECO instruments.

BROWN ELECTRO-MEASUREMENT CORPORATION

**4635-37 S. E. HAWTHORNE BOULEVARD
PORTLAND 15, OREGON**

Printed in U.S.A.



ALFRED CROSSLEY & ASSOCIATES
MIDWEST SALES ENGINEERS
4501 N. Ravenswood Ave., Chicago 40, Ill.
PHONE Uptown 8-1141

MODEL 850-B BRIDGE AMPLIFIER

BROWN ELECTRO-MEASUREMENT CORPORATION
MANUFACTURERS OF PRECISION ELECTRICAL AND SCIENTIFIC INSTRUMENTS

MODEL 850-B BRIDGE AMPLIFIER

The Model 850-B Amplifier is a compact two-stage amplifier having a highly selective response curve peaked at 1 kilocycle. It has been especially designed for use with BECO Impedance Bridges to increase null detection sensitivity. However, the convenience and excellent performance of the Model 850-B Amplifier make it useful wherever there is need for a 1 kilocycle tuned amplifier.

FEATURES

High Gain: Continuously adjustable to at least 52 db.

Lightweight: Approximately 1 pound complete with batteries.

Compact: Overall dimensions approximately 6" x 2 1/2" x 1 1/2".

Unusual Battery Economy: The single flashlight cell "A" battery has a service life of 100 to 150 hours. Service life of the "B" battery exceeds 1,000 hours.

Low Microphonic Level: The use of low microphonic sub-miniature tubes makes the amplifier exceptionally free from background noise.

Excellent Harmonic Rejection: Response down 20 db. at 2000 cps.

Automatic Transfer of Input to Output Terminals: The OFF-ON switch transfers the input terminals to the output terminals

when in the OFF position. This makes it possible to search for an initial null with the amplifier OFF without having to transfer the headphones or other null indicator from the amplifier terminals to the bridge terminals.

Limited Audio Output: The output of the amplifier cannot exceed a comfortable volume level in the headphones regardless of the gain setting or input level. This feature also protects the galvanometer from dangerous overloads when the galvanometer is used as a visual null indicator.

Provision for Visual Null Indication: A built-in rectifier circuit permits the amplifier to operate the bridge galvanometer as a sensitive null indicator on a-c impedance measurements.

No Warm-up Delay: The amplifier is available for immediate use at the throw of a switch.

Wiring Diagram, Model 850-B Bridge Amplifier

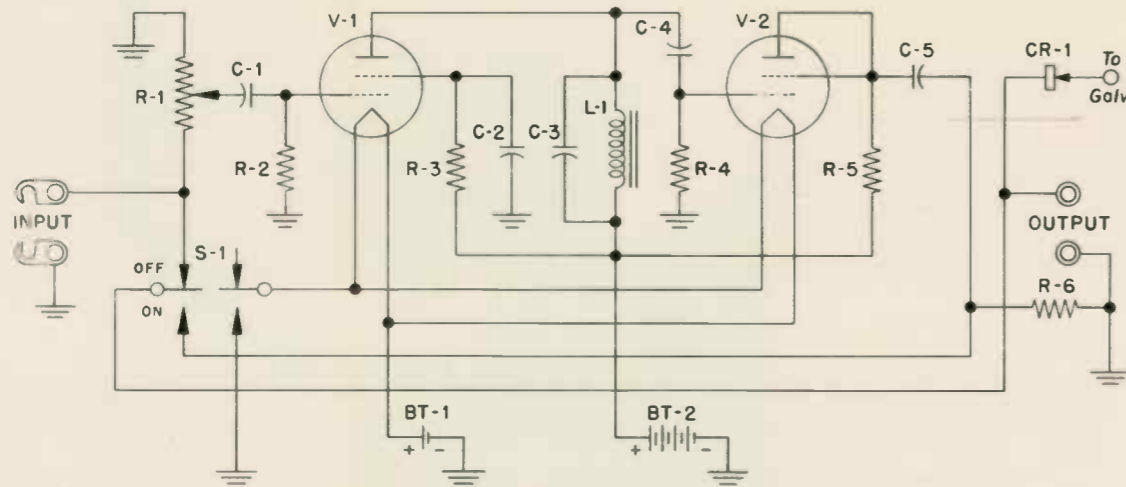

Figure 1.

COMPONENTS

BT-1	1.5 Volts, Size D Flashlight Cell	R-5	27 K Ohms \pm 10%, 1/2 Watt
BT-2	22.5 Volts, Eveready 425-P	R-6	100 K Ohms \pm 10%, 1/2 Watt
C-1	.001 μ f \pm 20%	CR-1	1N34 Diode
C-2	.05 μ f \pm 20%	V-1 and V-2	CK522AX
C-3	.004 μ f *	S-1	DPDT Toggle Switch
C-4	.001 μ f \pm 20%	TUBE LEAD CONNECTIONS	
C-5	.01 μ f \pm 20%	<i>Lead 1 is adjacent to Red Dot</i>	
L-1	6.5 Henrys *	1	Plate
R-1	3 Megohms, Centralab Type L108	2	Grid #2
R-2	10 Megohms \pm 10%, 1/2 Watt	3	Filament, positive
R-3	27 K Ohms \pm 10%, 1/2 Watt	4	Grid #1
R-4	10 Megohms \pm 10%, 1/2 Watt	5	Filament, negative

*C-3 and L-1 are selected to resonate at 1,000 cycles per second.

INSTALLATION AND OPERATING INSTRUCTIONS FOR BECO 850-B AMPLIFIER

Place the amplifier in the storage compartment of the bridge directly opposite the EXT. DET. terminals and fasten the input terminals of the amplifier to the EXT. DET. bridge terminals.

Connect the headphones to the output binding posts of the amplifier.

Secure an initial null on a-c measurements with the amplifier switch in the OFF position which connects the output terminals of the amplifier to the EXT. DET. bridge terminals.

When the null has been approximately located, switch the amplifier ON and balance for the final null. The gain control may be adjusted to give the required amplification. Clockwise rotation of the control increases gain.

Batteries may be replaced by unfastening the screw on the side of the case near the input terminals and the screw at the bottom of the case. The "A" battery is a single size D standard flashlight cell. The 22 1/2 volt Eveready No. 425-P "B" battery is a standard hearing aid battery. This battery may be removed by withdrawing it from the battery plug which is fastened to the amplifier chassis.

Two CK522AX Raytheon sub-miniature tubes are employed and may be replaced by lifting them from the special sockets. When inserting new tubes, be certain that the red dot on the tube base is on the same side as the dot on the tube socket.

If desired, the bridge galvanometer or other sensitive d-c meter may be used as the null indicator on impedance measurements in place of the headphones. The rectified output for operating the meter is available at the pin jack on the side of the amplifier case.

To employ the bridge galvanometer as the null indicator, insert the pin tip of the connecting wire furnished with the amplifier into the pin jack on the side of the amplifier and fasten the spade lug under the left hand filister

head screw on the galvanometer. The return circuit for the galvanometer is automatically supplied by the metal bridge panel to which the amplifier is connected by the grounded input terminal.

An external d-c meter may be used as the null indicator by connecting one terminal of the external meter to any grounded terminal on the bridge or amplifier and the other meter terminal to the pin jack on the side of the amplifier case. Approximately 50 microamperes is available to operate the meter. This current may be increased to approximately 100 microamperes by connecting headphones or a low resistance choke having several henrys inductance across the amplifier output terminals to provide a favorable d-c return path for the meter current.

With the amplifier ON, the amplifier cannot deliver enough current to damage the bridge galvanometer under any conditions of bridge unbalance.

With the amplifier OFF, the rectifier circuit is connected directly across the bridge output terminals and several milliamperes of current may be developed in the meter circuit under some operating conditions. For this reason, it is preferable to operate the amplifier at a reduced gain setting when searching for an initial null rather than switching the amplifier OFF if a meter is being used as the null indicator.

When making a-c impedance measurements, the detector switch on the bridge must be set at the EXT. DET. position. The SHUNTED METER and DIRECT METER detector switch positions are used only for d-c resistance measurements. When making d-c resistance measurements, it is advisable to disconnect the rectifier lead between the amplifier and bridge galvanometer to avoid any possibility of an error current being produced by a-c pickup at the amplifier terminals.

Net weight: 1 lb. Shipping weight: 3 lbs.

Price: \$60.00 F.O.B. Portland, Oregon*

Complete with batteries, tubes and instructions.

*When full payment accompanies an order for new equipment, we will pay transportation charges to any point in continental United States except Alaska.