

PT6-A INSTRUCTION MANUAL

Magnecord INC.



SALES OFFICE AND FACTORY
225 WEST OHIO STREET
CHICAGO 10, ILL.

OPERATING PROCEDURE FOR FAST FORWARD IN PT6-AH RECORDER MECHANISM

With the recorder set up in the normal operating condition and threaded with tape, set the control knob to STOP. Depressing the high speed knob clockwise to the right will start the main drive motor and engage the intermediate rubber drive wheel between the motor shaft and hub of the takeup shaft clutch. This will cause the right hand spool to rotate clockwise, thus winding the tape forward. Total forward winding time of 7" spool is approximately three minutes.

If high speed forward lever is depressed while the mechanism is driving the tape in the normal forward manner, the high speed overdrive will be engaged and place an undue strain on the tape between the capstan and take-up reel. It will be noted that this speeds up the tape only slightly. This causes no harm mechanically but the program material speeded up will sound peculiar.

Copyright 1949, Magnecord, Inc.

BIAS INDICATOR:

The bias indicator lamp (II in Fig. 1) will glow when plate supply voltage is being supplied to the oscillator tube. This indicates that any previous recording on the tape is being erased and a new recording may be made.

TERMINAL DESIGNATIONS:

All electrical connections are made to the Jones male and Cannon female connectors located in the rear of the PT6-A. Signal circuits are fed through the Cannon connector, and power is fed through the Jones connector. See schematic for terminal designations.

MAINTENANCE:

The PT6-A Basic Recorder Mechanism is ruggedly built to withstand the requirements of studio and field use. Maintenance is of a minor nature and should the unit require any repairs due to accident or misuse, it should be returned to the distributor from whom it was purchased. When writing in regard to the unit, the type number, serial number shown on the license notice and also the date of purchase should be mentioned.

ELECTRICAL:

The 12AU7 oscillator tube should be checked occasionally.

MECHANICAL:

All bearings in the PT6-A are either of the self-oiling type or the wick-fed type. The unit is properly lubricated before it leaves the factory and should not require any further lubrication for at least six months. Information on lubrication is supplied in the PT6 Series Service Notes.

Note: It is imperative that no oil be allowed to accumulate on any of the rubber covered idlers as this will cause slippage and impair tape speed regulation. A soft cloth moistened with carbon tetrachloride should be used to remove any oil from the idlers.

CLUTCH ADJUSTMENTS:

Tape tension is maintained by two friction clutches. Their correct adjustment causes the tape to move from one reel to the other in either direction without throwing or stalling.

The clutches are located on the rear ends of the supply reel spindle and the take-up reel spindle. The supply reel spindle clutch is located at the right (facing the rear of the unit) and consists of an oiled felt washer pressing

against a knurled disc which is free to rotate in a clockwise direction but prevented from turning in the opposite direction by a spring loaded pawl. Pressing against the opposite side of the felt washer is a sponge rubber pad. A split, knurled adjustment ring bears against the sponge rubber pad and is locked in place by means of a set screw. The set screw must be backed off before the adjustment ring can be turned. Rotating the adjustment ring clockwise increases the clutch friction.

The supply reel spindle clutch adjustment should maintain a drag as the supply reel rotates when the PT6-A is in forward operation. This drag should be sufficient to stop the supply reel without permitting the tape to loop or throw when the control switch is turned from "FORWARD" to "STOP". The amount of friction should be the minimum necessary to accomplish this.

Too much clutch friction will increase the tape drag to a point at which the tape speed will be below normal.

The take-up reel friction clutch is located on the left side (facing the rear). This is similar in appearance to the other clutch but employs no pawl. It is also necessary to back off the set screw before adjusting this clutch.

The take-up reel spindle friction clutch couples the spindle to the synchronous motor drive when the control knob is set to "FORWARD" and acts as a brake on the take-up reel when the control knob is set to "STOP". The clutch adjustment should provide sufficient friction for the take-up reel and capstan to move the tape at normal speed forward when the take-up reel is almost completely full and the supply reel nearly empty. It should also provide sufficient braking to maintain tape tension and prohibit tape throw when the control switch is turned to "STOP" after the take-up reel has been rotating at high speed during rewind. The split knurled ring should be adjusted to provide the minimum clutch friction to accomplish these two functions. About 5 inch oz. for each clutch is correct friction.

OILING THE CLUTCH FELTS:

The felt washers have been oil treated at the factory to provide the correct amount of slippage. It may be necessary to give each felt washer (supply spindle and take up spindle) one drop of high quality sewing machine oil after several months of use.

CAUTION:

(DO NOT OVER-OIL THE CLUTCH FELTS AS THIS MAY CAUSE OIL TO BE THROWN ON NEARBY IDLERS CAUSING SLIPPAGE IN THE DRIVE SYSTEM. ONE DROP PER FELT IS SUFFICIENT.)

CLEANING THE HEADS:

It is necessary that the portions of the erase head and the record-reproduce head which come into contact with the tape be kept free of dust, grease and foreign matter, or the frequency response characteristics will suffer. They should be cleaned with a soft cloth slightly moistened with carbon tetrachloride C.P. after every five hours of operation.

Note: Do not attempt to apply carbon tetrachloride to any part of the PT6-A when loaded reels are in place as the tape is soluble in carbon tetrachloride and will be ruined if it comes in contact with the solution. After using carbon tetrachloride

make sure the heads are completely dry before threading tape and be sure none of the solution is transferred to the tape from the fingers.

HEAD REPLACEMENT:

Replacement erase or record-reproduce heads may be obtained from the distributor from whom the unit was purchased provided the worn heads are returned at the same time.

GUARANTEE:

The Magnecord PT6-A is guaranteed to be free of defects in workmanship and materials (excepting tubes) for a period of 90 days from date of purchase.

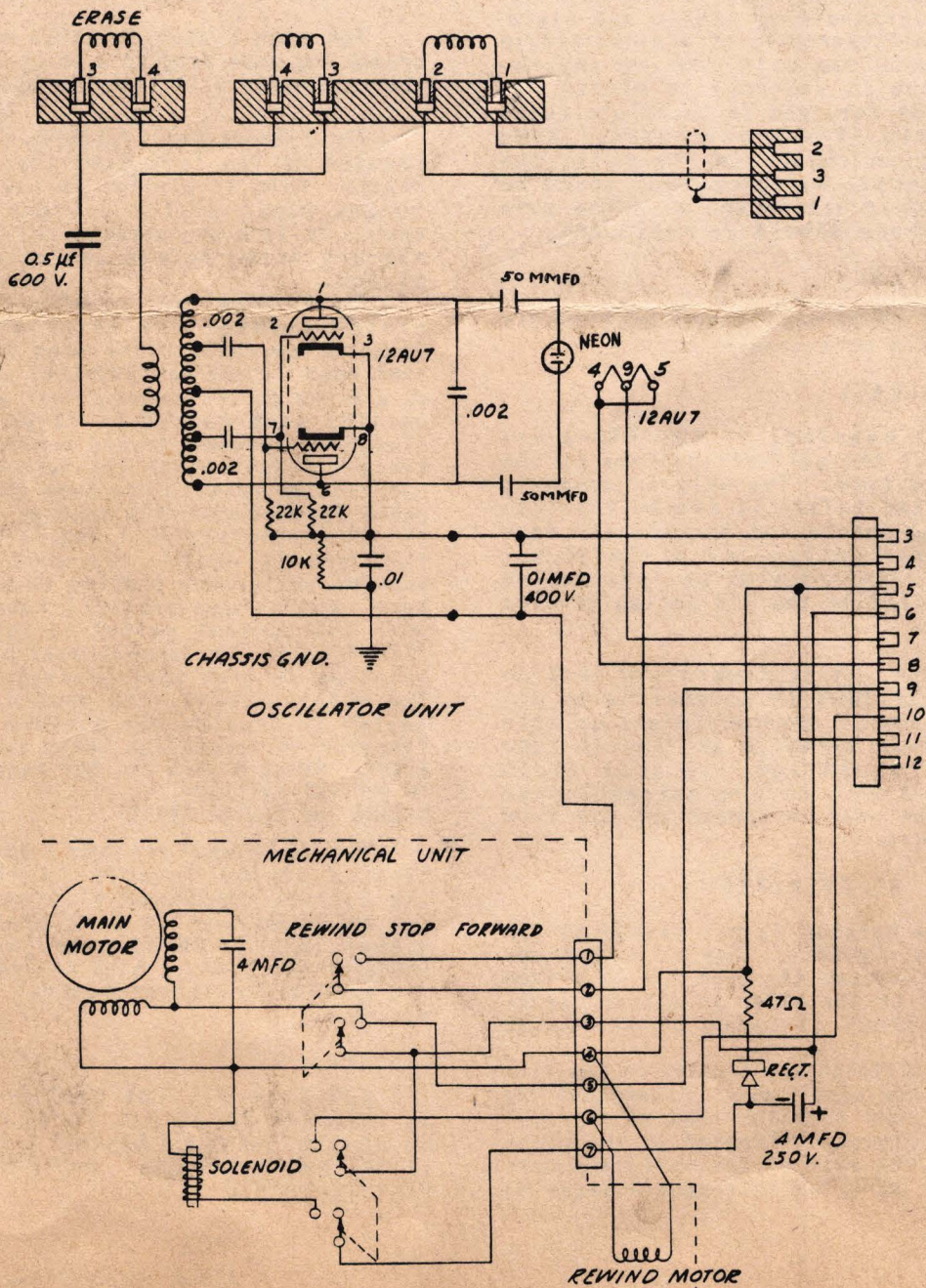

PT6-A

INSTRUCTION MANUAL

DESCRIPTION:

The Magnecorder PT6-A is a tape recording mechanism designed for use in combination with the amplifiers and other units of the PT6 Series. It consists of a tape transport mechanism, erase head, record-reproduce head, bias oscillator and control switch, assembled into a single unit.

Filament current and plate current for the bias oscillator tube must be supplied by an external source if the PT6-A is not used in conjunction with one of the PT6 Series amplifiers.

STANDARD EQUIPMENT:

Every PT6-A unit is supplied with one type 12AU7 tube already mounted in its socket. This is the bias oscillator. Two sets of capstan-pressure roller combinations are furnished with each unit; one set for operation at 15 inches per second, the other for 7½ inches per second. One set is in place on the front panel, the other set is contained in a shipping bag. The capstans are provided with tapered holes to mate with the tapered capstan shaft on the front panel. The large capstan and small pressure roller combination provides for the higher tape speed.

INSTALLATION:

Four knurled-head screws in the corners of the front panel of the PT6-A mount it in its portable case or the Magnecorder rack amplifiers or rack panels designed for use with the PT6-A unit.

PREPARING THE PT6-A FOR OPERATION:

The PT6-A motors and oscillator tube receive their power through the male Jones connector on the rear of the unit. See schematic for terminal designation. Motor operating power, oscillator filament power and plate supply voltage are supplied by the Magnecorder PT6 Series amplifiers. The female Cannon connector on the

rear of the PT6-A is connected to the record-reproduce head. See schematic.

(1) Make sure the oscillator tube located in the rear and at the right side is secure in its socket.

(2) Set the control knob (1 in Fig. 1) to "STOP".

(3) Make sure the correct capstan and pressure roller (2 & 10 in Fig. 1) are in place and that the knurled retaining screws are screwed down firmly. The small (7½"/sec) capstan operates with the large rubber covered pressure roller. Make sure that the tapered hole in the capstan and the tapered shaped capstan shaft are completely free of dirt or foreign particles before installing the capstan.

OPERATION:

(Operator facing front panel)

→ Note: Warped supply and/or take-up reels may interfere with the movement of the tape thus producing wows and flutter. The flanges of the warped reels should be straightened by bending them outwards and applying heat so that the plastic will soften and retain its new shape. ←

(1) Place the empty reel on the take-up spindle (3 in Fig. 1). Before a reel can be installed on the spindle it is necessary to remove the reel retainer by pushing it toward the unit and turning slightly counter-clockwise until the pins are released from the slots. Place the empty reel on the take-up spindle (3 in Fig. 1). Put the reel retainer on the shaft and push in until the 3 pins are in contact with the spindle. Make sure that the pins go down the slots in the end of the spindle and then turn the retainer slightly clockwise until it is locked in place.

(2) Place a loaded reel of tape on the supply spindle (5 in Fig. 1). The reel should be oriented so that the tape will unwind as the reel rotates clockwise. Tape should come off top of spool with coated, or dull side down.

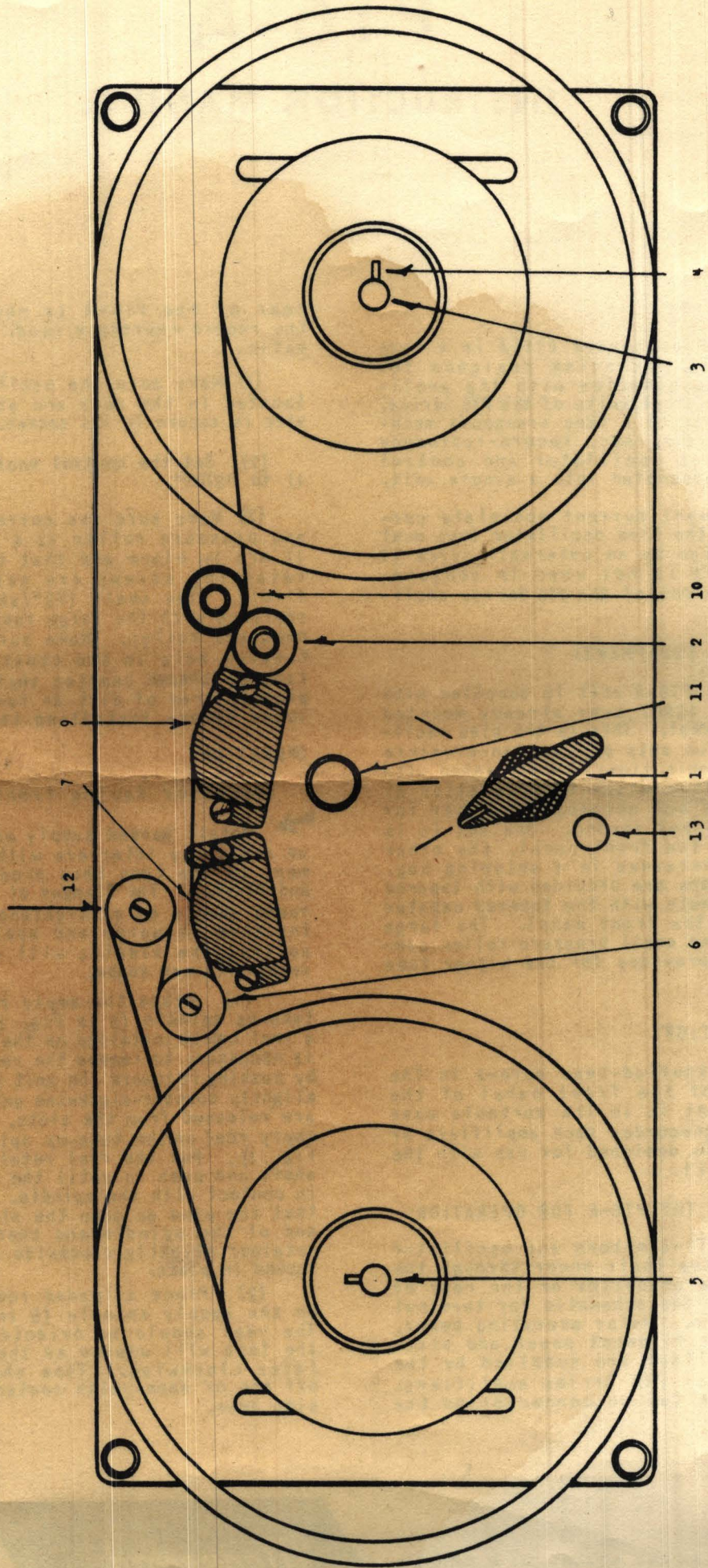

FIGURE 1

(3) Turn the supply reel clockwise by hand so that approximately 18 inches of tape or leader will unwind.

(4) Insert the end of the tape or leader in the slot on the inside of the take-up reel.

(5) Rotate the take-up reel clockwise until there are at least two full turns of tape on the reel.

(6) Slip the tape into its normal travel path; under the idler (6 in Fig. 1); over the erase head (7 in Fig. 1); over record-reproduce head (9 in Fig. 1); between capstan (2 in Fig. 1) and pressure roller (10 in Fig. 1).

(7) Rotate take-up reel to remove slack.

(8) Connect the unit to the Magrecorder PT6 amplifier. Note: If the PT6-A is to be used with some other amplifier, 117 volt 60 cycle AC must be supplied to the motors; and filament power at 6.3 volts .3 amperes and plate supply of 300 volts at 40 ma must be supplied to the oscillator tube. See schematic.

(9) Turn the control knob to "FORWARD". This puts the unit into forward operation at a speed determined by the capstan being used. If the tape does not move smoothly between the capstan and pressure roller, lift the pressure roller slightly to permit the tape to align itself properly.

(10) To rewind the tape, turn the control knob to "STOP", then place tape over lift bar so that the tape is lifted clear of the heads. Turn the control knob to "REWIND". The rewind mechanism, driven by a shaded pole motor, will completely rewind 1200 feet of tape (full 7½" reel) in approximately 40 seconds. The loaded reel will rotate at an increasingly higher speed as the tape is transferred back to the supply reel during rewind. The control knob may be turned to "STOP" at any time during rewind without danger of tape throw. Be sure that the tape is lowered to its normal position on the heads before attempting to record or reproduce.

Note: The control knob should never be turned quickly from "REWIND" to "FORWARD". If it is desired to reverse the direction of the tape travel from rewind to forward the knob must be turned to "STOP" and the tape allowed to come to a complete halt. Then the knob may be turned to "FORWARD".

(11) The bias indicator light (11 in Fig. 1) will glow when the oscillator tube plate supply voltage is applied through the Jones male connector. If the PT6-A is being used with any of the Magnecord PT6 Series amplifiers, the light will go on when the amplifier Selector Switch is turned to "RECORD". An inter-lock in the PT6-A will turn off the oscillator and the lamp whenever the PT6-A control is turned to "STOP" or "REWIND". See schematic.

SIGNAL INPUT:

It is necessary that the audio signal be suitably equalized both in recording and playback. Correct pre-emphasis and post-emphasis is supplied in the Magnecorder PT6 Series recording amplifiers by means of built-in circuits.

EQUALIZATION:

If the PT6-A, Basic Recorder Mechanism is to be used with some other amplifier, the curves shown in Figures 2 and 3 will be of value in the design of proper equalizers. Figure 2 shows the desired frequency response for the signal current fed into the recording head (pre-emphasis). Figure 3 shows the desired frequency response of the amplifier that is fed by the reproduce head (post-emphasis). The combination of these characteristics will yield a substantially flat response at the output of the playback amplifier from 40 to 15,000 cycles with a tape speed of 15" per second. To obtain essentially flat response from 50 to 7500 cps using 7½" per second tape speed it is necessary to use Magnecord plug-in equalizer designed specifically for slower speed.

IMPEDANCE MATCHING:

When the head is used for reproducing purposes it should work into a transformer of 60 ohms input impedance. When the head is used for recording it should have a maximum current of approximately one milliamperes in its coils. This current should be developed through a resistor of approximately 600 ohms in series with the head. This resistor makes the head circuit effectively a resistive load.

OSCILLATOR CURRENT SUPPLY:

Filament and plate current for the 12AU7 tube are supplied by Magnecorder PT6 Series amplifiers. If another amplifier is to be used a source of filament power of 6.3 volts at 0.3 amperes and plate power of 300 volts at 40 milliamperes must be supplied.

Note: The PT6-A is normally connected for 6.3 volts at 0.3 amperes for the oscillator tube heater. However, the connections to the tube may be changed for operation from 12.6 volts at 0.15 amperes. Refer to schematic.

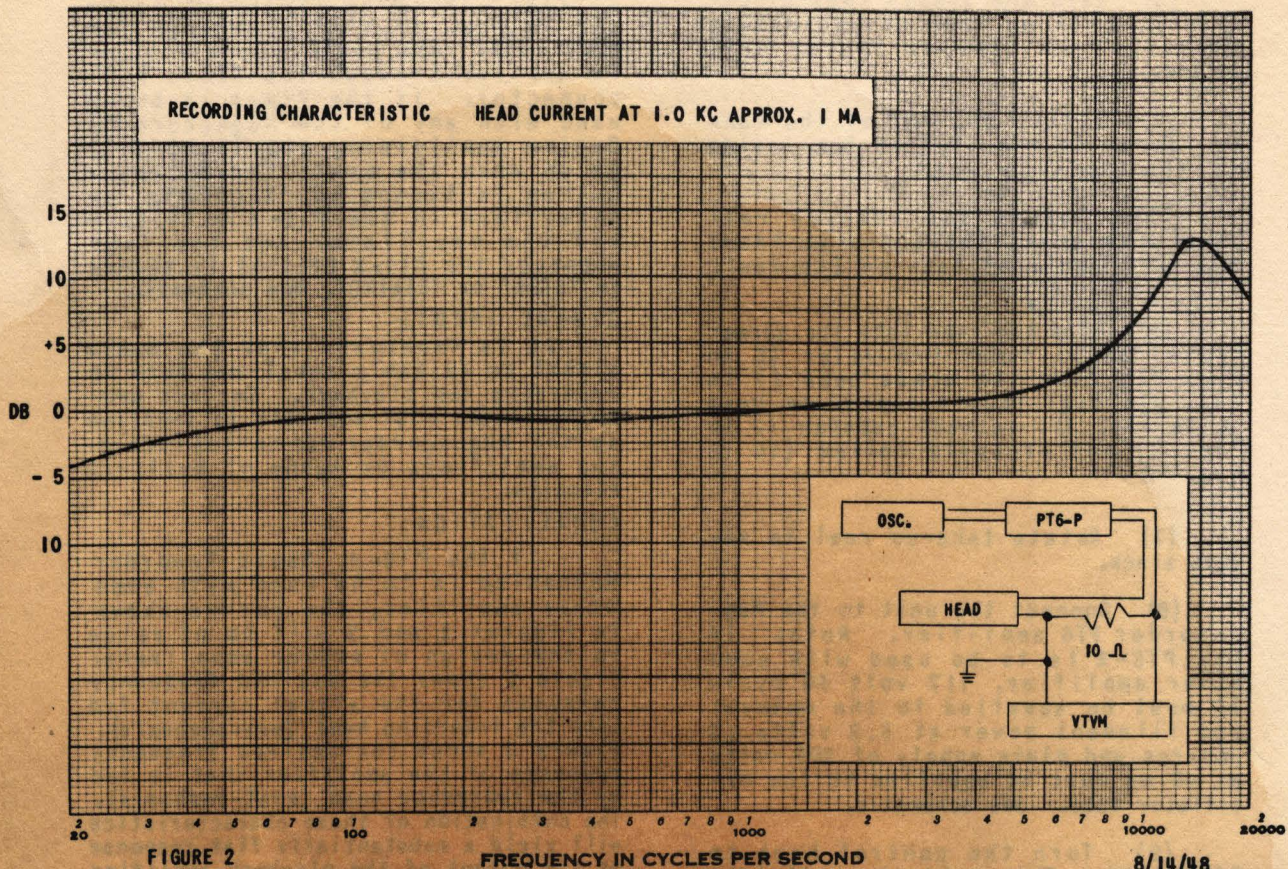

FIGURE 2

MAGNETIC TAPE RECORDING AMPLIFIER CHARACTERISTIC

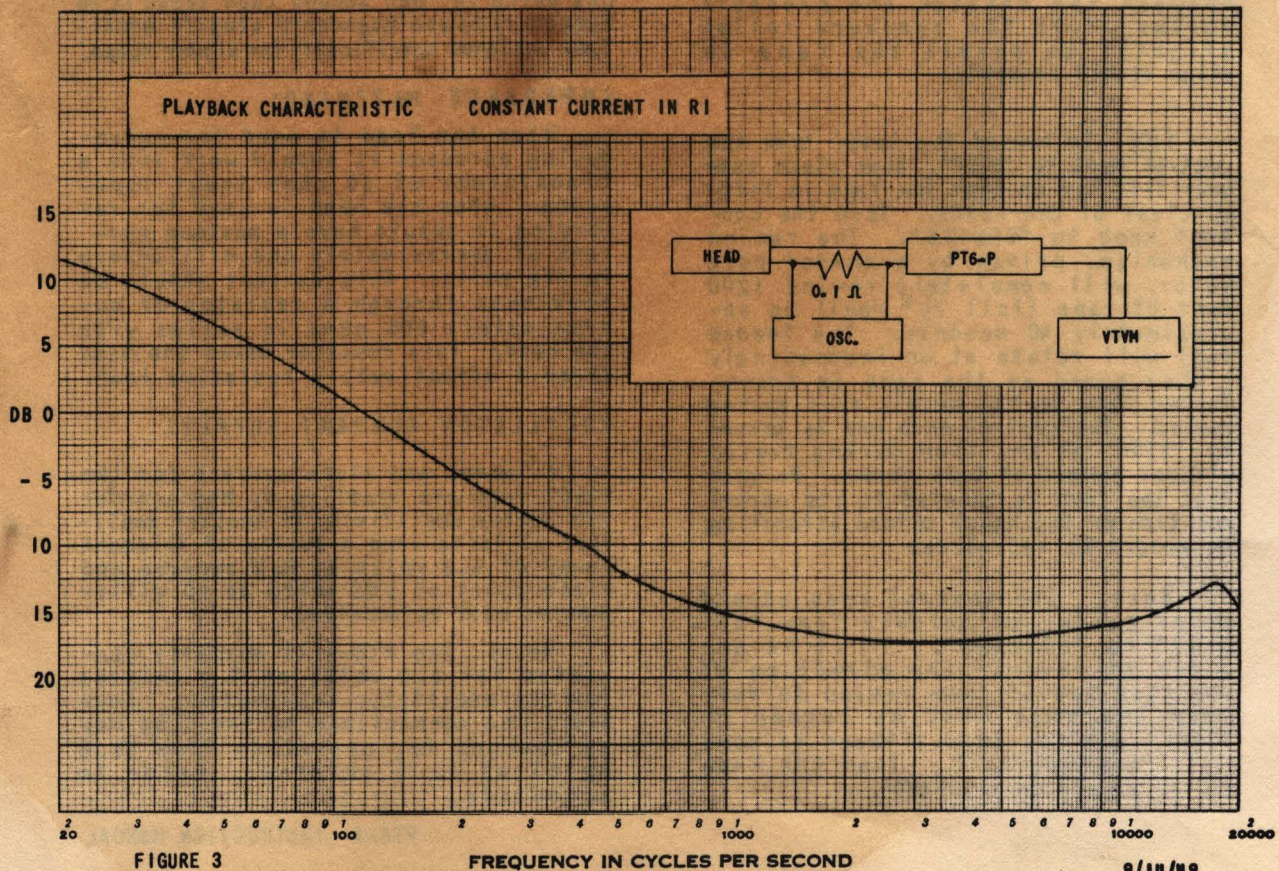

FIGURE 3

MAGNETIC TAPE PLAYBACK AMPLIFIER CHARACTERISTIC

PT6-A INSTRUCTION MANUAL

Magnecord INC.

SALES OFFICE
360 N. MICHIGAN AVE.
CHICAGO 1, ILL.

PLANT
225 W. OHIO ST.
CHICAGO 10, ILL.

PT-8-A INSTRUCTION MANUAL



FOR THE DIRECTOR OF THE
ARMY AIRCRAFT MATERIAL COMMAND
WASHINGTON, D. C.

BIAS INDICATOR:

The bias indicator lamp (11 in Fig. 1) will glow when plate supply voltage is being supplied to the oscillator tube. This indicates that any previous recording on the tape is being erased and a new recording may be made.

TERMINAL DESIGNATIONS:

All electrical connections are made to the Jones male and Cannon female connectors located in the rear of the PT6-A. Signal circuits are fed through the Cannon connector, and power is fed through the Jones connector. See schematic for terminal designations.

MAINTENANCE:

The PT6-A Basic Recorder Mechanism is ruggedly built to withstand the requirements of studio and field use. Maintenance is of a minor nature and should the unit require any repairs due to accident or misuse, it should be returned to the distributor from whom it was purchased. When writing in regard to the unit, the type number, serial number, the date and from whom purchased should be mentioned.

ELECTRICAL:

The 12AU7 oscillator tube should be checked occasionally.

MECHANICAL:

All bearings in the PT6-A are either of the self-oiling type or the wick-fed type. The unit is properly lubricated before it leaves the factory and should not require any further lubrication for at least six months. Information on lubrication is supplied in the PT6 Series Service Notes.

Note: It is imperative that no oil be allowed to accumulate on any of the rubber covered idlers as this will cause slippage and impair tape speed regulation. A soft cloth moistened with carbon tetrachloride should be used to remove any oil from the idlers.

CLUTCH ADJUSTMENTS:

Tape tension is maintained by two friction clutches. Their correct adjustment causes the tape to move from one reel to the other in either direction without throwing or stalling.

The clutches are located on the rear ends of the supply reel spindle and the take-up reel spindle. The supply reel spindle clutch is located at the right (facing the rear of the unit) and consists of an oiled felt washer pressing

against a knurled disc which is free to rotate in a clockwise direction but prevented from turning in the opposite direction by a spring loaded pawl. Pressing against the opposite side of the felt washer is a sponge rubber pad. A split, knurled adjustment ring bears against the sponge rubber pad and is locked in place by means of a set screw. The set screw must be backed off before the adjustment ring can be turned. Rotating the adjustment ring clockwise increases the clutch friction.

The supply reel spindle clutch adjustment should maintain a drag as the supply reel rotates when the PT6-A is in forward operation. This drag should be sufficient to stop the supply reel without permitting the tape to loop or throw when the control switch is turned from "FORWARD" to "STOP". The amount of friction should be the minimum necessary to accomplish this.

Too much clutch friction will increase the tape drag to a point at which the tape speed will be below normal.

The take-up reel friction clutch is located on the left side (facing the rear). This is similar in appearance to the other clutch but employs no pawl. It is also necessary to back off the set screw before adjusting this clutch.

The take-up reel spindle friction clutch couples the spindle to the synchronous motor drive when the control knob is set to "FORWARD" and acts as a brake on the take-up reel when the control knob is set to "STOP". The clutch adjustment should provide sufficient friction for the take-up reel and capstan to move the tape at normal speed forward when the take-up reel is almost completely full and the supply reel nearly empty. It should also provide sufficient braking to maintain tape tension and prohibit tape throw when the control switch is turned to "STOP" after the take-up reel has been rotating at high speed during rewind. The split knurled ring should be adjusted to provide the minimum clutch friction to accomplish these two functions.

OILING THE CLUTCH FELTS:

The felt washers have been oil treated at the factory to provide the correct amount of slippage. It may be necessary to give each felt washer (supply spindle and take up spindle) one drop of high quality sewing machine oil after several months of use.

CAUTION:

(DO NOT OVER-OIL THE CLUTCH FELTS AS THIS MAY CAUSE OIL TO BE THROWN ON NEARBY IDLERS CAUSING SLIPPAGE IN THE DRIVE SYSTEM. ONE DROP PER FELT IS SUFFICIENT.)

CLEANING THE HEADS:

It is necessary that the portions of the erase head and the record-reproduce head which come into contact with the tape be kept free of dust, grease and foreign matter, or the frequency response characteristics will suffer. They should be cleaned with a soft cloth slightly moistened with carbon tetrachloride C.P. after every five hours of operation.

Note: Do not attempt to apply carbon tetrachloride to any part of the PT6-A when loaded reels are in place as the tape is soluble in carbon tetrachloride and will be ruined if it comes in contact with the solution. After using carbon tetrachloride

make sure the heads are completely dry before threading tape and be sure none of the solution is transferred to the tape from the fingers.

HEAD REPLACEMENT:

Replacement erase or record-reproduce heads may be obtained from the distributor from whom the unit was purchased provided the worn heads are returned at the same time.

GUARANTEE:

The Magnecord PT6-A is guaranteed to be free of defects in workmanship and materials (excepting tubes) for a period of 90 days from date of purchase.

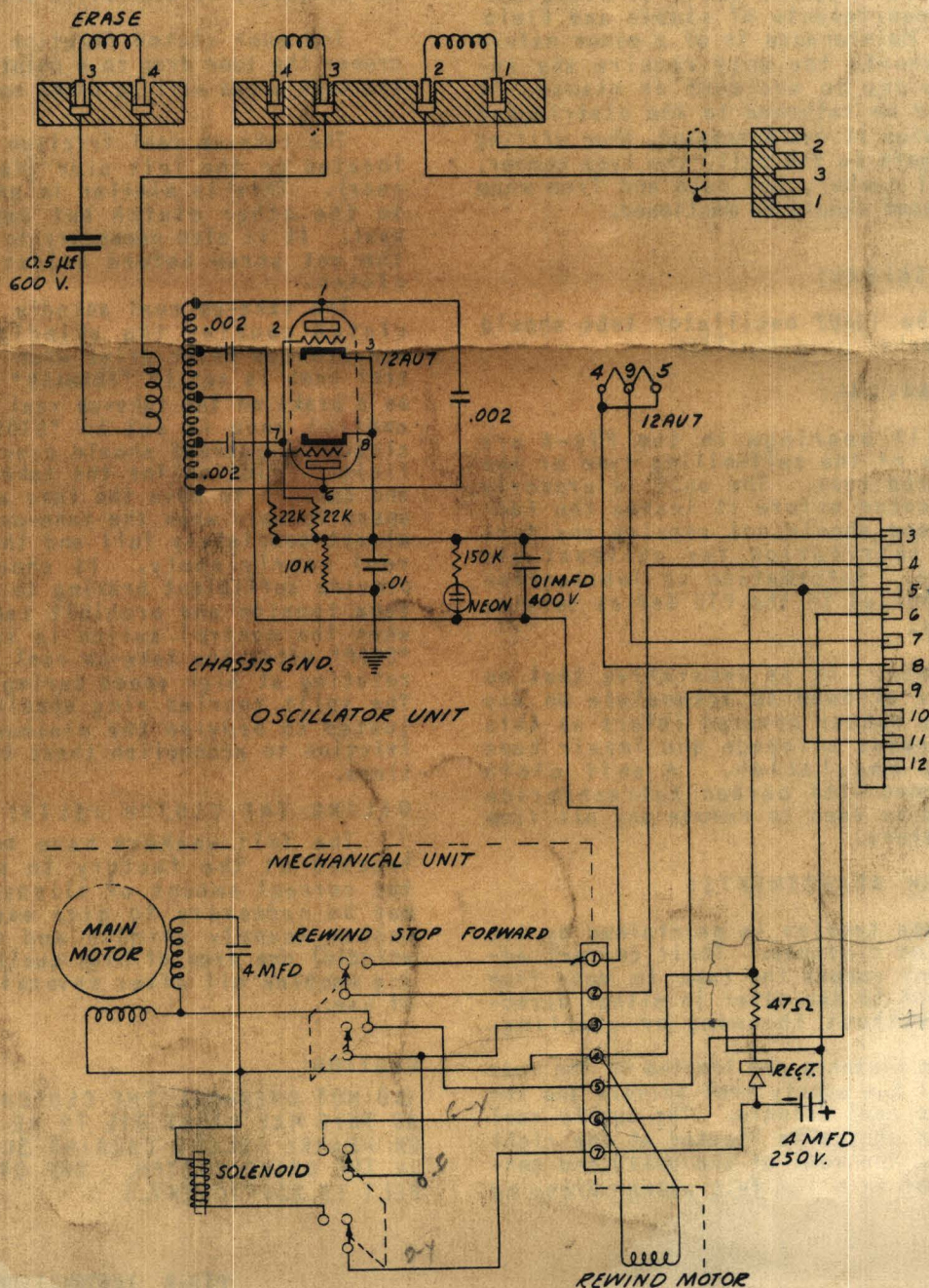

Voltage between #1 & #4 (low) for.

To Pin 5 #3 To Switch

1/3

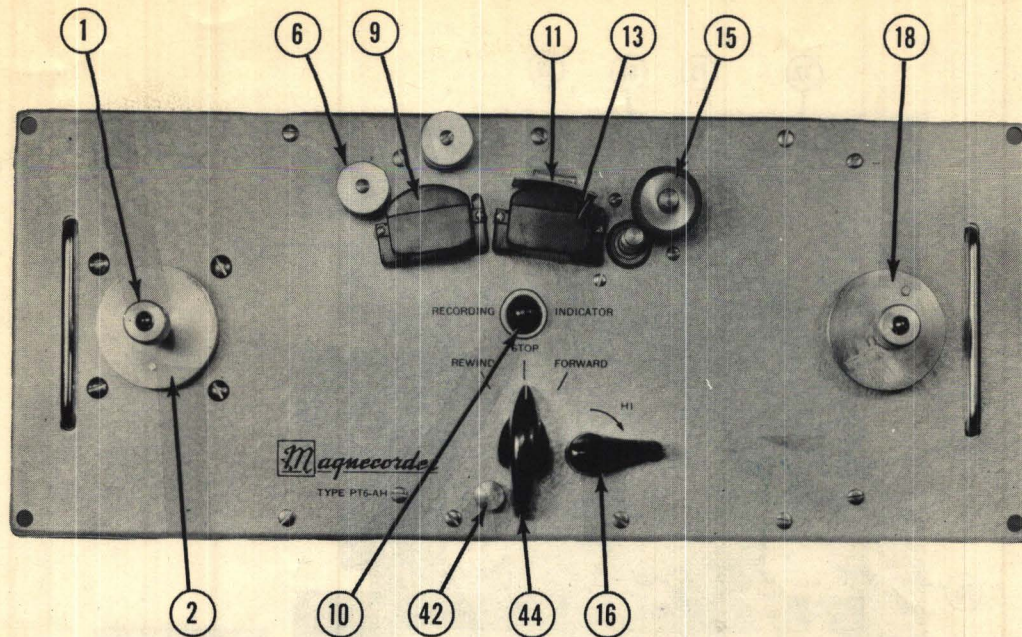

Figure 2

Pressure Roller -

The pressure roller (15), which is actuated by control knob (44) through the media of switch control shaft (40) and pressure roller pivot bracket (32), keeps a positive pressure against the tape and capstan to aid in maintaining the constant rate of tape travel.

Hi-Speed Forward -

The Hi-Speed Forward is put into operation by pressing the Hi-Speed Forward control knob (16), which, in turn, actuates control shaft and wire (59), pivot arm and wire (69), and the fast forward wheel mounting bracket (72). This pulls the fast forward wheel (73) into contact with the motor drive shaft and the take-up hub and tube (20). Simultaneously, pivot arm (69) moves against the fast forward actuating switch (79), starting the main drive motor (75).

Rewind System -

When control knob (44) is placed in "Rewind", rewind switch (80) is actuated starting the rewind motor (46). A DC operated solenoid is also energized during rewind, which pulls the forward idler wheel (65) away from the take-up hub (22), allowing the ball-bearing mounted take-up shaft (18) to turn freely. When the rewind operation is completed, and control knob (44) is returned to the "Stop" position, the solenoid is de-energized. This allows the forward idler wheel (65) to contact the take-up hub (22) applying a braking force sufficient to stop the reel.

The "one-way" pawl actuated clutch on the rear shaft extension of the rewind motor (46), operates in such a manner so that as the tape is unwound from the rewind spindle (2), a certain amount of drag is imparted to the motor shaft which is then transmitted to the tape as tension. When rewinding, the pawl is disengaged from the ratchet disc (52) by the direction sensitive rewind pawl spring (53) which allows the motor shaft to turn freely. A rapid rewind results.

Take-up System -

The take-up system is driven by the main drive motor

(75) through two rubber-tired idler wheels (61), which are mounted on sliding suspension arm supports (60 and 63). Idler wheels (61) are held in contact with the hub of the flywheel (33) and the forward motor shaft (75) by action of springs (64 and 68). This, in turn, drives the capstan (33A), which is secured to the flywheel shaft and, with the use of pinch roller (15), conveys the tape at a constant rate of speed.

The take-up shaft (18) is driven by the forward idler wheel (65), which makes contact with the forward motor shaft and the take-up hub (22). The take-up hub (22) is concentrically mounted on the take-up shaft (18) and is coupled to the shaft through a slipping assembly (20 thru 27) similar to that employed in the rewind system. With tape properly threaded on the recorder and the mechanism in "Forward", the take-up shaft (18) slips a certain amount due to the pressure applied on the tape by the slower running capstan and pressure roller. Consequently, the tension imparted to the tape causes the tape to move from one reel to the other without throwing or stalling.

ADJUSTMENTS

Head Alignment -

The primary purpose in head alignment is to provide the maximum frequency response. For this purpose it is not necessary to adjust the erase head.

NOTE: Before attempting to align the record/reproduce head make certain that the difficulty is not due to an accumulation of tape coating residue on the pole surfaces.

Alignment of PT63 Series Heads -

The head cover is provided with two holes through which a screw driver may be passed in order to adjust the alignment screws. Furthermore, screws provided with lock washers will be found on the bracket assembly which are used to lock the heads in place once they have been aligned. Under no condition should the plastic head cover be removed. The posi-

MAGNECORD MODELS
PT6-A, AH, AHX, AX, PT63-A, AH, AHX, AX

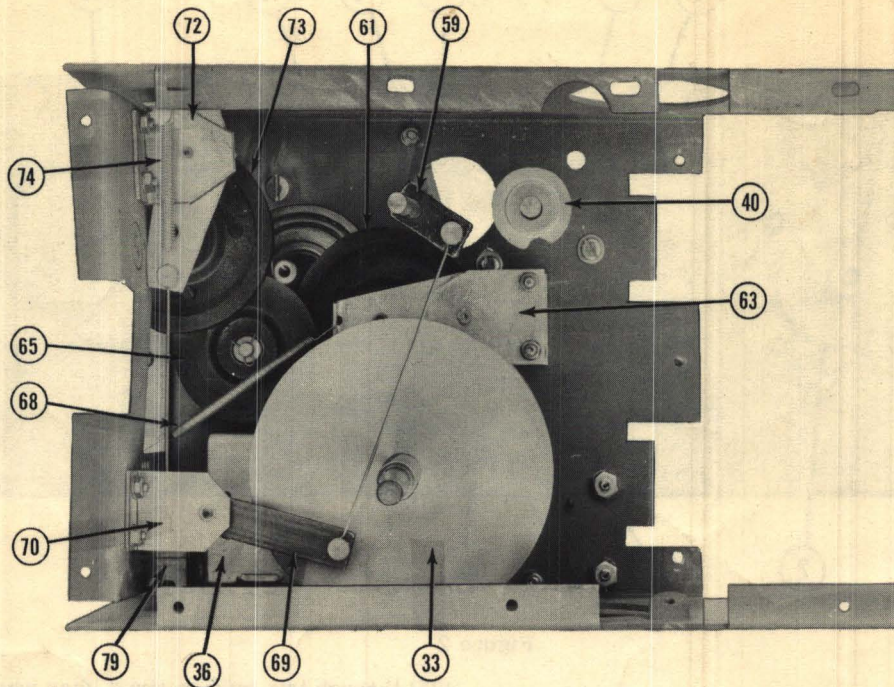

Figure 3

tion of this cover seriously affects the alignment. Using alignment tape, the following procedure should be followed:

1. Loosen the locking screws on the bottom of both record and playback head assemblies.

2. Running the alignment tape over the assembly on "Playback" determines meter reading of the maximum output. It is not necessary, or desirable at this step, that the head be adjusted for maximum output, as will be seen later.

3. Back off on the alignment screws until the playback head is definitely out of alignment. Be sure that backing off on the alignment screws actually allows the head assembly to turn.

4. Lock the playback head assembly in place as in Step 3 by means of the locking screw.

5. With the alignment screw bring the playback head into alignment as noted by the maximum output determined in Step 2.

NOTE: If the alignment screw is turned too far, it will be necessary to repeat Steps 1 through 5.

6. Remove the alignment tape and insert a blank tape which may be used for recording.

7. Repeat Steps 1 through 5 with the unit on "Record" using a frequency similar to that on the alignment tape. Align the record head accordingly.

Alignment of PT6 Series Head -

1. The right mounting screw of the record-reproduce head is drawn up securely. This side of the head holder is provided with a rocker action. The left adjustment screw (12) is associated with a compression spring. Rotating this screw changes the gap

alignment with respect to the tape. Proper alignment is achieved when the maximum signal, at a given setting of the gain control is reproduced from the alignment tape, as the alignment screw (12) is turned in or out.

Rewind Drag Adjustment -

Adjustments to this friction drag system are measured by means of a 0 to 1 pound spring scale on one end of a string wound several times around the hub of a 7" reel mounted in the normal manner on the rewind hub. Since the drag is being measured, the string should be wound on the reel to lead off in a clockwise direction and the spring scale should be pulled slowly upward against the friction drag. When properly adjusted, it should take about 4 to 5 ounces to rotate the reel.

Readjust by loosening the socket head set screw (58) in the knurled split nut (57). Then rotate this nut, lock the nut with the set screw after each adjustment and before measuring the result.

Take-up Torque Adjustment -

The torque transmitted to the take-up shaft should be measured in a similar manner to that described above under "Rewind Drag Adjustment". With the spring scale pulling the string vertically upward, with power on and recorder running forward, a reading of 4 to 5 ounces should be obtained.

The amount of torque is determined by the amount of pressure exerted on the take-up friction wheel (22) by friction felts (21 and 23). Tightening knurled-split nut (26) increases the torque. Always loosen set screw (27) in the split nut before adjusting and re-tighten before running or measuring.

Solenoid Adjustment -

Solenoid (36) which is energized during rewind, should

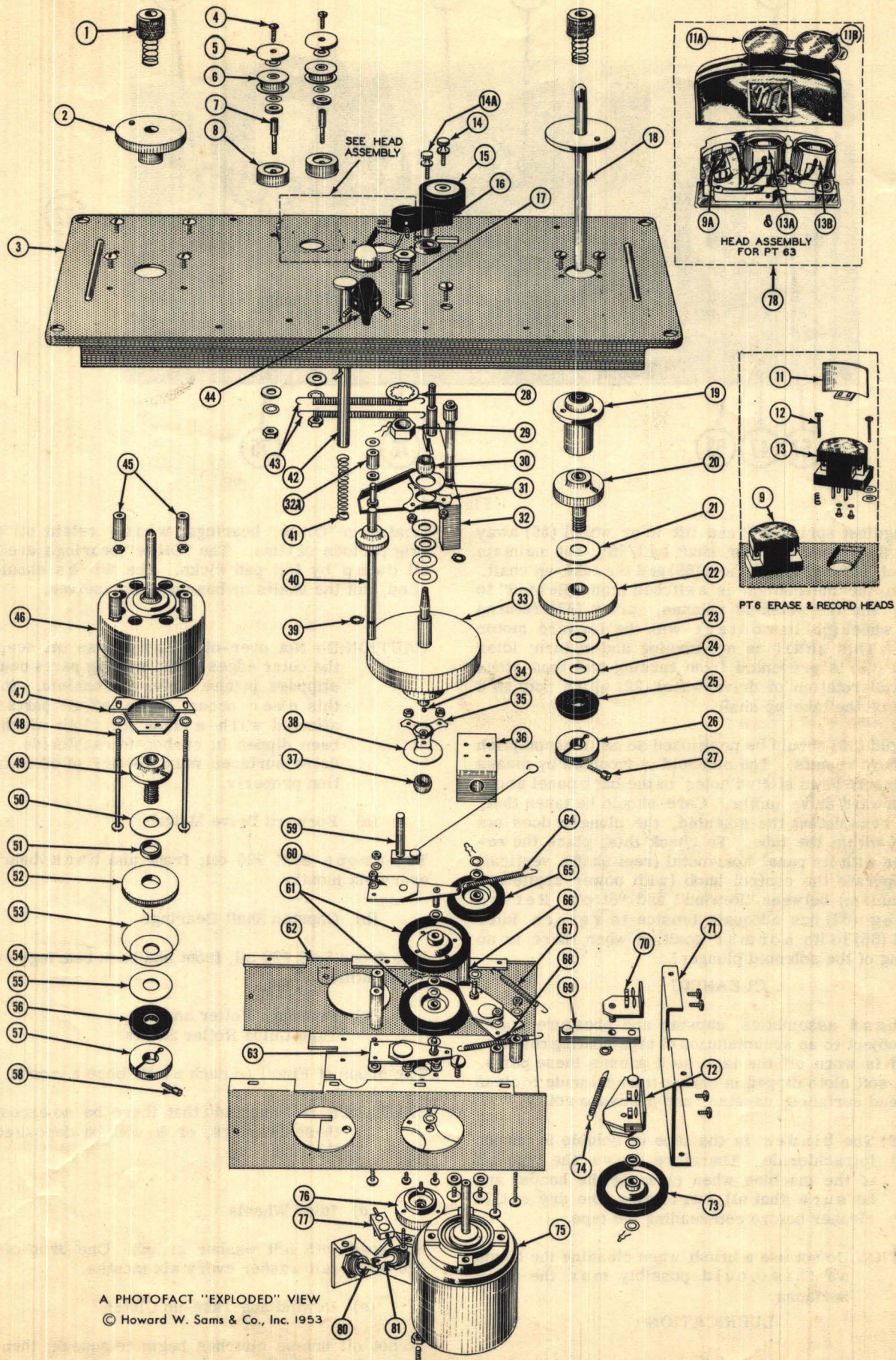

MAGNECORD MODELS
 PT6-A, AH, AHX, AX, PT63-A, AH, AHX, AX

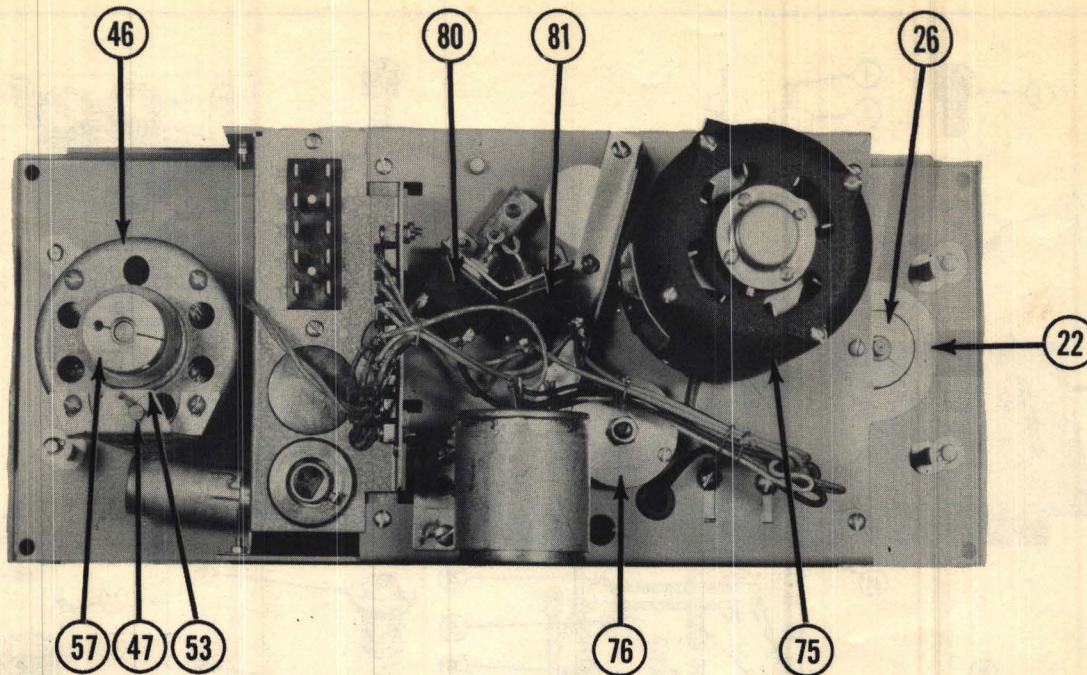

Figure 4

pull against spring (67) and lift idler wheel (65) away from the forward motor shaft by 1/16", but maintain contact between idler wheel (65) and the take-up shaft. When the mechanism is switched from "Rewind" to "Stop" and the solenoid relaxes, spring (67) returns idler wheel (65) to contact with the forward motor shaft. This shaft is not turning and in turn, idler wheel (65) is prevented from turning and thus stops the free rotation of drive wheel (22) which acts as a brake on the take-up shaft.

Solenoid (36) should be positioned so as to accomplish the above results. The solenoid is mounted by means of two screws in slotted holes in the back panel above the forward drive motor. Care should be taken that, when readjusting the solenoid, the plunger does not bind within the tube. To check this, place the recorder with its panel horizontal (reel shafts vertical) and operate the control knob (with power applied to mechanism) between "Rewind" and "Stop". Return spring (67) has adequate tension to return idler wheel (65) to its normal position when there is no binding of the solenoid plunger.

CLEANING

The head assemblies, capstan and pressure roller are subject to an accumulation of tape coating residue, which is worn off the tape as it passes these parts. Use a soft cloth dipped in carbon tetrachloride to clean the head surfaces, capstan, and pressure roller.

NOTE: The binder in the tape is soluble in carbon tetrachloride. Therefore, have the tape off of the machine when cleaning the heads; and be sure that all surfaces are dry of this cleaner before rethreading the tape.

CAUTION: Do not use a brush when cleaning the heads as this could possibly mar the pole surfaces.

LUBRICATION

1. Most moving parts in this recorder are

located in "Oilite" bearings, which retain oil over long periods of time. The "Oilite" bearings are kept oil damp by felt pad wicks. The wicks should be oiled, not the shafts or bearings themselves.

CAUTION: Do Not over-oil. Any excess oil seeps to the outer edges of the moving parts causing slippage in the drive mechanism. Should this ever occur, wipe off all parts thus affected with a clean soft cloth which has been dipped in carbon tetrachloride. The drive surfaces must be dry of oil to function properly.

(a) Forward Drive Motor

Two drops SAE #20 oil, front and back bearings every six months.

(b) Capstan Shaft Bearings

Two drops SAE #20 oil, front and back bearings every six months.

(c) Pressure Roller and Tape Guide Roller Shafts

Two drops of Finoil on each shaft, once a month.

CAUTION: It is important that there be no excess on these bearings, or it will be deposited on the tape.

(d) Idler Wheels

Equipped with felt washer at hub. One drop of SAE #20 oil on felt washer every six months.

(e) Rewind and Take-up Clutch

Do not oil unless clutches begin to squeak; then one or two drops of oil on each of two felt pads.

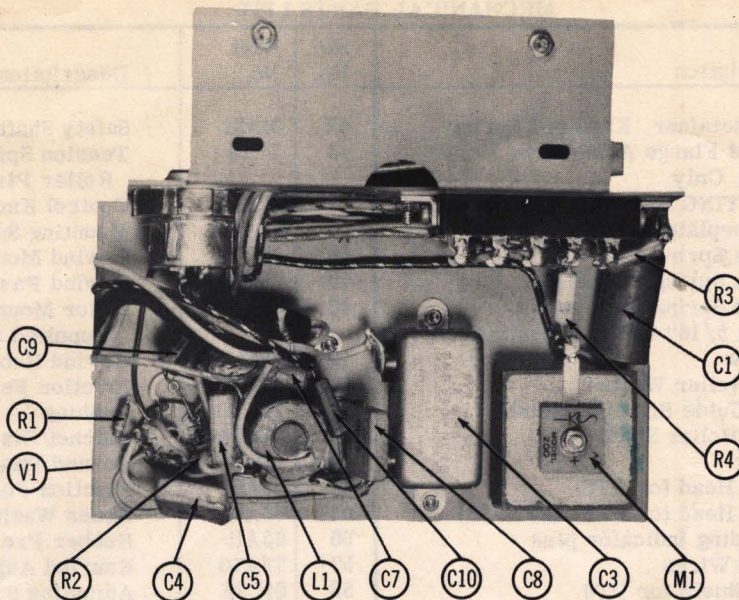
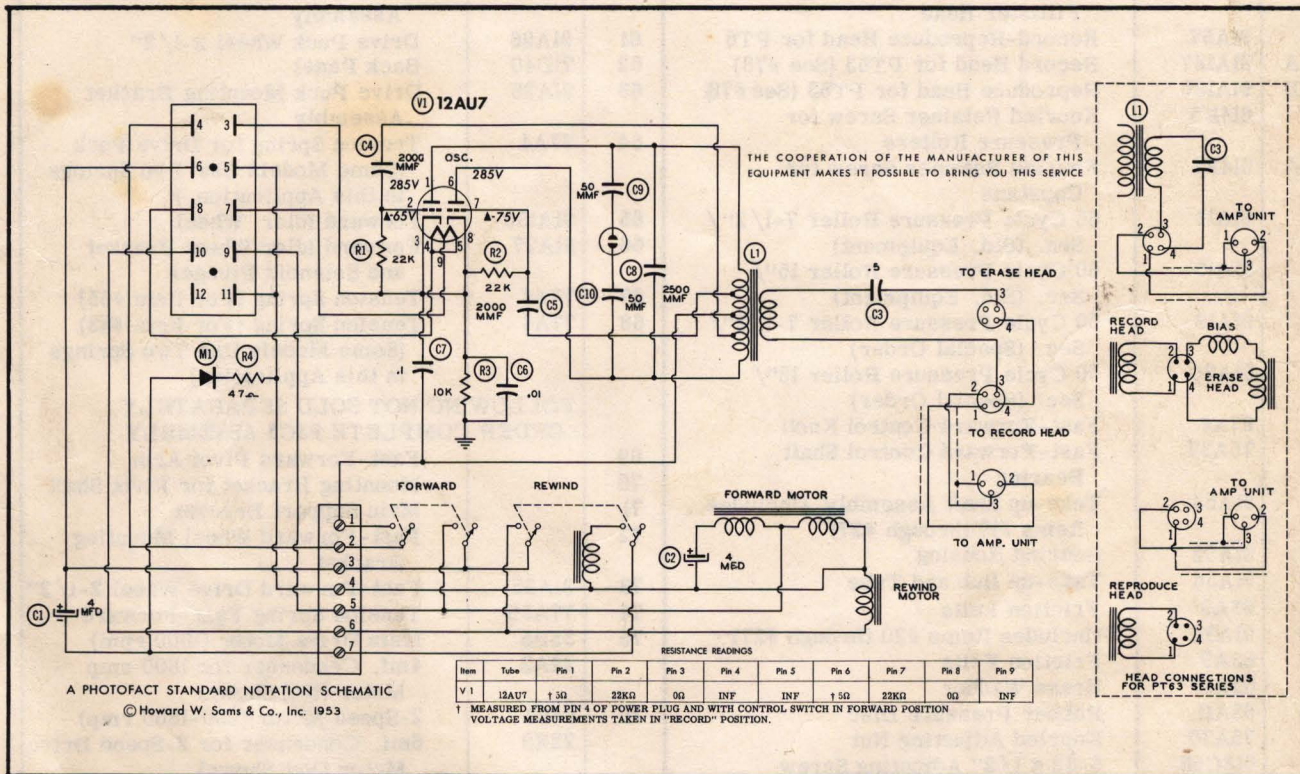

Figure 5



MAGNECORD MODELS
PT6-A, AH, AHX, AX, PT63-A, AH, AHX, AX

ELECTRICAL PARTS LIST

Ref. No.	Part No.	Description	Ref. No.	Part No.	Description
V1		12AU7, Oscillator	C8		Fixed Trimmer, 2500 mmf. @ 500 V
C1		Solenoid Filter, 4 mfd. @ 250 V	C9		Indicator Coupling, 50 mmf. @ 500 V
C2		Motor Starting, 4 mfd. @ 330 V	C10		Indicator Coupling, 50 mmf. @ 500 V
C3		Audio Coupling, .5 mfd. @ 600 V	R1		Oscillator Grid, 22KΩ, 1/2 W
C4		Bias Oscillator Grid, 2000 mmf. @ 500 V	R2		Oscillator Grid, 22KΩ, 1/2 W
C5		Bias Oscillator Grid, 2000 mmf. @ 500 V	R3		Isolation, 10KΩ, 1/2 W
C6		Chassis Isolation, .01 mfd. @ 400 V	R4		Surge Limiter, 47Ω, 1/2 W
C7		Bias Oscillator Decoupling, .1 mfd. @ 400 V	L1		Bias Oscillator Coil
			M1		Selenium Rectifier

MECHANICAL PARTS LIST

Ref. No.	Part No.	Description	Ref. No.	Part No.	Description
1	91A5	Reel Retainer, Knob and Spring	42	91A31	Safety Shaft
2	91A82	Rewind Flange Assembly	43	77A6	Tension Springs for Pressure Roller Pivot Bracket
3	71D1	Panel, Only	44	87A15	Control Knob
3A		CARRYING HANDLE ASSEMBLY	45	75A67	Mounting Spacers
	78A7	Chromeplated Handle	46	91B83	Rewind Motor Assembly
	77A1	Handle Spring	47	91A45	Rewind Pawl and Pawl Bracket
	67X1	Handle Spring Cotter Pin	48	6110B6S	Motor Mounting Screws (Supplied with Motor)
	63X14	Handle Spring Washer	49	91A43	Rewind Hub and Tube Assembly
4	614B5	4-40 x 5/16" Roller Mounting Screw	50	63A9	Friction Felt
5	63A5	Tape Roller Washer	51	74A70	Bushing
6	91A9	Tape Guide Roller Assembly	52	75A86	Ratchet Disc
7	76A8	Guide Roller Shaft	53	77A2	Rewind Pawl Spring
8	75A11	Spacer	54	63A9	Friction Felt
9	91A17	Erase Head for PT6	55	63A10	Brass Washer
9A	91A205	Erase Head for PT63 (See #78)	56	63A11	Rubber Pressure Disc
10	91A13	Recording Indicator plus Lead Wires	57	75A70	Knurled Adjusting Nut
11	91A18	Head Shield for PT6	58	61CS8	Adjusting Screw
11A	91A112	Record Head Shield for PT63	59	91A379	Fast-Forward Control Shaft and Wire (See Item #69)
11B	91A111	Reproduce Head Shield for PT63	60	91A26	Drive Puck Mounting Bracket Assembly
12	612F12	Mounting Screw 2/56 x 3/4 Fillister Head	61	91A86	Drive Puck Wheel 2-1/2"
13	91A57	Record-Reproduce Head for PT6	62	71D40	Back Panel
13A	91A187	Record Head for PT63 (See #78)	63	91A28	Drive Puck Mounting Bracket Assembly
13B	91A188	Reproduce Head for PT63 (See #78)	64	77A4	Tension Spring for Drive Puck (Some Models Use Two Springs in this Application.)
14	614K5	Knurled Retainer Screw for Pressure Rollers	65	91A130	Forward Idler Wheel
14A	614K6	Knurled Retainer Screw for Capstans	66	91A27	Forward Idler Wheel Bracket and Solenoid Plunger
15	91A14	60 Cycle Pressure Roller 7-1/2" / Sec. (Std. Equipment)	67	77A4	Tension Spring (For Item #65)
	91A15	60 Cycle Pressure Roller 15" / Sec. (Std. Equipment)	68	77A4	Tension Spring (For Item #63) (Some Models Use Two Springs in this Application)
	91A19	50 Cycle Pressure Roller 7-1/2" / Sec. (Special Order)	FOLLOWING NOT SOLD SEPARATELY ORDER COMPLETE 93C3 ASSEMBLY		
	91A20	50 Cycle Pressure Roller 15" / Sec. (Special Order)			
16	87A4	Fast-Forward Control Knob	69		Fast-Forward Pivot Arm
17	75A37	Fast-Forward Control Shaft Bearing	70		Mounting Bracket for Pivot Shaft
18	91A53	Take-up Shaft Assembly (Includes Items #19 through #27)	71		Main Support Bracket
19	91A52	Bearing Housing	72		Fast-Forward Wheel Mounting Bracket
20	91A36	Take-up Hub and Tube	73	91A85	Fast-Forward Drive Wheel 2-1/2"
21	63A9	Friction Felts	74	77A35	Tension Spring Fast-Forward
22	91A35	(Includes Items #20 through #27)	75	35B5	Main Drive Motor (1800 rpm)
23	63A9	Friction Felts		22A2	4mf. Condenser for 1800-rmp Motor (Not Shown)
24	63A10	Brass Washer	75	35S2	2-Speed Motor (900-1800 rmp)
25	63A11	Rubber Pressure Disc		22X8	6mf. Condenser for 2-Speed Drive Motor (Not Shown)
26	75A70	Knurled Adjusting Nut	76	91A39	Thrust Housing
27	618C58	8-32 x 1/2" Adjusting Screw	77	91A30	Switch Control Arm and Pin
28	63X34	Internal Tooth Lock Washer	78	91A121	PT63 THREE HEAD ASSEMBLY (Heads Not Sold Separately)
29	62-43H20	Locknut for Item 17		91A205	Erase Head (PT63)
30	74A21	Capstan Shaft Bearing		91A187	Record Head (PT63)
31	63A8	Felt Pad and Bearing Retainer (78A22)		91A188	Reproduce Head (PT63)
32	91A11	Complete Pressure Arm Assembly			Fast Forward Switch
32A	74A13	Roller for Pivot Bracket			Rewind Switch
33	91A12	Capstan Shaft Assembly	79		Forward Switch
34	78X28	Ball Bearing	80		
35	78A22	Bearing Retainer	81		
35A	624E4	4/40 Elastic Stop	CAPSTANS (NOT SHOWN IN EXPLODED VIEW)		
36	31S1	Solenoid (Less Plunger)		75A15	15" / Sec. Capstan for 60 Cycle AC
37	74A21	Capstan Shaft Bearing		75A16	7-1/2" Sec. Capstan for 60 Cycle AC
38	63A8	Felt Pad		75A21	15" / Sec. Capstan for 50 Cycle AC
39	67X13	Tru-Arc Retaining Ring		75A22	7-1/2" / Sec. Capstan for 50 Cycle AC
40	91A32	Switch Control Shaft			
41	77A1	Spring for Safety Shaft			



MAGNECORD MODELS
PT6-A, AH, AHX, AX, PT63-A, AH, AHX, AX

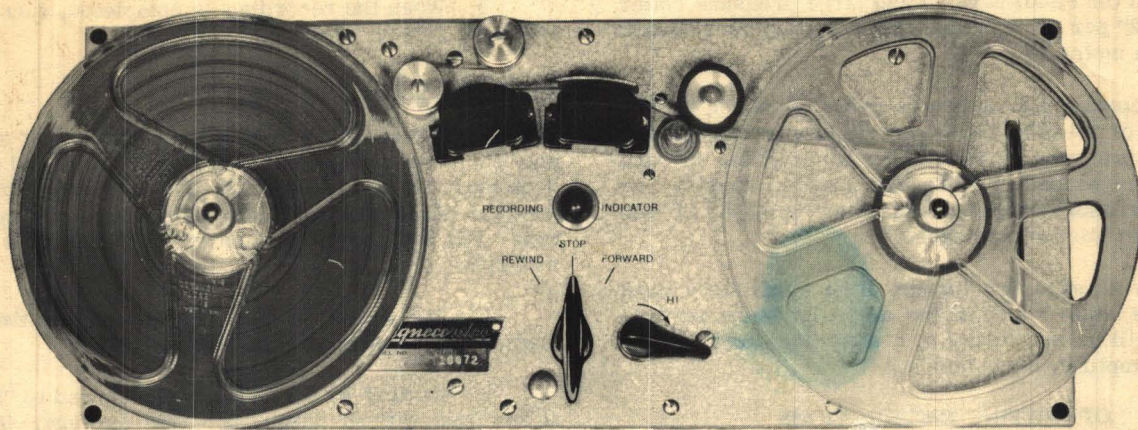

Figure 1

GENERAL INFORMATION

The Magnecord PT6 Series and PT63 Series Tape Recorders are mechanically similar. The PT6 Series is designed for use with the amplifiers and other units of the PT6 Series while the PT63 Series recorder mechanism is designed for use with all PT63 or PT7 Magnecord amplifiers. Other variations are as follows:

PT6-A. Basic recorder in portable carrying case. Includes 15" and 7-1/2" per second capstans and pressure rollers, four mounting bolts, oscillator tube, one empty reel and no connector cables.

PT6-AX. Same as above, less case.

PT6-AH. Same as PT6-A, plus Hi-Speed Forward for fast cueing in. Complete with case.

PT6-AHX. Same as above, less case.

PT63-A. Same as PT6-A, but has three heads for monitoring from the tape. Separate erase, record and playback heads.

PT63-AX. Same as above, less case.

PT63-AH. Same as PT63-A, plus Hi-Speed Forward.

PT63-AHX. Same as above, less case.

These units derive their power from the Magnecord Amplifier used - 117 volt, 60 cycle (or 50 cycle) AC.

Manufactured by:

Magnecord Incorporated
Sales Office: 360 North Michigan Avenue
Chicago 1, Illinois
Plant: 225 West Ohio Street
Chicago 10, Illinois

This material compiled and published by

HOWARD W. SAMS & CO., INC., INDIANAPOLIS, INDIANA

Copyright 1953 • All Rights Reserved

MAGNECORD MODELS
PT6-A, AH, AHX, AX, PT63-A, AH, AHX, AX

*Magnecord Co
3745 Montebello Ave
M. M. Minn 55716*

Speed Change -

Two sets of capstan-pressure roller combinations are furnished with each unit; the large capstan and small pressure roller provide for 15" per second tape speed and the small capstan and large pressure roller for 7-1/2" per second tape speed, using the standard 1800 rpm motor.

If the recorder mechanism is provided with a two-speed motor (900-1800 rpm) the larger capstan and smaller pressure roller may be used for 15" and 7-1/2" per second, while the smaller capstan and larger pressure roller are used for 3-3/4" and 7-1/2" per second tape speed.

NOTE: When changing speeds, if an equalizer switch is not provided on the amplifier being used, it will be necessary to change equalizers in the amplifier accordingly.

OPERATING INSTRUCTIONS

1. Insert the power cord into a receptacle of the proper rating.
2. Set control knob (44) in the "Stop" position.
3. Before a reel of tape can be placed on the spindle, reel retaining knob (1) must be removed. To remove the reel knob, push it in and turn counter-clockwise to release the bayonet pin.
4. Place an empty reel on the right (take-up) spindle (18), and replace the reel retaining knob.
5. Place a reel of tape on the left (rewind) spindle (2).

NOTE: This recorder uses Type "A" wound tape i.e. the dull magnetic coated side faces inward. If the tape to be used is Type "B" (coated side facing outward), place the reel of tape on the right (take-up) spindle (18) so that the tape will lead off in a clockwise direction. Thread the tape on to the left (rewind) spindle (2) as described in paragraph "To Rewind". Place control knob (44) in "Rewind" and allow the full reel of tape to wind on the empty reel. The magnetic side of the tape will now be facing inward.

6. Unwind about 18" of tape and thread it through the normal tape path of the recorder.

7. Insert the end of the tape in one of the radial slots of the take-up reel and wind at least two full turns of tape on to the reel.

To Make a Recording -

1. Turn power switch, on amplifier being used, to "On". This provides the necessary power for both amplifier and recorder mechanism.
2. Place the "Play-Record" control on the amplifier in "Record" position.
3. De-press safety button (42) and, simultaneously, turn control knob (44) to "Forward". This sets the tape in motion.

4. The red bias indicator will glow when the oscillator is operating properly. This indicates a new recording is being made and any previous recording on the tape will be erased.

5. When the recording is completed, turn control knob (44) to "Stop".

To Rewind a Tape -

1. Before rewinding, lift the tape clear of the pole surfaces on the record/playback head and place it on top of the head shield (11). This prevents excessive wear of the pole surfaces during the rewind operation. The balance of the tape may remain in its normal path.

2. The tape may be rewound at any time by placing control knob (44) in "Rewind".

3. Control knob (44) may be turned to "Stop" at any time without danger of tape spillage. These units will rewind 1200 feet of tape (7" reel) in less than forty seconds.

CAUTION: When switching from "Rewind" to "Forward", always pause in the "Stop" position long enough for the tape to come to a complete stop. Failure to do so will result in tape breakage due to the tight grip the capstan and pressure roller exert on the tape when control knob (44) is in "Forward" position.

To Playback a Tape -

NOTE: A PT63 three head assembly contains both a record head and a reproduce head. They should be used for these functions alone. (In PT6 units the head may be used for record or playback as necessary.)

1. Place the "Play-Record" control on the amplifier in "Play" position. If this is not done, the tape will be erased when set in forward motion.

2. De-press safety button (42) and place control knob (44) in "Forward" position.

3. Adjust volume and tone controls to suit.

Hi-Speed Forward -

On units so equipped, the Hi-Speed Forward mechanism is actuated by de-pressing control knob (16). In this position, the tape is driven at a rate of four times the normal capstan or drive speed. It permits fast cueing or editing of any recorded tape. Since the Hi-Speed Forward mechanism is spring loaded, the farther down control knob (16) is pressed, the faster the Hi-Speed Forward action.

MECHANICAL OPERATION

Flywheel and Capstan -

The balanced flywheel and capstan (33), which is driven by two rubber-tired wheels (61), provide a constant speed for the tape.