



Installation and Operation Instructions

RETROFIT KIT RET-041

For OPTIMOD-AM Model 9100A/1 (mono)

Purpose: Adds NRSC Pre-emphasis and 10kHz Low-pass Filter

(Retrofit Kit RET-033 must first be installed in units with serial numbers below 700000.)

This kit modifies the Model 9100A/1 OPTIMOD-AM® to provide the pre-emphasis and 10kHz low-pass filtering that is recommended by the National Radio Systems Committee (NRSC). 12kHz and 5kHz low-pass filtering are provided for stations that require them. The filters can be preset, or can be switched by OPTIMOD-AM's day/night logic. This kit also provides a means of de-emphasizing the NRSC pre-emphasized signal for monitoring.

Retrofit Kit RET-041 contains:

- 1 Card #1F10
- 1 BLUE NRSC Pre-emphasis Module
- 2 30-gauge wires
- 1 Label, "Special Modification"
- 1 Resistor, 100 Ω \pm 5%, 1/4-watt, carbon film
- 2 Resistors, 620 Ω \pm 5%, 1/4-watt, carbon film
- 1 Capacitor, 0.18 μ F \pm 5%, 100-volt, metallized polyester
- 1 NRSC Compliance Card
- 1 Installation and Operation Instructions

These instructions first discuss the reasons behind the NRSC recommendations (starting on the following page), then explain how to install the retrofit (on page 3).

Installation consists of positioning jumpers, setting controls, plugging a pre-emphasis module into a socket, and inserting a new circuit card into a rack slot. A simple de-emphasis circuit can be installed for off-air monitoring.

In older units (with serial numbers below 700000), two jumpers must be attached to the motherboard and a socket and interconnections for pre-emphasis modules must be installed. (The socket and interconnections are supplied as RET-033, to be ordered separately.)

Installation of this retrofit kit affects certain parts of the 9100A Operating Manual, so a list of changes to the manual is included (on page 9). Also included are field alignment and performance verification instructions (on page 11), a circuit description (on page 18), a parts list (on page 23), and schematics and assembly drawings (on page 26) for Card #1F10.

95307-000-01 6/87

Orban Associates Inc. 645 Bryant Street San Francisco, CA 94107

Main: (415) 957-1063 Sales: (415) 957-1067 Telex: 17-1480

World Radio History

Why the New NRSC Standard?

Over the years, as the air waves became more crowded, interference from first and second adjacent stations became more and more of a problem. Receiver manufacturers responded by producing receivers with decreased audio bandwidth, so that the encroachment of an adjacent station's modulation extremes would not be audible as interference. This truncating of the bandwidth had the effect of diminishing the receiver's high-frequency response, but it was felt that lower fidelity would be less obnoxious than interference. As long ago as 1978, Orban proposed and implemented pre-emphasis and low-pass filtering for AM broadcast to provide brighter sound at the receiver while minimizing interference. This approach has become widely accepted. Now the NRSC has formalized a standard which is acceptable to all industry segments, and which can, if promptly implemented, result in a vast improvement in AM radio.

AM Stereo Introduces a Pre-emphasis Dilemma

Certain AM receivers manufactured since 1984, particularly those designed for domestic AM stereo reception, have a frequency response which is substantially wider than that of the typical mono AM receiver. The frequency response was widened largely to enhance the sales potential of AM stereo by presenting a dramatic, audible improvement in fidelity in the showroom. As these new receivers became more prevalent, broadcasters had to choose whether the station's pre-emphasis would be optimized for the new AM stereo receivers or for the existing conventional receivers that form the vast majority of the market. If the choice was for conventional receivers (which implies a relatively extreme pre-emphasis), the newer receivers might sound strident or exceptionally bright. If the choice favored the newer receivers (less pre-emphasis and probably less processing), the majority of receivers would be deprived of much high-end energy and would sound both quieter and duller.

NRSC Standard Pre-emphasis and Low-pass Filtering

In response to this dilemma, the National Radio Systems Committee (NRSC) undertook the difficult task of defining a voluntary recommended pre-emphasis curve for AM radio that would be acceptable to broadcasters (who want the highest quality sound on the majority of their listeners' radios) and to receiver manufacturers (who are primarily concerned with interference from first- and second-adjacent stations).

After a year of deliberation, a "modified 75-microsecond" pre-emphasis/de-emphasis standard was approved. This provides a moderate amount of improvement for existing narrowband radios, while optimizing the sound of wideband radios. Most importantly, it generates substantially less first-adjacent interference than do steeper pre-emphasis curves.

The second part of the NRSC standard calls for a sharp upper limit of 10kHz for the audio presented to the transmitter. This essentially eliminates interference to second and higher adjacencies. While some have protested that this is inadequate and that 15kHz audio should be permitted, the unfortunate fact is that interference-free 15kHz audio could only be achieved by a complete re-allocation of the AM band! The *practical* effect of widespread implementation of the 10kHz standard is that 10kHz radios will then be feasible, and the bandwidth perceived

by the average consumer (now limited by the receiver to 3kHz, typically) will be dramatically improved. On much mass-market equipment, it will be difficult to tell AM from FM.

The radio manufacturers participating in the NRSC stated emphatically that reduction in interference *must be demonstrated by broadcasters* before receiver manufacturers would be willing to release true wideband (10kHz audio bandwidth) receivers to the mass market. This is rational — the receiver manufacturers can lose millions of dollars if they produce receivers that are rejected as noisy or interference-prone by consumers. In contrast, broadcasters can easily change pre-emphasis and filtering with very little expense.

Therefore, although this standard is voluntary, we *strongly recommend* conformance to it. We are convinced that use of this more modest pre-emphasis and sharp 10kHz filtering by broadcasters is the only factor that will eventually induce the receiver manufacturers to build and mass-market the high-fidelity, wideband radios which would allow AM stations to compete with FM in audio quality. The commitment to do so was strongly expressed by the receiver manufacturers involved in the NRSC's deliberations.

Installation

Allow about 30 minutes for this retrofit. If installation of Retrofit Kit RET-033 will be required (as it may for units with serial numbers below 700000), allow a total of up to 1½ hours.

1) Open the front panel of the 9100A/1, remove the subpanel.

It is not necessary to remove the unit from the rack (unless Retrofit Kit RET-033 must be installed — see step 4). The 9100A/1 must, however, be off the air during this procedure.

- a) Remove the three hex-socket screws at the top of the front panel with a $\frac{5}{64}$ -inch hex wrench (provided with the unit), then tilt the hinged front panel downward to reveal the interior.
- b) Set the AC POWER switch to OFF.
- c) Loosen the four DZUS fasteners on the subpanel by turning each $\frac{1}{4}$ -turn counterclockwise with a long $\frac{3}{16}$ -inch or $\frac{1}{4}$ -inch flat-blade screwdriver.
- d) Taking care not to stress the flat cables beneath it, tilt the top of the subpanel outward and to the left to clear the upper chassis lip and the door support rail at the right.

2) Reposition jumpers on Card #7.

- a) Remove Card #7 from its slot.
- b) Place jumper A on Card #7 in the "CARD 1 INSTALLED" position (see Fig. 1).
- c) Return Card #7 to its slot.

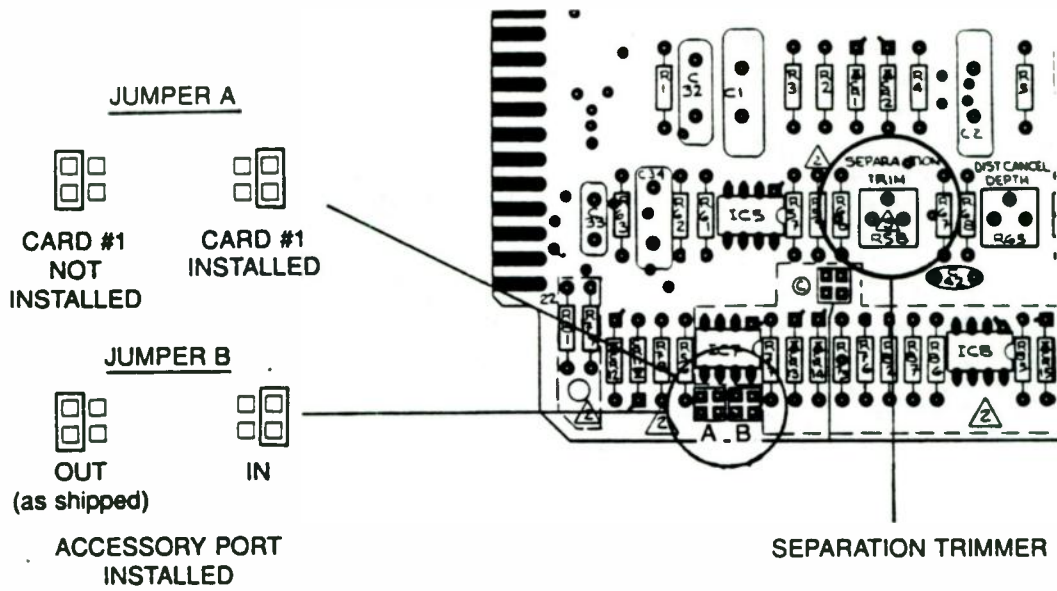

Fig. 1: Jumper Positions, Card #7

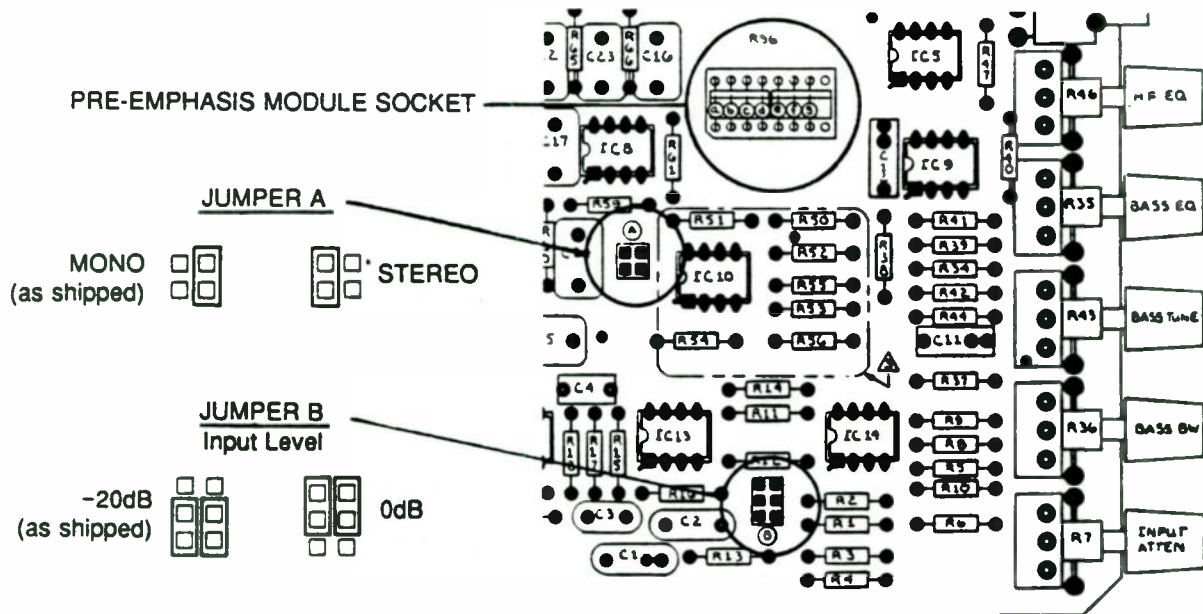

Fig. 2: Jumper Positions and Component Locations, Card #4

3) Install NRSC pre-emphasis module on Card #4.

- a) Remove Card #4 from its slot.
- b) If the serial number of your 9100A/1 is below 700000, install Retrofit Kit RET-033 on Card #4 before continuing (instructions are provided with that kit).
- c) Unplug the "equalization module" from the socket on Card #4.
Do not remove the module if it is BLUE. See Fig. 2 for location of the module. (On some earlier versions of Card #4, the socket is on a "transition board" assembly.)
- d) Insert the BLUE NRSC pre-emphasis module in the socket.
- e) Check that jumper A on Card #4 is in the "MONO" position.
- f) Return Card #4 to its slot.

4) If your serial number is below 700000, attach jumpers to motherboard.

[Skip this step if your serial number is 700000 or higher.]

- a) Plug an extender board into slot #1.
- b) Turn the POS PEAK THRESH control fully counterclockwise.
- c) Set the MODE switch to OPERATE.
- d) Set the AC POWER switch to ON.
- e) Measure the voltage between the chassis and pin U and between the chassis and pin V. If these voltages are about -4.1VDC and +4.1VDC, respectively, the jumpers are already in place and you may skip to step 5.
- f) Set the AC POWER switch to OFF.
- g) Disconnect OPTIMOD-AM and remove it from the rack.
- h) Remove the eight screws that attach the top cover to the rear panel of OPTIMOD-AM. Also remove the eight screws that attach the bottom cover to the rear panel.
- i) Set the unit on a padded surface with the rear panel facing you and the bottom cover down.
Leave about 6 inches (15cm) between the rear panel and the edge of the table. Be sure the AC power cord is unplugged.
- j) Remove the three groups of three screws circled in black on the rear panel.
- k) *Very carefully* pull the rear panel about $\frac{3}{4}$ -inch toward you, and then tilt the top of the rear panel down until the rear panel is horizontal.

Careful! Watch for snags in the wiring or stress on the ceramic capacitors on the internal divider wall or RF box. These capacitors are very fragile and are difficult to replace.

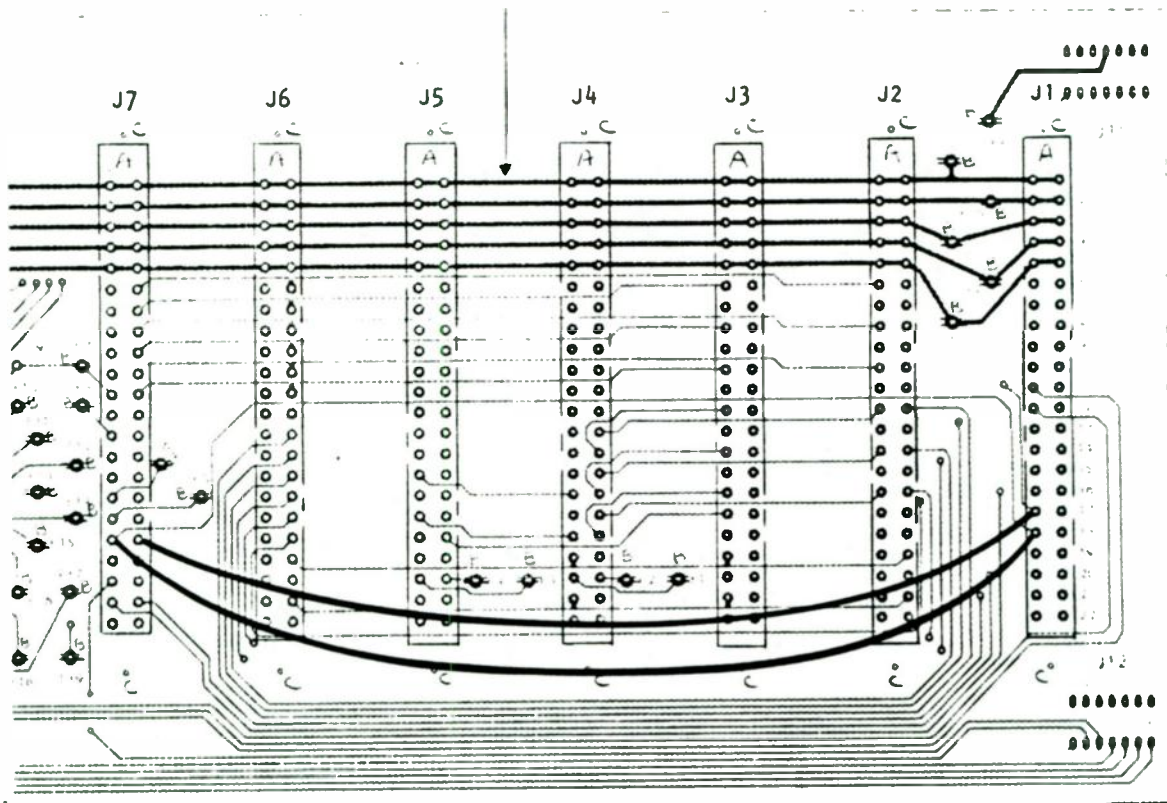

Fig. 3: Motherboard Modification
(Only for units with serial numbers below 700000)

- l) On the motherboard, tack solder the supplied 30-gauge insulated hook-up wire from pin 7-18 to pin 1-U (see Fig. 3).
- m) On the motherboard, tack solder the supplied 30-gauge insulated hook-up wire from pin 7-V to pin 1-V (see Fig. 3).
- n) Check your work carefully. Measure the voltage between the chassis and pin U and between the chassis and pin V with the POS PEAK THRESH control fully counterclockwise (these voltages should be near -4.1VDC and +4.1VDC, respectively).
- o) *Very carefully* tilt the rear panel up to the vertical position, and the push the rear panel forward into place.
Take care that no wires are pinched between the panel and the chassis.
- p) Replace the 25 screws removed above.
Do not tighten screws until all screws are loosely in place.
- q) Return OPTIMOD-AM to rack, connect and ground unit.

5) Install Card #1F10.

- a) Remove Card #1 or #1-F from slot #1, if present.
- b) Position jumpers A (night) and B (day) on Card #1F10 to select the desired low-pass filter (see Fig. 4).

You may select 5kHz, 10kHz, or 12kHz low-pass filtering in any combination for day and night operation. The NRSC standard specifies 10kHz low-pass filtering for both day and night.

- c) Insert Card #1F10 into slot #1.

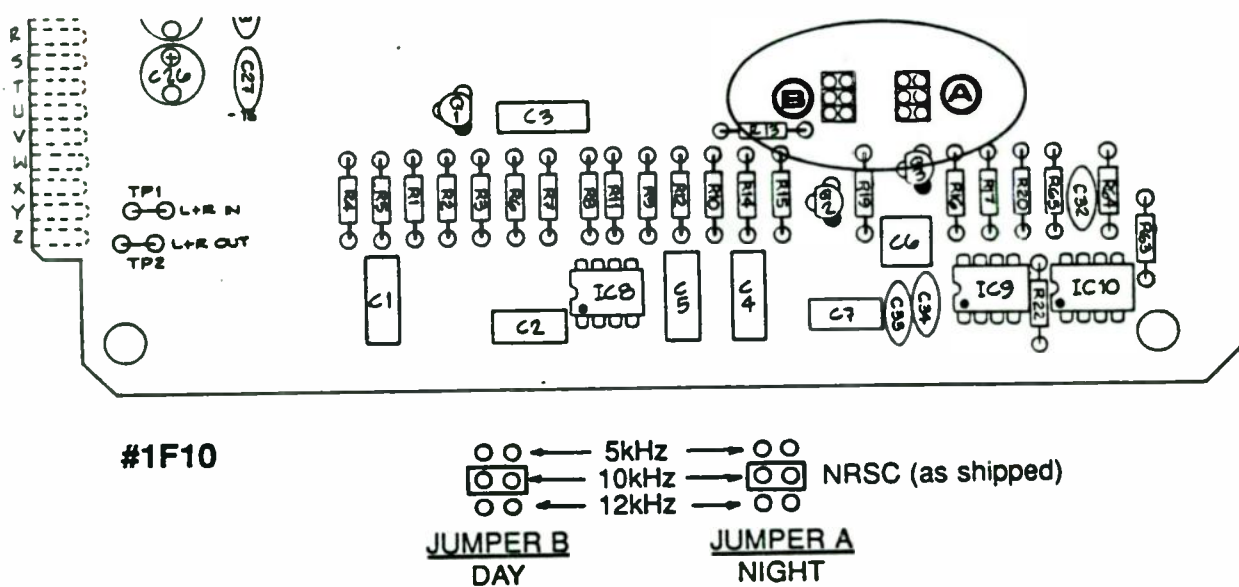

Fig. 4: Low-pass Filter Jumper Positions, Card #1F10

6) Reinstall subpanel and close the front panel.

The subpanel should always be replaced, since it is an integral part of the chassis RFI protection.

- a) Taking care not to stress the flat cables beneath it, tilt the top of the subpanel inward and to the left to clear the upper chassis lip and the door support at the right.
- b) Turn the DZUS fasteners $\frac{1}{4}$ -turn clockwise.
The DZUS fasteners turn only $\frac{1}{4}$ -turn. Don't force them, lest they be damaged in a way that is very time consuming to repair.
- c) Set the internal AC POWER switch to ON.
- d) Raise the front panel and fasten the three screws that secure it in place.

7) Turn the HF EQ control fully clockwise.

This instruction supersedes the settings shown in Fig. 4-6 ("Recommended Initial Control Adjustments") on page 4-7 of the Third Edition of the 9100A Operating Manual. You may wish to note this change on that figure.

8) Attach the supplied "Special Modification" label to the rear panel.

9) Install NRSC de-emphasis circuit for monitoring.

The ACC-5 Monitor Rolloff Filters supplied with 9100A/1 units were designed to complement the original GREEN module. When the BLUE module is used, a simple de-emphasis circuit can be placed between the audio output of the modulation monitor and the input of the monitor amplifier to provide complementary 75 μ s de-emphasis. For a more precise simulation of a "standard" NRSC receiver (including a 10kHz notch filter to reduce any audible artifacts that might result from ringing introduced by the very sharp 10kHz low-pass filter, and to eliminate 10kHz whistles encountered in off-air monitoring), we recommend our ACC-023 NRSC Monitor Rolloff Filter.

See Fig. 5 for a schematic of the simplified rolloff filter and information about installing it (the parts needed are included in this kit). Note that the frequency response of this filter is correct only when *both* its source and load impedances are approximately 600 ohms, and that resistors or pads may have to be added to achieve this.

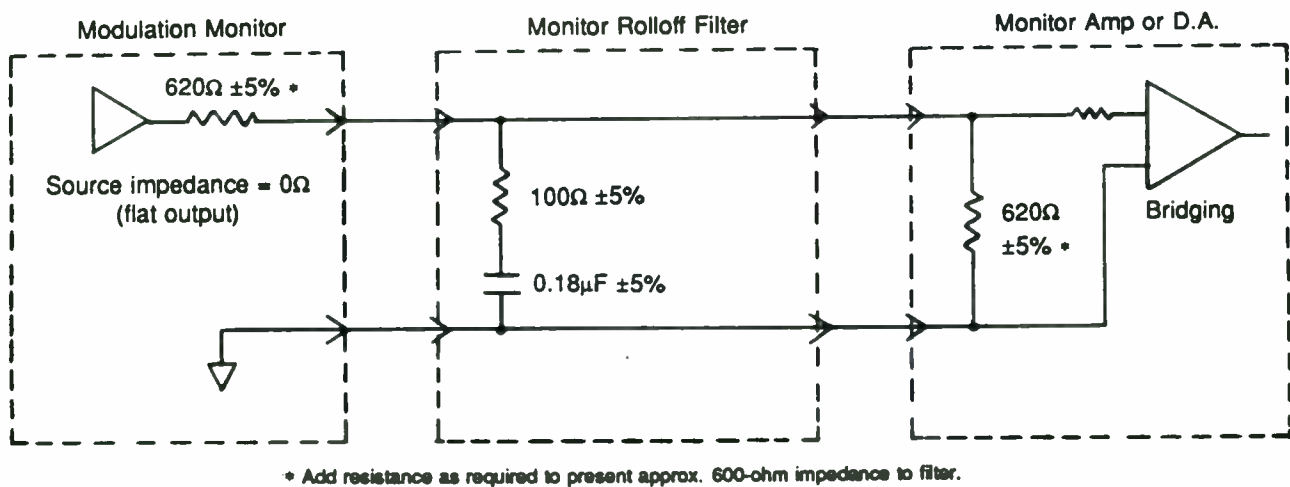

Fig. 5: NRSC Simplified 75 μ s Monitor Rolloff Filter Schematic

10) Complete and mail the supplied "NRSC Compliance Card".

As explained in the introduction to this kit, making AM audio quality competitive with that of FM depends on AM broadcasters demonstrating their commitment to the NRSC standard. The NAB is tallying AM stations as they implement the standard, so that the rate of implementation and the total number of equipped stations can be made known to receiver manufacturers. Now that you have upgraded your equipment to the standard, complete the job by returning the NRSC Compliance Card to the NAB.

Operating Manual Changes

Installing this retrofit kit changes or invalidates portions of the 9100A Operating Manual. The following changes to that manual update it to include this retrofit. To prevent future errors, we recommend marking each page mentioned below with "See Retrofit Kit RET-041 Instructions". (Page references are to the Third Edition of the 9100A Operating Manual; "Addendum #1" refers to Addendum #1 to that manual.)

- 1) NRSC pre-emphasis is supplied by a BLUE module on Card #4 in the mono 9100A/1. Addendum #1 provides information about these modules.

In the main body of the 9100A Operating Manual, the following pages are affected by this change:

- 1-4, 1-5 "Introduction: High-Frequency Equalizer"
- 3-10 "Installation: Option 7"
- 5-1, 5-2 "Operating Instructions: Where to Start"
- 5-4 "Operating Instructions: HF EQ"
- 5-7, 5-8 "Operating Instructions: On High-Frequency Equalization"
- 4-7 During initial set-up, the 9100A/1's HF EQ control should be turned fully clockwise. This instruction supersedes the settings shown in Fig. 4-6.
- 6-1 "Proof of Performance" is *unaffected* by this change.
- D-3 Program equalizer response will be as specified in Appendix D only if the GREEN module is installed.

We continue to supply the older RED, YELLOW, and GREEN modules mentioned in the 9100A Operating Manual for stations (particularly those outside North America) which may prefer other HF equalization. See Addendum #1 for more information.

- 2) The ACC-5 Monitor Rolloff Filter supplied with 9100A/1 units was designed to complement the original GREEN module. The installation instructions above describe how to apply a complementary de-emphasis for off-air monitoring of NRSC standard audio, and explain when it might be preferable to use the optional ACC-023 Monitor Rolloff Filter instead. (See Addendum #1 for information about monitor rolloff filtering if you choose to use one of the alternate pre-emphasis modules.)

This change affects the following pages in the 9100A Operating Manual:

- 2-3 "Various Application Notes: Monitor Rolloff Filters"
- 3-10 "Installation: Monitor Rolloff Filter"
- 5-3 "Operating Instructions: Monitor Rolloff Filter"

- 3) Low-pass filtering is selected by jumpers on Card #1F10. Day and night 10kHz low-pass filtering is specified in the NRSC standard. 5kHz and 12kHz low-pass filtering are also available. Any of these three low-pass filtering options may be chosen for day operation, and the same or either of the other two may be chosen for night operation.

These changes in low-pass filtering options affect the following pages:

- 1-1 "Introduction and System Description"
- 1-7, 1-8 "Introduction: Output Low-pass Filter and Safety Clipper"
- 2-5 "Various Application Notes: 5kHz Bandwidth Limitation"

- 4) Card #1F10 replaces Card #1 or #1-F. Schematics and assembly drawings for Card #1F10 are included in these instructions.

- 5) The specifications after installation of this retrofit are essentially the same as those given in Appendix L of the 9100A Operating Manual. With the NRSC 10kHz low-pass filter in the circuit, total system frequency response is better than +0.5dB, -2.0dB, 50-9600Hz.

Field Alignment and Performance Verification — Card #1F10

Use the following procedure to align and verify performance of Card #1F10 after the card has been repaired.

This procedure is not required for routine maintenance or Proof of Performance.

Record all current control settings before beginning, so these settings can be restored when this procedure is completed.

Record jumper positions when directed to reposition a jumper, so the jumpers can be returned to these positions when you are finished.

Jumper and component locations are shown in the assembly drawings in the 9100A Operating Manual and in installation instructions for retrofit kits containing Card #1F10.

In a mono OPTIMOD-AM, all connections are to the *left* input or output.

Always turn off the power to OPTIMOD-AM when removing circuit cards to move jumpers.

The alignment and verification procedure consists of:

- checking the accuracy of the DC reference voltage
- verifying the performance of the 5kHz and 10kHz low-pass filters
- checking DC servo operation
- adjusting the gain of the 10kHz low-pass filter
- adjusting the notch frequency of the 10kHz low-pass filter
- verifying distortion and noise performance

Follow instructions in the order given, without skipping steps.

Equipment required:**Low-frequency spectrum analyzer with tracking generator**

Tektronix 5L4N plug-in with 5111 bistable storage mainframe, or equivalent. Alternatively, a sweep generator with 20–20,000Hz logarithmic sweep can be used (with the oscilloscope in X/Y mode).

Oscilloscope

With DC-coupling, dual trace, triggered sweep, and 5MHz or greater vertical bandwidth. ×10 probe.

Audio oscillator

Residual distortion less than 0.0015%.

Frequency counter

Accurate to ±0.05%

Total harmonic distortion (THD) analyzer

Residual distortion less than 0.0015%.

Audio voltmeter

Accurate to ±2%. (Sound Technology 1700 A/B or 1710, for example.)

Pink noise generator**Digital voltmeter**

Accurate to ±0.1%.

It is assumed that the technician is thoroughly familiar with the operation of this equipment.

1) Open the front panel of the OPTIMOD-AM, remove the subpanel.

It is not necessary to remove the unit from the rack, as long as you have access to the input terminals on the rear panel. The OPTIMOD-AM must, however, be off the air during this procedure.

- a) Remove the three hex-socket screws at the top of the front panel with a $\frac{5}{64}$ -inch hex wrench (provided with the unit), then tilt the hinged front panel downward to reveal the interior.
- b) Loosen the four DZUS fasteners on the subpanel by turning each $\frac{1}{4}$ -turn counterclockwise with a long $\frac{3}{16}$ -inch or $\frac{1}{4}$ -inch flat-blade screwdriver.
- c) Taking care not to stress the flat cables beneath it, tilt the top of the subpanel outward and to the left to clear the upper chassis lip and the door support rail at the right.

2) Extend Card #1F10.

Remove Card #1F10, insert a card extender into slot #1 of OPTIMOD-AM's card cage, and then plug Card #1F10 into the extender card.

3) Verify DC voltages.

Measure voltages against circuit ground (available at pin C of the edge connector on Card #1F10.).

- a) Set the MODE switch to OPERATE.
- b) Turn the POS PEAK THRESH control fully counterclockwise.
- c) Measure the voltage at the anode of diode CR2 on Card #1F10 to verify that it is -4.1 volts DC, $\pm 0.4V$.
- d) Measure the voltage at the cathode of diode CR1 on Card #1F10 to verify that it is +4.1 volts DC, $\pm 0.4V$.
- e) Set the MODE switch to PROOF.
- f) Measure the voltage at the anode of diode CR2 on Card #1F10 to verify that it is approximately -14 volts DC.
- g) Measure the voltage at the cathode of diode CR1 on Card #1F10 to verify that it is approximately +14 volts DC.

4) Verify performance of the 5kHz low-pass filter, and of "bypass".

In "bypass", 12kHz low-pass filtering is provided by other OPTIMOD-AM cards.

- a) Connect the output of a sweep or tracking generator to OPTIMOD-AM's input.
- b) Connect the input of a spectrum analyzer or oscilloscope to TP2 on Card #1F10.
- c) Place jumpers A (night) and B (day) on Card #1F10 in the "12kHz" position.
- d) Verify that response is flat $\pm 1dB$ to 12kHz.
- e) Place jumpers A (night) and B (day) on Card #1F10 in the "5kHz" position.
- f) Verify that response is flat $\pm 1dB$ to 5.0kHz, and rolls off with a slope of greater than 30dB/octave above 5kHz.
It is normal to see a slight "glitch" at 10kHz about -30dB.
- g) Place jumper B (day) on Card #1F10 in the "12kHz" position.
- h) Verify that the 5kHz low-pass filter is activated when the TX EQ DAY/NIGHT switch is moved to the NIGHT position.

If the filter is operating, you will see a steep rolloff of frequencies higher than 5kHz, as above.

- i) Verify that the 5kHz low-pass filter is deactivated when the TX EQ DAY/NIGHT switch is moved to the DAY position.
If the filter is inactive, you will not see a steep rolloff above 5kHz.
- j) On Card #1F10, place jumper A (night) in the "12kHz" position, and jumper B (day) in the "5kHz" position.
- k) Verify that the 5kHz low-pass filter is activated when the TX EQ DAY/NIGHT switch is moved to the DAY position.
- l) Verify that the 5kHz low-pass filter is deactivated when the TX EQ DAY/NIGHT switch is moved to the NIGHT position.
- m) Disconnect the sweep or tracking generator and spectrum analyzer or oscilloscope from OPTIMOD-AM.

5) Check DC servo operation.

- a) Place jumper A (night) and B (day) on Card #1F10 in the "10kHz" position.
- b) With a digital voltmeter, verify that the DC offset is less than 15mV at TP2.

6) Adjust 10kHz low-pass filter gain.

- a) On Card #1F10, place jumper B (day) in the "12kHz" position.
- b) Connect an audio oscillator to OPTIMOD-AM's input.
- c) Set OPTIMOD-AM's VU meter selector to L AGC.
- d) Set the audio oscillator to 1kHz, and adjust its output level until OPTIMOD-AM's VU meter reads approximately "-6VU".
- e) Set OPTIMOD-AM's TX EQ DAY/NIGHT switch to DAY.
- f) Observe the level at TP2. Make a note of it.
- g) Move the TX EQ DAY/NIGHT switch to the NIGHT position.
- h) Adjust trimmer R62 until the level at TP2 is the same (± 0.1 dB) as that observed in step f, above.

7) Adjust frequency of the first 10kHz low-pass filter's notch.

- a) Place jumper B (day) on Card #1F10 in the "10kHz" position.
- b) Set the audio oscillator for 10,100Hz \pm 10Hz, and check the frequency with a counter.
The audio oscillator should still be connected to OPTIMOD-AM's input. Do not change the audio oscillator's output level.
- c) While observing TP2 with an audio voltmeter, adjust trimmer R17 to null the signal.
The null should be more than 45dB below the input signal level.

d) Disconnect the audio oscillator and voltmeter from OPTIMOD-AM.

8) Verify 10kHz low-pass filter performance.

- a) Connect the output of the sweep or tracking generator to OPTIMOD-AM's input.
- b) Connect the input of the spectrum analyzer or oscilloscope to TP2.
- c) Verify that response is flat +0.5dB, -2.0dB to 9600Hz, and rolls off with a slope of greater than 60dB/octave above 10kHz.
- d) Place jumper B (day) on Card #1F10 in the "12kHz" position.
- e) Verify that the 10kHz low-pass filter is activated when the TX EQ DAY/NIGHT switch is moved to the NIGHT position.
If the filter is operating, you will see a very steep rolloff of frequencies higher than 10kHz.
- f) Verify that the 10kHz low-pass filter is deactivated when the TX EQ DAY/NIGHT switch is moved to the DAY position.
If the filter is inactive, you will not see a steep rolloff above 10kHz.
- g) On Card #1F10, place jumper A (night) in the "12kHz" position, and jumper B (day) in the "10kHz" position.
- h) Verify that the 10kHz low-pass filter is activated when the TX EQ DAY/NIGHT switch is moved to the DAY position.
- i) Verify that the 10kHz low-pass filter is deactivated when the TX EQ DAY/NIGHT switch is moved to the NIGHT position.
- j) Disconnect the sweep or tracking generator and spectrum analyzer or oscilloscope from OPTIMOD-AM.

9) Verify distortion performance.

- a) Place jumper B (day) on Card #1F10 in the "5kHz" position.
- b) Connect the input of a THD analyzer to TP2.
- c) Set the TX EQ DAY/NIGHT switch to DAY.
- d) Verify that distortion is less than 0.2% with the audio oscillator set for 100Hz, 1.0kHz, and 4.0kHz in a 20-20,000Hz bandwidth.
- e) Set the TX EQ DAY/NIGHT switch to NIGHT.
- f) Verify that distortion is less than 0.2% with the audio oscillator set for 100Hz, 1.0kHz, 5.0kHz, and 10.0kHz in a 20-20,000Hz bandwidth.
- g) Place jumper A (night) on Card #1F10 in the "10kHz" position.
- h) Verify that distortion is less than 0.2% with the audio oscillator set for 100Hz, 1.0kHz, 5.0kHz, and 9.0kHz in a 20-20,000Hz bandwidth.

- i) Disconnect the THD analyzer from TP2.
- 10) Verify noise performance.**
- a) Check that jumper A (night) on Card #1F10 is in the "10kHz" position.
 - b) Connect the audio voltmeter to TP2.
 - c) Short OPTIMOD-AM's input by connecting the L INPUT +, -, and GROUND terminals together.
 - d) Set the TX EQ DAY/NIGHT switch to DAY.
 - e) Verify that the level of residual noise, as measured by the audio voltmeter, is less than -65dBu from 20-20,000Hz.
dBu = dBm at 600 ohms.
 - f) Set the TX EQ DAY/NIGHT switch to NIGHT.
 - g) Verify that the level of residual noise, as measured by the audio voltmeter, is less than -65dBu from 20-20,000Hz.
 - h) Remove the jumper(s) shorting OPTIMOD-AM's input.
- 11) Restore all jumpers to the positions they were in at the beginning of this alignment and performance verification procedure.**
- 12) Remove the card extender and return Card #1F10 to slot #1.**
- 13) Replace subpanel, close front panel.**
- The subpanel should always be replaced, since it is an integral part of the chassis RFI protection.*
- a) Disconnect all test instruments from OPTIMOD-AM.
 - b) Taking care not to stress the flat cables beneath it, tilt the top of the subpanel inward and to the left to clear the upper chassis lip and the door support at the right.
 - c) Turn the DZUS fasteners 1/4-turn clockwise.
The DZUS fasteners turn only 1/4-turn. Don't force them, lest they be damaged in a way that is very time consuming to repair.
 - d) Set the internal AC POWER switch to ON.
 - e) Raise the front panel and fasten the three screws that secure it in place.
- 14) Restore all controls to their settings prior to beginning this alignment and performance verification procedure.**

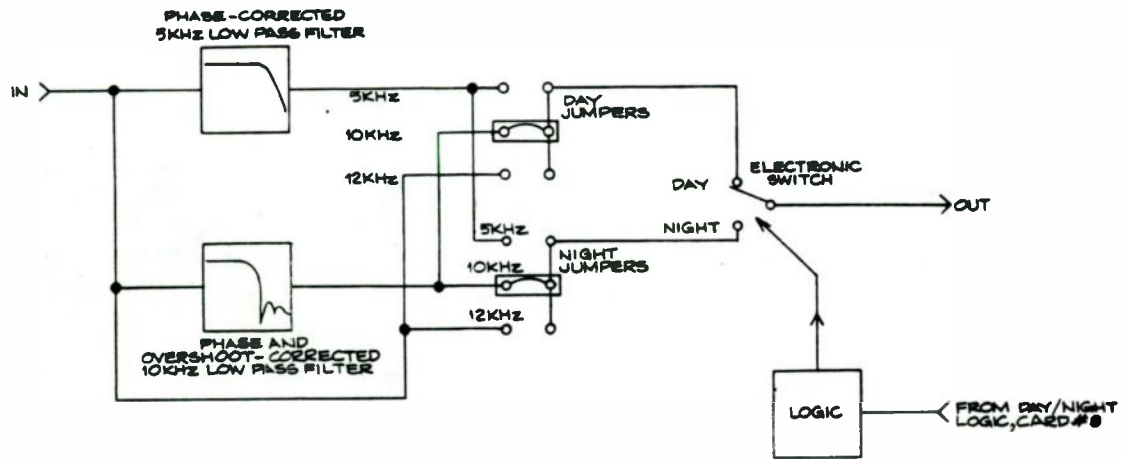

REPLACES CARD#1 IN MAIN BLOCK DIAGRAM.

Fig. 6: Block Diagram, Card #1F10

Circuit Description — Card #1F10

Card #1F10 is divided into two “subsystems”, which are described below in order of signal flow. The block diagram in Fig. 6 illustrates this description.

1) 5kHz Low-Pass Filter

This is a unity-gain, phase-corrected, 5th-order Chebychev filter with 0.1dB frequency response irregularity and a -0.1dB bandwidth of 5.0kHz.

IC8a and associated components form a third-order non-inverting filter with a gently rolled-off frequency response. The 5th-order filter's frequency response shaping is completed by IC9a and associated components, which form a 2nd-order inverting filter when the circuit path is completed by strapping jumper B (DAY) or A (NIGHT) to the “5kHz” position. IC8b and associated components form a phase corrector, which is an all-pass filter with flat magnitude response and frequency-dependent phase response. This filter adds delay as necessary to make the delay of the entire filter approximately constant with frequency, thereby minimizing overshoot.

DAY/NIGHT switching is effected by very simple logic. Pin T on the card is low (-15V) when OPTIMOD-AM is in NIGHT mode, and high (ground) when it is in DAY mode. The logic level at pin T drives JFET Q2 directly. Q1 inverts the logic and drives Q3. Q2 and Q3 are on when their gates are at ground, and off when their gates are at -15V. Thus Q3 turns on in NIGHT mode and connects jumper A into the circuit path, while Q2 turns on in DAY mode, and connects jumper B into the circuit path.

2) 10kHz (NRSC) Low-Pass Filter

The signal can be routed to a 10kHz overshoot-compensated low-pass filter, consisting of a first and second filter in series, with embedded clippers.

The signal enters the filter system and encounters clipper CR1, CR2, which provides main peak control for the signal. After buffering by IC1a, the clipped signal is applied to the first 10kHz filter IC2, IC3, IC4 (and associated components). This filter is very steep, and removes the harmonics introduced by the clipping in CR1, CR2, as well as any significant program energy above 10kHz.

The first filter is an active-RC analog of a passive LC ladder filter. It is realized by resistors, capacitors, and frequency-dependent negative resistors (FDNRs). An FDNR is realized with a dual opamp, three resistors, and two capacitors. When the passive LC filter is transformed into an active RC filter, inductors become resistors, resistors become capacitors, and capacitors become FDNRs.

Each FDNR resonates with a series resistor to create a notch in the frequency response of the filter. (This is analogous to a series LC circuit to ground.) The notches are located in the “stopband” (beyond approximately 10.05kHz). The circuit associated with IC2 produces a notch at 10.65kHz \pm 4%. The circuit associated with IC3 produces a notch at 12.00kHz \pm 4%. The circuit associated with IC4 is tuned by R39 to produce a notch at precisely 10.10kHz to

ensure that the filter's response falls accurately above 10kHz, and that NRSC specifications are met.

Measuring the frequency of these notches and their depth is the best way of diagnosing problems with such filters, since problems with a given notch can be associated with a given FDNR in most cases.

Because all parts of the filter interact, failures which cannot be cured merely by replacing opamps are best left to factory service, since special tight-tolerance, tight-temperature-coefficient parts are used in certain places. (The circuitry has been designed to be insensitive to normal unit-to-unit variations in opamps.) See Appendix F in the 9100A Operating Manual or Section 5 in the 9100B Operating Manual for information on how to obtain factory service.

To avoid possible clipping, the signal is attenuated 5dB with voltage divider R24, R25 before being applied to the filter. This gain is made up by IC5a to restore unity gain at low frequencies.

All-pass delay corrector IC5b adds frequency-dependent delay to the first filter as necessary to make its time delay more constant with frequency, thereby minimizing overshoot.

Any residual overshoot is then clipped in IC6a, and then the signal is applied to second 10kHz filter IC6b, IC7a. The primary purpose of this second filter is to remove harmonics caused by clipping in IC6a.

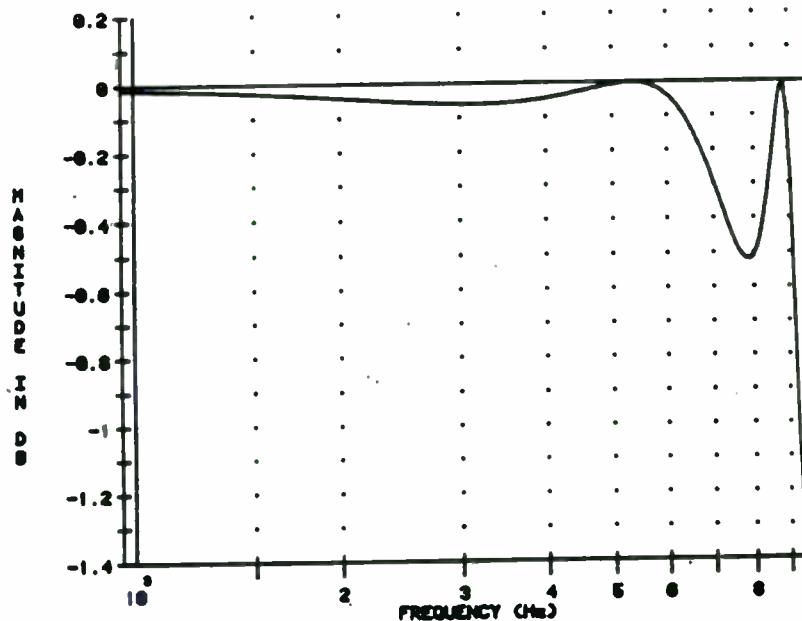

Fig. 7: Response of the First 10kHz Low-Pass Filter in the Passband

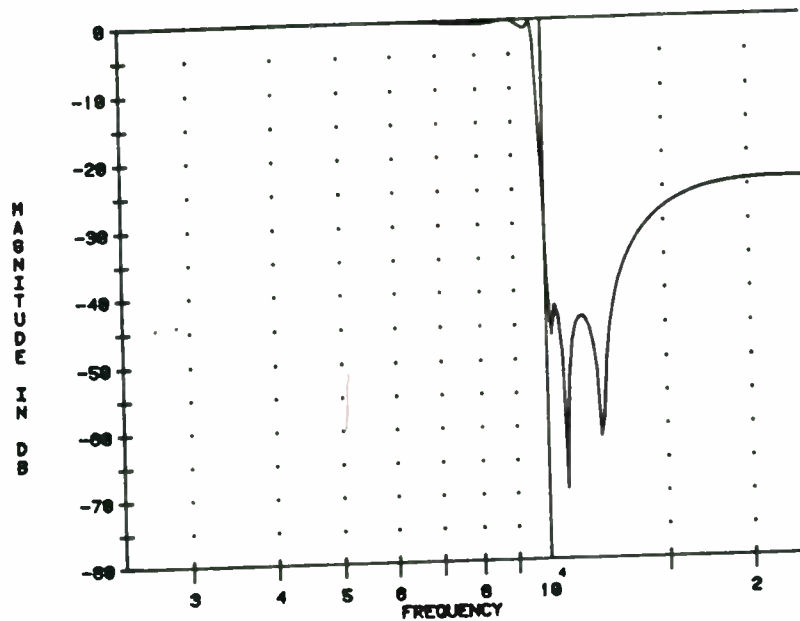

Fig. 8: Response of the First 10kHz Low-Pass Filter in the Passband and Stopband

Finally, all-pass delay corrector IC7b adds delay as necessary to make the delay of the second filter more constant with frequency.

Fig. 9 shows the normal frequency response of the part of the second filter associated with IC6b, while Fig. 10 shows the normal frequency response of the part of the second filter associated with IC7a. Fig. 11 shows the overall frequency response of the second filter.

The normal frequency response of each all-pass delay corrector (IC5b and IC7b) is flat, although each has a frequency-dependent phase shift. IC10b and associated components act as a servo to eliminate DC offset at the output of IC9b.

Fig. 12 shows the normal power spectrum measured at OPTIMOD-AM's output with the 10kHz filter strapped in and bright program material applied to OPTIMOD-AM's input. The measurement (made with an 801-line FFT spectrum analyzer operated in "peak hold" mode over a 20-minute observation period with OPTIMOD-AM controls at the normal recommended settings) verifies that NRSC power bandwidth specifications are met by the system.

The 10kHz filters can be strapped into the circuit with jumpers A and B. These jumpers can also be configured to bypass all filters on Card #1F10, retaining only the built-in 12kHz filtering provided elsewhere in OPTIMOD-AM.

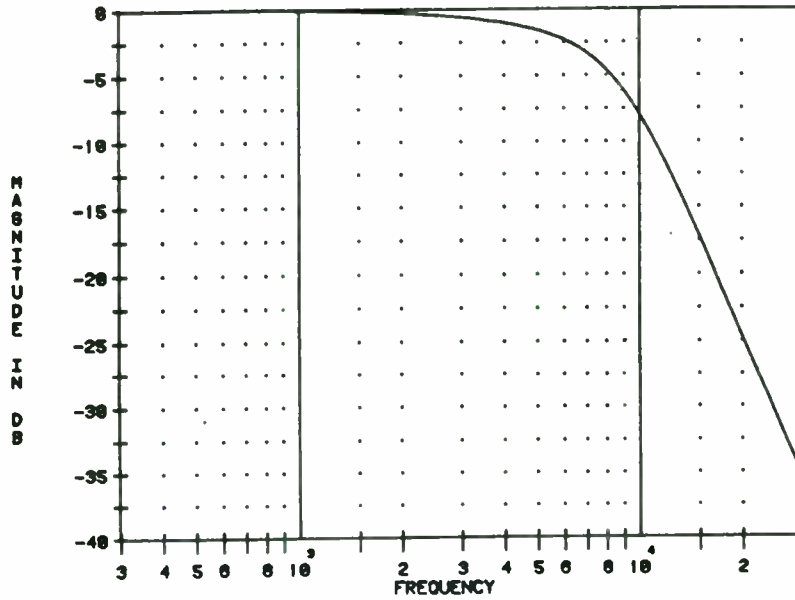

Fig. 9: Normal Frequency Response of that part of the Second 10kHz Filter associated with IC6b

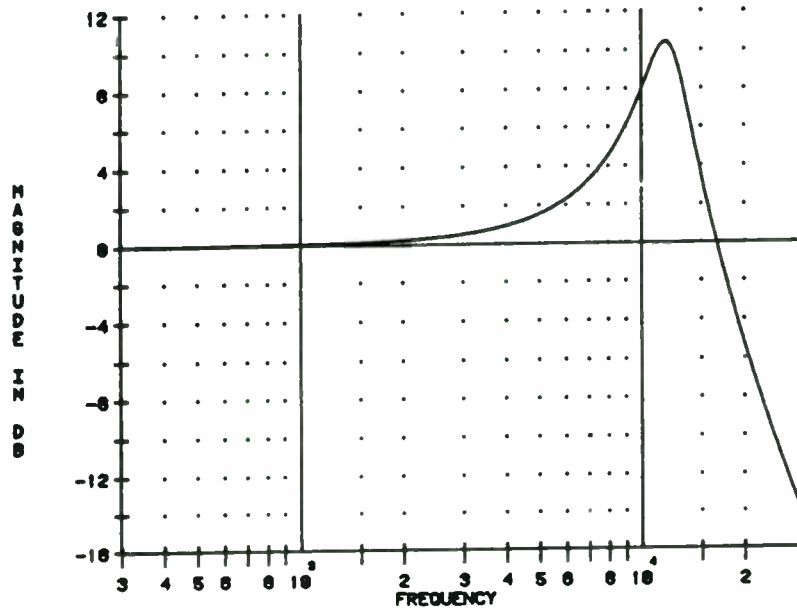

Fig. 10: Normal Frequency Response of that part of the Second 10kHz Filter associated with IC7a

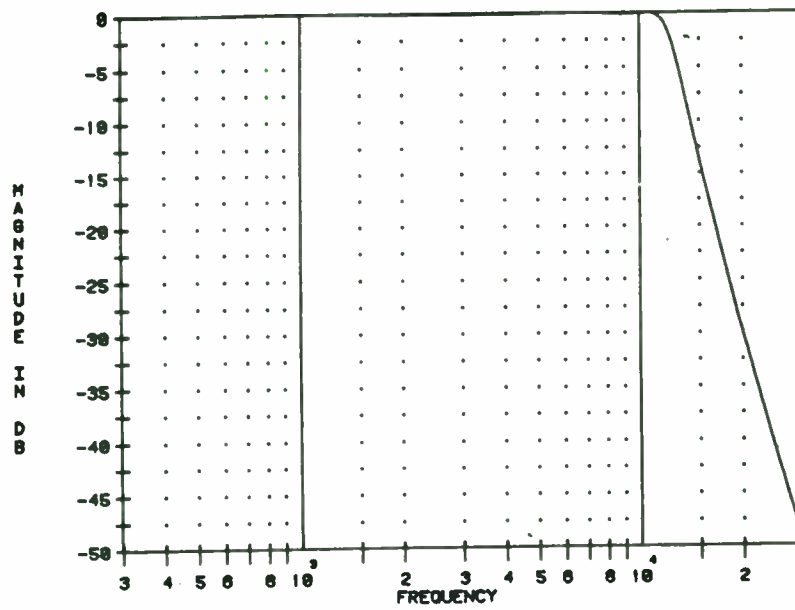

Fig. 11: Overall Frequency Response of the Second 10kHz Filter

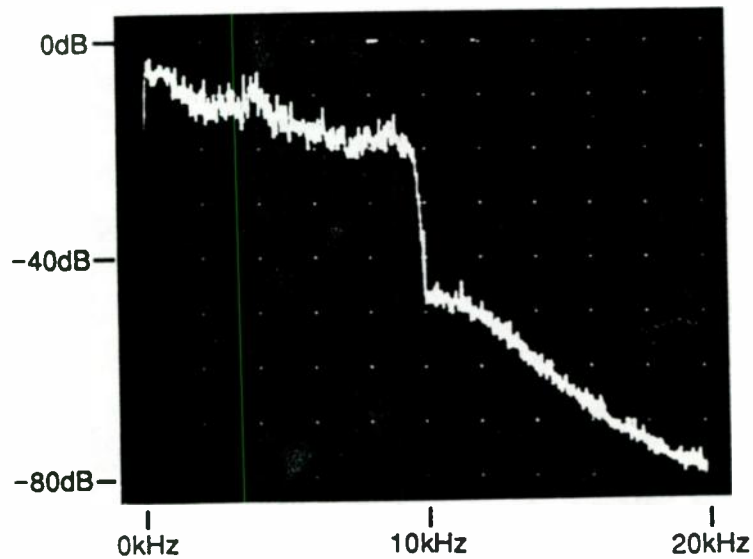

Fig. 12: Normal Output Power Spectrum of a Mono OPTIMOD-AM with 10kHz Filter

Parts List — Card #1F10

See Appendix J of the 9100A Operating Manual for information on ordering parts.

REF DES	DESCRIPTION	ORBAN P/N	VEN (1)	VENDOR P/N	ALTERNATE VENDORS (1)	NOTES
------------	-------------	-----------	------------	------------	--------------------------	-------

CARD #1F10

Capacitors

C1	Mica, 500V, 1%; 1000pF	21022-210	CD	CD19-FD102F03	SAN	
C2	Mica, 500V, 1%; 150pF	21018-115	CD	CD15-FD151F03	SAN	
C3-5	Mica, 500V, 1%; 1000pF	21022-210	CD	CD19-FD102F03	SAN	
C6	Polypropylene, 50V, 1%; 0.01uF	21701-310	NOB	CQ15PLH103FPP	WES	
C7	Mica, 500V, 1%; 100pF	21018-110	CD	CD15-FD101F03	SAN	
C8-15	Polypropylene, 50V, 1%; 4700pF	21701-247	NOB	CQ15PLH472FPP	WES	
C16,17	Mica, 500V, 1%; 1000pF	21022-210	CD	CD19-FD102F03	SAN	
C18,19	Polypropylene, 50V, 1%; 4700pF	21701-247	NOB	CQ15PLH472FPP	WES	
C20	Mica, 500V, 1%; 680pF	21022-168	CD	CD19-FD681F03	SAN	
C21	Polypropylene, 50V, 1%; 0.01uF	21701-310	NOB	CQ15PLH103FPP	WES	
C22	Mica, 500V, 1%; 220pF	21018-122	CD	CD15-FD221F03	SAN	
C23,24	Mica, 500V, 1%; 1000pF	21022-210	CD	CD19-FD102F03	SAN	
C25,26	Alum., Radial, 25V; 100uF	21206-710	PAN	ECE-ALEV101S		
C27-31	Monolythic Ceramic, 50V, 20%; 0.1uF	21123-410	SPR	1C25 Z5U104M050B	KEM	
C32	Polypropylene, 50V, 1%; 0.01uF	21701-310	NOB	CQ15PLH103FPP	WES	
C33,34	Monolythic Ceramic, 50V, 20%; 0.1uF	21123-410	SPR	1C25 Z5U104M050B	KEM	

FOOTNOTES:

- (1) See last page for abbreviations
- (2) No Alternate Vendors known at publication
- (3) Actual part is specially selected from part listed, consult Factory
- (4) Realignment may be required if replaced, see Circuit Description and/or Alignment Instructions

SPECIFICATIONS AND SOURCES FOR REPLACEMENT PARTS

OPTIMOD-AM Model 9100B
Card #1F10 - Capacitors

REF DES	DESCRIPTION	ORBAN P/N	VEN (1)	VENDOR P/N	ALTERNATE VENDORS (1)	NOTES
------------	-------------	-----------	------------	------------	--------------------------	-------

Diodes

CRL-4	Diode, Signal, Hot Carrier	22102-001	HP	HP5082-2800		
-------	----------------------------	-----------	----	-------------	--	--

Integrated Circuits

IC1-5	Linear, Dual Opamp	24206-202	TI	TL072CP	MOT	
IC6-9	Linear, Dual Opamp	24207-202	SIG	NE5532N	TI,EXR	
IC10	Linear, Dual Opamp	24209-202	NAT	LF412CN		

Resistors

R28	Resistor Set, MF, 2.00K	28520-002	ORB			3
R32	Resistor Set, MF, 2.00K	28520-002	ORB			3
R37	Resistor Set, MF, 2.00K	28520-002	ORB			3
R39	Trimpot, Cermet, 1 Turn; 200 OHM	20510-120	BEK	72PR200	BRN	
R43	Resistor Set, MF, 20.0K	28521-001	ORB			3
R58	Resistor Set, MF, 20.0K	28521-001	ORB			3
R62	Trimpot, Cermet, 1 Turn; 1K	20510-210	BEK	72PRLK	BRN	

Transistors

Q1	Transistor, Signal, NPN	23202-101	MOT	2N4400	FSC	
Q2,3	Transistor, JFET/N	23406-101	NAT	J113	SIL	

FOOTNOTES:

- (1) See last page for abbreviations
- (2) No Alternate Vendors known at publication
- (3) Actual part is specially selected from part listed, consult Factory
- (4) Realignment may be required if replaced, see Circuit Description and/or Alignment Instructions

SPECIFICATIONS AND SOURCES FOR
REPLACEMENT PARTS

OPTIMOD-AM Model 9100B
Card #1F10 - Diodes, IC's,
Resistors, Transistors

Schematics, Assembly Drawings — Card #1F10

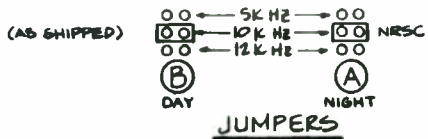
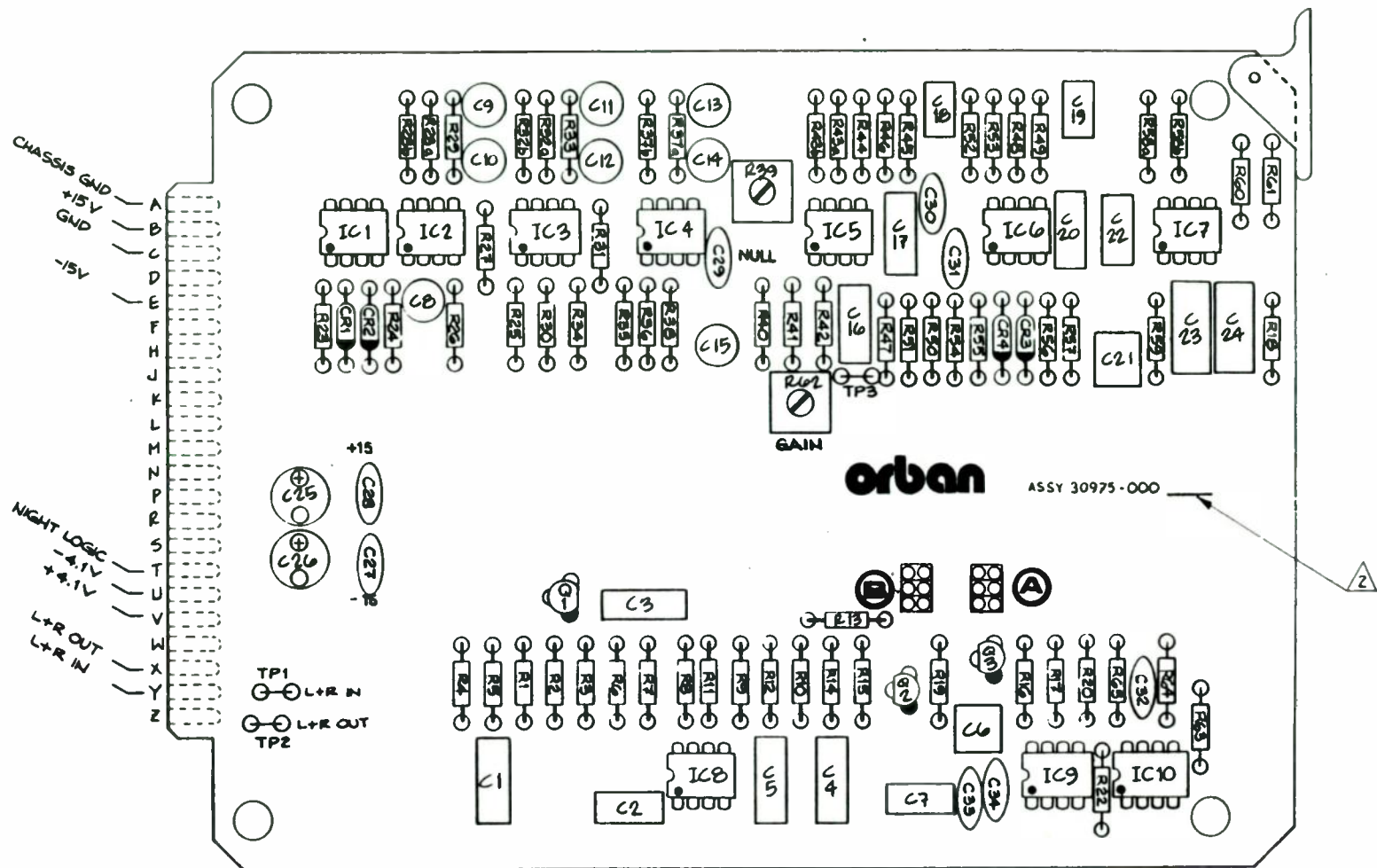

3. REFERENCE SCHEMATIC 61012-000

△ MARK ASSY REV LEVEL IN SPACE PROVIDED

1. TIC MARK INDICATES PIN 1 OF IC'S, CATHODE OF DIODE, POS. SIDE OF CAPS, EMITTERS OF TRANSISTORS.

NOTES: (UNLESS OTHERWISE SPECIFIED)

orban		Orban Associates Inc.
TITLE: ASSEMBLY DRAWING 1F10 CARD 30975-000-01		

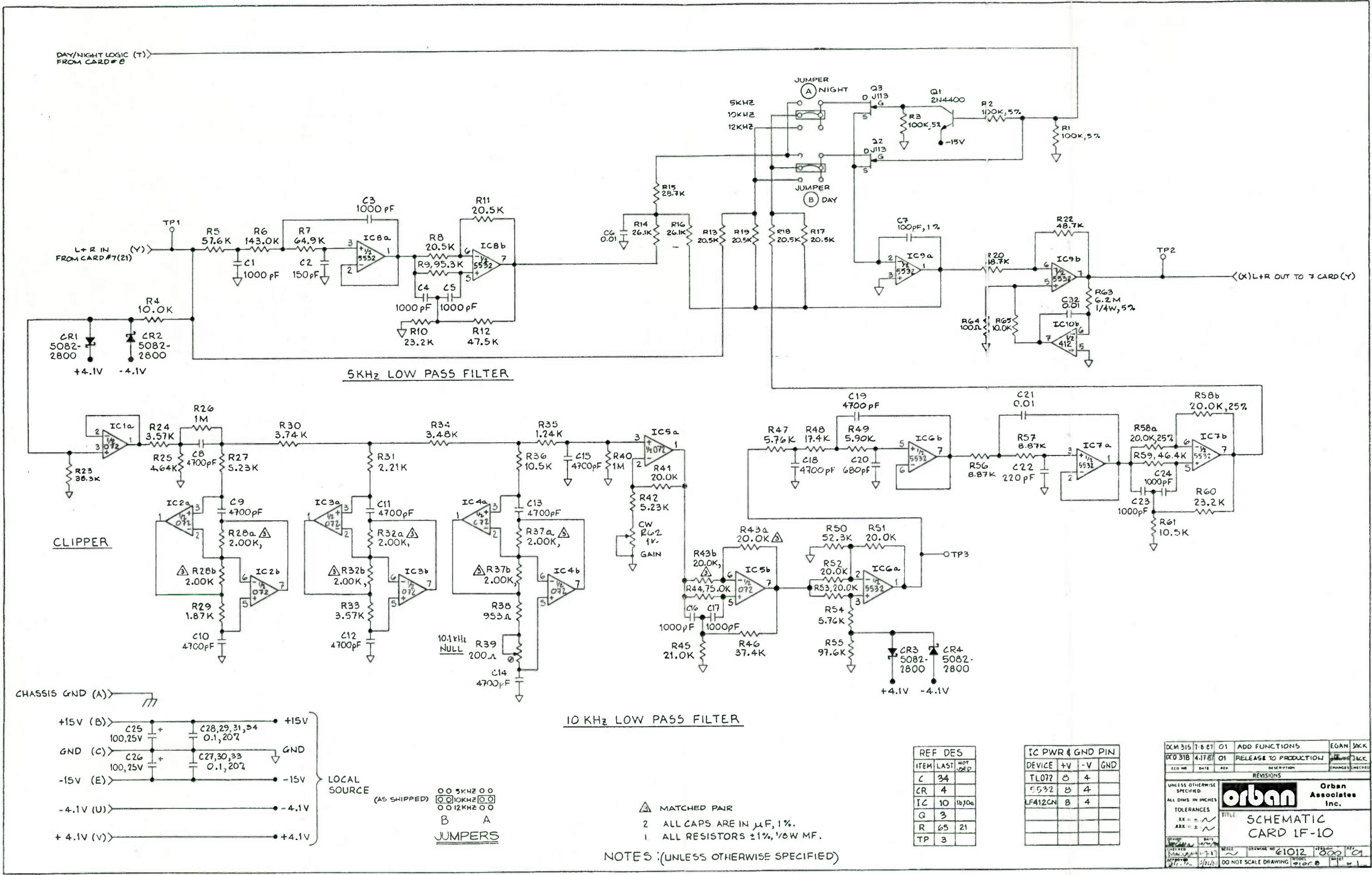

5KHz LOW PASS FILTER

CLIPPER

10 KHz LOW PASS FILTER

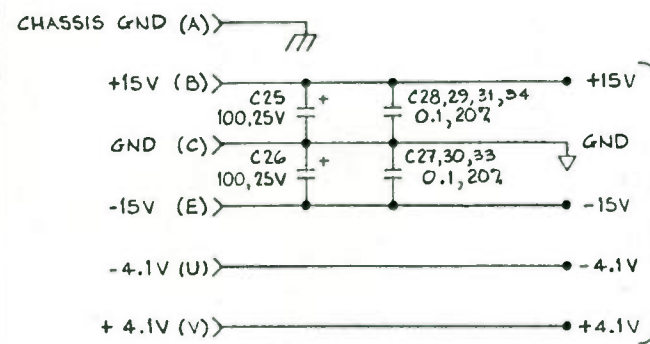

- △ MATCHED PAIR
- 2 ALL CAPS ARE IN μF, 1%.
- 1 ALL RESISTORS ±1%, 1/8W MF.

NOTES (UNLESS OTHERWISE SPECIFIED)

REF	DES
ITEM	LAST
C	34
CR	4
IC	10 1b30a
G	3
R	65 21
TP	3

IC PWR & GND PIN	DEVICE	+V	-V	GND
	TLO72	B	4	
	5532	B	4	
	LF412CN	B	4	

DCM 315	7-8-87	01	ADD FUNCTIONS	EGAN	WCK
DCD 318	4-17-87	01	RELEASE TO PRODUCTION	WCK	WCK
ECO NO	DATE	REV	DESCRIPTION	CHANGED	CHECKED
REVISIONS					
UNLESS OTHERWISE SPECIFIED					
ALL DIMS IN INCHES					
TOLERANCES					
XX = ±					
XXX = %					
TITLE: SCHEMATIC CARD LF-10					
SCALE	DRAWING NO	PROJECT NO	REV	DATE	BY
	61012	1800	1	11/87	WCK
DO NOT SCALE DRAWING					

