

Bulletin No. 36

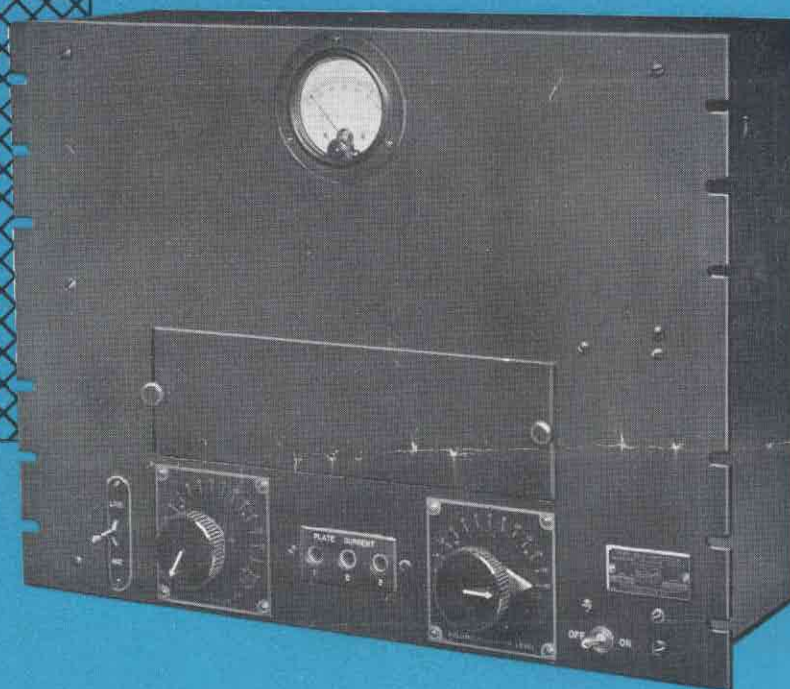

RCA Victor PROGRAM AMPLIFIER TYPE 40-C

a high quality, A. C. operated amplifier
with self-contained volume indicator

For use at the studios or
transmitter as a line amplifier



RCA Victor Company, Inc.
Camden, N. J., U. S. A.

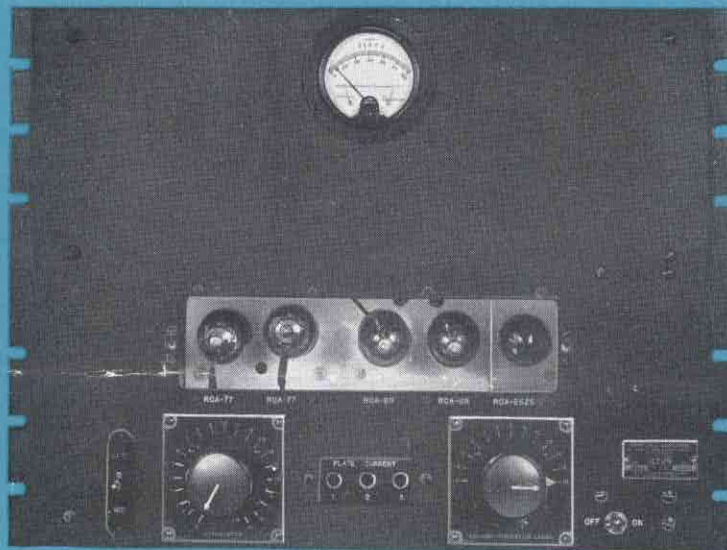

A Modern High Quality Amplifier

Modern broadcast practice requires simplified equipment, built to the highest standards. In order to provide a modern line amplifier useful in the control room or at remotely located transmitters, RCA Victor engineers have designed the type 40-C amplifier. This unit combines the functions of the usual line amplifier and volume indicator and makes it unnecessary to provide additional power supply equipment or batteries. Included as an integral part of the 40-C panel is a plate rectifier, which not only supplies the tubes in the amplifier, but which may also be used to furnish plate power for three of the type 41-B microphone pre-amplifiers. Since the tubes in the 40-C have heater type cathodes, a.c. can be used to excite the filaments. Hence the only power required is a 110 volt, 60 cycle a.c. line.

From a quality standpoint, the 40-C amplifier is the equal of any of the battery operated types. Its frequency characteristic is flat within 2 db. from 30 to 10,000 cycles. The hum level is at an inaudible point. And, perhaps most important, the price puts it within the reach of every station.

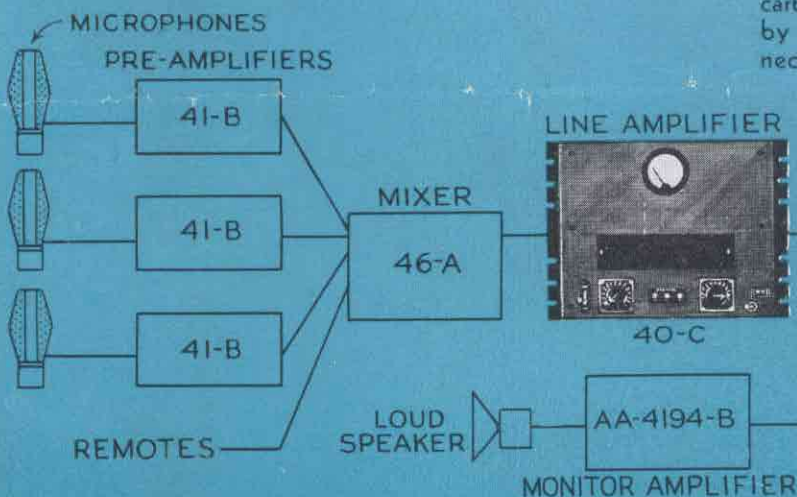

THE 40-C

Self-contained power supply and Volume Indicator

The 40-C amplifier is mounted on a standard speech input panel, 19" x 13 ¹¹/₁₆". A heavy metal dust cover is provided for the back. The front panel is without projections other than the knobs of the gain control and the volume indicator switch. The volume indicator meter is of the flush type. Tubes are mounted horizontally in a shielded chamber covered with a metal plate held in place by two thumbscrews.

Although the amplifier is compact, parts are easily accessible. Each transformer, condenser, or inductance is mounted in a metal case with the circuit diagram, part number, and electrical constants printed thereon. The input transformer is doubly shielded.

The total gain, 65 db., is equivalent to other standard RCA Victor line amplifiers, and it may be interchanged with the battery operated 12-B unit. The output level, plus 16 db., provides ample signal to feed a line or even to operate a loudspeaker.

The line input impedance and output impedance are both 500-ohms. An additional input has been provided for a carbon microphone, and microphone current will be supplied by the plate rectifier. This input may also be used in connection with any 250-ohm device.

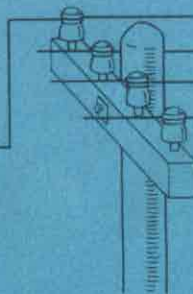

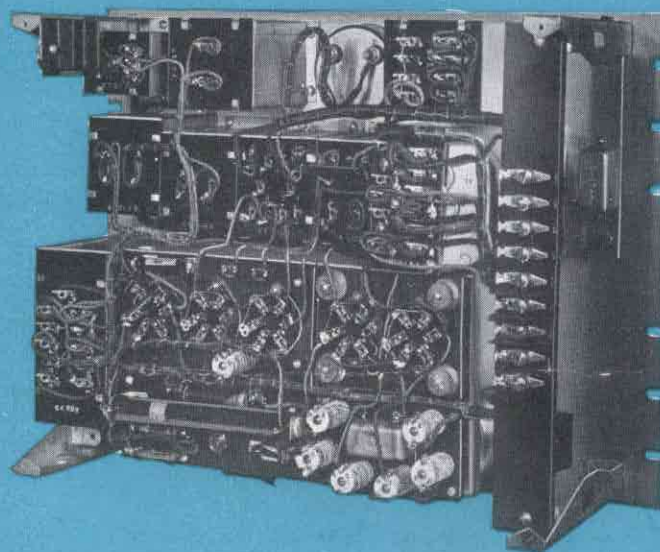

AMPLIFIER

New Type Tubes, Accessible Arrangement of Parts

The volume indicator is of the copper oxide type and is provided with a tap switch having an off position and taps from minus six to plus eighteen db. The meter is of the standard type calibrated at zero, minus one, two, and plus one and two decibels.

The gain control operates across the secondary of the input transformer and has twenty steps with an attenuation of 2 db. per step. It produces no change in the frequency characteristic.

Careful design of the circuit and shielding of the transformers has reduced the hum level to a very low value.

All parts as well as the back of the panel and inside of the dust cover are finished in opalescent gray lacquer, providing a stylish appearance as well as a durable finish.

An a.c. power switch is located on the front panel and breaks both sides of the a.c. line. Fuses are located within the amplifier to protect against possible shorting of the power supply.

An XT-1553 Isolating Transformer (which is to be located conveniently in the power supply to the amplifier) is required for operation of the amplifier from the a.c. supply circuit. One transformer is included with each equipment.

New Type High Efficiency Radiotrons

The 40-C Amplifier utilizes the latest type Radiotrons, resulting in higher amplification per stage, uniform frequency characteristics, and low hum level. An RCA-77 tube is used in the first and in the second stages, and two RCA-89 tubes in push-pull in the output stage.

The RCA-77, six-element tubes are connected as triodes. Because of the low plate impedance combined with high amplification, efficient operation is obtained without cut off of high frequency response. The RCA-89 tubes in the output stage permit an undistorted level of +16 db. to be secured.

The rectifier employs one 25-Z-5. Because of the use of this tube, no plate transformer is required and the chance of a.c. hum being introduced by magnetic coupling is further reduced.

Due to the use of heater type cathodes, the filament rheostat has been eliminated. The tubes will operate satisfactorily without adjustment of voltage within the normal limits of variation in line voltage. Jacks are provided for measuring all plate currents. A key switch on the panel changes the input from line to local microphone for emergency or local announcements.

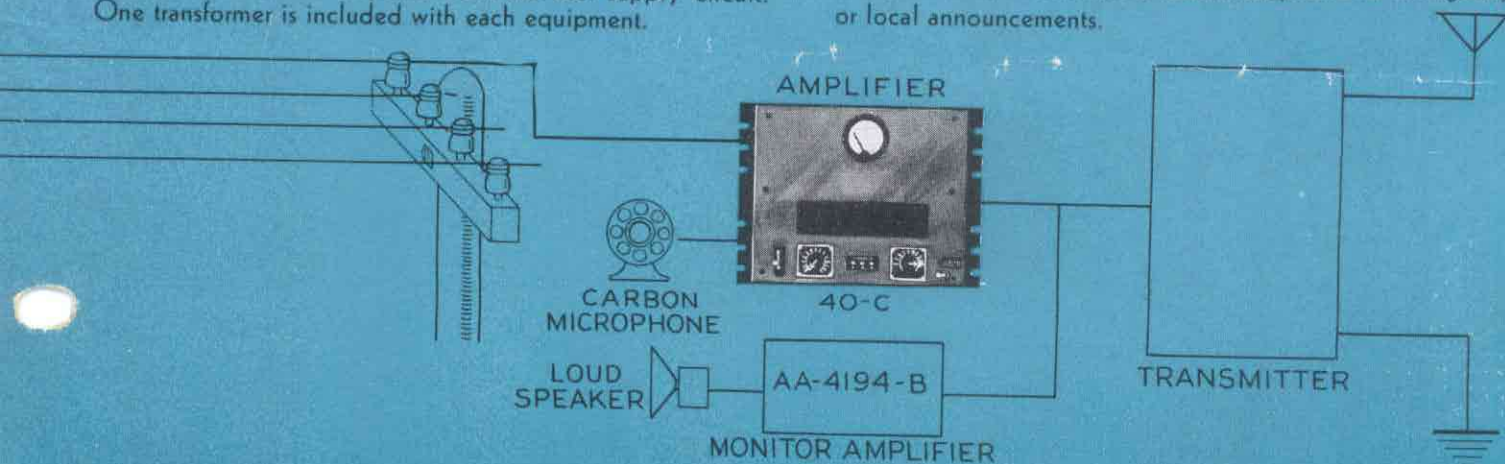

AN ALL PURPOSE AMPLIFIER

The 40-C amplifier is designed primarily to feed from a microphone or pre-amplifier into a telephone line or from a telephone line into a remotely located transmitter. In these instances it functions strictly as a line amplifier. At remotely located transmitters the 40-C is especially useful. Since it will furnish carbon microphone current, local announcements can be made by the operator. No extra mixer panels or batteries will be required. In addition it may be added to existing installations to furnish a spare amplifier or an extra channel. Since the gain is reasonably high, it may also be used as an audition amplifier to drive a loudspeaker from the output of a microphone amplifier, providing that not too high signal level is required from the speaker.

The 40-C amplifier requires no power supply equipment and hence may be added to existing installations without complications or difficulties. Its compact size permits installation, in many cases, without increasing the number of racks in the control room.

In new installations, the 40-C amplifier will provide the highest type of service without the necessity of power supply apparatus. Since the Volume Indicator has been included in the panel, rack space will be reduced still further. Every broadcasting station can use the 40-C amplifier to advantage in its control room.

FREQUENCY CHARACTERISTIC

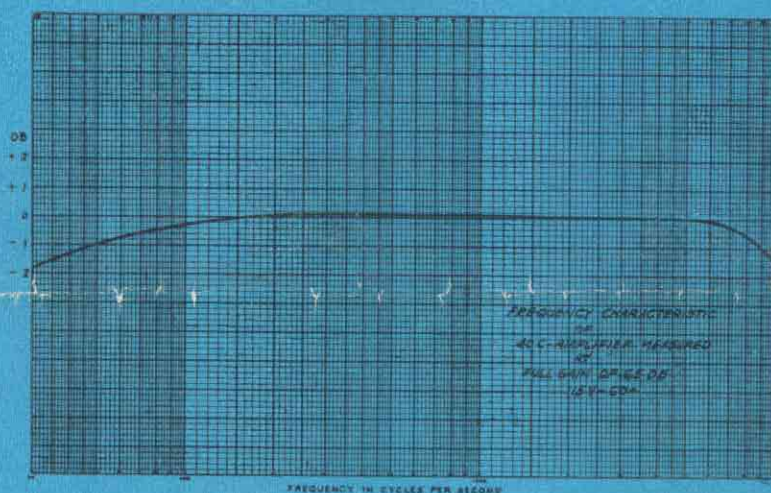

SPECIFICATIONS 40-C AMPLIFIER

DIMENSIONS: 19" x 6 $\frac{3}{4}$ " deep by 13 $\frac{11}{16}$ "— Mounts on Standard Rack.

POWER SUPPLY: 105-120 volts, 50-60 cycles, AC. Requires approximately 100 watts.

GAIN: 65 db. from 500-ohm input to 500-ohm output.

TERMINATION: 250 and 500-ohm inputs; 500-ohm output; 180-volt plate supply for pre-amplifiers and current supply, for one carbon microphone is provided.

FREQUENCY CHARACTERISTICS: Flat between 30 and 10,000 cycles. Within 2 db. from 500-ohm input to 500-ohm output.

OUTPUT LEVEL: +16 db. (12 $\frac{1}{2}$ milliwatt zero level).

TUBES: Two RCA-77—Two RCA-89—One RCA-25Z5.



RCA Victor Company, Inc.

CAMDEN, N. J., U. S. A.

153 East 24th Street
New York City, N. Y.

111 North Canal Street
Chicago, Ill.

Santa Fe Building
Dallas, Texas

235 Montgomery Street
San Francisco, Calif.

144 Walton Street, N. W.
Atlanta, Ga.



Form 8310 ia kij