

Broadcast Equipment

Instructions

BC-7A

**Stereo/Dual-Channel
Consolette**

MI-11657-A

EQUIPMENT LOST OR DAMAGED IN TRANSIT

When delivering the equipment to you, the truck driver or carrier's agent will present a receipt for your signature. Do not sign it until you have (a) inspected the containers for visible signs of damage and (b) counted the containers and compared with the amount shown on the shipping papers. If a shortage or if evidence of damage is noted, insist that notation to that effect be made on the shipping papers before you sign them.

Further, after receiving the equipment, unpack it and inspect thoroughly for concealed damage. If concealed damage is discovered, immediately

notify the carrier, confirming the notification in writing, and secure an inspection report. This item should be unpacked and inspected for damage WITHIN 15 DAYS after receipt. Report all shortages and damages to RCA, Commercial Electronic Systems Division - Camden, New Jersey 08102.

RCA will file all claims for loss and damage on this equipment so long as the inspection report is obtained. Disposition of the damaged item will be furnished by RCA.

FIELD ENGINEERING SERVICE

RCA Field Engineering Service is available at current rates. Requests for field engineering service may be addressed to your RCA Broadcast Field Representative or the RCA Service Company, Incorporated -

Broadcast Service Division - Camden, New Jersey 08102. Telephone 609-963-8000.

WARRANTY ITEMS

Particular parts and/or equipments covered by warranty are specifically stated as such in the warranty or contract given to the customer at the time of sale. The warranty or contract also stipulates the conditions under which the warranty may be exercised.

To obtain new replacement for such warranty items, contact your local RCA sales office and please supply Product Identification (including the Original Invoice Number, MI Number, Type Number, Model Number, and Serial Number) and Replacement Part Identification (including Stock Number and Description). Requests for warranty replacements may be unduly delayed if all this information is not supplied.

REPLACEMENT PARTS

When ordering replacement parts, please give Stock or Master Item (MI) Number, Description, and Symbol of each item ordered.

The part which will be supplied against an order for a replacement item may not be an exact duplicate of the original part. However, it will be a satisfactory replacement differing only in minor mechanical or electrical characteristics. Such differences will in no way impair

the operation of the equipment.

Emergency Service

For emergency services after working hours, contact RCA Parts and Accessories, Telephone 609-963-8000.

LOCATION	ORDERING INSTRUCTIONS
Continental United States, including Alaska and Hawaii	Replacement Parts bearing a STOCK NUMBER should be ordered from RCA Parts and Accessories- 2000 Clements Bridge Road - Deptford, New Jersey 08096. Replacement Parts bearing a MASTER ITEM (MI) NUMBER should be ordered from RCA, Commercial Electronic Systems Division - Attention Commercial Service - Camden, New Jersey 08102 or your nearest RCA Regional Office. Replacement Parts with NO STOCK or MASTER ITEM (MI) NUMBER are standard components. They are not stocked by RCA and should be obtained from your local electronics distributor.
Dominion of Canada	Order from your local RCA Sales Representative or his office or from: RCA Victor Company Limited, 1001 Lenoir Street, Montreal, Quebec.
Outside of Continental United States, Alaska, Hawaii, and the Dominion of Canada	Order from your local RCA Sales Representative or from: RCA International Division, Clark, New Jersey - U. S. A. - Wire: RADIOINTER Emergency: Cable RADIOPARTS, DEPTFORD, N. J.

RETURN OF ELECTRON TUBES

If for any reason it is desired to return tubes, please return them through your local RCA tube distributor, RCA Victor Company Limited, or RCA International Division, depending on your location.

Please do not return tubes directly to RCA without authorization and shipping instructions.

It is important that complete information regarding each tube (including type, serial number, hours of service and reason for its return) be given. When tubes are returned, they should be shipped to the address specified on the Return Authorization form. A copy of the Return Authorization and also a Service Report for each tube should be packed with the tubes.

LOCATION	ORDERING INSTRUCTIONS
Continental United States, including Alaska and Hawaii	Local RCA Tube Distributor.
Dominion of Canada	Order from your local RCA Sales Representative or his office or from: RCA Victor Company Limited, 1001 Lenoir Street, Montreal, Quebec.
Outside of Continental United States, Alaska, Hawaii, and the Dominion of Canada	Local RCA Tube Distributor or from: RCA International Division, Clark, New Jersey, U. S. A., Wire: RADIOINTER Emergency: Cable RADIOPARTS, DEPTFORD, N. J.

TECHNICAL DATA

Mixers

10 2 db per step 600-ohm attenuators. Includes dual section "synchronized" attenuators in positions 5 thru 8 and cue tap on mixers 5 thru 10 (cue tap on mixer 5 not factory connected to cue bus; tap may be jumped to cue bus in field if desired). Plug-in units provide choice of lo-level or hi-level, balanced or unbalanced input to any or all mixers.

Inputs

31 inputs available on switches to mixers. This includes 12 factory wired dual-channel stereo inputs to 4 dual-channel stereo mixers. Switch contacts are provided to wire companion right channel of any or all input switches. Any or all single-mixers can be directly replaced by stereo mixers. All mixer delegation switches are pre-wired for stereo-mixers. Three of the inputs are switchable to either mixer 9 or 10 for added flexibility. Four remote lines are switchable to program-cue, intercom or mixer 10. 4 auxiliary inputs available on switches to monitor amplifiers (2 for each monitor).

Amplifiers and Power Supply

(normally furnished for stereo operation)

- 6 plug-in transistor preamplifiers plus provision for 5 additional preamps (choice of either plug-in preamp, hi-level isolation unit, or jumper plug for all 10 mixers).
- 2 plug-in transistor program amplifiers.
- 2 plug-in transistor monitor amplifiers (consolette may be operated with only one monitor amplifier for mono.)
- 1 plug-in cue/intercom amplifier.
- 1 plug-in power supply.

Outputs

- 2 program lines (channels may feed either or both lines).
- 2 external monitor lines (one for each program channel).
- 10 speaker lines (each of 5 locations may monitor in stereo, each monitor line wired through on-air interlock muting relays).
- 1 program cue to 4 remotes.
- 5 intercom lines (4 wired thru on-air interlock relays, 1 spare).

Source Impedance

Microphones:

37.5/150/600 ohms

Net, Aux and Remote Lines:

600/150* ohms

Recorded Inputs (turntable, tape film)

600 ohms unbalanced (if jumper plug is used)

600/150* ohms (if plug-in isolation unit is used)

*Hi-level isolation unit has transformer tap for 150-ohm; input pad resistors can be easily replaced for 150-ohm operation.

Load Impedance

Line

600 ohms

Speaker

16 ohms*

*(Use external matching transformer for speaker of lower impedance.)

Headphone

High impedance

Output Levels

Program channel

+18 dbm (+8 vu) after 6 db isolation pad

Monitor amplifier

+40 dbm (10 watts; 2 watts to each of 5 speaker loads)

Program cue to remote

+18 dbm (+8 vu)

Program channel external monitor terminals

-6 dbm (-16 vu)

Input Levels

Microphone

Normal: -60 vu program level (-50 dbm continuous sine wave test input) to produce standard output (Note 1) of consolette, with normal operating position of mixer and master attenuators (Note 2).

Maximum: -32 vu program level (-22 dbm continuous sine wave test signal) maximum input to preamplifier.

Recorded Inputs (turntable, tape, etc.)

Normal: -20 vu program level (-10 dbm sine wave test signal) to produce standard output (Note 1) with normal operating position of mixer and master attenuators (Note 2).

Net, Aux. & Remote Lines

Normal: 0 vu program level (+10 dbm sine wave test signal) input to 20 db tap of tapped fixed attenuator. Input may be connected to taps at 0, 10, 20, 30, or 40 db to produce standard output (Note 1) with normal operating position of mixer and master attenuators (Note 2).

Auxiliary External Input to Monitor Amplifier

Normal: -20 vu (-10 dbm) for same operating position of the monitor gain control as used for monitoring program line.

TECHNICAL DATA (Continued)

Gain

Microphone input to program line
106 db
(preamp can be strapped to increase total maximum gain to 112 db)

Recorded Inputs (turntable, tape, etc.) to program line
max 66 db

Network, Auxiliary and Remote lines to program lines
max 66 db

Microphone input to speaker line
max 127 db (with 40 db preamp strapping)
max 133 db (with 46 db preamp strapping)

Auxiliary external-input-to-monitor to speaker line
max 57 db

Signal-to-Noise Ratio

Microphone to Program Line

Normal operating position of operating controls
(Note 2)
(68 db gain; +18 dbm output) 68 db

Notes

1. Standard Output Level is +8 vu program level (+18 dbm steady state sine wave test signal). (Consolette VU meters read "0" on VU scale [100%] for +8 vu output of consolette with program material, and will be pinned for +18 dbm output—this is standard practice and in no way damages meter during test.)
2. Normal operating position of Mixer and Master attenuators is "13" for mixer (14 db reserve gain) and "8" for master (24 db reserve gain): a total of 38 db reserve gain.

Frequency Response

program channels ± 1.5 db 30 to 15,000 cps;
monitor channels ± 2 db 30 to 15,000 cps

Distortion

Program Channel:
less than .5% 50-15,000 cps
less than .75% 30 cps

Monitor Amplifier:
less than 1% 50-15,000 cps

Dimensions

39 $\frac{1}{4}$ " wide, 12 $\frac{1}{2}$ " high, 20" deep.

Weight

MI-11657 Consolette housing (less all plug-in units)	100 lbs
ES-11157-AS Consolette with normal complement of plug-in units for stereo programming.	160 lbs
ES-11157-A Consolette with normal complement of plug-in units for monaural programming.	145 lbs

Finish

Main control panel—anodized brushed aluminum
Housing—shadow blue textured vinyl.

Power Required

115 or 230v 50-60 cps	Normal: 55-65 watts Maximum: Approx. 120 watts Stand by: 55 watts
-----------------------	---

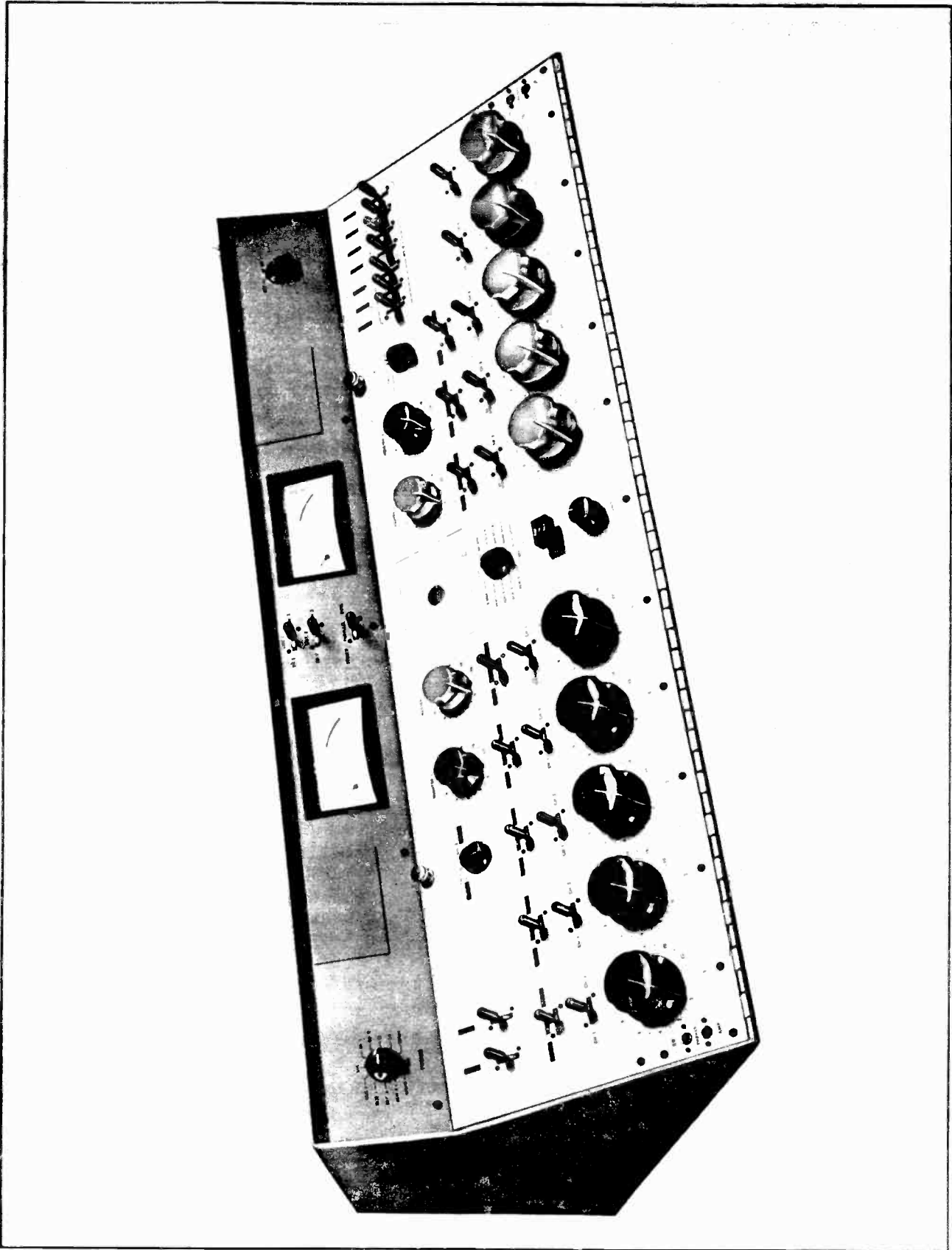

Figure 1. Type BC-7A Stereo/Dual Channel Consolette MI-11657-A

DESCRIPTION

Introductory Description

The BC-7A Stereo/Dual-Channel Console is a self-contained, audio system of broadcast quality, for stereo or monaural programming. It was designed primarily for radio and TV studio use, but its features are such that it may be found well adapted to more varied uses, wherever a high quality sound control console is needed. It has mixing, switching, and monitoring facilities, plus cue and intercom provisions which employ an independent amplifier with automatic gain control. It uses low impedance mixing circuits and dependable plug-in transistor amplifiers and power supply.

The console normally accommodates inputs from microphones, turntables, magnetic tape and remote lines. Its control circuits provide facilities for operating warning light relays, muting studio monitor and intercom speakers, and automatically starting recorded-input equipment such as turntables, tape reel and cartridge equipment, projectors, etc.

The console basically provides two independent high gain program amplifier channels, each receiving a signal from a separate input mixer bus. Each program amplifier has an associated master gain control, VU meter and line pad and is capable of producing line level output. Two program output lines are provided. Each output line has a three-position selector switch to provide selection of signal from either the left or right program amplifier and a center off position to terminate the line.

Ten variable attenuators (mixers or faders) provide facilities for simultaneous mixing of up to ten input channels. Above the mixer knobs are *source selector* lever switches with *colored* handles and *mixer delegation* lever switches with *black* handles. Switches associated with individual mixers are located immediately above the particular mixer with which they are associated. The "black" mixer delegation switches provide assignment of the output of each mixer to either the left channel mixer bus or the right channel mixer bus.

Within the console a receptacle is provided for each mixer to accept various plug-in units:

- (1) A preamplifier for use with microphone sources,
 - (2) A high-level isolation unit with strap adjustable pad for line level sources,
 - (3) A jumper plug for direct input to the mixer.
- Flexibility is thus achieved such that any or all mixers can accommodate a wide variety of sources.

Facilities are provided for two independent monitor amplifiers, each with a 2 db per step attenuator and a 4 position input selector switch by means of which each monitor may be connected to the left or right program amplifier or auxiliary sources. For stereo operation, the two monitor gain controls are electrically ganged together for simultaneous balanced control from a single knob. For monaural operation, the second monitor amplifier may be used for audition or to "preview" the signal or may be omitted or added later if desired. The combination of units selected is dependent upon individual requirements.

A combination microphone/loudspeaker is located in the center of the main control panel. A guide/receptacle assembly, located behind the panel on the lower deck, accepts a separate amplifier with AGC for two-way communication with studio intercom stations (MI-11452) and communication with remote lines. A 12-position selector switch on the main control panel provides positions to use the intercom amplifier to monitor the mixer cue-bus and network line, independent of other monitor facilities, as well as serve the intercom function.

A mode selector switch is provided to set up the console for Stereo-Programming or Dual-Channel Monaural-Programming with two independent channels. With the Mode switch in the Stereo position the left and right channel, master gain controls are electrically ganged for simultaneous control from a single knob. Similarly, the left and right channel monitor controls are connected for simultaneous balanced control from a single knob. A third position of the mode selector switch (labeled PARALLEL) ties the two program amplifiers together after the master gain controls. Thus each master becomes a submaster for deluxe monaural operation.

Flexibility and simplicity are outstanding features of the BC-7A console. Interchangeable plug-in units and liberal use of jumper terminals provide a wide choice of inputs for each mixer position, and easy access to key parts of the circuit. Functional grouping and color coding of controls, and particular attention to labeling, create an uncluttered panel and minimize operator error. Permanent panel designations are etched in black whereas controls with designations which are most dependent on individual needs are provided with uniform panel depressions provided to accept a wide assortment of pressure sensitive metal labels supplied with each unit. The labels give a neat, permanent appearance to the console yet provide concise accurate descriptive labeling which can be changed when necessary.

Detailed Description

Refer to the fold-out sheet at the back of this book immediately preceding the schematic diagram. When this sheet is folded out, the functional diagram (figure 25) and a view of the control panels, in which all controls are identified (figure 24) extend beyond the other pages of this book for reference while reading the explanations throughout this book.

Mixers, Selector and Delegation Switches

There are ten attenuators (often referred to as mixers or faders) arranged across the lower portion of the control panel in two groups of five equally spaced knobs. In a typical installation the left group of five mixers (1, 2, 3, 4 and 5) with black knobs may normally be used for microphone inputs. The three mixers to the right (mixers 6, 7 and 8) with blue knobs may normally be used for recorded inputs (turntable, tape, etc.). Mixer 9, with the green knob, would ordinarily be used for NETWORK and auxiliary inputs and mixer 10, with the red knob, would be used for remote inputs.

Above the mixer attenuator knobs are SOURCE SELECTOR SWITCHES, distinguished by *colored* handles, and MIXER DELEGATION SWITCHES, all of which have *black* handles. All source selector switches and mixer delegation switches are located immediately above the mixers with which they are associated, to minimize operator error.

The output of each mixer may be delegated to the left channel mixer bus (program amplifier 1) by throwing its black MIXER DELEGATION SWITCH to the left, or it may be delegated to the right channel mixer bus (program amplifier 2) by throwing the switch to the right. The center position is the off position.

Note that the left position of the mixer delegation switches located above mixers 5, 6, 7 and 8 (S-25, S-26, S-27 and S-28) has the designation STEREO in addition to the normal designation CH-1. This indicates that when the console is set up for stereo operation (see discussion under MODE switch, p. 8) and one of these mixer delegation switches is in the

CH-1 STEREO position, the output of the left channel section of the mixer is delegated to the left channel mixer bus and the output of the right channel section of the mixer is simultaneously delegated to the right channel mixer bus. The right position of these switches is not used for stereo operation. As may be seen on the audio functional diagram the right chan-

nel section of the dual section stereo mixer is terminated when the corresponding mixer delegation switch is in the CH-2 position.

The source selector switches for mixer 1 through 8 provide selection of 3 pre-wired sources to each mixer. In a typical installation, throwing mixer 1 source selector switch (S-1) to the left position (normally labeled studio A) would connect microphone number 1 of studio A to mixer 1 through its plug-in pre-amplifier. In a similar manner, microphones 2, 3, 4 and 5 of studio A could be connected to corresponding mixers 2, 3, 4 and 5 by throwing source selector switches S-2, S-3, S-4 and S-5 to the left position. The left position of each of the 5 source selector switches would thus be labeled studio A. The center position of source selector switches S-1, S-2, S-3 and S-4 would normally be labeled studio B and throwing these 4 switches to the center position would connect the 4 microphones in studio B to the corresponding mixers. In a similar manner the right hand position of these switches could be used for 4 microphones in studio C. The center position of mixer 5 source selector switch (S-5) would ordinarily be used for the announce booth microphone and the right hand position would normally be used for the control room microphone. Source selector switches S-1, S-2, S-3 and S-4 all have blue handles. Source selector switches S-5, S-6, S-7 and S-8 all have red handles. *The red handles (same color as mode switch handle) indicate that the mixers below these switches all have double section stereo attenuators.* The mixer 5 position is unique, in that it normally has two preamplifiers arranged such that for stereo programming, the input selected supplies equal signal to both left channel and right channel sections of the attenuator for balanced override of both channels, without upsetting the stereo relation of any stereo program material coming in on other mixers.

The three source selector switches with red handles, above mixers 6, 7 and 8 (S-6, S-7 and S-8) to the right of the center of the panel, are normally used for turntables, reel tape, cartridge tape, or projector inputs. Here again, *the red handles indicate dual section stereo attenuators,* which for stereo programming simultaneously adjust the level of both right and left channels. For monaural programming the right channel section of each stereo attenuator is terminated.

For additional flexibility, three inputs are provided with switching facilities for optional assignment to either mixer 9 or mixer 10. Above mixer 9 is a group of three vertical travel switches with green handles. Each switch controls the delegation of a single source. For example, throwing the left hand green handle

(switch S-9), normally labeled NET, to the up position (labeled MIX 9) connects the network line to mixer 9. The center position is an off position. Throwing the handle to the down position (labeled MIX 10) puts the network on mixer 10. The two adjacent switches with green handles to the right (S-10 and S-11) may normally be labeled AUX-1 and AUX-2 and are used for similar flexible input to either mixer 9 or mixer 10.

Above mixer 10 is a group of 4 vertical travel, three-position, lever switches with blue handles (S-12, S-13, S-14 and S-15). These switches are normally labeled REMOTE 1, REMOTE 2, REMOTE 3 and REMOTE 4. Throwing a remote switch to the up position (labeled PGM-CUE) sends program cue to that remote location. The cue signal is obtained from the output of monitor amplifier 1 and fed through a suitable attenuator, through the remote line, to the operator at the remote location. (If desired, monitor amplifier 2 can be used for the PGM-CUE feed instead of monitor amplifier 1 by changing the position of the jumper wires on TB-2, terminals 1/2, 7/8, and 13/14.) Throwing the switch to the down position (labeled MIX-10) connects the remote line to mixer 10. In the center position (labeled T.B. for talk back) the remote line is available for two-way communication between the console and the remote location using the cue/intercom amplifier.

Under typical operating conditions two-way communication between personnel in the control room and personnel at the remote location, necessary for setup of the remote pickup, can be carried on with the remote switch in the center position. Just before air time the remote switch can be thrown up to give the remote personnel *cue* from the on air program. Then at the desired time the remote can be cut in by throwing the remote switch down, connecting it to mixer 10 which has been preset at the desired gain.

Cue/Intercom

The CUE/INTERCOM selector switch (S-61) is located in the center of the main control panel. It is a 12-position rotary switch and is associated with the combination microphone/loudspeaker immediately above the selector switch, and the PUSH-TO-TALK switch (S-62) and GAIN control (AT-31) below the selector switch.

The four positions to the left of center, labeled REM 1, REM 2, REM 3 and REM 4 permit two-way communication with any one of the remote lines (provided they are not connected to mixer 10 or the program cue line). In the override position all remote lines can be monitored simultaneously.

The four positions to the right of center, labeled AN BTH, STU A, STU B and STU C are for two-way communication with individual announce booth and studio intercom stations. A spare position is also provided. The outgoing line from the spare intercom position is not wired through interlock muting relays.

The top position of the CUE/INTERCOM selector switch, labeled CUE, is used to monitor the mixer cue bus and the bottom position, labeled NET, is used to monitor the network line.

The plug-in cue/intercom amplifier employs AGC to maintain the output level of the amplifier essentially independent of input level over about a 25db range; therefore, the control below the PUSH-TO-TALK switch, labeled GAIN, since it follows the amplifier, could more accurately be described as an "output level control." It enables the console operator to establish, essentially independent of input, the level at which he wishes to listen to intercom stations and remote lines, as well as cue up records, tape and network.

Monitors

In addition to the CUE/INTERCOM amplifier, facilities are provided for two monitor amplifiers. For stereo operation monitor amplifier 1 is used to monitor the left channel (Channel-1) mixer bus and monitor amplifier 2 is used to monitor the right channel (Channel-2) mixer bus. For monaural operation, monitor amplifier 1 can be used to monitor the program bus and monitor 2 can be used to monitor the audition bus or "preview" the signal. The left monitor amplifier MON AMP-1 and its controls are located on the left side of the console as viewed from the operating position, and the right monitor amplifier MON AMP-2 and its controls are located on the right side of the console.

Immediately to the left of the intercom-grill is a red control knob labeled Master-1 (AT-21), which controls the gain of the left channel program amplifier (PGM AMP-1) for monaural operation and controls the gain of *both* program amplifiers for stereo operation (as determined by the MODE SWITCH S-43, see p. 8). Immediately to the right of the intercom-grill is a red control knob labeled Master-2 (AT-22) which controls the gain of the right channel program amplifier 2 for monaural operation, and is disconnected from the circuit for stereo operation. For dual channel monaural operation program amplifier 1 may be used for a *program* channel and program amplifier 2 may be used for *audition*. Both master gain controls are 20 step, 2 db per step, 40 db total

attenuators. The omission of an off position for these controls is an operating aid to prevent a completely dead program if the control is accidentally turned or left in the extreme counterclockwise position.

The attenuator with the green knob (labeled MON-1) to the left of the intercom grill is a *dual* section, 2 db per step attenuator (AT-11), which controls the gain of *only* monitor amplifier 1 for monaural operation and the gain of *both* monitor amplifiers for stereo operation. The attenuator with the green knob (labeled MON-2) to the right of the intercom grill is a *single* section 2 db per step attenuator (AT-12) which controls the gain of monitor amplifier 2 for monaural operation, and is disconnected from the circuit for stereo operation.

Immediately adjacent to each monitor amplifier gain control is located a four-position rotary monitor-input-selector switch. Each switch provides selection of Channel-1 (left channel), Channel-2 (right channel) and two auxiliary inputs. The auxiliary inputs are brought to the main terminal block (TB-2 45/46; 39/40; 33/34; 27/28) so that external sources can be monitored as desired. Thus a total of four auxiliary monitor inputs are available.

An input level of -20vu at the auxiliary input terminals of the monitor input selector switch will allow the same operating position of the monitor gain control as used for monitoring of the outgoing lines.

Auxiliary Switches

The two vertical-travel three-position lever switches in the upper left section of the main control panel are unwired auxiliary switches. The switch contacts provided are two form D contacts (make before break) each side of center position. These switches are provided for any special needs of individual stations.

Line Out Switches

In the center of the top panel are two lever switches with black handles. The top switch is labeled LINE 1 and the switch below it is labeled LINE 2. These are the selector switches for the two outgoing program lines from the console. Throwing LINE 1 switch (S-41) to the left position (labeled CH-1) connects outgoing line 1 to the output of the left channel program amplifier (pgm amp-1) through a 6 db isolation pad. Similarly, throwing it to the right position (labeled CH-2) connects it to the right channel program amplifier (pgm amp-2). The center position is an off position which terminates the outgoing line and back-loads the 6 db isolation/dividing network. LINE 2 switch (S-42) operates in a similar manner. Normally, for stereo operation Line 1 would be used for

the left channel signal by throwing S-41 to the left position (labeled CH-1) and Line 2 would be used for the right channel signal by throwing S-42 to the right position (labeled CH-2).

Mode Switch

The lever switch with the red handle located in the center of the upper panel is a MODE selector switch (S-43). Throwing the MODE switch to the left position, labeled STEREO, sets up the console for stereo operation; channel 1 is assigned to the left channel and channel 2 is assigned to the right channel. The right channel half of stereo mixers 5, 6, 7 and 8 are connected to the corresponding source selector switches and the channel 1 and channel 2 master gain controls are electrically ganged so that both program amplifier channel gains are equal and are controlled by the Master-1 gain control. In a like manner the channel 1 and channel 2 monitor gain controls are ganged and are both controlled by the MON 1 gain control.

When the MODE switch is in the center position labeled PARALLEL the two program amplifiers are internally connected in parallel after the gain control, thus effectively making master gain control 1, submaster 1 and master gain control 2, submaster 2. Throwing the mode selector switch to the right position labeled DUAL provides two independent channels, thus dual channel operation.

Monitor Phones

The 12-position rotary switch on the extreme left of the top panel (S-63) is a monitor phones selector switch which provides a roving monitor-phones facility to monitor key points throughout the console independent of all other amplifiers. Remote lines 1, 2, 3 and 4; channels 1 and 2; lines 1 and 2; cue bus; and network line are available, together with two spare positions. The monitor phones *jack* for this switch is located at the lower left corner of the main front panel. It is the top jack (J-3) labeled SW (for switch) of the pair of jacks labeled PHONES. The bottom jack of this pair (J-4) labeled AMP (for amplifier) connects to the CUE/INTERCOM amplifier. Normal-through contacts are provided so that inserting a phone plug lifts off the loudspeaker of the cue/intercom and substitutes the monitor phones ahead of the control room intercom speaker muting relay. The combination microphone/speaker still functions as a microphone for intercom use when the phone plug is inserted. The pair of phone jacks located at the lower right corner of the main front panel provide direct monitoring of the two outgoing lines L-1 (J-1) and L-2 (J-2).

REMOTE 3 0
 REMOTE 4 0
 NET
 STUDIO C
 STUDIO B
 STUDIO A
 STUDIO
 OTHER

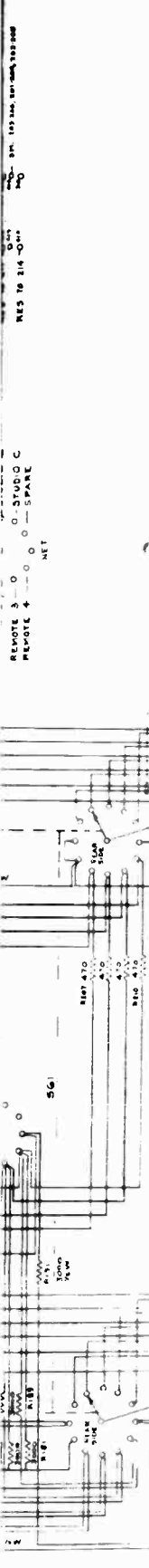

5G2
 PUSH TO TALK
 WIRING GUIDE
 0.1
 0.2
 0.3
 0.4
 0.5
 0.6
 0.7
 0.8
 0.9
 1.0

CONTACT TERMS
 0.1
 0.2
 0.3
 0.4
 0.5
 0.6
 0.7
 0.8
 0.9
 1.0

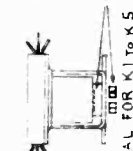

TYPICAL FOR K1 TO K5
 ALL RELAY CONTACTS SHOWN
 IN DE-ENERGIZED POSITION

ALL SWITCH (RELAY) JUMPERS .020 DIA WIRE
 ALL SWITCH CONTACT JUMPERS .032 DIA WIRE
 USE INSULATED TUBING WHERE NECESSARY

ALL RESISTOR VALUES IN OHMS
 1/4W UNLESS OTHERWISE NOTED

5G2
 PUSH TO TALK

K1

AT31

AT32

1131

1132

1133

1134

1135

1136

1137

1138

1139

1140

1141

1142

1143

1144

1145

1146

1147

1148

1149

1150

1151

1152

1153

1154

1155

1156

1157

1158

1159

1160

1161

1162

1163

1164

1165

1166

1167

1168

1169

1170

1171

1172

1173

1174

1175

1176

1177

1178

1179

1180

1181

1182

1183

1184

1185

1186

1187

1188

1189

1190

1191

1192

1193

1194

1195

1196

1197

1198

1199

1200

JOINT WORK AGREEMENT

JOINT POLE CATEGORY ↓ CE IBT I II III 2 IV REMOVALS I II III 2 IV	UG PLANT IN AREA - NUMBER TO CALL		AGREEMENT NO 467651	
	YES	NO	FOR LOCATING UNDERGROUND	FOR CONSTRUCTION
	CE	X		
	IBT			
GAS			DATE ISSUED 7-10-81	SHEET 1 OF 1 SHEETS
REASON FOR WORK Bored Poles + IBT Illegal Attach.			DATE REQUIRED <input checked="" type="checkbox"/> TRENCH 10/26/81 <input checked="" type="checkbox"/> POLES	CANCEL AGREEMENT DATED
DISTRICT MNR		TOWNSHIP ADIRCOCK	MUNICIPALITY DUF	
WIRE CENTER		GEO-LOCATION	ORDER NO	RELATED AGREEMENT NUMBERS
RESP CODE ORIGINATING		RESP CODE CHARGED		PRIMARY VOLTAGE 7.2KV
IBT ENGINEER		TELEPHONE NO		CE ENGINEER N.J. LSON
				PL NO 33-232-K
				SECTION 232
				BLK NO
				AREA/DIST 31260
				WO/LO FUNCT NO
				TELEPHONE NO 247-3217 EXT 294

STREET OR LEAD CODE	POLE NUMBER		WORK DESCRIPTION REMARKS	LOCATION	OVERTIME	POLE DETAIL			YR SET	IBT OWN	REIN (1)	CONT (2)	TAX DIST CODE	JT CO CODE	AMOUNT DUE		
	CE CO	IBT CO				LENGTH & CLASS	IBT CO	CE CO							IBT CO	CE CO	IBT CO
	F/S	D															
	1		CE POLE	4		30	B	40							\$	\$	
			CE SELL 1/2 DEP														
			ATTCH DATE - 1961														
			IBT Rem - NB			35	A	40									
			CE TRFR - IBT EXP														
	2		CE POLE	3		30	B	40									
			CE SELL 1/2 DEP														
			ATTCH DATE - 1961														
			IBT Rem - NB			30	B	40									
			CE TRFR - IBT EXP														
	3		CE POLE	1		30	B	47									
			CE SELL 1/2 DEP														
			ATTCH DATE - 1961														
	4		CE POLE	0		30	B	40									
			CE SELL 1/2 DEP														
			ATTCH DATE - 1961														

IBT WORK		YES	NO	(1) REINFORCEMENTS 1 SP 2 SSP 1 SSC	TOTAL	\$	\$
CONTACT F ATTACH RIGHTS				(2) CONTACT F ATTACH RIGHTS	LESS	\$	\$
FOREIGN ATTACHMENTS (OWNER)		IBT WORK COMPLETED (DATE)		CE WORK COMPLETED (DATE)	NET BILL	\$	\$

THE PARTIES AGREE THAT THIS WORK IS IN ACCORDANCE WITH THEIR CURRENT GENERAL AGREEMENT AND THAT THE MATERIAL USED SHALL REMAIN PERSONAL PROPERTY.

<input type="checkbox"/> ACCEPTED <input type="checkbox"/> REJECTED <input type="checkbox"/> ACCEPTED AS REVISED	<input type="checkbox"/> ACCEPTED <input type="checkbox"/> REJECTED <input type="checkbox"/> ACCEPTED AS REVISED
--	--

DISTRICT ENGINEERING MANAGER
ILLINOIS BELL TELEPHONE COMPANY

DATE

FOR DIVISION ENGINEER
COMMONWEALTH EDISON COMPANY

9-15-81

DATE

Tip-ring-sleeve jacks are used for all four jacks. The sleeves are left floating with no connection to the sleeve terminal. Either tip-ring-sleeve or tip-sleeve plugs may be used in any of the four jacks since the ring contact of the jack contacts the sleeve of tip-sleeve plugs. This arrangement permits the use of stereo headphones with a *double* tip-ring-sleeve phone plug to simultaneously plug into J-1 and J-2 jacks at the right of the console for stereo monitoring of the two balanced outgoing lines, L1 and L2.

The phone jacks are spaced on 11/16 inch centers which is correct for double tip-ring-sleeve plugs (ADC PJ-6 or WE-213). They purposely do not readily accept double tip-sleeve plugs (with sleeve connection *common* to both sleeves) which are spaced on 5/8" centers.

Meters

Two VU meters are located in the top panel of the console, one on each side of the group of switches in the center of the panel. The meter on the left monitors the output of program amplifier 1, thus for

stereo operation, the left channel program output of the console. Correspondingly the meter on the right monitors the output of program amplifier 2, which for stereo operation is the right channel program output of the console. The circuits are designed so that the reference level on the VU meters is +8vu. Thus when the program level on the console line out terminals (2-117/118 and 2-111/112) is +8vu, the VU meters will read 100% (0 vu).

The two cover plates each side of the VU meters can be removed to provide mounting holes for two smaller VU meters which may be installed and connected to read gain reduction of AGC amplifiers or indicate similar information.

Power Switch

The main power switch is located on the top control panel on the right side. It is a double pole single throw switch and controls AC power to the power supply, monitor amplifiers, and cue/intercom amplifier. It also controls power to a pair of terminals (TB-7 4/5) to supply switched power to one or more auxiliary consoles.

For convenient reference, the following six pages contain data on each type of plug-in unit used in the console. Each page has an identifying photograph; a simplified schematic showing transformer taps, plug and receptacle connections, and terminal assignment; and a summary of technical specifications. For detailed information, please refer to the individual instruction books.

TECHNICAL DATA — BA-71 SERIES* PREAMPLIFIER

Gain

40 ± 1 db (may be strapped for 46 db)

Rated Output

+ 18 dbm

Response

+0-1.5 db, 30 to 20,000 cps

Distortion

Less than 0.25% @ + 18 dbm @ 1 kc
 Less than 0.5%, 30-20,000 cps @ + 18 dbm

Source Impedance

150/600 ohms balanced or unbalanced
 37.5 ohms unbalanced

Load Impedance

150/600 ohms

Input Impedance

Unloaded input transformer: about 1200 ohms @ 50 cps
 @ 150 ohm input

Noise

-82 dbm at output 50-15,000 cps
 -122 dbm referred to input 50-15,000 cps

Maximum Input

-22 dbm

Power Required

30 volts, 45 ma drain from BX-71A

* BA-71C or later

Ambient Temperature

131°F (55°C) max.

Overall Dimensions

7 7/8" length x 4 3/8" high x 1 3/8" width

Weight

2 1/4 pounds

Finish

Cadmium plate with clear chromate dip

Transistor Complement (Supplied in Place)

Q1 — 2N2270 or 2N3391A

Q2 — 2N404

Q3 and Q4 — 2N2270

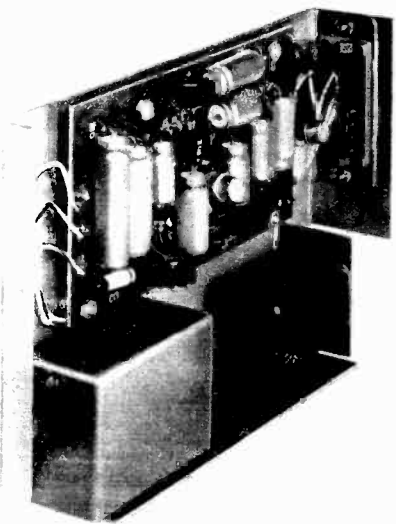
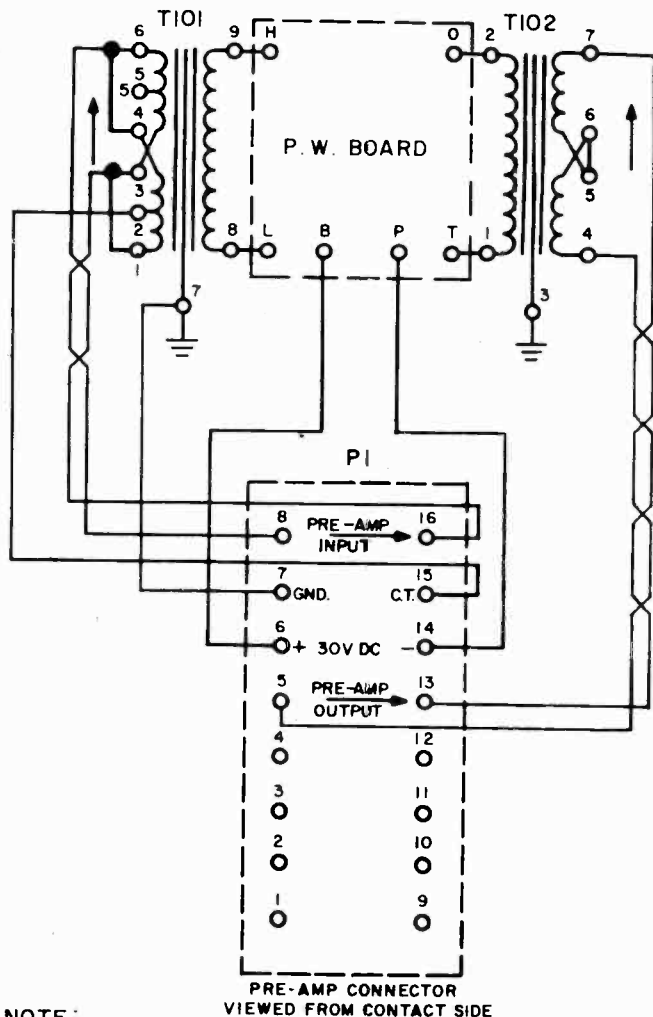

Figure 2. Type BA-71 Series Preamplifier



NOTE:
 T101 CONNECTIONS SHOWN FOR 150-OHM INPUT AND
 T102 CONNECTIONS SHOWN FOR 600-OHM OUTPUT.

Figure 3. Type BA-71 Series Preamplifier, Connection Diagram

TECHNICAL DATA — HIGH LEVEL ISOLATION UNIT

Source Impedance

600 ohms (transformer also has tap for 150 ohm source)

Input Impedance

600 ohms (transformer also has tap for 150 ohm source)

Maximum Input Level

0 dbm input to transformer
 +25 dbm input to attenuator

Minimum Insertion Loss

Not more than 0.75 dbm

Nominal Attenuation

0-60 db in 10 db steps

Frequency Response

+0-1 db, 20-20,000 cps
 Distortion 0.5% maximum, 30-15,000 cps

Shielding

Electrostatic shield connected to core and case
 Hum-bucking construction—
 Maximum induced voltage .005 volts on secondary in
 10 gauss, 60 cps field (primary and secondary loaded)

Overall Dimensions

7³/₈ length x 4⁵/₈ x 1¹/₈ width

Finish

Cadmium plate with clear chromate dip

Weight

1¹/₂ pounds

Accessories (Not Supplied)

Guide assembly, including hardware and connector, for
 mounting in BR-22B Shelf — MI-11759-1

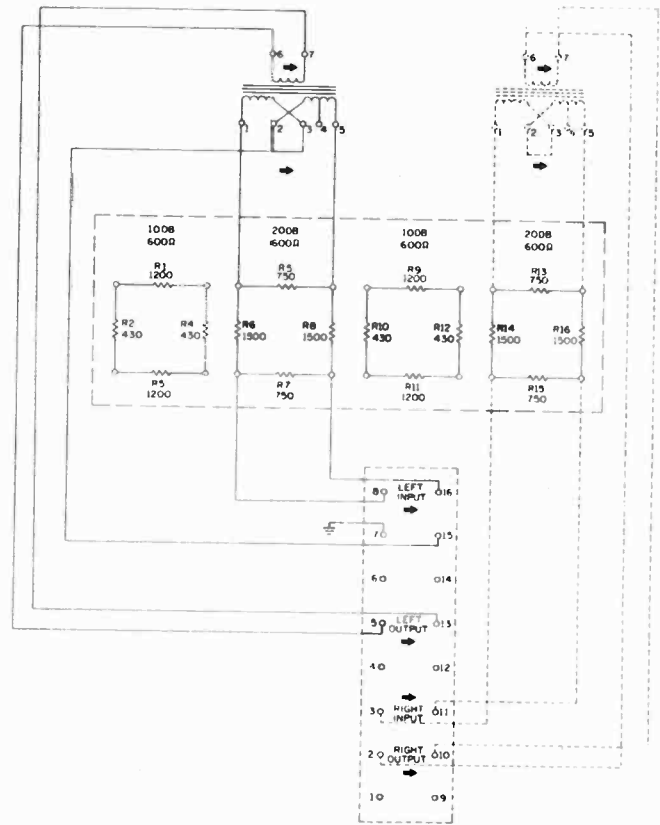

Figure 5. Hi-Level Isolation Unit, Connection Diagram

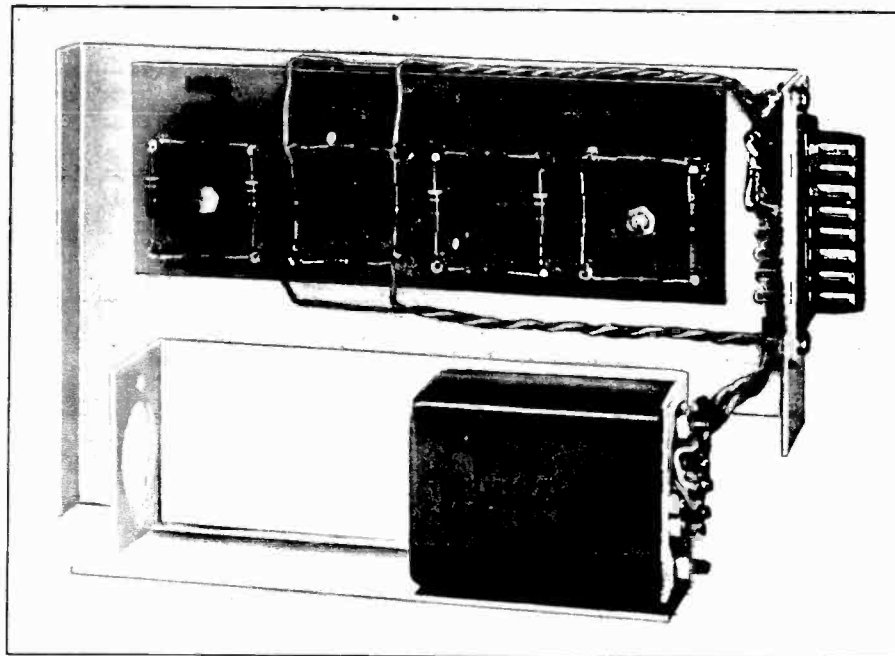

Figure 4. Hi-Level Isolation Unit

TECHNICAL DATA — BA-73 SERIES* PROGRAM AMPLIFIER

Gain

92 ± 1 db unloaded input
86 ± 1 db loaded input

Rated Output

+24 dbm

Response

+0-1 db, 30-20,000 cps

Distortion

Less than 0.25%, 1 kc @ +24 dbm
Less than 0.5%, 50-20,000 cps @ +24 dbm

Source Impedance

150/600 ohms

Load Impedance

150/600 ohms

Input Impedance

Unloaded input transformer, or 150/600 ohms

Noise

-122 dbm equivalent input noise at max. gain

Maximum Input

-30 dbm unloaded input, -24 dbm loaded input

Power Required

30 volts, 300 ma drain from BX-71A

Ambient Temperature

131°F (55°C) max.

Overall Dimensions (Inches)

9 length x 3¾ width x 4½ height

Weight

4 pounds

Finish

Cadmium plate with clear chromate dip

* BA-73C or later

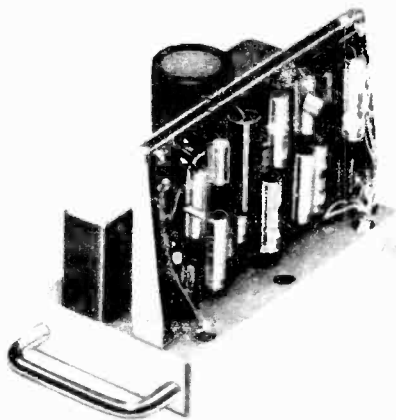

Figure 6. Type BA-73 Series Program Amplifier

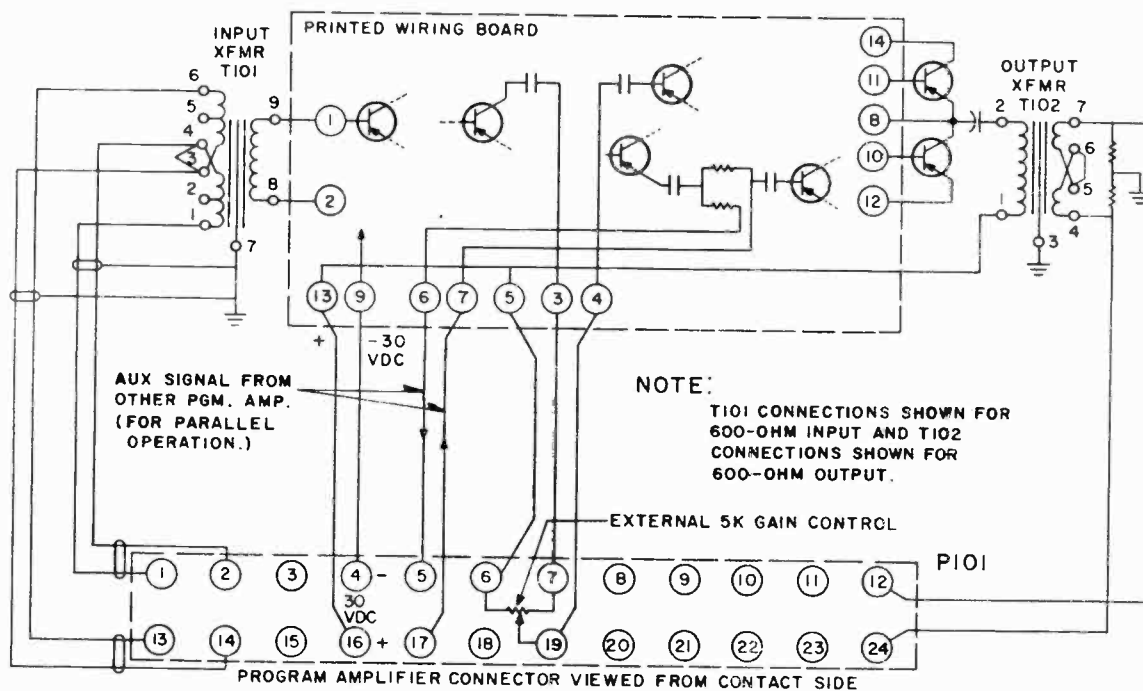

Figure 7. Type BA-73 Series Program Amplifier, Connection Diagram

TECHNICAL DATA — BA-78 SERIES* CUE/INTERCOM

Power Required

115/230v 50/60 cps.
 10 watts (no signal)
 17.8 watts (full signal)

Source Impedance

150 ohms

Input Impedance

150 ohms (nominal) with C. T. (See BA-78A instruction book for detail.)

Load Impedance

50 ohms floating/8 ohms unbalanced

Effective Input Level

Approx. -69 dbm minimum for verge of AGC action. (See BA-78 instruction book for detail.)

Output Level

Nominally set at 1 watt avg. (+30 dbm) by AGC action (approx. 8 watt max. with pgm. material)

AGC Action

Approx. 1/2 db change in output level for each 5 db change in input level. (See BA-78 instruction book for detail.)

Gain

Approx. 100 db with AGC disabled.

Approx. 85 db with max. gain reduction. (See BA-78 instruction book for detail.)

Frequency Response

Better than $\pm 1\frac{1}{2}$ db 30-20,000 cps. (10 db compression)

Distortion

Not over 3% 50-5,000 cps (10 db compression)

Hum and Noise Level

At least 60 db below max. output (AGC disabled)

Overall Dimensions (Inches)

8 1/2 lengths x 2-7/8 width x 4-5/8 height

Weight

5 pounds (approx.)

Finish

Cadmium Plate

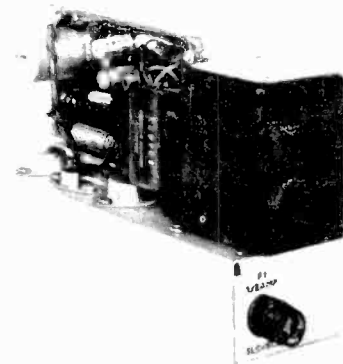

Figure 8. Type BA-78 Series Cue/Intercom Amplifier

* BA-78B or later

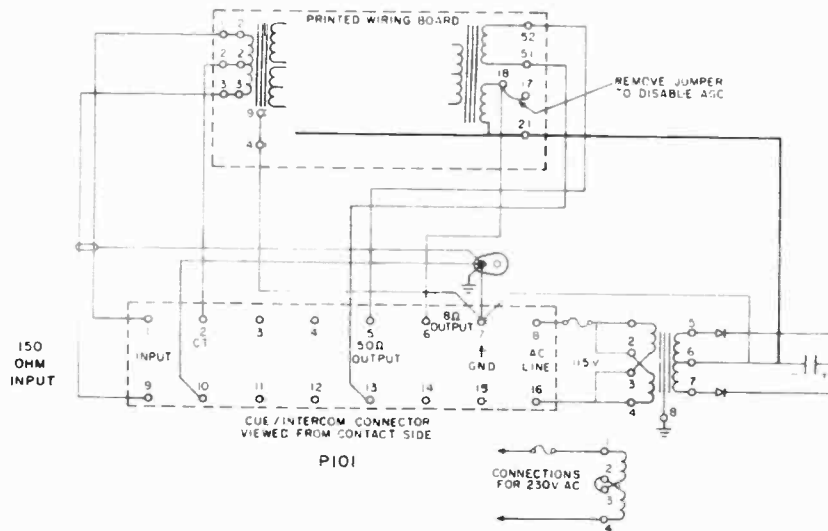

Figure 9. Type BA-78 Series Cue/Intercom Amplifier, Connection Diagram

TECHNICAL DATA — BA-74 SERIES* AMPLIFIER

Power Required

117 volts AC, 50/60 cps, taps 105, 115 and 125 V (primary connected in parallel on T103)
 230 volts AC, 50/60 cps, taps 210, 230 and 250 V (primary connected in series on T103)
 30 watt at rated output
 10 watt (approx.) at normal speaker volume

Source Impedance

600-ohm balanced source when shipped; may be reconnected to operate from a 150-ohm balanced or unbalanced source.

Input Impedance

Unloaded input transformer, high in comparison to source impedance.

Load Impedance 4/8/16/150/600 ohms and 70 V line

Maximum Input Level -23 ±2 dbm

Maximum Gain

70 ± 11 db unloaded input
 64 ± 1 db loaded input

Average Power Output 10 watts (40 dbm) max.

Frequency Response +0-1 db 30-20,000 cps

Noise Level (with 20 kc bandwidth)

50 dbm at output at 64 db gain
 114 dbm referred to input

Harmonic Distortion

At 10 watt output (40 dbm) less than 1%, 30 to 20,000 cps.

Ambient Temperature 55°C max. (131°F)

Fuses

AC Input (F-101)
 117 V — .75 amp. 3AG, SLO-BLO
 230 V — .375 amp. 3AG, SLO-BLO
 DC Supply (F-102)
 1.0 amp. 3AG, SLO-BLO

Dimensions and Weight

Length: 8 inches (overall 9-7/8 inches)
 Width: 4-15/16 inches
 Height: 4-5/8 inches
 Weight: 1.1 lbs.

* BA-74C or later

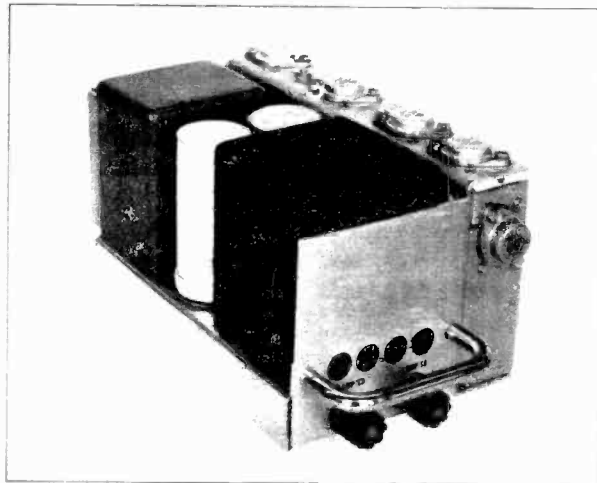

Figure 10. Type BA-74 Series Monitor Amplifier

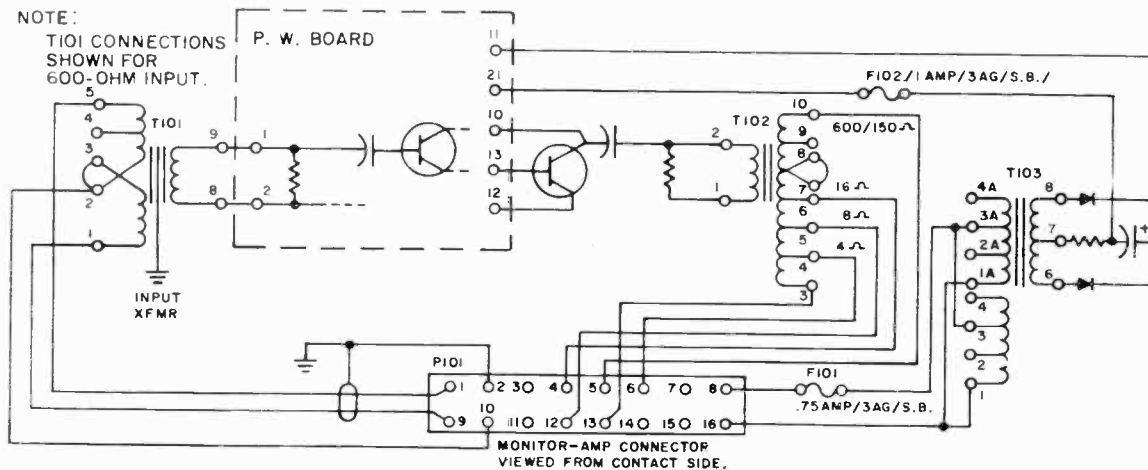

Figure 11. Type BA-74 Series Monitor Amplifier, Connection Diagram

TECHNICAL DATA — BX-71A SERIES POWER SUPPLY

Power Required

100 to 130v, or 200 to 260v, ac, 50/60 cps, 100 watts
 Taps at 105, 115, 125, 210, 230, and 250v

Power Output

— 30v at 1 amp, regulated
 + 24v at 0.56 amp, unregulated
 6v ac at 1.5 amp, unregulated

Regulation

On 30v supply, 0.35% no load to full load

Ripple 0.15 mv rms max. on 30v supply

Fuses

Primary 1.5 amp 3AG slow-blow
 30v 1.5 amp 3AG slow-blow
 24v 1.0 amp 3AG slow-blow

Mounting

Plug-in for consoles, as ES-11163 can be mounted in BR-22B shelf and requires 2/5 of shelf space.

Overall Dimensions (Inches)

8 7/8 length x 7 1/2 width x 4 3/8 height

Weight 14 pounds

Finish Cadmium plate with clear chromate dip

Transistor and Diode Complement

(Supplied in place)

- | | |
|------------|------------|
| 1 — 2N270 | 2 — 2N456 |
| 2 — 2N526 | 1 — 2N1090 |
| 6 — 1N3253 | 2 — 1N751 |
| 1 — 1N752 | |

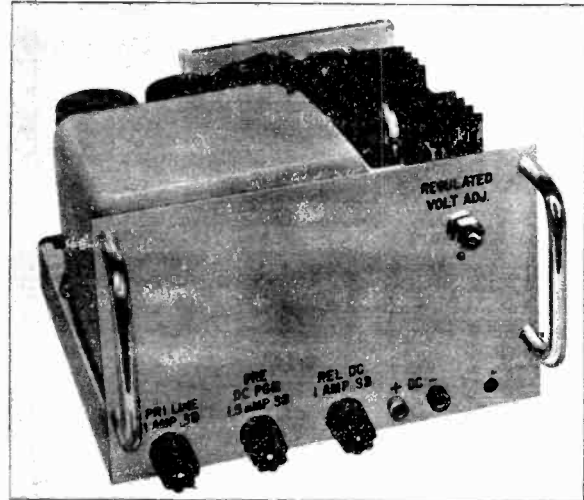

Figure 12. Type BX-71 Series Power Supply

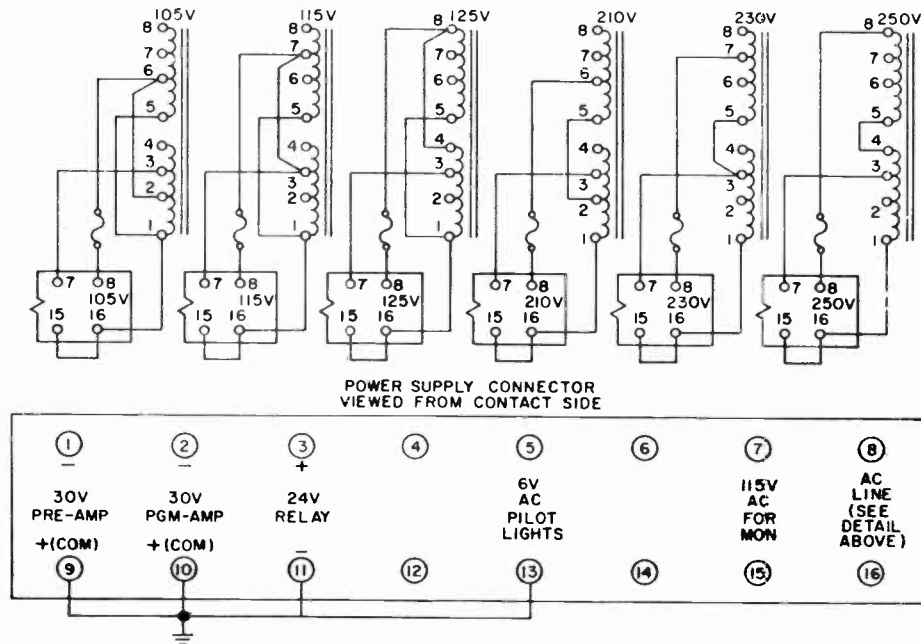

Figure 13. Type BX-71 Series Power Supply, Connection Diagram

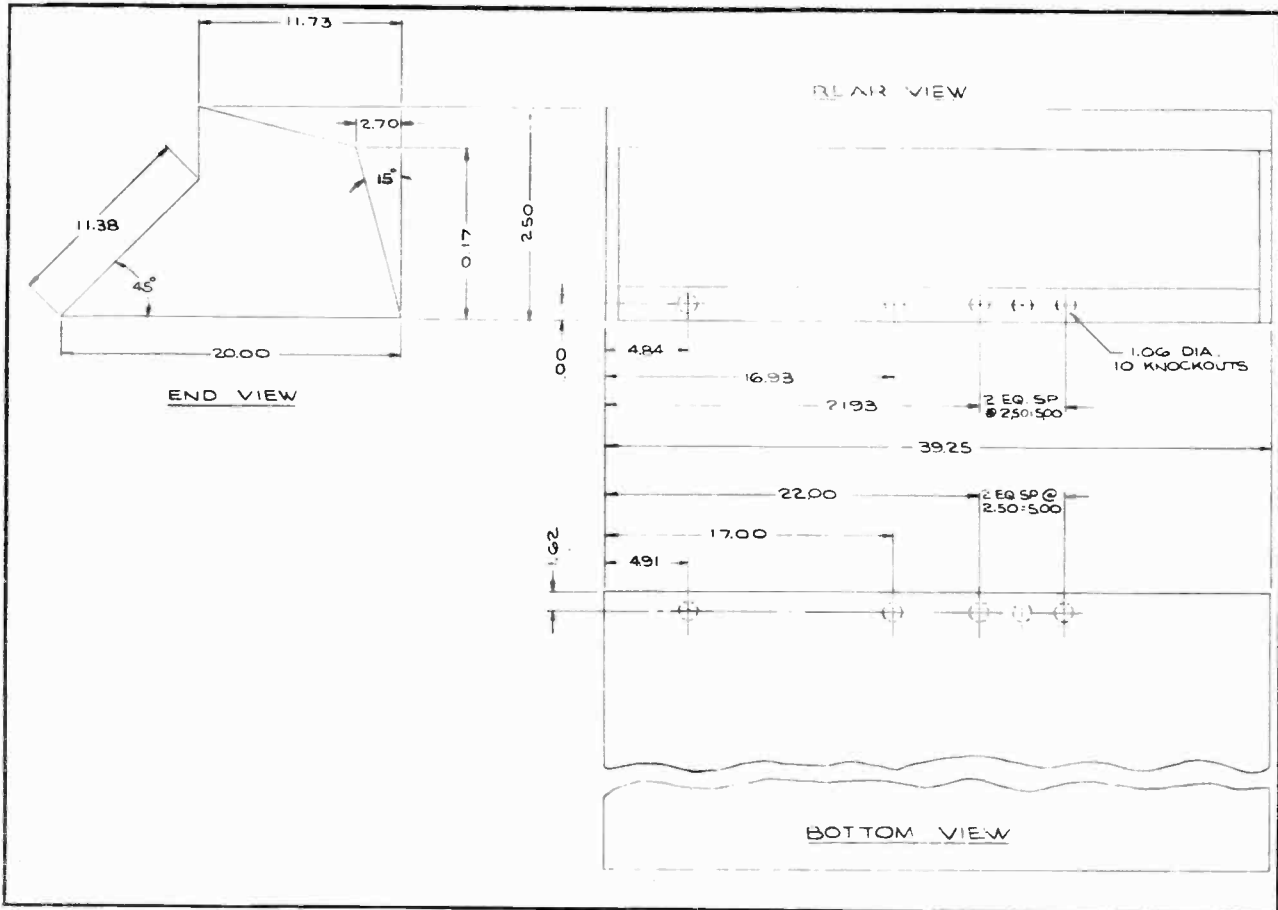

Figure 14. Installation Outline Diagram

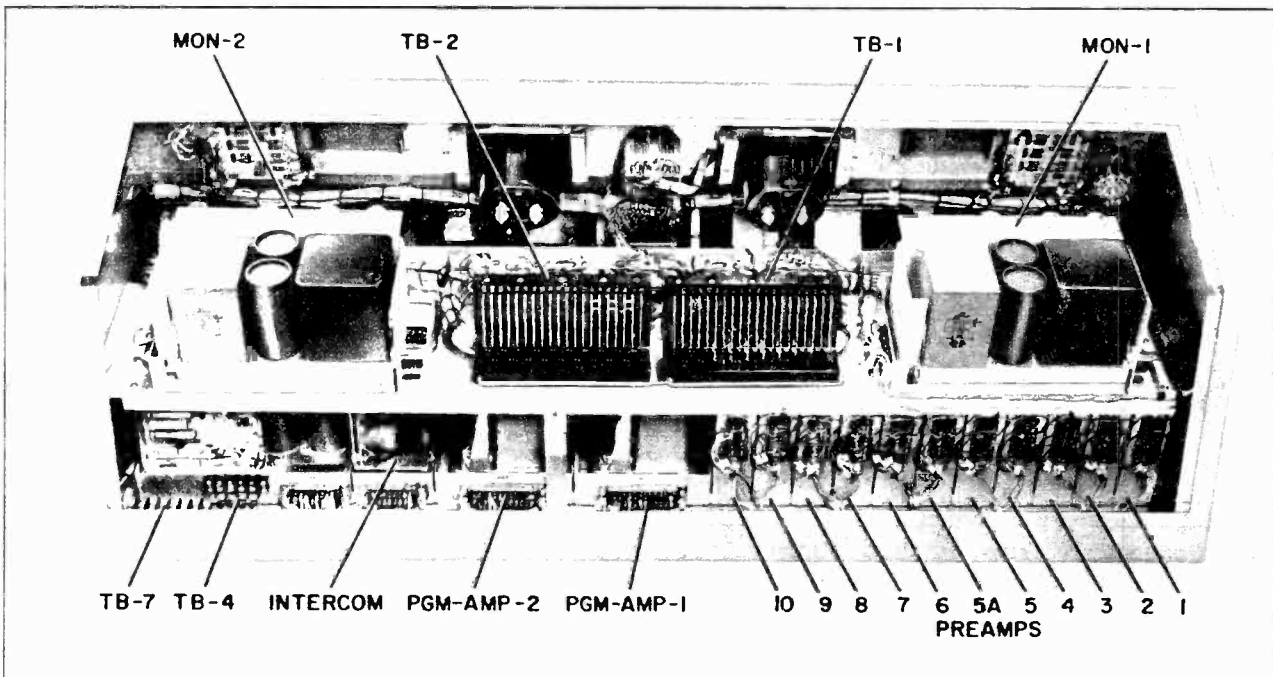

Figure 15. BC-7A Console, Rear Cover Removed

INSTALLATION

The BC-7A console is intended for flat top desk mounting. Knockouts are provided for 1" conduit along the rear of the cabinet housing and along the bottom, as shown in the outline drawing. This provides for connection of flexible conduit either through the back of the housing using service loops to wall junction boxes or conduit can be brought up through the table or pedestal.

In line with standard audio wiring practice it is recommended that the cables be grouped according to normal operating level and several separate conduits be used. Cables may be grouped as follows: (1) microphone lines, preamp outputs, turntable lines and other audio circuits with levels below approximately -20vu , (2) loudspeaker lines and other lines up to approximately $+30\text{vu}$, (3) control circuit lines, warning light relays, etc., (4) 115v or 230v, 50-60 cycle power.

All audio circuits should be twisted pair conductors shielded with a tinned copper braid, preferably with an insulating jacket over the shield (mandatory for microphone and low-level circuits). The shields should be grounded (at one end only) to the ground bus provided around the base of the terminal blocks.

Power Terminal Boards

Power connections (115 or 230v ac) are made to the console on a barrier type terminal board TB-7 located at the rear of the console behind the power supply. Terminals 1 and 2 at the left are used for incoming power; terminal 3 is used for the main ground to the station ground bus; and terminals 4 and 5 may be used to supply switched ac to one or more auxiliary consoles. Thirty volts dc for pre-amplifiers and twenty-four volts dc for relays, may be supplied to auxiliary consoles from the main power supply of the BC-7A by means of barrier type terminal board TB-4 located on the rear of the power supply guide assembly.

Audio Terminal Block Connections and Studio Signal Light Relay Connections

Two terminal blocks, each with 120 terminals, are provided for audio connections to the console. Input connections should be made using two conductor twisted pair with braided shield and insulated jacket over the shield. (MI-13342-2 cable meets the requirements and is available from stock.) For intercom connection, three of the above cables may be run to each intercom remote sub-station or a single cable consisting of three twisted pairs, each pair shielded, with an insulating jacket over all (such as Belden 8767) may

be used. For additional wiring inside the console, two conductor shielded wire same as used inside the console may be obtained from stock (MI-13395-1). Each shield should be connected to the ground bus provided around the base of each terminal block. Vertical pairs of terminals are used for each circuit. Phasing is maintained throughout the console by using the top terminal of each pair for the high side of the line and the bottom terminal of each pair for the low side of the line. Observe that stereo pairs are connected to adjacent terminals with the left pair connected to the left pair of terminals (as observed by the installer) and the right pair connected to the right pair of terminals.

Connections to input switches 1 through 11 are made through TB-1 (the terminal block on the right as viewed from the rear of the console, see figure 15). These connections include all *program* audio inputs to the console (including input to mixer bus from auxiliary console) except inputs from remote lines.

Refer to the terminal block connection diagram (figure 21) and note that the inputs on the terminal blocks are physically grouped in a manner corresponding to placement of controls on the operating panel. Connections to mixer 1 through source selector switch S-1 are made through terminals at the corresponding end of the console. The diagram of terminal block connections shows connections for a typical installation and are labeled accordingly.

Contacts are provided on all input *switches* for stereo inputs, therefore, stereo input terminals are provided for all input switch positions. However, since stereo mixers are normally supplied only in mixer positions 5, 6, 7 and 8, the right half of other input switches are not factory wired and corresponding terminals are not wired. The right channel terminals which are assigned but not wired are indicated on the terminal block diagram by an asterisk (*). (All mixer delegation switches *are* wired for stereo with wires brought up to dummy terminals on the mono-mixers so that any mono-mixer can be replaced by a stereo mixer. Spare terminals on all input switches and pre-assigned terminals on the input terminal blocks provide for expandable facilities.)

Input terminals for the *remote* lines are located on TERMINAL BLOCK 2 (the terminal block to the left as viewed by the installer from the rear of the console) in the lower right group of terminals. (TB-2 11/12; 23/24; 35/36; 47/48.) As with certain of the other inputs previously described, contacts and ter-

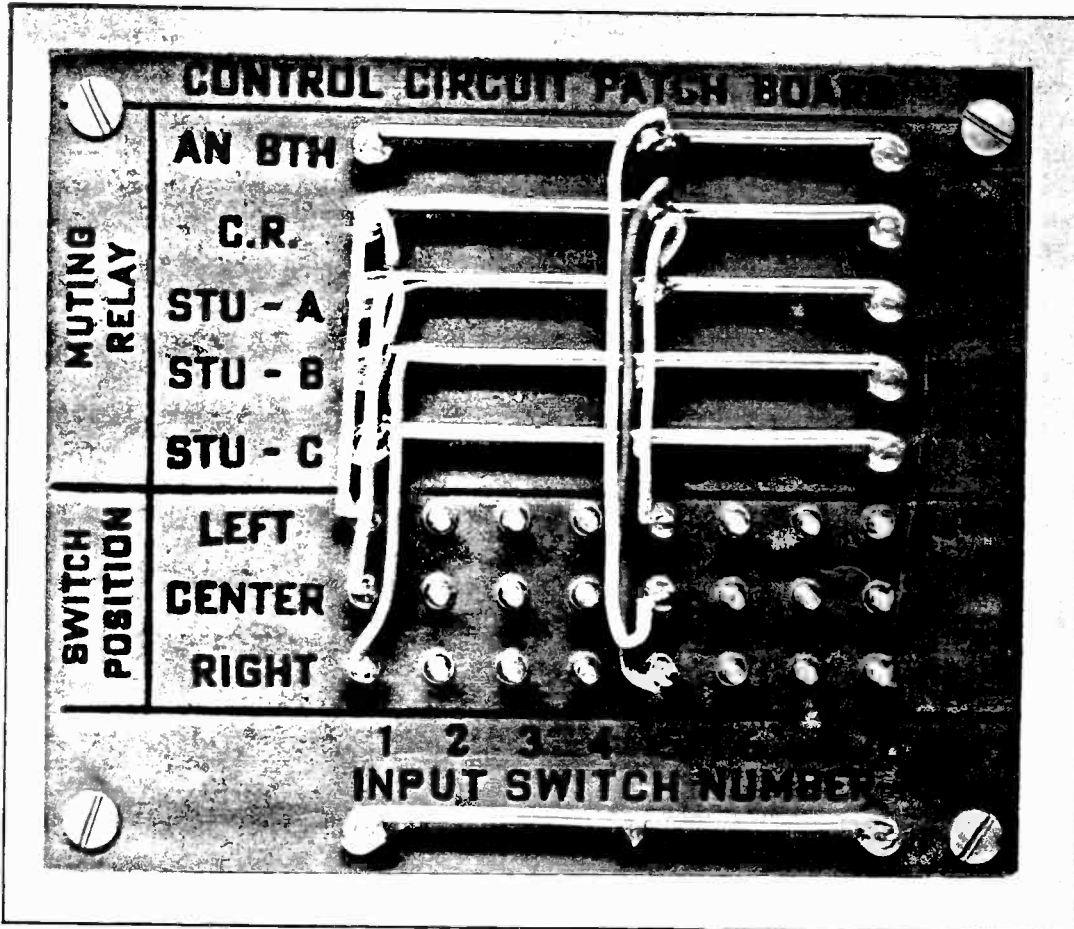

Figure 16. Control Circuit Patch Board

minals for companion right channel inputs are provided and assigned but not factory wired. These terminals are indicated on the "terminal-block connection" diagram by an asterisk (figure 21).

Terminals for *auxiliary inputs* to the *monitor amplifiers* (through monitor input selector switches S-51 and S-52) are located on terminal block 2 in the center group of terminals to the right of center. (TB-2 45/46; 39/40; 33/34; 27/28.)

Terminals for *jumper connections* are located on terminal block 2 in the two top groups of terminals right of center. The jumper connections which provide for breaking into the circuit immediately after the program amplifiers are 2-37/38 (amp out); 2-31/32 (pad in) for pgm amp 1 and 2-25/26 (amp out); 2-19/20 (pad in) for pgm amp 2. The jumper connections to select which monitor amplifier feeds program cue to remote are 2-13/14 (1 out); 2-7/8 (in); 2-1/2 (2 out).

Connections to studio, announce booth and control room *monitor speakers* are made to the top group of terminals left of center on TB-2. The center group of terminals of TB-2 are used for *intercom connections* (see the section on intercom installation for details), and the group of terminals immediately below are used for *studio warning light relay* lines. For example, when switches on the main panel of the console are thrown to connect a microphone in studio A, interlock relay K-3 mutes studio A intercom and monitor speakers, and supplies 24v D.C. to terminals 2-107 (+), and 2-108 (—) to energize a studio warning light relay (MI-11702-A) normally located near the studio. (A variety of warning lights in the MI-11706 series are available.) Terminal 2-102 is provided for relay control from an auxiliary console.

Auxiliary outputs from the program amplifiers through isolation pads to external monitors are provided in the group of four terminals in the lower left section of TB-2. (2-119/120 and 2-113/114.)

The terminals for the two *program output lines* of the console are located at the extreme left center section of TB-2. The left program channel terminals (line-1) are the left pair 2-117/118. The right program channel terminals (line-2) are the right pair 2-111/112.

The only other terminal block connections not discussed are 2-21/22 which are used for an intercom call-bus from the various studio intercom stations.

Jumper wires on spare terminals on the plug-in guide assembly connectors provide access to the cir-

cuit between plug-in input units and the mixers. These are easily accessible and due to location are readily identifiable with the individual plug-in unit. See figure 15 and figure 26. Note that each connector can be wired to accept plug-in *stereo* high level isolation units. (Each MI-11665 Hi-Level Isolation unit has mounting provisions for an extra transformer [stock No. 226965] for stereo applications.)

Control Circuit Patch Board

The BC-7A provides complete flexibility in assignment of lever switch positions to studios. The control circuit wiring and terminal arrangement is such that any position of any source selector switch (S-1 through 8) can be assigned to any studio and obtain correct speaker muting and warning light operation. As an added feature, provisions are made to use the control circuits for automatic turntable or tape starting.

The heart of the flexibility of the control circuit system is the descriptively labeled, pictorially laid out, control circuit patch board. When the main panel is opened for access to the plug-in units a small control panel is seen conveniently located at the top front of the panel in a horizontal position. See figure 16.

This panel contains a descriptively labeled bus for each muting relay and a set of pictorially laid out terminals, one for each switch position of each source selector switch. Thus any relay may be assigned to be actuated by any position of any source selector switch by connecting a jumper wire on the control circuit patch board from the terminal indicated for the switch position to the corresponding relay bus.

Below the group of switch position terminals is a common bus connected to the grounded negative side of the relay power supply. Reference to the overall schematic diagram, figure 26, will show that each switch position terminal is connected through the appropriate series of switches to the positive side of the relay power supply. Therefore, an external 24v dc relay for starting turntables or tape machines can be controlled by connecting a pair of leads between the lower bus and the corresponding desired switch position terminal.

Normally the key switches associated with mixers 9 and 10 would not require speaker muting, therefore, they are not wired to the control circuit patch board; however, extra contacts are provided on the control circuit stacks of these switches so that these switches can be wired for individual special requirements if they should occur.

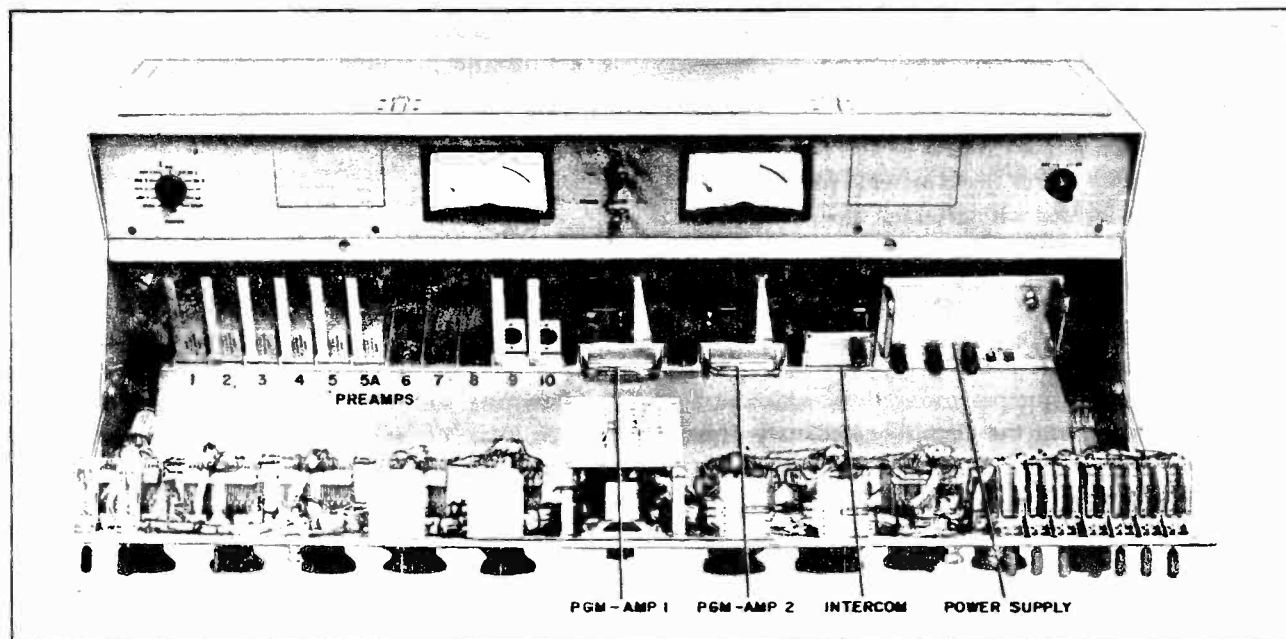

Figure 17. BC-7A Console, Front Panel Lowered

Location of Plug-in Units

Figure 17 shows the console with the front panel open for access to the plug-in units. The 11 ($1\frac{1}{2}$ " wide) guide slots on the left, as viewed by the operator, will accept either BA-71A (MI-11658), preamplifiers, MI-11665 hi-level isolation units or straight-through jumper plugs. The slots are numbered from 1 to 10, numbering from left to right. Each plug-in unit is associated with the mixer circuit bearing the corresponding number. Note that in addition to guide position 5 there is an additional adjacent guide position 5A. This additional guide position provides for two low-level (hi-gain) inputs to mixer position 5.

To the right of the plug-in input unit guides are two positions for two type BA-73A Plug-in Program-Amplifiers MI-11659. These slots are 5" wide and have a $3\frac{1}{2}$ " wide, flat guide plate to guide the $3\frac{1}{16}$ " wide plug-in program amplifiers. The program amplifier on the left, labeled pgm amp 1 is for the left channel and the program amplifier on the right, labeled pgm amp 2 is for the right channel program amplifier.

The 3" wide guide, adjacent to the $7\frac{1}{2}$ " wide guide at the right end, is labeled intercom, and is to accept the BA-78A MI-11662 cue/intercom amplifier, which has a built-in power supply and provision to be operated from either 115 or 230 volts 50-60 cps supply.

The $7\frac{1}{2}$ " wide guide on the extreme right is for the BX-71A MI-11663 power supply.

The guide assemblies for the monitor amplifier are reached by removing the rear cover of the console, figure 15. The rear cover can be easily removed and the monitor amplifiers can be conveniently changed from the operating position (in front of the console) Monitor amplifier 1, normally associated with program channel 1 which is used for the left channel for stereo operation, is located toward the operator's left on the shelf behind the top control panel. Monitor amplifier 2, normally associated with program channel 2 (audition for monaural or right channel for stereo operation) is located toward the operator's right on the shelf. All fuses are located on the individual plug-in units (Power Supply, Monitor Amplifier, Cue/Intercom Amplifier).

Labels

An assortment of pressure sensitive labels is supplied with each console. These labels are precision cut to fit into the indentations adjacent to lever switches with functions and positions that are most dependent on varying needs at individual installations.

Permanent panel designations are etched in black. Switches with designations that are most subject to change, depending on individual needs, are provided with uniform panel depressions at these locations to accept a wide assortment of pressure sensitive labels supplied with each unit. The labels give a neat, permanent appearance to the console, yet can easily be changed when necessary. The assortment is also available from stock (Stock Number 227350).

Optional Field Modifications

Conversion of single mixer positions to dual-stereo mixer positions: Examination of the simplified functional diagram or overall schematic diagram will reveal that all mixer delegation switches are factory wired for stereo. Dummy terminals are provided on all single section mixers. The single section mixers in positions 1, 2, 3, 4, 9 and 10 all have dummy terminals which are wired to provide convenient conversion of any of these single section mixers to dual-section mixers by transfer of wires to interchangeable dual-section stereo mixers available from stock.

Spare contacts are provided on source selector switches S-1, S-2, S-3 and S-4 and source delegation switches S-9 through S-15 to accommodate the additional right channel wiring required for switchable stereo inputs to these mixers.

Alternatively, if switchable inputs are not required to the proposed converted stereo mixers, permanent connection can be made at the respective guide assembly receptacles or directly to the mixers. Companion right channel terminals adjacent to each left channel input are provided on the Audio Terminal Blocks.

Additional low-level dual channel inputs, as provided for mixer position 5, may be obtained by utilizing one or more of the guide assembly positions normally used for jumper plugs (J-106, 107 or 108). Spare terminals are provided on the guide assembly

connectors so that the connections normally made by the jumper plugs can be permanently wired using the lower terminals, thus liberating the upper terminals which may be rewired to provide a companion right-channel preamplifier for other mixer positions. Thus one of the dual-stereo mixers (mix 6, 7 or 8) could be rewired for dual *lo-level* input, or up to 3 of the single mixer positions could be converted to *dual-channel lo-level* stereo inputs.

Provisions are made for mounting an additional isolation transformer on the hi-level isolation unit, thus obtaining a stereo hi-level isolation unit, utilizing the duplicate sections of the high level unit attenuator. (Isolation Transformer Stock No. 226965.)

In the intercom part of the circuit, a 1-ohm resistor R140 is connected between the two sections of the L type intercom output level control to prevent accidentally obtaining a "dead" control room station which could not be called due to inadvertently leaving the console intercom gain control turned down too far (off). This resistor limits the maximum attenuation of the control to approximately 35 db, which is about 20 to 25 db below the normal operating level and is sufficiently low for most purposes, yet is high enough that the attention of the console operator can be obtained by a loud call from a remote intercom station or remote line. If it is desired to eliminate this safety feature, the 1-ohm resistor can be shorted with a piece of bus wire to obtain a positive off position of the control.

OPERATION

Refer to the fold-out sheet at the rear of this book immediately preceding the Schematic Diagram. Figure 24 on this sheet shows an operator's view of the console in which all controls are identified and briefly described. Figure 25, also on this sheet, is the Audio Functional Diagram which may be used as a cross reference. When folded out these two figures extend beyond the pages of this instruction book for convenient reference while reading the various pages of explanation throughout this book. A tabulation chart of operating controls is shown on pages 36 and 37. This chart (which indicates location, description, and function of all operating controls) when used with the adjacent diagram and photograph should give considerable operating familiarity with the console.

The operator must become familiar with the location of these controls and their function in order to be able to realize maximum flexibility of the console.

It is ordinarily more desirable to use the input selector switches in low-level mixer channels (mixer channels in which plug-in preamplifiers are used) as preselect switches. Thus actual switching of a signal to the mixer bus is done at optimum level by using the mixer delegation switch or fading up the attenuator of a mixer channel previously connected. Input signals to mixer channels not utilizing preamplifiers may optimally be switched at the input switches or faded-in, using the mixers, since these are higher level parts of the circuit. However, for less critical operation either source switches, mixers, or mixer delegation switches may be used for live switching.

Stereo Operation

For stereo operation Line-1 switch (S-41) should be in the left position (CH-1); Line-2 switch (S-42) should be in the right position (CH-2); Mode switch (S-43) should be in the left position (STEREO); Monitor-1 (left channel) selector switch (S-51) should be in the CH-1 position; Monitor-2 (right channel) selector switch (S-52) should be in the CH-2 position.

Stereo recorded sources should normally be handled through mixers 6, 7 and 8. To simultaneously place both right and left channels of one of the "recorded inputs" mixers (6, 7 or 8) on the corresponding mixer bus, the mixer delegation switch should be moved to the left position (labeled $\begin{matrix} \text{CH-1} \\ \text{STEREO} \end{matrix}$). The center position is an off position. The right position should not normally be used for stereo since it puts the left channel signal on the CH-2 (right) mixer bus and does not connect the right channel signal.

Stereo Override Facility — Mixer 5

Mixer position 5 is wired to accept two plug-in preamplifiers, (one preamplifier for each channel, left and right). The inputs to the preamplifiers are wired through both left and right channel sections of source selector switch (S-5) to the set of stereo-pair input terminals on TB-1 for mixer position 5. Thus low level (high gain) stereo inputs are provided for mixer number 5. The left and right inputs of input selector switch S-5 may be paralleled at the terminal block for any or all of the three input positions and connected to a single microphone, (the preamplifier input impedance is effectively high enough not to load a microphone). This facility may normally be used for simultaneous announcement through both channels from a single microphone overriding stereo background music. Alternatively the inputs may not be tied together and may be run to a stereo pair of microphones.

Intercom Connection and Operation

Basically a combination microphone/loudspeaker transducer mounted on the main console panel is used with suitable switching and interlock facilities through a plug-in AGC CUE/INTERCOM amplifier for direct two-way communication with remote intercom sub-stations MI-11452 (figures 18, 19, and 20) normally located in the various studios. Each remote intercom sub-station incorporates a transducer, designed for optimum microphone/loudspeaker operation, and suitable switching facilities. The housing is styled to match the MI-11406 and MI-11407 monitor speaker housings, and utilizes the same convenient

multiple mounting provision, offering a choice of either 30° or 60° inclination or declination of the acoustic axis of the transducer. The same housing is equally suitable for desk top or overhead wall mounting. The three position switch provides a choice of operation. As normally connected when the lever switch is in the center position, the remote sub-station may receive calls from the control room yet maintain privacy. (Privacy, in that a manual switch must be actuated at the sending remote intercom sub-station before the remote intercom sub-station can be monitored.) To call the control room, the lever switch may be pushed to the spring return combination TALK/ CALL position. In this position the control room may be reached with the console intercom selector switch in any position (provided the control room speaker is not muted by ON AIR relays). If two-way communication is desired with the console without having to operate the push-to-talk switch, (at the remote intercom sub-station) each time the person at the remote station wishes to talk, the switch at the remote station can be moved to the locking combination TALK/LIST position, thus transferring all control to the console. This feature, together with the AGC feature, makes it quite convenient to work at a considerable distance from the intercom and obtain good two-way communication with the console.

For installations in which only this type of operation is desired, the remote sub-station can be wired with only a single pair shielded cable. (For this condition the intercom "input selector switch" and "output selector switch" terminals are jumpered together at the console terminal block, as indicated in the tabulation below.)

Connect 2-105 to 2-99 and 2-106 to 2-100 for Studio A

Connect 2-93 to 2-87 and 2-94 to 2-88 for Studio B

Connect 2-81 to 2-75 and 2-82 to 2-76 for Studio C

Connect 2-69 to 2-63 and 2-70 to 2-64 for An Bth

Connect 2-57 to 2-51 and 2-58 to 2-52 for Spare.

The call line normally connected to terminals 2-21/22 may also be omitted if desired. (Such an arrangement will, of course, disable the feature of providing the remote intercom station with the ability to call the console when the console intercom selector switch is in a position other than to select the particular station calling.) The remote intercom sub-stations are available as MI-11452.

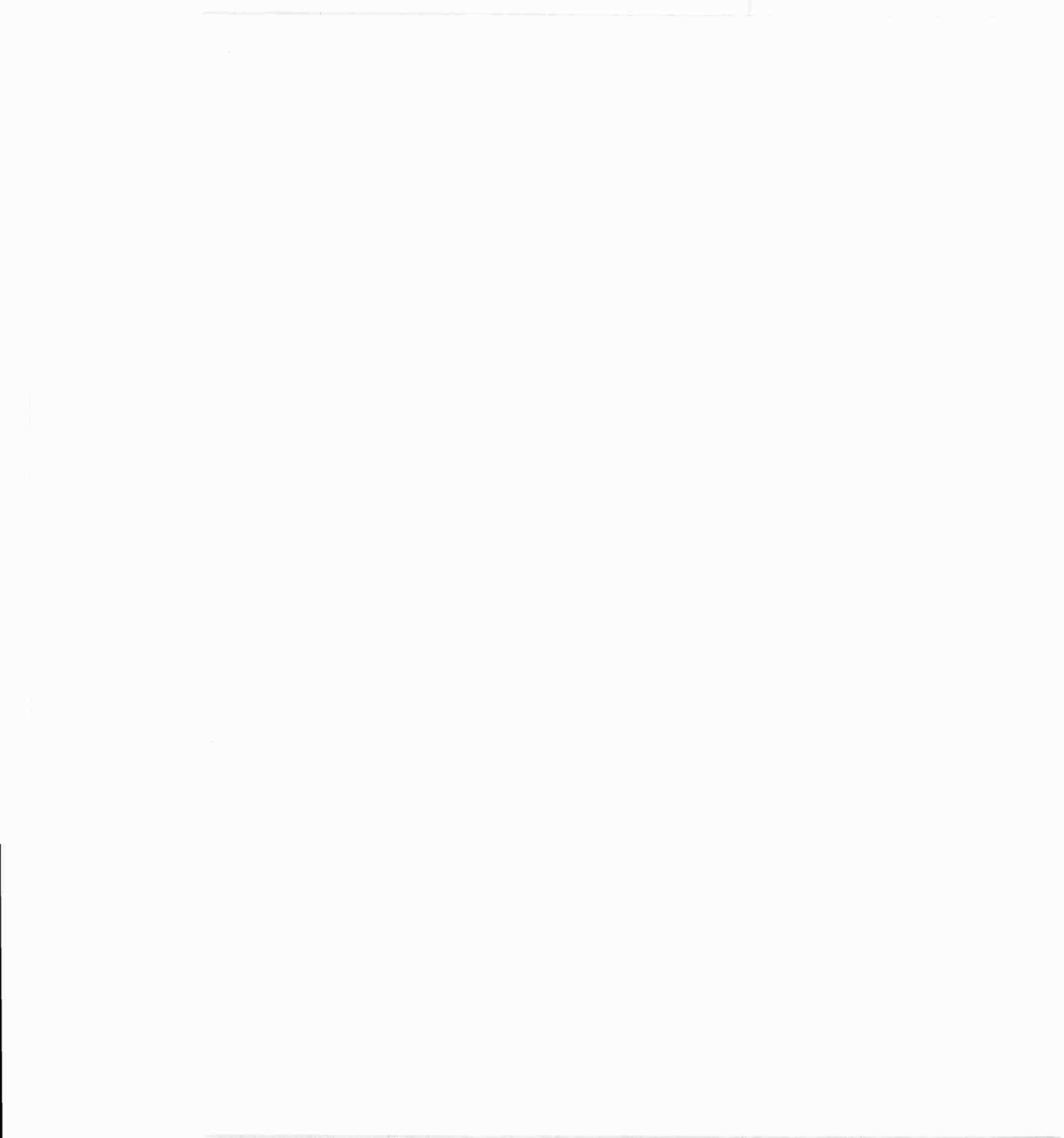

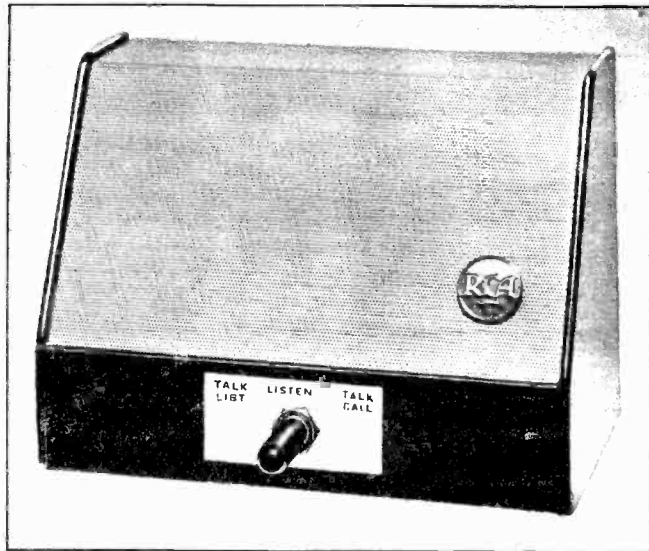

Figure 18. Intercom Remote Station

In addition to communication with the remote intercom sub-stations in the announce booth and studios, the consolette intercom is also used for communication through the consolette "remote lines" (telephone lines to locations remote from the studio). In this application a remote amplifier such as a BN-6B or BN-7A would be used at the remote location.

The consolette cue/intercom may also be used to monitor the cue bus and network line making use of the AGC feature and providing a facility independent of the program monitor amplifiers and monitor speakers.

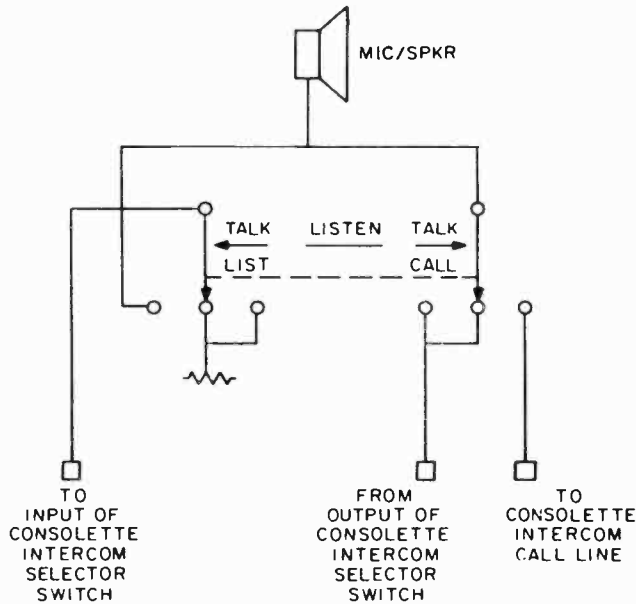

Figure 19. Intercom Remote Station Functional Diagram

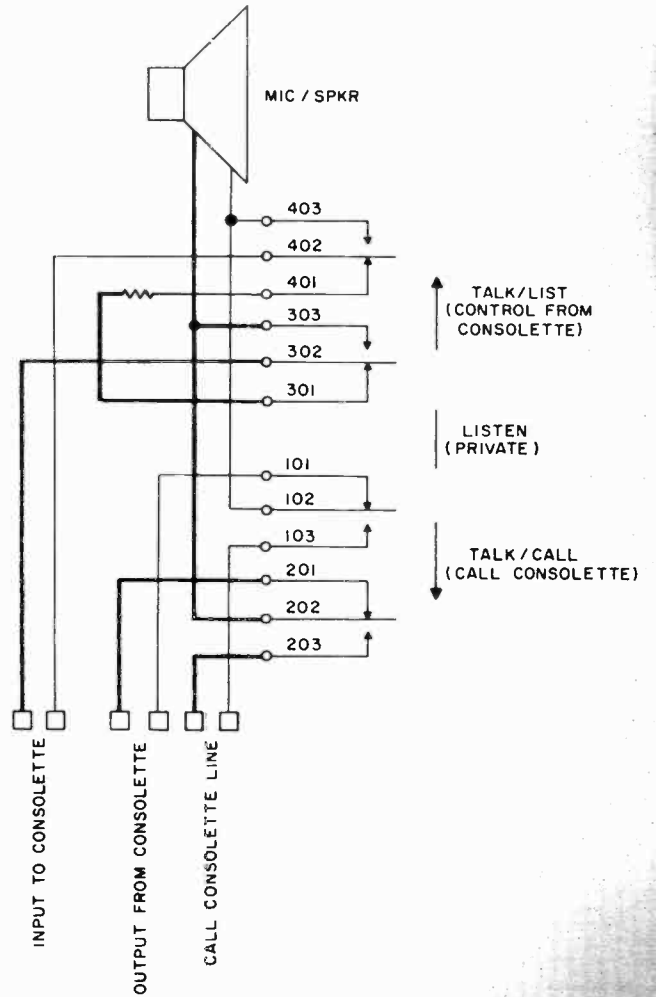

Figure 20. Intercom Remote Station Schematic Diagram

MAINTENANCE

The BC-7A Stereo Dual Channel Console may be easily serviced without disturbing the installation. The main front panel can be readily hinged open by grasping the two convenient handles located at the top of the panel. Opening the front panel brings the control-circuit patch-board into convenient horizontal position for adjustment of jumpers, and reveals the line of plug-in units which may be removed for bench servicing. Service of the individual plug-in units is covered in the instruction books for the individual units. The back cover can be removed by pressing the two spring latch catches which allows the back cover to be hinged back or be completely removed. Removing the back cover gives access to the two plug-in monitor amplifiers, the two audio terminal blocks, the power terminal boards and the plug-in-unit guide-assembly connectors.

Care of Variable Attenuators

Attenuator covers may be removed for access to the contacts. To clean the contacts apply mixer lubricant to the contacts and rotate the knob several times. Wipe the contacts clean, using a soft cloth, apply a thin film of mixer lubricant, and replace the attenuator cover. A bottle of mixer lubricant is packed with the console and is available from stock (Stock Number 20752).

Care of Switches, Relays and Plug-in Unit Contacts

The switch, relay and plug-in unit contacts do not require periodic maintenance. The contacts are self-cleaning and it has been found that usually more harm than good is done by periodic maintenance. If trouble should occur, the faulty contact should first

be located by signal tracing and the suspected pair of contacts confirmed by jumper wire check at the switch or relay solder lugs. In the case of trouble with the dust-shield-enclosed relay contacts, it will be seen that unused contacts are available for substitution. In the case of trouble with switch contacts, the contact may be cleaned by passing a standard switch contact tool between a pair of closed contacts or using one of the reputable liquid contact cleaners. The plug-in unit connector contacts are gold plated and should likewise require no periodic maintenance. If connector contact trouble is suspected, remove the plug-in unit and reinsert it several times.

Servicing of the Etched Wiring Board Assemblies

The etched wiring boards are made of .062 inch thick laminated epoxy to one side of which a thin sheet of copper is bonded. The conductor pattern is formed by an etching process. Component leads are threaded through holes in the board. The ends of the leads are bent over against the copper conductors and the complete assembly is dip-soldered.

If it is necessary to isolate a component to determine the source of trouble, loosen one of the component leads. This should be done by melting the solder surrounding the lead; be sure to use a small 25-watt soldering iron as a higher wattage iron may cause the copper to peel from the board. With long-nosed pliers, straighten the bent over portion of the lead before pulling it through the hole from the component side. If the component is found to be in good condition, reverse the above procedure. Be careful not to damage the copper foil by applying too much heat or force.

APPENDIX I

Figure 22 is a simplified diagram of a single channel showing gain, level, and normal setting of attenuators for response, distortion, signal-to-noise measurements and normal operation.

Figure 23 gives a more detailed representation of signal level throughout various portions of the console. It shows the level throughout the console required for full output, for various positions of the mixer and master attenuators. The heavy center line indicates the level throughout the console with NORMAL position of the operating controls. The lighter lines and dotted lines give an indication of the range of levels which can be handled with other settings of the operating controls. The light lines indicate the levels in the circuits following the mixers for minimum and maximum positions of the master gain control. The dotted lines indicate the gain-level relations for various positions of a mixer when the master

attenuator is in a normal position. Similar curves can be drawn for other positions of the master.

If jumper plugs are used in place of preamplifiers the sloping lines in the column at the left will become horizontal. If high level isolation units are used in place of preamplifiers, the lines in the column at the left will be horizontal if no input pad is used; or will have the opposite slope, the degree of which is determined by the tap selected, if the pad board is used.

NOTE: See the Audio Data Section (p. 107-11) of the 5th edition of the RCA Broadcast Audio Catalog (AUD 83062) which gives a reprint from EIA Standard TR-105B and Standards Proposal No. 599, formulated under the cognizance of the EIA Engineering Committee TR-10 on Broadcast Audio Facilities. This gives detail information on response, distortion, and signal-to-noise ratio definition and method of measurement.

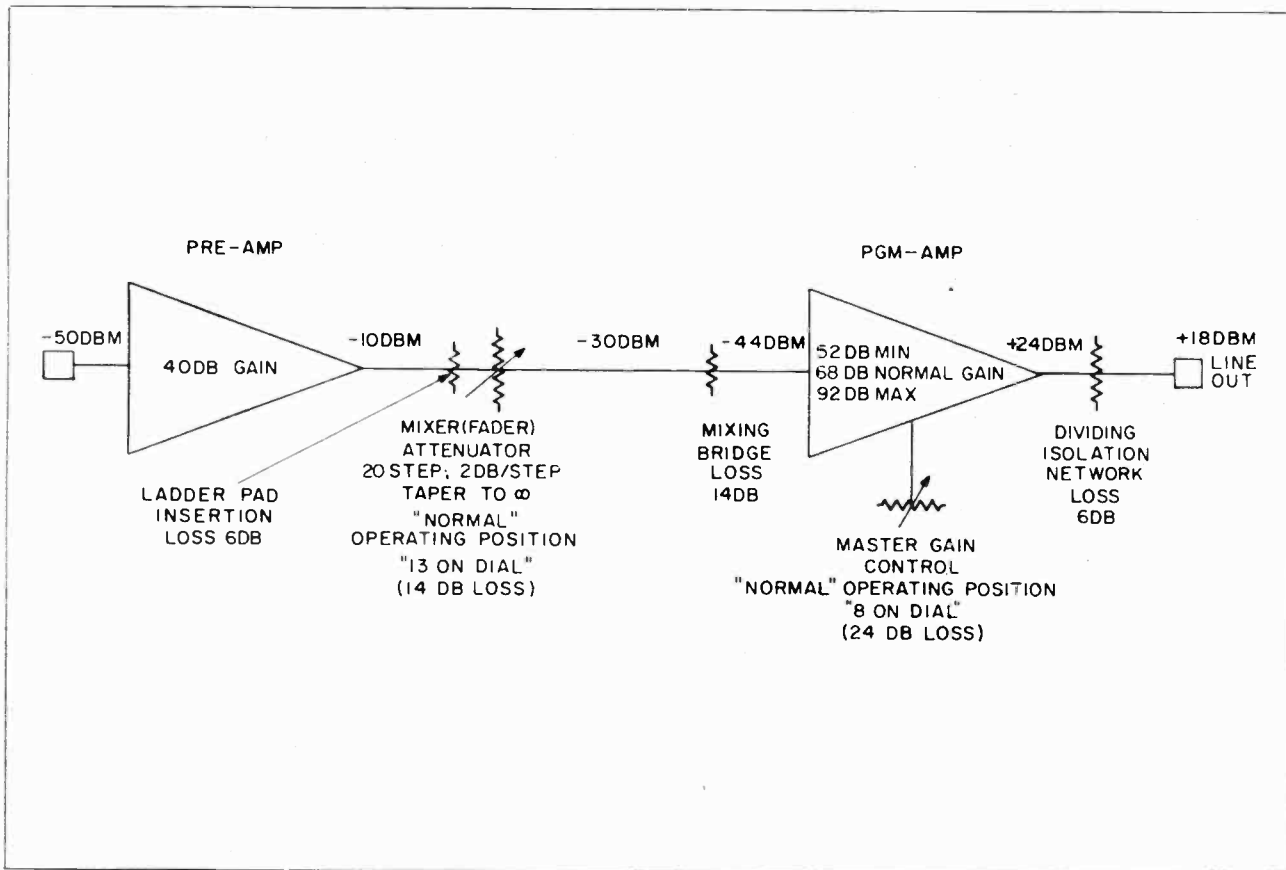

Figure 22. Simplified Level Diagram

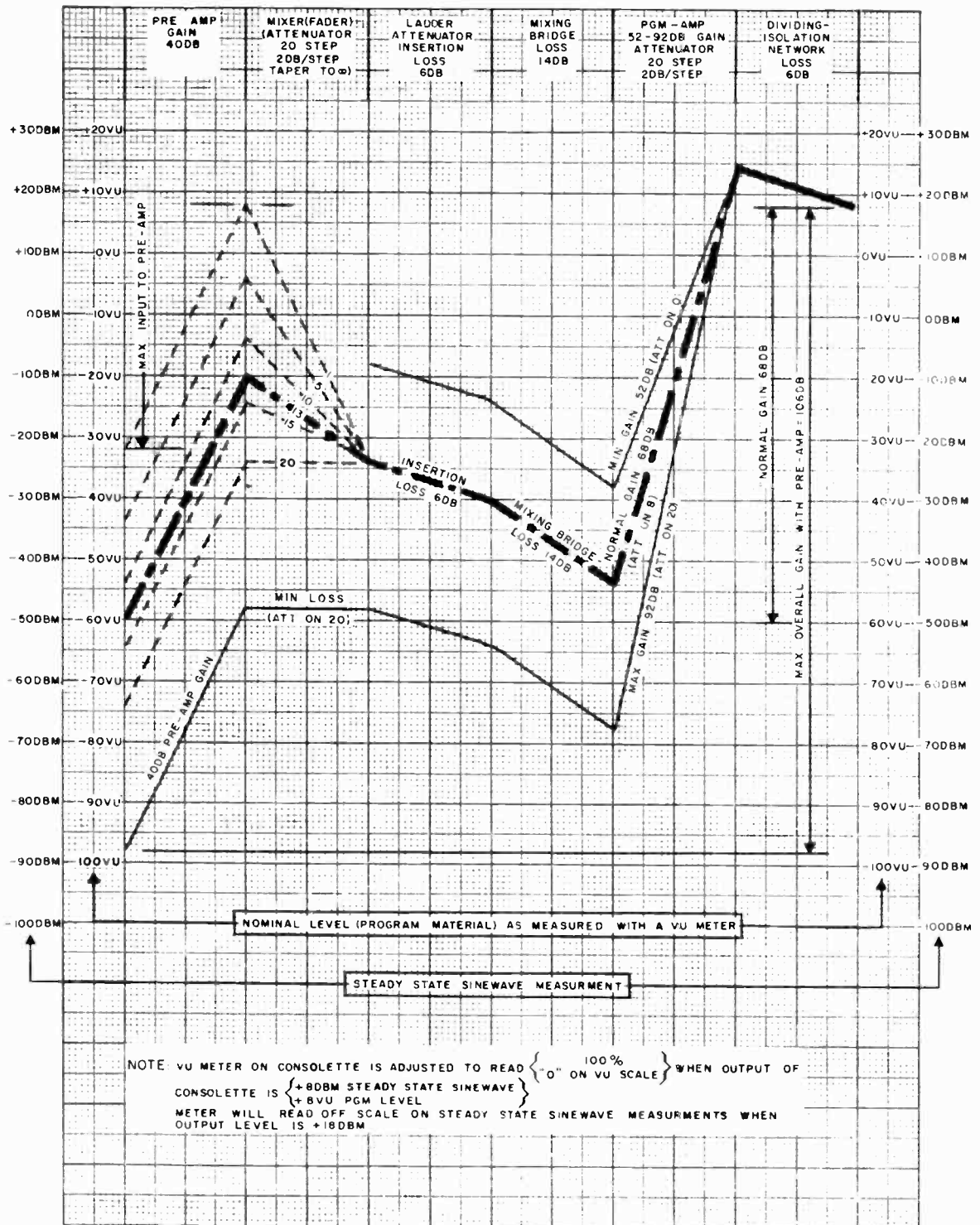

Figure 23. Level Diagram

APPENDIX II

NOTE: Nominal level expressed in VU indicates program material level as indicated on a VU meter (which has as definitely specified and controlled dynamic characteristics; See ASA Standard C16.5-1954 reaffirmed 1961 "American Standard Practice for Volume Measurements of Electrical Speech and Program Waves.")

VU meters are designed to give an indication proportional to apparent level as observed by the human ear and consequently do not give a good indication of instantaneous peak level.

Examination on a long retentivity oscilloscope will reveal that actual speech peaks often extend as much as 10 db above the peaks indicated on a VU meter. In order to not produce distortion the amplifiers

must be capable of handling these peaks. Therefore, performance tests using steady state sinewave measurements must be made at a level 10 db higher than the normal peak swings of the VU meter observed on program material.

The circuits associated with the VU meter on the BC-7A consolette are designed to give a meter reading of 100 (0 on VU scale) with an output of +8 dbm delivered to a 600-ohm load connected to the program output terminals of each channel. Therefore, when making tests at full output of the consolette (+18 dbm) the VU meter will be off scale. VU meters are designed to safely withstand several hundred percent overload and this will in no way damage the meters.

APPENDIX III

In stereo programming, an A + B signal (an equal mixture of right and left channel signal) is desirable under special operating conditions such as, when feeding a signal to an AM transmitter for simultaneous transmission of monophonic AM and stereophonic FM; when simulating the conditions of listening with receivers not incorporating multiplex facilities; or when monitoring with a single speaker due to limited studio space or to economy considerations.

To achieve an A + B output, a simple network which does not introduce excessive crosstalk can be constructed as illustrated below. In this diagram the numbers adjacent to the square terminals indicate the proper connections to TB-2 on the BC-7 consolette for connecting the network to the output of the program amplifiers ahead of the line out switches and dividing pads.

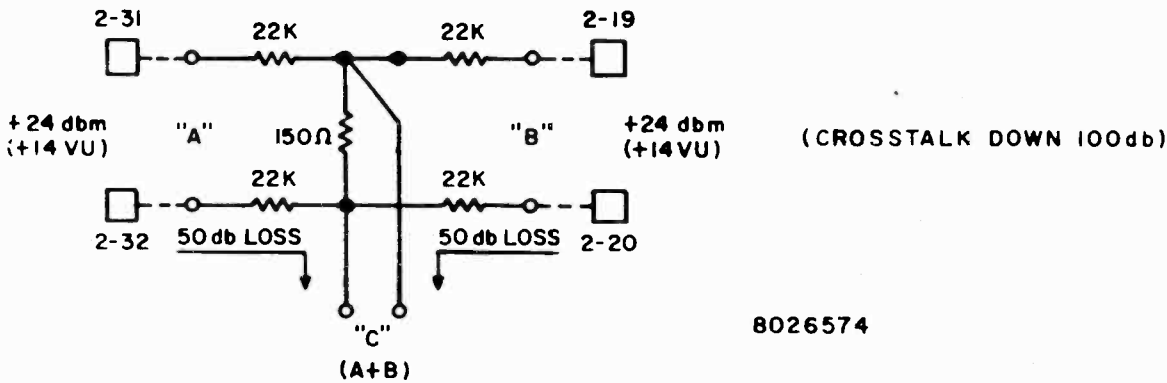

CALCULATION OF OUTPUT LEVEL AT C IN DBM OR VU FOR IN-PHASE SIGNALS

DBM (Sine Wave Osc. Test)	VU (Program Level Measured with VU Meter)	Explanation
+24 dbm 50 db	+14 dbm 50 db	Full output of BA-73 (At input A and input B, each) Loss from either A or B input to output C
-26 dbm 6 db	-36 dbm 6 db	Output level (Due to signal at either A or B) Additional signal (From either A or B, whichever not previously calculated)
-20 dbm	-30 VU	Total output level at C

Output C may be connected to the input of a BA-31 or BA-33 to bring the output up to a suitable level to operate a VU meter or approximately line level. Output C may also be connected to a BA-34 or BA-74 to be used to feed a monitor speaker.

Note that since A and B are vector quantities, the output at C is dependent on the frequency and phase of A and B as well as the rms magnitude. The portion of the output level at point C, due to signal A, is 50 db below the level at point A. The portion of the output level at point C, due to signal B, is 50 db below the level at point B.

1. If A and B are of equal frequency and amplitude and are in phase the combined output at C is 6 db higher than the level from the individual signals alone.

2. If A and B are of equal frequency and amplitude but are 180° out of phase, the combined output at C is zero.

3. If A and B are random signals of equal rms amplitude, the combined output at C is 3 db higher than the level from the individual signals.

The combined A and B signal for stereo programs varies depending on the instantaneous amplitude of both A and B signals, but at no time is more than 6 db higher than the larger of the two signals mixed. Thus it may be seen that monitoring the A and B signal, with a VU meter and a single monitor speaker, can be an aid in detecting out of phase signals and in setting level in multiplex stereo FM broadcasting.

PARTS LIST

Symbol	Stock No.	Drawing No.	Description
		-	MI-11657-A
		-	DUAL CHANNEL STEREO CONSOLETTA
		-	TYPE 6C7A
AT1 TO		-	
AT4	226024	8526065- 1	ATTENUATOR - 600 OHMS - SINGLE - TAPERED
AT5 TO		-	
AT8	226026	8529863- 1	ATTENUATOR - 600 OHMS - DUAL - TAPERED-CUE
AT9	226025	8526065- 2	ATTENUATOR - 600 OHMS - SINGLE TAPERED-CUE
AT10	226025	8526065- 2	ATTENUATOR - 600 OHMS - SINGLE TAPERED-CUE
AT11	226026	8529863- 1	ATTENUATOR - 600 OHMS - DUAL TAPERED-CUE
AT12	226024	8526065- 1	ATTENUATOR - 600 OHMS - SINGLE TAPERED-CUE
AT21	226027	8529863- 2	ATTENUATOR - 5000 OHMS - DUAL - 40 DB TOTAL
AT22	226028	8526065- 5	ATTENUATOR - 5000 OHM, SINGLE, 40 DB TOTAL
AT31	226052	8528803- 1	ATTENUATOR - 50 OHM L PAD
CR1 TO		-	
CR5	225592	-	DIODE - 1N3253
DS1 TO		-	
DS4	11891	990158- 13	LAMP - TYPE 44
J1 TO		-	
J3	226029	8526660- 1	JACK - PHONE
J4	226030	8526660- 2	JACK - PHONE
J101		-	
T0	209671	8414862- 53	CONNECTOR - FEMALE, 16 CONTACT
J112		-	
J121	221267	8414862- 54	CONNECTOR - FEMALE, 24 CONTACT
J122	221267	8414862- 54	CONNECTOR - FEMALE, 24 CONTACT
J131	209671	8414862- 53	CONNECTOR - FEMALE, 16 CONTACT
J141	209671	8414862- 53	CONNECTOR - FEMALE, 16 CONTACT
K1 TO		-	
K5	226031	8527565- 1	RELAY - 24 V D.C. 6 POLE D.T.
L1	226032	8443388- 2	REACTOR
LS1	218883	-	SPEAKER - 3 IN., 50 OHM
M1	226033	8745236- 2	METER - V.U.
M2	226033	8745236- 2	METER - V.U.
P106	217375	8414862- 3	CONNECTOR - MALE, 16 CONTACT
P107	217375	8414862- 3	CONNECTOR - MALE, 16 CONTACT
P108	217375	8414862- 3	CONNECTOR - MALE, 16 CONTACT
		-	RESISTORS - FIXED COMPOSITION, UNLESS NOTED
R1	300738	99206-160	1100 OHM $\pm 5\%$, 1/4 W
R2	108864	99206-151	470 OHM $\pm 5\%$, 1/4 W
R3	300738	99206-160	1100 OHM $\pm 5\%$, 1/4 W
R4	108864	99206-151	470 OHM $\pm 5\%$, 1/4 W
R5	300689	99206-154	620 OHM $\pm 5\%$, 1/4 W
R9	300738	99206-160	1100 OHM $\pm 5\%$, 1/4 W
R10	108864	99206-151	470 OHM $\pm 5\%$, 1/4 W
R11	300738	99206-160	1100 OHM $\pm 5\%$, 1/4 W
R12	108864	99206-151	470 OHM $\pm 5\%$, 1/4 W
R13	300689	99206-154	620 OHM $\pm 5\%$, 1/4 W
R17	300738	99206-160	1100 OHM $\pm 5\%$, 1/4 W
R18	108864	99206-151	470 OHM $\pm 5\%$, 1/4 W
R19	300738	99206-160	1100 OHM $\pm 5\%$, 1/4 W
R20	108864	99206-151	470 OHM $\pm 5\%$, 1/4 W
R21	300689	99206-154	620 OHM $\pm 5\%$, 1/4 W
R25	300738	99206-160	1100 OHM $\pm 5\%$, 1/4 W
R26	108864	99206-151	470 OHM $\pm 5\%$, 1/4 W
R27	300738	99206-160	1100 OHM $\pm 5\%$, 1/4 W
R28	108864	99206-151	470 OHM $\pm 5\%$, 1/4 W
R29	300689	99206-154	620 OHM $\pm 5\%$, 1/4 W
R33	300738	99206-160	1100 OHM $\pm 5\%$, 1/4 W
R34	108864	99206-151	470 OHM $\pm 5\%$, 1/4 W
R35	300738	99206-160	1100 OHM $\pm 5\%$, 1/4 W
R36	108864	99206-151	470 OHM $\pm 5\%$, 1/4 W
R37	300689	99206-154	620 OHM $\pm 5\%$, 1/4 W
R41	300738	99206-160	1100 OHM $\pm 5\%$, 1/4 W
R42	108864	99206-151	470 OHM $\pm 5\%$, 1/4 W
R43	300738	99206-160	1100 OHM $\pm 5\%$, 1/4 W
R44	108864	99206-151	470 OHM $\pm 5\%$, 1/4 W
R45	300689	99206-154	620 OHM $\pm 5\%$, 1/4 W

PARTS LIST (Continued)

Symbol	Stock No.	Drawing No.	Description
R51	300738	99206-160	1100 OHM $\pm 5\%$, 1/4 W
R52	108864	99206-151	470 OHM $\pm 5\%$, 1/4 W
R53	300738	99206-160	1100 OHM $\pm 5\%$, 1/4 W
R54	108864	99206-151	470 OHM $\pm 5\%$, 1/4 W
R55	300689	99206-154	620 OHM $\pm 5\%$, 1/4 W
R61	300738	99206-160	1100 OHM $\pm 5\%$, 1/4 W
R62	108864	99206-151	470 OHM $\pm 5\%$, 1/4 W
R63	300738	99206-160	1100 OHM $\pm 5\%$, 1/4 W
R64	108864	99206-151	470 OHM $\pm 5\%$, 1/4 W
R65	300689	99206-154	620 OHM $\pm 5\%$, 1/4 W
R71	300738	99206-160	1100 OHM $\pm 5\%$, 1/4 W
R72	108864	99206-151	470 OHM $\pm 5\%$, 1/4 W
R73	300738	99206-160	1100 OHM $\pm 5\%$, 1/4 W
R74	108864	99206-151	470 OHM $\pm 5\%$, 1/4 W
R75	300689	99206-154	620 OHM $\pm 5\%$, 1/4 W
R77	219462	99206-170	3000 OHM $\pm 5\%$, 1/4 W
R81	300738	99206-160	1100 OHM $\pm 5\%$, 1/4 W
R82	108864	99206-151	470 OHM $\pm 5\%$, 1/4 W
R83	300738	99206-160	1100 OHM $\pm 5\%$, 1/4 W
R84	108864	99206-151	470 OHM $\pm 5\%$, 1/4 W
R85	300689	99206-154	620 OHM $\pm 5\%$, 1/4 W
R87	228878	99206-129	56 OHM $\pm 5\%$, 1/4 W
R86	228878	99206-129	56 OHM $\pm 5\%$, 1/4 W
R91	300689	99206-154	620 OHM $\pm 5\%$, 1/4 W
R92	300689	99206-154	620 OHM $\pm 5\%$, 1/4 W
R93	300689	99206-154	620 OHM $\pm 5\%$, 1/4 W
R94	300689	99206-154	620 OHM $\pm 5\%$, 1/4 W
R101	300689	99206-154	620 OHM $\pm 5\%$, 1/4 W
R102	219446	99206-190	20,000 OHM $\pm 5\%$, 1/4 W
R103	219446	99206-190	20,000 OHM $\pm 5\%$, 1/4 W
R104	300689	99206-154	620 OHM $\pm 5\%$, 1/4 W
R105	300689	99206-154	620 OHM $\pm 5\%$, 1/4 W
R106	300689	99206-154	620 OHM $\pm 5\%$, 1/4 W
R110	300729	99206-175	4700 OHM $\pm 5\%$, 1/4 W
R111	300689	99206-154	620 OHM $\pm 5\%$, 1/4 W
R112	300729	99206-175	4700 OHM $\pm 5\%$, 1/4 W
R113	300729	99206-175	4700 OHM $\pm 5\%$, 1/4 W
R114	300689	99206-154	620 OHM $\pm 5\%$, 1/4 W
R115	300729	99206-175	4700 OHM $\pm 5\%$, 1/4 W
R119	300689	99206-154	620 OHM $\pm 5\%$, 1/4 W
R120	219446	99206-190	20,000 OHM $\pm 5\%$, 1/4 W
R121	219446	99206-190	20,000 OHM $\pm 5\%$, 1/4 W
R122	300689	99206-154	620 OHM $\pm 5\%$, 1/4 W
R123	300689	99206-154	620 OHM $\pm 5\%$, 1/4 W
R124	300689	99206-154	620 OHM $\pm 5\%$, 1/4 W
R128	-	-	-
TO	260044	8527503-112	W.W. 20 OHM $\pm 5\%$, 3 W
R137	-	-	-
R140	104382	867970-314	W.W. 1 OHM $\pm 10\%$, 1/2 W
R141	502024	82283-120	24 OHM $\pm 5\%$, 1/2 W
R142	502024	82283-120	24 OHM $\pm 5\%$, 1/2 W
R143	512110	90496-135	100 OHM $\pm 5\%$, 1 W
R145	-	-	-
TO	300163	8527503-122	W.W. 50 OHM $\pm 5\%$, 3 W
R150	-	-	-
R156	-	-	-
TO	502247	82283-175	4700 OHM $\pm 5\%$, 1/2 W
R165	-	-	-
R168	-	-	-
TO	502162	82283-154	620 OHM $\pm 10\%$, 1/2 W
R172	-	-	-
R174	-	-	-
TO	502230	82283-170	3000 OHM $\pm 5\%$, 1/2 W
R191	-	-	-
R195	-	-	-
TO	502010	82283-111	10 OHM $\pm 5\%$, 1/2 W
R200	-	-	-
R203	-	-	-
TO	502147	82283-151	470 OHM $\pm 5\%$, 1/2 W
R210	-	-	-

PARTS LIST (Continued)

































Symbol	Stock No.	Drawing No.	Description
R213 TO	300163	8527503-122	W.W. 50 OHM $\pm 5\%$, 3 W
R216			
R219	502122	82283-143	220 OHM $\pm 5\%$, 1/2 W
R220	502122	82283-143	220 OHM $\pm 5\%$, 1/2 W
R222	502010	82283-111	10 OHM $\pm 5\%$, 1/2 W
RV1 TO			
RV5	218583	8979094- 1	VARISTOR MI-11657 ONLY
S1 TO	226034	8526657- 1	SWITCH - LEVER
S8	226034	8526657- 1	SWITCH - LEVER
S9 TO	226035	8526657- 2	SWITCH - LEVER
S15	226035	8526657- 2	SWITCH - LEVER
S21 TO	226036	8526657- 3	SWITCH - LEVER
S30	226036	8526657- 3	SWITCH - LEVER
S41	226037	8526657- 4	SWITCH - LEVER
S42	226037	8526657- 4	SWITCH - LEVER
S43	226038	8526657- 6	SWITCH - LEVER
S51	226039	8480152- 1	SWITCH - ROTARY
S52	226039	8480152- 1	SWITCH - ROTARY
S61	226040	8746935- 1	SWITCH - ROTARY
S62	228701	8541081- 1	SWITCH - PUSH TO TALK
S62	226041	8480111- 1	SWITCH - PUSH MI-11657 ONLY
S63	226042	8480124- 1	SWITCH - ROTARY
S71	226043	8526657- 5	SWITCH - LEVER
S72	226043	8526657- 5	SWITCH - LEVER
S81	226044	449605- 12	SWITCH - D.P.S.T. POWER
XDS1 TO	227352	8532157- 1	SOCKET - LAMP
XDS4			
	226045	8526684-501	BOARD - PRINTED COMPONENT ASSEMBLY - 2 REQD
R1 TO			
R3	502162	82283-154	620 OHM $\pm 5\%$, 1/2 W
R4	502247	8228-317	4700 OHM $\pm 5\%$, 1/2 W
R5	502247	8228-317	4700 OHM $\pm 5\%$, 1/2 W
R6 TO			
R9	502310	82283-183	10,000 OHM $\pm 5\%$, 1/2 W
R10	502247	82283-175	4700 OHM $\pm 5\%$, 1/2 W
R11	502247	82283-175	4700 OHM $\pm 5\%$, 1/2 W
R12	502110	82283-135	100 OHM $\pm 5\%$, 1/2 W
R13	502110	82283-135	100 OHM $\pm 5\%$, 1/2 W
R14	502256	82283-177	5600 OHM $\pm 5\%$, 1/2 W
R15	502227	82283-169	2700 OHM $\pm 5\%$, 1/2 W
R16	502162	82283-154	620 OHM $\pm 5\%$, 1/2 W
R17 TO			
R20	502110	82283-135	100 OHM $\pm 5\%$, 1/2 W
R21	502220	82283-166	2000 OHM $\pm 5\%$, 1/2 W
			MISCELLANEOUS
	226046	8469384-501	BOARD - TERMINAL ASSEMBLY (CONTROL CIRCUIT PATCH BOARD)
	228699	8491355- 10	FASTENER - RECEPTACLE, PUSH BUTTON
	228698	8491355- 1	FASTENER - STUD, PUSH BUTTON
	96755	8877363- 1	HANDLE - BLACK, FOR LEVER SWITCH (12 USED)
	94442	8877363- 3	HANDLE - BLUE, FOR LEVER SWITCH (8 USED)
	96929	8877363- 5	HANDLE - GREEN, FOR LEVER SWITCH (3 USED)
	94441	8877363- 2	HANDLE - RED, FOR LEVER SWITCH (4 USED)
	250203	712336-507	KNOB - BLACK, GAIN - CUE/INTERCOM
	17269	737820-501	KNOB - BLACK, 2 1/8 IN. DIA., ATTENUATOR (5 USED)
	94444	737803-501	KNOB - BLUE, 2 1/8 IN. DIA. ATTENUATOR (3 USED)
	226049	737804-503	KNOB - GREEN, 1 1/2 IN. DIA. ATTENUATOR (2 USED)
	96928	737804-502	KNOB - GREEN, 2 1/8 IN. DIA.
	226050	737805-502	KNOB - RED, 1 1/2 IN. DIA. ATTENUATOR (2 USED)
	94446	737805-501	KNOB - RED, 2 1/8 IN. DIA.
	226047	8529802- 1	KNOB - PULL, PANEL (2 USED)
	97717	8527501- 1	KNOB - SWITCH (5 USED)
	227350	8486052- 3	LABELS - (1 SET OF PRESSURE SENSITIVE LABELS)
	226048	8469462- 1	LATCH - PANEL, (2 USED) MI-11657
	228700	8491355- 11	RETAINER - PUSH BUTTON FASTENER

PARTS LIST (Continued)

Symbol	Stock No.	Drawing No.	Description
	101592	8888539-143	SCREW - SET 8-32 X 1/4 LG. (KNOBS)
	14974	8888539-142	SCREW - SET, 8-32 FOR AT31 CONTROL KNOB
	94647	182167- 3	SUPPORT - FALL (2 USED)
	227697	-	TOUCH-UP PAINT FOR VINYL FINISH ONLY
		-	(16-OZ AEROSOL CAN - SHADOW BLUE)
		-	
		MI-13395--1	2 COND. SHIELDED CABLE VINYL JACKET,
		-	AS USED IN BC7A INTERNAL WIRING

CHART OF OPERATING CONTROLS

NOTE: Titles enclosed in rectangle  or  represent panel depression provided to accept changeable metal label. The label indicated is suggested as typical.

SYMBOL	Knob color & type	LOCATION ON PANEL	PANEL DESIGNATION	DESCRIPTION	FUNCTION.
INPUT SWITCHES					
S-1	BLUE lever	ABOVE MIXER #1	 STU A  STU B  STU C	MIXER #1 SOURCE SELECTOR SWITCH	Selects input to mixer #1 thru plug-in unit #1 (normally a pre-amplifier). Typical sources: Microphone #1 of studio A, B & C.
S-2	BLUE lever	ABOVE MIXER #2	 STU A  STU B  STU C	MIXER #2 SOURCE SELECTOR SWITCH	Selects input to mixer #2 thru plug-in unit #2 (normally a pre-amplifier). Typical sources: Microphone #2 of studio A, B & C.
S-3	BLUE lever	ABOVE MIXER #3	 STU A  STU B  STU C	MIXER #3 SOURCE SELECTOR SWITCH	Selects input to mixer #3 thru plug-in unit #3 (normally a pre-amplifier). Typical sources: Microphone #3 of studio A, B & C.
S-4	BLUE lever	ABOVE MIXER #4	 STU A  STU B  STU C	MIXER #4 SOURCE SELECTOR SWITCH	Selects input to mixer #4 thru plug-in unit #4 (normally a pre-amplifier). Typical sources: Microphone #4 of studio A, B & C.
S-5	RED lever	ABOVE MIXER #5	 STU A  AN  BTH  CR	MIXER #5 SOURCE SELECTOR SWITCH	Selects input to mixer #5 thru plug-in units 5 & 5A (normally 2 pre-amps (2nd pre-amp. for STEREO override)). Typical sources: Microphone 5 of studio A, Announce Booth Mic, Control Room Mic.
S-6	RED lever	ABOVE MIXER #6	 TT 1  TAPE 1  PROJ 1	MIXER #6 SOURCE SELECTOR SWITCH	Selects input to mixer #6 thru plug-in unit #6 (normally a jumper plug). Typical sources: Turntable, tape recorder, cartridge tape unit or projector.
S-7	RED lever	ABOVE MIXER #7	 TT 2  TAPE 2  PROJ 2	MIXER #7 SOURCE SELECTOR SWITCH	Selects input to mixer #7 thru plug-in unit #7 (normally a jumper plug). Typical sources: Turntable, tape recorder, cartridge tape unit or projector.
S-8	RED lever	ABOVE MIXER #8	 TT 3  TAPE 3  TAPE 4	MIXER #8 SOURCE SELECTOR SWITCH	Selects input to mixer #8 thru plug-in unit #8 (normally a jumper plug). Typical sources: Turntable, tape recorder, cartridge tape unit.
S-9	GREEN lever	ABOVE MIXER 9 left	 NET	MIXER #9 SOURCE DELEGATION SWITCH	Delegates network line to mixer #9 (up); termination (center) or mixer #10 (down) thru plug-in unit #9 or #10 (normally a high level isolation unit).
S-10	GREEN lever	ABOVE MIXER 9 center	 AUX 1	MIXER #9 SOURCE DELEGATION SWITCH	Delegates auxiliary line #1 to mixer #9 (up); termination (center) or mixer #10 (down) thru plug-in unit #9 or #10 (normally a high level isolation unit).
S-11	GREEN lever	ABOVE MIXER 9 right	 AUX 2	MIXER #9 SOURCE DELEGATION SWITCH	Delegates auxiliary line #2 to mixer #9 (up); termination (center) or mixer #10 (down) thru plug-in unit #9 or #10 (normally a high level isolation unit).
S-12	BLUE lever	ABOVE MIXER 10 left	 REM 1	PGM CUE MIXER #10 SOURCE DELEGATION SWITCH	Connects remote line #1 to monitor amplifier output (up); to intercom (center); or to mixer #10 (down) thru plug-in unit #10 (normally a high level isolation unit).
S-13	BLUE lever	ABOVE MIXER #10	 REM 2	PGM CUE MIXER #10 SOURCE DELEGATION SWITCH	Connects remote line #2 to monitor amplifier output (up); to intercom (center); or to mixer #10 (down) thru plug-in unit #10 (normally a high level isolation unit).
S-14	BLUE lever	ABOVE MIXER #10	 REM 3	PGM CUE MIXER #10 SOURCE DELEGATION SWITCH	Connects remote line #3 to monitor amplifier output (up); to intercom (center); or to mixer #10 (down) thru plug-in unit #10 (normally a high level isolation unit).
S-15	BLUE lever	ABOVE MIXER 10 right	 REM 4	PGM CUE MIXER #10 SOURCE DELEGATION SWITCH	Connects remote line #4 to monitor amplifier output (up); to intercom (center); or to mixer #10 (down) thru plug-in unit #10 (normally a high level isolation unit).
MIXER OUTPUT DELEGATION SWITCHES					
S-21	BLACK lever	ABOVE MIXER #1	CH 1 CH 2	MIXER #1 DELEGATION SWITCH	Delegates output of mixer #1 to either CH 1 (left channel program amplifier) or CH 2 (right channel program amplifier) mixer bus (center position is off).
S-22	BLACK lever	ABOVE MIXER #2	CH 1 CH 2	MIXER #2 DELEGATION SWITCH	Delegates output of mixer #2 to either CH 1 (left channel program amplifier) or CH 2 (right channel program amplifier) mixer bus (center position is off).
S-23	BLACK lever	ABOVE MIXER #3	CH 1 CH 2	MIXER #3 DELEGATION SWITCH	Delegates output of mixer #3 to either CH 1 (left channel program amplifier) or CH 2 (right channel program amplifier) mixer bus (center position is off).
S-24	BLACK lever	ABOVE MIXER #4	CH 1 CH 2	MIXER #4 DELEGATION SWITCH	Delegates output of mixer #4 to either CH 1 (left channel program amplifier) or CH 2 (right channel program amplifier) mixer bus (center position is off).
S-25	BLACK lever	ABOVE MIXER #5	CH 1 STEREO	MIXER #5 DELEGATION SWITCH	Delegates output of mixer #5 to CH 1 or CH 2 mixer bus for monaural operation; or delegates output to both CH 1 and CH 2 mixer busses (stereo override) for stereo operation.
S-26	BLACK lever	ABOVE MIXER #6	CH 1 STEREO	MIXER #6 DELEGATION SWITCH	Delegates monaural output of mixer #6 to CH 1 or CH 2 mixer bus for monaural operation; or delegates stereo output to R & L channel mixer busses for stereo operation (center position is off).
S-27	BLACK lever	ABOVE MIXER #7	CH 1 STEREO	MIXER #7 DELEGATION SWITCH	Delegates monaural output of mixer #7 to CH 1 or CH 2 mixer bus for monaural operation; or delegates stereo output to R & L channel mixer busses for stereo operation (center position is off).
S-28	BLACK lever	ABOVE MIXER #8	CH 1 STEREO	MIXER #8 DELEGATION SWITCH	Delegates monaural output of mixer #8 to CH 1 or CH 2 mixer bus for monaural operation; or delegates stereo output to R & L channel mixer busses for stereo operation (center position is off).

Continuation of chart of operating controls and the BC-7A Audio Functional Diagram and Control Panels appear on opposite page. Please fold up and out. The BC-7A Schematic/Wiring Diagram follows on page 39. For convenience, a larger Schematic is included on the envelope.

CHART OF OPERATING CONTROLS (Cont'd.)

SYMBOL	KNOB color & type	LOCATION OF PANEL	PANEL DESIGNATION	DESCRIPTION	FUNCTION
MIXER OUTPUT DELEGATION SWITCHES (Cont'd.)					
S-29	BLACK lever	ABOVE MIXER #9	CH 1 CH 2	MIXER #9 DELEGATION SWITCH	Delegates output of mixer #9 to CH 1 or CH 2, mixer bus. Center position is off.
S-30	BLACK lever	ABOVE MIXER #10	CH 1 CH 2	MIXER #10 DELEGATION SWITCH	Delegates output of mixer #10 to CH 1 or CH 2, mixer bus. Center position is off.
LINE OUT SWITCHES					
S-41	BLACK lever	TOP PANEL center	CH 1 LINE 1 CH 2	PROGRAM LINE 1 OUT SWITCH	Connects Program Output Line 1 thru 6 db dividing network to Pgm. Amp. 1 or Pgm. Amp. 2. Center position terminates line.
S-42	BLACK lever	TOP PANEL center	CH 1 LINE 2 CH 2	PROGRAM LINE 2 OUT SWITCH	Connects Program Output Line 2 thru 6 db dividing network to Pgm. Amp. 1 or Pgm. Amp. 2. Center position terminates line.
MODE SELECTOR SWITCH					
S-43	RED lever	TOP PANEL center	STEREO PARALLEL DUAL	MODE SELECTOR SWITCH	STEREO: Gains L & R Master & Monitor Gain controls and connects R input to Mixer 5, 6, 7 & 8. PARALLEL: Connects Pgm. amps in parallel after gain controls, thus Master 1 & 2 become Submaster 1 & 2. DUAL: Two independent channels.
MONITOR INPUT SELECTOR SWITCHES					
S-51	BLACK rotary	ABOVE MIXER #3	AUX 1 CH 1 CH 2 AUX 2	MONITOR 1 SOURCE SELECTOR SWITCH	Selects input to Monitor 1. Choice of right or left pgm. amp. or either of two external auxiliary sources.
S-52	BLACK rotary	ABOVE MIXER #8	AUX 1 CH 1 CH 2 AUX 2	MONITOR 2 SOURCE SELECTOR SWITCH	Selects input to Monitor 2. Choice of right or left pgm. amp. or either of two external auxiliary sources.
INTERCOM SWITCHES					
S-61	BLACK rotary	CENTER OF PANEL	REMOTES CUE STUDIOS MET	INTERCOM SELECTOR SWITCH	Selects studios or remote lines for two way communication, and monitors CUE bus and network line. OVERRIDE simultaneously monitors all remote lines.
S-62	BLACK push	CENTER OF PANEL	PUSH TO TALK	PUSH TO TALK SWITCH	Switches cue/intercom amplifier for consolette combination microphone/loudspeaker to "send" or "receive" signals from selected positions.
MONITOR PHONES SELECTOR SWITCH					
S-63	BLACK rotary	TOP PANEL left	PHONES	MONITOR PHONES SELECTOR SWITCH	Connects monitor phones (plugged in J-3) to key points in consolette through isolation network.
AUXILIARY SWITCHES					
S-71	BLACK lever	TOP LEFT		AUXILIARY SWITCH #1	Unwired auxiliary switch for special needs of individual stations. Two pair of form "D" (make before break) contacts are provided.
S-72	BLACK lever	TOP LEFT		AUXILIARY SWITCH #2	Unwired auxiliary switch for special needs of individual stations. Two pair of form "D" (make before break) contacts are provided.
POWER SWITCH					
S-81	BLACK rotary	TOP PANEL right	OFF ON	MAIN POWER SWITCH	Controls main 60 cps power to consolette. (also, auxiliary mixer consolettes if used).
VARIABLE ATTENUATORS (MIXERS OR FADERS)					
AT-1	BLACK	BOTTOM	1	MIXER#1 (2 dia)	Controls gain of mixer channel #1 (normally used for microphones).
AT-2	BLACK	BOTTOM	2	MIXER#2 (2 dia)	Controls gain of mixer channel #2 (normally used for microphones).
AT-3	BLACK	BOTTOM	3	MIXER#3 (2 dia)	Controls gain of mixer channel #3 (normally used for microphones).
AT-4	BLACK	BOTTOM	4	MIXER#4 (2 dia)	Controls gain of mixer channel #4 (normally used for microphones).
AT-5	BLACK	BOTTOM	5	MIXER#5 (2 dia)	Controls gain of mixer channel #5 (normally used for microphones).
AT-6	BLUE	BOTTOM	6	MIXER#6 (2 dia)	Controls gain of mixer channel #6 (normally used for rec. inputs).
AT-7	BLUE	BOTTOM	7	MIXER#7 (2 dia)	Controls gain of mixer channel #7 (normally used for rec. inputs).
AT-8	BLUE	BOTTOM	8	MIXER#8 (2 dia)	Controls gain of mixer channel #8 (normally used for rec. inputs).
AT-9	GREEN	BOTTOM	9	MIXER#9 (2 dia)	Controls gain of mixer channel #9 (normally used for Net or Aux.).
AT-10	RED	BOTTOM	10	MIXER#10 (2 dia)	Controls gain of mixer channel #10 (normally used for Remotes).
MONITOR - MASTER & INTERCOM GAIN CONTROLS					
AT-11	GREEN 1/4" dia.	TOP LEFT	MONITOR 1	LEFT OR STEREO MONITOR GAIN CONTROL	Controls gain of the left monitor amplifier (#1) for DUAL or PARALLEL operation and the gain of both monitors for STEREO operation.
AT-12	GREEN 1/4" dia.	TOP RIGHT	MONITOR 2	RIGHT MONITOR GAIN CONTROL	Controls gain of the right monitor amplifier (#2) for DUAL or PARALLEL operation and is disconnected from the circuit for STEREO operation.
AT-21	RED 1/4" dia.	TOP LEFT	MASTER 1	LEFT OR STEREO MASTER GAIN CONTROL	Controls gain of pgm. amp. #1 for DUAL operation; controls gain of input section of pgm. amp. #1 for PARALLEL operation (becoming Submaster 1); controls gain of both pgm. amps for STEREO.
AT-22	RED 1/4" dia.	TOP RIGHT	MASTER 2	RIGHT MASTER GAIN CONTROL	Controls gain of pgm. amp. #2 for DUAL operation; controls gain of input section of pgm. amp. #2 for PARALLEL operation (becoming Submaster 2); is disconnected for STEREO operation.
AT-31	BLACK rotary	BOTTOM CENTER	GAIN	INTERCOM OUTPUT LEVEL CONTROL	Controls listening level. (AGC feature automatically adjusts amplifier gain to minimize effect of input level variation. Manual gain control after AGC loop sets listening level.)

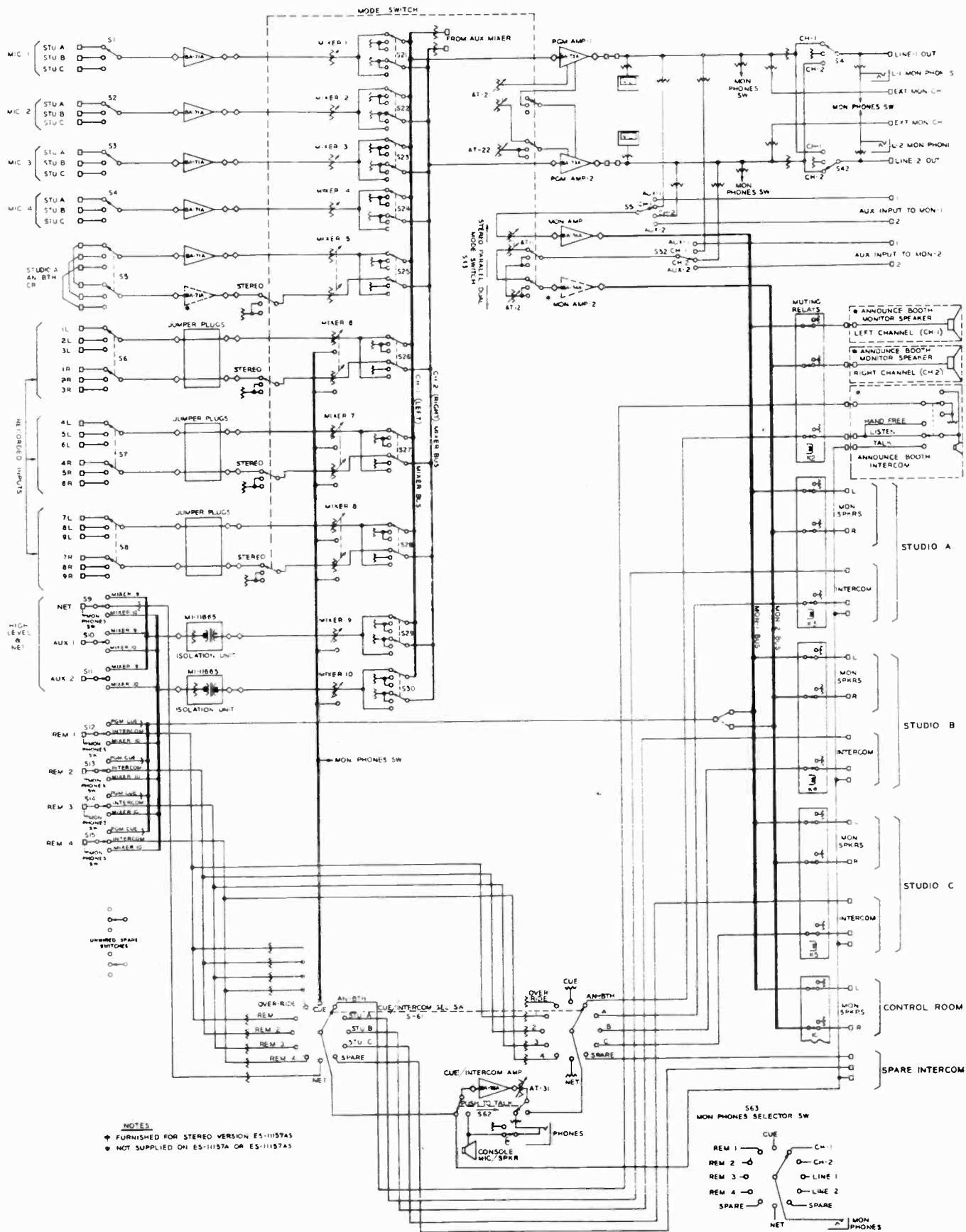

Figure 25. Audio Functional Diagram

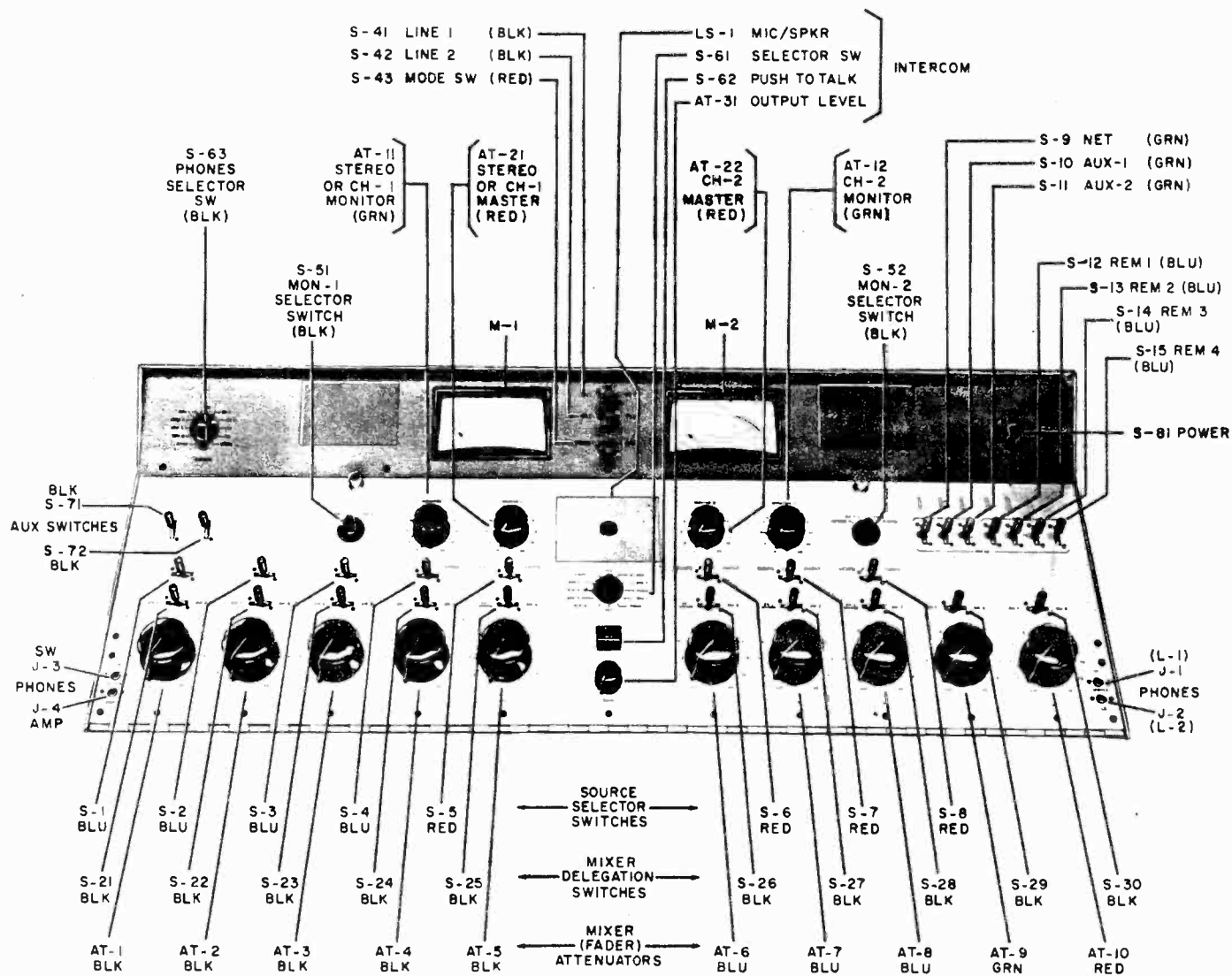
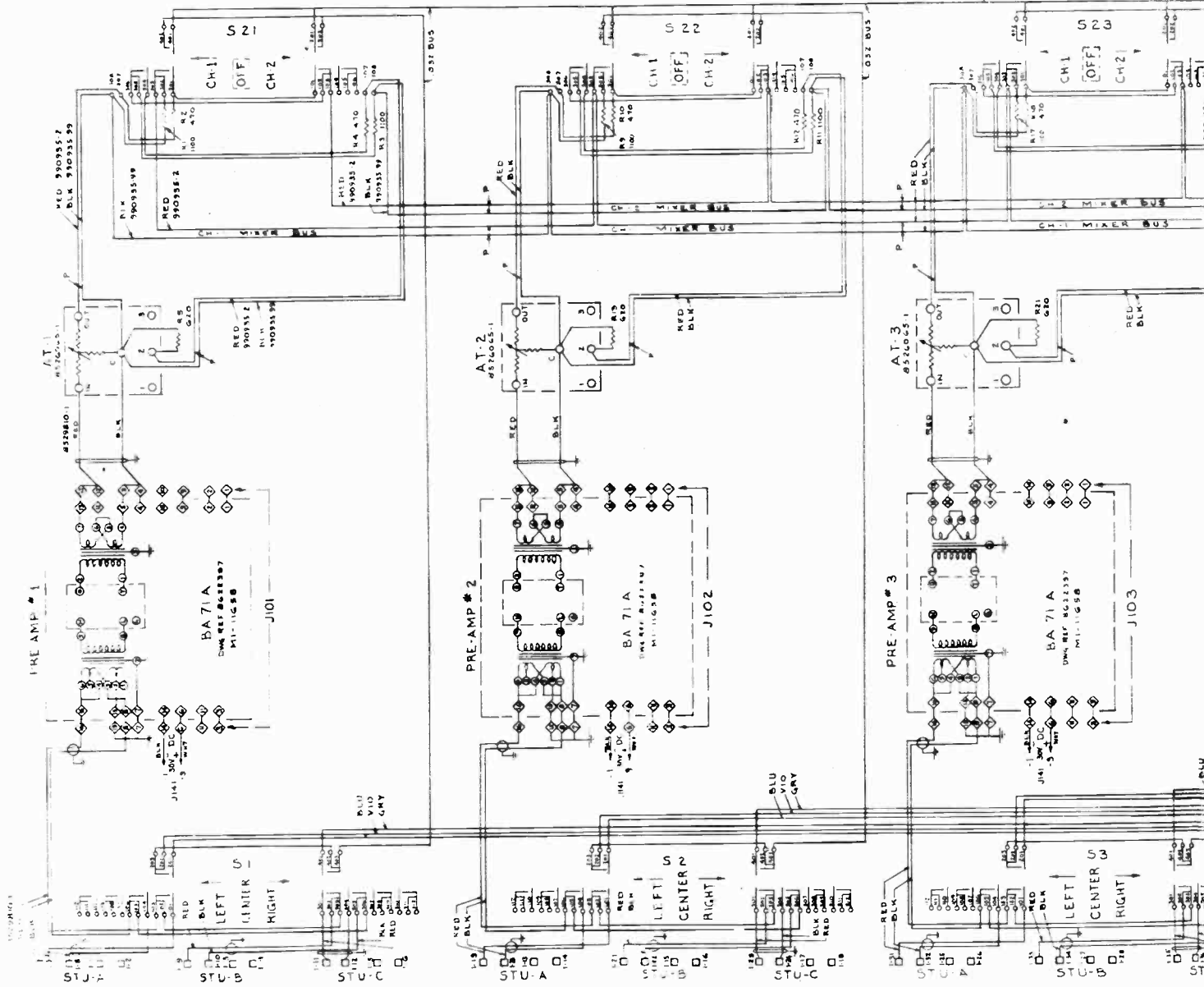

Figure 24. Control Panels



TEAR ALONG DOTTED LINE

MONITOR OUTPUTS
THRU INTERLOCK RELAYS

TERMINAL BLOCK CONNECTIONS
TB-2

AUX INPUTS
TO MONITORS

JUMPER
CONNECTIONS

1	MON-2 OUTPUT TO REMOOTES MI	2	MON-2 OUTPUT TO REMOOTES MI	3	MON-1 OUTPUT TO REMOOTES MI	4	MON-1 OUTPUT TO REMOOTES MI	5	MON-1 OUTPUT TO REMOOTES MI	6	MON-1 OUTPUT TO REMOOTES MI	7	MON-1 OUTPUT TO REMOOTES MI	8	MON-1 OUTPUT TO REMOOTES MI	9	MON-1 OUTPUT TO REMOOTES MI	10	MON-1 OUTPUT TO REMOOTES MI	11	MON-1 OUTPUT TO REMOOTES MI	12	MON-1 OUTPUT TO REMOOTES MI	13	MON-1 OUTPUT TO REMOOTES MI	14	MON-1 OUTPUT TO REMOOTES MI	15	MON-1 OUTPUT TO REMOOTES MI	16	MON-1 OUTPUT TO REMOOTES MI	17	MON-1 OUTPUT TO REMOOTES MI	18	MON-1 OUTPUT TO REMOOTES MI	19	MON-1 OUTPUT TO REMOOTES MI	20	MON-1 OUTPUT TO REMOOTES MI	21	MON-1 OUTPUT TO REMOOTES MI	22	MON-1 OUTPUT TO REMOOTES MI	23	MON-1 OUTPUT TO REMOOTES MI	24	MON-1 OUTPUT TO REMOOTES MI	25	MON-1 OUTPUT TO REMOOTES MI	26	MON-1 OUTPUT TO REMOOTES MI	27	MON-1 OUTPUT TO REMOOTES MI	28	MON-1 OUTPUT TO REMOOTES MI	29	MON-1 OUTPUT TO REMOOTES MI	30	MON-1 OUTPUT TO REMOOTES MI	31	MON-1 OUTPUT TO REMOOTES MI	32	MON-1 OUTPUT TO REMOOTES MI	33	MON-1 OUTPUT TO REMOOTES MI	34	MON-1 OUTPUT TO REMOOTES MI	35	MON-1 OUTPUT TO REMOOTES MI	36	MON-1 OUTPUT TO REMOOTES MI	37	MON-1 OUTPUT TO REMOOTES MI	38	MON-1 OUTPUT TO REMOOTES MI	39	MON-1 OUTPUT TO REMOOTES MI	40	MON-1 OUTPUT TO REMOOTES MI	41	MON-1 OUTPUT TO REMOOTES MI	42	MON-1 OUTPUT TO REMOOTES MI	43	MON-1 OUTPUT TO REMOOTES MI	44	MON-1 OUTPUT TO REMOOTES MI	45	MON-1 OUTPUT TO REMOOTES MI	46	MON-1 OUTPUT TO REMOOTES MI	47	MON-1 OUTPUT TO REMOOTES MI	48	MON-1 OUTPUT TO REMOOTES MI	49	MON-1 OUTPUT TO REMOOTES MI	50	MON-1 OUTPUT TO REMOOTES MI	51	MON-1 OUTPUT TO REMOOTES MI	52	MON-1 OUTPUT TO REMOOTES MI	53	MON-1 OUTPUT TO REMOOTES MI	54	MON-1 OUTPUT TO REMOOTES MI	55	MON-1 OUTPUT TO REMOOTES MI	56	MON-1 OUTPUT TO REMOOTES MI	57	MON-1 OUTPUT TO REMOOTES MI	58	MON-1 OUTPUT TO REMOOTES MI	59	MON-1 OUTPUT TO REMOOTES MI	60	MON-1 OUTPUT TO REMOOTES MI	61	MON-1 OUTPUT TO REMOOTES MI	62	MON-1 OUTPUT TO REMOOTES MI	63	MON-1 OUTPUT TO REMOOTES MI	64	MON-1 OUTPUT TO REMOOTES MI	65	MON-1 OUTPUT TO REMOOTES MI	66	MON-1 OUTPUT TO REMOOTES MI	67	MON-1 OUTPUT TO REMOOTES MI	68	MON-1 OUTPUT TO REMOOTES MI	69	MON-1 OUTPUT TO REMOOTES MI	70	MON-1 OUTPUT TO REMOOTES MI	71	MON-1 OUTPUT TO REMOOTES MI	72	MON-1 OUTPUT TO REMOOTES MI	73	MON-1 OUTPUT TO REMOOTES MI	74	MON-1 OUTPUT TO REMOOTES MI	75	MON-1 OUTPUT TO REMOOTES MI	76	MON-1 OUTPUT TO REMOOTES MI	77	MON-1 OUTPUT TO REMOOTES MI	78	MON-1 OUTPUT TO REMOOTES MI	79	MON-1 OUTPUT TO REMOOTES MI	80	MON-1 OUTPUT TO REMOOTES MI	81	MON-1 OUTPUT TO REMOOTES MI	82	MON-1 OUTPUT TO REMOOTES MI	83	MON-1 OUTPUT TO REMOOTES MI	84	MON-1 OUTPUT TO REMOOTES MI	85	MON-1 OUTPUT TO REMOOTES MI	86	MON-1 OUTPUT TO REMOOTES MI	87	MON-1 OUTPUT TO REMOOTES MI	88	MON-1 OUTPUT TO REMOOTES MI	89	MON-1 OUTPUT TO REMOOTES MI	90	MON-1 OUTPUT TO REMOOTES MI	91	MON-1 OUTPUT TO REMOOTES MI	92	MON-1 OUTPUT TO REMOOTES MI	93	MON-1 OUTPUT TO REMOOTES MI	94	MON-1 OUTPUT TO REMOOTES MI	95	MON-1 OUTPUT TO REMOOTES MI	96	MON-1 OUTPUT TO REMOOTES MI	97	MON-1 OUTPUT TO REMOOTES MI	98	MON-1 OUTPUT TO REMOOTES MI	99	MON-1 OUTPUT TO REMOOTES MI	100	MON-1 OUTPUT TO REMOOTES MI	101	MON-1 OUTPUT TO REMOOTES MI	102	MON-1 OUTPUT TO REMOOTES MI	103	MON-1 OUTPUT TO REMOOTES MI	104	MON-1 OUTPUT TO REMOOTES MI	105	MON-1 OUTPUT TO REMOOTES MI	106	MON-1 OUTPUT TO REMOOTES MI	107	MON-1 OUTPUT TO REMOOTES MI	108	MON-1 OUTPUT TO REMOOTES MI	109	MON-1 OUTPUT TO REMOOTES MI	110	MON-1 OUTPUT TO REMOOTES MI	111	MON-1 OUTPUT TO REMOOTES MI	112	MON-1 OUTPUT TO REMOOTES MI	113	MON-1 OUTPUT TO REMOOTES MI	114	MON-1 OUTPUT TO REMOOTES MI	115	MON-1 OUTPUT TO REMOOTES MI	116	MON-1 OUTPUT TO REMOOTES MI	117	MON-1 OUTPUT TO REMOOTES MI	118	MON-1 OUTPUT TO REMOOTES MI	119	MON-1 OUTPUT TO REMOOTES MI	120	MON-1 OUTPUT TO REMOOTES MI
---	---	---	---	---	---	---	---	---	---	---	---	---	---	---	---	---	---	----	---	----	---	----	---	----	---	----	---	----	---	----	---	----	---	----	---	----	---	----	---	----	---	----	---	----	---	----	---	----	---	----	---	----	---	----	---	----	---	----	---	----	---	----	---	----	---	----	---	----	---	----	---	----	---	----	---	----	---	----	---	----	---	----	---	----	---	----	---	----	---	----	---	----	---	----	---	----	---	----	---	----	---	----	---	----	---	----	---	----	---	----	---	----	---	----	---	----	---	----	---	----	---	----	---	----	---	----	---	----	---	----	---	----	---	----	---	----	---	----	---	----	---	----	---	----	---	----	---	----	---	----	---	----	---	----	---	----	---	----	---	----	---	----	---	----	---	----	---	----	---	----	---	----	---	----	---	----	---	----	---	----	---	----	---	----	---	----	---	----	---	----	---	----	---	----	---	----	---	-----	---	-----	---	-----	---	-----	---	-----	---	-----	---	-----	---	-----	---	-----	---	-----	---	-----	---	-----	---	-----	---	-----	---	-----	---	-----	---	-----	---	-----	---	-----	---	-----	---	-----	---

OUTPUTS FROM
PGM AMPS TO
EXT MONITORS

INTERCOM LINES AND
STUDIO MARKING
LIGHT LINES

NOTE
* INDICATES TERMINAL ASSIGNED BUT NOT FACTORY WIRED

444444

TEAR ALONG DOTTED LINE

TERMINAL BLOCK CONNECTIONS

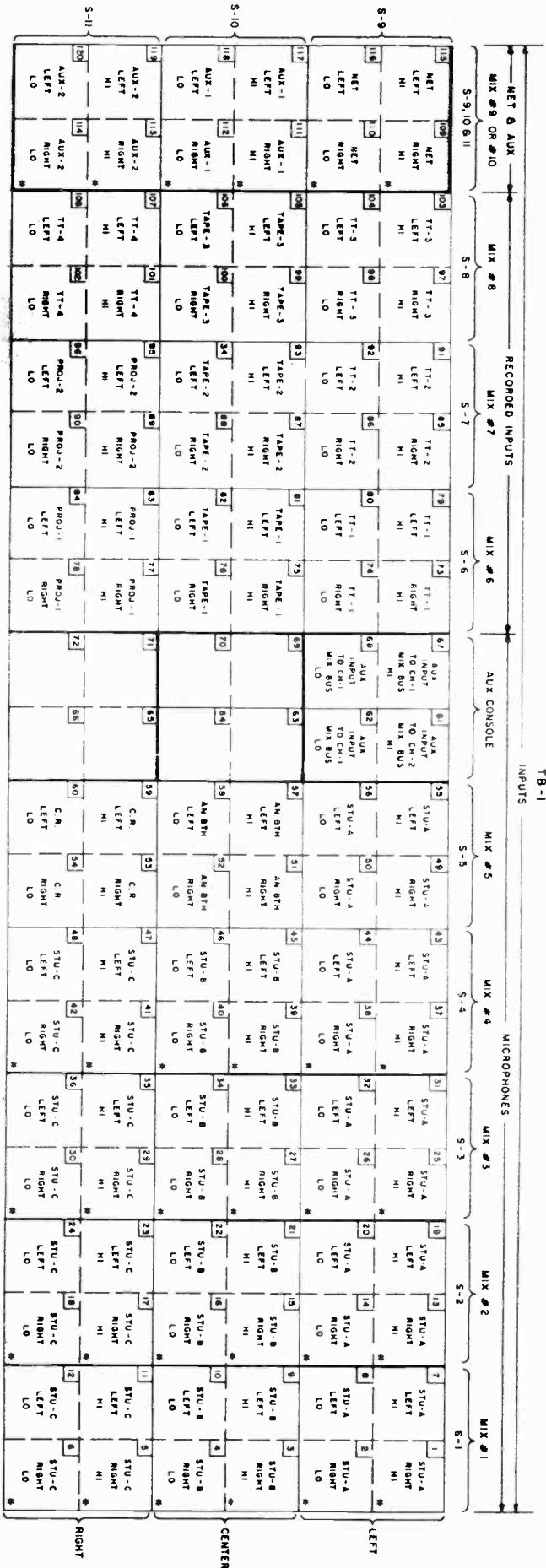

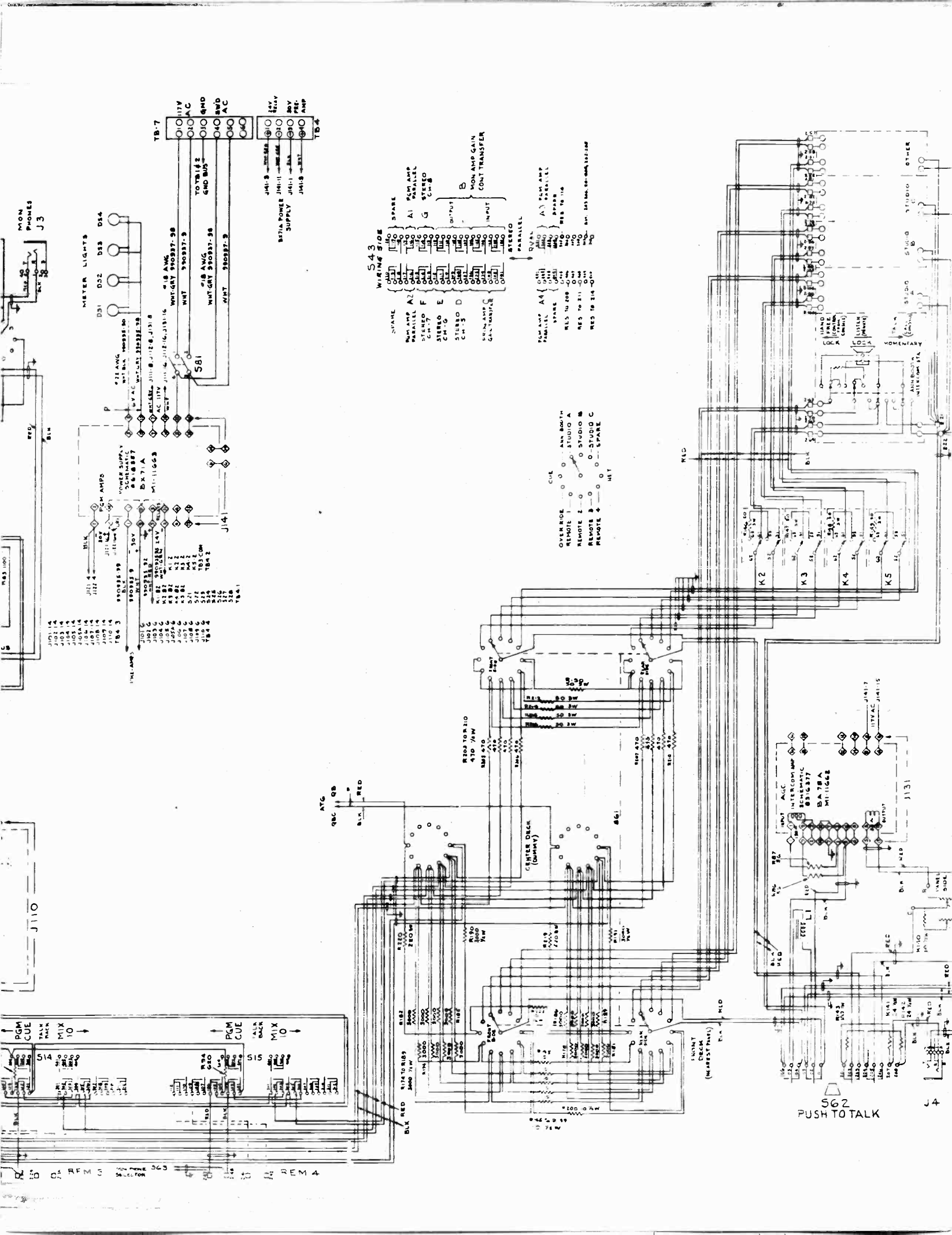

MON PHONES
J3

METER LIGHTS
DS1 DS2 DS3 DS4

PGM CUE
TALK MIX IO

CENTER DECK (OMNIV)

INTERCOM SYSTEM
J113

TO TALK
GND BUS

METER LIGHTS
DS1 DS2 DS3 DS4

PGM CUE
TALK MIX IO

WIRING SIDE
MON AMP
STEREO
MON AMP GAIN
PARALLEL

METER LIGHTS
DS1 DS2 DS3 DS4

MIX IO
TALK

TO TALK
GND BUS

INTERCOM SYSTEM
J113

WIRING SIDE
MON AMP
STEREO
MON AMP GAIN
PARALLEL

METER LIGHTS
DS1 DS2 DS3 DS4

TO TALK
GND BUS

METER LIGHTS
DS1 DS2 DS3 DS4

PGM CUE
TALK MIX IO

WIRING SIDE
MON AMP
STEREO
MON AMP GAIN
PARALLEL

METER LIGHTS
DS1 DS2 DS3 DS4

TO TALK
GND BUS

METER LIGHTS
DS1 DS2 DS3 DS4

PGM CUE
TALK MIX IO

WIRING SIDE
MON AMP
STEREO
MON AMP GAIN
PARALLEL

METER LIGHTS
DS1 DS2 DS3 DS4

TO TALK
GND BUS

METER LIGHTS
DS1 DS2 DS3 DS4

PGM CUE
TALK MIX IO

WIRING SIDE
MON AMP
STEREO
MON AMP GAIN
PARALLEL

METER LIGHTS
DS1 DS2 DS3 DS4

TO TALK
GND BUS

METER LIGHTS
DS1 DS2 DS3 DS4

PGM CUE
TALK MIX IO

WIRING SIDE
MON AMP
STEREO
MON AMP GAIN
PARALLEL

METER LIGHTS
DS1 DS2 DS3 DS4

TO TALK
GND BUS

METER LIGHTS
DS1 DS2 DS3 DS4

PGM CUE
TALK MIX IO

WIRING SIDE
MON AMP
STEREO
MON AMP GAIN
PARALLEL

METER LIGHTS
DS1 DS2 DS3 DS4

TO TALK
GND BUS

METER LIGHTS
DS1 DS2 DS3 DS4

PGM CUE
TALK MIX IO

WIRING SIDE
MON AMP
STEREO
MON AMP GAIN
PARALLEL

METER LIGHTS
DS1 DS2 DS3 DS4

TO TALK
GND BUS

METER LIGHTS
DS1 DS2 DS3 DS4

PGM CUE
TALK MIX IO

WIRING SIDE
MON AMP
STEREO
MON AMP GAIN
PARALLEL

METER LIGHTS
DS1 DS2 DS3 DS4

TO TALK
GND BUS

METER LIGHTS
DS1 DS2 DS3 DS4

PGM CUE
TALK MIX IO

WIRING SIDE
MON AMP
STEREO
MON AMP GAIN
PARALLEL

METER LIGHTS
DS1 DS2 DS3 DS4

TO TALK
GND BUS

METER LIGHTS
DS1 DS2 DS3 DS4

PGM CUE
TALK MIX IO

WIRING SIDE
MON AMP
STEREO
MON AMP GAIN
PARALLEL

METER LIGHTS
DS1 DS2 DS3 DS4

TO TALK
GND BUS

METER LIGHTS
DS1 DS2 DS3 DS4

PGM CUE
TALK MIX IO

WIRING SIDE
MON AMP
STEREO
MON AMP GAIN
PARALLEL

METER LIGHTS
DS1 DS2 DS3 DS4

TO TALK
GND BUS

METER LIGHTS
DS1 DS2 DS3 DS4

PGM CUE
TALK MIX IO

WIRING SIDE
MON AMP
STEREO
MON AMP GAIN
PARALLEL

METER LIGHTS
DS1 DS2 DS3 DS4

TO TALK
GND BUS

METER LIGHTS
DS1 DS2 DS3 DS4

PGM CUE
TALK MIX IO

WIRING SIDE
MON AMP
STEREO
MON AMP GAIN
PARALLEL

METER LIGHTS
DS1 DS2 DS3 DS4

MON AMP

STEREO

MON AMP GAIN

PARALLEL

MON AMP

STEREO

MON AMP GAIN

PARALLEL

MON AMP

STEREO

MON AMP

STEREO

MON AMP GAIN

PARALLEL

MON AMP

STEREO

MON AMP GAIN

PARALLEL

MON AMP

STEREO

MON AMP

STEREO

MON AMP GAIN

PARALLEL

MON AMP

STEREO

MON AMP GAIN

PARALLEL

MON AMP

STEREO

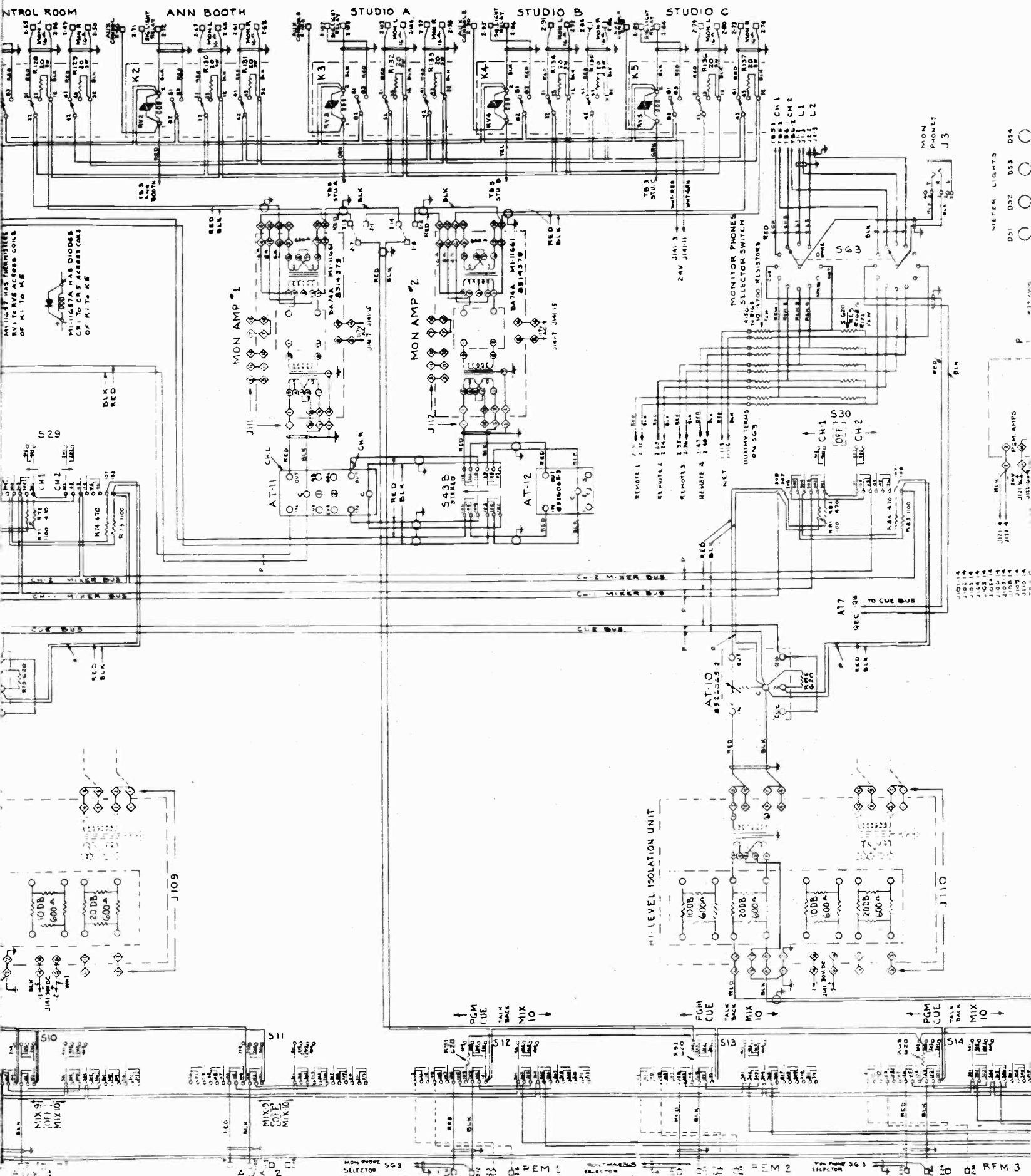

- METER LIGHTS
- DS1
 - DS2
 - DS3
 - DS4
- PGM AMPS
- J101-14
 - J101-14
 - J102-14
 - J103-14
 - J104-14
 - J105-14
 - J106-14
 - J107-14
 - J108-14
 - J109-14
 - J110-14

- 1.10
- 1.11
- 1.12
- 1.13
- 1.14
- 1.15
- 1.16
- 1.17
- 1.18
- 1.19
- 1.20
- 1.21
- 1.22
- 1.23
- 1.24
- 1.25
- 1.26
- 1.27
- 1.28
- 1.29
- 1.30

- 2.1
- 2.2
- 2.3
- 2.4
- 2.5
- 2.6
- 2.7
- 2.8
- 2.9
- 2.10
- 2.11
- 2.12
- 2.13
- 2.14
- 2.15
- 2.16
- 2.17
- 2.18
- 2.19
- 2.20

TYPICAL CONNECTIONS
S9 TO S15 WIRING SIDE

- 3.1
- 3.2
- 3.3
- 3.4
- 3.5
- 3.6
- 3.7
- 3.8
- 3.9
- 3.10
- 3.11
- 3.12
- 3.13
- 3.14
- 3.15
- 3.16
- 3.17
- 3.18
- 3.19
- 3.20

- 4.1
- 4.2
- 4.3
- 4.4
- 4.5
- 4.6
- 4.7
- 4.8
- 4.9
- 4.10
- 4.11
- 4.12
- 4.13
- 4.14
- 4.15
- 4.16
- 4.17
- 4.18
- 4.19
- 4.20

TYPICAL CONNECTIONS
S21 TO S30 WIRING SIDE

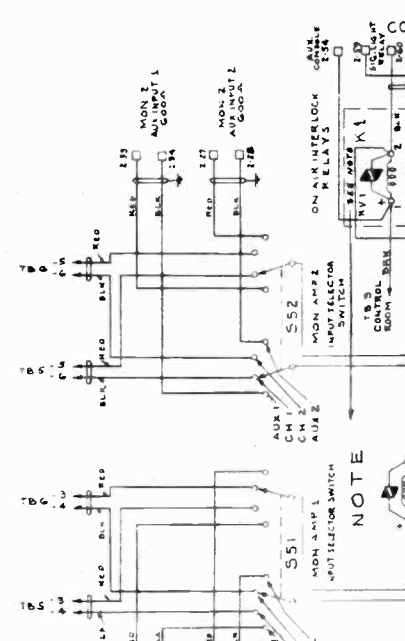
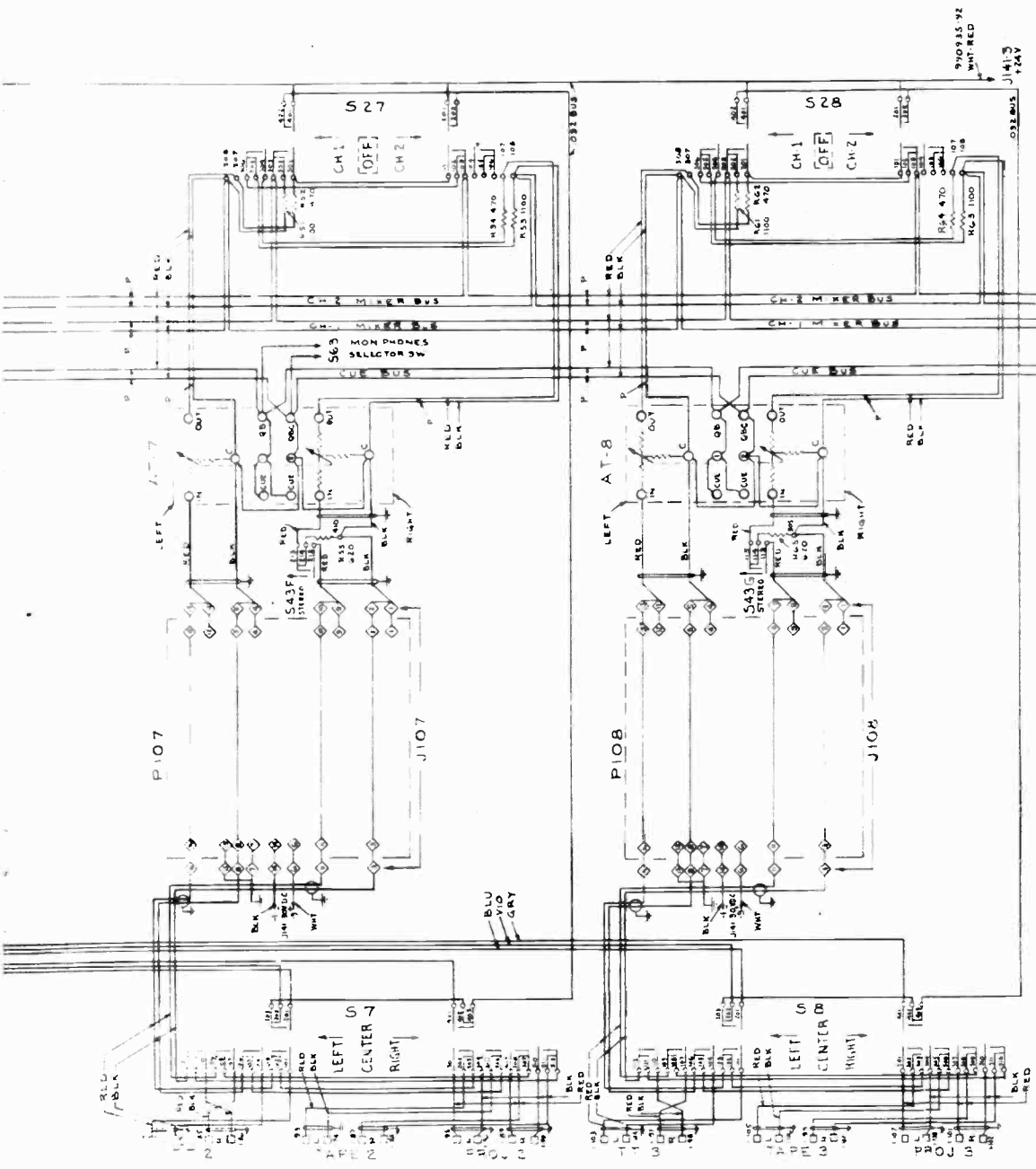

NOTE

PI109
HI-LEVEL ISOLATION UNIT

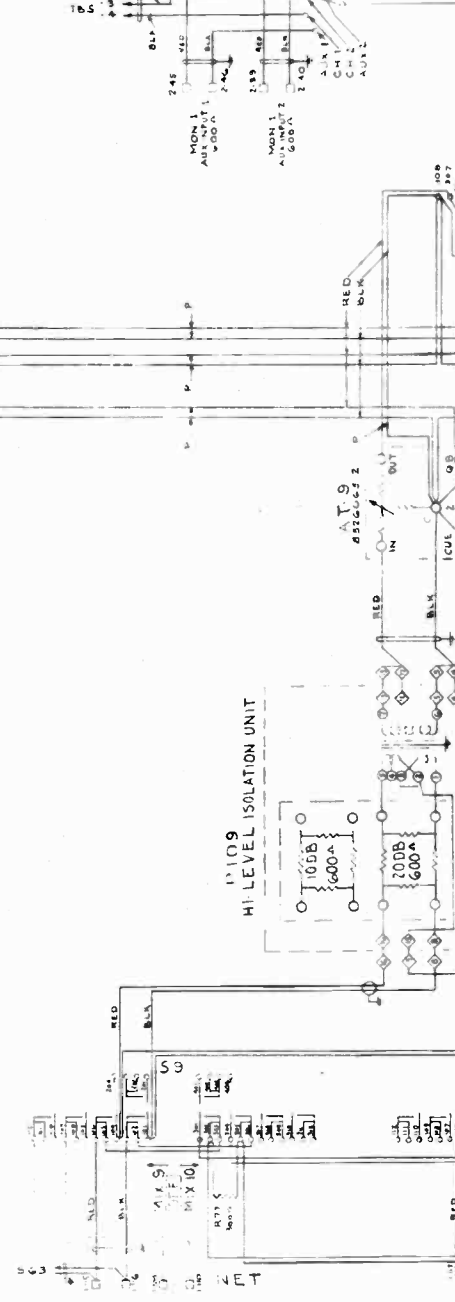

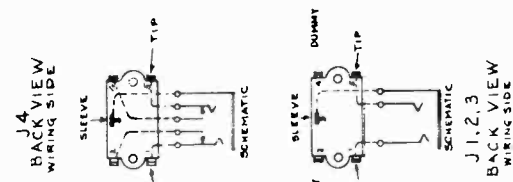
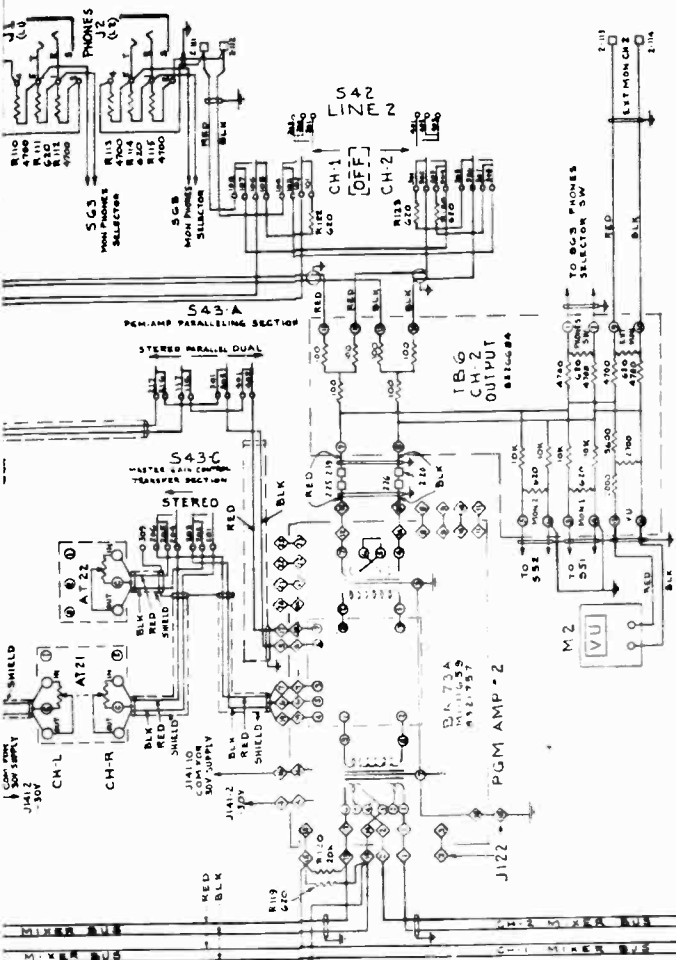

TYPICAL CONNECTIONS
S110 SB WIRING SIDE

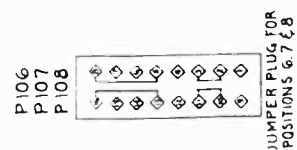
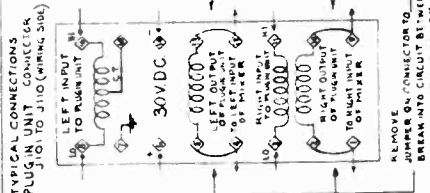
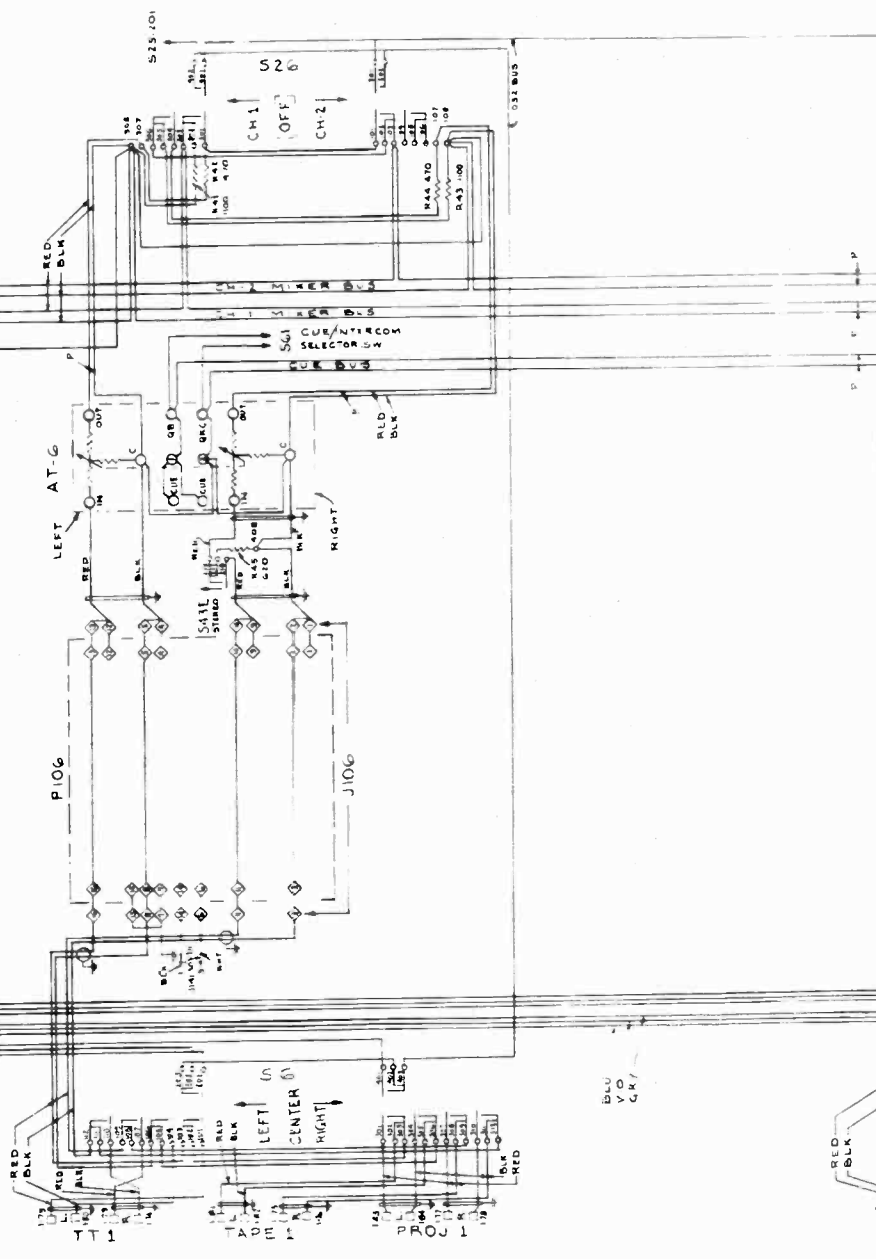
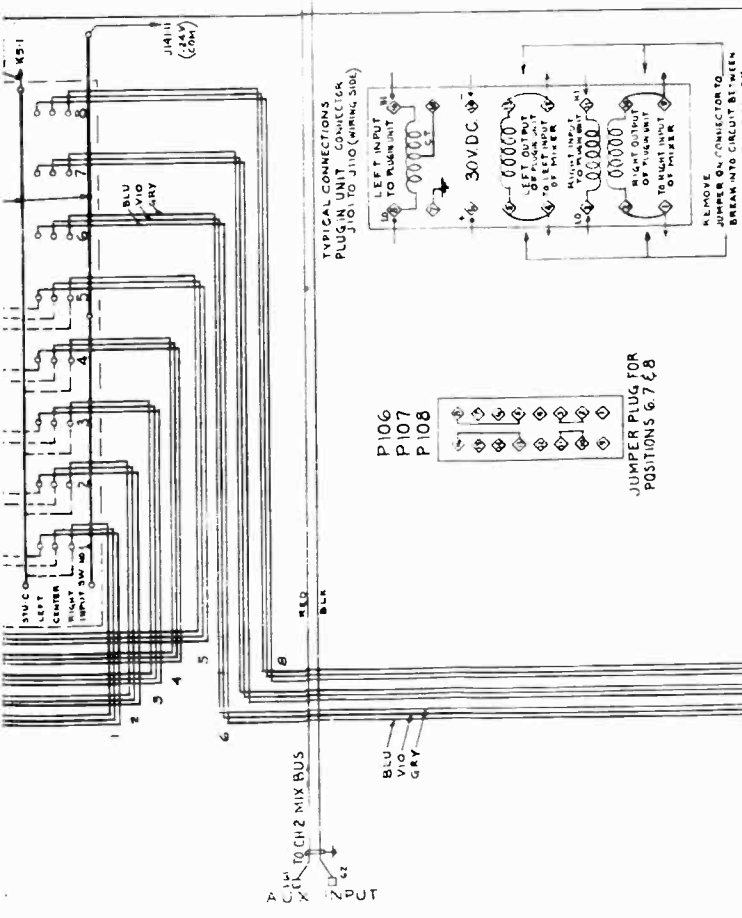

CH-1 TO CH-2 MIX BUS
 PUT

BLU
 VIO
 GR/

RED
 BLK

