

Broadcast Systems

RCA **Radio
Equipment**

AM Transmitters
FM Transmitters
Exciters, Monitors
STL, Remote Control
Transmission Line
Antennas, Towers

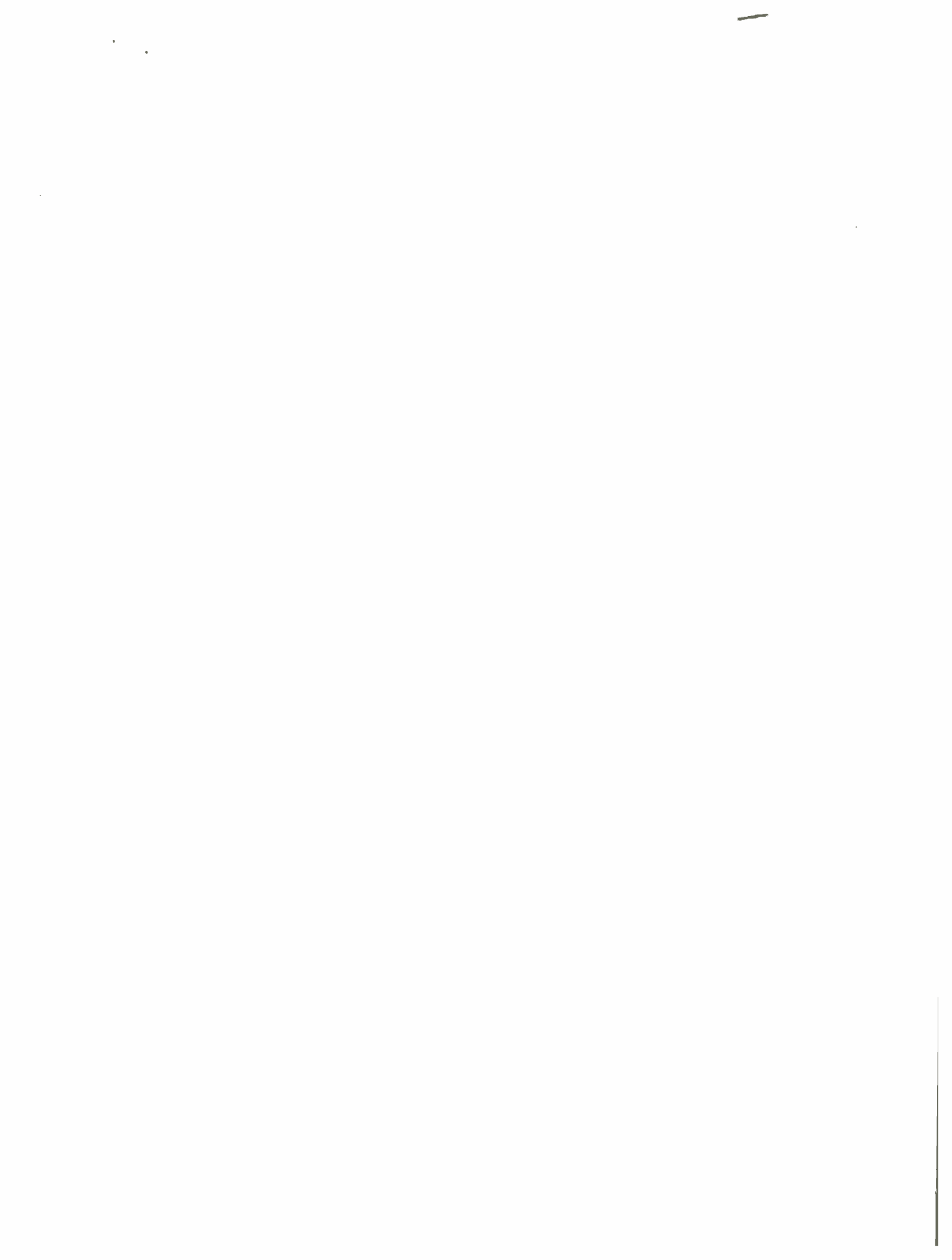



About This Catalog

This is one of several catalogs published by RCA Broadcast Systems Department. It describes products that serve the transmitter and antenna portions of the radio-broadcast plant.

For the audio portion of the plant, RCA publishes a companion catalog that describes microphones; control consoles; automatic program equipment; intercom/interphone gear; amplifiers and signal processors; racks, cabinets, furniture, rack equipment; turntables and tone arms; cartridge and reel tape equipment; loudspeakers and accessories and audio test equipment.

For TV broadcasting, companion catalogs describe camera equipment; terminal and switching gear; UHF- and VHF-TV transmitters, transmission line, towers and antennas.

These catalogs are available at RCA Regional Offices (see list, next page). Each office is staffed by a sales representative with broad experience in the broadcast business. He can help you plan your equipment facilities and supply the information you need.

Contents

AM Transmitters

One-Kilowatt Transmitter, Type BTA-1S	RA.1011A
One-Kilowatt Transmitter, Type BTA-1N1	RA.1021A
Five-Kilowatt Transmitter, Type BTA-5L1	RA.1031A
Ten-Kilowatt Transmitter, Type BTA-10L1	RA.1041A
Fifty-Kilowatt Transmitter, Type BTA-50J	RA.1061A
100-Kilowatt Transmitter, Type BTA-100J	RA.1071A
200-Kilowatt Transmitter, Type BTA-200J	RA.1071A

AM Monitors

Modulation and Frequency Monitor, BW-50	RA.1111A
RF Amplifier, Type BW-60	RA.1111A

FM Transmitters

FM Exciter System, Type BTE-15A	RA.2011A
Ten Watt Educational Transmitter, BTE-10AT	RA.2011A
One-Kilowatt Transmitter, Type BTF-1E2	RA.2021A
Two-Kilowatt Transmitter, Type BTF-1+1E2	RA.2021A
Two-Kilowatt Transmitter, Type BTF-1/1E2	RA.2021A
Three-Kilowatt Transmitter, Type BTF-3E1	RA.2031A
Six-Kilowatt Transmitter, Type BTF-3+3E1	RA.2031A
Three-Kilowatt Dual Transmitter, BTF-3/3E1	RA.2031A
Five-Kilowatt Economy Transmitter, BTF-5E2	RA.2037A
Five-Kilowatt Dual Transmitter, BTF-5E1	RA.2041A
Ten-Kilowatt Dual Transmitter, BTF-5+5E1	RA.2041A
Five-Kilowatt Dual Transmitter, BTF-5/5E1	RA.2041A
Ten-Kilowatt Transmitter, Type BTF-10E1	RA.2051A
Twenty-Kilowatt Transmitter, BTF-10+10E1	RA.2051A
Ten-Kilowatt Dual Transmitter, BTF-10/10E1	RA.2051A
Twenty-Kilowatt Transmitter, Type BTF-20E1	RA.2061A
Forty-Kilowatt Transmitter, Type BTF-40E1	RA.2071A

FM Monitors

Frequency and Modulation Monitor, BW-75A	RA.2111A
Stereo Freq. and Mod. Monitor, BW-85A	RA.2111A
SCA Freq. and Mod. Monitor, BW-95A	RA.2111A
RF Amplifier, Type BW-100	RA.2111A

Remote Control Equipment

Sixty-Function Remote Control, BTR-30A1	RA.3011A
Thirty-Function Remote Control, BTR-15B	RA.3021A
Extension Control/Metering Panel, BTC-2	RA.3031A
Remote Control Accessories	RA.3051A
Automatic Logging Equipment	RA.3061A

Remote Program Pickup and STL Equipment

RPL and STL Equipment (Radio)	RA.4011A
-------------------------------	----------

Transmission Line Equipment

Rigid and Flexible Transmission Line	RA.5011A
Transmission Line Hangers	RA.5021A
Transmission Line Pressurization Equipment	RA.5031A
Transmission Line Co-Ax Switches	RA.5041A

AM Antenna Equipment

Towers for AM or FM	RA.6011B
AM Tuning Units, 250, 1000W	RA.6111A
AM Antenna Phasing Equipment	RA.6211A
Accessories for Antennas	RA.6311A
Antenna Monitors, Type AM-19 (204), PM-19	RA.6411A
Field-Strength Meters	RA.6511A

FM Antenna Equipment

Towers for AM or FM	RA.6011B
Antenna, Type BFC-	RA.7011A
Antenna, Type BFG-	RA.7111A
Antenna, Type BFH-	RA.7211A
Antenna, Type BFI-	RA.7311A
Horizontally Polarized Antenna, Type BFA-	RA.7511A
Multiple-Station Antennas, BFD-, BFE-, BFF-	RA.7611A
RF Loads and Wattmeters	RA.7711A
Tower Isolators, Types BAF-15A, -16A	RA.7811A
Antenna Ice Detector, Rosemount	RA.7911A
Thermostatic Sleetmelter Control	RA.7921A



Regional Offices

(Subject to change without notice)

Atlanta, Ga. 30329
14 Executive Park Dr., N.E.
404-634-6131

Austin, Tex. 78758
Northwest Office Park Bldg.
8330 Burnet Rd., Suite 134
512-451-2500

Birmingham, Ala. 35223
Office Park Bldg. #10
Office Park Circle
205-871-1155

Boston Area:
Wellesley, Mass. 02181
Wellesley Office Park
617-237-6050

Camden, N. J. 08102
Front & Cooper Sts.
609-963-8000

Charlotte, N. C. 28210
6230 Fairview Rd., Suite 104
704-366-0626

Chicago, Ill. 60606
Gateway II Bldg., Suite 1400
120 S. Riverside Plaza
312-782-0700

Cincinnati, O. 45231
11430 Hamilton Ave.
513-825-1550

Dallas, Tex. 75247
RCA Center
8700 Stemmons Freeway
214-638-6200

Denver, Colo. 80211
2701 Alcott St., Suite 384
303-433-8484

Detroit: Southfield, Mich. 48075
24333 Southfield Rd., Suite 209
313-357-0080

Hollywood, Calif. 90028
RCA Corp., Suite 531
6363 Sunset Blvd.
213-461-9171

Jacksonville, Fla. 32207
2747 Art Museum Dr.
Suite 5
904-398-4588

Kansas City Area:
Overland Park, Kans. 66207
5750 West 95th St., Suite 111
913-642-3185, 6, 7

Pittsburgh, Pa. Area:
McMurray, Pa. 15317
761 N. Washington Blvd.
412-941-5570

Minneapolis, Minn. 55416
4522 Excelsior Blvd.
612-920-6395, 6

New York, N. Y. 10036
1133 Avenue of the Americas, 5th Floor
212-586-3000

San Francisco, Calif. 94102
420 Taylor St., Suite 401-408
415-441-2200

St. Louis, Mo. 63105
7701 Forsyth Blvd., Suite 455
314-862-3660

Seattle, Wash. 98119
408 Second Ave., W.
206-285-2375

Washington, D. C. Area:
Arlington, Va. 22209
1901 North Moore St.
703-558-4212

West Palm Beach, Fla. 33403
Palm Beach Gardens, Bldg. 110
3900 RCA Blvd.
305-622-1100

RCA International Marketing Subsidiaries (Subject to change without notice)

Argentina

Buenos Aires
RCA International Limited
Calle Paroissien 3960
Telephone: 70-4171

Australia 2113

North Ryde, N.S.W.
RCA Limited
11 Khartoum Road
Telephone: 888-5444

Australia 3121

Richmond, Victoria
RCA Limited
2-4 Stephenson Street
Telephone: 42-4586

Brazil

Rio de Janeiro-GB
RCA Telesistemas Ltda.
Rua Correa Dutra, 126-4And
Telephone: 245-9209

Canada

Ste. Anne de Bellevue, 810 P.Q.
RCA Limited
21001 North Service Road
Telephone: (514) 457-9000

Toronto 15, Ontario
RCA Limited
1450 Castlefield Avenue
Telephone: (416) 651-6550

Vancouver, British Columbia
RCA Limited
2876 Rupert Street
at Grandview Highway
Telephone: (604) 433-0541

Hong Kong

RCA International Limited
1927 Prince's Building
Chater Road, G.P.O. 112
Telephone: H 234181

Mexico

Mexico 17, D.F.
RCA S.A. de C.V.
Avenida Cuicahuac 2519
Telephone: 5-27-60-20 Ext. 104

Switzerland

Geneva
RCA International Marketing S.A.
118 rue du Rhone, CH 1204
Telephone: 35-82-00

United Kingdom

Jersey Isle
RCA Jersey Limited
Longueville Road, St. Saviour
Telephone: CENTRAL 35355



One-Kilowatt AM Transmitter, Type BTA-1S

- Excellent frequency response, low distortion
- Low operating costs
- Circuit breaker overload protection
- Positive peak modulation capability: 125%

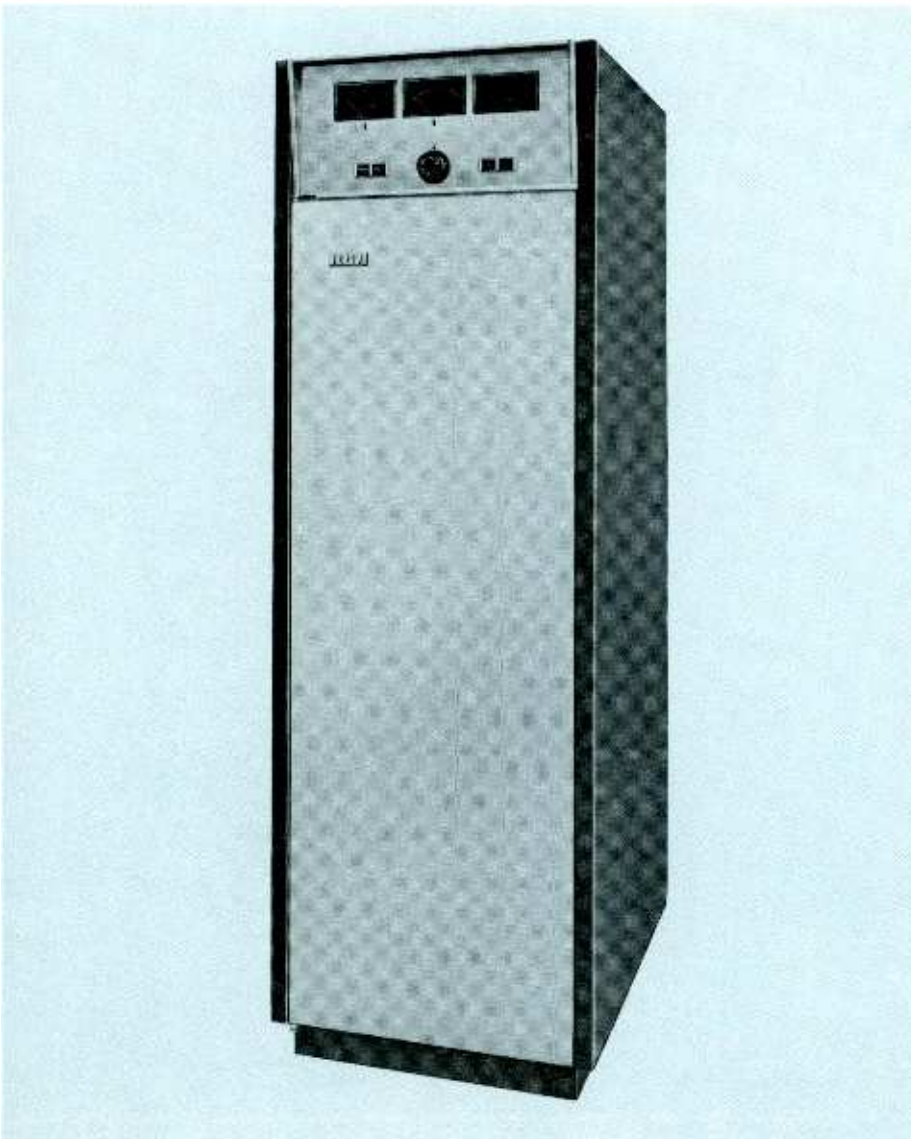

The RCA Type BTA-1S, 1-kilowatt AM Broadcast Transmitter is designed for reliability, outstanding fidelity, and economical operation. It provides a high quality amplitude modulated signal at any frequency in the 535 to 1620 kilohertz band and is capable of producing a maximum of 1100 watts.

Highly perfected audio circuits together with a large, high-quality modulation transformer and reactor provide 125-percent positive-peak modulation capability and unusually high fidelity sound. Stable, long-life tubes and solid-state devices have been used throughout the transmitter. Circuit breakers, *not fuses*, provide complete overload protection.

Provision for remote control and simplified power cutback are reflected in the BTA-1S design. Front panel or remote control selection of any two power levels of 1000, 500 or 250 watts is available. No unnecessarily complicated circuitry or superfluous parts have been included and all components are easily accessible for maintenance and inspection.

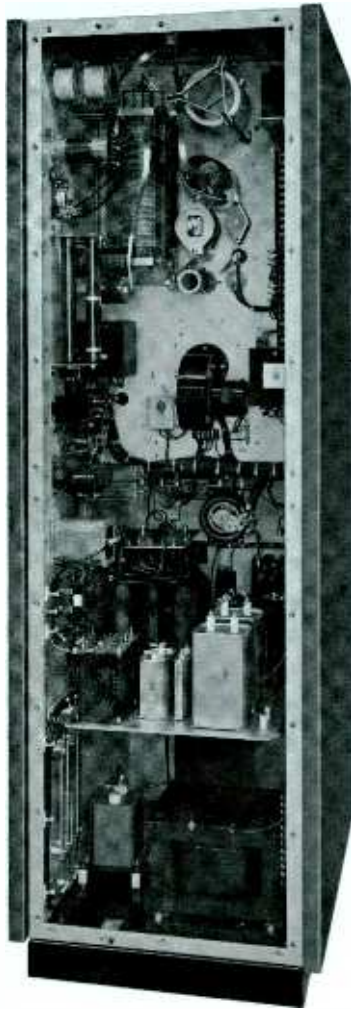

Unimpeded rear access to the transmitter is afforded by the full length door and the well laid out, vertical construction. Power supply components at bottom; r-f components at top.

Type BTA-1S Transmitter with outer and inner door open to display accessibility to the tubes. Power amplifier and modulator tubes are near top while the lower chassis carries the audio-amplifier and intermediate stages.

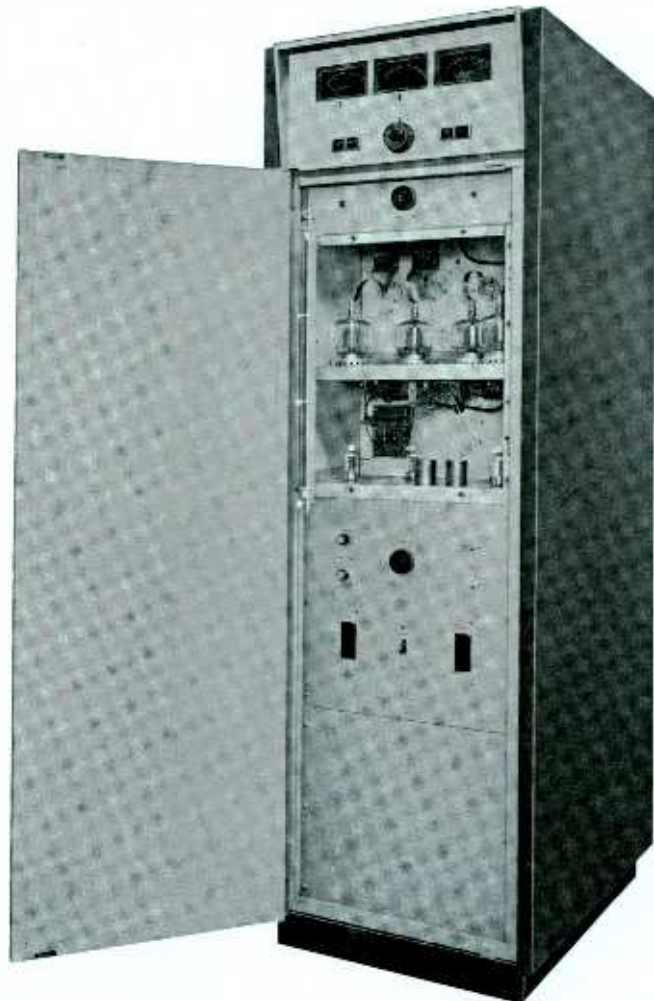

Functional Design

Improved functional design includes RCA's new color combination. Square construction permits locating the transmitter against the wall, or it can be installed against other equipment. The vertical construction makes it accessible from both front and rear for ease of maintenance. A single front panel tuning control provides simplified operation. Remote control provisions permit unattended operation of the transmitter.

Simplified Power Cutback

The BTA-1S easily fits into operations where power reduction at night is required. For "day-night" operation an optional Power Cutback Kit may be incorporated in the transmitter. By pressing a button on the front or at a remote panel, the transmitter can be cut back in power to either 500 or 250 watts. Efficient operation at the low power levels is achieved by reducing the high voltage by primary taps on the plate transformer.

Complete Accessibility

The entire transmitter is housed in a single steel cabinet that is mounted on a sturdy welded steel base. Control components are conveniently located on the panel above the front door and all meters are at eye level. Easy access is provided by a hinged front door and two interlocked removable rear panels. Most BTA-1S components are mounted on a vertical center chassis. Tubes and overload relays are mounted on the front and the other components are mounted on the rear. Larger power components are mounted on the base.

Solid State Power Supplies

Three power supplies are used: a low voltage supply for plate and screen voltages of all low voltage tubes, a bias supply for the modulator tubes, and a high voltage supply for the modulator and power amplifier tubes. All power supplies use silicon diodes which results in low power drain, cool operation and reliable performance. Automatic relays protect the transmitter against overload. These, in turn, are backed up with automatic circuit breakers. The design avoids the use of fuses anywhere in the unit.

Power Requirements

The transmitter operates from a 208-240-volt, 50/60-hertz, single-phase power source for the main power. In addition, the crystal heaters require 115-volt power source.

Solid-State Oscillator and Buffer Stages

Adding an extra measure of transmitter stability, the BTA-1S combines its oscillator and buffer amplifier into a single, solid-state subassembly. The combination of transistorized electronics and temperature-controlled crystals make for an adjustment-free facility which, in turn, reduces routine maintenance. The oscillator is equipped with two temperature-controlled crystals arranged through a front-panel selector switch so that a "hot" spare is always at hand, even via remote control.

Simple, Straightforward Circuitry

The buffer feeds a single 6146A driver tube which in turn feeds the power amplifier which consists of two 4-400A tubes connected in parallel. Tetrodes have been utilized throughout the RF section of the transmitter reducing the required stages and the power consumption. Tetrodes also eliminate the need for neutralization.

The modulator comprises two 2E26 tubes in push-pull, resistance coupled to two 4-400A modulator tubes. The modulator tubes operate as a class AB₁ ampli-

fier without grid current which results in an overall distortion of less than 2 percent up to 10,000 Hz.

Parallel/Redundant System

The BTA-1S is available also as a parallel/redundant transmitter system. This system consists of two identical BTA-1S transmitters and a combiner. In the "parallel" mode, the twin one-kilowatt outputs are combined to provide two kilowatts of power to the antenna system; in the "redundant" mode, the system operates one of the two transmitters as a hot standby while the other feeds the antenna system.

In either operational mode, the parallel/redundant system assures greater on-air dependability. For example, an outage in one transmitter or the other automatically switches the troubled transmitter to a dummy load while the operable one feeds a full kilowatt to the antenna system. This action is the result of a special-design combiner with essentially zero insertion loss. Further details of the BTA-1S parallel/redundant transmitter system are available from Aural Broadcast Equipment Marketing, RCA Building 2-5, Camden, N. J. 08102, U.S.A.

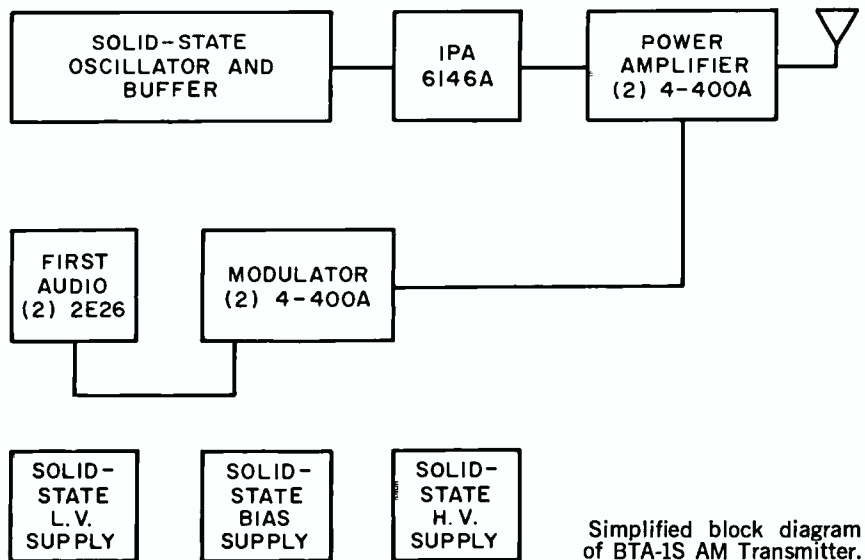

Simplified block diagram of BTA-1S AM Transmitter.

Specifications

Performance

AF Input Impedance	150/600 ohms
AF Input Level (100% modulation)	+10 ±2 dBm
AF Response:	
50-7500 Hz	±1 dB
30-10,000 Hz	±1.5 dB
AF Distortion (95% modulation):	
50-10,000 Hz	2%
50-12,000 Hz	3%
Noise (below 100% modulation)	60 dB
Frequency Range	535-1620 kHz
Frequency Stability	±2 Hz
Type of Output	Single ended
Carrier Shift (0-100% modulation)	3%
Output Impedance	40-250 ohms

Electrical

RF Voltage (for frequency monitoring)	6/10 V rms 75 ohms
RF Voltage (for modulation monitoring)	6/10 V rms 75 ohms
Power Output (nominal)	1000 watts
Power Output Capability	1100 watts
Power Supply	208/240 volts
Line Frequency	50/60 Hz
Phase	Single
Power Consumption (Approx.):	
0% modulation	2900 watts
100% modulation	3900 watts
Average program modulation	3200 watts
Power Factor	90%
Permissible combined line voltage variation and regulation	±5%
Crystal Heater Power Supply	115 volts 50/60 Hz

Tube Complement

1	6146A	Intermediate Power Amplifier
2	2E26	Audio Frequency Amplifier
2	4-400A	Modulator
2	4-400A	Power Amplifier

Mechanical

Height	77" (1955 mm)
Width	26" (660 mm)
Depth	30" (762 mm)
Weight (net)	900 pounds (408 kg) (approx.)
Altitude Range	0-5000 ft.* (0-1254 m)
Ambient Operating Temperature	-20 to 45°C (-4 - 113°F)
Shipping Data	1200 lbs (544 kg); 79 ft ³ (2.23 m ³)

Accessories

Operating Spare Tube Kit	ES-560655
Recommended Minimum Spare Tube Kit	ES-560656
Frequency and Modulation Monitor, Type BW-50	MI-560767
RF Amplifier (for BW-50)	MI-560762
Thirty-Function Remote Control, Type BTR-15	MI-561150
Sixty-Function Remote Control, Type BTR-30	MI-561440
High-Altitude Blower Kit	MI-34309-8
Spare Crystal Unit, Type TMV-130 (Specify Freq.)	MI-27493
RF Ammeters	MI-7157-F Series
Remote RF Pickup Unit (less meter)	MI-27966-B
Power Cutback Kit (Two Level)	MI-560657
Remote Power Adjust Kit	MI-560658
Oscillator-Buffer (Solid-State)	MI-27592

Ordering Information

One-Kilowatt AM Transmitter, Type BTA-1S	ES-560650
250- or 500-Watt AM Transmitter, Type BTA-1S (Specify power level)	ES-560947

*To 10,000 ft. (3048 m) with optional blower (MI-34309-8).



1 kW AM Broadcast Transmitter, Type BTA-1N1

- Silicon power supplies
- Low operating cost
- Remote control provisions
- Requires less than three square feet (0.258 square meters) of floor space
- High speed magnetic circuit breaker protection—eliminates fuses



The Type BTA-1N1 is an amplitude-modulated transmitter of unique design that in every way leads broadcasting's modern trend to combine greater economy, simplicity and reliability in a single compact unit. A real performer, the Type BTA-1N1 uses fewer and less expensive components, incorporates simplified tuning, and easily produces 1000 watts maximum power output at any frequency between 535 and 1620 kilohertz.

Remote, unattended operation of the transmitter is a practical reality—enhanced by simplified start-stop and power-control circuitry, remote metering and the long-term reliability of semiconductor power supplies. In the audio channel there are only two tubes, one transformer and a small modulation choke. Silicon rectifiers are used throughout.

Lower front with access panel removed showing oversized blower, plate transformers and reactors.



The Type BTA-1N1 1-kW Broadcast Transmitter is housed in a standard equipment rack that may be ganged with other racks. The transmitter is divided into three compartments: The upper compartment is completely enclosed in aluminum and contains the modulator, rf driver and power amplifier. The center compartment contains an oscillator/buffer assembly, bias supply, filter components for the high-voltage and intermediate high-voltage supplies and control circuit. The lower compartment contains the high-voltage plate transformer, rectifier and blower. The rear panel of the upper two compartments is removable and both front and rear panels of the lower compartments are removable to allow complete access to all components. The blower intake is thru a filter in the lower rear, thru the compartment containing the high-voltage plate transformer and rectifier, thus providing ample cooling.

Simplified, Reliable Circuits

Simplicity of the Type BTA-1N1 transmitter circuitry is shown by the block diagram. In the rf section, carrier frequency generated by the pentode section of a Type 6AX8 crystal oscillator is first amplified by a broadband tuned Type 6AX8 buffer using only the pentode section of the tube. The signal is then fed to a Type 7094 single-ended, Class C stage which drives an air-cooled 3X3000F1 triode operating with fixed bias as a Class AB₁ power amplifier. The PA output circuit is broadband neutralized and includes a harmonic trap which is adjustable from the front panel. Both the rf driver, which is the plate-modulated stage, and the power amplifier are tuned from the front panel by variable capacitors. Rf voltage for frequency monitoring is derived from the Type 6AX8 crystal oscillator and fed to the frequency monitor through the triode section of the tube. An rf sample for the modulation monitor is obtained from the low tap on the PA tank coil which also serves as a discharge path for static charges in the antenna circuit.

Audio is fed through a 150/600-ohm line input transformer and amplified by the triode section of a Type 6AX8 tube (pentode section utilized as rf buffer). This triode is resistance coupled to a Type 7094 Class A modulator which is choke-coupled to the plate circuit of the rf driver stage.

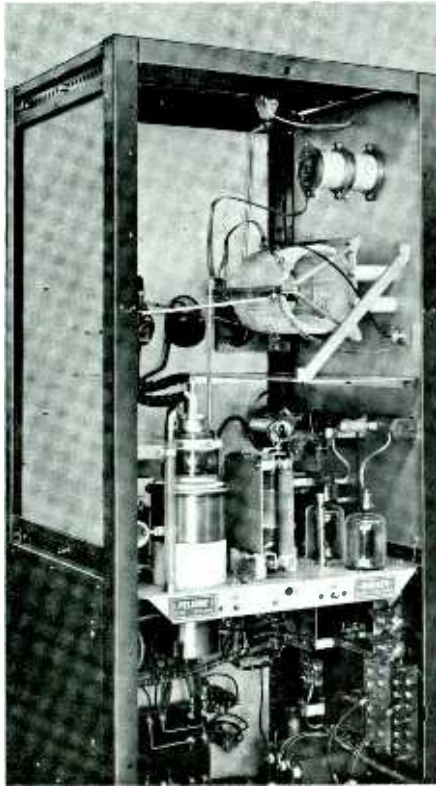

Solid State Power Supplies

A plate supply and bias supply each utilizing silicon diodes, equalizing resistors and printed wiring furnish all the dc voltages needed for the transmitter. The plate transformer is center tapped to provide plate voltage for the driver-modulator stages as well as regulated low voltage for the oscillator and buffer plates. Only two filament transformers are used in the transmitter.

Metering of all Stages

Individual meters are provided for reading PA plate voltage, PA plate current and rf output (optional). Remaining stages and circuits such as the oscillator, buffer, audio, and low voltage supplies, are monitored by a multimeter and selector switch combination which, in addition, provides other readings (useful in initial

Rear oblique view showing radio frequency driver and power compartment.

tune-up) such as the peak rf voltage at the grid and plate of the PA. There are also provisions for remote metering of PA plate voltage and current.

“Fail-Safe” Protection

Transmitter circuits are fail-safe protected by high-speed magnetic circuit breakers. A latching relay and an optional motor-driven power raise/lower control permits convenient remote control of the transmitter. Remote on-off switching is by a single control. This is made possible by interlocking of the bias and plate supplies, a feature which also prevents spurious overloads as a result of any brief power interruptions that may occur.

Ease of Tuning

Built-in facilities reduce the tuning and loading of the linear amplifier to a simple, three-step procedure which is performed at the control panel of the transmitter without need for accessory test equipment of any kind. Once initial adjustments are made, the transmitter can be operated over long periods of time with only the infrequent “touch-up” tuning required by any transmitter. Modulator circuits ordinarily require no adjustment.

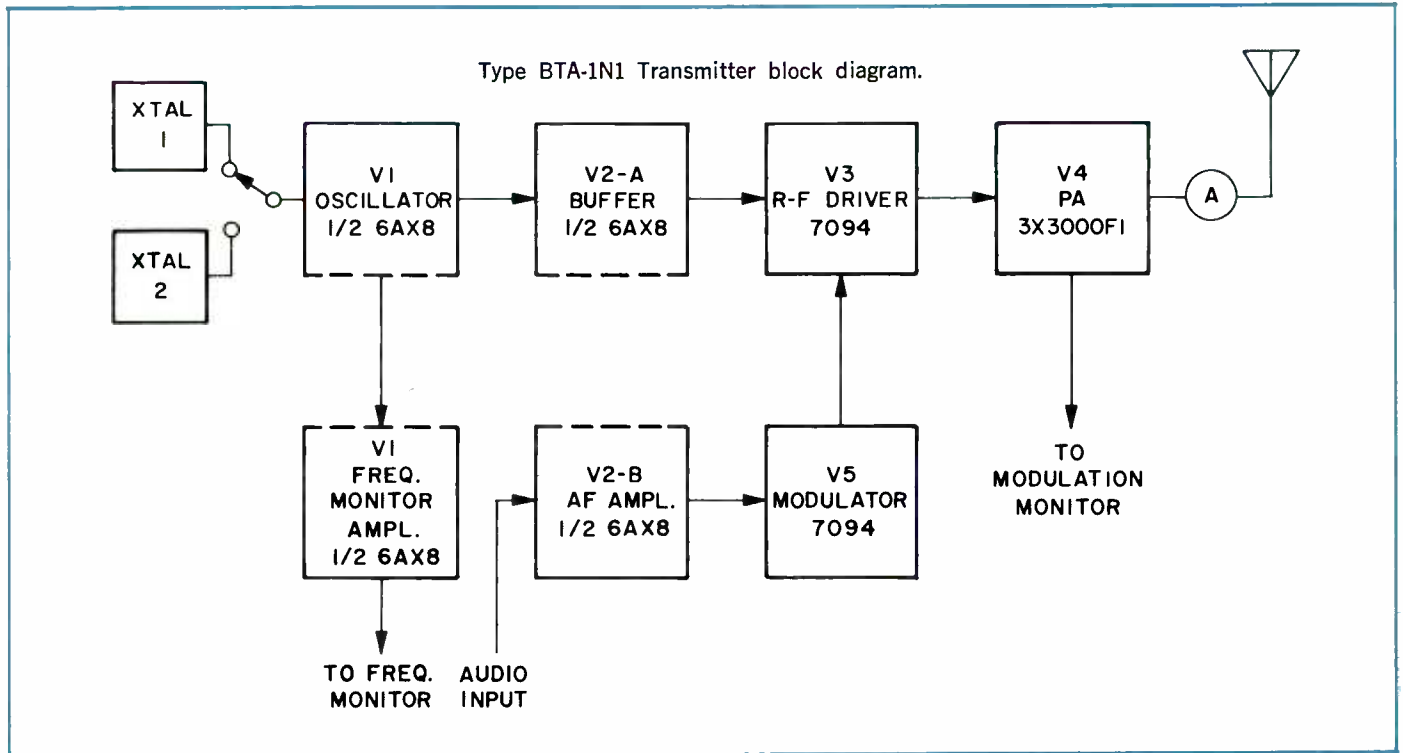

Specifications

Electrical

Frequency Range	535 to 1620 kHz
Power Output	500 to 1000 watts
Type of Output	Single-ended
Output Impedance	40 to 250 ohms
AF Input Impedance	150/600 ohms
AF Input Level (100% Modulation)	+10 ±2 dBm
AF Response (50 to 7500 Hertz)	±1.5 dB
AF Distortion (90% Modulation)	3%
Noise (Below 100% Modulation)	50 dB
Frequency Stability	±2 Hz
RF Voltage for Frequency Monitoring	10 volts, 75 ohms
RF Voltage for Modulation Monitoring	10 volts, 75 ohms
Total Harmonic Radiation	-73 dB

Tube Complement

1 6AX8 (pentode) (triode)	Crystal Oscillator Frequency Monitor Amplifier
1 6AX8 (pentode) (triode)	Buffer Amplifier Audio Amplifier
1 7094	Amplifier Driver
1 7094	Modulator
1 3X3000F1	Power Amplifier

Power Requirements

Transmitter:

Line	208 to 240 V., single phase, 50/60 Hz
Combined Line Voltage Variation and Regulation	±5%
Power Consumption (at 1000 watts)	4.5 kW (approx.)
Power Factor	90% (approx.)

Cabinet Lighting and Crystal Heaters:

Line	110 to 125 V., single phase, 50/60 Hz
------------	---------------------------------------

Mechanical

Dimensions (overall)	22" wide, 84" high, 18" deep (560 mm, 2134 mm, 458 mm)
Weight	625 lbs. (283 kg)
Maximum Altitude	7500 feet (2500 meters)
Ambient Temperature Range.....	-20° to +45°C (-4 to +113°F)
Air Intake	200 cf/m
Heat Loss (0% Modulation)	3500 watts (200 BTU/min) (12,000 BTU/hr)

Accessories

Set of Spare Tubes	ES-562202
Set of Spare Tubes (recommended spares)	ES-562201
RF Output Line Current Meter (range determined by antenna characteristics)	MI-7157-H*
Remote Antenna Meter	MI-28037-B*
Crystal, Type TMV-130B	MI-27493
Frequency and Modulation Monitor, Type BW-50	MI-560767
Power Cutback Kit	MI-561301
Remote Power Adjust Kit	MI-561302

*Specify scale.

Ordering Information

One-Kilowatt AM Transmitter, Type BTA-1N1	ES-562200
---	-----------

(Please specify operating frequency and transmission-line impedance.) (Includes harmonic filter and side panels.)

5 kW Ampliphase Transmitter, Type BTA-5L1

- Low-distortion audio
- Solid-state exciter/modulator
- Extra modulation capability
- Designed for remote control
- Only two tube types in entire unit
- No modulation transformer

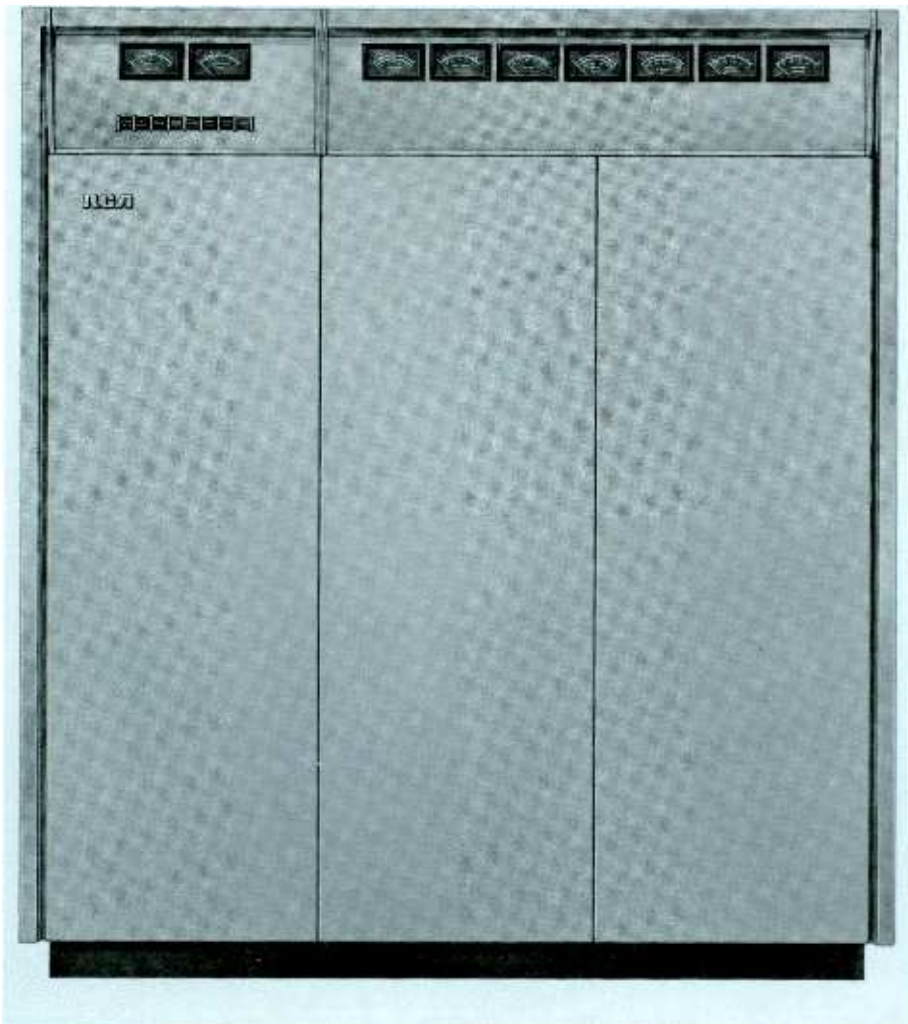

Offering superior audio quality, outstanding reliability and excellent efficiency, the BTA-5L1 is an Ampliphase transmitter for the AM-broadcast (medium-wave) band. The BTA-5L1 delivers 5 kW to the antenna transmission line.

As a result of the Ampliphase system, the BTA-5L1 Transmitter offers extended audio-frequency response at distortion levels well below average perception at enviable operating economy and dependability.

The BTA-5L1 is available also in dual-unit systems for parallel or redundant operation.

In the "parallel" arrangement, the outputs of the two transmitters in the system are combined for a 10-kilowatt power output; in the "redundant" system, one transmitter serves the load while the second operates in hot standby mode.

A special feature of the parallel system is that, in the event of outage in one transmitter, the other transmitter delivers a full five-kilowatt output to the load.

In the redundant arrangement, an outage in one transmitter or the other automatically connects the operable unit to the load.

Outstanding Audio Quality

Of particular interest to broadcasters who take pride in station "sound", the BTA-5L1 Transmitter offers outstandingly good audio quality. One reason for this is that the *Ampliphase* system eliminates iron-core high-level modulation components—and their inherent distortions—without adding the instabilities of separate "carrier" and "peak" power amplifiers. Even on ordinary AM radios, the outstanding audio quality of an *Ampliphase* transmitter is immediately apparent.

Extended Frequency Response

As evidence of the frequency-response characteristics the BTA-5L1 offers, it can put 30 kHz on-the-air—at full power—without strain. At the low-frequency end of the spectrum, frequencies below 30 Hz go on-the-air at full level and low distortion. Transformer-equipped transmitters usually cut off below 50 Hz and above 15 kHz.

Extra Modulation Capability

An advantage unique to the *Ampliphase* system is its capability for full modulation, even for extended periods, without overload. This is particularly important to stations programming music of high average level and low dynamics. Positive modulation peaks can go as high as 125 percent without transmitter overload. Another unique feature in *Ampliphase* is that it overmodulates without the "splatter" so common to other AM transmitter forms.

Provision for Spare Exciter/Modulator/Regulator

For those who prefer redundant exciters, the BTA-5L1 Transmitter provides rack space for a spare exciter. Offered as an option, the spare exciter includes switching gear for fast exciter substitution. A spare exciter is particularly valuable to the full-time station in that exciter maintenance is independent of transmitter operation.

Ready for Remote Control

Because the BTA-5L1 is built for the modern broadcaster it is engineered with remote control in mind. This manifests itself in extra components, wiring and connections fully compatible with remote control equipment carrying the RCA trademark. As a result, operating a BTA-5L1 via remote control requires investment only in control equipment and not in transmitter modification.

Two Tube Types

Being entirely solid-state at power levels below the IPA stage, the BTA-5L1 Transmitter uses a total of only four power tubes: two in each channel. Since



Front view, doors open. Note exciter unit.

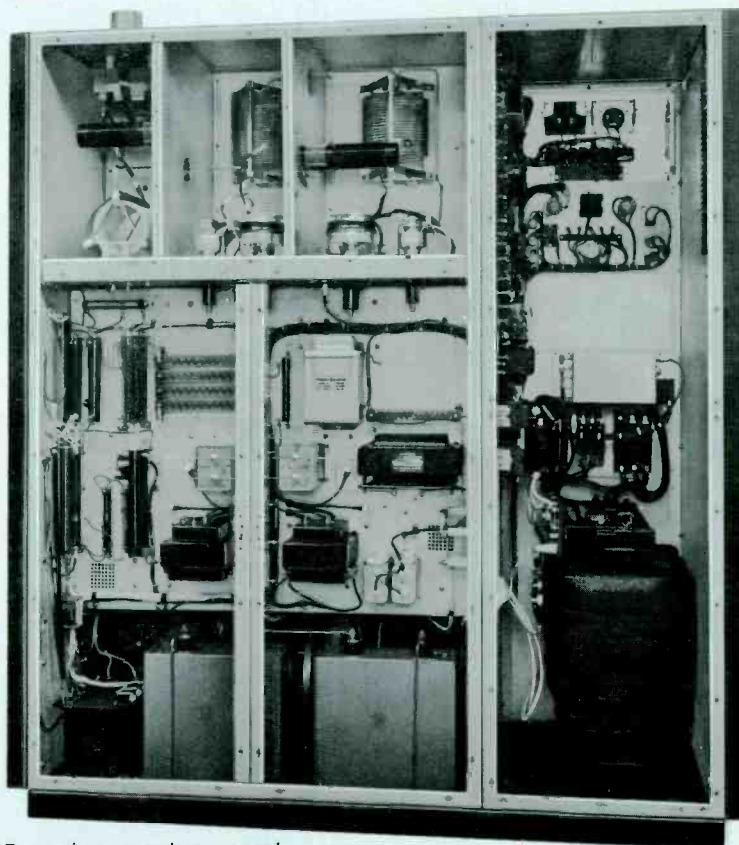

Rear view, panels removed.

these are of only two types, spares inventory need only be two tubes: one of each type. This reduces capital investment in spares and periodic rotation.

No Modulation Transformer

Using two identical R-F amplifier chains, the BTA-5L1 Transmitter uses *phase* modulation, at a low level, in such a manner that two phase-modulated carriers mix at the transmitter output to form an amplitude-modulated carrier. Since this system eliminates the modulation transformer and "carrier-peak" amplifiers, it eliminates the most-troublesome stages. This reflects itself in transmitter dependability that virtually eliminates unscheduled transmitter shutdown.

Faster Troubleshooting

A feature unique to *Ampliphase* makes routine repair easier. In a sense, a 5-kW *Ampliphase* transmitter is two identical 2.5-kW facilities in a single cabinet. Consequently, one amplifier chain is an excellent troubleshooting model for the other. Because the operating parameters of the two class-C amplifiers (operating as CW stages) can be quickly compared, the trouble can be isolated easily. Then, it's a simple matter of component replacement.

Ceramic Insulated PA Tubes

Ceramic power tubes have earned an enviable reputation among broadcasters



Ampliphase exciter unit. Completely solid-state, this unit is used in all RCA Ampliphase transmitters. Available separately for use as a spare. See Accessories.

for dependability and long life. The tube types selected for the BTA-5L1 operate well below ratings to take full advantage of their performance capabilities and built-in expected life. This pays dividends in low transmitter-operating expenses.

Fully Self-Contained

As the result of transistorization, the entire transmitter—including the power supply—fits within a single cabinet that occupies less than 14 square feet (1.3 m²) of floor space (see floor plan). This, of course, frees plant area for other productive purposes; office, studio or storage.

Parallel/Redundant Systems

The BTA-5L1 transmitter is available also as a parallel/redundant system. This arrangement uses two BTA-5L1 transmitters and a combiner. In the "parallel"

system, both transmitter outputs are combined to provide ten kilowatts to the load. Should one transmitter or the other have trouble, the operable transmitter continues to supply the load while the troubled transmitter is automatically switched from the antenna to a built-in dummy load.

In the redundant arrangement, one transmitter ordinarily feeds the antenna system while the other operates as a hot standby into a dummy load. Should the "air" unit fail, the system automatically connects the standby unit to the load and the troubled transmitter to the dummy load.

Further details are available from Aural Broadcast Marketing, RCA Building 2-2, Camden, N. J., 08102, U.S.A.

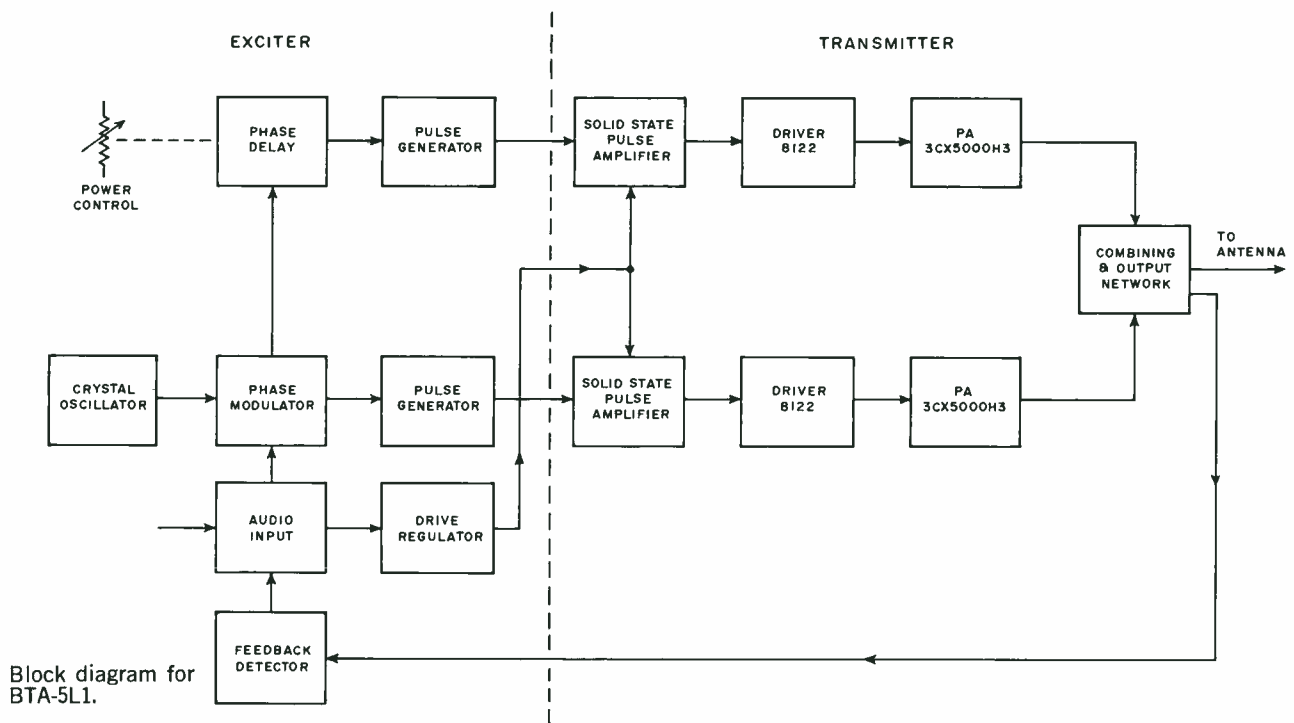

Block diagram for BTA-5L1.

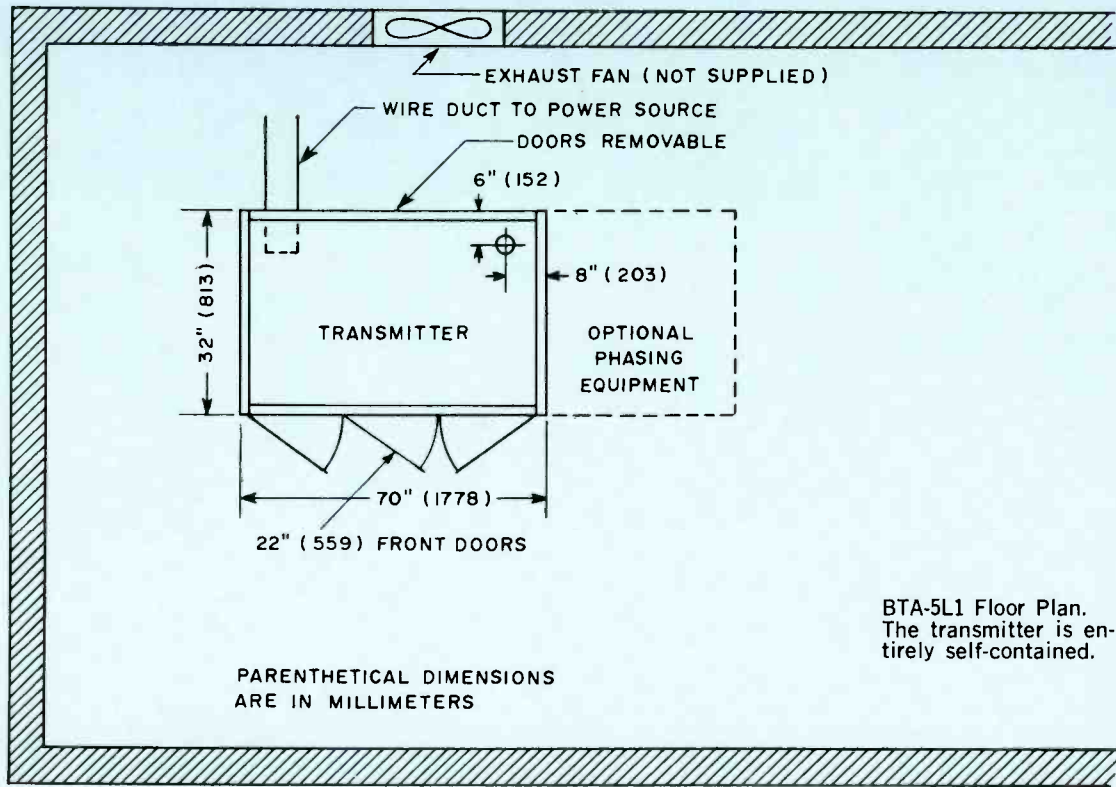

BTA-5L1 Floor Plan.
The transmitter is entirely self-contained.

Specifications

Power Output (Nominal)	5,000 watts
Power Output Capability	5,500 watts
AF Input Impedance	150/600 ohms
AF Input Level	+10 ± 2 dBm
AF Response	±1.5 dB 30-15,000 Hz
AF Distortion (95% Mod. 30-10,000 Hz)	2.0% max.
Noise (Below 100% Modulation)60 dB
Frequency Range	535-1620 kHz
Frequency Stability	±2 Hz
Type of Output	Unbalanced
Output Impedance	40 to 250 ohms
Carrier Shift (0-100% Modulation, 400 Hz)	3% max.
Power Source	208/240 volts, 3-phase, ±11 volts
Crystal Heater Power	117 volts, 50/60 Hz
Power Consumption (Approx.):	
0% Modulation	12 kW
Average Modulation	14 kW
100% Modulation	18 kW
Power Factor90%
Altitude Range	0-7500 Ft. AMSL (2286 m)
Ambient Operating Temperature	-20° to +45° C.
Tube Complement	Two 8122; Two 3CX5000H3
Height	77" (1955 mm)

Width	70" (1778 mm)
Depth	32" (813 mm)
Finish	EELM charcoal grey and shadow blue textured vinyl; Aluminum baked enamel
Weight (Approx.)	2500 lbs. (1134 kg)
Shipping Data (Approx.)	3000 lbs.; 180 ft ³ (1361 kg; 5.1 m ³)

Accessories and Options

Recommended Spare Tubes (Set)	ES-560682
Complete Spare Tubes (Set)	ES-560680
Spare Crystal Unit, Type TMV-130 (Specify freq.)	MI-27493
Conversion Kit, 10 kW Power Output	ES-560946
Spare Exciter System, Type BTE-20	ES-560752
Manual Exciter Changeover Panel	ES-561305
Power Cutback Kit (Two Power Levels)	ES-561009
Power Cutback Kit (Three Power Levels)	ES-561009A
Frequency and Modulation Monitor, Type BW-50	MI-560767
RF Amplifier (For BW-50, above), Type BW-60	MI-560762
Transmission Line Protection Kit (VSWR)	ES-560961

Ordering Information

Five-kW Ampliphase Transmitter, Type BTA-5L1	ES-560676
Dual-Unit Ten-kW Ampliphase Transmitter System	Built to Order
Redundant Five-kW Ampliphase Transmitter System	Built to Order



10 kW Ampliphase AM Transmitter, Type BTA-10L1

- Low-distortion audio
- Solid-state exciter/modulator
- Extra modulation capability
- Designed for remote control
- Only two tube types in entire unit
- No modulation transformer

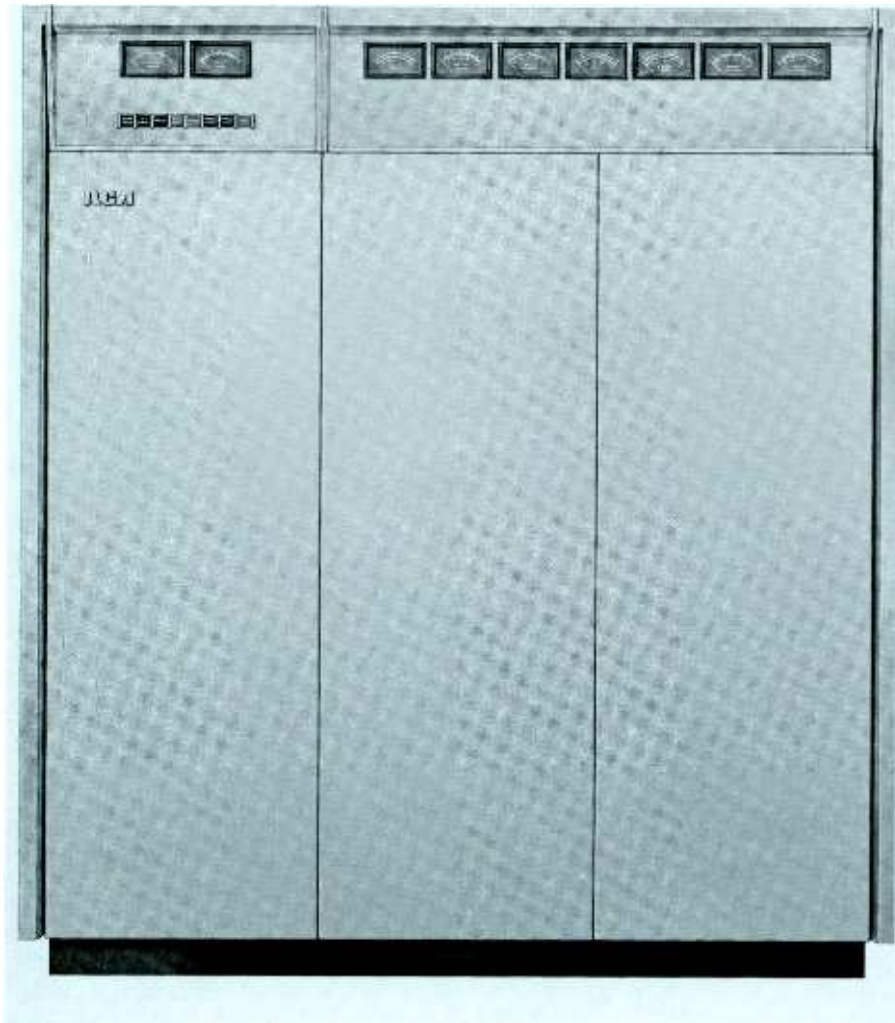

Offering superior audio quality, outstanding reliability and excellent efficiency, the BTA-10L1 is an Ampliphase transmitter for the AM-broadcast (medium-wave) band. The BTA-10L1 delivers 10 kW to the antenna transmission line.

As a result of the Ampliphase system, the BTA-10L1 Transmitter offers extended audio-frequency response at distortion levels well below average perception at enviable operating economy and dependability.

The BTA-10L1 is available also in dual-unit systems for parallel or redundant operation.

In the "parallel" arrangement, the outputs of the two transmitters in the system are combined for a 20-kilowatt power output; in the "redundant" system, one transmitter serves the load while the second operates in hot standby mode.

A special feature of the parallel system is that, in the event of outage in one transmitter, the other transmitter delivers a full ten-kilowatt output to the load.

In the redundant arrangement, an outage in one transmitter or the other automatically connects the operable unit to the load.

Outstanding Audio Quality

Of particular interest to broadcasters who take pride in station "sound", the BTA-10L1 Transmitter offers outstandingly good audio quality. One reason for this is that the *Ampliphase* system eliminates iron-core high-level modulation components—and their inherent distortions—without adding the instabilities of separate "carrier" and "peak" power amplifiers. Even on ordinary AM radios, the outstanding audio quality of an *Ampliphase* transmitter is immediately apparent.

Extended Frequency Response

As evidence of the frequency-response characteristics the BTA-10L1 offers, it can put 30 kHz "on-the-air"—at full power—without strain. At the low-frequency end of the spectrum, frequencies below 30 Hz go on-the-air at full level and low distortion. Transformer-equipped transmitters usually cut off below 50 Hz and above 15 kHz.

Extra Modulation Capability

An advantage unique to the *Ampliphase* system is its capability for full modulation, even for extended periods, without overload. This is particularly important to stations programming music of high average level and low dynamics. Positive modulation peaks can go as high as 125 percent without transmitter overload. Another unique feature in *Ampliphase* is that it overmodulates without the "splatter" so common to other AM transmitter forms.

Provision for Spare Exciter/Modulator/Regulator

For those who prefer redundant exciters, the BTA-10L1 Transmitter provides rack space for a spare exciter. Offered as an option, the spare exciter includes switching gear for fast exciter substitution. A spare exciter is particularly valuable to the full-time station in that exciter maintenance is independent of transmitter operation.

Ready for Remote Control

Because the BTA-10L1 is built for the modern broadcaster it is engineered with remote control in mind. This manifests itself in extra components, wiring and connections fully compatible with remote control equipment carrying the RCA trademark. As a result, operating a BTA-10L1 via remote control requires investment only in control equipment and not in transmitter modification.

Two Tube Types

Being entirely solid-state at power levels below the IPA stage, the BTA-10L1 Transmitter uses a total of only six power



Front view, doors open. Note exciter unit.

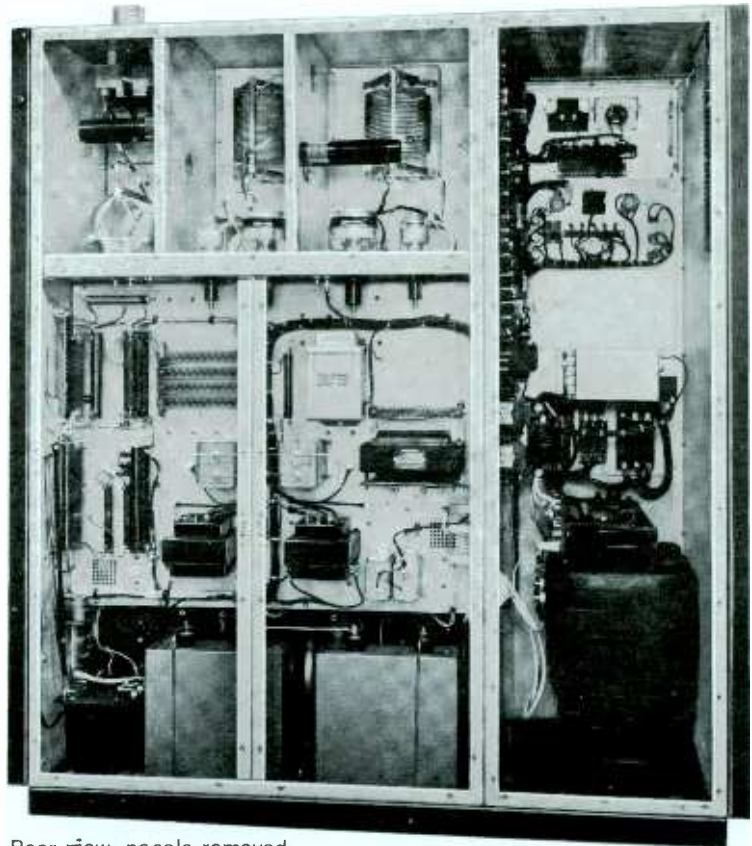

Rear view, panels removed.

tubes: three in each channel. Since these are of only two types, spares inventory need only be two tubes: one of each type. This reduces capital investment in spares and periodic spares rotation.

No Modulation Transformer

Using two identical R-F amplifier chains, the BTA-10L1 Transmitters uses phase modulation, at a low level, in such a manner that two phase-modulated carriers mix at the transmitter output to form an amplitude-modulated carrier. Since this system eliminates the modulation transformer and "carrier-peak" amplifiers, it eliminates the most-troublesome stages. This reflects itself in transmitter dependability that virtually eliminates unscheduled transmitter shutdown.

Faster Troubleshooting

A feature unique to *Ampliphase* makes routine repair easier. In a sense, a 10-kW *Ampliphase* transmitter is two identical 5-kW facilities in a single cabinet. Consequently, one amplifier chain is an excellent troubleshooting model for the other. Because the operating parameters of the two class-C amplifiers (operating as CW stages) can be quickly compared, the trouble can be easily isolated. Then, it's a simple matter of component replacement.

Ceramic Insulated PA Tubes

Ceramic power tubes have earned an enviable reputation among broadcasters

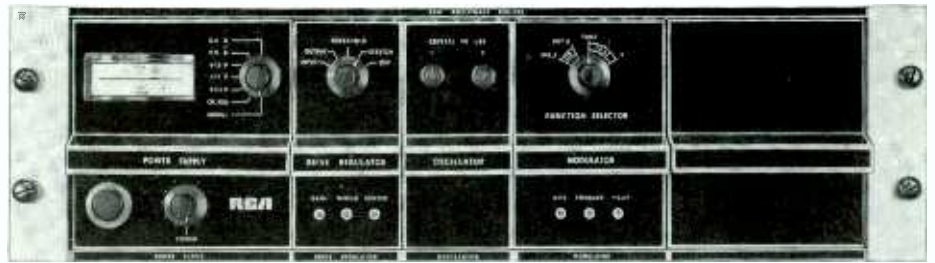

Ampliphase exciter unit. Completely solid-state, this unit is used in all RCA Ampliphase transmitters. Available separately for use as a spare. See Accessories.

for dependability and long life. The tube types selected for the BTA-10L1 operate well below ratings to take full advantage of their performance capabilities and built-in expected life. This pays dividends in low transmitter-operating expenses.

Fully Self-Contained

As the result of transistorization, the entire transmitter—including the power supply—fits within a single cabinet that occupies less than 14 square feet (1.3 m²) of floor space (see floor plan). This, of course, frees plant area for other productive purposes; office, studio or storage.

Parallel/Redundant Systems

The BTA-10L1 transmitter is available also as a parallel/redundant system. This arrangement uses two BTA-10L1 transmitters and a combiner. In the "parallel"

system, both transmitter outputs are combined to provide 20 kilowatts to the load. Should one transmitter or the other have trouble, the operable transmitter continues to supply the load while the troubled transmitter is automatically switched from the antenna to a built-in dummy load.

In the redundant arrangement, one transmitter ordinarily feeds the antenna system while the other operates as a hot standby into a dummy load. Should the "air" unit fail, the system automatically connects the standby unit to the load and the troubled transmitter to the dummy load.

Further details are available from Aural Broadcast Marketing, RCA Building 2-2, Camden, N. J., 08102, U.S.A.

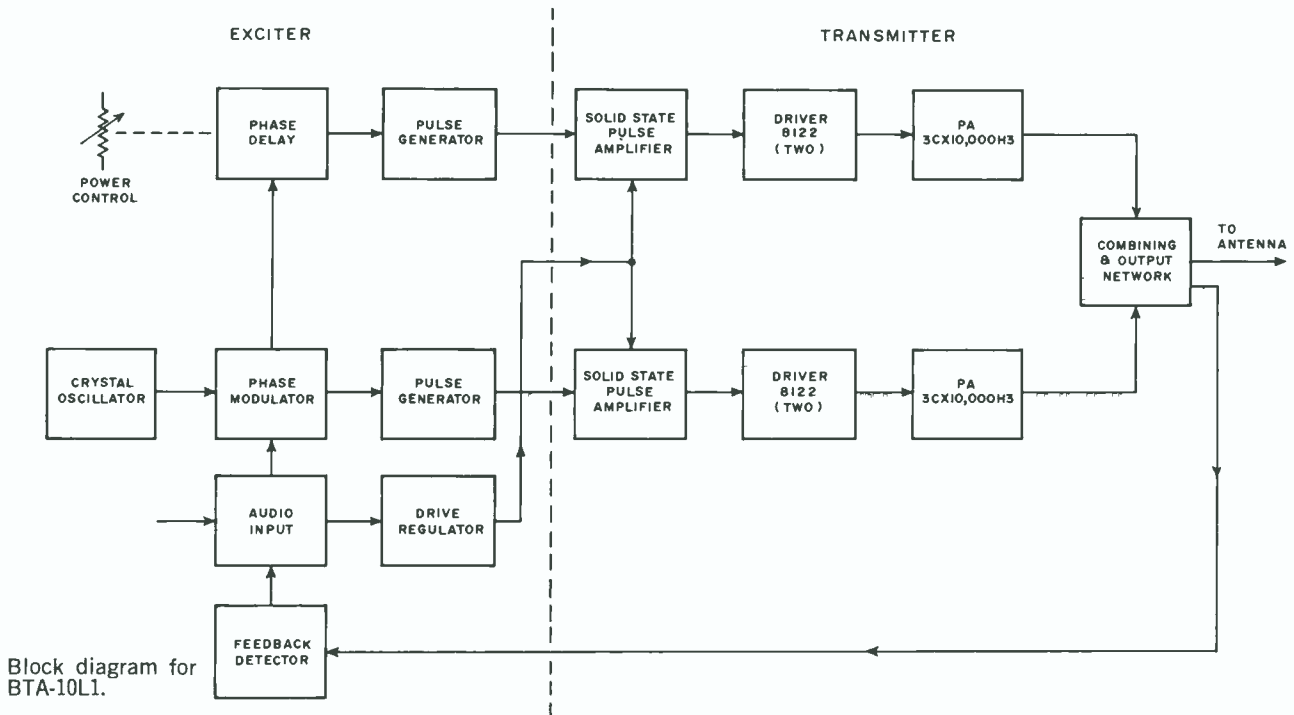

Block diagram for BTA-10L1.

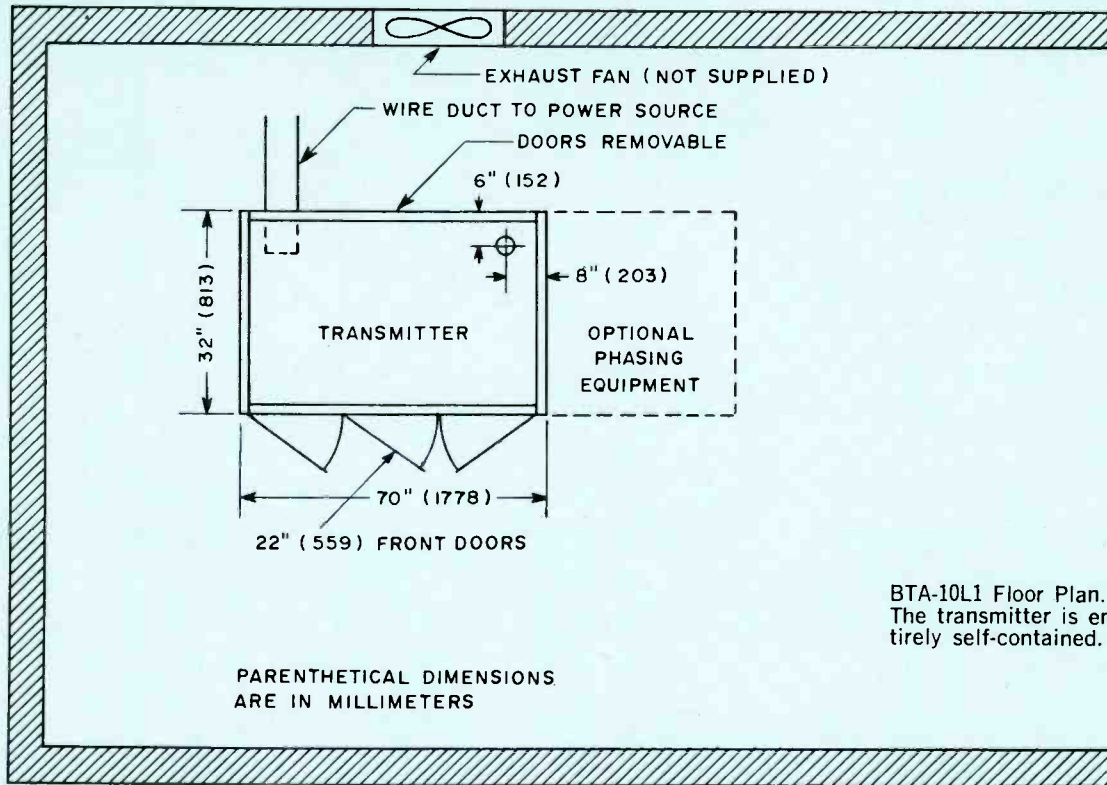

BTA-10L1 Floor Plan.
The transmitter is entirely self-contained.

PARENTHETICAL DIMENSIONS ARE IN MILLIMETERS

Specifications

AF Input Impedance	150/600 ohms
AF Input Level	+10 ±2 dBm
AF Response	±1.5 dB 30-15,000 Hz
AF Distortion	
(95% Modulation 30-10,000 Hz)	Less than 2.0%
Noise (Below 100% Modulation)	60 dB
Frequency Range	535-1620 kHz
Frequency Stability	±2 Hz
Type of Output	Unbalanced
Output Impedance	40 to 250 ohms
Carrier Shift (0-100% Modulation, 400 Hz)	3% max.
Power Source	208/240 volts, 3-phase, ±11 volts
Crystal Heater Power	117 volts, 50/60 Hz
Power Consumption (Approx.):	
0% Modulation	17 kW
Average Modulation	21 kW
100% Modulation	29 kW
Power Factor	90%
Altitude Range	0-7500 Ft. AMSL (2286 m)
Ambient Operating Temperature	-20° to +45° C.
Power Output (Nominal)	10,000 watts
Power Output Capability	11,000 watts
Tube Complement	Four 8122; Two 3CX10,000H3

Height	77" (1955 mm)
Width	70" (1778 mm)
Depth	32" (813 mm)
Finish	EELM charcoal grey and shadow blue textured vinyl; Aluminum baked enamel
Weight (Approx.)	2700 lbs. (1224 kg)
Shipping Data (Approx.)	3200 lbs.; 180 ft ³ (1452 kg; 5.1 m ³)

Accessories and Options

Recommended Spare Tubes S(et)	ES-560681
Complete Spare Tubes (Set)	ES-560679
Spare Crystal Unit, Type TMV-130 (Specify freq.)	MI-27493
Spare Exciter System, Type BTE-20	ES-560752
Manual Exciter Changeover Panel	ES-561305
Power Cutback Kit (Two Power Levels)	ES-561009
Power Cutback Kit (Three Power Levels)	ES-561009A
Frequency and Modulation Monitor, Type BW-50	MI-560767
RF Amplifier (For BW-50, above), Type BW-60	MI-560762
Transmission Line Protection Kit (VSWR)	ES-560961

Ordering Information

Ten-kW Ampliphase Transmitter, Type BTA-10L1	ES-560677
Dual-Unit Twenty-kW Ampliphase Transmitter System	Built to Order
Redundant Ten-kW Ampliphase Transmitter System	Built to Order



50 kW "Ampliphase" AM Transmitter, Type BTA-50J

- Excellent audio quality
- All solid-state exciter
- Only six tubes, three types
- High modulation capability

An AM transmitter with FM quality, the Type BTA-50J uses phase modulation in a way that results in high quality AM. The transmitter includes a fully solid-state exciter and modulator. "Ampliphase" applies modulation at a low level and uses Class C power amplifiers to provide the 50-kW output.





Compact in-line construction of BTA-50J showing left to right, left hand power amplifier, exciter, right hand power amplifier, and rectifier-control cubicle.

The RCA Type BTA-50J AM Broadcast Transmitter is a completely air-cooled, 50-kW phase-to-amplitude modulated transmitter designed for high fidelity transmission in the standard broadcast band (535 kHz to 1620 kHz). It provides a signal of exceptionally low distortion and extended frequency response. Measured response is flat within ± 3 dB from 35 Hz to 25,000 Hz. The equipment is capable of being modulated over the frequency range of 10 Hz to 30,000 Hz. Frequency response has been extended largely through the elimination of unnecessary transformers in the audio system as well as improved circuitry.

Low harmonic distortion with negligible carrier shift at maximum signal output has been achieved in the BTA-50J by selection of adequate power tube types and advanced solid state circuits in the exciter-modulator-drive regulator de-

sign throughout the entire equipment. The design features an inherently linear system capable of continuous high modulation levels impervious to inadvertent overmodulation. For example, the transmitter may be modulated 100 percent at any frequency between 30 and 15,000 Hz continuously for many hours without detrimental effects to any of the component parts. A small amount of overall feedback is incorporated to provide the exceptional performance. With the feedback circuit removed, the BTA-50J still meets FCC specifications for audio frequency response, harmonic distortion and noise.

Lowest Operating Cost in 50-kW Transmitters

A number of new refinements as well as time tested features which have proven their worth are incorporated in this modern 50-kW transmitter. Power requirements are moderate for the equipment.

Power amplifier plate efficiency of the order of 75 to 80 percent is obtained.

Fewer major components, as compared to those required by many 50-kW transmitters, are used in the BTA-50J. In addition to the low cost of operation of the transmitter a power-cutback kit can be added which permits operation at 10 kW. (Other power levels available on special order.)

Dual RF Chains

Two identical RF chains, each developing 25 kW, are incorporated in this equipment. Since they are identical, servicing is made easy by comparison of the two chains. Components are directly interchangeable, which allows substitution for comparison purposes. All components are easily accessible which results in a minimum schedule for maintenance. In addition, fewer replacement parts are required for adequate protection against lost air

time should a failure occur. Low power consumption, fewer major components and a reduced maintenance schedule make the BTA-50J operation cost the lowest.

Ready for Remote Control

Designed with unattended remote control in mind, the BTA-50J includes the components, wiring and connections to make it completely compatible with either of two RCA remote control systems (see *Accessories*). Such components as meter shunts, motorized controls and switching devices make remote control more efficient and dependable.

Lightweight Type 6697 Tubes in Final PA

One Type 6697 power amplifier tube is used in each of the two RF chains. Each amplifier tube is capable of delivering in excess of the normal 25 kW of modulated power to the common load. The Type 6697 is rated at 35 kW dissipation and under average modulation conditions it is only required to dissipate approximately 14 kW. Operation of the PA tubes so far below their maximum ratings assures long tube life. In addition, the 6697 is physically small in size and weighs only 43 pounds. One person, without the aid of mechanical assistance, can quickly and easily replace any tube in the transmitter.

One Type 4CX5000A tube is used in each of the driver stages in the two RF chains. The 4CX5000A is also operated well below its maximum ratings and gives long trouble free service. The only other tubes used in the transmitter are the two Type 4-250A intermediate power-amplifier tubes. Solid-state design extends into the monitor circuitry as well. Tube complement is such that inventory cost for required spares is kept at a minimum while adequate outage protection is maintained.

Solid State Rectifiers Used Throughout

All power supplies utilize solid state rectifiers. The plate supplies, bias supply and low-voltage supply use silicon units, very conservatively rated to assure long life. The current rating of the units is such that any conceivable load fault is cleared without jeopardizing the diode units. The use of solid state rectifiers permit the transmitter to operate in ambient temperatures as low as -20 degrees centigrade.

FCC and CCIR Harmonic Suppression

A completely shielded two section low pass filter is incorporated in the BTA-

50J. It consists of one π (π) section and one T section and each inductive series element is completely shielded. Two series-tuned, shunt-connected traps are used to provide added attenuation of the second harmonic.

Transmitter Equipment

Type BTA-50J AM Broadcast Transmitter consists of four equipment cabinets, two of which house the power amplifiers, one the exciter unit and the fourth cabinet the rectifier and control unit. The high-voltage reactor is housed in the lower rear compartment of the exciter cabinet, with the IHV plate transformer in the lower rear compartment of the rectifier and control cabinet.

Each of the four transmitter cabinets measure 44 inches wide by 60 inches deep by 84 inches high, and consists of an all aluminum cubicle erected on a welded steel base. This cubicle consists of a series of panels fabricated and assembled to form a rigid structure. The use of aluminum eliminates unnecessary weight and provides excellent shielding to assure effective confinement of spurious energy. Maximum accessibility to all transmitter components are afforded by 28-inch wide, six-foot front doors, while rear access is through two covers attached with quick-disconnect fasteners for easy removal.

A center vertical panel separates the cabinet into a front compartment and rear compartment which is further divided by a rear horizontal shelf into upper and lower compartments, giving each cabinet three basic totally shielded compartments in which to mount the electrical components. The eye-level meters, pilot lights and interlocks, mounted on eight-inch wide panels flanking each of the front doors, are also shielded.

In the rear at the top of each cabinet is a built-in wire duct. It joins similar ducts of adjacent cabinets to form a continuous duct on the four cabinets. This duct has a divider down the center on which the interconnection terminal boards are mounted. The rear half of the duct is used for interconnection wiring while the front half is used for internal cabinet wiring from the terminal boards. The internal wiring is carried through conduits to its destination in the cabinet thus shielding all power and control wiring from RF fields. Provision is also made at the top of the cabinets for the addition of an exhaust air duct.

Power Amplifiers

The first cabinet and the third cabinet from the left end are identical and

contain the final power amplifier stages. The 6697 tube and its grid circuits and part of the plate circuits are contained in the front portion of the cabinet. The upper rear section contains the plate tank coil, filament transformer and grid leak resistors. The lower rear section contains a low-noise blower which cools the 6697 tube and its cabinet and the adjacent half of the exciter cabinet. The two 6697 power amplifiers are designed to supply equal amounts of power to the output network. Because of the balanced dissipation in the two 6697 PA tubes, less air pressure with resultant lower air flow is required for adequate cooling of the power amplifier cubicles. The lower rear panel contains an impingement type air filter for the blower. The PA cabinets are constructed so that the blowers and filters can be mounted externally to the cabinets, if so desired.

The PA output circuit is a conventional pi-network type of tank circuit. Each tube has its own tank circuit, with a common output shunt element. Each network is adjusted to provide the proper load to the power amplifiers.

Solid-State Exciter-Modulator, Drive Regulator

Packaged in a series of four plug-in modules, the Ampliphase exciter-modulator uses a crystal-controlled, field-effect-transistor oscillator, a solid-state drive regulator, modulator and power supply. The entire assembly occupies only $5\frac{1}{4}$ inches (133 mm) of rack space in the left-of-center cabinet (see photo, facing page). As a result of untuned, digital-integrated circuits, the exciter-modulator is set up with but three trimmer adjustments. The RF chains in the exciter operate without tuned circuits.

The drive regulator circuitry uses entirely solid-state electronic devices; the regulator samples the audio, amplifies the sample and applies it to the grid circuits of the twin driver stages so as to adjust final amplifier drive in step with the level of the modulating audio. This system contributes significantly to the exceptional linearity of the *Ampliphase* system.

Solid-State Reflectometer

The far-right module in the exciter-modulator unit is a solid-state reflectometer that protects the transmitter from transmission line and/or antenna irregularities. The reflectometer senses changes in the voltage/current ratio on the load.

A large change in load characteristics causes the reflectometer system to momentarily interrupt the drive (to let the fault clear, if transient). If the fault persists

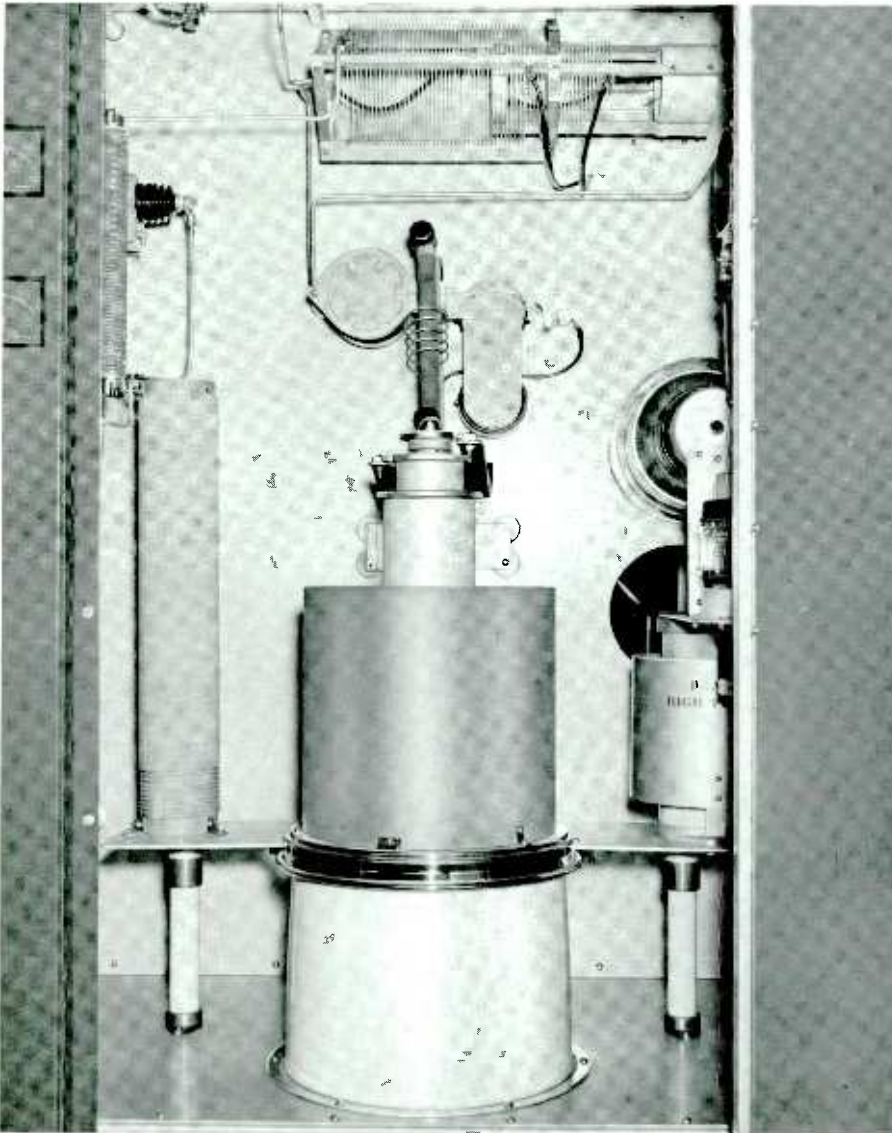

Close-up view of one of the dual final power amplifier stages. The new type 6697 tube together with grid circuits and part of the plate circuits are readily accessible from the front of the transmitter.

after several cycles, the reflectometer shuts down the transmitter thereby reducing the possibility of chain-reaction damage to any part of the system.

Above the exciter-modulator are two vertical sub-compartments, behind interlocked doors, which contain the 4CX5000A driver stages. A meter panel for these stages is located beneath the sub-compartments.

The common output capacitors of the two PA tanks and the harmonic filter are located in the upper rear of the cabinet. Sub-partitions are so arranged in this section that complete isolation and shielding is effected between the various sections of the filter and the output capacitor. The lower rear section of this cabinet contains high voltage filter reactor and driver dc filament supplies.

Provisions for Standby Operation

Space is provided in the exciter cabinet for the mounting of a second exciter-modulator unit. Each of the modulator-exciter units are complete and arranged so that either may be selected instantly by means of cutover switches. Thus, while one modulator is in operation, the other modulator is in standby condition. These provisions, with the extreme reliability designed into the high-power stages, essentially provide a second 50-kW transmitter for standby service.

Rectifier and Control Unit

The far right cabinet contains the high power rectifiers, low power distribution components, and the majority of the control components. The front portion of the cab-

inet contains the solid state 15-kV, 5-kV plate supplies and the low-voltage bias supplies. Also included here are the high-voltage grounding switches and the 15-kV filter capacitors. The top rear section of the cabinet contains control relays, overload relays, distribution contactors, and low-power distribution circuit breakers. The distribution breakers and overload relays are readily accessible, recessed so that they will not be damaged or improperly operated. The bottom rear of the cabinet contains the 5-kV rectifier components including plate transformer.

Solid-State Power Supplies

During periods of 100 percent modulation, the 6697 power amplifier tubes require 15-kV dc at 7.5 amperes, which is obtained from a three-phase, full-wave rectifier circuit. Two other plate voltages, 5-kV and 1-kV, are provided by separate supplies. Bias voltages for all tubes are supplied by an additional supply. The high-power distribution equipment for the transmitter consists of an electrically operated air circuit breaker, and a manually operated delta-wye switch for the 15-kV rectifier. The remaining transmitter power is distributed through a manually operated distribution circuit breaker to a 460- to 230-volt distribution transformer to voltage regulators and thence to the various low power distribution circuit breakers.

Transmitter Control

Control circuits in the BTA-50J contain a number of features which are designed to provide maximum flexibility in control, protection and operation. Among these are choice of single-button or step-by-step starting, automatic timing and sequencing of starting operations, and location of transmitter faults by a system of indicators. Protection of the operator is achieved by a system of interlocking grounding devices; protection of the equipment by conventional relays and circuit breakers.

Control of the transmitter is accomplished from the front of the rectifier and control cabinet. All necessary wiring to allow control from a remote location or console has been provided. Lamps, which show the status of the transmitter control circuits, are also mounted on the front of this cabinet. The control ladder is arranged and interlocked so that the BTA-50J can either be turned on by operating the control switches in sequence or by leaving all control switches in the "on" position with the exception of the start switch which, when operated to the "on"



Upper rear of exciter cabinet showing the combining and output networks.

position, allows the transmitter to come on automatically.

The two types of overload circuits used in this transmitter are the current type, instantaneous or time delay, that are connected directly in the tube circuit and rectifier ground leads, and the thermal magnetic circuit breakers connected in the a-c power leads used as back up protection and disconnect switches. The transmitter circuitry is arranged so that an overload either locks out the plate circuit or allows a single reclosure that resets if there are no further overloads. In either case, when a lockout position is reached, the transmitter resets by means of an Overload Reset control. The principal overload relays have indicating flags so that, even after the overload has cleared, there is a record of which overload relay operated. Another feature of the control circuit is the indicator lamps on each cabinet that indicate the interlock status in that particular cabinet.

Installation and Layout

Outstanding features of the BTA-50J are the small floor space requirements

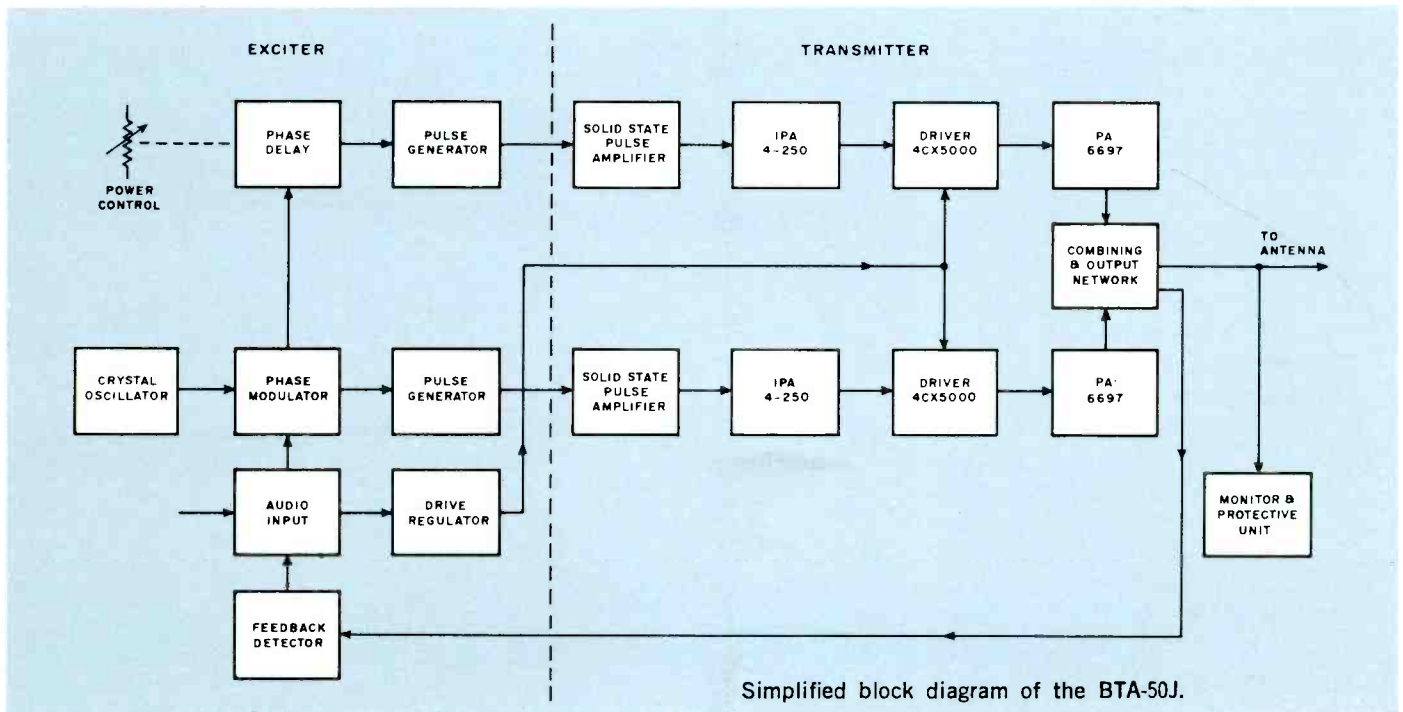

Simplified block diagram of the BTA-50J.

and ease of installation. In general, the transmitter layout consists of three basic units: the four, in-line cabinets which contain the major part of the transmitter; the wall-mounted switchgear components and the main plate transformers. The floor plan illustrates a typical layout of the complete equipment. Elimination of the need for under-floor cable trenches and considerable reduction in external air ducts, simplifies installation and reduces costs.

As shown in the layout, it is desirable to leave a passageway at the right end of the frontline cabinets since the circuit breakers and overload relays are most accessible from this end of the transmitter. The layout of the front line cabinets is such that a common exhaust duct can be used to carry off heated air from the transmitter.

Wall mounting of the switchgear as shown on the overall floor plan is suggested to make the BTA-50J most adaptable to existing transmitter buildings. The mounting of these components, however, is not critical as to location. They can be mounted in existing power distribution areas if desired. These components include the main plate circuit breaker, a delta-wye switch, a distribution circuit breaker, a 460- to 230-volt bank of distribution transformers, and two single-phase open delta connected regulators with their control panels. These components are wired through conduit and overhead ductwork to the main plate transformers and the transmitter cabinets.

Parallel/Redundant System

The BTA-50J is available also as a parallel/redundant transmitter system. This system consists of two identical BTA-50J transmitters and a combiner. In the "parallel" mode, the twin fifty-kilowatt outputs are combined to provide 100 kilowatts of power to the antenna system; in the "redundant" mode, the system operates one of the two transmitters as a hot standby while the other feeds the antenna system.

In either operational mode, the parallel/redundant system assures greater on-air dependability. For example, an outage in one transmitter or the other automatically switches the troubled transmitter to a dummy load while the operable one feeds a full fifty kilowatts to the antenna system. This action is the result of a special-design combiner with essentially zero insertion loss. Further details of the BTA-50J parallel/redundant transmitter system are available from Aural Broadcast Equipment Marketing, RCA Building 2-2, Camden, N. J. 08102, U.S.A.

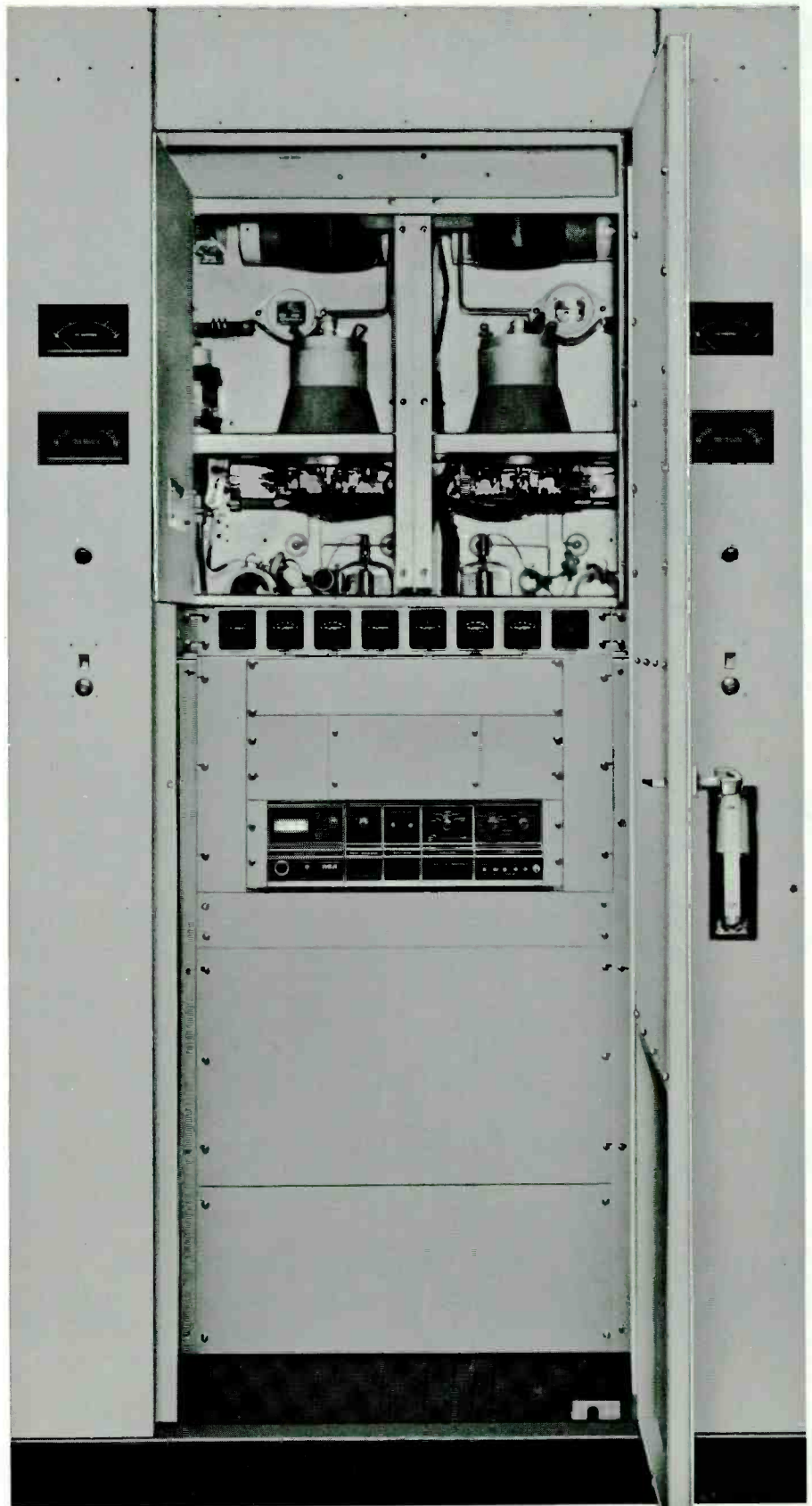

Front view of the exciter-modulator cabinet containing all sections from oscillator through driver stages.

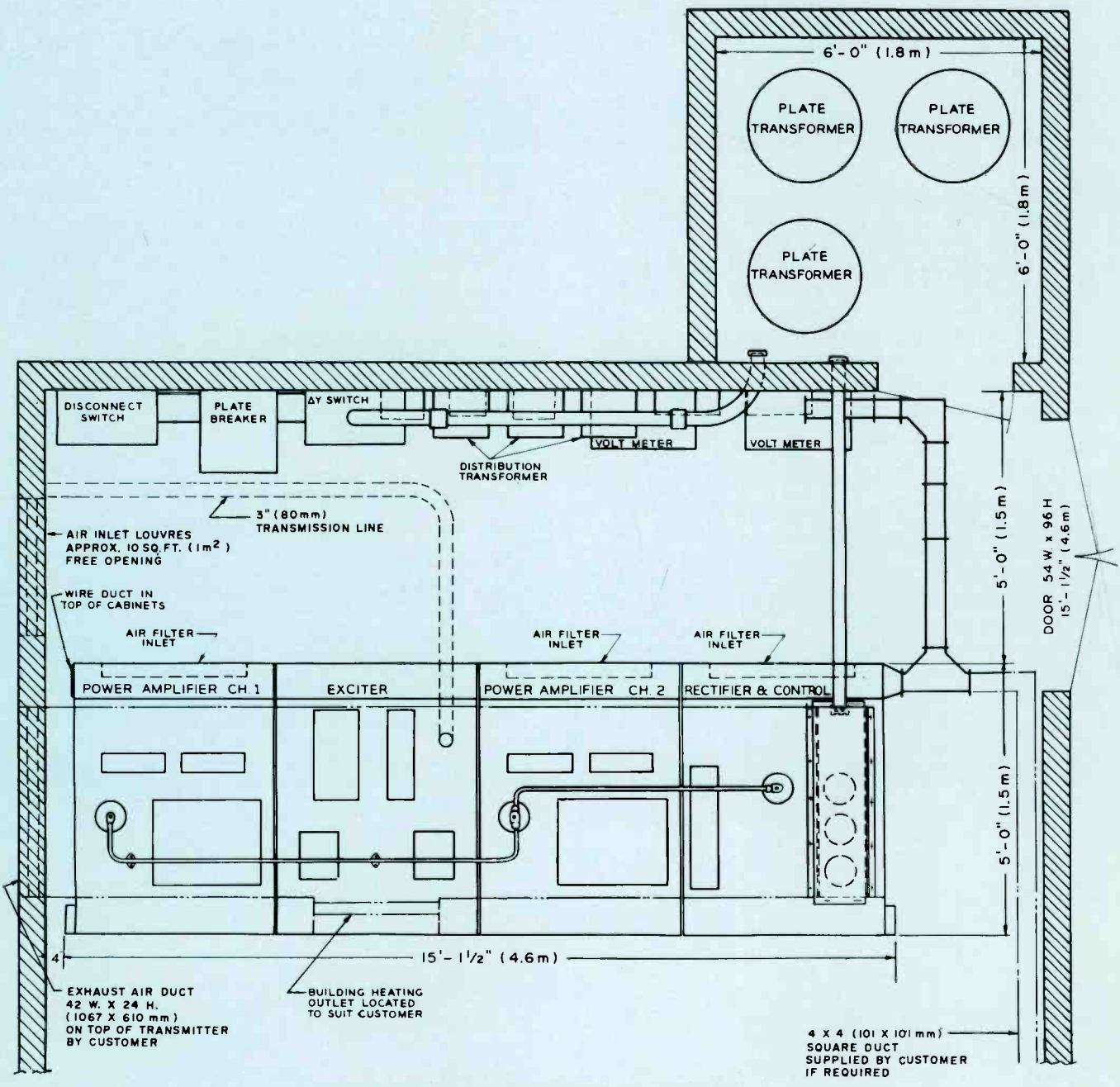

Typical floor plan for the BTA-50J Transmitter.

Specifications

General

Power Line Requirements:

Line	460 V, 50/60 Hz, 3 phase ¹
Combined Regulation and Variation	Not more than $\pm 5\%$
Power Consumption	96 kW (approx.) at zero modulation; 100 kW (approx.) at average modulation
Power Factor	90% min.
Crystal Heater Power	110 V
Type of Emission	A3
Power Output (at transmitter terminals)	56 kW (max.) ²
Frequency	Any specified between 535 and 1620 kHz
Frequency Stability	± 2 Hz
Type Modulation (High Level)	Phase to amplitude
AF Input Impedance	150/600 ohms
Audio Input Level	+10 ± 2 dBm
Audio Response	± 1.5 dB 30–10,000 Hz
AF Distortion	Less than 3% RMS 50–7500 Hz
Noise Level (Below 100% modulation)	60 dB
Carrier Shift (Neg. 100% modulation)	5% max.
Type Output	Unbalanced
Output Impedance	50 ohms ²
Spurious Emission (2nd Harmonic and above)	–83 dB

Mechanical

Cabinet Size	44" W, 84" H, 63" D (1118, 2134, 1600 mm)
Overall Weight (approx.)	11,500 lbs. (5216 kg) ³
Maximum Altitude	7500 ft. (2286 m)
Ambient Temperature	–20°C +45°C
PA Cabinet Weights (each) (approx.)	953 lbs. (432 kg)
Plate Transformer Weight (each) (approx.)	820 lbs. (372 kg)
Rectifier Cabinet Weight (approx.)	3,093 lbs. (1403 kg)
Exciter Cabinet Weight (approx.)	1,041 lbs. (472 kg)
Filter Reactor Weight (approx.)	570 lbs. (259 kg)

¹ Other line voltages available on request.

² Other output impedances available on request.

³ Operation at higher altitude available on request.

⁴ Cutback to other power levels available on request.

*Available in 100- and 200-kW systems as Types BTA-100J and BTA-200J.

Shipping Data

Weight, Domestic Packing (approx.)	13,500 lbs. (6124 kg)
Weight, Export Packing (approx.)	14,000 lbs. (6350 kg)

Tube Complement

Intermediate Power Amplifier: Type 4-250A
Driver Amplifier: Type 4CX5000A
Power Amplifier: Type 6697

Accessories

Spare Solid-State Exciter-Modulator	ES-560752
Complete Set of Operating Tubes	ES-27222E
Recommended Spare Set of Tubes	ES-27223D
Spare Crystal Unit, Type TMV-130B (Specify Frequency)	MI-27493
Type BTR-30 Remote Control (30 Functions)	MI-561446
Type BTR-15 Remote Control (15 Functions)	MI-561157/58
50/10-kW Cutback Kit	MI-27688C ⁴
Dummy Load	ES-34234
BPA-50 Antenna Tuner (230 ohms)	ES-28903
BPA-50 Antenna Tuner (70/51.5 ohms)	ES-28903
Remote RF Pickup Unit	MI-28027
Type BW-50 Frequency and Modulation Monitor	MI-560767
Type BW-60 RF Amplifier	MI-560762

Ordering Information

50-kW AM Broadcast Transmitter, Type BTA-50J, with two crystals, remote meter, one set of operating tubes, silicon rectifiers, and one exciter. Antenna tuning unit not included. (Specify operating frequency)	ES-272221D
---	------------



100 kW "Ampliphase" Medium-Wave, AM Transmitter, Type BTA-100J

- Excellent audio quality
- All solid-state exciter
- Only eight tubes, three types
- High modulation capability

An AM transmitter with FM quality, the Type BTA-100J uses phase modulation in a way that results in high fidelity AM. The transmitter includes a fully solid-state exciter and modulator. "Ampliphase" applies modulation at a low level and uses Class C, continuous-wave power amplifiers to provide the 100-kW output.

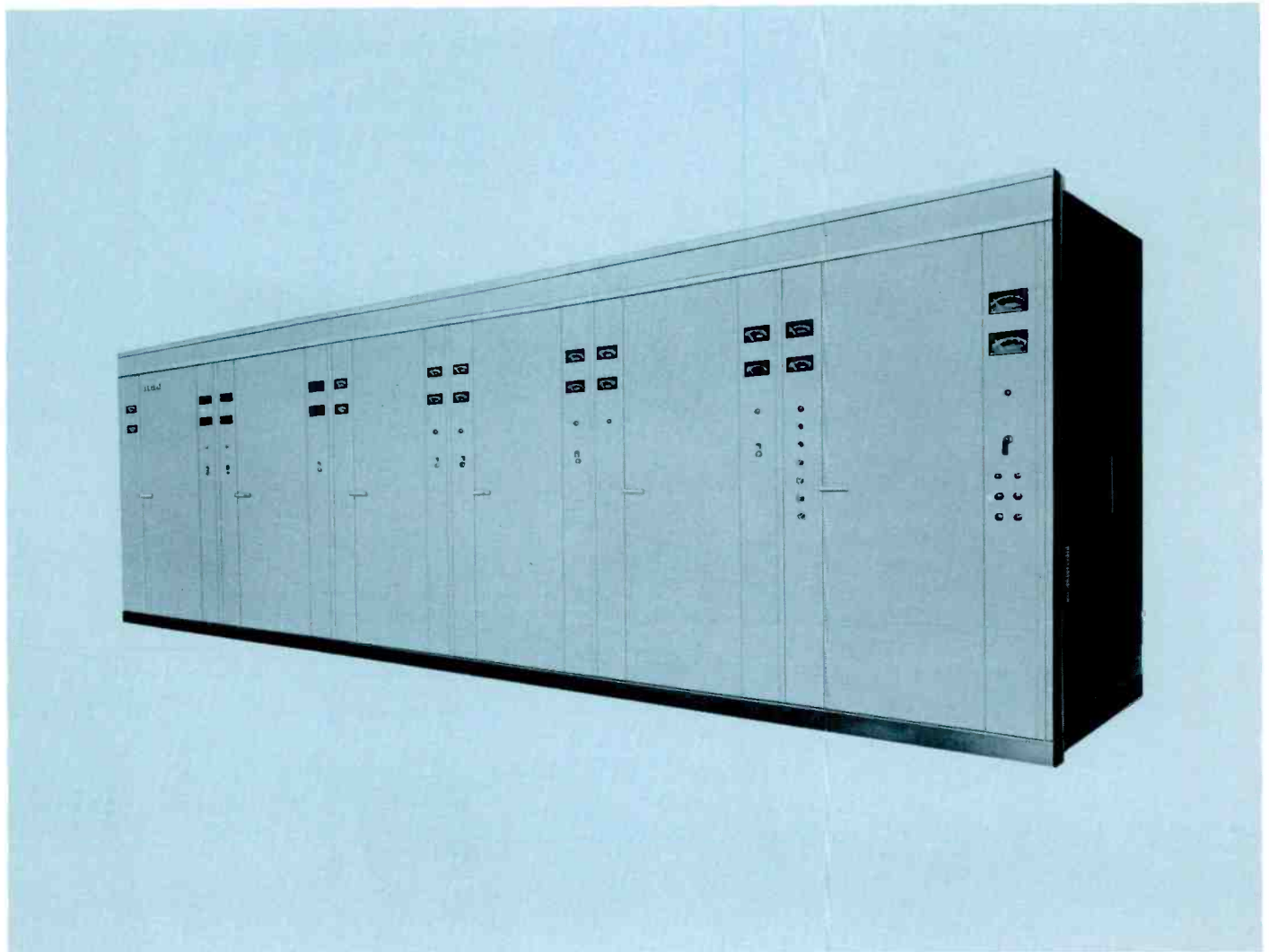

The RCA Type BTA-100J AM Broadcast Transmitter is a completely air-cooled, 100-kW phase-to-amplitude modulated transmitter designed for high fidelity transmission in the standard broadcast band (535 kHz to 1620 kHz). It provides a signal of exceptionally low distortion and extended frequency response. Measured response is flat within ± 3 dB from 35 Hz to 25,000 Hz. The equipment is capable of being modulated over the frequency range of 10 Hz to 30,000 Hz. Frequency response has been extended largely through the elimination of unnecessary transformers in the audio system as well as improved circuitry.

Low harmonic distortion with negligible carrier shift at maximum signal output has been achieved in the BTA-100J by selection of adequate power tube types and advanced solid state circuits in the exciter-modulator-drive regulator design throughout the entire equipment. The design features an inherently linear system capable of continuous high modulation levels impervious to inadvertent overmodulation. For example, the transmitter may be modulated 100 percent at any frequency between 30 and 15,000 Hz continuously for many hours without detrimental effects to any of the component parts. A small amount of overall feedback is incorporated to provide the exceptional performance.

Lowest Operating Cost in 100-kW Transmitters

A number of new refinements as well as time tested features which have proven their worth are incorporated in this modern 100-kW transmitter. Power requirements are moderate for the equipment. Power amplifier plate efficiency in the order of 75 to 80 percent is obtained.

Fewer major components, as compared to those required by many 100-kW transmitters, are used in the BTA-100J. In addition to the low cost of operation of the transmitter a power-cutback kit can be added which permits operation at 50 kW. (Other power levels available on special order).

Dual RF Chains

Two identical RF chains, each developing 50 kW, are incorporated in this equipment. Since they are identical, servicing is made easy by comparison of the two chains. Components are directly interchangeable, which allows substitution for comparison purposes. All components are easily accessible which results in a minimum schedule for maintenance. In addi-

tion, fewer replacement parts are required for adequate protection against lost air time should a failure occur. Low power consumption, fewer major components and a reduced maintenance schedule make the BTA-100J operation cost the lowest.

Ready for Remote Control

Designed with unattended remote control in mind, the BTA-100J includes the components, wiring and connections to make it completely compatible with either of two RCA remote control systems (see *Accessories*). Such components as meter shunts, motorized controls and switching devices make remote control more efficient and dependable.

Lightweight Type 6697 Tubes in Final PA

Two Type 6697 power amplifier tubes are used in each of the two RF chains.

Each final amplifier is capable of delivering in excess of the normal 50 kW of modulated power to the common load. The Type 6697 is rated at 35 kW dissipation and, under average modulation conditions, is only required to dissipate approximately 14 kW. Operation of the PA tubes so far below their maximum ratings assures long tube life. In addition, the 6697 is physically small in size and weighs only 43 pounds (20 kg). One person, without the aid of mechanical assistance, can quickly and easily replace any tube in the transmitter.

One Type 4CX5000A tube is used in each of the driver stages in the two RF chains. The 4CX5000A is also operated well below its maximum rating and gives long trouble free service. The only other tubes used in the transmitter are the two Type 4-250A intermediate power-amplifier tubes. Solid-state design extends into the monitor circuitry as well. Tube

Close-up view of one of the dual final power amplifier stages. The new type 6697 tube together with grid circuits and part of the plate circuits are readily accessible from the front of the transmitter.

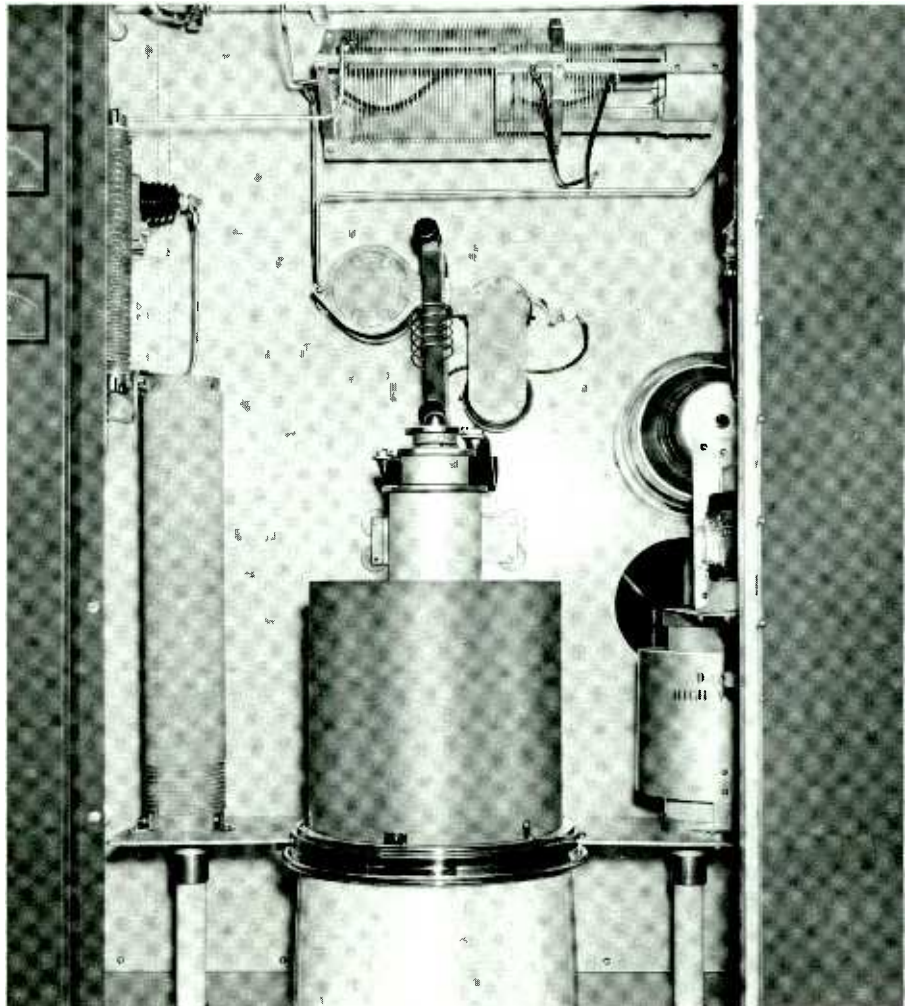

complement is such that inventory cost for spares is kept at a minimum while adequate outage protection is maintained.

Solid State Rectifiers Used Throughout

All power supplies utilize solid state rectifiers. The plate supplies, bias supply and low-voltage supply use silicon units, very conservatively rated to assure long life. The current rating of the units is such that any conceivable load fault is cleared without jeopardizing the diode units. The use of solid state rectifiers permit the transmitter to operate in ambient temperatures as low as -20 degrees centigrade.

FCC and CCIR Harmonic Suppression

A completely shielded two section low pass filter is incorporated in the BTA-100J. It consists of one pi (π) section and one T section and each inductive series element is completely shielded. Two series-tuned, shunt-connected traps are used to provide added attenuation of the second harmonic.

Operated in Parallel

Type BTA-100J Medium-Wave Transmitter consists of six equipment cabinets, four of which house the power amplifiers, one the exciter unit and the sixth cabinet, the rectifier and control unit.

Each of the six transmitter cabinets measure 44 inches wide by 60 inches deep by 84 inches high, (1118, 1524, 2133 mm) and consists of an all aluminum cubicle erected on a welded steel base. This cubicle consists of a series of panels fabricated and assembled to form a rigid structure. The use of aluminum eliminates unnecessary weight and provides excellent shielding to assure effective confinement of spurious energy. Accessibility to all transmitter components is through 28-inch (711 mm) wide, six-foot (1.8 m) front doors, while rear access is through two covers attached with quick-disconnect fasteners for easy removal.

A center vertical panel separates the cabinet into a front compartment and rear compartment which is further divided by a rear horizontal shelf into upper and lower compartments, giving each cabinet three basic totally shielded compartments in which to mount the electrical components. The eye-level meters, pilot lights and interlocks, mounted on eight-inch wide panels flanking each of the front doors, are also shielded.

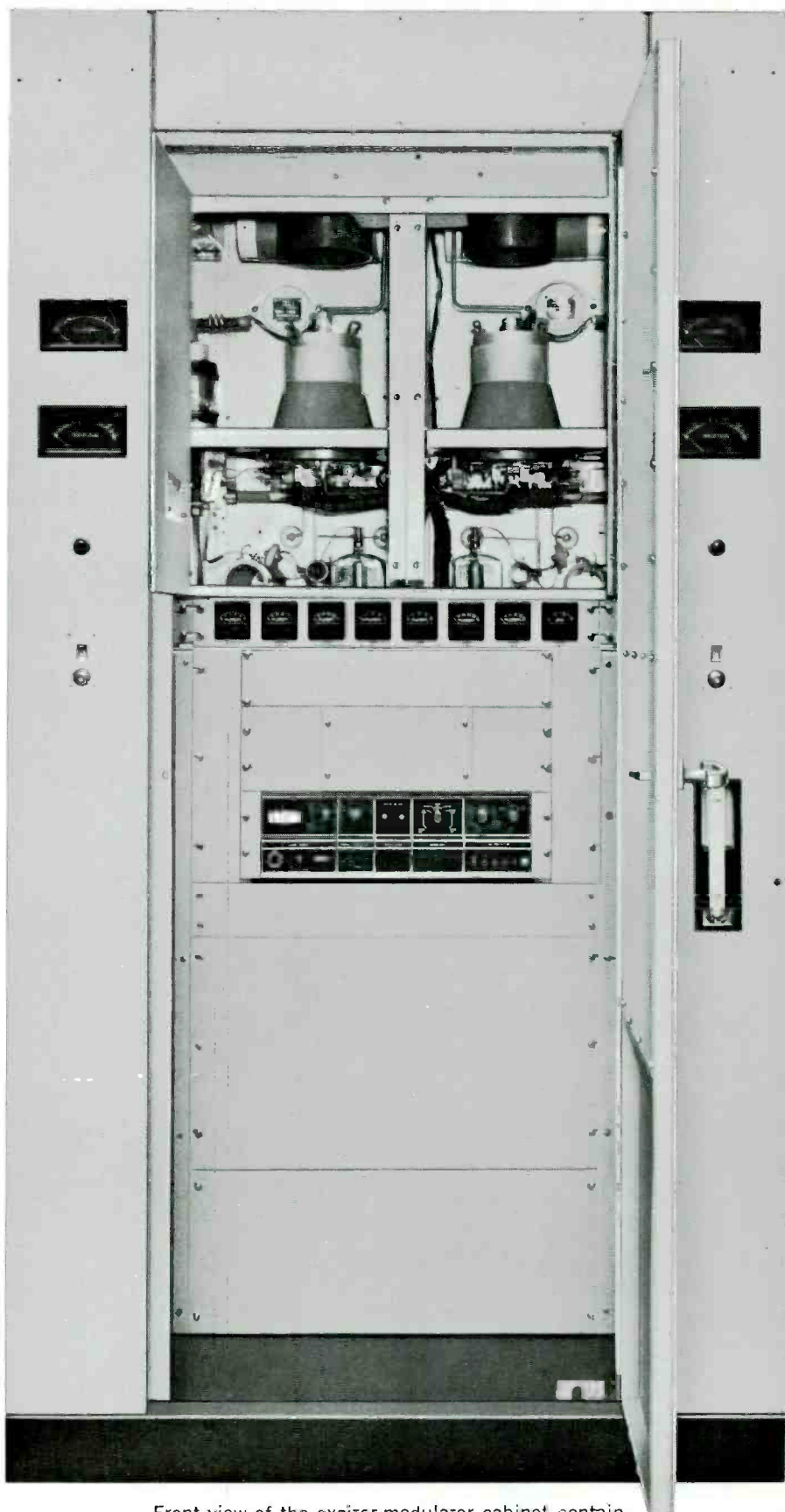

Front view of the exciter-modulator cabinet containing all sections from oscillator through driver stages.

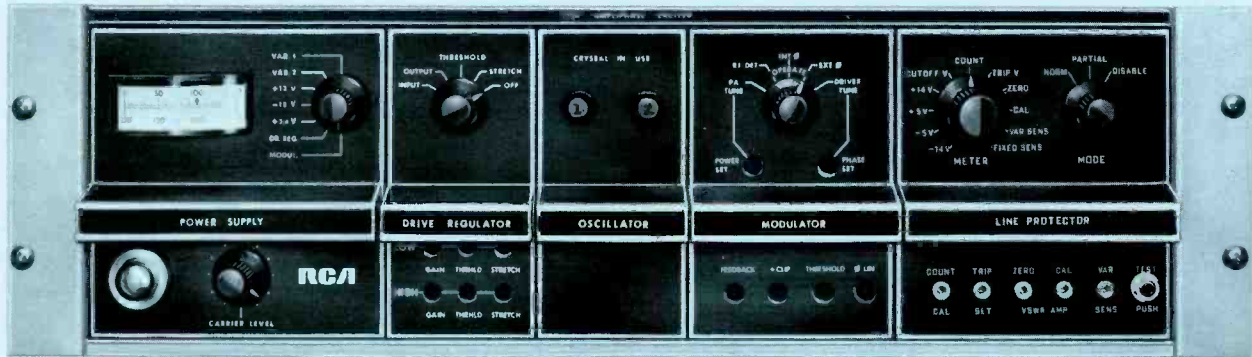

Exciter/modulator unit. Completely solid-state, this unit is used in all RCA Amphiphase transmitters. Available separately for use as a spare. See Accessories.

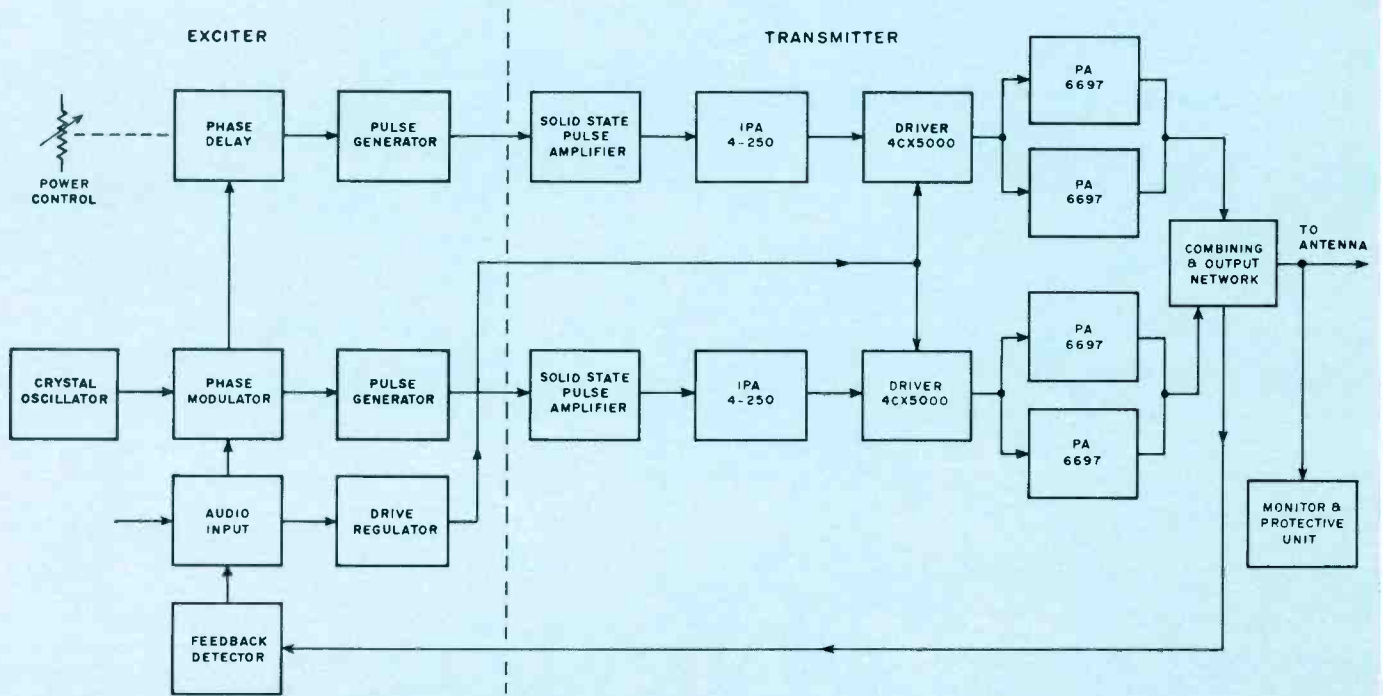

Simplified block diagram of the BTA-100J.

In the rear at the top of each cabinet is a built-in wire duct. It joins similar ducts of adjacent cabinets to form a continuous duct on the four cabinets. This duct has a divider down the center on which the interconnection terminal boards are mounted. The rear half of the duct is used for interconnection wiring while the front half is used for internal cabinet wiring from the terminal boards. The internal wiring is carried through conduits to its destination in the cabinet thus shielding all power and control wiring from RF fields. Provision is also made at the top of the cabinets for the addition of an exhaust air duct.

Power Amplifiers

The first and second cabinets and the fourth and fifth cabinets from the left end are identical and contain the final power amplifier stages. The 6697 tube and its grid circuits and part of the plate circuits are contained in the front portion of the cabinet. The upper rear section contains the plate tank coil, filament transformer and grid leak resistors. The lower rear section contains a low-noise blower which cools the 6697 tube and its cabinet. The blowers in cabinets two and four are arranged to cool the exciter cabinet. The two power amplifiers are designed to supply equal amounts of power to the output network. Because of the balanced dissipation in the PA tubes, less air pressure with resultant lower air flow is required for adequate cooling of the power amplifier cubicles. The lower rear panel contains an impingement type air filter for the blower. The PA cabinets are constructed so that the blowers and filters can be mounted externally to the cabinets, if so desired.

The PA output circuit is a conventional pi-network type of tank circuit. Each tube has its own tank circuit, with a common output shunt element. Each network is adjusted to provide the proper load to the power amplifiers.

Solid-State Exciter-Modulator, Drive Regulator

Packaged in a series of four plug-in modules, the *Ampliphase* exciter-modulator uses a crystal-controlled, field-effect-transistor oscillator, a solid-state drive regulator, modulator and power supply. The entire assembly occupies only 5¼ inches (133 mm) of rack space in the left-of-center cabinet (see photo). As a result of untuned, digital-integrated circuits, the exciter-modulator is set up with but three trimmer adjustments. The RF chains in the exciter operate with out tuned circuits.

The drive regulator circuitry uses entirely solid-state electronic devices; the regulator samples the audio, amplifies the sample and applies it to the grid circuits of the twin driver stages so as to adjust final amplifier drive in step with the level of the modulating audio. This system contributes significantly to the exceptional linearity of the *Ampliphase* system.

Solid-State Reflectometer

The far-right module in the exciter-modulator unit is a solid-state reflectometer that protects the transmitter from transmission line and/or antenna irregularities. The reflectometer senses changes in the voltage/current ratio on the load.

A large change in load characteristics causes the reflectometer system to momentarily interrupt the drive (to let the fault clear, if transient). If the fault persists after several cycles, the reflectometer shuts down the transmitter thereby reducing the possibility of chain-reaction damage to any part of the system.

Above the exciter-modulator are two vertical sub-compartments, behind interlocked doors, which contain the 4CX-5000A driver stages. A meter panel for these stages is located beneath the sub-compartments.

The common output capacitors of the two PA tanks and the harmonic filter are located in the upper rear of the cabinet. Sub-partitions are so arranged in this section that complete isolation and shielding is effected between the various sections of the filter and the output capacitor. The lower rear section of this cabinet contains high voltage filter reactor and driver dc filament supplies.

Provisions for Standby Operation

Space is provided in the exciter cabinet for the mounting of a second exciter-modulator unit. Each of the exciter-modulator units are complete and arranged so that either may be selected instantly by means of an accessory cutover panel. Thus, while one modulator is in operation, the other modulator is in standby condi-

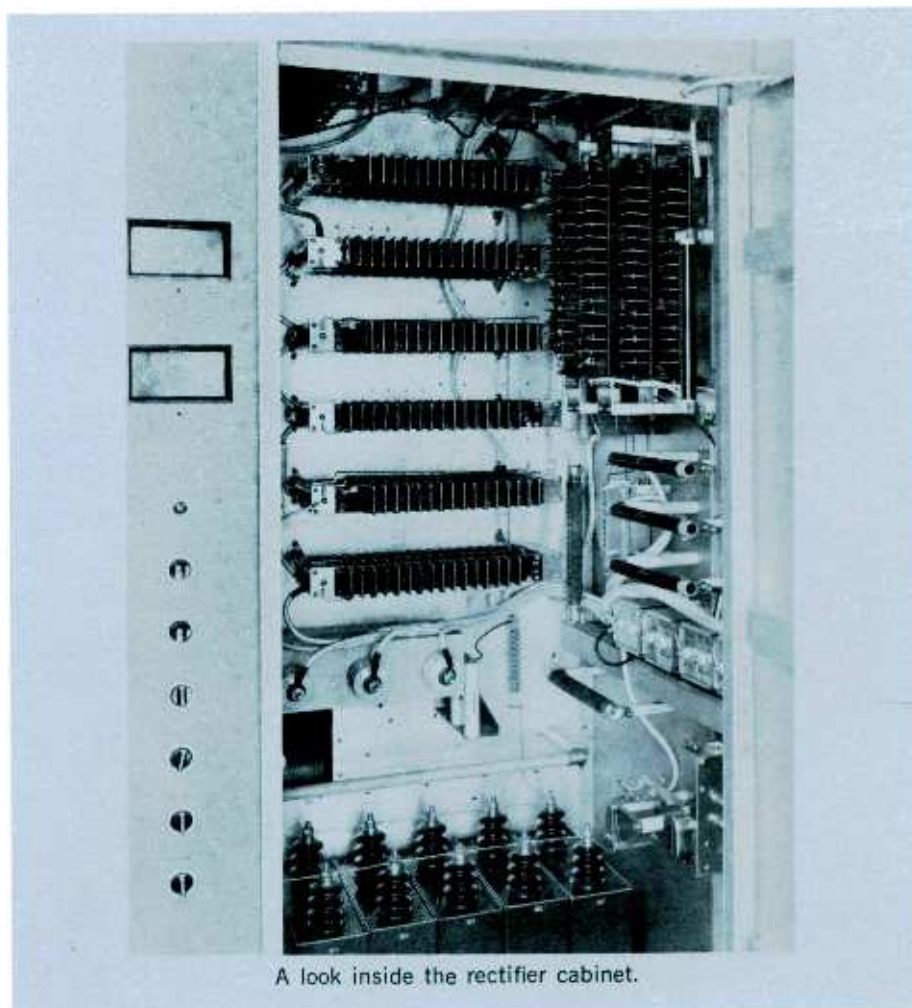

A look inside the rectifier cabinet.

tion. These provisions, with the extreme reliability designed into the high-power stages, essentially provide a second 100-kW transmitter for standby service.

Rectifier and Control Unit

The far right cabinet contains the high power rectifiers, low power distribution components, and the majority of the control components. The high-voltage and low-voltage transformers, filter capacitors and reactors are mounted externally to the transmitter cabinetry (see floor layout).

Solid-State Power Supplies

During periods of 100 percent modulation, each 6697 power amplifier tube requires 15kVdc at 7.5A, which is obtained from a three-phase, full-wave rectifier circuit. Two other plate voltages, 5kV and 1kV, are provided by separate supplies. Bias voltages for all tubes are supplied by an additional supply. The high-power distribution equipment for the transmitter consists of an electrically operated air circuit breaker, and a manually operated delta-wye switch for the 15-kV rectifier. The remaining transmitter power is distributed through a manually operated distribution circuit breaker to a 460- to 230-volt distribution transformer to voltage regulators and thence to the various low power distribution circuit breakers.

Transmitter Control

Control circuits in the BTA-100J contain a number of features which are designed to provide maximum flexibility in control, protection and operation. Among these are choice of single-button or step-by-step starting, automatic timing and sequencing of starting operations, and location of transmitter faults by a system of indicators. Protection of the operator is achieved by a system of interlocking grounding device, protection of the equipment by conventional relays and circuit breakers.

Control of the transmitter is accomplished from the front of the rectifier and control cabinet. All necessary wiring to allow control from a remote location or console has been provided. Lamps, which show the status of the transmitter control circuits, are also mounted on the front of this cabinet. The control ladder is arranged and interlocked so that the BTA-100J can either be turned on by operating the control switches in sequence or by leaving all control switches in the "on" position with the exception of the start switch which, when operated to the "on" position, allows the transmitter to come on automatically.

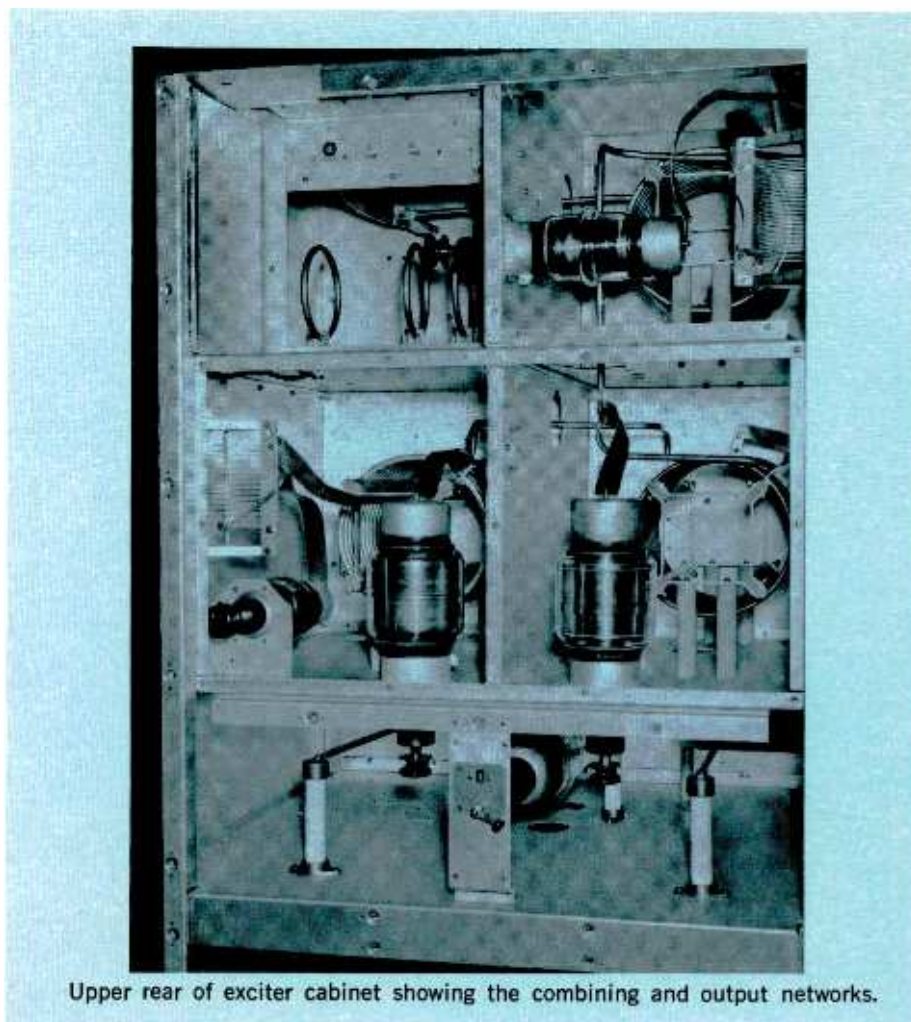

Upper rear of exciter cabinet showing the combining and output networks.

The two types of overload circuits used in this transmitter are the current type, instantaneous or time delay, that are connected directly in the tube circuit and rectifier ground leads, and the thermal magnetic circuit breakers connected in the a-c power leads used as back up protection and disconnect switches. The transmitter circuitry is arranged so that an overload either locks out the plate circuit or allows a single reclosure that resets if there are no further overloads. In either case, when a lockout position is reached, the transmitter resets by means of an Overload Reset control. The principal overload relays have indicating flags so that, even after the overload has cleared, there is a record of which overload relay operated. Another feature of the control circuit is the indicator lamps on each cabinet that indicate the interlock status in that particular cabinet.

Installation and Layout

Outstanding features of the BTA-100J are the small floor space requirements

and ease of installation. In general, the transmitter layout consists of three basic units: the six, in-line cabinets which contain the major part of the transmitter; the wall-mounted switchgear components, the main plate transformers, the HV filter capacitors and reactors and the LV power transformers. The floor plan illustrates a typical layout of the complete equipment. Elimination of the need for under-floor cable-trenches and considerable reduction in external air ducts, simplifies installation and reduces costs.

As shown in the layout, it is desirable to leave a passageway at the right end of the frontline cabinets since the circuit breakers and overload relays are most accessible from this end of the transmitter. The layout of the front line cabinets is such that a common exhaust duct can be used to carry off heated air from the transmitter.

Wall mounting of the switchgear as shown on the overall floor plan is suggested to make the BTA-100J most adapt-

able to existing transmitter buildings. The mounting of these components, however, is not critical as to location. They can be mounted in existing power distribution areas if desired. These components include the main plate circuit breaker, a delta-wye switch, a distribution circuit breaker, a 460- to 230-volt bank of distribution transformers, and two single-phase open delta connected regulators with their control panels. These components are wired through conduit and overhead ductwork to the main plate transformers and the transmitter cabinets.

Parallel/Redundant System

The BTA-100J is available also as a parallel/redundant transmitter system. This system consists of two identical BTA-100J transmitters and a combiner. In the "parallel" mode, the twin 100-kilowatt outputs are combined to provide 200 kilowatts of power to the antenna system; in the "redundant" mode, the system operates one of the two transmitters as a hot standby while the other feeds the antenna system.

In either operational mode, the parallel/

redundant system assures greater on-air dependability. For example, an outage in one transmitter or the other automatically switches the troubled transmitter to a dummy load while the operable one feeds a full hundred kilowatts to the antenna system. This action is the result of a special-design combiner with essentially zero insertion loss. Further details of the BTA-100J parallel/redundant transmitter system are available from Aural Broadcast Equipment Marketing, RCA Building 2-7, Camden, N. J. 08102, U.S.A.

Typical floor plan for the BTA-100J Transmitter.

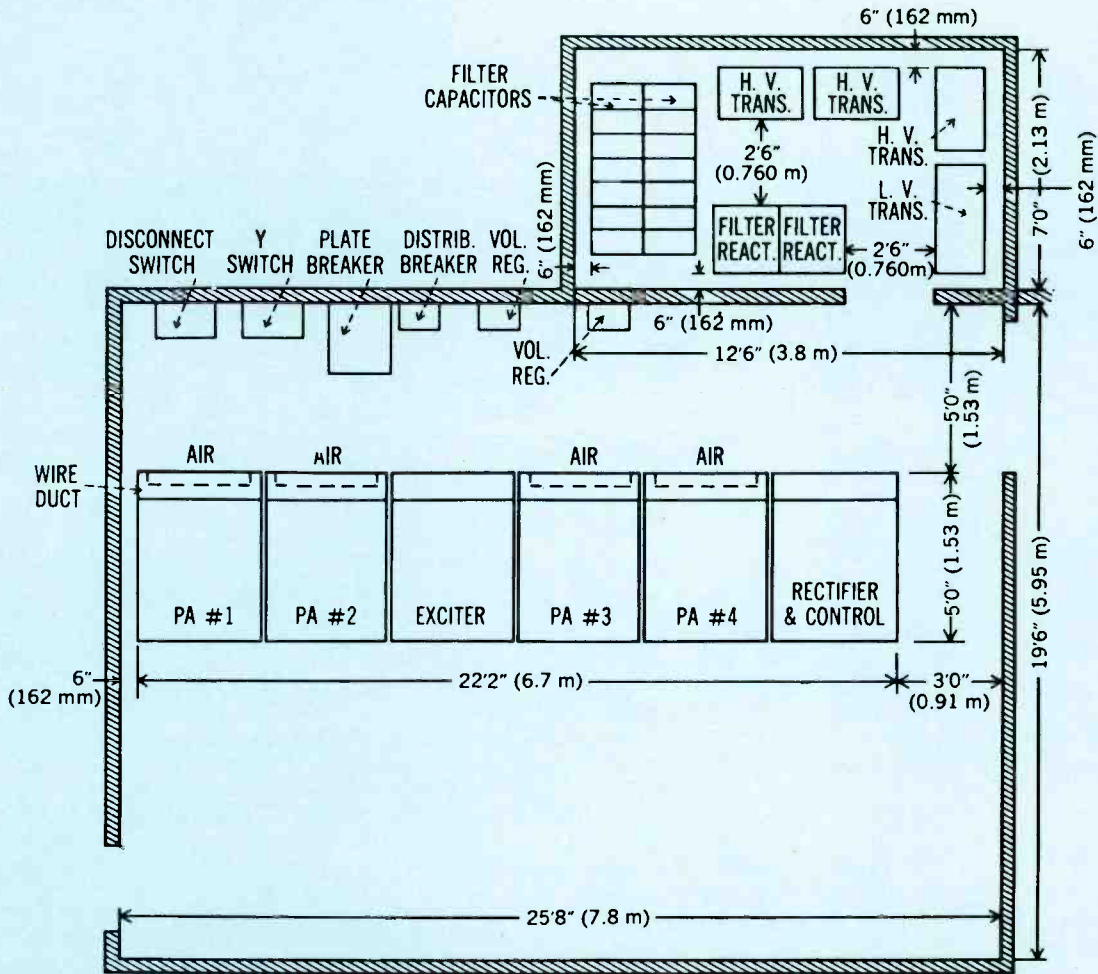

(All measurements in metric system are approximations... measurements in feet and inches are accurate)

Specifications

General

Power Line Requirements:

Line460/380 V, 50/60 Hz, 3 phase¹
 Combined Regulation and VariationNot more than $\pm 5\%$
 Power Consumption180 kW (approx.) at zero modulation;
 200 kW (approx.) at average modulation

Power Factor90% min.
 Crystal Heater Power110 V
 Type of EmissionA3
 Power Output (at transmitter terminals)110 kW (max.)*
 FrequencyAny specified between 535 and 1620 kHz
 Frequency Stability ± 2 Hz
 Type Modulation (High Level)Phase to amplitude
 AF Input Impedance150/600 ohms
 Audio Input Level $+10 \pm 2$ dBm
 Audio Response30-10,000 Hz ± 1.5 dB; 30-15,000 Hz ± 3 dB
 AF DistortionLess than 3% RMS 50—7500 Hz
 Noise Level (Below 100% modulation)60 dB
 Carrier Shift (Neg. 100% modulation)5% max.
 Type OutputUnbalanced
 Output Impedance50 or 230 ohms²
 Spurious Emission (2nd Harmonic and above)-83 dB

Mechanical

Cabinet Size (each)44" W, 84" H, 63" D
 (1118, 2134, 1600 mm)
 Overall Weight (approx.)17000 lbs. (7700 kg)
 Maximum Altitude7500 ft. (2286 m)³
 Ambient Temperature-20°C +45°C
 PA Cabinet Weights (each) (approx.)1000 lbs. (454 kg)
 Plate Transformer Weight (each) (approx.)1500 lbs. (680 kg)
 Rectifier Cabinet Weight (approx.)2000 lbs. (907 kg)
 Exciter Cabinet Weight (approx.)1200 lbs. (544 kg)
 Filter Reactor Weight (approx.)1500 lbs. (680 kg)

Shipping Data

Weight, Domestic Packing (approx.)19,000 lbs. (8618 kg)
 Weight, Export Packing (approx.)20,000 lbs. (9072 kg)

Tube Complement

Intermediate Power Amplifier: Type 4-250A (Two used)
 Driver Amplifier: Type 4CX5000A (Two used)
 Power Amplifier: Type 6697 (Four used)

Accessories

Spare Solid-State Exciter-ModulatorES-560752
 Complete Set of Operating TubesES-27222FX
 Recommended Spare Set of TubesES-27223EX
 Spare Crystal Unit, Type TMV-130B
 (Specify Frequency)MI-27493
 Type BTR-30 Remote Control
 (30 Functions)ES-561446
 Type BTR-15 Remote Control
 (15 Functions)ES-561157/58
 100/50-kW Cutback KitMI-27688CX⁴
 Remote RF Pickup UnitMI-28027
 Type BW-50 Frequency and Modulation
 MonitorMI-560767
 Type BW-60 RF AmplifierMI-560762

Ordering Information

100-kW AM Broadcast Transmitter, Type BTA-100J, with two
 crystals, remote meter, one set of operating tubes, silicon
 rectifiers, and one exciter.
 (Specify operating frequency)ES-34100CX
 200-kW AM Broadcast Transmitter, Type BTA-200J (Custom
 built from two BTA-100J Transmitters) (Please specify oper-
 ating frequency)ES-34100DX

¹ Other line voltages available on request.

² Other output impedances available on request.

³ Operation at higher altitude available on request.

⁴ Cutback to other power levels available on request.

* Available in 200-kW systems as Type BTA-200J.

AM Monitor Equipment: Frequency & Modulation Monitor, Type BW-50A and Monitor RF Amplifier, Type BW-60

- Two monitors in one
- Monitors positive peaks to 133%
- Carrier-off and calibration built-in
- Monitors off-air with RF amplifier

These are companion equipments for monitoring the carrier frequency and percentage of modulation of AM (medium wave) broadcast stations. The BW-50A accepts carrier frequencies from 200 to 2000 kHz while the BW-50AX extends this range to 25 MHz to include international broadcast frequencies. The BW-60 amplifies an off-air signal for the BW-50A when the unit is used at a remote monitoring point.

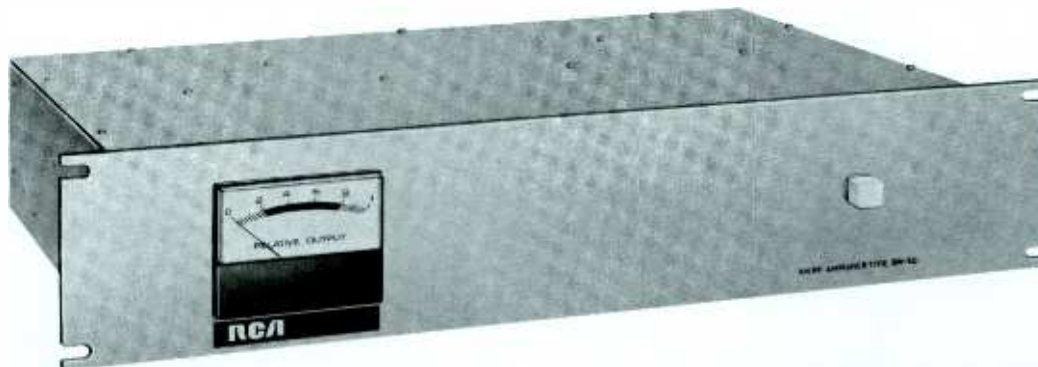
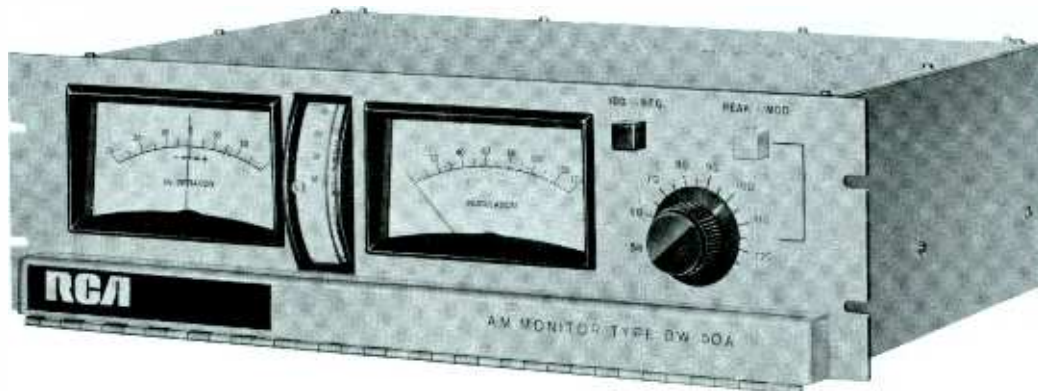

The BW-50 is a solid-state, sensitive AM receiver using a unique new approach to accurate AM transmitter monitoring. It incorporates a highly linear AM detector for modulation monitoring and a digital counter circuit for frequency-deviation monitoring.

Using digital-type, direct counting system minimizes the effect of circuit parameters upon the accuracy of measurement and avoids the need for an oven-stabilized crystal oscillator often used in conventional heterodyne monitors.

The three front panel meters display "frequency deviation", "relative carrier level" and "peak modulation".

Indicates Positive and Negative Modulation

The BW-50 reads positive or negative modulation polarities on the meter and the modulation-peak indicator. The peak indicator includes threshold adjustment. A separate peak indicator displays negative modulation peaks in excess of 99%. The

extended range modulation meter indicates up to 133 percent modulation.

Self-Calibration and Check

The BW-50 includes self-calibration of the frequency and modulation, modulation level and frequency deviation meters. The unit also includes facilities for the connection of an audible alarm for carrier loss and/or frequency deviation beyond prescribed limits.

Completely Solid State Circuitry

The BW-50 uses only silicon transistors and integrated circuit devices. All circuits use military grade, glass-epoxy printed-circuit boards. A hinged, front-cover bar hides seldom-used controls and test points while the power input, RF input and monitor output connectors are located at the rear.

Transmitter Measurements

Frequency response, distortion and noise measurements for transmitter proof-of-performance tests are made through a

front-panel connector. Five volts (rms) is available at this connector to allow the use of most distortion and noise analyzers.

RF Amplifier Type BW-60

The BW-60 RF Amplifier is a companion to the BW-50 Frequency and Modulation Monitor. The combination of the two allows frequency and modulation monitoring of the transmitter at some point away from the actual transmitter site. The BW-60 amplifies an off-air signal (100 μ V or greater) without alteration of the air signal's characteristics other than amplitude.

Shielded Loop Antenna

Optimum performance of the BW-60 depends on the antenna used. We recommend the use of a shielded loop antenna (see *Accessories*). The accessory antenna is three feet (914 mm) in diameter and of aluminum construction. The use of the shielded loop reduces electrostatic noises to a minimum and, through rotation, nulls out interfering signals.

Specifications

Input Sensitivity	5 to 10 V rms
Input Impedance (Bridgeable to lower impedance)	1000 ohms
Input Frequency Range	200 to 2000 kHz ¹
Frequency Deviation Meter Range	± 30 Hz
Frequency Reference Accuracy	Within 5 ppm 0 to 35 C. ²
Modulation Level Meter Range (Positive)	0-133%
Carrier Level Meter Range	80-110%
Modulation Meter Accuracy	Within 2% at 100% mod.
Peak Indicator Threshold Adjustment	50 to 120%
Negative Peak Indicator Threshold	99.5%
Audio Frequency Response	30-15,000 Hz ± 5 dB
Audio Frequency Distortion (95% mod.)	0.25% max.
Signal/Noise Ratio	75 dB
Remote Meter Loop Resistance	5,000 ohms
Power Requirements	117/234 V $\pm 10\%$, 50-60 Hz, 10 W
Dimensions	5 $\frac{1}{4}$ " H, 19" W, 11 $\frac{1}{8}$ " D (133, 483, 302 mm)
Weight	15 lbs. (6.8 kg)
Shipping Weight	19 lbs. (8.6 kg)
Package Dimensions	21 $\frac{1}{2}$ " x 16 $\frac{1}{2}$ " x 10" (546, 419, 254 mm)

¹200 kHz to 25 MHz in BW-50AX.

²Per year.

Accessories

Remote Meter and Flasher Panel	MI-560896-1
Antenna, Shielded Loop	MI-561325

Specifications (Type BW-60A)

Input Frequency Range	535 to 1600 kHz
Minimum Input Level (for threshold of limiting)	100 μ V
Maximum Input Level	0.5 V
Input Impedance	50 ohms
Output Impedance	1000 ohms
Output Level	Adjustable to 1 watt
Bandwidth (3 dB points)	± 16 kHz
I-F Frequency Rejection	Greater than 50 dB
I-F Frequency	260 kHz
Image Rejection	Greater than 50 dB
Response at ± 40 kHz: 40 dB down; at ± 10 kHz: 0.2 dB down	
AGC Characteristics:	
Carrier Shift (@ 12 dB change)	2% max.
Usable Range	30 dB
Power Requirements	117/234 V $\pm 10\%$, 50/60 Hz, 5 W.
Dimensions	3 $\frac{1}{2}$ " H, 19" W, 11 $\frac{1}{2}$ " D (89, 483, 292 mm)
Weight (Approx.)	12 lbs. (5.4 kg)
Shipping Weight (Approx.)	14 lbs. (6.4 kg)

Ordering Information

AM Freq. & Mod. Monitor:	Type BW-50A	Type BW-50AX
Factory wired for 117-volt power line	MI-560767-1	MI-560767-1X
Factory wired for 234-volt power line	MI-560767-2	MI-560767-2X

Monitor RF Amplifier, Type BW-60:

For operation on 117V power	MI-560762-1
For operation on 234V power	MI-560762-2

(Please specify operating frequency)

FM Exciter System, Type BTE-15A
 Stereo Generator, Type BTS-1B
 SCA Generator, Type BTX-1B

- Modular, integrated design
- Direct-FM modulation
- Built-in multimeters
- Automatic SCA subcarrier muting
- Built-in, off-frequency (phase-lock) detector

The BTE-15A is a completely solid-state, integrated-circuit exciter system for FM broadcast transmitters, using direct frequency modulation of the carrier for excellent frequency response, low noise.

The system is available in several configurations of mono or stereophonic with or without one or two subsidiary communications (SCA) channels. The basic exciter system handles monophonic programming only. Adding plug-in modules to the basic system expands it to handle stereophonic or SCA programming (see Ordering Information). Stations equipped with SCA facilities offer background music or other subscriber services while they maintain mono or stereo mass-market programming.

An important operational feature of this exciter system is its metering facility that uses two separate meters. One indicates operating parameters while the other indicates peak modulating-signal levels.

The main frame of the system houses the power-supply equipment and the two built-in multimeters. Into this main frame plug four individual modules: FM Exciter; Stereo Generator and one or two SCA Subcarrier Generators. When the system serves a transmitter operating only the monophonic main channel, an input module occupies the stereo module space. When subcarrier generators are not part of the system, the module space set aside is covered with blank panels. Description of each module begins on the next page.

For the low-power, educational-FM station the BTE-15A is available as a packaged, 10-watt transmitter.

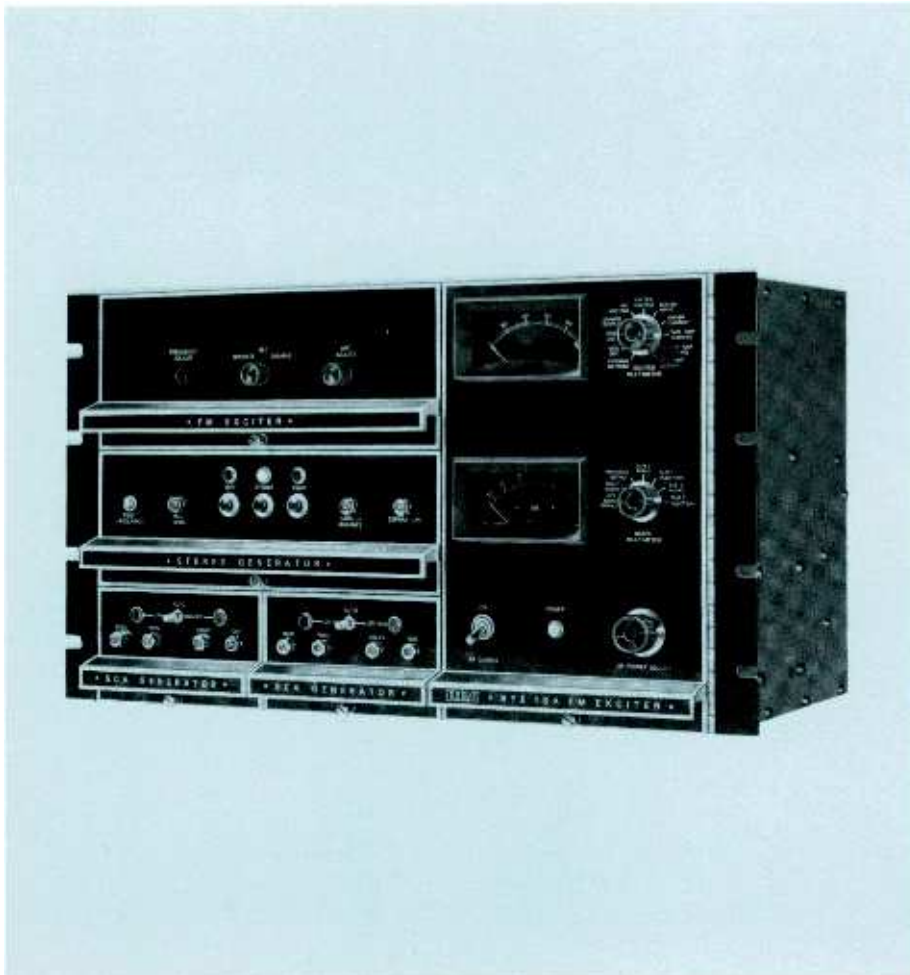

FM Exciter System, Type BTE-15A

- Entirely solid-state
- Direct FM applied at carrier frequency
- Easily adjustable power output
- Plug-in subcarrier generators
- Built-in d-c and peak-reading-audio multimeters

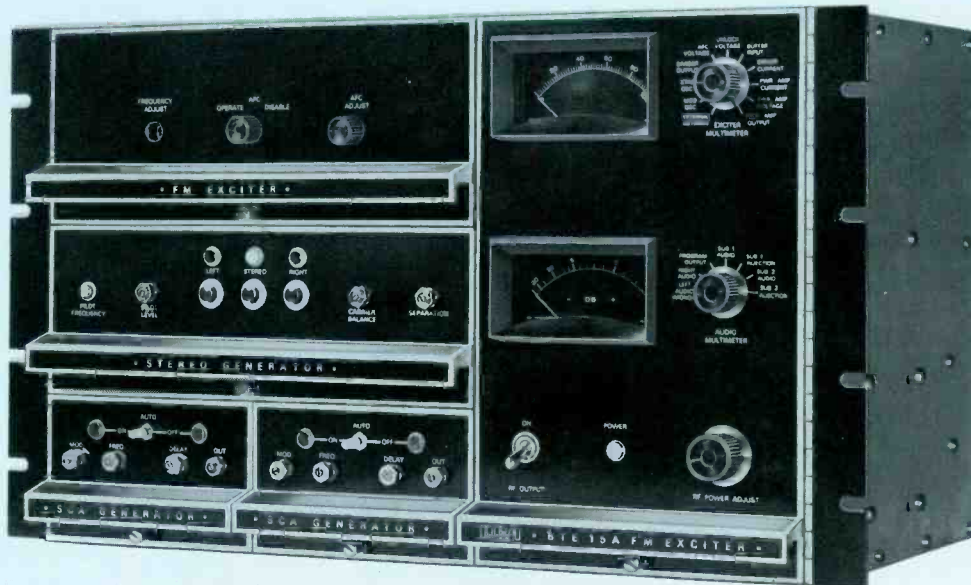

Solid-state exciter system as it appears equipped for stereo and two SCA subchannels. Stereo and SCA generators are optional.

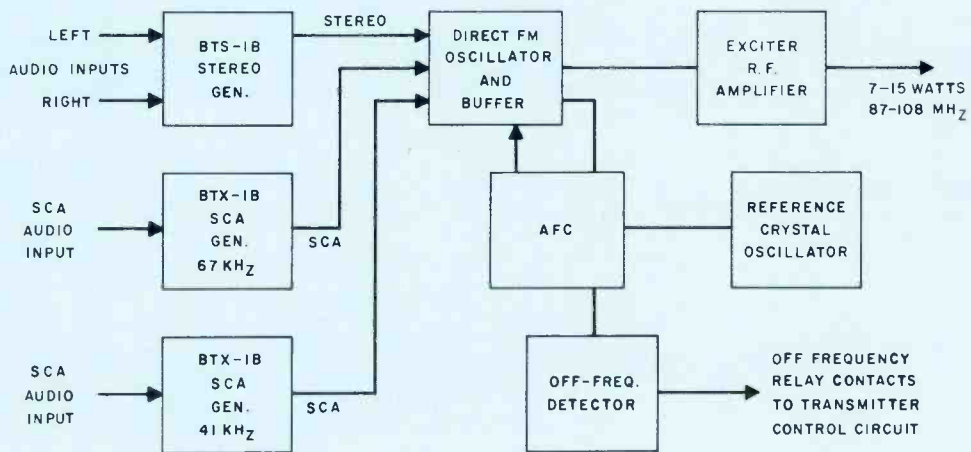

Simplified block diagram, Type BTE-15 Exciter equipped for stereo and two SCA subchannels.

The BTE-15A is a completely solid-state exciter system for FM broadcast transmitters. It employs a principle of direct frequency modulation that results in an FM signal of wide frequency response, low distortion and low noise.

The BTE-15A is used in all current RCA FM transmitters and it is directly interchangeable with the earlier, tube-powered exciter (Type BTE-10C) used in RCA FM transmitters. Minor connector rewiring in the transmitter allows substitution for the even earlier Type BTE-10B exciter. The system is fully self-contained, even when fitted with stereo and/or SCA subcarrier generators. The entire system operates directly from single phase, commercial power.

The system's main frame houses the power-supply equipment and the two built-in multimeters: one, a d-c meter for exciter parameters and another, a peak-reading a-c meter, for the audio sections.

In a mono-only configuration, the exciter system consists of a main frame, an FM generator module and an audio-input module (which plugs into the space otherwise occupied by the stereo module).

Equipped for stereo, the main frame holds two modules: the FM generator module and a stereo generator module. The two spaces at the lower left are covered with blank panels. Adding one or two SCA subchannels is a simple matter of adding one or two SCA generator modules. A special circuit within

the main frame precludes automatic simultaneous operation of a 41-MHz SCA subcarrier while the exciter operates in stereo mode.

Carrier Oscillator

A temperature-compensated, solid-state oscillator circuit generates the exciter signal at carrier frequency. True frequency modulation of this oscillator is performed with variable-capacitance diodes in a push-pull connection to the oscillator tank circuit. A 10dB resistive attenuator isolates the oscillator from the input of a solid-state buffer amplifier. The buffer amplifier raises carrier level to about 500 milliwatts for the RF amplifiers that follow and provides a sample for the AFC system as well.

RF Amplifier Chain

In three solid-state stages, the RF amplifier raises the 500mW carrier to a 15-watt level. The output level is adjustable between 7 and 15 watts while the output circuit tolerates load mismatches from dead-short to open-circuit for a reasonable time without damage to the output transistor.

AFC System

The automatic frequency control portion of the system uses an oven-heated crystal as the frequency reference. This crystal oscillates at 1/1024 of the carrier frequency and its frequency is divided by 16 in a binary divider. A sample of the carrier generator oscillator, (taken at

the buffer stage), is divided in a binary divider chain to a frequency that matches the reference oscillator subharmonic (at a 100.1 MHz carrier, the frequency is approximately six kHz). These two signals are phase detected in a time-sharing comparator. When an error between the two exists, the AFC system applies a correction to the carrier-generator oscillator through a pair of variable-capacitance diodes connected to the tank circuit. Thus, the carrier oscillator is phase locked to a low-frequency oven-controlled crystal through the binary chains.

Off-Frequency, Phase-Lock Detector

The BTE-15A includes a detector that senses a loss of phase lock between the carrier oscillator and the reference oscillator. This condition operates a relay in the exciter system which can be connected to the transmitter control circuit to shut down the transmitter should such an event take place.

Built-in Multimeters

The main frame of the exciter system houses the regulated power supply and the system's two built-in multimeters. The uppermost meter is a d-c unit and is connected, through a rotary selector switch, to monitor 11 exciter parameters; the lower meter is an audio-measuring, peak-reading device calibrated in dB (-20 to +5) which measures 7 audio parameters through a rotary selector.

Specifications

Carrier Frequency Range	87.5 to 108 MHz
Power Output (Adjustable level at 50 ohms)	7 to 15W
Output Connector	Type BNC
Modulation Capability	±125 kHz max.
Carrier Frequency Stability	±250 Hz
Audio Input Level (For 75kHz deviation, 400Hz)	10 ±2 dBm
Frequency Response (75µs pre-emphasis):	
50-10,000 Hz	Flat ±0.5 dB
10,000-15,000 Hz	Flat ±1.0 dB
Pre-emphasis Net Time Constants	50 or 75µs
Harmonic Distortion (50-15,000 Hz)	0.5% max.
Noise Level, FM (ref: 100% mod, 400 Hz)	-68dB max.
Noise Level, AM (ref: carrier)	-60dB max.
Power Requirements	117, 208, 240V; 50-60 Hz; 80W max.
Power Line Regulations (Slow voltage variation)	±5% max.
Dimensions	19" W; 10½" H; 9" D (483, 267, 229 mm)
Weight (Approx.)	40 lbs. (18kg)
Shipping Weight (Approx.)	50 lbs. (23 kg)
Operating Altitude (Above sea level)	12,500 ft. (3812 m)
Ambient Operating Temperature	-20 to 60°C (-10 to 140°F)

Accessories and Spares

Input/Output Plugs and Connectors, Set	MI-560734
Recommended Semiconductor Spare Kits for:	
Main Frame	RO-390

Exciter Module	RO-391
Stereo Generator Module	RO-392
SCA Generator Module	RO-393
Mono Input Adapter Module	RO-394
RF Portion of Exciter Module*	RO-381
Crystal, with Oven (Please specify carrier freq.)	MI-560717
Crystal Oven, less crystal	MI-560717A
FM Generator Module	
(Please specify carrier freq.)	MI-560712
Stereo Generator Module, Type BTS-1B	MI-560713
SCA Subcarrier Generator Module,	
Type BTX-1B (Specify Subcarrier freq.)	MI-560714

*Five in kit; duplicated in Exciter Module Spares Kit (RO-391). Order "RO" kits from RCA Parts and Accessories, Deptford, N. J.

Ordering Information

Exciter System, Type BTE-15A	
(Please specify assigned frequency):	
Mono only	ES-560631‡
Mono & 1 SCA Channel†	ES-560632‡
Mono & 2 SCA Channels†	ES-560633‡
Stereo	ES-560634‡
Stereo & 1SCA Channel†	ES-560635‡
Stereo & 2 SCA Channels†	ES-560636‡

‡Less input-output plugs and connectors. See Accessories.

†Please specify subcarrier frequency or frequencies.

Plug-In Stereo Generator, Type BTS-1B

- Identical audio channels
- Choice of pre-emphasis time constant
- Low distortion pilot signal
- Built-in 19-kHz program filter
- Negligible 76-kHz harmonic content



Entire generator contained in this plug-in module.



Generator module in rack mount unit for use external to BTE-15

The BTS-1B Stereo Generator is a plug-in module for the Type BTE-15A FM Exciter System. However, it is offered separately in a self-powered rack-mount assembly for use with RCA exciters and transmitters of earlier design. The self-powered generator is also useful to form a composite stereo signal for an STL system. (See *Ordering Information*, below.)

Among the many features of the BTS-1B are the identical left and right audio channels, the efficient 19-kHz program filters, the buffered 38-kHz switching signal, the negligible 38-kHz second harmonic in the output, the field-reconnectable pre-emphasis time-constant network and a built-in, phase-linear filter.

Identical Audio Channels

The "left" and "right" audio channels in the BTS-1B are essentially identical in all respects. For example, the gain differential between the two is adjustable to within one-half percent and the phase shift to within one-half degree at all frequencies between 30 and 15,000Hz. Each amplifier includes a resistive input termination, an isolation transformer, a 15-kHz low-pass filter, an operational amplifier and a pre-emphasis network. This network is connected for 75- μ s time constant and may be field reconnected for 50- μ s or "flat" (zero pre-emphasis). The low-pass filter in each channel attenuates 15-kHz program content less than one-half dB but response at 19kHz and higher is down at least 50dB. This assures minimum audible beatnotes between program and pilot/subcarrier frequencies.

Symmetrical Switching Signal

The left and right audio signals are switched at a 38kHz rate in the switching modulator. The switching signal is a buffered, balanced and symmetrical waveform from a bi-stable counter with minimum second and higher-order har-

monics in the output. The counter is driven by a crystal-controlled 76-kHz oscillator to assure a frequency stable 38-kHz subcarrier.

Low Distortion Pilot Signal

The switching modulator output and the 19-kHz sinusoidal pilot frequency (distortion less than one percent) are stripped of 38-kHz third and all higher-order harmonics in a phase-linear filter.

Pushbutton Switching

Front-panel pushbuttons operate internal relays that switch the generator's operating mode: left mono; stereo or right mono. Lighted indicators, immediately above the pushbuttons, indicate

operating mode. Additional front-panel controls adjust pilot frequency, pilot level, carrier balance and stereo separation.

Available in Two Forms

The BTS-1B Stereo Generator is available as a plug-in module for the exciter system from which it draws operating power. For use with earlier RCA exciter units, the BTS-1B is offered in a combination with a rack-mount frame. The module plugs into the frame in the same manner it does into the exciter system. The rack-mount frame includes a power supply for operation from commercial power lines. Requires 3½ inches (89 mm) rack space.

Specifications

Pilot Carrier Stability (19kHz)±1Hz
Subcarrier Suppression45dB min.
Frequency Response Characteristic:	
30 to 10,000HzFlat ±0.5dB
30 to 15,000HzFlat ±1.0dB
Pre-emphasis Time Constants50 or 75 μ s
Channel Separation (L to R and R to L)35dB min.
Crosstalk:	
L+R to L-R-45dB max.
L-R to L+R-45dB max.
Stereo Harmonic Distortion1% max.
Dimensions	
(Rack-Mount Unit).....	3½" H, 19" W; 10⅞" D (89, 483, 270 mm)
Weight, Rack-Mount Unit (Approx.)19 lbs. (9 kg)
Shipping Data:	
Dimensions (Approx.)5½" x 20" x 13"
Dimensions (mm)140 x 508 x 130
Weight (Approx.)24 lbs. (11kg)

Accessories and Spares

Recommended Semiconductor SparesRO-392
Frame and Power Supply, less Stereo ModuleMI-560711A
Module ExtenderMI-560719

Ordering Information

Stereo Generator Module, Type BTS-1BMI-560713
As Above, for Rack-Mount (Includes	
Power Supply & Module Extender)ES-560639

Plug-In SCA Subcarrier Generator, Type BTX-1B

- Adjustable pre-emphasis time constant
- Subcarrier harmonic filter built-in
- Automatic subcarrier mute
- Front-panel vernier frequency control



Rack-mount unit holds two generators and a power supply.



Entire generator contained in this plug-in module.

The BTX-1B SCA Subcarrier Generator is a plug-in module for the Type BTE-15A FM Exciter System. However, it is offered separately in a self-powered, rack-mount assembly for use with RCA exciters and transmitters of earlier design.

Among the many features of the BTX-1B is a resistive-terminating pad at the audio input, an adjustable pre-emphasis network and extra audio input, sensitivity that usually precludes the need for a line amplifier between the program source and the audio input.

Audio Portions

Program audio enters the BTX-1B through a resistive terminating pad and an isolation transformer before reaching the amplifier. A 5-kHz low-pass filter is included for use when the generator operates in a system which includes a stereo facility. The filter minimizes the generation of SCA sidebands that interfere with the L-R portion of the stereo information.

Active Pre-Emphasis Network

The audio amplifier includes an active pre-emphasis network that reconnects for 75 or 150 microsecond time constants or for no pre-emphasis at all which results in a "flat" characteristic for situations where the input audio is pre-emphasized earlier. Also included is a "telemetry input" which bypasses the pre-emphasis network to allow the transmission of subaudible 20 to 30 Hz metering information.

Integrated Circuit Modulator

The subcarrier is generated by a temperature compensated, solid-state oscillator. A front-panel frequency vernier provides touchup frequency control whenever appropriate. The subcarrier is frequency modulated in an intergrated circuit which provides both "coarse" and "fine" frequency control via potentiometers. The "fine" control is a front-panel control.

Automatic SCA Muting

The modulated oscillator drives a muting gate which is closed automatically when no modulation is present. A "mute-delay" circuit provides an adjustable time delay between the end of modulation and the muting of the subcarrier. A front-panel indicator lights as long as subcarrier is "on". Two buffers and a filter couple the modulated subcarrier to the adjustable output. An additional buffer amplifier connects a sample of the output to the metering circuit.

Built-In Subcarrier Harmonic Filter

The subcarrier harmonic filter is connected between the two buffer amplifiers

which couple the modulated oscillator to the module output.

Available in Two Forms

The BTX-1B SCA Subcarrier Generator is available as a plug-in module for the exciter system from which it draws operating power. For use with earlier RCA exciter units, the BTX-1B is offered in combination with a rack-mount frame. The module plugs into the frame in the same manner it does into the exciter system. The rack-mount frame accommodates two modules and includes a power supply for operation from commercial power lines. Requires 3½ inches (89 mm) rack space.

Specifications

Frequency Range of Subcarrier	Any SCA frequency between 30 to 75kHz
Output Level (Adjustable)	0-4V, 10k ohms
Modulation Capability	±15% of carrier frequency
Subcarrier Frequency Stability	±0.2%
Audio Input Impedance (Balanced)	600 ohms
Audio Input Level (Adjustable)	-15 to +10 dBm
Audio Frequency Response	50-10,000Hz ±1dB*
Harmonic Distortion (50-10,000 Hz)	1% max.
Noise Level, FM (Below 100% Mod)	-60dB max.
Noise Level, AM (Below Subcarrier Level)	-50dB max.
Dimensions (Rack-Mount Unit) (Approx.)	3½" H; 19" W; 10½" D (89, 483, 270 mm)
Weight (Approx.)	17 lbs. (8kg)
Shipping Data (Approx.):	
Dimensions	5½" x 20" x 13" (140, 508, 330 mm)
Weight	22 lbs. (10kg)

*50 or 150µs pre-emphasis, without low-pass filter, measured via wideband frequency discriminator.

Accessories and Spares

Recommended Semiconductor Spares	RO-393†
Rack-Mount Frame (Incl. Power Supply)	MI-560720
Low-Pass Audio Filter	MI-560721
Module Extender	MI-560719

†Order "RO" kits from RCA Parts and Accessories, Deptford, N. J.

Ordering Information

SCA Subcarrier Generator Module, Type BTX-1B (Includes low-pass audio filter)	MI-560714
Rack-Mount SCA Subcarrier Generator, Type BTX-1B (Includes above plus module extender and Blank Panel)	ES-560640
As Above, with two SCA Modules	ES-560641

Please specify subcarrier frequency or frequencies

Educational FM Transmitter, Type BTE-10AT

- Mono or stereo, one or two SCA subcarriers
- Fully self-contained all solid state
- Rack-mount or desk-top cabinet
- Plug-in module construction
- Built-in power-output control

The BTE-10AT Educational FM Transmitter uses a standard Type BTE-15A Exciter System with facilities for determination of power output. It is available in two forms: one, housed in a metal cabinet for desk- or table-top mount and, two, less cabinet, for mounting in ordinary 19-inch (483 mm) equipment racks.

All specifications are identical to those of the exciter system except for power output. The output of the BTE-10AT is limited to 10 watts, in accordance with the limitations of (FCC) Class D stations.

With the addition of a stereo module (see *Accessories*), the BTE-10AT transmits programming in stereo. SCA programming or telemetry return requires the addition of an SCA subcarrier generator module (see *Accessories*).

Although termed an "educational" transmitter, the BTE-10AT is useful as an STL transmitter wherever local rules allow. In such duty, it provides up to 15 watts of power output from its transistorized power amplifier.

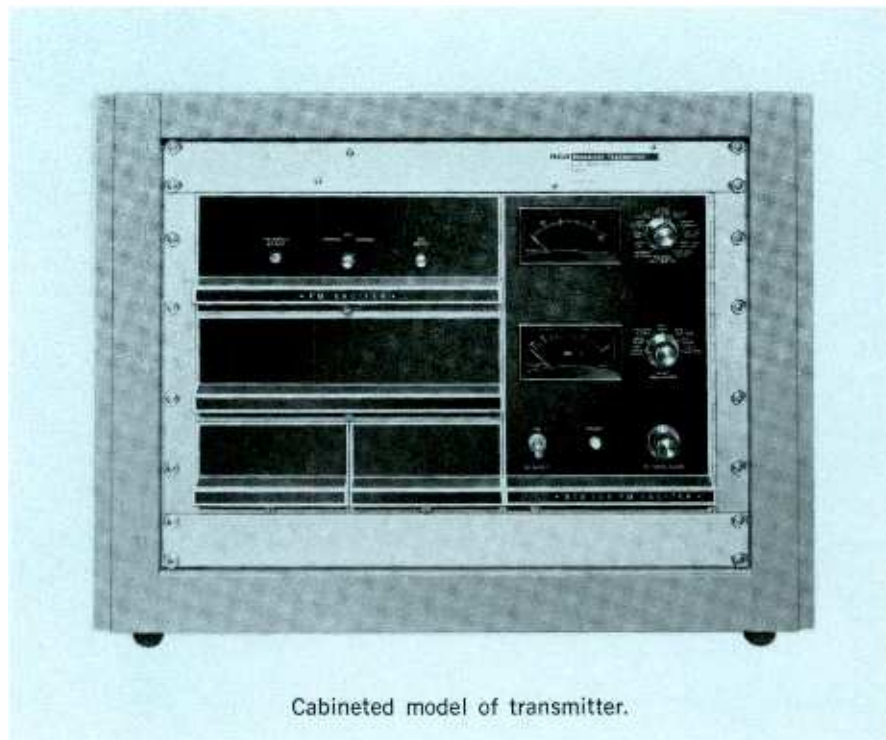

Specifications

Identical to those of BTE-15A Exciter except for:		
Power Output		10W ¹
Dimensions:		
Cabineted Model	17¼" H; 23½" W; 17¼" D	(438, 596, 438 mm)
Rack-Mount Model	12¼" H; 19" W; 12½" D	(311, 483, 321 mm)
Weight	Incl. Cabinet: 60 lbs. (27kg)	Less Cabinet: 40 lbs. (18kg)
Shipping Data:		
	Less Cabinet	Incl. Cabinet
Dimensions (Approx.).....	19" x 25" x 18"	22" x 28" x 24"
	(483, 635, 457)	(559, 711, 610)
Weight (Approx.)	59 lbs. (25kg)	75 lbs. (33kg)

¹ Operable at 15W output where local rules allow.

Accessories

Input/Output Plugs and Connectors, Set	MI-560734
Recommended Semiconductor Spare Kits for:	
Main Frame	RO-390

Exciter Module	RO-391
Stereo Generator Module	RO-392
SCA Generator Module	RO-393
Mono Input Adapter Module	RO-394
RF Portion of Exciter Module*	RO-381
Crystal, with Oven (Please specify carrier freq.)	MI-560717
Crystal Oven, less crystal	MI-560717A
FM Generator Module	
(Please specify carrier frequency)	MI-560712
Stereo Generator Module, Type BTS-1B	MI-560713
SCA Subcarrier Generator Module, Type BTX-1B	
(Please specify Subcarrier frequency)	MI-560714

*Five in kit; duplicated in Exciter Module Spares Kit (RO-391). Order "RO" kits from RCA Parts and Accessories, Deptford, N. J.

Ordering Information

Educational FM Transmitter, Type BTE,10AT:	
Cabineted Model	ES-560698
Rack-Mount Model	ES-560698A
(Please specify carrier frequency)	



1-kW FM Broadcast Transmitters, Types BTF-1E2, BTF-1+1E2, BTF-1/1E2

- All solid-state exciter
- For mono or stereo
—with or without SCA
- Designed for remote control
- Direct FM exciter

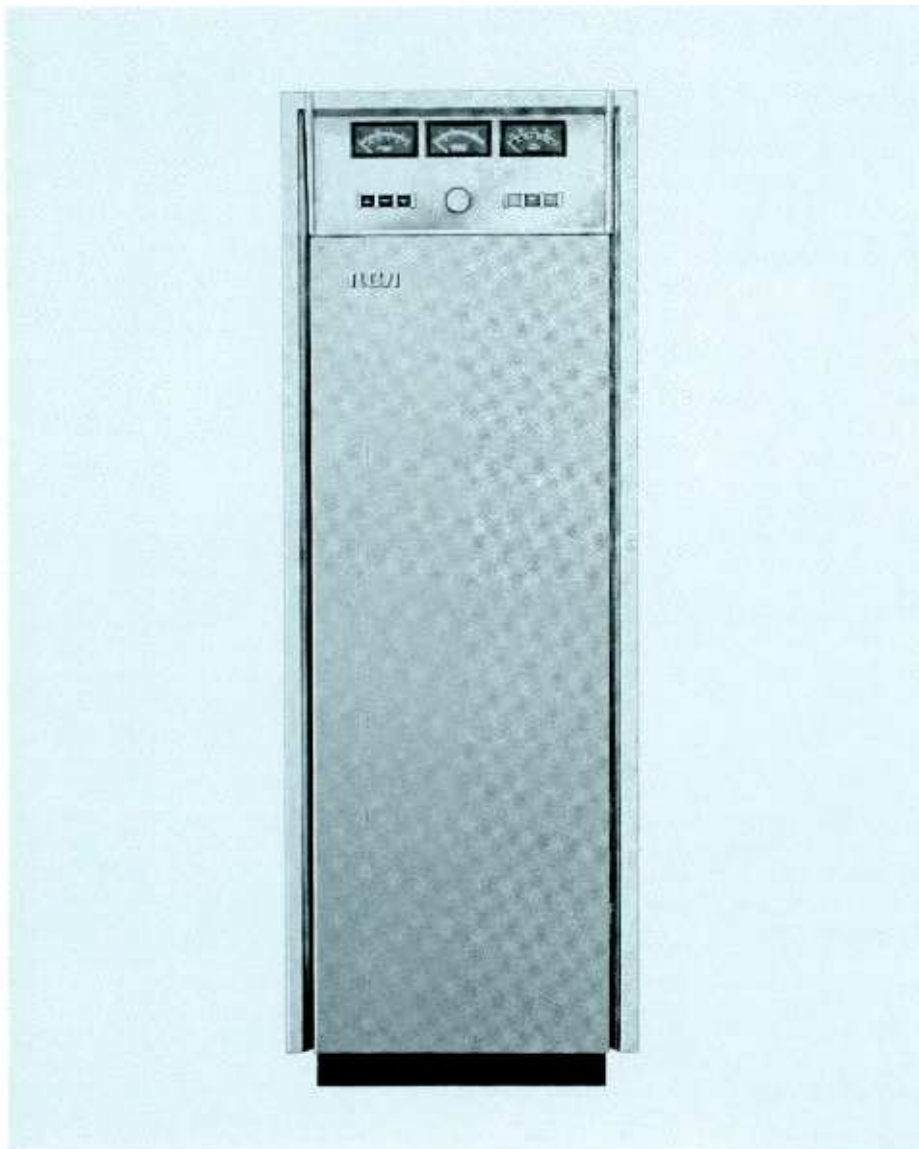

The Type BTF-1E2 is a one-kilowatt FM Broadcast Transmitter for any frequency between 87.5 and 108 MHz. It is designed to provide the finest possible performance and reliability and is specifically built to handle the stringent requirements of multiplex transmission. The transmitter is FCC type accepted and meets all requirements for harmonic and spurious radiation.

The transmitter uses a solid-state exciter that employs the time-tested and field-proven direct-FM system of modulation. This modulation principle gives the transmitter the wide frequency response and extra stability needed for stereo and other multiplex transmission.

The entire transmitter is housed in a single cabinet which occupies less than four square feet of floor space. All meters and operating controls are conveniently located on a panel near the top of the transmitter. The exciter unit includes a multimeter for monitoring its circuitry.

The Types BTF-1+1E2 and BTF-1/1E2 are expansions of the basic transmitter. The BTF-1+1E2 is a 2-kilowatt transmitter using the combined outputs of two 1-kW power amplifiers identical to the PA of the BTF-1E2. This arrangement results in a 2-kW transmitter with redundant power amplifiers.

The BTF-1/1E2 is a transmitter with two separate, 1-kW outputs for situations where separate antennas are used for vertical and horizontal polarization. The transmitter is essentially two BTF-1E2 units with a common-to-both exciter.

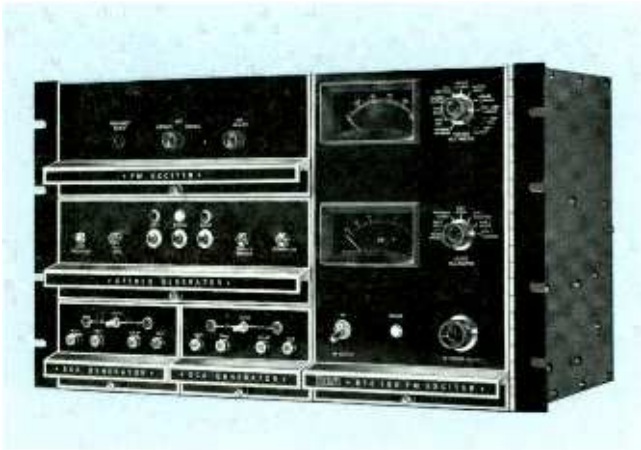

Entirely solid-state exciter system, showing "Direct FM" exciter housed with optional stereo generator and SCA generator units in place at the lower left.

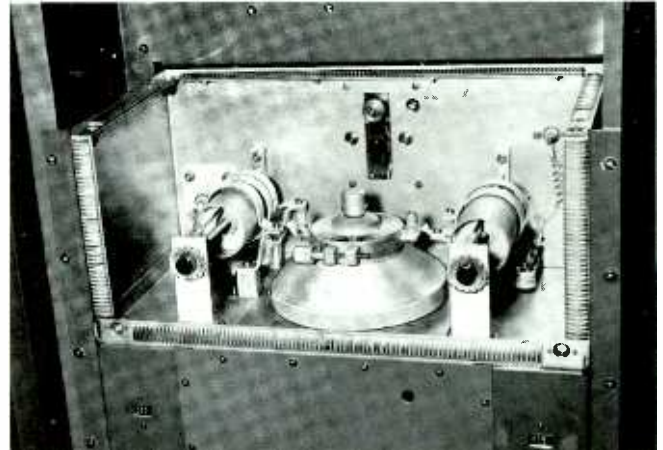

BTF-1E2 power-amplifier cavity with shield covers removed. Note well-spaced layout and component accessibility. The Type 4CX1000 tube is at center.

The Type BTF-1E2 FM Transmitter provides 1000 watts output for stations operating in the 87.5 to 108 MHz band. It is designed to provide the finest possible performance and reliability, and is specifically built to meet the stringent requirements of multiplex and stereo service transmission. It is a simple and compact unit, easy to install.

The BTF-1E2 Transmitter supplies the latest in FM broadcast techniques. Only one tube beyond the exciter is required to supply 1000 watts output. No IPA stage is required. The transmitter is extremely stable because it incorporates RCA's time-proven "Direct FM" Exciter. This exciter has all solid-state components. Cross-talk and noise are kept to an absolute minimum.

Easy to Install and Operate

Other features incorporated in the BTF-1E2 include silicon rectifiers which provide long life with a minimum of maintenance. Accessibility is assured through plug-in, modular design and relatively uncrowded circuit assemblies, and hinged mounting of the exciter. Mechanical and electrical overload protection is provided. To assure performance in accordance with FCC requirements, the transmitter is supplied with harmonic filter. Provisions for remote control have been provided in the transmitter.

Solid-State FM Exciter

Excellent monaural, stereo and SCA performance that more than meets industry and FCC standards are achieved by the new modular, solid-state "Direct FM" exciter.

High quality FM stereo transmission can be obtained by the addition of a Type BTS-1B Stereo Generator. SCA

programming may be transmitted simultaneously with stereo by the use of the optional BTX-1B subcarrier generator. The BTF-1E2 is type accepted for such simultaneous program transmission.

Single Cabinet

The Type BTF-1E2 FM Transmitter is completely housed in one cabinet with total floor dimensions of only 26 by 21 inches. The cabinet is functionally styled to present a pleasing appearance. All meters and operating controls are conveniently located. Front and rear hinged doors give easy access to all portions of the transmitter.

Located at the front are the overload relays and the tuning dials for the power amplifier. A control panel and screen supply are located next, followed by the hinged mounted exciter. Concealed in the bottom of the transmitter are the high voltage rectifier and power transformer. The rear of the transmitter gives access to the bias resistors, metering circuitry and blower, followed by the rear of the control panel and screen supply. A voltage regulating filament transformer is mounted on the control panel.

Simplified Circuits

Modulation of the temperature compensated basic on-frequency oscillator is achieved by applying the composite stereo or SCA signals from the BTS-1B and BTX-1B Generator modules, respectively, to a pair of push-pull variable-capacitance diodes which are coupled to the basic oscillator frequency determining resonant circuit. The output of the basic oscillator is isolated from the following buffer amplifier by a 10 dB resistive attenuator. Thus, the stability and modulation characteristics of the direct-FM oscillator

are not disturbed by following power amplifiers.

The output of the buffer amplifier, approximately 500 mW, is used to drive the 15-watt, three-stage amplifier as well as the binary divider chain in the AFC circuit. The basic oscillator, buffer amplifier, and AFC circuit are mounted inside an enclosure. The power amplifier is also completely shielded.

Automatic frequency control (AFC) for the on-frequency basic oscillator is achieved by taking a sample of the buffer output frequency and dividing it by two, 14 times. A low-frequency reference crystal operating at 1/1024th of the desired output frequency is divided by two, 4 times. Integrated circuits operating in the saturated mode are used in both binary dividing chains. The outputs from the reference and basic oscillator binary dividers are phase compared in a time-sharing IC comparator. The output of the circuit, which represents the AFC error voltage, is filtered and applied to another pair of variable-capacitance diodes coupled to the basic oscillator tuned circuit. Thus, the basic oscillator is phase locked to the 1024th harmonic of the oven controlled reference crystal.

An off-frequency detector is incorporated in the design of the BTE-15A FM Exciter. When the basic oscillator frequency is not phase locked to the reference crystal, an AC component appears at the AFC output. This voltage operates a relay whose contacts can be used to turn off the FM transmitter.

Two multimeters are located on the hinged door of the exciter in front of the regulated power supply section. One of these meters is used to indicate power supply and operating voltages within the

exciter and 15-watt RF Amplifier. The second meter is a peak-reading voltmeter that is used to indicate all modulating signal levels.

The RF power output of the BTE-15A can be continuously adjusted from the front panel control from 7 to 15 watts. The primary power is turned on with a circuit breaker. RF output is turned on with a front panel switch or through a 208/240-volt relay operated from the transmitter filament supply. The exciter will tolerate load mismatches from short circuit to open circuit for a reasonable time without damaging the output transistor. Another important feature prevents automatic operation of the 41 kHz SCA subcarrier when the BTS-1B Stereo Generator is in stereo mode.

Power Amplifier

The output of the exciter is fed to the input of the ceramic 4CX-1000A amplifier tube. The amplifier input circuit is a simple parallel resonant circuit, tuned by a variable inductance with resistance swamping for stability of operation. This stage is neutralized by varying inductance in series with the screen. The output circuit is a modified π network using variable inductors for plate tuning and loading. All capacitors in the final stage are of the fixed ceramic type. A blower mounted on the back of the RF compartment provides sufficient filtered air for cooling at stations operating below 7500 feet altitude. The filament transformer is of the automatic regulator type and keeps filament voltage constant within one percent.

The power amplifier is new in many respects. The variable inductors use no sliding contacts. There are no variable

capacitors in the power amplifier. A single tube, the 4CX1000A, is used in the BTF-1E2 power amplifier and it is driven directly by the output of the exciter.

Neutralizing Probe

A neutralizing probe is furnished with the transmitter. It utilizes the multimeter to indicate correct neutralization of the power amplifier.

The high voltage and screen power supplies make use of silicon rectifiers in a bridge circuit. This combined with choke input and adequate filtering results in a well-regulated power source. A variable transformer is used in the primary of the screen power supply to control power output of the transmitter. Filament voltage regulation is provided for the 4CX1000A power amplifier tube.

Harmonic Filter

The harmonic filter supplied with all RCA FM transmitters is more than a simple harmonic trap. The filter consists of two M -derived half- T sections and three constant- K , half- T sections. The M -derived sections at the input and output provide rapid cut-off in the second harmonic region, and a termination impedance at each end of the filter of 50 ohms. The use of such a filter assures compliance with FCC requirements regarding spurious and harmonic radiation.

Protective Circuits

Power circuits are protected by magnetically tripped circuit breakers as well as overload relays. An interlock relay prevents application of plate power until the filament has heated. Overload relays are used in the plate and screen

power supplies. There is also an interlock in the air-blower circuit. If the blower should fail or airflow be reduced below the proper level, the transmitter is shut down to avoid possible damage.

The overload relays are reset remotely or by means of a pushbutton switch on the front panel. An overload indicator lamp signals when an overload has taken place. All relays are easily accessible. Access to high voltage areas is protected by built-in high voltage shorting devices.

Control Features

The exciter includes a self-contained multimeter. In the amplifier, provision is made for metering plate current, plate voltage, output power and vswr; a probe is furnished for neutralizing the transmitter and is used in connection with the multimeter. All tuning controls are located on the front panel for easy accessibility. They include key switches for filament on-off, plate on-off, and overload reset. The variable power control is also mounted on the front as are the overload indicator and plate power-on lights. The use of latching relays make it possible to control the transmitter with one button.

Remote Control Provisions

The BTF-1E2 transmitter incorporates connections for remote control and remote meter reading when combined with a remote control system such as the Types BTR-15 or BTR-30. Terminals for transmitter on-off, plate on-off, overload reset, plate voltage, cathode current, and power output are provided. To control transmitter power output remotely, an accessory motor drive may be connected to the screen supply control.

Dual-Amplifier Units

The BTF-1E2 is available also as a 2-kW dual-power-amplifier transmitter in two versions: a "BTF-1-plus-1E2" and a "BTF-1-slash-1E2". The BTF-1+1E2 combines dual identical 1-kW outputs to result in a 2-kW transmitter with redundant power amplifiers. In the BTF-1/1E2, the dual amplifiers are equipped with individual harmonic filters and individual outputs. This configuration is useful in two ways: to power separate circularly-polarized antenna systems for increased on-air dependability or to power separate vertical and horizontal polarization antenna arrays.

The BTF-1+1E2 and BTF-1/1E2 units use separate power supplies for each power amplifier. This redundancy enhances on-air reliability. A redundant exciter is available at extra cost. See BTE-15A exciter catalog pages for ordering information.

Simplified Block Diagram of BTF-1E2 Transmitter, showing optional stereo and SCA subcarrier generators.

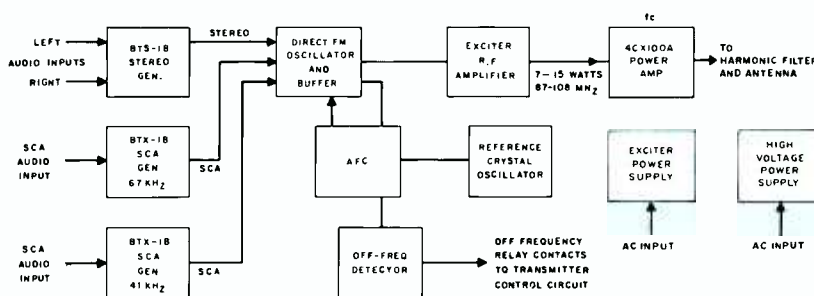

Specifications

Power Output (BTF-1E2)	250-1000 watts
Output Impedance (1½" O.D. Unflanged Line)	50 ohms
Frequency Deviation, 100% modulation	±75 kHz
Modulation Capability	±100 kHz
Carrier Frequency Stability	±250 Hz max.
Audio Input Impedance	600/150 ohms
Audio Input Level— ¹ (100% mod.)	+10±2 dBm
Audio Frequency Response— ² (50 Hz-15 kHz)	±1 dB max.
Pre-emphasis Network Time Constant	.75 or 50 µs or flat as desired
Harmonic Distortion— ³ (50 Hz-15 kHz)	0.5% or less
FM Noise Level (referred to 100% FM mod.)	-65 dB max.
AM Noise Level (referred to 100% AM mod.)	-50 dB max.
Subcarrier Input Level (100% mod.)	-15 to +10 dBm adjustable
Subcarrier Input Impedance	600/150 ohms bal.
Subcarrier Frequency	20-67 kHz
Main-to-Subchannel Crosstalk	-50 dB referred to ±6 kHz deviation of the subcarrier by a 400 Hz tone. Main channel modulation 70% by 50-15,000 Hz tones.
Sub-to-Main-Channel Crosstalk	-60 dB referred to ±75 kHz deviation of the main carrier by a 400 Hz tone. Subchannel modulated 100% (±6 kHz/s) by 50-5000 Hz tones. Subcarrier modulated 30% on main carrier.
Power Line Requirements:	
Line	240/208 volts, single phase, 60 or 50 Hz ⁴
Slow Voltage Variation	±5%
Power Consumption (BTF-1E2)	2800 watts (approx.)
Power Factor (approx.)	.80%
Dimensions	H (mm) W (mm) D (mm) Weight (kg)
BTF-1E2	77" (1956) 26" (660) 20½" (524) 790 lbs. (360)
BTF-1+1E2	77" (1956) 56" (1422) 20½" (524) 1630 lbs. (739)
BTF-1/1E2	77" (1956) 48" (1219) 20½" (524) 1580 lbs. (717)
Altitude	7500 ft. max. (2290 m)
Ambient Temperature Range	-20° to +45°C

¹ Level measured at input to pre-emphasis network.
² Audio Frequency response referred to 75 or 50 micro-second pre-emphasis curve.
³ Distortion includes all harmonics up to 30 kHz and is measured following a standard 75 or 50 micro-second de-emphasis network.
⁴ 50-Hz operation requires constant-voltage transformer (MI-34319-2).

Ordering Information

1-kW FM Broadcast Transmitter, Type BTF-1E2	ES-27279C*
2-kW FM Broadcast Transmitter, Type BTF-1+1E2	ES-560647*
2-kW FM Broadcast Transmitter, Type BTF-1/1E2	ES-560646*

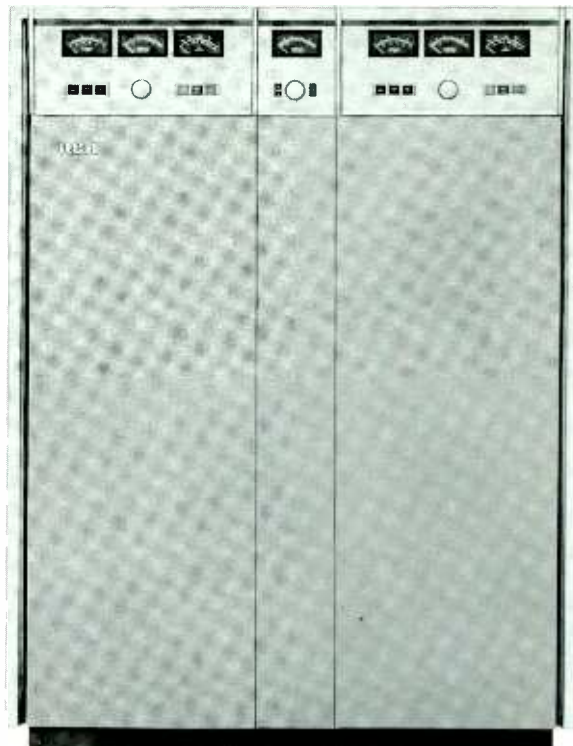

The BTF-1+1E2 consists of two transmitter cabinets plus a center section which houses the combiner network. The BTF-1/1E2 uses no center section. See text, preceding page.

Accessories

Remote Power Control	MI-27558
Recommended Spare Transistors for Exciter	MI-560718
Spare Crystal and Oven (Specify carrier frequency)	MI-560717
Spare Power Amplifier Tube	MI-34709
Remote Control System, Type BTR-15	ES-561150/1/2
Remote Control System, Type BTR-30	ES-561446
FM Freq. and Mod. Monitor, Type BW-75	MI-560735
Stereo Monitor, Type BW-85	MI-560740
SCA Monitor, Type BW-95	MI-560745
FM RF Amplifier, Type BW-100	MI-560738
Low-Pass Audio Filter (for SCA)	MI-560721
1-kW RF Load and Wattmeter	MI-19196L/H
Matching Transmission Line (Series)	MI-561565

*Includes one Solid-State Exciter (Type BTE-15A), equipped for main-channel operation only. Stereo and/or SCA subcarrier-generator modules optional. Please specify assigned frequency, power-line frequency, operational altitude (above sea level) and subcarrier-generator modules desired. Modules ordered with transmitter are factory installed.



3-kW FM Broadcast Transmitters, Types BTF-3E1, BTF-3+3E1, BTF-3/3E1

- All solid-state exciter
- For mono or stereo
—with or without SCA
- Designed for remote control
- Direct FM exciter

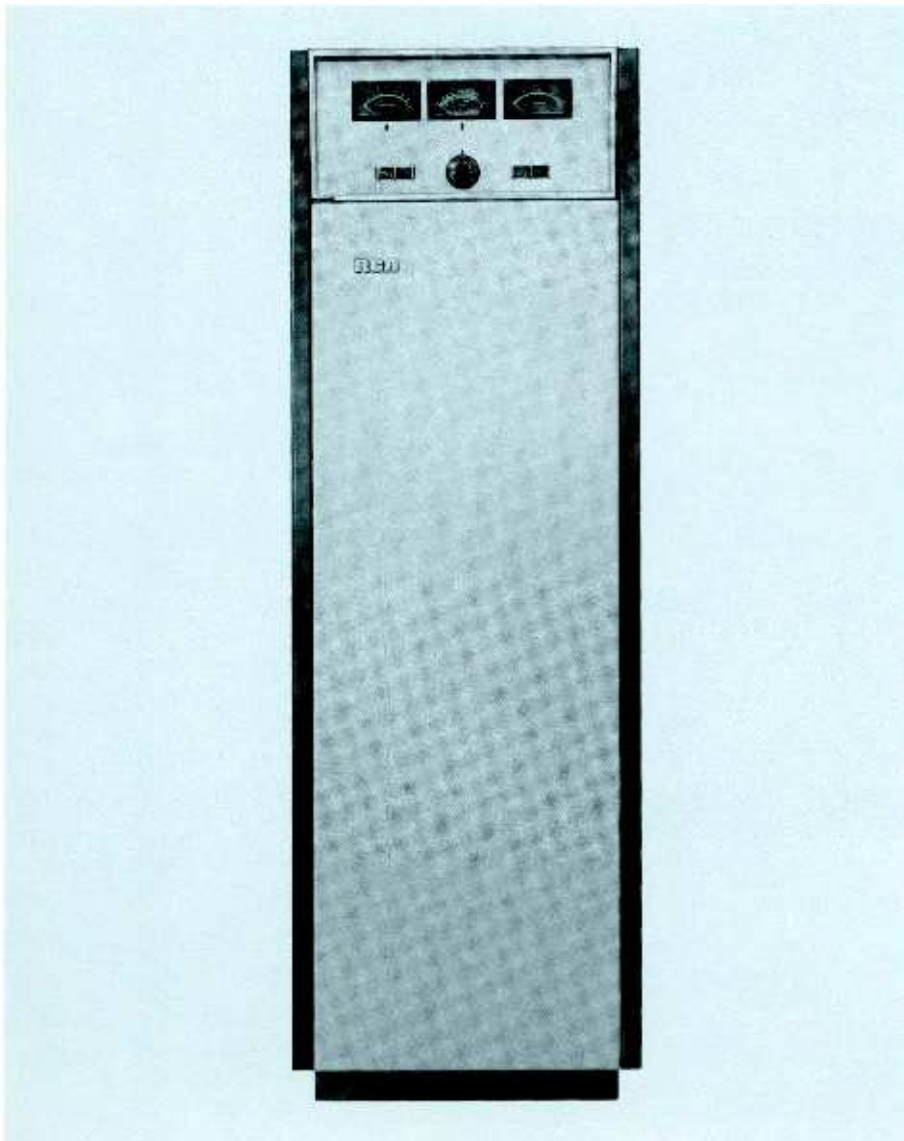

The Type BTF-3E1 is a three-kilowatt FM Broadcast Transmitter for any frequency between 87.5 and 108 MHz. It is designed to provide the finest possible performance and reliability and is specially built to handle the stringent requirements of multiplex transmission. The transmitter is FCC type accepted and meets all requirements for harmonic and spurious radiation.

The transmitter uses a solid-state exciter that employs the time-tested and field-proven direct-FM system of modulation. This modulation principle gives the transmitter the wide frequency response and extra stability needed for stereo and other multiplex transmission.

The entire transmitter is housed in a single cabinet which occupies less than six square feet of floor space. Meters and operating controls are conveniently located. The exciter unit includes a multimeter for monitoring its circuitry.

The Types BTF-3+3E1 and BTF-3/3E1 are expansions of the basic transmitter. The BTF-3+3E2 is a six-kilowatt transmitter using the combined outputs of two three-kilowatt power amplifiers identical to the PA of the BTF-3E1. This arrangement results in a six-kilowatt transmitter with redundant power amplifiers.

The BTF-3/3E1 is a transmitter with two separate, three-kilowatt outputs for situations where separate antennas are used for vertical and horizontal polarization. The transmitter is essentially two BTF-3E1 units with a common-to-both exciter.

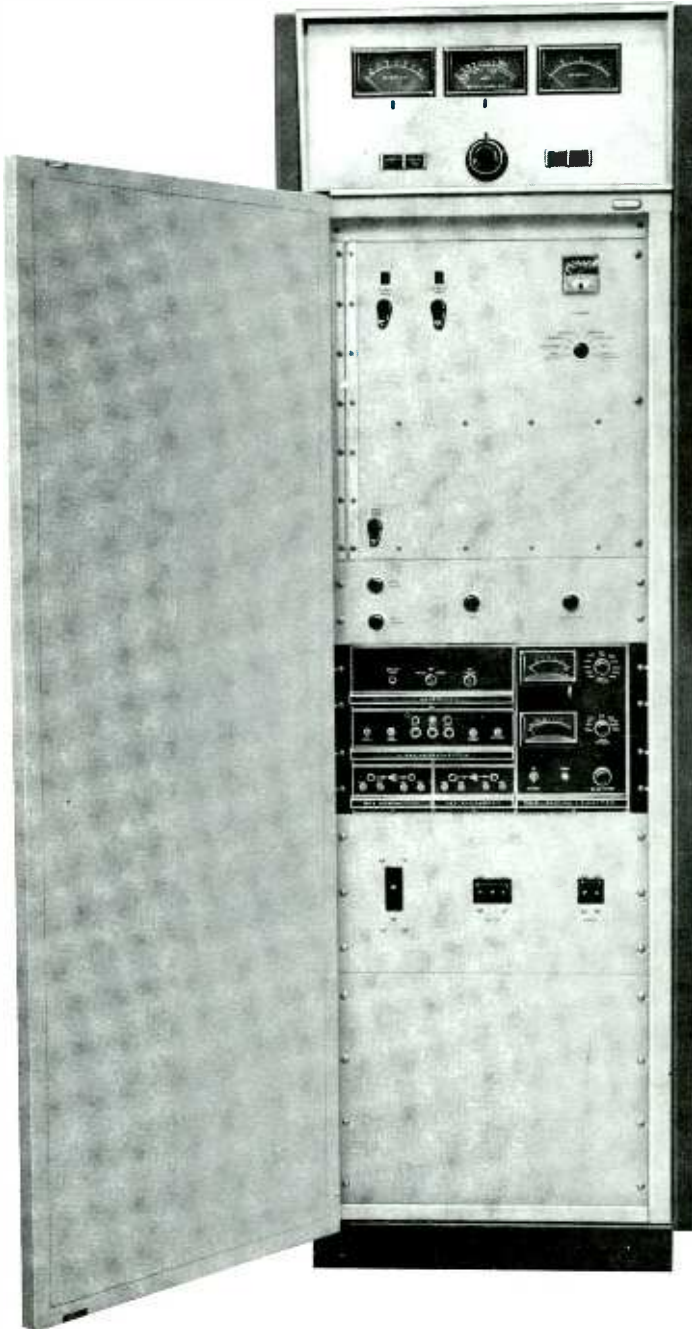

Heart of the BTF-3E1 Transmitter is the solid-state exciter, shown here with stereo and two SCA modules in place.

RCA's Type BTF-3E1 FM Transmitter provides 3,000 watts output for stations operating in the 87.5 to 108 MHz band. It is designed to provide the finest possible performance and reliability, and is specifically built to meet the stringent requirements of multiplex and stereo service transmission. It is a simple and compact unit easy to install.

Two Stages Follow Exciter

From the 15-watt output of the BTE-15A exciter, only two power stages are required to generate the three-kilowatt power level (see block diagram). The power output stage operates in a grounded-grid circuit.

Easy to Install and Operate

Other features incorporated in the BTF-3E1 include silicon rectifiers which provide long life with a minimum of maintenance. Accessibility is assured both front and rear by vertical chassis construction, surface mounting of components, and hinged control panel. Mechanical and electrical overload protection is provided. To assure performance in accordance with FCC requirements, the transmitter is supplied with harmonic filter. Provisions for remote control have been provided in the transmitter.

High quality FM stereo transmission can be obtained by the addition of an RCA BTS-1B Stereo Generator. SCA programming may be transmitted simultaneously with stereo by the use of the optional BTX-1B subcarrier generator. Space for two SCA generators is provided.

Single Cabinet

The Type BTF-3E1 FM Transmitter is completely housed in one cabinet with total floor dimensions of only 26 by 33 inches (660 x 838 mm). The cabinet is functionally styled to present a pleasing appearance. All meters and operating controls are located conveniently. Front and rear hinged doors give easy access to all portions of the transmitter.

Located at the front are the overload relays and tuning controls for the amplifier. A control panel and screen voltage control are located next, followed by the Type BTE-15A exciter system. Concealed in the bottom of the transmitter are the high voltage rectifier and power transformer. The rear of the transmitter gives access to the RF box, metering circuitry and blower, followed by the rear of the control panel.

BTE-15A Solid-State FM Exciter

Excellent monophonic, stereophonic and SCA subcarrier performance that more

than meets industry and FCC standards are achieved by the new RCA modular, solid-state "Direct FM" exciter, operating at carrier frequency.

Simplified Circuits

Modulation of the temperature compensated basic on-frequency oscillator is achieved by applying the composite stereo or SCA signals from the BTS-1B and BTX-1B Generators, respectively, to a pair of push-pull Varicap diodes which are coupled to the basic oscillator frequency determining resonant circuit. The output of the basic oscillator is isolated from the following buffer amplifier by a 10 dB resistive attenuator. Thus, the stability and modulation characteristics of the basic, direct-FM oscillator are not disturbed by following power amplifiers.

The output power of the buffer amplifier, approximately 500 mW, is used to drive the 15-watt, three-stage amplifier as well as the binary divider chain in the AFC circuit. The basic oscillator, buffer amplifier, and AFC circuit are mounted inside a shielded enclosure. The power amplifier is also completely shielded.

Automatic frequency control (AFC) for the on-frequency basic oscillator is achieved by taking a sample of the buffer output and dividing it by two, 14 times. A low-frequency reference crystal operating at 1/1024th of the desired output frequency is divided by two, 4 times. Integrated circuits operating in the saturated mode are used in both binary dividing chains. The outputs from the reference and basic oscillator binary dividers are phase compared in a time-sharing IC comparator. The output of the circuit, which represents the AFC error voltage, is filtered and applied to another pair of Varicap diodes coupled to the basic oscillator tuned circuit. Thus, the basic oscillator is phase locked to the 1024th harmonic of the oven controlled reference crystal.

An off-frequency detector is incorporated in the design of the BTE-15A Exciter. When the basic oscillator frequency is not phase locked to the reference crystal, an AC component appears at the AFC output. This voltage is rectified to operate a relay whose contacts can be used to turn off the FM transmitter.

Two multimeters are located on the hinged door of the exciter in front of the regulated power supply section. One of these meters is used to indicate power supply and operating voltages within the exciter and 15-watt RF Amplifier. The second meter is a peak-reading voltmeter that is used to indicate all modulating signal levels.

The RF power output of the BTE-15A can be continuously adjusted from the front panel control from 7 to 15 watts. The primary power is turned on with a circuit breaker. RF output is turned on with a front panel switch or through an internal relay with connections at the rear of the unit. The exciter tolerates load mismatches from short-circuit to open-circuit for a reasonable time without damaging the output transistor. Another feature prevents automatic operation of the 41-kHz SCA subcarrier when the Stereo Generator is in the stereo mode.

Grounded-Grid Power Amplifier

Two simplified, single-ended amplifiers follow the exciter. The 250-watt driver stage uses a Type 8122 tube, and the final power amplifier, operating grounded-grid uses a triode.

3-kW Final Amplifier

The output tube, a ceramic triode, offers high power-gain. Using this tube, only two stages of amplification are required between the exciter and the antenna for the 3,000-watt output. Fewer components results in improved reliability.

Adjustable Power-Output Control

Power output is controlled by means of a variable resistor which controls the screen-voltage supply. The use of semiconductor (silicon) rectifiers reduces operating and maintenance costs.

Harmonic Filter

The harmonic filter supplied with all RCA FM transmitters is not a simple harmonic trap. The filter consists of two M -derived half- T sections and three constant- K sections. The M -derived sections at the input and output provide rapid cut-off in the second harmonic region and a termination impedance at each end of the filter of 50 ohms. The use of such a filter assures compliance with FCC requirements regarding spurious radiation, including all harmonics through 1000 MHz.

Self-Protected Against Overload

Power circuits are protected by magnetically-tripped circuit breakers in addition to overload relays. An automatic sequencing system prevents turn-on of plate power before all filaments have heated. In addition, a stepping relay automatically cycles power-off three times before locking-out in the event of brief overloads or power interruptions. The overload relays are reset by pushbutton switches on the front panel. A tally light indicates overload in the driver cathode current, PA grid current, PA plate current or high-voltage power supply.

Control Features

The BTE-15A exciter has a self-contained multimeter. In the amplifier of the transmitter, provision is made for metering PA plate current, plate voltage,

Simplified Block Diagram of BTF-3E1 Transmitter, showing optional stereo and SCA.

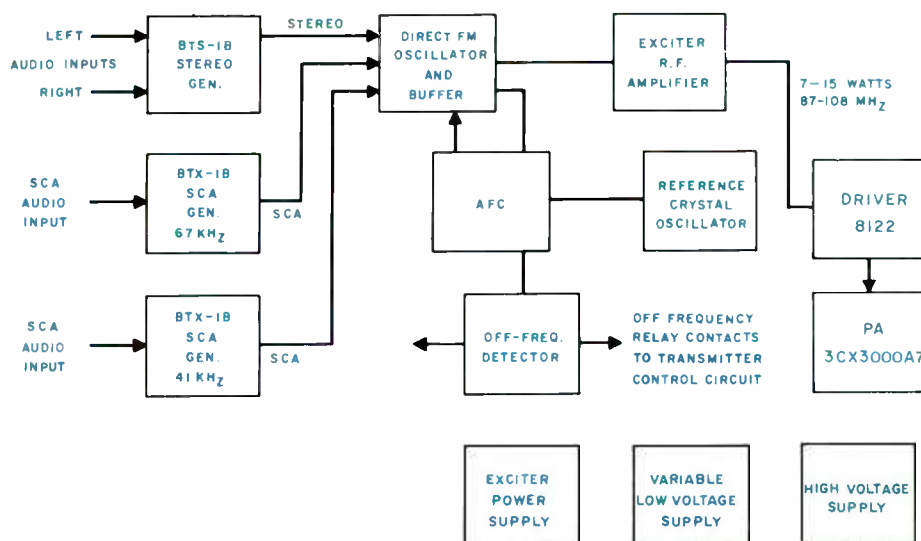

output power and VSWR. All tuning controls are located on the front panel for easy accessibility. They include switches for filament on-off, plate on-off, and overload reset. The variable power control is also mounted on the front as are the overload indicator and plate power-on lights. The use of latching relays make it possible to control the transmitter with one button.

Remote Control Provisions

The BTF-3E1 transmitter incorporates connections for remote control and remote meter reading when combined with

a remote control system such as the BTR-15 or BTR-30. Terminals for transmitter on-off, plate on-off, overload reset, plate voltage, cathode current, and power output are provided. To control transmitter power output remotely, an accessory motor drive may be connected to the screen voltage control.

Dual-Amplifier Units

The BTF-3E1 is available also as a six-kilowatt, dual-power-amplifier in two versions: a "BTF-3-plus-3E1" and a "BTF-3-slash-3E1". The BTF-3+3E1 combines dual identical outputs to result in a six-kilowatt transmitter with redun-

dant power amplifiers. In the BTF-3/3E1 the dual amplifiers are equipped with individual harmonic filters and individual outputs. This configuration is useful in two ways: to power separate circularly polarized antenna systems for increased on-air dependability or, to power separate vertical and horizontal polarization antenna arrays.

The dual-amplifier units use separate power supplies for each power amplifier. This redundancy enhances on-air reliability. A redundant exciter is available at extra cost. See BTE-15A exciter catalog pages for ordering information.

Specifications

Performance

Power Output	1000-3000 watts
Output Impedance (1 $\frac{1}{8}$ " O.D. unflanged)	50 ohms
Frequency Deviation, 100% modulation	± 75 kHz
Modulation Capability	± 100 kHz
Carrier Frequency Stability	± 1000 Hz max.
Audio Input Impedance	600/150 ohms
Audio Input Level— ¹ (100% mod.)	+10 ± 2 dBm
Audio Frequency Response— ² (50 Hz-15 kHz)	± 1 dB max.
Pre-emphasis Network Time Constant75 or 50 μ s
Harmonic Distortion— ³ (50 Hz-15 kHz)	0.5% or less
FM Noise Level (referred to 100% FM mod.)	-65 dB max.
AM Noise Level (referred to 100% AM mod.)	-50 dB max.
Subcarrier Input Level (100% mod.)	-15 to +10 dBm adjustable
Subcarrier Input Impedance	600/150 ohms bal.
Subcarrier Frequency	20-67 kHz
Main-to-Subchannel Crosstalk	-50 dB referred to ± 6.0 kHz deviation of the subcarrier by a 400 Hz tone. Main channel modulation 70% by 50-15,000 Hz tones.
Sub-to-Main-Channel Crosstalk	-60 dB referred to ± 75 kHz deviation of the main carrier by a 400 Hz tone. Subchannel modulated 100% (6.0 kHz/s) by 50-5000 Hz tones. Subcarrier modulated 30% on main carrier.

Electrical

Power Requirements:	
Line	240/208V, 50/60 Hz*
Combined Voltage Variation and Regulation	$\pm 5\%$
Power Consumption (approx.)	6000W
Power Factor (approx.)	90%

*Ordinarily three-phase power. Unit for single-phase power available. See "Ordering Information" below.

Mechanical

Dimensions (overall)	25" W, 77" H, 33" D (635, 1956, 840 mm)
Weight	850 lbs. (385 kg)
Finish	Textured vinyl in charcoal gray and shadow blue, satin aluminum trim
Altitude	7500 ft. max. (2290 m) ⁴
Ambient Temperature Range	-20° to +45°C

Accessories

Remote Power Output Control	MI-561023
Recommended Spare RF Transistors for Exciter	RO-381
Directional Coupler (for exciter output)	MI-561026
Spare Crystal and Oven (Specify operating frequency)	MI-560717
Spare Transmitter Tubes	ES-560920
RF Load and Wattmeter	MI-561422
Type BW-75A FM Frequency and Modulation Monitor	MI-560735
Type BW-100B RF Amplifier	MI-560738
Type BW-85A FM Stereo Frequency and Modulation Monitor	MI-560740
Type BW-95A SCA Frequency and Modulation Monitor	MI-560745

¹Level measured at input to pre-emphasis network.

²Audio Frequency response referred to 75 or 50 micro-second pre-emphasis curve.

³Distortion includes all harmonics up to 30 kHz and is measured following a standard 75 or 50 micro-second de-emphasis network.

⁴Blowers available for higher altitudes.

Ordering Information

Single-Amplifier, 3-kW FM Transmitter, Type BTF-3E1 (for three-phase power)	ES-560915*
Single-Amplifier, 3-kW FM Transmitter, Type BTF-3E1 (for single-phase power)	ES-560915A*
Dual-Amplifier, 6-kW FM Transmitter, Type BTF-3+3E1 (for three-phase power)	ES-560922*

Dual-Output, 6-kW FM Transmitter, Type BTF-3/3E1 (for three-phase power)	ES-560923*
---	------------

*Includes one Solid-State Exciter (Type BTE-15A) equipped for main-channel operation only. Stereo and/or SCA subcarrier-generator modules optional. Please specify assigned frequency, power line frequency, operational altitude (above sea level) and subcarrier-generator modules desired. Modules ordered with transmitter are factory installed.



5-kW FM Broadcast Transmitter, Types BTF-5E2, BTF-5+5E2, BTF-5/5E2

- All solid-state exciter
- For mono or stereo
—with or without SCA
- Designed for remote control
- Direct FM exciter

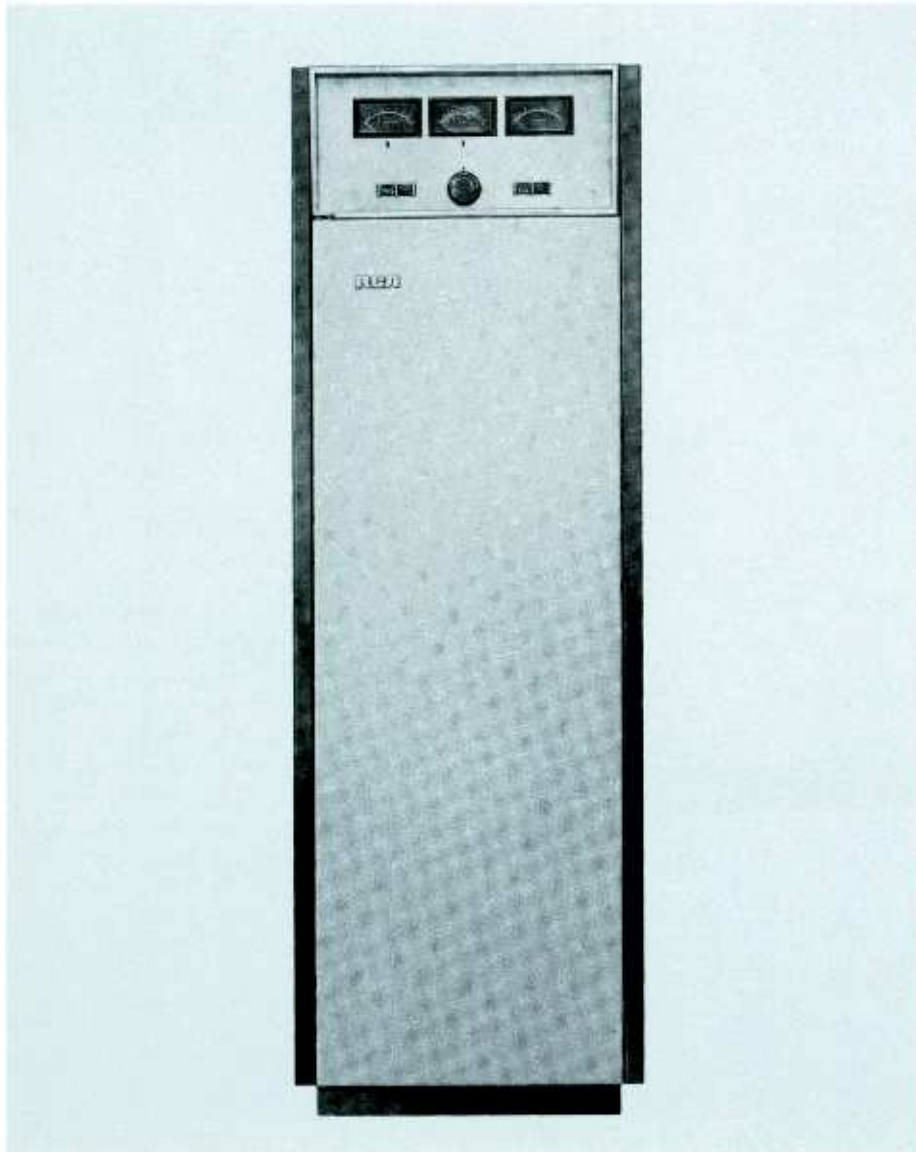

The Type BTF-5E2 is a five-kilowatt FM Broadcast Transmitter for any frequency between 87.5 and 108 MHz. It is designed to provide the finest possible performance and reliability and is specifically built to handle the stringent requirements of multiplex transmission. The transmitter is FCC type accepted and meets all requirements for harmonic and spurious radiation.

The transmitter uses a solid-state exciter that employs the time-tested and field-proven direct-FM system of modulation. This modulation principle gives the transmitter the wide frequency response and extra stability needed for stereo and other multiplex transmission.

The entire transmitter is housed in a single cabinet which occupies less than six square feet of floor space. All meters and operating controls are conveniently located. The exciter unit includes a multimeter for monitoring its circuitry.

The Types BTF-5+5E2 and BTF-5/5E2 are expansions of the basic transmitter. The BTF-5+5E2 is a ten-kilowatt transmitter using the combined outputs of two five-kilowatt power amplifiers identical to the PA of the BTF-5E2. This arrangement results in a ten-kilowatt transmitter with redundant power amplifiers.

The BTF-5/5E2 is a transmitter with two separate, five-kilowatt outputs for situations where separate antennas are used for vertical and horizontal polarization. Another use is in the "main-alternate-main" operation where one transmitter serves as a hot standby for the other which operates as a "main" transmitter. The transmitter is essentially two BTF-5E2 units with a common-to-both exciter.

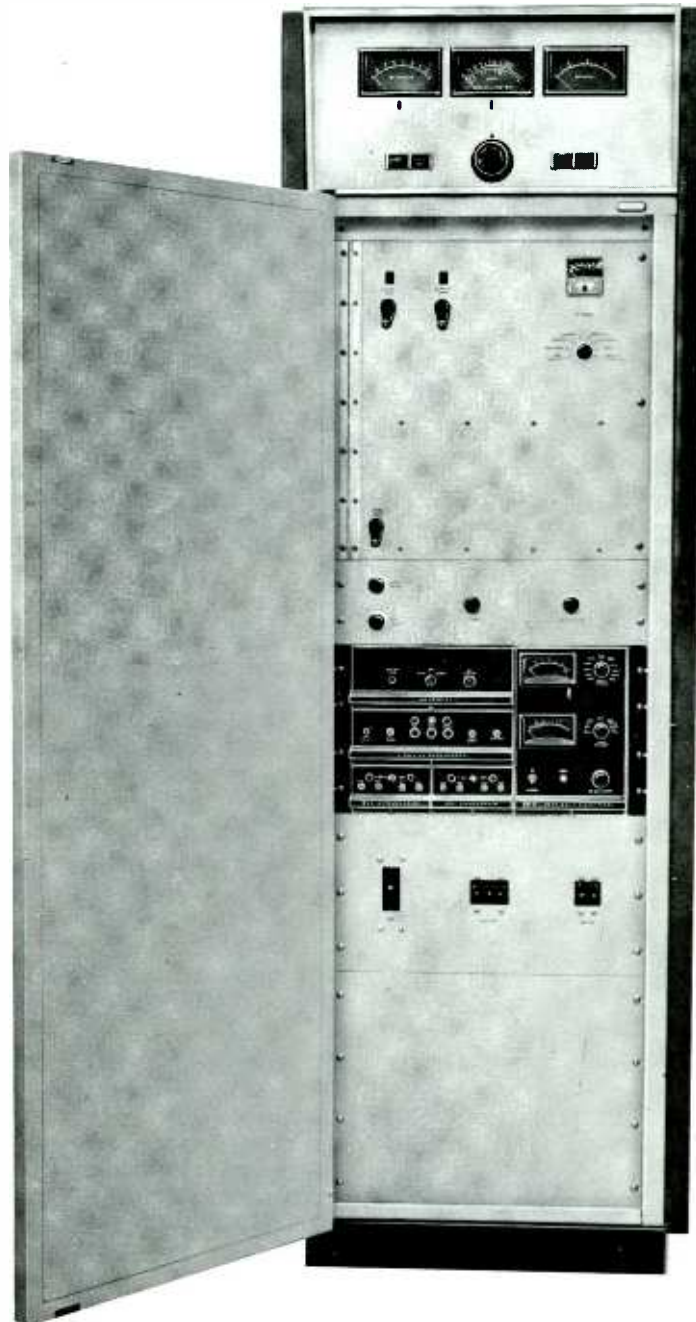

Heart of the BTF-5E2 Transmitter is the solid-state exciter, shown here with stereo and two SCA modules in place.

RCA's Type BTF-5E2 FM Transmitter provides 5,000 watts output for stations operations in the 87.5 to 108 MHz band. It is designed to provide the finest possible performance and reliability, and is specifically built to meet the stringent requirements of multiplex and stereo service transmission. It is a simple and compact unit easy to install.

Two Stages Follow Exciter

From the 15-watt output of the BTE-15A exciter, only two power stages are required to generate the five-kilowatt power level (see block diagram). The power output stage operates in a grounded-grid circuit.

Easy to Install and Operate

Other features incorporated in the BTF-5E2 include silicon rectifiers which provide long life with a minimum of maintenance. Accessibility is assured both front and rear by vertical chassis construction, surface mounting of components, and hinged control panel. Mechanical and electrical overload protection is provided. To assure performance in accordance with FCC requirements, the transmitter is supplied with harmonic filter. Provisions for remote control have been provided in the transmitter.

High quality FM stereo transmission can be obtained by the addition of an RCA BTS-1B Stereo Generator. SCA programming may be transmitted simultaneously with stereo by the use of the optional BTX-1B subcarrier generator. Space for two SCA generators is provided.

Single Cabinet

The Type BTF-5E2 FM Transmitter is completely housed in one cabinet with total floor dimensions of only 26 by 33 inches (660 x 838 mm). The cabinet is functionally styled to present a pleasing appearance. All meters and operating controls are located conveniently. Front and rear doors give easy access to all portions of the transmitter.

Located at the front are the overload relays and tuning controls for the amplifier. A control panel and screen voltage control are located next, followed by the Type BTE-15A exciter system. Concealed in the bottom of the transmitter are the high voltage rectifier and power transformer. The rear of the transmitter gives access to the RF box, metering circuitry and blower, followed by the rear of the control panel.

BTE-15A Solid-State FM Exciter

Excellent monophonic, stereophonic and SCA subcarrier performance that more than meets industry and FCC standards are achieved by the new RCA modular, solid-state "Direct FM" exciter, operating at carrier frequency.

Simplified Circuits

Modulation of the temperature compensated basic on-frequency oscillator is achieved by applying the composite stereo or SCA signals from the BTS-1B and BTX-1B Generators, respectively, to a pair of push-pull Varicap diodes which are coupled to the basic oscillator frequency determining resonant circuit. The output of the basic oscillator is isolated from the following buffer amplifier by a 10 dB resistive attenuator. Thus, the stability and modulation characteristics of the basic, direct-FM oscillator are not disturbed by following power amplifiers.

The output power of the buffer amplifier, approximately 500 mW, is used to drive the 15-watt, three-stage amplifier as well as the binary divider chain in the AFC circuit. The basic oscillator, buffer amplifier, and AFC circuit are mounted inside a shielded enclosure. The power amplifier is also completely shielded.

Automatic frequency control (AFC) for the on-frequency basic oscillator is achieved by taking a sample of the buffer output and dividing it by two, 14 times. A low-frequency reference crystal operating at 1/1024th of the desired output frequency is divided by two, 4 times. Integrated circuits operating in the saturated mode are used in both binary dividing chains. The outputs from the reference and basic oscillator binary dividers are phase compared in a time-sharing IC comparator. The output of the circuit, which represents the AFC error voltage, is filtered and applied to another pair of Varicap diodes coupled to the basic oscillator tuned circuit. Thus, the basic oscillator is phase locked to the 1024th harmonic of the oven controlled reference crystal.

A phase-lock detector is incorporated in the design of the BTE-15A Exciter. When the basic oscillator frequency is not phase locked to the reference crystal, an AC component appears at the AFC output. This voltage is rectified to operate a relay whose contacts can be used to turn off the FM transmitter.

Two multimeters are located on the hinged door of the exciter in front of the regulated power supply section. One of

these meters is used to indicate power supply and operating voltages within the exciter and 15-watt RF Amplifier. The second meter is a peak-reading voltmeter that is used to indicate all modulating signal levels.

The RF power output of the BTE-15A can be continuously adjusted from the front panel control from 7 to 15 watts. The primary power is turned on with a circuit breaker. RF output is turned on with a front panel switch or through an internal relay with connections at the rear of the unit. The exciter tolerates load mismatches from short-circuit to open-circuit for a reasonable time without damaging the output transistor. Another feature prevents automatic operation of the 41-kHz SCA subcarrier when the stereo generator is in the stereo mode.

Grounded-Grid Power Amplifier

Two simplified, single-ended amplifiers follow the exciter. The 250-watt driver stage uses a Type 8122 tube, and the final power amplifier, operating grounded-grid, uses a triode.

Five-kW Final Amplifier

The output tube, a ceramic triode, offers high power-gain. Using this tube, only two stages of amplification are required between the exciter and the antenna for the 5,000-watt output. Fewer components results in improved reliability.

Adjustable Power-Output Control

Power output is controlled by means of a variable resistor which controls the screen-voltage supply of the IPA. The use of semiconductor (silicon) rectifiers in the power supply reduces operating and maintenance costs.

Harmonic Filter

The harmonic filter supplied with all RCA FM transmitters is not a simple harmonic trap. The filter consists of two *M*-derived half-*T* sections and three constant-*K* sections. The *M*-derived sections at the input and output provide rapid cut-off in the second harmonic region and a termination impedance at each end of the filter of 50 ohms. The use of such a filter assures compliance with FCC requirements regarding spurious radiation, including all harmonics through 1000 MHz.

Self-Protected Against Overload

Power circuits are protected by magnetically-tripped circuit breakers in addition to overload relays. An automatic sequencing system prevents turn-on of plate power before all filaments have heated. In addition, a stepping relay automatically cycles power off three times before locking-out in the event of brief overloads or power interruptions. The overrelays are reset by pushbutton switches on the front panel. A tally light indicates overload in the driver, cathode current,

Simplified Block Diagram of BTF-5E2 Transmitter, showing optional stereo and SCA.

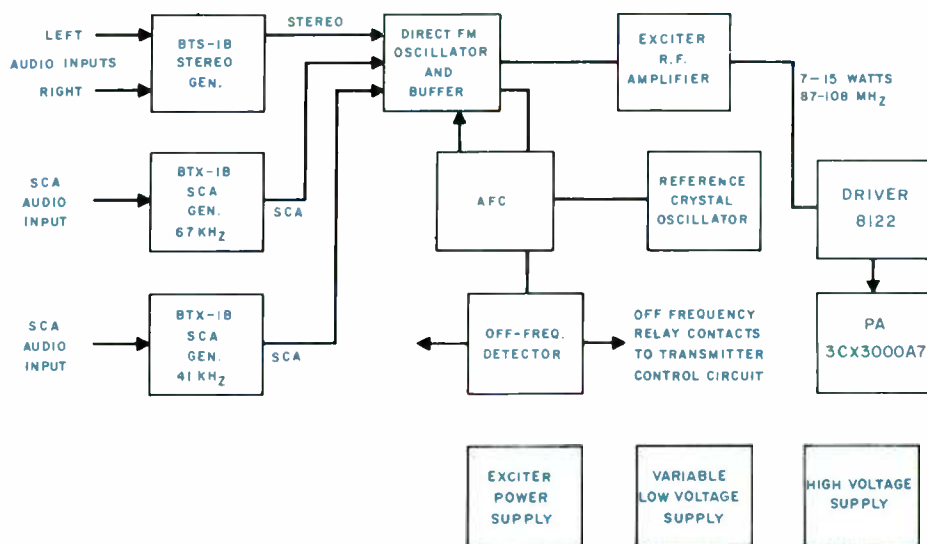

PA grid current, PA plate current or high-voltage power supply.

Control Features

The BTE-15A exciter has a self-contained multimeter. In the amplifier of the transmitter, provision is made for metering PA plate current, plate voltage, output power and VSWR. All tuning controls are located on the front panel for easy accessibility. They include switches for filament on-off, plate on-off, and overload reset. The variable power control is also mounted on the front as are the overload indicator and plate power-on lights. The use of latching relays make it possible to control the transmitter with one button.

Specifications

Performance

Power Output	1000-5000 watts
Output Impedance (1½" O.D., unflanged)	50 ohms
Frequency Deviation, 100% modulation	±75 kHz
Modulation Capability	±100 kHz
Carrier Frequency Stability	±1000 Hz max.
Audio Input Impedance	600/150 ohms
Audio Input Level— ¹ (100% mod.)	+10±2 dBm
Audio Frequency Response— ² (50 Hz-15 kHz)	±1 dB max.
Pre-emphasis Network Time Constant	75 or 50 µs
Harmonic Distortion— ³ (50 Hz-15 kHz)	0.5% or less
FM Noise Level (referred to 100% FM mod.)	-65 dB max.
AM Noise Level (referred to 100% AM mod.)	-50 dB max.
Subcarrier Input Level (100% mod.)	-15 to +10 dBm adjustable
Subcarrier Input Impedance	600/150 ohms bal.
Subcarrier Frequency	20-67 kHz
Main-to-Subchannel Crosstalk	-50 dB referred to ±6.0 kHz deviation of the subcarrier by a 400 Hz tone. Main channel modulation 70% by 50-15,000 Hz tones.
Sub-to-Main-Channel Crosstalk	-60 dB referred to ±75 kHz deviation of the main carrier by a 400 Hz tone. Subchannel modulated 100% (6.0 kHz/s) by 50-5000 Hz tones. Subcarrier modulated 30% on main carrier.

Electrical

Power Line Requirements:	
Line	240/208V, 50/60 Hz*
Combined Voltage Variation and Regulation	±5%
Power Consumption (approx.)	9000W
Power Factor (approx.)	90%

*Other line voltages available.

Ordering Information

Single-Amplifier, 5-kW FM Transmitter, Type BTF-5E2	ES-560916*
Dual-Amplifier, 5-kW FM Transmitter, Type BTF-5+5E2	ES-560962*
Dual-Output, 5-kW FM Transmitter, Type BTF-5/5E2	ES-560923*

Remote Control Provisions

The BTF-5E2 transmitter incorporates connections for remote control and remote meter reading when combined with a remote control system such as the BTR-15 or BTR-30. Terminals for transmitter on-off, plate on-off, overload reset, plate voltage, cathode current, and power output are provided. To control transmitter power output remotely, an accessory motor drive may be connected to the screen voltage control.

Dual-Amplifier Units

The BTF-5E2 is available also as a dual-power-amplifier in two versions: a "BTF-5-plus-5E2" and a "BTF-5-slash-

5E2". The BTF-5+5E2 combines dual identical outputs to result in a transmitter with redundant power amplifiers. In the BTF-5/5E2, the dual amplifiers are equipped with individual harmonic filters and individual outputs. This configuration is useful in two ways: to power separate circularly polarized antenna systems for increased on-air dependability or, to power separate vertical and horizontal polarization antenna arrays.

The dual-amplifier units use separate power supplies for each power amplifier. This redundancy enhances on-air reliability. A redundant exciter is available at extra cost. See BTE-15A exciter catalog pages for ordering information.

Mechanical

Dimensions (overall)	25" wide, 77" high, 33" deep (635 mm, 1956 mm, 840 mm)
Weight	850 lbs. (385 kg.)
Finish	Textured vinyl in charcoal gray and shadow blue, satin aluminum trim
Altitude	7500 ft. max. (2290 m) ⁴
Ambient Temperature Range	-20° to +45°C

Accessories

Remote Power Output Control	MI-561023
Recommended Spare RF Transistors for Exciter	RO-381
Directional Coupler (for exciter output)	MI-561026
Spare Crystal and Oven (Specify operating frequency)	MI-560717
Spare Transmitter Tubes	ES-560920
RF Load and Wattmeter	MI-561422
FM Freq. and Mod. Monitor, BW-75	MI-560735
RF Amplifier, BW-100	MI-560738
FM Stereo Freq. and Mod. Monitor, BW-85	MI-560740
SCA Freq. and Mod. Monitor, BW-95	MI-560745
Remote Control, Type BTR-30	ES-561446
Remote Control, Type BTR-15	ES-561157/8

1 Level measured at input to pre-emphasis network.

2 Audio Frequency response referred to 75 or 50 micro-second pre-emphasis curve.

3 Distortion includes all harmonics up to 30 kHz and is measured following a standard 75 or 50 micro-second de-emphasis network.

*Includes one Solid-State Exciter (Type BTE-15A) equipped for main-channel operation only. Stereo and/or SCA subcarrier-generator modules optional. Please specify assigned frequency, power line frequency, operational altitude (above sea level) and subcarrier-generator modules desired. Modules ordered with transmitter are factory installed.



Five-Kilowatt FM Transmitters, Types BTF-5E1, BTF-5-plus-5E1, BTF-5/5E1

- Entirely solid state exciter
- Mono or stereo, with or without SCA subcarriers
- Ready for remote control
- Expandable to 10- or 20-kW power level
- Available with redundant or dual-parallel power amplifiers

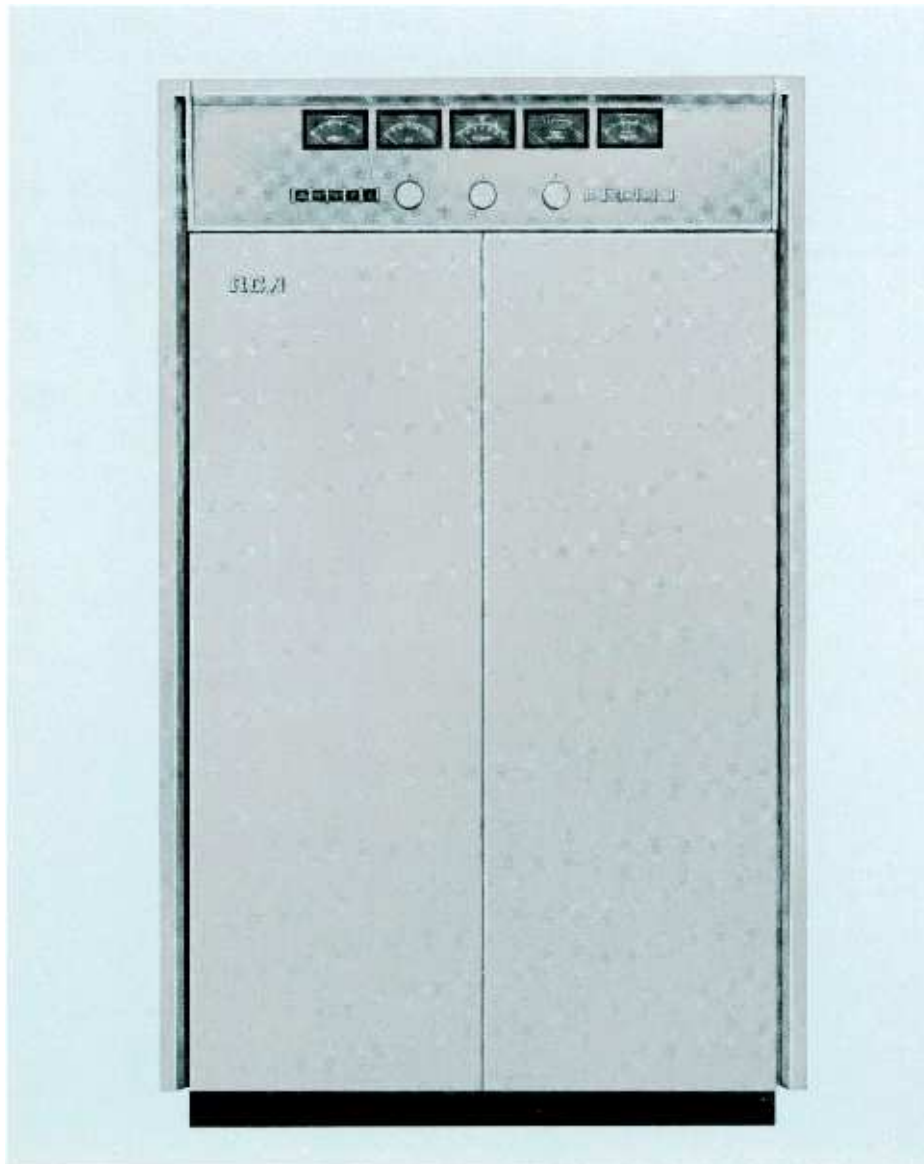

The RCA Type BTF-5E1 is a 5-kW FM Broadcast Transmitter designed for operation in the standard FM broadcast band (87.5 to 108 MHz) and is specifically engineered to the stringent requirements of stereo and multiplex service transmission.

The BTF-5E1 employs the time-tested and field proven "Direct-FM" exciter system. The circuits employ all solid-state components. The inherent long life and cool operation of these devices assure extended reliability in unattended remote operation.

The transmitter features a Type 4CX-5000A power tube driven by a 7203/4CX250B tube in the IPA stage. Silicon-rectifier power supplies also provide long life and dependability. All RF circuits are arranged for utmost tuning simplicity. Except for the high-voltage power supply, the transmitter is housed in a single two-door cabinet.

Frequency response of the transmitter's main channel is 30 to 15,000 Hz and typical distortion is less than one-half percent.

In addition to the five-kilowatt unit, the BTF-5 is available as a BTF-5-plus-5 and a BTF-5/5. The "5-plus-5" is essentially two separate and complete five-kilowatt transmitters with combined outputs for ten kilowatts of power. The "5/5" is two separate and complete five-kilowatt transmitters with separate outputs for energizing two separate antenna systems or operation as a main-alternate-main transmitter.

Mono or Stereo

The transmitter features an entirely solid-state exciter designed for stereo and multiplex. The exciter, including its self-contained power supply, is housed in a single cabinet.

Two Stages Follow Exciter

From the output of the exciter, only two tubes, one in the IPA and a ceramic-tetrode 4CX5000A in the PA generate the 5-kW signal. A harmonic filter is furnished to reduce spurious radiation.

Vacuum capacitors tune the IPA plate and PA grid. In the power amplifier, all adjustments are at ground potential.

Ready for Remote Control

The transmitter has been designed and built for remote controlled operation. Terminals are provided for remote control of transmitter on/off, raise/lower power and overload reset, while remote metering connections for the PA include cathode current, plate voltage and power output.

Maximum Accessibility

Functional styling together with fewer tubes and components has permitted the BTF-5E1 transmitter to be housed in a single, double-door cabinet, in a charcoal gray and shadow blue finish, set off with aluminum epoxy trim. Maximum accessibility is afforded by swing-out doors on the front and rear of the cabinet. All operating controls and meters used for rapid check of transmitter functions are located on a panel above the front doors. A separate unitized high-voltage power supply may be located anywhere in the station.

Direct-FM Exciter

Excellent monaural, stereo and SCA performance that more than meets industry, FCC and CCIR standards is achieved by the modular, solid-state exciter.

Simplified Exciter Circuits

Modulation of the temperature-compensated, basic on-frequency oscillator is achieved by applying the composite stereo or SCA signals from the BTS-1B and BTX-1B Generators, respectively, to a pair of push-pull Varacap diodes which are coupled to the basic oscillator frequency-determining resonant circuit. The output of the oscillator is isolated from the following buffer amplifier by a 10 dB resistive attenuator. Thus, the stability and modulation characteristics of the basic direct-FM oscillator are not disturbed by following RF-power amplifiers.

The output of the buffer amplifier, approximately 500 mW, is used to drive

a 15-watt, three-stage RF amplifier as well as the binary divider chain in the AFC circuit. The basic oscillator, buffer amplifier, and AFC circuit are inside a shielded enclosure. The RF-power amplifier is also completely shielded.

On-Carrier Operation

Automatic frequency control (AFC) for the on-frequency basic oscillator is achieved by taking a sample of the buffer output and dividing it by two, fourteen times. A low-frequency reference crystal, operating at 1/1024th of the desired output frequency is divided by two, four times. Integrated circuits operating in the saturated mode are used in both binary dividing chains. The outputs from the reference and basic oscillator binary dividers are phase compared in a time-sharing IC comparator. The output of the circuit, which represents the AFC error voltage, is filtered and applied to another pair of Varacap diodes coupled to the basic oscillator tuned circuit. Thus, the basic oscillator is phase-locked to the 1024th harmonic of the oven-controlled reference crystal.

An off-frequency detector (phase-lock) is incorporated in the design of the exciter. When the oscillator frequency is not phase-locked to the reference crystal, an alternating-current component appears at the AFC output. This voltage is rectified to operate a relay whose contacts can be used to turn off the transmitter.

Two multimeters are located in the hinged door in front of the regulated power supply section. One of these meters indicates operating voltages within the exciter and 15-watt RF Amplifier. The second meter is a peak-reading voltmeter that is used to indicate all modulating signal levels.

The RF power output of the exciter

can be continuously adjusted from the front panel control from 7 to 15 watts. The primary power is turned on with a circuit breaker. RF output is turned on with a front panel switch or through a relay operated from the transmitter filament supply. The exciter tolerates load mismatches from short-circuit to open circuit for a reasonable time without damaging the output transistor. Another feature prevents automatic operation of the 41 kHz SCA subcarrier while the Stereo Generator is in the stereo mode.

Single-Ended Driver Amplifier

Two simplified, single-ended amplifiers (operating Class "C") follow the exciter. The IPA stage consists of a Type 7203/4CX250B ceramic tetrode and the final power amplifier is a Type 4CX5000A tube. Variable vacuum capacitors are used to tune the interstage network between driver and PA.

5-kW Class "C" Final Amplifier

The power amplifier also uses pi-network circuitry, however, the tuning of this stage is accomplished by variable inductors operating at d-c ground potential. The output tube is designed for high power-gain with little drive. Power output is controlled by means of a motor-driven variable transformer connected in the primary of the low voltage power supply for the driver amplifier. This controls the IPA-plate and the PA-screen voltages simultaneously.

For increased transmitter stability and reliability, a separate grid bias supply is incorporated in the BTF-5E1. This supply, too, uses semi-conductor rectifiers.

Harmonic Filter Standard Equipment

To keep spurious emission at a minimum, the transmitter is furnished with a

Solid-state FM Exciter system, Type BTE-15A, showing "Direct FM" exciter at upper left with optional stereo generator unit shown in place. Right hand module is power supply and metering section.

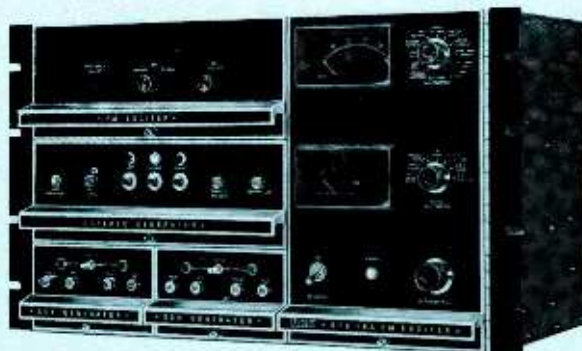

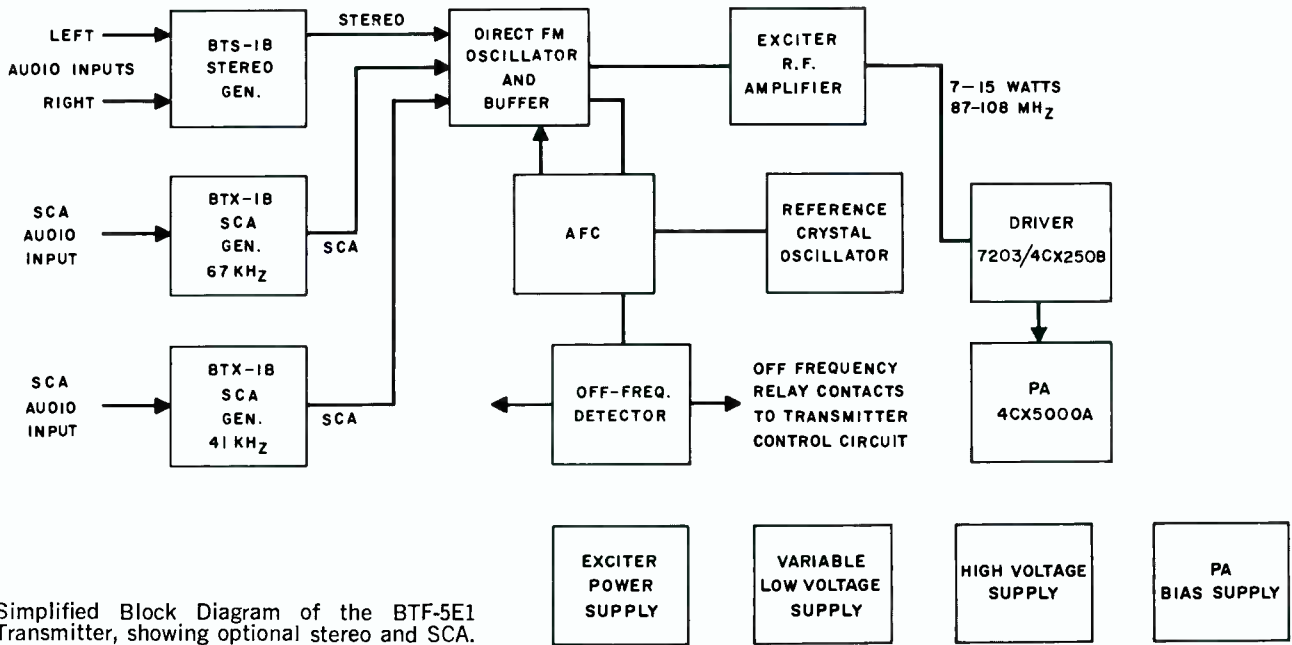

Simplified Block Diagram of the BTF-5E1 Transmitter, showing optional stereo and SCA.

3/8-inch harmonic filter as standard equipment. The filter consists of a series of transmission line elements with a uniform outer diameter conductor, a stepped inner conductor, and a shunt stub. The conductors are fabricated of a high-grade copper alloy. Attenuation of all harmonic radiation above channel limits is accomplished in an "M-derived" section, and a series of "constant-K" T-sections. This design provides a broad passband with a sharp high-frequency cut-off and excellent attenuation above the passband.

Self-Protected Against Overload

Power circuits are protected by magnetically-tripped circuit breakers in addition to overload relays. An interlocked system prevents turn-on of plate power until all filaments have heated. In addition, a latching relay automatically re-applies power to the transmitter once before locking-out in the event of brief overloads or power interruptions.

Optional Filter Monitor

Cooling air is supplied by means of a blower mounted below the amplifier stages. An optional manometer indicates the efficiency of the fiber-glass filter at the inlet and heavy sound insulation re-

duces blower noise to a minimum. The blower supplies forced air to both stages.

Simplified Control

The transmitter has all operating controls and meters located on a panel just above the front doors. The push-button controls include: transmitter on/off, plate on/off, overload reset and power raise/lower. A low-voltage circuit-breaker, and filament- and control-circuit breakers are located behind the left-hand door. The main-and low-power circuit breakers are located in the rectifier unitized cabinet.

Full Metering

Six easy-to-read front-panel meters are provided for each amplifier. One for PA-plate voltage, another for PA-plate current, and a third for AC-line and filament voltage. The remaining three are a reflectometer indicating output, a multi-meter and VSWR meter. Separate meters are used to measure the forward power and VSWR.

Ready for Remote Control

Remote control provisions are included in the transmitter and terminals are provided for use with remote control units such as the Type BTR-15 (or

BTR-30) and Automatic Logging Equipment. Additional terminals are provided for remote control of transmitter on/off, plate on/off, raise/lower power, and overload reset. Remote metering connections in the final amplifier for plate current, plate voltage, and power output are also provided.

Dual-Amplifier Units

The BTF-5E1 is available also as a ten-kilowatt, dual-power-amplifier transmitter in two versions: a "BTF-5-plus-5E1" and a "BTF-5-slash-5E1". The BTF-5+5E1 combines dual identical five-kilowatt outputs to result in a ten-kilowatt transmitter with dual-parallel power amplifiers. In the BTF-5/5E1, the dual amplifiers are equipped with individual harmonic filters and individual outputs. This arrangement is useful in two ways: to power separate, circularly polarized antenna systems for increased on-air dependability or to power separate antennas.

The BTF-5+5E1 and BTF-5/5E1 units are separate power supplies for each transmitter. This redundancy enhances on-air reliability. Both include dual exciter systems and automatic exciter switchover in the event of exciter system outage.

Ordering Information

Single-Amplifier, Five-Kilowatt FM Transmitter,
 Type BTF-5E1 ES-560600
 Dual-Amplifier, Ten-Kilowatt FM Transmitter,
 Type BTF-5+5E1 ES-560637

Dual-Output, Ten-Kilowatt FM Transmitter,
 Type BTF-5/5E1 ES-560603
 Please specify assigned frequency, operational altitude and
 exciter choices (mono, stereo, SCA).

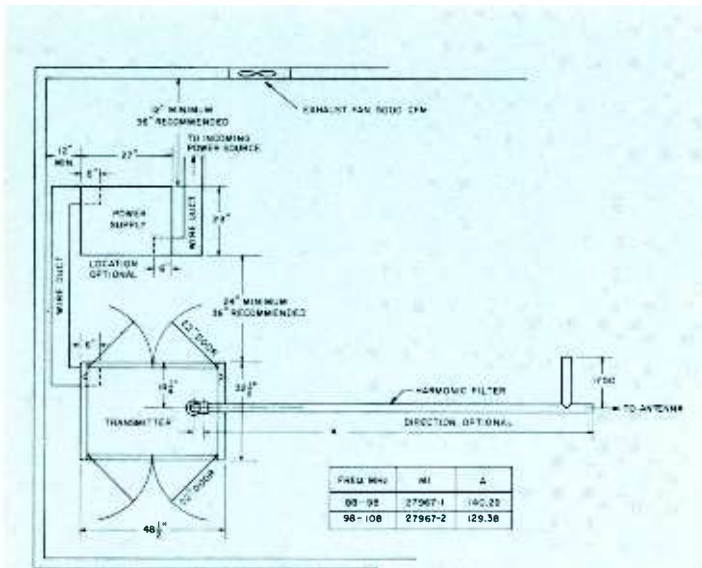

Space-saving floor plan of the BTF-5E1. The separate, unitized power supply may be installed in the basement, attic, closet, or other convenient place. (Wire duct and fan shown are not furnished.)

Specifications

Performance

- Type of Emission F3 and F9
- Frequency Range 87.5 to 108 MHz
- Power Output 5 kW
- Output Impedance (3 1/8" Unflanged Line) 50 ohms
- Frequency Deviation 100% modulation ±75 kHz
- Modulation Capability ±100 kHz
- Carrier Frequency Stability ±1000 Hz max.
- Audio Input Impedance 600/150 ohms
- Audio Input Level (100% mod.) +10 ±2 dBm¹
- Audio Frequency Response (50-15,000 Hz) ±1 dB max.²
- Pre-emphasis Network Time Constant 75 or 50 μs
- Harmonic Distortion (50-15,000 Hz) 0.5% or less³
- FM Noise Level (referred to 100% FM mod.)..... -65 dB max.
- AM Noise Level (referred to 100% AM mod.)..... -50 dB max.
- Subcarrier Input Level (100% mod.) -15 to +10 dBm adjustable
- Subcarrier Input Impedance 600/150 ohms bal.
- Subcarrier Frequency 20-67 kHz
- Main-to-Subchannel Crosstalk..... -50 dB referred to ±6.0 kHz deviation of the subcarrier by a 400 Hz tone. Main channel modulation 70% by 50-15,000 Hz tones.
- Sub-to-Main-Channel Crosstalk..... -60 dB referred to ±75 kHz deviation of the main carrier by a 400 Hz tone. Subchannel modulation 100% (±6.0 kHz) by 50-6000 Hz tones. Subcarrier modulated 30% on main carrier.

Accessories

- Recommended Spares RF Transistors (for exciter) RO-381⁴
- Spare Crystal and Oven (Specify carrier freq.) MI-560717
- Spare Tubes, Complete Set ES-560607
- Five-kW RF Load and Wattmeter MI-561422
- Thirty-Function Remote Control, Type BTR-15 ES-561157/53
- Sixty-Function Remote Control, Type BTR-30 ES-561446
- Power Conversion Kit (5- to 10-kW) ES-560642

Electrical

- Power Line Requirements:
 - Line 240/208V, 3 phase, 50/60 Hz⁵
 - Combined Line Voltage Variation and Regulation..... ±5%
 - Power Consumption (approx.) 10,000 W
 - Power Factor (approx.) 90%
- Crystal Heater:
 - Line 117 V, 50/60 Hz
 - Power Consumption 7 1/2 W

Tube Complement

Driver: 1—7203/4CX250B; Power Amplifier: 1—4CX5000A

Mechanical

- Dimensions:

	Transmitter	Power Supply
Width	48 1/2" (1230 mm)	32" (860 mm)
Height	77" (1956 mm)	46" (1381 mm)
Depth	32 1/2" (825 mm)	24" (721 mm)
Weight (approx.)	1250 lbs. (567 kg)	590 lbs. (268 kg)
- Shipping Weight (approx.) 2150 lbs. (975 kg)
- Finish.....Textured Vinyl in EELM charcoal gray and shadow blue, aluminum epoxy trim
- Altitude 60 Hz Power: 11,00 ft. (3353 m)¹
50 Hz Power: 9,000 ft. (2700 m)¹
- Ambient Temperature Range -20° to +45°C

¹ Level measured at input terminal.
² Audio Frequency response referred to 50- or 75-microsecond pre-emphasis curve.
³ Distortion includes all harmonics up to 30 kHz and is measured following a standard 50- or 75-microsecond de-emphasis network.
⁴ Blowers available for operation at higher altitudes.
⁵ Other voltages available optionally.

Specifications subject to change without notice.

- Power Conversion Kit (5- to 20-kW) ES-560643
- High Altitude Blower Kit MI-560347-3
- Mounting Kit (for Blower Kit) MI-560705
- AM Noise Reduction Kit MI-560307-31
- Indicator, Elapsed Time (60 Hz only) MI-561018-2
- Indicator, Elapsed Time (50 Hz only) MI-561018-4
- Manometer MI-560307-36

⁴Order "RO-" Kits from RCA Parts & Accessories, Deptford, N. J.



Ten-Kilowatt FM Transmitters, Types BTF-10E1, BTF-10-plus-10E1, BTF-10/10E1

- Entirely solid state exciter
- Mono or stereo, with or without SCA subcarriers
- Ready for remote control
- Expandable to 20-kW power level
- Available with redundant or dual-parallel power amplifiers

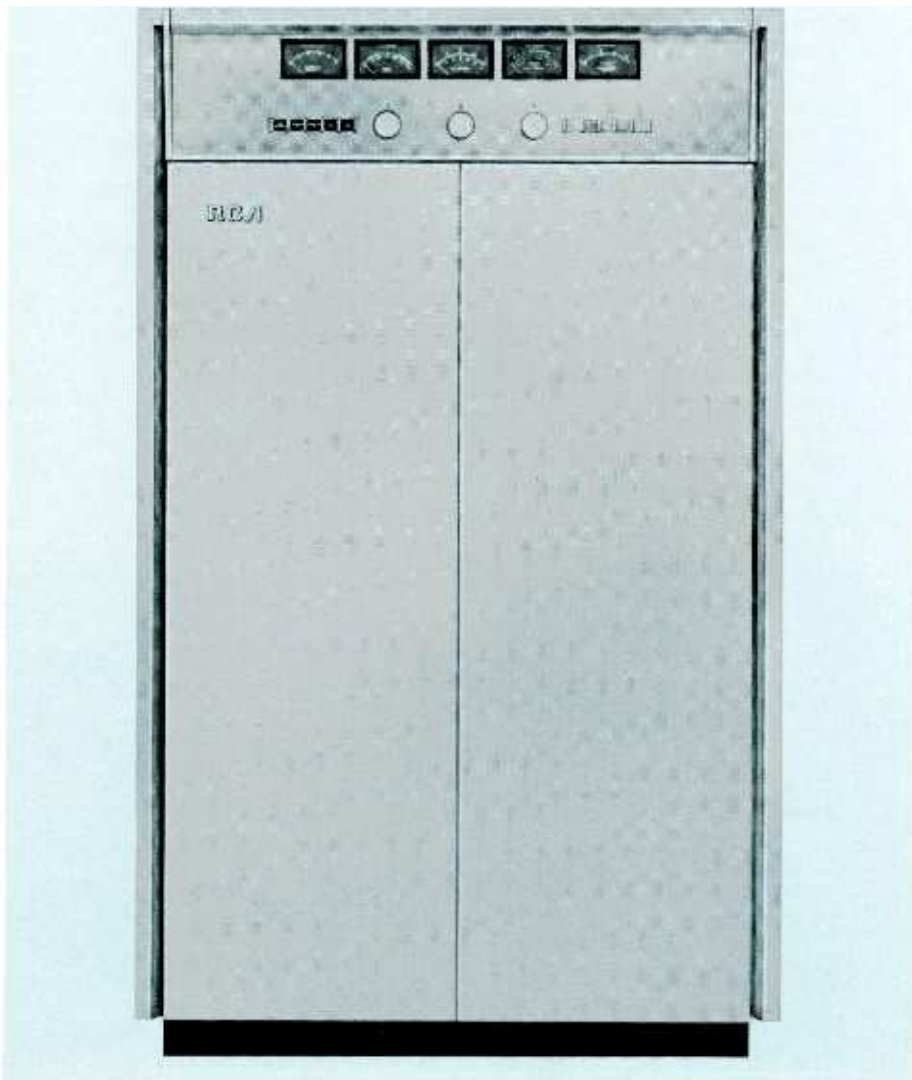

The RCA Type BTF-10E1 is a 10-kW FM Broadcast Transmitter designed for operation in the standard FM broadcast band (87.5 to 108 MHz) and is specifically engineered to the stringent requirements of stereo and multiplex service transmission.

The BTF-10E1 employs the time-tested and field proven Direct-FM exciter system. The circuits employ all solid-state components. The inherent long life and cool operation of these devices assure extended reliability in unattended remote operation.

The transmitter features a Type 4CX10000D power tube driven by 7203/4CX250B tube in the IPA stage. Silicon-rectifier power supplies also provide long life and dependability. All RF circuits are arranged for utmost tuning simplicity. Except for the high-voltage power supply, the transmitter is housed in a single two-door cabinet.

Frequency response of the transmitter's main channel is 30 to 15,000 Hz and typical distortion is less than one-half percent.

In addition to the ten-kilowatt unit, the BTF-10 is available as a BTF-10-plus-10 and a BTF-10/10. The "10-plus-10" is essentially two separate and complete ten-kilowatt transmitters with combined outputs for 20 kilowatts of power. The "10/10" is two separate and complete ten-kilowatt transmitters with separate outputs for energizing two separate antenna systems, or, operation as a main-alternate-main transmitter.

Mono or Stereo

The transmitter features a new exciter designed for stereo and multiplex. The exciter, including its self-contained power supply, is housed in a single cabinet.

Two Stages Follow Exciter

From the output of the exciter, only two tubes, one in the IPA and a ceramic-tetrode 4CX10000D in the PA generate the full 10-kW signal. A harmonic filter is furnished to reduce spurious radiation.

Vacuum capacitors tune the IPA plate and PA grid. In the power amplifier, all adjustments are at ground potential.

Ready for Remote Control

The transmitter has been designed and built for remote controlled operation. Terminals are provided for remote control of transmitter on/off, raise/lower power and overload reset, while remote metering connections for the PA include cathode current, plate voltage and power output.

Maximum Accessibility

Functional styling together with fewer tubes and components has permitted the BTF-10E1 transmitter to be housed in a single, double-door cabinet, in a charcoal gray and shadow blue finish, set off with aluminum epoxy trim. Maximum accessibility is afforded by swing-out doors on the front and rear of the cabinet. All operating controls and meters used for rapid check of transmitter functions are located on a panel above the front doors. A separate unitized high-voltage power supply may be located anywhere in the station.

Direct-FM Exciter

Excellent monaural, stereo and SCA performance that more than meets industry, FCC and CCIR standards is achieved by the modular, solid-state exciter.

Simplified Circuits

Modulation of the temperature-compensated, basic on-frequency oscillator is achieved by applying the composite stereo or SCA signals from the BTS-1B and BTX-1B Generators, respectively, to a pair of push-pull Varacap diodes which are coupled to the basic oscillator frequency-determining resonant circuit. The output of the oscillator is isolated from the following buffer amplifier by a 10 dB resistive attenuator. Thus, the stability and modulation characteristics of the basic direct-FM oscillator are not disturbed by following RF-power amplifiers.

The output of the buffer amplifier, approximately 500 mW, is used to drive a 15-watt, three-stage RF amplifier as well

as the binary divider chain in the AFC circuit. The basic oscillator, buffer amplifier, and AFC circuit are inside a shielded enclosure. The RF-power amplifier is also completely shielded.

On-Carrier Operation

Automatic frequency control (AFC) for the on-frequency basic oscillator is achieved by taking a sample of the buffer output and dividing it by two, fourteen times. A low-frequency reference crystal, operating at 1/1024th of the desired output frequency is divided by two, four times. Integrated circuits operating in the saturated mode are used in both binary dividing chains. The outputs from the reference and basic oscillator binary dividers are phase compared in a time-sharing IC comparator. The output of the circuit, which represents the AFC error voltage, is filtered and applied to another pair of Varacap diodes coupled to the basic oscillator tuned circuit. Thus, the basic oscillator is phase-locked to the 1024th harmonic of the oven-controlled reference crystal.

An off-frequency detector (phase-lock) is incorporated in the design of the exciter. When the oscillator frequency is not phase-locked to the reference crystal, an alternating-current component appears at the AFC output. This voltage is rectified to operate a relay whose contacts can be used to turn off the transmitter.

Two multimeters are located on the hinged door in front of the regulated power supply section. One of these meters indicates operating voltages within the exciter and 15-watt RF Amplifier. The second meter is a peak-reading voltmeter that is used to indicate all modulating signal levels.

The RF power output of the exciter can be continuously adjusted from the front panel control from 7 to 15 watts.

The primary power is turned on with a circuit breaker. RF output is turned on with a front panel switch or through a relay operated from the transmitter filament supply. The exciter tolerates load mismatches from short-circuit to open-circuit for a reasonable time without damaging the output transistor. Another feature prevents automatic operation of the 41 kHz SCA subcarrier while the stereo generator is in stereo mode.

Single-Ended Driver Amplifier

Two simplified, single-ended amplifiers (operating Class "C") follow the exciter. The IPA stage consists of a ceramic 7203/4CX250B tetrode and the final power amplifier is Type 4CX10000D tube. Variable vacuum capacitors are used to tune the interstage network between driver and PA.

10-kW Class "C" Final Amplifier

The power amplifier also uses pi-network circuitry, however, the tuning of this stage is accomplished by variable inductors operating at d-c ground potential. The output tube is designed for high power-gain with little drive. Power output is controlled by means of a motor-driven variable transformer connected in the primary of the low voltage power supply for the driver amplifier. This controls the IPA-plate and the PA-screen voltages simultaneously.

For increased transmitter stability and reliability, a separate grid bias supply is incorporated in the BTF-10E1. This supply, too, uses semi-conductor rectifiers.

Harmonic Filter Standard Equipment

To keep spurious emission at a minimum, the transmitter is furnished with a 3/8-inch harmonic filter as standard equipment. The filter consists of a series



Solid-state FM Exciter system, Type BTE-15A, showing "Direct FM" exciter at upper left with optional stereo generator units shown in place. Right hand module is power supply and metering section.

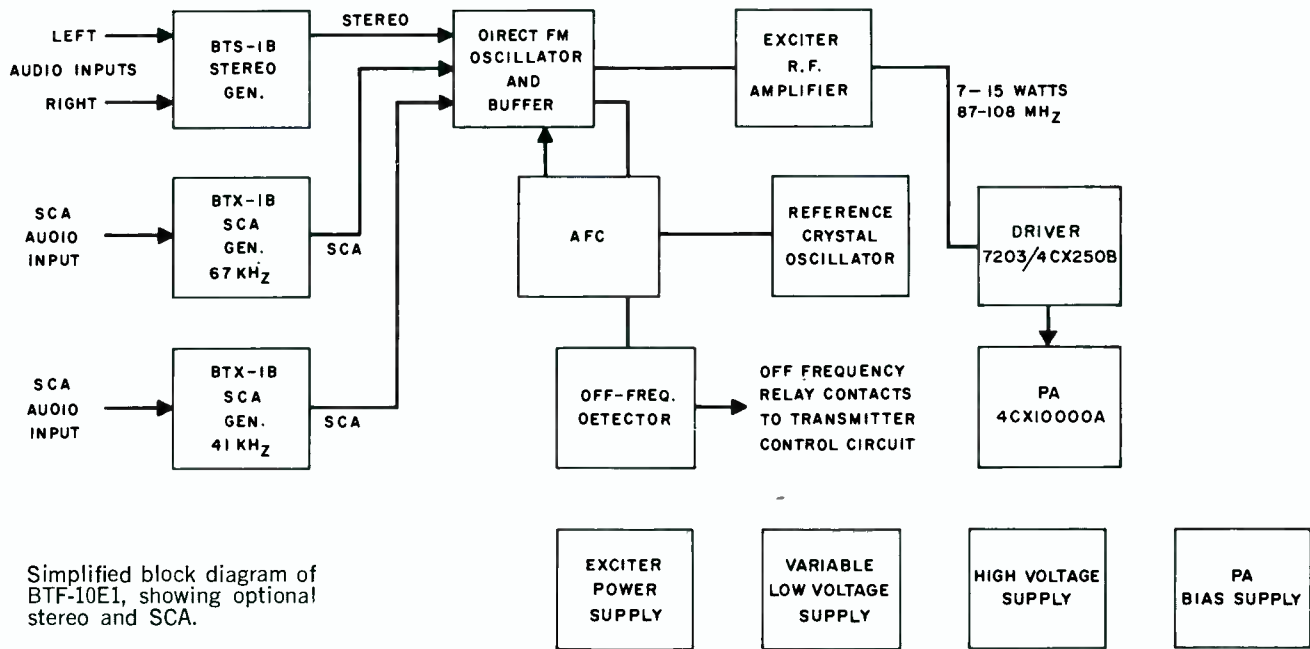

Simplified block diagram of BTF-10E1, showing optional stereo and SCA.

of transmission line elements with a uniform outer diameter conductor, a stepped inner conductor, and a shunt stub. The conductors are fabricated of a high-grade copper alloy. Attenuation of all harmonic radiation above channel limits is accomplished in an "M-derived" section, and a series of "constant-K" T-sections. This design provides a broad passband with a sharp high-frequency cut-off and excellent attenuation above the passband.

Self-Protected Against Overload

Power circuits are protected by magnetically-tripped circuit breakers in addition to overload relays. An interlocked system prevents turn-on of plate power until all filaments have heated and the exciter has reached a proper operating condition. In addition, a latching relay automatically re-applies power to the transmitter once before locking-out in the event of brief overloads or power interruptions.

Optional Filter Monitor

Cooling air is supplied by means of a blower mounted below the amplifier stages. An optional manometer indicates the efficiency of the fiber-glass filter at the inlet and heavy sound insulation reduces

blower noise to a minimum. The blower supplies forced air to both stages.

Simplified Control

The transmitter has all operating controls and meters located on a panel just above the front doors. The push-button controls include: transmitter on/off, plate on/off, overload reset and power raise/lower. A low-voltage circuit-breaker, and filament- and control-circuit breakers are located behind the left-hand door. The main- and low-power circuit breakers are located in the rectifier unitized cabinet.

Full Metering

Six easy-to-read front-panel meters are provided for each amplifier. One for PA-plate voltage, another for PA-plate current, and a third for AC-line and filament voltage. The remaining three are a reflectometer indicating output, a multimeter and VSWR meter. Separate meters are used to measure the forward power and VSWR.

Ready for Remote Control

Remote control provisions are included in the transmitter and terminals are provided for use with remote control units

such as the Type BTR-15 (or BTR-30) and Automatic Logging Equipment. Additional terminals are provided for remote control of transmitter on/off, plate on/off, raise/lower power, and overload reset. Remote metering connections in the final amplifier for plate current, plate voltage, and power output are also provided.

Dual-Amplifier Units

The BTF-10E1 is available also as a twenty-kilowatt, dual-power-amplifier transmitter in two versions: a "BTF-10-plus-10E1" and a "BTF-10-slash-10E1". The BTF-10+10E1 combines dual identical ten kilowatt outputs to result in a twenty-kilowatt transmitter with dual-parallel power amplifiers. In the BTF-10/10E1, the dual amplifiers are equipped with individual harmonic filters and individual outputs. This arrangement is useful in two ways: to power separate, circularly polarized antenna systems for increased on-air dependability or, to power separate vertical and horizontal antennas.

The BTF-10+10E1 and BTF-10/10E1 units use separate power supplies for each transmitter. This redundancy enhances on-air reliability. Both include dual exciter systems and automatic exciter switchover in the event of exciter system outage.

Ordering Information

Single Amplifier, Ten-Kilowatt FM Transmitter,
 Type BTF-10E1 ES-560601
 Dual-Amplifier, Twenty-Kilowatt FM Transmitter,
 Type BTF-10+10E1 ES-560638

Dual-Output, Twenty-Kilowatt FM Transmitter,
 Type BTF-10/10E1 ES-560604
 Please specify assigned frequency, operational altitude and
 exciter choices (mono, stereo, SCA).

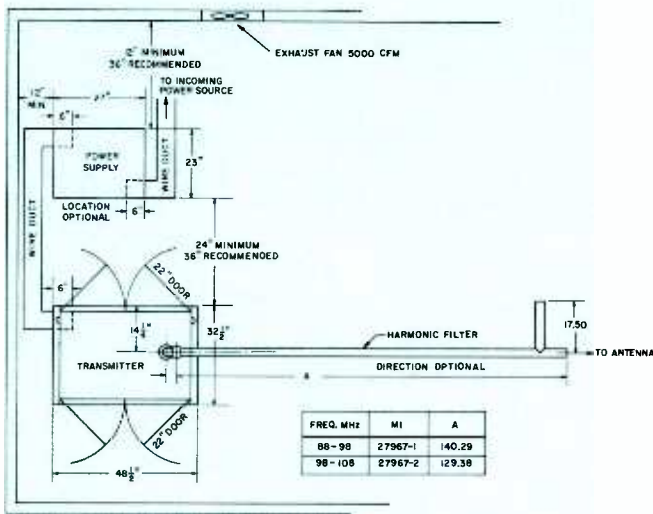

Space-saving floor plan of the BTF-10E1. The separate, unitized power supply may be installed in the basement, attic, closet, or other convenient place. (Wire duct and fan shown are not furnished.)

Specifications

Performance

- Type of Emission F3 and F9
- Frequency Range 87.5 to 108 MHz
- Power Output 10 kW
- Output Impedance (3/8" Unflanged Line) 50 ohms
- Frequency Deviation 100% modulation ±75 kHz
- Modulation Capability ±100 kHz
- Carrier Frequency Stability ±1000 Hz max.
- Audio Input Impedance 600/150 ohms
- Audio Input Level (100% mod.) +10 ±2 dBm¹
- Audio Frequency Response (50-15,000 Hz) ±1 dB max.²
- Pre-emphasis Network Time Constant 75 or 50µs
- Harmonic Distortion (50-15,000 Hz) 0.5% or less³
- FM Noise Level (referred to 100% FM mod.) -65 dB max.
- AM Noise Level (referred to 100% AM mod.) -50 dB max.
- Subcarrier Input Level (100% mod.) -15 to +10 dBm adjustable
- Subcarrier Input Impedance 600/150 ohms bal.
- Subcarrier Frequency 20-67 kHz
- Main-to-Subchannel Crosstalk -50 dB referred to ±5.0 kHz deviation of the subcarrier by a 400 Hz tone. Main channel modulation 70% by 50-15,000 Hz tones.
- Sub-to-Main Channel Crosstalk -60 dB referred to ±75 kHz deviation of the main carrier by a 400 Hz tone. Subchannel modulation 100% (±6.0 kHz) by 50-6000 Hz tones. Subcarrier modulated 30% on main carrier.

Electrical

- Power Line Requirements:**
- Line 240/208V, 3 phase, 50/60 Hz⁴
 - Combined Line Voltage Variation and Regulation ±5%
 - Power Consumption (approx.) 19,000 W
 - Power Factor (approx.) 90%

Tube Complement

Driver: 1—7203/4CX250B Power Amplifier: 1—4CX10000D

Mechanical

- Dimensions:**
- | | Transmitter | Power Supply |
|------------------|--------------------|-------------------|
| Width | 48 1/2" (1230 mm) | 32" (960 mm) |
| Height | 77" (1956 mm) | 46" (1381 mm) |
| Depth | 32 1/2" (825 mm) | 24" (721 mm) |
| Weight (approx.) | 1300 lbs. (590 kg) | 840 lbs. (381 kg) |
- Finish Textured vinyl in EELM charcoal gray and shadow blue, aluminum epoxy trim
- Altitude 60 Hz Power 9,000 ft. (2700 m)
50 Hz Power 7,500 ft. (2286 m)⁵
- Ambient Temperature Range -20° to +45°C

¹ Level measured at input terminal.
² Audio Frequency response referred to 50- or 75-microsecond pre-emphasis curve.
³ Distortion includes all harmonics up to 30 kHz and is measured following a standard 50- or 75-microsecond de-emphasis network.
⁴ Blowers can be provided for operation at higher altitudes.
⁵ Other voltages available optionally.

Specifications subject to change without notice.

Accessories

- Recommended Spares RF Transistors (for exciter) RO-381⁶
- Spare Crystal and Oven (Specify carrier freq.) MI-560717
- Spare Tubes, Complete Set ES-561608
- RF Load & Wattmeter, 10 kW Type 8634
- Remote Control, Thirty Function, Type BTR-15 ES-561157/58
- Remote Control, Sixty-Function, Type BTR-30 ES-561446
- Power Conversion Kit (10 kW to 20 kW) MI-560644
- High Altitude Blower Kit MI-560747-3
- Mounting Kit (for Blower Kit) MI-560705
- AM Noise Reduction Kit MI-560307-31

- Manometer MI-560307-36
- Indicator, Elapsed Time (60 Hz only) MI-561018-2
- Indicator, Elapsed Time (50 Hz only) MI-561018-4
- Frequency & Modulation Monitor, Type BW-75 MI-560735
- Stereo Frequency & Modulation Monitor, Type BW-85 MI-560740
- SCA Frequency & Modulation Monitor, Type BW-95 MI-560745
- RF Amplifier, Type BW-100 (for monitors above) MI-560738

⁶ Order "RO-" kit from RCA Parts & Accessories, Deptford, N. J.

Twenty-Kilowatt FM Transmitters, Types BTF-20E1, BTF-20/20E1

- Entirely solid state exciter
- Mono or stereo, with or without SCA
- 100 kW ERP with 6-section antenna
- Ready for remote control



The RCA Type BTF-20E1 is a 20-kW FM Broadcast Transmitter designed for operation in the standard FM band (87.5 to 108 MHz) and is specifically engineered to the stringent requirements of stereo and multiplex service transmission.

The BTF-20E1 employs the time-tested and field proven Direct-FM exciter system. The circuits employ all solid-state components. The inherent long life and cool operation of these devices assure extended reliability in unattended remote operation.

The transmitter features a Type 4CX15000A power tube driven by two 7203/4CX250B tubes in the IPA stage. Silicon-rectifier power supplies also provide long life and dependability. The RF power circuits are arranged for utmost tuning simplicity. Except for the high-voltage power supply, the transmitter is housed in a single two-door cabinet.

Frequency response of the transmitter's main channel is 30 to 15000 Hz and typical distortion is less than one-half percent.

In addition to the twenty-kilowatt unit, the BTF-20 is available as a BTF-40 and a BTF-20/20. The BTF-40 is essentially two separate and complete twenty-kilowatt transmitters with combined outputs for 40 kilowatts of power. The "20/20" is two separate and complete 20 kilowatt transmitters with separate outputs for energizing two separate antenna systems or for operation as main-alternate-main transmitters.

Mono or Stereo

The transmitter features an entirely solid-state exciter designed for stereo and multiplex. The exciter, including its self-contained power supply, is housed in a single cabinet.

Two Stages Follow Exciter

From the output of the exciter, only three tubes, two in the IPA and a ceramic-tetrode 4CX15000A PA generate the full 20-kW signal. A harmonic filter is furnished to reduce spurious radiation.

Vacuum capacitors tune the IPA plate and PA grid. In the power amplifier, all adjustments are at d-c ground potential.

Ready for Remote Control

The transmitter has been designed and built for remote controlled operation. Terminals are provided for remote control of transmitter on/off, raise/lower power and overload reset, while remote metering connections for the PA include cathode current, plate voltage and power output.

Maximum Accessibility

Functional styling together with fewer tubes and components has permitted the new BTF-20E1 transmitter to be housed in a single, double-door cabinet, in a EELM charcoal gray and shadow blue finish, set off with aluminum meter panel and trim. Maximum accessibility is afforded by swing-out doors on the front and rear of the cabinet. All operating controls and meters used for rapid check of transmitter functions are located on a panel above the front doors. A separate unitized high-voltage power supply may be located anywhere in the station.

Direct-FM Exciter

Excellent monaural, stereo and SCA performance that more than meets industry and FCC & CCR standards is achieved by the modular, solid-state exciter.

Simplified Circuits

Modulation of the temperature-compensated, basic on-frequency oscillator is achieved by applying the composite stereo or SCA signals from the BTS-1B and BTX-1B Generators, respectively, to a pair of push-pull Varacap diodes which are coupled to the basic oscillator frequency-determining resonant circuit. The output of the oscillator is isolated from the following buffer amplifier by a 10 dB resistive attenuator. Thus, the stability and modulation characteristics of the basic direct-FM oscillator are not disturbed by following RF-power amplifiers.

The output of the buffer amplifier, approximately 500 mW, is used to drive a 15-watt, three-stage RF amplifier as well as the binary divider chain in the AFC

circuit. The basic oscillator, buffer amplifier, and AFC circuit are inside a shielded enclosure. The RF-power amplifier is also completely shielded.

Automatic frequency control (AFC) for the on-frequency basic oscillator is achieved by taking a sample of the buffer output and dividing it by two, fourteen times. A low-frequency reference crystal, operating at 1/1024th of the desired output frequency is divided by two, four times. Integrated circuits operating in the saturated mode are used in both binary dividing chains. The outputs from the reference and basic oscillator binary dividers are phase compared in a time-sharing IC comparator. The output of the circuit, which represents the AFC error voltage, is filtered and applied to another pair of Varacap diodes coupled to the basic oscillator tuned circuit. Thus, the basic oscillator is phase-locked to the 1024th harmonic of the oven-controlled reference crystal.

An off-frequency phase-lock detector is incorporated in the design of the exciter. When the oscillator frequency is not phase-locked to the reference crystal, an alternating-current component appears at the AFC output. This voltage is rectified to operate a relay whose contacts can be used to turn off the transmitter.

Two multimeters are located on the hinged door in front of the regulated power supply section. One of these meters indicates power-supply and operating voltages within the exciter and 15-watt RF Amplifier. The second meter is a peak-reading voltmeter that is used to indicate all modulating signal levels.

The RF power output of the exciter can be continuously adjusted from the front panel control from 7 to 15 watts. The primary power is turned on with a circuit breaker. RF output is turned on with a front panel switch or through a 208/240-volt relay operated from the transmitter filament supply.

The exciter tolerates load mismatches from short-circuit to open-circuit for a reasonable time without damaging the output transistor. Another feature prevents automatic operation of the 41-kHz SCA subcarrier when the stereo generator is in the stereo mode.

Single-Ended Driver Amplifier

Two simplified, single-ended amplifiers (operating Class "C") follow the exciter. The IPA stage consists of two ceramic 7203/4CX250B tetrodes operating in parallel, and the final power amplifier is Type 4CX15000A tube. Variable vacuum capacitors are used to tune the interstage network between driver and PA.

20-kW Class "C" Final Amplifier

The power amplifier also uses pi-network circuitry, however, the tuning of this stage is accomplished by variable inductors operating at d-c ground potential. The output tube is designed for high power-gain with little drive. Power output is controlled by a motor-driven variable transformer in the primary of the low-voltage power supply. This controls the IPA-plate and the PA-screen voltages simultaneously and thus the power output.

For increased transmitter stability and reliability, a separate grid-bias supply is incorporated. This supply, too, uses semiconductor rectifiers.

Harmonic Filter Standard Equipment

To keep spurious emission at a minimum, the transmitter is furnished with a harmonic filter as standard equipment. The filter consists of a series of transmission line elements with a uniform outer diameter conductor, a stepped inner conductor, and a shunt stub. The conductors are fabricated of a high-grade copper alloy. Attenuation of all harmonic radiation above channel limits is accomplished in an "M-derived" section, and a



Solid-state FM Exciter system, Type BTE-15A, showing "Direct FM" exciter at upper left with optional subcarrier generator units shown in place. Right hand module is power supply and metering section.

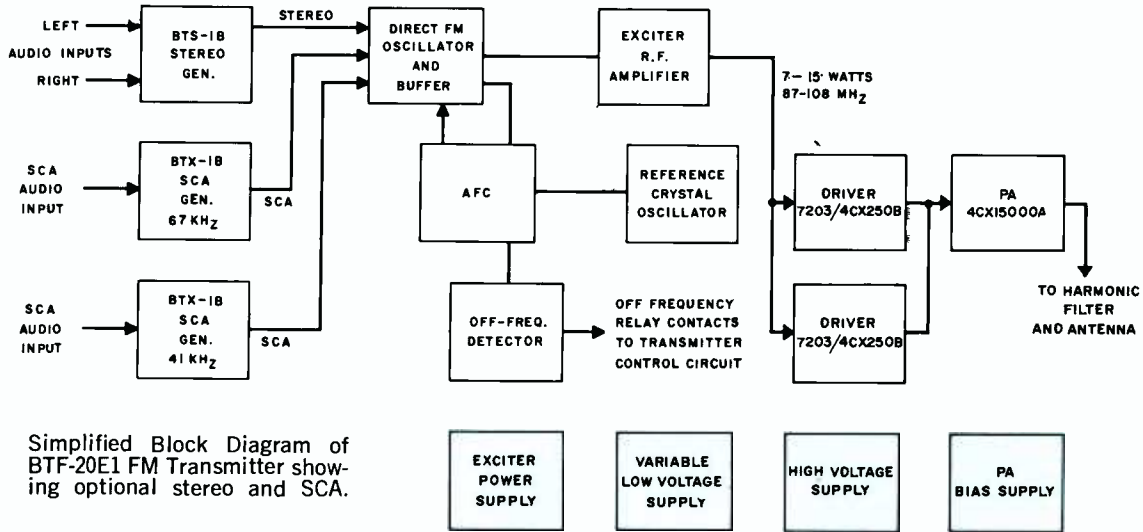

Simplified Block Diagram of BTF-20E1 FM Transmitter showing optional stereo and SCA.

series of "constant-K" T-sections. This design provides a broad passband with a sharp high-frequency cut-off and excellent attenuation above the passband.

Self-Protected Against Overload

Power circuits are protected by magnetically tripped circuit breakers in addition to overload relays. An interlocked system prevents turn-on of plate power until all filaments have heated. In addition, a latching relay automatically re-applies power to the transmitter once before lock-out in the event of brief overloads or power interruptions. The overload relays are reset by illuminated push-buttons on the front panel. Separate tally-light indicators are provided for overloads in the driver, power amplifier and low-voltage rectifier circuits.

Optional Filter Monitor

Cooling air for the BTF-20E1 is supplied by means of a blower mounted below the amplifier stages. An optional manometer indicates the efficiency of the fiber-glass filter at the inlet and heavy sound insulation reduces blower noise to a minimum. The blower supplies forced air to both the IPA and PA stages.

Simplified Control

The transmitter has all operating controls and meters located on a panel just above the front doors. The push-button controls include: transmitter on/off, plate

on/off, overload reset and power raise/lower. A low-voltage circuit-breaker, and filament- and control-circuit breakers are located behind the left-hand door. The main- and low-power circuit breakers are located in the rectifier unitized cabinet. Personnel are protected by fully interlocked rear doors, in addition to interlocked doors on the RF PA cubicle.

Full Metering

Six easy-to-read front-panel meters are provided for each amplifier. One for PA-plate voltage, another for PA-plate current, and a third for AC-line and filament voltage. The remaining three are a reflectometer indicating output, a multimeter and VSWR meter. Separate meters are used to measure the forward power and VSWR. The multimeter reads the grid current, the screen current and the screen voltage of both power tubes. In addition, the exciter has its own self-contained multimeter. This one provides complete information on operating conditions in the exciter.

Ready for Remote Control

Remote control provisions are included in the transmitter and terminals are provided for use with remote control units such as the Type BTR-15 (or BTR-30) and Automatic Logging Equipment. Additional terminals are provided for remote control (momentary contact) of transmitter on/off, plate on/off, raise/

lower power, and overload reset. Remote metering connections in the final amplifier for plate current, plate voltage, and power output are also provided.

High-Voltage Power Supply

The high-voltage power supply is housed in a unitized cabinet measuring 32" wide, 24" deep and 46" high (813 x 610 x 1168 mm). It can be installed at any convenient place in the station.

Parallel/Redundant Systems

The BTF-20E1 is available also as a dual-power-amplifier transmitter in two versions: a Type BTF-40E1 and a BTF-20/20E1. The BTF-40E1 combines dual identical twenty-kilowatt outputs to result in a forty-kilowatt transmitter with parallel amplifiers (see catalog pages on Type BTF-40E1). In the BTF-20/20E1, the dual power amplifiers are equipped with individual harmonic filters and individual outputs. This arrangement is useful in two ways: to power separate, circularly polarized antenna systems for increased on-air dependability or, to power separate vertical and horizontal polarization antenna arrays independently.

The BTF-40E1 and BTF-20/20E1 units use a separate power supplies for each transmitter unit. This redundancy enhances on-air reliability. Both transmitter systems include dual exciter systems and automatic exciter switchover in the event of exciter outage.

Ordering Information

Single Amplifier, 20-kW Transmitter,
 Type BTF-20E1ES-560602
 Dual-Amplifier, 40-kW Transmitter,
 Type BTF-40E1ES-560606

Dual-Output, 40-kW Transmitter,
 Type BTF-20/20E1ES-560605
 Please specify assigned frequency, operational altitude and exciter choices (mono, stereo, SCA).

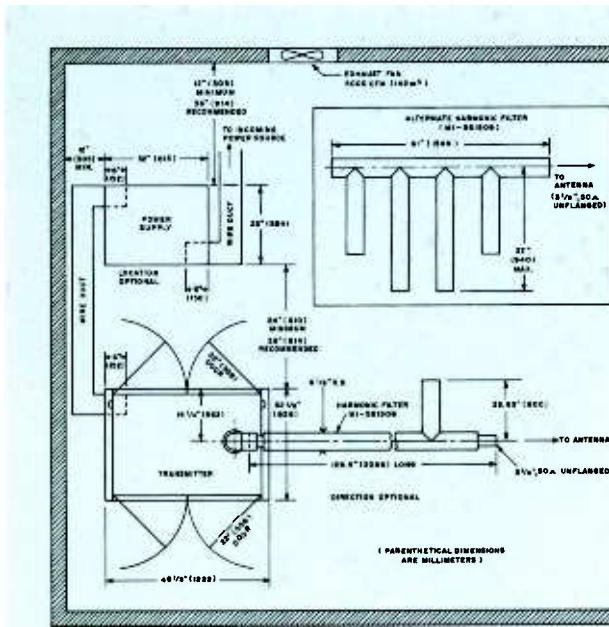

Space-saving floor plan of the BTF-20E1. Some units use three-inch diameter harmonic filter (inset). The separate, unitized power supply may be installed in a basement, attic, closet or other convenient place. (Wire duct and fan shown in drawing not furnished.)

Main-to-Subchannel Crosstalk-50 dB referred to ± 6.0 kHz deviation of the subcarrier by a 400 Hz tone. Main channel modulation 70% by 50-15,000 Hz tones.
 Sub-to-Main-Channel Crosstalk....-60 dB referred to ± 75 kHz deviation of the main carrier by a 400 Hz tone. Subchannel modulation 100% (± 6.0 kHz) by 50-6000 Hz tones. Subcarrier modulated 30% on main carrier.

Electrical

Power Line Requirements:

- Line240/208 volt, 3 phase, 50/60 Hz⁴
- Combined Line Voltage Variation and Regulation..... $\pm 5\%$
- Power Consumption (approx.)36,000 watts
- Power Factor (approx.)90%

Tube Complement

Driver: Two Type 7203/4CX250B; PA: One 4CX15000A

Mechanical

Dimensions (overall):	Transmitter	Power Supply
Width	48 1/2" (1230 mm)	32" (813 mm)
Height	77" (1956 mm)	46" (1168 mm)
Depth	32 1/2" (825 mm)	24" (610 mm)
Weight (approx.)	1425 lbs. (646 kg.)	1025 lbs. (465 kg.)
Shipping W. (approx)	1600 lbs. (726 kg.)	1100 lbs. (499 kg.)
Finish	Textured vinyl in EELM charcoal gray and shadow blue, aluminum enamel panels.	
Altitude		
50 Hz Power	3000 ft. (915 m)	
60 Hz Power	7500 ft. (2290 m) ⁵	
Ambient Temperature Range.....	-20° to +45°C	

¹ Level measured at input terminal.
² Audio Frequency response referred to 50- or 75- μ s pre-emphasis curve.
³ Distortion includes all harmonics up to 30 kHz and is measured following a standard 50- or 75- μ s de-emphasis network.
⁴ Other line voltages available optionally.
⁵ Using optional Blower Kit 50 Hz: 6500' (1983 m); 60 Hz: 11,000' (3355 m).

Specifications subject to change without notice.

Specifications

Performance

- Type of Emission.....F3 and F9
- Frequency Range87.5 to 108 MHz
- Power Output20 kW
- Output Impedance (3/8" O.D. unflanged)50 ohms
- Frequency Deviation 100% modulation..... ± 75 kHz
- Modulation Capability ± 100 kHz
- Carrier Frequency Stability..... ± 1000 Hz max.
- Audio Input ImpedanceResistive, 600/150 ohms
- Audio Input Level (100% mod.)+10 ± 2 dBm¹
- Audio Frequency Response (50-15,000 Hz) ± 1 dB max.²
- Pre-emphasis Network Time Constant...75 or 50 μ s, as desired
- Harmonic Distortion (50-15,000 Hz)0.5% or less³
- FM Noise Level (referred to 100% FM mod.).....-65 dB max.
- AM Noise Level (referred to 100% AM mod.).....-50 dB max.
- Subcarrier Input Level (100% mod.)-15 to +10 dBm adjustable
- Subcarrier Input Impedance600/150 ohms bal.
- Subcarrier Frequency20-67 kHz

Accessories

- Recommended Spares, RF Transistors (for exciter)RO-381⁶
- Spare Crystal and Oven (Specify Carrier Frequency)MI-560717
- Spare Tubes, Complete SetES-561609
- RF Load and Wattmeter, 20 kWMI-19267
- ManometerMI-560307-36
- Remote Control System Type BTR-15ES-561157/58
- Remote Control System Type BTR-30ES-561446
- High Altitude Blower KitMI-560347-3

- Blower Mounting KitMI-560705
- AM Noise Reduction KitMI-560307-31
- Indicator, Elapsed Time:
- 60 Hz power onlyMI-561018-2
- 50 Hz power onlyMI-561018-4
- Freq. & Mod. Monitor BW-75MI-560735
- Stereo Freq. & Mod. Monitor BW-85MI-560740
- SCA Freq. & Mod. Monitor BW-95MI-560745
- RF Amplifier BW-100MI-560738

⁶ Order from RCA Parts & Accessories, Deptford, N.J.



Forty-Kilowatt FM Transmitter, Type BTF-40E1

- Dual-redundant exciters, amplifiers, power supplies
- Ready for remote control
- Built for continuous operation
- Direct-FM for full-fidelity mono or stereo with or without SCA
- Only six tubes in entire transmitter—of only two types

The Type BTF-40E1 is a forty-kilowatt transmitter for the maximum-power FM-broadcast station where continuous operation is important. The transmitter combines two identical twenty-kilowatt transmitters to form a redundant forty-kilowatt system. The dual design even allows major maintenance without interruption of air-time.

The BTF-40E1 is a single-output transmitter. Those seeking a dual-output transmitter should consider the Type BTF-20/20E1 transmitter. This system uses two 20-kW systems designed for sectionalized antenna systems.

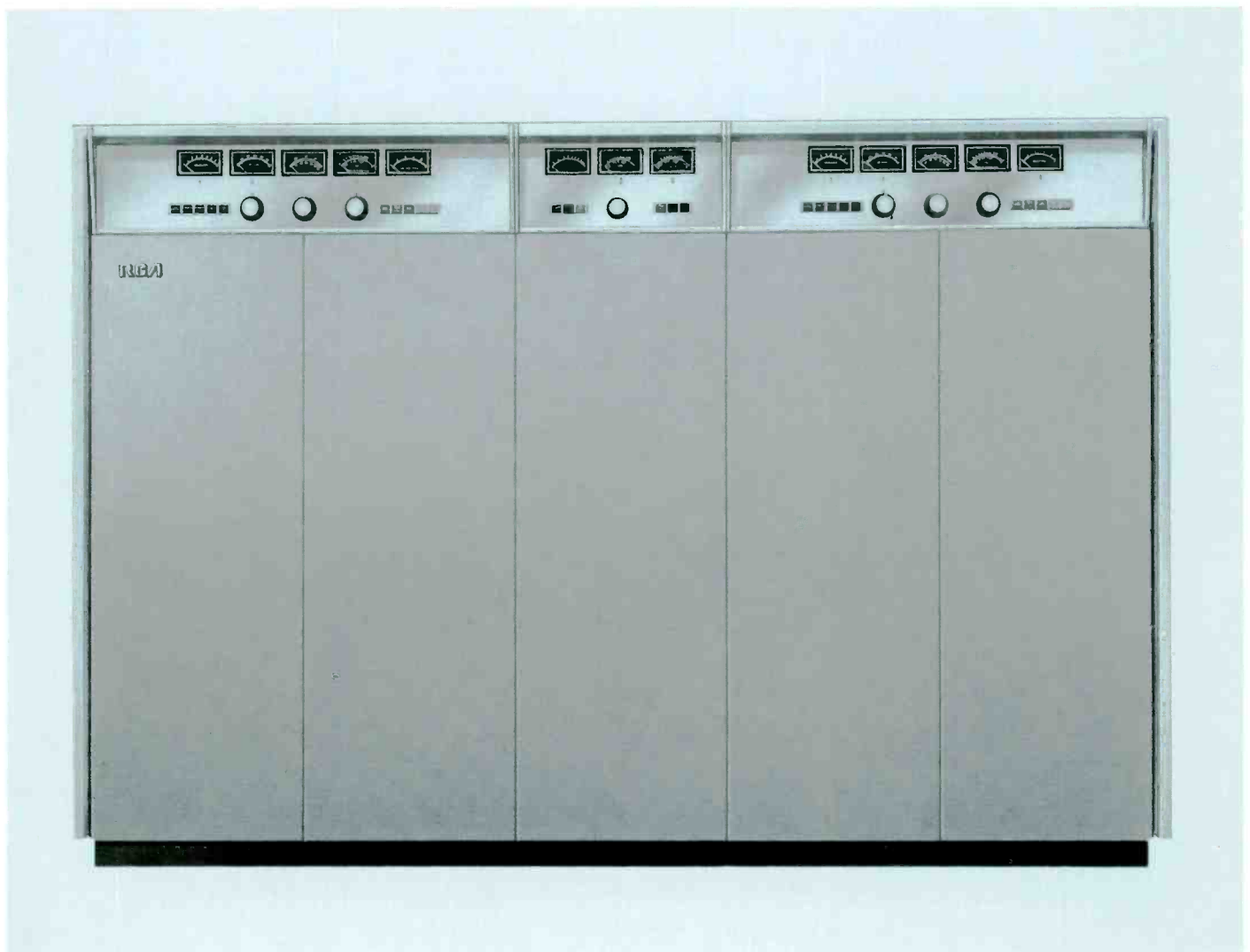

The BTF-40E1 is a forty-kilowatt, redundant transmitter for the maximum-power FM-broadcast station operating on a continuous schedule.

The transmitter is actually two complete twenty-kilowatt units, (Type BTF-20E1) combined to make continuous operation practical. All major components — except the combining equipment and the harmonic filter — are duplicated within the system: twin exciters, twin intermediate power amplifiers, twin finals, twin power supplies, etc. (see block diagrams, opposite).

The BTF-40E1 is intended for operation into a single transmission line and antenna system. Systems with redundant antenna systems or main alternate-main transmitters should use the Type BTF-20/20E1 transmitter. This unit is essentially a BTF-40E1 with dual, identical 20-kW outputs.

Dual, Switchable Exciters

The BTF-40E1 includes two solid-state exciter systems arranged so that one of the two serves the transmitter while the other operates as a hot standby. In the event of trouble in the on-air exciter, manual switchover puts the extra exciter

on the line. Lighted indicators on the control panel show the change in status.

The exciter systems are identical in all respects and the plug-in modules are interchangeable between systems. Each exciter unit uses four modules in a main frame. The main frame houses the exciter system power supply and two multimeters: one for d-c parameters and one for audio parameters.

The upper left module houses the RF portions of the system: the oscillator, AFC and amplifiers. The module at center left is a stereo generator module when the exciter is equipped for stereo programming.

In a mono-only exciter, this is an audio-input module which interfaces the program line with the frequency-modulated oscillator.

The spaces at the lower edge of the unit accommodate one or two SCA subcarrier generator modules. More information on the exciter system is available in a separate catalog section.

Power-Amplifier Stages

The exciter system delivers 15 watts of modulated carrier to a hybrid-ring power splitter which, in turn, provides two out-

puts. A pair of paralleled tetrodes, in each transmitter section, raise the power level to drive the final power amplifier in each section. The final stage raises the power level to 20 kW. The two 20-kW outputs are combined into a 40-kW in a hybrid combiner.

Hybrid Combiner Network

Ordinarily mounted above the transmitter cabinet, almost directly over the center unit, (see floor plan, next page) is the combiner network, a "three-dB hybrid" coaxial unit. This assembly combines the two 20-kW modulated carriers into one 40-kW output. The reject loads for the combiner are mounted within the center cabinet of the transmitter.

Coaxial Harmonic Filter

The harmonic filter is a series of transmission-line elements with a uniform $6\frac{1}{8}$ -inch outer-conductor diameter, a stepped inner conductor and a shunt stub. Attenuation of all harmonics is accomplished in an M-derived section and a series of constant- K , T sections. The filter has a broad passband with a sharp high-frequency cutoff and excellent attenuation above cutoff frequency.

Forty-Kilowatt FM Transmitter, Type BTF-40E1

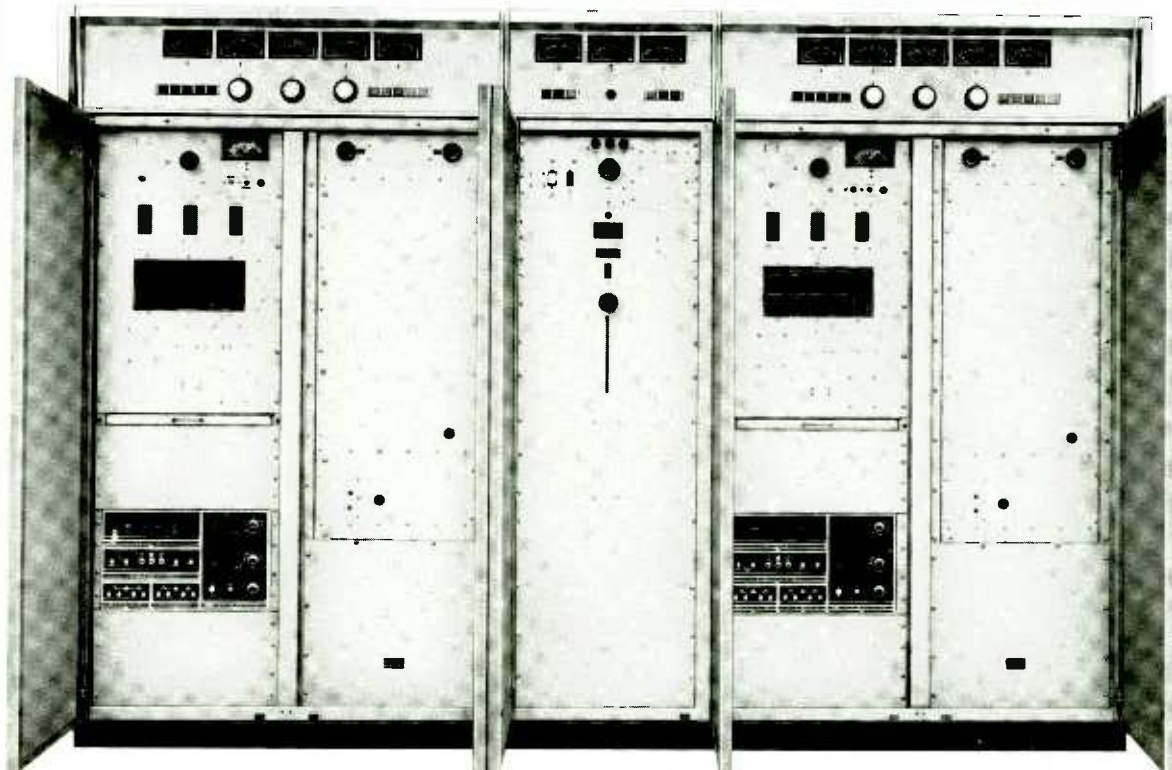

Central Transmitter Control

In the center cabinet are the control and metering functions for the combined transmitters. Push-buttons provide control of combined unit on/off and plate power on/off. Lighted indicators signal d-c overload and output line VSWR overload. Three meters, at the top edge, display reject power, reflected power and combined power output.

In the area immediately below the meter panel are reflectometer controls and adjustments. Next are the lighted control switches for the exciter systems, a control-ladder circuit-breaker and a meter that displays reject power. Next is the control knob for adjustment of the "line-stretcher," which adjusts the phase of the input circuits of the twin power-amplifier chains.

Relays in this section switch exciter system inputs, outputs and primary power. This means that the audio connections to the stereo and SCA subchannels are switched automatically when the exciters are switched.

Built for Continuous Operation

The BTF-40E1 Transmitter, by virtue of its two independent transmitter systems, is arranged so that either twenty-kilowatt system can be shut down for major (or minor) maintenance while the other feeds the antenna.

As a result, the station using a BTF-40E1 need only reduce power (instead of shutdown) while performing transmitter maintenance. The only transmitter elements common to both subsystems are the hybrid-ring power splitter, (between the exciter and the IPA stages) the output combiner network and the harmonic filter. All three of these are passive devices and require only minimal maintenance.

Redundant Power Supplies

The redundancy of the BTF-40E1 system extends even to separate power supplies for each twenty-kilowatt section. These are units using solid-state rectifiers throughout for reduced maintenance and minimal operating expense. The power supply cabinets need not be located in the same room as the transmitter unit where space is a problem. They might, for example, be located in a basement room or in a shelter external to the transmitter building. More information on the twenty-kilowatt transmitter will be found in the catalog section on the Type BTF-20E1.

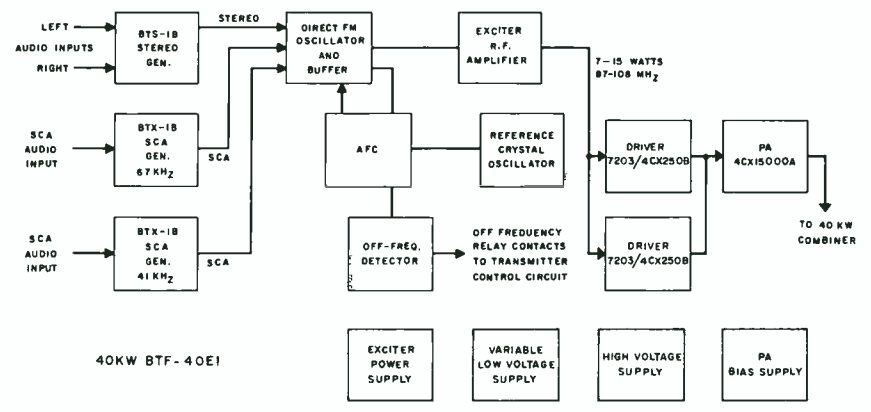
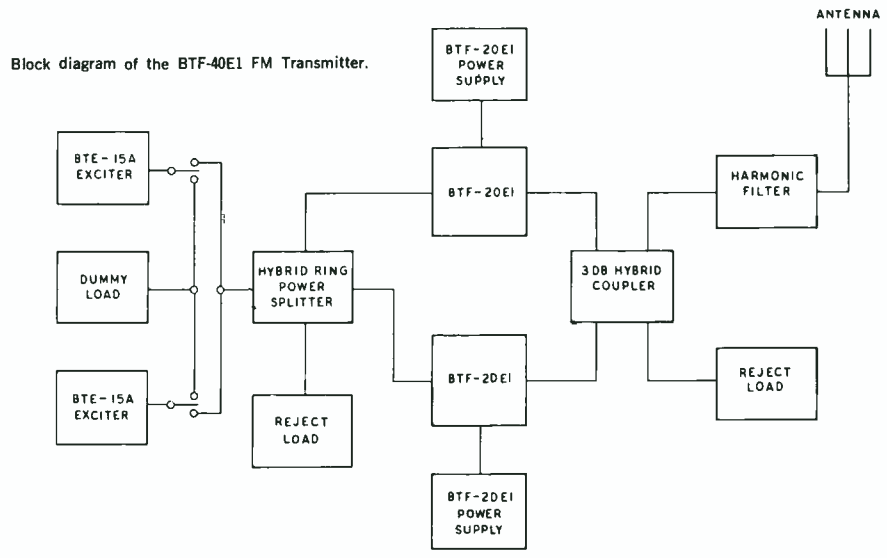

Block diagram of one of the diplexed 20-kW units of the BTF-40E1 Transmitter, showing optional Stereo and SCA.



Exciter unit. "Stereo Generator" and two "SCA Generators" are optional. Note dual meters, one for dc parameters, one for audio measurements.

Space-saving floor plan. The separate, unitized power supplies may be installed in a basement, another room or other convenient place. Wire ducts shown are not furnished.

Specifications

Performance

- Type of EmissionF3 and F9
- Frequency Range87.5 to 108 MHz
- Power Output40 kW
- Output Impedance (6 1/8" O.D. Unflanged Line)50 Ohms
- Frequency Deviation 100% modulation±75 kHz
- Modulation Capability±100 kHz
- Carrier Frequency Stability±1000 Hz max.
- Audio Input Impedance600/150 Ohms
- Audio Input Level—*(100% mod.)+10 ±2 dBm
- Audio Frequency Response—**(50-15,000 Hz)±1 dB max.
- Pre-emphasis Network Time Constant...75 or 50 μs, as desired
- Harmonic Distortion—*** (50-15,000 Hz)0.5% or less
- FM Noise Level (referred to 100% FM mod.)-65 dB max.
- AM Noise Level (referred to 100% AM mod.)-50 dB max.
- Subcarrier Input Level (100% mod.)-15 to +10 dBm adjustable
- Subcarrier Input Impedance600/150 Ohms bal.
- Subcarrier Frequency20-67 kHz
- Main-to-Subchannel Crosstalk...-50 dB referred to ±7.5 kHz deviation of the subcarrier by a 400 Hz tone. Main channel modulation 70% by 50-15,000 Hz tones.
- Sub-to-Main-Channel Crosstalk...-60 dB referred to ±75 kHz deviation of the main carrier by a 400 Hz tone. Subchannel modulation 100% (±7.5 kHz) by 50-6000 Hz tones. Subcarrier modulated 30% on main carrier.

Tube Complement

Driver: four 7203/4CX250B; Power Amplifier: two 4CX15000A

Electrical

Power Line Requirements:

- Line240/208 Volt, 3 phase, 50/60 Hz
- Combined Line Voltage Variation and Regulation±5%
- Power Consumption72,000 Watts (approx.)
- Power Factor (approx.)90%

Mechanical

Dimensions (overall):	Transmitter	High-Voltage Power Supply
Width	114 1/4" (2882 mm)	64" (1626 mm)
Height	77" (1956 mm)	49" (1245 mm)
Depth	32 1/2" (825 mm)	23 (585 mm)
Weight (approx.)	2950 lbs. (1336.4 kg)	2050 lbs. (329.8 kg.)
Finish	Textured Vinyl in midnight blue and shadow blue, satin-aluminum trim.	
Altitude	7500 ft. (2290 m)†	
Ambient Temperature Range	-20° to +45°C	

* Level measured at input to pre-emphasis network.
 ** Audio Frequency response referred to 50- or 75-microsecond pre-emphasis curve.
 *** Distortion includes all harmonics up to 30 kHz and is measured following a standard 50- or 75-microsecond de-emphasis network.
 † Blowers available for operation at higher altitudes.

Specifications subject to change without notice.

Ordering Information

Forty-Kilowatt FM Broadcast Transmitter, Type BTF-40E1 ES-560606
 Please specify assigned frequency, power line frequency (if other than 60 Hz), and installation altitude if greater than 7500 feet (2300m) above sea level. Stereo and/or SCA facilities ordered with transmitter are factory installed.

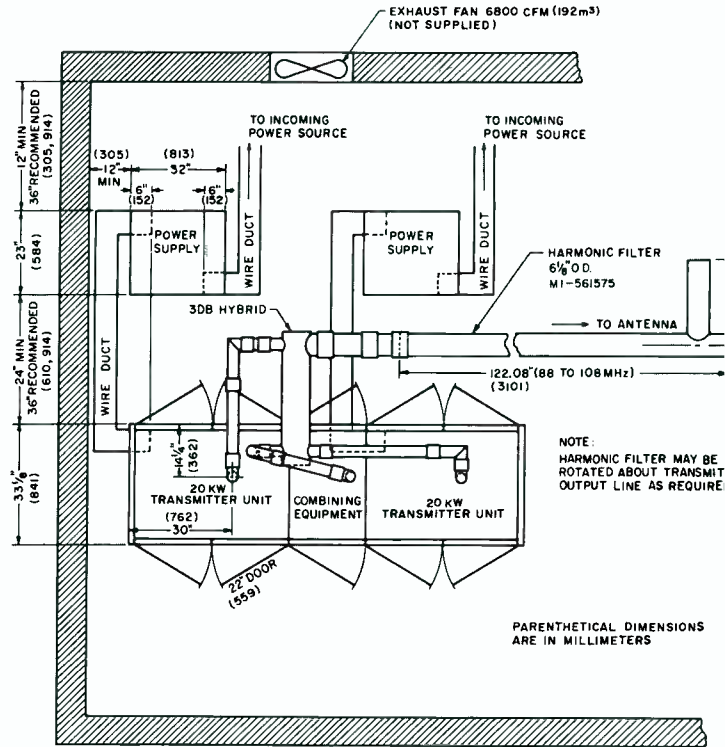

Accessories and Options

Manometer	MI-560307-36
Elapsed-Time Indicator	MI-561018-21
AM Noise Reduction Kit	MI-560307-31
Freq. & Mod. Monitor, Type BW-75	MI-560735
Stereo Freq. & Mod. Monitor, Type BW-85	MI-560740
SCA Freq. & Mod. Monitor, Type BW-95	MI-560745
RF Amplifier, Type BW-100 (for off-air mon.)	MI-560738
Semiconductor Spares Kit (for Exciter)	MI-560718
Crystal and Oven Spares Kit (for Exciter)	MI-560717
(Please specify carrier frequency)	
Electron Tube Spares, Complete Set	ES-560613
Remote Control System, Type BTR-15	ES-561157
Remote Control System, Type BTR-30	ES-561446
Exciter System Modules, Spare:	
Exciter Module	MI-560712
Stereo Module	MI-560713
SCA Module (Specify subcarrier freq.)	MI-560714
Directional Couplers (Mounted on 11" sections of unflanged 50-ohm line):	
Forty Kilowatt (6 1/8" line)	MI-560708A
Forty Kilowatt (3 1/8" line)	MI-560708E
Twenty Kilowatt (3 1/8" line)	MI-560708B
Ten Kilowatt (3 1/8" line)	MI-560708C
Five Kilowatt (3 1/8" line)	MI-560708D

†For 117V/60 Hz power only; use MI-561018-4 for 117V/50 Hz.



FM Transmitter Monitors and Accessories

- Expandable monitor system
- Fully solid-state electronics
- Main-channel, stereo and SCA monitoring
- Built-in calibration facilities
- Extendable meter circuitry

These four units, in combination, form a complete FM-transmitter monitoring facility. The unit packaging permits eight combinations that suit the monitoring task at hand without unnecessary investment. Too, unit packaging allows systems expansion as additional services are added to the transmitter. For example, a new station operating monophonic needs only a main-channel monitor; adding an SCA sub-channel requires an SCA monitor; adding stereo programming adds a stereo monitor to the system. Note that the additional needs do not obsolete existing monitor(s).

FM Monitor — Type BW-75A

The Type BW-75A monitors main carrier frequency and combined main-carrier modulation: main channel, stereo and all SCA-subcarriers, if used. It samples the transmitter output or uses an off-air signal amplified by the Type BW-100B described below.

Stereo Monitor — Type BW-85A

The Type BW-85A monitors pilot frequency and amplitude plus the other signal components associated with stereo transmission. It is designed to work with a Type BW-75A FM Monitor. The BW-75A supplies a demodulated maincarrier signal and power for the BW-85A.

SCA Monitor — Type BW-95A

The Type BW-95A SCA Monitor monitors up to four SCA subcarrier frequencies, subcarrier amplitude and modulation. Like the stereo monitor, it requires a Type BW-75A Monitor as a main-carrier demodulator.

FM RF Amplifier — Type BW-100B

The BW-100B is available for those who prefer or need to monitor from an off-air signal. It amplifies the signal to a level suitable for the input requirements of the Type BW-75A Monitor.

Each of these units is described in greater detail on the pages which follow.

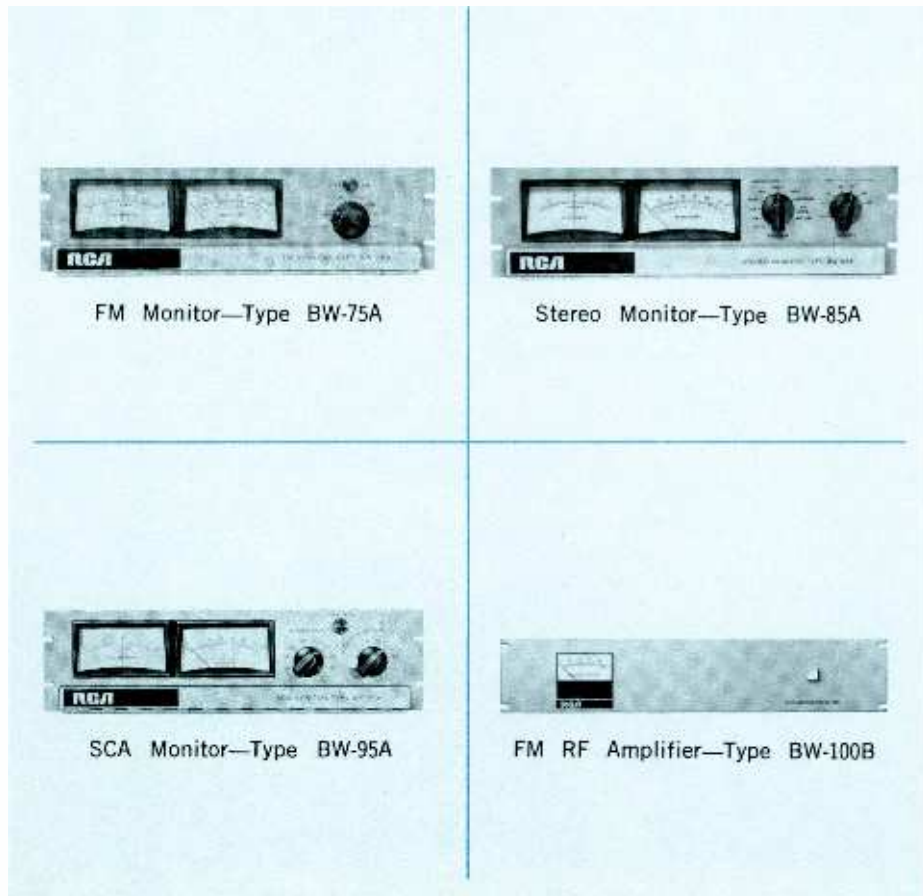

FM Monitor, Type BW-75A

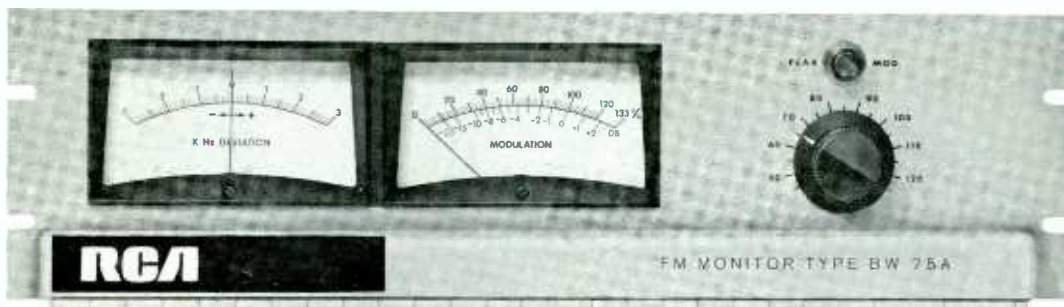

- Latest solid-state design
- Front-panel modulation calibrator
- Type approved for remote metering
- Total modulation meter responds accurately to peak amplitudes
- Provides pure signal for companion Stereo and SCA monitors

The Type BW-75A FM Carrier Frequency and Modulation Monitor combines two monitoring functions into one unit. As a carrier-frequency monitor, the unit displays deviation on a front-panel, center-zero meter. As a modulation monitor, it measures *total* transmitter modulation and displays it on a front-panel meter. The instrument includes provisions for remote metering with the optional Remote Meter Panel (see *Accessories*).

The addition of a stereo pilot-frequency and modulation monitor and/or SCA sub-carrier frequency and modulation monitor to the BW-75A expands the main-channel monitoring system into a stereo and/or SCA subchannel monitoring system as well. The BW-75A is essential to all monitoring systems. These two additional monitors are available as the Types BW-85A and BW-95A.

Built-In Modulation Calibrator

The frequency monitor section of the instrument uses a zero-center meter to indicate carrier frequency deviation from the assigned frequency. The meter range provides 3-kHz indication in either direction and modulation calibration accuracy is easily checked at any time with a front-panel modulation calibrator.

Specifications

RF Input Sensitivity	0.2 to 10 volts rms
RF Input Impedance	50 ohms
RF Frequency Range	87.5-108 MHz
Deviation Meter Range	± 3 kHz
Modulation Meter Range	133% (100% at 75 kHz)
Modulation Meter Accuracy	Greater than 5%
Peak Modulation Indicator	50 to 120%
Frequency Response	50-75,000 Hz, ± 0.1 dB, (3 dB down at 180 kHz)
Distortion	0.1% max. 50-75,000 Hz
Stereo Separation	50 dB (at composite output jack)
Signal-to-Noise Ratio	75 dB with 75 μ sec de-emphasis
Audio Monitor Output	+10 dBm 600 ohms
Outputs	four wideband, isolated outputs to drive the BW-85A and one or more Type BW-95A distortion meter out- put, and monitoring output
Remote Metering	Both carrier deviation and modula- tion meters may be remotely metered, 5,000-ohm external loop resistance
Power Requirements	117/234V, 50-60 Hz, 30W
Size	5 $\frac{1}{4}$ " H; 19" W; 10 $\frac{1}{2}$ " D (133 x 483 x 267 mm)
Weight (Approx.)	15 lbs. (7 kg)
Shipping Weight (Approx.)	18 lbs. (8 kg)
Finish	Aluminum baked enamel

Accessories

Stereo Frequency and Modulation Monitor, Type BW-85A	MI-560740
SCA Frequency and Modulation Monitor, Type BW-95A	MI-560745
Remote Meter Panel ("Local-remote" only)	MI-560736
RF Amplifier, Type BW-100 (for off-air operation)	MI-560738

Ordering Information

FM Frequency and Modulation Monitor, Type BW-75A	MI-560735
---	-----------

Stereo Monitor, Type BW-85A

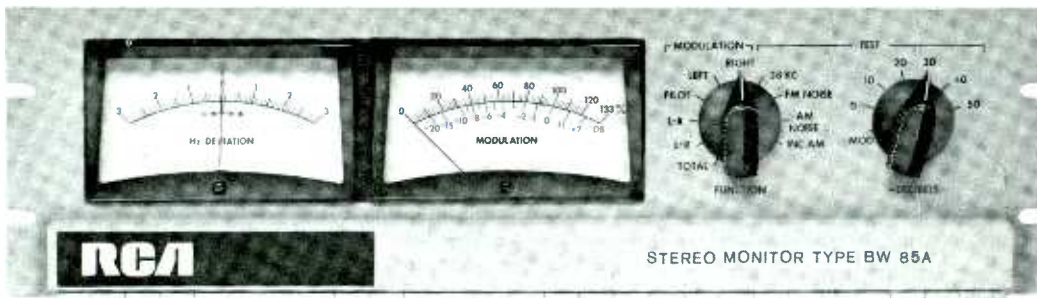

- Unique phase discriminator allows critical phase adjustments
- Complete stereo monitoring and test functions
- Convenient front panel metering

The Type BW-85A Stereo Frequency and Modulation Monitor is a companion unit to the BW-75A FM Monitor. It includes monitoring facilities for stereo programming: The BW-75A monitors main-carrier frequency and modulation while the BW-85A monitors stereo pilot frequency and stereo modulation. The BW-85A is type approved for use only with the BW-75A unit. (FCC Approval No. 3-146.)

The BW-85A monitors all required parameters of the stereo composite signal after demodulation of the main carrier by the Type BW-75A. In addition, the unit provides test facilities that aid in periodic maintenance checks.

The unit measures FM noise, AM noise, incidental AM, separation, cross talk, pilot frequency amplitude and subcarrier suppression. A unique filter system allows monitor use as an intermodulation analyzer which measures stereo distortion directly in the frequency range between five and fifteen kilohertz.

A special feature of the BW-85A is a pilot-phase regeneration system that utilizes a phase discriminator. This arrangement results in a null at the correct phase angle which, in turn, allows phase angle regeneration to within one-quarter degree.

A remote metering panel (see *Accessories*) allows meter displays at remote locations away from the monitor.

Specifications

Pilot Frequency Meter Range	± 3 Hz
Pilot Frequency Meter Accuracy	± 0.2 Hz (0.001%)
Modulation Meter Range	133% to -70 dB
Modulation Meter Accuracy	Better than 5%
Frequency Response (L and R)	± 0.5 dB (50-15,000 Hz)
Separation	45 dB (50-15,000 Hz); Meter Range -70 dB
Crosstalk	60 db L+R to L-R, 60 dB L-R to L+R, 66 dB SCA to L+R, L-R

Outputs:

Left & Right Channel Monitoring	+4 dBm, 600 ohms, unbal.
Left & Right Channel Test	10 kohms, unbal.
Distortion (Either Channel)	0.2%

Signal-to-Noise Ratio

(Either Channel)	70 dB with 75 μ sec. de-emphasis
------------------------	--------------------------------------

Monitoring Modes (Modulation Meter)

Switched 133% to -70 dB)	Left Channel Audio, Right Channel Audio, L+R, L-R, 38 kHz (May be measured with modulating frequencies greater than 5 kHz), 19 kHz Pilot Injection (12% full scale), Total Modulation, FM Noise, AM Noise, Incidental AM
----------------------------------	--

Remote Metering Both pilot frequency and modulation meters may be remotely metered, 5000 ohms external loop resistance

Power Requirements	Connects to BW-75A
Size	5 $\frac{1}{4}$ " H, 19" W, 10 $\frac{1}{2}$ " D (133 x 483 x 267 mm)
Weight (Approx.)	13 lbs. (6 kg)
Shipping Weight	16 lbs. (7 kg)
Finish	Aluminum baked enamel

Accessories

Remote Meter Panel ("Local-remote" only)	MI-560741
--	-----------

Ordering Information

Stereo Frequency and Modulation Monitor, Type BW-85A	MI-560740
--	-----------

SCA Monitor, Type BW-95A



- Complete SCA monitoring to four channels
- Three deviation ranges (6, 4 and 2 kHz)
- Remote metering facilities
- Minimum distortion and crosstalk
- Separate peak flasher for SCA modulation
- Built-in modulation calibrator

The Type BW-95A SCA Frequency and Modulation Monitor, used in conjunction with the BW-75A FM Frequency and Modulation Monitor, allows complete monitoring and test functions for subcarrier programming or remote telemetry applications. Four crystal-switch positions enable up to four channels to be operated and tested.

Partially integrated, the solid-state electronics of the BW-95A allow unlimited SCA frequency selection through a series of interchangeable crystals. With the appropriate crystals, it is possible to monitor four subcarrier channels through pushbutton selection. A frequency change is simply a matter of crystal change.

The BW-95A is a companion equipment to the RCA BW-75A and BW-85A monitor. It incorporates all the latest electronic-design techniques. Lightweight and occupying but 5¼ inches of rack space, it derives its signal, a virtually pure, distortionless demodulated signal, from the BW-75A Monitor.

Features of the BW-95A include three deviation ranges: Six, four and two kHz for optimum operation.

Specifications

Frequency Range	Any four SCA frequencies (switchable) up to 74 kHz
Deviation Meter Range	±2 kHz
Modulation Meter Range	133% (100% at ±6 kHz, ±4 kHz, or ±2 kHz, switched)
Modulation Meter Accuracy	Within 5% over entire scale
Maximum Modulation Frequency	5 kHz at 6 kHz deviation
SCA Modulation Calibrator	2 kHz
SCA Subcarrier	24 kHz to 74 kHz, four switched crystal positions. SCA subcarrier and deviation maintained in the FCC allowable total frequency deviation
SCA Injection Level	133% to 5%
Peak Indicator	Follows deviation scale 50 to 120%
Frequency Response	±1 dB, 50-5,000 Hz
Crosstalk Rejection	65 dB or greater
Crosstalk Meter Range	70 dB (10 dB steps)
Outputs	Distortion meter, aural monitor, oscilloscope
Audio Monitoring Output	0 dBm 600 ohms
Remote Metering Facility	Both meters, separate circuits, 5000 ohms external loop resistance
Power Requirements	117/234V, 50-60 Hz, 15W
Size	5¼" H, 19" W, 10½" D (133, 483, 267 mm)
Weight (Approx.)	14 lbs. (6 kg)
Shipping Weight (Approx.)	18 lbs. (8 kg)
Finish	Aluminum baked enamel

Special Note

The Type BW-95A monitors all required parameters of the SCA portion of a composite waveform which the RCA BW-75A demodulates from the carrier. As a result, the BW-95A SCA Monitor is FCC type-accepted only when used with the RCA Type BW-75A FM Monitor.

Accessories

Remote Metering Panel ("Local-remote" only)MI-560746

Ordering Information

SCA Monitor, Type BW-95A
(Specify SCA subcarrier frequencies)MI-560745

RF Amplifier, Type BW-100B



Specifications

Input Frequency Range	87.5 to 108 MHz
Minimum Input Level (for threshold of limiting)	100 µV
Maximum Input Level	0.5 V
Input Impedance	50 to 75 ohms
Output Impedance	50 ohms
Output Level	Adjustable to 1 watt
Bandwidth (3 dB points)	±225 kHz
Phase Linear Bandwidth	±300 kHz
Image Rejection	Greater than 80 dB
Response at ±800 kHz	50 dB below that of center frequency

A selective, radio-frequency amplifier for use with a BW-75A Monitor (and its loads) as an off-air monitor. The BW-100B is entirely solid-state with outstanding selectivity, wide dynamic range, linear phase-bandwidth, symmetrical (zero-axis) limiting and 100-microvolt sensitivity.

Response at ±400 kHz	-25 dB
Power Requirements	117 V ±10%, 50/60 Hz, 5 W
Dimensions	3½" H, 19" W, 10½" D (89, 483, 267 mm)
Weight	7½ lbs. (3 kg)
Shipping Weight (Approx.)	12 lbs. (5 kg)
Finish	Aluminum baked enamel

Recommended Antennas

Taco	Model Y51-FM
Scala	Model CA5-150

Ordering Information

Monitor RF Amplifier, Type BW-100B
(Specify operating frequency)MI-560738



Transmitter Remote Control System, Type BTR-30A1

- For AM or FM transmitters
- Fail-safe design
- Thirty metering channels
- Sixty control functions
- Computer-type logic circuitry

With 30 metering channels and 60 individual control functions, the all solid-state Type BTR-30A1 Remote Control System handles most of today's remote control requirements. Designed explicitly for the broadcaster, it incorporates many new features. Flexibility and adaptability are easily obtained with the BTR-30A1. Wire or radio (STL) service is selected by simply plugging in the appropriate printed-circuit modules. Audible or subaudible telemetry return is chosen in the same manner. No rewiring is necessary.

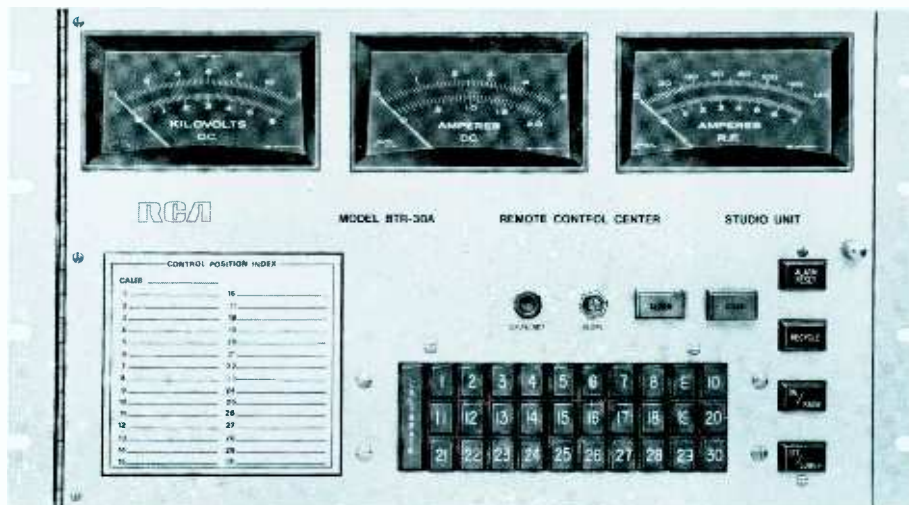

All Solid State

The circuitry of the BTR-30A1 is of modular construction, using carefully chosen combinations of integrated circuits and discrete components. Only one stepper relay is used in the transmitter unit. Separate switching decks are provided on the stepper relay to provide complete isolation between the controlled circuits and between the metered circuits in the transmitter. Solid-state, computer-type logic circuitry is used in the studio unit in place of a stepper relay or mechanical logic devices thus increasing reliability. The studio unit is essentially noiseless.

Quick Access to Circuitry

Some features of the Model BTR-30A1 are of special interest. An indication of the stepper relay position is provided on the front panel of the transmitter unit. This is especially useful during calibration. Color-coded, push-button switches on the transmitter unit are used for local control.

The Local Remote buttons are illuminated red and green for quick indication of system status. Swing-away front panels on both units provide access to all printed circuit modules, and all initial and routine adjustments are made from the front of the equipment. An extension board is provided for testing each module.

Five-Input Alarm System

Included with the BTR-30A1 is a five input alarm system. A contact closure is used to activate any one of the five inputs. This can be utilized for continuous surveillance, sensing such things as illegal entry, temperature, flooding and the like. The alarm signals are returned to the studio unit as part of the telemetry information. When an alarm condition exists, a visual indication is given at the control point by the amber *Alarm* lamp.

Fail-Safe Design

The Model BTR-30A1 requires one

two-way, communications-grade signal circuit between the control point and the transmitter site. Fail-safe provisions meet all existing FCC requirements for AM and FM broadcast and function with the loss of primary power or control information reception to the transmitter unit or malfunction of the equipment itself. The fail-safe tone generated in the studio unit also actuates the stepper relay at the transmitter unit. The tone is momentarily interrupted, creating, in effect, short-duration pulses which control the stepper. An interruption of approximately 15 seconds trips the fail-safe circuitry. Two functions, designated *On/Raise* and *Off/Lower*, can be performed on each of 30 control channels selected via individually numbered pushbuttons. A metered indication of the parameter being controlled can be observed simultaneously. The frequencies used are *Fail/Safe* 920 Hz, *On/Raise* 790 Hz, and *Off/Lower* 670 Hz. High-Q temperature-stabilized toroidal inductors

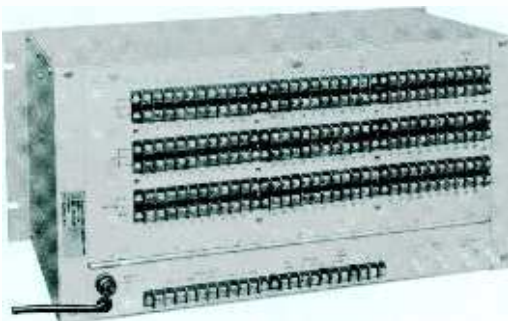

Rear view of transmitter-control unit showing barrier-strip connections for the 60 control and 30 metering function.



Fold-down front panel in transmitter-control unit provides quick access to all modules. Note 10-turn potentiometers on panel.



Transmitter-control unit, Type BTR-30A1. Note window at upper left which displays position of stepper relay. (See preceding page for Studio Unit.)

and capacitors are used in all oscillator and tone detector circuits to assure drift-free operation. Control outputs are available from the BTR-30A1 in the form of normally-open, isolated relay contacts. These contacts are rated for 50-watt non-inductive loads.

Voltage-Controlled Oscillator

Telemetry is accomplished by converting the DC sample voltages from the transmitter to a frequency in the 20 Hz to 30 Hz spectrum by means of a linear, voltage-controlled oscillator. This signal is relayed to the studio unit and converted back to a dc voltage proportional to the input sample for display on any of the 4-inch taut-band, panel-mounted meters. Multiturn calibration controls are provided on the transmitter unit.

For Wire or Radio Link

Two basic versions of the Type BTR-30A1 are available; one for wire interconnection and one for radio (STL) service.

Wire Service

For wire service, only a single voice-grade telephone line (full duplex) is required for interconnection, dc continuity in *not* required. The 20 Hz to 30 Hz telemetry information is returned to the studio unit by means of an amplitude-modulated 1280 Hz signal. Thus, all audio signals appearing on the telephone line are confined to 670 Hz to 1310 Hz spectrum.

Radio (STL) Service

For radio service, the BTR-30A1 is designed to mate with STL equipment. Control information is transmitted to the transmitter unit on subcarriers multiplexed on the STL. Included in the BTR-30A1 are a control subcarrier generator and detector. These are printed circuit modules. A 26-kHz control subcarrier frequency is used for monaural or dual-stereo aural STL systems and 110-kHz for composite-stereo aural STL. Telemetry information is sinusoidal and subaudible, 20 Hz to 30 Hz. The return path of the telemetry information can be via a 67-kHz SCA channel of the FM transmitter, the main channel of an AM transmitter or other radio circuit capable of handling 20 Hz to 30 Hz. The information may be recovered with a Type TMR-1 FM Multiplex Receiver. For AM situations, metering telemetry comes back via a subaudible signal modulated on the carrier using MIU-1 and MRU-1 units (see *Accessories*). Audible telemetry information is available on special order for voice radio circuits.

Ordering Information

The BTR-30 system is adaptable to virtually any transmitter remote-control situation. The several systems listed below are engineered to satisfy most situations in AM, FM mono or FM stereo broadcasting.

AM Radio Systems

Land Lines	Control via		Telemetry via		System Catalog Identification
	STL Subcarrier		Land Lines	Transmitter ³	
	26 kHz ¹	External Generator ²			
•			•		ES-561466-1
	•		•		ES-561466-5
	•			•	ES-561466-6
		•	•		ES-561466-15
		•		•	ES-561466-16

¹Subcarrier generator included in studio unit.

²External subcarrier generator not included.

³Subaudible telemetry equipment not included. See "Remote Control Accessories" section of catalog.

FM Mono Radio Systems

Land Lines	Control via		Land Lines	Telemetry via		System Catalog Identification
	STL Subcarrier			Transmitter Subcarrier		
	26 kHz ¹	External Generator ²		67 kHz ¹	External Generator ²	
•			•			ES-561466-1
	•			•		ES-561466-3
	•				•	ES-561466-4
	•		•			ES-561466-5
		•		•		ES-561466-13
		•			•	ES-561466-14
		•	•			ES-561466-15

¹Subcarrier generator included in system.

²Subcarrier generator not included in system.

FM-Stereo Radio Systems

Land Lines	Control via		Land Lines	Telemetry via		System Catalog Identification
	STL Subcarrier			Transmitter Subcarrier		
	110 kHz ¹	External Generator ²		67 kHz ¹	External Generator ²	
•			•			ES-561466-1
	•			•		ES-561466-8
	•				•	ES-561466-9
	•		•			ES-561466-10
		•		•		ES-561466-13
		•			•	ES-561466-14
		•	•			ES-561466-15

¹Subcarrier generator included in system.

²Subcarrier generator not included in system.

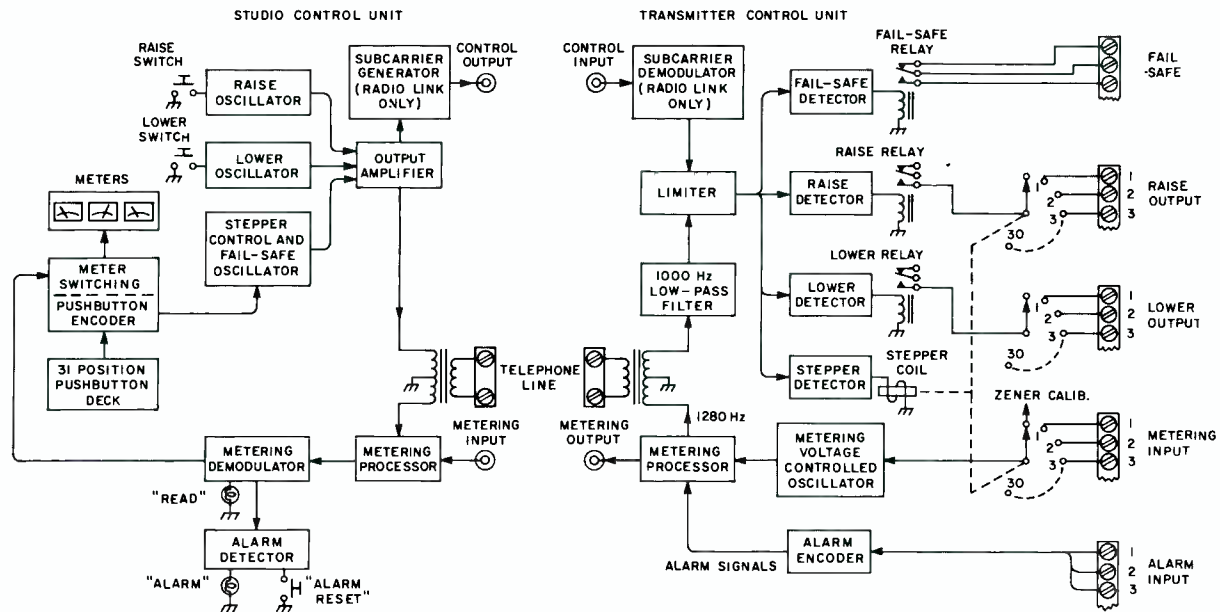

BTR-30A1 Block Diagram. The Subcarrier Generator and Demodulator units are required only when an air link between studio and transmitter replaces the land-line link.

Specifications

- Metering30 telemetry channels, plus calibration
- Control Functions60; 30 On/Raise, 30 Off/Lower
- Meters3, taut-band with carefully controlled ballistics. Provisions for 7 external meters
- Metering StabilityBetter than 1% with weekly checks
- Telemetry Input Voltage1-10Vdc
- Telemetry Input Impedance20,000 ohms
- Telemetry Frequencies:
 - Audible1280 Hz
 - Subaudible20-30 Hz
- Control FrequenciesFail-Safe—920 Hz; On/Raise—790 Hz; Off/Lower—670 Hz
- Control Subcarrier Frequencies26 kHz or 110 kHz
- Interconnection Requirements:
 - WireOrdinary voice-grade two-way telephone line, 600 ohms, 20 dB allowable loss from 650 Hz-1350 Hz. (DC continuity not required)
- Radio:
 - Control CircuitControl subcarrier generator and detector provided. Input and output 0.5V rms, 2,000 ohms nominal
 - Telemetry CircuitTelemetry return path capable of handling 20 Hz-30 Hz, sinusoidal
 - Transmitter Control Unit Output0 dBm, 500 ohms
 - Studio Unit Input0 dBm, 8,000 ohms nominal
 - Calibration ReferenceZener diode
 - Semiconductor DevicesAll silicon diodes, integrated circuits and JEDEC registered transistors
 - Operating Temperature Range-10°F to +140°F (-12°C to 60°C)
 - Power Requirements120/240 V, 50/60 Hz, Studio Control Unit—15W, Transmitter Control Unit—25W
 - Dimensions:
 - Studio Unit10½" (267mm) H, 19" (483mm) W, 8½" (216mm) D
 - Transmitter Unit8¾" H, 19" W, 10½" D (222 x 483 x 267 mm)
 - Weight (shipping, approx.)60 lbs. (27 kg)
 - Shipping Volume (approx.)2.2 cu. ft. (0.67m³)

Accessories

- Voltage Pickup, 115/230VacMI-27516
- Tower Light Monitor and Control UnitMI-27519
- Tower Light MonitorMI-27544
- Power to Linear Converter, Type PLC-1MI-561179
- Relay, DPDT, 120Vac CoilMI-561471
- Panel Relay (For 8 MI-561471 Relays)MI-561470
- Sampling Kit, Plate Voltage, 10 kV max., Type PVK-1MI-561482
- Sampling Kit, Plate Voltage, 10-20 kV, Type PVK-2MI-561483
- Relay, DPDT, 24Vdc Coil (socket included)MI-561448-1
- Relay, DPDT, 120Vac Coil (socket included)MI-561448-2
- Relay, Latching, DPDT, 24Vdc Coil (socket included)MI-561448-3
- Relay, Time-Delay, DPDT, 24Vdc Coil (socket included)MI-561448-4
- Panel, Relay (For 8 MI-561448 Relays)MI-561449
- Metering Insertion Unit, Type MIU-1MI-561458
- Metering Recovery Unit, Type MRU-1MI-561459
- Monitor Adapter, Modulation, Type MMA-1MI-561460
- Chopper-Stabilized DC Amplifier, Type CSA-3MI-561461
- Tower-Light Monitor Kit, Type TLK-1MI-561462
- Line-Voltage Monitor Kit, Type LVK-1MI-561463
- Sampling Kit, Plate Circuit, Type MBB-1MI-561464
- Temperature Sensing Kit, Type TSK-1MI-561465
- Indicator, Status-Studio System, Type SCS-2ES-561156
- Alarm, Tolerance, Type TAU-2 (Frame only)MI-561469
- Alarm, Tolerance, Type TAU-2 (Module for above)MI-561184
- Combiner, Multi-System, Type MSC-1MI-561479
- Receiver, Telemetry, Type TMR-1MI-561182



Transmitter Remote Control System, Type BTR-15B Series

- Wired or wireless control
- Noiseless studio unit
- Fail-safe design
- Provision for 4 external meters
- Convertible, accessible design

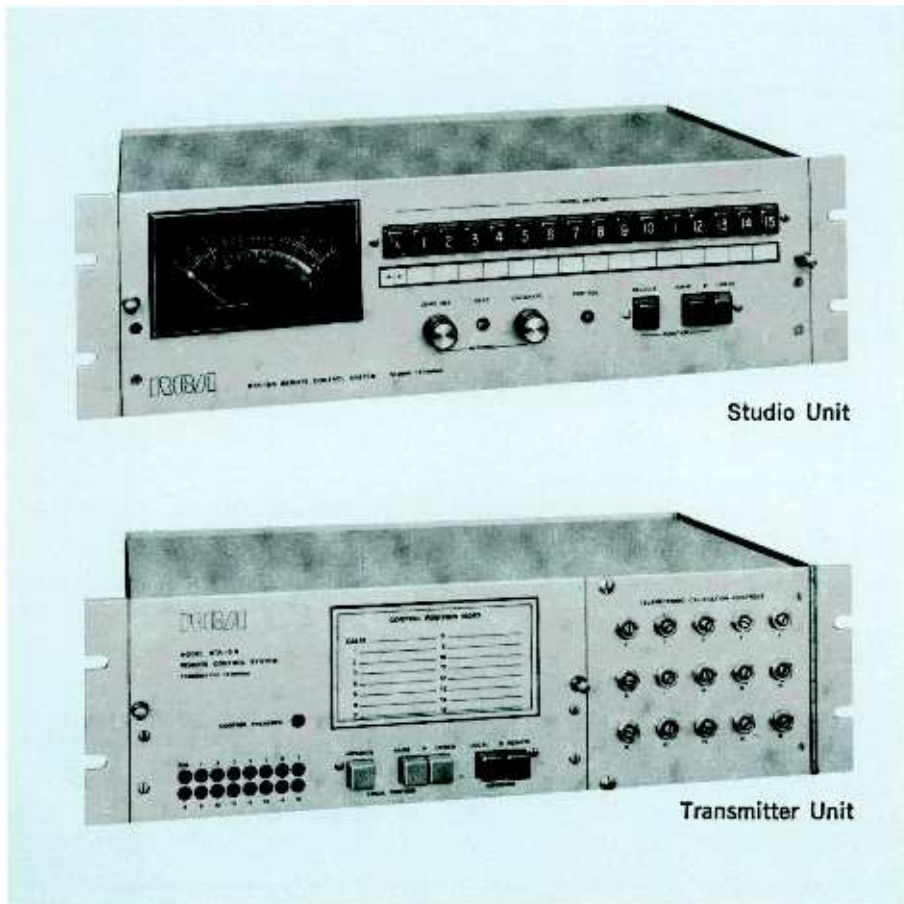

With 15 metering channels and 30 individual control functions, the entirely solid-state Type BTR-15B Series Remote Control Systems handle most of today's radio transmitter remote control requirements. Designed explicitly for broadcast operations, these systems incorporate many features not available in earlier designs.

Wired or Wireless Control

The BTR-15B is offered in two basic forms: one uses an a-c coupled, voice-grade, duplex telephone pair (Type BTR-15BW) and a second, (Type BTR-15BR) for use with a subcarrier on an STL or other suitable wireless link (see *Specifications*). Further, any of these are easily convertible at any time through certain module changes.

Noiseless Operation

In consideration that the studio unit might need to operate near an on-air microphone, it is designed to be essentially noiseless. The entire system is almost noiseless in operation, no stepper relay is used in either unit.

Fail-Safe Design

Meeting or exceeding all FCC requirements for AM/FM, the fail-safe facilities of the BTR-15B function automatically when either of two circumstances takes place: loss of commercial (primary) power; or a failure in the interconnecting circuitry (wired or wireless).

Provision for 4 External Meters

For those who want the extra convenience of a separate meter for each telemetry function, the BTR-15B includes provisions for the connection of up to 4 external meters. Each meter circuit is independent of the others to eliminate the common-return limitation.

Each external meter can be labelled and scaled according to its function (Requires additional meter panels, see *Accessories*).

Convertible, Accessible Design

Each model is convertible to the other through the changeover of certain plug-in modules. Consequently, the BTR-15B sidesteps premature obsolescence because of changing conditions at studio or transmitter.

As a result of the unit's excellent accessibility, changeover is extremely simple.

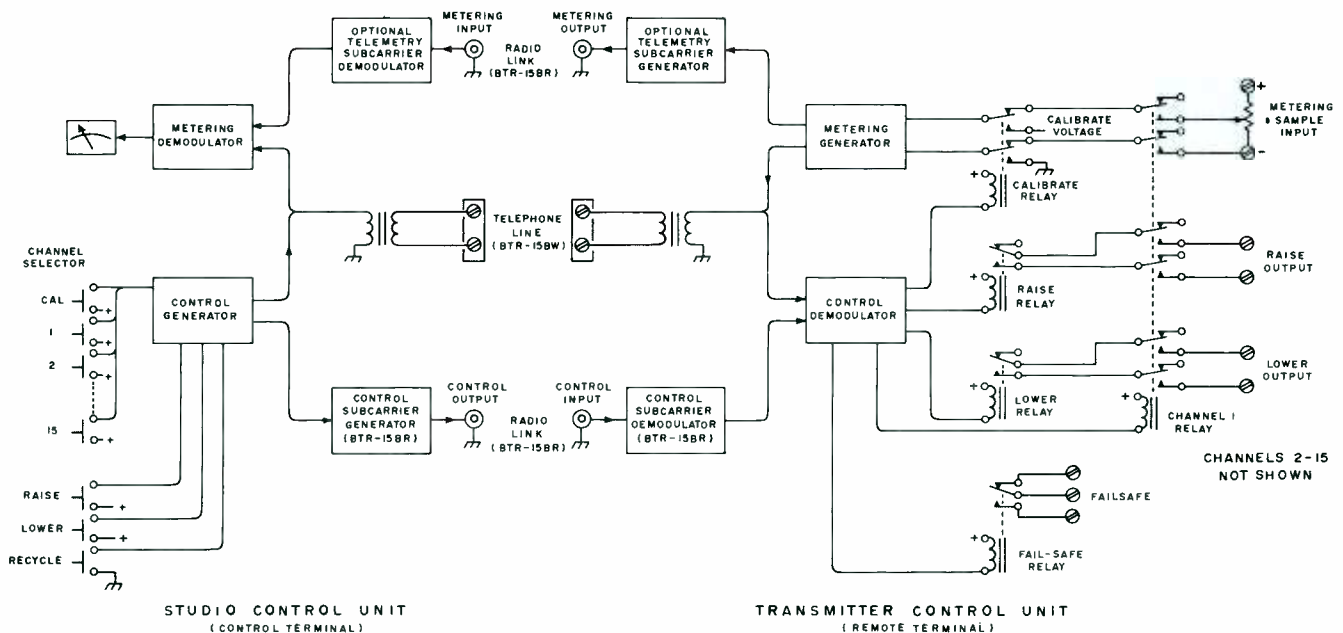

BLOCK DIAGRAM OF BTR-15BR / BTR-15BW

Specifications

- Telemetry Channels15 (plus calibration channel)
- Control Functions30 (15 on/raise; 15 off/level)
- Metering ProvisionsOne time-shared meter; provision for up to 4 external meters
- Metering StabilityWithin ±1% (with weekly transmitter-unit checks and daily studio-unit checks, exclusive of operator setting or reading error).
- Telemetry Source Voltage Requirements.....1 to 10 V, positive or negative
- Telemetry Input IsolationUp to 350 V to ground
- Telemetry Input Impedance20,000 ohms
- Telemetry Tone Frequencies (Approx.)800-1200 Hz or 20-30 Hz
- Control Frequencies (Approx.)300 to 400 Hz
- Sub-carrier Frequencies (nominal)26 kHz or 110 kHz

Interconnection Requirements

Type BTR-15BW: Ordinary voice-grade, duplex telephone circuit, 600-ohm impedance; up to 30 dB loss of frequencies between 400 and 1200 Hz. D-c continuity unnecessary.

Type BTR-15BR: Control sub-carrier and detector included. Input and output levels 0.5V rms @ 2,000 ohms nominal. Telemetry return path handles 20 to 30 Hz sinusoidal waveform. Transmitter Control Unit telemetry output: Up to 6V p-p behind 600 ohms, unbalanced. Studio Control Unit telemetry input: 1.5V p-p, bridging, unbalanced.

Power Requirements

- Transmitter Unit120/240 V; 50/60 Hz, 20 W. nom.
- Studio Unit120/240 V; 50/60 Hz, 20 W. nom.

Dimensions

- Transmitter Unit5¼" H; 19" W; 13⅝" D. (133 x 483 x 346 mm)
- Studio Unit5¼" H; 19" W; 13⅝" D. (133 x 483 x 346 mm)

- Weight (approx.)20 lbs. (9 kg)
- Shipping Weight (each unit, approx.)60 lbs. (27 kg)
- Cube5.7 ft.³ (0.16 m³)

Accessories

- Extra MetersMI-561444*
- Meter Panels:
 - One MeterES-561443-1
 - Two MeterES-561443-2
 - Three MeterES-561443-3
- Sub-carrier Generator (67 kHz; for telemetry)MI-561181-1

Ordering Information

- Transmitter Remote Control System, Type BTR-15B Series:
 - For use with voice-grade, two-way telephone circuit, (d-c continuity unnecessary):
 - Type BTR-15BWES-561151
 - For use with Studio-Transmitter Link (STL):
 - Type BTR-15BW:
 - (26 kHz sub-carrier)ES-561152-26
 - (110 kHz sub-carrier)ES-561152-110

*Please specify desired range(s)

Remote Meter Panel, Type BTC-2

- Extends basic transmitter control
- Meters display three transmitter parameters
- Controls filament and plate plus power output
- Connects easily to all current RCA AM/FM transmitters
- Sensitive 100- μ A meters

The Type BTC-2 Transmitter Extension Control Panel is a simple, in-plant, remote-control facility for any AM or FM radio transmitter equipped with plate-power and filament-power relays and motorized power-output controls. The Panel is most useful in station situations where plant layout precludes direct observation of the transmitter from the control room. The Panel displays three operating parameters and provides on/off control for filament and plate power and raise/lower control of power output.

Extends Basic Transmitter Control

Equipped with one or more Type BTC-2 Panels, a radio station can assign basic transmitter control to any point within the broadcast facility: master control, production control, engineering manager's office, etc. The panel connects to barrier strips within the transmitter via inexpensive audio-type cabling with three twisted pair and six pairs for the control circuits.

Meters Display Three Parameters

Similar to the meters mounted in current RCA transmitters, the three units on the BTC-2 Panel indicate plate voltage, plate current and transmitter power output. Each meter is a sensitive 100- μ A device of the same quality as the transmitter meters and, therefore, fully compatible.

Controls Filament and Plate Power, Power Output

Three momentary contact switches on the panel provide for filament power on/off, plate power on/off and power output raise/lower. The switches are interlocked between functions to preclude inadvertent operation of more than one function simultaneously. Screwdriver adjustments allow easy calibration of the three meters through ten-turn potentiometers, one in series with each meter.

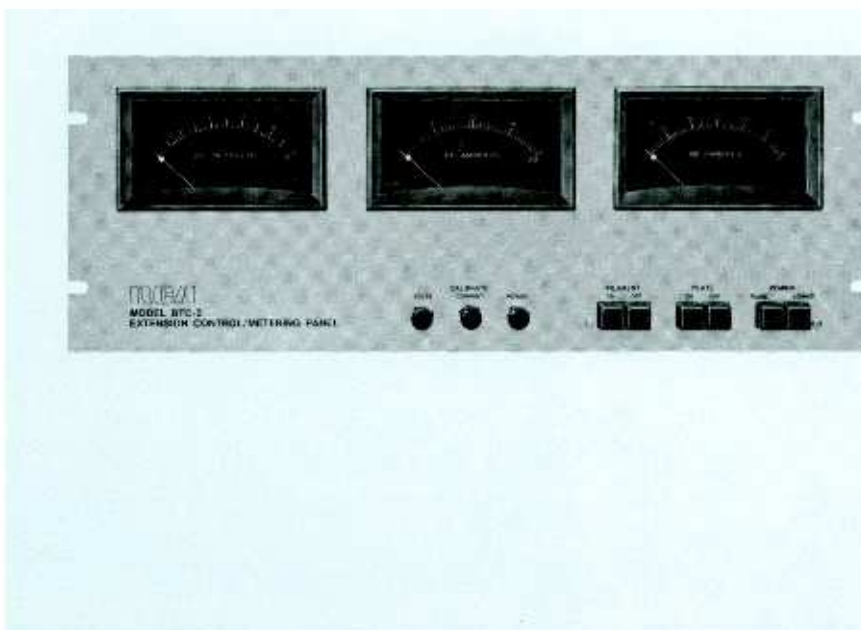

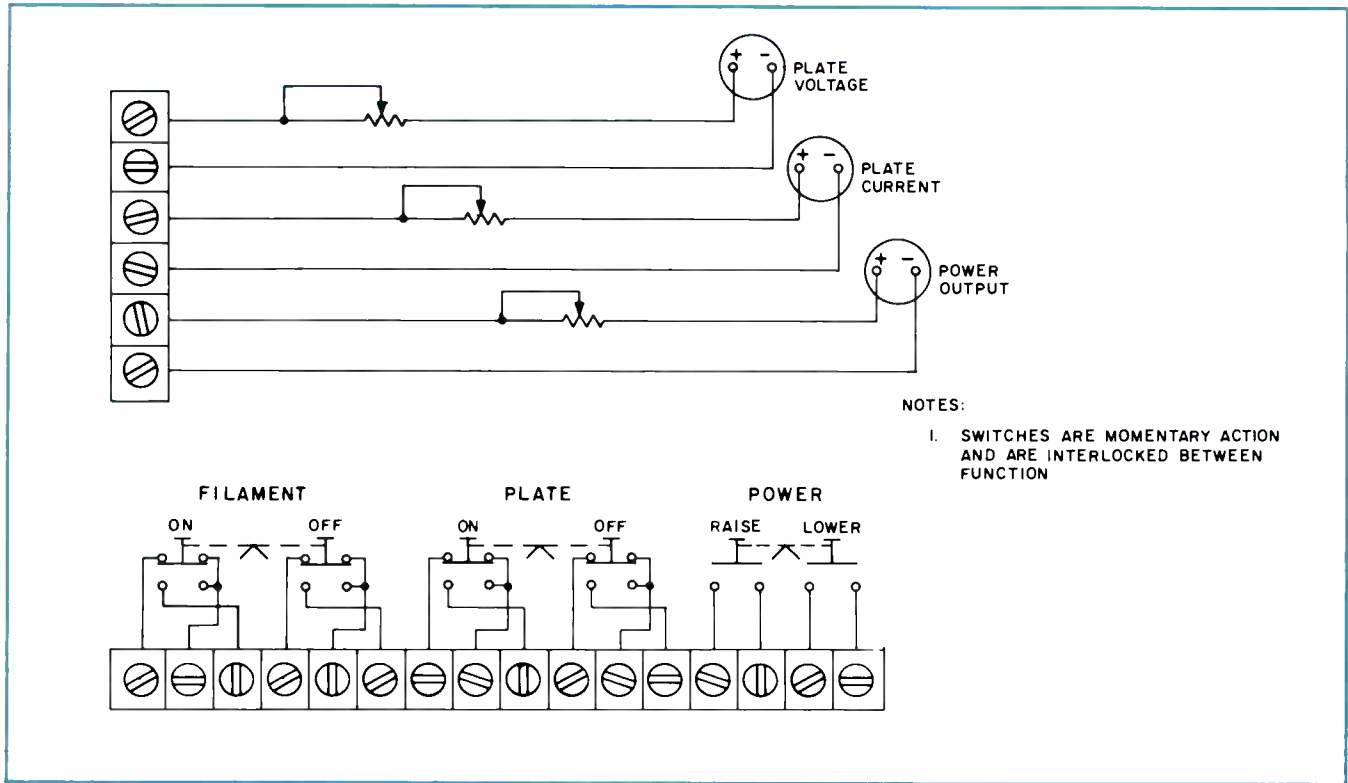

Specifications

Electrical

Basic Meter Sensitivity100 μ A
 Calibration Pot Range0-25k ohms
 Switches.....Interlocked, momentary contact

Mechanical

Panel Dimensions19" (483 mm) W; 7" (187 mm) H
 Depth Behind Panel3" (76 mm)

Weight (Approx.)5 lbs. (2.3 kg)
 Finish.....Aluminum color, epoxy-resin paint

Accessories

Interconnection Cable (RCA Transmitters)MI-13360

Ordering Information

Transmitter Extension Control Panel,
 Type BTC-2ES-560438
 (Please specify meter-scale ranges)



Remote Control Accessories

- Sensors
- Alarms
- Status control
- Sampling kits
- Converters

Here are devices and accessories to expand the telemetry and control functions of transmitter remote-control systems.

- Voltage Pickup — MI-27516
- Tower Light Monitor and Control Unit — MI-27519
- Tower Light Monitor — MI-27544
- Power to Linear Converter — MI-561179
- Relays and Relay Panels — MI-561470, 71, -561448, 49
- Plate Voltage Sampling Kits — MI-561482, 83
- Remote Power Output Control — MI-27558 & MI-561023
- Reversible Motor Kit — Type RMK-1
- Transmission Line Sampling Kits — Types RFK-1, -2, -3
- Metering Insertion Unit — MI-561458
- Metering Recovery Unit — MI-561459
- Modulation Monitor Adapter — MI-561460
- Chopper-Stabilized DC Amplifier — MI-561461
- Tower-Light Monitor Kit — MI-561462
- Line-Voltage Sampling Kit — MI-561463
- Plate-Circuit Sampling Kit — MI-561464
- Temperature Sensing Kit — MI-561465
- Status Indicator Units — MI-561467, 68
- Tolerance Alarm — MI-561469, 184
- Multi-System Combiner — MI-561479

Note:

See "AM Antenna Accessories" section for RF Ammeters; remote control accessories for phase monitors are listed in the phase monitor section.



Voltage Pickup Unit

Installed at the transmitter, this device senses the presence of a-c voltage—115 or 230V—and converts it into a signal compatible with the remote-control system.

Ordering Information

Voltage PickupMI-27516

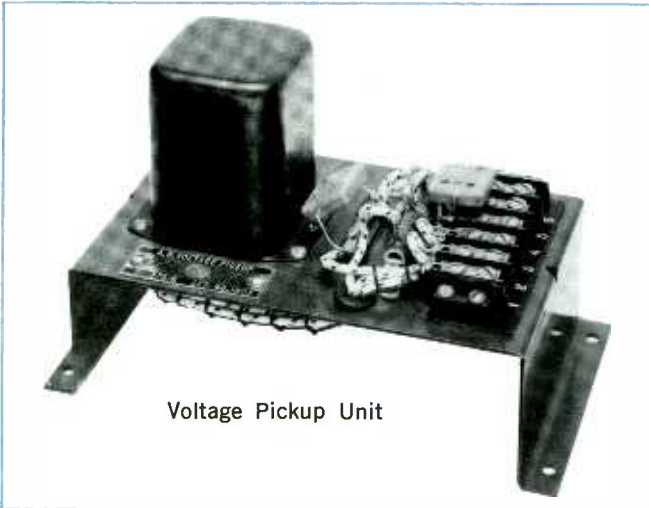

Voltage Pickup Unit

Tower Light Monitor Unit

Incorporating only the monitoring functions of the unit above, the Tower Light Monitor is intended for lighting circuits where control is separate. Handles up to 20A of a-c current.

Ordering Information

Tower Light MonitorMI-27544



Tower Light Monitor Unit

Tower-Light Monitor and Control Unit

Connected to the tower-lighting circuit of an antenna array, this unit provides metering and control of the circuit via the remote-control system. It provides a d-c voltage proportionate to the current (up to 20A) in the lighting circuit and includes a relay for on-off control of the lighting circuit.

Ordering Information

Tower Light Monitor and Control UnitMI-27519

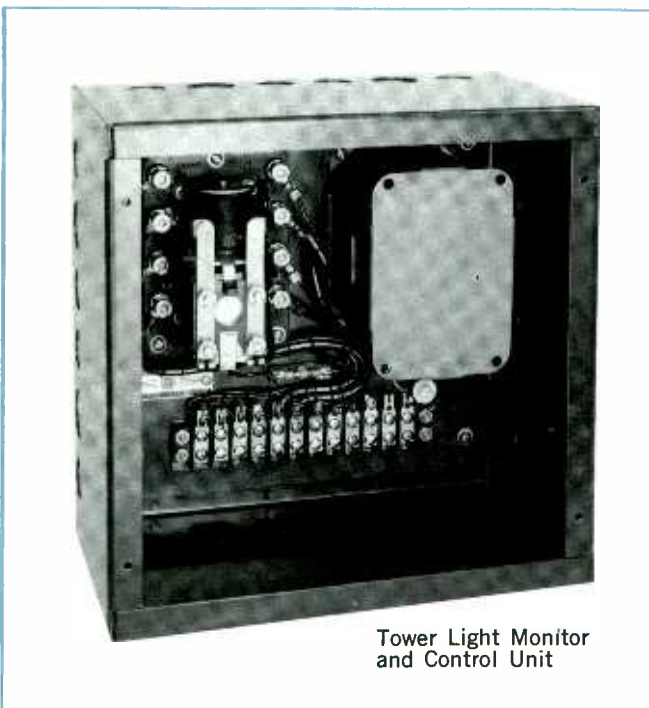

Tower Light Monitor and Control Unit

Power-to-Linear Converter, Type PLC-1

Amplifies a low-level d-c current sample (which represents the transmitter power output via reflectometer) and amplifies it to a level compatible with the BTR-30 or BTR-15 Remote Control System and/or automatic logging equipment. The unit includes both logarithmic and linear outputs.

Specifications

Input Impedance2200 ohms¹
 Input Level15 to 500 μ A
 Output Load5000 ohms (min.)
 Output Levels (log. and lin.)1.5V dc, 10k ohms
 Temperature Range0 to 150°F (-18 to 66°C)
 Power Requirements120V ac, 50-480 Hz, 5W
 Dimensions5" x 7½" x 2" (127, 191, 51 mm)
 Weight (Approx.)2 lbs. (910g)
 Shipping Weight (Approx.)3 lbs. (1.4 kg)

¹ Input impedance convertible in the field to any value less than 4700 ohms.

Ordering Information

Power-to-Linear Converter, Type PLC-1 (Not shown)MI-561179

Relays and Relay Panels

For use with early Type BTR-30, these relays and relay panels provide isolated control circuitry. Panels hold up to eight relays and require eight inches (203 mm) clearance behind. Relays are all double-pole, double-throw units.

Specifications

Panel Dimensions5¼" H, 19" W (133, 483 mm)
 Weight (Panel and eight relays, approx.)10 lbs. (4.5 kg)
 Shipping Weight (Approx.)12 lbs. (5.5 kg)

Ordering Information

Relay, DPDT, 120V coilMI-561471-1
 Relay Panel (for MI-561471-1 above)MI-561470

Plate Voltage Sampling Kits, Type PVK-1, -2

Samples plate voltage for telemetry via BTR-30 or BTR-15. PVK-1 kit for all voltages below to 10 kV; PVK-2 for voltages above 10 kV and less than 20 kV. (Photo below.)



Ordering Information

Plate Voltage Sampling Kits (Please specify nominal plate voltage):
 For Voltages 10kV and Less, Type PVK-1MI-561482
 For Voltages between 10 and 20 kV,
 Type PVK-2MI-561483

Reversible Motor Kit, Type RMK-1

A 120-volt, a-c, reversible motor for operation of transmitter controls. A flexible 6-inch (152 mm) shaft (included) couples the motor to any 1/4-inch (6 mm) control shaft. Motor operates at one rpm and is equipped with an adjustable clutch to prevent control-stop damage. Power connectors and local-control switch included. (Photo above.)



Specifications

Motor Torque120 inch-oz.
 Shaft Velocity1 rpm
 Power Requirements120V, 50-60 Hz, 5W
 Dimensions3" x 4" x 7" (76, 102, 178 mm)
 Weight (Approx.)1.5 lbs. (681g)
 Shipping Weight (Approx.)2 lbs. (910g)

Ordering Information

Reversible Motor KitType RMK-1

Transmission Line Sampling Kits, Type RFK-1, -2, -3

Converts RF voltage to d-c for telemetry of transmission line or common-point currents. RFK-1 is for AM-broadcast frequencies and uses an input coaxial cable that functions as one leg of a capacitive voltage-divider network; the RFK-2 and -3 are for FM-broadcast operations and use samples from an unpressurized coaxial transmission line. Connector is BNC-type. Attaches to line with stainless-steel straps.

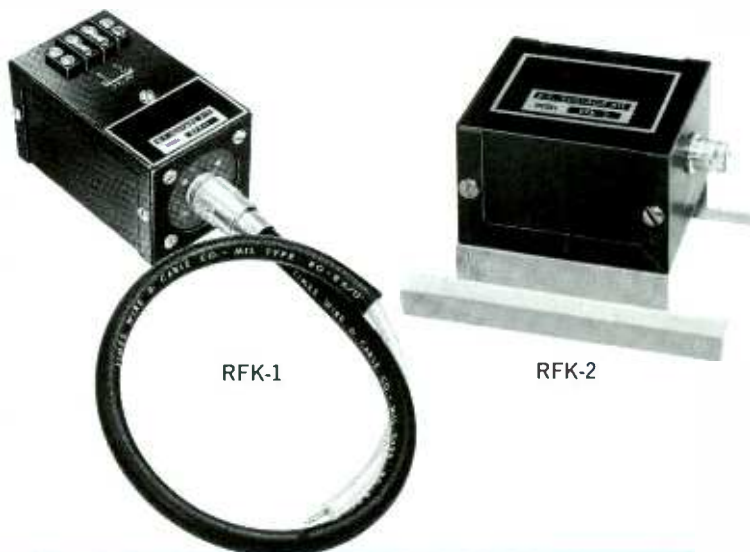

Ordering Information

Transmission Line Sampling Kits:
 For AM Broadcast FrequenciesType RFK-1
 For FM Broadcast, 3 1/8-inch T/LType RFK-2
 For FM Broadcast, 1 5/8-inch T/LType RFK-3

Modulation Monitor Adaptor, Type MMA-1

Develops a d-c voltage proportional to the audio output of any modulation monitor. Functioning as a peak-reading audio detector, the response of the system is limited only by the ballistics of the meter the unit drives. Internal strapping provides re-pre-emphasis for accurate modulation indication. The MMA-1 can drive local extension meters or an RCA remote control system. Powered from current production BTR-15 or -30 Remote Control Systems.

Specifications

Input Requirements:

Level	-20 to +10 dBm
Impedance	600 ohms, balanced
Output Level2V dc max.
Power Requirements (Regulated)	+10; -10V dc, 15 mA
Dimensions	2" x 9" x 3.5" (51, 229, 89 mm)
Weight (Approx.)	1 lb. (454g)
Shipping Weight (Approx.)	2 lbs. (910g)

Ordering Information

Modulation Monitor Adaptor, Type MMA-1MI-561460



Chopper-Stabilized DC Amplifier, Type CSA-3

Allows sampling of sensitive d-c circuits in frequency monitors, reflectometers and the like without affecting the usual operation of the sampled device. The amplifier uses a floating input so that the sampled circuit can be positive, negative or isolated by as much as 400V above ground. Gain and bias (zero-adjust) controls included (screw-driver adjustments).

Specifications

Gain Characteristics (Adjustable, voltage)45
Input Termination	2200 ohms ²
Input Sensitivity (1.5V output)	15 μ A
Ambient Temperature Range	0 to 150°F (-18 to 66°C)
Power Requirements	120V, 50-60 Hz, 10W
Dimensions	5.25" x 7.5" x 2" (133, 191, 51 mm)
Weight (Approx.)	2 lbs. (910g)
Shipping Weight (Approx.)	3 lbs. (1.4 kg)

²Input resistor field convertible to any value up to 4700 ohms.

Ordering Information

Chopper-Stabilized DC Amplifier, Type CSA-3MI-561461



Metering Insertion Unit, Type MIU-1

Connects between the program line and transmitter audio input to inject telemetry information as subaudible tones into the modulation envelope. Performs three additional functions: one, it filters out program audio in the spectrum used for telemetry; two, provides an on/off function for the subaudible metering signal; three, provides an audio pad for adjustment of total modulation to the 100-percent point when operating without subaudible telemetry. (Not illustrated.)

Specifications

Subaudible Frequency Range	20 to 30 Hz
Insertion Loss5 dB
Filter Attenuation (20-30 Hz)	50 dB min.
Power Requirements	None
Dimensions	3.75" x 19" x 4" (89, 483, 102 mm)
Weight (Approx.)	3 lbs. (1.4 kg)
Shipping Weight (Approx.)	6 lbs. (2.7 kg)

Ordering Information

Metering Insertion Unit, Type MIU-1 (Not shown)MI-561458

Tower Light Monitor Kit, Type TLK-1

Monitors a-c currents in tower-lighting systems. Provides a means of sampling current for display on remote metering. Responsive to flash rate of the beacon and to the number of obstruction lights in operation.

Specifications

Sensitivity Range2 to 20 A ac
 Dimensions4" x 2.25" x 2.25" (102, 57, 57 mm)
 Weight (Approx.)1 lb. (454g)
 Shipping Weight (Approx.)1.5 lbs. (671g)

Ordering Information

Tower Light Monitor Kit, Type TLK-1MI-561462



Line Voltage Sampling Kit, Type LVK-1

Samples power line voltage for remote monitoring. Contains transformer rectifier and filter for conversion of single-phase a-c voltage into proportional d-c voltage for telemetry.

Specifications

Voltage Range120 or 140V ac
 Dimensions3" x 5" x 2.5" (76, 127, 64 mm)
 Weight (Approx.)1.5 lbs. (671g)
 Shipping Weight (Approx.)2 lbs. (910g)

Ordering Information

Line Voltage Sampling Kit, Type LVK-1MI-561463



Metering Recovery Unit, Type MRU-1

A complementary device to the Metering Insertion Unit described above. The Type MRU-1 recovers the subaudible telemetry information from a demodulated air signal. Connects between the audio output of a modulation monitor and the telemetry input of a transmitter remote-control system unit. (Not illustrated.)

Specifications

Input:
 Impedance600 ohms
 Level (at 100% mod.)-20 to +10 dBm
 Power RequirementsNone
 Dimensions3.75" x 19" x 7" (89, 483, 118 mm)
 Weight (Approx.)8 lbs. (3.6 kg)

Ordering Information

Metering Recovery Unit (Not shown)Type MRU-1

Remote Power-Output Controls

A reversible, 120V a-c motor for operation of the power-output control of RCA low-power FM transmitters. Includes mounting brackets and all necessary hardware. (Not illustrated.)

Specifications

Weight (Approx.)1 lb. (454g)
 Shipping Weight (Approx.)2 lbs. (910g)

Ordering Information

Remote Power-Output Control:
 For RCA Type BTF-1E1, -1E2 TransmittersMI-27558
 For RCA Type BTF-3E1, -5E2 TransmittersMI-561023

Plate Circuit Sampling Kit, Type MBB-1

Samples plate current (or plate voltage using an external, series resistor). Particularly useful in circuits operating above ground potential or with a positive ground. External shunt or series resistors are required but not included. Shunt required when sample current exceeds 5mA.

Specifications

Sensitivity (1V output)3 mA
 Insulation Potential (Max. peak)10,000V dc
 Dimensions4" x 4" x 7" (102, 102, 178 mm)
 Weight (Approx.)1 lb. (454g)
 Shipping Weight (Approx.)2 lbs. (910g)

Ordering Information

Plate Circuit Sampling Kit, Type MBB-1MI-561464



Temperature Sensing Kit, Type TSK-2

Providing an accurate means for monitoring building, air-inlet, exhaust or similar temperatures, the kit converts a temperature into a d-c potential which may be indicated on a remote-control and/or automatic logging systems. Features a linear transfer characteristic and needs no conversion tables or graphs for interpretation. Operating power available from BTR-15 or -30 Remote Control System.

Specifications

Temperature Range0 to 140°F (-18 to 60°C)
 Power Requirements (Regulated)+10; -10V dc, 50 mA
 Dimensions3½" x 2" x 7" (89, 51, 178 mm)
 Weight (Approx.)1 lb. (454g)
 Shipping Weight (Approx.)1.5 lbs. (671g)

Ordering Information

Temperature Sensing KitType TSK-2





Status Indicator Receiver Unit

Status Indicator Unit, Type SCS-2

Automatically scans fourteen on/off functions every 0.4 seconds. Should any or all of the fourteen functions be other than normal, the system lights appropriate indications on both the transmitter and studio units. Alarm lights may be set, via front-panel switch, for “automatic reset” or “latch”. In “latch”, the alarmed channel stays on until reset whether or not the condition is corrected; in “auto reset”, the indicator stays on only for the duration of the alarm condition.

Specifications

- Indicator Channels14
- Response Time0.5s max.
- Interconnection Requirements:
 - WireVoice-grade pair
 - RadioContinuous one-way
 - Response2 to 3 kHz
 - Path Loss20 dB max.

Signal Levels:

- Transmitter Unit (Output)0 dBm, 600 ohms bal. or 1.5V rms, 600 ohms, unbal.
- Receiver (Studio) Unit (Input)0 dBm, 600 ohms bal. or 0.5V rms, 600 ohms, unbal.
- Transmitter Unit InputNormally closed external contacts. Open circuits for alarm. Reversible in the field by restrapping.
- Receiver Unit OutputVisual (lamps) and rear-apron terminals
- External Alarm OutputOne set SPDT contacts, rear apron
- Ambient Operating Temperature-20 to 135°F (-7 to 57°C)
- Power Requirements (Each unit)120/240V, 50/60 Hz, 20W
- Dimensions (Each unit)19" W; 3½" H; 10½" D (483, 89, 267 mm)
- Weight (each unit, approx.)19 lbs. (8.6 kg)
- Shipping Weight (Approx.)49 lbs. (12 kg)

Ordering Information

- Status Indicator System, Type SCS-2ES-561156 (Units available only as system, not separately.)

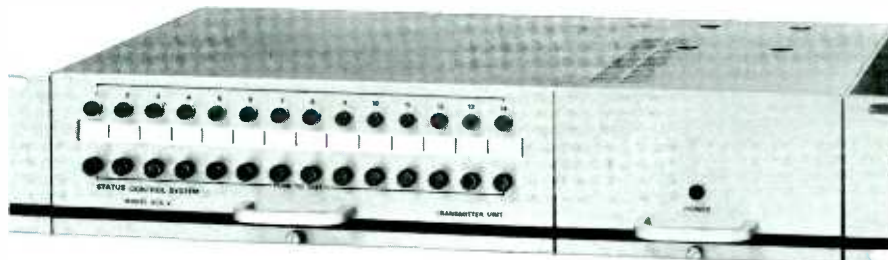

Status Indicator Transmitter Unit

Tolerance Alarm, Type TAU-2

Monitors telemetry sample voltages and triggers alarm when samples exceed preset limits. Handles one to ten samples per rack frame, is entirely electronic without moving parts, calibrates easily and provides visual indication of out-of-tolerance condition. Used with an external reference voltage, the tolerance alarm modules function as ratio-alarm units.

Specifications

Channels1 to 10 per frame, plug-in modules
 Trip Point Hysteresis (Centered on Input) $\pm 0.005V$
 Input Requirements (Gnd. ref.)-3 to +3V dc
 Input Impedance30,000 ohms
 Indicator (Each Module)Light-Emitting Diode

Outputs:

AlarmTransistor Switch
 Relay Power (Relay not supplied)16V dc, 600 ohm load
 External Reference Voltage
 (If Used)Twice Sample Voltage but less than +8V dc
 External Ref. Input Impedance22,000 ohms
 Ambient Operating Temperature0 to 140°F (-18 to 60°C)
 Power Requirements120/240V, 50-60 Hz, 30W max.
 Dimensions (Frame)19" W; 3½" H; 7½" D (483, 89, 191 mm)
 Weight (Frame & 10 Modules, approx.)9 lbs. (4.1 kg)
 Shipping Weight (Approx.)13 lbs. (5.9 kg)

Ordering Information

Tolerance Alarm System, Type TAU-2:
 ModuleMI-561184
 Main Frame (For 1 to 10 modules)MI-561469

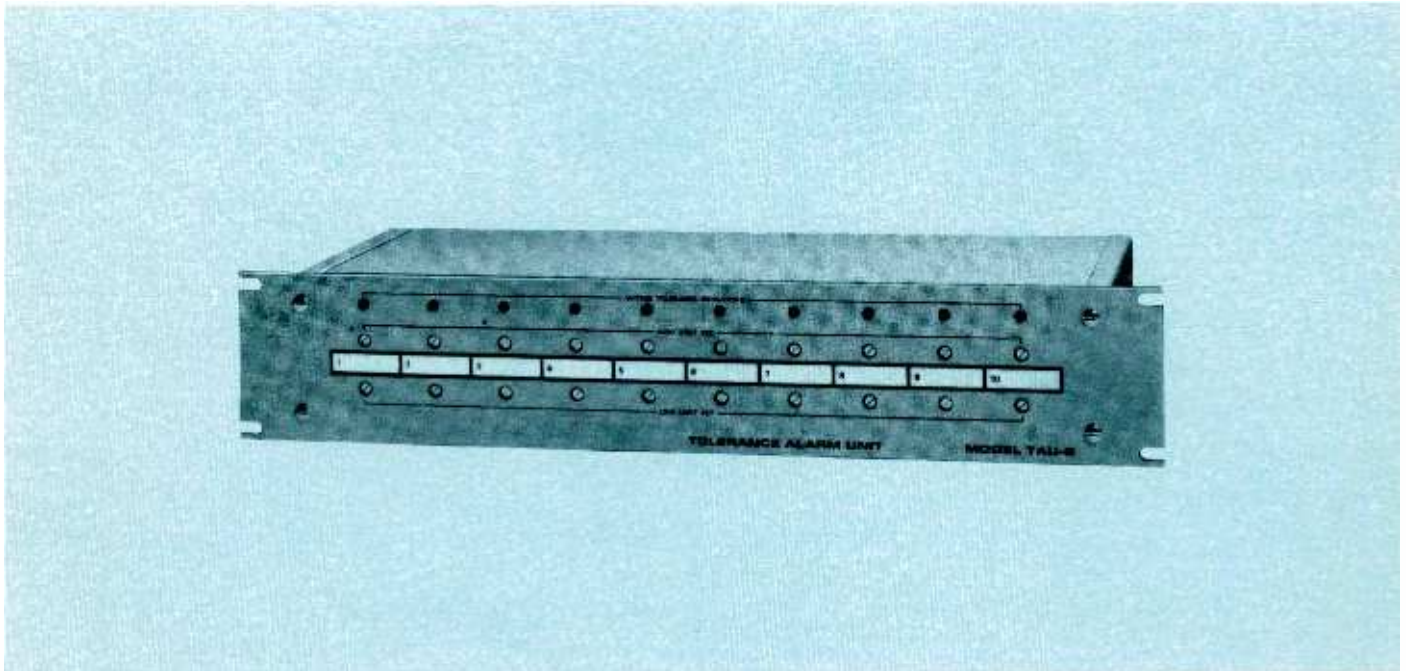

Multi-System Combiner, Type MSC-1

Allows one telephone circuit to handle a remote-control system, an automatic logging system and a status indicator system simultaneously. The combiner system consists of two rack-mount units: one for the studio location or "remote" location, another for the transmitter site. (Not illustrated.)

Specifications

Impedance600 ohms; bal.; floating; resistive
 Output Level (Adjustable)0 dBm composite max.
 Ambient Operating Temperature0 to 140°F (-18 to 60°C)
 Power Requirement120/240V, 50-60 Hz, 20W
 Dimensions19"W; 3½" H; 7½" D (483, 89, 191 mm)
 Weight (each unit, approx.)6 lbs. (2.7 kg)
 Shipping Weight (Approx.)18 lbs. (8.2 kg)

Line Requirements:

Type2-point, 2-wire, half-duplex, voice grade, data line
 Impedance600 ohms $\pm 10\%$, bal.
 Line Loss16 dB, 1000 Hz max.
 Line Loss Variations3 dB short term; 4 dB long term
 Response Roll-off8 dB, 2700 Hz max.
 Noise (Below Received Signal):
 Coherent Tones-40 dB max.
 Incoherent Noise-30 dB max.
 Distortion (Total Harmonic, 560 to 2700 Hz)1% max.
 Frequency Translation Error3 Hz max.
 DC ContinuityNot Required
 Envelope Delay DistortionNo Specification
 Phase JitterNo Specification

Ordering Information

Multi-System Combiner, Type MSC-1MI-561479



Automatic Logging Equipment Moseley Model ADP-220 Automatic Data Printer

- Up to 20 readings every 10 minutes
- Digital Readout—easy reading, easy filing
- Accurate log entries—error less than 0.1%
- Logs any parameter convertible to a d-c voltage



Automatic log entries are made dependably and accurately by the Model ADP-220 Automatic Data Printer. The system can log any parameter that can be sampled with a representative d-c voltage. It relieves station personnel from the tedium of log-keeping and releases them for more productive assignments.

Modular construction simplifies routine maintenance and fault location. Each plug-in module in the transmitter unit contains a logical portion of the overall circuitry. A full, four-digit, front-panel display lets one man, working alone, calibrate the system. The data-receiver unit is housed in a sturdy, cast-aluminum assembly that fits nicely beneath an electric typewriter. Slide-out drawer construction provides full access to all components of the data-receiver unit. Specifications and ordering information on next page.

Complete description of the ADP-220 is available to interested persons. Please request Moseley Bulletin 231 from Aural Broadcast Equipment Marketing, RCA Building 2-2, Camden, N.J. 08102, U.S.A.



ADP-220 Sampler Unit



ADP-220 Printer

Specifications (Subject to change without notice)

Readout	Digital
Printout Format:	
Columns	21
Parameters (Including Time)	21
Resolution (Full-scale)	0.01%
Accuracy	0.1% min
Parameters Inputs	20
Parameter Input Requirements:	
Polarity (Respect to Ground)	Pos. or Neg.
Voltage	1.0 to 7.5V
Full-Scale Sensitivity	1.0V
Input Impedance (Nominal)	30k ohms
Calibration Control	Multiturn potentiometer
Interconnection Requirements:	
Circuit	Full duplex
Frequency Spectrum	500 to 1800 Hz
Maximum Loss	20 dB
Telephone Line Requirements:	
Impedance (Nominal)	600 ohms
Operating Level	0 dBm
Connections	Barrier Strip
Subcarrier Channels:	
Impedance (Nominal), Unbalanced	2000 ohms
Voltage (Nominal)	0.5V rms
Connectors	Female BNC
Data Transmission Method	Modified Frequency-Shift Keying (FSK)
Tone Frequency:	
Command	560 Hz
Data	1600, 1800 Hz
Operating Ambient Temperature Range	0-70°C
Power Requirements (Approx.)	120V, 60 Hz ¹ , 125W
Dimensions:	
Transmitter/Sampler	7" H, 19" W, 11½" D (178, 483, 292 mm)
Receiver/Printer	4" H, 14¾" W, 15½" D (102, 365, 394 mm)
Typewriter	9" H, 23" W, 15" D (229, 574, 381 mm)
Weight (Approx.):	
Receiver	22 lbs. (10 kg)
Transmitter	22 lbs. (10 kg)
Typewriter	51 lbs. (23 kg)
Shipping Weight (Approx.):	
Transmitter	35 lbs. (16 kg)
Receiver	27 lbs. (13 kg)
Typewriter	61 lbs. (28 kg)

¹ Option: 240V operation on special order.

Accessories

Tolerance Alarm Unit, Type TAU-2	MI-561184
Non-Standard Programmable Sequence	Custom Built

Ordering Information

Automatic Data Printer, Type ADC-220	ES-561154
--	-----------



Studio-Transmitter Links and Remote-Pickup Links ("STL" and "RPL")

- STL equipment for 150, 220, 450 and 950 MHz
- RPL equipment for 150 and 450 MHz
- All systems entirely solid-state
- Receivers and transmitters of matched characteristics



Here are abridged specifications, in tabular form, for several studio-to-transmitter links and equipment for remote program pickup.

STL equipment provides a high-quality air link between the studio location and a transmitter site at some remote point. STL gear is used in AM, FM and, at times, TV facilities wherever quality with economy are the watchwords. Because the link is owned by the facility using it, it remains under the control of the facility which isn't the case with leased facilities. When local considerations allow, STL equipment carries high-quality programming cross-country as microwave links.

RPL equipment is used for the relay of programming, produced on-location, to the studio or transmitter sites via frequency-modulated radio. The equipment operates from an automotive electrical system (12V) or from commercial power lines.

RCA distributes the STL and RPL products as well as the appropriate accessories of two manufacturers: "Marti" and "Moseley". Marti gear is made by Marti Electronics, Inc., of Cleburne, Texas. Moseley equipment comes from Moseley Associates, Inc., of Goleta, California.

The specifications reproduced here are abridged and arranged tabularly for your convenience. The manufacturer's literature used as the source for this chart is available from any RCA Broadcast Sales Representative or the home office (Aural Broadcast Equipment Marketing, RCA Building 2-7, Camden, N.J. 08102). We recommend that you review the manufacturer's literature before placing your order for systems and accessories.

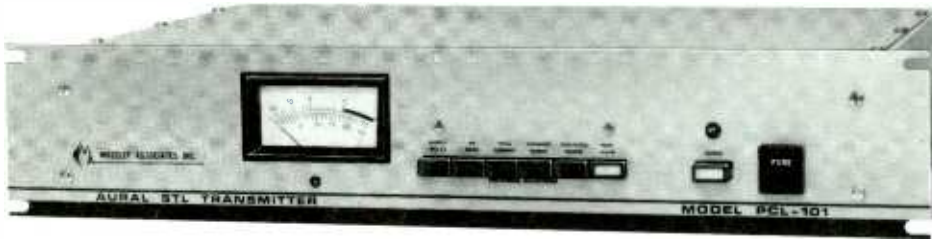

Moseley STL transmitter, PCL-101. Requires only 3.5 inches of rack space and turns out 10 to 15 watts of RF power. Available for 215-240 or 450-470 MHz operation.



Moseley STL Receiver, PCL-101. Companion to transmitter above. Occupies only 1.75 inches of rack space and uses only 15 watts of power.



Moseley STL transmitter, PCL-404. Operates in the 890-950 MHz radio spectrum at five watts output. Requires only 5.25 inches of rack space.

Moseley STL receiver, PCL-404. Companion to transmitter at left. Occupies only 5.25 inches of rack space and requires only 15 watts of power.

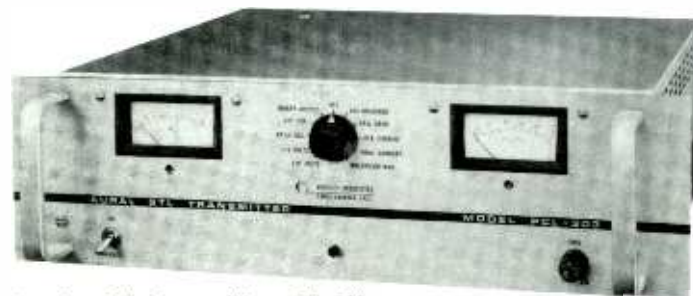

Moseley STL Transmitter, PCL-303. Provides up to eight watts power output in 890-950 MHz spectrum. Available for composite stereo as PCL-303C.

Moseley STL receiver, PCL-303. Companion to transmitter at left. Requires only 5.25 inches of rack space and only 15 watts power.

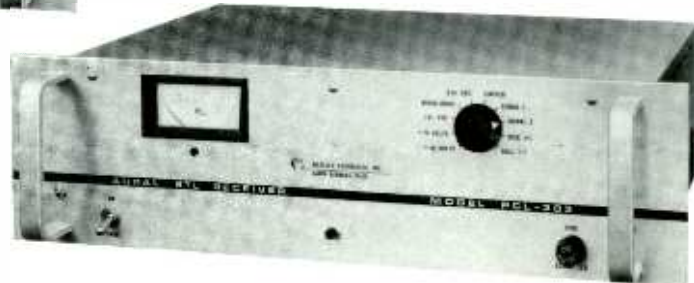

ABRIDGED SPECIFICATIONS — STUDIO-TRANSMITTER LINKS (STL)

Manufacturer & Model No.	SYSTEM CHARACTERISTICS										TRANSMITTER CHARACTERISTICS — TRANSMITTER CHARACTERISTICS										TRANSMITTER CHARACTERISTICS — TRANSMITTER CHARACTERISTICS														
	Freq. Resp.		Distortion		S/N Ratio (dB)		Power Out (W)		Deviation (kHz)		Freq. Stability (%)		Spurious ²		AM Noise ² (dB)		Temp Range ³		Input (600Ω)		Power Requirements		Dimensions			Millimeters			Weight						
	30-15k ±1 dB	50-15k ±1.5 dB	50-12.5k: 1%	50-15k: 1%	60	60	22-25	10-15	±6	±5	±0.0005	±0.0005	-60	-55	-70	-30 to 60	+10	110	50-60	115/230	50-60	8.25	19	8.25	222	483	210	20	9.1						
148-174 MEGAHERTZ SYSTEMS MARTI STL-25 MOSELEY PCL-101 ¹																																			
215-240 MEGAHERTZ SYSTEMS MARTI STL-18/215 MOSELEY PCL-101 ¹																																			
300-340 MEGAHERTZ SYSTEMS MARTI STL-18/300																																			
300-470 MEGAHERTZ SYSTEMS MOSELEY PCL-202																																			
450-470 MEGAHERTZ SYSTEMS MARTI STL-15 MOSELEY PCL-101 ¹																																			
890-960 MEGAHERTZ SYSTEMS MOSELEY PCL-303 MOSELEY PCL-404																																			
942-960 MEGAHERTZ SYSTEMS MARTI STL-8F																																			

Manufacturer & Model No.	RECEIVER CHARACTERISTICS — RECEIVER CHARACTERISTICS										RECEIVER CHARACTERISTICS — RECEIVER CHARACTERISTICS										RECEIVER CHARACTERISTICS																	
	Sensitivity ⁴		Stability (%)		Selectivity		Output (dBm 600Ω)		Power Requirements		Dimensions		Power Requirements		Dimensions			Millimeters			Weight																	
	32 @ 60	0.7 @ 20	±0.0005	±0.0005	220 kHz	45 kHz	+10	+30	115/230	120/240	50-60	50-60	8.25	19	8.25	222	483	210	8.25	19	8.25	222	483	279	16	7.3												
148-174 MEGAHERTZ SYSTEMS MARTI STL-25 MOSELEY PCL-101 ¹																																						
215-240 MEGAHERTZ SYSTEMS MARTI STL-18/215 MOSELEY PCL-101 ¹																																						
300-340 MEGAHERTZ SYSTEMS MARTI STL-18/300																																						
300-470 MEGAHERTZ SYSTEMS MOSELEY PCL-202																																						
450-470 MEGAHERTZ SYSTEMS MARTI STL-15 MOSELEY PCL-101 ¹																																						
890-960 MEGAHERTZ SYSTEMS MOSELEY PCL-303 MOSELEY PCL-404																																						
942-960 MEGAHERTZ SYSTEMS MARTI STL-8F																																						

¹Other frequencies in 148-470 MHz spectrum available on special order. ²Below carrier level (dB). ³For frequency stability (°C). ⁴Microvolts (rms) at quieting level (dB). ⁵These are horizontal unit dimensions; vertical mount dimensions are: 7" H; 8 1/2" W; 15" D (178, 216, 381 mm) 9 lbs. (4.1 kg) plus 10 lbs. (4.5 kg) for rack shelf adapter.

ABRIDGED SPECIFICATIONS — REMOTE PICKUP LINKS (RPL)

Manufacturer and Model Number	SYSTEM CHARACTERISTICS				TRANSMITTER CHARACTERISTICS				TRANSMITTER CHARACTERISTICS — TRANSMITTER CHARACTERISTICS				TRANSMITTER CHARACTERISTICS — TRANSMITTER CHARACTERISTICS						
	Frequency Response	Distortion	S/N Ratio (dB)	Power Out (W)	Deviation (kHz)	Freq. Stability (%)	Spurious ¹	Temp. Range (°C)	Input Lead	Primary Power		Dimensions		Millimeters		Weight			
										Volts	Freq.	H"	W"	D"	H		W	D	
148-174 MEGAHERTZ EQUIPMENT MOSELEY RPL-3	30-10k ±1.5 dB	30-10k: 1.3%	55	10-15	±5	±0.0005	-60	-30 to 60	-60 to 10 dBm ¹	120/240 11-15	50-60 DC	4	14.5	11	102	368	279	16	7.2
150-172 MEGAHERTZ EQUIPMENT MARTI RPT-40/R-30	30-7.5k ±1.5 dB	2% max	50	36-40 ²	±6	±0.0005	-60	-20 to 45	-70 to 4 dBm ³	115/230 13.5	50-60 DC	6.25	15	12	159	381	305	20	9.1
450-470 MEGAHERTZ EQUIPMENT MARTI RPT-25/R-50	30-12k ±1.5 dB	2% max	50	20-25 ²	±9	±0.0005	-60	-20 to 45	-70 to 4 dBm ³	115/230 13.6	50-60 DC	6.25	15	12	159	381	305	20	9.1
MOSELEY RPL-4	30-10k ±1.5 dB	30-10k: 1.3%	55	10-15	±15	±0.0005	-60	-30 to 60	-60 to 10 dBm ¹	120/240 11-15	50-60 DC	4	14.5	11	102	368	279	16	7.2

Manufacturer and Model Number	RECEIVER CHARACTERISTICS				RECEIVER CHARACTERISTICS — RECEIVER CHARACTERISTICS				RECEIVER CHARACTERISTICS — RECEIVER CHARACTERISTICS				RECEIVER CHARACTERISTICS — RECEIVER CHARACTERISTICS			
	Sensitivity ⁴	Stability (%)	Selectivity	Spurious ⁵	Output (dBm at 6000 ³)	Power Requirements		Dimensions		Millimeters		Weight				
						Volts	Freq.	H"	W"	D"	H	W	D	lbs	kg	
148-174 MEGAHERTZ EQUIPMENT MOSELEY RPL-3	0.7 @ 20 ²	±0.0005	±22 kHz	-65	+10	120/240	50-60	1.75	19	10	45	483	254	8	3.6	
150-172 MEGAHERTZ EQUIPMENT MARTI RPT-40/R-30	0.5 @ 20 ⁶	±0.0005	±17.5 kHz	-95	+10	115/230	50-60	8.75	19	8.25	222	483	210	16	7.3	
450-470 MEGAHERTZ EQUIPMENT MARTI RPT-25/R-50	0.5 @ 20 ⁶	±0.0005	±21 kHz	-95	+10	115/230	50-60	8.75	19	8.25	222	483	210	16	7.3	
MOSELEY RPL-4	0.7 @ 20 ²	±0.0005	±21 kHz	-65	+10	120/240	50-60	1.75	19	10	45	483	254	8	3.6	

¹Two 50-150 ohm mike inputs; one 50,000 ohm unbalanced input. Mike input level -60 to -40 dBm; line level, -15 to 10 dBm, 600-ohm source.

²For 45 dB quieting: 1.0 microvolt.

³Nominal 36W, 40W max.

⁴Below carrier level (dB).

⁵Three 150 to 600-ohm mike inputs; one 600 ohm line input. Mike input level -70 to -45 dBm; line level -20 to 4 dBm.

⁶Microvolts at quieting level. Measured through 4 kHz low-pass audio filter.

⁷Nominal 20W, 25W max.

⁸Optional preselector recommended where receiver operates near UHF transmitter.

⁹Microvolts at dB of quieting.

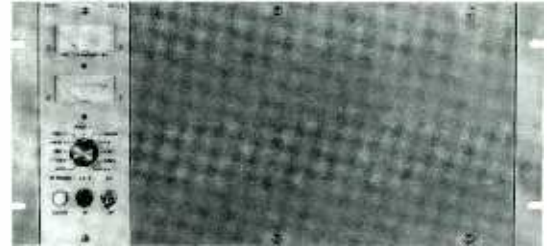

Marti STL transmitter, STL-8. Typical in appearance of all Marti STL and RPL transmitters. Available for 148-174, 215-240, 300-340, 450-470 and 942-960 MHz bands.



Marti remote-pickup transmitter. Four audio inputs and a multi-purpose front-panel meter. Available for 150-172 and 450-470 MHz bands.

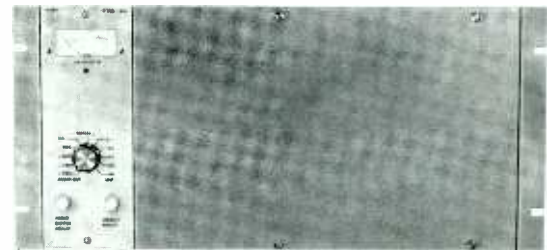

Marti STL/RPL receiver R-200. Typical in appearance of all Marti STL/RPL receivers. Companions to transmitters pictured above. Requires 8.75 inches of rack space.



Moseley RPL transmitter, RPL-3 or RPL-4. Identical in appearance, the two Moseley RPL transmitters are available for the 148-174 and 450-470 MHz bands. Equipped with two low-level inputs.



AM-FM Coaxial Transmission Line

- Wide selection of style and size
- High efficiency and minimum VSWR
- Precision-mated rigid-line flanges
- Rigid and semi-rigid
- Economical installation

RCA coaxial transmission line is an efficient means for transferring transmitter power to AM and FM antennas. Designed with economy, dependability and inexpensive installation in mind, the products described here are available in various nominal diameters and types to accommodate a wide variety of power and frequency requirements. The equipment described includes, elbows, flanges, adapters and other accessories.

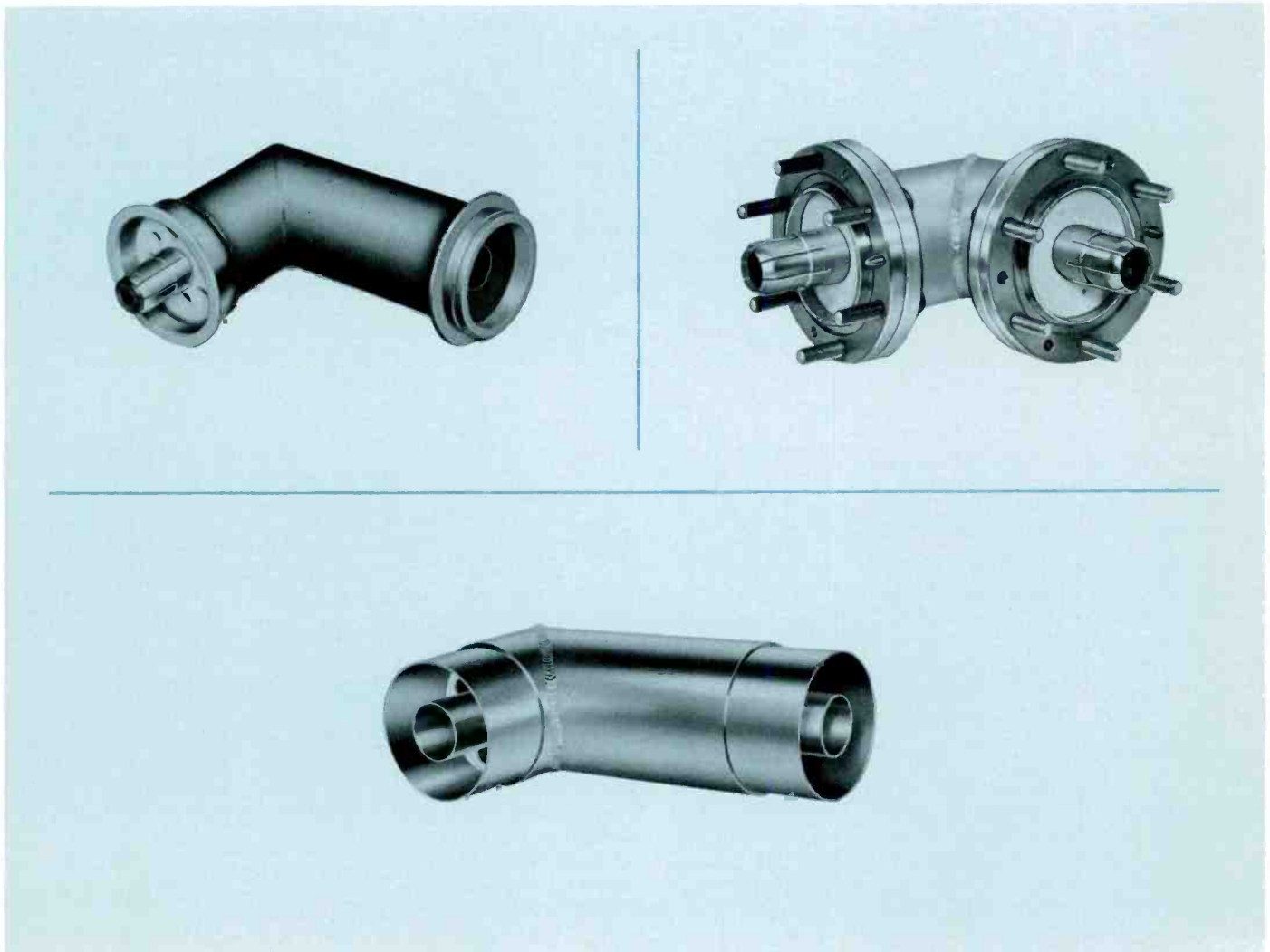

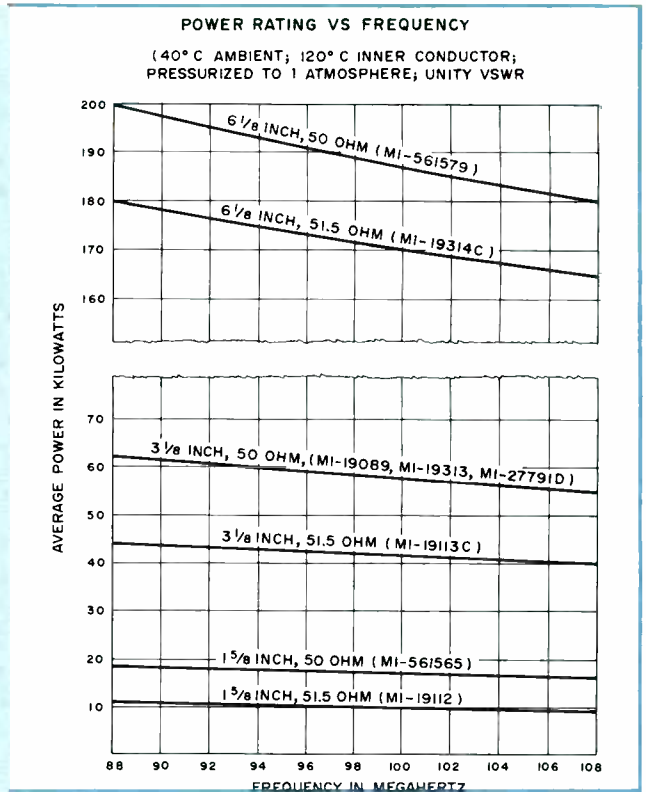
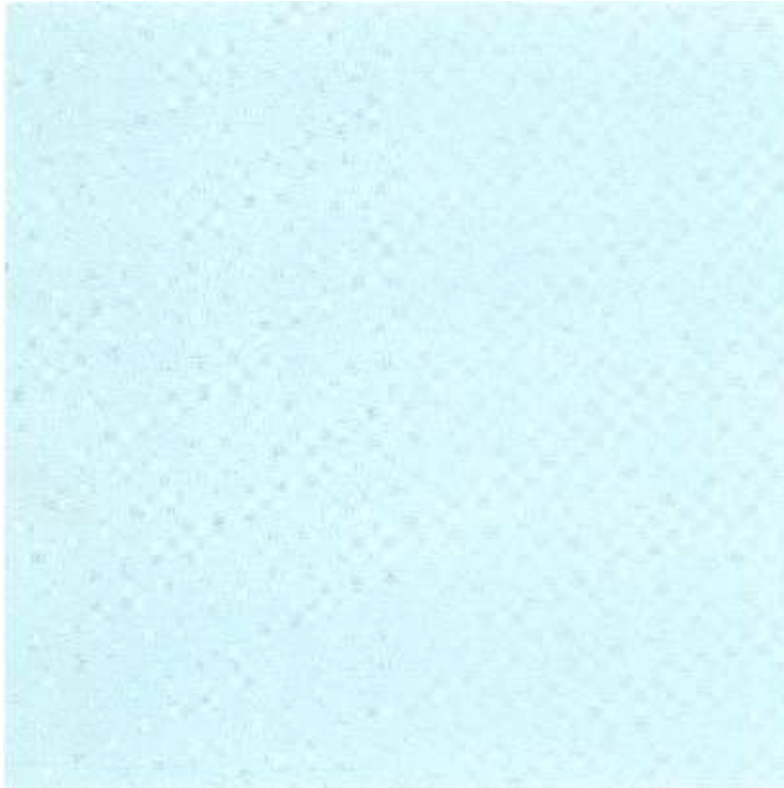

"Universal" Rigid Transmission Line

An RCA exclusive design, "Universal" transmission line features near-perfect reliability and easy, inexpensive installation. It is available for radio use in 3- and 6-inch nominal diameters and in 19.5- or 20-foot (5.94, 6.1 m) lengths.¹ Flanges are heliarc welded and use a marmon clamp instead of bolts in a circle. A captive O-ring gasket seals the joint pressure-tight. Installation avoids the radial alignment considerations of bolt-flange line because all "Universal" flanges swivel before clamping. Lengths shorter than those above are available on special order.

Universal line inner conductor is supported with polytetrafluoroethylene (Teflon) insulators. Axial support is through an insulator at the flange. Coupling adjacent sections makes the inner conductor captive for axial support.

Bolt-Flanged Line

RCA supplies bolt-flanged transmission line in steatite- and Teflon-insulated styles for those who prefer this type of connection. Some rigid lines have a rolled groove near one end of the outer conductor. This

anchors the inner conductor in both axial directions yet provides for inner conductor removal if ever necessary.

Heliax* Semi-Rigid Line

Heliax is a semi-rigid transmission line often specified in situations where odd bends and curves abound. The line installs quickly and, if the foam-dielectric type, requires no pressurization. However, FM antenna feed systems often require gas pressurization. When the foam heliax is used with such an antenna, a special pressure-tight tube must be installed along with the Heliax to carry the gas for pressurization to the antenna feed system.

In the event of line damage leading to failure, Heliax transmission line repair may require replacement of the entire length as the result of its construction. The segmented design of rigid line allows replacement of individual sections, including elbows.

Transmission Line Accessories

A line of adapters and reducers which permit coupling of line components of different configurations is included here. The hanger product line (described in a separate section) includes fixed and spring hangers

which are available in grounded and insulated versions. There are types for mount on round, or angle-iron tower legs.

Pressurization Equipment

Equipment used for transmission line pressurization is described in a separate catalog section. This equipment works with dehydrated air or bottled dry nitrogen.

Transmission Line Selection

Line selection depends essentially on the frequency and power level of the energy it is to transfer. As one might expect, proper line choice enhances economy, efficiency and longevity, in the long term.

The "Quick Reference Chart" shown opposite lists the broad characteristics of each line style and recommends the type of service for each style.

A dimensional layout, on paper, goes a long way in simplifying the planning of the system and, eventually, in ordering the proper components.

¹ FM channels between 97 and 99 MHz require 19.5-foot lengths; between 99 and 102 MHz require 20-foot lengths. Channels between 88 and 97 MHz and 102 and 108 MHz use either length.

*Andrew Corp. trademark

Elbow Right-Angle, Short End Female

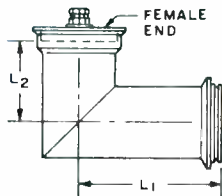

Specially reinforced elbow available as MI-27791D-2AR. Clamp and gasket included.

Catalog Number	Insert Length		Approx. Weight	Packaged Dimensions	Shipping Weight
	L1	L2			
MI-27791D-2A	8 ⁵ / ₁₆ " (205 mm)	4 ⁵ / ₁₆ " (116 mm)	10 ³ / ₄ lbs. (5 kg)	25 ¹ / ₂ x13x14 ¹ / ₂ " (648x330x368 mm)	15 lbs. (7 kg)

Elbow Right-Angle, Long End Female

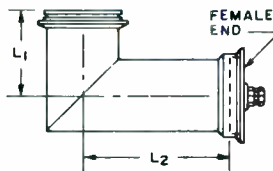

Specially reinforced elbow available as Cat. No. MI-27791D-2BR. Clamp and gasket included.

Catalog Number	Insert Length		Approx. Weight	Packaged Dimensions	Shipping Weight
	L1	L2			
MI-27791D-2B	4 ³ / ₁₆ " (106 mm)	8 ⁷ / ₁₆ " (214 mm)	10 ³ / ₄ lbs. (5 kg)	25 ¹ / ₂ x13x14 ¹ / ₂ " (648x330x368 mm)	15 lbs. (7 kg)

Gas Stop

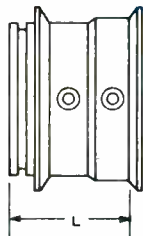

Seals pressurized from unpressurized section. Includes clamps and O-ring gasket.

Catalog Number	Insert Length (L)	Approx. Weight	Shipping Weight
MI-27791D-3A	4-27/32" (123 mm)	7 lbs. (3 kg)	10 lbs. (4536g)

Connector, Inner Conductor

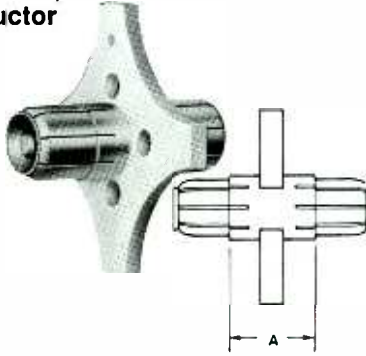

For use with elbows, gas stops and certain adapters.

Catalog Number	Insert Length (Dim. A)	Approx. Weight
MI-27791D-4D	1 3/4" (44 mm)	1 lb. (454g)

Flange, Soft-Solder, Female



Flanges field-cut line.

Catalog Number	Length (L)	Insert Length (A)	Approx. Weight	Shipping Weight
MI-27791D-4A	2 5/8" (59 mm)	5/8" (16 mm)	2 1/2 lbs. (1134g)	3 1/2 lbs. (1590g)

Flange, Soft-Solder, Male

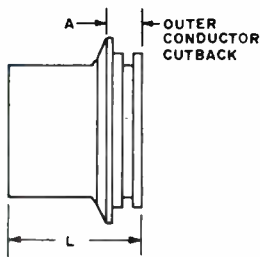

Flanges field-cut line.

Catalog Number	Length (L)	Insert Length (A)	Approx. Weight
MI-27791D-4B	1 7/8" (48 mm)	17/32" (13 mm)	2 lbs. (908g)

End Cap, Female Flange

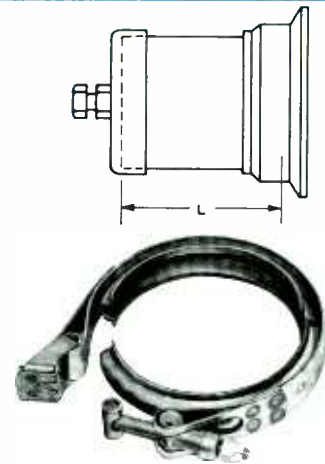

Caps male end of line temporarily to prevent moisture entry. Fitted for gassing and bleeding.

Catalog Number	Length (L)	Approx. Weight
MI-27791D-8A	2 7/8" (62 mm)	2 1/2 lbs. (1134g)

End Cap, Male Flange

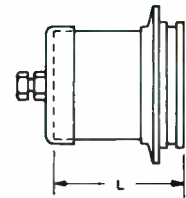

Caps female end of line temporarily to prevent moisture entry. Fitted for gassing and bleeding.

Catalog Number	Length (L)	Approx. Weight
MI-27791D-8B	4" (102 mm)	1 3/4 lbs. (794g)

Adapter, Female to Female



Couples female ends of line with two male flanges. Two O-ring gaskets included.

Catalog Number	Length (L)	Approx. Weight
MI-27791D-7C	12" (305 m)	5 lbs. (2268g)

Adapter, Universal Female to EIA Flange

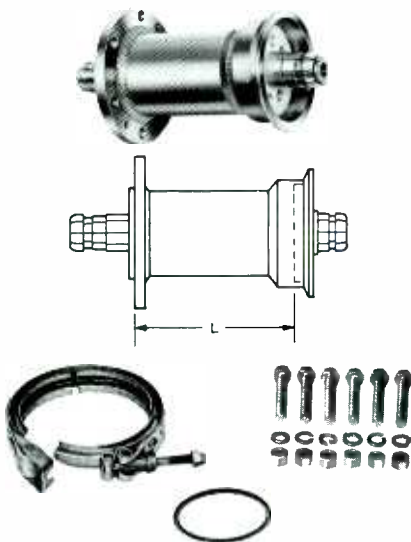

Couples male Universal end to EIA flange (or MI-19089).

Catalog Number	Length (L)	Approx. Weight
MI-27791D-7A	6" (152 mm)	7 lbs. (3 kg)

Adapter, Universal Male to EIA Flange

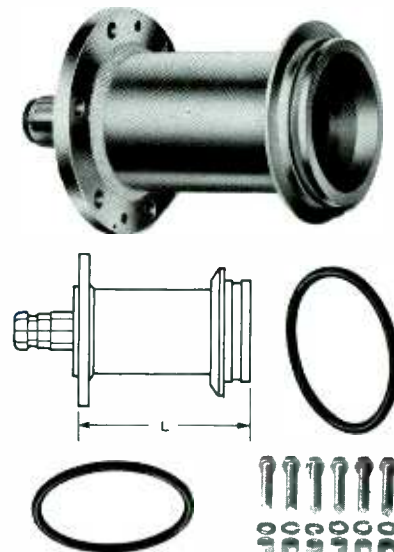

Couples female Universal end to EIA flange (or MI-19089).

Catalog Number	Length (L)	Approx. Weight
MI-27791D-7B	6" (152 mm)	5 lbs. (2268g)

Adapter, Universal Male to Bolt-Flange



Couples female Universal end to bolt-flanged line (MI-19113C or MI-19313).

Catalog Number	Length (L)	Approx. Weight
MI-27988-7B	6" (152 mm)	4.5 lbs. (2 kg)

Cutoff Guides, Inner and Outer Conductor



Inner and outer conductor cutoff. Guides that assure square cut.

Catalog Number	For	Approx. Weight
MI-19089-15	Outer Cond.	2¼ lbs. (1 kg)
MI-19089-16	Inner Cond.	6 oz. (171g)

Miscellaneous



Product	Catalog Number
O-Ring Gasket	MI-27791D-4E
V-Band Clamp	MI-27791D-4C
Silicone Grease, 2-oz. (56g) Tube	MI-19089-18

Bolt Flanged Transmission Line

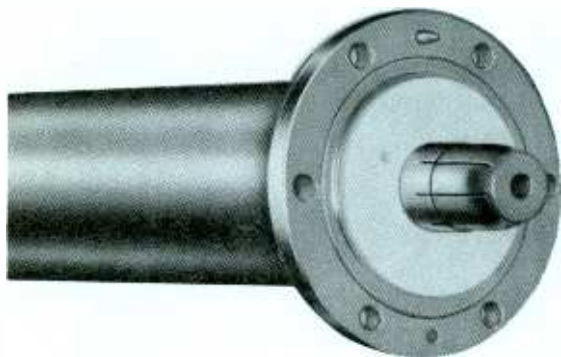

Efficient, precision-built line and line accessories. Featuring an electrically transparent Teflon insulator, this line uses the familiar bolt-flange connection. Insulator characteristics and precise inner-conductor centering allows cutting and re-flanging in the field without a change in operating impedance at the cut.

General Specifications

- Nominal Diameter3 $\frac{1}{8}$ inches
- InsulationPolytetrafluoroethylene Plastic (Teflon)
- Outer Conductor Dimensions:
 - Outer Diameter (3.027" 77 mm ID)3.125" (79 mm)
 - Flange Diameter5 $\frac{5}{8}$ " (132 mm)
- Inner Conductor Dimensions:
 - Outer Diameter1.315" (33 mm)
 - Inner Diameter1.231" (31 mm)
- Characteristic Impedance50 ohms
- Catalog Number SeriesMI-19089

Line Sections

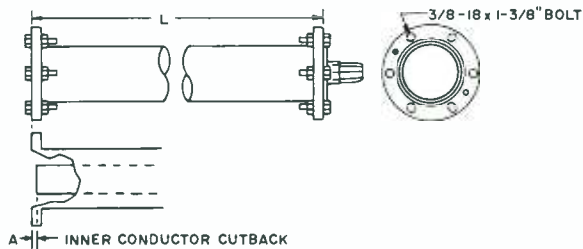
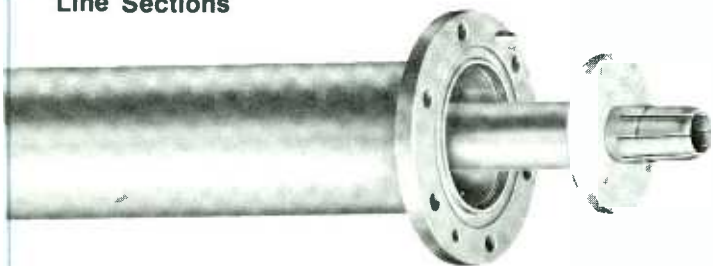

Shipped two sections per package. Each section includes one captive anchor insulator-connector, expansion joint, O-ring gasket, six bolts, nuts, lockwashers.



Catalog Number	Length (L)	Dimension A	Approx. Weight	Package Dimensions	Shipping Weight
MI-19089-1E	20' (6.1m)	1 $\frac{1}{8}$ " (29 mm)	60 lbs. (27 kg)	248x13x8" (6300x330x203 mm)	162 lbs. (74 kg)
MI-19089-1F	19 $\frac{1}{2}$ ' (5.9m)	1 $\frac{1}{8}$ " (29 mm)	57 lbs. (26 kg)	240x13x8" (6096x330x203 mm)	158 lbs. (72 kg)

Elbow, Right Angle, Female

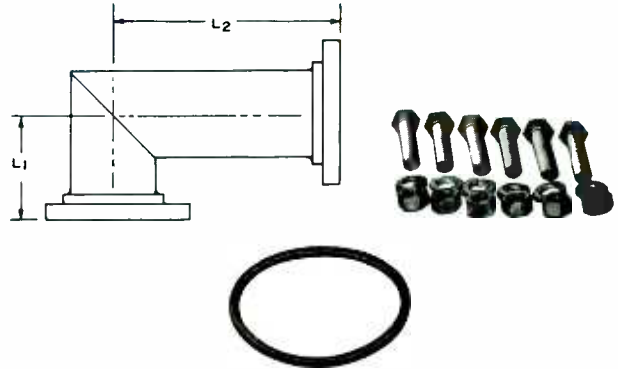
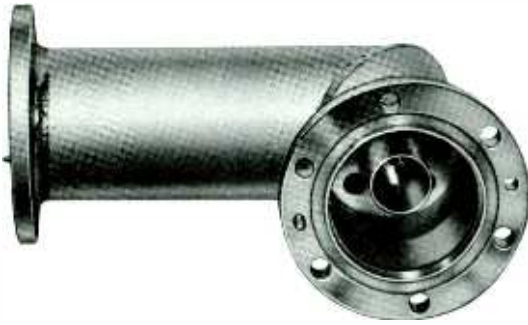

Reinforced elbow available as MI-19089-2CR. If anchor insulator connectors required, use MI-19089-10A. Both flanges swivel.

Catalog Number	Insert Length		Approx. Weight
	L1	L2	
MI-19089-2C	4¾" (111 mm)	8" (203 mm)	11 lbs. (5 kg)

Elbow, Right Angle, Male

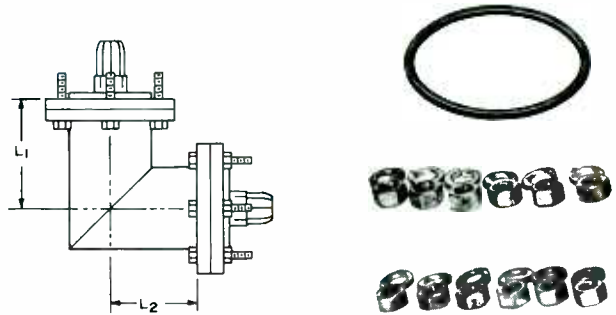

Equal length legs, both flanges swivel.

Catalog Number	L1 = L2	Approx. Weight
MI-19089-2A	4⅛" (105 mm)	13 lbs. (6 kg)

Elbow, Right Angle, Tandem

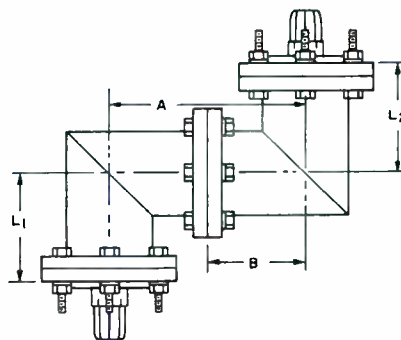
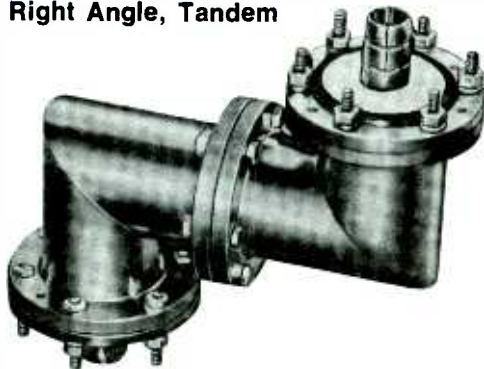

All flanges swivel. Includes one O-ring gasket, two captive connectors, twelve bolts, nuts, lockwashers.

Catalog Number	L1 / L2	Dimensions		Approx. Weight
		A	B	
MI-19089-6	4⅛" (105 mm)	7½" (190 mm)	3¾" (95 mm)	23 lbs. (10 kg)

Gas Stop



Seals pressurized line sections from unpressurized. Has four capped ports for pressure connections.

Catalog Number	Insert Length (L)	Approx. Weight
MI-19089-4	1½" (48 mm)	7 lbs. (3.2 kg)

Connector, Anchor Insulator

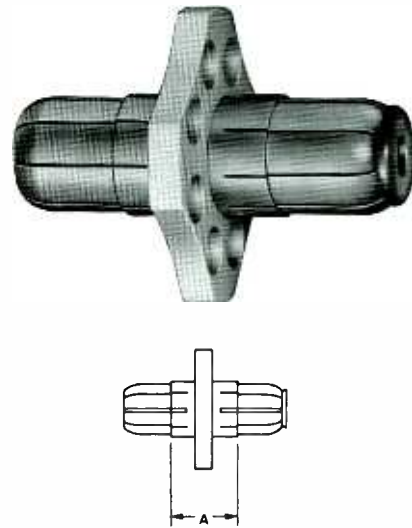

Joins inner conductors of bolt-flanged (MI-19089) line.

Catalog Number	Insert Length (Dimension A)	Approx. Weight
MI-19089-10A	1¾" (44 mm)	1 lb. (454g)

Flange, Mechanical

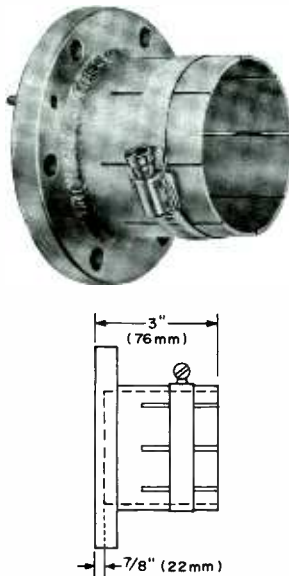

Flanges field-cut line. Not pressure-tight.

Catalog Number	Approx. Weight
MI-27988-4C	3 lbs. (1400g)

Flange, Soft Solder

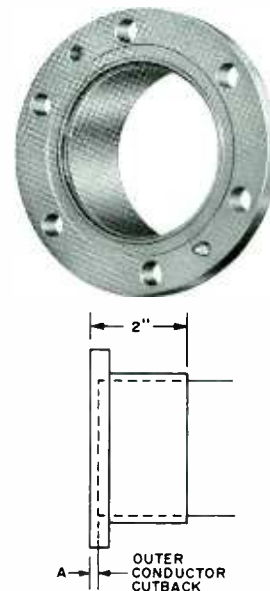

Flanges field-cut line. No swivel.

Catalog Number	Insert Length (A)	Approx. Weight
MI-19089-14	¼" (6 mm)	3 lbs. (1400g)

Adapter, "Universal" 3 1/8" Male

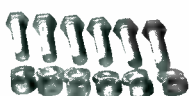
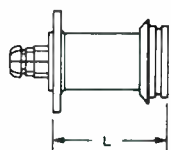

Adapts bolt-flanged (MI-19089) or EIA flanged line to "Universal" female flange.

Catalog Number	Insert Length (L)	Approx. Weight
MI-19089-25	6" (152 mm)	5 lbs. (2300g)

Adapter, "Universal" 3 1/8" Female

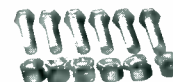
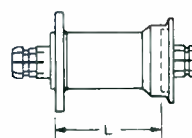

Complement to MI-19089-25 (left). Adapts bolt-flange to "Universal" male flange.

Catalog Number	Insert Length (L)	Approx. Weight
MI-19089-24	6" (152 mm)	7 lbs. (3200 kg)

Reducer, 1 5/8" EIA Flange

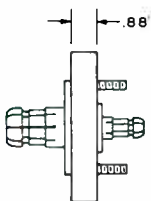

Reduces 3 1/8 inch flange (MI-19089 or EIA) to 1 5/8 inch (EIA) flange.

Catalog Number	Approx. Weight
MI-27988-5C	3 lbs. (1360g)

Reducer, 7/8" EIA Flange

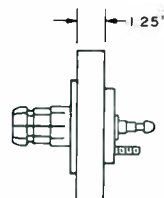

Reduces 3 1/8 inch flange (MI-19089) to 7/8 inch (EIA) flange.

Catalog Number	Approx. Weight
MI-27988-5D	3 lbs. (1360g)

Reducer to Type N Fitting



Connects 3 1/8 inch flange (MI-19089 or EIA) to a Type N female connector.

Catalog Number	Length	Approx. Weight
MI-19089-17	8" (203 mm)	5 3/4 lbs. (3 kg)

Reducer, Type HN Connector



Connects 3 1/8 inch flange (MI-19089 or EIA) to a Type HN female connector.

Catalog Number	Length	Approx. Weight
MI-19089-21	7 3/8" (187 mm)	4 lbs. (1800g)

Adapter, Inner Conductor

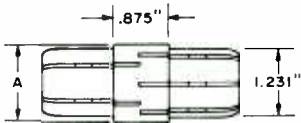

MI-27988-4A adapts inner conductors of MI-19089 line to inner conductors of MI-19113C; MI-27988-4B adapts MI-19089 to MI-19313C inner conductors.

Catalog Number	Dimension A	Approx. Weight
MI-27988-4A	1.136" (28 mm)	6 oz. (171g)
MI-27988-4B	1.232" (31 mm)	6 oz. (171g)

Adapter, Male-to-Male

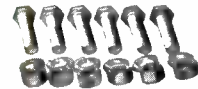
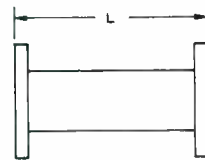

Connects male flanges of MI-19089 and EIA components.

Catalog Number	Insert Length (L)	Approx. Weight
MI-27938-7E	6" (152 mm)	5 1/2 lbs. (2500g)

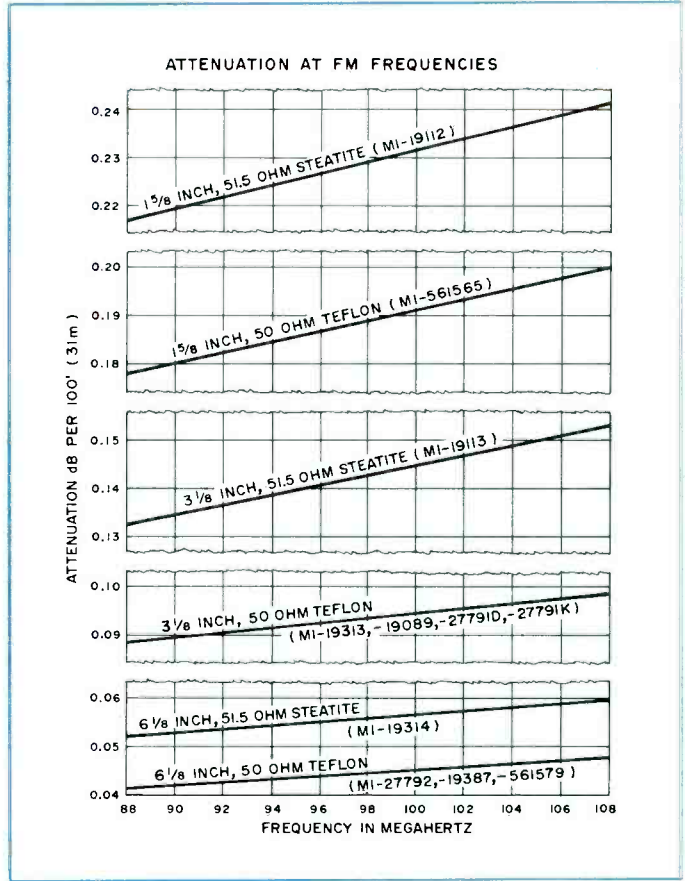
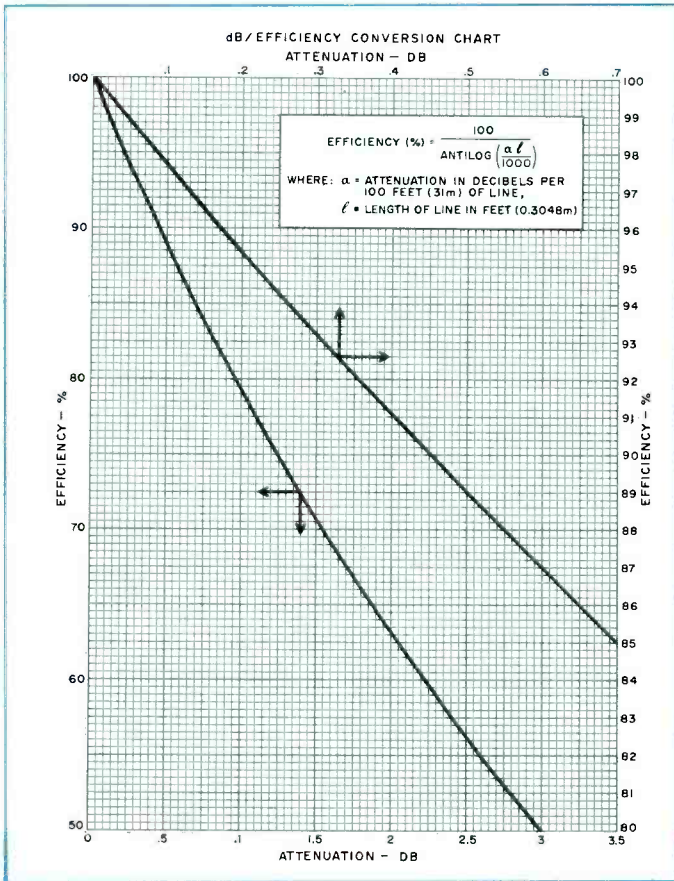

Nominal Diameter	Recommended Service	Coupling Device	Pressure Tight	Power Rating 1 MHz ¹	Power Rating 100 MHz	Efficiency	Wgt/100 Lbs/kg	Catalog Number	Catalog Page No.
RIGID 50-OHM IMPEDANCE—TEFLON INSULATED									
1 5/8"	FM, VHF-TV	Unflanged	No	28.5			115/52	MI-561565	RA.5011
3 3/8"	AM, FM, TV	Universal	Yes	94		See Curves, opposite page	280/127	MI-27791D	RA.5011
3 3/8"	AM, FM, VHF-TV	Unflanged	No	94		See Curves, next page	230/104	MI-27791K	RA.5011
3 3/8"	FM, TV	Bolt Flange	Yes	94		See Curves, next page	270/122	MI-19089	TR.2301 ²
6 1/8"	FM, VHF-TV	Unflanged	No			See Curves, next page	625/284	MI-561579	RA.5011
RIGID 51.5 OHM IMPEDANCE—STEATITE AND TEFLON INSULATED									
1 5/8"	AM, FM	Bolt Flange	Yes	25			125/57	MI-19112	TR.2401 ²
1 5/8"	AM, FM	Unflanged	No	25		See Curves, opposite page	120/54	MI-19112	TR.2401 ²
3 3/8"	AM, FM, VHF-TV	Bolt Flange	Yes	94		See Curves, next page	250/113	MI-19113C	RA.5011
3 3/8"	AM, FM	Unflanged	No	94		See Curves, next page	265/120	MI-19113C	RA.5011
3 3/8"	AM, FM, VHF-TV*	Bolt Flange*	Yes*	92		See Curves, opposite page	255/115*	MI-19313C*	RA.5011
3 3/8"	AM, FM, VHF-TV*	Unflanged*	No*	92		See Curves, next page	240/109*	MI-19313C*	RA.5011
6 1/8"	AM, FM, VHF-TV	Bolt Flange	Yes	288		See Curves, opposite page	730/331	MI-19314C	TR.2401 ²
6 1/8"	AM, FM, VHF-TV	Unflanged	No	288		See Curves, next page	695/316	MI-19314C	TR.2401 ²
*Teflon insulated.									
SEMI-RIGID 50-OHM IMPEDANCE—POLYETHYLENE INSULATED									
1/2"	AM, FM	Continuous ³	Yes	10.0		See Curves, subsequent page	27/12	HJ4-50	RA.5011
7/8"	AM, FM	Continuous ³	Yes	44.0		See Curves, subsequent page	53/24	HJ5-50	RA.5011
1 1/2"	AM, FM	Continuous ³	Yes	145.0		See Curves, subsequent page	104/47	HJ7-50	RA.5011
3"	AM, FM	Continuous ³	Yes	320.0		See Curves, subsequent page	178/81	HJ8-50	RA.5011
5"	AM, FM	Continuous ³	Yes	830.0		See Curves, subsequent page	330/150	HJ9-50	RA.5011
SEMI-RIGID 50-OHM IMPEDANCE—FOAM INSULATED									
1/4"	AM, FM	Continuous ³	No	5.0		See Curves, subsequent page	7/3	FHJ1-50	RA.5011
3/8"	AM, FM	Continuous ³	No	8.0		See Curves, subsequent page	12/5	FHJ2-50	RA.5011
1/2"	AM, FM	Continuous ³	No	19.0		See Curves, subsequent page	18/8	FHJ4-50	RA.5011
7/8"	AM, FM	Continuous ³	No	44.0		See Curves, subsequent page	44/20	FHJ5-50	RA.5011
1 1/2"	AM, FM	Continuous ³	No	145.0		See Curves, subsequent page	130/59	FHJ7-50	RA.5011

¹In kW at 100% modulation, unity VSWR.

²Available at any RCA Broadcast Field Office or Transmission Line Marketing, RCA Bldg. 2-2, Camden, N. J. 08102.

³Attachable connectors available.

Layout and Installation of Rigid Transmission Line.

A dimensioned layout of the entire transmission line run is helpful in selection of line components and fittings. FM-radio systems usually require a "horizontal" run between the tower base and the transmitter as well as a "vertical" run up the tower to the antenna. AM transmission lines terminate at a tuner at the base of the tower. If the AM tower is base-insulated and also supports an FM antenna, the FM transmission line must include an iso-coupler or be quarter-wave insulated from the tower.

Installation Precautions

Care is required in handling the various transmission line components to prevent damage and assure proper installation. Procedures are outlined in "Transmission Line Do's and Don'ts".

Tower steel must be designed to sup-

port the vertical run in a straight line, and maintain line clearance within spring hanger guide rings under load.

Vertical Run Considerations

Provision must be made to accommodate the difference in expansion coefficients between the copper of the line and the steel of the tower. This is accomplished by fixing the line at the tower top and "floating" it down the tower on spring hangers, with expansion accumulating at the bottom of the tower.

Generally, only standard lengths should be included in the vertical run except at the top. However, one or two special lengths may be inserted if it permits a better pattern of hangers. Positions of flanges relative to hangers, guide rings and tower members must be carefully planned to avoid interference as the line moves relative to the tower. Where interference between line flanges and spring

hangers may occur due to a peculiar spacing of tower horizontal members, a steel plate may be used to mount the hanger a sufficient distance above or below the flange to avoid such interference.

Ideally, spring hangers supporting the vertical run of transmission line should occur every 10 feet (3.1 m) however minor variations may be used provided an average of one hanger for each 10 feet of line is maintained. The vertical portion of line near the top of the run should be anchored firmly using appropriate hanger or hangers. Spring-loading charts are used to set spring tensions of expansion hangers. As finally installed, the line must be *vertical* and *free to move* in the hanger guides. When installing transmission line, the preferred method is to start at the bottom and work toward the top. Two transmission line series (MI-27791D and MI-19089) must be mounted with the anchor insulator of each section at the

Transmission Line Do's and Don'ts

DO'S

1. DO store packaged transmission line in clean dry place to prevent contamination.
2. DO check operation of inner expander assembly* and any components suspected of contamination with dirt or moisture.
3. DO cap all unpacked components against the entry of moisture.
4. DO hoist components with connector end up unless component is marked otherwise.
5. DO check the line in the spring hanger guides after each section is installed to insure free movement for expansion. Shiming of guides at tower support may be necessary.
6. DO consult spring-loading dimension chart (in Hangers section) for proper spring tension on expansion hangers and adjust each position on the tower accordingly.
7. DO ascertain that inner conductors of adjacent sections match alignment to prevent inadvertent damage to the connector. Hold top connector insulator in place and see that the insulator is well seated before installing the next section.
8. DO tap outside of universal line Marman clamps with plastic-faced hammer, all the way around, to seat clamp as it is tightened.
9. DO tighten flange bolts alternately, one side, then the other, before final torquing.
10. DO use torque wrench for final tightening.
11. DO pressurize line immediately following installation, and maintain 3 lbs/in² (0.2 atm.) at all times. Leaks must be repaired immediately.
12. DO keep ends of transmission line capped during installation. If installation is halted, seal installed line ends and pressurize to at least 0.5 lbs/in² (0.04 atm.) with dry air or nitrogen.
13. DO coat O-ring gaskets lightly with Dow-Corning DC-4 silicone compound to ease assembly.
14. DO check O-ring and its groove for dirt or other foreign material and ascertain that ring is properly seated before flange assembly.

DON'TS

1. DON'T hoist coupled sections of transmission line. The stresses involved damage components.
2. DON'T use force when fitting components one to another. If cause cannot be corrected or isn't evident visually, call for RCA assistance.
3. DON'T assemble line components that contain water or condensation.
4. DON'T assemble line components that contain dust, dirt, packing material or other foreign objects. Consult RCA regarding any loose or suspicious material in the line as it is unpacked.
5. DON'T assemble match-marked components unless the marking is clear and understood. DON'T interchange match-marked items. Consult RCA about proper assembly.
6. DON'T install any line component with dust, dirt or grease on insulators.
7. DON'T install line that exhibits any evidence of damage.
8. DON'T attempt to correct defects discovered unless instructed and authorized by RCA to do so.
9. DON'T dismiss rigger until transmission line is completely installed and pressurized for at least 12 hours and the appropriate electrical tests performed.
10. DON'T power the transmission line until the line is known to be dry and pressurized to at least 3 lbs/in² (0.2 atm.).
11. DON'T exceed specified torque for clamp or flange bolts.
12. DON'T use a line flange with evidence of overstress.
13. DON'T use a damaged O-ring gasket. Use a new gasket whenever in doubt. The same goes for Marman Clamps.
14. DON'T bend elbow components to fit. If leg angle is incorrect, consult RCA.
15. DON'T let rigging equipment damage components. Provide proper protection.
16. DON'T cut tubing without a cut-off gauge and remove all burrs and chips from inside and outside of tubing.
17. DON'T assemble a horizontal run without proper support.

*Check inner conductor expansion joint for an excursion of 0.2 inch (5 mm) travel and in the extended position check for presence of contacting spring through exposed groove on inner conductor. In some lines the contacting spring is not visible in the extended position. Presence of the spring can be determined by inserting a 6-mil (0.15 mm) thick feeler gauge (0.5-inch or 13-mm wide) between the tubing inner surface and the connector body outer surface. If spring is present the feeler gauge can be inserted 0.25 inch (6.4 mm). If gauge goes in 0.5 inch (13 mm), spring is missing and line section must not be used.

top end. Series MI-19313, MI-19113C, and MI-19112 lines must be mounted with the rolled outer conductor insulator-supporting grooves at the lower end. In most cases, the elbow which joins the vertical and horizontal runs is a reinforced type.

Horizontal Run Considerations

In complex horizontal-line layouts involving elevation and direction changes, care must be exercised not to overstress miter elbows or introduce excessive flexing of the line. Frequently back to back elbows will be required to achieve desired angles.

As shown in the drawing, three-point, horizontal-spring hangers must support the line for the distance specified from the tower base. The line should be secured at the wall of the building using a horizontal anchor plate. Lines should be protected from falling ice.

When installing 51.5-ohm, 3/8-inch line (MI-19113 and MI-19313), the sections in the horizontal run must connect the grooved end of one section with the grooved end of the adjacent section. Similarly, the ungrooved end of each section must connect with the ungrooved end of the adjacent section. This arrangement anchors the inner conductor in both directions.

Indoor Installation Considerations

The indoor part of the transmission line is normally not pressurized. Therefore, a Gas Stop is required inside the building and unflanged components used between that point and the transmitter.

Purging Moisture from New Line

A transmission line installation must be free of moisture before power is applied. To purge an installed line, vent the line at the uppermost flange or port. Admit dry nitrogen at the transmitter end. Once purged, lines should be continuously pressurized with nitrogen or dry air. After any complete loss of pressure, the line should be purged before it is used again.

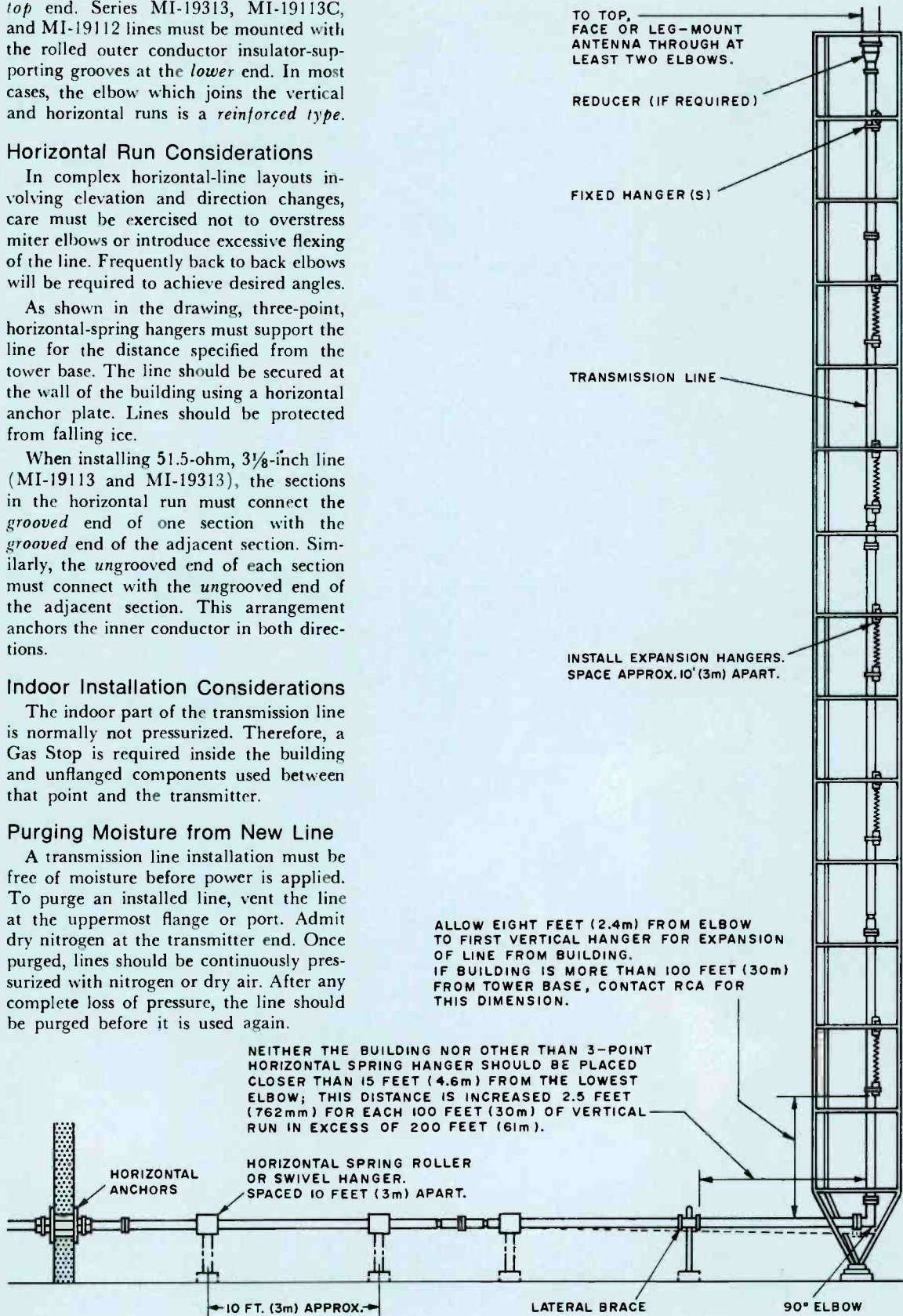

"Universal" Transmission Line

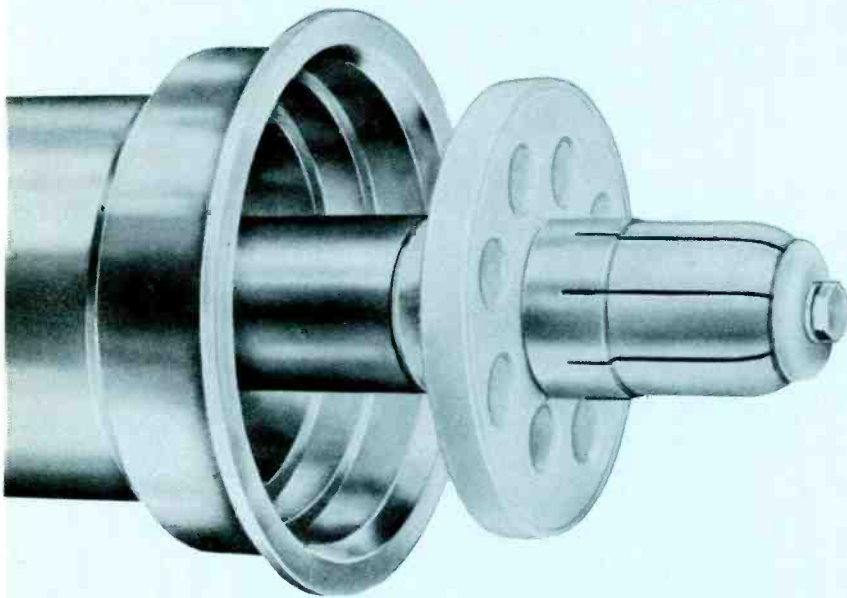

Universal transmission line uses a unique, error-proof coupling flange. There are no flange bolts; instead, a single, stainless-steel V-band clamp surrounds the beveled edges of the heliarc-welded, male and female flanges. This holds the flanges in complete alignment. The O-ring gasket is captive in a groove built into the male flange. This arrangement precludes an improperly seated gasket and hence, a leaky joint. Each Universal line coupling is a swivel joint inherently to eliminate the task of radial alignment during installation. A thick Teflon insulator, recessed in the female flange, supports the inner conductor. This design allows easy removal of the inner conductor whenever appropriate.

General Specifications

Nominal Diameter	3/8 inches
Insulation	Polytetrafluoroethylene Plastic (Teflon)
Outer Conductor Dimensions:	
Tube Outer Diameter (3.027" 77mm ID)	3.125" (79 mm)
Flange Diameter	4.531" (115 mm)
Clearance Hole Diameter (with Clamp)7" (178 mm)
Inner Conductor Dimensions:	
Tube Outer Diameter	1.315" (33 mm)
Tube Inner Diameter	1.231" (31 mm)
Characteristic Impedance	50 ohms
Catalog Number Series	MI-27791D

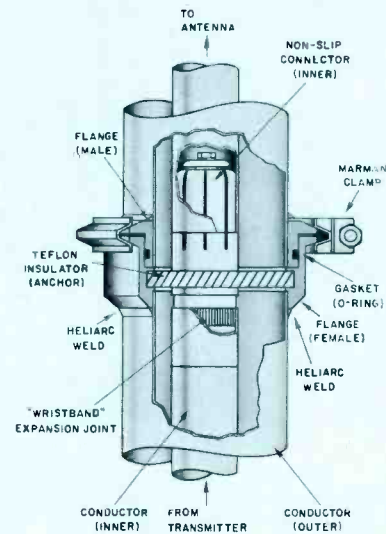

Line Sections



Shipped two sections per package. Each section includes connector, clamp, expansion joint and O-ring gasket.

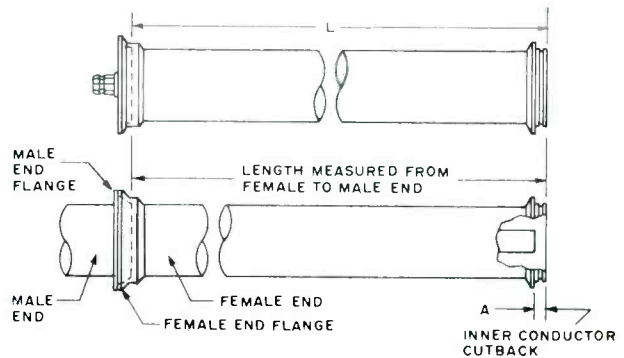

Catalog Number	Length (L)	Dim. A	Approx. Weight	Packaged Dimensions	Shipping Weight
MI-27791D-1A	20' (6.1 m)	.090-0.97	58 lbs. (26 kg)	248x12 1/2 x 8"	162 lbs. (73 kg)
MI-27791D-1B	19 1/2' (5.9)	(2.3-2.5mm)	52 lbs. (24 kg)	(6299x311x230)	149 lbs. (68 kg)

Couplings

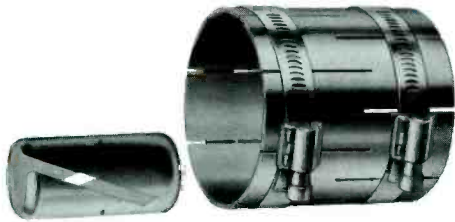

Join line sections and components.



Catalog Number	Nominal Diameter	Length (Dim. L)	Approx. Weight
MI-561565-4A	1 5/8"	2 3/8" (59 mm)	8 oz. (228g)
MI-27791K-4A	3 1/8"	4" (102 mm)	20 oz. (570g)
MI-565579-4A	6 1/8"	4 1/2" (114 mm)	65 oz. (1800g)

Connectors, Inner Conductor

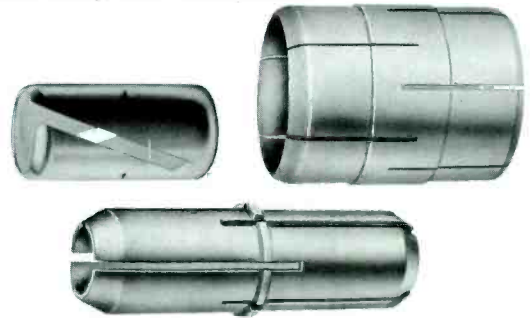

For joining inner conductors.

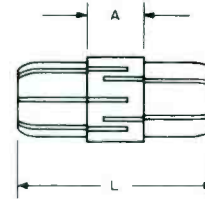

Catalog Number	Nominal Diameter	Length (Dim. L)	Insert Length (Dim. A)	Approx. Weight
MI-561565-4B	1 5/8"	2" (51 mm)	1/16" (1.6 mm)	2 oz. (57g)
MI-27791K-4B	3 1/8"	2 1/2" (64 mm)	1/16" (1.6 mm)	3 oz. (85g)
MI-561579-4B	6 1/8"	3 1/2" (89 mm)	1/16" (27 mm)	8 oz. (227g)

Adapter, Unflanged 1 5/8" to EIA Flanged 1 5/8"

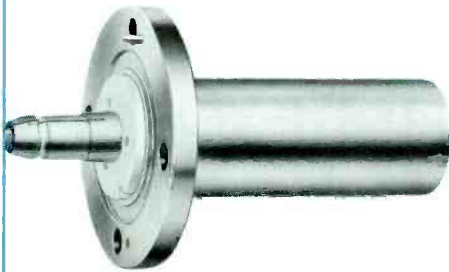

Converts unflanged MI-561565 to 1 5/8-inch EIA flanged components using coupling (MI-561565-4A) not supplied.

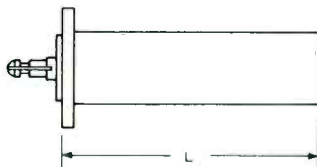

Catalog Number	Length (L)	Approx. Weight
MI-561565-7A	4 1/2" (114 mm)	1 1/2 lbs. (681g)

Adapter, Unflanged 3 1/8" to EIA Flange

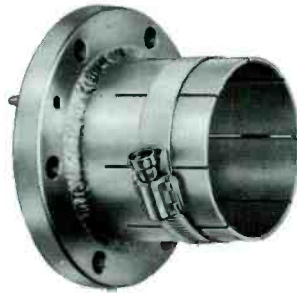

Flanges unflanged 3 1/8-inch (MI-27791K) line. Not pressure tight.

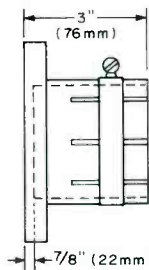

Catalog Number	Length (L)	Approx. Weight
MI-27988-4C	3" (76 mm)	2 1/2 lbs. (1100g)

Adapter, Unflanged 3 1/8" to "Universal" 3 1/8"

Provides Universal (MI-27791D) male flange on MI-27791K line. Not pressure tight.



Catalog Number	Length (L)	Approx. Weight
MI-27791K-7B	2 5/8" (66 mm)	2 1/4 lbs. (1000g)

Adapter, Unflanged 3/8" to "Universal" 3/8"

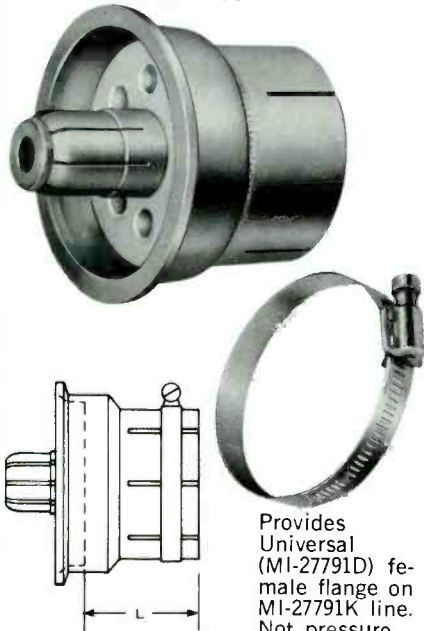

Provides Universal (MI-27791D) female flange on MI-27791K line. Not pressure tight.

Catalog Number	Length (L)	Approx. Weight
MI-27791K-7A	2 1/2" (63 mm)	3 1/2 lbs. (1400g)

Adapter, Unflanged 6 1/8" to Bolt-Flanged 6 1/8"

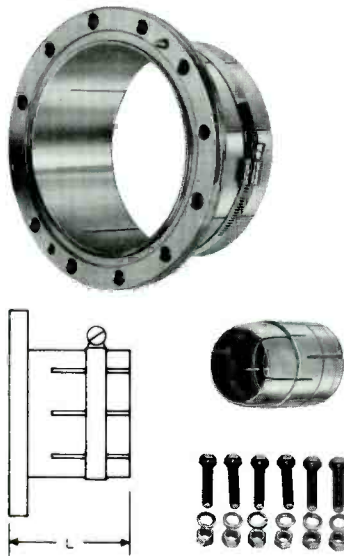

Flanges unflanged 6 1/8-inch (MI-561579) line to mate with 51.5 ohm bolt flanged line. Not pressure tight.

Catalog Number	Length (L)	Approx. Weight
MI-561579-7A	3 5/8" (93 mm)	8 lbs. (3.6 kg)

Reducer, Unflanged 1 5/8" to Type N



Converts unflanged 1 5/8 inch line (MI-561565) to a female Type N Connector.

Catalog Number	Approx. Weight
MI-561565-5B	8 oz. (227g)

Reducer, Unflanged 3/8" to Type N



Converts unflanged 3/8-inch line (MI-27791K) to a female Type N connector.

Catalog Number	Approx. Weight
MI-27791K-5A	4 1/4 lbs. (2 kg)

Reducer, Unflanged 6 1/8" to 3/8" EIA Flanged

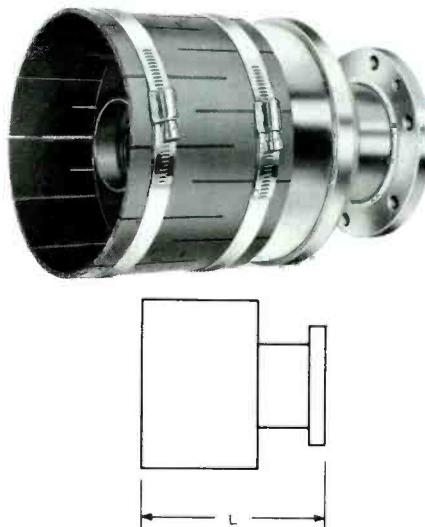

Reduces unflanged 6 1/8-inch 50 ohm line (MI-561579) to 3/8-inch EIA flanged 50 ohm line (MI-19089).

Catalog Number	Length (L)	Approx. Weight
MI-561579-5B	6 3/4" (171 mm)	9 lbs. (4 kg)

Reducer, Unflanged 3/8" to Unflanged 1 5/8"

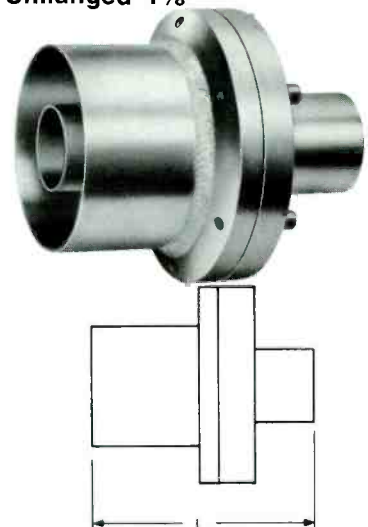

Reduces unflanged 3/8 inch line (MI-27791K) to unflanged 1 5/8 inch (MI-561565). Requires couplings (MI-27791K-4A and MI-561565-4A), not included.

Catalog Number	Length (L)	Approx. Weight
MI-561565-5A	5" (127 mm)	3 1/4 lbs. (1.5 kg)

Reducer, Unflanged 6 1/8" to Unflanged 3 1/8"

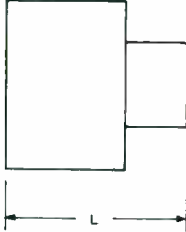

Reduces unflanged 6 1/8 inch line (MI-561579) to unflanged 3 1/8 inch line (MI-27791K). Requires coupling MI-27791K-4A (not supplied). Coupling for 6 1/2 inch end included with two clamps.

Catalog Number	Length	Approx. Weight
MI-561579-5A	6 3/4" (171 mm)	8.5 lbs. (3.8 kg)

Transformer-Adapter, Unflanged 6 1/8" to "Universal" 6 1/8"

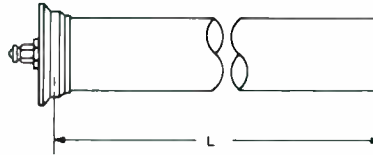

Transforms 6 1/8 inch 50 ohm (MI-27791K) to 6 1/8 inch 75 ohm (MI-27792D) and provides Universal female flanges. Specify channel or frequency when ordering.

Catalog Number	Length (L)	Approx. Weight
MI-561579-6T	52" (12m) (max.)	32 lbs. (17 kg) (max.)

Adapter, Inner Conductor, 1 5/8"

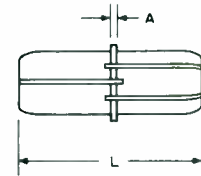

Couples inner conductor of 1 5/8 inch 50 ohm line (MI-561565) to inner conductor of 1 5/8 inch 51.5 ohm line (MI-19112).

Catalog Number	Length (L)	Dimension A	Approx. Weight
MI-561565-8A	2" (51 mm)	1/16" (1.6 mm)	2 oz. (57g)

Adapter, Inner Conductor, 3 1/8"

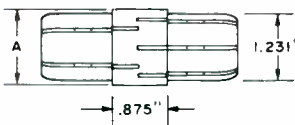

Couples inner conductor of 3 1/8-inch 50 ohm line (MI-27791K) to the inner conductor of 3 1/8-inch 51.5 ohm line (MI-19113C or MI-19313).

Catalog Number	Dimension A	Adapts To	Approx. Weight
MI-27988-4A	1.136" (28.9 mm)	MI-19313	6 oz.
MI-27988-4B	1.232" (31.3 mm)	MI-19113C	(171g)

Adapter, Inner Conductor 6 1/8" 50 ohm to 6 1/8" 51.5 ohm

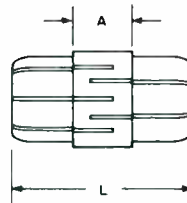

Couples inner conductor of 50 ohm line 6 1/8 inch, MI-561579, to the inner conductor of 51.5 ohm 6 1/8 inch, MI-19314C.

Catalog Number	Length (L)	Dimension A	Approx. Weight
MI-561579-8A	3 3/8" (81 mm)	1 1/8" (27 mm)	12 oz. (342g)

Clamps, Coupling



For Coupling	Catalog Number
1 5/8 inch (MI-561565-4A)	MI-561565-4C
3 1/8 inch (MI-27791K-4A)	MI-27791K-4C
6 1/8 inch (MI-561579-4A)	MI-561579-4C

Special Adapters

Reducer, 3 1/8" EIA to 7/8" EIA

Used between 3 1/8 inch EIA or MI-19089 7/8 inch EIA flanged components.

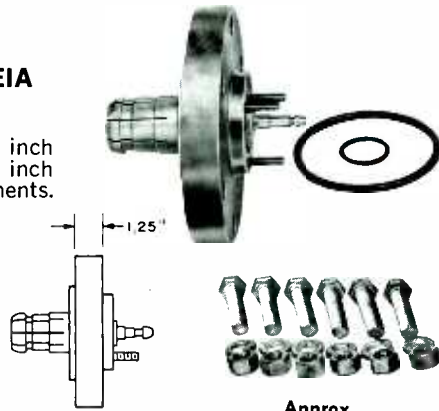

Catalog Number

Insert Length

Approx. Weight

MI-27988-5D

1.25" (32 mm)

3 lbs. (1.4 kg)

Reducer, 3 1/8" MI-19113C or 19313 to 7/8" EIA

Used between 51.5 ohm, 3 1/8 inch MI-19113C or MI-19313 line & 7/8 inch EIA flanged components. Includes two gaskets, six bolts, nuts, lockwashers (for 3 1/8 inch flange). Nuts and lockwashers for 7/8 inch flange included also.

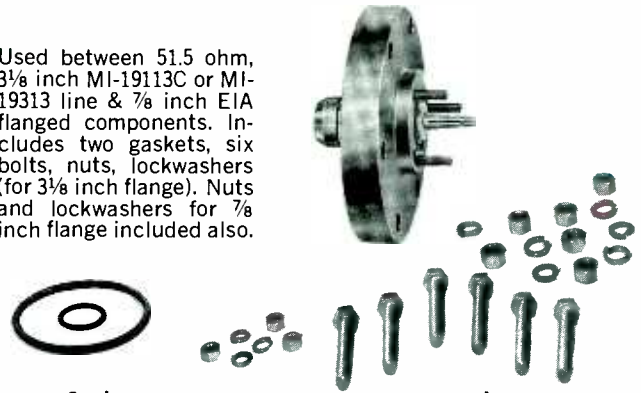

Catalog Number

Insert Length

Approx. Weight

MI-27988-5A

1.25" (32 mm)

3 lbs. (1.4 kg)

Reducer, 3 1/8" MI-19113C or 19313 to 1 5/8" EIA

Used between 3 1/8 inch line (MI-19113C or MI-19313) & 1 5/8 inch EIA flanged components.

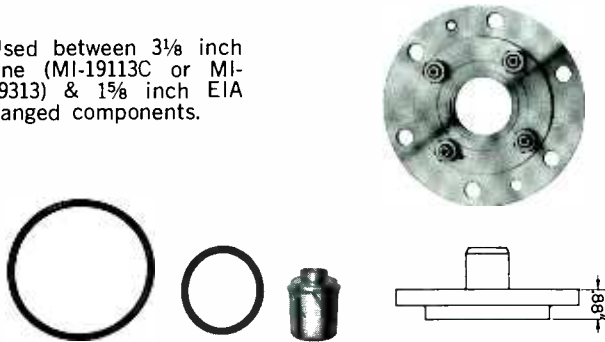

Catalog Number

Insert Length

Approx. Weight

MI-27988-5B

0.88" (22 mm)

8 oz. (227g)

Reducer, 1 5/8" EIA to 7/8" EIA

Used between 1 5/8 inch EIA flanged to 7/8 inch EIA flanged components. Includes two gaskets, seven bolts, nuts, lockwashers.

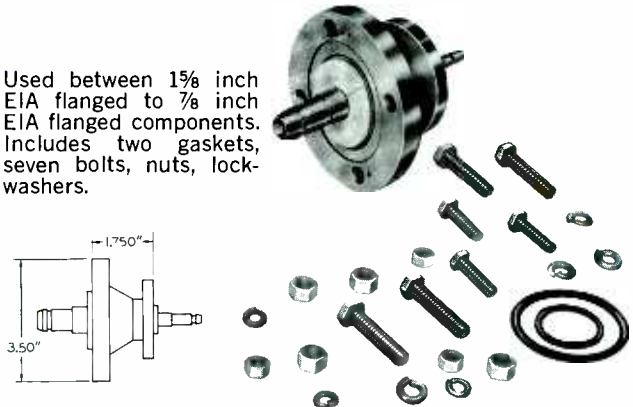

Catalog Number

Insert Length

Approx. Weight

MI-27988-5E

1.75" (44 mm)

3 lbs. (14 kg)

Semi-Rigid Transmission Line

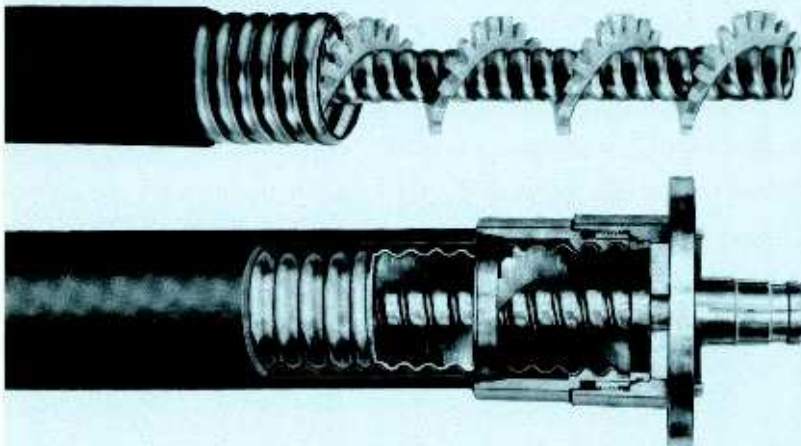

Heliax* is a semi-rigid coaxial cable suited to AM and FM power transmission. Its limited flexibility is the result of corrugated copper conductors. It is available in either 50 or 75 ohm impedance (only 50 ohm data included here). Semi-rigid line is of lighter weight than rigid, flanged line and, in some situations, less susceptible to damage than rigid line of comparable size. The line is available with either an air dielectric or filled with polyethylene foam. Sizes range from an instrumentation type 1/4 inch (6 mm) to a five-inch (127 mm) line with a high-power rating.

*Andrew Corporation Trademark.

Adapter, 51.5-Ohm

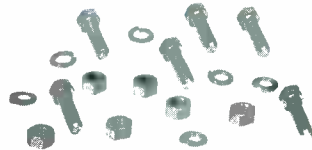
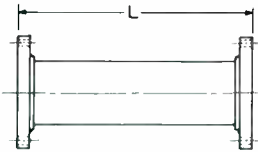

Adapts MI-19089 and EIA components to 51.5-ohm (MI-19113C or MI-19313).

Catalog Number	Insert Length (L)	Approx. Weight
MI-27988-7A	6" (152 mm)	5½ lbs. (2500g)

End Cap



For temporary closure of incomplete line installation to prevent entry of moisture. Includes plug for gas bleeding or pressurization.

Catalog Number	Approx. Weight
MI-19089-26	3 lbs. (1.4 kg)

Cutoff Guides



Inner and outer conductor guides that assure square cut.

Catalog Number	For	Approx. Weight
MI-19089-15	Outer	2.3 lbs. (1100g)
MI-19089-16	Inner	6 oz. (171g)

Miscellaneous



Product	Catalog Number
Gasket, O-Ring	MI-19113C-10
Kit, Hardware (6 Bolts, Nuts, Lockwashers)	MI-19113C-19
Tool, Lancing	MI-19089-29
Extractor, Anchor Insulator	MI-19089-20
Anchor Insulator Expansion Joint (Field Replacement Kit)	MI-19089-23
Inner Conductor (20' length). For use with Expansion Joint above	MI-19089-99-1
Grease, Silicone, 2 oz. Tube	MI-19089-18

Steatite Insulated 51.5 ohm Transmission Line

Steatite-insulated line is a 51.5 ohm line useful in AM and FM operations. Steatite is a fired ceramic insulator with a long history in power transmission. Steatite-insulated lines are available only in flanged styles in two nominal diameters: 3 1/8 and 6 1/8 inch. Only the 3 1/8 inch diameter is listed here because of its suitability to radio operations. Some components from the Teflon-insulated (MI-19313) series are compatible with steatite-insulated products. These Teflon components are described on the four pages following these two.



General Specifications

Nominal Diameter	3 1/8 inches
Insulation	Steatite Ceramic
Outer Conductor Dimensions:	
Tube Outer Diameter (3.027" 77 mm ID)	3.125" (79 mm)
Flange	5 1/8" (132 mm)
Inner Conductor Dimensions:	
Tube Outer Diameter	1.200" (30.5 mm)
Tube Inner Diameter	1.136" (28.9 mm)
Characteristic Impedance	51.5 ohms
Catalog Number Series	MI-19113C

Line Sections

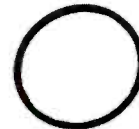
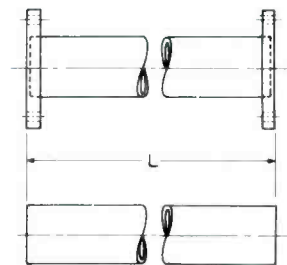
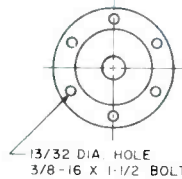
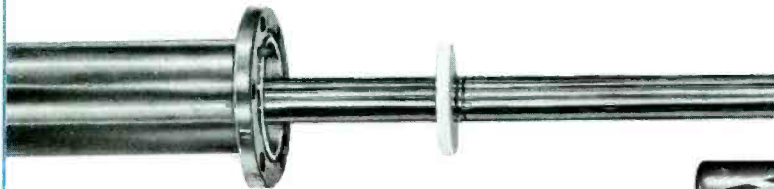

Shipped two sections per package. Use MI-19113C-1SF (swivel flange) for field replacement only. Channels between 97 and 99 MHz require 19 1/2 foot (5.94m) sections (special order only).

Catalog Number	Length (L)	Flanges	Approx. Weight	Package Dimensions	Shipping Weight
MI-19113C-1	20' (6.1m)	2 Fixed	53 lbs. (24 kg)	248x13x8 1/2"	150 lbs. (68 kg)
MI-19113C-1NF	20' (6.1m)	None	52 lbs. (24 kg)	(6300x330x216 mm)	148 lbs. (67 kg)

Elbows, Right Angle



Flanged elbow uses swivel flanges and includes inner-conductor connector, O-ring gasket, six bolts, nuts, lockwashers. Unflanged elbow includes inner-conductor connector only.

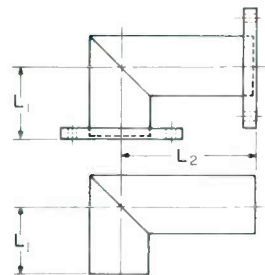
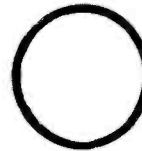

Catalog Number	L1	Insert Length	L2	Approx. Weight	Package Dimensions	Shipping Weight
MI-19113C-18	3 7/8" (98 mm)	8 1/8" (206 mm)	8 1/8" (206 mm)	11 1/4 lbs. (5 kg)	12 1/2 x 12 1/2 x 7" (317 x 317 x 178 mm)	14 lbs. (6 kg)
MI-19113C-18NF	3 7/8" (98 mm)	8 1/8" (206 mm)	8 1/8" (206 mm)	6 1/4 lbs. (3 kg)	10 x 6 x 4" (254 x 152 x 102 mm)	7 lbs. (3 kg)

Coupling, Unflanged

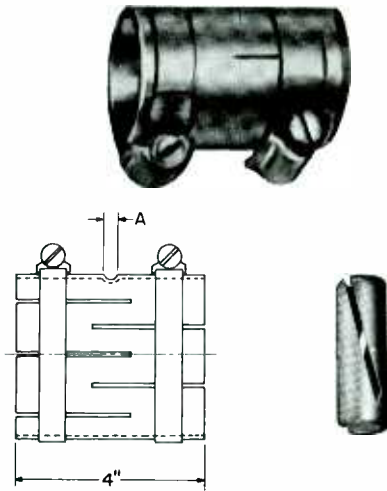

Couples unflanged line sections and components. MI-19113C-8NB inner connector.

Catalog Number	Insert Length (A)	Approx. Weight
MI-19113C-8B	$\frac{3}{8}$ " (5 mm)	1¼ lbs. (567g)
MI-19113C-8NB	$\frac{3}{8}$ " (5 mm)	1⅛ lbs. (510g)

Inner Conductor, Splicing

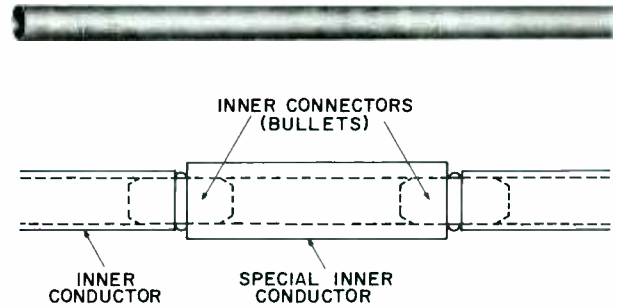

Enlarge inner-conductor tube for splicing MI-19113C line when cut at point other than midway between insulators. Each splice requires two MI-19113C-11 inner-conductor connectors. (Not supplied, see below.)

Catalog Number	ID	Dimensions OD	Length	Approx. Weight
MI-19113C-9	1.136" (29 mm)	1.282" (33 mm)	12' (3.7 m)	12½ lbs. (6 kg)

Connector, Inner Conductor

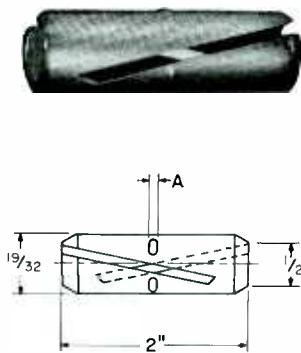

Joins inner conductors of MI-19113 components at joints or splices.

Catalog Number	Length	Approx. Weight
MI-19113C-11	2½" (64 mm)	2 oz. (57g)

Adapter, Inner Conductor

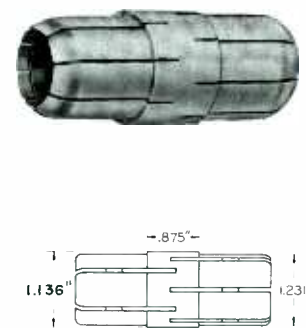

Connects inner conductor of MI-19113C line to inner conductor of MI-19089 line components.

Catalog Number	Insert Length	Approx. Weight
MI-27988-4A	$\frac{7}{8}$ " (22 mm)	6 oz. (171g)

Teflon-Insulated, 51.5 ohm Transmission Line



Teflon-insulated 51.5 ohm line is available in flanged and unflanged styles and features a "wristband spring" inner-conductor expansion joint that prevents galling and contamination of the insulation.

General Specifications

Nominal Diameter	3 ³ / ₈ inches
Insulation	Polytetrafluoroethylene Plastic (Teflon)
Outer Conductor Dimensions:	
Tube Outer Diameter (3.027" 77 mm ID)	3.125" (79 mm)
Flange Diameter	5 ¹ / ₈ " (132 mm)
Inner Conductor Dimensions:	
Tube Outer Diameter	1.282" (32.8 mm)
Tube Inner Diameter	1.231" (31.4 mm)
Characteristic Impedance	51.5 ohms
Catalog Number Series	MI-19313

Line Sections

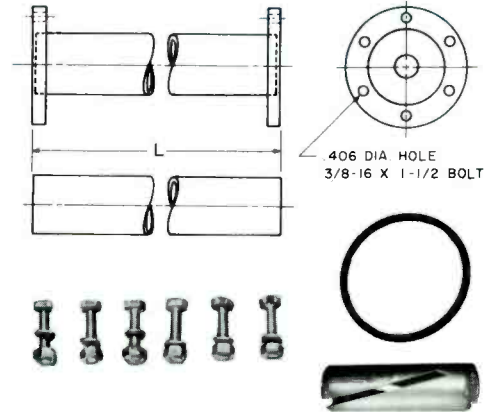
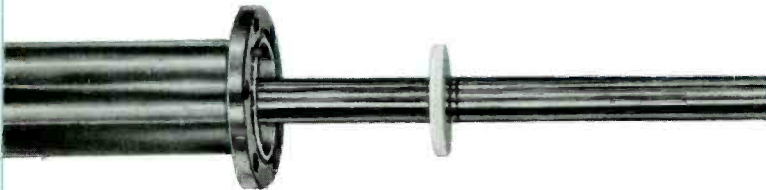

Inner conductor connector included with MI-19313-1NF. Use MI-19313-1SFH or MI-19313-1BSFH for replacement only. Channels between 97 and 99 MHz require 19¹/₂ foot (5.94 m) sections (MI-19313-1BH or -1BSFH).

Catalog Number	Length (L)	Flanges	Approx. Weight	Package Dimensions	Shipping Weight
MI-19313-1H	20' (6.1m)	2 Fixed	51 lbs. (23 kg)	248x13x8 ¹ / ₂ " (6300x330x216 mm)	149 lbs. (68 kg)
MI-19313-1NF	20' (6.1m)	None	48 lbs. (22 kg)		143 lbs. (65 kg)
MI-19313-1SFH	20' (6.1m)	1 Fixed 1 Swivel	52 lbs. (23 kg)		150 lbs. (68 kg)
MI-19313-1BH	19 ¹ / ₂ ' (5.9m)	2 Fixed	48 lbs. (22 kg)		147 lbs. (67 kg)
MI-19313-1BSFH	19 ¹ / ₂ ' (5.9m)	1 Fixed 1 Swivel	48 lbs. (22 kg)		148 lbs. (67 kg)

Elbows, Right-Angle

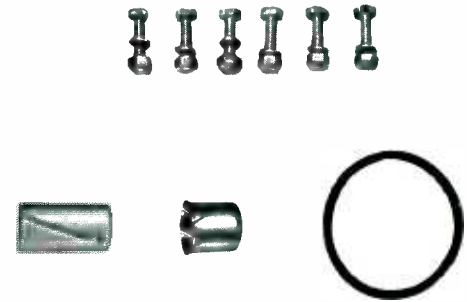
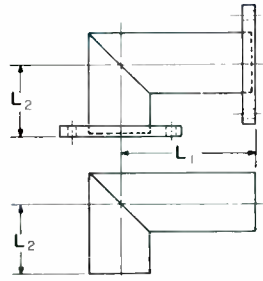
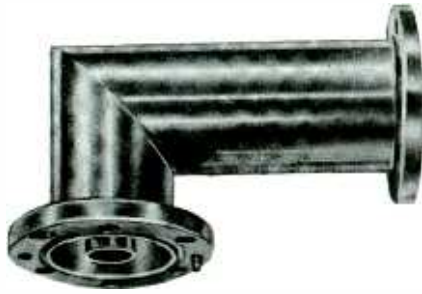

Flanged elbow uses swivel flanges and includes one inner-conductor connector, one inner-conductor-connector adapter, one O-ring gasket, six bolts, nuts, and lockwashers. MI-19313-2R is a reinforced version of the MI-19313-2. Unflanged elbow includes one inner-conductor connector and one inner-conductor-connector adapter.

Catalog Number	Insert Length L1	Insert Length L2	Flanges	Approx. Weight	Package Dimensions	Shipping Weight
MI-19313-2	8½" (216 mm)	37/8" (98 mm)	2 Swivel	11½ lbs. (5.2 kg)	12½x12½x7" (317x317x178 mm)	14 lbs. (6 kg)
MI-19313-2NF	8" (203 mm)	3¾" (95 mm)	None	6½ lbs. (3 kg)		9 lbs. (4 kg)

Coupling, Unflanged

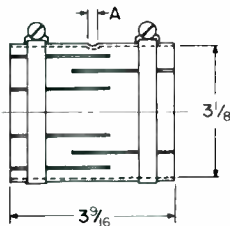

Couples unflanged line sections and components. Omits inner connector.

Catalog Number	Insert Length (A)	Approx. Weight
MI-19313-8	3/16" (5 mm)	1¼ lbs. (567g)
MI-19313-8NB	3/16" (5 mm)	1½ lbs. (510g)

Adapter, Inner Conductor

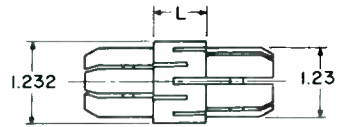

Connects MI-19313 inner conductor to that of MI-19089 or EIA flanged line components.

Catalog Number	Insert Length (L)	Approx. Weight
MI-27988-4B	7/8" (22 mm)	6 oz. (171g)

Connector, Inner Conductor

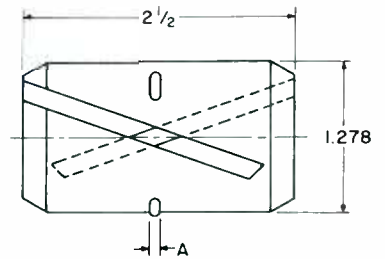

For joining inner conductors of MI-19313 transmission line sections.

Catalog Number	Insert Length (A)	Approx. Weight
MI-19313-9	1/16" (1 mm)	2 oz. (57g)

Gas Stop

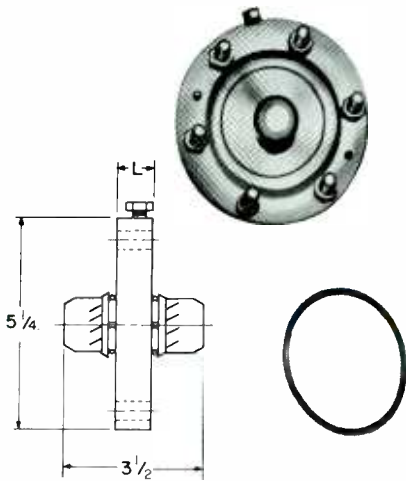

Seals pressurized section from unpressurized. Fits MI-19113C or MI-19313 components. O-ring gasket and hardware (six bolts, nuts, lockwashers) included.

Catalog Number	Insert Length (L)	Approx. Weight
MI-19113C-5	7/8" (22 mm)	4 3/4 lbs. (3 kg)

Flange, Mechanical

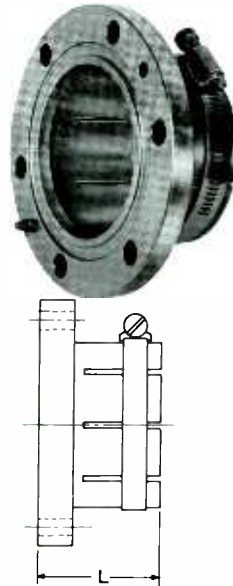

Flanges MI-193113C or MI-19313 unflanged line. Not pressure tight.

Catalog Number	Length (L)	Approx. Weight
MI-19113C-60	2" (51 mm)	3 1/4 lbs. (1.5 kg)

Flange, Soft-Solder

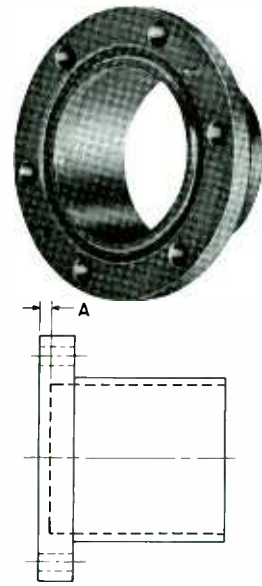

Flanges field-cut MI-19113C or MI-19313 line.

Catalog Number	Insert Length (A)	Approx. Weight
MI-19113C-55	1/4" (6.4 mm)	3 lbs. (1.4 kg)

Guides, Cutoff



Inner and outer conductor cutoff guides that assure square cut. Inner guide shown.

For	Approx. Weight	Catalog Number
MI-19113 Inner	5 oz. (143g)	MI-19113C-54
MI-19313 Inner	6 oz. (171g)	MI-19113C-51
MI-19113C-9 Inner	5 oz. (143g)	MI-19113C-54
MI-19113 Outer	10 oz. (286g)	MI-19089-15
MI-19313 Outer	10 oz. (286g)	MI-19089-15

Reducer, 1 5/8 Inch Flanged

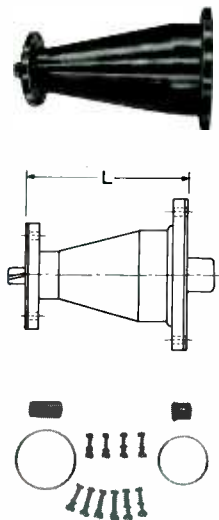

Reduces 3 3/8-inch (MI-19113C or MI-19313) line to mate with 1 5/8-inch (MI-19112) line.

Catalog Number	Insert Length (L)	Approx. Weight
MI-19113C-6	5-5/32" (131 mm)	5.6 lbs. (3 kg)

Reducer, 7/8 Inch EIA Flange

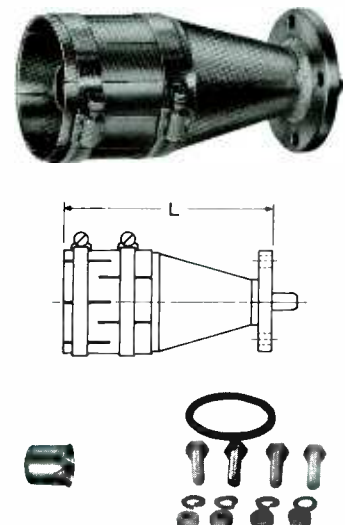

Reduces 3 3/8-inch (MI-19113C or MI-19313) unflanged line to mate with 7/8 inch EIA flanged components.

Catalog Number	Insert Length (L)	Approx. Weight
MI-27988-5A	1 1/4" (32 mm)	8 oz. (228g)

Reducer, 1 5/8 Inch Unflanged

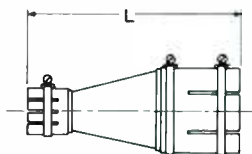

Reduces 3 7/8-inch (MI-19113C or MI-19313) unflanged line to mate with 1 5/8-inch (MI-19112) unflanged line.

Catalog Number	Insert Length (L)	Approx. Weight
MI-19113C-7	7" (178 mm)	3 lbs. (1.4 kg)

Reducer, Type N



Converts unflanged (MI-19113 or MI-19313) line to a Type N female coaxial connector.

Catalog Number	Length	Approx. Weight
MI-19113C-58	•	4 lbs. (2 kg)

Bushing, Adapter

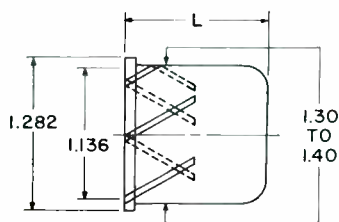

Reduces inner diameter of MI-19313 inner conductor to mate with MI-19113 component inner conductors.

Catalog Number	Length (L)	Approx. Weight
MI-19313-11	1 1/8" (33 mm)	2 oz. (57g)

Adapter, Inner Conductor

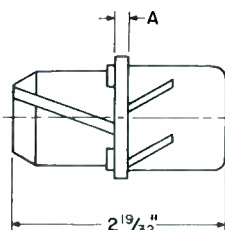

Connects inner conductors of MI-19113C line with those of MI-19313 line.

Catalog Number	Insert Length (A)	Approx. Weight
MI-19313-10	1/8" (3 mm)	4 oz. (114g)

End Cap



Temporarily caps open ends of line (MI-19113C or MI-19313) to prevent moisture entry during installation.

Catalog Number	Package Dimensions	Approx. Weight
MI-19113C-13	6x6x4 1/2" (152x152x114 mm)	14 1/4 lbs. (6.5 kg)

Unflanged, 50 ohm Transmission Line

Unflanged line is a hard tempered copper transmission line designed for unpressurized indoor applications in AM and FM. It employs a low loss Teflon dielectric and operates with high efficiency. A complete line of components in 1 5/8-, 3 1/8- and 6 1/8-inch nominal diameters provides installation versatility for a wide power range.

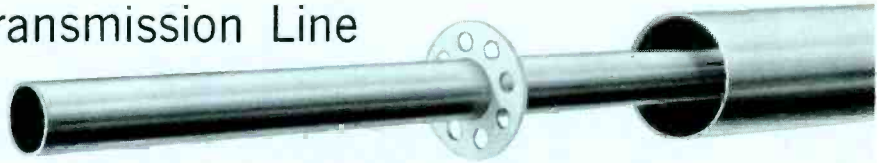

General Specifications

Nominal Diameter1 5/8; 3 1/8; 6 1/8 inches
 InsulationPolytetrafluoroethylene Plastic (Teflon)

Outer Conductor Dimensions:

Outer Dia.1.625" (41mm); 3.125" (79mm); 6.128" (168mm)
 Inner Dia.1.527" (38mm); 3.027" (77mm); 5.981" (152mm)
 Characteristic Impedance50 ohms
 Catalog Number SeriesMI-561565; MI-27791K; MI-561579

Line Sections

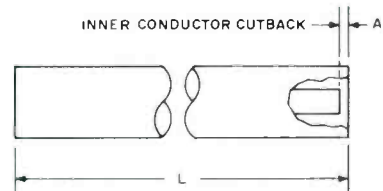
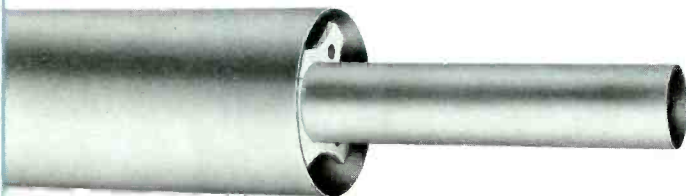

Each section 20 feet long (6.1m)

Catalog Number	Nominal Diameter	Dimension A	Approx. Weight	Package Dimensions	Lengths Per Package	Shipping Weight
MI-561565-1A	1 5/8"	0.015" (0.39 mm)	25 lbs. (11 kg)	8 1/2x13x248" (216x330x6299 mm)	6	203 lbs. (93 kg)
MI-27791K-1A	3 1/8"	0.215" (5.4 mm)	52 lbs. (24 kg)	8 1/2x13x248" (216x330x6299 mm)	2	148 lbs. (67 kg)
MI-561579-1A	6 1/8"	0.71" (18 mm)	67 lbs. (30 kg)	10x10x248" (254x254x6299 mm)	1	112 lbs. (51 kg)

Elbows, Right-Angle

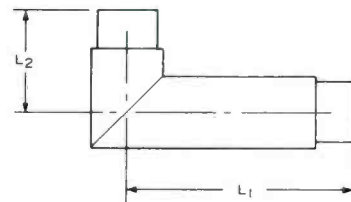

Catalog Number	Nominal Diameter	L1	Dimension L2	Approx. Weight
MI-561565-2A	1 5/8"	6" (151 mm)	2 1/6" (62 mm)	2 3/4 lbs. (1.3 kg)
MI-27791K-2A	3 1/8"	8" (205 mm)	3 3/4" (95 mm)	6 lbs. (2.7 kg)
MI-561579-2A	6 1/8"	12" (305 mm)	6" (152 mm)	21 1/2 lbs. (9.7 kg)

POWER CURVES
50-OHM AIR DIELECTRIC HELIAX AT UNITY VSWR

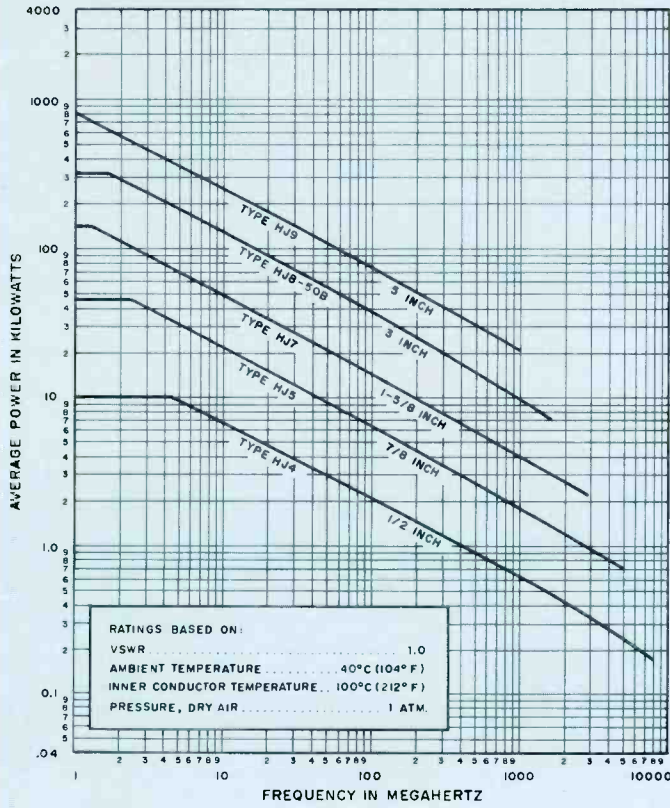

POWER CURVES
50-OHM FOAM DIELECTRIC HELIAX AT UNITY VSWR

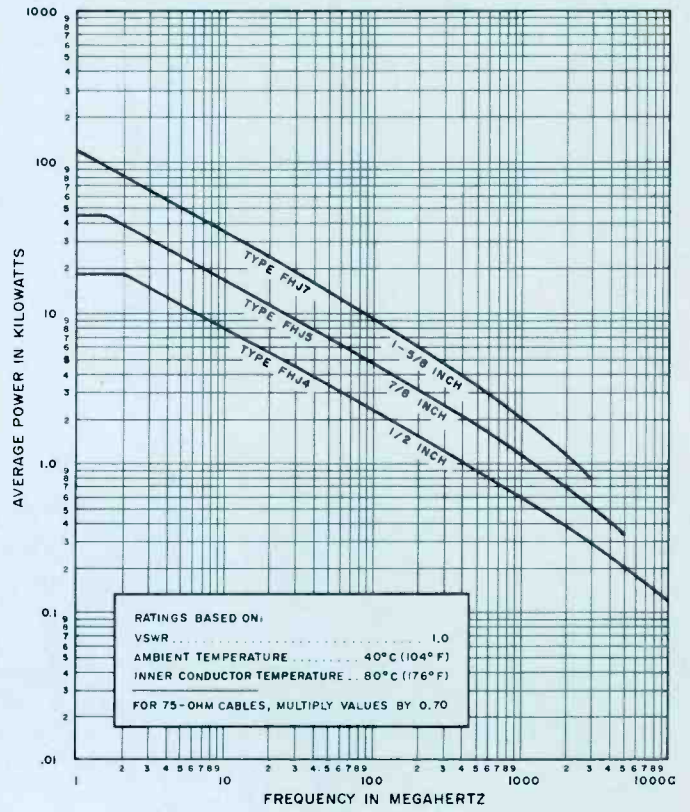

ATTENUATION CURVES
50-OHM, AIR DIELECTRIC HELIAX AT UNITY VSWR

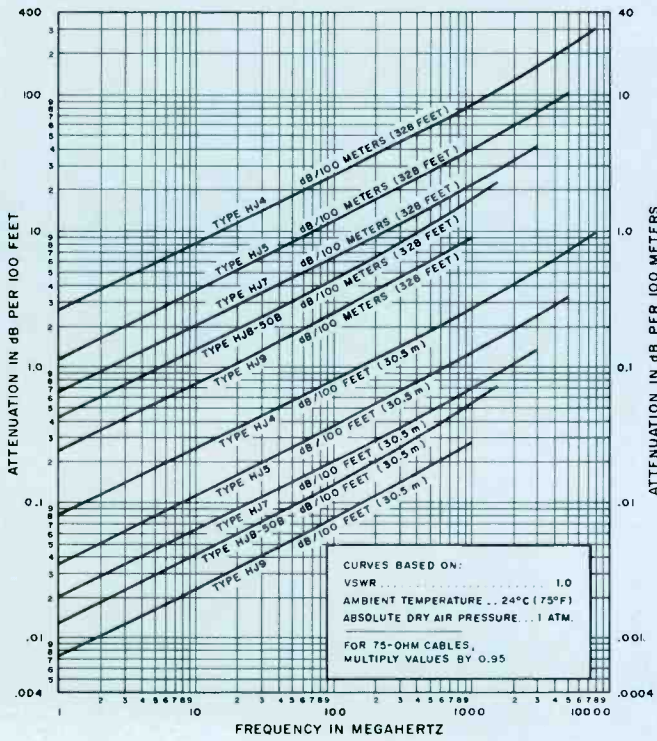

ATTENUATION CURVES
50-OHM, FOAM DIELECTRIC HELIAX AT UNITY VSWR

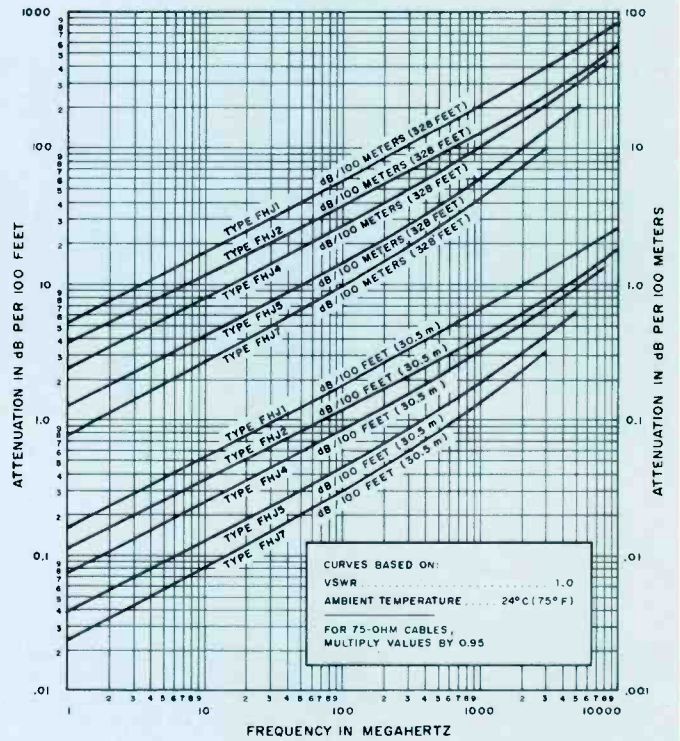

SPECIFICATIONS/ORDERING INFORMATION SEMI-RIGID CO-AX LINE

Nominal Diameter	Velocity	1 MHz Power Rating (kW)	Attenuation	Outside Diameter		Minimum Bend Radius		Weight		Catalog Number
				inches	(mm)	inches	(mm)	lbs/ft	kg/m	
AIR DIELECTRIC										
½"	91.4%	10	See Curve, preceding page	0.58	(14.7)	5	(127)	0.27(122g)	0.413	HJ4-50
⅞"	91.6	44		1.11	(28.2)	10	(254)	0.53(240g)	8.10	HJ5-50
1⅝"	92.1	145		2.00	(50.8)	20	(508)	1.04(470g)	1.59	HJ7-50
3"	92.3	320		3.02	(76.7)	30	(762)	1.78(807g)	2.72	HJ8-50
FOAM DIELECTRIC										
¼"	79	5	See Curve, preceding page	0.29	(7.4)	2.50	(63.5)	0.06(27g)	0.09	FHJ1-50
⅜"	79	8		0.44	(11.2)	3.75	(95.2)	0.12(54g)	0.18	FHJ2-50
½"	79	19		0.62	(15.7)	5.00	(127)	0.18(82g)	0.28	FHJ4-50
⅞"	79	44		1.09	(27.7)	10.0	(254)	0.44(200g)	0.67	FHJ5-50
1⅝"	79	145		2.00	(50.8)	20.0	(508)	1.35(612g)	2.06	FHJ7-50

lbs/ft x 3.37 = lb/m
lbs/m x 0.4536 = kg/m

SEMI-RIGID CO-AX LINE ACCESSORIES

Line Nominal Diameter (inches) Line Type Number	FOAM DIELECTRIC					AIR DIELECTRIC			
	¼"	⅜"	½"	⅞"	1⅝"	½"	⅞"	1⅝"	3"
	FJH1-50	FJH2-50	FHJ4-50	FHJ5-50	FHJ7-50	HJ4-50	HJ5-50	HJ7-50	HJ8-50
UHF Jack (Female)	41U	42U	44AU	45AU	—	—	75AU	—	—
UHF Plug (Male)	41P	42P	44AP	45AP	—	—	—	—	—
Type N Jack (Female)	41N	42N	44AW	45AW	—	74N	75AN	87N	—
Type N Plug (Male)	41W	42W	44AN	45AN	—	74W	75AW	—	—
Adapter, End Terminal	13212-2 ²	13212-2 ²	44AT	45AT	2061	—	75AT	2061	2062
Elbow, Mitre	—	—	—	—	—	—	1060	1061	1062
Wraplock, Stainless Steel	12395-1	12395-1	12395-1	12395-1	12395-1	12395-1	12395-1	12395-1	—
Tie Wires, Copperweld	27290A	27290A	—	—	—	—	—	—	—
Clamp, Mounting, Insulated	11662-3 ¹	11662-3 ¹	11662-3	11662-2	33948-3	—	—	—	—
Flange, EIA	—	—	44AR	45AR	47R	—	75AR	87R	78ARM
Flange, EIA w/Gas Barrier	—	—	—	—	—	—	75AG	87G	78AGM
Splice	—	—	44AZ	45AZ	47Z	—	75AZ	87Z	78AZ
Grip, Hoisting	—	—	—	—	—	—	19256B	24312A	26985A
Type LC Plug (Male)	—	—	44AM	45AM	47M	—	—	—	—
Type LC Jack (Female)	—	—	—	45AL	47L	—	—	—	—
Kit, Grounding (Copper Line)	—	—	26892-2	40993-5	40993-2	26892-2	40993-5	40993-2	40993-11
Kit, Hanger	—	—	—	31776-5 ⁵	31776-2 ⁵	—	31766-5 ⁵	31766-2 ⁵	33598-3 ⁵
Adapters, Hanger:									
Angle Iron Member	—	—	—	31768-1	31768-1	—	31768-1	31768-1	33981-1
Round Tower Member	—	—	—	31670- ³	31670- ³	—	31670- ³	31670- ³	33984-1 ⁴
Hanger, Insulated	—	—	—	—	—	11662-3	11662-2	33948-3	33948-2
Adapters, Insulated Hangers:									
Angle Iron Member	—	—	—	—	—	13555A	13555A	13555A	13555A
Round Tower Member	—	—	—	—	—	13550	13550	13550	13550
Barrier, Gas	—	—	—	—	—	—	1260A	1261B	1262A
Dehydrator, Automatic	—	—	—	—	—	1920A	1920A	1920A	1920A
Pump, Dry Air	—	—	—	—	—	878A	878A	878A	878A
Fittings, Nitrogen Tank	—	—	—	—	—	858C	858C	858C	858C

¹Clamp for half inch line, shim smaller diameters.

²Use with Type N Plug.

³Please specify diameter of tower member (-1 = 1-2"; -2 = 2-3"; -3 = 3-4"; -4 = 4-5"; -5 = 5-6").

⁴For 1-3" tower legs; for 3-4" legs, use 41108-1; for 4-5", use 41108-2; for 5-6" legs, use 41108-3.

⁵Kit contains hangers only. Tower adapters required. See "Adapters, Hanger" listing.



Transmission Line Hangers and Accessories

- For vertical support
- For horizontal support
- Rigid and expansion
- For indoor or outdoor use



Described here are hangers for 3/8 inch rigid transmission line. They can be supplied for vertical and horizontal runs and for indoor as well as outdoor use. Insulated types permit support of lines on insulated AM towers. Parenthetical dimensions in millimeters unless designated otherwise.

Vertical Support

SINGLE, FIXED

Long arm unit (8 5/8") matches standoff dimension of insulated hanger. Use heavy duty hanger (see below) for runs 750' (229 m) and longer. For 3 1/8-inch line only.

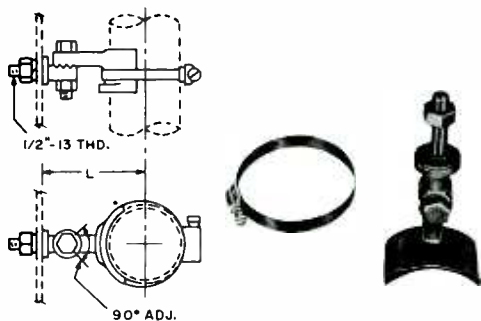

Dimension L	Approx. Weight	Catalog Number
5" (127)	1 1/2 lbs. (680g)	MI-19313-44
8 5/8" (217)	1 3/4 lbs. (794g)	MI-19313-47

SINGLE, EXPANSION

Long arm unit (8 5/8") matches standoff of insulated hanger (see below, left). For 3 1/8-inch line only.

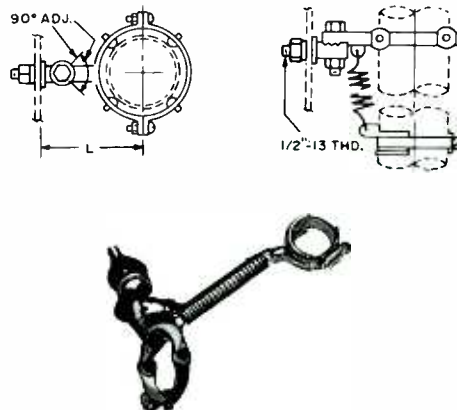

Dimension L	Spring Chart	Approx. Weight	Catalog Number
5" (127)	A	3 lbs. (1.4 kg)	MI-19313-32
8 5/8" (217)	A	3 1/4 lbs. (1.5 kg)	MI-19313-33

SINGLE, INSULATED; EXPANSION

Insulated counterpart of MI-19313-33 described above. For 3 1/8-inch line only.

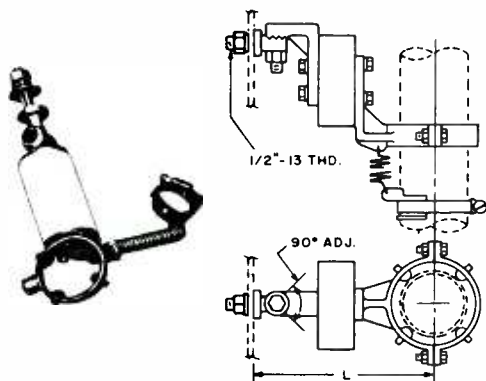

Dimension L	Spring Chart	Approx. Weight	Catalog Number
8 5/8" (217)	A	7 lbs. (3.2 kg)	MI-19313-34

FIXED, HEAVY DUTY

Use for runs 750' (229 m) and longer. Dotted lines in drawing are tower members. Mounting details packed with product. For 3 1/8-inch line only.

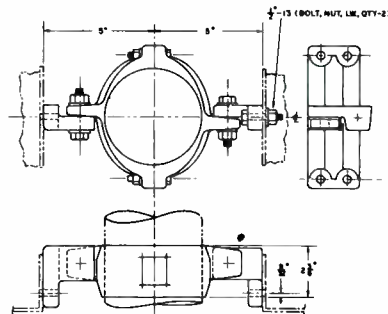

Approx. Weight	Catalog Number
13 lbs. (6 kg)	MI-19313-41

Horizontal Support

SWIVEL, SINGLE

Accommodates some horizontal line expansion, but no vertical movement. Use three point suspension unit (see below) when length of vertical run or line stiffness requires vertical as well as horizontal movement of the horizontal run. For 3/8-inch line.

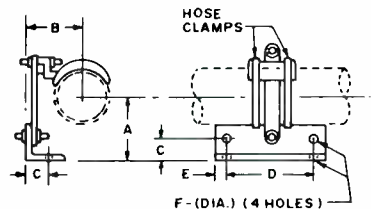

A	B	Dimensions		C	D	E	F	Approx. Weight	Catalog Number
2-17/32"	27/8"	1 1/8"	5"	1/2"	7/16"	3 lbs.	MI-19313-37		
(53)	(73)	(28)	(127)	(13)	(11)	(1.4 kg)			

SUSPENSION, THREE POINT SINGLE

For 3/8-inch horizontal line only.

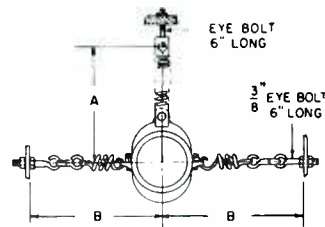

A	Dimensions	B	Approx. Weight	Catalog Number
20 3/4"	15"	5 1/4 lbs.	MI-19313-50	
(527)	(381)	(2.3 kg)		

ROLLER, HORIZONTAL

Supports horizontal line. Use two for dual lines. Mounting bolts not included. Accommodates no vertical movement; uses three-point suspension units for horizontal runs where vertical run length or line stiffness requires vertical as well as horizontal movement. For 3/8-inch line only.

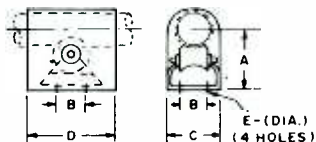
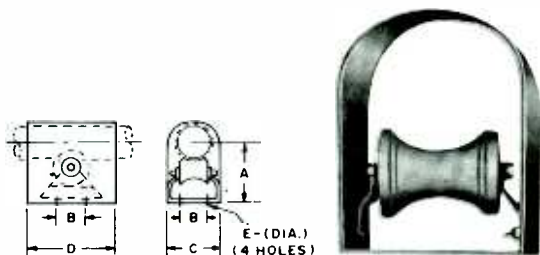

A	B	Dimensions		C	D	E	Approx. Weight	Catalog Number
4 1/4"	3"	4 3/4"	8"	7/32"	2 1/4 lbs.	MI-19313-35		
(108)	(76)	(121)	(203)	(6)	(1.1 kg)			

ANCHOR, HORIZONTAL, SINGLE

For 3/8-inch line only. Supports line at building wall. Use on both sides of wall. Clamp included; bolts not included.

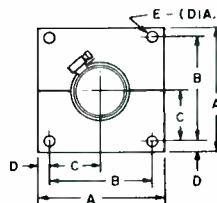
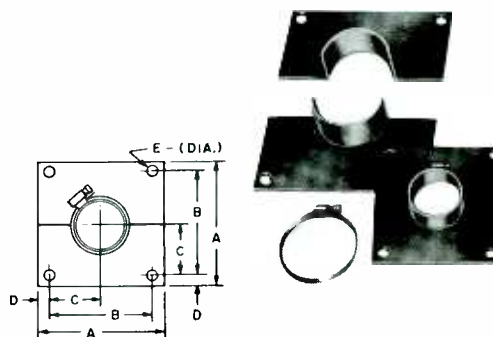

A	B	Dimensions		C	D	E	Approx. Weight	Catalog Number
8"	6 7/8"	3 7/16"	5/16"	5/16"	3 1/2 lbs.	MI-19313-17		
(203)	(174)	(87)	(14)	(14)	(1.5 kg)			

BRACE, LATERAL

Mounts in single hole. Two clamps included. Restricts lateral motion while allowing vertical and horizontal movement. For 3/8-inch line.

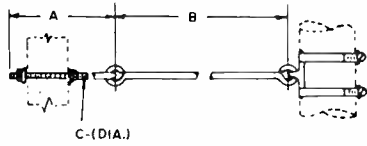

A	Dimensions B	C	Approx. Weight	Catalog Number
7 3/4" (203)	38 3/4" (978)	3/8" (13)	2 1/4 lbs. (1.1 kg)	MI-19313-36

Spring Chart A

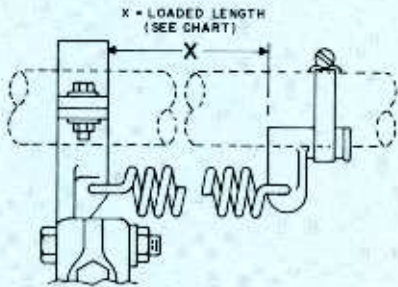

Distance Below Lowest Fixed Hanger		Loaded Length at Ambient in °F (°C)									
		0-20° (-18--7°)		20-40° (-7--4°)		40-60° (4-16°)		60-80° (16-27°)		80-100° (27-38°)	
Feet	Meters	in.	mm	in.	mm	in.	mm	in.	mm	in.	mm
0- 200	0- 61	15	381	15 1/8	384	15 1/4	387	15 1/4	387	15 3/8	391
200- 400	61-122	14 3/4	375	15	381	15 1/4	387	15 3/8	391	15 5/8	397
400- 600	122-183	14 1/2	368	14 7/8	378	15 1/4	387	15 1/2	394	15 7/8	403
600- 800	183-244	14 1/4	362	14 3/4	375	15 1/4	387	15 5/8	397	16 1/8	410
800-1000	244-305	14	356	14 5/8	371	15 1/4	387	15 3/4	400	16 3/8	416
1000-1200	305-366	13 7/8	352	14 1/2	368	15 1/4	387	15 7/8	403	16 1/2	413
1200-1400	366-427	13 3/4	349	14 1/2	368	15 1/4	387	15 7/8	403	16 5/8	422
1400-1600	427-488	13 5/8	346	14 1/2	368	15 1/4	387	16	406	16 3/4	425
1600-1800	488-549	13 1/2	343	14 3/8	365	15 1/4	387	16	406	16 7/8	429
1800-2000	549-610	13 1/2	343	14 3/8	365	15 1/4	387	16	406	16 7/8	429



Pressurizing Equipment: Dehydrators and Gassing System Kits

- Choice of two dehydrators
- Nitrogen-bottle regulators
- Expandable system kits
- Flexible plastic tubing
- Brass and bronze fittings

Described here is equipment and material for the pressurization of flanged transmission line. There are two dehydrator/compressors and three "gassing kits". The dehydrator/compressors differ in size and capacity, to accommodate various transmission-line system requirements. The three gassing kits combine the fittings and components into complete packages that simplify installation.

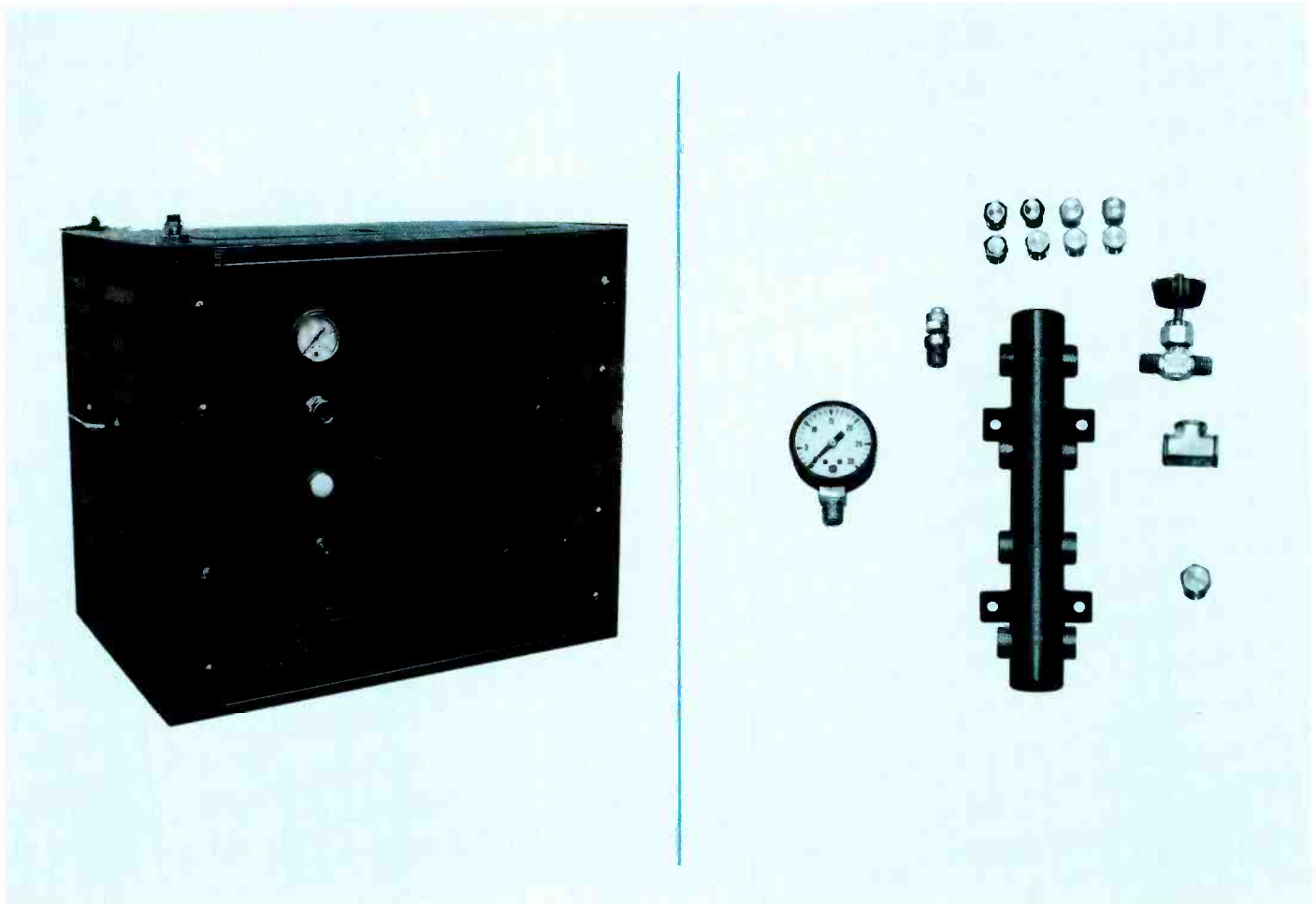

Heatless Compressor/Dehydrators

- Discharge air dewpoint -40°
- Available in two capacities
- Two-cylinder, oil-less compressors
- Adjustable outlet pressure

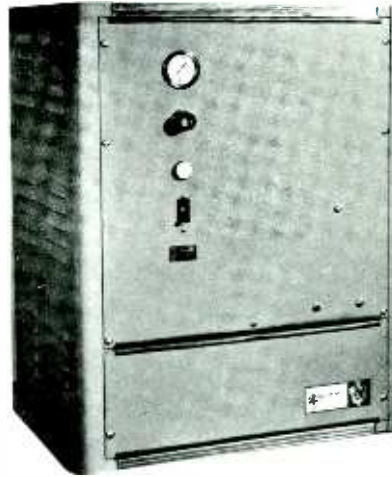

Engineered and manufactured specifically for pressurizing RF transmission lines, these two compressor/dehydrator units differ only in output capacity and physical dimensions. The units deliver dry, compressed air at the rate of one or two cubic feet per minute (0.028 or 0.056 m³).

Oil-Less Compressor

Both units use an oil-less, two-cylinder air compressor with a direct-drive 1/2- or 3/4-horsepower electric motor. All operate from 115/230 V, 60-Hz power (50-Hz units are available on special order, see *Ordering Information*).

“Dry-Pak” Dehydrator

The “Dry-Pak” dehydrator provides a continuous supply of dry air. The dew point of this air is below -40 degrees C. The Dry-Pak dehydrator uses a system of air expansion and silica-gel dessicants to achieve this dryness.

A program timer, within the Dry-Pak, recycles the dessicant as required and entirely automatically. The device includes an adjustable pressure switch which maintains discharge pressure at any level between 1 and 15 lbs./in² (0.07-1.05 kg/cm²). The switch is factory set for 4 to 7 lbs/in² (0.28 to 0.49 kg/cm²).

Maintenance-Free System

Dry-Pak Compressor Dehydrators require no routine maintenance. After many hours of use, the *Teflon* piston rings of the compressor might need replacement to restore the unit’s pressure capability. These are available as spare parts.

Specifications

Output Air:
 Dewpoint -40° C
 Pressure1-15 lbs/in² (0.07-1.05 kg/cm²)

Volume:
 Half-Horsepower Unit1 ft³/min. (0.0283 m³/min.)
 Three-Quarter Horsepower Unit2 ft³/min. (0.0566 m³/min.)

Input Air:
 Temperature125° F (52° C) max.
 Relative Humidity0-100%
 Power Requirements115/230 V, 60 Hz or 115/230 V, 50 Hz

Pressurizing Capacity	1 5/8" Line	3 1/8" Line	6 1/8" Line	9 1/8" Line
Half-Horsepower Unit (1 SCFM)*	10,000' (3048 m)	2500' (76 m)	700' (213 m)	250' (76 m)
Three-Quarter Horsepower Unit (2 SCFM)*	40,000' (1220 m)	10,000' (305 m)	3,000' (914 m)	1000' (305 m)

Dimensions
 Half-Horsepower Unit20" H; 22" W; 15" D (508, 558, 381 mm)
 Three-Quarter Horsepower Unit28" H; 22" W; 15" D (711, 558, 381 mm)

Weight
 Half-Horsepower Unit95 lbs. (43 kg)
 Three-Quarter Horsepower Unit117 lbs. (53 kg)

Ordering Information

Heatless Compressor/Dehydrator (115/230 V 60 Hz):
 Half-Horsepower UnitMI-563170-1
 Three-Quarter Horsepower UnitMI-563170-2
 Heatless Compressor/Dehydrator (for 50-Hz power)
 Half-Horsepower UnitMI-563170-1A
 Three-Quarter Horsepower UnitMI-563170-2A

*SCFM = Standard cubic feet per minute.

Gassing System Kits

- For one- to eight-line systems
- For dry air or dry nitrogen
- Precision needle valves
- Highly flexible PVC tubing
- Gauges included

Gassing Kit "A"

Kit "A" provides the fittings, tubing, valve and gauge required to pressurize a single transmission line from a compressor/dehydrator or a regulated source of compressed dry nitrogen.

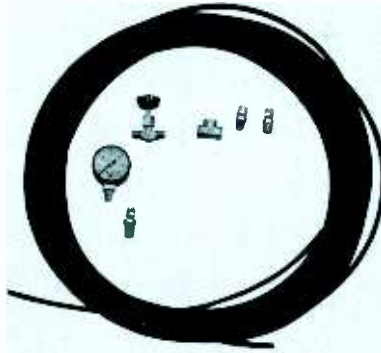

Gassing Kit "B"

Kit "B" expands the load capabilities of Kit "A" to handle a dual T/L system. It includes an eight-port manifold and the valve, gauge and fittings required for the additional transmission line. The kit includes no plastic tubing on the basis that surplus is available from Kit A. Should additional tubing be required, it is available separately, see *Accessories*.

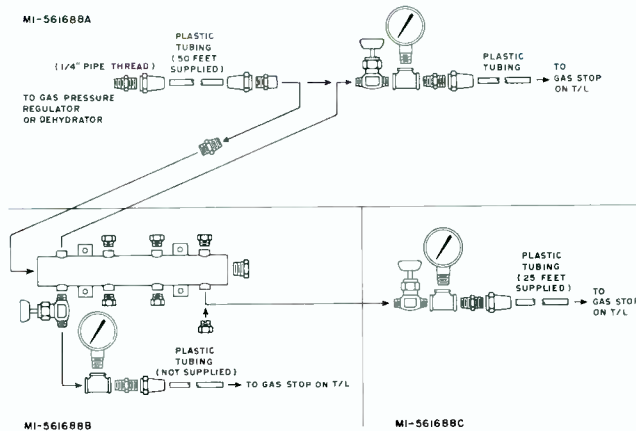
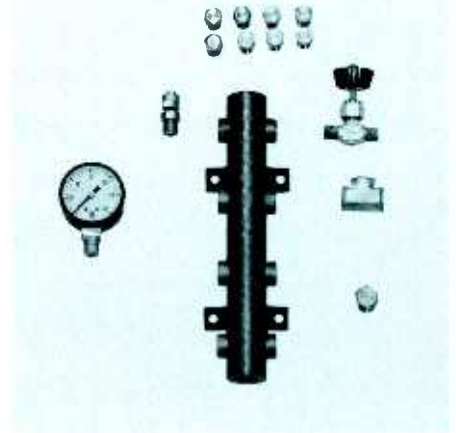

There are three gassing system kits: an "A" kit which is basic to Kit "B" which, in turn, is basic to Kit "C".

Accessories

Single-Stage Pressure Regulator (See photo below)

For use where bottled dry nitrogen is the pressurizing source instead of dehydrated compressed air. Connects between nitrogen flask valve and gassing system input fittingMI-19315-22

Plastic Tubing

For situations where the tubing included in Gassing Kits "A" and "C" is insufficient for requirements.
In 50-foot (15.2 m) coilsMI-561668A-1

Ordering Information

Gassing Kit AMI-561668A
Gassing Kit BMI-561668B
Gassing Kit CMI-561668C



Gassing Kit "C"

Kit "C" expands the capabilities of Kit "B" by one. It includes a valve, a gauge, 25 feet (7.6 m) of plastic tubing and the fittings necessary to connect a Kit A and a Kit B to an additional transmission line. Thus, if the system uses four pressurized transmission lines, it should be equipped with one Kit A, one Kit B and two Kits C. It is important to note that, to use a Kit C, Kits A and B must be available.





Coaxial Transmission Line Switches

- Low VSWR
- Maximum isolation
- High reliability
- Manual and motor-driven types

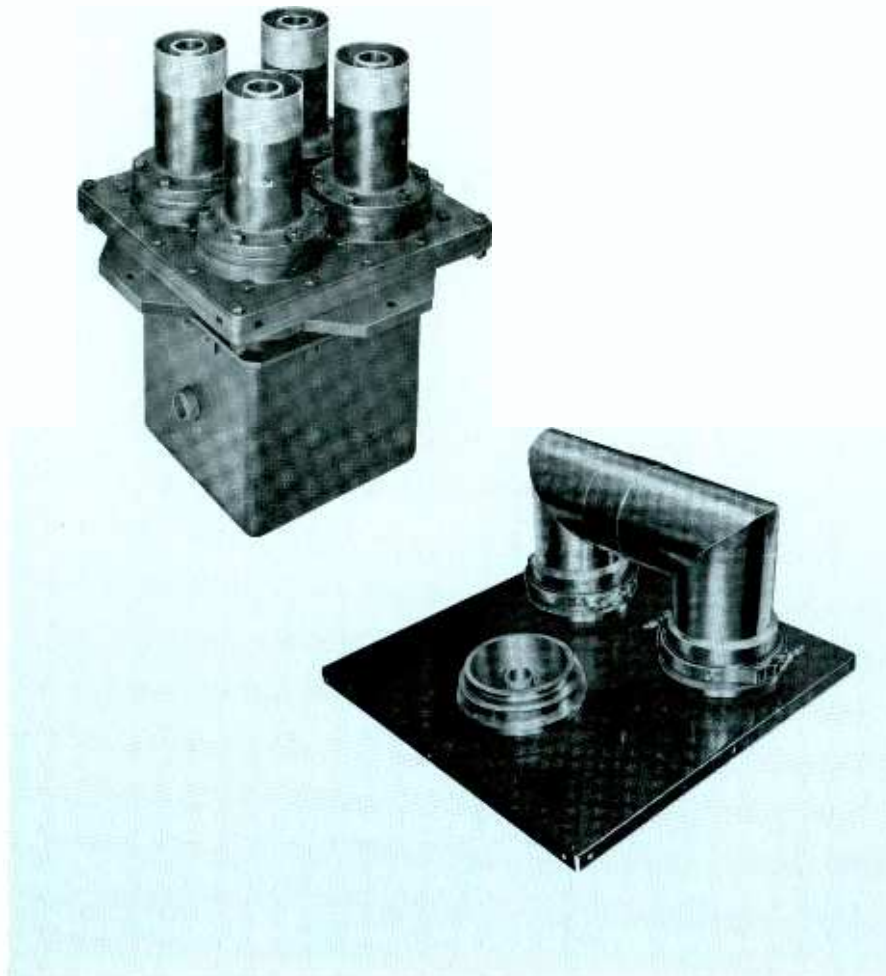

Coaxial transmission line switches provide convenient, rapid and reliable switching of rf power circuits. Standby transmitter changeover, emergency antenna selection, dummy load connections, temporary by-passing of components, and many other functions are readily accomplished.

Switches for either manual or powered switching accommodate different sizes and types of rigid lines and single- or multiple-line power transfer. They maintain high reliability, maximum isolation and low VSWR.

Motor Driven Coaxial Switches

The motor driven 3 1/8-inch coaxial switch, MI-561562, is a simple but extremely versatile component that provides reliable and fast switching of r-f energy between coaxial lines with control from a remote point.

Completely compatible with standard coaxial line components, the switch may be used as a four-port transfer switch or a three-port single-pole, double-throw switch. This versatility lets the switch serve a variety of switching situations.

Reliability is an outstanding feature of this switch. The mechanical drive is simple and the number of moving r-f conductors is at a minimum so that operations in excess of 100,000 cycles are possible without failure.

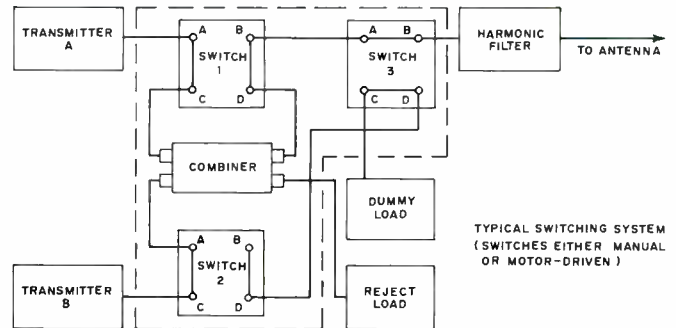
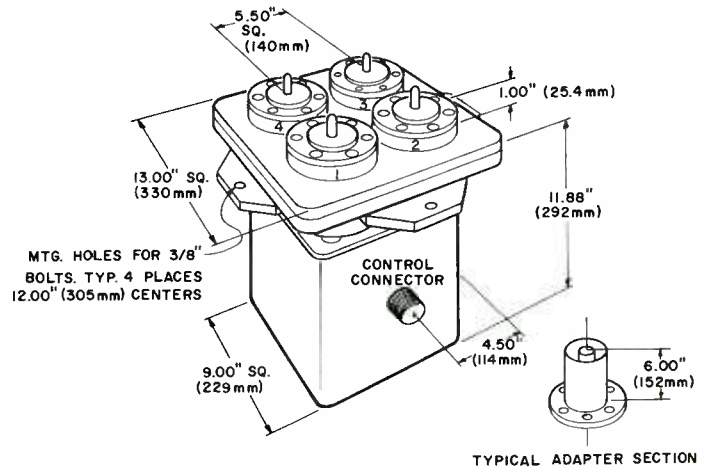
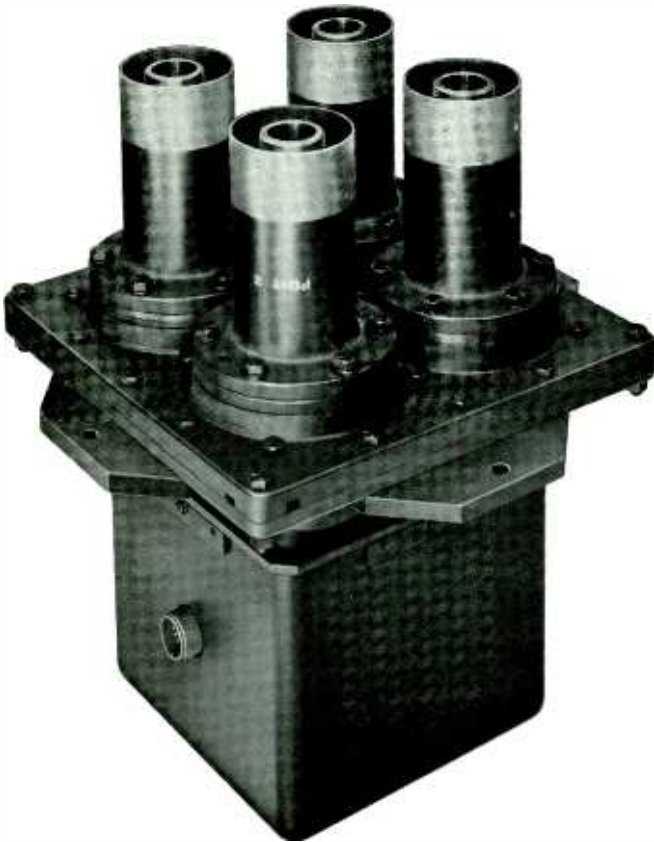

Specifications

Electrical

Operating Frequency	Any to 900 MHz
Characteristic Impedance	50 or 51.5 ohms
Power Rating	Identical to T/L used
VSWR	
50-220 MHz	1.05:1 or less
450-900 MHz	1.03:1 or less
Insertion Loss	0.05 dB or less
Isolation (50-880 MHz)	60 dB or more
Switchover Time (nominal)	2 seconds
Drive Motor:	
Voltage	115V ±10%
Frequency	50/60 Hz
Current:	
Start	2.0A
Run	0.48A
Current Rating of Auxiliary Relay Contacts	15A, 250Vac

Mechanical

Dimensions	see drawing
Weight	65 lbs. (28 kg)

Ordering Information

Motor Driven Coaxial SwitchMI-561562(*)

*Designate suffix letter from Table below:

MI-Designation	Transmission Line Type
MI-561562-A	MI-19089, 50 ohms, flanged
MI-561562-B	MI-27791-K, 50 ohms, unflanged
MI-561562-C	MI-19313-NF, 51.5 ohms, unflanged
MI-561562-D	MI-19313, 51.5 ohms, flanged
MI-561562-E	MI-27791-D, 50 ohms, male flange
MI-561562-F	MI-27791-D, 50 ohms, female flange

Accessory

An optional control panel for use with the MI-561562 Switch is available. It mounts in a standard 19-inch relay rack and includes an On-Off switch, operating switch and position-indicator lights. Order as MI-561596.

Note: Contact RCA representative for information about similar switches for other line sizes.

Manual Coaxial Switches

RCA manual coaxial switches for VHF provide a convenient and rapid means of switching r-f power circuits. They utilize standard coaxial transmission line fittings mounted on a panel in a way that switching functions are readily accomplished by the "patch cord" method. Switches differ in construction to meet the various sizes and types of transmission lines.

Fittings come in 3/8- or 6/8-inch sizes and the switch plugs are constructed of double 3/8- or 6/8-inch elbows which form a U section, maintaining line impedance throughout the switch. Panels are reinforced with angle bends on all four sides. Holes in the side angles provide

for mounting. The 3-pole switch has one U-type connector, the 4-pole, two and the 7-pole, three (see drawings next page). The U-connectors clamp to the fittings. Various connections and impedances are available. See *Ordering Information*, next page.



- **Sturdy, reinforced steel bases**
- **3-pole, 4-pole and 7-pole types**
- **Low VSWR**
- **Maximum isolation**

Specifications

Electrical

Power Rating Same as various Transmission Line to which they apply
 Ambient Temperature To 50° C
 Elevation 5000 ft. (1500 m) max. to full power rating
 VSWR 1.02 to 1 or better
 Impedance See Ordering Information

Mechanical

Dimensions See Outline Drawings
 Weight:
 3 Pole, 3/8" (79 mm) Models 32 lbs. (15 kg)
 4 Pole, 3/8" (79 mm) Models 52 lbs. (24 kg)
 7 Pole, 3/8" (79 mm) Models 67 lbs. (30 kg)
 3 Pole, 6/8" (156 mm) Models 75 lbs. (34 kg)
 7 Pole, 6/8" (156 mm) Models 220 lbs. (100 kg)

Accessories

3/8" 50 ohm adaptor used to connect straight sections of line to MI-27912-50 and 51 MI-27912-52
 3/8" 51.5 ohm adaptor used to connect straight sections of line to MI-27717 and MI-27718 MI-27337
 6/8" 51.5 ohm adaptor used to connect straight sections of line to MI-27719 and MI-27720 MI-27709
 Spare "U" bend, 3/8", 7" (178 mm) centers for use with MI-27717 and MI-27718 MI-27999
 Long "U" bend, 3/8", 14" (365 mm) centers for use with MI-27912-51 Switch MI-561679

INSTALLATION NOTE:

Because of inner conductor considerations, either an elbow or an adaptor component must connect to the several switch ports.

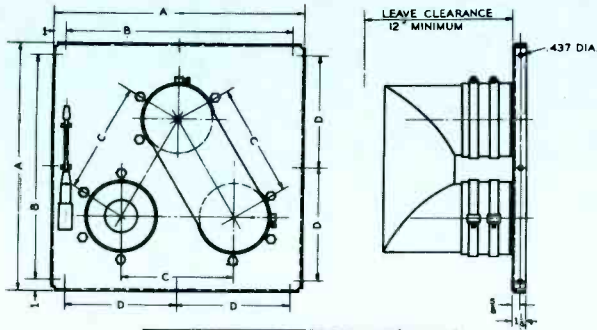

SIZE	A	B	C	D
3 1/8" 80 mm	15 1/2" 393	13 1/2" 343	7" 178	—
6 1/8" 156 mm	25" 635	23" 584	13" 330	11 1/2" 292

Outline Dimensions, 3-Pole Panels

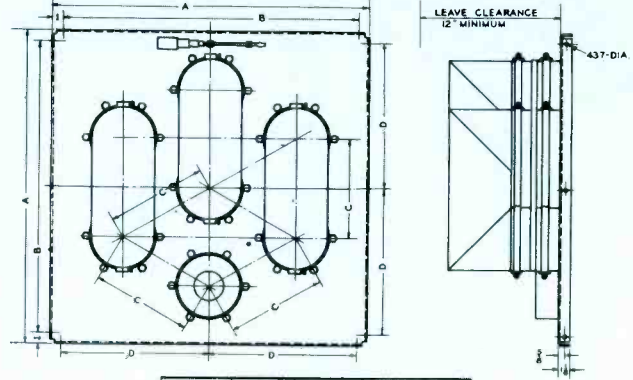

SIZE	A	B	C	D
3 1/8" 80 mm	23" 584	21" 533	7" 178	—
6 1/8" 156 mm	38" 965	36" 914	13" 330	18" 457

Outline Dimensions, 7-Pole Panels

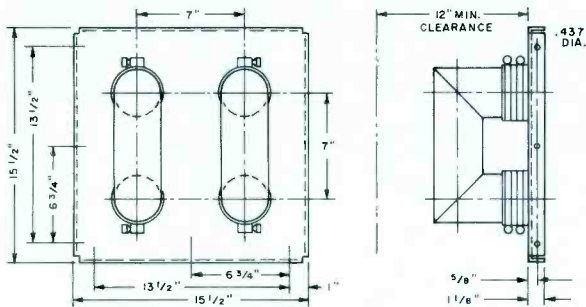

Outline Dimensions, 4-Pole Panels

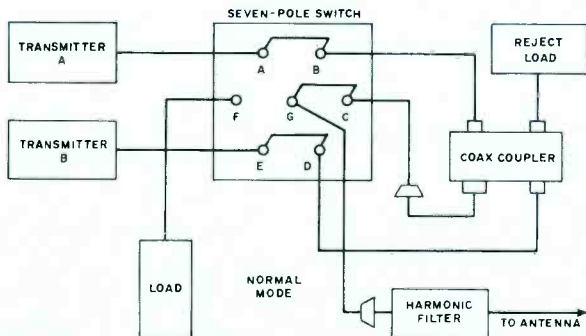

Typical two-transmitter switching system.

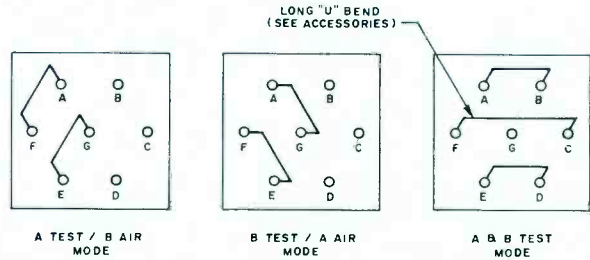

Ordering Information

Stock Identification	Diameter	Impedance	Poles	Type Connector	For Use with RCA Line
MI-27717	3 1/8" (79 mm)	51.5 ohms	3	Sleeve	MI-19113-C or MI-19313
MI-27718	3 1/8" (79 mm)	51.5 ohms	7	Sleeve	MI-19113-C or MI-19313
MI-27719	6 1/8" (156 mm)	51.5 ohms	3	Sleeve	MI-19314-C
MI-27720	6 1/8" (156 mm)	51.5 ohms	7	Sleeve	MI-19314-C
MI-27912-50	3 1/8" (79 mm)	50 ohms	3	Inside, Universal	MI-27791-K
MI-561680	3 1/8" (79 mm)	50 ohms	4	Inside, Universal	MI-27791-K
MI-27912-51	3 1/8" (79 mm)	50 ohms	7	Inside, Universal	MI-27791-K

The above are standard designs fitting most requirements. Other configurations to fit special switching requirements are available on special order.



(Replaces RA.6011A)

RCA can make a wide selection of towers available for all AM and FM applications . . . including standard self-supporting, guyed and custom designs.

AM-FM Antenna Towers

Guyed Towers

Where land area permits, towers are usually guyed and the usual cross sectional shape is triangular so that three point guying can be used. Guyed tower costs are usually lower than for self-supporting structures because less steel is used. A useful method for estimating the land required for a guyed structure is to consider the distance to the farthest guy anchorage as being about 80 percent the tower height.

Self-Supporting Towers

Self-supporting towers are especially advantageous in city and congested districts where land is expensive. For estimating required space for a self-supporting tower, the distance between tower legs can normally be considered as 10 percent the height of the structure.

Wind Load

Towers must be designed and installed to safely withstand the maximum wind velocities that may be encountered. Experienced tower builders rarely design for less than a 30/20-pound loading. This means that the tower members are designed to resist a horizontal wind pressure of 30 pounds per square foot of projected

- Wide selection of AM or FM antenna towers
- Complete line of tower accessories
- Self-supporting or guyed types
- Standard or custom designs

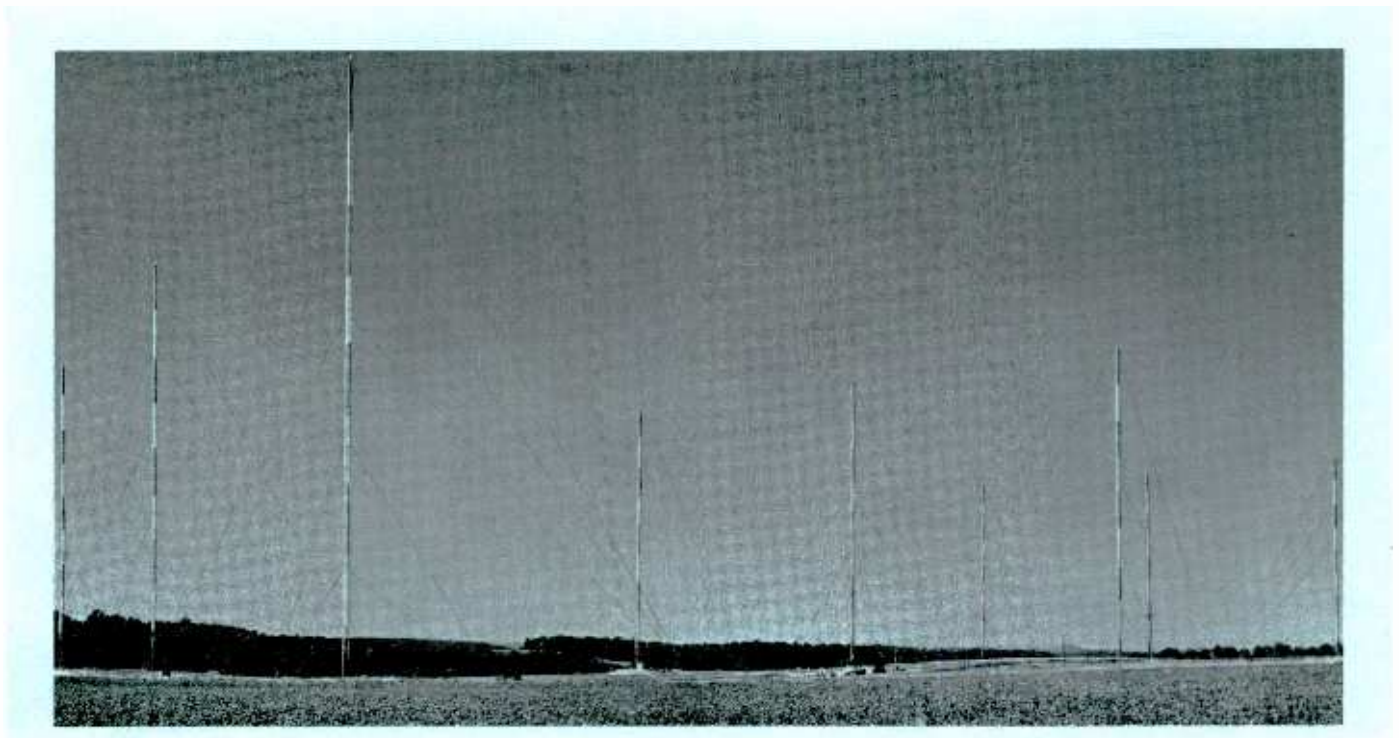

area on all flat surfaces and 20 pounds on round surfaces. This is the equivalent of an actual wind velocity of 86.6 mi/h (139 km/h). Towers with higher wind-load ratings are, of course, available. Towers are designed in accordance with EIA specifications RS-222B.

Tower Accessory Equipment

A number of accessories to complete various AM and FM broadcast towers are available. Most of them are fully described in specialized catalogs for these products. They include: FM antennas; FM transmission line, hangers and dehydrators; FM/AM isolation unit; material for ground systems; AM transmission line and hangers; antenna tuners; AM phasing systems (including power dividing networks, phase sampling loops, phase sampling lines and isolation coils); and tower lighting equipment (including tower lighting kits

and photo electric control, lighting chokes and air core lighting transformers).

FM Antenna Equipment

RCA has a complete line of FM antennas and accessories. Coaxial transmission line which may be either of the rigid or flexible type is used to conduct power from the transmitter to the antenna. Lines which use air as a dielectric will require pressurization using nitrogen or dry air to prevent condensation from accumulating inside the line. Various sized dehydrators and gassing hardware kits are available.

If the tower upon which the antenna is mounted is an insulated AM radiator, some means of isolating the effect of grounded transmission line where it crosses the base insulator must be provided. Using insulated hangers, a quarter wave balun at the AM frequency may be constructed or, under some circumstances, a Type

BAF-15 or -16 FM/AM Isolation Unit, may be used.

Material for AM Ground Systems

In order to obtain reasonable radiation efficiency and, in the case of directional arrays, to stabilize the radiation pattern a system of buried radial copper wires extending outward from the tower base must be installed. RCA can supply the wire, copper strap, and ground mats required to meet the consultant's ground system specifications. Ground system installation may be included with the tower contract.

Antenna Tuners

In most cases the impedance of the transmission line and the base impedance of the tower are not alike and it is necessary to install an antenna tuner at the base of the tower to transform the antenna impedance to the transmission line im-

Antenna Tower Questionnaire

LOCATION

City

State

QUOTATIONS TO BE FURNISHED

(Check those required)

- Number of Towers()
- Ground System()
- Tower Guyed()
- Self-Supporting()
- Tower Lighting Equipment.....()
- Tower Erection:
- Tower Installation()
- Transmission Line Installation (FM) ()

SPECIFICATIONS

- Tower Height:
- Ground to top of tower.....
- Ground to top of base insulator.....
- Tower Use:
- AM Radiator
- Antenna support(when used for FM or TV).....
- Channel or Frequency.....
- FM or TV Antenna: Type
- Description.....
- Transmission Lines: Size No.
- Design LoadLbs. per square foot (Based on local weather conditions and relevant building codes.)

Remarks:
(Special requirements, site accessibility, etc.)

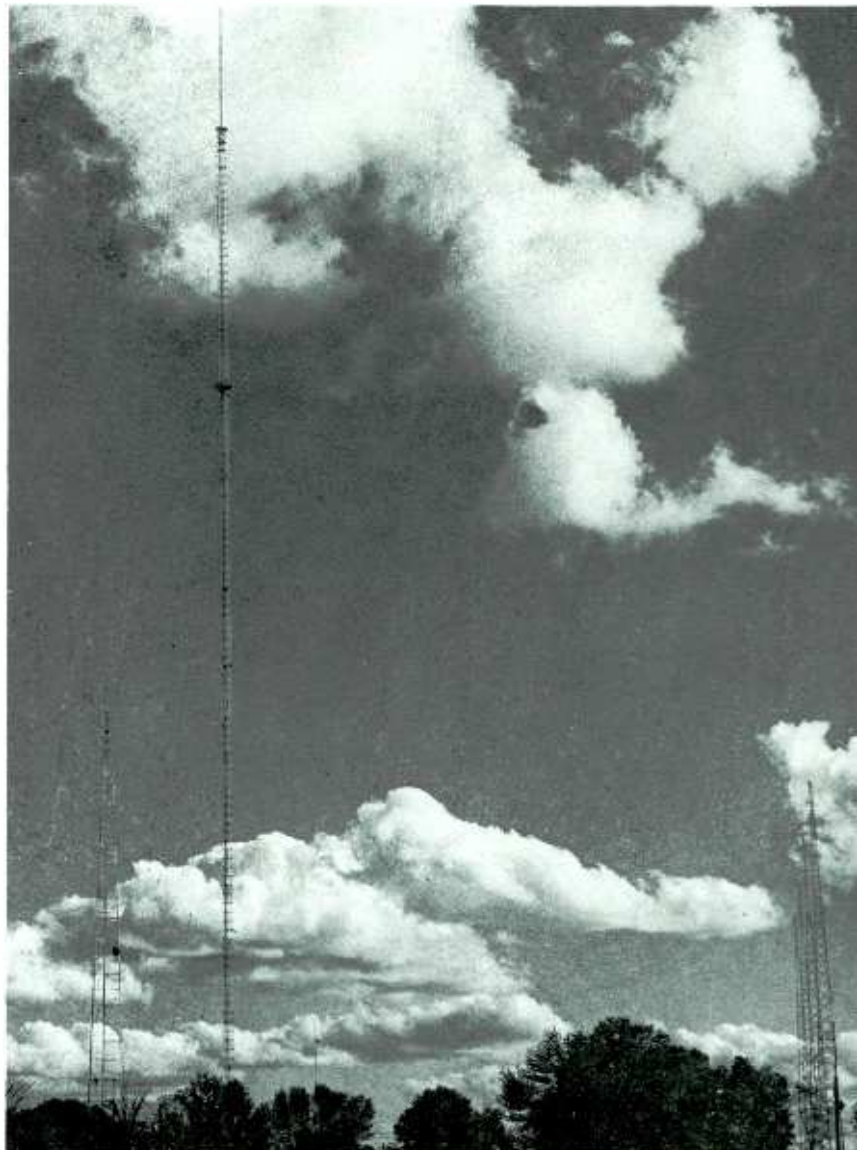

pedance. RCA markets a standard group of antenna tuners for low and medium power use. In the higher power range antenna tuning units are custom built.

AM Phasing Equipment

Multiple tower AM arrays are used to achieve specific horizontal and vertical radiation patterns as required by allocation or economic factors related to coverage. Varying amounts of power at various phase angles are fed to the various towers. RCA is in a position to supply all of the elements of phasing, power dividing, and antenna tuning units. In these multi-tower arrays, methods for sampling the phase and amplitude of the RF voltage in each tower and conveying this sample to the phase measuring equipment located in the transmitter house are required. Accessory phase sampling loops, which are normally mounted on the individual towers, phase

sampling lines to connect the loops to the measuring device, and means for isolating the grounded sampling lines where they cross the tower base insulator are also available.

Antenna Feed Bus

The antenna tuning unit output should be connected to the tower by means of copper tubing which is not normally supplied with the antenna or transmitting equipment. The tubing may be obtained from local sources and should be flattened and drilled at the ends so that it may be connected to the antenna tuning unit output feedthrough insulator and attached to the tower by bolt or brazing. At a point between the tower and the feedthrough insulator the line should be formed into a one or two turn coil, 12 to 18 inches in diameter. This coil can be self-supporting and is intended to retard

lightning and aid in the breakdown at the ball or horn gap provided at the tower base thus keeping lightning discharges from damaging the radio equipment.

Tower Lighting

The configuration of tower lights and the lighting equipment must conform to applicable government specifications. The a-c power required to operate the lights may be conducted on wires which are buried in the ground or carried on the same poles which carry the transmission line from the transmitter house to the antenna tuning unit. The a-c power lines will have to be isolated from the RF power where they cross the base insulator. This isolation can be provided either through the use of an antenna lighting choke and appropriate bypass condensers or by the use of an air core lighting transformer.

WIND VELOCITY AND CORRESPONDING WIND PRESSURE ON TOWERS—EIA STANDARD SPECIFICATION

Actual Wind Velocity mi/hr (km/hr)		Wind Pressure On Flat Surfaces ($P = 0.004 V^2$) lbs/ft ² (kg/m ²)		Wind Pressure On Round Surfaces lbs/ft ² (kg/m ²)		Estimated Survival Velocity (F.S. 1.65) mi/hr (km/hr)	
10	16.1	0.4	1.95	0.266	1.29	12.9	20.8
20	32.2	1.6	7.80	1.067	5.21	25.8	41.5
30	48.3	3.6	17.57	2.40	11.71	38.6	62.1
40	64.4	6.4	31.23	4.27	20.83	51.5	82.9
50	80.5	10.0	48.80	6.67	32.55	64.4	103.6
60	96.5	14.4	70.27	9.60	46.85	77.3	124.4
70.7	113.8	20.0	97.60	13.33	65.05	91.1	146.6
80	128.7	25.6	124.9	17.10	83.45	103.0	165.7
86.6	139.3	30.0	146.4	20.00	97.60	111.5	179.4
90	144.8	32.4	158.1	21.60	105.4	115.9	186.5
100	160.9	40.0	195.2	26.70	130.3	128.8	207.2
110	176.9	48.4	236.2	32.30	157.6	141.7	228.0
111.8	179.9	50.0	244.0	33.30	162.5	144.0	231.7
120	193.1	57.6	281.1	38.50	187.9	154.6	248.8
122.5	197.1	60.0	292.8	40.00	195.2	157.8	253.9
130	209.2	67.6	329.9	45.00	219.6	167.4	269.3
132.3	212.9	70.0	341.6	46.67	227.7	170.4	274.2
140	225.3	78.4	382.6	52.33	255.3	180.3	290.1
141.4	227.5	80.0	390.4	53.33	260.3	182.1	293.0
150	241.4	90.0	439.2	60.00	292.8	193.2	310.9
160	257.4	102.2	498.7	68.20	332.8	206.1	331.6
170	273.5	115.6	564.1	77.00	375.8	219.0	352.4
180	289.6	129.6	632.4	86.60	419.7	231.8	373.0
190	305.7	144.4	704.7	96.30	469.9	244.7	393.7
200	321.8	160.0	780.8	106.66	520.5	257.6	414.5

Ordering Information

Tower Accessories

- 8 ft. by 24 ft. (2.4 x 7.3 m) Section Expanded Copper Ground ScreenMI-27765
- No. 10 Copper Wire.....MI-28405-8
- 3" by 0.020 (76 x 0.5 mm) Ground StrapMI-28405-A4
- Double RF Antenna Lighting Choke.....MI-7112-C
- Triple RF Antenna Lighting ChokeMI-27726-A
- Capacitor for Lighting Chokes.....MI-27728-1
- Weatherproof HousingMI-27741
- 1750 W Hughey and Phillips TransformerMI-28215-A1
- 3500 W Hughey and Phillips TransformerMI-28215-A2

Tower Lighting Kits (Triangular Tower)

Tower Height ft (m)	No. Beacons	Obstruction Lights	Order No.
21'- 150' (6.4 - 45.7)	0	1 double (on top)	A-1
151'- 300' (46.0 - 91.4)	1	3 at one level	A-2
301'- 450' (91.7 - 137)	1	3 at two levels	A-3
451'- 600' (137 - 183)	2	3 at two levels	A-4

(Lighting Kits include all materials required to light and wire a tower of heights specified, such as original and 100 percent spare lamps, beacon flasher, photo-electric control, color coded wire, stainless steel wraplock tape condulets, locknuts, supporting arms, unions, pipe compound, installation print, and bill of materials in accordance with FCC, CAA and National Electric Code Requirements.)

For other Antenna Accessories, see appropriate RCA Catalogs.

At left—WSBT-AM/FM/TV antenna farm showing WSBT's first television tower and new high-rise guyed TV tower for increased coverage. At the far right are the four towers used in the WSBT-AM directional array.

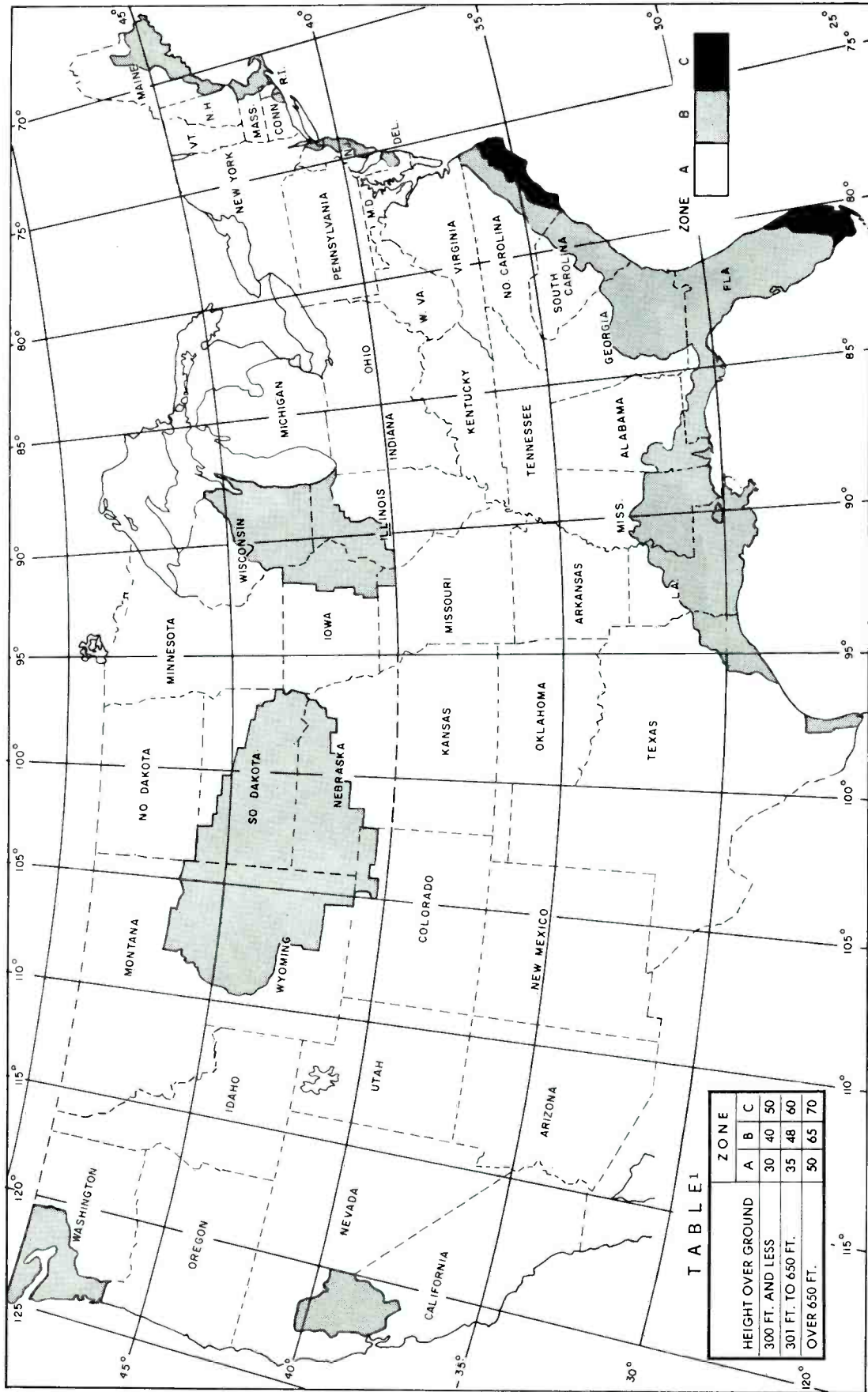

This map and table, extracted from EIA Standard RS-222B, gives minimum horizontal design windload pressures in pounds per square foot, on flat surfaces and with no ice for the zones indicated. The map, as well as the table, must be interpreted in view of local knowledge and applicable building codes. See RS-222B for zone boundaries defined by state and county.

¹Wind pressure specified in pounds per square foot only shall be assumed to be uniform over the entire height of the tower. Wind pressures specified by both zone and pressures, in pounds per square foot shall be designed for the more severe loading. (From Page 3 of RS-222B.)



250W, 1000W Antenna Tuning Units

The RCA Type BPA-Series Antenna Tuning Units provide an impedance match at broadcast frequencies between series-fed, vertical radiators and coaxial or open-wire transmission lines. They also aid in suppressing harmonics.

Four models of BPA-21 1-kW Antenna Tuning Units are available. They differ only in the type of accessories, such as remote metering or the tower-lighting chokes provided with the units. Remote-meter kits and tower-lighting chokes can be added at any time to the basic MI-27767A unit. An MI-27725 Antenna Tuning Unit, without provision for future addition of lighting chokes or remote meter, is available also.

All models of the BPA-21 and the MI-27725 include an RF antenna ammeter. Tower height and frequency should be specified on the order to permit determination of the correct ammeter-scale range. The antenna reactance and resistance should be specified if the antenna is other than a base-fed, vertical radiator of uniform cross section.

- Custom-built arrangements available for any requirement
- Make-before-break switches avoid damage to antenna ammeter from static discharges
- Optional remote metering provisions

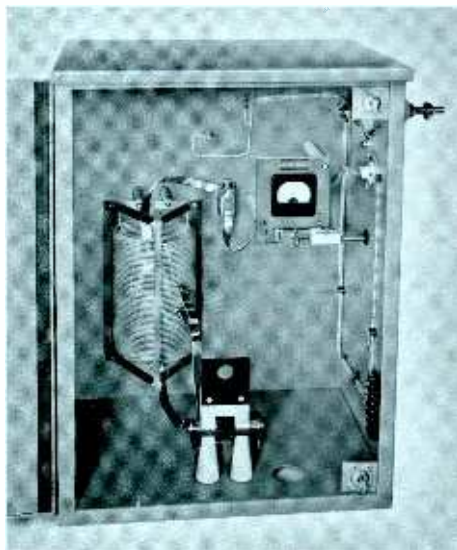

Specifications

Frequency Range	800 *kHz to 1600 kHz
Transmitter Power (maximum)	1 kW
Antenna Resistance	20 to 250 ohms
Transmission Line Impedance	50 to 230 ohms
Antenna Reactance	+j200 to -j200 ohms
(Can be extended in the positive direction by the addition of series capacitance and in a negative direction if operated from a transmission line of lower impedance than the antenna resistance at no extra cost.)	

*Low frequency limit may be extended to 540 kHz at extra cost.

Height	28 ¹ / ₆ " (714 mm)
Width	22 ¹ / ₈ " (562 mm)
Depth	16 ³ / ₄ " (425 mm)
Weight (Approx.)	65 lbs. (30 kg)

Accessories

Remote Meter Pick-up Unit (less meter)	MI-28027C
Double Winding RF Antenna Lighting Choke Coil with 2 Capacitors	ES-27241
Triple Winding RF Antenna Lighting Choke Coil with 4 Capacitors	ES-27242
Double Winding RF Antenna Lighting Choke Coil with 2 Capacitors and Weatherproof Housing	ES-27243
Triple Winding RF Antenna Lighting Choke Coil with 4 Capacitors and Weatherproof Housing	ES-27244

Ordering Information

Type BPA-21A Antenna Tuning Unit	MI-27767A
Type BPA-21B Antenna Tuning Unit with Remote Metering	MI-27767B
Type BPA-21C Antenna Tuning Unit with Remote Metering and Two-Wire Lighting Choke	MI-27767C
Type BPA-21D Antenna Tuning Unit with Remote Metering and Three-Wire Tower Lighting Choke	MI-27767D
250/1000 W Antenna Tuning Unit (less remote-meter kit and remote meter)	MI-27725

(Specify transmitter power, frequency, line impedance, tower height and type. If other than base-fed, vertical radiator of uniform cross section, specify antenna resistance and reactance.)



5/10 kW Antenna Tuning Units, Types BPA-5A/-10A

- For co-ax or open-wire lines
- Weatherproof housing
- Simple, efficient circuit
- Built-in current meter lamp
- Versatile mounting flanges

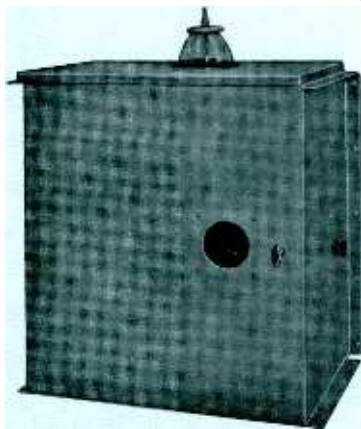

Specifications

Frequency Range	540 kHz to 1700 kHz
Transmitting Power:	
BPA-5A	5 kW max.
BPA-10A	10 kW max.
Antenna Resistance:	
BPA-5	10 to 1100 ohms
BPA-10A	20 to 1100 ohms
Transmission Line Impedance	50 to 350 ohms

The BPA-5A (5 kW) and BPA-10A (10 kW) Antenna Tuning Units match antennas to coaxial or open-wire transmission lines and suppress carrier harmonics.

All parts are enclosed in a weatherproof metal housing with a door. Flanges mount the unit on two upright posts or on a wall. The antenna ammeter is read through a circular window in the door and provision for a lamp to illuminate the meter is included.

The circuit of the antenna tuning unit consists essentially of a single *T*-section low-pass filter which reduces the number of elements to a minimum. Two series inductors permit separate adjustments of the transmission line and antenna terminating impedances. The shunt capacitors are fixed at values determined by the operating frequency.

An optional remote RF-pickup unit, (MI-28027C for the BPA-10A; MI-27966B for the BPA-5A) and a remote indicating ammeter (with a range corresponding to the tower base ammeter) can be added to the tuning units to provide a means of observing the antenna current at a remote location (transmitter house).

The units are custom built to meet customer requirements.

Antenna Reactance	+j500 to -j500 ohms (Can be extended, at no additional cost, in the positive direction by the addition of a series capacitor, and in a negative direction if operated from a line of lower impedance than the antenna resistance.)
Power Requirement (for lamp)	115/230V, 50/60 Hz
Finish	Durable gray
Overall Dimensions	41" H, 34" W, 23" D (1041, 863, 584 mm)
Weight (net)	330 lbs. (150 kg)

Accessories

Remote RF Pick-up Unit (less meter, 5 kW max.)	MI-28027C
Remote RF Pick-up Unit (less meter, 5-50 kW)	MI-27966B
Double Winding RF Antenna Lighting Choke Coil with 2 capacitors	ES-27241
Triple Winding RF Antenna Lighting Choke Coil with 4 capacitors	ES-27242

Ordering Information

Antenna Tuning Unit, 5 kW, Type BPA-5A	MI-27789A
Antenna Tuning Unit, 10 kW, Type BPA-10A	MI-27790A
(Specify transmitter power, frequency, line impedance, tower height and type. If other than base-fed vertical radiator of uniform cross section, specify antenna resistance and reactance.)	

AM Antenna Phasing Equipment

- Individually designed systems
- Adjustable under power
- Cabined or open-panel construction
- Rotary-adjustable inductors

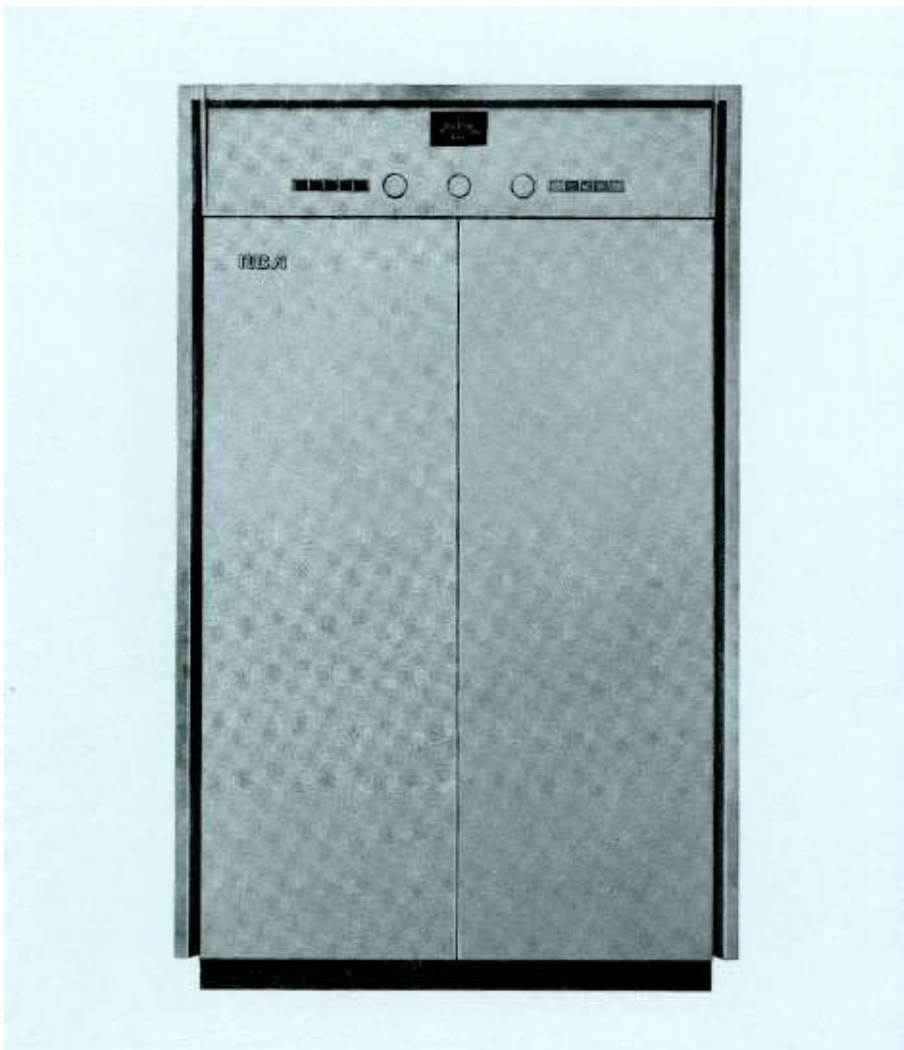

RCA antenna phasing and branching systems are built to the specific requirements of each antenna situation. RCA built its first antenna phasor before World War II and literally hundreds of systems carry the RCA monogram. Most systems use the "Jeep-Coil" design although "Ohm's-Law" phasors are available as well.

Where appropriate, RCA equipment uses front-panel-controlled rotary inductors to provide independent control of the current to each antenna tower. This affords increased system flexibility. The systems use "lagging-T" networks to phase the currents. The two series legs of each phasing network may be ganged rotary inductors with a single front-panel control. Networks provide wide-range, independent phase adjustment for each tower current with precise impedance match. The system uses series-resonant circuits for economy and stability. All controls can be motorized for remote control.

Tower Impedance Matching

Line-terminating units perform the impedance match between the transmission line and the antenna tower.

Reliable Switching Facilities

Indispensable for the changeover from daytime to nighttime patterns, the switching system use positive-latch relays wherever appropriate in the power-divider networks, the arms of the line terminator units and in the phasor networks. These relays have pilot-contacts which can be wired to lighted status indicators.

Cabined or Wall-Mounted Units

Phasing equipment is available mounted in cabinets that match current RCA AM transmitters or on open panels which are intended for wall mounting. Wall mount provides extra accessibility to the phasor and the line terminators.

When the system is cabined, the number of cabinets is proportional to the number of towers and system complexity. Most systems, however, fit into a cabinet 44 inches wide, 34 inches deep and 77 inches high (1118 x 865 x 1956 mm).

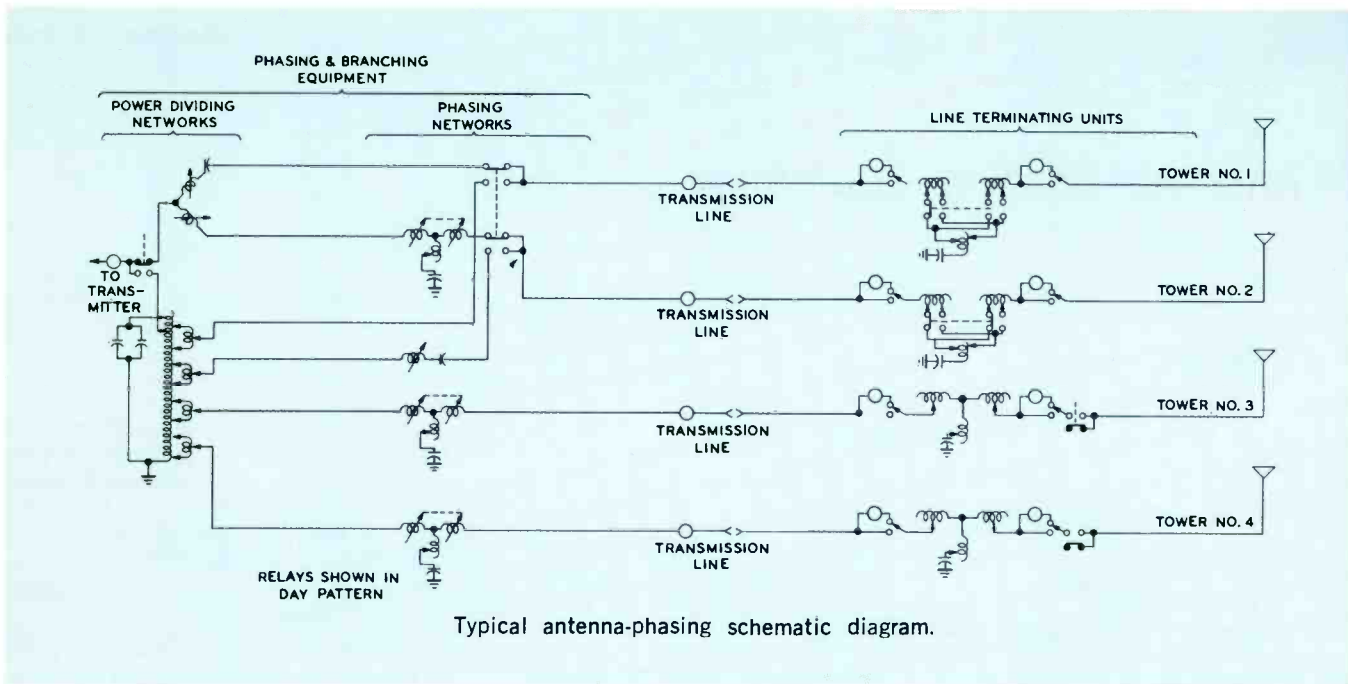

How to Order

RCA quotes price and delivery for phasing systems on an individual basis. The answers to the questions below provide the information needed for the preparation of a quote:

1. Assigned frequency _____ kHz
2. Operating power: Day _____ kW; Night _____ kW
3. No. of elements in array _____
4. Element description _____
5. Element spacing _____ feet
6. Element self-impedance _____ ohms
7. Current required in each element:

#1 _____ A	#2 _____ A	#3 _____ A
#4 _____ A	#5 _____ A	#6 _____ A
8. Phase Angle required in each element:

#1 _____ °	#2 _____ °	#3 _____ °
#4 _____ °	#5 _____ °	#6 _____ °
9. Length of transmission line to each element:

#1 _____ ft.	#2 _____ ft.	#3 _____ ft.
#4 _____ ft.	#5 _____ ft.	#6 _____ ft.
10. Characteristic impedance of transmission line (s) _____ ohms
11. Pattern-switching requirements (non-directional daytime; different patterns, night and day; etc.)

12. Cabined unit desired? Yes No
13. Antenna-current-sampling system preferred: _____
14. Motorized controls desired? Yes No

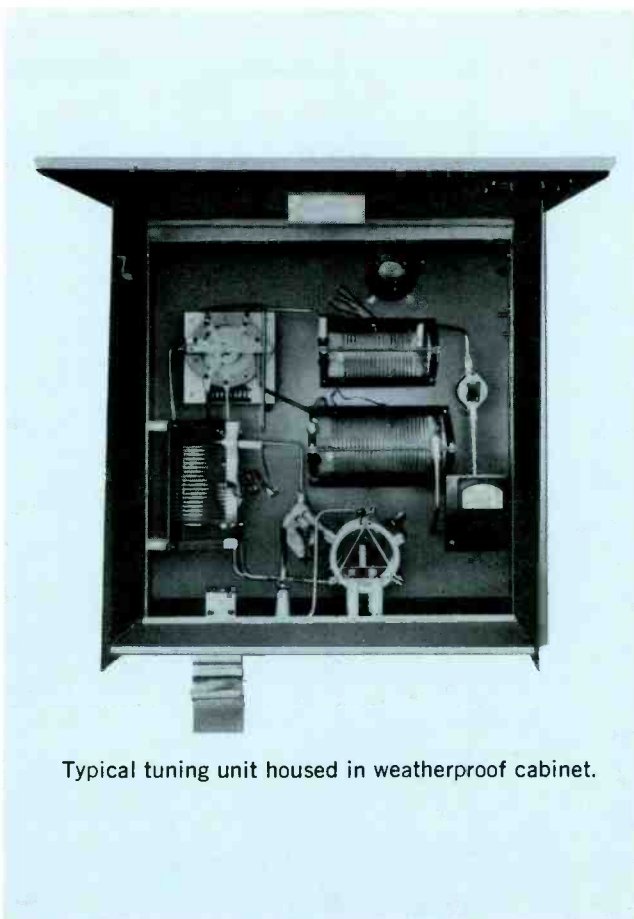

AM Antenna Accessories

- Phase sampling loops
- Isolation coils for sampling lines
- Dummy loads
- Antenna arameters
- Lighting chokes

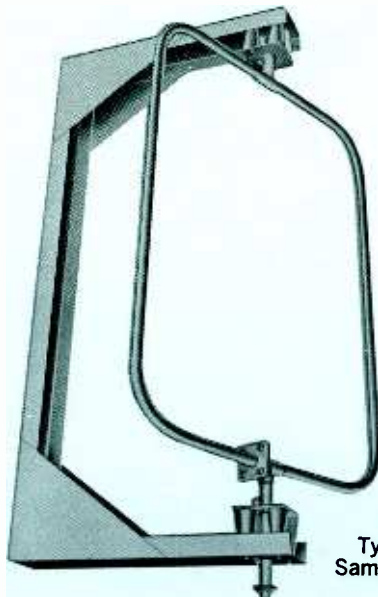

Type C0019
Sampling Loop.

Here are devices for monitoring, testing and evaluating the performance of AM-broadcast antenna systems. There are current-sampling loops, isolation inductors, air- and water-cooled dummy loads, meters, meter kits, compensating networks and inductors for tower hazard-lighting systems.

Sampling Loops

- **Shielded or unshielded**
- **Fixed or rotary**
- **Grounded or insulated**
- **Connect to co-ax cable**

Sampling loops develop a signal proportionate to the strength of the field which surrounds them. The signal thus developed is used to sample the tower currents and phase angles in an antenna system.

Shielded loops reject electrostatic energy with little reduction in electromagnetic response. Rotary loops allow fine adjustment of position for maximum sensitivity and insulated loops allow phase sampling without the need for isolation inductors in the sampling lines.



Shielded, Rotary, Insulated Loop, Type C0019

The Type C0019 provides a sensitive and accurate method for tower-current sampling in directional-antenna arrays. Shielded to eliminate response to electrostatic energy, the loop responds to only the electromagnetic field of the tower to which it mounts. The rotary aspect allows adjustment of the loop for maximum pickup without change in self-impedance. Connection to the co-ax cable is at the bottom pivot. Brackets for universal mount on tower leg included.

Specifications

Dimensions 33½" H, 25½" W (841, 648 mm)
 Connector UHF 83-1R
 Mating Connector UHF 83-1SP

Ordering Information

Shielded, Rotary, Insulated Sampling Loop,
 Type C0019 MI-561522

Unshielded, Fixed, Uninsulated Loop, Type 173-11-1

A three-sided loop designed for grounding to the tower leg (the leg serves as the fourth side of the loop), the type 173-11-1 Sampling Loop is constructed of heavily plated steel tubing. Sensitivity is adjusted by the spacing between the outside leg of the loop and the tower. The assembly includes changes and necessary hardware for mounting and for connection of a 70-ohm, coaxial line. Shipped unassembled with assembly instructions and special assembly tools. (Not illustrated.)

Specifications

Dimensions 72" H, 30" W (max) (1829, 762 mm)
 Connection Outer-cond. clamp; inner-cond. strap

Ordering Information

Unshielded, Fixed, Uninsulated Loop,
 Type 173-11-1 MI-27730

Air-Cooled Dummy Loads

Offered in any specified impedance, these inexpensive dummy loads are available in five power ranges. Wire wound, the loads are slightly inductive. Load reactance compensators, available separately (see above, right), are used to offset the inductive reactance in the load, where necessary.

Specifications

Frequency Range 540 to 1600 kHz
 Power Levels
 (100% modulation) 500, 1000, 5000, 10,000, 20,000W
 Input Impedance As required

Ordering Information

Ohm-Spun Dummy Load Type WG
 (Please specify power level required and input impedance;
 loads are built to order.)

Water-Cooled Dummy Loads

Available for either 50- or 230-ohm systems, these wire-wound loads are packaged in two forms: one, the resistor units mounted in a housing with water inlet and outlet connections and, two, in kits that include a water flow-meter, thermometers, valves, hoses, tubing and appropriate fittings for assembly into a load appropriate to the application. Loads require a supply of water of a quality safe for drinking.

Specifications

Input Impedance (ohms) 50 or 230
 Water Supply Requirement Potable quality
 Water Flow Requirement (U.S. Gal/min) 8-17 (30-65 l/min)
 Water Supply Temperature 75°F (24°C) max

Ordering Information

Water-Cooled Resistor Units:
 230-ohm Impedance MI-27029-2
 50-ohm Impedance MI-27029-3
 Water-Cooled Load Kits Assembled to Order

Load Reactance Compensators

Mounted in close proximity to Ohm-Spun dummy loads, these networks offset the small inductive reactance of the load. The networks consist of topped, fixed-value inductors and a mica-dielectric capacitor. Adjustment requires the use of an RF bridge instrument. Networks are built to order for use with Ohm-Spun loads only. (Not illustrated.)

Specifications

Input Impedance50 or 230 ohms
 Power Levels:
 At 50-ohm impedance1 or 5 kW
 At 230-ohm impedance10 or 20 kW

Ordering Information

Load Reactance CompensatorCustom Built
 (Please specify power level and impedance)

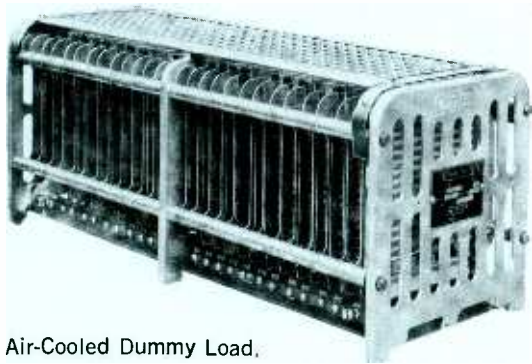

Air-Cooled Dummy Load.

Isolation Inductor

An isolation inductor takes the sampling-current co-ax across the tower-base insulator from the tower to ground without short-circuiting the insulator. The inductor is essential in every case where the sampling loop is bonded to the tower. The inductor is wound with coaxial cable and is equipped with appropriate connectors as specified by the customer.

Specifications

Characteristic Impedance (ohms)50
 ConnectorsPlease Specify by Mfg. Type Number

Ordering Information

Isolation Inductors:
 Jacketed Foam Heliax, 1/4" (6 mm)M150-FHJ1-50
 Foam Heliax, 3/8" (10 mm)M150-FH2-50
 Jacketed Foam Heliax, 3/8" (10 mm)M150-FHJ2-50
 Foam Heliax, 1/2" (13 mm)M150-FH4-50
 Jacketed Foam Heliax, 1/2" (13 mm)M150-FHJ4-50
 (Please specify connector type number desired)

Unshielded, Rotary, Insulated Loop, Type 173-11-2

An unshielded, insulated loop with adjustable sensitivity, the Type 173-11-2 allows phase-angle sampling on simple arrays and low-impedance towers without need for an isolation induction. Constructed of plated steel, the loop assembly includes mounting hardware (less U-bolts). Connector for sampling line also included. Unassembled, with assembly instructions and special tools. (Not illustrated.)

Specifications

Dimensions73" H, 41 1/2" W (1854, 1054 mm)
 ConnectionOuter-cond. clamp; inner-cond. strap

Ordering Information

Unshielded, Rotary, Insulated Loop,
 Type 173-11-2MI-27731

Remote Metering Kits

Remote metering kits include a meter and an RF-pickup unit which, in combination, allow measurement of antenna current at a point some distance away from the antenna system. The RF-pickup unit converts RF current into a low-voltage, d-c current of sufficient magnitude to deflect a one-milliamper meter.

Specifications

Pickup Unit:
 Sensitivity3-30A (540 kHz); 1-30A (1600 kHz)
 Dimensions7" H, 7 3/8" W, 5 3/8" D (178, 188, 137 mm)
 Meter:
 Sensitivity (Full Scale)0.001A dc
 Case DimensionSee list below

Ordering Information

RF-Pickup Unit:
 For 5 kW Systems (and lower)MI-27966
 For 10 to 50 kW SystemsMI-28027

Meter (Select to match transmitter meters and specify full-scale calibration):

Transmitter Type No.	Case Dimension	Catalog Number
BTA-1R1	4" (102 mm)	MI-27644A
BTA-5L/-10L	4" (102 mm)	MI-27644A
BTA-5L1/-10L1	4" (102 mm)	MI-27644A
BTA-5T	4" (102 mm)	MI-27644A
BTA-50/-10V	4" (102 mm)	MI-27644A
BTA-5V2/-10V2	4" (102 mm)	MI-27644A
BTA-50J	4 1/2" (115 mm)	MI-27644B
BTA-250M	3" (76 mm)	MI-28037
BTA-1M, -5G/H, -10G/H	4" (102 mm)	MI-28037B

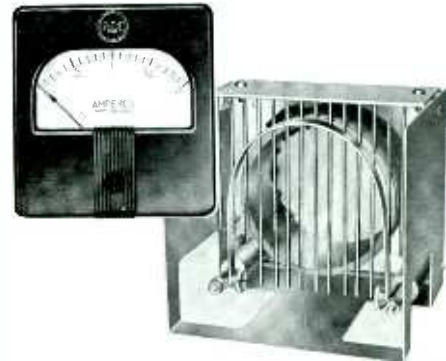

RF Ammeters, Thermocouple Type

Calibrated for mounting in 1/8-inch steel panels, these RF ammeters are offered for use with antenna phasing systems that match the transmitter from a styling viewpoint. Some use an internal thermocouple while others use an external. The thermocouple is included in either case. Available only from RCA Parts and Accessories, Deptford, N.J. Order by stock number.

Ordering Information

Meters to match BPA-10, -11, -50 Antenna Ammeters:

Range	MI (Ref only)	Stock Number
0-2A	MI-7147-2	423414
0-5A	MI-7147-5	423416
0-6A	MI-7147-6	423421
0-10A	MI-7147-10	423418
0-15A	MI-7147-15	423479
0-20A	MI-7147-20	423420

Meters to match BTA-250M Transmitter:

Range	MI (Ref only)	Stock Number
0-2A	MI-28048-2	423423
0-3A	MI-28048-3	423424
0-5A	MI-28048-5	423425
0-8A	MI-28048-8	423426
0-10A	MI-28048-10	423643

Meters to match BTA-1M, -1R1, -5H, -10H, -5T, -50H:

Range	MI (Ref only)	Stock Number
0-2A	MI-7157F-2	423396
0-5A	MI-7157F-5	423398
0-10A	MI-7157F-10	423399
0-15A	MI-7157F-15	423400
0-20A	MI-7157F-20	423410
0-25A	MI-7157F-25	423401

Meters to match BTA-5U1, -10U1 Transmitters:

Range	MI (Ref only)	Stock Number
0-2A	MI-7157G-2	423633
0-5A	MI-7157G-5	423427
0-10A	MI-7157G-10	423429
0-15A	MI-7157G-15	423430
0-20A	MI-7157G-20	423431
0-25A	MI-7157G-25	423432

Typical Antenna Tower Lighting System diagrams and close-up view of Choke Coil, MI-7112-C.

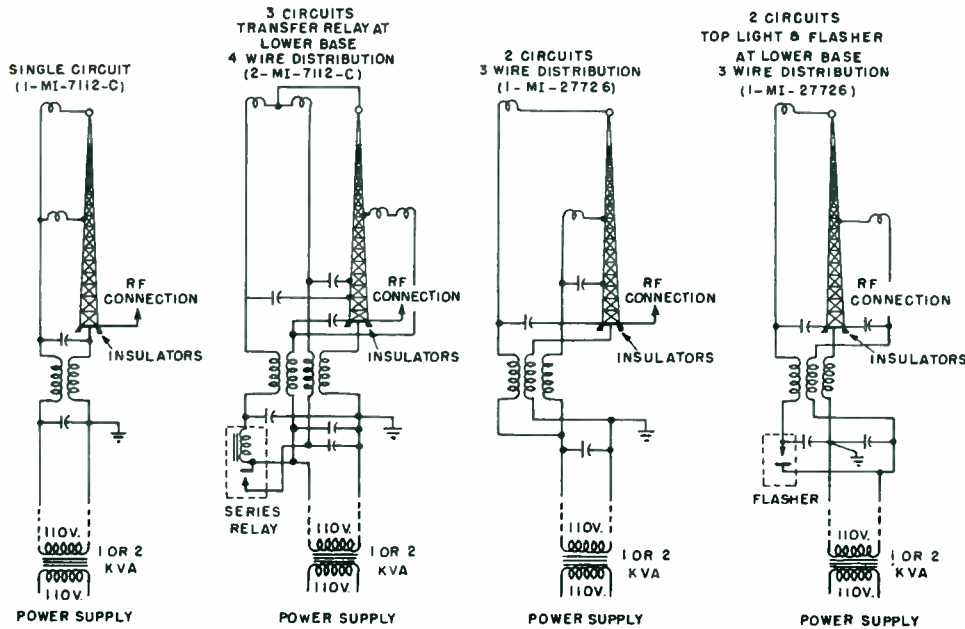

Tower Lighting Chokes

Used to couple 50 or 60 Hz power to tower hazard lights and minimize dissipation of RF energy into power line, these chokes are double or triple wound on Bakelite forms and coated with an insulating varnish. Used outdoors, the coils must be protected from weather. Any winding not connected to the tower or ground must be bypassed to the tower at the "hot" end and to ground at the "cold" end.

Specifications

Current Capacity (max. at 50/60 Hz)	15A
Winding Resistance (Approx., each winding)	0.15 ohms
Inductance (at 1 Mhz)	360 μH
Dimensions	11 1/8" L, 4" Dia. (295, 102 mm)
RF Power (max.)	5 kW

Accessories

Weatherproof Housing	MI-27741
Bypass Capacitor, 0.01 μF	MI-27728-1

Ordering Information

Lighting Choke, Double Winding	MI-7112C
Lighting Choke, Triple Winding	MI-27726
Lighting Choke Kit, Double Winding (1 Choke, 2 Capacitors)	ES-27241
As above with weatherproof housing	ES-27243
Lighting Choke Kit, Triple Winding (1 Choke, 4 Capacitors)	ES-27242
As above, with weatherproof housing	ES-27244





AM Antenna Phase Monitors, Types AM-19 (204), PM-19

- Two to twelve towers, entirely self-contained
- Analog or digital readout
- Ratio resolution: 0.1 percent
- Pushbutton tower selection
- All solid state electronics

An integrated system to fulfill the antenna monitoring requirements of any AM array of two to twelve towers, the Type AM-19 (204) makes no compromise in monitoring. The monitor is available with analog or digital readout, with or without remote readout. (The "204" in parentheses in the type number indicates the FCC approval number.)

For situations where extra precision and measurement repeatability is important, the PM-19 System is offered. This system uses the AM-19 (204) with an adapter that increases precision significantly.



Analog Readout Phase Monitor, Type AM-19 (204)

- **Absolute accuracy: ± 1 degree**
- **Loop current accuracy: ± 2 percent**
- **Long-life, mercury-wetted relay contacts**
- **Pushbutton tower selection**
- **Entirely maintenance-free**

The AM-19 (204) provides an absolute phase measurement accuracy of plus-or-minus one degree with a one-half degree resolution. Loop current indications are accurate to within 1.5 percent with a resolution of one-half percent. The meters are individually calibrated to assure a tracking accuracy of one-half percent and minimize error introduced by variations in meter

characteristics within production tolerances. Modulation on the carrier has no effect on phase measurement.

Easy Operation

Pushbutton switches permit tower sample selection in any order, without need for a special sequence. The phase-angle meter is calibrated in degrees to eliminate

interpretation and the loop-current meter calibration displays percentage of reference tower current. No calibration is required to obtain valid phase-angle and loop-current readings. A front-panel switch makes selection of day/night reference levels a matter of button pushing.

Mercury-Wetted Relays

Long-term relay dependability is the result of mercury-wetted contacts. This reduces contact wear almost to the vanishing point. Combined with all silicon transistorized electronics, this fact gives the AM-19 (204) optimum reliability and high-temperature stability. The meter movements are "taut-band" devices immune to pointer binding as the meter ages.

DA-1, DA-2 or DA-3 Patterns

The AM-19 (204) monitors the three directional patterns in arrays of two to twelve towers. The unit occupies only seven inches (178 mm) of rack space. A remote indicator unit, Type RMP-19 and a remote switching panel, Type RSA-19 are available (see *Accessories*) for control and indication at a point away from the monitor unit itself.

The AM-19 (204) provides outputs for automatic logging equipment.



Specifications

Operating Frequency Range	150 to 2000 kHz
Phase Angle Range (Lead or Lag)	0 to 180 degrees
Phase Angle Accuracy	± 1 degree
Phase Resolution	0.5 degree
Current-Ratio Range (of reference)	0 to 110 percent ¹
Current Ratio Accuracy	± 1.5 percent
Current Ratio Resolution	0.5 percent
Available Patterns	DA-1 (DA-N), DA-2, DA-3
Number of Towers	12 max.
RF Input Impedance	50 or 72 ohms ²
RF Input Level	0.5 to 20 Vrms
Input Connector(s)	Type UHF 50-239
Input Level from Ref. Tower (For 100% loop current reference)	2Vrms min.
Analog Outputs (Local and Remote):	
Phase (0-180 degrees) (Adjustable)	0 to 5Vdc
Loop Current (0-100 percent) (Adjustable)	0 to 5Vdc
Audio (50-15000 Hz, ± 1 dB; 1% THD ³ ; 600 ohms)	7Vrms
Remote Metering Circuit Resistance	11 kohms max.
Remote Control Relays	24 Vdc or contact closure
Power Requirements	105-130V, 50/60 Hz, 50W
Environmental Requirements	0 to 50°C (32-120°F), 0-95% RH

Dimensions	7" H; 19" W; 12 $\frac{3}{4}$ " D (178, 483, 324 mm)
Finish	Paint (Color: Fed. Std. 595-26555 ⁴)

¹Higher ranges available on special order.

²Other impedances available on special order.

³Other colors available optionally, at extra cost.

⁴Total harmonic distortion.

Accessories

Remote Metering Panel	Type RMP-19
Remote Switching Panel	Type RSA-19
Sampling Line Connector	PL-259

Ordering Information

Antenna Phase Monitor, Analog ReadoutType AM-19 (204)

Please specify station call; number of towers in array; sampling line type (Heliac, RG-8 etc.) and impedance; pattern type (DA-1, DA-2 etc.); reference tower number for each pattern and type of remote control system used, if any. For DA-3 pattern, please provide a tower configuration diagram and reference tower number for each pattern. For DA-N patterns, please provide the tower number used in the omni pattern.

Digital Readout Phase Monitor, Type AM-19D

- Digital readout
- Phase resolution: 0.1 degree
- Ratio resolution: 0.1 percent
- Ready for remote control
- Two to six towers, entirely self-contained

The Type AM-19D is, essentially, an AM-19 (204) with digital readouts instead of analog. The digital unit operates within a narrower frequency band, provides a wider range of current-ratio readout at increased accuracy and resolution, handles arrays with two to six towers, delivers less audio output and requires a narrower

range of environmental conditions than the AM-19 (204). The great advantage is the digital readout which eliminates the interpretation (and interpolation) analog readout requires. Both readouts are four-place "LED" (light-emitting diode) numeric displays with indication of over-range condition.

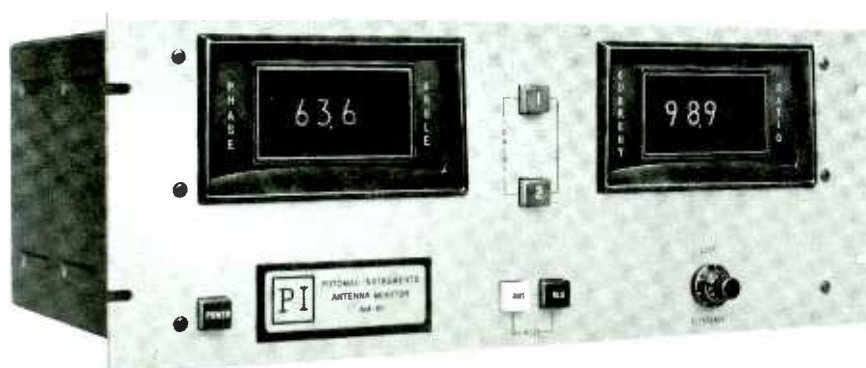

Specifications

Display	Four place, numeric, LED ¹
Display Accuracy	0.05% of full scale readout
Frequency Range	540 to 1600 kHz
Phase Angle Range (Lead or Lag)	0 to 180 degrees
Phase Angle Accuracy	±1 degree
Phase Resolution	0.1 degree
Current Ratio Range (of reference)	5 to 190 percent
Current Ratio Accuracy	0.1 percent ²
Current Ratio Resolution	0.1 percent
Available Patterns	DA-1 (DA-N), DA-2, DA-3
Number of Towers	6 max.
RF Input Impedance	50 to 72 ohms ³
RF Input Level	0.5 to 2Vrms
Input Connector(s)	Type UHF 50-239
Input Level from Ref. Tower (For 100% loop current reference)	2Vrms
Analog Outputs (Local and Remote):	
Phase (0-180 degrees) (Adjustable)	0 to 5Vdc
Loop Current (0-100 percent) (Adjustable)	0 to 5Vdc
Audio (50-15000 Hz, ±1 dB, 1% THD, 600 ohms)	0.4Vrms
Remote Control Relays	24Vdc or contact closure
Power Requirements	105 to 125V, 50/60 Hz, 65VA

Environmental Requirements	10 to 50°C (50 to 104°F), 0 to 95% RH
Dimensions	7" H; 19" W; 12¾" D (178, 483, 324 mm)
Finish	Paint (Color: Fed. Std. 595-26555 ⁴)

¹Readout includes indicator for overrange condition.

²Plus carrier shift with modulation.

³Other impedances available on special order.

⁴Other colors available optionally, extra cost.

Accessories

Remote Readout Panel, Analog	Type RMP-19
Remote Readout Panel, Digital	Type RMP-19D
Remote Switching Panel	Type RSA-19
Sampling Line Connector	PL-259

Ordering Information

Antenna Phase Monitor, Digital ReadoutType AM-19D
Please specify station call; number of towers in array; sampling line type (Heliac, RG-8 etc.) and impedance; pattern type (DA-1, DA-2 etc.); reference tower number for each pattern and type of remote control system used, if any. For DA-3 pattern, please provide a tower configuration diagram and reference tower number for each pattern. For DA-N patterns, please provide the tower number used in the omni pattern.

Precision Antenna Monitoring System, Type PM-19 (204)

- Increased precision and stability
- Analog and digital readout
- Calibration facilities included
- Adaptable to any array



The PM-19 system uses the AM-19 (204) Antenna Monitor as a base and adds to it a PMA-19 Precision Monitor Adapter. The combination of the two units increases resolution and repeatability to one-tenth degree for phase angle and one-tenth percent for current deviation measurements. The system reads out loop current ratios directly. The system provides both analog and digital readout of all three parameters.

Specifications

All specifications identical to those of AM-19 (204) except:

Phase Resolution	0.1 degree
Current Ratio Range	0 to 190 percent
Current Deviation Range	± 25 percent
Current Deviation Resolution	0.1 percent
Digital Output ¹	Four column (1-2-4-8) BCD code (Logic 0 = 0.4V max., 5 mA; Logic 1 = 2.3V min. Also 625 kHz serial code.)
Power Requirements	105-130V, 50-60 Hz, 80W
Environmental Requirements	10 to 45°C (50 to 112°F), 0-95% RH
Dimensions	14" H; 19" W; 16" D (356, 483, 407 mm) ²

¹ Digital Display Adapter, Type DDA-19 optional at extra cost see "Accessories".

² Allow 3/2 inches (89 mm) behind for cables.

Accessories

Digital Display Adapter	Type DDA-19
Remote Metering Panel	Type RMP-19
Remote Switching Panel	Type RSA-19

Ordering Information

Precision Antenna Monitoring System	Type PM-19
---	------------

Please specify station call; number of towers in array; sampling line type (Helix, RG-8 etc.) and impedance; pattern type (DA-1, DA-2 etc.); reference tower number for each pattern and type of remote control system used, if any. For DA-3 pattern, please provide a tower configuration diagram and reference tower number for each pattern. For DA-N patterns, please provide the tower number used in the omni pattern.



Transistorized Field-Intensity Meter, Potomac Instruments Types FIM-21 and FIM-41

- Stable over wide temperature range
- Long battery life—standard D-cells
- High adjacent-channel rejection
- Ganged oscillator/receiver tuning
- Illuminated meter and dial
- Front-panel speaker



Precision instruments for measuring electromagnetic fields in the 535 to 1605 kHz and 540 kHz to 4.8 MHz frequency spectrums, the Types FIM-21 and -41 indicate intensities between $10 \mu\text{V/m}$ and 10 V/m on a direct-reading, front-panel meter. They use ordinary size-D flashlight batteries which are replaced easily without instrument disassembly. The FIM-21 operates only in the 535 to 1605 kHz spectrum while the FIM-41 handles the frequencies between 540 kHz and 4.8 MHz (in two bands) so as to measure the field strengths of the fundamental and harmonics of transmitters operating in the broadcast (medium wave) band. Each unit weighs less than 12 lbs. (5.4 kg) with batteries installed.

The FIM-21 is a precision field-intensity meter for the frequency spectrum between 535 and 1605 kHz. It measures field intensities at all levels between 10 $\mu\text{V}/\text{m}$ and 10 V/m and displays the level on a direct-reading meter on the front panel. The instrument is housed in a rugged, drawn-aluminum case with a brown-suede finish. It operates from a self-contained battery of six size-D zinc-carbon or alkaline dry cells. The entire assembly weighs less than 12 lbs. (5.4 kg).

Special Features

The FIM-21 uses a printed-circuit loop antenna enclosed in the instrument cover. As the cover reaches the vertical position, a pair of rhodium-plated contacts connect the loop to the receiver input. An interlock switch prohibits operation while the cover is closed to prevent inadvertent exhaustion of the battery. The receiver's excellent selectivity is the result of a ceramic filter which maintains IF pass-band characteristics over a wide range of ambient temperature. The instrument even regulates battery voltage to offset

the drop in terminal voltage as the battery approaches end-life.

Simplified Calibration

The instrument includes a tuned oscillator for gain calibration. Coarse tuning of this oscillator is achieved with a mechanical coupling to the receiver tuner. The receiver-oscillator frequency resolves easily on an expanded-scale, lighted dial. A vernier adjustment trims oscillator frequency to the precise frequency. This arrangement avoids the cumbersome back-and-forth switching of earlier units to calibrate the receiver.

Tap-less Meter

The FIM-21 uses a "taut-band" meter which eliminates the familiar sticky-pointer problem and the tapping to nudge the pointer to the final indication. A front-panel loudspeaker is included for signal identification. The tuning dial and meter are lighted for extra convenience after dark.

Doubles As Tuned Voltmeter

The FIM-21 includes a shielded RF-

input in addition to the built-in loop. This input allows use of the instrument as a tuned RF voltmeter in RF-bridge circuits and other situations. The instrument offers two modes of operation: "Linear" and "Logarithmic". In the "Log" mode, the instrument accommodates a dynamic range in excess of a decade; in "Lin" mode, the meter provides a linear indication of the energy appearing at the input.

The FIM-41 is an expanded version of the FIM-21 described. This more-useful unit covers the frequency spectrum between 540 and 4,800 kHz in two bands and includes a special, high-Q, double-filtered input circuit. The additional frequency coverage is most useful in the measurement of AM-transmitter harmonics. The double-filtered input circuit rejects the fundamental frequency to minimize the generation of spurious signals in the instrument circuitry.

The FIM-41 is, in all other ways, an FIM-21.

Specifications , Type FIM-21

Frequency Range	535 to 1605 kHz
Field Intensity Range	10 $\mu\text{V}/\text{m}$ to 10 V/m
Calibration Accuracy*1%
Attenuator Range Accuracy2%
Selectivity:	
Bandwidth (6 db points)	7 kHz min.
IF Rejection	75 dB min.
Image Rejection	80 dB min.
Adjacent Channel Rejection (± 10 kHz)	50 dB min.
Meter Linearity2%
Antenna	Shielded Loop (in cover)
Audio Outputs	Headphone jack; hi or lo z
Recorder Output	0.4 to 4 Vdc across 2 k ohms
Illumination	Dial and Meter, front-panel switch
Power Supply	Six size-D zinc-carbon or alkaline dry cells
Expected Battery Life	500 to 1000 measurements
Ambient Operating Temperature	-10 to 130° F (-23 to 54° C)
Dimensions	8.75" H; 11.5" W; 5.13"D (3.88" cover open) (222, 292, 130, 98 mm)
Weight (Approx.)	11.5 lbs. (5.2 kg)

*Referenced to NBS Standard Field. Calibrated at 220 mV/m.

Specifications , Type FIM-41

Identical to Type FIM-21 with these exceptions:

Frequency Range	540 to 1610 kHz; 1.58 to 4.8 MHz
Image Rejection (min.)	80 dB @ 540 kHz; 50 dB @ 4.8 MHz
Harmonic Measurement Capability (Below fundamental)	80 dB min.

Accessories

Carrying (or Shipping) case
Unipod

Ordering Information

Broadcast Band Field Intensity Meter	Type FIM-21
Two-Band Field Intensity Meter	Type FIM-41

FM Broadcast Antenna, Type BFC

- Circularly polarized
- Radomes or de-icers optional
- Arrays to sixteen sections
- Tower-side or pole-mount
- Input power to 40 kW on array

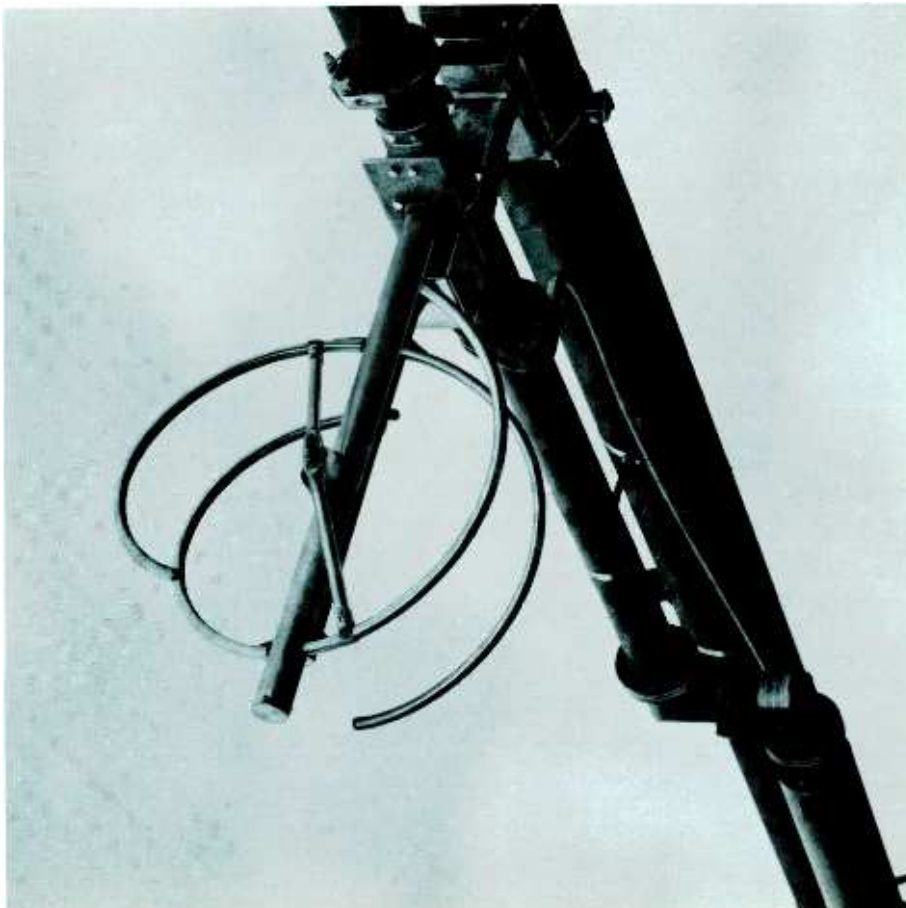

The most popular RCA FM antenna. The BFC-antenna is a circularly polarized device with a power rating of 4kW per section (10kW with radomes) and available in stacked arrays of up to 16 sections with an input rating to 40 kilowatts. For situations where ice formation is common, the arrays can be equipped with electrical de-icers or radomes. Both are options at extra cost.

Pattern Circularity ± 1 dB

The arrays described here offer radiation circularity within 1dB in free space. In side-mount situations, tower metal and guy wires affect the circularity to varying degrees. We recommend that side-mounted arrays be above the highest guy wire. When such is impractical, the guy wires can be insulated from the tower and at 3.5-foot (1.07m) intervals for a distance of 14 feet (4.4m) from the point where the guy touches the tower.

Pole or Tower-Leg Mount

BFC- antenna arrays side-mount on the corners or faces of towers or on a pole as a top-mount antenna. Mounting brackets are included for mounting on plumb poles or round tower legs up to 12 inches (305mm) in diameter or tower faces up to 3 feet (914mm) between leg centers. Brackets for self-supporting (tapered) tower legs, angle-iron tower legs and poles with diameters larger than 12 inches (305mm) are available at extra cost. Mounting on tower faces wider than 3 feet between leg centers is practical with certain additional materials. Practicality usually recommends leg mounting in such situations.

End-Fed or Center-Fed Arrays

Two power distribution methods are

used with the BFC- antenna. In arrays of seven sections and fewer, the array is end-fed (unless the array includes beam tilt and/or null-fill); in eight section and larger arrays, the sections are fed from a center point. The input connection in either case is a $3/8$ inch diameter, 50-ohm, EIA-flanged transmission line.

Integral, Effective De-Icers

The BFC- antenna is available with or without electrical de-icers. The system uses the resistance of the antenna element itself for de-icing by passing low-voltage, high-current energy through the element. This is a highly effective and reliable de-icing system. The de-icers operate from 208/240-volt a-c power with current transformers mounted near the antenna sections on the pole or tower.

Radomes Optional

For operating situations where icing conditions are frequent and/or severe, radomes are made available for BFC-arrays. Using radomes instead of de-icers saves about 18 pounds (8.6kg) of dead-weight per section and increases windload by about 134 pounds (60kg) per section at 50/55 lbs/ft.² (244/161 kg/m²) wind pressure. Using radomes increases the maximum power per section from 4 to 10kW in arrays of four sections and fewer.

Power Gain Proportional to Sections in Array

Each section of a multi-section array provides slightly less than 0.5 power gain in each polarization. This factor improves slightly (see specifications) as the number of sections in the array increases. To illustrate, a 16-section array provides a power gain of 8.9 in each polarization while a one-section array provides 0.46 power gain.

Low VSWR—Field Adjustable

VSWR of the BFC- antenna is adjusted at the factory for a ratio of 1.1:1 over the operating channel. The units are adjustable in the field and a VSWR of that value or better can be achieved with the antenna in its ultimate environment.

Beam Tilt and Null Fill, Directional Arrays

Beam-tilt and/or Null-Fill is an optional extra on the BFC-series. These options are ordinarily specified for the larger arrays (eight sections and more). However, arrays of seven sections and fewer may include one or both options. When such is the case, the array is supplied as a center-fed system (rather than end-fed) at additional expense.

The BFC antenna is available in directional arrays which are custom built to the needs of the directivity situation.

Mounting Dimensions and Feed Line Locations

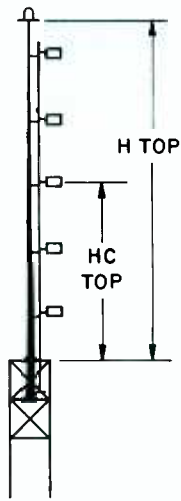

Pole Mounting

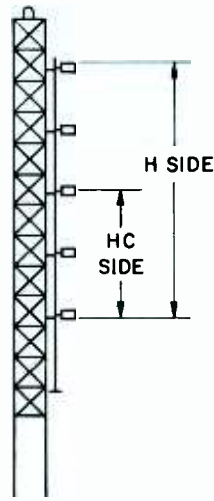

Side Mounting

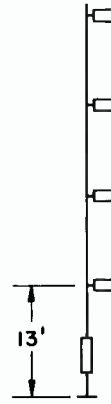

End Feed 1-7 Sections

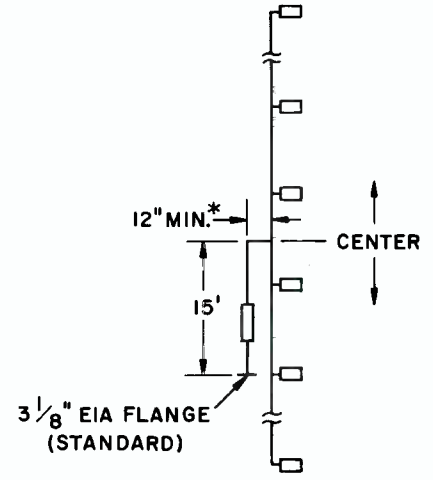

Center Feed 8-16 Sections

*Can be made to dimension desired to bring input line in line with main vertical run.

Mechanical Data

Antenna Type	Freq. MHz	Dimensions in Feet (Meters) ¹								Windload ¹ at 50/30 lbs/ft ² (244/146 kg/m ²)					
		Hc Top Feet Meters		Hc Side Feet Meters		H Top Feet Meters		H Side Feet Meters		Less De-Icers Lbs. Kg.		With De-Icers Lbs. Kg.		With Radomes Lbs. Kg.	
BFC-1	88	5.0	1.52	0.8	0.24	8.0	2.44	1.7	0.52	178	81	198	90	332	151
	98	5.0	1.52	0.8	0.24	8.0	2.44	1.7	0.52	178	81	198	90	332	151
	108	5.0	1.52	0.8	0.24	8.0	2.44	1.7	0.52	178	81	198	90	332	151
BFC-2	88	10.6	3.23	6.4	1.95	19.2	5.85	12.8	3.90	337	153	377	171	645	293
	98	10.0	3.05	5.8	1.77	19.0	5.79	11.7	3.57	327	148	367	167	635	288
	108	9.5	2.90	5.4	1.65	18.0	5.49	10.8	3.29	319	145	359	163	627	284
BFC-3	88	16.2	4.93	11.9	3.63	30.4	9.27	23.9	7.28	495	225	555	252	957	434
	98	15.0	4.57	10.9	3.32	28.9	8.81	21.8	6.64	475	215	535	243	937	425
	108	14.1	4.30	9.9	3.02	27.5	8.38	19.9	6.07	459	208	519	235	921	418
BFC-4	88	21.7	6.61	17.6	5.36	41.5	12.65	35.2	10.73	653	296	723	328	1269	576
	98	20.0	6.10	15.9	4.85	38.4	11.70	31.8	9.69	623	283	703	319	1239	562
	108	18.6	5.67	14.5	4.42	36.8	11.22	29.0	8.84	599	272	679	308	1215	551
BFC-5	88	27.3	8.32	23.2	7.07	52.7	16.06	46.4	14.14	810	367	911	413	1581	717
	98	25.0	7.62	20.9	6.37	49.4	15.06	41.8	12.74	791	359	871	395	1541	699
	108	23.2	7.07	19.0	5.79	46.1	14.05	38.1	11.61	763	346	839	381	1510	685
BFC-6	88	32.9	10.03	28.8	8.78	63.9	19.48	57.6	17.56	970	440	1090	494	1874	850
	98	30.0	9.14	25.4	7.74	59.3	18.07	50.9	15.51	920	417	1040	472	1824	827
	108	27.7	8.44	23.6	7.19	54.9	16.73	47.2	14.39	882	400	1000	454	1784	809
BFC-7	88	38.5	11.73	34.3	10.45	75.0	22.86	68.7	20.94	1128	512	1268	575	2183	990
	98	35.1	10.70	30.9	9.42	68.7	20.94	61.9	18.87	1068	484	1208	548	2123	963
	108	32.3	9.85	28.1	8.56	64.2	19.57	56.3	17.16	1020	463	1160	526	2075	941
BFC-8	88	44.0	13.41	40.0	12.19	86.2	26.27	80.0	24.38	1308	593	1468	666	2514	1140
	98	40.1	12.22	35.9	10.94	78.9	24.05	71.9	21.92	1238	562	1398	634	2454	1113
	108	36.8	11.22	32.7	9.97	73.2	22.31	65.4	19.93	1182	536	1342	609	2390	1084
BFC-10	88	55.2	16.82	51.1	15.58	108.6	33.22	102.2	33.22	1625	737	1875	851	3165	1436
	98	50.1	15.27	46.0	14.02	98.6	30.05	92.0	28.04	1535	696	1735	787	3075	1395
	108	45.9	13.99	41.8	12.74	91.2	27.80	83.7	25.51	1483	673	1663	754	3003	1362
BFC-12	88	66.4	20.24	62.3	18.99	131.0	39.93	124.7	38.10	1942	881	2182	990	3790	1719
	98	60.1	18.32	56.0	17.07	119.8	36.58	112.1	34.14	1832	831	2072	940	3680	1669
	108	55.0	16.76	51.0	15.54	109.6	33.53	101.9	31.09	1744	791	1984	900	3592	1629
BFC-14	88	POLE MOUNT NOT RECOMMENDED		73.5	22.40	POLE MOUNT NOT RECOMMENDED		147.0	44.81	2258	1024	2538	1151	4414	2002
	98	POLE MOUNT NOT RECOMMENDED		66.1	20.15	POLE MOUNT NOT RECOMMENDED		132.2	40.23	2128	965	2408	1092	4284	1943
	108	POLE MOUNT NOT RECOMMENDED		60.0	18.29	POLE MOUNT NOT RECOMMENDED		120.1	36.58	2088	947	2304	1045	4244	1925
BFC-16	88	POLE MOUNT NOT RECOMMENDED		84.7	25.82	POLE MOUNT NOT RECOMMENDED		169.4	51.51	2575	1168	2895	1313	5039	2286
	98	POLE MOUNT NOT RECOMMENDED		76.1	23.20	POLE MOUNT NOT RECOMMENDED		152.3	46.33	2425	1100	2745	1245	4889	2218
	108	POLE MOUNT NOT RECOMMENDED		69.1	21.06	POLE MOUNT NOT RECOMMENDED		138.3	42.06	2205	1000	2625	1191	4669	2118

¹Interpolate dimensions and windload for antennas of intermediate frequency.

Electrical Data

Antenna Type	Power Gain ¹			Field Intensity ²	Power Rating ³			
	Power	dB	Field		with Radomes		without Radomes	
					kW	dBk	kW	dBk
BFC-1	0.46	-3.37	0.678	93.2	10	10.0	4	6.02
BFC-2	1.0	0	1.00	137.5	20	13.01	8	9.03
BFC-3	1.5	1.76	1.23	169.1	30	14.77	12	10.79
BFC-4	2.1	3.22	1.45	199.2	40	16.02	16	12.04
BFC-5	2.7	4.31	1.64	225.5	40 ³	16.02	20	13.01
BFC-6	3.2	5.05	1.79	246.1	40 ³	16.02	24	13.80
BFC-7	3.8	5.80	1.95	268.1	40 ³	16.02	28	14.47
BFC-8	4.3	6.34	2.07	284.6	40 ³	16.02	32	15.05
BFC-10	5.5	7.40	2.35	323.1	40 ³	16.02	40	16.02
BFC-12	6.6	8.20	2.57	353.4	40 ³	16.02	40	16.02
BFC-14	7.8	8.92	2.79	383.6	40 ³	16.02	40	16.02
BFC-16	8.9	9.49	2.98	409.8	40 ³	16.02	40	16.02

¹Power gain in each polarization.

²Effective free-space field intensity at 1 mile (1.604 km) in mV/m for 1 kW antenna input power for either equivalent horizontally polarized component or equivalent vertically polarized component.

³Power Rating based on a 40° C ambient. Multiply values listed by 0.8 for 50° C ambient. BFC-5 and larger antennas with greater power ratings are available on special order.

General Specifications

- PolarizationCircular
- Horiz. Pattern Circularity in Free Space±1 dB
- Vert. Pattern Circularity in Free Space±1 dB
- VSWR at Input, Top Mounted, w/o field trim1.2:1 max.
- VSWR at Input, Side Mounted, w/o field trim1.5:1 max.
- VSWR at Input, Top- or Side-Mount, w/field trim (200 kHz)1.1:1
- Input Connection Diameter (50-ohm, EIA Flange)3½"
- Input Power Rating (in kilowatts)See Elec. Data Chart
- Section Dimensions20.7" (526mm) dia.; 20" (508mm) H
- WindloadSee Mech. Data Chart
- Feedpoint Locations (Approx.):
 - Seven Sections and Fewer (below lowest section)13' (4m)
 - Eight Sections and More (below array center)15' (4.6m)

Deadweight in Pounds (kg) ¹ :	Power Gain		With Radomes
	With De-Icers	Less De-Icers	
Single Section	76(34)	136(62)	118(54)
Two Sections	137(62)	257(117)	221(100)
Three Sections	198(90)	378(171)	334(152)
Four Sections	259(117)	499(226)	327(194)
Five Sections	320(145)	620(281)	530(240)
Six Sections	381(173)	741(336)	633(287)
Seven Sections	442(200)	862(391)	736(334)
Eight Sections	513(233)	993(450)	849(385)
Ten Sections	635(288)	1235(560)	1055(479)
Twelve Sections	757(343)	1477(670)	1261(572)
Fourteen Sections	879(399)	1719(780)	1467(665)
Sixteen Sections	1001(454)	1961(890)	1673(759)

¹Weight includes feed system from sections to input connection and 13- to 18-inch (330 to 457 mm) extension brackets for mounting.

Accessories

- Input Adapters:
 - Inner Conductor Adapters to connect:
 - MI-19113C LineMI-27988-4A
 - MI-19313 LineMI-27988-4B
 - Adapters to connect:
 - Male end of MI-27791D LineMI-27791D-7A
 - Female end of MI-27791D LineMI-27791D-7B
- Reducers, Quick-Step, to connect:
 - 1½-inch Flexible LineMI-27988-5C
 - ¾-inch Flexible LineMI-27988-5D
- Thermostatic De-Icer ControlMI-27369A
- Rosemount Antenna Ice DetectorMI-561572
- AM/FM Tower Isolator, Type BAF-15/16MI-561573/4

Ordering Information

Antenna Type No.	Sections	Power Gain		With De-Icers	With Radomes
		Per Polarization	Less De-Icers		
BFC-1	1	0.46	ES-561921A	ES-561921B	ES-561921C
BFC-2	2	1.00	ES-561922A	ES-561922B	ES-561922C
BFC-3	3	1.50	ES-561923A	ES-561923B	ES-561923C
BFC-4	4	2.10	ES-561924A	ES-561924B	ES-561924C
BFC-5	5	2.70	ES-561925A	ES-561925B	ES-561925C
BFC-6	6	3.20	ES-561926A	ES-561926B	ES-561926C
BFC-7	7	3.80	ES-561927A	ES-561927B	ES-561927C
BFC-8	8	4.30	ES-561928A	ES-561928B	ES-561928C
BFC-10	10	5.50	ES-561929A	ES-561929B	ES-561929C
BFC-12	12	6.60	ES-561930A	ES-561930B	ES-561930C
BFC-14	14	7.80	ES-561931A	ES-561931B	ES-561931C
BFC-16	16	8.90	ES-561932A	ES-561932B	ES-561932C



Tri-Pole FM Broadcast Antenna, Type BFG- Series

- Circularly polarized
- Adjustable polarization ratio
- Integral de-icers optional
- Arrays to 16 sections
- Pole or tower-leg mount

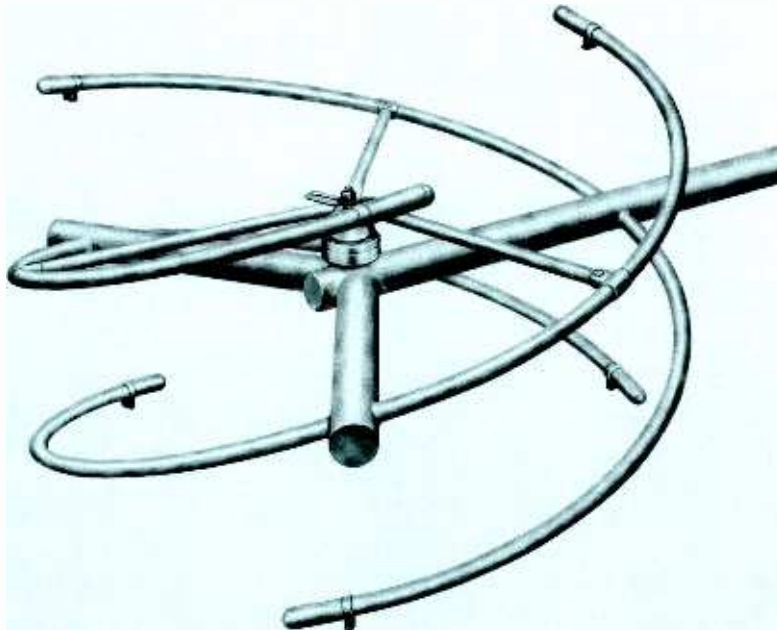

The BFG- Series of antennas are circularly polarized elements with a power rating of 6kW per section and available in stacked arrays of up to 16 sections with an input rating to 40 kilowatts. The BFG- antenna is a three-pole system with factory-adjustable elements that allow control of the ratio between vertical and horizontal polarization. The elements of the antenna section may be adjusted to provide maximum ERP in the horizontal plane and less in the vertical plane. This is most useful where available transmitter power is less than necessary for maximum ERP in both planes.

Pattern Circularity ±1dB

The arrays described here offer radiation circularity within 1dB in free space. In side-mount situations, tower metal and guy wires affect the circularity to varying degrees. We recommend that side-mounted arrays be above the highest guy wire. When such is impractical, the guy wires can be insulated from the tower and at 3.5-foot (1.07m) intervals for a distance of 14 feet (4.4m) from the point where the guy touches the tower.

Pole or Tower-Leg Mount

BFG- antenna arrays side-mount on the corners or faces of towers or on a pole as a top-mount antenna. Mounting brackets are included for mounting on plumb, round tower legs or poles up to 12 inches (305mm) in diameter or tower faces up to 3 feet (914mm) between leg centers. Brackets for self-supporting (tapered) tower legs, angle-iron tower legs and poles with diameters larger than 12 inches (305mm) are available at extra cost. Mounting on tower faces wider than 3 feet between leg centers is practical with certain additional materials. Practicality usually recommends leg mounting in such situations.

End-Fed or Center-Fed Arrays

Two power distribution methods are used with the BFG- antenna. In arrays of seven sections and fewer, the array is end-fed (unless the array includes beam tilt and/or null-fill); in eight section and larger arrays, the sections are fed from a center point. The input connection in either case is a 3/8 inch diameter, 50-ohm, EIA-flanged transmission line.

Integral, Effective De-Icers

The BFG- antenna is available with or without electrical de-icers. The system uses the resistance of the antenna element itself for de-icing by passing low-voltage, high-current energy through the element. This is a highly effective and reliable de-icing system. The de-icers operate from 208/240-volt a-c power with current transformers mounted near the antenna sections on the pole or tower.

Power Gain Proportional to Sections in Array

Each section of a multi-section array provides slightly less than 0.5 power gain in each polarization. This factor improves slightly (see specifications) as the num-

ber of sections in the array increases. To illustrate, a 16-section array provides a power gain of 8.9 in each polarization while a one-section array provides 0.46 power gain.

Low VSWR—Field Adjustable

VSWR of the BFG- antenna is adjusted at the factory for a ratio of 1.1:1 over the operating channel. The units are adjustable in the field and a VSWR of that value or better can be achieved with the antenna in its ultimate environment.

Beam Tilt and Null Fill, Directional Arrays

Beam-tilt and/or Null-Fill is an optional extra on the BFG-series. These options are ordinarily specified for the larger arrays (eight sections and more). However, arrays of seven sections and fewer may include one or both options. When such is the case, the array is supplied as a center-fed system (rather than end-fed) at additional expense.

The BFG antenna is available in directional arrays which are custom built to the needs of the directivity situation.

Mounting Dimensions and Feed Line Locations, BFG Series FM Antennas.

(See Table on opposite page)

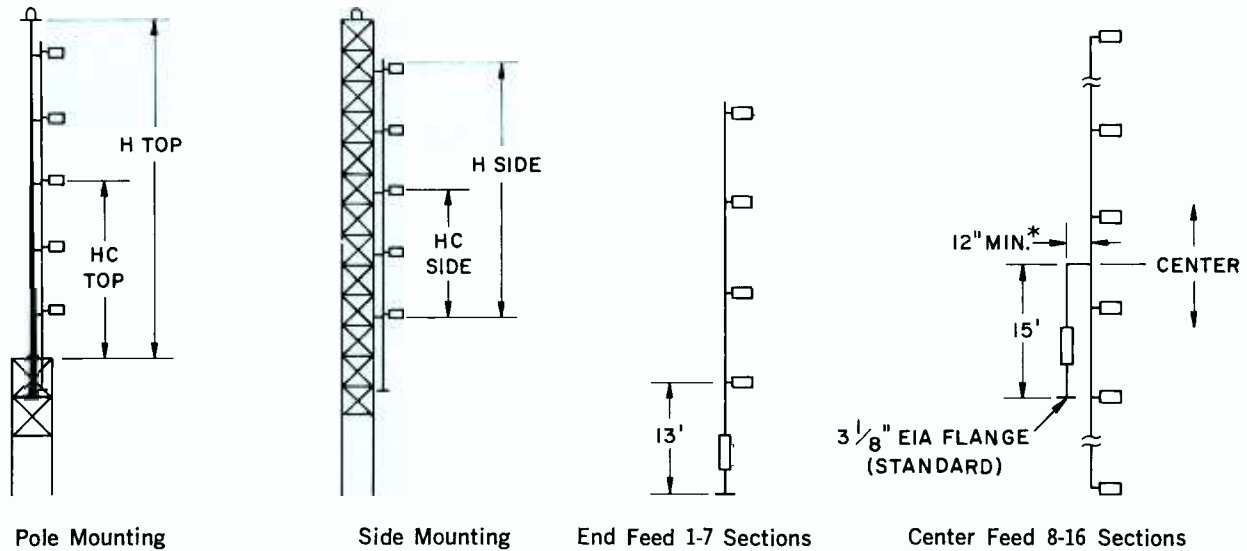

*Can be changed to dimension required to bring input in line with main vertical transmission line run

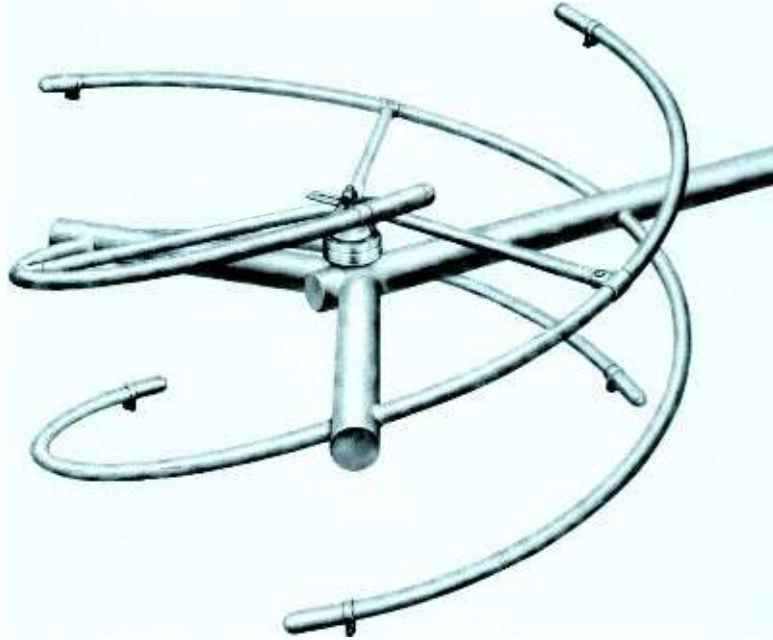

Mechanical Data

Antenna Type	Freq. MHz	Dimensions ¹ (See Drawing)								Windload ¹ at 50/30 lbs/ft ² (244/146 kg/m ²)					
		Hc Top Feet Meters		Hc Side Feet Meters		H Top Feet Meters		H Side Feet Meters		Less De-Icers Lbs. Kg.		With De-Icers Lbs. Kg.		With Radomes Lbs. Kg.	
BFG-1	88	5.0	1.52	0.8	0.24	8.0	2.44	1.7	0.52	178	81	198	90		
	98	5.0	1.52	0.8	0.24	8.0	2.44	1.7	0.52	178	81	198	90		
	108	5.0	1.52	0.8	0.24	8.0	2.44	1.7	0.52	178	81	198	90		
BFG-2	88	10.6	3.23	6.4	1.95	19.2	5.85	12.8	3.90	337	153	377	171		
	98	10.0	3.05	5.8	1.77	19.0	5.79	11.7	3.57	327	148	367	167		
	108	9.5	2.90	5.4	1.65	18.0	5.49	10.8	3.29	319	145	359	163		
BFG-3	88	16.2	4.93	11.9	3.63	30.4	9.27	23.9	7.28	495	225	555	252		
	98	15.0	4.57	10.9	3.32	28.9	8.81	21.8	6.64	475	215	535	243		
	108	14.1	4.30	9.9	3.02	27.5	8.38	19.9	6.07	459	208	519	235		
BFG-4	88	21.7	6.61	17.6	5.36	41.5	12.65	35.2	10.73	653	296	723	328		
	98	20.0	6.10	15.9	4.85	38.4	11.70	31.8	9.69	623	283	703	319		
	108	18.6	5.67	14.5	4.42	36.8	11.22	29.0	8.84	599	272	679	308		
BFG-5	88	27.3	8.32	23.2	7.07	52.7	16.06	46.4	14.14	810	367	911	413		
	98	25.0	7.62	20.9	6.37	49.4	15.06	41.8	12.74	791	359	871	395		
	108	23.2	7.07	19.0	5.79	46.1	14.05	38.1	11.61	763	346	839	381		
BFG-6	88	32.9	10.28	28.8	8.78	63.9	19.48	57.6	17.56	970	440	1090	494		
	98	30.0	9.14	25.4	7.74	59.3	18.07	50.9	15.51	920	417	1040	472		
	108	27.7	8.44	23.6	7.19	54.9	16.73	47.2	14.39	882	400	1000	454		
BFG-7	88	38.5	11.73	34.3	10.45	75.0	22.86	68.7	20.94	1128	512	1268	575		
	98	35.1	10.70	30.9	9.42	68.7	20.94	61.9	18.87	1068	484	1208	548		
	108	32.3	9.85	28.1	8.56	64.2	19.57	56.3	17.16	1020	463	1160	526		
BFG-8	88	44.0	13.41	40.0	12.19	86.2	26.27	80.0	24.38	1308	593	1468	666		
	98	40.1	12.22	35.9	10.94	78.9	24.05	71.9	21.92	1238	562	1398	634		
	108	36.8	11.22	32.7	9.97	73.2	22.31	69.4	21.15	1182	536	1342	609		
BFG-10	88	55.2	16.82	51.1	15.58	108.6	33.10	102.2	31.15	1625	737	1875	851		
	98	50.1	15.27	46.0	14.02	98.6	30.05	92.0	28.04	1535	692	1735	787		
	108	45.9	13.99	41.8	12.74	91.2	27.80	83.7	25.51	1483	673	1663	754		
BFG-12	88	66.4	20.24	62.3	18.99	131.0	39.92	124.7	38.01	1942	881	2182	990		
	98	60.1	18.32	56.0	17.07	119.8	36.52	112.1	34.17	1832	831	2072	1234		
	108	55.0	16.76	51.0	15.54	109.6	33.41	101.9	31.06	1744	791	1984	900		
BFG-14	88	POLE MOUNT		73.5	22.40	POLE MOUNT		147.0	44.81	2258	1024	2538	1151		
	98	NOT RECOMMENDED		66.1	20.15	NOT RECOMMENDED		132.2	40.29	2128	965	2408	1092		
	108	RECOMMENDED		60.0	18.29	RECOMMENDED		120.1	36.61	2088	947	2304	1045		
BFG-16	88	POLE MOUNT		84.7	25.82	POLE MOUNT		169.4	51.63	2575	1168	2895	1313		
	98	NOT RECOMMENDED		76.1	23.20	NOT RECOMMENDED		152.3	46.42	2425	1100	2745	1245		
	108	RECOMMENDED		69.1	21.06	RECOMMENDED		138.3	42.15	2205	1000	2625	1191		

NOT AVAILABLE

¹ Interpolate dimensions and windload for antennas of intermediate frequency.

General Specifications

Polarization	Circular
Horiz. Pattern Circularity in Free Space	±1dB
Vert. Pattern Circularity in Free Space	±1dB
VSWR at Input, Top Mounted, w/o field trim	1.2:1 max.
VSWR at Input, Side Mounted, w/o field trim	1.5:1 max.
VSWR at Input, Top- or Side-Mount, w/field trim (200 kHz)	1.1:1
Input Connection Diameter (50-ohm, EIA Flange)	3 ³ / ₈ "
Input Power Rating	See Elec. Data Chart
Section Dimensions	25" (635mm) dia.; 20" (508mm) H
Windload	See Mech. Data Chart
Feedpoint Locations (Approx.):	
Seven Sections and Fewer (below lowest section)	13' (4m)
Eight Sections and More (below array center)	15' (4.6m)
Weight in Pounds (kg): ¹	
	Less De-Icers With De-Icers
Single Section	76(34) 136(62)
Two Sections	137(62) 257(117)
Three Sections	198(90) 378(171)
Four Sections	259(117) 499(226)
Five Sections	320(145) 620(281)
Six Sections	381(173) 741(336)
Seven Sections	442(200) 862(391)
Eight Sections	513(233) 993(450)
Ten Sections	635(288) 1235(560)
Twelve Sections	757(343) 1477(670)
Fourteen Sections	879(399) 1719(780)
Sixteen Sections	1001(454) 1961(890)

¹Weight includes feed system to antenna input and 13- to 18-inch (330 to 457mm) extension brackets for mounting.

Accessories

Input Adapters:	
Inner Conductor Adapter to connect:	
MI-19113C Line	MI-27988-4A
MI-19313 Line	MI-27988-4B
Adapter to connect:	
Male end of MI-27791D Line	MI-27791D-7A
Female end of MI-27791D Line	MI-27791D-7B
Reducers, Quick-Step, to connect:	
1 ³ / ₈ -inch Flexible Line	MI-27988-5C
⁷ / ₈ -inch Flexible Line	MI-27988-5D
Thermostatic De-Icer Control	MI-27369A
Rosemount Antenna Ice Detector	MI-561572
AM/FM Tower Isolator, Type BAF-15/16	MI-561573/4

Electrical Data

Type BFG-

Antenna Type	Power Gain ¹			Field Intensity	Power Rating ²	
	Power	dB	Field		kW	dBk
BFG-1	0.9	-0.45	0.95	130.6	6	7.78
BFG-2	2.0	3.01	1.41	193.9	12	10.79
BFG-3	3.0	4.77	1.73	237.9	18	12.55
BFG-4	4.2	6.23	2.05	281.9	24	13.80
BFG-5	5.4	7.32	2.32	319.0	30	14.77
BFG-6	6.4	5.06	2.53	347.9	36	15.56
BFG-7	7.6	8.80	2.76	379.5	40 ²	16.02
BFG-8	8.6	9.34	2.93	402.9	40 ²	16.02
BFG-10	11.0	10.41	3.32	456.5	40 ²	16.02
BFG-12	13.2	11.20	3.63	499.1	40 ²	16.02
BFG-14	15.6	11.93	3.95	543.1	40 ²	16.02
BFG-16	17.8	12.50	4.22	580.3	40 ²	16.02

¹Horizontal and vertical gain combined. Horizontally polarized gain may be specified at any level between 50 and 90 percent of total gain listed. Vertical power gain is then equal to the combined gain less the horizontal gain. For each polarization, the field gain is equal to the square root of the power gain. The effective field intensity at one mile (1.604 km) for 1 kW input is equal to 137.5 times the field gain.

²Power Rating based on a 40° C ambient. Multiply values listed by 0.8 for 50° C ambient. BFG-7 and larger antennas with greater power ratings are available on special order.

Ordering Information

Type BFG-

Antenna Type No.	Sections	Power Gain* Hor. Plus Vert.	Less De-Icers	With De-Icers
BFG-1	1	0.9	ES-561951A	ES-561951B
BFG-2	2	2.0	ES-561952A	ES-561952B
BFG-3	3	3.0	ES-561953A	ES-561953B
BFG-4	4	4.2	ES-561954A	ES-561954B
BFG-5	5	5.4	ES-561955A	ES-561955B
BFG-6	6	6.4	ES-561956A	ES-561956B
BFG-7	7	7.6	ES-561957A	ES-561957B
BFG-8	8	8.6	ES-561958A	ES-561958B
BFG-10	10	11.0	ES-561959A	ES-561959B
BFG-12	12	13.2	ES-561960A	ES-561960B
BFG-14	14	15.6	ES-561961A	ES-561961B
BFG-16	16	17.8	ES-561962A	ES-561962B

*Power gain in horizontal polarization may be specified at any point between 50 and 75 percent of total gain shown.



catalog RA.7211A

(Replaces B.6753)

Economy FM Broadcast Antennas, Type BFH-Series

- Circularly polarized
- Integral de-icers optional
- Arrays to eight sections
- For Class A stations
- Input power to 8 kW on array



The BFH- antenna series is intended for the Class A FM station seeking performance on a budget. The BFH- antenna is a low-power version of the BFC- and is available in one through eight sections with a power-input rating to 8kW. The BFH- antenna provides BFC- antenna performance to the Class A FM station at purchase prices significantly lower than those of the high-power antenna.

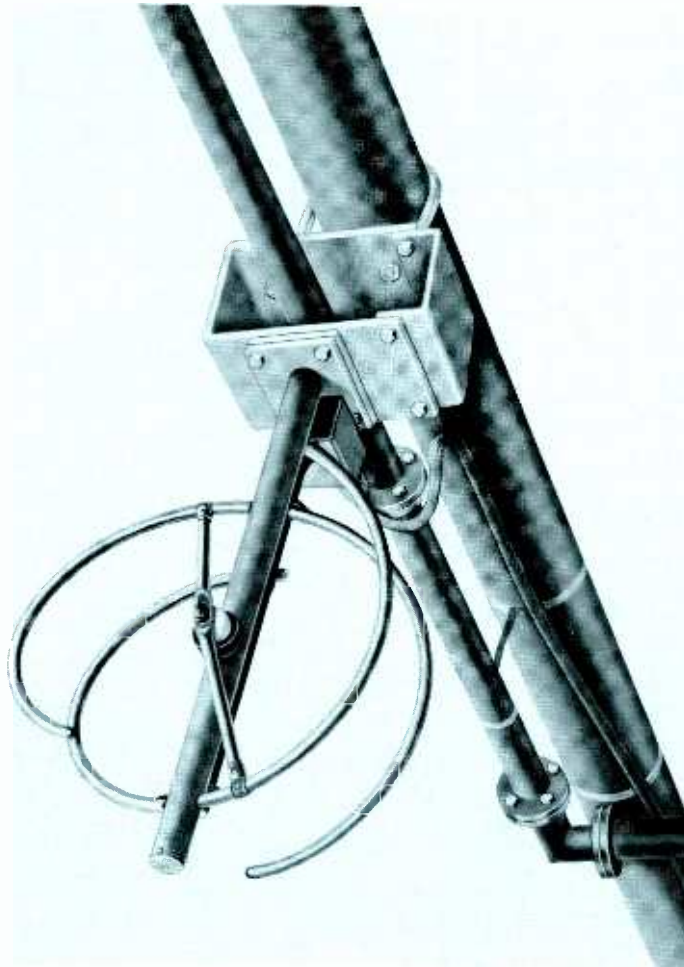

Pattern Circularity $\pm 1\text{dB}$

The arrays described here offer radiation circularity within 1dB in free space. In side-mount situations, tower metal and guy wires affect the circularity to varying degrees. We recommend that side-mounted arrays be above the highest guy wire. When such is impractical, the guy wires can be insulated from the tower and at 3.5-foot (1.07m) intervals for a distance of 14 feet (4.4m) from the point where the guy touches the tower.

Pole or Tower-Leg Mount

BFH- antenna arrays side-mount on the corners or faces of towers or on a pole as a top-mount antenna. Mounting brackets are included for mounting on plumb, round tower legs or poles up to 12 inches (305mm) in diameter or tower faces up to 3 feet (914mm) between leg centers. Brackets for self-supporting (tapered) tower legs, angle-iron tower legs and poles with diameters larger than 12 inches (305mm) are available at extra cost. Mounting on

tower faces wider than 3 feet between leg centers is practical with certain additional materials. Practicality usually recommends leg mounting in such situations.

End-Fed or Center-Fed Arrays

Two power distribution methods are used with the BFH- antenna. The array is usually end-fed unless it includes beam tilt and/or null-fill. In this case, the sections are fed from a center point. The input connection in either case is a 1 $\frac{5}{8}$ inch diameter, 50-ohm, EIA-flanged transmission line.

Integral, Effective De-Icers

The BFH- antenna is available with or without electrical de-icers. The system uses the resistance of the antenna element itself for de-icing by passing low-voltage, high-current energy through the element. This is a highly effective and reliable de-icing system. The de-icers operate from 208/240-volt a-c power with current trans-

formers mounted near the antenna sections on the pole or tower.

Power Gain Proportional to Sections in Array

Each section of a multi-section array provides slightly less than 0.5 power gain in each polarization. This factor improves slightly (see specifications) as the number of sections in the array increases. To illustrate, an 8-section array provides a power gain of 4.3 in each polarization while a one-section array provides 0.46 power gain.

Beam Tilt and Null Fill, Directional Arrays

Beam-tilt and/or Null-Fill is an optional extra on the BFH- series. These options are ordinarily specified for the larger arrays (eight sections). However, arrays of seven sections and fewer may include one or both options. When such is the case, the array is supplied as a center-fed system (rather than end-fed) at additional expense.

Mounting Dimensions and Feed Line Locations, BFH Series FM Antennas.

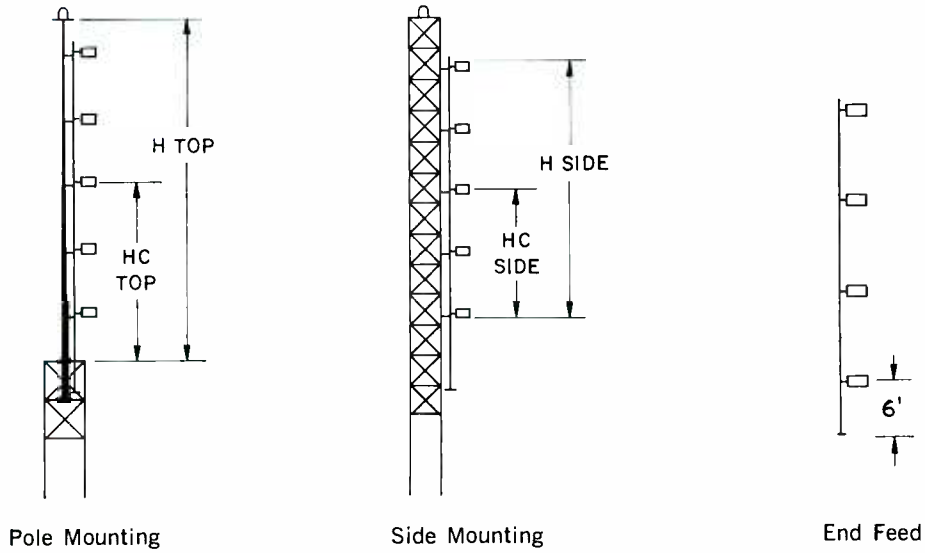

Mechanical Data

Antenna Type	Freq. MHz	Dimensions ¹ (See Drawing)								Windload ¹ at 50/30 lbs/ft ² (244/146/kg ²)			
		Hc Top Feet Meters		Hc Side Feet Meters		H Top Feet Meters		H Side Feet Meters		Less De-Icers Lbs. Kg.		With De-Icers Lbs. Kg.	
BFH-1	88	5.0	1.52	0.8	0.24	8.0	2.44	1.7	0.52	116	53	139	63
	98	5.0	1.52	0.8	0.24	8.0	2.44	1.7	0.52	116	53	139	63
	108	5.0	1.52	0.8	0.24	8.0	2.44	1.7	0.52	116	53	139	63
BFH-2	88	10.6	3.23	6.4	1.95	19.2	5.85	12.8	3.90	220	100	264	120
	98	10.0	3.05	5.8	1.77	19.0	5.79	11.7	3.57	213	97	257	117
	108	9.5	2.90	5.4	1.65	18.0	5.49	10.8	3.29	208	94	252	114
BFH-3	88	16.2	4.93	11.9	3.63	30.4	9.27	23.9	7.28	322	146	389	176
	98	15.0	4.57	10.9	3.32	28.9	8.81	21.8	6.64	309	140	375	170
	108	14.1	4.30	9.9	3.02	27.5	8.38	19.9	6.07	299	136	364	165
BFH-4	88	21.7	6.61	17.6	5.36	41.5	12.65	35.2	10.73	425	193	507	259
	98	20.0	6.10	15.9	4.85	38.4	11.70	31.8	9.69	405	184	493	224
	108	18.6	5.67	14.5	4.42	36.8	11.22	29.0	8.84	390	177	476	216
BFH-5	88	27.3	8.32	23.2	7.07	52.7	16.06	46.4	14.14	527	239	638	289
	98	25.0	7.62	20.9	6.37	49.4	15.06	41.8	12.74	515	234	610	277
	108	23.2	7.07	19.0	5.79	46.1	14.05	37.1	11.61	496	225	588	267
BFH-6	88	32.9	10.28	28.8	8.78	63.9	19.48	57.6	17.50	631	286	763	346
	98	30.0	9.14	25.4	7.74	59.3	18.07	50.9	15.51	599	272	728	330
	108	27.7	8.44	23.6	7.19	54.9	16.73	47.2	14.39	574	260	700	318
BFH-7	88	38.5	11.73	34.3	10.45	75.0	22.86	68.7	20.94	734	333	888	403
	98	35.1	10.70	30.9	9.42	68.7	20.94	61.9	18.87	695	315	846	384
	108	32.3	9.85	28.1	8.56	64.2	19.57	56.3	17.16	663	301	812	368
BFH-8	88	44.0	13.41	40.0	12.19	86.2	26.27	80.0	24.38	851	386	1028	466
	98	40.1	12.22	35.9	10.94	78.9	24.05	71.9	21.92	805	365	979	445
	108	36.8	11.22	32.7	9.97	73.2	22.31	65.4	21.15	769	349	940	426

¹ Interpolate dimensions and windload for antennas of intermediate frequencies.

General Specifications

Polarization	Circular	
Horiz. Pattern Circularity in Free Space	±1dB	
Vert. Pattern Circularity in Free Space	±1dB	
VSWR at Input (Adjusted at factory)	1.1:1*	
Input Connection Diameter (50-ohm, EIA Flange)	1 5/8"	
Input Power Rating (in kilowatts)	See Elec. Data Chart	
Section Dimensions	17" (432mm) dia.; 15" (381mm) H	
Windload	See Mech. Data Chart	
Feedpoint Locations (Approx.):		
Eight Sections and Fewer (below lowest section)	6' (1.8m)	
Weight (Approx):	With De-icers	Less De-icers
Single Section	82 lbs (37kg) ¹	30 lbs (14kg) ¹
Two Sections	154 lbs (70kg) ¹	51 lbs (23kg) ¹
Three Sections	226 lbs (103kg) ¹	79 lbs (36kg) ¹
Four Sections	300 lbs (136kg) ¹	104 lbs (47kg) ¹
Five Sections	372 lbs (169kg) ¹	128 lbs (58kg) ¹
Six Sections	446 lbs (202kg) ¹	153 lbs (69kg) ¹
Seven Sections	520 lbs (236kg) ¹	177 lbs (80kg) ¹
Eight Sections	595 lbs (270kg) ¹	205 lbs (93kg) ¹

¹Weight includes elements, feed system to antenna input and 13- to 18-inch (330- to 457mm) extension brackets for mounting.

Accessories

Reducer, Quick-Step, to connect 7/8-inch flexible line	MI-27988-5E
Thermostatic De-Icer Control	MI-27369A
Rosemount Antenna Ice Detector	MI-561572
AM/FM Tower Isolator, Type BAF-15/16	MI-561573/4

**Electrical Data
Type BFH-**

Antenna Type	Power Gain ¹			Field Intensity ²	Power Rating	
	Power	dB	Field		kW	dBk
BFH-1	0.46	-3.37	0.678	93.2	2	3.01
BFH-2	1.0	0	1.00	137.5	4	6.02
BFH-3	1.5	1.76	1.23	168.4	6	7.78
BFH-4	2.1	3.22	1.45	199.2	8	9.03
BFH-5	2.7	4.31	1.64	225.2	8	9.03
BFH-6	3.2	5.05	1.79	246.0	8	9.03
BFH-7	3.8	5.80	1.95	268.0	8	9.03
BFH-8	4.3	6.34	2.07	285.2	8	9.03

¹Power gain in each polarization.
²Effective free-space field intensity at 1 mile (1.604 km) at 1 kW antenna input power for either equivalent horizontally polarized component or equivalent vertically polarized component.

**Ordering Information
Type BFH-**

Antenna Type No.	Sections	Power Gain Per Polarization	Less De-Icers	With De-Icers
BFH-1	1	0.46	ES-561941A	ES-561941B
BFH-2	2	1.00	ES-561942A	ES-561942B
BFH-3	3	1.50	ES-561943A	ES-561943B
BFH-4	4	2.10	ES-561944A	ES-561944B
BFH-5	5	2.70	ES-561945A	ES-561945B
BFH-6	6	3.20	ES-561946A	ES-561946B
BFH-7	7	3.80	ES-561947A	ES-561947B
BFH-8	8	4.30	ES-561948A	ES-561948B

Brackets included for mounting to vertical (plumb) poles, round tower legs or vertical tower face with less than 3 feet (914 mm) between leg centers. Please specify antenna mount (corner, face, pole) and dimensions of structure near antenna (for bracket dimensions).



Educational FM Antenna, Type BFI- Series

- Circular or horizontal polarization
- Low cost, 10-watt power input
- Arrays of one or two sections
- Low windload
- Low cost cable feedline



The BFI- antenna series are low-power elements for the 10-watt educational/campus FM station. It is available in circular or horizontal polarization in one- or two-section arrays. Mounting brackets are not included. Connector is Type "N". Specifications and ordering information in next page.

General Specifications

	Type BFI-C	Type BFI-H
Polarization	Circular	Horizontal
Horiz. Pattern Circularity in Free Space	±1dB	±1dB
Vert. Pattern Circularity in Free Space	±1dB	±1dB
VSWR (Factory adjusted)*	1.1:1	1.1:1
Input Connection	Type N	Type N
Input Power Rating (in kilowatts)	See Elec. Data Chart	
Section Dimensions		
Diameter	17" (432mm)	17" (432mm)
Height (max.)	15" (381mm)	15" (381mm)
Windload	See Mech. Data Chart	
Deadweight:		
Single Section	18 lbs. (10kg)	18 lbs. (10kg)
Two Sections	36 lbs. (16kg)	36 lbs. (16kg)

*When mounted on tower, the VSWR may be greater than 1.1:1 due to coupling effects.

Mechanical Data

Antenna Type	Freq. MHz	Dimensions (See Drawing)				Windload at 50/30 lbs/ft ² (244/146/kg ²)	
		Hc Side		H Side		Less De-icers	
		Feet	Meters	Feet	Meters	Lbs.	Kg.
BFI-1C	88	0.8	0.24	1.7	0.52	50	23
	98	0.8	0.24	1.7	0.52	50	23
	108	0.8	0.24	1.7	0.52	50	23
BFI-2C	88	6.4	1.95	12.8	3.90	109	49
	98	5.8	1.77	11.7	3.57	109	49
	108	5.4	1.65	10.8	3.29	109	49
BFI-1H	88	0.8	0.24	1.7	0.52	46	21
	98	0.8	0.24	1.7	0.52	46	21
	108	0.8	0.24	1.7	0.52	46	21
BFI-2H	88	6.4	1.95	12.8	3.90	105	48
	98	5.8	1.77	11.7	3.57	105	48
	108	5.4	1.65	10.8	3.29	105	48

Electrical Data

Antenna Type	Power Gain			Field Intensity ¹	Power Rating	
	Power	dB	Field		kW	dBk
BFI-1C	0.46	-3.37	0.68	93.2	0.5	-3
BFI-2C	1.00	0	1.00	137.5	0.5	-3
BFI-1H	0.90	-0.45	0.95	130.0	0.5	-3
BFI-2H	1.90	3.01	1.41	194.0	0.5	-3

¹ Effective free-space field intensity at 1 mile (1.604 km) at 1 kW antenna input power for either equivalent horizontally polarized component or equivalent vertically polarized component.

Ordering Information

Antenna Type No.	Sections	Power Gain		Catalog Number
		Horiz.	Vert.	
BFI-1C	1	0.46	0.46	ES-561933
BFI-2C	2	1.00	1.00	ES-561934
BFI-1H	1	0.90	—	ES-561935
BFI-2H	2	1.90	—	ES-561936

Mounting brackets **not** included.

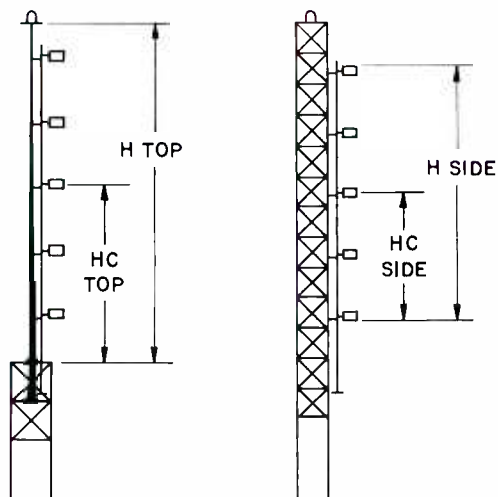

Pole Mounting

Side Mounting



Horizontally Polarized FM Antenna, Type BFA-Series

- Stainless-steel radiators
- Low weight and windload
- Side- or top-tower mount
- Dual-heat de-icer system
- Power gains to 12 dB

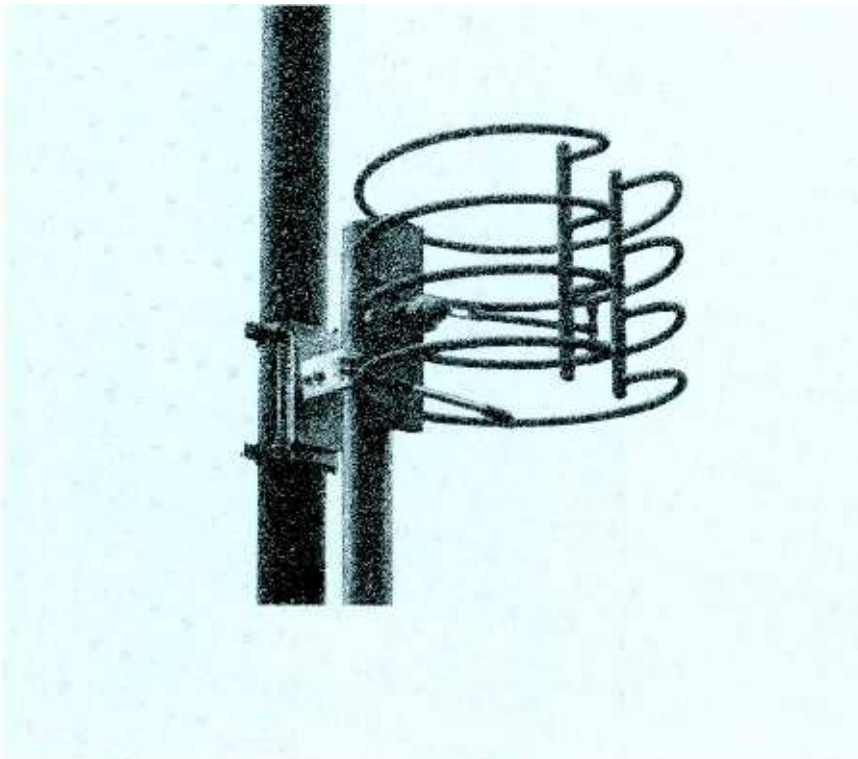

BFA- antennas are horizontally polarized units for pole-or tower-mount. They are available in arrays of up to 16 sections, with or without de-icers and with or without beam-tilt and/or null-fill.

Pattern Circularity ±1 dB

BFA-Series antennas offer radiation circularity within ±1 dB in free space. In side-mount situations, tower metal and guy wires offset the circularity to varying degrees. We recommend that side-mounted arrays be above the highest guy wire for greatest pattern circularity. As an alternative, when such isn't possible, the guy wires can be insulated from the tower and at 3½ foot (1.07 m) intervals for a distance of 14 feet (4.4 m) from the point where the guy touches the tower.

Pole- or Tower-Leg Mount

All BFA-Series antennas side mount on the corners or faces of antenna towers or on a pole as a top-mount antenna. All include mounting brackets for plumb, round tower legs up to 12 inches (305 mm) in diameter or tower faces up to 3 feet (914 mm) wide between leg centers. Brackets for mounting on self-supporting (tapered) towers, angle-iron tower legs and poles with diameters larger than 12 inches (305 mm) are available at extra cost. Mounting on tower faces with more than 3 feet (914 mm) between leg centers is possible with certain extra materials. Practicality usually recommends leg mounting in such situations.



End-Fed and Center-Fed Arrays

Two power-distribution schemes are used in the BFA- antenna series. In arrays with eight sections and fewer, the array is end-fed; in eight-section and larger arrays, the sections are fed from a center point. The input connection is a 3½-inch diameter, 50-ohm, transmission-line with an EIA flange.

Dual-Heat De-Icers

All BFA- antenna arrays are available with or without electrical de-icers. These are dual-heat systems which operate from 208/240-volt power.

Power Gain Proportional To Sections

Each section of a multi-section array provides approximately unity power gain. This number improves slightly as the number of sections in the array increases. To illustrate, a 16-section BFA- array provides a power gain of 16.5 times while a one-section array provides 0.9 power gain.

Input Connections—Low VSWR

BFA-Series antennas use a 3½-inch diameter, 50-ohm transmission line with an EIA flange for an input connection. A VSWR of 1.1:1 installed may be achieved with field adjustment of the input transformer.

Electrical Data:

Antenna Type	Power Gain		Power Rating			
	Power	dB	w/o Radomes		w/Radomes	
			kW	dBk	kW	dBk
BFA-1B	0.9	-0.50	5	7.00	NOT AVAILABLE	
BFA-2B	1.9	2.80	10	10.00		
BFA-3B	3.0	4.80	15	11.70		
BFA-4B	4.0	6.00	20	13.01		
BFA-5B	5.1	7.10	25	13.98		
BFA-6B	6.3	8.00	30	14.77		
BFA-7B	7.3	8.60	35	15.44		
BFA-8B	8.4	9.20	40	16.02		
BFA-10B	10.5	10.20	50	16.99		
BFA-12B	12.5	11.00	60	17.78		
BFA-14B	14.5	11.62	80	19.03		
BFA-16B	16.5	12.18	80	19.03		

Beam-Tilt and Null-Fill; Directional Arrays

Beam-tilt and/or null-fill is an optional extra on the arrays with 12, 14 or 16 sections. For example the BFA-12, -14 and

16 arrays can include beam-tilt and/or null-fill.

Directional arrays with BFA antennas are available, custom-built to the needs of the coverage situation.

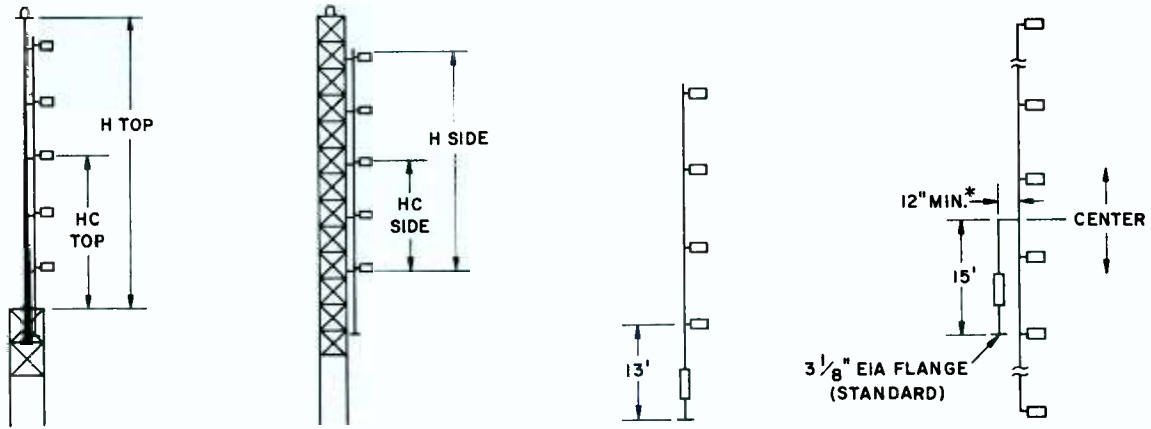

Pole Mounting

Side Mounting

End Feed 1-7 Sections

Center Feed 8-16 Sections

Drawing for Mechanical Data Chart (below).

Mechanical Data (See drawing above):

Antenna Type	Freq. MHz	Dimensions in Feet (Meters)								Windload at 50/33 lbs/ft ² (244/146 kg/m ²)					
		Hc Top		Hc Side		H Top		H Side		Less De-Icers	With De-Icers	With Radomes			
		Feet	Meters	Feet	Meters	Feet	Meters	Feet	Meters	lbs	kg	lbs	kg	lbs	kg
BFA-1B	88	5.0	1.52	0.50	0.15	8.0	2.44	1.0	0.30	58	26.3	70	31.8		
	98	5.0	1.52	0.50	0.15	8.0	2.44	1.0	0.30	58	26.3	70	31.8		
	108	5.0	1.52	0.5	0.15	8.0	2.44	1.0	0.30	58	26.3	70	31.8		
BFA-2B	88	10.0	3.05	5.55	1.69	18.1	5.52	11.1	3.38	221	100.2	267	121		
	98	9.5	2.90	5.00	1.69	17.0	5.18	10.0	3.05	212	96.1	256	116		
	108	9.1	2.77	4.60	1.40	16.2	4.94	9.2	2.80	206	93.4	248	112		
BFA-3B	88	15.1	4.60	10.55	3.22	28.1	8.56	21.1	6.43	319	144.7	385	175		
	98	14.0	4.27	9.55	2.91	26.1	7.96	19.1	5.82	303	137.4	365	166		
	108	13.2	4.02	8.70	2.65	24.4	7.44	17.4	5.30	289	131.1	348	158		
BFA-4B	88	20.1	6.12	15.60	4.75	38.2	11.64	31.2	9.51	416	188.7	502	228		
	98	18.6	5.67	14.05	4.28	35.1	10.70	28.1	8.56	391	177.4	471	214		
	108	17.3	5.27	12.80	3.90	32.6	9.94	25.6	7.80	371	168.3	446	202		
BFA-5B	88	25.2	7.68	20.65	6.29	48.3	14.72	41.3	12.58	514	233.2	620	281		
	98	23.1	7.04	18.60	5.67	44.2	13.47	37.2	11.34	481	218.2	579	263		
	108	21.4	6.52	16.90	5.15	40.8	12.43	33.8	10.30	454	205.9	545	247		
BFA-6B	88	31.6	9.63	27.10	8.26	61.2	18.65	54.2	16.52	635	288.0	767	348		
	98	28.9	8.80	24.40	7.44	55.8	17.01	48.8	14.87	591	268.0	713	323		
	108	26.7	8.14	22.20	6.77	51.4	15.67	44.4	13.53	556	252.2	669	303		
BFA-7B	88	36.8	11.22	32.35	9.86	71.7	21.85	64.7	19.72	736	333.8	889	403		
	98	33.6	10.24	29.15	8.88	65.3	19.90	58.3	17.76	684	310.3	825	374		
	108	31.0	9.45	26.50	8.08	60.0	18.29	53.0	16.15	642	291.2	772	350		
BFA-8B	88	42.2	12.86	37.70	11.49	82.4	25.12	75.4	22.98	839	380.6	1014	460		
	98	38.4	11.70	33.90	10.33	74.8	22.80	67.8	20.66	778	352.9	938	425		
	108	35.3	10.76	30.80	9.39	68.6	20.90	61.6	18.78	729	330.6	876	397		
BFA-10B	88	52.7	16.06	48.25	14.70	103.5	31.54	96.5	29.41	1431	649	1649	748		
	98	47.9	14.60	43.45	13.24	93.9	28.62	86.9	26.49	1318	598	1516	688		
	108	44.0	13.41	39.50	12.04	86.0	26.24	79.0	24.08	1225	556	1407	638		
BFA-12B	88	63.4	19.32	58.90	17.95	124.8	38.04	117.8	35.91	1712	777	1972	894		
	98	57.5	17.53	53.00	16.15	113.0	34.44	106.0	32.31	1591	722	1817	824		
	108	52.6	16.03	48.10	14.66	103.2	31.46	96.2	29.32	1464	664	1681	763		
BFA-14B	88	74.1	22.59	69.55	21.20	146.1	44.53	139.1	42.40	1993	904	2295	1041		
	98	67.1	20.45	62.55	19.07	132.1	40.26	125.1	38.13	1844	836	2118	961		
	108	61.2	18.65	56.70	17.28	120.4	36.70	113.4	34.56	1703	772	1955	887		
BFA-16B	88	84.8	25.85	80.20	24.44	167.4	51.02	160.4	48.89	2273	1031	2607	1183		
	98	76.7	23.38	72.10	21.98	151.2	46.09	144.2	43.95	2106	955	2418	1097		
	108	69.8	21.28	65.30	19.90	137.6	41.94	130.6	39.81	1941	880	2228	1011		

NOT AVAILABLE

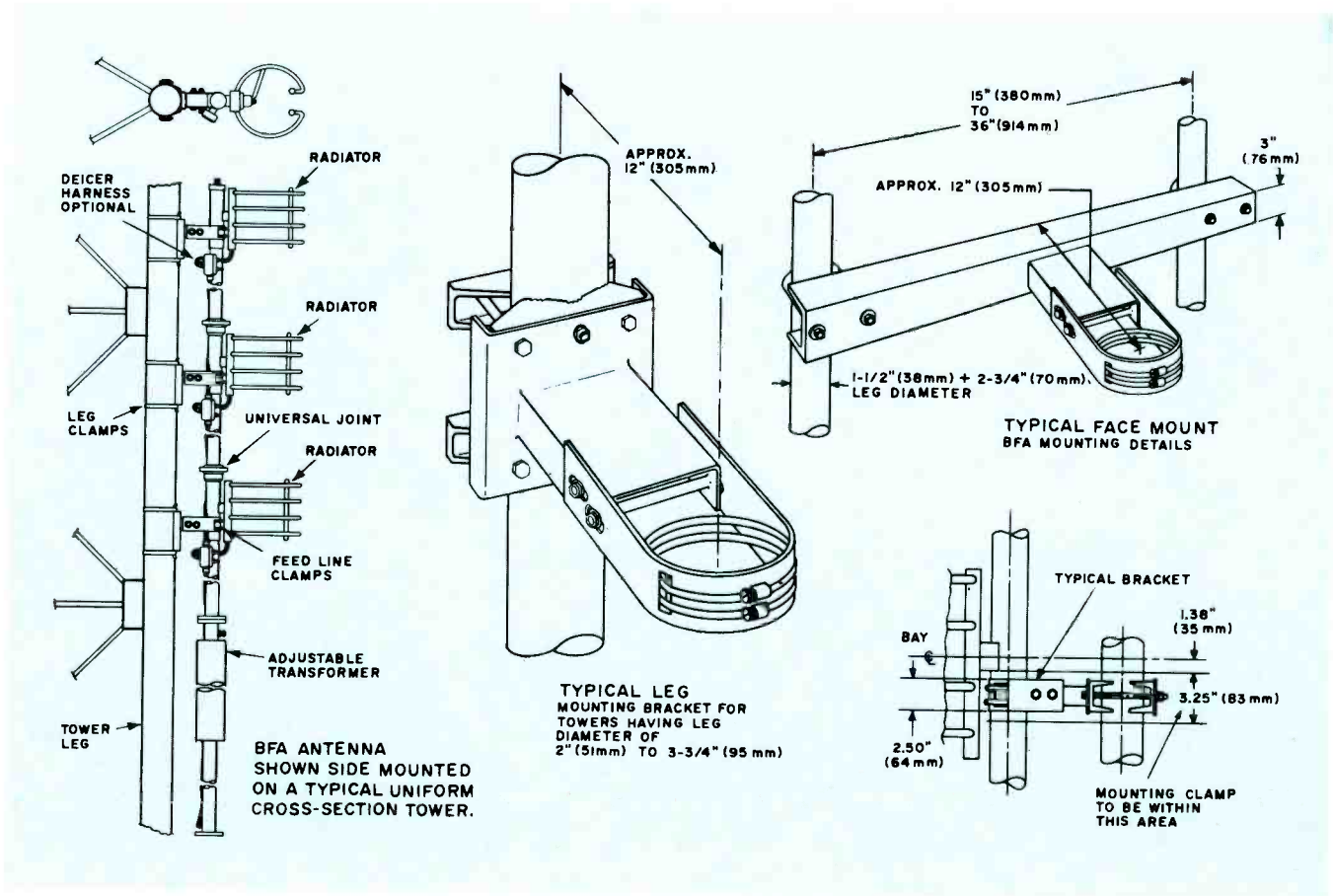

General Specifications

Polarization	Horizontal only
Power Gain per Section (Approx.)	1
Pattern Circularity in Free Space	±1 dB
VSWR at Input, Top Mounted, no field trim (max.)	1.2:1
VSWR at Input, Side Mounted, no field trim (max.)	1.5:1
VSWR at Input, Top or Side Mount, with field trim (200 kHz)	1.1:1
Input Connection Diameter (50-ohm, EIA flange)	3 1/8"
Input Power Rating (kW)	See "Electrical Data" Chart
Section Dimensions:	
Diameter	16 or 18" (406, 457 mm)
Height	12" (305 mm)
Windload [Based on true extreme 110 mi/hr (177 km/hr)]:	
On Flat Surfaces	50 lbs/ft ² (244 kg/m ²)
On Cylindrical Surfaces	33 lbs/ft ² (161 kg/m ²)
Feedpoint Location	See drawing, preceding page
Deadweight:	
One Section	86 lbs. (39 kg)
Two Sections	140 lbs. (64 kg)
Three Sections	192 lbs. (87 kg)
Four Sections	245 lbs. (111 kg)
Five Sections	298 lbs. (135 kg)
Six Sections	351 lbs. (159 kg)
Seven Sections	404 lbs. (183 kg)
Eight Sections	457 lbs. (207 kg)
Ten Sections	700 lbs. (318 kg)
Twelve Sections	830 lbs. (376 kg)
Fourteen Sections	970 lbs. (440 kg)
Sixteen Sections	1100 lbs. (499 kg)
Supporting Feedline (Approx.)	3 lbs/ft (4.5 kg/m)

Accessories

De-Icers (Factory-Installed only)	MI-27986
De-Icer Control (Thermostatic)	MI-27369A
Rosemount Antenna Ice Detector	MI-561572
FM/AM Tower Isolator, Type BAF-15/16	MI-561573/4
Input Adapters:	
Inner Conductor Adapter to connect:	
MI-19113 Line	MI-27988-4A
MI-19313 Line	MI-27988-4B
Outer Conductor Adapter to connect:	
Male end, MI-27791D Line	MI-27791D-7B
Female end, MI-27791D Line	MI-27791D-7A
Reducers, Quick-Step, to connect:	
1 5/8-inch Flexible Line	MI-27988-5C
7/8-inch Flexible Line	MI-27988-5D

Ordering Information

Horizontally Polarized FM Antenna, Type BFA - :	
Single Section, Type BFA-1B	MI-27985-1
Dual Section, Type BFA-2B	MI-27985-2
Three Section, Type BFA-3B	MI-27985-3
Four Section, Type BFA-4B	MI-27985-4
Five Section, Type BFA-5B	MI-27985-5
Six Section, Type BFA-6B	MI-27985-6
Seven Section, Type BFA-7B	MI-27985-7
Eight Section, Type BFA-8B	MI-27985-8
Ten Section, Type BFA-10B	MI-27985-10
Twelve Section, Type BFA-12B	MI-27985-12
Fourteen Section, Type BFA-14B	MI-27985-14
Sixteen Section, Type BFA-16B	MI-27985-16

Note: De-icers must be factory installed at time of original assembly. Each antenna includes brackets for side-mount on conventional towers.

Multi-Station FM Panel Antennas, Types BFB, BFD, BFE, BFF

- Circularly polarized
- Directional or omnidirectional patterns
- High power capability
- Radomed elements

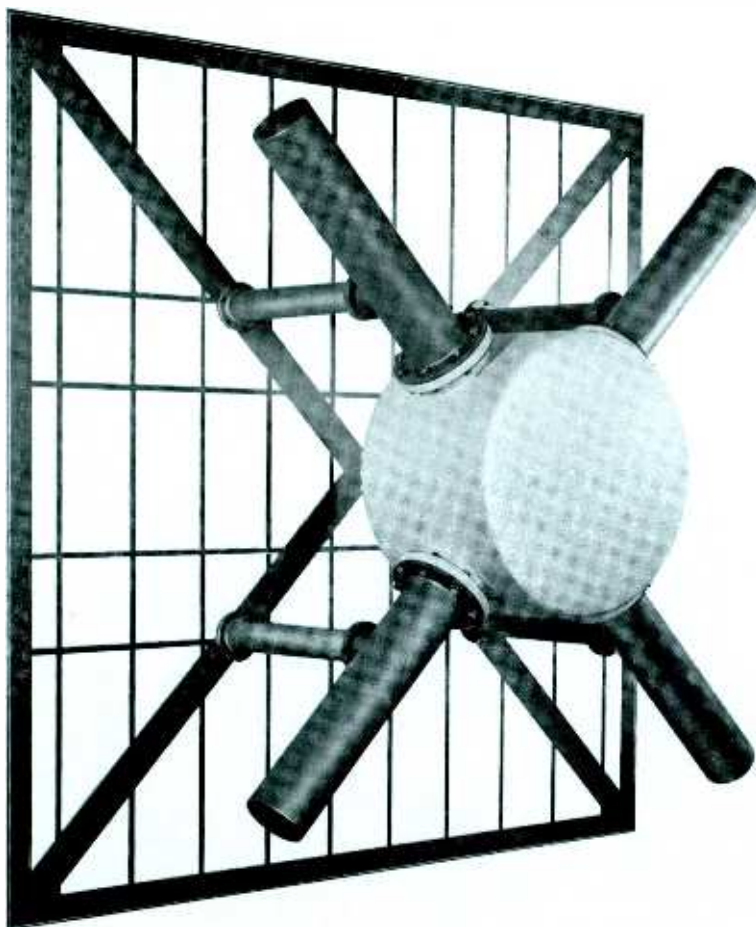

FM Panel Antennas, Types BFB, BFD, BFE and BFF are broadband, custom-tailored antenna systems that permit a number of high powered FM stations to share a common antenna. They are circularly polarized for optimum coverage and perform excellently in either omnidirectional or directional applications. Bandwidths range from 4.5 to 20 MHz in the FM broadcast band, and power ratings extend up to 80 kilowatts (CW) per panel.

Flexible Directivity

In omnidirectional use, three (or four) panels are mounted around a tower to make up an antenna layer, and as many layers as necessary are used to obtain the desired power gain. Power gain is equal to approximately one-half the number of antenna layers. Directional radiation is the result of asymmetrical location of panels and power distribution to the panels.

Fed in Phase Quadrature

Each panel consists of a pair of crossed dipoles with a reflecting screen. The two dipoles are fed in phase quadrature with separate transmission lines from a hybrid coupler. Each panel carries one-half the power of all the stations sharing the system.

A multi-station FM panel antenna system serving five stations is shown in the block diagram. Four or fewer stations are accommodated by use of *T* combiners to feed the *A* and *B* ports of the hybrid coupler. Ports *C* and *D* each contain half the total power of each station in phase quadrature. More than four stations are combined with notch diplexers as illustrated. In this case, the broadband input port of the last notch diplexer may be used in an emergency to take the output of either station #1 or #2 should the *T* combiner fail.

High Power Capability

Depending upon transmission line limitations, the power rating of a complete FM panel antenna is equal to the power

rating per panel times the number of panels. For example, assume a 12-layer antenna (gain = approximately 6) with three panels per layer and a rating of 80 kW per panel. The rating of this antenna is:

$$80 \times 12 \times 3 = 2880 \text{ kW}$$

Since the vector sum of the output voltages is greater for several transmitters as compared to those of a single transmitter of equivalent power, the antenna then becomes voltage rather than power limited. The equivalent power of a number of stations feeding the common is expressed as:

$$P = (\sqrt{P_1} + \sqrt{P_2} + \sqrt{P_3} \dots)^2$$

or, when all stations have equal power:

$$P = n^2 P$$

where n is the number of stations and P is the power per station.

The equivalent power of twelve 20-kW stations would be:

$$12^2 \times 20 = 2880 \text{ kW.}$$

Therefore, a 12-layer antenna can handle twelve 20-kW stations, and, with a gain of 6, provides an ERP of 100 kW per station.

Ordering Information

Types BFB, BFD, BFE and BFF FM Panel Antennas are sold only as part of a custom built array because of the individuality of each multi-channel arrangement. Your RCA Regional Representative stands ready to help plan and execute a multi-station FM antenna.

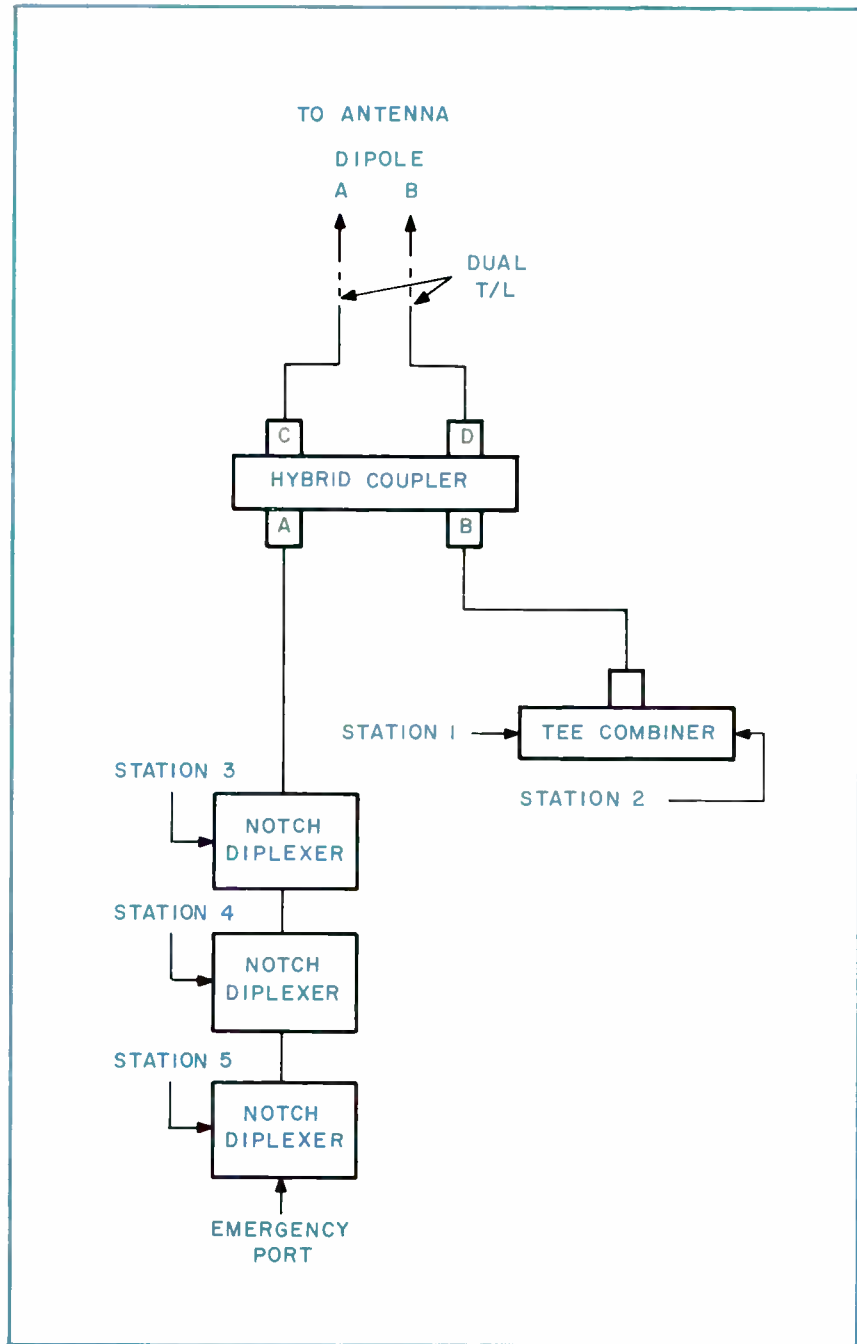

Typical five-station shared-antenna scheme for FM-broadcast stations using Type BFB-, BFD-, BFE- or BFF- Panel Antennas.



RF Load and Wattmeter Systems for FM

- Combined dummy antenna and wattmeter
- Compact—easily installed
- Direct-reading wattmeters
- Choice of six power ratings
- Air- or water-cooled



The loads and wattmeters described here are dual-purpose units. As non-inductive dummy loads, they aid in transmitter tune-up without radiation; as wattmeters, they terminate the transmitter output and indicate an accurate measure of power output.

The resistive elements in loads of one kilowatt and lower radiate the heat energy directly to the surrounding air. The larger loads use resistive elements immersed in a liquid coolant which transfers resistor heat to a heat exchanger. The loads with 10kW and greater capacity use a closed system of water as the coolant. When these loads are subject to freezing temperatures, a solution of 35 percent ethylene glycol and water is used instead of water alone.



This is the 20 kW system (Bird 8644/4805/25KB3/5-726) and is representative of the 10- and 40-kW loads as well. The 10-kW load is smaller while the 40- is larger. These loads require a source of commercial power for a coolant pump within the enclosure. An interlock connection, properly used, prevents application of power without coolant circulation. Dolly shown is optional as an extra-cost accessory.

Specifications

	10W System	1000W System	3/5 kW System	10 kW System	20 kW System	40 kW System
Input Impedance, Ohms	50	50	50	50	50	50
Input Connection	Type N Female	(MI-561565) 1 $\frac{5}{8}$ "	(MI-27791K) 3 $\frac{3}{8}$ "	(MI-27791K) 3 $\frac{3}{8}$ "	(MI-27791K) 3 $\frac{3}{8}$ "	(MI-27791K) 3 $\frac{3}{8}$ "
Coolant	Convection	Convection	Air (Fan)	Water ¹	Water ¹	Water ¹
Ambient Temp. Range (°C)	-40 to +45	-40 to +45	-40 to +45	5 to 45 ²	5 to 45 ²	5 to 45 ²
Power Requirements:						
Voltage	None	None	115V	115V ³	115V ³	115V ³
Frequency	None	None	50/60 Hz	60 Hz ⁴	60 Hz ⁴	60 Hz ⁴
Current	None	None	0.44A	9A	9A	25A
Dimensions (Approx.):						
Height, Inches (mm)	6.15" (171)	11" (279)	15.6" (396)	16" (406)	19.5" (495)	22" (558)
Width, Inches (mm)	8" (203)	7" (177)	7.8" (198)	16" (406)	19" (483)	20" (508)
Depth, Inches (mm)	3.5" (89)	36" (914)	32" (813)	25" (635)	28" (711)	54" (1371)
Weight, Lbs. (kg) Approx.	3.75 (1.7)	43 (20)	62 (28)	110 (50)	155 (70)	275 (124)

¹Self-contained, no external connections required.

²Range extends to -20°C using 35% solution of ethylene glycol and water as coolant.

³For operation on 208/240 volt power, order Bird 8630-120 Stepdown Transformer.

⁴System for operation from 220V 50 Hz power available on special order.

Ordering Information

RF Load and Wattmeter Systems:

Except for the five-kilowatt system, these are kits of components which assemble into loads and wattmeters of appropriate capability. Please observe footnotes.

Power: 10W max. Bird 43/10B/8053¹

Power: 1000W max. Bird 8813/2450-056/4712/1000B1/MI-561565-7A²

Power: 5 kW max. MI-561422L³

Power: 10 kW max. Bird 8634/4805/10KB3/5-726⁴

Power: 20 kW max. Bird 8644/4805/25KB3/5-726⁴

Power: 40 kW max. Bird 8654/4808/465-9/5-726⁴

¹Input is Type N Female connector. Mating connector not included.

²Adapter for 1 $\frac{5}{8}$ -inch EIA flanged line included.

³Coupling kits included. (One Bird 5-726 and one MI-27791-K4D.)

⁴Coupling kits included. (Two Bird 5-726.)

AM-FM Antenna Isolation Units, Type BAF-15A/16A

- Conducts FM power across AM tower base insulator with minimum effect on AM tower operating impedance
- Standard EIA connections—easy to install
- Rugged design includes weather and lightning protection
- Inserts directly into pressurized FM coaxial transmission line

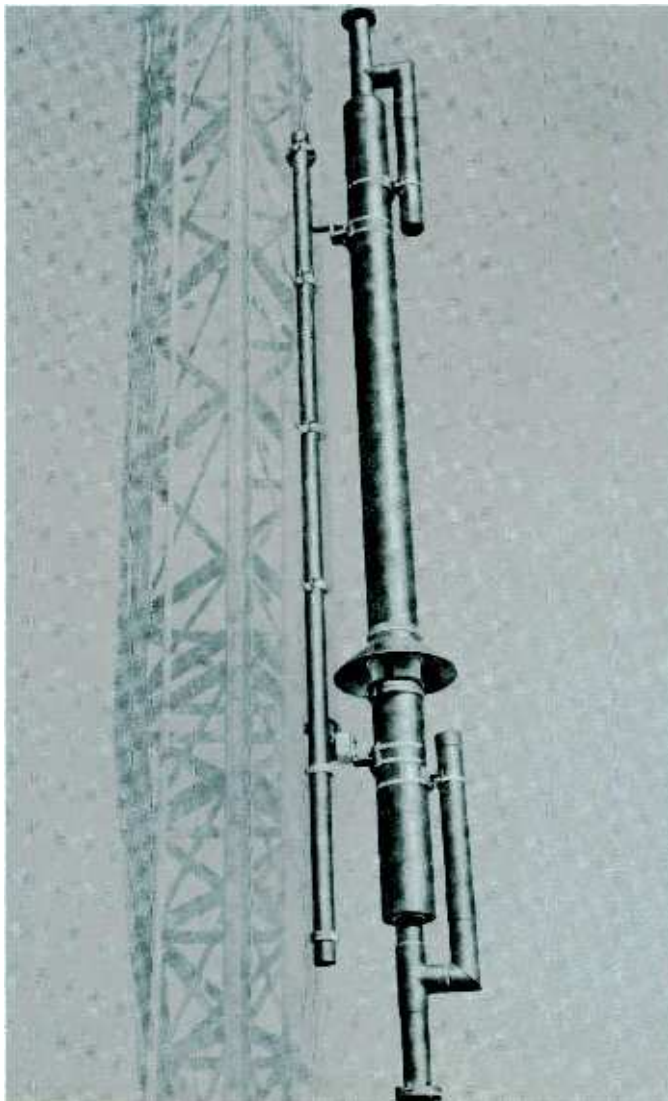

The RCA Type BAF-15A and BAF-16A FM-AM Isolation Units are designed to transfer FM power across the base insulator of an AM antenna tower to feed an FM antenna mounted atop the tower. The units provide isolation of FM and AM signals and efficient operation over the entire FM frequency range.

The BAF-15A Isolation unit is a rugged pressurized copper section designed to mount directly in 1 $\frac{5}{8}$ -inch FM transmission line between transmitter and antenna by means of standard EIA* fittings. It serves as a 10-kW isolation unit and second harmonic filter providing high harmonic attenuation. The BAF-16A Isolation unit provides the same functions and is designed to fit in 3 $\frac{1}{8}$ " EIA coaxial lines fed by transmitters with up to 40 kW FM power. Both units can be mounted to the tower leg by means of standard hangers. They are pressurized from the regular FM coaxial line and permit gas to pass through to thus pressurize the vertical run of line feeding the antenna. Protection against weather and lightning are design features.

Specifications

TYPE BAF-15A

Frequency Range88-108 MHz
 Nominal Impedance50 ohms
 Maximum VSWR with 50 ohm Load1.08
 Maximum Operating Power FM10 kW
 Maximum Tower Base Voltage AM10 kV peak
 Insertion Loss0.1 dB max.
 Internal Capacitance to AM130 pF
 Maximum Gas Pressure for Pressurizing30 psig (1.9 atm.)
 Weight (Approx.)55 lbs. (25 kg)
 DimensionsDiameter 3 1/8 inches (80mm)
Length 130 inches (3300mm)
 ConnectorsCoaxial line (1 5/8-inch) EIA* (41mm)
 2nd Harmonic Rejection70 dB
 4th Harmonic Rejection50 dB
 6th Harmonic Rejection30 dB

TYPE BAF-16A

Frequency Range88-108 MHz
 Nominal Impedance50 ohms
 Maximum VSWR with 50 ohm Load1.08
 Maximum Operating Power FM40 kW
 Maximum Tower Base Voltage AM14 kV
 Insertion Loss0.1 dB max.
 Internal Capacitance to AM130 pF
 Maximum Gas Pressure for Pressurizing12 psig (0.8 atm.)
 Weight (Approx.)100 lbs. (45 kg)
 DimensionsDiameter 6 1/8 inches (156mm)
Length 161 inches (4189mm)
 ConnectorsCoaxial line (3 1/8-inch) EIA (80mm)
 2nd Harmonic Rejection80 dB
 4th Harmonic Rejection60 dB
 6th Harmonic Rejection40 dB

*Use adapter (MI-19112-62) to connect with RCA 1 5/8" line.

Ordering Information

Isolation Unit; 10 kW, Type BAF-15A:

For assigned channels between:

88-93 MHzMI-561573-1
 93-98 MHzMI-561573-2
 98-103 MHzMI-561573-3
 103-108 MHzMI-561573-4

Isolation Unit; 40 kW, Type BAF-16A:

For assigned channels between:

88-93 MHzMI-561574-1
 93-98 MHzMI-561574-2
 98-103 MHzMI-561574-3
 103-108 MHzMI-561574-4

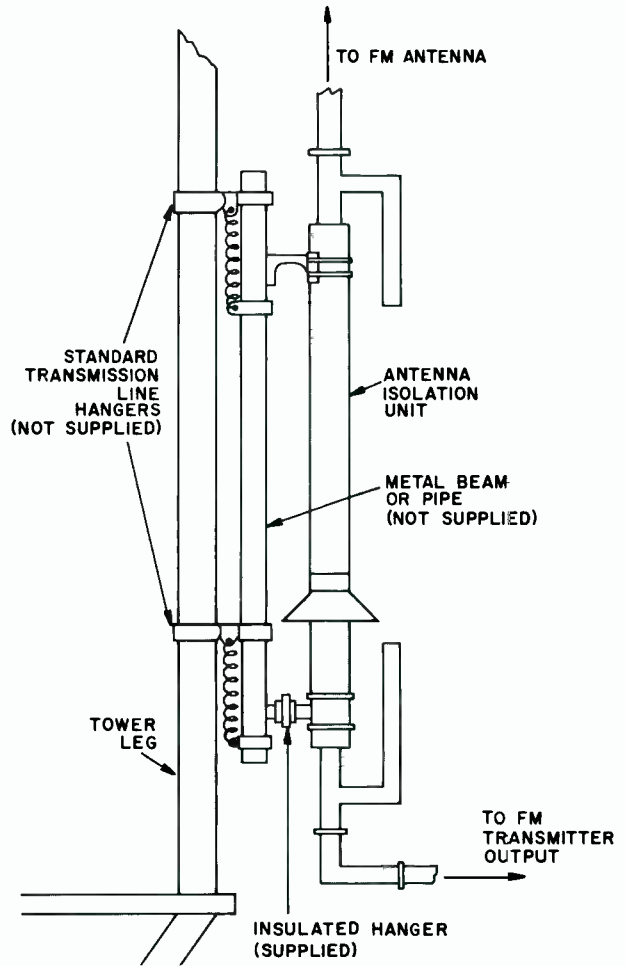



Rosemount Antenna Ice Detector

- Dependable ice detection
- Active only when icing conditions exist
- Anticipates antenna ice formation
- Improves de-icer economy and efficiency
- Detects end of icing conditions

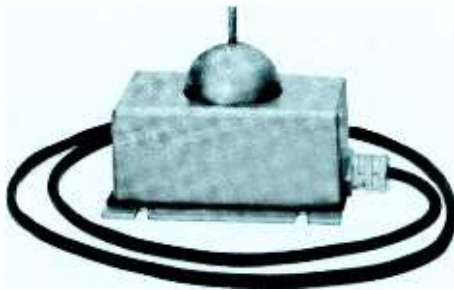

Active only during antenna-icing weather, the Rosemount Antenna Ice Detector senses buildup of broadcast-antenna ice and generates a signal which, with appropriate power-contactor equipment (not supplied), automatically energizes an antenna's sleetmelters. At the conclusion of icing conditions, the device automatically de-energizes the heaters after an adjustable time-delay period expires.

Dependable Ice Detection

Insensitive to almost everything but ice formation, the detector ignores cold, wind, rain, dry snow, soot, grease, insects and birds. As a result, the detector prevents unnecessary de-icer operation and thus increases the useful life of de-icer equipment by operating it only when necessary.

Active Only When Icing Conditions Exist

Since antenna ice cannot form under any weather condition at temperatures above 50°F. (10°C.), the Antenna Ice Detector ceases to operate. As soon as the ambient temperature drops below 50°F., a thermostat puts the system into operation, automatically.

Anticipates Ice-Forming Conditions

Because the ice-sensing element bears low thermal mass, it cools faster and begins to collect ice earlier than the larger thermal mass of the antenna it protects. As a result, the detector "sees" ice before it begins to form on the antenna surfaces. Because the heaters are warm before ice begins to form, they get a head start on the ice and avoid the burden of a backlog ice accumulation. Only completely still air—extremely rare during icing weather—can shorten materially the detector's ice anticipation.

Improves De-Icer Economy and Efficiency

Since the ice detector ignores all conditions except icing conditions, it never operates de-icer heaters unnecessarily in the way a thermostatic control does. Consequently, the ice detector eliminates needless use of kilowatt hours which increase power costs. Further, because the heater operates only when really required, the device materially extends heater life.

Detects End of Icing Conditions, Too

Unlike most other deicer control systems, the Rosemount Antenna Ice Detector senses the end of ice-forming conditions and sends out an electrical command that ceases de-icer power.

Magnetostrictive Sensor

The sensing element—the probe—of the detector is a 1/4-inch (6 mm) diameter tube precisely 1.10 inches (28 mm) long of a nickel alloy which responds, physically, to a magnetic force in an increase or decrease in axial length. Under the influence of an alternating magnetic field, the tube vibrates at a frequency proportionate to its physical length—its

resonant frequency. If the frequency of the alternating field is adjusted to coincide with the resonant frequency of the little nickel tube, a tuned circuit results.

In the ice detector circuitry, the probe serves as a link in the feedback circuit of an oscillator.

As ice forms on the sensing element, it restricts the magnetostrictive motion and lowers the resonant frequency of the little nickel tube. As the frequency approaches a pre-determined value, solid-state circuitry detects the changes in frequency and energizes a relay which controls a de-icing heater-current contactor. This relay holds for a period of 8 to 150* minutes (adjustable manually).

Self-Recycling

During the "hold" period, the ice detector probe de-ices itself and its supporting dome. Because of the low mass of the probe, de-icing takes but a few seconds. Once de-iced, the probe begins the sensing cycle again. If the ice coating accumulates to a thickness of a half millimeter or more, it issues a "sustaining" command for antenna de-icing. This sequence repeats until ice no longer forms.

Fail-Safe Design

In the extremely unlikely event of probe damage or failure, the system automatically issues a continuous de-icing command.

Specifications

Ice Detector Unit

Ice Sensing Range	0.02 to 0.25 inches on probe (0.5 to 6 mm)
Sensing Element Material	Ni-Span C
Maximum Length of Interconnecting Cable	Unlimited
Power Requirements:	
Sensing	115 V, 50/60 Hz 10W
Signalling	115 V, 50/60 Hz, 1.5A
Output Signal	115 V, 50/60 Hz, 60W max.
Sensing Element De-Ice Time	90 seconds, nominal
Ambient Temperature:	
Operating	-40 to 50°F (-40 to +10°C)
Storage	-50 to 160°F (-45 to 72°C)
Ambient Electromagnetic Field Intensity	50V/m max.
Physical Dimensions	See drawing
Weight	3.5 lbs. (1.6 kg)

Detector Control Unit

Power Requirements:	
Sensing	115 V, 50/60 Hz, 5 W
Signalling	115 V, 50/60 Hz, 15 W
Output Signal	115 V, 50/60 Hz, 500 W
Time-Delay Timer	8 to 150* min., adj.
Power Relay Current Capacity	10 A, max. non-inductive load
Ambient Operation Temperature	40 to 120°F. (4.4 to 49°C.)
Connections	Barrier strip and connector
Physical Dimensions	See drawing
Weight	4 lbs. (1.8 kg)

*180 on 50 Hz power.

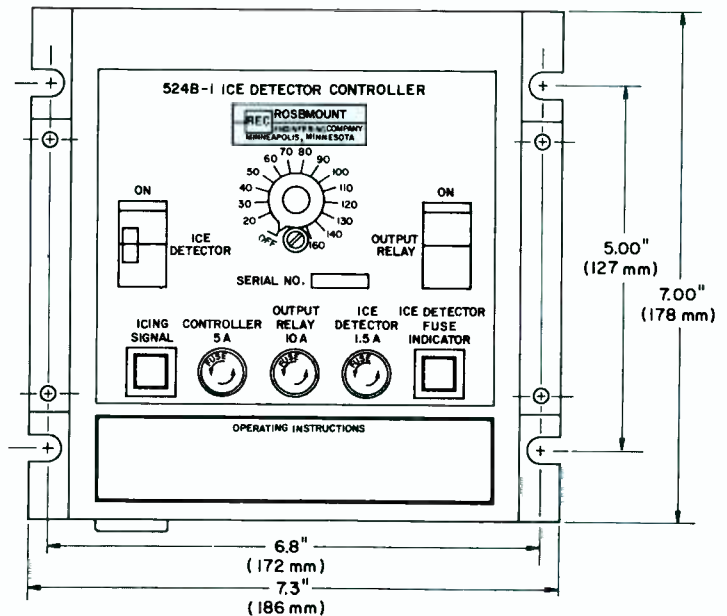

Ordering Information

Rosemount Antenna Ice Detector System (for 115 V, 50/60 Hz Power)MI-561572 (Interconnecting cable and contactor not supplied)

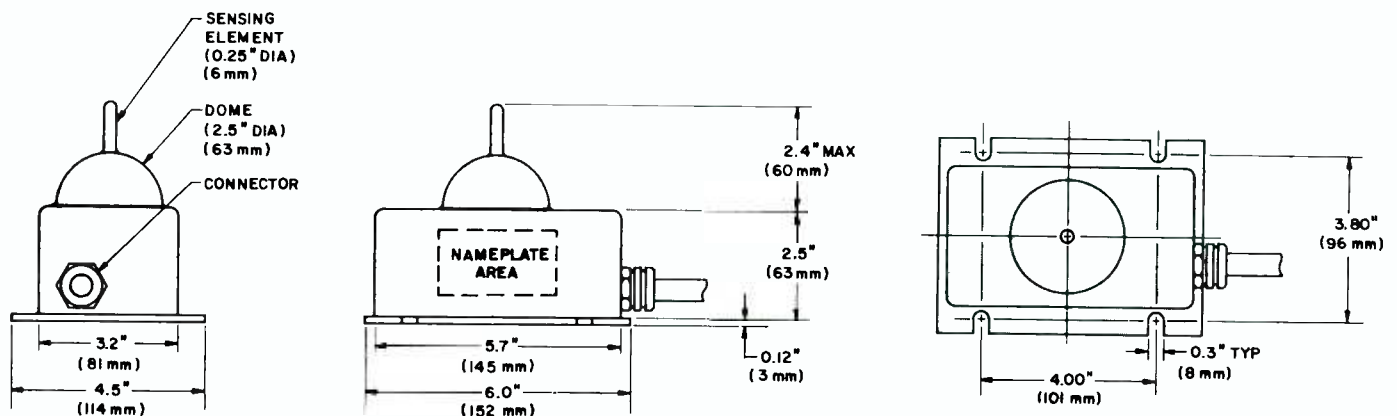

Automatic Sleet Melter Control Unit

- Automatic temperature monitoring at actual antenna location
- Adjustable temperature ranges to suit local weather conditions
- Waterproof aluminum housing
- Antenna deicing prevents severe damage to transmission systems



The Automatic Sleet Melter Control Unit prevents severe damage to transmission equipment through automatic thermostatic control of antenna de-icers. The control allows de-icers to be left unattended at all times and proper operation is assured. Furthermore, the antenna will be free of ice and in condition for immediate operation following possible icing conditions during the night.

The de-icer control has adjustable temperature ranges so that it can cut off above and below the temperatures chosen to conserve power when temperatures are higher than ice-forming range. A "stay-on" control is incorporated for added protection where rime ice is a problem.

Senses at Antenna Altitude

The control unit mounts at the top of the tower or, preferably, at the midpoint of the antenna on larger antennas. Considerable temperature variations often exist between the antenna at the tower top and the ground level, so that ice may form on the antenna while the temperature on the ground remains above the freezing point.

Weather-Tight Construction

The control unit is housed in a small cast-aluminum box. A waterproof cover, sealed with a neoprene gasket and a convenient mounting bracket are furnished. Adjustable terminal connections for selection of temperature ranges are provided.

Only Four Connections

A four-conductor cable, six feet long, is

furnished. The cable should terminate in an appropriate junction box where connections are made to the main cable run down the tower. Two of these four conductors connect to 117 volts (ac) for the relay coils; the other two are for the control circuit. The station is required to furnish the connecting cable from the transmitter building to the termination of the six-foot cable furnished with the control unit, as well as the actual relay contactors to switch power to the sleet melters.

Various types of antennas, methods of de-icer connections, etc., make it impractical to furnish the power relay contactors required with the Control Unit. The contacts of the MI-27369 are rated at 10 amperes which is more than adequate for contactor control.

Specifications

Automatic Temperature Limits (Adjustable):

Upper Limit32° or 40°F (0°C or 4.5°C)
 Lower Limit10° or 20°F, or no-cut-off
 (-12.6°C or -6.6°C)

Power Line Requirements117 V, 60 Hz
 Deicer Control Relay Contact Rating10 A
 Dimensions6½" x 4½" x 3" (165, 114, 76 mm)
 Weight (approx.)5 lbs. (2.27 kg)
 FinishWeatherproof cast-aluminum enclosure

Ordering Information

Automatic Sleet Melter ControlMI-27369A





RADIO EQUIPMENT PRICE LIST

Issued July 1, 1973

Prices listed here are valid only within the United States and are FOB our plant or warehouse. Any applicable taxes not included unless noted otherwise.

Reference Number
RA.9998A

All sales are subject to RCA's Standard Terms and Conditions of Sale which are available upon request from your Broadcast Equipment Field Sales Representative.

Prices subject to change without notice.

Catalog Number	Type Number	Description	Price
AM TRANSMITTERS, EXCITERS			
ES-560947	BTA-1S	250/500W AM Transmitter	\$ 6,595.00
ES-560650	BTA-1S	1000W AM Transmitter	6,895.00
MI-560657	—	Power Cutback Kit (250 or 500W)	600.00
MI-560658	—	Power Adjust Kit, Remote	240.00
ES-560655	—	Spare Tubes Kit, Complete Set ¹	229.00
ES-560656	—	Spare Tubes Kit, Recommended Spares ¹	116.00
MI-34309-8	—	Blower Kit, High Altitude	395.00
ES-562200	BTA-1N1	1 kW AM Transmitter	4,895.00
ES-562201	—	Spare Tubes Kit, Recommended Spares ¹	260.00
ES-562202	—	Spare Tubes Kit, Complete Set ¹	295.00
MI-561301	—	Power Cutback Kit	260.00
MI-561302	—	Power Adjust Kit, Remote	200.00
ES-560676A	BTA-5L1	5 kW AM Transmitter ²	22,995.00
ES-561009	—	Power Cutback Kit, Two Level	2,450.00
ES-561009A	—	Power Cutback Kit, Three Level	3,300.00
ES-560680	—	Spare Tubes Kit, Complete Set ¹	945.00
ES-560682	—	Spare Tubes Kit, Recommended Spares ¹	473.00
ES-560946	—	Conversion Kit, BTA-5L1 to BTA-10L1 (Price approximate)	3,995.00
ES-560961	—	Protection Kit, Transmission Line	1,360.00
ES-560677A	BTA-10L1	10 kW Am Transmitter, 10,000W	24,995.00
ES-561009	—	Power Cutback Kit, Two Level	2,450.00
ES-561009A	—	Power Cutback Kit, Three Level	3,300.00
ES-560679	—	Spare Tubes Kit, Complete Set ¹	1,232.00
ES-560681	—	Spare Tubes Kit, Recommended Spares ¹	616.00
ES-560961	—	Protection Kit, Transmission Line	1,360.00
—	BTA-20L1	20 kW AM Transmitter	59,990.00
ES-560679(2)	—	Tubes Kit, Complete Set ¹	2,464.00
ES-560752A(2)	—	Tubes Kit, Recommended Spares ¹	1,232.00
ES-27221D	BTA-50J	50 kW AM Transmitter, 50,000W ²	99,995.00
ES-560948	—	Power Cutback Kit, Two Level (Price approximate)	5,950.00
ES-560949	—	Power Cutback Kit, Three Level (Price approximate)	7,950.00
ES-27222E	—	Spare Tubes Kit, Complete Set	3,490.00
ES-27223D	—	Spare Tubes Kit, Recommended Spares	1,745.00
ES-560752A	BTE-20A	Exciter, Spare, Ampliphase, Solid State (For BTA-5L1/-10L1/-50J only)	4,980.00
ES-561305	—	Switch, Changeover, Exciter (For above exciter only; price approx.)	1,500.00
MI-561003A	—	Frame, for BTE-20A Exciter	770.00
MI-561004A	—	Module, Power Supply, for BTE-20A Exciter	1,225.00
MI-561005A	—	Module, Regulator, for BTE-20A Exciter	790.00
MI-561006A	—	Module, Oscillator, for BTE-20A Exciter	690.00
MI-561007A	—	Module, Modulator, for BTE-20A Exciter	1,310.00
MI-561020	—	Panel, Blank, for BTE-20A Exciter	45.00
MI-27592	—	Crystal Oscillator, Solid State (for BTA-IS)	295.00
TUBE HOUR METERS (For AM or FM Transmitters)			
MI-27896-1	—	Meter, Elapsed Time, 230V, 60 Hz	52.00
MI-27896-2	—	As Above, but for 230V, 50 Hz	52.00
MI-34684-1	—	Meter, Elapsed Time, 230V, 60 Hz	50.00
MI-34684-2	—	As Above, but for 115V, 60 Hz	50.00
MI-34684-3	—	As Above, but for 230V, 50 Hz	50.00
MI-34684-4	—	As Above, but for 115V, 50 Hz	50.00
MI-561018-1	—	Meter, Elapsed Time, 230V, 60 Hz	20.00
MI-561018-2	—	As Above, but for 115V, 60 Hz	20.00
MI-561018-3	—	As Above, but for 230V, 50 Hz	20.00
MI-561018-4	—	As Above, but for 115V, 50 Hz	20.00
AM MONITORS			
MI-560767-1	BW-50	Frequency and Modulation Monitor (115V power)	1,500.00
MI-560767-2	BW-50	As Above but for 230V power	1,500.00
MI-560767-1X	BW-50X	Extended Range BW-50 (115V power)	1,895.00
MI-560767-2X	BW-50X	As Above but for 230V power	1,895.00
MI-560762-1	BW-60	RF Amplifier for BW-50 (115V power)	450.00
MI-560762-2	BW-60	As Above but for 230V power	450.00
MI-560896-1	—	Panel, Remote Metering (for BW-50, in-plant metering only)	195.00
MI-561325	—	Antenna, Shielded Loop (for BW-60)	225.00

¹Tube kits sold only with transmitter.

²Available in parallel/redundant configuration. Prices on request.

Catalog Number	Type Number	Description	Price
RF AMMETERS AND ANTENNA CURRENT METERS			
MI-27712-	—	Ammeter, RF (Specify scale)	\$ 97.00
MI-27644A-	—	Ammeter, RF (Specify scale)	59.00
MI-27644B-	—	Ammeter, RF (Specify scale)	59.00
MI-7157H-	—	Ammeter, RF (Specify scale)	99.00
—	Air Alert 1	Receiver, Conelrad, Miratel	200.00
MI-560758	—	Autoformer, Three Phase, 360/240V, 35kVA	1,595.00
FM TRANSMITTERS, EXCITERS			
ES-560631	BTE-15A	Exciter System—Monophonic only	3,410.00
ES-560632	BTE-15A	Exciter System—Mono and one SCA Channel	4,070.00
ES-560633	BTE-15A	Exciter System—Mono and two SCA Channels	4,730.00
ES-560634	BTE-15A	Exciter System—Stereo only	4,670.00
ES-560635	BTE-15A	Exciter System—Stereo and one SCA Channel	5,330.00
ES-560636	BTE-15A	Exciter System—Stereo and two SCA Channels	5,990.00
MI-560734	—	Plugs, Connector (for BTE-15A only)	20.00
MI-560717	—	Crystal, with Oven, Spare for BTE-15A	74.00
MI-560717A	—	Oven, Crystal (less crystal)	50.00
MI-560712	—	Module, "FM Generator" (for BTE-15A)	1,665.00
MI-560713	BTS-1B	Module, "Stereo Generator" (for BTE-15A)	1,260.00
MI-560714	BTX-1B	Module, "SCA Generator" (for BTE-15A)	660.00
MI-560711	—	Main Frame, Module (for BTS-1B only, less BTS-1B module)	600.00
MI-560720	—	Main Frame, Module (for BTX-1B only, less BTX-1B modules)	625.00
MI-560715	—	Panel, Blank (for BTE-15A Frame, BTX-1B size panel)	36.00
MI-560716	—	Adapter, Mono Input, for BTE-15A	395.00
MI-560721	—	Filter, Audio, Lowpass	68.00
MI-560639	BTS-1B	Stereo Generator System, self-powered, rack mount	1,650.00
MI-560640	BTX-1B	SCA Generator System, self-powered, rack mount, one BTX-1B incl.	1,205.00
MI-561641	BTX-1B	As Above, but with two BTX-1B Generators	1,795.00
ES-560698	BTE-10AT	10W FM Transmitter with cabinet	3,595.00
ES-560698A	BTE-10AT	As Above, less cabinet (rack mount)	3,440.00
ES-27279D	BTF-1E2	1 kW FM Transmitter:	
		Mono only	8,070.00
		Mono plus one SCA	8,730.00
		Mono plus two SCA	9,390.00
		Stereo only	9,330.00
		Stereo plus one SCA	9,990.00
		Stereo plus two SCA	10,650.00
ES-34296A	—	Spare Tubes Kit, Complete Set ³	200.00
ES-560646	BTF-1/1E2	1/1 kW FM Transmitter, Single Exciter:	
		Mono only	13,620.00
		Mono plus one SCA	14,280.00
		Mono plus two SCA	14,940.00
		Stereo only	14,880.00
		Stereo plus one SCA	15,540.00
		Stereo plus two SCA	16,200.00
ES-560648	—	Spare Tubes Kit, Complete Set ³	400.00
MI-27558A	—	Kit, Power Output Control, Remote	247.00
ES-560647	BTF-1+1E2	2 kW FM Transmitter, Single Exciter:	
		Mono only	15,075.00
		Mono plus one SCA	15,735.00
		Mono plus two SCA	16,395.00
		Stereo only	16,335.00
		Stereo plus one SCA	16,995.00
		Stereo plus two SCA	17,655.00
ES-560648	—	Spare Tubes Kit, Complete Set ³	400.00
ES-560915	BTF-3E1	3 kW FM Transmitter, Three-Phase Power:	
		Mono only	13,495.00
		Mono plus one SCA	14,155.00
		Mono plus two SCA	14,815.00
		Stereo only	14,755.00
		Stereo plus one SCA	15,415.00
		Stereo plus two SCA	16,075.00
ES-560920	—	Spare Tubes Kit, Complete Set ³	313.00

³Tube kits sold only with transmitter.

Catalog Number	Type Number	Description	Price
FM TRANSMITTERS (continued)			
ES-560915A	BTF-3E1	3 kW FM Transmitter, Single-Phase Power:	
		Mono only	\$13,895.00
		Mono plus one SCA	14,555.00
		Mono plus two SCA	15,215.00
		Stereo only	15,155.00
		Stereo plus one SCA	15,815.00
		Stereo plus two SCA	16,475.00
ES-560920	—	Spare Tubes Kit, Complete Set ³	313.00
MI-561026	—	Coupler, Directional, Exciter Output	64.00
MI-561023	—	Control, Power, Remote	64.00
CB	—	Factory Installation of MI-561023	177.00
ES-560923	BTF-3/3E1	3/3 kW FM Transmitter, Single Exciter, Three-Phase Power:	
		Mono only (Price approximate)	29,995.00
		Mono plus one SCA (Price approximate)	30,655.00
		Mono plus two SCA (Price approximate)	31,315.00
		Stereo only (Price approximate)	31,255.00
		Stereo plus one SCA (Price approximate)	31,915.00
		Stereo plus two SCA (Price approximate)	32,575.00
ES-560920(2)	—	Spare Tubes Kit, Complete Set ³	626.00
MI-561026	—	Coupler, Directional, Exciter Output	64.00
MI-561023	—	Control, Power, Remote	64.00
CB	—	Factory Installation of MI-561023	177.00
ES-560600	BTF-3/3E1	3/3 kW FM Transmitter, Single Exciter, Single-Phase Power:	
		Mono only (Price approximate)	30,995.00
		Mono plus one SCA (Price approximate)	31,655.00
		Mono plus two SCA (Price approximate)	32,315.00
		Stereo only (Price approximate)	32,255.00
		Stereo plus one SCA (Price approximate)	32,915.00
		Stereo plus two SCA (Price approximate)	33,575.00
ES-560920(2)	—	Spare Tubes Kit, Complete Set ³	626.00
MI-561026	—	Coupler, Directional, Exciter Output	64.00
MI-561023	—	Control, Power, Remote	64.00
CB	—	Factory Installation of MI-561023	177.00
ES-560922	BTF-3+3E1	6 kW FM Transmitter, Single Exciter, Three-Phase Power:	
		Mono only (Price approximate)	34,195.00
		Mono plus one SCA (Price approximate)	34,855.00
		Mono plus two SCA (Price approximate)	35,515.00
		Stereo only (Price approximate)	35,455.00
		Stereo plus one SCA (Price approximate)	36,115.00
		Stereo plus two SCA (Price approximate)	36,775.00
ES-560920(2)	—	Spare Tubes Kit, Complete Set ³	626.00
MI-561026	—	Coupler, Directional, Exciter Output	64.00
MI-561023	—	Control, Power, Remote	64.00
ES-560922A	BTF-3+3E1	6 kW FM Transmitter, Single Exciter, Single-Phase Power:	
		Mono only (Price approximate)	34,995.00
		Mono plus one SCA (Price approximate)	35,655.00
		Mono plus two SCA (Price approximate)	36,315.00
		Stereo only (Price approximate)	36,255.00
		Stereo plus one SCA (Price approximate)	36,915.00
		Stereo plus two SCA (Price approximate)	37,575.00
MI-561920(2)	—	Spare Tubes Kit, Complete Set ³	626.00
MI-561026	—	Coupler, Directional, Exciter Output	64.00
MI-561023	—	Control, Power, Remote	64.00
CB	—	Factory Installation of MI-561023	177.00
ES-560916	BTF-5E2	5 kW FM Transmitter:	
		Mono only	14,995.00
		Mono plus one SCA	15,655.00
		Mono plus two SCA	16,315.00
		Stereo only	16,255.00
		Stereo plus one SCA	16,915.00
		Stereo plus two SCA	17,575.00
ES-560920	—	Spare Tubes Kit, Complete Set ³	313.00

³Tube kits sold only with transmitter.

Catalog Number	Type Number	Description	Price
FM TRANSMITTERS (continued)			
MI-561026	—	Coupler, Directional, Exciter Output	\$ 64.00
MI-561023	—	Control, Power, Remote	64.00
CB	—	Factory Installation of MI-561023	177.00
ES-560962	BTF-5+5E2	10 kW FM Transmitter, Single Exciter:	
		Mono only (Price approximate)	37,195.00
		Mono plus one SCA (Price approximate)	37,855.00
		Mono plus two SCA (Price approximate)	38,515.00
		Stereo only (Price approximate)	38,455.00
		Stereo plus one SCA (Price approximate)	39,115.00
		Stereo plus two SCA (Price approximate)	39,775.00
ES-560920(2)	—	Spare Tubes Kit, Complete Set ³	626.00
MI-561026	—	Coupler, Directional, Exciter Output	64.00
MI-561023	—	Control, Power, Remote	64.00
CB	—	Factory Installation of MI-561023	177.00
ES-560923	BTF-5/5E2	5/5 kW FM Transmitter, Single Exciter:	
		Mono only (Price approximate)	32,995.00
		Mono plus one SCA (Price approximate)	33,655.00
		Mono plus two SCA (Price approximate)	34,315.00
		Stereo only (Price approximate)	34,255.00
		Stereo plus one SCA (Price approximate)	34,915.00
		Stereo plus two SCA (Price approximate)	35,575.00
ES-560920(2)	—	Spare Tubes Kit, Complete Set ³	626.00
MI-561026	—	Coupler, Directional, Exciter Output	64.00
MI-561023	—	Control, Power, Remote	64.00
CB	—	Factory Installation of MI-561023	177.00
ES-560600	BTF-5E1	5 kW FM Transmitter:	
		Mono only	16,650.00
		Mono plus one SCA	17,310.00
		Mono plus two SCA	17,970.00
		Stereo only	17,910.00
		Stereo plus one SCA	18,570.00
		Stereo plus two SCA	19,230.00
ES-560607	—	Spare Tubes Kit, Complete Set ³	531.00
ES-560603	BTF-5/5E1	5/5 kW FM Transmitter, Single Exciter:	
		Mono only	46,400.00
		Mono plus one SCA	47,720.00
		Mono plus two SCA	49,040.00
		Stereo only	48,920.00
		Stereo plus one SCA	50,240.00
		Stereo plus two SCA	51,560.00
ES-560610	—	Spare Tubes Kit, Complete Set ³	1,062.00
ES-560637	BTF-5+5E1	10 kW FM Transmitter, Single Exciter:	
		Mono only	50,475.00
		Mono plus one SCA	51,795.00
		Mono plus two SCA	53,115.00
		Stereo only	52,995.00
		Stereo plus one SCA	54,315.00
		Stereo plus two SCA	55,635.00
ES-560273	—	Spare Tubes Kit, Complete Set ³	1,062.00
ES-560601	BTF-10E1	10 kW FM Transmitter:	
		Mono only	21,895.00
		Mono plus one SCA	22,555.00
		Mono plus two SCA	23,215.00
		Stereo only	23,155.00
		Stereo plus one SCA	23,815.00
		Stereo plus two SCA	24,475.00
ES-560608	—	Spare Tubes Kit, Complete Set ³	611.00
ES-560604	BTF-10/10E1	10/10 kW FM Transmitter:	
		Mono only	50,715.00
		Mono plus one SCA	52,035.00
		Mono plus two SCA	53,355.00
		Stereo only	53,235.00

³Tube kits sold only with transmitter.

Catalog Number	Type Number	Description	Price
FM TRANSMITTERS (continued)			
ES-560611	—	Stereo plus one SCA	\$54,555.00
ES-560638	BTF-10+10E1	Stereo plus two SCA	55,875.00
		Spare Tubes Kit, Complete Set ³	1,222.00
		20 kW FM Transmitter:	
		Mono only	55,215.00
		Mono plus one SCA	56,535.00
		Mono plus two SCA	57,855.00
		Stereo only	57,735.00
		Stereo plus one SCA	59,555.00
		Stereo plus two SCA	60,375.00
ES-560235	—	Spare Tubes Kit, Complete Set ³	1,222.00
ES-560602	BTF-20E1	20 kW FM Transmitter:	
		Mono only	29,225.00
		Mono plus one SCA	29,885.00
		Mono plus two SCA	30,545.00
		Stereo only	30,485.00
		Stereo plus one SCA	31,145.00
		Stereo plus two SCA	31,805.00
ES-560609	—	Spare Tubes Kit, Complete Set ³	767.00
MI-560307-31	—	AM Noise Reduction Kit	605.00
CB	—	Factory Installation of MI-560307-31	250.00
ES-560605	BTF-20/20E1	20/20 kW FM Transmitters:	
		Mono only	63,440.00
		Mono plus one SCA	64,760.00
		Mono plus two SCA	66,080.00
		Stereo only	65,960.00
		Stereo plus one SCA	67,280.00
		Stereo plus two SCA	68,600.00
ES-560612	—	Spare Tubes Kit, Complete Set ³	1,534.00
ES-560606	BTF-40E1	40 kW FM Transmitter:	
		Mono only	66,520.00
		Mono plus one SCA	67,840.00
		Mono plus two SCA	69,160.00
		Stereo only	69,040.00
		Stereo plus one SCA	70,360.00
		Stereo plus two SCA	71,680.00
ES-560613	—	Spare Tubes Kit, Complete Set ³	1,534.00
FM TRANSMITTER MISCELLANEOUS ACCESSORIES			
MI-561018-2	—	Meter, Elapsed Time, 115V, 60 Hz	20.00
MI-561018-4	—	As Above, but for 50 Hz	20.00
MI-560307-31	—	AM Noise Reduction Kit	605.00
CB	—	Factory Installation of above kit	250.00
MI-560347-3	—	High Altitude Blower Kit	278.00
MI-560705	—	Mounting Kit for above	300.00
MI-560758	—	Three-Phase Autoformer, 360/240V, 50/60 Hz, 35 kVA	1,595.00
MI-561026	—	Coupler, Directional, Exciter Output	64.00
MI-561707A	—	Probe, Monitor, for 3/8-inch T/L	64.00
MI-34319-2	—	Transformer, Filament, 50 Hz (for BTF-1E2)	70.00
MI-560307-36	—	Manometer	60.00
MI-560708A	—	Directional Coupler, 6 1/8", 50 ohms, 40 kW (Price approximate)	450.00
MI-560708E	—	As Above, but 3 1/8" (Price approximate)	300.00
MI-560708B	—	As Above, but 20 kW (Price approximate)	300.00
MI-560708C	—	As Above, but 10 kW (Price approximate)	300.00
MI-560708D	—	As Above, but 5 kW (Price approximate)	300.00
MI-561322	—	Connectors, Set, for BTS-1B System (ES-560639)	10.00
MI-561323	—	As Above, but for BTX-1B System (ES-560640/1)	10.00
POWER CONVERSION KITS			
ES-560642	—	Converts BTF-5E/E1 to BTF-10E/E1	6,500.00
ES-560643	—	Converts BTF-5E/E1 to BTF-20E/E1	13,455.00
ES-560644	—	Converts BTF-10E/E1 to BTF-20E/E1	8,310.00
ES-560645	—	Converts BTF-20E1 to BTF-40E1 (Mono only)	40,895.00
³ Tube kits sold only with transmitter.			

Catalog Number	Type Number	Description	Price
FM MONITORS			
MI-560735	BW-75A	Freq. & Mod. Monitor	\$ 1,550.00
MI-560736	—	Panel, Remote Metering (for BW-75A)	145.00
MI-560740	BW-85A	Stereo Freq. & Mod. Monitor	1,350.00
MI-560741	—	Panel, Remote Metering (for BW-85A)	145.00
MI-560745	BW-95A	SCA Freq. & Mod. Monitor (Each add'l subcarrier freq.: \$20.00)	1,250.00
MI-560746	—	Panel, Remote Metering (for BW-95A)	145.00
MI-560738	BW-100B	RF Amplifier (for BW-75A)	400.00
REMOTE CONTROL EQUIPMENT			
ES-561446-1	BTR-30A1	Remote Control System	2,995.00
ES-561446-4	BTR-30A1	Remote Control System	3,095.00
ES-561446-5	BTR-30A1	Remote Control System	3,095.00
ES-561446-6	BTR-30A1	Remote Control System	3,095.00
ES-561446-8	BTR-30A1	Remote Control System	3,315.00
ES-561446-9	BTR-30A1	Remote Control System	3,095.00
ES-561446-10	BTR-30A1	Remote Control System	3,095.00
ES-561446-11	BTR-30A1	Remote Control System	3,095.00
ES-561446-13	BTR-30A1	Remote Control System	3,155.00
ES-561446-14	BTR-30A1	Remote Control System	2,925.00
ES-561446-15	BTR-30A1	Remote Control System	2,925.00
ES-561446-16	BTR-30A1	Remote Control System	2,925.00
ES-561157	BTR-15BW	Remote Control System	1,595.00
ES-561158-26	BTR-15BR	Remote Control System	1,995.00
ES-561158-110	BTR-15BR	Remote Control System	1,995.00
MI-561181-1	—	Option, Internal Telemetry Subcarrier (for BTR-15BR)	125.00
CONTROL AND EXTENSION METER PANELS			
ES-561438	BTC-2	Panel, Extension Control/Metering (For local control only)	495.00
ES-561443-1	—	Panel, Meter, One Meter	90.00
ES-561443-2	—	Panel, Meter, Two Meters	120.00
ES-561443-3	—	Panel, Meter, Three Meters	150.00
MI-561444	—	Meter (Please specify full-scale calibration)	40.00
AUTOMATIC LOGGING EQUIPMENT			
ES-561154	ADP-220	Printer, Data, Digital, Automatic	7,350.00
REMOTE CONTROL ACCESSORIES			
MI-27516	—	Pickup, Voltage, AC, 115/230V	152.00
MI-27519	—	Unit, Monitoring and Control, Tower Lights	125.00
MI-27544	—	Unit, Monitor, Tower Lighting	120.00
MI-561179	PLC-1	Converter, Power-to-Linear	235.00
MI-561470	—	Panel, Relay (for eight MI-561471)	34.00
MI-561471-1	—	Relay, DPDT, 120Vac Coil (for above)	9.00
MI-561482	PVK-1	Kit, Sampling, Plate-Voltage, 0-10kV	30.00
MI-561483	PVK-2	Kit, Sampling, Plate-Voltage, 10-20kV	60.00
—	RMK-1	Kit, Motor, Reversible, with adj. clutch	83.00
—	RFK-1	Kit, Sampling, T/L, AM Frequencies	38.00
—	RFK-2	Kit, Sampling, T/L, FM, 3/8"	38.00
—	RFK-3	Kit, Sampling, T/L, FM, 1/8"	38.00
MI-561458	MIU-1	Unit, Insertion, Metering	195.00
MI-561459	MRU-1	Unit, Recovery, Metering	195.00
MI-561460	MMA-1	Adaptor, Modulation Monitor	105.00
MI-561461	CSA-3	Amplifier, Chopper-Stabilized	135.00
MI-561462	TLK-1	Kit, Tower Light Monitor	30.00
MI-561463	LVK-1	Kit, Sampling, Line Voltage	35.00
MI-561464	MBB-1	Kit, Sampling, Plate Voltage	90.00
MI-561465	TSK-1	Kit, Sensing, Temperature	75.00
ES-561156	SCS-2	System, Status Indicator	1,795.00
MI-561469	TAU-1	Frame, Tolerance Alarm	395.00
MI-561184	—	Module, Tolerance Alarm (for TAU-1 above)	65.00
MI-561182	TMR-1	Receiver, FM, Telemetry	190.00
MI-561479	MSC-1	Combiner, Multi-System	750.00
MI-561479(Mod)	MSC-1(Mod)	As Above, but for use with subcarrier generator	800.00

Catalog Number	Type Number	Description	Price
"PCL" STL EQUIPMENT			
—	PCL-303	STL System, 890-960 MHz	\$ 3,880.00
—	PCL-303/C	As Above, plus composite stereo	4,190.00
—	PCL-404	STL System, 890-960 MHz	3,095.00
—	PCL-202	STL System, 300-470 MHz	3,800.00
—	PCL-202/C	As Above, plus composite stereo	4,300.00
—	PCL-101	STL System, 148-174 MHz or 215-240 MHz ⁴	1,995.00
—	PCL-101	As Above, but for 450-470 MHz ⁴	2,250.00
—	ECP-1	Panel, Extension Control (for PCL-202, -202C, -303, -303C)	135.00
—	ECP-2	Panel, Extension Control (for PCL-404)	110.00
—	PR-450/U	Antenna, Paraflector, 950 and 450 MHz	290.00
—	CA5-950	Antenna, Yagi, 950 MHz	95.00
—	ICU-1	Isocoupler, 940-960 MHz	115.00
—	ICU-2	Isocoupler, 450-470 MHz	115.00
—	SCG-4T	Generator, Subcarrier, Program	695.00
—	2-1054A	Filter, Lowpass, 5 kHz (for SCG-4T)	49.00
—	SCG-6	Generator, Subcarrier, Telemetry	225.00
—	SCD-2	Detector, Subcarrier (for SCG-6)	325.00
—	SCD-2/P	Detector, Subcarrier (for SCG-4T or BTX-1B)	365.00
"STL-" STL EQUIPMENT			
—	STL-25/200	STL System, 148-174 MHz, 25W	1,770.00
—	STL-18/200	STL System, 215-240 MHz, 18W	1,840.00
—	STL-18/200	STL System, 300-340 MHz, 18W	1,870.00
—	STL-15/200	STL System, 450-470 MHz, 15W	1,870.00
—	STL-8F/200	STL System, 890-960 MHz, 8W	2,270.00
—	STL-8A/200	STL System, 890-960 MHz, 8W	2,073.50
Accessory prices on request.			
"RPL" REMOTE PICKUP EQUIPMENT			
—	RPL-3	RPL System, 148-174 MHz	1,885.00
—	RPL-4	RPL System, 450-470 MHz	1,945.00
—	—	Crystals, Set, for above	44.00
—	AMP	Power Amplifier, for RPL-3	225.00
—	AMP	As Above, but for RPL-4	275.00
—	RCP-1	Repeater Control Panel	325.00
—	—	Relay Transmitter Tone Encoder, Hand-Held, for above	95.00
—	ICU-3	Isocoupler, 150-172 MHz	95.00
—	ICU-2	Isocoupler, 450-470 MHz	115.00
—	RPT-40/30	RPL System, 150-172 MHz, 40W	1,250.00
—	RPT-25/50	RPL System, 450-470 MHz, 25W	1,270.00
Accessory prices on request.			
"UNIVERSAL" TRANSMISSION LINE			
MI-27791D-1A	—	Line Section, 20' long (6.1m)	198.00
MI-27791D-1B	—	Line Section, 19.5' long (5.9m)	198.00
Flanged sections shorter than 20': \$8.00/ft.; \$9.70 for female flange; \$8.10 for male flange; \$8.10 for clamp; \$0.50 for gasket; \$24.00 for connector or \$30.00 for inner expander connector. (Use inner expander connector on 10-foot lengths and longer.)			
MI-27791D-2A	—	Elbow, Right Angle	109.00
MI-27791D-2AR	—	Elbow, Right Angle, Reinforced	195.00
MI-27791D-2B	—	Elbow, Right Angle	109.00
MI-27791D-2BR	—	Elbow, Right Angle, Reinforced	195.00
MI-27791D-3A	—	Gas Stop	88.00
MI-27791D-4A	—	Flange, Soft Solder	41.75
MI-27791D-4B	—	Flange, Soft Solder	38.00
MI-27791D-4C	—	Clamp, V-Groove	8.10
MI-27791D-4D	—	Connector (Anchor Insulator)	24.00
MI-27791D-4E	—	Gasket, O-Ring	0.50
MI-27791D-7A	—	Adapter, Univ. to RETMA	94.00
MI-27791D-7B	—	Adapter, Univ. to RETMA	60.00
⁴ Other frequencies available on special order.			

Catalog Number	Type Number	Description	Price
"UNIVERSAL" TRANSMISSION LINE (continued)			
MI-27791D-7C	—	Adapter, Univ. Male	\$ 27.50
MI-27791D-8A	—	End Cap, Female	56.00
MI-27791D-8B	—	End Cap, Male	44.25
MI-27791-14	—	Flange, Female	9.70
MI-27791-16	—	Flange, Male	8.10
MI-19089-15	—	Guide, Cutoff	13.25
MI-19089-16	—	Guide, Cutoff	7.40
MI-19089-18	—	Grease, Silicone	3.50
BOLT-FLANGED TRANSMISSION LINE			
MI-19089-1E	—	Line Section, 20' long (6.1m)	210.00
MI-19089-1F	—	Line Section, 19.5' long (5.9m)	210.00
		Flange section shorter than 20': \$8.00/ft plus: \$17.75 each flange; \$2.30 each hardware set; \$0.60 each gasket; \$24.75 for standard connector OR \$36.00 for expansion connector. (Use expansion connector on 10-foot lengths and longer.)	
MI-19089-2A	—	Elbow, Right Angle, Male	128.00
MI-19089-2C	—	Elbow, Right Angle, Female	114.00
MI-19089-2CR	—	Elbow, Right Angle, Reinforced	204.00
MI-19089-4	—	Gas Stop	105.00
MI-19089-6	—	Elbows, Tandem	233.00
MI-19089-10A	—	Connector, Anchor Insulator	24.75
MI-19089-14	—	Flange, Soft Solder	38.25
MI-19089-15	—	Guide, Cutoff	13.25
MI-19089-16	—	Guide, Cutoff	7.40
MI-19089-17	—	Reducer, to Type N Connector	124.00
MI-19089-18	—	Grease, Silicone	3.50
MI-19089-19	—	Adapter, "N" to "HN"	33.75
MI-19089-20	—	Tool, Anchor Insulator Removal	12.00
MI-19089-21	—	Reducer, to "HN" Connector	123.00
MI-19089-24	—	Adapter, EIA to Univ. Male	94.00
MI-19089-25	—	Adapter, EIA to Univ. Female	60.00
MI-19089-26	—	Cap, End Seal	63.00
MI-19113C-10	—	Gasket, O-Ring	0.60
MI-19113C-19	—	Kit, Hardware	2.30
MI-27988-5D	—	Reducer, Quick-Step	80.00
MI-27988-5C	—	Reducer, Quick-Step	87.00
MI-27988-4A	—	Adapter, Inner Connector	15.25
MI-27988-4B	—	Adapter, Inner Connector	13.50
MI-27988-4C	—	Flange, Mechanical	32.25
MI-27988-7A	—	Adapter, Section	41.25
MI-27988-7E	—	Adapter, Male-to-Male	38.75
STEATITE INSULATED, 51.5-OHM TRANSMISSION LINE			
MI-19113C-1	—	Line Section, 20' long (6.1m), Flanged	187.00
MI-19113C-1NF	—	As Above, less flanges	158.00
		Lengths less than 20' long: \$8.00/ft plus: \$14.25 each fixed flange; \$2.30 each connector; \$2.30 each hardware set.	
MI-19113C-8	—	Coupling, Unflanged	9.80
MI-19113C-8NB	—	As Above, less Inner Connector	7.00
MI-19113C-9	—	Inner Conductor, Splicing, 20' long	28.75
MI-19113C-11	—	Connector, Inner Conductor	2.30
MI-19113C-18	—	Elbow, Right Angle, Flanged	90.00
MI-19113C-18NF	—	As Above, less flanges	65.00
TEFLON-INSULATED, 51.5-OHM TRANSMISSION LINE			
MI-19313-1H	—	Line Section, 20' long (6.1m)	198.00
MI-19313-1NF	—	Line Section, 20' long (6.1m), less flanges	158.00
		Lengths less than 20' long: \$8.00/ft plus \$14.25 for each fixed flange; \$2.30 for each hardware kit; \$2.80 each connector OR \$12.00 for expander connector. (Use expander on lengths greater than 10 feet.)	
MI-19313-1SFH	—	Line Section, 20' long (6.1m)	194.00
MI-19313-1BH	—	Line Section, 19.5' long (5.9m)	198.00
MI-19313-1BSFH	—	Line Section, 19.5' long (5.9m)	205.00
MI-19313-2	—	Elbow, Right Angle	90.00
MI-19313-2R	—	As Above, Reinforced	173.00

Catalog Number	Type Number	Description	Price
TEFLON-INSULATED, 51.5 OHM TRANSMISSION LINE (continued)			
MI-19313-2NF	—	Elbow, Right Angle, less flanges	\$ 65.00
MI-19313-8	—	Coupling, Unflanged	10.00
MI-19313-8NB	—	Coupling, Unflanged, less connector	7.00
MI-27988-4B	—	Adapter, Inner Connector	13.50
MI-19113C-5	—	Gas Stop	74.00
MI-19113C-51	—	Guide, Cutoff	7.00
MI-19113C-54	—	Guide, Cutoff	8.90
MI-19113C-55	—	Flange, Soft Solder	44.50
MI-19089-15	—	Guide, Cutoff	13.25
MI-19113C-60	—	Flange, Mechanical	35.75
MI-19113C-6	—	Reducer	57.00
MI-19113C-7	—	Reducer	46.00
MI-27988-5A	—	Reducer	78.00
MI-19113C-58	—	Reducer	124.00
MI-19313-11	—	Bushing, Adapter	1.30
MI-19313-10	—	Adapter, Inner Conductor	3.50
MI-19113C-13	—	End Cap	14.75
UNFLANGED, 50-OHM TRANSMISSION LINE			
MI-561565-1A	—	Line Section, 20' long (6.1m) (Lengths less than 20': \$3.70/foot)	88.00
MI-27791K-1A	—	Line Section, 20' long (6.1m) (Lengths less than 20': \$7.25/foot)	143.00
MI-561579-1A	—	Line Section, 20' long (6.1m) (Lengths less than 20': \$23.00/foot)	457.00
MI-561565-2A	—	Elbow, Right Angle	34.00
MI-27791K-2A	—	Elbow, Right Angle	55.00
MI-561579-2A	—	Elbow, Right Angle	165.00
MI-561565-4A	—	Coupling	12.00
MI-27791K-4A	—	Coupling	9.70
MI-561579-4A	—	Coupling	44.00
MI-561565-4B	—	Connector, Inner Conductor	6.80
MI-27791K-4B	—	Connector, Inner Conductor	3.10
MI-561579-4B	—	Connector, Inner Conductor	22.50
MI-561565-7A	—	Adapter	16.00
MI-27988-4C	—	Adapter	32.25
MI-27791K-7B	—	Adapter	20.50
MI-27791K-7A	—	Adapter	29.50
MI-561579-7A	—	Adapter	85.00
MI-561565-5B	—	Reducer	26.00
MI-27791K-5A	—	Reducer	124.00
MI-561579-5B	—	Reducer	238.00
MI-561565-5A	—	Reducer	87.00
MI-561579-5A	—	Reducer	218.00
MI-561579-6T	—	Transformer-Adapter	340.00
MI-561565-8A	—	Adapter, Inner Conductor	6.80
MI-27988-4A	—	Adapter, Inner Conductor	15.25
MI-27988-4B	—	Adapter, Inner Conductor	13.50
MI-561579-8A	—	Adapter, Inner Conductor	89.00
MI-561565-4C	—	Clamp, Worm-Drive	0.50
MI-27791K-4C	—	Clamp, Worm-Drive	0.75
MI-561579-4C	—	Clamp, Worm-Drive	1.00
SPECIAL ADAPTERS			
MI-19313-11	—	Adapter, Bushing	2.30
MI-27988-5C	—	Reducer	87.00
MI-27988-5B	—	Reducer	41.75
MI-27988-5D	—	Reducer	80.00
MI-27988-5A	—	Reducer	78.00
MI-27988-5E	—	Reducer	65.00
MI-27988-7E	—	Adapter, Male-to-Male	38.75
MI-27988-7D	—	Adapter, Male-to-Male	26.50
MI-27988-7C	—	Adapter, Male-to-Male	17.00
MI-27988-7A	—	Adapter	41.25
MI-27988-7B	—	Adapter	34.75
MI-27988-7G	—	Adapter	27.00
MI-27988-7F	—	Adapter, Male-to-Male	18.25

Catalog Number	Type Number	Description	Price
SEMI-RIGID TRANSMISSION LINE			
HJ4-50	—	Air Dielectric, 1/2" Dia., per foot	\$ 1.22
HJ5-50	—	Air Dielectric, 7/8" Dia., per foot	2.32
HJ7-50	—	Air Dielectric, 1 5/8" Dia., per foot	5.06
HJ8-50	—	Air Dielectric, 3" Dia., per foot	10.00
FHJ1-50	—	Foam Dielectric, 1/4" Dia., per foot	0.40
FHJ2-50	—	Foam Dielectric, 3/8" Dia., per foot	0.57
FHJ4-50	—	Foam Dielectric, 1/2" Dia., per foot	0.74
FHJ5-50	—	Foam Dielectric, 7/8" Dia., per foot	1.90
FHJ7-50	—	Foam Dielectric, 1 5/8" Dia., per foot	4.32
41U	—	UHF Jack (Female)	9.50
41P	—	UHF Plug (Male)	9.50
41N	—	Type N Jack (Female)	9.50
41W	—	Type N Plug (Male)	9.50
13212-2	—	Adapter, End Terminal	12.00
12395-1	—	Wraplock, Stainless Steel (100' or 30 m)	15.00
27290	—	Tie Wires, Copperweld (Qty 20)	3.00
11662-3	—	Clamp, Mounting	5.00
42U	—	UHF Jack (Female)	11.50
42P	—	UHF Plug (Male)	11.50
42N	—	Type N Jack (Female)	11.50
42W	—	Type N Plug (Male)	11.50
13212-2	—	Adapter, End Terminal	12.00
12395-1	—	Wraplock, Stainless Steel (100' or 30 m)	15.00
27290	—	Tie Wires, Copperweld	3.00
11662-3	—	Clamp, Mounting, Insulated	5.00
44AU	—	UHF Jack (Female)	6.30
44AP	—	UHF Plug (Male)	6.30
44AW	—	Type N Jack (Female)	7.40
44AN	—	Type N Plug (Male)	7.40
44AT	—	Adapter, End Terminal	26.00
12395-1	—	Wraplock, Stainless Steel (100' or 30 m)	15.00
11662-3	—	Clamp, Mounting, Insulated	5.00
45AR	—	Flange, EIA	26.00
45AZ	—	Splice	26.00
45AM	—	Type LC Plug (Male)	26.00
26892-2	—	Kit, Grounding	3.00
45AU	—	UHF Jack (Female)	17.00
45AP	—	UHF Plug (Male)	17.00
45AW	—	Type N Jack (Female)	20.00
45AN	—	Type N Plug (Male)	20.00
45AT	—	Adapter, End Terminal	34.00
12395-1	—	Wraplock, Stainless Steel (100' or 30 m)	15.00
11662-2	—	Clamp, Mounting, Insulated	5.00
45AR	—	Flange, EIA	25.00
45AZ	—	Splice	30.00
45AM	—	Type LC Jack (Female)	38.00
45AL	—	Type LC Plug (Male)	38.00
40993-5	—	Kit, Grounding	5.00
31766-5	—	Kit, Hanger (Qty 10)	18.00
31768-1	—	Adapter, Hanger (Qty 10)	20.00
31670-1	—	Adapter, Hanger (Qty 10)	8.00
31670-2	—	Adapter, Hanger (Qty 10)	8.00
31670-3	—	Adapter, Hanger (Qty 10)	10.00
31670-4	—	Adapter, Hanger (Qty 10)	10.00
31670-5	—	Adapter, Hanger (Qty 10)	10.00
2061	—	Adapter, End Terminal	70.00
12395-1	—	Wraplock, Stainless Steel (100' or 30 m)	15.00
33948-3	—	Clamp, Mounting, Insulated	10.00
47R	—	Flange, EIA	70.00
47Z	—	Splice	78.00
47M	—	Type LC Jack (Female)	78.00
47L	—	Type LC Plug (Male)	78.00
40993-2	—	Kit, Grounding	5.00
31766-2	—	Kit, Hanger (Qty 10)	18.00
31768-1	—	Adapter, Hanger (Qty 10)	20.00
31670-1	—	Adapter, Hanger (Qty 10)	8.00

Catalog Number	Type Number	Description	Price
SEMI-RIGID TRANSMISSION LINE (continued)			
31670-2	—	Adapter, Hanger (Qty 10)	\$ 8.00
31670-3	—	Adapter, Hanger (Qty 10)	10.00
31670-4	—	Adapter, Hanger (Qty 10)	10.00
31670-5	—	Adapter, Hanger (Qty 10)	10.00
74N	—	Type N Jack (Female)	21.00
74W	—	Type N Plug (Male)	21.00
12395-1	—	Wraplock, Stainless Steel (100' or 30 m)	15.00
26892-2	—	Kit, Grounding	3.00
11662-3	—	Hanger, Insulated	5.00
1920A	—	Dehydrator, Automatic	820.00
878A	—	Pump, Dry Air	100.00
858C	—	Fittings, Nitrogen Tank	116.00
75AU	—	UHF Jack (Female)	25.00
75AN	—	Type N Jack (Female)	25.00
75AW	—	Type N Plug (Male)	32.00
75AT	—	Adapter, End Terminal	50.00
1060	—	Elbow, Mitre, 90-degree	40.00
12395-1	—	Wraplock, Stainless Steel	15.00
75AR	—	Flange, EIA	32.00
75AG	—	Flange, EIA, w/Gas Barrier	51.00
75AZ	—	Splice	34.00
19256B	—	Grip, Hoisting	15.00
40993-5	—	Kit, Grounding	5.00
31766-5	—	Kit, Hanger	18.00
31768-1	—	Adapter, Hanger	20.00
31670-1	—	Adapter, Hanger (Qty 10)	8.00
31670-2	—	Adapter, Hanger (Qty 10)	8.00
31670-3	—	Adapter, Hanger (Qty 10)	10.00
31670-4	—	Adapter, Hanger (Qty 10)	10.00
31670-5	—	Adapter, Hanger (Qty 10)	10.00
11662-2	—	Hanger, Insulated	5.00
1260A	—	Barrier, Gas	38.00
1920A	—	Dehydrator, Automatic	820.00
878A	—	Pump, Dry Air	100.00
858C	—	Fittings, Nitrogen Tank	116.00
87N	—	Type N Jack (Female)	66.00
2061	—	Adapter, End Terminal	70.00
1061	—	Elbow, Mitre, 90-degree	60.00
12395-1	—	Wraplock, Stainless Steel (100' or 30 m)	15.00
87R	—	Flange, EIA	64.00
87G	—	Flange, EIA, w/Gas Barrier	76.00
87Z	—	Splice	84.00
24312A	—	Grip, Hoisting	19.00
40993-2	—	Kit, Grounding	5.00
31766-2	—	Kit, Hanger	18.00
31768-1	—	Adapter, Hanger, Angle Iron	20.00
31670-1	—	Adapter, Hanger (Qty 10)	8.00
31670-2	—	Adapter, Hanger (Qty 10)	8.00
31670-3	—	Adapter, Hanger (Qty 10)	10.00
31670-4	—	Adapter, Hanger (Qty 10)	10.00
31670-5	—	Adapter, Hanger (Qty 10)	10.00
33948-3	—	Hanger, Insulated	10.00
1261B	—	Barrier, Gas	64.00
1920A	—	Dehydrator, Automatic	820.00
878A	—	Pump, Dry Air	100.00
858C	—	Fittings, Nitrogen Tank	116.00
2062	—	Adapter, End Terminal	110.00
1062	—	Elbow, Mitre, 90-degree	100.00
78ARM	—	Flange, EIA	110.00
78AGM	—	Flange, EIA, w/Gas Barrier	122.00
78AZ	—	Splice	132.00
26985A	—	Grip, Hoisting	25.00
40993-11	—	Kit, Grounding	8.00
33598-3	—	Kit, Hanger	20.00
33981-1	—	Adapter, Hanger, Angle Iron	21.00
33984-1	—	Adapter, Hanger, Round	48.00

Catalog Number	Type Number	Description	Price
SEMI-RIGID TRANSMISSION LINE (continued)			
33948-2	—	Hanger, Insulated	\$ 22.00
1262A	—	Barrier, Gas	112.00
1920A	—	Dehydrator, Automatic	820.00
878A	—	Pump, Dry Air	100.00
858C	—	Fittings, Nitrogen Tank	116.00
HANGERS AND ACCESSORIES			
MI-19313-44	—	Hanger, Fixed	13.25
MI-19313-47	—	Hanger, Fixed	14.00
MI-19313-34	—	Hanger, Expansion	25.50
MI-19313-32	—	Hanger, Expansion	17.00
MI-19313-33	—	Hanger, Expansion	17.75
MI-19313-41	—	Hanger, Heavy Duty	48.00
MI-19313-37	—	Hanger, Swivel	59.00
MI-19313-38	—	Hanger, Dual Swivel	59.00
MI-19313-50	—	Hanger, Suspension	28.25
MI-19313-51	—	Hanger, Suspension	58.00
MI-19313-35	—	Roller, Horizontal	16.00
MI-19313-36	—	Brace, Lateral	9.70
MI-19313-17	—	Anchor, Horizontal	30.25
MI-19313-18	—	Anchor, Horizontal, Dual	60.50
MI-19113-16	—	Kit, Extension	3.50
PRESSURIZING EQUIPMENT			
MI-563170-1	—	Compressor/Dehydrator, ½ HP, 60 Hz	725.00
MI-563170-3	—	Compressor/Dehydrator, ¾ HP, 60 Hz	900.00
MI-561668A	—	Gassing Kit A	17.00
MI-561668B	—	Gassing Kit B	35.00
MI-561668C	—	Gassing Kit C	13.50
MI-561668A-1	—	Plastic Tubing	3.00
MI-19315-22	—	Pressure Regulator	112.00
COAXIAL SWITCHES			
MI-561562A	—	Motorized Co-Ax Switch	1,282.00
MI-561562B	—	Motorized Co-Ax Switch	1,282.00
MI-561562C	—	Motorized Co-Ax Switch	1,282.00
MI-561562D	—	Motorized Co-Ax Switch	1,282.00
MI-561562E	—	Motorized Co-Ax Switch	1,282.00
MI-561562F	—	Motorized Co-Ax Switch	1,282.00
MI-27717	—	Co-Ax-Switch, Three-Pole	240.00
MI-27718	—	Co-Ax Switch, Seven-Pole	632.00
MI-27719	—	Co-Ax-Switch, Three-Pole	472.00
MI-27720	—	Co-Ax Switch, Seven-Pole	1,342.00
MI-27912-50	—	Co-Ax-Switch, Three-Pole	243.00
MI-561680	—	Co-Ax Switch, Four-Pole	529.00
MI-27912-51	—	Co-Ax Switch, Seven-Pole	644.00
TOWER ACCESSORIES			
MI-27765	—	Ground Screen	120.00
MI-7112C	—	Choke, Lighting, Double	68.50
MI-27726	—	Choke, Lighting, Triple	72.50
MI-27728-1	—	Capacitor, Lighting Choke	4.25
MI-27741	—	Weatherproof Housing	79.00
MI-28215A-1	TI-2017	Transformer, Lighting, 1750W	340.00
MI-28215A-2	TI-2035	Transformer, Lighting, 3500W	395.00
ANTENNA TUNING UNITS			
MI-27767A	BPA-21A	Tuning Unit, Antenna	900.00
MI-27767B	BPA-21B	Tuning Unit, Antenna	1,095.00
MI-27767C	BPA-21C	Tuning Unit, Antenna	1,175.00
MI-27767D	BPA-21D	Tuning Unit, Antenna	1,185.00
MI-27725	—	Tuning Unit	440.00
MI-28027C	—	Pickup, Remote-Meter	190.00
ES-27241	BCP-1B	Kit, Isolation, Lighting	74.00
ES-27242	—	Kit, Isolation, Lighting	89.00

Catalog Number	Type Number	Description	Price
ANTENNA TUNING UNITS (continued)			
ES-27243	—	Kit, Isolation, Lighting	\$ 158.00
ES-27244	—	Kit, Isolation, Lighting	168.00
MI-27789A	BPA-5A	Tuning Unit, 5 kW	1,495.00
MI-27790A	BPA-10A	Tuning Unit, 10 kW	1,520.00
MI-28027C	—	RF Pickup Unit	190.00
MI-27966B	—	RF Pickup Unit	145.00
MI-561522	C0019	Sampling Loop	158.00
MI-27729	173-10-1	Sampling Loop	150.00
MI-27730	173-11-1	Sampling Loop	69.00
MI-27731	173-11-2	Sampling Loop	85.00
M150-FH1-50	—	Inductor, Isolation	235.00
M150-FHJ1-50	—	Inductor, Isolation	245.00
M150-FH2-50	—	Inductor, Isolation	255.00
M150-FHJ2-50	—	Inductor, Isolation	270.00
M135-FH4-50	—	Inductor, Isolation	305.00
M135-FHJ4-50	—	Inductor, Isolation	315.00
MI-27029-2	—	Dummy Load, Water Cooled	870.00
MI-27029-3	—	Dummy Load, Water Cooled	870.00
CB	—	Water Cooled Load Kit	3,150.00
MI-27966	—	RF Pickup Unit	145.00
MI-28027	—	RF Pickup Unit	190.00
MI-27644A	—	Meter	59.00
MI-27644B	—	Meter	59.00
MI-7112C	—	Lighting Choke	68.50
MI-27726	—	Lighting Choke	72.50
ES-27241	BCP-1	Kit, Lighting Choke	74.00
ES-27243	—	Kit, Lighting Choke	158.00
ES-27242	—	Kit, Lighting Choke	89.00
ES-27244	—	Kit, Lighting Choke	168.00
MI-27741	—	Weatherproof Housing	79.00
MI-27728-1	—	Capacitor, Bypass	4.25
ANTENNA PHASE MONITORS			
AM-19 (204)	—	Phase Monitor Transistorized:	
		Two Tower System	1,660.00
		Three Tower System	1,740.00
		Four Tower System	1,820.00
		Five Tower System	1,900.00
		Six Tower System	1,980.00
		Seven Tower System	2,060.00
		Eight Tower System	2,140.00
		Nine Tower System	2,220.00
PM-19	—	Phase Monitor, Precision:	
		Two Tower System	4,810.00
		Three Tower System	5,440.00
		Four Tower System	6,070.00
		Five Tower System	6,700.00
		Six Tower System	7,330.00
		Seven Tower System	7,960.00
		Eight Tower System	8,590.00
		Nine Tower System	9,220.00
RMP-19	—	Panel, Remote Metering	260.00
FIELD-STRENGTH METERS			
FIM-21	—	Field Strength Meter	1,150.00
FIM-41	—	Field Strength Meter, Two Band	1,595.00
FM ANTENNAS			
BFC- Antenna Series (less De-icers):			
ES-561921A	BFC-1	One Section	1,380.00
ES-561922A	BFC-2	Two Section	2,220.00
ES-561923A	BFC-3	Three Section	2,495.00
ES-561924A	BFC-4	Four Section	4,200.00
ES-561925A	BFC-5	Five Section	5,190.00
ES-561926A	BFC-6	Six Section	6,110.00
ES-561927A	BFC-7	Seven Section	7,105.00
ES-561928A	BFC-8	Eight Section	8,365.00

Catalog Number	Type Number	Description	Price
FM ANTENNAS (continued)			
ES-561929A	BFC-10	Ten Section	\$10,385.00
ES-561930A	BFC-12	Twelve Section	12,310.00
ES-561931A	BFC-14	Fourteen Section	14,365.00
ES-561932A	BFC-16	Sixteen Section	16,420.00
BFC- Antenna Series (with De-icers):			
ES-561921B	BFC-1	One Section	1,555.00
ES-561922B	BFC-2	Two Section	2,555.00
ES-561923B	BFC-3	Three Section	3,700.00
ES-561924B	BFC-4	Four Section	4,930.00
ES-561925B	BFC-5	Five Section	5,825.00
ES-561926B	BFC-6	Six Section	7,205.00
ES-561927B	BFC-7	Seven Section	8,365.00
ES-561928B	BFC-8	Eight Section	9,800.00
ES-561929B	BFC-10	Ten Section	12,225.00
ES-561930B	BFC-12	Twelve Section	14,455.00
ES-561931B	BFC-14	Fourteen Section	16,870.00
ES-561932B	BFC-16	Sixteen Section	19,295.00
BFC- Antenna Series (with Radomes):			
ES-561921C	BFC-1	One Section	1,750.00
ES-561922C	BFC-2	Two Section	2,935.00
ES-561923C	BFC-3	Three Section	4,240.00
ES-561924C	BFC-4	Four Section	5,660.00
ES-561925C	BFC-5	Five Section	7,010.00
ES-561926C	BFC-6	Six Section	8,310.00
ES-561927C	BFC-7	Seven Section	9,675.00
ES-561928C	BFC-8	Eight Section	11,325.00
ES-561929C	BFC-10	Ten Section	14,100.00
ES-561930C	BFC-12	Twelve Section	16,835.00
ES-561931C	BFC-14	Fourteen Section	19,540.00
ES-561932C	BFC-16	Sixteen Section	22,685.00
BFG- Antenna Series (less De-icers):			
ES-561951A	BFG-1	One Section	1,510.00
ES-561952A	BFG-2	Two Section	2,430.00
ES-561953A	BFG-3	Three Section	3,465.00
ES-561954A	BFG-4	Four Section	4,625.00
ES-561955A	BFG-5	Five Section	5,705.00
ES-561956A	BFG-6	Six Section	6,730.00
ES-561957A	BFG-7	Seven Section	7,835.00
ES-561958A	BFG-8	Eight Section	9,200.00
ES-561959A	BFG-10	Ten Section	11,445.00
ES-561960A	BFG-12	Twelve Section	13,535.00
ES-561961A	BFG-14	Fourteen Section	15,835.00
ES-561962A	BFG-16	Sixteen Section	18,095.00
BFG- Antenna Series (with De-icers):			
ES-561951B	BFG-1	One Section	1,755.00
ES-561952B	BFG-2	Two Section	3,125.00
ES-561953B	BFG-3	Three Section	4,575.00
ES-561954B	BFG-4	Four Section	6,105.00
ES-561955B	BFG-5	Five Section	7,590.00
ES-561956B	BFG-6	Six Section	8,980.00
ES-561957B	BFG-7	Seven Section	10,515.00
ES-561958B	BFG-8	Eight Section	12,190.00
ES-561959B	BFG-10	Ten Section	15,190.00
ES-561960B	BFG-12	Twelve Section	18,120.00
ES-561961B	BFG-14	Fourteen Section	21,140.00
ES-561962B	BFG-16	Sixteen Section	24,160.00
BFH- Antenna Series (less De-icers):			
ES-561941A	BFH-1	One Section	745.00
ES-561942A	BFH-2	Two Section	1,205.00
ES-561943A	BFH-3	Three Section	1,725.00
ES-561944A	BFH-4	Four Section	2,310.00
ES-561945A	BFH-5	Five Section	2,860.00
ES-561946A	BFH-6	Six Section	3,380.00
ES-561947A	BFH-7	Seven Section	3,930.00
ES-561948A	BFH-8	Eight Section	4,660.00

Catalog Number	Type Number	Description	Price
FM ANTENNAS (continued)			
BFH- Antenna Series (with De-icers):			
ES-561941B	BFH-1	One Section	\$ 830.00
ES-561942B	BFH-2	Two Section	1,410.00
ES-561943B	BFH-3	Three Section	2,050.00
ES-561944B	BFH-4	Four Section	2,750.00
ES-561945B	BFH-5	Five Section	3,420.00
ES-561946B	BFH-6	Six Section	4,020.00
ES-561947B	BFH-7	Seven Section	4,755.00
ES-561948B	BFH-8	Eight Section	5,535.00
BFI- Antenna Series:			
ES-561933	BFI-1C	One Section, Circular Polarization	238.00
ES-561934	BFI-2C	Two Section, Circular Polarization	690.00
ES-561935	BFI-1H	One Section, Horizontal Polarization	238.00
ES-561936	BFI-2H	Two Section, Horizontal Polarization	690.00
BFA- Antenna Series (less De-icers):			
MI-27985-1	BFA-1	One Section	875.00
MI-27985-2	BFA-2	Two Section	1,445.00
MI-27985-3	BFA-3	Three Section	2,065.00
MI-27985-4	BFA-4	Four Section	2,660.00
MI-27985-5	BFA-5	Five Section	3,530.00
MI-27985-6	BFA-6	Six Section	4,105.00
MI-27985-7	BFA-7	Seven Section	4,835.00
MI-27985-8	BFA-8	Eight Section	5,380.00
MI-27985-10	BFA-10	Ten Section	7,060.00
MI-27985-12	BFA-12	Twelve Section	8,360.00
MI-27985-14	BFA-14	Fourteen Section	9,755.00
MI-27985-16	BFA-16	Sixteen Section	11,150.00
BFA- Antenna Series (with De-icers):			
MI-27985H-1	BFA-1	One Section	975.00
MI-27985H-2	BFA-2	Two Section	1,665.00
MI-27985H-3	BFA-3	Three Section	2,410.00
MI-27985H-4	BFA-4	Four Section	3,110.00
MI-27985H-5	BFA-5	Five Section	4,080.00
MI-27985H-6	BFA-6	Six Section	4,770.00
MI-27985H-7	BFA-7	Seven Section	5,620.00
MI-27985H-8	BFA-8	Eight Section	6,300.00
MI-27985H-10	BFA-10	Ten Section	8,325.00
MI-27985H-12	BFA-12	Twelve Section	9,730.00
MI-27985H-14	BFA-14	Fourteen Section	11,350.00
MI-27985H-16	BFA-16	Sixteen Section	12,950.00
BFC- ANTENNA ACCESSORIES			
MI-27988-4A	—	Adapter, Inner Conductor	15.25
MI-27988-4B	—	Adapter, Inner Conductor	13.50
MI-27791D-7B	—	Adapter, Outer, Male	60.00
MI-27791D-7A	—	Adapter, Outer, Female	94.00
MI-27988-5C	—	Reducer, Quick-Step	87.00
MI-27988-5D	—	Reducer, Quick-Step	80.00
BFG- ANTENNA ACCESSORIES			
(See "BFC- Antenna Accessories" above)			
BFH- ANTENNA ACCESSORIES			
MI-27988-5E	—	Reducer, Quick-Step	65.00
BFA- ANTENNA ACCESSORIES			
(See "BFC- Antenna Accessories" above)			
TOWER ISOLATORS			
MI-561573	BAF-15	Antenna Isolation Unit	810.00
MI-561574	BAF-16	Antenna Isolation Unit	1,210.00
DE-ICER CONTROL SYSTEMS			
MI-561572	—	Rosemount Ice Detector	926.00
MI-27369	—	Sleet Melter Control	300.00

RCA | Broadcast Systems
Front and Cooper Streets | Camden, N.J. 08103