

Broadcast Systems

# **RCA** Radio Equipment

AM Transmitters  
FM Transmitters  
Exciters, Monitors  
STL, Remote Control  
Transmission Line  
Antennas, Towers





## About This Catalog

This is one of several catalogs published by RCA Broadcast Systems Department. It describes products that serve the transmitter and antenna portions of the radio-broadcast plant.

For the audio portion of the plant, RCA publishes a companion catalog that describes microphones; control consoles; automatic program equipment; intercom/interphone gear; amplifiers and signal processors; racks, cabinets, furniture, rack equipment; turntables and tone arms; cartridge and reel tape equipment; loudspeakers and accessories and audio test equipment.

For TV broadcasting, companion catalogs describe camera equipment; terminal and switching gear; UHF- and VHF-TV transmitters, transmission line, towers and antennas.

These catalogs are available at RCA Regional Offices (see list, next page). Each office is staffed by a sales representative with broad experience in the broadcast business. He can help you plan your equipment facilities and supply the information you need.

## Contents

### AM Transmitters

One-Kilowatt Transmitter, Type BTA-1S	RA.1011A
One-Kilowatt Transmitter, Type BTA-1N1	RA.1021A
Five-Kilowatt Transmitter, Type BTA-5L1	RA.1031A
Ten-Kilowatt Transmitter, Type BTA-10L1	RA.1041A
Fifty-Kilowatt Transmitter, Type BTA-50J	RA.1061A
100-Kilowatt Transmitter, Type BTA-100J	RA.1071A
200-Kilowatt Transmitter, Type BTA-200J	RA.1071A

### AM Monitors

Modulation and Frequency Monitor, BW-50	RA.1111A
RF Amplifier, Type BW-60	RA.1111A

### FM Transmitters

FM Exciter System, Type BTE-15A	RA.2011A
Ten Watt Educational Transmitter, BTE-10AT	RA.2011A
One-Kilowatt Transmitter, Type BTF-1E2	RA.2021A
Two-Kilowatt Transmitter, Type BTF-1+1E2	RA.2021A
Two-Kilowatt Transmitter, Type BTF-1/1E2	RA.2021A
Three-Kilowatt Transmitter, Type BTF-3E1	RA.2031A
Six-Kilowatt Transmitter, Type BTF-3+3E1	RA.2031A
Three-Kilowatt Dual Transmitter, BTF-3/3E1	RA.2031A
Five-Kilowatt Economy Transmitter, BTF-5E2	RA.2037A
Five-Kilowatt Dual Transmitter, BTF-5E1	RA.2041A
Ten-Kilowatt Dual Transmitter, BTF-5+5E1	RA.2041A
Five-Kilowatt Dual Transmitter, BTF-5/5E1	RA.2041A
Ten-Kilowatt Transmitter, Type BTF-10E1	RA.2051A
Twenty-Kilowatt Transmitter, BTF-10+10E1	RA.2051A
Ten-Kilowatt Dual Transmitter, BTF-10/10E1	RA.2051A
Twenty-Kilowatt Transmitter, Type BTF-20E1	RA.2061A
Forty-Kilowatt Transmitter, Type BTF-40E1	RA.2071A

### FM Monitors

Frequency and Modulation Monitor, BW-75A	RA.2111A
Stereo Freq. and Mod. Monitor, BW-85A	RA.2111A
SCA Freq. and Mod. Monitor, BW-95A	RA.2111A
RF Amplifier, Type BW-100	RA.2111A

### Remote Control Equipment

Sixty-Function Remote Control, BTR-30A1	RA.3011A
Thirty-Function Remote Control, BTR-15B	RA.3021A
Extension Control/Metering Panel, BTC-2	RA.3031A
Remote Control Accessories	RA.3051A
Automatic Logging Equipment	RA.3061A

### Remote Program Pickup and STL Equipment

RPL and STL Equipment (Radio)	RA.4011A
-------------------------------	----------

### Transmission Line Equipment

Rigid and Flexible Transmission Line	RA.5011A
Transmission Line Hangers	RA.5021A
Transmission Line Pressurization Equipment	RA.5031A
Transmission Line Co-Ax Switches	RA.5041A

### AM Antenna Equipment

Towers for AM or FM	RA.6011B
AM Tuning Units, 250, 1000W	RA.6111A
AM Antenna Phasing Equipment	RA.6211A
Accessories for Antennas	RA.6311A
Antenna Monitors, Type AM-19 (204), PM-19	RA.6411A
Field-Strength Meters	RA.6511A

### FM Antenna Equipment

Towers for AM or FM	RA.6011B
Antenna, Type BFC-	RA.7011A
Antenna, Type BFG-	RA.7111A
Antenna, Type BFH-	RA.7211A
Antenna, Type BFI-	RA.7311A
Horizontally Polarized Antenna, Type BFA-	RA.7511A
Multiple-Station Antennas, BFD-, BFE-, BFF-	RA.7611A
RF Loads and Wattmeters	RA.7711A
Tower Isolators, Types BAF-15A, -16A	RA.7811A
Antenna Ice Detector, Rosemount	RA.7911A
Thermostatic Sleetmelter Control	RA.7921A



## Regional Offices

(Subject to change without notice)

Atlanta, Ga. 30329  
14 Executive Park Dr., N.E.  
404-634-6131

Austin, Tex. 78758  
Northwest Office Park Bldg.  
8330 Burnet Rd., Suite 134  
512-451-2500

Birmingham, Ala. 35223  
Office Park Bldg. #10  
Office Park Circle  
205-871-1155

Boston Area:  
Wellesley, Mass. 02181  
Wellesley Office Park  
617-237-6050

Camden, N. J. 08102  
Front & Cooper Sts.  
609-963-8000

Charlotte, N. C. 28210  
6230 Fairview Rd., Suite 104  
704-366-0626

Chicago, Ill. 60606  
Gateway II Bldg., Suite 1400  
120 S. Riverside Plaza  
312-782-0700

Cincinnati, O. 45231  
11430 Hamilton Ave.  
513-825-1550

Dallas, Tex. 75247  
RCA Center  
8700 Stemmons Freeway  
214-638-6200

Denver, Colo. 80211  
2701 Alcott St., Suite 384  
303-433-8484

Detroit: Southfield, Mich. 48075  
24333 Southfield Rd., Suite 209  
313-357-0080

Hollywood, Calif. 90028  
RCA Corp., Suite 531  
6363 Sunset Blvd.  
213-461-9171

Jacksonville, Fla. 32207  
2747 Art Museum Dr.  
Suite 5  
904-398-4588

Kansas City Area:  
Overland Park, Kans. 66207  
5750 West 95th St., Suite 111  
913-642-3185, 6, 7

Pittsburgh, Pa. Area:  
McMurray, Pa. 15317  
761 N. Washington Blvd.  
412-941-5570

Minneapolis, Minn. 55416  
4522 Excelsior Blvd.  
612-920-6395, 6

New York, N. Y. 10036  
1133 Avenue of the Americas, 5th Floor  
212-586-3000

San Francisco, Calif. 94102  
420 Taylor St., Suite 401-408  
415-441-2200

St. Louis, Mo. 63105  
7701 Forsyth Blvd., Suite 455  
314-862-3660

Seattle, Wash. 98119  
408 Second Ave., W.  
206-285-2375

Washington, D. C. Area:  
Arlington, Va. 22209  
1901 North Moore St.  
703-558-4212

West Palm Beach, Fla. 33403  
Palm Beach Gardens, Bldg. 110  
3900 RCA Blvd.  
305-622-1100

## RCA International Marketing Subsidiaries (Subject to change without notice)

### Argentina

Buenos Aires  
RCA International Limited  
Calle Paroissien 3960  
Telephone: 70-4171

### Australia 2113

North Ryde, N.S.W.  
RCA Limited  
11 Khartoum Road  
Telephone: 888-5444

### Australia 3121

Richmond, Victoria  
RCA Limited  
2-4 Stephenson Street  
Telephone: 42-4586

### Brazil

Rio de Janeiro-GB  
RCA Telesistemas Ltda.  
Rua Correa Dutra, 126-4And  
Telephone: 245-9209

### Canada

Ste. Anne de Bellevue, 810 P.Q.  
RCA Limited  
21001 North Service Road  
Telephone: (514) 457-9000

Toronto 15, Ontario  
RCA Limited  
1450 Castlefield Avenue  
Telephone: (416) 651-6550

Vancouver, British Columbia  
RCA Limited  
2876 Rupert Street  
at Grandview Highway  
Telephone: (604) 433-0541

### Hong Kong

RCA International Limited  
1927 Prince's Building  
Chater Road, G.P.O. 112  
Telephone: H 234181

### Mexico

Mexico 17, D.F.  
RCA S.A. de C.V.  
Avenida Cuiclahuac 2519  
Telephone: 5-27-60-20 Ext. 104

### Switzerland

Geneva  
RCA International Marketing S.A.  
118 rue du Rhone, CH 1204  
Telephone: 35-82-00

### United Kingdom

Jersey Isle  
RCA Jersey Limited  
Longueville Road, St. Saviour  
Telephone: CENTRAL 35355



## One-Kilowatt AM Transmitter, Type BTA-1S

- Excellent frequency response, low distortion
- Low operating costs
- Circuit breaker overload protection
- Positive peak modulation capability: 125%



The RCA Type BTA-1S, 1-kilowatt AM Broadcast Transmitter is designed for reliability, outstanding fidelity, and economical operation. It provides a high quality amplitude modulated signal at any frequency in the 535 to 1620 kilohertz band and is capable of producing a maximum of 1100 watts.

Highly perfected audio circuits together with a large, high-quality modulation transformer and reactor provide 125-percent positive-peak modulation capability and unusually high fidelity sound. Stable, long-life tubes and solid-state devices have been used throughout the transmitter. Circuit breakers, *not fuses*, provide complete overload protection.

Provision for remote control and simplified power cutback are reflected in the BTA-1S design. Front panel or remote control selection of any two power levels of 1000, 500 or 250 watts is available. No unnecessarily complicated circuitry or superfluous parts have been included and all components are easily accessible for maintenance and inspection.

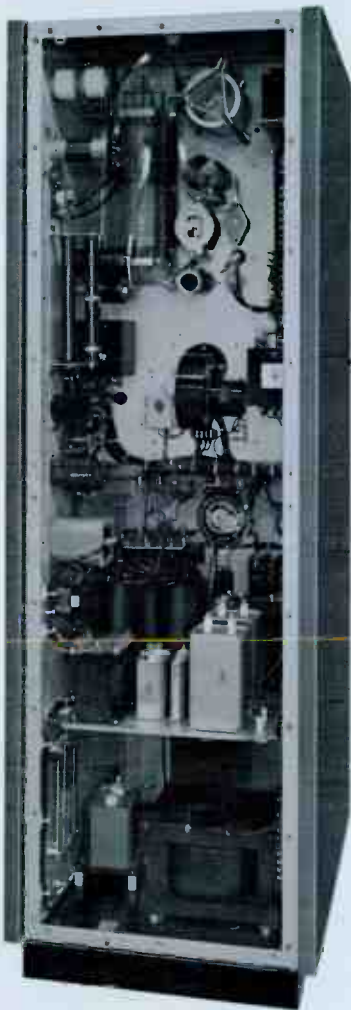

Unimpeded rear access to the transmitter is afforded by the full length door and the well laid out, vertical construction. Power supply components at bottom; r-f components at top.

Type BTA-1S Transmitter with outer and inner door open to display accessibility to the tubes. Power amplifier and modulator tubes are near top while the lower chassis carries the audio-amplifier and intermediate stages.





## Functional Design

Improved functional design includes RCA's new color combination. Square construction permits locating the transmitter against the wall, or it can be installed against other equipment. The vertical construction makes it accessible from both front and rear for ease of maintenance. A single front panel tuning control provides simplified operation. Remote control provisions permit unattended operation of the transmitter.

## Simplified Power Cutback

The BTA-1S easily fits into operations where power reduction at night is required. For "day-night" operation an optional Power Cutback Kit may be incorporated in the transmitter. By pressing a button on the front or at a remote panel, the transmitter can be cut back in power to either 500 or 250 watts. Efficient operation at the low power levels is achieved by reducing the high voltage by primary taps on the plate transformer.

## Complete Accessibility

The entire transmitter is housed in a single steel cabinet that is mounted on a sturdy welded steel base. Control components are conveniently located on the panel above the front door and all meters are at eye level. Easy access is provided by a hinged front door and two interlocked removable rear panels. Most BTA-1S components are mounted on a vertical center chassis. Tubes and overload relays are mounted on the front and the other components are mounted on the rear. Larger power components are mounted on the base.

## Solid State Power Supplies

Three power supplies are used: a low voltage supply for plate and screen voltages of all low voltage tubes, a bias supply for the modulator tubes, and a high voltage supply for the modulator and power amplifier tubes. All power supplies use silicon diodes which results in low power drain, cool operation and reliable performance. Automatic relays protect the transmitter against overload. These, in turn, are backed up with automatic circuit breakers. The design avoids the use of fuses anywhere in the unit.

## Power Requirements

The transmitter operates from a 208-240-volt, 50/60-hertz, single-phase power source for the main power. In addition, the crystal heaters require 115-volt power source.

## Solid-State Oscillator and Buffer Stages

Adding an extra measure of transmitter stability, the BTA-1S combines its oscillator and buffer amplifier into a single, solid-state subassembly. The combination of transistorized electronics and temperature-controlled crystals make for an adjustment-free facility which, in turn, reduces routine maintenance. The oscillator is equipped with two temperature-controlled crystals arranged through a front-panel selector switch so that a "hot" spare is always at hand, even via remote control.

## Simple, Straightforward Circuitry

The buffer feeds a single 6146A driver tube which in turn feeds the power amplifier which consists of two 4-400A tubes connected in parallel. Tetrodes have been utilized throughout the RF section of the transmitter reducing the required stages and the power consumption. Tetrodes also eliminate the need for neutralization.

The modulator comprises two 2E26 tubes in push-pull, resistance coupled to two 4-400A modulator tubes. The modulator tubes operate as a class AB<sub>1</sub> ampli-

fier without grid current which results in an overall distortion of less than 2 percent up to 10,000 Hz.

## Parallel/Redundant System

The BTA-1S is available also as a parallel/redundant transmitter system. This system consists of two identical BTA-1S transmitters and a combiner. In the "parallel" mode, the twin one-kilowatt outputs are combined to provide two kilowatts of power to the antenna system; in the "redundant" mode, the system operates one of the two transmitters as a hot standby while the other feeds the antenna system.

In either operational mode, the parallel/redundant system assures greater on-air dependability. For example, an outage in one transmitter or the other automatically switches the troubled transmitter to a dummy load while the operable one feeds a full kilowatt to the antenna system. This action is the result of a special-design combiner with essentially zero insertion loss. Further details of the BTA-1S parallel/redundant transmitter system are available from Aural Broadcast Equipment Marketing, RCA Building 2-5, Camden, N. J. 08102, U.S.A.

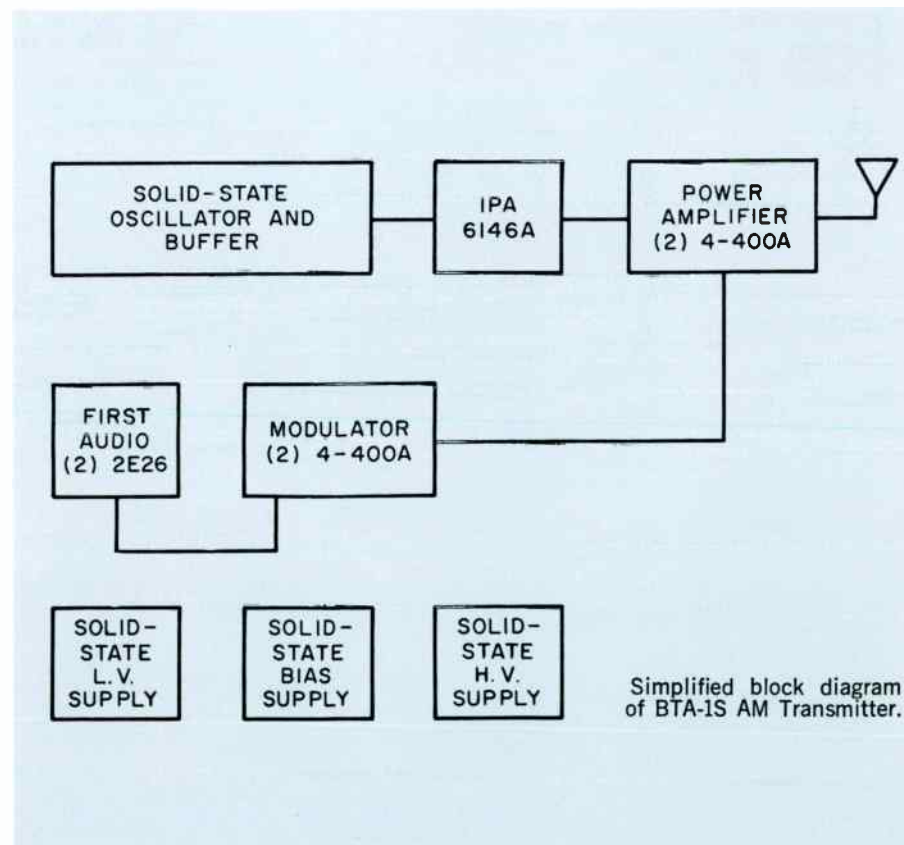

## Specifications

### Performance

AF Input Impedance .....	150/600 ohms
AF Input Level (100% modulation) .....	+10 ±2 dBm
AF Response:	
50-7500 Hz .....	±1 dB
30-10,000 Hz .....	±1.5 dB
AF Distortion (95% modulation):	
50-10,000 Hz .....	2%
50-12,000 Hz .....	3%
Noise (below 100% modulation) .....	60 dB
Frequency Range .....	535-1620 kHz
Frequency Stability .....	±2 Hz
Type of Output .....	Single ended
Carrier Shift (0-100% modulation) .....	3%
Output Impedance .....	40-250 ohms

### Electrical

RF Voltage (for frequency monitoring) .....	6/10 V rms 75 ohms
RF Voltage (for modulation monitoring) .....	6/10 V rms 75 ohms
Power Output (nominal) .....	1000 watts
Power Output Capability .....	1100 watts
Power Supply .....	208/240 volts
Line Frequency .....	50/60 Hz
Phase .....	Single
Power Consumption (Approx.):	
0% modulation .....	2900 watts
100% modulation .....	3900 watts
Average program modulation .....	3200 watts
Power Factor .....	90%
Permissible combined line voltage variation and regulation .....	±5%
Crystal Heater Power Supply .....	115 volts 50/60 Hz

### Tube Complement

1	6146A	Intermediate Power Amplifier
2	2E26	Audio Frequency Amplifier
2	4-400A	Modulator
2	4-400A	Power Amplifier

### Mechanical

Height .....	77" (1955 mm)
Width .....	26" (660 mm)
Depth .....	30" (762 mm)
Weight (net) .....	900 pounds (408 kg) (approx.)
Altitude Range .....	0-5000 ft.* (0-1254 m)
Ambient Operating Temperature .....	-20 to 45°C (-4 - 113°F)
Shipping Data .....	1200 lbs (544 kg); 79 ft <sup>3</sup> (2.23 m <sup>3</sup> )

### Accessories

Operating Spare Tube Kit .....	ES-560655
Recommended Minimum Spare Tube Kit .....	ES-560656
Frequency and Modulation Monitor, Type BW-50 .....	MI-560767
RF Amplifier (for BW-50) .....	MI-560762
Thirty-Function Remote Control, Type BTR-15 .....	MI-561150
Sixty-Function Remote Control, Type BTR-30 .....	MI-561440
High-Altitude Blower Kit .....	MI-34309-8
Spare Crystal Unit, Type TMV-130 (Specify Freq.) .....	MI-27493
RF Ammeters .....	MI-7157-F Series
Remote RF Pickup Unit (less meter) .....	MI-27966-B
Power Cutback Kit (Two Level) .....	MI-560657
Remote Power Adjust Kit .....	MI-560658
Oscillator-Buffer (Solid-State) .....	MI-27592

### Ordering Information

One-Kilowatt AM Transmitter, Type BTA-1S .....	ES-560650
250- or 500-Watt AM Transmitter, Type BTA-1S (Specify power level) .....	ES-560947

\*To 10,000 ft. (3048 m) with optional blower (MI-34309-8).





## 1 kW AM Broadcast Transmitter, Type BTA-1N1

- Silicon power supplies
- Low operating cost
- Remote control provisions
- Requires less than three square feet (0.258 square meters) of floor space
- High speed magnetic circuit breaker protection—eliminates fuses

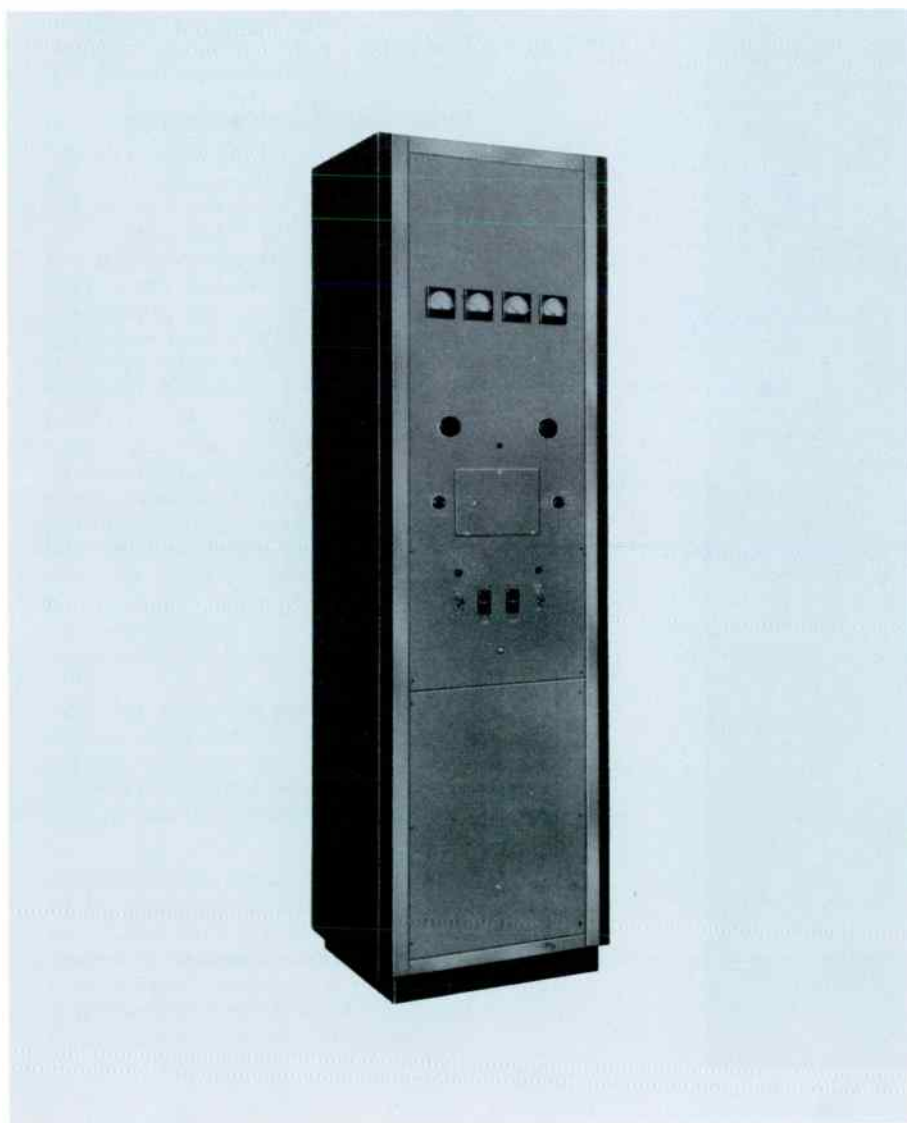

The Type BTA-1N1 is an amplitude-modulated transmitter of unique design that in every way leads broadcasting's modern trend to combine greater economy, simplicity and reliability in a single compact unit. A real performer, the Type BTA-1N1 uses fewer and less expensive components, incorporates simplified tuning, and easily produces 1000 watts maximum power output at any frequency between 535 and 1620 kilohertz.

Remote, unattended operation of the transmitter is a practical reality—enhanced by simplified start-stop and power-control circuitry, remote metering and the long-term reliability of semiconductor power supplies. In the audio channel there are only two tubes, one transformer and a small modulation choke. Silicon rectifiers are used throughout.

Lower front with access panel removed showing oversize blower, plate transformers and reactors.



The Type BTA-1N1 1-kW Broadcast Transmitter is housed in a standard equipment rack that may be ganged with other racks. The transmitter is divided into three compartments: The upper compartment is completely enclosed in aluminum and contains the modulator, rf driver and power amplifier. The center compartment contains an oscillator/buffer assembly, bias supply, filter components for the high-voltage and intermediate high-voltage supplies and control circuit. The lower compartment contains the high-voltage plate transformer, rectifier and blower. The rear panel of the upper two compartments is removable and both front and rear panels of the lower compartments are removable to allow complete access to all components. The blower intake is thru a filter in the lower rear, thru the compartment containing the high-voltage plate transformer and rectifier, thus providing ample cooling.

#### Simplified, Reliable Circuits

Simplicity of the Type BTA-1N1 transmitter circuitry is shown by the block diagram. In the rf section, carrier frequency generated by the pentode section of a Type 6AX8 crystal oscillator is first amplified by a broadband tuned Type 6AX8 buffer using only the pentode section of the tube. The signal is then fed to a Type 7094 single-ended, Class C stage which drives an air-cooled 3X3000F1 triode operating with fixed bias as a Class AB<sub>1</sub> power amplifier. The PA output circuit is broadband neutralized and includes a harmonic trap which is adjustable from the front panel. Both the rf driver, which is the plate-modulated stage, and the power amplifier are tuned from the front panel by variable capacitors. Rf voltage for frequency monitoring is derived from the Type 6AX8 crystal oscillator and fed to the frequency monitor through the triode section of the tube. An rf sample for the modulation monitor is obtained from the low tap on the PA tank coil which also serves as a discharge path for static charges in the antenna circuit.

Audio is fed through a 150/600-ohm line input transformer and amplified by the triode section of a Type 6AX8 tube (pentode section utilized as rf buffer). This triode is resistance coupled to a Type 7094 Class A modulator which is choke-coupled to the plate circuit of the rf driver stage.

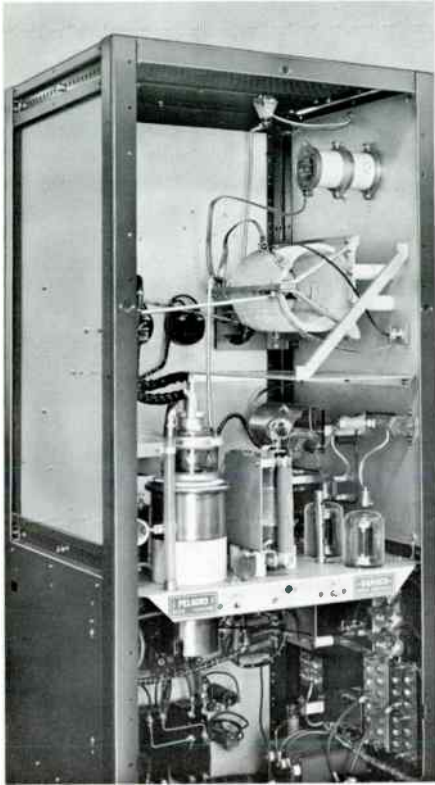

**Solid State Power Supplies**

A plate supply and bias supply each utilizing silicon diodes, equalizing resistors and printed wiring furnish all the dc voltages needed for the transmitter. The plate transformer is center tapped to provide plate voltage for the driver-modulator stages as well as regulated low voltage for the oscillator and buffer plates. Only two filament transformers are used in the transmitter.

**Metering of all Stages**

Individual meters are provided for reading PA plate voltage, PA plate current and rf output (optional). Remaining stages and circuits such as the oscillator, buffer, audio, and low voltage supplies, are monitored by a multimeter and selector switch combination which, in addition, provides other readings (useful in initial

tune-up) such as the peak rf voltage at the grid and plate of the PA. There are also provisions for remote metering of PA plate voltage and current.

**“Fail-Safe” Protection**

Transmitter circuits are fail-safe protected by high-speed magnetic circuit breakers. A latching relay and an optional motor-driven power raise/lower control permits convenient remote control of the transmitter. Remote on-off switching is by a single control. This is made possible by interlocking of the bias and plate supplies, a feature which also prevents spurious overloads as a result of any brief power interruptions that may occur.

**Ease of Tuning**

Built-in facilities reduce the tuning and loading of the linear amplifier to a simple, three-step procedure which is performed at the control panel of the transmitter without need for accessory test equipment of any kind. Once initial adjustments are made, the transmitter can be operated over long periods of time with only the infrequent “touch-up” tuning required by any transmitter. Modulator circuits ordinarily require no adjustment.

Rear oblique view showing radio frequency driver and power compartment.

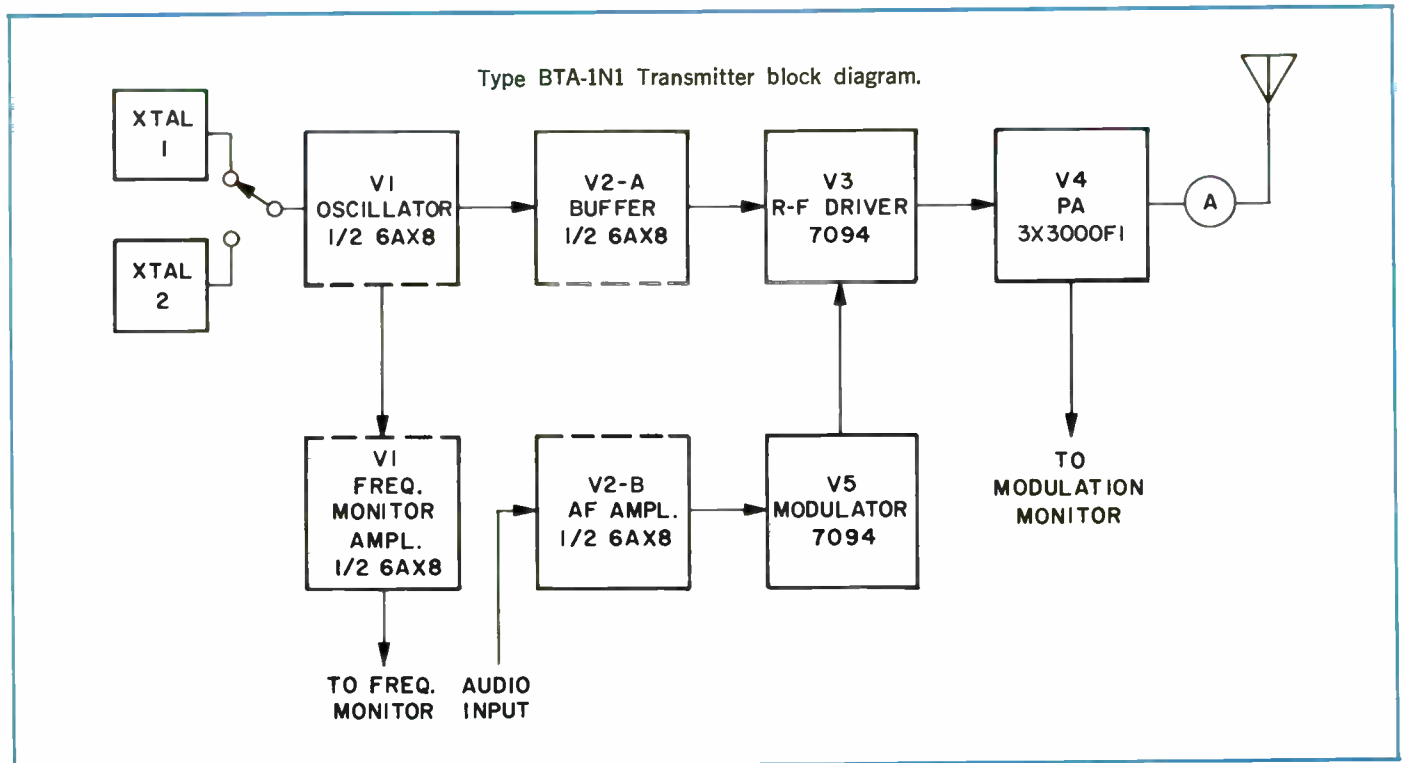

## Specifications

### Electrical

Frequency Range .....	535 to 1620 kHz
Power Output .....	500 to 1000 watts
Type of Output .....	Single-ended
Output Impedance .....	40 to 250 ohms
AF Input Impedance .....	150/600 ohms
AF Input Level (100% Modulation) .....	+10 ±2 dBm
AF Response (50 to 7500 Hertz) .....	±1.5 dB
AF Distortion (90% Modulation) .....	3%
Noise (Below 100% Modulation) .....	50 dB
Frequency Stability .....	±2 Hz
RF Voltage for Frequency Monitoring .....	10 volts, 75 ohms
RF Voltage for Modulation Monitoring .....	10 volts, 75 ohms
Total Harmonic Radiation .....	-73 dB

### Tube Complement

1 6AX8 (pentode) (triode)	Crystal Oscillator Frequency Monitor Amplifier
1 6AX8 (pentode) (triode)	Buffer Amplifier Audio Amplifier
1 7094	Amplifier Driver
1 7094	Modulator
1 3X3000F1	Power Amplifier

### Power Requirements

#### Transmitter:

Line .....	208 to 240 V., single phase, 50/60 Hz
Combined Line Voltage Variation and Regulation .....	±5%
Power Consumption (at 1000 watts) .....	4.5 kW (approx.)
Power Factor .....	90% (approx.)

#### Cabinet Lighting and Crystal Heaters:

Line .....	110 to 125 V., single phase, 50/60 Hz
------------	---------------------------------------

### Mechanical

Dimensions (overall) .....	22" wide, 84" high, 18" deep (560 mm, 2134 mm, 458 mm)
Weight .....	625 lbs. (283 kg)
Maximum Altitude .....	7500 feet (2500 meters)
Ambient Temperature Range .....	-20° to +45°C (-4 to +113°F)
Air Intake .....	200 cf/m
Heat Loss (0% Modulation) .....	3500 watts (200 BTU/min) (12,000 BTU/hr)

### Accessories

Set of Spare Tubes .....	ES-562202
Set of Spare Tubes (recommended spares) .....	ES-562201
RF Output Line Current Meter (range determined by antenna characteristics) .....	MI-7157-H*
Remote Antenna Meter .....	MI-28037-B*
Crystal, Type TMV-130B .....	MI-27493
Frequency and Modulation Monitor, Type BW-50 .....	MI-560767
Power Cutback Kit .....	MI-561301
Remote Power Adjust Kit .....	MI-561302

\*Specify scale.

### Ordering Information

One-Kilowatt AM Transmitter, Type BTA-1N1 .....	ES-562200
---	-----------

(Please specify operating frequency and transmission-line impedance.) (Includes harmonic filter and side panels.)



## 5 kW Ampliphase Transmitter, Type BTA-5L1

- Low-distortion audio
- Solid-state exciter/modulator
- Extra modulation capability
- Designed for remote control
- Only two tube types in entire unit
- No modulation transformer

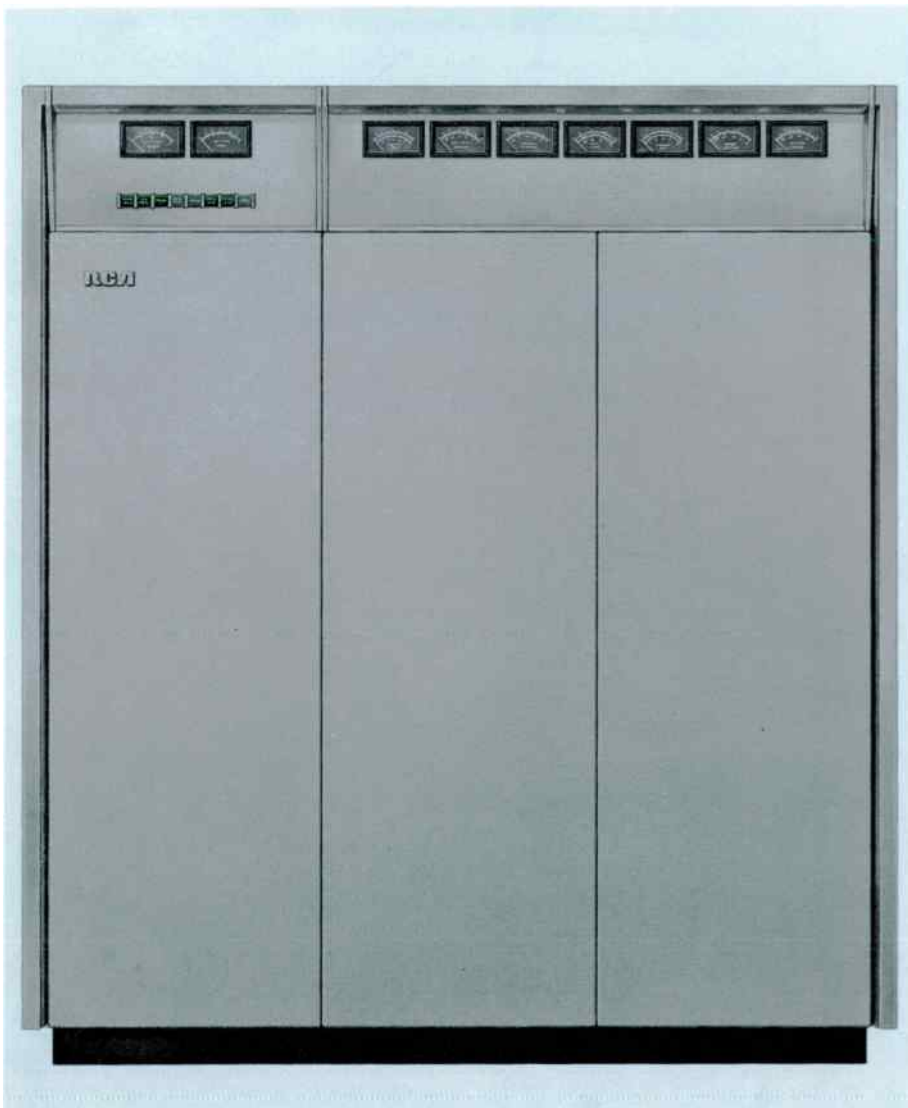

Offering superior audio quality, outstanding reliability and excellent efficiency, the BTA-5L1 is an Ampliphase transmitter for the AM-broadcast (medium-wave) band. The BTA-5L1 delivers 5 kW to the antenna transmission line.

As a result of the Ampliphase system, the BTA-5L1 Transmitter offers extended audio-frequency response at distortion levels well below average perception at enviable operating economy and dependability.

The BTA-5L1 is available also in dual-unit systems for parallel or redundant operation.

In the "parallel" arrangement, the outputs of the two transmitters in the system are combined for a 10-kilowatt power output; in the "redundant" system, one transmitter serves the load while the second operates in hot standby mode.

A special feature of the parallel system is that, in the event of outage in one transmitter, the other transmitter delivers a full five-kilowatt output to the load.

In the redundant arrangement, an outage in one transmitter or the other automatically connects the operable unit to the load.



## Outstanding Audio Quality

Of particular interest to broadcasters who take pride in station "sound", the BTA-5L1 Transmitter offers outstandingly good audio quality. One reason for this is that the *Ampliphase* system eliminates iron-core high-level modulation components — and their inherent distortions — without adding the instabilities of separate "carrier" and "peak" power amplifiers. Even on ordinary AM radios, the outstanding audio quality of an *Ampliphase* transmitter is immediately apparent.

## Extended Frequency Response

As evidence of the frequency-response characteristics the BTA-5L1 offers, it can put 30 kHz on-the-air—at full power—without strain. At the low-frequency end of the spectrum, frequencies below 30 Hz go on-the-air at full level and low distortion. Transformer-equipped transmitters usually cut off below 50 Hz and above 15 kHz.

## Extra Modulation Capability

An advantage unique to the Ampliphase system is its capability for full modulation, even for extended periods, without overload. This is particularly important to stations programming music of high average level and low dynamics. Positive modulation peaks can go as high as 125 percent without transmitter overload. Another unique feature in *Ampliphase* is that it overmodulates without the "splatter" so common to other AM transmitter forms.

## Provision for Spare Exciter/Modulator/Regulator

For those who prefer redundant exciters, the BTA-5L1 Transmitter provides rack space for a spare exciter. Offered as an option, the spare exciter includes switching gear for fast exciter substitution. A spare exciter is particularly valuable to the full-time station in that exciter maintenance is independent of transmitter operation.

## Ready for Remote Control

Because the BTA-5L1 is built for the modern broadcaster it is engineered with remote control in mind. This manifests itself in extra components, wiring and connections fully compatible with remote control equipment carrying the RCA trademark. As a result, operating a BTA-5L1 via remote control requires investment only in transmitter modification.

## Two Tube Types

Being entirely solid-state at power levels below the IPA stage, the BTA-5L1 Transmitter uses a total of only four power tubes: two in each channel. Since



Front view, doors open. Note exciter unit.

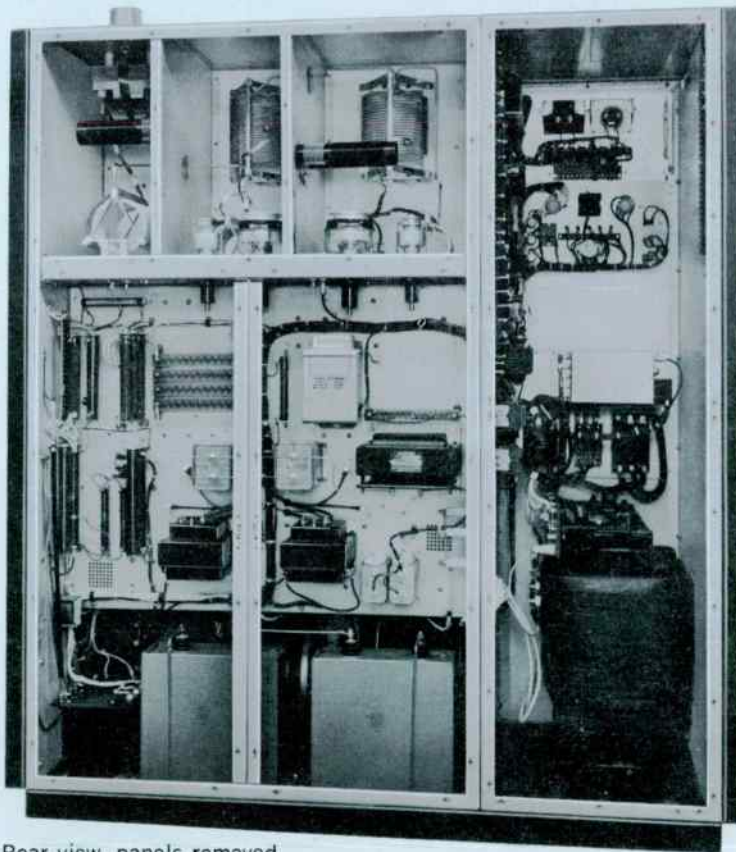

Rear view, panels removed.



these are of only two types, spares inventory need only be two tubes: one of each type. This reduces capital investment in spares and periodic rotation.

**No Modulation Transformer**

Using two identical R-F amplifier chains, the BTA-5L1 Transmitter uses *phase* modulation, at a low level, in such a manner that two phase-modulated carriers mix at the transmitter output to form an amplitude-modulated carrier. Since this system eliminates the modulation transformer and "carrier-peak" amplifiers, it eliminates the most-troublesome stages. This reflects itself in transmitter dependability that virtually eliminates unscheduled transmitter shutdown.

**Faster Troubleshooting**

A feature unique to *Ampliphase* makes routine repair easier. In a sense, a 5-kW *Ampliphase* transmitter is two identical 2.5-kW facilities in a single cabinet. Consequently, one amplifier chain is an excellent troubleshooting model for the other. Because the operating parameters of the two class-C amplifiers (operating as CW stages) can be quickly compared, the trouble can be isolated easily. Then, it's a simple matter of component replacement.

**Ceramic Insulated PA Tubes**

Ceramic power tubes have earned an enviable reputation among broadcasters



Ampliphase exciter unit. Completely solid-state, this unit is used in all RCA Ampliphase transmitters. Available separately for use as a spare. See Accessories.

for dependability and long life. The tube types selected for the BTA-5L1 operate well below ratings to take full advantage of their performance capabilities and built-in expected life. This pays dividends in low transmitter-operating expenses.

**Fully Self-Contained**

As the result of transistorization, the entire transmitter—including the power supply—fits within a single cabinet that occupies less than 14 square feet (1.3 m<sup>2</sup>) of floor space (see floor plan). This, of course, frees plant area for other productive purposes; office, studio or storage.

**Parallel/Redundant Systems**

The BTA-5L1 transmitter is available also as a parallel/redundant system. This arrangement uses two BTA-5L1 transmitters and a combiner. In the "parallel"

system, both transmitter outputs are combined to provide ten kilowatts to the load. Should one transmitter or the other have trouble, the operable transmitter continues to supply the load while the troubled transmitter is automatically switched from the antenna to a built-in dummy load.

In the redundant arrangement, one transmitter ordinarily feeds the antenna system while the other operates as a hot standby into a dummy load. Should the "air" unit fail, the system automatically connects the standby unit to the load and the troubled transmitter to the dummy load.

Further details are available from Aural Broadcast Marketing, RCA Building 2-2, Camden, N. J., 08102, U.S.A.

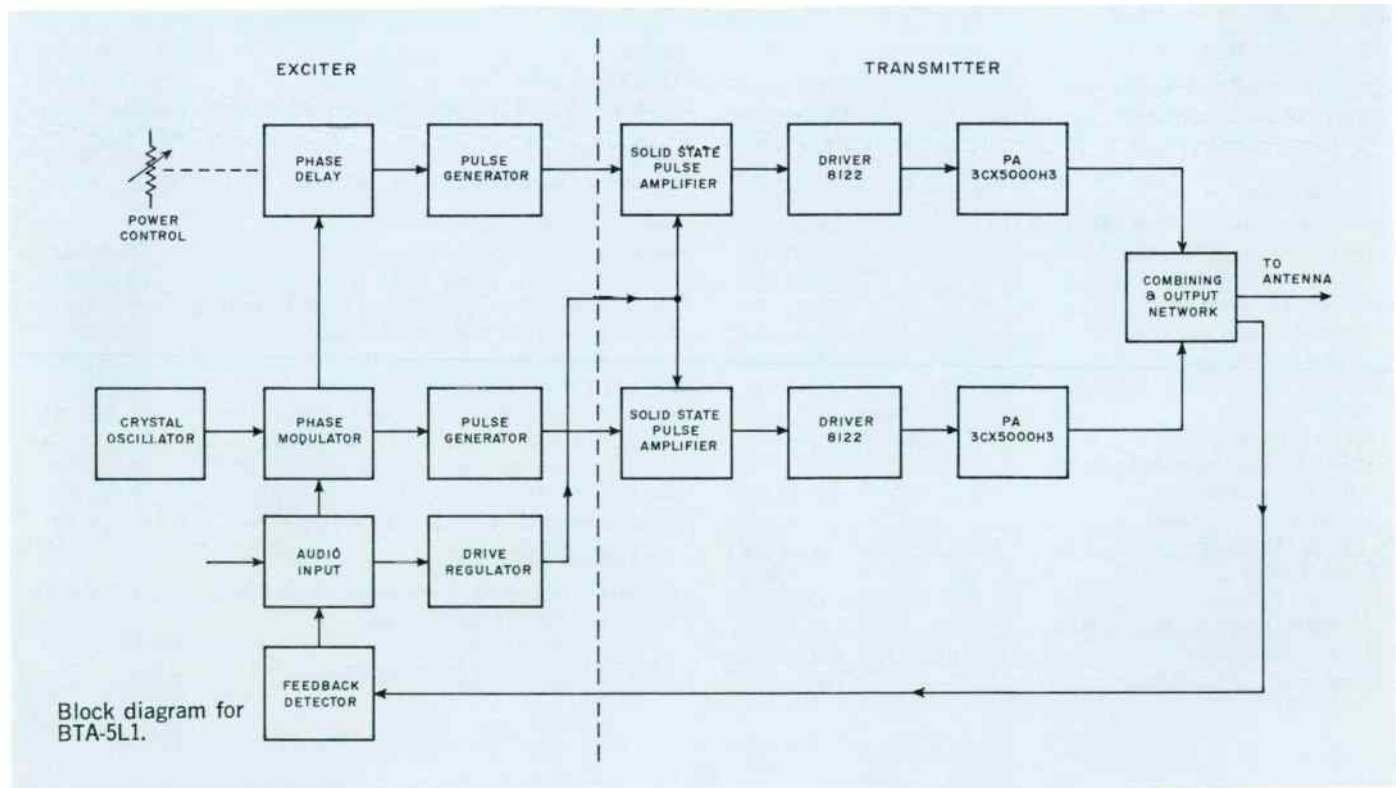

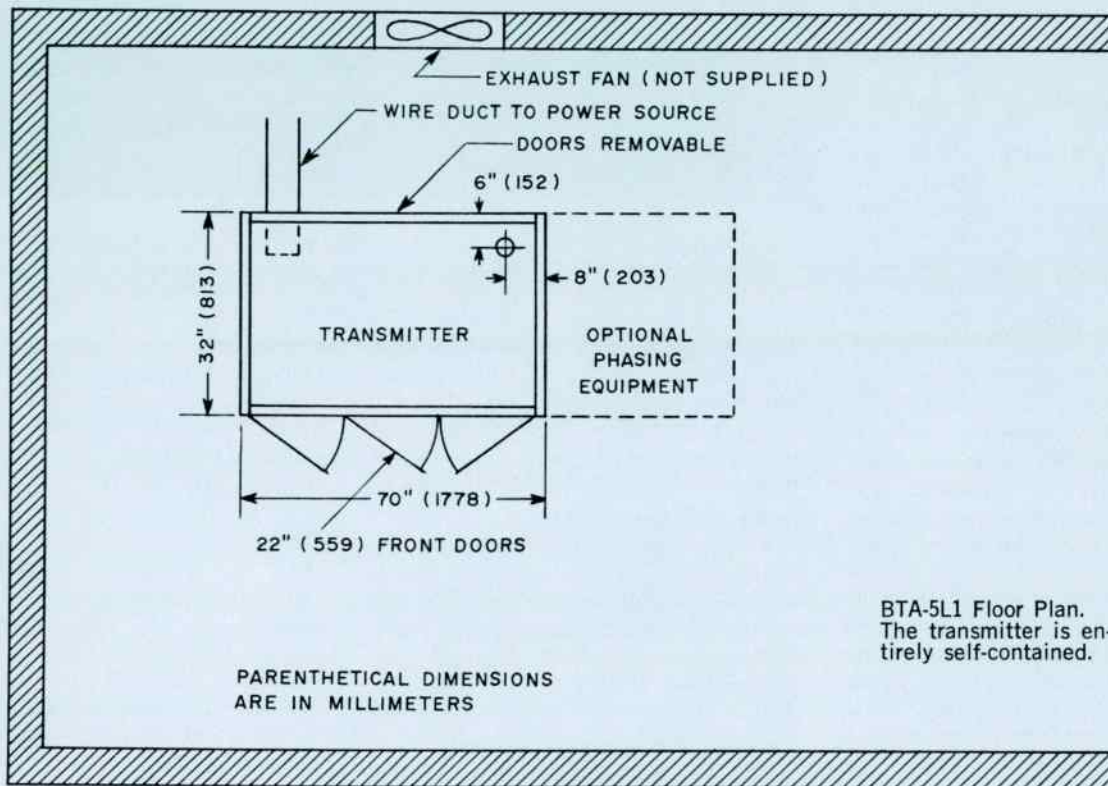

BTA-5L1 Floor Plan.  
The transmitter is entirely self-contained.

PARENTHETICAL DIMENSIONS ARE IN MILLIMETERS

**Specifications**

Power Output (Nominal) .....	5,000 watts
Power Output Capability .....	5,500 watts
AF Input Impedance .....	150/600 ohms
AF Input Level .....	+10 ± 2 dBm
AF Response .....	±1.5 dB 30-15,000 Hz
AF Distortion (95% Mod. 30-10,000 Hz) .....	2.0% max.
Noise (Below 100% Modulation) .....	60 dB
Frequency Range .....	535-1620 kHz
Frequency Stability .....	±2 Hz
Type of Output .....	Unbalanced
Output Impedance .....	40 to 250 ohms
Carrier Shift (0-100% Modulation, 400 Hz) .....	3% max.
Power Source .....	208/240 volts, 3-phase, ±11 volts
Crystal Heater Power .....	117 volts, 50/60 Hz
Power Consumption (Approx.):	
0% Modulation .....	12 kW
Average Modulation .....	14 kW
100% Modulation .....	18 kW
Power Factor .....	90%
Altitude Range .....	0-7500 Ft. AMSL (2286 m)
Ambient Operating Temperature .....	-20° to +45° C.
Tube Complement .....	Two 8122; Two 3CX5000H3
Height .....	77" (1955 mm)

Width .....	70" (1778 mm)
Depth .....	32" (813 mm)
Finish .....	EELM charcoal grey and shadow blue textured vinyl; Aluminum baked enamel
Weight (Approx.) .....	2500 lbs. (1134 kg)
Shipping Data (Approx.) .....	3000 lbs.; 180 ft <sup>3</sup> (1361 kg; 5.1 m <sup>3</sup> )

**Accessories and Options**

Recommended Spare Tubes (Set) .....	ES-560682
Complete Spare Tubes (Set) .....	ES-560680
Spare Crystal Unit, Type TMV-130 (Specify freq.) .....	MI-27493
Conversion Kit, 10 kW Power Output .....	ES-560946
Spare Exciter System, Type BTE-20 .....	ES-560752
Manual Exciter Changeover Panel .....	ES-561305
Power Cutback Kit (Two Power Levels) .....	ES-561009
Power Cutback Kit (Three Power Levels) .....	ES-561009A
Frequency and Modulation Monitor, Type BW-50 .....	MI-560767
RF Amplifier (For BW-50, above), Type BW-60 .....	MI-560762
Transmission Line Protection Kit (VSWR) .....	ES-560961

**Ordering Information**

Five-kW Ampliphase Transmitter, Type BTA-5L1 .....	ES-560676
Dual-Unit Ten-kW Ampliphase Transmitter System .....	Built to Order
Redundant Five-kW Ampliphase Transmitter System .....	Built to Order



## 10 kW Ampliphase AM Transmitter, Type BTA-10L1

- Low-distortion audio
- Solid-state exciter/modulator
- Extra modulation capability
- Designed for remote control
- Only two tube types in entire unit
- No modulation transformer

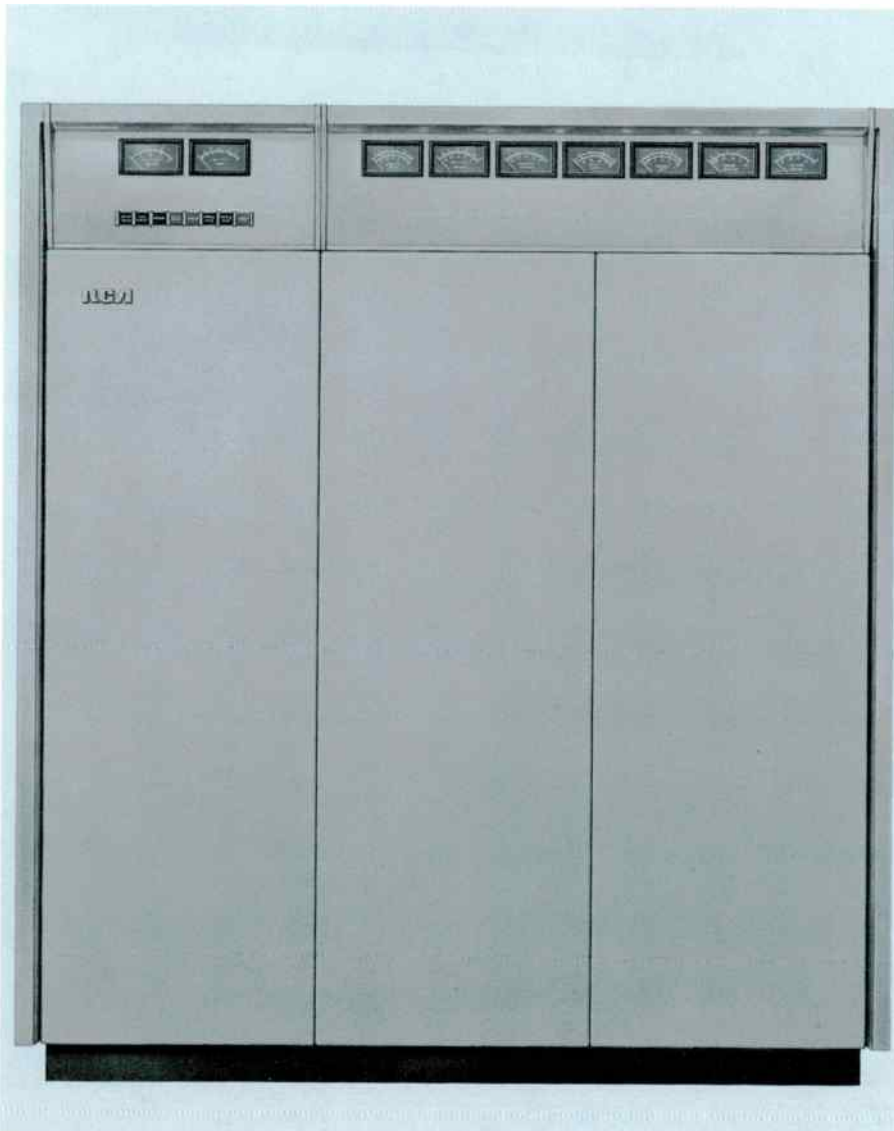

Offering superior audio quality, outstanding reliability and excellent efficiency, the BTA-10L1 is an Ampliphase transmitter for the AM-broadcast (medium-wave) band. The BTA-10L1 delivers 10 kW to the antenna transmission line.

As a result of the Ampliphase system, the BTA-10L1 Transmitter offers extended audio-frequency response at distortion levels well below average perception at enviable operating economy and dependability.

The BTA-10L1 is available also in dual-unit systems for parallel or redundant operation.

In the "parallel" arrangement, the outputs of the two transmitters in the system are combined for a 20-kilowatt power output; in the "redundant" system, one transmitter serves the load while the second operates in hot standby mode.

A special feature of the parallel system is that, in the event of outage in one transmitter, the other transmitter delivers a full ten-kilowatt output to the load.

In the redundant arrangement, an outage in one transmitter or the other automatically connects the operable unit to the load.



## Outstanding Audio Quality

Of particular interest to broadcasters who take pride in station "sound", the BTA-10L1 Transmitter offers outstandingly good audio quality. One reason for this is that the *Ampliphase* system eliminates iron-core high-level modulation components—and their inherent distortions—without adding the instabilities of separate "carrier" and "peak" power amplifiers. Even on ordinary AM radios, the outstanding audio quality of an *Ampliphase* transmitter is immediately apparent.

## Extended Frequency Response

As evidence of the frequency-response characteristics the BTA-10L1 offers, it can put 30 kHz "on-the-air"—at full power—without strain. At the low-frequency end of the spectrum, frequencies below 30 Hz go on-the-air at full level and low distortion. Transformer-equipped transmitters usually cut off below 50 Hz and above 15 kHz.

## Extra Modulation Capability

An advantage unique to the Ampliphase system is its capability for full modulation, even for extended periods, without overload. This is particularly important to stations programming music of high average level and low dynamics. Positive modulation peaks can go as high as 125 percent without transmitter overload. Another unique feature in *Ampliphase* is that it overmodulates without the "splatter" so common to other AM transmitter forms.

## Provision for Spare Exciter/Modulator/Regulator

For those who prefer redundant exciters, the BTA-10L1 Transmitter provides rack space for a spare exciter. Offered as an option, the spare exciter includes switching gear for fast exciter substitution. A spare exciter is particularly valuable to the full-time station in that exciter maintenance is independent of transmitter operation.

## Ready for Remote Control

Because the BTA-10L1 is built for the modern broadcaster it is engineered with remote control in mind. This manifests itself in extra components, wiring and connections fully compatible with remote control equipment carrying the RCA trademark. As a result, operating a BTA-10L1 via remote control requires investment only in control equipment and not in transmitter modification.

## Two Tube Types

Being entirely solid-state at power levels below the IPA stage, the BTA-10L1 Transmitter uses a total of only six power



Front view, doors open. Note exciter unit.

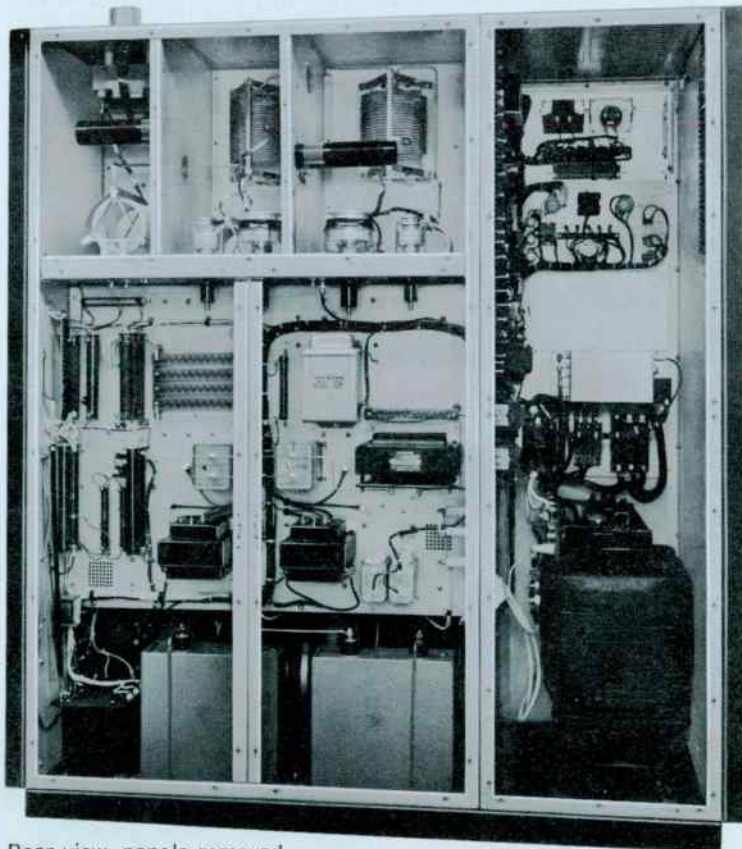

Rear view, panels removed.

tubes: three in each channel. Since these are of only two types, spares inventory need only be two tubes: one of each type. This reduces capital investment in spares and periodic spares rotation.

**No Modulation Transformer**

Using two identical R-F amplifier chains, the BTA-10L1 Transmitters uses phase modulation, at a low level, in such a manner that two phase-modulated carriers mix at the transmitter output to form an amplitude-modulated carrier. Since this system eliminates the modulation transformer and "carrier-peak" amplifiers, it eliminates the most-troublesome stages. This reflects itself in transmitter dependability that virtually eliminates unscheduled transmitter shutdown.

**Faster Troubleshooting**

A feature unique to *Ampliphase* makes routine repair easier. In a sense, a 10-kW *Ampliphase* transmitter is two identical 5-kW facilities in a single cabinet. Consequently, one amplifier chain is an excellent troubleshooting model for the other. Because the operating parameters of the two class-C amplifiers (operating as CW stages) can be quickly compared, the trouble can be easily isolated. Then, it's a simple matter of component replacement.

**Ceramic Insulated PA Tubes**

Ceramic power tubes have earned an enviable reputation among broadcasters



Ampliphase exciter unit. Completely solid-state, this unit is used in all RCA Ampliphase transmitters. Available separately for use as a spare. See Accessories.

for dependability and long life. The tube types selected for the BTA-10L1 operate well below ratings to take full advantage of their performance capabilities and built-in expected life. This pays dividends in low transmitter-operating expenses.

**Fully Self-Contained**

As the result of transistorization, the entire transmitter—including the power supply—fits within a single cabinet that occupies less than 14 square feet (1.3 m<sup>2</sup>) of floor space (see floor plan). This, of course, frees plant area for other productive purposes; office, studio or storage.

**Parallel/Redundant Systems**

The BTA-10L1 transmitter is available also as a parallel/redundant system. This arrangement uses two BTA-10L1 transmitters and a combiner. In the "parallel"

system, both transmitter outputs are combined to provide 20 kilowatts to the load. Should one transmitter or the other have trouble, the operable transmitter continues to supply the load while the troubled transmitter is automatically switched from the antenna to a built-in dummy load.

In the redundant arrangement, one transmitter ordinarily feeds the antenna system while the other operates as a hot standby into a dummy load. Should the "air" unit fail, the system automatically connects the standby unit to the load and the troubled transmitter to the dummy load.

Further details are available from Aural Broadcast Marketing, RCA Building 2-2, Camden, N. J., 08102, U.S.A.

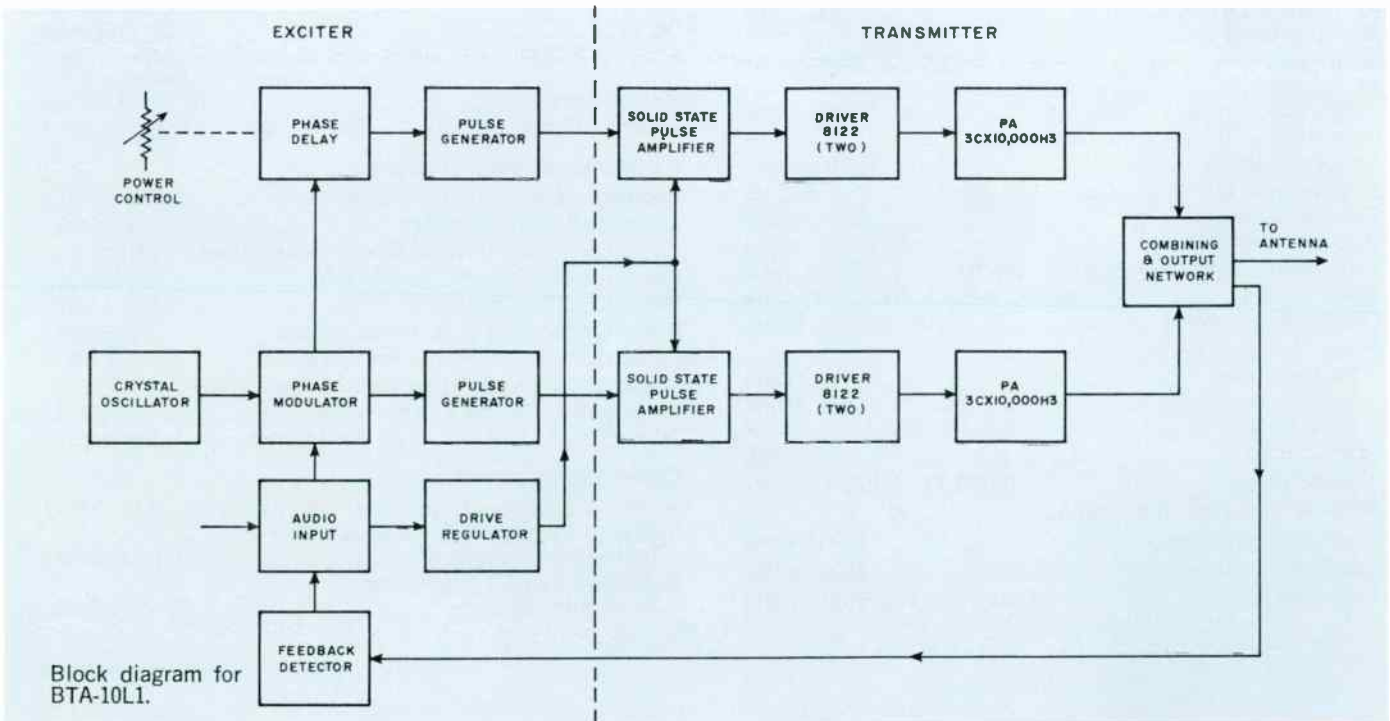

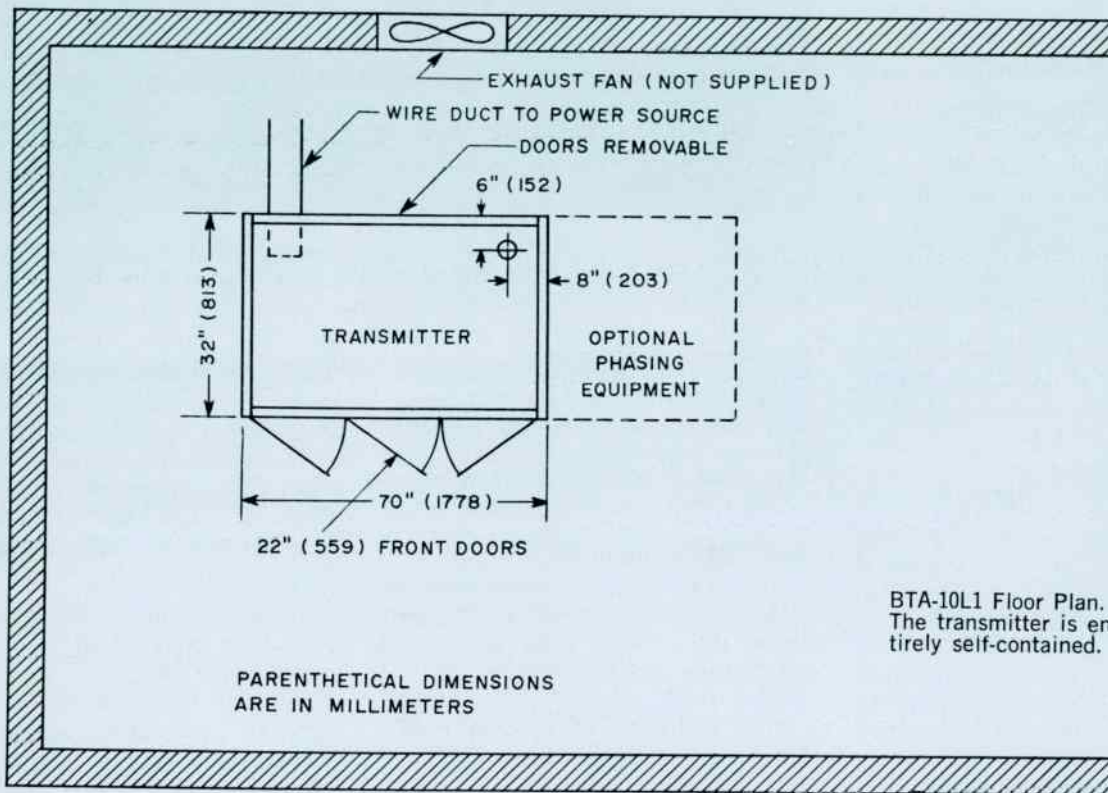

BTA-10L1 Floor Plan.  
The transmitter is entirely self-contained.

PARENTHETICAL DIMENSIONS ARE IN MILLIMETERS

**Specifications**

AF Input Impedance .....	150/600 ohms
AF Input Level .....	+10 ±2 dBm
AF Response .....	±1.5 dB 30-15,000 Hz
AF Distortion (95% Modulation 30-10,000 Hz) .....	Less than 2.0%
Noise (Below 100% Modulation) .....	60 dB
Frequency Range .....	535-1620 kHz
Frequency Stability .....	±2 Hz
Type of Output .....	Unbalanced
Output Impedance .....	40 to 250 ohms
Carrier Shift (0-100% Modulation, 400 Hz) .....	3% max.
Power Source .....	208/240 volts, 3-phase, ±11 volts
Crystal Heater Power .....	117 volts, 50/60 Hz
Power Consumption (Approx.):	
0% Modulation .....	17 kW
Average Modulation .....	21 kW
100% Modulation .....	29 kW
Power Factor .....	90%
Altitude Range .....	0-7500 Ft. AMSL (2286 m)
Ambient Operating Temperature .....	-20° to +45° C.
Power Output (Nominal) .....	10,000 watts
Power Output Capability .....	11,000 watts
Tube Complement .....	Four 8122; Two 3CX10,000H3

Height .....	77" (1955 mm)
Width .....	70" (1778 mm)
Depth .....	32" (813 mm)
Finish .....	EELM charcoal grey and shadow blue textured vinyl; Aluminum baked enamel
Weight (Approx.) .....	2700 lbs. (1224 kg)
Shipping Data (Approx.) .....	3200 lbs.; 180 ft <sup>3</sup> (1452 kg; 5.1 m <sup>3</sup> )

**Accessories and Options**

Recommended Spare Tubes S(et) .....	ES-560681
Complete Spare Tubes (Set) .....	ES-560679
Spare Crystal Unit, Type TMV-130 (Specify freq.) .....	MI-27493
Spare Exciter System, Type BTE-20 .....	ES-560752
Manual Exciter Changeover Panel .....	ES-561305
Power Cutback Kit (Two Power Levels) .....	ES-561009
Power Cutback Kit (Three Power Levels) .....	ES-561009A
Frequency and Modulation Monitor, Type BW-50 .....	MI-560767
RF Amplifier (For BW-50, above), Type BW-60 .....	MI-560762
Transmission Line Protection Kit (VSWR) .....	ES-560961

**Ordering Information**

Ten-kW Ampliphase Transmitter, Type BTA-10L1 .....	ES-560677
Dual-Unit Twenty-kW Ampliphase Transmitter System .....	Built to Order
Redundant Ten-kW Ampliphase Transmitter System .....	Built to Order



## 50 kW "Ampliphase" AM Transmitter, Type BTA-50J

- Excellent audio quality
- All solid-state exciter
- Only six tubes, three types
- High modulation capability

An AM transmitter with FM quality, the Type BTA-50J uses phase modulation in a way that results in high quality AM. The transmitter includes a fully solid-state exciter and modulator. "Ampliphase" applies modulation at a low level and uses Class C power amplifiers to provide the 50-kW output.





Compact in-line construction of BTA-50J showing left to right, left hand power amplifier, exciter, right hand power amplifier, and rectifier-control cubicle.

The RCA Type BTA-50J AM Broadcast Transmitter is a completely air-cooled, 50-kW phase-to-amplitude modulated transmitter designed for high fidelity transmission in the standard broadcast band (535 kHz to 1620 kHz). It provides a signal of exceptionally low distortion and extended frequency response. Measured response is flat within  $\pm 3$  dB from 35 Hz to 25,000 Hz. The equipment is capable of being modulated over the frequency range of 10 Hz to 30,000 Hz. Frequency response has been extended largely through the elimination of unnecessary transformers in the audio system as well as improved circuitry.

Low harmonic distortion with negligible carrier shift at maximum signal output has been achieved in the BTA-50J by selection of adequate power tube types and advanced solid state circuits in the exciter-modulator-drive regulator de-

sign throughout the entire equipment. The design features an inherently linear system capable of continuous high modulation levels impervious to inadvertent overmodulation. For example, the transmitter may be modulated 100 percent at any frequency between 30 and 15,000 Hz continuously for many hours without detrimental effects to any of the component parts. A small amount of overall feedback is incorporated to provide the exceptional performance. With the feedback circuit removed, the BTA-50J still meets FCC specifications for audio frequency response, harmonic distortion and noise.

#### Lowest Operating Cost in 50-kW Transmitters

A number of new refinements as well as time tested features which have proven their worth are incorporated in this modern 50-kW transmitter. Power requirements are moderate for the equipment.

Power amplifier plate efficiency of the order of 75 to 80 percent is obtained.

Fewer major components, as compared to those required by many 50-kW transmitters, are used in the BTA-50J. In addition to the low cost of operation of the transmitter a power-cutback kit can be added which permits operation at 10 kW. (Other power levels available on special order.)

#### Dual RF Chains

Two identical RF chains, each developing 25 kW, are incorporated in this equipment. Since they are identical, servicing is made easy by comparison of the two chains. Components are directly interchangeable, which allows substitution for comparison purposes. All components are easily accessible which results in a minimum schedule for maintenance. In addition, fewer replacement parts are required for adequate protection against lost air

time should a failure occur. Low power consumption, fewer major components and a reduced maintenance schedule make the BTA-50J operation cost the lowest.

### Ready for Remote Control

Designed with unattended remote control in mind, the BTA-50J includes the components, wiring and connections to make it completely compatible with either of two RCA remote control systems (see *Accessories*). Such components as meter shunts, motorized controls and switching devices make remote control more efficient and dependable.

### Lightweight Type 6697 Tubes in Final PA

One Type 6697 power amplifier tube is used in each of the two RF chains. Each amplifier tube is capable of delivering in excess of the normal 25 kW of modulated power to the common load. The Type 6697 is rated at 35 kW dissipation and under average modulation conditions it is only required to dissipate approximately 14 kW. Operation of the PA tubes so far below their maximum ratings assures long tube life. In addition, the 6697 is physically small in size and weighs only 43 pounds. One person, without the aid of mechanical assistance, can quickly and easily replace any tube in the transmitter.

One Type 4CX5000A tube is used in each of the driver stages in the two RF chains. The 4CX5000A is also operated well below its maximum ratings and gives long trouble free service. The only other tubes used in the transmitter are the two Type 4-250A intermediate power-amplifier tubes. Solid-state design extends into the monitor circuitry as well. Tube complement is such that inventory cost for required spares is kept at a minimum while adequate outage protection is maintained.

### Solid State Rectifiers Used Throughout

All power supplies utilize solid state rectifiers. The plate supplies, bias supply and low-voltage supply use silicon units, very conservatively rated to assure long life. The current rating of the units is such that any conceivable load fault is cleared without jeopardizing the diode units. The use of solid state rectifiers permit the transmitter to operate in ambient temperatures as low as  $-20$  degrees centigrade.

### FCC and CCIR Harmonic Suppression

A completely shielded two section low pass filter is incorporated in the BTA-

50J. It consists of one  $\pi$  ( $\pi$ ) section and one  $T$  section and each inductive series element is completely shielded. Two series-tuned, shunt-connected traps are used to provide added attenuation of the second harmonic.

### Transmitter Equipment

Type BTA-50J AM Broadcast Transmitter consists of four equipment cabinets, two of which house the power amplifiers, one the exciter unit and the fourth cabinet the rectifier and control unit. The high-voltage reactor is housed in the lower rear compartment of the exciter cabinet, with the IHV plate transformer in the lower rear compartment of the rectifier and control cabinet.

Each of the four transmitter cabinets measure 44 inches wide by 60 inches deep by 84 inches high, and consists of an all aluminum cubicle erected on a welded steel base. This cubicle consists of a series of panels fabricated and assembled to form a rigid structure. The use of aluminum eliminates unnecessary weight and provides excellent shielding to assure effective confinement of spurious energy. Maximum accessibility to all transmitter components are afforded by 28-inch wide, six-foot front doors, while rear access is through two covers attached with quick-disconnect fasteners for easy removal.

A center vertical panel separates the cabinet into a front compartment and rear compartment which is further divided by a rear horizontal shelf into upper and lower compartments, giving each cabinet three basic totally shielded compartments in which to mount the electrical components. The eye-level meters, pilot lights and interlocks, mounted on eight-inch wide panels flanking each of the front doors, are also shielded.

In the rear at the top of each cabinet is a built-in wire duct. It joins similar ducts of adjacent cabinets to form a continuous duct on the four cabinets. This duct has a divider down the center on which the interconnection terminal boards are mounted. The rear half of the duct is used for interconnection wiring while the front half is used for internal cabinet wiring from the terminal boards. The internal wiring is carried through conduits to its destination in the cabinet thus shielding all power and control wiring from RF fields. Provision is also made at the top of the cabinets for the addition of an exhaust air duct.

### Power Amplifiers

The first cabinet and the third cabinet from the left end are identical and

contain the final power amplifier stages. The 6697 tube and its grid circuits and part of the plate circuits are contained in the front portion of the cabinet. The upper rear section contains the plate tank coil, filament transformer and grid leak resistors. The lower rear section contains a low-noise blower which cools the 6697 tube and its cabinet and the adjacent half of the exciter cabinet. The two 6697 power amplifiers are designed to supply equal amounts of power to the output network. Because of the balanced dissipation in the two 6697 PA tubes, less air pressure with resultant lower air flow is required for adequate cooling of the power amplifier cubicles. The lower rear panel contains an impingement type air filter for the blower. The PA cabinets are constructed so that the blowers and filters can be mounted externally to the cabinets, if so desired.

The PA output circuit is a conventional pi-network type of tank circuit. Each tube has its own tank circuit, with a common output shunt element. Each network is adjusted to provide the proper load to the power amplifiers.

### Solid-State Exciter-Modulator, Drive Regulator

Packaged in a series of four plug-in modules, the Ampliphase exciter-modulator uses a crystal-controlled, field-effect-transistor oscillator, a solid-state drive regulator, modulator and power supply. The entire assembly occupies only  $5\frac{1}{4}$  inches (133 mm) of rack space in the left-of-center cabinet (see photo, facing page). As a result of untuned, digital-integrated circuits, the exciter-modulator is set up with but three trimmer adjustments. The RF chains in the exciter operate without tuned circuits.

The drive regulator circuitry uses entirely solid-state electronic devices; the regulator samples the audio, amplifies the sample and applies it to the grid circuits of the twin driver stages so as to adjust final amplifier drive in step with the level of the modulating audio. This system contributes significantly to the exceptional linearity of the *Ampliphase* system.

### Solid-State Reflectometer

The far-right module in the exciter-modulator unit is a solid-state reflectometer that protects the transmitter from transmission line and/or antenna irregularities. The reflectometer senses changes in the voltage/current ratio on the load.

A large change in load characteristics causes the reflectometer system to momentarily interrupt the drive (to let the fault clear, if transient). If the fault persists



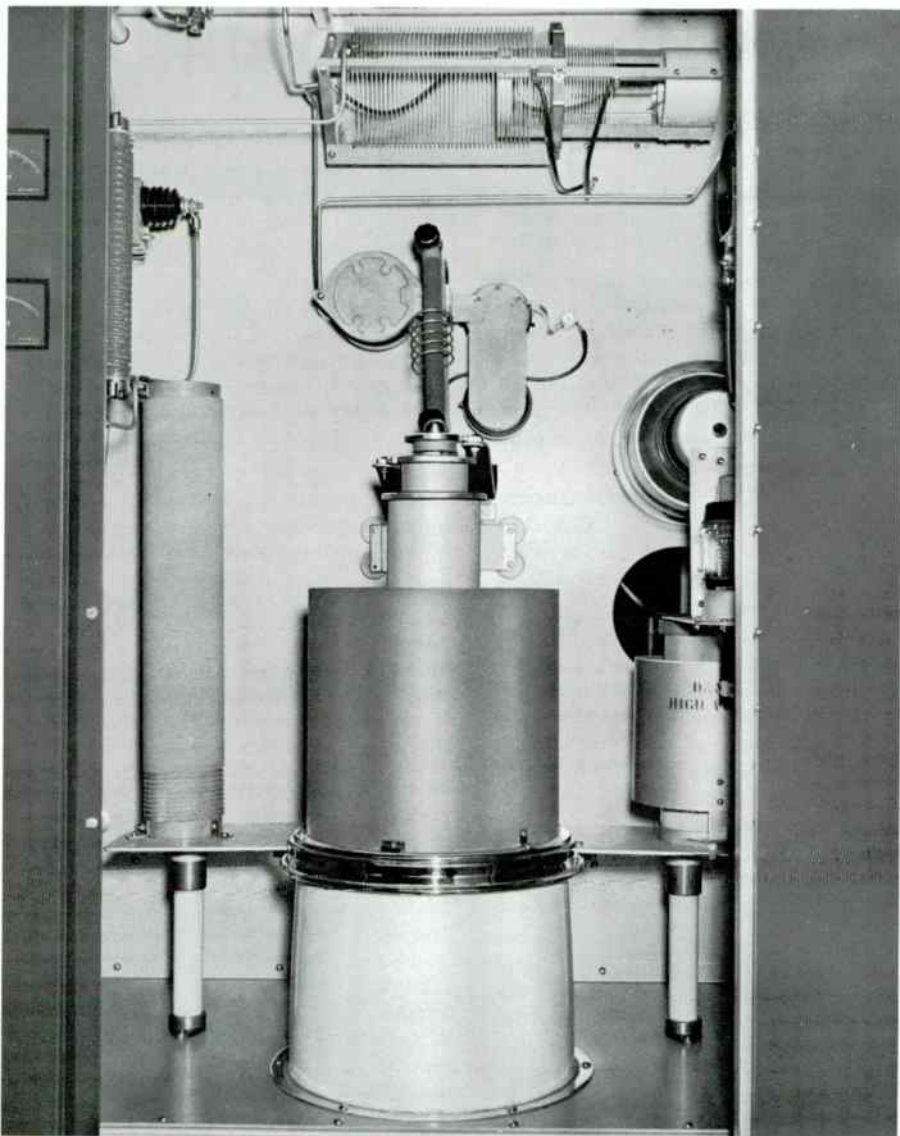

Close-up view of one of the dual final power amplifier stages. The new type 6697 tube together with grid circuits and part of the plate circuits are readily accessible from the front of the transmitter.

after several cycles, the reflectometer shuts down the transmitter thereby reducing the possibility of chain-reaction damage to any part of the system.

Above the exciter-modulator are two vertical sub-compartments, behind interlocked doors, which contain the 4CX5000A driver stages. A meter panel for these stages is located beneath the sub-compartments.

The common output capacitors of the two PA tanks and the harmonic filter are located in the upper rear of the cabinet. Sub-partitions are so arranged in this section that complete isolation and shielding is effected between the various sections of the filter and the output capacitor. The lower rear section of this cabinet contains high voltage filter reactor and driver dc filament supplies.

### Provisions for Standby Operation

Space is provided in the exciter cabinet for the mounting of a second exciter-modulator unit. Each of the modulator-exciter units are complete and arranged so that either may be selected instantly by means of cutover switches. Thus, while one modulator is in operation, the other modulator is in standby condition. These provisions, with the extreme reliability designed into the high-power stages, essentially provide a second 50-kW transmitter for standby service.

### Rectifier and Control Unit

The far right cabinet contains the high power rectifiers, low power distribution components, and the majority of the control components. The front portion of the cab-

inet contains the solid state 15-kV, 5-kV plate supplies and the low-voltage bias supplies. Also included here are the high-voltage grounding switches and the 15-kV filter capacitors. The top rear section of the cabinet contains control relays, overload relays, distribution contactors, and low-power distribution circuit breakers. The distribution breakers and overload relays are readily accessible, recessed so that they will not be damaged or improperly operated. The bottom rear of the cabinet contains the 5-kV rectifier components including plate transformer.

### Solid-State Power Supplies

During periods of 100 percent modulation, the 6697 power amplifier tubes require 15-kV dc at 7.5 amperes, which is obtained from a three-phase, full-wave rectifier circuit. Two other plate voltages, 5-kV and 1-kV, are provided by separate supplies. Bias voltages for all tubes are supplied by an additional supply. The high-power distribution equipment for the transmitter consists of an electrically operated air circuit breaker, and a manually operated delta-wye switch for the 15-kV rectifier. The remaining transmitter power is distributed through a manually operated distribution circuit breaker to a 460- to 230-volt distribution transformer to voltage regulators and thence to the various low power distribution circuit breakers.

### Transmitter Control

Control circuits in the BTA-50J contain a number of features which are designed to provide maximum flexibility in control, protection and operation. Among these are choice of single-button or step-by-step starting, automatic timing and sequencing of starting operations, and location of transmitter faults by a system of indicators. Protection of the operator is achieved by a system of interlocking grounding devices; protection of the equipment by conventional relays and circuit breakers.

Control of the transmitter is accomplished from the front of the rectifier and control cabinet. All necessary wiring to allow control from a remote location or console has been provided. Lamps, which show the status of the transmitter control circuits, are also mounted on the front of this cabinet. The control ladder is arranged and interlocked so that the BTA-50J can either be turned on by operating the control switches in sequence or by leaving all control switches in the "on" position with the exception of the start switch which, when operated to the "on"



Upper rear of exciter cabinet showing the combining and output networks.

position, allows the transmitter to come on automatically.

The two types of overload circuits used in this transmitter are the current type, instantaneous or time delay, that are connected directly in the tube circuit and rectifier ground leads, and the thermal magnetic circuit breakers connected in the a-c power leads used as back up protection and disconnect switches. The transmitter circuitry is arranged so that an overload either locks out the plate circuit or allows a single reclosure that resets if there are no further overloads. In either case, when a lockout position is reached, the transmitter resets by means of an Overload Reset control. The principal overload relays have indicating flags so that, even after the overload has cleared, there is a record of which overload relay operated. Another feature of the control circuit is the indicator lamps on each cabinet that indicate the interlock status in that particular cabinet.

### Installation and Layout

Outstanding features of the BTA-50J are the small floor space requirements

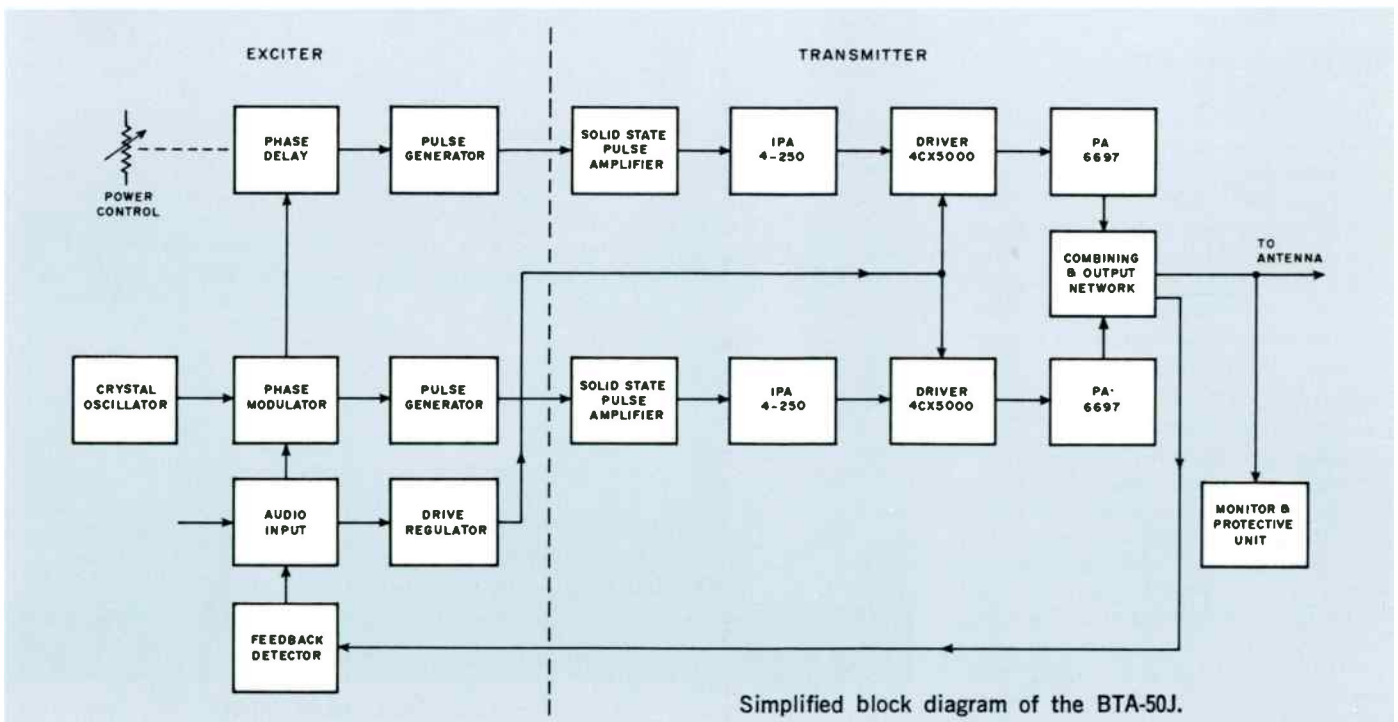

and ease of installation. In general, the transmitter layout consists of three basic units: the four, in-line cabinets which contain the major part of the transmitter; the wall-mounted switchgear components and the main plate transformers. The floor plan illustrates a typical layout of the complete equipment. Elimination of the need for under-floor cable trenches and considerable reduction in external air ducts, simplifies installation and reduces costs.

As shown in the layout, it is desirable to leave a passageway at the right end of the frontline cabinets since the circuit breakers and overload relays are most accessible from this end of the transmitter. The layout of the front line cabinets is such that a common exhaust duct can be used to carry off heated air from the transmitter.

Wall mounting of the switchgear as shown on the overall floor plan is suggested to make the BTA-50J most adaptable to existing transmitter buildings. The mounting of these components, however, is not critical as to location. They can be mounted in existing power distribution areas if desired. These components include the main plate circuit breaker, a delta-wye switch, a distribution circuit breaker, a 460- to 230-volt bank of distribution transformers, and two single-phase open delta connected regulators with their control panels. These components are wired through conduit and overhead ductwork to the main plate transformers and the transmitter cabinets.

### Parallel/Redundant System

The BTA-50J is available also as a parallel/redundant transmitter system. This system consists of two identical BTA-50J transmitters and a combiner. In the "parallel" mode, the twin fifty-kilowatt outputs are combined to provide 100 kilowatts of power to the antenna system; in the "redundant" mode, the system operates one of the two transmitters as a hot standby while the other feeds the antenna system.

In either operational mode, the parallel/redundant system assures greater on-air dependability. For example, an outage in one transmitter or the other automatically switches the troubled transmitter to a dummy load while the operable one feeds a full fifty kilowatts to the antenna system. This action is the result of a special-design combiner with essentially zero insertion loss. Further details of the BTA-50J parallel/redundant transmitter system are available from Aural Broadcast Equipment Marketing, RCA Building 2-2, Camden, N. J. 08102, U.S.A.



Front view of the exciter-modulator cabinet containing all sections from oscillator through driver stages.



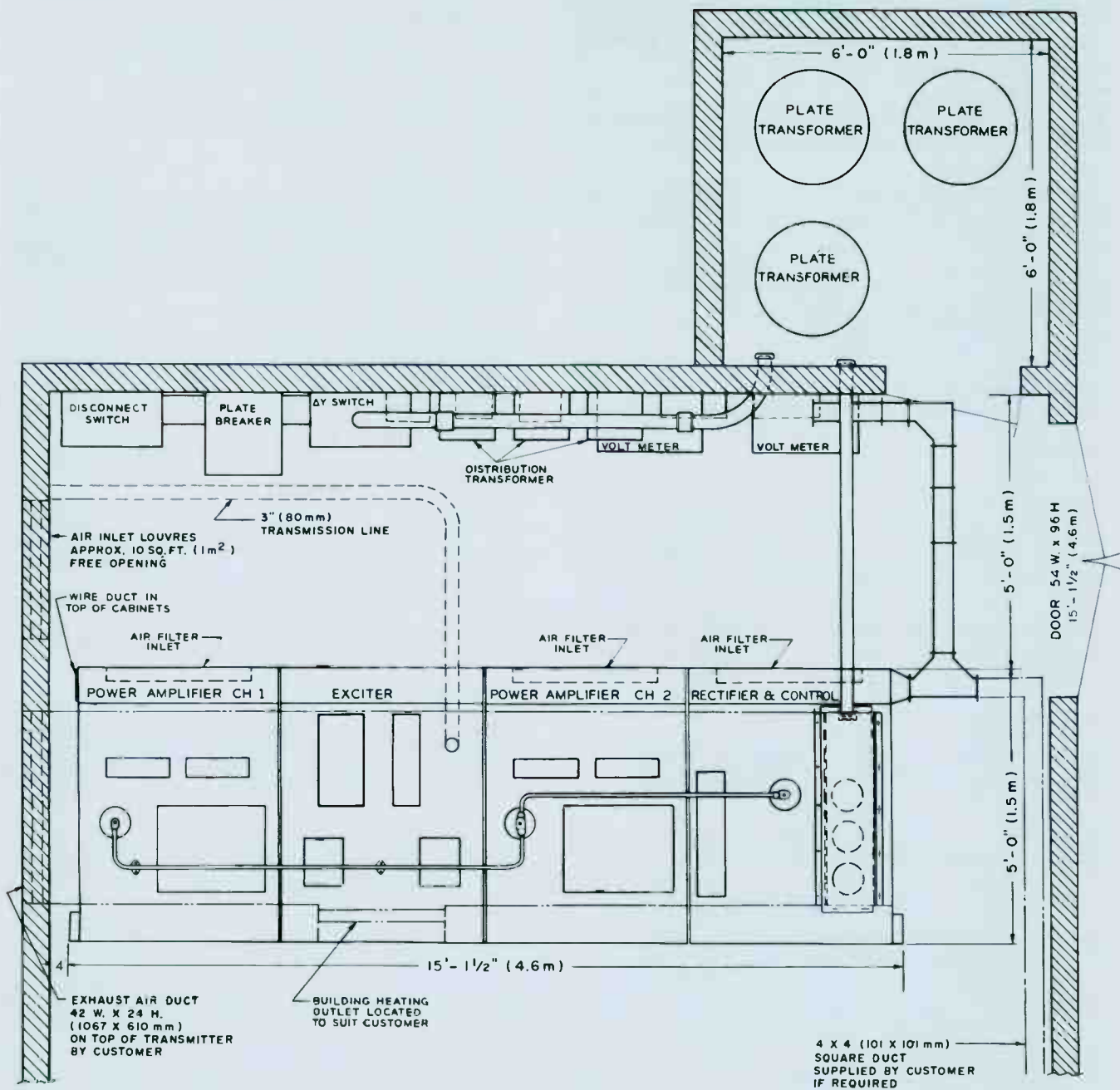

Typical floor plan for the BTA-50J Transmitter.

## Specifications

### General

Power Line Requirements:	
Line	460 V, 50/60 Hz, 3 phase <sup>1</sup>
Combined Regulation and Variation	Not more than $\pm 5\%$
Power Consumption	96 kW (approx.) at zero modulation; 100 kW (approx.) at average modulation
Power Factor	90% min.
Crystal Heater Power	110 V
Type of Emission	A3
Power Output (at transmitter terminals)	56 kW (max.) <sup>2</sup>
Frequency	Any specified between 535 and 1620 kHz
Frequency Stability	$\pm 2$ Hz
Type Modulation (High Level)	Phase to amplitude
AF Input Impedance	150/600 ohms
Audio Input Level	+10 $\pm 2$ dBm
Audio Response	$\pm 1.5$ dB 30–10,000 Hz
AF Distortion	Less than 3% RMS 50–7500 Hz
Noise Level (Below 100% modulation)	60 dB
Carrier Shift (Neg. 100% modulation)	5% max.
Type Output	Unbalanced
Output Impedance	50 ohms <sup>2</sup>
Spurious Emission (2nd Harmonic and above)	-83 dB

### Mechanical

Cabinet Size	44" W, 84" H, 63" D (1118, 2134, 1600 mm)
Overall Weight (approx.)	11,500 lbs. (5216 kg) <sup>3</sup>
Maximum Altitude	7500 ft. (2286 m)
Ambient Temperature	-20°C +45°C
PA Cabinet Weights (each) (approx.)	953 lbs. (432 kg)
Plate Transformer Weight (each) (approx.)	820 lbs. (372 kg)
Rectifier Cabinet Weight (approx.)	3,093 lbs. (1403 kg)
Exciter Cabinet Weight (approx.)	1,041 lbs. (472 kg)
Filter Reactor Weight (approx.)	570 lbs. (259 kg)

<sup>1</sup> Other line voltages available on request.

<sup>2</sup> Other output impedances available on request.

<sup>3</sup> Operation at higher altitude available on request.

<sup>4</sup> Cutback to other power levels available on request.

\* Available in 100- and 200-kW systems as Types BTA-100J and BTA-200J.

### Shipping Data

Weight, Domestic Packing (approx.)	13,500 lbs. (6124 kg)
Weight, Export Packing (approx.)	14,000 lbs. (6350 kg)

### Tube Complement

Intermediate Power Amplifier:	Type 4-250A
Driver Amplifier:	Type 4CX5000A
Power Amplifier:	Type 6697

### Accessories

Spare Solid-State Exciter-Modulator	ES-560752
Complete Set of Operating Tubes	ES-27222E
Recommended Spare Set of Tubes	ES-27223D
Spare Crystal Unit, Type TMV-130B (Specify Frequency)	MI-27493
Type BTR-30 Remote Control (30 Functions)	MI-561446
Type BTR-15 Remote Control (15 Functions)	MI-561157/58
50/10-kW Cutback Kit	MI-27688C <sup>4</sup>
Dummy Load	ES-34234
BPA-50 Antenna Tuner (230 ohms)	ES-28903
BPA-50 Antenna Tuner (70/51.5 ohms)	ES-28903
Remote RF Pickup Unit	MI-28027
Type BW-50 Frequency and Modulation Monitor	MI-560767
Type BW-60 RF Amplifier	MI-560762

### Ordering Information

50-kW AM Broadcast Transmitter, Type BTA-50J, with two crystals, remote meter, one set of operating tubes, silicon rectifiers, and one exciter. Antenna tuning unit not included. (Specify operating frequency)	ES-272221D
--	------------



## 100 kW "Ampliphase" Medium-Wave, AM Transmitter, Type BTA-100J

- Excellent audio quality
- All solid-state exciter
- Only eight tubes, three types
- High modulation capability

An AM transmitter with FM quality, the Type BTA-100J uses phase modulation in a way that results in high fidelity AM. The transmitter includes a fully solid-state exciter and modulator. "Ampliphase" applies modulation at a low level and uses Class C, continuous-wave power amplifiers to provide the 100-kW output.

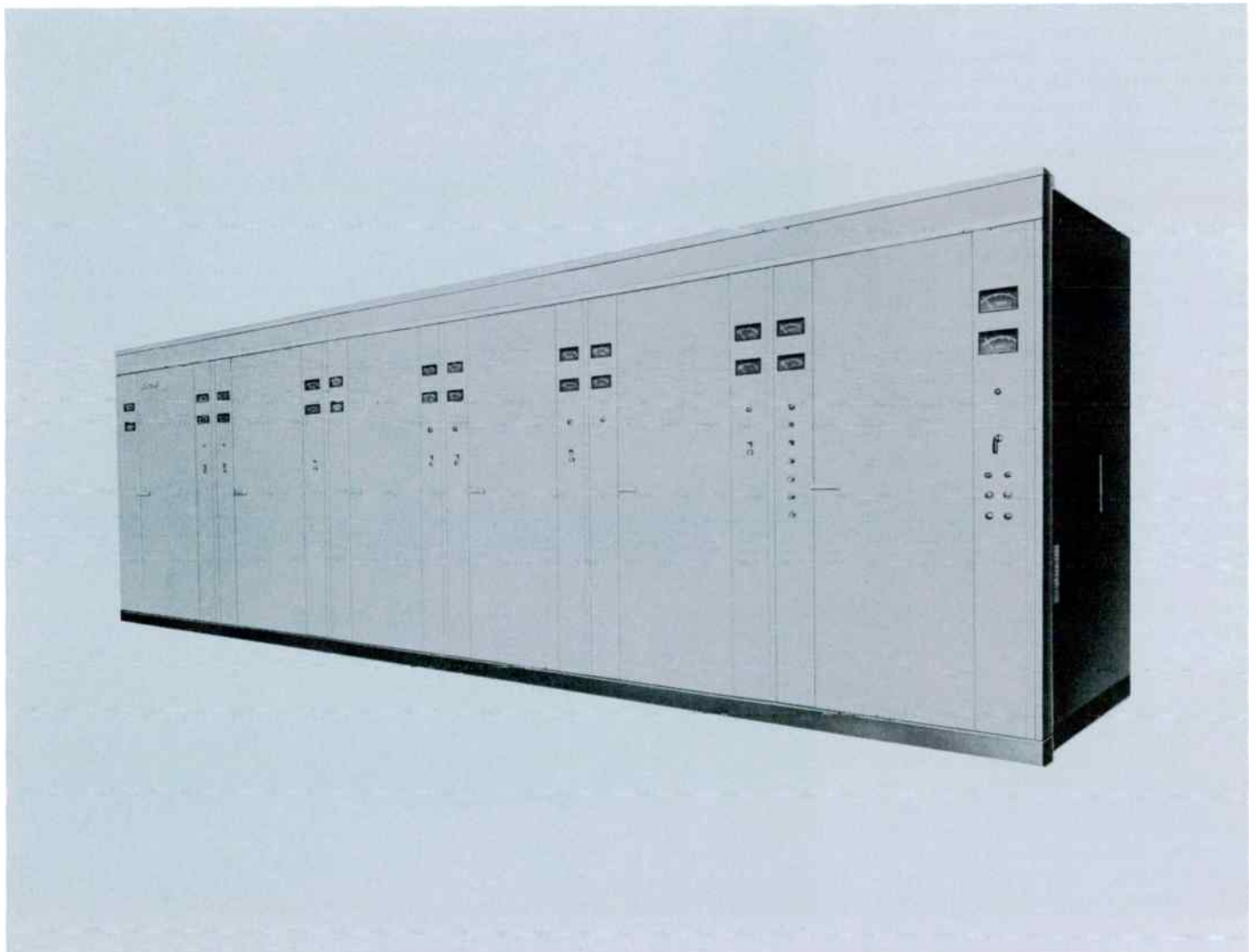

The RCA Type BTA-100J AM Broadcast Transmitter is a completely air-cooled, 100-kW phase-to-amplitude modulated transmitter designed for high fidelity transmission in the standard broadcast band (535 kHz to 1620 kHz). It provides a signal of exceptionally low distortion and extended frequency response. Measured response is flat within  $\pm 3$  dB from 35 Hz to 25,000 Hz. The equipment is capable of being modulated over the frequency range of 10 Hz to 30,000 Hz. Frequency response has been extended largely through the elimination of unnecessary transformers in the audio system as well as improved circuitry.

Low harmonic distortion with negligible carrier shift at maximum signal output has been achieved in the BTA-100J by selection of adequate power tube types and advanced solid state circuits in the exciter-modulator-drive regulator design throughout the entire equipment. The design features an inherently linear system capable of continuous high modulation levels impervious to inadvertent overmodulation. For example, the transmitter may be modulated 100 percent at any frequency between 30 and 15,000 Hz continuously for many hours without detrimental effects to any of the component parts. A small amount of overall feedback is incorporated to provide the exceptional performance.

#### Lowest Operating Cost in 100-kW Transmitters

A number of new refinements as well as time tested features which have proven their worth are incorporated in this modern 100-kW transmitter. Power requirements are moderate for the equipment. Power amplifier plate efficiency in the order of 75 to 80 percent is obtained.

Fewer major components, as compared to those required by many 100-kW transmitters, are used in the BTA-100J. In addition to the low cost of operation of the transmitter a power-cutback kit can be added which permits operation at 50 kW. (Other power levels available on special order).

#### Dual RF Chains

Two identical RF chains, each developing 50 kW, are incorporated in this equipment. Since they are identical, servicing is made easy by comparison of the two chains. Components are directly interchangeable, which allows substitution for comparison purposes. All components are easily accessible which results in a minimum schedule for maintenance. In addition,

fewer replacement parts are required for adequate protection against lost air time should a failure occur. Low power consumption, fewer major components and a reduced maintenance schedule make the BTA-100J operation cost the lowest.

#### Ready for Remote Control

Designed with unattended remote control in mind, the BTA-100J includes the components, wiring and connections to make it completely compatible with either of two RCA remote control systems (see *Accessories*). Such components as meter shunts, motorized controls and switching devices make remote control more efficient and dependable.

#### Lightweight Type 6697 Tubes in Final PA

Two Type 6697 power amplifier tubes are used in each of the two RF chains.

Each final amplifier is capable of delivering in excess of the normal 50 kW of modulated power to the common load. The Type 6697 is rated at 35 kW dissipation and, under average modulation conditions, is only required to dissipate approximately 14 kW. Operation of the PA tubes so far below their maximum ratings assures long tube life. In addition, the 6697 is physically small in size and weighs only 43 pounds (20 kg). One person, without the aid of mechanical assistance, can quickly and easily replace any tube in the transmitter.

One Type 4CX5000A tube is used in each of the driver stages in the two RF chains. The 4CX5000A is also operated well below its maximum rating and gives long trouble free service. The only other tubes used in the transmitter are the two Type 4-250A intermediate power-amplifier tubes. Solid-state design extends into the monitor circuitry as well. Tube

Close-up view of one of the dual final power amplifier stages. The new type 6697 tube together with grid circuits and part of the plate circuits are readily accessible from the front of the transmitter.

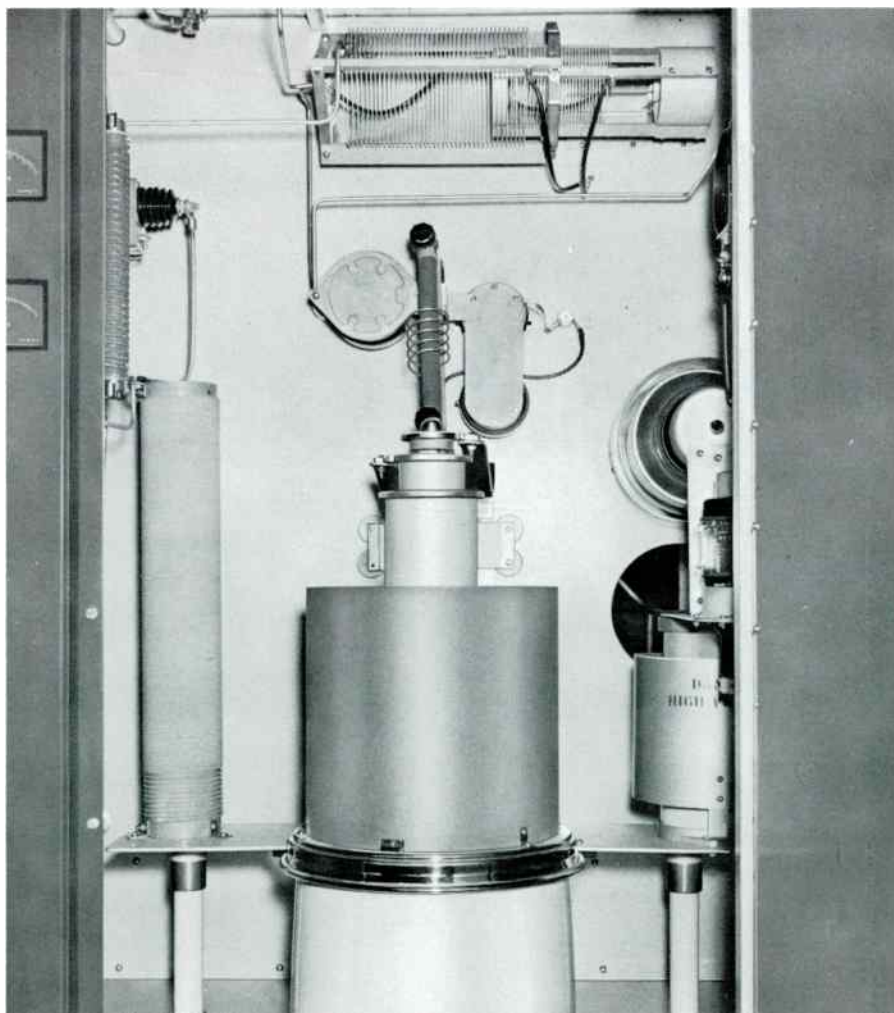



complement is such that inventory cost for spares is kept at a minimum while adequate outage protection is maintained.

### Solid State Rectifiers Used Throughout

All power supplies utilize solid state rectifiers. The plate supplies, bias supply and low-voltage supply use silicon units, very conservatively rated to assure long life. The current rating of the units is such that any conceivable load fault is cleared without jeopardizing the diode units. The use of solid state rectifiers permit the transmitter to operate in ambient temperatures as low as  $-20$  degrees centigrade.

### FCC and CCIR Harmonic Suppression

A completely shielded two section low pass filter is incorporated in the BTA-100J. It consists of one  $\pi$  ( $\pi$ ) section and one  $T$  section and each inductive series element is completely shielded. Two series-tuned, shunt-connected traps are used to provide added attenuation of the second harmonic.

### Operated in Parallel

Type BTA-100J Medium-Wave Transmitter consists of six equipment cabinets, four of which house the power amplifiers, one the exciter unit and the sixth cabinet, the rectifier and control unit.

Each of the six transmitter cabinets measure 44 inches wide by 60 inches deep by 84 inches high, (1118, 1524, 2133 mm) and consists of an all aluminum cubicle erected on a welded steel base. This cubicle consists of a series of panels fabricated and assembled to form a rigid structure. The use of aluminum eliminates unnecessary weight and provides excellent shielding to assure effective confinement of spurious energy. Accessibility to all transmitter components is through 28-inch (711 mm) wide, six-foot (1.8 m) front doors, while rear access is through two covers attached with quick-disconnect fasteners for easy removal.

A center vertical panel separates the cabinet into a front compartment and rear compartment which is further divided by a rear horizontal shelf into upper and lower compartments, giving each cabinet three basic totally shielded compartments in which to mount the electrical components. The eye-level meters, pilot lights and interlocks, mounted on eight-inch wide panels flanking each of the front doors, are also shielded.

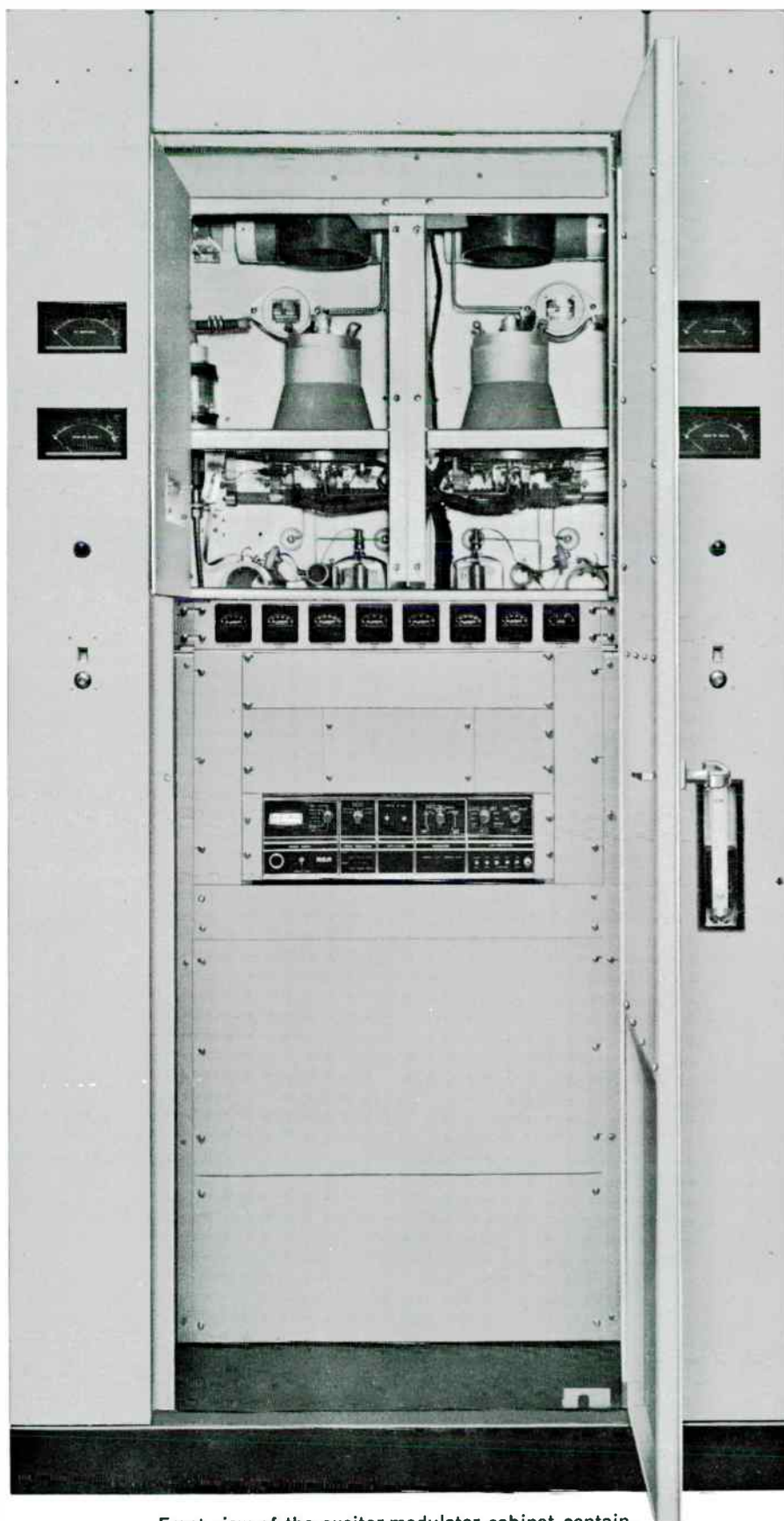

Front view of the exciter-modulator cabinet containing all sections from oscillator through driver stages.



Exciter/modulator unit. Completely solid-state, this unit is used in all RCA Amphiphase transmitters. Available separately for use as a spare. See Accessories.

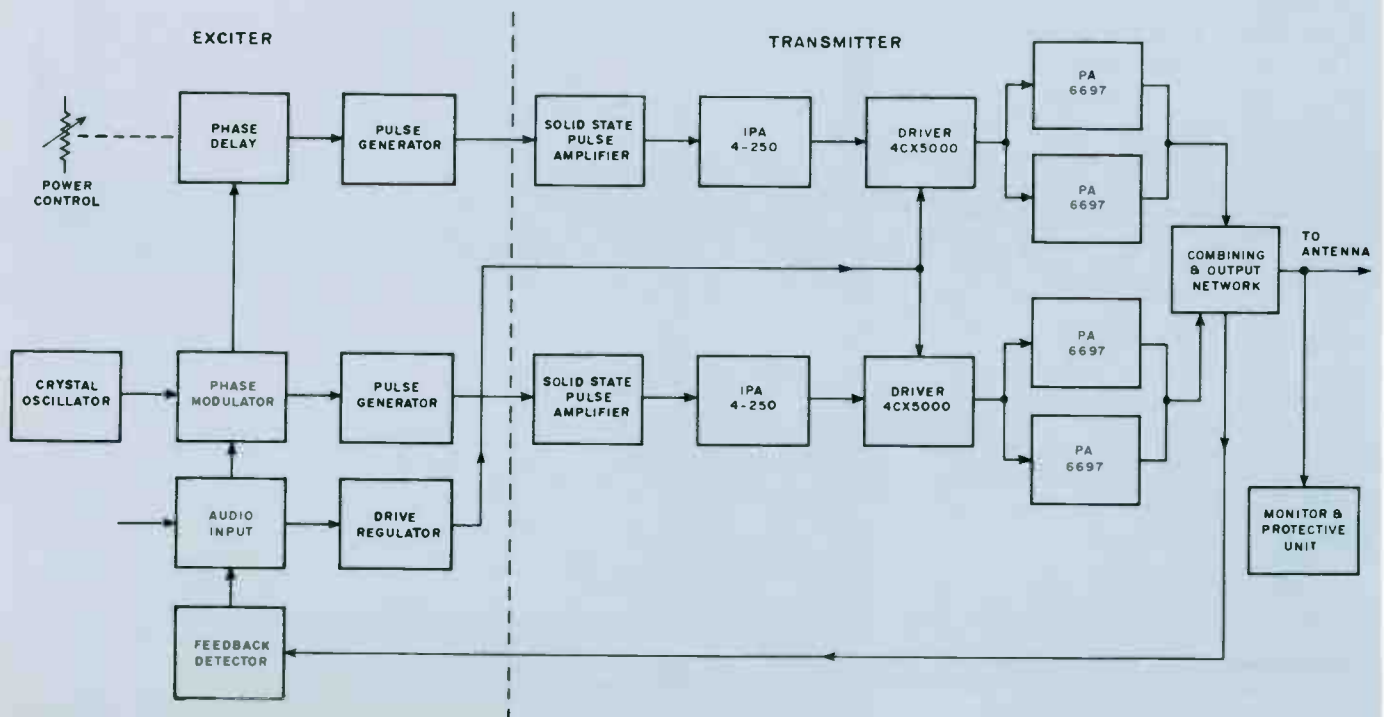

Simplified block diagram of the BTA-100J.



In the rear at the top of each cabinet is a built-in wire duct. It joins similar ducts of adjacent cabinets to form a continuous duct on the four cabinets. This duct has a divider down the center on which the interconnection terminal boards are mounted. The rear half of the duct is used for interconnection wiring while the front half is used for internal cabinet wiring from the terminal boards. The internal wiring is carried through conduits to its destination in the cabinet thus shielding all power and control wiring from RF fields. Provision is also made at the top of the cabinets for the addition of an exhaust air duct.

### Power Amplifiers

The first and second cabinets and the fourth and fifth cabinets from the left end are identical and contain the final power amplifier stages. The 6697 tube and its grid circuits and part of the plate circuits are contained in the front portion of the cabinet. The upper rear section contains the plate tank coil, filament transformer and grid leak resistors. The lower rear section contains a low-noise blower which cools the 6697 tube and its cabinet. The blowers in cabinets two and four are arranged to cool the exciter cabinet. The two power amplifiers are designed to supply equal amounts of power to the output network. Because of the balanced dissipation in the PA tubes, less air pressure with resultant lower air flow is required for adequate cooling of the power amplifier cubicles. The lower rear panel contains an impingement type air filter for the blower. The PA cabinets are constructed so that the blowers and filters can be mounted externally to the cabinets, if so desired.

The PA output circuit is a conventional pi-network type of tank circuit. Each tube has its own tank circuit, with a common output shunt element. Each network is adjusted to provide the proper load to the power amplifiers.

### Solid-State Exciter-Modulator, Drive Regulator

Packaged in a series of four plug-in modules, the *Ampliphase* exciter-modulator uses a crystal-controlled, field-effect-transistor oscillator, a solid-state drive regulator, modulator and power supply. The entire assembly occupies only 5¼ inches (133 mm) of rack space in the left-of-center cabinet (see photo). As a result of untuned, digital-integrated circuits, the exciter-modulator is set up with but three trimmer adjustments. The RF chains in the exciter operate without tuned circuits.

The drive regulator circuitry uses entirely solid-state electronic devices; the regulator samples the audio, amplifies the sample and applies it to the grid circuits of the twin driver stages so as to adjust final amplifier drive in step with the level of the modulating audio. This system contributes significantly to the exceptional linearity of the *Ampliphase* system.

### Solid-State Reflectometer

The far-right module in the exciter-modulator unit is a solid-state reflectometer that protects the transmitter from transmission line and/or antenna irregularities. The reflectometer senses changes in the voltage/current ratio on the load.

A large change in load characteristics causes the reflectometer system to momentarily interrupt the drive (to let the fault clear, if transient). If the fault persists after several cycles, the reflectometer shuts down the transmitter thereby reducing the possibility of chain-reaction damage to any part of the system.

Above the exciter-modulator are two vertical sub-compartments, behind interlocked doors, which contain the 4CX-5000A driver stages. A meter panel for these stages is located beneath the sub-compartments.

The common output capacitors of the two PA tanks and the harmonic filter are located in the upper rear of the cabinet. Sub-partitions are so arranged in this section that complete isolation and shielding is effected between the various sections of the filter and the output capacitor. The lower rear section of this cabinet contains high voltage filter reactor and driver dc filament supplies.

### Provisions for Standby Operation

Space is provided in the exciter cabinet for the mounting of a second exciter-modulator unit. Each of the exciter-modulator units are complete and arranged so that either may be selected instantly by means of an accessory cutover panel. Thus, while one modulator is in operation, the other modulator is in standby condi-

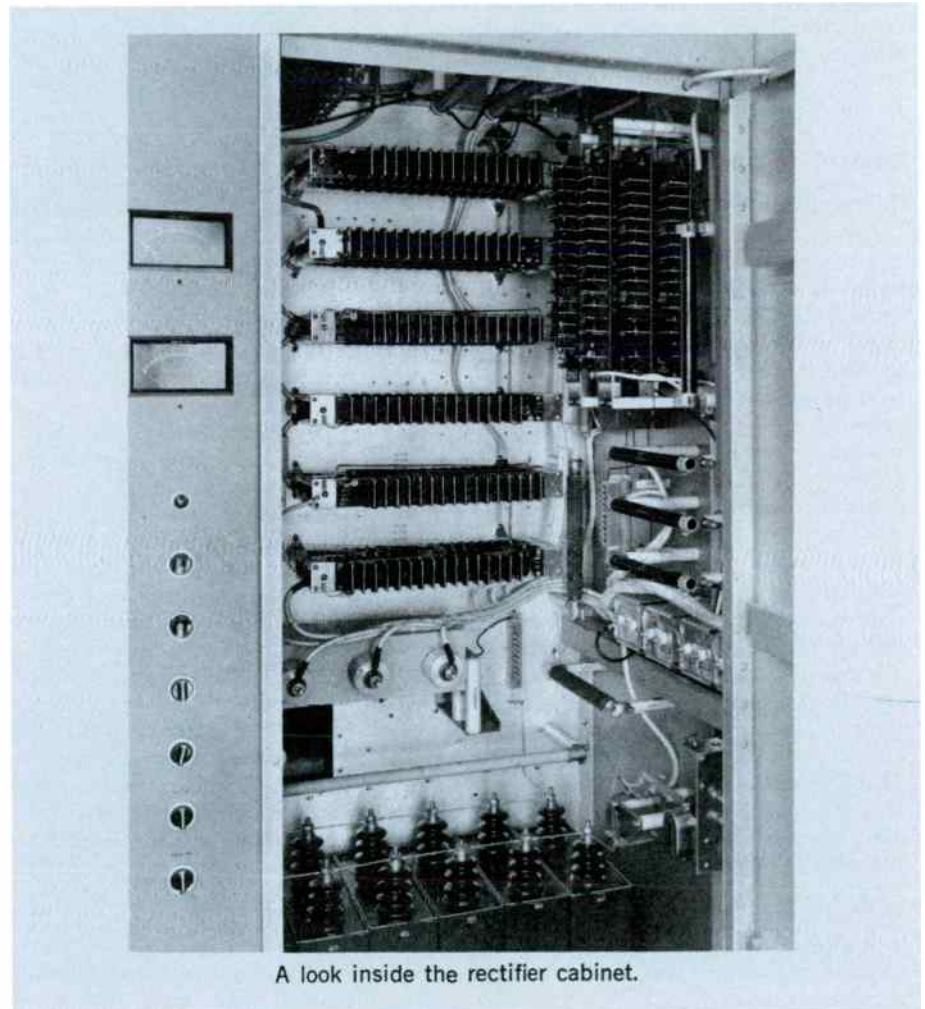

A look inside the rectifier cabinet.

tion. These provisions, with the extreme reliability designed into the high-power stages, essentially provide a second 100-kW transmitter for standby service.

### Rectifier and Control Unit

The far right cabinet contains the high power rectifiers, low power distribution components, and the majority of the control components. The high-voltage and low-voltage transformers, filter capacitors and reactors are mounted externally to the transmitter cabinetry (see floor layout).

### Solid-State Power Supplies

During periods of 100 percent modulation, each 6697 power amplifier tube requires 15kVdc at 7.5A, which is obtained from a three-phase, full-wave rectifier circuit. Two other plate voltages, 5kV and 1kV, are provided by separate supplies. Bias voltages for all tubes are supplied by an additional supply. The high-power distribution equipment for the transmitter consists of an electrically operated air circuit breaker, and a manually operated delta-wye switch for the 15-kV rectifier. The remaining transmitter power is distributed through a manually operated distribution circuit breaker to a 460- to 230-volt distribution transformer to voltage regulators and thence to the various low power distribution circuit breakers.

### Transmitter Control

Control circuits in the BTA-100J contain a number of features which are designed to provide maximum flexibility in control, protection and operation. Among these are choice of single-button or step-by-step starting, automatic timing and sequencing of starting operations, and location of transmitter faults by a system of indicators. Protection of the operator is achieved by a system of interlocking grounding device, protection of the equipment by conventional relays and circuit breakers.

Control of the transmitter is accomplished from the front of the rectifier and control cabinet. All necessary wiring to allow control from a remote location or console has been provided. Lamps, which show the status of the transmitter control circuits, are also mounted on the front of this cabinet. The control ladder is arranged and interlocked so that the BTA-100J can either be turned on by operating the control switches in sequence or by leaving all control switches in the "on" position with the exception of the start switch which, when operated to the "on" position, allows the transmitter to come on automatically.

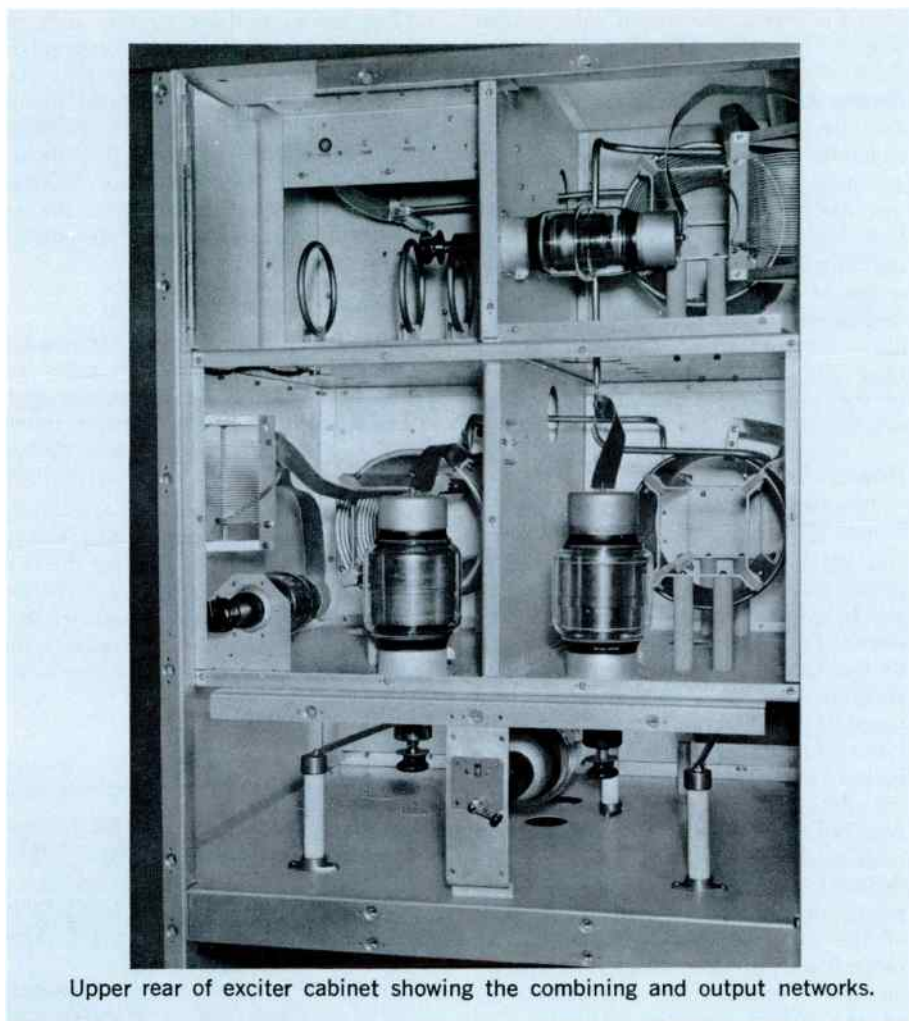

Upper rear of exciter cabinet showing the combining and output networks.

The two types of overload circuits used in this transmitter are the current type, instantaneous or time delay, that are connected directly in the tube circuit and rectifier ground leads, and the thermal magnetic circuit breakers connected in the a-c power leads used as back up protection and disconnect switches. The transmitter circuitry is arranged so that an overload either locks out the plate circuit or allows a single reclosure that resets if there are no further overloads. In either case, when a lockout position is reached, the transmitter resets by means of an Overload Reset control. The principal overload relays have indicating flags so that, even after the overload has cleared, there is a record of which overload relay operated. Another feature of the control circuit is the indicator lamps on each cabinet that indicate the interlock status in that particular cabinet.

### Installation and Layout

Outstanding features of the BTA-100J are the small floor space requirements

and ease of installation. In general, the transmitter layout consists of three basic units: the six, in-line cabinets which contain the major part of the transmitter; the wall-mounted switchgear components, the main plate transformers, the HV filter capacitors and reactors and the LV power transformers. The floor plan illustrates a typical layout of the complete equipment. Elimination of the need for under-floor cable trenches and considerable reduction in external air ducts, simplifies installation and reduces costs.

As shown in the layout, it is desirable to leave a passageway at the right end of the frontline cabinets since the circuit breakers and overload relays are most accessible from this end of the transmitter. The layout of the front line cabinets is such that a common exhaust duct can be used to carry off heated air from the transmitter.

Wall mounting of the switchgear as shown on the overall floor plan is suggested to make the BTA-100J most adapt-