

**TECHNICAL**

**MANUAL**

**RF AMPLIFIER MODULES, PLATINUM™ II Series**



T.M. No. 888-2001-450

© Copyright 1993

Harris Corporation

All rights reserved

### **Returns And Exchanges**

Damaged or undamaged equipment should not be returned unless written approval and a Return Authorization is received from HARRIS CORPORATION, Broadcast Division. Special shipping instructions and coding will be provided to assure proper handling. Complete details regarding circumstances and reasons for return are to be included in the request for return. Custom equipment or special order equipment is not returnable. In those instances where return or exchange of equipment is at the request of the customer, or convenience of the customer, a restocking fee will be charged. All returns will be sent freight prepaid and properly insured by the customer. When communicating with HARRIS CORPORATION, Broadcast Division, specify the HARRIS Order Number or Invoice Number.

### **Unpacking**

Carefully unpack the equipment and preform a visual inspection to determine that no apparent damage was incurred during shipment. Retain the shipping materials until it has been determined that all received equipment is not damaged. Locate and retain all PACKING CHECK LISTS. Use the PACKING CHECK LIST to help locate and identify any components or assemblies which are removed for shipping and must be reinstalled. Also remove any shipping supports, straps, and packing materials prior to initial turn on.

### **Technical Assistance**

HARRIS Technical and Troubleshooting assistance is available from HARRIS Field Service during normal business hours (8:00 AM - 5:00 PM Central Time). Emergency service is available 24 hours a day. Telephone 217/222-8200 to contact the Field Service Department or address correspondence to Field Service Department, HARRIS CORPORATION, Broadcast Division, P.O. Box 4290, Quincy, Illinois 62305-4290, USA. The HARRIS factory may also be contacted through a FAX facility (217/222-7041) or a TELEX service (650/372-2976).

### **Replaceable Parts Service**

Replacement parts are available 24 hours a day, seven days a week from the HARRIS Service Parts Department. Telephone 217/222-8200 to contact the service parts department or address correspondence to Service Parts Department, HARRIS CORPORATION, Broadcast Division, P.O. Box 4290, Quincy, Illinois 62305-4290, USA. The HARRIS factory may also be contacted through a FAX facility (217/222-7041) or a TELEX service (650/372-2976).

### **NOTE**

The # symbol used in the parts list means used with (e.g. #C001 = used with C001).

## Guide to Using Harris Parts List Information

The Harris Replaceable Parts List Index portrays a tree structure with the major items being leftmost in the index. The example below shows the Transmitter as the highest item in the tree structure. If you were to look at the bill of materials table for the Transmitter you would find the Control Cabinet, the PA Cabinet, and the Output Cabinet. In the Replaceable Parts List Index the Control Cabinet, PA Cabinet, and Output Cabinet show up one indentation level below the Transmitter and implies that they are used in the Transmitter. The Controller Board is indented one level below the Control Cabinet so it will show up in the bill of material for the Control Cabinet. The tree structure of this same index is shown to the right of the table and shows indentation level versus tree structure level.

Example of Replaceable Parts List Index and equivalent tree structure:

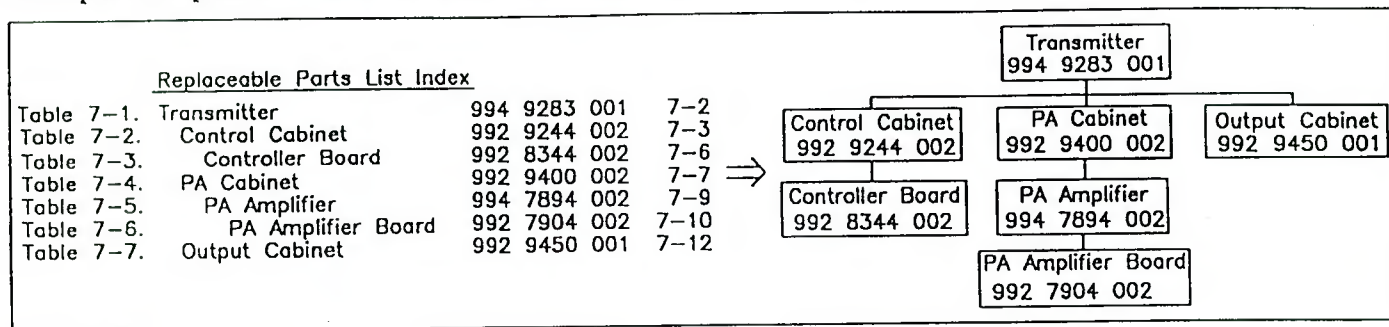

The part number of the item is shown to the right of the description as is the page in the manual where the bill for that part number starts.

Inside the actual tables, four main headings are used:

**Table #-#. ITEM NAME - HARRIS PART NUMBER** - this line gives the information that corresponds to the Replaceable Parts List Index entry;

**HARRIS P/N** column gives the ten digit Harris part number (usually in ascending order);

**DESCRIPTION** column gives a 25 character or less description of the part number;

**REF. SYMBOLS/EXPLANATIONS** column 1) gives the reference designators for the item (i.e., C001, R102, etc.) that corresponds to the number found in the schematics (C001 in a bill of material is equivalent to C1 on the schematic) or 2) gives added information or further explanation (i.e., "Used for 208V operation only," or "Used for HT 10LS only," etc.).

Inside the individual tables some standard conventions are used:

A # symbol in front of a component such as #C001 under the REF. SYMBOLS/EXPLANATIONS column means that this item is used on or with C001 and is not the actual part number for C001.

In the ten digit part numbers, if the last three numbers are 000, the item is a part that Harris has purchased and has not manufactured or modified. If the last three numbers are other than 000, the item is either manufactured by Harris or is purchased from a vendor and modified for use in the Harris product.

The first three digits of the ten digit part number tell which family the part number belongs to - for example, all electrolytic (can) capacitors will be in the same family (524 xxxx 000). If an electrolytic (can) capacitor is found to have a 9xx xxxx xxx part number (a number outside of the normal family of numbers), it has probably been modified in some manner at the Harris factory and will therefore show up farther down into the individual parts list (because each table is normally sorted in ascending order). Most Harris made or modified assemblies will have 9xx xxxx xxx numbers associated with them.

The term "SEE HIGHER LEVEL BILL" in the description column implies that the reference designated part number will show up in a bill that is higher in the tree structure. This is often the case for components that may be frequency determinant or voltage determinant and are called out in a higher level bill structure that is more customer dependent than the bill at a lower level.



**WARNING**

**THE CURRENTS AND VOLTAGES IN THIS EQUIPMENT ARE DANGEROUS. PERSONNEL MUST AT ALL TIMES OBSERVE SAFETY WARNINGS, INSTRUCTIONS AND REGULATIONS.**

This manual is intended as a general guide for trained and qualified personnel who are aware of the dangers inherent in handling potentially hazardous electrical/electronic circuits. It is not intended to contain a complete statement of all safety precautions which should be observed by personnel in using this or other electronic equipment.

The installation, operation, maintenance and service of this equipment involves risks both to personnel and equipment, and must be performed only by qualified personnel exercising due care. HARRIS CORPORATION shall not be responsible for injury or damage resulting from improper procedures or from the use of improperly trained or inexperienced personnel performing such tasks.

During installation and operation of this equipment, local building codes and fire protection standards must be observed. The following National Fire Protection Association (NFPA) standards are recommended as reference:

- Automatic Fire Detectors, No. 72E
- Installation, Maintenance, and Use of Portable Fire Extinguishers, No. 10
- Halogenated Fire Extinguishing Agent Systems, No. 12A

**WARNING**

**ALWAYS DISCONNECT POWER BEFORE OPENING COVERS, DOORS, ENCLOSURES, GATES, PANELS OR SHIELDS. ALWAYS USE GROUNDING STICKS AND SHORT OUT HIGH VOLTAGE POINTS BEFORE SERVICING. NEVER MAKE INTERNAL ADJUSTMENTS, PERFORM MAINTENANCE OR SERVICE WHEN ALONE OR WHEN FATIGUED.**

Do not remove, short-circuit or tamper with interlock switches on access covers, doors, enclosures, gates, panels or shields. Keep away from live circuits, know your equipment and don't take chances.

**WARNING**

**IN CASE OF EMERGENCY ENSURE THAT POWER HAS BEEN DISCONNECTED.**

**WARNING**

**IF OIL FILLED OR ELECTROLYTIC CAPACITORS ARE UTILIZED IN YOUR EQUIPMENT, AND IF A LEAK OR BULGE IS APPARENT ON THE CAPACITOR CASE WHEN THE UNIT IS OPENED FOR SERVICE OR MAINTENANCE, ALLOW THE UNIT TO COOL DOWN BEFORE ATTEMPTING TO REMOVE THE DEFECTIVE CAPACITOR. DO NOT ATTEMPT TO SERVICE A DEFECTIVE CAPACITOR WHILE IT IS HOT DUE TO THE POSSIBILITY OF A CASE RUPTURE AND SUBSEQUENT INJURY.**

## TREATMENT OF ELECTRICAL SHOCK

1. IF VICTIM IS NOT RESPONSIVE FOLLOW THE A-B-C'S OF BASIC LIFE SUPPORT.

PLACE VICTIM FLAT ON HIS BACK ON A HARD SURFACE

### **(A) AIRWAY**

IF UNCONSCIOUS.  
OPEN AIRWAY

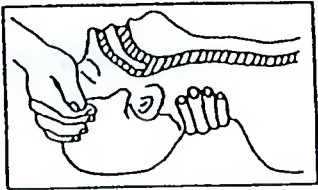

LIFT UP NECK  
PUSH FOREHEAD BACK  
CLEAR OUT MOUTH IF NECESSARY  
OBSERVE FOR BREATHING

### **(B) BREATHING**

IF NOT BREATHING.  
BEGIN ARTIFICIAL BREATHING

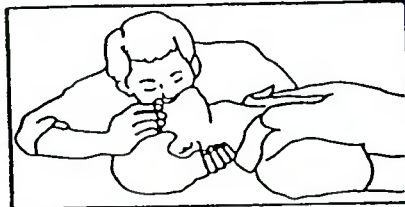

TILT HEAD  
PINCH NOSTRILS  
MAKE AIRTIGHT SEAL  
4 QUICK FULL BREATHS  
REMEMBER MOUTH TO MOUTH  
RESUSCITATION MUST BE  
COMMENCED AS SOON AS POSSIBLE

CHECK  
CAROTID PULSE

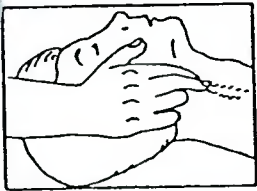

IF PULSE ABSENT.  
BEGIN ARTIFICIAL  
CIRCULATION

### **(C) CIRCULATION**

DEPRESS STERNUM 1 1/2 TO 2 INCHES

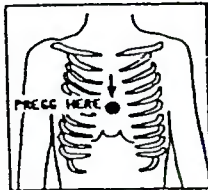

APPROX. RATE  
OF COMPRESSIONS  
--80. PER MINUTE

{ ONE RESCUER  
15 COMPRESSIONS  
2 QUICK BREATHS

APPROX. RATE  
OF COMPRESSIONS  
--60 PER MINUTE

{ TWO RESCUERS  
5 COMPRESSIONS  
1 BREATH

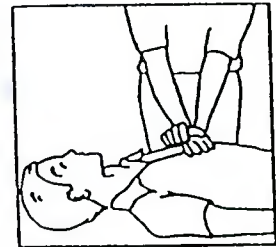

NOTE: DO NOT INTERRUPT RHYTHM OF COMPRESSIONS  
WHEN SECOND PERSON IS GIVING BREATH

CALL FOR MEDICAL ASSISTANCE AS SOON AS POSSIBLE.

2. IF VICTIM IS RESPONSIVE.

- A. KEEP THEM WARM
- B. KEEP THEM AS QUIET AS POSSIBLE
- C. LOOSEN THEIR CLOTHING
- D. A RECLINING POSITION IS RECOMMENDED

## FIRST-AID

Personnel engaged in the installation, operation, maintenance or servicing of this equipment are urged to become familiar with first-aid theory and practices. The following information is not intended to be complete first-aid procedures, it is a brief and is only to be used as a reference. It is the duty of all personnel using the equipment to be prepared to give adequate Emergency First Aid and thereby prevent avoidable loss of life.

### Treatment of Electrical Burns

1. Extensive burned and broken skin
  - a. Cover area with clean sheet or cloth. (Cleanest available cloth article.)
  - b. Do not break blisters, remove tissue, remove adhered particles of clothing, or apply any salve or ointment.
  - c. Treat victim for shock as required.
  - d. Arrange transportation to a hospital as quickly as possible.
  - e. If arms or legs are affected keep them elevated.

#### NOTE

If medical help will not be available within an hour and the victim is conscious and not vomiting, give him a weak solution of salt and soda: 1 level teaspoonful of salt and 1/2 level teaspoonful of baking soda to each quart of water (neither hot or cold). Allow victim to sip slowly about 4 ounces (a half of glass) over a period of 15 minutes. Discontinue fluid if vomiting occurs. (Do not give alcohol.)

2. Less severe burns - (1st & 2nd degree)
  - a. Apply cool (not ice cold) compresses using the cleanest available cloth article.
  - b. Do not break blisters, remove tissue, remove adhered particles of clothing, or apply salve or ointment.
  - c. Apply clean dry dressing if necessary.
  - d. Treat victim for shock as required.
  - e. Arrange transportation to a hospital as quickly as possible.
  - f. If arms or legs are affected keep them elevated.

#### REFERENCE:

ILLINOIS HEART ASSOCIATION

AMERICAN RED CROSS STANDARD FIRST AID AND PERSONAL SAFETY MANUAL (SECOND EDITION)

# Table of Contents

## Appendix A

### RF Amplifier Modules, Platinum II Series

General Information .....	A-1
Factory Module Repair .....	A-1
Local Module Repair .....	A-1
RF Amplifier Modules Theory of Operation .....	A-1
Driver Module, Low Band .....	A-2
Driver Module, High Band .....	A-2
PA Module .....	A-4
RF Quarter Modules .....	A-4
Low Band Quarter Module .....	A-4
High Band Quarter Module .....	A-5
Quarter Module Center Board .....	A-5
Protection, Control and Monitor Subsystem .....	A-6
Module Status LEDs .....	A-7
Module Troubleshooting .....	A-7
Platinum TV Module Extender (992-8556-001) .....	A-7
Platinum™ TV Module Test Fixture (992-8556-002) .....	A-9

Troubleshooting Based on Module Swapping .....	A-9
Troubleshooting Based on Module Blink Codes .....	A-9
Isolating Other Failures .....	A-12
Locating Failed RF FETs .....	A-13
Parts Replacement Procedures .....	A-14
Soldering Precautions .....	A-14
Quarter Module Replacement .....	A-14
RF FET Replacement .....	A-14
Testing and Replacing Isolation Resistors .....	A-16
Pass FET Replacement .....	A-16
Chip Cap Replacement .....	A-16
Test Procedure Solid State TV Modules .....	A-16
Pre-operational Checks .....	A-16
RF Testing .....	A-17

## Appendix B

### Replaceable Parts List



## A.1 General Information

This procedure is intended to be used as a guide in isolating faults and troubleshooting Platinum™ II TV RF power amplifiers.

Module faults are most easily verified by swapping the suspected faulty module with a known working module in another slot. If the fault follows the module, then the problem is probably internal to the module. If the fault remains at the same slot after substituting modules, then the search for the problem should probably focus on the rest of the transmitter system.

### A.1.1 Factory Module Repair

If a failure of a module occurs, the module may be returned to the factory for repair.

To return a module, contact Harris Repair Department:

By phone: 217-222-8200

By FAX: 217-224-2840

By mail:

Harris Repair Department  
P.O. Box 4290

Quincy, Illinois 62305-4290

Include the part number and serial number of the module when requesting service. Instructions to ship the module will be processed and communicated to you.

Please provide as detailed information as possible about the nature of the failure and the operating condition of the module at the time of failure. This data will help our Repair Department service your module promptly and efficiently.

If you do not stock a spare module and require another unit for operation, a spare may be obtained as a loaner unit from the Harris Repair Department while your unit is shipped to our factory for repair.

If you are located within the United States, you will be billed for shipping charges, and if your warranty has expired a nominal fee will be charged for use of the module.

If you are located outside the United States, the same loaner service will be offered wherever feasible, but in addition to any shipping charges you will be responsible for all import duties, transfer fees or international tariffs.

### A.1.2 Local Module Repair

If local repair is necessary, the following troubleshooting guide and repair procedures are recommended. We strongly recommend reading the appropriate parts of the Theory of Operation, paragraph A.2 before proceeding.

Optional PA Module Extender (Harris part number 992-8556-001)/or Module Test Fixture (992-8556-002) can be used for local testing or repair. The fixture will allow testing of a PA or driver module while using the transmitter as the source of DC power and RF drive.

## A.2 RF Amplifier Modules Theory of Operation

Three types of RF amplifier modules are used in a Platinum™ Series transmitter:

- **Driver Modules** are multiple-stage, high gain RF amplifiers used primarily to amplify an exciter output and drive subsequent amplifier stages.
- **525 Watt PA Modules** are built in driver module configuration. High band modules are biased class A for the two series configured quarter modules and class AB for the two parallel output quarter modules.

Low band modules are biased class A for the first quarter module and class AB for the two parallel output quarter modules.

525 watt PA modules have a polarizing key on the opposite side from driver modules. This will prevent interchanging of driver and 525 watt PA modules. Due to the differences between 525 watt PA's and drivers in bias, gain matching pads and the adjustment of the protection circuitry they are not interchangeable without complete testing and readjustment of the protection circuitry.

- **PA Modules** are single-stage, high-power, high-efficiency amplifiers which use four parallel amplifiers to achieve output power levels in excess of 1 kW each.

Both drivers and PAs share some common features. Drivers and PAs both contain smaller amplifier subassemblies called "quarter modules."

A multi-pin connector on the rear of each module feeds RF drive, 50 volts DC, and ENABLE commands to the module, and passes a fault status signal back to the slave controller. RF output is passed through a separate coaxial connector. The rear panels of drivers and PAs are keyed differently, so that drivers cannot be plugged into PA slots.

The modules are "hot-pluggable," meaning that they can be removed or inserted during transmitter operation without turning the transmitter off. A disable switch is located in the front handle of each module for this purpose.

The modules protect themselves by automatically disabling themselves if an improper operating condition is detected. A protection, control, and monitor (PCM) system monitors the module's operating conditions. If all of the conditions are acceptable, upon an ENABLE signal from the slave controller, the PCM system will enable the module. If a fault condition arises or the ENABLE signal is interrupted, the PCM system disables the module by shutting off the 50 volts DC.

Descriptions of the various subsystems of Platinum modules are given below. First, the RF signal paths of the modules are traced; then, the subsystems are described in more detail.

Refer to the cover sheet of the drawing package for your transmitter to locate the necessary drawing numbers for the module and subassemblies.

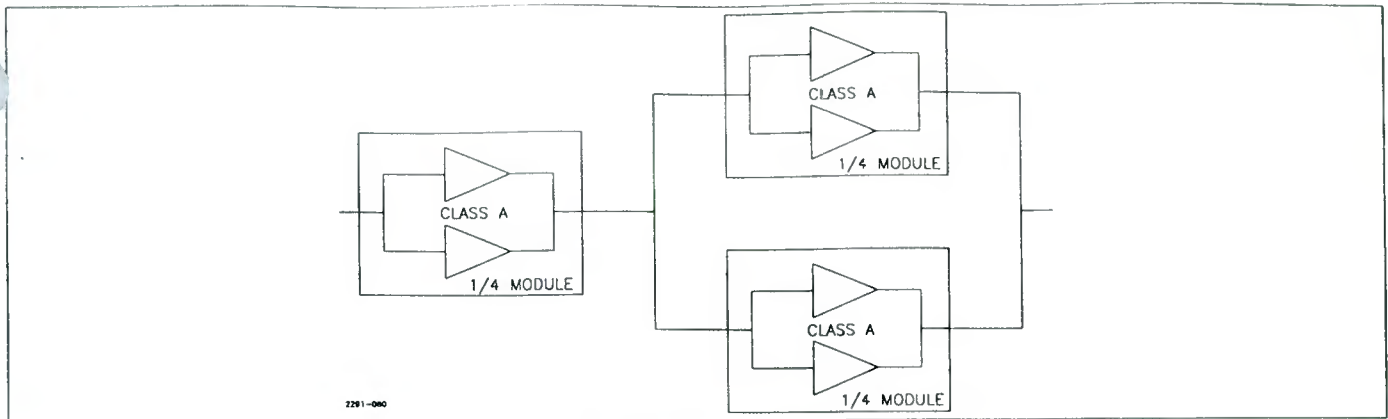

Figure A-1. Low Band Driver Module, Simplified Block Diagram

**A.2.1 Driver Module, Low Band**

(Refer to the Low Band Driver Amplifier Schematic 843-4999-535)

The low band driver module consists of a class A stage, driving a second stage consisting of two parallel class A amplifier blocks.

A pi input attenuator (R4, R5, R6 on the Driver RF input assembly) is used to set the overall gain of each low band driver to 35 dB. The input attenuator also serves to improve the module's input return loss.

The attenuator output feeds the first amplifier stage, which produces about 24 dB gain. The output passes to a 2 dB fixed attenuator, used to improve the output match seen by the first stage.

The RF signal then feeds the 2-way Divider assembly. On this divider assembly there is in the signal path a microstrip directional coupler (which provides a forward drive power sample for overdrive protection), a microstrip trombone line section (for phase adjustment), and a foreshortened Wilkinson 2-way microstrip divider. The divider's two outputs drive two parallel Class A amplifiers. The outputs are recombined using a foreshortened Wilkinson microstrip combiner, which passes the signal through a directional coupler to the module output. The directional coupler provides a reflected power sample to the module's protection, control and monitor (PCM) system.

On the input and output Driver RF Intraconnection assemblies are provided optional capacitors for response correction. On the input assembly, A5A4, are C1 and C15. On the driver RF intraconnect assembly is C4. A capacitor may be added where needed for frequency response correction and or input matching.

The low band driver's output is rated at 50 watts peak-of-sync visual, and 200 watts CW in aural service.

**A.2.2 Driver Module, High Band**

(Refer to the High Band Driver Amplifier Schematic 843-4999-534)

The high band driver module consists of two cascaded class A stages, driving a third stage consisting of two parallel class AB amplifier blocks.

A pi input attenuator (R4/R5/R6 on the input Driver RF intra-connection assembly) is used to set the overall gain of each high band driver to 35 dB. The input attenuator also serves to improve the module's input return loss.

The attenuator feeds the first amplifier stage, which produces about 17 dB gain. Its output passes to a 2 dB fixed attenuator, used to improve the output match seen by the first stage. The signal then passes through a L-section matching network to the second class A stage.

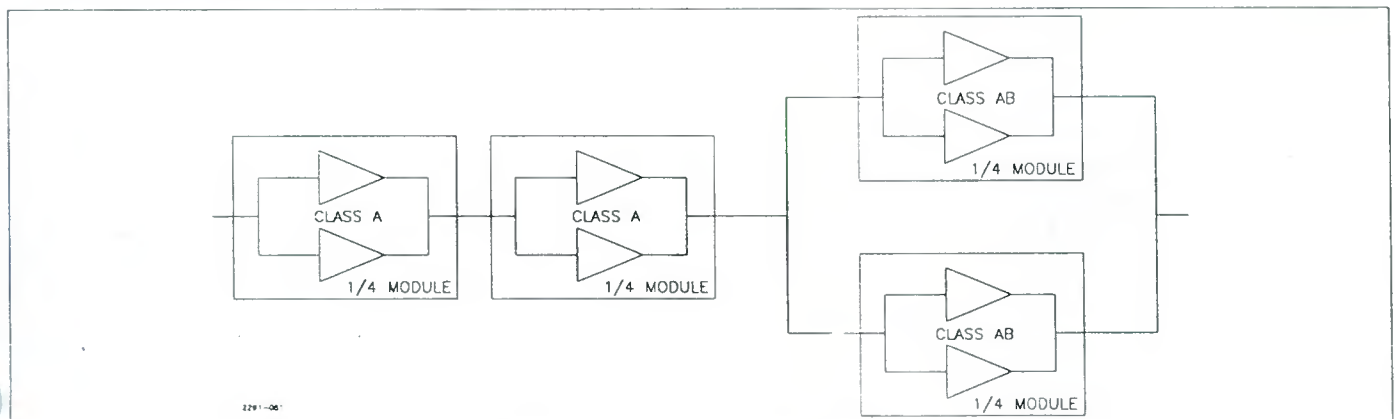

Figure A-2. High Band Driver Module, Simplified Block Diagram

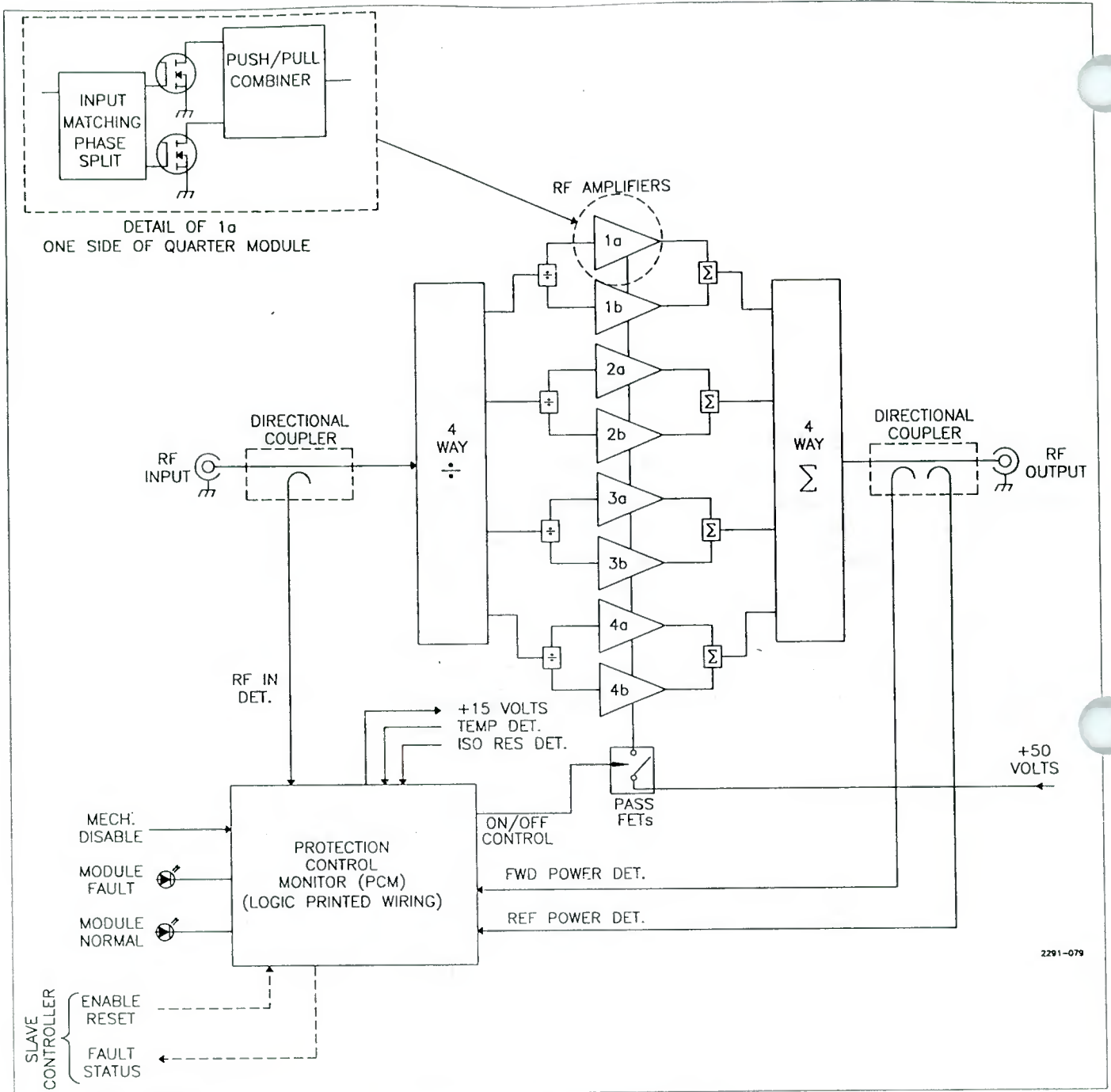

Figure A-3. PA Module Block Diagram

The RF signal then feeds the 2-way Divider assembly. On this divider assembly there is in the signal path a microstrip directional coupler (which provides a forward drive power sample for overdrive protection), a microstrip trombone line section (for phase adjustment), and a Wilkinson 2-way microstrip divider. The divider's two outputs drive two parallel Class AB amplifiers. The outputs are recombined using a Wilkinson microstrip combiner, which passes the signal through a directional coupler to the module output. The directional coupler provides a reflected

power sample to the module's protection, control and monitor (PCM) system.

On the input and output Driver RF Intraconnection assemblies are provisions for response correction. On the A5A6 assembly are C4 and C12. On the A5A4 RF intraconnection assembly is C13. On the two way divider RF Intraconnection assembly is C14.

High band drivers have a rated output of 250 watts peak-of-s visual, or 500 watts CW in aural service.

### A.2.3 PA Module

(Refer to the RF PA Module Schematic 843-4999-533)

PA modules consist of four parallel class AB amplifier blocks. Low Band PA modules produce 18.5 dB gain overall, and the gain for a high band PA is 13.7 dB.

The module RF input signal feeds the 2-way Divider assembly. On this divider assembly there is in the signal path a microstrip directional coupler (which provides a forward drive power sample for overdrive protection), a microstrip trombone line section (for phase adjustment), and a Wilkinson 2-way microstrip divider.

The Wilkinson combiner in the Low Band module is a foreshortened Wilkinson combiner. Resistors are used in the Wilkinson divider and combiner circuits to provide isolation between ports.

The Wilkinson divider's two outputs feeds the two 2-way Wilkinson microstrip/stripline dividers on the 2X2-Way Divider assembly. The 2X2-Way Divider assembly's four outputs feeds the four class AB amplifiers.

The outputs of the four amplifiers feed into the two 2-way Wilkinson combiners on the 2X2-way Combiner assembly. The output of the two combiners feeds into the two inputs of the 2-way Wilkinson 2-Way Combiner assembly. The output of this combiner passes through a directional coupler to the RF output jack. The directional coupler sends a voltage sample of the output port reflected power to the PCM system.

The Low Band and High Band PA modules are rated at 1050 watts peak-of-sync visual, and 1050 watts CW in aural service.

### A.2.4 RF Quarter Modules

The RF amplifier subassemblies within a driver or PA module are called "quarter modules." The quarter modules use n-channel Field Effect Transistors, or FETs, as their active devices. FETs offer several advantages over bipolar junction transistors (BJTs), including improved ruggedness, better linearity, and less susceptibility to thermal runaway.

N-channel FETs operate somewhat similarly to NPN Bipolar Junction Transistors. In a common-emitter bipolar amplifier, a small change in base-emitter voltage results in a small change in base current. The base current modulates the collector current, and the output is taken at the collector. Similarly, in a common-source FET amplifier, a small change in gate-source voltage modulates the drain current, and the amplifier output is taken at the drain.

Each quarter module uses four RF FETs. The input contains a gain matching pad, a phase matching coax line and a two-way power divider. Divider outputs each drive a push-pull FET pair. The FET outputs are recombined in a two way combiner, whose output is the output of the quarter module.

A "center board" is plugged into a card-edge connector on each quarter module. This board controls the bias voltage for each RF FET, and returns temperature status and reject power voltage samples to the PCM system.

For any given channel, class A and class AB amplifier blocks use the same quarter module circuit. The bias settings on the center board control the quiescent drain current for each FET, which determines each quarter module's class of operation.

In cases where quarter modules are biased class AB, as in the 1 kW PA module, each quarter module is capable producing 280 watts output into a 50 ohm load. The excess power is necessary to overcome losses in the combining stage.

When the quarter modules are biased class A, as in driver modules, they exhibit improved linearity and about 1-2 dB higher gain. The tradeoff, however, is lower power output capability and reduced efficiency. Thus, class A stages are used as preamp and driver stages, and class AB stages are used as intermediate and final power amplifier stages.

Because low band and high band quarter modules utilize slightly different architectures, the circuits are described individually below.

### A.2.5 Low Band Quarter Module

(Refer to Low Band Quarter module Schematic 839-7900-616)

The RF input signal first passes through TL1 (Phase setting coax) and then through AT1 Which sets the gain of the quarter module to 19.25 dB. The RF input signal then passes to T1, a two-w2ay coaxial power divider which also performs an impedance transformation. R5 provides isolation between the two divider output ports.

The upper and lower RF amplifier halves are identical. In the upper circuit, C1 blocks DC from the input. Components T2/T3 continue the impedance transformation from the divider to the gates of RF transistors Q1 and Q2. T3 also establishes a 180° phase relationship between the signal voltages sent to the two transistors, which is the basis for push-pull operation.

R2 and R3 "swamp" the transistor gate input impedances, which are highly capacitive. C6/C7/C9/C10 block the DC gate bias from reaching the quarter module input. C8/C5/C11 complete the input impedance transformation.

R1/L1/R10 (Channel four has additional resistors) form a drain-to-gate negative feedback loop around Q1, and R4/L2/R11 form a similar network around Q2. The feedback prevents the transistors from oscillating at low frequencies. C25 and C24 block the 50 volts present at the drains from reaching the gates through the feedback loops.

L5/L6/C23 form a balanced L-network, which act as both a low-pass filter and an impedance transformer between the FET's and T6. T6 continues the output impedance transformation and combines the transistor outputs in series. C28, C29/R19, and C4 bypass one port of T6 to ground, and C30 and C31 couple the RF to T8.

T8 is a two-way combining transformer which combines the outputs of the upper and lower amplifier halves and completes the output match. R15 provides isolation between T8's input ports.

If any phase or amplitude difference exists between the signal in the upper and lower amplifier halves a voltage will develop

across R15. This will cause RF to be coupled through toroidal transformer T9, to R17/CR1/C35/R16 an RF peak detector which produces a DC signal proportional to the amount of imbalance. This DC signal is called the ISO voltage sample, and it is sent to the PCM system through the center board.

The RF input signal passes through an attenuator pad AT1 and a phase matching coax to T1, a two-way coaxial power divider which also performs an impedance transformation. R5 provides isolation between the two divider output ports.

The upper and lower RF amplifier halves are identical. In the upper circuit, C1 blocks DC from the input. Components T2, C4 and T3 continue the impedance transformation from the divider to the gates of RF FETs Q1 and Q2. T3 also establishes a 180° phase relationship between the signal voltages sent to the two FETs, which is the basis for push-pull operation.

R2 and R3 “swamp” the FET gate input impedances, which are highly capacitive. C6, C7, C9 and C10 block the DC gate bias from reaching the quarter module input. C8, L9, C5, L10, and C11 complete the input impedance transformation.

R1, L1, and R10 form a drain-to-gate negative feedback loop around Q1, and R4, L2, R11 form a similar network around Q2. The feedback prevents the FETs from oscillating at low frequencies. C25 and C24 block the 50 volts present at the drains from reaching the gates through the feedback loops.

L5, L6, and C23 form a balanced L-network, which acts as both a low-pass filter and an impedance transformer between the FETs and T6. T6 continues the output impedance transformation and combines the FET outputs in series. C28 and C29 bypass one port of T6 to ground, and C30 and C31 couple the RF to T8.

T8 is a two-way combining transformer which combines the outputs of the upper and lower amplifier halves and completes the output match. R15 provides isolation between T8’s input ports.

If any phase or amplitude difference exists between the signals in the upper and lower amplifier halves, a voltage will develop across R15. This will cause RF to be coupled through toroidal transformer T9, to R17-CR1-C35-R16, an RF peak detector which produces a DC signal proportional to the amount of imbalance. This DC signal is called the ISO voltage sample, and it is sent to the PCM system through the center board.

### A.2.6 High Band Quarter Module

(Refer to High Band Quarter Module Schematic 839-7900-615)

The RF input to the quarter module passes through TL1 (Phase setting coax) and AT1 (Attenuator which sets the gain of the quarter module to 14.25 dB). The RF input then passes through a two-way Wilkinson power divider, consisting of two 75 ohm microstrip sections. R1 provides isolation between the divider outputs.

The upper and lower amplifier halves on the schematic are identical. In the upper amplifier, C9 couples RF into the amplifier while blocking DC. T1 is a coaxial balun transformer, which provides both a step-down impedance transformation and an unbalanced-to-balanced transformation. Its two output signals

differ in phase by 180°, which establishes push-pull operation in the RF FET pair Q1 and Q2.

R3 and R4 “swamp” the highly capacitive gate input impedance of the FET’s. C2, if present, completes the input impedance transformation. R7 and R8 feed bias voltages from the center board to the gates of the RF FET’s, controlling their quiescent drain currents.

L1 and L2 feed 50 volts to the FET drains, and act as RF chokes, blocking the RF from appearing on the power supply lines.

The sliding short section form small inductances. Together with C4/C5/C37 if present, they form a balanced L-net, which provides both a low-pass response and an impedance step-up transformation between the FET drains and the input of T3.

T3 is a coaxial balun, fabricated from semi-rigid coax. It adds the output voltages of Q1 and Q2 in series, and continues the output impedance transformation. Its outer conductor is grounded by C13, and the RF output is coupled through C15.

The outputs of the two amplifier halves are recombined by a two-way Wilkinson combiner, composed of two 75 ohm microstrip sections.

If any phase or amplitude difference exists between the signal in the upper and lower amplifier halves, an RF voltage develops across R11 and L9. L9 is the primary of a toroidal transformer, whose secondary is L10. Any RF voltage will be coupled through the toroidal transformer to R12/CR1/C33 an RF peak detector which produces a DC signal proportional to the amount of imbalance. This signal is called the ISO voltage sample, and it is sent to the PCM system through the center board.

### A.2.7 Quarter Module Center Board

(See Module Center Board schematic, 839-7900-645.)

Each quarter module contains a plug in circuit board called a “center board.” The center board provides four gate bias voltages, which control the quiescent drain current for each of the four RF transistors on that quarter module. The center board also reports temperature status and sends an ISO voltage sample to the PCM system.

Two cables attach to the center board. One is a single red wire connected to TB1, which supplies 50 volts DC to the quarter module. C13 provides an RF bypass at the quarter module DC input, and C14 provides a reserve of stored energy close to the RF FETs.

The other cable connected to the center board, P3, which supplies 15 volts DC for the op-amps on the center board, returns quarter module temperature and ISO voltage signals to the PCM board.

Q3, mounted to the quarter module heat sink, is a bipolar transistor connected as a diode and used as a temperature sensor. R22 on the center board determines the current through the transistor. The transistor’s collector-base junction voltage, nominally 0.6 volts, varies slightly with the temperature of the heat sink. This voltage is returned to the center board through P1-11 and P1-12, and is used for two purposes: to generate a temperature status signal for the PCM system, and to provide slight changes to the RF FET gate bias voltages based on temperature.

In one branch, the voltage signal passes through R15 to U1 pin 9. U1 is a quad op-amp, and this section acts as an inverting amplifier, whose gain is determined by R14 and R15. It amplifies the voltage in such a way that its output, which appears at TP1, is a scaled indication of the quarter module heatsink temperature. R6 calibrates TP1 to 2.5 volts at 25°C. The inverting amplifier's gain causes this voltage to change by 0.1 volt/°C.

Another section of U1 (pins 12, 13, 14) is configured as a comparator. The voltage at TP1 appears at the inverting (-) terminal, and an 8.2 volt reference established by voltage divider R16-R17, is fed to the non-inverting terminal (+). If the quarter module heatsink temperature is below 82°C, the voltage at U1-13 will be below 8.2 volts, which is less than the reference, and the comparator output will be high. If the quarter module rises above 82°C, pin 14 will be forced low, indicating a fault condition. R19 and CR1 form one branch of a diode OR gate. If any of the quarter modules exceed 82°C, terminal P3-4 will be pulled low, and this signal to the PCM board will disable the module.

Q3 also performs another function. The gate bias voltage required to achieve a given quiescent drain current in an RF FET has a negative temperature coefficient. Thus the gate voltage must decrease slightly with temperature in order to keep the bias current constant. The remaining sections of the op-amp (U1 pins 1-3 and pins 5-7), along with their associated feedback resistors, perform this action based on the voltage from Q3. Each output (U1 pins 1 and 7) becomes an end of each of four separate voltage dividers, formed by potentiometers R2 through R5. Each potentiometer sets the gate bias voltage, and hence the quiescent current, of one of the RF FETs on the quarter module.

The RF FETs can oscillate if they are operated with gate bias present before the DC power supply reaches about 30 volts. This is prevented by Q1, a p-channel junction field effect transistor (JFET), and CR2, a zener diode. Op-amp U1 maneuvers its output voltage at pin 1 in order to keep the input voltages at pins 2 and 3 equal. While the supply is ramping up, no current flows through CR2 and R31, and Q1 acts as a closed switch. Pin 3 is thus grounded, and pin 1 will move toward ground in order to keep pins 2 and 3 at equal voltages. Thus no gate bias is applied to the RF FETs.

As the supply voltage reaches CR2's zener voltage (36 volts), current begins to flow through the zener and R31, raising the voltage on the gate of Q1. At about 40 volts, Q1 becomes an open switch. The output voltage of U1 pin 1 is then based on the resistor values in its circuit and the voltage from Q3, the temperature sensor, and the normal gate bias voltage is sent to the four RF FETs.

The ISO imbalance voltage sample, described above in the section on quarter modules, also passes through the center board and cable P3 pin 3 on its way to the PCM system.

### A.2.8 Protection, Control and Monitor Subsystem

(Refer to "Logic Printed Wiring" schematic, 839-7900-161.)

Each module is controlled and monitored by a module protection, control, and monitor (PCM) subsystem. Drivers and PA modules utilize essentially the same PCM subsystem. It consists

of sensors and control logic within each module, and provides protection against improper operating conditions. The heart of the module PCM subsystem is a printed circuit assembly commonly known as the "module logic board."

The module logic board performs its protection from different detrimental operating conditions through an essentially common scheme. It collects from sensors several voltage samples that provide indications of the operating parameters, and compares these samples to reference voltages. Voltage comparators (U4, U6, U7) are used to compare the samples to the references, and their outputs are digital signals which indicate either a normal operating condition or a fault.

These digital signals drive PALs (Programmable Array Logic) (U1, U2, U3), which are ICs consisting of hundreds of digital logic gates. The PALs perform two functions. They send signals to the pass FETs, which are used as high-current switches to turn on or off the 50 volts DC supplied to the quarter modules. They also determine the operating status indications given by the front panel LEDs.

Upon a module ENABLE signal, after the cabinet DC power supply reaches 44 volts, the control logic turns on the pass FETs. If a fault is detected, the control logic will turn off the pass FETs, disabling the module.

The PCM subsystem performs several functions:

- \* Monitors input power level and protects the module from being overdriven. A sample from the coupler at the input of the power divider is received at P1-15. If the sample is above the reference established by voltage divider R20-R21, U6 pin 14 will go low, indicating normal drive in a PA module. If the sample goes above the reference set by R101, U6 pin 1 will go low, indicating an overdrive fault.

- \* Monitors output reflected power, and protects the module from elevated load VSWR. Output reflected samples from the output directional coupler assembly are received at P3-2. The VSWR fault threshold is established by R100. If the voltage at U6 pin 5, determined by the reflected power, is greater than the voltage at pin 4, then pin 2 will go low, indicating a VSWR fault.

- \* Monitors the DC power supply voltage, and protects the module from high and low voltage extremes. The DC supply is sampled at P1-1, and is scaled down by R48, R47, and R42. A maximum voltage reference is established by the +15 volt regulated supply, R43, and R44. If the sample exceeds the reference, U7 pin 1 will go high, indicating an overvoltage fault.

Likewise, a minimum voltage reference is established by R45 and R46. If the reference exceeds the DC supply sample, U7 pin 2 is driven high, indicating an undervoltage fault.

- \* Monitors ISO voltage samples of the quarter modules, protecting the amplifier from damage due to imbalances between the two halves of a quarter module. The ISO voltage samples are combined by a resistor OR circuit on the center boards, and collected at P1-5 on the controller board. A reference is established by R38 and R81. If the ISO voltage sample exceeds the reference, U6 pin 13 is driven low, indicating a fault.

\* Monitors the temperature of the quarter modules, turning off the amplifier if excessive temperatures are encountered. Temperature sensors and comparators are located on each quarter module (see the section on the quarter module center board, above). If one of the quarter modules exceeds 82°C, the signal received at the controller board P1-7 is a logic low. U5, an inverting buffer, then drives pin 2 high, indicating a temperature fault.

Enables the 50 volts DC to the quarter modules by controlling a pair of high-power switching FETs (“pass FETs”) located on the module rear panel. If no faults are present, PAL U1 pin 12 sends a signal to U7 pin 8, which controls a circuit that turns on the pass FETs, a pair of n-channel switching FETs. If a fault condition occurs, the switching FETs are turned off. The logic will not allow the module to enable if a fault condition exists, to protect the module from damage.

### A.2.9 Module Status LEDs

Each module uses two front panel LEDs to display its current operating status. The LEDs are driven by signals from the PALs and U8 and U9, which are NAND gates configured as buffers. The status can be interpreted from the LEDs as follows:

- a. **Steady Red** - 50 volts applied to the module, but the module is not enabled. This will normally occur if a module is removed and then reinserted in the slot.  
The red LEDs will illuminate then fade out as the supply capacitors discharge each time the transmitter is turned off.
- b. **1/2 Green LED Illuminated** - Module is enabled but little or no RF drive is supplied to the module.

Driver modules, because of their low input drive level, do not have a drive level indication. Thus, when a driver module is enabled, both halves of the green LED are illuminated regardless of drive level. This is the only difference between the PCM systems on drivers and PAs.

- a. **Full Green LED Illuminated** - A full green LED illuminated indicates normal module operation. - Module is enabled. Additionally, in PA modules, the presence of RF drive is indicated.
- b. **No LEDs Illuminated** - The 50 volt DC power is not reaching the module, or the module has been turned off by pulling on the front handle (“mechanical disable”).

In some cases this could be the symptom of a module control fault. If you have not disabled the module turn off the transmitter momentarily while removing the module. This will prevent possible arcing of the input connector pins if the module was in fact on but not lighting any LEDs.

#### A.2.9.1 Red LED Fault Blink Codes

If a module fault occurs, the red light will “blink” on and off. The number of blinks between pauses is the “blink code,” and is used to determine the type of fault. The blink code is as follows:

- a. **1 Blink** - High VSWR condition at the module output.
- b. **2 Blinks** - RF input overdriven

- c. **3 Blinks** - An elevated ISO voltage resulted from an imbalance between halves of a quarter module.
- d. **4 Blinks** - The power supply voltage applied to the module is too high or too low.
- e. **5 Blinks** - The quarter module temperature is too high.
- f. **6 Blinks** - The pass FET transistors that switch the 50 volts to the quarter modules have failed.

## A.3 Module Troubleshooting

### CAUTION

*Use extreme care when repairing or testing RF amplifier modules. Because they are capable of producing over 1000 watts of output power, serious RF burns can result from coming in contact with any high power points inside the module while it is operating.*

### IMPORTANT

*These modules operate with 50 volt power supplies capable of very high currents. Accidental short circuits occurring inside the modules can cause serious damage due to the high currents involved. Carefully inspect the module for any debris that could cause a short to occur after any repair activity.*

### IMPORTANT

*Failure to use proper soldering techniques or materials can cause damage to the replacement components, or may result in joints with poor electrical or mechanical integrity, causing subsequent damage to the module. Please read the section entitled “Soldering Precautions” before attempting any repair activity.*

### A.3.1 Platinum TV Module Extender (992-8556-001)

Refer to Figure A-4 and A-5 “Module Extender Fixture”

The Platinum TV PS Module Extender consists of three separate subassemblies: the Main Extender, which is inserted into any module slot to extend air, power and signal connections forward out of the front of the PA cabinet; the Front Support Extension, which is attached to the front of the Main Extender to provide support and cooling air for the module under test; and the Interlocked Safety Cover, which must be in place to activate RF drive to the module under test. Figure A-4 shows the steps to installing the extender unit and Figure A-5 shows the extender installed.

Refer to Figure A-6.

DC power and drive enter at P1. Breaker CB1 limits the current to 50 amps. Interlock switch S2 and driver relay K1 prevent application of RF drive until the cover is closed.

Fuse F1 provides protection for the small signal wiring in the extender.

Enable switch S1 allows local control of the module on the extender while the transmitter is on.

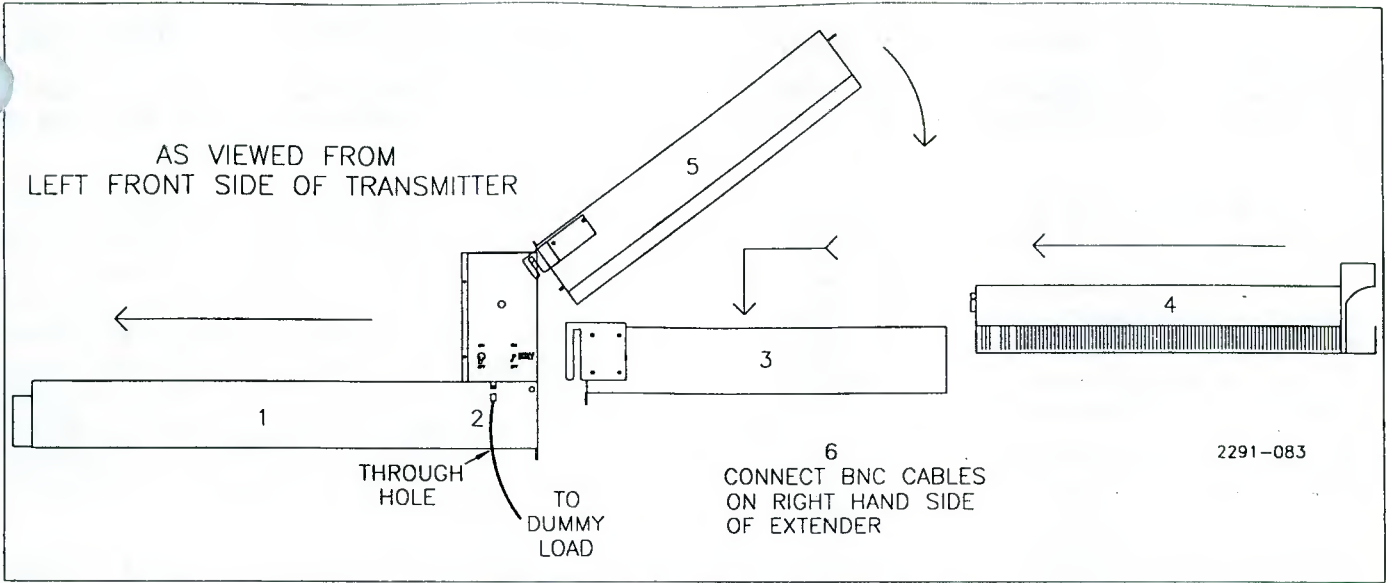

Figure A-4. Module Extender Installation Steps  
(Harris PN 992-8556-001)

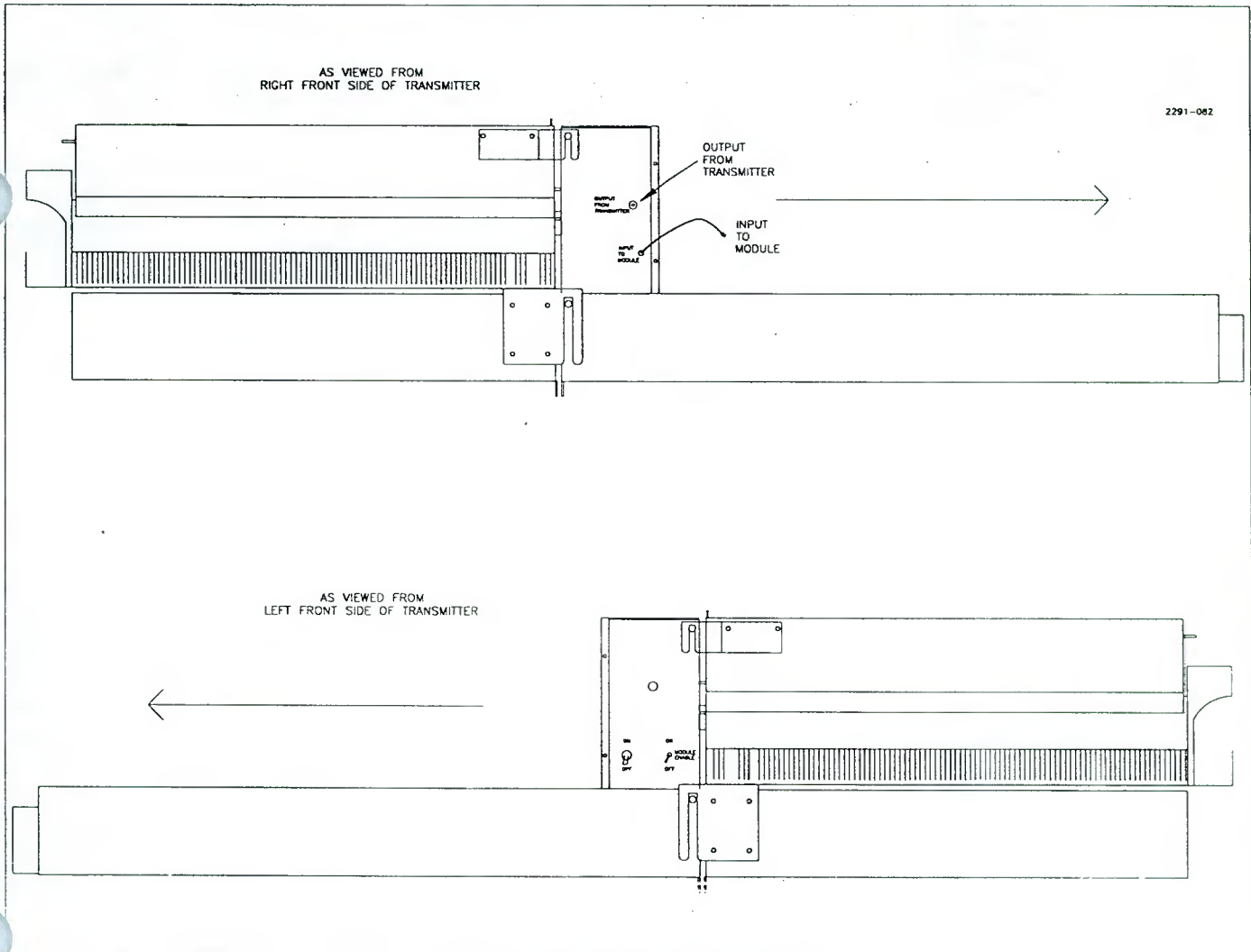

Figure A-5. Module Extender Installed  
(Harris PN 992-8556-001)



**CAUTION**

**AN EXTERNAL RF LOAD MUST BE CONNECTED TO THE MODULE AT ALL TIMES DURING TEST.  
BE SURE TO DISABLE AND REMOVE THE MODULE OR TURN OFF THE BREAKER BEFORE REMOVING THE EXTENDER FROM THE CABINET.**

**A.3.2 Platinum™ TV Module Test Fixture (992-8556-002)**  
Refer to Figures A-6 & A-7 "Module Test Fixture"

The Platinum TV Module Test Fixture consists of a table top assembly with a interconnect cable ending in a plug assembly that is inserted into an empty module slot. The cable to the test load is routed through the end cover opposite the fan and connected inside the test fixture by reaching through the cooling slot.

An interlocked Safety Cover must be in place to activate RF drive to the module under test.

Breaker CB1 limits the current to 50 amps, protecting the cable. Breaker CB2 at the test fixture trips from excess module current and can be used as module power switch. Interlock switch S2 and driver relay K1 prevent application of RF drive until the cover is closed.

Fuse F1 provides protection for the small signal wiring in the extender and the 50 volt DC fan.

Enable switch S1 allows local control of the module on the extender while the transmitter is on.

**CAUTION**

**AN EXTERNAL RF LOAD MUST BE CONNECTED TO THE MODULE AT ALL TIMES DURING TEST.  
BE SURE TO DISABLE AND REMOVE THE MODULE OR TURN OFF THE BREAKER BEFORE REMOVING THE EXTENDER FROM THE CABINET.**

**A.3.3 Troubleshooting Based on Module Swapping**

Many situations exist in which a problem exhibited by a module could be due to a problem either with the module itself, or somewhere else in the transmitter. For example, VSWR faults could be due to either a failure or misadjustment of the VSWR sensing circuitry in the module, or due to a problem with the transmitter cabinet RF connector, combiner cables, reject loads, etc. In fact, most fault indications could be caused by either module or system problems. Thus it is desirable to first isolate the problem to the module or system before continuing the troubleshooting process.

Since the modules are designed for interchangeability with other modules of the same type, one easy test to determine whether a problem lies in the system or in the module is the "swap test," which involves swapping the suspect module with another and observing whether the symptom follows the module.

**A.3.4 Troubleshooting Based on Module Blink Codes**

The general procedure for troubleshooting based on a module blink code involves several steps.

The first is to check for causes consistent with the blink code (such as checking the DC supply voltage if blink code 4 occurs). Often, this will give an indication of whether the problem lies within the system or the module.

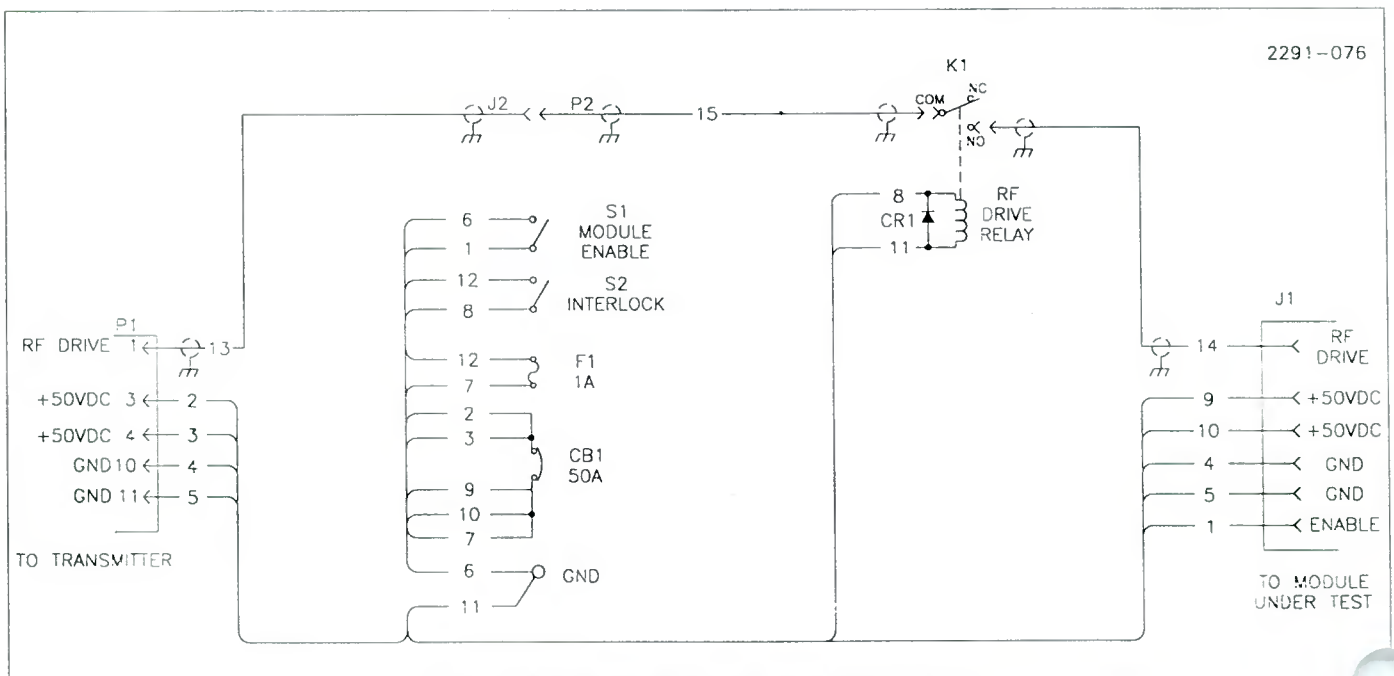

Figure A-6. Wiring Diagram PA Module Extender/ Test Fixture (Harris PN 992-8556-001)

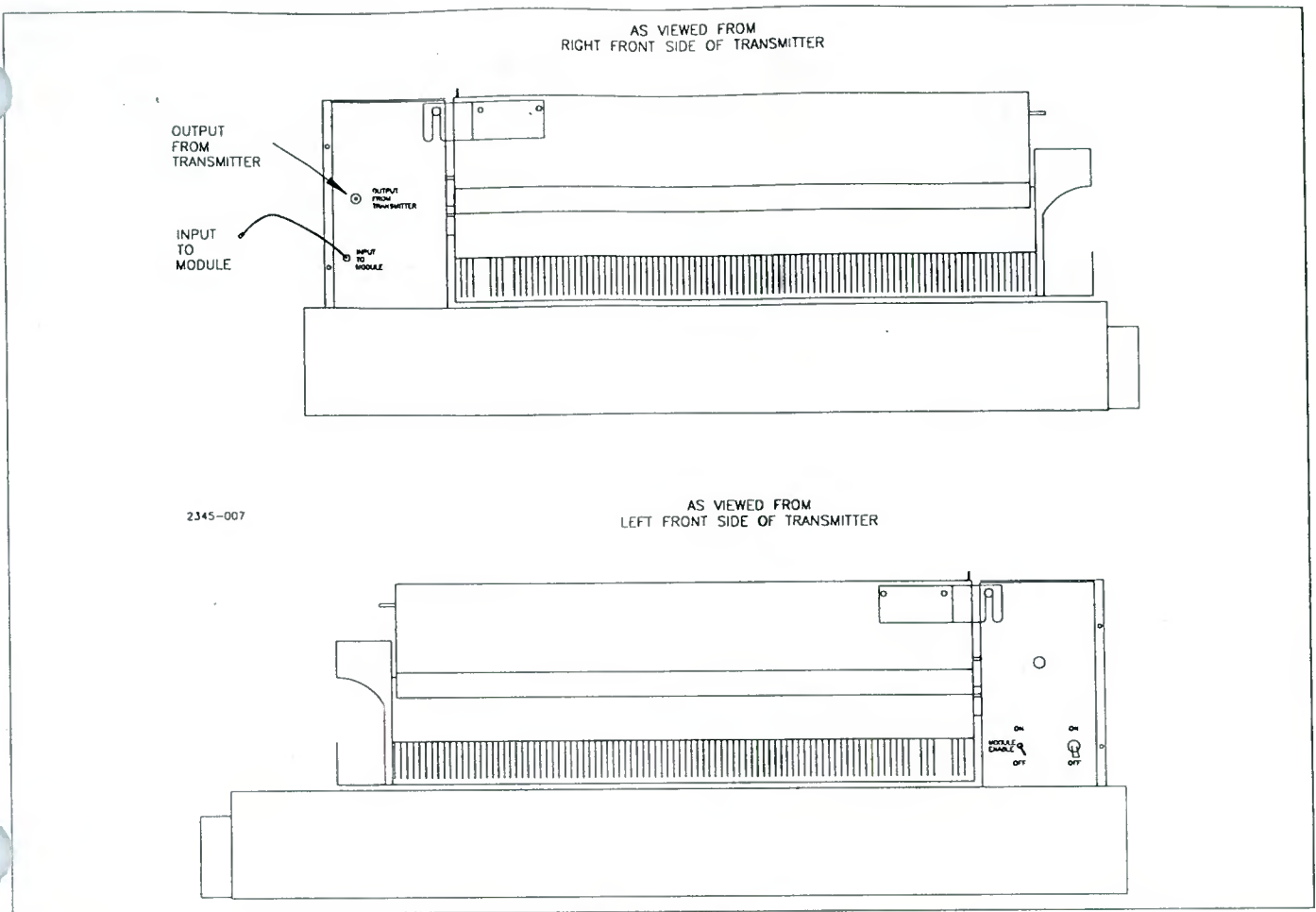

Figure A-7. Module Test Fixture

If this does not locate the problem, then the next step is to check for correct threshold voltages on the module logic board. Fault blink codes result from a sample voltage taken within the module exceeding some preset threshold. Thus, if no other module or system problem is found, the problem may be due to an incorrectly set fault threshold (as in the case of thresholds set with potentiometers), or a defective component (such as a resistor) used to establish a threshold. Section A.2.8, on the theory of operation of the module Protection, Control and Monitor subsystem, gives detailed descriptions of how these thresholds are derived and compared against the corresponding voltage samples.

Finally, if neither of these steps yields success, the problem may lie in a PAL or logic gate on the module control board. This type of problem is generally rare. Measuring voltages at various points in the logic circuitry on the module control board can isolate this type of problem.

A set of troubleshooting procedures, one procedure for each fault code, is given below:

**High Output VSWR Fault (1 blink)** — The cause for this fault is often external to the module. First, check the system VSWR on the display panel, and check for a VSWR foldback or VSWR

overload condition on the transmitter. Check the other modules in the same cabinet for VSWR faults as well. If either is found, suspect a problem in the system outside the cabinets.

If not, then the problem is either in the suspect module or its cabinet. The swap test is the easiest way to isolate the problem, but do so only after reading the precautions in Section A.3.2. After checking for +50 volts on the slot drive connector and module output connector if necessary, swap the VSWR faulting module with a properly working one from another slot. If the problem remains in the same slot, check the RF output cable, connector, and combiner reject load for that module slot.

If the problem follows the module, check the solder connections at the directional coupler and the RF output jack inside the module. If no problem is found, the problem could be an improperly set VSWR fault threshold or a defective module logic board. See paragraphs giving procedure used to check and set the VSWR threshold located on page A- 18.

**Input Overdrive Fault (2 blinks)** — Normally, this protects the module from damage due to excess RF drive (at least 3 dB above the drive required to drive the module to full power). To isolate the cause of fault, reduce the visual exciter RF output to zero, then enable the module with a transmitter ON command. If the

fault remains, the problem is likely to be with the module control board.

If the fault clears when RF drive is removed, check to see that the module is not being overdriven. If not, then the overdrive threshold on the control board may be misadjusted. See procedure located on page A-18 in this section to check the Overdrive Threshold.

**ISO Voltage Fault (3 blinks)** — The RF input to the quarter module passes through a two-way divider on the quarter module,

and is then fed to two parallel amplifiers on the quarter module. The outputs of these two amplifiers are recombined in a two way combiner on the same board. The combiner contains a 10 watt reject load resistor, called an ISO resistor because it is used to provide isolation between the combiner input ports.

If outputs of the two parallel amplifiers are equal in amplitude and phase, the voltage across the ISO resistor will be very small. Should some component fail on one of the amplifiers, its output would decrease to a level much lower than the other parallel

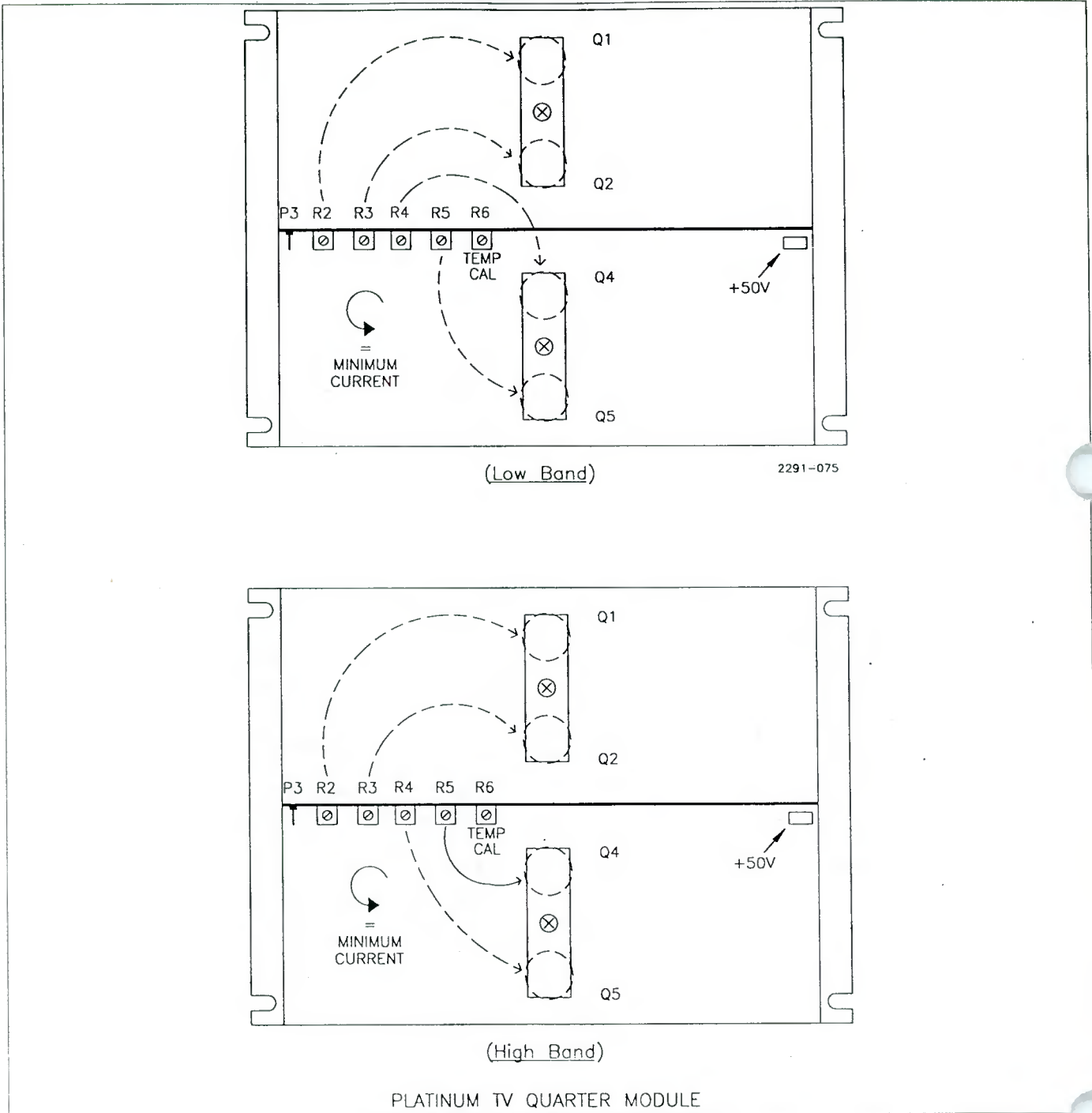

Figure A-8. Quarter Module RF FET Bias Pots

amplifier, which would cause the voltage across the ISO resistor to increase significantly. If the ISO voltage of any quarter module exceeds about 1.9 volts, the control board shuts the power amplifier module down and indicates an ISO fault.

A persistent ISO fault will almost always be caused by a component failure in a quarter module (RF FET, chip cap, ISO resistor, or open solder connection).

Connect a voltmeter (Simpson 260, or other meter not affected by RF) to the ISO sample line. These lines connect to the center boards at P3-3, and the lines from all four boards are tied together at a feedthrough capacitor near the logic board compartment. The voltage on this line is the voltage from the quarter module with the highest ISO voltage. NOTE: The voltages do not “sum” together; only the highest ISO voltage among the quarter modules will be measured. See the procedure located on page A-18 in this section to check for the correct ISO Fault Threshold.

**Power Supply Voltage Fault (4 blinks)** — The RF FET transistors operate on a nominal 50 volt DC supply. If the power supply voltage is too high or too low, the devices could be damaged. The control board monitors the voltage, and reports a power supply voltage fault if it is not between approximately 44 and 54 volts.

If several modules exhibit the same fault, check the voltage of the power supply and look for faulty connections. Remember that heavy current draw could cause the supply voltage to drop significantly lower than that measured with only a voltmeter loading the line. If only one module exhibits the fault, check the DC supply voltage and connections, plus the module power supply pins and the wiring to its slot. If no problem is found in the power supply or connections, then the problem could be on the control board, either in the control logic or the comparator thresholds. See the procedure for checking for correct Over/Under Voltage Fault Threshold located on page A-17 in this section.

**Over Temperature Fault (5 blinks)** — The module can be damaged if it is not cooled properly while operating. To protect the amplifier, each quarter module has a temperature sensing circuit that signals the control board to disable the power amplifier if the temperature of any quarter module temperature exceeds 82°C. When this occurs, the logic disables the module, and commands the red LED to blink five times.

First, check the cabinet air filters and module heatsink for accumulated dust, and check the room ambient temperature. If improper module operation is suspected, allow the module to cool for a time, then try the following: Supply +50 volts to the module and, without enabling it, check the voltages at test point TP-1 on each quarter module center board. This voltage represents the temperature of the heatsink at the location of the temperature sensor. The voltage is calibrated to be 2.5 volts at a temperature of 25°C, and increases 0.1 per 1°C rise. The calibration control is R6 on each center board.

The voltage at TP1 is compared against a reference voltage of 8.2 volts generated by a voltage divider (R16 and R17 on the center board), so also check this reference voltage.

**Pass FET Failure Fault (6 blinks)** — Should one of the pass FET DC switch transistors fail to a shorted condition, the control board will sense it and blink the red LED six times. The pass FETs are 60 amp 100 volt MOSFETs used as DC switches to enable and disable the module as necessary by applying or removing DC from the quarter modules.

#### CAUTION

*IF A PASS-FET FAILURE IS INDICATED, THE MODULE CANNOT BE TURNED OFF EXCEPT BY TURNING OFF THE PA CABINET OR BY DISABLING THE POWER SUPPLY WHICH POWERS THE PA. A MODULE INDICATING PASS-FET FAILURE SHOULD NOT BE REMOVED FOR SERVICE WITH POWER APPLIED, AS COMPONENT DAMAGE COULD RESULT.*

A shorted pass FET (drain-source short) is normally confirmed by measuring the resistance from the red 50 volt wire of any quarter module to the +50 volt pins of the input connector with an ohmmeter.

If open pass FETs are suspected check the voltage at collector (case) of Q1 of the Module Control Board as the module is enabled and disabled. This voltage is fed through resistance to the gate of the pass FETs. When Q1 collector is high (enabled), +50 volts should appear at the quarter modules. When Q1 collector is low (disabled), no voltage should be present at the quarter modules.

If a fault is suspected in the gate voltage circuit, trace signals back through CR4, R58, and C9 to the oscillator U4. Pin 7 should show a triangle wave with peaks at 0 and +15 volts. Buffer U7 pin 14 should be low if enabled. PAL U1 pin 12 should be low if enabled, and +5 volts if disabled.

#### A.3.5 Isolating Other Failures

This section includes troubleshooting procedures for situations where a problem is not indicated as a fault by the module logic and control circuit, and no blink code is given.

**Amplifier Module Will Not Enable, Has 50 Volts Applied To It But No LED's Will Light** — The cause could be a loss of the 15 volt DC supply in the module. Check the following:

If fuse F1 on the module control board is open, check for a short circuit on the 15 volt line after the 15 volt regulator. The short could be on the control board or one of the center boards. Plug P3 can be disconnected at the center boards to aid in isolating the problem.

If resistor R80 on the module control board is open, look at the 15 volt regulator U11 itself. The regulator's tab is internally connected to its output, and thus must be isolated from the chassis. Use an ohmmeter to check whether the regulator tab has shorted to the chassis.

**Amplifier Module Will Not Enable, Has a Steady Red LED Illuminated and Will Not Change to the Green LED Illuminated** — A possible cause could be that the module control board is not receiving the enable command from the slave controller. Try enabling the module on the bench or on extender, or try the swap test after reading the precautions in section A.3.2. If the

module now enables, use a multimeter to check the enable wiring in the transmitter cabinet.

If the module still will not enable while in a different cabinet slot, check the continuity of the yellow enable wire inside the module. This wire runs from the black plastic power connector on the module rear panel to a feedthrough capacitor, then to P1 on the module control board. If this wire is intact, then the module control board is probably defective. The module is normally enabled by grounding this control line.

**Module Has Only 1/2 Green LED Illuminated and Low or No RF Output** — The module has been enabled but little or no RF drive has been applied to the quarter modules. This indication is given only in PA modules; drivers have both green LEDs on during an enable condition, regardless of drive level. This indication is sometimes a normal condition in PA modules used in the drive chain of a transmitter whose output power is significantly below 30 kW.

If this is not the case, then the cause for loss of drive could be either in the module or in the transmitter cabinet. First, check for normal exciter and transmitter output levels.

In low band transmitters, or in high band if +50 volts is not found, and if the exciter drive level seems normal, try the module in a different cabinet slot that is known to have proper RF drive. If the problem doesn't follow the module, then inspect the cables leading to the module RF input for that transmitter slot. If the problem does follow the module, check the RF input cable inside the module, connected between the black power connector on the module inside rear panel and the 4-way power divider. If this connection is good, check the input attenuator.

#### **Module Has Full Green LED Illuminated But No RF Output**

**PA modules:** Since an insufficient drive level causes one of the green LEDs to go out, that cause is ruled out. This condition would most likely be caused by a failure of the pass FET driving circuitry on the module control board. The control board logic has illuminated the green enable LED, but it is not turning on the pass FETs. This will not allow the quarter modules to receive the 50 volts DC that they need in order to operate. See the paragraphs on Pass FET Failure Fault (6 blinks) located on page A-12 in this section.

**Driver modules:** The pass FET driving circuitry could also be the culprit, as in PA modules. In driver modules, however, a more likely cause is insufficient or no drive.

In a low band transmitter, or after checking for +50 volts at the output of a high band driver, try swapping driver modules. If the problem follows the module, check the module RF path, starting with the RF input cable inside the module, then moving to the input attenuator (R4, R5, R6) on the interconnect board, then to the first stage. Also, check the connections between each stage and the next.

If this doesn't isolate the problem, check the DC voltage and current supplied to each quarter module, through the red wire connected to the center board screw terminal TB1. Look for no voltage applied to one stage and/or no current drawn by a quarter

module. If a quarter module indicates 50 volts present but no current, check the 15 volts supplied to the center board through P3, pin5.

If the problem stays in the same transmitter slot, the problem is within the transmitter (AGC module, phase and gain module if present, preamp if present, power divider if parallel drivers are used, or RF cables).

### **A.3.6 Locating Failed RF FETs**

#### **A.3.6.1 DC Resistance Test**

The most common symptom of a bad FET is an ISO fault (3 blinks). Using a Simpson 260 (or equal), measure the DC resistance from the gate to ground of each FET. This is done with the module on the bench with neither RF or DC power applied. Compare the resistance measured from one FET to the next. The resistance indicated will vary with the voltage of the multimeter used. A resistance on one FET significantly lower than the others indicates a bad FET or leakage in a gate chip capacitor.

If no FET indicates a low gate to ground resistance proceed to idle current testing.

#### **A.3.6.2 Idle Current Test**

First, it is necessary to determine the original bias current per FET, and to determine on which quarter module the failed FET lies. For this procedure, no RF drive will be applied; however, a load resistor should still be placed at the module output to prevent oscillation.

Starting with the first quarter module (nearest the logic board) and working toward the front handle, measure the total idle current of each quarter module in turn. Either insert a current meter in line with the 50 volt wire at TB1, or use a clamp-on DC current meter if available. With no RF drive applied, apply 50 volts and enable the module. Note the quarter module current, disable the module, remove the 50 volts and move the current meter to the next quarter module.

If no current meter of sufficient range is available, a small resistance can be placed in series with the 50 V line, and the voltage drop used to calculate current from Ohm's Law ( $I=V/R$ ). Values from 0.1 to 0.2 ohms should be satisfactory. At 0.1 ohms, the voltage drop across the resistor will indicate 0.1 volts for every 1 amp of current. A sensitive digital meter with a millivolts range is needed to use this technique.

After taking the current measurements on each quarter module, determine the correct bias current setting per FET.

The nominal bias current per FET is given in the Table A-2.

Now that the correct bias current is known and the quarter module with failed FET(s) has been located, one can locate the failed FET. Move the current meter to the quarter module showing abnormally low current. Again, apply DC power only and enable the module. While observing idle current, slowly rotate the bias control (R2-R5 on the center board) for each transistor counterclockwise, one at a time; this should reduce the current for the corresponding FET.

If the idle current does not drop when the pot is turned fully counterclockwise, then the RF FET is probably bad. To determine which pot affects the idle current of each FET, refer to Figure A-5. Figure A-5 is a diagram showing the pots on the center board and the corresponding FETs on the main RF board. Note the difference between high band and low band quarter modules.

One other failure which can show the same symptoms on low band quarter modules is a shorted gate-source capacitor, which can prevent a FET from being properly biased. This capacitor (C5, C11, C16, or C22) is a chip capacitor. Before replacing a low band FET, try lifting the chip capacitor and slowly increasing the bias on the corresponding FET. If the correct bias can be set, replace the capacitor.

**Procedure for setting bias current on a quarter module:**

First, determine the correct bias current per FET. Connect a current meter to the quarter module. Next, set the bias pots R2-R5 on the center board fully counterclockwise, apply 50 volts, and enable the module. The current meter connected to the quarter module being adjusted should read almost zero current (less than 20 mA). Slowly turn R2 clockwise to set the current for the first FET, then adjust R3 until a total of twice the current per FET is reached, and so on, until the last FET is adjusted with R5 such that the total current is four times the current per FET.

Example: On a low band class AB stage, after determining that the correct bias for a given quarter module is 400 mA per FET, start with R2-R5 fully counterclockwise. Slowly turn R2 clockwise until 400 mA is reached, then turn R3 clockwise until 800 mA is reached, then R4 until 1.2 A is reached, and finally turn R5, stopping at 1.6 A total.

**CAUTION:** Adjusting the bias pots too far clockwise or too quickly can destroy an RF FET due to excessive current. Go slowly.

## A.4 Parts Replacement Procedures

### A.4.1 Soldering Precautions

Please read the following precautions before attempting any repair activity:

- a. Be sure to use the correct type of solder depending on the repair being made. For soldering coaxial cables, use a SN 96, AG 4 alloy for lowest loss and best mechanical strength. For all other joints, use SN 63, PB 37 for its low melting point.
- b. Always use electrical solder with a rosin flux. Never use plumbing solder or acid fluxes, which can cause copper to corrode. Start with clean, tinned leads, which will minimize the need for flux. If it is necessary to use additional flux, use as little as possible.
- c. Choose the correct soldering equipment for the job. Use tips that are the appropriate size for the components in-

olved. Use a grounded iron when installing static-sensitive components (most semiconductors).

- d. Choose a soldering temperature just hot enough to melt the solder quickly, while as low as possible to prevent damage to the new components. An iron with a temperature adjustment is best. Typical settings are:
  - 650°F for small chip caps
  - 750°F for RF FET tabs
  - 800°F for coax cables and wiring on large pads.
- e. Make the new joint as mechanically sound as possible before making the electrical solder connection. Provide mechanical strain relief for leads on components which are flange-mounted.
- f. Clean all flux residue away from the area when finished. When working around devices where thermal compound is used, be sure not to allow solvents to flow between the device and the heat sink, which can cause the heat sink compound to dissolve.
- g. Be sure to search for and remove solder splashes, solder bridges, loose solder wire or wire lead clippings, and screws before replacing the cover. Loose metal inside the module can lead to short circuits, which can cause serious damage to the module and possible injury.

### A.4.2 Quarter Module Replacement

Platinum II quarter modules can be field replaced with another quarter module FACTORY TUNED to the same channel. The gain of each quarter module is adjusted by the value of the quarter module input pad. The input to output phase relationship is set by TL1, the phase setting coax. This coax must remain with the quarter module, use the replacement cable already attached to the REPLACEMENT quarter module for proper phasing. Replacement quarter modules are furnished with a center card setting the bias for PA usage, for DRIVER usage the bias must be reset.

### A.4.3 RF FET Replacement

**IMPORTANT**

*The RF amplifier FETs are sensitive to damage from static electrical discharge, and should be handled in an anti-static environment. A grounded working surface, grounded iron, and electrostatic discharge bracelet should be used.*

**IMPORTANT**

*IN ORDER TO PROTECT THE NEW FETS FROM ACCIDENTAL DAMAGE TO OVERCURRENT, BE SURE TO TURN OFF THE BIAS (FULLY COUNTER-CLOCKWISE) TO ALL FOUR FET POSITIONS ON THE QUARTER MODULE BEFORE INSTALLING THE NEW FETS.*

**IMPORTANT**

*WHEN CLEANING THE OLD HEATSINK COMPOUND FROM UNDERNEATH THE FET AFTER REMOVAL, USE A SWAB WITH JUST ENOUGH SOLVENT TO CLEAN THE SURFACE. DO NOT USE TOO MUCH SOLVENT, AND DO NOT USE AN AEROSOL SPRAY CLEANER, AS EITHER MAY SEEP UNDERNEATH NEARBY FETS AND DISSOLVE THE THERMAL COMPOUND FROM UNDER THEM, CAUSING PREMATURE FAILURE.*

**WARNING**

RF TRANSISTORS, ISOLATION RESISTORS, AND INPUT ATTENUATORS CONTAIN BERYLLIUM OXIDE (BeO) CERAMIC, A HAZARDOUS MATERIAL. THE LIDS ARE MADE FROM Al<sub>2</sub>O<sub>3</sub> AND ARE HARMLESS. THE BeO IS HARMLESS WHILE INTACT, BUT THE DUST IS TOXIC. AVOID CRUSHING OR BREAKING THE BeO CERAMIC, AND DISPOSE OF FAILED DEVICES PROPERLY.

The Philips FET (ON4402H) is used for both low band and high band modules. Each FET is marked with a gain code and a threshold code. For replacement the gain code is the most important. The quarter module has been assembled in the factory with FET's that have the same gain code. When the quarter module is aligned the gain is set with an attenuator on the input. Therefore the FET being replaced must have the same gain code as the other FET's on the quarter module for proper performance. The gain code is a number (3 through 7) located above and to the left of the ON4402H marking on the cap.

Each gain code has a part number assigned to it. These are shown in the following table:

Gain Code	Harris Part Number
3	380-0737-003
4	380-0737-004
5	380-0737-005
6	380-0737-006
7	380-0737-007

Once a failed FET is isolated, remove it from the board using the following procedure:

- Turn off the bias to all four FETs by rotating the bias control pots counter-clockwise.
- Remove the clamp holding down the transistors.
- Using a 45 watt soldering iron with a wide blunt tip, desolder the leads lifting them with a small knife. It is important to use enough heat to quickly flow the solder and work quickly so as not to damage the foil.
- Remove the old heat sink compound. Use a small amount of solvent, such as Isopropyl Alcohol, on a swab, being careful not to allow it to run. Do not use sprays of any kind, as this may dissolve heat sink compound from underneath nearby FETs.
- Re-flow the solder left on the foil where the tabs will seat. Be sure the surface is smooth and that no solder bridges remain.

To install the new FET:

- Tin the bottom of the FET leads lightly with solder.
- Use the following procedure for filling a syringe with thermal compound.
  - Required Equipment:
    - A 5mL syringe
    - Zinc oxide (Wakefield) thermal compound
    - A stirrer (clean, no lint)
    - A clean cloth
  - Procedure:

- On a clean, dry surface open the heat sink compound jar and stir the compound thoroughly with a clean stirrer. Make sure there is no settling in the compound before proceeding.
  - Assemble the syringe if necessary.
  - Put syringe tip in the compound up to the beginning of the barrel of the syringe.
  - Push and pull plunger several times while the tip is in the compound (2 to 4 times) to make sure there are no air gaps when filling the syringe.
  - With the tip of the syringe still in the compound, begin swirling the tip around in the compound while drawing back the plunger to fill the syringe to 5mL.
  - Remove syringe from compound and clean off carefully with the clean cloth.
- Apply heat sink compound on the RF FET.
    - Required Equipment:
      - Xacto knife (blade #11). Use only a fresh blade for this procedure (no nicks or mars, has not been used for anything else. When in doubt, change the blade)
      - Cleaning solvent
      - Q-tip
      - Wakefield compound in new 5mL syringe
      - A clean cloth
      - ESD equipment**
    - Procedure:
      - Make sure you are ESD safe through the entire procedure.**
      - Take the FET to be installed and make sure the back side is clean. Make sure that the heat sink mounting surface is clean as well. If the surfaces are not clean, clean them with a Q-tip dipped in cleaning solvent. Make sure solvent is dry before proceeding.
      - Get the Xacto knife (blade #11). Only use a clean, fresh blade (this blade should only be used for this procedure). Measure out a small amount (1-2mm from the tip of the syringe) of compound from the dispensing syringe onto the Xacto blade.
      - Apply the compound evenly on the FET by moving the flat side of the blade in a circular motion on the back side of the FET. Clean excess compound off the blade.
      - Holding the Xacto blade at a 45 degree angle or less from the FET's surface, gently press down with the blade edge.
      - Continuing to hold the blade at 45 degrees or less, and starting at one end of the FET, sweep slowly across the FET. Make sure the blade does not lift up. There should be a thin opaque film left on the surface after sweeping. The gold flashed back of the FET is slightly concave, the heat sink compound should be thickest in the center. There should be excess heat sink compound on the blade. Carefully wipe the excess compound off on a clean cloth (do NOT re-use this compound).

- g) Place FET firmly into the holes of the PC board. Try to pull the FET up, applying moderate force. If the FET resists being pulled up, it is well seated. If it is easily pulled up, clean both surfaces, inspect for surface irregularities, and try again.
- d. Install the clamp, making sure the insulating washers remain seated in the counter bored holes. Observe the alignment of the washers and transistor leads as the screw is slowly tightened to 12 inch-pounds torque.
- e. Solder the leads using low-temperature solder. Inspect for solder bridges. Scrape away any flux using a small knife. Do not use any sprays or liquids that may run under the transistor and dissolve the heatsink compound. Inspect for proper flow of solder between the FET leads and the board foil.
- f. Check to see that all bias pots of the quarter module have been turned fully counter-clockwise before applying any power.

Refer to the section on Idle Current Testing to set bias controls.

#### A.4.4 Testing and Replacing Isolation Resistors

##### WARNING

RF TRANSISTORS, ISOLATION RESISTORS, AND INPUT ATTENUATORS CONTAIN BERYLLIUM OXIDE (BeO) CERAMIC, A HAZARDOUS MATERIAL. THE LIDS ARE MADE FROM Al<sub>2</sub>O<sub>3</sub> AND ARE HARMLESS. THE BeO IS HARMLESS WHILE INTACT, BUT THE DUST IS TOXIC. AVOID CRUSHING OR BREAKING THE BeO CERAMIC, AND DISPOSE OF FAILED DEVICES PROPERLY.

In order to test ISO resistors, it is necessary to desolder one of the leads before testing the resistor with an ohmmeter.

When replacing a flange-mounted ISO resistor, bend the resistor leads curving upward slightly to provide mechanical strain relief to allow for differing expansion between the circuit board and the heat sink. Be sure to clean away the old thermal compound from the heat sink surface, and apply just enough compound to the flange of the new device in order to assure a good thermal interface. After applying reasonable torque to the flange screws, solder the leads quickly using a hot iron.

#### A.4.5 Pass FET Replacement

If pass FET replacement is necessary, replace both FETs with the matching parts. If this is not done there may be a tendency for one FET to carry more of the current and lead to a repeated failure.

When pass FETs are replaced, change Q1 and R72 on the Module Control Board, and change the 5.6 ohm resistors and the zener diode on the pass FET buss bar assembly. These parts are typically stressed in the event of pass FET failure and replacing them will promote long term reliability.

Use the same ESD procedures outlined in the section on RF FET replacement. The FET drains are insulated from the chassis with "SIL-PADS", silicon insulating pads that need no heat sink compound.

Before enabling the module, check to see that the drains are not shorted to the chassis using an ohmmeter.

#### A.4.6 Chip Cap Replacement

It is a common technique to use two irons with small tips (one on each side) when removing or installing chip caps. Both sides of the chip cap should be heated simultaneously to avoid residual stresses which might later cause a failure.

Note that the capacitor values listed in the Parts List are typical values. Check the value of the capacitor to be replaced before ordering a replacement part.

### A.5 Test Procedure Solid State TV Modules

Install transmitter section of module extender into transmitter.

Attach RF output cable to module extender through access hole in bottom panel, and connect to wattmeter and 50 ohm load (1kW).

Install input wattmeter. Use RF input access cable on side of test fixture.

Attach extension section and install module onto fixture. (Do not install module protective cover at this time.)

Perform a complete visual inspection of the module to be repaired.

Remove red wire from center board TB1 and install a current meter in line. The current meter needs to be capable of measuring 400 mA steps accurately, and up to 10 Amps total. A clamp-on probe, if available, makes the task easier. Use an ammeter that is resistant to RFI.

#### A.5.1 Pre-operational Checks

##### A.5.1.1 Initial Power Up

Apply 50 volts DC only to module by turning on circuit breaker CB1. (Red LED on module front panel will be on.)

The +5 and +15 volt supplies can be checked when the Module Control Board is "powered up."

##### A.5.1.2 Temperature Sense Sample Voltage

The module should be cooled to room temperature and this procedure performed immediately at turn-on of DC only, before enabling the module.

To calibrate TP1 voltage on center boards first determine the room ambient temperature in Celsius degrees.

Connect a digital voltmeter to TP1 on each center board in turn and adjust R6 for a DC voltage representing the room temperature divided by 10.

Example: For a room temperature of 27 degrees C, adjust R6 for a voltage of 2.7 volts at TP1.

To save time, if a probe to measure temperature is available you may set the voltage based on the temperature of Q3 on the quarter module heat sink.

##### A.5.1.3 Idle Current Check

The module cover section of the extender assembly should be removed so that no RF drive can be applied.



Enable module with "MODULE ENABLE" switch on test fixture. Red LED will extinguish. On PA modules one half of green LED will illuminate. On driver modules both halves of green LED will be on.

Note the current reading of the quarter module. Compare this reading to the values found in the Table A-2 located at the end of this section. Check all four quarter modules.

If quarter module currents are all OK, the module is ready for RF testing. If the current is incorrect, refer to Idle Current Test procedures.

**A.5.1.4 Over/Under Voltage Check**

Since there are no adjustments this is an operational check only. Measure the voltages at U7:

- Pin 4 = 10.3v +/- 0.2v      50 volt supply sample approximately 1/5th ratio
- Pin 5 = 11.1v +/- 0.2v      Over threshold
- Pin 6 = 8.9v +/- 0.2v      Under threshold

To simulate over voltage fault, connect an isolated supply at the junction of R47 and R48. Monitor U7 pin 7 voltage to note trip point.

Inject increasing DC voltage until the circuit trips.

To simulate under voltage fault connect a 100k ohm variable resistor across R47.

Monitor U7 pin 7 and decrease the value of resistance until the circuit trips.

If an external 50 volt source is available to operate the entire module you may check the trip points for operation at 44 volts and 53.5 volts.

**A.5.2 RF Testing**

**CAUTION**

*IF THE UNIT BEING TESTED IS A DRIVER BE SURE IT IS IN A DRIVER POSITION IN THE TRANSMITTER. EXCESSIVE DRIVE WILL DESTROY THE INPUT ATTENUATOR IF A DRIVER IS OPERATED IN A PA SLOT.*

Testing of drivers may be done in a PA slot if the drive cable access loop on the extender is removed and a external source of RF is applied (i.e. the standby exciter in dual configurations).

**Note**

*IF YOU ATTEMPT TO OPERATE A PA IN A DRIVER SLOT, THE DRIVE LEVEL WILL BE INSUFFICIENT TO COMPLETE THE TESTS.*

**A.5.2.1 Application of Drive**

To test a driver module it is recommended to adjust exciter power to minimum before applying RF in the configurations with only one driver in the path.

Install protective cover on the module and note the power output on the watt meter. PA module output should be in proportion to the others in the system.

**A.5.2.2 Gain Check**

PA gain is measured in factory test at visual frequency with carrier only operating at 625 watts.

Low band driver gain is measured at 30 watts average black power. High band driver gain is measured at 150 watts average black power. Black picture (sync and blanking only) is the best approximation for this test. If possible set power out to 625 watts average with a black picture. Turn off transmitter and move the wattmeter to the input. Turn on transmitter and using an element of appropriate range measure the input power.

Calculate gain in dB using  $10 \log(P_{out}/P_{in})$ .

Since the driver input power is in mW, it will be necessary to use a power meter with an appropriate range to measure input power.

Results should be as shown in Table A-2.

**A.5.2.1 Alternate method for measurement under program conditions**

To measure gain insert a directional coupler of sufficient power capacity in the output coax. Note the sample level on a spectrum analyzer or field strength meter. Move the directional coupler to the input access loop and note the drive level.

On field strength meters peak sync levels may be used as the reference with program present but the gain figure may vary slightly from the standard test method. Blanking level can usually be clearly seen on the spectrum display and would be the preferred reference.

**NOTE**

*The remaining tests of this procedure are performed in an Aural slot.*

**INPUT/POWER DIVIDER PWA.**

In Driver modules the pad is constructed using three resistors. The resistors are selected using Table A-2, (817-2100-639) Input Attenuators/Driver.

**A.5.2.3 ISO Volts Check**

Adjust PA power to 1050 watts at aural frequency. For a high band driver use 500 watts aural and for a low band driver use 200 watts.

If necessary manually disable some of the other aural modules to bring the drive level up as required.

Measure the voltage at P3 pin 3 on any one of the four center boards. (They are wired in parallel.)

Verify the value to be 0.3 volts DC or less.

To test the fault threshold, remove the RF Drive.

Using an isolated DC supply (possibly a 9 volt battery and a variable resistance), inject voltage at P3 pin 3 of any quarter module and slowly increase voltage until the module faults.

The module should trip off between 1.7 and 2.1 volts.

**A.5.2.4 Overdrive Check**

Perform this check only after verifying that the module gain adjustment is correct. See paragraph on Gain Check located elsewhere in this section.

Pre-set the Overdrive Pot R101 fully clockwise

Set the input drive on the aural frequency per the following:

MODULE TYPE	DRIVE LEVEL	TRIP TOLERANCE
High Band PA	120 watts	2 watts

Low Band PA                      35 Watts                      1 watt  
 Low and High Band Drivers                      370 milliwatts                      10 milliwatts

To set the trip point adjust R101 CCW until the module faults and gives a blink code 2 on the red LED.

The red LED display has a few seconds time delay before indicating. It may be helpful to observe the power meter or quarter module current which will react instantaneously, while setting the overdrive trip point.

Check the setting by reducing the power, enable the module, and increase power. The drive power level must trip within the allowed tolerance. If not readjust R101 as required.

**A.5.2.5 VSWR Check**

**VSWR Protection Check**

**Precise Method:**

- a. Connect a 50 ohm termination to the module RF input. Connect a signal generator, test amplifier, and power meter to the module output per Figure A-7.
- b. Apply 50 V DC and enable the module.
- c. Set the signal generator to the Aural carrier frequency and apply 94.5 watts CW into the PA module RF output.
- d. Slowly adjust R8 CCW until the module disables and gives a blink code of one on the red LED.
- e. Reduce the signal generator level and enable the module. Slowly raise the signal generator level while monitoring the power applied to the module. The module should disable between 90 and 100 watts. If not, readjust R8 as required.
- f. Turn off the 50 V DC and restore the test setup to normal configuration.

**Alternate Procedure for approximated adjustment**

PAs are set using 1050 watts aural output as the forward reference.

For low band driver use 200 watts and for high band driver 500 watts.

R8 provides a DC offset to allow turn on in a complete transmitter where some crosstalk may exist.

Apply DC (No RF) to module. Adjust R8 for proper voltage at U6-pin 4.

M/NTSC	B/PAL	U6-4 Voltage
2	E2, E3	.35 volts
3	E4	.45 volts
4		.62 volts
5		.75 volts
6		.85 volts
7	E5	.45 volts
8	E6	.55 volts
9	E7	.62 volts
10		.70 volts
11	E8	.77 volts
12	E9	.85 volts
13	E10-E12	.95 volts

Using a test load with low VSWR, measure the DC voltage of the forward sample at the feed through to the logic printed wiring or at junction of R5 and C4 for reference.

At the reflected sample feedthrough or at the anode of CR1 inject a DC voltage. Slowly increase the voltage until the module faults.

It should trip at a voltage 0.84 times the reference +/-10%.

To adjust the trip threshold set the supply to a voltage 0.84 times the forward reference and adjust R101 until the module faults off.

This accounts for the 6 dB pad on the forward sample line and scales the trip point to be the equivalent of 2.5:1 VSWR.

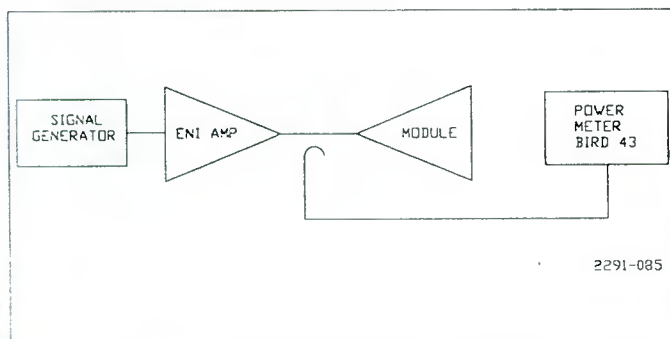
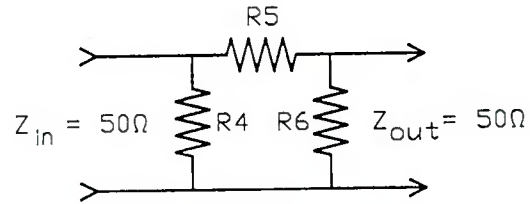

Figure A-9. VSWR Protection Test Setup

Atten.	R4 and R6	R5
0.5	1740 Ω 548-1390-000	2.87 Ω 548-2268-000
1.0	866 Ω 548-2280-000	5.76 Ω 548-2269-000
1.5	576 Ω 548-2279-000	8.66 Ω 548-2270-000
2.0	432 Ω 548-0856-000	11.5 Ω 548-2193-000
2.5	348 Ω 548-2267-000	14.7 Ω 548-2254-000
3.0	294 Ω 548-1991-000	17.8 Ω 548-2194-000
3.5	249 Ω 548-0712-000	20.5 Ω 548-2256-000
4.0	221 Ω 548-0839-000	23.7 Ω 548-2195-000
4.5	196 Ω 548-2266-000	26.7 Ω 548-2271-000
5.0	178 Ω 548-2053-000	30.1 Ω 548-2196-000
5.5	162 Ω 548-0828-000	34.0 Ω 548-2258-000
6.0	150 Ω 548-2207-000	37.4 Ω 548-2197-000
6.5	140 Ω 548-1047-000	41.2 Ω 548-2272-000
7.0	130 Ω 548-0227-000	45.3 Ω 548-2198-000
7.5	124 Ω 548-0332-000	48.7 Ω 548-2260-000
8.0	115 Ω 548-0581-000	52.3 Ω 548-2199-000
8.5	110 Ω 548-0276-000	57.6 Ω 548-2273-000
9.0	105 Ω 548-2203-000	61.9 Ω 548-0665-000
9.5	100 Ω 548-0363-000	66.5 Ω 548-2261-000
10.0	95.3 Ω 548-2202-000	71.5 Ω 548-2200-000
10.5	93.1 Ω 548-0814-000	76.8 Ω 548-2263-000
11.0	88.7 Ω 548-0754-000	82.5 Ω 548-0703-000
11.5	86.6 Ω 548-0813-000	86.6 Ω 548-0813-000
12.0	82.5 Ω 548-0703-000	93.1 Ω 548-0814-000
12.5	80.6 Ω 548-0372-000	100 Ω 548-0363-000
13.0	78.7 Ω 548-2201-000	107 Ω 548-2204-000
13.5	76.8 Ω 548-2263-000	113 Ω 548-2264-000
14.0	75.0 Ω 548-0576-000	121 Ω 548-2205-000
14.5	73.2 Ω 548-2262-000	127 Ω 548-2265-000
15.0	71.5 Ω 548-2200-000	137 Ω 548-2206-000

Atten.	R4 and R6	R5
15.5	69.8 Ω 548-0811-000	143 Ω 548-2276-000
16.0	68.1 Ω 548-0753-000	154 Ω 548-2074-000
16.5	68.1 Ω 548-0753-000	162 Ω 548-0828-000
17.0	66.5 Ω 548-2261-000	174 Ω 548-2277-000
17.5	64.9 Ω 548-2275-000	182 Ω 548-0756-000
18.0	64.9 Ω 548-2275-000	196 Ω 548-2266-000
18.5	63.4 Ω 548-2274-000	205 Ω 548-2278-000
19.0	61.9 Ω 548-0665-000	221 Ω 548-0839-000
19.5	61.9 Ω 548-0665-000	232 Ω 548-2054-000
20.0	61.9 Ω 548-0665-000	249 Ω 548-0712-000

CURRENT REVISION 0				DWG. NO. 817-2100-639			
ZONE	LTR	DATE	REVISION	DFTM	ENG	ECN	
.	.	.	.	.	.	.	
.	.	.	.	.	.	.	



NOTE: Not all applications will use the same Resistor Reference Designators as shown above.

QTY.	HOLE	DESCRIPTION
UNLESS NOTED: DIMENSIONS ARE IN INCHES TOLERANCES: .X ± .030 .XX ± .015 .XXX ± .005 ANGLES ± 1 DEG.		
THIS DOCUMENT CONTAINS PROPRIETARY DATA OF HARRIS CORPORATION. NO DISCLOSURE, REPRODUCTION, OR USE OF ANY PART THERE OF MAY BE MADE EXCEPT BY WRITTEN PERMISSION.		
DR. BY R.J. Crockett	TITLE	
ENG. CHK. R.J. Crockett	Assembly Instruction	
PROJ. ENG. Mortimore	Input Attenuator	
MFG. ENG. R.J. Crockett		
MAT'L.	SHEET 1 OF 1	DWG. NO. 817-2100-639

Table A-1. Input Attenuators

Table A-2. Summary of Module Specifications

SUMMARY OF MODULE SPECIFICATIONS					
MODULE BIAS (Quarter module #1 is next to module logic board)					
(Quarter module #4 is next to the front panel)					
	QM#1	QM#2	QM#3	QM#4	
992-8569-002 thru 112					
LB DRIVER (50-88)	1.0 A	1.0 A	NONE	1.0 A	
HB DRIVER (175-216)	0.40 A	0.40 A	1.0 A	1.0 A	
HB DRIVER (216-230)	0.40 A	0.40 A	1.0 A	1.0 A	
992-8793-002 thru 112					
LB 525W PA (50-88)	0.4 A	0.4 A	NONE	1.0 A	
HB 525W PA (175-216)	0.4 A	0.4 A	1.0 A	1.0 A	
HB 525W PA (216-230)	0.35 A	0.35 A	1.0 A	1.0 A	
992-8564-002 thru 112					
LB PWR AMP (50-88)	0.4 A	0.4 A	0.4 A	0.4 A	
HB PWR AMP (175-216)	0.4 A	0.4 A	0.4 A	0.4 A	
HB PWR AMP (216-230)	0.4 A	0.4 A	0.4 A	0.4 A	
	GAIN (dB)		Visual-AVG PWR-Aural		
	VISUAL	AURAL	NTSC	PAL	
992-8569-002 thru 112					
LB DRIVER (50-88)	35±0.5	35±1.5	30	28	200
HB DRIVER (175-216)	35±0.5	35±1.5	150	142	500
HB DRIVER (216-230)	35±0.5	35±1.5	150	142	500
992-8793-002 thru 112					
LB 525W PA (50-88)	35±0.5	35±1.5	312	298	525
HB 525W PA (175-216)	35±0.5	35±1.5	312	298	525
HB 525W PA (216-230)	35±0.5	35±1.5	312	298	525
992-8564-002 thru 112					
LB PWR AMP (50-88)	18.5±0.5	16.8-19.5	625	595	1050
HB PWR AMP (175-216)	13.7±0.5	12.0-14.7	625	595	1050
HB PWR AMP (216-240)	13.7±0.5	12.0-14.7	625	595	1050
992-8569-002 thru 112	OVERDRIVE FAULT		REVERSE POWER (VSWR) TRIP		
LB DRIVER (50-88)	140 mw CW		45 - 55 Watts CW		
HB DRIVER (175-216)	350 mw CW		45 - 55 Watts CW		
HB DRIVER (216-230)	350 mw CW		45 - 55 Watts CW		
992-8793-002 thru 112					
LB 525W PA (50-88)	370 mw CW		45 - 55 Watts CW		
HB 525W PA (175-216)	370 mw CW		45 - 55 Watts CW		
HB 525W PA (216-230)	370 mw CW		45 - 55 Watts CW		
992-8564-002 thru 112					
LB PWR AMP (50-88)	35±1 Watts CW		90 - 100 Watts CW		
HB PWR AMP (175-216)	120±2 Watts CW		90 - 100 Watts CW		
HB PWR AMP (216-240)	120±2 Watts CW		90 - 100 Watts CW		

## Appendix B Replaceable Parts List

### Table B-0. Replaceable Parts List Index

Table B-1.	<b>MODULE, RF, BASIC LB1 -</b> . . . . .	992 8561 102	B-2
Table B-2.	DIVIDER, 2-WAY, LB1 - . . . . .	992 8557 102	B-3
Table B-3.	COMB, LB1, 2 X 2 WAY - . . . . .	992 8558 102	B-4
Table B-4.	COMB, LB1, 2-WAY - . . . . .	992 8559 102	B-4
Table B-5.	DIVIDER, LB1, 2 X 2 WAY - . . . . .	992 8560 102	B-4
Table B-6.	<b>MODULE, RF, BASIC LB2 -</b> . . . . .	992 8561 104	B-4
Table B-7.	DIVIDER, LB2, 2-WAY, SSTV - . . . . .	992 8557 104	B-6
Table B-8.	COMB, LB2, 2X2 WAY, SSTV - . . . . .	992 8558 104	B-6
Table B-9.	COMB, LB2, 2-WAY, SSTV - . . . . .	992 8559 104	B-6
Table B-10.	DIVIDER, LB2, 2X2 WAY - . . . . .	992 8560 104	B-6
Table B-11.	DC PWA, LB COUPLER - . . . . .	992 8843 001	B-7
Table B-12.	ATTENUATOR,SELECT IN TEST - . . . . .	917 2100 612	B-7
Table B-13.	<b>1/4 MOD, BASIC, LB -</b> . . . . .	992 8562 102	B-7
Table B-14.	PWA, RF, 1/4 MODULE LB - . . . . .	992 8566 102	B-8
Table B-15.	PWA, CENTER, 1/4 MODULE - . . . . .	992 8571 001	B-8
Table B-16.	ATTENUATOR,UNBALANCED PIE - . . . . .	917 2100 639	B-9
Table B-17.	ATTENUATOR,SELECT IN TEST - . . . . .	917 2100 612	B-11
Table B-18.	DR MODULE, RF, BASIC LB1 - . . . . .	992 8570 102	B-11
Table B-19.	DC PWA, LB COUPLER - . . . . .	992 8843 001	B-13
Table B-20.	<b>MODULE, RF, BASIC HB -</b> . . . . .	992 8561 007	B-13
Table B-21.	DIVIDER, HB, 2-WAY - . . . . .	992 8557 007	B-15
Table B-22.	COMBINER, HB 2 X 2 WAY - . . . . .	992 8558 007	B-15
Table B-23.	COMB, HB, 2-WAY - . . . . .	992 8559 007	B-15
Table B-24.	DIVIDER, HB, 2 X 2 WAY - . . . . .	992 8560 007	B-15
Table B-25.	DC PWA, HB COUPLER - . . . . .	992 8844 001	B-15
Table B-26.	<b>1/4 MOD, BASIC, HB -</b> . . . . .	992 8562 007	B-16
Table B-27.	PWA, RF, 1/4 MODULE - . . . . .	992 8566 007	B-16
Table B-28.	PWA, CENTER, 1/4 MODULE - . . . . .	992 8571 001	B-17
Table B-29.	DR MODULE, RF, BASIC HB - . . . . .	992 8570 007	B-18
Table B-30.	TAPE SWITCH ASSY - . . . . .	917 2100 146	B-20
Table B-31.	PWA, LED BOARD - . . . . .	992 8023 001	B-20
Table B-32.	PWA, LOGIC BOARD - . . . . .	992 8127 001	B-20

**Table B-1. MODULE, RF, BASIC LB1 - 992 8561 102**

HARRIS P/N	DESCRIPTION	QTY/UM	REF. SYMBOLS/EXPLANATIONS
054 0014 103	CARTON, SHIPPING	1 ..	
054 0014 107	INSERT, FOAM PACKAGING	1 .. ST	
252 0414 000	WIRE, STRD 22AWG GREEN	.5 .. FT	
252 0415 000	WIRE, STRD 22AWG YELLOW	.5 .. FT	
252 0417 000	WIRE, STRD 22AWG RED	.5 .. FT	
252 0419 000	WIRE, STRD 22AWG BLACK	.5 .. FT	
252 0420 000	WIRE, RIBBON 5 X 100 MIL	.4 .. FT FT #TO/FROM 1/4 MODS	
252 0423 000	TEFLON INSULATED HOOK-UP	2 .. FT	
302 0051 000	SCR, 4-40 X 3/16	1 ..	
302 0052 000	SCR, 4-40 X 1/4	11 ..	
302 0053 000	SCR, 4-40 X 5/16	3 ..	
302 0106 000	SCR, 6-32 X 3/8	5 ..	2# OUTPUT COUPLER
302 0108 000	SCR, 6-32 X 1/2	10 ..	2# I/O CONNECTOR 8# COVER
302 0351 000	SCR, 4-40 X 1/2	2 ..	PASS FETS
302 0364 000	SCR, 4-40 X 3/16	11 ..	3# LOGIC CHASSIS, 2# LOGIC COVER 6# CHASSIS COVER
302 0378 000	SCR, 4-40 X 3/4	2 ..	
302 0380 000	SCR, 6-32 X 5/16	11 ..	#FRONT PANEL
302 0401 000	SCR, 4-40 X 1/4	6 ..	
306 0003 000	NUT, HEX 4-40	4 ..	2 PASS FET 2 BUSS BAR
306 0004 000	NUT, HEX 6-32	3 ..	
306 0071 000	NUT, HEX #6-32 UNDERSIZE	16 ..	
306 0072 000	NUT, HEX #4-40 UNDERSIZE	3 ..	3# RF LOADS
310 0003 000	WASHER, FLAT NO. 4	15 ..	
310 0012 000	WASHER FLAT 6	46 ..	2# MAIN CONNECTOR, #5 - 2 X 2 COMBINER #5 - 2 X 2 DIVIDER, #5 - 2-WAY COMBINER #5 - 2-WAY DIVIDER, 8# COVER, 20# PWB, 16# 1/4 MODULES
310 0017 000	WASHER FLAT #6	6 ..	#2 FILTER BRACKET #3 DIRECTIONAL COUPLES #1 LOGIC COVER
312 0006 000	WASHER, INT LOCK 8	21 ..	#508-0560-000
314 0003 000	WASHER, SPLIT-LOCK 4	21 ..	
314 0005 000	WASHER, SPLIT-LOCK 6	45 ..	
314 0037 000	WASHER, SPLIT-LOCK 4 SS	9 ..	#9 LOAD RESISTORS
336 1239 000	SCREW 6-32 X 3/8	12 ..	5# 2 X 2 DIVIDER 5# 2 X 2 COMBINER 2# FILTER BRKT
344 0009 000	SCREW, SET 8-32 X 3/16	2 ..	#EXT/FLAPPER
350 0105 000	RIVET 3/16 ALUM .126/.25	4 ..	4# FRONT PANEL
350 0155 000	RIVET POP .156 X .392	10 ..	5# DIVIDER PWB 5# COMBINER PWB
354 0386 000	TERM, LOCKING #10 RING	1 ..	#FRONT PANEL
356 0235 000	CABLE TIE 0.75" DIA.	20 ..	
356 0237 000	CLAMP CABLE 1/4" DIA	1 ..	#TAPE SWITCH
380 0715 000	XSTR MOSFET IXTH67N10 ESD	2 ..	Q001 Q002
384 0831 000	LED LIGHT BAR MOUNT	2 ..	
386 0438 000	ZENER, 1N5243, 13V 0.5W	1 ..	#BUSS BAR CR001
410 0335 000	INSULATOR SCREW	1 ..	#A2U011
410 0413 000	INSULATOR PAD FOR TO-247	3 ..	#A2U011, 2# PASS FETS
410 0414 000	THERMAL PAD 1.000 X .800	2 ..	
414 0214 000	TOROID FERRAMIC	6 ..	L006 L007 L008 L009 L010 L011 L014 L015 L016 L017
414 0292 000	CORE, BALUN 2500 PERM	4 ..	
424 0013 000	GROMMET .381 MTG DIA	1 ..	
424 0598 000	BUSHING, SPLIT, GUIDE PIN	2 ..	
508 0560 000	CAP, FEEDTHRU 1000PF	21 ..	C001 C002 C003 C004 C005 C006

	C007 C008 C009 C010 C011 C012
	C013 C014 C015 C016 C017 C018
	C019 C020 C022
508 0561 000 . EMI FILTER FEEDTHRU . . . . .	2... FL001 FL002
516 0417 000 . CAP 1000PF 10% 200V . . . . .	2... C023 C028
516 0831 000 . CAP 0.010UF 10% 100V . . . . .	4... 4# BUSS BAR, C024, C025,C026, C027
519 0011 000 . CAP RF CHIP 2.4PF 500V . . . . .	1... A5A1C003
540 0858 000 . RES 5.6 OHM 1/4W 5% . . . . .	2... #PASS FET, R001, R002
544 1654 000 . RES 100 OHM 250W 5% RF . . . . .	3... A5R001 A6R001 A6R002
544 1660 000 . RES 100 OHM 20W 5% . . . . .	3... A4R001 A4R002 A3R001
620 2536 001 . PLUG, PANEL COAXIAL . . . . .	1... J001
646 0665 000 . INSPECTION LABEL . . . . .	1...
646 1519 000 . LABEL, RF RADIATION WARN . . . . .	1...
843 4999 503 . FAMILY TREE, LB1 & LB2 PA. . . . .	0...
843 4999 528 . PWB, PASS FET GATE BIAS . . . . .	1...
843 4999 533 . SCHEMATIC, PA MODULE . . . . .	0...
917 2100 146 . TAPE SWITCH ASSY . . . . .	1...
917 2100 385 . WIRE ASSY, LOGIC PWA TO . . . . .	1...
917 2100 386 . CABLE, LED BOARD . . . . .	1...
917 2100 627 . CABLE ASSEMBLY, DC FEED . . . . .	1...
917 2100 654 . WIRE ASSY, . . . . .	1...
917 2100 655 . MAIN I/O CONN ASSY . . . . .	1...
939 7900 054 . EXTRUSION, FLAPPER . . . . .	1...
943 4999 084 . MODULE FACE EXTRUSION . . . . .	1...
943 4999 452 . LOGIC COVER . . . . .	1...
943 4999 453 . LOGIC COVER PLATE . . . . .	1...
943 4999 454 . MODULE FRONT PANEL . . . . .	1...
943 4999 455 . CHASSIS, MODULE . . . . .	1...
943 4999 456 . MODULE COVER . . . . .	1...
943 4999 518 . BUSS BAR, DC (VERTICAL) . . . . .	2...
943 4999 526 . INSULATOR, BUSS BAR . . . . .	3...
943 4999 543 . CABLE, LOGIC PWA TO 1/4 . . . . .	1...
943 4999 585 . ANGLE, HEATSINK MOUNTING . . . . .	2...
943 5140 015 . SPACER, INSULATOR . . . . .	2... #BUSS BAR
992 8023 001 . PWA, LED BOARD . . . . .	1... A007
992 8127 001 . PWA, LOGIC BOARD . . . . .	1... A002
992 8557 102 . DIVIDER, 2-WAY, LB1 . . . . .	1... A003
992 8558 102 . COMB, LB1, 2 X 2 WAY . . . . .	1... A006
992 8559 102 . COMB, LB1, 2-WAY . . . . .	1... A005
992 8560 102 . DIVIDER, LB1, 2 X 2 WAY . . . . .	1... A004
992 8565 102 . COUPLER ASSY, LB . . . . .	1... A001, NEED NEW NO. L.W.

**Table B-2. DIVIDER, 2-WAY, LB1 - 992 8557 102**

HARRIS P/N	DESCRIPTION	QTY/UM	REF. SYMBOLS/EXPLANATIONS
000 0000 010 .	B/M NOTE: . . . . .	0...	THIS ITEM USED AT HIGHERLEVEL, RES, 100 OHM, 20W, R001, 544-1660-000
384 0321 000 .	DIODE 5082-2800/1N5711 . . . . .	1...	CR001
515 0038 000 .	CAP CHIP 22PF 5% 50V . . . . .	1...	C001
515 0041 000 .	CAP CHIP 39PF 5% 50V . . . . .	1...	C002
516 0417 000 .	CAP 1000PF 10% 200V . . . . .	1...	C003
540 0912 000 .	RES 1.0K OHM 1/4W 5% . . . . .	1...	R003
548 0049 000 .	RES 100 OHM .5W 1% . . . . .	1...	R002
843 4999 492 .	PWB, DIVIDER 2-WAY . . . . .	1...	